

Motors

MCM synchronous servo motors

0.6 ... 26.4 Nm

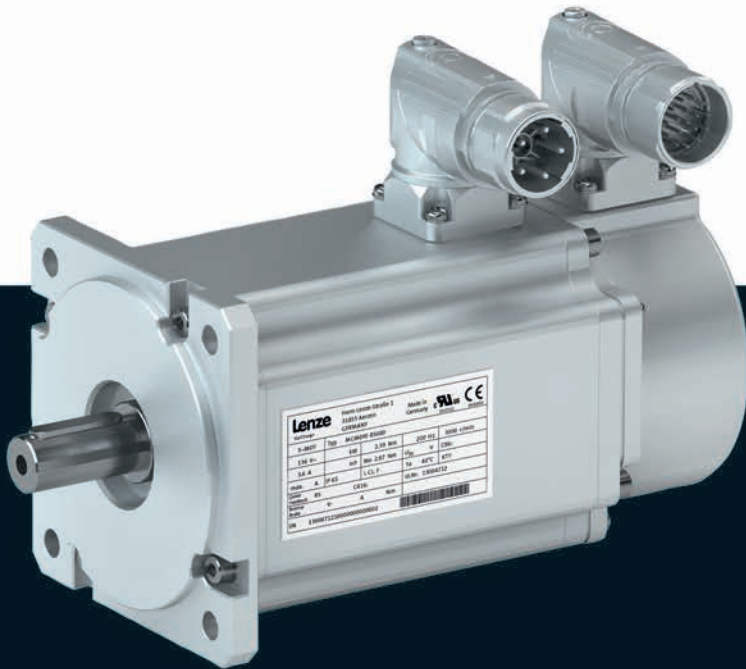

MCM synchronous servo motors



Contents

General information	List of abbreviations	5.2 - 4
	Product key	5.2 - 6
	Product information	5.2 - 7
	Functions and features	5.2 - 8
	Dimensioning	5.2 - 9
Technical data	Standards and operating conditions	5.2 - 13
	Permissible radial and axial forces	5.2 - 14
	Rated data, non-ventilated	5.2 - 15
	Selection tables, Servo-Inverter i700	5.2 - 16
	Selection tables, Servo Drives 9400 HighLine	5.2 - 17
	Selection tables, Inverter Drives 8400 TopLine	5.2 - 18
	Torque characteristics	5.2 - 19
	Dimensions, self-ventilated	5.2 - 23
Accessories	Spring-applied holding brake	5.2 - 27
	Resolver	5.2 - 29
	SinCos absolute value encoder	5.2 - 30
	Temperature monitoring	5.2 - 31
	ICN connector	5.2 - 32

MCM synchronous servo motors

General information



List of abbreviations

$\eta_{100\%}$	[%]	Efficiency
$\cos \phi$		Power factor
du/dt	[kV/ μ s]	Insulation resistance
$F_{ax,-}$	[N]	Min. axial force
$F_{ax,+}$	[N]	Max. axial force
$f_{in,max}$	[Hz]	Max. input frequency
f_{max}	[kHz]	Limit frequency
f_{max}	[kHz]	Max. switching frequency
f_N	[Hz]	Rated frequency
F_{rad}	[N]	Max. radial force
H_{max}	[m]	Site altitude
I_0	[A]	Standstill current
I_{max}	[A]	Max. short-time DC-bus current
I_{max}	[A]	Max. current
I_{max}	[A]	Max. current consumption
I_{max}	[A]	Max. current
I_{max}	[A]	Max. DC-bus current
I_N	[A]	Rated current
J	[kgcm ²]	Moment of inertia
J_{MB}	[kgcm ²]	Moment of inertia
$KE_{LL\ 150\ ^\circ C}$	[V/(1000 r/min)]	Voltage constant
$Kt_{0\ 150\ ^\circ C}$	[Nm/A]	Torque constant
L	[mH]	Mutual inductance
$L_{1\sigma}$	[mH]	Stator leakage inductance
$L_{2\sigma}$	[mH]	Rotor leakage inductance
L_N	[mH]	Rated inductance
m	[kg]	Mass
M_0	[Nm]	Stall torque
$M_{0,max}$	[Nm]	Max. standstill torque
M_{av}	[Nm]	Average dynamic torque
M_{max}	[Nm]	Max. torque
M_N	[Nm]	Rated torque
n_{eto}	[r/min]	Transition speed
n_k	[r/min]	Speed
n_{max}	[r/min]	Max. speed

n_N	[r/min]	Rated speed
P_N	[kW]	Rated power
Q_E	[J]	Maximum switching energy
R	[Ω]	Insulation resistance
R	[Ω]	Min. insulation resistance
R_1	[Ω]	Stator impedance
R_2	[Ω]	Charging resistor
R_2	[Ω]	Rotor impedance
$R_{UV\ 150\ ^\circ C}$	[Ω]	Stator impedance
$R_{UV\ 20\ ^\circ C}$	[Ω]	Stator impedance
$S_{h\u00fc}$	[1/h]	Transition operating frequency
T	[$^\circ C$]	Operating temperature
T	[$^\circ C$]	Rated temperature
T	[$^\circ C$]	Max. ambient temperature of bearing
T	[$^\circ C$]	Max. surface temperature
T	[$^\circ C$]	Max. ambient temperature for transport
T	[$^\circ C$]	Min. ambient storage temperature
T	[$^\circ C$]	Min. ambient temperature for transport
T	[$^\circ C$]	Ambient temperature
t_1	[ms]	Engagement time
t_2	[ms]	Disengagement time
$T_{opr,max}$	[$^\circ C$]	Max. ambient operating temperature
$T_{opr,min}$	[$^\circ C$]	Min. ambient operating temperature
$U_{in,max}$	[V]	Max. input voltage
$U_{in,min}$	[V]	Min. input voltage
U_{max}	[V]	Max. mains voltage
U_{max}	[V]	Min. input voltage
U_{min}	[V]	Min. mains voltage
$U_{N, AC}$	[V]	Rated voltage
$U_{N, DC}$	[V]	Rated voltage
Z_{ro}	[Ω]	Rotor impedance
Z_{rs}	[Ω]	Impedance
Z_{so}	[Ω]	Stator impedance

MCM synchronous servo motors

General information



List of abbreviations

CE	Communauté Européenne
CSA	Canadian Standards Association
DIN	Deutsches Institut für Normung e.V.
EMC	Electromagnetic compatibility
EN	European standard
EAC	Customs union Russia / Belarus / Kazakhstan certificate
IEC	International Electrotechnical Commission
IM	International Mounting Code
IP	International Protection Code
NEMA	National Electrical Manufacturers Association
UkrSEPRO	Certificate for Ukraine
UL	Underwriters Laboratory Listed Product
UR	Underwriters Laboratory Recognized Product
VDE	Verband deutscher Elektrotechniker (Association of German Electrical Engineers)

MCM synchronous servo motors

General information



Product key

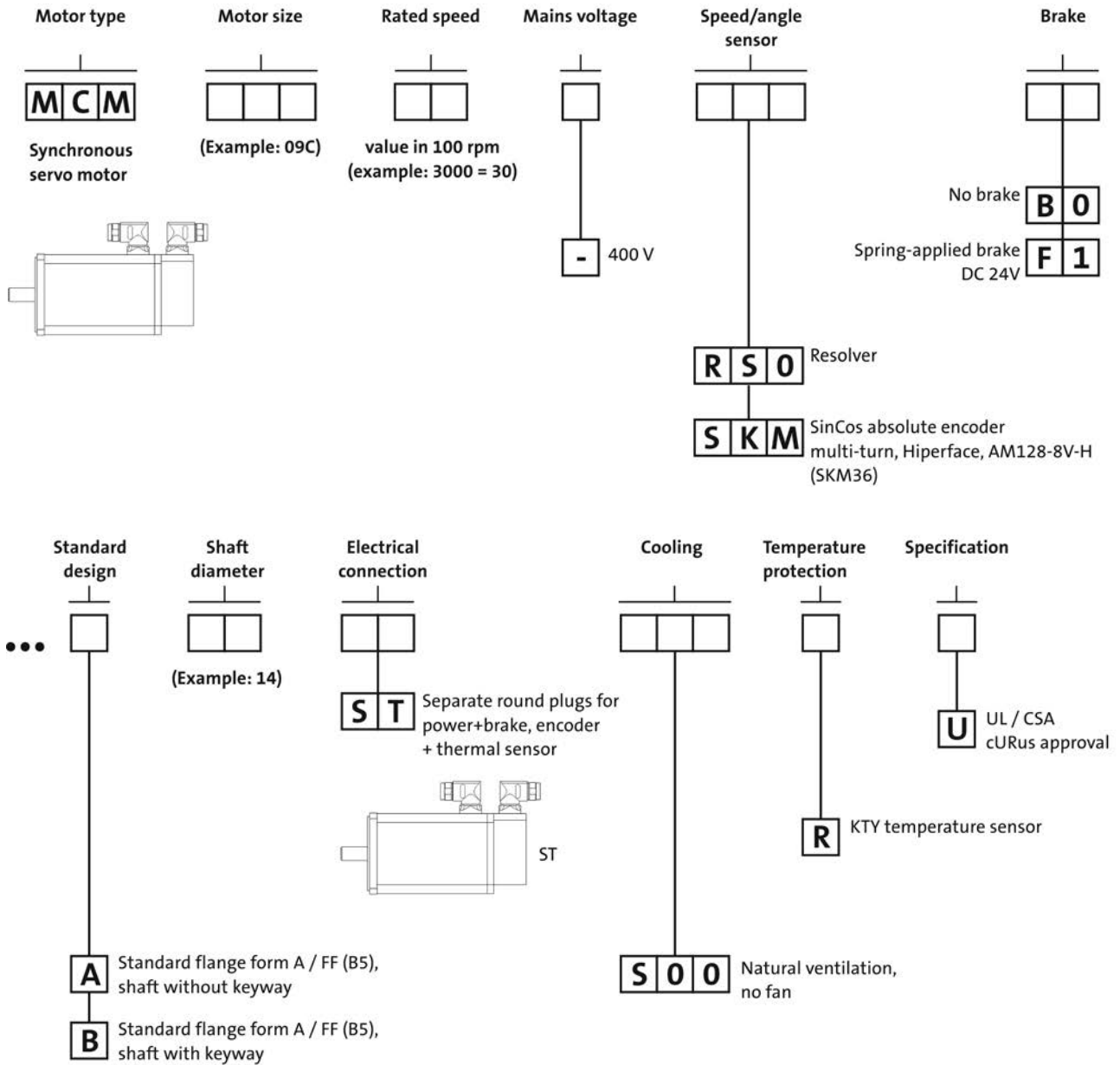

5.2

MCM synchronous servo motors

General information



Product information

MCM – the compact synchronous servo motor for applications in positioning, robotics and packaging technology as well as handling systems. In combination with the Servo-Inverters i700, 9400 and 8400 TopLine, the MCM is a powerful drive component within a torque range of 0.6 to 26.4 Nm.

Advantages

- Easy controllability thanks to a favourable mass inertia ratio of the load and the motor
- Excellent smooth running characteristics for exact work results
- A smooth surface of the housing provides for the use in the food industry
- Simplicity thanks to robust resolvers as standard and multiturn SinCos encoders
- Easy installation and servicing thanks to SpeedTec connectors with rotary connector boxes

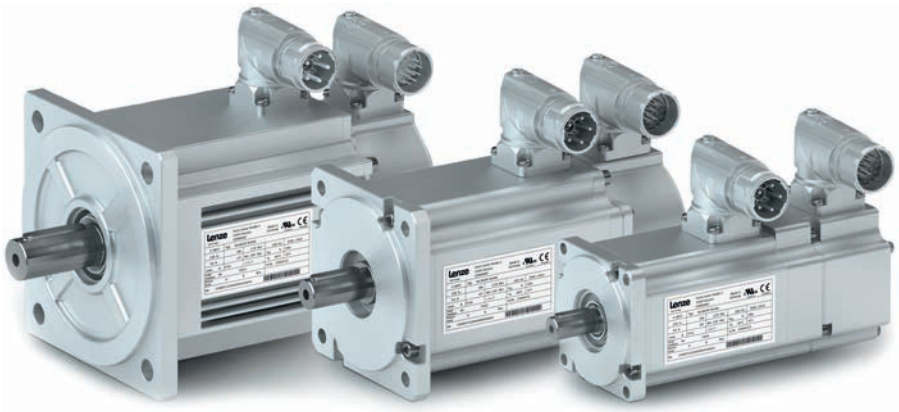

MCM12/MCM09/MCM06 synchronous servo motors

MCM synchronous servo motors

General information



Functions and features

	MCM06	MCM09	MCM12
Design			
	B5-FF75	B5-FF100	B5-FF130
Shaft end (with and without keyway)			
	11 x 23	14 x 30	19 x 40
A end shield	Not oil-tight		
Brake	DC 24 V		
Spring-applied brake			
Speed and angle encoder	Resolver SinCos multi-turn		
Cooling	Naturally ventilated		
Without blower			
Temperature sensor	KTY		
Thermal detector			
Motor connection: plug connector	Power + brake Encoder + thermal sensor		
Shaft bearings	Deep-groove ball bearing with high-temperature resistant grease, sealing disc or cover plate		
Bearing type			
Position of the locating bearing	Non-drive end		
Colour	Not coated		Primed

MCM synchronous servo motors



General information

Dimensioning

Cooling effect of mounting flange

Mounting on a thermally conducting / insulating plate or machine chassis has an influence on heating up the motor, particularly when using naturally ventilated motors.

The motor rating data specified in the catalogue applies when mounting on a steel plate with free convection with the following dimensions:

- MCM06: 270 x 270 mm
- MCM09: 330 x 330 mm
- MCM12: 450 x 450 mm

Vibrational severity

		MCM06	MCM09	MCM12
Vibrational severity				
IEC/EN 60034-14			A	
Maximum r.m.s. value of the vibration velocity	[mm/s]		1.60	

¹⁾ Free suspension

- ▶ at n = 600 to 3,600 rpm

MCM synchronous servo motors

General information



Dimensioning

Concentricity and axial run-out of the mounting flanges and smooth running of the shaft ends

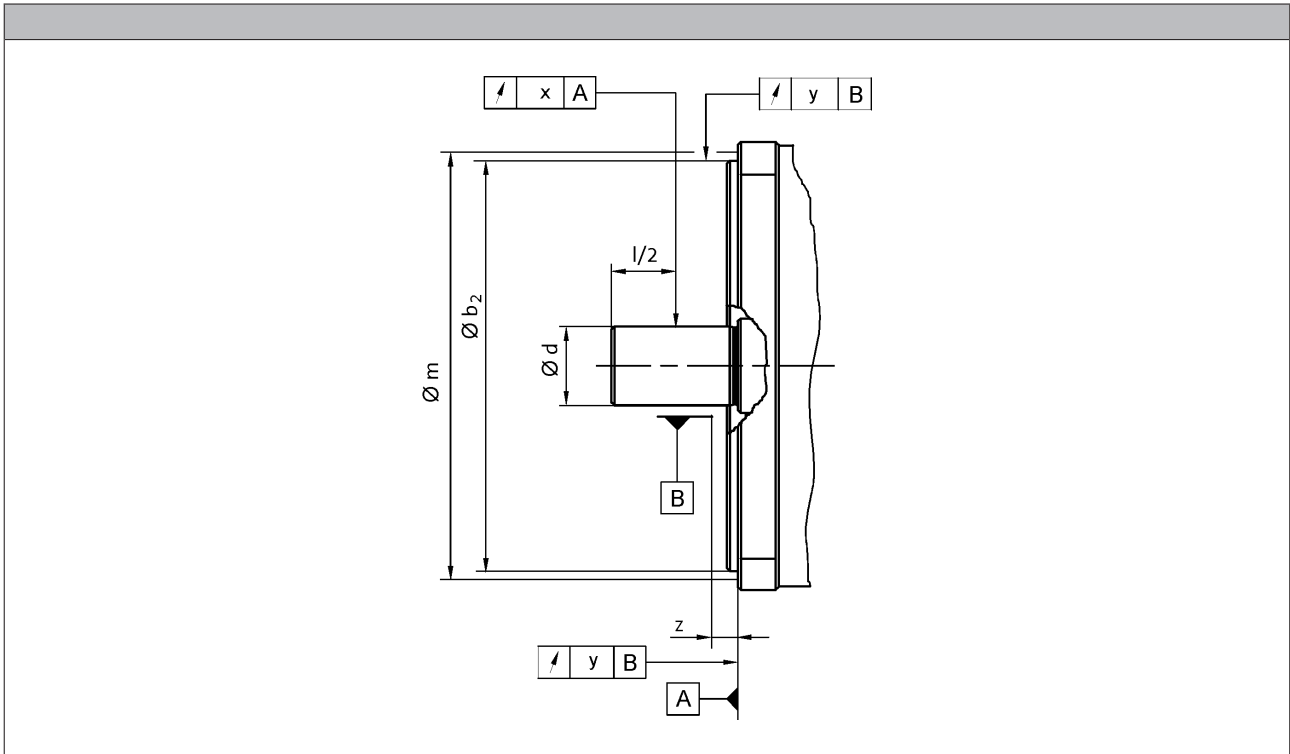

5.2

				MCM06	MCM09	MCM12
Flange size				FF75	FF100	FF130
Dimensions						
	b_2	j_6	[mm]	60	80	110
	d	k_6	[mm]	11	14	19
Distance						
Measuring diameter	m		[mm]	65.0	85.0	115
Dial gauge holder for flange check	z	± 1	[mm]	10.0		
Concentricity				Normal class		
IEC 60072				Normal class		
Value	y		[mm]	0.080		0.10
Axial run-out				Normal class		
IEC 60072				Normal class		
Value	y		[mm]	0.080		0.10
Smooth running				Normal class		
IEC 60072				Normal class		
Value	x		[mm]	0.035		0.040

- Limit values for checking the smooth running of the shaft ends as well as the concentricity and axial run-out of the mounting flange to IEC 60072

MCM synchronous servo motors

General information



Dimensioning

Notes on the selection tables

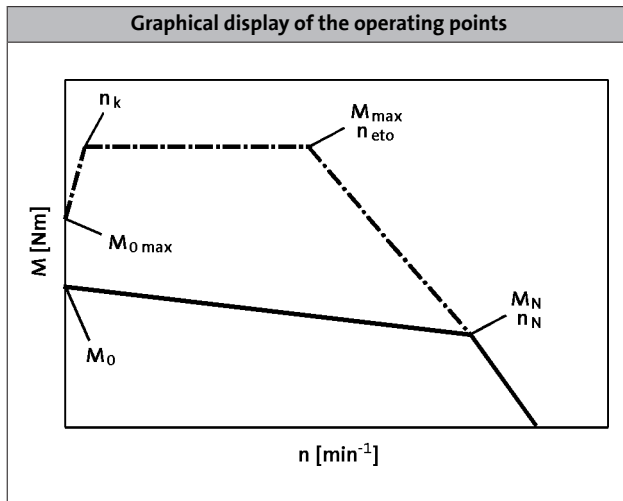

Please note:

- In case of an active load (e.g. vertical drive axes, hoists, test benches, unwinders), $M_{0\max}$ has to be considered
- In case of a passive load (e.g. horizontal drive axes), M_{\max} can be usually used
- In case of a speed $< n_k$ and inverter-specifically, the achievable torque $M_{0\max}$ is smaller than M_{\max}
- In case of a speed $n = 0$, the standstill torque M_0 and the standstill current I_0 have to be reduced by 30% after 2 seconds. In case of applications which require a longer holding of M_0 , we recommend the drive to be held via the holding brake and reduce the current, e.g. by controller inhibit.
- In case of servo inverters, the switching frequency dependent overload capacity is considered in the default setting. For more information, see the servo inverter catalogue.

	n_k
	[r/min]
MCM	75.0

MCM synchronous servo motors

General information



Dimensioning

Influence of ambient temperature and site altitude

The information relating to the servo motors in the tables and graphs is valid for a maximum ambient temperature (T_{opr}) of 40 °C and a site altitude (H) up to 1000 m above sea level. The torque correction factor (k_{M1}) shall be applied to the S1 torque characteristic ($M_0...M_N$) in the event of differing installation conditions.

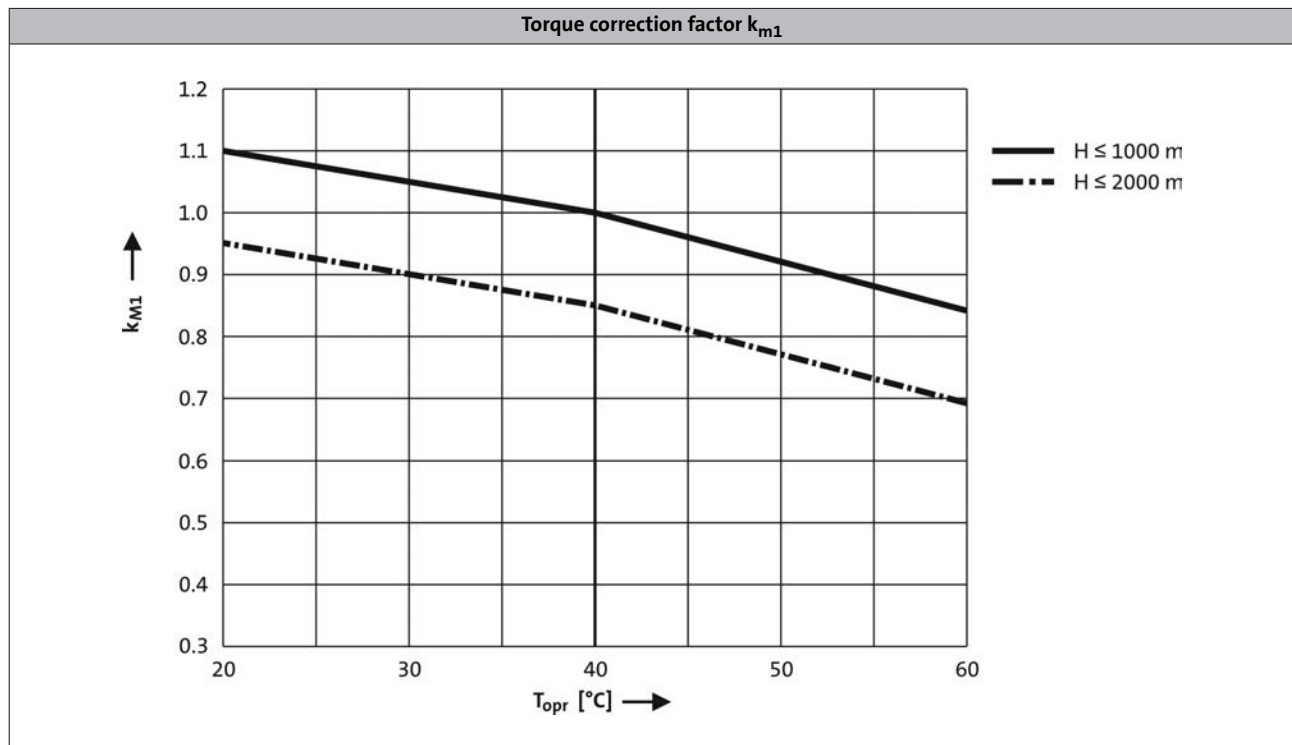

MCM synchronous servo motors

Technical data



Standards and operating conditions

			MCM
Cooling type			Naturally ventilated
Degree of protection			IP54 ¹⁾
EN 60529			
Temperature class			F
IEC/EN 60034-1; utilisation			F
IEC/EN 60034-1; insulation system (enamel-insulated wire)			
Conformity			Low-Voltage Directive
CE			2006/95/EC
Approval			CSA 22.2 No. 100
CSA			UL 1004-1
cURus			UL 1004-6
			Power Conversion Equipment (File-No. E210321)
Max. voltage load			Pulse voltage limiting curve A
IEC/TS 60034-25			
Smooth running			Normal class
IEC 60072			
Axial run-out			Normal class
IEC 60072			
Concentricity			Normal class
IEC 60072			
Mechanical ambient conditions (vibration)			3M6
IEC/EN 60721-3-3			
Min. ambient operating temperature			
Without brake	$T_{opr,min}$	[°C]	-15
With brake	$T_{opr,min}$	[°C]	-10
Max. ambient operating temperature			
	$T_{opr,max}$	[°C]	40
Max. surface temperature			
	T	[°C]	140
Mechanical tolerance			
Flange centring diameter			$b_2 \leq 230 \text{ mm} = j6$ $b_2 > 230 \text{ mm} = h6$
Shaft diameter			$d \leq 50 \text{ mm} = k6$ $d > 50 \text{ mm} = m6$
Site altitude			
Amsl	H_{max}	[m]	2000

¹⁾ IP65 housing

MCM synchronous servo motors

Technical data



Permissible radial and axial forces

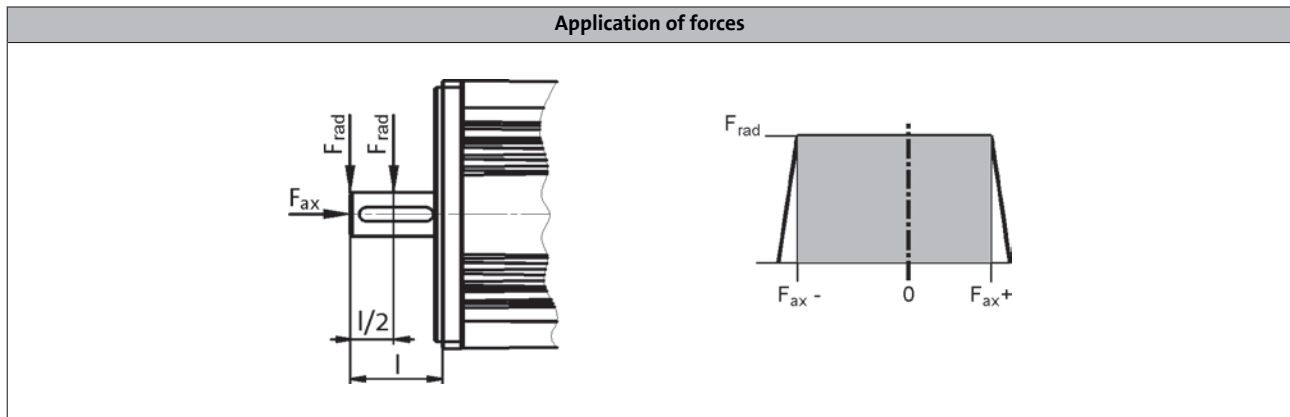

Application of force at $l/2$

Bearing service life L_{10}			
			20000 h
	F_{rad} [N]	$F_{ax,-}$ [N]	$F_{ax,+}$ [N]
MCM06	245	98	98
MCM09	392	147	147
MCM12	490	196	196

Application of force at l

Bearing service life L_{10}			
			20000 h
	F_{rad} [N]	$F_{ax,-}$ [N]	$F_{ax,+}$ [N]
MCM06	196	98	98
MCM09	294	147	147
MCM12		196	196

- The values for the bearing service life L_{10} refer to an average speed of 4000 r/min. Depending on the ambient temperatures, the service life of the bearings is also reduced by the grease life-time.

MCM synchronous servo motors

Technical data



Rated data, non-ventilated

► The data applies to a mains connection voltage of 3 x 400 V.

	n_N [r/min]	M_0 [Nm]	M_N [Nm]	M_{max} [Nm]	P_N [kW]	I_0 [A]	I_N [A]	I_{max} [A]	$U_{N, AC}$ [V]	f_N [Hz]
MCM06C30-	3000	0.70	0.60	1.80	0.19	1.00	0.90	2.50	183	200
MCM06E30-	3000	1.40	1.20	3.10	0.38	1.20	1.10	2.60	273	200
MCM09C30-	3000	1.50	1.30	3.50	0.40	1.10	1.10	2.60	300	200
MCM09E30-	3000	2.90	2.40	6.50	0.75	2.10	1.90	4.80	296	200
MCM12C30-	3000	2.90	2.40	6.50	0.75	2.10	1.80	4.80	283	250
MCM12F30-	3000	5.50	4.80	14.1	1.50	3.80	3.50	10.0	291	250
MCM12J30-	3000	9.60	8.00	26.4	2.50	6.80	5.80	19.0	274	250

	$\eta_{100\%}$ [%]	$J^{1)}$ [kgcm ²]	$KE_{LL 150\text{ °C}}$ [V/(1000 r/min)]	$R_{UV 20\text{ °C}}$ [Ω]	$R_{UV 150\text{ °C}}$ [Ω]	L_N [mH]	$Kt_{0 150\text{ °C}}$ [Nm/A]	$n_{max}^{2)}$ [r/min]	$m^{1)}$ [kg]
MCM06C30-	68.1	0.19	45.0	27.6	41.6	25.0	0.70	6000	1.40
MCM06E30-	77.5	0.34	71.6	26.8	40.4	30.0	1.17	6000	1.80
MCM09C30-	79.0	0.61	82.5	20.0	30.1	31.0	1.36	6000	2.30
MCM09E30-	84.9	0.88	80.0	11.2	16.9	19.0	1.38	6000	2.80
MCM12C30-	91.3	1.54	78.8	6.68	10.1	18.0	1.38	5000	3.40
MCM12F30-	93.0	2.80	83.6	3.04	4.58	9.60	1.45	5000	4.80
MCM12J30-	94.3	4.49	81.4	1.55	2.34	5.30	1.41	5000	6.70

¹⁾ Without brake.

²⁾ Mechanically permissible maximum speed.

MCM synchronous servo motors

Technical data



Selection tables, Servo-Inverter i700

Non-ventilated motors

- The data applies to a mains connection voltage of 3 x 400 V and an inverter switching frequency of 4 kHz.

					E70ACM	S□0054	S□0104	S□0204
					I_N	2.5	5.0	10.0
					$I_{0,max}$	5.0	10.0	20.0
MCM	M_N	n_N	I_N	P_N	I_{max}	5.0	10.0	20.0
06C30	0.6	3000	0.9	0.19	M_0	0.7		
					M_N	0.6		
					$M_{0,max}$	1.8		
					M_{max}	1.8		
					η_{eto}	-		
06E30	1.2	3000	1.1	0.38	M_0	1.4		
					M_N	1.2		
					$M_{0,max}$	3.1		
					M_{max}	3.1		
					η_{eto}	-		
09C30	1.3	3000	1.1	0.40	M_0	1.5		
					M_N	1.3		
					$M_{0,max}$	3.5		
					M_{max}	3.5		
					η_{eto}	-		
09E30	2.4	3000	1.9	0.75	M_0	2.9		
					M_N	2.4		
					$M_{0,max}$	6.5		
					M_{max}	6.5		
					η_{eto}	-		
12C30	2.4	3000	1.8	0.75	M_0	2.9		
					M_N	2.4		
					$M_{0,max}$	6.5		
					M_{max}	6.5		
					η_{eto}	-		
12F30	4.8	3000	3.5	1.50	M_0		5.5	
					M_N		4.8	
					$M_{0,max}$		14.1	
					M_{max}		14.1	
					η_{eto}		-	
12J30	8.0	3000	5.8	2.50	M_0			9.6
					M_N			8.0
					$M_{0,max}$			26.4
					M_{max}			26.4
					η_{eto}			-

- I... [A], M... [Nm], n... [r/min], P... [kW]

MCM synchronous servo motors

Technical data



Selection tables, Servo Drives 9400 HighLine

Non-ventilated motors

- The data applies to a mains connection voltage of 3 x 400 V and an inverter switching frequency of 4 kHz.

					E94A□□	E0024	E0034	E0044	E0074	E0094	E0134
					I_N	1.9	3.1	5.0	8.8	11.7	16.3
					$I_{0,max}$	6.0	10.0	16.0	21.0	28.0	39.0
MCM	M_N	n_N	I_N	P_N	I_{max}	6.0	10.0	16.0	21.0	28.0	39.0
06C30	0.6	3000	0.9	0.19	M_0	0.7					
					M_N	0.6					
					$M_{0,max}$	1.8					
					M_{max}	1.8					
					η_{eto}	-					
06E30	1.2	3000	1.1	0.38	M_0	1.4					
					M_N	1.2					
					$M_{0,max}$	3.1					
					M_{max}	3.1					
					η_{eto}	-					
09C30	1.3	3000	1.1	0.40	M_0	1.5					
					M_N	1.3					
					$M_{0,max}$	3.5					
					M_{max}	3.5					
					η_{eto}	-					
09E30	2.4	3000	1.9	0.75	M_0	2.6	2.9				
					M_N	2.4	2.4				
					$M_{0,max}$	5.4	6.5				
					M_{max}	6.5	6.5				
					η_{eto}	-	-				
12C30	2.4	3000	1.8	0.75	M_0	2.6	2.9				
					M_N	2.4	2.4				
					$M_{0,max}$	5.4	6.5				
					M_{max}	6.5	6.5				
					η_{eto}	-	-				
12F30	4.8	3000	3.5	1.50	M_0			5.5			
					M_N			4.8			
					$M_{0,max}$			14.1			
					M_{max}			14.1			
					η_{eto}			-			
12J30	8.0	3000	5.8	2.50	M_0				9.6	9.6	9.6
					M_N				8.0	8.0	8.0
					$M_{0,max}$				19.3	25.7	26.4
					M_{max}				26.4	26.4	26.4
					η_{eto}				-	-	-

- I... [A], M... [Nm], n... [r/min], P... [kW]

MCM synchronous servo motors

Technical data



Selection tables, Inverter Drives 8400 TopLine

Non-ventilated motors

- The data applies to a mains connection voltage of 3 x 400 V and an inverter switching frequency of 8 kHz.

					E84AVTC	□3714	□7514	□1524	□2224	□3024	□4024	□5524
					I_N	1.3	2.4	3.9	5.9	7.3	9.5	13.0
					$I_{0,max}$	2.0	3.6	5.9	8.4	11.0	14.3	19.5
MCM	M_N	n_N	I_N	P_N	I_{max}	2.6	4.8	7.8	11.2	14.6	19.0	26.0
06C30	0.6	3000	0.9	0.19	M_0	0.7						
					M_N	0.6						
					$M_{0,max}$	1.8						
					M_{max}	1.8						
					η_{eto}	-						
06E30	1.2	3000	1.1	0.38	M_0	1.4						
					M_N	1.2						
					$M_{0,max}$	3.1						
					M_{max}	3.1						
					η_{eto}	-						
09C30	1.3	3000	1.1	0.40	M_0	1.5						
					M_N	1.3						
					$M_{0,max}$	3.5						
					M_{max}	3.5						
					η_{eto}	-						
09E30	2.4	3000	1.9	0.75	M_0		2.9					
					M_N		2.4					
					$M_{0,max}$		6.5					
					M_{max}		6.5					
					η_{eto}		-					
12C30	2.4	3000	1.8	0.75	M_0		2.9					
					M_N		2.4					
					$M_{0,max}$		6.5					
					M_{max}		6.5					
					η_{eto}		-					
12F30	4.8	3000	3.5	1.50	M_0			5.5	5.5	5.5		
					M_N			4.8	4.8	4.8		
					$M_{0,max}$			8.4	11.8	14.1		
					M_{max}			11.1	14.1	14.1		
					η_{eto}			-	-	-		
12J30	8.0	3000	5.8	2.50	M_0					9.6	9.6	9.6
					M_N					8.0	8.0	8.0
					$M_{0,max}$					15.4	19.9	26.4
					M_{max}					20.4	26.4	26.4
					η_{eto}					-	-	-

- I... [A], M... [Nm], n... [r/min], P... [kW]

5.2

MCM synchronous servo motors

Technical data



Torque characteristics

► The data applies to a mains connection voltage of 3 x 400 V.

MCM06C30-

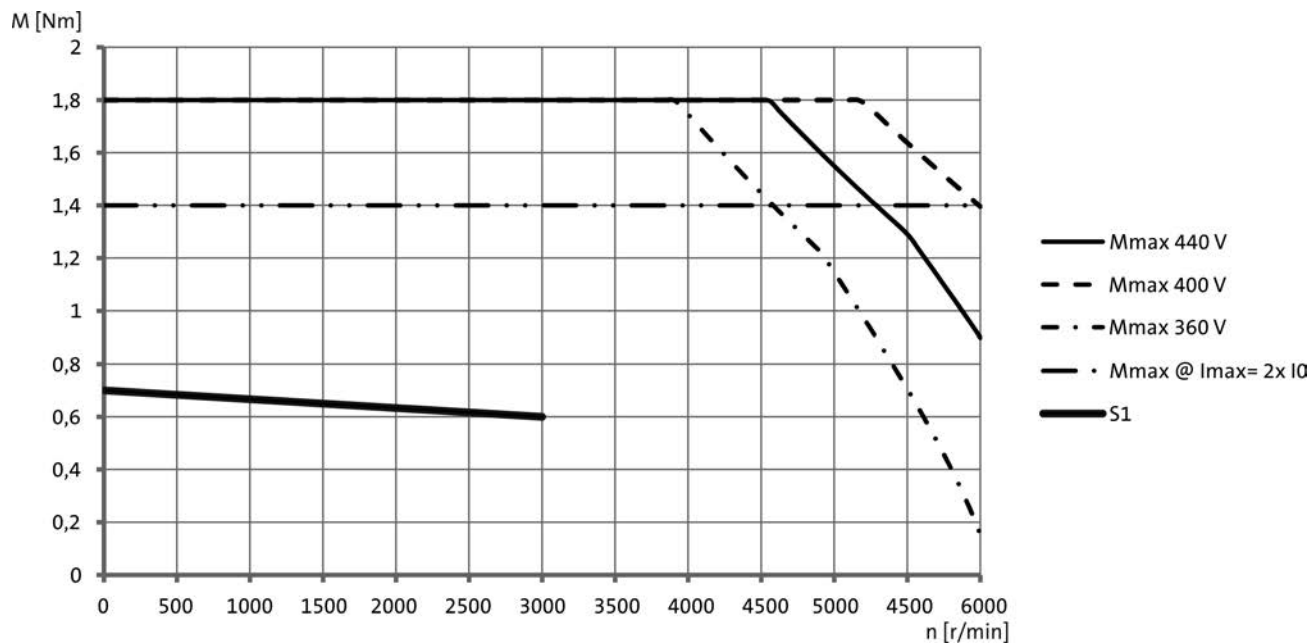

MCM06F30-

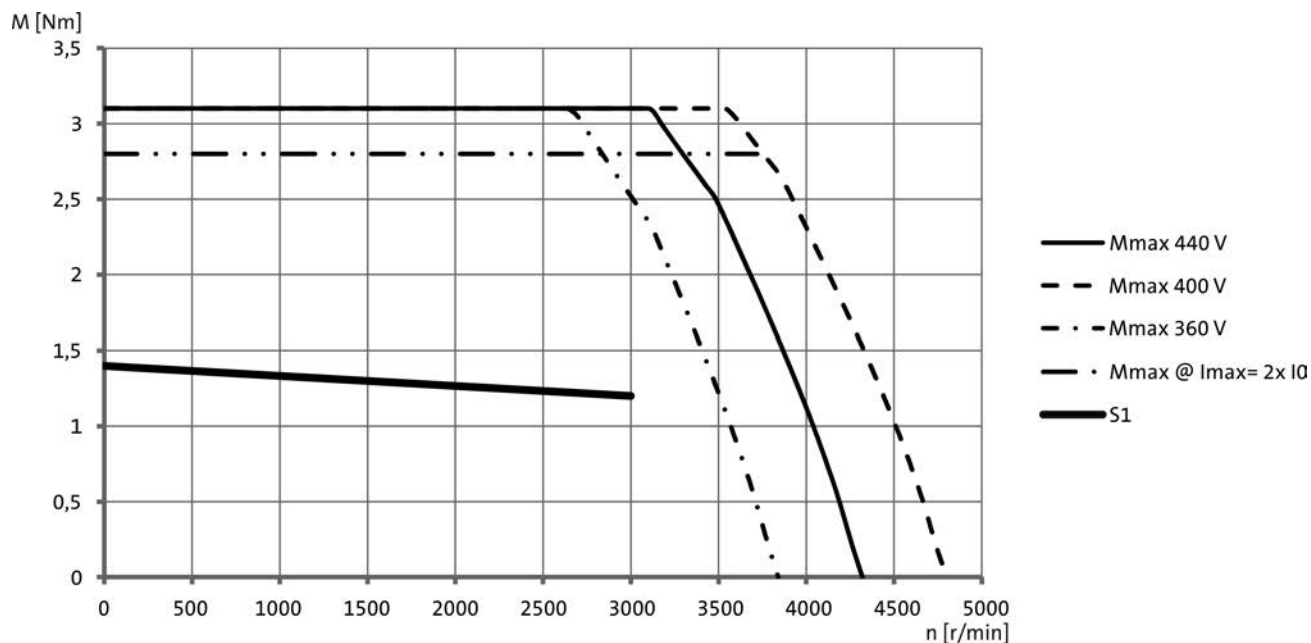

5.2

MCM synchronous servo motors

Technical data



Torque characteristics

► The data applies to a mains connection voltage of 3 x 400 V.

MCM09C30-

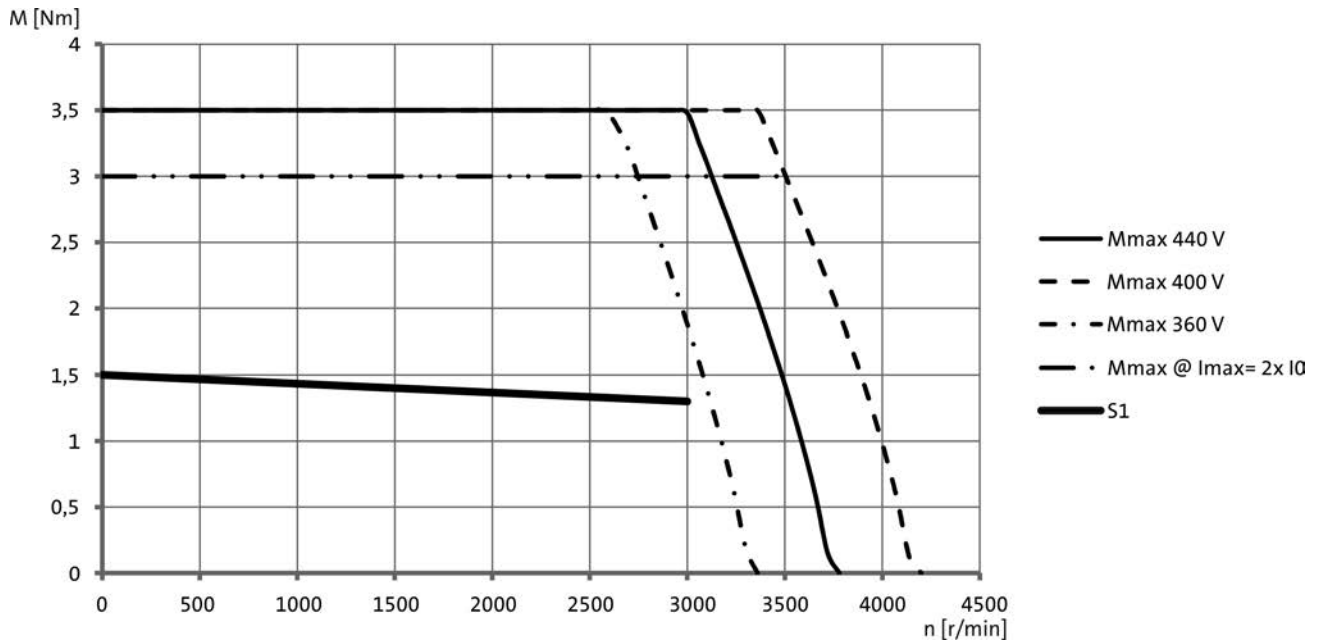

5.2

MCM09F30-

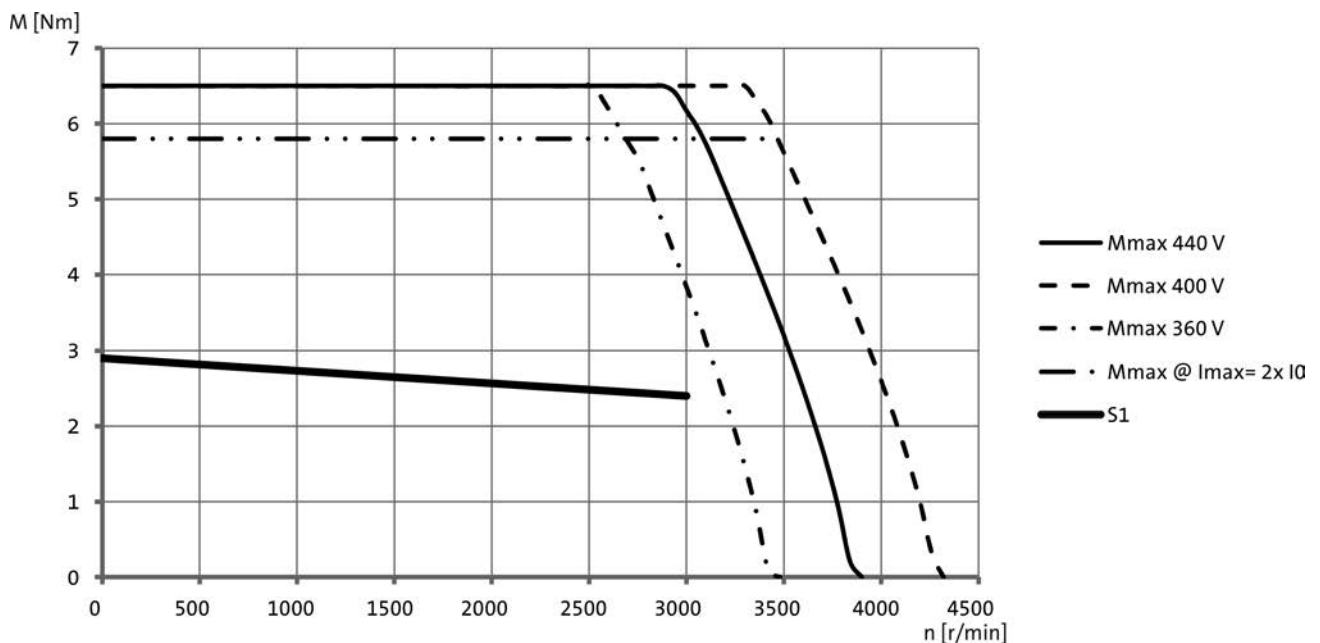

MCM synchronous servo motors

Technical data



Torque characteristics

► The data applies to a mains connection voltage of 3 x 400 V.

MCM12C30-

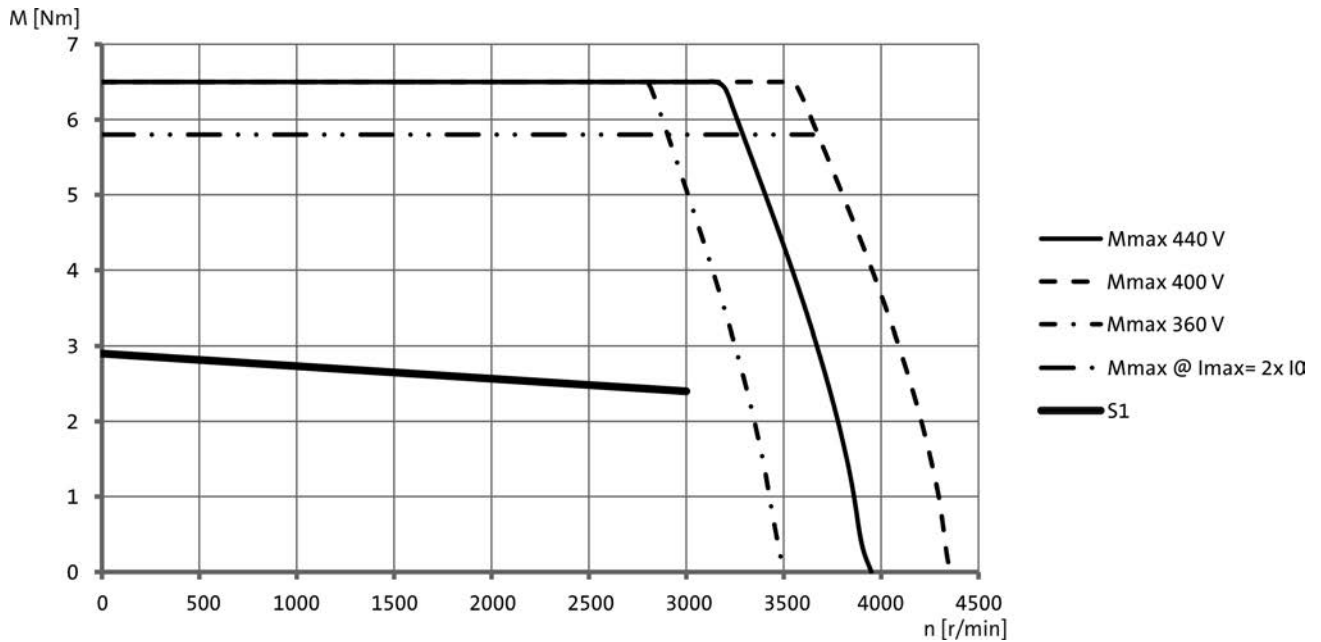

MCM12F30-

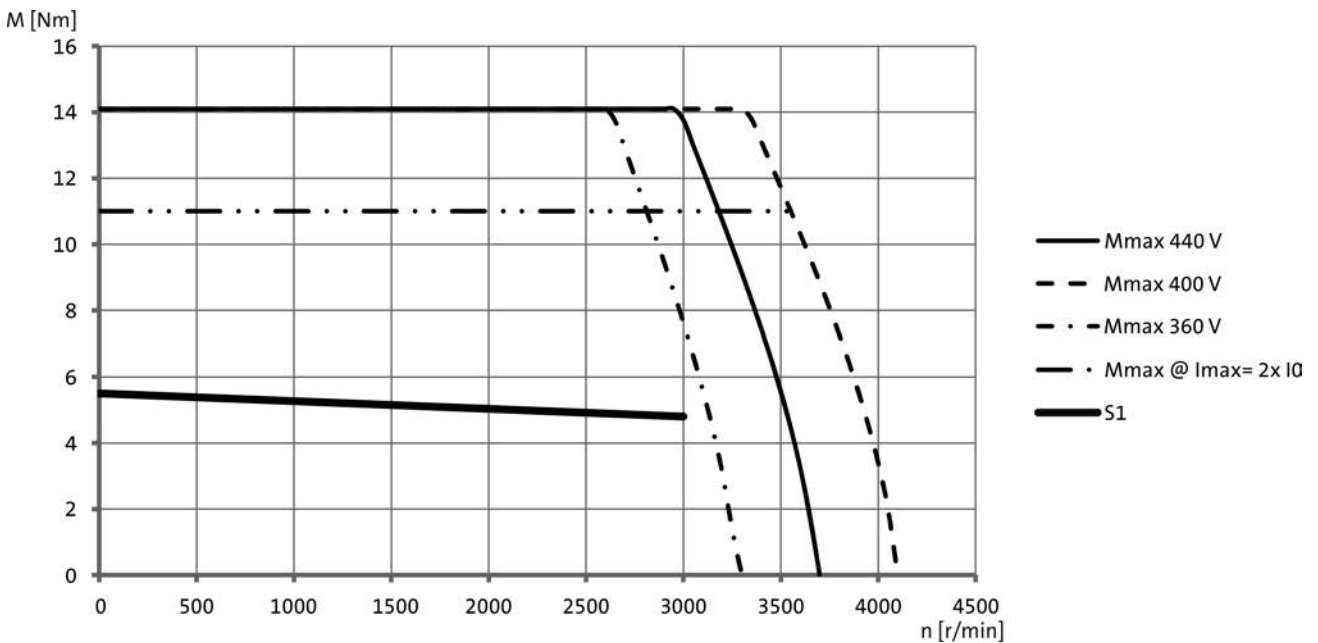

5.2

MCM synchronous servo motors

Technical data



Torque characteristics

► The data applies to a mains connection voltage of 3 x 400 V.

MCM12J30-

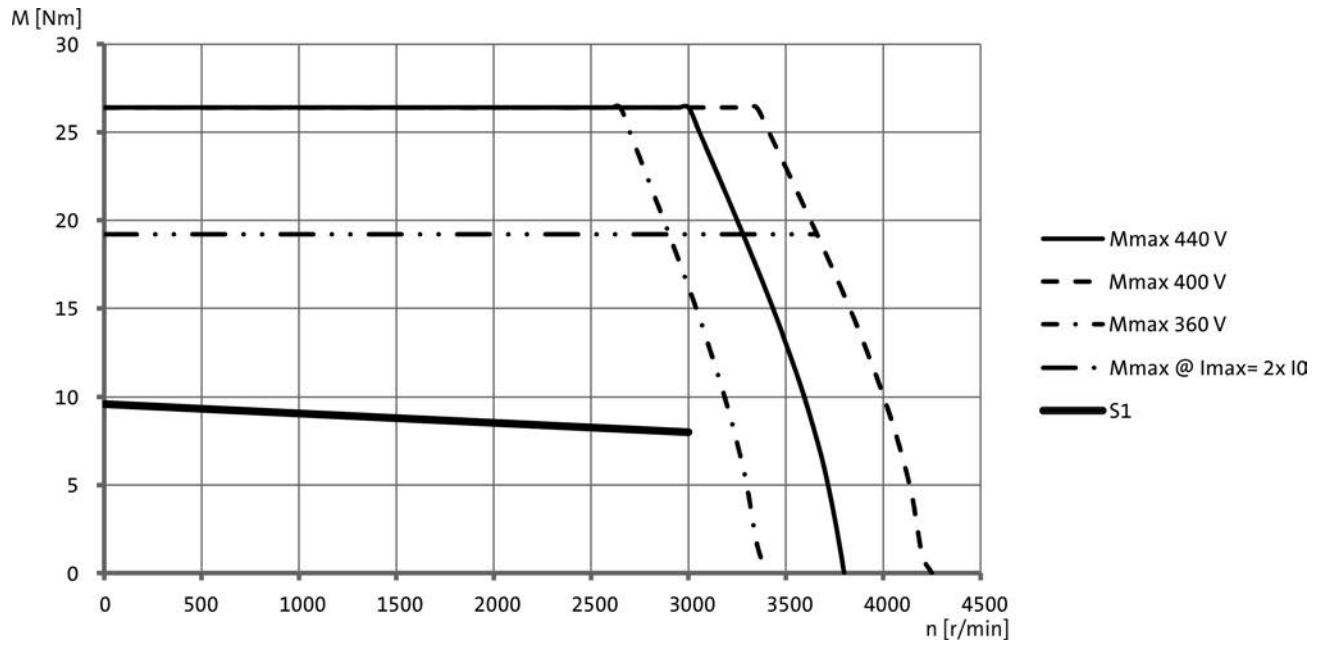

MCM synchronous servo motors

Technical data



Dimensions, self-ventilated

MCM06

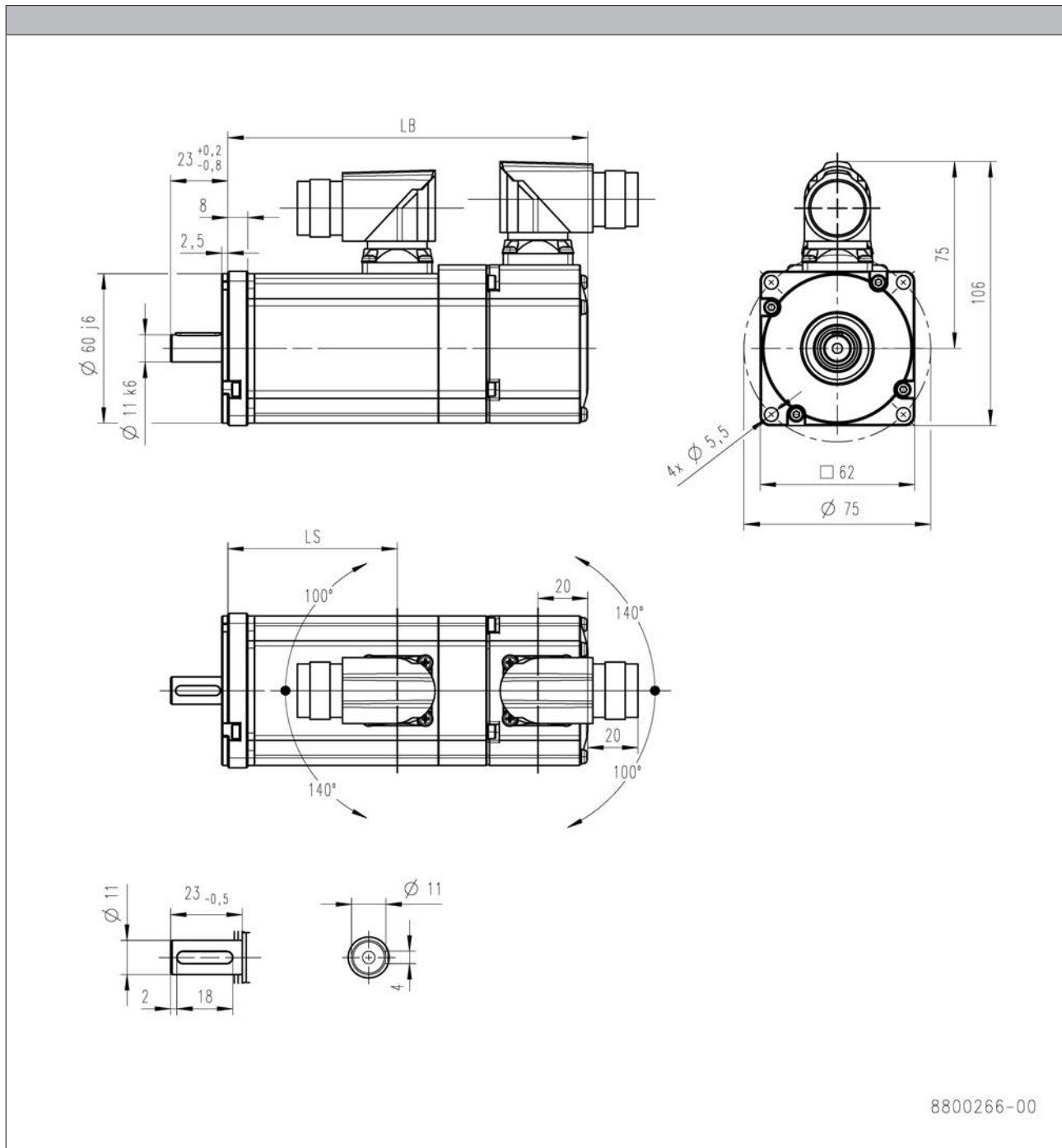

5.2

			MCM06C	MCM06E
RS0/SKM B0	LB	[mm]	146	171
RS0/SKM F1	LB	[mm]	182	207
	LS	[mm]	69.0	94.0

- ▶ Speed / angle sensor: R□□ / C□□ / S□□ / E□□
- ▶ Brake: B0 / F1 / F2

MCM synchronous servo motors

Technical data



Dimensions, self-ventilated

MCM09

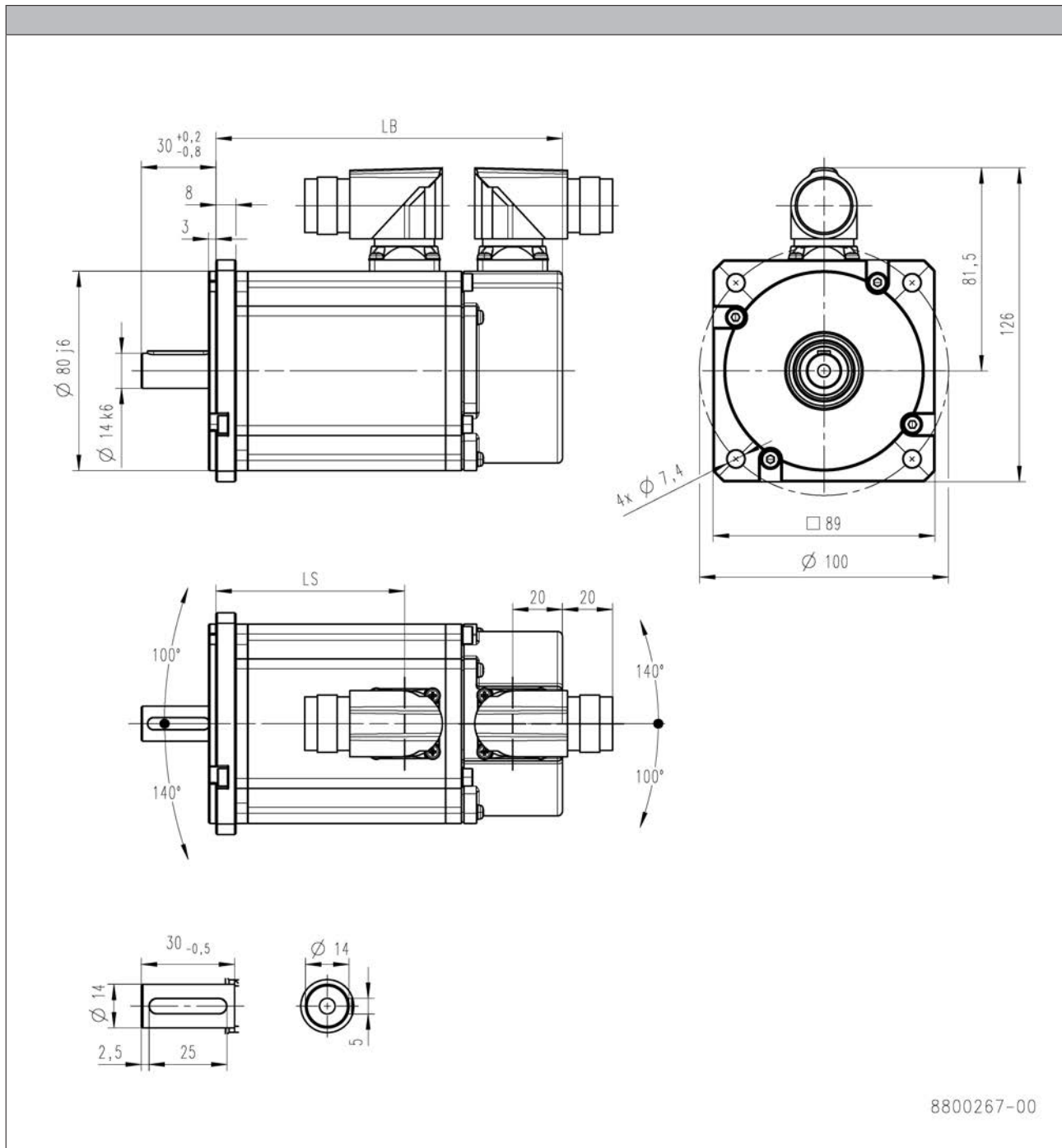

5.2

			MCM09C	MCM09E
RS0/SKM B0	LB	[mm]	140	155
RS0/SKM F1	LB	[mm]	176	191
	LS	[mm]	76.5	91.5

- ▶ Speed / angle sensor: R□□ / C□□ / S□□ / E□□
- ▶ Brake: B0 / F1 / F2

MCM synchronous servo motors

Technical data



Dimensions, self-ventilated

MCM12

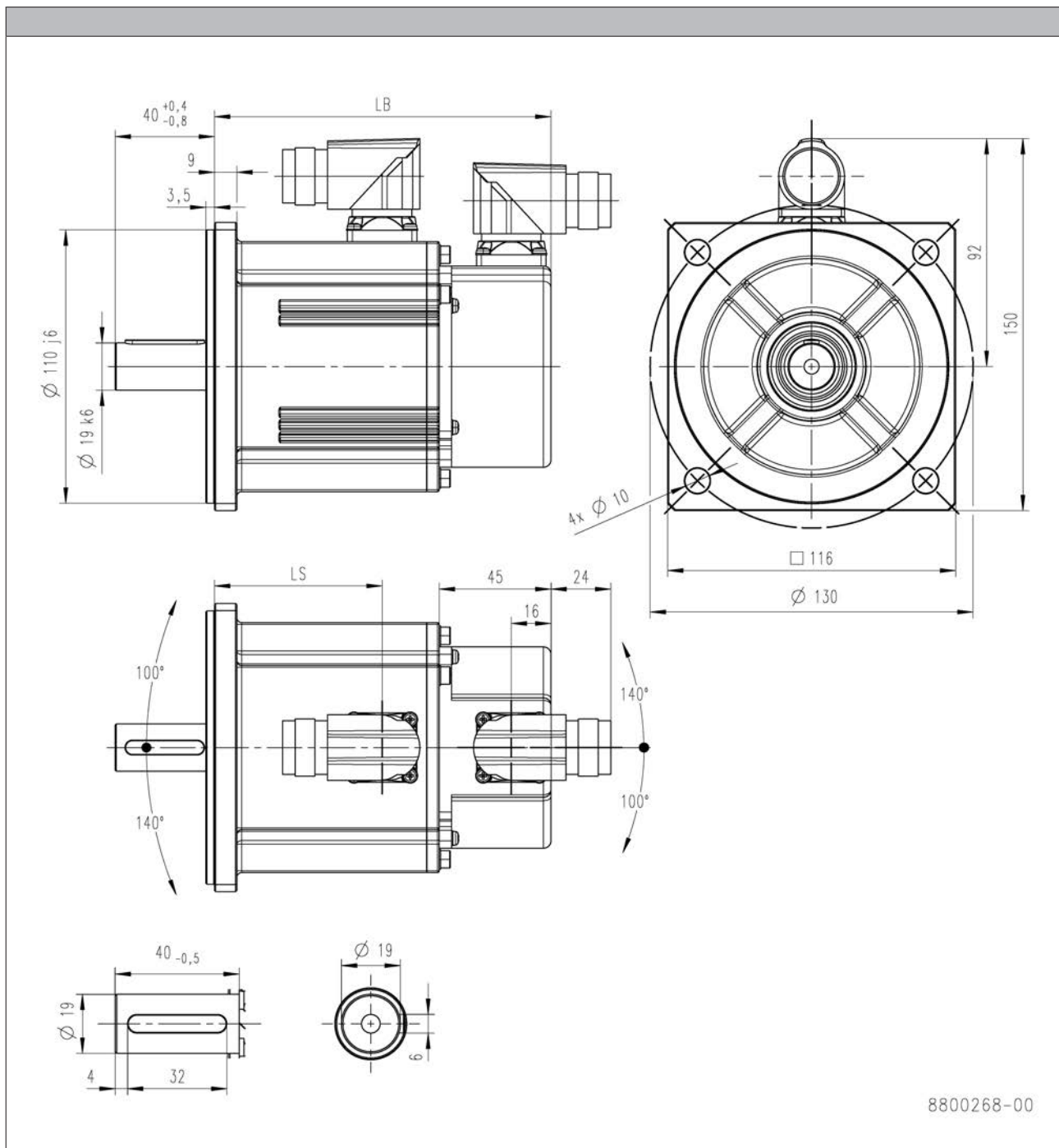

5.2

			MCM12C	MCM12F	MCM12J
RS0/SKM B0	LB	[mm]	136	164	201
RS0/SKM F1	LB	[mm]	178	206	243
	LS	[mm]	68.0	96.0	133

- ▶ Speed / angle sensor: R□□ / C□□ / S□□ / E□□
- ▶ Brake: B0 / F1 / F2

MCM synchronous servo motors

Accessories



Spring-applied holding brake

Spring-operated holding brakes are available for the MCM synchronous servo motors.

The brakes are activated when the supply voltage is disconnected (closed-circuit principle). When using the brakes purely as holding brakes, virtually no wear occurs on the friction surfaces.

Caution:

The brakes used are not safety brakes in the sense that a reduction in torque may arise as a result of disruptive factors that cannot be influenced, e.g. oil ingress.

The ohmic voltage drop along the cable must be taken into consideration in long motor supply cables and must be compensated for by a higher voltage at the line input.

The following applies for Lenze system cables:

$$U[V] = U_B[V] + 0.08 \frac{[V]}{[A] \cdot [m]} \cdot l_{lg}[m] \cdot I_B[A]$$

If no suitable voltage (incorrect value, incorrect polarity) is applied to the brake, the brake will be applied and can be overheated and destroyed by the motor continuing to rotate.

The shortest switching times of the brakes are achieved by DC switching of the voltage. A spark suppressor is required to suppress interference and to increase the service life of the relay contacts here.



Spring-applied holding brake

MCM synchronous servo motors

Accessories



Spring-applied holding brake

Rated data

	$U_{N,DC}^{3,5)}$	M_N 20 °C	M_N 120 °C	M_{av} 120 °C	$I_N^{2)}$	J	$t_1^{1)}$	$t_2^{1)}$	$Q_E^{4)}$	m
	[V]	[Nm]	[Nm]	[Nm]	[A]	[kgcm ²]	[ms]	[ms]	[J]	[kg]
MCM06C30-	24	1.35	1.30	0.82	0.36	0.018	15.0	50.0	30000	0.30
MCM06E30-										
MCM09C30-		2.90	2.50	1.57	0.42	0.075	20.0	70.0	115000	0.50
MCM09E30-										
MCM12C30-		8.00	7.00	5.00	0.81	0.17	15.0	50.0	490000	0.75
MCM12F30-										
MCM12J30-		12.0	11.0	7.70				80.0		

¹⁾ Engagement and disengagement times are valid for rated voltage ($\pm 0\%$) and protective circuit for brakes with varistor for DC switching. The times may increase without a protective circuit.

²⁾ The currents are the maximum values when the brake is cold (value used for dimensioning the current supply). The values for a motor at operating temperature are considerably lower.

³⁾ With 24V DC brake: smoothed DC voltage, ripple $\leq 1\%$.

⁴⁾ Maximum switching energy per emergency stop at $n = 3000$ r/min for at least 2000 emergency stops.

⁵⁾ Voltage tolerance:

MCM06/09 $\pm 5\%$

MCM12 $\pm 10\%$

MCM synchronous servo motors



Accessories



Resolver

Stator-fed resolver with two stator windings offset by 90° and one rotor winding with transformer winding.

Speed/angle sensor				
	1)			RS0
Product key				RS0
Resolution				
Angle			[°]	0.80
Accuracy				
			[°]	-10 ... 10
Absolute positioning				
				1 revolution
Max. speed				
	n_{max}		[r/min]	8000
Max. input voltage				
DC	$U_{in,max}$		[V]	10.0
Max. input frequency				
	$f_{in,max}$		[kHz]	4.00
Ratio				
Stator / rotor		$\pm 5\%$		0.30
Rotor impedance				
	Z_{r0}		[Ω]	$51 + j90$
Stator impedance				
	Z_{s0}		[Ω]	$102 + j150$
Impedance				
	Z_{rs}		[Ω]	$44 + j76$
Min. insulation resistance				
At DC 500 V	R		[M Ω]	10.0
Number of pole pairs				
				1
Max. angle error				
			[°]	-10 ... 10
Inverter assignment				
				i700 E84AVTC E94A ECS EVS93

¹⁾   6 - Product key > speed/angle sensor



MCM synchronous servo motors

Accessories



SinCos absolute value encoder

Encoder type			SinCos absolute value
Speed/angle sensor			SKM
Product key			AM128-8V-H
Encoder type			Multi-turn
Pulses			128
Output signals			1 Vss
Interfaces			Hiperface
Absolute revolutions			4096
Resolution			
Angle		[°]	0.40
Accuracy			
		[°]	-1.3 ... 1.3
Min. input voltage			
DC	$U_{in,min}$	[V]	7.00
Max. input voltage			
DC	$U_{in,max}$	[V]	12.0
Max. speed			
	n_{max}	[r/min]	9000
Max. current consumption			
	I_{max}	[A]	0.060
Limit frequency			
	f_{max}	[kHz]	200
Inverter assignment			
			i700 E84AVTC E94A ECS EVS93

¹⁾   6 - Product key > speed/angle sensor



Temperature monitoring

The KTY 83-110 thermal sensor used in the MCM motors continuously monitors the motor temperature. The temperature information is transmitted to the servo inverter by means of the system cable of the feedback system.

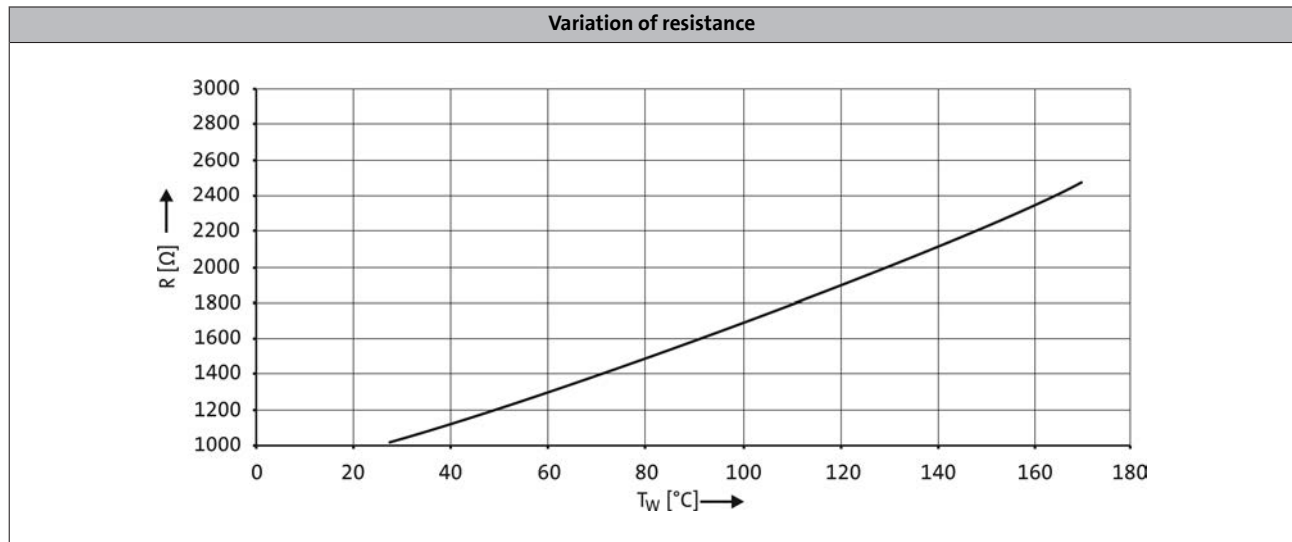

- If the thermal sensor is supplied with a measurement current of 1 mA, the above relationship between the temperature and the resistance applies.

MCM synchronous servo motors



Accessories

ICN connector

An ICN connector is used as standard for the electrical connection to the servo motors.

A connector is used for the connection of motor and brake. The connections to the feedback system/temperature monitoring and the blower each employ a separate connector.

The connectors can be rotated through 270° and are fitted with a bayonet catch for SpeedTec connectors. As the connector fixing is also compatible with conventional union nuts. Existing mating connectors can therefore still be used without difficulty.

Connection for power and brake

Pin assignment		
Contact	Designation	Meaning
1	BD1	Holding brake +
2	BD2	Holding brake -
PE	PE	PE conductor
4	U	Phase U power
5	V	Phase V power
6	W	Phase W power

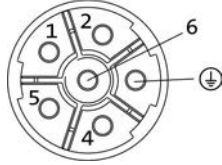

MCM synchronous servo motors

Accessories



ICN connector

Feedback connection

► Resolver

Pin assignment		
Contact	Designation	Meaning
1	+Ref	Transformer windings
2	-Ref	
3	+VCC ETS	Supply: Electronic nameplate
4	+COS	Cosine stator windings
5	-COS	
6	+SIN	Sine stator windings
7	-SIN	
8		Not assigned
9		
10		
11	+KTY	KTY temperature sensor
12	-KTY	

► Hiperface SinCos absolute value encoder

Pin assignment		
Contact	Designation	Meaning
1	B	Track B/+SIN
2	A ⁻	Track A inverse/-COS
3	A	Track A/+COS
4	+U _B	Supply +
5	GND	Mass
6	Z ⁻	Zero track inverse/-RS485
7	Z	Zero track/+RS485
8		Not assigned
9	B ⁻	Track B inverse/-SIN
10		Not assigned
11	+KTY	KTY temperature sensor
12	-KTY	