

Projector Parts

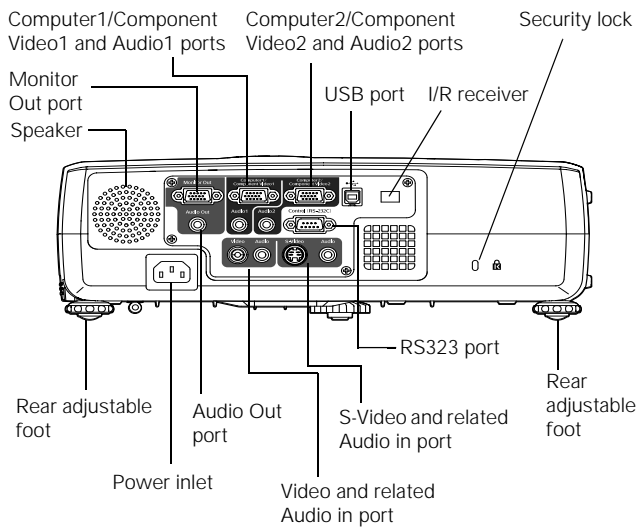
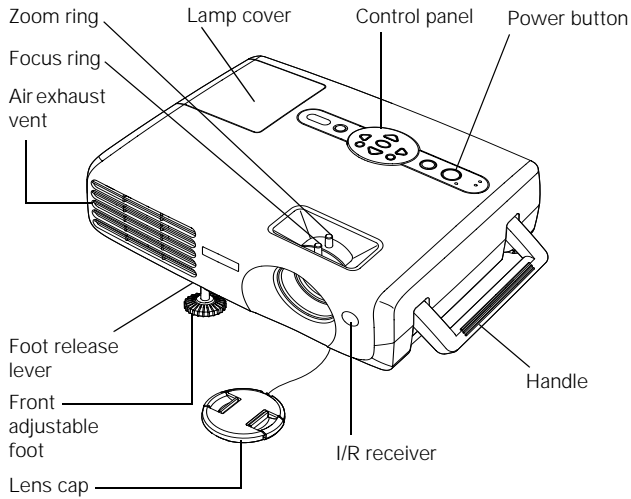

Brightness (ANSI)	2000 lumens (High brightness mode) 1500 lumens (Low brightness mode)
Contrast ratio	400:1
Image size	30 to 300 inches (0.8 to 7.6 meters)
Projection distance	2.9 to 35.5 feet (0.9 to 10.8 meters)
Projection methods	Front, rear, ceiling
Focus adjustment	Manual
Zoom adjustment	Manual
Internal sound system	5 W monaural
Optical aspect ratio	4:3 (horizontal:vertical)
Zoom ratio	1:1.2
Noise level	36 dB (High brightness mode) 30 dB (Low brightness mode)
Keystone correction angle	± 15° vertical (maximum)

Projection Lamp

Power consumption	200 W UHE
Lamp life	High brightness: about 2000 hours Low brightness: about 3000 hours
Part number	V13H010L30

Remote Control

Range	20 feet (6 meters)
Batteries (2)	Alkaline AAA

Note:

The remote control is not a user-replaceable part. To purchase a replacement remote, call (562) 276-4394 (U.S.) or (905) 709-3839 (for dealer referral in Canada).

Specifications

General

Type of display	Poly-silicon TFT active matrix
LCD panels (3)	Diagonal size: 0.7 inches (17.8 mm)
Lens	F=1.70 to 1.87, focal length=21.3 to 25.6 mm
Resolution (native format)	EMP-81p: 1024 × 768 pixels EMP-61p: 800 × 600 pixels
Color reproduction	Full color, 16.8 million colors

Mouse Compatibility

Supports USB

Dimensions

Height	4.3 to 4.8 inches foot extended (109 to 123 mm)
Width	13.8 inches (351 mm)
Depth	10.7 inches (272 mm)
Weight	8.9 lb (4.0 kg)

Epson PowerLite 61p/81p Projector

Electrical

Rated frequency	50/60 Hz
Power supply	100 to 120 VAC, 3.2 A 200 to 240 VAC, 1.6 A
Power consumption	Operating: 280 W Standby: 5 W

Environmental

Temperature	Operating: 41 to 95 °F (5 to 35 °C) Storage: 14 to 140 °F (-10 to 60 °C)
Humidity (non-condensing)	Operating: 20 to 80% RH, Storage: 10 to 90% RH

Safety and Approvals

United States	FCC 47CFR Part15B Class B (DoC) UL60950 Third Edition
Canada	ICES-003 Class B CSA C22.2 No. 60950 (cUL)
CE Marking	Directive 73/23/EEC, 89/336/EEC IEC60950 Third Edition EN 55022, EN 55024

Compatible Video Formats

The projector supports NTSC, PAL, and SECAM international video standards, as well as SDTV and HDTV display formats.

Mode	Refresh Rate (Hz)
NTSC	60
NTSC 4:3	60
PAL	50
PAL 4:3	50
SECAM	50
SECAM 4:3	50
HDTV (720p)	60
HDTV (1080i)	60
SDTV (480i)	60
SDTV (540i)	50
SDTV (480p)	60

Mode	Refresh Rate (Hz)	Resolution
VGA EGA	70	640 × 480
VGA—60	60	640 × 480
VESA—60	60	640 × 480
VESA—72	72	640 × 480
VESA—75	75	640 × 480
VESA—85	85	640 × 480
SVGA—56	56	800 × 600
SVGA—60	60	800 × 600
SVGA—72	72	800 × 600
SVGA—75	75	800 × 600
SVGA—85	85	800 × 600
XGA—60	60	1024 × 768
XGA—70	70	1024 × 768
XGA—75	75	1024 × 768
XGA—85	85	1024 × 768
SXGA1—70	70	1152 × 864
SXGA1—75	75	1152 × 864
SXGA1—85	85	1152 × 864
SXGA2—60	60	1280 × 960
SXGA2—75	75	1280 × 960
SXGA2—85	85	1280 × 960
SXGA3—60	60	1280 × 1024
SXGA3—75	75	1280 × 1024
SXGA3—85	85	1280 × 1024
UXGA—60	60	1600 × 1200
iMAC VGA	117	640 × 480
iMAC SVGA	95	800 × 600
iMAC XGA	75	1024 × 768
MAC13	67	640 × 480
MAC16	75	832 × 624
MAC19—60	59	1024 × 768
MAC19	75	1024 × 768
MAC21	75	1152 × 870
SDTV (540i)	50	720 × 540
SDTV (480i)	60	640 × 480
SDTV (480p)	60	640 × 480
HDTV (720p)	60	1280 × 720
HDTV (1080i)	60	1920 × 1080

Compatible Computer Display Formats

To project images from a computer, set the computer's video card at a refresh rate (vertical frequency) compatible with the projector; see the following table for compatible formats. For best results, set the computer's resolution to the projector's native resolution (1024 × 768 for the 81p, or 800 × 600 for the 61p). If this resolution isn't available, select one of the other compatible formats.

Positioning the Projector

Before connecting the projector, you need to decide where to place it. The location you choose depends on the size of the room and what you are projecting.

- ❑ Place the projector on a sturdy, level surface, between 2.9 and 35.5 feet from the screen.
- ❑ Make sure there is plenty of space for ventilation around and under the projector. Leave at least 8 inches between the projector and a wall.
- ❑ Make sure the projector is within 6 feet of an electrical outlet or extension cord and within 5 feet of your computer and/or video source.
- ❑ Place the projector directly in front of the center of the screen, facing the screen squarely. Otherwise, your image will not be rectangular.

Note:

It's easier to position the projector when the screen is directly in front of the room. If the screen is placed diagonally in a corner, it's much more difficult to aim the projector correctly at the screen and get a rectangular image.

Use the figure below as a guideline to help you determine how far from the screen to place the projector. Image size generally increases with distance, but may vary depending on how you position the zoom ring and whether you have adjusted the image size with other settings.

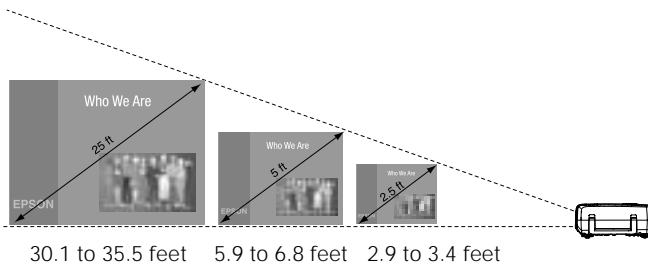

To calculate exact measurements, use the following formulas:

- ❑ To find the projection distance when you know the screen's diagonal dimension:

$$\text{Wide (inches)} = ((2.97334 \times \text{diagonal screen size [inches]}) - 2.3937) / 2.54$$

$$\text{Tele (inches)} = ((3.61474 \times \text{diagonal screen size [inches]}) - 2.06831) / 2.54$$

- ❑ To find how large a screen's diagonal dimension will be when you know the projection distance:

$$\text{Wide (inches)} = (\text{Projection distance [inches]} \times 0.32827 \times 2.54) + 1.6767$$

$$\text{Tele (inches)} = (\text{Projection distance [inches]} \times 0.203 \times 2.54) + 1.077$$

If you place the projector below the level of the screen, you'll have to tilt it up by extending the front adjustable foot, as shown. Tilting the projector upward causes the image to lose its rectangular shape, but the Auto Keystone feature corrects the distortion automatically. If the image does not regain its rectangular shape, the Auto Keystone feature may have been disabled. To turn it on, see page 6.

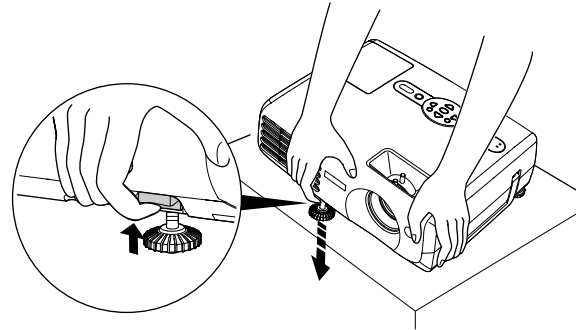

If you place the projector level with the bottom of the screen, the image will be rectangular and you won't have to adjust it. If you place the projector higher than the bottom of the screen, the image will still be rectangular, but you won't be able to fill the whole screen with the image.

Starting Up the Projector

Make sure your projector and other equipment are set up and connected correctly. Then turn on your projector, as described below.

If you turn on your connected computer or video equipment before starting the projector, the projector automatically detects and displays the image source. If you turn on the projector first, or have multiple pieces of connected equipment, you may have to select the image source manually. See "Selecting the Image Source" on page 5.

Follow these steps to plug in and turn on the projector:

1. Remove the lens cap.

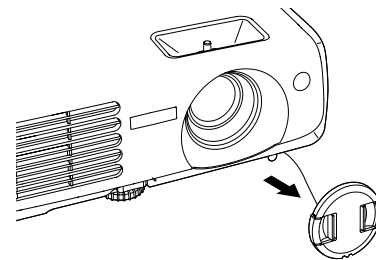

Caution



Do not use the projector with the lens cap in place. The heat generated by the lamp can damage the cap.

2. Connect one end of the power cord to the projector's power inlet. Then connect the other end to an electrical outlet.

The  Power light on top of the projector turns orange, indicating that the projector is receiving power but not yet turned on. Wait until the light stops flashing, but stays lit orange.

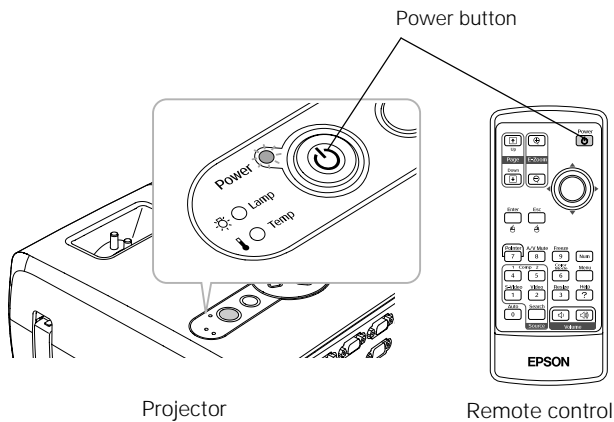
3. Press the  Power button on top of the projector or on the remote control.



The  Power light flashes green as the projector warms up, and the projection lamp comes on in about 45 seconds. The  Power light stays green.

Warning

Never look into the lens when the lamp is on. This can damage your eyes, and is especially dangerous for children.

- If you're using a computer, turn it on (if it is not already on). In a few moments, you should see your computer display projected. If you have two computers connected at the same time, press the Comp 1 or Comp 2 button on the remote control to select either the computer connected to the Computer 1/Component Video 1 port or the computer connected to the Computer 2/Component Video 2 port.

(Windows® only: If you see a message saying that it has found a plug-and-play monitor, click Cancel.)

- If you're projecting a video source, turn it on (if it is not already on). If you don't see an image, press the Source Search button on the projector or remote control repeatedly until you see your image. Then press the Play button on your DVD player or other device.
- If you are prompted to enter a password, see "Starting the Projector with a Password" on page 10.

If a projected image fails to appear, see "What To Do If You See a Blank Screen" in the next column.

When you're done with your presentation, shut down the projector as described on page 7. Shutting down the projector correctly prevents premature lamp failure and possible damage from overheating.

What To Do If You See a Blank Screen

If you see a blank screen or the No Signal message after turning on your computer or video source, try the following:

- Make sure the cables are connected correctly.
- Make sure the  Power light is green and not flashing and the lens cover is off.
- Press the Source Search button on top of the projector repeatedly until you see the image you want to project. See page 5 for more information about selecting the image source.
- Check the Signal menu to make sure the correct input source is selected.

If you're using a PC laptop:

- Hold down the Fn key and press the function key that lets you display on an external monitor. It may have an icon such as  or it may be labelled CRT/LCD. Allow a few seconds for the projector to sync up after pressing it. Check your laptop's manual or online help for details.

On most systems, the  or CRT/LCD key lets you toggle between the LCD screen and the projector, or display on both at the same time.

- Depending on your computer's video card, you might need to use the Display utility in the Control Panel to make sure that both the LCD screen and external monitor port are enabled. See your computer's documentation or online help for details.

If you're using a Macintosh laptop with OS X:

You may need to set up your system to display on the projector screen as well as the LCD screen. Follow these steps:

1. From the Apple menu, select System Preferences, then click Displays.
2. Select VGA Display or Color LCD, click Arrange or Arrangement, and make sure Mirror Displays is checked.

If you're using a Macintosh laptop with OS 9.x or earlier:

You may need to set up your system to display on the projector screen as well as the LCD screen. Follow these steps:

1. From the Apple menu, select Control Panels, then click Monitors or Monitors and Sound.
2. Click the Arrange icon.
3. Drag one monitor icon on top of the other.

If the Arrange option isn't available, try selecting one of the Simulscan resolution settings. Click the Monitor icon, if necessary, and then select a Simulscan resolution. (Allow a few seconds for the projector to sync up after making the selection.)

Selecting the Image Source

If multiple devices are connected to the projector, the easiest way to select the image source is to press the Source Search button on either the projector or remote control until the correct image is projected.

You can also press one of the following buttons on the remote control:

- Comp 1 to select the device connected to the projector's Computer 1/Component Video 1 port.
- Comp 2 button to select the device connected to the Computer 2/Component Video 2 port.
- S-Video to select the device connected to the S-Video port.
- Video button to select the device connected to the Video port.

After you select a source, the screen goes dark for a moment before the image appears. The name of the selected source (such as Computer1 or S-Video) appears briefly on the screen.

Adjusting the Image

Once you see your image, you may need to make certain adjustments, as described in this section.

Focusing and Zooming Your Image

Rotate the focus ring to sharpen the image.

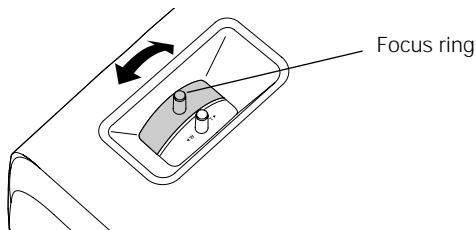

Rotate the zoom ring to reduce or enlarge the image.

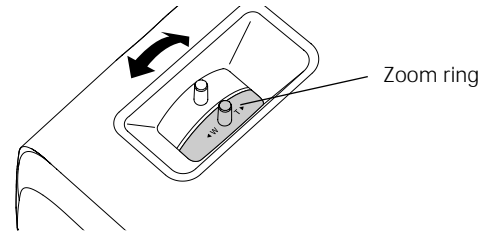

You can also change the image size by moving the projector closer to or farther away from the screen. You can use the E-Zoom buttons on the remote control to zoom in on a portion of the image. See "Zooming Your Image" on page 7 for instructions.

Adjusting the Height of Your Image

If the image is too low, you can raise it by extending the projector's front adjustable foot.

1. Stand behind the projector. Press up on the blue foot release lever and lift the front of the projector to extend the front adjustable foot.

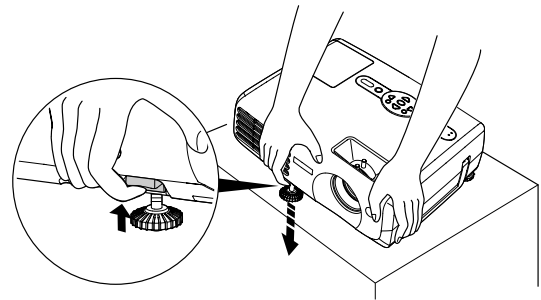





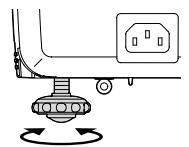

2. Once the image is positioned where you want it, release the lever to lock the foot in position.
3. To fine-tune the height of the image, rotate the feet at the back of the projector.

If the image is no longer rectangular after raising it, see the next section.



Adjusting the Image Shape

The projector automatically corrects images that are distorted when the projector is tilted up or down (up to a 15° tilt). The Keystone window appears on the screen while the projector makes the correction. If the projected image still isn't rectangular or has a "keystone" shape, do one or more of the following:

- ❑ If your image looks like  or , you've placed the projector off to one side of the screen, at an angle. Move it directly in front of the center of the screen, facing the screen squarely.
- ❑ If your image looks like  or , the Auto Keystone feature may have been disabled or you may need to manually adjust the keystone correction value. (Auto Keystone is not available when you're using ceiling or rear projection.) Follow the directions below:
 - ❑ To turn on Auto Keystone, press the Menu button on the projector or remote control. Use the  pointer button on the remote control (or the arrow buttons on the projector) to select the Setting menu, then press Enter. If Auto Keystone is OFF, highlight this option and press Enter. Select ON in the Auto Keystone window that appears and press Enter to save your changes. Exit the menu by pressing the Menu button.
 - ❑ To manually adjust the keystone correction value, press the  or  button on the projector to correct the shape of the image. After correction, your image will be slightly smaller.

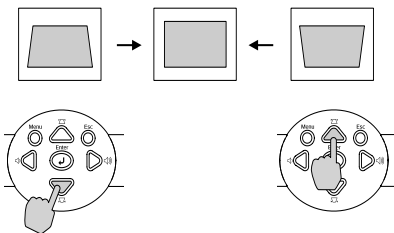

You can also make keystone adjustments using the projector's Setting menu.

Adjusting the Brightness

The brightness of an image depends on the source you are projecting and the amount of light in the room. If the image is too bright or not bright enough, do one of the following:

- ❑ Change the Brightness setting in the Image menu.
- ❑ Select Low or High for the Brightness Control option in the Setting menu. Low brightness mode extends the life of the lamp and decreases the fan noise.

Adjusting the Color Mode

You may want to adjust the color mode to select a setting that is appropriate for the image you're projecting and the environment in which you're projecting it.

If you're projecting computer or RGB video images, the default color mode is Presentation, which is appropriate for presentations in bright rooms. For other images, the default color mode is Dynamic, which optimizes video images using natural colors.

The following table lists the available color modes.

Color mode	Description
sRGB	Use when projecting computer images conforming to the sRGB color standard (the default setting when projecting from a computer with analog video).
Dynamic	Best for projecting movies with vivid color in bright rooms.
Presentation	Use when you're projecting a presentation in a bright room.
Theater	Use when projecting movies in a dark room.
Living Room	Best for playing video games or watching TV in a bright room.
Blackboard	Choose this fixed color mode when you need to project against a green blackboard.

To change the color mode, press the Color Mode button on the remote control until you see the mode you want. The currently selected setting appears in the upper right corner of the screen. You can also use the projector menu system to select the Color Mode in the Image menu.

Correcting Computer Images

If you've connected a computer and the image doesn't look right, or it doesn't fit properly on the screen, press the Auto button on the remote control. This automatically resets the projector's tracking, sync, resolution, and position settings. You must be projecting an image for this button to have any effect. Additionally, if the Auto Setup option in the Signal menu is set to OFF, the Auto function will not work.

Sleep/Standby Mode



When the projector has not received any input signals for 30 minutes, it automatically turns off the projector lamp and enters “sleep mode.” This conserves electricity, cools the projector, and extends the life of the lamp. If you are done using the projector, unplug the power cord. If you want to start projecting again, press the  Power button.



Note:

You can disable sleep (standby) mode in the Extended menu.

Shutting Down the Projector

When you’ve finished using the projector, follow the recommended procedure to shut it down. This extends the lamp life and protects the projector from possible overheating.

1. If you’re using a computer, shut it down first.
2. To turn off the projector, press the  Power button on the projector or remote control. You see a confirmation message. (If you don’t want to turn it off, press any other button.)
3. Press the  Power button again. The  Power light flashes orange for about 60 seconds as the projector cools down. When the projector beeps twice, it’s safe to unplug it.

To turn the projector on again, wait until the  Power light stops flashing. Then press the  Power button.

4. Press up on the blue foot release lever and lower the projector to retract the front adjustable foot, as shown.

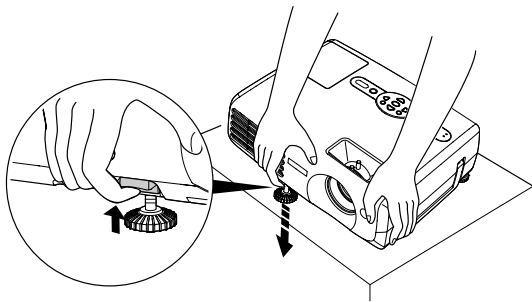

5. Replace the lens cap and unplug the power cord.

Caution

To avoid damaging the projector or lamp, never unplug the power cord when the  Power light is green or flashing orange.

6. Turn off and disconnect any equipment connected to the projector.
7. Store the projector in the soft case that came with it or in another protective case.

Using the Remote Control

Before using the remote control, insert the two AAA alkaline batteries, as described on your *Quick Setup* sheet.

When using the remote control, stand within 20 feet of the projector. Point the remote control either at the front or back of the projector or at the screen (the projector’s front sensor can detect signals bounced off the screen). Press the button for the function you want to use.

Turning Off the Picture and Sound

You can use the A/V Mute button on the remote control to turn off the image and sound and darken your screen. This is useful if you want to temporarily re-direct your audience’s attention without the distraction of a bright screen.

- To turn off the picture and sound, press the A/V Mute button. The screen goes dark.
- To turn the image and sound back on, press the A/V Mute button again.

You can create an image, such as a company logo or a picture, to display on the screen whenever you press the A/V Mute button. See the *User’s Guide* for more information.





Stopping Action

Press the Freeze button to stop the action in your video or computer image and keep the current image on the screen. The sound will continue, however; and if you have connected an external monitor for simultaneous display, the action continues on the monitor even though it is paused on the screen.

To restart the action, press the Freeze button again or press Esc.

Zooming Your Image



Follow these steps to zoom in on a portion of the image:

1. Press the E-Zoom  button on the remote control. You see a crosshair indicating the center of the zoom-in area.
2. Use the  pointer button to position the crosshair in the area you want to enlarge.
3. Continue pressing the E-Zoom  button to enlarge the selected area up to 4 times.
4. While the image is enlarged, you can:
 - Use the  pointer button to move the image.
 - Press the E-Zoom  button to zoom out.
5. When you’re done, press the Esc button to return the image to its original size.

Using the Remote Control as a Wireless Mouse

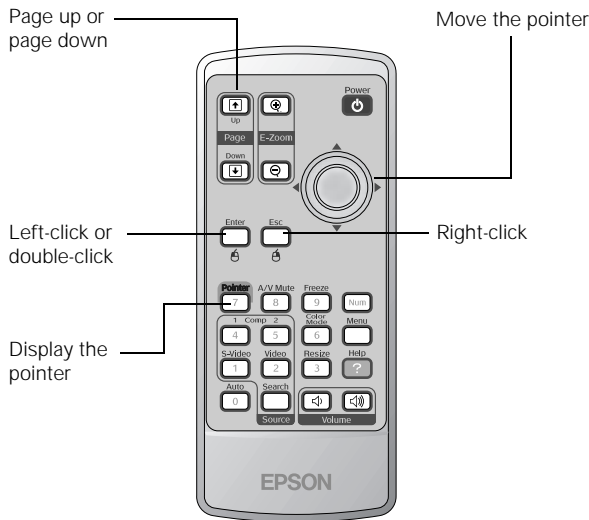
When you use the remote control as a wireless mouse, you can control your computer or click through slideshow-style presentations (such as PowerPoint) from up to 20 feet away. To control your computer with the remote, make sure you have connected the USB mouse cable between the projector and your computer.



- ❑ To advance slides in a PowerPoint presentation in Slide Show mode, press the Page Up or Enter button on the remote control. Press the Page Down or Esc button to go back a slide.
- ❑ To display the mouse pointer, press the Pointer button.
- ❑ To move the pointer on the screen, aim the remote at the screen and use the  pointer button.
- ❑ To click (or left-click), press the Enter button.
- ❑ To right-click, press the Esc button.
- ❑ To double-click, press the Enter button twice.
- ❑ To click and drag, press and hold the Enter button and use the  pointer button to move the pointer, then release the Enter button.

Replacing the Batteries

Caution:

When replacing batteries, take the following precautions:

- ❑ Replace the batteries as soon as they run out. If a battery leaks, wipe away battery fluid with a soft cloth. If fluid gets on your hands, wash them immediately.
- ❑ Do not expose batteries to heat or flame.
- ❑ Dispose of used batteries according to local regulations.
- ❑ Remove the batteries if you won't be using the projector for a long time.

Follow these steps to replace the AAA alkaline batteries:

1. Press in the tab to remove the battery cover.

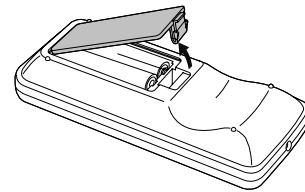

2. Remove the old batteries, then insert the new ones as shown.

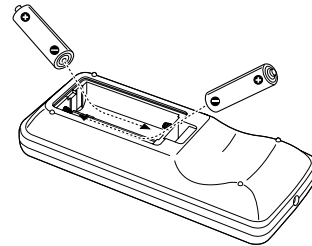

3. Replace the battery cover. (It should click into place.)

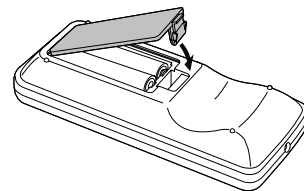

Using Password Protection

If you assign a password for the projector, a screen appears requesting the password whenever you turn on the projector. If you enter the password incorrectly three times in succession, the projector's operation is locked. Disconnect the projector and reconnect it. If you enter the incorrect password 30 times in a row, the projector is locked and remains locked until an authorized Epson servicer can unlock it.

You can also create a user's logo for the projector, to be displayed as the startup screen and/or AV/Mute screen. Unauthorized users cannot turn it off or change it. This discourages theft and provides a way to identify the projector should it be stolen.

Additionally, to make sure a borrowed projector is returned, you can temporarily disable the password for a set period of time. When that time has elapsed, the password function is reactivated and you must enter the password before you can use the projector.

Follow the instructions below to first set the password, and then turn on the password and/or user logo protection.

Note:

If you should happen to enable the password before you set one, and you see the prompt to enter the password, enter the default password 0000 to proceed.

Setting a Password

1. Press the Freeze button on the remote control for about 7 seconds, until you see the Password Protect menu:

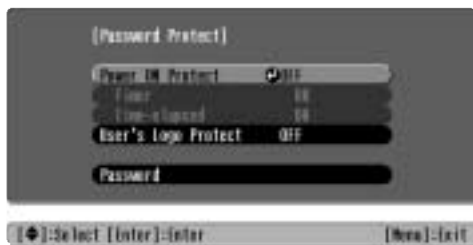

If a password has already been set, you see the Password Protect Release screen. See "Starting the Projector with a Password" on page 10.

2. Use the  pointer button to select Password and press Enter. You see the message Change the password?
3. Select Yes and press Enter.

4. Hold down the Num button on the remote control and use the numeric keypad to enter a 4-digit password.

The password will be displayed as ****. After you enter the last digit, a confirmation screen appears. Enter the password again.

5. After you finish setting the password, press the Esc button to return to the Password Protect menu.

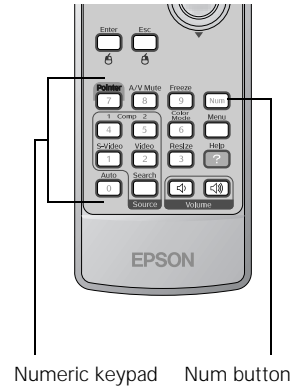

Make a note of the password and keep it in a safe place in case you forget it.

Turning On the Password and User's Logo

To enable the password and User's Logo, follow these steps:

1. Press the Freeze button on the remote control for about 7 seconds until you see the Password Protect menu.
2. Select Power ON Protect and press Enter.
3. Select ON and press Esc.
4. If you want to disable the password temporarily so someone can use the projector without entering the password, select Timer and press Enter. Then hold down the Num button while you use the numeric keypad to enter the number of hours (from 0 to 999) you want the password feature disabled. If you want the projector to request the password every time it is turned on, set the timer to 0H.

The timer starts counting as soon as you close the Password Protect menu. (You can check the elapsed time in this menu next to Time elapsed.)

When the period defined in the Time-elapased setting has passed, and the password is entered correctly, the elapsed time will be reset to 0H and the timer will start again. Remember to disable or change this setting when you're finished using it.

5. To enable your User's Logo, select User's Logo Protect and press Enter. Then select ON and press Enter.

When this feature is on, the logo appears whenever the projector is turned on (if the Startup Screen is enabled in the Extended menu) and as the A/V Mute screen (if you selected Logo as the Background Color in the Extended menu).

Note:

None of the User's Logo features can be changed when the User's Logo Protect function is enabled.

6. Press Menu to close the Password Protect menu.

Starting the Projector with a Password

Caution:

If you lose the remote control, you will not be able to enter the password; so keep the remote control in a safe place at all times.

When the password function is enabled, you see this screen when you turn on the projector:



Hold down the Num button on the remote control as you use the numeric keypad buttons to enter the password. Once you have entered the password correctly, the password screen closes, and projection begins.

If the password is not correct, you see the message Wrong password. Please try again. If you enter an incorrect password three times in succession, you see the message The projector's operation will be locked. Request code xxxxx and the projector switches to standby mode for approximately 5 minutes. Write down the request code. Then disconnect the projector's power cord from the electrical outlet, reconnect it, and turn the projector back on. When you see the Password Protect Release screen, enter the correct password.

If you have forgotten the password, contact Epson for assistance and give them the request code number that appears in the Password Protect Release screen.

If you enter an incorrect password 30 times in a row, the projector remains locked and you must contact an authorized Epson servicer to unlock it.

Disabling the Projector's Buttons

When you enable the Operation Lock function, all the projector's buttons are disabled except for the  Power button. This is useful, for example, if you want to prevent students in a classroom from playing with the projector.

1. Press the Menu button.
2. Select the Setting menu and press Enter.
3. Use the  pointer button on the remote control (or up and down arrow buttons on the projector) to select Operation Lock and press the Enter button.
4. Select ON and press Enter. Then select Yes and press Enter to confirm the setting.
5. Press the Menu button to exit the menu system.

Note:

You can cancel Operation Lock by pressing the projector's Enter button for 9 seconds.

Projector Status Lights

The lights on top of the projector indicate the projector's status and let you know when a problem occurs.

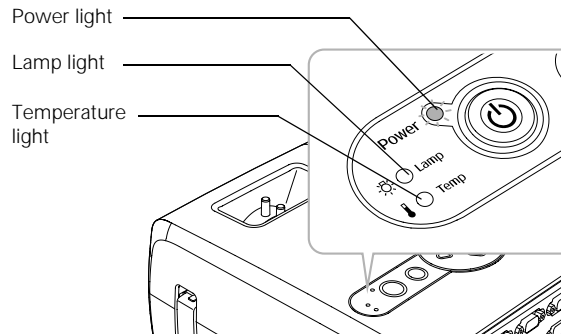

Power light	Lamp light	Temperature light	Description
Flashing green	Off	Off	The projector is warming up. Wait for the image to appear.
Green	Off	Off	The projector is operating normally.
Flashing orange	Off	Off	The projector is cooling down. Wait for the light to stop flashing and remain orange before unplugging it.
Red	Flashing red	Flashing red	There is an internal error in the projector. Turn off the projector and unplug it. Contact Epson for help.

Power light	Lamp light	Temperature light	Description
Flashing green	Off	Off	The projector is warming up. Wait for the image to appear.
Green	Off	Off	The projector is operating normally.
Flashing orange	Off	Off	The projector is cooling down. Wait for the light to stop flashing and remain orange before unplugging it.
Red	Off	Flashing red	There is a problem with the fan or a sensor. Turn off the projector and unplug it. Contact Epson for help.
Red	Flashing red	Off	The lamp is burned out, broken, or not installed correctly, or the lamp cover is open. Close the cover or replace or reseal the lamp, if necessary, as described on page 12.
—	Flashing orange	Off	Replace the lamp with a new one as soon as possible. See page 12 for instructions. If you continue to use the lamp, there is a risk it may break.
Red	Off	Red	The projector has overheated and turned itself off. Let it cool for about five minutes, then turn it back on. Make sure there is plenty of space around and under the projector for ventilation. Also clean the air filter and air exhaust vents. If it continues to overheat, you may need to replace the air filter.
Flashing red	Off	Flashing orange	The projector is too hot. Make sure the room is not above 95 °F and there is plenty of space around and under the projector for ventilation. Clean the air filter and air vents, if necessary.
Orange	Off	Off	The projector is in standby or sleep mode. You can unplug it or press the  Power button to turn it on.

Cleaning the Lens

Clean the lens whenever you notice dirt or dust on the surface.

- Use a canister of compressed air to remove dust.
- To remove dirt or smears on the lens, use lens-cleaning paper. If necessary, moisten a soft cloth with lens cleaner and gently wipe the lens .

Caution:

Do not use glass cleaner to clean the lens.

Cleaning the Projector Case

Before you clean the case, first turn off the projector and unplug the power cord.

- To remove dirt or dust, wipe the case with a soft, dry, lint-free cloth.
- To remove stubborn dirt or stains, wipe the case with a soft cloth moistened with a mild detergent.

Caution:

Do not use wax, alcohol, benzene, paint thinner, or other chemical detergents. These can damage the case.

Cleaning and Replacing the Air Filter

Clean the air filter and air intake and exhaust vents on the bottom and rear of the projector after every 100 hours of use. If not cleaned periodically, they can become clogged with dust, preventing proper ventilation. This can cause overheating and damage the projector. When the filter is clogged, the projector displays the message The projector is overheated.

To clean the air filter and air vents, follow these steps:

1. Turn off the projector, allow it to cool down, and unplug the power cord.
2. Clean the air vent on the back of the projector.

Use a small vacuum cleaner designed for computers and other office equipment. If you don't have one, use a very soft brush (such as an artist's brush).

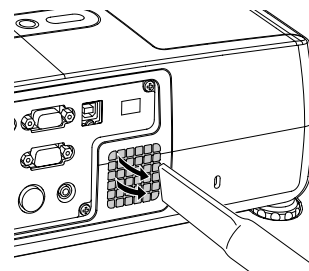

3. Turn the projector upside-down and clean the filter and air intake vents on the base of the projector.

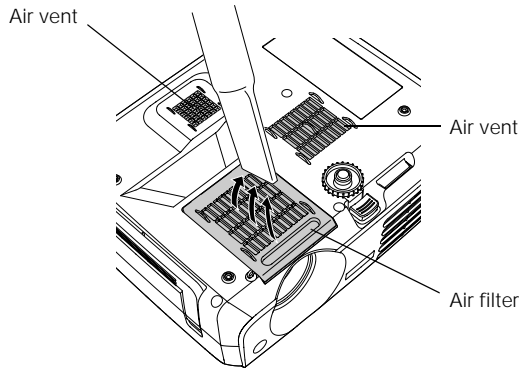

If dirt is difficult to remove or the filter is torn, replace it. The air filter set (part number V13H134A06) contains two filters. Contact your dealer or call Epson at (800) 873-7766 to obtain a new set. In Canada, please call (800) 463-7766 to locate a dealer.

Note:

When you get a replacement lamp for your projector, a new air filter is included. Replace the filter when you replace the lamp.

4. If you need to replace the filter, slide it off as shown.

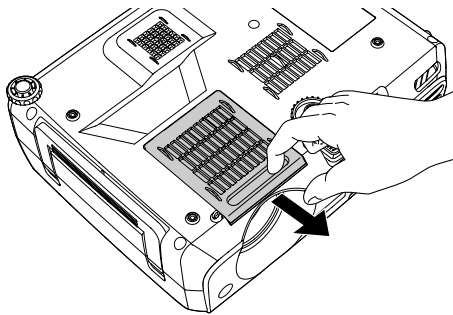

5. Align the new filter carefully as you slide it in until it clicks into place.

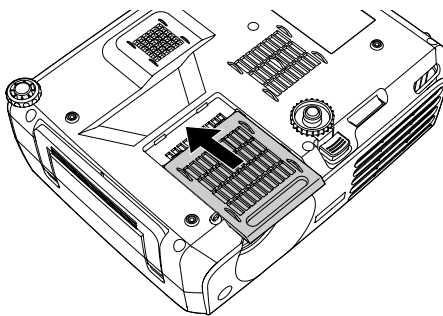

Replacing the Lamp

The projection lamp typically lasts for about 2000 hours of use (in high brightness mode) or 3000 hours (in low brightness mode). It is time to replace the lamp when:

- The projected image gets darker or starts to deteriorate.
- The  warning light is flashing orange.
- The message Replace the Lamp appears on the screen when the lamp comes on. To maintain brightness and image quality, replace the lamp as soon as possible.

Note:

You can check how many hours the lamp has been used in the Info menu.

Note:

Turn the projector off when not in use. Continuous use may reduce the overall life of the product.

Contact your dealer or call Epson at (800) 873-7766 in the United States for a replacement lamp. Request part number V13H010L30. In Canada, please call (800) 463-7766 to locate a dealer.

Follow these steps to replace the lamp:

1. Press the  Power button twice to turn off the projector. When you hear the projector beep twice, unplug the power cord.
2. If the projector has been on, allow it to cool down for at least half an hour (or until the lamp is cool).

Warning:

Let the lamp cool before replacing it. If the lamp breaks, handle the shards carefully to avoid injury.

3. Use the screwdriver included with the replacement lamp to loosen the screw holding the lamp cover (located on top of the projector).
4. Slide the cover out, then lift it off.

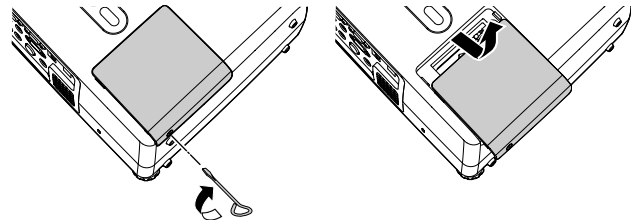

- Use the screwdriver to loosen the two screws holding the lamp in place. (You can't remove the screws.)

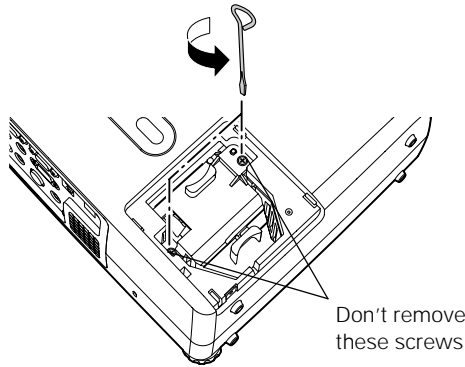

- Hold the lamp as shown and pull it straight out.

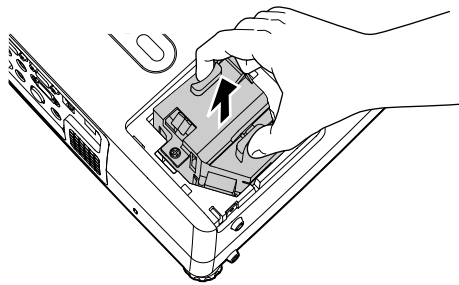

Warning:

This product includes a lamp component that contains mercury (Hg). Please consult your state and local regulations regarding disposal or recycling. Do not put it in the trash.

- Gently insert the new lamp. If it doesn't fit easily, make sure it's facing the correct way.
- Once the lamp is fully inserted, tighten its screws.

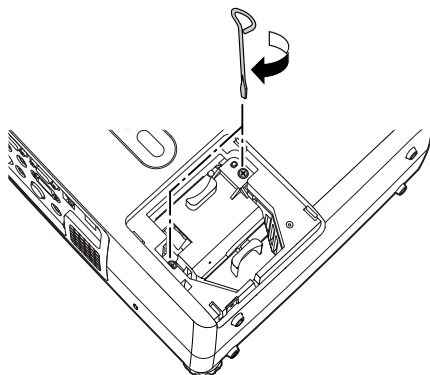

Caution:

Do not touch the glass portion of the lamp assembly. Touching the glass could result in premature lamp failure.

- Lower the lamp cover into place. (The opening should be almost covered, and the top of the lamp cover should be flush with the surface of the projector.) Then slide the cover closed and tighten the screw.

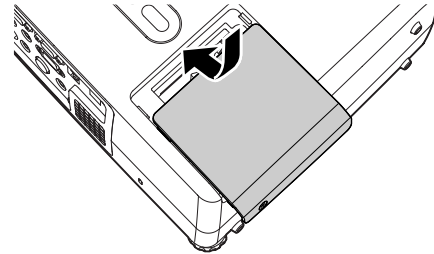

- Reset the lamp timer as described in the next section.

Resetting the Lamp Timer

You must reset the lamp timer after replacing the lamp to clear the Replace the Lamp message.

Note:

Do not reset the lamp timer if you have not replaced the lamp. If you do, the Lamp Hours will not accurately reflect the number of hours that the lamp has been used.

- Connect the power cable and turn on the projector.
- Press the Menu button on the remote control and select the Reset menu. Then press Enter. You see the following:



- Select Lamp-Hours Reset and press Enter. You see the following:



Epson PowerLite 61p/81p Projector

4. Select Yes and press Enter.
5. Press Esc to return to the Reset menu or the Menu button to exit the menu system.

Optional Accessories

Epson provides the following optional accessories for the projectors:

Product	Part number
Replacement lamp	V13H010L30
Air filter set (includes 2 filters)	V13H134A06
Samsonite® wheeled soft case	ELPKS35
ATA molded hard-shell carrying case	ELPKS51
Component video cable (VGA-to-RCA)	ELPKC19
S-Video cable	ELPSV01
Macintosh adapter set	ELPAP01
Distribution amplifier	ELPDA01
50-inch portable screen	ELPSC06
60-inch portable pop-up screen	ELPSC07
80-inch portable pop-up screen	ELPSC08
83.6-inch hanging pull-down screen	ELPSC09
Image presentation camera	V12H162020
High resolution document camera	V12H064020
Kensington® security lock	ELPSL01
Ceiling mount	ELPMB36
False ceiling plate	ELPMBFCP
Suspension adapter	ELPMBAPL
Security bracket/cabling for gyro lock mounts	ELPMBSEC
Adjustable ceiling channel	ELPMBACC

Note:

To purchase a replacement remote control, call (562) 276-4394 (U.S.) or (905) 709-3839 (for dealer referral in Canada).

Related Documentation

CPD-17998	Epson PowerLite 61p/81p <i>User's Guide</i>
CPD-18000	Epson PowerLite 61p/81p <i>Quick Setup</i>