

ASHE COUNTY SHERIFF'S OFFICE



PSAP Back-up Plan

Ashe County Communications Division

PSAP BACKUP PLAN FOR THE ASHE COUNTY SHERIFF'S OFFICE

Table of Contents	2
Forward	3
PSAP Back-up Plan	
I. About.....	3
a. Ashe County Sheriff's Office	
b. Family Central	
II. History.....	3
a. Ashe County Sheriff's Office	
b. Family Central	
III. Agencies Served and Call Volume.....	4
a. Ashe County Sheriff's Office	
IV. Staffing/Positions/Workstations.....	4
a. Ashe County Sheriff's Office	
b. Family Central	
V. Equipment.....	4-5
a. Ashe County Sheriff's Office	
b. Family Central	
VI. Distance Between Ashe County Sheriff's Office and Family Central	5
VII. Connection Between Centers/Rerouting/Redundancy.....	6
VIII. Transition 911 Call Answering.....	6
IX. Backup Power Systems.....	6
a. Ashe County Sheriff's Office	
b. Family Central	
X. Radio Configuration.....	6-7
a. Ashe County Sheriff's Office	
b. Family Central	
XI. Maintenance and Testing of Back-up Centers.....	7
XII. Employee Needs.....	7
XIII. Cost	7
XIV. Backup Center Methodology.....	8
XV. Activation Checklist.....	8
XVI. Reversal Checklist.....	9
XVII. Contact List.....	10
XVIII. PSAP Phone Numbers.....	11
XIX. Timeline of Implementation	11

Forward

The purpose of this plan is to provide a back-up site for the Ashe County Sheriff's Office should the existing PSAP require evacuation or experience an event that takes the call center out of service.

This plan is a work in progress and will require frequent updating. The plan is also dependent on additional funding to make this possible through a funding reconsideration. It will be reviewed each time the plan is tested or implemented by all call center personnel.

This plan is **awaiting approval** by the North Carolina 911 Board as a Back-up Center Plan and satisfies the requirements of N.C.G.S. 62A-46 (e) (4a).

I. About

a. About the Ashe County Sheriff's Office

The Communications Division of the Ashe County Sheriff's Office is located on the third floor of 140 Government Circle, Jefferson, NC 28640. This address contains the Detention Center, County Law Enforcement Staff and 911 Communications. It is located in the Jefferson city limits and is adjacent to the county courthouse. The Ashe County Sheriff's Office is located approximately 2.7 miles (1.62 miles direct over air) to the South West from the Family Central location. Ashe County is located in the most North West section of North Carolina, bordering Tennessee & Virginia. Estimated population is 27,126.

b. About the Family Central Enterprise Corporation

Family Central is owned by the Ashe County Government and operated by the Partnership for Children. It currently houses several departments including the Department of Social Services and Ashe County Parks & Recreation. Prior to 2001, the Family Central building was Ashe Central High School. The building currently has network access to the Ashe County Government via a VPN Air Fiber line.

II. History

This part of the plan provides general history about each PSAP.

a. History of the Ashe County Sheriff's Office

The Ashe County Sheriff's Office PSAP was previously located at on Academy Street from 1992 to 2010. In 2010 the new Ashe County Law Enforcement Center was completed, housing the three divisions of the Sheriff's Office. The Communications Center was placed on the uppermost, third floor. There are two fully staffed positions that dispatch the majority of the day. A third, remote position has been established in the Director's office. As of February 2016 this position is fully functional, taking calls and dispatching from this location.

b. History of the Family Central Enterprise Corporation building

Prior to 2001 the Family Central location was home to the Ashe Central High School. The building was built in 1956 and ended high school functions in 2001. In 2000 it was transferred to the Ashe County Government. The 27-acre property contains the primary building that is 22,358 square feet. It has been remodeled and is currently used by several entities.

PSAP BACKUP PLAN FOR THE ASHE COUNTY SHERIFF'S OFFICE

III. Agencies Served and Call Volume

a. Agencies Served and Call Volume – Ashe County Sheriff's Office

The Ashe County Sheriff's Office PSAP provides services to the Ashe County Sheriff's Office, West Jefferson Police Department, Jefferson Police Department, Ashe County EMS & Rescue Squad, Fire Marshal, Animal Control, Department of Social Services, Emergency Management and 17 local volunteer fire departments. In 2015 we received approximately 8,125 911 emergency calls and 37,204 administrative phone calls that do include some emergencies. Approximately 11,308 outbound phone calls were made for a total of 56,800 total calls to and from our PSAP. This resulted in a total of 29,160 documented calls for service for the year of 2015.

IV. Staffing/Positions/Workstations

a. Staffing/Positions/Workstations - Ashe County Sheriff's Office

Currently the Ashe Sheriff PSAP has 2 full-time consoles that contain two dispatchers for 18-20 hours a day. The remaining 4-6 hours have a single dispatcher. There is also a remote CommandPost position setup that is used on a daily basis, but not a full 24-hour position. In addition, there is an additional console that will be a remote CommandPost, portable position that is planned for setup this fall in the main dispatch center. This position allows us to have a third position for future and/or exigent circumstances. For the back-up plan, Ashe Comm. Center would remove the two remote portable positions and transfer them to the Family Central location.

b. Staffing/Positions/Workstations - Family Central

Currently the Family Central room 209, contains two empty rooms. For the back-up plan, there will be two desk setups with monitors. Our two remote positions would be placed in the room, allowing two staffers to dispatch from this room.

V. Equipment

a. Equipment - Ashe County Sheriff's Office

Software: CAD - Currently 2 CAD Machines with 911 Interface and Mapping. RMS with Calls For Service. One Command Post is fully operational and available to transport/use.

Vendor(s): Southern Software

911 Phone System: Motorola Intrado

Vendor(s): Intrado, Wireless Communications, Century Link

Radio: Our radio system is estimated at 10 or more years old. It is a Tait 150 Mhz 3 channel, 3 site VHF simulcast system. Radio consoles have an 800 Mhz patch with the ability to connect to any VIPER channel within North Carolina.

Vendor(s): Wireless Communications

Recording: Airbus Recording Software

PSAP BACKUP PLAN FOR THE ASHE COUNTY SHERIFF'S OFFICE

Vendor(s): Wireless Communications

b. Equipment – Family Central

Software: None in place. After funding and approval, an additional CommandPOST will be purchased and installed at our 3rd CAD station. When a backup situation arises, the two CommandPOST will be transported to this location and used.

Vendor(s): Southern Software

911 Phone System: None in place. Currently in the event our 911 system fails, our calls are routed to Wilkes County Communications. Our calls will be routed to our CommandPOST where we will dispatch from a room in Family Central.

Vendor(s): Intrado & Wireless Communications, Century Link

Radio: None in place. We are planning on using portable handheld radios at this location. We have 3 primary radio channels that are in use: Sheriff 1, EMS & Fire. We would use 2 new VHF radios for our EMS & Fire channels, allowing us to page the appropriate department. A new Dual-Band Viper/VHP radio would be used for our Sheriff 1 channel. Three antennas would be installed on the roof of Family Central. Each antenna would be run into the dispatch room and connected to the antenna connection on each handheld radio.

Vendor(s): Wireless Communications

Recording: Airbus Recording Software

Vendor(s): Wireless Communications

VI. Distance Between Ashe County Sheriff's Office and Family Central

The approximate linear distance between the Ashe Sheriff and Family Central buildings is 1.57 miles.

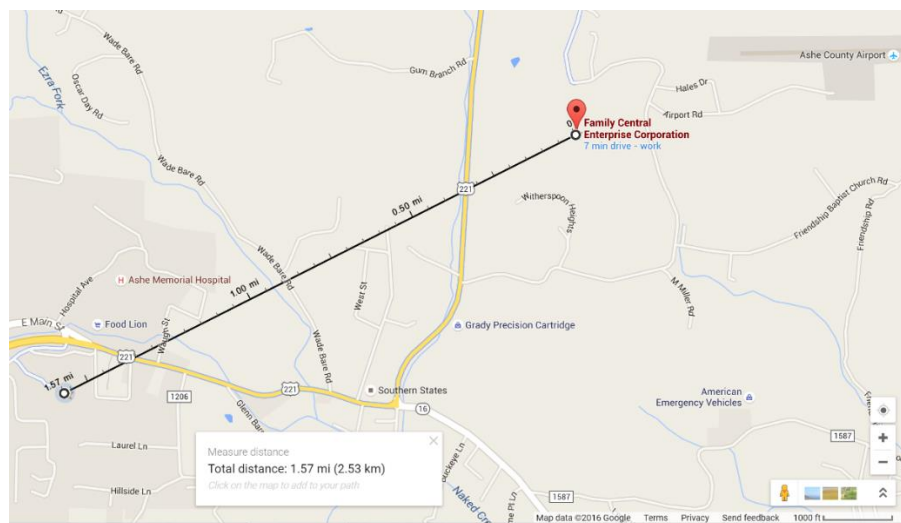

PSAP BACKUP PLAN FOR THE ASHE COUNTY SHERIFF'S OFFICE

VII. Connection Between Centers/Rerouting/Redundancy

A microwave link will be used in connection between the two PSAP locations. The network will consist of several components. The microwave link consists of 2 integrated links (5GHz and 24 GHz). The links are setup in a redundant configuration in which if the primary connection fails, the system will automatically switches to the secondary link. As plans for potential equipment failure, equipment is in place in which a 3rd link that can be activated if necessary at 5GHz. The two primary links are configured in a P2P configuration and the third is configured as a P2MP and only will be used if both the primary and secondary links fail and need maintenance. The microwave link described is used due to long geographical distance and is used as "last mile" in connecting the two PSAP locations.

The above mentioned Microwave link will be used to connect the primary server located at the Ashe County Sheriff's Office with the secondary server at the Family Central location. The primary CAD server's data will continually be replicated to the backup server.

Our 911 system is currently routed through Wilkes Communications Center. Our current Intrado 911 System is setup to send 911 calls to our CommandPost remote positions at any location with internet.

VIII. Transition 911 Call Answering

Calls for Ashe Sheriff automatically roll to Wilkes County Communications. Wilkes County will be notified in the event this plan is implemented. Wilkes County will then communicate any calls they receive to Ashe Sheriff via the states Viper emergency channels.

IX. Backup Power Systems

a. Backup Power Systems – Ashe Sheriff

The Ashe County Sheriff's Office has a large Cummins High Horsepower Commercial Industrial generator. It is 16 cylinder twin turbo diesel, capable of running the entire 60,000 square foot facility that includes the Detention Center, Law Enforcement Center and Communications Center for 24 continuous hours under a heavy load. It has a 2400 gallon diesel fuel capacity.

b. Backup Power Systems - Family Central

None in place. Installation: 100 amp service will be installed and provide service to 8 outlets are to be installed in each of the two rooms at Family Central. These outlets are for call taking of 911 and administrative lines, as well as our server and rack system. The remaining outlets will be used for additional items that are not 911 eligible. A Generac 6552 22kva generator and transfer switch will be installed for power in the event of a power failure.

X. Radio Configuration

a. Radio Configuration – Ashe Sheriff

Ashe Sheriff will use the three new handheld radios as a backup radio system inside the current communications center. These three units will be integrated into the existing Family Central facility in the event of the current communications center being unable to operate. During the transfer of our staff to the Family Central locations, these three radios will be used. One, a handheld Dual-Band Viper radio will be used to communicate with Wilkes County Communications while calls are forwarded to them.

PSAP BACKUP PLAN FOR THE ASHE COUNTY SHERIFF'S OFFICE

b. Radio Configuration – Family Central

Family Central currently has no radio equipment. Upon implementation of the backup plan, three antennas will be installed on the roof of the building. Direct lines will be brought into room 209 where our Backup PSAP will be located. Each antenna is for each of the primary channels that are used for Ashe County Emergencies; Sheriff 1, EMS & Fire. The handheld radios will be brought from the Ashe County Sheriff's Office and will be placed in charging docks. The portable antennas will be removed and each handheld will be directly connected to the antennas mounted on the roof. Two of these radios will be new VHS radios with paging functionality, allowing each radio to be dedicated to an EMS or Fire channel. The third radio is a dual-band Viper 800 radio just for Law Enforcement.

XI. Maintenance and Testing of Backup Centers

These back-up systems will be tested monthly. Testing will include turning on equipment; doing any needed updates, testing the redundant Ubiquity AirFiber connection and testing radios.

Mock walk through drills will be completed as needed during initial implementation and as new employees are added. This will also provide staff the opportunity to note any differences in systems, although we are very similar.

A monthly test of the phone and radio system will be conducted. This involves a visit from any of our staff, dispatching one or more calls using our CAD, phones & radio system.

A complete failover test will be conducted and back-up site will be in full use for a minimum 8 hour period on a semiannual basis. This involves a complete shift working from this location. The chosen morning or night shift would start their work day from the backup location, completing each and every call from these positions.

XII. Employee Needs

Both the Ashe County Sheriff's Office and Family Central contain necessary facilities for staff which include showers, and restrooms. Keys for the exterior Family Central building and Room 209 will be stored in two places. One set of keys will be kept inside a lock box in the current commutations center at the Ashe County Sheriff's Office. Another set of keys will be secured by the Director of Communications. In the future, a key fob system will be integrated inside the Family Central location.

XIII. Cost

Cost spreadsheet is attached as the front page of all quotes.

PSAP BACKUP PLAN FOR THE ASHE COUNTY SHERIFF'S OFFICE

XIV. Back-up Center Activation Methodology

In the event that the Ashe County Sheriff's Office PSAP experiences an event that triggers the implementation of this backup plan the on duty staff at that facility will immediately notify the PSAP Director and the Sheriff of Ashe County. One of these two positions will make the call to implement the plan or not. Once the decision is made that a fail over is necessary, the Back-up Center Activation Checklist will be executed to make the transition between the primary and the back-up site.

XV. Back-up Center Activation Checklist

- Incident has occurred warranting the implementation of this PSAP Back-up Plan. The steps below may be altered depending on the situation that has occurred.
 - Contact the following:
 - o PSAP Director Phil Howell 336-620-6988
 - o Sheriff of Ashe County James Williams 336-977-6280
 - o PSAP Director or active dispatchers will notify the following people that the plan has been executed:
 - Ashe County EMS Director Patty Gambill
 - Ashe County Manager Sam Yearick 1-704-477-6171
 - PSAP Liaison (David Dodd) 1-919-754-6625 david.dodd@nc.gov
 - Director of 911 Board (Richard Taylor) 1-919-754-6624 richard.taylor@nc.gov
 - o Major Bucky Absher 336-977-6283
 - o Lieutenant Kelley Stevens 336-977-9287
 - o Ashe County Head IT Cyrus Hurley 828-773-8693
 - o On-duty shift supervisor By Radio
 - Contact Wilkes County Communications 336-903-7600 to let them know they will receive our calls while in transition.
 - Contact Skyline at 1-800-759-2226 and ask to have all administrative lines forwarded to Wilkes County Communications.
 - Shift Supervisor will assist with transportation of personnel and remote equipment as needed to Family Central
 - Have supervisors call in essential personnel if needed (disaster).
 - IT will promote the backup CAD server at Family Central as the new primary CAD server.
 - Connect remote equipment to internet and monitors at Family Central.
 - Contact Skyline at 1-800-759-2226 and ask to have all administrative lines forwarded to Family Central.
- ***** At this point the back-up plan implementation is considered complete *****

- Operate 911 from the back-up center until the original site is deemed operational by the Sheriff of Ashe County

PSAP BACKUP PLAN FOR THE ASHE COUNTY SHERIFF'S OFFICE

XVI. Reversal Back to Normal Operations Checklist

- Prior to deploying the reversal, key sheriff, IT, and 911 staff will meet in a coordinated effort to deem the original site functional and staffed.
- The Sheriff has deemed the original site operational and called for the reversal cut over.
- Director & Shift Supervisor will assist with transportation of personnel and equipment back to the Ashe County Communications as needed.
- IT will sync the backup CAD server at Family Central with the primary CAD server at Ashe Communications.
- Contact the following:
 - o PSAP Director Phil Howell 336-620-6988
 - o Sheriff of Ashe County James Williams 336-977-6280
 - o Ashe County EMS Director Patty Gambill 336-877-0677
 - o Ashe County Manager Sam Yearick 1-704-477-6171
 - o PSAP Liaison (David Dodd) 1-919-754-6625 david.dodd@nc.gov
 - o Major Bucky Absher 336-977-6283
 - o Lieutenant Kelley Stevens 336-977-9287
 - o Ashe County Head IT Cyrus Hurley 828-773-8693
 - o On-duty shift supervisor By Radio
- Contact Wilkes County Communications 336-903-7600 to let them know they may receive our calls while in transition.
- Contact Skyline at 1-800-759-2226 and asked to have all phones un-forwarded from Family Central.
- Begin operations under the two established CAD positions at the Sheriff's Office. Remaining personnel can then remove the remote positons from Family Central and return them to Ashe County Communications.
- Sheriff or his designee will notify the following people that the plan has been reversed:
 - o Ashe County EMS Director Patty Gambill 336-877-0677
 - o PSAP Liaison (David Dodd) 1-919-754-6625 david.dodd@nc.gov
 - o Director of 911 Board (Richard Taylor) 1-919-754-6624 richard.taylor@nc.gov

***** At this point you should be back to normal operations *****

PSAP BACKUP PLAN FOR THE ASHE COUNTY SHERIFF'S OFFICE

XVII. Names and Telephone Numbers Cited in Back-up Plan

Agencies

Ashe County Sheriff's Office	1-336-846-5600
Family Central	No Phone at this time
Wilkes County Communications	1-336-838-9111

911 Board

Executive Director (Richard Taylor)	1-919-754-6624
Network Analyst/PSAP Liaison (David Dodd)	1-919-754-6625

Ashe Sheriff Key Personnel

Director of Communications Phil Howell	336-620-6988
Sheriff James Williams	336-977-6280
Major Bucky Absher	336-977-6283
IT Director Cyrus Hurley	828-773-8693
IT Technician Toby Bennett	336-846-5596
IT Technician Todd Chapman	336-846-5780
Ashe County EMS Director Patty Gambill	336-877-0677
Ashe County Manager Sam Yearick	1-704-477-6171

Vendors

Wireless Communications	1-800-346-5525
Wireless Communications – Bruce Williams	336-324-3627
Wireless Communications – Jimmy Laws	780-420-2303
Skyline Skybest Communications	1-800-759-2226
Southern Software	1-800-842-8190

PSAP BACKUP PLAN FOR THE ASHE COUNTY SHERIFF'S OFFICE

XVIII. List of Communications Center Telephone Numbers

Ashe Sheriff Admin Lines

336-846-5600a, 336-846-5600b, 336-846-5600c, 336-846-5600d.

Family Central Admin Lines will be purchased after plan and budget approval.

XIX. Timeline of Implementation

Due to the lack of monies to complete this, our implementation plan and timeline are dependent on the funding we are able to receive.

Our estimated timeline is:

- October 2016 – We hope to have the backup generator, additional outlets that solely rely on the generator installed.
- November 2016 – New monitors installed at the Ashe Comm. Center and used ones moved to Family Central backup location.
- December 2016 – We hope to have the network infrastructure with a new server that is a complete live mirror of our new 911 Server.
- March 2017 – Use the old CAD Machines that are replaced with new, reformat them and install at our backup location to be used there.
- June 1, 2017 – Date of implantation. This is extended in case an unexpected problem arises.

ASHE Backup PSAP Financial Documentation

<u>Non-Eligible Costs</u>		<u>Surcharge Eligible Expenses</u>			
		One-Time Costs		Recurring Costs Monthly	
Product/Service	Cost	Product/Service	Cost	Product/Service	Cost
Room at Family Central	\$ 4,080.90	Monitor Stands (Amazon)	\$ 455.85	911 Routing/Intrado (Motorola)	\$ 9,294.64
2 VHF Radios/Antennas/Install (Wireless)	\$ 3,250.52	CAD Machines/Laptops (CDW)	\$ 4,450.68		
Viper Radio/Antenna/Install (Wireless)	\$ 6,643.30	16 Monitors (CDW)	\$ 6,591.20		
		New 911 Servers (CDW)	\$ 22,007.67		
A		Generater & Electrical (J&B Electric)	\$ 11,376.00		
		2 Chairs & Bolts (Office Designs)	\$ 1,789.00		
		EMD/EFD/EPD Maint. (Priority Dispatch)	\$ 6,171.00		
		EMD/EFD/EPD License (Priority Dispatch)	\$ 12,937.50		
		PSAware (Southern Software)	\$ 3,750.00		
		2 CAD EOC Positions (Southern Software)	\$ -		
		Wireless Messaging, Neverfail, Installation (Southern Software)	\$ 10,745.00		
		CommandPost & Portable Setup	\$ 53,034.49		
	\$ 13,974.72		\$ 133,308.39	Multiplied by 12 for year	\$ 111,535.68

Shopping Cart

	Price	Quantity
	\$151.95	<input type="text" value="3"/>
EZM Deluxe Hex Monitor Mount Stand Free Standing Supports up to 6 28" (002-0023) by EasyMountLCD		
In Stock		
<input type="checkbox"/> This is a gift Learn more		
Delete	Save for later	

Subtotal (3 items): \$455.85

Subtotal (3 items): \$455.85

This order contains a gift

[Proceed to checkout](#)

or

[Sign in](#) to turn on 1-Click ordering.

Estimate your shipping and tax

Order summary

Shipping to: [B. Phil Howell- LAUREL SPRINGS](#)

Items (3)	\$455.85
Estimated shipping & handling	FREE
Total before tax	\$455.85
Estimated tax to be collected	\$0.00
Estimated order total	\$455.85



SALES QUOTATION

QUOTE NO.	ACCOUNT NO.	DATE
GXFN382	3128940	3/23/2016

BILL TO:
 COUNTY OF ASHE
 150 GOVERNMENT CIR STE 2500

SHIP TO:
 COUNTY OF ASHE
 Attention To: TODD CHAPMAN
 150 GOVERNMENT CIR STE 1400

Accounts Payable
 JEFFERSON , NC 28640-8967

JEFFERSON , NC 28640-9378
 Contact: TODD
 CHAPMAN 336.846.5780

Customer Phone #

Customer P.O. # 3RD QUOTE

ACCOUNT MANAGER	SHIPPING METHOD	TERMS	EXEMPTION CERTIFICATE
JOE BARESE 866.819.6497	FEDEX Ground	Net 30 Days-Govt State/Local	

QTY	ITEM NO.	DESCRIPTION	UNIT PRICE	EXTENDED PRICE
2	3926125	HP SB 470 I7-6500U 1TB 8GB W7/10P Mfg#: T6D90UT#ABA Contract: NC eProcurement System	952.60	1,905.20
2	3845327	HP SB 800 I5-6500 500GB 8GB W7/10P Mfg#: P4K16UT#ABA Contract: NC eProcurement System	819.94	1,639.88
2	2749521	HP USB 3.0 PORT REPLICATOR Mfg#: H1L08AA#ABA Contract: NC eProcurement System	221.44	442.88
2	2733469	LVO DISPLAYPORT/DUAL-DISPLAYPORT ADP Mfg#: 0B47092 Contract: NC eProcurement System	85.78	171.56
SUBTOTAL				4,159.52
FREIGHT				0.00
TAX				291.16

US Currency

TOTAL 4,450.68

CDW Government
 230 North Milwaukee Ave.
 Vernon Hills, IL 60061

Fax: 847.990.8027

Please remit payment to:
 CDW Government
 75 Remittance Drive
 Suite 1515
 Chicago, IL 60675-1515



SALES QUOTATION

QUOTE NO.	ACCOUNT NO.	DATE
GXFM795	3128940	3/23/2016

BILL TO:
 COUNTY OF ASHE
 150 GOVERNMENT CIR STE 2500

SHIP TO:
 COUNTY OF ASHE
 Attention To: TODD CHAPMAN
 150 GOVERNMENT CIR STE 1400

Accounts Payable
 JEFFERSON , NC 28640-8967

JEFFERSON , NC 28640-9378
 Contact: TODD
 CHAPMAN 336.846.5780

Customer Phone #

Customer P.O. # MONITORS QUOTE

ACCOUNT MANAGER		SHIPPING METHOD	TERMS	EXEMPTION CERTIFICATE
JOE BARESE 866.819.6497		FEDEX Ground	Net 30 Days-Govt State/Local	
QTY	ITEM NO.	DESCRIPTION	UNIT PRICE	EXTENDED PRICE
16	3770960	HP SB Z25N 25IN NARROW BEZEL IPS Mfg#: K7C01A8#ABA Contract: NC eProcurement System \$-26 instant rebate. Expires 2016-04-30	385.00	6,160.00
			SUBTOTAL	6,160.00
			FREIGHT	0.00
			TAX	431.20
				US Currency
TOTAL				6,591.20

Please remit payment to:
 CDW Government
 75 Remittance Drive
 Suite 1515
 Chicago, IL 60675-1515

CDW Government
 230 North Milwaukee Ave.
 Vernon Hills, IL 60061

Fax: 847.990.8027



SALES QUOTATION

QUOTE NO.	ACCOUNT NO.	DATE
HCXK250	3128940	6/6/2016

BILL TO:
 COUNTY OF ASHE
 150 GOVERNMENT CIR STE 2500

SHIP TO:
 COUNTY OF ASHE
 Attention To: TODD CHAPMAN
 150 GOVERNMENT CIR STE 1400

Accounts Payable
 JEFFERSON , NC 28640-8967

JEFFERSON , NC 28640-9378
 Contact: TODD
 CHAPMAN 336.846.5780

Customer Phone #

Customer P.O. # 2 SERVER QUOTE

ACCOUNT MANAGER	SHIPPING METHOD	TERMS	EXEMPTION CERTIFICATE
JOE BARESE 866.819.6497	UPS Ground (2- 3 Day)	Net 30 Days-Govt State/Local	

QTY	ITEM NO.	DESCRIPTION	UNIT PRICE	EXTENDED PRICE
2	3466973	HP DL380 GEN9 E5-2620V3 1P 12LFF SRV Mfg#: 779559-S01 Contract: MARKET	2,650.00	5,300.00
8	3624538	HP 4TB SATA 6G 7.2K 3.5IN 512E HDD Mfg#: 765253-B21 Contract: MARKET	650.00	5,200.00
2	3178328	MS GSA WIN SRV STD 2012 R2 2PROC Mfg#: P73-06309 Contract: MARKET	604.46	1,208.92
14	4077241	Electronic distribution - NO MEDIA HP 16GB 1RX4 PC4-2400T-R KIT Mfg#: 805349-B21 Contract: MARKET	275.00	3,850.00
1	642303	TRIPP 1500VA UPS SMART 120V 2U RM XL Mfg#: SMART1500RML2UA Contract: MARKET	600.00	600.00
5	4148260	MS GSA SQL CAL 2016 UCAL Mfg#: 359-06368 Contract: MARKET	145.00	725.00
2	2669162	Electronic distribution - NO MEDIA MS GSA SQL SRV STD 2 CORE SA Mfg#: 7NQ-00301-3 Contract: MARKET Electronic distribution - NO MEDIA	1,842.00	3,684.00
SUBTOTAL				20,567.92
FREIGHT				0.00
TAX				1,439.75

US Currency

TOTAL 22,007.67

CDW Government
 230 North Milwaukee Ave.
 Vernon Hills, IL 60061

Fax: 847.990.8027

Please remit payment to:
 CDW Government
 75 Remittance Drive
 Suite 1515
 Chicago, IL 60675-1515

**J and B Electric
527 Fulton Reeves Rd
Laurel Springs N.C. 28644**

Quote only

Phone 336-982-4251

Date: 4/21/16

To: Ashe County Communication

Description: Wring to new communication room including 100 amp feeder from main, 22kva generator and transfer switch, and 16 dedicated 20 amp circuits in communication room

Labor: \$ 3192.00

Material: \$ General Material \$ 1789.00

100 amp breaker

In service an link

Kit \$ 1194.00

Generator and

Transfer switch \$ 5201.00

— Generac 06552 22kw

Other:

Total: \$ 11376.00

Thank You

Bobby Reed

GENERAC®

16/20/22 kW

16/20/22 kW

GUARDIAN® SERIES Residential Standby Generators Air-Cooled Gas Engine

1 of 5

INCLUDES:

- True Power™ Electrical Technology
- Two Line LCD Multilingual Digital Evolution™ Controller (English/Spanish/French/Portuguese)
- Two Transfer Switch Options Available:
100 Amp Pre-Wired Switch or
200 Amp Service Rated Switch.
See Page 4 for Details.
- Electronic Governor
- External Main Circuit Breaker, System Status & Maintenance Interval LED Indicators
- GFCI Duplex Outlet
- Sound Attenuated Enclosure
- Flexible Fuel Line Connector
- Composite Mounting Pad
- Natural Gas or LP Gas Operation
- 5 Year Limited Warranty
- Capability to be installed within 18" (457 mm) of a building*

Standby Power Rating

Models 006459-2, 006461-1, 006462-2 (Steel - Bisque) - 16 kW 60 Hz

Model 006721-1 (Aluminum - Gray) - 16 kW 60 Hz

Models 006729-2, 006730-1 (Steel - Bisque) - 20 kW 60 Hz

Models 006551-2, 006552-1 (Aluminum - Gray) - 22 kW 60 Hz



QUIET-TEST

Note: CUL certification only applies to unbundled units and units packaged with pre-wired switches. Units packaged with the Smart Switch are UL certified in the USA only.

*Only if located away from doors, windows and fresh air intakes, and unless otherwise directed by local codes.

FEATURES

- **INNOVATIVE DESIGN & PROTOTYPE TESTING** are key components of GENERAC'S success in "IMPROVING POWER BY DESIGN." But it doesn't stop there. Total commitment to component testing, reliability testing, environmental testing, destruction and life testing, plus testing to applicable CSA, NEMA, EGSA, and other standards, allows you to choose GENERAC POWER SYSTEMS with the confidence that these systems will provide superior performance.
- **TRUE POWER™ ELECTRICAL TECHNOLOGY:** Superior harmonics and sine wave form produce less than 5% Total Harmonic Distortion for utility quality power. This allows confident operation of sensitive electronic equipment and micro-chip based appliances, such as variable speed HVAC systems.
- **TEST CRITERIA:**
 - ✓ **PROTOTYPE TESTED**
 - ✓ **SYSTEM TORSIONAL TESTED**
 - ✓ **NEMA MG1-22 EVALUATION**
 - ✓ **MOTOR STARTING ABILITY**
- **SOLID-STATE, FREQUENCY COMPENSATED VOLTAGE REGULATION.** This state-of-the-art power maximizing regulation system is standard on all Generac models. It provides optimized FAST RESPONSE to changing load conditions and MAXIMUM MOTOR STARTING CAPABILITY by electronically torque-matching the surge loads to the engine. Digital voltage regulation at $\pm 1\%$.
- **SINGLE SOURCE SERVICE RESPONSE** from Generac's extensive dealer network provides parts and service know-how for the entire unit, from the engine to the smallest electronic component.
- **GENERAC TRANSFER SWITCHES.** Long life and reliability are synonymous with GENERAC POWER SYSTEMS. One reason for this confidence is that the GENERAC product line includes its own transfer systems and controls for total system compatibility.

THE GENERAC
PROMISE



* Built in the USA using domestic and foreign parts.

Engine

- Generac (OHVI) design
Maximizes engine "breathing" for increased fuel efficiency. Plateau honed cylinder walls and plasma moly rings helps the engine run cooler, reducing oil consumption resulting in longer engine life.
- Quiet-Test™
Greatly reduces sound output and fuel consumption during bi-weekly exercise, compared to other brands.
- "Spiny-lok" cast iron cylinder walls
Rigid construction and added durability provide long engine life.
- Electronic ignition/spark advance
These features combine to assure smooth, quick starting every time.
- Full pressure lubrication system
Pressurized lubrication to all vital bearings means better performance, less maintenance and longer engine life. Now featuring up to a 2 year/200 hour oil change interval.
- Low oil pressure shutdown system
Shutdown protection prevents catastrophic engine damage due to low oil.
- High temperature shutdown
Prevents damage due to overheating.

Generator

- Revolving field
Allows for a smaller, light weight unit that operates 25% more efficiently than a revolving armature generator.
- Skewed stator
Produces a smooth output waveform for compatibility with electronic equipment.
- Displaced phase excitation
Maximizes motor starting capability.
- Automatic voltage regulation
Regulates the output voltage to $\pm 1\%$ prevents damaging voltage spikes.
- UL 2200 listed
For your safety.

Transfer Switch

- Fully automatic
Transfers your vital electrical loads to the energized source of power.
- Pre-wired, color-coded conduits (Pre-wired switches only)
Ensures the easiest, trouble-free installation.
- Remote mounting
Mounts near your existing distribution panel for simple, low-cost installation.

Evolution™ Controls

- Auto/Manual/Off illuminated buttons
Selects the operating mode and provides easy, at-a-glance status indication in any condition.
- Two-line LCD multilingual display
Provides homeowners easily visible logs of history, maintenance and events up to 50 occurrences.
- Sealed, raised buttons
Smooth, weather-resistant user interface for programming and operations.
- Utility voltage sensing
Constantly monitors utility voltage, setpoints 60% dropout, 80% pick-up, of standard voltage.
- Generator voltage sensing
Constantly monitors generator voltage to ensure the cleanest power delivered to the home.
- Utility interrupt delay
Prevents nuisance start-ups of the engine, adjustable 2-1500 seconds from the factory default setting of 5 seconds by a qualified dealer.
- Engine warm-up
Ensures engine is ready to assume the load, setpoint approximately 5 seconds.
- Engine cool-down
Allows engine to cool prior to shutdown, setpoint approximately 1 minute.
- Programmable exerciser
Operates engine to prevent oil seal drying and damage between power outages by running the generator for 5 minutes every other week. Also offers a selectable setting for weekly or monthly operation providing flexibility and potentially lower fuel costs to the owner.
- Smart battery charger
Delivers charge to the battery only when needed at varying rates depending on outdoor air temperature.
- Electronic governor
Maintains constant 60 Hz frequency.

Unit

- SAE weather protective enclosure
Sound attenuated enclosure ensures quiet operation and protection against mother nature, withstanding winds up to 150 mph. Hinged key locking roof panel for security. Lift-out front for easy access to all routine maintenance items. Electrostatically applied textured epoxy paint for added durability.
- Enclosed critical grade muffler
Quiet, critical grade muffler is mounted inside the unit to prevent injuries.
- Small, compact, attractive
Makes for an easy, eye appealing installation, as close as 18" away from a building.*

Installation System

- 1 ft (305 mm) flexible fuel line connector
Absorbs any generator vibration when connected to rigid pipe.
- Composite mounting pad
Eliminates the need to pour a concrete pad unless required by local municipalities.

16/20/22 kW

Generator

Model	006459-2, 006461-1, 006462-2, 006721-1 (16 kW)	006729-2, 006730-1, (20 kW)	006551-2, 006552-1 (22 kW)
Rated Maximum Continuous Power Capacity (LP)	16,000 Watts*	20,000 Watts*	22,000 Watts*
Rated Maximum Continuous Power Capacity (NG)	16,000 Watts*	18,000 Watts*	19,500 Watts*
Rated Voltage	240	240	240
Rated Maximum Continuous Load Current – 240 Volts (LP/NG)	66.6/66.6	83.3/75	91.6/81.3
Total Harmonic Distortion	Less than 5%	Less than 5%	Less than 5%
Main Line Circuit Breaker	65 Amp	90 Amp	100 Amp
Phase	1	1	1
Number of Rotor Poles	2	2	2
Rated AC Frequency	60 Hz	60 Hz	60 Hz
Power Factor	1.0	1.0	1.0
Battery Requirement (not included)	Group 26R, 12 Volts and 525 CCA Minimum		
Unit Weight (lb/kg)	455/206.4 (Steel) 419/190 (Aluminum)	505/229	476/216
Dimensions (L x W x H) in/mm	48 x 25 x 29/1218 x 638 x 732		
Sound output in dB(A) at 23 ft (7 m) with generator operating at normal load**	66	66	67
Sound output in dB(A) at 23 ft (7 m) with generator in Quiet-Test™ low-speed exercise mode**	60	60	58
Exercise duration	5 min	5 min	5 min

Engine

	GENERAC OHVI V-TWIN	GENERAC OHVI V-TWIN	GENERAC OHVI V-TWIN
Type of Engine	GENERAC OHVI V-TWIN	GENERAC OHVI V-TWIN	GENERAC OHVI V-TWIN
Number of Cylinders	2	2	2
Displacement	992 cc	999 cc	999 cc
Cylinder Block		Aluminum w/ Cast Iron Sleeve	
Valve Arrangement	Overhead Valve	Overhead Valve	Overhead Valve
Ignition System	Solid-state w/ Magneto	Solid-state w/ Magneto	Solid-state w/ Magneto
Governor System	Electronic	Electronic	Electronic
Compression Ratio	9.5:1	9.5:1	9.5:1
Starter	12 Vdc	12 Vdc	12 Vdc
Oil Capacity Including Filter	Approx. 1.9 qt/1.8 L	Approx. 1.9 qt/1.8 L	Approx. 1.9 qt/1.8 L
Operating rpm	3,600	3,600	3,600
Fuel Consumption			
Natural Gas	ft ³ /hr (m ³ /hr)		
1/2 Load	193 (5.47)	205 (5.8)	184 (5.21)
Full Load	312 (8.83)	308 (8.72)	281 (7.96)
Liquid Propane	ft ³ /hr (gal/hr) [l/hr]		
1/2 Load	72.4 (1.9) [7.2]	75.6 (2.08) [7.87]	83 (2.16) [8.16]
Full Load	130 (3.19) [12.07]	140 (3.85) [14.57]	127 (3.68) [13.94]

Note: **Fuel pipe must be sized for full load.** Required fuel pressure to generator fuel inlet at all load ranges - 3.5-7" water column (7-13 mm mercury) for natural gas, 10-12" water column (19-22 mm mercury) for LP gas. For Btu content, multiply ft³/hr x 2500 (LP) or ft³/hr x 1000 (NG). For Megajoule content, multiply m³/hr x 93.15 (LP) or m³/hr x 37.26 (NG)

Controls

2-Line Plain Text Multilingual LCD Display	Simple user interface for ease of operation.
Mode Buttons: Auto	Automatic Start on Utility failure. 7 day exerciser.
Manual	Start with starter control, unit stays on. If utility fails, transfer to load takes place.
Off	Stops unit. Power is removed. Control and charger still operate.
Ready to Run/Maintenance Messages	Standard
Engine Run Hours Indication	Standard
Programmable start delay between 2-1500 seconds	Standard (programmable by dealer only)
Utility Voltage Loss/Return to Utility Adjustable (Brownout Setting)	From 140-171 V/190-216 V
Future Set Capable Exerciser/Exercise Set Error Warning	Standard
Run/Alarm/Maintenance Logs	50 Events Each
Engine Start Sequence	Cyclic cranking: 16 sec on, 7 rest (90 sec maximum duration).
Starter Lock-out	Starter cannot re-engage until 5 sec after engine has stopped.
Smart Battery Charger	Standard
Charger Fault/Missing AC Warning	Standard
Low Battery/Battery Problem Protection and Battery Condition Indication	Standard
Automatic Voltage Regulation with Over and Under Voltage Protection	Standard
Under-Frequency/Overload/Stepper Overcurrent Protection	Standard
Safety Fused/Fuse Problem Protection	Standard
Automatic Low Oil Pressure/High Oil Temperature Shutdown	Standard
Overcrank/Overspeed (@ 72 Hz)/rpm Sense Loss Shutdown	Standard
High Engine Temperature Shutdown	Standard
Internal Fault/Incorrect Wiring Protection	Standard
Common External Fault Capability	Standard
Field Upgradable Firmware	Standard

** Sound levels are taken from the front of the generator. Sound levels taken from other sides of the generator may be higher depending on installation parameters. Rating definitions - Standby: Applicable for supplying emergency power for the duration of the utility power outage. No overload capability is available for this rating. (All ratings in accordance with BSS514, ISO3046 and DIN6271). * Maximum wattage and current are subject to and limited by such factors as fuel Btu/megajoule content, ambient temperature, altitude, engine power and condition, etc. Maximum power decreases about 3.5 percent for each 1,000 feet (304.8 meters) above sea level; and also will decrease about 1 percent for each 6 °C (10 °F) above 16 °C (60 °F).

16/20/22 kW

switch options

Pre-wired Features

available on Steel 16 kW models only

- Electrically operated, mechanically-held contacts for fast, positive connections.
- Rated for all classes of load, 100% equipment rated, both inductive and resistive.
- 2 pole, 250 VAC contactors.
- 30 millisecond transfer time.
- Dual coil design.
- Main contacts are silver plated or silver alloy to resist welding and sticking.
- NEMA 1 (indoor rated) enclosure is standard on the pre-wired switch.
- Multi listed for use with 1" standard, tandem, GFCI and AFCI breakers from Siemens, Murray, Eaton and Square D for the most flexible and cost effective install.
- Pre-wired 30 foot (9.1 meter) whip to connect to the provided 5 foot (1.5 meter) pre-wired whip and external connection box.
- Pre-wired 2 foot (0.61 meter) whip, color coded to connect into the existing electrical panel.

Model	006461-1 (16 kW)
No. of Poles	2
Current Rating (Amps)	100
Voltage Rating (VAC)	120/240, 1Ø
Utility Voltage Monitor (Fixed)*	
-Pick-up	80%
-Dropout	60%
Return to Utility*	approx. 15 sec.
Exercise bi-weekly for 12 minutes*	Standard
UL Listed	Standard
Total of Pre-wired Circuits	16
No. 15 A 120 V	5
No. 20 A 120 V	5
No. 20 A 240 V	1
No. 30 A 240 V	-
No. 40 A 240 V	1
No. 50 A 240 V	1
Tandem Breaker Capabilities	8 Tandems
Circuit Breaker Protected	
Available RMS Symmetrical Fault Current @ 250 Volts	10,000

*Function of Evolution Controller
Exercise can be set to weekly or monthly

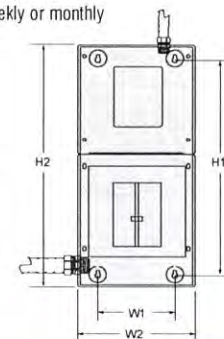

Dimensions

Mechanical Dimensions					
	Height		Width		Depth
	H1	H2	W1	W2	
in	23.5	26.4	8.3	12.6	6.3
mm	597	671.7	211	320.7	159.6

Wire Ranges		
Conductor Lug	Neutral Lug	Ground Lug
2/0 - #14	2/0 - #14	2/0 - #14

Service Rated Switch Features

- Electrically operated, mechanically-held contacts for fast, clean connections.
- Rated for all classes of load, 100% equipment rated, both inductive and resistive.
- 2 pole, 250 VAC contactors.
- Service equipment rated, dual coil design.
- Rated for both aluminum and copper conductors.
- NEMA/UL 3R aluminum outdoor enclosure.
- Main contacts are silver plated or silver alloy to resist welding and sticking.

Model	006462-2 (16 kW)/006729-2 (20 kW)/006551-2 (22 kW)
No. of Poles	2
Current Rating (Amps)	200
Voltage Rating (VAC)	120/240, 1Ø
Utility Voltage Monitor (Fixed)*	
-Pick-up	80%
-Dropout	60%
Return to Utility*	approx. 13 sec.
Exercise weekly for 12 minutes*	Standard
UL Listed	Standard
Enclosure Type	NEMA/UL 3R
Withstand Rating (Amps)	22,000
Lug Range	250 MCM - #6

*Function of Evolution Controller

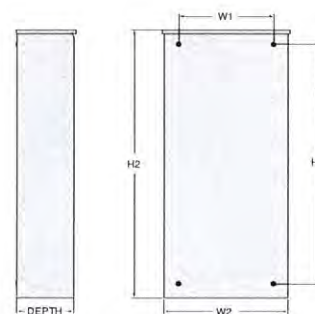

Dimensions

	200 Amps 120/240, 1Ø Open Transition Service Rated				
	Height		Width		Depth
	H1	H2	W1	W2	
in	27.24	30.0	11.4	13.5	7.09
mm	692.0	762.4	289.0	343.0	180.0

16/20/22 kW

available accessories

Model #	Product	Description
006463-3	Mobile Link™	Generac's Mobile Link allows you to check the status of your generator from anywhere that you have access to an Internet connection from a PC or with any smart device. You will even be notified when a change in the generator's status occurs via e-mail or text message. Available in the U.S. only.
005819-0	26R Wet Cell Battery	Every standby generator requires a battery to start the system. Generac offers the recommended 26R wet cell battery for use with all air-cooled standby product (excluding PowerPact®).
006212-0	Cold Weather Kit	If the temperature regularly falls below 32 °F (0 °C), a cold weather kit is required to maintain optimal battery and oil temperatures. Kit consists of a battery warmer and oil filter heater with built-in thermostats.
005621-0	Auxiliary Transfer Switch Contact Kit	The auxiliary transfer switch contact kit allows the transfer switch to lock out a single large electrical load you may not need. Not compatible with 50 amp pre-wired switches.
005839-0 - Bisque 005666-0 - Gray	Fascia Base Wrap Kit* (Standard on 22 kW)	The fascia base wrap snaps together around the bottom of the new air cooled generators. This offers a sleek, contoured appearance as well as offering protection from rodents and insects by covering the lifting holes located in the base.
005703-0 - Bisque 005704-0 - Gray	Paint Kit*	If the generator enclosure is scratched or damaged, it is important to touch-up the paint to protect from future corrosion. The paint kit includes the necessary paint to properly maintain or touch-up a generator enclosure.
006484-0 - 16 kW 006485-0 - 20 & 22 kW	Scheduled Maintenance Kit	Generac's scheduled maintenance kits provide all the hardware necessary to perform complete routine maintenance on a Generac automatic standby generator.
006664-0	Wireless Remote Monitor	Completely wireless and battery powered, Generac's wireless remote monitor provides you with instant status information without ever leaving the house. Not compatible with CorePower or EcoGen systems.
006873-0	Smart Management Module (50 Amps)	Smart Management Modules are used in conjunction with the Automatic Transfer Switch to increase its power management capabilities. It provides additional power management flexibility not found in any other power management system.

* Note: Bisque kits are used in conjunction with steel enclosures. Gray kits are used in conjunction with aluminum enclosures.

dimensions & UPCs

Dimensions shown are approximate. Refer to installation manual for exact dimensions. DO NOT USE THESE DIMENSIONS FOR INSTALLATION PURPOSES.

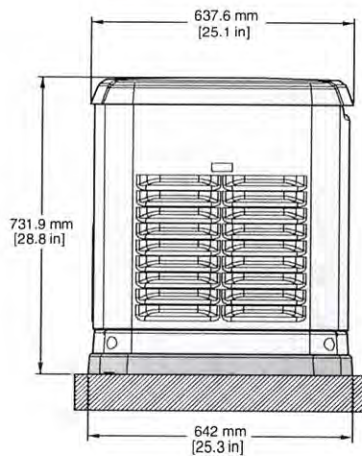

LEFT SIDE VIEW

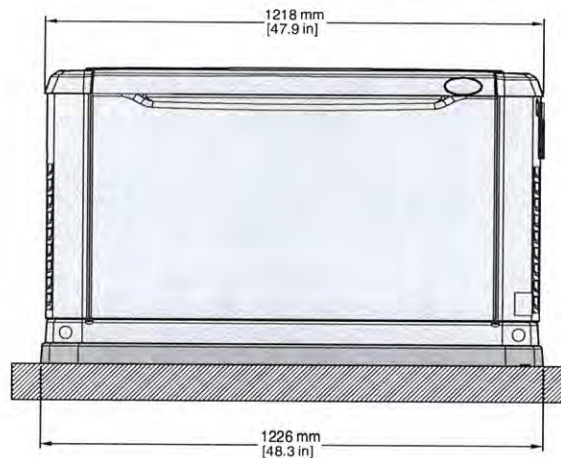

FRONT VIEW

Model	UPC
006459-2	696471064599
006461-1	696471064612
006721-1	696471067217
006729-2	696471067293
006730-1	696471067309
006551-2	696471065510
006552-1	696471065527
006462-2	696471064629



MOTOROLA

MOTOROLA SOLUTIONS, INC.

1301 E. Algonquin Road
Schaumburg, IL 60196

Visit our website at www.motorolasolutions.com

INVOICE

Page 1 of 2

TOTAL INVOICE AMOUNT:	\$9,294.64
MOTOROLA INVOICE NUMBER:	50105379
INVOICE DATE:	02/22/2016
PAYMENT DUE:	03/23/2016
CUSTOMER ACCOUNT NUMBER:	1035338806 0001
PURCHASE ORDER DATE:	
YOUR PURCHASE ORDER NUMBER:	

BILL TO ASHE COUNTY SHERIFF DEPT
ATTN: CAROLYN GENTRY
PO BOX 395
JEFFERSON, NC 28640

For questions concerning this Invoice please contact
Motorola at:

00010-00007-00006

Payment Terms: NET 30 INVOICE

Sales Order Number: S00001022987

Motorola Solutions, Inc. Federal Tax Id: 36-1115800

Invoice Detail

Item	Model Number	Qty	Description	Unit Price	Amount
			BILLING FOR YOUR SERVICE AGREEMENT SERVICE PERIOD FROM 09-FEB-16 TO 08-MAR-16 MOTOROLA CONTRACT # S00001022987		
			SERVICES CONTRACTED:		
2		1	SVC01SVC2007C SP - ONSITE INFRASTRUCTURE DISPATCH	1,813.56	1,813.56
3		1	SVC01SVC2011C SP - ASTRO DISPATCH SERVICES	71.33	71.33
4		1	SVC02SVC0362A SP - 911 LOCATION DATA MGMT -INTRADO	4,338.94	4,338.94
5		1	SVC02SVC0363A SP-911 ROUTING SVC - INTRADO	3,070.81	3,070.81

This bill includes state & local Taxes of \$608.06

Motorola 911 Routing Service, Motorola 911 Data Location Service, and Motorola 911 Text Services are all provided by Intrado Communications Inc., 1601

(Continued on Next Page)

Detach here and return bottom portion with your payment

INVOICE NUMBER	CUSTOMER ACCOUNT NUMBER	PAYMENT DUE
50105379	1035338806 0001	03/23/2016

Payment Coupon

Invoice Total	Amount Paid
\$9,294.64	

Please put your Invoice Number and your Customer Account Number on your check for prompt processing

ASHE COUNTY SHERIFF DEPT
ATTN: CAROLYN GENTRY
PO BOX 395
JEFFERSON, NC 28640

Send Payment To:



MOTOROLA

MOTOROLA SOLUTIONS, INC.

P.O. Box 404059

Atlanta, GA 30384-4059



MOTOROLA

MOTOROLA SOLUTIONS, INC.
1301 E. Algonquin Road
Schaumburg, IL 60196

Visit our website at :www.motorolasolutions.com

INVOICE

Page 2 of 2

TOTAL INVOICE AMOUNT:	\$9,294.64
MOTOROLA INVOICE NUMBER:	50105379
INVOICE DATE:	02/22/2016
PAYMENT DUE:	03/23/2016
CUSTOMER ACCOUNT NUMBER:	1035338806 0001
PURCHASE ORDER DATE:	
YOUR PURCHASE ORDER NUMBER:	

BILL TO ASHE COUNTY SHERIFF DEPT
ATTN: CAROLYN GENTRY
PO BOX 395
JEFFERSON, NC 28640

For questions concerning this Invoice please contact
Motorola at:

00011-00007-00006

Payment Terms: NET 30 INVOICE

Sales Order Number: S00001022987

Motorola Solutions, Inc. Federal Tax Id: 36-1115800

Invoice Detail Continued

Item	Model Number	Qty	Description	Unit Price	Amount
			Dry Creek Drive, Longmont, CO 80503-6493		
			THANK YOU FOR CHOOSING MOTOROLA SOLUTIONS		
			PLEASE PAY THIS AMOUNT (PAYMENT DUE: 03/23/2016)		9,294.64

Re: Quote

Jamie Asch <jamie@officedesigns.com>

Thu 3/24/2016 1:39 PM

To: P. Howell <PHowell@asheso.com>;

Hi Phil,

Please see below pricing and configuration for items we discussed.

Note that we include free shipping and no tax and guarantee the lowest price of any authorized retailer.

Please contact me with further questions or to place an order.

Thanks,

Jamie

[Aeron Work Stool](#)

SKU: 1012100104110182439

arm type : Fully Adjustable Arms - Height & Pivot
Model : ADJUSTABLE - Rear Tilt Lock & Forward Tilt Adjustment
base and frame finish : Graphite
Armpad Finish : Black Vinyl
Casters - Glides : Standard Carpet Casters
Color : Classic Carbon
Lumbar : Adjustable Lumbar Support
Size : High Height Stool
Regular Price \$1449
Your Price \$1299

[SPACE Matrex Executive Chair](#)

SKU: 1122100102111001779

Seat Color : Colored Mesh - Black
Regular Price \$499
Your Price \$474

Aeron Back Bolts

FB1011100143110000294
\$16

Jamie Asch
Sales Manager

722 Landwehr Road
Northbrook, Illinois 60062
Direct: [847.504.1718](tel:847.504.1718)
jamie@officedesigns.com
jamie@sit4life.com

On Thu, Mar 24, 2016 at 10:13 AM, P. Howell <PHowell@asheso.com> wrote:

Hey Jamie,

For now, lemme get a quote without the fixed chair.

Thanks,

B. Phil Howell

Director of Communications

BA of Science - North Carolina State University

Advanced Law Enforcement Certification

Specialized Firearms & General Instructor Certification

Sheriff's Emergency Response Team

NC Concealed Carry Instructor

office: [\(336\) 846-5624](tel:3368465624) | mobile: [\(336\) 620-6988](tel:3366206988)

Ashe County Sheriff's Office | www.AsheCountySheriff.com

From: Jamie Asch <jamie@officedesigns.com>

Sent: Wednesday, March 23, 2016 10:25 AM

To: P. Howell

Subject: Re: Quote

Hi Phil,

Thanks for the email and the continued opportunity.

Please provide exact specs for Aeron stool so I can give you an accurate quote.

Best,

Jamie

Jamie Asch

Sales Manager

722 Landwehr Road
Northbrook, Illinois 60062

Direct: [847.504.1718](tel:8475041718)

jamie@officedesigns.com

jamie@sit4life.com

On Tue, Mar 22, 2016 at 1:50 PM, P. Howell <PHowell@asheso.com> wrote:

Can I get a quote for three chairs:

Aeron Work Stool - Herman Miller - SKU# 26 with arms and lumber support, size B

SPACE Matrex Executive Chair - SKU #409

We have a chair that has fallen apart and the bolts are missing for the back rest. I believe it takes 4 bolts and its for the Aeron Chair sku:21 and it holds the back to the bottom. Is there any way we can get the four bolts added as well?

Thanks,

B. Phil Howell

Director of Communications

BA of Science - North Carolina State University

Advanced Law Enforcement Certification

Specialized Firearms & General Instructor Certification

Sheriff's Emergency Response Team

NC Concealed Carry Instructor

office: [\(336\) 846-5624](tel:3368465624) | mobile: [\(336\) 620-6988](tel:3366206988)

Ashe County Sheriff's Office | www.AsheCountySheriff.com

Pursuant to North Carolina General Statutes Chapter 132, Public Records, this electronic mail message and any attachments hereto, as well as any electronic mail message(s) that might be sent in response to it may be considered public record and as such are subject to request and review by, and disclosure to, third parties.

Pursuant to North Carolina General Statutes Chapter 132, Public Records, this electronic mail message and any attachments hereto, as well as any electronic mail message(s) that might be sent in response to it may be considered public record and as such are subject to request and review by, and disclosure to, third parties.

Date: 5/11/2016



Attn: Accounting Department
110 South Regent Street, Suite 500
Salt Lake City, UT 84111
(801) 363-9127 * (801) 363-9144 fax
(800) 363-9127 toll-free

INVOICE

No. 128736

Customer Id: 8604

Bill To: Ashe County Sheriffs Office
140 Government Circle
Jefferson, NC 28640

For: Ashe County Sheriffs Office
140 Government Circle
Jefferson, NC 28640

Phone: Fax: 336-219-2616

Sales Contact:
Payment Method: Purchase Order

Base license: 00000B03B9
Payment Terms: Net 30 Days

Qty	Description	Unit Price	Extended Price
1	Maintenance Agreement For Annual AQUA ESP (Medical - North American English) Date of ESP Renewal Expiration: Jun 14 2017 12:00AM	\$645.00	\$645.00
1	Maintenance Agreement For Annual Cardset ESP (Fire - North American English) Date of ESP Renewal Expiration: Jun 14 2017 12:00AM	\$147.00	\$147.00
1	Maintenance Agreement For Annual Cardset ESP (Medical - North American English) Date of ESP Renewal Expiration: Jun 14 2017 12:00AM	\$147.00	\$147.00
1	Maintenance Agreement For Annual Cardset ESP (Police - North American English) Date of ESP Renewal Expiration: Jun 14 2017 12:00AM	\$147.00	\$147.00
1	Maintenance Agreement For Annual ProQA ESP (Medical - North American English) Date of ESP Renewal Expiration: Jun 14 2017 12:00AM	\$5,085.00	\$5,085.00
<p>Payment of this invoice for the Extended Service Plan (ESP), as per the license agreement, extends the licensed use of the system for a period of 12 months. It also ensures that any updates within the current version will automatically be sent to licensed users or made available for download. Non-payment of this invoice for ESP is a violation of the license agreement and may result in the forfeiture of PDS licenses.</p>			
		Sub-Total:	\$6,171.00
		Tax:	\$0.00
		Shipping & Handling:	\$0.00
		Total:	\$6,171.00
		Amount due this Invoice:	\$6,171.00

Please pay this invoice in US Dollars. Make checks payable to Priority Dispatch Corporation.

"To lead the creation of meaningful change in public safety and health."



Sales Quote #129202

by Tim Martin

Date 5/26/2016

110 South Regent Street, Suite 500
Salt Lake City, UT 84111
(801) 363-9127 * (801) 363-9144 fax
(800) 363-9127 toll-free

Bill To: Ashe County Sheriffs Office
Attn: Phil Howell
140 Government Circle
Jefferson, NC 28640

Ship To: Ashe County Sheriffs Office
Attn: Phil Howell
140 Government Circle
Jefferson, NC 28640

For: Ashe County Sheriffs Office
Attn: Phil Howell
140 Government Circle
Jefferson, NC 28640

Phone: 336-846-5624 Fax: 336-219-2616

Qty	Description	Unit Price	Extended Price
1	ProQA Software Licenses (Medical - Paramount - Standard - North American English) Automated calltaking software	\$3,750.00	\$3,750.00
1	ProQA Software Licenses (Fire - Paramount - Standard - North American English) Automated calltaking software	\$3,750.00	\$3,750.00
1	ProQA Software Licenses (Police - Paramount - Standard - North American English) Automated calltaking software	\$3,750.00	\$3,750.00
1	Annual Maintenance - Basic Package (ESP) for ProQA Software (North American English) License renewal, service and support	\$1,687.50	\$1,687.50
		Sub-Total:	\$12,937.50
		Tax:	\$0.00
		Shipping & Handling:	\$0.00
		Total:	\$12,937.50

This quote is valid for 120 days from date of issue. Unless otherwise agreed to in writing, all prices quoted are exclusive of any applicable sales, use, withholding and other taxes, duties, or government assessments relating to this transaction, which are the sole obligation of Buyer. Payment terms are Net 30 unless otherwise noted.

Seller will use reasonable efforts to deliver products on time, but will not be liable for any expenses or damages incurred as a result of late delivery or for circumstances beyond Seller's reasonable control. Shipments are made F.O.B. origin, which is Salt Lake City, UT, USA. All insurance expenses and risk of loss are assumed by Buyer.

Purchasing or signing below acknowledges your agreement to the terms above and to the "break the seal" or "click to accept" license agreement associated with the licensed product(s). The license agreement is included with the licensed product(s) and you will have the opportunity to read it before opening or installing. If unacceptable, you may return the licensed product(s) within 10 days of receipt for a refund, less any applicable restocking fees and original shipping charges.

Sign here _____ Date _____

Payment Method: (Check enclosed, or...)

Purchase Order # _____

VISA/MasterCard/AMEX # _____

Expiration: _____

"To lead the creation of meaningful change in public safety and health."



SOUTHERN SOFTWARE, INC.
an employee-owned company

Agency: Ashe County Sheriff, NC

Contact: Phil Howell

Date: 3/22/2016

11-20 Devices

SOFTWARE (ANNUAL SUBSCRIPTION)

PSAware for up to 11-20 Devices

1 Year

\$3,750.00

TOTAL INVESTMENT (STATE TAX AND SHIPPING NOT INCLUDED)

\$3,750.00

CUSTOMER'S SIGNATURE _____ DATE _____

Please sign this document and return it to us by fax or mail. When the document is signed and returned to Southern Software, we will begin processing your order.

Proposal of software is valid for (60) days from date of proposal.

Proposal of hardware is valid for (30) days from date of proposal.

Management fees include training, installation, and project management.

Southern Software will install its software products only on computer configurations compatible with these products. Hardware specifications are available upon request.

Contact information for Public Safety Representative:

Mike Moody
Southern Software
150 Perry Drive
Southern Pines, NC 28387

Business: 800.842.8190
Mobile: 910.603.3481
Fax: 910.695.0251
E-Mail: mmood@southernsoftware.com



SOUTHERN SOFTWARE, INC.
an employee-owned company

Agency: **Ashe County, NC**

Contact: **Phil Howell**

Date: **3/23/2016**

CAD SOFTWARE

Qty

CAD with MDS - Additional Positions

2

FREE FOR EOC

ASSUMES ASSISTANCE WITH REMOTE INSTALLATION. IF ONSITE INSTALLATION IS REQUIRED THERE WILL BE ADDITIONAL CHARGES.

TOTAL INVESTMENT (STATE TAX AND SHIPPING NOT INCLUDED)

\$0.00

CUSTOMER'S SIGNATURE _____ DATE _____

Please sign this document and return it to us by fax or mail. When the document is signed and returned to Southern Software, we will begin processing your order.

NOTE: MICROSOFT® SQL SERVER 2008 R2™ IS REQUIRED.

Southern Software will install its software products only on computer configurations compatible with these products. Hardware specifications are available upon request.

Contact information for Public Safety Representative:

Mike Moody

Southern Software

150 Perry Drive

Southern Pines, NC 28387

Business: 800.842.8190

Mobile: 910.603.3481

Fax: 910.695.0251

E-Mail: mmoody@southernsoftware.com

SOUTHERN SOFTWARE'S ANNUAL SOFTWARE SUPPORT AGREEMENT CAD™ 24/7

Southern Software's CAD™ Computer Aided Dispatch. This Software Support Agreement covers 24 hours a day, seven days a week support.

Problem Resolution

Southern Software will provide customer software support for mission critical operation of **CAD™**, 24 hours a day, seven days a week. This period includes holidays and weekends. This Agreement does not constitute a warranty but provides for mission critical problem resolutions at any time and non-mission critical problem resolutions of repeatable errors during normal business hours, EST. Southern Software cannot warrant the product will operate free of problems in perpetuity. Southern Software does not warrant third party software applications used in programs provided to customers, i.e., Microsoft® Word. The purpose of this Agreement is to provide the necessary technical assistance to ensure a timely problem resolution and to minimize down time. This Agreement is not intended to provide around-the-clock assistance for problems not deemed to be operation critical. Mission critical is defined as "any problem that renders the entire system unstable or inoperable".

For problems covered under this Agreement, Southern Software will provide the following:

- Telephone response within three hours of notification of the problem from 8:30 a.m. to 5:00 p.m., EST, Monday thru Friday. During this initial response, support personnel will determine the nature of the problem and severity. An attempt to resolve the problem will be made by giving instructions to the customer. Any problem deemed mission critical will take top priority over all other calls.
- Telephone response within one hour of notification of the problem after 5:00 p.m., EST and during holidays that fall on a normal work day. During this initial response, support personnel will determine the nature of the problem and severity. An attempt to resolve the problem will be made by giving instructions to the customer.
- If this is unsuccessful or the severity too great, then Southern Software will escalate to a Level 2 response. A Level 2 response involves a support technician connecting remotely to the customer's network using industry standard secure remote diagnostic methods to attempt to resolve the problem.
- If the problem is unable to be detected or resolved with a Level 2 response then a technician will be scheduled for an on-site visit. There is no cost to the customer for the on-site visit as long as the problem is with a Southern Software product or equipment covered by a Southern Software support contract and as long as the problem is not due to a virus or negligent actions/treatment

The user understands support staff may provide a temporary fix. A permanent fix will be provided at a later date.

Program Updates

Southern Software will provide program updates to support customers as new updates, fixes and features are added. Updates will be made universally to all supported customers at one time. No custom programming will be performed.

Third Party

If, at any time, an update of a third party's software is required, Southern Software will not incur the cost of such upgrade.

System Administrator

The customer agrees to have a designated administrator (primary contact for support and update issues). It is highly desirable that the administrator be knowledgeable in networking and Windows® operating systems.

Data Backup Statement

The customer understands that it is the customer's responsibility to ensure data backups are being made daily and verified for accuracy.

Virus Statement

The customer agrees to have virus protection software loaded on each machine and agrees to update it weekly. (Southern Software recommends updating your virus protection software on each machine daily.) This support contract does not cover assistance in the recovery of damage caused by viruses. ***Southern Software will charge a fee for virus recovery assistance.***

Items not covered under this annual support agreement -

- **Installation and setup of new equipment.**
- **Transferring of data.**
- **Moving equipment from one site to another.**
- **On-site installation/reinstallation of Southern Software products or installation/reinstallation of third party software/products.**
- **Virus damage/recovery repair work.**
- **Recovery/repair work related to natural disasters such as lightning, floods, etc..**
- **Replacement of equipment that is out of warranty.**
- **Cost of upgrades to third party software including but not limited to Microsoft™ products (ie. Office, SQL, etc.), Anti-virus software, PcAnywhere™, etc. or cost of updates to operating systems.**
- **Data Conversions.**
- **On-site Training.**
- **Interfaces with third party products.**
- **Data loss due to drive crashes, machine failures, etc.**

- **Installation, Training and Data Conversions due to Re-architecture of Software.**

Benefits

- The Software Support Agreement only covers software developed by Southern Software.
- Toll-free telephone support, seven days a week, 24 hours a day including holidays.
- 24-hour fax availability
- Software Updates
- Remote System Support
- Annual User's Conference
- Free hardware/network assessments for upgrades.
- Free follow-up/new employee training at Southern Software's office.
- Free web training.

System Access/Customer Responsibility

The customer agrees to provide a dedicated computer capable of remote access for support purposes. The computer designated for remote connectivity shall allow access to all computers on the network requiring support.

This Annual Software Support Agreement provides coverage that begins July 1, 2016 and ends June 30, 2017 .

Annual Support: \$9,455.00

By signing this document you are confirming that you have read and understand the terms and conditions of this annual support agreement.

Important- Support Renewal Clause

A lapse in support renewal will require that all outstanding support balances be paid in full prior to reinstatement of support. Support fees are non-refundable.

Customer Representative Signature

Date

ASHE COUNTY SHERIFF (CAD), NC

Name of Department

NOTE: IF A PURCHASE ORDER NUMBER IS REQUIRED ON THE SUPPORT INVOICE PLEASE ENTER HERE _____. IF THE NUMBER IS NOT AVAILABLE AT THIS TIME, PLEASE FAX THE PURCHASE ORDER TO (910)695-0251 WHEN IT IS AVAILABLE.

SOUTHERN SOFTWARE'S ANNUAL SOFTWARE SUPPORT AGREEMENT MDIS (Mobile-Pak) 24/7

Southern Software's MDIS Mobile Data Information System. This Software Support Agreement covers 24 hours a day, seven days a week support.

Problem Resolution

Southern Software will provide customer software support for mission critical operation of **MDIS**, 24 hours a day, seven days a week. This period includes holidays and weekends. This Agreement does not constitute a warranty but provides for mission critical problem resolutions at any time and non-mission critical problem resolutions of repeatable errors during normal business hours, EST. Southern Software cannot warrant the product will operate free of problems in perpetuity. Southern Software does not warrant third party software applications used in programs provided to customers, i.e., Microsoft® Word. The purpose of this Agreement is to provide the necessary technical assistance to ensure a timely problem resolution and to minimize down time. This Agreement is not intended to provide around-the-clock assistance for problems not deemed to be operation critical. Mission critical is defined as "any problem that renders the entire system unstable or inoperable".

For problems covered under this Agreement, Southern Software will provide the following:

- Telephone response within three hours of notification of the problem from 8:30 a.m. to 5:00 p.m., EST, Monday thru Friday. During this initial response, support personnel will determine the nature of the problem and severity. An attempt to resolve the problem will be made by giving instructions to the customer. Any problem deemed mission critical will take top priority over all other calls.
- Telephone response within one hour of notification of the problem after 5:00 p.m., EST and during holidays that fall on a normal work day. During this initial response, support personnel will determine the nature of the problem and severity. An attempt to resolve the problem will be made by giving instructions to the customer.
- If this is unsuccessful or the severity too great, then Southern Software will escalate to a Level 2 response. A Level 2 response involves a support technician connecting remotely to the customer's network using industry standard secure remote diagnostic methods to attempt to resolve the problem.
- If the problem is unable to be detected or resolved with a Level 2 response then a technician will be scheduled for an on-site visit. There is no cost to the customer for the on-site visit as long as the problem is with a Southern Software product or equipment covered by a Southern Software support contract and as long as the problem is not due to a virus or negligent actions/treatment

The user understands support staff may provide a temporary fix. A permanent fix will be provided at a later date.

Program Updates

Southern Software will provide program updates to support customers as new updates, fixes and features are added. Updates will be made universally to all supported customers at one time. No custom programming will be performed.

Third Party

If, at any time, an update of a third party's software is required, Southern Software will not incur the cost of such upgrade.

System Administrator

The customer agrees to have a designated administrator (primary contact for support and update issues). It is highly desirable that the administrator be knowledgeable in networking and Windows® operating systems.

Data Backup Statement

The customer understands that it is the customer's responsibility to ensure data backups are being made daily and verified for accuracy.

Virus Statement

The customer agrees to have virus protection software loaded on each machine and agrees to update it weekly. (Southern Software recommends updating your virus protection software on each machine daily.) This support contract does not cover assistance in the recovery of damage caused by viruses.

Southern Software will charge a fee for virus recovery assistance.

Items not covered under this annual support agreement -

- **Installation and setup of new equipment.**
- **Transferring of data.**
- **Moving equipment from one site to another.**
- **On-site installation/reinstallation of Southern Software products or installation/reinstallation of third party software/products.**
- **Virus damage/recovery repair work.**
- **Recovery/repair work related to natural disasters such as lightning, floods, etc..**
- **Replacement of equipment that is out of warranty.**
- **Cost of upgrades to third party software including but not limited to Microsoft™ products (ie. Office, SQL, etc.), Anti-virus software, PcAnywhere™, etc. or cost of updates to operating systems.**
- **Data Conversions.**
- **On-site Training.**
- **Interfaces with third party products.**
- **Data loss due to drive crashes, machine failures, etc.**
- **Installation, Training and Data Conversions due to Re-architecture of Software.**

Benefits

- The Software Support Agreement only covers software developed by Southern Software.
- Toll-free telephone support, seven days a week, 24 hours a day including holidays.
- 24-hour fax availability
- Software Updates
- Remote System Support
- Annual User's Conference
- Free hardware/network assessments for upgrades.
- Free follow-up/new employee training at Southern Software's office.
- Free web training.

System Access/Customer Responsibility

The customer agrees to provide a dedicated computer capable of remote access for support purposes. The computer designated for remote connectivity shall allow access to all computers on the network requiring support.

This Annual Software Support Agreement provides coverage that begins July 2, 2016 and ends July 1, 2017.

Annual Support: \$3,891.00

By signing this document you are confirming that you have read and understand the terms and conditions of this annual support agreement.

Important- Support Renewal Clause

A lapse in support renewal will require that all outstanding support balances be paid in full prior to reinstatement of support. Support fees are non-refundable.

Customer Representative Signature

Date

ASHE COUNTY SHERIFF (MDIS), NC

Name of Department

NOTE: IF A PURCHASE ORDER NUMBER IS REQUIRED ON THE SUPPORT INVOICE PLEASE ENTER HERE _____. IF THE NUMBER IS NOT AVAILABLE AT THIS TIME, PLEASE FAX THE PURCHASE ORDER TO (910)695-0251 WHEN IT IS AVAILABLE.

SOUTHERN SOFTWARE'S ANNUAL SOFTWARE SUPPORT AGREEMENT MAPPING SOFTWARE 24/7

This Software Support Agreement covers support 24 hours a day, seven days a week.

Problem Resolution

Southern Software will provide customer software support for mission critical operation of the mapping software 24 hours a day, seven days a week. This Agreement does not constitute a warranty but provides for mission critical problem resolutions and non-mission critical problem resolutions of repeatable errors during normal business hours, EST. Southern Software cannot warrant the product will operate free of problems in perpetuity. Southern Software does not warrant third party software applications used in programs provided to customers, i.e., Microsoft® Word. The purpose of this Agreement is to provide the necessary technical assistance to ensure a timely problem resolution and to minimize down time. Mission critical is defined as “any problem that renders the entire system unstable or inoperable”.

For problems covered under this Agreement, Southern Software will provide the following:

- Telephone response within three hours of notification of the problem from 8:30 a.m. to 5:00 p.m., EST, Monday thru Friday. During this initial response, support personnel will determine the nature of the problem and severity. An attempt to resolve the problem will be made by giving instructions to the customer.
- Telephone response within one hour of notification of the problem after 5:00 p.m., EST and during holidays that fall on a normal work day. During this initial response, support personnel will determine the nature of the problem and severity. An attempt to resolve the problem will be made by giving instructions to the customer.
- If this is unsuccessful or the severity too great, then Southern Software will escalate to a Level 2 response. A Level 2 response involves a support technician connecting remotely to the customer's network using industry standard secure remote diagnostic methods to attempt to resolve the problem.
- If the problem is unable to be detected or resolved with a Level 2 response then a technician will be scheduled for an on-site visit. There is no cost to the customer for the on-site visit as long as the problem is with a Southern Software product or equipment covered by a Southern Software support contract and as long as the problem is not due to a virus or negligent actions/treatment

The user understands support staff may provide a temporary fix. A permanent fix will be provided at a later date.

Program Updates

Southern Software will provide program updates to support customers as new updates, fixes and features are added. Updates will be made universally to all supported customers at one time. No custom programming will be performed.

Third Party

If, at any time, an update of a third party's software is required, Southern Software will not incur the cost of such upgrade.

System Administrator

The customer agrees to have a designated administrator (primary contact for support and update issues). It is highly desirable that the administrator be knowledgeable in networking and Windows® operating systems.

Data Backup Statement

The customer understands that it is the customer's responsibility to ensure data backups are being made daily and verified for accuracy.

Virus Statement

The customer agrees to have virus protection software loaded on each machine and agrees to update it weekly. (Southern Software recommends updating your virus protection software on each machine daily.) This support contract does not cover assistance in the recovery of damage caused by viruses. ***Southern Software will charge a fee for virus recovery assistance.***

Items not covered under this annual support agreement -

- **Installation and setup of new equipment.**
- **Transferring of data.**
- **Moving equipment from one site to another.**
- **On-site installation/reinstallation of Southern Software products or installation/reinstallation of third party software/products.**
- **Virus damage/recovery repair work.**
- **Recovery/repair work related to natural disasters such as lightning, floods, etc..**
- **Replacement of equipment that is out of warranty.**
- **Cost of upgrades to third party software including but not limited to Microsoft™ products (ie. Office, SQL, etc.), Anti-virus software, PcAnywhere™, etc. or cost of updates to operating systems.**
- **Data Conversions.**
- **On-site Training.**
- **Interfaces with third party products.**
- **Data loss due to drive crashes, machine failures, etc.**
- **Installation, Training and Data Conversion due to Re-architecture of Software.**

Benefits

- The Software Support Agreement only covers software developed by Southern Software.
- Toll-free telephone support, seven days a week, 24 hours a day including holidays.
- 24-hour fax availability
- Software Updates
- Remote System Support
- Annual User's Conference
- Free hardware/network assessments for upgrades.
- Free follow-up/new employee training at Southern Software's office.
- Free web training.

System Access/Customer Responsibility

The customer agrees to provide a dedicated telephone line capable of remote access to a designated computer. The computer designated for remote connectivity shall allow access to all computers on the network.

This Annual Software Support Agreement provides coverage that begins July 1, 2016 and ends June 30, 2017.

Annual Support: \$3,903.00

By signing this document you are confirming that you have read and understand the terms and conditions of this annual support agreement.

Important- Support Renewal Clause

A lapse in support renewal will require that all outstanding support balances be paid in full prior to reinstatement of support. Support fees are non-refundable.

Customer Representative Signature

Date

ASHE COUNTY SHERIFF (MDS), NC

Name of Department

NOTE: IF A PURCHASE ORDER NUMBER IS REQUIRED ON THE SUPPORT INVOICE PLEASE ENTER HERE _____. IF THE NUMBER IS NOT AVAILABLE AT THIS TIME, PLEASE FAX THE PURCHASE ORDER TO (910)695-0251 WHEN IT IS AVAILABLE.

**SOUTHERN SOFTWARE'S
ANNUAL SOFTWARE SUPPORT AGREEMENT
NCIC INTERFACE
8:30 a.m., EST to 5:00 p.m., EST**

NCIC Interface. This Software Support Agreement covers support from 8:30 a.m. to 5:00 p.m., EST, Monday through Friday.

Problem Resolution

Southern Software will provide customer software support for mission critical operation of **NCIC Interface**, from 8:30 a.m. to 5:00 p.m., EST, Monday through Friday. This Agreement does not constitute a warranty but provides for mission critical problem resolutions and non-mission critical problem resolutions of repeatable errors during normal business hours, EST. Southern Software cannot warrant the product will operate free of problems in perpetuity. Southern Software does not warrant third party software applications used in programs provided to customers, i.e., Microsoft® Word. The purpose of this Agreement is to provide the necessary technical assistance to ensure a timely problem resolution and to minimize down time. Mission critical is defined as “any problem that renders the entire system unstable or inoperable”.

For problems covered under this Agreement, Southern Software will provide the following:

- Telephone response within five hours of notification of the problem. During this initial response, support personnel will determine the nature of the problem and severity. An attempt to resolve the problem will be made by giving instructions to the customer.
- If this is unsuccessful or the severity too great, then Southern Software will escalate to a Level 2 response. A Level 2 response involves a support technician connecting remotely to the customer's network using industry standard secure remote diagnostic methods to attempt to resolve the problem.
- If the problem is unable to be detected or resolved with a Level 2 response then a technician will be scheduled for an on-site visit. There is no cost to the customer for the on-site visit as long as the problem is with a Southern Software product or equipment covered by a Southern Software support contract and as long as the problem is not due to a virus or negligent actions/treatment.

The user understands support staff may provide a temporary fix. A permanent fix will be provided at a later date.

Program Updates

Southern Software will provide program updates to support customers as new updates, fixes and features are added. Updates will be made universally to all supported customers at one time. No custom programming will be performed.

Third Party

If, at any time, an update of a third party's software is required, Southern Software will not incur the cost of such upgrade.

System Administrator

The customer agrees to have a designated administrator (primary contact for support and update issues). It is highly desirable that the administrator be knowledgeable in networking and Windows® operating systems.

Data Backup Statement

The customer understands that it is the customer's responsibility to ensure data backups are being made daily and verified for accuracy.

Virus Statement

The customer agrees to have virus protection software loaded on each machine and agrees to update it weekly. (Southern Software recommends updating your virus protection software on each machine daily.) This support contract does not cover assistance in the recovery of damage caused by viruses.

Southern Software will charge a fee for virus recovery assistance.

Items not covered under this annual support agreement -

- **Installation and setup of new equipment.**
- **Transferring of data.**
- **Moving equipment from one site to another.**
- **On-site installation/reinstallation of Southern Software products or installation/reinstallation of third party software/products.**
- **Virus damage/recovery repair work.**
- **Recovery/repair work related to natural disasters such as lightning, floods, etc..**
- **Replacement of equipment that is out of warranty.**
- **Cost of upgrades to third party software including but not limited to Microsoft™ products (ie. Office, SQL, etc.), Anti-virus software, PcAnywhere™, etc. or cost of updates to operating systems.**
- **Data Conversions.**
- **On-site Training.**
- **Interfaces with third party products.**
- **Data loss due to drive crashes, machine failures, etc.**
- **Installation, Training and Data Conversions due to Re-architecture of Software.**

Benefits

- **The Software Support Agreement only covers software developed by Southern Software.**
- **Toll-free telephone support, Monday through Friday, 8:30 a.m. to 5:00 p.m., EST**

(Benefits continued)

- **24-hour fax availability**
- **Software Updates**
- **Remote System Support**
- **Annual User's Conference**
- **Free hardware/network assessments for upgrades.**
- **Free follow-up/new employee training at Southern Software's office.**
- **Free web training.**

System Access/Customer Responsibility

The customer agrees to provide a dedicated computer capable of remote access for support purposes. The computer designated for remote connectivity shall allow access to all computers on the network requiring support.

This Annual Software Support Agreement provides coverage that begins July 2, 2016 and ends July 1, 2017.

Annual Support: \$2,124.00

By signing this document you are confirming that you have read and understand the terms and conditions of this annual support agreement.

Important- Support Renewal Clause

A lapse in support renewal will require that all outstanding support balances be paid in full prior to reinstatement of support. Support fees are non-refundable.

Customer Representative Signature

Date

ASHE COUNTY SHERIFF (NCIC), NC

Name of Department

NOTE: IF A PURCHASE ORDER NUMBER IS REQUIRED ON THE SUPPORT INVOICE PLEASE ENTER HERE _____. IF THE NUMBER IS NOT AVAILABLE AT THIS TIME, PLEASE FAX THE PURCHASE ORDER TO (910)695-0251 WHEN IT IS AVAILABLE.

**SOUTHERN SOFTWARE'S
ANNUAL SOFTWARE SUPPORT AGREEMENT
ALPHA-NUMERIC PAGING
24/7**

Alpha-Numeric Paging. This Software Support Agreement covers support 24 hours a day, 7 days a week including holidays.

Problem Resolution

Southern Software will provide customer software support for mission critical operation of **Alpha-Numeric Paging**, 24 hours a day 7 days a week including holidays. This Agreement does not constitute a warranty but provides for mission critical problem resolutions and non-mission critical problem resolutions of repeatable errors during normal business hours, EST. Southern Software cannot warrant the product will operate free of problems in perpetuity. Southern Software does not warrant third party software applications used in programs provided to customers, i.e., Microsoft® Word. The purpose of this Agreement is to provide the necessary technical assistance to ensure a timely problem resolution and to minimize down time. Mission critical is defined as “any problem that renders the entire system unstable or inoperable”.

For problems covered under this Agreement, Southern Software will provide the following:

- Telephone response within five hours of notification of the problem. During this initial response, support personnel will determine the nature of the problem and severity. An attempt to resolve the problem will be made by giving instructions to the customer.
- If this is unsuccessful or the severity too great, then Southern Software will escalate to a Level 2 response. A Level 2 response involves a support technician connecting remotely to the customer's network using industry standard secure remote diagnostic methods to attempt to resolve the problem.
- If the problem is unable to be detected or resolved with a Level 2 response then a technician will be scheduled for an on-site visit. There is no cost to the customer for the on-site visit as long as the problem is with a Southern Software product or equipment covered by a Southern Software support contract and as long as the problem is not due to a virus or negligent actions/treatment.

The user understands support staff may provide a temporary fix. A permanent fix will be provided at a later date.

Program Updates

Southern Software will provide program updates to support customers as new updates, fixes and features are added. Updates will be made universally to all supported customers at one time. No custom programming will be performed.

Third Party

If, at any time, an update of a third party's software is required, Southern Software will not incur the cost of such upgrade.

System Administrator

The customer agrees to have a designated administrator (primary contact for support and update issues). It is highly desirable that the administrator be knowledgeable in networking and Windows® operating systems.

Data Backup Statement

The customer understands that it is the customer's responsibility to ensure data backups are being made daily and verified for accuracy.

Virus Statement

The customer agrees to have virus protection software loaded on each machine and agrees to update it weekly. (Southern Software recommends updating your virus protection software on each machine daily.) This support contract does not cover assistance in the recovery of damage caused by viruses.

Southern Software will charge a fee for virus recovery assistance.

Items not covered under this annual support agreement -

- **Installation and setup of new equipment.**
- **Transferring of data.**
- **Moving equipment from one site to another.**
- **On-site installation/reinstallation of Southern Software products or installation/reinstallation of third party software/products.**
- **Virus damage/recovery repair work.**
- **Recovery/repair work related to natural disasters such as lightning, floods, etc..**
- **Replacement of equipment that is out of warranty.**
- **Cost of upgrades to third party software including but not limited to Microsoft™ products (ie. Office, SQL, etc.), Anti-virus software, PcAnywhere™, etc. or cost of updates to operating systems.**
- **Data Conversions.**
- **On-site Training.**
- **Interfaces with third party products.**
- **Data loss due to drive crashes, machine failures, etc.**
- **Installation, Training and Data Conversion due to Re-architecture of Software.**

Benefits

- **The Software Support Agreement only covers software developed by Southern Software.**
- **Toll-free telephone support, 7 days a week, 24 hours a day including holidays.**

(Benefits continued)

- **24-hour fax availability**
- **Software Updates**
- **Remote System Support**
- **Annual User's Conference**
- **Free hardware/network assessments for upgrades.**
- **Free follow-up/new employee training at Southern Software's office.**
- **Free web training.**

System Access/Customer Responsibility

The customer agrees to provide a dedicated computer capable of remote access for support purposes. The computer designated for remote connectivity shall allow access to all computers on the network requiring support.

This Annual Software Support Agreement provides coverage that begins October 21, 2016 and ends October 20, 2017.

Annual Support: \$782.00

By signing this document you are confirming that you have read and understand the terms and conditions of this annual support agreement.

Important- Support Renewal Clause

A lapse in support renewal will require that all outstanding support balances be paid in full prior to reinstatement of support. Support fees are non-refundable.

Customer Representative Signature

Date

ASHE COUNTY SHERIFF (PAGING), NC

Name of Department

NOTE: IF A PURCHASE ORDER NUMBER IS REQUIRED ON THE SUPPORT INVOICE PLEASE ENTER HERE _____. IF THE NUMBER IS NOT AVAILABLE AT THIS TIME, PLEASE FAX THE PURCHASE ORDER TO (910)695-0251 WHEN IT IS AVAILABLE.

**SOUTHERN SOFTWARE'S
ANNUAL SOFTWARE SUPPORT AGREEMENT
Records Management (Police-Pak, Sheriff-Pak and RMS)
8:30 a.m., EST to 5:00 p.m., EST**

Police-Pak™, Sheriff-Pak™ and RMS. This Software Support Agreement covers support from 8:30 a.m. to 5:00 p.m., EST, Monday through Friday.

Problem Resolution

Southern Software will provide customer software support for the operation of **Police-Pak™, Sheriff-Pak and RMS**, from 8:30 a.m. to 5:00 p.m., EST, Monday through Friday. This Agreement does not constitute a warranty but provides for mission critical problem resolutions and non-mission critical problem resolutions of repeatable errors during normal business hours, EST. Southern Software cannot warrant the product will operate free of problems in perpetuity. Southern Software does not warrant third party software applications used in programs provided to customers, i.e., Microsoft® Word. The purpose of this Agreement is to provide the necessary technical assistance to ensure a timely problem resolution and to minimize down time. Mission critical is defined as "any problem that renders the entire system unstable or inoperable".

For problems covered under this Agreement, Southern Software will provide the following:

- Telephone response within five hours of notification of the problem. During this initial response, support personnel will determine the nature of the problem and severity. An attempt to resolve the problem will be made by giving instructions to the customer.
- If this is unsuccessful or the severity too great, then Southern Software will escalate to a Level 2 response. A Level 2 response involves a support technician connecting remotely to the customer's network using industry standard secure remote diagnostic methods to attempt to resolve the problem.
- If the problem is unable to be detected or resolved with a Level 2 response then a technician will be scheduled for an on site visit. There is no cost to the customer for the on site visit as long as the problem is with a Southern Software product or equipment covered by a Southern Software support contract and as long as the problem is not due to a virus or negligent actions/treatment.

The user understands support staff may provide a temporary fix. A permanent fix will be provided at a later date.

Program Updates

Southern Software will provide program updates to support customers as new updates, fixes and features are added. Updates will be made universally to all supported customers at one time. No custom programming will be performed.

Third Party

If, at any time, an update of a third party's software is required, Southern Software will not incur the cost of such upgrade.

System Administrator

The customer agrees to have a designated administrator (primary contact for support and update issues). It is highly desirable that the administrator be knowledgeable in networking and Windows® operating systems.

Data Backup Statement

The customer understands that it is the customer's responsibility to ensure data backups are being made daily and verified for accuracy.

Virus Statement

The customer agrees to have virus protection software loaded on each machine and agrees to update it weekly. (Southern Software recommends updating your virus protection software on each machine daily.) This support contract does not cover assistance in the recovery of damage caused by viruses.

Southern Software will charge a fee for virus recovery assistance.

Items not covered under this annual support agreement -

- **Installation and setup of new equipment.**
- **Transferring of data.**
- **Moving equipment from one site to another.**
- **On-site installation/reinstallation of Southern Software products or installation/reinstallation of third party software/products.**
- **Virus damage/recovery repair work.**
- **Recovery/repair work related to natural disasters such as lightning, floods, etc..**
- **Replacement of equipment that is out of warranty.**
- **Cost of upgrades to third party software including but not limited to Microsoft™ products (ie. Office, SQL, etc.), Anti-virus software, PcAnywhere™, etc. or cost of updates to operating systems.**
- **Data Conversions.**
- **On-site Training.**
- **Interfaces with third party products.**
- **Data loss due to drive crashes, machine failures, etc.**
- **Installation, Training and Data Conversions for Software Re-architecture.**

Benefits

- **The Software Support Agreement only covers software developed by Southern Software.**

(Benefits continued)

- Toll-free telephone support, Monday through Friday, 8:30 a.m. to 5:00 p.m., EST
- 24-hour fax availability
- Software Updates
- Remote System Support
- Annual User's Conference
- Free hardware/network assessments for upgrades.
- Free follow-up/new employee training at Southern Software's office.
- Free web training.

System Access/Customer Responsibility

The customer agrees to provide a dedicated computer capable of remote access for support purposes. The computer designated for remote connectivity shall allow access to all computers on the network requiring support.

This Annual Software Support Agreement provides coverage that begins July 1, 2016 and ends June 30, 2017.

Annual Support: \$5,352.00

By signing this document you are confirming that you have read and understand the terms and conditions of this annual support agreement.

Important- Support Renewal Clause

A lapse in support renewal will require that all outstanding support balances be paid in full prior to reinstatement of support. Support fees are non-refundable.

Customer Representative Signature

Date

ASHE COUNTY SHERIFF (REC), NC

Name of Department

NOTE: IF A PURCHASE ORDER NUMBER IS REQUIRED ON THE SUPPORT INVOICE PLEASE ENTER HERE _____. IF THE NUMBER IS NOT AVAILABLE AT THIS TIME, PLEASE FAX THE PURCHASE ORDER TO (910)695-0251 WHEN IT IS AVAILABLE.



SOUTHERN SOFTWARE, INC.
an employee-owned company

Agency: Ashe County Sheriff's Office, NC
Contact: Phil Howell
Date: 6/6/2016

HARDWARE AND SOFTWARE	Qty	
Wireless Messaging for CAD (with 5 additional Paging Connectors) <i>For Backup Center</i>	1	\$1,000.00
CAD with MDS for EOC	2	FREE
* Neverfail for Physical Server (1 Pair) (Note: first year support included; 2nd year payable to Neverfail - Approx. \$1,000) See Hardware Requirements Below	1	\$4,995.00
Installation/Configuration of Neverfail (Neverfail Installation Onsite)	1	\$4,750.00

TOTAL INVESTMENT (STATE TAX AND SHIPPING NOT INCLUDED) **\$10,745.00**

50% due upon signing proposal; 50% due upon completion of installation.

CUSTOMER'S SIGNATURE _____ **DATE** _____

Please sign this document and return it to us by fax or mail. When the document is signed and returned to Southern Software, we will begin processing your order.

Proposal is valid for (30) days from date of proposal..

Hardware Requirements

Primary Server

- Must meet Microsoft's requirements for one of the following installed operating systems:
 - Windows Server 2003 x86 and x64 Standard / Enterprise / R2 with SP1 or SP2
 - Windows Server 2008 x 86 and x64 Standard / Enterprise with SP1 or SP2
 - Windows Server 2008 R2 x64 Standard / Enterprise / Datacenter with SP1
 - Windows Server 2012 x64 Standard/Datacenter
 - 1 GB RAM minimum, 2 GB RAM recommended
 - Minimum available RAM required for Neverfail processes and components (recommended 1GB)
 - Minimum of 256 MB available for Neverfail processes and components on Windows Server 2003
 - Minimum of 512 MB available for Neverfail processes and components on Windows Server 2008/R2
 - Minimum of 512 MB available for Neverfail processes and components on Windows Server 2012
 - 2 GB of available hard disk space
 - Number of NICs:
 - In a Pair configuration: 2 non-teamed NICs required, 3 non-teamed NICs recommended
 - In a Trio configuration: minimum 3 NICs required (one for the Public connection and 2 for the Neverfail Channels)
- Note: Neverfail Heartbeat v6.7 and later supports use of a single NIC for both the Neverfail Channel and Principal (Public) network connection.
- Multiple hard disk drives are recommended as per application vendors' requirements. Avoid locating OS, database, and log files on the same disks

Secondary Server and Tertiary (if implemented)

- Must meet Microsoft's requirements for one of the following installed operating systems:
 - Windows Server 2003 x86 and x64 Standard / Enterprise / R2 with SP1 or SP2
 - Windows Server 2008 x 86 and x64 Standard / Enterprise with SP1 or SP2
 - Windows Server 2008 R2 x64 Standard / Enterprise / Datacenter with SP1
 - Windows Server 2012 x64 Standard / Datacenter
- 1 GB RAM minimum, 2 GB RAM recommended
- Minimum available RAM required for Neverfail processes and components
 - Minimum of 256 MB available for Neverfail processes and components on Windows Server 2003
 - Minimum of 512 MB available for Neverfail processes and components on Windows Server 2008/R2
 - Minimum of 512 MB available for Neverfail processes and components on Windows Server 2012
- Total hard disk space should be greater than or equal to the Primary Server
- Same number of NICs as the Primary Server
- Hard drive lettering scheme must match the Primary Server (although underlying hardware may be different)

Contact information for Public Safety Representative:

**Mike Moody
Southern Software
150 Perry Drive
Southern Pines, NC 28387**

**Business: 800.842.8190
Mobile: 910.603.3481
Fax: 910.695.0251
E-Mail mmoody@southernsoftware.com**

June 3, 2016

Customer: Ashe County

Quote: CommandPost Unit for Backup Plan

Qty.	Part No.	Description	Price
		VESTA® 9-1-1 CommandPOST System	
		VESTA® 9-1-1 Prime Standard Operations	
		License for connecting to both systems	
2	PS-0PR-VSSL	VPRIME PER SEAT LIC	\$14,666.67
2	SS-0PR-VSSL-1Y	SPT VPRIME 1YR	\$2,640.00
		ESInet Interface Module (EIM)	
2	873090-11102	R4 LIC EIM RFAI MOD	\$533.33
2	809800-01116	R4 LIC EIM RFAI SPT 1YR	\$96.00
		VESTA® 9-1-1 CDR Module	
2	873099-01102	R4 CDR PER SEAT LIC	\$240.00
		CommandPOST Hardware	
1	61050-G409602	LAPTOP ZBOOK15 G2 W7	\$2,412.00
1	04000-00490	ADV DOCK STATION 230W	\$536.00
1	64021-10025	KYBD/MOUSE BNDL	\$58.67
1	Wireless	22IN Touchscreen Monitor	\$827.24
1	64007-50021	KEYPD 24K 12F USBCBL CP24	\$145.33
1	853004-00401	SAM EXT SPKR KIT	\$224.00
1	853004-00301	CPOST SAM HDWR KIT	\$3,042.67
1	809800-35109	R4 IWS CFG	\$266.67
1	809800-35108	R4 IWS STG FEE	\$400.00
		VESTA® 9-1-1 IRR Module	
1	873099-00502	R4 IRR LIC/DOC/MED	\$1,326.67
1	809800-35110	R4 IRR SW SPT 1YR	\$238.67
		License for existing CommandPost unit to connect to Wilkes County	
1	PS-0PR-VSSL	VPRIME PER SEAT LIC	\$7,333.33
1	SS-0PR-VSSL-1Y	SPT VPRIME 1YR	\$1,320.00
1	873099-01102	R4 CDR PER SEAT LIC	\$120.00
		Spare Hardware	
2	04000-00490	ADV DOCK STATION 230W	\$1,072.00
2	64021-10025	KYBD/MOUSE BNDL	\$117.33
2	Wireless	22IN Touchscreen Monitor	\$1,654.48
2	64007-50021	KEYPD 24K 12F USBCBL CP24	\$290.67
2	853004-00401	SAM EXT SPKR KIT	\$448.00
2	853004-00301	CPOST SAM HDWR KIT	\$6,085.33
1	Wireless	Shipping	\$309.45
1	Wireless	1st Year Warranty Service	\$905.99
1	Wireless	Installation	\$5,000.00
1	Wireless	CommandPost Training	\$724.00
Total Cost:			\$53,034.49



Quote

To: Phil Howell, Ashe County Sheriff's Department

Date: 03/18/2016

Proposed Space – Suite 209 located in main building at Family Central

Total Square Footage – 446

Rental Rate - \$9.15/square foot

Total Rental Cost - \$340.08/month which calculates to \$4,080.90 annually

Note: Rental rate \$0.15 increase for fiscal year 2016-2017

Name: _____

Title: _____

Accepted: _____

Date: _____

Anticipated occupancy date: _____



Quote Number: QU0000356263

Effective: 22 MAR 2016

Effective To: 21 MAY 2016

Bill-To:

ASHE COUNTY SHERIFF DEPT
150 GOVERNMENT CIR STE 2500
JEFFERSON, NC 28640
United States

Attention:

Name: Phil Howell
Phone: 828-455-2904

Sales Contact:

Name: Randy Heaton MR
Email: rheaton@wirelessnc.com
Phone: 8284552904

Contract Number: NC STATE NON ARIBA -725G

Freight terms: FOB Destination

Payment terms: Net 30 Due

Item	Quantity	Nomenclature	Description	List price	Your price	Extended Price
1	2	AAH56JDN9KA1AN	XPR 7550 136-174 5W FKP GPS BT GOB	\$1,131.67	\$1,131.67	\$2,263.34
1a	2	QA04474AC	ALT: IMPRES 2800MAH LIION IP57 BATT	\$58.33	\$58.33	\$116.66
1b	2	QA02299AA	ADD: VHF HELICAL ANTENNA (136-155)	-	-	-
2	425	SVC03SVC0115D	SUBSCRIBER PROGRAMMING	\$1.00	\$1.00	\$425.00
3	2	WPLN4232A	CHARGER, SINGLE-UNIT, IMPRES, 1.25A, 115VAC, US/NA	\$69.30	\$53.36	\$106.72
(Notes)extra chargers						
4	2	NNTN8383B	AUDIO ACCESSORY-REMOTE SPEAKER MICROPHONE,IMPRES INC RSM, AUDIO JACK	\$220.00	\$169.40	\$338.80

Total Quote in USD

\$3,250.52

PO Issued to Motorola Solutions Inc. must:

- >Be a valid Purchase Order (PO)/Contract/Notice to Proceed on Company Letterhead. Note: Purchase Requisitions cannot be accepted
- >Have a PO Number/Contract Number & Date
- >Identify "Motorola Solutions Inc." as the Vendor
- >Have Payment Terms or Contract Number
- >Be issued in the Legal Entity's Name
- >Include a Bill-To Address with a Contact Name and Phone Number
- >Include a Ship-To Address with a Contact Name and Phone Number
- >Include an Ultimate Address (only if different than the Ship-To)
- >Be Greater than or Equal to the Value of the Order
- >Be in a Non-Editable Format
- >Identify Tax Exemption Status (where applicable)
- >Include a Signature (as Required)



Quote Number: QU0000356250

Effective: 22 MAR 2016

Effective To: 21 MAY 2016

Bill-To:

ASHE COUNTY SHERIFF DEPT
150 GOVERNMENT CIR STE 2500
JEFFERSON, NC 28640
United States

Attention:

Name: Phil Howell
Phone: 828-455-2904

Sales Contact:

Name: Randy Heaton MR
Email: rheaton@wirelessnc.com
Phone: 8284552904

Contract Number: NC STATE NON ARIBA -725G

Freight terms: FOB Destination

Payment terms: Net 30 Due

Item	Quantity	Nomenclature	Description	List price	Your price	Extended Price
1	1	H97TGD9PW1AN	APX7000 DIGITAL PORTABLE RADIO	\$3,359.00	\$2,519.25	\$2,519.25
1a	1	QA00569AA	ADD: 7/800MHZ PRIMARY BAND	-	-	-
1b	1	QA00781AA	ALT: LIION IMPRES 4200 MAH IP67 (NNTN7034A)	\$115.00	\$86.25	\$86.25
1c	1	QA00577AA	ADD: LARGE COLOR DISPLAY AND FULL KEYPAD	\$500.00	\$375.00	\$375.00
1d	1	Q806BK	ADD: ASTRO DIGITAL CAI OPERATION	\$515.00	\$386.25	\$386.25
1e	1	H38BS	ADD: SMARTZONE OPERATION	\$1,500.00	\$1,125.00	\$1,125.00
1f	1	QA00574AA	ADD: VHF SECONDARY BAND	-	-	-
1g	1	QA00579AA	ADD: ENABLE DUAL BAND OPERATION	\$1,000.00	\$750.00	\$750.00
1h	1	Q361AN	ADD: P25 9600 BAUD TRUNKING	\$300.00	\$225.00	\$225.00
1i	1	QA01833AB	ADD: EXTREME 1-SIDED NOISE REDUCTION	\$25.00	\$18.75	\$18.75
1j	1	H842BE	PACKAGING KIT,ADD: SINGLE PACK LTE UPGRADE KIT	-	-	-
2	2	WPLN7080A	CHR IMP SUC EXT US/NA/CA/LA	\$125.00	\$96.25	\$192.50
3	385	SVC03SVC0115D	SUBSCRIBER PROGRAMMING	\$1.00	\$1.00	\$385.00
(Notes)Electronic Template						
4	49	SVC03SVC0115D	SUBSCRIBER PROGRAMMING	\$1.00	\$1.00	\$49.00
5	2	HMN4103B	IMPRES RSM DSPLY W JACK, NO CHNL	\$345.00	\$265.65	\$531.30

Total Quote in USD

\$6,643.30

PO Issued to Motorola Solutions Inc. must:

- >Be a valid Purchase Order (PO)/Contract/Notice to Proceed on Company Letterhead. Note: Purchase Requisitions cannot be accepted
- >Have a PO Number/Contract Number & Date
- >Identify "Motorola Solutions Inc." as the Vendor
- >Have Payment Terms or Contract Number
- >Be issued in the Legal Entity's Name
- >Include a Bill-To Address with a Contact Name and Phone Number
- >Include a Ship-To Address with a Contact Name and Phone Number
- >Include an Ultimate Address (only if different than the Ship-To)

James D. Williams
Sheriff
Ashe County North Carolina

June 16th, 2016

North Carolina 911 Board
Attn: Richard Taylor, Executive Director
PO Box 17209
Raleigh, NC 27619-7209

Mr. Taylor,

On behalf of the Ashe County Sheriff's Office I am requesting an extension for the implementation of our Backup PSAP plan. The plan was submitted to the 911 Board staff on June 13th but has not been approved. Also a timeline for completion and implementation of the plan is on the last page of the Backup Plan.

Should you have any questions, please contact me.

B. Phil Howell
Director of Communications for the Ashe County Sheriff's Office

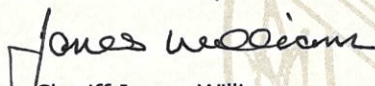
Sheriff James Williams
Sheriff of Ashe County

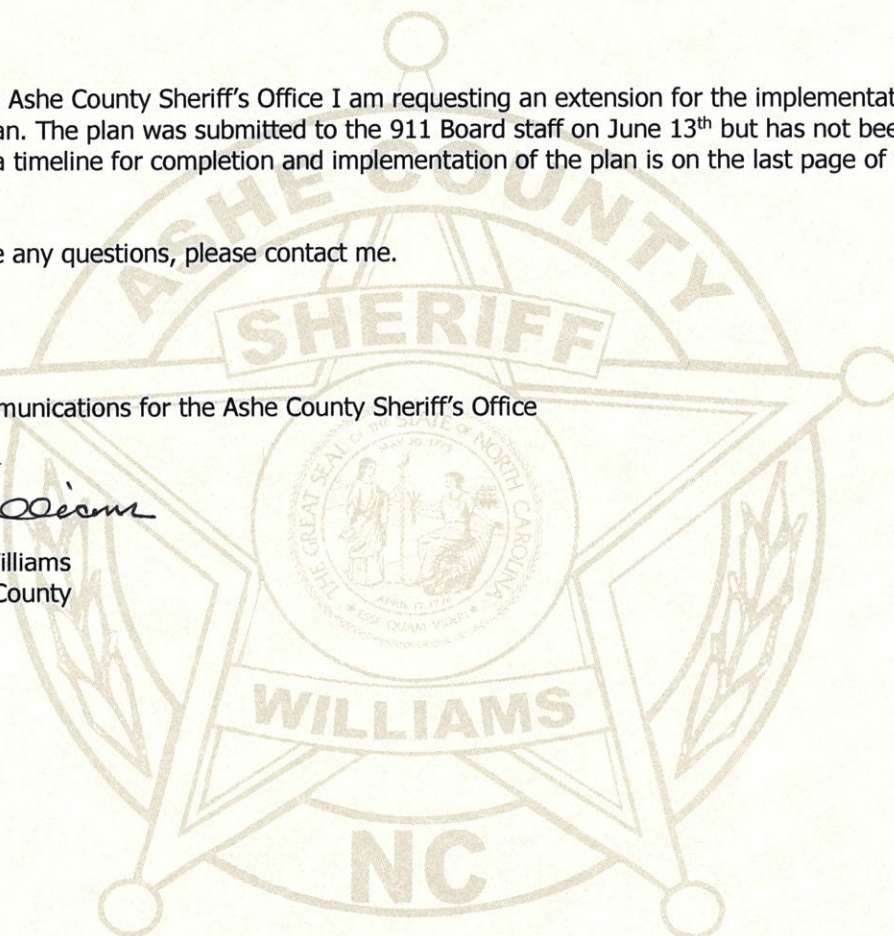

PSAP BACKUP PLAN FOR THE ASHE COUNTY SHERIFF'S OFFICE

XVIII. List of Communications Center Telephone Numbers

Ashe Sheriff Admin Lines

336-846-5600a, 336-846-5600b, 336-846-5600c, 336-846-5600d.

Family Central Admin Lines will be purchased after plan and budget approval.

XIX. Timeline of Implementation

Due to the lack of monies to complete this, our implementation plan and timeline are dependent on the funding we are able to receive.

Our estimated timeline is:

- October 2016 – We hope to have the backup generator, additional outlets that solely rely on the generator installed.
- November 2016 – New monitors installed at the Ashe Comm. Center and used ones moved to Family Central backup location.
- December 2016 – We hope to have the network infrastructure with a new server that is a complete live mirror of our new 911 Server.
- March 2017 – Use the old CAD Machines that are replaced with new, reformat them and install at our backup location to be used there.
- June 1, 2017 – Date of implantation. This is extended in case an unexpected problem arises.