

Data Sheet

Module name : IA9Q5 S83D-E Module

Model ID : SMM DIM 95

Project Code : SMMDIM9QC58RH4

Version 0.2

Aug. 22, 2017

Syncomm Technology Corp.

10F., No. 101, Sec. 2, Gongdao 5th Rd., East Dist., Hsinchu City, Taiwan, R.O.C.

Tel: +886-3-5169188

Fax: +886-3-5169111

<http://www.syncomm.com.tw>

INDEX

1. Features.....	3
2. Application	3
3. RF Specification	4
4. Audio Specification	5
5. Electrical Specification.....	6
6. Mechanical Specification	7
7. Block Diagram.....	11
8. Interface	12
9. Design Reference.....	13
10. Antenna Application	15
11. Ordering Information.....	20
12. Revision History	20

Confidential to TONY
under NDA 2017.08.29

*This document is proprietary and confidential to Syncomm Technology Corp.
SYNIC and Intelligent Wireless are trademarks of Syncomm Technology Corp.
All other trademarks and registered trademarks are the property of their respective owners.*

1. Features

- 5.2GHz/5.8GHz ISM Band
- GFSK modulation
- Low BOM cost
- Long distance > 30m (Line of sight)
- Support 1-1 duplex mode or 1-N broadcasting mode
- RF frequency hopping in 58 channels
- Digital I2S audio interface
- Support no audio detection function
- Audio format 24bit , 32/44.1/48KHz sampling rate
- Robust Packet error correction
- Low power consumption
- No RF induced audio noise
- Compatible with FCC/ CE regulations

2. Application

- Wireless HTiB Rear Speaker
- Wireless Outdoor Speaker
- Wireless TV theater
- Wireless Audio Sender
- Wireless Headphone
- Wireless Stereo Ear Microphone

3. RF Specification

Item	Min	Typ	Max	Unit	Note
Channel Range	5165	—	5200	MHz	
-20dB bandwidth	—	2.5	—	MHz	
RF Output Power		12		dBm	Peak power at Antenna port
Sensitivity	—	-90	-86	dBm	The smaller, the better

Table 1 5.2GHz RF Specification

Item	Min	Typ	Max	Unit	Note
Channel Range	5740	—	5840	MHz	
-20dB bandwidth	—	2.5	—	MHz	
RF Output Power		11		dBm	Peak power at Antenna port
Sensitivity	—	-89	-86	dBm	The smaller, the better

Table 2 5.8GHz RF Specification

4. Audio Specification

2.1 CH						
	Item	Min	Typ	Max	Unit	Note
2.0 CH	SNR	90	94	—	dBr	@1kHz
	THD + N	—	-80	-75	dB	@1kHz, the smaller, the better
	Frequency Response	20	—	20k	Hz	@±1dBm
	Dynamic range	90	94		dB	@1kHz
0.1 CH	SNR	90	94		dBr	@1kHz
	THD + N		-84	-80	dB	@1kHz, the smaller, the better
	Frequency Response	20		5k	Hz	@±3dBm
	Dynamic range	90	94		dB	@1kHz

Note: Test condition is that using Card type EVB board with ADC: AK5357 at master mode and DAC: AK4386 at master mode.

Table 3 ADC to DAC

2.1 CH						
	Item	Min	Typ	Max	Unit	Note
2.0 CH	SNR	135	140		dBr	@1kHz
	THD + N		-100	-95	dB	@1kHz, the smaller, the better
	Frequency response	20		20k	Hz	@±1dBm
	Dynamic range	95	100		dB	@1kHz
0.1 CH	SNR	130	135		dBr	@1kHz
	THD + N		-100	-95	dB	@1kHz, the smaller, the better
	Frequency response	20		5k	Hz	@±3dBm
	Dynamic range	95	100		dB	@1kHz

Note: Test condition is that using sample rate 48 kHz, NFsCLK factor 512 and resolution 24.

Table 4 I2S to I2S

5. Electrical Specification

Item	Min	Typ	Max	Unit	Note
Power Supply Voltage	3.0	3.3	3.6	V	
Consumption Current (TX_MODE)	85	100	115	mA	12dBm, continue mode, no GPIO driving
Consumption Current (RX_MODE)	60	65	75	mA	Receiving only, no GPIO driving
Operating Temperature	0	25	55	°C	

Table 5

Item						
Symbol	Parameter	Min	Typ	Max	Unit	Conditions
V _{IH}	Input High Threshold	2.0	—	3.33	V	LDO_OUT=3V
V _{IL}	Input Low Threshold	-0.3	—	0.8	V	LDO_OUT=3V
V _{OH}	Output High Threshold	2.4	—	—	V	LDO_OUT=3V
V _{OL}	Output Low Threshold	—	—	0.4	V	LDO_OUT=3V

Table 6

◆ Power On Reset Characteristics

Symbol	Parameter	Min	Typ	Max	Unit	Conditions
VDD_CORE	1.8V POR input	1.62	1.8	1.98	V	
PORN	1.8V POR output					
VR18	Rising Detection Level		1.5		V	
VF18	Falling Detection Level	1.33	1.4	1.47	V	
TLH18	Rising Delay	2			μS	VDD_CORE slew rate = 1V/μS
THL18	Falling Delay	2			μS	VDD_CORE slew rate = 1V/μS

Table 7

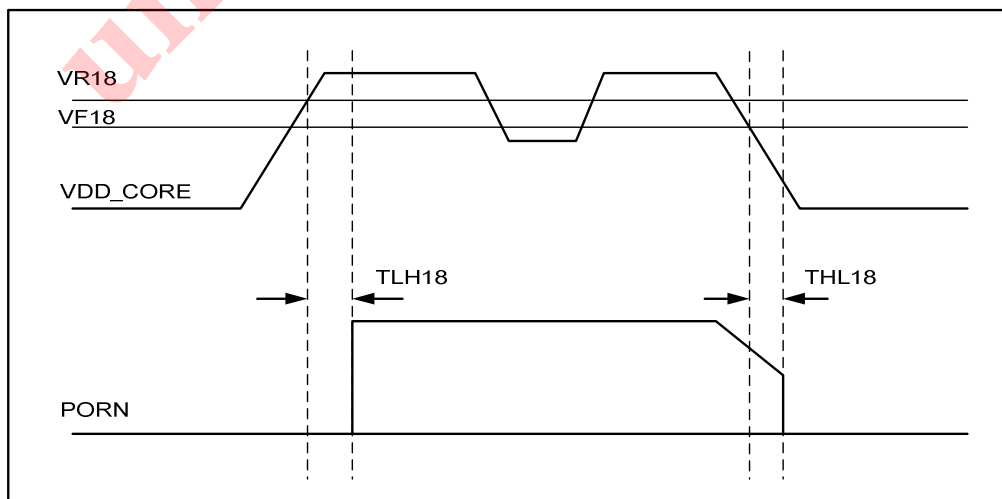

Fig 5.1 Power On Reset Timing Chart

6. Mechanical Specification

6.1 Without Shielding Case

- Dimension : 20 * 40 * 6.7 mm
 - PCB 4 Layers
- Mechanical Drawing :

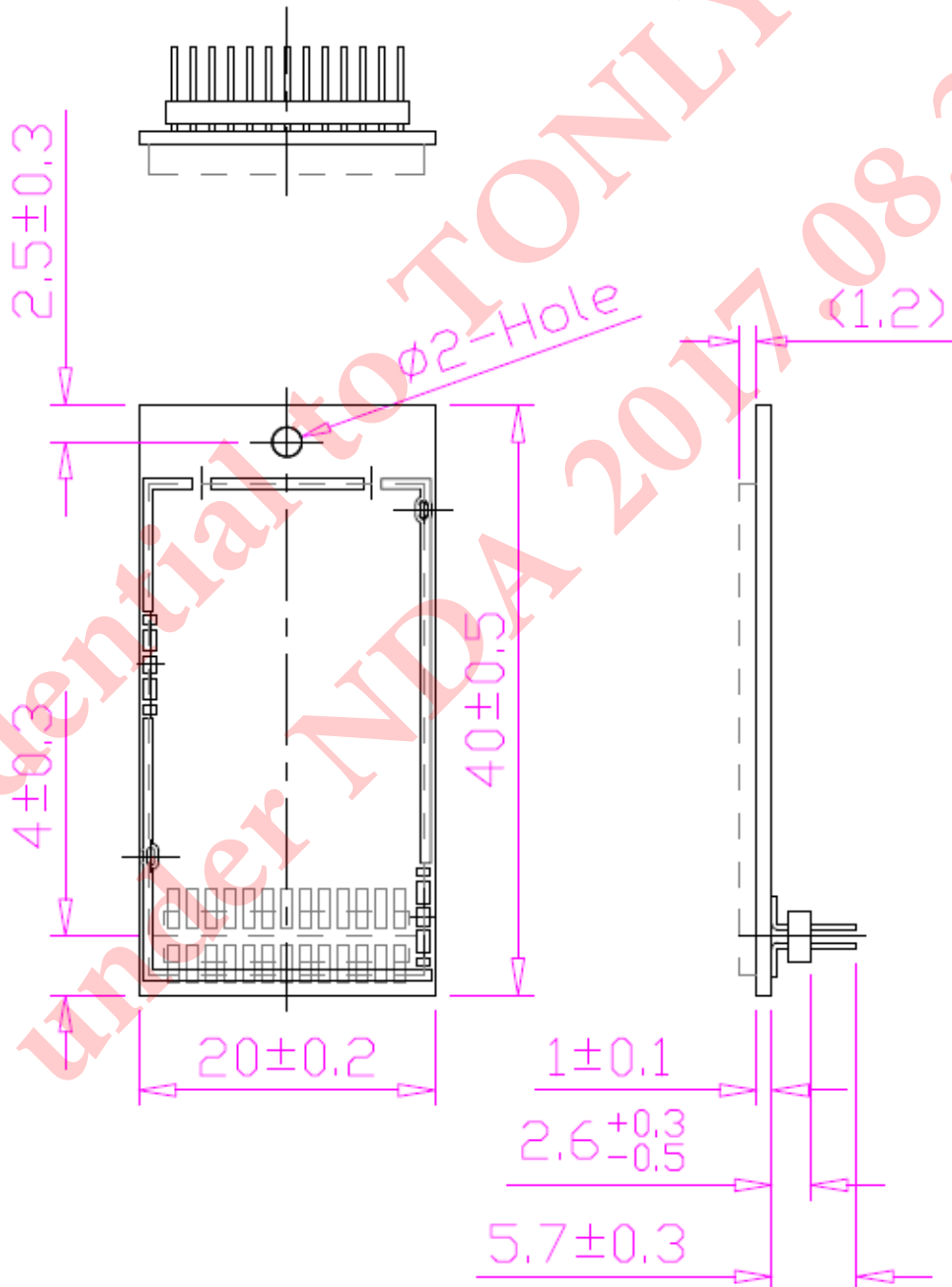
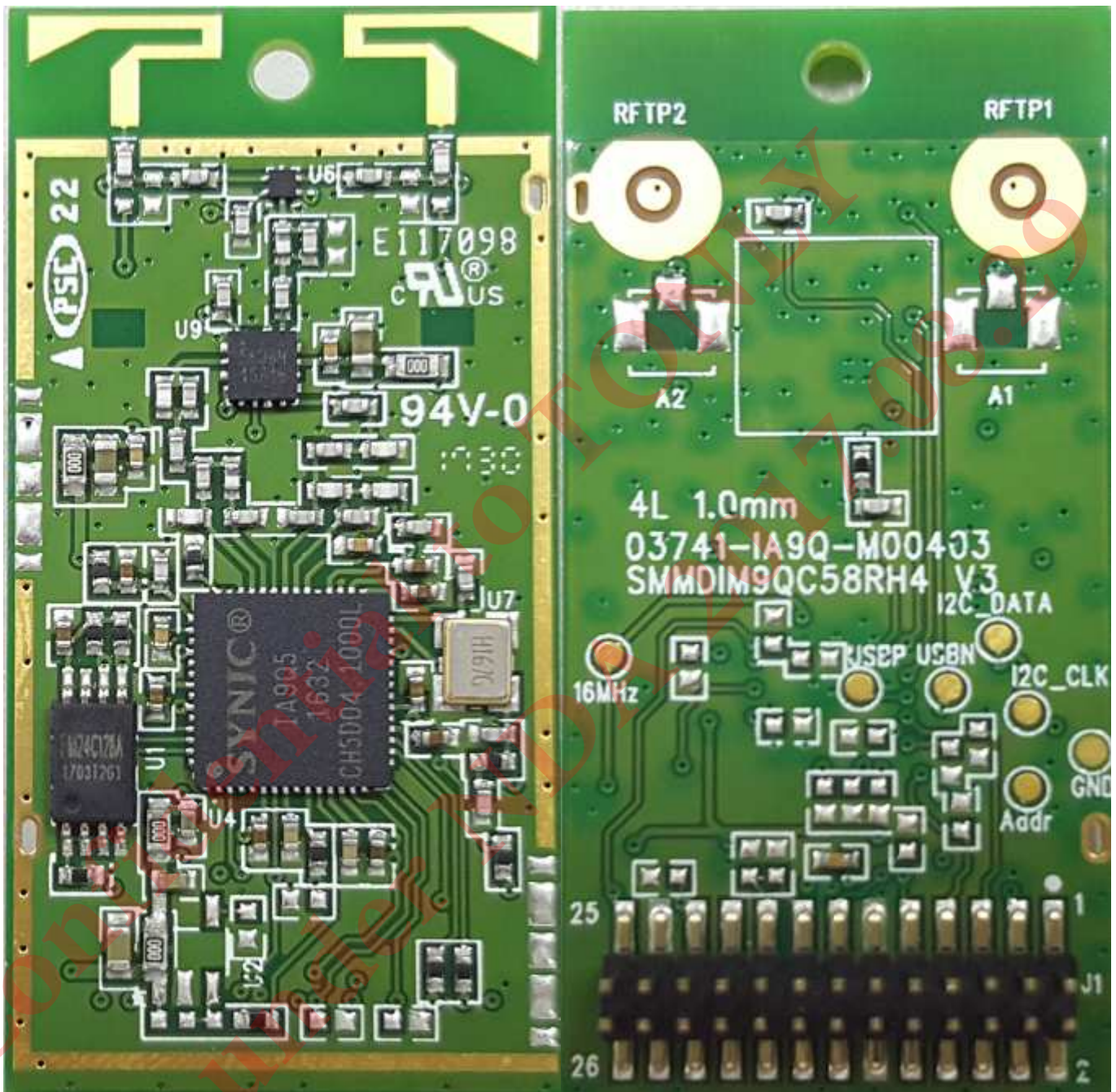
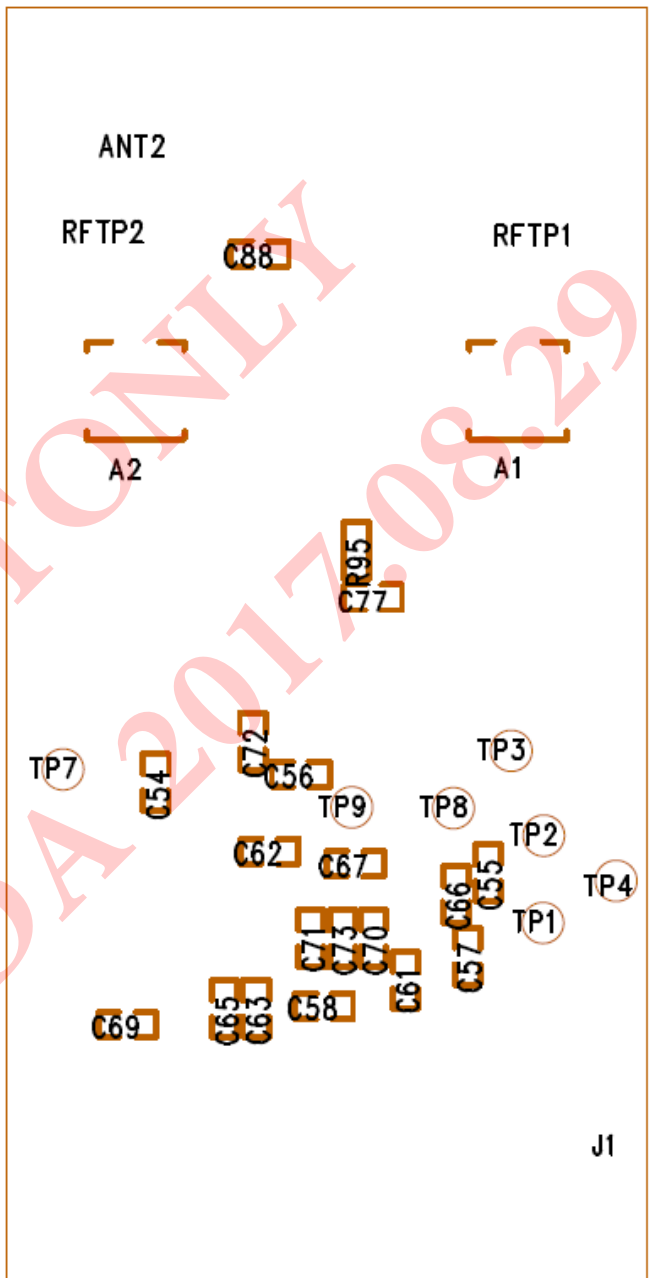
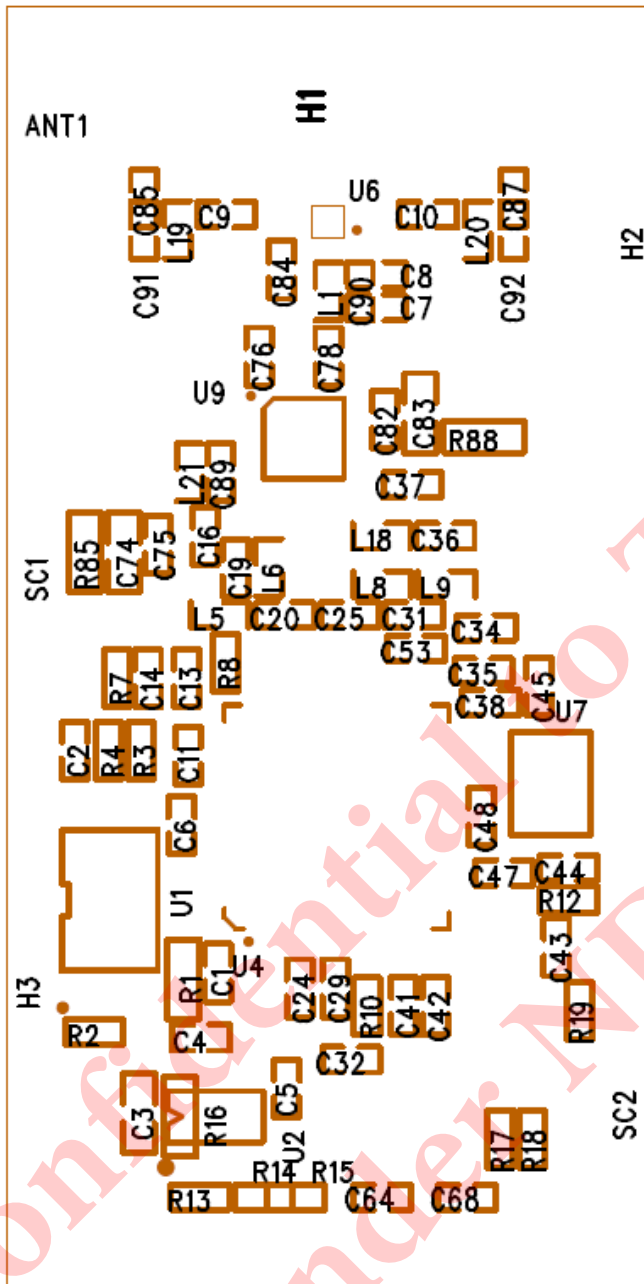

Fig 6.1 Mechanical Drawing of S83D-E Module

- ◆ Propose 1.27mm Female Header size : H: 4.3 ± 0.15 mm W: 3.0 ± 0.15 mm





7. Block Diagram

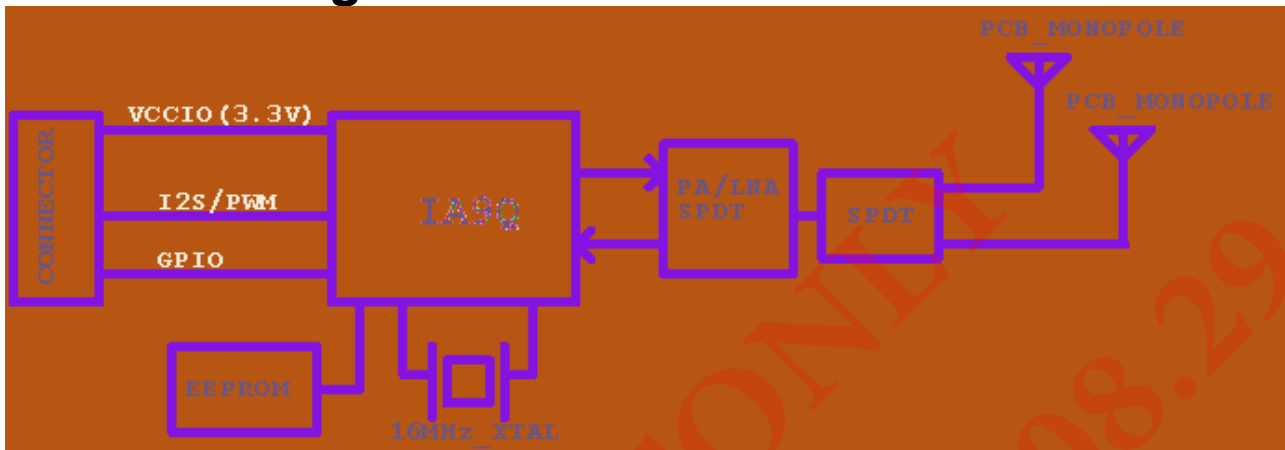

Fig 7.1 Block Diagram of IA9Q5 S83D-E Module

8. Interface

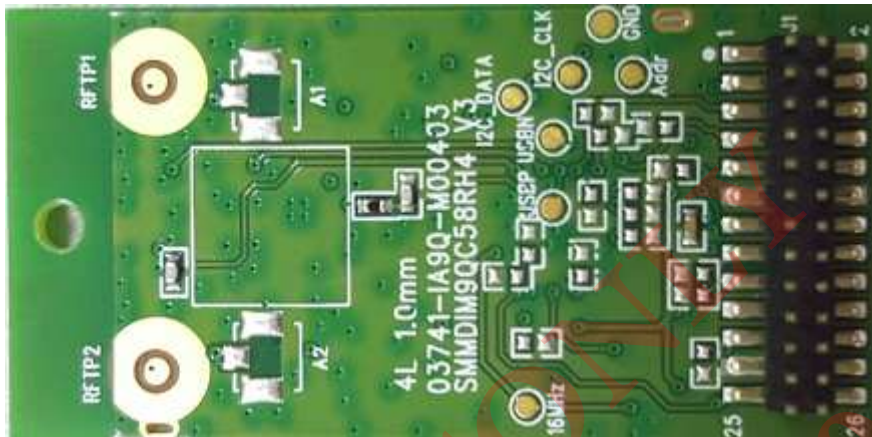

Fig 8.1 Pin sequence of S83D-E Module (Bottom View)

Pin	Name	I/O	TX Function Define	RX Function Define
1	VCCIO	P	DC 3.0 ~ 3.6V IN	DC 3.0 ~ 3.6V IN
2	DGND	P	Digital GND	Digital GND
3	SPB_I2S_MCLK	I/O	SPB I2S audio MCLK system clock output	SPB I2S audio MCLK system clock output
4	GPIO 32	I/O	GPIO	AMP MUTE
5	GPIO 14	I/O	GPIO	GPIO
6	GPIO 31	I/O	GPIO	GPIO
7	GPIO 17	I/O	GPIO	GPIO
8	GPIO 36	I/O	I2C_BUSY , Module Pull High	I2C_BUSY , Module Pull High
9	I2C_CLK	I/O	I2C Master/Slave clock signal	I2C Master/Slave clock signal
10	I2C_DATA	I/O	I2C Master/Slave data signal	I2C Master/Slave data signal
11	DGND	P	Digital GND	Digital GND
12	DGND	P	Digital GND	Digital GND
13	GPIO 27	I/O	GPIO	Pairing
14	GPIO 21	I/O	GPIO	GPIO
15	GPIO 16	I/O	GPIO	ON/OFF 12V
16	GPIO 34	I/O	I2S Master/Slave Select	I2S Master/Slave Select
17	M_RESET(PORN)	I/O	Internal power on reset (1)	Internal power on reset (1)
18	I2C_CLK	I/O	I2C Master/Slave clock signal	I2C Master/Slave clock signal
19	I2C_DATA	I/O	I2C Master/Slave data signal	I2C Master/Slave data signal
20	GPIO 30	I/O	GPIO	AMP RESET(L Act)
21	SPA_I2S_DATA	I/O	I2S DATA 0	SYNC LED
22	SPB_I2S_LRCK	I/O	SPB I2S audio LRCK	SPB I2S audio LRCK
23	DGND	P	Digital GND	Digital GND
24	SPB_I2S_BCK	I/O	SPB I2S audio BCK	SPB I2S audio BCK
25	GPIO 15	I/O	GPIO	ON/OFF 3.3V
26	SPB_I2S_DATA	I/O	SPB I2S audio Data	SPB I2S audio Data

Table 8 IO Function Define

- Note : (1) * .Not need external RC circuit to do RC reset
 *.Power On Reset Characteristics can reference section 5 Electrical Specification (page 6)
 *.External controller can direct control M_RESET but should assign the control IO as input for normal operation and output low to Reset S83D-E Module

9. Design Reference

9.1 ADC/DAC Reference Design

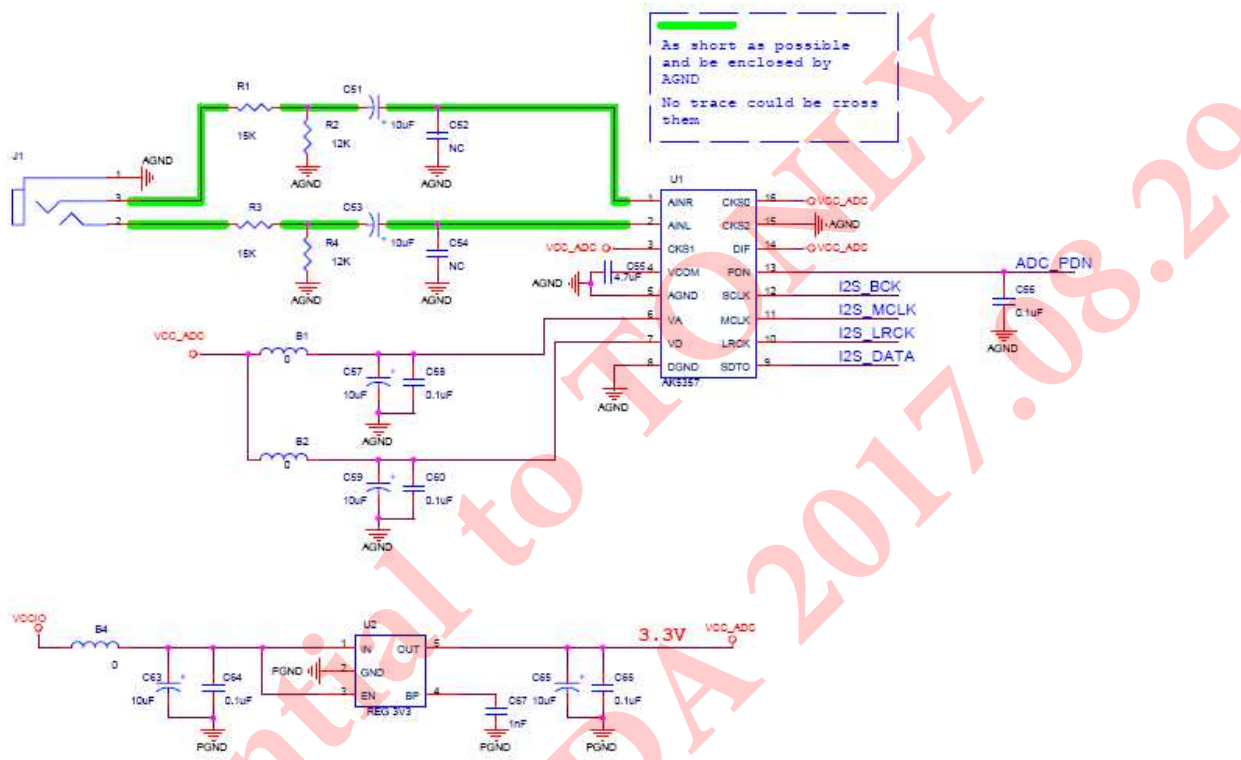

Fig 9.1 ADC reference design circuit

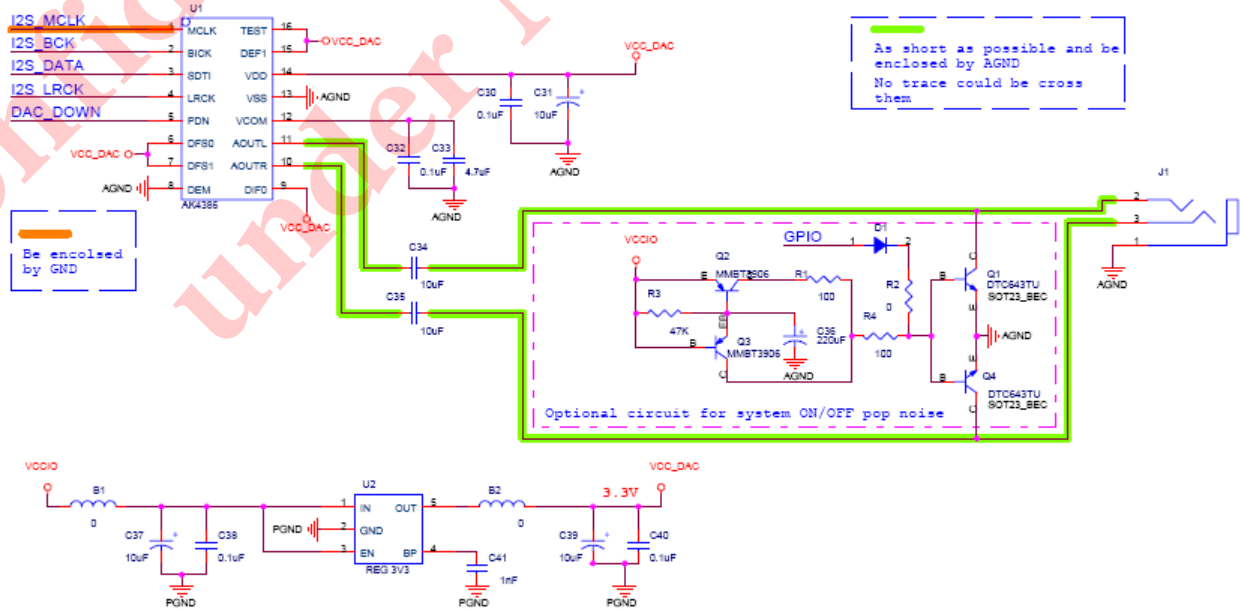

Fig 9.2 DAC reference design circuit

9.2 I2S Timing Chart

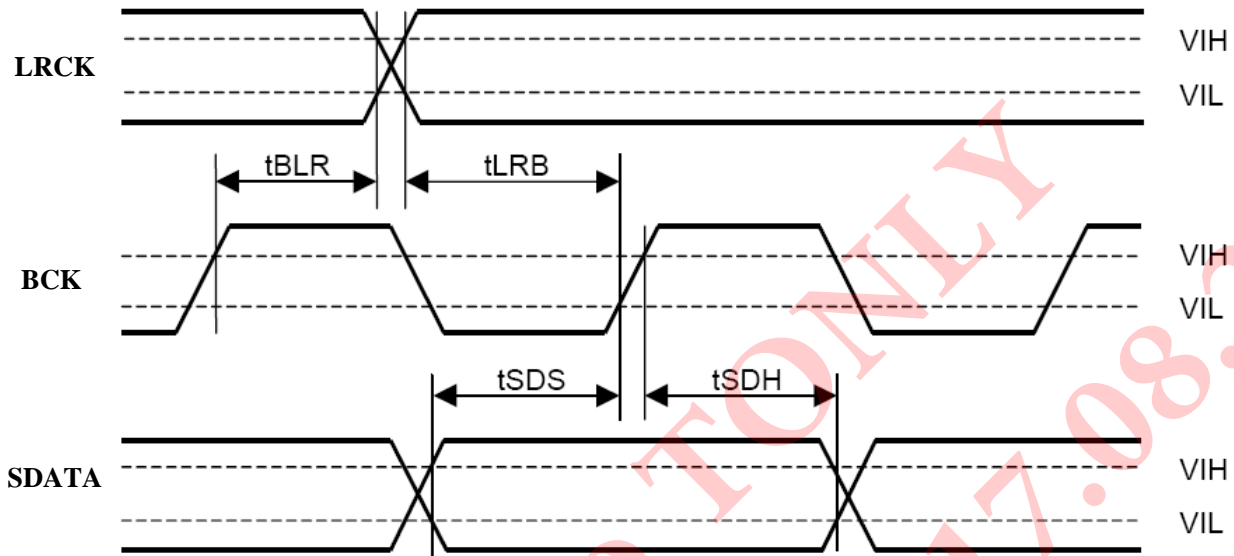

Fig 9.3 I2S timing chart

Symbol	Parameter	Min	Typ	Max	Unit
t_{BLR}	BCK rising to LRCK edge	60			ns
t_{LRB}	LRCK edge to BCK rise	60			ns
t_{SDS}	SDATA setup time	60			ns
t_{SDH}	SDATA hold time	60			ns

Table 9

10. Antenna Application

10.1 Suggested Clear Area

The recommended antenna clearance for embedded PCB antennas are shown below. Note that this clearance should be maintained when mounting the module on a motherboard.

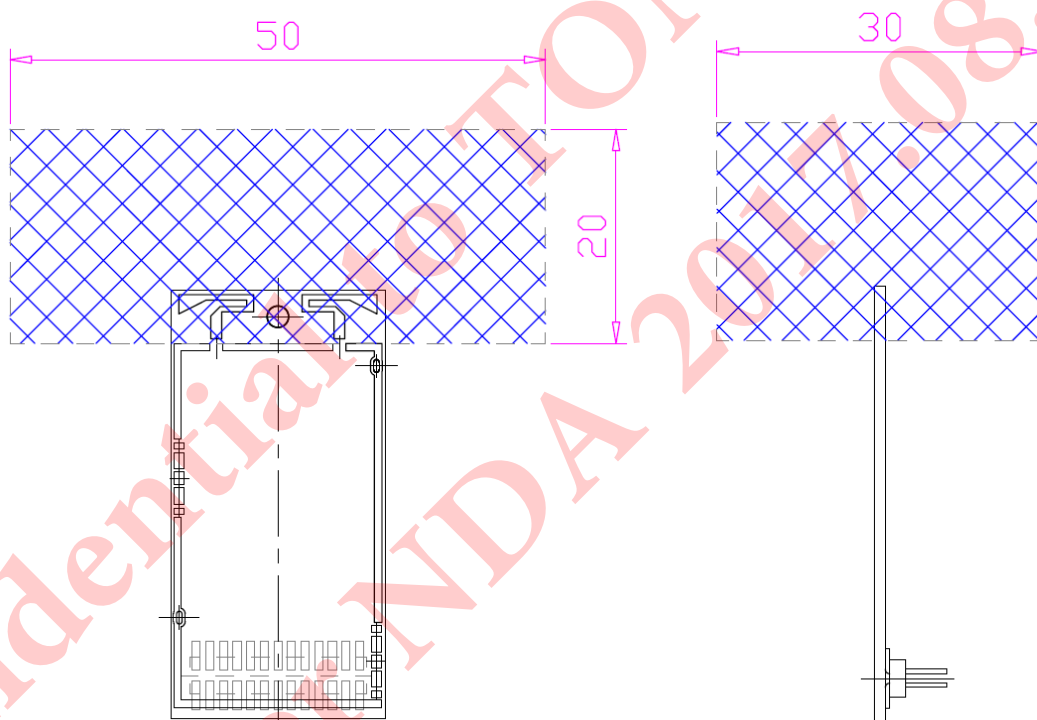

Unit : mm

*Do not place any copper, metal or even PCB
in the area marked with cross lines.*

Fig 10.1 Antenna Clearance Recommendations from Top and Side View

10.2 Antenna Drawing

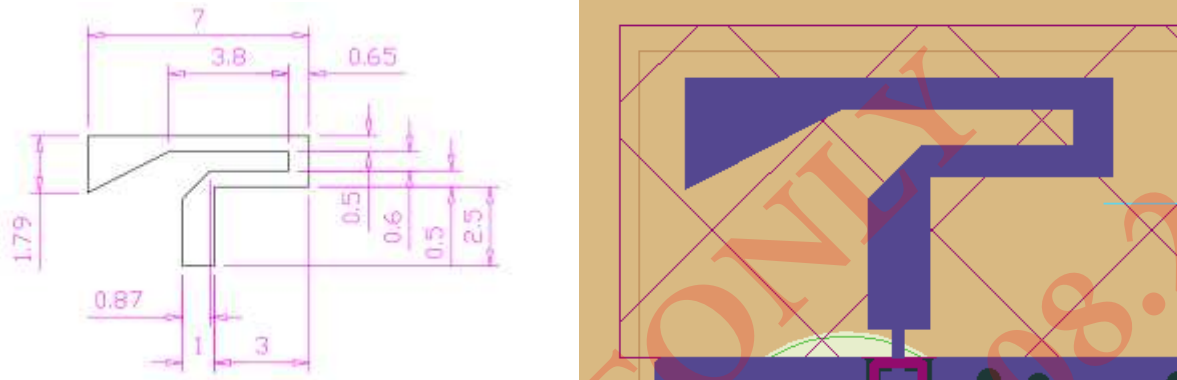

10.3 Antenna Pattern

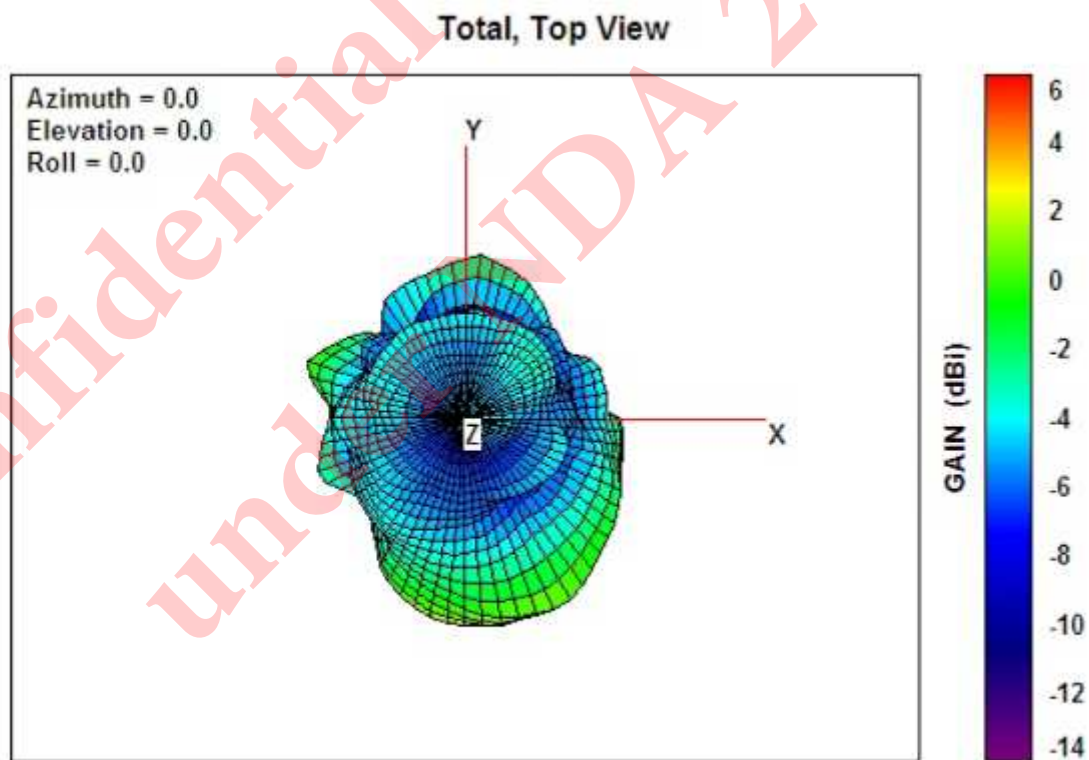

Free-Space Total GAIN, Top View, 5800.0 MHz

Total, Bottom View

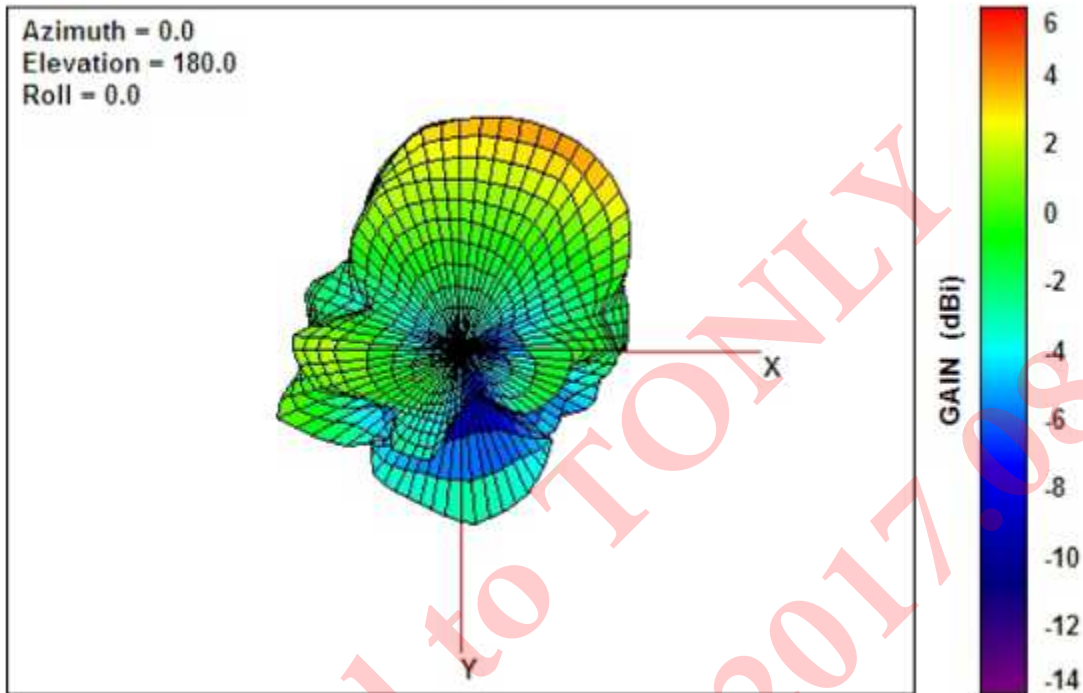

Free-Space Total GAIN, Bottom View, 5800.0 MHz

Total, Back Face View

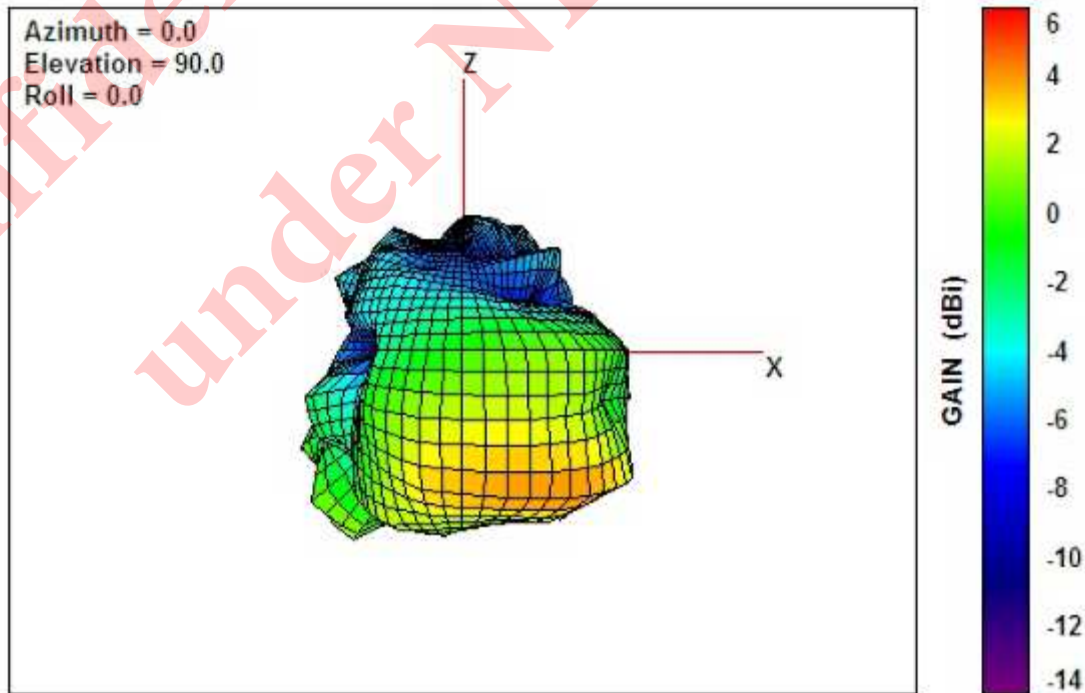

Free-Space Total GAIN, Back Face View, 5800.0 MHz

Total, Left Side View

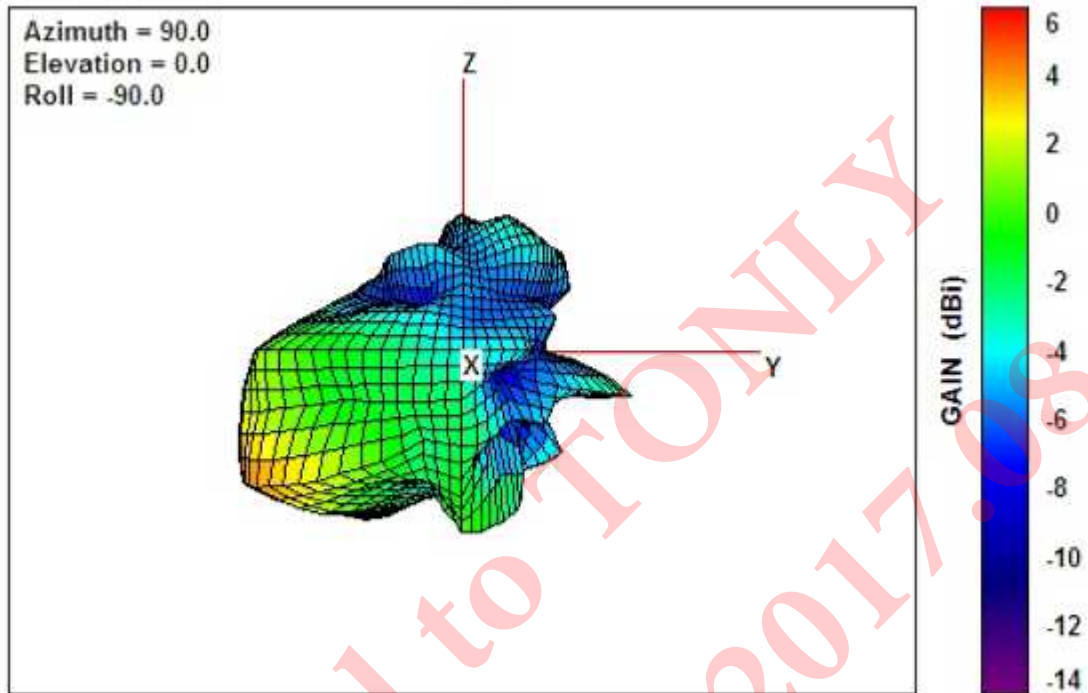

Free-Space Total GAIN, Left Side View, 5800.0 MHz

Total, Front Face View

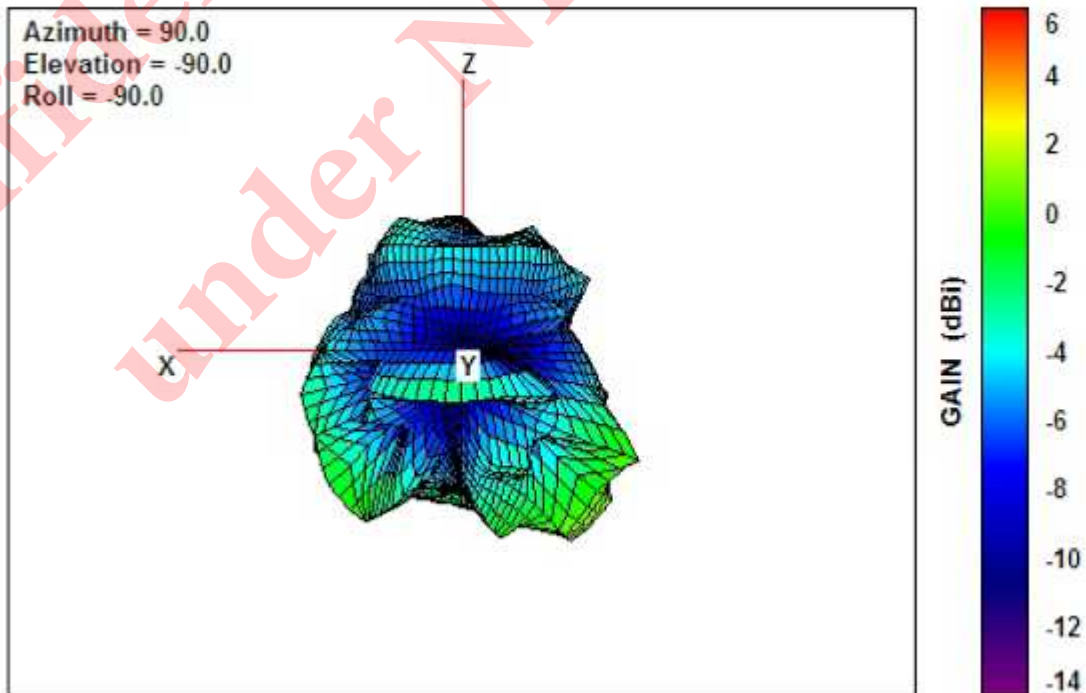

Free-Space Total GAIN, Front Face View, 5800.0 MHz

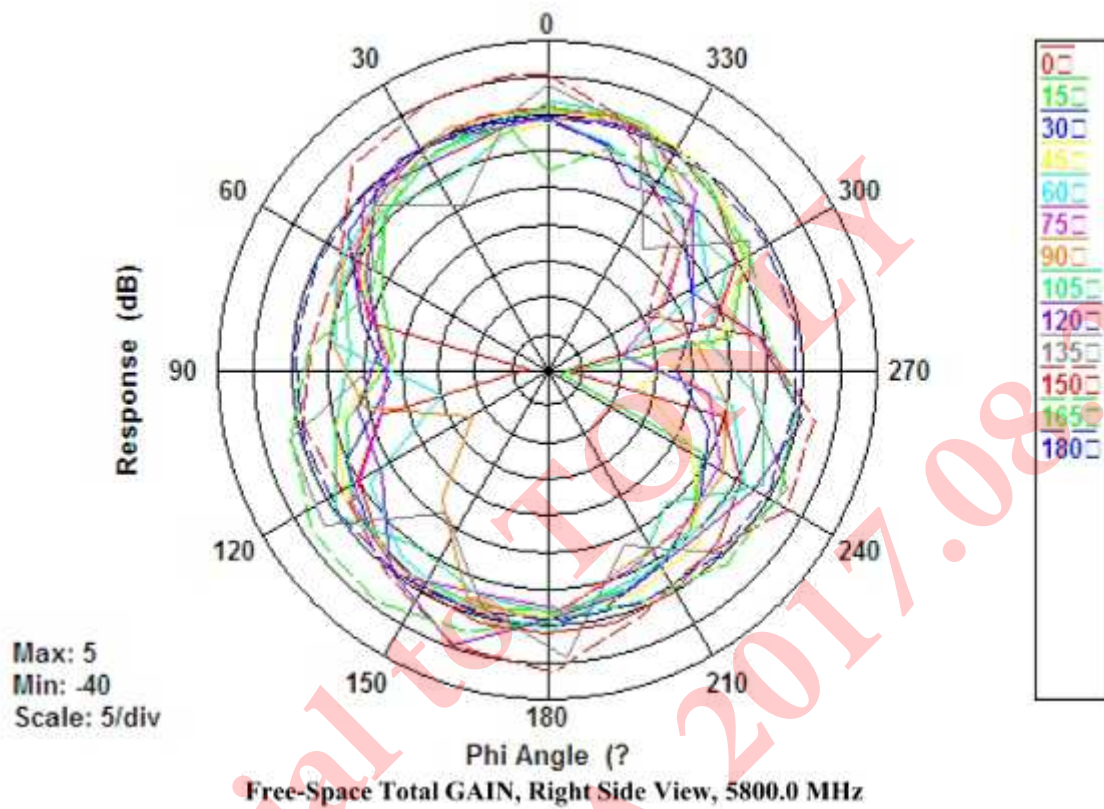

Max Antenna Gain : 2.85 dBi

11. Ordering Information

Feature Model Name	Antenna		Shielding Case		Clip		Ordering Info.	
	PCB	MHF	Without	With	Without	With	Part Number	Description
Model M		●	●		●			IA9Q5 S83D-E Model M TX
Model MC		●	●			●		IA9Q5 S83D-E Model MC TX
Model MS		●		●	●			IA9Q5 S83D-E Model MS TX
Model MSC		●		●		●		IA9Q5 S83D-E Model MSC TX
Model P	●		●		●		1A5UI-IA9Q-24T101	IA9Q5 S83D-E Model P TX
Model PC	●		●			●		IA9Q5 S83D-E Model PC TX
Model PS	●			●	●			IA9Q5 S83D-E Model PS TX
Model PSC	●			●		●	1A5UI-IA9Q-25T101	IA9Q5 S83D-E Model PSC TX

Note: Model Name is the abbreviation of Feature column which is written in bold.

For example **P** is the abbreviation of **PCB** antenna

Table 10

12. Revision History

Date	Revision	Descriptions
2017/07/13	0.1	First release
2017/08/15	0.2	Add Mechanical picture

Table 11

For IC:

This device complies with RSS247 of Industry Canada. Cet appareil se conforme à RSS247 de Canada d'Industrie. This device complies with Industry Canada license-exempt RSS standard(s). Operation is subject to the following two conditions: (1) this device may not cause interference, and (2) this device must accept any interference, including interference that may cause undesired operation of the device. appareils radio exempts de licence. Son fonctionnement est sujet aux deux conditions suivantes: (1) le dispositif ne doit pas produire de brouillage préjudiciable, et (2) ce dispositif doit accepter tout brouillage reçu, y compris un brouillage susceptible de provoquer un fonctionnement indésirable.

This Class B digital apparatus complies with Canadian ICES-003.

Cet appareil numérique de la classe B est conforme à la norme NMB-003 du Canada.

The device should be installed and operated with a minimum distance of 20cm between the radiator and your body.

L'appareil doit être installé et utilisé avec une distance minimale de 20 cm entre le radiateur et votre corps.

This module is intended for OEM integrator. The OEM integrator is still responsible for the FCC/IC compliance requirement of the end product which integrates this module.

LABEL OF THE END PRODUCT:

The final end product must be labeled in a visible area with the following " Contains TX FCC ID: ZVA14 ".

End Product Labeling

This transmitter module is authorized only for use in device where the antenna may be installed such that 20 cm may be maintained between the antenna and users. The final end product must be labeled in a visible area with the following: "Contains TX IC : 9976A-14".

Ce module est destiné à l'intégrateur OEM. L'intégrateur OEM est toujours responsable des exigences de conformité FCC / IC du produit final intégrant ce module.

ETIQUETTE DU PRODUIT FINAL:

Le produit final doit être clairement visible dans la zone "Contient le TX FCC ID: ZVA14".
étiquetage du produit final

Ce module émetteur est uniquement autorisé à être utilisé dans un appareil où l'antenne peut être installée de manière à ce que 20 cm puissent être maintenus entre l'antenne et les utilisateurs. Le produit final doit être étiqueté dans une zone visible avec les informations suivantes: "Contient le TX IC: 9976A-14".

For FCC:

Warning: Changes or modifications to this unit not expressly approved by the party responsible for compliance could void the user's authority to operate the equipment.

NOTE: This equipment has been tested and found to comply with the limits for a Class B digital device, pursuant to Part 15 of the FCC Rules. These limits are designed to provide reasonable protection against harmful interference in a residential installation. This equipment generates, uses and can radiate radio frequency energy and, if not installed and used in accordance with the instructions, may cause harmful interference to radio communications.

However, there is no guarantee that interference will not occur in a particular installation. If this equipment does cause harmful interference to radio or television reception, which can be determined by turning the equipment off and on, the user is encouraged to try to correct the interference by one or more of the following measures:

- Reorient or relocate the receiving antenna.
- Increase the separation between the equipment and receiver.
- Connect the equipment into an outlet on a circuit different from that to which the receiver is connected.
- Consult the dealer or an experienced radio/TV technician for help.

“The device must not be co-located or operating in conjunction with any other antenna or transmitter.”

FCC RF Radiation Exposure Statement Caution: To maintain compliance with the FCC's RF exposure guidelines, place the product at least 20cm from nearby persons.

FCC Conditions

This device complies with part 15 of the FCC Rules. Operation is subject to the following two conditions:

- 1.This device may not cause harmful interference.
- 2.This device must accept any interference received, including interference that may cause undesired operation.