



CR3L Module Datasheet

Hardware Product Development > Network Modules > Wi-Fi & BLE

Dual Mode Module

Version: 20201208

Contents

1	Product overview	2
1.1	Features	2
1.2	Applications	2
2	Change history	3
3	Module interfaces	3
3.1	Dimensions and footprint	3
3.2	Pin definition	5
4	Electrical parameters	8
4.1	Absolute electrical parameters	8
4.2	Working conditions	8
4.3	RF power consumption	9
4.4	Working power consumption	10
5	RF parameters	11
5.1	Basic RF features	11
5.2	TX performance	11
5.3	RX performance	13
6	Antenna	14
6.1	Antenna type	14
6.2	Antenna interference reduction	14
7	Power-on sequence and resetting	15
7.1	Power-on sequence	15
7.2	Resetting	15
8	Packaging information and production instructions	17
8.1	Mechanical dimensions	17
8.2	Recommended PCB layout	18
8.3	Pin header specifications	19
8.4	Production instructions	20
8.5	Recommended oven temperature curve	22

8.6 Storage conditions	23
9 MOQ and packaging information	24
10 Appendix: Statement	24



Contents

CR3L is a low-power embedded WiFi+BLE module that Tuya has developed. It consists of a highly integrated wireless RF chip (RTL8720CM), with an embedded WiFi network protocol stack and varied library functions.

1 Product overview

With the maximum CPU clock rate of 100MHz, CR3L also contains a low-power KM4 microcontroller unit (MCU), a WLAN MAC, a 1T1R WLAN module, 4-MB static random-access memory (SRAM), 4-MB flash memory, and extensive peripherals. CR3L is an RTOS platform that integrates all function libraries of the WiFi MAC and TCP/IP protocols. You can develop embedded WiFi products as required.

1.1 Features

- Embedded low-power KM4 MCU, which can also function as an application processor; Clock rate: 100MHz
- Working voltage: 3.0 to 3.6 V
- Peripherals: 9 GPIOs, 1 universal asynchronous receiver/transmitter (UART), and 1 log transmitter
- Wi-Fi/BT connectivity
 - 802.11 B/G/N20
 - Channels 1 to 14 at 2.4 Ghz (channels 1 to 11 for US/CA and channels 1 to 13 for EU/CN)
 - Support WEP/WPA/WPA2/WPA2 PSK (AES) security modes
 - Support BLE (Bluetooth Low Energy) 4.2
 - Up to +20 dBm output power in 802.11b mode
 - Support SmartConfig functions for Android and iOS devices
 - Onboard PCB antenna
 - Passed CE and FCC certification
 - Working temperature: -40°C to 105°C

1.2 Applications

- Intelligent building
- Smart household and home appliances
- Smart socket and light
- Industrial wireless control
- Baby monitor
- Network camera
- Intelligent bus

2 Change history

Update Date	Updated Content	Version after Update
12/8/2020	This is the first release.	V1.0.0

3 Module interfaces

3.1 Dimensions and footprint

CR3L has two rows of pins with a 2 mm pin spacing. Each row has 8 pins. The CR3L dimensions are 16 ± 0.35 mm (W) \times 24 ± 0.35 mm (L) \times 2.8 ± 0.15 mm (H). The dimensions of CR3L are as follows:

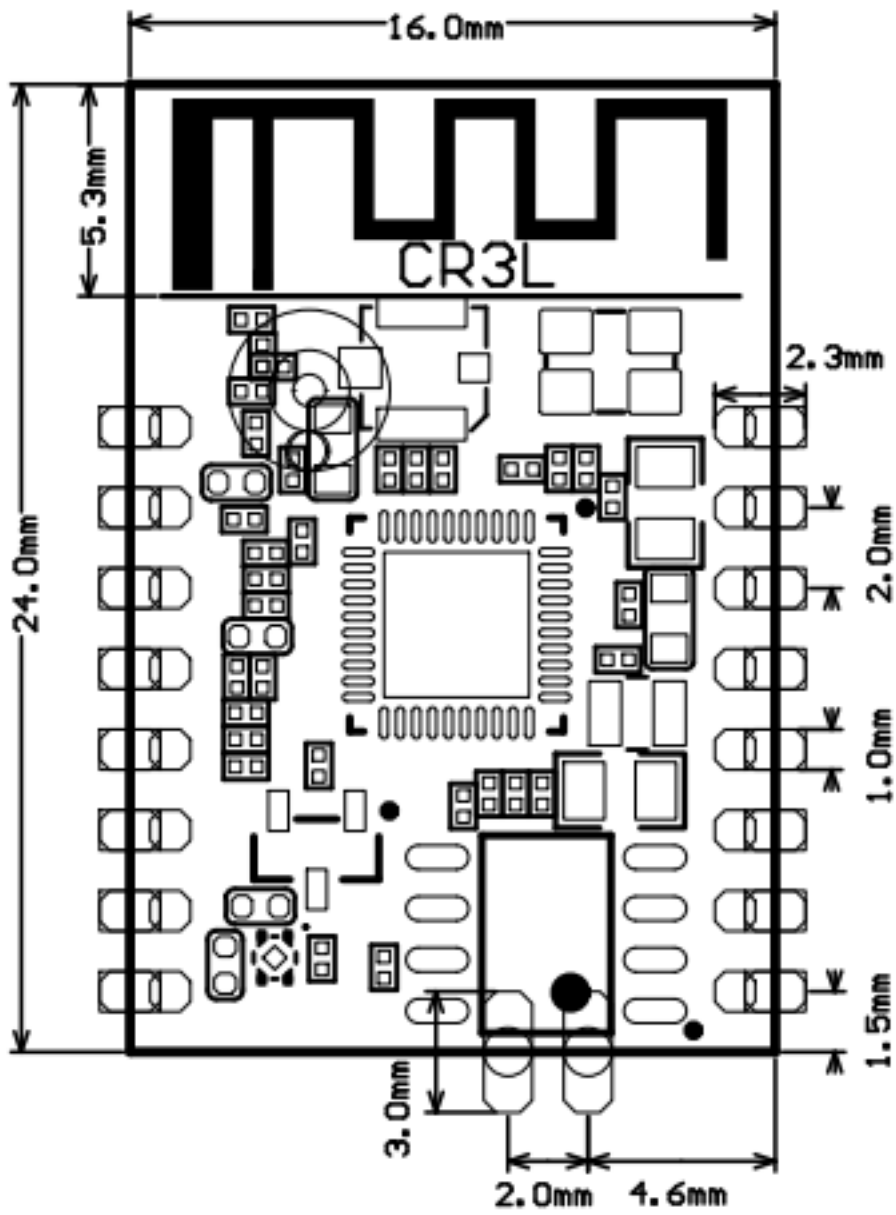

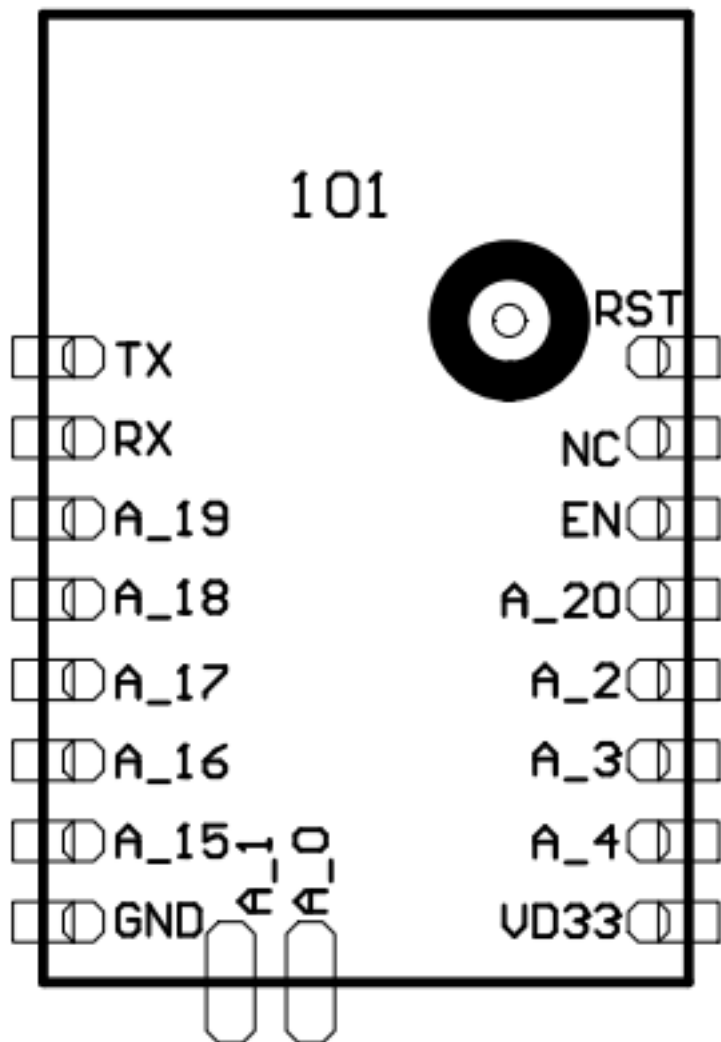

3.2 Pin definition

The definition of interface pins is shown in the following table:

Pin Number	Symbol	I/O Type	Function
1	RST	I/O	Reset pin, This pin is connected to the pin named EN

Pin Number	Symbol	I/O Type	Function
2	NC	I/O	It is pulled up to be compatible with other modules
3	EN	I/O	Enabling pin, which works at the high level and is pulled up and controlled by a user externally
4	A_20	I/O	GPIOA_20, GPIO, IC Pin1
5	A_2	I/O	GPIOA_2, hardware PWM, IC Pin18
6	A_3	I/O	GPIOA_3, hardware PWM, IC Pin19
7	A_4	I/O	GPIOA_4, hardware PWM, IC Pin20
8	VD33	P	Power supply pin (3.3V)
9	GND	P	Power supply reference ground
10	A_15	I/O	GPIOA_15, UART_Log_RXD, This pin can be used as GPIO.

Pin Number	Symbol	I/O Type	Function
11	A_16	I/O	GPIOA_16, UART_Log_TXD, which is used for displaying the module internal information and can be configured as a common GPIO
12	A_17	I/O	GPIOA_17, hardware PWM, IC Pin38
13	A_18	I/O	GPIOA_18, hardware PWM, IC Pin39
14	A_19	I/O	GPIOA_19, hardware PWM, IC Pin40
15	RXD	I/O	GPIOA_13, UART0_RXD, which is used as a user-side serial interface pin
16	TXD	I/O	GPIOA_14, UART0_TXD, which is used as a user-side serial interface pin

Note: P indicates power supply pins and I/O indicates input/output pins.

4 Electrical parameters

4.1 Absolute electrical parameters

Parameter	Description	Minimum Value	Maximum Value	Unit
Ts	Storage temperature	-40	125	°C
VDD	Power supply voltage	-0.3	3.6	V
Static electricity discharge voltage (human body model)	TAMB-25°C	-	2	KV
Static electricity discharge voltage (machine model)	TAMB-25°C	-	0.5	KV

4.2 Working conditions

Parameter	Description	Minimum Value	Typical Value	Maximum Value	Unit
Ta	Working temperature	-40	-	105	°C
VDD	Working voltage	3.0	-	3.6	V

Parameter	Description	Minimum Value	Typical Value	Maximum Value	Unit
VIL	I/O low-level input	-	-	0.8	V
VIH	I/O high-level input	2.0	-	-	V
VOL	I/O low-level output	-	-	0.4	V
VOH	I/O high-level output	2.4	-	-	V
I _{max}	I/O drive current	-	-	16	mA
C _{pad}	Input pin capacitance	-	2	-	pF

4.3 RF power consumption

TX power consumption:

Symbol	Mode	Average Value	Peak Value (Typical Value)	Unit
RF	11B 11M	63	65	mA
RF	11G 54M	65	67	mA
RF	11N HT20 MCS7	65	67	mA

RX power consumption:

Symbol	Mode	Average Value	Peak Value (Typical Value)	Unit
IRF	11B 11M	63	65	mA
IRF	11G 54M	65	67	mA
IRF	11N HT20 MCS7	65	67	mA

4.4 Working power consumption

Working Mode	Working Status (Ta = 25°C)	Average Value	Peak Value (Typical Value)	Unit
Quick connection network status	The module is in the fast network connection state and the WiFi indicator always flashes	75	324	mA
Network connection idle state	The module is connected to the network and the WiFi indicator is always on	64	314	mA
Network connection operation status	The module is connected to the network and the WiFi indicator is always on	66	305	mA

Working Mode	Working Status (Ta = 25°C)	Average Value	Peak Value (Typical Value)	Unit
Disconnected status	The module is offline and the WiFi indicator is dark	66	309	mA

5 RF parameters

5.1 Basic RF features

Parameter	Description
Frequency range	2.400 to 2.4835 GHz
WiFi standard	IEEE 802.11b/g/n (channels 1 to 14)
BLE standard	Bluetooth 4.2
Data transmission rate	Data transmission rate
Data transmission rate	11g: 6, 9, 12, 18, 24, 36, 48, 54 (Mbps)
Data transmission rate	11n: HT20 MCS 0 to 7
Antenna Type	PCB antenna with a gain of 1.88 dBi

5.2 TX performance

Parameter	Minimum Value	Typical Value	Maximum Value	Unit
Average RF output power, 802.11b CCK Mode, 1 Mbit/s	-	17	-	dBm
Average RF output power, 802.11g OFDM mode, 54 Mbit/s	-	14.5	-	dBm
Average RF output power, 802.11n OFDM mode, MCS7	-	13.5	-	dBm
Average RF output power, BLE 4.2, 1 Mbit/s	-	6.5	-	dBm
Frequency error	-20	-	20	ppm
EVM@802.11b CCK 11Mbps Mode 17.5dBm	-	-	-10	dB
EVM@802.11g OFDM 54Mbps Mode 14.5dBm	-	-	-29	dB

Parameter	Minimum Value	Typical Value	Maximum Value	Unit
EVM@802.11n OFDM MCS7 Mode 13.5dBm	-	-	-30	dB

5.3 RX performance

Parameter	Minimum Value	Typical Value	Maximum Value	Unit
PER<8%, RX sensitivity, 802.11b CCK Mode 1M	-	-91	-	dBm
PER<10%, RX sensitivity, 802.11g OFDM Mode 54M	-	-75	-	dBm
PER<10%, RX sensitivity, 802.11n OFDM Mode MCS7	-	-72	-	dBm
PER<10%, RX sensitivity, BLE 4.2 1M	-	-93	-	dBm

6 Antenna

6.1 Antenna type

CR3L uses only an onboard PCB antenna with a gain of 1.88 dBi.

6.2 Antenna interference reduction

To ensure optimal WiFi performance when the WiFi module uses an onboard PCB antenna, it is recommended that the antenna be at least 15 mm away from other metal parts.

7 Power-on sequence and resetting

7.1 Power-on sequence

The RTL8720CM chip has requirements on the power-on sequence. It is recommended that the voltage rises from 0 to 3.3V within 40mS.

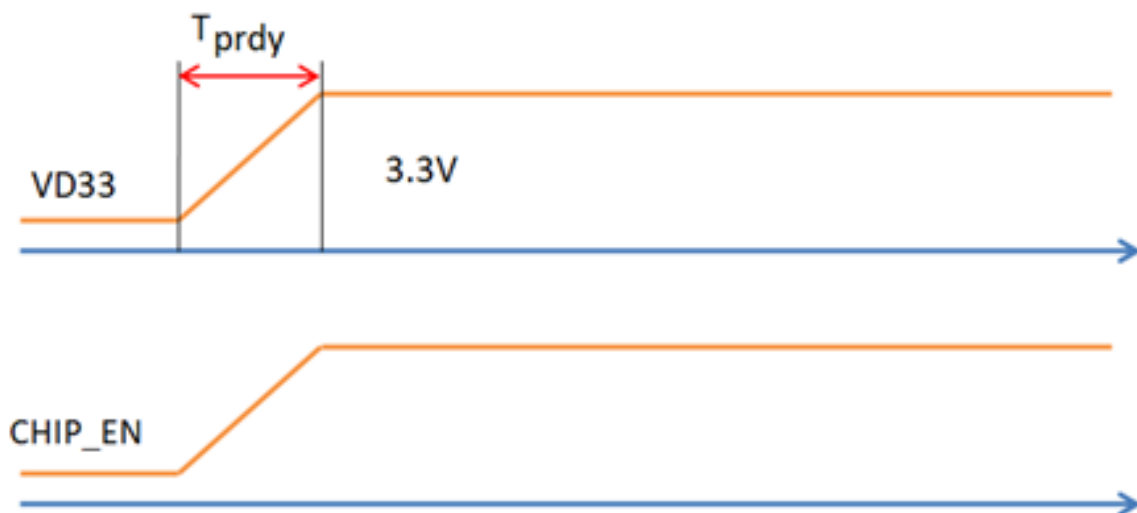

Symbol	Parameter	Minimum Value	Typical Value	Maximum Value	Unit
TPRDY	3.3V ready time	0.6		20	mS
CHIP_EN	CHIP_EN ready time	0.6		20	mS

7.2 Resetting

When designing a plate of a module, you should set a reset IC at the foot of CHIP_EN in advance. The preferable type of IC is BL8506-27NRO. The module is packaged in the form of SOT23. For solutions to starting a module in some cases, refer to the circuit in the following figure.

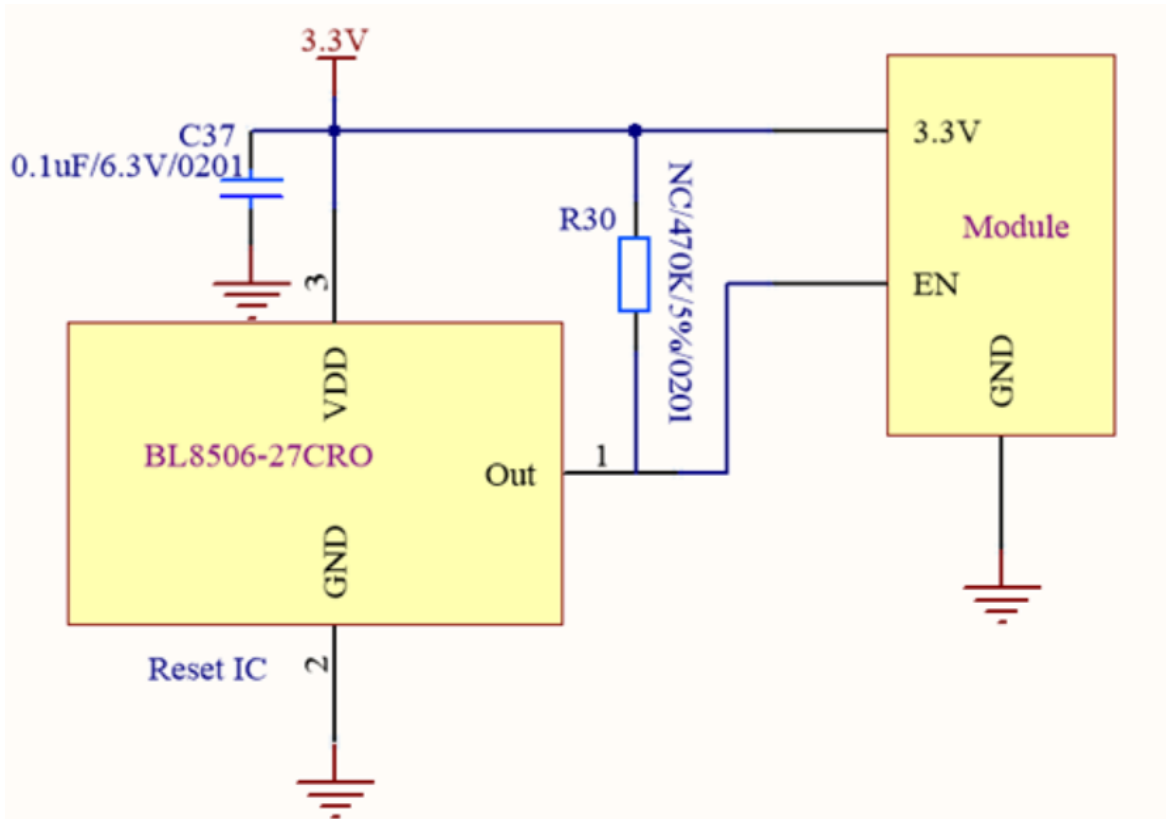

8 Packaging information and production instructions

8.1 Mechanical dimensions

The mechanical dimensions of the PCB of CR3L are 16 ± 0.35 mm (W) \times 24 ± 0.35 mm (L) \times 0.8 ± 0.1 mm (H). The following figure shows the mechanical dimensions of CR3L.

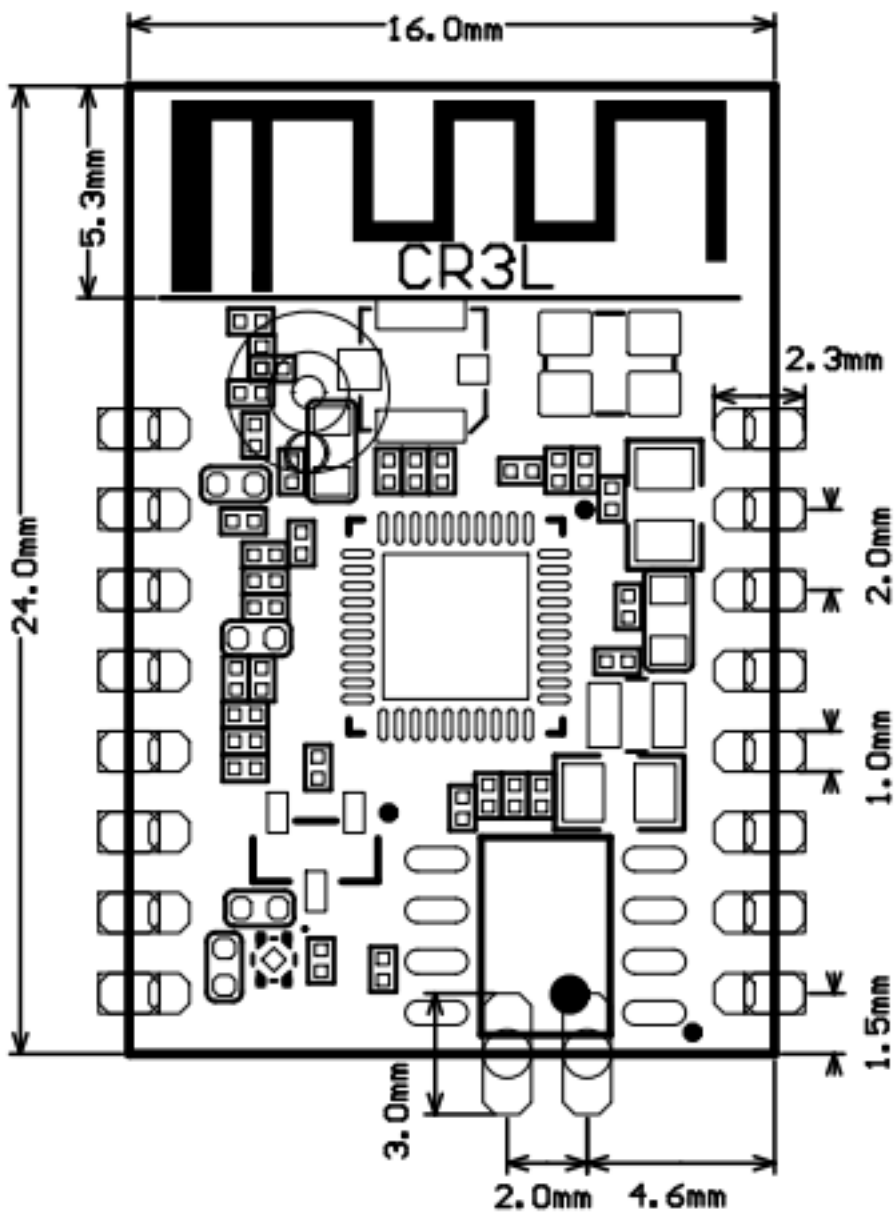

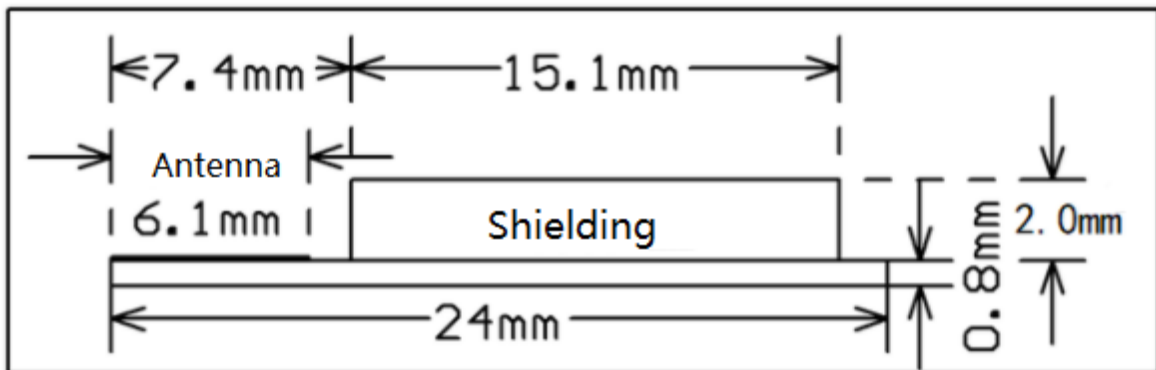

Note: The default dimensional tolerance is ± 0.35 mm. If you have specific requirements on dimensions, make them clear in the datasheet after communication.

8.2 Recommended PCB layout

The following figure is a schematic diagram of CR3L which shows how pins correspond to each other.

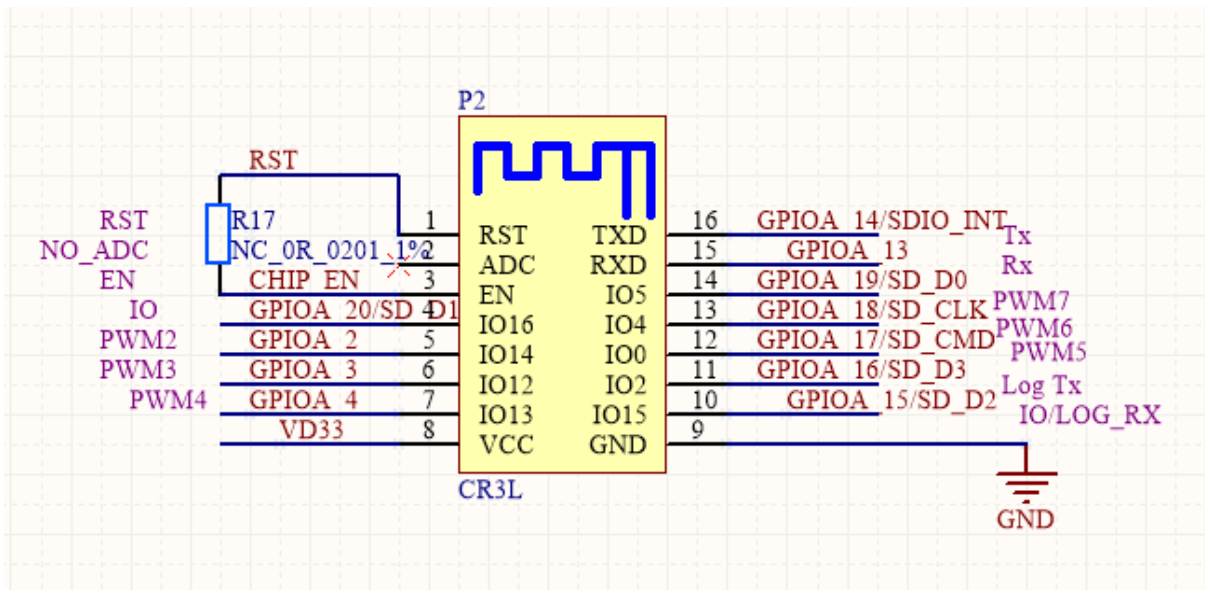

CR3L PCB Layout is shown as below:

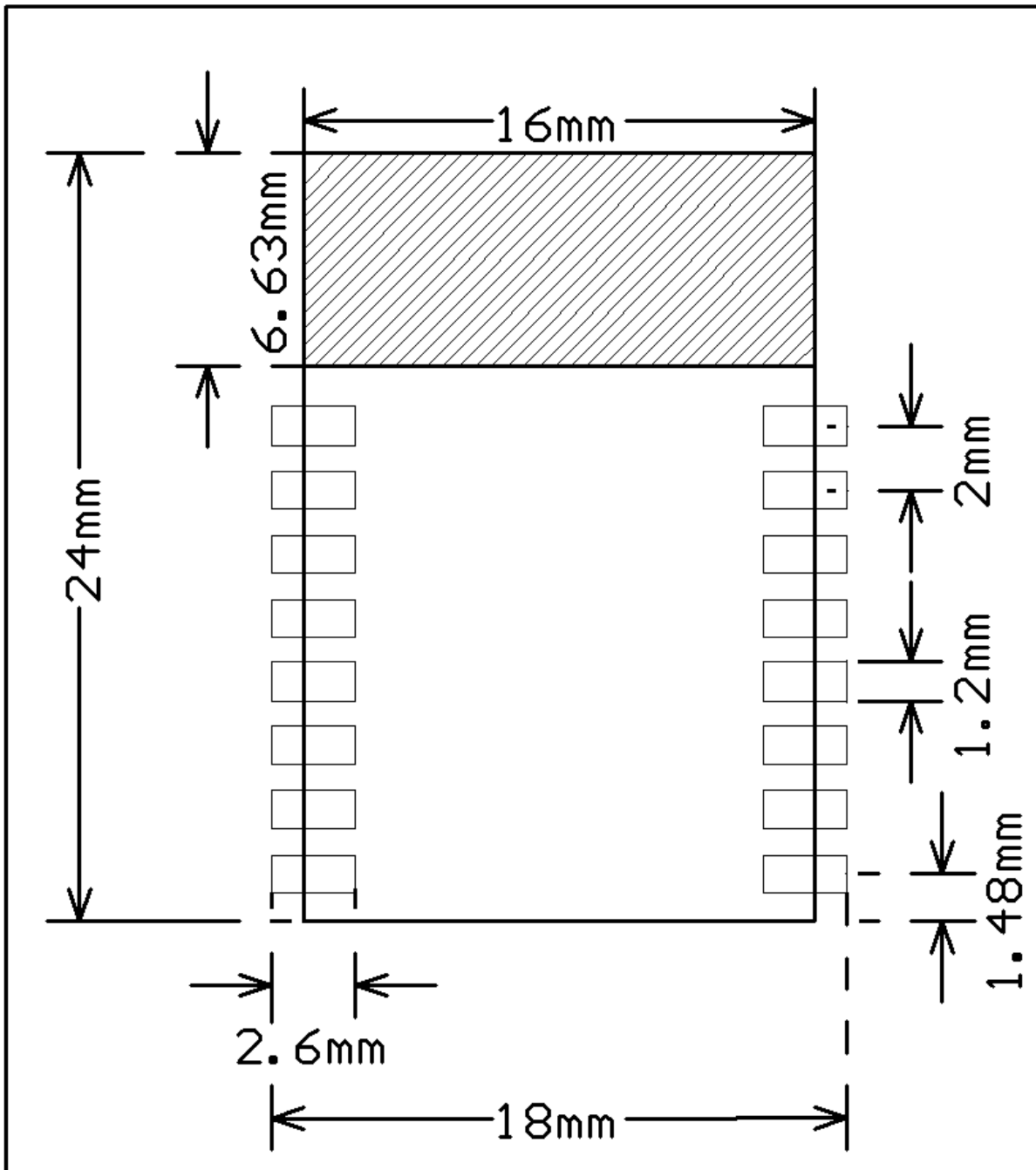

8.3 Pin header specifications

CR3L has two models: CR3L with pin headers and CR3L without pin headers. Which one is used depends on actual situations. Dimensions and recommended layout of pin headers are as follows (unit: mm):

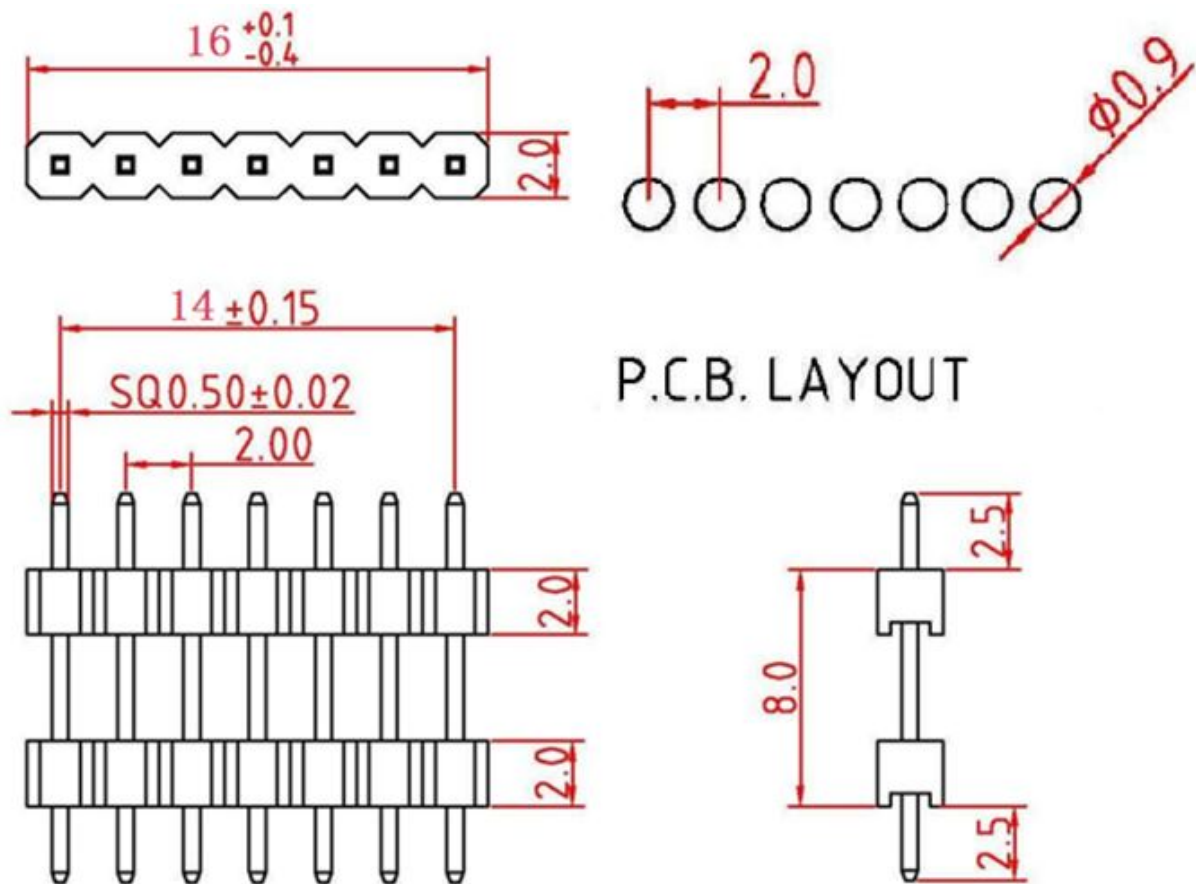

8.4 Production instructions

1. Tuya's stamp hole package module must be mounted by an SMT machine within 24 hours after unpacking and programming of the firmware. Otherwise, it must be packaged again under a vacuum. The module must be baked before mounting.

- SMT equipment
 - Reflow soldering machine
 - Automated optical inspection (AOI) equipment
 - Nozzle with a 6 mm to 8 mm diameter
- Baking equipment
 - Cabinet oven
 - Anti-static heat-resistant trays
 - Anti-static heat-resistant gloves

2. Storage conditions for a delivered module are as follows:

- The moisture-proof bag is placed in an environment where the temperature is below 30°C and the relative humidity is lower than 70%.
- The shelf life of a dry-packaged product is 6 months from the date when the product is packaged and sealed.
- There is a humidity indicator card in the moisture-proof bag as below:

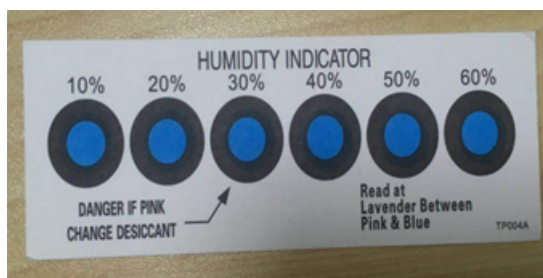

3. Bake a module based on HIC status as follows when you unpack the module package:

- If the 30%, 40%, and 50% circles are blue, bake the module for 2 consecutive hours.
- If the 30% circle is pink, bake the module for 4 consecutive hours.
- If the 30% and 40% circles are pink, bake the module for 6 consecutive hours.
- If the 30%, 40%, and 50% circles are pink, bake the module for 12 consecutive hours.

4. Baking settings:

- Baking temperature: 125±5°C
- Alarm temperature: 130°C
- SMT ready temperature after natural cooling: < 36°C
- The number of drying times: 1
- Rebaking condition: The module is not soldered within 12 hours after baking

5. Do not use SMT to process modules that have been unpacked for more than 3 months, because electroless nickel/immersion gold (ENIG) is used for PCBs and they are seriously oxidized after more than 3 months. SMT is very likely to cause pseudo and missing soldering. Tuya is not liable for such problems and consequences.

6. Before SMT, take electrostatic discharge (ESD) protective measures.
7. To reduce the reflow defect rate, draw 10% of the products for visual inspection and AOI before the first mounting to determine proper methods for controlling the oven temperature and attaching and placing components. Draw 5 to 10 modules from subsequent batches each hour for visual inspection and AOI.

8.5 Recommended oven temperature curve

Perform SMT based on the following reflow oven temperature curve. The highest temperature is 245°C. The reflow temperature curve is shown below:

Refer to IPC/JEDEC standard; Peak Temperature: $\leq 245^{\circ}\text{C}$; The number of Times: ≤ 2 times

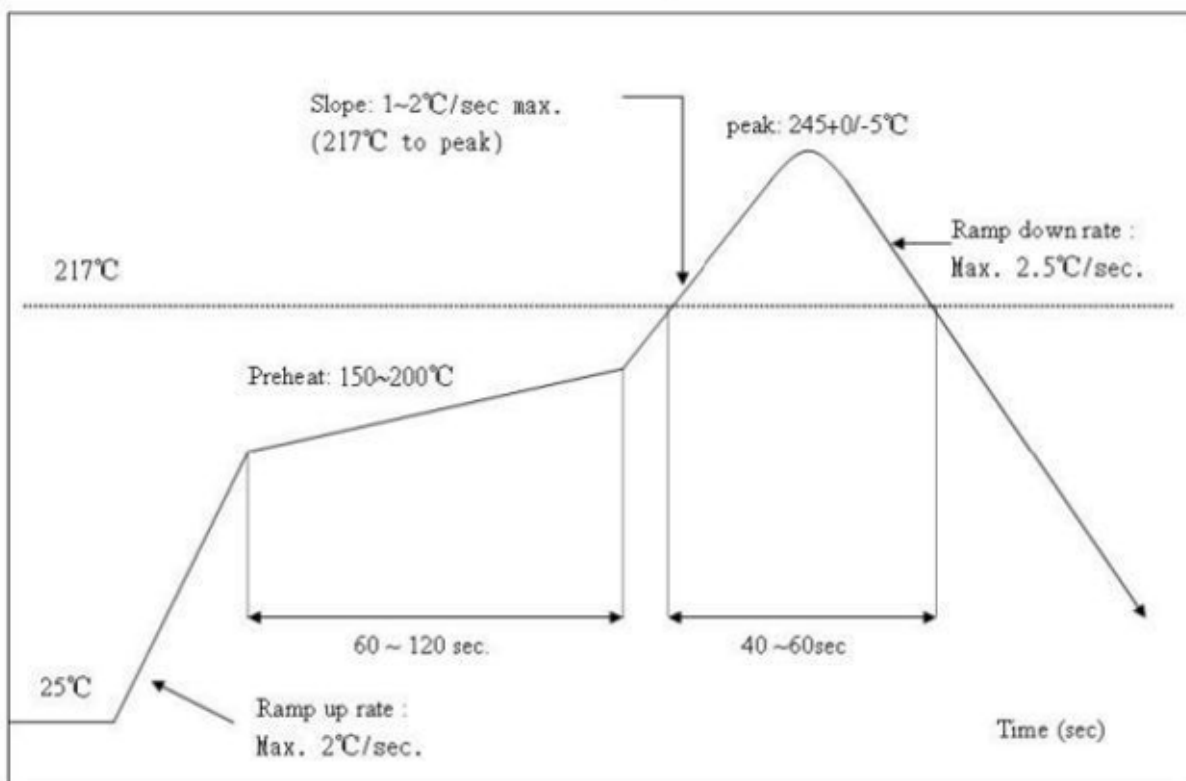

8.6 Storage conditions



CAUTION
This bag contains
MOISTURE-SENSITIVE DEVICES

LEVEL
3

If Blank, see adjacent bar code label

1. Calculated shelf life in sealed bag: 12 months at < 40°C and < 90% relative humidity (RH)
2. Peak package body temperature: 260 °C
If Blank, see adjacent bar code label
3. After bag is opened, devices that will be subjected to reflow solder or other high temperature process must
 - a) Mounted within: 168 hrs. of factory conditions
If Blank, see adjacent bar code label
 - ≤ 30°C/60%RH, OR
 - b) Stored at <10% RH
4. Devices require bake, before mounting, if:
 - a) Humidity Indicator Card is > 10% when read at 23 ± 5°C
 - b) 3a or 3b not met.
5. If baking is required, devices may be baked for 48 hrs. at 125 ± 5°C

Note: If device containers cannot be subjected to high temperature or shorter bake times are desired, reference IPC/JEDEC J-STD-033 for bake procedure

Bag Seal Date: _____
If Blank, see adjacent bar code label

Note: Level and body temperature defined by IPC/JEDEC J-STD-020

9 MOQ and packaging information

Product Number	MOQ (pcs)	Shipping packaging method	The number of modules per reel (pcs)	The number of reels per carton (reel)
CR3L	3600	Tape reel	900	4

10 Appendix: Statement

FCC Caution: Any changes or modifications not expressly approved by the party responsible for compliance could void the user’s authority to operate this device.

This device complies with Part 15 of the FCC Rules. Operation is subject to the following two conditions: (1) This device may not cause harmful interference, and (2) this device must accept any interference received, including interference that may cause undesired operation.

Note: This device has been tested and found to comply with the limits for a Class B digital device, according to part 15 of the FCC Rules. These limits are designed to provide reasonable protection against harmful interference in a residential installation. This device generates, uses, and can radiate radio frequency energy and, if not installed and used following the instructions, may cause harmful interference to radio communications. However, there is no guarantee that interference will not occur in a particular installation.

If this device does cause harmful interference to radio or television reception, which can be determined by turning the device off and on, the user is encouraged to try to correct the interference by one or more of the following measures:

- Reorient or relocate the receiving antenna.
- Increase the separation between the device and receiver.
- Connect the device into an outlet on a circuit different from that to which the receiver is connected.
- Consult the dealer or an experienced radio/TV technician for help.

Radiation Exposure Statement

This device complies with FCC radiation exposure limits set forth for an uncontrolled

rolled environment. This device should be installed and operated with a minimum distance of 20cm between the radiator and your body.

Important Note

This radio module must not be installed to co-locate and operating simultaneously with other radios in the host system except following FCC multi-transmitter product procedures. Additional testing and device authorization may be required to operate simultaneously with other radios.

The availability of some specific channels and/or operational frequency bands are country dependent and are firmware programmed at the factory to match the intended destination. The firmware setting is not accessible by the end-user.

The host product manufacturer is responsible for compliance with any other FCC rules that apply to the host not covered by the modular transmitter grant of certification. The final host product still requires Part 15 Subpart B compliance testing with the modular transmitter installed.

The end-user manual shall include all required regulatory information/warnings as shown in this manual, including “This product must be installed and operated with a minimum distance of 20 cm between the radiator and user body”.

This device has got an FCC ID: 2ANDL-CR3L. The end product must be labeled in a visible area with the following: “Contains Transmitter Module FCC ID: 2ANDL-CR3L”.

This device is intended only for OEM integrators under the following conditions:

The antenna must be installed such that 20cm is maintained between the antenna and users, and the transmitter module may not be co-located with any other transmitter or antenna.

As long as the 2 conditions above are met, further transmitter tests will not be required. However, the OEM integrator is still responsible for testing their end-product for any additional compliance requirements required with this module installed.

Declaration of Conformity European Notice



Hereby, Hangzhou Tuya Information Technology Co., Ltd declares that this module product is in compliance with essential requirements and other relevant provisions

of Directive 2014/53/EU,2011/65/EU. A copy of the Declaration of conformity can be found at <https://www.tuya.com>.



This product must not be disposed of as normal household waste, in accordance with the EU directive for waste electrical and electronic equipment (WEEE-2012/19/EU). Instead, it should be disposed of by returning it to the point of sale, or to a municipal recycling collection point.

The device could be used with a separation distance of 20cm to the human body.