



**SHELVING  
WALL SHELVES  
TABLES  
SINKS/FLOOR TROUGHS  
HOT FOOD TABLES  
DIRECTOR'S CHOICE® CAFETERIA LINE**



**COOKING & WARMING EQUIPMENT  
UNDERBAR EQUIPMENT  
DISHTABLES  
VENTILATION HOODS  
PANCO® TRANSPORT SYSTEMS  
SPECFAB® CUSTOM EQUIPMENT**



# - Table of Contents -

Detailed contents listing at the start of each individual section.

	<b>Shelving / Retail Display .....</b>	<b>5-102</b>
	<b>Wall Shelves .....</b>	<b>103-114</b>
	<b>Tables.....</b>	<b>115-160</b>
	<b>Sinks / Floor Troughs.....</b>	<b>161-212</b>
	<b>Hot Food Tables .....</b>	<b>213-238</b>
	<b>Director's Choice® Cafeteria Line....</b>	<b>239-260</b>
	<b>Cooking / Warming Equipment .....</b>	<b>261-278</b>
	<b>Underbar Equipment .....</b>	<b>279-316</b>
	<b>Dishtables .....</b>	<b>317-330</b>
	 <b>Ventilation Hoods ....</b>	<b>331-336</b>
	 .....	<b>337-368</b>
<b>Alphanumeric Index .....</b>		<b>381-430</b>
<b>Custom Options &amp; Accessories .....</b>		<b>369-372</b>
<b>SpecFAB® Custom Fabrications .....</b>		<b>373-380</b>
<b>Terms &amp; Conditions .....</b>		<b>431</b>
<b>Distribution Locations .....</b>		<b>431</b>
<b>Warranty Information .....</b>		<b>2-3</b>

## How to order:

### EAGLE'S Customer Service Center

Committed to customer service and customer satisfaction along with quality products.

**Toll Free: 1-800-441-8440**

**Phone: (302) 653-3000**

**Fax: (302) 653-2065**

**Email: customerservice@eaglegrp.com**

### VISIT US ON THE WEB

To find an EAGLE representative, dealer or service center in your area go to **www.eaglegrp.com**

### STOCK STATUS IS INDICATED BY:

MTS (•) - make-to-stock items with shipment same day or next day.

MTO ( ) - make-to-order items.

### LOOK!

#### FOR THESE EMBLEMS

Located to the right of or below each appropriate product title and/or product subtitle:

see spec sheet **EG10.42** - catalog spec sheet reference (available online [www.eaglegrp.com](http://www.eaglegrp.com))



- approved by the National Sanitation Foundation



- approved by Underwriters Laboratories for U.S.A. ONLY



- approved by Underwriters Laboratories for use in Canada and U.S.A.



- approved by Underwriters Laboratories for use in Canada and U.S.A. (gas-fired units)



- recognized component by Underwriters Laboratories

**NFPA-96** - Meets the standards of the National Fire Protection Association, Bulletin #96

#### REGISTERED TRADEMARKS OF EAGLE FOODSERVICE EQUIPMENT - a division of EAGLE GROUP

Add-A-Shelf®, adjusTable®, Chef's Line®, Director's Choice®, EAGLEbrite®, EAGLEgard®, FLEX-MASTER®, Floor-Trak®, MasterSeal®, Master Trak®, MICROGARD®, PANCO®, Q-LEVER®, Quad-Adjust®, QuadPLUS®, QuadTruss®, Quik-Set®, REDHOTS®, Redi-Pak®, SPEC AIR®, Spec-Bar®, SpecFAB®, SPEC-MASTER®, Snap-n-Slide®, TEMP-GARD®, uni-lok®, Uni-Wall®, Valu-Gard®, VALU-MASTER®, and WALSTOR®

#### TRADEMARKS OF EAGLE FOODSERVICE EQUIPMENT - a division of EAGLE GROUP

Lok-n-Fold™, Shelf Select™, Spec-Bar Select™, Spec-SHIELD™, and STAND-OUTS™

# WARRANTY INFORMATION

## EAGLE Shelving Warranty

EAGLE Foodservice warrants that goods supplied hereunder manufactured by EAGLE Foodservice will be free from defects in material and workmanship at the time they leave our factory. Upon factory inspection, we guarantee to replace any shelf that is defective for a period of up to one year from the date of original installation, not to exceed 18 months from date of shipment from EAGLE, provided that it has been properly installed and maintained. If a shelf proves to be defective, or not in conformity with the specification, customers are entitled only to replacement of such unit. Under no circumstances will we be liable for any claims for labor or subsequent damage.

To the original owner, EAGLE GROUP warrants against rust formation over more than 5% of the shelving surface as stated below following original date of installation:

	<b>WARRANTY</b>	<b>DRY STORAGE</b>	<b>COOLER STORAGE</b>
Chrome	1-year warranty	✓	-
EAGLEbrite®	3-year warranty	✓	-
VALU-MASTER® and Valu-Gard®	5-year warranty	✓	✓
EAGLEgard® (with MICROGARD®)	12-year warranty	✓	✓
Stainless Steel	15-year warranty	✓	✓
QuadPLUS®	*	✓	✓
* Polymer Shelf Mats have a lifetime warranty against rust and corrosion. * Wire Truss Frames, based on finish, have same warranty duration as outlined above.			
Solid Shelving	1-year warranty	✓	✓

EAGLE wire shelving must be cleaned with soft cloths and mild detergents. Using harsh detergents, abrasive materials, scrapers or stiff brushes will void this warranty, as will physical damage, rupturing the coating or sustained exposure to corrosive substances and vapors. Warranty applies only when shelves have been continuously used within a temperature range from -20°F to +120°F, with intermittent exposure up to +200°F for Valu-Gard®, Valu-Master® or EAGLEgard® epoxy finishes, and up to +175°F for chrome or EAGLEbrite® zinc finishes.

In the event of a warranty claim, an EAGLE GROUP representative will examine the installation and determine return or repair disposition. Repairs will be handled by the initial owner. Returns, including disassembly and subsequent reassembly, become the responsibility of the initial owner. Replacements will be shipped prepaid FOB the nearest distribution point.

There are no warranties which extend beyond these warranties. All other expressed or implied warranties, including those of merchantability or fitness for a particular purpose, which exceed the warranties stated above, are disclaimed by EAGLE Foodservice and excluded from this agreement. No employee or agent of ours has any authority to make any representation or warranty which exceeds the warranties stated above.

**NO EAGLE EQUIPMENT MAY BE RETURNED EXCEPT UPON WRITTEN AUTHORIZATION FROM EAGLE FOODSERVICE EQUIPMENT.**

**SEE PAGE 431 FOR TERMS & CONDITIONS.**

## EAGLE Worktable, Sink, Dishtable, and Ventilation Hood Warranty

EAGLE Foodservice warrants that goods supplied hereunder manufactured by EAGLE Foodservice will be free from defects in material and workmanship at the time they leave our factory.

Within a period of one year from the date of original installation of the equipment, not to exceed 18 months from date of shipment from EAGLE, EAGLE Foodservice will replace, without charge, any defective parts or component material upon demonstration to its satisfaction that a breach of warranty did not exist. Under no circumstances will we be liable for any claims for labor or subsequent damage.

Using harsh chemicals, abrasive materials, scrapers or stiff brushes may void this warranty.

There are no warranties which extend beyond these warranties. All other expressed or implied warranties, including those of merchantability or fitness for a particular purpose, which exceed the warranties stated above, are disclaimed by EAGLE Foodservice and excluded from this agreement. No employee or agent of ours has any authority to make any representation or warranty which exceeds the warranties stated above.

**NO EAGLE EQUIPMENT MAY BE RETURNED EXCEPT UPON WRITTEN AUTHORIZATION FROM EAGLE FOODSERVICE EQUIPMENT.**

**SEE PAGE 431 FOR TERMS & CONDITIONS.**

**EAGLE Foodservice Equipment is a division of EAGLE GROUP.**  
*(formerly known as Metal Masters)*

## Limited Warranty for Hot Food Table Buffet Equipment, Cold Pan Units, Portable Food Warming Equipment, Heated Drawers, and Transport Holding Cabinets

EAGLE Foodservice Equipment warrants to the original owner that goods supplied hereunder manufactured by EAGLE Foodservice Equipment will be free from defects in materials and workmanship for a period of one year from date of original installation, not to exceed 18 months from date of shipment from the factory. EAGLE Foodservice Equipment will replace, without charge, any defective parts or component material, upon demonstration to its satisfaction that a breach of warranty did not exist.

Contact factory for a listing of the authorized parts and service centers near you or call the factory for assistance.

This warranty does not cover any cost associated with maintenance, misuse, abuse, improper installation, pilot light adjustments, pilot outage, improper ventilation, adjustments, alteration, calibration, wrong voltage, wrong gas, voltage or gas conversions, resetting of circuit breakers or safety controls, overtime charges, mileage in excess of 100 miles, operation contrary to the installation and operating instructions, damage caused by flood, fire, or acts of God. This warranty shall not apply if the nameplate has been removed or altered.

There are no warranties, which extend beyond these warranties. All other expressed or implied warranties, including those of merchantability or fitness for a particular purpose, which exceed the warranties stated above, are disclaimed by EAGLE Foodservice Equipment and excluded from this agreement. No employee or agent of ours has any authority to make any representation or warranty, which exceeds the warranties stated above.

**NO EAGLE FOODSERVICE EQUIPMENT MAY BE RETURNED EXCEPT UPON WRITTEN AUTHORIZATION FROM EAGLE FOODSERVICE EQUIPMENT.**

\* \* \*

## Limited Warranty for Cooking Equipment—including but not limited to all Gas and Electric Griddles, all Gas and Electric Charbroilers, all Gas and Electric Hot Plates, and all Gas and Electric Fryers

EAGLE Foodservice Equipment warrants to the original owner that goods supplied hereunder manufactured by EAGLE Foodservice Equipment will be free from defects in materials and workmanship for a period of one year from date of original installation, not to exceed 18 months from date of shipment from the factory. EAGLE Foodservice Equipment will replace, without charge, any defective parts or component material, upon demonstration to its satisfaction that a breach of warranty did not exist.

Contact factory for a listing of the authorized parts and service centers near you or call the factory for assistance.

This warranty does not cover any cost associated with maintenance, misuse, abuse, improper installation, pilot light adjustments, pilot outage, improper ventilation, adjustments, alteration, calibration, wrong voltage, wrong gas, voltage or gas conversions, resetting of circuit breakers or safety controls, overtime charges, mileage in excess of 100 miles, operation contrary to the installation and operating instructions, damage caused by flood, fire, or acts of God. This warranty shall not apply if the nameplate has been removed or altered.

**INTENDED FOR OTHER THAN HOUSEHOLD USE. THESE COMMERCIAL APPLIANCES MUST BE INSTALLED WITHIN SURROUNDINGS AND VENTILATION REQUIREMENTS AS DICTATED BY NATIONAL AND/OR LOCAL CODE.**

There are no warranties, which extend beyond these warranties. All other expressed or implied warranties, including those of merchantability or fitness for a particular purpose, which exceed the warranties stated above, are disclaimed by EAGLE Foodservice Equipment and excluded from this agreement. No employee or agent of ours has any authority to make any representation or warranty, which exceeds the warranties stated above.

**NO EAGLE FOODSERVICE EQUIPMENT MAY BE RETURNED EXCEPT UPON WRITTEN AUTHORIZATION FROM EAGLE FOODSERVICE EQUIPMENT.**

\* \* \*

## EAGLE Underbar Warranty

EAGLE Foodservice Equipment warrants that goods supplied hereunder manufactured by EAGLE Foodservice Equipment will be free from defects in material and construction at the time they leave our factory.

Within a period of one year from the date of original installation of the equipment not to exceed 18 months from date of shipment from EAGLE, EAGLE Foodservice Equipment will replace without charge any defective parts or component material upon demonstration to its satisfaction that a breach of warranty did not exist. This warranty applies to parts or component material only. All parts, whether covered by warranty or purchased for replacement or repair, will be shipped FOB Factory. All parts returned to the factory must be shipped prepaid. Under no circumstances will we be liable for any claims for labor or subsequent damage.

**WARRANTY AUTOMATICALLY BECOMES NULL AND VOID IF UNDERBAR UNIT HAS BEEN USED WITH A GAS BURNER.**

There are no warranties which extend beyond these warranties. All other expressed or implied warranties, including those of merchantability or fitness for a particular purpose, which exceed the warranties stated above, are disclaimed by EAGLE foodservice Equipment and excluded from this agreement. No employee or agent of ours has any authority to make any representation or warranty which exceeds the warranties stated above.

**NO EAGLE FOODSERVICE EQUIPMENT MAY BE RETURNED EXCEPT UPON WRITTEN AUTHORIZATION FROM EAGLE FOODSERVICE EQUIPMENT.**

\* \* \*

## Panco® Transport Systems Warranty

EAGLE Foodservice Equipment warrants to the original owner that goods supplied hereunder manufactured by EAGLE Foodservice Equipment will be free from defects in materials and workmanship for a period of one year from date of original installation, not to exceed 18 months from date of shipment from the factory. EAGLE Foodservice Equipment will replace, without charge, any defective parts or component material, upon demonstration to its satisfaction that a breach of warranty did not exist.

Contact factory for a listing of the authorized parts and service centers near you or call the factory for assistance.

This warranty does not cover any cost associated with maintenance, misuse, abuse, improper installation, alteration, operation contrary to the installation and operating instructions, damage caused by flood, fire, or acts of God. This warranty shall not apply if the nameplate has been removed or altered.

There are no warranties, which extend beyond these warranties. All other expressed or implied warranties, including those of merchantability or fitness for a particular purpose, which exceed the warranties stated above, are disclaimed by EAGLE Foodservice Equipment and excluded from this agreement. No employee or agent of ours has any authority to make any representation or warranty, which exceeds the warranties stated above.

**NO EAGLE FOODSERVICE EQUIPMENT MAY BE RETURNED EXCEPT UPON WRITTEN AUTHORIZATION FROM EAGLE FOODSERVICE EQUIPMENT.**

# OTHERS' WIRE SHELVES COMPARED TO EAGLE GROUP'S...

(18" x 60" shelves shown)

## EAGLE GROUP's shelves...

...incorporate more perimeter and interior serpentine trusses and mat continuity support wires than any competitive shelves.

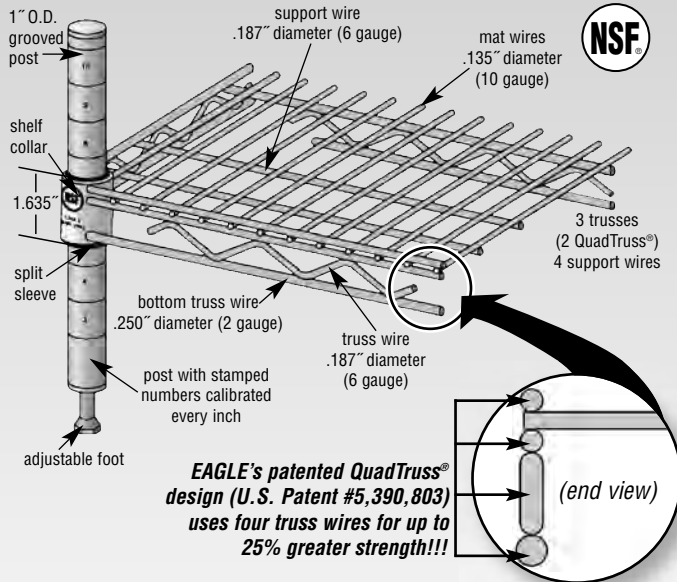

## Metro and most imported shelves...

...incorporate both perimeter and interior serpentine trusses and mat continuity support wires, but fewer than EAGLE GROUP's.

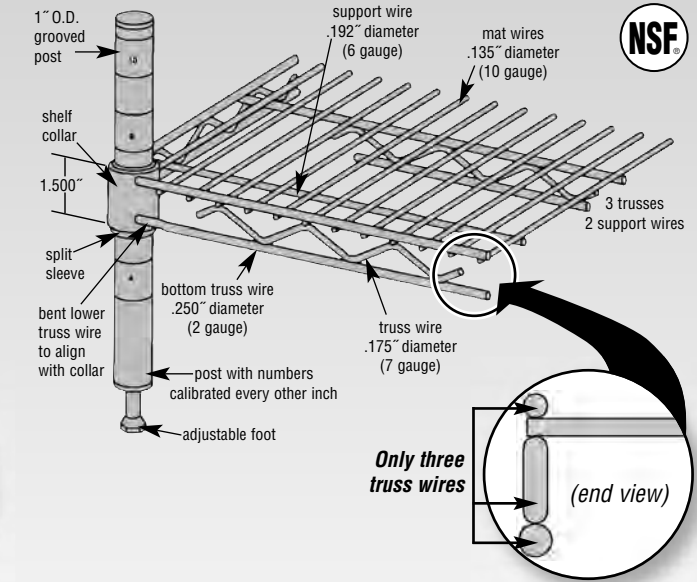

**Eagle Group has the strongest wire shelf in the industry—no matter how you stack it!**

## SHELF AND POST FINISHES AVAILABLE

### Stainless Steel Finish—OUR BEST!

Stainless Steel

- NSF-listed for all environments.
- Type 304 stainless steel.

NOTE: Stainless steel shelving is electropolished.

15-YEAR LIMITED WARRANTY

### EAGLEgard® Hybrid Epoxy

Zinc Chloride  
Clear Chromate  
MasterSeal® Sealer  
Blue Green (translucent)  
- hybrid epoxy with MICROGARD®\*

- NSF-listed for all environments.
- Zinc chloride plating followed by clear chromate plating with MasterSeal® Sealer and a hybrid epoxy final coat.

12-YEAR LIMITED WARRANTY

### Valu-Gard® Green Epoxy

Phosphate Conversion Coating  
MasterSeal® Sealer  
Green (opaque)  
- hybrid metallic epoxy

- NSF-listed for wet or dry storage environments.
- Phosphate conversion coating followed by green hybrid epoxy coating.

5-YEAR LIMITED WARRANTY

### VALU-MASTER® Gray Epoxy

Phosphate Conversion Coating  
MasterSeal® Sealer  
Pewter Gray Epoxy

- NSF-listed for wet or dry storage environments.
- Phosphate conversion coating followed by metallic gray epoxy coating.

5-YEAR LIMITED WARRANTY

### Chrome Finish

Bright Nickel  
Chrome  
Air-dry Lacquer

- NSF-listed for dry storage environments.
- Bright nickel plating followed by chrome plating.

NOTE: Optional clear hybrid epoxy, NSF-listed for all environments, is available.

1-YEAR LIMITED WARRANTY

### EAGLEbrite® Zinc

Zinc chloride  
Clear Chromate  
MasterSeal® Sealer

- NSF-listed for dry storage environments.
- Bright zinc chloride plating followed by clear chromate plating with MasterSeal® sealer for improved rust protection.

NOTE: Wire shelves feature MasterSeal® Sealer. NSF-listed for all environments.

3-YEAR LIMITED WARRANTY

### \* MICROGARD®...

...is an antimicrobial agent which contains built-in protection to retard the growth of a broad range of bacteria, mold and mildew on shelf surface that causes stains, odors and degradation.

...combines inorganic antimicrobial silver ions with a patented delivery system. The silver ions react with bacteria in three ways:

1) suffocates the cell, 2) stops the cell reproduction system, and 3) stops the cell from growing.

...is standard on all EAGLEgard® shelving.

# Shelving / Retail Display

## Accessories/Components

Casters .....	14, 15, 66, 79
Enclosure Panels .....	28
Inlays .....	66
Label Holders .....	25, 42
Ledges .....	53, 67
Rods & Tabs .....	28, 51
“S” Hooks .....	51
More Accessories and Components.....	12-15, 51-59

## Add-A-Shelf® and Accessories .....22-23

## Cantilever Shelving System Wall Mount .....81-85

## Carts

Cart Covers .....	34
Hardwood Top Demo & Wine Carts ..	70
Merchandising Carts .....	35-36
Polymer Utility Carts .....	32
Stem Caster Carts .....	33
Utility Carts .....	25, 30-32

## Dolly Frames / Dolly Trucks

Aluminum Truck Dollies .....	41
Dolly Frames .....	42
Dolly Trucks .....	37

## Posts .....13, 23

## Q-LEVER® Cantilever Shelving System .....86-99

Accessories .....	98-99
Four- and Five-Tier Units .....	89-94
Manager's Stations .....	97
Overhead Storage Systems.....	96
Task Stations .....	96
Utility Stations .....	97
Worktables .....	95

## QuadPLUS® Polymer Shelf Mats Shelf Units, Accessories .....9-12

## Quik-Set® Solid Shelving ....76-80

## Racks and Platforms

Beer Keg Racks/Accessories.....	64
Dunnage Racks .....	39-41
Platforms .....	38
Polymer Dunnage Racks.....	40
Syrup Tank Racks/Accessories .....	47
Wire Can Rack/Systems .....	29

## Redi-Pak®

Utility Carts .....	25
Wire Shelving Units .....	24

## Retail Display Shelving and Accessories

Accessories/Components .....	66-69
Decorative Shelves .....	65
Front Case Merchandise Shelving.....	69
Garment Racks/Accessories .....	38
Gondola Shelving/Accessories ....	72-74
Plate Display Shelving/Accessories.....	29
Pot/Pan Rack and Accessories .....	71
Retail Display Workstation .....	70
Secure Display Merchandiser .....	71
Soft Goods Display .....	69
Wire Display Shelving/ Accessories .....	74-75

## Security Units and Accessories .....43-46

## Shelves / Shelving Units

Adjustable Wire Shelving	
• Add-A-Shelf® .....	22-23
• Quad-Adjust® .....	7-8

Cantilever Shelves.....	29, 68
Double-Mat Shelves/Starter Units.....	26
Dunnage Shelves/Starter Units ....	39-40
Four-/Five-Shelf Add-On Units .....	19, 21
Four-/Five-Shelf Starter Units ..	8, 18, 20
Reverse Mat Shelves/ Label Holders .....	8, 25
Seismic Footplate Kits .....	17
Slanted Shelves .....	52
Sliding Shelf .....	56
Solid Shelves/Accessories .....	16
Triangle Shelf .....	55
Wire Basket Shelf .....	42
Wire Shelves.....	6

## Shelving Task Stations Packages

Biscuit Workstation.....	49
Carry-Out Worktable .....	49
Cup Tower.....	49
Drive-Through Task Station .....	49
Microwave Prep Table.....	49
Pizza Carry-Out Workstation.....	49
Pizza Prep Area.....	49
Sandwich Prep Station .....	49

## Tables .....50

## Track Systems

Floor Track	
Storage Systems .....	62-63
Overhead Track	
Storage Systems .....	60-61

## Wine Shelves and Components .....27-28

## Workstations

Mobile Computer Workstations .....	48
Modular Desks / Workstations .....	48

For the “Wall Shelves” section, go to pages 103–114.

### Wire Shelves

see spec sheet **EG01.00**

#### WEIGHT CAPACITIES:

- Shelves up to 48" (1219mm): 800 lb. (363 kg).
- 54"-72" (1372-1829mm) shelves: 600 lb. (272 kg) - evenly distributed static load.

**Note:** Shelving units should not exceed 2400 lbs. (1089 kg) per set of four posts.

- 24"-48" (610-1219mm) lengths: Four per box.
- 54"-72" (1372-1829mm) lengths: Two per box.
- Four pairs of split sleeves per shelf.

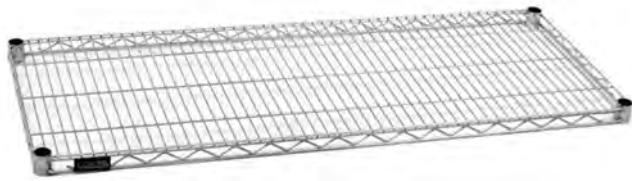

patented  
**QuadTruss®**  
design

#### Patented QuadTruss® Design

makes shelves up to 25% stronger and provides a retaining ledge for increased strength and product retention.

(Patent #5,390,803)

#### PACKAGING:

**Freight class is 70.0.**

(•) MTS (made to stock) / ( ) MTO (made to order)

	length		weight		cu ft	EAGLEbrite®		chrome		VALU-MASTER®		Valu-Gard®		EAGLEgard®		stainless	
	in.	mm	lb.	kg		model #	list	model #	list	model #	list	model #	list	model #	list	model #	list
14" width (356mm)	24"	610	6	2.7	0.5	1424Z •	66	1424C •	69	1424V •	66	1424VG •	66	1424E •	69	1424S	257
	30"	762	7	3.2	0.5	1430Z •	69	1430C •	74	1430V •	69	1430VG •	69	1430E •	74	1430S	260
	36"	914	8	3.6	0.5	1436Z •	74	1436C •	82	1436V •	74	1436VG •	74	1436E •	82	1436S	262
	42"	1067	9	4.1	0.7	1442Z •	82	1442C •	94	1442V •	82	1442VG •	82	1442E •	94	1442S	320
	48"	1219	10	4.5	0.7	1448Z •	86	1448C •	96	1448V •	86	1448VG •	86	1448E •	96	1448S	321
	54"	1372	12	5.5	0.9	1454Z •	95	1454C •	102	1454V •	95	1454VG •	95	1454E •	102	1454S	399
	60"	1524	14	6.4	0.9	1460Z •	102	1460C •	109	1460V •	102	1460VG •	102	1460E •	109	1460S	411
72"	1829	17	7.7	1.1	1472Z •	119	1472C •	125	1472V •	119	1472VG •	119	1472E •	125	1472S	461	
18" width (457mm)	24"	610	7	3.2	0.7	1824Z •	81	1824C •	82	1824V •	81	1824VG •	81	1824E •	82	1824S	318
	30"	762	8	3.6	0.7	1830Z •	83	1830C •	85	1830V •	83	1830VG •	83	1830E •	85	1830S	320
	36"	914	9	4.1	0.7	1836Z •	86	1836C •	87	1836V •	86	1836VG •	86	1836E •	87	1836S	325
	42"	1067	11	5.0	0.9	1842Z •	96	1842C •	102	1842V •	96	1842VG •	96	1842E •	102	1842S	382
	48"	1219	12	5.5	0.9	1848Z •	100	1848C •	106	1848V •	100	1848VG •	100	1848E •	106	1848S	385
	54"	1372	15	6.8	1.2	1854Z •	116	1854C •	120	1854V •	116	1854VG •	116	1854E •	120	1854S	486
	60"	1524	17	7.7	1.2	1860Z •	119	1860C •	123	1860V •	119	1860VG •	119	1860E •	123	1860S	492
72"	1829	20	9.1	1.3	1872Z •	139	1872C •	147	1872V •	139	1872VG •	139	1872E •	147	1872S	583	
21" width (533mm)	24"	610	8	3.6	0.7	2124Z •	87	2124C •	92	2124V •	87	2124VG •	87	2124E •	92	2124S	365
	30"	762	9	4.1	0.7	2130Z •	91	2130C •	100	2130V •	91	2130VG •	91	2130E •	100	2130S	368
	36"	914	11	5.0	0.8	2136Z •	95	2136C •	103	2136V •	95	2136VG •	95	2136E •	103	2136S	371
	42"	1067	12	5.5	1.1	2142Z •	106	2142C •	118	2142V •	106	2142VG •	106	2142E •	118	2142S	427
	48"	1219	14	6.4	1.1	2148Z •	109	2148C •	120	2148V •	109	2148VG •	109	2148E •	120	2148S	432
	54"	1372	16	7.3	1.3	2154Z •	129	2154C •	138	2154V •	129	2154VG •	129	2154E •	138	2154S	568
	60"	1524	18	8.2	1.3	2160Z •	134	2160C •	140	2160V •	134	2160VG •	134	2160E •	140	2160S	572
72"	1829	24	10.9	1.4	2172Z •	161	2172C •	172	2172V •	161	2172VG •	161	2172E •	172	2172S	677	
24" width (610mm)	24"	610	9	4.1	0.8	2424Z •	95	2424C •	102	2424V •	95	2424VG •	95	2424E •	102	2424S	396
	30"	762	11	5.0	0.8	2430Z •	98	2430C •	106	2430V •	98	2430VG •	98	2430E •	106	2430S	399
	36"	914	13	5.9	0.8	2436Z •	102	2436C •	109	2436V •	102	2436VG •	102	2436E •	109	2436S	403
	42"	1067	15	6.8	1.2	2442Z •	119	2442C •	126	2442V •	119	2442VG •	119	2442E •	126	2442S	483
	48"	1219	16	7.3	1.2	2448Z •	121	2448C •	133	2448V •	121	2448VG •	121	2448E •	133	2448S	485
	54"	1372	19	8.6	1.5	2454Z •	145	2454C •	153	2454V •	145	2454VG •	145	2454E •	153	2454S	594
	60"	1524	21	9.5	1.5	2460Z •	148	2460C •	155	2460V •	148	2460VG •	148	2460E •	155	2460S	596
72"	1829	26	11.8	1.6	2472Z •	173	2472C •	183	2472V •	173	2472VG •	173	2472E •	183	2472S	744	
30" width (762mm)	30"	762	16	7.3	1.0	3030Z •	122	3030C •	141	3030V •	122	3030VG •	122	3030E •	141	3030S	487
	36"	914	17	7.7	1.0	3036Z •	124	3036C •	144	3036V •	124	3036VG •	124	3036E •	144	3036S	516
	48"	1219	20	9.1	1.5	3048Z •	153	3048C •	171	3048V •	153	3048VG •	153	3048E •	171	3048S	601
	60"	1524	25	11.4	1.8	3060Z •	201	3060C •	227	3060V •	201	3060VG •	201	3060E •	227	3060S	694
36" width (914mm)	36"	914	21	9.5	1.3	3636Z •	145	3636C •	161	3636V •	145	3636VG •	145	3636E •	161	3636S	576
	48"	1219	26	11.8	1.9	3648Z •	174	3648C •	189	3648V •	174	3648VG •	174	3648E •	189	3648S	682
	60"	1524	34	15.4	2.3	3660Z •	235	3660C •	263	3660V •	235	3660VG •	235	3660E •	263	3660S	794
	72"	1829	43	19.5	2.8	3672Z •	278	3672C •	303	3672V •	278	3672VG •	278	3672E •	303	3672S	944



## Catalog Section 1

### Quad-Adjust® Wire Shelving (NSF)

see spec sheet **EG01.14**



**PATENTED!**  
(patent #7,992,731)

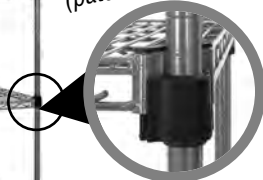

Each shelf corner fits in collar mounted to split sleeve

patented  
**QuadTruss®**  
design  
(Patent #5,390,803)

**Patented QuadTruss® Design**

makes shelves up to 25% stronger and provides a retaining ledge for increased strength and product retention.

**FEATURES:**

- Shelves feature special interlocking corners that fit in collars mounted to split sleeves, allowing addition or removal of a shelf without the need to disassemble the entire shelf unit.
- Tapered split sleeves create a positive lock that becomes stronger as the load increases.
- Posts (page 13) are numbered in increments of 1" (25mm) to ensure fast and level assembly.
- Leveling feet are provided to help compensate for uneven floor surfaces.
- Shelves utilize patented QuadTruss® design: the mat wires are sandwiched between two top truss wires, adding significant strength and distributing the entire load without stress and strain on the welds.

**Note:** To create a mobile shelf unit, top and bottom shelves must be standard shelves (page 6).

Quad-Adjust® shelves assembled with posts (see page 13 for posts)

Weight capacities and packaging are the same as that of Wire Shelves (page 6).

**Freight class is 70.0.**

(•) MTS (made to stock) / ( ) MTO (made to order)

**HOW TO ASSEMBLE:**



1. Snap split sleeves onto post over number of your choice.



2. Attach Quad-Adjust® collar onto split sleeves.



3. Slide shelf into slots in collar to complete.

### Quad-Adjust® Shelves

	length		weight		cu ft	EAGLEbrite®		chrome		VALU-MASTER®		Valu-Gard®		EAGLEgard®		stainless steel	
	in.	mm	lb.	kg		model #	list	model #	list	model #	list	model #	list	model #	list	model #	list
14" width (356mm)	24"	610	6	2.7	0.5	QA1424Z	103	QA1424C	113	QA1424V	108	QA1424VG	108	QA1424E	124	QA1424S	322
	30"	762	7	3.2	0.5	QA1430Z	108	QA1430C	118	QA1430V	115	QA1430VG	115	QA1430E	127	QA1430S	327
	36"	914	8	3.6	0.5	QA1436Z	112	QA1436C	120	QA1436V	122	QA1436VG	122	QA1436E	134	QA1436S	329
	42"	1067	9	4.1	0.7	QA1442Z	120	QA1442C	133	QA1442V	137	QA1442VG	137	QA1442E	147	QA1442S	393
	48"	1219	10	4.6	0.7	QA1448Z	124	QA1448C	135	QA1448V	139	QA1448VG	139	QA1448E	154	QA1448S	394
	54"	1372	12	5.5	0.9	QA1454Z	134	QA1454C	140	QA1454V	143	QA1454VG	143	QA1454E	157	QA1454S	483
	60"	1524	14	6.4	0.9	QA1460Z	140	QA1460C	147	QA1460V	157	QA1460VG	157	QA1460E	163	QA1460S	493
72"	1829	17	7.7	1.1	QA1472Z	156	QA1472C	163	QA1472V	171	QA1472VG	171	QA1472E	182	QA1472S	551	
18" width (457mm)	24"	610	7	3.2	0.7	QA1824Z	119	QA1824C	120	QA1824V	119	QA1824VG	119	QA1824E	139	QA1824S	389
	30"	762	8	3.6	0.7	QA1830Z	121	QA1830C	123	QA1830V	129	QA1830VG	129	QA1830E	141	QA1830S	393
	36"	914	9	4.1	0.7	QA1836Z	124	QA1836C	• 125	QA1836V	• 138	QA1836VG	• 138	QA1836E	• 145	QA1836S	397
	42"	1067	11	5.0	0.9	QA1842Z	135	QA1842C	140	QA1842V	148	QA1842VG	148	QA1842E	163	QA1842S	461
	48"	1219	12	5.5	0.9	QA1848Z	139	QA1848C	143	QA1848V	• 157	QA1848VG	• 157	QA1848E	• 171	QA1848S	466
	54"	1372	15	6.8	1.2	QA1854Z	154	QA1854C	157	QA1854V	171	QA1854VG	171	QA1854E	186	QA1854S	577
	60"	1524	17	7.7	1.2	QA1860Z	156	QA1860C	161	QA1860V	• 177	QA1860VG	• 177	QA1860E	• 192	QA1860S	584
72"	1829	20	9.1	1.3	QA1872Z	177	QA1872C	183	QA1872V	206	QA1872VG	206	QA1872E	214	QA1872S	686	
21" width (533mm)	24"	610	8	3.6	0.8	QA2124Z	125	QA2124C	135	QA2124V	127	QA2124VG	127	QA2124E	154	QA2124S	443
	30"	762	9	4.1	0.8	QA2130Z	127	QA2130C	139	QA2130V	140	QA2130VG	140	QA2130E	156	QA2130S	448
	36"	914	11	5.0	0.8	QA2136Z	134	QA2136C	141	QA2136V	154	QA2136VG	154	QA2136E	159	QA2136S	451
	42"	1067	12	5.5	1.1	QA2142Z	143	QA2142C	155	QA2142V	161	QA2142VG	161	QA2142E	177	QA2142S	514
	48"	1219	14	6.4	1.1	QA2148Z	147	QA2148C	157	QA2148V	171	QA2148VG	171	QA2148E	179	QA2148S	516
	54"	1372	16	7.3	1.3	QA2154Z	171	QA2154C	176	QA2154V	181	QA2154VG	181	QA2154E	203	QA2154S	668
	60"	1524	18	8.2	1.3	QA2160Z	173	QA2160C	178	QA2160V	183	QA2160VG	183	QA2160E	207	QA2160S	672
72"	1829	24	10.9	1.4	QA2172Z	200	QA2172C	208	QA2172V	223	QA2172VG	223	QA2172E	244	QA2172S	789	
24" width (610mm)	24"	610	9	4.1	0.8	QA2424Z	134	QA2424C	140	QA2424V	141	QA2424VG	141	QA2424E	162	QA2424S	477
	30"	762	11	5.0	0.8	QA2430Z	137	QA2430C	143	QA2430V	154	QA2430VG	154	QA2430E	165	QA2430S	481
	36"	914	13	5.9	0.8	QA2436Z	140	QA2436C	147	QA2436V	• 159	QA2436VG	• 159	QA2436E	• 172	QA2436S	486
	42"	1067	15	6.8	1.2	QA2442Z	156	QA2442C	165	QA2442V	174	QA2442VG	174	QA2442E	196	QA2442S	573
	48"	1219	16	7.3	1.2	QA2448Z	159	QA2448C	• 172	QA2448V	• 185	QA2448VG	• 185	QA2448E	• 200	QA2448S	576
	54"	1372	19	8.6	1.5	QA2454Z	182	QA2454C	191	QA2454V	204	QA2454VG	204	QA2454E	224	QA2454S	697
	60"	1524	21	9.5	1.5	QA2460Z	185	QA2460C	193	QA2460V	• 214	QA2460VG	• 214	QA2460E	• 228	QA2460S	700
72"	1829	26	11.8	1.6	QA2472Z	209	QA2472C	223	QA2472V	248	QA2472VG	248	QA2472E	261	QA2472S	864	

**Note:** MICROGARD® antimicrobial protection standard on all EAGLEgard® shelving.



100 Industrial Boulevard, Clayton, DE 19938-8903 U.S.A.  
Phone: 800-441-8440 or 302-653-3000. Fax: 302-653-2065  
http://www.eaglegrp.com

### Quad-Adjust® Wire Shelving (continued) NSF

see spec sheet **EG01.14**

Freight class is 70.0.

(\*) MTS (made to stock) / ( ) MTO (made to order)

#### Quad-Adjust® Reverse Mat Shelves

Built-in ledges prevent shelf contents from falling off.

	length		weight		cu ft	EAGLEbrite®		chrome		VALU-MASTER®		Valu-Gard®		EAGLEgard®		stainless steel	
	in.	mm	lb.	kg		model #	list	model #	list	model #	list	model #	list	model #	list	model #	list
<b>14"</b> (356mm)	24"	610	6	2.7	0.5	QAR1424Z	111	QAR1424C	120	QAR1424V	115	QAR1424VG	115	QAR1424E	134	QAR1424S	341
	36"	914	8	3.6	0.5	QAR1436Z	119	QAR1436C	126	QAR1436V	129	QAR1436VG	129	QAR1436E	141	QAR1436S	349
	48"	1219	10	4.6	0.7	QAR1448Z	126	QAR1448C	143	QAR1448V	148	QAR1448VG	148	QAR1448E	162	QAR1448S	420
<b>18"</b> (457mm)	24"	610	7	3.2	0.7	QAR1824Z	125	QAR1824C	126	QAR1824V	125	QAR1824VG	125	QAR1824E	148	QAR1824S	415
	36"	914	9	4.1	0.7	QAR1836Z	134	QAR1836C	135	QAR1836V	145	QAR1836VG	145	QAR1836E	155	QAR1836S	422
	48"	1219	12	5.5	0.9	QAR1848Z	148	QAR1848C	153	QAR1848V	167	QAR1848VG	167	QAR1848E	179	QAR1848S	496
<b>21"</b> (533mm)	24"	610	8	3.6	0.7	QAR2124Z	135	QAR2124C	143	QAR2124V	139	QAR2124VG	139	QAR2124E	162	QAR2124S	472
	36"	914	11	5.0	0.8	QAR2136Z	141	QAR2136C	152	QAR2136V	162	QAR2136VG	162	QAR2136E	171	QAR2136S	479
	48"	1219	14	6.4	1.1	QAR2148Z	156	QAR2148C	167	QAR2148V	179	QAR2148VG	179	QAR2148E	191	QAR2148S	548
<b>24"</b> (610mm)	24"	610	9	4.1	0.8	QAR2424Z	141	QAR2424C	151	QAR2424V	152	QAR2424VG	152	QAR2424E	175	QAR2424S	508
	36"	914	13	5.9	0.8	QAR2436Z	151	QAR2436C	156	QAR2436V	171	QAR2436VG	171	QAR2436E	180	QAR2436S	516
	48"	1219	16	7.3	1.2	QAR2448Z	171	QAR2448C	180	QAR2448V	199	QAR2448VG	199	QAR2448E	212	QAR2448S	613

Note: MICROGARD® antimicrobial protection standard on all EAGLEgard® shelving.

#### Quad-Adjust® 4-Tier Starter Units — Convenient easy-to-order starter unit kits.

see product announcement **EG8115**

patented  
**QuadTruss®**  
design  
(Patent #5,390,803)

Consists of (2) standard wire shelves, (2) Quad-Adjust® shelves (patent #7,992,731), and (4) 74" (1880mm) posts.

	length		weight		cu ft	EAGLEbrite®		chrome		VALU-MASTER®		Valu-Gard®		EAGLEgard®		stainless steel	
	in.	mm	lb.	kg		model #	list	model #	list	model #	list	model #	list	model #	list	model #	list
<b>18"</b> (457mm)	36"	914	65	40	2.7	F2QA2-74-1836Z	554	F2QA2-74-1836C	558	F2QA2-74-1836V	606	F2QA2-74-1836VG	606	F2QA2-74-1836E	657	F2QA2-74-1836S	1792
	48"	1219	78	36	3.6	F2QA2-74-1848Z	606	F2QA2-74-1848C	628	F2QA2-74-1848V	689	F2QA2-74-1848VG	689	F2QA2-74-1848E	748	F2QA2-74-1848S	2056
	60"	1524	102	46	4.3	F2QA2-74-1860Z	673	F2QA2-74-1860C	700	F2QA2-74-1860V	766	F2QA2-74-1860VG	766	F2QA2-74-1860E	839	F2QA2-74-1860S	2504
	72"	1819	117	53	5.1	F2QA2-74-1872Z	759	F2QA2-74-1872C	794	F2QA2-74-1872V	881	F2QA2-74-1872VG	881	F2QA2-74-1872E	931	F2QA2-74-1872S	2891
<b>24"</b> (610mm)	36"	914	81	37	3.6	F2QA2-74-2436Z	611	F2QA2-74-2436C	644	F2QA2-74-2436V	696	F2QA2-74-2436VG	696	F2QA2-74-2436E	753	F2QA2-74-2436S	2128
	48"	1219	98	45	4.6	F2QA2-74-2448Z	689	F2QA2-74-2448C	734	F2QA2-74-2448V	804	F2QA2-74-2448VG	804	F2QA2-74-2448E	873	F2QA2-74-2448S	2473
	60"	1524	122	55	5.7	F2QA2-74-2460Z	799	F2QA2-74-2460C	825	F2QA2-74-2460V	917	F2QA2-74-2460VG	917	F2QA2-74-2460E	985	F2QA2-74-2460S	2942
	72"	1819	149	68	6.9	F2QA2-74-2472Z	797	F2QA2-74-2472C	842	F2QA2-74-2472V	936	F2QA2-74-2472VG	936	F2QA2-74-2472E	997	F2QA2-74-2472S	3569

Note: MICROGARD® antimicrobial protection standard on all EAGLEgard® shelving.



Contact us:  
**revit@eaglegrp.com**

Access Eagle's Revit Libraries on  
AutoQuotes, KCL, and AutoDesk Seek.



Profit from the Eagle Advantage®

## Catalog Section 1

### QuadPLUS® Polymer Shelf Mats with Wire Truss Frames



see spec sheets **EG01.47A** **EG01.47B**

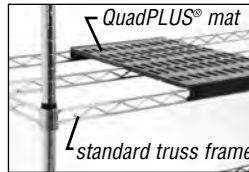

- Green\* polymer louvered or solid shelf mats.
- MICROGARD® protection standard on mats and on EAGLEgard® coated truss frames.
- Easy assembly—no tools required!

Note: Packaging is the same as that of Wire Shelves (page 6).

#### ...with Standard Wire Truss Frames...

	...with Louvered Mats					...with Solid Mats							
	length		weight		cu ft	w/Valu-Gard® finish*		w/EAGLEgard® finish*		w/Valu-Gard® finish*		w/EAGLEgard® finish*	
	in.	mm	lb.	kg		model #	list	model #	list	model #	list	model #	list
<b>18" width</b> (457mm)	24"	610	7	3.2	0.7	QPF-1824VG-GL	115	QPF-1824E-GL	125	QPF-1824VG-GS	120	QPF-1824E-GS	134
	30"	762	8	3.6	0.7	QPF-1830VG-GL	120	QPF-1830E-GL	133	QPF-1830VG-GS	125	QPF-1830E-GS	140
	36"	914	10	4.5	0.7	QPF-1836VG-GL	120	QPF-1836E-GL	134	QPF-1836VG-GS	125	QPF-1836E-GS	140
	42"	1067	11	5.0	0.9	QPF-1842VG-GL	144	QPF-1842E-GL	160	QPF-1842VG-GS	153	QPF-1842E-GS	171
	48"	1219	12	5.4	0.9	QPF-1848VG-GL	144	QPF-1848E-GL	160	QPF-1848VG-GS	153	QPF-1848E-GS	171
	54"	1372	15	6.8	1.2	QPF-1854VG-GL	173	QPF-1854E-GL	192	QPF-1854VG-GS	180	QPF-1854E-GS	201
	60"	1524	17	7.7	1.2	QPF-1860VG-GL	173	QPF-1860E-GL	192	QPF-1860VG-GS	180	QPF-1860E-GS	201
72"	1829	20	9.0	1.3	QPF-1872VG-GL	196	QPF-1872E-GL	217	QPF-1872VG-GS	206	QPF-1872E-GS	228	
<b>21" width</b> (533mm)	24"	610	8	3.6	0.7	QPF-2124VG-GL	129	QPF-2124E-GL	144	QPF-2124VG-GS	138	QPF-2124E-GS	153
	30"	762	9	4.1	0.7	QPF-2130VG-GL	135	QPF-2130E-GL	151	QPF-2130VG-GS	141	QPF-2130E-GS	157
	36"	914	11	5.0	0.8	QPF-2136VG-GL	135	QPF-2136E-GL	151	QPF-2136VG-GS	141	QPF-2136E-GS	157
	42"	1067	13	5.9	1.1	QPF-2142VG-GL	157	QPF-2142E-GL	176	QPF-2142VG-GS	165	QPF-2142E-GS	183
	48"	1219	14	6.4	1.1	QPF-2148VG-GL	157	QPF-2148E-GL	176	QPF-2148VG-GS	165	QPF-2148E-GS	183
	54"	1372	16	7.3	1.3	QPF-2154VG-GL	183	QPF-2154E-GL	206	QPF-2154VG-GS	196	QPF-2154E-GS	215
	60"	1524	18	8.2	1.3	QPF-2160VG-GL	183	QPF-2160E-GL	206	QPF-2160VG-GS	196	QPF-2160E-GS	215
72"	1829	23	10.4	1.4	QPF-2172VG-GL	226	QPF-2172E-GL	251	QPF-2172VG-GS	238	QPF-2172E-GS	263	
<b>24" width</b> (610mm)	24"	610	10	4.5	0.8	QPF-2424VG-GL	143	QPF-2424E-GL	159	QPF-2424VG-GS	152	QPF-2424E-GS	167
	30"	762	11	5.0	0.8	QPF-2430VG-GL	145	QPF-2430E-GL	161	QPF-2430VG-GS	154	QPF-2430E-GS	172
	36"	914	13	5.9	0.8	QPF-2436VG-GL	145	QPF-2436E-GL	161	QPF-2436VG-GS	154	QPF-2436E-GS	172
	42"	1067	15	6.8	1.2	QPF-2442VG-GL	178	QPF-2442E-GL	198	QPF-2442VG-GS	186	QPF-2442E-GS	208
	48"	1219	16	7.3	1.2	QPF-2448VG-GL	178	QPF-2448E-GL	198	QPF-2448VG-GS	186	QPF-2448E-GS	208
	54"	1372	19	8.6	1.5	QPF-2454VG-GL	211	QPF-2454E-GL	234	QPF-2454VG-GS	222	QPF-2454E-GS	247
	60"	1524	21	9.5	1.5	QPF-2460VG-GL	211	QPF-2460E-GL	234	QPF-2460VG-GS	222	QPF-2460E-GS	247
72"	1829	25	11.3	1.6	QPF-2472VG-GL	247	QPF-2472E-GL	275	QPF-2472VG-GS	260	QPF-2472E-GS	288	

#### ...with Quad-Adjust® Truss Frames...

	...with Louvered Mats					...with Solid Mats							
	length		weight		cu ft	w/Valu-Gard® finish*		w/EAGLEgard® finish*		w/Valu-Gard® finish*		w/EAGLEgard® finish*	
	in.	mm	lb.	kg		model #	list	model #	list	model #	list	model #	list
<b>18" width</b> (457mm)	24"	610	7	3.2	0.7	QPF-QA1824VG-GL	135	QPF-QA1824E-GL	148	QPF-QA1824VG-GS	141	QPF-QA1824E-GS	156
	30"	762	8	3.6	0.7	QPF-QA1830VG-GL	141	QPF-QA1830E-GL	156	QPF-QA1830VG-GS	147	QPF-QA1830E-GS	163
	36"	914	10	4.5	0.7	QPF-QA1836VG-GL	141	QPF-QA1836E-GL	156	QPF-QA1836VG-GS	147	QPF-QA1836E-GS	163
	42"	1067	11	5.0	0.9	QPF-QA1842VG-GL	171	QPF-QA1842E-GL	189	QPF-QA1842VG-GS	179	QPF-QA1842E-GS	199
	48"	1219	12	5.4	0.9	QPF-QA1848VG-GL	171	QPF-QA1848E-GL	189	QPF-QA1848VG-GS	179	QPF-QA1848E-GS	199
	54"	1372	15	6.8	1.2	QPF-QA1854VG-GL	203	QPF-QA1854E-GL	224	QPF-QA1854VG-GS	213	QPF-QA1854E-GS	236
	60"	1524	17	7.7	1.2	QPF-QA1860VG-GL	203	QPF-QA1860E-GL	224	QPF-QA1860VG-GS	213	QPF-QA1860E-GS	236
72"	1829	20	9.0	1.3	QPF-QA1872VG-GL	231	QPF-QA1872E-GL	257	QPF-QA1872VG-GS	241	QPF-QA1872E-GS	267	
<b>21" width</b> (533mm)	24"	610	8	3.6	0.7	QPF-QA2124VG-GL	154	QPF-QA2124E-GL	172	QPF-QA2124VG-GS	161	QPF-QA2124E-GS	179
	30"	762	9	4.1	0.7	QPF-QA2130VG-GL	157	QPF-QA2130E-GL	176	QPF-QA2130VG-GS	167	QPF-QA2130E-GS	183
	36"	914	11	5.0	0.8	QPF-QA2136VG-GL	157	QPF-QA2136E-GL	176	QPF-QA2136VG-GS	167	QPF-QA2136E-GS	183
	42"	1067	13	5.9	1.1	QPF-QA2142VG-GL	185	QPF-QA2142E-GL	207	QPF-QA2142VG-GS	196	QPF-QA2142E-GS	217
	48"	1219	14	6.4	1.1	QPF-QA2148VG-GL	185	QPF-QA2148E-GL	207	QPF-QA2148VG-GS	196	QPF-QA2148E-GS	217
	54"	1372	16	7.3	1.3	QPF-QA2154VG-GL	217	QPF-QA2154E-GL	241	QPF-QA2154VG-GS	228	QPF-QA2154E-GS	254
	60"	1524	18	8.2	1.3	QPF-QA2160VG-GL	217	QPF-QA2160E-GL	241	QPF-QA2160VG-GS	228	QPF-QA2160E-GS	254
72"	1829	23	10.4	1.4	QPF-QA2172VG-GL	264	QPF-QA2172E-GL	295	QPF-QA2172VG-GS	279	QPF-QA2172E-GS	309	
<b>24" width</b> (610mm)	24"	610	10	4.5	0.8	QPF-QA2424VG-GL	171	QPF-QA2424E-GL	186	QPF-QA2424VG-GS	178	QPF-QA2424E-GS	198
	30"	762	11	5.0	0.8	QPF-QA2430VG-GL	172	QPF-QA2430E-GL	191	QPF-QA2430VG-GS	180	QPF-QA2430E-GS	200
	36"	914	13	5.9	0.8	QPF-QA2436VG-GL	172	QPF-QA2436E-GL	191	QPF-QA2436VG-GS	180	QPF-QA2436E-GS	200
	42"	1067	15	6.8	1.2	QPF-QA2442VG-GL	209	QPF-QA2442E-GL	233	QPF-QA2442VG-GS	220	QPF-QA2442E-GS	244
	48"	1219	16	7.3	1.2	QPF-QA2448VG-GL	209	QPF-QA2448E-GL	233	QPF-QA2448VG-GS	220	QPF-QA2448E-GS	244
	54"	1372	19	8.6	1.5	QPF-QA2454VG-GL	248	QPF-QA2454E-GL	276	QPF-QA2454VG-GS	261	QPF-QA2454E-GS	291
	60"	1524	21	9.5	1.5	QPF-QA2460VG-GL	248	QPF-QA2460E-GL	276	QPF-QA2460VG-GS	261	QPF-QA2460E-GS	291
72"	1829	25	11.3	1.6	QPF-QA2472VG-GL	291	QPF-QA2472E-GL	322	QPF-QA2472VG-GS	304	QPF-QA2472E-GS	338	

\*Available with blue polymer mats and truss frames coated with chrome finish or Valu-Master® gray epoxy finish.

See spec sheets **EG01.47A** and **EG01.47B**.



### QuadPLUS® 5-Tier Starter Units — Convenient easy-to-order starter unit kits.

see spec sheet **EG01.36**

Consists of:

- (1) Standard collar truss frame with louvered QuadPLUS® green shelf mats
- (3) Quad-Adjust® collar truss frames with louvered QuadPLUS® green shelf mats
- (1) Standard collar truss frame with solid QuadPLUS® green shelf mats
- (4) 74" (1880mm) posts. Mobile units feature 5" (127mm) resilient swivel stem casters—two with brake.

	Stationary				Mobile				
	length in. mm	with Valu-Gard® model #	with EAGLEgard® list	with Valu-Gard® model #	with EAGLEgard® list	with Valu-Gard® model #	with EAGLEgard® list		
18" width (457mm)	36" 914	QPSU1836VG-G5-74	804	QPMU1836VG-G5-74	1039	QPSU1836E-G5-74	891	QPMU1836E-G5-74	1125
	48" 1219	QPSU1848VG-G5-74	941	QPMU1848VG-G5-74	1177	QPSU1848E-G5-74	1045	QPMU1848E-G5-74	1280
	60" 1524	QPSU1860VG-G5-74	1096	QPMU1860VG-G5-74	1333	QPSU1860E-G5-74	1214	QPMU1860E-G5-74	1449
21" width (533mm)	36" 914	QPSU2136VG-G5-74	882	QPMU2136VG-G5-74	1118	QPSU2136E-G5-74	983	QPMU2136E-G5-74	1220
	48" 1219	QPSU2148VG-G5-74	1014	QPMU2148VG-G5-74	1248	QPSU2148E-G5-74	1128	QPMU2148E-G5-74	1365
	60" 1524	QPSU2160VG-G5-74	1163	QPMU2160VG-G5-74	1401	QPSU2160E-G5-74	1296	QPMU2160E-G5-74	1531
24" width (610mm)	36" 914	QPSU2436VG-G5-74	946	QPMU2436VG-G5-74	1182	QPSU2436E-G5-74	1051	QPMU2436E-G5-74	1286
	48" 1219	QPSU2448VG-G5-74	1126	QPMU2448VG-G5-74	1362	QPSU2448E-G5-74	1257	QPMU2448E-G5-74	1492
	60" 1524	QPSU2460VG-G5-74	1309	QPMU2460VG-G5-74	1545	QPSU2460E-G5-74	1456	QPMU2460E-G5-74	1692

### QuadPLUS® Wire Baskets and Truss Frames

see product announcement **EG8155**

QuadPLUS® Wire Baskets are used in conjunction with specially-made truss frames. Once truss frame is assembled to posts, set basket inside frame.

#### QuadPLUS® Wire Baskets

	length		depth		Valu-Gard® green epoxy		EAGLEgard® green epoxy	
	in.	mm	in.	mm	model #	list	model #	list
18" width (457mm)	16"	406	6"	152	QPB1816VG-6	258	QPB1816E-6	268
	16"	406	9"	229	QPB1816VG-9	277	QPB1816E-9	288
	22"	559	6"	152	QPB1822VG-6	286	QPB1822E-6	304
	22"	559	9"	229	QPB1822VG-9	306	QPB1822E-9	323
24" width (610mm)	16"	406	6"	152	QPB2416VG-6	267	QPB2416E-6	281
	16"	406	9"	229	QPB2416VG-9	287	QPB2416E-9	299
	22"	559	6"	152	QPB2422VG-6	298	QPB2422E-6	315
	22"	559	9"	229	QPB2422VG-9	318	QPB2422E-9	336

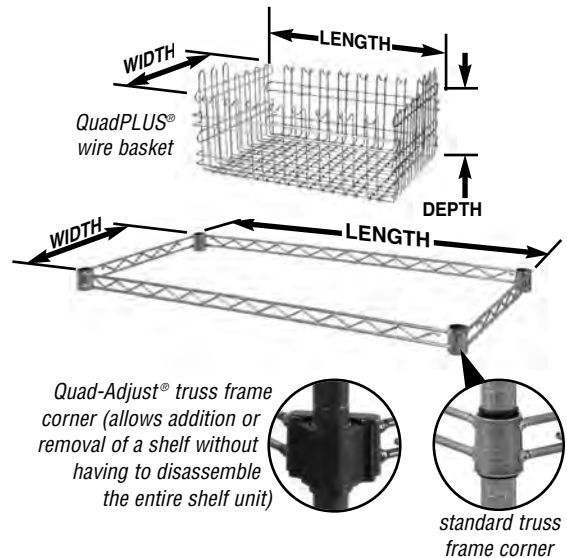

	Truss Frames with Standard Corners				Truss Frames with Quad-Adjust® Corners				Basket Capacity per Truss Frame		
	length in. mm	Valu-Gard® green epoxy model #	EAGLEgard® green epoxy list	model #	list	Valu-Gard® green epoxy model #	EAGLEgard® green epoxy list	model #	list	quantity of 16" wide basket	quantity of 22" wide basket
18" width (457mm)	24" 610	QPAF-1824VG	78	QPAF-1824E	92	QPAF-QA1824VG	165	QPAF-QA1824E	177		1
	30" 760	QPAF-1830VG	81	QPAF-1830E	96	QPAF-QA1830VG	169	QPAF-QA1830E	180		1
	36" 914	QPAF-1836VG	83	QPAF-1836E	100	QPAF-QA1836VG	169	QPAF-QA1836E	183	2	
	42" 1060	QPAF-1842VG	85	QPAF-1842E	105	QPAF-QA1842VG	172	QPAF-QA1842E	189	1	1
	48" 1220	QPAF-1848VG	87	QPAF-1848E	109	QPAF-QA1848VG	174	QPAF-QA1848E	197		2
	54" 1372	QPAF-1854VG	88	QPAF-1854E	116	QPAF-QA1854VG	178	QPAF-QA1854E	200		2
	60" 1524	QPAF-1860VG	91	QPAF-1860E	121	QPAF-QA1860VG	181	QPAF-QA1860E	209	2	1
	72" 1829	QPAF-1872VG	95	QPAF-1872E	124	QPAF-QA1872VG	182	QPAF-QA1872E	214		3
24" width (610mm)	24" 610	QPAF-2424VG	88	QPAF-2424E	106	QPAF-QA2424VG	175	QPAF-QA2424E	192		1
	30" 760	QPAF-2430VG	92	QPAF-2430E	113	QPAF-QA2430VG	179	QPAF-QA2430E	196		1
	36" 914	QPAF-2436VG	98	QPAF-2436E	118	QPAF-QA2436VG	182	QPAF-QA2436E	204	2	
	42" 1060	QPAF-2442VG	100	QPAF-2442E	124	QPAF-QA2442VG	186	QPAF-QA2442E	209	1	1
	48" 1220	QPAF-2448VG	106	QPAF-2448E	137	QPAF-QA2448VG	191	QPAF-QA2448E	224		2
	54" 1372	QPAF-2454VG	107	QPAF-2454E	138	QPAF-QA2454VG	194	QPAF-QA2454E	227		2
	60" 1524	QPAF-2460VG	107	QPAF-2460E	140	QPAF-QA2460VG	195	QPAF-QA2460E	231	2	1
	72" 1829	QPAF-2472VG	119	QPAF-2472E	154	QPAF-QA2472VG	201	QPAF-QA2472E	241		3

## Catalog Section 1

### **NEW** QuadPLUS® Polymer Dunnage Racks

see product announcement **EG8166**



stationary QuadPLUS® polymer dunnage rack

patented  
**QuadTruss®**  
design  
(Patent #5,390,803)  
**Patented QuadTruss®  
Design**

makes shelves up to 25% stronger and provides a retaining ledge for increased strength and product retention.

- Green\* polymer louvered or solid shelf mats lay on top of wire shelf.
- MICROGARD® protection standard on mats and on EAGLEgard® coated shelves.
- 1" (25mm)-diameter posts grooved on 1" (25mm) centers, allowing for the adjustment of the shelf and 3-sided frame.
- Temperature rating for mats: Up to 200°F for intermittent exposure to cleaning, such as a dishwasher.
- Mats have a temperature rating of -20°F to 125°F under continuous use.
- Easy assembly—no tools required!
- 14" (356mm) height.

### Stationary Racks — 1,000 lbs. (453.6 kg) weight capacity.

	length		weight		EAGLEgard® green epoxy				Valu-Gard® green epoxy			
					with solid mat		with louvered mat		with solid mat		with louvered mat	
	in.	mm	lb.	kg	model #	list	model #	list	model #	list	model #	list
<b>18" width</b> (457mm)	24"	610	33	15.0	QP-DR1824E-GS	472	QP-DR1824E-GL	470	QP-DR1824VG-GS	432	QP-DR1824VG-GL	430
	30"	760	36	16.3	QP-DR1830E-GS	491	QP-DR1830E-GL	488	QP-DR1830VG-GS	444	QP-DR1830VG-GL	441
	36"	914	43	19.5	QP-DR1836E-GS	512	QP-DR1836E-GL	508	QP-DR1836VG-GS	468	QP-DR1836VG-GL	464
	48"	1220	49	22.2	QP-DR1848E-GS	578	QP-DR1848E-GL	573	QP-DR1848VG-GS	525	QP-DR1848VG-GL	520
	60"	1524	55	24.9	QP-DR1860E-GS	647	QP-DR1860E-GL	640	QP-DR1860VG-GS	575	QP-DR1860VG-GL	569
<b>21" width</b> (533mm)	24"	610	36	16.3	QP-DR2124E-GS	496	QP-DR2124E-GL	493	QP-DR2124VG-GS	451	QP-DR2124VG-GL	448
	30"	760	39	17.7	QP-DR2130E-GS	515	QP-DR2130E-GL	511	QP-DR2130VG-GS	464	QP-DR2130VG-GL	460
	36"	914	45	20.4	QP-DR2136E-GS	542	QP-DR2136E-GL	538	QP-DR2136VG-GS	486	QP-DR2136VG-GL	482
	48"	1220	51	23.1	QP-DR2148E-GS	615	QP-DR2148E-GL	609	QP-DR2148VG-GS	548	QP-DR2148VG-GL	542
	60"	1524	57	25.9	QP-DR2160E-GS	686	QP-DR2160E-GL	679	QP-DR2160VG-GS	595	QP-DR2160VG-GL	587
<b>24" width</b> (610mm)	24"	610	40	18.1	QP-DR2424E-GS	514	QP-DR2424E-GL	511	QP-DR2424VG-GS	472	QP-DR2424VG-GL	469
	30"	760	42	19.1	QP-DR2430E-GS	538	QP-DR2430E-GL	533	QP-DR2430VG-GS	476	QP-DR2430VG-GL	471
	36"	914	47	21.3	QP-DR2436E-GS	558	QP-DR2436E-GL	553	QP-DR2436VG-GS	508	QP-DR2436VG-GL	497
	48"	1220	53	24.0	QP-DR2448E-GS	644	QP-DR2448E-GL	637	QP-DR2448VG-GS	573	QP-DR2448VG-GL	566
	60"	1524	63	28.6	QP-DR2460E-GS	713	QP-DR2460E-GL	704	QP-DR2460VG-GS	627	QP-DR2460VG-GL	619

### Mobile Racks — 800 lbs. (362.8 kg) weight capacity. Comes with four 5" heavy duty swivel casters with rubber tread (two with brake).

	length		weight		EAGLEgard® green epoxy				Valu-Gard® green epoxy			
					with solid mat		with louvered mat		with solid mat		with louvered mat	
	in.	mm	lb.	kg	model #	list	model #	list	model #	list	model #	list
<b>18" width</b> (457mm)	24"	610	33	15.0	QP-MDR1824E-GS	631	QP-MDR1824E-GL	628	QP-MDR1824VG-GS	593	QP-MDR1824VG-GL	591
	30"	760	36	16.3	QP-MDR1830E-GS	650	QP-MDR1830E-GL	647	QP-MDR1830VG-GS	605	QP-MDR1830VG-GL	602
	36"	914	43	19.5	QP-MDR1836E-GS	671	QP-MDR1836E-GL	667	QP-MDR1836VG-GS	629	QP-MDR1836VG-GL	625
	48"	1220	49	22.2	QP-MDR1848E-GS	737	QP-MDR1848E-GL	732	QP-MDR1848VG-GS	686	QP-MDR1848VG-GL	681
	60"	1524	55	24.9	QP-MDR1860E-GS	806	QP-MDR1860E-GL	799	QP-MDR1860VG-GS	736	QP-MDR1860VG-GL	730
<b>21" width</b> (533mm)	24"	610	36	16.3	QP-MDR2124E-GS	655	QP-MDR2124E-GL	652	QP-MDR2124VG-GS	613	QP-MDR2124VG-GL	609
	30"	760	39	17.7	QP-MDR2130E-GS	673	QP-MDR2130E-GL	670	QP-MDR2130VG-GS	625	QP-MDR2130VG-GL	621
	36"	914	45	20.4	QP-MDR2136E-GS	701	QP-MDR2136E-GL	697	QP-MDR2136VG-GS	648	QP-MDR2136VG-GL	643
	48"	1220	51	23.1	QP-MDR2148E-GS	774	QP-MDR2148E-GL	768	QP-MDR2148VG-GS	709	QP-MDR2148VG-GL	703
	60"	1524	57	25.9	QP-MDR2160E-GS	845	QP-MDR2160E-GL	838	QP-MDR2160VG-GS	756	QP-MDR2160VG-GL	748
<b>24" width</b> (610mm)	24"	610	40	18.1	QP-MDR2424E-GS	673	QP-MDR2424E-GL	670	QP-MDR2424VG-GS	633	QP-MDR2424VG-GL	630
	30"	760	42	19.1	QP-MDR2430E-GS	696	QP-MDR2430E-GL	692	QP-MDR2430VG-GS	637	QP-MDR2430VG-GL	633
	36"	914	47	21.3	QP-MDR2436E-GS	717	QP-MDR2436E-GL	712	QP-MDR2436VG-GS	670	QP-MDR2436VG-GL	665
	48"	1220	53	24.0	QP-MDR2448E-GS	803	QP-MDR2448E-GL	796	QP-MDR2448VG-GS	734	QP-MDR2448VG-GL	728
	60"	1524	63	28.6	QP-MDR2460E-GS	871	QP-MDR2460E-GL	863	QP-MDR2460VG-GS	788	QP-MDR2460VG-GL	780

## QuadPLUS® Options & Accessories

see product announcement **EG8165**



### Tray Drying Racks

Perfect for bun pans, cutting boards, server trays and pizza pans. Fits over existing QuadPLUS® polymer shelving. Constructed of 6-gauge wire with Valu-Gard® or Eaglegard® green epoxy coating. 24" width. Lengths range from 24" to 60" long. For additional sizes, contact factory.

	...with 1-1/2" (38mm) Spacing						...with 3" (76mm) Spacing			
	length		with Valu-Gard®		with EAGLEgard®		with Valu-Gard®		with EAGLEgard®	
	in.	mm	model #	list	model #	list	model #	list	model #	list
24" width (610mm)	36"	914	QTR24361-VG	247	QTR24361-E	267	QTR24363-VG	242	QTR24363-E	263
	48"	1219	QTR24481-VG	259	QTR24481-E	287	QTR24483-VG	256	QTR24483-E	283
	60"	1524	QTR24601-VG	276	QTR24601-E	311	QTR24603-VG	269	QTR24603-E	305

### Drop-In Drying Racks

For items such as pots, pans etc. Stainless steel wire rack hangs onto front, center and rear trusses of Valu-Gard® or EAGLEgard® frame included.



drop-in drying rack

	length		w/Valu-Gard® finish		w/EAGLEgard® finish	
	in.	mm	model #	list	model #	list
	24" width (610mm)	36"	914	QDR2436-VG	327	QDR2436-E
	48"	1219	QDR2448-VG	340	QDR2448-E	371
	60"	1524	QDR2460-VG	362	QDR2460-E	396

### Ledges for QuadPLUS® Polymer Shelf Mats

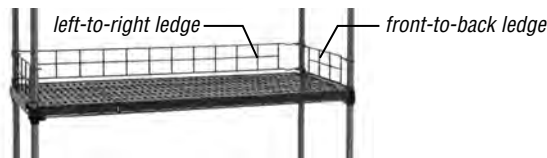

left-to-right ledge

front-to-back ledge

#### Front-to-Back Ledges...

width	cu	1"-high (25mm)				4"-high (102mm)								
		weight		w/Valu-Gard®		w/EAGLEgard®		weight		w/Valu-Gard®		w/EAGLEgard®		
		in.	mm	lb.	kg	model #	list	model #	list	lb.	kg	model #	list	model #
18"	457	0.3	0.3	0.1	QL18W-1VG	39	QL18W-1E	52	0.9	0.4	QL18W-4VG	41	QL18W-4E	54
21"	533	0.3	0.4	0.2	QL21W-1VG	43	QL21W-1E	58	1.0	0.5	QL21W-4VG	46	QL21W-4E	60
24"	610	0.3	0.5	0.2	QL24W-1VG	45	QL24W-1E	62	1.2	0.6	QL24W-4VG	46	QL24W-4E	64

#### Left-to-Right Ledges...

width	cu	1"-high (25mm)				4"-high (102mm)								
		weight		w/Valu-Gard®		w/EAGLEgard®		weight		w/Valu-Gard®		w/EAGLEgard®		
		in.	mm	lb.	kg	model #	list	model #	list	lb.	kg	model #	list	model #
24"	610	0.3	0.5	0.2	QL24L-1VG	45	QL24L-1E	62	1.2	0.6	QL24L-4VG	46	QL24L-4E	64
30"	762	0.5	0.7	0.3	QL30L-1VG	52	QL30L-1E	63	1.4	0.6	QL30L-4VG	57	QL30L-4E	73
36"	914	0.6	0.9	0.4	QL36L-1VG	60	QL36L-1E	65	1.6	0.7	QL36L-4VG	67	QL36L-4E	82
42"	1067	0.6	1.1	0.5	QL42L-1VG	63	QL42L-1E	67	1.8	0.8	QL42L-4VG	69	QL42L-4E	84
48"	1092	0.7	1.3	0.6	QL48L-1VG	64	QL48L-1E	68	2.0	0.9	QL48L-4VG	71	QL48L-4E	85
54"	1372	0.8	1.5	0.7	QL54L-1VG	71	QL54L-1E	74	2.2	1.0	QL54L-4VG	74	QL54L-4E	89
60"	1524	0.8	1.7	0.8	QL60L-1VG	78	QL60L-1E	87	2.4	1.1	QL60L-4VG	83	QL60L-4E	105
72"	1829	1.0	2.1	1.0	QL72L-1VG	85	QL72L-1E	99	2.6	1.2	QL72L-4VG	89	QL72L-4E	116

### Optional QuadPLUS® Dividers

8" (203mm) height.



length	with Valu-Gard®		with EAGLEgard®		
	in.	mm	model #	list	model #
18"	457	QPSD18-VG	84	QPSD18-E	85
21"	533	QPSD21-VG	86	QPSD21-E	87
24"	610	QPSD24-VG	88	QPSD24-E	89

### Optional Post Clamps

Provides maximum strength when shelving units are connected by clamping posts securely together.



stainless steel		black epoxy	
model #	list	model #	list
ADD-A-CLAMP	13	ADD-A-CLAMP-BL	17

## Catalog Section 1

### Posts (NSF)

see spec sheets **EG01.00** **EG01.01** **EG01.11A** **EG01.14**

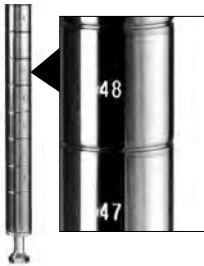

**Posts are numbered on vertical 1" (25mm) increments to help ensure fast and level assembly.**

- Height includes leveling bolt insert and cap.
- EAGLEbrite® posts feature air-dry lacquer and can be used for walk-in coolers.

#### FEATURES:

**Notes:** For special length post, apply price at next higher length plus a cutting charge of **\$13.00 list per post.**

**Freight class is 50.0.**

(•) MTS (made to stock) / ( ) MTO (made to order)

### For Stationary Applications

height in.	mm	cu ft	weight lb.	kg	EAGLEbrite®		chrome		Valu-Gard®		VALU-MASTER®		EAGLEgard®		stainless steel	
					model #	list	model #	list	model #	list	model #	list	model #	list	model #	list
7"	178	0.1	1.0	0.5	P7-Z •	17	P7-C	18	P7-VG	17	P7-V	17	P7-E •	18	P7-S	39
14"	356	0.1	1.0	0.5	P14-Z •	21	P14-C •	23	P14-VG	21	P14-V	21	P14-E •	23	P14-S	43
18"	457	0.1	1.5	0.7	P18-Z •	23	P18-C •	24	P18-VG	23	P18-V	23	P18-E	24	P18-S •	51
33"	838	0.1	2.0	0.9	P33-Z •	24	P33-C •	25	P33-VG •	24	P33-V •	24	P33-E •	25	P33-S •	68
54"	1372	0.1	3.0	1.4	P54-Z •	29	P54-C •	31	P54-VG •	29	P54-V •	29	P54-E •	31	P54-S •	80
63"	1600	0.3	3.5	1.8	P63-Z •	31	P63-C •	32	P63-VG •	31	P63-V •	31	P63-E •	32	P63-S •	83
74"	1880	0.5	4.0	1.8	P74-Z •	34	P74-C •	35	P74-VG •	34	P74-V •	34	P74-E •	35	P74-S •	94
86"	2184	0.8	5.0	2.3	P86-Z •	41	P86-C •	43	P86-VG •	41	P86-V •	41	P86-E •	43	P86-S •	113
96"	2438	0.9	6.0	2.7	n/a		P96-C •*	51	n/a		n/a		n/a		P96-S •*	119

\* 96" (2438mm) posts are NOT to be used on units less than 24" (610mm) front-to-back. Recommend using in conjunction with foot plates to affix to floor, and with post clamps where applicable.

### For Mobile Applications — See page 14 for appropriate stem casters.

height in.	mm	cu ft	weight lb.	kg	EAGLEbrite®		chrome		Valu-Gard®		VALU-MASTER®		EAGLEgard®		stainless	
					model #	list	model #	list	model #	list	model #	list	model #	list	model #	list
7"	178	0.1	1.0	0.5	CP7-Z	17	CP7-C	18	CP7-VG	17	CP7-V	17	CP7-E	18	CP7-S	39
14"	356	0.1	1.0	0.5	CP14-Z	21	CP14-C	23	CP14-VG	21	CP14-V	21	CP14-E	23	CP14-S	43
18"	457	0.1	1.5	0.7	CP18-Z	23	CP18-C	24	CP18-VG	23	CP18-V	23	CP18-E	24	CP18-S	51
33"	838	0.1	2.0	0.9	CP33-Z •	24	CP33-C •	25	CP33-VG •	24	CP33-V	24	CP33-E	25	CP33-S •	68
54"	1372	0.1	3.0	1.4	CP54-Z •	29	CP54-C •	31	CP54-VG	29	CP54-V	29	CP54-E	31	CP54-S	80
63"	1600	0.3	3.5	1.8	CP63-Z •	31	CP63-C •	32	CP63-VG •	31	CP63-V •	31	CP63-E •	32	CP63-S •	83
74"	1880	0.5	4.0	1.8	CP74-Z •	34	CP74-C •	35	CP74-VG •	34	CP74-V •	34	CP74-E •	35	CP74-S •	94
86"	2184	0.8	5.0	2.3	CP86-Z •	41	CP86-C •	43	CP86-VG •	41	CP86-V	41	CP86-E •	43	CP86-S	113

### Stationary Wire Wall Mounts (NSF)

see spec sheet **EG02.12**



stationary wall mount  
(end unit)

**Designed for fixed application**

**Note:** Shelves (page 6) sold separately.

**END UNIT:** • One single shelf support and mounting plate.

**MID UNIT:** • One double shelf support and mounting plate.

**Freight class is 70.0.**

(•) MTS (made to stock) / ( ) MTO (made to order)

length in.	mm	cu ft	weight** lbs.	kg	End Units*						Mid Units							
					chrome		Valu-Gard®		stainless**		weight**		chrome		Valu-Gard®		stainless**	
					model #	list	model #	list	model #	list	lbs.	kg	model #	list	model #	list	model #	list
14"	356	0.5	6	2.7	WB14-C •	53	WB14-VG •	54	WB14-S •	126	8	3.6	DWB14-C •	80	DWB14-VG	81	DWB14-S	192
18"	457	0.5	8	3.6	WB18-C •	54	WB18-VG •	55	WB18-S •	135	10	4.5	DWB18-C •	82	DWB18-VG	83	DWB18-S	203
21"	533	0.7	10	4.5	WB21-C •	54	WB21-VG	55	WB21-S	138	12	5.5	DWB21-C	82	DWB21-VG	83	DWB21-S	208
24"	610	0.7	12	5.5	WB24-C •	55	WB24-VG	57	WB24-S •	142	14	6.4	DWB24-C •	83	DWB24-VG	85	DWB24-S	217

\*End Units priced per piece; \*\*For stainless steel units, add 1 lb. (0.5 kg) weight.



100 Industrial Boulevard, Clayton, DE 19938-8903 U.S.A.  
Phone: 800-441-8440 or 302-653-3000. Fax: 302-653-2065  
<http://www.eaglegrp.com>

### Stem Casters

see spec sheet **EG01.05A**



resilient



step-pedal  
brake caster

**Add  
mobility to your  
stationary unit.**

#### FEATURES:

- Use with posts.
- Donut bumpers.
- Swivel casters have a temperature rating of -15°F.

**Note:** Decorative stem casters also available. See page 66. These casters cannot be used with Master Trak®.

**Freight class is 65.0.**

(•) MTS (made to stock) / ( ) MTO (made to order)

### Resilient

type	wheel diameter		wheel face		weight		cu ft	capacity		zinc		stainless steel			
	in.	mm	in.	mm	lbs.	kg		lbs.	kg	model #	list	lbs.	kg	model #	list
stem/swivel	4"	102	1"	25	1.1	0.5	0.1	125	56.7	<b>CSS4-125</b> •	39	-	-	-	-
stem/swivel	5"	127	1"	25	2.0	0.9	0.1	125	56.7	<b>CSS5-125</b> •	47	-	-	-	-
stem/swivel	5"	127	1¼"	32	2.5	1.2	0.1	300	136.1	<b>CSS5-300</b> •	54	200	90.7	<b>CSS5S-200</b>	191
stem/brake	5"	127	1¼"	32	2.8	1.3	0.1	300	136.1	<b>CSB5-300</b> •	64	200	90.7	<b>CSB5S-200</b>	218
stem w/step-pedal brake	5"	127	1¼"	32	2.8	1.3	0.1	300	136.1	<b>CSPB5-300</b>	88	-	-	-	-
stem/rigid ▼	5"	127	1¼"	32	3.5	1.6	0.1	300	136.1	<b>CSR5-300</b> •	60	200	90.7	<b>CSR5S-200</b>	157

### Polyurethane

type	capacity		wheel diameter		wheel face		weight		cu ft	nickel plated		stainless steel	
	lbs.	kg	in.	mm	in.	mm	lbs.	kg		model #	list	model #	list
stem/swivel	300	136.1	5"	127	1¼"	32	2.5	1.2	0.1	<b>CSS5P-300</b> •	55	<b>CSS5PS-300</b> •	235
stem/brake	300	136.1	5"	127	1¼"	32	2.8	1.3	0.1	<b>CSB5P-300</b> •	60	<b>CSB5PS-300</b> •	263
stem/rigid ▼	300	136.1	5"	127	1¼"	32	3.5	1.6	0.1	<b>CSR5P-300</b> •	62	<b>CSR5PS-300</b>	198



(nickel plated) swivel stem caster with polyurethane tread

### Polymer Casters

- With polyurethane wheel.

type	type of bearing	capacity		wheel diameter		wheel face		weight		cu ft	model #	list
		lbs.	kg	in.	mm	in.	mm	lbs.	kg			
stem/swivel	delrin	250	113.4	5"	127	1¼"	32	2.0	0.9	0.1	<b>CPSS5-250</b> •	109
stem/brake	delrin	250	113.4	5"	127	1¼"	32	2.0	0.9	0.1	<b>CPSB5-250</b> •	118



### ▼ Channel Frames for Rigid Stem Casters

**Please note:** Shelf width must be known when ordering rigid stem casters in order to ship appropriate channel frame to lock rigid casters.

shelf width in.	mm	weight		cubic feet	model #	list
		lbs.	kg			
14"	356	1.5	0.7	0.1	<b>A201706</b>	23
18"	457	2.0	0.9	0.1	<b>A201007</b>	29
21"	533	2.5	1.1	0.1	<b>A201008</b>	34
24"	610	2.8	1.3	0.1	<b>A201009</b>	35
30"	762	3.5	1.6	0.1	<b>A204795</b>	37
36"	914	4.0	1.8	0.1	<b>A207562</b>	39



channel frame for rigid stem casters

### Replacement Donut Bumpers for Stem Casters

description	model #	list
3½" (89mm) diameter	<b>A200019</b> •	4
5" (127mm) diameter, with swivel center	<b>A213261</b> •	7



donut bumper



## Catalog Section 1

### Plate Casters

see spec sheet **EG01.05B**

Freight class is 65.0.

(•) MTS (made to stock) / ( ) MTO (made to order)

**Polymer** - Polyurethane tread.

type	capacity		wheel diameter		wheel face		weight		model #	list
	lbs.	kg	in.	mm	in.	mm	lbs.	kg		
swivel	250	90.7	5"	127	1 1/4"	32	2.8	1.3	<b>PCPS5-250</b>	82
lock	250	90.7	5"	127	1 1/4"	32	2.8	1.3	<b>PCPL5-250</b>	85



### Resilient

type	capacity		wheel diameter		wheel face		weight		cu ft	EAGLEbrite® zinc	
	lbs.	kg	in.	mm	in.	mm	lbs.	kg		model #	list
swivel	200	90.7	5"	127	1 1/4"	29	2.8	1.3	0.5	<b>CPS5-200</b>	35
brake	200	90.7	5"	127	1 1/4"	29	2.8	1.3	0.5	<b>CPB5-200</b>	40
rigid	200	90.7	5"	127	1 1/4"	29	2.8	1.3	0.5	<b>CPR5-200</b>	40
swivel	250	113.4	5"	127	1 1/4"	32	3.0	1.4	0.5	<b>CPS5-250 •</b>	58
brake	250	113.4	5"	127	1 1/4"	32	3.0	1.4	0.5	<b>CPB5-250</b>	64
rigid	250	113.4	5"	127	1 1/4"	32	3.0	1.4	0.5	<b>CPR5-250</b>	64
swivel	500	226.8	6"	152	2"	51	9.0	4.1	0.5	<b>CPS6-500</b>	111
brake	500	226.8	6"	152	2"	51	9.0	4.1	0.5	<b>CPB6-500</b>	125
rigid	500	226.8	6"	152	2"	51	9.0	4.1	0.5	<b>CPR6-500</b>	125



### Polyurethane

type	capacity		wheel diameter		wheel face		weight		cu ft	EAGLEbrite® zinc	
	lbs.	kg	in.	mm	in.	mm	lbs.	kg		model #	list
swivel	300	136.1	5"	127	1 1/4"	32	3.0	1.4	0.5	<b>CPS5P-300 •</b>	58
brake	300	136.1	5"	127	1 1/4"	32	3.0	1.4	0.5	<b>CPB5P-300 •</b>	62
rigid	300	136.1	5"	127	1 1/4"	32	3.0	1.4	0.5	<b>CPR5P-300</b>	62
swivel	500	226.8	5"	127	2"	51	8.0	3.6	0.5	<b>CPS5P-500 •</b>	103
brake	500	226.8	5"	127	2"	51	8.0	3.6	0.5	<b>CPB5P-500 •</b>	119
rigid	500	226.8	5"	127	2"	51	8.0	3.6	0.5	<b>CPR5P-500</b>	119
swivel	600	272.1	6"	152	2"	51	9.0	4.1	0.5	<b>CPS6P-600 •</b>	86
brake	600	272.1	6"	152	2"	51	9.0	4.1	0.5	<b>CPB6P-600 •</b>	108
rigid	600	272.1	6"	152	2"	51	9.0	4.1	0.5	<b>CPR6P-600</b>	108
swivel	700	317.5	8"	203	2"	51	10.5	4.8	1.0	<b>CPS8P-700</b>	125
brake	700	317.5	8"	203	2"	51	10.5	4.8	1.0	<b>CPB8P-700</b>	141
rigid	700	317.5	8"	203	2"	51	10.5	4.8	1.0	<b>CPR8P-700</b>	141



with brake

### Stainless Steel Cart Washable Casters - Polyurethane tread.

type	capacity		wheel diameter		wheel face		weight		cu ft	stainless steel	
	lbs.	kg	in.	mm	in.	mm	lbs.	kg		model #	list
swivel	300	136.1	5"	127	1 1/4"	32	3.0	1.4	0.5	<b>CPS5S-300</b>	213
brake	300	136.1	5"	127	1 1/4"	32	3.0	1.4	0.5	<b>CPB5S-300</b>	251



with brake

## Go Green. Go ECO-Built™ by EAGLE.

For restaurants and other institutions concerned about meeting their own green standards, buying ECO-Built™ is simply the right thing to do.

Look for the ECO-Built™ tag on the bar code 



### Solid Shelves

see spec sheet **EG01.01**

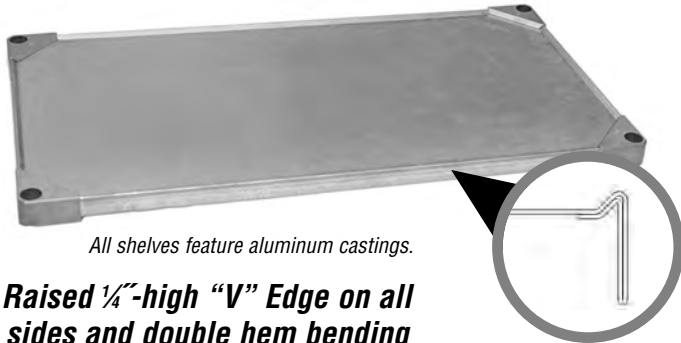

All shelves feature aluminum castings.

**Raised 1/4"-high "V" Edge on all sides and double hem bending provides quality and strength!**

side view of solid shelf, showing raised "V" edge

- Aluminum corner castings create locking mechanism to fasten shelves to posts with tapered split sleeves.

**FEATURES:**

**Notes:** Contact factory for availability of 72"-long shelves. Availability based on application.

- 24"-48" (610-1219mm) lengths: Four per box.
- 54"-72" (1372-1829mm) lengths: Two per box.
- Four pairs of split sleeves per shelf.

**All items can be shipped UPS.**

**PACKAGING:**

**Freight class is 70.0.**

(•) MTS (made to stock) / ( ) MTO (made to order)

	length		weight		cu ft	galvanized		VALU-MASTER®		Valu-Gard®		stainless	
	in.	mm	lb.	kg		model #	list	model #	list	model #	list	model #	list
<b>14" width</b> (356mm)	24"	610	10	4.5	0.5	<b>SS1424G</b>	195	<b>SS1424V</b>	215	<b>SS1424VG</b>	215	<b>SS1424S</b>	321
	30"	762	12	5.5	0.5	<b>SS1430G</b>	199	<b>SS1430V</b>	221	<b>SS1430VG</b>	221	<b>SS1430S</b>	326
	36"	914	14	6.4	0.5	<b>SS1436G</b>	212	<b>SS1436V</b>	227	<b>SS1436VG</b>	227	<b>SS1436S</b> •	328
	42"	1067	15	6.8	0.7	<b>SS1442G</b>	215	<b>SS1442V</b>	238	<b>SS1442VG</b>	238	<b>SS1442S</b>	391
	48"	1219	17	7.7	0.7	<b>SS1448G</b>	218	<b>SS1448V</b>	240	<b>SS1448VG</b>	240	<b>SS1448S</b> •	399
	54"	1372	20	9.1	0.9	<b>SS1454G</b>	235	<b>SS1454V</b>	263	<b>SS1454VG</b>	263	<b>SS1454S</b>	412
<b>18" width</b> (457mm)	60"	1524	22	10.0	0.9	<b>SS1460G</b>	238	<b>SS1460V</b>	268	<b>SS1460VG</b>	268	<b>SS1460S</b> •	475
	24"	610	11	5.0	0.7	<b>SS1824G</b>	195	<b>SS1824V</b>	221	<b>SS1824VG</b>	221	<b>SS1824S</b> •	363
	30"	762	14	6.4	0.7	<b>SS1830G</b>	204	<b>SS1830V</b>	225	<b>SS1830VG</b>	225	<b>SS1830S</b> •	367
	36"	914	16	7.3	0.7	<b>SS1836G</b> •	204	<b>SS1836V</b>	232	<b>SS1836VG</b>	232	<b>SS1836S</b> •	372
	42"	1067	18	8.2	0.9	<b>SS1842G</b>	221	<b>SS1842V</b>	242	<b>SS1842VG</b>	242	<b>SS1842S</b>	452
	48"	1219	20	9.1	0.9	<b>SS1848G</b> •	225	<b>SS1848V</b> •	242	<b>SS1848VG</b>	242	<b>SS1848S</b> •	456
<b>21" width</b> (533mm)	54"	1372	22	10.0	1.2	<b>SS1854G</b>	241	<b>SS1854V</b>	268	<b>SS1854VG</b>	268	<b>SS1854S</b>	474
	60"	1524	24	10.9	1.2	<b>SS1860G</b> •	246	<b>SS1860V</b>	275	<b>SS1860VG</b>	275	<b>SS1860S</b> •	536
	24"	610	13	5.9	0.7	<b>SS2124G</b>	209	<b>SS2124V</b>	229	<b>SS2124VG</b>	229	<b>SS2124S</b>	404
	30"	762	15	6.8	0.7	<b>SS2130G</b>	215	<b>SS2130V</b>	238	<b>SS2130VG</b>	238	<b>SS2130S</b>	407
	36"	914	18	8.2	0.8	<b>SS2136G</b>	227	<b>SS2136V</b>	253	<b>SS2136VG</b>	253	<b>SS2136S</b> •	411
	42"	1067	21	9.5	1.1	<b>SS2142G</b>	232	<b>SS2142V</b>	261	<b>SS2142VG</b>	261	<b>SS2142S</b>	516
<b>24" width</b> (610mm)	48"	1219	23	10.5	1.1	<b>SS2148G</b>	240	<b>SS2148V</b>	266	<b>SS2148VG</b>	266	<b>SS2148S</b>	520
	54"	1372	25	11.4	1.3	<b>SS2154G</b>	260	<b>SS2154V</b>	292	<b>SS2154VG</b>	292	<b>SS2154S</b>	540
	60"	1524	28	12.7	1.3	<b>SS2160G</b>	264	<b>SS2160V</b>	294	<b>SS2160VG</b>	294	<b>SS2160S</b>	603
	24"	610	15	6.8	0.8	<b>SS2424G</b> •	213	<b>SS2424V</b>	232	<b>SS2424VG</b>	232	<b>SS2424S</b> •	438
	30"	762	17	7.7	0.8	<b>SS2430G</b>	220	<b>SS2430V</b>	239	<b>SS2430VG</b>	239	<b>SS2430S</b>	442
	36"	914	19	8.6	0.8	<b>SS2436G</b> •	229	<b>SS2436V</b> •	256	<b>SS2436VG</b>	256	<b>SS2436S</b> •	444
<b>24" width</b> (610mm)	42"	1067	23	10.5	1.2	<b>SS2442G</b>	239	<b>SS2442V</b>	266	<b>SS2442VG</b>	266	<b>SS2442S</b> •	540
	48"	1219	24	10.9	1.2	<b>SS2448G</b> •	248	<b>SS2448V</b>	273	<b>SS2448VG</b>	273	<b>SS2448S</b> •	543
	54"	1372	27	12.3	1.5	<b>SS2454G</b>	266	<b>SS2454V</b>	297	<b>SS2454VG</b>	297	<b>SS2454S</b>	560
	60"	1524	31	14.1	1.5	<b>SS2460G</b> •	273	<b>SS2460V</b>	305	<b>SS2460VG</b>	305	<b>SS2460S</b> •	642

### Solid Shelf Joining Clamp

see spec sheet **EG01.03D**



model #      list per pair

**A203078**      33

**Note:** Two required per shelf.

**FEATURES:**

- Clamp and two additional posts create various shelving add-on configurations.
- Joins shelves end-to-end, back-to-back, or at right angles.

(•) MTS (made to stock) / ( ) MTO (made to order)

## Catalog Section 1

### Seismic Footplate Kits

see product announcement **EG8144**



bolt plate for #SFP10-1

two-post bolt plate for #SFP10-2

four-post bolt plate for #SFP10-4

- For 1"-diameter posts of pre-existing shelf units.
- 20 PSF per shelf weight capacity.
- Includes hardware to attach to posts.
- Bolt plate is zinc-plated.
- Post straps are chrome-plated.

#### FEATURES

**Note:** Shelves and posts sold separately.

**Freight class is 50.0.**

**Converts standard shelving into seismic shelving!**



post strap for #SFP10-2 and #SFP10-4

description	quantity of bolt plates per kit	width x length x height in.	width x length x height mm	kit model #	list
one-post bolt plate	4	2 7/8" x 7" x 4 1/4"	73 x 178 x 108	<b>SFP10-1</b>	216
two-post bolt plate, 2 sets of post straps*	2	8" x 11" x 4 1/4"	203 x 279 x 108	<b>SFP10-2</b>	365
four-post bolt plate, 4 sets of post straps*	1	11" x 11" x 4 1/4"	279 x 279 x 108	<b>SFP10-4</b>	334

\* Post straps come with hardware for assembly, and split sleeves for attaching to posts.

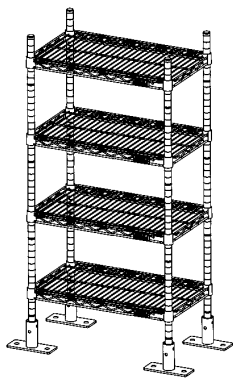

For single shelving unit, you need...

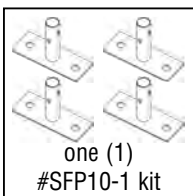

one (1) #SFP10-1 kit

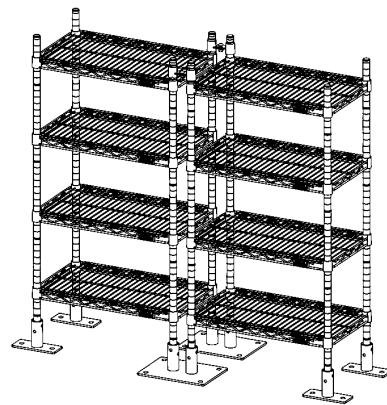

For TWO adjacent shelving units, you need...

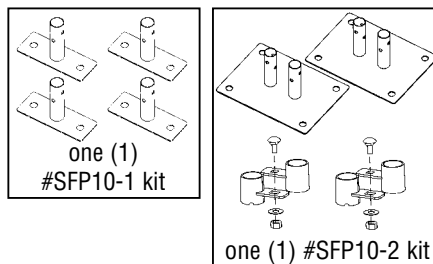

one (1) #SFP10-1 kit

one (1) #SFP10-2 kit

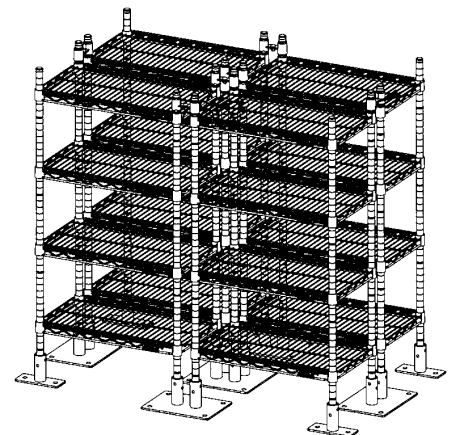

For FOUR adjacent shelving units, you need...

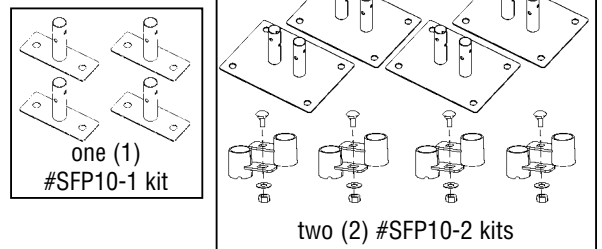

one (1) #SFP10-1 kit

two (2) #SFP10-2 kits

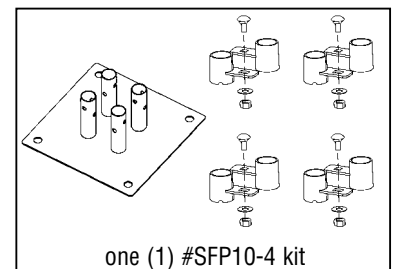

one (1) #SFP10-4 kit

**OSHPD APPROVED**

OPM-0349-13

**Approved by the California Office of Statewide Health Planning and Development.**

**Note:** OSHPD ongoing evaluation may affect EAGLE GROUP's approve/pre-approve status. Consult factory.

### Four-Shelf Starter Units NSF

see spec sheet **EG01.25**

- Four shelves.
- Four posts (same finish as shelves).
- Shipped knocked-down.

INCLUDES:

Note: 54" (1372mm) shelves available see page 6.



**EAGLEgard®** finish standard with **MICROGARD®** protection.

See bottom of page 4 for details.

**Freight class is 70.0.**

(•) MTS (made to stock) / ( ) MTO (made to order)

**patented**  
**QuadTruss®**  
**design**  
(Patent #5,390,803)

**Patented QuadTruss® Design** makes shelves up to 25% stronger and provides a retaining ledge for increased strength and product retention.

### Models with 63" (1600mm) Height

	length		cu ft	EAGLEbrite®		chrome		VALU-MASTER®		Valu-Gard®		EAGLEgard®		stainless	
	in.	mm		model #	list	model #	list	model #	list	model #	list	model #	list	model #	list
<b>18" width (457mm)</b>	24"	610	42 19	1.8	S4-63-1824Z • 442	S4-63-1824C • 453	S4-63-1824V • 472	S4-63-1824VG • 472	S4-63-1824E • 544	S4-63-1824S • 1602					
	30"	762	47 21	2.2	S4-63-1830Z • 453	S4-63-1830C • 466	S4-63-1830V • 506	S4-63-1830VG • 506	S4-63-1830E • 554	S4-63-1830S • 1612					
	36"	914	53 24	2.6	S4-63-1836Z • 466	S4-63-1836C • 477	S4-63-1836V • 528	S4-63-1836VG • 528	S4-63-1836E • 577	S4-63-1836S • 1632					
	42"	1067	57 26	3.0	S4-63-1842Z • 506	S4-63-1842C • 528	S4-63-1842V • 577	S4-63-1842VG • 577	S4-63-1842E • 649	S4-63-1842S • 1862					
	48"	1219	63 29	3.5	S4-63-1848Z • 520	S4-63-1848C • 548	S4-63-1848V • 615	S4-63-1848VG • 615	S4-63-1848E • 664	S4-63-1848S • 1876					
	60"	1524	82 37	4.2	S4-63-1860Z • 597	S4-63-1860C • 621	S4-63-1860V • 687	S4-63-1860VG • 687	S4-63-1860E • 766	S4-63-1860S • 2300					
<b>21" width (533mm)</b>	24"	610	46 21	2.1	S4-63-2124Z • 472	S4-63-2124C • 495	S4-63-2124V • 520	S4-63-2124VG • 520	S4-63-2124E • 606	S4-63-2124S • 1789					
	30"	762	52 24	2.6	S4-63-2130Z • 486	S4-63-2130C • 524	S4-63-2130V • 539	S4-63-2130VG • 539	S4-63-2130E • 621	S4-63-2130S • 1804					
	36"	914	59 27	3.0	S4-63-2136Z • 499	S4-63-2136C • 534	S4-63-2136V • 597	S4-63-2136VG • 597	S4-63-2136E • 631	S4-63-2136S • 1814					
	42"	1067	65 30	3.5	S4-63-2142Z • 544	S4-63-2142C • 597	S4-63-2142V • 631	S4-63-2142VG • 631	S4-63-2142E • 698	S4-63-2142S • 2045					
	48"	1219	71 32	4.0	S4-63-2148Z • 558	S4-63-2148C • 606	S4-63-2148V • 655	S4-63-2148VG • 655	S4-63-2148E • 707	S4-63-2148S • 2054					
	60"	1524	88 40	5.0	S4-63-2160Z • 649	S4-63-2160C • 683	S4-63-2160V • 766	S4-63-2160VG • 766	S4-63-2160E • 823	S4-63-2160S • 2617					
<b>24" width (610mm)</b>	24"	610	50 23	2.4	S4-63-2424Z • 499	S4-63-2424C • 528	S4-63-2424V • 544	S4-63-2424VG • 544	S4-63-2424E • 644	S4-63-2424S • 1909					
	30"	762	57 26	2.9	S4-63-2430Z • 511	S4-63-2430C • 548	S4-63-2430V • 597	S4-63-2430VG • 597	S4-63-2430E • 655	S4-63-2430S • 1925					
	36"	914	65 30	3.5	S4-63-2436Z • 524	S4-63-2436C • 563	S4-63-2436V • 621	S4-63-2436VG • 621	S4-63-2436E • 668	S4-63-2436S • 1943					
	42"	1067	72 33	4.0	S4-63-2442Z • 597	S4-63-2442C • 635	S4-63-2442V • 668	S4-63-2442VG • 668	S4-63-2442E • 771	S4-63-2442S • 2261					
	48"	1219	79 36	4.5	S4-63-2448Z • 606	S4-63-2448C • 649	S4-63-2448V • 732	S4-63-2448VG • 732	S4-63-2448E • 788	S4-63-2448S • 2271					
	60"	1524	98 45	5.6	S4-63-2460Z • 717	S4-63-2460C • 746	S4-63-2460V • 842	S4-63-2460VG • 842	S4-63-2460E • 904	S4-63-2460S • 2714					

### Models with 74" (1880mm) Height

	length		cu ft	EAGLEbrite®		chrome		VALU-MASTER®		Valu-Gard®		EAGLEgard®		stainless	
	in.	mm		model #	list	model #	list	model #	list	model #	list	model #	list	model #	list
<b>18" width (457mm)</b>	24"	610	51 23	1.9	S4-74-1824Z • 457	S4-74-1824C • 466	S4-74-1824V • 481	S4-74-1824VG • 481	S4-74-1824E • 558	S4-74-1824S • 1645					
	30"	762	58 26	2.3	S4-74-1830Z • 466	S4-74-1830C • 481	S4-74-1830V • 515	S4-74-1830VG • 515	S4-74-1830E • 567	S4-74-1830S • 1654					
	36"	914	65 30	2.7	S4-74-1836Z • 481	S4-74-1836C • 491	S4-74-1836V • 539	S4-74-1836VG • 539	S4-74-1836E • 593	S4-74-1836S • 1674					
	42"	1067	70 32	3.1	S4-74-1842Z • 520	S4-74-1842C • 544	S4-74-1842V • 586	S4-74-1842VG • 586	S4-74-1842E • 664	S4-74-1842S • 1905					
	48"	1219	78 36	3.6	S4-74-1848Z • 534	S4-74-1848C • 563	S4-74-1848V • 626	S4-74-1848VG • 626	S4-74-1848E • 679	S4-74-1848S • 1919					
	60"	1524	102 46	4.3	S4-74-1860Z • 611	S4-74-1860C • 635	S4-74-1860V • 698	S4-74-1860VG • 698	S4-74-1860E • 779	S4-74-1860S • 2343					
<b>21" width (533mm)</b>	24"	610	57 26	2.2	S4-74-2124Z • 486	S4-74-2124C • 511	S4-74-2124V • 528	S4-74-2124VG • 528	S4-74-2124E • 621	S4-74-2124S • 1833					
	30"	762	64 29	2.7	S4-74-2130Z • 499	S4-74-2130C • 539	S4-74-2130V • 548	S4-74-2130VG • 548	S4-74-2130E • 635	S4-74-2130S • 1846					
	36"	914	73 33	3.1	S4-74-2136Z • 515	S4-74-2136C • 548	S4-74-2136V • 606	S4-74-2136VG • 606	S4-74-2136E • 644	S4-74-2136S • 1857					
	42"	1067	81 37	3.6	S4-74-2142Z • 558	S4-74-2142C • 611	S4-74-2142V • 639	S4-74-2142VG • 639	S4-74-2142E • 713	S4-74-2142S • 2087					
	48"	1219	88 40	4.1	S4-74-2148Z • 573	S4-74-2148C • 621	S4-74-2148V • 664	S4-74-2148VG • 664	S4-74-2148E • 721	S4-74-2148S • 2098					
	60"	1524	109 50	5.1	S4-74-2160Z • 664	S4-74-2160C • 698	S4-74-2160V • 775	S4-74-2160VG • 775	S4-74-2160E • 837	S4-74-2160S • 2660					
<b>24" width (610mm)</b>	24"	610	62 28	2.5	S4-74-2424Z • 515	S4-74-2424C • 544	S4-74-2424V • 554	S4-74-2424VG • 554	S4-74-2424E • 660	S4-74-2424S • 1953					
	30"	762	71 32	3.0	S4-74-2430Z • 524	S4-74-2430C • 563	S4-74-2430V • 606	S4-74-2430VG • 606	S4-74-2430E • 668	S4-74-2430S • 1967					
	36"	914	81 37	3.6	S4-74-2436Z • 539	S4-74-2436C • 577	S4-74-2436V • 631	S4-74-2436VG • 631	S4-74-2436E • 683	S4-74-2436S • 1986					
	42"	1067	89 40	3.7	S4-74-2442Z • 611	S4-74-2442C • 649	S4-74-2442V • 679	S4-74-2442VG • 679	S4-74-2442E • 784	S4-74-2442S • 2304					
	48"	1219	98 45	4.6	S4-74-2448Z • 621	S4-74-2448C • 664	S4-74-2448V • 741	S4-74-2448VG • 741	S4-74-2448E • 804	S4-74-2448S • 2314					
	60"	1524	122 55	5.7	S4-74-2460Z • 732	S4-74-2460C • 759	S4-74-2460V • 853	S4-74-2460VG • 853	S4-74-2460E • 919	S4-74-2460S • 2757					



### Five-Shelf Starter Units (NSF)

see spec sheet **EG01.25**



**EAGLEgard® finish standard with MICROGARD® protection.**  
See bottom of page 4 for details.

- Five wire shelves.
- Four posts (*same finish as shelves*).
- Shipped knocked-down.

**INCLUDES:**

**Note:** 54" (1372mm) shelves available see page 6.

**Freight class is 70.0.**

(•) MTS (*made to stock*) / ( ) MTO (*made to order*)

**patented**  
**QuadTruss®**  
**design**  
(Patent #5,390,803)

**Patented QuadTruss® Design**  
makes shelves up to 25% stronger and provides a retaining ledge for increased strength and product retention.

### Models with 74" (1880mm) Height

	length		weight		cu ft	EAGLEbrite®		chrome		VALU-MASTER®		Valu-Gard®		EAGLEgard®		stainless	
	in.	mm	lb.	kg		model #	list	model #	list	model #	list	model #	list	model #	list	model #	list
<b>18" width (457mm)</b>	24"	610	51	23	1.9	S5-74-1824Z • 538	S5-74-1824C • 548	S5-74-1824V • 565	S5-74-1824VG • 565	S5-74-1824E • 659	S5-74-1824S • 1963						
	30"	762	58	26	2.3	S5-74-1830Z • 549	S5-74-1830C • 566	S5-74-1830V • 607	S5-74-1830VG • 607	S5-74-1830E • 669	S5-74-1830S • 1975						
	36"	914	65	30	2.7	S5-74-1836Z • 567	S5-74-1836C • 578	S5-74-1836V • 637	S5-74-1836VG • 637	S5-74-1836E • 700	S5-74-1836S • 1999						
	42"	1067	70	32	3.1	S5-74-1842Z • 615	S5-74-1842C • 644	S5-74-1842V • 698	S5-74-1842VG • 698	S5-74-1842E • 789	S5-74-1842S • 2286						
	48"	1219	78	36	3.6	S5-74-1848Z • 634	S5-74-1848C • 668	S5-74-1848V • 746	S5-74-1848VG • 746	S5-74-1848E • 808	S5-74-1848S • 2305						
	60"	1524	102	46	4.3	S5-74-1860Z • 731	S5-74-1860C • 758	S5-74-1860V • 836	S5-74-1860VG • 836	S5-74-1860E • 934	S5-74-1860S • 2835						
72"	1829	117	53	5.1	S5-74-1872Z • 826	S5-74-1872C • 879	S5-74-1872V • 980	S5-74-1872VG • 980	S5-74-1872E • 1042	S5-74-1872S • 3292							
<b>21" width (533mm)</b>	24"	610	57	26	2.2	S5-74-2124Z • 574	S5-74-2124C • 602	S5-74-2124V • 626	S5-74-2124VG • 626	S5-74-2124E • 737	S5-74-2124S • 2197						
	30"	762	64	29	2.7	S5-74-2130Z • 593	S5-74-2130C • 638	S5-74-2130V • 649	S5-74-2130VG • 649	S5-74-2130E • 754	S5-74-2130S • 2215						
	36"	914	73	33	3.1	S5-74-2136Z • 609	S5-74-2136C • 651	S5-74-2136V • 721	S5-74-2136VG • 721	S5-74-2136E • 767	S5-74-2136S • 2227						
	42"	1067	81	37	3.6	S5-74-2142Z • 664	S5-74-2142C • 729	S5-74-2142V • 762	S5-74-2142VG • 762	S5-74-2142E • 849	S5-74-2142S • 2515						
	48"	1219	88	40	4.1	S5-74-2148Z • 682	S5-74-2148C • 741	S5-74-2148V • 794	S5-74-2148VG • 794	S5-74-2148E • 862	S5-74-2148S • 2528						
	60"	1524	109	50	5.1	S5-74-2160Z • 796	S5-74-2160C • 837	S5-74-2160V • 932	S5-74-2160VG • 932	S5-74-2160E • 1006	S5-74-2160S • 3232						
72"	1829	122	55	7.7	S5-74-2172Z • 941	S5-74-2172C • 994	S5-74-2172V • 1065	S5-74-2172VG • 1065	S5-74-2172E • 1193	S5-74-2172S • 3760							
<b>24" width (610mm)</b>	24"	610	62	28	2.5	S5-74-2424Z • 609	S5-74-2424C • 644	S5-74-2424V • 656	S5-74-2424VG • 656	S5-74-2424E • 784	S5-74-2424S • 2347						
	30"	762	71	32	3.0	S5-74-2430Z • 622	S5-74-2430C • 668	S5-74-2430V • 721	S5-74-2430VG • 721	S5-74-2430E • 796	S5-74-2430S • 2365						
	36"	914	81	37	3.6	S5-74-2436Z • 639	S5-74-2436C • 686	S5-74-2436V • 752	S5-74-2436VG • 752	S5-74-2436E • 814	S5-74-2436S • 2389						
	42"	1067	89	40	3.7	S5-74-2442Z • 731	S5-74-2442C • 777	S5-74-2442V • 812	S5-74-2442VG • 812	S5-74-2442E • 941	S5-74-2442S • 2787						
	48"	1219	98	45	4.6	S5-74-2448Z • 742	S5-74-2448C • 795	S5-74-2448V • 891	S5-74-2448VG • 891	S5-74-2448E • 964	S5-74-2448S • 2799						
	60"	1524	122	55	6.9	S5-74-2460Z • 881	S5-74-2460C • 916	S5-74-2460V • 1029	S5-74-2460VG • 1029	S5-74-2460E • 1108	S5-74-2460S • 3352						
72"	1829	149	68	5.7	S5-74-2472Z • 995	S5-74-2472C • 1059	S5-74-2472V • 1191	S5-74-2472VG • 1191	S5-74-2472E • 1271	S5-74-2472S • 4098							

### Models with 86" (2184mm) Height

	length		weight		cu ft	EAGLEbrite®		chrome		VALU-MASTER®		Valu-Gard®		EAGLEgard®		stainless	
	in.	mm	lb.	kg		model #	list	model #	list	model #	list	model #	list	model #	list	model #	list
<b>18" width (457mm)</b>	24"	610	55	25	3.9	S5-86-1824Z • 572	S5-86-1824C • 582	S5-86-1824V • 603	S5-86-1824VG • 603	S5-86-1824E • 686	S5-86-1824S • 2040						
	30"	762	60	27	3.9	S5-86-1830Z • 583	S5-86-1830C • 600	S5-86-1830V • 645	S5-86-1830VG • 645	S5-86-1830E • 699	S5-86-1830S • 2052						
	36"	914	65	30	3.9	S5-86-1836Z • 601	S5-86-1836C • 612	S5-86-1836V • 675	S5-86-1836VG • 675	S5-86-1836E • 729	S5-86-1836S • 2076						
	42"	1067	75	34	4.9	S5-86-1842Z • 649	S5-86-1842C • 679	S5-86-1842V • 737	S5-86-1842VG • 737	S5-86-1842E • 819	S5-86-1842S • 2364						
	48"	1219	80	36	4.9	S5-86-1848Z • 667	S5-86-1848C • 702	S5-86-1848V • 784	S5-86-1848VG • 784	S5-86-1848E • 837	S5-86-1848S • 2383						
	60"	1524	105	48	6.4	S5-86-1860Z • 762	S5-86-1860C • 792	S5-86-1860V • 874	S5-86-1860VG • 874	S5-86-1860E • 963	S5-86-1860S • 2912						
72"	1829	120	54	7.4	S5-86-1872Z • 860	S5-86-1872C • 913	S5-86-1872V • 1018	S5-86-1872VG • 1018	S5-86-1872E • 1072	S5-86-1872S • 3368							
<b>21" width (533mm)</b>	24"	610	60	27	3.9	S5-86-2124Z • 607	S5-86-2124C • 636	S5-86-2124V • 664	S5-86-2124VG • 664	S5-86-2124E • 766	S5-86-2124S • 2275						
	30"	762	65	30	3.9	S5-86-2130Z • 626	S5-86-2130C • 672	S5-86-2130V • 687	S5-86-2130VG • 687	S5-86-2130E • 783	S5-86-2130S • 2292						
	36"	914	75	34	4.4	S5-86-2136Z • 643	S5-86-2136C • 684	S5-86-2136V • 759	S5-86-2136VG • 759	S5-86-2136E • 795	S5-86-2136S • 2304						
	42"	1067	80	36	5.9	S5-86-2142Z • 698	S5-86-2142C • 761	S5-86-2142V • 802	S5-86-2142VG • 802	S5-86-2142E • 879	S5-86-2142S • 2593						
	48"	1219	90	41	5.9	S5-86-2148Z • 716	S5-86-2148C • 775	S5-86-2148V • 832	S5-86-2148VG • 832	S5-86-2148E • 892	S5-86-2148S • 2604						
	60"	1524	110	50	6.9	S5-86-2160Z • 829	S5-86-2160C • 871	S5-86-2160V • 971	S5-86-2160VG • 971	S5-86-2160E • 1036	S5-86-2160S • 3309						
72"	1829	140	64	8.4	S5-86-2172Z • 975	S5-86-2172C • 1028	S5-86-2172V • 1103	S5-86-2172VG • 1103	S5-86-2172E • 1222	S5-86-2172S • 3838							
<b>24" width (610mm)</b>	24"	610	65	30	4.4	S5-86-2424Z • 643	S5-86-2424C • 679	S5-86-2424V • 695	S5-86-2424VG • 695	S5-86-2424E • 813	S5-86-2424S • 2424						
	30"	762	75	34	4.4	S5-86-2430Z • 656	S5-86-2430C • 702	S5-86-2430V • 759	S5-86-2430VG • 759	S5-86-2430E • 825	S5-86-2430S • 2442						
	36"	914	85	39	4.4	S5-86-2436Z • 673	S5-86-2436C • 720	S5-86-2436V • 789	S5-86-2436VG • 789	S5-86-2436E • 843	S5-86-2436S • 2466						
	42"	1067	95	43	6.4	S5-86-2442Z • 762	S5-86-2442C • 811	S5-86-2442V • 849	S5-86-2442VG • 849	S5-86-2442E • 969	S5-86-2442S • 2863						
	48"	1219	100	45	6.4	S5-86-2448Z • 776	S5-86-2448C • 828	S5-86-2448V • 928	S5-86-2448VG • 928	S5-86-2448E • 994	S5-86-2448S • 2876						
	60"	1524	125	57	7.9	S5-86-2460Z • 914	S5-86-2460C • 948	S5-86-2460V • 1067	S5-86-2460VG • 1067	S5-86-2460E • 1137	S5-86-2460S • 3428						
72"	1829	150	68	9.4	S5-86-2472Z • 1029	S5-86-2472C • 1093	S5-86-2472V • 1229	S5-86-2472VG • 1229	S5-86-2472E • 1300	S5-86-2472S • 4175							



### Add-A-Shelf®

see spec sheet **EG01.11A** **WEIGHT CAPACITY:**

- 300 lb. (136.1 kg); per shelf.
- using an evenly distributed load.



#### Add-A-Shelf® Collars

allows addition or removal of shelf without breaking down the entire unit

description	model #	list
set of four	<b>A208891</b>	13

- One set of four included with each shelf.
- Must be used with **SPLIT SLEEVES**, list (per set of four): \$5.

**Note:** Top and bottom shelves of unit must be standard shelves. Post are sold separately. See page 23.

(For shelves with **EAGLEbrite®** or chrome finish, see page 6; For shelves with black, red, or white epoxy finish, see page 65).

#### WARNING:

- Use Add-A-Shelf® shelves for intermediate shelves. Add-A-Shelf® is not recommended for mobile applications.

**Freight class is 70.0.**

(•) MTS (made to stock) / ( ) MTO (made to order)

**patented**  
**QuadTruss®**  
**design**  
(Patent #5,390,803)

**Patented QuadTruss® Design** makes shelves up to 25% stronger and provides a retaining ledge for increased strength and product retention.

### Add-A-Shelf® Adjustable Shelves - Patent # 5,884,567

	length		weight		cu ft	EAGLEbrite®		chrome		black		red		white	
	in.	mm	lb.	kg		model #	list	model #	list	model #	list	model #	list	model #	list
<b>14" width</b> (356mm)	36"	914	8	3.6	0.5	<b>A1436Z</b>	82	<b>A1436C</b> •	91	<b>A1436BL</b> •	94	<b>A1436R</b>	94	<b>A1436W</b>	94
	48"	1219	10	4.5	0.7	<b>A1448Z</b>	94	<b>A1448C</b> •	106	<b>A1448BL</b>	109	<b>A1448R</b>	109	<b>A1448W</b>	109
<b>18" width</b> (457mm)	36"	914	9	4.1	0.7	<b>A1836Z</b>	95	<b>A1836C</b> •	96	<b>A1836BL</b>	99	<b>A1836R</b>	99	<b>A1836W</b>	99
	48"	1219	12	5.5	0.9	<b>A1848Z</b>	109	<b>A1848C</b> •	116	<b>A1848BL</b>	119	<b>A1848R</b>	119	<b>A1848W</b>	119
	60"	1524	15	6.8	1.0	<b>A1860Z</b>	125	<b>A1860C</b>	134	<b>A1860BL</b>	138	<b>A1860R</b>	138	<b>A1860W</b>	138
<b>21" width</b> (533mm)	36"	914	11	5.0	0.8	<b>A2136Z</b>	103	<b>A2136C</b>	112	<b>A2136BL</b>	116	<b>A2136R</b>	116	<b>A2136W</b>	116
	48"	1219	14	6.4	1.1	<b>A2148Z</b>	119	<b>A2148C</b>	126	<b>A2148BL</b>	133	<b>A2148R</b>	133	<b>A2148W</b>	133
	60"	1524	17	7.7	1.3	<b>A2160Z</b>	141	<b>A2160C</b>	151	<b>A2160BL</b>	155	<b>A2160R</b>	155	<b>A2160W</b>	155
<b>24" width</b> (610mm)	36"	914	13	5.9	0.8	<b>A2436Z</b>	111	<b>A2436C</b> •	119	<b>A2436BL</b>	122	<b>A2436R</b>	122	<b>A2436W</b>	122
	48"	1219	16	7.3	1.2	<b>A2448Z</b>	129	<b>A2448C</b> •	140	<b>A2448BL</b>	143	<b>A2448R</b>	143	<b>A2448W</b>	143
	60"	1524	21	9.5	1.5	<b>A2460Z</b>	156	<b>A2460C</b> •	167	<b>A2460BL</b>	173	<b>A2460R</b>	173	<b>A2460W</b>	173

#### PACKAGING:

- 36" and 48" lengths: Four per box.
- 60" lengths: Two per box.
- Four pairs split sleeves per shelf.
- Four-pack collars per shelf.

### Add-A-Shelf® Reverse Mat Shelves - Patent # 5,884,567

	length		weight		cu ft	EAGLEbrite®		chrome		black		red		white	
	in.	mm	lb.	kg		model #	list	model #	list	model #	list	model #	list	model #	list
<b>14" width</b> (356mm)	36"	914	8	3.6	0.5	<b>D1436Z</b>	85	<b>D1436C</b>	94	<b>D1436BL</b>	96	<b>D1436R</b>	96	<b>D1436W</b>	96
	48"	1219	10	4.5	0.7	<b>D1448Z</b>	96	<b>D1448C</b>	109	<b>D1448BL</b>	113	<b>D1448R</b>	113	<b>D1448W</b>	113
<b>18" width</b> (457mm)	36"	914	9	4.1	0.7	<b>D1836Z</b>	98	<b>D1836C</b>	100	<b>D1836BL</b>	103	<b>D1836R</b>	103	<b>D1836W</b>	103
	48"	1219	12	5.5	0.9	<b>D1848Z</b>	112	<b>D1848C</b>	119	<b>D1848BL</b>	122	<b>D1848R</b>	122	<b>D1848W</b>	122
<b>21" width</b> (533mm)	36"	914	11	5.0	0.8	<b>D2136Z</b>	108	<b>D2136C</b>	118	<b>D2136BL</b>	121	<b>D2136R</b>	121	<b>D2136W</b>	121
	48"	1219	14	6.4	1.1	<b>D2148Z</b>	121	<b>D2148C</b>	133	<b>D2148BL</b>	137	<b>D2148R</b>	137	<b>D2148W</b>	137
<b>24" width</b> (610mm)	36"	914	13	5.9	0.8	<b>D2436Z</b>	116	<b>D2436C</b>	121	<b>D2436BL</b>	124	<b>D2436R</b>	124	<b>D2436W</b>	124
	48"	1219	16	7.3	1.2	<b>D2448Z</b>	134	<b>D2448C</b>	144	<b>D2448BL</b>	148	<b>D2448R</b>	148	<b>D2448W</b>	148



#### HOW TO ASSEMBLE: Add-A-Shelf® Collar

Numerically calibrated grooved posts, tapered plastic split sleeves and shelf collars combine to make shelving assembly a **SIMPLE 3 STEP EXERCISE:**



1. Snap split sleeves onto post over the number of your choice.



2. Slide collar over split sleeves. When together, a positive lock is created without the use of tools.

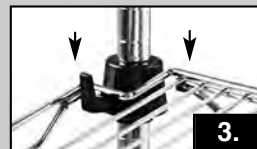

3. Place shelf over collar to complete.



Add-A-Shelf® as a merchandise display unit



## Catalog Section 1

### Posts for Add-A-Shelf®

see spec sheet **EG01.11A**

Freight class is 50.0.

(•) MTS (made to stock) / ( ) MTO (made to order)



post height in. mm	weight		cu ft	EAGLEbrite®		chrome		black		red		white	
	lb.	kg		model #	list	model #	list	model #	list	model #	list	model #	list
7"	178	0.8 0.4	0.1	P7-Z •	17	P7-C •	18	P7-BL •	20	P7-R	20	P7-W	20
14"	356	1.0 0.5	0.1	P14-Z •	21	P14-C •	23	P14-BL •	24	P14-R	24	P14-W	24
33"	838	2.0 0.9	0.1	P33-Z •	24	P33-C •	25	P33-BL •	27	P33-R	27	P33-W	27
54"	1372	3.0 1.4	0.1	P54-Z •	29	P54-C •	31	P54-BL •	32	P54-R	32	P54-W	32
63"	1600	3.5 1.8	0.3	P63-Z •	31	P63-C •	32	P63-BL •	34	P63-R •	34	P63-W	34
74"	1880	4.0 1.8	0.5	P74-Z •	34	P74-C •	35	P74-BL •	36	P74-R	36	P74-W	36
86"	2184	5.0 2.3	0.8	P86-Z •	41	P86-C •	43	P86-BL •	46	P86-R	46	P86-W	46

### Add-A-Shelf® Post Clamps

see spec sheet **EG01.11A**

Freight class is 70.0.

(•) MTS (made to stock) / ( ) MTO (made to order)



stainless steel		black epoxy	
model #	list	model #	list
ADD-A-CLAMP	13	ADD-A-CLAMP-BL	17

### Add-A-Shelf® Starter Units (NSF)

see spec sheet **EG01.11B**

FEATURES:

- Front edge of shelf can be lowered 4" (102mm) to create slanted shelf.

Note: Top and bottom shelves of unit must be standard shelves.

WARNING:

- Use Add-A-Shelf® shelves for intermediate shelves. Add-A-Shelf® is not recommended for mobile applications.

Freight class is 70.0.



#### KIT INCLUDES:

- Two standard shelves.
- Two Add-A-Shelf® shelves.
- Four Redi-Pak® posts.
- Four bags of split sleeves.
- Two bags of Add-A-Shelf® collars.

**ALL IN ONE BOX  
LOWERING SHIPPING COST!**

patented  
**QuadTruss®**  
design  
(Patent #5,390,803)

**Patented QuadTruss® Design** makes shelves up to 25% stronger and provides a retaining ledge for increased strength and product retention.

#### Units with 63" (1600mm) Posts

#### Units with 74" (1880mm) Posts

	length		chrome		black epoxy		chrome		black epoxy	
	in.	mm	model #	list	model #	list	model #	list	model #	list
<b>14" width</b> (356mm)	36"	914	RS4-63-A1436C	657	RS4-63-A1436BL	668	RS4-74-A1436C	699	RS4-74-A1436BL	714
	48"	1219	RS4-63-A1448C	700	RS4-63-A1448BL	715	RS4-74-A1448C	743	RS4-74-A1448BL	757
<b>18" width</b> (457mm)	36"	914	RS4-63-A1836C	702	RS4-63-A1836BL	717	RS4-74-A1836C	746	RS4-74-A1836BL	759
	48"	1219	RS4-63-A1848C	758	RS4-63-A1848BL	776	RS4-74-A1848C	801	RS4-74-A1848BL	818
<b>21" width</b> (533mm)	36"	914	RS4-63-A2136C	722	RS4-63-A2136BL	739	RS4-74-A2136C	766	RS4-74-A2136BL	782
	48"	1219	RS4-63-A2148C	797	RS4-63-A2148BL	813	RS4-74-A2148C	837	RS4-74-A2148BL	854
<b>24" width</b> (610mm)	36"	914	RS4-63-A2436C	768	RS4-63-A2436BL	783	RS4-74-A2436C	807	RS4-74-A2436BL	824
	48"	1219	RS4-63-A2448C	875	RS4-63-A2448BL	894	RS4-74-A2448C	916	RS4-74-A2448BL	933

## Redi-Pak® Wire Shelving Units NSF

see spec sheet **EG01.26**



# Redi-Pak®



Packed and shipped in one box.

**SAVES UP TO 50%  
ON SHIPPING COSTS!**

4-SHELF UNITS:

- Four wire shelves.
- Four two-piece posts.

5-SHELF UNITS:

- Five wire shelves.
- Four two-piece posts.

Can be shipped UPS.

Freight class is 70.0.

patented  
**QuadTruss®**  
design  
(Patent #5,390,803)

**Patented QuadTruss® Design**  
makes shelves up to 25% stronger and provides  
a retaining ledge for increased strength and  
product retention.

### 4-Shelf Units, 63" (1600mm) Height

	length		weight		cu ft	EAGLEbrite®		chrome		VALU-MASTER®		Valu-Gard®		EAGLEgard®	
	in.	mm	lb.	kg		model #	list	model #	list	model #	list	model #	list	model #	list
18" width (457mm)	36"	914	52	23.6	2.8	1836Z63	497	1836C63	531	1836V63	572	1836VG63	572	1836E63	642
	48"	1219	64	29.0	3.6	1848Z63	561	1848C63	601	1848V63	646	1848VG63	646	1848E63	739
	60"	1524	84	38.1	4.8	1860Z63	663	1860C63	682	1860V63	734	1860VG63	734	1860E63	844
24" width (610mm)	36"	914	68	30.8	3.2	2436Z63	569	2436C63	619	2436V63	666	2436VG63	666	2436E63	744
	48"	1219	80	36.3	4.8	2448Z63	652	2448C63	715	2448V63	768	2448VG63	768	2448E63	878
	60"	1524	100	45.4	6.0	2460Z63	766	2460C63	827	2460V63	891	2460VG63	891	2460E63	1000

### 4-Shelf Units, 74" (1880mm) Height

	length		weight		cu ft	EAGLEbrite®		chrome		VALU-MASTER®		Valu-Gard®		EAGLEgard®	
	in.	mm	lb.	kg		model #	list	model #	list	model #	list	model #	list	model #	list
18" width (457mm)	36"	914	52	23.6	2.8	1836Z74	508	1836C74	540	1836V74	582	1836VG74	582	1836E74	644
	48"	1219	74	33.6	3.6	1848Z74	586	1848C74	626	1848V74	672	1848VG74	672	1848E74	761
	60"	1524	84	38.1	4.8	1860Z74	651	1860C74	698	1860V74	753	1860VG74	753	1860E74	896
24" width (610mm)	36"	914	68	30.8	3.2	2436Z74	588	2436C74	629	2436V74	677	2436VG74	677	2436E74	759
	48"	1219	80	36.3	4.8	2448Z74	682	2448C74	732	2448V74	785	2448VG74	785	2448E74	911
	60"	1524	100	45.4	6.0	2460Z74	794	2460C74	848	2460V74	912	2460VG74	912	2460E74	1028

### 5-Shelf Units, 63" (1600mm) Height

	length		weight		cu ft	EAGLEbrite®		chrome		VALU-MASTER®		Valu-Gard®		EAGLEgard®	
	in.	mm	lb.	kg		model #	list	model #	list	model #	list	model #	list	model #	list
18" width (457mm)	36"	914	61	27.7	3.5	1836Z63-5	599	1836C63-5	637	1836V63-5	685	1836VG63-5	685	1836E63-5	768
	48"	1219	76	34.5	4.5	1848Z63-5	685	1848C63-5	726	1848V63-5	783	1848VG63-5	783	1848E63-5	899
	60"	1524	101	45.8	6.0	1860Z63-5	751	1860C63-5	836	1860V63-5	901	1860VG63-5	901	1860E63-5	1035
24" width (610mm)	36"	914	81	36.7	4.0	2436Z63-5	698	2436C63-5	754	2436V63-5	808	2436VG63-5	808	2436E63-5	909
	48"	1219	96	43.6	6.0	2448Z63-5	807	2448C63-5	882	2448V63-5	949	2448VG63-5	949	2448E63-5	987
	60"	1524	121	54.9	7.5	2460Z63-5	944	2460C63-5	1001	2460V63-5	1078	2460VG63-5	1078	2460E63-5	1221

### 5-Shelf Units, 74" (1880mm) Height

	length		weight		cu ft	EAGLEbrite®		chrome		VALU-MASTER®		Valu-Gard®		EAGLEgard®	
	in.	mm	lb.	kg		model #	list	model #	list	model #	list	model #	list	model #	list
18" width (457mm)	36"	914	61	27.7	3.5	1836Z74-5	600	1836C74-5	664	1836V74-5	715	1836VG74-5	715	1836E74-5	805
	48"	1219	76	34.5	4.5	1848Z74-5	708	1848C74-5	761	1848V74-5	821	1848VG74-5	821	1848E74-5	933
	60"	1524	101	45.8	6.0	1860Z74-5	761	1860C74-5	866	1860V74-5	932	1860VG74-5	932	1860E74-5	1074
24" width (610mm)	36"	914	81	36.7	4.0	2436Z74-5	720	2436C74-5	782	2436V74-5	843	2436VG74-5	843	2436E74-5	945
	48"	1219	96	43.6	6.0	2448Z74-5	832	2448C74-5	907	2448V74-5	978	2448VG74-5	978	2448E74-5	1118
	60"	1524	121	54.9	7.5	2460Z74-5	967	2460C74-5	1028	2460V74-5	1103	2460VG74-5	1103	2460E74-5	1258

## Catalog Section 1

### Redi-Pak® Utility Carts (NSF)

see spec sheet **EG01.10**



## Redi-Pak®



Packed and shipped in one box.

**SAVES UP TO 50%  
ON SHIPPING COSTS!**

WEIGHT CAPACITY:

- Medium-duty 500 lb. (227 kg).

- 36½" (927mm) height.
- One handle.
- Two posts.
- Four resilient 4" (102mm) casters with donut bumpers.
- Either two or three chrome shelves with built-in 1" (25mm) ledge on three sides.

INCLUDES:

Can be shipped UPS.

Freight class is 70.0.

(•) MTS (made to stock) / ( ) MTO (made to order)

**Easy handling and inventory tracking!**

				2-Shelf Unit				3-Shelf Unit				patented QuadTruss® design (Patent #5,390,803)
width	length in.	length mm	cubic feet	weight lb.	weight kg	model #	list	weight lbs.	weight kg	model #	list	
18" (457mm)	36"	914	3.0	38	17.2	U2-1836C-RP	403	45	20.4	U3-1836C-RP	488	

### Reverse Mat Shelves

see spec sheet **EG01.03E**

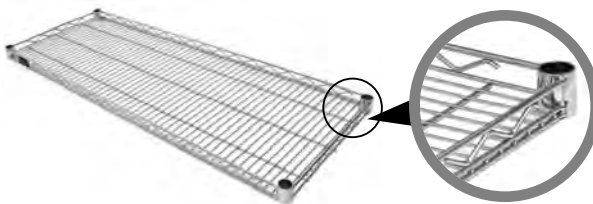

**Shelves have  
built-in ledges  
which prevent  
contents from  
falling off!**

WEIGHT CAPACITY:

- 250 lb. (113 kg); per shelf.

Freight class is 70.0.

(•) MTS (made to stock) / ( ) MTO (made to order)

patented  
QuadTruss®  
design  
(Patent #5,390,803)

**Patented QuadTruss® Design**  
makes shelves up to 25% stronger and  
provides a retaining ledge for increased  
strength and product retention.

	length		weight		cu ft	EAGLEbrite®		chrome		black		red		white	
	in.	mm	lb.	kg		model #	list	model #	list	model #	list	model #	list	model #	list
<b>14" width</b> (356mm)	36"	914	7	3.2	0.5	RM1436Z	77	RM1436C	85	RM1436BL	87	RM1436R	87	RM1436W	87
	48"	1219	10	4.5	0.7	RM1448Z	87	RM1448C	100	RM1448BL	103	RM1448R	103	RM1448W	103
<b>18" width</b> (457mm)	36"	914	9	4.1	0.7	RM1836Z	88	RM1836C	91	RM1836BL	94	RM1836R	94	RM1836W	94
	48"	1219	11	4.9	0.9	RM1848Z	103	RM1848C	109	RM1848BL	113	RM1848R	113	RM1848W	113
<b>21" width</b> (533mm)	36"	914	11	4.9	0.8	RM2136Z	98	RM2136C	108	RM2136BL	112	RM2136R	112	RM2136W	112
	48"	1219	13	5.9	1.1	RM2148Z	112	RM2148C	123	RM2148BL	126	RM2148R	126	RM2148W	126
<b>24" width</b> (610mm)	24"	610	9	4.1	0.8	RM2424Z	98	RM2424C	106	RM2424BL	109	RM2424R	109	RM2424W	109
	36"	914	12	5.4	0.8	RM2436Z	106	RM2436C	112	RM2436BL	116	RM2436R	116	RM2436W	116
	48"	1219	15	6.8	1.2	RM2448Z	124	RM2448C	135	RM2448BL	139	RM2448R	139	RM2448W	139

### Label Holders for Reverse Mat Shelves

see spec sheet **EG01.03E**



length		fits shelf size		model #	list
in.	mm	in.	mm		
3¼"	83	all		A225494	6
13"	330	18"	457	A225512	11
19"	483	24"	610	A225513	13
25"	635	30"	762	A225514	18
31"	787	36"	914	A225515	31
43"	1092	48"	1219	A225516	33
45"	1143	48"	1219	A225517	57
55"	1397	60"	1524	A225518	59
67"	1702	72"	1829	A225519	62

FEATURES:

- Clear plastic.
- Snaps onto shelf edge.
- Provides easy identification of shelf contents or section.
- Holds 1¼" (32mm) high labels.

Freight class is 70.0.

(•) MTS (made to stock) / ( ) MTO (made to order)

### Double-Mat Wire Shelves

see spec sheet **EG01.49**



double-mat wire shelves assembled with 33" (838mm) posts (posts sold separately - see page 13)

Accommodates round-bottomed soda bottles and small-legged appliances.

FEATURES:

- Heavy duty open wire shelf design: mat wires are spaced only  $\frac{1}{16}$ " (11mm) apart.

Freight class is 70.0.

(•) MTS (made to stock) / ( ) MTO (made to order)

patented  
**QuadTruss®**  
design  
(Patent #5,390,803)

**Patented QuadTruss® Design** makes shelves up to 25% stronger and provides a retaining ledge for increased strength and product retention.

	length		weight		EAGLEbrite® zinc		VALU-MASTER®		Valu-Gard®	
	in.	mm	lb.	kg	model #	list	model #	list	model #	list
18" width (457mm)	36"	914	14	6.4	DWS1836Z	107	DWS1836V	125	DWS1836VG	125
	48"	1219	18	8.2	DWS1848Z	126	DWS1848V	145	DWS1848VG	145
	60"	1524	22	10.0	DWS1860Z	154	DWS1860V	176	DWS1860VG	176
24" width (610mm)	36"	914	17	7.7	DWS2436Z	126	DWS2436V	152	DWS2436VG	152
	48"	1219	22	10.0	DWS2448Z	153	DWS2448V	180	DWS2448VG	180
	60"	1524	27	12.2	DWS2460Z	186	DWS2460V	215	DWS2460VG	215

### Double-Mat Wire Shelf Starter Units

see spec sheet **EG01.49**



Accommodates round-bottomed soda bottles and small-legged appliances.

FEATURES:

- Heavy duty open wire shelf design: mat wires are spaced only  $\frac{1}{16}$ " (11mm) apart.
- Four double-mat wire shelves.
- Four 63" or 74" (1600 or 1880mm) high posts (same finish as shelves).

Freight class is 70.0.

patented  
**QuadTruss®**  
design  
(Patent #5,390,803)

**Patented QuadTruss® Design** makes shelves up to 25% stronger and provides a retaining ledge for increased strength and product retention.

#### Models with 63" (1600mm) Height

	length		weight		EAGLEbrite® zinc		VALU-MASTER®		Valu-Gard®	
	in.	mm	lb.	kg	model #	list	model #	list	model #	list
18" width (457mm)	36"	914	70	31.8	DWS4-63-1836Z	548	DWS4-63-1836V	639	DWS4-63-1836VG	639
	48"	1219	86	39.0	DWS4-63-1848Z	631	DWS4-63-1848V	717	DWS4-63-1848VG	717
	60"	1524	102	46.3	DWS4-63-1860Z	737	DWS4-63-1860V	837	DWS4-63-1860VG	837
24" width (610mm)	36"	914	82	37.2	DWS4-63-2436Z	631	DWS4-63-2436V	741	DWS4-63-2436VG	741
	48"	1219	102	46.3	DWS4-63-2448Z	732	DWS4-63-2448V	857	DWS4-63-2448VG	857
	60"	1524	122	55.3	DWS4-63-2460Z	865	DWS4-63-2460V	997	DWS4-63-2460VG	997

#### Models with 74" (1880mm) Height

	length		weight		EAGLEbrite® zinc		VALU-MASTER®		Valu-Gard®	
	in.	mm	lb.	kg	model #	list	model #	list	model #	list
18" width (457mm)	36"	914	72	32.7	DWS4-74-1836Z	563	DWS4-74-1836V	649	DWS4-74-1836VG	649
	48"	1219	88	39.9	DWS4-74-1848Z	644	DWS4-74-1848V	725	DWS4-74-1848VG	725
	60"	1524	104	47.2	DWS4-74-1860Z	751	DWS4-74-1860V	846	DWS4-74-1860VG	846
24" width (610mm)	36"	914	84	38.1	DWS4-74-2436Z	644	DWS4-74-2436V	751	DWS4-74-2436VG	751
	48"	1219	104	47.2	DWS4-74-2448Z	746	DWS4-74-2448V	865	DWS4-74-2448VG	865
	60"	1524	124	56.2	DWS4-74-2460Z	881	DWS4-74-2460V	1005	DWS4-74-2460VG	1005

# WINE SHELVES

Convert your existing shelving unit by adding cradle wine shelves onto standard posts.

## Cradle Wine Shelves (NSF)

see spec sheet **EG01.20**

Freight class is 70.0.

(•) MTS (made to stock) / ( ) MTO (made to order)



(posts sold separately — see page 13)

Each bottle is “cradled” by heavy gauge wire to avoid movement.

	length		weight		cu	capacity (750ml bottles)	chrome		black epoxy	
	in.	mm	lb.	kg	ft		model #	list	model #	list
<b>14" width</b> (356mm)	36"	914	7	3.2	1.0	9	<b>W1436C</b> •	156	<b>W1436BL</b>	161
	48"	1219	9	4.1	1.3	12	<b>W1448C</b> •	179	<b>W1448BL</b>	183

## Bulk Wine Shelf Units (NSF)

see spec sheet **EG01.24**



Largest capacity offered in the industry; bottles are stored in bulk.

- Each compartment is adjustable for bottle diameter.
- Holds one dozen bottles per compartment.
- Bottles are retained with removable dividers, back panels and end panels.
- Panels are chrome plated.
- 74" (1880mm) height.

FEATURES:

Note: Not for mobile applications.

Freight class is 70.0.

	length		weight		cu	capacity (750ml bottles)	chrome		black epoxy	
	in.	mm	lb.	kg	ft		model #	list	model #	list
<b>14" width</b> (356mm)	36"	914	140	63.5	5	180	<b>BW1436C</b>	2794	<b>BW1436BL</b>	2880
	48"	1219	160	72.5	9	240	<b>BW1448C</b>	3576	<b>BW1448BL</b>	3686

### Bulk Wine Shelf Units with Security Doors

	length		weight		cu	capacity (750ml bottles)	chrome		black epoxy	
	in.	mm	lb.	kg	ft		model #	list	model #	list
<b>14" width</b> (356mm)	36"	914	183	83.0	5	180	<b>BW1436C-SC</b>	4235	<b>BW1436BL-SC</b>	4366
	48"	1219	205	93.0	9	240	<b>BW1448C-SC</b>	4991	<b>BW1448BL-SC</b>	5144

## Wine Glass Racks

see spec sheet **EG01.03E**



FEATURES:

- Fits onto underside of existing wire shelves or wire overshelves.
- 18" & 24" (457 & 610mm) lengths available.
- No hardware or tools required for installation.

Freight class is 70.0.

length		zinc		chrome	
in.	mm	model #	list ea	model #	list ea
18"	457	<b>WGR18-Z</b>	39	<b>WGR18-C</b>	43
24"	610	<b>WGR24-Z</b>	46	<b>WGR24-C</b>	49

# SHELVING CONFIGURATIONS FOR WINE STORAGE

*Created with standard shelving by adding a series of rods, tabs and enclosure panels.*

## Enclosure Panels

see spec sheet **EG01.03A**

- Includes four retaining clamps.

**Helps secure shelf contents, enclosing the back and sides of unit.**

**Freight class is 70.0.**

(•) MTS (made to stock) / ( ) MTO (made to order)

**Note:** These do not work with corner castings of solid shelves. Recommended for use with wire shelves only.

shelf	panel width		post height		weight		cubic feet	chrome		stainless	
	in.	mm	in.	mm	lb.	kg		model #	list	model #	list
<b>18" width</b> (457mm)	14"	356	54"	1372	6	2.7	1.5	<b>E1854-C</b>	108	<b>E1854-S</b>	209
	14"	356	63"	1600	7	3.2	1.8	<b>E1863-C •</b>	113	<b>E1863-S</b>	218
	14"	356	74"	1880	8	3.6	2.0	<b>E1874-C •</b>	118	<b>E1874-S</b>	235
	14"	356	86"	2184	9	4.1	2.3	<b>E1886-C</b>	182	<b>E1886-S</b>	259
<b>24" width</b> (610mm)	20"	508	54"	1372	9	4.1	2.1	<b>E2454-C</b>	127	<b>E2454-S</b>	252
	20"	508	63"	1600	10	4.5	2.3	<b>E2463-C •</b>	135	<b>E2463-S</b>	273
	20"	508	74"	1880	11	5.0	2.6	<b>E2474-C •</b>	142	<b>E2474-S</b>	286
	20"	508	86"	2184	12	5.4	2.8	<b>E2486-C</b>	206	<b>E2486-S</b>	309

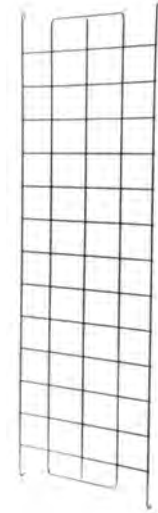

## CONSULT THESE TABLES FOR NUMBER OF PANELS REQUIRED:

Panels sold individually. Consult charts below for number of panels needed.

For the Back of Unit	shelf length		54" (1372mm) post ht.	63" (1600mm) post ht.	74" (1880mm) post ht.	86" (2184mm) post ht.
	in.	mm	—panel(s) required	—panel(s) required	—panel(s) required	—panel(s) required
	30"	762	(1) <b>E2454</b>	(1) <b>E2463</b>	(1) <b>E2474</b>	(1) <b>E2486</b>
	36"	914	(2) <b>E1854</b>	(2) <b>E1863</b>	(2) <b>E1874</b>	(2) <b>E1886</b>
	42"	1067	(1) <b>E1854</b>	(1) <b>E1863</b>	(1) <b>E1874</b>	(1) <b>E1886</b>
			(1) <b>E2454</b>	(1) <b>E2463</b>	(1) <b>E2474</b>	(1) <b>E2486</b>
	48"	1092	(2) <b>E2454</b>	(2) <b>E2463</b>	(2) <b>E2474</b>	(2) <b>E2486</b>
	54"	1372	(2) <b>E1854</b>	(2) <b>E1863</b>	(2) <b>E1874</b>	(2) <b>E1886</b>
			(1) <b>E2454</b>	(1) <b>E2463</b>	(1) <b>E2474</b>	(1) <b>E2486</b>
	60"	1524	(2) <b>E2454</b>	(2) <b>E2463</b>	(2) <b>E2474</b>	(2) <b>E2486</b>
			(1) <b>E1854</b>	(1) <b>E1863</b>	(1) <b>E1874</b>	(1) <b>E1886</b>
	72"	1829	(3) <b>E2454</b>	(3) <b>E2463</b>	(3) <b>E2474</b>	(3) <b>E2486</b>

For Each End	shelf width		54" (1372mm) post ht.	63" (1600mm) post ht.	74" (1880mm) post ht.	86" (2184mm) post ht.
	in.	mm	—panel(s) required	—panel(s) required	—panel(s) required	—panel(s) required
	18"	457	(1) <b>E1854</b>	(1) <b>E1863</b>	(1) <b>E1874</b>	(1) <b>E1886</b>
	21"	533	(1) <b>E1854</b>	(1) <b>E1863</b>	(1) <b>E1874</b>	(1) <b>E1886</b>
	24"	610	(1) <b>E2454</b>	(1) <b>E2463</b>	(1) <b>E2474</b>	(1) <b>E2486</b>
	30"	762	(1) <b>E2454</b>	(1) <b>E2463</b>	(1) <b>E2474</b>	(1) <b>E2486</b>
	36"	914	(2) <b>E1854</b>	(2) <b>E1863</b>	(2) <b>E1874</b>	(1) <b>E1886</b>

## Clips for Solid Shelves (ONLY)

spec sheet **EG01.03A**

...for Bottom Shelves ONLY

Set of four.



model #	list per set of 4
<b>SSENCBKT</b>	73

...for All Other Solid Shelves Sold individually.

model #	list each
<b>A204318</b>	2

## Rods and Tabs

see spec sheet **EG01.03D**



chrome		stainless steel	
model #	list ea	model #	list ea
<b>R54-C</b>	37	<b>R54-S</b>	55
<b>R63-C •</b>	40	<b>R63-S</b>	58
<b>R74-C •</b>	48	<b>R74-S</b>	69
<b>R86-C •</b>	53	<b>R86-S</b>	76

FEATURES:

- Used to enclose backs or sides of shelving units to prevent contents from falling.
- Also used to partition shelving units by positioning rods interior to shelves.
- Model number indicates height.
- Each rod comes with four tabs.

**Freight class is 70.0.**

(•) MTS (made to stock) / ( ) MTO (made to order)

## Catalog Section 1

### Wire Can Rack and Wire Can Rack Systems

see spec sheets **EG01.03E** **EG01.15**

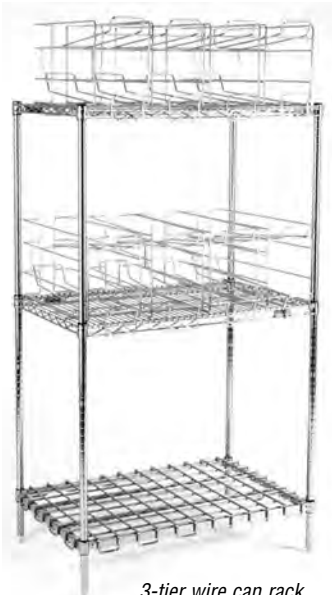

3-tier wire can rack system with dunnage shelf



wire can rack

- Fits on 24" (610mm) wide shelves.
- Rack is front loading.
- Front dispensing.
- Gravity fed.
- Made of chrome-plated mild steel and heavy gauge wire.
- Each rack holds eight #10 cans or twelve #5 cans.

**CAN RACK:**

- 24" x 36" (610 x 914mm) wire shelves.
- Four 1" (125mm)-diameter posts.
- Standard can rack.

**RACK SYSTEMS:**

**Freight class is 70.0.**

(•) MTS (made to stock) / ( ) MTO (made to order)

description	weight lb. kg	cu ft	capacity (#10 cans)	model #	list
individual wire can rack	7 3.2	1.8	8	<b>CRC</b> •	151
2-tier plus bottom dunnage, four 63" posts	120 54.4	19.3	124	<b>CRC2</b> *	1806
3-tier unit, 24" x 36" shelves, four 63" posts	137 62.1	25.2	96	<b>CRC3</b>	2268
4-tier unit, 24" x 36" shelves, four 74" posts	178 80.7	33.2	128	<b>CRC4</b>	2980

\* System holds 64 racked cans plus 10 boxes of 6 cans each on the dunnage shelf.

### Plate Display Shelving

see spec sheet **EG01.37**



four plate display shelves and posts shown assembled

**Wire shelves allow for smaller items to be displayed also, while open-wire construction helps prevent dust build-up!**

#### Reverse Mat Shelf for Plate Display Shelving

- Includes one pair of end-to-end truss rails, and one pair of front-to-back truss assemblies.

width	length		weight		cu ft	list per shelf
	in.	mm	lbs.	kg		
18" (457mm)	72"	1829	30	13.6	2.1	<b>PDS1872BL</b> 320

- Black epoxy finish.
- Reverse mat wire shelf features built-in ledges.
- Bottom of plates rest behind built-in ledges, and top of plates rest on truss rails that run end-to-end.

**FEATURES:**

**Note:** Shelves and posts sold separately.

**Freight class is 70.0.**

(•) MTS (made to stock) / ( ) MTO (made to order)

#### Posts for Plate Display Shelving

height in. mm	weight lbs. kg	cu ft	model #	list
33" 838	2.0 0.9	0.1	<b>P33-BL</b> •	27
54" 1372	3.0 1.4	0.1	<b>P54-BL</b> •	32
63" 1600	3.5 1.8	0.3	<b>P63-BL</b> •	34
74" 1880	4.0 1.8	0.5	<b>P74-BL</b> •	36
86" 2184	5.0 2.3	0.8	<b>P86-BL</b> •	46

### Cantilever Shelves

see spec sheet **EG01.03E**

length in. mm	weight		cubic feet	chrome		stainless steel	
	lb.	kg		model #	list	model #	list
24" 610	5	2.3	0.5	<b>CS1224-C</b>	77	<b>CS1224-S</b>	273
30" 762	5	2.3	0.8	<b>CS1230-C</b>	84	<b>CS1230-S</b>	293
36" 914	6	2.7	0.8	<b>CS1236-C</b>	95	<b>CS1236-S</b>	311
42" 1067	7	3.2	0.9	<b>CS1242-C</b>	108	<b>CS1242-S</b>	329
48" 1219	8	3.6	1.0	<b>CS1248-C</b>	111	<b>CS1248-S</b>	344
54" 1372	9	4.1	1.1	<b>CS1254-C</b>	118	<b>CS1254-S</b>	368
60" 1524	10	4.5	1.3	<b>CS1260-C</b>	125	<b>CS1260-S</b>	408

- 1" (25mm) wraparound ledge.
- 12" (305mm) wide shelves.

**FEATURES:**

**NOTE:** When ordering back posts, confirm with customer service, the correct post height to accommodate these shelves.

**Freight class is 70.0.**



**Ideal for adding extra storage above an existing shelving unit.  
Packaged two per box.**

*A highly flexible and maneuverable transport product which can be configured in either wire or solid shelves, or a combination of both.*

### Medium Duty Utility Carts

see spec sheet **EG01.10**



patented  
**QuadTruss®**  
design

(Patent #5,390,803)

**Patented QuadTruss® Design**  
makes shelves up to 25% stronger and provides a retaining ledge for increased strength and product retention.

**WEIGHT CAPACITY:**

- 500 lb. (227 kg) maximum.

**INCLUDES:**

- Two chrome handles.
- Four resilient rubber casters.
- 18" (457mm) wide carts have 4" (102mm) casters.
- 21" & 24" (533 & 610mm) carts have 5" (127mm) casters.

**Note:** See page 31 for optional stainless steel handles.

**Freight class is 70.0.**

(•) MTS (made to stock) / ( ) MTO (made to order)

### 2-Shelf Units

	width	length		cu ft	weight		EAGLEbrite®		chrome		stainless steel	
		in.	mm		lbs.	kg	model #	list	model #	list	model #	list
40" height* (1016mm)	18" (457mm)	24"	610	2.5	32	14.5	<b>EU2-1824Z</b> •	483	<b>EU2-1824C</b> •	537	<b>EU2-1824S</b>	1171
		30"	762	2.5	35	15.8	<b>EU2-1830Z</b> •	496	<b>EU2-1830C</b> •	546	<b>EU2-1830S</b>	1177
		36"	914	2.5	38	17.2	<b>EU2-1836Z</b> •	509	<b>EU2-1836C</b> •	572	<b>EU2-1836S</b>	1185
including casters	21" (533mm)	36"	914	2.9	42	19.1	<b>EU2-2136Z</b> •	531	<b>EU2-2136C</b> •	595	<b>EU2-2136S</b>	1319
		24" (610mm)	36"	914	2.9	45	20.4	<b>EU2-2436Z</b> •	569	<b>EU2-2436C</b> •	634	<b>EU2-2436S</b>

\* Stainless steel carts are 40" (1016mm) height. Chrome carts 37 3/4" (959mm) height including casters.

### 3-Shelf Units

	width	length		cu ft	weight		EAGLEbrite®		chrome		stainless steel	
		in.	mm		lbs.	kg	model #	list	model #	list	model #	list
40" height* (1016mm)	18" (457mm)	24"	610	2.5	37	16.7	<b>EU3-1824Z</b> •	561	<b>EU3-1824C</b> •	622	<b>EU3-1824S</b>	1523
		30"	762	2.5	41	18.5	<b>EU3-1830Z</b> •	583	<b>EU3-1830C</b> •	639	<b>EU3-1830S</b>	1531
		36"	914	2.5	45	20.4	<b>EU3-1836Z</b> •	601	<b>EU3-1836C</b> •	672	<b>EU3-1836S</b>	1544
including casters	21" (533mm)	36"	914	2.9	48	21.8	<b>EU3-2136Z</b> •	641	<b>EU3-2136C</b> •	719	<b>EU3-2136S</b>	1731
		24" (610mm)	36"	914	2.9	58	26.3	<b>EU3-2436Z</b> •	680	<b>EU3-2436C</b> •	755	<b>EU3-2436S</b>

\* Stainless steel carts are 40" (1016mm) height. Chrome carts 37 3/4" (959mm) height including casters.

### Utility Carts with Solid Shelf

see spec sheet **EG01.10**



patented  
**QuadTruss®**  
design

(Patent #5,390,803)

**Patented QuadTruss® Design**  
makes shelves up to 25% stronger and provides a retaining ledge for increased strength and product retention.

**INCLUDES:**

- Two chrome handles.
- Four casters.
- Two chrome finish open-wire shelves.
- One stainless steel solid shelf.

**Note:** See page 31 for optional stainless steel handles.

**Freight class is 70.0.**

	width	length		caster diameter		weight		cu ft	model #	list
		in.	mm	in.	mm	lbs.	kg			
37 3/4" height (959mm)	18" (457mm)	24"	610	4"	102	36	16.3	2.5	<b>EU3-1824CS</b>	896
		30"	762	4"	102	39	17.7	2.5	<b>EU3-1830CS</b>	922
		36"	914	4"	102	42	19.1	2.5	<b>EU3-1836CS</b>	984
including casters	21" (533mm)	36"	914	5"	127	65	29.5	2.9	<b>U3-2136CS</b>	1032
		24" (610mm)	36"	914	5"	127	71	32.2	3.3	<b>U3-2436CS</b>



## Catalog Section 1

### Heavy Duty Utility Carts

see spec sheet **EG01.10**



patented  
**QuadTruss®**  
design

(Patent #5,390,803)

**Patented QuadTruss® Design**  
makes shelves up to 25% stronger and provides a retaining ledge for increased strength and product retention.

**WEIGHT CAPACITY:** • 800 lb. (363 kg) maximum.

**INCLUDES:** • Two handles (see below)—one on each end.  
• Four 5" (127mm) resilient rubber swivel casters.

**Freight class is 70.0.**

(•) MTS (made to stock) / ( ) MTO (made to order)

### 2-Shelf Units

	length	cu		weight		EAGLEbrite®		chrome		stainless steel		
		in.	mm	ft	lbs.	kg	model #	list	model #	list	model #	list
40" height* (1016mm) including casters	18" width (457mm)	36"	914	2.5	38	17.2	<b>U2-1836Z</b> •	519	<b>U2-1836C</b> •	581	<b>U2-1836S</b>	1308
		42"	1067	2.9	41	18.5	<b>U2-1842Z</b> •	651	<b>U2-1842C</b> •	604	<b>U2-1842S</b>	1456
	21" width (533mm)	36"	914	2.9	42	19.1	<b>U2-2136Z</b> •	578	<b>U2-2136C</b> •	649	<b>U2-2136S</b>	1423
		42"	1067	3.4	44	20.0	<b>U2-2142Z</b> •	602	<b>U2-2142C</b> •	672	<b>U2-2142S</b>	1558
		48"	1219	3.9	48	21.8	<b>U2-2148Z</b> •	624	<b>U2-2148C</b> •	702	<b>U2-2148S</b>	1564
	24" width (610mm)	36"	914	3.3	46	20.9	<b>U2-2436Z</b> •	586	<b>U2-2436C</b> •	606	<b>U2-2436S</b>	1505
		42"	1067	3.9	50	22.7	<b>U2-2442Z</b> •	622	<b>U2-2442C</b> •	641	<b>U2-2442S</b>	1686
		48"	1219	4.4	52	23.6	<b>U2-2448Z</b> •	627	<b>U2-2448C</b> •	671	<b>U2-2448S</b>	1697
		60"	1524	5.5	62	28.1	<b>U2-2460Z</b> •	684	<b>U2-2460C</b> •	741	<b>U2-2460S</b>	1957

\* Stainless steel carts are 40" (1016mm) height. Chrome carts 37 1/4" (959mm) height including casters.

### 3-Shelf Units

	length	cu		weight		EAGLEbrite®		chrome		stainless steel		
		in.	mm	ft	lbs.	kg	model #	list	model #	list	model #	list
40" height* (1016mm) including casters	18" width (457mm)	36"	914	2.5	48	21.8	<b>U3-1836Z</b> •	618	<b>U3-1836C</b> •	694	<b>U3-1836S</b>	1685
		42"	1067	2.9	52	23.6	<b>U3-1842Z</b> •	651	<b>U3-1842C</b> •	725	<b>U3-1842S</b>	1906
	21" width (533mm)	36"	914	2.9	53	24.0	<b>U3-2136Z</b> •	699	<b>U3-2136C</b> •	778	<b>U3-2136S</b>	1858
		42"	1067	3.4	56	25.4	<b>U3-2142Z</b> •	732	<b>U3-2142C</b> •	815	<b>U3-2142S</b>	2059
		48"	1219	3.9	62	28.1	<b>U3-2148Z</b> •	760	<b>U3-2148C</b> •	860	<b>U3-2148S</b>	2068
	24" width (610mm)	36"	914	3.3	59	26.8	<b>U3-2436Z</b> •	696	<b>U3-2436C</b> •	738	<b>U3-2436S</b>	1979
		42"	1067	3.9	65	29.5	<b>U3-2442Z</b> •	744	<b>U3-2442C</b> •	786	<b>U3-2442S</b>	2252
		48"	1219	4.4	68	30.8	<b>U3-2448Z</b> •	753	<b>U3-2448C</b> •	836	<b>U3-2448S</b>	2260
		60"	1524	5.5	83	37.6	<b>U3-2460Z</b> •	841	<b>U3-2460C</b> •	940	<b>U3-2460S</b>	2653

\* Stainless steel carts are 40" (1016mm) height. Chrome carts 37 1/4" (959mm) height including casters.

### Handles for Utility Carts

see spec sheet **EG01.03B**

**Freight class is 70.0.**

(•) MTS (made to stock) / ( ) MTO (made to order)



width	weight		cubic	chrome*		stainless steel**		
	in.	mm		lbs.	kg	feet	model #	list
18"	457	4.0	1.8	0.9	<b>UH18-C</b> •	69	<b>UH18-S</b>	139
21"	533	4.2	1.9	0.9	<b>UH21-C</b> •	83	<b>UH21-S</b>	140
24"	610	4.5	2.1	0.9	<b>UH24-C</b> •	87	<b>UH24-S</b>	143

\*31 1/2" (800mm) height without casters

\*\*33 3/8" (848mm) height without casters

## Wire Basket Utility Carts <sup>(NSF)</sup>

see spec sheet **EG01.35**



**FEATURES:**

- Four 4" (102mm) swivel stem casters with bumpers and two push handles.
- 40" (1016mm) overall cart height.

**Note:** Additional Wire Basket Shelf available (see page 42).

**Freight class is 70.0.**

description	weight		model #	list
	lbs.	kg		
1 chrome basket shelf, 1 chrome standard shelf	31	14.1	<b>WBC1836C-1B1W</b>	463
2 chrome basket shelves	32	14.5	<b>WBC1836C-2B</b>	408

## Black Polymer Utility Cart <sup>(NSF)</sup>

see spec sheet **EG01.06**



**Utilizes three heavy duty black polymer shelves and utility handles!**

**WEIGHT CAPACITY:**

- 200 lb. (90.7 kg).

**FEATURES:**

- Four 4" (102mm) diameter swivel casters, two with brake.
- Stylish brushed aluminum uprights.

**Freight class is 70.0.**

height	width	length		weight		model #	list
		in.	mm	lbs.	kg		
<b>37<math>\frac{1}{4}</math>" (959mm)</b> including casters	<b>18<math>\frac{1}{2}</math>" (473mm)</b>	33 $\frac{1}{2}$ "	854	30	13.6	<b>EU3-2030-P</b>	944

## Stainless Utility Carts <sup>(NSF)</sup>

see spec sheet **EG01.42**

**Shelves are hemmed for further strength and stability!**



#UC-322



#UUC-322

**FEATURES:**

- Type 430 stainless steel construction.
- Three stainless steel hemmed shelves welded to angle legs.
- Galvanized bottom channel frame featuring four 4" (102mm) swivel plate casters.
- 1"-diameter handle on one end.

**Freight class is 70.0.**

## Standard Duty Carts — 300-lb. weight capacity.

overall width x length x height		shelf width x length (inner dimensions)		shelf clearance		weight		with * standard upturns		with upturn on all sides of all shelves	
in.	mm	in.	mm	in.	mm	lbs.	kg	model #	list	model #	list
16 $\frac{1}{4}$ " x 27 $\frac{1}{2}$ " x 32"	426 x 702 x 813	16 $\frac{1}{2}$ " x 25 $\frac{1}{8}$ "	419 x 643	12 $\frac{1}{2}$ "	318	29	13.2	<b>UC-311</b>	774	<b>UUC-311</b>	812
19" x 31" x 32"	483 x 787 x 813	18 $\frac{1}{4}$ " x 28 $\frac{1}{8}$ "	476 x 729	12 $\frac{1}{2}$ "	318	32	14.5	<b>UC-322</b>	801	<b>UUC-322</b>	841

\* Upturn on sides and rear of top and center shelves.

## Medium Duty Carts — 500-lb. weight capacity.

overall width x length x height		shelf width x length (inner dimensions)		shelf clearance		weight		with * standard upturns		with upturn on all sides of all shelves	
in.	mm	in.	mm	in.	mm	lbs.	kg	model #	list	model #	list
16 $\frac{1}{4}$ " x 27 $\frac{1}{2}$ " x 32"	426 x 702 x 813	16 $\frac{1}{2}$ " x 25 $\frac{1}{8}$ "	419 x 643	12 $\frac{1}{2}$ "	318	39	17.6	<b>UC-411</b>	789	<b>UUC-411</b>	829
19" x 31" x 32"	483 x 787 x 813	18 $\frac{1}{4}$ " x 28 $\frac{1}{8}$ "	476 x 729	12 $\frac{1}{2}$ "	318	42	19.1	<b>UC-422</b>	818	<b>UUC-422</b>	859

\* Upturn on sides and rear of top and center shelves.

### Stem Caster Carts NSF

Freight class is 70.0.

see spec sheet **EG01.07**

(•) MTS (made to stock) / ( ) MTO (made to order)



**INCLUDES:**

- Four 63" (1600mm) posts.
- Four shelves.
- Plastic split sleeves.
- Donut bumpers.
- Indicated 5" x 1 1/4" (127 x 32mm) casters.
- 68" (1727mm) overall height.
- Fast assembly without the use of tools.
- Shipped knocked-down.

**patented**  
**QuadTruss®**  
**design**  
(Patent #5,390,803)

**Patented QuadTruss® Design**

makes shelves up to 25% stronger and provides a retaining ledge for increased strength and product retention.

		weight		cu ft	caster type	wheel tread	EAGLEbrite®		chrome		
		lbs.	kg				model #	list	model #	list	
<b>18" width</b> (457mm)	<b>36" length</b> (914mm)	58	26.3	2.6	swivel	resilient	CC1836Z-S •	732	CC1836C-S •	749	
					swivel	poly	CC1836Z-SP •	795	CC1836C-SP •	815	
					swivel/brake	resilient	CC1836Z-SB •	744	CC1836C-SB •	759	
					swivel/brake	poly	CC1836Z-SBP •	807	CC1836C-SBP •	827	
					swivel/rigid	resilient	CC1836Z-SR •	791	CC1836C-SR •	809	
						swivel/rigid	poly	CC1836Z-SRP •	864	CC1836C-SRP •	882
	<b>48" length</b> (1219mm)	70	31.7	3.5	swivel	resilient	CC1848Z-S •	806	CC1848C-S •	847	
					swivel	poly	CC1848Z-SP •	872	CC1848C-SP •	913	
					swivel/brake	resilient	CC1848Z-SB •	820	CC1848C-SB •	863	
					swivel/brake	poly	CC1848Z-SBP •	883	CC1848C-SBP •	927	
					swivel/rigid	resilient	CC1848Z-SR •	867	CC1848C-SR •	907	
					swivel/rigid	poly	CC1848Z-SRP •	938	CC1848C-SRP •	980	
	<b>60" length</b> (1524mm)	86	39.0	4.4	swivel	resilient	CC1860Z-S •	961	CC1860C-S •	986	
					swivel	poly	CC1860Z-SP •	1025	CC1860C-SP •	1051	
					swivel/brake	resilient	CC1860Z-SB •	973	CC1860C-SB •	1001	
swivel/brake					poly	CC1860Z-SBP •	1038	CC1860C-SBP •	1063		
swivel/rigid					resilient	CC1860Z-SR •	1020	CC1860C-SR •	1045		
				swivel/rigid	poly	CC1860Z-SRP •	1092	CC1860C-SRP •	1118		
<b>21" width</b> (533mm)	<b>36" length</b> (914mm)	67	30.4	3.0	swivel	resilient	CC2136Z-S •	809	CC2136C-S •	835	
					swivel	poly	CC2136Z-SP •	828	CC2136C-SP •	899	
					swivel/brake	resilient	CC2136Z-SB •	823	CC2136C-SB •	846	
					swivel/brake	poly	CC2136Z-SBP •	885	CC2136C-SBP •	912	
					swivel/rigid	resilient	CC2136Z-SR •	873	CC2136C-SR •	897	
					swivel/rigid	poly	CC2136Z-SRP •	945	CC2136C-SRP •	971	
	<b>48" length</b> (1219mm)	79	35.8	4.0	swivel	resilient	CC2148Z-S •	902	CC2148C-S •	954	
					swivel	poly	CC2148Z-SP •	965	CC2148C-SP •	1016	
					swivel/brake	resilient	CC2148Z-SB •	914	CC2148C-SB •	964	
					swivel/brake	poly	CC2148Z-SBP •	979	CC2148C-SBP •	1031	
					swivel/rigid	resilient	CC2148Z-SR •	964	CC2148C-SR •	1015	
					swivel/rigid	poly	CC2148Z-SRP •	1038	CC2148C-SRP •	1088	
	<b>60" length</b> (1524mm)	96	43.5	5.0	swivel	resilient	CC2160Z-S •	1039	CC2160C-S •	1087	
					swivel	poly	CC2160Z-SP •	1104	CC2160C-SP •	1153	
					swivel/brake	resilient	CC2160Z-SB •	1052	CC2160C-SB •	1100	
swivel/brake					poly	CC2160Z-SBP •	1117	CC2160C-SBP •	1163		
swivel/rigid					resilient	CC2160Z-SR •	1103	CC2160C-SR •	1152		
				swivel/rigid	poly	CC2160Z-SRP •	1174	CC2160C-SRP •	1203		
<b>24" width</b> (610mm)	<b>36" length</b> (914mm)	74	33.5	3.5	swivel	resilient	CC2436Z-S •	817	CC2436C-S •	843	
					swivel	poly	CC2436Z-SP •	879	CC2436C-SP •	906	
					swivel/brake	resilient	CC2436Z-SB •	828	CC2436C-SB •	855	
					swivel/brake	poly	CC2436Z-SBP •	845	CC2436C-SBP •	922	
					swivel/rigid	resilient	CC2436Z-SR •	882	CC2436C-SR •	909	
					swivel/rigid	poly	CC2436Z-SRP •	957	CC2436C-SRP •	982	
	<b>48" length</b> (1219mm)	90	40.8	4.5	swivel	resilient	CC2448Z-S •	929	CC2448C-S •	982	
					swivel	poly	CC2448Z-SP •	994	CC2448C-SP •	1047	
					swivel/brake	resilient	CC2448Z-SB •	942	CC2448C-SB •	998	
					swivel/brake	poly	CC2448Z-SBP •	1007	CC2448C-SBP •	1059	
					swivel/rigid	resilient	CC2448Z-SR •	999	CC2448C-SR •	1049	
					swivel/rigid	poly	CC2448Z-SRP •	1069	CC2448C-SRP •	1122	
	<b>60" length</b> (1524mm)	110	49.9	5.6	swivel	resilient	CC2460Z-S •	1043	CC2460C-S •	1133	
					swivel	poly	CC2460Z-SP •	1107	CC2460C-SP •	1198	
					swivel/brake	resilient	CC2460Z-SB •	1057	CC2460C-SB •	1145	
swivel/brake					poly	CC2460Z-SBP •	1119	CC2460C-SBP •	1209		
swivel/rigid					resilient	CC2460Z-SR •	1109	CC2460C-SR •	1199		
				swivel/rigid	poly	CC2460Z-SRP •	1182	CC2460C-SRP •	1269		

### Cart Covers

see spec sheet **EG01.09**

**Meets J.C.A.H. standards  
for transporting clean linen!**



cart cover  
enveloping entire cart/truck



cart cover with panel folded back for  
easy shelf accessibility

#### FEATURES:

- Top corners are reinforced.
- Choice of white coated, white uncoated, or transparent vinyl.
- Coated cart covers available in powder blue (suffix "PB") and light green (suffix "LG"). Example: CVC-63-1836PB. Other colors available—consult factory.
- 10" x 12" (254 x 305mm) paperwork pouch at right side, when facing front of cart cover.
- Covers are nonreturnable.

**Light weight,  
easy to handle!**

**Note:** Cart covers to fit Security Units (pages 44-45) available.

To order cart cover for Stationary or Mobile Security Unit, add suffix "-S" to end of model number (ex: CV-63-2436-S) and add 20% to list price.

**Double-Flap option available. \$24 upcharge.**

To order, add suffix "-DF" to model number (ex: CV-63-2436-DF).

To order cart cover for Dolly Truck Security Unit, add suffix "-D" to end of model number (ex: CV-63-2436-D) and add 20% to list price.

**Freight class is 70.0.**

				White Coated Nylon*				White Uncoated Polyester				Transparent**					
	length		post height		weight		cu ft	zipper		velcro		zipper		zipper			
	in.	mm	in.	mm	lbs.	kg		model #	list	model #	list	model #	list	model #	list		
18" width (457mm)	36"	914	54"	1372	3	1.4	1	CZC-54-1836	292	CVC-54-1836	292	CZ-54-1836	233	CV-54-1836	233	CZ-54-1836-T	338
			63"	1600				CZC-63-1836	293	CVC-63-1836	296	CZ-63-1836	238	CV-63-1836	263	CZ-63-1836-T	349
	48"	1219	54"	1372	4	1.8	1	CZC-54-1848	298	CVC-54-1848	293	CZ-54-1848	233	CV-54-1848	233	CZ-54-1848-T	357
			63"	1600				CZC-63-1848	304	CVC-63-1848	298	CZ-63-1848	263	CV-63-1848	263	CZ-63-1848-T	380
60"	1524	54"	1372	5	2.3	1	CZC-54-1860	311	CVC-54-1860	304	CZ-54-1860	261	CV-54-1860	261	CZ-54-1860-T	376	
		63"	1600				CZC-63-1860	319	CVC-63-1860	311	CZ-63-1860	266	CV-63-1860	267	CZ-63-1860-T	401	
21" width (533mm)	48"	1219	54"	1372	4	1.8	1	CZC-54-2148	335	CVC-54-2148	357	CZ-54-2148	265	CV-54-2148	284	CZ-54-2148-T	397
			63"	1600				CZC-63-2148	357	CVC-63-2148	362	CZ-63-2148	318	CV-63-2148	299	CZ-63-2148-T	422
			74"	1880				CZC-74-2148	376	CVC-74-2148	386	CZ-74-2148	320	CV-74-2148	325	CZ-74-2148-T	444
	60"	1524	54"	1372	5	2.3	1	CZC-54-2160	357	CVC-54-2160	366	CZ-54-2160	284	CV-54-2160	298	CZ-54-2160-T	441
63"	1600	CZC-63-2160	366	CVC-63-2160				371	CZ-63-2160	318	CV-63-2160	318	CZ-63-2160-T	469			
74"	1880	CZC-74-2160	386	CVC-74-2160				386	CZ-74-2160	379	CV-74-2160	340	CZ-74-2160-T	493			
24" width (610mm)	24"	610	54"	1372	3	1.4	1	CZC-54-2424	338	CVC-54-2424	340	CZ-54-2424	277	CV-54-2424	252	CZ-54-2424-T	364
			63"	1600				CZC-63-2424	344	CVC-63-2424	352	CZ-63-2424	308	CV-63-2424	300	CZ-63-2424-T	378
	36"	914	54"	1372	3	1.4	1	CZC-54-2436	357	CVC-54-2436	359	CZ-54-2436	292	CV-54-2436	264	CZ-54-2436-T	427
			63"	1600				CZC-63-2436	364	CVC-63-2436	371	CZ-63-2436	325	CV-63-2436	318	CZ-63-2436-T	434
			74"	1880				CZC-74-2436	371	CVC-74-2436	386	CZ-74-2436	311	CV-74-2436	333	CZ-74-2436-T	474
			86"	2184				CZC-86-2436	378	CVC-86-2436	393	CZ-86-2436	322	CV-86-2436	338	CZ-86-2436-T	499
	48"	1219	54"	1372	4	1.8	1	CZC-54-2448	364	CVC-54-2448	365	CZ-54-2448	284	CV-54-2448	265	CZ-54-2448-T	440
			63"	1600				CZC-63-2448	371	CVC-63-2448	373	CZ-63-2448	296	CV-63-2448	325	CZ-63-2448-T	444
			74"	1880				CZC-74-2448	386	CVC-74-2448	386	CZ-74-2448	340	CV-74-2448	346	CZ-74-2448-T	499
			86"	2184				CZC-86-2448	397	CVC-86-2448	400	CZ-86-2448	346	CV-86-2448	352	CZ-86-2448-T	526
	60"	1524	54"	1372	5	2.3	1	CZC-54-2460	366	CVC-54-2460	366	CZ-54-2460	292	CV-54-2460	284	CZ-54-2460-T	452
			63"	1600				CZC-63-2460	379	CVC-63-2460	378	CZ-63-2460	318	CV-63-2460	329	CZ-63-2460-T	459
74"			1880	CZC-74-2460				393	CVC-74-2460	399	CZ-74-2460	346	CV-74-2460	340	CZ-74-2460-T	547	
86"			2184	CZC-86-2460				419	CVC-86-2460	419	CZ-86-2460	351	CV-86-2460	353	CZ-86-2460-T	576	
72"	1829	54"	1372	6	2.7	1	CZC-54-2472	404	CVC-54-2472	426	CZ-54-2472	301	CV-54-2472	301	CZ-54-2472-T	501	
		63"	1600				CZC-63-2472	412	CVC-63-2472	427	CZ-63-2472	341	CV-63-2472	322	CZ-63-2472-T	512	
		74"	1880				CZC-74-2472	419	CVC-74-2472	437	CZ-74-2472	346	CV-74-2472	372	CZ-74-2472-T	561	
		86"	2184				CZC-86-2472	424	CVC-86-2472	445	CZ-86-2472	364	CV-86-2472	382	CZ-86-2472-T	593	

\* White-Coated Nylon Covers are fire-retardant; \*\* Entire cover is transparent except for the seams. Transparent covers with velcro available at same price.

**Helps keep equipment clean on shelf carts and shelf trucks.**

## Catalog Section 1

### Angled Shelf/ Visual Merchandising Carts <sup>NSF</sup>

see spec sheet **EG01.44**



visual merchandising cart with optional shelf dividers

**Ideal for displaying  
POINT-OF-SALE  
or SPECIAL SALE ITEMS.**

**FEATURES:**

- 68" (1727mm) height.
- 3/4" (83mm) upturn at front
- 1/4" (32mm) downturn at rear.
- Shelves are reversible.
- Units available in 3', 4', and 5' (914, 1219 and 1524mm) lengths.

**WEIGHT CAPACITY:**

- 300 lbs. (136.1 kg) per shelf.

**INCLUDES:**

- Four shelves adjust on 1" (25mm) vertical increments and the 0°-30° slope of each shelf.
- Four posts.
- Four 5" x 1 1/4" (127 x 32mm) standard resilient swivel casters, two with brake.
- Additional caster sizes are available.
- Standard wire shelves (page 6) can be used.

**Note:** To order red or white epoxy finish, add suffix "R" (red) or "W" (white). **Example: M1836R.** Priced same as black epoxy.

Additional shelves and wire dividers available as options.

**Freight class is 70.0.**

(\*) MTS (made to stock) / ( ) MTO (made to order)

length		weight		cu	EAGLEbrite®		chrome		black		VALU-MASTER®		Valu-Gard®	
in.	mm	lb.	kg		ft	model #	list	model #	list	model #	list	model #	list	model #
24"	610	52	23.6	3.6	M1824Z-4	638	M1824C-4	659	M1824BL-4	692	M1824V-4	692	M1824VG-4	692
36"	914	60	27.2	4.4	M1836Z-4	672	M1836C-4	694	M1836BL-4	725	M1836V-4	725	M1836VG-4	725
48"	1219	68	30.8	5.8	M1848Z-4	775	M1848C-4	789	M1848BL-4	837	M1848V-4	837	M1848VG-4	837
60"	1524	76	34.5	7.3	M1860Z-4	843	M1860C-4	855	M1860BL-4	909	M1860V-4	909	M1860VG-4	909

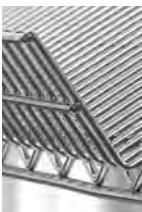

### Additional Angled Shelves for Angled Shelf / Visual Merchandising Carts - Hanger rails included.

length		weight		cu	EAGLEbrite®		chrome		black		VALU-MASTER®		Valu-Gard®	
in.	mm	lb.	kg		ft	model #	list	model #	list	model #	list	model #	list	model #
24"	610	4	1.8	2.2	M1824Z	123	M1824C	145	M1824BL	151	M1824V	151	M1824VG	151
36"	914	9	4.1	2.5	M1836Z	134	M1836C	153	M1836BL	155	M1836V	155	M1836VG	155
48"	1219	12	5.5	2.8	M1848Z	155	M1848C	161	M1848BL	173	M1848V	173	M1848VG	173
60"	1524	17	7.7	3.1	M1860Z	173	M1860C	178	M1860BL	185	M1860V	185	M1860VG	185

**Note:** If purchased as component piece for unit assembly, two 3-sided truss frames must be ordered (see page 36).

### Shelf Dividers for Angled Shelf / Visual Merchandising Carts - 4 1/2" (114mm) height.



length		weight		cu	chrome		black		VALU-MASTER®		Valu-Gard®	
in.	mm	lb.	kg		ft	model #	list	model #	list	model #	list	model #
18"	457	1.0	0.5	0.6	M18C	53	M18BL	59	M18V	59	M18VG	59

### Front-to-Back Hanger Rail for Angled Shelf / Visual Merchandising Carts



length		weight		cu	EAGLEbrite®		chrome		black		VALU-MASTER®		Valu-Gard®	
in.	mm	lb.	kg		ft	model #	list	model #	list	model #	list	model #	list	model #
18"	457	0.7	0.3	2.0	WR18-Z	28	WR18-C	32	WR18-BL	33	WR18-V	33	WR18-VG	33

### Side-to-Side Hanger Rails for Angled Shelf / Visual Merchandising Carts

length		weight		cu	EAGLEbrite®		chrome		black		VALU-MASTER®		Valu-Gard®	
in.	mm	lb.	kg		ft	model #	list	model #	list	model #	list	model #	list	model #
24"	610	1.5	0.7	0.3	LR24-Z	29	LR24-C	35	LR24-BL	37	LR24-V	37	LR24-VG	37
36"	914	1.9	0.9	0.6	LR36-Z	31	LR36-C	40	LR36-BL	47	LR36-V	47	LR36-VG	47
48"	1219	2.1	1.0	0.7	LR48-Z	33	LR48-C	52	LR48-BL	54	LR48-V	54	LR48-VG	54
60"	1524	2.5	1.1	0.8	LR60-Z	35	LR60-C	58	LR60-BL	60	LR60-V	60	LR60-VG	60

### ...Merchandising Carts (continued)

see spec sheet **EG01.44**

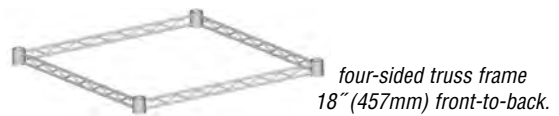
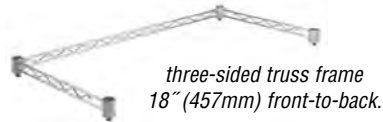

Freight class is 70.0.

(•) MTS (made to stock) / ( ) MTO (made to order)

#### 3-Sided Truss Frames

length in. mm	wt. lb. kg	cu ft	EAGLEbrite®		chrome		black		VALU-MASTER®		Valu-Gard®		
			model #	list	model #	list	model #	list	model #	list	model #	list	
36"	914	3.5 1.6	2	3TF1836-Z 51	3TF1836-C 83	3TF1836-BL 88	3TF1836-V 88	3TF1836-VG 88	4TF1836-Z 69	4TF1836-C 76	4TF1836-BL 81	4TF1836-V 81	4TF1836-VG 81
48"	1219	4.0 1.8	3	3TF1848-Z 55	3TF1848-C 91	3TF1848-BL 98	3TF1848-V 98	3TF1848-VG 98	4TF1848-Z 76	4TF1848-C 83	4TF1848-BL 87	4TF1848-V 87	4TF1848-VG 87
60"	1524	4.5 2.0	4	3TF1860-Z 59	3TF1860-C 102	3TF1860-BL 109	3TF1860-V 109	3TF1860-VG 112	4TF1860-Z 81	4TF1860-C 92	4TF1860-BL 100	4TF1860-V 100	4TF1860-VG 100

#### 4-Sided Truss Frames

length in. mm	wt. lb. kg	cu ft	EAGLEbrite®		chrome		black		VALU-MASTER®		Valu-Gard®		
			model #	list	model #	list	model #	list	model #	list	model #	list	
36"	914	3.5 1.6	2	3TF1836-Z 51	3TF1836-C 83	3TF1836-BL 88	3TF1836-V 88	3TF1836-VG 88	4TF1836-Z 69	4TF1836-C 76	4TF1836-BL 81	4TF1836-V 81	4TF1836-VG 81
48"	1219	4.0 1.8	3	3TF1848-Z 55	3TF1848-C 91	3TF1848-BL 98	3TF1848-V 98	3TF1848-VG 98	4TF1848-Z 76	4TF1848-C 83	4TF1848-BL 87	4TF1848-V 87	4TF1848-VG 87
60"	1524	4.5 2.0	4	3TF1860-Z 59	3TF1860-C 102	3TF1860-BL 109	3TF1860-V 109	3TF1860-VG 112	4TF1860-Z 81	4TF1860-C 92	4TF1860-BL 100	4TF1860-V 100	4TF1860-VG 100

### Aisle Merchandising Carts

see product announcement **EG8129**

- Top & bottom standard wire shelves.
- Intermediate Add-A-Shelf® shelves, adjustable on 1" (25mm) increments, can be sloped or flat.
- Four posts with 2 3/8" (60mm)-diameter decorative black swivel casters, all with brake.

INCLUDES:

#### 48" (1219mm) Height, with Four Shelves

	length		black		red		white		VALU-MASTER®		Valu-Gard®	
	in.	mm	model #	list	model #	list	model #	list	model #	list	model #	list
14" width (356mm)	22"	559	MC1422-48-4BL	695	MC1422-48-4R	695	MC1422-48-4W	695	MC1422-48-4V	695	MC1422-48-4VG	695
	24"	610	MC1424-48-4BL	666	MC1424-48-4R	666	MC1424-48-4W	666	MC1424-48-4V	666	MC1424-48-4VG	666
	30"	762	MC1430-48-4BL	677	MC1430-48-4R	677	MC1430-48-4W	677	MC1430-48-4V	677	MC1430-48-4VG	677
	36"	914	MC1436-48-4BL	682	MC1436-48-4R	682	MC1436-48-4W	682	MC1436-48-4V	682	MC1436-48-4VG	682

#### 54" (1372mm) Height, with Four Shelves

	length		black		red		white		VALU-MASTER®		Valu-Gard®	
	in.	mm	model #	list	model #	list	model #	list	model #	list	model #	list
14" width (356mm)	22"	559	MC1422-54-4BL	722	MC1422-54-4R	722	MC1422-54-4W	722	MC1422-54-4V	722	MC1422-54-4VG	722
	24"	610	MC1424-54-4BL	695	MC1424-54-4R	695	MC1424-54-4W	606	MC1424-54-4V	695	MC1424-54-4VG	695
	30"	762	MC1430-54-4BL	704	MC1430-54-4R	704	MC1430-54-4W	704	MC1430-54-4V	704	MC1430-54-4VG	704
	36"	914	MC1436-54-4BL	712	MC1436-54-4R	712	MC1436-54-4W	712	MC1436-54-4V	712	MC1436-54-4VG	712

#### 63" (1600mm) Height, with Five Shelves

	length		black		red		white		VALU-MASTER®		Valu-Gard®	
	in.	mm	model #	list	model #	list	model #	list	model #	list	model #	list
14" width (356mm)	22"	559	MC1422-63-5BL	735	MC1422-63-5R	735	MC1422-63-5W	735	MC1422-63-5V	735	MC1422-63-5VG	735
	24"	610	MC1424-63-5BL	701	MC1424-63-5R	701	MC1424-63-5W	701	MC1424-63-5V	701	MC1424-63-5VG	701
	30"	762	MC1430-63-5BL	717	MC1430-63-5R	717	MC1430-63-5W	717	MC1430-63-5V	717	MC1430-63-5VG	717
	36"	914	MC1436-63-5BL	721	MC1436-63-5R	721	MC1436-63-5W	721	MC1436-63-5V	721	MC1436-63-5VG	721

#### 74" (1880mm) Height, with Six Shelves

	length		black		red		white		VALU-MASTER®		Valu-Gard®	
	in.	mm	model #	list	model #	list	model #	list	model #	list	model #	list
14" width (356mm)	22"	559	MC1422-74-6BL	847	MC1422-74-6R	847	MC1422-74-6W	847	MC1422-74-6V	847	MC1422-74-6VG	847
	24"	610	MC1424-74-6BL	807	MC1424-74-6R	807	MC1424-74-6W	807	MC1424-74-6V	807	MC1424-74-6VG	807
	30"	762	MC1430-74-6BL	821	MC1430-74-6R	821	MC1430-74-6W	821	MC1430-74-6V	821	MC1430-74-6VG	821
	36"	914	MC1436-74-6BL	827	MC1436-74-6R	827	MC1436-74-6W	827	MC1436-74-6V	827	MC1436-74-6VG	827



Ideal for  
**POINT-OF-PURCHASE**  
displays or **SEASONAL**  
**PROMOTIONS.**

patented  
**QuadTruss®**  
design  
(Patent #5,390,803)

Patented  
**QuadTruss® Design**  
makes shelves up to  
25% stronger and provides a  
retaining ledge for increased  
strength and product retention.

#### Additional Add-A-Shelf® Adjustable Shelves for Aisle Merchandising Carts - Patent # 5,884,567

	length		weight lb. kg	cu ft	black		red		white		VALU-MASTER®		Valu-Gard®		
	in.	mm			model #	list	model #	list	model #	list	model #	list	model #	list	
14" width (356mm)	22"	559	6	2.7	0.5	A1422BL 96	A1422R 96	A1422W 96	A1422V 96	A1422VG 96	D1422BL 102	D1422R 102	D1422W 102	D1422V 102	D1422VG 102
	24"	610	6	2.7	0.5	A1424BL 88	A1424R 88	A1424W 88	A1424V 88	A1424VG 88	D1424BL 102	D1424R 102	D1424W 102	D1424V 102	D1424VG 102
	30"	762	7	3.2	0.5	A1430BL 91	A1430R 91	A1430W 91	A1430V 91	A1430VG 91	D1430BL 94	D1430R 94	D1430W 94	D1430V 94	D1430VG 94
	36"	914	8	3.6	0.5	A1436BL 94	A1436R 94	A1436W 94	A1436V 94	A1436VG 94	D1436BL 96	D1436R 96	D1436W 96	D1436V 96	D1436VG 96

## Catalog Section 1

### Dolly Trucks

see spec sheet **EG01.08**



#### FEATURES:

- Fast assembly without tools.
- Open wire construction.
- Shipped knocked-down.

#### INCLUDES:

- Four shelves.
- Four posts.
- Plastic split sleeves.
- Four designated 5" x 1 1/4" (127 x 32mm) casters.
- Aluminum truck dolly with wraparound bumper.

**Freight class is 70.0.**

**patented**  
**QuadTruss®**  
**design**  
(Patent #5,390,803)

**Patented QuadTruss® Design**  
makes shelves up to 25% stronger and  
provides a retaining ledge for increased  
strength and product retention.

		Shelf dimensions		weight		cu ft	caster type	wheel tread	with EAGLEbrite® shelf unit		with chrome shelf unit			
		width in.	length mm	lbs.	kg				model #	list	model #	list		
69" height (1753mm)	23 3/4" width (603mm)	40 1/8" length (1038mm)	18" x 36"	457 x 914	72	32.7	4.2	swivel	resilient	DT1836-ZS	1308	DT1836-CS	1320	
								swivel	poly	DT1836-ZSP	1308	DT1836-CSP	1320	
								swivel/brake	resilient	DT1836-ZSB	1320	DT1836-CSB	1335	
									swivel/brake	poly	DT1836-ZSBP	1318	DT1836-CSBP	1329
		52 1/8" length (1343mm)	18" x 48"	457 x 1219	86	39.0	5.6	swivel	resilient	DT1848-ZS	1409	DT1848-CS	1445	
								swivel	poly	DT1848-ZSP	1409	DT1848-CSP	1445	
							swivel/brake	resilient	DT1848-ZSB	1422	DT1848-CSB	1456		
								swivel/brake	poly	DT1848-ZSBP	1420	DT1848-CSBP	1454	
	26 3/4" width (680mm)	40 1/8" length (1038mm)	18" x 36"	457 x 914	100	45.4	6.8	swivel	resilient	DT1860-ZS	1552	DT1860-CS	1585	
								swivel	poly	DT1860-ZSP	1552	DT1860-CSP	1585	
								swivel/brake	resilient	DT1860-ZSB	1567	DT1860-CSB	1599	
									swivel/brake	poly	DT1860-ZSBP	1560	DT1860-CSBP	1597
52 1/8" length (1343mm)		21" x 48"	533 x 1219	98	44.5	6.4	swivel	resilient	DT2148-ZS	1477	DT2148-CS	1533		
							swivel	poly	DT2148-ZSP	1477	DT2148-CSP	1533		
						swivel/brake	resilient	DT2148-ZSB	1493	DT2148-CSB	1546			
							swivel/brake	poly	DT2148-ZSBP	1489	DT2148-CSBP	1542		
29 3/4" width (756mm)	40 1/8" length (1038mm)	21" x 60"	533 x 1524	114	51.7	7.9	swivel	resilient	DT2160-ZS	1637	DT2160-CS	1675		
							swivel	poly	DT2160-ZSP	1637	DT2160-CSP	1675		
							swivel/brake	resilient	DT2160-ZSB	1653	DT2160-CSB	1685		
								swivel/brake	poly	DT2160-ZSBP	1648	DT2160-CSBP	1683	
	52 1/8" length (1343mm)	24" x 36"	610 x 914	90	40.8	5.6	swivel	resilient	DT2436-ZS	1411	DT2436-CS	1453		
							swivel	poly	DT2436-ZSP	1411	DT2436-CSP	1453		
						swivel/brake	resilient	DT2436-ZSB	1424	DT2436-CSB	1466			
							swivel/brake	poly	DT2436-ZSBP	1421	DT2436-CSBP	1463		
29 3/4" width (756mm)	52 1/8" length (1343mm)	24" x 48"	610 x 1219	112	50.8	7.2	swivel	resilient	DT2448-ZS	1546	DT2448-CS	1600		
							swivel	poly	DT2448-ZSP	1546	DT2448-CSP	1600		
							swivel/brake	resilient	DT2448-ZSB	1559	DT2448-CSB	1618		
								swivel/brake	poly	DT2448-ZSBP	1557	DT2448-CSBP	1614	
	64 1/8" length (1648mm)	24" x 60"	610 x 1524	134	60.8	8.9	swivel	resilient	DT2460-ZS	1723	DT2460-CS	1765		
							swivel	poly	DT2460-ZSP	1723	DT2460-CSP	1765		
						swivel/brake	resilient	DT2460-ZSB	1737	DT2460-CSB	1780			
							swivel/brake	poly	DT2460-ZSBP	1734	DT2460-CSBP	1777		

### Garment Racks

see spec sheet **EG01.28**



model #  
URS1836C

patented  
**QuadTruss®**  
design

(Patent #5,390,803)

#### Patented QuadTruss® Design

makes shelves up to 25% stronger and provides a retaining ledge for increased strength and product retention.

- Four chrome post with adjustable feet.
- Two wire chrome plated shelves.
- 74" (1880mm) height on stationary units.
- 80" (3032mm) height on mobile units.
- Mobile racks four 5" (127mm) polyurethane tread casters, with rubber donut bumper.

INCLUDES:

**Freight class is 70.0.**

(•) MTS (made to stock) / ( ) MTO (made to order)

**Convenient storage of coats, uniforms, or garments.**

18" width (457mm)	length		weight		cu ft	description	STATIONARY		MOBILE	
	in.	mm	lbs.	kg			model #	list	model #	list
	36"	914	48	21.8	2.2	2 wire shelves	<b>GR1836C</b>	352	<b>UR1836C</b>	568
	36"	914	64	29.0	2.2	same, plus 1 solid shelf	<b>GRS1836C</b>	487	<b>URS1836C</b>	747
	48"	1219	52	23.6	2.6	2 wire shelves	<b>GR1848C</b>	382	<b>UR1848C</b>	609
	48"	1219	72	32.7	2.6	same, plus 1 solid shelf	<b>GRS1848C</b>	536	<b>URS1848C</b>	819
	60"	1524	58	26.3	3.2	2 wire shelves	<b>GR1860C</b>	431	<b>UR1860C</b>	659
	60"	1524	82	37.2	3.2	same, plus 1 solid shelf	<b>GRS1860C</b>	613	<b>URS1860C</b>	935

#### Optional Wire Shelves

	length		weight		cu ft	model #	list
	in.	mm	lbs.	kg			
18" width (457mm)	36"	914	9	4.1	0.7	<b>1836C</b> •	87
	48"	1219	12	5.5	0.9	<b>1848C</b> •	106
	60"	1524	17	7.7	1.2	<b>1860C</b> •	123

#### Replacement Coat Hanger Tubes

length	weight		cu ft	model #	list
	in.	mm			
24"	610	1.5	0.7	<b>CH24</b>	80
30"	762	1.7	0.8	<b>CH30</b>	81
36"	914	2.2	1.0	<b>CH36</b>	86
42"	1067	2.7	1.2	<b>CH42</b>	92
48"	1219	3.2	1.5	<b>CH48</b> •	99
54"	1372	3.5	1.6	<b>CH54</b>	100
60"	1524	3.8	1.7	<b>CH60</b>	106



#### Optional Hangers

description	weight		cu ft	chrome	
	lbs.	kg		model #	list
open loop hanger	0.4	0.2	0.3	<b>OLH-C</b> •	16
closed loop hanger	0.4	0.2	0.3	<b>CLH-C</b>	16

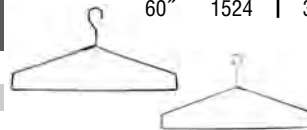

### Platforms NSF

see spec sheet **EG01.13**



**600 lbs. weight capacity**

- Open-wire construction for improved air circulation, minimizing dust.

FEATURES:

**Freight class is 70.0.**

(•) MTS (made to stock) / ( ) MTO (made to order)

patented  
**QuadTruss®**  
design  
(Patent #5,390,803)

**Patented QuadTruss® Design** makes shelves up to 25% stronger and provides a retaining ledge for increased strength and product retention.

14" height (356mm)		length		weight		cu ft	EAGLEbrite®		chrome		EAGLEgard®	
		in.	mm	lbs.	kg		model #	list	model #	list	model #	list
18" width (457mm)	24"	610	10	4.5	0.7	<b>PF1824-Z</b> •	161	<b>PF1824-C</b> •	162	<b>PF1824-E</b> •	193	
	30"	762	11	5.0	0.7	<b>PF1830-Z</b> •	163	<b>PF1830-C</b> •	167	<b>PF1830-E</b> •	197	
	36"	914	13	5.9	0.7	<b>PF1836-Z</b> •	171	<b>PF1836-C</b> •	172	<b>PF1836-E</b> •	200	
21" width (533mm)	24"	610	12	5.4	0.7	<b>PF2124-Z</b> •	172	<b>PF2124-C</b> •	178	<b>PF2124-E</b> •	208	
	30"	762	13	5.9	0.7	<b>PF2130-Z</b> •	174	<b>PF2130-C</b> •	181	<b>PF2130-E</b> •	211	
	36"	914	14	6.4	0.8	<b>PF2136-Z</b> •	177	<b>PF2136-C</b> •	183	<b>PF2136-E</b> •	213	
24" width (610mm)	24"	610	13	5.9	0.8	<b>PF2424-Z</b> •	177	<b>PF2424-C</b> •	182	<b>PF2424-E</b> •	217	
	30"	762	15	6.8	0.8	<b>PF2430-Z</b> •	179	<b>PF2430-C</b> •	185	<b>PF2430-E</b> •	221	
	36"	914	17	7.7	0.8	<b>PF2436-Z</b> •	182	<b>PF2436-C</b> •	191	<b>PF2436-E</b> •	224	



## Catalog Section 1

### Dunnage Shelves (NSF)

see spec sheet **EG01.13**



**Improves your system's weight-bearing capacity.**

#### FEATURES:

- Four-sided frame with center supports.
- Removable heavy duty 5/16" (8mm)-diameter wire mat assembly.

**Note:** All weights and cubic feet are approximate.

**Freight class is 70.0.**

(•) MTS (made to stock) / ( ) MTO (made to order)

	length		weight		cu ft	chrome		EAGLEgard®		stainless steel	
	in.	mm	lbs.	kg		model #	list	model #	list	model #	list
18" width (457mm)	24"	610	14	6.4	0.6	DS1824-C	199	DS1824-E	258	n/a	n/a
	30"	762	18	8.2	0.7	DS1830-C	218	DS1830-E	265	n/a	n/a
	36"	914	21	9.5	0.8	DS1836-C	227	DS1836-E	275	DS1836-S	739
	48"	1219	28	12.7	1.1	DS1848-C	263	DS1848-E •	316	DS1848-S	896
	60"	1524	33	15.0	1.3	DS1860-C	299	DS1860-E •	362	DS1860-S	1052
21" width (533mm)	24"	610	15	6.8	0.6	DS2124-C	209	DS2124-E	262	n/a	n/a
	30"	762	19	8.6	0.8	DS2130-C	224	DS2130-E	277	n/a	n/a
	36"	914	22	10.0	0.9	DS2136-C	235	DS2136-E	292	n/a	n/a
	48"	1219	28	12.7	1.2	DS2148-C	275	DS2148-E	320	n/a	n/a
	60"	1524	34	15.4	1.5	DS2160-C	314	DS2160-E	371	n/a	n/a
24" width (610mm)	24"	610	16	7.3	0.8	DS2424-C	214	DS2424-E	278	n/a	n/a
	30"	762	20	9.0	0.9	DS2430-C	227	DS2430-E	287	n/a	n/a
	36"	914	24	10.9	1.1	DS2436-C	241	DS2436-E	296	DS2436-S	805
	48"	1219	30	13.6	1.4	DS2448-C	278	DS2448-E •	338	DS2448-S	969
	60"	1524	37	16.8	1.8	DS2460-C	331	DS2460-E •	399	DS2460-S	1162

### Dunnage Racks (NSF)

see spec sheet **EG01.13**



**Store large items off the floor!**

**Snag-free wire surface.**

#### WEIGHT CAPACITY:

- Up to 36" (914mm) long: 1600 lbs. (635 kg).
- 48" (1219mm) long: 1300 lbs. (590 kg).
- 60" (1524mm) long: 1000 lbs. (454 kg).
- static load equally distributed.

**Note:** All weights and cubic feet are approximate.

**Freight class is 70.0.**

(•) MTS (made to stock) / ( ) MTO (made to order)

		length		weight		cu ft	chrome		EAGLEgard®		stainless steel	
		in.	mm	lbs.	kg		model #	list	model #	list	model #	list
14" overall height (356mm)	18" width (457mm)	24"	610	21	9.5	0.5	DR1824-C	358	DR1824-E	444	n/a	n/a
		30"	762	24	10.9	1.0	DR1830-C	379	DR1830-E	461	n/a	n/a
		36"	914	31	14.1	1.6	DR1836-C	386	DR1836-E	471	DR1836-S	964
		48"	1219	37	16.8	2.2	DR1848-C	427	DR1848-E •	516	DR1848-S	1242
		60"	1524	43	19.5	3.0	DR1860-C	479	DR1860-E	578	n/a	n/a
	21" width (533mm)	24"	610	24	10.9	0.8	DR2124-C	366	DR2124-E	455	n/a	n/a
		30"	762	27	12.2	2.0	DR2130-C	385	DR2130-E	473	n/a	n/a
		36"	914	33	15.0	2.0	DR2136-C	400	DR2136-E	491	n/a	n/a
		48"	1219	39	17.6	2.9	DR2148-C	443	DR2148-E	527	n/a	n/a
		60"	1524	45	20.4	3.3	DR2160-C	507	DR2160-E	598	n/a	n/a
	24" width (610mm)	24"	610	27	12.2	1.4	DR2424-C	376	DR2424-E	471	n/a	n/a
		30"	762	30	13.6	1.8	DR2430-C	389	DR2430-E	484	n/a	n/a
36"		914	35	15.9	2.1	DR2436-C •	412	DR2436-E •	494	DR2436-S	1071	
48"		1219	41	18.6	2.8	DR2448-C •	455	DR2448-E •	545	DR2448-S	1361	
60"		1524	47	21.3	3.5	DR2460-C	527	DR2460-E	629	n/a	n/a	

### Mobile Dunnage Racks <sup>NSF</sup>

see spec sheet **EG01.13** WEIGHT CAPACITY:



**Easy to maneuver!**

- 800 lbs. (363 kg) - equally distributed on the top surface.
- Four 5" (127mm) swivel polyurethane tread casters, two with brakes.
- 3-sided frame with 1" (25mm)-square tubing.
- Snag-free wire surface.

INCLUDES:

Note: All weights and cubic feet are approximate.

**Freight class is 70.0.**

		length		weight		cu ft	chrome		EAGLEgard®		stainless steel	
		in.	mm	lbs.	kg		model #	list	model #	list	model #	list
14" overall height (356mm)	18" width (457mm)	24"	610	33	15.0	1.0	MDR1824-C	546	MDR1824-E	635	n/a	n/a
		30"	762	36	16.3	2.3	MDR1830-C	572	MDR1830-E	651	n/a	n/a
		36"	914	43	19.5	2.3	MDR1836-C	577	MDR1836-E	662	MDR1836-S	1561
		48"	1219	49	22.2	3.0	MDR1848-C	621	MDR1848-E	708	MDR1848-S	1657
		60"	1524	55	24.9	4.5	MDR1860-C	668	MDR1860-E	769	n/a	n/a
	21" width (533mm)	24"	610	36	16.3	3.1	MDR2124-C	554	MDR2124-E	639	n/a	n/a
		30"	762	39	17.6	3.3	MDR2130-C	576	MDR2130-E	665	n/a	n/a
		36"	914	45	20.4	3.0	MDR2136-C	591	MDR2136-E	680	n/a	n/a
		48"	1219	51	23.1	4.0	MDR2148-C	634	MDR2148-E	717	n/a	n/a
		60"	1524	57	25.9	5.0	MDR2160-C	695	MDR2160-E	789	n/a	n/a
	24" width (610mm)	24"	610	40	18.1	3.0	MDR2424-C	566	MDR2424-E	662	n/a	n/a
		30"	762	42	19.1	3.0	MDR2430-C	580	MDR2430-E	672	n/a	n/a
		36"	914	47	21.3	3.0	MDR2436-C	598	MDR2436-E	685	MDR2436-S	1496
		48"	1219	53	24.0	4.0	MDR2448-C	639	MDR2448-E	735	MDR2448-S	1766
		60"	1524	63	28.6	5.0	MDR2460-C	717	MDR2460-E	819	n/a	n/a

### Polymer Dunnage Racks <sup>NSF</sup>

see spec sheet **EG01.17**



FEATURES:

- No assembly required.

**Freight class is 70.0.**

(•) MTS (made to stock) / ( ) MTO (made to order)

**Durable polyethylene construction prevents corrosion and rust.**

	width		length		weight		cubic feet	capacity		color	model #	list
	in.	mm	in.	mm	lbs.	kg		lbs.	kg			
12" height (305mm)	22"	559	36"	914	18	8.2	5.5	2000	907	black	PD3622	334
	22"	559	48"	1219	24	10.9	7.4	3000	1361	black	PD4822	403
	22"	559	60"	1524	28	12.7	9.2	3000	1361	black	PD6022	460
	36"	914	48"	1219	35	15.9	12.0	3500	1588	black	PD4836	463

### Starter Units with Dunnage Shelf <sup>NSF</sup>

see spec sheet **EG01.19**



**Heavy duty dunnage shelf improves the units overall weight-bearing capacity.**

FEATURES:

- Tapered split sleeves create a positive lock that becomes stronger as the load increases.
- 74" (1880mm) posts numbered in increments of 1" (25mm) to ensure fast and level assembly.

**Freight class is 70.0.**

#### Stationary

width x length	zinc	chrome		EAGLEgard®			
		in.	mm	model #	list	model #	list
24" x 48"	610 x 1219	DS4-P74-2448Z	949	DS4-P74-2448C	1088	DS4-P74-2448E	1115

#### Mobile

width x length	zinc	chrome		EAGLEgard®			
		in.	mm	model #	list	model #	list
24" x 48"	610 x 1219	DS4-CP74-2448Z	1087	DS4-CP74-2448C	1229	DS4-CP74-2448E	1252

patented  
**QuadTruss®**  
design  
(Patent #5,390,803)

Note: Mobile models feature 5" resilient swivel casters with bumpers.

## Catalog Section 1

### Aluminum Dunnage Racks NSF

see spec sheet **EG01.17**



- 1½" (38mm) square tubing.
- Plastic feet.

FEATURES:

**Freight class is 70.0.**

(•) MTS (made to stock) / ( ) MTO (made to order)

	length		weight		cubic feet	weight capacity		number of lats	RACKS WITH 8" (203mm) HEIGHT		RACKS WITH 12" (305mm) HEIGHT	
	in.	mm	lbs.	kg		lbs.	kg		model #	list	model #	list
20" width (508mm)	36"	914	10	4.5	6.8	2000	907	4	WDR203608-A •	305	WDR203612-A •	305
	48"	1219	14	6.4	8.9	2000	907	4	WDR204808-A •	354	WDR204812-A •	354
	60"	1524	18	8.2	11.0	1500	680	4	WDR206008-A •	400	WDR206012-A •	400
24" width (610mm)	36"	914	12	5.4	8.0	2000	907	5	WDR243608-A •	344	WDR243612-A •	344
	48"	1219	16	7.3	10.5	2000	907	5	WDR244808-A •	386	WDR244812-A •	386
	60"	1524	20	9.1	13.1	1500	680	5	WDR246008-A •	448	WDR246012-A •	448

### Nesting Dunnage Racks NSF

see spec sheet **EG01.17**



- All-aluminum construction.

FEATURES:

**Freight class is 70.0.**

*Racks are stackable, saving space when not in use.*

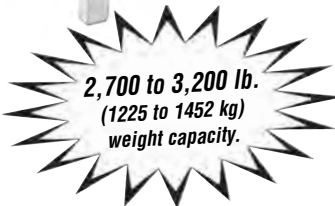

**2,700 to 3,200 lb.**  
(1225 to 1452 kg)  
weight capacity.

		length		weight		cubic feet	weight capacity		model #	list
		in.	mm	lbs.	kg		lbs.	kg		
12" height (305mm)	18" width (457mm)	24"	610	8	3.6	3.0	3200	1452	NDR182412-A	293
		36"	914	10	4.5	4.5	3200	1452	NDR183612-A	337
		48"	1219	12	5.4	6.0	2700	1225	NDR184812-A	376
	20" width (508mm)	24"	610	8	3.6	3.4	3200	1452	NDR202412-A	293
		36"	914	10	4.5	5.1	3200	1452	NDR203612-A	337
		48"	1219	12	5.4	6.7	2700	1225	NDR204812-A	376
24" width (610mm)	24"	610	9	4.1	4.0	3200	1452	NDR242412-A	345	
	36"	914	11	5.0	6.0	3200	1452	NDR243612-A	384	
	48"	1219	14	6.4	8.0	2700	1225	NDR244812-A	448	

### Aluminum Truck Dollies

see spec sheet **EG01.03B**



- Four designated 5" x 1¼" (127 x 32mm) casters with poly tread.
- Wraparound bumpers.

INCLUDES:

**Freight class is 70.0.**

	length		weight		cubic feet	caster type	caster load rate (each)		model #	list
	in.	mm	lbs.	kg			lbs.	kg		
29¾" width (756mm)	52½"	1343	41	18.6	6.3	swivel	300	136.1	TD2448-SP	1273
	52½"	1343	44	20.0	6.3	swivel/brake	300	136.1	TD2448-BSP	1477
	64"	1648	48	21.8	7.6	swivel	300	136.1	TD2460-SP	1478
	64"	1648	50	22.7	7.6	swivel/brake	300	136.1	TD2460-BSP	1681

### Dolly Frames with Wraparound Bumper

see spec sheet **EG01.03B**



dolly frames  
with wraparound bumper

- If ordering casters list dolly frame and caster model numbers separately.
- Holes are prepunched for use with plate casters on page 15.

ORDERING:

**Freight class is 70.0.**

(•) MTS (made to stock) / ( ) MTO (made to order)

	length		Aluminum					Chrome Plated Steel				
			weight		cu			weight		cu		
	in.	mm	lbs.	kg	ft	model #	list	lbs.	kg	ft	model #	list
23 3/4" width (603mm)	40 7/8"	1038	14	6.4	1.6	DF1836-A	463	16	7.3	1.6	DF1836-C	823
	46 1/8"	1191	16	7.3	1.9	DF1842-A	493	18	8.2	1.9	DF1842-C	848
	52 1/8"	1343	18	8.2	2.1	DF1848-A	506	20	9.1	2.1	DF1848-C	876
	64 1/8"	1648	21	9.6	2.6	DF1860-A	560	23	10.4	2.6	DF1860-C	931
	76 1/8"	1953	23	10.4	2.9	DF1872-A	644	25	11.3	2.9	DF1872-C	991
26 3/4" width (680mm)	40 7/8"	1038	17	7.7	1.8	DF2136-A	493	19	8.6	1.8	DF2136-C	853
	46 1/8"	1191	19	8.6	2.1	DF2142-A	513	21	9.6	2.1	DF2142-C	882
	52 1/8"	1343	21	9.6	2.4	DF2148-A	527	24	10.9	2.4	DF2148-C	914
	64 1/8"	1648	23	10.4	2.9	DF2160-A	572	23	11.8	2.9	DF2160-C	965
	76 1/8"	1953	25	11.3	3.5	DF2172-A	606	28	12.7	3.5	DF2172-C	1109
29 3/4" width (756mm)	40 7/8"	1038	21	9.6	2.1	DF2436-A	498	23	10.4	2.1	DF2436-C	848
	46 1/8"	1191	26	11.8	2.4	DF2442-A	516	29	13.2	2.4	DF2442-C	873
	52 1/8"	1343	29	13.2	3.9	DF2448-A	542	32	14.5	3.9	DF2448-C	909
	64 1/8"	1648	31	14.1	4.2	DF2460-A •	583	34	15.4	4.2	DF2460-C	965
	76 1/8"	1953	39	17.7	4.5	DF2472-A	685	42	19.1	4.5	DF2472-C	1100

### Plastic Label Holders

see spec sheet **EG01.03D**



gray plastic label holder

black plastic label holder

clear plastic label holder

- Snaps onto shelf edge.
- Provides easy identification of shelf contents or section.
- Holds labels up to 1 1/2" (38mm)-tall.

FEATURES:

**Freight class is 70.0.**

(•) MTS (made to stock) / ( ) MTO (made to order)

length		fits shelf size		gray		black		clear	
in.	mm	in.	mm	model #	list	model #	list	model #	list
3"	76	all	all	A204331*	3	A206216 *	3	A208746	3
13"	330	18"	457	A206196	9	A206217	9	A208747	9
19"	483	24"	610	A206197	13	A206218	13	A208749	13
25"	635	30"	762	A206198	16	A206219	16	A208750	16
31"	787	36"	914	A206199	18	A206220	18	A208751 •	18
33"	838	36"	914	A213096	20	A227763	20	A227764	20
37"	940	42"	1067	A223747	21	A223748	21	A223749	21
43"	1092	48"	1219	A206200	22	A206221	22	A208752	22
45"	1143	48"	1219	A212494	23	A225208	23	A217621	23
55"	1397	60"	1524	A206201	25	A206222	25	A208753	25
67"	1702	72"	1829	A227842	29	A227841	29	A222144	29

\* Actual length: 3 3/8" (83mm)



### Wire Basket Shelf



see spec sheet **EG01.03E**

**400-lb. (181.4 kg) weight capacity!**

FEATURES:

- Chrome-plated.
- For use with standard shelving posts.
- 4 1/4" (107mm) depth.



width	length		weight		chrome	
	in	mm	lbs.	kg	model #	list
18" (457mm)	36"	914	10	4.5	WBS1836C	129

**Freight class is 70.0.**

### Security Modules

see spec sheet **EG01.16**



shown with hinged door  
(shown mounted to shelf unit  
sold separately)



shown with flip-up door  
(shown mounted to shelf unit  
sold separately)

- End panels.
- Rear panel.
- Door(s).
- Fits in between two wire shelves spaced 20" (508mm) apart.

INCLUDES:

**Note:** Shelving units sold separately—see pages 18 and 20.

**Freight class is 70.0.**

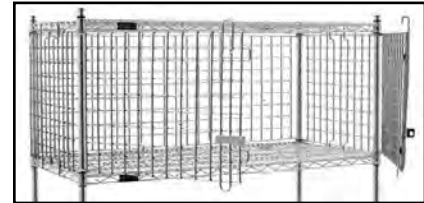

**Converts portion of shelf unit into a lockable enclosed security unit, adding versatility to shelf unit. More than one module can be added to unit, depending on unit's overall height.**

### Hinged Doors

	length		weight		EAGLEbrite® zinc		chrome		Valu-Gard® green		EAGLEgard®		stainless steel	
	in.	mm	lb.	kg	model #	list	model #	list	model #	list	model #	list	model #	list
<b>18" width</b> (457mm)	30"	762	20	9.0	SECM1830Z	473	SECM1830C	621	SECM1830VG	647	SECM1830E	652	SECM1830S	1505
	36"	914	23	10.4	SECM1836Z	483	SECM1836C	628	SECM1836VG	654	SECM1836E	663	SECM1836S	1536
	48"	1219	27	12.2	SECM1848Z	514	SECM1848C	665	SECM1848VG	693	SECM1848E	699	SECM1848S	1644
	60"	1524	32	14.5	SECM1860Z	519	SECM1860C	747	SECM1860VG	778	SECM1860E	785	SECM1860S	1648
<b>21" width</b> (533mm)	30"	762	21	9.5	SECM2130Z	481	SECM2130C	627	SECM2130VG	653	SECM2130E	662	SECM2130S	1531
	36"	914	24	10.9	SECM2136Z	492	SECM2136C	637	SECM2136VG	664	SECM2136E	669	SECM2136S	1563
	48"	1219	29	13.2	SECM2148Z	526	SECM2148C	680	SECM2148VG	708	SECM2148E	717	SECM2148S	1681
	60"	1524	33	15.0	SECM2160Z	536	SECM2160C	757	SECM2160VG	789	SECM2160E	799	SECM2160S	1697
<b>24" width</b> (610mm)	30"	762	24	10.9	SECM2430Z	488	SECM2430C	635	SECM2430VG	661	SECM2430E	667	SECM2430S	1555
	36"	914	27	12.2	SECM2436Z	506	SECM2436C	680	SECM2436VG	708	SECM2436E	716	SECM2436S	1611
	48"	1219	31	14.1	SECM2448Z	539	SECM2448C	772	SECM2448VG	804	SECM2448E	811	SECM2448S	1720
	60"	1524	35	15.9	SECM2460Z	572	SECM2460C	861	SECM2460VG	897	SECM2460E	906	SECM2460S	1829

### Flip-Up Door

	length		weight		EAGLEbrite® zinc		chrome		Valu-Gard® green		EAGLEgard®		stainless steel	
	in.	mm	lb.	kg	model #	list	model #	list	model #	list	model #	list	model #	list
<b>18" width</b> (457mm)	30"	762	24	10.9	SECM1830FZ	557	SECM1830FC	664	SECM1830FVG	692	SECM1830FE	698	SECM1830FS	1759
	36"	914	29	13.2	SECM1836FZ	563	SECM1836FC	669	SECM1836FVG	697	SECM1836FE	704	SECM1836FS	1785
	48"	1219	34	15.4	SECM1848FZ	589	SECM1848FC	702	SECM1848FVG	731	SECM1848FE	741	SECM1848FS	1872
	60"	1524	39	17.6	SECM1860FZ	596	SECM1860FC	758	SECM1860FVG	790	SECM1860FE	801	SECM1860FS	1883
<b>21" width</b> (533mm)	30"	762	26	11.8	SECM2130FZ	561	SECM2130FC	668	SECM2130FVG	696	SECM2130FE	703	SECM2130FS	1782
	36"	914	30	13.6	SECM2136FZ	572	SECM2136FC	679	SECM2136FVG	707	SECM2136FE	716	SECM2136FS	1808
	48"	1219	35	15.9	SECM2148FZ	599	SECM2148FC	717	SECM2148FVG	747	SECM2148FE	753	SECM2148FS	1905
	60"	1524	40	18.1	SECM2160FZ	609	SECM2160FC	772	SECM2160FVG	804	SECM2160FE	811	SECM2160FS	1927
<b>24" width</b> (610mm)	30"	762	28	12.7	SECM2430FZ	569	SECM2430FC	677	SECM2430FVG	705	SECM2430FE	713	SECM2430FS	1801
	36"	914	32	14.5	SECM2436FZ	583	SECM2436FC	713	SECM2436FVG	743	SECM2436FE	749	SECM2436FS	1846
	48"	1219	38	17.2	SECM2448FZ	611	SECM2448FC	780	SECM2448FVG	813	SECM2448FE	821	SECM2448FS	1937
	60"	1524	43	19.5	SECM2460FZ	637	SECM2460FC	853	SECM2460FVG	889	SECM2460FE	896	SECM2460FS	2031

# FULL-SIZE SECURITY UNITS

Safely store and transport costly materials and items subject to pilferage.

## Full-Size Stationary Security Units

see spec sheet **EG01.22**

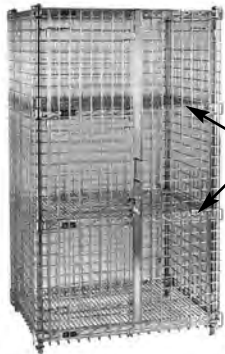

additional center shelves  
(see page 45)

patented  
**QuadTruss®**  
design  
(Patent #5,390,803)

**Patented QuadTruss® Design**  
makes shelves up to 25% stronger and provides a retaining ledge for increased strength and product retention.

FEATURES:

- 2" x 2" (51 x 51mm) mesh.
- Shipped knocked-down.

**Freight class is 70.0.**

(•) MTS (made to stock) / ( ) MTO (made to order)

**Note:** See page 34 for optional cart covers available. Doors on front and rear of unit available. To order, add suffix "-2D" (ex: SC2436S-2D). **20% upcharge.**

		length		weight		cu ft	chrome		EAGLEgard®		stainless steel	
		in.	mm	lbs.	kg		model #	list	model #	list	model #	list
67" overall height (1702mm)	17 1/4" width (438mm)	33 1/4"	845	114	51.7	5	SC1430	1412	SC1430E	1688	SC1430S	4189
		39 1/4"	997	123	55.8	5	SC1436 •	1567	SC1436E	1877	SC1436S	4657
		51 1/4"	1302	141	64.0	9	SC1448 •	1949	SC1448E	2283	SC1448S	5629
		63 1/4"	1607	159	72.1	10	SC1460	2320	SC1460E	2613	SC1460S	5784
	27 1/4" width (692mm)	33 1/4"	845	123	55.8	9	SC2430	1444	SC2430E	1841	SC2430S	4212
		39 1/4"	997	145	65.8	9	SC2436 •	1603	SC2436E •	2047	SC2436S	4679
		51 1/4"	1302	171	77.6	13	SC2448 •	1989	SC2448E •	2546	SC2448S	5706
		63 1/4"	1607	197	89.4	15	SC2460 •	2387	SC2460E	2767	SC2460S	5904
	33 1/4" width (845mm)	33 1/4"	845	145	65.8	15	SC3030	2111	SC3030E	2405	SC3030S	5928
		39 1/4"	997	163	73.9	13	SC3036	2344	SC3036E	2675	SC3036S	6586
		51 1/4"	1302	181	82.1	15	SC3048	2918	SC3048E	3354	SC3048S	8036
		63 1/4"	1607	207	93.9	18	SC3060	3142	SC3060E	3608	SC3060S	8373

## Full-Size Mobile Security Units

see spec sheet **EG01.22**

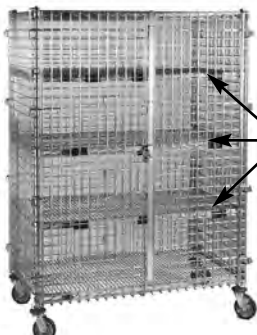

additional center shelves  
(see page 45)

patented  
**QuadTruss®**  
design  
(Patent #5,390,803)

**Patented QuadTruss® Design**  
makes shelves up to 25% stronger and provides a retaining ledge for increased strength and product retention.

FEATURES:

- Four swivel 5" x 1 1/4" (127 x 32mm) stem casters with polyurethane tread—two with brake.
- 2" x 2" (51 x 51mm) mesh.
- Shipped knocked-down.

**Note:** All stainless steel mobile security units come with stainless steel casters with polyurethane tread. See page 14 for other stem casters available. See page 34 for optional cart covers available. Doors on front and rear of unit available. To order, add suffix "-2D" (ex: CSC2430-2D). **20% upcharge.**

**Freight class is 70.0.**

(•) MTS (made to stock) / ( ) MTO (made to order)

		length		weight		cu ft	chrome		EAGLEgard®		stainless steel	
		in.	mm	lbs.	kg		model #	list	model #	list	model #	list
69" overall height (1753mm)	27 1/4" width (692mm)	33 1/4"	845	135	61.2	9	CSC2430	1722	CSC2430E	2109	CSC2430S	4212
		39 1/4"	997	161	73.0	9	CSC2436 •	1914	CSC2436E •	2343	CSC2436S	4679
		51 1/4"	1302	185	83.9	13	CSC2448 •	2304	CSC2448E •	2843	CSC2448S	5706
		63 1/4"	1607	204	92.5	15	CSC2460 •	2712	CSC2460E	3063	CSC2460S	5904
	33 1/4" width (845mm)	33 1/4"	845	161	73.0	15	CSC3030	2475	CSC3030E	2760	CSC3030S	5928
		39 1/4"	997	179	87.2	13	CSC3036	2749	CSC3036E	3066	CSC3036S	6586
		51 1/4"	1302	203	92.1	15	CSC3048	3320	CSC3048E •	3724	CSC3048S	8036
		63 1/4"	1607	221	100.2	18	CSC3060 •	3585	CSC3060E	4007	CSC3060S	8373

## Catalog Section 1

### Full-Size Dolly Truck Security Units <sup>NSF</sup>

see spec sheet **EG01.22**



optional  
center  
shelves

patented  
**QuadTruss®**  
design

(Patent #5,390,803)

#### Patented QuadTruss® Design

makes shelves up to 25% stronger and provides a retaining ledge for increased strength and product retention.

- Dolly with wraparound bumper.
- 2" x 2" (51 x 51mm) mesh.
- Four swivel 5" x 1 1/4" (127 x 32mm) poly plate casters, two with brakes.
- Shipped knocked down.

#### INCLUDES:

**Note:** See page 15 for optional plate casters.  
See page 34 for optional cart covers available.  
Doors on front and rear of unit available. To order, add suffix "-2D" (ex: DTSC2448-2D). **20% upcharge.**

**Freight class is 70.0.**

(•) MTS (made to stock) / ( ) MTO (made to order)

		length		weight		cu ft	chrome shelf unit with aluminum dolly		EAGLEgard® shelf unit with aluminum dolly		stainless steel shelf unit with stainless steel dolly	
		in.	mm	lbs.	kg		model #	list	model #	list	model #	list
<b>69" overall height</b> (1753mm)	<b>29 1/4" width</b> (756mm)	34 1/2"	886	161	73.0	7.3	<b>DTSC2430</b>	2186	<b>DTSC2430E</b>	3057	<b>DTSC2430S</b>	5705
		40 1/2"	1038	177	80.3	10.7	<b>DTSC2436</b>	2427	<b>DTSC2436E</b>	3402	<b>DTSC2436S</b>	6338
		52 1/2"	1343	214	97.1	18.5	<b>DTSC2448</b>	2852	<b>DTSC2448E</b>	4052	<b>DTSC2448S</b>	7521
		64 1/2"	1648	245	111.1	22.9	<b>DTSC2460</b>	3285	<b>DTSC2460E</b>	4468	<b>DTSC2460S</b>	7722

#### Optional Posts for Full-Size Security Units

post height		weight		cu ft	chrome		EAGLEgard®		stainless steel	
in.	mm	lbs.	kg		model #	list	model #	list	model #	list
74"	1880	4	1.8	0.5	<b>SP74-CS</b>	37	<b>SP74-ES</b>	36	<b>SP74-SS</b>	119
86"	2184	5	2.3	0.8	<b>SP86-CS</b>	47	<b>SP86-ES</b>	46	<b>SP86-SS</b>	140

#### Optional Shelves for Full-Size Security Units

	Wire Shelves										Optional Quad-Adjust® Shelves					
	Must be installed when assembling unit.										For use as intermediate shelves only.					
	length		weight		cu ft	chrome		EAGLEgard®		stainless steel		chrome		EAGLEgard®		stainless steel
in.	mm	lbs.	kg	model #		list	model #	list	model #	list	model #	list	model #	list	model #	list
<b>14" width*</b> (356mm)	30"	762	7	3.2	0.5	<b>1430C</b> • 74	<b>1430E</b> • 74	<b>1430S</b>	260	n/a	n/a	n/a	n/a	n/a	n/a	n/a
	36"	914	8	3.6	0.5	<b>1436C</b> • 82	<b>1436E</b> • 82	<b>1436S</b> •	262	<b>QA1436C</b>	120	<b>QA1436E</b>	134	<b>QA1436S</b>	329	
	48"	1219	10	4.5	0.7	<b>1448C</b> • 96	<b>1448E</b> • 96	<b>1448S</b> •	321	<b>QA1448C</b>	135	<b>QA1448E</b>	154	<b>QA1448S</b>	394	
	60"	1524	14	6.4	0.9	<b>1460C</b> • 109	<b>1460E</b> • 109	<b>1460S</b> •	411	<b>QA1460C</b>	147	<b>QA1460E</b>	163	<b>QA1460S</b>	493	
<b>24" width</b> (610mm)	30"	762	11	5.0	0.8	<b>2430C</b> • 106	<b>2430E</b> • 106	<b>2430S</b> •	399	n/a	n/a	n/a	n/a	n/a	n/a	
	36"	914	13	5.9	0.8	<b>2436C</b> • 109	<b>2436E</b> • 109	<b>2436S</b> •	403	<b>QA2436C</b>	147	<b>QA2436E</b>	172	<b>QA2436S</b>	486	
	48"	1219	16	7.3	1.2	<b>2448C</b> • 133	<b>2448E</b> • 133	<b>2448S</b> •	485	<b>QA2448C</b>	172	<b>QA2448E</b>	200	<b>QA2448S</b>	576	
	60"	1524	21	9.5	1.5	<b>2460C</b> • 155	<b>2460E</b> • 155	<b>2460S</b> •	596	<b>QA2460C</b>	193	<b>QA2460E</b>	228	<b>QA2460S</b>	700	
<b>30" width*</b> (762mm)	30"	762	16	7.3	1.0	<b>3030C</b>	141	<b>3030E</b>	141	<b>3030S</b>	487	n/a	n/a	n/a	n/a	
	36"	914	17	7.7	1.0	<b>3036C</b> •	144	<b>3036E</b> •	144	<b>3036S</b> •	516	n/a	n/a	n/a	n/a	
	48"	1219	20	9.1	1.5	<b>3048C</b> •	171	<b>3048E</b> •	171	<b>3048S</b> •	601	n/a	n/a	n/a	n/a	
	60"	1524	25	11.4	1.8	<b>3060C</b> •	227	<b>3060E</b> •	227	<b>3060S</b> •	694	n/a	n/a	n/a	n/a	

\* 14" and 30" widths (356 and 762mm) do not fit Full-Size Dolly Truck Security Units.

#### Ordering Full Size Security Units Assembled:

- Security carts shipped assembled, add \$1250 to list price and add suffix "-A". **Example: SC1460E-A.**
- For assembled unit with center shelves installed (evenly spaced), indicate number of center shelves wanted by adding a number before the "A" in suffix "-A".
- For example, suffix "-1A" indicates assembled unit with one center shelf, suffix "-2A" indicates assembled unit with two center shelves, and so on. **Example: SC1460E-2A.**
- **PRICING:** add \$1250 to list price of security unit, and add list price of each applicable center shelf to be added.



100 Industrial Boulevard, Clayton, DE 19938-8903 U.S.A.  
Phone: 800-441-8440 or 302-653-3000. Fax: 302-653-2065  
http://www.eaglegrp.com

### Mini Security Units <sup>(NSF)</sup>

see spec sheet **EG01.22**



**patented**  
**QuadTruss®**  
**design**

(Patent #5,390,803)

**Patented QuadTruss® Design**  
makes shelves up to 25% stronger and provides a retaining ledge for increased strength and product retention.

- Stationary chrome plated units.
- 40" (1016mm) height.
- Shipped knocked down.

FEATURES:

**Freight class is 70.0.**

(•) MTS (made to stock) / ( ) MTO (made to order)

	length		weight		cubic feet	model #	list
	in.	mm	lbs.	kg			
<b>16" width</b> (406mm)	38"	965	88	39.9	8.6	<b>MSC1436</b> •	1516
	50"	1270	104	47.2	9.6	<b>MSC1448</b>	1904
<b>26" width</b> (660mm)	38"	965	100	45.4	9.2	<b>MSC2436</b> *	1566
	50"	1270	114	51.7	10.6	<b>MSC2448</b> *	1969

\* Optional stem casters (page 14) available only for these models.

### Optional Shelves for Mini Security Units

- With chrome plated finish.

	length		weight		cubic feet	model #	list
	in.	mm	lbs.	kg			
<b>14" width</b> (356mm)	36"	914	8	3.6	0.5	<b>1436C</b> •	82
	48"	1219	10	4.5	0.7	<b>1448C</b> •	96
<b>24" width</b> (610mm)	36"	914	13	6.0	0.8	<b>2436C</b> •	109
	48"	1219	16	7.3	1.2	<b>2448C</b> •	133



### Optional Add-A-Shelf® Adjustable Shelves for All Security Units

see spec sheet **EG01.22**



optional Add-A-Shelf®  
being added to  
security unit

WEIGHT CAPACITY:

- 300 lb. (136.1 kg) per shelf.

**Note:** Top and bottom shelves of unit must be standard shelves—see page 45.

WARNING:

- Use Add-A-Shelf® shelves for intermediate shelves.

FEATURES:

- Chrome finish.

**Freight class is 70.0.**

(•) MTS (made to stock) / ( ) MTO (made to order)

**patented**  
**QuadTruss®**  
**design**

(Patent #5,390,803)

**Patented QuadTruss® Design**

makes shelves up to 25% stronger and provides a retaining ledge for increased strength and product retention.

Just a quick note...



**GET FREE DOWNLOADS**

- Spec Sheets • Product Instructions •
- Special Flyers • Brochures •

**www.eaglegrp.com**

	length		weight		cubic feet	model #	list
	in.	mm	lbs.	kg			
<b>14" width</b> (356mm)	36"	914	8	3.6	0.5	<b>A1436C</b> •	91
	48"	1219	10	4.5	0.7	<b>A1448C</b> •	106
<b>24" width</b> (610mm)	36"	914	13	5.9	0.8	<b>A2436C</b> •	119
	48"	1219	16	7.3	1.2	<b>A2448C</b> •	140
	60"	1524	21	9.5	1.5	<b>A2460C</b> •	167



## Catalog Section 1

### Syrup Tank Racks

see spec sheet **EG01.31**

**FEATURES:**

- All models chrome-plated.
- Two styles available.

**Freight class is 70.0.**



style "B" syrup tank rack with optional drip pan shown



style "A" syrup tank rack with optional drip pan shown

**Style "A" – 33" (838mm) height**

**Includes:**

- One dunnage mat with frame.
- One 3-sided frame.
- Four 33" (838mm) posts.
- Cable assembly.

**Style "B" – 74" (1880mm) height**

**Includes:**

- One dunnage mat with frame.
- One 3-sided frame.
- Four 74" (1880mm) posts.
- Cable assembly.
- Two standard shelves.

	length		weight		cu	model #	list	weight		cu	model #	list
	in.	mm	lb.	kg	ft			lb.	kg	ft		
<b>24" width (610mm)</b>	30"	762	40	18.1	0.2	<b>STR2430A</b>	537	68	30.8	0.3	<b>STR2430B</b>	817
	48"	1219	50	22.7	0.3	<b>STR2448A</b>	638	88	39.9	0.4	<b>STR2448B</b>	989

### Optional Drip Pans for Syrup Tank Racks

- Stainless steel.



	length		weight		cu	model #	list
	in.	mm	lb.	kg	ft		
<b>24" width (610mm)</b>	30"	762	8	3.6	0.2	<b>DP30</b>	284
	48"	1219	12	5.4	0.3	<b>DP48</b>	319

### Optional Cylinder Retainer for Tank Racks

- Chrome-plated.
- Cylinders are secured to retainer to further prevent damage.

	width		weight		cu	model #	list
	in.	mm	lb.	kg	ft		
24"	610	7	3.2	0.3		<b>CRR24-C</b>	135



### Modular Bag-N-Box Systems

see spec sheet **EG01.29**

**INCLUDES:**

- One slanted shelf to allow syrup to run to front of box.
- Front 1" (25mm) ledge is provided on slanted shelf.
- All units are chrome-plated finish.

**Freight class is 70.0.**

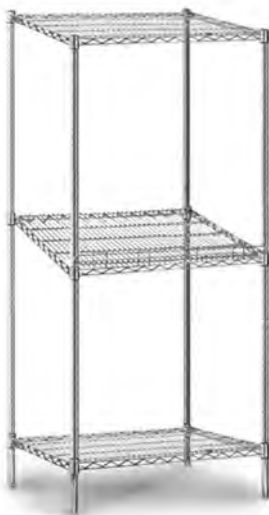

*For storage and usage of syrup boxes.*

**patented QuadTruss<sup>®</sup> design**  
(Patent #5,390,803)

**Patented QuadTruss<sup>®</sup> Design** makes shelves up to 25% stronger and provides a retaining ledge for increased strength and product retention.

# of shelves & description	width x length x height		weight		cu	model #	list
	in.	mm	lb.	kg	ft		
1 slanted shelf; 2 straight shelves	21" x 36" x 54"	533 x 914 x 1372	46	20.9	0.6	<b>B2136C</b>	359
1 slanted shelf; 3 straight shelves	21" x 36" x 54"	533 x 914 x 1372	57	25.9	1.8	<b>2B2136C</b>	444
1 slanted shelf; 4 straight shelves	21" x 36" x 54"	533 x 914 x 1372	68	30.8	2.8	<b>3B2136C</b>	528
1 slanted shelf; 2 straight shelves	21" x 48" x 54"	533 x 1219 x 1372	55	24.9	0.7	<b>B2148C</b>	420
1 slanted shelf; 3 straight shelves	21" x 48" x 54"	533 x 1219 x 1372	69	31.3	2.2	<b>2B2148C</b>	519
1 slanted shelf; 4 straight shelves	21" x 48" x 54"	533 x 1219 x 1372	83	37.6	3.3	<b>3B2148C</b>	622

## Modular Desks / Workstations <sup>NSF</sup>

see spec sheet **EG01.02**



- Heavy gauge type 304 stainless steel.
- Two chrome cantilever open-wire shelves.
- 16 gauge 1" (25mm) diameter chrome-plated posts with exclusive MasterSeal® coating.
- Rear grid panel constructed of chrome
- Three-sided 1" (25mm) channel frame.
- Leveling feet.

**FEATURES:**

**Note:** Optional keyboard drawer available. To order add suffix "-K" to model number (example: MD2448-K) and \$431 to list price.

**Freight class is 70.0.**

	length		weight		cubic feet	model #	list
	in.	mm	lb.	kg			
<b>24" width</b>	36"	914	78	35.3	1.0	<b>MD2436</b>	1474
<i>(610mm)</i>	48"	1219	85	38.6	1.0	<b>MD2448</b>	1596

### Optional Keyboard Station

- Mounts under tabletop.
- 20½" wide x 11½" deep (521 x 292mm).

weight lbs.	cu ft	chrome		stainless		
		model #	list	model #	list	
6.0	2.7	0.35	<b>KBD-1</b>	334	<b>KBD-1/SS</b>	431



## Mobile Computer Workstations

see spec sheet **EG01.04**



shown with optional mouse shelf

patented **QuadTruss®** design

(Patent #5,390,803)

**Patented QuadTruss® Design** makes shelves up to 25% stronger and provides a retaining ledge for increased strength and product retention.

- Two 48" (1219mm) rear posts.
- Two 33" (838mm) front posts.
- One 12" (305mm) wide cantilevered shelf.
- One wire tabletop.
- One 3-sided frame.
- One full-length wire undershelf.
- Keyboard drawer.
- 5" (127mm) casters—two with brake.
- 38¾" (981mm) working height.
- 53¾" (1362mm) overall height.

**INCLUDES:**

**Note:** See page 14 for other casters available.

**Freight class is 70.0.**

(•) MTS (made to stock) / ( ) MTO (made to order)

### WITH RESILIENT-TREAD CASTERS | W/POLYURETHANE-TREAD CASTERS

width**	length		weight		cu ft	chrome		stainless steel		chrome		stainless steel	
	in.	mm	lbs.	kg		model #	*list	model #	*list	model #	*list	model #	*list
<b>24" (610mm)</b>	24"	610	40	18.1	3.7	<b>MCWS2424C</b>	• 1174	<b>MCWS2424S</b>	2085	<b>MCWS2424C-P</b>	1180	<b>MCWS2424S-P</b>	2266
<b>30" (762mm)</b>	30"	762	56	25.4	4.5	<b>MCWS3030C</b>	1280	<b>MCWS3030S</b>	2188	<b>MCWS3030C-P</b>	1286	<b>MCWS3030S-P</b>	2368

\* List prices do not include cost of mouse shelf.

\*\* 24" x 24" (610 x 610mm) units feature 14" x 24" (357 x 610mm) undershelf, 30" x 30" (762 x 762mm) units feature 18" x 30" (457 x 762mm) undershelf.

### Optional Mouse Shelf for Mobile Computer Workstations

width	length		weight		cu ft	model #	list
	in.	mm	lbs.	kg			
<b>7" (178mm)</b>	7"	178	0.1	2.0	0.9	<b>MS-C</b>	20



### Shelving Task Station Packages

Freight class is 70.0.

*A variety of applications, each task station is designed for certain tasks.*

- Designed for easy reach and maximum use of space.
- Many sizes available.
- Finishes available in chrome or zinc.
- Easy to clean.
- Easy to assemble.
- Utilizes standard catalog items.



Microwaves not included.

#### Biscuit Workstation

see spec sheet **EG01.51**

- NSF-approved components.
- Keeps tasks together.
- 16 gauge type 304 stainless steel top with hat channel supports.
- 24" x 60" x 63" overall dimensions.

<b>model #</b>	<b>list</b>	<b>weight:</b>
<b>TSB2460Z</b>	2436	189 lbs. 85.7 kg

#### Sandwich Prep Station

see spec sheet **EG01.50**



- Flexible design allows for custom look while using standard components.
- Unit allows for various width, length and height refrigerators.
- Keeps task-related items together.
- 14" x 36" x 74" overall dimensions (excluding bins mounted).

<b>model #</b>	<b>list</b>	<b>weight:</b>
<b>TSSP1436Z</b>	697	50 lbs. 22.7 kg



Refrigerator, drink dispensers and drawer not included.

#### Drive-Through Task Station

see spec sheet **EG01.52**

- Easy to clean work surface and bins.
- Customize using standard components.
- Keeps work-related tasks together.
- Open design allows for easy restocking.
- 36" x 60" x 74" overall dimensions.

<b>model #</b>	<b>list</b>	<b>weight:</b>
<b>TSD3660Z</b>	1304	168 lbs. 76.2 kg

#### Microwave Prep Table

see spec sheet **EG01.55**



Microwaves not included.

- Open-wire construction.
- Three full-length wire overshelves.
- 18 gauge type 304 stainless steel top with hat channel supports.
- Two wire undershelves.
- Each overshelf accommodates two standard-size microwaves.
- Comes with bins, dividers, and grid panels.
- 30" x 48" x 74" overall dimensions (excluding bins mounted).

<b>model #</b>	<b>list</b>	<b>weight:</b>
<b>TSM3048C</b>	2369	146 lbs. 66.2 kg



#### Carry-Out Worktable

see spec sheet **EG01.53**

- Keeps work-related tasks together.
- Customize using standard components.
- 18 gauge type 304 stainless steel top and undershelf, both utilizing hat channel supports.
- 24" x 60" x 74" overall dimensions (82½" height with dividers mounted).

<b>model #</b>	<b>list</b>	<b>weight:</b>
<b>TSC02460Z</b>	1380	138 lbs. 62.6 kg

#### Cup Tower

see spec sheet **EG01.56**

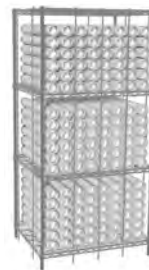

- Allows for easy inventory count.
- Easy identification of product.
- 30" x 36" x 74" overall dimensions.

<b>model #</b>	<b>list</b>	<b>weight:</b>
<b>TSC3036Z</b>	987	104 lbs. 47.2 kg



#### Pizza Prep Area

see spec sheet **EG01.54**

- Utilizes valuable wall space.
- Standard parts create customized look.
- Keeps task-related items together.
- 14 gauge type 304 stainless steel top with hat channel supports.
- 24" x 60" x 38½" worktable with galvanized adjustable undershelf.

<b>model #</b>	<b>list</b>	<b>weight:</b>
<b>TSP2460Z</b>	2019	113 lbs. 51.3 kg

#### Pizza Carry-Out Workstation

see spec sheet **EG01.57**



- Gravity-feed dividers keep boxes organized.
- Minimize damage to boxes.
- Rotated product.
- 33" x 48" x 98" overall dimensions (including pizza box dividers mounted).

<b>model #</b>	<b>list</b>	<b>weight:</b>
<b>TSP1448Z</b>	1124	94 lbs. 42.6 kg

### adjuSTable® Work Surface Systems

see spec sheet **EG10.09**

**CUSTOM:**

- Unit can be further expanded and customized by adding optional shelving accessories (pages 51-59).
- Custom configurations available, including alternate finishes and solid shelving. Contact factory to configure your custom workstation.
- Optional drawers available (see pages 152-155).



basic unit

### CUSTOMIZABLE WORK SURFACE CONFIGURATIONS TO MEET YOUR NEEDS!



1-tier unit



2-tier unit

**Note:** To order table with 5" (127mm) resilient-tread casters, add suffix "-CAH" and add to list price \$635. Example: T3036EBW-1-CAH.

To order table with 5" (127mm) poly-tread casters, add suffix "-CAHP" and add to list price \$549. Example: T3036EBW-1-CAHP.

**Freight class is 70.0.**

(•) MTS (made to stock) / ( ) MTO (made to order)

**patented QuadTruss® design**  
(Patent #5,390,803)

**Patented QuadTruss® Design** makes shelves up to 25% stronger and provides a retaining ledge for increased strength and product retention.

# adjuSTable®

Additional wire undershelves, solid stainless steel undershelves, chrome wire overshelves, or solid stainless steel overshelves make the possibilities almost unlimited.

		Basic Units 33½" (851mm) overall height.				1-tier Units 54½" (1384mm) overall height.				2-tier Units 62½" (1588mm) overall height.										
length	cu	weight		16/304		14/304		weight	16/304		14/304		weight	16/304		14/304				
		ft	lbs.	kg	model #	list	model #		list	lbs.	kg	model #		list	model #	list	lbs.	kg	model #	list
<b>24"</b>	36" 914	4.5	65	29.5	T2436EBW	1002	T2436EW	1098	73	33.1	T2436EBW-1	1246	T2436EW-1	1343	81	36.7	T2436EBW-2	1367	T2436EW-2	1464
<b>width</b>	48" 1219	5.7	81	36.7	T2448EBW	1088	T2448EW	1261	91	41.3	T2448EBW-1	1397	T2448EW-1	1528	101	45.8	T2448EBW-2	1541	T2448EW-2	1674
<b>(610mm)</b>	60" 1524	7.1	99	44.9	T2460EBW	1274	T2460EW	1449	113	51.3	T2460EBW-1	1578	T2460EW-1	1726	127	57.6	T2460EBW-2	1734	T2460EW-2	1883
<b>30"</b>	36" 914	4.5	75	34.0	T3036EBW	1109	T3036EW	1243	83	37.6	T3036EBW-1	1354	T3036EW-1	1493	91	41.3	T3036EBW-2	1473	T3036EW-2	1613
<b>width</b>	48" 1219	5.7	94	42.6	T3048EBW	1252	T3048EW	1426	104	47.2	T3048EBW-1	1521	T3048EW-1	1689	114	51.7	T3048EBW-2	1663	T3048EW-2	1842
<b>(762mm)</b>	60" 1524	7.1	115	52.2	T3060EBW	1449	T3060EW	1649	129	58.5	T3060EBW-1	1726	T3060EW-1	1931	143	64.9	T3060EBW-2	1882	T3060EW-2	2089
				<b>CONSISTS OF:</b>				<b>CONSISTS OF:</b>				<b>CONSISTS OF:</b>								
				<ul style="list-style-type: none"> <li>• Stainless steel table top/work surface with hat channel supports.</li> <li>• Four 33" (838mm) chrome posts.</li> <li>• Two chrome wire undershelves.*</li> </ul>				<ul style="list-style-type: none"> <li>• Stainless steel table top/work surface with hat channel supports.</li> <li>• Two 54" (1372mm) rear chrome posts.</li> <li>• Two 33" (838mm) front chrome posts.</li> <li>• Two 21" (533mm) front chrome posts for overshelf.</li> <li>• One 14" (356mm) wide chrome wire overshelf.</li> <li>• Two chrome wire undershelves.*</li> </ul>				<ul style="list-style-type: none"> <li>• Stainless steel table top/work surface with hat channel supports.</li> <li>• Two 63" (1600mm) rear chrome posts.</li> <li>• Two 33" (838mm) front chrome posts.</li> <li>• Two 29" (737mm) front chrome posts for overshelves.</li> <li>• Two 14" (356mm) wide chrome wire overshelves.</li> <li>• Two chrome wire undershelves.*</li> </ul>								

\*18" (457mm) wide undershelves used for 24" (610mm) wide tables; 24" (610mm) wide undershelves used for 30" (762mm) wide tables.

### Optional Keyboard Stations

- 20½" wide x 11½" deep (521 x 292mm).

Table Mount				Wire Mount						
weight	cu	chrome		stainless		chrome		stainless		
		lbs.	kg	model #	list	model #	list	model #	list	model #
6.0	2.7	0.35	KBD-1	334	KBD-1/SS	431	KBD-2•	289	KBD-2/SS	454



table mount keyboard station



wire mount keyboard station

### Post Clamp for 1-tier and 2-tier Units

- Attaches 3" x 3" (76 x 76mm) grid panel (see enclosure panels on page 28 and wall mats on page 104) onto AdjuSTable® systems with overshelves.
- Chrome-plated collar with ¼-20 weld stud, chrome acorn nut and heavy gauge clamp.

model # **A210098** list each **23**



## Catalog Section 1

### Shelving Components / Accessories

see spec sheets **EG01.03A** **EG01.03D**

Freight class is 70.0.

(•) MTS (made to stock) / ( ) MTO (made to order)

#### Collar Plug

- Fills shelf corner openings where posts have been eliminated by use of "S" hooks.
- Packed four per bag.

model #	list
<b>COLLAR PLUG</b> (set of four)	9



#### Post Cap

- Fills post end openings at top of shelving unit.

model #	list ea
<b>POST CAP</b>	2



#### Post Clamps

- Provides maximum strength when shelving units are connected by clamping posts securely together.



chrome		black epoxy	
model #	list ea	model #	list ea
<b>POST CLAMP</b>	13	<b>A214169</b>	17

Note: Will not work with QuadPLUS® or Add-A-Shelf®

#### Retaining Clamp

- Chrome-plated.
- For use with enclosure panels (page 28) in conjunction with wire shelf.



model #	list ea
<b>RETAINING CLAMP</b>	4

#### Glides

- Fits under leveling bolt to protect floors from abrasion.



model #	list ea
<b>GLIDES</b>	3

#### Foot Plates

- These allow unit to be bolted to the floor.
- Can be used without bolts when a wider foot is desired for more stability.

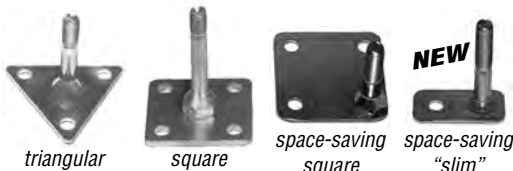

#### Aluminum Split Sleeves

- For conductive, over-the-road or high-temperature installations.
- Set of four.



with zinc rings		with stainless rings	
model #	list	model #	list
<b>A208909</b> •	20	<b>A208908</b> •	35

#### Plastic Split Sleeves

- Four included with each shelf.
- High-temperature-resistant ABS plastic create a positive lock that becomes stronger as the load increases.



model #	list
<b>PLASTIC SPLIT SLEEVES</b> (set of four)	5

#### Plastic Conductive Split Sleeves

- Packed four per bag.



model #	list
<b>A219236</b>	9

#### Casting

- Stabilizes leveling foot.

model #	list ea
<b>A203568</b>	3

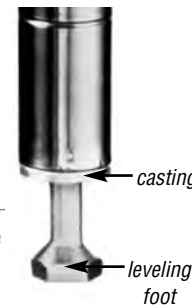

#### Leveling Foot

- Use these to accommodate for uneven floors.

model #	list ea
<b>LEVELING FOOT</b>	2

#### Security "S" Hooks

- Discourages separation of adjoined shelf units.
- Hardware included.

model #	list ea
<b>S-HOOKS-SK</b>	13

#### "S" Hooks

- Join individual shelving units in a number of combinations using "S" hooks.
- Joins end-to-end, back-to-back, or at right angles.
- Two required per connection.



model #	list ea
<b>A200012</b> •	3

#### Rods and Tabs

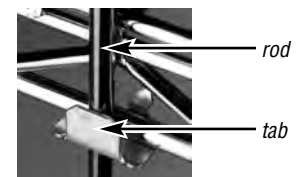

chrome		stainless steel	
model #	list ea	model #	list ea
<b>R54-C</b>	37	<b>R54-S</b>	55
<b>R63-C</b> •	40	<b>R63-S</b>	58
<b>R74-C</b> •	48	<b>R74-S</b>	69
<b>R86-C</b> •	53	<b>R86-S</b>	76

### Dividers

see spec sheet **EG01.03A**

**FEATURES:**

- 8" high (203mm) dividers keep shelf contents organized.

**Freight class is 70.0.**

(•) MTS (made to stock) / ( ) MTO (made to order)

#### Solid Shelving Dividers

length		cubic feet	weight		chrome		stainless steel	
in.	mm		lb.	kg	model #	list	model #	list
14"	356	0.6	1.0	0.5	<b>SSD14-C</b>	36	<b>SSD14-S</b>	113
18"	457	0.6	1.3	0.6	<b>SSD18-C</b>	43	<b>SSD18-S</b>	121
21"	533	0.8	1.5	0.7	<b>SSD21-C</b>	51	<b>SSD21-S</b>	129
24"	610	1.0	1.8	0.8	<b>SSD24-C</b> •	59	<b>SSD24-S</b>	134
30"	762	1.2	2.3	1.0	<b>SSD30-C</b>	74	<b>SSD30-S</b>	159
36"	914	1.4	3.0	1.4	<b>SSD36-C</b>	86	<b>SSD36-S</b>	161



#### Wire Shelving Dividers **NSF**

length		cubic feet	weight		chrome		VALU-MASTER®		Valu-Gard®		EAGLEgard®		stainless	
in.	mm		lb.	kg	model #	list	model #	list	model #	list	model #	list	model #	list
14"	356	0.6	1.0	0.5	<b>SD14-C</b> •	32	<b>SD14-V</b>	47	<b>SD14-VG</b>	47	<b>SD14-E</b>	54	<b>SD14-S</b>	85
18"	457	0.6	1.0	0.5	<b>SD18-C</b> •	41	<b>SD18-V</b>	54	<b>SD18-VG</b>	54	<b>SD18-E</b>	64	<b>SD18-S</b>	99
21"	533	0.8	2.0	0.9	<b>SD21-C</b> •	47	<b>SD21-V</b>	58	<b>SD21-VG</b>	58	<b>SD21-E</b>	67	<b>SD21-S</b>	112
24"	610	1.0	2.0	0.9	<b>SD24-C</b> •	51	<b>SD24-V</b>	68	<b>SD24-VG</b>	68	<b>SD24-E</b>	76	<b>SD24-S</b> •	122
30"	762	1.2	2.0	0.9	<b>SD30-C</b>	62	<b>SD30-V</b>	74	<b>SD30-VG</b>	74	n/a	n/a	<b>SD30-S</b>	153
36"	914	1.4	3.0	1.4	<b>SD36-C</b>	80	<b>SD36-V</b>	76	<b>SD36-VG</b>	76	n/a	n/a	<b>SD36-S</b>	186

### Pizza Box Divider

see spec sheet **EG01.03A**

**FEATURES:**

- 26" (660mm) height.
- Attaches onto 14" (356mm) wide shelving.
- Zinc finish.
- Sold individually.

**Freight class is 70.0.**

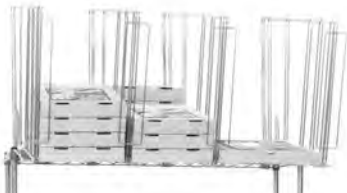

width		cubic feet	weight		model #	
in.	mm		lb.	kg	model #	list
28"	711	1.5	5	2.3	<b>PZD-Z</b>	177

### Slanted Shelves

see spec sheet **EG01.03E**

**PACKAGING:**

- 2" (51mm) slope.
- 36" - 48" (914-1219mm) lengths: Four per box.
- 60" (1524mm) length: Two per box.
- Four pairs of split sleeves per shelf.

**Freight class is 70.0.**

**patented QuadTruss® design**  
(Patent #5,390,803)

**Patented QuadTruss® Design** makes shelves up to 25% stronger and provides a retaining ledge for increased strength and product retention.

*Increased visibility allows easy access to shelf contents.*

*optional slanted shelves*



	length		weight		cubic feet	EAGLEbrite®		chrome		EAGLEgard®	
	in.	mm	lb.	kg		model #	list	model #	list	model #	list
<b>21" width (533mm)</b>	36"	914	11	5.0	0.8	<b>SL2136Z</b>	111	<b>SL2136C</b>	121	<b>SL2136E</b>	144
	48"	1219	14	6.4	1.1	<b>SL2148Z</b>	144	<b>SL2148C</b>	157	<b>SL2148E</b>	191
	60"	1524	18	8.2	1.3	<b>SL2160Z</b>	154	<b>SL2160C</b>	172	<b>SL2160E</b>	221
<b>24" width (610mm)</b>	36"	914	13	5.9	0.8	<b>SL2436Z</b>	137	<b>SL2436C</b>	152	<b>SL2436E</b>	179
	48"	1219	16	7.3	1.2	<b>SL2448Z</b>	160	<b>SL2448C</b>	176	<b>SL2448E</b>	213
	60"	1524	21	9.5	1.5	<b>SL2460Z</b>	174	<b>SL2460C</b>	183	<b>SL2460E</b>	226

## Catalog Section 1

### Ledges

see spec sheet **EG01.03A**

FEATURES:

- Prevents contents from falling off unit.
- Easily attaches without the use of tools.

**Freight class is 70.0.**

(•) MTS (made to stock) / ( ) MTO (made to order)

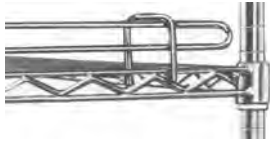

1"-high (25mm) ledge  
for wire shelving



4"-high (102mm) ledge  
for wire shelving

### Solid Shelving Ledges

#### 1"-high (25mm) Ledges \*

#### 4"-high (102mm) Ledges

length in.	mm	cu ft	weight		chrome		stainless steel		weight lb.	kg	chrome		stainless steel	
			lb.	kg	model #	list	model #	list			model #	list	model #	list
14"	356	0.2	0.2	0.1	<b>SL14-1C</b>	24	<b>SL14-1S</b>	43	0.8	0.4	<b>SL14-4C</b>	37	<b>SL14-4S</b>	60
18"	457	0.3	0.3	0.1	<b>SL18-1C</b>	25	<b>SL18-1S</b>	52	0.9	0.4	<b>SL18-4C</b>	41	<b>SL18-4S</b>	64
21"	533	0.3	0.4	0.2	<b>SL21-1C</b>	29	<b>SL21-1S</b>	53	1.0	0.5	<b>SL21-4C</b>	43	<b>SL21-4S</b>	74
24"	610	0.3	0.5	0.2	<b>SL24-1C</b>	35	<b>SL24-1S</b>	57	1.2	0.6	<b>SL24-4C</b>	43	<b>SL24-4S</b>	82
30"	762	0.5	0.7	0.3	<b>SL30-1C</b>	36	<b>SL30-1S</b>	76	1.4	0.6	<b>SL30-4C</b>	55	<b>SL30-4S</b>	92
36"	914	0.6	0.9	0.4	<b>SL36-1C</b>	39	<b>SL36-1S</b>	86	1.6	0.7	<b>SL36-4C</b>	66	<b>SL36-4S</b>	115
42"	1067	0.6	1.1	0.5	<b>SL42-1C</b>	48	<b>SL42-1S</b>	95	1.8	0.8	<b>SL42-4C</b>	69	<b>SL42-4S</b>	125
48"	1092	0.7	1.3	0.6	<b>SL48-1C</b>	51	<b>SL48-1S</b>	96	2.0	0.9	<b>SL48-4C</b>	81	<b>SL48-4S</b>	141
54"	1372	0.8	1.5	0.7	<b>SL54-1C</b>	52	<b>SL54-1S</b>	112	2.2	1.0	<b>SL54-4C</b>	83	<b>SL54-4S</b>	157
60"	1524	0.8	1.7	0.8	<b>SL60-1C</b>	55	<b>SL60-1S</b>	124	2.4	1.1	<b>SL60-4C</b>	84	<b>SL60-4S</b>	163
72"	1829	1.0	2.1	1.0	<b>SL72-1C</b>	62	<b>SL72-1S</b>	137	2.6	1.2	<b>SL72-4C</b>	99	<b>SL72-4S</b>	180

\* When installed, actual height of ledge is 1½" (38mm).

### Wire Shelving 1"-high (25mm) Ledges \*

length in.	mm	cu ft	weight		chrome		VALU-MASTER®		Valu-Gard®		stainless	
			lb.	kg	model #	list	model #	list	model #	list	model #	list
14"	356	0.2	0.2	0.1	<b>L14-1C</b>	21	<b>L14-1V</b>	22	<b>L14-1VG</b>	22	<b>L14-1S</b>	32
18"	457	0.3	0.3	0.1	<b>L18-1C</b>	23	<b>L18-1V</b>	24	<b>L18-1VG</b>	24	<b>L18-1S</b>	33
21"	533	0.3	0.4	0.2	<b>L21-1C</b>	25	<b>L21-1V</b>	27	<b>L21-1VG</b>	27	<b>L21-1S</b>	35
24"	610	0.3	0.5	0.2	<b>L24-1C</b> •	29	<b>L24-1V</b>	31	<b>L24-1VG</b>	31	<b>L24-1S</b>	37
30"	762	0.5	0.7	0.3	<b>L30-1C</b>	31	<b>L30-1V</b>	32	<b>L30-1VG</b>	32	<b>L30-1S</b>	53
36"	914	0.6	0.9	0.4	<b>L36-1C</b>	33	<b>L36-1V</b>	34	<b>L36-1VG</b>	34	<b>L36-1S</b>	58
42"	1067	0.6	1.1	0.5	<b>L42-1C</b>	36	<b>L42-1V</b>	37	<b>L42-1VG</b>	37	<b>L42-1S</b>	67
48"	1092	0.7	1.3	0.6	<b>L48-1C</b> •	37	<b>L48-1V</b>	38	<b>L48-1VG</b>	38	<b>L48-1S</b>	68
54"	1372	0.8	1.5	0.7	<b>L54-1C</b> •	39	<b>L54-1V</b>	40	<b>L54-1VG</b>	40	<b>L54-1S</b>	78
60"	1524	0.8	1.7	0.8	<b>L60-1C</b> •	43	<b>L60-1V</b>	46	<b>L60-1VG</b>	46	<b>L60-1S</b>	85
72"	1829	1.0	2.1	1.0	<b>L72-1C</b>	51	<b>L72-1V</b>	52	<b>L72-1VG</b>	52	<b>L72-1S</b>	91

\* When installed, actual height of ledge is 1½" (38mm).

### Wire Shelving 4"-high (102mm) Ledges

length in.	mm	cu ft	weight		chrome		VALU-MASTER®		Valu-Gard®		EAGLEgard®		stainless	
			lb.	kg	model #	list	model #	list	model #	list	model #	list	model #	list
14"	356	0.2	0.8	0.4	<b>L14-4C</b> •	25	<b>L14-4V</b>	29	<b>L14-4VG</b>	29	<b>L14-4E</b>	32	<b>L14-4S</b>	52
18"	457	0.3	0.9	0.4	<b>L18-4C</b> •	29	<b>L18-4V</b>	32	<b>L18-4VG</b>	32	<b>L18-4E</b>	34	<b>L18-4S</b> •	55
21"	533	0.3	1.0	0.5	<b>L21-4C</b> •	31	<b>L21-4V</b>	33	<b>L21-4VG</b>	33	<b>L21-4E</b>	35	<b>L21-4S</b>	68
24"	610	0.3	1.2	0.6	<b>L24-4C</b> •	33	<b>L24-4V</b>	35	<b>L24-4VG</b>	35	<b>L24-4E</b>	37	<b>L24-4S</b> •	74
30"	762	0.5	1.4	0.6	<b>L30-4C</b> •	39	<b>L30-4V</b>	39	<b>L30-4VG</b>	39	<b>L30-4E</b>	47	<b>L30-4S</b>	87
36"	914	0.6	1.6	0.7	<b>L36-4C</b> •	47	<b>L36-4V</b>	49	<b>L36-4VG</b>	49	<b>L36-4E</b>	51	<b>L36-4S</b> •	104
42"	1067	0.6	1.8	0.8	<b>L42-4C</b> •	51	<b>L42-4V</b>	58	<b>L42-4VG</b>	58	<b>L42-4E</b>	60	<b>L42-4S</b>	118
48"	1092	0.7	2.0	0.9	<b>L48-4C</b> •	54	<b>L48-4V</b>	60	<b>L48-4VG</b>	60	<b>L48-4E</b>	62	<b>L48-4S</b>	133
54"	1372	0.8	2.2	1.0	<b>L54-4C</b>	55	<b>L54-4V</b>	66	<b>L54-4VG</b>	66	<b>L54-4E</b>	67	<b>L54-4S</b>	151
60"	1524	0.8	2.4	1.1	<b>L60-4C</b> •	59	<b>L60-4V</b>	69	<b>L60-4VG</b>	69	<b>L60-4E</b>	71	<b>L60-4S</b>	152
72"	1829	1.0	2.6	1.2	<b>L72-4C</b> •	71	<b>L72-4V</b>	73	<b>L72-4VG</b>	73	<b>L72-4E</b>	81	<b>L72-4S</b> •	189

### Slide Systems

see spec sheet **EG01.03C**

LOAD CAPACITY: • Up to 35 lbs. (15.9 kg).

FEATURES: • Easily attaches without the use of tools.

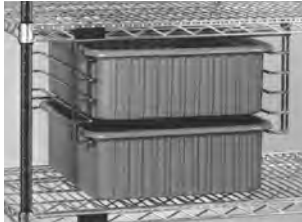

slide system with tote boxes

**Clever way to improve space efficiency.**

**Freight class is 70.0.**

(•) MTS (made to stock) / ( ) MTO (made to order)

fits shelf width	adaptable tote boxes	width x length x depth	weight		cubic	model #	list
			lbs.	kg	feet		
24" (610mm)	TB1722-3, TB1722-6, TB1722-9	21 1/2" x 20" x 10 1/4" (683 x 508 x 260mm)	7.5	3.4	3.8	<b>TS2021</b> •	162
21" (533mm)	TB1016-3, TB1016-6	17 1/2" x 14" x 10 1/4" (543 x 356 x 260mm)	4.0	1.8	1.8	<b>TS1417</b>	155
21" (533mm)	TB1722-3*, TB1722-6*, TB1722-9*	17 1/2" x 25 1/2" x 10 1/4" (543 x 797 x 260mm)	5.0	2.3	4.0	<b>TS2517</b>	153



\* Fits TS2517 sideways

### Tote Boxes for Slide Systems

see spec sheet **EG01.03C**

- Dividable up to 1 1/8" (29mm) square compartments.
- Injection molded from high-density polyethylene material.

FEATURES:

**Note:** Also available in molded fiberglass. See page 55.

**Freight class is 70.0.**

(•) MTS (made to stock) / ( ) MTO (made to order)



fits slide system	width x length x depth inches	width x length x depth mm	weight		cubic	color	model #	list
			lbs.	kg	feet			
TS1417	10 7/8" x 16 1/2" x 3 1/2"	276 x 419 x 89	1.0	0.5	0.4	gray	<b>TB1016-3</b>	37
TS1417	10 7/8" x 16 1/2" x 6"	276 x 419 x 152	1.5	0.7	0.8	gray	<b>TB1016-6</b>	39
TS2021, TS2517	17 1/2" x 22 1/2" x 3"	444 x 572 x 76	2.3	1.0	0.8	gray	<b>TB1722-3</b> *	71
TS2021, TS2517	17 1/2" x 22 1/2" x 6"	444 x 572 x 152	3.5	1.6	1.5	gray	<b>TB1722-6</b> * •	82
TS2021, TS2517	17 1/2" x 22 1/2" x 8"	444 x 572 x 203	4.0	1.8	3.0	gray	<b>TB1722-9</b> *	95

\* Fits TS2517 sideways

### Tote Box Dividers and Covers

fits tote box	color	Long Dividers			Short Dividers			Covers	
		model #	list	max. # accepted	model #	list	max. # accepted	model #	list
TB1016-3	gray	<b>A217766</b>	4	7	<b>A217760</b>	6	11	<b>A217765</b>	47
TB1016-6	gray	<b>A203841</b>	4	7	<b>A203843</b>	6	11	<b>A217765</b>	47
TB1722-3	gray	<b>A217763</b>	7	11	<b>A217764</b>	5	15	<b>A217638</b>	60
TB1722-6	gray	<b>A203842</b>	5	11	<b>A203844</b>	6	15	<b>A217638</b>	60
TB1722-9	gray	<b>A203845</b>	5	11	<b>A203846</b>	6	15	<b>A217638</b>	60



cover



dividers



## Catalog Section 1

### Card Holders for Tote Boxes

FEATURES: • Clear vinyl.

see spec sheet **EG01.03C**

Freight class is 70.0.



holds labels		model #	list
in.	mm		
2" x 8"	51 x 203	<b>CH28</b>	9
3" x 5"	76 x 127	<b>CH35</b>	11
5" x 8"	127 x 203	<b>CH58</b>	12

### Molded Fiberglass Boxes and Trays

see spec sheet **EG01.03C**

FEATURES:

- Made of thermoset polyester composite material.
- Flame and chemical resistant.

Freight class is 70.0.

**Boxes are stackable for maximum storage efficiency!**



assorted molded fiberglass boxes and trays

description	bottom inside dimensions length x width x depth		top outside dimensions length x width x height		cu ft	model #	list
	in.	mm	in.	mm			
tray	24 $\frac{3}{4}$ " x 16 $\frac{1}{4}$ " x 1"	619 x 413 x 25	25 $\frac{3}{4}$ " x 17 $\frac{1}{4}$ " x 1 $\frac{1}{8}$ "	654 x 454 x 29	0.1	<b>A208505</b>	86
stacking box	23 $\frac{3}{8}$ " x 15 $\frac{1}{8}$ " x 2 $\frac{1}{8}$ "	606 x 403 x 73	25 $\frac{3}{4}$ " x 17 $\frac{1}{4}$ " x 3"	654 x 451 x 76	0.6	<b>A208506</b>	118
stacking box	23 $\frac{3}{8}$ " x 15 $\frac{1}{8}$ " x 4 $\frac{1}{2}$ "	606 x 403 x 114	25 $\frac{3}{4}$ " x 17 $\frac{1}{4}$ " x 4 $\frac{1}{2}$ "	654 x 451 x 114	1.0	<b>A208507</b>	107
stacking box	23 $\frac{3}{8}$ " x 15 $\frac{1}{8}$ " x 5 $\frac{3}{4}$ "	606 x 403 x 146	25 $\frac{3}{4}$ " x 17 $\frac{1}{4}$ " x 6"	654 x 451 x 152	1.3	<b>A208508</b>	102
lid	—	—	25 $\frac{3}{4}$ " x 17 $\frac{1}{4}$ "	654 x 451	—	<b>A208513*</b>	60

\* Model #A208513 lid fits models A208506, A208507, and A208508 stacking boxes.

### Storage Baskets

see spec sheet **EG01.03E**

FEATURES:

- Chrome-plated.
- Easily attaches to hanger rail or side of wire shelf.

Freight class is 70.0.



width x length x height		weight		cubic feet	model #	list
in.	mm	lbs.	kg			
13 $\frac{3}{8}$ " x 5" x 7"	340 x 127 x 178	9	4.1	0.4	<b>A216650</b>	46
17 $\frac{3}{8}$ " x 7 $\frac{1}{2}$ " x 5"	441 x 191 x 127	7	3.2	0.6	<b>A216651</b>	49
17 $\frac{3}{8}$ " x 7 $\frac{1}{2}$ " x 10"	441 x 191 x 254	11	5.0	1.0	<b>A216652</b>	66

### File Basket

see spec sheet **EG01.03E**

FEATURES:

- Chrome-plated.
- Fits all widths.

Freight class is 70.0.



**Ideal for organizing standard-sized file folders.**

width x length x height		weight		cubic feet	model #	list
in.	mm	lbs.	kg			
2 $\frac{5}{8}$ " x 12 $\frac{1}{4}$ " x 8 $\frac{1}{4}$ "	67 x 324 x 222	2	0.9	0.3	<b>A216649</b>	54

### Triangle Shelf

see spec sheet **EG01.03E**

FEATURES:

- Attached to standard posts (*sold separately—see pages 13 and 23*), can be a freestanding unit.
- Or added onto standard 18" (457mm) wide wire shelving (*page 6*) via "S" hooks (*page 51*).

Freight class is 70.0.



width	weight		chrome		black epoxy	
	lbs.	kg	model #	list	model #	list
18" (457mm)	16	7.3	<b>TR18C</b>	80	<b>TR18BL</b>	80

### Sliding Shelf

see spec sheet **EG01.03E**

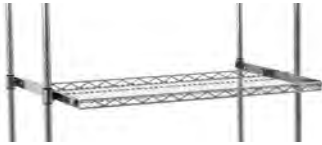

width x length		weight		chrome	
in	mm	lbs.	kg	model #	list
18" x 36"	457 x 914	9	4.1	<b>SLS1836C</b>	108

#### FEATURES:

- Chrome-plated.
- For use with standard 1" (25mm)-diameter posts—on 18" (457mm)-wide wire shelf or solid shelf units.
- 20 lb. (9.0 kg) weight capacity per shelf.

**Freight class is 70.0.**

### Tray Slides

see spec sheet **EG01.03C**

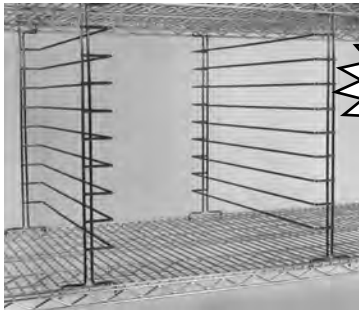

**Slides help maximize your use of space!**

#### FEATURES:

- 1¾" (45mm) spacing, 22" (559mm) height.
- Sold as a set of two.
- 18" or 24" (457 or 610mm) wide applications.
- Can be used with tote boxes on page 54 and with sheet pans on page 347.

**Freight class is 70.0.**

#### Standard

Holds 9 trays.

#### Heavy Duty

Holds 11 trays. Features panel assembly welded to the back of slides

width	cu		weight		chrome		EAGLEgard®		weight		chrome		EAGLEgard®	
	ft		lbs.	kg	model #	list	model #	list	lbs.	kg	model #	list	model #	list
<b>17½"</b> (435mm)	2.3		9	4.1	<b>TS18-C</b>	120	<b>TS18-E</b>	160	12	5.4	<b>HDTS18-C</b>	242	<b>HDTS18-E</b>	251
<b>23½"</b> (587mm)	3.0		11	5.0	<b>TS24-C</b>	126	<b>TS24-E</b>	165	15	6.8	<b>HDTS24-C</b>	258	<b>HDTS24-E</b>	278

### Adjustable Undershelf Slides

see spec sheet **EG01.03C**



adjustable undershelf slides with tote box

#### FEATURES:

- Stainless steel.
- Accommodates any tote box side-to-side dimension.
- Sold as a set.

**Freight class is 70.0.**

(•) MTS (made to stock) / ( ) MTO (made to order)

description	weight		model #		list
	lbs.	kg			
slides for 18" (457mm) wide shelf	3	1.4	<b>US18-S</b>	95	
slides for 21" (533mm) wide shelf	3	1.4	<b>US21-S</b>	115	
slides for 24" (610mm) wide shelf	3	1.4	<b>US24-S</b>	122	
slides for 30" (762mm) wide shelf	4	1.8	<b>US30-S</b>	138	
slides with side-to-side mount, for 24" (610mm) wide shelf	3	1.4	<b>USS24-S</b>	161	
slides with side-to-side mount, for 30" (762mm) wide shelf	4	1.8	<b>USS30-S</b>	196	

### Tote Boxes for Adjustable Undershelf Slides

width x length x depth		weight		cubic feet	model #		list
in.	mm	lbs.	kg				
17½" x 22½" x 3"	446 x 568 x 76	2	0.9	0.8	<b>TB1722-3</b>	71	
17½" x 22½" x 6"	446 x 568 x 152	3	1.4	1.4	<b>TB1722-6•</b>	82	
17½" x 22½" x 8"	446 x 568 x 203	4	1.8	2.3	<b>TB1722-9</b>	95	

### One-Piece Slides

see spec sheet **EG01.03C**



one-piece slide with tote box

#### FEATURES:

- Easily attaches to shelf.

**Freight class is 70.0.**

(•) MTS (made to stock) / ( ) MTO (made to order)

**Helps prevent shelf clutter!**

### Tote Box for One-Piece Slides

width x length x depth		weight		cubic feet	model #		list
in.	mm	lbs.	kg				
17½" x 22½" x 6"	446 x 568 x 152	3.5	1.6	1.5	<b>TB1722-6•</b>	82	

### 3-Sided Double Truss Frames

see spec sheet **EG01.03B**

Note: See page 58 for 3-Sided Channel Frames.

Freight class is 70.0.

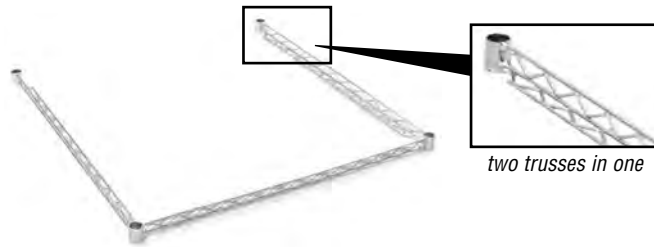

*Improves support  
and stability!*

	length		weight		cu ft	chrome		EAGLEgard®		stainless steel	
	in.	mm	lbs.	kg		model #	list	model #	list	model #	list
<b>18" width</b> (457mm)	24"	610	5	2.2	0.7	<b>DTF1824-C</b>	108	<b>DTF1824-E</b>	126	<b>DTF1824-S</b>	278
	30"	762	6	2.7	0.7	<b>DTF1830-C</b>	111	<b>DTF1830-E</b>	135	<b>DTF1830-S</b>	291
	36"	914	6	2.7	0.7	<b>DTF1836-C</b>	115	<b>DTF1836-E</b>	137	<b>DTF1836-S</b>	295
	42"	1067	7	3.2	0.8	<b>DTF1842-C</b>	118	<b>DTF1842-E</b>	139	<b>DTF1842-S</b>	299
	48"	1219	7	3.2	0.8	<b>DTF1848-C</b>	119	<b>DTF1848-E</b>	141	<b>DTF1848-S</b>	306
	60"	1524	8	3.6	1.0	<b>DTF1860-C</b>	134	<b>DTF1860-E</b>	160	<b>DTF1860-S</b>	353
	72"	1829	9	4.1	1.4	<b>DTF1872-C</b>	148	<b>DTF1872-E</b>	179	<b>DTF1872-S</b>	389
<b>21" width</b> (533mm)	24"	610	5	2.2	0.8	<b>DTF2124-C</b>	109	<b>DTF2124-E</b>	129	<b>DTF2124-S</b>	282
	30"	762	6	2.7	0.8	<b>DTF2130-C</b>	115	<b>DTF2130-E</b>	137	<b>DTF2130-S</b>	291
	36"	914	6	2.7	0.8	<b>DTF2136-C</b>	118	<b>DTF2136-E</b>	139	<b>DTF2136-S</b>	294
	42"	1067	7	3.2	0.9	<b>DTF2142-C</b>	120	<b>DTF2142-E</b>	144	<b>DTF2142-S</b>	308
	48"	1219	8	3.6	0.9	<b>DTF2148-C</b>	121	<b>DTF2148-E</b>	145	<b>DTF2148-S</b>	311
	60"	1524	8	3.6	1.1	<b>DTF2160-C</b>	143	<b>DTF2160-E</b>	174	<b>DTF2160-S</b>	364
	72"	1829	10	4.5	1.4	<b>DTF2172-C</b>	199	<b>DTF2172-E</b>	240	<b>DTF2172-S</b>	402
<b>24" width</b> (610mm)	24"	610	6	2.7	1.5	<b>DTF2424-C</b>	115	<b>DTF2424-E</b>	137	<b>DTF2424-S</b>	291
	30"	762	7	3.2	1.5	<b>DTF2430-C</b>	118	<b>DTF2430-E</b>	139	<b>DTF2430-S</b>	296
	36"	914	7	3.2	1.5	<b>DTF2436-C</b>	120	<b>DTF2436-E</b>	144	<b>DTF2436-S</b>	306
	42"	1067	8	3.6	2.0	<b>DTF2442-C</b>	121	<b>DTF2442-E</b>	145	<b>DTF2442-S</b>	319
	48"	1219	9	4.1	2.5	<b>DTF2448-C</b>	123	<b>DTF2448-E</b>	148	<b>DTF2448-S</b>	322
	60"	1524	10	4.5	2.5	<b>DTF2460-C</b>	148	<b>DTF2460-E</b>	179	<b>DTF2460-S</b>	373
	72"	1829	11	5.0	2.7	<b>DTF2472-C</b>	208	<b>DTF2472-E</b>	251	<b>DTF2472-S</b>	412
<b>30" width</b> (762mm)	36"	914	7	3.2	2.0	<b>DTF3036-C</b>	126	<b>DTF3036-E</b>	153	<b>DTF3036-S</b>	373
	48"	1219	9	4.1	2.5	<b>DTF3048-C</b>	133	<b>DTF3048-E</b>	160	<b>DTF3048-S</b>	389
	60"	1524	10	4.5	2.5	<b>DTF3060-C</b>	138	<b>DTF3060-E</b>	191	<b>DTF3060-S</b>	449
	72"	1829	11	5.0	2.7	<b>DTF3072-C</b>	191	<b>DTF3072-E</b>	266	<b>DTF3072-S</b>	494
<b>36" width</b> (914mm)	36"	914	7	3.2	2.5	<b>DTF3636-C</b>	138	<b>DTF3636-E</b>	167	<b>DTF3636-S</b>	384
	48"	1219	9	4.1	2.7	<b>DTF3648-C</b>	143	<b>DTF3648-E</b>	174	<b>DTF3648-S</b>	399
	60"	1524	10	4.5	2.7	<b>DTF3660-C</b>	231	<b>DTF3660-E</b>	207	<b>DTF3660-S</b>	456
	72"	1829	11	5.0	3.0	<b>DTF3672-C</b>	276	<b>DTF3672-E</b>	288	<b>DTF3672-S</b>	507



### 3-Sided Channel Frames

see spec sheet **EG01.03B**



- 1" (25mm) square channel frame.
- Chrome and EAGLEgard® channel frames are 12 gauge mild steel.
- Stainless steel channel frames are 14 gauge.

**FEATURES:**

**Freight class is 70.0.**

(•) MTS (made to stock) / ( ) MTO (made to order)

**Improves support  
and stability!**

	length		weight		cu ft	chrome		EAGLEgard®		stainless steel	
	in.	mm	lbs.	kg		model #	list	model #	list	model #	list
<b>18" width (457mm)</b>	24"	610	5	2.2	0.7	<b>CF1824-C</b>	99	<b>CF1824-E</b>	118	<b>CF1824-S</b>	261
	30"	762	6	2.7	0.7	<b>CF1830-C</b>	102	<b>CF1830-E</b>	123	<b>CF1830-S</b>	291
	36"	914	6	2.7	0.7	<b>CF1836-C</b>	103	<b>CF1836-E</b>	124	<b>CF1836-S</b>	295
	42"	1067	7	3.2	0.8	<b>CF1842-C</b>	107	<b>CF1842-E</b>	126	<b>CF1842-S</b>	300
	48"	1219	7	3.2	0.8	<b>CF1848-C</b>	108	<b>CF1848-E</b>	127	<b>CF1848-S</b>	305
	60"	1524	8	3.6	1.0	<b>CF1860-C</b>	122	<b>CF1860-E</b>	147	<b>CF1860-S</b>	353
	72"	1829	9	4.1	1.4	<b>CF1872-C</b>	137	<b>CF1872-E</b>	165	<b>CF1872-S</b>	387
<b>21" width (533mm)</b>	24"	610	5	2.2	0.8	<b>CF2124-C</b>	100	<b>CF2124-E</b>	120	<b>CF2124-S</b>	279
	30"	762	6	2.7	0.8	<b>CF2130-C</b>	103	<b>CF2130-E</b>	124	<b>CF2130-S</b>	291
	36"	914	6	2.7	0.8	<b>CF2136-C</b>	107	<b>CF2136-E</b>	126	<b>CF2136-S</b>	294
	42"	1067	7	3.2	0.9	<b>CF2142-C</b>	109	<b>CF2142-E</b>	133	<b>CF2142-S</b>	306
	48"	1219	8	3.6	0.9	<b>CF2148-C</b>	111	<b>CF2148-E</b>	134	<b>CF2148-S</b>	309
	60"	1524	8	3.6	1.1	<b>CF2160-C</b>	129	<b>CF2160-E</b>	157	<b>CF2160-S</b>	365
	72"	1829	10	4.5	1.4	<b>CF2172-C</b>	181	<b>CF2172-E</b>	222	<b>CF2172-S</b>	403
<b>24" width (610mm)</b>	24"	610	6	2.7	1.5	<b>CF2424-C</b>	103	<b>CF2424-E</b>	124	<b>CF2424-S</b>	291
	30"	762	7	3.2	1.5	<b>CF2430-C</b>	107	<b>CF2430-E</b>	126	<b>CF2430-S</b>	299
	36"	914	7	3.2	1.5	<b>CF2436-C</b>	109	<b>CF2436-E</b>	133	<b>CF2436-S</b>	305
	42"	1067	8	3.6	2.0	<b>CF2442-C•</b>	111	<b>CF2442-E•</b>	134	<b>CF2442-S</b>	319
	48"	1219	9	4.1	2.5	<b>CF2448-C•</b>	115	<b>CF2448-E•</b>	137	<b>CF2448-S</b>	322
	60"	1524	10	4.5	2.5	<b>CF2460-C</b>	137	<b>CF2460-E</b>	165	<b>CF2460-S</b>	372
	72"	1829	11	5.0	2.7	<b>CF2472-C</b>	191	<b>CF2472-E</b>	231	<b>CF2472-S</b>	412
<b>30" width (762mm)</b>	36"	914	7	3.2	2.0	<b>CF3036-C</b>	118	<b>CF3036-E</b>	141	<b>CF3036-S</b>	372
	48"	1219	9	4.1	2.5	<b>CF3048-C</b>	121	<b>CF3048-E</b>	147	<b>CF3048-S</b>	387
	60"	1524	10	4.5	2.5	<b>CF3060-C</b>	125	<b>CF3060-E</b>	176	<b>CF3060-S</b>	449
	72"	1829	11	5.0	2.7	<b>CF3072-C</b>	176	<b>CF3072-E</b>	244	<b>CF3072-S</b>	494
<b>36" width (914mm)</b>	36"	914	7	3.2	2.5	<b>CF3636-C</b>	125	<b>CF3636-E</b>	154	<b>CF3636-S</b>	384
	48"	1219	9	4.1	2.7	<b>CF3648-C</b>	129	<b>CF3648-E</b>	157	<b>CF3648-S</b>	402
	60"	1524	10	4.5	2.7	n/a	n/a	<b>CF3660-E</b>	189	<b>CF3660-S</b>	456
	72"	1829	11	5.0	3.0	n/a	n/a	<b>CF3672-E</b>	264	<b>CF3672-S</b>	508

### MICROGARD® ...

...is an antimicrobial agent which contains built-in protection to retard the growth of a broad range of bacteria, mold and mildew on shelf surface that causes stains, odors and degradation.

...combines inorganic antimicrobial silver ions with a patented delivery system. The silver ions react with bacteria in three ways:

- 1) suffocates the cell,
- 2) stops the cell reproduction system,
- and 3) stops the cell from growing.

...is standard on all EAGLEgard® shelving and components.

## Catalog Section 1

### Post Extension Kit and Components

see spec sheet **EG01.03D**

FEATURES:

- Screw posts together with double-threaded bolt and extra foot casting.

#### Post Extension Kit

description	model #	list
consists of components listed below, set of four	<b>4PEK</b>	106

#### Components

item	model #	list
double-threaded bolt	<b>A200868</b>	3
wall bracket	<b>B201023</b>	18
casting	<b>A207351</b>	10

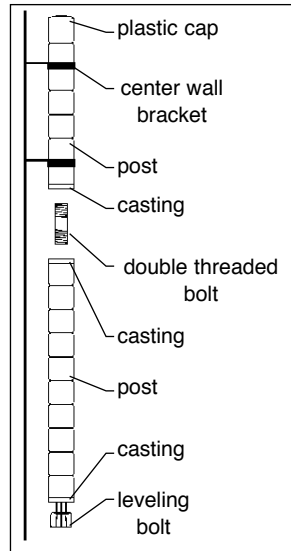

post extension assembly

**Note:** DO NOT attempt to use any higher combinations than P54 and P86 maximum, 140" (3556mm) total. Any combinations higher than 86" (2184mm) must be attached to walls using wall bracket on post adjacent to wall. Place units only against wall, not in center of room.

### Handles for Caster Carts

see spec sheet **EG01.03B**

FEATURES:

- Fits unit widths only.

#### Push Handles

Easily slips over posts.

width		weight		cubic feet	chrome		stainless steel	
in.	mm	lbs.	kg		model #	list	model #	list
14"	356	1.7	0.8	0.1	<b>PH14-C</b>	69	<b>PH14-S</b>	95
18"	457	1.9	0.9	0.1	<b>PH18-C</b>	71	<b>PH18-S</b>	108
21"	533	2.1	1.0	0.1	<b>PH21-C</b>	73	<b>PH21-S</b>	120
24"	610	2.3	1.1	0.2	<b>PH24-C•</b>	73	<b>PH24-S</b>	127
30"	762	2.6	1.2	0.3	<b>PH30-C</b>	74	<b>PH30-S</b>	165
36"	914	3.0	1.4	0.3	<b>PH36-C</b>	76	<b>PH36-S</b>	182



#### Extended Push Handles

Designed to prevent damage to knuckles.

width		weight		cubic feet	chrome		stainless steel	
in.	mm	lbs.	kg		model #	list	model #	list
14"	356	1.7	0.8	0.2	<b>EH14-C</b>	123	<b>EH14-S</b>	148
18"	457	1.9	0.9	0.3	<b>EH18-C</b>	126	<b>EH18-S</b>	163
21"	533	2.1	1.0	0.3	<b>EH21-C</b>	127	<b>EH21-S</b>	174
24"	610	2.3	1.1	0.4	<b>EH24-C•</b>	129	<b>EH24-S</b>	183
30"	762	2.6	1.2	0.5	<b>EH30-C</b>	134	<b>EH30-S</b>	217
36"	914	3.0	1.4	0.5	<b>EH36-C</b>	135	<b>EH36-S</b>	236

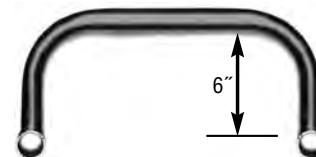



patented  
**QuadTruss®**  
design  
(Patent #5,390,803)

**Patented QuadTruss® Design**  
makes shelves up to 25% stronger and provides a retaining ledge for increased strength and product retention.



### UNIQUE ROLLER DESIGN

- Patent #5,680,942.
- Makes moving mobile units easy.
- Eliminates binding due to uneven floors.
- Rollers also support track.



**SHELVES**  
sold separately (see page 6) are available in EAGLEbrite® zinc, chrome, VALU-MASTER® pewter gray epoxy, EAGLEgard® green epoxy, and stainless steel finish.

Maximum shelf length should not exceed 60" (1524mm).

## Master Trak® Overhead Track High-Density Storage System

Note: Master Trak® not recommended for use in carpeted areas.

### Components

Shelves sold separately (see page 6).

- A** front & rear overhead tracks
- B** stationary end units
- C** mobile units
- D** open aisle—30" to 36" (762 to 914mm) is recommended
- E** stationary mid unit (optional—use same model # as stationary end unit kit)

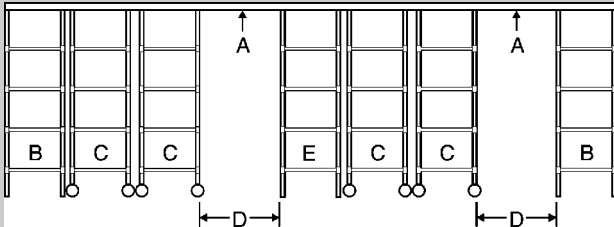

## Stationary End / Intermediate Unit Kits

see spec sheet **EG01.18**

- Posts.
- Hardware necessary for connecting stationary end units to track.
- One kit is required for each end unit.
- End units must be anchored to the floor to prevent movement.
- Priced per kit.

Note: Shelves sold separately see page 6.

Freight class is 70.0.

(•) MTS (made to stock) / ( ) MTO (made to order)

### 74" (1880mm) Posts

weight	cu	EAGLEbrite®		chrome		EAGLEgard®		
lbs.	kg	ft	model #	list	model #	list	model #	list
17	7.7	0.1	EP74-Z•	209	EP74-C•	223	EP74-E•	244

### 86" (2184mm) Posts

weight	cu	EAGLEbrite®		chrome		EAGLEgard®		
lbs.	kg	ft	model #	list	model #	list	model #	list
21	9.5	0.1	EP86-Z	217	EP86-C	236	EP86-E	260

## Catalog Section 1

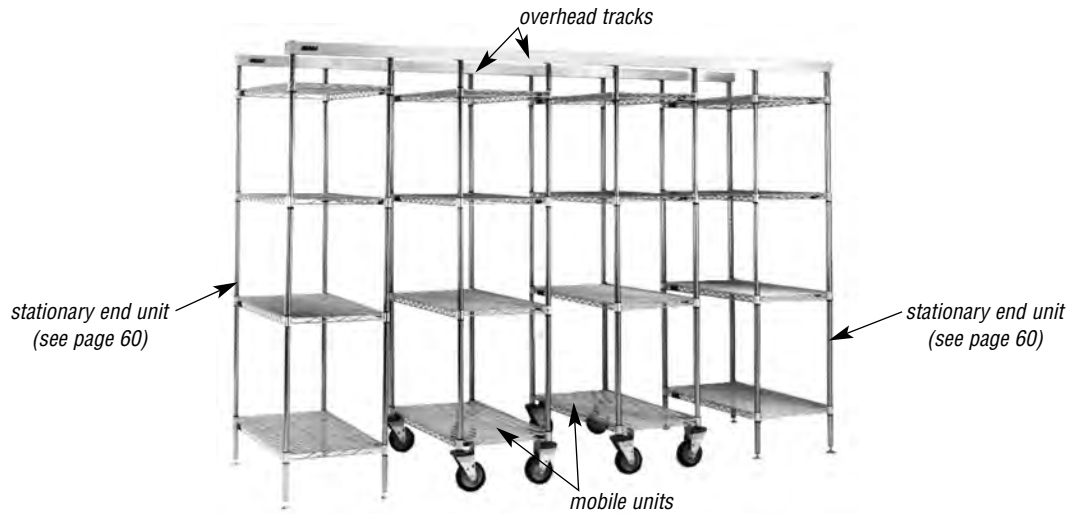

(Shelves shown are sold separately—see page 6)

### Master Trak® Mobile Unit Kits

see spec sheet **EG01.18**

WEIGHT CAPACITY: • 900 lbs. (408 kg).

Note: Shelves sold separately see page 6.

- Posts.
- Casters are 5" x 1½" (127 x 38mm) polymer.
- All parts and necessary hardware.
- One kit is required for each mobile unit.
- Priced per kit.

**Freight class is 70.0.**

(•) MTS (made to stock) / ( ) MTO (made to order)

#### 74" (1880mm) Height\*

#### 86" (2184mm) Height\*

width in. mm	cu ft	weight		EAGLEbrite®		chrome		EAGLEgard®		weight lbs. kg	EAGLEbrite®		chrome		EAGLEgard®			
		lbs.	kg	model #	list	model #	list	model #	list		model #	list	model #	list	model #	list		
18"	457	0.1	33	15.0	MUK18-Z	491	MUK18-C•	545	MUK18-E	866	37	16.8	MUK18-Z86	512	MUK18-C86	568	MUK18-E86	879
21"	533	0.1	34	15.4	MUK21-Z	511	MUK21-C	560	MUK21-E	878	38	17.2	MUK21-Z86	528	MUK21-C86	582	MUK21-E86	902
24"	610	0.1	35	15.9	MUK24-Z	515	MUK24-C•	569	MUK24-E•	891	39	17.6	MUK24-Z86	538	MUK24-C86	594	MUK24-E86	924
30"	762	0.1	35	15.9	MUK30-Z	524	MUK30-C•	582	MUK30-E	914	39	17.6	MUK30-Z86	545	MUK30-C86	606	MUK30-E86	948
36"	914	0.1	36	16.3	MUK36-Z	537	MUK36-C	609	MUK36-E	942	40	18.1	MUK36-Z86	554	MUK36-C86	634	MUK36-E86	971

\* Casters are included in post height.

### Master Trak® Overhead Track Kits

see spec sheet **EG01.18**

PACKAGING: • Kits 13' (3962mm) and longer are wood-crated.

**Freight class is 70.0.**

- All necessary sections of front and rear tracks for assembling track lengths of 6' to 21' (1829 to 6401mm), plus all hardware.

Note: Any kits 9' (2743mm) or longer include two or more front and rear track sections, with joiner pieces and all hardware. A mid-stationary unit is recommended on lengths of over 30' (9144mm).

(•) MTS (made to stock) / ( ) MTO (made to order)

length ft. mm	weight		cu ft	model # list	
	lbs.	kg		model #	list
6'	1829	18 8.2	1.8	OHT-6	538
7'	2134	21 9.5	2.1	OHT-7	598
8'	2438	24 10.9	2.4	OHT-8	901
9'	2743	27 12.2	2.7	OHT-9	980
10'	3048	30 13.6	3.0	OHT-10	1059

length ft. mm	weight		cu ft	model # list	
	lbs.	kg		model #	list
11'	3353	33 15.0	3.3	OHT-11	1141
12'	3658	36 16.3	3.6	OHT-12	1222
13'	3962	39 17.7	3.9	OHT-13	1298
14'	4267	42 19.1	4.2	OHT-14	1373
15'	4572	45 20.4	4.5	OHT-15	1667

length ft. mm	weight		cu ft	model # list	
	lbs.	kg		model #	list
16'	4877	48 21.8	4.8	OHT-16	1748
17'	5181	51 23.1	5.1	OHT-17•	1826
18'	5486	54 24.5	5.4	OHT-18	1907
19'	5791	57 25.9	5.7	OHT-19	1985
20'	6096	60 27.2	6.0	OHT-20	2057
21'	6401	63 28.6	6.3	OHT-21	2137

## Single-Deep Floor-Trak® High-Density Storage System <sup>(NSF)</sup>

see spec sheet **EG01.39A**

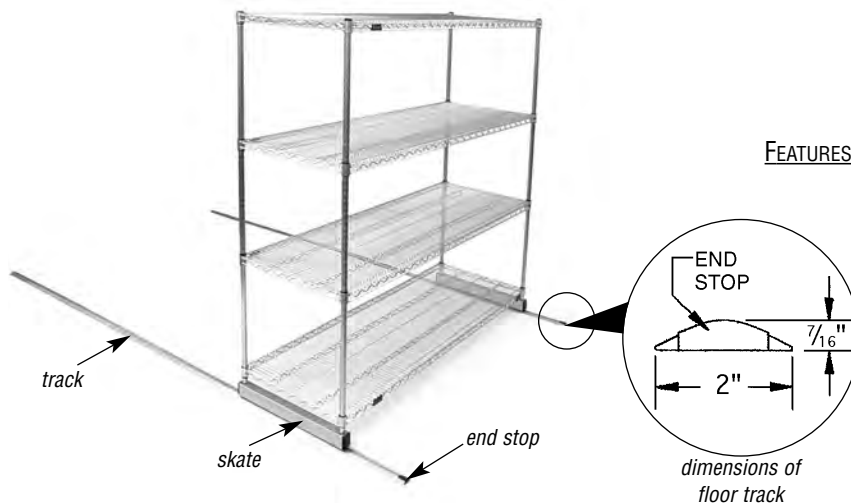

single deep unit shown assembled with wire starter unit

- Non-corrosive track constructed of anodized aluminum.
- The system is ADA-compliant.
- Simple and easy to install.
- Easy to add on additional units.
- Open construction allows for the use of cart covers when required.
- Industrial-type, hardened steel bearings allow loaded units to glide effortlessly over the track.

**FEATURES:**

**Note:** Unit will tilt if not loaded properly.  
**LOAD BOTTOM FIRST!**

**Freight class is 70.0.**

### Single-Deep Skate Kits

- Two skates.
- All necessary parts and hardware.
- One kit is required for each mobile unit.
- Skates are aircraft-quality aluminum with stainless steel inserts and hardened steel ball bearings.
- Weight capacity of 2000 lbs. (907.2 kg) per mobile section.

**Note:** Shelves (page 6) and posts (page 13) sold separately.

width		weight		cu	model #	list
in.	mm	lbs.	kg	ft		
18"	457	6	2.7	0.09	<b>SDSK-18</b>	761
21"	533	7	3.2	0.11	<b>SDSK-21</b>	789
24"	610	7	3.2	0.23	<b>SDSK-24</b>	824
30"	762	8	3.6	0.15	<b>SDSK-30</b>	920
36"	914	10	4.5	0.18	<b>SDSK-36</b>	1215

### Anti-Tip Brackets for use with Floor-Trak® Skate Kits

Stainless steel. Set of four.



model #	list
<b>SDSKATB-S</b>	339

...sold individually

Hardware included.

model #	list
<b>SKATB-S</b>	85

### Optional Shim Kits

Accommodates uneven floors.

model #	list
<b>912991</b>	208

### Optional Foot Brake Kit

Mounts onto frontmost skate.

model #	list
<b>MFBK-S</b>	129

### Single-Deep Floor Track Kits

- Pair of aluminum tracks with plastic end stops.
- All hardware included.

**Note:** Not recommended to piece tracks together. Order length needed. Custom lengths available. Consult factory.

length		weight		cu	model #	list
ft.	mm	lbs.	kg	ft		
6'	1829	5	2.3	0.06	<b>SDFT-6</b>	775
7'	2134	5	2.3	0.07	<b>SDFT-7</b>	876
8'	2438	6	2.7	0.08	<b>SDFT-8</b>	982
9'	2743	7	3.2	0.09	<b>SDFT-9</b>	1085
10'	3048	8	3.6	0.10	<b>SDFT-10</b>	1188
11'	3353	8	3.6	0.11	<b>SDFT-11</b>	1294
12'	3658	9	4.1	0.12	<b>SDFT-12</b>	1394
13'	3962	10	4.5	0.13	<b>SDFT-13</b>	1501
14'	4267	11	5.0	0.14	<b>SDFT-14</b>	1603
15'	4572	11	5.0	0.15	<b>SDFT-15</b>	1708
16'	4877	12	5.4	0.16	<b>SDFT-16</b>	1812
17'	5181	13	5.8	0.17	<b>SDFT-17</b>	1915
18'	5486	14	6.4	0.18	<b>SDFT-18</b>	2019
19'	5791	14	6.4	0.19	<b>SDFT-19</b>	2124
20'	6096	15	6.8	0.20	<b>SDFT-20</b>	2226
21'	6401	16	7.3	0.21	<b>SDFT-21</b>	2331
22'	6706	17	7.7	0.21	<b>SDFT-22</b>	2437
23'	7010	18	8.2	0.21	<b>SDFT-23</b>	2543
24'	7315	19	8.6	0.21	<b>SDFT-24</b>	2647
25'	7620	20	9.0	0.21	<b>SDFT-25</b>	2752
26'	7925	21	9.5	0.21	<b>SDFT-26</b>	2855
27'	8230	22	10.0	0.21	<b>SDFT-27</b>	2959
28'	8534	23	10.4	0.21	<b>SDFT-28</b>	3063
29'	8839	24	10.9	0.21	<b>SDFT-29</b>	3167
30'	9144	25	11.3	0.21	<b>SDFT-30</b>	3271



## Catalog Section 1

### Double-Deep Floor-Trak® High-Density Storage System NSF

see spec sheet **EG01.39B**

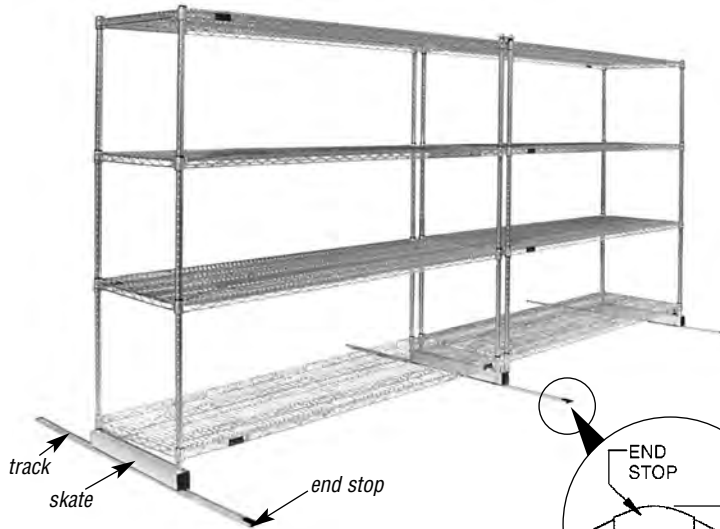

double deep unit shown assembled with wire starter unit

#### Double-Deep Skate Kits

- Three skates.
- All necessary parts and hardware.
- One kit is required for each mobile unit.
- Skates are aircraft-quality aluminum with stainless steel inserts and hardened steel ball bearings.
- Weight capacity of 1500 lbs. (680.4 kg) per mobile section —3000 lbs (1361 kg) at middle skate.

**Note:** Shelves (page 6) and posts (page 13) sold separately.

width		weight		cu	model #	list
in.	mm	lbs.	kg			
18"	457	10	4.5	0.14	<b>DDSK-18</b>	1385
21"	533	11	5.0	0.16	<b>DDSK-21</b>	1423
24"	610	12	5.4	0.18	<b>DDSK-24</b>	1476
30"	762	14	6.4	0.23	<b>DDSK-30</b>	1620
36"	914	16	7.3	0.27	<b>DDSK-36</b>	2064

#### Optional Shim Kits

Accommodates uneven floors.

model #	list
<b>912991</b>	208

#### Optional Foot Brake Kit

Mounts onto frontmost skate.

model #	list
<b>MFBK-S</b>	129

#### Inside Posts for Double-Deep Units

- Each double-deep unit requires a set of four 'inside' posts (listed below) along with four standard stationary posts.

**Note:** See page 13 for standard stationary posts and page 6 for wire shelves (sold separately).

##### Sets of four 74" (1880mm) posts

weight	cu	EAGLEbrite®		chrome		EAGLEgard®		
		model #	list	model #	list	model #	list	
17	7.7	0.1	<b>TEP74-Z</b>	209	<b>TEP74-C</b>	223	<b>TEP74-E</b>	244

##### Sets of four 86" (2184mm) posts

weight	cu	EAGLEbrite®		chrome		EAGLEgard®		
		model #	list	model #	list	model #	list	
21	9.5	0.1	<b>TEP86-Z</b>	217	<b>TEP86-C</b>	236	<b>TEP86-E</b>	260

**IMPORTANT:** Maximum post height per skate size: 18", 21", and 24" (457, 533, and 610mm)-wide skates on 74" (1880mm) post height or less; 30" and 36" (762 and 914mm)-wide skates on 86" (2184mm) post height or less.

**Note:** Unit will tilt if not loaded properly.  
**LOAD BOTTOM FIRST!**

**Freight class is 70.0.**

#### Double-Deep Floor Track Kits

- Three aluminum tracks with plastic end stops.
- All hardware included.

**Note:** Not recommended to piece tracks together. Order length needed. Custom lengths available. Consult factory.

Double-deep units should not exceed depths of 12' (3658mm). 11' and 12' (2794 and 3658mm)-deep units should be used only with 24", 30" or 36" (610, 762, or 914mm)-wide shelves.

length	weight		cu	model #	list	
	ft.	mm				lbs.
6'	1829	7	3.2	0.09	<b>DDFT-6</b>	1161
7'	2134	8	3.6	0.11	<b>DDFT-7</b>	1317
8'	2438	9	4.1	0.12	<b>DDFT-8</b>	1471
9'	2743	10	4.5	0.14	<b>DDFT-9</b>	1627
10'	3048	13	5.8	0.16	<b>DDFT-10</b>	1783
11'	3353	14	6.4	0.17	<b>DDFT-11</b>	1937
12'	3658	15	6.8	0.18	<b>DDFT-12</b>	2095
13'	3962	16	7.3	0.20	<b>DDFT-13</b>	2251
14'	4267	16	7.3	0.21	<b>DDFT-14</b>	2405
15'	4572	17	7.7	0.23	<b>DDFT-15</b>	2562
16'	4877	18	8.2	0.24	<b>DDFT-16</b>	2717
17'	5181	19	8.6	0.26	<b>DDFT-17</b>	2875
18'	5486	21	9.5	0.27	<b>DDFT-18</b>	3031
19'	5791	22	10.0	0.29	<b>DDFT-19</b>	3183
20'	6096	23	10.4	0.30	<b>DDFT-20</b>	3341
21'	6401	24	10.9	0.32	<b>DDFT-21</b>	3496
22'	6706	25	11.3	0.32	<b>DDFT-22</b>	3660
23'	7010	26	11.8	0.32	<b>DDFT-23</b>	3813
24'	7315	27	12.2	0.32	<b>DDFT-24</b>	3969
25'	7620	28	12.7	0.32	<b>DDFT-25</b>	4126
26'	7925	29	13.2	0.32	<b>DDFT-26</b>	4282
27'	8230	30	13.6	0.32	<b>DDFT-27</b>	4439
28'	8534	31	14.1	0.32	<b>DDFT-28</b>	4595
29'	8839	32	14.5	0.32	<b>DDFT-29</b>	4751
30'	9144	33	15.0	0.32	<b>DDFT-30</b>	4905

#### Anti-Tip Brackets for use with Floor-Trak® Skate Kits

Stainless steel. Set of six.



model #	list
<b>DDSKATB-S</b>	484

...sold individually

Hardware included.

model #	list
<b>SKATB-S</b>	85

### Aluminum Beer Keg Racks <sup>NSF</sup>

see spec sheet **EG01.38**

# PANCO<sup>®</sup>



- Adjustable cooler shelving for quarter- or half-kegs.
- Compatible with any wet or dry storage environment.
- Resists corrosion and rust.
- Racks feature three shelves.
  - two of which are heavy duty for kegs.
  - third (*usually on top*) is for general storage.
- Shelf corners features a heavy-duty extruded aluminum collar with set screw.
- Shelves are adjustable in 2" (51mm) increments.
- Shipped knocked down.
- Easy to assemble.

**FEATURES:**

**Freight class is 70.0.**

(•) MTS (*made to stock*) / ( ) MTO (*made to order*)

width x length x height		weight		keg	cu	model #	list
in.	mm	lb.	kg	capacity	ft		
18" x 42" x 76"	457 x 1067 x 1930	41	18.6	4	3.9	<b>KR1842A</b>	933
18" x 60" x 76"	457 x 1524 x 1930	64	29.0	6	5.6	<b>KR1860A</b> •	1257
18" x 80" x 76"	457 x 2032 x 1930	78	35.4	8	7.5	<b>KR1880A</b> •	1445
18" x 93" x 76"	457 x 2362 x 1930	93	42.2	10	8.7	<b>KR1893A</b> *	1721

\* 93" (2362mm) long units come with six posts. Mid posts are protruded. Add 6" (152mm) to width.

### Options for Aluminum Beer Keg Racks

see spec sheet **EG01.38**

#### Additional Heavy Duty Shelves

- Sold individually.

	length		weight		keg capacity	cu ft	model #	list
	in.	mm	lb.	kg				
<b>18" width</b> (457mm)	42"	1067	12	5.4	2	1.3	<b>KRS1842A</b>	240
	60"	1524	15	6.8	3	1.8	<b>KRS1860A</b>	378
	80"	2032	19	8.6	4	2.5	<b>KRS1880A</b>	456
	93"	2362	23	10.4	5	2.9	<b>KRS1893A</b> *	540

\* 93" (2362mm) long shelf features protruded front and rear collars midway of shelf. Add 6" (152mm) to width.

#### Floor Post Brackets

- Secures rack's 1<sup>5</sup>/<sub>16</sub>" (33mm)-diameter posts to floor.
- Designed to help racks withstand earthquakes.
- Sold individually.

weight		model #	list
lb.	kg		
0.5	0.23	<b>374136</b>	51



#### Posts for Aluminum Beer Keg Racks

- 1<sup>5</sup>/<sub>16</sub>" (33mm) diameter, marked in 2" (51mm) increments.
- Sold individually.

height		weight		cubic feet	model #	list	height		weight		cubic feet	model #	list
in.	mm	lb.	kg				in.	mm	lb.	kg			
12"	305	0.6	0.3	0.01	<b>KP12-A</b>	22	68"	1727	3.5	1.6	0.09	<b>KP68-A</b>	45
34"	864	2.0	0.9	0.04	<b>KP34-A</b>	31	72"	1829	3.5	1.6	0.09	<b>KP72-A</b>	48
48"	1219	2.5	1.1	0.06	<b>KP48-A</b>	32	76"	1930	4.0	1.8	0.10	<b>KP76-A</b>	50
54"	1372	3.0	1.4	0.07	<b>KP54-A</b>	36	84"	2134	4.5	2.0	0.11	<b>KP84-A</b>	58

**Freight class is 50.0.**

#### 3-Sided Frames

	length		weight		model #	list
	in.	mm	lb.	kg		
<b>18" width</b> (457mm)	42"	1067	5	2.3	<b>KRB1842A</b>	125
	60"	1524	8	3.6	<b>KRB1860A</b>	145
	80"	2032	9	4.1	<b>KRB1880A</b>	155
	93"	2362	10	4.5	<b>KRB1893A</b> *	183

\* 93" (2362mm) long frame features protruded front and rear collars midway of frame. Add 6" (152mm) to width.

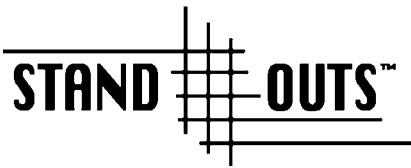

**Show-off your merchandise when you use our wire display shelving units in various configurations highlighted by our brilliant finishes.**

- Open wire grid shelf allows maximum merchandise visibility.
- Easy to assemble.
- Shelf spacing adjusts in seconds.
- Choose from our custom and standard colors.

### Decorative Shelves NSF

see spec sheet **EG01.34A**



**patented**  
**QuadTruss®**  
**design**

(Patent #5,390,803)

#### Patented QuadTruss® Design

makes shelves up to 25% stronger and provides a retaining ledge for increased strength and product retention.

#### INCLUDES:

- Four plastic split sleeves per shelf ordered, packaged four per bag.
- Black sleeves except white shelves.
- White shelves come with white sleeves.

**Note:** To order custom decorative colors, add suffix "BM" (black matte), "L" (lilac), "M" (maroon), "SV" (silver vein), "SA" (sapphire), "SG" (smoked glass), "T" (teal), "GV" (gold vein), "CV" (copper vein), or "RU" (ruby) to the desired shelf size model number when ordering. **Call for custom decorative color pricing.**

**Freight class is 70.0.**

(•) MTS (made to stock) / ( ) MTO (made to order)



	length		weight		cubic feet	red		white		black	
	in.	mm	lbs.	kg		model #	list	model #	list	model #	list
<b>14" width</b> (356mm)	24"	610	6	2.9	0.5	<b>1424R</b> •	73	<b>1424W</b> •	73	<b>1424BL</b> •	73
	30"	762	7	3.2	0.5	<b>1430R</b>	77	<b>1430W</b>	77	<b>1430BL</b>	77
	36"	914	8	3.6	0.5	<b>1436R</b>	84	<b>1436W</b>	84	<b>1436BL</b>	84
	42"	1067	9	3.9	0.7	<b>1442R</b>	98	<b>1442W</b>	98	<b>1442BL</b>	98
	48"	1219	10	4.4	0.7	<b>1448R</b>	100	<b>1448W</b>	100	<b>1448BL</b>	100
	54"	1372	12	5.4	0.9	<b>1454R</b>	106	<b>1454W</b>	106	<b>1454BL</b>	106
	60"	1524	14	6.4	0.9	<b>1460R</b>	120	<b>1460W</b>	120	<b>1460BL</b>	120
	72"	1829	17	7.7	1.1	<b>1472R</b>	129	<b>1472W</b>	129	<b>1472BL</b>	129
<b>18" width</b> (457mm)	24"	610	7	3.2	0.7	<b>1824R</b>	84	<b>1824W</b>	84	<b>1824BL</b>	84
	30"	762	8	3.6	0.7	<b>1830R</b>	92	<b>1830W</b> •	92	<b>1830BL</b> •	92
	36"	914	9	3.9	0.7	<b>1836R</b>	99	<b>1836W</b>	99	<b>1836BL</b>	99
	42"	1067	11	5.0	0.9	<b>1842R</b>	111	<b>1842W</b>	111	<b>1842BL</b>	111
	48"	1219	12	5.4	0.9	<b>1848R</b>	120	<b>1848W</b>	120	<b>1848BL</b>	120
	54"	1372	15	6.8	1.2	<b>1854R</b>	129	<b>1854W</b>	129	<b>1854BL</b>	129
	60"	1524	17	7.7	1.2	<b>1860R</b>	139	<b>1860W</b>	139	<b>1860BL</b>	139
	72"	1829	20	9.1	1.3	<b>1872R</b>	167	<b>1872W</b>	167	<b>1872BL</b>	167
<b>21" width</b> (533mm)	24"	610	8	3.7	0.7	<b>2124R</b>	96	<b>2124W</b>	96	<b>2124BL</b>	96
	30"	762	9	4.1	0.7	<b>2130R</b>	102	<b>2130W</b>	102	<b>2130BL</b> •	102
	36"	914	11	5.0	0.8	<b>2136R</b>	116	<b>2136W</b>	116	<b>2136BL</b>	116
	42"	1067	12	5.4	1.1	<b>2142R</b>	123	<b>2142W</b>	123	<b>2142BL</b> •	123
	48"	1219	14	6.4	1.1	<b>2148R</b>	129	<b>2148W</b>	129	<b>2148BL</b>	129
	54"	1372	16	7.3	1.3	<b>2154R</b>	147	<b>2154W</b>	147	<b>2154BL</b>	147
	60"	1524	18	8.2	1.3	<b>2160R</b>	157	<b>2160W</b>	157	<b>2160BL</b>	157
	72"	1829	24	10.9	1.4	<b>2172R</b>	183	<b>2172W</b>	183	<b>2172BL</b> •	183
<b>24" width</b> (610mm)	24"	610	9	4.1	0.8	<b>2424R</b>	103	<b>2424W</b>	103	<b>2424BL</b>	103
	30"	762	11	5.0	0.8	<b>2430R</b> •	116	<b>2430W</b>	116	<b>2430BL</b> •	116
	36"	914	13	5.9	0.8	<b>2436R</b>	121	<b>2436W</b>	121	<b>2436BL</b>	121
	42"	1067	15	6.8	1.2	<b>2442R</b>	135	<b>2442W</b>	135	<b>2442BL</b> •	135
	48"	1219	16	7.3	1.2	<b>2448R</b>	148	<b>2448W</b>	148	<b>2448BL</b>	148
	54"	1372	19	8.6	1.5	<b>2454R</b>	165	<b>2454W</b>	165	<b>2454BL</b> •	165
	60"	1524	21	9.5	1.5	<b>2460R</b>	177	<b>2460W</b>	177	<b>2460BL</b> •	177
	72"	1829	26	11.8	1.6	<b>2472R</b>	209	<b>2472W</b>	209	<b>2472BL</b>	209

## STAND-OUTS™ Decorative Shelving Accessories

see spec sheets **EG01.34A** **EG01.34B**

Freight class is 70.0.

(•) MTS (made to stock) / ( ) MTO (made to order)

### Decorative Casters

- For use with Stationary Posts (page 67).

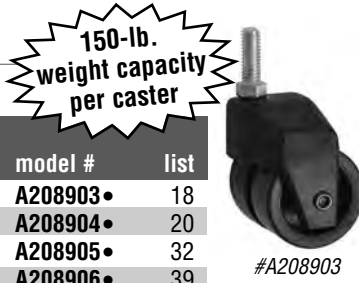

type	wheel diameter		weight ea.		cubic feet	model #		list
	in.	mm	lbs.	kg		model #	list	
swivel	2"	51	0.4	0.2	0.03	<b>A208903</b> •	18	
swivel/brake	2"	51	0.4	0.2	0.03	<b>A208904</b> •	20	
swivel	4"	102	0.7	0.3	0.03	<b>A208905</b> •	32	
swivel/brake	4"	102	0.8	0.4	0.03	<b>A208906</b> •	39	

### Decorative Foot Plate

diameter		model #	list
in.	mm		
2"	51	<b>A204942</b>	7



### Inlays

- Fits between posts and levels with top of shelf edge.

	length		weight**		cu ft	Black & White Hardboard Reversible. Priced per inlay. 1/8"-thick.		Clear * Plastic Priced per pack of four. 1/2"-thick.	
	in.	mm	lbs.	kg		model #	list	model #	list
<b>14" width</b> (356mm)	30"	762	1.0	0.5	0.2	<b>DSI-1430</b>	59	<b>CSI-1430</b>	86
	36"	914	1.0	0.5	0.2	<b>DSI-1436</b>	62	<b>CSI-1436</b>	92
	48"	1219	1.0	0.5	0.2	<b>DSI-1448</b>	71	<b>CSI-1448</b> •	112
	60"	1524	1.0	0.5	0.2	<b>DSI-1460</b>	80	<b>CSI-1460</b>	144
<b>18" width</b> (457mm)	36"	914	1.0	0.5	0.2	<b>DSI-1836</b>	69	<b>CSI-1836</b> •	96
	48"	1219	1.0	0.5	0.2	<b>DSI-1848</b>	80	<b>CSI-1848</b>	116
	60"	1524	1.0	0.5	0.2	<b>DSI-1860</b>	87	<b>CSI-1860</b>	134
	72"	1829	1.0	0.5	0.2	<b>DSI-1872</b>	98	<b>CSI-1872</b>	153
<b>21" width</b> (533mm)	36"	914	1.1	0.5	0.2	<b>DSI-2136</b>	77	<b>CSI-2136</b>	102
	48"	1219	1.2	0.5	0.3	<b>DSI-2148</b>	85	<b>CSI-2148</b>	120
	60"	1524	1.3	0.6	0.3	<b>DSI-2160</b>	99	<b>CSI-2160</b>	137
	72"	1829	1.4	0.6	0.3	<b>DSI-2172</b>	106	<b>CSI-2172</b>	155
<b>24" width</b> (610mm)	24"	610	1.0	0.5	0.2	<b>DSI-2424</b>	66	<b>CSI-2424</b>	87
	30"	762	1.0	0.5	0.3	<b>DSI-2430</b>	76	<b>CSI-2430</b>	92
	36"	914	1.0	0.5	0.3	<b>DSI-2436</b>	80	<b>CSI-2436</b>	107
	48"	1219	1.1	0.5	0.3	<b>DSI-2448</b>	91	<b>CSI-2448</b>	123
	54"	1372	1.3	0.6	0.3	<b>DSI-2454</b>	102	<b>CSI-2454</b>	138
	60"	1524	1.4	0.6	0.3	<b>DSI-2460</b>	111	<b>CSI-2460</b>	156
<b>30" width</b> (762mm)	60"	1524	2.0	0.9	0.3	<b>DSI-3060</b>	115	<b>CSI-3060</b>	247
	72"	1829	2.5	1.1	0.3	<b>DSI-3072</b>	125	<b>CSI-3072</b>	252

\* Actual width of CSI Inlays is minus 1/4" (32mm).

\*\* Weight shown per inlay.

### Display Arms

- For everything from pots to purses; perfect for 'quick-pick' items.
- Easily attaches to standard posts.

length	weight	EAGLEbrite®		chrome		red		white		black			
		in.	mm	lbs.	kg	model #	list	model #	list	model #	list	model #	list
6"	25	20	9	<b>DA6-Z</b>	30	<b>DA6-C</b>	31	<b>DA6-R</b>	33	<b>DA6-W</b>	33	<b>DA6-BL</b>	33



### Posts

Freight class is 50.0.

see spec sheet **EG01.34A**

(•) MTS (made to stock) / ( ) MTO (made to order)



					For Stationary Applications				For Mobile Applications			
height		weight		cu ft	Model #				Model #			
in.	mm	lbs.	kg		red	white	black	list	red	white	black	list
7"	178	0.8	0.4	0.1	P7-R	P7-W	P7-BL	20	CP7-R	CP7-W	CP7-BL	20
14"	356	1.0	0.5	0.1	P14-R	P14-W	P14-BL •	24	CP14-R	CP14-W	CP14-BL	24
33"	838	2.0	0.9	0.1	P33-R	P33-W	P33-BL •	27	CP33-R	CP33-W	CP33-BL	27
54"	1372	3.0	1.4	0.1	P54-R	P54-W	P54-BL •	32	CP54-R	CP54-W	CP54-BL •	32
63"	1600	3.5	1.8	0.3	P63-R	P63-W	P63-BL •	34	CP63-R	CP63-W	CP63-BL	34
74"	1880	4.0	1.8	0.5	P74-R	P74-W	P74-BL •	36	CP74-R	CP74-W	CP74-BL •	36
86"	2184	5.0	2.3	0.8	P86-R	P86-W	P86-BL •	46	CP86-R	CP86-W	CP86-BL	46

### Ledges

Freight class is 70.0.

see spec sheet **EG01.34A**

(•) MTS (made to stock) / ( ) MTO (made to order)

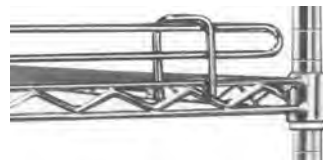

1" (25mm) Ledges\*

4" (102mm) Ledges

length		cu ft	weight		Model numbers				weight		Model numbers				list
in.	mm		lbs.	kg	red	white	black	list	lbs.	kg	red	white	black	list	
14"	356	0.2	0.2	0.1	L14-1R	L14-1W	L14-1BL	22	0.8	0.4	L14-4R	L14-4W	L14-4BL	29	
18"	457	0.3	0.3	0.1	L18-1R	L18-1W	L18-1BL	24	0.9	0.4	L18-4R	L18-4W	L18-4BL	32	
21"	533	0.3	0.4	0.2	L21-1R	L21-1W	L21-1BL	27	1.0	0.5	L21-4R	L21-4W	L21-4BL	33	
24"	610	0.3	0.5	0.2	L24-1R	L24-1W	L24-1BL	31	1.2	0.6	L24-4R	L24-4W	L24-4BL	35	
30"	762	0.5	0.7	0.3	L30-1R	L30-1W	L30-1BL	32	1.4	0.6	L30-4R	L30-4W	L30-4BL	39	
36"	914	0.6	0.9	0.4	L36-1R	L36-1W	L36-1BL	34	1.6	0.7	L36-4R	L36-4W	L36-4BL •	49	
42"	1067	0.6	1.1	0.5	L42-1R	L42-1W	L42-1BL	37	1.8	0.8	L42-4R	L42-4W	L42-4BL	58	
48"	1219	0.7	1.3	0.6	L48-1R	L48-1W	L48-1BL	38	2.0	0.9	L48-4R	L48-4W	L48-4BL •	60	
54"	1372	0.8	1.5	0.7	L54-1R	L54-1W	L54-1BL	40	2.2	1.0	L54-4R	L54-4W	L54-4BL	66	
60"	1524	0.8	1.7	0.8	L60-1R	L60-1W	L60-1BL	46	2.4	1.1	L60-4R	L60-4W	L60-4BL	69	
72"	1829	1.0	2.1	1.0	L72-1R	L72-1W	L72-1BL	52	2.6	1.2	L72-4R	L72-4W	L72-4BL	73	

\* When installed, actual height of ledge is 1 1/2" (38mm).

### Shelf Dividers

Freight class is 70.0.

see spec sheet **EG01.34A**

Organize shelf contents with these snap-on dividers!

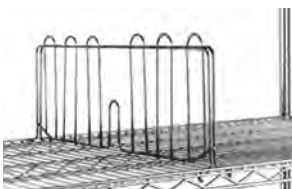

length		weight		cubic feet	red		white		black	
in.	mm	lbs.	kg		model #	list	model #	list	model #	list
14"	356	1.0	0.5	0.6	SD14-R	47	SD14-W	47	SD14-BL	47
18"	457	1.3	0.6	0.6	SD18-R	54	SD18-W	54	SD18-BL	54
21"	533	1.5	0.7	0.8	SD21-R	58	SD21-W	58	SD21-BL	58
24"	610	1.8	0.8	1.0	SD24-R	68	SD24-W	68	SD24-BL	68
30"	762	2.2	1.0	1.2	SD30-R	74	SD30-W	74	SD30-BL	74
36"	914	2.7	1.2	1.4	SD36-R	76	SD36-W	76	SD36-BL	76

## Cantilever Shelves

see spec sheet **EG01.34B**

FEATURES:

- 1" (25mm) wraparound ledge.
- 12" (305mm) wide shelves.

**NOTE:** When ordering back posts, confirm with customer service, the correct post height to accommodate these shelves.

Freight class is 70.0.



*Ideal for adding extra storage above an existing shelving unit.*

*Packaged two per box.*

	length		weight		cu ft	red		white		black	
	in.	mm	lbs.	kg		model #	list	model #	list	model #	list
12" width (305mm)	24"	610	4	1.8	0.5	CS1224-R	80	CS1224-W	80	CS1224-BL	80
	30"	762	5	2.3	0.8	CS1230-R	86	CS1230-W	86	CS1230-BL	86
	36"	914	6	2.7	0.8	CS1236-R	98	CS1236-W	98	CS1236-BL	98
	42"	1067	7	3.2	0.9	CS1242-R	112	CS1242-W	112	CS1242-BL	112
	48"	1219	8	3.6	1.0	CS1248-R	115	CS1248-W	115	CS1248-BL	115
	54"	1371	8	3.6	1.0	CS1254-R	121	CS1254-W	121	CS1254-BL	121
	60"	1524	9	4.1	1.0	CS1260-R	129	CS1260-W	129	CS1260-BL	129

## Etagere Top

see spec sheet **EG01.34B**

FEATURES:

- Decorative top fits 24" (610mm) long shelving.

Freight class is 70.0.



length	in.	mm	weight		cu ft	red		white		black	
			lbs.	kg		model #	list	model #	list	model #	list
24"	305		1.5	0.7	1.3	ET24-R	33	ET24-W	33	ET24-BL	33

## Hanger Rails

see spec sheet **EG01.34B**

Freight class is 70.0.

### Front-to-Back

width	in.	mm	weight		cu ft	red		white		black	
			lbs.	kg		model #	list	model #	list	model #	list
14"	356		1.0	0.5	0.2	WR14-R	31	WR14-W	31	WR14-BL	31
18"	457		1.1	0.5	0.3	WR18-R	33	WR18-W	33	WR18-BL	33
24"	610		1.5	0.7	0.3	WR24-R	34	WR24-W	34	WR24-BL	34
30"	762		1.7	0.8	0.5	WR30-R	35	WR30-W	35	WR30-BL	35
36"	914		1.9	0.9	0.6	WR36-R	37	WR36-W	37	WR36-BL	37



### Left-to-Right

width	in.	mm	weight		cu ft	red		white		black	
			lbs.	kg		model #	list	model #	list	model #	list
24"	610		1.5	0.7	0.3	LR24-R	37	LR24-W	37	LR24-BL	37
30"	762		1.7	0.8	0.5	LR30-R	43	LR30-W	43	LR30-BL	43
36"	914		1.9	0.9	0.6	LR36-R	47	LR36-W	47	LR36-BL	47
42"	1067		2.0	0.9	0.6	LR42-R	51	LR42-W	51	LR42-BL	51
48"	1092		2.1	1.0	0.7	LR48-R	54	LR48-W	54	LR48-BL	54
54"	1372		2.3	1.0	0.8	LR54-R	57	LR54-W	57	LR54-BL	57
60"	1524		2.5	1.1	0.8	LR60-R	60	LR60-W	60	LR60-BL	60
66"	1676		2.7	1.2	0.9	LR66-R	66	LR66-W	66	LR66-BL	66
72"	1829		2.9	1.3	1.0	LR72-R	77	LR72-W	77	LR72-BL	77

## Catalog Section 1

### Hooks

see spec sheet **EG01.34B**

*These snap-on hooks are heavy-gauge mild steel.*

length x width x height		weight		cu	description	chrome		black	
in.	mm	lbs.	kg	ft		model #	list	model #	list
1 1/4" x 4 1/4" x 3/8"	32 x 108 x 10	0.3	0.1	0.1	small snap hook	SH-C	16	SH-BL	16
2 1/4" x 4 1/4" x 3/8"	57 x 108 x 10	0.3	0.1	0.1	large snap hook	LH-C	16	LH-BL	20
2 1/4" x 4 1/4" x 3/8"	57 x 108 x 10	0.3	0.1	0.1	large double hook	LDH-C	33	LDH-BL	33

Freight class is 70.0.

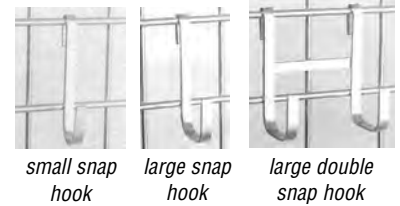

### Front Case Merchandise Shelving NSF

see product announcement **EG8105**

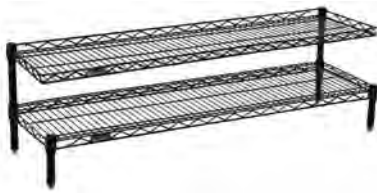

patented  
**QuadTruss**<sup>®</sup>  
design  
(Patent #5,390,803)

- 14" (356mm) standard height.
- Set of four split sleeves per shelf.

Freight class is 70.0.

**Note:** To order unit with decorative casters, add suffix "-DC" to model number (example: FCM1448V-DC) and \$42.

To order unit with 18" (457mm)-high posts, add suffix "-18" to model number (example: HDFCM1424C-18). For units with cantilever overshef, add \$9. For units with two standard shelves, add \$19.

#### Units with 12" (305mm)-wide Cantilever Overshef

width (356mm)	length		chrome		black		red		VALU-MASTER <sup>®</sup>		Valu-Gard <sup>®</sup>		white	
	in.	mm	model #	list	model #	list	model #	list	model #	list	model #	list	model #	list
14"	24"	610	FCM1424C	257	FCM1424BL	263	FCM1424R	263	FCM1424V	263	FCM1424VG	263	FCM1424W	263
	30"	762	FCM1430C	267	FCM1430BL	277	FCM1430R	277	FCM1430V	277	FCM1430VG	277	FCM1430W	277
	36"	914	FCM1436C	284	FCM1436BL	294	FCM1436R	294	FCM1436V	294	FCM1436VG	294	FCM1436W	294
	42"	1067	FCM1442C	312	FCM1442BL	322	FCM1442R	322	FCM1442V	322	FCM1442VG	322	FCM1442W	322
	48"	1219	FCM1448C	319	FCM1448BL	328	FCM1448R	328	FCM1448V	328	FCM1448VG	328	FCM1448W	328
	54"	1372	FCM1454C	333	FCM1454BL	341	FCM1454R	341	FCM1454V	341	FCM1454VG	341	FCM1454W	341
60"	1524	FCM1460C	351	FCM1460BL	363	FCM1460R	363	FCM1460V	363	FCM1460VG	363	FCM1460W	363	

#### Units with Two Standard Shelves

width (356mm)	length		chrome		black		red		VALU-MASTER <sup>®</sup>		Valu-Gard <sup>®</sup>		white	
	in.	mm	model #	list	model #	list	model #	list	model #	list	model #	list	model #	list
14"	24"	610	HDFCM1424C	228	HDFCM1424BL	235	HDFCM1424R	235	HDFCM1424V	235	HDFCM1424VG	235	HDFCM1424W	235
	30"	762	HDFCM1430C	240	HDFCM1430BL	248	HDFCM1430R	248	HDFCM1430V	248	HDFCM1430VG	248	HDFCM1430W	248
	36"	914	HDFCM1436C	253	HDFCM1436BL	261	HDFCM1436R	261	HDFCM1436V	261	HDFCM1436VG	261	HDFCM1436W	261
	42"	1067	HDFCM1442C	279	HDFCM1442BL	288	HDFCM1442R	288	HDFCM1442V	288	HDFCM1442VG	288	HDFCM1442W	288
	48"	1219	HDFCM1448C	284	HDFCM1448BL	294	HDFCM1448R	294	HDFCM1448V	294	HDFCM1448VG	294	HDFCM1448W	294
	54"	1372	HDFCM1454C	296	HDFCM1454BL	304	HDFCM1454R	304	HDFCM1454V	304	HDFCM1454VG	304	HDFCM1454W	304
60"	1524	HDFCM1460C	312	HDFCM1460BL	322	HDFCM1460R	322	HDFCM1460V	322	HDFCM1460VG	322	HDFCM1460W	322	

### Soft Goods Display

see product announcement **EG8084**



shown with optional hooks

- Standard adjustable feet.
- Standard color is red.
- Three shelves.
- Display arm.
- Two hanger rails.
- Two etagere tops used for signage.

INCLUDES:

Freight class is 70.0.

**Note:** Options include the finish of your choice (see page 65 for custom colors and suffix codes), additional shelves and hooks, hanger tube, and decorative casters.

height	width	length		weight		cubic feet	model #	list
		in.	mm	lbs.	kg			
64" (1626mm)	24" (610mm)	24"	610	49	22.2	3	SDG2424R	483

## Retail Display Workstation

see product announcement **EG8082**



retail display workstation shown with optional accessories

**Available accessories:**

- Hanger rails
- Display arms
- Ledges
- Dividers
- Wire grids panels
- Display hooks

**Available options:**

- Additional wood tabletop choices.
- Laminate top in lieu of wood.
- Your custom logo displayed on wood caps.
- European-style corners on wood caps.

**CONSULT FACTORY.**

**FEATURES:**

- 63" (1600mm) high freestanding rear shelf unit.
- 34" (864mm) high table, both capped with a hardwood finish.

**SHELVES  
FEATURES:**

- Four 14" (356mm) wide chrome shelves and posts.

**TABLE  
FEATURES:**

- Two 18" (457mm) wide chrome wire undershelves and posts.

**Freight class is 70.0.**

width	length		weight		cu ft	model #	list
	in.	mm	lbs.	kg			
36" (914mm)	50"	1270	110	49.9	6	<b>RDW48CB</b>	3659

## Hardwood Top Wine Cart

see spec sheet **EG01.48**

patented  
**QuadTruss®**  
design  
(Patent #5,390,803)

**Patented QuadTruss® Design**

makes shelves up to 25% stronger and provides a retaining ledge for increased strength and product retention.



**INCLUDES:**

- 1 1/4" (45mm) thick hardwood butcher block top.
- Two chrome wine racks that can hold up to 18 bottles of wine.
- Chrome wire shelf for storage.

**Freight class is 70.0.**

width	length		weight		cu ft	model #	list
	in.	mm	lbs.	kg			
18" (457mm)	40"	1016	69	31.3	7.7	<b>WR1840C</b>	1320

**Smooth rolling casters for easy mobility.**

## Hardwood Top Demo Carts

see product announcement **EG8181**



**INCLUDES:**

- 1 1/4" (45mm) thick hardwood butcher block top.
- Two wire undershelves, Valu-Master® gray finish.
- 5" (127mm)-diameter decorative casters with donut bumpers.

**Note:** Available accessories include laminate top in lieu of wood, wire basket, and utility hooks.

Options include the finish of your choice (see page 65 for custom colors and suffix codes).

**Freight class is 70.0.**

height	width	length		weight		cubic feet	model #	list
		in.	mm	lbs.	kg			
34" (864mm)	24" (610mm)	36"	914	61	27.7	4.0	<b>DC2436V</b>	1528
		48"	1219	73	33.1	5.0	<b>DC2448V</b>	1592
		60"	1524	91	41.3	6.0	<b>DC2460V</b>	1780



## Catalog Section 1

### Pot / Pan Rack

see product announcement **EG8085**



**Designed for displaying items such as cookware, while allowing plenty of tabletop room for other display.**

pot/pan rack shown with additional bracket

- 33" (838mm) high.
- Chrome plated.
- Overall bracket length is 10" (254mm).
- Base is screwed into bottom of post.
- Entire assembly screws onto tabletop.
- Threaded stud welded into middle of 12" (305mm) square heavy gauge mild steel base.
- Three display brackets with 8" (203mm) hexagon pad welded onto each bracket.

**FEATURES:**

**Note:** Options include the finish of your choice (see page 65 for custom colors and suffix codes), specified post height and additional brackets.

**Freight class is 70.0.**

width	length in. mm	weight lbs. kg	cu ft	model #	list
12" (305mm)	12" 305	15 6.8	1.2	<b>A210115</b>	115

### Optional Freestanding Base for Pot / Pan Rack

- Chrome.
- 22" x 30" (559 x 762mm).
- Available as an option to mounting.

model #	list
<b>A210109</b>	49



### Additional Bracket for Pot / Pan Rack

- Chrome.

model #	list
<b>A210075</b>	25



### Secure Display Merchandiser

see product announcement **EG8083**



secure display merchandiser shown with optional accessories

- Posts and shelves are chrome plated.
- Mylar inlay for top shelf.
- Four 2 3/8" (60mm) decorative casters.

**FEATURES:**

**Freight class is 70.0.**

(•) MTS (made to stock) / ( ) MTO (made to order)

height	width	length in. mm	weight lbs. kg	cubic feet	model #	list
40" (1016mm)	14" (356mm)	36" 914	90 40.8	9	<b>SDM1436C</b>	1491

### Options for Secure Display Merchandiser

description	model #	list
center wire shelf	<b>A1436C</b> •	91
polymer top	<b>SDM1436C-P</b>	145
natural wood top	<b>SDM1436C-W</b>	117
laminated top	<b>SDM1436C-L</b>	466
wall grid panel / sign holder	<b>SDMB36-C</b>	246

## STAND-OUTS™ Gondola Wire Shelving

see spec sheet **EG01.33**



**STAND SOLD SEPARATELY!**

Manufacturers' ID numbers			
1-Kent		4-Madix/Lozier	
2-Universal Nolin		5-Royston	
3-Streater		6-PermaSteel	

- Use on all major shelving fixtures (see "Manufacturers' ID numbers" box).
- Pair of shelf brackets notched to securely hold the display shelf in place. Brackets can be positioned horizontally or slanted.
- Available in 3' and 4' (914 and 1219mm) lengths.
- Available in 18", 21", and 24" (457, 533, and 508mm) depths.
- Choose from custom and standard colors.

**FEATURES:**

**Steps to follow when ordering:**

- 1) **Determine decorative color of gondola shelf.** For standard colors, refer to chart (below). For custom colors, add suffix below to the desired model number when ordering:  
**BM** (black matte), **L** (lilac), **M** (maroon),  
**SV** (silver vein), **SA** (sapphire), **SG** (smoked glass),  
**T** (teal), **GV** (gold vein), **CV** (copper vein), **RU** (ruby)  
*Call factory for pricing.*
- 2) **Determine correct brackets.** Refer to the "Manufacturers' ID numbers" table (left) and add the corresponding ID number to the end of the desired gondola shelf model number when ordering. **Example: Model #HG1836BL-3** indicates an 18" x 36" (457 x 914mm) gondola shelf with black epoxy finish and brackets that fit a gondola made by Streater.

**Freight class is 70.0.**

**Gondola Shelves - Patent # 6,345,795**

- Price includes shelf with standard color and pair of shelf brackets.

	length		weight		cu	chrome		red		white		black	
	in.	mm	lbs.	kg		ft	model #	list	model #	list	model #	list	model #
<b>18" width</b> (457mm)	36"	914	12	5.8	0.7	<b>HG1836C</b>	109	<b>HG1836R</b>	113	<b>HG1836W</b>	113	<b>HG1836BL</b>	113
	48"	1219	15	6.8	0.9	<b>HG1848C</b>	125	<b>HG1848R</b>	129	<b>HG1848W</b>	129	<b>HG1848BL</b>	129
<b>21" width</b> (533mm)	36"	914	14	6.4	0.8	<b>HG2136C</b>	118	<b>HG2136R</b>	121	<b>HG2136W</b>	121	<b>HG2136BL</b>	121
	48"	1219	17	7.7	1.1	<b>HG2148C</b>	134	<b>HG2148R</b>	138	<b>HG2148W</b>	138	<b>HG2148BL</b>	138
<b>24" width</b> (610mm)	36"	914	16	7.3	0.8	<b>HG2436C</b>	123	<b>HG2436R</b>	126	<b>HG2436W</b>	126	<b>HG2436BL</b>	126
	48"	1219	19	8.6	1.2	<b>HG2448C</b>	141	<b>HG2448R</b>	144	<b>HG2448W</b>	144	<b>HG2448BL</b>	144

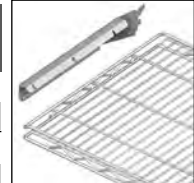

*gondola shelf and bracket*

**Replacement Brackets - Patent # D 435,787**

- Sold in pairs.
- Order replacement brackets to utilize standard shelves in different gondola systems.

length	weight	cu	Kent		U. Nolin		Streater		Madix/Lozier		Royston		PermaSteel			
			in.	mm	lbs.	kg	ft	model #	list	model #	list	model #	list	model #	list	
18"	457	4.8	2.2	1.0	<b>HGK18</b>	37	<b>HGU18</b>	37	<b>HGS18</b>	37	<b>HGML18</b>	37	<b>HGR18</b>	37	<b>HGP18</b>	37
21"	533	5.3	2.4	1.0	<b>HGK21</b>	43	<b>HGU21</b>	43	<b>HGS21</b>	43	<b>HGML21</b>	43	<b>HGR21</b>	43	<b>HGP21</b>	43
24"	610	5.8	2.6	1.0	<b>HGK24</b>	52	<b>HGU24</b>	52	<b>HGS24</b>	52	<b>HGML24</b>	52	<b>HGR24</b>	52	<b>HGP24</b>	52

**Wall Standards**

- Use for mounting directly to walls instead of gondolas, if desired.
- Sold and priced individually.
- 12 gauge zinc plated mild steel.

**Note:** Shelving used only with Universal Nolin (suffix "-2") will fit wall standards.

height	weight	cu	Kent		U. Nolin		Streater		Madix/Lozier		Royston		PermaSteel	
			in.	mm	lbs.	kg	ft	model #	list	model #	list	model #	list	model #
24"	610	3.0	1.4	0.1	<b>NUR24</b>	35								
36"	914	4.5	2.0	0.1	<b>NUR36</b>	37								
48"	1219	6.0	2.7	0.1	<b>NUR48</b>	39								



*wall standard shown with Universal Nolin gondola bracket*

## Catalog Section 1

### Freestanding Gondola Inset Adjustable Wire Shelving <sup>(NSF)</sup>

see spec sheet **EG01.32**

FEATURES:

- These units can stand side-by-side on gondolas without size interference, giving shelf contents a cleaner, more efficient appearance.
- Easy assembly — no tools required.

**Note:** For posts, collars and split sleeves see page 74.

#### Two Wire Shelves (top and bottom)

Featuring patented QuadTruss® Design, making shelves up to 25% stronger. Shelves consist of a top mat assembly using 10 gauge mat wires spaced on 7/8" (22mm) centers and welded to full length 6 gauge serpentine trusses.



*gondola inset adjustable wire shelving unit used with gondola*

patented **QuadTruss®** design

(Patent #5,390,803)

#### Two Add-A-Shelf® Center Shelves

300 lb. (136.1 kg) capacity. Shelves can be added or removed without disassembling the entire shelf unit. Add-A-Shelf® Reverse Mat Shelves, featuring a built-in ledge, available as an alternative. See below.

**STAND SOLD SEPARATELY!**

**Freight class is 70.0.**

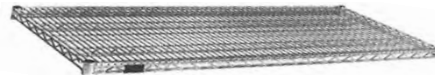

#### Gondola Inset Wire Shelves\*

	length		weight		EAGLEbrite®		chrome		black		red		white	
	in.	mm	lb.	kg	model #	list	model #	list	model #	list	model #	list	model #	list
<b>14" width</b> (356mm)	35 1/2"	902	8	3.6	<b>G1436Z</b>	71	<b>G1436C</b>	80	<b>G1436BL</b>	82	<b>G1436R</b>	82	<b>G1436W</b>	82
	47 1/2"	1207	10	4.5	<b>G1448Z</b>	82	<b>G1448C</b>	91	<b>G1448BL</b>	94	<b>G1448R</b>	94	<b>G1448W</b>	94
<b>18" width</b> (457mm)	35 1/2"	902	9	4.1	<b>G1836Z</b>	83	<b>G1836C</b>	87	<b>G1836BL</b>	89	<b>G1836R</b>	89	<b>G1836W</b>	89
	47 1/2"	1207	12	5.5	<b>G1848Z</b>	99	<b>G1848C</b>	108	<b>G1848BL</b>	112	<b>G1848R</b>	112	<b>G1848W</b>	112
<b>21" width</b> (533mm)	35 1/2"	902	11	5.0	<b>G2136Z</b>	91	<b>G2136C</b>	103	<b>G2136BL</b>	107	<b>G2136R</b>	107	<b>G2136W</b>	107
	47 1/2"	1207	14	6.4	<b>G2148Z</b>	107	<b>G2148C</b>	120	<b>G2148BL</b>	123	<b>G2148R</b>	123	<b>G2148W</b>	123
<b>24" width</b> (610mm)	35 1/2"	902	13	5.9	<b>G2436Z</b>	100	<b>G2436C</b>	109	<b>G2436BL</b>	113	<b>G2436R</b>	113	<b>G2436W</b>	113
	47 1/2"	1207	16	7.3	<b>G2448Z</b>	119	<b>G2448C</b>	129	<b>G2448BL</b>	135	<b>G2448R</b>	135	<b>G2448W</b>	135

\*These shelves are designed specifically for use with gondolas. They are 1/2" (13mm) shorter than our regular wire shelving (see page 6).

#### Add-A-Shelf® for Gondola Inset Wire Shelving - Patented # 5,884,567

- To specify finish, add suffix **Z** (EAGLEbrite® zinc), **C** (chrome), **BL** (black), **R** (red), or **W** (white) to model number when ordering. For example: **A1448W** indicates a white Add-A-Shelf® shelf.

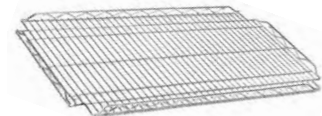

#### Add-A-Shelf® Shelves

#### Add-A-Shelf® Reverse Mat Shelves

	length**		weight		model #	List prices					model #	List prices				
	in.	mm	lb.	kg		EAGLEbrite®	chrome	black	red	white		EAGLEbrite®	chrome	black	red	white
<b>14" width</b> (356mm)	36"	914	8	3.6	<b>A1436</b>	82	91	94	94	94	<b>D1436</b>	85	94	96	96	96
	48"	1219	10	4.5	<b>A1448</b>	94	106	109	109	109	<b>D1448</b>	96	109	113	113	113
<b>18" width</b> (457mm)	36"	914	9	4.1	<b>A1836</b>	95	96	99	99	99	<b>D1836</b>	98	100	103	103	103
	48"	1219	12	5.5	<b>A1848</b>	109	116	119	119	119	<b>D1848</b>	112	119	122	122	122
<b>21" width</b> (533mm)	36"	914	11	5.0	<b>A2136</b>	103	112	116	116	116	<b>D2136</b>	108	118	121	121	121
	48"	1219	14	6.4	<b>A2148</b>	119	126	133	133	133	<b>D2148</b>	121	133	137	137	137
<b>24" width</b> (610mm)	36"	914	13	5.9	<b>A2436</b>	111	119	122	122	122	<b>D2436</b>	116	121	124	124	124
	48"	1219	16	7.3	<b>A2448</b>	129	140	143	143	143	<b>D2448</b>	134	144	148	148	148

\*\* Dimensions are nominal

## Posts for Gondola Inset Wire Shelving

see spec sheet **EG01.32**

Freight class is 50.0.

(•) MTS (made to stock) / ( ) MTO (made to order)

**Patented**  
# D 395,000



**Add-A-Shelf® Collar**  
allows addition or removal of shelf without disassembling the entire unit.

model #	list
A208891	13

- Packed four per bag.

Quantity of four included with each shelf.

posts

### Split Sleeves

description	model #	list
plastic split sleeves for all shelves, set of four	<b>PLASTIC SPLIT SLEEVES</b>	5



height		weight		EAGLEbrite®		chrome		black		red		white	
in.	mm	lb.	kg	model #	list	model #	list	model #	list	model #	list	model #	list
14"	356	1.0	0.5	<b>P14-Z</b> • 21		<b>P14-C</b> • 23		<b>P14-BL</b> • 24		<b>P14-R</b> 24		<b>P14-W</b> 24	
33"	838	2.0	0.9	<b>P33-Z</b> • 24		<b>P33-C</b> • 25		<b>P33-BL</b> • 27		<b>P33-R</b> 27		<b>P33-W</b> 27	
54"	1372	3.0	1.4	<b>P54-Z</b> • 29		<b>P54-C</b> • 31		<b>P54-BL</b> • 32		<b>P54-R</b> 32		<b>P54-W</b> 32	
63"	1600	3.5	1.6	<b>P63-Z</b> • 31		<b>P63-C</b> • 32		<b>P63-BL</b> • 34		<b>P63-R</b> 34		<b>P63-W</b> 34	
74"	1880	4.0	1.8	<b>P74-Z</b> • 34		<b>P74-C</b> • 35		<b>P74-BL</b> • 36		<b>P74-R</b> 36		<b>P74-W</b> 36	
86"	2184	5.0	2.3	<b>P86-Z</b> • 41		<b>P86-C</b> • 43		<b>P86-BL</b> • 46		<b>P86-R</b> 46		<b>P86-W</b> 46	

## Wire Display Shelving <sup>NSF</sup>

see spec sheet **EG01.21** WEIGHT CAPACITY:



**STAND SOLD SEPARATELY!**

**MasterSeal® coating**  
for improved rust protection.

Manufacturers' ID numbers	
1-Kent	4-Madix/Lozier
2-Universal Nolin	5-Royston
3-Streater	6-PermaSteel

FEATURES:

- Heavy-duty shelves can hold up to 40 lbs. (18 kg) per linear foot.
- EAGLEbrite® zinc finish with MasterSeal® coating.
- Used primarily for gondolas.
- Designed for use on all major shelving fixtures such as Kent, Madix/Lozier, Royston, Streater, Universal Nolin, and PermaSteel.
- One-piece shelf bracket, tier notched to securely hold the display shelf in place.
- Brackets can be positioned horizontally or slanted.
- Shelving can be displayed using the 1" or 3" (25 or 76mm) integral fence by simply rotating the shelf 180°.
- Available in 3' and 4' (914 and 1219mm) lengths.

Freight class is 70.0.

	width		weight		cu ft	model #	list
	in.	mm	lbs.	kg			
<b>36" length</b> (914mm)	10"	254	10	4.5	0.5	<b>81036</b>	102
	12"	309	11	5.0	0.7	<b>81236</b>	108
	14"	356	11	5.0	0.7	<b>81436</b>	112
	16"	406	12	5.5	0.7	<b>81636</b>	118
	18"	457	12	5.5	0.7	<b>81836</b>	125
<b>48" length</b> (1219mm)	10"	254	12	5.5	0.7	<b>81048</b>	107
	12"	309	13	5.9	0.7	<b>81248</b>	119
	14"	356	14	6.4	0.9	<b>81448</b>	124
	16"	406	15	6.8	0.9	<b>81648</b>	126
	18"	457	16	7.3	1.1	<b>81848</b>	137
	20"	508	17	7.7	1.1	<b>82048</b>	141

Note: Price includes shelf & brackets.

### Steps to follow when ordering:

- Find your shelving system supplier in "Manufacturers' ID Numbers" table at middle of this page.
- Determine correct brackets. Add the corresponding ID number to the end of the desired display shelf model number when ordering. **Example: Model #810365** indicates a 10" x 36" (254 x 914mm) display shelf with brackets that fit a shelving fixture made by Royston.

## Catalog Section 1

### Wire Display Shelving Accessories

see spec sheet **EG01.21**

Freight class is 70.0.

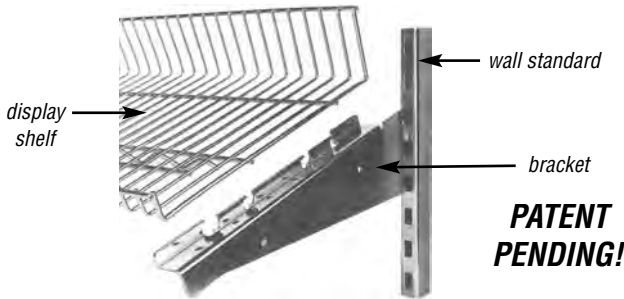

wall standard shown with display shelf and Universal Nolin bracket



### Replacement Brackets

- Sold in pairs.
- Order replacement brackets to utilize standard shelves in different gondola systems.

length		weight		cu	Kent		U. Nolin		Streater		Madix/Lozier		Royston		PermaSteel	
in.	mm	lbs.	kg	ft	model #	list	model #	list	model #	list	model #	list	model #	list	model #	list
10"	254	2.6	1.2	0.6	<b>K10</b>	52	<b>U10</b>	52	<b>S10</b>	52	<b>ML10</b>	52	<b>R10</b>	52	<b>P10</b>	52
12"	309	3.2	1.5	0.6	<b>K12</b>	55	<b>U12</b>	55	<b>S12</b>	55	<b>ML12</b>	55	<b>R12</b>	55	<b>P12</b>	55
14"	356	3.7	1.7	0.6	<b>K14</b>	59	<b>U14</b>	59	<b>S14</b>	59	<b>ML14</b>	59	<b>R14</b>	59	<b>P14</b>	59
16"	406	4.3	2.0	0.6	<b>K16</b>	66	<b>U16</b>	66	<b>S16</b>	66	<b>ML16</b>	66	<b>R16</b>	66	<b>P16</b>	66
18"	457	4.8	2.2	0.6	<b>K18</b>	69	<b>U18</b>	69	<b>S18</b>	69	<b>ML18</b>	69	<b>R18</b>	69	<b>P18</b>	69
20"	508	5.3	2.4	0.6	<b>K20</b>	73	<b>U20</b>	73	<b>S20</b>	73	<b>ML20</b>	73	<b>R20</b>	73	<b>P20</b>	73

### Dividers / Ends

length		weight		cu	model # list	
in.	mm	lbs.	kg	ft	model #	list
10"	254	0.5	0.2	0.3	<b>D10</b>	36
12"	309	0.6	0.3	0.4	<b>D12</b>	39
14"	356	0.7	0.3	0.4	<b>D14</b>	41
16"	406	0.8	0.4	0.7	<b>D16</b>	43
18"	457	0.9	0.4	0.7	<b>D18</b>	47
20"	508	1.0	0.5	1.0	<b>D20</b>	54



### Wall Standards

- Use for mounting directly to walls.
- Sold and priced individually.
- Order shelving with ID #2 (Universal Nolin – see chart below) for use with wall standards.

height		weight		cu	model # list	
in.	mm	lbs.	kg	ft	model #	list
24"	610	3.0	1.4	0.1	<b>NUR24</b>	35
36"	914	4.5	2.0	0.1	<b>NUR36</b>	37
48"	1219	6.0	2.7	0.1	<b>NUR48</b>	39

## Manufacturers' I.D. Numbers

Match your bracket to one of these drawings to determine manufacturer's I.D. number.

(Note: Bracket diagrams are not to scale - for reference purposes only)

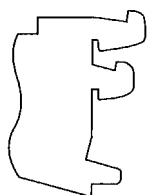

1 - Kent

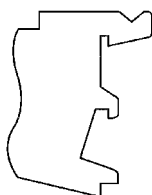

2 - Universal Nolin



3 - Streater



4 - Madix/Lozier

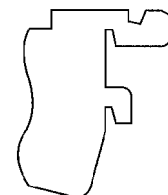

5 - Royston

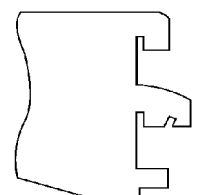

6 - PermaSteel

## Quik-Set® Flat Solid Shelves NSF

see spec sheet **EG01.23**

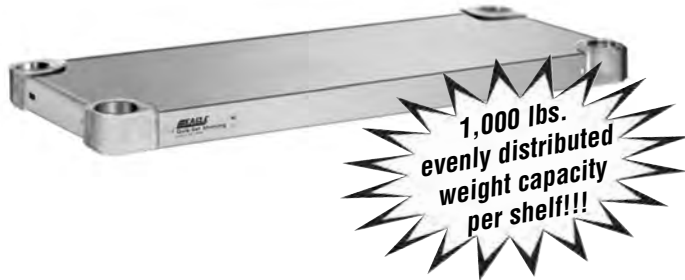

- Heavy duty.
- All sides of shelves are constructed with a 2" (51mm) downturn and marine edge.
- Each corner is fitted with a heavy-duty aluminum casting to accept a split sleeve.
- No tools are required for assembly.

**FEATURES:**

**Freight class is 70.0.**

### Stainless Steel

	length		cu ft	14 gauge				16 gauge			
	weight			weight		weight		weight			
	in.	mm		lb.	kg	model #	list	lb.	kg	model #	list
<b>18" width</b> (457mm)	36"	914	0.8	24	10.9	SHDS1836SF	523	19	8.6	HDS1836SF	502
	42"	1067	0.9	26	11.8	SHDS1842SF	583	21	9.5	HDS1842SF	544
	48"	1219	1.0	29	13.2	SHDS1848SF	635	24	10.9	HDS1848SF	589
	54"	1372	1.1	33	15.0	SHDS1854SF	694	27	12.2	HDS1854SF	644
	60"	1524	1.3	36	16.3	SHDS1860SF	744	29	13.2	HDS1860SF	702
<b>24" width</b> (610mm)	36"	914	1.0	35	15.9	SHDS2436SF	682	28	12.7	HDS2436SF	625
	42"	1067	1.2	39	17.6	SHDS2442SF	746	32	14.5	HDS2442SF	702
	48"	1219	1.3	43	19.5	SHDS2448SF	836	36	16.3	HDS2448SF	759
	54"	1372	1.5	48	21.8	SHDS2454SF	904	41	18.6	HDS2454SF	828
	60"	1524	1.7	55	24.9	SHDS2460SF	967	47	21.3	HDS2460SF	861

### VALU-MASTER® Gray Epoxy

	length		cu ft	14 gauge				16 gauge			
	weight			weight		weight		weight			
	in.	mm		lb.	kg	model #	list	lb.	kg	model #	list
<b>18" width</b> (457mm)	36"	914	0.8	24	10.9	SHDS1836VF	303	19	8.6	HDS1836VF	293
	42"	1067	0.9	26	11.8	SHDS1842VF	320	21	9.5	HDS1842VF	304
	48"	1219	1.0	29	13.2	SHDS1848VF	329	24	10.9	HDS1848VF	316
	54"	1372	1.1	33	15.0	SHDS1854VF	353	27	12.2	HDS1854VF	318
	60"	1524	1.3	36	16.3	SHDS1860VF	368	29	13.2	HDS1860VF	347
<b>24" width</b> (610mm)	36"	914	1.0	35	15.9	SHDS2436VF	327	28	12.7	HDS2436VF	311
	42"	1067	1.2	39	17.6	SHDS2442VF	341	32	14.5	HDS2442VF	326
	48"	1219	1.3	43	19.5	SHDS2448VF	356	36	16.3	HDS2448VF	336
	54"	1372	1.5	48	21.8	SHDS2454VF	385	41	18.6	HDS2454VF	365
	60"	1524	1.7	55	24.9	SHDS2460VF	400	47	21.3	HDS2460VF	378

### Valu-Gard® Green Epoxy

	length		cu ft	14 gauge				16 gauge			
	weight			weight		weight		weight			
	in.	mm		lb.	kg	model #	list	lb.	kg	model #	list
<b>18" width</b> (457mm)	36"	914	0.8	24	10.9	SHDS1836VGF	303	19	8.6	HDS1836VGF	293
	42"	1067	0.9	26	11.8	SHDS1842VGF	320	21	9.5	HDS1842VGF	304
	48"	1219	1.0	29	13.2	SHDS1848VGF	329	24	10.9	HDS1848VGF	316
	54"	1372	1.1	33	15.0	SHDS1854VGF	353	27	12.2	HDS1854VGF	318
	60"	1524	1.3	36	16.3	SHDS1860VGF	368	29	13.2	HDS1860VGF	347
<b>24" width</b> (610mm)	36"	914	1.0	35	15.9	SHDS2436VGF	327	28	12.7	HDS2436VGF	311
	42"	1067	1.2	39	17.6	SHDS2442VGF	341	32	14.5	HDS2442VGF	326
	48"	1219	1.3	43	19.5	SHDS2448VGF	356	36	16.3	HDS2448VGF	336
	54"	1372	1.5	48	21.8	SHDS2454VGF	385	41	18.6	HDS2454VGF	365
	60"	1524	1.7	55	24.9	SHDS2460VGF	400	47	21.3	HDS2460VGF	378

## Catalog Section 1

### Quik-Set® Embossed Solid Shelves

see spec sheet **EG01.23**

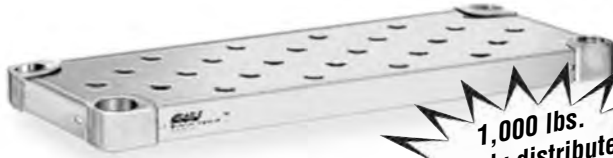

- Heavy duty.
- Constructed with a 2" (51mm) downturn and marine edge.
- Each corner is fitted with a heavy-duty aluminum casting to accept a split sleeve.
- Top of shelf is die stamped with a 1" (25mm) diameter drawn impression to provide a raised area for air circulation.
- Each emboss is on 3" (76mm) centers for the width and 3" (76mm) centers for the length.

FEATURES:

Freight class is 70.0.

### Stainless Steel

	length		cu ft	14 gauge				16 gauge			
	weight			weight		weight		weight			
	in.	mm		lb.	kg	model #	list	lb.	kg	model #	list
18" width (457mm)	36"	914	0.8	24	10.9	SHDS1836SE	573	19	8.6	HDS1836SE	554
	42"	1067	0.9	26	11.8	SHDS1842SE	635	21	9.5	HDS1842SE	613
	48"	1219	1.0	29	13.2	SHDS1848SE	689	24	10.9	HDS1848SE	672
	54"	1372	1.1	33	15.0	SHDS1854SE	742	27	12.2	HDS1854SE	702
	60"	1524	1.3	36	16.3	SHDS1860SE	788	29	13.2	HDS1860SE	740
24" width (610mm)	36"	914	1.0	35	15.9	SHDS2436SE	714	28	12.7	HDS2436SE	664
	42"	1067	1.2	39	17.6	SHDS2442SE	735	32	14.5	HDS2442SE	719
	48"	1219	1.3	43	19.5	SHDS2448SE	794	36	16.3	HDS2448SE	762
	54"	1372	1.5	48	21.8	SHDS2454SE	889	41	18.6	HDS2454SE	854
	60"	1524	1.7	55	24.9	SHDS2460SE	989	47	21.3	HDS2460SE	912

### VALU-MASTER® Gray Epoxy

	length		cu ft	14 gauge				16 gauge			
	weight			weight		weight		weight			
	in.	mm		lb.	kg	model #	list	lb.	kg	model #	list
18" width (457mm)	36"	914	0.8	24	10.9	SHDS1836VE	311	19	8.6	HDS1836VE	299
	42"	1067	0.9	26	11.8	SHDS1842VE	327	21	9.5	HDS1842VE	314
	48"	1219	1.0	29	13.2	SHDS1848VE	335	24	10.9	HDS1848VE	321
	54"	1372	1.1	33	15.0	SHDS1854VE	363	27	12.2	HDS1854VE	344
	60"	1524	1.3	36	16.3	SHDS1860VE	373	29	13.2	HDS1860VE	356
24" width (610mm)	36"	914	1.0	35	15.9	SHDS2436VE	334	28	12.7	HDS2436VE	320
	42"	1067	1.2	39	17.6	SHDS2442VE	347	32	14.5	HDS2442VE	333
	48"	1219	1.3	43	19.5	SHDS2448VE	363	36	16.3	HDS2448VE	343
	54"	1372	1.5	48	21.8	SHDS2454VE	391	41	18.6	HDS2454VE	372
	60"	1524	1.7	55	24.9	SHDS2460VE	408	47	21.3	HDS2460VE	383

### Valu-Gard® Green Epoxy

	length		cu ft	14 gauge				16 gauge			
	weight			weight		weight		weight			
	in.	mm		lb.	kg	model #	list	lb.	kg	model #	list
18" width (457mm)	36"	914	0.8	24	10.9	SHDS1836VGE	311	19	8.6	HDS1836VGE	299
	42"	1067	0.9	26	11.8	SHDS1842VGE	327	21	9.5	HDS1842VGE	314
	48"	1219	1.0	29	13.2	SHDS1848VGE	335	24	10.9	HDS1848VGE	321
	54"	1372	1.1	33	15.0	SHDS1854VGE	363	27	12.2	HDS1854VGE	344
	60"	1524	1.3	36	16.3	SHDS1860VGE	373	29	13.2	HDS1860VGE	356
24" width (610mm)	36"	914	1.0	35	15.9	SHDS2436VGE	334	28	12.7	HDS2436VGE	320
	42"	1067	1.2	39	17.6	SHDS2442VGE	347	32	14.5	HDS2442VGE	333
	48"	1219	1.3	43	19.5	SHDS2448VGE	363	36	16.3	HDS2448VGE	343
	54"	1372	1.5	48	21.8	SHDS2454VGE	391	41	18.6	HDS2454VGE	372
	60"	1524	1.7	55	24.9	SHDS2460VGE	408	47	21.3	HDS2460VGE	383

## Quik-Set® Louvered Solid Shelves

see spec sheet **EG01.23**

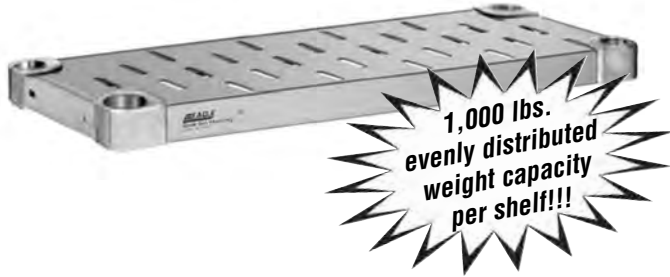

- Heavy duty.
- Shelves are constructed with a 2" (51mm) downturn and marine edge.
- Each corner is fitted with a heavy-duty aluminum casting to accept a split sleeve.
- Top of shelf is die stamped with a 2¾" x ½" (70 x 13mm) opening with a ¼" (2mm) drawn depression around the opening to provide reinforcement.
- Each opening is on 3" (76mm) centers for the width and 3" (76mm) centers for the length.

FEATURES:

**Freight class is 70.0.**

### Stainless Steel

	length		cu ft	14 gauge				16 gauge			
	weight			weight		weight		weight			
	in.	mm		lb.	kg	model #	list	lb.	kg	model #	list
18" width (457mm)	36"	914	0.8	24	10.9	SHDS1836SL	573	17	7.7	HDS1836SL	554
	42"	1067	0.9	26	11.8	SHDS1842SL	635	19	8.6	HDS1842SL	613
	48"	1219	1.0	29	13.2	SHDS1848SL	689	22	10.0	HDS1848SL	672
	54"	1372	1.1	33	15.0	SHDS1854SL	742	25	11.3	HDS1854SL	702
	60"	1524	1.3	36	16.3	SHDS1860SL	788	27	12.2	HDS1860SL	740
24" width (610mm)	36"	914	1.0	35	15.9	SHDS2436SL	714	26	11.8	HDS2436SL	664
	42"	1067	1.2	39	17.6	SHDS2442SL	735	30	13.6	HDS2442SL	719
	48"	1219	1.3	43	19.5	SHDS2448SL	794	34	15.4	HDS2448SL	785
	54"	1372	1.5	48	21.8	SHDS2454SL	889	39	17.6	HDS2454SL	854
	60"	1524	1.7	55	24.9	SHDS2460SL	989	45	20.4	HDS2460SL	912

### VALU-MASTER® Gray Epoxy

	length		cu ft	14 gauge				16 gauge			
	weight			weight		weight		weight			
	in.	mm		lb.	kg	model #	list	lb.	kg	model #	list
18" width (457mm)	36"	914	0.8	22	10.4	SHDS1836VL	316	17	7.7	HDS1836VL	301
	42"	1067	0.9	24	10.9	SHDS1842VL	329	19	8.6	HDS1842VL	318
	48"	1219	1.0	27	12.2	SHDS1848VL	338	22	10.0	HDS1848VL	326
	54"	1372	1.1	31	14.5	SHDS1854VL	346	25	11.3	HDS1854VL	337
	60"	1524	1.3	34	15.4	SHDS1860VL	379	27	12.2	HDS1860VL	351
24" width (610mm)	36"	914	1.0	33	15.0	SHDS2436VL	336	26	11.8	HDS2436VL	322
	42"	1067	1.2	37	16.8	SHDS2442VL	352	30	13.6	HDS2442VL	335
	48"	1219	1.3	41	18.6	SHDS2448VL	366	34	15.4	HDS2448VL	346
	54"	1372	1.5	47	21.3	SHDS2454VL	399	39	17.6	HDS2454VL	379
	60"	1524	1.7	53	24.0	SHDS2460VL	414	45	20.4	HDS2460VL	387

### Valu-Gard® Green Epoxy

	length		cu ft	14 gauge				16 gauge			
	weight			weight		weight		weight			
	in.	mm		lb.	kg	model #	list	lb.	kg	model #	list
18" width (457mm)	36"	914	0.8	22	10.4	SHDS1836VGL	316	17	7.7	HDS1836VGL	301
	42"	1067	0.9	24	10.9	SHDS1842VGL	329	19	8.6	HDS1842VGL	318
	48"	1219	1.0	27	12.2	SHDS1848VGL	338	22	10.0	HDS1848VGL	326
	54"	1372	1.1	31	14.5	SHDS1854VGL	346	25	11.3	HDS1854VGL	337
	60"	1524	1.3	34	15.4	SHDS1860VGL	380	27	12.2	HDS1860VGL	351
24" width (610mm)	36"	914	1.0	33	15.0	SHDS2436VGL	336	26	11.8	HDS2436VGL	322
	42"	1067	1.2	37	16.8	SHDS2442VGL	352	30	13.6	HDS2442VGL	335
	48"	1219	1.3	41	18.6	SHDS2448VGL	366	34	15.4	HDS2448VGL	346
	54"	1372	1.5	47	21.3	SHDS2454VGL	399	39	17.6	HDS2454VGL	379
	60"	1524	1.7	53	24.0	SHDS2460VGL	414	45	20.4	HDS2460VGL	387



## Catalog Section 1

### Quik-Set® Solid Shelving Accessories

see spec sheet **EG01.23A**

Freight class is 50.0.

#### Posts

- 1½" (42mm) diameter.
- Grooved in 2" (51mm) increments.

height		weight		cubic feet	stainless steel	
in.	mm	lb.	kg		model #	list
14"	356	1.0	0.5	0.2	<b>HDSP14-S</b>	64
33"	838	2.0	0.9	0.2	<b>HDSP33-S</b>	88
54"	1372	3.0	1.4	0.2	<b>HDSP54-S</b>	95
63"	1600	3.5	1.8	0.2	<b>HDSP63-S</b>	109
74"	1880	4.0	1.8	0.2	<b>HDSP74-S</b>	125

#### Caster Posts

- 1½" (42mm) diameter.
- Grooved in 2" (51mm) increments.

height		weight		cubic feet	stainless steel	
in.	mm	lb.	kg		model #	list
14"	356	1.0	0.5	0.2	<b>HDSCP14-S</b>	64
33"	838	2.0	0.9	0.2	<b>HDSCP33-S</b>	88
54"	1372	3.0	1.4	0.2	<b>HDSCP54-S</b>	95
63"	1600	3.5	1.8	0.2	<b>HDSCP63-S</b>	109
74"	1880	4.0	1.8	0.2	<b>HDSCP74-S</b>	125



#### Adjustable Foot

- Adjust from minimum height of 1½" to maximum height of 2½" (38 to 64mm).

weight		model #	list
lb.	kg		
0.25	0.1	<b>301036</b>	11



#### Post Cap

- Black plastic cap fits inside 1½" (32mm) diameter post.

weight		model #	list
lb.	kg		
0.25	0.1	<b>330010</b>	6



#### Casters

see spec sheet **EG01.23A**



FEATURES:

- 5" (127mm) diameter.
- Set of four (two swivel, two with brake).

Freight class is 65.0.

(•) MTS (made to stock) / ( ) MTO (made to order)

#### Polymer Cart Washable with Polymer Tread

weight capacity per caster		model #	list per set
lbs.	kg		
250	113.4	<b>CAHW4-SB •</b>	682

#### Zinc with Poly Tread

weight capacity per caster		model #	list per set
lbs.	kg		
250	113.4	<b>CAHP4-SB •</b>	549

## SPEC-MASTER® Quik-Set® Pot & Pan Racks with Embossed Shelves

see spec sheet **EG01.23B**



- 69" (1753mm) overall height.
- 2" (51mm) downturn and marine edge.
- Top of shelf is die stamped with a 1" (25mm) diameter drawn impression to provide a raised area for air circulation.
- Each emboss is on 3" (76mm) centers for the width and length.
- Each shelf corner is fitted with a heavy duty aluminum casting to accept a split sleeve.
- No tools required for assembly.

**SHELVES FEATURE:**

- Offered in stainless steel, VALU-MASTER® pewter gray epoxy, or Valu-Gard® green epoxy finish.
- 1 1/2" (41mm) diameter posts are grooved and numbered in 2" (51mm) increments to ensure easy leveling and quick adjustments, and fitted with 5" (127mm) diameter all-polymer cart-washable swivel casters, two with brake.

**POST FEATURE:**

**Freight class is 70.0.**

### Stainless Steel

	length		cu ft	14 gauge				16 gauge			
	in.	mm		weight		model #	list	weight		model #	list
				lb.	kg			lb.	kg		
<b>24" width</b> (610mm)	48"	1219	1.5	188	85.3	<b>PR2448SE14</b>	4185	160	72.6	<b>PR2448SE16</b>	4065
	60"	1524	1.9	236	106.6	<b>PR2460SE14</b>	4967	204	92.5	<b>PR2460SE16</b>	4659

### VALU-MASTER® Gray Epoxy

	length		cu ft	14 gauge				16 gauge			
	in.	mm		weight		model #	list	weight		model #	list
				lb.	kg			lb.	kg		
<b>24" width</b> (610mm)	48"	1219	1.5	188	85.3	<b>PR2448VE14</b>	2191	160	72.6	<b>PR2448VE16</b>	2120
	60"	1524	1.9	236	106.6	<b>PR2460VE14</b>	2375	204	92.5	<b>PR2460VE16</b>	2278

### Valu-Gard® Green Epoxy

	length		cu ft	14 gauge				16 gauge			
	in.	mm		weight		model #	list	weight		model #	list
				lb.	kg			lb.	kg		
<b>24" width</b> (610mm)	48"	1219	1.5	188	85.3	<b>PR2448VGE14</b>	2191	160	72.6	<b>PR2448VGE16</b>	2120
	60"	1524	1.9	236	106.6	<b>PR2460VGE14</b>	2375	204	92.5	<b>PR2460VGE16</b>	2278

## Catalog Section 1

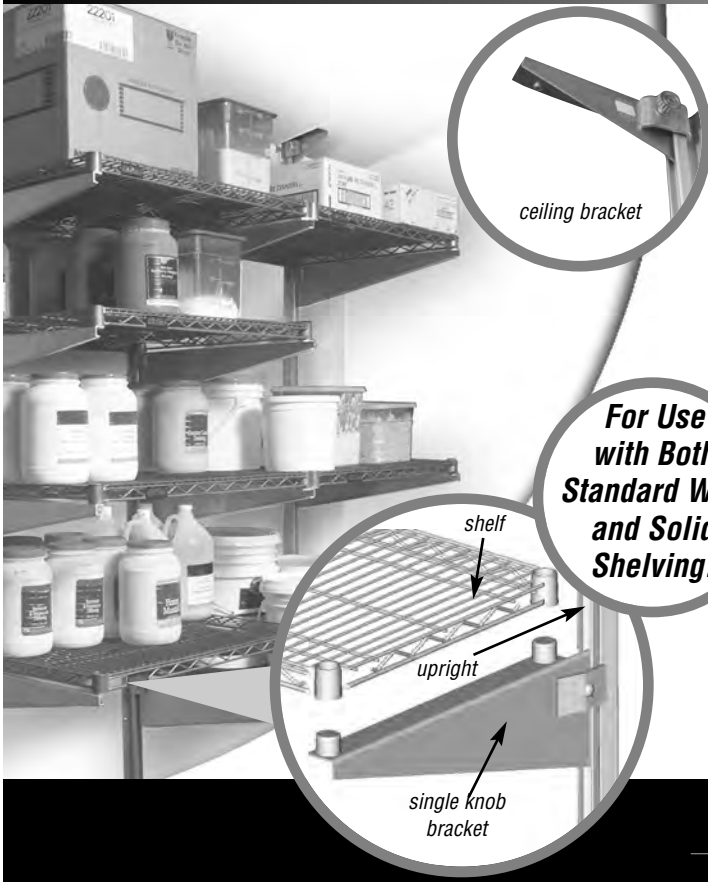

**For Use with Both Standard Wire and Solid Shelving!**

Weight Capacities					
Allowable Bracket Loading (per bracket)				Shelf Load Capacity (per shelf)	
				Shelves not included.	
bracket length	in.	mm	maximum load recommended	shelf description	weight capacity
			lb.		lb. kg
14"	356		540 244.9	Shelves 24" to 48" (610 to 1219mm) long	800 362.8
18"	457		465 210.9		
21"	533		395 179.2	Shelves 54" to 72" (1372 to 1829mm) long	600 272.2
24"	610		360 163.3		

### Features:

- Requires no post supports to get in the way, making shelf loading and unloading easier.
- 100% usable shelving surface, from section to section, wall to wall, and front to back.
- Floor is unobstructed.
- Infinite height adjustability, no slots or keyholes to line up for leveling.
- Heavy-duty, rugged construction.
- Cantilever shelving components are listed on pages 82 through 85.

Freight class is 70.0.

## Cantilever Shelving Systems

## Standard Uprights

see spec sheet **EG01.45A**



**For wall-mounted storage.**

- 14 gauge.
- Continuously seam-welded.
- Rust and corrosion resistant.

### FEATURES:

**Note:** Prices do not include ceiling brackets.

Freight class is 70.0.

					Gray Epoxy				Stainless Steel				Aluminum							
height		cu	weight		REGULAR		NSF		weight		REGULAR		NSF		weight		REGULAR		NSF	
in.	mm	ft	lb.	kg	model #	list	model #	list	lb.	kg	model #	list	model #	list	lb.	kg	model #	list	model #	list
12"	305	0.02	1	0.5	MMU-1	31	MMNSU-1	34	1	0.5	MMUSS-1	102	MMNSUSS-1	109	1	0.5	MMU/A-1	31	MMNSU/A-1	34
24"	610	0.04	3	1.4	MMU-2	54	MMNSU-2	57	3	1.4	MMUSS-2	182	MMNSUSS-2	192	2	0.9	MMU/A-2	54	MMNSU/A-2	57
36"	914	0.06	4	1.8	MMU-3	85	MMNSU-3	89	4	1.8	MMUSS-3	278	MMNSUSS-3	288	2	0.9	MMU/A-3	85	MMNSU/A-3	89
48"	1219	0.08	6	2.7	MMU-4	100	MMNSU-4	109	5	2.3	MMUSS-4	366	MMNSUSS-4	385	3	1.4	MMU/A-4	100	MMNSU/A-4	109
60"	1524	0.10	7	3.2	MMU-5	125	MMNSU-5	138	7	3.2	MMUSS-5	460	MMNSUSS-5	486	4	1.8	MMU/A-5	125	MMNSU/A-5	138
72"	1829	0.13	9	4.1	MMU-6	151	MMNSU-6	160	8	3.6	MMUSS-6	546	MMNSUSS-6	574	4	1.8	MMU/A-6	151	MMNSU/A-6	160
84"	2134	0.15	10	4.5	MMU-7	177	MMNSU-7	192	9	4.1	MMUSS-7	636	MMNSUSS-7	669	5	2.3	MMU/A-7	177	MMNSU/A-7	192
96"	2438	0.17	11	5.0	MMU-8	203	MMNSU-8	220	11	5.0	MMUSS-8	725	MMNSUSS-8	760	6	2.7	MMU/A-8	203	MMNSU/A-8	220
108"	2743	0.19	13	5.8	MMU-9	231	MMNSU-9	249	12	5.4	MMUSS-9	815	MMNSUSS-9	859	7	3.2	MMU/A-9	231	MMNSU/A-9	248
120"	3048	0.21	14	6.4	MMU-10	258	MMNSU-10	276	13	5.8	MMUSS-10	905	MMNSUSS-10	954	7	3.2	MMU/A-10	258	MMNSU/A-10	276
144"	3658	0.23	17	7.7	MMU-12	314	MMNSU-12	338	16	7.3	MMUSS-12	1088	MMNSUSS-12	1143	9	4.1	MMU/A-12	314	MMNSU/A-12	338
156"	3962	0.25	20	9.0	MMU-14	368	n/a	n/a	-	-	n/a	n/a	n/a	n/a	10	4.5	MMU/A-14	353	MMNSU/A-14	378
168"	4267	0.30	23	10.4	MMU-16	419	n/a	n/a	-	-	n/a	n/a	n/a	n/a	12	5.4	MMU/A-16	419	MMNSU/A-16	478

### Back-To-Back Uprights — Floor-To-Ceiling

see spec sheet **EG01.45A**

FEATURES:

- Attaches to floor and ceiling.
- Two uprights are bolted or welded back-to-back.

**Note:** Prices do not include ceiling brackets.



*For center room storage.*

**Freight class is 70.0.**

Gray Epoxy					Stainless Steel					Aluminum									
height		cu		weight		REGULAR		NSF		weight		REGULAR		NSF		weight		REGULAR	
in.	mm	ft	lb.	kg	model #	list	model #	list	lb.	kg	model #	list	model #	list	lb.	kg	model #	list	
48"	1219	0.29	11	5.0	MMBB/FC-4	218	MMNSBB/FC-4	236	11	5.0	MMBBSS/FC-4	732	MMNSBBSS/FC-4	838	11	5.0	MMBB/FC/A-4	218	
60"	1524	0.37	14	6.4	MMBB/FC-5	269	MMNSBB/FC-5	296	24	10.9	MMBBSS/FC-5	918	MMNSBBSS/FC-5	1054	14	6.4	MMBB/FC/A-5	269	
72"	1829	0.44	17	7.7	MMBB/FC-6	329	MMNSBB/FC-6	357	28	12.7	MMBBSS/FC-6	1088	MMNSBBSS/FC-6	1252	17	7.7	MMBB/FC/A-6	329	
84"	2134	0.51	20	9.0	MMBB/FC-7	385	MMNSBB/FC-7	417	33	15.0	MMBBSS/FC-7	1269	MMNSBBSS/FC-7	1461	20	9.0	MMBB/FC/A-7	385	
96"	2438	0.59	23	10.4	MMBB/FC-8	443	MMNSBB/FC-8	481	38	17.2	MMBBSS/FC-8	1449	MMNSBBSS/FC-8	1666	23	10.4	MMBB/FC/A-8	443	
108"	2743	0.66	26	11.8	MMBB/FC-9	499	MMNSBB/FC-9	542	42	19.1	MMBBSS/FC-9	1629	MMNSBBSS/FC-9	1873	26	11.8	MMBB/FC/A-9	499	
120"	3048	0.73	29	13.2	MMBB/FC-10	689	MMNSBB/FC-10	601	47	21.3	MMBBSS/FC-10	1808	MMNSBBSS/FC-10	2083	29	13.2	MMBB/FC/A-10	689	
144"	3658	0.88	34	15.4	MMBB/FC-12	712	MMNSBB/FC-12	747	57	25.9	MMBBSS/FC-12	2174	MMNSBBSS/FC-12	2498	34	15.4	MMBB/FC/A-12	712	

### Heavy-Duty Back-To-Back Uprights — Floor-To-Ceiling

see spec sheet **EG01.45C**

FEATURES:

- Double-faced unitized uprights.
- Attaches to floor and ceiling.
- Two uprights are bolted or welded back-to-back.

**Note:** Prices do not include ceiling brackets.



*For center room storage.*

**Freight class is 70.0.**

Gray Epoxy					Stainless Steel					Aluminum									
height		cu		weight		REGULAR		NSF		weight		REGULAR		NSF		weight		REGULAR	
in.	mm	ft	lb.	kg	model #	list	model #	list	lb.	kg	model #	list	model #	list	lb.	kg	model #	list	
48"	1219	0.29	20	9.0	MMBB-4	423	MMNSBB-4	481	11	5.0	MMBBSS-4	980	MMNSBBSS-4	1124	14	6.4	MMBB/A-4	431	
60"	1524	0.37	25	11.3	MMBB-5	499	MMNSBB-5	575	24	10.9	MMBBSS-5	1234	MMNSBBSS-5	1417	17	7.7	MMBB/A-5	487	
72"	1829	0.44	30	13.6	MMBB-6	600	MMNSBB-6	689	28	12.7	MMBBSS-6	1326	MMNSBBSS-6	1707	21	9.5	MMBB/A-6	581	
84"	2134	0.51	35	15.9	MMBB-7	701	MMNSBB-7	804	33	15.0	MMBBSS-7	1734	MMNSBBSS-7	1985	24	10.9	MMBB/A-7	683	
96"	2438	0.59	40	18.1	MMBB-8	804	MMNSBB-8	916	38	17.2	MMBBSS-8	1980	MMNSBBSS-8	2268	28	12.7	MMBB/A-8	778	
108"	2743	0.66	45	20.4	MMBB-9	904	MMNSBB-9	1032	42	19.1	MMBBSS-9	2225	MMNSBBSS-9	2555	31	14.1	MMBB/A-9	878	
120"	3048	0.73	50	22.7	MMBB-10	1004	MMNSBB-10	1152	47	21.3	MMBBSS-10	2472	MMNSBBSS-10	2838	34	15.4	MMBB/A-10	972	
144"	3658	0.88	60	27.2	MMBB-12	1201	MMNSBB-12	1379	57	25.9	MMBBSS-12	2978	MMNSBBSS-12	3401	41	18.6	MMBB/A-12	1171	

### Ceiling Brackets for Standard and Back-To-Back Uprights

see spec sheet **EG01.45B**

**Freight class is 70.0.**

**Note:** Required for all installations.

**Note:** In a run of shelving, left or right brackets can be used as "center" brackets.



description	Gray Epoxy				Stainless Steel				Aluminum			
	REGULAR		NSF		REGULAR		NSF		REGULAR		NSF	
	model #	list	model #	list	model #	list	model #	list	model #	list	model #	list
left	MMCB-6-L	32	MMNSCB-6-L	32	MMCBSS-6-L	68	MMNSCBSS-6-L	68	MMCB/A6-L	43	MMNSCB/A6-L	43
right	MMCB-6-R	32	MMNSCB-6-R	32	MMCBSS-6-R	68	MMNSCBSS-6-R	68	MMCB/A6-R	43	MMNSCB/A6-R	43

## Catalog Section 1

### Heavy Duty Crossbraces

see spec sheet **EG01.45C**

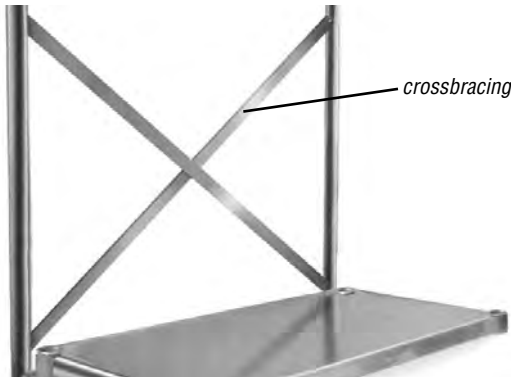

- Adds to stability of unit.
- 1" (25mm) wide 7-gauge steel.

FEATURES:

Freight class is 70.0.

fits shelf length		crossbrace length		weight		Gray Epoxy		Nickel			
in.	mm	in.	mm	lb.	kg	model #	list	lb.	kg	model #	list
36"	914	48"	1219	2	0.9	<b>MMXB-48</b>	32	2	0.9	<b>MMXB-N-48</b>	83
48"	1219	60"	1524	3	1.4	<b>MMXB-60</b>	37	3	1.4	<b>MMXB-N-60</b>	100
60"	1524	72"	1829	4	1.8	<b>MMXB-72</b>	43	4	1.8	<b>MMXB-N-72</b>	120
72"	1829	84"	2134	5	2.3	<b>MMXB-84</b>	52	5	2.3	<b>MMXB-N-84</b>	140

### Single Knob Brackets

see spec sheet **EG01.45B**



- With flange on top left or right, these brackets support single shelf or end of shelf run.

FEATURES:

Freight class is 70.0.

#### Left Single Knob Brackets

length		cu	weight		Gray Epoxy				Stainless Steel				Aluminum							
in.	mm	ft	lb.	kg	REGULAR		NSF		REGULAR		NSF		REGULAR		NSF					
					model #	list	model #	list	model #	list	model #	list	model #	list	model #	list				
14"	356	0.09	2	0.9	<b>MMB-K-14-L</b>	74	<b>MMNSB-K-14-L</b>	84	2	0.9	<b>MMBSS-K-14-L</b>	162	<b>MMNSBSS-K-14-L</b>	173	1	0.5	<b>MMB-K/A-14-L</b>	85	<b>MMNSB-K/A-14-L</b>	91
18"	457	0.12	3	1.4	<b>MMB-K-18-L</b>	91	<b>MMNSB-K-18-L</b>	100	2	0.9	<b>MMBSS-K-18-L</b>	222	<b>MMNSBSS-K-18-L</b>	228	1	0.5	<b>MMB-K/A-18-L</b>	95	<b>MMNSB-K/A-18-L</b>	108
21"	533	0.15	3	1.4	<b>MMB-K-21-L</b>	102	<b>MMNSB-K-21-L</b>	113	3	1.4	<b>MMBSS-K-21-L</b>	264	<b>MMNSBSS-K-21-L</b>	279	1	0.5	<b>MMB-K/A-21-L</b>	109	<b>MMNSB-K/A-21-L</b>	119
24"	610	0.17	3	1.4	<b>MMB-K-24-L</b>	113	<b>MMNSB-K-24-L</b>	122	3	1.4	<b>MMBSS-K-24-L</b>	286	<b>MMNSBSS-K-24-L</b>	298	2	0.9	<b>MMB-K/A-24-L</b>	122	<b>MMNSB-K/A-24-L</b>	138

#### Right Single Knob Brackets

length		cu	weight		Gray Epoxy				Stainless Steel				Aluminum							
in.	mm	ft	lb.	kg	REGULAR		NSF		REGULAR		NSF		REGULAR		NSF					
					model #	list	model #	list	model #	list	model #	list	model #	list	model #	list				
14"	356	0.09	2	0.9	<b>MMB-K-14-R</b>	74	<b>MMNSB-K-14-R</b>	84	2	0.9	<b>MMBSS-K-14-R</b>	162	<b>MMNSBSS-K-14-R</b>	173	1	0.5	<b>MMB-K/A-14-R</b>	85	<b>MMNSB-K/A-14-R</b>	91
18"	457	0.12	3	1.4	<b>MMB-K-18-R</b>	91	<b>MMNSB-K-18-R</b>	100	2	0.9	<b>MMBSS-K-18-R</b>	222	<b>MMNSBSS-K-18-R</b>	228	1	0.5	<b>MMB-K/A-18-R</b>	95	<b>MMNSB-K/A-18-R</b>	108
21"	533	0.15	3	1.4	<b>MMB-K-21-R</b>	102	<b>MMNSB-K-21-R</b>	113	3	1.4	<b>MMBSS-K-21-R</b>	264	<b>MMNSBSS-K-21-R</b>	279	1	0.5	<b>MMB-K/A-21-R</b>	109	<b>MMNSB-K/A-21-R</b>	119
24"	610	0.17	3	1.4	<b>MMB-K-24-R</b>	113	<b>MMNSB-K-24-R</b>	122	3	1.4	<b>MMBSS-K-24-R</b>	286	<b>MMNSBSS-K-24-R</b>	298	2	0.9	<b>MMB-K/A-24-R</b>	122	<b>MMNSB-K/A-24-R</b>	138

### Double Knob Brackets

see spec sheet **EG01.45B**



**For use with wire or solid shelving**

- With flanges on top left and right, these brackets support two adjoining wire or solid shelves on a common upright.

FEATURES:

Freight class is 70.0.

length		cu	weight		Gray Epoxy				Stainless Steel				Aluminum							
in.	mm	ft	lb.	kg	REGULAR		NSF		REGULAR		NSF		REGULAR		NSF					
					model #	list	model #	list	model #	list	model #	list	model #	list	model #	list				
14"	356	0.19	3	1.4	<b>MMDB-K-14</b>	127	<b>MMNSDB-K-14</b>	126	3	1.4	<b>MMDBSS-K-14</b>	227	<b>MMNSDBSS-K-14</b>	241	1	0.5	<b>MMDB-K/A-14</b>	126	<b>MMNSDB-K/A-14</b>	141
18"	457	0.25	4	1.8	<b>MMDB-K-18</b>	151	<b>MMNSDB-K-18</b>	167	3	1.4	<b>MMDBSS-K-18</b>	316	<b>MMNSDBSS-K-18</b>	334	2	0.9	<b>MMDB-K/A-18</b>	167	<b>MMNSDB-K/A-18</b>	181
21"	533	0.29	4	1.8	<b>MMDB-K-21</b>	167	<b>MMNSDB-K-21</b>	182	4	1.8	<b>MMDBSS-K-21</b>	380	<b>MMNSDBSS-K-21</b>	400	2	0.9	<b>MMDB-K/A-21</b>	177	<b>MMNSDB-K/A-21</b>	194
24"	610	0.33	5	2.3	<b>MMDB-K-24</b>	174	<b>MMNSDB-K-24</b>	191	4	1.8	<b>MMDBSS-K-24</b>	414	<b>MMNSDBSS-K-24</b>	425	2	0.9	<b>MMDB-K/A-24</b>	186	<b>MMNSDB-K/A-24</b>	207

## Optional Single Foot Brackets with Knobs

see spec sheet **EG01.45B**

- Serves as a base for bottom shelf.
- Left brackets and right brackets available.
- 9 3/8" (238mm) height.

FEATURES:

**Freight class is 70.0.**



*For use with wire and solid shelving*

### Left Single Foot Brackets with Knobs

		Gray Epoxy						Stainless Steel						
length		weight		REGULAR		NSF		weight		REGULAR		NSF		
in.	mm	ft	lb.	kg	model #	list	model #	list	lb.	kg	model #	list	model #	list
14"	356	0.13	4	1.8	MMFB-K-14-L	124	MMNSFB-K-14-L	139	4	1.8	MMFBSSK-149-L	364	MMNSFBSSK-149-L	419
18"	457	0.17	5	2.3	MMFB-K-18-L	148	MMNSFB-K-18-L	163	6	2.7	MMFBSSK-189-L	484	MMNSFBSSK-189-L	551
21"	533	0.19	6	2.7	MMFB-K-21-L	171	MMNSFB-K-21-L	186	-	-	n/a	n/a	n/a	n/a
24"	610	0.21	6	2.7	MMFB-K-24-L	182	MMNSFB-K-24-L	203	7	3.2	MMFBSSK-249-L	625	MMNSFBSSK-249-L	714

### Right Single Foot Brackets with Knobs

		Gray Epoxy						Stainless Steel						
length		weight		REGULAR		NSF		weight		REGULAR		NSF		
in.	mm	ft	lb.	kg	model #	list	model #	list	lb.	kg	model #	list	model #	list
14"	356	0.13	4	1.8	MMFB-K-14-R	124	MMNSFB-K-14-R	139	4	1.8	MMFBSSK-149-R	364	MMNSFBSSK-149-R	419
18"	457	0.17	5	2.3	MMFB-K-18-R	148	MMNSFB-K-18-R	163	6	2.7	MMFBSSK-189-R	484	MMNSFBSSK-189-R	551
21"	533	0.19	6	2.7	MMFB-K-21-R	171	MMNSFB-K-21-R	186	-	-	n/a	n/a	n/a	n/a
24"	610	0.21	6	2.7	MMFB-K-24-R	182	MMNSFB-K-24-R	203	7	3.2	MMFBSSK-249-R	625	MMNSFBSSK-249-R	714

## Optional Double Foot Brackets with Knobs

see spec sheet **EG01.45B**

- For use with wire or solid shelving.
- Serves as a base for adjoining two bottom shelves.
- 9 3/8" (238mm) height.

FEATURES:

**Freight class is 70.0.**



		Gray Epoxy						Stainless Steel						
length		weight		REGULAR		NSF		weight		REGULAR		NSF		
in.	mm	ft	lb.	kg	model #	list	model #	list	lb.	kg	model #	list	model #	list
14"	356	0.26	4	1.8	MMDFB-K-14	201	MMNSDFB-K-14	221	5	2.3	MMDFBSSK-149	416	MMNSDFBSSK-149	483
18"	457	0.33	5	2.3	MMDFB-K-18	261	MMNSDFB-K-18	293	7	3.2	MMDFBSSK-189	532	MMNSDFBSSK-189	614
21"	533	0.39	6	2.7	MMDFB-K-21	291	MMNSDFB-K-21	314	-	-	n/a	n/a	n/a	n/a
24"	610	0.42	7	3.2	MMDFB-K-24	298	MMNSDFB-K-24	327	8	3.6	MMDFBSSK-249	712	MMNSDFBSSK-249	815

## Catalog Section 1

### Heavy Duty Single Knob "C" Brackets

see spec sheet **EG01.45C**

- For dynamic loads.
- For use with wire or solid shelving.

FEATURES:

Freight class is 70.0.



#### Left Single Knob Brackets

		Gray Epoxy				Stainless Steel				Aluminum										
length		weight		REGULAR		NSF		weight		REGULAR		NSF		weight		REGULAR		NSF		
in.	mm	ft	lb.	kg	model #	list	model #	list	lb.	kg	model #	list	model #	list	lb.	kg	model #	list	model #	list
18"	457	0.12	3	1.4	MMBC-K-18-L	88	MMNSBC-K-18-L	94	2	0.9	MMBCSS-K-18-L	163	MMNSBCSS-K-18-L	173	1	0.5	MMBC-K/A-18-L	83	MMNSBC-K/A-18-L	88
21"	533	0.15	3	1.4	MMBC-K-21-L	100	MMNSBC-K-21-L	109	3	1.4	MMBCSS-K-21-L	203	MMNSBCSS-K-21-L	221	1	0.5	MMBC-K/A-21-L	94	MMNSBC-K/A-21-L	100
24"	610	0.17	3	1.4	MMBC-K-24-L	115	MMNSBC-K-24-L	120	3	1.4	MMBCSS-K-24-L	240	MMNSBCSS-K-24-L	260	2	0.9	MMBC-K/A-24-L	100	MMNSBC-K/A-24-L	109

#### Right Single Knob Brackets

		Gray Epoxy				Stainless Steel				Aluminum										
length		weight		REGULAR		NSF		weight		REGULAR		NSF		weight		REGULAR		NSF		
in.	mm	ft	lb.	kg	model #	list	model #	list	lb.	kg	model #	list	model #	list	lb.	kg	model #	list	model #	list
18"	457	0.12	3	1.4	MMBC-K-18-R	88	MMNSBC-K-18-R	94	2	0.9	MMBCSS-K-18-R	163	MMNSBCSS-K-18-R	173	1	0.5	MMBC-K/A-18-R	83	MMNSBC-K/A-18-R	88
21"	533	0.15	3	1.4	MMBC-K-21-R	100	MMNSBC-K-21-R	109	3	1.4	MMBCSS-K-21-R	203	MMNSBCSS-K-21-R	221	1	0.5	MMBC-K/A-21-R	94	MMNSBC-K/A-21-R	100
24"	610	0.17	3	1.4	MMBC-K-24-R	115	MMNSBC-K-24-R	120	3	1.4	MMBCSS-K-24-R	240	MMNSBCSS-K-24-R	260	2	0.9	MMBC-K/A-24-R	100	MMNSBC-K/A-24-R	109

### Heavy Duty Double Knob "C" Brackets

see spec sheet **EG01.45C**

- For dynamic loads.
- With flanges on top left and right, these brackets support two adjoining wire or solid shelves on a common upright.

FEATURES:

Freight class is 70.0.



		Gray Epoxy				Stainless Steel				Aluminum										
length		weight		REGULAR		NSF		weight		REGULAR		NSF		weight		REGULAR		NSF		
in.	mm	ft	lb.	kg	model #	list	model #	list	lb.	kg	model #	list	model #	list	lb.	kg	model #	list	model #	list
18"	457	0.25	4	1.8	MMDBC-K-18	145	MMNSDBC-K-18	157	3	1.4	MMDBCSS-K-18	247	MMNSDBCSS-K-18	260	2	0.9	MMDBC-K/A-18	133	MMNSDBC-K/A-18	145
21"	533	0.29	4	1.8	MMDBC-K-21	163	MMNSDBC-K-21	177	4	1.8	MMDBCSS-K-21	284	MMNSDBCSS-K-21	303	2	0.9	MMDBC-K/A-21	152	MMNSDBC-K/A-21	162
24"	610	0.33	5	2.3	MMDBC-K-24	173	MMNSDBC-K-24	182	4	1.8	MMDBCSS-K-24	316	MMNSDBCSS-K-24	340	2	0.9	MMDBC-K/A-24	163	MMNSDBC-K/A-24	163

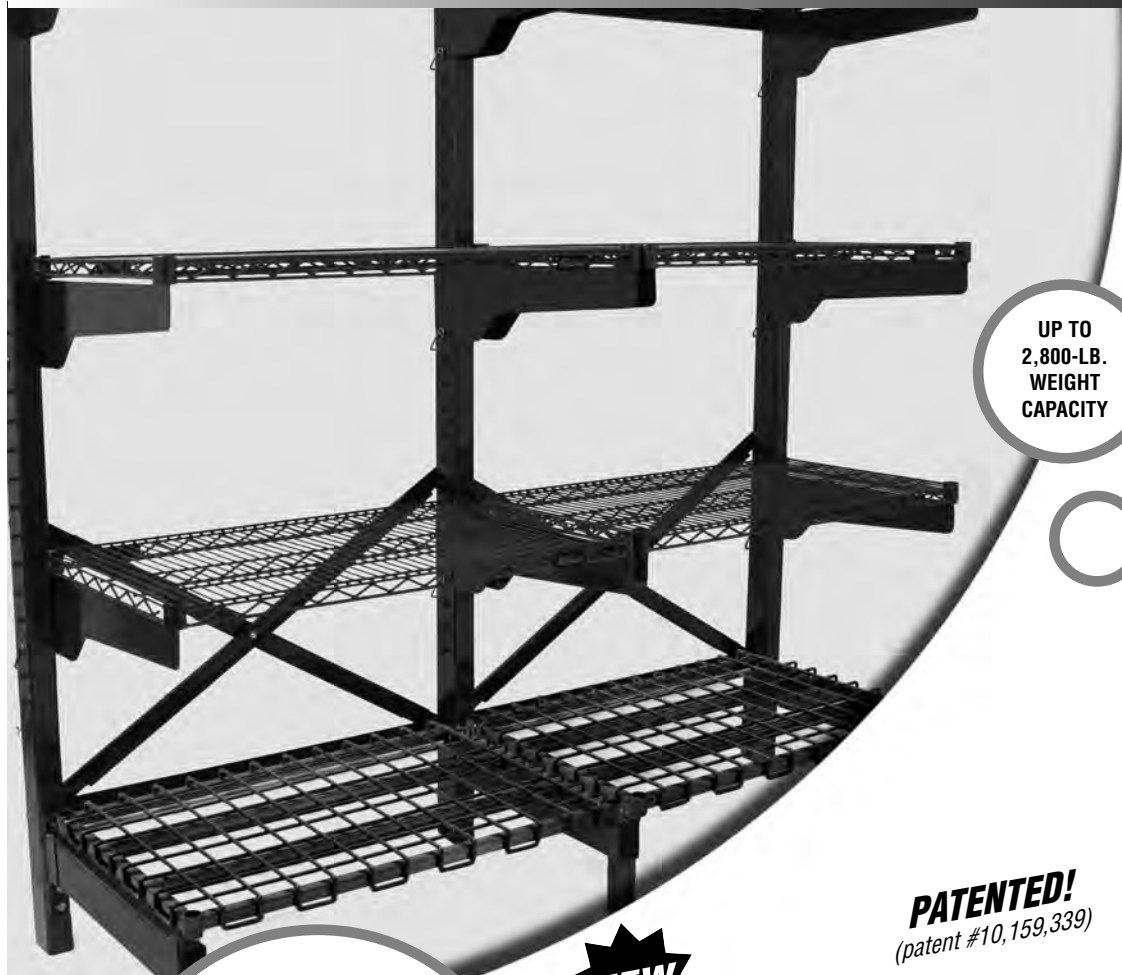

UP TO  
2,800-LB.  
WEIGHT  
CAPACITY



**PATENTED!**  
(patent #10,159,339)

**NEW**

See pages 87 through 94 for Q-LEVER® Starter and Add-On units.  
See pages 95 through 97 for various Q-LEVER® Workstations.

# Q-LEVER

CLEVER STORAGE SOLUTIONS

Heavy Duty Cantilever Shelving Systems



(pages 87 through 99)

No one else offers brackets that can be positioned...





# Q-LEVER

## CLEVER STORAGE SOLUTIONS



up to  
2,800-lb.  
CAPACITY

**PATENTED!**  
(patent #10,159,339)

**Q-LEVER® Shelving**  
has a load bearing capacity of  
600 lbs. per shelf and 1,000 lbs.  
on the bottom dunnage shelf.  
Unit safely holds up to 2,800 lbs.

#### ADDITIONAL NOTES

- Evenly distribute the weight across each shelf, and keep heavier loads on the bottom.
- Unit must be bolted to the floor if bottom shelf is removed.
- Unit must be placed on a level surface to avoid a tipping hazard.



5-Tier Starter Unit



Starter and Add-On Units joined

### Overview...

- Maximizes storage, free standing shelving allows access to all corners.
- With no front uprights, accessibility and productivity are improved.
- Uprights utilize 2" adjustment for shelf and accessory spacing.
- Shelves and accessories can be easily adjusted without tools.
- Can be expanded side to side with Add-On units which share a common upright with existing unit; saving cost and space.
- Units allow for sheet metal or wire overlays.
- Sizing available:
  - Widths: 18", 21", 24" and 30".
  - Lengths: 24", 30", 36", 42", 48", 54", 60", 66" and 72".

# Q-LEVER

CLEVER STORAGE SOLUTIONS

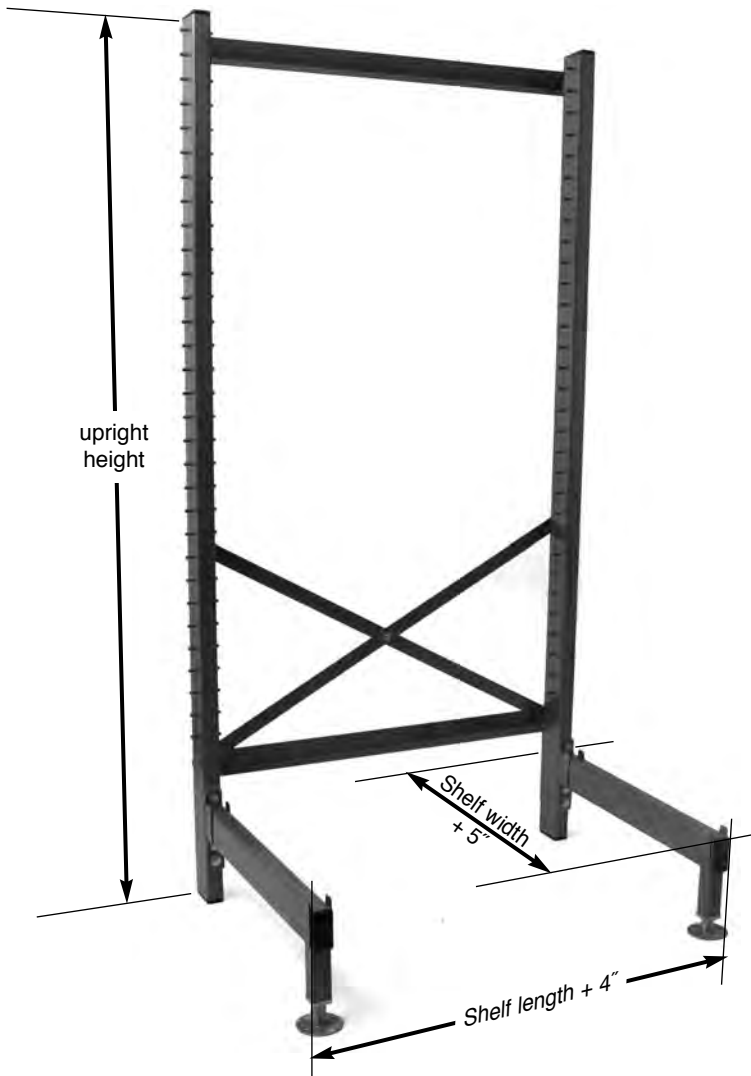

### Overview of chart dimensions...

- Add 4" to the shelf length for nominal length of starter unit.
- Add 1/2" to the shelf length for nominal length of add-on unit.
- Add 5" to the shelf width for both starter unit and add-on unit.

Applicable charts are on pages 89 through 94.

**Q-LEVER® standard starter and add-on units feature standard wire shelves and dunnage shelves. The Q-LEVER® system can also accommodate...**

Solid Shelves • Quad-PLUS® • Double Wire Mat Shelves • Reverse Mat Shelves • Dunnage Shelves  
 ...or a mixture of same based upon your storage needs.



Contact Factory for a quotation on a Q-LEVER® System utilizing these shelving options.

## Catalog Section 1

### Q-LEVER® 76" (1930mm) Four-Tier Starter Units



unit with  
all wire shelves

unit with bottom  
dunnage shelf

- Features two 76" (1930mm) uprights, two braces, X-brace assembly, and hardware.
- Uprights utilize pins on 2" (51mm) centers for maximum flexibility for shelves and accessories
- Choice of Valu-Master® gray or Valu-Gard® green epoxy finish on shelves
- Valu-Master® gray epoxy finish on uprights.

**FEATURES:**

**Freight class is 70.0.**

**Consult factory for pricing.**

#### Starter Units with All Wire Shelves

Includes four wire shelves and three pairs of brackets.

		...with 18" (457mm)-wide Shelves *		...with 21" (533mm)-wide Shelves *		...with 24" (610mm)-wide Shelves *		...with 30" (762mm)-wide Shelves *	
shelf length	unit** length	Shelves with Valu-Master® finish	Shelves with Valu-Gard® finish	Shelves with Valu-Master® finish	Shelves with Valu-Gard® finish	Shelves with Valu-Master® finish	Shelves with Valu-Gard® finish	Shelves with Valu-Master® finish	Shelves with Valu-Gard® finish
in. mm	in. mm								
24" 610	28" 711	Q1824V76-4	Q1824VG76-4	Q2124V76-4	Q2124VG76-4	Q2424V76-4	Q2424VG76-4	-	-
30" 762	34" 864	Q1830V76-4	Q1830VG76-4	Q2130V76-4	Q2130VG76-4	Q2430V76-4	Q2430VG76-4	Q3030V76-4	Q3030VG76-4
36" 914	40" 1016	Q1836V76-4	Q1836VG76-4	Q2136V76-4	Q2136VG76-4	Q2436V76-4	Q2436VG76-4	Q3036V76-4	Q3036VG76-4
42" 1067	46" 1168	Q1842V76-4	Q1842VG76-4	Q2142V76-4	Q2142VG76-4	Q2442V76-4	Q2442VG76-4	Q3042V76-4	Q3042VG76-4
48" 1219	52" 1320	Q1848V76-4	Q1848VG76-4	Q2148V76-4	Q2148VG76-4	Q2448V76-4	Q2448VG76-4	Q3048V76-4	Q3048VG76-4
54" 1372	58" 1473	Q1854V76-4	Q1854VG76-4	Q2154V76-4	Q2154VG76-4	Q2454V76-4	Q2454VG76-4	Q3054V76-4	Q3054VG76-4
60" 1524	64" 1626	Q1860V76-4	Q1860VG76-4	Q2160V76-4	Q2160VG76-4	Q2460V76-4	Q2460VG76-4	Q3060V76-4	Q3060VG76-4
66" 1676	70" 1778	Q1866V76-4	Q1866VG76-4	Q2166V76-4	Q2166VG76-4	Q2466V76-4	Q2466VG76-4	Q3066V76-4	Q3066VG76-4
72" 1829	76" 1930	Q1872V76-4	Q1872VG76-4	Q2172V76-4	Q2172VG76-4	Q2472V76-4	Q2472VG76-4	Q3072V76-4	Q3072VG76-4

\* For unit width, add 5" (127mm) to shelf width.

\*\* Dimensions are nominal.

#### Starter Units with Bottom Dunnage Shelf

Includes three wire shelves, three pairs of brackets and one dunnage shelf.

		...with 18" (457mm)-wide Shelves *		...with 21" (533mm)-wide Shelves *		...with 24" (610mm)-wide Shelves *		...with 30" (762mm)-wide Shelves *	
shelf length	unit** length	Shelves with Valu-Master® finish	Shelves with Valu-Gard® finish	Shelves with Valu-Master® finish	Shelves with Valu-Gard® finish	Shelves with Valu-Master® finish	Shelves with Valu-Gard® finish	Shelves with Valu-Master® finish	Shelves with Valu-Gard® finish
in. mm	in. mm								
24" 610	28" 711	Q1824V76-4D	Q1824VG76-4D	Q2124V76-4D	Q2124VG76-4D	Q2424V76-4D	Q2424VG76-4D	-	-
30" 762	34" 864	Q1830V76-4D	Q1830VG76-4D	Q2130V76-4D	Q2130VG76-4D	Q2430V76-4D	Q2430VG76-4D	Q3030V76-4D	Q3030VG76-4D
36" 914	40" 1016	Q1836V76-4D	Q1836VG76-4D	Q2136V76-4D	Q2136VG76-4D	Q2436V76-4D	Q2436VG76-4D	Q3036V76-4D	Q3036VG76-4D
42" 1067	46" 1168	Q1842V76-4D	Q1842VG76-4D	Q2142V76-4D	Q2142VG76-4D	Q2442V76-4D	Q2442VG76-4D	Q3042V76-4D	Q3042VG76-4D
48" 1219	52" 1320	Q1848V76-4D	Q1848VG76-4D	Q2148V76-4D	Q2148VG76-4D	Q2448V76-4D	Q2448VG76-4D	Q3048V76-4D	Q3048VG76-4D
54" 1372	58" 1473	Q1854V76-4D	Q1854VG76-4D	Q2154V76-4D	Q2154VG76-4D	Q2454V76-4D	Q2454VG76-4D	Q3054V76-4D	Q3054VG76-4D
60" 1524	64" 1626	Q1860V76-4D	Q1860VG76-4D	Q2160V76-4D	Q2160VG76-4D	Q2460V76-4D	Q2460VG76-4D	Q3060V76-4D	Q3060VG76-4D
66" 1676	70" 1778	Q1866V76-4D	Q1866VG76-4D	Q2166V76-4D	Q2166VG76-4D	Q2466V76-4D	Q2466VG76-4D	Q3066V76-4D	Q3066VG76-4D
72" 1829	76" 1930	Q1872V76-4D	Q1872VG76-4D	Q2172V76-4D	Q2172VG76-4D	Q2472V76-4D	Q2472VG76-4D	Q3072V76-4D	Q3072VG76-4D

\* For unit width, add 5" (127mm) to shelf width.

\*\* Dimensions are nominal.

### Q-LEVER® 76" (1930mm) Four-Tier Add-On Units



unit with  
all wire shelves

unit with bottom  
dunnage shelf

- Features one 76" (1930mm) upright, two braces, X-brace assembly, and hardware.
- Uprights utilize pins on 2" (51mm) centers for maximum flexibility for shelves and accessories
- Choice of Valu-Master® gray or Valu-Gard® green epoxy finish on shelves
- Valu-Master® gray epoxy finish on upright.

**FEATURES:**

Freight class is 70.0.

Consult factory for pricing.

#### Add-On Units with All Wire Shelves

Includes four wire shelves and three pairs of brackets.

shelf length in. mm	unit** length in. mm	...with 18" (457mm)-wide Shelves *		...with 21" (533mm)-wide Shelves *		...with 24" (610mm)-wide Shelves *		...with 30" (762mm)-wide Shelves *			
		Shelves with Valu-Master® finish	Shelves with Valu-Gard® finish	Shelves with Valu-Master® finish	Shelves with Valu-Gard® finish	Shelves with Valu-Master® finish	Shelves with Valu-Gard® finish	Shelves with Valu-Master® finish	Shelves with Valu-Gard® finish		
24"	610	25½"	648	Q1824V76A-4	Q1824VG76A-4	Q2124V76A-4	Q2124VG76A-4	Q2424V76A-4	Q2424VG76A-4	-	-
30"	762	31½"	800	Q1830V76A-4	Q1830VG76A-4	Q2130V76A-4	Q2130VG76A-4	Q2430V76A-4	Q2430VG76A-4	Q3030V76A-4	Q3030VG76A-4
36"	914	37½"	953	Q1836V76A-4	Q1836VG76A-4	Q2136V76A-4	Q2136VG76A-4	Q2436V76A-4	Q2436VG76A-4	Q3036V76A-4	Q3036VG76A-4
42"	1067	43½"	1105	Q1842V76A-4	Q1842VG76A-4	Q2142V76A-4	Q2142VG76A-4	Q2442V76A-4	Q2442VG76A-4	Q3042V76A-4	Q3042VG76A-4
48"	1219	49½"	1257	Q1848V76A-4	Q1848VG76A-4	Q2148V76A-4	Q2148VG76A-4	Q2448V76A-4	Q2448VG76A-4	Q3048V76A-4	Q3048VG76A-4
54"	1372	55½"	1410	Q1854V76A-4	Q1854VG76A-4	Q2154V76A-4	Q2154VG76A-4	Q2454V76A-4	Q2454VG76A-4	Q3054V76A-4	Q3054VG76A-4
60"	1524	61½"	1562	Q1860V76A-4	Q1860VG76A-4	Q2160V76A-4	Q2160VG76A-4	Q2460V76A-4	Q2460VG76A-4	Q3060V76A-4	Q3060VG76A-4
66"	1676	67½"	1715	Q1866V76A-4	Q1866VG76A-4	Q2166V76A-4	Q2166VG76A-4	Q2466V76A-4	Q2466VG76A-4	Q3066V76A-4	Q3066VG76A-4
72"	1829	73½"	1867	Q1872V76A-4	Q1872VG76A-4	Q2172V76A-4	Q2172VG76A-4	Q2472V76A-4	Q2472VG76A-4	Q3072V76A-4	Q3072VG76A-4

\* For unit width, add 5" (127mm) to shelf width.

\*\* Dimensions are nominal.

#### Add-On Units with Bottom Dunnage Shelf

Includes three wire shelves, three pairs of brackets and one dunnage shelf.

shelf length in. mm	unit** length in. mm	...with 18" (457mm)-wide Shelves *		...with 21" (533mm)-wide Shelves *		...with 24" (610mm)-wide Shelves *		...with 30" (762mm)-wide Shelves *			
		Shelves with Valu-Master® finish	Shelves with Valu-Gard® finish	Shelves with Valu-Master® finish	Shelves with Valu-Gard® finish	Shelves with Valu-Master® finish	Shelves with Valu-Gard® finish	Shelves with Valu-Master® finish	Shelves with Valu-Gard® finish		
24"	610	28"	711	Q1824V76A-4D	Q1824VG76A-4D	Q2124V76A-4D	Q2124VG76A-4D	Q2424V76A-4D	Q2424VG76A-4D	-	-
30"	762	34"	864	Q1830V76A-4D	Q1830VG76A-4D	Q2130V76A-4D	Q2130VG76A-4D	Q2430V76A-4D	Q2430VG76A-4D	Q3030V76A-4D	Q3030VG76A-4D
36"	914	40"	1016	Q1836V76A-4D	Q1836VG76A-4D	Q2136V76A-4D	Q2136VG76A-4D	Q2436V76A-4D	Q2436VG76A-4D	Q3036V76A-4D	Q3036VG76A-4D
42"	1067	46"	1168	Q1842V76A-4D	Q1842VG76A-4D	Q2142V76A-4D	Q2142VG76A-4D	Q2442V76A-4D	Q2442VG76A-4D	Q3042V76A-4D	Q3042VG76A-4D
48"	1219	52"	1320	Q1848V76A-4D	Q1848VG76A-4D	Q2148V76A-4D	Q2148VG76A-4D	Q2448V76A-4D	Q2448VG76A-4D	Q3048V76A-4D	Q3048VG76A-4D
54"	1372	58"	1473	Q1854V76A-4D	Q1854VG76A-4D	Q2154V76A-4D	Q2154VG76A-4D	Q2454V76A-4D	Q2454VG76A-4D	Q3054V76A-4D	Q3054VG76A-4D
60"	1524	64"	1626	Q1860V76A-4D	Q1860VG76A-4D	Q2160V76A-4D	Q2160VG76A-4D	Q2460V76A-4D	Q2460VG76A-4D	Q3060V76A-4D	Q3060VG76A-4D
66"	1676	70"	1778	Q1866V76A-4D	Q1866VG76A-4D	Q2166V76A-4D	Q2166VG76A-4D	Q2466V76A-4D	Q2466VG76A-4D	Q3066V76A-4D	Q3066VG76A-4D
72"	1829	76"	1930	Q1872V76A-4D	Q1872VG76A-4D	Q2172V76A-4D	Q2172VG76A-4D	Q2472V76A-4D	Q2472VG76A-4D	Q3072V76A-4D	Q3072VG76A-4D

\* For unit width, add 5" (127mm) to shelf width.

\*\* Dimensions are nominal.

## Catalog Section 1

### Q-LEVER® 76" (1930mm) Five-Tier Starter Units



unit with  
all wire shelves

unit with bottom  
dunnage shelf

- Features two 76" (1930mm) uprights, two braces, X-brace assembly, and hardware.
- Uprights utilize pins on 2" (51mm) centers for maximum flexibility for shelves and accessories
- Choice of Valu-Master® gray or Valu-Gard® green epoxy finish on shelves
- Valu-Master® gray epoxy finish on uprights.

**FEATURES:**

**Freight class is 70.0.**

**Consult factory for pricing.**

#### Starter Units with All Wire Shelves

Includes five wire shelves and four pairs of brackets.

		...with 18" (457mm)-wide Shelves *		...with 21" (533mm)-wide Shelves *		...with 24" (610mm)-wide Shelves *		...with 30" (762mm)-wide Shelves *	
shelf length	unit**	Shelves with Valu-Master® finish	Shelves with Valu-Gard® finish	Shelves with Valu-Master® finish	Shelves with Valu-Gard® finish	Shelves with Valu-Master® finish	Shelves with Valu-Gard® finish	Shelves with Valu-Master® finish	Shelves with Valu-Gard® finish
in. mm	in. mm								
24" 610	28" 711	Q1824V76-5	Q1824VG76-5	Q2124V76-5	Q2124VG76-5	Q2424V76-5	Q2424VG76-5	-	-
30" 762	34" 864	Q1830V76-5	Q1830VG76-5	Q2130V76-5	Q2130VG76-5	Q2430V76-5	Q2430VG76-5	Q3030V76-5	Q3030VG76-5
36" 914	40" 1016	Q1836V76-5	Q1836VG76-5	Q2136V76-5	Q2136VG76-5	Q2436V76-5	Q2436VG76-5	Q3036V76-5	Q3036VG76-5
42" 1067	46" 1168	Q1842V76-5	Q1842VG76-5	Q2142V76-5	Q2142VG76-5	Q2442V76-5	Q2442VG76-5	Q3042V76-5	Q3042VG76-5
48" 1219	52" 1320	Q1848V76-5	Q1848VG76-5	Q2148V76-5	Q2148VG76-5	Q2448V76-5	Q2448VG76-5	Q3048V76-5	Q3048VG76-5
54" 1372	58" 1473	Q1854V76-5	Q1854VG76-5	Q2154V76-5	Q2154VG76-5	Q2454V76-5	Q2454VG76-5	Q3054V76-5	Q3054VG76-5
60" 1524	64" 1626	Q1860V76-5	Q1860VG76-5	Q2160V76-5	Q2160VG76-5	Q2460V76-5	Q2460VG76-5	Q3060V76-5	Q3060VG76-5
66" 1676	70" 1778	Q1866V76-5	Q1866VG76-5	Q2166V76-5	Q2166VG76-5	Q2466V76-5	Q2466VG76-5	Q3066V76-5	Q3066VG76-5
72" 1829	76" 1930	Q1872V76-5	Q1872VG76-5	Q2172V76-5	Q2172VG76-5	Q2472V76-5	Q2472VG76-5	Q3072V76-5	Q3072VG76-5

\* For unit width, add 5" (127mm) to shelf width.

\*\* Dimensions are nominal.

#### Starter Units with Bottom Dunnage Shelf

Includes four wire shelves, four pairs of brackets and one dunnage shelf.

		...with 18" (457mm)-wide Shelves *		...with 21" (533mm)-wide Shelves *		...with 24" (610mm)-wide Shelves *		...with 30" (762mm)-wide Shelves *	
shelf length	unit**	Shelves with Valu-Master® finish	Shelves with Valu-Gard® finish	Shelves with Valu-Master® finish	Shelves with Valu-Gard® finish	Shelves with Valu-Master® finish	Shelves with Valu-Gard® finish	Shelves with Valu-Master® finish	Shelves with Valu-Gard® finish
in. mm	in. mm								
24" 610	28" 711	Q1824V76-5D	Q1824VG76-5D	Q2124V76-5D	Q2124VG76-5D	Q2424V76-5D	Q2424VG76-5D	-	-
30" 762	34" 864	Q1830V76-5D	Q1830VG76-5D	Q2130V76-5D	Q2130VG76-5D	Q2430V76-5D	Q2430VG76-5D	Q3030V76-5D	Q3030VG76-5D
36" 914	40" 1016	Q1836V76-5D	Q1836VG76-5D	Q2136V76-5D	Q2136VG76-5D	Q2436V76-5D	Q2436VG76-5D	Q3036V76-5D	Q3036VG76-5D
42" 1067	46" 1168	Q1842V76-5D	Q1842VG76-5D	Q2142V76-5D	Q2142VG76-5D	Q2442V76-5D	Q2442VG76-5D	Q3042V76-5D	Q3042VG76-5D
48" 1219	52" 1320	Q1848V76-5D	Q1848VG76-5D	Q2148V76-5D	Q2148VG76-5D	Q2448V76-5D	Q2448VG76-5D	Q3048V76-5D	Q3048VG76-5D
54" 1372	58" 1473	Q1854V76-5D	Q1854VG76-5D	Q2154V76-5D	Q2154VG76-5D	Q2454V76-5D	Q2454VG76-5D	Q3054V76-5D	Q3054VG76-5D
60" 1524	64" 1626	Q1860V76-5D	Q1860VG76-5D	Q2160V76-5D	Q2160VG76-5D	Q2460V76-5D	Q2460VG76-5D	Q3060V76-5D	Q3060VG76-5D
66" 1676	70" 1778	Q1866V76-5D	Q1866VG76-5D	Q2166V76-5D	Q2166VG76-5D	Q2466V76-5D	Q2466VG76-5D	Q3066V76-5D	Q3066VG76-5D
72" 1829	76" 1930	Q1872V76-5D	Q1872VG76-5D	Q2172V76-5D	Q2172VG76-5D	Q2472V76-5D	Q2472VG76-5D	Q3072V76-5D	Q3072VG76-5D

\* For unit width, add 5" (127mm) to shelf width.

\*\* Dimensions are nominal.

### Q-LEVER® 76" (1930mm) Five-Tier Add-On Units



unit with all wire shelves

unit with bottom dunnage shelf

- Features one 76" (1930mm) upright, two braces, X-brace assembly, and hardware.
- Uprights utilize pins on 2" (51mm) centers for maximum flexibility for shelves and accessories
- Choice of Valu-Master® gray or Valu-Gard® green epoxy finish on shelves
- Valu-Master® gray epoxy finish on upright(s)

**FEATURES:**

Freight class is 70.0.

Consult factory for pricing.

#### Add-On Units with All Wire Shelves

Includes five wire shelves and four pairs of brackets.

shelf length in. mm	unit** length in. mm	...with 18" (457mm)-wide Shelves *		...with 21" (533mm)-wide Shelves *		...with 24" (610mm)-wide Shelves *		...with 30" (762mm)-wide Shelves *			
		Shelves with Valu-Master® finish	Shelves with Valu-Gard® finish	Shelves with Valu-Master® finish	Shelves with Valu-Gard® finish	Shelves with Valu-Master® finish	Shelves with Valu-Gard® finish	Shelves with Valu-Master® finish	Shelves with Valu-Gard® finish		
24"	610	25½"	648	Q1824V76A-5	Q1824VG76A-5	Q2124V76A-5	Q2124VG76A-5	Q2424V76A-5	Q2424VG76A-5	-	-
30"	762	31½"	800	Q1830V76A-5	Q1830VG76A-5	Q2130V76A-5	Q2130VG76A-5	Q2430V76A-5	Q2430VG76A-5	Q3030V76A-5	Q3030VG76A-5
36"	914	37½"	953	Q1836V76A-5	Q1836VG76A-5	Q2136V76A-5	Q2136VG76A-5	Q2436V76A-5	Q2436VG76A-5	Q3036V76A-5	Q3036VG76A-5
42"	1067	43½"	1105	Q1842V76A-5	Q1842VG76A-5	Q2142V76A-5	Q2142VG76A-5	Q2442V76A-5	Q2442VG76A-5	Q3042V76A-5	Q3042VG76A-5
48"	1219	49½"	1257	Q1848V76A-5	Q1848VG76A-5	Q2148V76A-5	Q2148VG76A-5	Q2448V76A-5	Q2448VG76A-5	Q3048V76A-5	Q3048VG76A-5
54"	1372	55½"	1410	Q1854V76A-5	Q1854VG76A-5	Q2154V76A-5	Q2154VG76A-5	Q2454V76A-5	Q2454VG76A-5	Q3054V76A-5	Q3054VG76A-5
60"	1524	61½"	1562	Q1860V76A-5	Q1860VG76A-5	Q2160V76A-5	Q2160VG76A-5	Q2460V76A-5	Q2460VG76A-5	Q3060V76A-5	Q3060VG76A-5
66"	1676	67½"	1715	Q1866V76A-5	Q1866VG76A-5	Q2166V76A-5	Q2166VG76A-5	Q2466V76A-5	Q2466VG76A-5	Q3066V76A-5	Q3066VG76A-5
72"	1829	73½"	1867	Q1872V76A-5	Q1872VG76A-5	Q2172V76A-5	Q2172VG76A-5	Q2472V76A-5	Q2472VG76A-5	Q3072V76A-5	Q3072VG76A-5

\* For unit width, add 5" (127mm) to shelf width.

\*\* Dimensions are nominal.

#### Add-On Units with Bottom Dunnage Shelf

Includes four wire shelves, four pairs of brackets and one dunnage shelf.

shelf length in. mm	unit** length in. mm	...with 18" (457mm)-wide Shelves *		...with 21" (533mm)-wide Shelves *		...with 24" (610mm)-wide Shelves *		...with 30" (762mm)-wide Shelves *			
		Shelves with Valu-Master® finish	Shelves with Valu-Gard® finish	Shelves with Valu-Master® finish	Shelves with Valu-Gard® finish	Shelves with Valu-Master® finish	Shelves with Valu-Gard® finish	Shelves with Valu-Master® finish	Shelves with Valu-Gard® finish		
24"	610	28"	711	Q1824V76A-5D	Q1824VG76A-5D	Q2124V76A-5D	Q2124VG76A-5D	Q2424V76A-5D	Q2424VG76A-5D	-	-
30"	762	34"	864	Q1830V76A-5D	Q1830VG76A-5D	Q2130V76A-5D	Q2130VG76A-5D	Q2430V76A-5D	Q2430VG76A-5D	Q3030V76A-5D	Q3030VG76A-5D
36"	914	40"	1016	Q1836V76A-5D	Q1836VG76A-5D	Q2136V76A-5D	Q2136VG76A-5D	Q2436V76A-5D	Q2436VG76A-5D	Q3036V76A-5D	Q3036VG76A-5D
42"	1067	46"	1168	Q1842V76A-5D	Q1842VG76A-5D	Q2142V76A-5D	Q2142VG76A-5D	Q2442V76A-5D	Q2442VG76A-5D	Q3042V76A-5D	Q3042VG76A-5D
48"	1219	52"	1320	Q1848V76A-5D	Q1848VG76A-5D	Q2148V76A-5D	Q2148VG76A-5D	Q2448V76A-5D	Q2448VG76A-5D	Q3048V76A-5D	Q3048VG76A-5D
54"	1372	58"	1473	Q1854V76A-5D	Q1854VG76A-5D	Q2154V76A-5D	Q2154VG76A-5D	Q2454V76A-5D	Q2454VG76A-5D	Q3054V76A-5D	Q3054VG76A-5D
60"	1524	64"	1626	Q1860V76A-5D	Q1860VG76A-5D	Q2160V76A-5D	Q2160VG76A-5D	Q2460V76A-5D	Q2460VG76A-5D	Q3060V76A-5D	Q3060VG76A-5D
66"	1676	70"	1778	Q1866V76A-5D	Q1866VG76A-5D	Q2166V76A-5D	Q2166VG76A-5D	Q2466V76A-5D	Q2466VG76A-5D	Q3066V76A-5D	Q3066VG76A-5D
72"	1829	76"	1930	Q1872V76A-5D	Q1872VG76A-5D	Q2172V76A-5D	Q2172VG76A-5D	Q2472V76A-5D	Q2472VG76A-5D	Q3072V76A-5D	Q3072VG76A-5D

\* For unit width, add 5" (127mm) to shelf width.

\*\* Dimensions are nominal.

## Catalog Section 1

### Q-LEVER® 86" (2184mm) Five-Tier Starter Units



unit with  
all wire shelves

unit with bottom  
dunnage shelf

- Features two 86" (2184mm) uprights, two braces, X-brace assembly, and hardware.
- Uprights utilize pins on 2" (51mm) centers for maximum flexibility for shelves and accessories
- Choice of Valu-Master® gray or Valu-Gard® green epoxy finish on shelves
- Valu-Master® gray epoxy finish on upright(s)

**FEATURES:**

Freight class is 70.0.

Consult factory for pricing.

#### Starter Units with All Wire Shelves

Includes five wire shelves and four pairs of brackets.

		...with 18" (457mm)-wide Shelves *		...with 21" (533mm)-wide Shelves *		...with 24" (610mm)-wide Shelves *		...with 30" (762mm)-wide Shelves *	
shelf length	unit**	Shelves with Valu-Master® finish	Shelves with Valu-Gard® finish	Shelves with Valu-Master® finish	Shelves with Valu-Gard® finish	Shelves with Valu-Master® finish	Shelves with Valu-Gard® finish	Shelves with Valu-Master® finish	Shelves with Valu-Gard® finish
in. mm	in. mm								
24" 610	28" 711	Q1824V86-5	Q1824VG86-5	Q2124V86-5	Q2124VG86-5	Q2424V86-5	Q2424VG86-5	-	-
30" 762	34" 864	Q1830V86-5	Q1830VG86-5	Q2130V86-5	Q2130VG86-5	Q2430V86-5	Q2430VG86-5	Q3030V86-5	Q3030VG86-5
36" 914	40" 1016	Q1836V86-5	Q1836VG86-5	Q2136V86-5	Q2136VG86-5	Q2436V86-5	Q2436VG86-5	Q3036V86-5	Q3036VG86-5
42" 1067	46" 1168	Q1842V86-5	Q1842VG86-5	Q2142V86-5	Q2142VG86-5	Q2442V86-5	Q2442VG86-5	Q3042V86-5	Q3042VG86-5
48" 1219	52" 1320	Q1848V86-5	Q1848VG86-5	Q2148V86-5	Q2148VG86-5	Q2448V86-5	Q2448VG86-5	Q3048V86-5	Q3048VG86-5
54" 1372	58" 1473	Q1854V86-5	Q1854VG86-5	Q2154V86-5	Q2154VG86-5	Q2454V86-5	Q2454VG86-5	Q3054V86-5	Q3054VG86-5
60" 1524	64" 1626	Q1860V86-5	Q1860VG86-5	Q2160V86-5	Q2160VG86-5	Q2460V86-5	Q2460VG86-5	Q3060V86-5	Q3060VG86-5
66" 1676	70" 1778	Q1866V86-5	Q1866VG86-5	Q2166V86-5	Q2166VG86-5	Q2466V86-5	Q2466VG86-5	Q3066V86-5	Q3066VG86-5
72" 1829	76" 1930	Q1872V86-5	Q1872VG86-5	Q2172V86-5	Q2172VG86-5	Q2472V86-5	Q2472VG86-5	Q3072V86-5	Q3072VG86-5

\* For unit width, add 5" (127mm) to shelf width.

\*\* Dimensions are nominal.

#### Starter Units with Bottom Dunnage Shelf

Includes four wire shelves, four pairs of brackets and one dunnage shelf.

		...with 18" (457mm)-wide Shelves *		...with 21" (533mm)-wide Shelves *		...with 24" (610mm)-wide Shelves *		...with 30" (762mm)-wide Shelves *	
shelf length	unit**	Shelves with Valu-Master® finish	Shelves with Valu-Gard® finish	Shelves with Valu-Master® finish	Shelves with Valu-Gard® finish	Shelves with Valu-Master® finish	Shelves with Valu-Gard® finish	Shelves with Valu-Master® finish	Shelves with Valu-Gard® finish
in. mm	in. mm								
24" 610	28" 711	Q1824V86-5D	Q1824VG86-5D	Q2124V86-5D	Q2124VG86-5D	Q2424V86-5D	Q2424VG86-5D	-	-
30" 762	34" 864	Q1830V86-5D	Q1830VG86-5D	Q2130V86-5D	Q2130VG86-5D	Q2430V86-5D	Q2430VG86-5D	Q3030V86-5D	Q3030VG86-5D
36" 914	40" 1016	Q1836V86-5D	Q1836VG86-5D	Q2136V86-5D	Q2136VG86-5D	Q2436V86-5D	Q2436VG86-5D	Q3036V86-5D	Q3036VG86-5D
42" 1067	46" 1168	Q1842V86-5D	Q1842VG86-5D	Q2142V86-5D	Q2142VG86-5D	Q2442V86-5D	Q2442VG86-5D	Q3042V86-5D	Q3042VG86-5D
48" 1219	52" 1320	Q1848V86-5D	Q1848VG86-5D	Q2148V86-5D	Q2148VG86-5D	Q2448V86-5D	Q2448VG86-5D	Q3048V86-5D	Q3048VG86-5D
54" 1372	58" 1473	Q1854V86-5D	Q1854VG86-5D	Q2154V86-5D	Q2154VG86-5D	Q2454V86-5D	Q2454VG86-5D	Q3054V86-5D	Q3054VG86-5D
60" 1524	64" 1626	Q1860V86-5D	Q1860VG86-5D	Q2160V86-5D	Q2160VG86-5D	Q2460V86-5D	Q2460VG86-5D	Q3060V86-5D	Q3060VG86-5D
66" 1676	70" 1778	Q1866V86-5D	Q1866VG86-5D	Q2166V86-5D	Q2166VG86-5D	Q2466V86-5D	Q2466VG86-5D	Q3066V86-5D	Q3066VG86-5D
72" 1829	76" 1930	Q1872V86-5D	Q1872VG86-5D	Q2172V86-5D	Q2172VG86-5D	Q2472V86-5D	Q2472VG86-5D	Q3072V86-5D	Q3072VG86-5D

\* For unit width, add 5" (127mm) to shelf width.

\*\* Dimensions are nominal.

### Q-LEVER® 86" (2184mm) Five-Tier Add-On Units



unit with all wire shelves

unit with bottom dunnage shelf

- Features one 86" (2184mm) upright, two braces, X-brace assembly, and hardware.
- Uprights utilize pins on 2" (51mm) centers for maximum flexibility for shelves and accessories
- Choice of Valu-Master® gray or Valu-Gard® green epoxy finish on shelves
- Valu-Master® gray epoxy finish on upright(s)

**FEATURES:**

Freight class is 70.0.

Consult factory for pricing.

#### Add-On Units with All Wire Shelves

Includes five wire shelves and four pairs of brackets.

shelf length in. mm	unit** length in. mm	...with 18" (457mm)-wide Shelves *		...with 21" (533mm)-wide Shelves *		...with 24" (610mm)-wide Shelves *		...with 30" (762mm)-wide Shelves *			
		Shelves with Valu-Master® finish	Shelves with Valu-Gard® finish	Shelves with Valu-Master® finish	Shelves with Valu-Gard® finish	Shelves with Valu-Master® finish	Shelves with Valu-Gard® finish	Shelves with Valu-Master® finish	Shelves with Valu-Gard® finish		
24"	610	25½"	648	Q1824V86A-5	Q1824VG86A-5	Q2124V86A-5	Q2124VG86A-5	Q2424V86A-5	Q2424VG86A-5	-	-
30"	762	31½"	800	Q1830V86A-5	Q1830VG86A-5	Q2130V86A-5	Q2130VG86A-5	Q2430V86A-5	Q2430VG86A-5	Q3030V86A-5	Q3030VG86A-5
36"	914	37½"	953	Q1836V86A-5	Q1836VG86A-5	Q2136V86A-5	Q2136VG86A-5	Q2436V86A-5	Q2436VG86A-5	Q3036V86A-5	Q3036VG86A-5
42"	1067	43½"	1105	Q1842V86A-5	Q1842VG86A-5	Q2142V86A-5	Q2142VG86A-5	Q2442V86A-5	Q2442VG86A-5	Q3042V86A-5	Q3042VG86A-5
48"	1219	49½"	1257	Q1848V86A-5	Q1848VG86A-5	Q2148V86A-5	Q2148VG86A-5	Q2448V86A-5	Q2448VG86A-5	Q3048V86A-5	Q3048VG86A-5
54"	1372	55½"	1410	Q1854V86A-5	Q1854VG86A-5	Q2154V86A-5	Q2154VG86A-5	Q2454V86A-5	Q2454VG86A-5	Q3054V86A-5	Q3054VG86A-5
60"	1524	61½"	1562	Q1860V86A-5	Q1860VG86A-5	Q2160V86A-5	Q2160VG86A-5	Q2460V86A-5	Q2460VG86A-5	Q3060V86A-5	Q3060VG86A-5
66"	1676	67½"	1715	Q1866V86A-5	Q1866VG86A-5	Q2166V86A-5	Q2166VG86A-5	Q2466V86A-5	Q2466VG86A-5	Q3066V86A-5	Q3066VG86A-5
72"	1829	73½"	1867	Q1872V86A-5	Q1872VG86A-5	Q2172V86A-5	Q2172VG86A-5	Q2472V86A-5	Q2472VG86A-5	Q3072V86A-5	Q3072VG86A-5

\* For unit width, add 5" (127mm) to shelf width.

\*\* Dimensions are nominal.

#### Add-On Units with Bottom Dunnage Shelf

Includes four wire shelves, four pairs of brackets and one dunnage shelf.

shelf length in. mm	unit** length in. mm	...with 18" (457mm)-wide Shelves *		...with 21" (533mm)-wide Shelves *		...with 24" (610mm)-wide Shelves *		...with 30" (762mm)-wide Shelves *			
		Shelves with Valu-Master® finish	Shelves with Valu-Gard® finish	Shelves with Valu-Master® finish	Shelves with Valu-Gard® finish	Shelves with Valu-Master® finish	Shelves with Valu-Gard® finish	Shelves with Valu-Master® finish	Shelves with Valu-Gard® finish		
24"	610	28"	711	Q1824V86A-5D	Q1824VG86A-5D	Q2124V86A-5D	Q2124VG86A-5D	Q2424V86A-5D	Q2424VG86A-5D	-	-
30"	762	34"	864	Q1830V86A-5D	Q1830VG86A-5D	Q2130V86A-5D	Q2130VG86A-5D	Q2430V86A-5D	Q2430VG86A-5D	Q3030V86A-5D	Q3030VG86A-5D
36"	914	40"	1016	Q1836V86A-5D	Q1836VG86A-5D	Q2136V86A-5D	Q2136VG86A-5D	Q2436V86A-5D	Q2436VG86A-5D	Q3036V86A-5D	Q3036VG86A-5D
42"	1067	46"	1168	Q1842V86A-5D	Q1842VG86A-5D	Q2142V86A-5D	Q2142VG86A-5D	Q2442V86A-5D	Q2442VG86A-5D	Q3042V86A-5D	Q3042VG86A-5D
48"	1219	52"	1320	Q1848V86A-5D	Q1848VG86A-5D	Q2148V86A-5D	Q2148VG86A-5D	Q2448V86A-5D	Q2448VG86A-5D	Q3048V86A-5D	Q3048VG86A-5D
54"	1372	58"	1473	Q1854V86A-5D	Q1854VG86A-5D	Q2154V86A-5D	Q2154VG86A-5D	Q2454V86A-5D	Q2454VG86A-5D	Q3054V86A-5D	Q3054VG86A-5D
60"	1524	64"	1626	Q1860V86A-5D	Q1860VG86A-5D	Q2160V86A-5D	Q2160VG86A-5D	Q2460V86A-5D	Q2460VG86A-5D	Q3060V86A-5D	Q3060VG86A-5D
66"	1676	70"	1778	Q1866V86A-5D	Q1866VG86A-5D	Q2166V86A-5D	Q2166VG86A-5D	Q2466V86A-5D	Q2466VG86A-5D	Q3066V86A-5D	Q3066VG86A-5D
72"	1829	76"	1930	Q1872V86A-5D	Q1872VG86A-5D	Q2172V86A-5D	Q2172VG86A-5D	Q2472V86A-5D	Q2472VG86A-5D	Q3072V86A-5D	Q3072VG86A-5D

\* For unit width, add 5" (127mm) to shelf width.

\*\* Dimensions are nominal.



## Catalog Section 1

### Q-LEVER® Workstations with Open Base



worktable with open base

		...with 24" (610mm)-wide Tabletop		...with 30" (762mm)-wide Tabletop			
shelf length in. mm	unit* length in. mm	Shelves with Valu-Master® finish	Shelves with Valu-Gard® finish	Shelves with Valu-Master® finish	Shelves with Valu-Gard® finish		
36"	914	37½"	953	Q2436V36-WO	Q2436VG36-WO	Q3036V36-WO	Q3036VG36-WO
42"	1067	43½"	1105	Q2442V36-WO	Q2442VG36-WO	Q3042V36-WO	Q3042VG36-WO
48"	1219	49½"	1257	Q2448V36-WO	Q2448VG36-WO	Q3048V36-WO	Q3048VG36-WO
54"	1372	55½"	1410	Q2454V36-WO	Q2454VG36-WO	Q3054V36-WO	Q3054VG36-WO
60"	1524	61½"	1562	Q2460V36-WO	Q2460VG36-WO	Q3060V36-WO	Q3060VG36-WO

\* Dimensions are nominal.

- Features tabletop, two 36" (914mm) uprights with legs & feet, and X-brace assembly.
- Tabletop constructed of 14 gauge type 304 stainless steel.
- Removable tabletop, no need for tools.
- 4½" backsplash.
- Valu-Master® gray epoxy finish on uprights.

**FEATURES:**

**Freight class is 70.0.**

**Consult factory for pricing.**

### Q-LEVER® Workstations with Storage Shelf



worktable with storage shelf

		...with 24" (610mm)-wide Tabletop		...with 30" (762mm)-wide Tabletop			
shelf length in. mm	unit* length in. mm	Shelves with Valu-Master® finish	Shelves with Valu-Gard® finish	Shelves with Valu-Master® finish	Shelves with Valu-Gard® finish		
36"	914	37½"	953	Q2436V36-WS	Q2436VG36-WS	Q3036V36-WS	Q3036VG36-WS
42"	1067	43½"	1105	Q2442V36-WS	Q2442VG36-WS	Q3042V36-WS	Q3042VG36-WS
48"	1219	49½"	1257	Q2448V36-WS	Q2448VG36-WS	Q3048V36-WS	Q3048VG36-WS
54"	1372	55½"	1410	Q2454V36-WS	Q2454VG36-WS	Q3054V36-WS	Q3054VG36-WS
60"	1524	61½"	1562	Q2460V36-WS	Q2460VG36-WS	Q3060V36-WS	Q3060VG36-WS

\* Dimensions are nominal.

- Features tabletop, two 36" (914mm) uprights with legs & feet, X-brace assembly, and heavy duty dunnage shelf.
- Tabletop constructed of 14 gauge type 304 stainless steel.
- Removable tabletop, no need for tools.
- 4½" backsplash.
- Valu-Master® gray epoxy finish on uprights.

**FEATURES:**

**Freight class is 70.0.**

**Consult factory for pricing.**

## Q-LEVER® Overhead Storage Stations



- Features two 76" (1930mm) uprights with legs & feet, X-brace assembly, and two overshelves.
- Overshelves adjust on 2" (51mm) increments.
- Choice of Valu-Master® gray or Valu-Gard® green epoxy finish on shelves.
- Valu-Master® gray epoxy finish on uprights.

**FEATURES:**

**Freight class is 70.0.**

**Consult factory for pricing.**

shelf length in. mm	unit* length in. mm	...with 24" (610mm)-wide Overall Width		...with 30" (762mm)-wide Overall Width	
		Shelves with Valu-Master® finish	Shelves with Valu-Gard® finish	Shelves with Valu-Master® finish	Shelves with Valu-Gard® finish
36" 914	37½" 953	Q2436V76-OS	Q2436VG76-OS	Q3036V76-OS	Q3036VG76-OS
42" 1067	43½" 1105	Q2442V76-OS	Q2442VG76-OS	Q3042V76-OS	Q3042VG76-OS
48" 1219	49½" 1257	Q2448V76-OS	Q2448VG76-OS	Q3048V76-OS	Q3048VG76-OS
54" 1372	55½" 1410	Q2454V76-OS	Q2454VG76-OS	Q3054V76-OS	Q3054VG76-OS
60" 1524	61½" 1562	Q2460V76-OS	Q2460VG76-OS	Q3060V76-OS	Q3060VG76-OS

\* Dimensions are nominal.

## Q-LEVER® Task Stations



- Features tabletop, two 76" (1930mm) uprights with legs & feet, X-brace assembly, wall grid, and two adjustable overshelves.
- Wall grid features 3" x 3" (76 x 76mm) mesh.
- Tabletop is removable, no need for tools.
- Choice of Valu-Master® gray or Valu-Gard® green epoxy finish on shelves.
- Valu-Master® gray epoxy finish on uprights.

**FEATURES:**

**Freight class is 70.0.**

**Consult factory for pricing.**

shelf length in. mm	unit* length in. mm	...with 24" (610mm)-wide Tabletop		...with 30" (762mm)-wide Tabletop	
		Shelves with Valu-Master® finish	Shelves with Valu-Gard® finish	Shelves with Valu-Master® finish	Shelves with Valu-Gard® finish
36" 914	37½" 953	Q2436V76-TS	Q2436VG76-TS	Q3036V76-TS	Q3036VG76-TS
42" 1067	43½" 1105	Q2442V76-TS	Q2442VG76-TS	Q3042V76-TS	Q3042VG76-TS
48" 1219	49½" 1257	Q2448V76-TS	Q2448VG76-TS	Q3048V76-TS	Q3048VG76-TS
54" 1372	55½" 1410	Q2454V76-TS	Q2454VG76-TS	Q3054V76-TS	Q3054VG76-TS
60" 1524	61½" 1562	Q2460V76-TS	Q2460VG76-TS	Q3060V76-TS	Q3060VG76-TS

\* Dimensions are nominal.

## Catalog Section 1

### Q-LEVER® Utility Stations



- Features tabletop, drawers, two 76" (1930mm) uprights with legs & feet, X-brace assembly, wall grid, two adjustable overshelves, and heavy duty dunnage shelf.
- Overshelves adjust on 2" (51mm) increments.
- Tabletop is removable, no need for tools.
- Choice of Valu-Master® gray or Valu-Gard® green epoxy finish on shelves.
- Valu-Master® gray epoxy finish on uprights.

**FEATURES:**

**Freight class is 70.0.**

**Consult factory for pricing.**

		...with 24" (610mm)-wide Tabletop		...with 30" (762mm)-wide Tabletop			
shelf length	unit* length	Shelves with Valu-Master® finish	Shelves with Valu-Gard® finish	Shelves with Valu-Master® finish	Shelves with Valu-Gard® finish		
in. mm	in. mm						
36"	914	37½"	953	Q2436V76-US	Q2436VG76-US	Q3036V76-US	Q3036VG76-US
42"	1067	43½"	1105	Q2442V76-US	Q2442VG76-US	Q3042V76-US	Q3042VG76-US
48"	1219	49½"	1257	Q2448V76-US	Q2448VG76-US	Q3048V76-US	Q3048VG76-US
54"	1372	55½"	1410	Q2454V76-US	Q2454VG76-US	Q3054V76-US	Q3054VG76-US
60"	1524	61½"	1562	Q2460V76-US	Q2460VG76-US	Q3060V76-US	Q3060VG76-US

\* Dimensions are nominal.

### Q-LEVER® Manager's Stations



*shown with optional storage  
baskets, supply bins and hooks*

- Features tabletop, drawers, two 76" (1930mm) uprights with legs & feet, X-brace assembly, power strip, overhead light, monitor arm, wall grid, and bin holder.
- Tabletop is removable, no need for tools.
- Choice of Valu-Master® gray or Valu-Gard® green epoxy finish on shelves.
- Valu-Master® gray epoxy finish on uprights.

**FEATURES:**

**Freight class is 70.0.**

**Consult factory for pricing.**

		...with 24" (610mm)-wide Tabletop		...with 30" (762mm)-wide Tabletop			
shelf length	unit* length	Shelves with Valu-Master® finish	Shelves with Valu-Gard® finish	Shelves with Valu-Master® finish	Shelves with Valu-Gard® finish		
in. mm	in. mm						
36"	914	37½"	953	Q2436V76-MS	Q2436VG76-MS	Q3036V76-MS	Q3036VG76-MS
42"	1067	43½"	1105	Q2442V76-MS	Q2442VG76-MS	Q3042V76-MS	Q3042VG76-MS
48"	1219	49½"	1257	Q2448V76-MS	Q2448VG76-MS	Q3048V76-MS	Q3048VG76-MS
54"	1372	55½"	1410	Q2454V76-MS	Q2454VG76-MS	Q3054V76-MS	Q3054VG76-MS
60"	1524	61½"	1562	Q2460V76-MS	Q2460VG76-MS	Q3060V76-MS	Q3060VG76-MS

\* Dimensions are nominal.

## Q-LEVER® Accessories

### Drawers

- Stainless steel construction.
- Choice of two 3" (76mm) tall drawers, or one 6" tall drawer.
- Screws into existing holes in underside of Q-LEVER® workstation top.
- Precision steel ball bearing drawer slides for medium-duty applications.
- Drawer profile features an easy to operate disconnect finger release trigger.
- Load capacity is 100 lbs. (45 kg).

description	model #
one 6"-tall drawers	<b>QDRAWER-1</b>
two 3"-tall drawers	<b>QDRAWER-2</b>



### Tabletops

- Heavy gauge polished stainless steel construction.
- 4½" (114mm) backsplash.
- Square edges are turned down 90°, with a 30° kick in the front.
- Reinforced with hat channel construction underneath.
- Channel construction provides holes to accept drawers.
- Tabletops are removable.



length in. mm	24" (610mm)-wide		30" (762mm)-wide	
	model		model	
24" 610	<b>Q2424T</b>		<b>Q3024T</b>	
30" 762	<b>Q2430T</b>		<b>Q3030T</b>	
36" 914	<b>Q2436T</b>		<b>Q3036T</b>	
42" 1067	<b>Q2442T</b>		<b>Q3042T</b>	
48" 1219	<b>Q2448T</b>		<b>Q3048T</b>	
54" 1372	<b>Q2454T</b>		<b>Q3054T</b>	
60" 1524	<b>Q2460T</b>		<b>Q3060T</b>	
72" 1829	<b>Q2460T</b>		<b>Q3060T</b>	

### Overhead Lights

- Overhead light shelf is powder-coated Valu-Master® gray.
- Dimmable light fixture is powder white.
- Built-in ON/OFF switch with a high/low output option.
- Color temp = Warm White
- Power cord is 78" (1981mm) in length.
- Adjustable on Q-LEVER® uprights.



length			length		
in.	mm	model	in.	mm	model
24"	610	<b>Q24VL</b>	48"	1219	<b>Q48VL</b>
30"	762	<b>Q30VL</b>	54"	1372	<b>Q54VL</b>
36"	914	<b>Q36VL</b>	60"	1524	<b>Q60VL</b>
42"	1067	<b>Q42VL</b>	72"	1829	<b>Q60VL</b>

### Power Strips

- Power strip is powder-coated black, mount is powder-coated Valu-Master® gray.
- 120-volt, NEMA 5-15P.
- Outlets are placed at right angle to accommodate bulky transformers.
- Comes with a 15' AC power cord.
- Lighted power switch confirms power ON/OFF status.
- Snap-in switch guard prevents accidental turnoff.
- Uses a 15-amp circuit breaker.
- Adjustable on Q-LEVER® uprights.



length		length	
in.	mm	in.	mm
24"	610	48"	1219
30"	762	54"	1372
36"	914	60"	1524
42"	1067	72"	1829

### Flat Panel Monitor Arm

- Plated powder-coated black.
- Can pivot left-to-right.
- Universal VESA mount – 100 x 100mm and 75 x 75 mm hole pattern.
- Accepts all flat pattern monitors 10" to 30".
- Has internal area for internal cable management for a neat appearance.
- Adjustable on Q-LEVER® uprights.
- Can be mounted on either side of upright.
- Weight capacity is 14 lbs (6.4 kg).



model #  
**QARM**

**Consult factory for pricing.**

## Catalog Section 1

### Q-LEVER® Accessories

#### Wall Grids

- Wires are 2-gauge mild steel, crisscrossed to create a 3" x 3" mesh.
- Easily hooks onto uprights without the need for tools.
- Holds wall mat accessories.
- Valu-Master® gray epoxy finish.

height x length		model
in.	mm	
18" x 36"	457 x 914	<b>Q1836VW</b>
18" x 48"	457 x 1219	<b>Q1848VW</b>
18" x 60"	457 x 1524	<b>Q1860VW</b>
30" x 36"	762 x 914	<b>Q3036VW</b>
30" x 48"	762 x 1219	<b>Q3048VW</b>

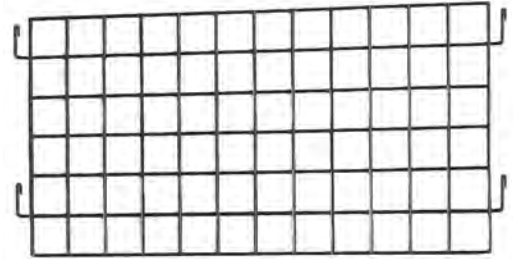

#### Hanger Rails

- Easily hooks onto uprights.
- Accommodates all accessories.
- Can be used as a backstop.
- Valu-Master® gray epoxy finish.

length		model	length		model
in.	mm		in.	mm	
24"	610	<b>Q24VH</b>	48"	1219	<b>Q48VH</b>
30"	762	<b>Q30VH</b>	54"	1372	<b>Q54VH</b>
36"	914	<b>Q36VH</b>	60"	1524	<b>Q60VH</b>
42"	1067	<b>Q42VH</b>	72"	1829	<b>Q60VH</b>



#### Supply Bins

- Made of durable polypropylene, providing longlasting years of service.
- Integral molded slots accept ID labels.

color	width x length x height		carton quantity	model
	in.	mm		
blue	5½" x 10½" x 5"	140 x 276 x 127	12	<b>A203877</b>
blue	11" x 10½" x 5"	279 x 276 x 127	6	<b>A203879</b>
blue	8¼" x 14½" x 7"	210 x 375 x 178	12	<b>A203881</b>
blue	16½" x 14½" x 7"	419 x 375 x 178	6	<b>A203883</b>



#### Storage Baskets

- Easily attaches to hanger rail or side of wire shelf.
- Valu-Master® gray epoxy finish.

width x length x height		model
in.	mm	
5" x 13½" x 7"	127 x 340 x 178	<b>WB-V</b>
7½" x 17½" x 5"	191 x 441 x 127	<b>WB-M-V</b>
7½" x 17½" x 10"	191 x 441 x 254	<b>WB-L-V</b>



**Consult factory for pricing.**

# Shelf Select™

***A No-Cost Design & Layout Service for Shelving Products.***



***Typical Shelf Select™ applications include walk-in coolers and freezers; dry storage areas; supermarkets; and department stores.***

## Provide Us With:

- Dimensions of a storage space available.
- Number of shelves per unit.
- Post heights.
- Indicate stationary, mobile or high density shelving.
- Any additional specific or pertinent storage requirements.

## And We'll Provide You With:

- **Plan View**  
Shelving system layout makes the most efficient utilization of your space available.
- **Perspective View\***  
Illustrates the proposed equipment assembled in the available space. A great tool for presentation which reduces field assembly time when provided to your installer.
- **Quote\***  
Includes model numbers, net prices and shipping weights for all components in specified job.

\* Will be provided after plan view is approved.

***For more information about Shelf Select™, request Shelf Select™ service announcement EG8027***

**Simply**

**Email: [quotes@eaglegrp.com](mailto:quotes@eaglegrp.com)**

**Fax: 302-653-2065**

in your order and our trained staff will begin planning, layout and quotation upon receipt.

A completed Shelf Select™ custom layout and quotation will be mailed, emailed or faxed back to you within 48 hours.

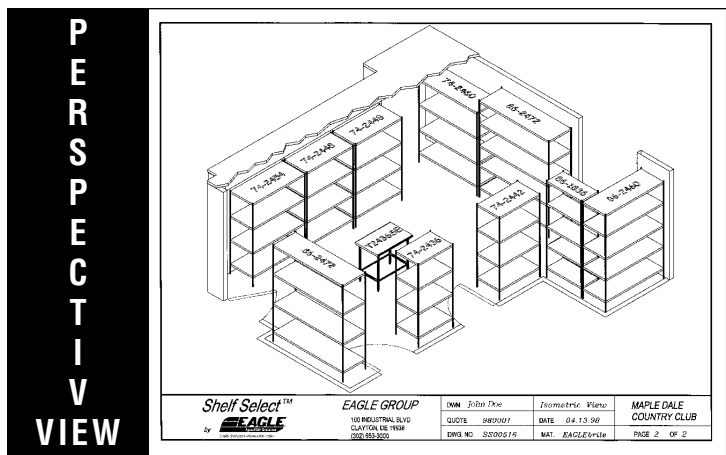
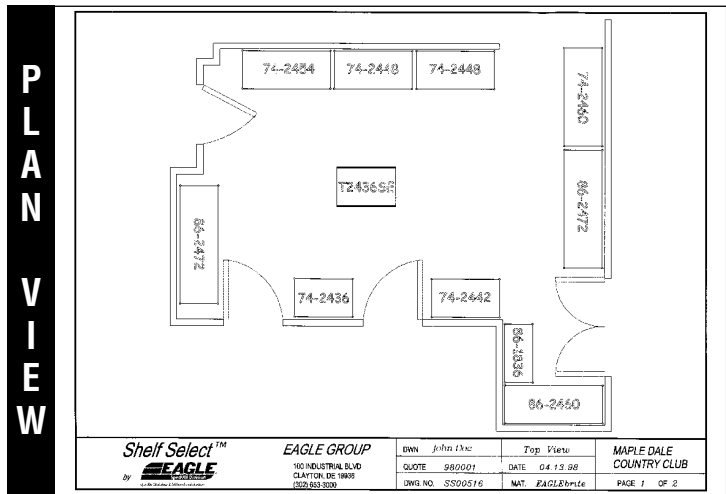

**FINAL OUTCOME!**



Two columns of horizontal lines for writing notes.





# Wall Shelves

## Adjustable Post Wire Wall Mounts

Sold as Components.....	112
Sold as Prepackaged Units.....	111

## Snap-n-Slide®

Wall Shelves.....	106
Wire Wall Shelves.....	107
with Ticket Rail.....	107

## Wall Shelves

Microwave Shelves.....	110
Pass-Thru Shelves.....	110

Piggyback Wall Mounted Shelf Kits.....	108
Shelves with Removable Hooks.....	109
Single Bar Pot Racks.....	107
Stationary Wire Wall Mounts.....	112
Tab Lock Shelves.....	110
Wall Mounted Shelves.....	108
Wire Wall Shelf Kits.....	111

## WALSTOR® Modular Wall System ..... 104

## WALSTOR® Modular Wall System Accessories ..... 105

## Wall Mounted Drop Tables/Shelves

see product announcement **EG02.15**

- 3/4" (19mm) thick shelf.
- Pair of chrome-plated drop brackets.
- Weight capacity of 80 lbs. (36.3 kg).

FEATURES:

Freight class is 70.0.

Convert wasted wall space into an organized work area.

		Poly *				Richlite® **				16/3 Stainless Steel with Wooden Core					
width		length		weight		weight		weight		weight		weight			
in.	mm	in.	mm	lb.	kg	model #	list	lb.	kg	model #	list	lb.	kg	model #	list
10"	254	24"	610	7	3.2	<b>DSP-1024</b>	291	7	3.2	<b>DSR-1024</b>	438	11	5.0	<b>DSS-1024</b>	340
10"	254	30"	762	9	4.1	<b>DSP-1030</b>	303	9	4.1	<b>DSR-1030</b>	499	13	5.9	<b>DSS-1030</b>	346
10"	254	36"	914	11	5.0	<b>DSP-1036</b>	320	11	5.0	<b>DSR-1036</b>	566	15	6.8	<b>DSS-1036</b>	363
12"	305	24"	610	8	3.6	<b>DSP-1224</b>	298	8	3.6	<b>DSR-1224</b>	475	12	5.4	<b>DSS-1224</b>	343
12"	305	30"	762	10	4.5	<b>DSP-1230</b>	314	10	4.5	<b>DSR-1230</b>	478	14	6.4	<b>DSS-1230</b>	362
12"	305	36"	914	12	5.4	<b>DSP-1236</b>	335	12	5.4	<b>DSR-1236</b>	643	16	7.3	<b>DSS-1236</b>	372

\* Poly tables/shelves can withstand hot items up to 180°F without discoloration.

\*\* Richlite® tables/shelves can withstand hot items up to 350°F without discoloration.



drop bracket



shown in  
dropped-down position

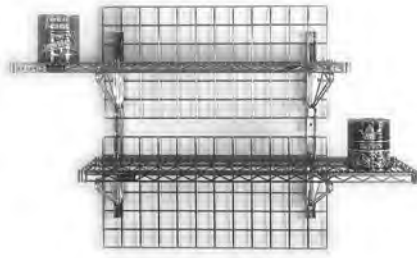

**WalStor® system  
shown demonstrating  
an uneven load capability.**

## Modular Wall System NSF

see spec sheet **EG02.00A**

### Wall Mats

- 3" x 3" (76 x 76mm) zinc-plated grids.
- Required only for hanging accessories.

	length		weight		cubic feet	model #	list
	height in.	mm	lbs.	kg			
<b>18" (457mm)</b>	36"	914	9	4.1	0.2	<b>WM1836</b> •	99
	48"	1219	11	5.0	0.3	<b>WM1848</b> •	127
	60"	1524	14	6.4	0.3	<b>WM1860</b>	148
<b>24" (609mm)</b>	48"	1219	13	5.8	0.3	<b>WM2448</b> •	151
	72"	1828	19	8.6	0.5	<b>WM2472</b>	174
	84"	2133	22	9.9	0.6	<b>WM2484</b>	208
	96"	2438	25	11.3	0.7	<b>WM2496</b>	220
<b>33" (838mm)</b>	54"	1372	22	9.9	0.5	<b>WM3354</b>	254
<b>48" (1219mm)</b>	48"	1219	19	8.6	0.7	<b>WM4848</b>	246

### Vertical Wall Uprights

- Zinc-plated finish.
- Sold in pairs.

height in.	mm	weight lbs.	kg	cu ft	model #	list
12"	305	2	0.9	0.2	<b>PR12VU</b> •	57
30"	762	4	1.8	0.4	<b>PR30VU</b> •	94
45"	1143	5	2.3	0.5	<b>PR45VU</b> •	117

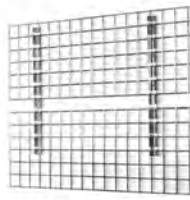

wall mats and vertical wall uprights

### Wire Shelf Brackets

- Zinc-plated finish.
- Sold in pairs.

(Note: Must be ordered with Vertical Wall Uprights)

depth in.	mm	weight lbs.	kg	cubic feet	model #	list
14"	356	3	1.5	0.1	<b>PR14B</b> •	125
18"	457	4	2.0	0.1	<b>PR18B</b> •	137
21"	533	4	2.0	0.1	<b>PR21B</b>	141
24"	610	5	2.0	0.1	<b>PR24B</b>	181

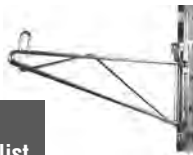

**Note:** WalStor® must be mounted to a solid surface or studs in a wall. User needs to determine installation materials and methods suitable to hold and support the WalStor® system.

**Freight class is 70.0.**

(•) MTS (made to stock) / ( ) MTO (made to order)

### Single Shelf Kits

- One EAGLEbrite® shelf.
- One wall mat.
- One pair of 30" (762mm) vertical wall uprights.
- One pair of 18" (457mm) wire shelf brackets.

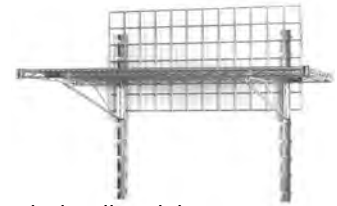

	shelf and wall mat size		weight		cu ft	model #	list
	in.	mm	lbs.	kg			
<b>18" width (457mm)</b>	36"	914	35	15.9	3.5	<b>WAL-1-1836</b>	415
	48"	1219	36	16.3	4.5	<b>WAL-1-1848</b>	459

### Double Shelf Kits

- Two EAGLEbrite® shelves.
- Two wall mats.
- One pair of 45" (1143mm) vertical wall uprights.
- Two pairs of 18" (457mm) wire shelf brackets.

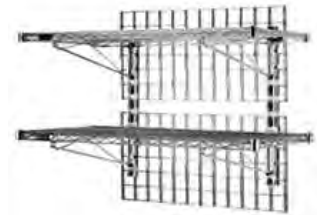

	shelf dimensions		weight		cubic feet	model #	list
	in.	mm	lbs.	kg			
<b>18" width (457mm)</b>	36"	914	41	18.6	2.0	<b>WAL-2-1836</b>	759
	48"	1219	49	22.2	2.4	<b>WAL-2-1848</b>	847

### Wall Grid Shelving - see spec sheet **EG02.00C**

width x length in.	mm	weight		cubic feet	chrome		Valu-Gard®		EAGLEbrite®	
		lbs.	kg		model #	list	model #	list	model #	list
14" x 30"	356 x 762	7	3.2	3.1	<b>1430WGS-C</b>	141	<b>1430WGS-VG</b>	145	<b>1430WGS-Z</b>	129
14" x 36"	356 x 914	9	4.1	3.6	<b>1436WGS-C</b>	146	<b>1436WGS-VG</b>	152	<b>1436WGS-Z</b>	138
18" x 30"	457 x 762	9	4.1	3.7	<b>1830WGS-C</b>	151	<b>1830WGS-VG</b>	155	<b>1830WGS-Z</b>	141
18" x 36"	457 x 914	12	5.4	4.5	<b>1836WGS-C</b>	157	<b>1836WGS-VG</b>	162	<b>1836WGS-Z</b>	144
18" x 48"	457 x 1219	15	6.8	6.0	<b>1848WGS-C</b>	181	<b>1848WGS-VG</b> •	186	<b>1848WGS-Z</b>	167

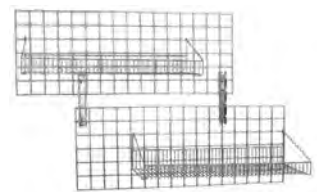



Custom configurations allow you to personalize your WalStor® system for merchandise displays or over-the-workstation storage. Engineered with the idea that a perfect storage system adapts easily to individual requirements.

### Modular Wall System Accessories

see spec sheet **EG02.00B**

Freight class is 70.0.

(•) MTS (made to stock) / ( ) MTO (made to order)

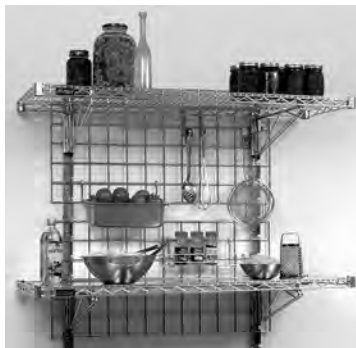

WalStor® system with optional accessories shown

#### shelf collar plugs

Model #: **COLLAR PLUG**   
(4 per shelf required)

#### utensil rack

Model #: **SCOOP10-VG** List: \$73  
5" depth x 10-1/2" length (127 x 267mm),  
2 lbs., 0.5 cu. ft. ValuGuard® epoxy finish.



small\*\*  
snap  
hook



large\*\*  
snap  
hook



utensil\*\*  
hook



large\*\*  
double  
hook



book  
holder



light duty  
utility  
shelf



grid  
shelf



triangle  
shelf

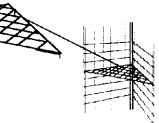

towel  
rack



spice  
rack



merchandising\*\*  
display hook



#### Vertical uprights for display shelf

See page 74 for display shelves.  
Specify Universal Nolin (manufacturer ID #2).  
Requires a pair of DSS (display shelf standards).

large  
bin



small  
bin



hanging  
file  
holder



plastic  
bin  
holder

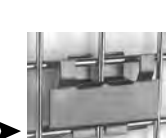

grid panel  
wall bracket



1/2-size  
pan  
holder



drop  
basket

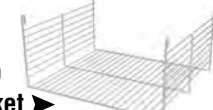

wire  
basket



grid  
panel  
basket

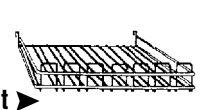

description	length x width x height		weight		cu ft	model #	list	description	length x width x height		weight		cu ft	model #	list
	in.	mm	lbs.	kg					in.	mm	lbs.	kg			
1/2 size pan holder	12" x 8" x 3"	305 x 203 x 76	1.0	0.5	0.2	PH3RD	63	merch. dspl hook	12" x 3"	304 x 76	0.2	0.1	0.1	MDH-12**	28
book holder	3" x 12" x 10"	76 x 305 x 254	2.0	0.9	0.2	BH-1	178	plastic bin dividers	10 1/2" x 5"	276 x 127	2.0	0.9	0.1	A204237	24
vertical uprights	2" x 8 3/4"	51 x 222	2.0	0.9	0.3	DSS	121	plastic bin holder	4" x 2"	102 x 51	0.3	0.1	0.4	PBH •	46
drop basket (for 18" wire shelf)	22" x 18" x 11"	559 x 457 x 280	3.0	1.4	0.3	DB	136	small plastic bin	10 1/2" x 5 1/2" x 5"	276 x 140 x 127	0.75	0.3	0.2	A203877 *	21
grid shelf	16 1/2" x 16 1/2"	426 x 426	4.0	1.8	0.6	GS17	176	small snap hook	1 1/4" x 4 1/4" x 3 1/2"	32 x 127 x 76	0.3	0.1	0.1	SH ** •	4
hanging file holder	12" x 8" x 3"	305 x 203 x 76	1.0	0.5	0.2	HFH	62	spice rack	14" x 2"	356 x 51	1.0	0.5	0.1	SR14	77
large double hook	2 1/4" x 4 1/4" x 3 1/2"	57 x 108 x 3	0.3	0.1	0.1	LDH** •	11	spice rack	24" x 2"	610 x 51	1.5	0.7	0.2	SR24	82
large plastic bin	10 1/2" x 11" x 5"	276 x 280 x 127	1.0	0.5	0.3	A203879 *	28	towel rack	10 1/2" x 5" x 3.5"	267 x 127 x 76	1.0	0.5	0.3	TR10	62
large snap hook	2 1/4" x 4 1/4" x 3 1/2"	57 x 108 x 3	0.3	0.1	0.1	LH** •	7	utensil hook	2 1/2" x 2"	64 x 51	0.3	0.1	0.1	UH ** •	15
lt. duty utility shelf	11 1/2" x 8" x 3 1/2"	286 x 203 x 89	2.0	0.9	0.2	LDUS12	75	wire basket	13 3/8" x 5" x 7"	340 x 127 x 178	0.5	0.2	0.2	WB •	40
merch. dspl hook	4" x 3"	101 x 76	0.2	0.1	0.1	MDH-4**	17	2-deck can rack	8 1/2" x 13" x 14"	219 x 330 x 356	1.0	0.5	0.1	CR2D	201
merch. dspl hook	6" x 3"	152 x 76	0.2	0.1	0.1	MDH-6**	18	4-deck can rack	8 1/2" x 8 1/2" x 28 1/2"	210 x 216 x 724	3.0	1.3	1.2	CR4D	225
merch. dspl hook	8" x 3"	203 x 76	0.2	0.1	0.1	MDH-8**	24	wall bracket	3" x 4" x 4"	76 x 102 x 102	0.2	0.1	0.1	GPWB	27
merch. dspl hook	10" x 3"	254 x 76	0.2	0.1	0.1	MDH-10**	25	triangle shelf	24" x 24"	610 x 610	3.6	1.6	0.5	GPS24-C	87
								grid panel basket	15" x 24"	381 x 610	2.8	1.2	0.4	GBP15-C	98

\*A203877 requires (1) PBH. A203879 requires (2) PBH. \*\*All hooks are heavy gauge chrome-plated.

## Snap-n-Slide® Wall Shelves NSF

see spec sheet **EG02.01**



- Brackets can be mounted to wall studs – no wall backing required.
- 1½" (38mm) upturn on rear and ends.
- Heavy gauge stainless steel construction.
- No tools required to attach shelf to wall brackets.

FEATURES:

**Freight class is 70.0.**

(•) MTS (made to stock) / ( ) MTO (made to order)

### Optional Dividers for Snap-n-Slide® Wall Shelves

- 4" (102mm) height.

description	model #	list
for 12" (305mm) shelving	<b>358114</b>	47
for 15" (381mm) shelving	<b>358115</b>	49



### 12" (305mm) wide Snap-n-Slide® Shelves with Rolled Front Edge

length in. mm	weight		wt. capacity*		cu ft	16 gauge type 430		16 gauge type 304		14 gauge type 304	
	lbs.	kg	lbs.	kg		model #	list	model #	list	model #	list
24" 610	12	5.4	90	40.8	0.7	<b>SWS1224-16/4</b> •	287	<b>SWS1224-16/3</b> •	345	<b>SWS1224-14/3</b>	366
36" 915	14	6.4	135	61.2	1.1	<b>SWS1236-16/4</b> •	311	<b>SWS1236-16/3</b> •	437	<b>SWS1236-14/3</b> •	466
48" 1219	17	7.7	180	81.6	1.4	<b>SWS1248-16/4</b> •	382	<b>SWS1248-16/3</b> •	484	<b>SWS1248-14/3</b> •	521
60" 1524	23	10.4	225	102.1	1.8	<b>SWS1260-16/4</b> •	406	<b>SWS1260-16/3</b> •	528	<b>SWS1260-14/3</b>	563
72" 1829	25	11.3	270	122.5	2.1	<b>SWS1272-16/4</b> •	502	<b>SWS1272-16/3</b> •	651	<b>SWS1272-14/3</b>	713

### 15" (381mm) wide Snap-n-Slide® Shelves with Rolled Front Edge

length in. mm	weight		wt. capacity*		cu ft	16 gauge type 430		16 gauge type 304		14 gauge type 304	
	lbs.	kg	lbs.	kg		model #	list	model #	list	model #	list
24" 610	15	6.8	90	40.8	1.1	<b>SWS1524-16/4</b>	311	<b>SWS1524-16/3</b>	378	<b>SWS1524-14/3</b>	411
36" 915	17	7.7	135	61.2	1.7	<b>SWS1536-16/4</b> •	320	<b>SWS1536-16/3</b> •	451	<b>SWS1536-14/3</b>	508
48" 1219	21	9.5	180	81.6	2.2	<b>SWS1548-16/4</b> •	385	<b>SWS1548-16/3</b> •	548	<b>SWS1548-14/3</b>	618
60" 1524	28	12.7	225	102.1	2.7	<b>SWS1560-16/4</b> •	419	<b>SWS1560-16/3</b> •	601	<b>SWS1560-14/3</b>	636
72" 1829	30	13.6	270	122.5	3.3	<b>SWS1572-16/4</b>	512	<b>SWS1572-16/3</b>	749	<b>SWS1572-14/3</b>	846

### 15" (381mm) wide Snap-n-Slide® Shelves with "V" Marine Front Edge 14 gauge

length in. mm	weight		wt. capacity*		cu ft	14 gauge type 304		14 gauge type 316	
	lbs.	kg	lbs.	kg		model #	list	model #	list
24" 610	15	6.8	90	40.8	1.1	<b>SWS1524-14/304-VMAR</b>	534	<b>SWS1524-14/316-VMAR</b>	596
36" 915	17	7.7	135	61.2	1.7	<b>SWS1536-14/304-VMAR</b>	559	<b>SWS1536-14/316-VMAR</b>	689
48" 1219	21	9.5	180	81.6	2.2	<b>SWS1548-14/304-VMAR</b>	726	<b>SWS1548-14/316-VMAR</b>	857
60" 1524	28	12.7	225	102.1	2.7	<b>SWS1560-14/304-VMAR</b>	808	<b>SWS1560-14/316-VMAR</b>	963
72" 1829	30	13.6	270	122.5	3.3	<b>SWS1572-14/304-VMAR</b>	957	<b>SWS1572-14/316-VMAR</b>	1129

### 15" (381mm) wide Snap-n-Slide® Shelves with "V" Marine Front Edge 16 gauge

length in. mm	weight		wt. capacity*		cu ft	16 gauge type 430		16 gauge type 304	
	lbs.	kg	lbs.	kg		model #	list	model #	list
24" 610	15	6.8	90	40.8	1.1	<b>SWS1524-16/430-VMAR</b>	466	<b>SWS1524-16/304-VMAR</b>	524
36" 915	17	7.7	135	61.2	1.7	<b>SWS1536-16/430-VMAR</b>	506	<b>SWS1536-16/304-VMAR</b>	583
48" 1219	21	9.5	180	81.6	2.2	<b>SWS1548-16/430-VMAR</b>	597	<b>SWS1548-16/304-VMAR</b>	698
60" 1524	28	12.7	225	102.1	2.7	<b>SWS1560-16/430-VMAR</b>	641	<b>SWS1560-16/304-VMAR</b>	766
72" 1829	30	13.6	270	122.5	3.3	<b>SWS1572-16/430-VMAR</b>	754	<b>SWS1572-16/304-VMAR</b>	897

\* Weight capacities pertain to evenly distributed weight.

## Catalog Section 2

### Snap-n-Slide® Wire Wall Shelves (NSF)

see spec sheet **EG02.02**



**FEATURES:**

- Wire design allows for air circulation.
- Brackets can be mounted to studs with no backing required.

**Note:** See page 106 for Snap-n-Slide® with solid shelves.

**Freight class is 70.0.**

	length		weight		weight * capacity		cu ft	chrome		VALU-MASTER®		Valu-Gard®		EAGLEgard®	
	in.	mm	lbs.	kg	lbs.	kg		model #	list	model #	list	model #	list	model #	list
<b>12" width (305mm)</b>	24"	610	5	2.3	70	31.8	0.7	<b>SNSW1224C</b>	133	<b>SNSW1224V</b>	139	<b>SNSW1224VG</b>	139	<b>SNSW1224E</b>	154
	36"	915	7	3.2	105	47.6	1.1	<b>SNSW1236C</b>	174	<b>SNSW1236V</b>	183	<b>SNSW1236VG</b>	183	<b>SNSW1236E</b>	199
	48"	1219	9	4.1	140	63.5	1.4	<b>SNSW1248C</b>	217	<b>SNSW1248V</b>	227	<b>SNSW1248VG</b>	227	<b>SNSW1248E</b>	242
	60"	1524	11	5.0	175	79.5	1.8	<b>SNSW1260C</b>	235	<b>SNSW1260V</b>	247	<b>SNSW1260VG</b>	247	<b>SNSW1260E</b>	265
	72"	1829	14	6.4	210	95.3	2.1	<b>SNSW1272C</b>	301	<b>SNSW1272V</b>	318	<b>SNSW1272VG</b>	318	<b>SNSW1272E</b>	333

\* Weight capacity pertains to evenly distributed weight.

### Snap-n-Slide® Wall Shelves with Ticket Rail

see spec sheet **EG02.03**



**FEATURES:**

- Front of shelf is flat and features "tape-on" ticket rails, which are supplied with tape and are to be attached in the field.
- Floating ball mechanism holds checks in place.
- Heavy gauge type 430 construction.

**Freight class is 70.0.**

	length		weight		weight cap.		cu ft	model #	list
	in.	mm	lbs.	kg	lbs.	kg			
<b>12" width (305mm)</b>	12"	305	8	3.6	45	20.4	0.4	<b>SWS1212TR-16/4</b>	242
	18"	457	10	4.5	68	30.8	0.5	<b>SWS1218TR-16/4</b>	264
	24"	610	14	6.4	90	40.8	0.7	<b>SWS1224TR-16/4</b>	303
	36"	915	17	7.7	135	61.2	1.1	<b>SWS1236TR-16/4</b>	338
	48"	1219	21	9.5	180	81.6	1.4	<b>SWS1248TR-16/4</b>	427
	60"	1524	28	12.7	225	102.1	1.8	<b>SWS1260TR-16/4</b>	471
	72"	1829	31	14.1	270	122.5	2.1	<b>SWS1272TR-16/4</b>	581
	96"	2438	39	17.6	360	163.3	2.8	<b>SWS1296TR-16/4</b>	747

### Replacement Ticket Rails

For 96"-long shelf, use two 48" (1219mm)-long ticket rails (#354566).

length				weight				length				weight					
in.	mm	lbs.	kg	model #	list	in.	mm	lbs.	kg	model #	list	in.	mm	lbs.	kg	model #	list
12"	305	5	2.3	<b>354562</b>	40	48"	1219	16	7.3	<b>354566</b>	91	60"	1524	20	9.0	<b>356902</b>	111
18"	457	6	2.7	<b>354563</b>	48	72"	1829	30	13.6	<b>356903</b>	129						
24"	610	8	3.6	<b>354564</b>	55												
36"	915	12	5.4	<b>354565</b>	77												

### Single Bar Pot Racks

see spec sheet **EG10.06**

	ALUMINUM				STAINLESS STEEL					
	length*		weight		weight					
	in.	mm	lbs.	kg	model #	list	lbs.	kg	model #	list
<b>8½" width (216mm)</b>	24"	610	5	2.3	<b>SBPR-24-A</b>	188	9	4.1	<b>SBPR-24-S</b>	254
	36"	915	6	2.7	<b>SBPR-36-A</b>	286	12	5.4	<b>SBPR-36-S</b>	359
	48"	1219	7	3.2	<b>SBPR-48-A</b>	304	15	6.8	<b>SBPR-48-S</b>	403
	60"	1524	9	4.1	<b>SBPR-60-A</b>	327	18	8.2	<b>SBPR-60-S</b>	446
	72"	1829	11	5.0	<b>SBPR-72-A</b>	451	21	9.5	<b>SBPR-72-S</b>	582
	84"	2134	13	5.9	<b>SBPR-84-A</b>	468	25	11.3	<b>SBPR-84-S</b>	621
	96"	2438	15	6.8	<b>SBPR-96-A</b>	584	29	13.2	<b>SBPR-96-S</b>	751
	108"	2743	17	7.7	<b>SBPR-108-A</b>	625	34	15.4	<b>SBPR-108-S</b>	812
120"	3048	20	9.0	<b>SBPR-120-A</b>	643	39	17.6	<b>SBPR-120-S</b>	852	

\* For overall lengths, add 5-1/8" (130mm).

**FEATURES:**

- Flat 3/16" (5mm)-thick, 2" (51mm)-wide solid bar.
- 24" (610mm) racks are one-piece, all others come with support brackets.
- Includes one two-prong hook per foot.

**Freight class is 70.0.**



### Additional Pot Hook for Single Bar Pot Racks

- Stainless steel.

weight		cu ft	list	
lbs.	kg		model #	ea.
0.2	0.1	0.1	<b>300696</b>	32

### Wall Mounted Shelves

see spec sheet **EG02.05**



**Die-formed stainless steel mounting brackets are stud-welded to shelf.**

- 1½" (38mm) roll on front.
- 1½" (38mm) upturn on rear and ends.

**FEATURES:**

**Note:** 15" and 18" (381 and 457mm) wide shelves available. To order, replace "12" in model number with a "15" or "18" indicating desired shelf width (example: **WS1548-16/3**). For 15" (381mm) wide shelves, add 15% to list price of 12" (305mm) wide models. For 18" wide shelves, add 30% to list price of 12" (305mm) shelves.

**Freight class is 70.0.**

(•) MTS (made to stock) / ( ) MTO (made to order)

	length		weight		cubic feet	16 gauge, type 430		16 gauge, type 304		14 gauge, type 304	
	in.	mm	lbs.	kg		model #	list	model #	list	model #	list
<b>10" width</b> (254mm)	24"	610	10	4.5	0.5	<b>WS1024-16/4</b>	547	<b>WS1024-16/3</b>	641	<b>WS1024-14/3</b>	705
	36"	915	12	5.4	0.7	<b>WS1036-16/4</b> •	588	<b>WS1036-16/3</b>	723	<b>WS1036-14/3</b>	797
	48"	1219	15	6.8	0.9	<b>WS1048-16/4</b> •	595	<b>WS1048-16/3</b>	772	<b>WS1048-14/3</b>	844
	60"	1524	20	9.0	1.2	<b>WS1060-16/4</b> •	635	<b>WS1060-16/3</b>	853	<b>WS1060-14/3</b>	934
	72"	1829	22	10.0	1.4	<b>WS1072-16/4</b> •	677	<b>WS1072-16/3</b>	931	<b>WS1072-14/3</b>	1019
	84"	2133	24	10.9	1.7	<b>WS1084-16/4</b>	714	<b>WS1084-16/3</b>	1009	<b>WS1084-14/3</b>	1105
	96"	2438	29	13.2	1.9	<b>WS1096-16/4</b>	826	<b>WS1096-16/3</b>	1163	<b>WS1096-14/3</b>	1279
	108"	2743	32	14.5	2.1	<b>WS10108-16/4</b>	898	<b>WS10108-16/3</b>	1276	<b>WS10108-14/3</b>	1405
<b>12" width</b> (305mm)	120"	3048	34	15.4	2.3	<b>WS10120-16/4</b>	942	<b>WS10120-16/3</b>	1441	<b>WS10120-14/3</b>	1584
	24"	610	12	5.4	0.6	<b>WS1224-16/4</b> •	588	<b>WS1224-16/3</b> •	684	<b>WS1224-14/3</b>	754
	36"	915	14	6.4	0.9	<b>WS1236-16/4</b> •	632	<b>WS1236-16/3</b> •	769	<b>WS1236-14/3</b>	843
	48"	1219	17	7.7	1.1	<b>WS1248-16/4</b> •	646	<b>WS1248-16/3</b> •	824	<b>WS1248-14/3</b>	906
	60"	1524	23	10.4	1.4	<b>WS1260-16/4</b> •	688	<b>WS1260-16/3</b> •	909	<b>WS1260-14/3</b>	998
	72"	1829	25	11.3	1.7	<b>WS1272-16/4</b> •	737	<b>WS1272-16/3</b> •	994	<b>WS1272-14/3</b> •	1089
	84"	2133	28	12.7	2.0	<b>WS1284-16/4</b> •	779	<b>WS1284-16/3</b> •	1078	<b>WS1284-14/3</b>	1186
	96"	2438	31	14.1	2.2	<b>WS1296-16/4</b> •	914	<b>WS1296-16/3</b> •	1180	<b>WS1296-14/3</b>	1297
108"	2743	36	16.3	2.5	<b>WS12108-16/4</b>	1000	<b>WS12108-16/3</b>	1384	<b>WS12108-14/3</b>	1519	
120"	3048	39	17.6	2.8	<b>WS12120-16/4</b>	1041	<b>WS12120-16/3</b>	1462	<b>WS12120-14/3</b>	1609	

### Piggyback Wall Mounted Shelf Kits

see spec sheet **EG02.13**

**PATENTED!**  
(patent #8,025,163 B2)



five-tier unit with three shelves

**Additional Brackets (pair)**

18" (457mm) width. Chrome.

description	weight		model #	list
	lbs.	kg		
three-tier	7.3	3.3	<b>SSW18B3-C</b>	107
five-tier	10.8	4.9	<b>SSW18B5-C</b>	126

**FEATURES:**

- Brackets can be mounted to studs – no wall backing required.
- Freedom to move the shelves left or right.
- Wire design allows for air circulation.
- 18" (457mm) width.
- No tools required to attach shelf to wall brackets.

**Freight class is 70.0.**

### Three-Tier Units – Includes one pair of 23¾" (606mm)-high brackets.

shelf width x length in. mm	Units with One Chrome Shelf				Units with Two Chrome Shelves				Units with Three Chrome Shelves				Additional Shelves chrome			
	weight		model #	list	weight		model #	list	weight		model #	list	weight		model #	list
lbs.	kg	lbs.			kg	lbs.			kg	lbs.			kg	lbs.		
18" x 24" 457 x 610	12	5.4	<b>S1-3B-SSW1824C</b>	137	17	7.7	<b>S2-3B-SSW1824C</b>	208	22	10.0	<b>S3-3B-SSW1824C</b>	279	5	2.3	<b>SSW1824C</b>	73
18" x 30" 457 x 762	13	5.9	<b>S1-3B-SSW1830C</b>	153	19	8.6	<b>S2-3B-SSW1830C</b>	239	25	11.3	<b>S3-3B-SSW1830C</b>	323	6	2.7	<b>SSW1830C</b>	88
18" x 36" 457 x 914	14	6.4	<b>S1-3B-SSW1836C</b>	162	21	9.5	<b>S2-3B-SSW1836C</b>	258	28	12.7	<b>S3-3B-SSW1836C</b>	353	7	3.2	<b>SSW1836C</b>	99
18" x 42" 457 x 1067	16	7.3	<b>S1-3B-SSW1842C</b>	177	24	10.9	<b>S2-3B-SSW1842C</b>	293	33	15.0	<b>S3-3B-SSW1842C</b>	407	9	4.1	<b>SSW1842C</b>	119
18" x 48" 457 x 1219	17	7.7	<b>S1-3B-SSW1848C</b>	186	27	12.2	<b>S2-3B-SSW1848C</b>	308	37	16.8	<b>S3-3B-SSW1848C</b>	427	10	4.5	<b>SSW1848C</b>	124
18" x 60" 457 x 1524	22	10.0	<b>S1-3B-SSW1860C</b>	218	37	16.8	<b>S2-3B-SSW1860C</b>	371	51	23.1	<b>S3-3B-SSW1860C</b>	523	15	6.8	<b>SSW1860C</b>	159

### Five-Tier Units – Includes one pair of 33¾" (860mm)-high brackets.

shelf width x length in. mm	Units with Three Chrome Shelf				Units with Four Chrome Shelves				Units with Five Chrome Shelves				Additional Shelves chrome			
	weight		model #	list	weight		model #	list	weight		model #	list	weight		model #	list
lbs.	kg	lbs.			kg	lbs.			kg	lbs.			kg	lbs.		
18" x 24" 457 x 610	19	8.6	<b>S3-5B-SSW1824C</b>	303	22	10.0	<b>S4-5B-SSW1824C</b>	372	29	13.2	<b>S5-5B-SSW1824C</b>	441	5	2.3	<b>SSW1824C</b>	73
18" x 30" 457 x 762	22	10.0	<b>S3-5B-SSW1830C</b>	347	28	12.7	<b>S4-5B-SSW1830C</b>	436	34	15.4	<b>S5-5B-SSW1830C</b>	522	6	2.7	<b>SSW1830C</b>	88
18" x 36" 457 x 914	25	11.3	<b>S3-5B-SSW1836C</b>	378	32	14.5	<b>S4-5B-SSW1836C</b>	473	39	17.6	<b>S5-5B-SSW1836C</b>	568	7	3.2	<b>SSW1836C</b>	99
18" x 42" 457 x 1067	30	13.6	<b>S3-5B-SSW1842C</b>	431	38	17.2	<b>S4-5B-SSW1842C</b>	546	47	21.3	<b>S5-5B-SSW1842C</b>	660	9	4.1	<b>SSW1842C</b>	119
18" x 48" 457 x 1219	34	15.4	<b>S3-5B-SSW1848C</b>	453	44	20.0	<b>S4-5B-SSW1848C</b>	574	54	24.5	<b>S5-5B-SSW1848C</b>	695	10	4.5	<b>SSW1848C</b>	124
18" x 60" 457 x 1524	49	22.2	<b>S3-5B-SSW1860C</b>	547	64	29.0	<b>S4-5B-SSW1860C</b>	700	79	35.8	<b>S5-5B-SSW1860C</b>	853	15	6.8	<b>SSW1860C</b>	159

## Catalog Section 2

### Shelves with Removable Hooks

see spec sheet **EG02.06**



**FEATURES:**

- 16 gauge type 430 shelf with type 304 stainless steel pot rack bar.
- 1½" (38mm) roll on front.
- 1½" (38mm) upturn on rear and ends
- Fitted with one two-prong pot hook per foot.

**Freight class is 70.0.**

(•) MTS (made to stock) / ( ) MTO (made to order)



pot hook

#### Additional Pot Hook for Shelves with Removable Hooks

- Stainless steel.

weight	cu	list
lbs. kg	ft model #	ea.
0.2 0.1	0.1 <b>300696</b>	32

10" (254mm) Wide Shelves						12" (305mm) Wide Shelves					
length		weight		cu	model #	list	weight		cu	model #	list
in.	mm	lbs.	kg	ft			lbs.	kg	ft		
36"	914	12	5.4	1.0	<b>WSP1036</b>	995	15	6.8	1.1	<b>WSP1236</b>	1033
48"	1219	23	10.4	1.3	<b>WSP1048</b>	1016	29	13.2	1.5	<b>WSP1248</b> •	1069
60"	1524	37	16.8	1.6	<b>WSP1060</b>	1060	43	19.5	1.8	<b>WSP1260</b> •	1120
72"	1829	51	23.1	1.9	<b>WSP1072</b>	1098	57	25.9	2.2	<b>WSP1272</b> •	1162
84"	2134	65	29.5	2.2	<b>WSP1084</b>	1152	71	32.2	2.6	<b>WSP1284</b>	1229
96"	2438	79	35.8	2.5	<b>WSP1096</b>	1231	85	38.6	2.9	<b>WSP1296</b>	1257
108"	2743	93	42.2	2.8	<b>WSP10108</b>	1615	99	44.9	3.3	<b>WSP12108</b>	1716
120"	3048	107	48.5	3.1	<b>WSP10120</b>	1652	113	51.3	3.6	<b>WSP12120</b>	1756
132"	3353	121	54.9	3.4	<b>WSP10132</b>	1751	127	57.6	4.0	<b>WSP12132</b>	1846
144"	3658	135	61.2	3.7	<b>WSP10144</b>	1788	141	64.0	4.4	<b>WSP12144</b>	1880

15" (381mm) Wide Shelves						18" (457mm) Wide Shelves					
length		weight		cu	model #	list	weight		cu	model #	list
in.	mm	lbs.	kg	ft			lbs.	kg	ft		
36"	914	21	9.5	1.3	<b>WSP1536</b>	1349	27	12.2	1.6	<b>WSP1836</b>	1615
48"	1219	35	15.9	1.8	<b>WSP1548</b>	1378	41	18.6	2.2	<b>WSP1848</b>	1642
60"	1524	49	22.2	2.3	<b>WSP1560</b>	1567	55	24.9	2.7	<b>WSP1860</b>	1727
72"	1829	63	28.6	2.7	<b>WSP1572</b>	1701	69	31.3	3.2	<b>WSP1872</b>	1849
84"	2134	77	34.9	3.2	<b>WSP1584</b>	1948	83	37.6	3.7	<b>WSP1884</b>	2006
96"	2438	91	41.3	3.6	<b>WSP1596</b>	2041	97	44.0	4.3	<b>WSP1896</b>	2124
108"	2743	105	47.6	4.0	<b>WSP15108</b>	2216	111	50.3	4.8	<b>WSP18108</b>	2581
120"	3048	119	54.0	4.5	<b>WSP15120</b>	2252	125	56.7	5.3	<b>WSP18120</b>	2621
132"	3353	133	60.3	4.9	<b>WSP15132</b>	2420	139	63.1	5.9	<b>WSP18132</b>	2672
144"	3658	147	66.7	5.4	<b>WSP15144</b>	2460	153	69.4	6.4	<b>WSP18144</b>	2714

### Wall Cabinets

see spec sheet **EG02.07**

**FEATURES:**

- Heavy gauge stainless steel.
- Back is recessed w/full-length concealed mounting plate for easy installation.
- Fixed center shelf.
- Hinged doors with lift-off pin hinges.
- 15" (381mm) width. 28" (711mm) overall height.

**Freight class is 100.0.**



wall cabinet with hinged doors

length		cu		weight		Open Front		Hinged Doors		Sliding Doors				
in.	mm	ft	lbs.	kg	model #	list	lbs.	kg	model #	list	lbs.	kg	model #	list
24"	610	13.5	117	53.1	<b>WCO-24</b>	3960	136	61.7	<b>WCH-24</b>	5373	136	61.7	<b>WCS-24</b>	4479
30"	762	17.3	129	58.5	<b>WCO-30</b>	3964	154	69.9	<b>WCH-30</b>	5955	154	69.9	<b>WCS-30</b>	5458
36"	914	18.0	141	64.0	<b>WCO-36</b>	4111	172	78.0	<b>WCH-36</b>	6058	172	78.0	<b>WCS-36</b>	5627
42"	1067	18.2	-	-	-	-	191	86.6	<b>WCH-42</b>	6367	191	86.6	<b>WCS-42</b>	5654
48"	1219	18.3	165	74.8	<b>WCO-48</b>	4736	208	94.3	<b>WCH-48</b>	6563	208	94.3	<b>WCS-48</b>	6164
54"	1372	25.4	-	-	-	-	226	102.5	<b>WCH-54</b>	6712	226	102.5	<b>WCS-54</b>	6279
60"	1524	22.6	189	85.7	<b>WCO-60</b>	5182	244	110.7	<b>WCH-60</b>	7526	244	110.7	<b>WCS-60</b>	7128
66"	1676	30.6	-	-	-	-	256	115.1	<b>WCH-66</b>	7580	-	-	-	-
72"	1829	26.8	213	96.6	<b>WCO-72</b>	5499	262	118.8	<b>WCH-72</b>	8432	262	118.8	<b>WCS-72</b>	7984
84"	2134	38.5	225	102.1	<b>WCO-84</b>	5802	281	127.5	<b>WCH-84*</b>	8668	281	127.5	<b>WCS-84*</b>	8191
90"	2286	41.7	-	-	-	-	298	135.3	<b>WCH-90*</b>	9160	298	135.3	<b>WCS-90*</b>	8674
96"	2438	35.2	249	112.9	<b>WCO-96</b>	6497	316	143.3	<b>WCH-96*</b>	9444	316	143.3	<b>WCS-96*</b>	8943
120"	3048	55.8	-	-	-	-	-	-	-	-	359	162.9	<b>WCS-120*</b>	10775

\* Features two pairs of doors.

## Pass-Thru Shelves

see spec sheet **EG02.08**

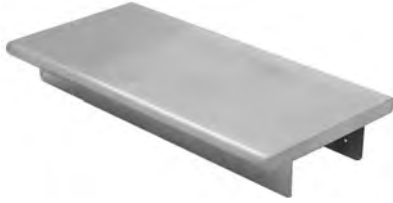

Promotes "pass-thru" from kitchen to serving area!

- 16 gauge type 304 stainless steel construction.
- Rolled edge on front and back, with ends turned down 90°.
- With self-drilling screws.
- Heavy gauge support channel and wall brackets.

FEATURES:

Freight class is 70.0.

(•) MTS (made to stock) / ( ) MTO (made to order)

	length		weight		cu ft	model #	list
	in.	mm	lbs.	kg			
<b>18" width</b> (457mm)	24"	610	24	10.9	2.3	<b>PTS-1824</b>	641
	36"	915	34	15.4	3.3	<b>PTS-1836</b>	777
	48"	1219	44	20.0	4.3	<b>PTS-1848</b>	1402
	60"	1524	56	25.4	5.4	<b>PTS-1860</b>	1511
	72"	1829	68	30.8	6.4	<b>PTS-1872</b>	1562
	84"	2134	81	36.7	7.4	<b>PTS-1884</b>	1616
	96"	2438	93	42.2	8.4	<b>PTS-1896</b>	1677
	108"	2743	105	47.6	9.4	<b>PTS-18108</b>	1742
	120"	3048	117	53.1	10.5	<b>PTS-18120</b>	1778
	132"	3353	129	58.5	11.5	<b>PTS-18132</b>	1940
	144"	3658	141	64.0	12.5	<b>PTS-18144</b>	2211

	length		weight		cu ft	model #	list
	in.	mm	lbs.	kg			
<b>24" width</b> (610mm)	24"	610	32	14.5	3.8	<b>PTS-2424</b>	698
	36"	915	42	19.1	3.9	<b>PTS-2436</b>	960
	48"	1219	52	23.6	5.0	<b>PTS-2448</b>	1753
	60"	1524	64	29.0	6.2	<b>PTS-2460</b>	1885
	72"	1829	76	34.5	8.3	<b>PTS-2472</b>	2019
	84"	2134	89	40.4	8.7	<b>PTS-2484</b>	2211
	96"	2438	101	45.8	10.8	<b>PTS-2496</b>	2364
	108"	2743	113	51.3	11.1	<b>PTS-24108</b>	2376
	120"	3048	126	57.2	15.4	<b>PTS-24120</b>	2405
	132"	3353	137	62.1	17.6	<b>PTS-24132</b>	2629
	144"	3658	149	67.6	12.4	<b>PTS-24144</b>	2821

## Tab Lock Shelves

see spec sheet **EG02.09**



- 16 gauge, type 430 stainless steel.
- 1½" (38mm) roll on front.
- 1½" (38mm) upturn on rear and ends.
- Tab lock for easy assembly.
- Die-formed stainless steel mounting brackets.
- Not available in other widths.
- 60" (1524mm) length max.

FEATURES:

Freight class is 70.0.

(•) MTS (made to stock) / ( ) MTO (made to order)

	length		weight		cubic feet	model #	list
	in.	mm	lbs.	kg			
<b>10" width</b> (254mm)	24"	610	10	4.5	0.6	<b>WS1024TL</b>	• 239
	36"	915	12	5.4	0.9	<b>WS1036TL</b>	• 256
	48"	1219	15	6.8	1.3	<b>WS1048TL</b>	• 292
	60"	1524	20	9.0	1.6	<b>WS1060TL</b>	• 329
<b>12" width</b> (305mm)	24"	610	12	5.4	0.6	<b>WS1224TL</b>	• 257
	36"	915	14	6.4	0.9	<b>WS1236TL</b>	• 278
	48"	1219	17	7.7	1.3	<b>WS1248TL</b>	• 314
	60"	1524	23	10.4	1.6	<b>WS1260TL</b>	• 351

## Wall Mounted Microwave Shelves

see spec sheet **EG02.10**



	width		weight		cubic feet	model #	list
	in.	mm	lbs.	kg			
	18"	457	17	7.7	4.8	<b>MWS1824</b>	• 583
	24"	610	23	10.4	4.8	<b>MWS2424</b>	• 665

FEATURES:

- 24" (610mm) length.
- Made of highly polished heavy gauge type 430 stainless steel.
- Marine counter edge in front.
- Hole with grommet at center rear for wiring.

Freight class is 70.0.

(•) MTS (made to stock) / ( ) MTO (made to order)



## Catalog Section 2

### Adjustable Post Wire Wall Mounts Sold as Prepackaged Units <sup>NSF</sup>

see spec sheet **EG02.11**

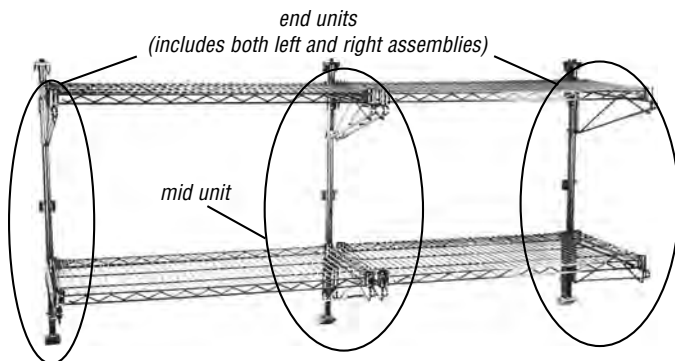

**Adjustable post wall mounts are sold as prepackaged end and mid units, or sold as components (see page 112). The prepackaged units contain all needed components except shelves and wall bolts. Wall bolts must be selected according to wall type.**

**Note:** Shelves (page 6) and accessories (pages 51-59) are sold separately.

#### END UNITS.

- Two posts, single shelf brackets, post supports.
- Number of shelf brackets depends on the height of the posts.
  - 14" (356mm) posts: one row of brackets.
  - 33" (838mm) posts: two rows of brackets
  - ...and so on.

#### MID UNITS

- One post, double shelf brackets, post supports.
- Number of shelf brackets corresponds to post height the same as end units.

#### FEATURES:

- One shelf long, order only one end unit.
- Two shelves long, order one end and one mid unit.
- Three shelves long, order one end and two mid units
- ...and so on.

#### ORDERING:

**Freight class is 70.0.**

#### Prepackaged End Units

#### Prepackaged Mid Units

	post height		# of shelves	cu ft	weight* lbs. kg	chrome		Valu-Gard®		stainless steel		chrome		Valu-Gard®		stainless steel	
	in.	mm				model #	list	model #	list	model #	list	model #	list	model #	list	model #	list
<b>14" width (356mm)</b>	14"	356	1	0.6	7 3.2	PWE14-1C	221	PWE14-1VG	221	PWE14-1S	593	PWM14-1C	142	PWM14-1VG	142	PWM14-1S	397
	33"	838	2	0.7	14 6.4	PWE14-2C	357	PWE14-2VG	357	PWE14-2S	1093	PWM14-2C	241	PWM14-2VG	241	PWM14-2S	719
	54"	1372	3	0.7	22 10.0	PWE14-3C	495	PWE14-3VG	495	PWE14-3S	1405	PWM14-3C	340	PWM14-3VG	340	PWM14-3S	959
	63"	1600	4	0.7	28 13.0	PWE14-4C	598	PWE14-4VG	598	PWE14-4S	1723	PWM14-4C	422	PWM14-4VG	422	PWM14-4S	1201
<b>18" width (457mm)</b>	14"	356	1	0.6	8 3.6	PWE18-1C	223	PWE18-1VG	223	PWE18-1S	636	PWM18-1C	144	PWM18-1VG	144	PWM18-1S	409
	33"	838	2	0.6	15 6.8	PWE18-2C	357	PWE18-2VG	357	PWE18-2S	1141	PWM18-2C	242	PWM18-2VG	242	PWM18-2S	749
	54"	1372	3	0.7	23 10.0	PWE18-3C	497	PWE18-3VG	497	PWE18-3S	1471	PWM18-3C	345	PWM18-3VG	345	PWM18-3S	993
	63"	1600	4	0.7	29 13.0	PWE18-4C	600	PWE18-4VG	600	PWE18-4S	1813	PWM18-4C	425	PWM18-4VG	425	PWM18-4S	1156
<b>21" width (533mm)</b>	14"	356	1	0.7	9 4.1	PWE21-1C	226	PWE21-1VG	226	PWE21-1S	641	PWM21-1C	148	PWM21-1VG	148	PWM21-1S	416
	33"	838	2	0.8	16 7.3	PWE21-2C	368	PWE21-2VG	368	PWE21-2S	1148	PWM21-2C	258	PWM21-2VG	258	PWM21-2S	756
	54"	1372	3	0.9	25 11.0	PWE21-3C	514	PWE21-3VG	514	PWE21-3S	1481	PWM21-3C	362	PWM21-3VG	362	PWM21-3S	1007
	63"	1600	4	0.9	32 15.0	PWE21-4C	625	PWE21-4VG	625	PWE21-4S	1813	PWM21-4C	452	PWM21-4VG	452	PWM21-4S	1241
<b>24" width (610mm)</b>	14"	356	1	0.7	10 4.5	PWE24-1C	226	PWE24-1VG	226	PWE24-1S	654	PWM24-1C	151	PWM24-1VG	151	PWM24-1S	420
	33"	838	2	0.8	17 7.7	PWE24-2C	372	PWE24-2VG	372	PWE24-2S	1173	PWM24-2C	258	PWM24-2VG	258	PWM24-2S	759
	54"	1372	3	0.9	26 12.0	PWE24-3C	521	PWE24-3VG	521	PWE24-3S	1516	PWM24-3C	365	PWM24-3VG	365	PWM24-3S	1019
	63"	1600	4	0.9	34 16.0	PWE24-4C	631	PWE24-4VG	631	PWE24-4S	1873	PWM24-4C	454	PWM24-4VG	454	PWM24-4S	1285

\* For stainless steel units, add 1 lb. (0.5 kg) weight.

### Wire Wall Shelf Kits

see spec sheet **EG02.04**

- One wire shelf.
- Two stationary wire wall mounts.



	length		weight		chrome		VALU-MASTER®		Valu-Gard®	
	in.	mm	lb.	kg	model #	list	model #	list	model #	list
<b>14" width (356mm)</b>	36"	914	12	5.4	GWB1436C	137	GWB1436V	139	GWB1436VG	139
	48"	1219	14	6.4	GWB1448C	152	GWB1448V	155	GWB1448VG	155
<b>18" width (457mm)</b>	36"	914	14	6.4	GWB1836C	144	GWB1836V	155	GWB1836VG	155
	48"	1219	17	7.7	GWB1848C	161	GWB1848V	176	GWB1848VG	176

**Freight class is 70.0.**

### Adjustable Post Wire Wall Mounts Sold as Components <sup>(NSF)</sup>

see spec sheet **EG02.11**

FEATURES:

- Designed to allow inter-mixing of shelf widths or customizing of units to fit specification needs.
- All components priced individually.

**Freight class is 70.0.**

(\*) MTS (made to stock) / ( ) MTO (made to order)

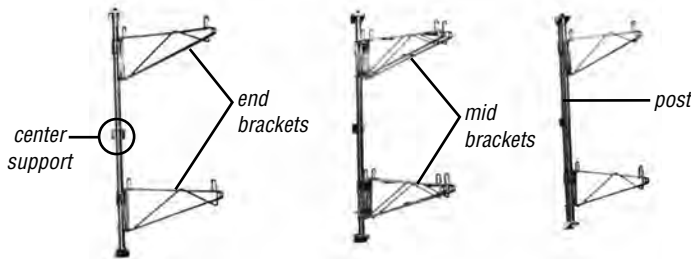

brackets used in conjunction with posts and center supports

#### End Brackets

length in. mm	weight		cu ft	chrome		Valu-Gard®		stainless steel	
	lbs.	kg		model #	list	model #	list	model #	list
14"	356	3	1.4	0.5	PWB14C • 53	PWB14VG • 53	PWB14S • 173		
18"	457	4	1.8	0.6	PWB18C • 54	PWB18VG • 54	PWB18S • 176		
21"	533	5	2.3	1.0	PWB21C • 55	PWB21VG • 55	PWB21S • 186		
24"	610	6	2.7	1.0	PWB24C • 58	PWB24VG • 58	PWB24S • 192		

**Note:** Must be used with posts to mount to the wall.

#### Posts

height in. mm	weight		cu ft	chrome		Valu-Gard®		stainless steel	
	lbs.	kg		model #	list	model #	list	model #	list
14"	356	2	0.9	0.1	PW14C • 62	PW14VG • 62	PW14S • 176		
33"	838	3	1.4	0.1	PW33C • 78	PW33VG • 78	PW33S • 282		
54"	1372	5	2.3	0.1	PW54C • 98	PW54VG • 98	PW54S • 286		
63"	1524	6	2.7	0.2	PW63C • 100	PW63VG • 100	PW63S • 293		

#### Mid Brackets

length in. mm	weight		cu ft	chrome		Valu-Gard®		stainless steel	
	lbs.	kg		model #	list	model #	list	model #	list
14"	356	6	2.7	0.5	PDWB14C • 83	PDWB14VG • 83	PDWB14S • 262		
18"	457	8	3.6	0.6	PDWB18C • 86	PDWB18VG • 86	PDWB18S • 269		
21"	533	10	4.5	1.0	PDWB21C • 89	PDWB21VG • 89	PDWB21S • 282		
24"	610	12	5.4	1.0	PDWB24C • 92	PDWB24VG • 92	PDWB24S • 286		

**Note:** Must be used with posts to mount to the wall.

#### Center Support for Posts

weight lbs. kg	cu ft	chrome		Valu-Gard®		stainless steel	
		model #	list	model #	list	model #	list
1	0.5	0.5	A228162 • 15	A218017 • 15	A207016 • 52		

**Note:** Must be used in conjunction with post.

### Stationary Wire Wall Mounts <sup>(NSF)</sup>

see spec sheet **EG02.12**



stationary wall mount with shelf support and mounting plate

**Designed for fixed application where vertical adjustment is not required.**

**Note:** Shelves (page 6) sold separately.

END UNIT:

- One single shelf support and mounting plate.

MID UNIT:

- One double shelf support and mounting plate.

**Freight class is 70.0.**

(\*) MTS (made to stock) / ( ) MTO (made to order)

#### End Units\*

#### Mid Units

length in. mm	cu ft	weight**		chrome		Valu-Gard®		stainless**		weight** lbs. kg	chrome		Valu-Gard®		stainless**	
		lbs.	kg	model #	list	model #	list	model #	list		model #	list	model #	list		
14"	356	0.5	6	2.7	WB14-C • 53	WB14-VG • 54	WB14-S • 126	8	3.6	DWB14-C • 80	DWB14-VG • 81	DWB14-S • 192				
18"	457	0.5	8	3.6	WB18-C • 54	WB18-VG • 55	WB18-S • 135	10	4.5	DWB18-C • 82	DWB18-VG • 83	DWB18-S • 203				
21"	533	0.7	10	4.5	WB21-C • 54	WB21-VG • 55	WB21-S • 138	12	5.5	DWB21-C • 82	DWB21-VG • 83	DWB21-S • 208				
24"	610	0.7	12	5.5	WB24-C • 55	WB24-VG • 57	WB24-S • 142	14	6.4	DWB24-C • 83	DWB24-VG • 85	DWB24-S • 217				

\*End Units priced per piece; \*\*For stainless steel units, add 1 lb. (0.5 kg) weight.

## Catalog Section 2



### Printer Shelves

see spec sheet **EG02.17**



slanted printer shelf

standard printer shelf

*Designed for label printers!*

- Heavy gauge stainless steel.
- Hole with grommet, for wiring, located at rear.
- Four mounting holes.
- Available in standard or slanted.

FEATURES:

**Can be shipped UPS.**

**Freight class is 70.0.**

side-to-side in. mm	front-to-rear in. mm	weight lbs. kg	Standard		Slanted	
			model #	list	model #	list
7" 178	10" 254	2.48 1.22	MWS0710-PS 92	MWS0710-SPS 95		
9" 229	12" 305	2.80 1.27	MWS0912-PS 109	MWS0912-SPS 112		



### Cooking Line Wall Shelves

see spec sheet **EG02.16**

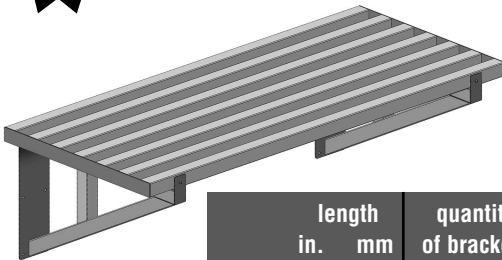

- Consists of one stainless steel shelf and two to four stainless steel brackets, depending on length. Shelves and brackets are all-welded construction.
- 1½" (38mm) square tubing.
- Shelf can be screwed to brackets, or welded.

FEATURES:

**Freight class is 70.0.**

length in. mm	quantity of brackets	model #	list	length in. mm	quantity of brackets	model #	list
<b>18" width</b> (457mm) 72" 1829	3	CLHDWS-1872	5313	<b>21" width</b> (533mm) 72" 1829	3	CLHDWS-2172	5592
96" 2438	3	CLHDWS-1896	7083	96" 2438	3	CLHDWS-2196	7456
120" 3048	4	CLHDWS-18120	8854	120" 3048	4	CLHDWS-21120	9320
144" 3658	4	CLHDWS-18144	10624	144" 3658	4	CLHDWS-21144	11183

For **Optional Additional 18" Bracket...**  
Model #: CLHDWS-18B; List: \$330

For **Optional Additional 21" Bracket...**  
Model #: CLHDWS-21B; List: \$348

## NOTES

---

---

---

---

---

---

---

---

---

---

---

---

---

---

---

---

---

---

---

---

---

---

---

---

---

---

# NOTES



Two columns of horizontal lines for taking notes.

## Accessories/Components

Casters .....130, 131, 141  
 More Accessories  
 and Components .....130, 132,  
 147-151

## Custom Options .....158

## Drawers .....152-155

## Hardwood Worktables .....131

## Overshelves / Table Mounted

Flex-Master® Adjustable.....147-148  
 Microwave .....151  
 Non-Adjustable / All-Welded.....150

## Poly Top Tables /

## Boat Racks .....144-146

## Pot/Pan Racks .....156-157

## SPEC-MASTER®

Enclosed Worktables  
 with Backsplash .....135  
 with Flat Top .....133  
 with Upturn .....134

## Specialty Tables

adjuTable® Work Surface Systems ....140  
 Beverage Counters .....136  
 Demo Tables .....142  
 Folding Tables .....139  
 Pizza Cut-n-Pack.....138  
 Pizza Holding .....138  
 Plate Cabinets .....137  
 Prep Tables .....136-137  
 Rice Cooker .....139  
 Slicer Tables .....139

## Stands

Griddle / Equipment .....143  
 Mixer.....141  
 Mobile Equipment.....142  
 Mobile Mixer.....142

## Wall Cabinets .....149

## Worktables w/Stainless Steel Top

with Backsplash and  
 Tubular Base .....128-129  
 with Backsplash and  
 Undershelf Base .....126-127  
 with Flat Top and  
 Tubular Base .....120-121  
 with Flat Top and  
 Undershelf Base .....118-119  
 with Upturn and  
 Tubular Base .....124-125  
 with Upturn and  
 Undershelf Base .....122-123  
 Filler Tables .....122  
 Knock Down Worktables  
 with Cabinet Kit .....132

**For Wall Shelves,  
 see pages 103-114.**

## Wall Mounted Stainless Steel Tables

see spec sheet **EG10.01**

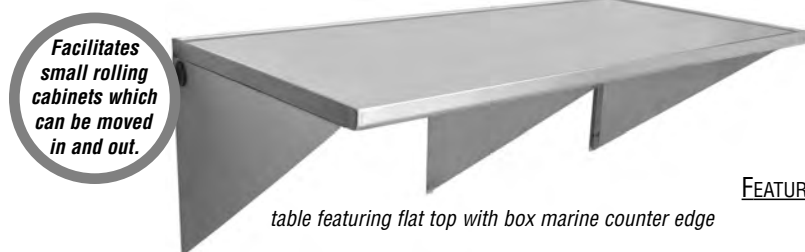

FEATURES:

- Tabletop available in 16- or 14-gauge type 304 stainless steel.
- Stainless steel brackets with hole for electrical wire run.
- Wall mounted for environments with frequent wash downs.
- 200-lb. (90.7 kg) weight capacity.
- Options available include integral sink bowls, drawers, end splashes, and sound deadening.

**Freight class is 70.0.**

		16/304 TABLETOP WITH ROLLED EDGE		14/304 TABLETOP * WITH ROLLED EDGE		14/304 TABLETOP WITH * BOX MARINE COUNTER EDGE			
	length in. mm	weights* lbs. kg	no. of brackets	model #	list	model #	list	model #	list
<b>Tables with Flat Top</b>									
<b>30" width</b>	48" 1219	71 32.2	3	WT3048SEB	695	WT3048SE	982	WT3048SEM	1380
	60" 1524	82 37.6	3	WT3060SEB	813	WT3060SE	1122	WT3060SEM	1471
(762mm)	72" 1829	95 43.1	4	WT3072SEB	912	WT3072SE	1312	WT3072SEM	1662
<b>Tables with 1½" Upturn</b>									
<b>30" width</b>	48" 1219	71 32.2	3	UWT3048SEB	817	UWT3048SE	1156	UWT3048SEM	1621
	60" 1524	83 37.6	3	UWT3060SEB	957	UWT3060SE	1319	UWT3060SEM	1731
(762mm)	72" 1829	95 43.1	4	UWT3072SEB	1073	UWT3072SE	1542	UWT3072SEM	1954
<b>Tables with 4½" Backsplash</b>									
<b>30" width</b>	48" 1219	73 33.1	3	WT3048SEB-BS	866	WT3048SE-BS	1228	WT3048SEM-BS	1725
	60" 1524	84 38.1	3	WT3060SEB-BS	1016	WT3060SE-BS	1403	WT3060SEM-BS	1839
(762mm)	72" 1829	97 44.0	4	WT3072SEB-BS	1138	WT3072SE-BS	1639	WT3072SEM-BS	2076

\* Increase stated weight by 10%.

### Optional table edges available:

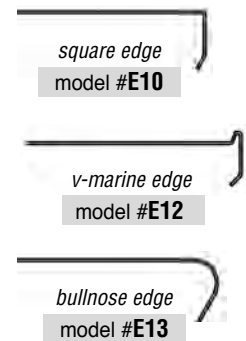

# SPEC-MASTER® Marine Series

14 gauge, 300 series stainless steel tabletop.  
Features a marine counter edge to prevent spillage.

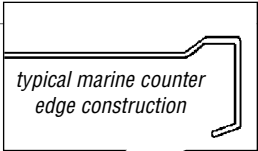

**WITH  
FLAT TOP AND  
UNDERSHELF...**  
*See pages 118-119*



**WITH  
FLAT TOP AND  
TUBULAR BASE...**  
*See pages 120-121*



**WITH  
4½" (267mm)  
BACKSPASH AND  
UNDERSHELF...**  
*See pages 126-127*



**WITH  
4½" (267mm)  
BACKSPASH AND  
TUBULAR BASE...**  
*See pages 128-129*

EM, SEM, GTEM, and STEM series

# SPEC-MASTER® Series

14 gauge, 300 series stainless steel tabletop.

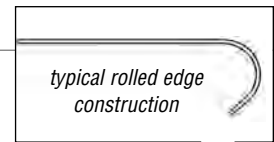

**WITH  
FLAT TOP AND  
UNDERSHELF...**  
*See pages 118-119*



**WITH  
UPTURN AND  
UNDERSHELF...**  
*See pages 122-123*



**WITH  
BACKSPASH AND  
UNDERSHELF...**  
*See pages 126-127*



**WITH  
FLAT TOP AND  
TUBULAR BASE...**  
*See pages 120-121*



**WITH  
UPTURN AND  
TUBULAR BASE...**  
*See pages 124-125*



**WITH  
BACKSPASH AND  
TUBULAR BASE...**  
*See pages 128-129*

E, SE, GTE, and STE series

# Deluxe Series

16 gauge, 300 series stainless steel table top.

typical rolled edge construction



**WITH  
FLAT TOP AND  
UNDERSHELF...**

*See pages 118-119*



**WITH  
UPTURN AND  
UNDERSHELF...**

*See pages 122-123*



**WITH  
BACKSPLASH AND  
UNDERSHELF...**

*See pages 126-127*



**WITH  
FLAT TOP AND  
TUBULAR BASE...**

*See pages 120-121*



**WITH  
UPTURN AND  
TUBULAR BASE...**

*See pages 124-125*



**WITH  
BACKSPLASH AND  
TUBULAR BASE...**

*See pages 128-129*

**EB, SEB, GTEB, and STEB series**

# Budget Series

16 gauge, type 430 stainless steel table top.

typical rolled edge construction



**WITH  
FLAT TOP AND  
UNDERSHELF...**

*See pages 118-119*



**WITH  
UPTURN AND  
UNDERSHELF...**

*See pages 122-123*



**WITH  
BACKSPLASH AND  
UNDERSHELF...**

*See pages 126-127*



**WITH  
FLAT TOP AND  
TUBULAR BASE...**

*See pages 120-121*



**WITH  
UPTURN AND  
TUBULAR BASE...**

*See pages 124-125*



**WITH  
BACKSPLASH AND  
TUBULAR BASE...**

*See pages 128-129*

**B, SB, GTB, and STB series**

### Worktables with Stainless Steel Flat Top & Galvanized Legs/Undershelf <sup>NSF</sup>

see spec sheets **EG10.40A** **EG10.40B** **EG10.40C** **EG10.40D**



FEATURES:

- 1½" (41mm)-diameter legs and adjustable undershelf are heavy gauge galvanized steel.
- Heavy gauge polished stainless steel top.
- Offers worktables with a rolled edge on front and rear, with ends turned 90°, except SPEC-MASTER® Marine edge.
- 35½"–36½" (892–918mm) adjustable working height.

Note: All shipping weights and cubic feet are approximate.

NSF sprayed-on sound deadening available. To order, add \$818 to list price and suffix "SD". Example: T2424B-SD.

Optional fixed undershelf available in place of standard adjustable undershelf. To order, add 10% to list price, and "-F" to end of suffix. Example: T2424EB-F.

patented  
**uni-lok**<sup>®</sup>  
system  
(Patent #5,165,349)

Freight class is 70.0.

For FLEX-MASTER® overshelf kits, see page 148.

For drawer kits, see page 155.



See page 130 for optional casters available.

(•) MTS (made to stock) / ( ) MTO (made to order)

	length		# of legs	weight		cu ft	BUDGET		DELUXE		*SPEC-MASTER®		* ▼ Marine	
	in.	mm		lbs.	kg		16 ga. type 430 top model #	list	16 ga. 300 series top model #	list	14 ga. 300 series top model #	list	14 ga. 300 series top model #	list
24" width (610mm)	24"	610	4	40	18.1	3.5	T2424B •	828	T2424EB	914	T2424E	960	T2424EM	1603
	30"	762	4	45	20.4	3.8	T2430B •	898	T2430EB	997	T2430E	1062	T2430EM	1718
	36"	914	4	50	22.7	4.4	T2436B •	977	T2436EB	1072	T2436E	1137	T2436EM	1793
	48"	1219	4	60	27.2	5.7	T2448B •	995	T2448EB	1089	T2448E	1157	T2448EM	1822
	60"	1524	4	70	31.8	7.1	T2460B •	1049	T2460EB	1181	T2460E	1268	T2460EM	1928
	72"	1829	4	80	36.3	8.5	T2472B •	1123	T2472EB	1279	T2472E	1375	T2472EM	2046
	84"	2134	4	90	40.8	11.2	T2484B •	1433	T2484EB	1829	T2484E	1873	T2484EM	2498
	96"	2438	6	100	45.4	11.2	T2496B •	1629	T2496EB	1962	T2496E	2012	T2496EM	2642
	108"	2743	6	110	49.9	14.0	T24108B	2651	T24108EB	2833	T24108E	2774	T24108EM	3466
	120"	3048	6	120	54.4	14.0	T24120B	2725	T24120EB	2914	T24120E	3055	T24120EM	3546
30" width (762mm)	132"	3353	8	130	59.0	16.8	T24132B	2740	T24132EB	2966	T24132E	3215	T24132EM	3805
	144"	3658	8	140	63.5	16.8	T24144B	2742	T24144EB	3055	T24144E	3226	T24144EM	3887
	30"	762	4	46	20.9	3.8	T3030B •	924	T3030EB	1033	T3030E	1098	T3030EM	1756
	36"	914	4	52	23.6	4.4	T3036B •	998	T3036EB	1107	T3036E	1173	T3036EM	1837
	48"	1219	4	64	29.0	5.7	T3048B •	1013	T3048EB •	1141	T3048E	1220	T3048EM	1883
	60"	1524	4	76	34.5	7.1	T3060B •	1107	T3060EB •	1254	T3060E	1344	T3060EM	2020
	72"	1829	4	84	38.1	8.5	T3072B •	1204	T3072EB •	1375	T3072E	1471	T3072EM	2156
	84"	2134	4	96	43.6	11.2	T3084B •	1502	T3084EB	1858	T3084E	1976	T3084EM	2607
	96"	2438	6	108	49.0	11.2	T3096B •	1739	T3096EB	2025	T3096E	2159	T3096EM	2789
	108"	2743	6	120	54.4	14.0	T30108B	2677	T30108EB	3001	T30108E	3159	T30108EM	3729
36" width (914mm)	120"	3048	6	132	59.9	14.0	T30120B	2766	T30120EB	3089	T30120E	3244	T30120EM	3811
	132"	3353	8	144	65.3	16.8	T30132B	2905	T30132EB	3260	T30132E	3351	T30132EM	4036
	144"	3658	8	156	70.8	16.8	T30144B	2991	T30144EB	3284	T30144E	3537	T30144EM	4121
	48"	1219	4	70	31.8	7.0	T3648B	1262	T3648EB	1388	T3648E	1431	T3648EM	2266
	60"	1524	4	82	37.2	8.8	T3660B	1421	T3660EB	1558	T3660E	1603	T3660EM	2442
	72"	1829	4	96	43.6	10.5	T3672B	1556	T3672EB	1689	T3672E	1748	T3672EM	2601
	84"	2134	4	108	49.0	12.2	T3684B	2138	T3684EB	2295	T3684E	2339	T3684EM	3137
	96"	2438	6	120	54.4	13.9	T3696B	2273	T3696EB	2433	T3696E	2502	T3696EM	3287
	108"	2743	6	132	59.9	17.3	T36108B	3231	T36108EB	3603	T36108E	3688	T36108EM	4308
	120"	3048	6	144	65.3	17.3	T36120B	3302	T36120EB	3688	T36120E	3775	T36120EM	4394
48" width (1219mm)	132"	3353	8	156	70.8	20.7	T36132B	3386	T36132EB	3811	T36132E	3943	T36132EM	4653
	144"	3658	8	168	76.2	20.7	T36144B	3574	T36144EB	3894	T36144E	4145	T36144EM	4742
	48"	1219	4	124	56.2	9.3	–	–	–	–	T4848E	3336	T4848EM	4445
	60"	1524	4	146	66.2	14.0	–	–	–	–	T4860E	3729	T4860EM	4840
	72"	1829	6	171	77.6	14.0	–	–	–	–	T4872E	4048	T4872EM	5162
	84"	2134	6	197	89.4	18.7	–	–	–	–	T4884E	5498	T4884EM	6606
	96"	2438	8	241	109.3	18.7	–	–	–	–	T4896E	5814	T4896EM	6926
	108"	2743	8	278	126.1	23.3	–	–	–	–	T48108E	8699	T48108EM	9817
	120"	3048	8	316	143.3	23.3	–	–	–	–	T48120E	8800	T48120EM	9896
	132"	3353	10	353	160.1	27.9	–	–	–	–	T48132E	9558	T48132EM	10659
144"	3658	10	391	177.4	27.9	–	–	–	–	T48144E	9627	T48144EM	10744	

\* On SPEC-MASTER® and SPEC-MASTER® Marine tables, increase stated weight by 10%. ▼ SPEC-MASTER® Marine tables feature a marine counter edge to prevent spillage.



## Worktables with Stainless Steel Flat Top & Stainless Steel Legs/Undershelf (NSF)

see spec sheets **EG10.41A EG10.41B EG10.41C EG10.41D**



**patented uni-lok system**

(Patent #5,165,349)



See page 130 for optional casters available.

**FEATURES:**

- 1½" (41mm)-diameter legs and adjustable undershelf are heavy gauge stainless steel.
- Heavy gauge polished stainless steel top.
- Offers worktables with a rolled edge on front and rear, with ends turned 90°, except SPEC-MASTER® Marine.
- 35½"-36½" (892-918mm) adjustable working height.

**Note:** All shipping weights and cubic feet are approximate.

NSF sprayed-on sound deadening available. To order, add **\$818 to list price** and suffix "-SD". Example: **T2424SB-SD**.

For FLEX-MASTER® overshelf kits, see page 148.

For drawer kits, see page 155.

**Freight class is 70.0.**

(•) MTS (made to stock) / ( ) MTO (made to order)

	length		# of legs	weight		cu ft	BUDGET		DELUXE		*SPEC-MASTER®		* ▼ Marine	
	in.	mm		lbs.	kg		16 ga. type 430 top model #	list	16 ga. 300 series top model #	list	14 ga. 300 series top model #	list	14 ga. 300 series top model #	list
<b>24" width (610mm)</b>	24"	610	4	40	18.1	3.5	<b>T2424SB</b>	1163	<b>T2424SEB</b> •	1242	<b>T2424SE</b> •	1339	<b>T2424SEM</b>	2001
	30"	762	4	45	20.4	3.8	<b>T2430SB</b>	1268	<b>T2430SEB</b>	1367	<b>T2430SE</b>	1487	<b>T2430SEM</b>	2145
	36"	914	4	50	22.7	4.4	<b>T2436SB</b> •	1340	<b>T2436SEB</b> •	1442	<b>T2436SE</b>	1562	<b>T2436SEM</b>	2222
	48"	1219	4	60	27.2	5.7	<b>T2448SB</b> •	1379	<b>T2448SEB</b> •	1494	<b>T2448SE</b>	1629	<b>T2448SEM</b>	2291
	60"	1524	4	70	31.8	7.1	<b>T2460SB</b>	1489	<b>T2460SEB</b>	1626	<b>T2460SE</b>	1776	<b>T2460SEM</b>	2437
	72"	1829	4	80	36.3	8.5	<b>T2472SB</b>	1597	<b>T2472SEB</b>	1755	<b>T2472SE</b>	1925	<b>T2472SEM</b>	2588
	84"	2134	4	90	40.8	11.2	<b>T2484SB</b>	1973	<b>T2484SEB</b>	2414	<b>T2484SE</b>	2631	<b>T2484SEM</b>	3193
	96"	2438	6	100	45.4	11.2	<b>T2496SB</b>	2118	<b>T2496SEB</b>	2581	<b>T2496SE</b>	2821	<b>T2496SEM</b>	3375
	108"	2743	6	110	49.9	14.0	<b>T24108SB</b>	3438	<b>T24108SEB</b>	3584	<b>T24108SE</b>	4037	<b>T24108SEM</b>	4361
	120"	3048	6	120	54.4	14.0	<b>T24120SB</b>	3519	<b>T24120SEB</b>	3806	<b>T24120SE</b>	4119	<b>T24120SEM</b>	4444
<b>30" width (762mm)</b>	132"	3353	8	130	59.0	16.8	<b>T24132SB</b>	3597	<b>T24132SEB</b>	3916	<b>T24132SE</b>	4256	<b>T24132SEM</b>	4792
	144"	3658	8	140	63.5	16.8	<b>T24144SB</b>	3785	<b>T24144SEB</b>	3995	<b>T24144SE</b>	4466	<b>T24144SEM</b>	4877
	30"	762	4	46	20.9	3.8	<b>T3030SB</b>	1320	<b>T3030SEB</b> •	1453	<b>T3030SE</b>	1575	<b>T3030SEM</b>	2238
	36"	914	4	52	23.6	4.4	<b>T3036SB</b> •	1412	<b>T3036SEB</b> •	1525	<b>T3036SE</b>	1654	<b>T3036SEM</b>	2314
	48"	1219	4	64	29.0	5.7	<b>T3048SB</b> •	1468	<b>T3048SEB</b> •	1603	<b>T3048SE</b> •	1754	<b>T3048SEM</b>	2406
	60"	1524	4	76	34.5	7.1	<b>T3060SB</b> •	1607	<b>T3060SEB</b> •	1766	<b>T3060SE</b> •	1928	<b>T3060SEM</b>	2589
	72"	1829	4	84	38.1	8.5	<b>T3072SB</b> •	1740	<b>T3072SEB</b> •	1925	<b>T3072SE</b> •	2112	<b>T3072SEM</b>	2861
	84"	2134	4	96	43.6	11.2	<b>T3084SB</b>	2045	<b>T3084SEB</b>	2521	<b>T3084SE</b>	2747	<b>T3084SEM</b>	3302
	96"	2438	6	108	49.0	11.2	<b>T3096SB</b> •	2292	<b>T3096SEB</b> •	2788	<b>T3096SE</b> •	3043	<b>T3096SEM</b>	3437
	108"	2743	6	120	54.4	14.0	<b>T30108SB</b>	3647	<b>T30108SEB</b>	3982	<b>T30108SE</b>	4313	<b>T30108SEM</b>	4717
<b>36" width (914mm)</b>	120"	3048	6	132	59.9	14.0	<b>T30120SB</b>	3731	<b>T30120SEB</b>	4067	<b>T30120SE</b>	4400	<b>T30120SEM</b>	4802
	132"	3353	8	144	65.3	16.8	<b>T30132SB</b>	3963	<b>T30132SEB</b>	4347	<b>T30132SE</b>	4721	<b>T30132SEM</b>	5118
	144"	3658	8	156	70.8	16.8	<b>T30144SB</b>	4046	<b>T30144SEB</b>	4436	<b>T30144SE</b>	4808	<b>T30144SEM</b>	5203
	48"	1219	4	70	31.8	7.0	<b>T3648SB</b>	1694	<b>T3648SEB</b>	1892	<b>T3648SE</b>	2001	<b>T3648SEM</b>	2811
	60"	1524	4	82	37.2	8.8	<b>T3660SB</b>	1875	<b>T3660SEB</b>	2074	<b>T3660SE</b>	2203	<b>T3660SEM</b>	3023
	72"	1829	4	96	43.6	10.5	<b>T3672SB</b>	2051	<b>T3672SEB</b>	2264	<b>T3672SE</b>	2405	<b>T3672SEM</b>	3241
	84"	2134	4	108	49.0	12.2	<b>T3684SB</b>	2835	<b>T3684SEB</b>	3077	<b>T3684SE</b>	3258	<b>T3684SEM</b>	3953
	96"	2438	6	120	54.4	13.9	<b>T3696SB</b>	3056	<b>T3696SEB</b>	3298	<b>T3696SE</b>	3503	<b>T3696SEM</b>	4195
	108"	2743	6	132	59.9	17.3	<b>T36108SB</b>	4339	<b>T36108SEB</b>	4731	<b>T36108SE</b>	5013	<b>T36108SEM</b>	5438
	120"	3048	6	144	65.3	17.3	<b>T36120SB</b>	4427	<b>T36120SEB</b>	4814	<b>T36120SE</b>	5100	<b>T36120SEM</b>	5517
<b>48" width (1219mm)</b>	132"	3353	8	156	70.8	20.7	<b>T36132SB</b>	4583	<b>T36132SEB</b>	5018	<b>T36132SE</b>	5481	<b>T36132SEM</b>	5895
	144"	3658	8	168	76.2	20.7	<b>T36144SB</b>	4797	<b>T36144SEB</b>	5248	<b>T36144SE</b>	5564	<b>T36144SEM</b>	5982
	48"	1219	4	124	56.2	9.3	-	-	-	-	<b>T4848SE</b>	3867	<b>T4848SEM</b>	4980
	60"	1524	4	146	66.2	14.0	-	-	-	-	<b>T4860SE</b>	4278	<b>T4860SEM</b>	5396
	72"	1829	6	171	77.6	14.0	-	-	-	-	<b>T4872SE</b>	4672	<b>T4872SEM</b>	5789
	84"	2134	6	197	89.4	18.7	-	-	-	-	<b>T4884SE</b>	6317	<b>T4884SEM</b>	7428
	96"	2438	8	241	109.3	18.7	-	-	-	-	<b>T4896SE</b>	6818	<b>T4896SEM</b>	7934
	108"	2743	8	278	126.1	23.3	-	-	-	-	<b>T48108SE</b>	9941	<b>T48108SEM</b>	11060
120"	3048	8	316	143.3	23.3	-	-	-	-	<b>T48120SE</b>	10028	<b>T48120SEM</b>	11141	
132"	3353	10	353	160.1	27.9	-	-	-	-	<b>T48132SE</b>	10783	<b>T48132SEM</b>	11895	
144"	3658	10	391	177.4	27.9	-	-	-	-	<b>T48144SE</b>	10863	<b>T48144SEM</b>	11979	

\* SPEC-MASTER® and SPEC-MASTER® Marine tables feature all stainless steel construction. Increase stated weight by 10%.

▼ SPEC-MASTER® Marine tables feature a marine counter edge to prevent spillage.

## Worktables with Stainless Steel Flat Top & Galvanized Tubular Base NSF

see spec sheets **EG10.42A** **EG10.42B** **EG10.42C** **EG10.42D**



**FEATURES:**

- Tubular base.
- 1 1/2" (41mm)-diameter legs and 1 1/4" (32mm)-diameter crossbracing are heavy gauge galvanized steel.
- Heavy gauge polished stainless steel top.
- Offers worktables with a rolled edge on front and rear, with ends turned 90°, except SPEC-MASTER® Marine.
- 35 1/2"-36 1/2" (892-918mm) adjustable working height.

**Note:** All shipping weights and cubic feet are approximate.

NSF sprayed-on sound deadening available. To order, add **\$818 to list price** and suffix **"-SD"**. Example: **T2424GTB-SD**.

For FLEX-MASTER® overshelf kits, see page 148.

For drawer kits, see page 155.

**Freight class is 70.0.**

(•) MTS (made to stock) / ( ) MTO (made to order)

	length		# of legs	weight		cu ft	BUDGET		DELUXE		*SPEC-MASTER®		* ▼ Marine	
	in.	mm		lbs.	kg		16 ga. type 430 top model #	list	16 ga. 300 series top model #	list	14 ga. 300 series top model #	list	14 ga. 300 series top model #	list
24" width (610mm)	24"	610	4	40	18.1	3.5	T2424GTB	968	T2424GTB	1058	T2424GTE	1100	T2424GTEM	1749
	30"	762	4	45	20.4	3.8	T2430GTB	1039	T2430GTB	1141	T2430GTE	1205	T2430GTEM	1856
	36"	914	4	50	22.7	4.4	T2436GTB	1115	T2436GTB	1217	T2436GTE	1279	T2436GTEM	1935
	48"	1219	4	60	27.2	5.7	T2448GTB	1131	T2448GTB	1233	T2448GTE	1304	T2448GTEM	1967
	60"	1524	4	70	31.8	7.1	T2460GTB	1188	T2460GTB	1323	T2460GTE	1408	T2460GTEM	2074
	72"	1829	4	80	36.3	8.5	T2472GTB	1264	T2472GTB	1423	T2472GTE	1514	T2472GTEM	2195
	84"	2134	4	90	40.8	11.2	T2484GTB	1569	T2484GTB	1976	T2484GTE	2019	T2484GTEM	2644
	96"	2438	6	100	45.4	11.2	T2496GTB	1766	T2496GTB	2107	T2496GTE	2148	T2496GTEM	2783
	108"	2743	6	110	49.9	14.0	T24108GTB	2697	T24108GTB	2968	T24108GTE	3265	T24108GTEM	3609
	120"	3048	6	120	54.4	14.0	T24120GTB	2794	T24120GTB	3052	T24120GTE	3300	T24120GTEM	3688
132"	3353	8	130	59.0	16.8	T24132GTB	2862	T24132GTB	3112	T24132GTE	3346	T24132GTEM	3947	
144"	3658	8	140	63.5	16.8	T24144GTB	2874	T24144GTB	3196	T24144GTE	3357	T24144GTEM	4032	
30" width (762mm)	30"	762	4	47	21.3	3.8	T3030GTB	1065	T3030GTB	1175	T3030GTE	1242	T3030GTEM	1902
	36"	914	4	53	24.0	4.4	T3036GTB	1136	T3036GTB	1254	T3036GTE	1317	T3036GTEM	1978
	48"	1219	4	65	29.5	5.7	T3048GTB	1155	T3048GTB	1280	T3048GTE	1364	T3048GTEM	2027
	60"	1524	4	77	34.9	7.1	T3060GTB	1247	T3060GTB	1397	T3060GTE	1492	T3060GTEM	2164
	72"	1829	4	89	40.4	8.5	T3072GTB	1339	T3072GTB •	1514	T3072GTE	1615	T3072GTEM	2300
	84"	2134	4	101	45.8	11.2	T3084GTB	1639	T3084GTB	2002	T3084GTE	2116	T3084GTEM	2751
	96"	2438	6	113	51.3	11.2	T3096GTB	1879	T3096GTB	2167	T3096GTE	2304	T3096GTEM	2935
	108"	2743	6	125	56.7	14.0	T30108GTB	2822	T30108GTB	3141	T30108GTE	3298	T30108GTEM	3871
	120"	3048	6	137	62.1	14.0	T30120GTB	2905	T30120GTB	3229	T30120GTE	3386	T30120GTEM	3958
	132"	3353	8	149	67.6	16.8	T30132GTB	2954	T30132GTB	3313	T30132GTE	3492	T30132GTEM	4179
144"	3658	8	161	73.0	16.8	T30144GTB	3125	T30144GTB	3498	T30144GTE	3678	T30144GTEM	4264	
36" width (914mm)	48"	1219	4	73	33.1	7.0	T3648GTB	1404	T3648GTB	1531	T3648GTE	1749	T3648GTEM	2406
	60"	1524	4	87	39.5	8.8	T3660GTB	1562	T3660GTB	1698	T3660GTE	1754	T3660GTEM	2581
	72"	1829	4	101	45.8	10.5	T3672GTB	1694	T3672GTB	1829	T3672GTE	1892	T3672GTEM	2747
	84"	2134	4	115	52.2	12.2	T3684GTB	2276	T3684GTB	2437	T3684GTE	2503	T3684GTEM	3284
	96"	2438	6	129	58.5	13.9	T3696GTB	2385	T3696GTB	2575	T3696GTE	2645	T3696GTEM	3436
	108"	2743	6	143	64.9	17.3	T36108GTB	3267	T36108GTB	3638	T36108GTE	3833	T36108GTEM	4454
	120"	3048	6	157	71.2	17.3	T36120GTB	3445	T36120GTB	3833	T36120GTE	3920	T36120GTEM	4540
	132"	3353	8	171	77.6	20.7	T36132GTB	3520	T36132GTB	3951	T36132GTE	4084	T36132GTEM	4802
144"	3658	8	185	83.9	20.7	T36144GTB	3709	T36144GTB	4154	T36144GTE	4167	T36144GTEM	4888	
48" width (1219mm)	48"	1219	4	87	39.5	9.3	-	-	-	T4848GTE	3474	T4848GTEM	4562	
	60"	1524	4	101	45.8	14.0	-	-	-	T4860GTE	3875	T4860GTEM	4980	
	72"	1829	6	115	52.2	14.0	-	-	-	T4872GTE	4193	T4872GTEM	5402	
	84"	2134	6	120	54.4	18.7	-	-	-	T4884GTE	5643	T4884GTEM	6746	
	96"	2438	8	143	64.9	18.7	-	-	-	T4896GTE	5949	T4896GTEM	7068	
	108"	2743	8	157	71.2	23.3	-	-	-	T48108GTE	8837	T48108GTEM	9954	
	120"	3048	8	171	77.6	23.3	-	-	-	T48120GTE	8936	T48120GTEM	10039	
	132"	3353	10	185	83.9	27.9	-	-	-	T48132GTE	9701	T48132GTEM	10796	
144"	3658	10	199	90.3	27.9	-	-	-	T48144GTE	9782	T48144GTEM	10879		

\* On SPEC-MASTER® and SPEC-MASTER® Marine tables, increase stated weight by 10%. ▼ SPEC-MASTER® Marine tables feature a marine counter edge to prevent spillage.

**Catalog Section 10**

**Worktables with Stainless Steel Flat Top & Stainless Steel Tubular Base (NSF)**

see spec sheets **EG10.43A EG10.43B EG10.43C EG10.43D**



**FEATURES:**

- Tubular base.
- 1 1/8" (41mm)-diameter legs and 1 1/4" (32mm)-diameter crossbracing are heavy gauge stainless steel.
- Heavy gauge polished stainless steel top.
- Offers worktables with a rolled edge on front and rear, with ends turned 90°, except SPEC-MASTER® Marine.
- 35 1/2"-36 1/2" (892-918mm) adjustable working height.

**Note:** All shipping weights and cubic feet are approximate.

NSF sprayed-on sound deadening available. To order, add **\$818 to list price** and suffix "-SD". **Example: T2424STB-SD.**

For FLEX-MASTER® overshelf kits, see page 148.

For drawer kits, see page 155.

**Freight class is 70.0.**

(•) MTS (made to stock) / ( ) MTO (made to order)

	length		# of legs	weight		cu ft	BUDGET		DELUXE		*SPEC-MASTER®		* ▼ Marine	
	in.	mm		lbs.	kg		16 ga. type 430 top model #	list	16 ga. 300 series top model #	list	14 ga. 300 series top model #	list	14 ga. 300 series top model #	list
24" width (610mm)	24"	610	4	40	18.1	3.5	T2424STB	1301	T2424STEB	1384	T2424STE	1483	T2424STEM	2143
	30"	762	4	45	20.4	3.8	T2430STB	1408	T2430STEB	1511	T2430STE	1629	T2430STEM	2291
	36"	914	4	50	22.7	4.4	T2436STB	1481	T2436STEB	1588	T2436STE	1705	T2436STEM	2367
	48"	1219	4	60	27.2	5.7	T2448STB	1516	T2448STEB	1638	T2448STE	1772	T2448STEM	2376
	60"	1524	4	70	31.8	7.1	T2460STB	1626	T2460STEB	1766	T2460STE	1919	T2460STEM	2580
	72"	1829	4	80	36.3	8.5	T2472STB	1738	T2472STEB	1901	T2472STE	2069	T2472STEM	2736
	84"	2134	4	90	40.8	11.2	T2484STB	2109	T2484STEB	2561	T2484STE	2769	T2484STEM	3335
	96"	2438	6	100	45.4	11.2	T2496STB	2260	T2496STEB	2732	T2496STE	2960	T2496STEM	3589
	108"	2743	6	110	49.9	14.0	T24108STB	3471	T24108STEB	3864	T24108STE	4183	T24108STEM	4499
	120"	3048	6	120	54.4	14.0	T24120STB	3656	T24120STEB	3949	T24120STE	4261	T24120STEM	4586
	132"	3353	8	130	59.0	16.8	T24132STB	3733	T24132STEB	4056	T24132STE	4397	T24132STEM	4931
144"	3658	8	140	63.5	16.8	T24144STB	3813	T24144STEB	4138	T24144STE	4479	T24144STEM	5017	
30" width (762mm)	30"	762	4	47	21.3	3.8	T3030STB	1476	T3030STEB	1595	T3030STE	1721	T3030STEM	2382
	36"	914	4	53	24.0	4.4	T3036STB	1551	T3036STEB	1668	T3036STE	1797	T3036STEM	2457
	48"	1219	4	65	29.5	5.7	T3048STB	1609	T3048STEB •	1749	T3048STE	1899	T3048STEM	2558
	60"	1524	4	77	34.9	7.1	T3060STB	1749	T3060STEB •	1908	T3060STE	2087	T3060STEM	2737
	72"	1829	4	89	40.4	8.5	T3072STB	1880	T3072STEB •	2069	T3072STE	2256	T3072STEM	3005
	84"	2134	4	101	45.8	11.2	T3084STB •	2191	T3084STEB	2665	T3084STE	2891	T3084STEM	3454
	96"	2438	6	113	51.3	11.2	T3096STB	2428	T3096STEB	2933	T3096STE	3193	T3096STEM	3579
	108"	2743	6	125	56.7	14.0	T30108STB	3785	T30108STEB	4123	T30108STE	4455	T30108STEM	4861
	120"	3048	6	137	62.1	14.0	T30120STB	3871	T30120STEB	4212	T30120STE	4541	T30120STEM	4943
	132"	3353	8	149	67.6	16.8	T30132STB	3984	T30132STEB	4361	T30132STE	4729	T30132STEM	5265
	144"	3658	8	161	73.0	16.8	T30144STB	4185	T30144STEB	4574	T30144STE	4952	T30144STEM	5349
36" width (914mm)	48"	1219	4	73	33.1	7.0	T3648STB	1837	T3648STEB	2037	T3648STE	2143	T3648STEM	2953
	60"	1524	4	87	39.5	8.8	T3660STB	2014	T3660STEB	2217	T3660STE	2348	T3660STEM	3169
	72"	1829	4	101	45.8	10.5	T3672STB	2193	T3672STEB	2405	T3672STE	2556	T3672STEM	3385
	84"	2134	4	115	52.2	12.2	T3684STB	2977	T3684STEB	3213	T3684STE	3398	T3684STEM	4099
	96"	2438	6	129	58.5	13.9	T3696STB	3195	T3696STEB	3445	T3696STE	3643	T3696STEM	4345
	108"	2743	6	143	64.9	17.3	T36108STB	4356	T36108STEB	4823	T36108STE	5154	T36108STEM	5578
	120"	3048	6	157	71.2	17.3	T36120STB	4564	T36120STEB	4963	T36120STE	5241	T36120STEM	5661
	132"	3353	8	171	77.6	20.7	T36132STB	4716	T36132STEB	5241	T36132STE	5455	T36132STEM	6034
144"	3658	8	185	83.9	20.7	T36144STB	4797	T36144STEB	5393	T36144STE	5714	T36144STEM	6123	
48" width (1219mm)	48"	1219	4	87	39.5	9.3	-	-	-	T4848STE	4158	T4848STEM	5120	
	60"	1524	4	101	45.8	14.0	-	-	-	T4860STE	4418	T4860STEM	5539	
	72"	1829	6	115	52.2	14.0	-	-	-	T4872STE	4812	T4872STEM	5924	
	84"	2134	6	120	54.4	18.7	-	-	-	T4884STE	6466	T4884STEM	7572	
	96"	2438	8	143	64.9	18.7	-	-	-	T4896STE	6957	T4896STEM	8068	
	108"	2743	8	157	71.2	23.3	-	-	-	T48108STE	10100	T48108STEM	11197	
	120"	3048	8	171	77.6	23.3	-	-	-	T48120STE	10168	T48120STEM	11278	
132"	3353	10	185	83.9	27.9	-	-	-	T48132STE	10937	T48132STEM	12035		
144"	3658	10	199	90.3	27.9	-	-	-	T48144STE	10997	T48144STEM	12117		

\* SPEC-MASTER® and SPEC-MASTER® Marine tables feature all stainless steel construction. Increase stated weight by 10%.

▼ SPEC-MASTER® Marine tables feature a marine counter edge to prevent spillage.



100 Industrial Boulevard, Clayton, DE 19938-8903 U.S.A.  
 Phone: 800-441-8440 or 302-653-3000. Fax: 302-653-2065  
<http://www.eaglegrp.com>

## Worktables with Stainless Steel Top, Upturn & Galvanized Legs/Undershelf <sup>(NSF)</sup>

see spec sheets **EG10.02A** **EG10.02B** **EG10.02C**

FEATURES:

- 1½" (38mm) upturn at the rear of the table.
- 1½" (41mm)-diameter legs and adjustable undershelf are heavy gauge galvanized steel.
- Heavy gauge polished stainless steel top.
- 35½"-36½" (892-918mm) adjustable working height.

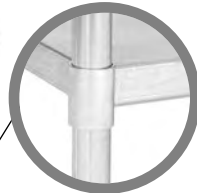

adjustable undershelf welded gusset

**NOW STANDARD!**

patented **uni-lok** system  
(Patent #5,165,349)



See page 130 for optional casters available.

**Note:** All shipping weights and cubic feet are approximate.

NSF sprayed-on sound deadening available. To order, add **\$818 to list price** and suffix **"-SD"**. Example: **UT2424B-SD**.

Optional fixed undershelf available in place of standard adjustable undershelf. To order, add **10% to list price**, and **"-F"** to end of suffix. Example: **UT2424B-F**.

For FLEX-MASTER® overshelf kits, see page 148.

For drawer kits, see page 155.

**Freight class is 70.0.**

(•) MTS (made to stock) / ( ) MTO (made to order)

	length		# of legs	weight		cu ft	BUDGET		DELUXE		*SPEC-MASTER®	
	in.	mm		lbs.	kg		16 gauge type 430 top		16 gauge 300 series top		14 gauge 300 series top	
							model #	list	model #	list	model #	list
24" width (610mm)	24"	610	4	40	18.1	3.5	UT2424B	938	UT2424EB	1031	UT2424E	1072
	30"	762	4	45	20.4	3.8	UT2430B •	1012	UT2430EB	1107	UT2430E	1175
	36"	914	4	50	22.7	4.4	UT2436B •	1081	UT2436EB	1182	UT2436E	1254
	48"	1219	4	60	27.2	5.7	UT2448B •	1099	UT2448EB	1205	UT2448E	1276
	60"	1524	4	70	31.8	7.1	UT2460B •	1162	UT2460EB	1296	UT2460E	1381
	72"	1829	4	80	36.3	8.5	UT2472B •	1235	UT2472EB	1392	UT2472E	1487
	84"	2134	4	90	40.8	11.2	UT2484B	1539	UT2484EB	1952	UT2484E	1991
	96"	2438	6	100	45.4	11.2	UT2496B	1740	UT2496EB	2078	UT2496E	2122
	108"	2743	6	110	49.9	14.0	UT24108B	2752	UT24108EB	2857	UT24108E	3000
	120"	3048	6	120	54.4	14.0	UT24120B	2808	UT24120EB	3027	UT24120E	3175
30" width (762mm)	132"	3353	8	130	59.0	16.8	UT24132B	2836	UT24132EB	3085	UT24132E	3344
	144"	3658	8	140	63.5	16.8	UT24144B	2853	UT24144EB	3261	UT24144E	3444
	30"	762	4	50	22.7	3.8	UT3030B •	1037	UT3030EB	1147	UT3030E	1208
	36"	914	4	55	24.9	4.4	UT3036B •	1107	UT3036EB	1224	UT3036E	1284
	48"	1219	4	65	29.5	5.7	UT3048B •	1123	UT3048EB	1253	UT3048E	1331
	60"	1524	4	75	34.0	7.1	UT3060B •	1218	UT3060EB	1375	UT3060E	1461
	72"	1829	4	85	38.6	8.5	UT3072B •	1312	UT3072EB	1487	UT3072E	1588
	84"	2134	4	95	43.1	11.2	UT3084B	1613	UT3084EB	1973	UT3084E	2093
	96"	2438	6	105	47.6	11.2	UT3096B •	1849	UT3096EB	2142	UT3096E	2273
	108"	2743	6	115	52.2	14.0	UT30108B	2788	UT30108EB	3113	UT30108E	3274
36" width (914mm)	120"	3048	6	125	56.7	14.0	UT30120B	2869	UT30120EB	3204	UT30120E	3359
	132"	3353	8	135	61.2	16.8	UT30132B	3013	UT30132EB	3292	UT30132E	3462
	144"	3658	8	145	65.8	16.8	UT30144B	3099	UT30144EB	3372	UT30144E	3543
	48"	1219	4	75	34.0	7.0	UT3648B	1375	UT3648EB	1506	UT3648E	1547
	60"	1524	4	85	38.6	8.8	UT3660B	1533	UT3660EB	1668	UT3660E	1721
	72"	1829	4	95	43.1	10.5	UT3672B	1666	UT3672EB	1806	UT3672E	1858
	84"	2134	4	105	47.6	12.2	UT3684B	2247	UT3684EB	2405	UT3684E	2476
	96"	2438	6	115	52.2	13.9	UT3696B	2382	UT3696EB	2545	UT3696E	2616
	108"	2743	6	125	56.7	17.3	UT36108B	3337	UT36108EB	3585	UT36108E	3699
	120"	3048	6	135	61.2	17.3	UT36120B	3422	UT36120EB	3806	UT36120E	3891
132"	3353	8	145	65.8	20.7	UT36132B	3494	UT36132EB	3922	UT36132E	4057	
144"	3658	8	155	70.3	20.7	UT36144B	3684	UT36144EB	4007	UT36144E	4140	

\* On SPEC-MASTER® tables, increase stated weight by 10%.

**Catalog Section 10**

**Worktables with Stainless Steel Top <sup>NSF</sup>  
Upturn & Stainless Steel Legs/Undershelf**

see spec sheets **EG10.48A EG10.48B EG10.48C**



**patented  
uni-lok<sup>®</sup>  
system**  
(Patent #5,165,349)



See page 130 for optional casters available.

**FEATURES:**

- 1½" (38mm) upturn at the rear of the table.
- 1½" (41mm)-diameter legs and adjustable undershelf are heavy gauge stainless steel.
- Heavy gauge polished stainless steel top.
- 35½"-36½" (892-918mm) adjustable working height.

**Note:** All shipping weights and cubic feet are approximate.

NSF sprayed-on sound deadening available. To order, add **\$818 to list price** and suffix **"-SD"**. Example: **UT2424SB-SD**.

For FLEX-MASTER<sup>®</sup> overshelf kits, see page 148.

For drawer kits, see page 155.

**Freight class is 70.0.**

	length		# of legs	weight		cu ft	BUDGET		DELUXE		*SPEC-MASTER <sup>®</sup>	
	in.	mm		lbs.	kg		16 gauge type 430 top		16 gauge 300 series top		14 gauge 300 series top	
							model #	list	model #	list	model #	list
<b>24"</b> width (610mm)	24"	610	4	40	18.1	3.5	UT2424SB	1278	UT2424SEB	1354	UT2424SE	1454
	30"	762	4	45	20.4	3.8	UT2430SB	1380	UT2430SEB	1480	UT2430SE	1602
	36"	914	4	50	22.7	4.4	UT2436SB	1453	UT2436SEB	1561	UT2436SE	1679
	48"	1219	4	60	27.2	5.7	UT2448SB	1492	UT2448SEB	1611	UT2448SE	1748
	60"	1524	4	70	31.8	7.1	UT2460SB	1597	UT2460SEB	1738	UT2460SE	1897
	72"	1829	4	80	36.3	8.5	UT2472SB	1705	UT2472SEB	1865	UT2472SE	2042
	84"	2134	4	90	40.8	11.2	UT2484SB	2082	UT2484SEB	2531	UT2484SE	2746
	96"	2438	6	100	45.4	11.2	UT2496SB	2231	UT2496SEB	2694	UT2496SE	2933
	108"	2743	6	110	49.9	14.0	UT24108SB	3546	UT24108SEB	3833	UT24108SE	4145
	120"	3048	6	120	54.4	14.0	UT24120SB	3628	UT24120SEB	3920	UT24120SE	4231
	132"	3353	8	130	59.0	16.8	UT24132SB	3704	UT24132SEB	4144	UT24132SE	4363
	144"	3658	8	140	63.5	16.8	UT24144SB	3897	UT24144SEB	4228	UT24144SE	4583
<b>30"</b> width (762mm)	30"	762	4	50	22.7	3.8	UT3030SB	1449	UT3030SEB	1564	UT3030SE	1689
	36"	914	4	55	24.9	4.4	UT3036SB	1522	UT3036SEB	1644	UT3036SE	1762
	48"	1219	4	65	29.5	5.7	UT3048SB	1578	UT3048SEB	1721	UT3048SE	1863
	60"	1524	4	75	34.0	7.1	UT3060SB	1716	UT3060SEB	1881	UT3060SE	2046
	72"	1829	4	85	38.6	8.5	UT3072SB	1856	UT3072SEB	2042	UT3072SE	2228
	84"	2134	4	95	43.1	11.2	UT3084SB	2162	UT3084SEB	2635	UT3084SE	2861
	96"	2438	6	105	47.6	11.2	UT3096SB	2401	UT3096SEB	2909	UT3096SE	3159
	108"	2743	6	115	52.2	14.0	UT30108SB	3760	UT30108SEB	4096	UT30108SE	4433
	120"	3048	6	125	56.7	14.0	UT30120SB	3844	UT30120SEB	4180	UT30120SE	4517
	132"	3353	8	135	61.2	16.8	UT30132SB	3960	UT30132SEB	4329	UT30132SE	4837
	144"	3658	8	145	65.8	16.8	UT30144SB	4038	UT30144SEB	4543	UT30144SE	4926
	<b>36"</b> width (914mm)	48"	1219	4	75	34.0	7.0	UT3648SB	1804	UT3648SEB	2002	UT3648SE
60"		1524	4	85	38.6	8.8	UT3660SB	1983	UT3660SEB	2195	UT3660SE	2318
72"		1829	4	95	43.1	10.5	UT3672SB	2165	UT3672SEB	2382	UT3672SE	2522
84"		2134	4	105	47.6	12.2	UT3684SB	2944	UT3684SEB	3193	UT3684SE	3374
96"		2438	6	115	52.2	13.9	UT3696SB	3167	UT3696SEB	3412	UT3696SE	3625
108"		2743	6	125	56.7	17.3	UT36108SB	4451	UT36108SEB	4704	UT36108SE	5127
120"		3048	6	135	61.2	17.3	UT36120SB	4539	UT36120SEB	4931	UT36120SE	5216
132"		3353	8	145	65.8	20.7	UT36132SB	4824	UT36132SEB	5131	UT36132SE	5431
144"	3658	8	155	70.3	20.7	UT36144SB	4916	UT36144SEB	5368	UT36144SE	5681	

\* On SPEC-MASTER<sup>®</sup> tables, increase stated weight by 10%. All stainless steel construction.

**Worktables with Stainless Steel Top,  
Upturn & Galvanized Tubular Base** 

see spec sheets **EG10.03A** **EG10.03B** **EG10.03C**



**FEATURES:**

- 1½" (38mm) upturn at the rear of the table.
- Tubular base.
- 1½" (41mm)-diameter legs and 1¼" (32mm)-diameter crossbracing are heavy gauge galvanized steel.
- Heavy gauge polished stainless steel top.
- 35½"-36½" (892-918mm) adjustable working height.

**Note:** All shipping weights and cubic feet are approximate.

NSF sprayed-on sound deadening available. To order, add **\$818 to list price** and suffix "-SD". Example: **UT2424GTB-SD**.

For FLEX-MASTER® overshelf kits, see page 148.

For drawer kits, see page 155.

**Freight class is 70.0.**



See page 130 for optional casters available.

	length		# of legs	weight		cu ft	BUDGET		DELUXE		*SPEC-MASTER®	
	in.	mm		lbs.	kg		16 gauge type 430 top		16 gauge 300 series top		14 gauge 300 series top	
							model #	list	model #	list	model #	list
<b>24" width</b> (610mm)	24"	610	4	40	18.1	3.5	UT2424GTB	1077	UT2424GTB	1174	UT2424GTE	1321
	30"	762	4	45	20.4	3.8	UT2430GTB	1151	UT2430GTB	1253	UT2430GTE	1381
	36"	914	4	50	22.7	4.4	UT2436GTB	1224	UT2436GTB	1327	UT2436GTE	1404
	48"	1219	4	60	27.2	5.7	UT2448GTB	1241	UT2448GTB	1346	UT2448GTE	1472
	60"	1524	4	70	31.8	7.1	UT2460GTB	1299	UT2460GTB	1440	UT2460GTE	1521
	72"	1829	4	80	36.3	8.5	UT2472GTB	1376	UT2472GTB	1541	UT2472GTE	1629
	84"	2134	4	90	40.8	11.2	UT2484GTB	1680	UT2484GTB	2093	UT2484GTE	2136
	96"	2438	6	100	45.4	11.2	UT2496GTB	1880	UT2496GTB	2222	UT2496GTE	2266
	108"	2743	6	110	49.9	14.0	UT24108GTB	2808	UT24108GTB	2999	UT24108GTE	3137
	120"	3048	6	120	54.4	14.0	UT24120GTB	2980	UT24120GTB	3171	UT24120GTE	3313
<b>30" width</b> (762mm)	30"	762	4	50	22.7	3.8	UT3030GTB	1174	UT3030GTB	1292	UT3030GTE	1354
	36"	914	4	53	24.0	4.4	UT3036GTB	1247	UT3036GTB	1367	UT3036GTE	1431
	48"	1219	4	57	25.9	5.7	UT3048GTB	1264	UT3048GTB	1394	UT3048GTE	1478
	60"	1524	4	67	30.4	7.1	UT3060GTB	1356	UT3060GTB	1514	UT3060GTE	1603
	72"	1829	4	77	34.9	8.5	UT3072GTB	1449	UT3072GTB	1629	UT3072GTE	1729
	84"	2134	4	87	39.5	11.2	UT3084GTB	1754	UT3084GTB	2115	UT3084GTE	2238
	96"	2438	6	97	44.0	11.2	UT3096GTB	1988	UT3096GTB	2284	UT3096GTE	2416
	108"	2743	6	107	48.5	14.0	UT30108GTB	2852	UT30108GTB	3261	UT30108GTE	3412
	120"	3048	6	117	53.1	14.0	UT30120GTB	3005	UT30120GTB	3346	UT30120GTE	3503
	132"	3353	8	127	57.6	16.8	UT30132GTB	3068	UT30132GTB	3432	UT30132GTE	3708
<b>36" width</b> (914mm)	48"	1219	4	61	27.7	7.0	UT3648GTB	1513	UT3648GTB	1648	UT3648GTE	1689
	60"	1524	4	73	33.1	8.8	UT3660GTB	1674	UT3660GTB	1815	UT3660GTE	1860
	72"	1829	4	85	38.6	10.5	UT3672GTB	1804	UT3672GTB	1952	UT3672GTE	2002
	84"	2134	4	97	44.0	12.2	UT3684GTB	2391	UT3684GTB	2556	UT3684GTE	2617
	96"	2438	6	109	49.4	13.9	UT3696GTB	2521	UT3696GTB	2688	UT3696GTE	2760
	108"	2743	6	121	54.9	17.3	UT36108GTB	3476	UT36108GTB	3754	UT36108GTE	3838
	120"	3048	6	133	60.3	17.3	UT36120GTB	3559	UT36120GTB	3949	UT36120GTE	4036
	132"	3353	8	145	65.8	20.7	UT36132GTB	3629	UT36132GTB	4064	UT36132GTE	4194
144"	3658	8	157	71.2	20.7	UT36144GTB	3712	UT36144GTB	4151	UT36144GTE	4278	

\* On SPEC-MASTER® tables, increase stated weight by 10%.

Catalog Section 10

Worktables with Stainless Steel Top, <sup>(NSF)</sup>  
Upturn & Stainless Steel Tubular Base

see spec sheets **EG10.49A** **EG10.49B** **EG10.49C**



- 1½" (38mm) upturn at the rear of the table.
- Tubular base.
- 1½" (41mm)-diameter legs and 1¼" (32mm)-diameter crossbracing are heavy gauge stainless steel.
- Heavy gauge polished stainless steel top.
- 35½"-36½" (892-918mm) adjustable working height.

FEATURES:

Note: All shipping weights and cubic feet are approximate.

NSF sprayed-on sound deadening available. To order, add **\$818 to list price** and suffix **"-SD"**. Example: **UT2424STB-SD**.

For FLEX-MASTER® overshelf kits, see page 148.

For drawer kits, see page 155.

Freight class is 70.0.



See page 130 for optional casters available.

	length		# of legs	weight		cu ft	BUDGET		DELUXE		*SPEC-MASTER®	
	in.	mm		lbs.	kg		16 gauge type 430 top		16 gauge 300 series top		14 gauge 300 series top	
							model #	list	model #	list	model #	list
24" width (610mm)	24"	610	4	40	18.1	3.5	UT2424STB	1439	UT2424STEB	1495	UT2424STE	1595
	30"	762	4	45	20.4	3.8	UT2430STB	1519	UT2430STEB	1626	UT2430STE	1748
	36"	914	4	50	22.7	4.4	UT2436STB	1595	UT2436STEB	1701	UT2436STE	1822
	48"	1219	4	60	27.2	5.7	UT2448STB	1628	UT2448STEB	1755	UT2448STE	1892
	60"	1524	4	70	31.8	7.1	UT2460STB	1738	UT2460STEB	1881	UT2460STE	2038
	72"	1829	4	80	36.3	8.5	UT2472STB	1848	UT2472STEB	2013	UT2472STE	2186
	84"	2134	4	90	40.8	11.2	UT2484STB	2223	UT2484STEB	2673	UT2484STE	2885
	96"	2438	6	100	45.4	11.2	UT2496STB	2366	UT2496STEB	2843	UT2496STE	3082
	108"	2743	6	110	49.9	14.0	UT24108STB	3581	UT24108STEB	3867	UT24108STE	4291
	120"	3048	6	120	54.4	14.0	UT24120STB	3767	UT24120STEB	4064	UT24120STE	4380
	132"	3353	8	130	59.0	16.8	UT24132STB	3843	UT24132STEB	4165	UT24132STE	4504
144"	3658	8	140	63.5	16.8	UT24144STB	3846	UT24144STEB	4252	UT24144STE	4725	
30" width (762mm)	30"	762	4	50	22.7	3.8	UT3030STB	1592	UT3030STEB	1713	UT3030STE	1829
	36"	914	4	53	24.0	4.4	UT3036STB	1665	UT3036STEB	1788	UT3036STE	1907
	48"	1219	4	57	25.9	5.7	UT3048STB	1721	UT3048STEB	1860	UT3048STE	2012
	60"	1524	4	67	30.4	7.1	UT3060STB	1857	UT3060STEB	2025	UT3060STE	2195
	72"	1829	4	77	34.9	8.5	UT3072STB	1989	UT3072STEB	2186	UT3072STE	2373
	84"	2134	4	87	39.5	11.2	UT3084STB	2300	UT3084STEB	2782	UT3084STE	3005
	96"	2438	6	97	44.0	11.2	UT3096STB	2540	UT3096STEB	3048	UT3096STE	3298
	108"	2743	6	107	48.5	14.0	UT30108STB	3791	UT30108STEB	4239	UT30108STE	4572
	120"	3048	6	117	53.1	14.0	UT30120STB	3982	UT30120STEB	4325	UT30120STE	4653
	132"	3353	8	127	57.6	16.8	UT30132STB	4092	UT30132STEB	4472	UT30132STE	4980
	144"	3658	8	137	62.1	16.8	UT30144STB	4178	UT30144STEB	4688	UT30144STE	5067
36" width (914mm)	48"	1219	4	61	27.7	7.0	UT3648STB	1941	UT3648STEB	2145	UT3648STE	2262
	60"	1524	4	73	33.1	8.8	UT3660STB	2125	UT3660STEB	2334	UT3660STE	2461
	72"	1829	4	85	38.6	10.5	UT3672STB	2306	UT3672STEB	2522	UT3672STE	2666
	84"	2134	4	97	44.0	12.2	UT3684STB	3085	UT3684STEB	3335	UT3684STE	3514
	96"	2438	6	109	49.4	13.9	UT3696STB	3301	UT3696STEB	3558	UT3696STE	3761
	108"	2743	6	121	54.9	17.3	UT36108STB	4461	UT36108STEB	4845	UT36108STE	5271
	120"	3048	6	133	60.3	17.3	UT36120STB	4675	UT36120STEB	5073	UT36120STE	5358
	132"	3353	8	145	65.8	20.7	UT36132STB	4820	UT36132STEB	5267	UT36132STE	5547
144"	3658	8	157	71.2	20.7	UT36144STB	4905	UT36144STEB	5511	UT36144STE	5660	

\* On SPEC-MASTER® tables, increase stated weight by 10%.  
SPEC-MASTER® tables feature all stainless steel construction.

## Worktables with Stainless Steel Top, Backsplash & Galvanized Legs/Undershelf

see spec sheets **EG10.44A EG10.44B EG10.44C EG10.44D**



adjustable undershelf welded gusset  
**NOW STANDARD!**

patented **uni-lok** system

(Patent #5,165,349)



- 4½" (114mm) backsplash at the rear of the table.
- 1½" (41mm)-diameter legs and adjustable undershelf are heavy gauge galvanized steel.
- Heavy gauge polished stainless steel top.
- SPEC-MASTER® Marine series worktables feature a marine counter edge on front and both ends.
- 35½"-36½" (892-918mm) adjustable working height.

**FEATURES:**

**Note:** All shipping weights and cubic feet are approximate.

NSF sprayed-on sound deadening available. To order, add **\$818 to list price** and suffix "-SD". Example: **T2424B-BS-SD**.

Optional fixed undershelf available in place of standard adjustable undershelf. To order, add **10% to list price**, and "-F" to end of suffix. Example: **T3048EM-BS-F**.

**Freight class is 70.0.**

For FLEX-MASTER® overshelf kits, see page 148.

For drawer kits, see page 155.



See page 130 for optional casters available.

(•) MTS (made to stock) / ( ) MTO (made to order)

	length		# of legs	weight		cu ft	BUDGET		DELUXE		*SPEC-MASTER®		* ▼ Marine	
	in.	mm		lbs.	kg		16 ga. type 430 top model #	list	16 ga. 300 series top model #	list	14 ga. 300 series top model #	list	14 ga. 300 series top model #	list
<b>24"</b> width (610mm)	24"	610	4	43	19.5	3.5	<b>T2424B-BS</b>	1138	<b>T2424EB-BS</b>	1243	<b>T2424E-BS</b>	1275	<b>T2424EM-BS</b>	2141
	30"	762	4	48	21.8	3.8	<b>T2430B-BS</b>	1218	<b>T2430EB-BS</b>	1344	<b>T2430E-BS</b>	1384	<b>T2430EM-BS</b>	2321
	36"	914	4	53	24.0	4.4	<b>T2436B-BS</b>	1291	<b>T2436EB-BS</b>	1420	<b>T2436E-BS</b>	1460	<b>T2436EM-BS</b>	2331
	48"	1219	4	63	28.6	5.7	<b>T2448B-BS</b> •	1298	<b>T2448EB-BS</b>	1452	<b>T2448E-BS</b>	1494	<b>T2448EM-BS</b>	2437
	60"	1524	4	73	33.1	7.1	<b>T2460B-BS</b> •	1385	<b>T2460EB-BS</b>	1558	<b>T2460E-BS</b>	1603	<b>T2460EM-BS</b>	2481
	72"	1829	4	85	38.6	8.5	<b>T2472B-BS</b> •	1464	<b>T2472EB-BS</b>	1662	<b>T2472E-BS</b>	1721	<b>T2472EM-BS</b>	2599
	84"	2134	4	97	44.0	11.2	<b>T2484B-BS</b>	1796	<b>T2484EB-BS</b>	2115	<b>T2484E-BS</b>	2188	<b>T2484EM-BS</b>	3060
	96"	2438	6	114	51.7	11.2	<b>T2496B-BS</b>	2004	<b>T2496EB-BS</b>	2282	<b>T2496E-BS</b>	2334	<b>T2496EM-BS</b>	3209
	108"	2743	6	142	64.4	14.0	<b>T24108B-BS</b>	3020	<b>T24108EB-BS</b>	3233	<b>T24108E-BS</b>	3341	<b>T24108EM-BS</b>	4068
	120"	3048	6	154	69.9	14.0	<b>T24120B-BS</b>	3099	<b>T24120EB-BS</b>	3306	<b>T24120E-BS</b>	3412	<b>T24120EM-BS</b>	4276
<b>30"</b> width (762mm)	132"	3353	8	166	75.3	16.8	<b>T24132B-BS</b>	3175	<b>T24132EB-BS</b>	3311	<b>T24132E-BS</b>	3496	<b>T24132EM-BS</b>	4419
	144"	3658	8	178	80.7	16.8	<b>T24144B-BS</b>	3346	<b>T24144EB-BS</b>	3568	<b>T24144E-BS</b>	3685	<b>T24144EM-BS</b>	4504
	30"	762	4	50	22.7	3.8	<b>T3030B-BS</b> •	1241	<b>T3030EB-BS</b>	1384	<b>T3030E-BS</b>	1423	<b>T3030EM-BS</b>	2278
	36"	914	4	53	24.0	4.4	<b>T3036B-BS</b> •	1316	<b>T3036EB-BS</b>	1460	<b>T3036E-BS</b>	1498	<b>T3036EM-BS</b>	2291
	48"	1219	4	70	31.8	5.7	<b>T3048B-BS</b> •	1338	<b>T3048EB-BS</b>	1506	<b>T3048E-BS</b>	1557	<b>T3048EM-BS</b>	2502
	60"	1524	4	81	36.7	7.1	<b>T3060B-BS</b> •	1436	<b>T3060EB-BS</b>	1629	<b>T3060E-BS</b>	1685	<b>T3060EM-BS</b>	2648
	72"	1829	4	94	42.6	8.5	<b>T3072B-BS</b> •	1532	<b>T3072EB-BS</b>	1758	<b>T3072E-BS</b>	1822	<b>T3072EM-BS</b>	2708
	84"	2134	4	108	49.0	11.2	<b>T3084B-BS</b>	1879	<b>T3084EB-BS</b>	2213	<b>T3084E-BS</b>	2291	<b>T3084EM-BS</b>	3268
<b>36"</b> width (914mm)	96"	2438	6	130	59.0	11.2	<b>T3096B-BS</b> •	2125	<b>T3096EB-BS</b>	2400	<b>T3096E-BS</b>	2485	<b>T3096EM-BS</b>	3472
	108"	2743	6	150	68.0	14.0	<b>T30108B-BS</b>	3181	<b>T30108EB-BS</b>	3398	<b>T30108E-BS</b>	3514	<b>T30108EM-BS</b>	4351
	120"	3048	6	170	77.1	14.0	<b>T30120B-BS</b>	3267	<b>T30120EB-BS</b>	3487	<b>T30120E-BS</b>	3600	<b>T30120EM-BS</b>	4433
	132"	3353	8	188	85.3	16.8	<b>T30132B-BS</b>	3460	<b>T30132EB-BS</b>	3688	<b>T30132E-BS</b>	3822	<b>T30132EM-BS</b>	4667
	144"	3658	8	207	93.9	16.8	<b>T30144B-BS</b>	3541	<b>T30144EB-BS</b>	3775	<b>T30144E-BS</b>	3909	<b>T30144EM-BS</b>	4744
	48"	1219	4	77	34.9	7.0	<b>T3648B-BS</b>	1739	<b>T3648EB-BS</b>	1813	<b>T3648E-BS</b>	1865	<b>T3648EM-BS</b>	2829
	60"	1524	4	90	40.8	8.8	<b>T3660B-BS</b>	1882	<b>T3660EB-BS</b>	2074	<b>T3660E-BS</b>	2143	<b>T3660EM-BS</b>	3007
	72"	1829	4	106	48.1	10.5	<b>T3672B-BS</b>	1999	<b>T3672EB-BS</b>	2216	<b>T3672E-BS</b>	2295	<b>T3672EM-BS</b>	3174
<b>36"</b> width (914mm)	84"	2134	4	123	55.8	12.2	<b>T3684B-BS</b>	2361	<b>T3684EB-BS</b>	2594	<b>T3684E-BS</b>	2688	<b>T3684EM-BS</b>	3731
	96"	2438	6	132	59.9	13.9	<b>T3696B-BS</b>	2654	<b>T3696EB-BS</b>	2918	<b>T3696E-BS</b>	3022	<b>T3696EM-BS</b>	3883
	108"	2743	6	169	76.7	17.3	<b>T36108B-BS</b>	3754	<b>T36108EB-BS</b>	3986	<b>T36108E-BS</b>	4121	<b>T36108EM-BS</b>	4952
	120"	3048	6	192	87.1	17.3	<b>T36120B-BS</b>	3836	<b>T36120EB-BS</b>	4071	<b>T36120E-BS</b>	4208	<b>T36120EM-BS</b>	5033
	132"	3353	8	216	98.0	20.7	<b>T36132B-BS</b>	3942	<b>T36132EB-BS</b>	4191	<b>T36132E-BS</b>	4466	<b>T36132EM-BS</b>	5313
	144"	3658	8	239	108.4	20.7	<b>T36144B-BS</b>	4022	<b>T36144EB-BS</b>	4400	<b>T36144E-BS</b>	4557	<b>T36144EM-BS</b>	5396

\* On SPEC-MASTER® and SPEC-MASTER® Marine tables, increase stated weight by 10%.

▼ SPEC-MASTER® Marine tables feature a marine counter edge to prevent spillage.



## Catalog Section 10

### Worktables with Stainless Steel Top, <sup>(NSF)</sup> Backsplash & Stainless Steel Legs/Undershelf

see spec sheets **EG10.45A** **EG10.45B** **EG10.45C** **EG10.45D**



patented  
**uni-lok**<sup>®</sup>  
system

(Patent #5,165,349)



See page 130 for optional casters available.

#### FEATURES:

- 4½" (114mm) backsplash at the rear of the table.
- 1½" (41mm)-diameter legs and adjustable undershelf are heavy gauge stainless steel.
- Heavy gauge polished stainless steel top.
- SPEC-MASTER<sup>®</sup> Marine series worktables feature a marine counter edge on front and both ends.
- 35½"–36½" (892–918mm) adjustable working height.

**Note:** All shipping weights and cubic feet are approximate.

NSF sprayed-on sound deadening available. To order, add **\$818 to list price** and suffix **"-SD"**. Example: **T2424SB-BS-SD**.

For FLEX-MASTER<sup>®</sup> overshelf kits, see page 148.

For drawer kits, see page 155.

**Freight class is 70.0.**

(•) MTS (made to stock) / ( ) MTO (made to order)

	length		# of legs	weight		cu ft	BUDGET		DELUXE		*SPEC-MASTER <sup>®</sup>		* ▼ Marine	
	in.	mm		lbs.	kg		16 ga. type 430 top model #	list	16 ga. 300 series top model #	list	14 ga. 300 series top model #	list	14 ga. 300 series top model #	list
24" width (610mm)	24"	610	4	43	19.5	3.5	T2424SB-BS	1564	T2424SEB-BS	1632	T2424SE-BS	1723	T2424SEM-BS	2521
	30"	762	4	48	21.8	3.8	T2430SB-BS	1685	T2430SEB-BS	1756	T2430SE-BS	1874	T2430SEM-BS	2666
	36"	914	4	53	24.0	4.4	T2436SB-BS	1758	T2436SEB-BS •	1837	T2436SE-BS	1991	T2436SEM-BS	2746
	48"	1219	4	63	28.6	5.7	T2448SB-BS	1796	T2448SEB-BS •	1901	T2448SE-BS •	2037	T2448SEM-BS	2817
	60"	1524	4	73	33.1	7.1	T2460SB-BS	1904	T2460SEB-BS	2042	T2460SE-BS •	2188	T2460SEM-BS	2959
	72"	1829	4	85	38.6	8.5	T2472SB-BS	2017	T2472SEB-BS	2186	T2472SE-BS •	2347	T2472SEM-BS	3106
	84"	2134	4	97	44.0	11.2	T2484SB-BS	2391	T2484SEB-BS	2803	T2484SE-BS	3005	T2484SEM-BS	3708
	96"	2438	6	114	51.7	11.2	T2496SB-BS	2534	T2496SEB-BS	2985	T2496SE-BS	3205	T2496SEM-BS	3893
	108"	2743	6	142	64.4	14.0	T24108SB-BS	3600	T24108SEB-BS	4160	T24108SE-BS	4466	T24108SEM-BS	4891
	120"	3048	6	154	69.9	14.0	T24120SB-BS	3934	T24120SEB-BS	4243	T24120SE-BS	4543	T24120SEM-BS	4969
30" width (762mm)	132"	3353	8	166	75.3	16.8	T24132SB-BS	4005	T24132SEB-BS	4492	T24132SE-BS	4686	T24132SEM-BS	5311
	144"	3658	8	178	80.7	16.8	T24144SB-BS	4208	T24144SEB-BS	4577	T24144SE-BS	4914	T24144SEM-BS	5396
	30"	762	4	50	22.7	3.8	T3030SB-BS	1757	T3030SEB-BS	1843	T3030SE-BS	1968	T3030SEM-BS	2758
	36"	914	4	53	24.0	4.4	T3036SB-BS	1831	T3036SEB-BS •	1919	T3036SE-BS	2045	T3036SEM-BS	2835
	48"	1219	4	70	31.8	5.7	T3048SB-BS •	1892	T3048SEB-BS •	2004	T3048SE-BS •	2148	T3048SEM-BS	2932
	60"	1524	4	81	36.7	7.1	T3060SB-BS •	2024	T3060SEB-BS •	2182	T3060SE-BS •	2339	T3060SEM-BS	3111
	72"	1829	4	94	42.6	8.5	T3072SB-BS •	2152	T3072SEB-BS •	2351	T3072SE-BS •	2532	T3072SEM-BS	3291
	84"	2134	4	108	49.0	11.2	T3084SB-BS	2463	T3084SEB-BS	2909	T3084SE-BS	3121	T3084SEM-BS	3827
	96"	2438	6	130	59.0	11.2	T3096SB-BS	2709	T3096SEB-BS •	3193	T3096SE-BS	3435	T3096SEM-BS	4111
	108"	2743	6	150	68.0	14.0	T30108SB-BS	4065	T30108SEB-BS	4409	T30108SE-BS	4740	T30108SEM-BS	5241
36" width (914mm)	120"	3048	6	170	77.1	14.0	T30120SB-BS	4151	T30120SEB-BS	4497	T30120SE-BS	4827	T30120SEM-BS	5326
	132"	3353	8	188	85.3	16.8	T30132SB-BS	4381	T30132SEB-BS	4802	T30132SE-BS	5169	T30132SEM-BS	5645
	144"	3658	8	207	93.9	16.8	T30144SB-BS	4464	T30144SEB-BS	4888	T30144SE-BS	5252	T30144SEM-BS	5734
	48"	1219	4	77	34.9	7.0	T3648SB-BS	2109	T3648SEB-BS	2355	T3648SE-BS	2531	T3648SEM-BS	3338
	60"	1524	4	90	40.8	8.8	T3660SB-BS	2292	T3660SEB-BS	2659	T3660SE-BS	2853	T3660SEM-BS	3548
	72"	1829	4	106	48.1	10.5	T3672SB-BS	2475	T3672SEB-BS	2852	T3672SE-BS	3057	T3672SEM-BS	3765
	84"	2134	4	123	55.8	12.2	T3684SB-BS	3251	T3684SEB-BS	3389	T3684SE-BS	3643	T3684SEM-BS	4480
	96"	2438	6	132	59.9	13.9	T3696SB-BS	3469	T3696SEB-BS	3628	T3696SE-BS	3904	T3696SEM-BS	4725
	108"	2743	6	169	76.7	17.3	T36108SB-BS	4760	T36108SEB-BS	5146	T36108SE-BS	5532	T36108SEM-BS	5947
	120"	3048	6	192	87.1	17.3	T36120SB-BS	4843	T36120SEB-BS	5228	T36120SE-BS	5620	T36120SEM-BS	6035
132"	3353	8	216	98.0	20.7	T36132SB-BS	5134	T36132SEB-BS	5427	T36132SE-BS	5840	T36132SEM-BS	6417	
144"	3658	8	239	108.4	20.7	T36144SB-BS	5224	T36144SEB-BS	5513	T36144SE-BS	6102	T36144SEM-BS	6504	

\* SPEC-MASTER<sup>®</sup> and SPEC-MASTER<sup>®</sup> Marine tables feature all stainless steel construction. Increase stated weight by 10%.

▼ SPEC-MASTER<sup>®</sup> Marine tables feature a marine counter edge to prevent spillage.

## Worktables with Stainless Steel Top, Backsplash & Galvanized Tubular Base <sup>NSF</sup>

see spec sheets **EG10.46A** **EG10.46B** **EG10.46C** **EG10.46D**



- 4½" (114mm) backsplash at the rear of the table.
- Tubular base.
- 1½" (41mm)-diameter legs and 1¼" (32mm)-diameter crossbracing are heavy gauge galvanized steel.
- Heavy gauge polished stainless steel top.
- SPEC-MASTER® Marine series worktables feature a marine counter edge on front and both ends.
- 35½"-36½" (892-918mm) adjustable working height.

**FEATURES:**

**Note:** All shipping weights and cubic feet are approximate.

NSF sprayed-on sound deadening available. To order, add \$818 to list price and suffix "-SD". Example: T2424GTB-BS-SD.

**Freight class is 70.0.**

For FLEX-MASTER® overshelf kits, see page 148.

For drawer kits, see page 155.



See page 130 for optional casters available.

	length		# of legs	weight		cu ft	BUDGET		DELUXE		*SPEC-MASTER®		* ▼ Marine	
	in.	mm		lbs.	kg		16 ga. type 430 top model #	list	16 ga. 300 series top model #	list	14 ga. 300 series top model #	list	14 ga. 300 series top model #	list
<b>24" width (610mm)</b>	24"	610	4	41	18.6	3.5	T2424GTB-BS	1280	T2424GTB-BS	1385	T2424GTE-BS	1419	T2424GTEM-BS	2348
	30"	762	4	46	20.9	3.8	T2430GTB-BS	1355	T2430GTB-BS	1492	T2430GTE-BS	1523	T2430GTEM-BS	2471
	36"	914	4	51	23.1	4.4	T2436GTB-BS	1434	T2436GTB-BS	1564	T2436GTE-BS	1602	T2436GTEM-BS	2543
	48"	1219	4	61	27.7	5.7	T2448GTB-BS	1436	T2448GTB-BS	1592	T2448GTE-BS	1638	T2448GTEM-BS	2580
	60"	1524	4	71	32.2	7.1	T2460GTB-BS	1525	T2460GTB-BS	1698	T2460GTE-BS	1749	T2460GTEM-BS	2694
	72"	1829	4	81	36.7	8.5	T2472GTB-BS	1604	T2472GTB-BS	1806	T2472GTE-BS	1860	T2472GTEM-BS	2821
	84"	2134	4	91	41.3	11.2	T2484GTB-BS	1934	T2484GTB-BS	2263	T2484GTE-BS	2332	T2484GTEM-BS	3296
	96"	2438	6	101	45.8	11.2	T2496GTB-BS	2142	T2496GTB-BS	2402	T2496GTE-BS	2479	T2496GTEM-BS	3454
	108"	2743	6	111	50.3	14.0	T24108GTB-BS	3068	T24108GTB-BS	3279	T24108GTE-BS	3388	T24108GTEM-BS	4341
	120"	3048	6	121	54.9	14.0	T24120GTB-BS	3239	T24120GTB-BS	3456	T24120GTE-BS	3558	T24120GTEM-BS	4416
<b>30" width (762mm)</b>	132"	3353	8	131	59.4	16.8	T24132GTB-BS	3306	T24132GTB-BS	3525	T24132GTE-BS	3634	T24132GTEM-BS	4698
	144"	3658	8	141	64.0	16.8	T24144GTB-BS	3386	T24144GTB-BS	3628	T24144GTE-BS	3719	T24144GTEM-BS	4779
	30"	762	4	51	23.1	3.8	T3030GTB-BS	1380	T3030GTB-BS	1523	T3030GTE-BS	1564	T3030GTEM-BS	2504
	36"	914	4	56	25.4	4.4	T3036GTB-BS	1453	T3036GTB-BS	1602	T3036GTE-BS	1644	T3036GTEM-BS	2580
	48"	1219	4	66	29.9	5.7	T3048GTB-BS	1472	T3048GTB-BS	1648	T3048GTE-BS	1695	T3048GTEM-BS	2645
	60"	1524	4	76	34.5	7.1	T3060GTB-BS	1574	T3060GTB-BS	1772	T3060GTE-BS	1826	T3060GTEM-BS	2788
<b>36" width (914mm)</b>	72"	1829	4	86	39.0	8.5	T3072GTB-BS	1671	T3072GTB-BS	1905	T3072GTE-BS	1967	T3072GTEM-BS	2933
	84"	2134	4	96	43.6	11.2	T3084GTB-BS	2021	T3084GTB-BS	2355	T3084GTE-BS	2436	T3084GTEM-BS	3411
	96"	2438	6	106	48.1	11.2	T3096GTB-BS	2263	T3096GTB-BS	2542	T3096GTE-BS	2624	T3096GTEM-BS	3625
	108"	2743	6	116	52.6	14.0	T30108GTB-BS	3325	T30108GTB-BS	3444	T30108GTE-BS	3656	T30108GTEM-BS	4621
	120"	3048	6	126	57.2	14.0	T30120GTB-BS	3402	T30120GTB-BS	3633	T30120GTE-BS	3741	T30120GTEM-BS	4703
	132"	3353	8	136	61.7	16.8	T30132GTB-BS	3597	T30132GTB-BS	3726	T30132GTE-BS	3849	T30132GTEM-BS	4943
<b>36" width (914mm)</b>	144"	3658	8	146	66.2	16.8	T30144GTB-BS	3688	T30144GTB-BS	3809	T30144GTE-BS	3935	T30144GTEM-BS	5033
	48"	1219	4	71	32.1	7.0	T3648GTB-BS	1879	T3648GTB-BS	1954	T3648GTE-BS	2013	T3648GTEM-BS	3051
	60"	1524	4	81	36.7	8.8	T3660GTB-BS	2024	T3660GTB-BS	2217	T3660GTE-BS	2286	T3660GTEM-BS	3236
	72"	1829	4	91	41.3	10.5	T3672GTB-BS	2071	T3672GTB-BS	2356	T3672GTE-BS	2437	T3672GTEM-BS	3409
	84"	2134	4	101	45.8	12.2	T3684GTB-BS	2501	T3684GTB-BS	2744	T3684GTE-BS	2835	T3684GTEM-BS	3983
	96"	2438	6	111	50.3	13.9	T3696GTB-BS	2703	T3696GTB-BS	3057	T3696GTE-BS	3167	T3696GTEM-BS	4143
<b>36" width (914mm)</b>	108"	2743	6	121	54.9	17.3	T36108GTB-BS	3780	T36108GTB-BS	4014	T36108GTE-BS	4264	T36108GTEM-BS	5239
	120"	3048	6	131	59.4	17.3	T36120GTB-BS	3973	T36120GTB-BS	4217	T36120GTE-BS	4352	T36120GTEM-BS	5322
	132"	3353	8	141	64.0	20.7	T36132GTB-BS	4078	T36132GTB-BS	4328	T36132GTE-BS	4479	T36132GTEM-BS	5609
	144"	3658	8	151	68.5	20.7	T36144GTB-BS	4155	T36144GTB-BS	4412	T36144GTE-BS	4562	T36144GTEM-BS	5695

\* On SPEC-MASTER® and SPEC-MASTER® Marine tables, increase stated weight by 10%.

▼ SPEC-MASTER® Marine tables feature a marine counter edge to prevent spillage.

Catalog Section 10

### Worktables with Stainless Steel Top, <sup>NSF</sup> Backsplash & Stainless Steel Tubular Base

see spec sheets **EG10.47A** **EG10.47B** **EG10.47C** **EG10.47D**



patented **uni-lok**<sup>®</sup> system  
(Patent #5,165,349)

corner connection

**FEATURES:**

- 4½" (114mm) backsplash at the rear of the table.
- Tubular base.
- 1½" (41mm)-diameter legs and 1¼" (32mm)-diameter crossbracing are heavy gauge stainless steel.
- Heavy gauge polished stainless steel top.
- SPEC-MASTER<sup>®</sup> Marine series worktables feature a marine counter edge on front and both ends.
- 35½"-36½" (892-918mm) adjustable working height.

**Note:** All shipping weights and cubic feet are approximate.

NSF sprayed-on sound deadening available. To order, add **\$818** to list price and suffix **"-SD"**. Example: **T2424STB-BS-SD**.

**Freight class is 70.0.**

For FLEX-MASTER<sup>®</sup> overshelf kits, see page 148.

For drawer kits, see page 155.



See page 130 for optional casters available.

(•) MTS (made to stock) / ( ) MTO (made to order)

	length		# of legs	weight		cu ft	BUDGET		DELUXE		*SPEC-MASTER <sup>®</sup>		* ▼ Marine	
	in.	mm		lbs.	kg		16 ga. type 430 top	16 ga. 300 series top	14 ga. 300 series top	14 ga. 300 series top	16 ga. 300 series top	14 ga. 300 series top	14 ga. 300 series top	14 ga. 300 series top
	model #	list		model #	list		model #	list	model #	list	model #	list		
24" width (610mm)	24"	610	4	41	18.6	3.5	T2424STB-BS	1703	T2424STEB-BS	1776	T2424STE-BS •	1863	T2424STEM-BS	2665
	30"	762	4	46	20.9	3.8	T2430STB-BS	1824	T2430STEB-BS	1902	T2430STE-BS	2020	T2430STEM-BS	2815
	36"	914	4	51	23.1	4.4	T2436STB-BS	1899	T2436STEB-BS	1978	T2436STE-BS	2098	T2436STEM-BS	2888
	48"	1219	4	61	27.7	5.7	T2448STB-BS	1934	T2448STEB-BS	2042	T2448STE-BS	2175	T2448STEM-BS	2954
	60"	1524	4	71	32.2	7.1	T2460STB-BS	2041	T2460STEB-BS	2186	T2460STE-BS	2332	T2460STEM-BS	3105
	72"	1829	4	81	36.7	8.5	T2472STB-BS	2157	T2472STEB-BS	2329	T2472STE-BS	2488	T2472STEM-BS	3253
	84"	2134	4	91	41.3	11.2	T2484STB-BS	2526	T2484STEB-BS	2947	T2484STE-BS	3148	T2484STEM-BS	3849
	96"	2438	6	101	45.8	11.2	T2496STB-BS	2673	T2496STEB-BS	3124	T2496STE-BS	3348	T2496STEM-BS	4038
	108"	2743	6	111	50.3	14.0	T24108STB-BS	3879	T24108STEB-BS	4178	T24108STE-BS	4472	T24108STEM-BS	5028
	120"	3048	6	121	54.9	14.0	T24120STB-BS	4074	T24120STEB-BS	4385	T24120STE-BS	4688	T24120STEM-BS	5115
30" width (762mm)	132"	3353	8	131	59.4	16.8	T24132STB-BS	4140	T24132STEB-BS	4502	T24132STE-BS	4832	T24132STEM-BS	5456
	144"	3658	8	141	64.0	16.8	T24144STB-BS	4220	T24144STEB-BS	4721	T24144STE-BS	4914	T24144STEM-BS	5541
	30"	762	4	51	23.1	3.8	T3030STB-BS	1898	T3030STEB-BS	1986	T3030STE-BS	2112	T3030STEM-BS	2902
	36"	914	4	56	25.4	4.4	T3036STB-BS	1972	T3036STEB-BS	2064	T3036STE-BS	2193	T3036STEM-BS	2982
	48"	1219	4	66	29.9	5.7	T3048STB-BS	2025	T3048STEB-BS	2147	T3048STE-BS	2308	T3048STEM-BS	3081
	60"	1524	4	76	34.5	7.1	T3060STB-BS	2164	T3060STEB-BS	2326	T3060STE-BS	2487	T3060STEM-BS	3159
	72"	1829	4	86	39.0	8.5	T3072STB-BS	2300	T3072STEB-BS	2498	T3072STE-BS	2674	T3072STEM-BS	3437
	84"	2134	4	96	43.6	11.2	T3084STB-BS	2603	T3084STEB-BS	3048	T3084STE-BS	3265	T3084STEM-BS	3972
	96"	2438	6	106	48.1	11.2	T3096STB-BS	2852	T3096STEB-BS	3335	T3096STE-BS	3574	T3096STEM-BS	4259
	108"	2743	6	116	52.6	14.0	T30108STB-BS	4208	T30108STEB-BS	4501	T30108STE-BS	4883	T30108STEM-BS	5387
36" width (914mm)	120"	3048	6	126	57.2	14.0	T30120STB-BS	4292	T30120STEB-BS	4552	T30120STE-BS	4973	T30120STEM-BS	5475
	132"	3353	8	136	61.7	16.8	T30132STB-BS	4393	T30132STEB-BS	4943	T30132STE-BS	5313	T30132STEM-BS	5791
	144"	3658	8	146	66.2	16.8	T30144STB-BS	4469	T30144STEB-BS	5033	T30144STE-BS	5397	T30144STEM-BS	5877
	48"	1219	4	71	32.1	7.0	T3648STB-BS	2247	T3648STEB-BS	2502	T3648STE-BS	2673	T3648STEM-BS	3189
	60"	1524	4	81	36.7	8.8	T3660STB-BS	2428	T3660STEB-BS	2797	T3660STE-BS	2998	T3660STEM-BS	3581
	72"	1829	4	91	41.3	10.5	T3672STB-BS	2607	T3672STEB-BS	2994	T3672STE-BS	3206	T3672STEM-BS	3912
	84"	2134	4	101	45.8	12.2	T3684STB-BS	3387	T3684STEB-BS	3537	T3684STE-BS	3792	T3684STEM-BS	4626
	96"	2438	6	111	50.3	13.9	T3696STB-BS	3614	T3696STEB-BS	3773	T3696STE-BS	4047	T3696STEM-BS	4869
	108"	2743	6	121	54.9	17.3	T36108STB-BS	4900	T36108STEB-BS	5139	T36108STE-BS	5677	T36108STEM-BS	6095
	120"	3048	6	131	59.4	17.3	T36120STB-BS	4984	T36120STEB-BS	5376	T36120STE-BS	5758	T36120STEM-BS	6180
132"	3353	8	141	64.0	20.7	T36132STB-BS	5119	T36132STEB-BS	5574	T36132STE-BS	6162	T36132STEM-BS	6558	
144"	3658	8	151	68.5	20.7	T36144STB-BS	5199	T36144STEB-BS	5653	T36144STE-BS	6256	T36144STEM-BS	6644	

\* SPEC-MASTER<sup>®</sup> and SPEC-MASTER<sup>®</sup> Marine tables feature all stainless steel construction. Increase stated weight by 10%.

▼ SPEC-MASTER<sup>®</sup> Marine tables feature a marine counter edge to prevent spillage.

**Optional Casters** 

see spec sheet **EG10.59**

**Note:** To determine set of casters applicable, see “# of legs” column in Worktables charts (pages 118-129).

**Freight class is 65.0.**

(•) MTS (made to stock) / ( ) MTO (made to order)

description	wt. cap. per caster		model #	list
	lbs.	kg		
<b>Zinc with Resilient Tread</b>				
4" (102mm) dia., set of four (two swivel, two w/brake)	115	52.2	<b>CA4-SB •</b>	479
4" (102mm) dia., set of six (three swivel, three w/brake)	115	52.2	<b>CA6-SB</b>	717
4" (102mm) dia., set of eight (four swivel, four w/brake)	115	52.2	<b>CA8-SB</b>	958
5" (127mm) dia., set of four (two swivel, two w/brake)	200	90.7	<b>CAH4-SB •</b>	635
5" (127mm) dia., set of six (three swivel, three w/brake)	200	90.7	<b>CAH6-SB</b>	953
5" (127mm) dia., set of eight (four swivel, four w/brake)	200	90.7	<b>CAH8-SB</b>	1271
<b>Nickel with Poly Tread</b>				
5" (127mm) dia., set of four (two swivel, two w/brake)	250	113.4	<b>CAHP4-SB •</b>	549
5" (127mm) dia., set of six (three swivel, three w/brake)	250	113.4	<b>CAHP6-SB</b>	825
5" (127mm) dia., set of eight (four swivel, four w/brake)	250	113.4	<b>CAHP8-SB</b>	1099
<b>Polymer Cart Washable with Polymer Tread</b>				
5" (127mm) dia., set of four (two swivel, two w/brake)	250	113.4	<b>CAHW4-SB</b>	682
5" (127mm) dia., set of six (three swivel, three w/brake)	250	113.4	<b>CAHW6-SB</b>	1024
5" (127mm) dia., set of eight (four swivel, four w/brake)	250	113.4	<b>CAHW8-SB</b>	1364



zinc casters



cart washable casters

**Contact us:**  
[revit@eaglegrp.com](mailto:revit@eaglegrp.com)

**Access Eagle's Revit Libraries on AutoQuotes, KCL, and AutoDesk Seek.**



*Profit from the Eagle Advantage®*

**Catalog Section 10**

**Hardwood Worktables**

“BAKERS’ TABLES” 

see spec sheet **EG10.10**

FEATURES:

- 1¼” (44mm) hardwood tops.
- With flat top or with 4” (102mm) covered backsplash and end splashes.
- Shipped knocked down.

**Note:** All shipping weights and cubic feet are approximate. For optional drawer assemblies, see page 154.

**Freight class is 55.0.**

(•) MTS (made to stock) / ( ) MTO (made to order)



hardwood table with flat top and undershelf...

...with flat top and tubular base...

...with backsplash and undershelf...

...with backsplash and tubular base

**Flat Top Hardwood Worktables...**

36¼” (921mm) overall height.

		...with Adjustable Undershelf						...with Tubular Base							
	length		cu ft	weight		galvanized legs & undershelf		stainless steel legs and undershelf		weight		galvanized tubular base		stainless steel tubular base	
	in.	mm		lbs.	kg	model #	list	model #	list	lbs.	kg	model #	list	model #	list
<b>24” width (610mm)</b>	48”	1219	5.3	94	42.6	<b>MT2448B</b>	1063	<b>MT2448S</b>	1279	92	41.7	<b>MT2448GT</b>	944	<b>MT2448ST</b>	1205
	60”	1524	6.6	118	53.5	<b>MT2460B</b>	1193	<b>MT2460S</b>	1452	117	53.1	<b>MT2460GT</b>	1045	<b>MT2460ST</b>	1349
	72”	1829	8.0	141	64.0	<b>MT2472B</b>	1322	<b>MT2472S</b>	1621	138	62.6	<b>MT2472GT</b>	1146	<b>MT2472ST</b>	1499
	96”	2438	10.7	189	85.7	<b>MT2496B</b>	1875	<b>MT2496S</b>	2264	182	82.6	<b>MT2496GT</b>	1644	<b>MT2496ST</b>	1874
<b>30” width (762mm)</b>	48”	1219	6.7	141	64.0	<b>MT3048B</b>	1174	<b>MT3048S</b>	1452	139	63.1	<b>MT3048GT</b>	1060	<b>MT3048ST</b>	1379
	60”	1524	8.3	147	66.7	<b>MT3060B</b>	1334	<b>MT3060S</b>	1664	145	65.8	<b>MT3060GT</b>	1192	<b>MT3060ST</b>	1572
	72”	1829	9.9	177	80.3	<b>MT3072B</b>	1492	<b>MT3072S</b>	1876	174	77.8	<b>MT3072GT</b>	1319	<b>MT3072ST</b>	1759
	96”	2438	13.2	235	106.6	<b>MT3096B</b>	2138	<b>MT3096S</b>	2616	230	104.3	<b>MT3096GT</b>	1900	<b>MT3096ST</b>	2459

**Hardwood Worktables with Backsplash & End Splashes...**

40¼” (1022mm) overall height.

		...with Adjustable Undershelf						...with Tubular Base							
	length		cu ft	weight		galvanized legs & undershelf		stainless steel legs and undershelf		weight		galvanized tubular base		stainless steel tubular base	
	in.	mm		lbs.	kg	model #	list	model #	list	lbs.	kg	model #	list	model #	list
<b>30” width (762mm)</b>	48”	1219	7.0	110	49.9	<b>MT3048B-BS</b>	2243	<b>MT3048S-BS</b>	2884	119	54.0	<b>MT3048GT-BS</b>	2154	<b>MT3048ST-BS</b>	2736
	60”	1524	9.8	149	67.6	<b>MT3060B-BS</b>	2346	<b>MT3060S-BS</b>	3036	147	66.7	<b>MT3060GT-BS</b>	2194	<b>MT3060ST-BS</b>	2880
	72”	1829	11.7	180	81.6	<b>MT3072B-BS</b>	2821	<b>MT3072S-BS</b>	3471	177	80.3	<b>MT3072GT-BS</b>	2636	<b>MT3072ST-BS</b>	3382
	96”	2438	15.5	240	108.9	<b>MT3096B-BS</b>	3857	<b>MT3096S-BS</b>	4593	235	106.6	<b>MT3096GT-BS</b>	3614	<b>MT3096ST-BS</b>	4351

**Optional Casters for Hardwood Worktables**



zinc casters

cart washable casters

description	Zinc with Resilient Tread			Nickel with Poly Tread			Polymer Cart Washable with Polymer Tread		
	wt. cap. per caster lbs.	kg	list per set	wt. cap. per caster lbs.	kg	list per set	wt. cap. per caster lbs.	kg	list per set
4” (102mm) dia., set of 4 (2 swivel, 2 w/brake)	115	52.2	<b>CA4-SB</b> • 479	–	n/a	n/a	–	n/a	n/a
4” (102mm) dia., set of 6 (3 swivel, 3 w/brake)	115	52.2	<b>CA6-SB</b> 717	–	n/a	n/a	–	n/a	n/a
5” (127mm) dia., set of 4 (2 swivel, 2 w/brake)	200	90.7	<b>CAH4-SB</b> • 635	250	113.4	<b>CAHP4-SB</b> • 549	250	113.4	<b>CAHW4-SB</b> 682
5” (127mm) dia., set of 6 (3 swivel, 3 w/brake)	200	90.7	<b>CAH6-SB</b> 953	250	113.4	<b>CAHP6-SB</b> 825	250	113.4	<b>CAHW6-SB</b> 1024

**Knock Down Worktables with Cabinet Kit** NSF

see spec sheet **EG10.36**



patented  
**uni-lok**  
system  
(Patent #5,165,349)



- Type 430 stainless steel tabletop and side panels.
- Tabletop is 30" (762mm) front-to-back, with 4½" (114mm) high backsplash.
- Stainless steel side panels and front doors with open rear.
- Easy assembly via machine screws and threaded inserts.
- 34½" (876mm) height.

FEATURES:

**Freight class is 70.0.**

...with Hinged Doors

...with Sliding Doors

	length		cubic feet	weight		model #		list	
	in.	mm		lbs.	kg				
<b>30" width</b> (914mm)	36"	914	4.4	52	23.6	<b>T3036BA-BS-HGD</b>	1913	<b>T3036BA-BS-SLD</b>	2105
	48"	1219	5.4	66	29.9	<b>T3048BA-BS-HGD</b>	2042	<b>T3048BA-BS-SLD</b>	2247
	60"	1524	7.1	79	35.8	<b>T3060BA-BS-HGD</b>	2191	<b>T3060BA-BS-SLD</b>	2405

**Filler Tables** NSF

see spec sheet **EG10.51**



patented  
**uni-lok**  
system  
(Patent #5,165,349)

FEATURES:

- Standard flanged feet adds stability.
- 1½" (38mm) upturn
- Stainless steel legs crossbraced front-to-back and side-to-side.

**Note:** Filler tables are not designed to stand alone or to hold heavy equipment loads. Application and safe installation are the responsibility of the end user.

**Freight class is 70.0.**

(•) MTS (made to stock) / ( ) MTO (made to order)

**Deluxe**  
16 gauge type 304 stainless steel top.

**SPEC-MASTER® \***  
14 gauge type 304 stainless steel top.

	length		cubic feet	weight *		model #		list	
	in.	mm		lbs.	kg				
<b>24" width</b> (610mm)	12"	305	2.9	30	13.6	<b>UT2412STEB</b>	943	<b>UT2412STE</b>	1025
	15"	381	2.9	34	15.4	<b>UT2415STEB</b>	965	<b>UT2415STE</b>	1049
	18"	457	2.9	36	16.3	<b>UT2418STEB</b>	1009	<b>UT2418STE</b>	1096
<b>30" width</b> (762mm)	12"	305	2.9	34	15.4	<b>UT3012STEB •</b>	1018	<b>UT3012STE</b>	1107
	15"	381	2.9	36	16.3	<b>UT3015STEB •</b>	1041	<b>UT3015STE</b>	1131
	18"	457	2.9	40	18.1	<b>UT3018STEB •</b>	1099	<b>UT3018STE</b>	1195
<b>36" width</b> (914mm)	12"	305	3.5	37	16.8	<b>UT3612STEB</b>	1086	<b>UT3612STE</b>	1180
	15"	381	3.5	40	18.1	<b>UT3615STEB</b>	1120	<b>UT3615STE</b>	1216
	18"	457	3.5	45	20.4	<b>UT3618STEB</b>	1162	<b>UT3618STE</b>	1264

\* Add 10% weight for SPEC-MASTER®.

**Worktable Stabilizer Bars (pair)**

see spec sheet **EG10.59**



model #	list
<b>WTA30</b>	212

FEATURES:

- Fits standard 30" and 36" width worktables.
- Heavy 12 gauge steel angle and gussets.
- Valu-Master® epoxy coated.

**Freight class is 70.0.**

**Note:** Cannot fit Griddle/Equipment Stands (page 143).

Catalog Section 10

**SPEC-MASTER® Enclosed Worktables with Flat Top** 

see spec sheet **EG10.30**



**FEATURES:**

- All-welded cabinet.
- Top mechanically polished to satin finish.
- Sound-deadened between top and frame.
- 1½" (42mm) diameter type 304 stainless legs.
- 1" (25mm) adjustable feet.
- 1½" (38mm) sanitary rolled rim on front and back with square edge on ends for flush fit.

**patented uni-lok® system**  
(Patent #5,165,349)

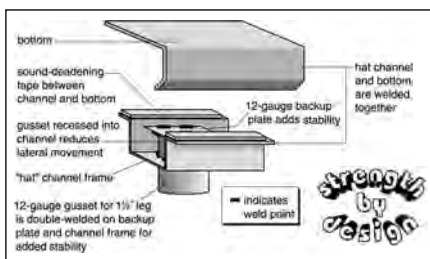

**Note:** Full length fixed center shelf available. To order full width, add 20% to list price and suffix "-FCS". To order two-thirds width, add 20% to list price and suffix "-CS". **Example: OB2436SE-CS.**

To order table with 4" (102mm) casters, add suffix "-CA" and add to list price \$479 (for tables with four legs) or \$717 (for tables with six legs). **Example: OB2436SE-CA.**

To order table with 5" (127mm) casters, add suffix "-CAH" and add to list price \$635 (for tables with four legs) or \$953 (for tables with six legs). **Example: OB2436SE-CAH.**

NSF sprayed-on sound deadening available. To order, add \$818 to list price and suffix "-SD". **Example: OB2436SE-SD.**

For enhanced utility, add overselves from page 150.

Freight class is 125.0.

					with Open Front				with Sliding Doors*				with Hinged Doors*			
	length in.	length mm	# of legs	cu ft	weight lbs.	weight kg	model #	list	weight lbs.	weight kg	model #	list	weight lbs.	weight kg	model #	list
<b>24" width (610mm)</b>	36"	914	4	36	132	59.9	<b>OB2436SE</b>	2840	138	62.6	<b>CB2436SE</b>	3626	138	62.6	<b>CBH2436SE</b>	4443
	48"	1219	4	49	160	72.6	<b>OB2448SE</b>	2949	170	77.1	<b>CB2448SE</b>	4056	170	77.1	<b>CBH2448SE</b>	4652
	60"	1524	4	63	200	90.7	<b>OB2460SE</b>	3156	212	96.2	<b>CB2460SE</b>	4357	212	96.2	<b>CBH2460SE</b>	4961
	72"	1829	4	72	240	108.9	<b>OB2472SE</b>	3364	254	115.2	<b>CB2472SE</b>	4672	254	115.2	<b>CBH2472SE</b>	5264
	84"	2134	6	83	281	127.5	<b>OB2484SE</b>	3660	299	135.6	<b>CB2484SE**</b>	5341	299	135.6	<b>CBH2484SE**</b>	5923
	96"	2438	6	95	322	146.1	<b>OB2496SE</b>	3845	339	153.8	<b>CB2496SE**</b>	5771	339	153.8	<b>CBH2496SE**</b>	6353
	120"	3048	6	105	366	166.0	<b>OB24120SE</b>	4559	384	174.2	<b>CB24120SE**</b>	6666	384	174.2	<b>CBH24120SE**</b>	7245
<b>30" width (762mm)</b>	36"	914	4	36	136	61.7	<b>OB3036SE</b>	2999	142	64.4	<b>CB3036SE</b>	3786	142	64.4	<b>CBH3036SE</b>	4593
	48"	1219	4	49	166	75.3	<b>OB3048SE</b>	3104	173	78.5	<b>CB3048SE</b>	4208	173	78.5	<b>CBH3048SE</b>	4803
	60"	1524	4	63	199	90.3	<b>OB3060SE</b>	3337	219	99.3	<b>CB3060SE</b>	4541	219	99.3	<b>CBH3060SE</b>	5141
	72"	1829	4	72	248	112.5	<b>OB3072SE</b>	3575	261	118.4	<b>CB3072SE</b>	4879	261	118.4	<b>CBH3072SE</b>	5476
	84"	2134	6	83	294	133.4	<b>OB3084SE</b>	3818	312	141.5	<b>CB3084SE**</b>	5488	312	141.5	<b>CBH3084SE**</b>	6078
	96"	2438	6	95	340	154.2	<b>OB3096SE</b>	4214	350	158.8	<b>CB3096SE**</b>	6012	350	158.8	<b>CBH3096SE**</b>	6594
	120"	3048	6	105	432	196.0	<b>OB30120SE</b>	4847	450	204.1	<b>CB30120SE**</b>	6953	450	204.1	<b>CBH30120SE**</b>	7527

\* 20 gauge stainless steel doors. To order optional door locks, add suffix "-L" and \$178 list price; \*\* Tables 84" (2134mm) and longer have two sets of doors.

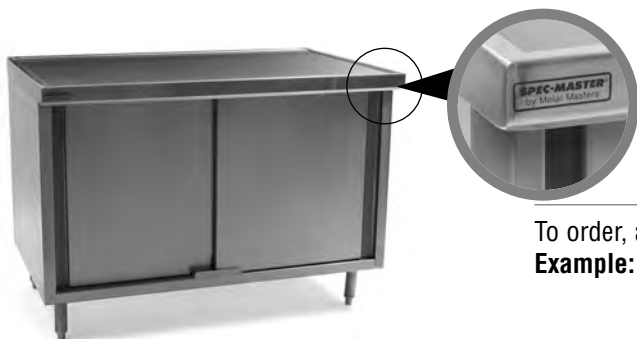

**ALSO AVAILABLE!**

**SPEC-MASTER® Marine Counter Edge Cabinets**

To order, add 20% to list price and add "M" after "SE" in model number. **Example: CB2436SEM.**

see spec sheet **EG10.33A**

**SPEC-MASTER® Enclosed Worktables with Upturn NSF**

see spec sheet **EG10.31**



**FEATURES:**

- All-welded cabinet.
- Top mechanically polished to satin finish.
- Top is 14 gauge type 304 stainless steel reinforced with a full length "hat" channel support.
- Body is heavy gauge type 430 stainless steel.
- Sound-deadened between top and frame.
- 1½" (42mm) diameter type 304 stainless legs.
- 1" (25mm) adjustable feet.
- 1½" (38mm) sanitary rolled rim on front, 1½" (38mm) rear upturn, and square edge on ends for flush fit.

**patented uni-lok® system**  
(Patent #5,165,349)

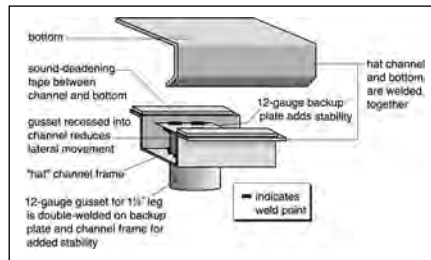

**Note:** Full length fixed center shelf available. To order full width, add 20% to list price and suffix "-FCS". To order two-thirds width, add 20% to list price and suffix "-CS". Example: UOB2436SE-CS.  
To order table with 4" (102mm) casters, add suffix "-CA" and add to list price \$479 (for tables with four legs) or \$717 (for tables with six legs). Example: UOB3036SE-CA.  
To order table with 5" (127mm) casters, add suffix "-CAH" and add to list price \$635 (for tables with four legs) or \$953 (for tables with six legs). Example: UOB3036SE-CAH.  
NSF sprayed-on sound deadening available. To order, add \$818 to list price and suffix "-SD". Example: UOB3036SE-SD.  
For enhanced utility, add overselves from page 150.

**Freight class is 125.0.**

					with Open Front				with Sliding Doors*				with Hinged Doors*			
	length in. mm	# of legs	cu ft	weight lbs. kg	model #	list	weight lbs. kg	model #	list	weight lbs. kg	model #	list				
<b>24" width (610mm)</b>	36" 914	4	36	132 59.9	UOB2436SE	2840	138 62.6	UCB2436SE	3626	138 62.6	UCBH2436SE	4443				
	48" 1219	4	49	160 72.6	UOB2448SE	2949	170 77.1	UCB2448SE	4056	170 77.1	UCBH2448SE	4652				
	60" 1524	4	63	200 90.7	UOB2460SE	3156	212 96.2	UCB2460SE	4357	212 96.2	UCBH2460SE	4961				
	72" 1829	4	72	240 108.9	UOB2472SE	3364	254 115.2	UCB2472SE	4672	254 115.2	UCBH2472SE	5264				
	84" 2134	6	83	281 127.5	UOB2484SE	3660	299 135.6	UCB2484SE**	5341	299 135.6	UCBH2484SE**	5923				
	96" 2438	6	95	322 146.1	UOB2496SE	3845	339 153.8	UCB2496SE**	5771	339 153.8	UCBH2496SE**	6353				
120" 3048	6	105	366 166.0	UOB24120SE	4559	384 174.2	UCB24120SE**	6666	384 174.2	UCBH24120SE**	7245					
<b>30" width (762mm)</b>	36" 914	4	36	136 61.7	UOB3036SE	2999	142 64.4	UCB3036SE	3786	142 64.4	UCBH3036SE	4593				
	48" 1219	4	49	166 75.3	UOB3048SE	3104	173 78.5	UCB3048SE	4208	173 78.5	UCBH3048SE	4803				
	60" 1524	4	63	199 90.3	UOB3060SE	3337	219 99.3	UCB3060SE	4541	219 99.3	UCBH3060SE	5141				
	72" 1829	4	72	248 112.5	UOB3072SE	3569	261 118.4	UCB3072SE	4879	261 118.4	UCBH3072SE	5476				
	84" 2134	6	83	294 133.4	UOB3084SE	3818	312 141.5	UCB3084SE**	5488	312 141.5	UCBH3084SE**	6078				
	96" 2438	6	95	340 154.2	UOB3096SE	4214	350 158.8	UCB3096SE**	6012	350 158.8	UCBH3096SE**	6594				
120" 3048	6	105	432 196.0	UOB30120SE	4847	450 204.1	UCB30120SE**	6953	450 204.1	UCBH30120SE**	7527					

\* 20 gauge stainless steel doors. To order optional door locks, add suffix "-L" and \$178 list price; \*\* Tables 84" (2134mm) and longer have two sets of doors.



**SPEC-MASTER® Marine Counter Edge Cabinets**

To order, add 20% to list price and add "M" after "SE" in model number.  
Example: UOB2436SEM.

see spec sheet **EG10.33B**





**Catalog Section 10**

**SPEC-MASTER® Enclosed Worktables with Backsplash** 

see spec sheet **EG10.32**



**patented uni-lok® system**  
(Patent #5,165,349)

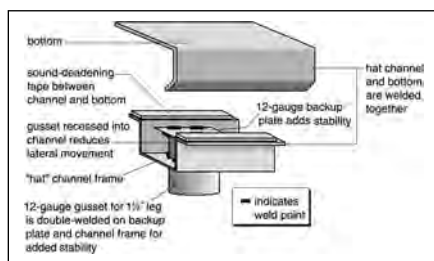

- All-welded cabinet.
- Top mechanically polished to satin finish.
- Top is 14 gauge type 304 stainless steel reinforced with a full length "hat" channel support.
- Body is heavy gauge type 430 stainless steel.
- Sound-deadened between top and frame.
- 1 1/8" (42mm) diameter type 304 stainless legs.
- 1" (25mm) adjustable stainless steel feet.
- 1 1/2" (38mm) sanitary rolled rim on front, 4 1/2" (114mm) backsplash on rear, and square edge on ends for flush fit.

**FEATURES:**

**Note:** Full length fixed center shelf available. To order full width, add **20% to list price** and suffix **"-FCS"**. To order two-thirds width, add **20% to list price** and suffix **"-CS"**. **Example: OB2436SE-BS-CS**.  
Door lock also available. For enhanced utility, add overselves from page 150.  
To order table with 4" (102mm) casters, add suffix **"-CA"** and add to list price **\$479** (for tables with four legs) or **\$717** (for tables with six legs). **Example: OB3036SE-BS-CA**.  
To order table with 5" (127mm) casters, add suffix **"-CAH"** and add to list price **\$635** (for tables with four legs) or **\$953** (for tables with six legs). **Example: OB3036SE-BS-CAH**.  
NSF sprayed-on sound deadening available. To order, add **\$818 to list price** and suffix **"-SD"**. **Example: OB3036SE-BS-SD**.

**Freight class is 125.0.**

	length in. mm	# of legs	cu ft	with Open Front				with Sliding Doors*				with Hinged Doors*			
				weight lbs. kg	model #	list	weight lbs. kg	model #	list	weight lbs. kg	model #	list			
<b>24" width</b> (610mm)	36" 914	4	36	133 60.3	<b>OB2436SE-BS</b>	2873	139 63.1	<b>CB2436SE-BS</b>	3811	139 63.1	<b>CBH2436SE-BS</b>	4475			
	48" 1219	4	49	161 73.0	<b>OB2448SE-BS</b>	2979	171 77.6	<b>CB2448SE-BS</b>	4084	171 77.6	<b>CBH2448SE-BS</b>	4683			
	60" 1524	4	63	202 91.6	<b>OB2460SE-BS</b>	3194	214 97.1	<b>CB2460SE-BS</b>	4399	214 97.1	<b>CBH2460SE-BS</b>	4995			
	72" 1829	4	72	243 110.2	<b>OB2472SE-BS</b>	3411	256 116.1	<b>CB2472SE-BS</b>	4721	256 116.1	<b>CBH2472SE-BS</b>	5313			
	84" 2134	6	83	284 128.8	<b>OB2484SE-BS</b>	3714	304 137.9	<b>CB2484SE-BS**</b>	5392	304 137.9	<b>CBH2484SE-BS**</b>	5980			
	96" 2438	6	95	326 147.9	<b>OB2496SE-BS</b>	3905	343 155.6	<b>CB2496SE-BS**</b>	5826	343 155.6	<b>CBH2496SE-BS**</b>	6418			
120" 3048	6	105	390 176.9	<b>OB24120SE-BS</b>	4636	390 176.9	<b>CB24120SE-BS**</b>	6742	390 176.9	<b>CBH24120SE-BS**</b>	7318				
<b>30" width</b> (762mm)	36" 914	4	36	137 62.1	<b>OB3036SE-BS</b>	3123	143 64.9	<b>CB3036SE-BS</b>	3936	143 64.9	<b>CBH3036SE-BS</b>	4624			
	48" 1219	4	49	167 75.8	<b>OB3048SE-BS</b>	3133	174 78.9	<b>CB3048SE-BS</b>	4234	174 78.9	<b>CBH3048SE-BS</b>	4832			
	60" 1524	4	63	201 91.2	<b>OB3060SE-BS</b>	3498	221 100.2	<b>CB3060SE-BS</b>	4585	221 100.2	<b>CBH3060SE-BS</b>	5174			
	72" 1829	4	72	251 113.9	<b>OB3072SE-BS</b>	3618	264 119.8	<b>CB3072SE-BS</b>	4925	264 119.8	<b>CBH3072SE-BS</b>	5516			
	84" 2134	6	83	299 135.6	<b>OB3084SE-BS</b>	3869	319 144.7	<b>CB3084SE-BS**</b>	5541	319 144.7	<b>CBH3084SE-BS**</b>	6134			
	96" 2438	6	95	344 156.0	<b>OB3096SE-BS</b>	4274	355 161.0	<b>CB3096SE-BS**</b>	6067	355 161.0	<b>CBH3096SE-BS**</b>	7051			
120" 3048	6	105	438 198.7	<b>OB30120SE-BS</b>	4924	458 207.8	<b>CB30120SE-BS**</b>	7028	458 207.8	<b>CBH30120SE-BS**</b>	7601				

\* 20 gauge stainless steel doors. To order optional door locks, add suffix **"-L"** and \$178 list price; \*\* Tables 84" (2134mm) and longer have two sets of doors.

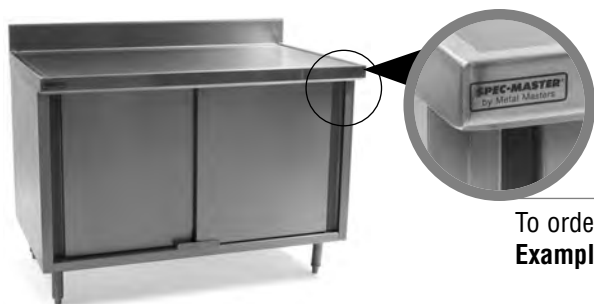

**SPEC-MASTER® Marine Counter Edge Cabinets**

To order, add **20% to list price** and add **"M"** after **"SE"** in model number. **Example: OB2436SEM-BS**.

see spec sheet **EG10.33C**



**SPEC-MASTER® Marine Beverage Counters** NSF

see spec sheet **EG10.35**

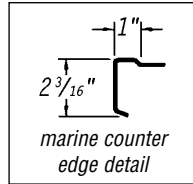
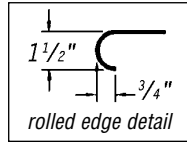

patented  
**uni-lok®**  
system  
(Patent #5,165,349)

FEATURES:

- All stainless steel construction.
- 1 1/2" (41mm) diameter legs with adjustable feet.
- 10" (254mm) high backsplash.
- Set of three pairs of rack slides\* with end caps.
- 24" x 4 1/2" x 1 1/4" (610 x 114 x 32mm) urn trough with 1 1/2" (38mm) drain & louvered grate.
- 10" x 14" x 9 1/2" (254 x 356 x 241mm) sink bowl with deck-mounted gooseneck faucet, single phase duplex receptacle (NEMA 5-20R) on opposite end of sink.
- Hinged doors\*\*.
- 30" (762mm) front-to-back.
- 34 1/2" (876mm) working height.
- 44 1/2" (1130mm) overall height.

\* Units 96" and longer have TWO sets of three pairs of rack slides.

\*\* 48"-long units have one door. Units 60" to 96"-long have a pair of doors. Units 120" and longer have two pairs of doors.

**Freight class is 92.5.**

**...with Rolled Edges**

length in. mm	SINK ON LEFT SIDE		SINK ON RIGHT SIDE		SINK ON LEFT SIDE		SINK ON RIGHT SIDE	
	model #	list	model #	list	model #	list	model #	list
48" 1219	BEV3048SE-10BS/L	6754	BEV3048SE-10BS/R	6754	BEV3048SEM-10BS/L	7104	BEV3048SEM-10BS/R	7104
60" 1524	BEV3060SE-10BS/L	7163	BEV3060SE-10BS/R	7163	BEV3060SEM-10BS/L	7539	BEV3060SEM-10BS/R	7539
72" 1829	BEV3072SE-10BS/L	7627	BEV3072SE-10BS/R	7627	BEV3072SEM-10BS/L	8024	BEV3072SEM-10BS/R	8024
84" 2134	BEV3084SE-10BS/L	8848	BEV3084SE-10BS/R	8848	BEV3084SEM-10BS/L	9317	BEV3084SEM-10BS/R	9317
96" 2439	BEV3096SE-10BS/L	9269	BEV3096SE-10BS/R	9269	BEV3096SEM-10BS/L	9756	BEV3096SEM-10BS/R	9756
120" 3048	BEV30120SE-10BS/L	13912	BEV30120SE-10BS/R	13912	BEV30120SEM-10BS/L	14643	BEV30120SEM-10BS/R	14643
144" 3658	BEV30144SE-10BS/L	14777	BEV30144SE-10BS/R	14777	BEV30144SEM-10BS/L	15556	BEV30144SEM-10BS/R	15556

**...with Boxed Marine Edges**

**SPEC-MASTER® Marine Prep Tables**

see spec sheet **EG10.34**

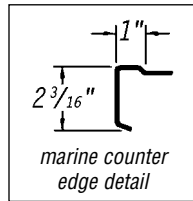

patented  
**uni-lok®**  
system  
(Patent #5,165,349)

FEATURES:

- All stainless steel construction.
- 14 gauge type 304 stainless steel top with marine counter edge.
- 1 1/2" (41mm) diameter legs.
- Gussets with uni-lok® design.
- Adjustable flanged feet.
- Welded base features heavy gauge stainless steel undershelf with 1 1/2" (38mm) rear upturn.
- Two 24" x 18" x 12" (610 x 457 x 305mm) sink bowls, each with twist handle drain with overflow.
- 10" (254mm) high backsplash with Z-clip wall-mounting bracket.
- 1/2" (13mm) thick poly cutting board is 16" x 24" (406 x 610mm).
- NSF-approved drawer and poly cutting board with storage slides.
- 8" (203mm) T & S faucet.

**Freight class is 125.0.**

	length		weight		model #	list
	in.	mm	lbs.	kg		
<b>30" width</b> (762mm)	96"	2439	452	205.0	SMPT3096	9637
	108"	2743	480	217.7	SMPT30108	10235
	120"	3048	555	251.8	SMPT30120	10840
	144"	3658	591	268.1	SMPT30144	12041

**Catalog Section 10**

**SPEC-MASTER® Plate Cabinets** (NSF)

see spec sheet **EG10.56**



- All-welded design.
- Center shelf.
- Body and center shelf are heavy gauge type 430 stainless steel.
- Top is 14 gauge type 304 stainless steel.
- 1½" (38mm) sanitary rolled rim on front.
- Square edge on rear and ends for flush fit.

**FEATURES:**

**Note:** SPEC-MASTER® Plate Cabinets are for stationary use only.

**Freight class is 125.0.**

*For use in modular design of chef's counters and cook lines.*

	...with Open Base				...with Hinged Doors*				...with Sliding Doors*			
	length in. mm	# of legs	weight lbs. kg	model # list	weight lbs. kg	model # list	weight lbs. kg	model # list				
<b>15" width</b> (381mm)	48" 1219	4	135 61.2	<b>PC1548SE-CS</b> 3038	150 68.0	<b>PCH1548SE-CS</b> 4075	150 68.0	<b>PCS1548SE-CS</b> 4033				
	60" 1524	4	175 79.5	<b>PC1560SE-CS</b> 3245	190 86.2	<b>PCH1560SE-CS</b> 4281	190 86.2	<b>PCS1560SE-CS</b> 4238				
	72" 1829	4	215 97.5	<b>PC1572SE-CS</b> 3607	230 104.3	<b>PCH1572SE-CS</b> 4645	230 104.3	<b>PCS1572SE-CS</b> 4598				
	84" 2134	6	265 120.2	<b>PC1584SE-CS</b> 3761	295 133.8	<b>PCH1584SE-CS</b> 4814	295 133.8	<b>PCS1584SE-CS</b> 4755				
	96" 2438	6	305 137.0	<b>PC1596SE-CS</b> 4080	365 165.6	<b>PCH1596SE-CS</b> 5116	365 165.6	<b>PCS1596SE-CS</b> 5071				
	120" 3048	6	345 156.5	<b>PC15120SE-CS</b> 4961	405 183.7	<b>PCH15120SE-CS</b> 5996	405 183.7	<b>PCS15120SE-CS</b> 5951				
144" 3658	6	425 192.9	<b>PC15144SE-CS</b> 6087	445 201.9	<b>PCH15144SE-CS</b> 7125	445 201.9	<b>PCS15144SE-CS</b> 7078					
<b>18" width</b> (457mm)	48" 1219	4	140 63.5	<b>PC1848SE-CS</b> 3242	155 70.3	<b>PCH1848SE-CS</b> 4278	155 70.3	<b>PCS1848SE-CS</b> 4233				
	60" 1524	4	180 83.9	<b>PC1860SE-CS</b> 3505	195 88.5	<b>PCH1860SE-CS</b> 4543	195 88.5	<b>PCS1860SE-CS</b> 4497				
	72" 1829	4	220 99.8	<b>PC1872SE-CS</b> 4296	235 106.6	<b>PCH1872SE-CS</b> 5331	235 106.6	<b>PCS1872SE-CS</b> 5286				
	84" 2134	6	270 122.5	<b>PC1884SE-CS</b> 4633	300 136.1	<b>PCH1884SE-CS</b> 5668	300 136.1	<b>PCS1884SE-CS</b> 5626				
	96" 2438	6	310 140.6	<b>PC1896SE-CS</b> 4961	370 168.6	<b>PCH1896SE-CS</b> 5996	370 168.6	<b>PCS1896SE-CS</b> 5951				
	120" 3048	6	350 158.8	<b>PC18120SE-CS</b> 5636	410 186.0	<b>PCH18120SE-CS</b> 6675	410 186.0	<b>PCS18120SE-CS</b> 6629				
144" 3658	6	430 195.1	<b>PC18144SE-CS</b> 6762	450 204.1	<b>PCH18144SE-CS</b> 7801	450 204.1	<b>PCS18144SE-CS</b> 7758					

\* Doors are 20 gauge type 430 stainless steel. 48" - to 72"-long units have one pair of doors. 84" - to 144"-long units have two pairs of doors.

**SPEC-MASTER® Prep Tables** (NSF)

see spec sheet **EG10.18**



**patented uni-lok® system**  
(Patent #5,165,349)

- 14 gauge, type 304 all-stainless steel construction.
- 4½" Backsplash.
- Deck mount faucet with 12" (305mm) spout.
- 16" x 20" x 8" (406 x 508 x 203mm) deep drawn sink.
- 20" x 20" x 5" (508 x 508 x 127mm) drawer.
- Heavy gauge stainless steel adjustable undershelf.
- 18¼" x 20¼" (464 x 527mm) poly cutting board doubles as a sink cover.

**FEATURES:**

**Freight class is 70.0.**

	length in. mm	weight lbs. kg	cubic feet	w/Left-End Sink, Right-End Drawer		w/Right-End Sink, Left-End Drawer	
				model #	list	model #	list
<b>30" width</b> (762mm)	72" 1829	150 68.0	19.2	<b>PT 3072</b>	4962	<b>PT 3072-R</b>	4962
	84" 2134	175 79.4	22.4	<b>PT 3084</b>	5476	<b>PT 3084-R</b>	5476
	96" 2438	212 96.2	25.5	<b>PT 3096</b>	5866	<b>PT 3096-R</b>	5866

## Pizza Cut-n-Pack Tables (NSF)

see spec sheet **EG10.19**



- All stainless steel base.
- Plastic laminated divider panel.
- Full base storage.
- Four 4" (102mm)-diameter swivel stem caster, (two with brakes).
- Variety of colors and patterns to choose from (standard is red).

**FEATURES:**

**Note:** All shipping weights are approximate.

**Freight class is 92.5.**

	length		weight		cubic feet	model #	list
	in.	mm	lbs.	kg			
<b>49 3/4" width</b> (1264mm)	60"	1524	318	144.3	93.2	<b>PIC60R</b> *	10341
	72"	1829	368	167.0	110.6	<b>PIC72R</b> **	11109
	84"	2134	432	196.0	128.0	<b>PIC84R</b> **	11807

\* 60" (1524mm) model utilizes four casters.

\*\* 72" and 84" (1829 and 2134mm) units utilize four casters and two center support legs.

### Optional Cash Drawer for Pizza Cut-n-Pack Tables

weight	cubic			
		lbs.	kg	feet
26	11.8	0.8	<b>CD-1</b>	1271

## Pizza Holding Tables (NSF)

see spec sheet **EG10.20**



- Unit designed for field wiring.
- Stainless steel top, undershelf, and overshelves.
- 12-gauge galvanized angle framing.
- Two chrome-plated wire racks.
- Two U.L. listed infrared food warmers.
- Stainless steel undershelf is adjustable.
- 64 1/2" (1638mm) total height.
- Electricity is single phase.

**FEATURES:**

**Note:** All shipping weights and cubic feet are approximate.

**Freight class is 70.0.**

	length		weight		electrical	cubic feet	model #	list
	in.	mm	lbs.	kg				
<b>21" width</b> (533mm)	48"	1219	135	61.2	120V, 5.62A, 675W	16.4	<b>PIH48-120</b>	5131
	48"	1219	135	61.2	208V, 3.25A, 675W	16.4	<b>PIH48-208</b>	5131
	48"	1219	135	61.2	240V, 2.82A, 675W	16.4	<b>PIH48-240</b>	5131

### Replacement Wire Rack for Pizza Holding Tables

width	length		weight		cubic feet	model #	list
	in.	mm	lbs.	kg			
<b>16" (406mm)</b>	39"	991	6	2.7	0.9	<b>WR-39</b>	192

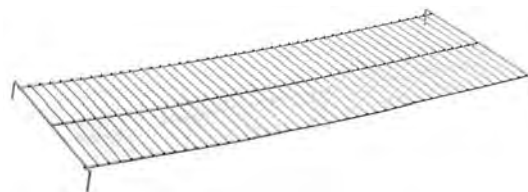

## Catalog Section 10

### Slicer Tables

see product announcement **EG8127**



stationary model

**600-lb. (272.2 kg)  
total weight capacity**  
(evenly distributed static load)

patented  
**uni-lok**<sup>®</sup>  
system  
(Patent #5,165,349)

FEATURES:

- 14 gauge type 304 stainless steel tabletop with box marine edge on all four sides.
- Stainless steel 5-pan slides accommodates 18" x 26" (457 x 660mm) pans, spaced 4½" (114mm) apart, mounted to removable angle.
- Welded bottom solid shelf.
- Stainless steel legs.

**Freight class is 70.0.**

width in. mm	length in. mm	height in. mm	weight lbs. kg	STATIONARY		MOBILE *					
				model #	list	model #	list				
31½"	791	27½"	689	34"	864	95	43.1	<b>T3030SEM-ST</b>	2966	<b>T3030SEM-ST-CAH</b>	3559

\* Stainless steel legs with 5" (127mm)-dia. heavy duty resilient swivel casters, two with brake.

### Rice Cooker Tables <sup>NSF</sup>

see spec sheet **EG10.58**



**Accommodates most popular  
brand cookers including  
Panasonic, Sharp, Tiger,  
and Zojirushi!**

FEATURES:

- 16 gauge type 430 stainless steel tabletop.
- Edges turned down at 90° on all four sides.
- Cutout for rice cooker.
- Heavy duty zinc-plated gussets.
- 1½" (41mm) diameter galvanized or stainless steel legs.
- Adjustable high-impact plastic feet.
- Two adjustable 18 gauge galvanized or stainless steel undershelves.

**Freight class is 70.0.**

	width		weight		cubic feet	GALVANIZED LEGS & UNDERSHELF		STAINLESS STEEL LEGS & UNDERSHELF	
	in.	mm	lbs.	kg		model #	list	model #	list
<b>24" length</b> (610mm)	32"	813	53	24.0	4.2	<b>T3224RCB</b>	702	<b>T3224RCSB</b>	1043
	34"	864	56	25.4	4.4	<b>T3424RCB</b>	707	<b>T3424RCSB</b>	1049

### Stainless Steel Lok-n-Fold™ Tables

see spec sheet **EG10.57**



with removable undershelf

FEATURES:

- 18 gauge type 430 stainless steel top.
- Folding legs constructed of heavy gauge painted mild steel.
- Locking dimples, a safety mechanism, ensure legs are locked in place.
- 30½" (784mm) non-adjustable height.

**Freight class is 70.0.**

	length		weight capacity		WITH OPEN BASE				WITH REMOVABLE GALVANIZED UNDERSHELF				WITH REMOVABLE STAINLESS STEEL UNDERSHELF				
					cu ft	weight		model #	list	weight		model #	list	weight		model #	list
	in.	mm	lbs.	kg		lbs.	kg			lbs.	kg			lbs.	kg		
<b>24" width</b> (610mm)	48"	1219	360	163.3	6.0	44	20.0	<b>T2448F</b>	738	61	27.7	<b>T2448F-US</b>	889	61	27.7	<b>T2448F-USS</b>	964
	60"	1524	450	204.1	7.5	48	21.8	<b>T2460F</b>	777	65	29.5	<b>T2460F-US</b>	960	65	29.5	<b>T2460F-USS</b>	1048
	72"	1829	540	244.9	8.9	52	23.6	<b>T2472F</b>	887	70	31.8	<b>T2472F-US</b>	1017	70	31.8	<b>T2472F-USS</b>	1125
<b>30" width</b> (762mm)	48"	1219	450	204.1	7.4	46	20.9	<b>T3048F</b>	809	63	28.6	<b>T3048F-US</b>	914	63	28.6	<b>T3048F-USS</b>	983
	60"	1524	562	254.9	9.2	50	22.7	<b>T3060F</b>	866	69	31.3	<b>T3060F-US</b>	985	69	31.3	<b>T3060F-USS</b>	1066
	72"	1829	675	306.2	11.0	56	25.4	<b>T3072F</b>	919	75	34.0	<b>T3072F-US</b>	1051	75	34.0	<b>T3072F-USS</b>	1147

adjustable® Work Surface Systems NSF

see spec sheet **EG10.09**

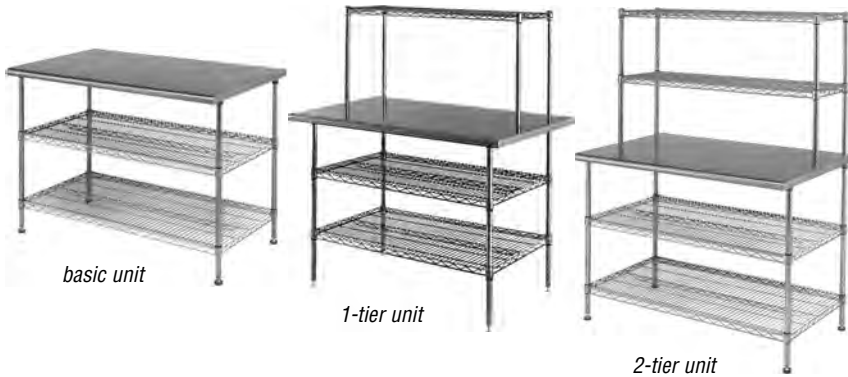

basic unit

1-tier unit

2-tier unit

adjustable®

Additional wire undershelves, solid stainless steel undershelves, chrome wire overshelves, or solid stainless steel overshelves make the possibilities almost unlimited.

patented QuadTruss® design (Patent #5,390,803) Patented QuadTruss® Design makes shelves up to 25% stronger and provides a retaining ledge for increased strength and product retention.

Freight class is 70.0.

Basic Units — 33½" (851mm) overall height.

	length		cu ft	weight		16/304		14/304	
	in.	mm		lbs.	kg	model #	list	model #	list
24" width (610mm)	36"	914	4.5	65	29.5	T2436EBW	1002	T2436EW	1098
	48"	1219	5.7	81	36.7	T2448EBW	1088	T2448EW	1261
	60"	1524	7.1	99	44.9	T2460EBW	1274	T2460EW	1449
30" width (762mm)	36"	914	4.5	75	34.0	T3036EBW	1109	T3036EW	1243
	48"	1219	5.7	94	42.6	T3048EBW	1252	T3048EW	1426
	60"	1524	7.1	115	52.2	T3060EBW	1449	T3060EW	1649

1-tier Units — 54½" (1384mm) overall height.

	length		cu ft	weight		16/304		14/304	
	in.	mm		lbs.	kg	model #	list	model #	list
24" width (610mm)	36"	914	4.5	73	33.1	T2436EBW-1	1246	T2436EW-1	1343
	48"	1219	5.7	91	41.3	T2448EBW-1	1397	T2448EW-1	1528
	60"	1524	7.1	113	51.3	T2460EBW-1	1578	T2460EW-1	1726
30" width (762mm)	36"	914	4.5	83	37.6	T3036EBW-1	1354	T3036EW-1	1493
	48"	1219	5.7	104	47.2	T3048EBW-1	1521	T3048EW-1	1689
	60"	1524	7.1	129	58.5	T3060EBW-1	1726	T3060EW-1	1931

2-tier Units — 62½" (1588mm) overall height.

	length		cu ft	weight		16/304		14/304	
	in.	mm		lbs.	kg	model #	list	model #	list
24" width (610mm)	36"	914	4.5	81	36.7	T2436EBW-2	1367	T2436EW-2	1464
	48"	1219	5.7	101	45.8	T2448EBW-2	1541	T2448EW-2	1674
	60"	1524	7.1	127	57.6	T2460EBW-2	1734	T2460EW-2	1883
30" width (762mm)	36"	914	4.5	91	41.3	T3036EBW-2	1473	T3036EW-2	1613
	48"	1219	5.7	114	51.7	T3048EBW-2	1663	T3048EW-2	1842
	60"	1524	7.1	143	64.9	T3060EBW-2	1882	T3060EW-2	2089

\* 18" (457mm) wide undershelves used for 24" (610mm) wide tables; 24" (610mm) wide undershelves used for 30" (762mm) wide tables.

CUSTOM:

- Unit can be further expanded and customized by adding optional shelving accessories (pages 51-59).
- Custom configurations available, including alternate finishes and solid shelving. Contact factory to configure your custom workstation.
- Optional drawers available (see pages 152-155).

Note: To order table with 5" (127mm) resilient tread casters, add suffix "-CAH" and add to list price \$635. Example: T3036EBW-1-CAH.

To order table with 5" (127mm) poly tread casters, add suffix "-CAHP" and add to list price \$549. Example: T3036EBW-1-CAHP.

For Post Clamps for 1-tier and 2-tier unit, see page 50. For Keyboard Stations, see page 50.

CONSISTS OF:

- Stainless steel table top/work surface with hat channel supports.
- Four 33" (838mm) chrome posts.
- Two chrome wire undershelves.\*

CONSISTS OF:

- Stainless steel table top/work surface with hat channel supports.
- Two 54" (1372mm) rear chrome posts.
- Two 33" (838mm) front chrome posts.
- Two 21" (533mm) front chrome posts for overshelf.
- One 14" (356mm) wide chrome wire overshelf.
- Two chrome wire undershelves.\*

CONSISTS OF:

- Stainless steel table top/work surface with hat channel supports.
- Two 63" (1600mm) rear chrome posts.
- Two 33" (838mm) front chrome posts.
- Two 29" (737mm) front chrome posts for overshelves.
- Two 14" (356mm) wide chrome wire overshelves.
- Two chrome wire undershelves.\*

**Catalog Section 10**

**Mixer Stands** 

see spec sheet **EG10.26A**



**FEATURES:**

- Highly polished 16 gauge, 300 series stainless steel flat top.
- Adjustable undershelf or adjustable crossbracing.
- 24" (610mm) working height.

**WEIGHT CAPACITY:**

- 600 lb. (272.2 kg) weight capacity of top.
- 150 lb. (68.0 kg) weight capacity of undershelf.
- evenly distributed static load.

**Freight class is 70.0.**

(•) MTS (made to stock) / ( ) MTO (made to order)

**patented uni-lok® system**  
(Patent #5,165,349)

**...with Undershelf**

**...with Tubular Base**

width	length		weight		cubic feet	galvanized legs		stainless steel legs		galvanized legs		stainless steel legs	
	in.	mm	lbs.	kg		model #	list	model #	list	model #	list	model #	list
24" (610mm)	24"	610	42	19.1	3.5	MS2424	• 1012	MS2424S	1229	TMS2424	1012	TMS2424S	1229
	24"	610	47	21.3	3.8	MS3024	• 1055	MS3024S	1291	TMS3024	1055	TMS3024S	1291
30" (762mm)	30"	762	49	22.2	3.8	MS3030	• 1175	MS3030S	1462	TMS3030	1175	TMS3030S	1462
	36"	914	51	23.1	4.0	MS3036	• 1206	MS3036S	1487	TMS3036	1206	TMS3036S	1487
36" (914mm)	36"	914	53	24.0	4.2	MS3636	1265	MS3636S	1557	TMS3636	1265	TMS3636S	1557

**Go Green.  
Go EAGLE.**

Look for the tag on the bar code. 



**Optional Utensil Rack for Mixer Stands**

- Stainless steel.
- 54" (1371mm) height.

weight lbs.	kg	cubic feet	add to model #	unit list
23	10.4	5.3	UR-501	820



mixer stand with undershelf and optional utensil rack

**Optional Casters for Mixer Stands**

description	wt. cap. per caster		model #	list
	lbs.	kg		
4" (102mm) dia., set of four (two swivel, two w/brake)	115	52.2	CA4-SB •	479
4" (102mm) dia., set of six (three swivel, three w/brake)	115	52.2	CA6-SB	717
5" (127mm) dia., set of four (two swivel, two w/brake)	200	90.7	CAH4-SB •	635
5" (127mm) dia., set of six (three swivel, three w/brake)	200	90.7	CAH6-SB	953



caster

caster with brake

**Stainless Steel Cleaner & Polish**

weight		model #	list
oz.	kg		
15	0.4	004026	22



**FEATURES:**

- Cleans and polishes in one step.
- Does not streak or leave fingerprints.
- Leaves a protective invisible coating.

Mobile Mixer Stands

see spec sheet **EG10.26B**



patented  
**uni-lok**<sup>®</sup>  
system  
(Patent #5,165,349)

- 34" (864mm) working height.
- 14 gauge 300 series stainless steel top with no-drip marine counter edge.
- Stainless steel crossbracing on three sides.
- Four 4" (102mm) casters (two with brakes).
- Pan rack slide holds six 18" x 26" (457 x 660mm) pans.
- 400 lb. (181.4 kg) total weight capacity (top and slides) - evenly distributed static load.

FEATURES:

**Freight class is 70.0.**

(•) MTS (made to stock) / ( ) MTO (made to order)

	length		weight		cubic feet	galvanized		stainless steel	
	in.	mm	lbs.	kg		model #	list	model #	list
30" width (762mm)	30"	762	55	24.9	3.8	MMT3030G	2586	MMT3030S•	2885
	36"	914	60	27.2	4.1	MMT3036G	2646	MMT3036S	2972

Mobile Equipment Stand

see spec sheet **EG10.26B**



patented  
**uni-lok**<sup>®</sup>  
system  
(Patent #5,165,349)

- Top is 14 gauge 300 series stainless steel with no-drip marine counter edge.
- Stainless steel undershelf.
- Two 4" (102mm) casters with brake.

FEATURES:

**Freight class is 70.0.**

(•) MTS (made to stock) / ( ) MTO (made to order)

	width	length		weight		cubic feet	model #	list
		in.	mm	lbs.	kg			
24" (610mm)	30"	30"	762	47	21.3	3.8	MET2430S	2256

SPEC-MASTER<sup>®</sup> Demo Tables <sup>(NSF)</sup>

see spec sheet **EG10.17**



patented  
**uni-lok**<sup>®</sup>  
system  
(Patent #5,165,349)

- For instructional/educational applications.
- Stainless steel construction.
- Tilting frame with acrylic mirror.

FEATURES:

**Freight class is 70.0.**

(•) MTS (made to stock) / ( ) MTO (made to order)

Demo Tables

- Tabletop with marine counter edge. Adjustable heavy gauge stainless steel undershelf.

table size width x length		mirror size width x length		weight		cubic feet	model #	list
in.	mm	in.	mm	lbs.	kg			
36" x 60"	914 x 1524	24¼" x 49½"	616 x 1257	250	113.4	7.0	DT3660SE	8235
36" x 72"	914 x 1829	24¼" x 61½"	616 x 1562	275	124.7	10.0	DT3672SE	9696



Ceiling Mounted Demo Mirrors

- Specify post length when ordering.

mirror size width x length*		weight		cubic feet	model #	list
in.	mm	lbs.	kg			
24¼" x 49½"	616 x 1257	90	40.8	3.6	CMM49	4739
24¼" x 61½"	616 x 1562	115	52.2	4.5	CMM61	5561

\* Excludes posts.



## Catalog Section 10

### Griddle / Equipment Stands

see spec sheet **EG10.27**



griddle/equipment stand with optional hardwood cutting board

patented  
**uni-lok**<sup>®</sup>  
system  
(Patent #5,165,349)

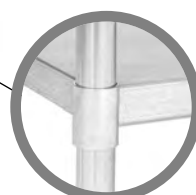

adjustable undershelf welded gusset

#### FEATURES:

- Highly polished 16 gauge, type 300 stainless steel flat top.
- 1¼" (32mm) upturn on sides and rear.
- Units 72" (1829mm) and longer have six legs.

**Note:** All shipping weights are approximate.

Units designed for light and medium duty cooking equipment only. Heavy equipment usage should be reviewed with factory.

Griddle/Equipment Stands cannot accept optional Worktable Stabilizer Bars (page 132).

**Freight class is 70.0.**

(•) MTS (made to stock) / ( ) MTO (made to order)

	table top length		# of legs	weight		cu ft	weight cap. with bullet feet		weight cap. with optional casters		galvanized legs and undershelf		stainless steel legs and undershelf	
	in.	mm		lbs.	kg		lbs.	kg	lbs.	kg	model #	list	model #	list
<b>24¾" width (619mm)</b>	24"	619	4	48	21.8	3.5	1000	453.6	600	272.2	<b>T2424GS</b> •	1153	<b>T2424SGS</b>	1319
	36"	924	4	54	24.5	4.4	1000	453.6	600	272.2	<b>T2436GS</b>	1273	<b>T2436SGS</b>	1460
	48"	1229	4	62	28.1	5.7	1000	453.6	600	272.2	<b>T2448GS</b>	1431	<b>T2448SGS</b>	1600
	60"	1534	4	74	33.6	7.1	1000	453.6	600	272.2	<b>T2460GS</b>	1511	<b>T2460SGS</b>	1744
	72"	1838	6	86	39.0	8.5	1500	680.4	800	362.9	<b>T2472GS</b>	1634	<b>T2472SGS</b>	1887
	84"	2143	6	99	44.9	9.6	1500	680.4	800	362.9	<b>T2484GS</b>	1995	<b>T2484SGS</b>	2354
<b>30¾" width (772mm)</b>	24"	619	4	48	21.8	4.3	1000	453.6	600	272.2	<b>T3024GS</b> •	1179	<b>T3024SGS</b>	1376
	36"	924	4	55	24.9	5.6	1000	453.6	600	272.2	<b>T3036GS</b> •	1321	<b>T3036SGS</b> •	1544
	48"	1229	4	71	32.2	5.7	1000	453.6	600	272.2	<b>T3048GS</b> •	1466	<b>T3048SGS</b> •	1715
	60"	1534	4	83	37.6	6.9	1000	453.6	600	272.2	<b>T3060GS</b> •	1613	<b>T3060SGS</b> •	1892
	72"	1838	6	96	43.6	8.5	1500	680.4	800	362.9	<b>T3072GS</b> •	1758	<b>T3072SGS</b> •	2064
	84"	2143	6	112	50.8	11.2	1500	680.4	800	362.9	<b>T3084GS</b>	2742	<b>T3084SGS</b>	3159
	96"	2448	6	125	56.7	13.4	1500	680.4	800	362.9	<b>T3096GS</b>	2796	<b>T3096SGS</b>	3213

### Optional Hardwood Cutting Board for Griddle/Equipment Stands

- 1¼" (32mm) thick.
- 1" (25mm) diameter stainless steel tubular supports integrally welded to adjustable stainless steel sleeve assembly.

	length		weight		cubic feet	model #	list
	in.	mm	lbs.	kg			
<b>8" width (203mm)</b>	24"	610	12	5.4	0.6	<b>313970</b>	520
	36"	914	16	7.3	0.9	<b>307105</b> •	584
	48"	1219	21	9.5	1.4	<b>307106</b> •	654
	60"	1524	26	11.8	1.8	<b>307107</b>	725
	72"	1829	31	14.1	2.1	<b>307108</b>	799
	84"	2134	39	17.6	2.5	<b>307109</b>	936
	96"	2438	46	20.9	2.9	<b>307110</b>	1072

### Optional Plate Shelf for Griddle/Equipment Stands

- Heavy gauge stainless steel.
- Adjustable height.
- Must be ordered in conjunction with hardwood cutting board.

	length		weight		cubic feet	model #	list
	in.	mm	lbs.	kg			
<b>8" width (203mm)</b>	24"	610	5	2.3	1.2	<b>APS2</b>	507
	36"	914	6	2.7	1.4	<b>APS3</b>	574
	48"	1219	7	3.2	1.6	<b>APS4</b>	631
	60"	1524	11	5.0	1.9	<b>APS5</b>	699
	72"	1829	13	5.8	2.2	<b>APS6</b>	761
	84"	2134	16	7.3	2.5	<b>APS7</b>	953
	96"	2438	20	9.0	2.8	<b>APS8</b>	1103

### Optional Zinc Swivel Casters

- 5" (127mm)-diameter wheel.
- 200 lb. (90.7 kg) weight capacity per wheel.
- Resilient tread.

description	model #	list
Set of four (two with brake)	<b>CAH4-SB</b> •	635
Set of six (three with brake)	<b>CAH6-SB</b>	953



zinc casters

All Poly Top Tables

Freight class is 250.0.

Cutting Tables 

see spec sheet **EG10.16**



Richlite® heat-resistant brown tabletops available. Resists up to 360°F. To order, add suffix “-RL” to model number (example: CT2436S-RL) and call factory for pricing.

FEATURES:

- ½” (13mm) thick poly top pieces.
- 1½” (41mm) type 304 stainless steel legs welded to tabletop frame.
- Adjustable stainless steel crossbracing.
- Adjustable metal feet.
- Units shipped assembled and crated.

**Note:** All-welded construction available. To order, add \$606 to list price and suffix “-AW”. Example: CT2436S-AW.

Undershelf available. Fits over adjustable crossbracing. To order, add 15% to list price and suffix “-US”. Example: CT2436S-US.

To order table with 4” (76mm) resilient-tread casters, add suffix “-CA” and add to list price \$479 (for tables 36” to 84” long), or \$717 (for tables 96” and longer). Example: CT2484S-CA.

To order table with 5” (127mm) resilient-tread casters, add suffix “-CAH” and add to list price \$635 (for tables 36” to 84” long), or \$953 (for tables 96” and longer). Example: CT2484S-CAH.

	...with Flat Top						...with 4½” (114mm) Removable Backsplash					
	length		weight		cu	model #	list	weight		cu	model #	list
	in.	mm	lbs.	kg	ft			lbs.	kg	ft		
24” (610mm) width	36”	914	110	49.9	20.9	CT2436S	1531	110	49.9	23.2	CT2436S-BS	1541
	48”	1219	120	54.4	27.4	CT2448S	1698	120	54.4	30.5	CT2448S-BS	1715
	60”	1524	150	68.0	34.0	CT2460S	1849	150	68.0	37.8	CT2460S-BS	1873
	72”	1829	176	79.8	40.6	CT2472S	2474	180	81.6	45.1	CT2472S-BS	2494
	84”	2134	196	88.9	47.2	CT2484S	2755	198	89.8	52.4	CT2484S-BS	2858
	96”	2438	215	97.5	53.8	CT2496S	3036	217	98.4	59.7	CT2496S-BS	3113
	108”	2743	225	102.1	60.4	CT24108S	3205	230	104.3	67.0	CT24108S-BS	3296
30” (762mm) width	120”	3048	243	110.2	67.0	CT24120S	3464	250	113.4	74.3	CT24120S-BS	3493
	36”	914	115	52.2	25.7	CT3036S	1632	118	53.5	28.7	CT3036S-BS	1648
	48”	1219	130	59.0	33.8	CT3048S	1812	135	61.2	37.5	CT3048S-BS	1831
	60”	1524	157	71.2	41.9	CT3060S	1981	160	72.6	46.5	CT3060S-BS	2001
	72”	1829	178	80.3	50.0	CT3072S	2618	181	82.1	55.5	CT3072S-BS	2662
	84”	2134	198	89.8	58.1	CT3084S	3011	205	93.0	64.5	CT3084S-BS	3116
	96”	2438	220	99.8	66.2	CT3096S	3151	228	103.4	73.5	CT3096S-BS	3346
108”	2743	230	104.3	74.4	CT30108S	3382	235	106.6	82.5	CT30108S-BS	3509	
120”	3048	255	115.7	82.5	CT30120S	3556	260	117.9	91.5	CT30120S-BS	3594	

Optional Drawer Support Angles for Cutting Tables and Chopping Tables

fits tables	model #	list
24” w/flat top	609542	123
24” w/backsplash	609541	123
30” w/flat top	609540	137
30” w/backsplash	609539	137

Chopping Tables 

see spec sheet **EG10.11**



To order table with 4” (76mm) resilient-tread casters, add suffix “-CA” and add to list price \$428. Example: CHT2424S-CA.

To order table with 5” (127mm) resilient-tread casters, add suffix “-CAH” and add to list price \$567. Example: CHT2436S-CAH.

FEATURES:

- Two layers of ½” (13mm) thick removable poly top, 1” (25mm) total thickness.
- Adjustable stainless steel crossbracing.
- 1½” (41mm) type 304 stainless steel legs welded to tabletop frame.
- Adjustable metal feet.
- Units shipped assembled and crated.

**Note:** All-welded construction available. To order, add \$606 to price list and suffix “-AW”. Example: CHT2436S-AW.

Undershelf available. Fits over adjustable crossbracing. To order, add 15% to list price and suffix “-US”. Example: CHT2436S-US.

Richlite® heat-resistant brown tabletops available. Resists up to 360°F. To order, add suffix “-RL” to model number (example: CHT2436S-RL) and call factory for pricing.

	length		weight		cubic	model #	list
	in.	mm	lbs.	kg	feet		
24” width (610mm)	24”	610	110	49.9	14.3	CHT2424S	1516
	30”	762	118	53.5	17.6	CHT2430S	1625
	36”	914	126	57.2	20.9	CHT2436S	1762
	48”	1219	142	64.4	27.5	CHT2448S	1960
30” width (762mm)	30”	762	126	57.2	21.6	CHT3030S	1721
	36”	914	134	60.8	25.7	CHT3036S	1909
	48”	1219	150	68.0	33.8	CHT3048S	2161

**Catalog Section 10**

**Trimming Tables** 

see spec sheet **EG10.15**

**FEATURES:**

- 4" high (102mm) type 304 stainless steel removable backsplash.
- 12" (152mm) removable type 304 stainless steel deck.
- 1/2" (13mm) thick removable poly top.
- 1 5/8" (41mm) diameter 16 gauge type 304 stainless steel legs welded to tabletop frame.
- Adjustable 16 gauge type 304 stainless steel crossbracing.
- Adjustable metal feet.
- 4" or 5" (102 or 127mm) diameter casters. Tables 84" (2134mm) and longer require a set of six casters.
- Units shipped assembled and crated.



**Optional Drawer Supports for Trimming Tables**

fits tables	model #	list
30" w/backsplash	<b>609539</b>	137
36" w/backsplash	<b>609543</b>	142

	length		weight		# of bds per table	cubic feet	model #	list
	in.	mm	lbs.	kg				
<b>30" width</b> (762mm)	36"	914	120	54.4	1	28.5	<b>TB3036S</b>	2454
	48"	1219	142	64.4	2	37.5	<b>TB3048S</b>	2795
	60"	1524	164	74.4	2	46.5	<b>TB3060S</b>	3363
	72"	1829	188	85.3	2	55.5	<b>TB3072S</b>	3821
	84"	2134	210	95.3	3	64.5	<b>TB3084S</b>	4203
	96"	2438	232	105.2	3	73.5	<b>TB3096S</b>	4944
	108"	2743	254	115.2	4	82.5	<b>TB30108S</b>	5418
<b>36" width</b> (914mm)	120"	3048	266	120.7	4	91.5	<b>TB30120S</b>	5733
	36"	914	126	57.2	1	33.8	<b>TB3636S</b>	2621
	48"	1219	148	67.1	2	44.5	<b>TB3648S</b>	3322
	60"	1524	170	77.1	2	55.2	<b>TB3660S</b>	3935
	72"	1829	192	87.1	2	65.9	<b>TB3672S</b>	4415
	84"	2134	214	97.1	3	76.6	<b>TB3684S</b>	4916
	96"	2438	236	107.0	3	87.3	<b>TB3696S</b>	5595
108"	2743	258	117.0	4	98.0	<b>TB36108S</b>	6144	
120"	3048	280	127.0	4	108.7	<b>TB36120S</b>	6935	

**Note:** All-welded construction available. To order, add **\$606 to price list** and suffix **"-AW"**. Example: TB3036S-AW. Undershef available. Fits over adjustable crossbracing. To order, add **15% to list price** and suffix **"-US"**. Example: TB3036S-US.

Richlite® heat-resistant brown tabletops available. Resists up to 360°F. To order, add suffix **"-RL"** to model number (example: TB3036S-RL) and call factory for pricing.

To order table with 4" (76mm) resilient-tread casters, add suffix **"-CA"** and **add to list price \$479** (for tables 36" to 84" long), or **\$717** (for tables 96" and longer). Example: TB3036S-CA.

To order table with 5" (127mm) resilient-tread casters, add suffix **"-CAH"** and **add to list price \$635** (for tables 36" to 84" long), or **\$953** (for tables 96" and longer). Example: TB3036S-CAH.

**Boat Racks for Poly Top Tables**

see spec sheet **EG10.22**

**FEATURES:**

- Used in conjunction with poly top tables.
- Table mounted attaches easily to poly top tables of the same length.
- Chrome\* or stainless\*\* wire shelves and posts.
- 26" (660mm) rods.

**Note:** All shipping weights and cubic feet are approximate.

On Table-Mounted Racks, 48"-72" lengths include two posts, one 3-sided truss frame, and one shelf. 84"-96" lengths include four posts, two 3-sided truss frames, and two shelves.

On Wall-Mounted Racks, 48"-72" lengths include two posts, four shelf brackets, and two shelves. 84"-96" lengths include three posts, six shelf brackets, and four shelves.

On Ceiling-Mounted Racks, 48"-72" lengths include four posts and two shelves. 84"-96" lengths include six posts and four shelves.

**Freight class is 70.0.**

patented  
**QuadTruss®**  
design  
(Patent #5,390,803)



table mounted boat rack

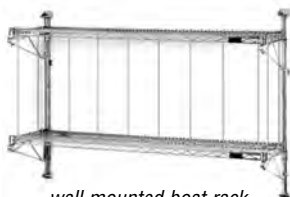

wall mounted boat rack



ceiling mounted boat rack

	Table Mounted						Wall Mounted						Ceiling Mounted														
	length		cu		weight		chrome*		stainless**		weight		chrome*		stainless**		weight		chrome*		stainless**						
	in.	mm	ft	lbs.	kg	model #	list	model #	list	model #	list	lbs.	kg	model #	list	model #	list	lbs.	kg	model #	list	model #	list				
<b>14" width</b> (356mm)	48"	1219	2.6	45	20.4	<b>BRT4</b>	713	<b>BRT4-S</b>	927	40	18.1	<b>BRW4</b>	684	<b>BRW4-S</b>	892	40	18.1	<b>BRC4</b>	699	<b>BRC4-S</b>	909	50	22.7	<b>BRC5</b>	792	<b>BRC5-S</b>	1033
	60"	1524	3.3	55	24.9	<b>BRT5</b>	805	<b>BRT5-S</b>	1047	50	22.7	<b>BRW5</b>	776	<b>BRW5-S</b>	1011	50	22.7	<b>BRC5</b>	792	<b>BRC5-S</b>	1033	60	27.2	<b>BRC6</b>	811	<b>BRC6-S</b>	1056
	72"	1829	4.0	65	29.5	<b>BRT6</b>	819	<b>BRT6-S</b>	1066	60	27.2	<b>BRW6</b>	792	<b>BRW6-S</b>	1033	60	27.2	<b>BRC6</b>	811	<b>BRC6-S</b>	1056	78	35.4	<b>BRC7</b>	1056	<b>BRC7-S</b>	1376
	84"	2134	4.6	75	34.0	<b>BRT7</b>	1087	<b>BRT7-S</b>	1417	78	35.4	<b>BRW7</b>	1040	<b>BRW7-S</b>	1354	78	35.4	<b>BRC7</b>	1056	<b>BRC7-S</b>	1376	80	36.3	<b>BRC8</b>	1067	<b>BRC8-S</b>	1388
	96"	2438	5.3	85	38.6	<b>BRT8</b>	1089	<b>BRT8-S</b>	1419	80	36.3	<b>BRW8</b>	1047	<b>BRW8-S</b>	1364	80	36.3	<b>BRC8</b>	1067	<b>BRC8-S</b>	1388						

\* Chrome used in dry areas. Clean with mild soap and water.

\*\*Stainless steel should be used in meat prep areas where degreasers are used.



100 Industrial Boulevard, Clayton, DE 19938-8903 U.S.A.  
Phone: 800-441-8440 or 302-653-3000. Fax: 302-653-2065  
http://www.eaglegrp.com

### Poly Top Boning Tables NSF

see spec sheet **EG10.07**



To order table with 4" (76mm) resilient-tread casters, add suffix **"-CA"** and **add to list price \$479** (for tables 36" to 84" long), or **\$717** (for tables 96" and longer). **Example:** BT2484S-CA.

To order table with 5" (127mm) resilient-tread casters, add suffix **"-CAH"** and **add to list price \$635** (for tables 36" to 84" long), or **\$953** (for tables 96" and longer). **Example:** BT2448S-CAH.

**FEATURES:**

- 4" (102mm) removable backslash.
- 6" (152mm) removable stainless steel deck.
- ½" (13mm) thick removable poly top.
- 1⅝" (41mm) diameter 16 gauge stainless steel legs welded to tabletop frame.
- Adjustable 16 gauge stainless steel crossbracing.
- Adjustable metal feet.
- 4" or 5" (102 or 127mm) diameter casters. Tables 84" (2134mm) and longer require a set of six casters.
- Units shipped assembled and crated.

**Note:** All-welded construction available. To order, add **\$606 to price list** and suffix **"-AW"**. **Example:** BT2436S-AW.

Undershelf available. Fits over adjustable crossbracing. To order, **add 15% to list price** and suffix **"-US"**. **Example:** BT2436S-US.

Richlite® heat-resistant brown tabletops available. Resists up to 360°F. To order, add suffix **"-RL"** to model number (**example:** BT2436S-RL) and call factory for pricing.

	length		weight		# of bds per table	cubic feet	model #	list
	in.	mm	lbs.	kg				
<b>24" width (610mm)</b>	36"	914	110	49.9	1	23.2	<b>BT2436S</b>	1904
	48"	1219	132	59.9	2	30.5	<b>BT2448S</b>	2295
	60"	1524	135	61.2	2	37.8	<b>BT2460S</b>	2672
	72"	1829	160	72.6	2	45.1	<b>BT2472S</b>	3099
	84"	2134	180	81.6	3	52.4	<b>BT2484S</b>	3533
	96"	2438	215	97.5	3	59.7	<b>BT2496S</b>	3986
	108"	2743	225	102.1	4	67.0	<b>BT24108S</b>	4306
	120"	3048	245	111.1	4	74.3	<b>BT24120S</b>	4583
<b>30" width (762mm)</b>	36"	914	115	52.2	1	28.7	<b>BT3036S</b>	2247
	48"	1219	138	62.6	2	37.5	<b>BT3048S</b>	2529
	60"	1524	140	63.5	2	46.5	<b>BT3060S</b>	3029
	72"	1829	165	74.8	2	55.5	<b>BT3072S</b>	3419
	84"	2134	185	83.9	3	64.5	<b>BT3084S</b>	3733
	96"	2438	220	99.8	3	73.5	<b>BT3096S</b>	4403
	108"	2743	230	104.3	4	82.5	<b>BT30108S</b>	4811
	120"	3048	250	113.4	4	91.5	<b>BT30120S</b>	5055
<b>36" width (914mm)</b>	36"	914	120	54.4	1	33.8	<b>BT3636S</b>	2420
	48"	1219	143	64.9	2	44.5	<b>BT3648S</b>	3053
	60"	1524	145	65.8	2	55.2	<b>BT3660S</b>	3604
	72"	1829	170	77.1	2	65.9	<b>BT3672S</b>	4014
	84"	2134	190	86.2	3	76.6	<b>BT3684S</b>	4448
	96"	2438	225	102.1	3	87.3	<b>BT3696S</b>	5059
	108"	2743	235	106.6	4	98.0	<b>BT36108S</b>	5538
	120"	3048	255	115.7	4	108.7	<b>BT36120S</b>	6263

**Freight class is 250.0.**

#### Optional Drawer Supports for Boning Tables

fits tables	model #	list
24" w/flat top	<b>609542</b>	123
24" w/backslash	<b>609541</b>	123
30" w/flat top	<b>609540</b>	137
30" w/backslash	<b>609539</b>	137
36" w/flat top	<b>609544</b>	142
36" w/backslash	<b>609543</b>	142

### Mobile Prep Table

see product announcement **EG8124**



**PATENTED!**  
(patent #8,733,253)

tabletop width x length*		model #	list
in.	mm		
30" x 42"	762 x 1067	<b>MPT3042</b>	5427

\* Dimensions do not include cutting board holder and knife rack.

**FEATURES:**

- Removable poly cutting board mounts onto 14/304 stainless steel raised prep area with slanted sides for drainage.
- Positive drainage to full-length trough.
- 16/304 stainless steel adjustable undershelf with marine edge.
- 22-gallon removable waste tank.
- Three-bay cutting board holder at left end.
- Removable knife rack at right end.
- Two stainless steel perforated half-size pans.
- 5" (127mm)-diameter poly swivel casters.

**Freight class is 70.0.**

## Catalog Section 10



patented  
**uni-lok**<sup>®</sup>  
system  
(Patent #5,165,349)

### Features:

- Any table can be customized with overshelves of the same length.
- System can easily be changed or expanded as needed.
- Tables are caster-capable for workstation mobility.
- Overshelves' height adjustable in 1" (25mm) increments for flexible and accurate placement.
- 10" and 12" (254 and 305mm) shelf widths can be intermixed on same posts.
- Split sleeves.
- Tapered collar for easy assembly.
- Overshelves shipped knocked-down.
- All shipping weights and cubic feet are approximate.

## FLEX-MASTER<sup>®</sup> Overshelf System

Continued on page 148

## Overshelves

see spec sheet **EG10.08**

### FEATURES:

- 14 gauge 300 series shelves available upon request.
- Priced per shelf.

**Freight class is 70.0.**

(•) MTS (made to stock) / ( ) MTO (made to order)

	length		weight		cubic feet	16/430		16/300	
	in.	mm	lbs.	kg		model #	list ea	model #	list ea
10" width (254mm)	30"	762	10.1	4.6	0.5	411030	380	421030	415
	36"	915	12.1	5.5	0.6	411036	384	421036	427
	48"	1219	13.1	6.0	0.8	411048	415	421048	472
	60"	1524	15.2	6.9	1.0	411060	453	421060	529
	72"	1829	17.2	7.8	1.2	411072	513	421072	593
	84"	2133	19.3	8.8	1.5	411084	573	421084	651
	96"	2438	21.3	9.7	1.7	411096	631	421096	737
	108"	2743	23.4	10.6	1.9	411010	683	421010	789
	120"	3048	25.4	11.5	2.1	411012	738	421012	841
	132"	3353	27.4	12.5	2.3	411013	799	421013	902
12" width (305mm)	144"	3658	29.4	13.4	2.5	411014	857	421014	981
	30"	762	11.1	5.1	0.6	411230	384	421230	427
	36"	915	12.3	5.6	0.8	411236	403	421236	478
	48"	1219	14.8	6.7	1.0	411248	438	421248	499
	60"	1524	17.2	7.8	1.3	411260	471	421260	556
	72"	1829	19.7	9.1	1.5	411272	539	421272	629
	84"	2133	22.1	10.0	1.8	411284	600	421284	705
	96"	2438	24.6	11.2	2.0	411296	649	421296	788
	108"	2743	27.0	12.3	2.3	411210	722	421210	846
	120"	3048	29.5	13.4	2.5	411212	805	421212	909
132"	3353	31.5	14.3	2.7	411213	862	421213	967	
144"	3658	33.5	15.2	2.9	411214	919	421214	1024	

**Note: 15" and 18" (381 and 457mm) wide shelves available.** To order, replace "12" in model number with a "15" or "18" indicating desired shelf width (example: 411584). For 15" (381mm) wide shelves, add 15% to list price of 12" (305mm) wide models. For 18" (457mm) wide shelves, add 30% to list price of 12" (305mm) shelves.

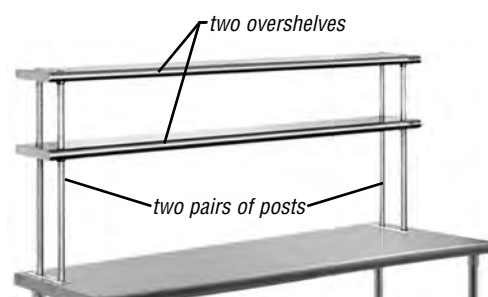

## Posts

see spec sheet **EG10.08**

height	in.	mm	weight		cubic feet	chrome		stainless steel	
			lbs.	kg		model #	list/pair	model #	list/pair
18"	457		1.7	0.8	0.1	418202	165	418002	193
30"	762		2.4	1.1	0.2	430202	181	430002	247
48"	1219		5.6	2.5	0.2	448202	221	448002	326

### ORDERING:

- Sold in pairs.
- Each pair includes mounting plate.
- Order two pairs of posts for 30" to 72" (762 to 1829mm) shelves; three pairs for 84" to 120" (2134 to 3048mm) shelves; four pairs for 132" and 144" (3353 and 3658mm) shelves.

**Freight class is 50.0.**

(•) MTS (made to stock) / ( ) MTO (made to order)

### Utility Racks

see spec sheet **EG10.08**



- FEATURES:
- Chrome plated.

**Freight class is 50.0.**

(•) MTS (made to stock) / ( ) MTO (made to order)

for overshelf length					for overshelf length								
in.	mm	lbs.	kg	cubic feet	model #	list	in.	mm	lbs.	kg	cubic feet	model #	list
30"	762	1.7	0.8	0.2	<b>PRT30-C</b>	88	84"	2133	4.1	1.9	0.4	<b>PRT84-C *</b>	182
36"	915	1.9	0.9	0.2	<b>PRT36-C</b>	104	96"	2438	4.9	2.2	0.4	<b>PRT96-C *</b>	214
48"	1219	2.1	1.0	0.2	<b>PRT48-C</b>	115	108"	2743	5.6	2.5	0.5	<b>PRT108-C *</b>	217
60"	1524	2.5	1.1	0.3	<b>PRT60-C</b>	135	120"	3048	6.2	2.8	0.5	<b>PRT120-C *</b>	224
72"	1829	2.9	1.3	0.4	<b>PRT72-C •</b>	157	132"	3353	6.9	3.1	0.6	<b>PRT132-C **</b>	242
							144"	3658	7.6	3.5	0.6	<b>PRT144-C **</b>	263

\* Utility racks 84" to 120" (2133 to 3048mm) come in two pieces.

\*\*132" and 144" (3353 and 3658mm) racks come in three pieces.

### Mounting Plate

see spec sheet **EG10.08**



model #	list each
<b>311915 •</b>	29

- FEATURES:
- Aluminum.
  - Designed to accommodate both 10" and 12" (254 and 305mm) wide shelves.

**Freight class is 70.0.**

(•) MTS (made to stock) / ( ) MTO (made to order)

### Pot Hooks

see spec sheet **EG10.08**



#379769

For use with utility racks.

description	weight		cubic feet	model #	list each
	lbs.	kg			
stainless double-prong pot hook	0.2	0.1	0.1	<b>300696 •</b>	32
6" (176mm)-long chrome hook	0.1	0.1	0.1	<b>379769</b>	6



#300696

- FEATURES:
- Stainless steel double-prong with 2¼" (57mm) prongs, or 6" (176mm)-long chrome.
  - Slips over utility racks.

**Freight class is 70.0.**

(•) MTS (made to stock) / ( ) MTO (made to order)

## FLEX-MASTER® Kits for All Stainless Steel Worktables NSF

see spec sheet **EG10.08**

#### Kit A

description	for Budget tables* add to list	for all other tables add to list
fits 36" (914mm) long worktables	1584	1734
fits 48" (1219mm) long worktables	1677	1801
fits 60" (1524mm) long worktables	1780	1951
fits 72" (1829mm) long worktables	1965	2144

\* **Note:** Kits for "Budget" worktables include 16 gauge type 430 shelves and stainless steel posts.

#### Kit B

description	for Budget tables* add to list	for all other tables add to list
fits 36" (914mm) long worktables	1299	1448
fits 48" (1219mm) long worktables	1368	1494
fits 60" (1524mm) long worktables	1523	1604
fits 72" (1829mm) long worktables	1569	1752

\* **Note:** Kits for "Budget" worktables include 16 gauge type 430 shelves and stainless steel posts.

- Two 12" (305mm) wide 16 gauge type 304 shelves.
- Two 30" (762mm) stainless steel front posts.
- Two 48" (1219mm) stainless steel rear posts.
- Two utility racks.

To order, add suffix "-FM-PL" to model number.

**Example: T3060SE-FM-PL.**

Kit A

INCLUDES:

**Freight class is 70.0.**

(•) MTS (made to stock) / ( ) MTO (made to order)

**Tabletops are predrilled for rear mounting of posts and shelves.**

- Two 12" (305mm) wide 16 gauge type 304 shelves.
  - Four 30" (762mm) stainless steel posts.
- To order, add suffix "-FM" to model number.

**Example: T3060SE-FM.**

Kit B

INCLUDES:

**Catalog Section 10**

**Wall Cabinets** 

see spec sheet **EG02.07**



wall cabinet with hinged doors

**FEATURES:**

- Heavy gauge stainless steel.
- Back is recessed with full-length concealed mounting plate for easy installation.
- Fixed center shelf.
- Hinged doors provided with lift-off pin hinges.
- 15" (381mm) width. 28" (711mm) overall height.

**Freight class is 100.0.**

		Open Front				Hinged Doors				Sliding Doors					
length in.	mm	cu		weight		model #	list	weight		model #	list	weight		model #	list
		ft	lbs.	kg	lbs.			kg	lbs.			kg			
24"	610	13.5	117	53.1	<b>WCO-24</b>	3960	136	61.7	<b>WCH-24</b>	5373	136	61.7	<b>WCS-24</b>	4479	
30"	762	17.3	129	58.5	<b>WCO-30</b>	3964	154	69.9	<b>WCH-30</b>	5955	154	69.9	<b>WCS-30</b>	5458	
36"	914	18.0	141	64.0	<b>WCO-36</b>	4111	172	78.0	<b>WCH-36</b>	6058	172	78.0	<b>WCS-36</b>	5627	
42"	1067	18.2	-	-	-	-	191	86.6	<b>WCH-42</b>	6367	191	86.6	<b>WCS-42</b>	5654	
48"	1219	18.3	165	74.8	<b>WCO-48</b>	4736	208	94.3	<b>WCH-48</b>	6563	208	94.3	<b>WCS-48</b>	6164	
54"	1372	25.4	-	-	-	-	226	102.5	<b>WCH-54</b>	6712	226	102.5	<b>WCS-54</b>	6279	
60"	1524	22.6	189	85.7	<b>WCO-60</b>	5182	244	110.7	<b>WCH-60</b>	7526	244	110.7	<b>WCS-60</b>	7128	
66"	1676	30.6	-	-	-	-	256	115.1	<b>WCH-66</b>	7580	256	115.1	-	-	
72"	1829	26.8	213	96.6	<b>WCO-72</b>	5499	262	118.8	<b>WCH-72</b>	8432	262	118.8	<b>WCS-72</b>	7984	
84"	2134	38.5	225	102.1	<b>WCO-84</b>	5802	281	127.5	<b>WCH-84*</b>	8668	281	127.5	<b>WCS-84*</b>	8191	
90"	2286	41.7	-	-	-	-	298	135.3	<b>WCH-90*</b>	9160	298	135.3	<b>WCS-90*</b>	8674	
96"	2438	35.2	249	112.9	<b>WCO-96</b>	6497	316	143.3	<b>WCH-96*</b>	9444	316	143.3	<b>WCS-96*</b>	8943	
120"	3048	55.8	-	-	-	-	359	162.9	-	-	359	162.9	<b>WCS-120*</b>	10775	

\* Features two pairs of doors.

**Spice Bins**

see spec sheet **EG10.59**



width x length x height		weight		cubic feet	model #	list
in.	mm	lbs.	kg			
6½" x 5½" x 6"	165 x 140 x 152	1.5	0.7	0.1	<b>SB-1</b>	349

**FEATURES:**

- Designed for either overshef or wall shelf applications.
- 22 gauge stainless steel with fully covered deep-drawn construction, complete with label holders.
- Removable bin must be allowed 7¾" (197mm) space and slides on stainless steel angle supports secured to underside of shelf.

**Note:** Shipping weight and cubic feet are approximate.

**Freight class is 85.0.**

**Utensil Bars**

see spec sheet **EG10.52**



utensil bar

fits table width		weight		cu ft	model #	list
in.	mm	lbs.	kg			
24"	610	5	2.3	0.03	<b>UB-24</b>	284
30", 36"	762, 914	6	2.7	0.04	<b>UB-30</b>	363

**FEATURES:**

- For stainless steel worktables (pages 118-129).
- Fits onto legs under tabletop, running front-to-back.
- Constructed of heavy gauge stainless steel.
- 2" x ¼" (51 x 7mm) bar with two stainless steel gussets.
- Can add on to existing table.
- Complete with six pot hooks.

**Freight class is 70.0.**

Overshelves, Non-Adjustable **NSF**

see spec sheet **EG10.28**



single deck overshelf



double deck overshelf

- Mounted on four stainless steel, 1" (25mm) diameter tubular base legs.
- Special width shelves available.

FEATURES:

**Note:** Recommended that overshelves be ordered when ordering tables. Specify choice of centered or rear-mounted on table. Otherwise, table must be field-drilled for mounting overshelves.

**Freight class is 70.0.**

Optional heat lamp brackets available. Standard 12" (305mm) shorter than overshelf. To order, add suffix "-HLB" to model number (example: OS1236-16/4-HLB) and \$244 per pair. Two pairs required for lengths 84" (2133mm) and over. For cantilever option, see page 364.

Single Deck Overshelves, Non-Adjustable - Shipped knocked-down.

	length		# of legs	weight		cu ft	16 gauge, type 430		16 gauge, type 304		14 gauge, type 304	
	in.	mm		lbs.	kg		model #	list	model #	list	model #	list
10" width (254mm)	36"	915	4	15	6.8	0.9	OS1036-16/4	689	OS1036-16/3	835	OS1036-14/3	923
	48"	1219	4	19	8.6	1.3	OS1048-16/4	735	OS1048-16/3	913	OS1048-14/3	1014
	60"	1524	4	24	10.9	1.6	OS1060-16/4	779	OS1060-16/3	1002	OS1060-14/3	1113
	72"	1829	4	29	13.2	1.9	OS1072-16/4	835	OS1072-16/3	1093	OS1072-14/3	1212
	84"	2133	6	34	15.4	2.2	OS1084-16/4	883	OS1084-16/3	1180	OS1084-14/3	1309
	96"	2438	6	37	16.8	2.5	OS1096-16/4	1078	OS1096-16/3	1405	OS1096-14/3	1562
	108"	2743	6	38	17.2	2.8	OS10108-16/4	1105	OS10108-16/3	1446	OS10108-14/3	1603
	120"	3048	6	39	17.6	3.1	OS10120-16/4	1146	OS10120-16/3	1567	OS10120-14/3	1748
	132"	3353	8	42	19.1	3.7	OS10132-16/4	1199	OS10132-16/3	1665	OS10132-14/3	1853
	144"	3658	8	46	20.9	4.2	OS10144-16/4	1243	OS10144-16/3	1751	OS10144-14/3	1945
12" width (305mm)	36"	915	4	16	7.3	0.9	OS1236-16/4	731	OS1236-16/3	871	OS1236-14/3	967
	48"	1219	4	20	9.0	1.3	OS1248-16/4	774	OS1248-16/3	957	OS1248-14/3	1062
	60"	1524	4	25	11.3	1.6	OS1260-16/4	826	OS1260-16/3	1047	OS1260-14/3	1163
	72"	1829	4	30	13.6	1.9	OS1272-16/4	884	OS1272-16/3	1146	OS1272-14/3	1274
	84"	2133	6	35	15.9	2.2	OS1284-16/4	940	OS1284-16/3	1238	OS1284-14/3	1379
	96"	2438	6	38	17.2	2.5	OS1296-16/4	1146	OS1296-16/3	1493	OS1296-14/3	1662
	108"	2743	6	39	17.6	2.5	OS12108-16/4	1218	OS12108-16/3	1603	OS12108-14/3	1785
	120"	3048	6	40	18.1	3.1	OS12120-16/4	1260	OS12120-16/3	1685	OS12120-14/3	1873
	132"	3353	8	43	19.5	3.7	OS12132-16/4	1332	OS12132-16/3	1800	OS12132-14/3	2002
	144"	3658	8	47	21.3	4.2	OS12144-16/4	1374	OS12144-16/3	1882	OS12144-14/3	2091

Double Deck Overshelves, Non-Adjustable - All welded construction, shipped assembled.

	length		# of legs	weight		cu ft	16 gauge, type 430		16 gauge, type 304		14 gauge, type 304	
	in.	mm		lbs.	kg		model #	list	model #	list	model #	list
10" width (254mm)	36"	915	4	31	14.1	8.6	DOS1036-16/4	1354	DOS1036-16/3	1517	DOS1036-14/3	1668
	48"	1219	4	39	17.6	11.4	DOS1048-16/4	1397	DOS1048-16/3	1595	DOS1048-14/3	1757
	60"	1524	4	48	21.8	14.2	DOS1060-16/4	1502	DOS1060-16/3	1740	DOS1060-14/3	1915
	72"	1829	4	59	26.8	17.0	DOS1072-16/4	1595	DOS1072-16/3	1881	DOS1072-14/3	2067
	84"	2134	6	69	31.3	19.8	DOS1084-16/4	1688	DOS1084-16/3	2015	DOS1084-14/3	2216
	96"	2438	6	75	34.0	22.6	DOS1096-16/4	2062	DOS1096-16/3	2436	DOS1096-14/3	2681
	108"	2743	6	77	34.9	25.4	DOS10108-16/4	2208	DOS10108-16/3	2631	DOS10108-14/3	2892
	120"	3048	6	79	35.8	28.2	DOS10120-16/4	2253	DOS10120-16/3	2715	DOS10120-14/3	2984
	132"	3353	8	85	38.6	35.8	DOS10132-16/4	2402	DOS10132-16/3	2913	DOS10132-14/3	3204
	144"	3658	8	92	41.7	41.8	DOS10144-16/4	2446	DOS10144-16/3	2987	DOS10144-14/3	3287
12" width (305mm)	36"	915	4	32	14.5	8.6	DOS1236-16/4	1433	DOS1236-16/3	1594	DOS1236-14/3	1849
	48"	1219	4	40	18.1	11.4	DOS1248-16/4	1472	DOS1248-16/3	1715	DOS1248-14/3	1985
	60"	1524	4	48	21.8	14.2	DOS1260-16/4	1588	DOS1260-16/3	1842	DOS1260-14/3	2136
	72"	1829	4	60	27.2	17.0	DOS1272-16/4	1701	DOS1272-16/3	1973	DOS1272-14/3	2293
	84"	2134	6	70	31.8	19.8	DOS1284-16/4	1808	DOS1284-16/3	2162	DOS1284-14/3	2463
	96"	2438	6	76	34.5	22.6	DOS1296-16/4	2197	DOS1296-16/3	2560	DOS1296-14/3	2732
	108"	2743	6	78	35.4	25.4	DOS12108-16/4	2379	DOS12108-16/3	2667	DOS12108-14/3	2935
	120"	3048	6	80	36.3	28.3	DOS12120-16/4	2423	DOS12120-16/3	2801	DOS12120-14/3	3084
	132"	3353	8	87	39.5	35.9	DOS12132-16/4	2601	DOS12132-16/3	3113	DOS12132-14/3	3426
	144"	3658	8	95	43.1	42.0	DOS12144-16/4	2644	DOS12144-16/3	3199	DOS12144-14/3	3516



## Catalog Section 10

### Extra Undershelves

see spec sheet **EG10.59**



- For tables with uni-lok® hat channel frame.
- Designed for storage of shorter, smaller items under worktable where only one undershelf might not suffice.
- Available in galvanized or stainless steel.

**FEATURES:**

**Note:** When ordering an extra or replacement undershelf, please order per the size of your tabletop. Please note the "for table size" column in chart.

**Freight class is 70.0.**

	for table size *		weight		cu ft	galvanized (adjustable)		stainless steel (adjustable)				
	length in.	mm	lbs.	kg		model #	list	model #	list	model #	list	
<b>24" width (610mm)</b>	24"	610	15	6.6	1.6	2424GADJUS	213	2424SADJUS-18/4	475	2424SADJUS-18/3	522	
	30"	762	18	8.2	1.9	2430GADJUS	254	2430SADJUS-18/4	521	2430SADJUS-18/3	572	
	36"	915	21	9.6	2.3	2436GADJUS	259	2436SADJUS-18/4	548	2436SADJUS-18/3	599	
	48"	1219	27	12.2	3.0	2448GADJUS	268	2448SADJUS-18/4	601	2448SADJUS-18/3	659	
	60"	1524	33	15.0	3.7	2460GADJUS	279	2460SADJUS-18/4	677	2460SADJUS-18/3	740	
	72"	1829	39	17.6	4.5	2472GADJUS	283	2472SADJUS-18/4	758	2472SADJUS-18/3	832	
	84"	2134	45	20.4	5.2	2484GADJUS	285	2484SADJUS-18/4	845	2484SADJUS-18/3	923	
	96"	2438	51	23.1	5.9	2496GADJUS	303	2496SADJUS-18/4	912	2496SADJUS-18/3	998	
	108"	2743	57	25.9	6.6	24108GADJUS	314	24108SADJUS-18/4	1039	24108SADJUS-18/3	1126	
	120"	3048	63	28.6	7.3	24120GADJUS	338	24120SADJUS-18/4	1045	24120SADJUS-18/3	1137	
	132"	3353	69	31.3	8.1	24132GADJUS	378	24132SADJUS-18/4	1117	24132SADJUS-18/3	1217	
	144"	3658	75	34.0	8.8	24144GADJUS	417	24144SADJUS-18/4	1323	24144SADJUS-18/3	1436	
	<b>30" width (762mm)</b>	24"	610	17	7.5	1.9	3024GADJUS	221	3024SADJUS-18/4	555	3024SADJUS-18/3	603
		30"	762	21	9.5	2.4	3030GADJUS	268	3030SADJUS-18/4	596	3030SADJUS-18/3	652
36"		915	24	10.7	2.8	3036GADJUS	271	3036SADJUS-18/4	631	3036SADJUS-18/3	687	
48"		1219	30	13.6	3.7	3048GADJUS •	279	3048SADJUS-18/4	686	3048SADJUS-18/3	753	
60"		1524	36	16.3	4.6	3060GADJUS •	285	3060SADJUS-18/4	786	3060SADJUS-18/3	861	
72"		1829	42	19.1	5.5	3072GADJUS •	303	3072SADJUS-18/4	879	3072SADJUS-18/3	961	
84"		2134	48	21.8	6.4	3084GADJUS	312	3084SADJUS-18/4	973	3084SADJUS-18/3	1063	
96"		2438	54	24.5	7.3	3096GADJUS	314	3096SADJUS-18/4	1081	3096SADJUS-18/3	1182	
108"		2743	60	27.2	8.2	30108GADJUS	359	30108SADJUS-18/4	1194	30108SADJUS-18/3	1332	
120"		3048	66	29.9	9.0	30120GADJUS	382	30120SADJUS-18/4	1327	30120SADJUS-18/3	1405	
132"		3353	72	32.7	9.9	30132GADJUS	411	30132SADJUS-18/4	1469	30132SADJUS-18/3	1547	
144"		3658	78	35.4	10.8	30144GADJUS	455	30144SADJUS-18/4	1592	30144SADJUS-18/3	1729	

\* Undershelves for 30" (762mm) wide tables listed above also fit 36" (915mm) wide tables.

### Table Mounted Microwave Shelves

see spec sheet **EG10.25**



**FEATURES:**

- 16 gauge type 304 stainless steel.
- 24" x 24" (610 x 610mm) microwave area.
- 16 1/2" (422mm) clearance above tabletop.
- Six stainless steel posts.

**Freight class is 70.0.**

	length		weight		cu ft	Left Side		Right Side		Center				
	in.	mm	lbs.	kg		model #	list	model #	list	weight lbs.	kg	cu ft	model #	list
<b>12" width (305mm)</b>	60"	1524	30	13.6	1.9	MOS1260L	1293	MOS1260R	1293	32	14.5	2.1	MOS1260C	1466
	72"	1829	35	15.9	2.4	MOS1272L	1463	MOS1272R	1463	38	17.2	2.6	MOS1272C	1637
	84"	2133	40	18.1	3.0	MOS1284L	1583	MOS1284R	1583	43	19.5	3.2	MOS1284C	1754
	96"	2438	45	20.4	3.4	MOS1296L	1754	MOS1296R	1754	48	21.8	3.7	MOS1296C	1826

## Drawers

- For stainless steel and hardwood tables.
- Type 430 stainless steel.

**Note:** To specify drawer assemblies for hardwood tables (page 131), you must order model #605500 mounting kit (at no additional charge) along with drawer selected.

To specify drawer assemblies for custom equipment (fabricated through SpecFAB®) which requires angle frame construction, you must order model #605499 (at no additional charge) mounting kit along with drawer selected.

### Drawer Capacity Per Table

Drawers can be centered, left or right.

Holes are predrilled for 20" x 20" (508 x 508mm) drawers only.

table length in. mm	15" x 20" (381 x 508mm) drawer capacity per table	20" x 20" (508 x 508mm) drawer capacity per table
24" 610	0	0
30" 762	1 centered	0
36" 914	1 centered	1 centered
48" 1219	1 centered; or 1 left & 1 right	1 centered
60" 1524	1 centered; or 1 left & 1 right	1 centered; or 1 left & 1 right
72" 1829	3 (1 centered, 1 left, 1 right)	1 centered; or 1 left & 1 right
84" 2134	4	1 centered; or 1 left & 1 right
96" 2438	4 (2 left, 2 right)	2 (1 left, 1 right)
108" 2743	4 (2 left, 2 right)	4 (2 left, 2 right)
120" 3048	4 (2 left, 2 right)	4 (2 left, 2 right)
132" 3353	6 (3 left, 3 right)	4 (2 left, 2 right)
144" 3658	6 (3 left, 3 right)	4 (2 left, 2 right)

## Drawers with Polymer Slides

see spec sheet **EG10.13A**



**Note:** For use on standard worktables only, not for equipment using angle frame construction.

No locks are available for these drawers.

**Weight Capacity up to 20 lbs.**

**FEATURES:**

- 1/2" (13mm) thick polycarbonate grooved friction slides.
- To specify drawer assemblies for tabletops with box marine edge, you must order one of the following based on the table width, along with drawer selected:
  - #611383 for 24"-wide tables
  - #611384 for 30"-wide tables
  - For tables 36" and wider, consult factory.

**Freight class is 85.0.**

(•) MTS (made to stock) / ( ) MTO (made to order)

		For ALL 24" STANDARD tables				For ALL 30" & 36" STANDARD tables				For 36" tables with FRAMING specified AT 30% CENTER LINES			
width x length x height in. mm		cu ft	weight lbs. kg	model #	list	weight lbs. kg	model #	list	weight lbs. kg	model #	list		
20" x 15" x 5"	508 x 381 x 127	1.4	13 5.8	502976*	• 214	13 5.8	503007*	• 214	13 5.8	503011*	214		
20" x 20" x 5"	508 x 508 x 127	1.4	13 5.8	502975**	• 254	13 5.8	503006	• 254	13 5.8	503010	254		

\* Tables must be field drilled for mounting; \*\* #502975 will protrude past tabletop width.

## Drawers with Pull Flange

see spec sheet **EG10.13A**



**FEATURES:**

- Includes full-extension zinc-plated steel slides with rubber stops.

**Note:** No locks are available for these drawers.

**Freight class is 85.0.**

(•) MTS (made to stock) / ( ) MTO (made to order)

width x length x height in. mm	weight lbs. kg	cubic feet	model #	list
20" x 15" x 5"	508 x 381 x 127	13 5.8	1.4	502941* • 292
20" x 20" x 5"	508 x 508 x 127	13 5.8	1.4	500772 • 336

\* Tables must be field drilled for mounting.

## Catalog Section 10

### Drawers with Pull Flange & Full Front

see spec sheet **EG10.13A**



width x length x height		weight		cubic	model #	list
in.	mm	lbs.	kg	feet		
20" x 15" x 5"	508 x 381 x 127	25	11.3	3.0	<b>502942</b> *•	434
20" x 20" x 5"	508 x 508 x 127	25	11.3	3.0	<b>501571</b> •	474

\* Tables must be field drilled for mounting.

**FEATURES:**

- Includes full-extension zinc-plated steel slides with rubber stops.
- Hemmed safety pull handle.

**Note:** No locks are available for these drawers.

**Freight class is 85.0.**

(•) MTS (made to stock) / ( ) MTO (made to order)

### Tier Drawers - Regular

see spec sheet **EG10.13B**



tier drawer



tier drawer with legs

**FEATURES:**

- Heavy gauge type 430 stainless steel cabinet with three roller-track drawers.
- With or without legs.
- Guides.
- Full-extension zinc-plated steel slides.
- Stainless steel drawer.
- Hemmed safety pull handle on each drawer.

**Note:** All shipping weights and cubic feet are approximate.

**Freight class is 85.0.**

(•) MTS (made to stock) / ( ) MTO (made to order)

width x length x height		description	weight		cubic	model #	list
inches	mm		lbs.	kg	feet		
22½" x 24" x 22"	572 x 610 x 559	3 drawers, nylon feet	75	34.0	9.8	<b>TD3</b> •	2916
22½" x 24" x 34½"	572 x 610 x 876	3 drawers, with legs	78	35.4	9.8	<b>TD3L</b>	3292

### NSF-Approved Tier Drawers

see spec sheet **EG10.13B**



model #NTD3L  
with NSF-certified drawer

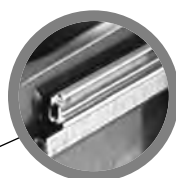

removable NSF  
drawer slide

**FEATURES:**

- Utilizes totally removable drawer slides certified by the National Sanitation Foundation.
- Otherwise, design and features are the same as tier drawers mentioned above.
- Hemmed safety pull handle on each drawer.

**Notes:** These drawers can be integrated into a table.

**Model #NTD3I. \$4220 list.**

Optional Pan Replacement available.

**Model #608120. \$160 list.**

**Freight class is 85.0.**

width x length x height		description	weight		cubic	model #	list
inches	mm		lbs.	kg	feet		
22½" x 24" x 22"	572 x 610 x 559	3 drawers, nylon feet	75	34.0	9.8	<b>NTD3</b>	3124
22½" x 24" x 34½"	572 x 610 x 876	3 drawers, with legs	78	35.4	9.8	<b>NTD3L</b>	3296

Drawer Assemblies

see spec sheet **EG10.13B**



enclosed drawer assembly



SPEC-MASTER® heavy duty drawer assembly

FEATURES:

- Removable drawer pan.

**Note:** All shipping weights and cubic feet are approximate.

Lock available. **\$178 list**. To order, add suffix “-L”.  
**Example: 502972-L.**

To determine number of drawers per table, see chart on page 152.

**Freight class is 85.0.**

(•) MTS (made to stock) / ( ) MTO (made to order)

For Stainless Steel and Hardwood Tables!

Enclosed Assemblies **NSF**

Type 430 stainless steel, front with hemmed safety pull handle, and full-extension stainless steel slides.

SPEC-MASTER® Heavy Duty Assemblies **NSF**

Type 304 stainless steel, insulated front and self-closing drawer slides that fully extend from housing.  
**THESE ASSEMBLIES ARE STACKABLE!!**

width x length x height (drawer pan only)		cu ft	weight		model #	list	OPTIONAL PAN REPLACEMENT		weight	model #	list	OPTIONAL PAN REPLACEMENT		
in.	mm		lbs.	kg			model #	list				lbs.	kg	model #
20" x 15" x 5"	508 x 381 x 127	3.0	35	15.9	<b>502943</b> * •	828	<b>608115</b>	229	40	18.1	<b>502972</b> * •	1339	<b>608117</b>	279
20" x 20" x 5"	508 x 508 x 127	3.0	35	15.9	<b>501572</b> •	862	<b>608118</b> **	241	40	18.1	<b>502971</b> •	1385	<b>606826</b>	288

\* Tables must be field drilled for mounting.

\*\* Pan replacement #608118 does NOT fit drawer assembly #501572 with optional lock (#501572-L).  
Drawer assembly #501572-L only accepts pan replacement #608119, **list \$323.**

Drawer Assemblies With NSF-Approved Slides **NSF**

see spec sheet **EG10.13B**

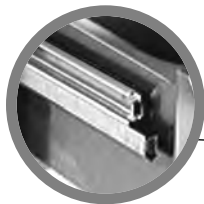

removable NSF drawer slide



#502946 or 502947 drawer assembly

FEATURES:

- Type 430 stainless steel.
- Utilizes a totally removable drawer slide, making it easy to clean for complete sanitation.
- Requires no tools.
- All-stainless steel housing, frame, drawer front complete with full-length front pull flange, and removable drawer pan with large radius corners.
- Hemmed safety pull handle.

**Note:** To determine number of drawers per table, see chart on page 152. Optional lock available. **\$178 list**. To order, add suffix “-L”. **Example: 502946-L.**

**Freight class is 85.0.**

(•) MTS (made to stock) / ( ) MTO (made to order)

width x length x height (drawer pan only)		weight	cubic feet	OPTIONAL PAN REPLACEMENT		
in.	mm			model #	list	
20" x 15" x 5"	508 x 381 x 127	35	15.9	3.0	<b>502947</b> * • 853	<b>608115</b> 229
20" x 20" x 5"	508 x 508 x 127	35	15.9	3.0	<b>502946</b> • 894	<b>608116</b> ** 229

\* Tables must be field drilled for mounting.

\*\* Pan replacement #608116 does NOT fit drawer assembly #502946 with optional lock (#502946-L).  
Drawer assembly #502946-L only accepts pan replacement #608119, **list \$323.**

**Catalog Section 10**

**Polymer Drawers** 

see spec sheet **EG10.13A**

FEATURES:

- Made of heavy gauge polymer.
- With pull flange and built-in drawer stop.



width x length x depth in. mm	weight lbs. kg	cubic feet	model #	list
13 $\frac{3}{4}$ " x 19" x 3"	352 x 483 x 76	9 4.1	1.4	<b>502948</b> 344
13 $\frac{3}{4}$ " x 19" x 6"	352 x 483 x 152	13 5.8	3.0	<b>502949</b> 412
13 $\frac{3}{4}$ " x 19" x 9"	352 x 483 x 229	18 8.2	4.5	<b>502950</b> 501

**Freight class is 85.0.**

**Drawer Kits for All Stainless Steel Worktables**

see spec sheet **EG10.13A**

**Freight class is 70.0.**

description	add * suffix #	add to list
enclosed assembly (#501572) with 20" x 20" x 5" (508 x 508 x 127mm) drawer pan	<b>-D1</b>	862
20" x 20" x 5" (508 x 508 x 127mm) drawer with pull flange and full front (#501571)	<b>-D2</b>	474
20" x 20" x 5" (508 x 508 x 127mm) drawer with pull flange (#500772)	<b>-D3</b>	336

\* Example: **T3060SB-D3**

**ADA/Ergonomic Height Adjustable Tables**

see product announcement **EG10.37**



*Adjusts from  
32" to 40" height!*

patented  
**uni-lok**<sup>®</sup>  
system  
(Patent #5,165,349)

**For optional mobility...**

...only these heavy duty casters can be used. 5" (127mm) swivel urethane. 250-lb. (113 kg) capacity.

**IMPORTANT: Not for cart-wash use.**

description	weight lbs. kg	cu ft	list model #	ea.
swivel	3.0 1.4	0.1	<b>A205340</b>	98
with brake	3.5 1.6	0.1	<b>A205341</b>	111

5" (127mm) rotary bumper: **Model #A205342. List \$21 each.**

- All tabletops reinforced with stainless steel hat and leg channels, with 90° downturn sides and 1 $\frac{1}{2}$ " rolled front edge.
- Rear edges can be ordered with 1 $\frac{1}{2}$ " roll or a 4"-high back splash.
- 1 $\frac{1}{2}$ " O.D. stainless steel legs, with 1 $\frac{1}{2}$ " O.D. stainless steel expanding sections.
- 1" stainless steel adjustable bullet feet.
- Heavy gauge stainless steel adjustable undershelf with marine edge.
- Crank pump case can be located on the left, right or center of the table.

**Freight class is 250.0.**

**Note:** Optional H- and C-frame tubular bases available in lieu of undershelf. Consult factory.

		...with Flat Top				...with 4" Backsplash						
width	length		weight cap.		16/304 top		14/304 top		16/304 top		14/304 top	
	in.	mm	lbs.	kg	model #	list	model #	list	model #	list	model #	list
<b>24"</b> (610mm)	48"	1219	575	260.8	<b>T2448SEB-HA</b>	5472	<b>T2448SE-HA</b>	5599	<b>T2448SEB-BS-HA</b>	5858	<b>T2448SE-BS-HA</b>	6346
	60"	1524	550	249.5	<b>T2460SEB-HA</b>	5596	<b>T2460SE-HA</b>	5738	<b>T2460SEB-BS-HA</b>	5993	<b>T2460SE-BS-HA</b>	6491
	72"	1829	525	238.1	<b>T2472SEB-HA</b>	5718	<b>T2472SE-HA</b>	5880	<b>T2472SEB-BS-HA</b>	6126	<b>T2472SE-BS-HA</b>	6642
<b>30"</b> (762mm)	48"	1219	575	260.8	<b>T3048SEB-HA</b>	5574	<b>T3048SE-HA</b>	5717	<b>T3048SEB-BS-HA</b>	5957	<b>T3048SE-BS-HA</b>	6455
	60"	1524	550	249.5	<b>T3060SEB-HA</b>	5732	<b>T3060SE-HA</b>	5883	<b>T3060SEB-BS-HA</b>	6124	<b>T3060SE-BS-HA</b>	6635
	72"	1829	525	238.1	<b>T3072SEB-HA</b>	5880	<b>T3072SE-HA</b>	6057	<b>T3072SEB-BS-HA</b>	6284	<b>T3072SE-BS-HA</b>	6818

To indicate location of crank case, add suffix "-L" (left end), "-R" (right end), or "-C" (center) at end of model number. Example: T2448-SE-HA-L

## Table Mounted Pan/Pot Racks

see spec sheet **EG10.12**



- Furnished with 1½" (41mm) stainless steel tubular supports extending through tabletop and fastened securely to adjustable undershelf.
- Racks are triple-bar type made of ⅝" x 2" (5 x 51mm), aluminum or type 304 stainless steel bars bolted together and fitted with one two-prong sliding hook per foot.

**FEATURES:**

**NOTE:** All shipping weights and cubic feet are approximate. Worktables with Pan/Pot Rack not recommended for use with casters.

**Freight class is 70.0.**

(•) MTS (made to stock) / ( ) MTO (made to order)

fits table length		rack length		weight		cu	Aluminum		Stainless Steel		weight		cu	model #		list	
in.	mm	in.	mm	lbs.	kg	ft	model #	list	lbs.	kg	ft	model #	list	lbs.	kg	ft	list
36"	914	28"	711	38	17.2	1.7	<b>TM36APR</b>	1106	50	22.7	1.7	<b>TM36PR</b>	1322				
48"	1219	40"	1016	42	19.1	1.9	<b>TM48APR</b>	1151	57	25.9	1.9	<b>TM48PR</b>	1397				
60"	1524	52"	1321	46	20.9	1.9	<b>TM60APR</b>	1189	64	29.0	1.9	<b>TM60PR</b>	1472				
72"	1829	64"	1626	50	22.7	1.9	<b>TM72APR</b>	1245	70	31.8	1.9	<b>TM72PR</b> •	1549				
84"	2134	76"	1930	54	24.5	1.9	<b>TM84APR</b>	1485	77	34.9	1.9	<b>TM84PR</b>	1831				
96"	2438	88"	2235	58	26.3	2.1	<b>TM96APR</b>	1531	83	37.6	2.1	<b>TM96PR</b>	1907				
108"	2743	100"	2540	62	28.1	2.3	<b>TM108APR*</b>	1857	89	40.4	2.3	<b>TM108PR*</b>	2306				
120"	3048	112"	2845	66	29.9	2.5	<b>TM120APR*</b>	1913	95	43.1	2.5	<b>TM120PR*</b>	2402				
132"	3353	124"	3150	71	32.2	2.8	<b>TM132APR*</b>	1969	102	46.3	2.8	<b>TM132PR*</b>	2522				
144"	3658	136"	3454	76	34.5	3.1	<b>TM144APR*</b>	2036	109	49.4	3.1	<b>TM144PR*</b>	2569				

\* These racks include center tubular support.

### Optional Adjustable Shelves for Table Mounted Pan/Pot Racks

12" (305mm) wide. 16 gauge, type 304 stainless steel.

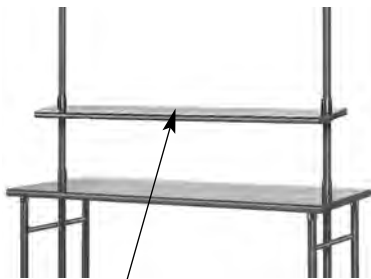

optional adjustable shelf for table mounted pot/pan racks

shelf length		weight		cubic	model #		list
in.	mm	lbs.	kg	feet	model #	list	
36"	914	16	7.3	0.9	<b>TM36PRS</b>	539	
48"	1219	20	9.0	1.3	<b>TM48PRS</b>	582	
60"	1524	25	11.3	1.6	<b>TM60PRS</b>	625	
72"	1829	30	13.6	1.9	<b>TM72PRS</b>	673	
84"	2134	35	15.9	2.2	<b>TM84PRS</b>	722	
96"	2438	39	17.6	2.5	<b>TM96PRS</b>	800	
108"	2743	41	18.6	3.1	<b>TM108PRS</b>	1998	
120"	3048	45	20.4	3.6	<b>TM120PRS</b>	2018	
132"	3353	49	22.2	4.1	<b>TM132PRS</b>	2107	
144"	3658	53	24.0	4.7	<b>TM144PRS</b>	2131	

## Single Bar Pot Racks

see spec sheet **EG10.06**

	ALUMINUM				STAINLESS STEEL					
	length		weight		length		weight			
	in.	mm	lbs.	kg	in.	mm	lbs.	kg		
8½" width (216mm)	24"	610	5	2.3	<b>SBPR-24-A</b>	188	9	4.1	<b>SBPR-24-S</b>	254
	36"	915	6	2.7	<b>SBPR-36-A</b>	286	12	5.4	<b>SBPR-36-S</b>	359
	48"	1219	7	3.2	<b>SBPR-48-A</b>	304	15	6.8	<b>SBPR-48-S</b>	403
	60"	1524	9	4.1	<b>SBPR-60-A</b>	327	18	8.2	<b>SBPR-60-S</b>	446
	72"	1829	11	5.0	<b>SBPR-72-A</b>	451	21	9.5	<b>SBPR-72-S</b>	582
	84"	2134	13	5.9	<b>SBPR-84-A</b>	468	25	11.3	<b>SBPR-84-S</b>	621
	96"	2438	15	6.8	<b>SBPR-96-A</b>	584	29	13.2	<b>SBPR-96-S</b>	751
	108"	2743	17	7.7	<b>SBPR-108-A</b>	625	34	15.4	<b>SBPR-108-S</b>	812
	120"	3048	20	9.0	<b>SBPR-120-A</b>	643	39	17.6	<b>SBPR-120-S</b>	852

**FEATURES:**

- Flat ⅝" (5mm)-thick, 2" (51mm)-wide solid bar.
- 24" (610mm) racks are one-piece, all others come with support brackets.
- Includes one two-prong hook per foot.

**Freight class is 70.0.**

(•) MTS (made to stock) / ( ) MTO (made to order)

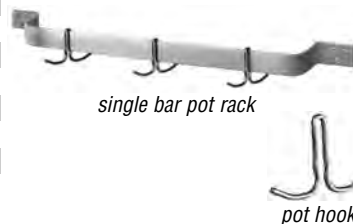

### Additional Pot Hook for Single Bar Pot Racks

- Stainless steel.

weight	cu	list
lbs.	kg	ft
0.2	0.1	0.1
		<b>300696</b> • 32

Catalog Section 10

### Ceiling Mounted Pan / Pot Racks

see spec sheet **EG10.12**

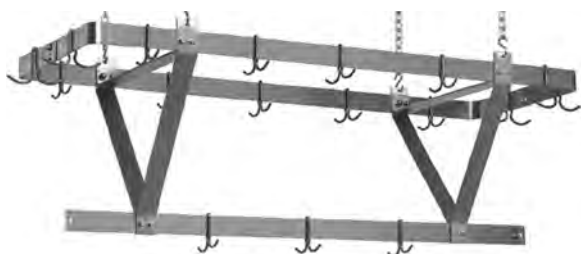

- Furnished with chain hangers for ceiling suspension.
- Racks are triple-bar type made of  $\frac{3}{16}$ " x 2" (5 x 51mm), aluminum or type 304 stainless steel bars bolted together and fitted with one two-prong sliding hook per foot.

FEATURES:

**Note:** All shipping weights and cubic feet are approximate.

**Freight class is 70.0.**

(•) MTS (made to stock) / ( ) MTO (made to order)

rack length		Aluminum					Stainless Steel				
in.	mm	weight lbs.	weight kg	cu ft	model #	list	weight lbs.	weight kg	cu ft	model #	list
28"	711	28	12.7	0.7	CM36APR	891	41	18.6	0.7	CM36PR	1137
40"	1016	32	14.5	0.9	CM48APR •	935	48	21.8	0.9	CM48PR •	1188
52"	1321	36	16.3	1.2	CM60APR •	978	54	24.5	1.2	CM60PR •	1268
64"	1626	40	18.1	1.6	CM72APR •	1034	60	27.2	1.6	CM72PR •	1343
76"	1930	44	20.0	1.9	CM84APR	1278	67	30.4	1.8	CM84PR	1634
88"	2235	48	21.8	2.1	CM96APR	1319	74	33.6	2.1	CM96PR	1705
100"	2540	53	24.0	2.5	CM108APR	1542	81	36.7	2.5	CM108PR	2147
112"	2845	58	26.3	2.9	CM120APR	1561	87	39.5	2.9	CM120PR	2266
124"	3150	63	28.6	3.3	CM132APR	1643	94	42.6	3.3	CM132PR	2297
136"	3454	68	30.8	3.7	CM144APR	1677	101	45.8	3.7	CM144PR	2620

### Wall Mounted Pan / Pot Racks <sup>NSF</sup>

see spec sheet **EG10.12**



- Racks are double-bar type made of  $\frac{3}{16}$ " x 2" (5 x 51mm), aluminum or type 304 stainless steel bars bolted together and fitted with one two-prong sliding hook per foot.
- Stainless steel brackets.
- 16" (406mm) height.

FEATURES:

**Freight class is 70.0.**

(•) MTS (made to stock) / ( ) MTO (made to order)

rack length		Aluminum					Stainless Steel				
in.	mm	weight lbs.	weight kg	cu ft	model #	list	weight lbs.	weight kg	cu ft	model #	list
36"	914	13	5.8	1.0	WM36APR •	321	18	8.2	1.0	WM36PR •	371
48"	1219	15	6.8	1.2	WM48APR •	336	22	10.0	1.2	WM48PR •	448
60"	1524	17	7.7	1.4	WM60APR •	383	26	11.8	1.4	WM60PR •	478
72"	1829	19	8.6	1.8	WM72APR •	491	29	13.2	1.8	WM72PR •	607
84"	2134	21	9.5	2.0	WM84APR •	516	33	15.0	2.0	WM84PR •	660
96"	2438	23	10.4	2.3	WM96APR •	634	37	16.8	2.3	WM96PR •	936
108"	2743	25	11.3	2.6	WM108APR	766	41	18.6	2.6	WM108PR	1051
120"	3048	28	12.7	2.9	WM120APR	775	45	20.4	2.9	WM120PR	1113
132"	3353	31	14.1	3.2	WM132APR	897	50	22.7	3.3	WM132PR	1129
144"	3658	34	15.4	3.5	WM144APR	963	55	24.9	3.5	WM144PR	1420

### Corner Guards

see spec sheet **EG10.14**

- Adheres to corner of adjacent wall(s).
- Heavy gauge stainless steel.
- Adhesive tape backing.

		2" x 2" Inner Corner Guards		2" x 2" Outer Corner Guards	
height in.	mm	model #	list	model #	list
36"	914	CG-I-36	127	CG-O-36	127
48"	1219	CG-I-48	151	CG-O-48	151
60"	1524	CG-I-60	172	CG-O-60	172
72"	1829	CG-I-72	189	CG-O-72	189

## - Options / Accessories / Replacements -

Please allow six to eight weeks shipping cycle for custom fabrication after receipt of approved drawings.  
Add 10% upcharge to expedite 4-week shipping cycle.



see spec sheet **EG10.50** NSF

See pages 369-372 for more custom options and accessories.

model #	description	unit	list	model #	description	unit	list
E10	Square edge table - front and/or rear	per table	256	300720	Lever drains - 1.5" I.P.S. (38mm)	each	279
E11	Marine counter edge	per table	549	300721	Lever drains - 2" I.P.S. (51mm)	each	279
E12	"V" type marine edge	per table	549	300722	Lever drains - 2" I.P.S. (51mm) with overflow	each	573
E13	Bullnose edge	per table	522	341189 ***	Twist handle drains - 1.5" I.P.S. (38mm)	each	294
E15	Vertical tray dividers - 4-section assembly, 3" on centers	each	812	336002 ***	Twist handle drains - 2" I.P.S. (51mm)	each	294
300698	Casters - 4" (102mm)-diameter with brake	each	124	341190 ***	Twist handle drains - 2" I.P.S. (51mm) with overflow	each	665
300699	Casters - 4" (102mm)-diameter without brake	each	119	E27	Top cutout - square or round (Specify location)	each	344
317635	Casters - 5" (127mm)-diameter with brake	each	162	E28	Angle slides for pans, up to six pairs Specify location and pan size.	set	713
317636	Casters - 5" (127mm)-diameter without brake	each	162	E29	Urn trough, 4.5" wide x 1.25" deep (114 x 32mm) with 1.5" (38mm) drain, complete with louvered grate. (Length must be maximum of 6" shorter than table. Specify location.)	lin. ft	174
313835	Stainless steel flanged bullet feet	each	32	E30	End splash — per end (Specify end), all heights	each	375
300692	Bullet feet - stainless steel	each	22	E31	1.5" (38mm) rear upturn for undershelf	table	151
301036	Bullet feet - white metal	each	11	E32	Can opener hole with under table support (Specify location)		244
300293	Bullet feet - plastic	each	2	E33	Sink splashes — single thickness 4" tall (102mm)	each	386
E17	Special height legs	per table	192	E34	Column cutout (Send floor plan/sketch)	each	801
E18 *	Duplex receptacle and mounting plate (under table)	each	481	<b>NOT PICTURED</b>			
E18.1 *	Duplex receptacle in splash (requires at least 6"-high splash)	each	464	model #	description	unit	list
E18.2 *	Pedestal duplex receptacle (top of table or overshelf)	each	537	606329	Scrap chute, 6" (152mm)-diameter	each	269
E19	Stainless steel gussets	each	41	606331	Knife rack (fits rolled rim, poly, and square edge tables)	each	393
Sinks — complete with faucet and basket drain (Specify location)				E35	16 gauge s/s apron in front of sinks or cutouts	lin. ft	189
E20	- 10" x 14" x 9.5" bowl (254 x 356 x 241mm)	each	1297	E36	Fully welded - top, undershelf & legs	each	606
E21	- 14" x 16" x 9.5" bowl (356 x 406 x 241mm)	each	1361	E36A	Welded base only - undershelf & legs	each	407
E22 **	- 16" x 20" x 8" bowl (406 x 508 x 203mm)	each	1452	E37	NSF sprayed-on sound deadening up to 12' (3658mm)	table	818
E23 **	- 16" x 20" x 14" bowl (406 x 508 x 356mm)	each	1611	E37A	- for each additional foot	lin. ft	65
E24 **	- 18" x 20" x 14" bowl (457 x 508 x 356mm)	each	1765	E38-6****	Cantilever mount up to 6' (1829mm) - add to wall shelf price	each	475
E24A **	- 20" x 20" x 14" (508 x 508 x 356mm)	each	1778	E38-12****	Cantilever mount up to 12' (3658mm) - add to wall shelf price	each	712
E25	- 24" x 24" x 14" (610 x 610 x 356mm) for 36" (914mm)-wide tables	each	2405	E39	Enclosed backsplash	lin. ft	102
313304	T&S faucet upgrade - deck mount 4" (102mm) centers	each	720				

\* For GFI receptacle, add "-GFI" to E number (example: E18.1-GFI) and \$48 to list price.

\*\* These sink bowls will not fit in a table any less than 30" (762mm) wide.

\*\*\* Optional twist drain brackets available for use with twist handle drains.

\*\*\*\* Applicable to wall mount shelves and pot racks.

### Optional Sinks Built Into Tables – Standard Locations

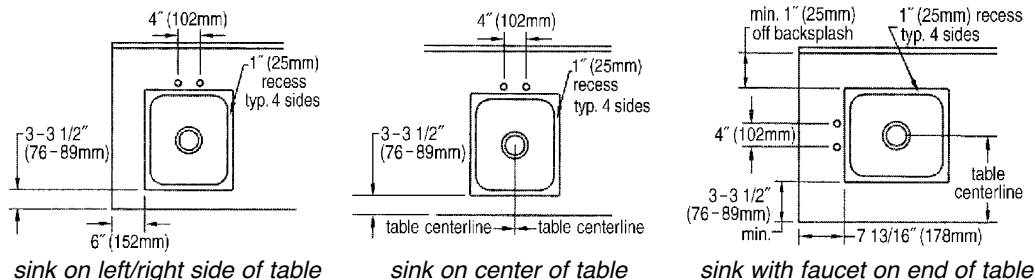

### Optional Table Edges

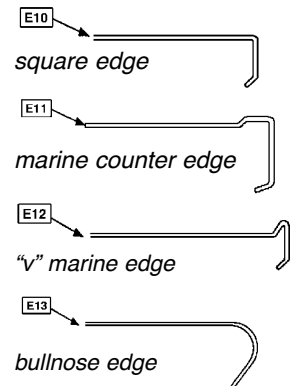





Two columns of horizontal lines for taking notes.



## Accessories/Replacements

Hand Sinks .....	173-176
All Other Sinks .....	177, 186, 203-206

## Custom Options .....203

## 412, 414, and 314 Series Sinks

One-Compartment .....	178
Two-Compartment .....	179
Three-Compartment .....	180
Four-Compartment .....	181

## Cool Trough® Water Tempering Systems .....209-210

Portable Cool Trough® .....	206
-----------------------------	-----

## Counter Drop-In Sinks

Counter Drop-Ins.....	198-200
-----------------------	---------

## Floor Drains/Troughs .....207-208

## Hand Sinks.....162-176

Accessories .....	173-176
Electronic.....	165-166
HFL-5000 Handwashing System.....	162
Physically Challenged / ADA.....	169
With Waste Receptacle .....	172

## Specialty Sinks

314 Series Corner .....	195
Convenience Store .....	195
Lavatory .....	176
Mop Sinks.....	196
Mop Sink Storage Cabinets .....	197

## SPEC-MASTER® FN Series Heavy Duty Sinks

One-Compartment .....	182
Two-Compartment .....	183

Three-Compartment .....	184
Four-Compartment .....	185

## SPEC-MASTER® FNP Series Prep Sinks

One-Compartment .....	187
Two-Compartment .....	187
Three-Compartment .....	188
With Corner Design .....	188
FFN Series Flush Front .....	193
Supermarket Meat-Platter.....	194

## Seamless

## Welded-In Sink .....201-202

## Utility Sinks .....189-192

# EAGLE HAND SINKS WITH MICROGARD® Antimicrobial Protection.

**THE  
INDUSTRY'S  
CLEAN  
LEADER.**



### NOW HERE'S A GREAT IDEA:

making your handwashing stations more convenient and accessible by integrating them into your work sequence. What better way to attain more frequent handwashing.

Let the industry's clean leader help by giving you the widest range of hand sink choices – many available with exclusive MICROGARD® Antimicrobial Protection. More models, configurations and accessories mean more design options for you... so you'll have more efficient work areas along with improved hygiene.

For all the details on how EAGLE hand sinks add up to better sanitation, visit [www.eaglegrp.com](http://www.eaglegrp.com).



# Quality...Value...Reliability!

The **EAGLE Advantage** can be summed up in two concise points: price/value leadership and value-added service. EAGLE GROUP is committed to providing you and your customer high-quality products while maintaining the cost competitiveness necessary in today's marketplace.



## All 414 Series Sinks

- 14" (356mm) deep seamless deep-drawn bowls to meet the most stringent health codes while maintaining the value and quality only a drawn bowl can offer.
- Have an extra-high 9½" (241mm) backsplash with upturn for easy and clean installation.
- Incorporate the "strength by design" feature of leg gussets welded to plates adjacent to bowls for maximum weight support and stability.
- Integral drainboards are creased for maximum drainage and fully incorporate NSF standards
- Are available in more standard sizes than the competition.
- All sinks shipped fully crated.

## All FN SPEC-MASTER® Series Sinks:

- Are constructed of 14 gauge type 304 stainless steel.
- Include 14" (356mm) deep fabricated type bowls to meet the most stringent health codes.
- Adjustable crossbracing on all four sides.
- Utilize a fabricated bowl design for those jobs where quality and durability are paramount.
- Have an extra-high 9½" (241mm) backsplash with upturn for easy and clean installation.
- Utilizes heavy duty stainless steel gussets and legs with stainless steel side stretchers.
- Integral drainboards are creased for maximum drainage and fully incorporate NSF standards.
- Are available in more standard sizes than the competition.
- All sinks shipped fully crated.

## HFL-5000 Touch-Free Handwashing Systems

see spec sheet **EG20.55**

- EAGLE hand sink with MICROGARD® antimicrobial protection.
- Automated paper towel dispenser. EAGLE part #384796.
- Splash-mount gooseneck faucet, with electronic eye sensor. Eagle part #384969 or EAGLE part #369865.
- Hand sanitizing dispenser. EAGLE part #377455.
- Hand soap dispenser. EAGLE part #377456.
- Glove rack with single service gloves. EAGLE part #352855.
- Soft bristle white nail brush. EAGLE part #348602

Refer to specification sheet for full component details and specifications.



## Optional MICROGARD®\* for Hand Sinks!

(See pages 163-172 for applicable hand sinks.)

- MICROGARD® is an antimicrobial agent which contains built-in protection to retard the growth of a broad range of bacteria, mold and mildew on the surface that cause stains, odors and degradation.
- MICROGARD® combines inorganic antimicrobial silver ions with a patented delivery system. The patented delivery system triggers the release of silver ions which react with bacteria in three ways:
  - 1) Suffocates the cell.
  - 2) Stops the cell reproduction system.
  - 3) Stops the cell from growing.
- MICROGARD® is a second line of defense. In keeping with good hygiene practices, clean this product as usual. The protection will not wash out, while organic bactericides may.\*\*
- MICROGARD® is applied onto top and underside of sink deck, backsplash, and inside & outside of sink bowl (excludes faucets, drains, towel/soap dispensers, waste receptacle, skirt, pedal valves, and nail brush holder).

description of hand sink included	model #	list
with waste receptacle	<b>HFL-5000</b>	5046
with skirt (no waste receptacle)	<b>HFL-5000-S</b>	4499
with waste receptacle and end splashes	<b>HFL-5000-LRS</b>	5346

**NOTE:**  
Listed under Kochman  
AutoCAD symbol library  
for foodservice equipment.

\* MICROGARD® does not protect users or others against bacteria, viruses, germs or other disease organisms. Always clean this product thoroughly after each use.

\*\* Note: To clean, use mild soap and water, rinse, and wipe entire surface dry. Soft non-abrasive cleaners may be used when necessary. Strong abrasive cleaners will scratch and dull the surface.

## Catalog Section 20

### Traditional Hand Sinks

see spec sheet **EG20.40**

#### MICROGARD®

an antimicrobial agent which contains built-in protection to retard the growth of a broad range of bacteria, mold and mildew that causes stains, odors and degradation.

**Cleanest sinks in the industry!**

- All sinks are wall mountable.
- Deep-drawn seamless design.
- Positive drain, included on all models.
- All type 304 stainless steel.
- Splash mount gooseneck faucet included on all models except HSA-10.

#### FEATURES:

**Freight class is 85.0.**

(•) MTS (made to stock) / ( ) MTO (made to order)

HSA-10* •		list:	615
	<b>bowl size:</b>	9¼" x 13½" x 6¼" (248 x 343 x 173mm)	
	<b>overall size:</b>	14¼" x 18½" x 12¼" (376 x 480 x 324mm)	
	<b>weight:</b>	10 lbs. (4.5 kg)	
	<b>cubic feet:</b>	3.0	
<b>MICROGARD® available:</b> To order, add suffix "-MG" to model # / add \$140 to list price.		<b>includes:</b>	4" (102mm) centerline faucet holes, basket drain.

HSA-10-FAW •		list:	968
	<b>bowl size:</b>	9¼" x 13½" x 6¼" (248 x 343 x 173mm)	
	<b>overall size:</b>	14¼" x 18½" x 12¼" (376 x 480 x 324mm)	
	<b>weight:</b>	14 lbs. (6.4 kg)	
	<b>cubic feet:</b>	2.8	
<b>MICROGARD® available:</b> To order, add suffix "-MG" to model # / add \$140 to list price.		<b>includes:</b>	Faucet with wrist handles, p-trap, tail piece, basket drain.

HSA-10-F •		list:	720
	<b>bowl size:</b>	9¼" x 13½" x 6¼" (248 x 343 x 173mm)	
	<b>overall size:</b>	14¼" x 18½" x 12¼" (376 x 480 x 324mm)	
	<b>weight:</b>	12 lbs. (5.2 kg)	
	<b>cubic feet:</b>	2.8	
<b>MICROGARD® available:</b> To order, add suffix "-MG" to model # / add \$140 to list price.		<b>includes:</b>	Faucet, basket drain.

HSA-10-FL •		list:	1031
	<b>bowl size:</b>	10" x 14" x 5" (254 x 356 x 127mm)	
	<b>overall size:</b>	14¼" x 18½" x 12½" (376 x 480 x 318mm)	
	<b>weight:</b>	15 lbs. (6.6 kg)	
	<b>cubic feet:</b>	3.0	
		<b>includes:</b>	Faucet, polymer lever drain.

HSA-10-FA •		list:	760
	<b>bowl size:</b>	9¼" x 13½" x 6¼" (248 x 343 x 173mm)	
	<b>overall size:</b>	14¼" x 18½" x 12¼" (376 x 480 x 324mm)	
	<b>weight:</b>	14 lbs. (6.4 kg)	
	<b>cubic feet:</b>	3.0	
<b>MICROGARD® available:</b> To order, add suffix "-MG" to model # / add \$140 to list price.		<b>includes:</b>	Faucet, p-trap, tail piece, basket drain.

HSA-10-FO •		list:	854
	<b>bowl size:</b>	10" x 14" x 5" (254 x 356 x 127mm)	
	<b>overall size:</b>	14¼" x 18½" x 12½" (376 x 480 x 318mm)	
	<b>weight:</b>	13 lbs. (5.6 kg)	
	<b>cubic feet:</b>	3.0	
		<b>includes:</b>	Faucet, polymer lever drain w/overflow.

\* To order hand sink with no faucet holes, add suffix "-NH" to model number (example: HSA-10-NH). \$179 upcharge.

## Hand Sinks with Standard Towel Dispenser and/or Soap Dispenser

see spec sheets **EG20.05** **EG20.41**

### MICROGARD®

an antimicrobial agent which contains built-in protection to retard the growth of a broad range of bacteria, mold and mildew that causes stains, odors and degradation.

- Deep-drawn positive drain and splash mount gooseneck faucet included on all models.
- All 304 series stainless steel, including towel dispenser.
- Soap dispenser on all models holds 12 ounces, except #HSA-10-F-DS (holds 16 ounces).
- Towel dispenser holds 4" x 10" (102 x 254mm) C-fold disposable paper towels.

FEATURES:

Freight class is 85.0.

HSA-10-FDP		list: 1516
	<b>bowl size:</b>	9 3/4" x 13 1/2" x 6 3/4" (248 x 343 x 173mm)
	<b>overall size:</b>	14 3/4" x 19 1/4" x 28 3/4" (376 x 489 x 718mm)
	<b>weight:</b>	29 lbs. (13.2 kg)
	<b>cubic feet:</b>	6.2
<b>MICROGARD® available:</b> To order, add suffix "-MG" to model # / add \$140 to list price.		<b>includes:</b> Faucet, towel dispenser, soap dispenser, basket drain.

HSA-10-FODP		list: 1860
	<b>bowl size:</b>	10" x 14" x 5" (254 x 356 x 127mm)
	<b>overall size:</b>	14 3/4" x 19 1/4" x 28" (376 x 489 x 711mm)
	<b>weight:</b>	30 lbs. (13.6 kg)
	<b>cubic feet:</b>	6.2
<b>MICROGARD® available:</b> To order, add suffix "-MG" to model # / add \$140 to list price.		<b>includes:</b> Faucet, towel dispenser, soap dispenser, polymer lever drain w/overflow.

HSA-10-FDPS		list: 2314
	<b>bowl size:</b>	9 3/4" x 13 1/2" x 6 3/4" (248 x 343 x 173mm)
	<b>overall size:</b>	14 3/4" x 19 1/4" x 30" (376 x 489 x 762mm)
	<b>weight:</b>	29 lbs. (13.2 kg)
	<b>cubic feet:</b>	6.2
<b>MICROGARD® available:</b> To order, add suffix "-MG" to model # / add \$140 to list price.		<b>includes:</b> Faucet, towel dispenser, soap dispenser, skirt, basket drain.

HSA-10-F-DS*		list: 947
	<b>bowl size:</b>	9 3/4" x 13 1/2" x 6 1/2" (248 x 343 x 165mm)
	<b>overall size:</b>	14 13/16" x 18 1/8" x 12 3/4" (376 x 480 x 324mm)
	<b>weight:</b>	12 lbs. (5.2 kg)
	<b>cubic feet:</b>	2.8
<b>MICROGARD® available:</b> To order, add suffix "-MG" to model # / add \$140 to list price.		<b>includes:</b> Faucet, 16-oz deck-mt soap dispenser, basket drain.

(see page 171 for #HSAN-10-F-DS)

HSA-10-FLDP		list: 1820
	<b>bowl size:</b>	10" x 14" x 5" (254 x 356 x 127mm)
	<b>overall size:</b>	14 3/4" x 19 1/4" x 28" (376 x 489 x 711mm)
	<b>weight:</b>	32 lbs. (14.5 kg)
	<b>cubic feet:</b>	6.2
<b>MICROGARD® available:</b> To order, add suffix "-MG" to model # / add \$140 to list price.		<b>includes:</b> Faucet, towel dispenser, soap dispenser, polymer lever drain.

HSA-10-FWLDP-LRS		list: 2456
	<b>bowl size:</b>	10" x 14" x 5" (254 x 356 x 127mm)
	<b>overall size:</b>	14 3/4" x 19 1/4" x 28" (376 x 489 x 711mm)
	<b>weight:</b>	30 lbs. (13.6 kg)
	<b>cubic feet:</b>	6.2
<b>MICROGARD® available:</b> To order, add suffix "-MG" to model # / add \$140 to list price.		<b>includes:</b> Faucet with wrist handles, towel dispenser, soap dispenser, polymer lever drain, and side splashes.

\* Overall height does not include soap dispenser bottle. See page 171 for "Space-Saver" hand sink with deck-mount soap dispenser.

## Catalog Section 20

### Electronic Eye Hand Sinks - AC POWER <sup>NSF</sup>

see spec sheet **EG20.42**

**Note:** For regulating water temperature, Temperature Adjustment Valve (see page 174) is required.

#### MICROGARD®

an antimicrobial agent which contains built-in protection to retard the growth of a broad range of bacteria, mold and mildew that causes stains, odors and degradation.

- Electronic “eye” sensor beam activates water flow and adjusts from 3” to 12” (76 to 305mm).
- Requires 120-volt, 15-amp electricity.
- 120-volt AC adapter.
- Splash mount gooseneck spout.
- Lever or basket drain.
- Y-Inlet Non-Adjustable Mixing Valve.

#### FEATURES:

**Freight class is 85.0.**

(•) MTS (made to stock) / ( ) MTO (made to order)

<b>HSA-10-FE*•</b>		<b>list: 2620</b>
	<b>bowl size:</b>	9¼" x 13½" x 6¼" (248 x 343 x 173mm)
	<b>overall size:</b>	14¾" x 18¾" x 12¾" (376 x 480 x 324mm)
	<b>weight:</b>	14 lbs. (6.3 kg)
	<b>cubic feet:</b>	3.0
<b>MICROGARD® available:</b> To order, add suffix “-MG” to model # / add \$140 to list price.		<b>includes:</b> Spout, electronic eye, and basket drain.

<b>HSA-10-FDPE*</b>		<b>list: 3751</b>
	<b>bowl size:</b>	9¼" x 13½" x 6¼" (248 x 343 x 173mm)
	<b>overall size:</b>	14¾" x 19¼" x 28¼" (376 x 489 x 718mm)
	<b>weight:</b>	31 lbs. (14.1 kg)
	<b>cubic feet:</b>	6.2
<b>MICROGARD® available:</b> To order, add suffix “-MG” to model # / add \$140 to list price.		<b>includes:</b> Spout, electronic eye, soap dispenser, towel dispenser, and basket drain.

<b>HSA-10-FOE</b>		<b>list: 2755</b>
	<b>bowl size:</b>	10" x 14" x 5" (254 x 356 x 127mm)
	<b>overall size:</b>	14¾" x 18¾" x 12½" (376 x 480 x 318mm)
	<b>weight:</b>	13 lbs. (5.7 kg)
	<b>cubic feet:</b>	3.0
		<b>includes:</b> Spout, electronic eye, and polymer lever drain with overflow.

<b>HSA-10-FODPE</b>		<b>list: 3767</b>
	<b>bowl size:</b>	10" x 14" x 5" (254 x 356 x 127mm)
	<b>overall size:</b>	14¾" x 19¼" x 28" (376 x 489 x 711mm)
	<b>weight:</b>	30 lbs. (13.6 kg)
	<b>cubic feet:</b>	6.2
		<b>includes:</b> Spout, electronic eye, soap dispenser, towel dispenser, and polymer lever drain with overflow.

<b>HSA-10-FA-PE</b>		<b>list: 3488</b>
	<b>bowl size:</b>	9¼" x 13½" x 6¼" (248 x 343 x 173mm)
	<b>overall size:</b>	14¾" x 18¾" x 40¼" (376 x 480 x 1036mm)
	<b>weight:</b>	28 lbs. (12.7 kg)
	<b>cubic feet:</b>	9.5
<b>MICROGARD® available:</b> To order, add suffix “-MG” to model # / add \$140 to list price.		<b>includes:</b> Spout, electronic eye, soap dispenser, P-trap, tail piece, and basket drain.

<b>HSA-10-FDPEE</b>		<b>list: 4108</b>
	<b>bowl size:</b>	9¼" x 13½" x 6¼" (248 x 343 x 173mm)
	<b>overall size:</b>	14¾" x 19¼" x 31¼" (376 x 489 x 794mm)
	<b>weight:</b>	30 lbs. (13.6 kg)
	<b>cubic feet:</b>	6.2
<b>MICROGARD® available:</b> To order, add suffix “-MG” to model # / add \$140 to list price.		<b>includes:</b> Spout, electronic eye, towel dispenser, electronic soap dispenser, and basket drain.

\* Optional waste receptacle available for models HSA-10-FE, HSA-10-FDPE, and HSA-10-FDPEE. See page 175.

## Electronic Hand Sinks - Battery Power

see spec sheets **EG20.07** **EG20.49**

### MICROGARD®

an antimicrobial agent which contains built-in protection to retard the growth of a broad range of bacteria, mold and mildew that causes stains, odors and degradation.

- Battery-powered electronic-eye faucet which operates on four "AA" batteries (included).
- Y-Inlet Non-Adjustable Mixing Valve.
- "Low battery" indicator light.

FEATURES:

**Freight class is 85.0.**

<b>HSA-10-FDPEE-B-T</b>		<b>list: 5766</b>
	<b>bowl size:</b>	9¼" x 13½" x 6¾" (248 x 343 x 173mm)
	<b>overall size:</b>	14¾" x 19¼" x 47½" (376 x 489 x 1207mm)
	<b>weight:</b>	54 lbs. (24.5 kg)
	<b>cubic feet:</b>	9.8
<b>MICROGARD® available:</b> To order, add suffix "-MG" to model # / add \$140 to list price.		<b>includes:</b> Battery-powered electronic eye faucet, towel dispenser, electronic soap dispenser, waste receptacle & skirt, and basket drain.

<b>HSAP-14-ADA-FE-B</b>		<b>list: 5749</b>
	<b>bowl size:</b>	16" x 14" x 5" (406 x 356 x 127mm)
	<b>overall size:</b>	24" x 22" x 24½" (610 x 559 x 623mm)
	<b>weight:</b>	65 lbs. (29.5 kg)
	<b>cubic feet:</b>	19.2
<b>MICROGARD® available:</b> To order, add suffix "-MG" to model # / add \$140 to list price.		<b>includes:</b> Battery-powered electronic eye faucet, basket drain, c-fold towel dispenser in front, deck-mount soap dispenser, skirt.

<b>HSA-10-FE-B-DS*</b>		<b>list: 3256</b>
	<b>bowl size:</b>	9¼" x 13½" x 6¾" (248 x 343 x 173mm)
	<b>overall size:</b>	14¼" x 18" x 12¼" (376 x 480 x 324mm)
	<b>weight:</b>	16 lbs. (7.3 kg)
	<b>cubic feet:</b>	3.0
<b>MICROGARD® available:</b> To order, add suffix "-MG" to model # / add \$140 to list price.		<b>includes:</b> Battery-powered electronic eye faucet, deck-mount soap dispenser, basket drain.

<b>HSA-10-FE-B-NB-MG</b>		<b>list: 3319</b>
	<b>bowl size:</b>	9¼" x 13½" x 6¾" (248 x 343 x 173mm)
	<b>overall size:</b>	14¼" x 18" x 12¼" (376 x 480 x 324mm)
	<b>weight:</b>	26 lbs. (11.8 kg)
	<b>cubic feet:</b>	3.0
<b>MICROGARD® Standard</b>		<b>includes:</b> Battery-powered electronic eye faucet, splash-mount nail brush holder, nail brush, MICROGARD®, basket drain.

<b>HSAN-10-FE-B-DS*</b>		<b>list: 3647</b>
	<b>bowl size:</b>	13½" x 9¼" x 6¾" (343 x 248 x 171mm)
	<b>overall size:</b>	17¼" x 12¼" x 14¼" (457 x 308 x 362mm)
	<b>weight:</b>	16 lbs. (7.3 kg)
	<b>cubic feet:</b>	2.8
<b>MICROGARD® available:</b> To order, add suffix "-MG" to model # / add \$140 to list price.		<b>includes:</b> Battery-powered electronic eye faucet, deck-mount soap dispenser, basket drain.

<b>HSA-10-FE-B-T-NB-MG</b>		<b>list: 4091</b>
	<b>bowl size:</b>	9¼" x 13½" x 6¾" (248 x 343 x 173mm)
	<b>overall size:</b>	14¼" x 18" x 29" (376 x 480 x 740mm)
	<b>weight:</b>	25 lbs. (11.3 kg)
	<b>cubic feet:</b>	8.1
<b>MICROGARD® Standard</b>		<b>includes:</b> Battery-powered electronic eye faucet, splash-mount nail brush holder, nail brush, MICROGARD®, waste receptacle & skirt, basket drain.

\* Overall height does not include soap dispenser bottle.



## Catalog Section 20

### Miscellaneous Hand Sinks

see spec sheets **EG20.21** **EG20.44**

Freight class is 85.0.

(•) MTS (made to stock) / ( ) MTO (made to order)

#### MICROGARD®

an antimicrobial agent which contains built-in protection to retard the growth of a broad range of bacteria, mold and mildew that causes stains, odors and degradation.

#### HSA-10-FKP

list: 1740



**MICROGARD® available:**  
To order, add suffix “-MG” to model # / add \$140 to list price.

<b>bowl size:</b>	9¼" x 13½" x 6¼" (248 x 343 x 173mm)
<b>overall size:</b>	14¾" x 18½" x 17½" (376 x 480 x 445mm)
<b>weight:</b>	26 lbs. (11.8 kg)
<b>cubic feet:</b>	6.0
<b>includes:</b>	Spout, single pedal knee valve, skirt, basket drain.

#### HSA-10-FA-P•

list: 1593



with Foot Valve Operation

**MICROGARD® available:**  
To order, add suffix “-MG” to model # / add \$140 to list price.

<b>bowl size:</b>	9¼" x 13½" x 6¼" (248 x 343 x 173mm)
<b>overall size:</b>	14¾" x 18½" x 40½" (376 x 480 x 1019mm)
<b>weight:</b>	32 lbs. (14.5 kg)
<b>cubic feet:</b>	7.4
<b>includes:</b>	Spout, foot pedal valves, P-trap, tail piece, basket drain.

#### HSA-10-1FK\*•

list: 1561



with Knee Valve Operation

**MICROGARD® available:**  
To order, add suffix “-MG” to model # / add \$140 to list price.

<b>bowl size:</b>	9¼" x 13½" x 6¼" (248 x 343 x 173mm)
<b>overall size:</b>	14¾" x 18½" x 17½" (376 x 480 x 445mm)
<b>weight:</b>	27 lbs. (12.2 kg)
<b>cubic feet:</b>	4.0
<b>includes:</b>	Spout, single knee pedal, skirt, and basket drain.

#### HSA-10-FA-1P•

list: 1593



with Foot Valve Operation

**MICROGARD® available:**  
To order, add suffix “-MG” to model # / add \$140 to list price.

<b>bowl size:</b>	9¼" x 13½" x 6¼" (248 x 343 x 173mm)
<b>overall size:</b>	14¾" x 18½" x 40½" (376 x 480 x 1019mm)
<b>weight:</b>	32 lbs. (14.5 kg)
<b>cubic feet:</b>	10.2
<b>includes:</b>	Spout, single foot pedal valve, P-trap, tail piece, basket drain.

#### HSA-10-FDPK\*

list: 2391



with Knee Valve Operation

**MICROGARD® available:**  
To order, add suffix “-MG” to model # / add \$140 to list price.

<b>bowl size:</b>	9¼" x 13½" x 6¼" (248 x 343 x 173mm)
<b>overall size:</b>	14¾" x 19¼" x 33" (376 x 489 x 838mm)
<b>weight:</b>	44 lbs. (20.0 kg)
<b>cubic feet:</b>	6.2
<b>includes:</b>	Spout, knee pedals, skirt, soap dispenser, towel dispenser, basket drain.

#### HSA-10-FK\*•

list: 1561



with Knee Valve Operation

**MICROGARD® available:**  
To order, add suffix “-MG” to model # / add \$140 to list price.

<b>bowl size:</b>	9¼" x 13½" x 6¼" (248 x 343 x 173mm)
<b>overall size:</b>	14¾" x 18½" x 17½" (376 x 480 x 445mm)
<b>weight:</b>	27 lbs. (12.2 kg)
<b>cubic feet:</b>	3.9
<b>includes:</b>	Spout, knee pedals, skirt, and basket drain.

#### HSA-10-FW•

list: 832



with Standard Wrist Handles

**MICROGARD® available:**  
To order, add suffix “-MG” to model # / add \$140 to list price.

<b>bowl size:</b>	9¼" x 13½" x 6¼" (248 x 343 x 173mm)
<b>overall size:</b>	14¾" x 18½" x 12¼" (376 x 480 x 324mm)
<b>weight:</b>	14 lbs. (6.4 kg)
<b>cubic feet:</b>	3.0
<b>includes:</b>	Faucet with wrist handles, basket drain.

\* Overall height does not include skirt and knee valves.

## Portable Hand Sinks

see product announcements

**EG8120**

**EG8132**



portable hand sink with stainless steel cabinet and single sink bowl



portable hand sink with laminate cabinet and removable water plate.

**PATENTED!**  
(U.S. Patent #9,790,674)

**FEATURES:**

- Stainless steel top features box marine edge and rear backsplash.
- 5-gallon fresh water tank, 7-gallon gray water tank.
- Deck mount faucet with 1/4-turn handles.
- Towel rack and trash chute included.
- NEMA 5-15 plug & cord.

**Notes:** Optional Poly Cutting Board available. 3/4"-thick. Green color. Model #376509, list \$211.

Custom portable hand sinks available through SpecFAB®.

**Freight class is 85.0.**

### Sinks with Stainless Steel Cabinet—Comes with 4" (102mm) swivel casters<sup>▼</sup> (two with brake).

description	bowl size		overall size		WITH COLD WATER ONLY		WITH HOT & COLD WATER					
	width x length x depth in.	mm	width x length x height in.	mm	weight * lbs.	kg	model #	list	lbs.	kg	model #	list
with single S/S bowl	14" x 10" x 5"	356 x 254 x 127	24" x 26" x 44½"	610 x 660 x 1130	232	105.2	<b>PHS-S-C</b>	6120	204	92.5	<b>PHS-S-H</b>	7556
with 3-compartment bowl	11½" x 6½" x 5"	295 x 156 x 127	24" x 26" x 44½"	610 x 660 x 1130	232	105.2	<b>PHS-S3-C</b>	6318	251	113.9	<b>PHS-S3-H</b>	7954
with acrylic water plate**	12½" x 16"	32 x 406	24" x 26" x 44½"	610 x 660 x 1130	232	105.2	<b>PHS-A-C</b>	7339	251	113.9	<b>PHS-A-H</b>	8703

### Sinks with Laminated Cabinet—Features Wilsonart® "Biltmore Cherry." Comes with 3" (76mm) swivel casters<sup>▼</sup> (two with brake).

description	bowl size		overall size		WITH COLD WATER ONLY		WITH HOT & COLD WATER					
	width x length x depth in.	mm	width x length x height in.	mm	weight * lbs.	kg	model #	list	lbs.	kg	model #	list
with single S/S bowl	14" x 10" x 5"	356 x 254 x 127	25" x 28" x 44½"	635 x 711 x 1130	237	107.5	<b>PHS-S-C-LB</b>	6854	214	97.1	<b>PHS-S-H-LB</b>	7677
with 3-compartment bowl	11½" x 6½" x 5"	295 x 156 x 127	25" x 28" x 44½"	635 x 711 x 1130	237	107.5	<b>PHS-S3-C-LB</b>	6949	262	118.8	<b>PHS-S3-H-LB</b>	9041
with acrylic water plate**	12½" x 16"	32 x 406	25" x 28" x 44½"	635 x 711 x 1130	237	107.5	<b>PHS-A-C-LB</b>	8073	237	107.5	<b>PHS-A-H-LB</b>	9574

<sup>▼</sup> 150 lb. (68.0 kg) weight capacity per caster.

\* Weights shown reflect empty tanks.

\*\* Features 12½" x 16" (32 x 406mm) removable polycarbonate water plate which drains into a stainless steel trough, and deck-mount faucet.

## Hand Wash Sinks

see spec sheet **EG20.47**



Model # HWC-E



Model # HWB-E

**FEATURES:**

- Type 304 stainless steel all-welded construction.
- 1½" (38mm) bull nose front edge.
- Hinged door with pull handle and magnetic catch.
- Pump-action soap dispenser on rear deck.
- Built-in front-loading C-fold towel dispenser located in front of sink bowl.
- Deck-mounted faucet.
- Basket drain.
- Crumb cup.

**Freight class is 85.0.**

### Space-Saver Models—Wall-mountable. Furnished with Z-clips to secure to wall.

bowl size	overall size	WITH STANDARD FAUCET		WITH T&S FAUCET							
		width x length x depth in.	mm	width x length x height in.	mm	weight lbs.	kg	model #	list	weight lbs.	kg
9¼" x 11½" x 6"	235 x 292 x 152	16⅝" x 14" x 21¼"	421 x 356 x 540	36	16.3	<b>HWC-E</b>	2888	37	16.8	<b>HWC-T</b>	3153

### Drop-In Models

bowl size	overall size	cutout dimensions	WITH STANDARD FAUCET		WITH T&S FAUCET									
			width x length in.	mm	width x length in.	mm	weight lbs.	kg	model #	list	weight lbs.	kg	model #	list
9¼" x 11½" x 6"	235 x 292 x 152	17⅞" x 16½" x 17¼"	445 x 419 x 438	16"	14¼"	406 x 378	32	14.5	<b>HWB-E</b>	3022	33	15.0	<b>HWB-T</b>	3284

100 Industrial Boulevard, Clayton, DE 19938-8903 U.S.A.

Phone: 800-441-8440 or 302-653-3000. Fax: 302-653-2065

http://www.eaglegrp.com



## Catalog Section 20

### Physically Challenged Hand Sinks

see spec sheet **EG20.45**

*Designed for unique applications!*

FEATURES: • Standard with faucet and basket drain.

**Freight class is 85.0.**

(•) MTS (made to stock) / ( ) MTO (made to order)

<b>HSAP-14-FW •</b>		<b>list: 2073</b>
	<b>bowl size:</b>	16" x 14" x 5" (406 x 356 x 127mm)
	<b>overall size:</b>	24 1/8" x 19" x 16 1/2" (613 x 483 x 419mm)
	<b>weight:</b>	26 lbs. (11.8 kg)
	<b>cubic feet:</b>	6.5
<b>includes:</b> Faucet, basket drain, and wall brackets.		

<b>HSAP-14-ADA-FE-B</b>		<b>list: 5749</b>
	<b>bowl size:</b>	16" x 14" x 5" (406 x 356 x 127mm)
	<b>overall size:</b>	24" x 22" x 24 1/2" (610 x 559 x 623mm)
	<b>weight:</b>	65 lbs. (29.5 kg)
	<b>cubic feet:</b>	19.2
<b>includes:</b> Battery-powered electronic eye splash-mount faucet, c-fold towel dispenser in front, deck mount soap dispenser, skirt, basket drain.		

<b>HSAP-14-ADA-FW</b>		<b>list: 4917</b>
	<b>bowl size:</b>	16" x 14" x 5" (406 x 356 x 127mm)
	<b>overall size:</b>	24" x 22" x 24 1/2" (610 x 559 x 623mm)
	<b>weight:</b>	55 lbs. (24.9 kg)
	<b>cubic feet:</b>	14.1
<b>includes:</b> Splash-mount faucet w/wrist handles, c-fold towel dispenser in front, deck mount soap dispenser, skirt, basket drain.		

Just a quick note...

**GET FREE DOWNLOADS**

- Spec Sheet • Product Instructions •
- Special Flyers • Brochures •

**www.eaglegrp.com**

#### Replacement T&S Faucet for HSAP-14-ADA-FW

- Top quality splash-mount faucets. 4" center.

features	model #	list
gooseneck spout	<b>306134</b>	643
wrist handles, gooseneck spout	<b>313305</b>	641



#313305

### Wall Mounted Multi-Station Hand Sinks



#### Optional Faucet

description	model #	list
gooseneck spout, 8" (203mm) center	<b>313075</b>	173

FEATURES:

- Single full-length bowl with basket drain(s)\* and rolled edge.
- 14/3 stainless steel construction.
- Wall-mounted tubular supports consists of 16 gauge 1 1/2" (41mm)-diameter tubing.
- Faucet holes at 8" (203mm) on center.
- 9 1/2" (241mm) backsplash.

\* Two basket drains on #HSA-WM-96.

**Freight class is 175.0.**

overall width x length x height in.	overall width x length x height mm	bowl width x length x depth in.	bowl width x length x depth mm	# of faucets required	weight lbs.	weight kg	model #	list
21 1/16" x 48" x 27 1/8"	551 x 1219 x 538	14" x 43" x 8"	356 x 1092 x 203	2	61	27.2	<b>HSA-WM-48</b>	5314
21 1/16" x 60" x 27 1/8"	551 x 1524 x 538	14" x 55" x 8"	356 x 1397 x 203	2	72	32.7	<b>HSA-WM-60</b>	5566
21 1/16" x 72" x 27 1/8"	551 x 1829 x 538	14" x 67" x 8"	356 x 1702 x 203	3	81	36.7	<b>HSA-WM-72</b>	5583
21 1/16" x 96" x 27 1/8"	551 x 2438 x 538	14" x 91" x 8"	356 x 2311 x 203	4	102	46.3	<b>HSA-WM-96</b>	6480

## Hand Sinks with Side Splashes NSF

see spec sheet **EG20.56**

FEATURES: • Standard with faucet and basket drain.

**Freight class is 85.0.**

(•) MTS (made to stock) / ( ) MTO (made to order)

<b>HSA-10-F-LRS •</b>		<b>list: 1273</b>
	<b>bowl size:</b>	9¼" x 13½" x 6¼" (248 x 343 x 173mm)
	<b>overall size:</b>	14¾" x 18½" x 12¼" (376 x 480 x 324mm)
	<b>weight:</b>	14 lbs. (6.4 kg)
	<b>cubic feet:</b>	3.9
<b>includes:</b> Faucet, basket drain, and side splashes.		

<b>HSAN-10-F-LRS •</b>		<b>list: 1408</b>
	<b>bowl size:</b>	13½" x 9¼" x 6¼" (343 x 248 x 173mm)
	<b>overall size:</b>	18" x 12" x 14¼" (457 x 305 x 362mm)
	<b>weight:</b>	13 lbs. (5.9 kg)
	<b>cubic feet:</b>	2.8
<b>includes:</b> 12" (305mm) side-to-side, faucet, basket drain, and side splashes.		

<b>HSA-10-FTWS-LRS</b>		<b>list: 1688</b>
	<b>bowl size:</b>	9¼" x 13½" x 6¼" (248 x 343 x 173mm)
	<b>overall size:</b>	14¾" x 18½" x 12¼" (376 x 480 x 324mm)
	<b>weight:</b>	21 lbs. (9.5 kg)
	<b>cubic feet:</b>	3.5
<b>includes:</b> Faucet, tubular wall brackets, basket drain, and side splashes.		

<b>HSA-10-FDPE-LRS</b>		<b>list: 4302</b>
	<b>bowl size:</b>	9¼" x 13½" x 6¼" (248 x 343 x 173mm)
	<b>overall size:</b>	14¾" x 19¼" x 28¼" (376 x 489 x 718mm)
	<b>weight:</b>	31 lbs. (14.1 kg)
	<b>cubic feet:</b>	2.8
<b>includes:</b> Spout with electronic eye, towel dispenser, soap dispenser, basket drain, and side splashes.		

## Miscellaneous Hand Sinks NSF

see spec sheets **EG20.31** **EG20.40**

**Freight class is 85.0.**

(•) MTS (made to stock) / ( ) MTO (made to order)

### MICROGARD®

an antimicrobial agent which contains built-in protection to retard the growth of a broad range of bacteria, mold and mildew that causes stains, odors and degradation.

<b>HSA-10-FAW •</b>		<b>list: 968</b>
 <i>with Standard Wrist Handles</i>	<b>bowl size:</b>	9¼" x 13½" x 6¼" (248 x 343 x 173mm)
	<b>overall size:</b>	14¾" x 18½" x 12¼" (376 x 480 x 324mm)
	<b>weight:</b>	14 lbs. (6.4 kg)
	<b>cubic feet:</b>	2.8
<b>MICROGARD® available:</b> To order, add suffix "-MG" to model # / add \$140 to list price.		
<b>includes:</b> Faucet with wrist handles, P-trap, tail piece, basket drain.		

<b>HSA-10-FTWS</b>		<b>list: 1136</b>
 <i>with Tubular Wall Support</i>	<b>bowl size:</b>	9¼" x 13½" x 6¼" (248 x 343 x 173mm)
	<b>overall size:</b>	14¾" x 18½" x 12¼" (376 x 480 x 324mm)
	<b>weight:</b>	20 lbs. (9.0 kg)
	<b>cubic feet:</b>	3.0
<b>MICROGARD® available:</b> To order, add suffix "-MG" to model # / add \$140 to list price.		
<b>includes:</b> Faucet, tubular wall brackets, basket drain.		

## Catalog Section 20

### Space-Saver Series Hand Sinks

see spec sheets **EG20.05** **EG20.43**

#### MICROGARD®

an antimicrobial agent which contains built-in protection to retard the growth of a broad range of bacteria, mold and mildew that causes stains, odors and degradation.

FEATURES: 

- Standard with faucet and basket drain.

**Freight class is 85.0.**

(•) MTS (made to stock) / ( ) MTO (made to order)

HSAN-10-F•		list:	857
	<b>bowl size:</b>	13½" x 9¼" x 6¼" (343 x 248 x 171mm)	
	<b>overall size:</b>	18" x 12" x 14¼" (457 x 305 x 362mm)	
	<b>weight:</b>	12 lbs. (5.2 kg)	
	<b>cubic feet:</b>	2.8	
<p><i>Only 12" (305mm) side-to-side to maximum space efficiency.</i></p> <p><b>MICROGARD® available:</b> To order, add suffix "-MG" to model # / add \$140 to list price.</p>		<b>includes:</b>	Splash mount faucet, basket drain.

HSAND-10-F•		list:	715
	<b>bowl size:</b>	13½" x 9¼" x 6¼" (343 x 248 x 171mm)	
	<b>overall size:</b>	19½" x 12" x 14¼" (498 x 305 x 362mm)	
	<b>weight:</b>	12 lbs. (5.2 kg)	
	<b>cubic feet:</b>	2.8	
<p><i>Only 12" (305mm) side-to-side to maximum space efficiency.</i></p>		<b>includes:</b>	Deck mount faucet, basket drain.

HSANT-FS		list:	1012
	<b>bowl size:</b>	13½" x 9¼" x 6¼" (343 x 248 x 171mm)	
	<b>overall size:</b>	18" x 12" x 26½" (457 x 305 x 673mm)	
	<b>weight:</b>	26 lbs. (11.8 kg)	
	<b>cubic feet:</b>	6.5	
<p><i>19½" (495mm) backsplash and skirt</i></p>		<b>includes:</b>	Faucet, 19½" (495mm) high backsplash, basket drain.

HSAN-10-F-DS*		list:	1093
	<b>bowl size:</b>	13½" x 9¼" x 6¼" (343 x 248 x 165mm)	
	<b>overall size:</b>	17½" x 12½" x 14¼" (457 x 308 x 362mm)	
	<b>weight:</b>	12 lbs., 5.2 kg	
	<b>cubic feet:</b>	2.8	
		<b>includes:</b>	Faucet, 12-oz deck-mt soap dispenser, basket drain.

\* Overall height does not include soap dispenser bottle.

### Stainless Steel Cleaner & Polish



- Cleans and polishes in one step.
- Does not streak or leave fingerprints.
- Leaves a protective invisible coating.

weight		model #		list
oz.	kg			
15	0.4	004026		22

## Special Purpose Hand Sinks

see spec sheets **EG20.20** **EG20.36** **EG20.37** **EG20.48**

### Hand Sink with Deck Mount Faucet

<b>HSAD-10-F •</b>		<b>list: 665</b>
	<b>bowl size:</b>	9¼" x 13½" x 6¾" (249 x 343 x 171mm)
	<b>overall size:</b>	16½" x 18¾" x 12¼" (419 x 479 x 324mm)
	<b>weight:</b>	14 lbs. (6.4 kg)
	<b>cubic feet:</b>	3.0
	<b>includes:</b>	Faucet and basket drain.

### Economical Hand Sink

- Faucet is deck mounted gooseneck.

<b>HSAE-10-FA •</b>		<b>list: 801</b>
	<b>bowl size:</b>	10" x 14" x 5" (254 x 356 x 127mm)
	<b>overall size:</b>	15" x 16¾" x 9" (381 x 425 x 229mm)
	<b>weight:</b>	10 lbs. (4.5 kg)
	<b>cubic feet:</b>	3.0
	<b>includes:</b>	Faucet, p-trap, tail piece, basket drain, wall brackets, 4" (102mm) high backsplash.

### Hand Sink with 8" (203mm) Centerline Faucet Holes

- Accommodates splash-mount faucet with 8" (203mm) centerline.

<b>HSA-10-8</b>		<b>list: 597</b>
	<b>bowl size:</b>	9¼" x 13½" x 6¾" (248 x 343 x 173mm)
	<b>overall size:</b>	14¾" x 18¾" x 12¼" (376 x 480 x 324mm)
	<b>weight:</b>	10 lbs. (4.5 kg)
	<b>cubic feet:</b>	3.0
	<b>includes:</b>	8" (203mm) centerline faucet holes (no faucet), basket drain
<b>MICROGARD® available:</b> To order, add suffix "-MG" to model # / add \$140 to list price.		

FEATURES: • Standard with faucet and basket drain.

Freight class is 85.0.

(•) MTS (made to stock) / ( ) MTO (made to order)

*Designed for unique applications!*

### MICROGARD®

an antimicrobial agent which contains built-in protection to retard the growth of a broad range of bacteria, mold and mildew that causes stains, odors and degradation.

### Hand Sink with Waste Receptacle-*Patent protected*

- U.S. Patent #5,732,422.
- Faucet is splash mounted gooseneck.

<b>HSA-10-FDP-T</b>		<b>list: 2209</b>
	<b>bowl size:</b>	9¼" x 13½" x 6¾" (248 x 343 x 173mm)
	<b>overall size:</b>	14¾" x 19¼" x 44¾" (376 x 480 x 1133mm)
	<b>weight:</b>	29 lbs. (13.2 kg)
	<b>cubic feet:</b>	6.2
	<b>includes:</b>	Faucet, basket drain, 12-oz soap dispenser, towel dispenser, waste skirt, and waste receptacle.
<b>MICROGARD® available:</b> To order, add suffix "-MG" to model # / add \$140 to list price.		

### Hand Sink with 8" (203mm) Centerline Faucet

- Faucet is splash mounted gooseneck.

<b>HSA-10-8F</b>		<b>list: 767</b>
	<b>bowl size:</b>	9¼" x 13½" x 6¾" (248 x 343 x 173mm)
	<b>overall size:</b>	14¾" x 18¾" x 12¼" (376 x 480 x 324mm)
	<b>weight:</b>	12 lbs. (5.2 kg)
	<b>cubic feet:</b>	3.0
	<b>includes:</b>	Faucet on 8" (203mm) center, basket drain.
<b>MICROGARD® available:</b> To order, add suffix "-MG" to model # / add \$140 to list price.		

## Catalog Section 20

### Hand Sink Accessories - Faucets & Valves

see spec sheet **EG20.52A**

FEATURES:

- All faucets below feature 4" (102mm) centers, except where noted.

Note: Faucets listed are lead-free AB1953-compliant.

**Can be shipped UPS.**



#### Standard Faucets

- With 4" (102mm) center, except #313075.

description	model #	list
splash mounted, gooseneck spout	<b>303987</b>	199
wrist handles	<b>307120</b>	124
splash mounted with wrist handles, gooseneck spout	<b>306495</b>	414
deck mounted, gooseneck spout, 1/4-turn handles	<b>302004</b>	220
deck mounted, 8" (203mm) spout, 1/4-turn handles	<b>301248</b>	197
drinking bubbler	<b>318495</b>	698
splash mounted, gooseneck spout, 8" (203mm) center	<b>313075</b>	194

#### Repair Kit for Standard Faucets

- For faucets #303987, 302004, and 301248 only.



description	model #	list
hot/cold ceramic cartridge	<b>368421</b>	35

#### Faucet-Mount Emergency Eyewash Units

- Fits in place of standard aerator on spout.



description	model #	list
pull valve activation, includes two dust covers, chrome finish	<b>326272</b>	566
rotate to activate, polished stainless finish, "eye-pod" design	<b>377563</b>	1131

**IMPORTANT NOTE:** If anti-scald valve (see below) is needed, order #373848 only.

#### Anti-Scald Valve for Faucet-Mount Emergency Eyewash Units

- This is the only anti-scald valve to be used with faucet-mount emergency eyewash units (above).
- Meets ANSI Z358.1 and ASSE 1071 standards.

description	model #	list
1/2" (13mm) NPT, 65 - 90°F	<b>373848</b>	2556

#### Battery-Powered Electronic-Eye Faucets

- Used as a replacement to sinks on page 165 (by adding suffix "-B"), or as a replacement faucet for sinks on page 166 via the model number below.



description	model #	list
Splash mount. Comes with four "AA" batteries and built-in low-battery indicator	<b>326014</b>	1882
Upgrade: T&S electric-eye faucet, splash-mtd with batteries and AC adapter for dual operation. With AC adapter plugged in, faucet automatically switches to AC power to conserve batteries.	<b>356128</b>	2016

#### Short 90° for Splash Mount Faucets

description	model #	list
set of two, 1/2" NPT female x male	<b>376740</b>	66



#### Spouts/Spout Assemblies

description	model #	list
splash-mount replacement gooseneck for knee/foot valve-operated models	<b>312162</b>	403



#### Shut-Off Valve <sup>NSF</sup>

- Antibacterial surface.
- Screws onto faucet aerator.
- Polished chrome finish.

description	model #	list
shut-off push bar	<b>349921</b>	83



#### Anti-Scald Valve

- Automatic shutdown with either hot or cold water failure.
- ASSE 1016 and 1017 listed.

**IMPORTANT: Not for use with Faucet-Mount Emergency Eyewash Units.**

description	model #	list
1/2" (13mm) NPT, 100 - 145°F	<b>326696</b>	753



## Hand Sink Accessories - Valves

see spec sheet **EG20.52A**

### Temperature Adjustment Valve ("Mixing Valve")

- For hand sinks with AC-powered electronic faucet or hand sinks with single pedal valves.
- Cast brass body.
- 3/8" (10mm) all connections.



description	model #	list
built-in check valves to prevent backflow and adjustment screw valves to mix hot and cold	<b>326015</b>	129

### Non-Adjustable Y-Inlet Mixing Valve

- For electronic hand sinks and hand sinks with single pedal valves only.
- "Y" shaped single-piece component. Chrome-plated brass body.



description	model #	list
Male connections; threads are 3/16-24 UNEF	<b>342938</b>	38

Can be shipped UPS.

(\*) MTS (made to stock) / ( ) MTO (made to order)

### Tempering Valve

- Maximum output of 120°F.
- Maximum pressure of 150 psi.
- ASSE 1016 and 1070 listed.



description	model #	list
thermoplastic body, 3/8" (10mm) male compression fittings, 80°F-120°F, 0.5-2.5 gpm, built-in check valve	<b>375612</b>	406



single foot pedal valve



double foot pedal valve



knee pedal valve

### Pedal Valves

description	DOUBLE PEDALS		SINGLE PEDALS	
	model #	list	model #	list
foot pedal valve, floor mount	<b>300604</b>	449	<b>355994</b>	449
knee pedal valve	<b>313481</b>	600	<b>351738</b>	600

Replacement Cartridge for all Pedal Valves: **Model # 374955. List: \$41**

## Hand Sink Accessories - Miscellaneous

see spec sheet **EG20.52B**



#318496 towel dispenser



#DP-10 towel dispenser



#384796 towel dispenser

### Towel/Soap Dispensers

description	model #	list
type 304 with conventional soap dispenser	<b>DP-10 *</b>	985
type 304 stainless, with electric eye soap dispenser	<b>DP-20 *</b>	2051
type 304 stainless, wall mounted	<b>318496</b>	344
break-resistant plastic, touchless, wall mounted	<b>384796</b>	246

\* Fits all HSA hand sinks except Space Saver models.

### Hand Sanitizing Dispenser

description	model #	list
Purell/LTX, wall mounted	<b>377455</b>	315



hand sanitizing dispenser

### Plumbing

description	model #	list
tail piece, nickel-plated	<b>300791</b>	20
P-trap, nickel-plated	<b>300789</b>	109



tail piece



P-trap

Can be shipped UPS.

(\*) MTS (made to stock) / ( ) MTO (made to order)



conventional soap dispenser



soap dispenser with electric eye



deck mount soap dispenser

### Soap Dispensers

description	model #	list
soap dispenser, conventional, 12-oz	<b>300602</b>	37
soap dispenser, wall mounted with electric eye	<b>377456</b>	315
soap dispenser, deck-mount, 16-oz	<b>324074</b>	144

nail brush

nail brush holder

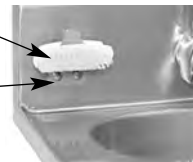

### Nail Brush and Nail Brush Holder

- To order nail brush and nail brush holder, add suffix "-NB" to hand sink model number. **Example: HSA-10-F-NB .**

description	model #	list each
infectious-control nail brush made of FDA-approved material, splash-mount stainless steel nail brush holder	add suffix "-NB"	135



## Catalog Section 20

### Hand Sink Accessories - Miscellaneous

see spec sheet **EG20.52B**

Can be shipped UPS.

(•) MTS (made to stock) / ( ) MTO (made to order)

#### Waste Receptacle

- U.S. Patent #5,732,422.
- 20 gauge stainless steel.
- Removable.
- Comes with skirt.
- Must be factory installed.

**Note:** To order, add suffix “-T” to hand sink model number.

**Example:** HSA-10-F-T.

**PATENTED DESIGN**



waste receptacle

HSA-10-FDP-T

hand sink with waste receptacle

for models:	model #	list
HSA-10; HSA-10-F; HSA-10-FA; HSA-10-FDP; HSA-10-FE; HSA-10-FDPE; HSA-10-FDPEE; and HSA-10-FW	add suffix “-T”	746

#### End Splashes...

- Type 304 stainless steel.

**Note:** Will not work with Space Saver Hand Sinks (page 171) that have faucets with wrist handles.

#### ...Factory-installed

**Notes:** To order, add suffix “-LS” (left end splash), “-RS” (right end splash), or “-LRS” (both end splashes). **Example:** HSA-10-F-LRS.

MICROGARD® cannot be put on hand sinks with end splashes.



hand sink with optional end splashes

descriptions	model #	list
left end splash only	add suffix “-LS”	278
right end splash only	add suffix “-RS”	278
left and right end splash	add suffix “-LRS”	556

#### ...for Field-installation

descriptions	model #	list each
one self-adhesive side splash, can be used for right or left application	HSA-SSK •	176
same as above, but fits only on Physically Challenged sinks (page 169)	HSAP-SSK	214



pair of end splashes for field installation



polymer lever drain

#### Wall Brackets

- 14 gauge type 304 stainless steel.

descriptions	model #	list
side mounting, one pair	606396 •	259
same as above, but fit only Space Saver models	611869	259



pair of wall brackets

#### Skirt Assembly

- Type 304 stainless steel.

fits models:	model #	list
HSA-10; HSA-10-F; HSA-10-FA; HSA-10-FDP; HSA-10-FE; HSA-10-FDPE; HSA-10-FDPEE; and HSA-10-FW.	606215 •	582
HSAN-10-F	607560	412



#### Drains

description	maximum flow rate		model #	list
	gallons per minute	gallons per hour		
polymer lever drain fits 3½" (89mm) diameter holes	11	660	319931	94
overflow assembly for lever drain #319931 (above)	-	-	319932	43
1½" (38mm) drain assembly, fits 2" (51mm) dia. hole	12	720	300886	16
mini crumb cup for 1½" (38mm) drain	-	-	300966	5
s/s basket drain assembly fits 3½" (89mm) diameter holes w/crumb cups	18	1080	300287	25
cast metal lever drain with overflow assembly, with 7¼" (185mm) long lever, fits 3½" (89mm) diameter holes	-	-	347771*	264

\* Applicable only for hand sinks with overflow, replaces #319931/319932 assembly.

## Hot Water Heater

see spec sheet **EG20.52B**



**with TANKLESS WATER HEATER**

**99% EFFICIENT!**  
Flow switch activates heater only on demand—no standby heat loss.

No temperature/pressure relief valve needed (check local codes), reducing installation cost.

applicable hand sinks include:	add suffix #	list each
HSA-10; HSA-10-F; HSA-10-FA; HSA-10-FDP; HSA-10-FE; HSA-10-FDPE; HSA-10-FDPEE; HSA-10-FW; HSA-10-FA-P; and HSAD-10-F.	“-WH”	2747

**FEATURES:**

- For EAGLE hand sinks with 10" x 14" (254 x 356mm) rounded bowl.
- Stainless steel pedestal base features notches for electrical wiring and front access panel.
- Unit comes equipped with an energy-saving tankless water heater. 120V 29A electricity. 0.5 GPM. 150 PSI maximum operating pressure (minimum 25 PSI).
- Water is heated instantaneously when faucet is on.
- To order, add suffix “-WH” to model number and **add \$2747 to list price** of hand sink.  
**Example: HSA-10-FDPEE-WH**

**Note:** Must be field-wired.

**Freight class is 70.0.**

(•) MTS (made to stock) / ( ) MTO (made to order)

## Lavatory Sinks

see spec sheet **EG20.12**

### Replacements for Lavatory Sinks

description	to fit process sink model #	model #	list
splash mount spout	P1916, P1916FE, W1916	<b>300600</b>	226
drain assembly	P1916, P1916FE, W1916,	<b>300287</b>	25
temperature adjustment valve, or “mixing valve”	P1916FE	<b>326015</b>	129

**FEATURES:**

- A marine edge.
- Type 304 stainless steel sink bowl.
- Gooseneck spout.
- Soap dispenser.
- Basket drain.
- Wall mount and pedestal models available.

**Freight class is 85.0.**

(•) MTS (made to stock) / ( ) MTO (made to order)

<b>W1916-FA •</b>		<b>list: 1766</b>
 <i>wall mounted</i>	<b>bowl size:</b>	15¼" x 19¼" x 8⅞" (400 x 500 x 225mm)
	<b>sink overall size:</b>	23" x 24¼" x 16⅞" (584 x 616 x 408mm)
	<b>shipping wt:</b>	35 lbs., 15.9 kg
	<b>cubic feet:</b>	1.6
<b>includes:</b> Gooseneck faucet, soap dispenser, basket drain.		

<b>P1916 •</b>		<b>list: 2979</b>
 <i>pedestal mounted, foot pedal valve</i>	<b>bowl size:</b>	15¼" x 19¼" x 8⅞" (400 x 500 x 225mm)
	<b>sink overall size:</b>	23" x 24¼" x 39⅞" (584 x 616 x 992mm)
	<b>shipping wt:</b>	48 lbs., 21.8 kg
	<b>cubic feet:</b>	1.6
<b>includes:</b> Gooseneck spout, soap dispenser, pedestal with foot valves, basket drain.		

<b>W1916</b>		<b>list: 3384</b>
 <i>wall mounted, knee valve operation</i>	<b>bowl size:</b>	15¼" x 19¼" x 8⅞" (400 x 500 x 225mm)
	<b>sink overall size:</b>	23" x 24¼" x 16⅞" (584 x 616 x 408mm)
	<b>shipping wt:</b>	43 lbs., 19.5 kg
	<b>cubic feet:</b>	1.6
<b>includes:</b> Gooseneck spout, soap dispenser, knee valves, basket drain.		

<b>P1916FE</b>		<b>list: 3988</b>
 <i>pedestal mounted, electronic-eye operation</i>	<b>bowl size:</b>	15¼" x 19¼" x 8⅞" (400 x 500 x 225mm)
	<b>sink overall size:</b>	23" x 24¼" x 39⅞" (584 x 616 x 992mm)
	<b>shipping wt:</b>	48 lbs., 21.8 kg
	<b>cubic feet:</b>	1.6
<b>includes:</b> Gooseneck spout with electronic-eye operation, soap dispenser, pedestal, basket drain.		

2"-wide  
euro-style  
edging on front  
and sides.

### Sink Kits for 314, 412, and 414 Series Sinks

see spec sheet **EG20.51A**

#### Standard Sink Kit components:

- Stainless steel gussets (welded to sink)
- Stainless steel crossbraced legs
- Stainless steel feet
- T&S faucet #313293

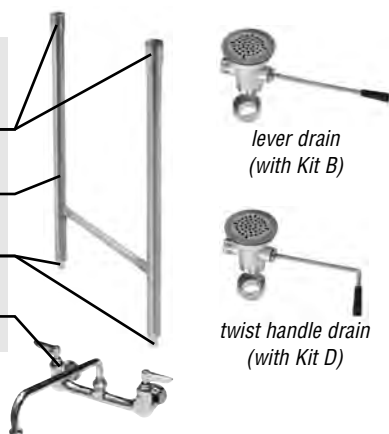

#### Kit A

Add suffix **"-CLF"** to sink model number.

description	add to list price
1 faucet	1446
2 faucets	2169

#### Kit B

Standard sink kit components plus lever drain. Add suffix **"-CLFD"** to sink model number.

description	add to list price
1 faucet	1446
2 faucets	2169
per lever drain	279

#### Kit C

Standard sink kit components plus lever drain with overflow. Add suffix **"-CLFDO"** to sink model number.

description	add to list price
1 faucet	1446
2 faucets	2169
per lever drain with overflow	573

#### Kit D

Standard sink kit components plus twist handle drain and twist handle bracket. Add suffix **"-CLFDT"** to sink model number.

description	add to list price
1 faucet	1446
2 faucets	2169
per twist handle drain	294

#### Kit E

Standard sink kit components plus twist handle drain with overflow and twist handle bracket. Add suffix **"-CLFDOT"** to sink model number.

description	add to list price
1 faucet	1446
2 faucets	2169
per twist handle drain with overflow	665

### 412, 414, and 314 Series Sinks Deep Drawn Construction

- Deep drawn seamless covered corner sink bowls of all units have a generous radius and are rectangular for maximum capacity.
- Legs are galvanized, 1½" (41mm) diameter.
- Crossbraced front-to-back with 1" (25mm) diameter galvanized tubing.
- Leg gussets are welded to a die-cut heavy-gauge reinforcing plate, and welded adjacent to sink bowl for maximum stability and support.
- 9½" (241mm) standard backsplash includes 1" (25mm) upturn and tile edge for easy installation and feathering to wall/splash surface.
- Basket-type waste drains are included to fit sink bowl's 3½" (89mm) opening and feature 1½" (38mm) outlet.
- 30" and 36" (762 and 914mm) drainboards available upon request.

**Note:** Stainless steel legs with front-to-back crossbracing available (does not include stainless steel feet).

To order, add **\$433 to list price** and suffix **"-SL"** to model number (example: 414-16-1-SL).

To order stainless steel legs and gussets, add **\$599 to list price** and suffix **"-SLG"** to model number (example: 414-16-1-SLG).

**Adjustable front-to-back crossbracing available.** Add suffix **"-ACB"** to model number, and add **\$201 to list price**. Example: 414-16-1-ACB

**Left-to-right crossbracing available.** For galvanized, add **5% to list price** and suffix **"-CBG"** to model number.

For stainless steel (does not include stainless steel legs), add **10% to list price** and suffix **"-CBS"** to model number (example: 414-16-1-CBS).

**Twist drain brackets available.** Works in conjunction with optional twist handle drains (not included - see page 204). To order, add **\$35 per compartment to list price** and suffix **"-TB"** to model number. Example: 414-16-1-TB.

For overflow hole (does not include drain), add **\$52 per compartment to list price** and suffix **"-OF"** to model number (example: 414-16-1-OF).

Sink accessories, see pages 204-206.

All shipping weights and cubic feet are approximate.

**ALL SINKS SHIPPED FULLY CRATED.**

**Freight class is 175.0.**

## 412, 414, and 314 Series Sinks One-Compartment Sinks

see spec sheets **EG20.03** **EG20.23** **EG20.27**

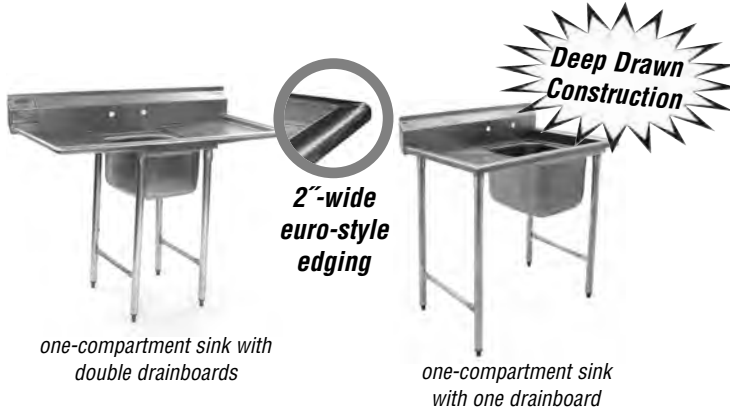

- All heavy gauge type 430 construction.
- 10½" (267mm) deep sink bowl.
- 44" (1118mm) overall height.

412 SERIES:

- 14" (356mm) deep heavy gauge type 304 sink bowl with type 430 drainboards, and backsplash.
- 44" (1118mm) overall height.

414 SERIES:

- All heavy gauge type 304 construction.
- 14" (356mm) deep sink bowl.
- 44" (1118mm) overall height.

314 SERIES:

Note: For sink kits, see page 177.

**Freight class is 175.0.**

(•) MTS (made to stock) / ( ) MTO (made to order)

### One Compartment, No Drainboards

bowl size		drainboard length		weight		cu ft	overall size		GOOD 412 Series		BETTER 414 Series		BEST 314 Series	
width in.	length mm	in.	mm	lbs.	kg		width in.	length mm	- see spec sheet - <b>EG20.03</b>		- see spec sheet - <b>EG20.23</b>		- see spec sheet - <b>EG20.27</b>	
in.	mm	in.	mm	lbs.	kg	in.	mm	model #	list	model #	list	model #	list	
20" x 16"	508 x 406	-	-	40	18.1	10.5	27½" x 23¼"	699 x 591	412-16-1•	2013	414-16-1•	2314	314-16-1•	2617
24" x 18"	610 x 457	-	-	45	20.4	10.0	31¼" x 25½"	807 x 648	-	-	414-18-1•	2709	314-18-1	3029
22" x 22"	559 x 559	-	-	55	24.9	14.5	29¾" x 29½"	756 x 749	-	-	414-22-1•	2880	314-22-1	3047
24" x 24"	610 x 610	-	-	60	27.2	16.5	31¼" x 31½"	807 x 800	-	-	414-24-1•	2920	314-24-1	3253

### One Compartment, One Drainboard (right or left)

bowl size		drainboard length		weight		cu ft	overall size		GOOD 412 Series		BETTER 414 Series		BEST 314 Series	
width in.	length mm	in.	mm	lbs.	kg		width in.	length mm	- see spec sheet - <b>EG20.03</b>		- see spec sheet - <b>EG20.23</b>		- see spec sheet - <b>EG20.27</b>	
in.	mm	in.	mm	lbs.	kg	in.	mm	model #	list	model #	list	model #	list	
20" x 16"	508 x 406	18"	457	59	26.8	18.1	27½" x 38½"	699 x 987	412-16-1-18R or L•	2823	414-16-1-18R or L•	3171	314-16-1-18R or L	3514
		24"	610	65	29.5	19.5	27½" x 44½"	699 x 1140	412-16-1-24R or L•	2845	414-16-1-24R or L•	3208	314-16-1-24R or L•	3557
24" x 18"	610 x 457	18"	457	64	29.0	22.0	31¼" x 40¾"	807 x 1035	-	-	414-18-1-18R or L	3488	314-18-1-18R or L	3838
		24"	610	70	31.8	22.9	31¼" x 46¾"	807 x 1188	-	-	414-18-1-24R or L	3514	314-18-1-24R or L	3864
22" x 22"	559 x 559	18"	457	74	33.6	23.0	29¾" x 45"	756 x 1143	-	-	414-22-1-18R or L	3811	314-22-1-18R or L	3949
		24"	610	80	36.3	26.0	29¾" x 51"	756 x 1295	-	-	414-22-1-24R or L	3837	314-22-1-24R or L	3977
24" x 24"	610 x 610	18"	457	79	35.8	25.0	31¼" x 46¾"	807 x 1188	-	-	414-24-1-18R or L	4211	314-24-1-18R or L	4583
		24"	610	85	38.6	28.6	31¼" x 52¾"	787 x 1340	-	-	414-24-1-24R or L•	4254	314-24-1-24R or L	4649

### One Compartment, Double Drainboards

bowl size		drainboard length		weight		cu ft	overall size		GOOD 412 Series		BETTER 414 Series		BEST 314 Series	
width in.	length mm	in.	mm	lbs.	kg		width in.	length mm	- see spec sheet - <b>EG20.03</b>		- see spec sheet - <b>EG20.23</b>		- see spec sheet - <b>EG20.27</b>	
in.	mm	in.	mm	lbs.	kg	in.	mm	model #	list	model #	list	model #	list	
20" x 16"	508 x 406	18"	457	78	35.4	25.7	27½" x 54½"	699 x 1384	412-16-1-18•	2994	414-16-1-18	3319	314-16-1-18	3672
		24"	610	90	40.8	30.8	27½" x 66½"	699 x 1689	412-16-1-24	3001	414-16-1-24	3426	314-16-1-24	3783
24" x 18"	610 x 457	18"	457	83	37.6	29.6	31¼" x 56"	807 x 1422	-	-	414-18-1-18	3792	314-18-1-18	4165
		24"	610	95	43.1	38.1	31¼" x 68"	807 x 1727	-	-	414-18-1-24	3827	314-18-1-24	4203
22" x 22"	559 x 559	18"	457	93	42.2	30.3	29¾" x 60¾"	756 x 1537	-	-	414-22-1-18	4152	314-22-1-18	4297
		24"	610	105	47.6	37.1	29¾" x 72½"	756 x 1842	-	-	414-22-1-24	4186	314-22-1-24	4332
24" x 24"	610 x 610	18"	457	98	44.5	32.5	31¼" x 62"	807 x 1575	-	-	414-24-1-18	4382	314-24-1-18	4688
		24"	610	110	49.9	40.6	31¼" x 74"	807 x 1880	-	-	414-24-1-24	4448	314-24-1-24	4856

## Catalog Section 20

### 412, 414, and 314 Series Sinks Two-Compartment Sinks

see spec sheets **EG20.03** **EG20.24** **EG20.28**



two-compartment sink  
with double drainboards

two-compartment sink  
with no drainboards

- All heavy gauge type 430 construction.
- 10½" (267mm) deep sink bowls.
- 44" (1118mm) overall height.

412 SERIES:

- 14" (356mm) deep heavy gauge type 304 sink bowls with type 430 drainboards, and backsplash.
- 44" (1118mm) overall height.

414 SERIES:

- All heavy gauge type 304 construction.
- 14" (356mm) deep sink bowls.
- 44" (1118mm) overall height.

314 SERIES:

Note: For sink kits, see page 177.

Freight class is 175.0.

(•) MTS (made to stock) / ( ) MTO (made to order)

#### Two Compartments, No Drainboards

bowl size width x length in. mm	drainboard length in. mm	weight lbs. kg	cu ft	overall size width x length in. mm	GOOD 412 Series <i>- see spec sheet -</i> <b>EG20.03</b>		BETTER 414 Series <i>- see spec sheet -</i> <b>EG20.24</b>		BEST 314 Series <i>- see spec sheet -</i> <b>EG20.28</b>	
					model #	list	model #	list	model #	list
20" x 16"	508 x 406	64 29.0	18.1	27½" x 41"	699 x 1041	412-16-2 • 2752	414-16-2 • 3169	314-16-2 • 3513		
24" x 18"	610 x 457	75 33.8	24.0	31¼" x 45½"	807 x 1156	-	414-18-2 • 3646	314-18-2 4212		
22" x 22"	559 x 559	80 36.3	25.8	29¾" x 53½"	756 x 1359	-	414-22-2 3979	314-22-2 4337		
24" x 24"	610 x 610	90 40.8	29.6	31¼" x 57½"	807 x 1461	-	414-24-2 • 4397	314-24-2 • 4996		

#### Two Compartments, One Drainboard (right or left)

bowl size width x length in. mm	drainboard length in. mm	weight lbs. kg	cu ft	overall size width x length in. mm	GOOD 412 Series <i>- see spec sheet -</i> <b>EG20.03</b>		BETTER 414 Series <i>- see spec sheet -</i> <b>EG20.24</b>		BEST 314 Series <i>- see spec sheet -</i> <b>EG20.28</b>	
					model #	list	model #	list	model #	list
20" x 16"	18"	457	83 37.6	25.7	27½" x 56½"	699 x 1438	412-16-2-18R or L • 3648	414-16-2-18R or L • 4192	314-16-2-18R or L 4586	
	24"	610	89 40.4	28.3	27½" x 62½"	699 x 1591	412-16-2-24R or L 3685	414-16-2-24R or L • 4258	314-16-2-24R or L 4848	
24" x 18"	18"	457	94 42.6	33.0	31¼" x 60¾"	807 x 1543	-	414-18-2-18R or L 4897	314-18-2-18R or L 5517	
	24"	610	100 45.4	35.0	31¼" x 66¾"	807 x 1696	-	414-18-2-24R or L 4927	314-18-2-24R or L 5549	
22" x 22"	18"	457	99 44.9	34.0	29¾" x 69"	756 x 1753	-	414-22-2-18R or L 5451	314-22-2-18R or L 5787	
	24"	610	105 47.6	37.1	29¾" x 75"	756 x 1905	-	414-22-2-24R or L 5480	314-22-2-24R or L 5818	
24" x 24"	18"	457	109 49.4	38.0	31¼" x 72¾"	807 x 1847	-	414-24-2-18R or L 5914	314-24-2-18R or L 6426	
	24"	610	115 52.2	41.6	31¼" x 78¾"	807 x 2000	-	414-24-2-24R or L • 6042	314-24-2-24R or L 6856	

#### Two Compartments, Double Drainboards

bowl size width x length in. mm	drainboard length in. mm	weight lbs. kg	cu ft	overall size width x length in. mm	GOOD 412 Series <i>- see spec sheet -</i> <b>EG20.03</b>		BETTER 414 Series <i>- see spec sheet -</i> <b>EG20.24</b>		BEST 314 Series <i>- see spec sheet -</i> <b>EG20.28</b>	
					model #	list	model #	list	model #	list
20" x 16"	18"	457	102 46.3	32.8	27½" x 72¼"	699 x 1848	412-16-2-18 • 3769	414-16-2-18 • 4356	314-16-2-18 4952	
	24"	610	114 51.7	38.5	27½" x 84¼"	660 x 2140	412-16-2-24 3828	414-16-2-24 • 4436	314-16-2-24 5034	
24" x 18"	18"	457	113 51.3	43.8	31¼" x 76"	807 x 1930	-	414-18-2-18 5043	314-18-2-18 5673	
	24"	610	125 56.7	48.7	31¼" x 88"	807 x 2235	-	414-18-2-24 5100	314-18-2-24 5733	
22" x 22"	18"	457	118 53.5	42.0	29¾" x 84½"	756 x 2146	-	414-22-2-18 5622	314-22-2-18 5959	
	24"	610	130 59.0	48.5	29¾" x 96½"	756 x 2451	-	414-22-2-24 5686	314-22-2-24 6021	
24" x 24"	18"	457	128 58.1	47.0	31¼" x 88"	807 x 2235	-	414-24-2-18 6111	314-24-2-18 6694	
	24"	610	140 63.5	53.6	31¼" x 100"	807 x 2540	-	414-24-2-24 • 6300	314-24-2-24 6988	

## 412, 414, and 314 Series Sinks Three-Compartment Sinks

see spec sheets **EG20.03** **EG20.25** **EG20.29**



three-compartment sink with double drainboards (faucet not included)

three-compartment sink with no drainboards

- All heavy gauge type 430 construction.
  - 10½" (267mm) deep sink bowls.
  - 44" (1118mm) overall height.
- 412 SERIES:**
- 14" (356mm) deep heavy gauge type 304 sink bowls with type 430 drainboards, and backsplash.
  - 44" (1118mm) overall height.
- 414 SERIES:**
- All heavy gauge type 304 construction.
  - 14" (356mm) deep sink bowls.
  - 44" (1118mm) overall height.
- 314 SERIES:**

Note: For sink kits, see page 177.

**Freight class is 175.0.**

(•) MTS (made to stock) / ( ) MTO (made to order)

### Three Compartments, No Drainboards

bowl size width x length in. mm	drainboard length in. mm	weight lbs. kg	cu ft	overall size width x length in. mm	GOOD 412 Series <i>- see spec sheet -</i> <b>EG20.03</b>		BETTER 414 Series <i>- see spec sheet -</i> <b>EG20.25</b>		BEST 314 Series <i>- see spec sheet -</i> <b>EG20.29</b>			
					model #	list	model #	list	model #	list		
20" x 16"	508 x 406	-	85 38.6	25.7	27½" x 58¾"	699 x 1492	<b>412-16-3</b> •	3489	<b>414-16-3</b> •	3841	<b>314-16-3</b> •	4394
24" x 18"	610 x 457	-	114 51.7	33.0	31¾" x 65½"	807 x 1664	-	-	<b>414-18-3</b> •	4744	<b>314-18-3</b> *	5560
22" x 22"	559 x 559	-	120 54.4	37.1	29¾" x 77½"	756 x 1969	-	-	<b>414-22-3</b> *	5274	<b>314-22-3</b> *	5823
24" x 24"	610 x 610	-	125 56.7	41.5	31¾" x 83½"	807 x 2121	-	-	<b>414-24-3</b> •	5755	<b>314-24-3</b> *	5797

\* Features two sets of faucet holes.

### Three Compartments, One Drainboard (right or left)

bowl size width x length in. mm	drainboard length in. mm	weight lbs. kg	cu ft	overall size width x length in. mm	GOOD 412 Series <i>- see spec sheet -</i> <b>EG20.03</b>		BETTER 414 Series <i>- see spec sheet -</i> <b>EG20.25</b>		BEST 314 Series <i>- see spec sheet -</i> <b>EG20.29</b>			
					model #	list	model #	list	model #	list		
20" x 16"	18"	457	104 47.2	33.3	27½" x 74¾"	699 x 1889	<b>412-16-3-18R</b> or L •	3687	<b>414-16-3-18R</b> or L •	4858	<b>314-16-3-18R</b> or L	5899
	24"	610	110 49.9	35.8	27½" x 80¾"	699 x 2042	<b>412-16-3-24R</b> or L	3725	<b>414-16-3-24R</b> or L	4896	<b>314-16-3-24R</b> or L	5940
24" x 18"	18"	457	133 60.3	42.0	31¾" x 80¾"	807 x 2051	-	-	<b>414-18-3-18R</b> or L*	6102	<b>314-18-3-18R</b> or L*	6977
	24"	610	139 63.1	68.0	31¾" x 86¾"	807 x 2203	-	-	<b>414-18-3-24R</b> or L*	6126	<b>314-18-3-24R</b> or L*	7001
22" x 22"	18"	457	139 63.1	45.0	29¾" x 93"	756 x 2362	-	-	<b>414-22-3-18R</b> or L*	6867	<b>314-22-3-18R</b> or L*	7392
	24"	610	145 65.8	48.4	29¾" x 99"	756 x 2515	-	-	<b>414-22-3-24R</b> or L*	6894	<b>314-22-3-24R</b> or L*	7422
24" x 24"	18"	457	144 65.3	50.0	31¾" x 98¾"	807 x 2508	-	-	<b>414-24-3-18R</b> or L*	7589	<b>314-24-3-18R</b> or L*	8298
	24"	610	150 68.0	54.6	31¾" x 104¾"	807 x 2661	-	-	<b>414-24-3-24R</b> or L*	7696	<b>314-24-3-24R</b> or L*	8645

\* Features two sets of faucet holes.

### Three Compartments, Double Drainboards

bowl size width x length in. mm	drainboard length in. mm	weight lbs. kg	cu ft	overall size width x length in. mm	GOOD 412 Series <i>- see spec sheet -</i> <b>EG20.03</b>		BETTER 414 Series <i>- see spec sheet -</i> <b>EG20.25</b>		BEST 314 Series <i>- see spec sheet -</i> <b>EG20.29</b>			
					model #	list	model #	list	model #	list		
20" x 16"	18"	457	123 55.8	40.9	27½" x 90"	699 x 2286	<b>412-16-3-18</b> •	3817	<b>414-16-3-18</b> •	4989	<b>314-16-3-18</b> •	6042
	24"	610	135 61.2	46.0	27½" x 102"	699 x 2591	<b>412-16-3-24</b> •	3467	<b>414-16-3-24</b> •	4002	<b>314-16-3-24</b> •	4841
24" x 18"	18"	457	152 68.9	50.5	31¾" x 96"	807 x 2438	-	-	<b>414-18-3-18</b> •	6261	<b>314-18-3-18</b> •	7144
	24"	610	164 74.4	57.0	31¾" x 108"	807 x 2743	-	-	<b>414-18-3-24</b> •	6417	<b>314-18-3-24</b> •	7267
22" x 22"	18"	457	158 71.6	54.0	29¾" x 108¾"	756 x 2756	-	-	<b>414-22-3-18</b> •	7054	<b>314-22-3-18</b> *	7578
	24"	610	170 77.1	59.6	29¾" x 120½"	756 x 3061	-	-	<b>414-22-3-24</b> •	7236	<b>314-22-3-24</b> •	7759
24" x 24"	18"	457	163 73.9	60.0	31¾" x 114"	807 x 2896	-	-	<b>414-24-3-18</b> •	7594	<b>314-24-3-18</b> *	8224
	24"	610	175 79.4	65.2	31¾" x 126"	807 x 3200	-	-	<b>414-24-3-24</b> •	7929	<b>314-24-3-24</b> *	8891

\* Features two sets of faucet holes.

## Catalog Section 20

### 414 and 314 Series Sinks Four-Compartment Sinks NSF

see spec sheets **EG20.26** **EG20.30**



four-compartment sink with double drainboards



**2"-wide  
euro-style edging**

414 SERIES:

- 14" (356mm) deep heavy gauge type 304 sink bowls with type 430 drainboards, and backsplash.
- 44" (1118mm) overall height.
- Two sets of faucet holes.

314 SERIES:

- All heavy gauge type 304 construction.
- 14" (356mm) deep sink bowls.
- 44" (1118mm) overall height.
- Two sets of faucet holes.

Note: For sink kits, see page 177.

**Freight class is 175.0.**

(•) MTS (made to stock) / ( ) MTO (made to order)

#### Four Compartments, No Drainboards

bowl size width x length		drainboard length		weight		cu ft	overall size width x length		<b>BETTER</b> 414 Series <small>- see spec sheet -</small> <b>EG20.26</b>		<b>BEST</b> 314 Series <small>- see spec sheet -</small> <b>EG20.30</b>	
in.	mm	in.	mm	lbs.	kg		in.	mm	model #	list	model #	list
20" x 16"	508 x 406	n/a	n/a	125	56.7	33.3	27½" x 76½"	699 x 1943	<b>414-16-4</b>	5186	<b>314-16-4</b>	6209
24" x 18"	610 x 457	n/a	n/a	135	61.2	48.4	31¾" x 85½"	807 x 2172	<b>414-18-4</b>	5994	<b>314-18-4</b>	7054
24" x 24"	610 x 610	n/a	n/a	153	69.4	55.6	31¾" x 109¾"	807 x 2783	<b>414-24-4</b>	7387	<b>314-24-4</b>	8516

#### Four Compartments, One Drainboard (right or left)

bowl size width x length		drainboard length		weight		cu ft	overall size width x length		<b>BETTER</b> 414 Series <small>- see spec sheet -</small> <b>EG20.26</b>		<b>BEST</b> 314 Series <small>- see spec sheet -</small> <b>EG20.30</b>	
in.	mm	in.	mm	lbs.	kg		in.	mm	model #	list	model #	list
20" x 16"	508 x 406	18"	457	144	65.3	41.0	27½" x 92½"	699 x 2340	<b>414-16-4-18R or L</b>	6301	<b>314-16-4-18R or L</b>	7384
		24"	610	150	68.0	43.4	27½" x 98½"	699 x 2492	<b>414-16-4-24R or L</b>	6343	<b>314-16-4-24R or L</b>	7427
24" x 18"	610 x 457	18"	457	154	69.9	49.0	31¾" x 100½"	807 x 2559	<b>414-18-4-18R or L</b>	7567	<b>314-18-4-18R or L</b>	8675
		24"	610	160	72.6	59.6	31¾" x 106½"	807 x 2711	<b>414-18-4-24R or L</b>	7762	<b>314-18-4-24R or L</b>	8703
24" x 24"	610 x 610	18"	457	172	78.0	61.0	31¾" x 124½"	807 x 3169	<b>414-24-4-18R or L</b>	9077	<b>314-24-4-18R or L</b>	10495
		24"	610	178	80.7	67.7	31¾" x 130½"	807 x 3321	<b>414-24-4-24R or L</b>	9766	<b>314-24-4-24R or L</b>	11009

#### Four Compartments, Double Drainboards

bowl size width x length		drainboard length		weight		cu ft	overall size width x length		<b>BETTER</b> 414 Series <small>- see spec sheet -</small> <b>EG20.26</b>		<b>BEST</b> 314 Series <small>- see spec sheet -</small> <b>EG20.30</b>	
in.	mm	in.	mm	lbs.	kg		in.	mm	model #	list	model #	list
20" x 16"	508 x 406	18"	457	163	73.9	48.5	27½" x 107¾"	699 x 2737	<b>414-16-4-18</b> •	6562	<b>314-16-4-18</b>	7652
		24"	610	175	79.5	53.6	27½" x 119¾"	699 x 3042	<b>414-16-4-24</b>	6661	<b>314-16-4-24</b>	7759
24" x 18"	610 x 457	18"	457	173	78.5	65.0	31¾" x 116"	807 x 2946	<b>414-18-4-18</b>	7689	<b>314-18-4-18</b>	8831
		24"	610	185	83.9	70.9	31¾" x 128"	807 x 3251	<b>414-18-4-24</b>	7779	<b>314-18-4-24</b>	8928
24" x 24"	610 x 610	18"	457	191	86.6	73.0	31¾" x 140"	807 x 3556	<b>414-24-4-18</b>	9552	<b>314-24-4-18</b>	10717
		24"	610	203	92.1	79.7	31¾" x 152"	807 x 3861	<b>414-24-4-24</b> •	9987	<b>314-24-4-24</b>	11236

### Stainless Steel Cleaner & Polish

weight		model #	list
oz.	kg		
15	0.4	<b>004026</b>	22



FEATURES:

- Cleans and polishes in one step.
- Does not streak or leave fingerprints.
- Leaves a protective invisible coating.

## SPEC-MASTER® FN Series Coved Corner Sinks One-Compartment Sinks NSF

see spec sheet **EG20.32**



**Notes:** Twist drain brackets available.

Works in conjunction with optional twist handle drains (*not included* – see page 204). To order, add \$35 per compartment to list price and suffix “-TB” to model number (example: FN2016-1-14/3-TB).

For overflow hole (*does not include drain*), add \$52 per compartment to list price and suffix “-OF” to model number (example: FN2016-1-14/3-OF).

- 14 gauge 300 Series 18-8 stainless steel.
- All bowls are 14” (356mm) deep and have 5/8” (16mm) radius corners, both vertical and horizontal.
- Stainless steel gussets, feet, legs and crossbracing.
- Adjustable crossbracing front-to-back and side-to-side for increased stability.
- 9½” (241mm) standard backsplash includes 1” (25mm) upturn tile edge.
- Basket-type waste drains are included to fit sink bowl’s 3½” (89mm) opening and feature 1½” (38mm) outlet.
- 30” and 36” (762 and 914mm) drainboards\* available upon request.

**FEATURES:**

\* On sinks with drainboard(s) 30” and 36”, legs are under the outer end of the drainboard(s).

**Note:** All shipping weights and cubic feet are approximate.

**ALL SINKS SHIPPED FULLY CRATED.**

For sink accessories, see pages 204-206.

For sink kits, see page 186.

**Freight class is 175.0.**

(•) MTS (*made to stock*) / ( ) MTO (*made to order*)

### One Compartment, No Drainboards

bowl size width x length in. mm		drainboard length in. mm		weight lbs. kg		cubic feet	overall size width x length in. mm		model #	list
20" x 16"	508 x 406	–	–	55	24.9	10.1	27" x 21"	686 x 533	FN2016-1-14/3	3471
20" x 18"	508 x 457	–	–	58	26.3	11.9	27" x 23"	686 x 584	FN2018-1-14/3 •	3912
20" x 20"	508 x 508	–	–	60	27.2	12.9	27" x 25"	686 x 635	FN2020-1-14/3	3912
24" x 24"	610 x 610	–	–	69	31.2	17.8	31" x 29"	787 x 737	FN2424-1-14/3	4187
28" x 20"	711 x 508	–	–	79	35.8	16.7	35" x 25"	889 x 635	FN2820-1-14/3	4618



### One Compartment, One Drainboard (right or left)

bowl size width x length in. mm		drainboard length in. mm		weight lbs. kg		cubic feet	overall size width x length in. mm		model #	list
20" x 16"	508 x 406	18"	457	74	30.8	18.7	27" x 37½"	686 x 953	FN2016-1-18R or L-14/3	3696
		24"	610	80	33.1	21.5	27" x 43½"	686 x 1105	FN2016-1-24R or L-14/3	3757
20" x 18"	508 x 457	18"	457	76	34.4	20.3	27" x 39½"	686 x 1003	FN2018-1-18R or L-14/3	4052
		24"	610	81	36.7	22.4	27" x 45½"	686 x 1156	FN2018-1-24R or L-14/3	4121
20" x 20"	508 x 508	24"	610	85	37.2	23.4	27" x 47½"	686 x 1207	FN2020-1-24R or L-14/3	4121
24" x 24"	610 x 610	24"	610	88	37.6	30.5	31" x 51½"	787 x 1308	FN2424-1-24R or L-14/3	4714
28" x 20"	711 x 508	24"	610	104	43.1	30.2	35" x 47½"	889 x 1207	FN2820-1-24R or L-14/3	4817



### One Compartment, Double Drainboards

bowl size width x length in. mm		drainboard length in. mm		weight lbs. kg		cubic feet	overall size width x length in. mm		model #	list
20" x 16"	508 x 406	18"	457	93	37.6	26.3	27" x 54"	686 x 1372	FN2016-1-18-14/3	3840
		24"	610	105	42.1	32.0	27" x 66"	686 x 1676	FN2016-1-24-14/3	3991
20" x 18"	508 x 457	18"	457	96	43.5	28.7	27" x 56"	686 x 1422	FN2018-1-18-14/3	4216
		24"	610	106	48.1	32.9	27" x 68"	686 x 1727	FN2018-1-24-14/3	4351
20" x 20"	508 x 508	24"	610	110	48.5	33.9	27" x 70"	686 x 1778	FN2020-1-24-14/3	4351
24" x 24"	610 x 610	24"	610	119	49.0	43.9	31" x 74"	787 x 1880	FN2424-1-24-14/3	4988
28" x 20"	711 x 508	24"	610	129	55.3	43.8	35" x 70"	889 x 1778	FN2820-1-24-14/3	5038





**Catalog Section 20**

**SPEC-MASTER® FN Series Coved Corner Sinks  
Two-Compartment Sinks **

see spec sheet **EG20.33**



(faucet not included)



- 14 gauge 300 Series 18-8 stainless steel.
- All bowls are 14" (356mm) deep and have 5/8" (16mm) radius corners, both vertical and horizontal.
- Stainless steel gussets, feet, legs and crossbracing.
- Adjustable crossbracing front-to-back and side-to-side for increased stability.
- 9 1/2" (241mm) standard backsplash includes 1" (25mm) upturn tile edge.
- Basket-type waste drains are included to fit sink bowl's 3 1/2" (89mm) opening and feature 1 1/2" (38mm) outlet.
- 30" and 36" (762 and 914mm) drainboards\* available upon request.

**FEATURES:**

\* On sinks with drainboard(s) 30" and 36", legs are under the outer end of the drainboard(s).

**Note:** All shipping weights and cubic feet are approximate. **ALL SINKS SHIPPED FULLY CRATED.**

For sink accessories, see pages 204-206.

For sink kits, see page 186.

**Freight class is 175.0.**

(•) MTS (made to stock) / ( ) MTO (made to order)

**Notes: Twist drain brackets available.**

Works in conjunction with optional twist handle drains (not included – see page 204). To order, add \$35 per compartment to list price and suffix "-TB" to model number (example: FN2032-2-14/3-TB).

For overflow hole (does not include drain), add \$52 per compartment to list price and suffix "-OF" to model number (example: FN2032-2-14/3-OF).

**Two Compartments, No Drainboards**

bowl size width x length in. mm		drainboard length in. mm		weight lbs. kg		cubic feet	overall size width x length in. mm		model #	list
20" x 16"	508 x 406	-	-	77	34.9	20.4	27" x 39"	686 x 991	FN2032-2-14/3	4642
20" x 18"	508 x 457	-	-	82	37.2	22.4	27" x 43"	686 x 1092	FN2036-2-14/3	5098
20" x 20"	508 x 508	-	-	86	39.0	23.9	27" x 47"	686 x 1194	FN2040-2-14/3	5098
24" x 24"	610 x 610	-	-	91	41.3	32.2	31" x 55"	787 x 1397	FN2448-2-14/3	6060
28" x 20"	711 x 508	-	-	96	43.6	31.3	35" x 47"	889 x 1194	FN2840-2-14/3	6071



**Two Compartments, One Drainboard (right or left)**

bowl size width x length in. mm		drainboard length in. mm		weight lbs. kg		cubic feet	overall size width x length in. mm		model #	list
20" x 16"	508 x 406	18"	457	96	43.6	28.2	27" x 55 1/2"	686 x 1410	FN2032-2-18R or L-14/3	4988
		24"	610	102	46.3	31.1	27" x 61 1/2"	686 x 1562	FN2032-2-24R or L-14/3	5075
20" x 18"	508 x 457	18"	457	101	45.8	30.6	27" x 59 1/2"	686 x 1511	FN2036-2-18R or L-14/3	5644
		24"	610	107	48.5	33.1	27" x 65 1/2"	686 x 1664	FN2036-2-24R or L-14/3	5714
20" x 20"	508 x 508	24"	610	111	50.3	35.0	27" x 69 1/2"	686 x 1763	FN2040-2-24R or L-14/3	5714
24" x 24"	610 x 610	24"	610	116	52.6	45.0	31" x 77 1/2"	787 x 1969	FN2448-2-24R or L-14/3	6873
28" x 20"	711 x 508	24"	610	121	54.9	45.0	35" x 69 1/2"	889 x 1763	FN2840-2-24R or L-14/3	6873



**Two Compartments, Double Drainboards**

bowl size width x length in. mm		drainboard length in. mm		weight lbs. kg		cubic feet	overall size width x length in. mm		model #	list
20" x 16"	508 x 406	18"	457	115	52.2	36.0	27" x 72"	686 x 1829	FN2032-2-18-14/3	5162
		24"	610	127	57.6	41.8	27" x 84"	686 x 2134	FN2032-2-24-14/3	5287
20" x 18"	508 x 457	18"	457	120	54.4	39.4	27" x 76"	686 x 1930	FN2036-2-18-14/3 •	5533
		24"	610	132	59.9	43.8	27" x 88"	686 x 2235	FN2036-2-24-14/3	5922
20" x 20"	508 x 508	24"	610	136	61.7	45.7	27" x 92"	686 x 2337	FN2040-2-24-14/3	5922
24" x 24"	610 x 610	24"	610	141	64.0	58.4	31" x 100"	787 x 2540	FN2448-2-24-14/3	7119
28" x 20"	711 x 508	24"	610	146	66.2	58.8	35" x 92"	889 x 2337	FN2840-2-24-14/3	7165



## SPEC-MASTER® FN Series Coved Corner Sinks Three-Compartment Sinks

see spec sheet **EG20.34**



(faucets not included)



- 14 gauge 300 Series 18-8 stainless steel.
- All bowls are 14" (356mm) deep and have 5/8" (16mm) radius corners, both vertical and horizontal.
- Stainless steel gussets, feet, legs and crossbracing.
- Adjustable crossbracing front-to-back and side-to-side for increased stability.
- 9 1/2" (241mm) standard backsplash includes 1" (25mm) upturn tile edge.
- Basket-type waste drains are included to fit sink bowls' 3 1/2" (89mm) opening and feature 1 1/2" (38mm) outlet.
- 30" and 36" (762 and 914mm) drainboards\* available upon request.

**FEATURES:**

\* On sinks with drainboard(s) 30" and 36", legs are under the outer end of the drainboard(s).

**Note:** All shipping weights and cubic feet are approximate. **ALL SINKS SHIPPED FULLY CRATED.**

For sink accessories, see pages 204-206.

For sink kits, see page 186.

**Freight class is 175.0.**

(•) MTS (made to stock) / ( ) MTO (made to order)

**Notes:** Twist drain brackets available.

Works in conjunction with optional twist handle drains (not included – see page 204). To order, add \$35 per compartment to list price and suffix "-TB" to model number (example: FN2048-3-14/3-TB).

For overflow hole (does not include drain), add \$52 per compartment to list price and suffix "-OF" to model number (example: FN2048-3-14/3-OF).

### Three Compartments, No Drainboards

bowl size width x length in. mm		drainboard length in. mm		weight lbs. kg		cubic feet	overall size width x length in. mm		model #	list
20" x 16"	508 x 406	–	–	99	44.9	29.2	27" x 57"	686 x 1448	FN2048-3-14/3	5739
20" x 18"	508 x 457	–	–	102	46.3	32.1	27" x 63"	686 x 1600	FN2054-3-14/3 *	6560
20" x 20"	508 x 508	–	–	114	51.7	35.0	27" x 69"	686 x 1753	FN2060-3-14/3 *	6560
24" x 24"	610 x 610	–	–	127	57.6	46.7	31" x 81"	787 x 2057	FN2472-3-14/3 *	7629
28" x 20"	711 x 508	–	–	130	59.0	45.0	35" x 69"	889 x 1753	FN2860-3-14/3 *	7859



\* Features two sets of faucet holes.

### Three Compartments, One Drainboard (right or left)

bowl size width x length in. mm		drainboard length in. mm		weight lbs. kg		cubic feet	overall size width x length in. mm		model #	list
20" x 16"	508 x 406	18"	457	118	53.5	36.9	27" x 73 1/2"	686 x 1867	FN2048-3-18R or L-14/3	5978
		24"	610	124	56.2	39.9	27" x 79 1/2"	686 x 2019	FN2048-3-24R or L-14/3	6038
20" x 18"	508 x 457	18"	457	121	54.9	40.4	27" x 79 1/2"	686 x 2019	FN2054-3-18R or L-14/3 *	7049
		24"	610	127	57.6	42.8	27" x 85 1/2"	686 x 2172	FN2054-3-24R or L-14/3 *	7098
20" x 20"	508 x 508	24"	610	139	63.1	45.7	27" x 91 1/2"	686 x 2324	FN2060-3-24R or L-14/3 *	7098
24" x 24"	610 x 610	24"	610	152	68.9	59.5	31" x 103 1/2"	787 x 2629	FN2472-3-24R or L-14/3 *	8628
28" x 20"	711 x 508	24"	610	155	70.3	58.8	35" x 91 1/2"	889 x 2324	FN2860-3-24R or L-14/3 *	8784



\* Features two sets of faucet holes.

### Three Compartments, Double Drainboards

bowl size width x length in. mm		drainboard length in. mm		weight lbs. kg		cubic feet	overall size width x length in. mm		model #	list
20" x 16"	508 x 406	18"	457	137	61.7	44.7	27" x 90"	686 x 2286	FN2048-3-18-14/3	6124
		24"	610	149	67.6	50.6	27" x 102"	686 x 2591	FN2048-3-24-14/3	6248
20" x 18"	508 x 457	18"	457	140	63.5	49.1	27" x 96"	686 x 2438	FN2054-3-18-14/3 •	7213
		24"	610	158	71.6	53.5	27" x 108"	686 x 2743	FN2054-3-24-14/3 *	7423
20" x 20"	508 x 508	24"	610	164	74.4	56.4	27" x 114"	686 x 2896	FN2060-3-24-14/3 *	7423
24" x 24"	610 x 610	24"	610	177	80.3	72.8	31" x 126"	787 x 3200	FN2472-3-24-14/3 *	8856
28" x 20"	711 x 508	24"	610	180	81.6	72.5	35" x 114"	889 x 2896	FN2860-3-24-14/3 *	9091



\* Features two sets of faucet holes.

## Catalog Section 20

### SPEC-MASTER® FN Series Coved Corner Sinks Four-Compartment Sinks

see spec sheet **EG20.35**



**ALL FOUR-COMPARTMENT SINKS HAVE  
TWO SETS OF FAUCET HOLES**

**Notes:** Twist drain brackets available.

Works in conjunction with optional twist handle drains (*not included* – see page 204). To order, add **\$35 per compartment** to list price and suffix “-TB” to model number (example: FN2064-4-14/3-TB).

For overflow hole (*does not include drain*), add **\$52 per compartment to list price** and suffix “-OF” to model number (example: FN2064-4-14/3-OF).

**FEATURES:**

- 14 gauge 300 Series 18-8 stainless steel.
- All bowls are 14” (356mm) deep and have 5/8” (16mm) radius corners, both vertical and horizontal.
- Stainless steel gussets, feet, legs and crossbracing.
- Adjustable crossbracing front-to-back and side-to-side for increased stability.
- 9½” (241mm) standard backsplash includes 1” (25mm) upturn tile edge.
- Basket-type waste drains are included to fit sink bowls’ 3½” (89mm) opening and feature 1½” (38mm) outlet.
- 30” and 36” (762 and 914mm) drainboards\* available upon request.

\* On sinks with drainboard(s) 30” and 36”, legs are under the outer end of the drainboard(s).

**Note:** All shipping weights and cubic feet are approximate.  
**ALL SINKS SHIPPED FULLY CRATED.**

For sink accessories, see pages 204-206.

For sink kits, see page 186.

**Freight class is 175.0.**

(•) MTS (*made to stock*) / ( ) MTO (*made to order*)

#### Four Compartments, No Drainboards

bowl size width x length in. mm		drainboard length in. mm		weight lbs. kg		cubic feet	overall size width x length in. mm		model #	list
20" x 16"	508 x 406	–	–	121	54.9	35.4	27" x 75"	686 x 1905	FN2064-4-14/3	7338
20" x 18"	508 x 457	–	–	132	59.9	39.0	27" x 83"	686 x 2108	FN2072-4-14/3	8244
20" x 20"	508 x 508	–	–	142	64.4	42.7	27" x 91"	686 x 2311	FN2080-4-14/3	8244
24" x 24"	610 x 610	–	–	163	73.9	57.1	31" x 107"	787 x 2718	FN2496-4-14/3	9485
28" x 20"	711 x 508	–	–	170	77.1	54.9	35" x 91"	889 x 2311	FN2880-4-14/3	10033



#### Four Compartments, One Drainboard (right or left)

bowl size width x length in. mm		drainboard length in. mm		weight lbs. kg		cubic feet	overall size width x length in. mm		model #	list
20" x 16"	508 x 406	18"	457	140	63.5	45.7	27" x 91½"	686 x 2324	FN2064-4-18R or L-14/3	7391
		24"	610	146	66.2	48.6	27" x 97½"	686 x 2477	FN2064-4-24R or L-14/3	7458
20" x 18"	508 x 457	18"	457	151	68.5	50.1	27" x 99½"	686 x 2527	FN2072-4-18R or L-14/3	8724
		24"	610	157	71.2	52.5	27" x 105½"	686 x 2680	FN2072-4-24R or L-14/3	8774
20" x 20"	508 x 508	24"	610	167	75.8	56.4	27" x 113½"	686 x 2883	FN2080-4-24R or L-14/3	8774
24" x 24"	610 x 610	24"	610	188	85.3	68.5	31" x 129½"	787 x 3289	FN2496-4-24R or L-14/3	10381
28" x 20"	711 x 508	24"	610	195	88.5	67.7	35" x 113½"	889 x 2883	FN2880-4-24R or L-14/3	10673

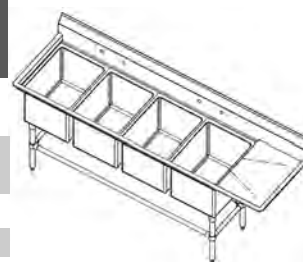

#### Four Compartments, Double Drainboards

bowl size width x length in. mm		drainboard length in. mm		weight lbs. kg		cubic feet	overall size width x length in. mm		model #	list
20" x 16"	508 x 406	18"	457	159	72.1	53.5	27" x 108"	686 x 2743	FN2064-4-18-14/3	7664
		24"	610	171	77.6	55.4	27" x 120"	686 x 3048	FN2064-4-24-14/3	7807
20" x 18"	508 x 457	18"	457	170	77.1	54.9	27" x 116"	686 x 2646	FN2072-4-18-14/3 •	8944
		24"	610	182	82.6	59.0	27" x 128"	686 x 3251	FN2072-4-24-14/3	9028
20" x 20"	508 x 508	24"	610	192	87.1	62.6	27" x 136"	686 x 3454	FN2080-4-24-14/3	9028
24" x 24"	610 x 610	24"	610	213	96.6	81.4	31" x 152"	787 x 3861	FN2496-4-24-14/3	10671
28" x 20"	711 x 508	24"	610	220	99.8	110.2	35" x 136"	889 x 3454	FN2880-4-24-14/3	10978



## Sink Kits for SPEC-MASTER® FN Series Sinks

Can be shipped UPS.

- Includes T&S faucet #313293.

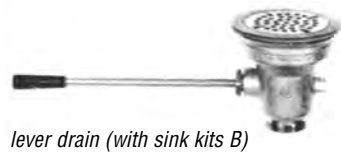

### Kit A

- Add suffix “-F” to sink model number.

description	add to list price
1 faucet	722
2 faucets	1444

### Kit B

- T&S faucet plus lever drain. Add suffix “-FD” to sink model number.

description	add to list price
1 faucet	722
2 faucets	1444
per lever drain	279

### Kit C

- T&S faucet plus lever drain with overflow. Add suffix “-FDO” to sink model number.

description	add to list price
1 faucet	722
2 faucets	1444
per lever drain with overflow	573

### Kit D

- T&S faucet plus twist handle drain and twist handle bracket. Add suffix “-FDT” to sink model number.

description	add to list price
1 faucet	722
2 faucets	1444
per twist handle drain	294

### Kit E

- T&S faucet plus twist handle drain with overflow and twist handle bracket. Add suffix “-FDOT” to sink model number.

description	add to list price
1 faucet	722
2 faucets	1444
per twist handle drain with overflow	665



## CUSTOM GRAPHICS AVAILABLE!!

Laser-Cutting and Custom Decal Services for Sinks with Drawn Bowls!

### Laser-Cutting Service...

- Offers a “high-tech” look.
- Creates smooth curves along text and/or artwork.
- Materials includes various plastics, woods, and designer aluminum.

### Decal Service...

- Factory-applied decals are industrial-strength, yet more economical.
- Image(s) printed on vinyl material with adhesive backing.

## Catalog Section 20

### SPEC-MASTER® FNP Series Prep Sinks NSF

see spec sheets **EG20.60** **EG20.61**

**PATENTED!**  
(patent #8,733,253)



**Custom configurations available!**

- Prep area includes 6" (152mm)- and 3" (76mm)- wide slanted troughs with three flush nozzles.
- Magnetic utensil holder, rinse basket, and removable bun pan holder included.
- Multi-polyboard assembly, affixed to bowl in drainboard area, includes three colored polyboards.
- 14 gauge type 304 stainless steel drainboard, prep area, backsplash, rolled rims, and sink bowl.
- Same construction as Spec-Master® FN Series sinks (pages 182-185).

**FEATURES:**

**Freight class is 175.0.**

### One Compartment

BOWL DIMENSIONS		DRAINBOARD		PREP AREA		OVERALL DIMENSIONS		model #	list						
width	length	length	at left or right end	length	at left or right end	width	length								
in.	mm	in.	mm	in.	mm	in.	mm								
28"	711	20"	508	-	-	48"	1219	right	35"	889	71½"	1816	<b>FNP2820-1-48TR</b>	8467	
28"	711	20"	508	-	-	48"	1219	left	35"	889	71½"	1816	<b>FNP2820-1-48TL</b>	8467	
28"	711	20"	508	18"	457	left	48"	1219	right	35"	889	88"	2235	<b>FNP2820-1-18L-48TR</b>	8941
28"	711	20"	508	18"	457	right	48"	1219	left	35"	889	88"	2235	<b>FNP2820-1-18R-48TL</b>	8941
28"	711	20"	508	24"	610	left	48"	1219	right	35"	889	94"	2388	<b>FNP2820-1-24L-48TR</b>	9100
28"	711	20"	508	24"	610	right	48"	1219	left	35"	889	94"	2388	<b>FNP2820-1-24R-48TL</b>	9100

**PATENTED!**  
(patent #8,733,253)



**Custom configurations available!**

### Two Compartments

BOWL DIMENSIONS		DRAINBOARD		PREP AREA		OVERALL DIMENSIONS		model #	list						
width	length	length	at left or right end	length	at left or right end	width	length								
in.	mm	in.	mm	in.	mm	in.	mm								
28"	711	20"	508	-	-	48"	1219	right	35"	889	93½"	2375	<b>FNP2840-2-48TR</b>	9655	
28"	711	20"	508	-	-	48"	1219	left	35"	889	93½"	2375	<b>FNP2840-2-48TL</b>	9655	
28"	711	20"	508	18"	457	left	48"	1219	right	35"	889	110"	2794	<b>FNP2840-2-18L-48TR</b>	10126
28"	711	20"	508	18"	457	right	48"	1219	left	35"	889	110"	2794	<b>FNP2840-2-18R-48TL</b>	10126
28"	711	20"	508	24"	610	left	48"	1219	right	35"	889	116"	2946	<b>FNP2840-2-24L-48TR</b>	10287
28"	711	20"	508	24"	610	right	48"	1219	left	35"	889	116"	2946	<b>FNP2840-2-24R-48TL</b>	10287

## SPEC-MASTER® FNP Series Prep Sinks NSF

see spec sheets **EG20.62** **EG20.63**

**PATENTED!**  
(patent #8,733,253)

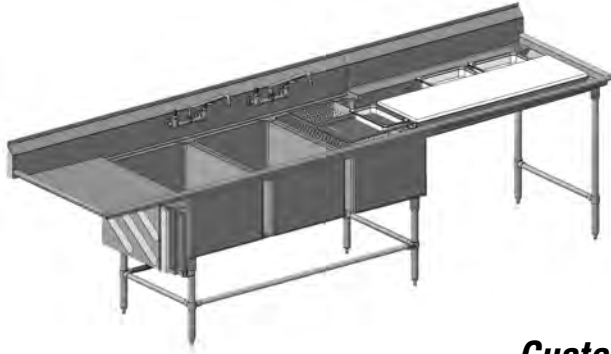

- Prep area includes 6" (152mm)- and 3" (76mm)- wide slanted troughs with three flush nozzles.
- Magnetic utensil holder, rinse basket, and removable bun pan holder included.
- Multi-polyboard assembly, affixed to bowl in drainboard area, includes three colored polyboards.
- 14 gauge type 304 stainless steel drainboard, prep area, backsplash, rolled rims, and sink bowl.
- Same construction as Spec-Master® FN Series sinks (pages 182-185).

FEATURES:

Freight class is 175.0.

**Custom configurations available!**

**Three Compartments** — Two sets of faucet holes featured.

BOWL DIMENSIONS				DRAINBOARD		PREP AREA		OVERALL DIMENSIONS				model #	list	
width		length		length	at left or right end	length	at left or right end	width		length				
in.	mm	in.	mm	in.	mm	in.	mm	in.	mm	in.	mm			
28"	711	20"	508	-	-	48"	1219	right	35"	889	115½"	2934	<b>FNP2860-3-48TR</b>	11085
28"	711	20"	508	-	-	48"	1219	left	35"	889	115½"	2934	<b>FNP2860-3-48TL</b>	11085
28"	711	20"	508	18"	457	48"	1219	right	35"	889	132"	3353	<b>FNP2860-3-18L-48TR</b>	11558
28"	711	20"	508	18"	457	48"	1219	left	35"	889	132"	3353	<b>FNP2860-3-18R-48TL</b>	11558
28"	711	20"	508	24"	610	48"	1219	right	35"	889	138"	3505	<b>FNP2860-3-24L-48TR</b>	11718
28"	711	20"	508	24"	610	48"	1219	left	35"	889	138"	3505	<b>FNP2860-3-24R-48TL</b>	11718

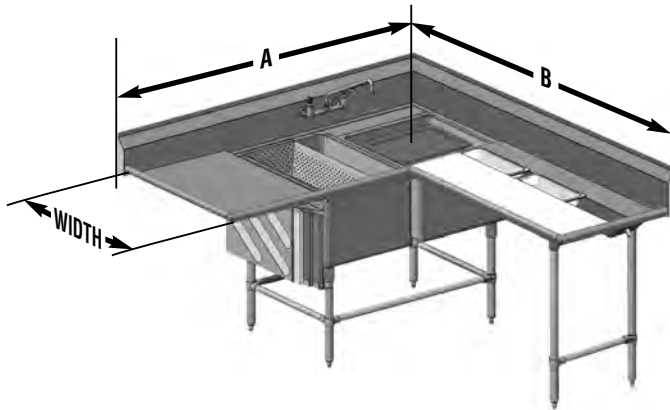

**PATENTED!**  
(patent #8,733,253)

**Custom configurations available!**

**Two Compartments, with Corner Design**

BOWL DIMENSIONS				DRAINBOARD		PREP AREA		OVERALL DIMENSIONS			model #	list				
width		length		length	at left or right end	length	at left or right end	width	length A	length B						
in.	mm	in.	mm	in.	mm	in.	mm	in.	mm	in.	mm					
28"	711	20"	508	-	-	48"	1219	right	35"	889	56½"	1435	81"	2057	<b>CFNP2840-2-48TR</b>	10220
28"	711	20"	508	-	-	48"	1219	left	35"	889	56½"	1435	81"	2057	<b>CFNP2840-2-48TL</b>	10220
28"	711	20"	508	18"	457	48"	1219	right	35"	889	73"	1854	81"	2057	<b>CFNP2840-2-18L-48TR</b>	10691
28"	711	20"	508	18"	457	48"	1219	left	35"	889	73"	1854	81"	2057	<b>CFNP2840-2-18R-48TL</b>	10691
28"	711	20"	508	24"	610	48"	1219	right	35"	889	79"	2007	81"	2057	<b>CFNP2840-2-24L-48TR</b>	10853
28"	711	20"	508	24"	610	48"	1219	left	35"	889	79"	2007	81"	2057	<b>CFNP2840-2-24R-48TL</b>	10853

**Utility Sinks  
One-Compartment Sinks**

see spec sheet **EG20.13A**



**Note:** Overflow hole available (*does not include drain*). To order, add \$52 per compartment to list price and suffix “-OF” to model number (example: 1818-1-16/3-OF).

For detachable drainboards, see page 192.

For NSF-approved utility sinks, add 35% to list price and add prefix “N-” to model number. Example: N-2436-1-16/3.

- For numerous applications when NSF construction is not required.
- Square-corner construction.
- 8” (203mm) backsplash.
- Adjustable bullet feet.
- Heavy gauge stainless steel.
- 304 and 430 series construction available.
- Sink compartment is 13 $\frac{3}{8}$ ” (340mm) deep.
- Legs are 1 $\frac{1}{2}$ ” (41mm) diameter galvanized tubing and are located directly under sink compartments for maximum stability and weight support.
- 42 $\frac{3}{4}$ ” (1086mm) overall height.

**FEATURES:**

**Freight class is 175.0.**

(•) MTS (*made to stock*) / ( ) MTO (*made to order*)

**One Compartment, No Drainboards**

bowl size		drainboard		weight		cubic feet	overall size		type 430 stainless steel		type 304 stainless steel	
width	length	length		lbs.	kg		width	length	model #	list	model #	list
in.	mm	in.	mm			in.	mm					
18” x 18”	457 x 457	–		53	24.0	0.9	22” x 19 $\frac{1}{2}$ ”	559 x 492	1818-1-16/4 •	1136	1818-1-16/3	1326
18” x 24”	457 x 610	–		56	25.4	11.6	22” x 25 $\frac{1}{2}$ ”	559 x 645	1824-1-16/4	1145	1824-1-16/3	1386
21” x 18”	533 x 457	–		56	25.4	10.5	25” x 19 $\frac{1}{2}$ ”	635 x 492	2118-1-16/4 •	1131	2118-1-16/3	1359
21” x 24”	533 x 610	–		59	26.8	13.1	25” x 25 $\frac{1}{2}$ ”	635 x 645	2124-1-16/4 •	1172	2124-1-16/3	1424
21” x 36”	533 x 914	–		65	29.5	18.1	25” x 37 $\frac{1}{2}$ ”	635 x 949	2136-1-16/4	1261	2136-1-16/3	1583
24” x 24”	610 x 610	–		60	27.2	14.6	28” x 25 $\frac{1}{2}$ ”	711 x 645	2424-1-16/4 •	1220	2424-1-16/3	1495
24” x 36”	610 x 914	–		68	30.8	20.2	28” x 37 $\frac{1}{2}$ ”	711 x 949	2436-1-16/4 •	1298	2436-1-16/3	1657

**One Compartment, Double Drainboards**

bowl size		drainboard		weight		cubic feet	overall size		type 430 stainless steel		type 304 stainless steel	
width	length	length		lbs.	kg		width	length	model #	list	model #	list
in.	mm	in.	mm			in.	mm					
21” x 24”	533 x 610	18”	457	99	44.9	28.3	25” x 60 $\frac{1}{4}$ ”	635 x 1530	2124-1-18-16/4	2521	2124-1-18-16/3	3074
24” x 24”	610 x 610	24”	610	108	49.0	37.1	28” x 72 $\frac{1}{4}$ ”	711 x 1835	2424-1-24-16/4	2713	2424-1-24-16/3	3176

Just a quick note...



**GET FREE DOWNLOADS**

- Spec Sheets • Product Instructions •
- Special Flyers • Brochures •

**www.eaglegrp.com**

## Utility Sinks Two-Compartment Sinks

see spec sheet **EG20.13B**



- For numerous applications when NSF construction is not required.
- Square-corner construction.
- 8" (203mm) backsplash.
- Adjustable bullet feet.
- Heavy gauge stainless steel.
- 304 and 430 series construction available.
- Sink compartments are 13 $\frac{3}{4}$ " (340mm) deep.
- Legs are 1 $\frac{5}{8}$ " (41mm) diameter galvanized tubing and are located directly under sink compartments for maximum stability and weight support.
- 42 $\frac{3}{4}$ " (1086mm) overall height.

**FEATURES:**

**Freight class is 175.0.**

(•) MTS (made to stock) / ( ) MTO (made to order)

**Note:** Overflow hole available (does not include drain). To order, add \$52 per compartment to list price and suffix "-OF" to model number (example: 1836-2-16/3-OF).

For detachable drainboards, see page 192.

For NSF-approved utility sinks, add 35% to list price and add prefix "N-" to model number. Example: N-2460-2-16/3.

### Two Compartments, No Drainboards

bowl size		drainboard		weight		cubic feet	overall size		type 430 stainless steel		type 304 stainless steel	
width	length	length		lbs.	kg		width	length	model #	list	model #	list
in.	mm	in.	mm			in.	mm					
18" x 18"	457 x 457	-		75	34.0	16.1	22" x 37"	559 x 949	1836-2-16/4 •	1533	1836-2-16/3	1874
18" x 24"	457 x 610	-		80	36.3	20.6	22" x 49"	559 x 1254	1848-2-16/4	1607	1848-2-16/3	2019
21" x 18"	533 x 457	-		80	36.3	18.1	25" x 37"	635 x 949	2136-2-16/4 •	1567	2136-2-16/3	1929
21" x 24"	533 x 610	-		85	38.6	23.2	25" x 49"	635 x 1254	2148-2-16/4	1585	2148-2-16/3	2038
24" x 24"	610 x 610	-		89	40.4	25.8	28" x 49"	711 x 1254	2448-2-16/4 •	1739	2448-2-16/3	2164
24" x 30"	610 x 762	-		95	43.1	31.5	28" x 61"	711 x 1559	2460-2-16/4	2157	2460-2-16/3	2485

### Two Compartments, Double Drainboards

bowl size		drainboard		weight		cubic feet	overall size		type 430 stainless steel		type 304 stainless steel	
width	length	length		lbs.	kg		width	length	model #	list	model #	list
in.	mm	in.	mm			in.	mm					
21" x 18"	533 x 457	18"	457	120	3048	33.3	25" x 72"	635 x 1835	2136-2-18-16/4	3107	2136-2-18-16/3	3783
24" x 24"	610 x 610	24"	610	139	3531	48.4	28" x 96"	711 x 2445	2448-2-24-16/4	3236	2448-2-24-16/3	3885

## Go Green. Go ECO-Built™ by EAGLE.

For restaurants and other institutions concerned about meeting their own green standards, buying ECO-Built™ is simply the right thing to do.

Look for the ECO-Built™ tag on the bar code





### Utility Sinks Three-Compartment Sinks

see spec sheet **EG20.13C**



- For numerous applications when NSF construction is not required.
- Square-corner construction.
- 8" (203mm) backsplash.
- Adjustable bullet feet.
- Heavy gauge stainless steel.
- 304 and 430 series construction available.
- Sink compartments are 13 3/8" (340mm) deep.
- Legs are 1 1/8" (41mm) diameter galvanized tubing and are located directly under sink compartments for maximum stability and weight support.
- 42 3/4" (1086mm) overall height.

FEATURES:

**Freight class is 175.0.**

**Note:** Overflow hole available (does not include drain). To order, add \$52 per compartment to list price and suffix "-OF" to model number (example: 1848-3-16/3-OF).

For detachable drainboards, see page 192.

For NSF-approved utility sinks, add 35% to list price and add prefix "N-" to model number. Example: N-2154-3-16/3.

(•) MTS (made to stock) / ( ) MTO (made to order)

#### Three Compartments, No Drainboards

bowl size		drainboard		weight		cubic feet	overall size		type 430 stainless steel		type 304 stainless steel	
width in.	length mm	length in.	length mm	lbs.	kg		width in.	length mm	model #	list	model #	list
18" x 12"	457 x 305	-		79	35.8	16.1	22" x 37"	559 x 949	1836-3-16/4 •	1766	1836-3-16/3	2147
18" x 16"	457 x 406	-		90	40.8	20.6	22" x 49"	559 x 1254	1848-3-16/4	1842	1848-3-16/3	2281
18" x 18"	457 x 457	-		97	44.0	22.8	22" x 55"	559 x 1407	1854-3-16/4 •	2093	1854-3-16/3	2491
21" x 12"	533 x 305	-		85	38.6	18.1	25" x 37"	635 x 949	2136-3-16/4 •	1812	2136-3-16/3	2217
21" x 16"	533 x 406	-		87	39.5	23.2	25" x 49"	635 x 1254	2148-3-16/4 •	1892	2148-3-16/3	2355
21" x 18"	533 x 457	-		100	45.4	25.7	25" x 55"	635 x 1407	2154-3-16/4 •	2100	2154-3-16/3	2559
21" x 20"	533 x 508	-		110	49.9	28.3	25" x 61"	635 x 1559	2160-3-16/4 *	2171	2160-3-16/3 *	2659
24" x 16"	610 x 406	-		92	41.7	25.8	28" x 49"	711 x 1254	2448-3-16/4	1986	2448-3-16/3	2461
24" x 20"	610 x 508	-		115	52.2	31.5	28" x 61"	711 x 1559	2460-3-16/4 *	2297	2460-3-16/3 *	2762
24" x 24"	610 x 610	-		125	56.7	37.1	28" x 73"	711 x 1864	2472-3-16/4 *•	2353	2472-3-16/3 *	2923

\* Features two sets of faucet holes.

#### Three Compartments, Double Drainboards

bowl size		drainboard		weight		cubic feet	overall size		type 430 stainless steel		type 304 stainless steel	
width in.	length mm	length in.	length mm	lbs.	kg		width in.	length mm	model #	list	model #	list
21" x 12"	533 x 305	18"	457	125	56.7	33.3	25" x 72 1/4"	635 x 1835	2136-3-18-16/4	3175	2136-3-18-16/3	3755
21" x 16"	533 x 406	18"	457	127	57.6	38.4	25" x 84 1/4"	635 x 2140	2148-3-18-16/4	3279	2148-3-18-16/3	4042
21" x 18"	533 x 457	18"	457	140	63.5	40.9	25" x 90 1/4"	635 x 2292	2154-3-18-16/4	3582	2154-3-18-16/3	4296
24" x 24"	610 x 610	24"	610	175	79.4	59.6	28" x 120 1/4"	711 x 3054	2472-3-24-16/4*	3865	2472-3-24-16/3 *	4923

\* Features two sets of faucet holes.

## Utility Sinks Four-Compartment Sinks

see spec sheet **EG20.13D**



- For numerous applications when NSF construction is not required.
- Square-corner construction.
- 8" (203mm) backsplash.
- Adjustable bullet feet.
- Heavy gauge stainless steel.
- 304 and 430 series construction available.
- Sink compartments are 13 3/4" (340mm) deep.
- Legs are 1 5/8" (41mm) diameter galvanized tubing and are located directly under sink compartments for maximum stability and weight support.
- 42 3/4" (1086mm) overall height.

**FEATURES:**

**Note:** Overflow hole available (*does not include drain*). To order, add \$52 per compartment to list price and suffix "-OF" to model number (example: 1872-4-16/3-OF).

For NSF-approved utility sinks, add 35% to list price and add prefix "N-" to model number. Example: N-2172-4-16/3

**Freight class is 175.0.**

### Four Compartments, No Drainboards (All sinks feature two sets of faucet holes.)

bowl size		drainboard		weight	cubic	overall size		type 430 stainless steel		type 304 stainless steel		
width in.	length mm	length in.	length mm			lbs.	kg	width in.	length mm	model #	list	model #
18" x 18"	457 x 457	-	-	110	49.9	29.5	22" x 73 3/4"	559 x 1864	1872-4-16/4	2406	1872-4-16/3	3000
21" x 18"	533 x 457	-	-	115	52.2	33.3	25" x 73 3/4"	635 x 1864	2172-4-16/4	2521	2172-4-16/3	3048
24" x 18"	610 x 457	-	-	125	56.7	37.1	28" x 73 3/4"	711 x 1864	2472-4-16/4	2591	2472-4-16/3	3189

### Four Compartments, Double Drainboards - (All sinks feature two sets of faucet holes.)

bowl size		drainboard		weight	cubic	overall size		type 430 stainless steel		type 304 stainless steel		
width in.	length mm	length in.	length mm			lbs.	kg	width in.	length mm	model #	list	model #
21" x 18"	533 x 457	18"	457	155	70.3	48.5	25" x 108 3/4"	635 x 2750	2172-4-18-16/4	3972	2172-4-18-16/3	4636

## Detachable Drainboards for Utility Sinks

see spec sheet **EG20.13E**

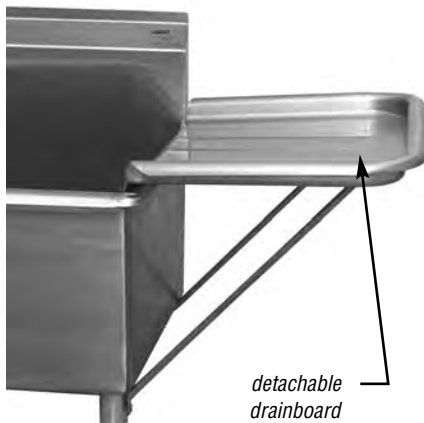

detachable drainboard

**Available in 430 or 304 series stainless steel!**

**FEATURES:**

- Unique die-stamped rolled rim construction.
- Fully reversible, for left- or right-hand operation.
- "Easy clip-on installation" utilizes two support brackets that bolt to sink gussets.
- Drainboards 30" (762mm) long are furnished with legs.

**Freight class is 70.0.**

(•) MTS (made to stock) / ( ) MTO (made to order)

**Note:** Drainboards will not work on NSF utility sinks.

width (front-to-back) x length (side-to-side)		weight		cu ft	16 gauge type 430 stainless steel		16 gauge type 304 stainless steel	
width in.	length mm	lbs.	kg		model #	list	model #	list
18" x 18"	457 x 457	19	8.6	1.8	18x18 RRDEDB •	319	18x18 RRDEDB-16/3	534
18" x 24"	457 x 610	23	10.4	1.9	18x24 RRDEDB •	338	18x24 RRDEDB-16/3	561
18" x 30"	457 x 762	27	12.2	2.8	18x30 RRDEDB	576	18x30 RRDEDB-16/3	628
21" x 18"	533 x 457	20	9.0	1.8	21x18 RRDEDB •	319	21x18 RRDEDB-16/3	534
21" x 24"	533 x 610	24	10.9	2.1	21x24 RRDEDB •	343	21x24 RRDEDB-16/3	561
21" x 30"	533 x 762	28	12.7	2.5	21x30 RRDEDB	643	21x30 RRDEDB-16/3	675
24" x 18"	610 x 457	21	9.5	2.3	24x18 RRDEDB •	329	24x18 RRDEDB-16/3	526
24" x 24"	610 x 610	25	11.3	2.4	24x24 RRDEDB •	356	24x24 RRDEDB-16/3	580
24" x 30"	610 x 762	29	13.2	2.7	24x30 RRDEDB	631	24x30 RRDEDB-16/3	665

**SPEC-MASTER® FFN Series Flush Front Sinks**

see spec sheet **EG20.54**



three-compartment sink

- Full front and 10" (254mm) high backsplash are 14 gauge stainless steel.
- 1" (25mm) downturn at rear.
- 14 gauge double drainboards, rolled rims and sink bowl partitions.
- 14" (356mm) water level and swirl-away drainage.
- Sink compartments feature 3/4" (19mm) covered inside radii.
- Legs are located directly under sink bowls.
- All-welded base constructed of 1 1/8" (41mm) diameter tubular stainless steel.
- Adjustable stainless steel bullet feet.
- Basket-type waste drain fits 3 1/2" (89mm) opening and features 1 1/2" (38mm) outlet.

FEATURES:

**Freight class is 175.0.**

**Two Compartments**

bowl size width x length		drainboard length		overall size width x length		model #	list
in.	mm	in.	mm	in.	mm		
27" x 18"	686 x 457	24"	610	30 1/2" x 85 1/2"	775 x 2216	<b>FFN2736-2-24-14/3</b>	13227
27" x 18"	686 x 457	30"	762	30 1/2" x 97 1/2"	775 x 2480	<b>FFN2736-2-30-14/3</b>	14805
27" x 20"	686 x 508	24"	610	30 1/2" x 89 1/2"	775 x 2318	<b>FFN2740-2-24-14/3</b>	13837
27" x 20"	686 x 508	30"	762	30 1/2" x 101 1/2"	775 x 2581	<b>FFN2740-2-30-14/3</b>	15407
27" x 24"	686 x 610	24"	610	30 1/2" x 97 1/2"	775 x 2521	<b>FFN2748-2-24-14/3</b>	15048
27" x 24"	686 x 610	30"	762	30 1/2" x 109 1/2"	775 x 2785	<b>FFN2748-2-30-14/3</b>	16625
27" x 30"	686 x 762	24"	610	30 1/2" x 109 1/2"	775 x 2826	<b>FFN2760-2-24-14/3</b>	16871
27" x 30"	686 x 762	30"	762	30 1/2" x 121 1/2"	775 x 3089	<b>FFN2760-2-30-14/3</b>	18440

**Three Compartments \***

bowl size width x length		drainboard length		overall size width x length		model #	list
in.	mm	in.	mm	in.	mm		
27" x 18"	686 x 457	24"	610	30 1/2" x 105 1/4"	775 x 2673	<b>FFN2754-3-24-14/3</b>	15957
27" x 18"	686 x 457	30"	762	30 1/2" x 117 1/4"	775 x 2978	<b>FFN2754-3-30-14/3</b>	17776
27" x 20"	686 x 508	24"	610	30 1/2" x 111 1/4"	775 x 2826	<b>FFN2760-3-24-14/3</b>	16871
27" x 20"	686 x 508	30"	762	30 1/2" x 123 1/4"	775 x 3131	<b>FFN2760-3-30-14/3</b>	18691
27" x 24"	686 x 610	24"	610	30 1/2" x 123 1/4"	775 x 3131	<b>FFN2772-3-24-14/3</b>	18691
27" x 24"	686 x 610	30"	762	30 1/2" x 135 1/4"	775 x 3435	<b>FFN2772-3-30-14/3</b>	20506
27" x 30"	686 x 762	24"	610	30 1/2" x 141 1/4"	775 x 3588	<b>FFN2790-3-24-14/3</b>	21419
27" x 30"	686 x 762	30"	762	30 1/2" x 153 1/4"	775 x 3893	<b>FFN2790-3-30-14/3</b>	23240

\* Three-Compartment sinks feature two sets of faucet holes.

**Go Green.  
Go EAGLE.**

Look for the tag  
on the bar code



## SPEC-MASTER® Supermarket Meat-Platter Sinks

see spec sheet **EG20.38**



**FEATURES:**

- All bowls have 14" depth (356mm), 5/8" (16mm) radius corners.
- 14 gauge type 304 18-8 stainless steel construction.
- Available with one, two, or no drainboards.

**Note:** All shipping weights and cubic feet are approximate.

**Freight class is 175.0.**

### Two Compartments

inside bowl dimensions width x length		overall dimensions width x length		drain boards	weight		cu ft	model #	list
in.	mm	in.	mm		lbs.	kg			
14" x 32"	356 x 813	37" x 37"	902 x 940	none	155	70.3	23	<b>SFN2832-2-14/3</b>	5904
14" x 32"	356 x 813	37" x 53 1/2"	902 x 1359	one 18" (457mm) R or L	175	79.3	26	<b>SFN2832-2-18R or L-14/3</b>	6644
14" x 32"	356 x 813	37" x 70"	902 x 1778	two 18" (457mm) R & L	200	90.7	46	<b>SFN2832-2-18-14/3</b>	7274

### Three Compartments

inside bowl dimensions width x length		overall dimensions width x length		drain boards	weight		cu ft	model #	list
in.	mm	in.	mm		lbs.	kg			
two 14" x 32" (356 x 813mm) bowls, & one 20" x 30" (508 x 762mm) bowl		37" x 59"	902 x 1499	none	164	74.4	36	<b>SFN3052-3-14/3</b>	7567
		37" x 75 1/2"	902 x 1918	one 18" (457mm) R or L	192	87.1	47	<b>SFN3052-3-18R or L-14/3</b>	8191
		37" x 92"	902 x 2337	two 18" (457mm) R & L	210	95.3	58	<b>SFN3052-3-18-14/3</b>	8400
three 32" x 14" (813 x 356mm) bowls		39" x 51"	991 x 1265	none	160	72.6	32	<b>SFN3242-3-14/3</b>	7885
		39" x 67 1/2"	991 x 1715	one 18" (457mm) R or L	175	79.4	45	<b>SFN3242-3-18R or L-14/3</b>	8129
		39" x 84"	991 x 2134	two 18" (457mm) R & L	200	90.7	56	<b>SFN3242-3-18-14/3</b>	8421

## Stainless Steel Fabricated Sinks

see spec sheets **EG20.14** **EG20.15**

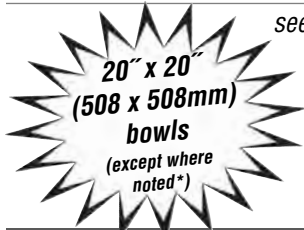

**FEATURES:**

- 14"-deep (356mm) bowls with 5/8" (16mm) radius corners.
- 8" (203mm)-high backsplash with 3/4" (19mm) upturn tile edge.

**Freight class is 100.0.**

### S14 Series

- Stainless steel legs, crossbracing, gussets and bullet feet.

### S16 Series

- Galvanized legs, crossbracing and gussets.
- Plastic bullet feet.

# of bowls	drainboard length		# of drbds	overall length		14 gauge type 304 stainless steel construction		16 gauge type 304 stainless steel construction	
	in.	mm		in.	mm	model #	list	model #	list
1	n/a		0	29"	737	<b>S14-20-1-SL</b>	1946	<b>S16-20-1</b>	1714
2	18"	457	1	67 1/2"	1715	<b>S14-20-2-18R-SL</b>	3382	<b>S16-20-2-18R</b>	2977
	18"	457	1	67 1/2"	1715	<b>S14-20-2-18L-SL</b>	3382	<b>S16-20-2-18L</b>	2977
3	18"	457	2	81"	2057	<b>S14-20-2-18-SL</b>	3558	<b>S16-20-2-18</b>	3133
	18"	457	1	89 1/2"	2273	<b>S14-20-3-18R-SL</b>	4461	<b>S16-20-3-18R</b>	3924
	18"	457	1	89 1/2"	2273	<b>S14-20-3-18L-SL</b>	4461	<b>S16-20-3-18L</b>	3924
	18"	457	2	103"	2616	<b>S14-20-3-18-SL</b>	4695	<b>S16-20-3-18</b>	4131
	24"	610	1	95 1/2"	2426	<b>S14-20-3-24R-SL</b>	4651	<b>S16-20-3-24R</b>	4094
	24"	610	1	95 1/2"	2426	<b>S14-20-3-24L-SL</b>	4651	<b>S16-20-3-24L</b>	4094
3	18"	457	2	115"	2921	<b>S14-20-3-24-SL</b>	4898	<b>S16-20-3-24</b>	4308
3	18"	457	2	103"	2616	<b>S14-28-3-18-SL*</b>	5946	<b>S16-28-3-18*</b>	5228



\* #S14-28-3-18-SL and #S16-28-3-18 sinks feature 28"-wide x 20"-long (711 x 508mm) sink bowls and two sets of faucet holes.

**Catalog Section 20**

**Convenience Store Sinks** 

see spec sheet **EG20.19**



(faucet not included)



**Faucet for Convenience Store Sinks**

description	model #	list
10" (254mm) spout	<b>300489</b>	331

- Heavy gauge type 304 construction.
- Sink bowls are deep-drawn; except where noted.
- 9½" (241mm) backsplash includes 1" (25mm) upturn tile edge for easy installation and feathering to wall/splash surface.

**FEATURES:**

**Note:** All shipping weights and cubic feet are approximate.

**Twist drain brackets available.**

Works in conjunction with optional twist handle drains (not included – see page 204). To order, add **\$35 per compartment to list price** and suffix “-TB” to model number (example: **310-10-3-12-TB**).

**Freight class is 175.0.**

(•) MTS (made to stock) / ( ) MTO (made to order)

**310 Series**

no. bowls	bowl size width x length x depth	drain boards	overall size width x length	shipping weight	cu ft	model #	list
3	14" x 10" x 9½" (355 x 254 x 247mm)	two 12" (305mm)	21½" x 60" (551 x 1524mm)	71 lbs. (32.2 kg)	23	<b>310-10-3-12</b> •	3579
3	14" x 10" x 9½" (355 x 254 x 247mm)	two 18" (457mm)	21½" x 72" (551 x 1829mm)	78 lbs. (35.4 kg)	27	<b>310-10-3-18</b> •	3669
3	14" x 10" x 9½" (355 x 254 x 247mm)	two 24" (610mm)	21½" x 84" (551 x 2134mm)	87 lbs. (39.5 kg)	32	<b>310-10-3-24</b>	3734

**312 Series**

no. bowls	bowl size width x length x depth	drain boards	overall size width x length	shipping weight	cu ft	model #	list
3	20" x 12" x 12" (508 x 305 x 305mm)	two 12" (305mm)	27½" x 66" (703 x 1676mm)	89 lbs. (40.4 kg)	22	<b>312-12-3-12</b> ••	3797
3	14" x 16" x 12" (356 x 406 x 305mm)	two 12" (305mm)	23½" x 72" (602 x 1829mm)	105 lbs. (47.6 kg)	46	<b>312-14-3-12</b> •	4067

\* #312-12-3-12 features fabricated sink bowls.

**314 Series Corner Sinks** 

see spec sheet **EG20.09**



all sinks have two sets of faucets holes

- Deep-drawn, heavy gauge type 304 construction.
- Poly cutting board/sink cover.

**FEATURES:**

**Note:** All shipping weights and cubic feet are approximate.

**Twist drain brackets available.**

Works in conjunction with optional twist handle drains (not included – see page 204). To order, add **\$35 per compartment to list price** and suffix “-TB” to model number. **Example: C314-10-3-12-TB.**

**ALL SINKS SHIPPED FULLY CRATED.**

**Freight class is 175.0.**

(•) MTS (made to stock) / ( ) MTO (made to order)

no. bowls	bowl size width x length x depth	drain boards	overall size width x length	shipping weight	cu ft	model #	list
3	10" x 14" x 10" (254 x 355 x 254mm)	two 12" (305mm)	39" x 43" (991 x 1092mm)	152 lbs. (68.9 kg)	30	<b>C314-10-3-12</b>	6004
3	16" x 20" x 14" (406 x 508 x 356mm)	two 18" (457mm)	57¼" x 59¼" (1454 x 1518mm)	211 lbs. (95.7 kg)	77	<b>C314-16-3-18</b> •	7899
3	22" x 22" x 14" (558 x 558 x 356mm)	two 18" (457mm)	69" x 69" (1753 x 1753mm)	227 lbs. (103.0 kg)	90	<b>C314-22-3-18</b>	8568
3	24" x 24" x 14" (610 x 610 x 356mm)	two 24" (610mm)	79" x 79" (2007 x 2007mm)	258 lbs. (117.0 kg)	108	<b>C314-24-3-24</b>	9260



100 Industrial Boulevard, Clayton, DE 19938-8903 U.S.A.  
 Phone: 800-441-8440 or 302-653-3000. Fax: 302-653-2065  
 http://www.eaglegrp.com

## Mop Sinks

see spec sheet **EG20.01**

- 304 18-8 stainless steel construction.
- Sink bowl is heavy gauge with deep-drawn coved corners.
- Drain with flat strainer plate.

**FEATURES:**

**Freight class is 85.0.**

(•) MTS (made to stock) / ( ) MTO (made to order)



bowl width x length x depth		cu	overall width x length x height		sh. weight		model #	list
in	mm	ft	in.	mm	lbs.	kg		
16" x 20" x 8"	406 x 508 x 203	8.4	21½" x 24¾" x 15½"	546 x 625 x 394	35	15.8	<b>F1916</b> ••	1766
16" x 20" x 12"	406 x 508 x 305	8.4	21½" x 24¾" x 19½"	546 x 625 x 495	53	24.0	<b>F1916-12</b> ••	1829
20" x 28" x 8"	508 x 711 x 203	11.9	25½" x 32¾" x 15½"	648 x 829 x 394	68	30.8	<b>F2820</b> *	2021
20" x 28" x 12"	508 x 711 x 305	11.9	25½" x 32¾" x 19½"	648 x 829 x 495	86	39.0	<b>F2820-12</b> ••	2245

\* Includes 3¼" high backsplash. 12½" deck height.

\*\* Includes 3¼" high backsplash. 16½" deck height.

### Optional Accessories for Mop Sink

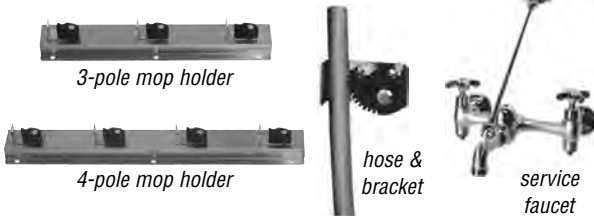

description	weight		model #	list
	lbs.	kg		
3-pole mop holder, 18" (457mm) length	4	1.8	<b>312688</b>	226
4-pole mop holder, 24" (610mm) length	4.5	2.0	<b>321561</b> •	331
30" (762mm) hose & wall mounted bracket	8	3.6	<b>312689</b>	217
service faucet (comes with vacuum breaker)	11	5.0	<b>312690</b>	633



### Optional 16" Splash Kits for Mop Sinks

16 gauge type 304 stainless steel. 3" radius on front of end splashes. Kits come with hardware for attaching to mop sink.



descriptions	fits "F1916" mop sinks		fits "F2820" mop sinks	
	model #	list	model #	list
left and rear splash kit	<b>503095</b>	636	<b>503098</b>	673
right and rear splash kit	<b>503096</b>	636	<b>503099</b>	673
left, right and rear splash kit	<b>503097</b>	1002	<b>503100</b>	1098

## Utility Shelves with Mop Hangers

see spec sheet **EG20.02**

- 16 gauge type 304 stainless steel.
- Mop hangers. Flat hooks.
- Hangers and hooks are riveted to front of shelf.

**FEATURES:**

**Freight class is 70.0.**

(•) MTS (made to stock) / ( ) MTO (made to order)



width x length		model #	list
in.	mm		
8" x 24"	203 x 610	<b>US0824-16/3</b> •	707
8" x 36"	203 x 914	<b>US0836-16/3</b>	813
8" x 48"	203 x 1219	<b>US0848-16/3</b>	1029

**Catalog Section 20**

**Mop Sink Storage Cabinets** 

see spec sheet **EG20.04**

**FEATURES:**

- Heavy gauge type 430 stainless steel construction.
- Overhead shelf (Double-width units feature four shelves).
- Double-pan 20 gauge stainless steel hinged doors.
- Transverse rod handles featuring keyed locks.
- Top is slanted at a 15° angle.
- Sides are louvered along the top for ventilation.
- Mop sink holds two mops.
- Cabinets comes with service faucet, 30" (762mm) hose and wall mounted bracket.



**Double-Width Cabinets available!**

**All cabinets include one 16" x 20" x 8" stainless steel mop sink!**

(mops shown not included)

**Freight class is 125.0.**

**Note:** Optional upgrade to type 300 stainless steel cabinet available. To order, add 15% to list price and suffix "-SE" to model number (example: F1916-VSCS-SE).

description	width x length x height		weight		cubic feet	model #	list
	in.	mm	lbs.	kg			
single-width cabinet	22¼" x 25" x 84¼"	565 x 635 x 2140	274	124.3	39.0	<b>F1916-VSCS</b>	6569
double-width cabinet, mop sink at left	22¼" x 47½" x 84¼"	565 x 1207 x 2140	544	246.7	81.9	<b>F1916-VSCS-DL</b>	7504
double-width cabinet, mop sink at right	22¼" x 47½" x 84¼"	565 x 1207 x 2140	544	246.7	81.9	<b>F1916-VSCS-DR</b>	7504

**NEW** **Chemical Storage Wall Cabinets**

see product announcement **EG8092**

**FEATURES:**

- Top is sloped forward to help reduce dust build-up.
- Stationary center shelf features safety edges. Additional shelves can be specified and are factory installed.
- Ends, back and bottom are folded and spot-welded together. All feature safety edges.
- Back is recessed, with full-length concealed mounting plate for easy installation\*. "Z"-brackets included.
- Both side panels are vented.
- All doors are double-panel and removable for easy cleaning.



**Overall dimensions of all units: 15" width x 24" length x 28" height.**

\* Wall mounting hardware not included.

**Freight class is 100.0.**

features	TYPE 430 STAINLESS		TYPE 300 STAINLESS	
	model #	list	model #	list
left-hinged door	<b>WCH4-24C-L</b>	4496	<b>WCH-24C-L</b>	4982
left-hinged door with key lock	<b>WCH4-24C-LL</b>	4800	<b>WCH-24C-LL</b>	5286
right-hinged door	<b>WCH4-24C-R</b>	4496	<b>WCH-24C-R</b>	4982
right-hinged door with key lock	<b>WCH4-24C-RL</b>	4800	<b>WCH-24C-RL</b>	5286



### Countertop Drop-In Sinks with Self Rim Design

**FEATURES:**

- 304 series stainless steel.
- Faucet and 1½" (38mm) outlet basket drain.

**Freight class is 85.0.**

(•) MTS (made to stock) / ( ) MTO (made to order)

**Note:** Faucet holes are punched on 4" (102mm) centers.  
To order sinks with faucet holes punched on 8" (203mm) centers, add \$186 to list price and add suffix "-8CL" (example: SR18-24-13.5-2-8CL). Faucets sold separately for "-8CL" sinks. See page 199.

All weights and cubic feet in charts are approximate.

Recommended for 1" thick countertops. If countertop is thicker than 1", please indicate at time of order.

see spec sheet **EG20.39**

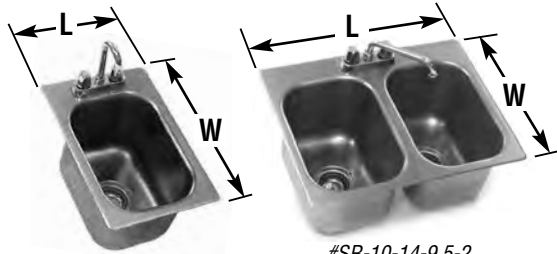

#SR-10-14-9.5-1  
one-compartment sink

#SR-10-14-9.5-2  
two-compartment sink

**Not NSF approved for warewashing and/or food preparation operations. Not intended for NSF installation into stainless steel worksurface. Please consult factory if need arises.**

**One Compartment** – Furnished with #302004 faucet with gooseneck spout, except where noted. See page 199 for other available faucets.

inside bowl dimensions width x length x depth in. mm		overall width x length in. mm		TOP MOUNT cutout width x length in. mm		BOTTOM MOUNT cutout* width x length in. mm		weight lbs. kg	cu ft	model #	list	
14" x 10" x 5"	356 x 254 x 127	19" x 12¼"	483 x 324	17½" x 11¼"	448 x 286	14⅜" x 10⅜"	376 x 275	10	4.5	0.7	SR10-14-5-1•▲	581
14" x 10" x 9½"	356 x 254 x 241	18½" x 12¼"	480 x 324	17½" x 11¼"	445 x 286	14⅜" x 10⅜"	376 x 275	12	5.4	1.4	SR10-14-9.5-1•	637
14" x 12" x 9½"	356 x 305 x 241	19" x 14¼"	483 x 375	17" x 13¼"	448 x 337	14" x 12"	365 x 314	14	6.4	1.7	SR12-14-9.5-1•▲	857
10" x 14" x 5"	254 x 356 x 127	15" x 16¼"	381 x 426	13" x 15¼"	346 x 387	10⅜" x 14⅜"	275 x 376	10	4.5	0.8	SR14-10-5-1▲	581
10" x 14" x 5"	254 x 356 x 127	15" x 16¼"	381 x 426	13" x 15¼"	346 x 387	n/a		12	5.4	0.8	SRU14-10-5-1**▲	1096
10" x 14" x 9½"	254 x 356 x 241	15" x 16¼"	381 x 422	13" x 15¼"	346 x 384	10⅜" x 14⅜"	275 x 376	12	5.4	1.6	SR14-10-9.5-1	832
12" x 14" x 9½"	305 x 356 x 241	17" x 16¼"	432 x 426	15" x 15¼"	397 x 387	12" x 14"	314 x 365	14	6.4	1.8	SR14-12-9.5-1▲	847
16" x 14" x 9½"	406 x 356 x 241	21" x 16¼"	533 x 425	19" x 15¼"	499 x 387	16" x 14"	422 x 372	23	10.4	2.1	SR14-16-9.5-1▲	998
14" x 16" x 9½"	356 x 406 x 241	19" x 18¼"	483 x 476	17" x 17¼"	448 x 448	14" x 16"	372 x 422	23	10.4	2.1	SR16-14-9.5-1▲	998
20" x 16" x 8"	508 x 406 x 203	24¼" x 18½"	629 x 470	23" x 17"	594 x 432	20" x 16"	524 x 422	26	11.8	2.2	SR16-19-8-1★	854
20" x 16" x 13½"	508 x 406 x 343	24¼" x 18½"	629 x 470	23" x 17"	594 x 432	20" x 16"	524 x 422	28	12.7	3.9	SR16-19-13.5-1★	1069
24" x 18" x 13½"	610 x 457 x 343	28¼" x 20½"	730 x 521	27" x 19"	695 x 483	24" x 18"	626 x 473	32	14.5	4.9	SR18-24-13.5-1★	1133
16" x 20" x 8"	406 x 508 x 203	20¼" x 22¼"	527 x 572	19" x 21"	492 x 533	16" x 20"	422 x 524	24	10.9	2.3	SR19-16-8-1■•	998
16" x 20" x 13½"	406 x 508 x 343	20¼" x 22¼"	527 x 572	19" x 21"	492 x 533	16" x 20"	422 x 524	25	11.3	3.9	SR19-16-13.5-1■•	1069
12" x 20" x 6½"	305 x 508 x 165	17" x 22¼"	432 x 578	15" x 21¼"	397 x 540	12" x 20"	310 x 511	28	12.7	1.6	SR20-12-6.5-1▲	1078
22" x 22" x 13½"	559 x 559 x 343	27" x 24¼"	686 x 629	25" x 23¼"	651 x 591	see template included w/sink		34	15.4	5.5	SR22-22-13.5-1■	1056
18" x 24" x 13½"	457 x 610 x 343	22¼" x 26½"	578 x 673	21" x 25"	543 x 635	18" x 24"	473 x 626	32	14.5	5.0	SR24-18-13.5-1★	1041
24" x 24" x 13½"	610 x 610 x 343	28¼" x 26½"	730 x 673	27" x 25"	695 x 635	24⅜" x 24⅜"	627 x 627	36	16.3	6.4	SR24-24-13.5-1■	1364

\* See page 199 for Bottom Mount Kit; \*\* #SRU14-10-5-1 features an upturn on sides and rear; ▲ 20 gauge stainless steel. All others constructed of 18 gauge stainless steel; ★ These sinks utilize #301248 faucet with 8" (203mm) swivel spout; ■ These sinks utilize #300490 faucet with 12" (305mm) swivel spout



### Optional Deck-Mount Electronic-Eye Faucet for One Compartment Drop-In Sinks only

To order, add suffix "-FE" to model #.  
Example: SR10-14-5-1-FE. Consult factory for list price.

**Two Compartment** – Furnished with #300490 faucet with 12" (203mm) spout, except where noted. See page 199 for other available faucets.

inside bowl dimensions width x length x depth in. mm		overall width x length in. mm		TOP MOUNT cutout width x length in. mm		BOTTOM MOUNT cutout* width x length in. mm		weight lbs. kg	cu ft	model #	list	
14" x 10" x 9½"	356 x 254 x 241	18½" x 24¼"	480 x 629	17½" x 23¼"	445 x 591	14⅜" x 23"	376 x 584	25	11.3	2.8	SR10-14-9.5-2■•	1349
14" x 12" x 9½"	356 x 305 x 241	19" x 28¼"	483 x 730	17" x 27¼"	448 x 692	14" x 26"	365 x 676	27	12.2	3.2	SR12-14-9.5-2▲	1484
16" x 14" x 9½"	406 x 356 x 241	21" x 32¼"	525 x 832	19" x 31¼"	499 x 794	16" x 30"	422 x 778	42	19.1	4.0	SR14-16-9.5-2▲	1582
20" x 16" x 8"	508 x 406 x 203	24¼" x 36¼"	527 x 921	23" x 34¼"	594 x 883	20" x 34¼"	524 x 870	48	21.8	4.3	SR16-19-8-2	1774
20" x 16" x 13½"	508 x 406 x 343	24¼" x 36¼"	527 x 921	23" x 34¼"	594 x 883	20" x 34¼"	524 x 870	52	23.6	7.5	SR16-19-13.5-2•	1863
24" x 18" x 13½"	610 x 457 x 343	28¼" x 40¼"	578 x 1022	27" x 38¼"	695 x 984	24" x 38½"	626 x 978	56	24.9	9.7	SR18-24-13.5-2	2136
22" x 22" x 13½"	559 x 559 x 343	27" x 48¼"	686 x 1238	25" x 47¼"	651 x 1200	see template included w/sink		57	25.9	10.7	SR22-22-13.5-2	3198
24" x 24" x 13½"	610 x 610 x 343	28¼" x 52¼"	730 x 1324	27" x 50¼"	695 x 1286	24⅜" x 50¼"	630 x 1276	64	29.0	12.5	SR24-24-13.5-2	2882

\* See page 199 for Bottom Mount Kit; ■ Model #SR10-14-9.5-2 utilizes #301248 faucet with 8" (203mm) swivel spout; ▲ 20 gauge stainless steel. All others constructed of 18 gauge stainless steel.



## Catalog Section 20

### Countertop Drop-In Sinks <sup>(NSF)</sup> with Self Rim Design

see spec sheet **EG20.39**

Not NSF approved for warewashing and/or food preparation operations. Not intended for NSF installation into stainless steel worksurface. Please consult factory if need arises.

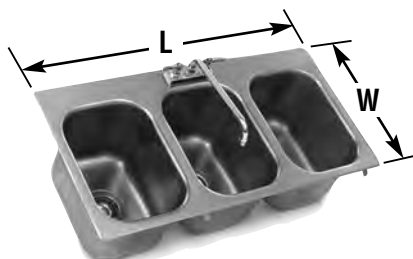

#SR-10-14-9.5-3  
three-compartment sink

**FEATURES:**

- 304 series stainless steel.
- Faucet and 1½" (38mm) outlet basket drain.

**Freight class is 85.0.**

(•) MTS (made to stock) / ( ) MTO (made to order)

**Note:** Faucet holes are punched on 4" (102mm) centers. To order sinks with faucet holes punched on 8" (203mm) centers, add \$186 to list price and add suffix "-8CL" (example: SR18-24-13.5-3-8CL). Faucets sold separately for "-8CL" sinks. See "T&S Deck Mount Faucets" chart below.  
All weights and cubic feet in charts are approximate. Recommended for 1"-thick countertops. For countertops thicker than 1", consult factory.

**Three Compartment** – Furnished with #300490 faucet with 12" (305mm) spout, except where noted. See below for other available faucets.

inside bowl dimensions width x length x depth in. mm		overall width x length in. mm		TOP MOUNT cutout width x length in. mm		BOTTOM MOUNT cutout* width x length in. mm		weight lbs. kg	cu ft	model #	list
14" x 10" x 9½"	356 x 254 x 241	18¾" x 36¾"	480 x 933	17½" x 35¼"	445 x 895	14¾" x 35"	376 x 889	37 16.8	4.1	SR10-14-9.5-3•	1804
14" x 12" x 9½"	356 x 305 x 241	19" x 42¾"	483 x 1086	17¾" x 41¼"	448 x 1031	14¾" x 40¾"	365 x 1032	39 17.6	4.7	SR12-14-9.5-3▲	2177
16" x 14" x 9½"	406 x 356 x 241	21" x 48¾"	533 x 1238	19¾" x 47¼"	498 x 1200	16¾" x 46¾"	422 x 1184	66 29.9	6.0	SR14-16-9.5-3▲	2222
20" x 16" x 8"	508 x 406 x 203	24¾" x 54"	629 x 1372	23¾" x 52½"	594 x 1334	20¾" x 52¼"	524 x 1327	72 32.7	6.3	SR16-19-8-3	2308
20" x 16" x 13½"	508 x 406 x 343	24¾" x 54"	629 x 1372	23¾" x 52½"	594 x 1334	20¾" x 52¼"	524 x 1327	77 34.9	10.9	SR16-19-13.5-3•	2443
24" x 18" x 13½"	610 x 457 x 343	28¾" x 60"	730 x 1524	27¾" x 58½"	695 x 1486	24¾" x 58¼"	626 x 1480	82 37.2	14.1	SR18-24-13.5-3■	2964

\* See below for Bottom Mount Kit; ■ These sinks utilize #301440 faucet with 14" (356mm) swivel spout; ▲ 20 gauge stainless steel. All others constructed of 18 gauge stainless steel.

### Options for Countertop Drop-In Sinks

see spec sheet **EG20.39**

**Note:** Faucets listed are lead-free AB1953-compliant.

**Faucets can be shipped UPS.**

(•) MTS (made to stock) / ( ) MTO (made to order)

#### Standard Deck Mount Faucets — with 1/4-turn handles

description	model #	list
gooseneck faucet, 4" (102mm) center, for single bowls	302004	220
8" (203mm) spout, 4" (102mm) centers, for single and double bowls	301248	197
12" (305mm) spout, 4" (102mm) centers, for triple bowls	300490	209
14" (356mm) spout, 4" (102mm) centers, for triple bowls	301440	227



#302004 faucet



#301248 faucet

#### T&S Deck Mount Faucets <sup>(T&S)</sup> **OUR BEST**

description	model #	list
gooseneck faucet, 4" (102mm) center, for single bowls	313308	525
8" (203mm) spout, 4" (102mm) center, for single and double bowls	313306	507
8" (203mm) spout, 4" (102mm) center, for single and double bowls, with spray arm	377430*	522
8" (203mm) spout, 8" (203mm) center, for single and double bowls, with spray arm	303560*	584
12" (305mm) spout, 4" (102mm) center, for triple bowls	313303	524
12" (305mm) spout, 8" (203mm) center, for triple bowls, with spray arm	303561*	661
14" (356mm) spout, 4" (102mm) center, for triple bowls	313307	525
14" (356mm) spout, 8" (203mm) center, for triple bowls, with spray arm	303562*	659

\* Faucets with spray arm require special faucet holes.



#303560 faucet

**Bottom-Mount Kit** — One kit per one-compartment sinks, two kits per two-compartment sink, three kits per three-compartment sink.

description	model #	list
8 undermount clips per kit	362188	31



undermount clip

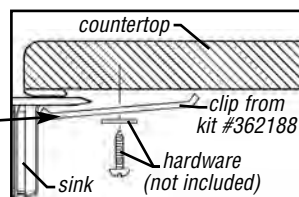



## Countertop Drop-Ins with No Deck

see product announcement **EG8207**

- 304 series stainless steel.
- Basket drain.
- 1 3/8" trim on all four sides.

FEATURES:

Freight class is 85.0.



### One Compartment

inside bowl dimensions width x length x depth in. mm		overall width x length in. mm		TOP MOUNT cutout width x length in. mm		BOTTOM MOUNT cutout* width x length in. mm		weight lbs. kg	cu ft	model #	list
14" x 10" x 5"	356 x 254 x 127	16 1/2" x 12 1/4"	422 x 324	15 1/4" x 11 1/4"	387 x 286	14 1/8" x 10 1/8"	376 x 275	10 4.5	0.7	SR10-14-5-1-ND▲	529
14" x 10" x 9 1/2"	356 x 254 x 241	16 1/2" x 12 1/4"	419 x 324	15 1/4" x 11 1/4"	387 x 286	14 1/8" x 10 1/8"	376 x 275	12 5.4	1.4	SR10-14-9.5-1-ND●	696
14" x 12" x 9 1/2"	356 x 305 x 241	16 1/2" x 14"	422 x 375	15 1/4" x 13 1/4"	387 x 337	14 3/8" x 12 1/8"	365 x 314	14 6.4	1.7	SR12-14-9.5-1-ND●▲	838
16" x 14" x 9 1/2"	406 x 356 x 241	18 1/2" x 16 1/2"	473 x 425	17 1/4" x 15 1/4"	438 x 387	16 1/8" x 14 1/8"	422 x 372	23 10.4	2.1	SR14-16-9.5-1-ND●▲	953
20" x 16" x 8"	508 x 406 x 203	22 1/2" x 18 1/2"	568 x 470	21" x 17"	533 x 432	20 1/8" x 16 1/8"	524 x 422	26 11.8	2.2	SR16-19-8-1-ND	858
20" x 16" x 13 1/2"	508 x 406 x 343	22 1/2" x 18 1/2"	568 x 470	21" x 17"	533 x 432	20 1/8" x 16 1/8"	524 x 422	28 12.7	3.9	SR16-19-13.5-1-ND	944
24" x 18" x 13 1/2"	610 x 457 x 343	26 1/2" x 20 1/2"	670 x 521	25" x 19"	635 x 483	24 1/8" x 18 1/8"	626 x 473	32 14.5	4.9	SR18-24-13.5-1-ND	1006
22" x 22" x 13 1/2"	559 x 559 x 343	24 1/2" x 24 1/2"	626 x 629	23 1/4" x 23 1/4"	591 x 591	22 1/8" x 22 1/8"	575 x 575	34 15.4	5.5	SR22-22-13.5-1-ND	1738
24" x 24" x 13 1/2"	610 x 610 x 343	26 1/2" x 26 1/2"	670 x 673	25" x 25"	635 x 635	24 1/8" x 24 1/8"	627 x 627	36 16.3	6.4	SR24-24-13.5-1-ND	1102

\* See page 199 for Bottom Mount Kit; ▲ 20 gauge stainless steel. All others constructed of 18 gauge stainless steel.

### Two Compartment

inside bowl dimensions width x length x depth in. mm		overall width x length in. mm		TOP MOUNT cutout width x length in. mm		BOTTOM MOUNT cutout* width x length in. mm		weight lbs. kg	cu ft	model #	list
14" x 10" x 9 1/2"	356 x 254 x 241	16 1/2" x 24 1/4"	419 x 629	15 1/4" x 23 1/4"	387 x 591	14 1/8" x 23"	376 x 584	25 11.3	2.8	SR10-14-9.5-2-ND●	1317
14" x 12" x 9 1/2"	356 x 305 x 241	16 1/2" x 28 1/4"	422 x 730	15 1/4" x 27 1/4"	387 x 692	14 1/8" x 26 1/8"	365 x 676	27 12.2	3.2	SR12-14-9.5-2-ND▲	1521
16" x 14" x 9 1/2"	406 x 356 x 241	18 1/2" x 32 1/4"	473 x 832	17 1/4" x 31 1/4"	438 x 794	16 1/8" x 30 1/8"	422 x 778	42 19.1	4.0	SR14-16-9.5-2-ND▲	1627
20" x 16" x 8"	508 x 406 x 203	22 1/2" x 36 1/4"	568 x 921	21" x 34 1/4"	533 x 883	20 1/8" x 34 1/8"	524 x 876	48 21.8	4.3	SR16-19-8-2-ND	1295
20" x 16" x 13 1/2"	508 x 406 x 343	22 1/2" x 36 1/4"	568 x 921	21" x 34 1/4"	533 x 883	20 1/8" x 34 1/8"	524 x 876	52 23.6	7.5	SR16-19-13.5-2-ND●	1466
24" x 18" x 13 1/2"	610 x 457 x 343	26 1/2" x 40 1/4"	670 x 1022	25" x 38 1/4"	635 x 984	24 1/8" x 38 1/8"	626 x 978	56 24.9	9.7	SR18-24-13.5-2-ND	1760
22" x 22" x 13 1/2"	559 x 559 x 343	24 1/2" x 48 1/4"	626 x 1238	23 1/4" x 47 1/4"	591 x 1200	22 1/8" x 46 1/8"	575 x 1184	57 25.9	10.7	SR22-22-13.5-2-ND	3231
24" x 24" x 13 1/2"	610 x 610 x 343	26 1/2" x 52 1/4"	670 x 1324	25" x 50 1/4"	635 x 1286	24 1/8" x 50 1/8"	630 x 1276	64 29.0	12.5	SR24-24-13.5-2-ND	1860

\* See page 199 for Bottom Mount Kit; ▲ 20 gauge stainless steel. All others constructed of 18 gauge stainless steel.

### Three Compartment

inside bowl dimensions width x length x depth in. mm		overall width x length in. mm		TOP MOUNT cutout width x length in. mm		BOTTOM MOUNT cutout* width x length in. mm		weight lbs. kg	cu ft	model #	list
14" x 10" x 9 1/2"	356 x 254 x 241	16 1/2" x 36 1/4"	419 x 933	15 1/4" x 35 1/4"	387 x 895	14 1/8" x 35"	376 x 889	37 16.8	4.1	SR10-14-9.5-3-ND●	1403
14" x 12" x 9 1/2"	356 x 305 x 241	16 1/2" x 42 1/4"	422 x 1086	15 1/4" x 41 1/4"	387 x 1031	14 1/8" x 40 1/8"	331 x 1032	39 17.6	4.7	SR12-14-9.5-3-ND▲	2094
16" x 14" x 9 1/2"	406 x 356 x 241	18 1/2" x 48 1/4"	473 x 1238	17 1/4" x 47 1/4"	438 x 1200	16 1/8" x 46 1/8"	422 x 1184	66 29.9	6.0	SR14-16-9.5-3-ND●▲	2246
20" x 16" x 8"	508 x 406 x 203	22 1/2" x 54"	568 x 1372	21" x 52 1/2"	533 x 1334	20 1/8" x 52 1/8"	524 x 1327	72 32.7	6.3	SR16-19-8-3-ND	1823
20" x 16" x 13 1/2"	508 x 406 x 343	22 1/2" x 54"	568 x 1372	21" x 52 1/2"	533 x 1334	20 1/8" x 52 1/8"	524 x 1327	77 34.9	10.9	SR16-19-13.5-3-ND●	2023
24" x 18" x 13 1/2"	610 x 457 x 343	26 1/2" x 60"	670 x 1524	25" x 58 1/2"	635 x 1486	24 1/8" x 58 1/8"	626 x 1480	82 37.2	14.1	SR18-24-13.5-3-ND	2431

\* See page 199 for Bottom Mount Kit; ▲ 20 gauge stainless steel. All others constructed of 18 gauge stainless steel.

## Catalog Section 20

### Seamless Welded-In Sinks

see spec sheet **EG20.18**

- For NSF-approved welded fabrication only.
- Deep-drawn seamless bowls.
- Type 304 stainless steel construction.
- Basket drain.

**FEATURES:**

**Note:** All shipping weights and cubic feet are approximate.

**Freight class is 85.0.**



**For Undermount...**

An understructure\* is secured atop cabinet, then the sink's flanges are secured between understructure and countertop.

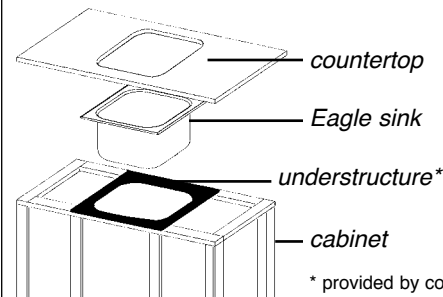

#### One Compartment

inside bowl dimensions width x length x depth in. mm		overall dimensions width x length in. mm		gauge	drain		weight		cu ft	model #	list
					in.	mm	lbs.	kg			
14" x 10" x 5"	356 x 254 x 127	16" x 12"	406 x 305	20	3½"	89	9	4.1	1.4	<b>FDI-10-14-5-1</b>	383
14" x 10" x 9½"	356 x 254 x 241	16" x 12"	406 x 305	18	3½"	89	11	5.0	1.4	<b>FDI-10-14-9.5-1</b>	425
14" x 12" x 9½"	356 x 305 x 241	16" x 14"	406 x 356	20	3½"	89	13	5.8	2.4	<b>FDI-12-14-9.5-1</b>	443
20" x 12" x 6½"	508 x 305 x 165	22" x 14"	559 x 356	20	2"	51	14	6.4	2.6	<b>FDI-12-20-6.5-1</b>	463
16" x 14" x 6"	406 x 356 x 152	18" x 16"	457 x 406	20	3½"	89	14	6.4	2.5	<b>FDI-14-16-6-1</b>	475
16" x 14" x 9½"	406 x 356 x 241	18" x 16"	457 x 406	20	3½"	89	14	6.4	2.3	<b>FDI-14-16-9.5-1</b>	488
20" x 16" x 8"	508 x 406 x 203	21¼" x 18"	552 x 457	18	3½"	89	23	10.4	3.7	<b>FDI-16-19-8-1</b>	598
20" x 16" x 13½"	508 x 406 x 343	21¼" x 18"	552 x 457	18	3½"	89	25	11.3	3.7	<b>FDI-16-19-13.5-1</b>	603
24" x 18" x 13½"	610 x 457 x 343	26" x 20"	660 x 508	18	3½"	89	37	16.8	8.6	<b>FDI-18-24-13.5-1</b>	732
20" x 20" x 5"	508 x 508 x 127	22" x 22"	559 x 559	20	3½"	89	19	8.6	1.5	<b>FDI-20-20-5-1</b>	468
22" x 22" x 13½"	559 x 559 x 343	24" x 24"	610 x 610	18	3½"	89	39	17.6	7.3	<b>FDI-22-22-13.5-1</b>	854
24" x 24" x 13½"	610 x 610 x 343	26" x 26"	660 x 660	18	3½"	89	41	18.6	8.3	<b>FDI-24-24-13.5-1</b>	891

#### Two Compartment

inside bowl dimensions width x length x depth in. mm		overall dimensions width x length in. mm		gauge	drain		weight		cu ft	model #	list
					in.	mm	lbs.	kg			
14" x 10" x 9½"	356 x 254 x 241	16" x 24"	406 x 610	18	3½"	89	19	8.6	6.5	<b>FDI-10-14-9.5-2</b>	818
14" x 12" x 9½"	356 x 305 x 241	16" x 28"	406 x 711	20	3½"	89	21	9.5	4.5	<b>FDI-12-14-9.5-2</b>	883
16" x 14" x 9½"	406 x 356 x 241	18" x 32"	457 x 813	20	3½"	89	25	11.3	6.2	<b>FDI-14-16-9.5-2</b>	951
20" x 16" x 8"	508 x 406 x 203	21¼" x 36"	552 x 914	18	3½"	89	43	19.5	5.1	<b>FDI-16-19-8-2</b>	1156
20" x 16" x 13½"	508 x 406 x 343	21¼" x 36"	552 x 914	18	3½"	89	50	22.7	7.6	<b>FDI-16-19-13.5-2</b>	1188
24" x 18" x 13½"	610 x 457 x 343	26" x 40"	660 x 1016	18	3½"	89	73	33.1	15.7	<b>FDI-18-24-13.5-2</b>	1388
22" x 22" x 13½"	559 x 559 x 343	24" x 48"	610 x 1219	18	3½"	89	75	34.0	12.6	<b>FDI-22-22-13.5-2</b>	1646
24" x 24" x 13½"	610 x 610 x 343	26" x 52"	660 x 1321	18	3½"	89	81	36.7	15.0	<b>FDI-24-24-13.5-2</b>	1716

## Seamless Welded-In Sinks

see spec sheet **EG20.18**



**Three Compartment**

- For NSF-approved welded fabrication only.
- Deep-drawn seamless bowls.
- Type 304 stainless steel construction.
- 3/2" (89mm) basket drain.

**FEATURES:**

**Note:** All shipping weights and cubic feet are approximate.

See page 201 for undermount.

**Freight class is 85.0.**

inside bowl dimensions width x length x depth		overall dimensions width x length			gauge	drain		weight		cu ft	model #	list
in.	mm	in.	mm	in.		mm	lbs.	kg				
14" x 10" x 9 1/2"	356 x 254 x 241	16" x 36"	406 x 914	18	3 1/2"	89	27	12.2	4.0	<b>FDI-10-14-9.5-3</b>	1222	
14" x 12" x 9 1/2"	356 x 305 x 241	16" x 42"	406 x 1067	20	3 1/2"	89	30	13.6	5.3	<b>FDI-12-14-9.5-3</b>	1234	
16" x 14" x 9 1/2"	406 x 356 x 241	18" x 48"	457 x 1219	20	3 1/2"	89	36	16.3	7.2	<b>FDI-14-16-9.5-3</b>	1385	
20" x 16" x 8"	508 x 406 x 203	21 1/4" x 54"	552 x 1372	18	3 1/2"	89	63	28.6	11.3	<b>FDI-16-19-8-3</b>	1668	
20" x 16" x 13 1/2"	508 x 406 x 343	21 1/4" x 54"	552 x 1372	18	3 1/2"	89	75	34.0	15.9	<b>FDI-16-19-13.5-3</b>	1740	
24" x 18" x 13 1/2"	610 x 457 x 343	26" x 60"	660 x 1524	18	3 1/2"	89	101	45.8	21.8	<b>FDI-18-24-13.5-3</b>	2017	
22" x 22" x 13 1/2"	559 x 559 x 343	24" x 72"	610 x 1829	18	3 1/2"	89	113	51.3	19.8	<b>FDI-22-22-13.5-3</b>	2286	
24" x 24" x 13 1/2"	610 x 610 x 343	26" x 78"	660 x 1981	18	3 1/2"	89	123	55.8	21.8	<b>FDI-24-24-13.5-3</b>	2385	

**Four Compartment**

inside bowl dimensions width x length x depth		overall dimensions width x length			gauge	drain		weight		cu ft	model #	list
in.	mm	in.	mm	in.		mm	lbs.	kg				
14" x 10" x 9 1/2"	356 x 254 x 241	16" x 48"	406 x 1219	18	3 1/2"	89	35	15.9	6.0	<b>FDI-10-14-9.5-4</b>	1469	
14" x 12" x 9 1/2"	356 x 305 x 241	16" x 56"	406 x 1422	20	3 1/2"	89	39	17.6	7.2	<b>FDI-12-14-9.5-4</b>	1642	
16" x 14" x 9 1/2"	406 x 356 x 241	18" x 64"	457 x 1626	20	3 1/2"	89	47	21.3	9.7	<b>FDI-14-16-9.5-4</b>	1704	
20" x 16" x 8"	508 x 406 x 203	21 1/4" x 72"	552 x 1829	18	3 1/2"	89	83	37.6	16.9	<b>FDI-16-19-8-4</b>	2017	
20" x 16" x 13 1/2"	508 x 406 x 343	21 1/4" x 72"	552 x 1829	18	3 1/2"	89	100	45.4	14.8	<b>FDI-16-19-13.5-4</b>	2082	
24" x 18" x 13 1/2"	610 x 457 x 343	26" x 80"	660 x 3032	18	3 1/2"	89	129	58.5	28.4	<b>FDI-18-24-13.5-4</b>	2373	
22" x 22" x 13 1/2"	559 x 559 x 343	24" x 96"	610 x 2438	18	3 1/2"	89	151	68.6	23.5	<b>FDI-22-22-13.5-4</b>	2774	
24" x 24" x 13 1/2"	610 x 610 x 343	26" x 104"	660 x 2642	18	3 1/2"	89	163	73.9	28.5	<b>FDI-24-24-13.5-4</b>	2887	

## Seamless Welded-In Sinks with Fabricated Wall

see spec sheet **EG20.16**

*Tapered bowls allow for 60% nesting, which facilitates shipping and storage!*

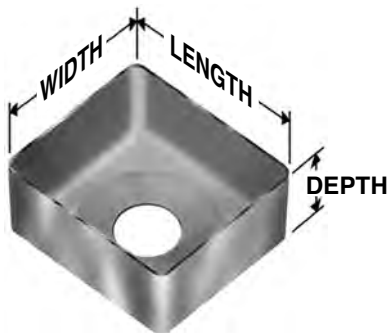

- For NSF-approved welded fabrication only.
- Type 304 18-8 stainless steel construction.
- 5/8" (16mm) radius corners.
- 3 1/2" (89mm) drain hole with sump.
- Swirl away drainage.

**FEATURES:**

**Freight class is 85.0.**

inside bowl dimensions (W x L x D)		gauge	weight		cu ft	model #	list
in.	mm		lbs.	kg			
9" x 12" x 6"	229 x 305 x 432	16	6	2.7	0.4	<b>FNWNF-9-12-6-1</b>	788
9" x 14" x 8"	229 x 356 x 203	16	8	3.6	0.5	<b>FNWNF-9-14-8-1</b>	836
12" x 14" x 8"	305 x 356 x 203	16	11	5.0	0.8	<b>FNWNF-12-14-8-1</b>	861
14" x 16" x 8"	356 x 406 x 203	16	12	5.4	1.0	<b>FNWNF-14-16-8-1</b>	902
18" x 18" x 10"	457 x 457 x 254	14	24	10.9	1.9	<b>FNWNF-18-18-10-1</b>	807
18" x 18" x 12"	457 x 457 x 305	14	27	12.2	2.3	<b>FNWNF-18-18-12-1</b>	818
20" x 20" x 10"	508 x 508 x 254	14	25	11.3	2.3	<b>FNWNF-20-20-10-1</b>	854
20" x 20" x 12"	508 x 508 x 305	14	29	13.2	2.8	<b>FNWNF-20-20-12-1</b>	897
20" x 20" x 14"	508 x 508 x 356	14	32	14.5	3.2	<b>FNWNF-20-20-14-1</b>	945
20" x 27" x 6"	508 x 686 x 432	14	20	9.0	1.5	<b>FNWNF-20-27-6-1</b>	807
20 1/2" x 20 1/2" x 5"	521 x 521 x 127	14	18	8.2	1.2	<b>FNWNF-20.5-20.5-5-1</b>	742
20 1/2" x 20 1/2" x 8"	521 x 521 x 203	14	24	10.9	1.9	<b>FNWNF-20.5-20.5-8-1</b>	814
24" x 24" x 12"	610 x 610 x 305	14	38	17.2	4.0	<b>FNWNF-24-24-12-1</b>	998
24" x 24" x 14"	610 x 610 x 356	14	42	19.1	4.7	<b>FNWNF-24-24-14-1</b>	1048

**Custom Sink Modifications**

see spec sheet **EG20.50**

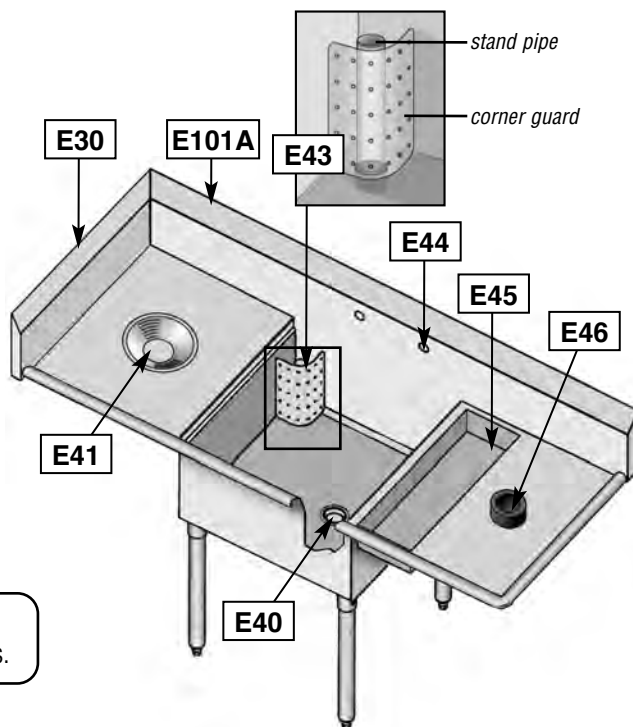

See pages 369-372 for more custom options and accessories.

model #	description	list
E30	End splash - per end, all heights	375
E40	Provision for sink heater	213
E41	Disposal provision package—collar	882
E41A	Disposal provision package—cone	882
E43	Stand pipe with corner guard, available only on FN-style and utility sinks	265
E44	Faucet hole revision - adding or moving	198
E45	Trough installed in drainboard	1081
E46	Rubber scrap block installed	433
E101A	Turn down backsplash - per sink, includes Z-clips	292

**Not Pictured**

model #	description	list
E37	NSF sprayed-on sound deadening - up to 12' (3658mm)	818
E37A	- for each additional foot	65
E38-6*	Cantilever mount up to 6' (1829mm) - add to wall shelf price	475
E38-12*	Cantilever mount up to 12' (3658mm) - add to wall shelf price	712
E39	Enclosed backsplash	102/lin. ft.
E47	Sink cover holders, sized for stainless steel or poly (includes upper and lower track)	812/slot
E48	Stainless steel apron, to cover sink bowls - 2 or 3 compartment	1300
E48A	- for each additional compartment over 3	217
E49	s/s undershelf under drainboards - up to 24" (610mm) w/short legs	699
E49A	- for each additional foot over 24" (610mm)	306
E50	Provision for water pump	1822
E51	Optional size drainboard	403/lin. ft.
E52	High backsplash up to 13" (330mm)	209/lin. ft.
E53	High backsplash up to 18" (457mm)	374/lin. ft.
E54	Working height revision	354/sink
E55	Drainboard corner turn	1639/ea.
E56	overflow hole	52

\* Applicable to wall mount shelves and pot racks.

## Sink Accessories/Replacements

see spec sheet **EG20.51A**

Can be shipped UPS.



polyboard sink cover



stainless steel sink cover

### Sink Covers...

For 412, 414, 314, and Spec-Master® FN Series Sinks only.

fits sink bowl size	...Polyboard		...Stainless Steel	
	model #	list	model #	list
14" x 10" (356 x 254mm)	<b>313207</b>	161	<b>321555</b>	199
16" x 20" (483 x 508mm)	<b>351584</b>	182	<b>351585</b>	226
20" x 18" (508 x 457mm)	<b>335377</b>	188	<b>346175</b>	239
20" x 20" (508 x 508mm)	<b>326267</b>	192	<b>305428</b>	241
22" x 22" (559 x 559mm)	<b>313204</b>	197	<b>321557</b>	254
24" x 18" (610 x 457mm)	<b>326268</b>	193	<b>326270</b>	246
24" x 24" (610 x 610mm)	<b>313205</b>	213	<b>321558</b>	311
28" x 20" (711 x 508mm)	<b>326269</b>	212	<b>326271</b>	249



### Control Bracket

description	model #	list each
3" x 5" (76 x 127mm), extra heavy duty	<b>309796</b>	83

Note: Requires custom mounting.



stainless steel flanged bullet foot

### Leg Components

description	model #	list each
19" (483mm) stainless steel leg for utility sinks	<b>300315</b>	38
stainless steel bullet feet	<b>300692</b>	22
stainless steel flanged bullet feet	<b>313835</b>	32
plastic bullet feet	<b>300293</b>	2



lever handle drain with overflow



crumb cup strainer



twist handle drain



lever handle drain

### Drains

description	max. flow rate		model #	list
	gal. per minute	gal. per hour		
lever handle drain with 1.5" or 2" (38 or 51mm) NPS connection	27	1620	<b>300720</b>	279
lever handle drain with 2" (51mm) NPS connection	32	1920	<b>300721</b>	279
lever handle drain with 2" (51mm) NPS connection and overflow	32	1920	<b>300722</b>	573
twist handle drain with 1.5" or 2" (38 or 51mm) NPS connection	27	1620	<b>341189*</b>	294
twist handle drain with 2" (51mm) NPS connection	32	1920	<b>336002*</b>	294
twist handle drain with 2" (51mm) NPS connection and overflow	32	1920	<b>341190*</b>	665
nickel-plated brass rotary drain with 1.5" or 2" (38 or 51mm) NPS connection	40	2400	<b>369653</b>	474
crumb cup strainer with 1.5" (38mm) outlet	18	1080	<b>300287</b>	25

\* Twist handle bracket, for use with twist handle drain, should be ordered as sink option "TB" at time of sink order — or see 'Sink Kits' on page 177 (for 314, 412, or 414 Series sinks) or page 186 (for FN Series sinks).

## Catalog Section 20

### Sink Accessories/Replacements

see spec sheets **EG20.51A** and **EG20.51B**

(\*) MTS (made to stock) / ( ) MTO (made to order)

Note: Faucets listed are lead-free AB1953-compliant.

**Can be shipped UPS.**

#### Plumbing Components

description	model #	list each
P-trap, nickel-plated	<b>300789</b>	109
tail piece for 1.5" (38.1mm) IPS connection, nickel-plated	<b>300791</b>	20
anti-siphon vacuum breaker	<b>313832</b>	212
backflow preventer	<b>313834</b>	247



#### Standard Faucets

- 8" (203mm) centers.
- Splash mounted

description	model #	list
8" (203mm) spout, standard	<b>313918</b>	263
12" (305mm) spout, standard	<b>300716</b>	269
14" (356mm) spout, standard	<b>300804</b>	278
16" (406mm) spout, standard	<b>313919</b>	279
12" (305mm) spout, heavy duty	<b>301001</b>	651
14" (356mm) spout, heavy duty	<b>301002</b>	659
19" (489mm) double-jointed spout	<b>301003</b>	731
gooseneck, 8" (203mm) center	<b>313075</b>	194



#### Repair Kits for Standard Faucets

description	for faucets #	model #	list
hot/cold stems, handles, seats, bonnet nuts, O-rings	313918, 313919	<b>304146</b>	120
hot/cold ceramic cartridge	300716, 300804	<b>368421</b>	35

#### Standard Faucets with Wrist Handles

- Deck mounted with 4" (102mm) centers.
- 4" (102mm) long wrist handles and gooseneck spout.

description	model #	list
standard, rigid gooseneck spout	<b>301005</b>	372
heavy duty, swivel gooseneck spout	<b>301004</b>	606



#### OUR BEST

#### T&S Extra Heavy Duty Faucets

- Top-of-the-line.
- Splash mounted with 8" (203mm) centers.
- T&S quality products.

description	model #	list
8" (203mm) spout	<b>313920</b>	704
10" (254mm) spout	<b>340380</b>	719
12" (305mm) spout	<b>313293</b>	722
14" (356mm) spout	<b>313294</b>	729



#### OUR BEST

#### T&S Extra Heavy Duty Faucet with Wrist Handles

- Top-of-the-line T&S quality.
- Deck mounted with 4" (102mm) centers.
- 4" (102mm) long wrist handles and rigid gooseneck spout.

description	model #	list
extra heavy duty	<b>313304</b>	720



## Prerinse Units and Components

Can be shipped UPS.

### Standard

description	model #	list
splash mounted spray unit	<b>300719</b>	1348
deck mounted spray unit	<b>300718</b>	1344
faucet add-on with 12" (305mm) spout	<b>301189</b>	357
wall bracket	<b>301190</b>	89
prerinse hose, 36" (914mm) length	<b>313116</b>	257
prerinse spray valve assembly for spray units #300718 and 300719	<b>313323</b>	221

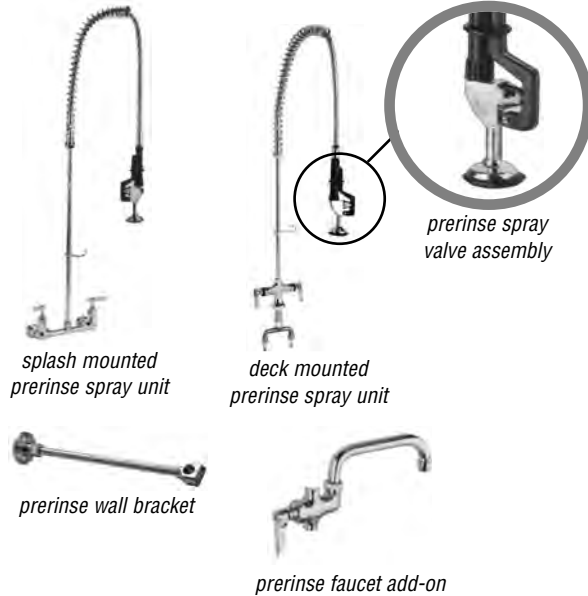

### T&S Extra Heavy Duty - Top-of-the-line. **OUR BEST**

description	model #	list
splash mounted spray unit with wall bracket	<b>313296</b>	1764
deck mounted spray unit with wall bracket	<b>313295</b>	1662
faucet add-on with 12" (305mm) spout for use with #313296 faucet	<b>313297</b>	439

### PowerPulse™ Prerinse Spray Valves

High Efficiency Prerinse Spray Valves from Encore Premium Plumbing Products is a patent-pending design, using pulsating jets of water to power-off dried and baked-on food in only 12 seconds (Fisher-Nickel test). Saves water, but does not sacrifice cleaning performance. Easily retrofits onto most existing pre-rinse.

description	model #	list
High-efficiency pre-spray rinse valve uses less water (0.74gpm), features pulsing action	<b>384794</b>	392
High-efficiency pre-spray rinse valve uses only 1.05gpm water, features pulsing action	<b>384795</b>	392



## Portable Cool Trough® Water Tempering System

see spec sheet **EG25.03C**

**PATENTED!**  
(patent #9,588,525)



- Integral mechanical temperature sensor maintains water temperature of 130°F or less.
- Built-in pitch towards drain ensures complete drainage.
- 3" (76mm)-diameter casters—two rigid, two swivel with brake.
- No electrical connection required.
- 12 gauge base.

FEATURES:

**Freight class is 85.0.**

**Note:** Water line and connection provided by plumbing contractor.

overall side-to-side		overall * front-to-back		overall height		model #	list
in.	mm	in.	mm	in.	mm		
15"	381	12"	305	36"	914	<b>PWTFT-1215</b>	11433

\* Includes base and handle.

See pages 209 & 210 for more Cool Trough® Water Tempering Systems.



**Catalog Section 20**

**Floor Troughs** 

see spec sheet **EG25.00**



floor trough with subway-style grating

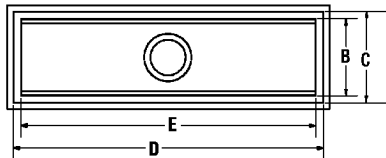

(see chart below for dimensions A through E)

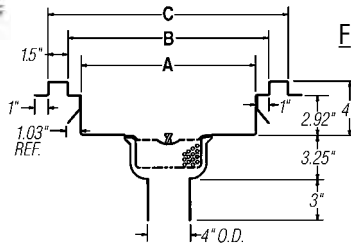

**FEATURES:**

- Built-in pitch towards drain ensures complete drainage.
- Secured with anchor straps.
- Stainless steel drain accommodates up to a 4" (102mm) diameter pipe, and removable perforated stainless steel basket.
- Stainless steel subway-style grating or fiberglass grating.

**Note:** Custom sizes available. Contact factory for pricing.

**Gray Fiberglass Grating available.**  
To order add suffix "G" to model #.  
**Example FT-1218-FGG.**

**Freight class is 85.0.**

(•) MTS (made to stock) / ( ) MTO (made to order)

**Note:** Floor Troughs with ADA-compliant Grating\* available! Provides a more solid walking area, and objects are less likely to fall through. Available for Floor Troughs with Fiberglass AND Stainless Steel Grating! To order, add suffix "-ADA". **Example: FT-1224-FG-ADA.**

**...with Yellow Fiberglass Grating**

\* Troughs with optional ADA-compliant Fiberglass Grating features wider T-bars resistant to corrosion, skid, fire, chipping and cracking. To order, add 5% to list price.

12" (305mm) WIDE TROUGHES	15" (381mm) WIDE TROUGHES	18" (457mm) WIDE TROUGHES	24" (610mm) WIDE TROUGHES
dimension A: 7" (178mm)	dimension A: 10" (254mm)	dimension A: 13" (330mm)	dimension A: 19" (483mm)
dimension B: 9" (229mm)	dimension B: 12" (305mm)	dimension B: 15" (381mm)	dimension B: 21" (533mm)
dimension C: 12" (305mm)	dimension C: 15" (381mm)	dimension C: 18" (457mm)	dimension C: 24" (610mm)

dimension D in. mm	dimension E in. mm	model #	list	model #	list	model #	list	model #	list
18" 457	15" 381	FT-1218-FG	2295	-	-	-	-	-	-
24" 610	21" 533	FT-1224-FG	2488	FT-1524-FG	2539	FT-1824-FG	2725	FT-2424-FG	2917
30" 762	27" 686	FT-1230-FG	2732	FT-1530-FG	2758	FT-1830-FG	3009	FT-2430-FG	3287
36" 914	33" 838	FT-1236-FG	2861	FT-1536-FG	2885	FT-1836-FG	3224	FT-2436-FG •	3544
48" 1219	45" 1143	FT-1248-FG	3284	FT-1548-FG	3323	FT-1848-FG	3733	FT-2448-FG	4161
60" 1524	57" 1448	FT-1260-FG	3556	FT-1560-FG	3712	FT-1860-FG	4169	FT-2460-FG	4771
72" 1829	69" 1753	FT-1272-FG	4017	FT-1572-FG	4096	FT-1872-FG	4660	FT-2472-FG	4814
84" 2134	81" 2057	FT-1284-FG	4394	FT-1584-FG	4519	FT-1884-FG	5201	FT-2484-FG	5998
96" 2438	93" 2362	FT-1296-FG	4795	FT-1596-FG	4877	FT-1896-FG	5681	FT-2496-FG	6563
120" 3048	117" 2972	FT-12120-FG	5596	FT-15120-FG	5902	FT-18120-FG	6881	FT-24120-FG	7983

**...with Subway-Style Stainless Steel Grating**

\* Troughs with optional ADA-compliant Stainless Steel Grating features added stainless steel flat bars spaced only 1/4" apart. Call factory for pricing

12" (305mm) WIDE TROUGHES	15" (381mm) WIDE TROUGHES	18" (457mm) WIDE TROUGHES	24" (610mm) WIDE TROUGHES
dimension A: 7" (178mm)	dimension A: 10" (254mm)	dimension A: 13" (330mm)	dimension A: 19" (483mm)
dimension B: 9" (229mm)	dimension B: 12" (305mm)	dimension B: 15" (381mm)	dimension B: 21" (533mm)
dimension C: 12" (305mm)	dimension C: 15" (381mm)	dimension C: 18" (457mm)	dimension C: 24" (610mm)

dimension D in. mm	dimension E in. mm	model #	list	model #	list	model #	list	model #	list
18" 457	15" 381	FT-1218-SG	3191	-	-	-	-	-	-
24" 610	21" 533	FT-1224-SG •	3346	FT-1524-SG	3558	FT-1824-SG •	3762	FT-2424-SG	4556
30" 762	27" 686	FT-1230-SG	3449	FT-1530-SG	3643	FT-1830-SG	3972	FT-2430-SG	4743
36" 914	33" 838	FT-1236-SG •	3555	FT-1536-SG	4139	FT-1836-SG •	4183	FT-2436-SG •	5408
48" 1219	45" 1143	FT-1248-SG •	4393	FT-1548-SG	5038	FT-1848-SG	4973	FT-2448-SG	6263
60" 1524	57" 1448	FT-1260-SG	5268	FT-1560-SG	5899	FT-1860-SG	6137	FT-2460-SG	7022
72" 1829	69" 1753	FT-1272-SG	6054	FT-1572-SG	6785	FT-1872-SG	6718	FT-2472-SG	8162
84" 2134	81" 2057	FT-1284-SG	7116	FT-1584-SG	7673	FT-1884-SG	8159	FT-2484-SG	8922
96" 2438	93" 2362	FT-1296-SG	7319	FT-1596-SG	8505	FT-1896-SG	8367	FT-2496-SG	9871
120" 3048	117" 2972	FT-12120-SG	9621	FT-15120-SG	10357	FT-18120-SG	11088	FT-24120-SG	11957

### Anti-Splash Floor Troughs

see spec sheet **EG25.01**

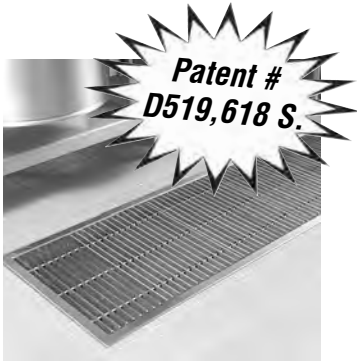

**"Anti-Splash" design assures complete drainage while preventing splashing back onto the floor.**

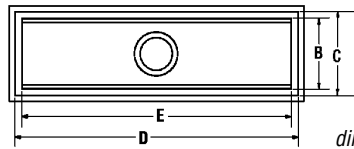
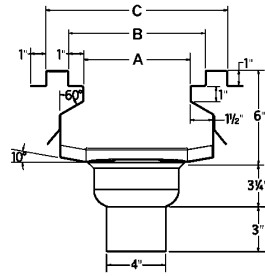

(see chart below for dimensions A through E)

- Built-in pitch towards drain ensures complete drainage.
- Secured with anchor straps.
- Stainless steel drain accommodates up to a 4" (102mm) diameter pipe, and removable perforated stainless steel basket.
- Stainless steel subway-style grating or fiberglass grating.

#### FEATURES:

**Note:** Custom sizes available. Contact factory for pricing.

**Gray Fiberglass Grating available.**  
To order add suffix "G" to model #.  
**Example ASFT-1218-FGG.**

**Freight class is 85.0.**

**Note:** Floor Troughs with ADA-compliant Grating\* available! Provides a more solid walking area, and objects are less likely to fall through. Available for Floor Troughs with Fiberglass AND Stainless Steel Grating! To order, add suffix "ADA". **Example: ASFT-1224-SG-ADA.**

### ...with Yellow Fiberglass Grating

\* Troughs with optional ADA-compliant Fiberglass Grating features wider T-bars resistant to corrosion, skid, fire, chipping and cracking. To order, add 5% to list price.

dimension D		dimension E		12" (305mm) WIDE TROUGHS		15" (381mm) WIDE TROUGHS		18" (457mm) WIDE TROUGHS		24" (610mm) WIDE TROUGHS	
in.	mm	in.	mm	model #	list	model #	list	model #	list	model #	list
18"	457	15"	381	ASFT-1218-FG	2577	-	-	-	-	-	-
24"	610	21"	533	ASFT-1224-FG	2796	ASFT-1524-FG	2853	ASFT-1824-FG	3062	ASFT-2424-FG	3279
30"	762	27"	686	ASFT-1230-FG	3069	ASFT-1530-FG	3095	ASFT-1830-FG	3382	ASFT-2430-FG	3697
36"	914	33"	838	ASFT-1236-FG	3214	ASFT-1536-FG	3242	ASFT-1836-FG	3622	ASFT-2436-FG	3984
48"	1219	45"	1143	ASFT-1248-FG	3688	ASFT-1548-FG	3733	ASFT-1848-FG	4194	ASFT-2448-FG	4677
60"	1524	57"	1448	ASFT-1260-FG	3994	ASFT-1560-FG	4175	ASFT-1860-FG	4683	ASFT-2460-FG	5359
72"	1829	69"	1753	ASFT-1272-FG	4514	ASFT-1572-FG	4603	ASFT-1872-FG	5234	ASFT-2472-FG	5412
84"	2134	81"	2057	ASFT-1284-FG	4938	ASFT-1584-FG	5075	ASFT-1884-FG	5848	ASFT-2484-FG	6741
96"	2438	93"	2362	ASFT-1296-FG	5388	ASFT-1596-FG	5480	ASFT-1896-FG	6382	ASFT-2496-FG	7373
120"	3048	117"	2972	ASFT-12120-FG	6287	ASFT-15120-FG	6633	ASFT-18120-FG	7731	ASFT-24120-FG	8520

### ...with Subway-Style Stainless Steel Grating

\* Troughs with optional ADA-compliant Stainless Steel Grating features added stainless steel flat bars spaced only 1/4" apart. Call factory for pricing

dimension D		dimension E		12" (305mm) WIDE TROUGHS		15" (381mm) WIDE TROUGHS		18" (457mm) WIDE TROUGHS		24" (610mm) WIDE TROUGHS	
in.	mm	in.	mm	model #	list	model #	list	model #	list	model #	list
18"	457	15"	381	ASFT-1218-SG	3574	-	-	-	-	-	-
24"	610	21"	533	ASFT-1224-SG	3589	ASFT-1524-SG	3472	ASFT-1824-SG	4007	ASFT-2424-SG	4800
30"	762	27"	686	ASFT-1230-SG	3754	ASFT-1530-SG	3857	ASFT-1830-SG	4277	ASFT-2430-SG	5560
36"	914	33"	838	ASFT-1236-SG	3919	ASFT-1536-SG	4484	ASFT-1836-SG	4548	ASFT-2436-SG	5774
48"	1219	45"	1143	ASFT-1248-SG	4879	ASFT-1548-SG	5397	ASFT-1848-SG	5457	ASFT-2448-SG	6752
60"	1524	57"	1448	ASFT-1260-SG	5875	ASFT-1560-SG	5965	ASFT-1860-SG	6746	ASFT-2460-SG	7629
72"	1829	69"	1753	ASFT-1272-SG	6783	ASFT-1572-SG	7294	ASFT-1872-SG	7451	ASFT-2472-SG	8893
84"	2134	81"	2057	ASFT-1284-SG	7963	ASFT-1584-SG	8298	ASFT-1884-SG	9011	ASFT-2484-SG	9773
96"	2438	93"	2362	ASFT-1296-SG	8294	ASFT-1596-SG	9148	ASFT-1896-SG	9339	ASFT-2496-SG	10842
120"	3048	117"	2972	ASFT-12120-SG	10838	ASFT-15120-SG	11380	ASFT-18120-SG	12301	ASFT-24120-SG	13174

## Catalog Section 20

### Cool Trough® Water Tempering Systems

see spec sheet **EG25.03A**

**PATENTED!**  
(patent #9,588,525)



#WTFT-1215-FGG  
Cool Trough®

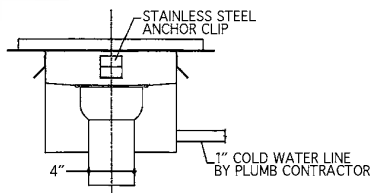

**FEATURES:**

- Integral mechanical temperature sensor maintains water temperature of 130°F or less.
- Built-in pitch towards drain ensures complete drainage.
- No electrical connection required.

**Freight class is 85.0.**

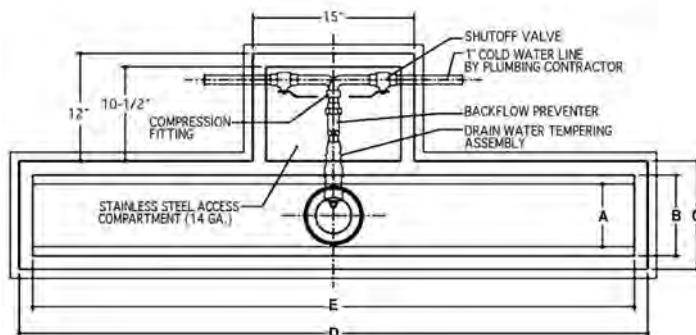

(see chart below for dimensions A through E)

#### ...with Gray Fiberglass Grating

12" (305mm) WIDE TROUGHS	15" (381mm) WIDE TROUGHS	18" (457mm) WIDE TROUGHS	24" (610mm) WIDE TROUGHS
dimension A: 7" (178mm)	dimension A: 10" (254mm)	dimension A: 13" (330mm)	dimension A: 19" (483mm)
dimension B: 9" (229mm)	dimension B: 12" (305mm)	dimension B: 15" (381mm)	dimension B: 21" (533mm)
dimension C: 12" (305mm)	dimension C: 15" (381mm)	dimension C: 18" (457mm)	dimension C: 24" (610mm)

dimension D	dimension E	model #		list	model #	list	model #	list	model #	list	
in.	mm	in.	mm								
15"	381	12"	305	WTFT-1215-FGG	12311	-	-	-	-	-	
18"	457	15"	381	WTFT-1218-FGG	12929	WTFT-1518-FGG	12580	-	-	-	
24"	610	21"	533	WTFT-1224-FGG	13133	WTFT-1524-FGG	13183	WTFT-1824-FGG	13381	WTFT-2424-FGG	13581
30"	762	27"	686	WTFT-1230-FGG	13385	WTFT-1530-FGG	13412	WTFT-1830-FGG	13675	WTFT-2430-FGG	13966
36"	914	33"	838	WTFT-1236-FGG	13522	WTFT-1536-FGG	13547	WTFT-1836-FGG	13900	WTFT-2436-FGG	14235
48"	1219	45"	1143	WTFT-1248-FGG	13963	WTFT-1548-FGG	14004	WTFT-1848-FGG	14434	WTFT-2448-FGG	14881
60"	1524	57"	1448	WTFT-1260-FGG	14248	WTFT-1560-FGG	14356	WTFT-1860-FGG	14889	WTFT-2460-FGG	15519
72"	1829	69"	1753	WTFT-1272-FGG	14729	WTFT-1572-FGG	14812	WTFT-1872-FGG	15968	WTFT-2472-FGG	15562
84"	2134	81"	2057	WTFT-1284-FGG	15123	WTFT-1584-FGG	15254	WTFT-1884-FGG	15968	WTFT-2484-FGG	16799
96"	2438	93"	2362	WTFT-1296-FGG	15544	WTFT-1596-FGG	15627	WTFT-1896-FGG	16468	WTFT-2496-FGG	17391

#### ...with Subway-Style Stainless Steel Grating

12" (305mm) WIDE TROUGHS	15" (381mm) WIDE TROUGHS	18" (457mm) WIDE TROUGHS	24" (610mm) WIDE TROUGHS
dimension A: 7" (178mm)	dimension A: 10" (254mm)	dimension A: 13" (330mm)	dimension A: 19" (483mm)
dimension B: 9" (229mm)	dimension B: 12" (305mm)	dimension B: 15" (381mm)	dimension B: 21" (533mm)
dimension C: 12" (305mm)	dimension C: 15" (381mm)	dimension C: 18" (457mm)	dimension C: 24" (610mm)

dimension D	dimension E	model #		list	model #	list	model #	list	model #	list	
in.	mm	in.	mm								
15"	381	12"	305	WTFT-1215-SG	13563	-	-	-	-	-	
18"	457	15"	381	WTFT-1218-SG	13864	WTFT-1518-SG	13741	-	-	-	
24"	610	21"	533	WTFT-1224-SG	14028	WTFT-1524-SG	14251	WTFT-1824-SG	14463	WTFT-2424-SG	15294
30"	762	27"	686	WTFT-1230-SG	14137	WTFT-1530-SG	14338	WTFT-1830-SG	14682	WTFT-2430-SG	15489
36"	914	33"	838	WTFT-1236-SG	14246	WTFT-1536-SG	14858	WTFT-1836-SG	14902	WTFT-2436-SG	16185
48"	1219	45"	1143	WTFT-1248-SG	15122	WTFT-1548-SG	15796	WTFT-1848-SG	16382	WTFT-2448-SG	17076
60"	1524	57"	1448	WTFT-1260-SG	16038	WTFT-1560-SG	16698	WTFT-1860-SG	16944	WTFT-2460-SG	17871
72"	1829	69"	1753	WTFT-1272-SG	16858	WTFT-1572-SG	17622	WTFT-1872-SG	18409	WTFT-2472-SG	19060
84"	2134	81"	2057	WTFT-1284-SG	17966	WTFT-1584-SG	18549	WTFT-1884-SG	19057	WTFT-2484-SG	19855
96"	2438	93"	2362	WTFT-1296-SG	18180	WTFT-1596-SG	19418	WTFT-1896-SG	20405	WTFT-2496-SG	20845



100 Industrial Boulevard, Clayton, DE 19938-8903 U.S.A.  
Phone: 800-441-8440 or 302-653-3000. Fax: 302-653-2065  
<http://www.eaglegrp.com>

## Anti-Splash Cool Trough® Water Tempering Systems (NSF)

see spec sheet **EG25.03B**

- Integral mechanical temperature sensor maintains water temperature of 130°F or less.
- Built-in pitch towards drain ensures complete drainage.
- No electrical connection required.

FEATURES:

**Freight class is 85.0.**

(•) MTS (made to stock) / ( ) MTO (made to order)



#ASWTFT-1215-FGG  
Cool Trough®

**PATENTED!**  
(patent #9,588,525)

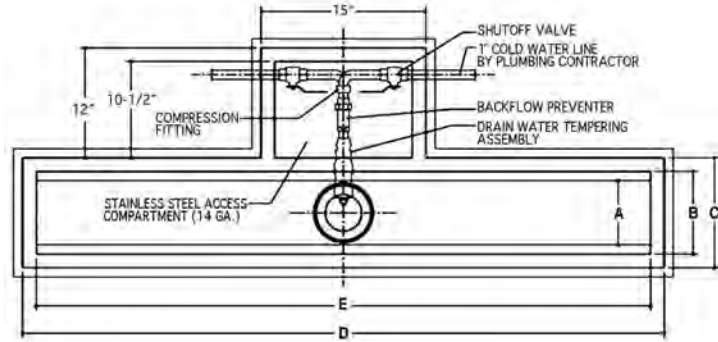
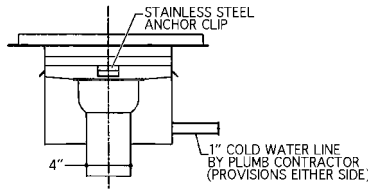

(see chart below for dimensions A through E)

### ...with Gray Fiberglass Grating

12" (305mm) WIDE TROUGHS	15" (381mm) WIDE TROUGHS	18" (457mm) WIDE TROUGHS	24" (610mm) WIDE TROUGHS
dimension A: 7" (178mm)	dimension A: 10" (254mm)	dimension A: 13" (330mm)	dimension A: 19" (483mm)
dimension B: 9" (229mm)	dimension B: 12" (305mm)	dimension B: 15" (381mm)	dimension B: 21" (533mm)
dimension C: 12" (305mm)	dimension C: 15" (381mm)	dimension C: 18" (457mm)	dimension C: 24" (610mm)

dimension D	dimension E	12" (305mm) WIDE TROUGHS		15" (381mm) WIDE TROUGHS		18" (457mm) WIDE TROUGHS		24" (610mm) WIDE TROUGHS	
in.	mm	in.	mm	model #	list	model #	list	model #	list
15"	381	12"	305	ASWTFT-1215-FGG	12933	-	-	-	-
18"	457	15"	381	ASWTFT-1218-FGG	13224	ASWTFT-1518-FGG	13194	-	-
24"	610	21"	533	ASWTFT-1224-FGG	13454	ASWTFT-1524-FGG	13512	ASWTFT-1824-FGG	13733
30"	762	27"	686	ASWTFT-1230-FGG	13739	ASWTFT-1530-FGG	13766	ASWTFT-1830-FGG	14065
36"	914	33"	838	ASWTFT-1236-FGG	13891	ASWTFT-1536-FGG	13919	ASWTFT-1836-FGG	14317
48"	1219	45"	1143	ASWTFT-1248-FGG	14385	ASWTFT-1548-FGG	14434	ASWTFT-1848-FGG	14916
60"	1524	57"	1448	ASWTFT-1260-FGG	14705	ASWTFT-1560-FGG	14893	ASWTFT-1860-FGG	15426
72"	1829	69"	1753	ASWTFT-1272-FGG	15247	ASWTFT-1572-FGG	15343	ASWTFT-1872-FGG	16001
84"	2134	81"	2057	ASWTFT-1284-FGG	15694	ASWTFT-1584-FGG	15836	ASWTFT-1884-FGG	16644
96"	2438	93"	2362	ASWTFT-1296-FGG	16162	ASWTFT-1596-FGG	16259	ASWTFT-1896-FGG	17201

### ...with Subway-Style Stainless Steel Grating

12" (305mm) WIDE TROUGHS	15" (381mm) WIDE TROUGHS	18" (457mm) WIDE TROUGHS	24" (610mm) WIDE TROUGHS
dimension A: 7" (178mm)	dimension A: 10" (254mm)	dimension A: 13" (330mm)	dimension A: 19" (483mm)
dimension B: 9" (229mm)	dimension B: 12" (305mm)	dimension B: 15" (381mm)	dimension B: 21" (533mm)
dimension C: 12" (305mm)	dimension C: 15" (381mm)	dimension C: 18" (457mm)	dimension C: 24" (610mm)

dimension D	dimension E	12" (305mm) WIDE TROUGHS		15" (381mm) WIDE TROUGHS		18" (457mm) WIDE TROUGHS		24" (610mm) WIDE TROUGHS	
in.	mm	in.	mm	model #	list	model #	list	model #	list
15"	381	12"	305	ASWTFT-1215-SG	12657	-	-	-	-
18"	457	15"	381	ASWTFT-1218-SG	14264	ASWTFT-1518-SG	13512	-	-
24"	610	21"	533	ASWTFT-1224-SG	14283	ASWTFT-1524-SG	14160	ASWTFT-1824-SG	14719
30"	762	27"	686	ASWTFT-1230-SG	14454	ASWTFT-1530-SG	14562	ASWTFT-1830-SG	15000
36"	914	33"	838	ASWTFT-1236-SG	14627	ASWTFT-1536-SG	15218	ASWTFT-1836-SG	15284
48"	1219	45"	1143	ASWTFT-1248-SG	15631	ASWTFT-1548-SG	16171	ASWTFT-1848-SG	16235
60"	1524	57"	1448	ASWTFT-1260-SG	16672	ASWTFT-1560-SG	16765	ASWTFT-1860-SG	17581
72"	1829	69"	1753	ASWTFT-1272-SG	17618	ASWTFT-1572-SG	17618	ASWTFT-1872-SG	18317
84"	2134	81"	2057	ASWTFT-1284-SG	18854	ASWTFT-1584-SG	19224	ASWTFT-1884-SG	19946
96"	2438	93"	2362	ASWTFT-1296-SG	19198	ASWTFT-1596-SG	20092	ASWTFT-1896-SG	20292

## Catalog Section 20

### Replacement Subway-Style Grating for Floor Troughs and Drains

see spec sheet **EG25.02**

Freight class is 85.0.

#### Stainless Steel Grating

- Constructed of  $\frac{3}{16}$ " x 1" (5 x 25mm) vertically positioned bars, spaced 1" (25mm) apart to allow ease of drainage.
- $\frac{1}{16}$ " (21mm) clearance between bars prevents casters on mobile equipment from wedging in grate.
- Two  $\frac{3}{16}$ " (8mm) rods, set  $2\frac{1}{4}$ " (57mm) in from each edge, are welded to the bars to eliminate swaying.
- Standard on floor troughs.
- Sizes available fit floor drains up to 24" (610mm) wide.
- Grates 12" and 15" (305 and 381mm) wide feature three rods.
- Grates 21" (533mm) wide feature five rods.



for floor trough widths		grate width x length		model #	list each
in.	mm	in.	mm		
12"	305	9" x 7½"	229 x 191	<b>341169</b>	440
12"	305	9" x 9"	229 x 229	<b>341117</b>	561
12"	305	9" x 12"	229 x 305	<b>341123</b>	612
15"	381	12" x 9"	305 x 229	<b>340992</b>	669
15"	381	12" x 12"	305 x 305	<b>331006</b>	722
18"	457	15" x 6"	381 x 154	<b>341330</b>	621
18"	457	15" x 7½"	381 x 191	<b>341110</b>	660
18"	457	15" x 9"	381 x 229	<b>341113</b>	707
18"	457	15" x 12"	381 x 305	<b>336992</b>	773
18"	457	15" x 15"	381 x 381	<b>345934</b>	839
24"	610	21" x 9"	533 x 229	<b>341109</b>	800
24"	610	21" x 11"	533 x 279	<b>351572</b>	858
24"	610	21" x 12"	533 x 305	<b>336976</b>	884

#### Wide "T" Bar Fiberglass Grating — ADA-compliant!

- Conforms with the Americans with Disabilities Act for use with the physically handicapped.
- Provides a more solid walking area than traditional "T" bar shape, and prevents objects from falling through grating.
- Corrosion-, skid- and fire-resistant.
- High strength, low thermal conductivity.
- Resistant to chipping and cracking.
- Temperature rating of 250°F.



#### Fiberglass Grating

- Constructed of 1" (25mm) high yellow or gray polyester material with a non-slip grit on top surface.
- Tapered "I" beam construction for ease of cleaning and draining.
- Temperature rating of 250°F.
- Other sizes available—consult factory.

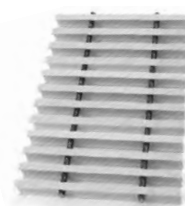

**GRAY OR YELLOW**

for floor trough widths		grate width x length		Gray	
in.	mm	in.	mm	model #	list ea
12"	305	9" x 9"	229 x 229	<b>370000</b>	172
12"	305	9" x 12"	229 x 305	<b>370001</b>	209
12"	305	9" x 15"	229 x 381	<b>370002</b>	226
15"	381	12" x 9"	305 x 229	<b>370003</b>	179
15"	381	12" x 12"	305 x 305	<b>370004</b>	220
18"	457	15" x 9"	381 x 229	<b>370005</b>	229
18"	457	15" x 12"	381 x 305	<b>370006</b>	285
18"	457	15" x 15"	381 x 381	<b>370007</b>	353
24"	610	21" x 9"	533 x 229	<b>370008</b>	291
24"	610	21" x 12"	533 x 305	<b>370009</b>	366

for floor trough widths		grate width x length		Yellow		Gray	
in.	mm	in.	mm	model #	list ea	model #	list ea
12"	305	9" x 9"	229 x 229	<b>362648</b>	139	<b>374015</b>	145
12"	305	9" x 12"	229 x 305	<b>362647</b>	165	<b>374018</b>	175
12"	305	9" x 15"	229 x 381	<b>373030</b>	176	<b>374021</b>	185
15"	381	12" x 9"	305 x 229	<b>362650</b>	139	<b>374044</b>	145
15"	381	12" x 12"	305 x 305	<b>362649</b>	165	<b>374047</b>	175
18"	457	15" x 9"	381 x 229	<b>362652</b>	178	<b>374073</b>	188
18"	457	15" x 12"	381 x 305	<b>362651</b>	217	<b>374076</b>	227
18"	457	15" x 15"	381 x 381	<b>373206</b>	267	<b>374079</b>	284
24"	610	21" x 9"	533 x 229	<b>362654</b>	218	<b>374102</b>	229
24"	610	21" x 12"	533 x 305	<b>362653</b>	271	<b>374105</b>	287

### Floor Drains

see spec sheet **EG25.00**



shown without grating

description	width x length		model #	list
	in.	mm		
with yellow fiberglass grating	12" x 12"	305 x 305	<b>FD-FG</b>	1826
with subway-style grating	12" x 12"	305 x 305	<b>FD-SG</b>	2433

Note: Floor opening = 11½" x 11½" (292 x 292)

#### FEATURES:

- Perforated waste cup can be inverted to double as a bee hive strainer.
- Yellow fiberglass grating or subway-style stainless steel grating.

Note: **Gray Fiberglass Grating** available. To order add suffix "G" to model #. Example FD-FGG.

Freight class is 85.0.

(•) MTS (made to stock) / ( ) MTO (made to order)

# NOTES



Two columns of horizontal lines for taking notes.

# Hot Food Tables

## Accessories/Replacements

Buffet Shelves .....	228
Caster Stabilizing Device .....	230
Cutting Boards .....	230
Dish Shelves.....	229
Food Pans, Lids, Insets .....	232
Rolltop Cover .....	231
Serving Shelves .....	227, 228
Spillage Pans .....	231
Tray Shelves .....	229
Tray Slides .....	229
All Others .....	227, 231, 232

## Cold Pan Units

Buffet Style.....	235
Enclosed Base .....	224
Open Base .....	225

## Deluxe Service Mates/ Buffet Units

Accessories .....	236
Beef Cart.....	235
Cashiers Stand .....	236
Cold Pan Units .....	235
Hot Food Tables .....	234
Solid Top Units.....	235

## Flex-Master®

<b>Overshelf System .....</b>	<b>233</b>
-------------------------------	------------

## Hot Food Tables - Electric

Buffet Style.....	234
Enclosed Base - Dry .....	218-219
Open Base - Dry .....	214-215
Sealed Well - Wet or Dry .....	217, 221
Water Bath .....	222

## Hot Food Tables - Gas

Enclosed Base - Dry .....	220
Open Base - Dry .....	216
Water Bath .....	223

## Solid Top Units

Buffet Style.....	235
Enclosed Base .....	225
Open Base .....	226

## Sealed Well Hot Food Tables

Enclosed Base .....	221
Open Base .....	217

## Tray Stands ..... 227

## Urn Stands ..... 226

## HOT TIPS ABOUT HOT FOOD TABLES

*Why EAGLE Is The Smart Choice  
For All Your Hot Food Table Needs...*

*It's More Than Just  
The Stainless Steel Body...*

### EAGLE Advantages Include:

- Stainless steel body.
- Full-height tubular legs and gusset assembly welded to body for quick and easy assembly.
- 8" (203mm) wide cutting board.
- Cutting board and optional shelves can be mounted on either or both sides of unit.
- Optional bolted-on undershelf available.

### FLEX-MASTER® Overshelf System

- 16 gauge type 304 stainless steel shelves.
- Shelf widths are 10" and 15" (254 and 381mm).
- Shelf height can be adjusted in 1" (25mm) increments without the use of tools.
- Heat lamps can also be mounted underneath overshelves.



All of the features of the EAGLE hot food table offer benefits in style, strength and flexibility that are unmatched in our marketplace, and are standard on every hot food table from our product line. EAGLE is committed to providing you the highest quality products while maintaining the cost competitiveness necessary in today's marketplace.

For more information about the Chef's Counter,  
see page 380, or request product announcement **EG8123**

## Electric Hot Food Tables — Open Base Stationary

see spec sheet **EG30.00**









2-well stationary hot food table



3-well stationary unit

### Receptacle Configurations Required

See chart below for applicable NEMA plug.

					
15A 120V	15A 240V	20A 240V	30A 240V	30A 120V	20A 3Ø 240V
furnished with NEMA 5-15 plug	furnished with NEMA 6-15 plug	furnished with NEMA 6-20 plug	furnished with NEMA 6-30 plug	furnished with NEMA 5-30 plug	furnished with NEMA 15-20 plug

New York M.E.A. No. 376-84-E

- Table body and top are polished 22 gauge 430 series stainless steel.
- Top openings are sized to accommodate 12" x 20" (305 x 508mm) food pans.
- 8" (203mm) wide, ½" (13mm) thick poly cutting board.
- Recessed control panel, infinite controls.
- Each element has a rating of 500-watt at 120-volt and 750-watt at 208V and 240-volt.
- 8" (203mm) deep insulated heating compartments lined with 22 gauge galvanized steel.
- Galvanized adjustable undershelf.
- 6' (1829mm) cord on right-hand side.
- 30½" (775mm) front-to-back including cutting board.
- Primarily for dry operation, but adaptable for wet application with spillage pan.

### FEATURES:

**Notes:** 1000-watt heaters available for 208-volt and 240-volt models. To order, add suffix "-1" to model number and \$86 per well to list price. Example: DHT2-240-1.

**Bolted-in undershelf available.** To specify, add 20% to list price of unit and add suffix "B" to model number. Example: DHT2-120B.

**Stainless steel liners in place of galvanized.**

**Add \$111 per compartment to list price of unit and add "S" after "HT" in model number. Example: DHTS3-120.**

**Freight class is 92.5.**

(•) MTS (made to stock) / ( ) MTO (made to order)

"DHT" units features galvanized legs & undershelf. "SDHT" units feature stainless steel legs & undershelf. Non-marking adjustable plastic feet adjusts height of unit from 34½" to 35½" (876 to 902mm).

# of top openings	length in.	weight lbs.	cu ft	volts	watts	amps	NEMA plug	Single-Phase		Three-Phase*					
								GALVANIZED BASE model #	STAINLESS BASE list	amps	NEMA plug	GALVANIZED BASE model #	STAINLESS BASE list	GALVANIZED BASE model #	STAINLESS BASE list
2	33"	838	91	41.3	15.4	120	1000	8.3	5-15P	DHT2-120• 2117	SDHT2-120 2376	-	-	n/a	n/a
2	33"	838	91	41.3	15.4	208	1500	7.2	6-15P	DHT2-208 2117	SDHT2-208 2376	6.3	15-20P	DHT2-208-3 2460	SDHT2-208-3 2720
2	33"	838	91	41.3	15.4	240	1500	6.25	6-15P	DHT2-240 2117	SDHT2-240 2376	5.4	15-20P	DHT2-240-3 2460	SDHT2-240-3 2720
3	48"	1219	128	58.1	15.4	120	1500	12.5	5-15P	DHT3-120• 2386	SDHT3-120• 2674	-	-	n/a	n/a
3	48"	1219	128	58.1	15.4	208	2250	10.8	6-15P	DHT3-208• 2386	SDHT3-208 2674	6.3	15-20P	DHT3-208-3 2732	SDHT3-208-3 3018
3	48"	1219	128	58.1	15.4	240	2250	9.38	6-15P	DHT3-240• 2386	SDHT3-240 2674	5.4	15-20P	DHT3-240-3 2732	SDHT3-240-3 3018
4	63½"	1613	191	86.6	26.6	120	2000	16.6	5-30P	DHT4-120• 3243	SDHT4-120 3631	-	-	n/a	n/a
4	63½"	1613	191	86.6	26.6	208	3000	14.4	6-20P	DHT4-208• 3243	SDHT4-208 3631	9.5A	15-20P	DHT4-208-3 3588	SDHT4-208-3 3977
4	63½"	1613	191	86.6	26.6	240	3000	12.5	6-20P	DHT4-240• 3243	SDHT4-240 3631	8.3A	15-20P	DHT4-240-3 3588	SDHT4-240-3 3977
5*	79"	2007	241	109.3	32.2	208	3750	18.0	6-30P	DHT5-208• 4077	SDHT5-208 4567	12.5A	15-20P	DHT5-208-3 4422	SDHT5-208-3 4914
5*	79"	2007	241	109.3	32.2	240	3750	15.6	6-30P	DHT5-240• 4077	SDHT5-240 4567	10.8A	15-20P	DHT5-240-3 4422	SDHT5-240-3 4914

\* Single-Phase 5-well units, and all Three-Phase units, available in 208V and 240V only.

**NOTE: UNITS ARE NOT DESIGNED FOR COOKING OR HEATING REFRIGERATED OR FROZEN FOODS. WHEN USED PER THE OPERATING INSTRUCTIONS, UNITS ARE DESIGNED TO MAINTAIN PREHEATED FOODS AT PROPER TEMPERATURES.**

## Spillage Pans

see spec sheet **EG30.20**

- Required for wet applications.
- Deep-drawn, fully covered.
- 6½" (165mm) deep.



Freight class is 100.0.

description	weight lbs.	kg	model #	list
stainless steel	7	3.2	302027	263
aluminum	3	1.4	304141	142

## FLEX-MASTER® Overshelf Kits

Both kits include two 16/304 overshelves and four 30" (762mm) posts. Add suffix specified to order kit (example: SDHT2-120-FM), or design your own using standard components from page 233.

description	add suffix	List Prices			
		2-well	3-well	4-well	5-well
10" (254mm) overshelves	-FM	1568	1619	1683	1998
15" (381mm) overshelves, plus one ladle rack	-FMU	2111	2197	2287	2811



## Catalog Section 30

### Electric Hot Food Tables — Open Base Portable

see spec sheet **EG30.01**









4-well portable



5-well portable unit with optional FLEX-MASTER® overshelves

#### Receptacle Configurations Required

See chart below for applicable NEMA plug.

					
15A 120V	15A 240V	20A 240V	30A 240V	30A 120V	20A 3Ø 240V
furnished with NEMA 5-15 plug	furnished with NEMA 6-15 plug	furnished with NEMA 6-20 plug	furnished with NEMA 6-30 plug	furnished with NEMA 5-30 plug	furnished with NEMA 15-20 plug

New York M.E.A. No. 376-84-E

“PDHT” units features galvanized legs & undershelf. “SPDHT” units feature stainless steel legs & undershelf. 4” (102mm) diameter NSF-approved ball-bearing casters (two swivel and two with brake), push bar attached to end panel at operator’s right, and drop brackets on cutting board.

# of top openings	length in.	length mm	weight lbs.	weight kg	cu ft	volts	watts	amps	NEMA plug	Single-Phase		Three-Phase*		amps	NEMA plug	GALVANIZED BASE		STAINLESS BASE	
										model #	list	model #	list			model #	list	model #	list
2	35½"	902	101	45.8	15.7	120	1000	8.3	5-15P	PDHT2-120	2608	SPDHT2-120	2920	-	-	n/a	n/a	n/a	n/a
2	35½"	902	101	45.8	15.7	208	1500	7.2	6-15P	PDHT2-208	2608	SPDHT2-208	2920	6.3	15-20P	PDHT2-208-3	2954	SPDHT2-208-3	3267
2	35½"	902	101	45.8	15.7	240	1500	6.25	6-15P	PDHT2-240	2608	SPDHT2-240	2920	5.4	15-20P	PDHT2-240-3	2954	SPDHT2-240-3	3267
3	50½"	1283	129	59.0	15.7	120	1500	12.5	5-15P	PDHT3-120	2879	SPDHT3-120	3220	-	-	n/a	n/a	n/a	n/a
3	50½"	1283	129	59.0	15.7	208	2250	10.8	6-15P	PDHT3-208	2879	SPDHT3-208	3220	6.3	15-20P	PDHT3-208-3	3223	SPDHT3-208-3	3565
3	50½"	1283	129	59.0	15.7	240	2250	9.38	6-15P	PDHT3-240	2879	SPDHT3-240	3220	5.4	15-20P	PDHT3-240-3	3223	SPDHT3-240-3	3565
4	66"	1676	162	73.5	26.6	120	2000	16.6	5-30P	PDHT4-120	3948	SPDHT4-120	4422	-	-	n/a	n/a	n/a	n/a
4	66"	1676	162	73.5	26.6	208	3000	14.4	6-20P	PDHT4-208	3948	SPDHT4-208	4422	9.5A	15-20P	PDHT4-208-3	4295	SPDHT4-208-3	4767
4	66"	1676	162	73.5	26.6	240	3000	12.5	6-20P	PDHT4-240	3948	SPDHT4-240	4422	8.3A	15-20P	PDHT4-240-3	4295	SPDHT4-240-3	4767
5*	81½"	2070	199	90.3	32.2	208	3750	18.0	6-30P	PDHT5-208	4854	SPDHT5-208	5433	12.5A	15-20P	PDHT5-208-3	5197	SPDHT5-208-3	5776
5*	81½"	2070	199	90.3	32.2	240	3750	15.6	6-30P	PDHT5-240	4854	SPDHT5-240	5433	10.8A	15-20P	PDHT5-240-3	5197	SPDHT5-240-3	5776

\* Single-Phase 5-well units, and all Three-Phase units, available in 208V and 240V only.

**NOTE: UNITS ARE NOT DESIGNED FOR COOKING OR HEATING REFRIGERATED OR FROZEN FOODS. WHEN USED PER THE OPERATING INSTRUCTIONS, UNITS ARE DESIGNED TO MAINTAIN PREHEATED FOODS AT PROPER TEMPERATURES.**

#### Spillage Pans

see spec sheet **EG30.20**

- Required for wet applications.
- Deep-drawn, fully covered.
- 6½" (165mm) deep.



description	weight		model #	list
	lbs.	kg		
stainless steel	7	3.2	302027	263
aluminum	3	1.4	304141	142

Freight class is 100.0.

#### FLEX-MASTER® Overshelf Kits

Both kits include two 16/304 overshelves and four 30" (762mm) posts. Add suffix specified to order kit (example: PDHT2-120-FM), or design your own using standard components from page 233.

description	add suffix	List Prices			
		2-well	3-well	4-well	5-well
10" (254mm) overshelves	-FM	1568	1619	1683	1998
15" (381mm) overshelves, plus one ladle rack	-FMU	2111	2197	2287	2811

#### FEATURES:

- Table body and top are polished 22 gauge 430 series stainless steel.
- Top openings are sized to accommodate 12" x 20" (305 x 508mm) food pans.
- 8" (203mm) wide, ½" (13mm) thick poly cutting board.
- Recessed control panel, infinite controls.
- Each element has a rating of 500-watt at 120-volt and 750-watt at 208V and 240-volt.
- 8" (203mm) deep insulated heating compartments lined with 22 gauge galvanized steel.
- Galvanized adjustable undershelf.
- 6" (152mm) cord on right-hand side.
- 30½" (775mm) front-to-back including cutting board.
- Primarily for dry operation, but adaptable for wet application with spillage pan.
- 34" (864mm) height.

**Notes:** 1000-watt heaters available for 208-volt and 240-volt models. To order, add suffix "-1" to model number and \$86 per well to list price. Example: PDHT2-240-1.

Bolted-in undershelf available. To specify, add 20% to list price of unit and add suffix "B" to model number. Example: PDHT2-120B.

Stainless steel liners in place of galvanized.

Add \$111 per compartment to list price of unit and add "S" after "HT" in model number. Example: PDHTS3-120.

**Freight class is 92.5.**

(•) MTS (made to stock) / ( ) MTO (made to order)

## Gas Hot Food Tables — Open Base

see spec sheet **EG30.02**



2-well unit



3-well unit shown with optional FLEX-MASTER® overshelves

### FEATURES:

- Table body and top are polished 22 gauge 430 series stainless steel.
- Top openings are sized to accommodate 12" x 20" (305 x 508mm) food pans.
- 8" (203mm) wide, 1/2" (13mm) thick poly cutting board.
- Recessed control panel; individual controls.
- High-output jet burners rated at 3500 BTUs.
- 8" (203mm) deep insulated heating compartments lined with heavy gauge galvanized steel.
- Adjustable galvanized undershelf.
- Adjustable non-marking plastic feet.
- Cutting board can be mounted on either side of unit.
- 30 1/2" (775mm) front-to-back including cutting board.
- Adjustable from 34 1/2" to 35 1/2" (876 to 902mm) height.
- Primarily for dry operation, but adaptable for wet application with spillage pan.

**Note:** To order LP gas models. Insert suffix "-LP" in place of "-NG" in appropriate model number. **Example:** HT2-LP.

**Bolted-in undershelf available.** To specify, add 20% to list price of unit and add suffix "B" to model number. **Example:** HT2-NGB.

**Stainless steel liners in place of galvanized.** Add \$111 per compartment to list price of unit and add "S" after "HT" in model number. **Example:** HTS2-NG.

**Units with thermostatic control.** Add \$524 per well to list price and suffix "T". **Example:** HT2-NGT.

**Auto safety pilot.** Add \$331 per well to list price and suffix "S". **Example:** HT2-NGS.

**Units with thermostatic control and auto safety pilot.** Add \$856 per well to list price and suffix "TS". **Example:** HT2-NGTS.

1/2" (13mm) N.P.T. pipe connection is on right side.

**Freight class is 85.0.**

(•) MTS (made to stock) / ( ) MTO (made to order)

Models with prefix "S" indicate standard stainless steel undershelf and legs.

# of top openings	length		weight		cu ft	total BTU rating	model #	list
	in.	mm	lbs.	kg				
2	33"	838	91	41.3	15.7	7,000	HT2-NG •	2147
2	33"	838	91	41.3	15.7	7,000	SHT2-NG	2384
3	48"	1219	128	58.1	15.7	10,500	HT3-NG •	2574
3	48"	1219	128	58.1	15.4	10,500	SHT3-NG	2859
4	63 1/2"	1613	191	86.6	26.6	14,000	HT4-NG •	3147
4	63 1/2"	1613	191	86.6	26.6	14,000	SHT4-NG	3498
5	79"	2007	241	109.3	32.6	17,500	HT5-NG •	3792
5	79"	2007	241	109.3	32.6	17,500	SHT5-NG	4212

### FLEX-MASTER® Overshelf Kits

Both kits include two 16/304 overshelves and four 30" (762mm) posts. Add suffix specified to order kit (**example:** SHT2-NG-FM), or design your own using standard components from page 233.

description	add suffix	List Prices			
		2-well	3-well	4-well	5-well
10" (254mm) overshelves	-FM	1568	1619	1683	1998
15" (381mm) overshelves, plus one ladle rack	-FMU	2111	2197	2287	2811

New York M.E.A. No. 375-84-E

## Spillage Pans

see spec sheet **EG30.20**



- Required for wet applications.
- Deep-drawn, fully covered.
- 6 1/2" (165mm) deep.

**Freight class is 100.0.**

description	weight		model #	list
	lbs.	kg		
stainless steel	7	3.2	302027	263
aluminum	3	1.4	304141	142

## Catalog Section 30

### Sealed Well Hot Food Tables — Open Base

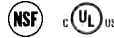

#### FEATURES:

- Sealed-in heat wells, each with individual controls, allow for wet or dry application.
- Built-in drainage eliminates the need for spillage pans, reducing clean-up time.
- All type 430 stainless steel construction.
- Stainless steel legs and gussets.
- Heavy gauge stainless steel adjustable undershelf.
- Poly cutting board.
- Stainless steel dish shelf.
- 32 1/4" (819mm) front-to-back, including cutting board and dish shelf.
- Each element has a rating of 750-watt at 120-volt, 714-watt at 208-volt, and 950-watt at 240-volt.
- 6' (1829mm) cord and plug.

see spec sheet **EG30.19**



3-compartment stationary unit

#### Receptacle Configurations Required

See charts below for applicable NEMA plug.

15A 120V	15A 240V	20A 240V	30A 120V	30A 240V	50A 120V	20A 3Ø 240V
furnished with NEMA 5-15 plug	furnished with NEMA 6-15 plug	furnished with NEMA 6-20 plug	furnished with NEMA 5-30 plug	furnished with NEMA 6-30 plug	furnished with NEMA 5-50 plug	furnished with NEMA 15-20 plug

New York M.E.A. No. 376-84-E

#### Stationary Units

Non-marking adjustable plastic feet adjusts height of unit from 34 1/2" to 35 1/2" (876 to 902mm).

# of top openings	length in.	length mm	weight lbs.	weight kg	cu ft	volts	watts	amps	SINGLE-PHASE			THREE-PHASE			
									NEMA plug	model #	list	amps	NEMA plug	model #	list
2	33"	838	101	45.8	15.7	120	1500	12.5	5-15P	SHT2-120	3852	-	-	n/a	
2	33"	838	101	45.8	15.7	208	1428	6.9	6-15P	SHT2-208	3852	6.0	15-20P	SHT2-208-3	4195
2	33"	838	101	45.8	15.7	240	1900	7.9	6-15P	SHT2-240	3852	6.9	15-20P	SHT2-240-3	4195
3	48"	1219	129	58.5	15.7	120	2250	18.8	5-30P	SHT3-120 •	5100	-	-	n/a	
3	48"	1219	129	58.5	15.7	208	2142	10.3	6-15P	SHT3-208	5100	6.0	15-20P	SHT3-208-3	5444
3	48"	1219	129	58.5	15.7	240	2850	11.9	6-15P	SHT3-240 •	5100	6.9	15-20P	SHT3-240-3	5444
4	63 1/2"	1613	162	73.5	27.4	120	3000	25.0	5-50P	SHT4-120 •	6257	-	-	n/a	
4	63 1/2"	1613	162	73.5	27.4	208	2856	13.7	6-20P	SHT4-208	6257	9.1	15-20P	SHT4-208-3	6601
4	63 1/2"	1613	162	73.5	27.4	240	3800	15.8	6-20P	SHT4-240 •	6257	10.5	15-20P	SHT4-240-3	6601
5*	79"	2007	199	90.3	32.2	208	3570	17.2	6-30P	SHT5-208	7674	11.9	15-20P	SHT5-208-3	8019
5*	79"	2007	199	90.3	32.2	240	4750	19.8	6-30P	SHT5-240 •	7674	13.7	15-20P	SHT5-240-3	8019

\* Single-Phase 5-well units, and all Three-Phase units, available in 208V and 240V only.

#### Portable Units

4" (102mm) diameter NSF-approved ball-bearing swivel casters (two with brake), and push bar attached to end panel at operator's right.

# of top openings	length in.	length mm	weight lbs.	weight kg	cu ft	volts	watts	amps	SINGLE-PHASE			THREE-PHASE			
									NEMA plug	model #	list	amps	NEMA plug	model #	list
2	35 1/2"	902	101	45.8	15.7	120	1500	12.5	5-15P	SPHT2-120	3977	-	-	n/a	
2	35 1/2"	902	101	45.8	15.7	208	1428	6.9	6-15P	SPHT2-208	3977	6.0	15-20P	SPHT2-208-3	4322
2	35 1/2"	902	101	45.8	15.7	240	1900	7.9	6-15P	SPHT2-240	3977	6.9	15-20P	SPHT2-240-3	4322
3	50 1/2"	1283	129	58.5	15.7	120	2250	18.8	5-30P	SPHT3-120	5264	-	-	n/a	
3	50 1/2"	1283	129	58.5	15.7	208	2142	10.3	6-15P	SPHT3-208	5264	6.0	15-20P	SPHT3-208-3	5608
3	50 1/2"	1283	129	58.5	15.7	240	2850	11.9	6-15P	SPHT3-240	5264	6.9	15-20P	SPHT3-240-3	5608
4	66"	1676	162	73.5	20.0	120	3000	25.0	5-50P	SPHT4-120	6349	-	-	n/a	
4	66"	1676	162	73.5	20.0	208	2856	13.7	6-20P	SPHT4-208	6349	9.1	15-20P	SPHT4-208-3	6694
4	66"	1676	162	73.5	20.0	240	3800	15.8	6-20P	SPHT4-240	6349	10.5	15-20P	SPHT4-240-3	6694
5*	81 1/2"	2070	199	90.3	24.1	208	3570	17.2	6-30P	SPHT5-208	8057	11.9	15-20P	SPHT5-208-3	8402
5*	81 1/2"	2070	199	90.3	27.1	240	4750	19.8	6-30P	SPHT5-240	8057	13.7	15-20P	SPHT5-240-3	8402

\* Single-Phase 5-well units, and all Three-Phase units, available in 208V and 240V only.

Freight class is 92.5.

(•) MTS (made to stock) / ( ) MTO (made to order)

See page 221 for **NEW Enclosed Base Sealed Well Hot Food Tables**



**AutoFill® automatic water fill system available.**

NSF- and UL-approved. To order, add \$1714 to list price and add "A" in front of the dash in model number. Example: SHT2A-240.

**FLEX-MASTER® Overshelf Kits — see page 216.**



3-compartment portable unit

## SPEC-MASTER® Electric Hot Food Tables Enclosed Base Stationary



see spec sheet **EG30.04**

### OUR BEST



3-well enclosed base hot food table shown with optional FLEX-MASTER® overshelves

Non-marking adjustable plastic feet adjusts height of unit from 34½" to 35½" (876 to 902mm)

All stationary units designed for field wiring.

- 20 gauge table body and 22 gauge top are polished type 430 series stainless steel.
- Top openings are sized to accommodate 12" x 20" (305 x 508mm) food pans.
- 8" (203mm) wide, ½" (13mm) thick poly cutting board.
- Recessed control panel; individual thermostatic controls.
- Each element has a rating of 750-watt at both 120-volt and 240-volt.
- 8" (203mm) deep insulated heating compartments lined with 22 gauge galvanized steel.
- 30½" (775mm) front-to-back including cutting board.
- Primarily for dry operation, but adaptable for wet application with spillage pan (see page 231).
- Available with open front or 22 gauge stainless steel sliding doors.

#### FEATURES:

**Notes:** 1000-watt heaters available for 208-volt and 240-volt models. To order, add suffix "-1" to model number and \$86 per well to list price. Example: HT40B-240-1.

Stainless steel liners in place of galvanized.

Add \$111 per compartment to list price of unit and add "S" after "HT" in model number. Example: HTS3CB-120.

**Freight class is 92.5.**

(•) MTS (made to stock) / ( ) MTO (made to order)

# of top openings	length		weight		cu ft	volts	watts	Open Front			Sliding Doors					
	in.	mm	lbs.	kg				SINGLE-PHASE			THREE-PHASE					
							amps	model #	list	amps	model #	list	amps	model #	list	
2	33"	838	200	90.7	28.7	120V	1500W	12.5A	HT20B-120	5025	n/a	n/a	n/a	12.5A	HT2CB-120	5577
2	33"	838	200	90.7	28.7	240V	1500W	6.3A	HT20B-240*	5025	5.4A	HT20B-240-3*	5544	6.3A	HT2CB-240*	5577
3	48"	1219	240	108.9	39.8	120V	2250W	18.8A	HT30B-120	5773	n/a	n/a	n/a	18.8A	HT3CB-120	6824
3	48"	1219	240	108.9	39.8	240V	2250W	9.4A	HT30B-240*	5773	5.4A	HT30B-240-3*	6288	9.4A	HT3CB-240*	6824
4	63½"	1613	280	127.0	51.5	120V	3000W	25.0A	HT40B-120	7095	n/a	n/a	n/a	25.0A	HT4CB-120	8383
4	63½"	1613	280	127.0	51.5	240V	3000W	12.5A	HT40B-240*	7095	8.3A	HT40B-240-3*	7612	12.5A	HT4CB-240*	8383
5	79"	2007	320	145.2	62.6	240V	3750W	15.7A	HT50B-240*	8364	10.8A	HT50B-240-3*	8880	15.7A	HT5CB-240*	9063
6	94½"	2400	363	164.7	74.3	240V	4500W	18.8A	HT60B-240*	9294	10.8A	HT60B-240-3*	9866	18.8A	HT6CB-240*	10069
														10.8A	HT6CB-240-3*	10643

\* Available in 208 volt. To order replace suffix "-240" with suffix "-208".

### FLEX-MASTER® Overshelf Kits

Both kits include two 16/304 overshelves and four 30" (762mm) posts. Add suffix specified to order kit (example: HT20B-120-FM), or design your own using standard components from page 233.

description	add suffix	List Prices			
		2-well	3-well	4-well	5-well
10" (254mm) overshelves	-FM	1568	1619	1683	1998
15" (381mm) overshelves, plus one ladle rack	-FMU	2111	2197	2287	2811

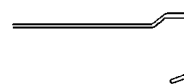

### SPEC-MASTER® Marine Edge

For front edge only. Heavy gauge type 304 stainless steel. Retards spillage.

**Consult factory.**



### Decorative Laminates

Standard Wilsonart® Black trimmed in stainless steel. A variety of patterns and colors to choose from. Hundreds of laminates available.

**Consult factory.**

## Catalog Section 30

### SPEC-MASTER® Electric Hot Food Tables Enclosed Base Portable US

see spec sheet **EC30.05**

#### OUR BEST



3-well portable enclosed hot food table with open front

5" (127mm) diameter NSF-approved ball-bearing swivel casters (two with brake), push bar attached to end panel at operator's right, and drop brackets on cutting board.

- Full perimeter vinyl bumper guards.
- 6' (1829mm) cord.
- 34" (864mm) height.
- 20 gauge table body and 22 gauge top are polished type 430 series stainless steel.
- Top openings are sized to accommodate 12" x 20" (305 x 508mm) food pans.
- 8" (203mm) wide, 1/2" (13mm) thick poly cutting board.
- Recessed control panel; individual thermostatic controls.
- Each element has a rating of 750-watt at 120-volt, 208-volt and 240-volt.
- 8" (203mm) deep insulated heating compartments lined with 22 gauge galvanized steel.
- 30 1/2" (775mm) front-to-back including cutting board.
- Primarily for dry operation, but adaptable for wet application with spillage pan (see page 231).
- Available with open front or 22 gauge stainless steel sliding doors.

#### FEATURES:

**Notes:** 1000-watt heaters available for 208-volt and 240-volt models. To order, add suffix "-1" to model number and \$86 per well to list price. Example: PHT40B-240-1.

Stainless steel liners in place of galvanized.







Add \$111 per compartment to list price of unit and add "S" after "HT" in model number. Example: PHTS3CB-120.

Freight class is 92.5.

**Optional FLEX-MASTER® Overshelf Kits**  
see page 218

#### Receptacle Configurations Required

See chart below for applicable NEMA plug.

					
15A 120V	15A 240V	20A 240V	30A 240V	50A 120V	20A 3Ø 240V
furnished with NEMA 5-15 plug	furnished with NEMA 6-15 plug	furnished with NEMA 6-20 plug	furnished with NEMA 6-30 plug	furnished with NEMA 5-50 plug	furnished with NEMA 15-20 plug

New York M.E.A. No. 376-84-E

#### SPEC-MASTER® Marine Edge

For front edge only. Heavy gauge type 304 stainless steel. Retards spillage. **Consult factory.**



#### Decorative Laminates

Standard Wilsonart® Black trimmed in stainless steel. A variety of patterns and colors to choose from. Hundreds of laminates available.

**Consult factory.**

# of top openings	length in.	length mm	weight lbs.	weight kg	cu ft	volts	watts	amps	Single-Phase				Three-Phase*						
									NEMA plug	with OPEN FRONT model #	list	with SLIDING DOORS model #	list	NEMA plug	with OPEN FRONT model #	list	with SLIDING DOORS model #	list	
2	35 1/4"	908	200	90.7	28.7	120	1500	12.5	5-15P	PHT20B-120	7259	PHT2CB-120	8718	-	-	n/a	n/a		
2	35 1/4"	908	200	90.7	28.7	208	1500	7.2	6-15P	PHT20B-208	7259	PHT2CB-208	8718	6.3	15-20P	PHT20B-208-3	7602	PHT2CB-208-3	9064
2	35 1/4"	908	200	90.7	28.7	240	1500	6.3	6-15P	PHT20B-240	7259	PHT2CB-240	8718	5.4	15-20P	PHT20B-240-3	7602	PHT2CB-240-3	9064
3	50 1/4"	1289	240	108.9	39.8	120	2250	18.8	5-30P	PHT30B-120	8988	PHT3CB-120	10128	-	-	n/a	n/a		
3	50 1/4"	1289	240	108.9	39.8	208	2250	10.8	6-15P	PHT30B-208	8988	PHT3CB-208	10128	6.3	15-20P	PHT30B-208-3	9334	PHT3CB-208-3	10476
3	50 1/4"	1289	240	108.9	39.8	240	2250	9.4	6-15P	PHT30B-240	8988	PHT3CB-240	10128	5.4	15-20P	PHT30B-240-3	9334	PHT3CB-240-3	10476
4	66 1/4"	1683	280	127.0	51.5	120	3000	25.0	5-50P	PHT40B-120	10198	PHT4CB-120	11568	-	-	n/a	n/a		
4	66 1/4"	1683	280	127.0	51.5	208	3000	14.4	6-20P	PHT40B-208	10198	PHT4CB-208	11568	9.5	15-20P	PHT40B-208-3	10542	PHT4CB-208-3	11914
4	66 1/4"	1683	280	127.0	51.5	240	3000	12.5	6-20P	PHT40B-240	10198	PHT4CB-240	11568	8.3	15-20P	PHT40B-240-3	10542	PHT4CB-240-3	11914
5*	81 1/4"	2076	320	145.2	62.6	208	3750	18.0	6-30P	PHT50B-208	12969	PHT5CB-208	14652	12.5	15-20P	PHT50B-208-3	13317	PHT5CB-208-3	14996
5*	81 1/4"	2076	320	145.2	62.6	240	3750	15.6	6-20P	PHT50B-240	12969	PHT5CB-240	14652	10.8	15-20P	PHT50B-240-3	13317	PHT5CB-240-3	14996
6*	97 1/4"	2470	363	164.7	74.3	208	4500	21.6	6-30P	PHT60B-208	14701	PHT6CB-208	16700	12.5	15-20P	PHT60B-208-3	15046	PHT6CB-208-3	17046
6*	97 1/4"	2470	363	164.7	74.3	240	4500	18.8	6-30P	PHT60B-240	14701	PHT6CB-240	16700	10.8	15-20P	PHT60B-240-3	15046	PHT6CB-240-3	17046

\* Single-Phase 5- and 6-well units, and all Three-Phase units, are available only in 208V and 240V.



100 Industrial Boulevard, Clayton, DE 19938-8903 U.S.A.  
Phone: 800-441-8440 or 302-653-3000. Fax: 302-653-2065  
http://www.eaglegrp.com

## SPEC-MASTER® Gas Hot Food Tables Enclosed Base



see spec sheet **EG30.06**

### OUR BEST



4-well enclosed base unit



### Decorative Laminates

Standard Wilsonart® Black trimmed in stainless steel. A variety of patterns and colors to choose from. Hundreds of laminates available.

**Consult factory.**

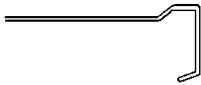

### SPEC-MASTER® Marine Edge

For front edge only. Heavy gauge type 304 stainless steel. Retards spillage.

New York M.E.A. No. 375-84-E Vol. II

- 20 gauge outer wrapper and 22 gauge top are polished type 430 series stainless steel.
- Top openings are sized to accommodate 12" x 20" (305 x 508mm) food pans.
- 8" (203mm) wide, ½" (13mm) thick poly cutting board.
- Recessed control panel; individual controls.
- High-output jet burners rated at 3500 BTUs.
- 8" (203mm) deep insulated heating compartments lined with heavy gauge galvanized steel.
- Stainless steel bottom shelf.
- Stainless steel legs.
- Adjustable non-marking plastic feet.
- Open front or 22 gauge stainless steel sliding doors.
- 34½" to 35½" (876 to 902mm) adjustable height.

#### FEATURES:

**Note:** Units with thermostatic control.

Add \$524 per well to list price and suffix "T".

Example HT2CB-NGT.

**Auto safety pilot.**

Add \$331 per well to list price and suffix "S".

Example HT2CB-NGS.

**Units with thermostatic control and auto safety pilot.**

Add \$856 per well to list price and suffix "TS".

Example HT2CB-NGTS.

**Stainless steel liners in place of galvanized.**

Add \$111 per compartment to list price of unit and add "S" after "HT" in model number. Example: HTS40B-NG.

½" (13mm) N.P.T. pipe connection is on right side.

**Freight class is 85.0.**

(\*) MTS (made to stock) / ( ) MTO (made to order)

# of top openings	length		weight		cu ft	total BTU rating	Open Front		Sliding Doors	
	in.	mm	lbs.	kg			model #	list	model #	list
2	33"	838	207	93.9	28.7	7,000	HT20B-NG	5220	HT2CB-NG	5383
3	48"	1219	248	112.5	39.8	10,500	HT30B-NG	5966	HT3CB-NG	6152
4	63½"	1613	289	131.1	51.5	14,000	HT40B-NG	6987	HT4CB-NG	7205
5	79"	2007	330	149.7	62.6	17,500	HT50B-NG	8353	HT5CB-NG	8612
6	94½"	2400	375	170.1	74.3	21,000	HT60B-NG	9760	HT6CB-NG	10065

**Note:** To order LP gas models, insert suffix "-LP" in place of "-NG" in appropriate model number. Example: HT20B-LP.

### FLEX-MASTER® Overshelf Kits

Both kits include two 16/304 overshelves and four 30" (762mm) posts. Add suffix specified to order kit (example: HT20B-NG-FM), or design your own using standard components from page 233.

description	add suffix	List Prices			
		2-well	3-well	4-well	5-well
10" (254mm) overshelves	-FM	1568	1619	1683	1998
15" (381mm) overshelves, plus one ladle rack	-FMU	2111	2197	2287	2811

### SPEC-MASTER® Sealed Well Hot Food Tables — Enclosed Base

see spec sheets **EG30.17A** **EG30.17B**



3-compartment  
stationary unit

**FEATURES:**

- Sealed-in heat wells, each with individual controls, allow for wet or dry application.
- Built-in drainage eliminates the need for spillage pans, reducing clean-up time.
- All type 430 stainless steel construction.
- Poly cutting board.
- Stainless steel dish shelf.
- 32½" (819mm) front-to-back, including cutting board and dish shelf.
- Each element has a rating of 750-watt at 120-volt, 713-watt at 208-volt, and 950-watt at 240-volt.
- Available with open front or stainless steel sliding doors.
- 6' (1829mm) cord and plug.

### Receptacle Configurations Required

See charts below for applicable NEMA plug.

15A 120V	15A 240V	20A 240V	30A 120V	30A 240V	50A 120V	20A 3Ø 240V
furnished with NEMA 5-15 plug	furnished with NEMA 6-15 plug	furnished with NEMA 6-20 plug	furnished with NEMA 5-30 plug	furnished with NEMA 6-30 plug	furnished with NEMA 5-50 plug	furnished with NEMA 15-20 plug
models: SHT2_120	models: SHT2_240 SHT3_240	models: SHT4_240	models: SHT3_120	models: SHT5_240	models: SHT4_120	models: all 3-Phase units

New York M.E.A. No. 376-84-E

**Freight class is 92.5.**

(•) MTS (made to stock) / ( ) MTO (made to order)

**AutoFill® automatic water fill system available.**

**NSF- and UL-approved.** To order, add **\$1714** to list price and add "A" before the **OB** or **CB** in model number. Example: SHT2A0B-240.

**FLEX-MASTER® Overshelf Kits — see page 220.**

### Stationary Units

Non-marking adjustable plastic feet adjusts height of unit from 34½" to 35½" (876 to 902mm).

# of top openings	length in. mm	weight lbs. kg	cu ft	volts	watts	Open Front						Sliding Doors					
						SINGLE-PHASE			THREE-PHASE			SINGLE-PHASE			THREE-PHASE		
						amps	model #	list	amps	model #	list	amps	model #	list	amps	model #	list
2	33"	838	200 90.7	28.7	120V 1500W	12.5A	SHT20B-120	5584	-	-	-	12.5A	SHT2CB-120	6197	-	-	-
2	33"	838	200 90.7	28.7	240V 1900W	7.9A	SHT20B-240	5584	6.9A	SHT20B-240-3	6159	7.9A	SHT2CB-240	6197	6.9A	SHT2CB-240-3	6771
3	48"	1219	240 108.9	39.8	120V 2250W	18.8A	SHT30B-120	6415	-	-	-	18.8A	SHT3CB-120	7582	-	-	-
3	48"	1219	240 108.9	39.8	240V 2850W	11.9A	SHT30B-240	6415	6.9A	SHT30B-240-3	6987	11.9A	SHT3CB-240	7582	6.9A	SHT3CB-240-3	8157
4	63½"	1613	280 127.0	51.5	120V 3000W	25.0A	SHT40B-120	7883	-	-	-	25.0A	SHT4CB-120	9315	-	-	-
4	63½"	1613	280 127.0	51.5	240V 3800W	15.8A	SHT40B-240	7883	10.5A	SHT40B-240-3	8458	15.8A	SHT4CB-240	9315	10.5A	SHT4CB-240-3	9888
5	79"	2007	320 145.2	62.6	240V 4750W	19.8A	SHT50B-240	9294	13.7A	SHT50B-240-3	9866	19.8A	SHT5CB-240	10069	13.7A	SHT5CB-240-3	10643

\* Available in 208 volt. To order replace suffix "-240" with suffix "-208".

### Portable Units

5" (127mm) diameter NSF-approved ball-bearing swivel casters (two with brake), and push bar attached to end panel at operator's right.

# of top openings	length in. mm	weight lbs. kg	cu ft	volts	watts	Open Front						Sliding Doors					
						SINGLE-PHASE			THREE-PHASE			SINGLE-PHASE			THREE-PHASE		
						amps	model #	list	amps	model #	list	amps	model #	list	amps	model #	list
2	33"	838	200 90.7	28.7	120V 1500W	12.5A	SPHT20B-120	6359	-	-	-	12.5A	SPHT2CB-120	6973	-	-	-
2	33"	838	200 90.7	28.7	240V 1900W	7.9A	SPHT20B-240	6359	6.9A	SPHT20B-240-3	6934	7.9A	SPHT2CB-240	6973	6.9A	SPHT2CB-240-3	7546
3	48"	1219	240 108.9	39.8	120V 2250W	18.8A	SPHT30B-120	7189	-	-	-	18.8A	SPHT3CB-120	8358	-	-	-
3	48"	1219	240 108.9	39.8	240V 2850W	11.9A	SPHT30B-240	7189	6.9A	SPHT30B-240-3	7762	11.9A	SPHT3CB-240	8358	6.9A	SPHT3CB-240-3	8932
4	63½"	1613	280 127.0	51.5	120V 3000W	25.0A	SPHT40B-120	8660	-	-	-	25.0A	SPHT4CB-120	10088	-	-	-
4	63½"	1613	280 127.0	51.5	240V 3800W	15.8A	SPHT40B-240	8660	10.5A	SPHT40B-240-3	9233	15.8A	SPHT4CB-240	10088	10.5A	SPHT4CB-240-3	10663
5	79"	2007	320 145.2	62.6	240V 4750W	19.8A	SPHT50B-240	10069	13.7A	SPHT50B-240-3	10643	19.8A	SPHT5CB-240	10844	13.7A	SPHT5CB-240-3	11418

\* Available in 208 volt. To order replace suffix "-240" with suffix "-208".

See page 217 for Open Base Sealed Well Hot Food Tables

## Electric Water Bath Steam Tables US

see spec sheet **EG30.13**



3-well water bath steam table shown with optional FLEX-MASTER® overshelves

New York M.E.A. No. 330-84-E

Prefix “S” indicate that stainless steel undershelf and legs are standard.

# of top openings	length		weight		cu ft	electrical data	model #	list
	in.	mm	lbs.	kg				
2	33"	838	94	42.6	15.4	3000W, 208V, 14.4A	<b>WT2-208</b>	6325
2	33"	838	94	42.6	15.4	3000W, 208V, 14.4A	<b>SWT2-208</b>	6954
2	33"	838	94	42.6	15.4	3000W, 240V, 12.5A	<b>WT2-240</b>	6325
2	33"	838	94	42.6	15.4	3000W, 240V, 12.5A	<b>SWT2-240</b>	6954
3	48"	1219	125	56.7	15.4	3000W, 208V, 14.4A	<b>WT3-208</b>	6905
3	48"	1219	125	56.7	15.4	3000W, 208V, 14.4A	<b>SWT3-208</b>	7595
3	48"	1219	125	56.7	15.4	3000W, 240V, 12.5A	<b>WT3-240</b>	6905
3	48"	1219	125	56.7	15.4	3000W, 240V, 12.5A	<b>SWT3-240</b>	7595
4	63½"	1613	146	66.2	19.7	4000W, 208V, 19.2A	<b>WT4-208</b>	7846
4	63½"	1613	146	66.2	19.7	4000W, 208V, 19.2A	<b>SWT4-208</b>	8628
4	63½"	1613	146	66.2	19.7	4000W, 240V, 16.7A	<b>WT4-240</b>	7846
4	63½"	1613	146	66.2	19.7	4000W, 240V, 16.7A	<b>SWT4-240</b>	8628
5	79"	2007	183	83.0	24.1	5000W, 208V, 24.1A	<b>WT5-208</b>	8288
5	79"	2007	183	83.0	24.1	5000W, 208V, 24.1A	<b>SWT5-208</b>	9116
5	79"	2007	183	83.0	24.1	5000W, 240V, 20.8A	<b>WT5-240</b>	8288
5	79"	2007	183	83.0	24.1	5000W, 240V, 20.8A	<b>SWT5-240</b>	9116

### FLEX-MASTER® Overshelf Kits

Both kits include two 16/304 overshelves and four 30" (762mm) posts. Add suffix specified to order kit (example: **WT2-208-FM**), or design your own using standard components from page 233.

description	add suffix	List Prices			
		2-well	3-well	4-well	5-well
10" (254mm) overshelves	<b>-FM</b>	1568	1619	1683	1998
15" (381mm) overshelves, plus one ladle rack	<b>-FMU</b>	2111	2197	2287	2811

- Constructed of highly polished stainless steel—304 series for water pan and 430 series for tops and enclosures.
- Top is removable for cleaning or replacement.
- All-welded water pan is 16 gauge with recessed well and accommodates a copper sheathed immersion heater assembly complete with thermostatic control and low water cutoff.
- All wiring terminates within junction box adjacent to control.
- Legs are 1½" (41mm) diameter galvanized tubing fitted with adjustable non-marking plastic feet.
- Undershelf is galvanized steel.
- All top openings are sized to accommodate 12" x 20" (305 x 508mm) food pans.
- 8" (203mm) wide x ½" (13mm) thick poly cutting board and stainless steel dish shelf.
- 34½" to 35½" (876 to 902mm) adjustable height.
- All units are single phase.

#### FEATURES:

**Note:** Units are designed for field wiring by others.

**Bolted-in undershelf available.**

To specify, add 20% to list price of unit and add suffix “B” to model number. Example: **WT2-240B**.

**Freight class is 92.5.**



**AutoFill® automatic water fill system available.**

For models with drain. NSF- and UL-approved. To order, add \$1714 to list price and add “A” in front of the dash in model number. Example: **WT3A-208**.



### Gas Water Bath Steam Tables

see spec sheet **EG30.12**



3-well water bath steam table

New York M.E.A. No. 318-84-E

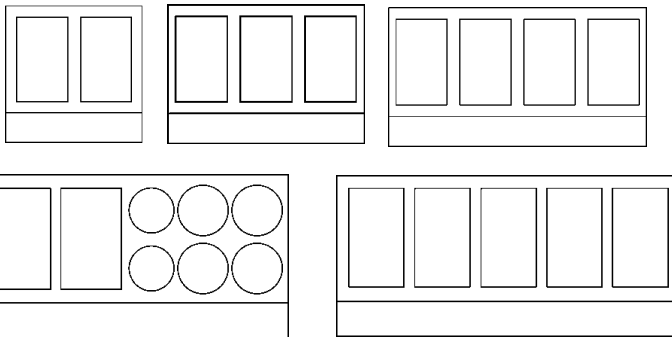

- Constructed of highly polished stainless steel – 304 series for water pan and 430 series for tops and enclosures.
- Top and water pan are removable for cleaning or replacement.
- Furnished with a straight flow tubular gas burner and pressure regulator as standard equipment.
- Legs are 1½" (41mm) diameter galvanized tubing fitted with adjustable non-marking plastic feet.
- Undershelf is galvanized steel.
- All top openings accommodate 12" x 20" (305 x 508mm) food pans.
- 8" (203mm) wide x ½" (13mm) thick poly cutting board and stainless steel dish shelf.
- 34½" to 35½" (876 to 902mm) adjustable height.

**FEATURES:**

**Note:** Standard stainless steel legs and undershelf. Add 10% to list price of unit and prefix "S" to model number after letter "A". Example: ASWT2-NG.

**Bolted-in undershelf available.**

To specify, add 20% to list price of unit and add suffix "B" to model number. Example: AWT2-NGB.

**AutoFill® automatic water fill system** available for models with drain. NSF- and UL-approved. To order, add \$1714 to list price and add "A" in front of the dash in model number. Example: AWT2A-NG.

½" (13mm) N.P.T. pipe connection is on right side.

**Freight class is 85.0.**

(•) MTS (made to stock) / ( ) MTO (made to order)

Prefix "AWTP" come with safety pilots with automatic shut-off features.

description	weight		cu	model #	list
	lbs.	kg	ft		
33" (838mm) long unit with 2 top openings	73	33.1	15.4	<b>AWT2-NG •</b>	2815
as above, with safety pilot	73	33.1	15.4	<b>AWTP2-NG</b>	3205
replacement top	—	—	—	<b>305169</b>	403
replacement water pan	—	—	—	<b>305315</b>	665
48" (1219mm) long unit with 3 top openings	127	57.6	15.4	<b>AWT3-NG •</b>	3143
as above, with safety pilot	127	57.6	15.4	<b>AWTP3-NG</b>	3819
replacement top	—	—	—	<b>305170</b>	496
replacement water pan	—	—	—	<b>305313</b>	739
63½" (1613mm) long unit with 4 top openings	198	89.8	19.7	<b>AWT4-NG •</b>	3977
as above, with safety pilot	198	89.8	19.7	<b>AWTP4-NG</b>	4900
replacement top	—	—	—	<b>305171</b>	649
replacement water pan	—	—	—	<b>305314</b>	964
63½" (1613mm) long unit with 8 top openings	198	89.8	19.7	<b>AWT4-NG-1</b>	3977
as above, with safety pilot	198	89.8	19.7	<b>AWTP4-NG-1</b>	4900
replacement top	—	—	—	<b>305259</b>	649
replacement water pan	—	—	—	<b>305314</b>	964
79" (2007mm) long unit with 5 top openings	256	116.1	24.1	<b>AWT5-NG •</b>	4764
as above, with safety pilot	256	116.1	24.1	<b>AWTP5-NG</b>	5940
replacement top	—	—	—	<b>305172</b>	707
replacement water pan	—	—	—	<b>305316</b>	1218

### Optional FLEX-MASTER® Overshelf Kits see page 222

#### 2 Top Openings

15,000 BTU total. Accommodates **two** 12" x 20" (305 x 508mm) food pans.

#### 3 Top Openings

15,000 BTU total. Accommodates **three** 12" x 20" (305 x 508mm) food pans.

#### 4 Top Openings

30,000 BTU total. Accommodates **four** 12" x 20" (305 x 508mm) food pans.

#### 8 Top Openings

30,000 BTU total. Accommodates **two** 12" x 20" (305 x 508mm) food pans, **two** 6½" (165mm) diameter 4-quart insets, and **four** 8½" (216mm) diameter 7-quart insets.

#### 5 Top Openings

30,000 BTU total. Accommodates **five** 12" x 20" (305 x 508mm) food pans.

**Note:** To order LP gas models, insert suffix "-LP" in place of "-NG" in appropriate model number. Example: AWT2-LP.

## SPEC-MASTER® Cold Pan Units Enclosed Base (NSF)

see spec sheet **EG30.08**

### OUR BEST



**Top-of-the-line stationary cold pan units!**

- 20" (508mm) wide x 6" (152mm) deep cold pans made of 304 series stainless steel with 1" (25mm) I.P.S. drain connection.
- Highly polished 20 gauge stainless steel table body.
- 1 5/8" (41mm) diameter stainless steel tubular legs with non-marking plastic feet.
- Stainless steel bottom shelf is full depth of unit and welded to outer wrapper.
- 22 5/16" (573mm) front-to-back.
- 34 1/2" to 35 1/2" (876 to 902mm) adjustable height.

**FEATURES:**

**Note: Casters.**

Add prefix "P" and add \$311 to list price. Example: PCP30B.

**Center shelf.**

Add 20% to list price of unit.

For optional accessories and replacements, see pages 227-233.

**Freight class is 100.0.**

(\*) MTS (made to stock) / ( ) MTO (made to order)

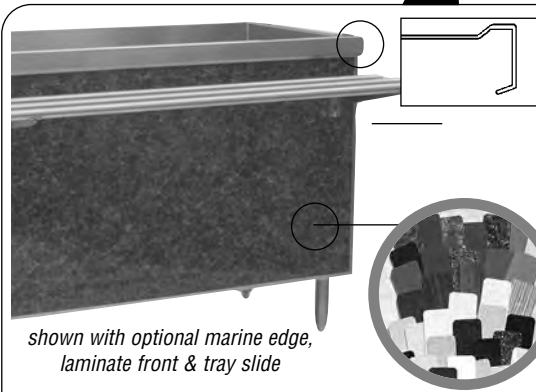

shown with optional marine edge, laminate front & tray slide

**SPEC-MASTER® Marine Edge**

For front edge only. Heavy gauge type 304 stainless steel. Retards spillage.

**Decorative Laminates**

Standard Wilsonart® Black trimmed in stainless steel. A variety of patterns and colors to choose from. Hundreds of laminates available.

Consult factory for SPEC-MASTER® Marine edge and decorative laminate.

					Open Front		Sliding Doors				
length		cubic feet	weight		model #	list	weight		model #	list	
in.	mm		lbs.	kg			lbs.	kg			
48"	1219	39.8	230	104.3	<b>CP30B</b>	4727	235	106.6	<b>CP3CB</b>	6055	
63 1/2"	1613	51.5	270	122.5	<b>CP40B</b>	5124	275	124.7	<b>CP4CB</b>	6754	
79"	2007	62.6	310	140.6	<b>CP50B</b>	5412	315	142.9	<b>CP5CB</b>	7168	

## Stainless Steel Cleaner & Polish



- Cleans and polishes in one step.
- Does not streak or leave fingerprints.
- Leaves a protective invisible coating.

weight		model #	list
oz.	kg		
15	0.4	<b>004026</b>	22

## Catalog Section 30

### Cold Pan Units – Open Base <sup>NSF</sup>

see spec sheet **EG30.15**



#### Stationary models

Non-marking adjustable feet that adjust height of unit from 34½" to 35½" (876 to 902mm).



#### Portable models

4" (102mm) diameter swivel casters (two with brakes) and push handle.

shown with optional laminated hardwood cutting board

#### FEATURES:

- Fully insulated units feature 20" (508mm) wide x 6" (152mm) deep cold pans made of 304 series stainless steel with 1½" (38mm) NPS drain connection.
- Table body is highly polished 22 gauge stainless steel.
- Galvanized tubular legs and galvanized undershelf.
- All units are 22⅝" (573mm) front-to-back.

#### Note: Bolted-in undershelf available.

To specify, add 20% to list price of unit and add suffix "B" to model number. Example: CP-3B.

For optional accessories and replacements, see pages 227-233.

**Freight class is 100.0.**

Prefix "S" indicate standard stainless steel undershelf and legs.

		Stationary					Portable*				
length in.	mm	cubic feet	weight		model #	list	weight		model #	list	
			lbs.	kg			lbs.	kg			
48"	1219	15.4	93	42.2	CP-3	1978	99	44.9	PCP-3	2100	
48"	1219	15.4	93	42.2	SCP-3	2328	99	44.9	SPCP-3	2948	
63½"	1613	19.7	112	50.8	CP-4	2426	118	53.5	PCP-4	2505	
63½"	1613	19.7	112	50.8	SCP-4	2831	118	53.5	SPCP-4	3467	
79"	2007	24.1	133	60.3	CP-5	2799	139	63.1	PCP-5	3334	
79"	2007	24.1	133	60.3	SCP-5	3294	139	63.1	SPCP-5	3920	

\* For portable models, add 2½" (64mm) to length.

### SPEC-MASTER® Solid Top Units Enclosed Base <sup>NSF</sup>

see spec sheet **EG30.09**

#### OUR BEST



Top-of-the-line stationary solid top units!

unit shown with optional laminated hardwood cutting board

#### FEATURES:

- 16 gauge stainless steel top with table body made of 20 gauge 430 series stainless steel.
- 1½" (41mm) diameter stainless steel tubular legs with adjustable non-marking plastic feet.
- Stainless steel bottom shelf that is full depth of unit and welded to outer wrapper.
- 22⅝" (573mm) front-to-back.
- Recessed handle and rollerless track assembly.

#### Note: Casters.

Add prefix "P" and add \$311 to list price. Example: PST40B.

#### Center shelf.

Add 20% to list price of unit.

Optional accessories and replacements see pages 227-233.

**Freight class is 100.0.**

		Open Front				Sliding Doors				
length in.	mm	cubic feet	weight		model #	list	weight		model #	list
			lbs.	kg			lbs.	kg		
48"	1219	39.8	225	102.1	ST30B	5281	233	105.7	ST3CB	6662
63½"	1613	51.5	265	120.2	ST40B	6153	274	124.3	ST4CB	7833
79"	2007	62.6	305	138.3	ST50B	7614	315	142.9	ST5CB	8913



#### Decorative Laminates

Standard Wilsonart® Black trimmed in stainless steel. A variety of patterns and colors to choose from. Hundreds of laminates available.



#### SPEC-MASTER® Marine Edge

For front edge only. Heavy gauge type 304 stainless steel. Retards spillage.

**Consult factory.**

## Solid Top Units – Open Base <sup>NSF</sup>

see spec sheet **EG30.14**



**Stationary models**

Non-marking adjustable feet that adjust height of unit from 34½" to 35½" (876 to 902mm).



**Portable models**

4" (102mm) diameter swivel casters (two with brakes) and push handle.

shown with optional laminated hardwood cutting board

**FEATURES:**

- Type 430 construction
- 22 gauge stainless steel body.
- 16 gauge stainless steel top.
- Galvanized tubular legs.
- Galvanized undershelf.
- 22½" (573mm) front-to-back.

**Note:** Bolted-in undershelf available.

To specify, add 20% to list price of unit and add suffix "B" to model number. **Example: ST-3B.**

For optional accessories and replacements, see pages 227-233.

**Freight class is 85.0.**

(•) MTS (made to stock) / ( ) MTO (made to order)

Prefix "S" indicate standard stainless steel undershelf and legs.

length		cubic feet	Stationary			Portable*				
in.	mm		weight lbs.	weight kg	model #	list	weight lbs.	weight kg	model #	list
48"	1219	15.4	83	37.6	<b>ST-3</b>	1513	89	40.4	<b>PST-3</b>	2017
48"	1219	15.4	83	37.6	<b>SST-3</b>	1766	89	40.4	<b>SPST-3</b>	2355
63½"	1613	19.7	102	46.3	<b>ST-4</b>	1756	108	49.0	<b>PST-4</b>	2263
63½"	1613	19.7	102	46.3	<b>SST-4</b>	2048	108	49.0	<b>SPST-4</b>	2639
79"	2007	24.1	123	55.8	<b>ST-5</b>	2181	129	58.5	<b>PST-5</b>	2684
79"	2007	24.1	123	55.8	<b>SST-5</b>	2542	129	58.5	<b>SPST-5</b>	3126

\* For portable models, add 2½" (64mm) to length.

## Urn Stands <sup>NSF</sup>

see spec sheet **EG30.10**



- Stationary, enclosed base.
- 16 gauge stainless steel top.
- 20 gauge stainless steel table body.
- Stainless steel tubular legs with adjustable non-marking plastic feet.
- Heavy gauge stainless steel bottom shelf that is full depth of unit and welded to outer wrapper.
- 4¾" (121mm) urn trough slopes to a 1" (25mm) drain and comes complete with full length removable louvered grate.
- 22½" (573mm) front-to-back.
- 34½" to 35½" (876 to 902mm) adjustable height.

**FEATURES:**

**Note:** Casters, add prefix "P" and add \$311 to list price.

**Example: PUS3CB.**

Center shelf, add 20% to list price of unit and add suffix "-CS" to model number. **Example: US30B-CS**

If urn trough is desired on rear side, add suffix "R" to end of model number. **Example: US30BR.**

For optional accessories and replacements, see pages 227-233.

**Freight class is 70.0.**

(•) MTS (made to stock) / ( ) MTO (made to order)

length		cubic feet	Open Front			Sliding Doors				
in.	mm		weight lbs.	weight kg	model #	list	weight lbs.	weight kg	model #	list
48"	1219	39.8	225	102.1	<b>US30B</b>	5060	233	105.7	<b>US3CB</b>	6383
63½"	1613	51.5	265	120.2	<b>US40B</b>	5897	274	124.3	<b>US4CB</b>	7507
79"	2007	62.6	305	138.3	<b>US50B</b>	7297	315	142.9	<b>US5CB</b>	8991

## Catalog Section 30

### Tray Stands

see spec sheet **EG30.11**



- Stationary.
- 16 gauge stainless steel top.
- Heavy gauge cabinet.
- Stainless steel tubular legs with adjustable non-marking bullet feet.
- 18" (457mm) working height, 44¼" (1137mm) with silverware unit.
- 22½" (572mm) front-to-back.

FEATURES:

**Freight class is 70.0.**

(•) MTS (made to stock) / ( ) MTO (made to order)

#### Optional Silverware Unit for Tray Stand

Polished die-formed heavy gauge stainless steel wrapper; 1" (25mm) square stainless steel tubing; and eight plastic silverware holders.

length		cubic		weight		model #	list
in.	mm	feet	lbs.	kg			
33"	838	135	61.2	12.3	<b>TU-1</b>	2291	

length		cubic		weight		model #	list
in.	mm	feet	lbs.	kg			
33"	838	35	15.9	10.3	<b>SW-1</b>	917	

### Overshelves

see spec sheet **EG30.20B**



FEATURES:

- 10" (254mm) wide.

**Freight class is 70.0.**

(•) MTS (made to stock) / ( ) MTO (made to order)

#### Single Shelf, Non-Adjustable

16 gauge type 430 stainless steel shelf with stainless steel tubular legs.

#### Double Shelf, Non-Adjustable

Two 16 gauge type 430 stainless steel shelves with stainless steel tubular legs. All-welded construction.

#### Optional Heat Lamp Brackets for Overshelves

To mount full-length lamps to underside of overshelf. Spaced to fit heat lamps. Custom sizes and configurations available. Consult factory.

length		weight		cu	model #	list	weight		cu	model #	list
in.	mm	lbs.	kg				lbs.	kg			
33"	838	18	8.2	1.2	<b>OS-HT2</b>	962	36	16.3	1.8	<b>DOS-HT2</b>	1629
48"	1219	20	9.0	1.6	<b>OS-HT3</b>	987	40	18.1	2.3	<b>DOS-HT3</b>	1795
63½"	1613	24	10.9	2.1	<b>OS-HT4</b>	1015	48	21.8	3.2	<b>DOS-HT4</b>	1846
79"	2007	35	15.9	2.6	<b>OS-HT5</b>	1380	70	31.8	3.9	<b>DOS-HT5</b>	2379
94½"	2400	45	20.4	3.1	<b>OS-HT6</b>	1519	90	40.8	4.7	<b>DOS-HT6</b>	2477

for overshelf length		heat lamp length		number of brackets (pairs)	add suffix	list per pair
in.	mm	in.	mm			
33"	838	18"	457	1	<b>-HLB</b>	244
48"	1219	36"	914	1	<b>-HLB</b>	244
63½"	1613	48"	1219	1	<b>-HLB</b>	244
79"	2007	66"	1676	1	<b>-HLB</b>	244
94½"	2400	36"	914	2	<b>-HLB</b>	244

### Serving Shelves

see spec sheet **EG30.20A**



18" (457mm) wide.

**Freight class is 70.0.**

(•) MTS (made to stock) / ( ) MTO (made to order)

length		weight		cu	with Open Front 10" (254mm) wide		w/Acrylite® Front Panel 18" (457mm) wide	
in.	mm	lbs.	kg		model #	list	model #	list
33"	838	20	9.0	1.2	<b>SS-HT2</b>	922	<b>SSP-HT2</b>	1067
48"	1219	25	11.3	1.7	<b>SS-HT3</b>	1033	<b>SSP-HT3•</b>	1127
63½"	1613	35	15.9	2.3	<b>SS-HT4</b>	1105	<b>SSP-HT4•</b>	1246
79"	2007	40	18.1	2.9	<b>SS-HT5</b>	1414	<b>SSP-HT5•</b>	1614
94½"	2400	55	24.9	3.5	<b>SS-HT6</b>	1460	<b>SSP-HT6</b>	1664

## Buffet Shelves

see spec sheet **EG30.20A**



- Front sneeze guard.
- Heavy gauge stainless steel top located 20" (508mm) above surface.
- ¼" (6mm) clear Acrylite® front and end panels.
- 15" (381mm)-wide top (excluding clear panels).

**FEATURES:**

**Freight class is 70.0.**

(•) MTS (made to stock) / ( ) MTO (made to order)

...with Sneeze Guard on One Side — 25½" (651mm) overall front-to-back.

length		without infrared bullet lamps			with infrared bullet lamps						
in.	mm	weight lbs.	weight kg	cu ft	model #	list	weight lbs.	weight kg	cu ft	model #	list
33"	838	27	12.2	10.9	<b>BS1-HT2</b>	1134	38	17.2	10.8	<b>BS1-HT2-IL</b>	1740
48"	1219	38	17.2	16.3	<b>BS1-HT3</b>	1308	48	21.8	16.4	<b>BS1-HT3-IL</b>	1902
63½"	1613	58	26.3	19.3	<b>BS1-HT4</b>	1461	76	34.5	19.3	<b>BS1-HT4-IL</b>	2536
79"	2007	83	37.6	21.4	<b>BS1-HT5</b>	1595	114	51.7	21.4	<b>BS1-HT5-IL</b>	2951
94½"	2400	104	47.2	23.5	<b>BS1-HT6</b>	2107	130	59.0	23.5	<b>BS1-HT6-IL</b>	3006

...with Sneeze Guard on Both Sides — 36¼" (921mm) overall front-to-back.

length		without infrared bullet lamps			with infrared bullet lamps						
in.	mm	weight lbs.	weight kg	cu ft	model #	list	weight lbs.	weight kg	cu ft	model #	list
33"	838	36	16.3	10.8	<b>BS2-HT2</b>	1199	46	20.9	11.7	<b>BS2-HT2-IL</b>	1820
48"	1219	48	21.8	15.1	<b>BS2-HT3</b>	1366	62	28.1	16.0	<b>BS2-HT3-IL</b>	1954
63½"	1613	68	30.8	19.9	<b>BS2-HT4</b>	1517	78	35.4	19.0	<b>BS2-HT4-IL</b>	2601
79"	2007	93	42.2	21.4	<b>BS2-HT5</b>	1665	116	52.6	24.1	<b>BS2-HT5-IL</b>	3022
94½"	2400	114	51.7	27.4	<b>BS2-HT6</b>	2174	132	59.9	26.5	<b>BS2-HT6-IL</b>	3071

## Deluxe Serving Shelves

see spec sheet **EG30.20A**



- Front sloped back for increased visibility.
- ¼" (6mm) clear Acrylite® at front and ends.
- Stainless steel end panel assemblies.
- 14½" (368mm)-wide stainless steel top panel.

**FEATURES:**

**Freight class is 70.0.**

(•) MTS (made to stock) / ( ) MTO (made to order)

length		weight		cu	model #	list
in.	mm	lbs.	kg	ft		
33"	838	27	12.2	1.4	<b>DSSP-HT2</b>	1944
48"	1219	37	16.8	2.0	<b>DSSP-HT3 •</b>	1998
63½"	1613	47	21.3	2.6	<b>DSSP-HT4 •</b>	2145
79"	2007	55	24.9	3.3	<b>DSSP-HT5 •</b>	2586
94½"	2400	69	31.3	3.7	<b>DSSP-HT6</b>	2633

### Also available:



#### REDHOTS® Heat Lamps

see page 267

Or download our spec sheet **EG35.23** off our website [www.eaglegrp.com](http://www.eaglegrp.com)



#### REDHOTS® Display Lights

see page 268

Or download our spec sheet **EG35.09** off our website [www.eaglegrp.com](http://www.eaglegrp.com)

## Catalog Section 30

### Tray Shelves

see spec sheet **EG30.20A**

FEATURES:

- 10" (254mm) wide.
- Stainless steel.

**Freight class is 70.0.**

(•) MTS (made to stock) / ( ) MTO (made to order)

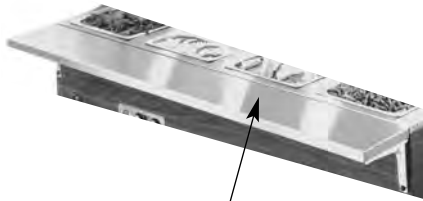

tray shelf shown with hinged drop brackets

length		weight		cubic	with Stationary Brackets		with Drop Brackets	
in.	mm	lbs.	kg	feet	model #	list	model #	list
33"	838	14	6.4	0.3	<b>TS-HT2</b>	755	<b>TS-DB-HT2</b>	827
48"	1219	18	8.2	0.5	<b>TS-HT3</b>	924	<b>TS-DB-HT3</b>	997
63½"	1613	21	9.5	0.7	<b>TS-HT4</b>	1227	<b>TS-DB-HT4</b>	1302
79"	2007	24	10.9	0.8	<b>TS-HT5</b>	1525	<b>TS-DB-HT5</b>	1634
94½"	2400	31	14.1	1.0	<b>TS-HT6</b>	1611	<b>TS-DB-HT6</b>	1665

### Dish Shelves

see spec sheet **EG30.20A**

FEATURES:

- Removable without the use of tools.
- Stainless steel.
- 8" (203mm) wide.
- 1¼" (32mm) thick.
- Mounts under preexisting cutting board.

**Freight class is 70.0.**

(•) MTS (made to stock) / ( ) MTO (made to order)



length		weight		cubic	model #	list
in.	mm	lbs.	kg	feet		
33"	838	6	2.7	0.3	<b>353985</b>	977
48"	1219	7	3.2	0.4	<b>353986</b>	1038
63½"	1613	11	5.0	0.6	<b>353987</b>	1177
79"	2007	14	6.4	0.7	<b>353988</b>	1477
94½"	2400	20	9.0	0.9	<b>355196</b>	1546

### Tray Slides

see spec sheet **EG30.20A**

FEATURES:

- 10½" (267mm) wide.
- Three tubular stainless steel rails.

**Freight class is 70.0.**

(•) MTS (made to stock) / ( ) MTO (made to order)

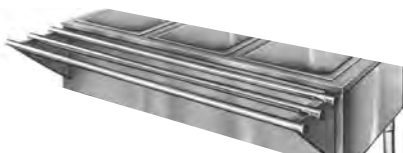

tray slide shown with stationary brackets

length		weight		cubic	Stationary Brackets		Drop Brackets	
in.	mm	lbs.	kg	feet	model #	list	model #	list
33"	838	14	6.4	4.0	<b>TSL-HT2</b>	615	<b>TSL-DB-HT2</b>	695
48"	1219	18	8.2	5.5	<b>TSL-HT3</b> •	742	<b>TSL-DB-HT3</b> •	820
63½"	1613	21	9.5	6.8	<b>TSL-HT4</b> •	1006	<b>TSL-DB-HT4</b>	1083
79"	2007	24	10.9	8.2	<b>TSL-HT5</b> •	1253	<b>TSL-DB-HT5</b>	1373
94½"	2400	31	14.1	9.5	<b>TSL-HT6</b>	1323	<b>TSL-DB-HT6</b>	1458

## Cutting Boards Upgrade

see spec sheet **EG30.20A**

Freight class is 55.0.

(•) MTS (made to stock) / ( ) MTO (made to order)

### Thermoplastic Cutting Board Replacement

- 8" (203mm) wide x ½" (13mm) thick, white.

length		weight		cubic feet	for model #	model #	list
in.	mm	lbs.	kg				
33"	838	12	5.4	2.5	HT2	<b>353996</b>	471
48"	1219	17	7.7	3.0	HT3	<b>353997</b>	516
63½"	1613	23	10.4	3.5	HT4	<b>353998</b>	595
79"	2007	30	13.6	4.0	HT5	<b>388075</b>	778
94½"	2400	37	16.8	4.5	HT6	<b>354066</b>	879



### Richlite® Heat-Resistant

- 8" (203mm) wide x ½" (13mm) thick, sand-color.
- Resists up to 360°F.
- Stainless steel mounting brackets.

length		weight		cubic feet	for model #	model #	list
in.	mm	lbs.	kg				
33"	838	14	6.3	2.5	HT2	<b>RLB-2</b>	621
48"	1219	18	8.2	3.0	HT3	<b>RLB-3</b>	774
63½"	1613	21	9.5	3.5	HT4	<b>RLB-4</b>	831
79"	2007	24	10.9	4.0	HT5	<b>RLB-5</b>	1001
94½"	2400	31	14.1	4.5	HT6	<b>RLB-6</b>	1323



### Hardwood...

- 8" (203mm) wide x 1¼" (32mm) thick.

length		weight		cubic feet	Stationary Brackets		Drop Brackets	
in.	mm	lbs.	kg		model #	list	model #	list
33"	838	14	6.4	2.5	<b>WB-HT2</b>	471	<b>WB-DB-HT2</b>	817
48"	1219	18	8.2	3.0	<b>WB-HT3</b>	516	<b>WB-DB-HT3</b>	862
63½"	1613	21	9.5	3.5	<b>WB-HT4</b>	595	<b>WB-DB-HT4</b>	941
79"	2007	24	10.9	4.0	<b>WB-HT5</b>	778	<b>WB-DB-HT5</b>	1299
94½"	2400	31	14.1	4.5	<b>WB-HT6</b>	977	<b>WB-DB-HT6</b>	1724

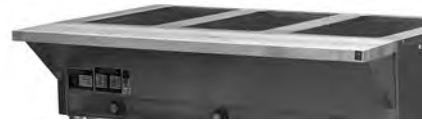

## Stainless Steel Caster Cradle®

see product announcement **EG30.21**



**PATENTED!**  
(patent #US 8,678,335 B2)

FEATURES:

- The only caster stabilizing device with a patented uniform circular design (patent #US 8,678,335 B2) that allows for approach from any angle.
- Conforms to NFPA 17A 5.6.4 requirements for stabilizing cooking equipment and correct placement under fire system nozzles.
- Units are secured to the floor where the casters are to be centered.

Freight class is 85.0.

(•) MTS (made to stock) / ( ) MTO (made to order)

description	model #	list/pkg
quantity of 2 per package	<b>CC-S-2</b>	106
quantity of 10 per package	<b>CC-S-10</b>	422
quantity of 60 per package	<b>CC-S-60</b>	2364



## Catalog Section 30

### Stainless Steel Bottle Holders

see spec sheet **EG30.20B**



#SBH-1/6

(bottles not included)

#SBH-1/3

**U.S. Patent  
#7,003,969**

**FEATURES:**

- For plastic condiment bottles.
- Type 300 series stainless steel construction.
- 2 $\frac{1}{16}$ " (63mm) diameter holes punched for bottle dispensers.
- Fits traditional one third- or one sixth-size food pan applications.

**Freight class is 85.0.**

(•) MTS (made to stock) / ( ) MTO (made to order)

description	model #	list
7" x 6 $\frac{1}{2}$ " x 5 $\frac{1}{2}$ " (178 x 165 x 140mm), holds four bottles	<b>SBH-1/6</b>	111
7" x 12 $\frac{1}{4}$ " x 5 $\frac{1}{2}$ " (178 x 324 x 140mm), holds eight bottles	<b>SBH-1/3</b>	123

### Spillage Pans

see spec sheet **EG30.20B**



description	weight each		EACH		6-PACK	
	lbs.	kg	model #	list	model #	list
stainless steel	7	3.2	<b>302027</b>	263	<b>502808</b> •	1580
aluminum	3	1.4	<b>304141</b>	142	<b>502809</b> •	853

**FEATURES:**

- Required for wet applications.
- Deep-drawn, fully covered.
- 6 $\frac{1}{2}$ " (165mm) deep.

**Freight class is 100.0.**

(•) MTS (made to stock) / ( ) MTO (made to order)

### Bullet Feet

see spec sheet **EG30.20B**



**Can be shipped UPS**

(•) MTS (made to stock) / ( ) MTO (made to order)

description	model #	list
plastic	<b>300293</b>	2

### Rolltop Cover

see spec sheet **EG30.20B**



**Freight class is 70.0.**

(•) MTS (made to stock) / ( ) MTO (made to order)

description	model #	list
fits over heat well	<b>501585</b> •	532

Contact us:  
**revit@eaglegrp.com**

Access Eagle's Revit Libraries on  
AutoQuotes, KCL, and AutoDesk Seek.



Profit from the Eagle Advantage®

## Food Pans and Round Insets

see spec sheet **EG30.20B**

FEATURES:

- All pans, lids, and insets are stainless steel.
- **Minimum purchase \$175 net**, any assortment.

Freight class is 70.0.

### Stainless Steel Food Pans/Lids/Adapter Bars

description	model #	list
full size pan, 20 $\frac{1}{4}$ " x 12 $\frac{3}{4}$ " x 2 $\frac{1}{2}$ " (527 x 324 x 64mm)	301669	95
full size pan, 20 $\frac{1}{4}$ " x 12 $\frac{3}{4}$ " x 4" (527 x 324 x 102mm)	303775	116
half size pan, 10 $\frac{1}{2}$ " x 12 $\frac{3}{4}$ " x 2 $\frac{1}{2}$ " (264 x 324 x 64mm)	304050	55
half size pan, 10 $\frac{1}{2}$ " x 12 $\frac{3}{4}$ " x 4" (264 x 324 x 102mm)	304051	71
one-third size pan, 6 $\frac{1}{2}$ " x 12 $\frac{3}{4}$ " x 2 $\frac{1}{2}$ " (175 x 324 x 64mm)	304052	47
one-third size pan, 6 $\frac{1}{2}$ " x 12 $\frac{3}{4}$ " x 4" (175 x 324 x 102mm)	304053	59
one-fourth size pan, 6 $\frac{1}{2}$ " x 10 $\frac{1}{2}$ " x 2 $\frac{1}{2}$ " (162 x 264 x 64mm)	304054	43
one-fourth size pan, 6 $\frac{1}{2}$ " x 10 $\frac{1}{2}$ " x 4" (162 x 264 x 102mm)	304055	52
one-sixth size pan, 6 $\frac{1}{2}$ " x 6 $\frac{1}{8}$ " x 2 $\frac{1}{2}$ " (162 x 175 x 64mm)	304025	43
one-sixth size pan, 6 $\frac{1}{2}$ " x 6 $\frac{1}{8}$ " x 4" (162 x 175 x 102mm)	304026	52
full size lid, with handle	304056	94
half size lid, with handle	304057	51
one-third size lid, with handle	304058	37
one-fourth size lid, with handle	304059	47
one-sixth size lid, with handle	304041	47
10" (254mm) adapter bar	301792	35
12" (305mm) adapter bar	301791	37

(•) MTS (made to stock) / ( ) MTO (made to order)



food pans

### Stainless Steel Round Insets and Lids

description	model #	list
4-quart inset for 6 $\frac{1}{2}$ " (165mm) opening	304020	89
7-quart inset for 8 $\frac{1}{2}$ " (216mm) opening	304021	136
11-quart inset for 10 $\frac{1}{2}$ " (267mm) opening	304060	142
lid for 4-quart round inset	304018	24
lid for 7-quart round inset	304019	51
lid for 11-quart round inset	304049	51



round inset with optional lid

### Polycarbonate Food Pans & Lids

description	model #	list
one-sixth size pan, 6 $\frac{1}{2}$ " x 6 $\frac{1}{8}$ " x 2 $\frac{1}{2}$ " (162 x 175 x 64mm)	304027	43
one-sixth size pan, 6 $\frac{1}{2}$ " x 6 $\frac{1}{8}$ " x 4" (162 x 175 x 102mm)	304028	52
one-sixth size lid, with handle	304042	52

### Other

description	model #	list
brass drain	305300	71
stopper	303974	29

## Adapter Tops for Round Insets Stainless steel.

### 2-Pot Adapter Tops

description	model #	list
two 8 $\frac{1}{2}$ " (216mm) diameter openings, each for 7 qts. (6.6 liters)	501600 •	146
one 8 $\frac{1}{2}$ " (216mm) diameter opening for 7 qts. (6.6 liters), and one 10 $\frac{1}{2}$ " (267mm) diameter opening for 11 qts. (10.4 liters)	501912 •	146
one 6 $\frac{1}{2}$ " (165mm) diameter opening for 4 qts. (3.8 liters), and one 10 $\frac{1}{2}$ " (267mm) diameter opening for 11 qts. (10.4 liters)	501913	146
one 6 $\frac{1}{2}$ " (165mm) diameter opening for 4 qts. (3.8 liters), and one 8 $\frac{1}{2}$ " (216mm) diameter opening for 7 qts. (6.6 liters)	501915	146



### 3-Pot Adapter Top

description	model #	list
three 6 $\frac{1}{2}$ " (165mm) diameter openings, each for 4 qts (3.8 liters)	501914 •	146

## Catalog Section 30

### FLEX-MASTER® Overshelf System NSF

see spec sheet **EG30.18**



hot food table with optional FLEX-MASTER® Overshelf System

**Create your own customized design using standard components.**



- Adjustable height in 1" (25mm) increments for flexible and accurate shelf placement.
- 10" (254mm) and 15" (381mm) shelf widths can be intermixed on same posts.

**FEATURES:**

**Note:** All shipping weights and cubic feet are approximate.

Heat lamp brackets available—\$244 per pair. Heat lamps are furnished and installed by others. Specify location of brackets.

**Freight class is 70.0.**

(•) MTS (made to stock) / ( ) MTO (made to order)

#### 10" (254mm) wide Overshelves

- 16 gauge type 304 stainless steel.
- Priced per shelf.

length in.	mm	number of wells	weight lbs.	kg	cubic feet	model #	list each
33"	838	2	10	4.5	1.2	<b>421002</b>	528
48"	1219	3	14	6.4	1.6	<b>421003 •</b>	555
63½"	1613	4	24	10.9	2.1	<b>421004 •</b>	585
79"	2007	5	29	13.2	2.6	<b>421005</b>	743
94½"	2400	6	35	15.9	3.1	<b>421006</b>	865

#### 15" (381mm) wide Overshelves

- 16 gauge type 304 stainless steel.
- Priced per shelf.

length in.	mm	number of wells	weight lbs.	kg	cubic feet	model #	list each
33"	838	2	14	6.4	1.6	<b>421502</b>	754
48"	1219	3	19	8.6	2.2	<b>421503</b>	788
63½"	1613	4	30	13.6	2.7	<b>421504</b>	820
79"	2007	5	37	16.3	3.3	<b>421505</b>	1066
94½"	2400	6	44	20.0	3.7	<b>421506</b>	1224

#### Pot & Ladle Racks - Chrome plated.

length in.	mm	weight lbs.	kg	cubic feet	model #	list each
33"	838	1.9	0.9	0.2	<b>PRT2-C</b>	89
48"	1219	2.1	1.0	0.2	<b>PRT3-C</b>	109
63½"	1613	2.5	1.1	0.3	<b>PRT4-C</b>	138
79"	2007	4.1	1.9	0.3	<b>PRT5-C</b>	169
94½"	2400	4.9	2.2	0.4	<b>PRT6-C *</b>	221

\*PRT6-C is provided in two sections.

#### Hooks

For use with pot & label racks.

description	weight lbs.	kg	cubic feet	model #	list each
stainless steel pot hook	0.2	0.1	0.1	<b>300696 •</b>	32
6" (176mm)-long chrome hook	0.1	0.1	0.1	<b>379769</b>	6

#### Stainless Steel Posts

- With plates.
- Calibrated in 1" (25mm) increments.
- Sold in pairs.
- 2-well to 5-well units require two pairs of posts.
- 6-well units require three pairs. **Freight class is 50.0.**

height in.	mm	weight lbs.	kg	cubic feet	model #	list per pair
18"	457	1.7	0.8	0.1	<b>418012 •</b>	200
30"	762	2.4	1.1	0.2	<b>430012 •</b>	257
48"	1219	5.6	2.5	0.2	<b>448012</b>	349



FLEX-MASTER® with optional pot & ladle racks and stainless steel posts

## Deluxe Service Mates - pages 234-236

**UNITS INCLUDE:**

- Clear polycarbonate sneeze guard (*except cashiers stand*).
- Polished stainless steel top with black vinyl-clad 22 gauge steel body.
- Portable models feature 4" (102mm) swivel casters (*two with brake*) and black vinyl-clad 18 gauge steel base.
- Tabletop models feature adjustable feet.
- All units are 22 $\frac{5}{16}$ " (573mm) front-to-back—36 $\frac{1}{4}$ " (921mm) including the sneeze guard.

**Note:** Stainless steel liners in place of galvanized, add \$111 per compartment to list price of unit and add "S" after "HT" in model number. Example: BPDHTS3-120. Stainless steel body upgrade, add 20% to list price of unit and add suffix "-S" to end of model number. Example: BPDHT2-120-S.

### Buffet Hot Food Tables

see spec sheet **EG30.16A**

**FEATURES:**

- Individual controls for each heat well.
- Units are now available with recessed control panel.





**Note:** 1000-watt heaters available for 240V models. To order, add suffix "-1" to model number and \$86 per well to list price. Example: BPDHT2-240-1.

**Freight class is 125.0.**

(•) MTS (*made to stock*) / ( ) MTO (*made to order*)

### Receptacle Configurations Required

See chart below for applicable NEMA plug.

				
15A 120V	15A 240V	20A 240V	30A 120V	20A 3Ø 240V
furnished with NEMA 5-15 plug	furnished with NEMA 6-15 plug	furnished with NEMA 6-20 plug	furnished with NEMA 5-30 plug	furnished with NEMA 15-20 plug

New York M.E.A. No. 376-84



portable buffet hot food table



tabletop buffet hot food table

### Portable Models — All Three-Phase units available in 208V and 240V only.

# of top openings	length in.	length mm	weight lbs.	weight kg	cu ft	volts	watts	SINGLE-PHASE			THREE-PHASE				
								amps	NEMA plug	model #	list	amps	NEMA plug	model #	list
2	33"	838	212	96.2	42.4	120V	1000W	8.3A	5-15P	BPDHT2-120	5573	-	-	n/a	
2	33"	838	212	96.2	42.4	208V	1500W	7.2A	6-15P	BPDHT2-208	5573	6.3A	15-20P	BPDHT2-208-3	6401
2	33"	838	212	96.2	42.4	240V	1500W	6.25A	6-15P	BPDHT2-240	5573	5.4A	15-20P	BPDHT2-240-3	6401
3	48"	1219	264	119.8	59.6	120V	1500W	12.5A	5-15P	BPDHT3-120	6273	-	-	n/a	
3	48"	1219	264	119.8	59.6	208V	2250W	10.8A	6-15P	BPDHT3-208	6273	6.3A	15-20P	BPDHT3-208-3	7163
3	48"	1219	264	119.8	59.6	240V	2250W	9.4A	6-15P	BPDHT3-240	6273	5.4A	15-20P	BPDHT3-240-3	7163
4	63 $\frac{1}{2}$ "	1613	312	141.5	75.6	120V	2000W	16.6A	5-30P	BPDHT4-120	7078	-	-	n/a	
4	63 $\frac{1}{2}$ "	1613	312	141.5	75.6	208V	3000W	14.4A	6-20P	BPDHT4-208	7078	9.5A	15-20P	BPDHT4-208-3	8039
4	63 $\frac{1}{2}$ "	1613	312	141.5	75.6	240V	3000W	12.5A	6-20P	BPDHT4-240	7078	8.3A	15-20P	BPDHT4-240-3	8039

### Tabletop Models — All Three-Phase units available in 208V and 240V only.

# of top openings	length in.	length mm	weight lbs.	weight kg	cu ft	volts	watts	SINGLE-PHASE			THREE-PHASE				
								amps	NEMA plug	model #	list	amps	NEMA plug	model #	list
2	33"	838	149	67.6	33.8	120V	1000W	8.3A	5-15P	CDHT2-120	4063	-	-	n/a	
2	33"	838	149	67.6	33.8	208V	1500W	7.2A	6-15P	CDHT2-208	4063	6.3A	15-20P	CDHT2-208-3	4762
2	33"	838	149	67.6	33.8	240V	1500W	6.25A	6-15P	CDHT2-240	4063	5.4A	15-20P	CDHT2-240-3	4762
3	48"	1219	189	85.7	44.2	120V	1500W	12.5A	5-15P	CDHT3-120	4753	-	-	n/a	
3	48"	1219	189	85.7	44.2	208V	2250W	10.8A	6-15P	CDHT3-208	4753	6.3A	15-20P	CDHT3-208-3	5512
3	48"	1219	189	85.7	44.2	240V	2250W	9.4A	6-15P	CDHT3-240	4753	5.4A	15-20P	CDHT3-240-3	5512
4	63 $\frac{1}{2}$ "	1613	234	106.1	57.1	120V	2000W	16.6A	5-30P	CDHT4-120	5661	-	-	n/a	
4	63 $\frac{1}{2}$ "	1613	234	106.1	57.1	208V	3000W	14.4A	6-20P	CDHT4-208	5661	9.5A	15-20P	CDHT4-208-3	6498
4	63 $\frac{1}{2}$ "	1613	234	106.1	57.1	240V	3000W	12.5A	6-20P	CDHT4-240	5661	8.3A	15-20P	CDHT4-240-3	6498

## Catalog Section 30

### Buffet Cold Pan Units

see spec sheet **EG30.16A**

- Polished 22 gauge stainless steel top.
- Black vinyl-clad 22 gauge steel body.
- 6" (152mm)-deep insulated ice pan is 20 gauge type 304 stainless steel.

FEATURES:

**Freight class is 125.0.**

(•) MTS (made to stock) / ( ) MTO (made to order)

New York M.E.A. No. 376-84



portable buffet cold pan unit



table top buffet cold pan unit

#### Portable Models

length		weight		cu	model #	list
in.	mm	lbs.	kg	ft		
33"	838	167	75.8	42.4	<b>BPCP-2</b>	4653
48"	1219	203	92.1	59.6	<b>BPCP-3</b> •	5329
63½"	1613	240	108.9	75.6	<b>BPCP-4</b> •	5649

#### Tabletop Models

length		weight		cu	model #	list
in.	mm	lbs.	kg	ft		
33"	838	137	62.1	33.8	<b>CCP-2</b>	4271
48"	1219	157	71.2	44.2	<b>CCP-3</b>	4840
63½"	1613	188	85.3	57.1	<b>CCP-4</b>	4994

### Portable Buffet Solid Top Units

see spec sheet **EG30.16B**

- Polished 16 gauge stainless steel top.
- Black vinyl-clad 22 gauge steel body.
- Black vinyl-clad 18 gauge steel base.
- 4" (102mm) swivel casters (two with brakes).
- Polycarbonate sneeze guard.

FEATURES:

**Freight class is 125.0.**

New York M.E.A. No. 376-84



portable solid top buffet unit

length		weight		cu	model #	list
in.	mm	lbs.	kg	ft		
33"	838	157	71.2	42.4	<b>BPST-2</b>	4049
48"	1219	193	87.5	59.6	<b>BPST-3</b>	4446
63½"	1613	230	104.3	75.6	<b>BPST-4</b>	5073

### Beef Cart

see spec sheet **EG30.16B**

- Polished 22 gauge stainless steel top.
- Black vinyl-clad 18 gauge steel body.
- Black vinyl-clad 18 gauge steel base.
- 12" x 20" (305 x 508mm) heat well.
- 250W heat lamp.
- Poly top carving board.
- 4" (102mm) swivel casters (two with brakes).
- Adjustable polycarbonate sneeze guard.

FEATURES:

**Freight class is 125.0.**

New York M.E.A. No. 376-84



#### Receptacle Configuration Required



15 AMP 120V  
furnished with  
NEMA 5-15 plug

length		weight		cubic	electrical data	NEMA plug	model #	list
in.	mm	lbs.	kg	feet				
33"	838	167	75.8	42.4	1450W, 120V, 12.1A	5-15P	<b>BC-1</b>	7253

## Cashiers Stand

see spec sheet **EG30.16B**



length		weight		cu	model #	list
in.	mm	lbs.	kg	ft		
24"	610	110	49.9	19.3	<b>CS-1</b>	2313

**FEATURES:**

- Polished 18 gauge stainless steel top.
- Black vinyl-clad 22 gauge steel body.
- 22 gauge stainless steel bottom panel.
- 4" (102mm) swivel casters (two with brakes).
- Enclosed storage area under stainless steel faced cashier drawer.

**Note:** Tray shelves for cashier stand available. Stainless steel. Set of two. **Model #:** PTS-1. **List:** \$1615

**Freight class is 100.0.**

(•) MTS (made to stock) / ( ) MTO (made to order)

## Accessories for Deluxe Service Mates

see spec sheet **EG30.16B**



service mate shown with optional heat lamps, food pans with insets, and wood-trimmed sneeze guard

**Freight class is 85.0.**

(•) MTS (made to stock) / ( ) MTO (made to order)

New York M.E.A. No. 376-84

description	model #	list each
Service Mate Select	<b>DSG-2</b>	4844
wood-trimmed polycarbonate sneeze guards	<b>DSG-3</b>	5038
	<b>DSG-4</b>	5302
fluorescent lights with plastic shields (factory installation required)	<b>FL-2</b>	1914
	<b>FL-3</b>	2028
	<b>FL-4</b>	2078
infrared bullet lamps (has separate cord. Not wired to base unit)	<b>IL-2</b>	1879
	<b>IL-3</b>	2162
	<b>IL-4</b>	2416
vinyl skirts for portable buffets (each price shown is for one piece)	<b>VS-2</b>	256
	<b>VS-3</b>	309
	<b>VS-4</b>	337
stainless steel skirts for portable buffets (each price shown is for one piece)	<b>SS-2</b>	303
	<b>SS-3</b>	368
	<b>SS-4</b>	401
stainless steel 8" (203mm) wide tray shelves, set of two	<b>PTS-2</b>	1865
	<b>PTS-3</b>	1964
	<b>PTS-4 •</b>	2129
stainless steel undershelf for portable buffets	<b>US-2</b>	323
	<b>US-3</b>	372
	<b>US-4</b>	427

## REDHOTS® Heat Lamps (OPTION)

see spec sheet **EG35.23**



For more information on this product see page 267.

## REDHOTS® Display Lights (OPTION)

see spec sheet **EG35.09**



For more information on this product see page 268.



Two columns of horizontal lines for taking notes.





# Director's Choice® Modular Cafeteria Line

## Accessories/Components

Buffet Shelves .....	256
Custom Accessories.....	257-258
Rear Doors and Panels .....	256
Serving Shelves.....	256
Sneeze Guards.....	255, 257
Stainless Steel Front Panels .....	253
Tray Slides .....	253
Undershelves .....	256
Various Working Heights.....	253
Work Shelves.....	255

## Director's Choice® Units

Beverage Units.....	247
Carving Station Unit .....	245
Cashier Units .....	246
Cold Food Units .....	241-242
Corner Transition Units .....	248
Dish/Cup Dispenser Units .....	252
Drop-In Adjustable Dispensers .....	251
Frost Top Units .....	247
Heated Surface Units.....	243
Hot/Cold Units .....	244

Hot Food Service Counters .....	245
Hot Food Units.....	240
Ice Cream Units.....	244
Rack/Tray Dispenser Units.....	250
Solid Top Refrigerated Base Units....	243
Solid Top Utility Carts .....	243
Stainless Steel Bottle Holders .....	251
Tray & Silverware Unit.....	249
Tray Platform Unit .....	249
Tray/Silverware/Napkin Dispenser Unit .....	248

## INTRODUCING Spec-SHIELD™ Food Guards

**NOW PATENTED**  
Patent Nos. 9,538,868; 9,516,958;  
9,339,131; 9,326,621; 9,723,935

*Food guard angles and height adjust easily!*

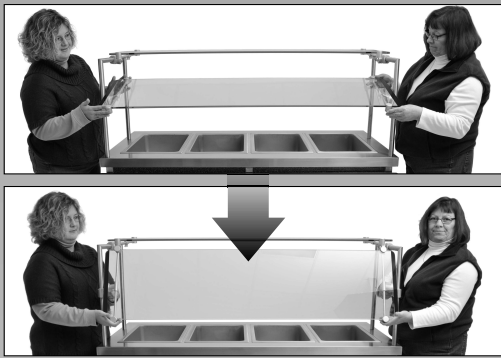

*Food guards are easily removable!*



**A variety of sizes and styles available! See page 254.**

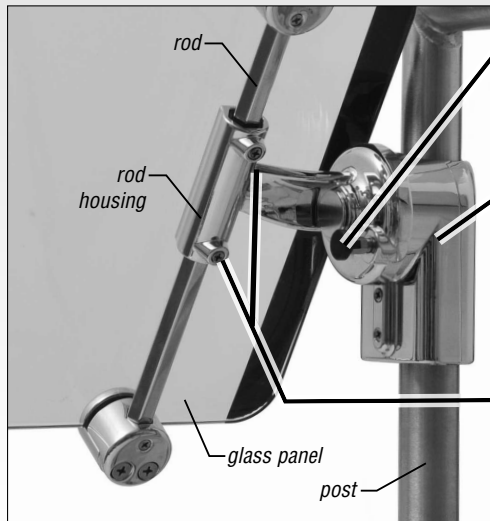

### Pull knob for angle adjustment of panels

- Angle adjusts in 18° increments.

### Split casting for removal or adjustment

- Loosen set screws to separate split casting, allowing for removal of entire food guard assembly and adjustment of height.

### Set screws for adjustment of panels

- When loosened, adjacent rod can slide freely inside the housing, allowing for movement of panel without the need to move or take apart the split casting.

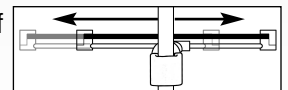
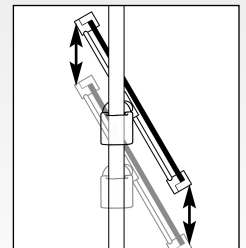
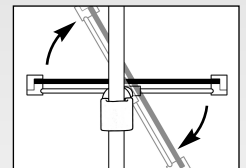

**See page 259 for NEW Director's Choice® Adjustable Height Option.**

## Hot Food Units

see spec sheet **EG33.02**



hot food unit – customer side shown with optional laminate end panels

Refer to page 253 for optional overall heights and optional heights of tray slides available for units on this page.

### Optional Individual Drains for Hot Food Units

- Individual drain for each well with manifold to single valve.
- 3/4" (19mm) ball valve provided (NPTF).

# of wells	add suffix #	add to list
2	-D	603
3	-D	906
4	-D	1208
5	-D	1511
6	-D	1813

### Receptacle Configurations Required

30 AMP 120V model # <b>DCS2-HFU-A</b>	50 AMP 120V model # <b>DCS3-HFU-A</b>	15 AMP 240V model # <b>DCS2-HFU-B</b>	20 AMP 240V model # <b>DCS2-HFU-C</b> <b>DCS3-HFU-B</b>	30 AMP 240V model # <b>DCS3-HFU-C</b> <b>DCS4-HFU-B</b>	50 AMP 240V model # <b>DCS4-HFU-C</b> <b>DCS5-HFU-B</b> <b>DCS5-HFU-C</b> <b>DCS6-HFU-B</b> <b>DCS6-HFU-C</b>
furnished with NEMA 5-30 plug	furnished with NEMA 5-50 plug	furnished with NEMA 6-15 plug	furnished with NEMA 6-20 plug	furnished with NEMA 6-30 plug	furnished with NEMA 6-50 plug
	model # <b>DCS2-HFU-B-3</b> <b>DCS2-HFU-C-3</b> <b>DCS3-HFU-B-3</b> <b>DCS3-HFU-C-3</b> <b>DCS4-HFU-B-3</b>		model # <b>DCS4-HFU-C-3</b> <b>DCS5-HFU-B-3</b> <b>DCS5-HFU-C-3</b> <b>DCS6-HFU-B-3</b> <b>DCS6-HFU-C-3</b>		furnished with NEMA 15-20 plug
20A 3Ø 240V furnished with NEMA 15-20 plug	furnished with NEMA 15-30 plug		furnished with NEMA 15-30 plug		

# of top openings	length in.	weight lbs.	cu ft	volts	watts	amps	SINGLE-PHASE		THREE-PHASE				
							model #	list	amps	model #	list		
2	36"	914	165	74.8	22	120V	2400W	20.0A	<b>DCS2-HFU-A</b>	8040	n/a		
2	36"	914	165	74.8	22	240V	2400W	10.0A	<b>DCS2-HFU-B</b>	8040	8.7A	<b>DCS2-HFU-B-3</b>	8389
2	36"	914	165	74.8	22	240V	3200W	13.3A	<b>DCS2-HFU-C</b>	8040	11.6A	<b>DCS2-HFU-C-3</b>	8389
3	50"	1270	200	90.7	30	120V	3600W	30.0A	<b>DCS3-HFU-A</b>	9695	n/a		
3	50"	1270	200	90.7	30	240V	3600W	15.0A	<b>DCS3-HFU-B</b>	9695	8.7A	<b>DCS3-HFU-B-3</b>	10043
3	50"	1270	200	90.7	30	240V	4800W	20.0A	<b>DCS3-HFU-C</b>	9695	11.6A	<b>DCS3-HFU-C-3</b>	10043
4	64"	1626	250	113.4	38	240V	4800W	20.0A	<b>DCS4-HFU-B</b>	11685	13.2A	<b>DCS4-HFU-B-3</b>	12034
4	64"	1626	250	113.4	38	240V	6400W	26.7A	<b>DCS4-HFU-C</b>	11685	17.7A	<b>DCS4-HFU-C-3</b>	12034
5	78"	1981	305	138.3	46	240V	6000W	25.0A	<b>DCS5-HFU-B</b>	13688	17.3A	<b>DCS5-HFU-B-3</b>	14039
5	78"	1981	305	138.3	46	240V	8000W	33.4A	<b>DCS5-HFU-C</b>	13688	23.1A	<b>DCS5-HFU-C-3</b>	14039
6	96"	2438	355	161.0	57	240V	7200W	30.0A	<b>DCS6-HFU-B</b>	16131	17.3A	<b>DCS6-HFU-B-3</b>	16479
6	96"	2438	355	161.0	57	240V	9600W	40.0A	<b>DCS6-HFU-C</b>	16131	23.1A	<b>DCS6-HFU-C-3</b>	16479

### Features:

- Type 304 stainless steel construction.
- 16 gauge type 304 stainless steel top is 30" (762mm) front-to-back and 2" (51mm) tall.
- 34" (864mm) standard working height complies with ADA guidelines for accessibility standards.
- Welded 1 1/2" (38mm) square tubular type 304 stainless steel base construction.
- Open base on three sides – 7 5/8" (183mm) tall type 304 stainless steel apron on operator's side.
- 5" (127mm) poly tread swivel casters (two with brake).
- Holly berry red front laminate panel (Wilsonart® D307-60) on heavy gauge galvanized subpanel.
- Insulated 12" x 20" (305 x 508mm) sealed heat wells with individual thermostatic controls.
- Wells offered with optional drains – specify when ordering.
- Optional drains connect to common manifold, drain to left end.
- Accepts 12" x 20" (305 x 508mm) food pans.
- Wired to cord and plug.
- Wet or dry operation.
- 1200W per well at 120V.
- 240V units listed in chart below can run at 208V operation. This will reduce available wattage by 25%.

**Note:** Accommodate accessories such as tray slides, work shelves, and removable undershelves (see pages 253, 255 and 256).

Laminate end panels available. To order, add suffix "-LEP" to model number and \$432 to list price. Example: DCS2-HFU-A-LEP.

**Stainless steel front panels available.**

To order, add suffix "-S" to model number. See chart on page 253 for list price.

Example: DCS2-HFU-A-S.

**Stainless steel end panels available.**

To order, add suffix "-SEP" to model number and \$566 to list price.

Example: DCS2-HFU-A-SEP.

Stainless steel bottle holders available—see page 251.

**Freight class is 100.0.**

### Cold Food Units with Refrigerated Mechanical Cold Pan



see spec sheet **EG33.01A**



cold food unit shown with optional double sneeze guard, optional tray slide and optional laminate end panels.

**Note:** Optional sneeze guards are factory-installed.

#### Receptacle Configurations Required

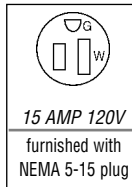

**Refer to page 253 for optional overall heights and optional heights of tray slides available for units on this page.**

#### Featuring Refrigerated Mechanical Cold Pan with Recessed Top (NSF-7)

- 3" (76mm) recessed top. 9" (229mm) deep. Removable front-to-back and end-to-end adapter bars provided.

# of pans	length in.	length mm	weight lbs.	weight kg	cu ft	electrical data	model #	list
2	36"	914	275	124.7	22	1/4HP, 120V, 6.0A	<b>DCS2-CFURN</b>	11625
3	50"	1270	325	147.4	30	1/4HP, 120V, 6.0A	<b>DCS3-CFURN</b>	12779
4	64"	1626	385	174.6	38	1/3HP, 120V, 7.8A	<b>DCS4-CFURN</b>	14014
5	78"	1981	435	197.3	46	1/2HP, 120V, 10.7A	<b>DCS5-CFURN</b>	15721
6	96"	2438	520	235.9	57	1/2HP, 120V, 10.7A	<b>DCS6-CFURN</b>	17437

**Note:** For 5-year compressor warranty, add **List Price of \$309**. Must be ordered when ordering Cold Food Unit(s).

#### Featuring Refrigerated Mechanical Cold Pans (Standard Depth)

- 4 1/8" (117mm) deep x 19 1/8" (505mm) wide refrigerated cold pan. Removable front-to-back adapter bars provided.

**Note:** Not compliant with NSF-7. Check local health codes for applications required.

# of pans	length in.	length mm	weight lbs.	weight kg	cu ft	electrical data	model #	list
2	36"	914	210	95.3	22	1/5HP, 120V, 3.9A	<b>DCS2-CFUR</b>	9999
3	50"	1270	260	117.9	30	1/5HP, 120V, 3.9A	<b>DCS3-CFUR</b>	11099
4	64"	1626	320	145.2	38	1/4HP, 120V, 6.8A	<b>DCS4-CFUR</b>	12614
5	78"	1981	370	168.8	46	1/3HP, 120V, 9.8A	<b>DCS5-CFUR</b>	13969
6	96"	2438	460	208.7	57	1/3HP, 120V, 9.8A	<b>DCS6-CFUR</b>	15674

**Note:** For 5-year compressor warranty, add **List Price of \$309**. Must be ordered when ordering Cold Food Unit(s).

#### Features:

- Type 304 stainless steel construction.
- 16 gauge type 304 stainless steel top is 30" (762mm) front-to-back and 2" (51mm) tall.
- 34" (864mm) standard working height complies with ADA guidelines for accessibility standards.
- Welded 1 1/2" (38mm) square tubular type 304 stainless steel base construction.
- Open base on three sides – 7 5/16" (183mm) tall type 304 stainless steel apron on operator's side.
- 5" (127mm) poly tread swivel casters (two with brake).
- Holly Berry red front laminate panel (Wilsonart® D307-60) on heavy gauge galvanized subpanel.
- Available only in 120-volt 60Hz, wired to 6' (1829mm) cord and plug.
- 3/4" (19mm) diameter drain and valve.
- Accepts 12" x 20" (305 x 508mm) food pans, with the use of adapter bars provided.

**Note:** All units are predrilled to accommodate accessories such as tray slides, work shelves, and removable undershelves (see pages 253, 255 and 256).

#### Laminate end panels available.

To order, add suffix "-LEP" to model number and **\$484 to list price**.

**Example:** DCS2-CFURN-LEP.

#### Stainless steel front panels available.

To order, add suffix "-S" to model number.

See chart on page 253 for list price.

**Example:** DCS2-CFURN-S.

#### Stainless steel end panels available.

To order, add suffix "-SEP" to model number and **\$566 to list price**.

**Example:** DCS2-CFURN-SEP.

Stainless steel bottle holders available—see page 251.

**Freight class is 100.0.**

## Cold Food Units with Refrigerated Mechanical Cold Pan (Cont.)

see spec sheet **EG33.01A**



cold food unit shown with optional double sneeze guard, optional tray slide and optional laminate end panels

**Note:** Optional sneeze guards are factory-installed.

### Optional 9<sup>3</sup>/<sub>4</sub>" (248mm) full depth cold pans for "...-CFUR" Units only

**Note:** Not compliant with NSF-7. Check local health codes for applications required.

# of pans	FULL DEPTH COLD PAN		FULL DEPTH COLD PAN WITH SIDE COILS	
	add suffix # *	add to list	add suffix # *	add to list
2	-F	339	-FS	624
3	-F	548	-FS	733
4	-F	729	-FS	1187
5	-F	828	-FS	1318
6	-F	887	-FS	1562

\* Examples: DCS3-CFUR-F is a unit with optional full depth cold pan.  
DCS3-CFUR-FS is a unit with optional full depth cold pan with side coils.

## Cold Food Units with Iced Cold Pan (Standard Depth)

• 4<sup>5</sup>/<sub>8</sub>" (117mm) deep x 19<sup>1</sup>/<sub>8</sub>" (505mm) wide iced cold pan. **EG33.01B**

# of pans	length		weight		cu ft	model #	list
	in.	mm	lbs.	kg			
2	36"	914	130	59.0	22	DCS2-CFUI	6575
3	50"	1270	160	72.6	30	DCS3-CFUI	7416
4	64"	1626	190	86.2	38	DCS4-CFUI	8593
5	78"	1981	235	106.6	46	DCS5-CFUI	9717
6	96"	2438	270	122.5	57	DCS6-CFUI	11137

### Optional 9<sup>3</sup>/<sub>4</sub>" (248mm) Full-Depth Cold Pans for above Units with Iced Cold Pan

# of wells	add suffix #	add to list
2	-F	252
3	-F	277
4	-F	379
5	-F	435
6	-F	491

\* Example: DCS3-CFUI-F is a unit with optional full depth cold pan.

### Features:

- Type 304 stainless steel construction.
- 16 gauge type 304 stainless steel top is 30" (762mm) front-to-back and 2" (51mm) tall.
- 34" (864mm) standard working height complies with ADA guidelines for accessibility standards.
- Welded 1<sup>1</sup>/<sub>2</sub>" (38mm) square tubular type 304 stainless steel base construction.
- Open base on three sides – 7<sup>5</sup>/<sub>16</sub>" (183mm) tall type 304 stainless steel apron on operator's side.
- 5" (127mm) poly tread swivel casters (two with brake).
- Holly berry red front laminate panel (Wilsonart® D307-60) on heavy gauge galvanized subpanel.
- 3/4" (19mm) diameter drain and valve.
- Accepts 12" x 20" (305 x 508mm) food pans, with the use of adapter bars provided.

**Note:** All units are predrilled to accommodate accessories such as tray slides, work shelves, and removable undershelves—see pages 253, 255 and 256.

#### Laminate end panels available.

To order, add suffix "-LEP" to model number and **\$460 to list price.**

**Example:** DCS2-CFUI-LEP.

#### Stainless steel front panels available.

To order, add suffix "-S" to model number. See chart on page 253 for list price.

**Example:** DCS2-CFUI-S.

#### Stainless steel end panels available.

To order, add suffix "-SEP" to model number and **\$566 to list price.**

**Example:** DCS2-CFUI-SEP.

Stainless steel bottle holders available—see page 251.

**Freight class is 100.0.**

**Refer to page 253 for optional overall heights and optional heights of tray slides available for units on this page.**

# DIRECTOR'S CHOICE® MODULAR CAFETERIA SERVING UNITS

## Catalog Section 33

### Solid Top Utility Carts

see spec sheet **EG33.04**



solid top utility cart shown with optional double-tier sneeze guard, optional tray slide and optional side laminate panels

- Reinforced solid top constructed of 16 gauge type 304 stainless steel, die-formed, fully welded, polished, and reinforced with full length hat channel.

length		weight		cubic	model #	list
in.	mm	lbs.	kg	feet		
36"	914	115	52.2	22	<b>DCS2-STU</b>	4218
50"	1270	155	70.3	30	<b>DCS3-STU</b>	4767
64"	1626	180	81.6	38	<b>DCS4-STU</b>	5392
78"	1981	205	93.0	46	<b>DCS5-STU</b>	6093
96"	2438	245	111.1	57	<b>DCS6-STU</b>	7168

### Solid Top Refrigerated Base Units

see spec sheet **EG33.15**



solid top refrigerated base unit with optional single-tier sneeze guard and laminate end panels (back panel removed to show compressor housing)

- Ready-to-operate refrigeration system included.

description	length		weight		electrical data (single phase)	model #	list
	in.	mm	lbs.	kg			
single door	64"	1626	180	81.6	120V, 6.8A, 1/4HP	<b>DCS4-STURB</b>	22087
double door	78"	1981	205	93.0	120V, 6.8A, 1/4HP	<b>DCS5-STURB</b>	28236

**Note:** For 5-year compressor warranty, add List Price of \$282. Must be ordered when ordering unit(s).

### Features:

- Type 304 stainless steel construction.
- 16 gauge type 304 stainless steel top is 30" (762mm) front-to-back and 2" (51mm) tall.
- 34" (864mm) standard working height complies with ADA guidelines for accessibility standards.
- Welded 1½" (38mm) square tubular type 304 stainless steel base construction.
- Open base on three sides – 7⅝" (183mm) tall type 304 stainless steel apron on operator's side.
- 5" (127mm) poly tread swivel casters (two with brake).
- Standard holly berry red front laminate panel (Wilsonart® D307-60) on heavy gauge galvanized subpanel.

**Note:** All units are predrilled to accommodate accessories such as tray slides, work shelves, and removable undershelves—see pages 253, 255 and 256.

**Laminate end panels available for all units.** To order, add suffix "-LEP" to model number and **\$460 to list price.**  
**Example: DCS2-STU-LEP.**

**Stainless steel front panels available for all units.** To order, add suffix "-S" to model number. See chart on page 253 for list price.  
**Example: DCS2-STU-S.**

**Stainless steel end panels available for all units.** To order, add suffix "-SEP" to model number and **\$566 to list price.**  
**Example: DCS2-STU-SEP.**

### Heated Surface Units

see spec sheet **EG33.13**



heated surface unit shown with optional tray slide and optional laminate end panels

- Recessed aluminum top with blanket-type foil for uniform heat. Control thermostat with a range of 80° to 200°F (27° to 93°C) and On/Off switch.

length		heated surface area width x length		electrical data	model #	list
in.	mm	in.	mm			
50"	1270	19½" x 42"	495 x 1067	120V, 7.4A, 885W	<b>DCS3-HS</b>	9563
64"	1626	19½" x 54"	495 x 1372	120V, 9.3A, 1110W	<b>DCS4-HS</b>	10547
78"	1981	19½" x 66"	495 x 1676	120V, 11.1A, 1330W	<b>DCS5-HS</b>	11113
96"	2438	19½" x 72"	495 x 1829	120V, 12.0A, 1440W	<b>DCS6-HS</b>	12397

Freight class is 100.0.

Refer to page 253 for optional overall heights and optional heights of tray slides available for units on this page.

**Receptacle Configurations Required for Heated Surface Units**

For 50"-64" Units | For 78"-96" Units

15 AMP 120V furnished with NEMA 5-15 plug	20 AMP 120V furnished with NEMA 5-20 plug

**Receptacle Configurations Required for Solid Top Refrigerated Base Units**

15 AMP 120V furnished with NEMA 5-15 plug

## Hot/Cold Units



hot/cold unit with optional tray slide and end panels

see spec sheet **EG33.23**



- Dual temperature hot or cold operation.
- Fiberglass insulation on all sides.
- Stainless steel inner liner with coved corners and 3/4" (20mm) I.P.S. drain.
- Hot Mode: Immersion-type heating element (water required), with stainless steel sheath cover.

- Cold Mode: Self-contained condensing unit with sealed compressor. Fully charged with CFC-free refrigerant.
- Thermostatic control for hot and cold service.
- Pre-wired with hot/cold selector switch, required thermostatic controls and pilot light. Provided with 6-foot long cord with twist-lock plug.

### Features:

- Type 304 stainless steel construction.
- 16 gauge type 304 stainless steel top is 30" (762mm) front-to-back and 2" (51mm) tall.
- 34" (864mm) standard working height complies with ADA guidelines for accessibility standards.
- Welded 1 1/2" (38mm) square tubular type 304 stainless steel base construction.
- Open base on three sides – 7 5/8" (183mm) tall type 304 stainless steel apron on operator's side.
- 5" (127mm) poly tread swivel casters (two with brake).
- Standard holly berry red front laminate panel (Wilsonart® D307-60) on heavy gauge galvanized subpanel.

**Note:** All units are predrilled to accommodate accessories such as tray slides, work shelves, and removable undershelves—see pages 253, 255 and 256.

**Laminate end panels available for all units.** To order, add suffix "**-LEP**" to model number and **\$484 to list price.**

**Example:** DCS3-HCFU-A-LEP.

**Stainless steel front panels available for all units.** To order, add suffix "**-S**" to model number. See chart on page 253 for list price. **Example:** DCS4-HCFU-B-S.

**Stainless steel end panels available for all units.** To order, add suffix "**-SEP**" to model number and **\$566 to list price.** **Example:** DCS3-HCFU-A-SEP.

# of top openings	length		weight		cu ft	NEMA plug	electrical data		model #	list
	in.	mm	lbs.	kg			Hot Mode	Cold Mode		
2	36"	914	190	86.2	22	L5-30P	16.7A 120V 2,000W	2.4A 120V 1/5HP	DCS2-HCFU-A	24634
3	50"	1270	220	99.8	30	L5-30P	16.7A 120V 2,000W	2.4A 120V 1/5HP	DCS3-HCFU-A	26436
4	64"	1626	250	113.4	38	L14-30P	14.4A 208V 3,000W	7.5A 120V 1/4HP	DCS4-HCFU-B	29403
4	64"	1626	250	113.4	38	L14-30P	12.5A 240V 3,000W	7.5A 120V 1/4HP	DCS4-HCFU-C	29403
5	78"	1981	270	122.5	46	L14-30P	19.3A 208V 4,000W	9.8A 120V 1/3HP	DCS5-HCFU-B	31707
5	78"	1981	270	122.5	46	L14-30P	16.7A 240V 4,000W	9.8A 120V 1/3HP	DCS5-HCFU-C	31707
6	96"	2438	340	154.2	57	L14-30P	19.3A 208V 4,000W	9.8A 120V 1/3HP	DCS6-HCFU-B	34277
6	96"	2438	340	154.2	57	L14-30P	16.7A 240V 4,000W	9.8A 120V 1/3HP	DCS6-HCFU-C	34277

## Ice Cream Units



ice cream unit with optional tray slide and end panels

see spec sheet **EG33.11**



- Stainless steel insulated, hinged, lift-off lid with plastic coated pulls.
- 2 1/2" (64mm) thick insulation on all sides, enclosed with galvanized steel outer liner.
- Heavy gauge type 304 stainless steel inner liner is one-piece construction, all welded, ground and polished.
- The liner features coved corners and copper tubing soldered to exterior sides and bottom.
- Wired to 6' (1829mm) cord & plug.

**Note:** Locking lid device available. To order, add **\$539 to list price** and add suffix **-L** to model number. **Example:** DCS2-ICU-L

length	ice cream capacity		cu ft cap.	weight		cu ft	electrical data	model #	list	
	in.	mm		lbs.	kg					
36"	914	100	45.4	2.6	250	113.4	22	1/4HP, 120V, 6.8A	DCS2-ICU	12643
50"	1270	150	68.0	4.2	285	129.3	30	1/4HP, 120V, 6.8A	DCS3-ICU	14695

**Note:** For 5-year compressor warranty, add **List Price of \$295.** Must be ordered when ordering Ice Cream Unit(s).

Freight class is 100.0.

Refer to page 253 for optional overall heights and optional heights of tray slides available for units on this page.

### Receptacle Configurations Required for Ice Cream Units

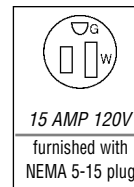

# DIRECTOR'S CHOICE® MODULAR CAFETERIA SERVING UNITS

## Catalog Section 33

### Carving Station Unit



shown with optional tray slide

see spec sheet **EG33.12**



- Fully insulated.
- Adapter plate, meat spike and gravy pan.
- 3/4" (19mm) drain with valve.
- Thermostatic controls.
- 120V operation wired to 6' (1829mm) cord and plug.
- Two laminate end panels included.

length in. mm	weight lbs. kg	cu ft	electrical data	model #	list
36" 914	275 124.7	22	1200W, 120V, 10.4A	<b>DCS2-CSU</b>	11506

#### Optional Bullet Lamps for Carving Station Unit

- Stainless steel tubular frame, 8" (203mm) adjustable height.
- Aluminum bulb shield. On/Off switch.
- 6' (1829mm) cord and NEMA 5-15 plug. (Includes two cords and plugs when ordered with bullet lamp.)

description	bulb clearance in. mm	electrical data	add suffix #	add to list
bullet lamp only	9"-17" 245-448	120V, 4.2A, 500W	<b>-BL</b>	1721
with sneeze guard	9"-17" 245-448	120V, 4.2A, 500W	<b>-BLS</b>	4729

#### Receptacle Configuration Required for Carving Station

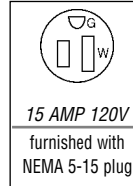

### Hot Food Service Counters...

see spec sheet **EG33.20**



- Type 304 stainless steel top is welded and polished.
- Welded 1/2" (38mm) type 304 stainless steel square tubular base construction.
- Fully-insulated heat wells are sealed, accept 12" x 20" (305 x 508mm) food pans, and feature individual thermostat controls.
- Standard 5" (127mm) casters with poly tread.

Consult factory for pricing.

Freight class is 100.0.

Refer to page 253 for optional overall heights and optional heights of tray slides available for units on this page.



"U" shaped – ideal for tray makeup conveyor or school-serving line



"L" shaped – ideal for tray makeup line.

#### ...with "U" shaped Configuration

# of wells	length		volts	watts	SINGLE-PHASE		THREE-PHASE	
	in.	mm			amps	model #	amps	model #
3	50"	1270	120V	3600W	30.0A	<b>DCS3-TMU-A</b>	n/a	n/a
3	50"	1270	208/240V	2700/3600W	13.0/15.0A	<b>DCS3-TMU-B</b>	7.5/8.7A	<b>DCS3-TMU-B-3</b>
3	50"	1270	208/240V	3600/4800W	17.3/20.0A	<b>DCS3-TMU-C</b>	10.0/11.6A	<b>DCS3-TMU-C-3</b>
4	64"	1626	208/240V	3600/4800W	17.3/20.0A	<b>DCS4-TMU-B</b>	11.5/13.2A	<b>DCS4-TMU-B-3</b>
4	64"	1626	208/240V	4800/6400W	23.1/26.7A	<b>DCS4-TMU-C</b>	15.3/17.7A	<b>DCS4-TMU-C-3</b>
5	78"	1981	208/240V	4500/6000W	21.6/25.0A	<b>DCS5-TMU-B</b>	15.0/17.3A	<b>DCS5-TMU-B-3</b>
5	78"	1981	208/240V	6000/8000W	28.8/33.4A	<b>DCS5-TMU-C</b>	20.0/23.1A	<b>DCS5-TMU-C-3</b>
6	96"	2438	208/240V	5400/7200W	26.0/30.0A	<b>DCS6-TMU-B</b>	15.0/17.3A	<b>DCS6-TMU-B-3</b>
6	96"	2438	208/240V	7200/9600W	34.6/40.0A	<b>DCS6-TMU-C</b>	20.0/23.1A	<b>DCS6-TMU-C-3</b>

#### ...with "L" shaped Configuration

# of wells	length		volts	watts	SINGLE-PHASE		THREE-PHASE	
	in.	mm			amps	model #	amps	model #
4	64"	1626	208/240V	3600/4800W	17.3/20.0A	<b>DCS4-TMLL-B</b>	11.5/13.2A	<b>DCS4-TMLL-B-3</b>
4	64"	1626	208/240V	4800/6400W	23.1/26.7A	<b>DCS4-TMLL-C</b>	15.3/17.7A	<b>DCS4-TMLL-C-3</b>

**Note:** Models listed indicate fourth well at left, standing at operator's side of unit. For unit with reverse layout, replace "-TMLL" with "-TMLR" in model number (example: DCS4-TMLR-B-3)

## Cashier Units

see spec sheet **EG33.03**



cashier unit – server side  
– shown with optional laminate end panels  
and removable undershelf

length		weight		cu	INLINE		LEFT END*		RIGHT END**	
in.	mm	lbs.	kg	ft	model #	list	model #	list	model #	list
24"	610	235	106.6	14	DCS-CUI-24	5814	DCS-CUEL-24	5814	DCS-CUER-24	5814
36"	914	285	129.3	22	DCS-CUI-36	9071	DCS-CUEL-36	9071	DCS-CUER-36	9071

\* Drawer is located on left end as viewed from Server Side of Director's Choice®.  
\*\* Drawer is located on right end as viewed from Server Side of Director's Choice®.

### Optional Tray Slides for 24" (610mm) Cashier "End" Units

- Stainless steel drop brackets. See page 253 for tray slides to fit 36" (914mm) units.

description	length		SQUARE tubular		ROUND tubular		Solid Ribbed	
	in.	mm	model #	list	model #	list	model #	list
11½" (292mm) wide	24"	610	DC24-TS-TS	968	DC24-TS-TSR	968	DC24-TS-SRS	968

### Optional Work Shelves for 24" (610mm) Cashier "End" Units

- Stainless steel drop brackets. See page 255 for work shelves to fit 36" (914mm) units.

description	length		1¼"-THICK HARDWOOD		18/304 Stainless		poly	
	in.	mm	model #	list	model #	list	model #	list
8" (203mm) wide	24"	610	DC24-WS-MT	972	DC24-WS-ST	935	DC24-WS-PT	893

### Optional Removable Undershelves for Cashier Units

description	Solid Undershelves		Louvered Undershelves	
	model #	list	model #	list
For inline units	DC24I-RSU	767	DC24I-RSUL	1034
For 24" (610mm) long units	DC24E-RSU	767	DC24E-RSUL	1034
For 36" (914mm) long units	DC36E-RSU	919	DC36E-RSUL	1240

### Optional Cash Trays and Covers for Cashier Units

- Fits inside drawer. Lightweight, but constructed of durable ABS thermoplastic.

description	Tray Cover			
	model #	list	model #	list
4-bill tray	366458	98	n/a	n/a
5-bill tray	366456	126	366457	58

### Features:

- Foot rest welded to frame for strength.
- Standard flush-fitting drawer with keyed tumbler lock – 18" x 20½" x 3" (457 x 519 x 76mm) inner dimensions.
- Drawer features double-pan front and recessed pull.
- Type 304 stainless steel construction.
- 16 gauge type 304 stainless steel top is 30" (762mm) front-to-back and 2" (51mm) tall.
- 34" (864mm) standard working height complies with ADA guidelines for accessibility standards.
- Welded 1½" (38mm) square tubular type 304 stainless steel base construction.
- Open base on three sides – 7¾" (183mm) tall type 304 stainless steel apron on operator's side.
- 5" (127mm) poly tread swivel casters (two with brake).
- Standard holly berry red front laminate panel (Wilsonart® D307-60) on heavy gauge galvanized subpanel.

**Note:** All units are predrilled to accommodate accessories such as tray slides, work shelves, and removable undershelves—see pages 253, 255 and 256.

**Laminate end panels available for all units.** To order, add suffix "-LEP" to model number and **\$484 to list price.**  
**Example:** DCS-CUI-24-LEP

**Stainless steel front panels available for all units.** To order, add suffix "-S" to model number. See chart on page 253 for list price.  
**Example:** DCS-CUI-24-S.

**Stainless steel end panels available for all units.** To order, add suffix "-SEP" to model number and **\$566 to list price.**  
**Example:** DCS-CUI-24-SEP.

**Electrical options:** convenience outlet 120V, low-voltage raceway.  
**Consult factory for pricing.**

**Freight class is 100.0.**

**Refer to page 253 for optional overall heights and optional heights of tray slides available for units on this page.**



# DIRECTOR'S CHOICE® MODULAR CAFETERIA SERVING UNITS

## Catalog Section 33

### Beverage Units

see spec sheet **EG33.06**



single-urn trough beverage unit shown with optional tray shelf and laminate end panels

- Used in conjunction with countertop water coolers, beverage dispensers, etc.
- Urn troughs are 2" deep x 4½"-wide (51 x 114mm).
- Hat channel reinforced top.
- Trough is sloped to a 1" (25mm) diameter drain to operator's left.
- Removable trough cover features louvered "anti-splash" design, and is sectional to fit in dishwasher for sanitation.

length in. mm	weight		cu ft	drip trough length		SINGLE-URN TROUGH		DOUBLE-URN TROUGH	
	lbs.	kg		in.	mm	model #	list	model #	list
36" 914	150	68.0	22	28½"	724	DCS2-BSU	5515	DCS2-BDU	6609
50" 1270	180	81.6	30	42¾"	1086	DCS3-BSU	6274	DCS3-BDU	7589
64" 1626	220	99.8	38	57¾"	1451	DCS4-BSU	7017	DCS4-BDU	8596
78" 1981	270	122.5	46	71½"	1816	DCS5-BSU	7821	DCS5-BDU	9507

### Frost Top Units

see spec sheet **EG33.08**



frost top unit shown with optional tray slide

- Used primarily for presentation of pre-plated cold foods.
- 14 gauge stainless steel raised frost top stands 1" (25mm) above unit and features ½" (13mm) full perimeter gutter for melted condensate.
- Gasket seal to top.
- Fully insulated. 120V operation wired to 6' (1829mm) cord & plug.

length in. mm	weight		cubic feet	electrical data	model #	list
	lbs.	kg				
36" 914	220	99.8	22	1/5HP, 120V, 3.9A	DCS2-FTU	10753
50" 1270	275	124.7	30	1/4HP, 120V, 6.8A	DCS3-FTU	12027
64" 1626	325	147.4	38	1/3HP, 120V, 9.8A	DCS4-FTU	13322
78" 1981	365	165.6	46	1/3HP, 120V, 9.8A	DCS5-FTU	14549
96" 2438	470	213.2	57	1/2HP, 120V, 10.7A	DCS6-FTU	16997

**Note:** For 5-year compressor warranty, add List Price of \$252. Must be ordered when ordering Frost Top Unit(s).

### Features:

- Type 304 stainless steel construction.
- 16 gauge type 304 stainless steel top is 30" (762mm) front-to-back and 2" (51mm) tall.
- 34" (864mm) standard working height complies with ADA guidelines for accessibility standards.
- Welded 1½" (38mm) square tubular type 304 stainless steel base construction.
- Open base on three sides – 7⅞" (183mm) tall type 304 stainless steel apron on operator's side.
- 5" (127mm) poly tread swivel casters (two with brake).
- Standard holly berry red front laminate panel (Wilsonart® D307-60) on heavy gauge galvanized subpanel.

**Note:** All units are predrilled to accommodate accessories such as tray slides, work shelves, and removable undershelves—see pages 253, 255 and 256.

**Laminate end panels available for all units.** To order, add suffix "-LEP" to model number and \$484 to list price.

**Example:** DCS2-BSU-LEP.

**Stainless steel front panels available for all units.** To order, add suffix "-S" to model number. See chart on page 253 for list price. **Example:** DCS2-BSU-S.

**Stainless steel end panels available for all units.** To order, add suffix "-SEP" to model number and \$566 to list price. **Example:** DCS2-BSU-SEP.

**Freight class is 100.0.**

### Receptacle Configurations Required for Frost Top Unit

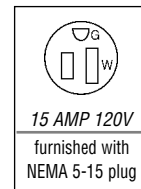

## Corner Transition Units



see spec sheet **EG33.10**



corner transition unit –  
outside miter shown with optional  
tray slide and work shelf



corner transition unit –  
outside corner shown with  
optional tray slide and work shelf

- Front laminated panels on Customer side of unit.
- Consult factory for design specifics relating to floor plan intentions.

**Note:** #DCE end-only tray slides, work shelves, and rear doors and panels will NOT work with these units.

description	weight		cubic feet	model #	list
	lbs.	kg			
outside corner	165	74.8	22	<b>DCSC-CTU-OC</b>	3543
outside miter	165	74.8	22	<b>DCSC-CTU-OM</b>	3727
inside corner	165	74.8	22	<b>DCSC-CTU-IC</b>	3543
inside miter	165	74.8	22	<b>DCSC-CTU-IM</b>	3727

### Optional Tray Slides for Corner Transition Units

With fixed brackets.

SQUARE tubular		ROUND tubular		Solid Ribbed	
model #	list	model #	list	model #	list
<b>DCOC-TS-TS</b>	1652	<b>DCOC-TS-TR</b>	1652	<b>DCOC-TS-SRS</b>	2476

### Optional Work Shelves for Corner Transition Units

With fixed brackets. 8" x 8" (203mm) filler.

1 1/4"-THICK Hardwood		18/304 Stainless	
model #	list	model #	list
<b>DCOC-WS-MT</b>	339	<b>DCOC-WS-ST</b>	297

## Tray/Silverware/Napkin Dispenser Unit



see spec sheet **EG33.16**



- Elevating dispenser tray accommodates up to 100 10 1/8" x 15" (276 x 381mm) trays.
- Four 3 3/4" diameter nylon silverware cylinders.
- Napkin dispenser holds up to 500 napkins.

length	description	model #	list
in. mm			
30" 762	with dispensers	<b>DCS3030-TSND</b>	13615

### Features:

- Type 304 stainless steel construction.
- 16 gauge type 304 stainless steel top is 30" (762mm) front-to-back and 2" (51mm) tall.
- 34" (864mm) standard working height complies with ADA guidelines for accessibility standards.
- Welded 1 1/2" (38mm) square tubular type 304 stainless steel base construction.
- Open base on three sides – 7 3/8" (183mm) tall type 304 stainless steel apron on operator's side.
- 5" (127mm) poly tread swivel casters (two with brake).
- Standard holly berry red front laminate panel (Wilsonart® D307-60) on heavy gauge galvanized subpanel.

**Note:** All units are predrilled to accommodate accessories such as tray slides, work shelves, and removable undershelves—see pages 253, 255 and 256.

**Stainless steel front panels available for all units.** To order, add suffix "-S" to model number. See chart on page 253 for list price. **Example:** DCS3030-TSND-S.

**Stainless steel end panels available for Tray/Silverware/Napkin Dispenser Unit.** To order, add suffix "-SEP" to model number and **\$566** to list price. **Example:** DCS3030-TSND-SEP.

**Laminate end panels available for Tray/Silverware/Napkin Dispenser Unit.** To order, add suffix "-LEP" to model number and **\$484** to list price. **Example:** DCS3030-TSND-LEP.

**Freight class is 100.0.**

# DIRECTOR'S CHOICE® MODULAR CAFETERIA SERVING UNITS

## Catalog Section 33

### Tray & Silverware Unit

see spec sheet **EG33.09**



- Elevating dispenser and eight nylon silver cylinders.
- Locks to other units in serving line.

length		weight		cu ft	tray capacity (10 1/2" x 15" trays)	model #	list
in.	mm	lbs.	kg				
36"	914	270	122.5	22	100	DCS2-TSU	9167

#### Features:

- Type 304 stainless steel construction.
- 16 gauge type 304 stainless steel top is 30" (762mm) front-to-back and 2" (51mm) tall.
- 34" (864mm) standard working height complies with ADA guidelines for accessibility standards.
- Welded 1 1/2" (38mm) square tubular type 304 stainless steel base construction.
- Open base on three sides – 7 5/8" (183mm) tall type 304 stainless steel apron on operator's side.
- 5" (127mm) poly tread swivel casters (two with brake).
- Standard holly berry red front laminate panel (Wilsonart® D307-60) on heavy gauge galvanized subpanel.

**Note:** All units are predrilled to accommodate accessories such as tray slides, work shelves, and removable undershelves— see pages 253, 255 and 256.

**Laminate end panels available for Tray & Silverware Unit.** To order, add suffix "-LEP" to model number and \$484 to list price.

**Example: DCS2-TSU-LEP.**

**Stainless steel front panels available for Tray & Silverware Unit.** To order, add suffix "-S" to model number. See chart on page 253 for list price. **Example: DCS2-TSU-S.**

**Stainless steel end panels available for Tray & Silverware Unit.** To order, add suffix "-SEP" to model number and \$566 to list price. **Example: DCS2-TSU-SEP.**

### Tray Platform Unit

see spec sheet **EG33.21**



- All-welded stainless steel construction.
- Open tubular design.
- Removable two-section undershelf.
- 10 nylon silverware cylinders.
- Holds up to 200 trays.

**Note:** This is a freestanding unit not designed to lock together with other units. Optional laminates, front/end panels, tray slides, workboards, and serving shelves do not apply.

width x length		weight		cubic feet	model #	list
in.	mm	lbs.	kg			
24" x 36"	610 x 914	250	113.4	22	DCS2-TPU	4394

**Freight class is 100.0.**



### The EAGLE Advantage

## HAVE YOU PROFITED TODAY?

Right Down The Line, Director's Choice® Modular Cafeteria Serving Units Work For You At Every Stop. From Hot Food Units To Frost Top Units, We Have it Covered. With Numerous Options and Custom Accessories, THEY ARE NOT ONLY FUNCTIONAL BUT STYLISH.

**Call Your EAGLE GROUP Representative Now To Place Your Order.**



100 Industrial Boulevard, Clayton, DE 19938-8903 U.S.A.  
Phone: 800-441-8440 or 302-653-3000. Fax: 302-653-2065  
<http://www.eaglegrp.com>

## Rack/Tray Dispenser Units

see spec sheets **EG33.19** and **EG33.22**



rack/tray dispenser unit shown with optional tray slide

**Note:** All units are predrilled to accommodate accessories such as tray slides, work shelves, and removable undershelves—see pages 253, 255 and 256.

**Stainless steel front panels available for all units.** To order, add suffix “-S” to model number. See chart on page 253 for list price.  
**Example:** DCS2020RD-S.

**Stainless steel end panels available.** To order, add suffix “-SEP” to model number and **\$566 to list price.**  
**Example:** DCS2020RD-SEP.

- Enclosed on all four sides.
- Lightweight stainless steel dispenser is easily removable for cleaning and uses a self-leveling carrier mechanism to dispense cups, glasses or trays in a serving line or beverage service point.
- Carrier is suspended by nylon-coated braided metal cables fed off power drums on two sides.
- Cable-stop limits carrier travel to 24" (620mm).
- Weight capacity varies with height.
- Type 304 stainless steel construction.
- 16 gauge type 304 stainless steel top is 30" (762mm) front-to-back and 2" (51mm) tall.
- 34" (864mm) standard working height complies with ADA guidelines for accessibility standards.
- Welded 1½" (38mm) square tubular type 304 stainless steel base construction.
- 5" (127mm) poly tread swivel casters (two with brake).
- Standard holly berry red laminate panel (Wilsonart® D307-60) on heavy gauge galvanized subpanel.

**FEATURES:**

**Freight class is 100.0.**

description	weight		model #	list
	lbs.	kg		
cup or glass rack dispenser, for one stack of 20" x 20" (508 x 508mm) racks	230	104.3	<b>DCS2020RD</b>	6546
cup & saucer dispenser, for one stack of 20" x 20" (508 x 508mm) racks and two stacks of saucers	280	127.0	<b>DCS2020RDS *</b>	7440
tray dispenser, for one stack of 16" x 20" (406 x 508mm) max. size trays	180	81.6	<b>DCS1620TD</b>	6384
tray & silverware dispenser, for one stack of 16" x 20" (406 x 508mm) max. size trays and eight silverware cylinders	210	95.3	<b>DCS1620TDS</b>	8428

\* This model uses #359106 drop-in dish dispensers. see page 251 for more information on drop-in dish dispensers.



#381167 dispenser unit

### Drop-In Dispensers for Rack/Tray Dispenser Units

Factory-installed. 28¼" (718mm) overall height.

maximum capacities		overall (W x L)		cutout (W x L)		weight		model #	list
content description	quantity	in.	mm	in.	mm	lbs.	kg		
10" x 20" (254 x 508mm) racks* ..... 6 ea.		14½"	371	13⅞"	332	38	17.2	<b>383390</b>	3446
14" x 18" (356 x 457mm) trays..... 150 ea.		19⅞"	492	18" x 21⅞"	457	46	20.9	<b>381167</b>	3446
15" x 20" (381 x 508mm) trays..... 150 ea.		23¼"	591	21⅞"	541	47	21.3	<b>382444</b>	3446
10" x 20" (254 x 508mm) racks* ..... 14 ea.			640		605				
20" x 20" (508 x 508mm) racks* ..... 6 ea.									

\* 4" height. Rack capacity varies, depending on rack size.

## CUSTOM GRAPHICS AVAILABLE!!

Laser-Cutting and Custom Decal Services!



**YOUR LOGO**  
(laser-cut)



**Laser-cutting...**

- Offers a "high-tech" look.
- Creates smooth curves along text/artwork.

**Decals...**

- Industrial-strength, factory-applied, yet more economical.
- Vinyl with adhesive backing.

# DIRECTOR'S CHOICE® MODULAR CAFETERIA SERVING UNITS

## Catalog Section 33

### Drop-In Adjustable Dispensers

see spec sheet **EG33.18**



drop-in adjustable plate dispenser

drop-in dish dispenser

#### Optional Dome Covers for Heated Dispensers

for plate dia.	weight		model #	list
	lbs.	kg		
2¼"-6"	1	0.5	<b>381250</b>	425
4¼"-7½"	1	0.5	<b>381251</b>	432
6½"-9¼"	1	0.5	<b>381252</b>	442
8¾"-12"	1	0.5	<b>381253</b>	453

FEATURES:

- Field-adjustable weight and diameter.
- Stainless steel and aluminum construction.
- Heated and unheated units available.
- Spring rate adjustable without the use of tools.
- Stylized nonmarking guideposts reduce chance of chipping.
- Assured levelness via stabilizing mechanism.
- On heated units, temperature range is 80°-100°F minimum, 110°-160°F maximum.
- Heated units come with 5' (1524mm) long metal conduit that connects to 120V junction box.

Freight class is 70.0.

### Drop-In Adjustable Plate Dispensers

- Adjusts to accommodate plates in various diameters.

plate diameter		cutout diameter		UNSHIELDED/UNHEATED				SHIELDED/UNHEATED				electrical data	SHIELDED/HEATED			
in.	mm	in.	mm	lbs.	kg	model #	list	lbs.	kg	model #	list		lbs.	kg	model #	list
2¼"-6"	70-152	9¾"	232	13	5.8	<b>381136</b>	1902	20	9.0	<b>381141</b>	2387	-	-	-	-	
4¼"-7½"	108-191	10¾"	270	15	6.8	<b>381137</b>	1842	22	10.0	<b>381142</b>	2448	120V, 2.5A	25	11.3	<b>381146</b>	4414
6½"-9¼"	165-248	12¾"	327	18	8.2	<b>381138</b>	2040	27	12.2	<b>381143</b>	2457	120V, 3.8A	30	13.6	<b>381147</b>	4462
8¾"-12"	222-305	15¼"	384	20	9.0	<b>381139</b>	2077	31	14.1	<b>381144</b>	2832	120V, 3.8A	34	15.4	<b>381148</b>	4462
10"-13¼"	254-337	16¼"	413	21	9.5	<b>381140</b>	2822	32	14.5	<b>381145</b>	3555	120V, 3.8A	35	15.9	<b>381149</b>	5106

### Drop-In Dish Dispensers

plate diameter		cutout diameter		UNSHIELDED/UNHEATED				SHIELDED/UNHEATED				electrical data	SHIELDED/HEATED			
in.	mm	in.	mm	lbs.	kg	model #	list	lbs.	kg	model #	list		lbs.	kg	model #	list
up to 5"	127	7¼"	189	10	4.5	<b>359106</b>	1186	15	6.8	<b>359115</b>	1438	120V, 1.8A	18	8.2	<b>359124</b>	2652
5½"-5¾"	130-146	8¾"	208	11	5.0	<b>359107</b>	1264	16	7.3	<b>359116</b>	1516	120V, 2.0A	20	9.0	<b>359125</b>	2800
5½"-6½"	149-165	8½"	227	12	5.4	<b>359108</b>	1318	17	7.7	<b>359117</b>	1541	120V, 2.3A	26	11.8	<b>359126</b>	2847
6"-7¼"	168-184	9¼"	246	13	5.8	<b>359109</b>	1352	18	8.2	<b>359118</b>	1620	120V, 2.5A	26	11.8	<b>359127</b>	3037
7"-8¼"	187-206	10¾"	268	15	6.8	<b>359110</b>	1531	24	10.9	<b>359119</b>	1797	120V, 2.7A	27	12.2	<b>359128</b>	3258
8¼"-9¼"	210-232	11¾"	294	17	7.7	<b>359111</b>	1564	25	11.3	<b>359120</b>	1819	120V, 3.2A	28	12.7	<b>359129</b>	3385
9¼"-10¼"	235-257	12¾"	319	20	9.0	<b>359112</b>	1620	25	11.3	<b>359121</b>	1842	120V, 3.5A	30	13.6	<b>359130</b>	3552
10¼"-11¼"	260-302	13¾"	345	21	9.5	<b>359113</b>	1899	30	13.6	<b>359122</b>	2223	120V, 4.2A	34	15.4	<b>359131</b>	3929
11¼"-13"	302-330	14¼"	373	22	10.0	<b>359114</b>	2087	32	14.5	<b>359123</b>	2442	120V, 4.6A	36	16.3	<b>359132</b>	4339

### Stainless Steel Bottle Holders

see spec sheet **EG33.07A**



#SBH-1/6



#SBH-1/3

(bottles not included)

U.S. Patent #7,003,969

FEATURES:

- For plastic condiment bottles.
- Fits Cold Food Units (pages 241-242), Hot Food Units (page 240), and Hot Food Service Counters (page 245).
- Type 300 series stainless steel construction.
- 2½" (63mm) diameter holes punched for bottle dispensers.
- Fits on traditional one third- or sixth-size food pan applications.

Freight class is 70.0.

description	model #	list
7" x 6½" x 5½" (178 x 165 x 140mm), holds four bottles	<b>SBH-1/6</b>	111
7" x 12¼" x 5½" (178 x 324 x 140mm), holds eight bottles	<b>SBH-1/3</b>	123

## Dish/Cup Dispenser Units

see spec sheet **EG33.17**



model #DCS-PUD-4T  
-with optional tray slide

- Dispensers included.
- Fully mobile - standard 5" (127mm) casters, two with brake (brake casters on server side).
- Standard holly berry red (Wilsonart® D307-60) laminate mounted on 18 gauge galvanized sub-panel on all four sides.

FEATURES:

**Freight class is 92.5.**

### Heated Units

- Temperature range is 80°–100°F minimum, 110°–160°F maximum.
- Heated units feature shielded dispensers and come with 5' (1524mm) long cord(s) and plug(s).

description	dish/cup MAXIMUM diameter	weight		applicable drop-in dispenser model #	model #	list
		lbs.	kg			
two-tube dispenser, heater: 760W, 120V or 208V	9" (232mm) plates	220	99.8	<b>359129</b>	<b>DCS-PUD-2TH</b>	10580
three-tube dispenser, heater: 900W, 120V or 208V	7" (184mm) plates	270	122.5	<b>359127</b>	<b>DCS-PUD-3TH</b>	12675
four-tube dispenser, heater: 1200W, 120V or 208V	7" (184mm) plates	320	145.2	<b>359127</b>	<b>DCS-PUD-4TH</b>	15419
four-tube dispenser, heater: 1520W, 120V or 208V	9" (232mm) plates	350	158.8	<b>359129</b>	<b>DCS-PUD-5TH</b>	18700
cup/saucer dispenser, tubular type, heater: 800W, 120V or 208V	11" (302mm) trays	240	108.9	<b>359131</b>	<b>DCS-PUDT-CSH</b>	10403

### Optional Dome Covers for Heated Dispensers



for plate dia.	weight		model #	list
	lbs.	kg		
2¼"–6"	1	0.5	<b>381250</b>	425
4¼"–7½"	1	0.5	<b>381251</b>	432
6½"–9¼"	1	0.5	<b>381252</b>	442
8¼"–12"	1	0.5	<b>381253</b>	453

### Non-Heated Units

Includes unshielded dispensers.

description	dish/cup MAXIMUM diameter	weight		applicable drop-in dispenser model #	model #	list
		lbs.	kg			
two-tube dispenser	9" (232mm) plates	150	68.0	<b>359111</b>	<b>DCS-PUD-2T</b>	7278
three-tube dispenser	7" (184mm) plates	165	74.8	<b>359109</b>	<b>DCS-PUD-3T</b>	8109
four-tube dispenser	7" (184mm) plates	180	81.6	<b>359109</b>	<b>DCS-PUD-4T</b>	9338
four-tube dispenser	9" (232mm) plates	210	95.3	<b>359111</b>	<b>DCS-PUD-5T</b>	12092
cup/saucer dispenser, tubular type	11" (302mm) trays	160	72.6	<b>359113</b>	<b>DCS-PUDT-CS</b>	7218

## Stainless Steel Cleaner & Polish

weight		model #	list
oz.	kg		
15	0.4	<b>004026</b>	22



FEATURES:

- Cleans and polishes in one step.
- Does not streak or leave fingerprints.
- Leaves a protective invisible coating.

# DIRECTOR'S CHOICE® MODULAR CAFETERIA SERVING UNITS

## Catalog Section 33

### Varied Working Heights of Director's Choice® Units

see spec sheet **EG33.07A**

description	working height of unit	tray slide height*	add prefix** in front of DCS #
"Elementary School"	28" (711mm)	25" (635mm)	E***
"Middle School"	30" (762mm)	27" (686mm)	M
"High School"	34" (864mm)****	31" (787mm)	

\* To order units with varied tray slide heights, consult factory.

\*\* Example: MDCS3-HFU-A

\*\*\* Elementary School height currently not available for "-CFURN" Cold Food Units—page 241.

\*\*\*\* Standard overall height of all units.

FEATURES:

- Available for Director's Choice® units on pages 241-251.
- No charge.
- Consult factory for limitations.

### Stainless Steel Front Panels

see spec sheet **EG33.07A**

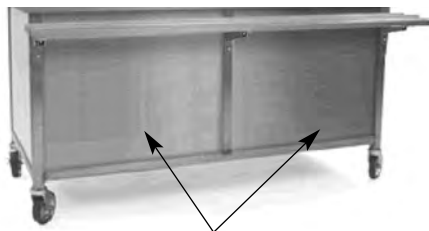

stainless steel front panels

FEATURES:

- Heavy gauge type 304 stainless steel.
- Available in place of standard laminate front panels.

**Note:** Laminate end panels available for all units except Tray Platform Unit. To order, add suffix "-LEP" to model number and \$484 to list price. Example: DCS2-TSU-LEP.

Stainless steel end panels available for all units except Tray Platform Unit. To order, add suffix "-SEP" to model number and \$566 to list price. Example: DCS2-TSU-SEP.

description	add suffix #	add to list
For 24" (610mm) long units	-S	138
For 36" (914mm) long units	-S	201
For 50" (1270mm) long units	-S	231
For 64" (1626mm) long units	-S	260
For 78" (1981mm) long units	-S	305
For 96" (2438mm) long units	-S	341

### Tray Slides

see spec sheet **EG33.07A**



tray slide

FEATURES:

- 11½" (292mm) wide.
- Heavy gauge type 304 stainless steel.
- Stainless steel drop brackets included.
- Available in 1" (25mm) square tubular 3-bar style, 1¼" (32mm) diameter round tubular 3-bar style, or solid with two raised "ribs".

Freight class is 70.0.

description	length		weight		cu ft	SQUARE tubular		ROUND tubular		Solid Ribbed	
	in.	mm	lbs.	kg		model #	list	model #	list	model #	list
For end only *	30"	762	26	11.8	1.0	DCE-TS-TS	968	DCE-TS-TSR	968	DCE-TS-SRS	1467
For 36" (914mm) long units	36"	914	30	13.6	1.0	DC2-TS-TS	1169	DC2-TS-TSR	1169	DC2-TS-SRS	1758
For 50" (1270mm) long units	50"	1270	36	16.3	1.4	DC3-TS-TS	1257	DC3-TS-TSR	1257	DC3-TS-SRS	1887
For 64" (1626mm) long units	64"	1626	40	18.1	1.8	DC4-TS-TS	1349	DC4-TS-TSR	1349	DC4-TS-SRS	2031
For 78" (1981mm) long units	78"	1981	52	23.6	2.2	DC5-TS-TS	1484	DC5-TS-TSR	1484	DC5-TS-SRS	2234
For 96" (2438mm) long units	96"	2438	75	34.0	2.7	DC6-TS-TS	1823	DC6-TS-TSR	1823	DC6-TS-SRS	2719

\* Must be factory-installed.

## Spec-SHIELD™ Food Guards



see spec sheets **EG33.24A** **EG33.24B** **EG33.24C** **EG33.24D**

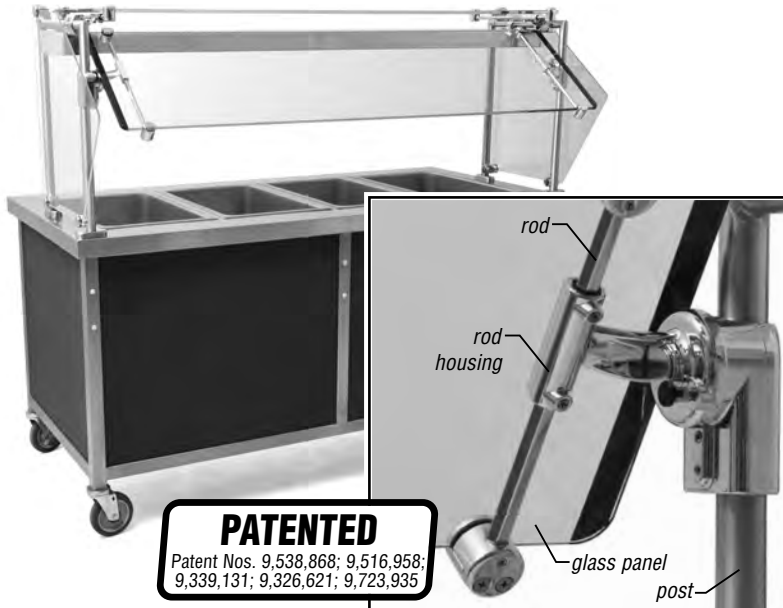

**PATENTED**  
 Patent Nos. 9,538,868; 9,516,958;  
 9,339,131; 9,326,621; 9,723,935

### Design & Construction Features

- Adjustable height and angle of glass panels!
- No holes in glass panels allows for flexibility in mounting locations.
- Meets latest NSF standards.
- Material: Die-cast high-strength aluminum.
- Finish: Chrome.
- Mounting options: Above or below countertop configurations available.
- End panels as required per NSF.

### Tempered Glass Features

- Top flat glass (if applicable): 3/8"-thick.
- Front and side: 1/4"-thick typical.
- 3/4" radius corners on all glass panels.
- Optional polycarbonate end panels available.
- Optional stainless steel top shelf available.

### Post System Features

- 1"-diameter legs.
- Stainless steel.

### Accessories

- Heat lamps.
- Lights.
- Various mounting plates.



**Consult factory for pricing.**

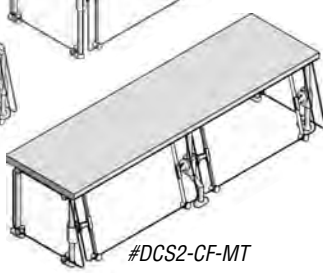
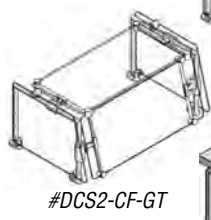
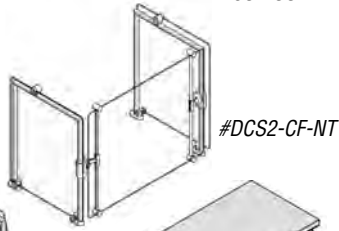
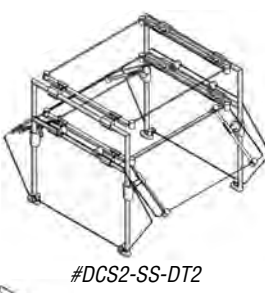
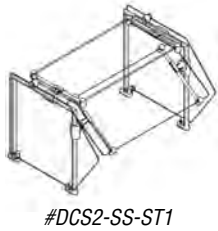

### Self-Service Food Guards

fits Series	# of legs	length in.	mm	SINGLE-TIER model #	DOUBLE-TIER model #
DCS2	2	36"	914	<b>DCS2-SS-ST1</b>	<b>DCS2-SS-DT1</b>
DCS3	2	50"	1270	<b>DCS3-SS-ST1</b>	<b>DCS3-SS-DT1</b>
DCS4	3	64"	1626	<b>DCS4-SS-ST1</b>	<b>DCS4-SS-DT1</b>
DCS5	3	78"	1981	<b>DCS5-SS-ST1</b>	<b>DCS5-SS-DT1</b>
DCS6	3	96"	2438	<b>DCS6-SS-ST1</b>	<b>DCS6-SS-DT1</b>

### Self-Service Buffet Food Guards

fits Series	# of legs	length in.	mm	SINGLE-TIER model #	DOUBLE-TIER model #
DCS2	2	36"	914	<b>DCS2-SS-ST2</b>	<b>DCS2-SS-DT2</b>
DCS3	2	50"	1270	<b>DCS3-SS-ST2</b>	<b>DCS3-SS-DT2</b>
DCS4	3	64"	1626	<b>DCS4-SS-ST2</b>	<b>DCS4-SS-DT2</b>
DCS5	3	78"	1981	<b>DCS5-SS-ST2</b>	<b>DCS5-SS-DT2</b>
DCS6	3	96"	2438	<b>DCS6-SS-ST2</b>	<b>DCS6-SS-DT2</b>

### Carving Station Food Guards

### Cafeteria Food Guards

fits Series	# of legs	length in.	mm	WITH NO TOP model #	WITH GLASS TOP model #	WITH SOLID TOP model #
DCS2	2	36"	914	<b>DCS2-CF-NT</b>	<b>DCS2-CF-GT</b>	<b>DCS2-CF-MT</b>
DCS3	2	50"	1270	<b>DCS3-CF-NT</b>	<b>DCS3-CF-GT</b>	<b>DCS3-CF-MT</b>
DCS4	3	64"	1626	<b>DCS4-CF-NT</b>	<b>DCS4-CF-GT</b>	<b>DCS4-CF-MT</b>
DCS5	3	78"	1981	<b>DCS5-CF-NT</b>	<b>DCS5-CF-GT</b>	<b>DCS5-CF-MT</b>
DCS6	3	96"	2438	<b>DCS6-CF-NT</b>	<b>DCS6-CF-GT</b>	<b>DCS6-CF-MT</b>



# DIRECTOR'S CHOICE® MODULAR CAFETERIA SERVING UNITS

## Catalog Section 33

### Sneeze Guards

see spec sheet **EG33.07B**



single tier sneeze guard



double tier sneeze guard

**Sneeze guards must be ordered at the same time as base unit. Factory installation of sneeze guards and sneeze guard options is required.**

#### FEATURES:

- Stainless steel top panel.
- Front panel and end guards consist of clear  $\frac{1}{8}$ " (6mm)-thick fixed abrasion-resistant polycarbonate.

**Note:** Fully Enclosed Sneeze Guards available. For 'pass-over' operation. Facilitates complete food protection. To order, replace "SO" in model number with "SOF" (example: DC2-SOF-ST), and add 25% to list price.

Tempered glass panels available—add 20% to list price.  
**ALLOW FOUR-WEEK LEAD TIME.**

**Freight class is 70.**

#### Single Tier

14"-tall x  $15\frac{1}{16}$ "-wide (356 x 386mm). Lengths noted in chart are nominal.

description	length		weight		cu ft	model #	list	REDHOTS® Display Lights* (add suffix "-L")***	REDHOTS® 120V Heat Lamps** (add suffix "-F")	
	in.	mm	lbs.	kg				list	electrical data	list
For 36" (914mm) long units	36"	914	50	22.7	6.7	DC2-SO-ST	2871	836	120V, 3.8A, 450W	1322
For 50" (1270mm) long units	50"	1270	88	39.9	9.3	DC3-SO-ST	3171	965	120V, 5.6A, 675W	1380
For 64" (1626mm) long units	64"	1626	125	56.7	11.9	DC4-SO-ST	4222	1120	120V, 8.8A, 1050W	1423
For 78" (1981mm) long units	78"	1981	155	70.3	14.4	DC5-SO-ST	4717	1269	120V, 10.6A, 1275W	1639
For 96" (2438mm) long units	96"	2438	240	108.9	17.8	DC6-SO-ST	5456	1421	120V, 12.5A, 1500W	1913

#### Options for Single Sneeze Guards

#### Double Tier

24"-tall x  $24\frac{1}{2}$ "-wide (610 x 622mm). Lengths noted in chart are nominal.

description	length		weight		cu ft	model #	list	REDHOTS® Display Lights* (add suffix "-L")***	REDHOTS® 120V Heat Lamps** (add suffix "-F")	
	in.	mm	lbs.	kg				list	electrical data	list
For 36" (914mm) long units	36"	914	80	36.3	16.3	DC2-SO-DT	6238	1671	120V, 3.8A, 450W	1322
For 50" (1270mm) long units	50"	1270	118	53.5	22.6	DC3-SO-DT	6499	1932	120V, 5.6A, 675W	1380
For 64" (1626mm) long units	64"	1626	155	70.3	28.9	DC4-SO-DT	7840	2239	120V, 8.8A, 1050W	1423
For 78" (1981mm) long units	78"	1981	185	83.9	35.2	DC5-SO-DT	9125	2540	120V, 10.6A, 1275W	1639
For 96" (2438mm) long units	96"	2438	270	122.5	43.3	DC6-SO-DT	10242	2937	120V, 12.5A, 1500W	1913

#### Options for Double Sneeze Guards

\* Display lights are 120V and come with 6' (1829mm) cord and NEMA 5-15P plug to exit through base at operator's right. Cannot be used on hot food units or with optional heat lamps. One light fixture per tier.

\*\* Heat lamps attach to underside of sneeze guard (or to underside of bottom sneeze guard

for double-tier). 120V. Includes 6' (1829mm) cord and NEMA 5-15P plug (NEMA 5-20P on 1500W unit). Heat lamps cannot be used with optional display lights. 450 to 1500W output depending on length. See page 267 for REDHOTS® Heat Lamps.

\*\*\* Example of suffixes: DC3-SO-ST-L

### Work Shelves

see spec sheet **EG33.07A**



work shelf

#### FEATURES:

- 8" (203mm) wide.
- Stainless steel drop brackets.

**Freight class is 70.0.**

description	length		weight		cu ft	1½"-thick hardwood		18/304 stainless		½"-thick poly		½"-thick Richlite®	
	in.	mm	lbs.	kg		model #	list	model #	list	model #	list	model #	list
For end only *	30"	762	26	11.8	1.0	DCE-WS-MT	924	DCE-WS-ST	935	DCE-WS-PT	893	DCE-WS-RL	1040
For 36" (914mm) long units	36"	914	30	13.6	1.0	DC2-WS-MT	1104	DC2-WS-ST	1121	DC2-WS-PT	1072	DC2-WS-RL	1245
For 50" (1270mm) long units	50"	1270	36	16.3	1.4	DC3-WS-MT	1188	DC3-WS-ST	1295	DC3-WS-PT	1231	DC3-WS-RL	1435
For 64" (1626mm) long units	64"	1626	40	18.1	1.8	DC4-WS-MT	1276	DC4-WS-ST	1458	DC4-WS-PT	1392	DC4-WS-RL	1616
For 78" (1981mm) long units	78"	1981	52	23.6	2.2	DC5-WS-MT	1404	DC5-WS-ST	1614	DC5-WS-PT	1546	DC5-WS-RL	1801
For 96" (2438mm) long units	96"	2438	75	34.0	2.7	DC6-WS-MT	1724	DC6-WS-ST	1981	DC6-WS-PT	1897	DC6-WS-RL	2208

\* Must be factory-installed.



100 Industrial Boulevard, Clayton, DE 19938-8903 U.S.A.  
Phone: 800-441-8440 or 302-653-3000. Fax: 302-653-2065  
<http://www.eaglegrp.com>

## Serving Shelves and Buffet Shelves

see spec sheet **EG33.07B**



serving shelf



buffet shelf

FEATURES:

- Clear polycarbonate sneeze guards.

Freight class is 85.0.

description	weight		Serving Shelves		Buffet Shelves		Tilt/Adjustable Serving Shelves	
	lbs.	kg	model #	list	model #	list	model #	list
For 36" (914mm) long units	25	11.3	SSH2	2833	BSH2	4336	ASH2	3257
For 50" (1270mm) long units	30	13.6	SSH3	3167	BSH3	4580	ASH3	3638
For 64" (1626mm) long units	35	15.9	SSH4	3672	BSH4	4863	ASH4	4224
For 78" (1981mm) long units	40	18.1	SSH5	4760	BSH5	6473	ASH5	5476
For 96" (2438mm) long units	50	22.7	SSH6	5265	BSH6	7705	ASH6	6056



tilt/adjustable serving shelf

## Undershelves, Rear Doors and Panels

see spec sheet **EG33.07A**

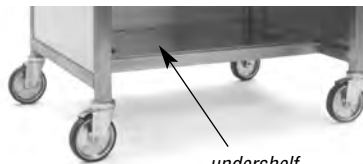

undershelf

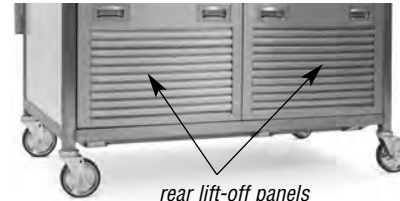

rear lift-off panels  
(louvered shown)

### Removable Undershelves

Type 304 stainless steel. Lifts out without tools. Available for all units except Ice Cream Units. Consult factory for limitations.

description	Solid Undershelves		Louvered Undershelves	
	model #	list	model #	list
For 36" (914mm) long units	DC2-RSU	872	DC2-RSUL	1177
For 50" (1270mm) long units	DC3-RSU	977	DC3-RSUL	1277
For 64" (1626mm) long units	DC4-RSU	1169	DC4-RSUL	1469
For 78" (1981mm) long units	DC5-RSU	1402	DC5-RSUL	1706
For 96" (2438mm) long units	DC6-RSU	1660	DC6-RSUL	1964

\* Optional locks available for Rear Doors. \$218 list.

### Rear Doors and Panels

Stainless steel. Call factory for available models.

description	Rear Doors*		Rear Panels	
	Hinged	Sliding	Fixed	Lift-Off
For 36" (914mm) long units	1804	1566	722	976
For 50" (1270mm) long units	2087	1818	831	1120
For 64" (1626mm) long units	2594	2254	981	1320
For 78" (1981mm) long units	2735	2380	1085	1462
For 96" (2438mm) long units	3060	2663	1649	2224

## Also available:

### REDHOTS® Heat Lamps

see page 267

Or download our spec sheet **EG35.23** off our website [www.eaglegrp.com](http://www.eaglegrp.com)



### REDHOTS® Display Lights

see page 268

Or download our product announcement **EG35.09** off our website [www.eaglegrp.com](http://www.eaglegrp.com)



# DIRECTOR'S CHOICE® MODULAR CAFETERIA SERVING UNITS

Catalog Section 33

## Custom Accessories for Director's Choice® – Per Application

### Decorative Deluxe Sneeze Guards

see product announcement **EG8154**



### Single-Tier Sneeze Guards

fits Series	# of legs	length in. mm	CAFETERIA STYLE		BUFFET STYLE	
			model #	list	model #	list
DCS2	2	36" 914	DCS2-DSG-CST	3905	DCS2-DSG-BST	5867
DCS3	2	50" 1270	DCS3-DSG-CST	4357	DCS3-DSG-BST	6632
DCS4	3	64" 1626	DCS4-DSG-CST	4812	DCS4-DSG-BST	7385
DCS5	3	78" 1981	DCS5-DSG-CST	6678	DCS5-DSG-BST	10771
DCS6	3	96" 2438	DCS6-DSG-CST	7385	DCS6-DSG-BST	12286



### Double-Tier Sneeze Guards

fits Series	# of legs	length in. mm	CAFETERIA STYLE		BUFFET STYLE	
			model #	list	model #	list
DCS2	2	36" 914	DCS2-DSG-CDT	8072	DCS2-DSG-BDT	8244
DCS3	2	50" 1270	DCS3-DSG-CDT	9231	DCS3-DSG-BDT	9581
DCS4	3	64" 1626	DCS4-DSG-CDT	10241	DCS4-DSG-BDT	10394
DCS5	3	78" 1981	DCS5-DSG-CDT	14988	DCS5-DSG-BDT	15389
DCS6	3	96" 2438	DCS6-DSG-CDT	17364	DCS6-DSG-BDT	18069

### Powder Coating

Coating over mild steel. Specify model number with EAGLE's SpecFAB® department.

fits Series	length in. mm	White, Black, Gray, or Red list price	EAGLE Stand-Outs™ colors*	
			list price	list price
DCS2	36" 914	529		1155
DCS3	50" 1270	705		1387
DCS4	64" 1626	794		1665
DCS5	78" 1981	813		1995
DCS6	96" 2438	1059		2398

\* See page 65 for the entire list of decorative Stand-Outs™ custom colors.

### FEATURES:

- Fabricated from stainless steel tubing.
- Frame finish available in stainless steel, or color epoxy (see "Powder Coating" chart below).
- Clear polycarbonate front panel and end guards.
- Tempered glass (meets ANSI Z97.1) available—**add 20% to list price.**
- Edges trimmed with a metal channel and available with optional end guards for further protection.
- Sneeze guards must be factory located and installed to Director's Choice® equipment.

**Note:** Fully Enclosed Sneeze Guards available. For Cafeteria-Style Sneeze Guards only. Facilitates 'pass-over' operation for complete food protection. To order, replace "DSG" in model number with "DSGF" (example: DCS2-DSGF-CST), and add 25% to list price.

**Freight class is 85.0.**



### Heat Lamps

Attaches to underside of sneeze guard (or to underside of bottom sneeze guard on double-tier units). Wired to cord and plug, exit base of unit. Specify model number with EAGLE's SpecFAB® department.

fits Series	length in. mm	electrical data	add * suffix	list price
DCS2	36" 914	120V, 3.8A, 450W	-F	1322
DCS3	50" 1270	120V, 5.6A, 675W	-F	1380
DCS4	64" 1626	120V, 8.8A, 1050W	-F	1423
DCS5	78" 1981	120V, 10.6A, 1275W	-F	1639
DCS6	96" 2438	120V, 12.5A, 1500W	-F	1913

\* Example: DCS2-DSG-CST-F



### REDHOTS® Display Lights

Wired to cord and plug, exit base of unit. Must be factory-installed. Consult factory.

fits Series	length in. mm	FOR SINGLE-TIER UNITS		FOR DOUBLE-TIER UNITS	
		add suffix*	list	add suffix*	list
DCS2	36" 914	-L	836	-L	1672
DCS3	50" 1270	-L	965	-L	1932
DCS4	64" 1626	-L	1120	-L	2240
DCS5	78" 1981	-L	1269	-L	2540
DCS6	96" 2438	-L	1421	-L	2843

\* Example: DCS2-DSG-BST-L

## Decorative Perimeter Skirts

see product announcement **EG8154**



perimeter skirt

- Matches framework construction of unit base.
- Serves as fixed skirt and kick plate.

FEATURES:

Freight class is 85.0.

## Front Skirts and Rear Skirts

- Front Skirts feature recessed casters which are hidden by perimeter bumper, giving the unit a sleek modern look.

description	length		FRONT SKIRTS		REAR SKIRTS	
	in.	mm	model #	list	model #	list
For 36" (914mm) long units	36"	914	DC2-FS	1217	DC2-RS	346
For 50" (1270mm) long units	50"	1270	DC3-FS	1264	DC3-RS	384
For 64" (1626mm) long units	64"	1626	DC4-FS	1295	DC4-RS	422
For 78" (1981mm) long units	78"	1981	DC5-FS	1391	DC5-RS	509
For 96" (2438mm) long units	96"	2438	DC6-FS	1594	DC6-RS	719

## End Skirts

description	length		model #	list
	in.	mm		
For end only	30"	762	DC2-ES	321

## Other Custom Accessories available – per application



drain valve extension



recessed casters

- Drain Valve Extensions (see page 274)
- Cutting Boards
- Receptacles and Remote Switches
- Custom Cutouts
- Recessed Casters
- Pricing for Convenience Outlets
  - Outlet/Box only field-wired\*.
  - Outlet/Box/Cord & Plug.
  - Outlet/Box/Cord & Plug/Fuse.



\* **Note:** Outlet/Box should have a tether when field-wired.



## CUSTOM GRAPHICS AVAILABLE!!

Laser-Cutting and Custom Decal Services!

**YOUR LOGO**  
(laser-cut)

**SMYRNA**  
*Eagles*  
(custom decal for Smyrna High School, Smyrna, DE)

### Laser-cutting...

- Offers a "high-tech" look.
- Creates smooth curves along text/artwork.

### Decals...

- Industrial-strength, factory-applied, yet more economical.
- Vinyl with adhesive backing.

## The SpecFAB® Division

Catering to the custom fabrication needs of the Foodservice and Retail Display industries.

Email: [quotes@eaglegrp.com](mailto:quotes@eaglegrp.com) • Fax: 302-653-2065

Our trained staff will begin planning, layout and quotation upon receipt.



## Director's Choice® Adjustable Height Option

*Easily adjusts for changing requirements*

see product announcement **EG8210**



### Electric Option



switch



### Design & Construction Features

- Adjusts to adapt for both customer and employee ergonomics.
- Allows adjustment from 28.5" to 34.5" height.
- Available with manual or electric controls.
- Stationary or mobile applications.
- Mobile applications provided with 5" casters, two with brake.



### Manual Option



crank



**Consult factory for pricing.**

## **NEW** Spec-SHIELD™ Lighting Options

see product announcement **EG8203**

...for Spec-SHIELD™ Self-Service Food Guards (page 254).



FEATURES:

- Fits within the space of the food guard.
- Mounting and electrical is independent of the food guard.
- Constructed of an aluminum exterior with reflector (which help heat lamps focus heat).
- Stainless steel legs.
- Mounting plate is cast aluminum with chrome-plated cover plate.

**Freight class is 85.0.**

### Display Lights

120-volt operation. High-efficiency halogen bulbs with Teflon coating and standard screw shell base. LED bulbs available for cold displays. Bulbs are warm white to improve food appearance. Exterior extruded aluminum housing. Stainless steel legs and brackets. Built-in or remote switches.

Fits Series	length		with halogen bulbs*		with LED bulbs*	
	in.	mm	model #	list	model #	list
DCS2	36"	914	<b>DCS2-SS-RHDL</b>	2232	<b>DCS2-SS-RHDL-L</b>	2259
DCS3	50"	1270	<b>DCS3-SS-RHDL</b>	2330	<b>DCS3-SS-RHDL-L</b>	2362
DCS4	64"	1626	<b>DCS4-SS-RHDL</b>	2424	<b>DCS4-SS-RHDL-L</b>	2461
DCS5	78"	1981	<b>DCS5-SS-RHDL</b>	2599	<b>DCS5-SS-RHDL-L</b>	2645
DCS6	95"	2413	<b>DCS6-SS-RHDL</b>	2678	<b>DCS6-SS-RHDL-L</b>	2728

\* To indicate remote operation, add suffix **-R** to model number.

### Heat Lamps

120-, 208-, and 240-volt options available. Exterior extruded aluminum housing. Stainless steel legs and brackets. Built-in or remote switches. Infinite switches available in remote application.

Fits Series	length		with standard wattage*		with high wattage*	
	in.	mm	model #	list	model #	list
DCS2	36"	914	<b>DCS2-SS-RHHL</b>	2542	<b>DCS2-SS-RHHL-H</b>	2556
DCS3	50"	1270	<b>DCS3-SS-RHHL</b>	2587	<b>DCS3-SS-RHHL-H</b>	2601
DCS4	64"	1626	<b>DCS4-SS-RHHL</b>	2630	<b>DCS4-SS-RHHL-H</b>	2640
DCS5	78"	1981	<b>DCS5-SS-RHHL</b>	2798	<b>DCS5-SS-RHHL-H</b>	2807
DCS6	95"	2413	<b>DCS6-SS-RHHL</b>	2898	<b>DCS6-SS-RHHL-H</b>	2906

\* Add suffix **-120**, **-208**, or **-240** to specify voltage.

To indicate remote operation, add suffix **-R** to model number.

### Heat Lamps with Display Lights

Features Teflon-coated halogen bulbs with standard screw shell base.

Fits Series	length		with standard wattage*		with high wattage*	
	in.	mm	model #	list	model #	list
DCS2	36"	914	<b>DCS2-SS-RHHL-L</b>	2710	<b>DCS2-SS-RHHL-L-H</b>	2773
DCS3	50"	1270	<b>DCS3-SS-RHHL-L</b>	2835	<b>DCS3-SS-RHHL-L-H</b>	2906
DCS4	64"	1626	<b>DCS4-SS-RHHL-L</b>	2959	<b>DCS4-SS-RHHL-L-H</b>	3036
DCS5	78"	1981	<b>DCS5-SS-RHHL-L</b>	3241	<b>DCS5-SS-RHHL-L-H</b>	3330
DCS6	95"	2413	<b>DCS6-SS-RHHL-L</b>	3420	<b>DCS6-SS-RHHL-L-H</b>	3519

\* Add suffix **-120**, **-208**, or **-240** to specify voltage.

To indicate remote operation, add suffix **-R** to model number.



# Cooking & Warming Equipment

## Accessories/Replacements

Adapter Tops .....	269
Bulbs for Bulb Warmers .....	266
Griddle Plate .....	263
Baskets for Fryers .....	270
Food Pans, Lids, Insets .....	276
Roll Top Cover .....	276
Mounting Plates .....	273, 274
Night Cover .....	265, 266, 270
Recessed Control Panels .....	274

## Drop-In Style Food Warmers

Rectangular .....	274
Round .....	273

## Gang Drop-In

Electric Hot Food Units .....	273
Sealed Well Hot Food Units .....	272

## Hot Dog Sterno Units and Hot Food Merchandising Cart

Hot Dog Sterno Units .....	275
Hot Food Merchandising Carts .....	275

## REDHOTS®

Bulb Warmers .....	266
Countertop Cooker/Warmers .....	269
Countertop Food Warmers .....	268
Display Lights .....	268

Electric Fryers .....	270
Heat Lamps .....	267
Heated Drawers .....	271
Pass-Thru Heated Drawers .....	269

## REDHOTS® Chef's Line®

Charbroilers .....	263
Fryers - Double .....	266
Fryers - Single .....	265
Griddles - Electric .....	265
Griddles - Gas .....	264
Hot Plates - Electric .....	264
Hot Plates - Gas .....	263

## Look what's on the menu...

### REDHOTS® Gas Fryers

see product announcement **EG35.24**



Optional night cover available.  
Model #383949. List: \$86

**30-lb.  
(13.6 kg)  
capacity!**

#### FEATURES:

- Stainless steel construction with stainless steel fry pot.
- Stainless steel open burners at 13,250 BTU per burner.
- Two 5-lb. capacity iron mesh nickel-plated fry baskets.
- Furnished with thermostatic control, push-button ignition and pilot light.
- Stainless steel hinged front door for access to thermostatic control and ignitor.
- Stainless steel tube style tank.
- Hi-limit safety shutoff.
- Flame failure.
- Burner safety valves.
- Attachable drain connection to facilitate draining down.
- Heavy duty adjustable feet.
- 3/4" rear male gas connection.
- Unit supplied with gas regulator.

**Freight class is 65.0.**

width x depth*		height**		# of burners	total BTU per hour	NATURAL *** GAS		PROPANE *** GAS	
in.	mm	in.	mm			model #	list	model #	list
17 1/4" x 29"	438 x 737	25"	635	4	53,000	CLGF30-NG	3278	CLGF30-LP	3278

\* Add 4" (102mm) depth to allow for regulator.

\*\* Add 5" (127mm) height to allow for removable baffle.

\*\*\* Must specify NG or LP at time of order. Unit is NOT convertible.

**NOTE: INTENDED FOR OTHER THAN HOUSEHOLD USE. THIS COMMERCIAL APPLIANCE MUST BE INSTALLED WITHIN SURROUNDINGS AND VENTILATION REQUIREMENTS AS DICTATED BY NATIONAL AND/OR LOCAL CODE.**

**Introducing...**

# REDHOTS®

*Chef's Line*

Comprising a full range of models including *fryers, charbroilers, griddles and hot plates*, the Chef's Line® series is especially engineered for foodservice operations where heavy-duty equipment use is encountered on a daily basis. ***Bullnosed edge provides solid protection to controls.*** Controls are front-mounted for easier and safer operation.

**See pages 263 through 266 for models available.**



### Gas Hot Plates

- 25,000 BTU/hr burners on all units.
- Full-size polished stainless steel crumb tray.
- Available in flat-top and step-up styles.
- Complete with convertible pressure regulator and orifices for field conversion to liquid propane.



### Electric Hot Plates

- Electric units feature swing-up elements with individual crumb trays, removable for easy cleaning.
- Infinite controls provide adjustable heat settings and are equipped with an On-Off light.



### Gas Charbroilers

- Heavy duty cast iron cooking grates can be individually positioned flat or angled.
- 40,000 BTU/hr burners on NG radiant units; 32,000 BTU/hr burners on lava rock units.
- Front trough with chute located at left end.



### Gas or Electric Griddles

- ¾" (19mm) thick smooth polished steel griddle plate fully welded to top assembly.
- 13¾" (349mm) working height adjustable to 14¾" (375mm).
- 4" (102mm) sides and rear splash sloped front-to-back.
- 7½-quart polished stainless steel grease drawer.



### Electric Single-Tank and Double-Tank Fryers

- All-stainless steel deep-drawn one-piece construction fry tanks, removable for easy cleaning.
- Snap-action thermostat complete with indicator light for accurate temperature control.
- Heavy-plated fry baskets—two provided with single-tank units; four provided with double-tank units.



**We are  
"UL 197 Rev 9"  
compliant!**

"UL" stands for Underwriters Laboratories Inc. (UL), a non-governmental organization formed in 1894 to help reduce injury, loss of life and property damage. UL scientifically investigates and tests thousands of types of products, materials, constructions and systems to evaluate electric, fire and casualty hazards.

The UL mark is one of the most recognized and trusted symbols in the world. It means that UL has tested samples of our products and has conducted unannounced periodic inspections. It's an assurance that steps have been taken in the interest of safety.

The latest edition of "UL 197" is the UL Standard for Safety for Commercial Electric Cooking Appliances.

***Our electric REDHOTS®  
and REDHOTS® Chef's  
Line® equipment comply  
with UL 197 Rev 9  
—THE BEST!***



## Catalog Section 35

### REDHOTS® Chef's Line® Charbroilers

see spec sheet **EG35.17**

**NOTE: INTENDED FOR OTHER THAN HOUSEHOLD USE. THIS COMMERCIAL APPLIANCE MUST BE INSTALLED WITHIN SURROUNDINGS AND VENTILATION REQUIREMENTS AS DICTATED BY NATIONAL AND/OR LOCAL CODE.**



**Bullnosed edge provides solid protection to controls.**

Radiant and Lava Rock Units look the same.

#### Radiant Units

- Heavy gauge stainless steel radiants combine with cast iron burner assembly for even heat distribution.

width in.	width mm	weight lbs.	weight kg	cubic feet	BTU* rating	model #	list
24"	610	178	80.7	10	80,000	CLCHRB-24-NG•	3575
36"	914	245	111.1	13	120,000	CLCHRB-36-NG•	4931
48"	1524	309	140.2	17	160,000	CLCHRB-48-NG•	6839

\* NG units rated at 40,000 BTU per 12" (305mm), rated at 38,000 BTU per 12" (305mm) when converted to LP.

#### Lava Rock Units

- Grate for lava rock placement and natural lava rocks for even heat distribution with cast iron burner assembly.
- Lava rocks supplied. Use maximum of 4 lbs. (1.8 kg) per burner. Replacement lava rocks available. 4-lb. (1.8 kg) bag: Part #375952, \$21 list price; 8-lb. (3.6 kg) bag: Part #332130, \$36 list price.

width in.	width mm	weight lbs.	weight kg	cubic feet	BTU rating	model #	list
24"	610	178	80.7	10	64,000	CLCHRBL-24-NG•	2588
36"	914	245	111.1	13	96,000	CLCHRBL-36-NG•	3580
48"	1524	309	140.2	17	128,000	CLCHRBL-48-NG•	5057

### REDHOTS® Chef's Line® Hot Plates - Gas

see spec sheet **EG35.21**

**NOTE: INTENDED FOR OTHER THAN HOUSEHOLD USE. THIS COMMERCIAL APPLIANCE MUST BE INSTALLED WITHIN SURROUNDINGS AND VENTILATION REQUIREMENTS AS DICTATED BY NATIONAL AND/OR LOCAL CODE.**



#CLHP-4-NG

**Bullnosed edge provides solid protection to controls.**

FEATURES:

- Controls are at a 45° angle for ergonomic operation.
- 3½" (89mm) wide front trough, with chute located at left end, accommodates standard spatula.
- Heavy duty cast metal legs with flanged feet adjustable from 4" to 5" (102 to 127mm).
- Heavy duty cast iron cooking grates can be individually positioned flat or angled.
- 4⅞" (124mm) sides and rear splash sloped front-to-back.
- Natural gas (NG) complete with convertible pressure regulator and orifices for field conversion to liquid propane (LP).
- ¾" (19mm) NPT gas connection.
- Full size polished stainless steel grease pan with baffles—48" (1219mm) units provided with two grease pans.

**Freight class is 65.0.**

(•) MTS (made to stock) / ( ) MTO (made to order)

#### Removable Griddle Plate for all Charbroilers

- 12" (305mm) wide.
- ¾" (19mm) thick.
- Replaces two cooking grates.

weight lbs.	weight kg	cubic feet	model #	list
86	39.0	3.25	RGP-2	1705



### REDHOTS® Chef's Line® Hot Plates - Gas

see spec sheet **EG35.21**

**NOTE: INTENDED FOR OTHER THAN HOUSEHOLD USE. THIS COMMERCIAL APPLIANCE MUST BE INSTALLED WITHIN SURROUNDINGS AND VENTILATION REQUIREMENTS AS DICTATED BY NATIONAL AND/OR LOCAL CODE.**



#CLHP-4-NG

**Bullnosed edge provides solid protection to controls.**

FEATURES:

- Controls, with 1/4 turn, are at a 45° angle for easier operation.
- Standing pilot for safe and easy operation, heavy duty cast metal legs with flanged feet adjustable from 4" to 5" (102 to 127mm), and heavy duty cast iron grates.
- All units are for natural gas (NG), complete with convertible pressure regulator and orifices for field conversion to liquid propane (LP).
- Full size polished stainless steel drip pan included.

**Freight class is 92.5.**

(•) MTS (made to stock) / ( ) MTO (made to order)

#### Flat Top Units

#### Step-Up Units

width x depth		BTU rating	weight		cu ft	model #		list	weight		cu ft	model #		list
in.	mm		lbs.	kg		lbs.	kg		lbs.	kg		lbs.	kg	
12¾"	28¾"	50,000	70	31.8	7	CLHP-2-NG•	1568	78	35.4	9	CLUHP-2-NG	2133		
24¾"	28¾"	100,000	110	49.9	14	CLHP-4-NG	2527	125	56.7	18	CLUHP-4-NG	3043		
36¾"	28¾"	150,000	190	86.2	21	CLHP-6-NG	3637	210	95.3	27	CLUHP-6-NG	4417		

## REDHOTS® Chef's Line® Hot Plates - Electric

see spec sheet **EG35.20**



**NOTE: INTENDED FOR OTHER THAN HOUSEHOLD USE. THIS COMMERCIAL APPLIANCE MUST BE INSTALLED WITHIN SURROUNDINGS AND VENTILATION REQUIREMENTS AS DICTATED BY NATIONAL AND/OR LOCAL CODE.**



**Bullnosed edge provides solid protection to controls.**

FEATURES:

- Top and front are constructed of highly polished stainless steel.
- Exterior wrapper is aluminized steel.
- Swing-up elements with individual crumb trays, removable for easy cleaning.
- 13 $\frac{3}{4}$ " (349mm) working height adjustable to 14 $\frac{3}{4}$ " (375mm).
- Infinite controls provide adjustable heat setting and are equipped with an Off-On light.
- All units are 60 cycle single phase.
- Models #CLC-240-2 and CLC-208-2 are field-wired. #CLCW-120-2 comes complete with cord and 120-volt 15-amp NEMA 5-15 plug.

**Freight class is 92.5.**

(•) MTS (made to stock) / ( ) MTO (made to order)

width x depth*		weight		cu ft	electrical data			model #	list	
in.	mm	lbs.	kg		volts	amps	watts (front burner)			watts (rear burner)
18"	27 $\frac{5}{8}$ "	43	19.5	7	120V	13.5A	1100W	525W	CLCW-120-2	1793
18"	27 $\frac{5}{8}$ "	43	19.5	7	208V	15.1A	1575W	1575W	CLC-208-2 •	1793
18"	27 $\frac{5}{8}$ "	43	19.5	7	240V	17.5A	2100W	2100W	CLC-240-2	1793

\* Depth dimension does not include 2" (51mm) junction box on models CLC-208-2 and CLC-240-2.

## REDHOTS® Chef's Line® Griddles - Gas

see spec sheet **EG35.26**



**NOTE: INTENDED FOR OTHER THAN HOUSEHOLD USE. THIS COMMERCIAL APPLIANCE MUST BE INSTALLED WITHIN SURROUNDINGS AND VENTILATION REQUIREMENTS AS DICTATED BY NATIONAL AND/OR LOCAL CODE.**



3 $\frac{1}{2}$ " (89mm) wide front trough, with chute located at left end, accommodates standard spatula.



**Bullnosed edge provides solid protection to controls.**

FEATURES:

- 3/4" (19mm) NPT gas connection.
- 31,250 BTU burner every 12" (305mm) for even heat distribution.
- Controls are at a 45° angle for ergonomic operation.
- Heavy duty cast metal legs with flanged feet adjustable from 4" to 5" (102 to 127mm).
- 3/4" (19mm) thick smooth polished steel griddle plate fully welded to top assembly.
- 4" (102mm) sides and rear splash sloped front-to-back.
- 7 $\frac{1}{2}$ -quart polished stainless steel oversized grease drawer.

**Freight class is 92.5.**

(•) MTS (made to stock) / ( ) MTO (made to order)

Natural Gas units (NG) listed in chart below. Liquid Propane units (LP) available at the same list price. To order, replace suffix "-NG" in model number with suffix "-LP" (ex: CLAGGD-24-LP).

width in.	width mm	weight		BTU rating	cubic feet	cooking surface	water* column pressure	manual controls		thermostatic snap-action controls		thermostatic snap-action controls w/safety pilot	
		lbs.	kg					model #	list	model #	list	model #	list
15"	381	173	78.5	31,250	10	315 sq in	3 $\frac{1}{2}$ "	CLAGGD-15-NG	2152	CLAGGDT-15-NG	2874	CLAGGDTS-15-NG	3736
24"	610	234	106.1	62,500	10	504 sq in	3 $\frac{1}{2}$ "	CLAGGD-24-NG •	2401	CLAGGDT-24-NG •	3828	CLAGGDTS-24-NG	4955
36"	914	341	154.7	94,000	13	756 sq in	3 $\frac{1}{2}$ "	CLAGGD-36-NG •	3072	CLAGGDT-36-NG •	4832	CLAGGDTS-36-NG	6248
48"	1219	401	181.9	125,000	17	1008 sq in	3 $\frac{1}{2}$ "	CLAGGD-48-NG •	4142	CLAGGDT-48-NG •	6259	CLAGGDTS-48-NG	7872

\* 3 $\frac{1}{2}$ " (89mm) water column pressure for natural gas ("NG") units, 9 $\frac{1}{2}$ " (241mm) for liquid propane ("LP") units.

## Catalog Section 35

### REDHOTS® Chef's Line® Griddles - Electric

see spec sheet **EG35.26**



**NOTE: INTENDED FOR OTHER THAN HOUSEHOLD USE. THIS COMMERCIAL APPLIANCE MUST BE INSTALLED WITHIN SURROUNDINGS AND VENTILATION REQUIREMENTS AS DICTATED BY NATIONAL AND/OR LOCAL CODE.**



**Bullnosed edge provides solid protection to controls.**

- Thermostatic controls, adjustable from 100° to 450°F.
- 4000-watt tubular heating elements are secured to underside of griddle plate to provide uniform distribution of heat over entire griddle surface.
- Internal wiring terminated in a junction box at rear for field wiring.
- Controls are at a 45° angle for ergonomic operation.
- 3½" (89mm) wide front trough, with chute located at left end, accommodates standard spatula.
- Heavy duty cast metal legs with flanged feet adjustable from 4" to 5" (102 to 127mm).
- ¾" (19mm) thick smooth polished steel griddle plate fully welded to top assembly.
- 4" (102mm) sides and rear splash sloped front-to-back.
- 7½-quart polished stainless steel grease drawer.

FEATURES:

**Freight class is 65.0.**

(•) MTS (made to stock) / ( ) MTO (made to order)

width in.	width mm	weight lbs.	weight kg	cubic feet	cooking surface	electrical data*	model #	list
24"	610	237	107.6	10	504 sq in	240V, 28.9A/33.3A, 6000W/8000W	<b>CLEGD-24-240 •</b>	3204
36"	914	344	156.0	13	756 sq in	240V, 43.3A/50.0A, 9000W/12000W	<b>CLEGD-36-240 •</b>	4046
48"	1219	404	183.2	17	1008 sq in	240V, 57.7A/66.7A, 12000W/16000W	<b>CLEGD-48-240 •</b>	5635

\* Electrical data is based on single phase connection.

### REDHOTS® Chef's Line® Fryers - Single

see spec sheet **EG35.19**



**NOTE: INTENDED FOR OTHER THAN HOUSEHOLD USE. THIS COMMERCIAL APPLIANCE MUST BE INSTALLED WITHIN SURROUNDINGS AND VENTILATION REQUIREMENTS AS DICTATED BY NATIONAL AND/OR LOCAL CODE.**



Shown with two single-fry baskets, nickel-plated, each 4" x 11" (102 x 279mm) heavy-plated mesh construction.



optional night cover available.  
Model #361993. List: \$163.

**15-lb. (6.8 kg) fat capacity!**

- Line cord included. CLEF10-120(-1) furnished with NEMA 5-15 plug, CLEF10-120M(-1) with NEMA 5-20 plug (meets Canadian requirements), CLEF10-240(-1) with NEMA 6-30 plug & cord for 208V or 240V use.
- Fry tanks are 10" x 14" (254 x 356mm) and are all-stainless steel deep-drawn one-piece construction, removable for easy cleaning or filtering of fat.
- Snap action thermostat complete with indicator light for accurate temperature control.
- Hi limit safety control provides total system shutdown in case of malfunction, and comes complete with reset button and indicator light.
- Heating elements are self-cleaning Incoloy® sheath for long life and high performance.
- 13¾"-14¾" (349-375mm) working height, 19½"-20½" (499-524mm) total height, and 60-cycle single-phase.

FEATURES:

**Freight class is 92.5.**

(•) MTS (made to stock) / ( ) MTO (made to order)

width x depth in.	width x depth mm	weight lbs.	weight kg	cu ft	electrical data*	**performance— french fries, raw-to-finish	WITH TWO 4" x 11" SINGLE-FRY BASKETS		WITH ONE 8½" x 9½" DOUBLE-FRY BASKET	
							model #	list	model #	list
16¾" x 24½"	426 x 613	31	14.1	6.0	120V, 15A, 1800W	120V: 6 lbs. (2.7 kg)/hr	<b>CLEF10-120 •</b>	2243	<b>CLEF10-120-1</b>	2243
16¾" x 24½"	426 x 613	31	14.1	6.0	120V, 15A, 1800W	120V: 6 lbs. (2.7 kg)/hr	<b>CLEF10-120M***</b>	2243	<b>CLEF10-120M-1***</b>	2243
16¾" x 24½"	426 x 613	31	14.1	6.0	208/240V, 19.8/22.9A, 4125/5500W	208V: 20 lbs. (9.1 kg)/hr 240V: 30 lbs. (13.6 kg)/hr	<b>CLEF10-240****•</b>	2667	<b>CLEF10-240-1****</b>	2667

\* Based on single-phase 60-cycle electricity. Three-phase also available.

\*\* Double the performance for pre-cooked convenience foods. Preheat to 350°F for 4½ minutes. Fryer performance is limited by the maximum available voltage in line.

\*\*\* Models #CLEF10-120M and CLEF10-120M-1 furnished with NEMA 5-20 plug—meets Canadian approval.

\*\*\*\* 240-volt models can be used for 208V or 240V operation.



100 Industrial Boulevard, Clayton, DE 19938-8903 U.S.A.  
Phone: 800-441-8440 or 302-653-3000. Fax: 302-653-2065  
http://www.eaglegrp.com

## REDHOTS® Chef's Line® Fryers - Double

see spec sheet **EG35.19** 

**NOTE: INTENDED FOR OTHER THAN HOUSEHOLD USE. THIS COMMERCIAL APPLIANCE MUST BE INSTALLED WITHIN SURROUNDINGS AND VENTILATION REQUIREMENTS AS DICTATED BY NATIONAL AND/OR LOCAL CODE.**



Four fry baskets, nickel-plated, each 4" x 11" (102 x 279mm) heavy-plated mesh construction.



Optional night cover available. Two needed for double-tank unit. Model #361993. List: \$163 each.

**30-lb. (13.6 kg) fat capacity!**

FEATURES:

- Dual voltage: 208V and 240V.
- Designed for direct field wiring.
- Equipped with junction box for field wiring.
- Fry tanks are 10" x 14" (254 x 356mm) and are all-stainless steel deep-drawn one-piece construction, removable for easy cleaning or filtering of fat.
- Snap action thermostat complete with indicator light for accurate temperature control.
- Hi limit safety control provides total system shutdown in case of malfunction, and comes complete with reset button and indicator light.
- Heating elements are self-cleaning Incoloy® sheath for long life and high performance.
- 13¾"-14¾" (349-375mm) working height, 19½"-20½" (499-524mm) total height, and 60 cycle single phase.

**Freight class is 92.5.**

(•) MTS (made to stock) / ( ) MTO (made to order)

width x depth		weight		cu	electrical data*	**performance— french fries, raw-to-finish	WITH FOUR 4" x 11" SINGLE-FRY BASKETS		WITH TWO 8½" x 9½" DOUBLE-FRY BASKETS	
in.	mm	lbs.	kg	ft			model #	list	model #	list
32" x 24½"	813 x 613	61	27.7	12	208/240V, 39.6/45.8A, 8250/11000W	208V: 40 lbs. (18.1 kg)/hr 240V: 60 lbs. (27.2 kg)/hr	<b>CLEF102-240</b> ***•	4837	<b>CLEF102-240-1</b> ***	4837

\* Based on single-phase 60-cycle electricity. Three-phase also available.

\*\* Double the performance for pre-cooked convenience foods. Preheat to 350°F for 4½ minutes. Fryer performance is limited by the maximum available voltage in line.

\*\*\* 240-volt models can be used for 208V or 240V operation.

## REDHOTS® Bulb Warmers

see spec sheet **EG35.02**



BW-2-120 bulb warmer



BW-2-120I bulb warmer

FEATURES:

- Freestanding portable food warmers.
- Adjustable frame of heavy gauge steel with chrome finish, ensuring lasting beauty and durability.
- Two 250-watt infrared white bulbs, a 6' (1829mm) 3-conductor cord fitting all standard 15-amp wall receptacles.
- 8" (203 mm) high lamp shields constructed of polished aluminum, and chrome-plated bottom plate.
- The BW-2-120I comes with 20" x 12" x 2½" (508 x 305 x 64mm) stainless steel pan and drain insert.
- Height adjusts from 19½" to 27½" (499 to 702mm).
- 60 cycle single phase.

**Freight class is 92.5.**

(•) MTS (made to stock) / ( ) MTO (made to order)

width x depth*		weight		cu	electrical data	model #	list
in.	mm	lbs.	kg	ft			
14¾" x 19¼"	362 x 489	10	4.5	3.6	120V, 4.2A, 500W	<b>BW-2-120</b> •	578
14¾" x 19¼"	362 x 489	18	8.2	3.6	120V, 4.2A, 500W	<b>BW-2-120I</b> •	700

\*Dimensions of bottom plate.

### Accessories/Replacements for Bulb Warmers

description	model #	list
20¾" x 12¾" x 2½" (527 x 324 x 64mm) pan	<b>301669</b>	95
stainless steel drain insert	<b>301757</b>	88
red infrared bulb	<b>301759</b>	104
white infrared bulb	<b>301628</b>	47
white infrared shatter-proof Teflon-coated bulb	<b>360332</b>	63



pan with drain insert

### REDHOTS® Heat Lamps

see spec sheet **EG35.23**

Freight class is 92.5.



**NOTE:** 18" (457mm) long units available in 208V only.

24" to 108" (457 to 2743mm) long units\* available in 120V, 208V, or 240V voltage.

120" to 144" (3048 to 3658mm) long units\* available in 208V or 240V only.

\* For units 24" to 144" long: If 120V or 208V is desired, replace "-240" in model number with "-120" or "-208" (ex: RHHL-30-120).

### Standard- and High-Watt Units

length			STANDARD WATT, NO LIGHTS			STANDARD WATT, WITH LIGHTS			HIGH WATT, NO LIGHTS			HIGH WATT, WITH LIGHTS		
in.	mm	voltage	wattage	model #	list	wattage*	model #	list	wattage	model #	list	wattage*	model #	list
18"	457	208V	250W	RHHL-18-208	349	310W	RHHL-18-208-L	538	350W	RHHL-18-208-H	362	410W	RHHL-18-208-H-L	548
24"	610	240V	350W	RHHL-24-240	374	470W	RHHL-24-240-L	556	500W	RHHL-24-240-H	384	620W	RHHL-24-240-H-L	573
30"	762	240V	450W	RHHL-30-240	396	570W	RHHL-30-240-L	629	660W	RHHL-30-240-H	408	780W	RHHL-30-240-H-L	642
36"	914	240V	575W	RHHL-36-240	422	755W	RHHL-36-240-L	702	862.5W	RHHL-36-240-H	434	1042.5W	RHHL-36-240-H-L	713
42"	1067	240V	675W	RHHL-42-240	441	855W	RHHL-42-240-L	769	1025W	RHHL-42-240-H	458	1205W	RHHL-42-240-H-L	783
48"	1219	240V	800W	RHHL-48-240	466	1040W	RHHL-48-240-L	839	1200W	RHHL-48-240-H	478	1440W	RHHL-48-240-H-L	849
54"	1372	240V	925W	RHHL-54-240	489	1165W	RHHL-54-240-L	909	1250W	RHHL-54-240-H	499	1490W	RHHL-54-240-H-L	922
60"	1524	240V	1050W	RHHL-60-240	539	1350W	RHHL-60-240-L	1006	1400W	RHHL-60-240-H	549	1700W	RHHL-60-240-H-L	1014
66"	1676	240V	1160W	RHHL-66-240	583	1460W	RHHL-66-240-L	1098	1560W	RHHL-66-240-H	596	1860W	RHHL-66-240-H-L	1105
72"	1829	240V	1275W	RHHL-72-240	667	1635W	RHHL-72-240-L	1224	1725W	RHHL-72-240-H	677	2085W	RHHL-72-240-H-L	1234
84"	2134	240V	1500W	RHHL-84-240	774	1920W	RHHL-84-240-L	1423	2050W	RHHL-84-240-H	783	2470W	RHHL-84-240-H-L	1436
96"	2438	240V	1725W	RHHL-96-240	862	2205W	RHHL-96-240-L	1607	2400W	RHHL-96-240-H	879	2880W	RHHL-96-240-H-L	1619
108"	2743	240V	1850W	RHHL-108-240	1049	2330W	RHHL-108-240-L	1887	2500W	RHHL-108-240-H	1063	2980W	RHHL-108-240-H-L	1900
120"	3048	240V	2100W	RHHL-120-240	1146	2640W	RHHL-120-240-L	2076	2800W	RHHL-120-240-H	1155	3340W	RHHL-120-240-H-L	2085
132"	3353	240V	2320W	RHHL-132-240	1236	2920W	RHHL-132-240-L	2261	3120W	RHHL-132-240-H	1252	3720W	RHHL-132-240-H-L	2275
144"	3658	240V	2550W	RHHL-144-240	1331	3210W	RHHL-144-240-L	2449	3450W	RHHL-144-240-H	1344	4110W	RHHL-144-240-H-L	2457

### Standard- and High-Watt Units with Remote - When ordering, please specify toggle or infinite switch. See chart at bottom of page.

length			STANDARD WATT, NO LIGHTS			STANDARD WATT, WITH LIGHTS			HIGH WATT, NO LIGHTS			HIGH WATT, WITH LIGHTS		
in.	mm	voltage	wattage	model #	list	wattage*	model #	list	wattage	model #	list	wattage*	model #	list
18"	457	208V	250W	RHHL-18-208-R	825	310W	RHHL-18-208-L-R	1012	350W	RHHL-18-208-H-R	835	410W	RHHL-18-208-H-L-R	1020
24"	610	240V	350W	RHHL-24-240-R	846	470W	RHHL-24-240-L-R	1031	500W	RHHL-24-240-H-R	859	620W	RHHL-24-240-H-L-R	1045
30"	762	240V	450W	RHHL-30-240-R	869	570W	RHHL-30-240-L-R	1103	660W	RHHL-30-240-H-R	883	780W	RHHL-30-240-H-L-R	1116
36"	914	240V	575W	RHHL-36-240-R	895	755W	RHHL-36-240-L-R	1177	862.5W	RHHL-36-240-H-R	906	1042.5W	RHHL-36-240-H-L-R	1185
42"	1067	240V	675W	RHHL-42-240-R	917	855W	RHHL-42-240-L-R	1243	1025W	RHHL-42-240-H-R	932	1205W	RHHL-42-240-H-L-R	1257
48"	1219	240V	800W	RHHL-48-240-R	941	1040W	RHHL-48-240-L-R	1314	1200W	RHHL-48-240-H-R	953	1440W	RHHL-48-240-H-L-R	1323
54"	1372	240V	925W	RHHL-54-240-R	963	1165W	RHHL-54-240-L-R	1382	1250W	RHHL-54-240-H-R	973	1490W	RHHL-54-240-H-L-R	1394
60"	1524	240V	1050W	RHHL-60-240-R	1013	1350W	RHHL-60-240-L-R	1480	1400W	RHHL-60-240-H-R	1022	1700W	RHHL-60-240-H-L-R	1488
66"	1676	240V	1160W	RHHL-66-240-R	1058	1460W	RHHL-66-240-L-R	1569	1560W	RHHL-66-240-H-R	1068	1860W	RHHL-66-240-H-L-R	1580
72"	1829	240V	1275W	RHHL-72-240-R	1141	1635W	RHHL-72-240-L-R	1698	1725W	RHHL-72-240-H-R	1152	2085W	RHHL-72-240-H-L-R	1707
84"	2134	240V	1500W	RHHL-84-240-R	1247	1920W	RHHL-84-240-L-R	1898	2050W	RHHL-84-240-H-R	1257	2470W	RHHL-84-240-H-L-R	1908
96"	2438	240V	1725W	RHHL-96-240-R	1337	2205W	RHHL-96-240-L-R	2080	2400W	RHHL-96-240-H-R	1352	2880W	RHHL-96-240-H-L-R	2095
108"	2743	240V	1850W	RHHL-108-240-R	1523	2330W	RHHL-108-240-L-R	2361	2500W	RHHL-108-240-H-R	1537	2980W	RHHL-108-240-H-L-R	2374
120"	3048	240V	2100W	RHHL-120-240-R	1618	2640W	RHHL-120-240-L-R	2548	2800W	RHHL-120-240-H-R	1629	3340W	RHHL-120-240-H-L-R	2560
132"	3353	240V	2320W	RHHL-132-240-R	1713	2920W	RHHL-132-240-L-R	2735	3120W	RHHL-132-240-H-R	1725	3720W	RHHL-132-240-H-L-R	2747
144"	3658	240V	2550W	RHHL-144-240-R	1804	3210W	RHHL-144-240-L-R	2920	3450W	RHHL-144-240-H-R	1819	4110W	RHHL-144-240-H-L-R	2932

\* Wattage listed includes output of the lights.



toggle switch box



infinite switch box

### Switch Boxes for Heat Lamps with Remote

applicable heat lamps	heat lamp lengths*		TOGGLE SWITCH BOXES		INFINITE SWITCH BOXES		
	in.	mm	FOR 120V*, 208V, and 240V HEAT LAMPS	model #	FOR 120V * HEAT LAMPS	FOR 208V HEAT LAMPS	FOR 240V HEAT LAMPS
standard-watt units without lights (heat lamp model #s with suffix "-R")	18" - 96"	457 - 2438		410301	411182	411172	410302
	108" - 144"	2743 - 3658		410303	411184	411174	410304
standard-watt units with lights (heat lamp model #s with suffix "-L-R")	18" - 96"	457 - 2438		410308	411185	411175	410305
	108" - 144"	2743 - 3658		410306	411187	411177	410307
high-watt units without lights (heat lamp model #s with suffix "-H-R")	18" - 60"	457 - 1524		410301	411182	411172	410302
	66" - 144"	1676 - 3658		410303	411184	411174	410304
high-watt units with lights (heat lamp model #s with suffix "-H-L-R")	18" - 60"	457 - 1524		410308	411185	411175	410305
	66" - 144"	1676 - 3658		410306	411187	411177	410307

\* 120-volt heat lamps available up to 108"-length.

## REDHOTS® Display Lights

see spec sheet **EG35.09**



**FEATURES:**

- Exterior extruded aluminum housing with mirror finish reflector for maximum brightness.
- Designed for field wiring.
- Lighted rocker switch.
- Includes bulbs with shatter-proof Teflon coating.
- Can be chain-mounted from ceiling or mounted under a shelf.

**Note:** For Display Lights with cord/plug, add \$121 to list cost of non-cp units and add suffix "-CP" to model number.  
Example RHDL-30-I-CP.

**Freight class is 92.5.**

length		Built-In Switch				Remote Switch			
in.	mm	voltage	max. wattage	model #	list	max. wattage	model #	list	
18"	457	120V	60W	RHDL-18-I	464	60W	RHDL-18-I-R	492	
24"	610	120V	120W	RHDL-24-I	492	120W	RHDL-24-I-R	519	
30"	762	120V	120W	RHDL-30-I	514	120W	RHDL-30-I-R	540	
36"	914	120V	180W	RHDL-36-I	597	180W	RHDL-36-I-R	622	
42"	1067	120V	180W	RHDL-42-I	621	180W	RHDL-42-I-R	644	
48"	1219	120V	240W	RHDL-48-I	698	240W	RHDL-48-I-R	720	
54"	1372	120V	240W	RHDL-54-I	719	240W	RHDL-54-I-R	743	
60"	1524	120V	300W	RHDL-60-I	800	300W	RHDL-60-I-R	826	
66"	1676	120V	300W	RHDL-66-I	826	300W	RHDL-66-I-R	849	
72"	1829	120V	360W	RHDL-72-I	904	360W	RHDL-72-I-R	929	

*Ideal for lighting  
up food prep, holding,  
and display areas.*

## REDHOTS® Countertop Food Warmers

see spec sheet **EG35.00**



model #1220FWD-120  
shown with optional  
food pan



model #11QFW-120  
"soup warmer"

*Meets the  
highest standards  
of construction.*

**FEATURES:**

- Infinite controls.
- Highly polished stainless steel exterior ensures lasting beauty and durability.

**Freight class is 92.5.**

(•) MTS (made to stock) / ( ) MTO (made to order)



### 12" x 20" (305 x 508mm) Opening

- Deep drawn type 304 stainless steel 12" x 20" (305 x 508mm) openings, providing wet or dry operation. 11" (279mm) height.

width x depth		weight		cu ft	# of openings	120-VOLT MODELS			208-VOLT MODELS			240-VOLT MODELS		
in.	mm	lbs.	kg			electrical data	model #	list	electrical data	model #	list	electrical data	model #	list
14 1/4" x 22 1/2"	362 x 562	24	10.9	3.4	1	120V, 6.3A, 750W	1220FWE-120•	732	208V, 3.4A, 712W	1220FWE-208	732	240V, 3.1A, 750W	1220FWE-240	732
14 1/4" x 22 1/2"	362 x 562	24	10.9	3.4	1	120V, 10A, 1200W	1220FWD-120•	737	208V, 5.8A, 1200W	1220FWD-208	737	240V, 5.0A, 1200W	1220FWD-240	737
29 3/8" x 22 1/2"	741 x 573	54	24.5	9.9	2	120V, 15A, 1800W	1220FW2-120	1680	208V, 8.7A, 1800W	1220FW2-208	1680	240V, 7.9A, 1900W	1220FW2-240	1680

### Round Inset

- Also known as "soup warmers". Round well holds 7 qts. (6.6 liters) or 11 qts. (10.4 liters) round inset. 10 1/4" (273mm) height. To order round inset, see page 276.

width x depth		weight		cu ft	electrical data	120-VOLT MODELS		208-VOLT MODELS		240-VOLT MODELS			
in.	mm	lbs.	kg			model #	list	electrical data	model #	list	electrical data	model #	list
12" x 12"	305 x 305	18	8.2	1.3	120V, 4.6A, 550W	7QFW-120 •	828	208V, 2.4A, 495W	7QFW-208	828	240V, 2.8A, 660W	7QFW-240	828
14 1/4" x 16 1/4"	375 x 426	20	9.0	3.4	120V, 4.6A, 550W	11QFW-120•	904	208V, 2.4A, 495W	11QFW-208	904	240V, 2.8A, 660W	11QFW-240	904

## Catalog Section 35

### REDHOTS® Countertop Cooker/Warmers

see spec sheet **EG35.01**



model #1220CWD-120  
with optional food pan



model #11QCW-120  
with optional inset



FEATURES:

- Exterior body is stainless steel.
- Thermostatically controlled and offers a degree range setting from 100° to 450°F in 50° increments.
- Degree range is 100° to 212° with wet usage, 100° to 450°F with dry usage.

**Freight class is 92.5.**

(•) MTS (made to stock) / ( ) MTO (made to order)

**Among the most versatile of countertop equipment.  
Capable of cooking, warming or serving.**

### 12" x 20" (305 x 508mm) Opening

- Deep drawn type 304 stainless steel 12" x 20" (305 x 508mm) openings, providing wet or dry operation. 11" (279mm) height.

width x depth		weight		cu	120-VOLT MODELS			208-VOLT MODELS			240-VOLT MODELS				
in.	mm	lbs.	kg	ft	electrical data	model #	list	electrical data	model #	list	electrical data	model #	list		
14 1/4"	x 22 1/2"	362	x 562	26	11.8	3.4	120V, 10A, 1200W	<b>1220CWD-120</b> •	968	208V, 5.8A, 1200W	<b>1220CWD-208</b>	968	240V, 5A, 1200W	<b>1220CWD-240</b>	968

### Round Inset

- These units hold one 11 qt. (10.4 liter) round inset. 12 1/2" (318mm) height. To order round inset, see page 276.

width x depth		weight		cu	120-VOLT MODELS			208-VOLT MODELS			240-VOLT MODELS				
in.	mm	lbs.	kg	ft	electrical data	model #	list	electrical data	model #	list	electrical data	model #	list		
14 1/4"	x 16 1/8"	372	x 424	20	9.0	3.4	120V, 6.3A, 750W	<b>11QCW-120</b> •	1007	208V, 2.7A, 562W	<b>11QCW-208</b>	1007	240V, 3.1A, 750W	<b>11QCW-240</b>	1007

All specifications are subject to change without notice. New York M.E.A. No. 376-84-E

### Accessories for REDHOTS® Food Warmers & Cooker/Warmers

see spec sheets **EG35.00** **EG35.01**

**Note:** For additional accessories, including round insets and lids, see page 276.

**Freight class is 85.0.**

(•) MTS (made to stock) / ( ) MTO (made to order)

### Adapter Tops

description	model #	list
two 8 1/2" (216mm) diameter inserts, each for 7 qts. (6.6 liters)	<b>501600</b> •	146
one 8 1/2" (216mm) diameter insert for 7 qts. (6.6 liters), and one 10 1/2" (267mm) diameter insert for 11 qts. (10.4 liters)	<b>501912</b> •	146
one 6 1/2" (165mm) diameter insert for 4 qts. (3.8 liters), and one 10 1/2" (267mm) diameter insert for 11 qts. (10.4 liters)	<b>501913</b>	146
one 6 1/2" (165mm) diameter insert for 4 qts. (3.8 liters), and one 8 1/2" (216mm) diameter insert for 7 qts. (6.6 liters)	<b>501915</b>	146
three 6 1/2" (165mm) diameter inserts, each for 4 qts. (3.8 liters)	<b>501914</b> •	146



model #501600  
2-pot adapter top



model #501912  
2-pot adapter top



model #501913  
2-pot adapter top



model #501915  
2-pot adapter top



model #501914  
3-pot adapter top

### Pass-Thru Heated Drawers

see product announcement **EG35.14**



front of unit shown  
with drawer in the  
closed position

electrical data	Left Hand Cord		Right Hand Cord	
	model #	list	model #	list
120V, 3.75A, 450W	<b>DWP-1L-120</b>	4116	<b>DWP-1R-120</b>	4116
240V, 1.88A, 450W	<b>DWP-1L-240</b>	4116	<b>DWP-1R-240</b>	4116

FEATURES:

- Handles and controls are provided on both sides of drawer for functionality from either side.
- Heavy gauge stainless steel interior and exterior with 1 1/2" (38mm) fiberglass insulation.
- Food-grade silicone rubber gaskets provide sealing around the drawer fronts to help boost efficiency.
- Stainless steel liners that accept standard full-size and fractional steam table pans up to 6" (152mm) deep.
- Standard black 4" (102mm) adjustable non-marking feet.

**Freight class is 100.0.**

## REDHOTS® Electric Fryers US

see spec sheet **EG35.03**

**NOTE: INTENDED FOR OTHER THAN HOUSEHOLD USE. THIS COMMERCIAL APPLIANCE MUST BE INSTALLED WITHIN SURROUNDINGS AND VENTILATION REQUIREMENTS AS DICTATED BY NATIONAL AND/OR LOCAL CODE.**



single tank electric fryer

double tank electric fryer

FEATURES:

- Fry tanks are 10" x 14" (254 x 356mm) and are all-stainless steel deep-drawn one-piece construction, removable for easy cleaning or filtering of fat.
- Snap action thermostat comes complete with indicator light for accurate temperature control.
- Hi limit safety control provides total system shutdown in case of malfunction and comes complete with reset button and indicator light.
- Heating elements are self-cleaning Incoloy® for long life and high performance.
- All baskets are heavy-plated mesh construction.
- Body construction features highly polished stainless steel.
- All units are 10 5/8" (270mm) working height, 15 3/4" (391mm) total height, and 60 cycle single phase.

**Freight class is 85.0.**

(•) MTS (made to stock) / ( ) MTO (made to order)

For information on griddle stands, refer to page 143.

### Single Tank—15 lb. (6.8kg) capacity

- Line cord and plug included. EF10-120(-1) furnished with NEMA 5-15 plug. EF10-120M(-1) furnished with NEMA 5-20 plug, which meets Canadian requirements. EF10-240(-1) furnished with NEMA 6-30 plug and cord for 208- or 240-volt application.

width x depth in. mm	weight lbs. kg	cu ft	electrical data	*performance— french fries, raw-to-finish	WITH TWO 4" x 11" SINGLE-FRY BASKETS		WITH ONE 8 1/2" x 9 1/2" DOUBLE-FRY BASKET	
					model #	list	model #	list
12" x 19 1/4"	305 x 489	31 14.1	4.0 120V, 15A, 1800W	120V: 6 lbs. (2.7 kg)/hr	EF10-120 •	1753	EF10-120-1	1998
12" x 19 1/4"	305 x 489	31 14.1	4.0 120V, 15A, 1800W	120V: 6 lbs. (2.7 kg)/hr	EF10-120M	1753	EF10-120M-1	1998
12" x 19 1/4"	305 x 489	31 14.1	4.0 208/240V, 19.8/22.9A, 4125/5500W	208V: 20 lbs. (9.1 kg)/hr 240V: 30 lbs. (13.6 kg)/hr	EF10-240 •	2043	EF10-240-1	2043

### Double Tank—30 lb. (13.6kg) capacity

- Dual voltage: 208V and 240V.
- Designed for direct field wiring.

width x depth in. mm	weight lbs. kg	cu ft	electrical data	*performance— french fries, raw-to-finish	WITH FOUR 4" x 11" SINGLE-FRY BASKETS		WITH TWO 8 1/2" x 9 1/2" DOUBLE-FRY BASKETS	
					model #	list	model #	list
25" x 19 1/4"	635 x 489	61 27.7	8.0 208/240V, 39.6/45.8A, 8250/11000W	208V: 40 lbs. (18.1 kg)/hr 240V: 60 lbs. (27.2 kg)/hr	EF102-240 •	4351	EF102-240-1	4351

\* Double the performance for pre-cooked convenience foods. Preheat to 350°F for 4 1/2 minutes. Fryer performance is limited by the maximum available voltage in line.

All specifications are subject to change without notice. New York M.E.A. No. 449-84-E

### Accessories/Replacements for Electric Fryers

description	model #	list
replacement basket, left side, for single-tank fryers only	307543	104
replacement basket, right side, for single-tank fryers only	307546	104
2 1/4" (57mm) high legs, set of four	309197	43
double-fry basket, 8 1/2" x 9 1/2" x 4" (216 x 241 x 102mm)	309781	138
divider for double-tank fryer	340859	68
night cover – two required for double-tank model	361673	82



optional double fry basket



### REDHOTS® Heated Drawers NSF cULus

see spec sheets **EG35.15** **EG35.16**



1-tier freestanding unit



2-tier built-in unit



3-tier freestanding unit with optional casters

**Ideal for  
crisp or moist foods.**

- Freestanding styles feature 72" (1829mm) three wire grounded cord.
- Built-in styles feature 4' (1219mm) flexible conduit for field termination to a junction box.
- Heavy duty stainless steel construction with 1½" (38mm) fiberglass insulation.
- Drawer liners are 12" (305mm) front-to-back, 20" (508mm) side-to-side, and 6½" (165mm) deep.
- Individual recessed thermostat control and indicator lamp for each drawer.
- Heating element configuration heats quickly and evenly from 100° to 200°F.
- Adjustable louvers on each drawer retain ideal product moisture levels.
- Drawers are interchangeable and include stainless steel liners that accept standard full-size and fractional steam table pans up to 6" (152mm) deep.
- 4" (102mm) adjustable non-marking feet.

**FEATURES:**

**Note:** Perforated well pan bottom available.

For use if water was to be in the bottom and buns or rolls on top. Fits inside stainless steel spillage pan insert. One per drawer as required. **Model #: DW-PERF. List price: \$76**

4" (102mm) diameter casters available for freestanding models. Set of four. **Model #: DW-C4. List price: \$333**

Replacement drawer liner available for all models.

**Model #: 331160. List price: \$220**

New York M.E.A. No. 246-02-E

**Freight class is 92.5.**

(•) MTS (made to stock) / ( ) MTO (made to order)

#### 1-Drawer Units

#### Narrow Width

#### Wide Width

electrical data	FREESTANDING *		BUILT-IN**		FREESTANDING***		BUILT-IN****	
	model #	list	model #	list	model #	list	model #	list
120V, 3.75A, 450W	DWN-1-120	3515	DWN-1BI-120	3515	DWW-1-120	3515	DWW-1BI-120	3515
240V, 1.88A, 450W	DWN-1-240	3515	DWN-1BI-240	3515	DWW-1-240	3515	DWW-1BI-240	3515

\* 21" W x 27¼" D x 16¼" H (533 x 705 x 413mm) overall dimensions

\*\*\* 29" W x 23¼" D x 16¼" H (737 x 591 x 413mm) overall dimensions

\*\* 21¼" W x 26" D x 10" H (553 x 676 x 276mm) cutout dimensions

\*\*\*\* 29¼" W x 23" D x 10" H (756 x 606 x 276mm) cutout dimensions

#### 2-Drawer Units

#### Narrow Width

#### Wide Width

electrical data	FREESTANDING *		BUILT-IN**		FREESTANDING***		BUILT-IN****	
	model #	list	model #	list	model #	list	model #	list
120V, 7.5A, 900W	DWN-2-120	5735	DWN-2BI-120	5735	DWW-2-120 •	5735	DWW-2BI-120	5735
240V, 3.75A, 900W	DWN-2-240	5735	DWN-2BI-240	5735	DWW-2-240	5735	DWW-2BI-240	5735

\* 21" W x 27¼" D x 26" H (533 x 705 x 676mm) overall dimensions

\*\*\* 29" W x 23¼" D x 26" H (737 x 591 x 676mm) overall dimensions

\*\* 21¼" W x 26" D x 21¼" H (553 x 676 x 553mm) cutout dimensions

\*\*\*\* 29¼" W x 23" D x 21¼" H (756 x 606 x 553mm) cutout dimensions

#### 3-Drawer Units

#### Narrow Width

#### Wide Width

electrical data	FREESTANDING *		BUILT-IN**		FREESTANDING***		BUILT-IN****	
	model #	list	model #	list	model #	list	model #	list
120V, 11.25A, 1350W	DWN-3-120	7779	DWN-3BI-120	7779	DWW-3-120	7779	DWW-3BI-120	7779
240V, 5.63A, 1350W	DWN-3-240	7779	DWN-3BI-240	7779	DWW-3-240	7779	DWW-3BI-240	7779

\* 21" W x 27¼" D x 37" H (533 x 705 x 940mm) overall dimensions

\*\*\* 29" W x 23¼" D x 37" H (737 x 591 x 940mm) overall dimensions

\*\* 21¼" W x 26" D x 32" H (553 x 676 x 829mm) cutout dimensions

\*\*\*\* 29¼" W x 23" D x 32" H (756 x 606 x 829mm) cutout dimensions

## Sealed Well Hot Food Gang Drop-In Units

see spec sheet **EG35.12**



**Designed for installation into a counter fixture.**

**Note:** 240V units shown as "240T6" (example: SGDI-1-240T6) may be operated at 208V. This will reduce available amperage and wattage by 25%.

AutoFill® automatic water fill system available for 2- to 6-well models with drain. **NSF- and UL-approved.** To order, add \$1714 to list price and replace prefix "SGDI" in model number with prefix "SGDIA". Example: SGDIA-2-240T-D

- Completely wired and ready for installation.
- Well openings accommodate 12" x 20" (308 x 508mm) pans up to 6" (152mm) deep.
- Wet or dry operation.
- Wired for single-phase operation, and can easily be converted for three-phase operation in the field—except on one-well units.
- Top constructed of heavy-gauge 300 series stainless steel.
- The body is enclosed with galvanized steel and lined by 2" (51mm) of fiberglass thermal wool insulation.
- The bottom is easily removed for servicing.
- All units are supplied with a front-mounted control panel.
- Individual thermostatic control with a positive "Off" position and an amber light to signal a power-on condition.
- Control knobs are recessed into a one-piece, front-mounted control panel.
- The flexible conduit connecting the body enclosure and control panel is 24" (610mm) on all models except one-well units, which have a 36" (914mm) flexible conduit.
- All wiring terminates in a junction box.
- Units ordered with drains are connected by 3/4" (19mm) diameter copper pipe and fittings to a single ball valve.
- Units with multiple wells are designed so the valve can be mounted to the operator's left or right with the drains closest to the operator.
- Valve is shipped loose, to be field-installed.

FEATURES:

**Freight class is 92.5.**

no. wells	width x depth		weight		cu ft	cutout dimensions* for control panels		cutout dimensions for drop-in unit		electrical data**	without drain		with drain***	
	in.	mm	lbs.	kg		in.	mm	in.	mm		model #	list	model #	list
1	18" x 26"	457 x 660	21	9.5	3.0	5" x 8"	127 x 203	16 1/2" x 23 3/4"	416 x 594	120V, 1200W, 10.0A 240V, 1200W, 5.0A 240V, 1600W, 6.7A	SGDI-1-120T 2787 SGDI-1-240T 2787 SGDI-1-240T6 2793	SGDI-1-120T-D 3098 SGDI-1-240T-D 3098 SGDI-1-240T6-D 3105		
2	32" x 26"	813 x 660	51	23.1	6.0	5" x 17" *	127 x 432	30 3/4" x 23 3/4"	772 x 594	120V, 2400W, 20.0A 240V, 2400W, 10.0A 240V, 3200W, 13.3A	SGDI-2-120T 3777 SGDI-2-240T 3777 SGDI-2-240T6 3789	SGDI-2-120T-D* 4317 SGDI-2-240T-D* 4317 SGDI-2-240T6-D* 4331		
3	46" x 26"	1168 x 660	73	33.1	8.0	5" x 17" *	127 x 432	44 1/2" x 23 3/4"	1127 x 594	120V, 3600W, 30.0A 240V, 3600W, 15.0A 240V, 4800W, 20.0A	SGDI-3-120T 4622 SGDI-3-240T 4622 SGDI-3-240T6 4639	SGDI-3-120T-D* 5313 SGDI-3-240T-D* 5313 SGDI-3-240T6-D* 5652		
4	60" x 26"	1524 x 660	95	43.1	11.0	5" x 33 3/4"	127 x 860	57 1/2" x 23 3/4"	1470 x 594	240V, 4800W, 20.0A 240V, 6400W, 26.7A	SGDI-4-240T 5517 SGDI-4-240T6 5540	SGDI-4-240T-D 6306 SGDI-4-240T6-D 6332		
5	74" x 26"	1880 x 660	105	47.6	13.5	5" x 33 3/4"	127 x 860	71 1/2" x 23 3/4"	1813 x 594	240V, 6000W, 25.0A 240V, 8000W, 33.4A	SGDI-5-240T 6383 SGDI-5-240T6 6414	SGDI-5-240T-D 7322 SGDI-5-240T6-D 7767		
6	86 1/2" x 26"	2197 x 660	120	54.4	16.0	5" x 33 3/4"	127 x 860	85 3/4" x 23 3/4"	2169 x 594	240V, 7200W, 30.0A 240V, 9600W, 40.0A	SGDI-6-240T 7168 SGDI-6-240T6 7192	SGDI-6-240T-D 8229 SGDI-6-240T6-D 8265		

\* These cutout dimensions are for standard units only. When optional AutoFill® is installed to 2- and 3-well units with drain (noted in chart), cutout dimensions for control panel are 5" x 23 3/4" (127 x 600mm). On 4-, 5-, and 6-well units, cutout dimensions for control panel remain as listed (AutoFill® not available for 1-well units).

\*\* Total watts and total amperage indicated in electrical data.

\*\*\* Plumbing available only on units with drain.

## Catalog Section 35

### Electric Hot Food Gang Drop-In Units

see spec sheet **EG35.13**



model # GDI-2-240



model # GDI-3-240 unit

#### Replacement Recessed Control Panels

Stainless steel construction. Punched.

description, cutout dimensions	model #	list
double, 8 $\frac{3}{16}$ " x 2 $\frac{1}{16}$ " (213 x 68mm)	<b>305173</b>	89
triple, 11 $\frac{3}{16}$ " x 2 $\frac{1}{16}$ " (300 x 68mm)	<b>305174</b>	113

#### FEATURES:

- Top constructed of heavy-gauge stainless steel with 1" (25mm) overhang on all four sides with reinforced angles.
- Infinite control offers high and low selections along with eight other temperature settings.
- Each heat compartment accommodates a 12" x 20" (305 x 508mm) food pan and is furnished with a 750-watt exposed rectangular shaped heating element.
- All wiring terminates within junction box.
- Units are design for field wiring by others.

**Freight class is 92.5.**

**Note: NOT UL-RECOGNIZED FOR CANADA.**

# of pan openings	# of panels	fits cutout measuring in.	mm	type of remote control panel(s), and cutout dimensions	electrical data	model #	list
2	1	23 $\frac{3}{16}$ " x 30 $\frac{3}{4}$ "	592 x 781	double, 8 $\frac{3}{16}$ " x 2 $\frac{1}{16}$ " (213 x 68mm)	240V, 6.25A, 1500W,	<b>GDI-2-240</b>	2331
3	1	23 $\frac{3}{16}$ " x 46 $\frac{1}{8}$ "	592 x 1172	triple, 11 $\frac{3}{16}$ " x 2 $\frac{1}{16}$ " (300 x 68mm)	240V, 9.38A, 2250W	<b>GDI-3-240</b>	2787
4	2	23 $\frac{3}{16}$ " x 61 $\frac{1}{2}$ "	592 x 1562	double, 8 $\frac{3}{16}$ " x 2 $\frac{1}{16}$ " (213 x 68mm)	240V, 12.5A, 3000W	<b>GDI-4-240</b>	3560
5	2	23 $\frac{3}{16}$ " x 76 $\frac{3}{8}$ "	592 x 1953	double, 8 $\frac{3}{16}$ " x 2 $\frac{1}{16}$ " (213 x 68mm); & triple, 11 $\frac{3}{16}$ " x 2 $\frac{1}{16}$ " (300 x 68mm)	240V, 15.6A, 3750W	<b>GDI-5-240</b>	4011

**Spillage Pans required for wet operation.** Deep-drawn, fully covered. 6-1/2" deep.  
For stainless steel pan:  
**Model #302027, \$263 list.**  
For aluminum pan:  
**Model #304141, \$142 list.**

**NOTE:** 240-volt units will not allow field wiring to 208 volts. 208-volt models available. To order, replace suffix "-240" with "-208".

**Example: GDI-2-208**

### Drop-In Style Food Warmers - Round

see spec sheet **EG35.10**



7-qt. (6.6 liters)  
drop-in style food warmer

**Consult factory for pricing and availability of UL listed models**

#### FEATURES:

- Designed to accept either a 7-qt. (6.6 liter) or 11-qt. (10.4 liter) round inset.
- One-piece deep-drawn 18-8 stainless steel.
- Thermostatic or infinite control, indicator light and die stamped recessed control panel.
- Heating element securely clamped to underside allowing for service through bottom.

**Freight class is 92.5.**

**Note:** Replacement Recessed Control Panels and Drain Valve Extensions available. See page 274.

**Note: NOT UL-RECOGNIZED FOR CANADA.**

#### 7-qt. (6.6 liters) Capacity — Cutout diameter: 8 $\frac{3}{16}$ " (222mm).

diameter x height in. mm	weight lbs. kg	cu ft	electrical data	INFINITE		THERMOSTATIC*	
				model #	list	model #	list
10 $\frac{1}{2}$ " x 8 $\frac{1}{2}$ " 267 x 216	10 4.5	1.0	120V, 4.6A, 550W	<b>7QDI-120</b>	891	<b>7QDI-120T</b>	1069
				<b>7QDI-120D**</b>	995	<b>7QDI-120TD**</b>	1174
10 $\frac{1}{2}$ " x 8 $\frac{1}{2}$ " 267 x 216	10 4.5	1.0	208/240V, 2.4/2.8A, 500/660W	<b>7QDI-240</b>	891	n/a	n/a
				<b>7QDI-240D**</b>	995	n/a	n/a

#### Mounting Plates for Laminated Plastic or Wood Countertops



description	model #	list
for 7-qt. (6.6 liters)	<b>7QP</b>	120
for 11-qt. (10.4 liters)	<b>11QP</b>	129

#### 11-qt. (10.4 liters) Capacity — Cutout diameter: 10 $\frac{3}{4}$ " (273mm).

diameter x height in. mm	weight lbs. kg	cu ft	electrical data	INFINITE		THERMOSTATIC*	
				model #	list	model #	list
12 $\frac{1}{2}$ " x 8 $\frac{1}{2}$ " 318 x 216	14 6.4	1.4	120V, 4.6A, 550W	<b>11QDI-120</b>	928	<b>11QDI-120T</b>	1105
				<b>11QDI-120D**</b>	1009	<b>11QDI-120TD**</b>	1189
12 $\frac{1}{2}$ " x 8 $\frac{1}{2}$ " 318 x 216	14 6.4	1.4	208/240V, 2.4/2.8A, 500/660W	<b>11QDI-240</b>	928	n/a	n/a
				<b>11QDI-240D**</b>	1009	n/a	n/a

\*Thermostatic models available with 72" (1829mm) capillary. To order, add suffix "-72". **Example: 7QDI-120-72**

\*\* Comes with drain.

## Drop-In Style Food Warmers Rectangular



see spec sheet **EG35.11**



top mount...  
cutout size: 12½" x 20½"  
(318 x 521mm)



...bottom mount...  
cutout size: 12" x 20"  
(305 x 508mm)



...insulated bottom mount  
cutout size: 12" x 20"  
(305 x 508mm)

**FEATURES:**

- Constructed of one piece deep-drawn 304 series 18-8 stainless steel with coved corners.
- Heating element securely clamped to underside, allowing for service through bottom.
- The insulated bottom mount hot food units feature exterior wrapper of galvanized steel fully insulated with dense fiberglass. 9" (229mm) height.
- Models with suffix "-D" come with drain.

**Freight class is 92.5.**

(•) MTS (made to stock) / ( ) MTO (made to order)

**Note: NOT UL-RECOGNIZED FOR CANADA.**

### Infinite Controls

- Infinite control offers high and low selections along with eight other temperature settings.

width x depth in. mm	weight lbs. kg	cu ft	electrical data	Top Mount		Bottom Mount		Insulated Bottom MT	
				model #	list	model #	list	model #	list
13¾" x 21¾" 352 x 556	13 5.9	1.7	120V, 1200W, 10.0A	TM1220FW-120	762	BM1220FW-120	720	BM1220FW-120I	866
				TM1220FW-120-D	826	BM1220FW-120-D	777	BM1220FW-120I-D	936
13¾" x 21¾" 352 x 556	13 5.9	1.7	240V, 1200W, 5.0A	TM1220FW-240	788	BM1220FW-240	743	BM1220FW-240I	912
				TM1220FW-240-D	848	BM1220FW-240-D	800	BM1220FW-240I-D	978

### Thermostat Controls

- Thermostatic control—snap acting type—degree range of 86° to 550°F for rapid heat recovery.

width x depth in. mm	weight lbs. kg	cu ft	electrical data	Top Mount		Bottom Mount		Insulated Bottom MT	
				model #	list	model #	list	model #	list
13¾" x 21¾" 352 x 556	13 5.9	1.7	120V, 1200W, 10.0A	TM1220FW-120T	815	BM1220FW-120T	717	BM1220FW-120TI	849
				TM1220FW-120T-D •	894	BM1220FW-120T-D	818	BM1220FW-120TI-D	936
13¾" x 21¾" 352 x 556	13 5.9	1.7	240V, 1200W, 5.0A	TM1220FW-240T	815	BM1220FW-240T	717	BM1220FW-240TI	849
				TM1220FW-240T-D	894	BM1220FW-240T-D	818	BM1220FW-240TI-D	936
13¾" x 21¾" 352 x 556	13 5.9	1.7	208/240V, 1200/1600W, 5.8/6.6A	TM1220FW-240T6	815	BM1220FW-240T6	717	BM1220FW-240T6I	849
				TM1220FW-240T6-D •	894	BM1220FW-240T6-D	818	BM1220FW-240T6I-D	936
13¾" x 21¾" 352 x 556	13 5.9	1.7	208/240/277V, 900/1200/1600W 4.3/5.0/5.8A	TM1220FW-277T	815	BM1220FW-277T	717	BM1220FW-277TI	849
				TM1220FW-277T-D	894	BM1220FW-277T-D	818	BM1220FW-277TI-D	936

### Top Mounting Plates for Laminated Plastic or Wood Countertops

description	model #	list
for top mount units	TMP	173

## For Round Drop-Ins (page 273) and Rectangular Drop-Ins (top of this page)...

### Replacement Recessed Control Panels

Stainless steel construction. Available for OEM installations or other applications.



punched

**Freight class is 85.0.**

description	cutout dimensions		PUNCHED		NOT PUNCHED	
	in.	mm	model #	list	model #	list
single	5¼"	21¼"	129 x 68	305198 57	305197	53

### Drain Valve Extensions

Adjusts from 7" to 28". 2¾"-diameter cutout required for handle. Comes with ball valve.



description	model #	list
for 1/2" valves	DVE-50	318
for 3/4" valves	DVE-75	318

## Catalog Section 35

### Hot Food Merchandising Cart

see spec sheet **EG35.05**



- Two heating wells.
- Solid top work surface.
- Two spillage pans.
- One full-size inset with rolltop cover.
- One ½-size inset with lid.
- One ¼-size inset with lid.
- Two 1¼-quart insets.
- All-white umbrella.
- Complete with cord and 120V 20A NEMA 5-20 plug.

**FEATURES:**

**Note:** Consult factory for available models which require special order graphics.

**Freight class is 92.5.**

description	width x length		weight		cu	model #	list
	in.	mm	lbs.	kg	ft		
with hinged lids	22½" x 48"	572 x 1219	467	212	63	<b>HDC48-120NYF</b>	17624

### Hot Dog Sterno Units

see spec sheet **EG35.06**



- Units are countertop models.
- Units include one ½-size inset with lid.
- Hinged or lift-off lids.
- Hi-impact black nylon feet.
- Two 6" (152mm)-diameter wheels with black rubber tread.
- Holds two 8-oz. fuel cans (*not included*).
- Holds 25 hot dogs.

**FEATURES:**

**Note: CAN BE SHIPPED UPS**

**Freight class is 92.5.**

description	width x length		weight		cu	model #	list
	in.	mm	lbs.	kg	ft		
with hinged lids	8¼" x 14"	210 x 356	17	7.7	3.0	<b>HD612FW-SH</b>	1791
with lift-off lids	8¼" x 14"	210 x 356	17	7.7	3.0	<b>HD612FW-S</b>	1707

### REDHOTS® Hot Dog Roller Grill

see product announcement **EG8191**



- Stainless steel construction with nonstick rollers.
- Rollers sloped front-to-back.
- Separate dual zone controls for front and rear, removable drip tray and nonslip feet.
- Supplied with cord and NEMA 5-15P plug.

**FEATURES:**

**Freight class is 92.5.**

width x depth		height		electrical data	model #	list
in.	mm	in.	mm			
24" x 20½"	610 x 520	13"	330	120V, 60 Hz, 11.9A, 1430W	<b>HDR-10-24-120</b>	1653

#### Accessories for Roller Grill

description	model #	list
food shield, 10½" height	<b>SHDR-10-24</b>	506
bun drawer, 11" height	<b>HDBW-10-24</b>	884

## Food Pans and Round Insets

see spec sheet **EG30.20B**

FEATURES:

- All pans, lids, and insets are stainless steel.
- **Minimum purchase \$196 net**, any assortment.

Freight class is 70.0.

### Stainless Steel Food Pans/Lids/Adapter Bars

description	model #	list
full size pan, 20 $\frac{3}{4}$ " x 12 $\frac{3}{4}$ " x 2 $\frac{1}{2}$ " (527 x 324 x 64mm)	301669	95
full size pan, 20 $\frac{3}{4}$ " x 12 $\frac{3}{4}$ " x 4" (527 x 324 x 102mm)	303775	116
half size pan, 10 $\frac{1}{2}$ " x 12 $\frac{3}{4}$ " x 2 $\frac{1}{2}$ " (264 x 324 x 64mm)	304050	55
half size pan, 10 $\frac{1}{2}$ " x 12 $\frac{3}{4}$ " x 4" (264 x 324 x 102mm)	304051	71
one-third size pan, 6 $\frac{1}{2}$ " x 12 $\frac{3}{4}$ " x 2 $\frac{1}{2}$ " (175 x 324 x 64mm)	304052	47
one-third size pan, 6 $\frac{1}{2}$ " x 12 $\frac{3}{4}$ " x 4" (175 x 324 x 102mm)	304053	59
one-fourth size pan, 6 $\frac{1}{2}$ " x 10 $\frac{1}{2}$ " x 2 $\frac{1}{2}$ " (162 x 264 x 64mm)	304054	43
one-fourth size pan, 6 $\frac{1}{2}$ " x 10 $\frac{1}{2}$ " x 4" (162 x 264 x 102mm)	304055	52
one-sixth size pan, 6 $\frac{1}{2}$ " x 6 $\frac{1}{2}$ " x 2 $\frac{1}{2}$ " (162 x 175 x 64mm)	304025	43
one-sixth size pan, 6 $\frac{1}{2}$ " x 6 $\frac{1}{2}$ " x 4" (162 x 175 x 102mm)	304026	52
full size lid, with handle	304056	94
half size lid, with handle	304057	51
one-third size lid, with handle	304058	37
one-fourth size lid, with handle	304059	47
one-sixth size lid, with handle	304041	47
10" (254mm) adapter bar	301792	35
12" (305mm) adapter bar	301791	37



food pans

### Stainless Steel Round Insets and Lids

description	model #	list
4-quart inset for 6 $\frac{1}{2}$ " (165mm) opening	304020	89
7-quart inset for 8 $\frac{1}{2}$ " (216mm) opening	304021	136
11-quart inset for 10 $\frac{1}{2}$ " (267mm) opening	304060	142
lid for 4-quart round inset	304018	24
lid for 7-quart round inset	304019	51
lid for 11-quart round inset	304049	51



round inset with optional lid

### Polycarbonate Food Pans & Lids

description	model #	list
one-sixth size pan, 6 $\frac{1}{2}$ " x 6 $\frac{1}{2}$ " x 2 $\frac{1}{2}$ " (162 x 175 x 64mm)	304027	43
one-sixth size pan, 6 $\frac{1}{2}$ " x 6 $\frac{1}{2}$ " x 4" (162 x 175 x 102mm)	304028	52
one-sixth size lid, with handle	304042	52

### Other

description	model #	list
brass drain	305300	71
stopper	303974	29

## Rolltop Cover

see spec sheet **EG30.20B**



description	model #	list
fits over heat well	501585	532

Freight class is 70.0.



### Cooking Line Wall Shelves

see spec sheet **EG02.16**

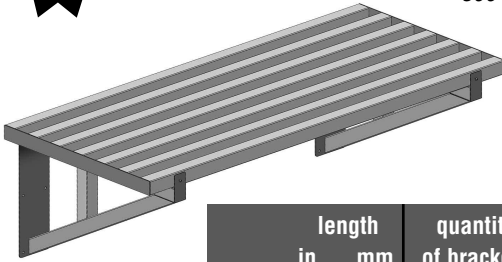

**FEATURES:**

- Consists of one stainless steel shelf and two to four stainless steel brackets, depending on length. Shelves and brackets are all-welded construction.
- 1½" (38mm) square tubing.
- Shelf can be screwed to brackets, or welded.

**Freight class is 70.0.**

	length		quantity of brackets	model #	list
	in.	mm			
<b>18" width (457mm)</b>	48"	1219	2	<b>CLHDWS-1848</b>	3542
	72"	1829	3	<b>CLHDWS-1872</b>	5313
	96"	2438	3	<b>CLHDWS-1896</b>	7083
	120"	3048	4	<b>CLHDWS-18120</b>	8854
	144"	3658	4	<b>CLHDWS-18144</b>	10624

For **Optional Additional 18" Bracket...**  
Model #: **CLHDWS-18B**; List: **\$330**

	length		quantity of brackets	model #	list
	in.	mm			
<b>21" width (533mm)</b>	48"	1219	2	<b>CLHDWS-2148</b>	3728
	72"	1829	3	<b>CLHDWS-2172</b>	5592
	96"	2438	3	<b>CLHDWS-2196</b>	7456
	120"	3048	4	<b>CLHDWS-21120</b>	9320
	144"	3658	4	<b>CLHDWS-21144</b>	11183

For **Optional Additional 21" Bracket...**  
Model #: **CLHDWS-21B**; List: **\$348**

## NOTES

---

---

---

---

---

---

---

---

---

---

---

---

---

---

---

---

---

---

---

---

---

---

---

---

---







## Accessories

1800/2200 Series ..295-296

## Custom Options .....297

### 1800 Series

Blender Modules .....285  
 Cocktail Units .....283  
 Cocktail Workstations.....283  
 Combination Units .....282  
 Glass Rack  
     Storage Units .....285  
 Ice Chests.....284  
 Liquor Display Units.....286  
 Sinks .....281  
 Workboards .....286

### 2200 Series

Blender Modules .....291  
 Cocktail Units .....289

Cocktail Workstations.....289  
 Combination Units .....288  
 Glass Rack  
     Storage Units .....291  
 Ice Chests.....290  
 Liquor Display Units.....292  
 Sinks .....287  
 Workboards .....292

### 1800/2200 Series

Corner Drainboards .....293  
 Modular Angle Fillers ....293  
 Pass-Thru Ice Chests ....295

### Modular Add-On Service Units

Fillers, Storage Units,  
 Workboards .....294  
 Hand Sinks .....293  
 Stepdown Units .....294

## Spec-Bar®

**BLENDER STATIONS .....309**

**COCKTAIL STATIONS .....310**

### ICE CHESTS

Bottle Racks .....299  
 Combination .....300  
 Drop-In.....301  
 Pass-Thru.....301  
 Standard.....299

### MOYER DIEBEL

**GLASSWASHERS .....308**

**PORTABLE BARS .....314**

### SINKS

Four-Compartment .....304  
 Hand Sinks .....302  
 Three-Compartment .....303  
 Two-Compartment .....303  
 Wet Waste Sinks .....304

## WORKBOARDS

Angle .....306  
 Cabinets .....307  
 Corner .....306  
 Recessed .....305  
 Standard.....305

## OTHER SPEC-BAR®

Beer Drainers .....308  
 Beverage Dispensers ....310  
 Dry Waste &  
     Tubing Chases.....311  
 Filler Boards .....307  
 Glass Rack  
 Storage Units .....313  
 Liquor Displays .....311  
 Mini Bottle Racks .....313  
 Modular Bar Die .....301  
 Speed Rails .....312-313

CUSTOM



## EAGLE's Modular Bar Die now available for 1800 Series and 2200 Series underbar equipment.

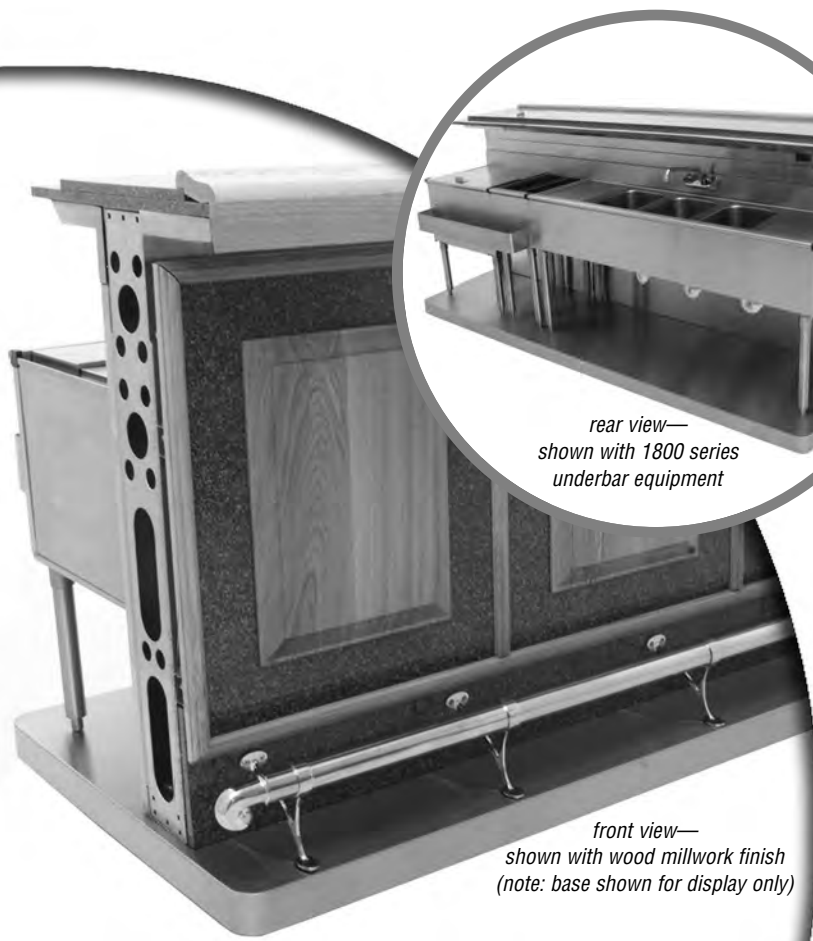

front view—  
 shown with wood millwork finish  
 (note: base shown for display only)

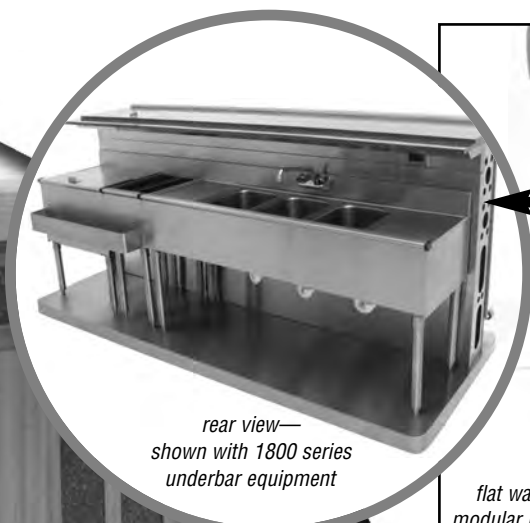

rear view—  
 shown with 1800 series  
 underbar equipment



flat wall style  
 modular bar die

- Underbar equipment can be mounted to, or just placed against, modular bar dies. Bar dies must be securely fastened to the floor. For added stability, fasten one or both ends to a wall.
- Bar dies enclose and hide soda, beer, electrical and plumbing lines in a chase incorporated into the unit.
- The chase serves as a rear wall and splash. Front of the bar can be covered by removable panels that provide easy access to the chase for future modifications and maintenance.
- Panels can be covered in a decorative laminate, an elegant wood millwork finish or a stunning stainless steel finish.
- Add decorative brass or chrome rails and fittings to match any decor.
- Optional factory U.L. wiring and plumbing package.

See page 301  
 for Spec-Bar® Modular Bar Dies.

# What's The Difference Between Better And Best?

*Please note the difference in the chart below, showing our 2200 Series (page 290) and our Spec-Bar® Series ice chests (page 299) as an example.*

## 2200 Series Ice Chest

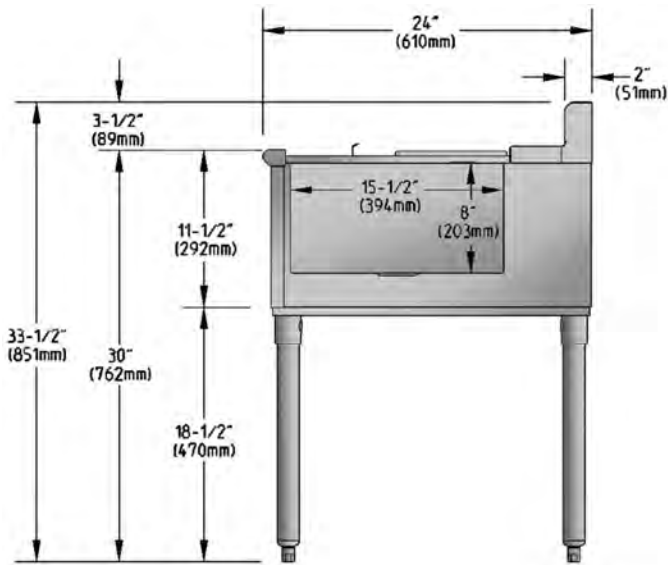

## Spec-Bar® Series Ice Chest

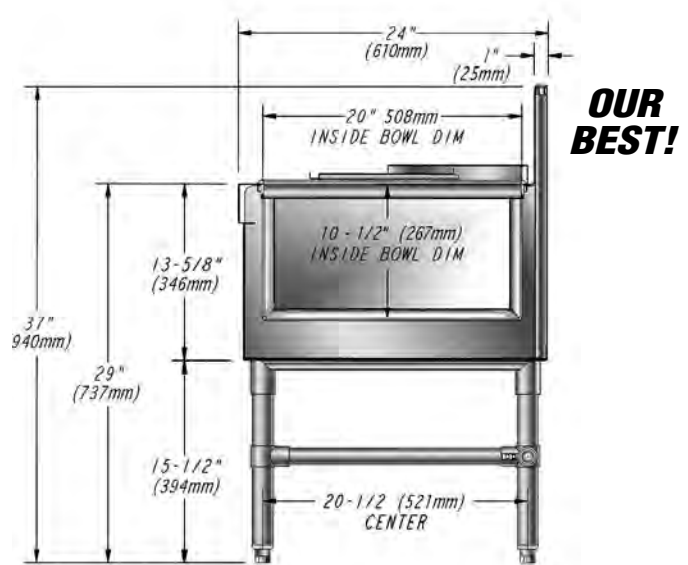

COMPONENTS	MATERIALS USED IN 2200 SERIES ICE CHEST	MATERIALS USED IN SPEC-BAR® ICE CHEST
Front	22 gauge type 304	20 gauge type 304
End panels	22 gauge, galvanized	20 gauge type 304
Ice bin	20 gauge type 304 stainless steel, fabricated stainless steel, with fiberglass insulation	20 gauge type 304 fabricated stainless steel, with foamed-in-place insulation, polymer breaker strip
Sliding lid	20 gauge type 304	20 gauge type 304
Backsplash	22 gauge type 304 stainless steel	20 gauge type 304 stainless steel
Back panel	22 gauge, galvanized	18 gauge, galvanized
Exterior bottom	22 gauge, galvanized	18 gauge type 304 stainless steel
Gussets	zinc plated	stainless steel
Legs	1 1/8" diameter, galvanized	1 1/8" diameter, stainless steel
Crossbraces	n/a	1/4" diameter, adjustable, type 304 stainless steel
Feet	ABS plastic, adjustable	stainless steel, adjustable

**EITHER WAY, YOU CAN'T GO WRONG!**

**Whatever your underbar needs might be, EAGLE will meet those needs.**

**From ice chests to combination units to custom configurations,**

**WE DELIVER!**

## Catalog Section 40

### 1800 Series Underbar Sinks <sup>NSF</sup>

see spec sheet **EG40.07**



model #B5C-18

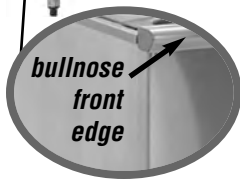

**FEATURES:**

- 20" (508mm) front-to-back.
- 10" x 14" x 10" (254 x 356 x 254mm) bowls.
- 1½" (38mm) drains with standpipes.
- Faucets (four-bowls feature two faucets).

**PACKAGING:**

- Units 8' (2438mm) and longer are wood-crated.

**Freight class is 110.0.**

(•) MTS (made to stock) / ( ) MTO (made to order)

**Note:** Stainless steel leg kits available. See page 296.

**EASY TO ORDER! Leg & Faucet Upgrade Kits**

Stainless steel legs (#305540) and T&S faucet (#313302).

**Example: B3L-2-18-LF.**

4 stainless steel legs and 1 faucet <b>add suffix list</b> "-LF" 918	4 stainless steel legs and 2 faucets <b>add suffix list</b> "-LF" 1625	stainless steel legs <b>add suffix list</b> "-SL" 211 per unit
--	--	--

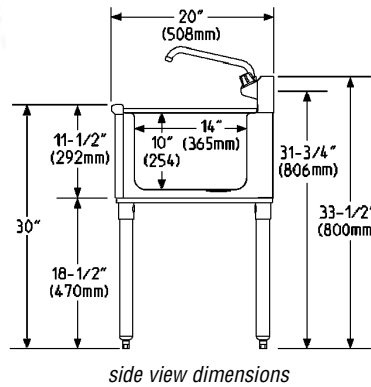

side view dimensions

<b>B3L-2-18</b> list: 1741	<b>B3R-2-18 •</b> list: 1741	<b>B4C-2-18</b> list: 1766	<b>B4L-2-18</b> list: 1766	<b>B4R-2-18</b> list: 1766
----------------------------	------------------------------	----------------------------	----------------------------	----------------------------

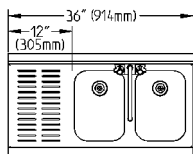

**weight:** 68lbs. 30.8kg  
**cu. ft.:** 10.9

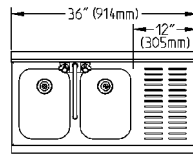

**weight:** 68lbs. 30.8kg  
**cu. ft.:** 10.9

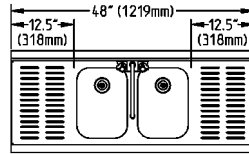

**weight:** 74lbs. 33.6kg  
**cu. ft.:** 14.1

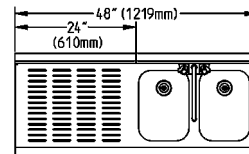

**weight:** 74lbs. 33.6kg  
**cu. ft.:** 14.1

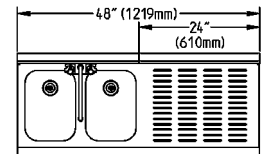

**weight:** 74lbs. 33.6kg  
**cu. ft.:** 14.1

<b>B4L-18 •</b> list: 1985	<b>B4R-18 •</b> list: 1985	<b>B5L-18</b> list: 2043	<b>B5R-18</b> list: 2043	<b>B5C-18 •</b> list: 2043
----------------------------	----------------------------	--------------------------	--------------------------	----------------------------

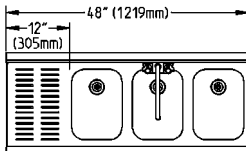

**weight:** 74lbs. 33.6kg  
**cu. ft.:** 14.1

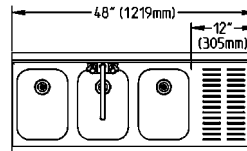

**weight:** 74lbs. 33.6kg  
**cu. ft.:** 14.1

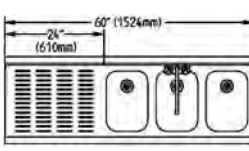

**weight:** 80lbs. 36.3kg  
**cu. ft.:** 17.3

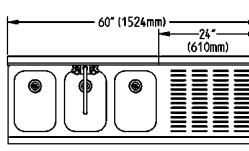

**weight:** 80lbs. 36.3kg  
**cu. ft.:** 17.3

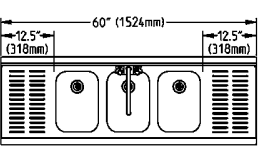

**weight:** 80lbs. 36.3kg  
**cu. ft.:** 17.3

<b>B6C-18 •</b> list: 2159	<b>B7C-18 •</b> list: 2399	<b>B8C-18</b> list: 2624
----------------------------	----------------------------	--------------------------

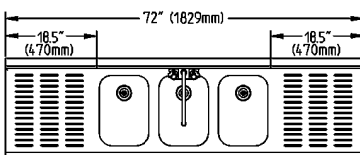

**weight:** 86lbs. 39.0kg **cu. ft.:** 20.2

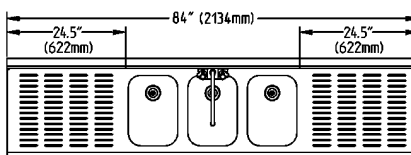

**weight:** 92lbs. 41.7kg **cu. ft.:** 23.7

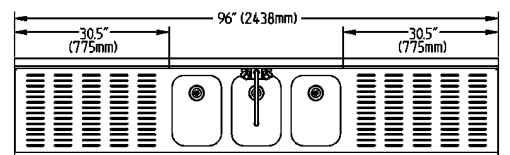

**weight:** 98lbs. 44.5kg **cu. ft.:** 26.9

<b>B6C-4-18 •</b> list: 2546	<b>B7C-4-18 •</b> list: 2712	<b>B8C-4-18 •</b> list: 2949
------------------------------	------------------------------	------------------------------

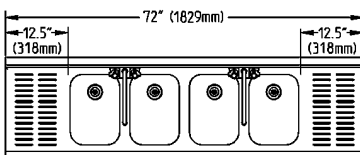

**weight:** 86lbs. 39.0kg **cu. ft.:** 20.5

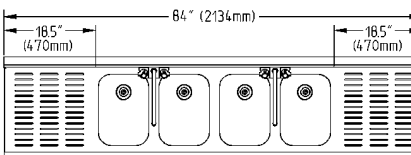

**weight:** 90lbs. 40.8kg **cu. ft.:** 23.7

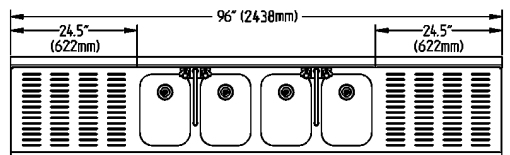

**weight:** 104lbs. 47.2kg **cu. ft.:** 26.9



100 Industrial Boulevard, Clayton, DE 19938-8903 U.S.A.  
Phone: 800-441-8440 or 302-653-3000. Fax: 302-653-2065  
<http://www.eaglegrp.com>

## 1800 Series Combination Units

see spec sheet **EG40.08**

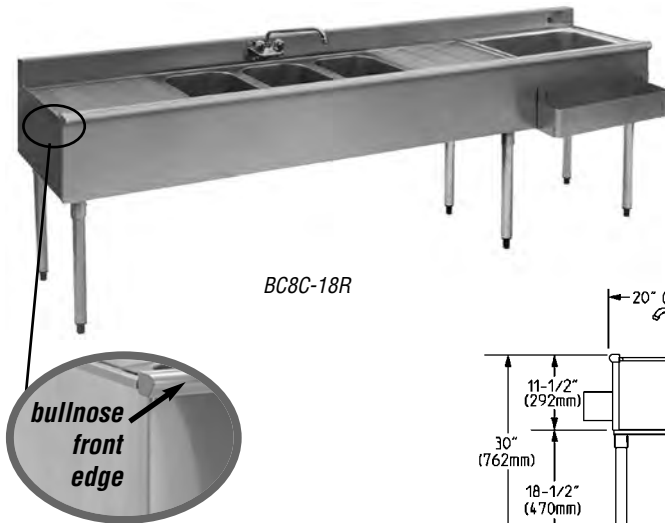

- 10" x 14" x 10" (254 x 356 x 254mm) bowls.
- Six galvanized legs.
- 1½" (38mm) drains with standpipes.
- Fabricated ice bins.
- Speed rail.
- Faucet.
- Front-to-back is 20" (508mm) on all units, excluding speed rail.
- Ice bins are 15½" x 19¾" x 8" (394 x 502 x 203mm) and are located on left or right ends.

**FEATURES:**

**PACKAGING:**

- Units 8' (2438mm) and longer are wood-crated.

**Freight class is 110.0.**

**Note:** All units with cold plate are wood-crated.

**Note:** Stainless steel leg kits available. See page 296.

**EASY TO ORDER! Leg & Faucet Upgrade Kits**

Stainless steel legs (#305540) and T&S faucet (#313302).

Example: **BC9C-18R-LF**.

6 stainless steel legs and 1 faucet

<b>add suffix</b>	<b>list</b>
"-LF"	1021

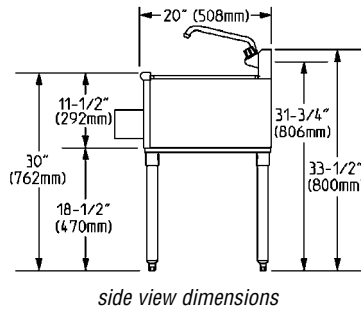

<p><b>BC7C-18R</b> list: 3104</p> <p>weight: 113lbs. 51.3kg cu. ft.: 23.7</p>	<p><b>BC7C-18L</b> list: 3104</p> <p>weight: 113lbs. 51.3kg cu. ft.: 23.7</p>	<p><b>BC8C-18R</b> list: 3214</p> <p>weight: 229lbs. 103.9kg cu. ft.: 25.3</p>
<p><b>BC8C-18L</b> list: 3214</p> <p>weight: 229lbs. 103.9kg cu. ft.: 25.3</p>	<p><b>BC9C-18R</b> list: 3541</p> <p>weight: 239lbs. 108.4kg cu. ft.: 30.0</p>	<p><b>BC9C-18L</b> list: 3541</p> <p>weight: 239lbs. 108.4kg cu. ft.: 30.0</p>
<p><b>BC10C-18L</b> list: 3783</p> <p>weight: 251lbs. 113.9kg cu. ft.: 33.2</p>	<p><b>BC10C-18R</b> list: 3783</p> <p>weight: 251lbs. 113.9kg cu. ft.: 33.2</p>	

### Optional Components for Combination Units

description	add suffix #	list
stainless steel (s/s) legs	-SL	315 per unit
sealed-in post-mix cold plate, 7-circuit	-7	1796

description	add suffix #	list
s/s legs & s/s feet	-SLF	502 per unit
s/s legs & s/s gussets	-SLG	567 per unit
s/s legs, s/s feet & s/s gussets	-SLGF	755 per unit

## Catalog Section 40

### 1800 Series Cocktail Units

see spec sheet **EG40.02**

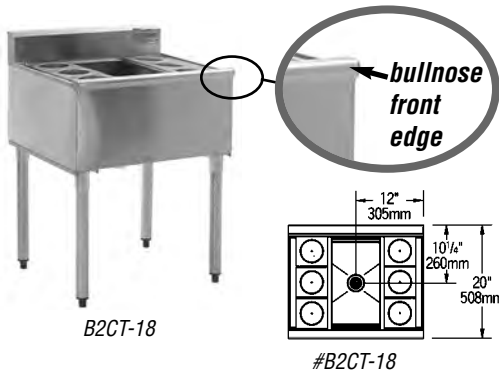

B2CT-18

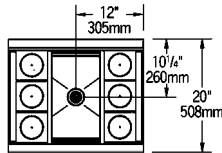

#B2CT-18

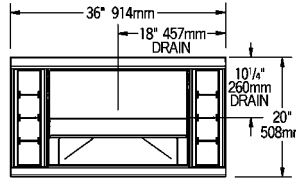

#B3CT-18

- Insulated ice bins.
- 6- or 8-bottle capacity.
- Modular, providing for custom configuration using standard components.
- Fabricated ice bins.
- Front-to-back is 20" (508mm).

**FEATURES:**

**PACKAGING:**

- Units with cold plate are wood-crated.

**Note:** Stainless steel leg kits available. To order, add \$211 per unit (\$315 per unit for models requiring six legs) and suffix "-SL".  
Example: B2CT-18-SL

For more stainless steel leg kits, see page 296.

**Freight class is 110.0.**

(•) MTS (made to stock) / ( ) MTO (made to order)

	without 7-circuit post-mix cold plate				with 7-circuit post-mix cold plate					
	length in. mm	ice bin depth in. mm	ice capacities lbs. kg	cu ft	sh. weight lbs. kg	model #	list	sh. weight lbs. kg	model #	list
20" width (508mm)	24" 610	8" 203	63 28.6	7.8	52 23.6	<b>B2CT-18</b> •	1296	146 66.2	<b>B2CT-18-7</b> •	2895
	24" 610	12" 305	94 42.6	7.8	55 24.9	<b>B2CT-12D-18</b>	1574	149 67.6	<b>B2CT-12D-18-7</b>	3175
	24" 610	16" 406	125 56.7	7.8	58 26.3	<b>B2CT-16D-18</b>	2018	151 68.5	<b>B2CT-16D-18-7</b>	3618
	36" 914	8" 203	63 28.6	11.0	72 32.7	<b>B3CT-18</b> ▽ •	1563	219 99.3	<b>B3CT-18-7</b> ▽ •	3233
	36" 914	12" 305	94 42.6	11.0	75 34.0	<b>B3CT-12D-18</b> ▽	1908	221 100.2	<b>B3CT-12D-18-7</b> ▽	3579
	36" 914	16" 406	125 56.7	11.0	78 35.4	<b>B3CT-16D-18</b> ▽	2458	224 101.6	<b>B3CT-16D-18-7</b> ▽	4128
	36" 914	16" 406	125 56.7	11.0	78 35.4	<b>B3CT-16D-18</b> ▽	2458	224 101.6	<b>B3CT-16D-18-7</b> ▽	4128

▽ includes stainless steel sliding cover

### 1800 Series Cocktail Workstations

see spec sheet **EG40.03**

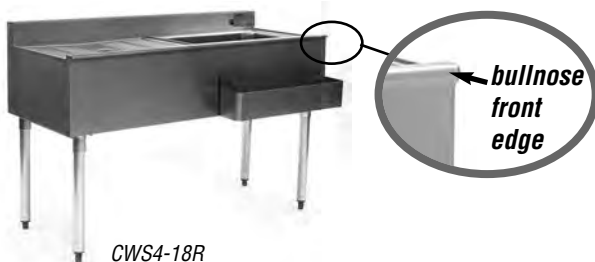

CWS4-18R

- 8" (203mm) deep ice bins can be located on left (L) or right (R) side.
- Single speed rail.
- Modular, providing for custom configuration using standard components.
- Fabricated ice bins.
- Front-to-back is 20" (508mm) excluding speedrail.

**FEATURES:**

**Note:** Stainless steel leg kits available. To order, add \$211 per unit (\$315 per unit for models requiring six legs) and suffix "-SL".  
Example: CWS5-18R-SL

For more stainless steel leg kits, see page 296.

**Freight class is 110.0.**

	length	weight		ice bin depth		cu	model #	list
	in. mm	lbs.	kg	in.	mm	ft		
20" width (508mm)	48" 1219	63	28.6	8" 203	14.1	<b>CWS4-18R</b>	1854	
	48" 1219	93	42.2	8" 203	14.1	<b>CWS4-18R-7</b> *	3520	
	48" 1219	63	28.6	8" 203	14.1	<b>CWS4-18L</b>	1854	
	48" 1219	93	42.2	8" 203	14.1	<b>CWS4-18L-7</b> *	3520	
	60" 1524	73	33.1	8" 203	17.3	<b>CWS5-18R</b>	2055	
	60" 1524	103	46.3	8" 203	17.3	<b>CWS5-18R-7</b> *	4489	
	60" 1524	73	33.1	8" 203	17.3	<b>CWS5-18L</b>	2055	
	60" 1524	103	46.3	8" 203	17.3	<b>CWS5-18L-7</b> *	4489	

\* includes 7-circuit post-mix cold plate and 6 legs

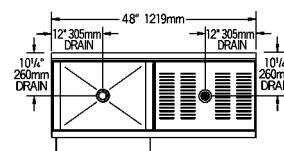

#CWS4-18L

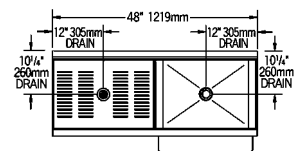

#CWS4-18R

### 1800 Series Ice Chests NSF

see spec sheets **EG40.04A** **EG40.04B**

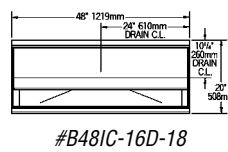
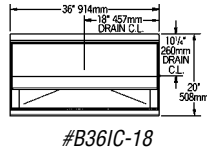
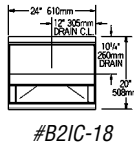
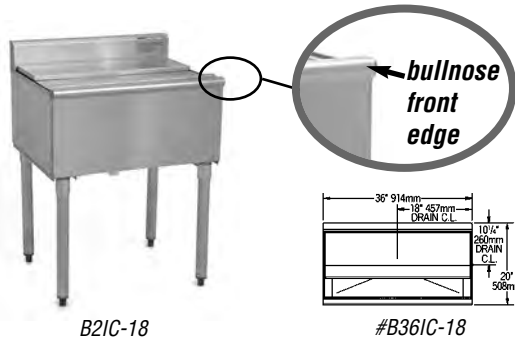

- Stainless steel sliding cover.
- Modular, providing for custom configuration using standard components.
- Fabricated ice bins.
- Front-to-back is 20" (508mm).

**FEATURES:**

**PACKAGING:**

- Units with cold plate are wood-crated.

**Note:** Stainless steel leg kits available.  
To order, add \$211 per unit and suffix "-SL".  
**Example:** B30IC-18-SL

For more stainless steel leg kits, see page 296.

**Freight class is 110.0.**

(•) MTS (made to stock) / ( ) MTO (made to order)

	without 7-circuit post-mix cold plate				with 7-circuit post-mix cold plate										
	length in. mm	ice bin depth in. mm	ice capacity lbs. kg	cu ft	sh. weight lbs. kg	model #	list	sh. weight lbs. kg	model #	list					
20" width (508mm)	12"	305	8"	203	14	6.5	3.9	42	19.1	<b>B12IC-18</b>	1275	n/a	n/a	n/a	
	12"	305	12"	305	22	9.8	3.9	44	20.0	<b>B12IC-12D-18</b>	1492	n/a	n/a	n/a	
	12"	305	16"	406	29	13.0	3.9	46	20.9	<b>B12IC-16D-18</b>	1837	n/a	n/a	n/a	
	18"	457	8"	203	25	11.5	5.8	48	21.8	<b>B18IC-18</b>	1464	n/a	n/a	n/a	
	18"	457	12"	305	38	17.3	5.8	52	23.6	<b>B18IC-12D-18</b>	1712	n/a	n/a	n/a	
	18"	457	16"	406	51	23.1	5.8	58	26.3	<b>B18IC-16D-18</b>	2105	n/a	n/a	n/a	
	24"	610	8"	203	37	16.6	7.8	52	23.6	<b>B2IC-18 •</b>	1657	132	59.9	<b>B2IC-18-7 •</b>	3509
	24"	610	12"	305	55	24.9	7.8	61	27.7	<b>B2IC-12D-18</b>	1938	167	75.8	<b>B2IC-12D-18-7</b>	3791
	24"	610	16"	406	73	33.1	7.8	66	29.9	<b>B2IC-16D-18</b>	2382	175	79.4	<b>B2IC-16D-18-7</b>	4233
	30"	762	8"	203	48	21.6	9.5	60	27.2	<b>B30IC-18</b>	1845	136	61.7	<b>B30IC-18-7</b>	3698
	30"	762	12"	305	71	32.4	9.5	74	33.6	<b>B30IC-12D-18</b>	2161	168	76.2	<b>B30IC-12D-18-7</b>	4014
	30"	762	16"	406	95	43.2	9.5	87	39.5	<b>B30IC-16D-18</b>	2656	193	87.5	<b>B30IC-16D-18-7</b>	4508
	36"	914	8"	203	59	26.6	11.0	74	33.6	<b>B36IC-18 •</b>	2038	152	68.9	<b>B36IC-18-7</b>	3889
	36"	914	12"	305	88	40.0	11.0	95	43.1	<b>B36IC-12D-18</b>	2383	187	84.8	<b>B36IC-12D-18-7</b>	4234
	36"	914	16"	406	117	53.3	11.0	101	45.8	<b>B36IC-16D-18</b>	2933	198	89.8	<b>B36IC-16D-18-7</b>	4784
	42"	1067	8"	203	70	31.7	13.6	71	32.7	<b>B42IC-18</b>	2229	169	76.7	<b>B42IC-18-7</b>	4081
42"	1067	12"	305	105	47.5	13.6	98	44.5	<b>B42IC-12D-18</b>	2608	189	85.7	<b>B42IC-12D-18-7</b>	4461	
42"	1067	16"	406	140	63.4	13.6	104	47.2	<b>B42IC-16D-18</b>	3207	228	103.4	<b>B42IC-16D-18-7</b>	5059	
48"	1219	8"	203	81	36.7	15.5	82	37.2	<b>B48IC-18</b>	2417	211	95.7	<b>B48IC-18-7</b>	4267	
48"	1219	12"	305	121	55.1	15.5	101	45.8	<b>B48IC-12D-18</b>	2827	233	105.7	<b>B48IC-12D-18-7</b>	4679	
48"	1219	16"	406	162	73.5	15.5	113	51.3	<b>B48IC-16D-18</b>	3659	245	111.1	<b>B48IC-16D-18-7</b>	5511	

### Sliding Cover Kits

see spec sheet **EG40.56**

**Freight class is 70.0.**

(•) MTS (made to stock) / ( ) MTO (made to order)

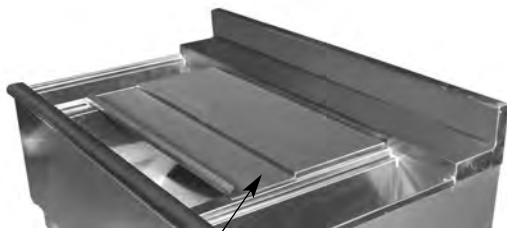

type 304 stainless steel sliding cover

description	model #	list
for 12" (305mm) long ice chests	<b>SC-18/22-12</b>	136
for 18" (457mm) long ice chests	<b>SC-18/22-18</b>	167
for 24" (610mm) long ice chests	<b>SC-18/22-24 •</b>	181
for 28" (711mm) long ice chests	<b>SC-18/22-28</b>	183
for 30" (762mm) long ice chests	<b>SC-18/22-30</b>	206
for 36" (914mm) long ice chests	<b>SC-18/22-36</b>	244
for 42" (1067mm) long ice chests	<b>SC-18/22-42</b>	296
for 48" (1219mm) long ice chests	<b>SC-18/22-48</b>	354

## Catalog Section 40

### 1800 Series Blender Modules (NSF)

see spec sheet **EG40.05**

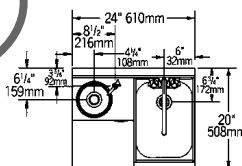
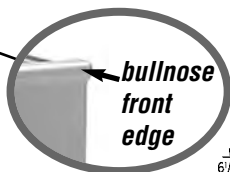

model # **BD24-18L**

- 15A 120V receptacle supplied for field wiring.
- Choose between left- (L) or right-hand (R) models.
- Modular, providing for custom configuration using standard components.
- Stainless steel construction
- Front-to-back is 20" (508mm).

**FEATURES:**

- Units with cold plate are wood-crated.

**PACKAGING:**

**Note:** Stainless steel leg kits available. To order, add \$211 per unit (\$281 per unit for models requiring six legs; \$421 per unit for models requiring eight legs) and suffix "-SL". Example: **BM62-18L-SL**. For more stainless steel leg kits, see page 296.

**Freight class is 100.0.**

(•) MTS (made to stock) / ( ) MTO (made to order)

...with 10" x 14" x 9.5" (254 x 356 x 241mm) Sink

	length		weight		cubic feet	model #	list
	in.	mm	lbs.	kg			
20" width (508mm)	24"	610	40	18.1	7.7	<b>BD24-18R</b>	1952
	24"	610	40	18.1	7.7	<b>BD24-18L</b>	1952

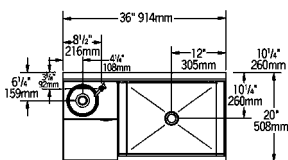

model # **BM3-18L**

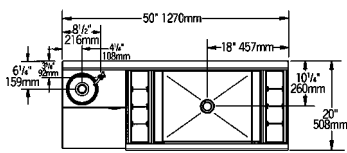

model # **BM50-18L**

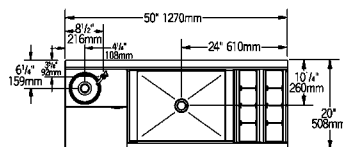

model # **BM50R-18L**

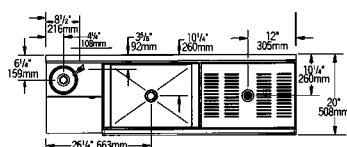

model # **BM62-18L**

...with 15.5" x 19.75" x 8" (394 x 502 x 203mm) Ice Chest

	length		weight		cubic feet	model #	list
	in.	mm	lbs.	kg			
20" width (508mm)	36"	914	67	30.4	10.9	<b>BM3-18R</b>	2147
	36"	914	97	44.0	10.9	<b>BM3-18R-7 *</b>	4601
	36"	914	67	30.4	10.9	<b>BM3-18L</b>	2147
	36"	914	97	44.0	10.9	<b>BM3-18L-7 *</b>	4601
	50"	1270	90	40.8	16.1	<b>BM50-18R **</b>	2913
	50"	1270	120	54.4	16.1	<b>BM50-18R-7 *</b>	5368
	50"	1270	90	40.8	16.1	<b>BM50-18L **</b>	2913
	50"	1270	120	54.4	16.1	<b>BM50-18L-7 *</b>	5368
	50"	1270	90	40.8	16.1	<b>BM50L-18R **</b>	2913
	50"	1270	120	54.4	16.1	<b>BM50L-18R-7 ***</b>	5368
62"	1575	90	40.8	16.1	<b>BM50R-18L **</b>	2913	
50"	1270	120	54.4	16.1	<b>BM50R-18L-7 ***</b>	5368	
62"	1575	110	49.9	19.3	<b>BM62-18R **</b>	3828	
62"	1575	140	63.5	19.3	<b>BM62-18R-7 ***</b>	5496	
62"	1575	110	49.9	19.3	<b>BM62-18L **</b>	3828	
62"	1575	140	63.5	19.3	<b>BM62-18L-7 ***</b>	5496	

\* includes 7-circuit post-mix cold plate and 6 legs

\*\* includes 6 legs

\*\*\* includes 7-circuit post-mix cold plate and 8 legs

### 1800 Series Glass Rack Storage Units (NSF)

see spec sheet **EG40.00**

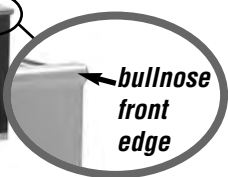

model # **FBGR24-18**



model # **GR24-18**

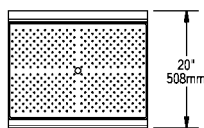

**WBGR24-18**

- Modular, providing for custom configuration using standard components. Stainless steel construction

**FEATURES:**

**Note:** Stainless steel leg kits available. To order, add \$211 per unit and suffix "-SL". Example: **FBGR24-18-SL**

For stainless steel legs with stainless steel feet, add \$336 per unit and suffix "-SLF". Example: **FBGR24-18-SLF**

**Note:** Center shelf available for **WBGR24-18**. To order, add 20% to list price and suffix "-CS". Example: **FBGR24-18-CS**

**Freight class is 100.0.**

width x length in. mm	cu ft	with Flatboard Top				with Recessed Worktop				with Open Top*			
		weight lbs. kg	model #	list	weight lbs. kg	model #	list	weight lbs. kg	model #	list	weight lbs. kg	model #	list
20" x 12" 508 x 305	13.5	18 8.2	<b>FBGR12-18</b>	1476	18 8.2	<b>WBGR12-18</b>	1588	14 6.4	<b>GR12-18</b>	1167			
20" x 18" 508 x 457	15.6	27 12.2	<b>FBGR18-18</b>	1554	27 12.2	<b>WBGR18-18</b>	1669	18 8.2	<b>GR18-18</b>	1227			
20" x 24" 508 x 610	17.7	36 16.3	<b>FBGR24-18</b>	1634	36 16.3	<b>WBGR24-18</b>	1757	27 12.2	<b>GR24-18</b>	1293			

\*19½" (954mm) front-to-back.



100 Industrial Boulevard, Clayton, DE 19938-8903 U.S.A.  
Phone: 800-441-8440 or 302-653-3000. Fax: 302-653-2065  
http://www.eaglegrp.com

## 1800 Series Workboards <sup>NSF</sup>

see spec sheet **EG40.06**

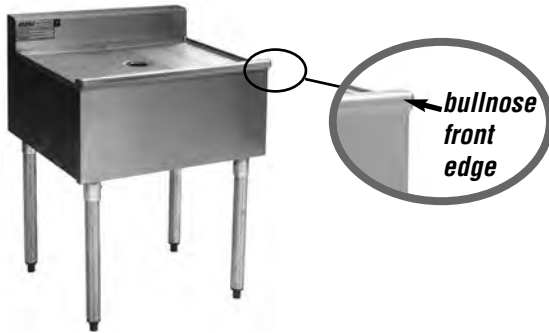

- Embossed drain surface for ease of draining.
- Modular, providing for custom configuration using standard components.
- Stainless steel construction
- Front-to-back is 20" (508mm).

**FEATURES:**

**Note:** Stainless steel leg kits available. To order, add \$211 per unit and suffix "-SL".  
**Example:** WB2-18-SL

For more stainless steel leg kits, see page 296.

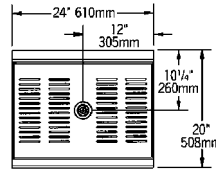

WB2-18

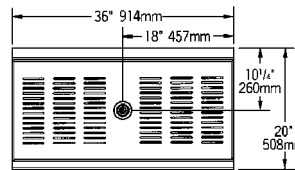

WB3-18

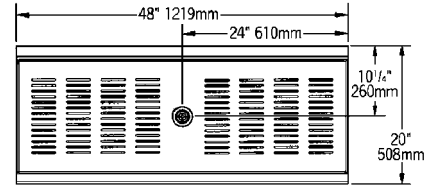

WB4-18

**Freight class is 100.0.**

(•) MTS (made to stock) / ( ) MTO (made to order)

	length		weight		cubic feet	model #	list
	in.	mm	lbs.	kg			
20" width (508mm)	24"	610	26	11.8	7.7	WB2-18 •	940
	36"	914	55	25.0	10.9	WB3-18	1196
	48"	1219	58	26.3	14.1	WB4-18	1472

## 1800 Series Liquor Display Unit <sup>NSF</sup>

see spec sheet **EG40.01**

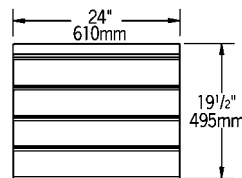

- Nominal 4 3/8" (111mm) wide steps.
- Modular, providing for custom configuration using standard components.
- Stainless steel construction
- Front-to-back is 19 1/2" (495mm).

**FEATURES:**

**Note:** Stainless steel leg kits available. To order, add \$211 per unit and suffix "-SL".  
**Example:** LD24-18-SL

For more stainless steel leg kits, see page 296.

**Freight class is 100.0.**

width x length	weight	cubic	model #	list
19" x 24"	46	7.7	LD24-18	1425

## 1800 Series Lower-Tier Liquor Display Unit <sup>NSF</sup>

see spec sheet **EG40.01**

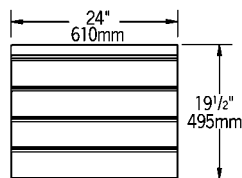

- Steps are lower for more underbar clearance.
- Modular, providing for custom configuration using standard components.
- Stainless steel construction
- Front-to-back is 19 1/2" (495mm).

**FEATURES:**

**Note:** Stainless steel leg kits available. To order, add \$211 per unit and suffix "-SL".  
**Example:** LLD24-18-SL

For more stainless steel leg kits, see page 296.

**Freight class is 100.0.**

width x length	weight	cubic	model #	list
19 1/2" x 24"	46	7.7	LLD24-18	1513



## Catalog Section 40

### 2200 Series Underbar Sinks (NSF)

see spec sheet **EG40.14**

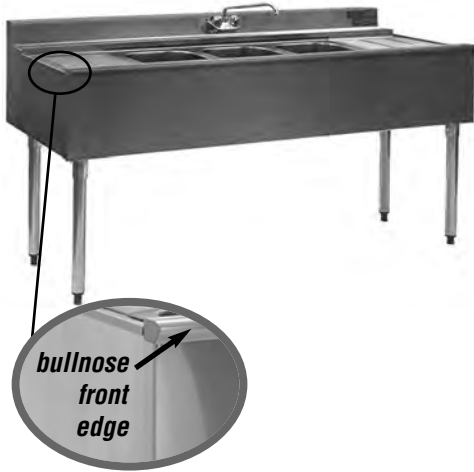

- 10" x 14" x 10" (254 x 356 x 254mm) bowls.
- 1½" (38mm) drains with standpipes.
- 4" (102mm) rear deck.
- Splash mount faucets (four-bowls feature two faucets).
- Front-to-back is 24" (610mm).

**FEATURES:**

**PACKAGING:**

- Units 8' (2438mm) and longer are wood-crated.

**Freight class is 150.0.**

(•) MTS (made to stock) / ( ) MTO (made to order)

**Note:** Stainless steel leg kits available. See page 296.

**EASY TO ORDER! Leg & Faucet Upgrade Kits**

Stainless steel legs (#305540) and T&S faucet (#313302).

Example: B3L-2-22-LF.

4 stainless steel legs and 1 faucet	4 stainless steel legs and 2 faucets	stainless steel legs
<b>add suffix list</b>	<b>add suffix list</b>	<b>add suffix list</b>
"-LF" 918	"-LF" 1625	"-SL" 211
		per unit

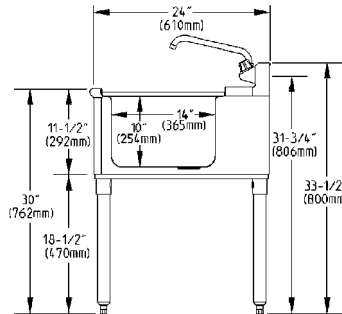

side view dimensions

<b>B3L-2-22</b> list: 1842	<b>B3R-2-22</b> list: 1842	<b>B4C-2-22</b> list: 1895	<b>B4L-2-22</b> list: 1895	<b>B4R-2-22</b> list: 1895
----------------------------	----------------------------	----------------------------	----------------------------	----------------------------

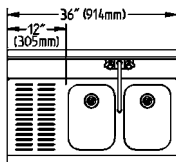

weight: 70 lbs. (31.8kg)  
cu. ft.: 11.9

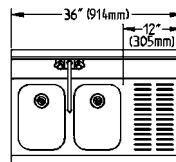

weight: 70 lbs. (31.8kg)  
cu. ft.: 11.9

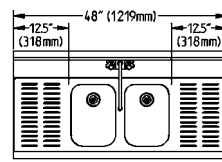

weight: 76lbs. (34.5kg)  
cu. ft.: 16.5

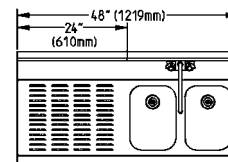

weight: 76lbs. (34.5kg)  
cu. ft.: 16.5

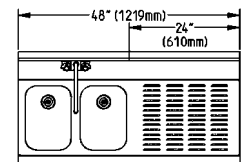

weight: 76lbs. (34.5kg)  
cu. ft.: 16.5

<b>B4L-22</b> list: 2099	<b>B4R-22</b> list: 2099	<b>B5L-22</b> list: 2192	<b>B5R-22</b> list: 2192	<b>B5C-22</b> list: 2192
--------------------------	--------------------------	--------------------------	--------------------------	--------------------------

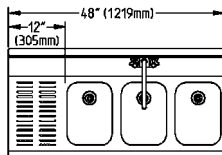

weight: 70 lbs. (31.8kg)  
cu. ft.: 11.9

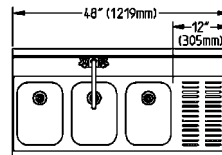

weight: 70 lbs. (31.8kg)  
cu. ft.: 11.9

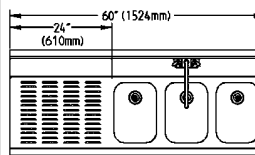

weight: 78lbs. (35.4kg)  
cu. ft.: 20.3

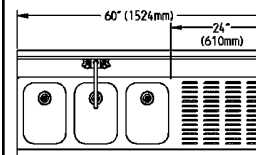

weight: 78lbs. (35.4kg)  
cu. ft.: 20.3

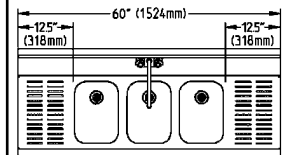

weight: 78lbs. (35.4kg)  
cu. ft.: 20.3

<b>B6C-22</b> list: 2306	<b>B7C-22</b> list: 2565	<b>B8C-22</b> list: 2815
--------------------------	--------------------------	--------------------------

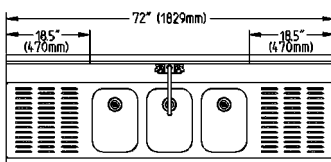

weight: 93 lbs. (42.2kg) cu. ft.: 24.0

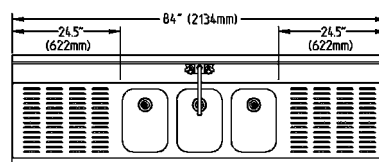

weight: 100 lbs. (45.4kg) cu. ft.: 27.8

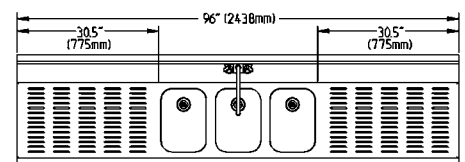

weight: 118 lbs. (53.5kg) cu. ft.: 31.5

<b>B6C-4-22</b> list: 2715	<b>B7C-4-22</b> list: 2902	<b>B8C-4-22</b> list: 3141
----------------------------	----------------------------	----------------------------

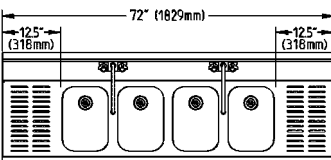

weight: 100 lbs. (45.4kg) cu. ft.: 24.0

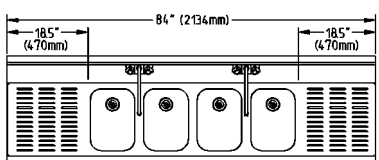

weight: 113 lbs. (51.3kg) cu. ft.: 27.8

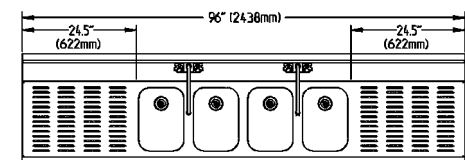

weight: 123 lbs. (55.8kg) cu. ft.: 31.5



100 Industrial Boulevard, Clayton, DE 19938-8903 U.S.A.  
Phone: 800-441-8440 or 302-653-3000. Fax: 302-653-2065  
http://www.eaglegrp.com

### 2200 Series Combination Units

see spec sheet **EG40.15**



model # BC8C-22R

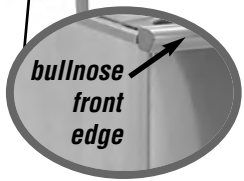

- 10" x 14" x 10" (254 x 356 x 254mm) bowls.
- Speed rail, faucet (4-bowl units feature two faucets), and fabricated ice bins.
- 1½" (38mm) drains with standpipes.
- Front-to-back is 24" (610mm) on all units.
- Ice bins are 15½" x 19¾" x 8" (394 x 502 x 203mm) and are located on left, right or both ends.

**FEATURES:**

**PACKAGING:**

- Units 8' (2438mm) and longer are wood-crated.

**Freight class is 110.0.**

**EASY TO ORDER! Leg & Faucet Upgrade Kits**

Stainless steel legs (#305540) and T&S faucet (#313302). Example: BC8C-22L-LF

6 stainless steel legs and 1 faucet <b>add suffix list</b> "-LF" 1021	8 stainless steel legs and 1 faucet <b>add suffix list</b> "-LF" 1127	6 stainless steel legs and 2 faucets <b>add suffix list</b> "-LF" 1729	8 stainless steel legs and 2 faucets <b>add suffix list</b> "-LF" 1836
---	---	--	--

<b>BC7C-22R list: 3317</b>  <b>weight:</b> 121 lbs. (54.9 kg) <b>cu. ft.:</b> 27.8	<b>BC7C-22L list: 3317</b>  <b>weight:</b> 121 lbs. (54.9 kg) <b>cu. ft.:</b> 27.8	<b>BC8C-22R list: 3428</b>  <b>weight:</b> 132 lbs. (59.9 kg) <b>cu. ft.:</b> 31.5	<b>BC8C-22L list: 3428</b>  <b>weight:</b> 132 lbs. (59.9 kg) <b>cu. ft.:</b> 31.5	<b>BC8-4C-22R list: 3920</b>  <b>weight:</b> 205 lbs. (93.0 kg) <b>cu. ft.:</b> 31.5
<b>BC8-4C-22L list: 3920</b>  <b>weight:</b> 205 lbs. (93.0 kg) <b>cu. ft.:</b> 31.5	<b>BC9C-22R list: 3757</b>  <b>weight:</b> 177 lbs. (80.3 kg) <b>cu. ft.:</b> 35.3	<b>BC9C-22L list: 3757</b>  <b>weight:</b> 177 lbs. (80.3 kg) <b>cu. ft.:</b> 35.3	<b>BC9C-22 R&amp;L list: 4543</b>  <b>weight:</b> 208 lbs. (94.3 kg) <b>cu. ft.:</b> 35.3	<b>BC9-4C-22R list: 4088</b>  <b>weight:</b> 215 lbs. (97.5 kg) <b>cu. ft.:</b> 35.3
<b>BC9-4C-22L list: 4088</b>  <b>weight:</b> 215 lbs. (97.5 kg) <b>cu. ft.:</b> 35.3	<b>BC10C-22R list: 4005</b>  <b>weight:</b> 211 lbs. (95.7 kg) <b>cu. ft.:</b> 39.0	<b>BC10C-22L list: 4005</b>  <b>weight:</b> 211 lbs. (95.7 kg) <b>cu. ft.:</b> 39.0	<b>BC10C-22 R&amp;L list: 4665</b>  <b>weight:</b> 211 lbs. (95.7 kg) <b>cu. ft.:</b> 39.0	<b>BC10-4C-22 R&amp;L list: 5085</b>  <b>weight:</b> 235 lbs. (106.6 kg) <b>cu. ft.:</b> 39.0

### Optional Components for Combination Units

description	add suffix #	list	description	add suffix #	list
6 stainless steel (s/s) legs	-SL	315 per unit	6 s/s legs & s/s feet	-SLF	502 per unit
8 s/s legs (for models with suffix "R&L")	-SL	421 per unit	8 s/s legs & s/s feet	-SLF	671 per unit
sealed-in post-mix cold plate, 7-circuit (on "R&L" models, 2 are required)	"-7"	1706	6 s/s legs & s/s gussets	-SLG	567 per unit
			8 s/s legs & s/s gussets	-SLG	757 per unit
			6 s/s legs, s/s feet & s/s gussets	-SLGF	755 per unit
			8 s/s legs, s/s feet & s/s gussets	-SLGF	1007 per unit

## Catalog Section 40

### 2200 Series Cocktail Units NSF

see spec sheet **EG40.09**

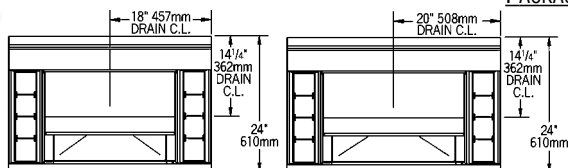

#B3CT-22

#B40CT-22

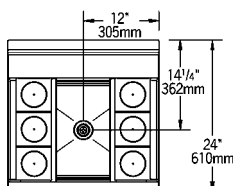

#B2CT-22

					without cold plate				with 7-circuit post-mix cold plate					
	length		ice bin depth	ice capacities	cu	sh. weight			sh. weight					
	in.	mm	in.	lbs.	kg	ft	lbs.	kg	model #	list	lbs.	kg	model #	list
20" width (508mm)	24"	610	8"	63	28.6	7.8	56	25.4	<b>B2CT-22</b> *	1296	133	60.3	<b>B2CT-22-7</b> *	2895
	24"	610	12"	94	42.6	7.8	59	26.8	<b>B2CT-12D-22</b>	1574	137	62.1	<b>B2CT-12D-22-7</b>	3175
	24"	610	16"	125	56.7	7.8	61	27.7	<b>B2CT-16D-22</b>	2018	141	64.0	<b>B2CT-16D-22-7</b>	3618
	36"	914	8"	63	28.6	11.0	71	32.2	<b>B3CT-22</b> *	1563	153	69.4	<b>B3CT-22-7</b> *	3233
	36"	914	12"	94	42.6	11.0	75	34.0	<b>B3CT-12D-22</b> *	1908	159	72.1	<b>B3CT-12D-22-7</b> *	3579
	36"	914	16"	125	56.7	11.0	78	35.4	<b>B3CT-16D-22</b> *	2458	163	73.9	<b>B3CT-16D-22-7</b> *	4128
	40"	1016	8"	74	33.6	11.0	88	39.9	<b>B40CT-22</b> *	2472	173	78.3	<b>B40CT-22-7</b> *	5234
	40"	1016	12"	110	49.9	11.0	92	41.7	<b>B40CT-12D-22</b> *	2817	177	80.3	<b>B40CT-12D-22-7</b> *	4484
	40"	1016	16"	146	66.2	11.0	95	43.1	<b>B40CT-16D-22</b> *	3366	181	82.1	<b>B40CT-16D-22-7</b> *	5034

▼ includes stainless steel sliding cover

- Insulated 8" (203mm) deep ice bins.
- 5" (127mm) backsplash.
- 6- or 8-bottle capacity.
- Modular, providing for custom configuration using standard components.
- Fabricated ice bins.
- Front-to-back is 24" (610mm).

**FEATURES:**

- Units with cold plate are wood-crated.

**PACKAGING:**

**Note:** Stainless steel leg kits available. To order, add \$211 per unit and suffix "-SL".  
**Example:** B2CT-22-SL

For more stainless steel leg kits, see page 296.

**Freight class is 110.0.**

(•) MTS (made to stock) / ( ) MTO (made to order)

### 2200 Series Cocktail Workstations NSF

see spec sheet **EG40.10**

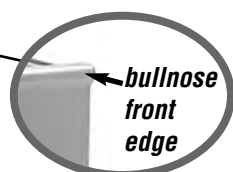

CWS4-22L

- 24" (610mm) fabricated ice bins can be located on left (L) or right (R) side.
- Single speed rail.
- Modular, providing for custom configuration using standard components.
- Front-to-back is 24" (610mm), excluding speedrail.

**FEATURES:**

- Units with cold plate are wood-crated.

**PACKAGING:**

**Note:** Stainless steel leg kits available. To order, add \$211 per unit (\$315 per unit for models requiring six legs) and suffix "-SL".  
**Example:** CWS4-22R-SL

For more stainless steel leg kits, see page 296.

**Freight class is 110.0.**

	length		weight		ice bin depth		cu	model #	list
	in.	mm	lbs.	kg	in.	mm	ft		
24" width (610mm)	48"	1219	65	29.5	8"	203	16.5	<b>CWS4-22R</b>	1978
	48"	1219	95	43.1	8"	203	16.5	<b>CWS4-22R-7</b> *	3646
	48"	1219	65	29.5	8"	203	16.5	<b>CWS4-22L</b>	1978
	48"	1219	95	43.1	8"	203	16.5	<b>CWS4-22L-7</b> *	3646
	60"	1524	75	34.0	8"	203	20.3	<b>CWS5-22R</b>	2251
	60"	1524	105	47.6	8"	203	20.3	<b>CWS5-22R-7</b> *	4513
	60"	1524	75	34.0	8"	203	20.3	<b>CWS5-22L</b>	2251
	60"	1524	105	47.6	8"	203	20.3	<b>CWS5-22L-7</b> *	4513

\* includes 7-circuit post-mix cold plate and 6 legs

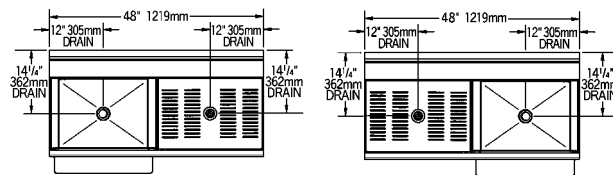

#CWS4-22L

#CWS4-22R

### 2200 Series Ice Chests NSF

see spec sheets **EG40.11A** **EG40.11B**

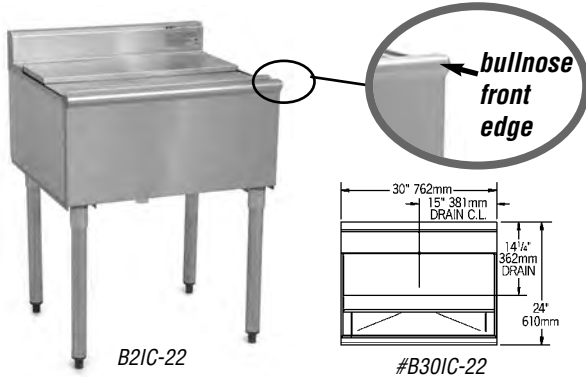

- Stainless steel sliding cover.
- Ice bins are fabricated.
- Modular, providing for custom configuration using standard components.
- Front-to-back is 24" (610mm).

**FEATURES:**

**PACKAGING:**

- Units with cold plate are wood-crated.

**Note:** Stainless steel leg kits available. To order, add \$211 per unit and suffix "-SL".  
**Example:** B30IC-22-SL

For more stainless steel leg kits, see page 296.

**Freight class is 110.0.**

(•) MTS (made to stock) / ( ) MTO (made to order)

length in. mm	ice bin depth in. mm	ice capacity lbs. kg	cu ft	without 7-circuit post-mix cold plate				with 7-circuit post-mix cold plate					
				sh. weight lbs.	kg	model #	list	sh. weight lbs.	kg	model #	list		
12"	305	8"	203	25	11.3	3.9	44	20.0	<b>B12IC-22</b>	1275	n/a	n/a	n/a
12"	305	12"	305	37	16.8	3.9	46	20.9	<b>B12IC-12D-22</b>	1492	n/a	n/a	n/a
12"	305	16"	406	49	22.2	3.9	51	23.1	<b>B12IC-16D-22</b>	1837	n/a	n/a	n/a
18"	457	8"	203	44	20.0	5.8	53	24.0	<b>B18IC-22</b>	1464	n/a	n/a	n/a
18"	457	12"	305	65	29.5	5.8	98	44.5	<b>B18IC-12D-22</b>	1712	n/a	n/a	n/a
18"	457	16"	406	87	39.5	5.8	64	29.0	<b>B18IC-16D-22</b>	2105	n/a	n/a	n/a
24"	610	8"	203	63	28.6	7.8	149	67.6	<b>B24IC-22 •</b>	1657	185	83.9	<b>B24IC-22-7 •</b> 3509
24"	610	12"	305	94	42.6	7.8	159	72.1	<b>B24IC-12D-22</b>	1938	195	88.4	<b>B24IC-12D-22-7</b> 3791
24"	610	16"	406	125	56.7	7.8	169	76.7	<b>B24IC-16D-22</b>	2382	205	93.0	<b>B24IC-16D-22-7</b> 4233
28"	711	8"	203	75	34.0	11.0	159	72.1	<b>B28IC-22</b>	1557	195	88.5	<b>B28IC-22-7</b> 3509
30"	762	8"	203	82	37.2	9.5	169	76.7	<b>B30IC-22</b>	1845	205	93.0	<b>B30IC-22-7</b> 3698
30"	762	12"	305	123	55.8	9.5	179	81.2	<b>B30IC-12D-22</b>	2161	215	97.5	<b>B30IC-12D-22-7</b> 4014
30"	762	16"	406	163	73.9	9.5	189	85.7	<b>B30IC-16D-22</b>	2656	225	102.1	<b>B30IC-16D-22-7</b> 4508
36"	914	8"	203	101	45.8	11.0	176	79.8	<b>B36IC-22 •</b>	2038	213	96.6	<b>B36IC-22-7</b> 3889
36"	914	12"	305	151	68.5	11.0	186	84.4	<b>B36IC-12D-22</b>	2383	221	100.2	<b>B36IC-12D-22-7</b> 4234
36"	914	16"	406	201	91.2	11.0	196	88.9	<b>B36IC-16D-22</b>	2933	231	104.8	<b>B36IC-16D-22-7</b> 4784
42"	1067	8"	203	120	54.4	13.6	205	93.0	<b>B42IC-22</b>	2229	241	109.3	<b>B42IC-22-7</b> 4081
42"	1067	12"	305	180	81.6	13.6	214	97.0	<b>B42IC-12D-22</b>	2608	251	113.9	<b>B42IC-12D-22-7</b> 4461
42"	1067	16"	406	239	108.4	13.6	225	102.1	<b>B42IC-16D-22</b>	3207	261	118.4	<b>B42IC-16D-22-7</b> 5059
48"	1219	8"	203	139	63.1	15.5	215	97.5	<b>B48IC-22</b>	2417	251	113.9	<b>B48IC-22-7</b> 4267
48"	1219	12"	305	208	94.3	15.5	224	101.6	<b>B48IC-12D-22</b>	2827	261	118.4	<b>B48IC-12D-22-7</b> 4679
48"	1219	16"	406	278	126.1	15.5	235	106.6	<b>B48IC-16D-22</b>	3659	271	122.9	<b>B48IC-16D-22-7</b> 5511

### Sliding Cover Kits

see spec sheet **EG40.56**

**Freight class is 70.0.**

(•) MTS (made to stock) / ( ) MTO (made to order)

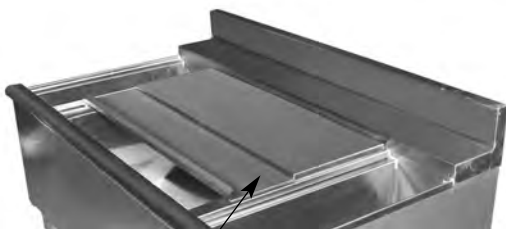

Type 304 stainless steel sliding cover

description	model #	list
for 12" (305mm) long ice chests	<b>SC-18/22-12</b>	136
for 18" (457mm) long ice chests	<b>SC-18/22-18</b>	167
for 24" (610mm) long ice chests	<b>SC-18/22-24 •</b>	181
for 28" (711mm) long ice chests	<b>SC-18/22-28</b>	183
for 30" (762mm) long ice chests	<b>SC-18/22-30</b>	206
for 36" (914mm) long ice chests	<b>SC-18/22-36</b>	244
for 42" (1067mm) long ice chests	<b>SC-18/22-42</b>	296
for 48" (1219mm) long ice chests	<b>SC-18/22-48</b>	354

## Catalog Section 40

### 2200 Series Blender Modules <sup>(NSF)</sup>

see spec sheet **EG40.12**

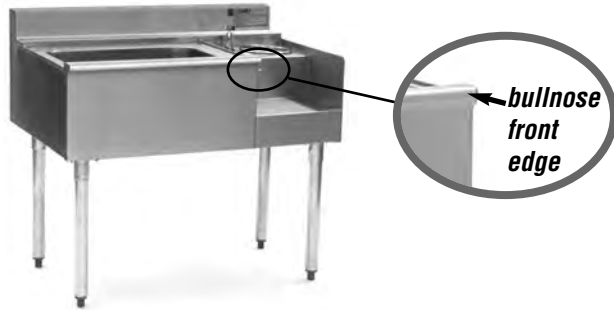

...with 10" x 14" x 9.5" (254 x 356 x 241mm) Sink

	length		weight		cubic feet	model #	list
	in.	mm	lbs.	kg			
<b>24" width (610mm)</b>	24"	610	44	20.0	9.1	<b>BD24-22R</b>	2242
	24"	610	44	20.0	9.1	<b>BD24-22L</b>	2242

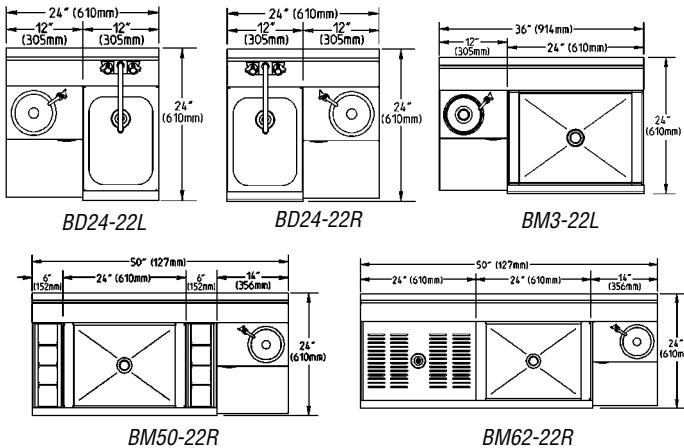

...with 15.5" x 19.75" x 8" (394 x 502 x 203mm) Ice Chest

	length		weight		cubic feet	model #	list
	in.	mm	lbs.	kg			
<b>24" width (610mm)</b>	36"	914	69	31.3	12.8	<b>BM3-22R</b>	2405
	36"	914	99	44.9	12.8	<b>BM3-22R-7 *</b>	5035
	36"	914	69	31.3	12.8	<b>BM3-22L</b>	2405
	36"	914	99	44.9	12.8	<b>BM3-22L-7 *</b>	5035
	50"	1270	96	43.6	18.5	<b>BM50-22R **</b>	3357
	50"	1270	126	57.2	18.5	<b>BM50-22R-7 *</b>	5527
	50"	1270	96	43.6	18.5	<b>BM50-22L **</b>	3357
	50"	1270	126	57.2	18.5	<b>BM50-22L-7 *</b>	5527
	50"	1270	96	43.6	18.5	<b>BM50L-22R **</b>	3357
	50"	1270	126	57.2	18.5	<b>BM50L-22R-7 ***</b>	5527
	50"	1270	96	43.6	18.5	<b>BM50R-22L **</b>	3357
	50"	1270	126	57.2	18.5	<b>BM50R-22L-7 ***</b>	5527
62"	1575	110	49.9	22.3	<b>BM62-22R **</b>	4069	
62"	1575	146	66.2	22.3	<b>BM62-22R-7 ***</b>	5740	
62"	1575	110	49.9	22.3	<b>BM62-22L **</b>	4069	
62"	1575	146	66.2	22.3	<b>BM62-22L-7 ***</b>	5740	

\* includes 7-circuit post-mix cold plate and 6 legs

\*\* includes 6 legs

\*\*\* includes 7-circuit post-mix cold plate and 8 legs

### 2200 Series Glass Rack Storage Units <sup>(NSF)</sup>

see spec sheet **EG40.21**

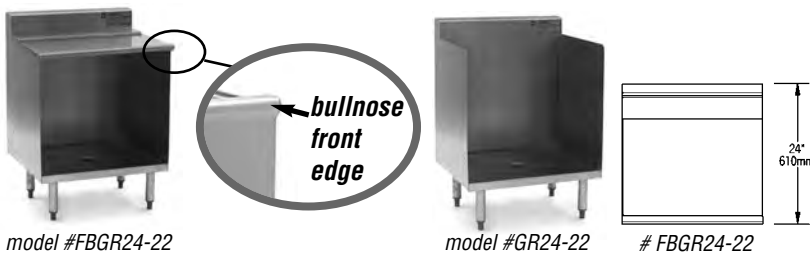

model #FBGR24-22

model #GR24-22

# FBGR24-22

- FEATURES:**
- Modular, providing for custom configuration using standard components.
  - Stainless steel construction.

**Note:** Stainless steel leg kits available. To order, add \$211 per unit and suffix "-SL". Example: WBGR24-22-SL

For stainless steel legs with stainless steel feet, add \$315 per unit and suffix "-SLF". Example: WBGR24-22-SLF

**Note:** Center shelf available for WBGR24-18. To order, add 20% to list price and suffix "-CS". Example: WBGR24-22-CS

**Freight class is 100.0.**

width x length in. mm	cu ft	with Flatboard Top				with Recessed Worktop				with Open Top*			
		weight lbs.	kg	model #	list	weight lbs.	kg	model #	list	weight lbs.	kg	model #	list
24" x 12" 610 x 305	13.5	39	17.6	<b>FBGR12-22</b>	1476	39	17.6	<b>WBGR12-22</b>	1588	36	16.5	<b>GR12-22</b>	1167
24" x 18" 610 x 457	15.6	53	24.0	<b>FBGR18-22</b>	1554	53	24.0	<b>WBGR18-22</b>	1669	47	21.3	<b>GR18-22</b>	1227
24" x 24" 610 x 610	17.7	67	30.4	<b>FBGR24-22</b>	1634	67	30.4	<b>WBGR24-22</b>	1757	41	18.6	<b>GR24-22</b>	1293

\*23 1/2" (597mm) front-to-back.

## 2200 Series Workboards <sup>(NSF)</sup>

see spec sheet **EG40.13**



- Embossed drain surface for ease of draining.
- Modular, providing for custom configuration using standard components.
- Stainless steel construction
- Front-to-back is 24" (610mm).

**FEATURES:**

**Note:** Stainless steel leg kits available. To order, add \$211 per unit (\$315 per unit for models requiring six legs; \$421 per unit for models requiring eight legs) and suffix "-SL". Example: WB2-22-SL

For more stainless steel leg kits, see page 296.

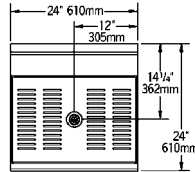

WB2-22

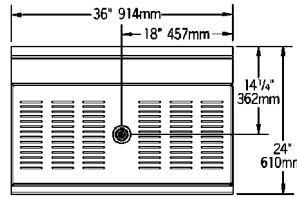

WB3-22

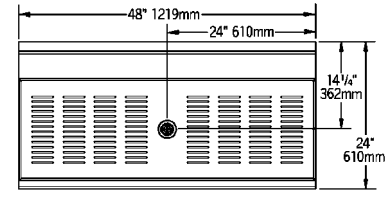

WB4-22

**Freight class is 110.0.**

	length		weight		cubic feet	model #	list
	in.	mm	lbs.	kg			
<b>24"</b>	24"	610	27	12.2	9.1	<b>WB2-22</b>	1001
<b>width</b>	36"	914	56	25.4	12.8	<b>WB3-22</b>	1267
(610mm)	48"	1219	58	26.3	14.1	<b>WB4-22</b>	1563

## 2200 Series Liquor Display Unit <sup>(NSF)</sup>

see spec sheet **EG40.22**

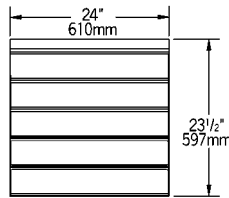

- Nominal 4" (102mm) wide steps.
- Modular, providing for custom configuration using standard components.
- Stainless steel construction
- Front-to-back is 23½" (597mm).

**FEATURES:**

**Note:** Stainless steel leg kits available. To order, add \$211 per unit (\$315 per unit for models requiring six legs; \$421 per unit for models requiring eight legs) and suffix "-SL". Example: LD24-22-SL

For more stainless steel leg kits, see page 296.

**Freight class is 110.0.**

width x length	weight		cubic feet	model #	list
in. mm	lbs.	kg			
23½" x 24"	48	21.8	9.1	<b>LD24-22</b>	1508

## 2200 Series Lower-Tier Liquor Display Unit <sup>(NSF)</sup>

see spec sheet **EG40.22**

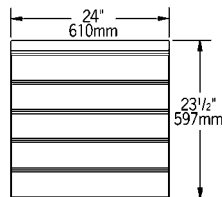

- Steps are lower for more underbar clearance.
- Modular, providing for custom configuration using standard components.
- Stainless steel construction
- Front-to-back is 23½" (597mm).

**FEATURES:**

**Note:** Stainless steel leg kits available. To order, add \$211 per unit (\$315 per unit for models requiring six legs; \$421 per unit for models requiring eight legs) and suffix "-SL". Example: LLD24-22-SL

For more stainless steel leg kits, see page 296.

**Freight class is 110.0.**

width x length	weight		cubic feet	model #	list
in. mm	lbs.	kg			
23½" x 24"	48	21.8	7.7	<b>LLD24-22</b>	1652

## Catalog Section 40

### Modular Angle Fillers

see spec sheets **EG40.57** **EG40.58**

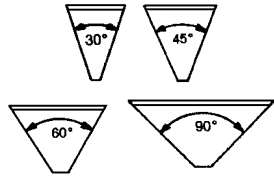

rear filler angles



rear angle filler

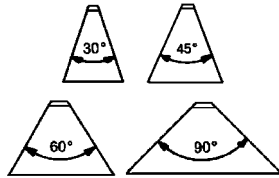

front filler angles



front angle filler

- Joins two 1800 or 2200 units by the corners.
- Front and rear fillers available in angles of 30°, 45°, 60°, and 90°.

FEATURES:

**Freight class is 100.0.**

description	weight		cubic feet	FRONT		REAR	
	lbs.	kg		model #	list	model #	list
30° angle	15	6.8	2.7	<b>MF30-18</b>	819	<b>MR30-18</b>	819
	16	7.3	2.9	<b>MF30-22</b>	853	<b>MR30-22</b>	853
45° angle	16	7.3	2.8	<b>MF45-18</b>	819	<b>MR45-18</b>	819
	17	7.7	3.0	<b>MF45-22</b>	853	<b>MR45-22</b>	853
60° angle	19	8.6	3.2	<b>MF60-18</b>	819	<b>MR60-18</b>	819
	20	9.0	3.5	<b>MF60-22</b>	853	<b>MR60-22</b>	853
90° angle	21	9.5	3.9	<b>MF90-18</b>	819	<b>MR90-18</b>	819
	22	10.0	4.2	<b>MF90-22</b>	853	<b>MR90-22</b>	853

Suffix “-18” indicates angle fillers that fit 1800 series units.  
Suffix “-22” indicates angle fillers that fit 2200 series units.

### Corner Drainboards

see spec sheets **EG40.57** **EG40.58**



front corner drainboard



rear corner drainboard

weight lbs.	kg	cubic feet	FRONT		REAR	
			model #	list	model #	list
37	16.8	3.7	<b>MFC-18</b>	1054	<b>MRC-18</b>	1054
42	19.1	4.2	<b>MFC-22</b>	1054	<b>MRC-22</b>	1054

Suffix “-18” indicates corner drainboards that fit 1800 series units.  
Suffix “-22” indicates corner drainboards that fit 2200 series units.

FEATURES:

- Joins two 1800 or 2200 units by the corners.
- Rear corner drainboards come with one 1/8" (41mm) leg.
- All units have predrilled mounting holes.

**Freight class is 100.0.**

### Modular Add-On Service Units— Hand Sinks (NSF)

see spec sheet **EG40.59**



model # MA2-18

**bullnose front edge**

FEATURES:

- Predrilled mounting holes.
- Standard faucets.
- Basket drain.
- Tubular legs.

**Note:** Stainless steel leg kits available.  
To order, add \$211 and suffix “-SL”.  
Example: MA2-22-SL

For more stainless steel leg kits, see page 296.

**Freight class is 110.0.**

(•) MTS (made to stock) / ( ) MTO (made to order)

description	width x length		weight		cu ft	model #	list
	in.	mm	lbs.	kg			
hand sink	20" x 12"	508 x 305	26	11.8	6.4	<b>MA2-18</b> •	843
	24" x 12"	610 x 305	34	15.4			

Suffix “-18” indicate modular add-on fits 1800 series units.  
Suffix “-22” indicate modular add-on fits 2200 series units.

## Modular Add-On Service Units— Stepdown Units

see spec sheets **EG40.60A** **EG40.60B**



single



double



liquid waste



sink

- Predrilled mounting holes.
- 120-volt 20-amp GFCI duplex receptacle.
- Standard faucet on #MA4's and MA7's.
- Faucet and 1½" NPS drain on #MA7's.
- Tubular legs.

**FEATURES:**

**Note:** Stainless steel leg kits available. To order, add \$211 and suffix "-SL". Example: MA1-22-SL

For more stainless steel leg kits, see page 296.

**Freight class is 110.0.**

(•) MTS (made to stock) / ( ) MTO (made to order)

description	width x length		weight		cu ft	model #	list
	in.	mm	lbs.	kg			
single step-down units	19½" x 12"	495 x 305	15	6.8	6.4	<b>MA1-18</b>	708
	23½" x 12"	597 x 305	16	7.3	6.4	<b>MA1-22</b>	752
liquid waste step-down units	19½" x 12"	495 x 305	17	7.7	6.4	<b>MA4-18</b>	881
	23½" x 12"	597 x 305	21	9.5	6.4	<b>MA4-22</b>	931
double step-down units	19½" x 18"	495 x 457	20	9.0	3.3	<b>MA6-18</b>	667
	23½" x 18"	597 x 457	22	10.1	3.5	<b>MA6-22</b>	707
sink, step-down units	19½" x 18"	495 x 457	35	15.9	3.3	<b>MA7-18</b> •	1095
	23½" x 18"	597 x 457	37	16.8	3.5	<b>MA7-22</b> •	1127

Suffix "-18" indicate modular add-ons that fit 1800 series units.

Suffix "-22" indicate modular add-ons that fit 2200 series units.

## Modular Add-On Service Units— Fillers, Storage Units, and Workboards

see spec sheets **EG40.61A** **EG40.61B**



filler with tube chase



bottle storage unit

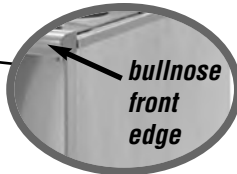

bullnose front edge



storage base unit



workboard

- Predrilled mounting holes.
- 1½" NPS drain on bottle storage units and workboards.
- Tubular legs.

**FEATURES:**

**Note:** Stainless steel leg kits available. To order, add \$211 and suffix "-SL". Example: TCS6-18-SL

For more stainless steel leg kits, see page 296.

**Freight class is 110.0.**

Suffix "-18" indicate modular add-ons that fit 1800 series units.

Suffix "-22" indicate modular add-ons that fit 2200 series units.

description	width x length		weight		cu ft	model #	list
	in.	mm	lbs.	kg			
fillers with tube chase	19" x 6"	483 x 152	18	8.2	4.2	<b>TCS6-18</b>	715
	23" x 6"	584 x 152	20	9.0	5.6	<b>TCS6-22</b>	753
bottle storage units	20" x 12"	508 x 305	17	7.7	6.4	<b>MA5-18</b>	742
	24" x 12"	610 x 305	21	9.5	6.4	<b>MA5-22</b>	785
insulated bottle storage units	20" x 12"	508 x 305	32	14.5	6.4	<b>MA5I-18</b>	1047
	24" x 12"	610 x 305	37	16.8	6.4	<b>MA5I-22</b>	1122
storage base units (slides underneath underbar)	19½" x 12"	495 x 305	26	11.8	6.4	<b>MAB12-18</b>	827
	23½" x 12"	597 x 305	30	13.6	6.4	<b>MAB12-22</b>	893
	19½" x 18"	495 x 457	37	16.8	6.4	<b>MAB18-18</b>	960
	23½" x 18"	597 x 457	41	18.6	6.4	<b>MAB18-22</b>	1037
workboards	20" x 12"	508 x 305	21	9.5	6.4	<b>MAWB12-18</b>	593
	24" x 12"	610 x 305	22	10.0	6.4	<b>MAWB12-22</b>	633



## Catalog Section 40

### Pass-Thru Ice Chests NSF

see spec sheet **EG40.16**



side-to-side x front-to-back in. mm	weight lbs. kg	cubic feet	model #	list
18" x 36" 457 x 914	70 31.8	10.0	<b>B18ICPT</b> *	2684
	106 48.1	12.8	<b>B18ICPT-7</b>	5139
24" x 36" 610 x 914	85 38.6	13.5	<b>B24ICPT</b> *	2822
	121 54.9	13.5	<b>B24ICPT-7</b>	5012

\* 7-circuit post-mix cold plate included

- For 1800 and 2200 Series.
- Sliding cover.

#### FEATURES:

**Note:** Stainless steel legs, add suffix "-SL" and 211 to list price of unit.

For more stainless steel leg kits, see page 296.

**Freight class is 100.0.**

### Accessories/Replacements

see spec sheet **EG40.56**

**Can be shipped UPS.**



#303365 standard faucet

#### Standard Faucet

With 4" (102mm) centers.

description	model #	list each
standard, splash mount, 4" (102mm) centers, 10" (254mm) spout	<b>303365</b>	209



#313302 T&S faucet

#### T&S Faucet T&S

With 4" (102mm) centers.

description	model #	list each
T&S, splash mount, 4" (102mm) centers, 10" (254mm) spout	<b>313302</b>	707

#### Faucet Repair Kit

Fits faucet #303365.

description	model #	list
hot/cold ceramic cartridge	<b>368421</b>	35



overflow pipe



mini crumb cup



drain

#### P-Trap

description	model #	list
nickel-plated	<b>300789</b>	109



#### Drains

description	model #	list each
1/2" (38mm) drain only, for underbar sinks	<b>300886</b> *	16
1/2" (38mm) overflow pipes only	<b>300887</b>	31
mini crumb cup	<b>300966</b>	5
PVC tail piece for ice chest drains	<b>350037</b> *	9
lock nut for 1/2" (38mm) drains	<b>300889</b>	3
1/2" x 4" (13 x 102mm) nipple drain for 7-circuit post-mix cold plate	<b>312007</b>	5

\* #350037 and 300886 not to be used with units containing 7-circuit post-mix cold plate

### Accessories/Replacements

see spec sheet **EG40.56**

Can be shipped UPS.

(•) MTS (made to stock) / ( ) MTO (made to order)

#### Speed Rails

Made for liter-size bottles.

length		number of keyholes	Single-Tier, Keyhole 4 $\frac{1}{16}$ " (113mm) wide.				Double-Tier, Keyhole 8 $\frac{1}{8}$ " (225mm) wide.					
in.	mm		lbs.	kg	cu ft	model #	list	lbs.	kg	cu ft	model #	list
22"	559	2	4	1.8	0.5	<b>500778 •</b>	123	18	8.2	2.1	<b>501883 •</b>	235
34"	864	3	7	3.2	0.7	<b>500779 •</b>	157	27	12.2	3.2	<b>501884 •</b>	313
46"	1168	3	8	3.6	0.9	<b>500780 •</b>	201	31	14.1	4.2	<b>501885 •</b>	412
58"	1473	3	10	4.5	1.2	<b>502956 •</b>	241	36	16.1	5.3	<b>502957 •</b>	516
70"	1778	3	12	5.4	1.4	<b>501045 •</b>	285	40	18.1	6.3	<b>501886 •</b>	621



single-tier speed rail



double-tier speed rail

#### Optional Hanging Straps for Speed Rails

When ordering, order number of straps per number of holes on speed rail.

Not recommended for speed rails over 60" (1524mm) in length.

model #	list each
<b>300708</b>	23

#### Miscellaneous

description	model #	list each
cocktail rack; 15 $\frac{3}{8}$ " x 19 $\frac{3}{8}$ " (391 x 502mm) bowl	<b>300325</b>	177
bottle holder—plastic, single	<b>300491</b>	47
bottle holder tray—holds 4 bottles	<b>300805</b>	86
bottle opener	<b>300713</b>	75
cap catcher	<b>300819</b>	75



bottle holder



bottle opener



bottle holder tray



cap catcher

#### Optional Stainless Steel Leg Kits...

description	add suffix #	...for units requiring 4 legs	...for units requiring 6 legs	...for units requiring 8 legs
		list per unit	list per unit	list per unit
stainless steel (s/s) legs	<b>-SL</b>	211	315	421
s/s legs & s/s feet	<b>-SLF</b>	336	502	671
s/s legs & s/s gussets *	<b>-SLG</b>	379	567	757
s/s legs, s/s feet & s/s gussets *	<b>-SLGF</b>	503	755	1007

\* Does not apply to Glass Rack Storage Units (pages 285 and 291).

#### Clip-On Condiment Tray/Holder

Six pint-sized removable condiment tray inserts. Stainless steel body. Plexiglass lid with stainless steel hinge.

length x width x height		weight		cu	model #	list
in.	mm	lbs.	kg	ft		
18" x 5 $\frac{1}{2}$ " x 3 $\frac{1}{4}$ "	457 x 140 x 89	9	4.1	3.5	<b>CS-CCD</b>	548



### Custom Underbar — 1800 and 2200 Series

see spec sheet **EG40.55**

**For 1800 Series**

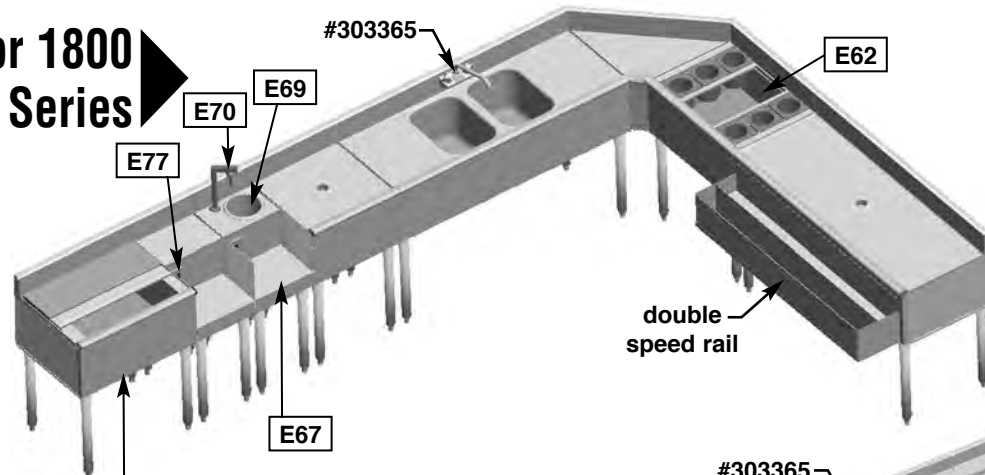

See pages 369-372 for more custom options and accessories.

**For 2200 Series**

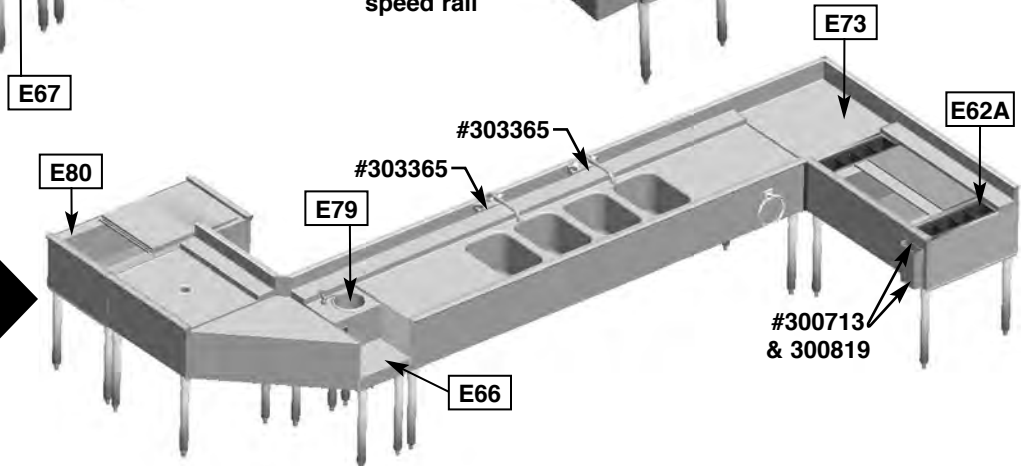

model #	description	1800 Series list price	2200 Series list price	model #	description	1800 Series list price	2200 Series list price
E60	Workboards (minimum 4' 0") per linear foot	427	520	300712	Towel bar, 24" (610mm)-long, stainless steel - shipped loose	111	111
	Sinks:			300670	Sliding s/s ice cover for 15½" x 19¾" bowl (non NSF)	488	488
E61	- hand sink 10" x 14" x 5" w/drain faucet	400	400	300325	Rack for round bottle wells	177	177
E61A	- sink bowl 10" x 14" x 9¾" w/drain, faucet & overflow	466	466	300491	Bottle holder, individual	47	47
E61B	- sink bowl 12" x 14" x 9¾" w/drain, faucet & overflow	581	581	300805	Bottle holder trays (not installed) hold 4 bottles each	86	86
	Cocktail units 15½" x 19¾" bowls:			326636	Poly cutting board 15" x 15" x ½" (not attached) poly-plastic	194	194
E62	- 24" unit, 6 bottle wells, inside liner, no cover	1602	1758	303365	Faucet - 10" spout, splash mount	209	209
E62A	- 36" unit, 8 bottle wells, outside liner, sliding s/s cover	2109	2266	E76	Divider for ice chest (removable), installed at factory	435	435
E63	Ice chest 15½" x 19¾" x 8" deep	2052	2928	300713	- Bottle opener and	75	75
E64	Ice chest w/sliding s/s cover 15½" x 19¾" x 8" deep	1566	1724	300819	- Cap catcher (not attached)	75	75
E65	Higher backsplash up to 9" high per linear foot	124	124	E77	Duplex GFCI receptacle, installed	376	376
	Blender step unit w/liquid waste chute, faucet, electrical outlet:			359032	Post-mix cold plate for 15½" x 19¾" bowl, 7-circuit, sealed-in (NSF)	1853	1853
E66	- 12" wide single station	1506	1747	E78	Glass rack storage, holds (2) 20" x 20" racks	1617	1617
E66A	- 14" wide double station	1619	1855	E79	Dipperwell with faucet	872	872
E67	Blender recess 12" (305mm) wide with electrical GFCI outlets	1092	1205		Pass-thru ice chests:		
E68	Open waste chute installed	487	487	E80	- 18" x 36" x 8"	3078	3078
E69	Liquid waste chute installed	584	584	E80A	- 24" x 36" x 8"	3473	3473
E70	Glass filler	403	403	E81	Stainless steel leg, each	53	53
E71	Cutout in back (2200 Series only)	-	169	300293	Plastic bullet foot, each	2	2
E72	End splash per end	682	697	E83	NSF sprayed-on sound deadening, up to 12' (3658mm) length - for each additional foot	777	777
E73	"L" shape corner welded per corner (except sink bowls)	price upon application			Modular Angle Fillers and Corner Drainboards—front and rear sections		see page 293 for models and list prices
E74	Pass-thru	894	1063		Double speed rail		see page 296 for models and list prices
E75	Blender shelf 12" (305mm) wide, removable hook-on type	492	492				

---

# Spec-Bar®

## Modular Underbar Equipment

---

*The most flexible design in stainless steel underbar equipment that allows you to customize your specifications with simple modular design for easy installation.*

***You can have it all!*** – The convenience of one-stop-shopping for all your equipment needs, design assistance through EAGLE's SpecFAB® division, and the elegance of brass, hardwoods, and stylish laminates.

***All this is yours, with the assurance of impeccable quality and workmanship.***

### **EAGLE Advantages Include:**

---

- Stainless steel construction.
- Decorative solid brass and chrome rails and fittings available.
- Solid surface design (*optional*) lends natural tones and rich textures to your unit.
- Laminates available are in the hundreds, making the possibilities virtually endless.
- The solid elegance of walnut, oak, cherry, maple, red oak, and mahogany bar panels makes your Spec-Bar® blend in to any decor.

### **Step Up To The Bar...**

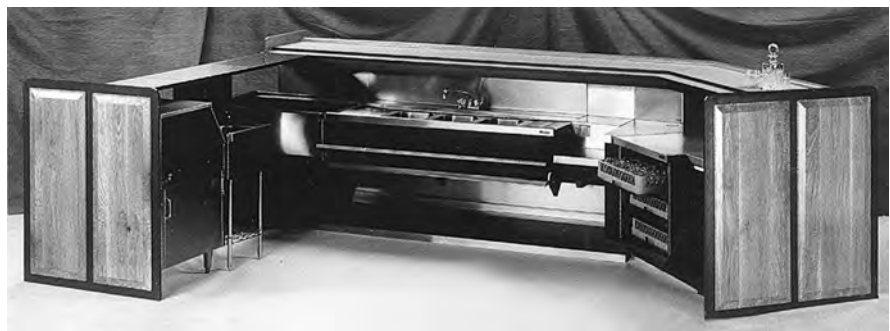

**Catalog Section 40**

**Spec-Bar® Standard Ice Chests** 

see spec sheet **EG40.17**

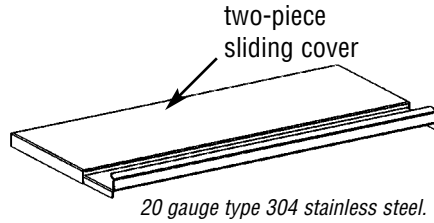

- Body and crossbracing made of type 304 stainless steel.
- 10½" (267mm) deep ice bin with foamed-in-place insulation.
- Removable stainless steel cover.
- Stainless steel adjustable bullet feet.
- Non-metallic breaker strip to prevent heat transfer to ice bin.
- 37" (940mm) overall height.

**FEATURES:**

**Note: Post-mix cold plates available.** To order 8-circuit post-mix cold plate, add **\$2316 to list price** (to fit all models, except otherwise noted) and add suffix **"-8"** to model number.  
To order 2-circuit post-mix cold plate, add **\$1319 to list price** (to fit all models, except otherwise noted) and add suffix **"-2"** to model number. **Example: B24IC-19-2.**  
To order 10-circuit post-mix cold plate, add **\$2316 to list price** and add suffix **"-10"** to model number. **Example: B24IC-19-10.**

**Extra deep ice chests available.** 14½" (368mm) deep. To order, add **\$267 to list price** and replace "IC-" in model number with "ICD-". **Example: B48ICD-19.** Sliding covers included.

**Freight class is 110.0.**

(\*) MTS (made to stock) / ( ) MTO (made to order)

	length		weight		cubic feet	capacity		model #	list
	in.	mm	lbs.	kg		lbs.	kg		
<b>19" width</b> (483mm)	12"	305	30	13.6	5.3	34	15.2	<b>B12IC-19*</b>	1328
	18"	457	37	16.8	7.3	50	22.8	<b>B18IC-19*</b>	1533
	24"	610	50	22.7	9.3	67	30.4	<b>B24IC-19</b>	1738
	30"	762	70	31.8	11.3	84	38.0	<b>B30IC-19</b>	1941
	36"	914	80	36.3	13.3	101	45.6	<b>B36IC-19</b>	2142
	42"	1067	90	40.8	15.3	117	53.2	<b>B42IC-19</b>	2349
<b>24" width</b> (610mm)	48"	1219	100	45.4	17.3	134	30.7	<b>B48IC-19</b>	2551
	12"	305	35	15.9	6.5	43	19.3	<b>B12IC-24*</b>	1524
	18"	457	40	18.1	8.9	64	28.9	<b>B18IC-24**</b>	1748
	24"	610	60	27.2	11.2	85	38.5	<b>B24IC-24</b>	1973
	30"	762	75	34.0	13.8	106	48.2	<b>B30IC-24</b>	2195
	36"	914	85	36.3	16.2	127	57.8	<b>B36IC-24</b>	2421
	42"	1067	90	40.8	18.6	149	67.4	<b>B42IC-24</b>	2644
	48"	1219	100	45.4	21.1	170	77.7	<b>B48IC-24</b>	2869

\* There are no optional cold plates available for these models.  
\*\* For B18IC-24, only an optional 2-circuit post-mix cold plate is available.

**Replacement Ice Bin Covers**

see spec sheet **EG40.23**

for ice chest length		19" width		for ice chest length		24" width	
in.	mm	model #	list	in.	mm	model #	list
12"	305	<b>IC3-12</b>	80	12"	305	<b>IC4-12</b>	85
18"	457	<b>IC3-18</b>	87	18"	457	<b>IC4-18</b>	98
24"	610	<b>IC3-24</b>	99	24"	610	<b>IC4-24</b>	111
30"	762	<b>IC3-30</b>	109	30"	762	<b>IC4-30</b>	123
36"	914	<b>IC3-36</b>	119	36"	914	<b>IC4-36</b>	137
42"	1067	<b>IC3-42</b>	127	42"	1067	<b>IC4-42</b>	148
48"	1219	<b>IC3-48</b>	139	48"	1219	<b>IC4-48</b>	162

**Spec-Bar® Bottle Racks**  
**for Standard Ice Chests** 

see spec sheet **EG40.23**

width	weight		cubic feet	bottle capacity	model #	list
	in.	mm				
19"	483	2	0.9	0.6	3	<b>BR3-19</b> 167
19"	483	4	1.8	1.0	6	<b>BR6-12-19</b> 285
19"	483	6	2.7	1.0	6	<b>BR6-18-19</b> 285
19"	483	8	3.6	1.0	6	<b>BR6-24-19</b> 285
19"	483	10	4.5	1.0	6	<b>BR6-30-19</b> 285
19"	483	12	5.4	1.0	6	<b>BR6-36-19</b> 285
19"	483	14	6.4	1.0	6	<b>BR6-42-19</b> 285
19"	483	16	1.8	1.0	6	<b>BR6-48-19</b> 285
24"	610	2	0.9	0.7	4	<b>BR4-24</b> 197
24"	610	4	1.8	1.0	8	<b>BR8-12-24</b> 329
24"	610	6	2.7	1.0	8	<b>BR8-18-24</b> 329
24"	610	8	3.6	1.0	8	<b>BR8-24-24</b> 329
24"	610	10	4.5	1.0	8	<b>BR8-30-24</b> 329
24"	610	12	5.4	1.0	8	<b>BR8-36-24</b> 329
24"	610	14	6.4	1.0	8	<b>BR8-42-24</b> 329
24"	610	16	1.8	1.0	8	<b>BR8-48-24</b> 329

- One or two 3-bottle or 4-bottle configured vinyl-coated wire racks.
- Divider walls are 20 gauge type 304 stainless steel.

**FEATURES:**

**Freight class is 110.0.**



Spec-Bar® Combination Ice Chests (NSF)

see spec sheet EG40.19



- Bottle compartment and ice bin, each with separate insulation and drains.
- Rectangle openings provided in backsplash for tubing.
- Units available with bottle rack on left or right or both sides.
- Body and crossbracing made of type 304 stainless steel.
- 10½" (267mm) deep ice bin with foamed-in-place insulation.
- Removable stainless steel cover.
- Stainless steel adjustable bullet feet.
- Non-metallic breaker strip to prevent heat transfer to ice bin.
- 36⅝" (930mm) overall height.

FEATURES:

Note: Post-mix cold plates available.

To order 8-circuit post-mix cold plate, add \$2316 to list price (to fit all models, except otherwise noted) and add suffix "-8" to model number.

To order 2-circuit post-mix cold plate, add \$1319 to list price (to fit all models, except otherwise noted) and add suffix "-2" to model number. Example: BCT36R-19-2.

To order 10-circuit post-mix cold plate, add \$2316 to list price and add suffix "-10" to model number. Example: BCT36R-19-10.

Extra deep ice chests available.

14½" (368mm) deep. To order, add \$267 to list price and replace "-" in model number with "D".

Example: BCT48RD-24.

Freight class is 110.0.

...with Bottle Rack on Both Sides

	overall length		ice bin width x length		weight		cu ft	ice capacity		model #	list
	in.	mm	in.	mm	lbs.	kg		lbs.	kg		
19" width (483mm)	48"	1219	15" x 23"	381 x 584	169	76.7	17.3	67	30.4	BCT48-19	3882
	54"	1372	15" x 29"	381 x 737	179	87.2	19.3	84	38.0	BCT54-19	4093
	60"	1524	15" x 35"	381 x 889	189	85.7	21.3	100	45.6	BCT60-19	4297
24" width (610mm)	48"	1219	20" x 23"	508 x 584	189	85.7	19.8	85	38.5	BCT48-24	4512
	54"	1372	20" x 29"	508 x 737	199	90.3	21.8	106	48.2	BCT54-24	4734
	60"	1524	20" x 35"	508 x 889	209	94.8	23.8	127	54.8	BCT60-24	4961

...with Bottle Rack on One Side

	overall length		ice bin width x length		weight		cu ft	ice capacity		bottle rack on left		bottle rack on right	
	in.	mm	in.	mm	lbs.	kg		lbs.	kg	model #	list	model #	list
19" width (483mm)	24"	610	15" x 11"	381 x 279	119	86.2	9.3	40	18.1	BCT24L-19*	2425	BCT24R-19*	2425
	30"	762	15" x 17"	381 x 432	132	59.9	11.3	50	22.8	BCT30L-19*	2633	BCT30R-19*	2633
	36"	914	15" x 23"	381 x 584	153	69.4	13.3	67	30.4	BCT36L-19	2837	BCT36R-19	2837
	42"	1067	15" x 29"	381 x 737	181	82.1	15.3	84	38.0	BCT42L-19	3040	BCT42R-19	3040
24" width (610mm)	48"	1219	15" x 35"	381 x 889	196	88.9	17.3	100	45.6	BCT48L-19	3257	BCT48R-19	3257
	30"	762	20" x 17"	508 x 432	158	71.6	13.8	64	28.9	BCT30L-24*	3023	BCT30R-24*	3023
	36"	914	20" x 23"	508 x 584	161	73.0	15.8	85	38.5	BCT36L-24	3245	BCT36R-24	3245
	42"	1067	20" x 29"	508 x 737	163	73.9	17.8	106	48.2	BCT42L-24	3469	BCT42R-24	3469
	48"	1219	20" x 35"	508 x 889	179	87.2	19.5	127	54.8	BCT48L-24	3697	BCT48R-24	3697

\* There are no optional post-mix cold plates available for these models.

The EAGLE Advantage

HAVE YOU PROFITED TODAY?

EAGLE's SpecFAB® Division was formed to fill the gap between ready-made standard equipment and high-cost, "wish-and-wait" highly customized equipment. With SpecFAB®, you get quality custom equipment, built to your specifications and delivered to you fast - at affordable prices.

To learn more about what EAGLE's SpecFAB® Division can do for you, see pages 373-380 or...

...visit us at [www.eaglegrp.com](http://www.eaglegrp.com)

**Catalog Section 40**

**Spec-Bar® Drop-In Ice Chests** 

see spec sheet **EG40.20**



overall width x length		cut-out dimensions width x length		weight		cubic feet	ice cube capacity		model #	list
in.	mm	in.	mm	lbs.	kg		lbs.	kg		
18" x 24"	457 x 610	16 1/4" x 22 1/4"	413 x 565	80	36.3	3.8	72	32.7	<b>DIC1420</b>	1603
24" x 18"	610 x 457	22 1/4" x 16 1/4"	565 x 413	80	36.3	3.8	72	32.7	<b>DIC2014</b>	1603
20" x 30"	508 x 762	18 1/4" x 28 1/4"	464 x 718	122	55.3	5.0	121	54.9	<b>DIC1626</b>	2023
30" x 20"	762 x 508	28 1/4" x 18 1/4"	718 x 464	122	55.3	5.0	121	54.9	<b>DIC2616</b>	2023

Optional Post-Mix Cold Plates:

#DIC1420 and DIC2014 can accept 2-circuit post-mix cold plate only.

#DIC1626 and DIC2616 can accept 2-, 8-, or 10-circuit post-mix cold plates.

- Body made of type 304 stainless steel.
- 10 1/2" (267mm) deep ice bin with foamed-in-place insulation.
- Removable stainless steel sliding cover.
- Non-metallic breaker strip to prevent heat transfer to ice bin.

**FEATURES:**

**Note:** To order 8-circuit post-mix cold plate, add **\$2316 to list price** (to fit all models, except otherwise noted) and add suffix **"-8"** to model number.

To order 2-circuit post-mix cold plate, add **\$1319 to list price** and add suffix **"-2"** to model number.

**Example: DIC1420-2.**

To order 10-circuit post-mix cold plate, add **\$2316 to list price** and add suffix **"-10"** to model number.

**Example: DIC1626-10.**

**Freight class is 110.0.**

(•) MTS (made to stock) / ( ) MTO (made to order)

**Spec-Bar® Pass Thru Ice Chest** 

see spec sheet **EG40.18**



overall width x length		weight		cubic feet	capacity		model #	list
in.	mm	lbs.	kg		lbs.	kg		
36" x 24"	914 x 610	100	45.5	15.8	175	79.4	<b>B24PTIC</b>	2963

- Body and crossbracing made of type 304 stainless steel.
- 10 1/2" (267mm) deep ice bin with foamed-in-place insulation.
- Removable stainless steel sliding cover.
- Stainless steel adjustable bullet feet.
- Non-metallic breaker strip to prevent heat transfer to ice bin.
- 29 5/16" (741mm) overall height.

**FEATURES:**

**Note:** To order 8-circuit post-mix cold plate, add **\$2316 to list price** and add suffix **"-8"** to model number.

To order 2-circuit post-mix cold plate, add **\$1319 to list price** and add suffix **"-2"** to model number.

**Example: B24PTIC-2.**

To order 10-circuit post-mix cold plate, add **\$2316 to list price** and add suffix **"-10"** to model number. **Example: B24PTIC-10.**

**Freight class is 110.0.**

**Spec-Bar® Modular Bar Die**  

Custom

see spec sheet **EG40.45**



pedestal base style shown  
(note: base shown for display only)

- Flexibility of freestanding equipment in one easy unit.
- Stone gray color, unless specified.
- Available in flat wall style and pedestal base style.
- Built-in chaseways for beverage, electrical and plumbing lines.
- Duplex outlets and dispenser access holes as requested.

- On pedestal base style, equipment is mounted onto die before shipping. Arrives pre-assembled from factory in sections for easy installation. Simply connect sections and secure unit.
- Optional factory U.L. wiring and plumbing package.

**Call factory for pricing.**

**Freight class is 110.0.**

**Spec-Bar® Hand Sinks** 

see spec sheet **EG40.34**



- 8" (203mm) high backsplash, sides, front panel or door, and bowl are 20 gauge stainless steel.
- Leg channels, legs, and crossbracing are 16 gauge stainless steel.
- 9¼" x 11½" x 6" (235 x 292 x 152mm) 20 gauge stainless steel bowls.
- T&S faucet.
- 1½" (38mm) stainless steel I.P.S. threaded drain with nut and washer.
- 36½" (927mm) overall height.

**FEATURES:**

**Freight class is 85.0.**

(•) MTS (made to stock) / ( ) MTO (made to order)

	length	weight	cu			model #	list
	in.	mm	lbs.	kg	ft		
<b>19"</b>	12"	305	30	13.6	5.3	w/front panel and deck-mount faucet	<b>HS12-19 •</b> 1632
<b>width</b>	18"	457	35	15.9	8.0	w/front panel and deck-mount faucet	<b>HS18-19</b> 1733
<b>(483mm)</b>	18"	457	45	20.4	8.0	w/front door, soap & towel disp., splash-mt faucet	<b>HSD18-19</b> 2211
<b>24"</b>	12"	305	35	15.9	6.5	w/front panel and deck-mount faucet	<b>HS12-24 •</b> 1697
<b>width</b>	12"	305	45	20.4	6.5	w/front door, soap & towel disp., splash-mt faucet	<b>HSD12-24</b> 2177
<b>(610mm)</b>	18"	457	40	18.1	9.0	w/front panel and deck-mount faucet	<b>HS18-24</b> 1806
	18"	457	50	22.7	9.0	w/front door, soap & towel disp., splash-mt faucet	<b>HSD18-24</b> 2287

"D" in model number indicates units with front door, soap and paper towel dispensers, and splash mount faucet.

**Spec-Bar® Wall Mounted Sinks** 

see spec sheet **EG40.35**



- Backsplash, sides, bottom, front panel or door, trim rail, and bowls are 20 gauge stainless steel.
- Wall mounting bracket and top drop-in model are 18 gauge stainless steel.
- 9¼" x 11½" x 6" (235 x 292 x 152mm) 20 gauge stainless steel bowls.
- T&S faucet.
- 1½" (38mm) stainless steel I.P.S. threaded drain with nut and washer.

**FEATURES:**

**Freight class is 150.0.**

	length	weight	cubic			model #	list
	in.	mm	lbs.	kg	feet		
<b>15"</b>	14"	356	22	10.0	5.0	w/front panel	<b>WS14-15</b> 1211
<b>width</b>	14"	356	30	13.6	5.0	w/front door & dispensers	<b>WSD14-15</b> 1692
<b>(381mm)</b>	14"	356	25	11.3	5.0	w/perforated sink strainer	<b>WSS14-15</b> 1211
	12"	305	15	6.8	4.4	drop-in model	<b>WSSD12-15</b> 869

**The EAGLE Advantage**

**HAVE YOU PROFITED TODAY?**  
**Call Your EAGLE GROUP Representative Now To Place Your Order.**



## Catalog Section 40

### Spec-Bar® Two-Compartment Sinks NSF

see spec sheet **EG40.37**



- 10" x 14" x 9½" (254 x 356 x 241mm) bowls.
- Splash mounted T&S faucet
- 1½" (38mm) I.P.S. threaded drain with nut and washer.
- 37" (940mm) overall height.

FEATURES:

**Freight class is 150.0.**

width x length		weight		cubic feet	model #	list
in.	mm	lbs.	kg			
19" x 24"	483 x 610	50	22.7	9.3	<b>B2-2-19</b>	2367
24" x 24"	610 x 610	55	24.9	11.3	<b>B2-2-24</b>	2451

### Spec-Bar® Three-Compartment Sinks NSF

see spec sheet **EG40.38**



3-compartment sink with optional speed rail

- 19" (940mm) units feature splash mount T&S faucet with 10" (254mm) spout; 24" (610mm) units come with double-hinged splash mount T&S faucet.
- 10" x 14" x 9½" (254 x 356 x 241mm) bowls.
- 1½" (38mm) I.P.S. threaded drain with nut and washer.
- 37" (940mm) overall height.

FEATURES:

**Freight class is 150.0.**

...with One Drainboard - except where noted.

	overall length		drainboard(s) length		weight		cu ft	DRAINBOARD ON LEFT		DRAINBOARD ON RIGHT	
	in.	mm	in.	mm	lbs.	kg		model #	list	model #	list
<b>19" width (483mm)</b>	36"	914	n/a	n/a	60	27.2	13.3	<b>B3-3-19 *</b>	2981	n/a	n/a
	48"	1219	12"	305	70	31.8	17.3	<b>B4-3-L-19</b>	3309	<b>B4-3-R-19</b>	3309
	60"	1524	24"	610	80	36.3	21.3	<b>B5-3-L-19</b>	3551	<b>B5-3-R-19</b>	3551
	66"	1676	30"	762	85	38.6	23.3	<b>B5.5-3-L-19</b>	3673	<b>B5.5-3-R-19</b>	3673
	72"	1829	36"	914	90	40.8	25.3	<b>B6-3-L-19</b>	3878	<b>B6-3-R-19</b>	3878
<b>24" width (610mm)</b>	36"	914	n/a	n/a	65	29.5	16.2	<b>B3-3-24 *</b>	3074	n/a	n/a
	48"	1224	12"	305	75	34.0	21.1	<b>B4-3-L-24</b>	3431	<b>B4-3-R-24</b>	3431
	60"	1524	24"	610	85	38.6	25.9	<b>B5-3-L-24</b>	3714	<b>B5-3-R-24</b>	3714
	66"	1676	30"	762	90	40.8	28.4	<b>B5.5-3-L-24</b>	3859	<b>B5.5-3-R-24</b>	3859
	72"	1829	36"	914	95	43.1	30.8	<b>B6-3-L-24</b>	4073	<b>B6-3-R-24</b>	4073

\* These models do not have drainboards.

...with Two Drainboards - shipped wood-crated.

	overall length		drainboard(s) length		weight		cu ft	model #	list
	in.	mm	in.	mm	lbs.	kg			
<b>19" width (483mm)</b>	60"	1524	12"	305	180	81.7	21.3	<b>B5-3-LR-19</b>	3634
	72"	1829	18"	457	190	86.2	25.3	<b>B6-3-LR-19</b>	3878
	84"	2134	24"	610	205	92.9	29.3	<b>B7-3-LR-19</b>	4123
	96"	2438	30"	762	220	99.8	33.3	<b>B8-3-LR-19</b>	4366
<b>24" width (610mm)</b>	60"	1524	12"	305	185	83.9	25.9	<b>B5-3-LR-24</b>	3784
	72"	1829	18"	457	195	88.5	30.8	<b>B6-3-LR-24</b>	4073
	84"	2134	24"	610	210	95.3	35.7	<b>B7-3-LR-24</b>	4358
	96"	2438	30"	762	225	102.1	40.5	<b>B8-3-LR-24</b>	4642

## Spec-Bar® Four-Compartment Sinks NSF

see spec sheet **EG40.39**



- Double-hinged splash mount T&S faucet.
- 10" x 14" x 9½" (254 x 356 x 241mm) bowls.
- 1½" (38mm) I.P.S. threaded drain with nut and washer.
- 37" (940mm) overall height.

**FEATURES:**

**Freight class is 150.0.**

(\*) MTS (made to stock) / ( ) MTO (made to order)

...with One Drainboard - except where noted.

	overall length		drainboard(s) length		weight		cu	DRAINBOARD ON LEFT		DRAINBOARD ON RIGHT	
	in.	mm	in.	mm	lbs.	kg	ft	model #	list	model #	list
<b>19" width</b> (483mm)	48"	1219	n/a	n/a	70	31.8	17.3	<b>B4-4-19 *</b>	3697	n/a	n/a
	60"	1524	12"	305	80	36.3	21.3	<b>B5L-4-19</b>	4021	<b>B5R-4-19</b>	4021
	66"	1676	18"	457	85	38.6	23.3	<b>B5.5L-4-19</b>	4143	<b>B5.5R-4-19</b>	4143
	72"	1829	24"	610	90	40.8	25.3	<b>B6L-4-19</b>	4263	<b>B6R-4-19</b>	4263
<b>24" width</b> (610mm)	48"	1224	n/a	n/a	75	34.0	21.1	<b>B4-4-24 *</b>	3838	n/a	n/a
	60"	1524	12"	305	85	38.6	25.9	<b>B5L-4-24</b>	4193	<b>B5R-4-24</b>	4193
	66"	1676	18"	457	90	40.8	28.4	<b>B5.5L-4-24</b>	4336	<b>B5.5R-4-24</b>	4336
	72"	1829	24"	610	95	43.1	30.8	<b>B6L-4-24</b>	4479	<b>B6R-4-24</b>	4479

\* These models do not have drainboards.

...with Two Drainboards

	overall length		drainboard(s) length		weight		cu	model #		list
	in.	mm	in.	mm	lbs.	kg	ft	model #	list	
<b>19" width</b> (483mm)	72"	1829	12"	305	90	40.8	25.3	<b>B6RL-4-19</b>	4349	
	84"	2134	18"	457	105	47.6	29.3	<b>B7RL-4-19</b>	4595	
	96"	2438	24"	610	120	54.4	33.3	<b>B8RL-4-19</b>	4838	
<b>24" width</b> (610mm)	72"	1829	12"	305	95	43.1	30.8	<b>B6RL-4-24</b>	4551	
	84"	2134	18"	457	110	49.9	35.7	<b>B7RL-4-24</b>	4838	
	96"	2438	24"	610	125	56.7	40.5	<b>B8RL-4-24</b>	4865	



### Optional Scrap Basket

For 10" x 14" bowls (254 x 356mm).

model #	list
<b>SB1014</b>	214

## Spec-Bar® Wet Waste Sinks NSF

see spec sheet **EG40.36**



- For chemical storage or disposal.
- T&S faucet and perforated pan.
- 9¼" x 11½" x 6" (235 x 292 x 152mm) 20 gauge stainless steel bowls.
- 1½" (38mm) stainless steel I.P.S. threaded drain with nut and washer.
- 36¾" (930mm) overall height.

**FEATURES:**

**Freight class is 150.0.**

(\*) MTS (made to stock) / ( ) MTO (made to order)

	length		weight		cu	description	model #	list
	in.	mm	lbs.	kg	ft			
<b>19" width</b> (483mm)	12"	305	32	14.5	5.3	w/front panel	<b>WS12-19</b>	1603
	18"	457	35	15.9	8.0	w/front panel	<b>WS18-19</b>	1704
<b>24" width</b> (610mm)	12"	305	37	16.8	6.5	w/front panel	<b>WS12-24</b>	1669
	12"	305	40	18.1	10.1	w/front door, holds (3) 1-gal. containers	<b>WSC12-24*</b>	2271
	18"	457	42	19.1	9.0	w/front panel	<b>WS18-24</b>	1780
	18"	457	40	18.1	13.1	w/dry waste chute	<b>WSW18-24</b>	2511

\* #WSC12-24 is a cabinet-style unit

## Catalog Section 40

### Spec-Bar® Standard Workboards NSF

see spec sheet **EG40.27**

	length		weight		cubic feet	model #	list
	in.	mm	lbs.	kg			
<b>19" width</b> (483mm)	12"	305	25	11.3	5.3	<b>WB12-19</b>	869
	18"	457	30	13.6	7.3	<b>WB18-19</b>	968
	24"	610	35	15.9	9.3	<b>WB24-19</b>	1074
	30"	762	40	18.1	11.3	<b>WB30-19</b>	1178
	36"	914	45	20.4	13.3	<b>WB36-19</b>	1276
	42"	1067	50	22.7	15.3	<b>WB42-19</b>	1380
<b>24" width</b> (610mm)	12"	305	27	12.2	6.5	<b>WB12-24</b>	968
	18"	457	32	14.5	8.9	<b>WB18-24</b>	1074
	24"	610	37	16.8	11.3	<b>WB24-24</b>	1178
	30"	762	42	19.1	13.8	<b>WB30-24</b>	1276
	36"	914	47	21.3	16.2	<b>WB36-24</b>	1380
	42"	1067	52	23.6	18.6	<b>WB42-24</b>	1483
	48"	1219	57	25.6	21.1	<b>WB48-24</b>	1584

FEATURES:

- Type 304 stainless steel construction.
- Adjustable stainless steel bullet feet.
- Perforated stainless steel insert.
- 1½" (38mm) I.P.S. threaded drain with nut and washer.
- 37" (940mm) overall height.

**Freight class is 100.0.**



### Spec-Bar® Recessed Workboards NSF

see spec sheet **EG40.28**



cutout aligns with speed rail of other equipment



24" (610mm)  
RDBSR



29" (737mm)  
RDBDR



24" (610mm)  
RDB



29" (737mm)  
RDBSR

FEATURES:

- Type 304 stainless steel construction.
- Adjustable stainless steel bullet feet.
- Perforated stainless steel insert.
- 1½" (38mm) I.P.S. threaded drain with nut and washer.
- 37" (940mm) overall height.

**Freight class is 100.0.**

...designed to align with single speed rail adjoined to Spec-Bar® 19" (483mm) wide equipment.

	length		weight		cubic feet	model #	list
	in.	mm	lbs.	kg			
<b>24" width</b> (610mm)	12"	305	25	11.3	6.5	<b>RDBSR12-19</b>	968
	18"	457	30	13.6	8.9	<b>RDBSR18-19</b>	1074
	24"	610	35	15.9	11.3	<b>RDBSR24-19</b>	1178
	30"	762	40	18.1	13.8	<b>RDBSR30-19</b>	1276
	36"	914	45	20.4	16.2	<b>RDBSR36-19</b>	1380

...designed to align with Spec-Bar® 24" (610mm) wide equipment with no speed rail.

	length		weight		cubic feet	model #	list
	in.	mm	lbs.	kg			
<b>24" width</b> (610mm)	12"	305	25	11.3	6.5	<b>RDB12-24</b>	968
	18"	457	30	13.6	8.9	<b>RDB18-24</b>	1074
	24"	610	35	15.9	11.3	<b>RDB24-24</b>	1178
	30"	762	40	18.1	13.8	<b>RDB30-24</b>	1276
	36"	914	45	20.4	16.2	<b>RDB36-24</b>	1309

...designed to align with double speed rail adjoined to Spec-Bar® 19" (483mm) wide equipment.

	length		weight		cubic feet	model #	list
	in.	mm	lbs.	kg			
<b>29" width</b> (737mm)	12"	305	37	16.8	7.7	<b>RDBDR12-19</b>	1074
	18"	457	42	19.1	10.5	<b>RDBDR18-19</b>	1178
	24"	610	49	22.2	13.4	<b>RDBDR24-19</b>	1276
	30"	762	56	25.4	16.2	<b>RDBDR30-19</b>	1380
	36"	914	61	27.7	19.1	<b>RDBDR36-19</b>	1483

...designed to align with Spec-Bar® 24" (610mm) wide equipment with single speed rail.

	length		weight		cubic feet	model #	list
	in.	mm	lbs.	kg			
<b>29" width</b> (737mm)	12"	305	37	16.8	7.7	<b>RDBSR12-24</b>	1074
	18"	457	42	19.1	10.5	<b>RDBSR18-24</b>	1178
	24"	610	49	22.2	13.4	<b>RDBSR24-24</b>	1276
	30"	762	56	25.4	16.2	<b>RDBSR30-24</b>	1380
	36"	914	61	27.7	19.1	<b>RDBSR36-24</b>	1483

## Spec-Bar® Corner Workboards NSF

see spec sheet **EG40.30**



inner corner workboard



outside corner workboard

description	weight		cubic feet	model #	list
	lbs.	kg			
inside full corner to fit 19" (483mm) underbar equipment	35	15.9	7.7	ICWB-19/19	1185
inside full corner to fit 19" (483mm) underbar equipment	40	18.1	9.3	ICWB-19/24L	1217
inside full corner to fit 19" (483mm) underbar equipment	40	18.1	9.3	ICWB-19/24R	1217
inside full corner to fit 19" (483mm) underbar equipment	45	20.4	11.3	ICWB-19/30L	1235
inside full corner to fit 19" (483mm) underbar equipment	45	20.4	11.3	ICWB-19/30R	1235
90° outer corner to fit 19" (483mm) underbar equipment	50	22.7	7.7	90OCWB-19	1235
90° inner corner to fit 19" (483mm) underbar equipment	50	22.7	7.7	90ICWB-19	1235
45° outer corner to fit 19" (483mm) underbar equipment	46	20.9	7.7	45OCWB-19	788
45° inner corner to fit 19" (483mm) underbar equipment	46	20.9	7.7	45ICWB-19	788
inside full corner to fit 24" (610mm) underbar equipment	45	20.4	11.4	ICWB-24/24	1235
inside full corner to fit 24" (610mm) underbar equipment	50	22.7	13.4	ICWB-24/30L	1268
inside full corner to fit 24" (610mm) underbar equipment	50	22.7	13.4	ICWB-24/30R	1268
90° outer corner to fit 24" (610mm) underbar equipment	55	24.9	11.4	90OCWB-24	1268
90° inner corner to fit 24" (610mm) underbar equipment	55	24.9	11.4	90ICWB-24	1268
45° outer corner to fit 24" (610mm) underbar equipment	48	21.8	11.4	45OCWB-24	968
45° inner corner to fit 24" (610mm) underbar equipment	48	21.8	11.4	45ICWB-24	968

- Removable stainless steel perforated insert and mounting clips.
- Type 304 stainless steel construction.
- 1½" (38mm) I.P.S. threaded drain with nut and washer.

**FEATURES:**

**Note:** Leg channel and stainless steel crossbraced leg assembly available. To order, add \$246 and suffix -LC. Example: ICWB-19/19-LC.

Two leg channel and stainless steel crossbraced leg assemblies available to create freestanding unit. To order, add \$491 and suffix -2LC. Example: ICWB-19/19-2LC.

**Freight class is 100.0.**

## Spec-Bar® Angle Workboards NSF

see spec sheet **EG40.31**

description	weight		cubic feet	model #	list
	lbs.	kg			
75° outer corner to fit 19" (483mm) underbar equipment	42	19.1	7.7	WBOC75-19	726
75° inner corner to fit 19" (483mm) underbar equipment	42	19.1	7.7	WBIC75-19	726
60° outer corner to fit 19" (483mm) underbar equipment	36	16.3	7.7	WBOC60-19	583
60° inner corner to fit 19" (483mm) underbar equipment	36	16.3	7.7	WBIC60-19	583
45° outer corner to fit 19" (483mm) underbar equipment	30	13.6	7.7	WBOC45-19	583
45° inner corner to fit 19" (483mm) underbar equipment	30	13.6	7.7	WBIC45-19	583
30° outer corner to fit 19" (483mm) underbar equipment	24	10.9	7.7	WBOC30-19	583
30° inner corner to fit 19" (483mm) underbar equipment	24	10.9	7.7	WBIC30-19	583
15° outer corner to fit 19" (483mm) underbar equipment	20	9.1	7.7	WBOC15-19	583
15° inner corner to fit 19" (483mm) underbar equipment	20	9.1	7.7	WBIC15-19	583
75° outer corner to fit 24" (610mm) underbar equipment	44	20.0	11.3	WBOC75-24	892
75° inner corner to fit 24" (610mm) underbar equipment	44	20.0	11.3	WBIC75-24	892
60° outer corner to fit 24" (610mm) underbar equipment	38	17.2	11.3	WBOC60-24	724
60° inner corner to fit 24" (610mm) underbar equipment	38	17.2	11.3	WBIC60-24	724
45° outer corner to fit 24" (610mm) underbar equipment	33	15.0	11.3	WBOC45-24	724
45° inner corner to fit 24" (610mm) underbar equipment	33	15.0	11.3	WBIC45-24	724
30° outer corner to fit 24" (610mm) underbar equipment	27	12.2	11.3	WBOC30-24	724
30° inner corner to fit 24" (610mm) underbar equipment	27	12.2	11.3	WBIC30-24	724
15° outer corner to fit 24" (610mm) underbar equipment	23	10.4	11.3	WBOC15-24	724
15° inner corner to fit 24" (610mm) underbar equipment	23	10.4	11.3	WBIC15-24	724

- Removable stainless steel perforated insert and mounting clips.
- Inner and outer workboards available in angles of 30°, 45°, 60°, and 90°.
- Type 304 stainless steel construction.
- 1½" (38mm) I.P.S. threaded drain with nut and washer.

**FEATURES:**

**Freight class is 100.0.**



inner angle workboard



outer angle workboard

## Catalog Section 40

### Spec-Bar® Workboard Cabinets NSF

see spec sheet **EG40.32**



...with Closed Base — Locks are standard.

	length		weight		cubic feet	model #	list
	in.	mm	lbs.	kg			
<b>19"</b> width (483mm)	24"	610	50	22.7	14.9	<b>WBCB24-19</b>	1837
	30"	762	55	24.9	18.1	<b>WBCB30-19</b>	2305
	36"	914	60	27.2	21.3	<b>WBCB36-19</b>	2542
	42"	1067	65	29.5	24.5	<b>WBCB42-19</b>	2776
	48"	1219	70	31.8	27.7	<b>WBCB48-19</b>	3009
<b>24"</b> width (610mm)	24"	610	55	24.9	18.1	<b>WBCB24-24</b>	2297
	30"	762	60	27.2	22.0	<b>WBCB30-24</b>	2551
	36"	914	65	29.5	25.9	<b>WBCB36-24</b>	2807
	42"	1067	70	31.8	29.8	<b>WBCB42-24</b>	3062
	48"	1219	75	34.0	33.7	<b>WBCB48-24</b>	3318

- Type 304 stainless steel construction.
- Removable perforated insert, adjustable shelf, and adjustable bullet feet—all stainless steel.
- 1½" (38mm) I.P.S. threaded drain with nut and washer.
- 37" (940mm) overall height.

FEATURES:

**Note:** These units cannot use speed rails.

**Freight class is 100.0.**

...with Open Base

	length		weight		cubic feet	model #	list
	in.	mm	lbs.	kg			
<b>19"</b> width (483mm)	24"	610	45	20.4	14.9	<b>WBOB24-19</b>	1686
	30"	762	50	22.7	18.1	<b>WBOB30-19</b>	1876
	36"	914	55	24.9	21.3	<b>WBOB36-19</b>	2066
	42"	1067	60	27.2	24.5	<b>WBOB42-19</b>	2267
	48"	1219	65	29.5	27.7	<b>WBOB48-19</b>	2458
<b>24"</b> width (610mm)	24"	610	50	22.7	18.1	<b>WBOB24-24</b>	1901
	30"	762	55	24.9	22.0	<b>WBOB30-24</b>	2113
	36"	914	60	27.2	25.9	<b>WBOB36-24</b>	2329
	42"	1067	65	29.5	29.8	<b>WBOB42-24</b>	2542
	48"	1219	70	31.8	22.7	<b>WBOB48-24</b>	2758

### Spec-Bar® Filler Boards NSF

see spec sheet **EG40.29**

	length		weight		cubic feet	model #	list
	in.	mm	lbs.	kg			
<b>19"</b> width (483mm)	6"	152	18	8.2	3.3	<b>FB6-19</b>	775
	12"	305	22	10.0	5.6	<b>FB12-19</b>	869
	18"	457	26	11.8	7.3	<b>FB18-19</b>	968
	24"	610	30	13.6	9.3	<b>FB24-19</b>	1074
	30"	762	34	15.4	11.3	<b>FB30-19</b>	1178
	36"	914	37	16.8	13.3	<b>FB36-19</b>	1276
	42"	1067	41	18.6	15.3	<b>FB42-19</b>	1388
	48"	1219	45	20.4	17.3	<b>FB48-19</b>	1492
	60"	1524	49	22.2	21.3	<b>FB60-19</b>	1594
<b>24"</b> width (610mm)	6"	152	19	8.6	4.0	<b>FB6-24</b>	879
	12"	305	23	10.4	6.5	<b>FB12-24</b>	968
	18"	457	27	12.2	8.9	<b>FB18-24</b>	1074
	24"	610	30	13.6	11.3	<b>FB24-24</b>	1178
	30"	762	35	15.9	13.8	<b>FB30-24</b>	1276
	36"	914	39	17.7	16.2	<b>FB36-24</b>	1380
	42"	1067	43	19.5	18.6	<b>FB42-24</b>	1492
	48"	1219	47	21.3	21.1	<b>FB48-24</b>	1594
	60"	1524	51	23.1	25.9	<b>FB60-24</b>	1698

FEATURES:

- Work surface reinforced with heavy gauge support channels.
- Type 304 stainless steel construction
- Adjustable stainless steel bullet feet
- Perforated stainless steel insert
- 1½" (38mm) I.P.S. threaded drain with nut and washer.
- 37" (940mm) overall height.

**Note:** These units cannot use speed rails.

**Freight class is 100.0.**



## Spec-Bar® Beer Drainers



see spec sheet **EG40.33**



	length		weight		cubic feet	model #	list
	in.	mm	lbs.	kg			
<b>19" width</b> (483mm)	18"	457	25	11.3	7.3	<b>BD18-19</b>	968
	24"	610	30	13.6	9.3	<b>BD24-19</b>	1074
	30"	762	35	15.9	11.3	<b>BD30-19</b>	1178
<b>24" width</b> (610mm)	18"	457	28	12.7	8.9	<b>BD18-24</b>	1074
	24"	610	33	15.0	11.3	<b>BD24-24</b>	1178
	30"	762	42	19.1	13.8	<b>BD30-24</b>	1276

FEATURES:

- Removable perforated stainless steel insert, adjustable bullet feet and tubing chase built into rear deck.
- Type 304 stainless steel construction
- 1½" (38mm) I.P.S. threaded drain with nut and washer.
- 37" (940mm) overall height.

**Freight class is 100.0.**

## Automatic Glasswashers by MOYER DIEBEL



see spec sheet **EG40.40**



**Ultrahigh efficiency wash pumps for superior cleaning.**

FEATURES:

- 11" (279mm) glass clearance.
- Counterbalanced door.
- Reduced water usage.
- Built-in detergent and rinse aid dispensing pumps.
- 24" (610mm) side-to-side.
- 26" (660mm) front-to-back.
- 38" (965mm) total height.
- Processes 30 racks per hour.
- 5/8" (16mm) drain connection.
- Two 20" (508mm) square racks included.

**Freight class is 70.0.**

**Price upon application.**

description	weight		cubic feet	model #
	lbs.	kg		
low-temp model, 115V, 12A, with sanitizer pump	178	80.2	20	<b>MD240LT</b>
high-temp model, 208/240V, 32/26A, built-in booster heater	178	80.2	20	<b>MD240HT</b>

## Rotary Glasswashers by MOYER DIEBEL



see spec sheet **EG40.41**



**Ultrahigh efficiency wash pumps for superior cleaning.**

FEATURES:

- Upper and lower wash and rinse arms produce sparkling clean glasses every time.
- Three-pump injection system allows the use of separate sanitizer and rinse aid.
- 25¼" (641mm) side-to-side.
- 25½" (638mm) front-to-back.
- 39" (991mm) total height.
- Quiet operation.
- Splash protection.
- Stores three 1-gal. containers.

**Freight class is 70.0.**

**Price upon application.**

description	weight		cubic feet	model #
	lbs.	kg		
one door on front, clockwise conveyor	156	71	25	<b>DF</b>

**Catalog Section 40**

**Spec-Bar® Blender Stations**   
with T&S Faucet

see spec sheet **EG40.24**



*Designed to align with single speed rails on adjoining equipment.*

**FEATURES:**

- Sink bowl with T&S gooseneck faucet and lift-out perforated sink strainer.
- Constructed of type 304 stainless steel with sink, workboard, and wet waste configurations for the perfect mixing component.
- 8" (203mm) high backsplash.
- Blender shelf with rear cord access hole.
- Stainless steel adjustable feet.

**Note:** These units cannot use speed rails.

**Freight class is 100.0.**

	length		weight		cubic feet	model #	list
	in.	mm	lbs.	kg			
<b>19" width*</b> (483mm)	14"	356	42	19.1	7.3	<b>BS14-19</b>	1876
	18"	457	55	24.9	8.9	<b>BS18-19</b>	1989
<b>24" width*</b> (610mm)	14"	356	47	21.3	8.6	<b>BS14-24</b>	2083
	18"	457	65	29.5	10.5	<b>BS18-24</b>	2186

\* Dimensions do not include 5" (127mm) additional width to align with equipment with single speed rail.

**Spec-Bar® Wet Waste Blender Stations** 

see spec sheet **EG40.25**



*Designed to align with single speed rails on adjoining equipment.*

**FEATURES:**

- 6" (152mm) diameter wet waste sink with T&S glass filler.
- Constructed of type 304 stainless steel with sink, workboard, and wet waste configurations for the perfect mixing component.
- 8" (203mm) high backsplash.
- Blender shelf with rear cord access hole.
- Lift-out stainless steel perforated sink strainer.
- Stainless steel adjustable feet.

**Note:** These units cannot use speed rails.

**Freight class is 100.0.**

	length		weight		cubic feet	model #	list
	in.	mm	lbs.	kg			
<b>19" width*</b> (483mm)	12"	305	40	18.1	6.5	<b>BWBS12-19</b>	1686
	14"	356	42	19.1	8.9	<b>BWBS14-19</b>	1757
<b>24" width*</b> (610mm)	12"	305	45	20.4	7.6	<b>BWBS12-24</b>	1876
	14"	356	47	21.3	8.6	<b>BWBS14-24</b>	1959

\* Dimensions do not include 5" (127mm) additional width to align with equipment with single speed rail.

**Spec-Bar® Drainboard**   
Blender Stations

see spec sheet **EG40.26**



*Designed to align with single speed rails on adjoining equipment.*

**FEATURES:**

- Drain also included.
- Constructed of type 304 stainless steel with sink, workboard, and wet waste configurations for the perfect mixing component.
- 8" (203mm) high backsplash.
- Blender shelf with rear cord access hole.
- Lift-out stainless steel perforated sink strainer.
- Stainless steel adjustable feet.

**Note:** These units cannot use speed rails.

**Freight class is 100.0.**

	length		weight		cubic feet	model #	list
	in.	mm	lbs.	kg			
<b>19" width*</b> (483mm)	12"	305	40	18.1	6.5	<b>BDBS12-19</b>	1022
	18"	457	42	19.1	8.9	<b>BDBS18-19</b>	1206
<b>24" width*</b> (610mm)	12"	305	45	20.4	7.6	<b>BDBS12-24</b>	1085
	18"	457	47	21.3	8.6	<b>BDBS18-24</b>	1268

\* Dimensions do not include 5" (127mm) additional width to align with equipment with single speed rail.

## Spec-Bar® Cocktail Stations

see spec sheet **EG40.43**



**Flexibility of freestanding equipment in one easy unit.**

description	weight		cubic feet	model #	list
	lbs.	kg			
ice bin is on left, sinks are on right	345	156.5	37.0	<b>CS42-32L</b>	10743
ice bin is on right, sinks are on left	345	156.5	37.0	<b>CS42-32R</b>	10743

FEATURES:

- T&S quality faucets.
- Stone gray color, unless specified. Other colors available.
- 32" (813mm) overall width.
- 42" (1067mm) length.
- Blender shelf.
- Two 6" (152mm) deep sinks.
- Overshelf with removable perforated inserts, ice bin, tubing chase, work surface, and double speed rail.
- 8-circuit post-mix cold plate.
- Front and end panels are stone gray plastic laminate over wood core.

**Freight class is 110.0.**

## Spec-Bar® Combination Cocktail Stations

see spec sheet **EG40.44**



FEATURES:

- T&S quality faucets.
- Stone gray color, unless specified.
- Recessed workboard and/or liquor display area.
- Blender station.
- 12" (305mm) long wet waste sink area.
- Double speed rail.
- Combination ice bin.
- Condiment dispenser.
- Tubing access holes.

**Freight class is 110.0.**

	overall length		weight		cu ft	recessed wkbd. length		combination ice bin length		liquor display length		model #	list
	in.	mm	lbs.	kg		in.	mm	in.	mm	in.	mm		
<b>29" width (737mm)</b>	60"	1524	308	139.7	38.0	n/a	n/a	36"	914	12"	305	<b>CCS-60-1</b>	7412
	60"	1524	313	142.0	38.0	12"	305	36"	914	n/a	n/a	<b>CCS-60-2</b>	6931
	66"	1676	341	154.7	42.0	n/a	n/a	42"	1067	12"	305	<b>CCS-66-1</b>	7692
	66"	1676	319	144.7	42.0	12"	305	42"	1067	n/a	n/a	<b>CCS-66-2</b>	7212
	66"	1676	328	148.8	42.0	18"	457	36"	914	n/a	n/a	<b>CCS-66-3</b>	7033
	66"	1676	373	169.2	42.0	n/a	n/a	36"	914	18"	457	<b>CCS-66-4</b>	7675
	72"	1829	316	143.3	44.0	12"	305	36"	914	12"	305	<b>CCS-72</b>	8480
	72"	1829	336	152.4	44.0	n/a	n/a	42"	1067	18"	457	<b>CCS-72-1</b>	7957
	72"	1829	331	150.1	44.0	18"	457	42"	1067	n/a	n/a	<b>CCS-72-2</b>	7313

**Note:** 8-circuit post-mix cold plates available. To order, add \$2316 to list price and add suffix "-8" to model number.  
**Example:** CCS-60-1-8.

**Note:** To order 10-circuit post-mix cold plate, add \$2316 to list price and add suffix "-10" to model number.  
**Example:** CCS-60-1-10.

## Spec-Bar® Beverage Dispensers

see spec sheet **EG40.46**



description	weight		cubic feet	model #	list
	lbs.	kg			
stainless steel, 4 faucets	23	10.4	3.8	<b>BT4S-DT</b>	2293
brass, 4 faucets	23	10.4	3.8	<b>BT4B-DT</b>	4258
stainless steel, 5 faucets	25	11.3	3.8	<b>BT5S-DT</b>	2686
brass, 5 faucets	25	11.3	3.8	<b>BT5B-DT</b>	4649

FEATURES:

- 16" (406mm) working height.
- Drain pan with lift-out perforated insert for cleaning ease.
- Available with four or five faucet configurations.
- Tarnish-free solid brass or stainless steel.

**Freight class is 110.0.**



## Catalog Section 40

### Spec-Bar® Liquor Displays NSF

see spec sheet **EG40.47**

cutout aligns with speed rail of other equipment

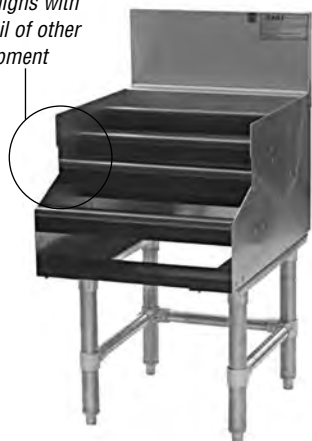

**Designed to align with speed rails installed on adjoining equipment.**

FEATURES:

- Step-and-rail open design.
- 24" (610mm) wide models feature four levels of storage. 29" (770mm) wide models have five.
- Each level has a retaining front rail.
- 37" (940mm) overall height.

**Freight class is 110.0.**

**Note:** Widths listed in charts below do not include additional 5" (127mm) to align with equipment with single speed rail.

...designed to align with single speed rail adjoined to Spec-Bar® 19" (483mm) wide equipment.

	length		weight		cubic	model #	list
	in.	mm	lbs.	kg	feet		
24" width (610mm)	12"	305	20	9.1	6.5	<b>LDSR12-19</b>	1347
	18"	457	25	11.3	8.9	<b>LDSR18-19</b>	1584
	24"	610	30	13.6	11.3	<b>LDSR24-19</b>	1820
	30"	762	35	15.9	13.7	<b>LDSR30-19</b>	2052
	36"	914	40	18.1	16.2	<b>LDSR36-19</b>	2287

...designed to align with double speed rail adjoined to Spec-Bar® 19" (483mm) wide equipment.

	length		weight		cubic	model #	list
	in.	mm	lbs.	kg	feet		
29" width (737mm)	12"	305	22	10.0	7.6	<b>LDDR12-19</b>	1551
	18"	457	30	13.6	10.5	<b>LDDR18-19</b>	1820
	24"	610	35	15.9	13.4	<b>LDDR24-19</b>	2083
	30"	762	45	20.4	16.2	<b>LDDR30-19</b>	2349
	36"	914	55	24.9	19.1	<b>LDDR36-19</b>	2613

...designed to align with Spec-Bar® 24" (610mm) wide equipment with no speed rail.

	length		weight		cubic	model #	list
	in.	mm	lbs.	kg	feet		
24" width (610mm)	12"	305	20	9.1	6.5	<b>LD12-24</b>	1347
	18"	457	25	11.3	8.9	<b>LD18-24</b>	1584
	24"	610	30	13.6	11.3	<b>LD24-24</b>	1820
	30"	762	35	15.9	13.7	<b>LD30-24</b>	2052
	36"	914	45	20.4	16.2	<b>LD36-24</b>	2287

...designed to align with single speed rail adjoined to Spec-Bar® 24" (610mm) wide equipment.

	length		weight		cubic	model #	list
	in.	mm	lbs.	kg	feet		
29" width (737mm)	12"	305	20	9.1	7.6	<b>LDSR12-24</b>	1551
	18"	457	25	11.3	10.5	<b>LDSR18-24</b>	1820
	24"	610	30	13.6	13.4	<b>LDSR24-24</b>	2083
	30"	762	35	15.9	16.2	<b>LDSR30-24</b>	2349
	36"	914	40	20.4	19.1	<b>LDSR36-24</b>	2613

### Spec-Bar® Dry Waste & Tubing Chases NSF

see spec sheet **EG40.52**



FEATURES:

- Fits between 19" or 24" (457 or 610mm) wide Spec-Bar® equipment.
- Mounting clips provided.
- Dry waste units feature front hinged access door and 6" (153mm) round opening.

**Freight class is 100.0.**

description	width x length		weight		cubic	model #	list
	in.	mm	lbs.	kg	feet		
dry waste unit	12" x 24"	305 x 610	25	11.3	6.5	<b>DW12-24</b>	858
dry waste unit	18" x 19"	457 x 483	25	11.3	7.3	<b>DW18-19</b>	858
dry waste unit	18" x 24"	457 x 610	28	12.7	8.9	<b>DW18-24</b>	994
tubing chase	6" x 19"	152 x 583	15	6.8	3.3	<b>TC6-19</b>	564
tubing chase	6" x 24"	152 x 610	17	7.7	4.1	<b>TC6-24</b>	643

## Spec-Bar® Permanent Speed Rails <sup>NSF</sup> and Locking Covers

see spec sheet **EG40.50**



Spec-Bar® permanent speed rail

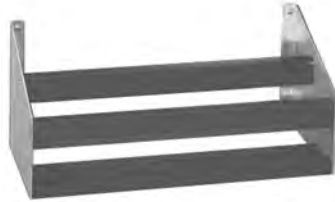

Spec-Bar® permanent double speed rail

**FEATURES:**

- Single speed rails are 5" (127mm) wide.
- Double speed rails are 10" (254mm) wide.
- Locking covers accommodate up to 12<sup>3</sup>/<sub>8</sub>" (314mm) high bottles. Taller covers available upon request.
- Locking covers include storage hangers when ordered with original single speed rails.

**Note:** When ordering, specify desired speed rail length by indicating in model number suffix. **Example:** SSR-12 indicates a 12" (305mm)-long single speed rail.

**Freight class is 70.0.**

description	length		weight		cubic feet	model #	list
	in.	mm	lbs.	kg			
single speed rails	12" to 17"	305 to 432	4	1.8	0.4	<b>SSR-12 to 17</b>	197
	18" to 23"	457 to 584	6	2.7	0.5	<b>SSR-18 to 23</b>	229
	24" to 29"	610 to 737	7	3.2	0.6	<b>SSR-24 to 29</b>	257
	30" to 35"	762 to 889	10	4.5	0.7	<b>SSR-30 to 35</b>	294
	36" to 41"	914 to 1041	12	5.4	0.9	<b>SSR-36 to 41</b>	334
	42" to 47"	1067 to 1194	18	8.2	1.0	<b>SSR-42 to 47</b>	372
	48" to 53"	1219 to 1346	22	10.0	1.1	<b>SSR-48 to 53</b>	411
	54" to 59"	1372 to 1499	25	11.3	1.2	<b>SSR-54 to 59</b>	452
	60" to 65"	1524 to 1651	28	12.7	1.4	<b>SSR-60 to 65</b>	488
	66" to 71"	1676 to 1803	32	14.5	1.5	<b>SSR-66 to 71</b>	526
	72" to 77"	1829 to 1956	35	15.9	1.6	<b>SSR-72 to 77</b>	566
	78" to 83"	1981 to 2108	38	17.2	1.7	<b>SSR-78 to 83</b>	602
84"	2134	42	19.1	1.9	<b>SSR-84</b>	642	
locking cover for single speed rails	12" to 17"	305 to 432	15	6.8	0.4	<b>SSRLC-12 to 17</b>	209
	18" to 23"	457 to 584	22	10.0	0.5	<b>SSRLC-18 to 23</b>	244
	24" to 29"	610 to 737	28	12.7	0.6	<b>SSRLC-24 to 29</b>	314
	30" to 35"	762 to 889	30	13.6	0.7	<b>SSRLC-30 to 35</b>	375
	36" to 41"	914 to 1041	32	14.5	0.8	<b>SSRLC-36 to 41</b>	439
42"	1067	35	15.9	1.0	<b>SSRLC-42</b>	503	
double speed rails	12" to 17"	305 to 432	8	3.6	1.4	<b>DSR-12 to 17</b>	354
	18" to 23"	457 to 584	12	5.4	1.9	<b>DSR-18 to 23</b>	431
	24" to 29"	610 to 737	14	6.4	2.4	<b>DSR-24 to 29</b>	511
	30" to 35"	762 to 889	20	9.1	2.9	<b>DSR-30 to 35</b>	585
	36" to 41"	914 to 1041	24	10.9	3.4	<b>DSR-36 to 41</b>	664
	42" to 47"	1067 to 1194	36	16.3	3.9	<b>DSR-42 to 47</b>	742
	48" to 53"	1219 to 1346	44	20.0	4.4	<b>DSR-48 to 53</b>	817
	54" to 59"	1372 to 1499	50	22.7	4.9	<b>DSR-54 to 59</b>	896
	60" to 65"	1524 to 1651	56	25.4	5.4	<b>DSR-60 to 65</b>	965
	66" to 71"	1676 to 1803	64	29.0	5.9	<b>DSR-66 to 71</b>	1051
	72" to 77"	1829 to 1956	70	31.8	6.4	<b>DSR-72 to 77</b>	1128
	78" to 83"	1981 to 2108	76	34.5	6.9	<b>DSR-78 to 83</b>	1206
84"	2134	84	38.1	7.5	<b>DSR-84</b>	1282	
locking cover for double speed rails	12" to 17"	305 to 432	30	13.6	1.4	<b>DSRLC-12 to 17</b>	378
	18" to 23"	457 to 584	44	20.0	1.9	<b>DSRLC-18 to 23</b>	488
	24" to 29"	610 to 737	56	25.4	2.4	<b>DSRLC-24 to 29</b>	632
	30" to 35"	762 to 889	60	27.2	2.9	<b>DSRLC-30 to 35</b>	746
	36" to 41"	914 to 1041	64	29.0	3.4	<b>DSRLC-36 to 41</b>	876
42"	1067	70	31.8	3.9	<b>DSRLC-42</b>	1007	

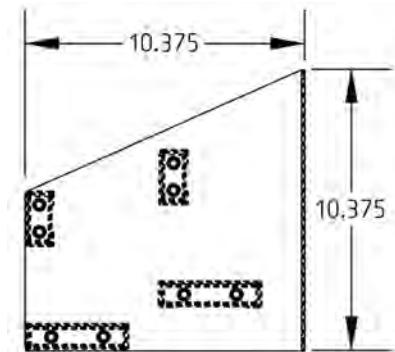
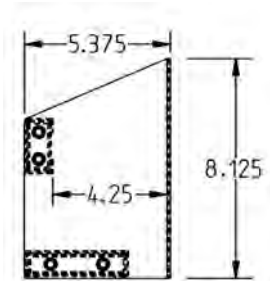

## Catalog Section 40

### Spec-Bar® Removable Single Speed Rails NSF

see spec sheet **EG40.51**

FEATURES:

- Keyhole models are removable and are for existing equipment.
- Hanging models clip onto existing single speed rails.

**Freight class is 70.0.**

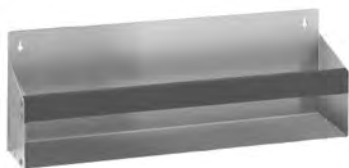

Spec-Bar® keyhole speed rail



Spec-Bar® hanging speed rail

	a length		weight		cubic feet	KEYHOLE SPEED RAILS		HANGING SPEED RAILS	
	in.	mm	lbs.	kg		model #	list	model #	list
<b>5" width (127mm)</b>	12"	305	4	1.8	0.4	<b>KSR-12</b>	363	<b>HSR-12</b>	254
	18"	457	6	2.7	0.5	<b>KSR-18</b>	366	<b>HSR-18</b>	261
	24"	610	7	3.2	0.6	<b>KSR-24</b>	387	<b>HSR-24</b>	303
	30"	762	10	4.5	0.7	<b>KSR-30</b>	399	<b>HSR-30</b>	341
	36"	914	12	5.4	0.9	<b>KSR-36</b>	416	<b>HSR-36</b>	380

### Spec-Bar® Mini Bottle Racks NSF

see spec sheet **EG40.48**

FEATURES:

- Type 304 stainless steel construction.
- Countertop and underbar models available.

**Freight class is 70.0.**



description	width x length		weight		cubic feet	model #	list
	in.	mm	lbs.	kg			
countertop model, holds 252 bottles	12" x 24"	305 x 610	35	15.9	6.5	<b>BRM-24CT</b>	1034
underbar model, holds 510 bottles	24" x 24"	610 x 610	95	43.1	11.3	<b>BRM-24</b>	2532

#### Optional Locking Covers

description	model #	list
fits bottle rack #BRM-24CT	<b>BRM-CTLC-24</b>	532
fits bottle rack #BRM-24	<b>BRM-LC-24</b>	738

### Spec-Bar® Glass Rack Storage Units NSF

see spec sheet **EG40.49**

FEATURES:

- GR series provide storage for three glass racks.
- WBGR series include a stainless steel workboard top surface with lift-out perforated inset and accommodates two glass racks.
- Removable clips and pilasters included on all units.

**Freight class is 110.0.**



WBGR18-24



GR24-24

	length		weight		cubic feet	model #	list
	in.	mm	lbs.	kg			
<b>19" width (483mm)</b>	18"	457	40	18.1	11.7	<b>GR18-19</b>	1268
	24"	610	45	20.4	14.9	<b>GR24-19</b>	1472
<b>24" width (610mm)</b>	18"	457	40	18.1	14.3	<b>GR18-24</b>	1472
	24"	610	50	22.7	18.1	<b>GR24-24</b>	1686
	18"	457	47	21.3	14.3	<b>WBGR18-24</b>	1686
	24"	610	55	24.9	18.1	<b>WBGR24-24</b>	1901

## Standard Portable Bar

see spec sheet **EG40.53**



**Offers both functionality and durability at an economical price.**

**COMES WITH A TOWEL RING!**

**IMPORTANT: PORTABLE BARS ARE FOR INDOOR USE ONLY.**

- 5' (1524mm).
- Choice of black, white, or "vintage" melamine exterior, with matching formica top.
- Stainless steel interior working surface.
- 15 $\frac{3}{8}$ " x 19 $\frac{3}{4}$ " x 8" (391 x 502 x 203mm) ice bin with 1 $\frac{1}{2}$ " (38mm) NPS drain.
- 4" (102mm) plate casters (two with brake).
- Two soda gun openings, speed rails and front corner guards.

FEATURES:

**ALL PORTABLE BARS ARE SHIPPED ASSEMBLED.**

**Note:** For 7-circuit post-mix sealed-in cold plate, add suffix "-7" to model number and add **\$1993 to list price.**

**Example:** PB-5-7. Additional note: On bars with cold plate, ice bin is 15 $\frac{1}{2}$ " x 18 $\frac{1}{2}$ " x 8" (384 x 470 x 203mm).

**Freight class is 100.0.**

weight		cubic	black		white		vintage	
lbs.	kg	feet	model #	list	model #	list	model #	list
292	132.5	55.9	PB-5	4093	PB-5-W	4298	PB-5-V	4502



## Deluxe Portable Bars

see spec sheet **EG40.53**



**IMPORTANT: PORTABLE BARS ARE FOR INDOOR USE ONLY.**

- Choice of black, white, or "vintage" melamine exterior, with matching formica top.
- Stainless steel interior working surface.
- 15 $\frac{3}{8}$ " x 19 $\frac{3}{4}$ " x 8" (391 x 502 x 203mm) ice bin with 1 $\frac{1}{2}$ " (38mm) NPS drain.
- Double tier stainless steel speed rail.
- Adjustable stainless steel glides for storage racks.
- Center locking storage cabinet.
- Two soda gun openings and front corner guards.
- Working height accommodates all soda system tanks.

FEATURES:

**Note:** For 7-circuit post-mix sealed-in cold plate, add suffix "-7" to model number and add **\$2076 to list price.**

**Example:** DPB-5-7. Additional note: On bars with cold plate, ice bin is 15 $\frac{1}{2}$ " x 18 $\frac{1}{2}$ " x 8" (384 x 470 x 203mm).

**Freight class is 100.0.**

...with features listed above.

weight		cubic	black		white		vintage	
lbs.	kg	feet	model #	list	model #	list	model #	list
225	102.1	77.9	DPB-5	5082	DPB-5-W	5336	DPB-5-V	5590

...with features listed above, plus left ("L") or right ("R") locking cabinet and stainless steel speed rail.

weight		cubic	black		white		vintage	
lbs.	kg	feet	model #	list	model #	list	model #	list
240	108.9	80.1	DPB-5L	5102	DPB-5L-W	5357	DPB-5L-V	5612
			DPB-5R	5102	DPB-5R-W	5357	DPB-5R-V	5612

...with features listed above, plus two locking cabinets and two stainless steel speed rails.

weight		cubic	black		white		vintage	
lbs.	kg	feet	model #	list	model #	list	model #	list
250	113.4	80.1	DPB-5LR	5288	DPB-5LR-W	5552	DPB-5LR-V	5817



## CUSTOM GRAPHICS AVAILABLE!!

**Laser-Cutting and Custom Decal Services for Portable Bars!**



(custom laser-cut for Rehoboth Beach Country Club, Rehoboth Beach, DE)



Lined writing area on the left side of the page.

Lined writing area on the right side of the page.



# Dishtables

## Accessories/Options

Anti-Siphon Breaker .....	328
Bullet Feet .....	328
Condensate Vents and Hoods .....	325
Control Panel Bracket.....	328
Custom Modifications .....	326
Disposal Provision Packages .....	329
Drain Trough .....	328
Gussets .....	328
Legs / Crossbrace Assemblies .....	329
Lever Drains.....	328
Polymer Undershelves .....	329
Prerinse Basket with Slide Bar .....	328
Prerinse Units .....	328

PVC Rollers .....	329
Rack Shelves .....	327
Rack Slide .....	328
Scrap Basket .....	328
Sink Covers .....	329
Soiled Dishtable Kit.....	320-324
Stainless Steel Legs, Gussets, Feet .....	318-324
Undershelves .....	328

## Clean Dishtables

Corner Design .....	318
Island Design .....	319
Straight Design .....	318

## Soiled Dishtables

Corner Design .....	321
Island Design .....	322
Straight Design .....	320
with 3-Compartment Pot Sink .....	324
with Landing Shelf .....	323

## More Dishtables

Dishtable Package Special .....	319
Mobile Soak Sinks .....	325
Undercounter Dishtables .....	324

## General specifications:

*Dishtables available are corner, straight, and island design; clean, soiled, and undercounter; left- and right-handed models.*



**Tops:** 14 gauge type 304 stainless steel, 16/304 or 16/430 stainless steel with all seams welded, grounded smooth and polished. Where indicated, front and ends have a 3" (76mm) high turn-up and be finished with a 1½" (38mm) diameter sanitary rolled edge. 8" (203mm) high backsplash is 5" (127mm) high with a 2" (51mm) 45° return to wall, plus a 1" (25mm) upturn and tile edge for easy installation and feathering to wall/splash surface. All vertical and horizontal bends are covered to a ¾" (10mm) radius. Table is constructed in full compliance with NSF requirements.

**Underbracing:** "U"-type channel constructed of 14 gauge 304-18-8 stainless steel, welded to underside of table. Whenever necessary, there are full enclosed plated or stainless steel gussets welded to channel to accept legs.

**Legs:** 1½" (41mm) outside dimension, seamlessly welded galvanized or stainless steel tubing. Connecting legs front-to-back are 1" (25mm) diameter galvanized or stainless steel tubing fully welded to same. Leg assembly complete with corrosion-resistant fully adjustable bullet feet.

**Prerinse Sink:** Soiled table equipped with an integrally welded recessed sink 20" x 20" x 5" (508 x 508 x 127mm), complete with a 3½" (89mm) diameter hole to accommodate a 1½" (38mm) basket drain furnished by EAGLE GROUP.

**Scrap Block:** Soiled table furnished with a 5¾" (146mm) diameter die-stamped hole with a ½" (13mm) high raised edge to prevent spillage. Fitted within is a removable gray neoprene scrap block.

## Clean Dishtables

see spec sheets **EG50.00** **EG50.01**



clean dishtable straight design  
— right-hand model with optional undershelf

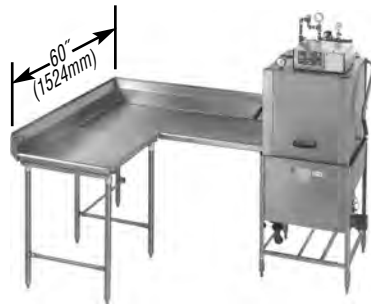

clean dishtable corner design  
— left-hand model

SPEC-MASTER®  
FEATURES:

- 14/304 dishtables.
- Stainless steel crossbraced legs.
- Stainless steel gussets and stainless steel feet.

FEATURES:

- 30" (762mm) width.
- Polished stainless steel work surface.
- 20½" (521mm) opening to accept dishwasher.
- Crossbraced legs.
- Rolled edges.
- 8" (203mm) backsplash.
- Left or right operation.
- L or R in model numbers indicate left- or right-hand models.

**Note:** For accessories, see pages 328-329.

**Freight class is 70.0.**

(•) MTS (made to stock) / ( ) MTO (made to order)

### Straight Design **EG50.00**

length		weight		cu	16 gauge type 430		16 gauge type 304		14 gauge type 304	
in.	mm	lb.	kg	ft	model #	list	model #	list	model #	list
24"	610	36	16.3	8.3	CDTL-24-16/4 •	1420	CDTL-24-16/3 •	1541	CDTL-24-14/3	1808
24"	610	36	16.3	8.3	CDTR-24-16/4 •	1420	CDTR-24-16/3 •	1541	CDTR-24-14/3	1808
30"	762	42	19.1	10.1	CDTL-30-16/4	1531	CDTL-30-16/3 •	1643	CDTL-30-14/3	1958
30"	762	42	19.1	10.1	CDTR-30-16/4	1531	CDTR-30-16/3 •	1643	CDTR-30-14/3 •	1958
36"	914	49	22.2	12.4	CDTL-36-16/4 •	1648	CDTL-36-16/3 •	1766	CDTL-36-14/3	2196
36"	914	49	22.2	12.4	CDTR-36-16/4 •	1648	CDTR-36-16/3 •	1766	CDTR-36-14/3	2196
48"	1219	63	28.6	15.3	CDTL-48-16/4 •	1809	CDTL-48-16/3 •	1927	CDTL-48-14/3	2299
48"	1219	63	28.6	15.3	CDTR-48-16/4 •	1809	CDTR-48-16/3 •	1927	CDTR-48-14/3 •	2299
60"	1524	77	34.9	18.9	CDTL-60-16/4 •	1925	CDTL-60-16/3 •	2040	CDTL-60-14/3	2451
60"	1524	77	34.9	18.9	CDTR-60-16/4 •	1925	CDTR-60-16/3 •	2040	CDTR-60-14/3	2451
72"	1829	91	41.3	22.4	CDTL-72-16/4	2023	CDTL-72-16/3 •	2139	CDTL-72-14/3	2586
72"	1829	91	41.3	22.4	CDTR-72-16/4	2023	CDTR-72-16/3 •	2139	CDTR-72-14/3	2586
84"	2134	105	47.6	25.9	CDTL-84-16/4	2204	CDTL-84-16/3	2375	CDTL-84-14/3	2827
84"	2134	105	47.6	25.9	CDTR-84-16/4	2204	CDTR-84-16/3	2375	CDTR-84-14/3	2827
96"	2438	119	54.0	29.4	CDTL-96-16/4	2261	CDTL-96-16/3	2576	CDTL-96-14/3	2887
96"	2438	119	54.0	29.4	CDTR-96-16/4	2261	CDTR-96-16/3	2576	CDTR-96-14/3	2887
108"	2743	134	60.8	32.7	CDTL-108-16/4	2822	CDTL-108-16/3	2975	CDTL-108-14/3	3604
108"	2743	134	60.8	32.7	CDTR-108-16/4	2822	CDTR-108-16/3	2975	CDTR-108-14/3	3604
120"	3048	147	66.7	33.2	CDTL-120-16/4	2969	CDTL-120-16/3	3129	CDTL-120-14/3	3794
120"	3048	147	66.7	33.2	CDTR-120-16/4	2969	CDTR-120-16/3	3129	CDTR-120-14/3	3794

### Corner Design **EG50.01**

length		weight		cu	16 gauge type 430		16 gauge type 304		14 gauge type 304	
in.	mm	lb.	kg	ft	model #	list	model #	list	model #	list
48"	1219	120	54.4	29.8	CDTCL-48-16/4	3847	CDTCL-48-16/3	4195	CDTCL-48-14/3	4848
48"	1219	120	54.4	29.8	CDTCR-48-16/4	3847	CDTCR-48-16/3	4195	CDTCR-48-14/3	4848
60"	1524	130	59.0	36.8	CDTCL-60-16/4	3952	CDTCL-60-16/3	4298	CDTCL-60-14/3	4986
60"	1524	130	59.0	36.8	CDTCR-60-16/4	3952	CDTCR-60-16/3	4298	CDTCR-60-14/3	4986
72"	1829	140	63.5	43.8	CDTCL-72-16/4	4126	CDTCL-72-16/3	4472	CDTCL-72-14/3	5200
72"	1829	140	63.5	43.8	CDTCR-72-16/4	4126	CDTCR-72-16/3	4472	CDTCR-72-14/3	5200
84"	2134	150	68.0	50.8	CDTCL-84-16/4	4303	CDTCL-84-16/3	4645	CDTCL-84-14/3	5444
84"	2134	150	68.0	50.8	CDTCR-84-16/4	4303	CDTCR-84-16/3	4645	CDTCR-84-14/3	5444
96"	2438	160	72.6	57.8	CDTCL-96-16/4	4361	CDTCL-96-16/3	4703	CDTCL-96-14/3	5504
96"	2438	160	72.6	57.8	CDTCR-96-16/4	4361	CDTCR-96-16/3	4703	CDTCR-96-14/3	5504
108"	2754	170	77.1	64.8	CDTCL-108-16/4	5461	CDTCL-108-16/3	5774	CDTCL-108-14/3	6789
108"	2754	170	77.1	64.8	CDTCR-108-16/4	5461	CDTCR-108-16/3	5774	CDTCR-108-14/3	6789
120"	3048	180	81.6	73.8	CDTCL-120-16/4	5749	CDTCL-120-16/3	6078	CDTCL-120-14/3	7146
120"	3048	180	81.6	73.8	CDTCR-120-16/4	5749	CDTCR-120-16/3	6078	CDTCR-120-14/3	7146

### Stainless Steel Options

description	add* suffix #	add to list price
<b>Stainless Steel Legs</b> for lengths 24" through 72" for lengths 84" and longer	-SL -SL	221 440
<b>Stainless Steel Legs and Gussets</b> for lengths 24" through 72" for lengths 84" and longer	-SLG -SLG	286 573
<b>Stainless Steel Legs, Gussets, and Feet</b> for lengths 24" through 72" for lengths 84" and longer	-SLGF -SLGF	329 660

\* Example: CDTL-24-16/3-SL

### Stainless Steel Options

description	add* suffix #	add to list price
<b>Stainless Steel Legs</b> for lengths 48" through 84" for lengths 96" and longer	-SL -SL	435 620
<b>Stainless Steel Legs and Gussets</b> for lengths 48" through 84" for lengths 96" and longer	-SLG -SLG	628 841
<b>Stainless Steel Legs, Gussets, and Feet</b> for lengths 48" through 84" for lengths 96" and longer	-SLGF -SLGF	735 989

\* Example: CDTCL-48-16/4-SL



## Catalog Section 50

### Clean Dishtables - Island Design

see spec sheet **EG50.08**

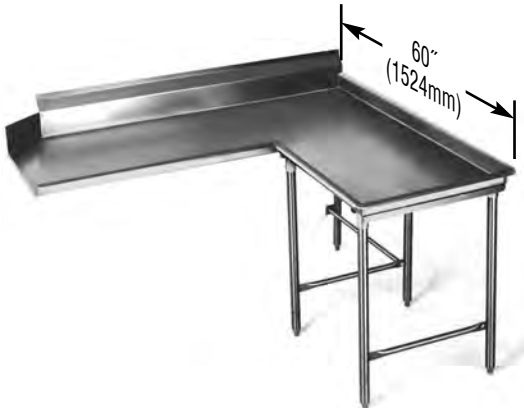

clean dishtable island design  
— right-hand model

SPEC-MASTER®  
FEATURES:

- 14/304 dishtables.
- Stainless steel crossbraced legs.
- Stainless steel gussets and stainless steel feet.

FEATURES:

- 30" (762mm) width.
- Polished stainless steel work surface.
- 20½" (521mm) opening to accept dishwasher.
- Crossbraced legs.
- Rolled edges.
- 8" (203mm) backsplash.
- Left or right operation.
- L or R in model numbers indicate left- or right-hand models.

**Note:** For accessories, see pages 328-329.

**Freight class is 70.0.**

length		weight		cu	16 gauge type 430		16 gauge type 304		14 gauge type 304	
in.	mm	lb.	kg	ft	model #	list	model #	list	model #	list
48"	1219	118	53.5	29.8	CDTCIL-48-16/4	3722	CDTCIL-48-16/3	4069	CDTCIL-48-14/3	4708
48"	1219	118	53.5	29.8	CDTCIR-48-16/4	3722	CDTCIR-48-16/3	4069	CDTCIR-48-14/3	4708
60"	1524	128	58.1	36.8	CDTCIL-60-16/4	3827	CDTCIL-60-16/3	4176	CDTCIL-60-14/3	4849
60"	1524	128	58.1	36.8	CDTCIR-60-16/4	3827	CDTCIR-60-16/3	4176	CDTCIR-60-14/3	4849
72"	1829	138	62.6	43.0	CDTCIL-72-16/4	3999	CDTCIL-72-16/3	4345	CDTCIL-72-14/3	5064
72"	1829	138	62.6	43.0	CDTCIR-72-16/4	3999	CDTCIR-72-16/3	4345	CDTCIR-72-14/3	5064
96"	2438	157	71.2	57.0	CDTCIL-96-16/4	4231	CDTCIL-96-16/3	4574	CDTCIL-96-14/3	5362
96"	2438	157	71.2	57.0	CDTCIR-96-16/4	4231	CDTCIR-96-16/3	4574	CDTCIR-96-14/3	5362
108"	2743	172	78.0	64.0	CDTCIL-108-16/4	5223	CDTCIL-108-16/3	5536	CDTCIL-108-14/3	6078
108"	2743	172	78.0	64.0	CDTCIR-108-16/4	5223	CDTCIR-108-16/3	5536	CDTCIR-108-14/3	6078
120"	3048	184	83.4	71.0	CDTCIL-120-16/4	5498	CDTCIL-120-16/3	5826	CDTCIL-120-14/3	6872
120"	3048	184	83.4	71.0	CDTCIR-120-16/4	5498	CDTCIR-120-16/3	5826	CDTCIR-120-14/3	6872

### Stainless Steel Options for 16 Gauge Clean Dishtables

description	add* suffix #	add to list price
<b>Stainless Steel Legs</b> for lengths 48" - 72" (1219 - 1829mm) for lengths 96" (2438mm) and longer	-SL -SL	435 620
<b>Stainless Steel Legs and Gussets</b> for lengths 48" - 72" (1219 - 1829mm) for lengths 96" (2438mm) and longer	-SLG -SLG	628 841
<b>Stainless Steel Legs, Gussets, and Feet</b> for lengths 48" - 72" (1219 - 1829mm) for lengths 96" (2438mm) and longer	-SLGF -SLGF	735 989

\* Example: CDTCIL-48-16/4-SL

### Dishtable Package Special

see spec sheet **EG50.13**

Clean dishtable and soiled dishtable, both 48" (1219mm) 16 gauge 304 stainless steel. Rubber scrap block; prerinse faucet #300718; prerinse basket & slide bar; and 42" (1067mm) KD tubular rack shelf. (Dishwasher not included.) **Freight class is 70.0.**

model #	list
DTC-48LR-16/3	8115
DTC-48RL-16/3	8115

**Note:** DTC-48RL-16/3 does not come with scrap block.



#DTC-48LR-16/3 left-to-right operation shown

## Soiled Dishtables - Straight Design

see spec sheet **EG50.02**



soiled dishtable straight design  
— left-hand model with optional accessories

SPEC-MASTER®  
FEATURES:

- 14/304 dishtables.
- Stainless steel crossbraced legs.
- Stainless steel gussets and stainless steel feet.

FEATURES:

- 30" (762mm) width.
- Polished stainless steel work surface.
- 20½" (521mm) opening to accept dishwasher.
- Crossbraced legs.
- Rolled edges.
- 8" (203mm) backsplash.
- Prerinse sink, and left or right operation.
- L or R in model numbers indicate left- or right-hand models.
- Scrap block hole and rubber scrap block are included on all models except 30", 36" L and R, and 48" R\*.

**Note:** For accessories, see pages 328-329.

**Freight class is 70.0.**

(•) MTS (made to stock) / ( ) MTO (made to order)

length		weight		cu	16 gauge type 430		16 gauge type 304		14 gauge type 304	
in.	mm	lb.	kg	ft	model #	list	model #	list	model #	list
30"	762	42	19.1	10.1	<b>SDTL-30-16/4</b>	2421	<b>SDTL-30-16/3</b>	2592	<b>SDTL-30-14/3</b>	3076
30"	762	42	19.1	10.1	<b>SDTR-30-16/4</b>	2421	<b>SDTR-30-16/3</b>	2592	<b>SDTR-30-14/3</b>	3076
36"	914	49	22.2	12.4	<b>SDTL-36-16/4</b> •	2792	<b>SDTL-36-16/3</b> •	2896	<b>SDTL-36-14/3</b>	4218
36"	914	49	22.2	12.4	<b>SDTR-36-16/4</b> •	2792	<b>SDTR-36-16/3</b>	2896	<b>SDTR-36-14/3</b>	4218
48"	1219	63	28.6	15.3	<b>SDTL-48-16/4</b> ••	2888	<b>SDTL-48-16/3</b> ••	2993	<b>SDTL-48-14/3</b> *	4362
48"	1219	63	28.6	15.3	<b>SDTR-48-16/4</b> •	2888	<b>SDTR-48-16/3</b> •	2993	<b>SDTR-48-14/3</b>	4362
60"	1524	77	34.9	18.9	<b>SDTL-60-16/4</b> ••	2989	<b>SDTL-60-16/3</b> ••	3092	<b>SDTL-60-14/3</b> *	4504
60"	1524	77	34.9	18.9	<b>SDTR-60-16/4</b> ••	2989	<b>SDTR-60-16/3</b> ••	3092	<b>SDTR-60-14/3</b> *	4504
72"	1829	91	41.3	22.4	<b>SDTL-72-16/4</b> *	3144	<b>SDTL-72-16/3</b> ••	3252	<b>SDTL-72-14/3</b> *	4715
72"	1829	91	41.3	22.4	<b>SDTR-72-16/4</b> *	3144	<b>SDTR-72-16/3</b> ••	3252	<b>SDTR-72-14/3</b> *	4715
84"	2134	105	47.6	25.9	<b>SDTL-84-16/4</b> *	3329	<b>SDTL-84-16/3</b> *	3487	<b>SDTL-84-14/3</b> *	4968
84"	2134	105	47.6	25.9	<b>SDTR-84-16/4</b> *	3329	<b>SDTR-84-16/3</b> *	3487	<b>SDTR-84-14/3</b> *	4968
96"	2438	119	54.0	29.6	<b>SDTL-96-16/4</b> *	3384	<b>SDTL-96-16/3</b> *	3802	<b>SDTL-96-14/3</b> *	5033
96"	2438	119	54.0	29.6	<b>SDTR-96-16/4</b> *	3384	<b>SDTR-96-16/3</b> *	3802	<b>SDTR-96-14/3</b> *	5033
108"	2743	129	58.5	30.3	<b>SDTL-108-16/4</b> *	4019	<b>SDTL-108-16/3</b> *	4160	<b>SDTL-108-14/3</b> *	5796
108"	2743	129	58.5	30.3	<b>SDTR-108-16/4</b> *	4019	<b>SDTR-108-16/3</b> *	4160	<b>SDTR-108-14/3</b> *	5796
120"	3048	147	66.7	33.6	<b>SDTL-120-16/4</b> *	4231	<b>SDTL-120-16/3</b> *	4380	<b>SDTL-120-14/3</b> *	6101
120"	3048	147	66.7	33.6	<b>SDTR-120-16/4</b> *	4231	<b>SDTR-120-16/3</b> *	4380	<b>SDTR-120-14/3</b> *	6101

\* Scrap block provided with these models. To order without scrap block, deduct \$56 off list price and add suffix "-NSB" to model number.

Example: **SDTL-48-16/3-NSB**

### Stainless Steel Options for 16 Gauge Soiled Dishtables

description	add* suffix #	add to list price
<b>Stainless Steel Legs</b> for lengths 30" - 72" (762 - 1829mm)	-SL	221
for lengths 84" (2134mm) and longer	-SL	440
<b>Stainless Steel Legs and Gussets</b> for lengths 30" - 72" (762 - 1829mm)	-SLG	286
for lengths 84" (2134mm) and longer	-SLG	573
<b>Stainless Steel Legs, Gussets, and Feet</b> for lengths 30" - 72" (762 - 1829mm)	-SLGF	329
for lengths 84" (2134mm) and longer	-SLGF	660

\* Example: **SDTL-30-16/4-SL**

### Soiled Dishtable Kit

see spec sheet **EG50.07**

**For all soiled dishtables listed above.**

- Scrap basket.
- Rack slide.
- T&S prerinse faucet #313295.

Add suffix "-SRP" to model # and add \$2545.

Example: **SDTL-30-16/4-SRP**

## Catalog Section 50

### Soiled Dishtables - Corner Design

see spec sheet **EG50.03**

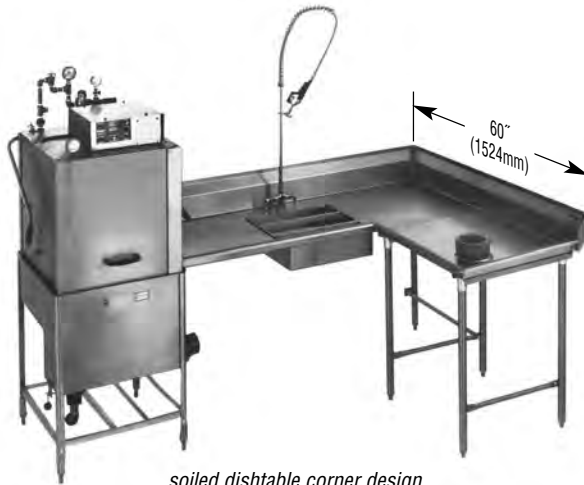

soiled dishtable corner design  
— right-hand model with optional accessories

SPEC-MASTER®  
FEATURES:

- 14/304 dishtables.
- Stainless steel crossbraced legs.
- Stainless steel gussets and stainless steel feet.

FEATURES:

- 30" (762mm) width.
- Polished stainless steel work surface.
- 20½" (521mm) opening to accept dishwasher.
- Crossbraced legs.
- Rolled edges.
- 8" (203mm) backsplash.
- Prerinse sink, and left or right operation.
- L or R in model numbers indicate left- or right-hand models.

**Note:** For accessories, see pages 328-329.

**Freight class is 70.0.**

length		weight		cu ft	16 gauge type 430		16 gauge type 304		14 gauge type 304	
in.	mm	lb.	kg		model #	list	model #	list	model #	list
60"	1524	170	77.1	36.8	<b>SDTCL-60-16/4</b>	5483	<b>SDTCL-60-16/3</b>	6007	<b>SDTCL-60-14/3</b>	7063
60"	1524	170	77.1	36.8	<b>SDTCR-60-16/4</b>	5483	<b>SDTCR-60-16/3</b>	6007	<b>SDTCR-60-14/3</b>	7063
72"	1829	180	81.6	43.8	<b>SDTCL-72-16/4</b>	5638	<b>SDTCL-72-16/3</b>	6163	<b>SDTCL-72-14/3</b>	7274
72"	1829	180	81.6	43.8	<b>SDTCR-72-16/4</b>	5638	<b>SDTCR-72-16/3</b>	6163	<b>SDTCR-72-14/3</b>	7274
84"	2134	190	86.2	50.8	<b>SDTCL-84-16/4</b>	5819	<b>SDTCL-84-16/3</b>	6336	<b>SDTCL-84-14/3</b>	7523
84"	2134	190	86.2	50.8	<b>SDTCR-84-16/4</b>	5819	<b>SDTCR-84-16/3</b>	6336	<b>SDTCR-84-14/3</b>	7523
96"	2438	200	90.7	57.8	<b>SDTCL-96-16/4</b>	5874	<b>SDTCL-96-16/3</b>	6394	<b>SDTCL-96-14/3</b>	7584
96"	2438	200	90.7	57.8	<b>SDTCR-96-16/4</b>	5874	<b>SDTCR-96-16/3</b>	6394	<b>SDTCR-96-14/3</b>	7584
108"	2743	210	95.3	64.3	<b>SDTCL-108-16/4</b>	6719	<b>SDTCL-108-16/3</b>	7201	<b>SDTCL-108-14/3</b>	8353
108"	2743	210	95.3	64.3	<b>SDTCR-108-16/4</b>	6719	<b>SDTCR-108-16/3</b>	7201	<b>SDTCR-108-14/3</b>	8353
120"	3048	220	99.8	71.8	<b>SDTCL-120-16/4</b>	7072	<b>SDTCL-120-16/3</b>	7580	<b>SDTCL-120-14/3</b>	8794
120"	3048	220	99.8	71.8	<b>SDTCR-120-16/4</b>	7072	<b>SDTCR-120-16/3</b>	7580	<b>SDTCR-120-14/3</b>	8794

### Stainless Steel Options for 16 Gauge Soiled Dishtables

description	add* suffix #	add to list price
<b>Stainless Steel Legs</b> for lengths 60" - 84" (1524 - 2134mm)	-SL	435
for lengths 96" (2438mm) and longer	-SL	620
<b>Stainless Steel Legs and Gussets</b> for lengths 60" - 84" (1524 - 2134mm)	-SLG	628
for lengths 96" (2438mm) and longer	-SLG	841
<b>Stainless Steel Legs, Gussets, and Feet</b> for lengths 60" - 84" (1524 - 2134mm)	-SLGF	735
for lengths 96" (2438mm) and longer	-SLGF	989

\* Example: SDTCL-60-16/4-SL

### Soiled Dishtable Kit

see spec sheet **EG50.07**

**For all soiled dishtables listed above.**

- Scrap basket.
  - Rack slide.
  - T&S prerinse faucet (313295).
- Add suffix "-SRP" to model # and add \$2545.  
**Example: SDTCL-60-16/4-SRP**

## Soiled Dishtables - Island Design

see spec sheet **EG50.09**

SPEC-MASTER®  
FEATURES:

- 14/304 dishtables.
- Stainless steel crossbraced legs.
- Stainless steel gussets and stainless steel feet.



soiled dishtable island design  
—right-hand model shown

FEATURES:

- 30" (762mm) width.
- Polished stainless steel work surface.
- 20½" (521mm) opening to accept dishwasher.
- Crossbraced legs.
- Rolled edges.
- 8" (203mm) backsplash.
- Pre-rinse sink, and left or right operation.
- L or R in model numbers indicate left- or right-hand models.

Note: For accessories, see pages 328-329.

**Freight class is 70.0.**

length		weight		cu ft	16 gauge type 430		16 gauge type 304		14 gauge type 304	
in.	mm	lb.	kg		model #	list	model #	list	model #	list
60"	1524	168	76.2	36.6	SDTCIL-60-16/4	5355	SDTCIL-60-16/3	5882	SDTCIL-60-14/3	6925
60"	1524	168	76.2	36.6	SDTCIR-60-16/4	5355	SDTCIR-60-16/3	5882	SDTCIR-60-14/3	6925
72"	1829	178	80.7	43.6	SDTCIL-72-16/4	5514	SDTCIL-72-16/3	6039	SDTCIL-72-14/3	7129
72"	1829	178	80.7	43.6	SDTCIR-72-16/4	5514	SDTCIR-72-16/3	6039	SDTCIR-72-14/3	7129
84"	2134	188	85.3	50.8	SDTCIL-84-16/4	5691	SDTCIL-84-16/3	6213	SDTCIL-84-14/3	7385
84"	2134	188	85.3	50.8	SDTCIR-84-16/4	5691	SDTCIR-84-16/3	6213	SDTCIR-84-14/3	7385
96"	2438	198	89.9	57.6	SDTCIL-96-16/4	5746	SDTCIL-96-16/3	6268	SDTCIL-96-14/3	7444
96"	2438	198	89.9	57.6	SDTCIR-96-16/4	5746	SDTCIR-96-16/3	6268	SDTCIR-96-14/3	7444
108"	2743	208	94.3	64.6	SDTCIL-108-16/4	6369	SDTCIL-108-16/3	6857	SDTCIL-108-14/3	8174
108"	2743	208	94.3	64.6	SDTCIR-108-16/4	6369	SDTCIR-108-16/3	6857	SDTCIR-108-14/3	8174
120"	3048	218	98.9	71.6	SDTCIL-120-16/4	6879	SDTCIL-120-16/3	7387	SDTCIL-120-14/3	8659
120"	3048	218	98.9	71.6	SDTCIR-120-16/4	6879	SDTCIR-120-16/3	7387	SDTCIR-120-14/3	8659

### Stainless Steel Options for 16 Gauge Soiled Dishtables

description	add* suffix #	add to list price
<b>Stainless Steel Legs</b> for lengths 60" - 84" (1524 - 2134mm) for lengths 96" (2438mm) and longer	-SL -SL	435 620
<b>Stainless Steel Legs and Gussets</b> for lengths 60" - 84" (1524 - 2134mm) for lengths 96" (2438mm) and longer	-SLG -SLG	628 841
<b>Stainless Steel Legs, Gussets, and Feet</b> for lengths 60" - 84" (1524 - 2134mm) for lengths 96" (2438mm) and longer	-SLGF -SLGF	735 989

\* Example: SDTCIL-60-16/4-SL

### Soiled Dishtable Kit

see spec sheet **EG50.07**

For all soiled dishtables listed above.

- Scrap basket.
- Rack slide.
- T&S pre-rinse faucet (313295).

Add suffix "-SRP" to model # and add \$2545.

Example: SDTCIL-60-16/4-SRP

### Stainless Steel Cleaner & Polish

weight		model #	list
oz.	kg		
15	0.4	004026	22



FEATURES:

- Cleans and polishes in one step.
- Does not streak or leave fingerprints.
- Leaves a protective invisible coating.

## Catalog Section 50

### Soiled Dishtables with Landing Shelf

see spec sheet **EG50.10**

SPEC-MASTER®

FEATURES:

- 14/304 dishtables.
- Stainless steel crossbraced legs.
- Stainless steel gussets and stainless steel feet.

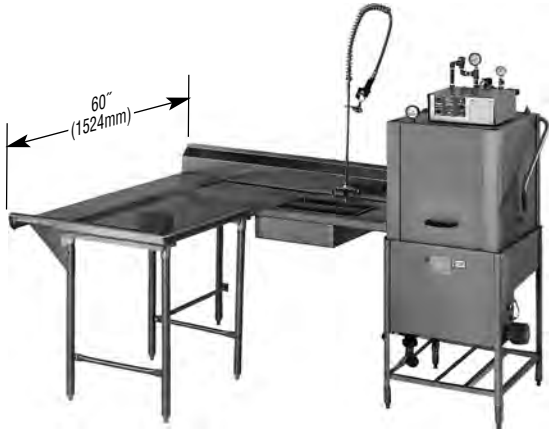

soiled dishtable with landing shelf  
— left-hand model with optional accessories shown

FEATURES:

- 20½" (521mm) opening to accept dishwasher.
- 12" (305mm) wide landing shelf on a 40½" (1029mm) landing area.
- L or R in model numbers indicate left- or right-hand models.

**Note:** For accessories, see pages 328-329.

**Predrilled double rack shelf or double-sided sorting rack now available.** To order double rack shelf, add suffix "-DRS" to model number and **\$2909 to list price**. To order **double-sided sorting rack**, add suffix "-DSS" to model number and **\$2998 to list price**.  
**Example: SDTLR-72-16/4-DSS**

**Freight class is 70.0.**

length		weight		cu	16 gauge type 430		16 gauge type 304		14 gauge type 304	
in.	mm	lb.	kg	ft	model #	list	model #	list	model #	list
66"	1676	165	74.8	40.2	<b>SDTLL-66-16/4</b>	4880	<b>SDTLL-66-16/3</b>	5531	<b>SDTLL-66-14/3</b>	6563
66"	1676	165	74.8	40.2	<b>SDTLR-66-16/4</b>	4880	<b>SDTLR-66-16/3</b>	5531	<b>SDTLR-66-14/3</b>	6563
72"	1829	175	79.4	43.8	<b>SDTLL-72-16/4</b>	6519	<b>SDTLL-72-16/3</b>	7033	<b>SDTLL-72-14/3</b>	8235
72"	1829	175	79.4	43.8	<b>SDTLR-72-16/4</b>	6519	<b>SDTLR-72-16/3</b>	7033	<b>SDTLR-72-14/3</b>	8235
78"	1981	185	83.9	48.8	<b>SDTLL-78-16/4</b>	6694	<b>SDTLL-78-16/3</b>	7206	<b>SDTLL-78-14/3</b>	8424
78"	1981	185	83.9	48.8	<b>SDTLR-78-16/4</b>	6694	<b>SDTLR-78-16/3</b>	7206	<b>SDTLR-78-14/3</b>	8424
84"	2134	195	88.5	50.8	<b>SDTLL-84-16/4</b>	6749	<b>SDTLL-84-16/3</b>	7235	<b>SDTLL-84-14/3</b>	8485
84"	2134	195	88.5	50.8	<b>SDTLR-84-16/4</b>	6749	<b>SDTLR-84-16/3</b>	7235	<b>SDTLR-84-14/3</b>	8485
96"	2438	210	95.3	57.8	<b>SDTLL-96-16/4</b>	6802	<b>SDTLL-96-16/3</b>	7259	<b>SDTLL-96-14/3</b>	8545
96"	2438	210	95.3	57.8	<b>SDTLR-96-16/4</b>	6802	<b>SDTLR-96-16/3</b>	7259	<b>SDTLR-96-14/3</b>	8545
108"	2743	220	99.8	61.8	<b>SDTLL-108-16/4</b>	7088	<b>SDTLL-108-16/3</b>	7825	<b>SDTLL-108-14/3</b>	8958
108"	2743	220	99.8	61.8	<b>SDTLR-108-16/4</b>	7088	<b>SDTLR-108-16/3</b>	7825	<b>SDTLR-108-14/3</b>	8958
120"	3048	230	107.3	65.2	<b>SDTLL-120-16/4</b>	8748	<b>SDTLL-120-16/3</b>	9238	<b>SDTLL-120-14/3</b>	10747
120"	3048	230	107.3	65.2	<b>SDTLR-120-16/4</b>	8748	<b>SDTLR-120-16/3</b>	9238	<b>SDTLR-120-14/3</b>	10747

### Stainless Steel Options for 16 Gauge Soiled Dishtables

description	add* suffix #	add to list price
<b>Stainless Steel Legs</b>		
for lengths 60" - 84" (1524 - 2134mm)	-SL	435
for lengths 96" (2438mm) and longer	-SL	620
<b>Stainless Steel Legs and Gussets</b>		
for lengths 60" - 84" (1524 - 2134mm)	-SLG	628
for lengths 96" (2438mm) and longer	-SLG	841
<b>Stainless Steel Legs, Gussets, and Feet</b>		
for lengths 60" - 84" (1524 - 2134mm)	-SLGF	735
for lengths 96" (2438mm) and longer	-SLGF	989

\* Example: SDTLL-66-16/4-SL

### Soiled Dishtable Kit

see spec sheet **EG50.07**

**For all soiled dishtables listed above.**

- Scrap basket.
  - Rack slide.
  - T&S prerinse faucet (313295).
- Add suffix **"-SRP"** to model # and **add \$2545**.

**Example: SDTLL-66-16/4-SRP**

## Soiled Dishtables with 3-Compartment Pot Sink

see spec sheet **EG50.11**

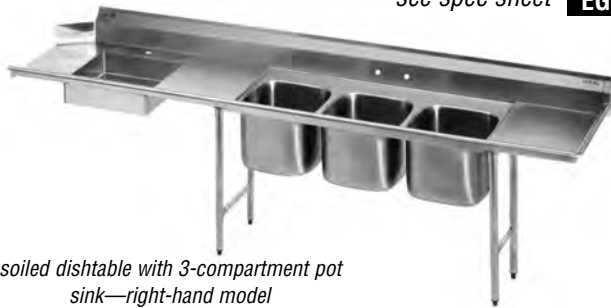

soiled dishtable with 3-compartment pot sink—right-hand model

SPEC-MASTER®  
FEATURES:

- 14/304 dishtables.
- Stainless steel crossbraced legs.
- Stainless steel gussets and stainless steel feet.

FEATURES:

- 20½" (521mm) opening to accept dishwasher.
- L or R in model numbers indicate left- or right-hand models.

Note: For accessories, see pages 328-329.

**Freight class is 70.0.**

length		weight		cu ft	16 gauge type 430		16 gauge type 304		14 gauge type 304	
in.	mm	lb.	kg		model #	list	model #	list	model #	list
124"	3150	190	86.2	60.4	SDTPL-124-16/4	7971	SDTPL-124-16/3	9288	SDTPL-124-14/3	11258
124"	3150	190	86.2	60.4	SDTPR-124-16/4	7971	SDTPR-124-16/3	9288	SDTPR-124-14/3	11258

### Stainless Steel Options for 16 Gauge Soiled Dishtables

description	add* suffix #	add to list price
<b>Stainless Steel Legs</b> for lengths 30" - 72" (762 - 1829mm) for lengths 84" (2134mm) and longer	-SL -SL	221 440
<b>Stainless Steel Legs and Gussets</b> for lengths 30" - 72" (762 - 1829mm) for lengths 84" (2134mm) and longer	-SLG -SLG	286 573
<b>Stainless Steel Legs, Gussets, and Feet</b> for lengths 30" - 72" (762 - 1829mm) for lengths 84" (2134mm) and longer	-SLGF -SLGF	329 660

\* Example: SDTPL-124-16/4-SL

## Soiled Dishtable Kit

see spec sheet **EG50.07**

For all soiled dishtables listed above.

- Scrap basket.
- Rack slide.
- T&S prerinse faucet (313295).

Add suffix "-SRP" to model # and add \$2545.

Example: SDTPL-124-16/4-SRP

## Undercounter Dishtables

see spec sheet **EG50.05**



undercounter dishtable with optional accessories shown—right-hand model

FEATURES:

- Sized to accept all 24" (620mm) wide undercounter dishwashers.
- L or R in model numbers indicate left or right placement of dishwasher.

Note: To order stainless steel crossbrace legs, order part #316660. See page 329.

**Freight class is 70.0.**

(•) MTS (made to stock) / ( ) MTO (made to order)

length		weight		cu ft	16 gauge type 430		16 gauge type 304		14 gauge type 304	
in.	mm	lb.	kg		model #	list	model #	list	model #	list
48"	1219	95	43.1	15.3	UDT-4L-16/4 •	2262	UDT-4L-16/3 •	2588	UDT-4L-14/3	2880
48"	1219	95	43.1	15.3	UDT-4R-16/4 •	2262	UDT-4R-16/3 •	2588	UDT-4R-14/3	2880
60"	1524	105	47.6	18.9	UDT-5L-16/4	2421	UDT-5L-16/3	2803	UDT-5L-14/3	3181
60"	1524	105	47.6	18.9	UDT-5R-16/4	2421	UDT-5R-16/3	2803	UDT-5R-14/3	3181

**Catalog Section 50**

**Mobile Soak Sinks** 

see spec sheet **EG50.04**



#MSS2020

**2"-WIDE  
EURO-STYLE EDGING**

- 8" (203mm) deep sink.
- 14 gauge.
- Lever drain.
- 5" (127mm) casters (two with brake).
- Stainless steel legs.
- Stainless steel gussets.
- Stainless steel crossbraces.

FEATURES:

**Freight class is 150.0.**

(•) MTS (made to stock) / ( ) MTO (made to order)

overall width x length in. mm	cu ft	33" (838mm) HEIGHT				20" (508mm) HEIGHT WITH REMOVABLE SILVER CHUTE & SILVERWARE BASKET			
		weight lb. kg	model #	list	weight lb. kg	model #	list		
24" x 24" 610 x 610	14	80 36.3	<b>MSS2020</b>	3645	75 34.0	<b>MSS2020SC</b> •	4000		
28" x 28" 711 x 711	15	90 40.8	<b>MSS2424</b> •	3713	85 38.6	<b>MSS2424SC</b>	4084		

**Dishwasher Condensate Vents,  
DVS Series** 

see spec sheets **EG50.07B** **EG55.03**



outer width x length x height* in. mm	weight lbs. kg	list price each
4" x 16" x 48" 102 x 406 x 1219	60 27.2	<b>DVS-48</b> 1618
4" x 16" x 60" 102 x 406 x 1524	75 34.0	<b>DVS-60</b> 1774
4" x 16" x 72" 102 x 406 x 1829	90 40.8	<b>DVS-72</b> 1908

\* If you have other size requirements, please call the factory.  
Outer width and length dimensions exclude flange.

- Mounts to dishwasher end vents.
- Seams are continuously liquid-tight.
- 18 gauge type 304 stainless steel.

FEATURES:

**Freight class is 70.0.**

**Dishwasher Condensate and Type II  
Hoods, HDC Series**  **NFPA-96** for TYPE II

see spec sheets **EG50.07B** **EG55.03**



overall width x length* in. mm	weight lbs. kg	cubic feet	model #	list
36" x 36" 914 x 914	150 68.0	30.5	<b>HDC3636</b>	3156
36" x 42" 914 x 1067	155 70.3	35.5	<b>HDC3642</b>	3541
36" x 48" 914 x 1219	175 79.4	40.4	<b>HDC3648</b>	3736
42" x 42" 1067 x 1067	194 88.0	40.0	<b>HDC4242</b>	4015
48" x 48" 1219 x 1219	206 93.4	57.2	<b>HDC4848</b>	4648
48" x 60" 1219 x 1524	226 102.5	00	<b>HDC4860</b>	5254

\* If you have other size requirements, please call the factory.

- 12" x 12" (305 x 305mm) collar opening for exhaust connection.
- 20" (508mm) height.
- Type 304 stainless steel construction.
- Full perimeter gutter with drain tube located on the left.

FEATURES:

**Note: For Type II applications, optional baffles are available.**  
To order, add suffix "S" to model number (example: **HDC3636S**) and **30% to list price.**

**Freight class is 70.0.**

## Dishtable Custom Modifications

Custom dishtables built to fit your needs. Please allow six to eight weeks shipping cycle for custom fabrication after receipt of approved drawings.

See pages 327-329 for more dishtable accessories and options.

For SpecFAB® Custom Fabrications, see pages 373-380.

See pages 369-372 for more custom options and accessories.

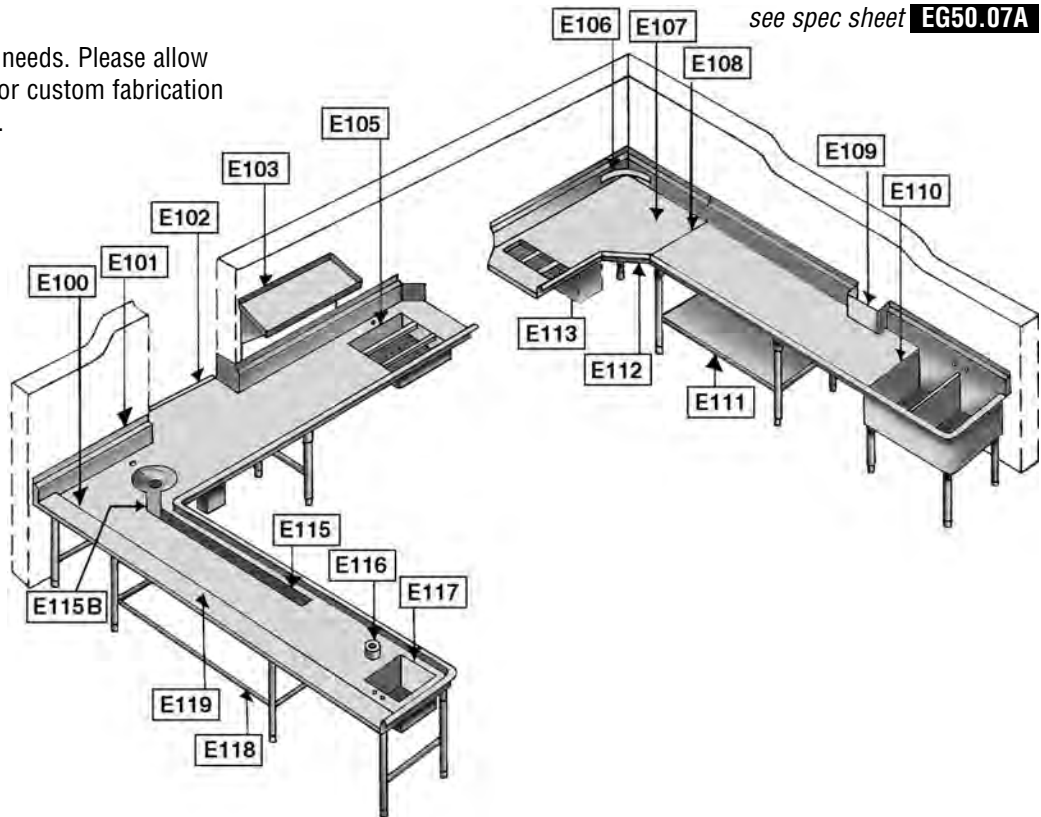

see spec sheet EG50.07A

model #	description	unit	list	model #	description	unit	list
<b>OVERSHELF MODIFICATIONS AND OPTIONS:</b>				<b>DISHTABLE SCRAPPING MODIFICATIONS AND OPTIONS (continued):</b>			
E38-6**	Cantilever mount up to 6', add to wall shelf price	EA	475	E116	Rubber Scrap Block installed, 6.5" outer dia.	EA	433
E38-12**	Cantilever mount up to 12', add to wall shelf price	EA	712	300691	Replacement rubber scrap block	EA	122
<b>DISHTABLE RACK SHELF MODIFICATIONS AND OPTIONS:</b>				<b>DISHTABLE SINK WELDMENT MODIFICATIONS AND OPTIONS:</b>			
E103	Rack shelf, wall mounted	FT	603	E105	Prerinse sink 20" x 20" x 5"	EA	1243
E104	Drain, bleeder type	EA	151	E105A	for each additional 2" in depth	EA	151
<b>DISHTABLE BACKSPLASH MODIFICATIONS AND OPTIONS:</b>				E110	Sink 24" x 26 1/2" x 14"	EA	2251
E101	Splash 10" per linear ft.	LIN. FT	74	E117	Soak sink 16" x 20" x 13 1/2"	EA	1611
E101A	Turn down back splash (with z-clips)	TABLE	292	E122	Faucet Holes	EA	200
E30	End splash - per end, all heights	EA	375	<b>FAUCETS:</b>			
E39	Enclosed backsplash	LIN. FT	102	300490	Faucet - 4" centers, 12" spout, deck mount	EA	209
<b>DISHTABLE TOP MODIFICATIONS AND OPTIONS:</b>				<b>DISPOSAL PROVISION PACKAGES (for more information, see page 329):</b>			
E100	Additional length NSF Construction	LIN. FT	424	E41	Disposal provision package, collar	EA	882
E102	Pass-thru shelf max. 12" up to 3 lin. ft.	LIN. FT	2439	E41A	Disposal provision package, cone (top must be 14/304 s/s)	EA	882
E102A	additional over 36" for pass-thru shelf	LIN. FT	812	E41B	Provision for scrap collector and troughveyor	EA	1639
E106	Rack guide curved 2" x 1/4" s/s flat bar (requires E112)	EA	426	<b>CONTROL PANEL BRACKETS (for more information, see page 328):</b>			
E107	Corner turn 90 degrees	EA	1639	E96	Control Panel Bracket - 6" x 9"	EA	287
E108	Field joint, bolted or ready for field welding by others	EA	320	E96A	Control Panel Bracket - 9" x 12"	EA	433
E109	Cutout for pipes, columns	EA	801	<b>DISHTABLE BASE MODIFICATIONS AND OPTIONS:</b>			
E112	Mitered Corner	EA	818	E111	Undershelving stainless steel, per linear foot	LIN. FT	335
E119	Landing shelf 12"W integral with top	LIN. FT	288	E113	Brackets for booster heater, installation only, brackets by others	EA	186
E120	Limit switch	EA	213	E118	Crossbracing left-to-right, stainless steel	LIN. FT	109
<b>DISHTABLE SCRAPPING MODIFICATIONS AND OPTIONS:</b>							
E115	Scrapping Trough 6" x 4" deep—up to 60"	LIN. FT	1989				
E115A	additional over 60"	LIN. FT	340				
E115B	Mitered angle in scrapping trough	EA	862				

\*\* - applicable to wall mount shelves and pot racks



### Dishtable Rack Shelves

see spec sheet **EG50.06**



slanted rack shelf with drip tube on right

**An efficient operation setup, these shelves provide extra rack storage.**

#### Slanted Rack Shelves

- Stainless steel (16 gauge) construction.
- Wall mounting brackets.
- Drip tube on left or right side.

shelf width* x length		shipping weight		TUBE ON LEFT		TUBE ON RIGHT	
in.	mm	lbs.	kg	model #	list	model #	list
21" x 21"	533 x 533	20	9.0	<b>605380</b> •	1323	<b>606641</b> •	1323
21" x 42"	533 x 1067	30	13.6	<b>605381</b> •	1411	<b>606642</b> •	1411
21" x 63"	533 x 1600	40	18.1	<b>605382</b> •	1541	<b>606643</b>	1541
21" x 84"	533 x 2134	50	22.7	<b>606294</b>	1632	<b>606644</b>	1632

\* Front-to-back of unit, when mounted to wall, is 19 1/4" (502mm).



#### Double Sided Sorting Shelf

- For soiled dishtables with island design (pages 322) and soiled dishtables with landing shelf (pages 323).

width x length		shipping weight			
in.	mm	lbs.	kg	model #	list
30 3/4" x 60"	784 x 1524	75	34.0	<b>606295</b>	2998

#### Notes:

Not interchangeable with Double Rack Shelf #605383.  
Racks cannot be positioned back-to-back.  
One end is wall-mounted.

#### KD Tubular Design Rack Shelves

- Wall mounted. Knock-down construction.

width x length		shipping weight			
in.	mm	lbs.	kg	model #	list
15 1/2" x 21"	394 x 533	17	7.7	<b>606296</b> •	1049
15 1/2" x 42"	394 x 1067	26	11.8	<b>606297</b> •	1174
15 1/2" x 63"	394 x 1600	35	15.9	<b>606298</b> •	1267
15 1/2" x 84"	394 x 2134	44	20.0	<b>606299</b>	1339



Freight class is 70.0.

(•) MTS (made to stock) / ( ) MTO (made to order)



#### Tubular Design Rack Shelves

- Wall mounted, all-welded construction.

width x length		shipping weight			
in.	mm	lbs.	kg	model #	list
15 1/2" x 21"	394 x 533	16	7.3	<b>606300</b>	1155
15 1/2" x 42"	394 x 1067	25	11.3	<b>606301</b>	1293
15 1/2" x 63"	394 x 1600	34	15.4	<b>606302</b>	1392
15 1/2" x 84"	394 x 2134	43	19.5	<b>606303</b>	1472



#### Double Rack Shelf

- For soiled dishtables with island design (pages 322) and soiled dishtables with landing shelf (pages 323).
- Drip tubes on wall mounted end.

width x length		shipping weight			
in.	mm	lbs.	kg	model #	list
22 3/4" x 60"	578 x 1524	61	27.7	<b>605383</b> •	2909

#### Notes:

Not interchangeable with Double Sided Sorting Shelf #606295.  
Racks cannot be positioned back-to-back.  
One end is wall-mounted.

Just a quick note...



#### GET FREE DOWNLOADS

- Spec Sheet • Product Instructions •
- Special Flyers • Brochures •

[www.eaglegrp.com](http://www.eaglegrp.com)

## Dishtable Accessories and Options

see spec sheet **EG50.07B**

Can be shipped UPS.

(•) MTS (made to stock) / ( ) MTO (made to order)

### Scrap Basket

- This model features all-16 gauge stainless steel construction.
- Tabs provide proper height and basket drainage.



*Improves prerinse efficiency.*

shipping wt.		model #	list
lbs.	kg		
15	6.8	<b>301630</b>	546

### Rack Slide

- 16 gauge construction.



*A must for any prerinse operation.*

shipping wt.		model #	list
lbs.	kg		
4	1.8	<b>301124</b>	339

### Drain Trough

- 5" (127mm) wide and 2" (51mm) deep with a 1½" (38mm) center drain opening.
- Removable basket with handles.
- All stainless steel construction.

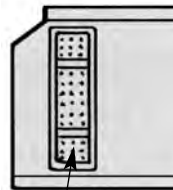

scrap trough

shipping wt.		model #	list
lbs.	kg		
13	5.8	<b>SCRAP TROUGH</b>	1068

### Control Panel Brackets

- Please specify location.

description	model #	list
6" x 9" (152 x 229mm)	<b>E96</b>	287
9" x 12" (229 x 305mm)	<b>E96A</b>	433

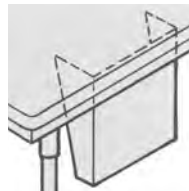

### Stainless Steel Gussets

- Optional only for 16 gauge tables.
- Standard on SPEC-MASTER® tables.

description	model #	list
stainless steel gussets	<b>316743</b>	41



gusset

### Bullet Feet

With a full 1" (25mm) adjustment.

description	model #	list
stainless steel	<b>300692</b>	22
white metal	<b>301036</b>	11
plastic feet	<b>300293</b>	2



### Anti-Siphon Breaker

model #	list
<b>313832</b>	212



## Prerinse Units...

- Temperature adjustment for hot water with preset cold water adjustment for anti-scald protection.



### ...Standard Prerinse Components

description	model #	list
splash mounted spray unit	<b>300719</b>	1348
deck mounted spray unit	<b>300718</b>	1344
faucet add-on with 12" (305mm) spout	<b>301189</b>	357
wall bracket	<b>301190</b>	89

### ...T&S Extra Heavy Duty Prerinse Components

- Top-of-the-line.

description	model #	list
deck mounted spray unit with wall bracket	<b>313295</b>	1662
faucet add-on with 12" (305mm) spout	<b>313297</b>	439

### Prerinse Baskets with Slide Bar

- An all-in-one combination.
- Type 304 construction throughout.
- For 20" x 20" prerinse sink.



width x length x depth			shipping wt.		model #	list
in.	mm	lbs.	kg			
17½" x 19½" x 2½"	445 x 493 x 74	3	1.4	<b>606434</b> •	672	
19½" x 19½" x 4"	493 x 493 x 102	4	1.8	<b>383671</b>	677	

### Dishtable Undershelves

- 24½" (612mm) wide.
- NOTE: Order one size smaller than dishtable.



*Provides extra space for rack storage and operation equipment.*

length	weight	galvanized		400 series		300 series			
		model #	list	model #	list	model #	list		
24"	610	10	4.5	<b>605371</b>	654	<b>605374</b>	839	<b>606479</b>	1036
36"	914	15	6.8	<b>605372</b>	795	<b>605375</b>	935	<b>606480</b>	1154
48"	1219	20	9.0	<b>605373</b>	985	<b>605376</b>	1156	<b>606481</b>	1334

### Lever Drains

description	model #	list
1.5" or 2" (38 or 51mm) NPS connection	<b>300720</b>	279
2" (51mm) NPS connection	<b>300721</b>	279



## Catalog Section 50

### Dishtable Accessories and Options

see spec sheet **EG50.07B**

Can be shipped UPS.

#### Legs and Crossbrace Assemblies

- Stainless steel welded construction.
- Note:** Standard only on SPEC-MASTER® series dishtables.

*When durability and appearance are important.*



description	model #	list
crossbrace assembly	<b>311772</b>	223
crossbrace assembly for undercounter dishtables	<b>316660</b>	213
single leg for undershelf	<b>300765</b>	89



#### Sink Covers

- 18 gauge stainless steel with holes provided for handling.

width x length		shipping weight		model #	list price
in.	mm	lbs.	kg		
20" x 20"	508 x 508	11	5.0	<b>305428</b>	241
16" x 20"	406 x 508	10	4.5	<b>351585</b>	226

#### PVC Rollers

- 2" (51mm) diameter.
- Free-wheel.
- For 14/304 dishtables only.
- For ease of sliding dish racks.
- For stainless steel rollers, **contact factory.**
- Three rollers required for every 12" (305mm).  
Example: For a 6' (1829mm) table, at the required three per foot: 6' table x 3 per foot = 18 rollers needed.



corner dishtable with optional PVC rollers

length		shipping weight		table setup charge	model #	list each
in.	mm	lbs.	kg			
24"	610	3	1.4	\$607	<b>DTRA-24</b>	257

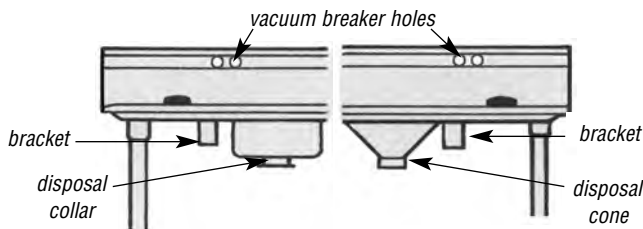

#### Disposal Provision Package

- Disposal collar adapters can be installed on any prerinse sink.
- Both collar and cone are to be supplied by the customer.

description	model #	list
disposal collar weldment, bracket for disposal switch, and vacuum breaker holes	<b>E41</b>	882
disposal cone* weldment, bracket for disposal switch, and vacuum breaker holes	<b>E41A</b>	882

\* If cone is welded to dishtable top, the top must be 14 gauge type 304 stainless steel.

#### Provision for Scrap Collector or Troughveyor

- Cutout in top for collector mounting.
- Does not include welding of unit to dishwasher.
- All welding is by others.

description	model #	list
Flange in opening or trough to accept collector or troughveyor when required	<b>E41B</b>	1639



# NOTES



A large area consisting of two vertical columns of horizontal lines, intended for writing notes. The lines are evenly spaced and extend across most of the page's width.

# SPEC AIR® Ventilation Hoods

## Accessories

Air Space.....	335
Bullet Lights .....	335
Collars.....	335
Enclosure Panels.....	335
Filter Frames .....	334
Furring Channels.....	335
Grease Cups .....	334
Grease Filters .....	334
Insulated Back.....	335
Insulated Make-Up Air Plenum .....	335
Light Switch .....	335
Mounting Channel.....	335
Supply Fire Damper .....	335
Trim Strips .....	334

## Ventilation Hoods

Dishwasher Condensate and Type II Hoods, HDC Series .....	334
Dishwasher Condensate Vents DVS Series .....	333
Exhaust-Only Hoods, HES & HEB Series .....	332
Front Discharge Make-Up Air Exhaust Hoods, HEF & HESFA Series .....	332
Internal Discharge Make-Up Air Hoods, HEIA Series.....	333

## Standard Features Include: NFPA-96

- Hood surfaces are constructed of 18 gauge type 430 stainless steel. Seams of the canopy are continuously welded liquid-tight.
- U.L. Listed vapor-proof incandescent light fixtures are mounted and provided with a junction box mounted on top of the hood.
- U.L. Classified filters are aluminum, non-clogging, baffle-type, and easily removable for cleaning.
- Full-length stainless steel grease trough is pitched to drain grease from filters and exhaust plenum.
- Grease drains from trough into a removable grease container for disposal.
- 3" (76mm) air space at rear of exhaust hood.
- Exhaust collar(s).
- Supply collars included with make-up air exhaust hoods.
- Supply collar(s) with fire damper(s) on internal make-up air models.
- Front and rear mounting brackets.



*For use in commercial cooking including restaurant, kitchen, fast food, and deli.*

SPEC AIR® hoods come standard with accessories that most other manufacturers offer as options, with extra charge.

However, should you require additional accessories, please select from our list. Include quantity and model number with your order. If you require an accessory not listed, please contact the factory for assistance.

**Spec AIR®**

## Exhaust-Only Hoods, HES & HEB Series

see spec sheet **EG55.00**



exhaust-only hood...



...with short front fascia



**NFPA-96**

FEATURES:

- 51" (1295mm) deep and 24" (610mm) height.
- Designed for use where make-up air is supplied by other vent systems.

**Note:** Prices do not include the following:

Installation supplies and materials, hanging of ventilator, exhaust and supply fans, curbs, ductwork, transitions, penetrating and sealing of roof or ceiling, trim, flashing, permits, fire protection system or tests, air balancing, electrical of any nature or any special requirements from local authorities.

**Freight class is 70.0.**

**Regular and short front models  
(for low ceilings) available.**

				Regular		Short Front		
length	weight		cubic	model #	list	model #	list	
in.	mm	lbs.	kg					
48"	1219	275	124.7	69.5	HEB96-48	6762	HES96-48	5978
54"	1372	309	140.2	76.9	HEB96-54	7538	HES96-54	6735
60"	1524	344	156.0	84.0	HEB96-60	8293	HES96-60	7473
66"	1676	378	171.5	91.5	HEB96-66	9040	HES96-66	8901
72"	1829	412	186.9	98.5	HEB96-72	9881	HES96-72	8972
78"	1981	481	218.2	112.9	HEB96-78	10631	HES96-78	9706
84"	2134	550	249.5	127.5	HEB96-84	11474	HES96-84	10466
90"	2286	567	257.2	131.0	HEB96-90	12223	HES96-90	11201
96"	2438	584	264.9	134.5	HEB96-96	13063	HES96-96	11958
102"	2591	601	272.6	138.1	HEB96-102	13813	HES96-102	12706
108"	2743	618	280.3	141.7	HEB96-108	14565	HES96-108	13436
114"	2896	653	296.2	148.9	HEB96-114	15404	HES96-114	14194
120"	3048	687	311.6	156.0	HEB96-120	16158	HES96-120	14933
126"	3200	721	327.0	163.5	HEB96-126	16997	HES96-126	15654
132"	3353	756	342.9	170.5	HEB96-132	17748	HES96-132	16426
138"	3505	790	358.3	177.7	HEB96-138	18588	HES96-138	17139
144"	3658	825	374.2	184.9	HEB96-144	19338	HES96-144	17887

## Front Discharge Make-Up Air Exhaust Hoods, HEF & HESFA Series

see spec sheet **EG55.01**



front discharge make-up air exhaust hood...



...with short front fascia

FEATURES:

- 51" (1295mm) deep and 24" (610mm) height.
- Supplies make-up air through the hood, independent of other ventilation systems, at ceiling level.

**Note:** Prices do not include the following:

Installation supplies and materials, hanging of ventilator, exhaust and supply fans, curbs, ductwork, transitions, penetrating and sealing of roof or ceiling, trim, flashing, permits, fire protection system or tests, air balancing, electrical of any nature or any special requirements from local authorities.

**Freight class is 70.0.**

**Regular and short front models  
(for low ceilings) available.**

				Regular		Short Front		
length	weight		cubic	model #	list	model #	list	
in.	mm	lbs.	kg					
48"	1219	302	137.0	69.5	HEF96-48	9778	HESFA96-48	9366
54"	1372	339	153.8	76.9	HEF96-54	9807	HESFA96-54	9398
60"	1524	378	171.5	84.0	HEF96-60	14424	HESFA96-60	11607
66"	1676	415	188.2	91.5	HEF96-66	14434	HESFA96-66	11618
72"	1829	453	205.5	98.5	HEF96-72	16765	HESFA96-72	13848
78"	1981	491	222.7	112.9	HEF96-78	16776	HESFA96-78	13856
84"	2134	529	240.0	127.5	HEF96-84	18615	HESFA96-84	16088
90"	2286	567	257.2	131.0	HEF96-90	18785	HESFA96-90	16099
96"	2438	605	274.4	134.5	HEF96-96	18960	HESFA96-96	18142
102"	2591	642	291.2	138.1	HEF96-102	21126	HESFA96-102	18341
108"	2743	679	308.0	141.7	HEF96-108	21364	HESFA96-108	20549
114"	2896	718	325.7	148.9	HEF96-114	21503	HESFA96-114	20581
120"	3048	755	342.5	156.0	HEF96-120	23817	HESFA96-120	22793
126"	3200	793	359.7	163.5	HEF96-126	23845	HESFA96-126	22821
132"	3353	831	376.9	170.5	HEF96-132	26492	HESFA96-132	25032
138"	3505	869	394.2	177.7	HEF96-138	26931	HESFA96-138	25062
144"	3658	907	411.4	184.9	HEF96-144	28503	HESFA96-144	27275

## Catalog Section 55

### Internal Discharge Make-Up Air Hoods, HEIA Series NFPA-96

see spec sheet **EG55.02**



**Positive  
air flow design!**

- 51" (1295mm) deep and 24" (610mm) height.
- Designed to save energy by keeping outside air inside the hood. Outside air is mixed and exhausted with the grease-laden air.

**FEATURES:**

**Note: Prices do not include the following:**

Installation supplies and materials, hanging of ventilator, exhaust and supply fans, curbs, ductwork, transitions, penetrating and sealing of roof or ceiling, trim, flashing, permits, fire protection system or tests, air balancing, electrical of any nature or any special requirements from local authorities.

**Freight class is 70.0.**

length		weight		cubic feet	model #	list
in.	mm	lbs.	kg			
48"	1219	322	146.1	69.5	<b>HEIA96-48</b>	10483
54"	1372	359	162.9	76.9	<b>HEIA96-54</b>	11806
60"	1524	379	171.9	84.0	<b>HEIA96-60</b>	13107
66"	1676	435	197.3	91.5	<b>HEIA96-66</b>	14405
72"	1829	473	214.6	98.5	<b>HEIA96-72</b>	15732
78"	1981	509	231.9	112.9	<b>HEIA96-78</b>	17029
84"	2134	549	249.0	127.5	<b>HEIA96-84</b>	18352
90"	2286	585	265.4	131.0	<b>HEIA96-90</b>	19651
96"	2438	622	282.2	134.5	<b>HEIA96-96</b>	20973
102"	2591	660	299.4	138.1	<b>HEIA96-102</b>	22284
108"	2743	699	317.1	141.7	<b>HEIA96-108</b>	23575
114"	2896	738	334.8	148.9	<b>HEIA96-114</b>	24897
120"	3048	775	351.5	156.0	<b>HEIA96-120</b>	26198
126"	3200	813	368.8	163.5	<b>HEIA96-126</b>	27511
132"	3353	851	386.0	170.5	<b>HEIA96-132</b>	28819
138"	3505	889	403.3	177.7	<b>HEIA96-138</b>	31361
144"	3658	930	421.8	184.9	<b>HEIA96-144</b>	33914



### Dishwasher Condensate Vents, DVS Series

see spec sheets **EG50.07B** **EG55.03**



- Mounts to dishwasher end vents.
- Seams are continuously liquid-tight.
- 18 gauge type 304 stainless steel.

**FEATURES:**

**Note: Prices do not include the following:**

Installation supplies and materials, hanging of ventilator, exhaust and supply fans, curbs, ductwork, transitions, penetrating and sealing of roof or ceiling, trim, flashing, permits, fire protection system or tests, air balancing, electrical of any nature or any special requirements from local authorities.

**Freight class is 70.0.**

outer width x length x height*		weight		model #	list price each
in.	mm	lbs.	kg		
4" x 16" x 48"	102 x 406 x 1219	60	27.2	<b>DVS-48</b>	1618
4" x 16" x 60"	102 x 406 x 1524	75	34.0	<b>DVS-60</b>	1774
4" x 16" x 72"	102 x 406 x 1829	90	40.8	<b>DVS-72</b>	1908

\* If you have other size requirements, please call the factory.  
Outer width and length dimensions exclude flange.

## Dishwasher Condensate and Type II Hoods, HDC Series NFPA-96 for TYPE II

see spec sheets **EG50.07B** **EG55.03**

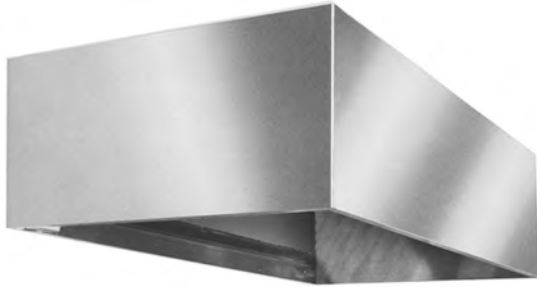

overall width x length* in. mm	weight lbs. kg	cubic feet	model #	list
36" x 36" 914 x 914	150 68.0	30.5	<b>HDC3636</b>	3156
36" x 42" 914 x 1067	155 70.3	35.5	<b>HDC3642</b>	3541
36" x 48" 914 x 1219	175 79.4	40.4	<b>HDC3648</b>	3736
42" x 42" 1067 x 1067	194 88.0	40.0	<b>HDC4242</b>	4015
48" x 48" 1219 x 1219	206 93.4	57.2	<b>HDC4848</b>	4648
48" x 60" 1219 x 1524	226 102.5	00	<b>HDC4860</b>	5254

\* If you have other size requirements, please call the factory.

- 12" x 12" (305 x 305mm) collar opening for exhaust connection.
- 20" (508mm) height.
- Type 304 stainless steel construction.
- Full perimeter gutter with drain tube located on the left.

**FEATURES:**

**Note:** For Type II applications, optional baffles are available. To order, add suffix "S" to model number (example: **HDC3636S**) and **30% to list price**.

**Prices do not include the following:**

Installation supplies and materials, hanging of ventilator, exhaust and supply fans, curbs, ductwork, transitions, penetrating and sealing of roof or ceiling, trim, flashing, permits, fire protection system or tests, air balancing, electrical of any nature or any special requirements from local authorities.

**Freight class is 70.0.**

## SPEC AIR® Ventilation Hood Accessories

see spec sheet **EG55.05**

### Filter Frames

(Maryland, Virginia, Washington D.C. Code) Stainless steel.

model #	list each
<b>E168</b>	140

### Extra Grease Cups (#11)

model #	list each
<b>331677</b>	122

### Extra Grease Filters (#12)

20" x 20" (508 x 508mm), baffle type.

ALUMINUM		STAINLESS STEEL	
model #	list each	model #	list each
<b>332493</b>	102	<b>332494</b>	178



grease cups



grease filter

**Note:** To order the following ventilation hood accessories or options, include quantity and model number of each desired accessory or option with the model number of the ventilation hood ordered. **Example:** an "HEB96-48" hood (page 332), when accompanied with "E161," indicates a hood with optional stainless steel trim strip on the front.

### Stainless Steel Trim Strips

Seals off ceilings and/or walls

description	model #	list per linear foot
on front side of unit	<b>E161</b>	36
on back side of unit	<b>E162</b>	36
on left side of unit	<b>E163</b>	36
on right side of unit	<b>E164</b>	36

## Stainless Steel Cleaner & Polish



- Cleans and polishes in one step.
- Does not streak or leave fingerprints.
- Leaves a protective invisible coating.

weight		model #		list
oz.	kg			
15	0.4	<b>004026</b>		22



## Catalog Section 55

### SPEC AIR® Ventilation Hood Accessories

see spec sheet **EG55.05**

#### Extra Bullet Lights (#1) - Vapor proof.

model #	list each
E170	422

#### 3" (76mm) Air Space on sides (#2)

For vent hoods placed in corners or near neighboring walls.

description	model #	list
on front side of unit	E150	\$87 per linear foot
on left side of unit	E151	371 per side
on right side of unit	E152	371 per side

#### Insulated Back (#3) - Reduces condensation

description	model #	list per linear foot
on front side of unit	E153	87
on back side of unit	E154	87
on left side of unit	E155	87
on right side of unit	E156	87

#### Stainless Steel Furring Channel (#4)

Used primarily for display signs, menus etc.

description	model #	list per linear foot
on front side of unit	E157	179
on back side of unit	E158	179
on left side of unit	E159	179
on right side of unit	E160	179

#### Enclosure Panels (#5)

24" (610mm) height. Seals off ceilings and/or walls. Includes trim strips.

model #	list per linear foot
E174	286

#### Additional Collars (#6)

description	model #	list each
extra exhaust collar	E165	674
extra supply collar	E166	674

#### Additional Supply Fire Damper (#7) — Fusible link

model #	list each
E167	443

#### Light Switch (#8)

Flush Mounted. 115 VAC. Field wiring required.

model #	list each
E169	303

#### Insulated Make-Up Air Plenum (#9) - Reduces condensation

model #	list per linear foot
E175	375



bullet light

**Note:** To order the following ventilation hood accessories or options, include quantity and model number of each desired accessory or option with the model number of the ventilation hood ordered. **Example:** an "HEB96-48" hood (page 332), when accompanied with "E161," indicates a hood with optional stainless steel trim strip on the front.

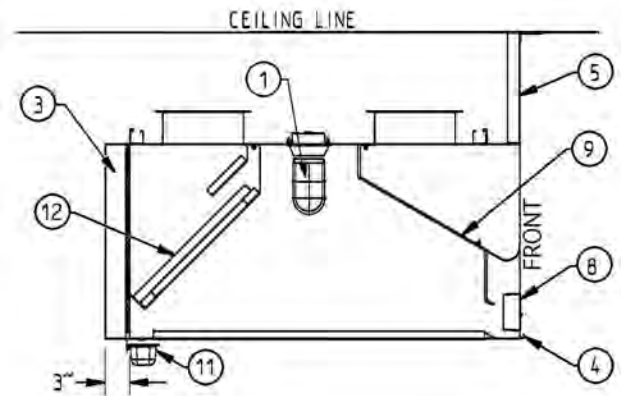
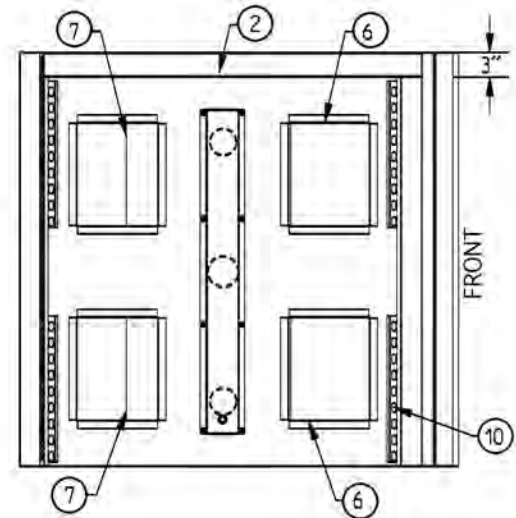

#### Additional Mounting Channel (#10)

1 1/2" (41mm) square. 12 gauge galvanized steel. Single strut. Slotted.

model #	list per linear foot
361269	45

# NOTES

---

Two columns of horizontal lines for notes, each containing 25 lines.

# PANCO® Transport Systems

## Accessories/Components

Cart Covers .....	338
Casters .....	354
Pan Stops .....	354
Perimeter Bumpers .....	354
Rotary Bumpers .....	354
Universal Angle Racks .....	354
Vertical Bumpers .....	354

## Carts

Banquet .....	350
Mobile Platform .....	353
Open Bus Box .....	350

## Dolly

Bun Pan .....	351
Glass Rack .....	352
Pan Truck .....	352

## LIFETIME Series Racks

Bun Pan .....	355
Dunnage .....	355

Enclosed Pan .....	357
Stepped-Angle .....	357
Universal Pan .....	356
Universal Roll-In .....	356

## Pans

Aluminum Sheet .....	353
NSF Sheet .....	353

## Racks

18 Series Deluxe .....	338
18 Series Working Height .....	339
26 Series .....	339
All-Welded Pan .....	340
Aluminum Dunnage .....	351
Aluminum with Side Panels .....	341
Can .....	346
Carrier .....	340
Combination .....	342
Compartment .....	342
Donut .....	349
Drip .....	352

Multiple Purpose .....	343
Nesting Dunnage .....	351
Open Lug .....	349
Oval Tray .....	344
Oven .....	346
Pizza Dough Box .....	348
Pizza Pan .....	348
Platter .....	347
Roll-In Refrigerator .....	345
Stainless Steel .....	341
Universal Angle .....	343
Wire Pan .....	347
"Z" Type Nesting .....	345

## Transport Holding Cabinets

Heated Cabinets .....	359-360
Heated/Proofing Cabinets .....	361-362
Slides .....	365
Cook & Hold Cabinets .....	365

*A simple solution to a frustrating situation...*

***“HOW CAN WE GET ALL THIS FROM HERE TO THERE?”***

**PANCO®  
Transport Racks  
provide the most efficient  
way to handle the many  
items required in the  
preparation, serving and  
storage of your  
products.**



PANCO® Transport Racks succeed in pairing efficiency with durability. Developed in conjunction with the needs of the customer, the following features make PANCO® mobile open utility racks the choice of the foodservice industry.

- Designed with the end user in mind to endure the test of time. All PANCO® racks are constructed of stainless steel or high-strength extruded aluminum sections.
- Units roll, glide and maneuver easily with non-marking NSF® approved swivel casters.
- Rack slides are designed to fit most popular tray sizes and are configured to accommodate a variety of products.
- Available in several widths and heights, PANCO® provides the perfect size open transport rack to fit your needs.
- While all transport units can also be used as storage areas, there are workstation and refrigerator roll-in models as well.



### 18 Series Deluxe Racks

see spec sheet **EG60.00A**



#### Optional Perimeter Bumper

- Factory welded assembly is required on aluminum knocked-down units specified with perimeter bumpers.

#### FEATURES:

- For 18" x 26" (457 x 660mm) pans.
- Narrow opening.
- 5" (127mm) casters.
- Front-to-back and side-to-side crossbracing.
- 1" (25mm) square tubing.
- Aluminum models shipped knocked down.
- Stainless steel models assembled.
- Dimensions shown include caster hub.
- Add 2 3/4" (70mm) to dimensions for caster trail.

**Note:** Accessories available include casters with locking brakes, rotary donut bumpers, vertical bumpers, and pan stops. See page 354.

**Freight class is 70.0.**

(•) MTS (made to stock) / ( ) MTO (made to order)

description	weight lbs. kg	accessory model #	add to unit list
full perimeter bumper	4 1.8	<b>D</b>	391

#### Aluminum

overall dimensions width x depth x height in. mm		sliding space in. mm		pan capacity	weight lbs. kg		cu ft	model #	list
21" x 26 1/2" x 64 1/4"	533 x 673 x 1632	5"	127	11	29 13.2	4	<b>OUR-1811-5</b> •	652	
21" x 26 1/2" x 64 1/4"	533 x 673 x 1632	3"	76	18	36 16.3	4	<b>OUR-1818-3</b> •	809	
21" x 26 1/2" x 69 1/4"	533 x 673 x 1759	3"	76	20	37 16.8	4	<b>OUR-1820-3</b> •	818	
21" x 26 1/2" x 69 1/4"	533 x 673 x 1759	2 1/4"	57	24	42 19.1	4	<b>OUR-1824-2</b> •	944	

#### Optional Factory Assembly for Aluminum Units

- Otherwise shipped knocked down.

accessory model #	add to unit list
<b>L</b>	224

#### Stainless steel

overall dimensions width x depth x height in. mm		sliding space in. mm		pan capacity	weight lbs. kg		cu ft	model #	list
20 1/2" x 28" x 66 1/2"	521 x 711 x 1689	5"	127	11	105 47.6	27	<b>OUR-1811-5-SR</b>	2335	
20 1/2" x 28" x 66 1/2"	521 x 711 x 1689	3"	76	18	122 55.3	27	<b>OUR-1818-3-SR</b>	2924	
20 1/2" x 28" x 72 1/2"	521 x 711 x 1832	3"	76	20	127 57.6	27	<b>OUR-1820-3-SR</b>	3125	
20 1/2" x 28" x 66 1/2"	521 x 711 x 1689	2 1/4"	57	24	137 62.1	27	<b>OUR-1824-2-SR</b>	3214	

#### Optional Cart Covers for 18 Series Racks

- Covers are fire, mildew, and rot resistant.
- Easy to clean, waterproof, and feature dual zippers.
- Available in white PVC laminate or transparent.
- White laminate features a clear window on one narrow side.

width x depth x height in. mm		fits units	WHITE		TRANSPARENT	
			model #	list	model #	list
24" x 30" x 61 1/2"	610 x 762 x 1562	OUR-1811-5 OUR-1818-3 OUR-1824-2	<b>P2RCW-3</b>	375	<b>P2RC-3</b>	271
24" x 30" x 69"	610 x 762 x 1753	OUR-1820-3	<b>P2RCW-4</b>	375	<b>P2RC-4</b>	271



rack with optional  
transparent cart cover



rack with optional  
white cart cover

Catalog Section 60

18 Series Working Height Rack 

see spec sheet **EG60.00B**



optional hardwood and pans

**Optional Factory Assembly for Aluminum Units**

- Otherwise shipped knocked down.

accessory model #	add to unit list
L	224

**FEATURES:**

- For 18" x 26" (457 x 660mm) pans.
- Top pan guides.
- Outrigger pan mount.
- 5" (127mm) swivel casters.
- Aluminum models shipped knocked down.
- Stainless steel models assembled.
- Dimensions shown include caster hub.
- Add 2 3/4" (70mm) to dimensions for caster trail.

**Note:** Accessories available include casters with locking brakes, rotary donut bumpers, vertical bumpers, and pan stops. See page 354.

**Freight class is 70.0.**

**Optional Tops for Working Height Rack**

description	weight		model #	list
	lbs.	kg		
hardwood for OUR-1807-3	30	13.6	<b>606376</b>	657
poly top for OUR-1807-3	25	11.3	<b>606377</b>	783
stainless steel top for OUR-1807-3	30	13.6	<b>606378</b>	632

overall dimensions		sliding space		pan capacity	ALUMINUM			STAINLESS STEEL						
width	depth x height	in.	mm		weight	cu	model #	list	weight	cu	model #	list		
in.	mm	in.	mm	lbs.	kg	ft		lbs.	kg	ft				
22"	28 1/2" x 35"	3"	76	9*	29	13.2	3.6	<b>OUR-1807-3</b>	1181	78	35.4	12.7	<b>OUR-1807-3-SR</b>	2228

\* Total pan capacity is 9 when outrigger pan mounts are in use.

26 Series Racks 

see spec sheet **EG60.01**



**Optional Perimeter Bumper**

- Factory welded assembly is required on aluminum knocked-down units specified with perimeter bumpers.

description	weight	accessory	add to
	lbs.	kg	unit list
full perimeter bumper	4	1.8	<b>D</b> 391

**FEATURES:**

- For 18" x 26" (457 x 660mm) sheet pans.
- Aluminum and stainless steel models available.
- Wide opening.
- 5" (127mm) casters.
- Front-to-back/side-to-side crossbracing.
- Aluminum models shipped knocked down.
- Stainless steel models shipped assembled.
- Dimensions shown include caster hub.
- Add 2 3/4" (70mm) to dimensions for caster trail.

**Note:** Accessories available include casters with locking brakes, rotary donut bumpers, vertical bumpers, and pan stops. See page 354.

**Freight class is 70.0.**

**Aluminum**

overall dimensions		sliding space		pan capacity	ALUMINUM			list	
width	depth x height	in.	mm		weight	cu	model #	list	
in.	mm	in.	mm	lbs.	kg	ft			
28 1/2"	19" x 69"	5"	127	11	37	16.8	10	<b>OUR-2611-5</b>	758
28 1/2"	20" x 66 1/2"	3"	76	18	43	19.5	10	<b>OUR-2618-3</b>	957
28 1/2"	20" x 72"	3"	76	20	53	24.0	10	<b>OUR-2620-3</b>	968
28 1/2"	20" x 66 1/2"	2 1/4"	57	24	56	25.4	10	<b>OUR-2624-2</b>	1106

**Optional Factory Assembly for Aluminum Units**

- Otherwise shipped knocked down.

accessory model #	add to unit list
L	224

**Stainless Steel**

overall dimensions		sliding space		pan capacity	ALUMINUM			list	
width	depth x height	in.	mm		weight	cu	model #	list	
in.	mm	in.	mm	lbs.	kg	ft			
28 1/2"	20" x 66 1/2"	5"	127	11	112	50.8	27	<b>OUR-2611-5-SR</b>	3021
28 1/2"	20" x 66 1/2"	3"	76	18	129	58.5	27	<b>OUR-2618-3-SR</b>	3116
28 1/2"	20" x 72 1/2"	3"	76	20	158	71.6	27	<b>OUR-2620-3-SR</b>	3206
28 1/2"	20" x 66 1/2"	2 1/4"	57	24	161	73.0	27	<b>OUR-2624-2-SR</b>	3295

All-Welded Pan Racks (NSF)

see spec sheet **EG60.02**

- For 18" x 26" (457 x 660mm) pans.
- Heavy duty all-welded aluminum construction.
- 5" (127mm) stem casters.
- 1" (25mm) square tubing.
- Side-to-side crossbracing.

FEATURES:

**Note:** Accessories available include casters with locking brakes, rotary donut bumpers, vertical bumpers, perimeter bumper and pan stops. See page 354.

**Freight class is 300.0.**

(•) MTS (made to stock) / ( ) MTO (made to order)



#OUR-1830-2/W

18 Series

description	overall dimensions width x depth x height		weight		cu ft	sliding space		full size pan capacity	model #	list
	in.	mm	lbs.	kg		in.	mm			
front load	20½" x 26" x 38"	518 x 660 x 965	19	8.6	14.7	3"	76	10	<b>OUR-1810-3/W**</b>	812
front load	20½" x 26" x 69"	518 x 660 x 1753	25	11.3	25.8	5"	127	12	<b>OUR-1812-5/W</b>	818
front load	20½" x 26" x 69"	518 x 660 x 1753	38	17.2	21.0	3"	76	20	<b>OUR-1820-3/W</b>	• 882
front load	20½" x 26" x 69"	518 x 660 x 1753	47	21.3	21.0	2"	51	30	<b>OUR-1830-2/W</b>	• 1271

26 Series

description	overall dimensions width x depth x height		weight		cu ft	sliding space		full size pan capacity	model #	list
	in.	mm	lbs.	kg		in.	mm			
side load	28½" x 20" x 72¼"	724 x 457 x 1835	27	12.2	25.2	5"	127	12	<b>OUR-2612-5/W</b>	1015
side load	28½" x 19" x 69"	724 x 483 x 1753	27	12.2	25.2	3"	76	20	<b>OUR-2620-3/W</b>	1154
side load	28½" x 19" x 69"	724 x 483 x 1753	32	14.5	25.2	2"	51	30	<b>OUR-2630-2/W</b>	1222

\* Model #OUR-1810-3/W features stainless steel top. All other models feature open top.

Carrier Racks (NSF)

see spec sheet **EG60.05**

- For 20" x 20" (508 x 508mm) utensil/glass racks.
- 5" (127mm) swivel casters.
- Aluminum and stainless steel models available.
- Aluminum models shipped knocked down.
- Stainless steel models shipped assembled.
- Dimensions shown include caster hub.
- Add 2¾" (70mm) to dimensions for caster trail.

FEATURES:

**Note:** Accessories available include casters with locking brakes, rotary donut bumpers, vertical bumpers, and pan stops. See page 354.

**Freight class is 70.0.**

Optional Perimeter Bumper

- Factory welded assembly is required on aluminum knocked-down units specified with perimeter bumpers.

description	weight lbs.	kg	accessory model #	add to unit list
full perimeter bumper	4	1.8	<b>D</b>	391



Aluminum

overall dimensions width x depth x height		sliding space		pan capacity	weight		cu ft	model #	list
in.	mm	in.	mm		lbs.	kg			
22" x 20½" x 69"	559 x 521 x 1753	10"	254	6	44	20.0	12	<b>OUR-2006-9A</b>	1109
22" x 20½" x 65"	559 x 521 x 1651	7"	178	8	45	20.4	12	<b>OUR-2008-6A</b>	1126

Stainless Steel

overall dimensions width x depth x height		sliding space		pan capacity	weight		cu ft	model #	list
in.	mm	in.	mm		lbs.	kg			
22¾" x 22½" x 65¼"	578 x 572 x 1670	9"	254	6	100	45.4	22	<b>OUR-2006-9SR</b>	2124
22¾" x 22½" x 64¼"	578 x 572 x 1629	6½"	178	8	102	46.3	22	<b>OUR-2008-6SR</b>	2156

Optional Factory Assembly for Aluminum Units

- Otherwise shipped knocked down.

accessory model #	add to unit list
L	224

Catalog Section 60

**Stainless Steel Racks** (NSF)

see spec sheet **EG60.03**



- For 12" x 20" (305 x 508mm) pans.
- Stainless steel models only.
- 5" (127mm) swivel casters.
- Stainless steel channel tray slides.
- Shipped assembled.
- Dimensions shown include caster hub.
- Add 2 3/4" (70mm) to dimensions for caster trail.

**FEATURES:**

**Note:** Accessories available include casters with locking brakes, rotary donut bumpers, vertical bumpers, perimeter bumper and pan stops. See page 354.

**Freight class is 70.0.**

description	overall dimensions width x depth x height		weight		cu ft	sliding space		full size pan capacity	model #	list
	in.	mm	lbs.	kg		in.	mm			
single width	16 1/2"	22 3/4" x 64 1/2"	410	57.6	15	3"	76	18	<b>OUR-1218-3-SR</b>	2704
double width	31 1/2"	22 3/4" x 64 1/2"	800	113.4	27	3"	76	36	<b>OUR-1236-3-SR</b>	5795

**Aluminum Racks with Side Panels** (NSF)

see spec sheet **EG60.07**



- Shipped knocked down.
- 5" (127mm) swivel casters.

#ORO-1840:

**Note:** Accessories available for this model include casters with locking brakes, vertical bumpers, and pan stops. See page 354.

- Shipped assembled
- Solid top and bottom.
- 5" (127mm) swivel casters.

#OR-1840:

**Note:** Accessories available for this model include casters with locking brakes, rotary donut bumpers, vertical bumpers, and pan stops. See page 354.

**Freight class is 70.0.**

overall dimensions width x depth x height		description	weight		cubic feet	sliding space		18" x 26" tray capacity	model #	list
in.	mm		lbs.	kg		in.	mm			
20 3/4" x 28" x 70 3/4"	527 x 711 x 1788	standard	68	30.8	15.0	1 1/2"	38	40	<b>ORO-1840</b>	2724
20 3/4" x 28" x 70 3/4"	530 x 711 x 1788	heavy duty	88	39.9	25.1	1 1/2"	38	40	<b>OR-1840</b>	3514



**Optional Perimeter Bumper**

- Factory welded assembly is required on aluminum knocked-down units specified with perimeter bumpers.

description	weight lbs. kg	accessory model #	add to unit list
full perimeter bumper	4 1.8	<b>D</b>	391

**Optional Factory Assembly for Aluminum Units**

- Otherwise shipped knocked down.

accessory model #	add to unit list
<b>L</b>	224

Combination Racks 

see spec sheet **EG60.04**



- For 12" x 20" (305 x 508mm) pans, 18" x 26" (457 x 660mm) sheet pans or 14" x 18" (356 x 457mm) trays.
- Aluminum models only.
- 5" (127mm) swivel casters.
- Shipped assembled.
- Dimensions shown include caster hub.
- Add 2 3/4" (70mm) to dimensions for caster trail.

FEATURES:

**Note:** Accessories available include casters with locking brakes, rotary donut bumpers, perimeter bumper, vertical bumpers, and pan stops. See page 354.

**Freight class is 70.0.**

overall dimensions			weight	cu	sliding	pan/tray capacity			model #	list					
width	depth	height				pan	tray	tray							
in.	mm	mm	lbs.	kg	ft	in.	mm	mm							
20 1/2"	29 1/2"	66 1/2"	521	749	1699	70	31.8	27	5"	127	11	11	22	<b>OUR-1211-5</b>	1634
20 1/2"	29 1/2"	66 1/2"	521	749	1689	75	34.0	27	3"	76	18	18	36	<b>OUR-1220-3</b>	1793

Compartment Racks 

see spec sheets **EG60.06A** **EG60.06B**



double-compartment rack



four-compartment rack

- For 18" x 26" (457 x 660mm) sheet pans.
- 5" (127mm) swivel casters.
- Aluminum and stainless steel models available.
- All models shipped assembled.
- Dimensions shown include caster hub.
- Add 2 3/4" (70mm) to dimensions for caster trail.

DOUBLE FEATURES:

- For 10" x 14" (254 x 356mm) trays or 14" x 18" (356 x 457mm) trays.
- 5" (127mm) swivel casters.
- Aluminum models only.
- Shipped assembled with center tray stop.
- Dimensions shown include caster hub.
- Add 2 3/4" (70mm) to dimensions for caster trail.

FOUR FEATURES:

**Freight class is 70.0.**

**Note:** Accessories available include casters with locking brakes, rotary donut bumpers, perimeter bumper, vertical bumpers, and pan stops for double racks. See page 354.

Double-Compartment Tray Racks

overall dimensions			cu	sliding	pan	ALUMINUM				STAINLESS STEEL							
width	depth	height				weight	weight	weight	weight	model #	list	lbs.	kg	model #	list		
in.	mm	mm	ft	in.	mm	capacity	lbs.	kg	model #	list	lbs.	kg	model #	list			
40"	28"	66 1/2"	1016	711	1689	45	5"	127	22	135	61.2	<b>OUR-1822-5</b>	2709	270	122.5	<b>OUR-1822-5-SR</b>	5517
40"	28"	66 1/2"	1016	711	1689	45	3"	76	36	150	68.0	<b>OUR-1836-3</b>	3168	300	136.1	<b>OUR-1836-3-SR</b>	7028
40"	28"	66 1/2"	1016	711	1689	45	2 1/4"	57	48	176	79.8	<b>OUR-1848-2</b>	3614	350	158.8	<b>OUR-1848-2-SR</b>	8016

Four-Compartment Tray Racks

overall dimensions			weight	cubic	sliding	tray		model #	list					
width	depth	height				tray size	quantity							
in.	mm	mm	lbs.	kg	feet	in.	mm	model #	list					
40"	30"	69 1/2"	154	69.9	51	4 1/2"	114	14" x 18"	52	<b>OUR-1452-4</b>	3206			
32"	22"	69 1/2"	813	559	1772	100	45.4	34	4 1/2"	114	10" x 14"	52	<b>OUR-1052-4-A</b>	3141
34 3/4"	24 1/2"	68 3/4"	883	622	1743	100	45.4	35	4 1/2"	114	10" x 14 3/4"	52	<b>OUR-1052-4-B</b>	2983



## Catalog Section 60

### Multiple Purpose Racks <sup>(NSF)</sup>

see spec sheet **EG60.10**



- Adjustable universal slides accommodate almost any popular size tray or pan (see chart).
- 5" (127mm) swivel casters.
- Slides adjustable in increments of 2½" (64mm).
- Channel base.
- Aluminum models only.
- Shipped assembled.

**FEATURES:**

**Note:** Accessories available include casters with locking brakes, pan stops, and rotary bumpers. See page 354.

**Freight class is 70.0.**

overall dimensions width x depth x height		weight		cubic feet	universal slides supplied	model #	list
in.	mm	lbs.	kg				
25¾" x 28" x 69¾"	640 x 711 x 1762	71	32.2	30	10 sets	<b>MPR-10</b>	1666
25¾" x 28" x 69¾"	640 x 711 x 1762	81	36.7	30	12 sets	<b>MPR-12</b>	1805

### Pan/Tray Sizes for Multiple Purpose Rack

width x depth		width x depth		width x depth	
in.	mm	in.	mm	in.	mm
10¾" x 19¾"	276 x 502	14" x 18"	356 x 457	20" x 22"	508 x 559
11¾" x 20"	302 x 508	15" x 20"	381 x 508	18" x 13"	457 x 330
12" x 20"	305 x 508	20" x 20"	508 x 508	18" x 26"	457 x 660
12" x 18"	305 x 457	22½" x 20½"	571 x 521		

### Universal Angle Racks <sup>(NSF)</sup>

see spec sheet **EG60.12**



- Each set of universal slides holds two 12" x 20" (305 x 508mm) pans, plus one 18" x 26" (457 x 660mm) sheet pan, one 15" x 20" (381 x 508mm) tray or one 20" x 20" (305 x 305mm) rack.
- Adjustable universal slides, solid top, solid bottom, and 5" (127mm) swivel plate casters.
- Aluminum and stainless steel models available.
- Shipped assembled.

**FEATURES:**

**Note:** Accessories available include casters with locking brakes, perimeter bumper, pan stops, and extra universal angle slides. See page 354.

**Freight class is 70.0.**

overall dimensions width x depth x height		cu ft	sliding space		number of slides	ALUMINUM				STAINLESS STEEL *			
in.	mm		in.	mm		weight lbs.	kg	model #	list	weight lbs.	kg	model #	list
23½" x 26" x 64¾"	597 x 660 x 1635	23	2½"	64	11	127	57.6	<b>UAR-64-A</b>	2878	140	63.5	<b>UAR-64-SR</b>	3298
23½" x 26" x 69¾"	597 x 660 x 1762	24	2½"	64	13	135	61.2	<b>UAR-70-A</b>	2924	147	66.7	<b>UAR-70-SR</b>	3601

\*All stainless steel units are supplied with standard extruded aluminum universal slides.

Oval Tray Racks - Vertical <sup>NSF</sup>

see spec sheet **EG60.09A**



- For 23" x 28" (584 x 711mm) oval trays.
- 5" (127mm) swivel casters.
- Dimensions shown include caster hub.
- Add 2 3/4" (70mm) to depth for caster trail.
- Bottom panel sloped toward center.
- Single-tier and double-tier models available.
- Aluminum and stainless steel.
- All units shipped assembled.

FEATURES:

**Note:** Accessories available include casters with locking brakes, rotary donut bumpers, and vertical bumpers. See page 354.

**Freight class is 70.0.**

overall dimensions		cu ft	tray capacity	ALUMINUM				STAINLESS STEEL			
width in.	depth x height mm			weight lbs.	kg	model #	list	weight lbs.	kg	model #	list
26 1/4"	31 1/4" x 38 1/2"	20	40	60	27.2	OTS-128-A	1760	100	45.4	OTS-128-SR	3029
26 1/4"	31 1/4" x 66"	33	80	110	49.9	OTS-228-A*	2277	150	68.0	OTS-228-SR*	3722

\* Double-tier models

Oval Tray Racks - Horizontal <sup>NSF</sup>

see spec sheet **EG60.09B**



- For 23" x 28" (584 x 711mm) oval trays.
- 5" (127mm) swivel casters.
- Dimensions shown include caster hub.
- Add 2 3/4" (70mm) to depth for caster trail.
- Vertical tubing to prevent trays from extending out.
- All-welded aluminum models only.

FEATURES:

**Note:** Accessories available include casters with locking brakes, rotary donut bumpers, perimeter bumper, vertical bumpers, and pan stops. See page 354.

**Freight class is 70.0.**

(•) MTS (made to stock) / ( ) MTO (made to order)

overall dimensions		weight		cubic feet	sliding space		tray capacity	model #	list
width in.	depth x height mm	lbs.	kg		in.	mm			
26"	30" x 69"	28	12.7	34.6	6"	152	10	OTR-2810-A/W•	1260
27"	29 1/2" x 72 1/2"	35	15.9	34.6	3"	76	20	OTR-2820-A/W	1757

Just a quick note...



GET FREE DOWNLOADS

- Spec Sheet • Product Instructions •
- Special Flyers • Brochures •

[www.eaglegrp.com](http://www.eaglegrp.com)

## Catalog Section 60

### Roll-In Refrigerator Racks <sup>NSF</sup>

see spec sheets **EG60.13A** **EG60.13B**



- Models UARR employ universal slides.
- Units fit specifications of most major refrigerator manufacturers, including Hobart, Traulsen, Victory, True, and Continental.
- Dolly frame with recessed plate casters.
- Aluminum and stainless steel models available.
- Shipped assembled.

**FEATURES:**

**Note:** Accessories available include casters with locking brakes and pan stops. See page 354.

**Freight class is 70.0.**

#### Aluminum

overall dimensions width x depth x height		weight		cu ft	sliding space		tray sizes		tray capacity	model #	list
in.	mm	lbs.	kg		in.	mm	in.	mm			
20½" x 26" x 64"	521 x 660 x 1626	62	28.1	20	2¼"	57	18" x 26"	457 x 660	24	<b>OARR-1824-2-A</b>	1838
20½" x 26" x 64"	521 x 660 x 1626	52	23.6	20	3"	76	18" x 26"	457 x 660	18	<b>OARR-1818-3-A</b>	1791
20½" x 26" x 64"	521 x 660 x 1626	42	19.1	20	5"	127	18" x 26"	457 x 660	11	<b>OARR-1811-5-A</b>	1634
23" x 26" x 64"	584 x 660 x 1626	62	28.1	20	3"	76	12" x 20"	305 x 508	36*	<b>OARR-2036-3-A</b>	2951
24½" x 26" x 64"	622 x 660 x 1626	86	40.4	23	1½"	38	UAS**		**	<b>UARR-64-A</b>	2887

\* Two 12" x 20" (305 x 508mm) trays per set of tray slides.

\*\* Model #UARR-64-A comes with 12 "stepped angle" Universal Angle Slides. Each set holds two 12" x 20" (305 x 508mm) pans, one 18" x 26" (457 x 660mm) tray, plus one 15" x 20" (381 x 508mm) tray or one 20" x 20" (305 x 305mm) rack.

#### Stainless Steel

overall dimensions width x depth x height		weight		cu ft	sliding space		tray sizes		tray capacity	model #	list
in.	mm	lbs.	kg		in.	mm	in.	mm			
20½" x 26" x 63¾"	521 x 660 x 1610	187	84.8	20	2¼"	57	18" x 26"	457 x 660	24	<b>OARR-1824-2-SR</b>	3478
20½" x 26" x 63¾"	521 x 660 x 1610	151	68.5	20	3"	76	18" x 26"	457 x 660	18	<b>OARR-1818-3-SR</b>	3015
20½" x 26" x 63¾"	521 x 660 x 1610	121	54.9	20	5"	127	18" x 26"	457 x 660	11	<b>OARR-1811-5-SR</b>	2782
23" x 26" x 64"	584 x 660 x 1626	154	69.9	20	3"	76	12" x 20"	305 x 508	36*	<b>OARR-2036-3-SR</b>	3526
23½" x 26" x 64"	597 x 660 x 1626	160	72.6	23	2½"	64	UAS**		**	<b>UARR-64-SR**</b>	3426

\* Two 12" x 20" (305 x 508mm) trays per set of tray slides.

\*\* Model UARR-64-SR comes with 11 standard extruded aluminum Universal Angle Slides. Each set holds two 12" x 20" (305 x 508mm) pans, one 18" x 26" (457 x 660mm) tray, plus one 15" x 20" (381 x 508mm) tray or one 20" x 20" (305 x 305mm) rack.

### "Z" Type Nesting Racks <sup>NSF</sup>

see spec sheet **EG60.29**

**WEIGHT CAPACITY:**

- 1200 lbs. (544.3 kg) max per unit.
- 60 lbs. (27.2 kg) max per slide



**When not in use, these racks take up less square footage than standard racks do by "nesting" inside each other.**

**FEATURES:**

- For 18" x 26" (457 x 660mm) pans.
- All-welded aluminum construction.
- 5" (127mm) plate casters.

**Note:** Accessories available include casters with locking brakes and vertical bumpers. See page 354.

**Freight class is 70.0.**

overall dimensions width x depth x height		weight		cubic feet	sliding space		pan capacity	model #	list
in.	mm	lbs.	kg		in.	mm			
20½" x 26" x 69½"	521 x 660 x 1765	72	32.7	22	3"	76	20	<b>OUR-1820-3-N</b>	1440
20½" x 26" x 69½"	521 x 660 x 1765	86	39.0	22	2"	51	30	<b>OUR-1830-2-N</b>	1459

Can Racks 

see spec sheets **EG60.15A** **EG60.15B**



- All racks constructed of high strength extruded aluminum sections.
- All welded construction.
- All mobile units feature heavy duty 4" (102mm) plate casters.

FEATURES:

**Note:** Accessories available include casters with locking brakes, perimeter bumper, and vertical bumpers. See page 354.

**Freight class is 70.0.**

(•) MTS (made to stock) / ( ) MTO (made to order)

description	type of top	overall dimensions width x depth x height		weight		cu ft	sliding space		can capacity		model #	list
		in.	mm	lbs.	kg		in.	mm	#10	#5		
full size, stationary	open top	25" x 35" x 71"	635 x 889 x 1803	63	28.6	39.0	7½"	191	162	216	<b>FCR-10-9A</b> •	1566
full size, mobile	open top	25" x 35" x 78¼"	635 x 889 x 1988	63	28.6	39.0	7½"	191	162	216	<b>OCR-10-9A</b> •	2139
half size, mobile	aluminum	25" x 35" x 35"	635 x 889 x 889	39	17.6	23.1	7½"	191	54	72	<b>OCR-10-3A</b>	1502
half size, mobile	aluminum	25" x 35" x 41"	635 x 889 x 1041	36	16.3	26.7	7½"	191	72	96	<b>OCR-10-4A</b>	1697
half size, mobile	poly	25½" x 35½" x 32¾"	648 x 892 x 822	51	23.1	23.1	7½"	191	54	72	<b>OCR-10-3AP</b>	1688
half size, mobile	poly	25½" x 35½" x 40¾"	648 x 892 x 1038	54	24.5	26.7	7½"	191	72	96	<b>OCR-10-4AP</b>	1865

Oven Racks

see spec sheet **EG60.16**



- For 18" x 26" (457 x 660mm) pans.
- Aluminum.
- Heavy duty welded construction.
- 4" (102mm) oven plate casters.
- 1" (25mm) square tubing.
- Side-to-side crossbracing.

FEATURES:

**Note:** Accessories available include oven plate casters with brake (rated up to 475°F) and pan stop. See page 354.

**Freight class is 70.0.**

Optional Accessories for Oven Racks

description	model #	list
track pin	consult factory	100

description	overall dimensions width x depth x height		weight		cu ft	sliding space		pan capacity	model #	list
	in.	mm	lbs.	kg		in.	mm			
front load	20½" x 26" x 69"	521 x 660 x 1753	28	12.7	25.6	6"	152	10	<b>ORF-1810-6</b>	934
front load	20½" x 26" x 69"	521 x 660 x 1753	29	13.2	25.6	5"	127	12	<b>ORF-1812-5</b>	987
front load	20½" x 26" x 69"	521 x 660 x 1753	31	14.1	25.6	4"	102	15	<b>ORF-1815-4</b>	1028
front load	20½" x 26" x 69"	521 x 660 x 1753	33	15.0	25.6	3"	76	20	<b>ORF-1820-3</b>	1180
front load	20½" x 26" x 69"	521 x 660 x 1753	41	18.6	25.6	2"	51	30	<b>ORF-1830-2</b>	1232
side load	19" x 28½" x 69"	483 x 724 x 1753	28	12.7	24.9	6"	152	10	<b>ORS-2610-6</b>	900
side load	19" x 28½" x 69"	483 x 724 x 1753	29	13.2	24.9	5"	127	12	<b>ORS-2612-5</b>	951
side load	19" x 28½" x 69"	483 x 724 x 1753	31	14.1	24.9	4"	102	15	<b>ORS-2615-4</b>	973
side load	19" x 28½" x 69"	483 x 724 x 1753	33	15.0	24.9	3"	76	20	<b>ORS-2620-3</b>	1066
side load	19" x 28½" x 69"	483 x 724 x 1753	37	16.8	24.9	2"	51	30	<b>ORS-2630-2</b>	1218

## Catalog Section 60

### Platter Racks

see spec sheet **EG60.14**



- Rack slides are designed to hold either 10½" or 12½" (267 or 318mm) plastic platters.
- All racks are all welded aluminum construction.
- 5" (127mm) casters.
- Add 2¾" (70mm) to dimensions for caster trail.

**FEATURES:**

**Note:** Accessories available include casters with locking brakes, vertical bumpers, and pan stops. See page 354.

**Freight class is 70.0.**

description	overall rack dimensions width x depth x height		weight		cu ft	sliding space		platter size		platter cap.	model #	list
	in.	mm	lbs.	kg		in.	mm	in.	mm			
half size	13½" x 30" x 38½"	352 x 762 x 984	18	8.2	11.9	6"	152	10½"	267	5	<b>OPL-10-5A</b>	580
half size	13½" x 30" x 38½"	352 x 762 x 984	18	8.2	11.9	5"	127	10½"	267	6	<b>OPL-10-6A</b>	603
full size	13½" x 30" x 69½"	352 x 762 x 1759	26	11.8	20.8	6"	152	10½"	267	10	<b>OPL-10-10A</b>	708
full size	13½" x 30" x 69½"	352 x 762 x 1759	27	12.2	20.8	5"	127	10½"	267	12	<b>OPL-10-12A</b>	731
half size	15½" x 30" x 38½"	403 x 762 x 984	19	8.6	11.9	6"	152	12½"	318	5	<b>OPL-12-5A</b>	621
half size	15½" x 30" x 38½"	403 x 762 x 984	17	7.7	11.9	5"	127	12½"	318	6	<b>OPL-12-6A</b>	643
full size	15½" x 30" x 69½"	403 x 762 x 1759	28	12.7	20.8	6"	152	12½"	318	10	<b>OPL-12-10A</b>	731
full size	15½" x 30" x 69½"	403 x 762 x 1759	25	11.3	20.8	5"	127	12½"	318	12	<b>OPL-12-12A</b>	756

### Plastic Pans and Platters for Platter Racks

description	width x depth x height in.	mm	model #	list
white display pan	18" x 26" x 1½"	457 x 660 x 29	<b>DP1826-W</b>	40
platter	12½" x 24" x ¾"	318 x 610 x 19	<b>PL1224</b>	27
platter	12½" x 30" x ¾"	318 x 762 x 19	<b>PL1230</b>	31
platter	10½" x 30" x ¾"	267 x 762 x 19	<b>PL1030</b>	29

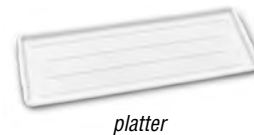

### Wire Pan Racks

see spec sheet **EG60.17**



- All welded aluminum square frame construction.
- Front load and side load models offered.
- Nickel chrome-plated steel wire racks.
- 5" (127mm) casters.

**FEATURES:**

**Note:** Accessories available include casters with locking brakes, rotary bumpers, perimeter bumper, vertical bumpers, and pan stop. See page 354.

**Freight class is 70.0.**

description	overall dimensions width x depth x height		weight		cu ft	sliding space		pan capacity	model #	list
	in.	mm	lbs.	kg		in.	mm			
front load	20½" x 28" x 69"	521 x 711 x 1753	64	29.0	26.9	1½"	38	36	<b>WPR-FL-36</b>	1154
side load	20" x 28½" x 69"	508 x 724 x 1753	64	29.0	26.6	1½"	38	36	<b>WPR-SL-36</b>	1232

**Pizza Pan Rack** 

see spec sheet **EG60.18A**



*pizza pan rack (adjustable)*



*pizza pan rack (all-welded)*

- All welded aluminum construction.
- Adjustable and all-welded models available.
- Both models feature 5" (127mm) casters.
- Holds round and square pans.
- Adjustable model features adjustable pan opening for 10" to 16" (254 to 406mm) pans.
- Knock-down construction.
- All-welded model features solid aluminum top and slides that accommodate nominal 16" to 20" (406 to 508mm) wide pans.

**FEATURES:**

**Note:** Accessories available for both the pizza rack and pizza dough box rack below include casters with locking brakes, rotary bumpers, perimeter bumper, vertical bumpers, and pan stop. See page 354.

**Freight class is 70.0.**

description	overall dimensions width x depth x height		weight		cu ft	sliding space		pan capacity	model #	list
	in.	mm	lbs.	kg		in.	mm			
adjustable	adj. x 13¾" x 34¾"	adj. x 340 x 883	26	11.8	2.0	2"	51	13	<b>OUR-PZA-12A</b>	1068
all-welded	22" x 20" x 33¾"	559 x 508 x 857	36	16.3	10.9	2"	51	12	<b>OUR-PZ-12A</b>	1217

**Pizza Dough Box Rack** 

see spec sheet **EG60.18B**



- For 18" x 26" (457 x 660mm) pizza dough boxes.
- Solid aluminum top.
- All welded aluminum frame construction.
- 5" (127mm) casters.
- Holds pizza dough boxes.

**FEATURES:**

**Freight class is 70.0.**

overall dimensions width x depth x height	weight	cubic	sliding	box	model #	list
21" x 26¾" x 35"	29	11.4	3¾"	7	<b>OUR-DB-7A</b>	1193

**Pizza Dough Box**

Made of durable thermoplastic. Stackable design.

description	width x depth x height		weight/dz.		cu ft	model #	list
	in.	mm	lbs.	kg			
pizza dough box	17¾" x 25¾" x 3"	451 x 654 x 76	46	20.9	1.2	<b>A208506</b>	118
cover	17¾" x 25¾"	451 x 654	14	6.4	0.6	<b>A208513</b>	60

Catalog Section 60

Donut Rack 

see spec sheet **EG60.22**



- For 23" x 23" (584 x 584mm) donut screens.
- Heavy duty, all aluminum welded construction.
- Six crossbraces.
- 1" (25mm) square tubing,
- 5" (127mm) heavy duty casters.
- Add 2 3/4" (70mm) to dimensions for caster trail.

FEATURES:

**Note:** Accessories available include casters with locking brakes, rotary bumpers, perimeter bumper, vertical bumpers, and pan stop. See page 354.

**Freight class is 70.0.**

overall rack dimensions width x depth x height		weight		cubic	sliding space		23" x 23" (584 x 584mm)	model #	list
in.	mm	lbs.	kg	feet	in.	mm	donut screen cap.		
26 1/4" x 24" x 69 1/4"	667 x 610 x 1759	30	13.6	28.1	3"	76	20	<b>ODR-2320-3</b>	1043

Open Lug Racks 

see spec sheet **EG60.19**



- For 15 1/2" x 26 1/2" x 8" (394 x 673 x 203mm), maximum 10" deep, nesting lug bins.
- All welded aluminum construction.
- 5" (127mm) heavy duty casters.
- Add 2 3/4" (70mm) to dimensions for caster trail.

FEATURES:

**Note:** Accessories available include casters with locking brakes, rotary bumpers, perimeter bumper, vertical bumpers, and pan stop. See page 354.

**Freight class is 70.0.**

overall rack dimensions width x depth x height			weight		cubic	sliding space		lug capacity	model #	list
in.	mm	lbs.	kg	feet	in.	mm				
19 1/2" x 26 3/4" x 70"	495 x 679 x 1778	25	9.0	24.4	10 1/16"	272	6	<b>OLR-6A</b>	580	
19 1/2" x 26 3/4" x 51"	495 x 679 x 1295	20	7.3	18.6	10 1/16"	272	4	<b>OLR-4A</b>	474	
19" x 26" x 31 1/2"	482 x 660 x 797	13	5.8	11.5	10 1/16"	272	2	<b>OLR-2A</b>	682	
15 3/4" x 26" x 20 3/4"	400 x 660 x 524	9	4.1	4.8	n/a	n/a	1	<b>OLR-1A</b>	638	

Nesting Lug Bin

width x depth x height		model #	list
in.	mm		
15 1/2" x 26 1/2" x 8"	394 x 673 x 203	<b>NL1626</b>	54



**Open Bus Box Cart** 

see spec sheet **EG60.20**



- Holds three 21¼" x 15¾" x 5" (553 x 400 x 127mm) bus boxes.
- All welded aluminum construction.
- 5" (127mm) heavy duty casters

**FEATURES:**

**Note:** Accessories available include casters with locking brakes, rotary bumpers, vertical bumpers, and pan stop. See page 354.

**Freight class is 70.0.**

overall dimensions width x depth x height		weight		cubic feet	sliding space		box capacity	model #	list
in.	mm	lbs.	kg		in.	mm			
18½" x 26" x 36"	470 x 660 x 914	26	11.8	11.6	10" 254	3	<b>OBC-3A</b>	564	

**Bus Box Tubs**

Made of high-density polyethylene.

width x length x depth		model #	list
in.	mm		
21¼" x 15¾" x 5"	553 x 400 x 127	<b>BBT-5</b>	51
21¼" x 15¾" x 7"	553 x 400 x 178	<b>BBT-7</b>	52



**Banquet Carts** 

see product announcement **EG60.08**



stainless steel banquet cart



aluminum banquet cart

- Aluminum units feature all-welded aluminum construction.
- Stainless steel units feature all-welded aluminum frame with stainless steel shelves.
- Smooth radius handles and uprights.
- Two handles—one on each end of unit.
- Solid shelves with marine edge.
- Standard perimeter bumper.
- Heavy duty 8" x 2" (203 x 51mm) platform casters—two swivel, two rigid.

**FEATURES:**

**Freight class is 70.0.**

**For transporting big loads for banquets, catering, and bussing.**

depth x height in. mm		weight lbs. kg		weight capacity lbs. kg		# of shelves	ALUMINUM				STAINLESS STEEL							
							length in. mm		shelf spacing in. mm		length in. mm		shelf spacing in. mm		model # list			
29" x 66"	737 x 1676	147	66.7	3000	1360.8	5	62"	1575	12"	305	<b>QM2962-5-A/D</b>	4288	65½"	1664	10½"	267	<b>QM2966-5-SR/D</b>	5472
29" x 66"	737 x 1676	180	81.6	2500	1134.0	5	75"	1905	12"	305	<b>QM2975-5-A/D</b>	5603	76½"	1943	10½"	267	<b>QM2977-5-SR/D</b>	6416
29" x 66"	737 x 1676	135	61.2	2500	1134.0	4	62"	1575	16½"	419	<b>QM2962-4-A/D</b>	4027	65½"	1664	14½"	368	<b>QM2966-4-SR/D</b>	4963
29" x 66"	737 x 1676	156	70.8	3000	1360.8	6	62"	1575	9¼"	235	<b>QM2962-6-A/D</b>	4888	65½"	1664	8¾"	210	<b>QM2966-6-SR/D</b>	6369



## Catalog Section 60

### Aluminum Dunnage Racks NSF

see spec sheet **EG01.17**



- 1½" (38mm) square tubing.
- Plastic feet.

FEATURES:

**Freight class is 70.0.**

(•) MTS (made to stock) / ( ) MTO (made to order)

	length		weight		cubic feet	weight capacity		number of lats	RACKS WITH 8" (203mm) HEIGHT		RACKS WITH 12" (305mm) HEIGHT	
	in.	mm	lbs.	kg		lbs.	kg		model #	list	model #	list
<b>20" width (508mm)</b>	36"	914	10	4.5	6.8	2000	907	4	<b>WDR203608-A • 305</b>		<b>WDR203612-A • 305</b>	
	48"	1219	14	6.4	8.9	2000	907	4	<b>WDR204808-A • 354</b>		<b>WDR204812-A • 354</b>	
	60"	1524	18	8.2	11.0	1500	680	4	<b>WDR206008-A • 400</b>		<b>WDR206012-A • 400</b>	
<b>24" width (610mm)</b>	36"	914	12	5.4	8.0	2000	907	5	<b>WDR243608-A • 344</b>		<b>WDR243612-A • 344</b>	
	48"	1219	16	7.3	10.5	2000	907	5	<b>WDR244808-A • 386</b>		<b>WDR244812-A • 386</b>	
	60"	1524	20	9.1	13.1	1500	680	5	<b>WDR246008-A • 448</b>		<b>WDR246012-A • 448</b>	

### Nesting Dunnage Racks NSF

see spec sheet **EG01.17**



**2,700 to 3,200 lb.**  
(1225 to 1452 kg)  
weight capacity.

**Racks are stackable, saving space when not in use.**

FEATURES:

- All-aluminum construction.

**Freight class is 70.0.**

		length		weight		cubic feet	weight capacity		model #	list
		in.	mm	lbs.	kg		lbs.	kg		
<b>12" height (305mm)</b>	<b>18" width (457mm)</b>	24"	610	8	3.6	3.0	3200	1452	<b>NDR182412-A</b>	293
		36"	914	10	4.5	4.5	3200	1452	<b>NDR183612-A</b>	337
		48"	1219	12	5.4	6.0	2700	1225	<b>NDR184812-A</b>	376
<b>20" width (508mm)</b>	<b>12" height (305mm)</b>	24"	610	8	3.6	3.4	3200	1452	<b>NDR202412-A</b>	293
		36"	914	10	4.5	5.1	3200	1452	<b>NDR203612-A</b>	337
		48"	1219	12	5.4	6.7	2700	1225	<b>NDR204812-A</b>	376
<b>24" width (610mm)</b>	<b>12" height (305mm)</b>	24"	610	9	4.1	4.0	3200	1452	<b>NDR242412-A</b>	345
		36"	914	11	5.0	6.0	3200	1452	<b>NDR243612-A</b>	384
		48"	1219	14	6.4	8.0	2700	1225	<b>NDR244812-A</b>	448

### Bun Pan Dolly NSF

see spec sheet **EG60.21**



- For use with 18" x 26" (457 or 660mm) or 18" x 13" (457 or 330mm) bun pans.
- Heavy duty welded, all-aluminum construction.
- 5" (127mm) plate casters.
- Shipped assembled.

FEATURES:

**Note:** Accessories available include casters with locking brakes. See page 354.

**Freight class is 70.0.**

overall dimensions width x depth x height		weight		cubic feet	weight capacity		full size pan capacity	model #	list
in.	mm	lbs.	kg		lbs.	kg			
18½" x 27" x 7"	479 x 686 x 178	20	9.0	2.5	800	363	75	<b>BPD-1826-A</b>	445

**Glass Rack Dolly** 

see spec sheet **EG60.21**

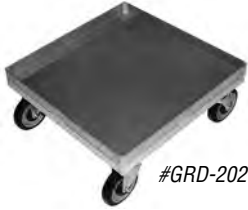

#GRD-2020-A

- For use with 20" x 20" (508 x 508mm) racks.
- Heavy duty welded all-aluminum construction.
- 5" (127mm) plate casters.
- Shipped assembled.

**FEATURES:**

**Note:** Accessories available include casters with locking brakes. See page 354.

**Freight class is 70.0.**

overall dimensions width x depth x height		weight		weight capacity		cubic feet	model #	list
in.	mm	lbs.	kg	lbs.	kg			
20 1/2" x 22 1/2" x 9 1/4"	524 x 524 x 235	21	9.5	1200	544	2.4	<b>GRD-2020-A</b>	522
20 1/2" x 22 1/2" x 39"	524 x 524 x 991	25	11.3	1200	544	9.0	<b>GRDH-2020-A*</b>	726

\* #GRDH-2020-A comes with push handle.

**Pan Truck** 

see spec sheet **EG60.21**



- For use with 18" x 26" (457 or 660mm) bun pans.
- Heavy duty all-aluminum construction.
- 1" (25mm) square tubing.
- 5" (127mm) casters.
- Rear pan strap.

**FEATURES:**

**Note:** Accessories available include casters with locking brakes. See page 354.

**Freight class is 70.0.**

overall dimensions width x depth x height		weight		cubic feet	weight capacity		full size pan capacity	model #	list
in.	mm	lbs.	kg		lbs.	kg			
21" x 27" x 33 1/2"	534 x 686 x 851	14	6.4	12.3	1000	454	75	<b>PT-1826-A</b>	684

**Drip Racks**

see spec sheet **EG60.23**

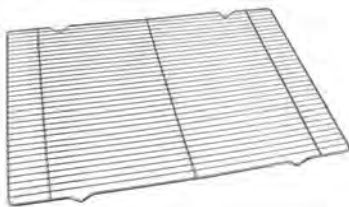

drip rack

- Designed to fit inside half size and full size PANCO® sheet pans.
- Chrome (packed 12 per box).
- Integral supports hold the mat approximately 5/8" (16mm) off the working surface.

**FEATURES:**

**Freight class is 70.0.**

description	width x length x depth		weight		cu ft	chrome	
	in.	mm	lbs.	kg		model #	list
half size rack	11 1/2" x 16 1/2" x 3/4"	302 x 410 x 19	2	0.9	0.08	<b>DPRK1216C</b>	35
full size rack	16 1/2" x 24 1/4" x 1"	416 x 629 x 25	3	1.4	0.23	<b>DPRK1725C</b>	65

Catalog Section 60

Mobile Platform Carts **NSF**

see spec sheet **EG60.36**



- Heavy duty all-aluminum construction.
- 1½" x 2¾" (38 x 70mm) square tubing.
- 5" (127mm) casters—two swivel with brake and two rigid.
- Lifetime guarantee against rust and corrosion; 5-year guarantee against workmanship and material defects.

FEATURES:

**Freight class is 70.0.**

overall dimensions		deck size		weight capacity		model #	list
width	depth x height	width	depth	lbs.	kg		
in.	mm	in.	mm				
20" x 37¼" x 42"	508 x 959 x 1067	20" x 36"	508 x 914	1200	544.3	<b>1202</b>	792
20" x 49¾" x 42"	508 x 1264 x 1067	20" x 48"	508 x 1219	1200	544.3	<b>1203</b>	873
20" x 61¾" x 42"	508 x 1569 x 1067	20" x 60"	508 x 1524	1200	544.3	<b>1212</b>	1016

Aluminum Sheet Pans

see spec sheet **EG60.23**

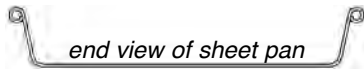

end view of sheet pan



**Made from H-24 3003 aluminum alloy, the industry's best, proven to be harder and more durable.**

- All aluminum pans feature a rust-resistant wire bead for rust-free durability and extended use.
- Packed 12 per box.

FEATURES:

**Freight class is 70.0.**

(•) MTS (made to stock) / ( ) MTO (made to order)

Solid Sheet Pans 18 gauge.

description	dimensions		model #	list per pan
	in.	mm		
solid, half size	17¼" x 12½"	451 x 327	<b>SP1813-18 •</b>	24
solid, full size	17¾" x 25½"	451 x 651	<b>SP1826-18 •</b>	32

Perforated Sheet Pans 18 gauge.

description	dimensions		model #	list per pan
	in.	mm		
perforated, half size	17¼" x 12½"	451 x 327	<b>PP1813-18 •</b>	37
perforated, full size	17¾" x 25½"	451 x 651	<b>PP1826-18 •</b>	43

Glazed Sheet Pan 18 gauge.

description	dimensions		model #	list per pan
	in.	mm		
glazed, full size	17¾" x 25½"	451 x 651	<b>SP1826-G</b>	53

Heavy Duty 16 Gauge Sheet Pan

description	dimensions		model #	list per pan
	in.	mm		
solid, full size	17¾" x 25½"	451 x 651	<b>SP1826-16 •</b>	43

NSF Sheet Pans **NSF**

see spec sheet **EG60.23**



end view of NSF sheet pan



- All NSF pans are solid and 12 gauge construction, heavier than the standard aluminum sheet pans.
- Instead of a wire bead around the perimeter of the pan, the bead is open.
- Packed 12 per box.

FEATURES:

**Freight class is 70.0.**

(•) MTS (made to stock) / ( ) MTO (made to order)

description	dimensions		model #	list per pan
	in.	mm		
solid, full size, NSF	17¾" x 25½"	451 x 654	<b>SP1826-N •</b>	85
solid, full size, clear anodized NSF	17¾" x 25½"	451 x 654	<b>SP1826-NCA</b>	102

Accessories

see spec sheet **EG60.24**

**Casters with Locking Brakes**

For all units except Oven Racks.

description	weight lbs. kg	accessory model #	add to unit list
set of two, with brake	2 0.9	<b>A</b>	48
set of four, with brake	4 1.8	<b>B</b>	96



**Note:** These accessory prices are for add-on at time of original purchase. To order accessories, **add a slash "/"** followed by suffix indicating corresponding option or accessory model number(s). For example, model number **UAR-64-A/ADG** indicates a universal angle rack with the following accessories: set of two casters with locking brakes ("A"), perimeter bumper ("D"), and aluminum pan stop ("G").

**Can be shipped UPS.**

(•) MTS (*made to stock*) / ( ) MTO (*made to order*)

**Casters**

description	accessory model #	list each
4" (102mm) hi-temp oven plate caster with built-in grease fitting	<b>606587</b>	155
4" (102mm) hi-temp oven plate caster with brake	<b>606588</b>	165
4" (102mm) plate caster with built-in grease fitting	<b>606589</b>	89
4" (102mm) plate caster with brake	<b>606590</b>	106
5" (127mm) pan truck caster	<b>606593</b>	104
5" (127mm) stem caster	<b>606594</b> •	71
5" (127mm) stem caster with brake	<b>606595</b>	80
5" (127mm) plate caster	<b>606598</b> •	77
5" (127mm) plate caster with brake	<b>606599</b> •	88

**Vertical Bumpers**

For all units.

description	weight lbs. kg	accessory model #	add to unit list
set of four, 12" (305mm)	2 0.9	<b>F</b>	224



**Rotary Bumpers**

For use with stem casters.

description	weight lbs. kg	accessory model #	add to unit list
set of four, 5" (127mm) diameter	2 0.9	<b>C</b>	391



**Perimeter Bumper**

• Factory welded assembly is required on aluminum knocked-down units specified with perimeter bumpers.

description	weight lbs. kg	accessory model #	add to unit list
full perimeter bumper	4 1.8	<b>D</b>	391



**Pan Stops**

Prevents pans and/or trays from sliding out of unit.

description	weight lbs. kg	accessory model #	add to unit list
aluminum	1 0.5	<b>G</b>	200
stainless steel	2 0.9	<b>H</b>	309



pan stop

**Extra Universal Angle Slides**

Per pair. Accommodates a variety of different size trays and pans.

description	weight lbs. kg	accessory model #	add to unit list
for universal angle rack	5 2.3	<b>606570</b>	126



universal  
angle slide for  
universal angle rack

**LIFETIME Series Racks** NSF

*All heavy duty alloy aluminum fully welded construction.*



**LIFETIME Dunnage Racks** NSF

see spec sheet **EG60.30**



- All heavy duty type 6063-T5 alloy aluminum construction.
- Fully-welded frame features 2" (51mm) square tubing, with feet capped and welded.

FEATURES:

**Freight class is 70.0.**

overall dimensions width x length x height		weight		weight capacity		model #	list
in.	mm	lbs.	kg	lbs.	kg		
20" x 36" x 12"	508 x 914 x 305	17	7.7	5000	2268	<b>4004</b>	669
20" x 48" x 12"	508 x 1219 x 305	21	9.5	4000	1814	<b>4005</b>	742
20" x 60" x 12"	508 x 1524 x 305	25	11.3	3400	1542	<b>4006</b>	817
24" x 36" x 12"	610 x 914 x 305	20	9.0	4000	1814	<b>4008</b>	779
24" x 48" x 12"	610 x 1219 x 305	25	11.3	4000	1814	<b>4009</b>	869
24" x 60" x 12"	610 x 1524 x 305	29	13.2	4000	1814	<b>4010</b>	958
30" x 48" x 12"	762 x 1219 x 305	31	14.1	4000	1814	<b>4027</b>	1052
36" x 48" x 12"	914 x 1219 x 305	35	15.9	4000	1814	<b>4065</b>	1234

**LIFETIME Bun Pan Racks** NSF

see spec sheet **EG60.31**



- For 18" x 26" (457 x 660mm) pans.
- All heavy duty 6063-T5 alloy aluminum type construction.
- Fully-welded frame features 1½" x 1¼" (38 x 45mm) "D"-shaped tubing.
- Crossbracing consists of 1" (25mm) square tubing.
- 1½" (38mm) square tube base includes 6" x 2" (152 x 51mm) non-marking swivel plate casters.
- 2" (51mm) wide aluminum angle slides are welded to frame.

FEATURES:

**Freight class is 70.0.**

overall dimensions width x depth x height		weight		slide spacing		pan capacity	model #	list
in.	mm	lbs.	kg	in.	mm			
21½" x 26" x 73"	546 x 660 x 1854	86	39.0	2"	51	30	<b>4330</b>	3215
21½" x 26" x 73"	546 x 660 x 1854	70	31.6	3"	76	20	<b>4331</b>	2725
21½" x 26" x 73"	546 x 660 x 1854	54	24.5	5"	127	12	<b>4333</b>	2425

**LIFETIME Universal Pan Racks** 

see spec sheet **EG60.32**



**LIFETIME GUARANTEE!**  
against rust and corrosion, and against material defects and workmanship.

- For 12" x 20" (305 x 508mm) pans, 18" x 26" (457 x 660mm) pans, 13" x 18" (330 x 457mm) pans, or 14" x 18" (356 x 457mm) trays.
- All heavy duty 6063-T5 alloy aluminum type construction.
- Fully-welded frame features 1½" x 1¼" (38 x 45mm) "D"-shaped tubing.
- Crossbracing consists of 1" (25mm) square tubing.
- 1½" (38mm) square tube base includes 6" x 2" (152 x 51mm) non-marking recessed swivel plate casters.
- ¾" (86mm) wide aluminum angle slides are welded to frame.

FEATURES:

**Freight class is 70.0.**

overall dimensions		weight		sliding space		pan/tray capacity				model #	list
width	depth x height	lbs.	kg	in.	mm	12" x 20"	18" x 26"	13" x 18"	14" x 18"		
in.	mm					pan	pan	pan	tray		
21½" x 26" x 73"	546 x 660 x 1854	92	41.7	3"	76	19	20	40	40	<b>4339</b>	3444
21½" x 26" x 73"	546 x 660 x 1854	74	33.6	5"	127	11	12	24	24	<b>4340</b>	2720

**LIFETIME Universal Roll-In Racks** 

see spec sheet **EG60.33**



**LIFETIME GUARANTEE!**  
against rust and corrosion, and against material defects and workmanship.

- For 12" x 20" (305 x 508mm) pans, 18" x 26" (457 x 660mm) pans, 13" x 18" (330 x 457mm) pans, or 14" x 18" (356 x 457mm) trays.
- All heavy duty 6063-T5 alloy aluminum type construction.
- Fully-welded frame features 1½" x 1¼" (38 x 45mm) "D"-shaped tubing.
- Crossbracing consists of 1" (25mm) square tubing.
- 1½" (38mm) square tube base includes 5" x 1½" (127 x 35mm) non-marking recessed swivel plate casters.
- ¾" (86mm) wide aluminum angle slides are welded to frame.

FEATURES:

**Freight class is 70.0.**

overall dimensions		weight		sliding space		pan/tray capacity				model #	list
width	depth x height	lbs.	kg	in.	mm	12" x 20"	18" x 26"	13" x 18"	14" x 18"		
in.	mm					pan	pan	pan	tray		
21½" x 26" x 64"	546 x 660 x 1626	68	30.8	5"	127	10	11	22	22	<b>4337</b>	2532
21½" x 26" x 64"	546 x 660 x 1626	81	36.7	3"	76	17	18	36	36	<b>4338</b>	3022

Catalog Section 60

**LIFETIME Stepped-Angle Racks** 

see spec sheet **EG60.34**



**SIZES OF APPLICABLE PANS & TRAYS:**

- Roast/bake pans: 20" x 22", 18" x 26", 10" x 20"
- Steamtable pans: 12" x 18", 12" x 20"
- Bun pans: 18" x 13", 18" x 26"
- Service trays: 15" x 20", 14" x 18"
- Maxi pan: 20¾" x 25½"
- Standard gastro-norm pans: 20¾" x 25½"

**LIFETIME GUARANTEE!**  
against rust and corrosion, and against material defects and workmanship.

- Accepts popular sizes of roast & bake pans, steam table pans, service trays, and more.
- Constructed of heavy duty extruded primary type 6463-T5 aluminum alloy.
- Fully-welded frame features 1½" x 1¼" (38 x 45mm) "D"-shaped tubing.
- Crossbracing consists of 1" (25mm) square tubing.
- 1½" (38mm) square tube base includes 6" x 2" (152 x 51mm) non-marking swivel plate casters.
- 6¾" (157mm) wide aluminum "stepped" angle slides are welded to uprights of frame.

FEATURES:

**Freight class is 70.0.**

**Pan Racks**

**Roll-In Racks**

overall dimensions width x depth		slide spacing		# of slides	overall height		weight		model #	list	overall height		weight		model #	list
in.	mm	in.	mm		in.	mm	lbs.	kg			in.	mm	lbs.	kg		
25" x 26"	635 x 660	4½"	114	12	73" 1854	92	41.7	<b>4640</b>	3718	64"	1626	91	41.3	<b>4635</b>	3175	
25" x 26"	635 x 660	3"	76	18	73" 1854	74	33.6	<b>4642</b>	4698	64"	1626	114	51.7	<b>4637</b>	4007	

**LIFETIME Enclosed Pan Racks** 

see spec sheet **EG60.35**



**LIFETIME GUARANTEE!**  
against rust and corrosion, and against material defects and workmanship.

- For 18" x 26" (457 x 660mm) pans or 13" x 18" (330 x 457mm) pans.
- Constructed of heavy duty extruded type 6063-T5 aluminum alloy.
- Fully welded construction includes top bracing, interior bracing, and bottom frame.
- Side panels welded to uprights, top bracing, and bottom frame.
- Heavy duty base includes 6" x 2" (152 x 51mm) non-marking swivel plate casters.
- 3¼" (86mm) wide aluminum angle slides are welded to frame.

FEATURES:

**Freight class is 70.0.**

overall dimensions width x depth x height			weight		slide spacing		18" x 26" pan capacity	type of 6" (152mm) caster	model #	list
in.	mm	mm	lbs.	kg	in.	mm				
20¾" x 27¾" x 69"	530 x 702 x 1753	132	59.9	1½"	38	38	polyolefin	<b>1290PP</b> *	3556	
20¾" x 27¾" x 69"	530 x 702 x 1753	132	59.9	1½"	38	38	K-urethane	<b>1290WDW</b>	4638	
20¾" x 27¾" x 69"	530 x 702 x 1753	132	59.9	1½"	38	38	polyolefin	<b>1292</b>	3581	

\* #1290PP "Prison Package" includes: (4) aluminum welded hinges; (4) 6" casters; (2) padlock holes in door; extra interior bracing; and tamper-proof screws and bolts.

# PANCO<sup>®</sup> TRANSPORT Systems

## Transport Holding Cabinets for Heated and Heated/Proofing

See Pages 359 - 362.

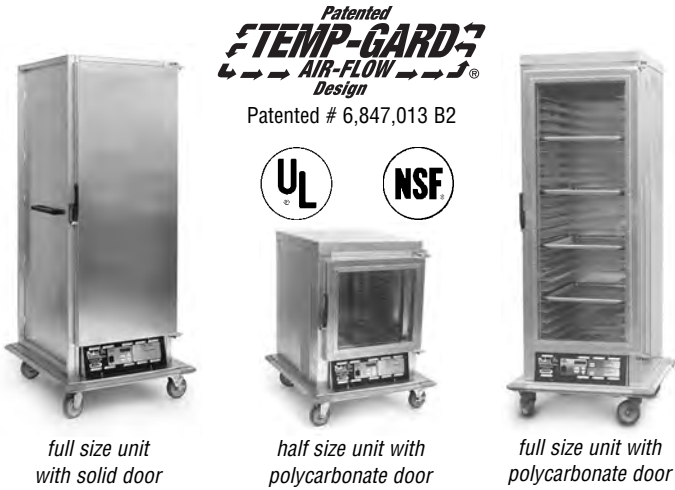

full size unit  
with solid door

half size unit with  
polycarbonate door

full size unit with  
polycarbonate door

- Aluminum construction on exterior and interior.
- Bottom mounted control panel and heating system removes easily for cleaning or servicing.
- Adjustable digital temperature control system with LCD readout.
- Ability to hold humidity levels up to four hours without refilling reservoir (*heated/proofing models*). Adjustable humidity control.
- 2000-Watt heating capacity with internal air temperature up to 200°F. 1500-Watt is optional on 120V only.
- High-temperature protection device with caution alarm and auto reset.
- Full 270 degree open door swing via  $\frac{3}{16}$ " (5mm) thick heavy duty aluminum hinges with stainless steel pin.
- Positive closing magnetic door latch.
- Full-size, half-size, and undercounter models available.
- Units with narrow width and optional wide width feature  $2\frac{1}{4}$ " (57mm) increment slide spacing. Units with extended width feature 3" (76mm) increment slide spacing. See pages 359, 361, and 363 for further information about widths available for full-size, half-size, and undercounter models.
- Standard removable slides.
- Available in both insulated and non-insulated.
- Insulated units feature identity color stripe on both sides.
- 8' (2438mm) cord and plug provided.
- Available in 120V, 208V, and 240V models.
- Full perimeter bumper on all models.
- Heavy duty polymer swivel casters, two with brake.

### Digital Control System on all units!



- Easy-touch front control panel w/membrane switches.
- Liquid Crystal Display (LCD) read-out.
- Digital setting of air temperature.
- Overheat caution alarm.
- Embedded LED technology.
- Upgrade software control.

### Maximum Pan Capacities of Transport Holding Cabinets

Based on standard slide spacings of:  $2\frac{1}{4}$ " (57mm) for units with Narrow width or optional Wide width, and for all units with aluminum slides; and 3" (76mm) spacing for units with Extended width, and for all units with wire slides. For information about standard number of slides that come with units, see charts on pages 359 through 362. For information about additional and replacement slides available, see page 365.

#### WEIGHT CAPACITIES PER PAIR

Wire Universal slides: 50 lbs. (22.7 kg)  
Wire slides: 80 lbs. (36.3 kg)

#### ...of Half-Size Units and Extended Undercounter Units\*

Cabinet Width	Slide Type	18" x 26" sheet pans	13" x 18" sheet pans	12" x 20" x 2 1/2" food pans
Narrow	Wire Angle	8	16	n/a
Narrow	Wire Universal	8	16	4
Extended	Wire Angle	n/a	n/a	10
Extended	Wire Universal	5	10	10
Wide	Wire Angle	8	n/a	n/a
Wide	Wire Universal	8	n/a	4

#### ...of Full-Size Units

Cabinet Width	Slide Type	18" x 26" sheet pans	13" x 18" sheet pans	12" x 20" x 2 1/2" food pans
Narrow	Wire Angle	24	48	n/a
Narrow	Wire Universal	24	48	12
Extended	Wire Angle	n/a	n/a	36
Extended	Wire Universal	18	36	36
Wide	Wire Angle	24	n/a	n/a
Wide	Wire Universal	24	n/a	12

\* Narrow cabinet width does not apply to Undercounter Units.



## Heated Cabinets

**For use in operations where hot food is to be stored or transported and held at hot food serving temperatures. 2000-watt heating capacity via two 1000-watt elements for heated air.**

- Aluminum construction on exterior and interior.
- Bottom mounted control panel and heating system removes easily for cleaning or servicing.
- Adjustable digital temperature control system with LCD read-out.
- 2000-Watt heating capacity with internal air temperature up to 200°F. 1500-Watt is optional on 120V only.
- High-temperature protection device with caution alarm and auto reset.
- Full 270 degree open door swing via  $\frac{5}{16}$ " (5mm) thick heavy duty aluminum hinges with stainless steel pin.
- Positive closing magnetic door latch.
- Units with narrow width and optional wide width feature  $2\frac{1}{4}$ " (57mm) increment slide spacing. Units with extended width feature 3" (76mm) increment slide spacing.
- Standard removable slides.
- Available in both insulated and non-insulated.
- Insulated units feature identity color stripe on both sides.
- 8' (2438mm) cord and plug provided.
- Available in 120V, 208V, and 240V models.
- Full perimeter bumper on all models.

- **Full-size units\* feature the following:**
    - 76 $\frac{1}{2}$ " (1943mm) overall height.
    - 31 $\frac{1}{2}$ " (810mm) "narrow" width.
    - Heavy duty 5" (127mm) polymer swivel casters, two with brake.
    - About 75 cubic feet.
  - **Half-size units\* feature the following:**
    - 40" (1016mm) overall height.
    - 31 $\frac{1}{2}$ " (810mm) "narrow" width.
    - Heavy duty 5" (127mm) polymer swivel casters, two with brake.
    - About 41 cubic feet.
  - **Extended Undercounter units\*\* feature the following:**
    - 30 $\frac{1}{2}$ " (775mm) overall height.
    - 32 $\frac{1}{2}$ " (826mm) "extended" width.
    - Heavy duty 3" (76mm) polymer swivel casters, two with brake.
    - About 35 cubic feet.
- \* Optional 32 $\frac{1}{2}$ " (826mm) "extended" width and 39 $\frac{1}{2}$ " (1013mm) "wide" width available for full-size and half-size units.  
 \*\* Extended undercounter units available only with "extended" width. 30 $\frac{1}{2}$ " (775mm) overall height allows unit to fit underneath counters.

### Full-Size Heated Cabinets

see spec sheet **EG60.25A**



#### Plug Configurations of Heated Cabinets



**NEMA 5-20** for  
120V 20A units

See page 364 for other  
plug configurations  
available.

New York M.E.A. No. 245-02-E



#### FEATURES:

- All "quick-order" numbers—listed in the following charts—reflect units with narrow width, removable slides with  $2\frac{1}{4}$ " (57mm) standard spacing, and 120-volt 20-amp electricity.

**Note:** Additional slides are required to obtain maximum pan capacity. See page 365 for further information about additional slides available.  
 See page 358 for further information about maximum pan capacities.  
 Dutch doors and pass-through doors available. See pages 363-364 for all options & accessories.

**Freight class is 100.0.**

(•) MTS (made to stock) / ( ) MTO (made to order)

#### Units with Wire Slides

12 pairs of slides. Max pan capacities: (24) 18" x 26" sheet pans, or (48) 13" x 18" sheet pans.

door style (single door)	width x depth x height		weight		NON-INSULATED		INSULATED	
	in.	mm	lbs.	kg	quick-order #	list	quick-order #	list
solid	31 $\frac{1}{2}$ " x 35 $\frac{1}{4}$ " x 76 $\frac{1}{2}$ "	810 x 895 x 1943	229	103.9	<b>FSHC-A</b> •	7224	<b>FSHC-C</b>	9233
with poly window	31 $\frac{1}{2}$ " x 35 $\frac{1}{4}$ " x 76 $\frac{1}{2}$ "	810 x 895 x 1943	209	94.8	<b>FSHC-B</b>	8277	<b>FSHC-D</b>	10286

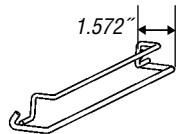

#### Units with Wire Universal Slides

12 pairs of slides. Max pan capacities: (24) 18" x 26" sheet pans, (48) 13" x 18" sheet pans, or (12) 12" x 20" x 2 $\frac{1}{2}$ " food pans.

door style (single door)	width x depth x height		weight		NON-INSULATED		INSULATED	
	in.	mm	lbs.	kg	quick-order #	list	quick-order #	list
solid	31 $\frac{1}{2}$ " x 35 $\frac{1}{4}$ " x 76 $\frac{1}{2}$ "	810 x 895 x 1943	229	103.9	<b>FSHC-E</b>	7454	<b>FSHC-G</b>	9459
with poly window	31 $\frac{1}{2}$ " x 35 $\frac{1}{4}$ " x 76 $\frac{1}{2}$ "	810 x 895 x 1943	209	94.8	<b>FSHC-F</b>	8508	<b>FSHC-H</b>	10515

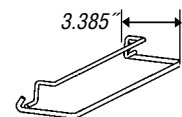

Half-Size Heated Cabinets  

see spec sheet **EG60.25B**



**40" (1016mm) High**  
with solid door

Plug Configurations of Heated Cabinets



**NEMA 5-20** for  
120V 20A units

See page 364 for other  
plug configurations  
available

New York M.E.A. No. 245-02-E

FEATURES:

- All "quick-order" numbers—listed in the following charts—reflect units with narrow width, removable slides with 2¼" (57mm) standard spacing, and 120-volt 20-amp electricity.

**Note:** On half-size units, maximum pan capacity is met without the need for additional slides. See page 365 for further information about replacement slides. See page 358 for further information about maximum pan capacities. Pass-through doors available. See pages 363-364 for all options & accessories.



**Freight class is 100.0.**

Units with Wire Slides

8 pairs of slides. Max pan capacities: (8) 18" x 26" sheet pans, or (16) 13" x 18" sheet pans.

door style (single door)	width x depth x height		weight		NON-INSULATED		INSULATED	
	in.	mm	lbs.	kg	quick-order #	list	quick-order #	list
solid	31¾" x 35¼" x 40"	810 x 895 x 1016	155	70.3	<b>HSHC-A</b>	6489	<b>HSHC-C</b>	7541
with poly window	31¾" x 35¼" x 40"	810 x 895 x 1016	171	77.6	<b>HSHC-B</b>	7478	<b>HSHC-D</b>	8531

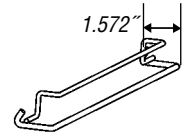

Units with Wire Universal Slides

8 pairs of slides. Max pan capacities: (8) 18" x 26" sheet pans, (16) 13" x 18" sheet pans, or (4) 12" x 20" x 2½" food pans.

door style (single door)	width x depth x height		weight		NON-INSULATED		INSULATED	
	in.	mm	lbs.	kg	quick-order #	list	quick-order #	list
solid	31¾" x 35¼" x 40"	810 x 895 x 1016	155	70.3	<b>HSHC-E</b>	6606	<b>HSHC-G</b>	7659
with poly window	31¾" x 35¼" x 40"	810 x 895 x 1016	171	77.6	<b>HSHC-F</b>	7595	<b>HSHC-H</b>	8648

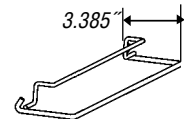

Extended Undercounter Heated Cabinets  

see spec sheet **EG60.25C**



**30½" (775mm) High**  
with polycarbonate door

Plug Configurations of Heated Cabinets



**NEMA 5-20** for  
120V 20A units

See page 364 for other  
plug configurations  
available

New York M.E.A. No. 245-02-E

FEATURES:

- All "quick-order" numbers—listed in the following charts—reflect units with extended width, removable slides with 3" (76mm) standard spacing, and 120-volt 20-amp electricity.

**Note:** On undercounter units, maximum pan capacity is met without the need for additional slides. See page 365 for further information about replacement slides. See page 358 for further information about maximum pan capacities. Pass-through doors available. See pages 363-364 for all options & accessories.



**Freight class is 100.0.**

Units with Wire Slides

5 pairs of slides. Max pan capacities: (10) 12" x 20" x 2½" food pans.

door style (single door)	width x depth x height		weight		NON-INSULATED		INSULATED	
	in.	mm	lbs.	kg	quick-order #	list	quick-order #	list
solid	32½" x 35¼" x 30½"	826 x 895 x 775	155	70.3	<b>EUHC-A</b>	7208	<b>EUHC-C</b>	8259
with poly window	32½" x 35¼" x 30½"	826 x 895 x 775	171	77.6	<b>EUHC-B</b>	8196	<b>EUHC-D</b>	9251

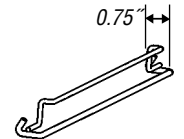

Units with Wire Universal Slides

5 pairs of slides. Max pan capacities: (5) 18" x 26" sheet pans, (10) 13" x 18" sheet pans, or (10) 12" x 20" x 2½" food pans.

door style (single door)	width x depth x height		weight		NON-INSULATED		INSULATED	
	in.	mm	lbs.	kg	quick-order #	list	quick-order #	list
solid	32½" x 35¼" x 30½"	826 x 895 x 775	155	70.3	<b>EUHC-E</b>	7327	<b>EUHC-G</b>	8376
with poly window	32½" x 35¼" x 30½"	826 x 895 x 775	171	77.6	<b>EUHC-F</b>	8316	<b>EUHC-H</b>	9367

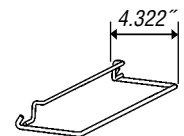

## Heated/Proofing Cabinets

*For use in operations where hot food is to be stored or transported and held at hot food serving temperatures. 2000-watt heating capacity. "Heating mode" uses two 1000-watt elements for heated air. "Proofing Mode" uses one 1000-watt element for heated air, and one 1000-watt element for humidity control.*

- Aluminum construction on exterior and interior.
- Bottom mounted control panel and heating system removes easily for cleaning or servicing.
- Adjustable digital temperature control system with LCD read-out.
- 2000-Watt heating capacity with internal air temperature up to 200°F. 1500-Watt is optional on 120V only.
- Ability to hold humidity levels up to 4 hours without refilling reservoir. Adjustable humidity control.
- High-temperature protection device with caution alarm and auto reset.
- Full 270 degree open door swing via 3/8" (5mm) thick heavy duty aluminum hinges with stainless steel pin.
- Positive closing magnetic door latch.
- Units with "narrow" width and optional "wide" width feature 2 1/4" (57mm) increment slide spacing. Units with "extended" width feature 3" (76mm) increment slide spacing.
- Standard removable slides.
- Available in both insulated and non-insulated.
- Insulated units feature identity color stripe on both sides.
- 8' (2438mm) cord and plug provided.
- Available in 120V, 208V, and 240V models.
- Full perimeter bumper on all models.

**• Full-size units\* feature the following:**

- 76 1/2" (1943mm) overall height.
- 31 1/2" (810mm) "narrow" width.
- Heavy duty 5" (127mm) polymer swivel casters, two with brake.
- About 75 cubic feet.

**• Half-size units\* feature the following:**

- 40" (1016mm) overall height.
- 31 1/2" (810mm) "narrow" width.
- Heavy duty 5" (127mm) polymer swivel casters, two with brake.
- About 41 cubic feet.

**• Extended Undercounter units\*\* feature the following:**

- 30 1/2" (775mm) overall height.
- 32 1/2" (826mm) "extended" width.
- Heavy duty 3" (76mm) polymer swivel casters, two with brake.
- About 35 cubic feet.

\* Optional 32 1/2" (826mm) "extended" width and 39 1/2" (1013mm) "wide" width available for full-size and half-size units.

\*\* Extended undercounter units available only with "extended" width. 30 1/2" (775mm) overall height allows unit to fit underneath counters.

### Full-Size Heated/Proofing Cabinets

see spec sheet **EG60.27A**



with solid door

#### Plug Configurations of Heated/Proofing Cabinets



**NEMA 5-20** for 120V 20A units

See page 364 for other plug configurations available

New York M.E.A. No. 245-02-E



**FEATURES:**

- All "quick-order" numbers—listed in the following charts—reflect units with narrow width, removable slides with 2 1/4" (57mm) standard spacing, and 120-volt 20-amp electricity.

**Note:** Additional slides are required to obtain maximum pan capacity. See page 365 for further information about additional slides available.

See page 358 for further information about maximum pan capacities.

Dutch doors and pass-through doors available. See pages 363-364 for all options & accessories.

**Freight class is 100.0.**

(•) MTS (made to stock) / ( ) MTO (made to order)

#### Units with Wire Slides

12 pairs of slides. Max pan capacities: (24) 18" x 26" sheet pans, or (48) 13" x 18" sheet pans.

door style (single door)	width x depth x height		weight		NON-INSULATED		INSULATED	
	in.	mm	lbs.	kg	quick-order #	list	quick-order #	list
solid	31 1/2" x 35 1/4" x 76 1/2"	810 x 895 x 1943	229	103.9	<b>FSHPC-A</b> •	7302	<b>FSHPC-C</b>	9311
with poly window	31 1/2" x 35 1/4" x 76 1/2"	810 x 895 x 1943	209	94.8	<b>FSHPC-B</b> •	8353	<b>FSHPC-D</b>	10363

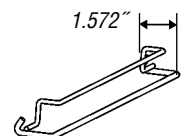

#### Units with Wire Universal Slides

12 pairs of slides. Max pan capacities: (24) 18" x 26" sheet pans, (48) 13" x 18" sheet pans, or (12) 12" x 20" x 2 1/2" food pans.

door style (single door)	width x depth x height		weight		NON-INSULATED		INSULATED	
	in.	mm	lbs.	kg	quick-order #	list	quick-order #	list
solid	31 1/2" x 35 1/4" x 76 1/2"	810 x 895 x 1943	229	103.9	<b>FSHPC-E</b>	7531	<b>FSHPC-G</b>	9542
with poly window	31 1/2" x 35 1/4" x 76 1/2"	810 x 895 x 1943	209	94.8	<b>FSHPC-F</b>	8583	<b>FSHPC-H</b>	10594

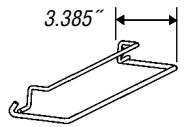

### Half-Size Heated/Proofing Cabinets

see spec sheet **EG60.27B**



- All "quick-order" numbers—listed in the following charts—reflect units with narrow width, removable slides with 2 1/4" (57mm) standard spacing, and 120-volt 20-amp electricity.



**40" (1016mm) High**  
with polycarbonate door

#### Plug Configurations of Heated/Proofing Cabinets



**NEMA 5-20** for  
120V 20A units

See page 364 for other plug configurations available.

FEATURES:

- Note:** On half-size units, maximum pan capacity is met without the need for additional slides. See page 365 for further information about replacement slides. See page 358 for further information about maximum pan capacities. Pass-through doors available. See pages 363-364 for all options & accessories.



New York M.E.A. No. 245-02-E

**Freight class is 100.0.**

(•) MTS (made to stock) / ( ) MTO (made to order)

#### Units with Wire Slides

8 pairs of slides. Max pan capacities: (8) 18" x 26" sheet pans, or (16) 13" x 18" sheet pans.

door style (single door)	width x depth x height		weight		NON-INSULATED		INSULATED	
	in.	mm	lbs.	kg	quick-order #	list	quick-order #	list
solid	31 1/2" x 35 1/4" x 40"	810 x 895 x 1016	155	70.3	<b>HSHPC-A</b> •	6617	<b>HSHPC-C</b>	7668
with poly window	31 1/2" x 35 1/4" x 40"	810 x 895 x 1016	171	77.6	<b>HSHPC-B</b>	7606	<b>HSHPC-D</b>	8659

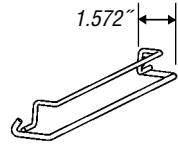

#### Units with Wire Universal Slides

8 pairs of slides. Max pan capacities: (8) 18" x 26" sheet pans, (16) 13" x 18" sheet pans, or (4) 12" x 20" x 2 1/2" food pans.

door style (single door)	width x depth x height		weight		NON-INSULATED		INSULATED	
	in.	mm	lbs.	kg	quick-order #	list	quick-order #	list
solid	31 1/2" x 35 1/4" x 40"	810 x 895 x 1016	155	70.3	<b>HSHPC-E</b>	6735	<b>HSHPC-G</b>	7785
with poly window	31 1/2" x 35 1/4" x 40"	810 x 895 x 1016	171	77.6	<b>HSHPC-F</b>	7723	<b>HSHPC-H</b>	8774

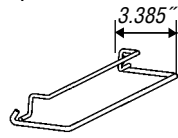

### Extended Undercounter Heated/Proofing Cabinets

see spec sheet **EG60.27C**



- All "quick-order" numbers—listed in the following charts—reflect units with extended width, removable slides with 3" (76mm) standard spacing, and 120-volt 20-amp electricity.



**30 1/2" (775mm) High**  
with polycarbonate door

#### Plug Configurations of Heated/Proofing Cabinets



**NEMA 5-20** for  
120V 20A units

See page 364 for other plug configurations available.

FEATURES:

- Note:** On undercounter units, maximum pan capacity is met without the need for additional slides. See page 365 for further information about replacement slides. See page 358 for further information about maximum pan capacities. Pass-through doors available. See pages 363-364 for all options & accessories.



New York M.E.A. No. 245-02-E

**Freight class is 100.0.**

#### Units with Wire Slides

5 pairs of slides. Max pan capacities: (10) 12" x 20" x 2 1/2" food pans.

door style (single door)	width x depth x height		weight		NON-INSULATED		INSULATED	
	in.	mm	lbs.	kg	quick-order #	list	quick-order #	list
solid	32 1/2" x 35 1/4" x 30 1/2"	826 x 895 x 775	155	70.3	<b>EUHPC-A</b>	7336	<b>EUHPC-C</b>	8388
with poly window	32 1/2" x 35 1/4" x 30 1/2"	826 x 895 x 775	171	77.6	<b>EUHPC-B</b>	8325	<b>EUHPC-D</b>	9376

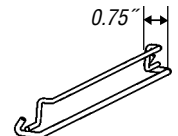

#### Units with Wire Universal Slides

5 pairs of slides. Max pan capacities: (5) 18" x 26" sheet pans, (10) 13" x 18" sheet pans, or (10) 12" x 20" x 2 1/2" food pans.

door style (single door)	width x depth x height		weight		NON-INSULATED		INSULATED	
	in.	mm	lbs.	kg	quick-order #	list	quick-order #	list
solid	32 1/2" x 35 1/4" x 30 1/2"	826 x 895 x 775	155	70.3	<b>EUHPC-E</b>	7454	<b>EUHPC-G</b>	8507
with poly window	32 1/2" x 35 1/4" x 30 1/2"	826 x 895 x 775	171	77.6	<b>EUHPC-F</b>	8442	<b>EUHPC-H</b>	9494

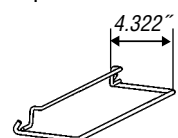

# Transport Holding Cabinets for Heated and Heated/Proofing

To order cabinet with options & accessories, the cabinet “quick-order” numbers (seen on pages 359-362) must be translated.

The new model number can then be altered to reflect any factory-installed optional features desired. Please refer to the appropriate chart below for translation, then go to page 364.

## To translate “quick-order” numbers:

see spec sheet **EG60.28**

### Heating Cabinets

(pages 359-360)

quick-order #      translation for ordering  
options/accessories

#### Full-Size (page 359)

FSHC-A . . . . . HCFNSSN-RA2.25-120  
FSHC-B . . . . . HCFNLSN-RA2.25-120  
FSHC-C . . . . . HCFNSSI-RA2.25-120  
FSHC-D . . . . . HCFNLSI-RA2.25-120  
FSHC-E . . . . . HCFNSSN-RC2.25-120  
FSHC-F . . . . . HCFNLSN-RC2.25-120  
FSHC-G . . . . . HCFNSSI-RC2.25-120  
FSHC-H . . . . . HCFNLSI-RC2.25-120

#### Half-Size (page 360)

HSHC-A . . . . . HCHNSSN-RA2.25-120  
HSHC-B . . . . . HCHNLSN-RA2.25-120  
HSHC-C . . . . . HCHNSSI-RA2.25-120  
HSHC-D . . . . . HCHNLSI-RA2.25-120  
HSHC-E . . . . . HCHNSSN-RC2.25-120  
HSHC-F . . . . . HCHNLSN-RC2.25-120  
HSHC-G . . . . . HCHNSSI-RC2.25-120  
HSHC-H . . . . . HCHNLSI-RC2.25-120

#### Undercounter (page 360)

EUHC-A . . . . . HCUESSN-RA3.00-120  
EUHC-B . . . . . HCUELSN-RA3.00-120  
EUHC-C . . . . . HCUESSI-RA3.00-120  
EUHC-D . . . . . HCUELSI-RA3.00-120  
EUHC-E . . . . . HCUESSN-RC3.00-120  
EUHC-F . . . . . HCUELSN-RC3.00-120  
EUHC-G . . . . . HCUESSI-RC3.00-120  
EUHC-H . . . . . HCUELSI-RC3.00-120

### Heated/Proofing Cabinets

(pages 363-362)

quick-order #      translation for ordering  
options/accessories

#### Full-Size (page 363)

FSHPC-A . . . . . HPFNSSN-RA2.25-120  
FSHPC-B . . . . . HPFNLSN-RA2.25-120  
FSHPC-C . . . . . HPFNSSI-RA2.25-120  
FSHPC-D . . . . . HPFNLSI-RA2.25-120  
FSHPC-E . . . . . HPFNSSN-RC2.25-120  
FSHPC-F . . . . . HPFNLSN-RC2.25-120  
FSHPC-G . . . . . HPFNSSI-RC2.25-120  
FSHPC-H . . . . . HPFNLSI-RC2.25-120

#### Half-Size (page 362)

HSHPC-A . . . . . HPHNSSN-RA2.25-120  
HSHPC-B . . . . . HPHNLSN-RA2.25-120  
HSHPC-C . . . . . HPHNSSI-RA2.25-120  
HSHPC-D . . . . . HPHNLSI-RA2.25-120  
HSHPC-E . . . . . HPHNSSN-RC2.25-120  
HSHPC-F . . . . . HPHNLSN-RC2.25-120  
HSHPC-G . . . . . HPHNSSI-RC2.25-120  
HSHPC-H . . . . . HPHNLSI-RC2.25-120

#### Undercounter (page 362)

EUHPC-A . . . . . HPUESSN-RA3.00-120  
EUHPC-B . . . . . HPUELSN-RA3.00-120  
EUHPC-C . . . . . HPUESSI-RA3.00-120  
EUHPC-D . . . . . HPUELSI-RA3.00-120  
EUHPC-E . . . . . HPUESSN-RC3.00-120  
EUHPC-F . . . . . HPUELSN-RC3.00-120  
EUHPC-G . . . . . HPUESSI-RC3.00-120  
EUHPC-H . . . . . HPUELSI-RC3.00-120

After translating, go to page 364 to order cabinet with options & accessories



## To order Transport Holding Cabinets with options/accessories:

see spec sheet **EG60.28**

### 1) Build a model number, based on the chart on page 363.

The following chart lists the design elements available. Each chart column contains two or more choices of each design element (examples: half or full size, etc.). To spell out a model number, choose the designated letters and numbers in the chart below from left to right. **Example: #HCFWSDI-RA2.25-240** indicates a full size Heating Cabinet (HCF), wide width (W), with solid (S) dutch door (D), insulated (I-), wire slides (RA), 2.25" slide spacing (2.25-), and 240-volt 15-amp electricity (240).

**Note:** Standard design elements are indicated in **bold** text in the chart below.

Full, Half, Undercounter/ Type of Holding Cabinet	Cabinet Width*	Door Style	Door Type	Insulation****	Slide Type	Slide Spacing**	Voltage Type
Full Heating = HCF Half Heating = HCH Undercounter Heating = HCU* Full Heating/Proofing = HPF Half Heating/Proofing = HPH Undercounter H/P = HPU*	Narrow = N** Extended = E** Wide = W**	Solid = S w/Poly Window = L	Standard Single Door = S Dutch Doors = D*** Pass-through Single Door = P Pass-through Dutch Doors = PD***	None = N- Insulated = I-	Wire = RA Wire Universal = RC	2.25" = 2.25- Custom = (other #)-	120V 20amp = 120 120V 15amp = 120A 208V 15amp = 208 240V 15amp = 240

\* Undercounter units available with Extended-width only.

\*\* 2 1/4" (57mm) standard slide spacing for Narrow- and Wide-width units, and for units with wire universal slides (3" for Extended-width units). If a different spacing is required, please indicate desired slide spacing in inches.

\*\*\* Available only on Full-Size units.

\*\*\*\* Wide-width units available insulated only.

### 2) Establish a list price.

The following chart lists the pricing for each design element choice seen in the first chart. To establish a total list price, add the price indicated for each chosen design element of the model number spelled out in Step 1. **Example: #HCFWSDI-RA2.25-240** is a full size Heating Cabinet at \$7224, with wide width at \$265, solid dutch doors at \$1907, insulation (for full size unit) at \$1907, and 240-volt 15-amp electricity at \$265. Each of the other design elements in this model is \$0. Therefore, total list price is \$11568.

**Note:** Standard design elements are indicated in **bold** text in the chart below.

Full, Half, Undercounter/ Type of Holding Cabinet	Cabinet Width	Door Style	Door Type	Insulation	Slide Type	Slide Spacing	Voltage Type
Full Heating = \$7224 Half Heating = \$6489 Undercounter Heating = \$7267 Full Heating/Proofing = \$7302 Half Heating/Proofing = \$6617 Undercounter H/P = \$6968	Narrow = \$0 Extended = \$683 Wide = \$265	Solid = \$0 w/Poly Window - for Full-Size = \$1001 - for Half-Size = \$940 - for U/C = \$940	Standard Single Door = \$0 Dutch Doors = \$1907 Pass-through Single Door - for Full-Size = \$2335 - for Half-Size = \$1929 - for Undercounter = \$1988 Pass-through Dutch Door = \$5982	No insulation = \$0 With insulation - for Full-Size = \$1907 - for Half-Size = \$1001 - for Undercounter = \$1001	Wire = \$0 Wire Universal - for Full-Size = \$220 - for Half-Size = \$113 - for Undercounter = \$113	2.25" = \$0 Custom = \$265	120V 20A = \$0 120V 15A = \$265 208V 15A = \$265 240V 15A = \$265

#### Plug Configurations of optional voltage types:



**NEMA 5-15** for  
120V 15A units



**NEMA 5-20** for  
120V 20A units



**NEMA 6-15** for 208V 15A  
and 240V 15A units

Catalog Section 60

## Additional/Replacement Slides for Transport Holding Cabinets

### Wire and Wire Universal Slides...

see spec sheet **EG60.28**

- 8 pairs of slides come with half-size units with narrow and wide width.
- 5 pairs of slides come with undercounter units and half-size units with extended width.
- On undercounter and half-size units, maximum pan capacity is met without additional slides required.
- 12 pairs of slides come with full-size units. On full-size units, additional slides are required to obtain maximum pan capacity. Priced individually.

description of slides	model #	...for Narrow-Width Units	...for Extended-Width Units	...for Wide-Width Units
		list price each	list price each	list price each
Wire Slides ("RA" in translated #)	357068	34	n/a	34
	357074	n/a	34	n/a
	357080	n/a	n/a	30
Wire Universal Slides ("RC" in translated #)	357071	38	n/a	n/a
	357077	n/a	38	n/a
	357083	n/a	n/a	38

## Cook & Hold Cabinets

see spec sheet **EG60.11**



full-height unit



Patented # 6,847,013 B2



half-height unit

- Absolute precise control over temperature and humidity with 8° variance anywhere within cabinet.
- Humidity is controlled via solenoid plumbed directly to water supply.
- Even convection heating through engineered airflow design.
- Triple wall insulated cabinet body for better heat retention.
- 18 gauge type 300 stainless steel interior and exterior walls.
- Easily-reversible doors swing 180°, and include positive closing latch.
- Four input buttons: Enter, Recall, and Up/Down selection buttons.
- Standard top-mounted digital control panel includes 2" x 16" (51 x 406mm) character LCD readout; digital setting of temperatures; memory for 16 programs; embedded LEDs for Power, Preheat, Temperature Probe, Cook, and Hold; and overheat/power outage caution alarms. Easy-touch with membrane switches.
- Automatically changes from cooking to holding when time/temperature parameters have been met.
- Cooks by time or temperature probe.
- Cook/probe temperature: 100-350°F.
- Holding temperature: 145-200°F.
- Convertible from Fahrenheit to Celsius.
- Cook/hold time up to 24 hours.
- Heavy duty 5" (127mm) polymer swivel casters, two with brake.
- Full perimeter bumper.
- Chrome wire tray slides.

FEATURES:

Freight class is 100.0.

### Full-Height Unit

Features three 2000W heating elements.

width* x depth* x height in.	width* x depth* x height mm	weight lbs. kg	cubic feet	voltage	total wattage	number of slides	model #	list
27½" x 32½" x 77½"	699 x 835 x 1959	462 210	36.6	240	6000	18	CH6000D-240	27134
27½" x 32½" x 77½"	699 x 835 x 1959	462 210	36.6	208	6000	18	CH6000D-208	27134
27½" x 32½" x 74½"	699 x 826 x 1883	462 210	36.6	240	6000	18	CH6000B-240	27134
27½" x 32½" x 74½"	699 x 826 x 1883	462 210	36.6	208	6000	18	CH6000B-208	27134

### Half-Height Unit

46½" (1181mm) height. Features three 1000W elements.

width* x depth* x height in.	width* x depth* x height mm	weight lbs. kg	cubic feet	voltage	total wattage	number of slides	model #	list
27½" x 32½" x 46½"	699 x 826 x 1181	327 148	22.6	240	3000	9	CH3000B-240	18818
27½" x 32½" x 46½"	699 x 826 x 1181	327 148	22.6	208	3000	9	CH3000B-208	18818

\* width and depth include perimeter bumper.

**DOOR CODE (IN MODEL #S):**

"B" indicates solid door  
"D" indicates dutch door

### Water Filter Kit

model #	list
369370	538

### Replacement Filter for Water Filter Kit

model #	list
369371	369







Two columns of horizontal lines for writing notes.

# NOTES



Lined writing area on the left side of the page.

Lined writing area on the right side of the page.

# Custom Options / Accessories

- for Tables, Sinks and Dishtables . . . . . 370-371
- for Underbar . . . . . 372
- for Ventilation Hoods . . . . . 372

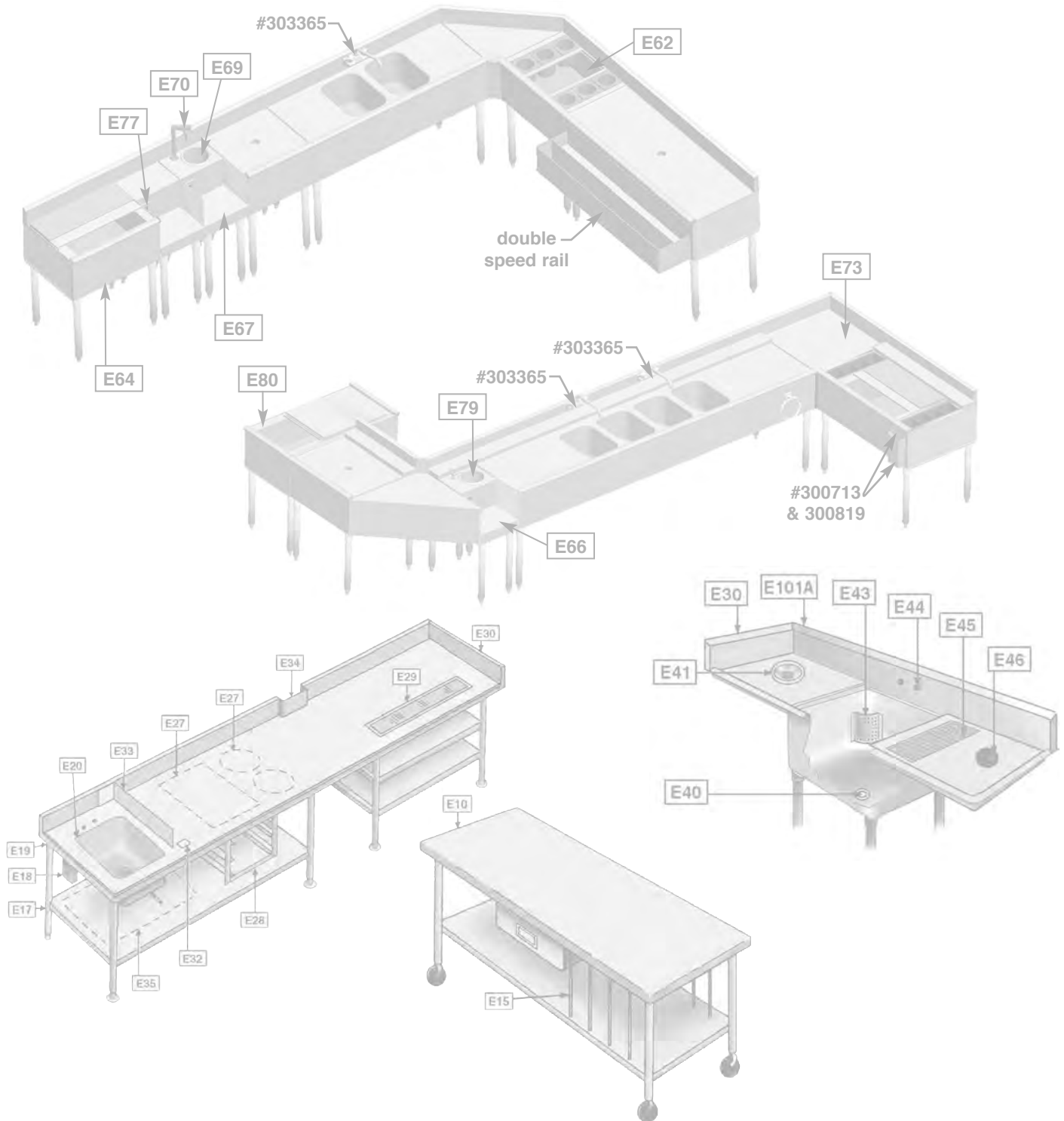

# CUSTOM OPTIONS / ACCESSORIES

## For Tables, Sinks, and Dishtables

Please note: Suffixes are typically indicated by the dash ("-") preceding numbers and/or letters.

model # or suffix	description	unit	list	model # or suffix	description	unit	list
<b>TABLE EDGES:</b>				<b>TABLE CASTERS AND FEET:</b>			
E10	Square edge table	PER TABLE	256	300698	Casters 4" with brake	EA	124
E11	Counter type marine edge	PER TABLE	549	300699	Casters 4" without brake	EA	119
E12	"V" type marine edge	PER TABLE	549	317635	Casters 5" with brake	EA	162
E13	Bullnose edge	PER TABLE	522	317636	Casters 5" without brake	EA	162
E13A	Inverted roll edge (flour gutter), up to 96" long	PER TABLE	522	313835	Flanged bullet foot, stainless steel	EA	32
E10A	tray lock-rear edge turned up, then forward	PER TABLE	260	300692	Bullet foot, stainless steel	EA	22
<b>TABLE SPLASH MODIFICATIONS AND OPTIONS:</b>				<b>ELECTRIC &amp; PLUMBING MODIFICATIONS AND OPTIONS:</b>			
-6BS	6" backsplash	LIN. FT.	31	E18*	Duplex receptacle & mounting plate (under table)	EA	481
-8BS	8" backsplash	LIN. FT.	46	E18.1*	Duplex receptacle in splash		
-10BS	10" backsplash	LIN. FT.	53		(requires at least 6"-high backsplash)	EA	464
-12BS	12" backsplash	LIN. FT.	68	E18.2*	Pedestal duplex receptacle (top of table or overshef)	EA	537
-18BS	18" backsplash	LIN. FT.	88	<b>ENCLOSED BASE CABINET MODIFICATIONS AND OPTIONS:</b>			
-PBS	Partial backsplash	LIN. FT.	31	E85	Removable access panel in front	EA	522
-UE	1-1/2" upturn end	EA	113	E27B	Cutout in cabinet back or undershef for plumbing	EA	386
E30	End splash, all heights	EA	375	E86	Provision for undercounter equipment	EA	882
E33	Sink splash, single thickness, 4" high	EA	386	E87	Tubular Tray Slide w/dropdown s/s brackets	LIN. FT.	201
E39	Enclosed backsplash	LIN. FT.	102	E88	Solid Tray Slide w/dropdown s/s brackets	LIN. FT.	337
E57	Backsplash capping strip, for two tables back-to-back	LIN. FT.	53	E89	Modify enclosed base table to 36" wide	TABLE	add 20%
<b>CORNER</b>				<b>OVERSHELF MODIFICATIONS AND OPTIONS:</b>			
GUARD-A	Corner guard, angle type, 2" x 2" x 48" high, stainless	EA	151	E90	Bullnose all sides shef - no charge		0
<b>CORNER</b>				-HLB	heat lamp brackets	PR	244
GUARD-C	Corner guard, channel type, 2" x 8" x 48" high, stainless	EA	224	E38-6**	Cantilever mount up to 6', add to wall shef price	EA	475
<b>TABLE TOP MODIFICATIONS AND OPTIONS:</b>				E38-12**	Cantilever mount up to 12', add to wall shef price	EA	712
E27	Top cutout square or round	EA	344	E91	pair L brackets for adding overshef	PR	113
E27A	Top cutout and reinforcement, for heavy drop-in equipment (specify model)	EA	499	E92	Microwave extension	EA	486
E29	Urn Trough w/drain and louvered grate	LIN. FT.	174	<b>SINK WELDMENTS, MODIFICATIONS AND OPTIONS:</b>			
E32	Can Opener Provision	EA	244	E20A	10" x 14" x 5" sink	EA	1297
E34	Column cutout	EA	801	E20	10" x 14" x 9.5" Bowl	EA	1297
E37	NSF sprayed-on sound deadening	PER TABLE	818	E21	14" x 16" x 9.5" Bowl	EA	1361
E37A	Sound deadening over 12 ft. (for ea. additional foot)	LIN. FT.	65	E22	16" x 20" x 8" Bowl	EA	1452
606329	Scrap Chute	EA	269	E23	16" x 20" x 14" Bowl	EA	1611
E108	Field joint, bolted or ready for field welding by others	EA	320	E24	18" x 20" x 14" Bowl	EA	1765
E112	Mitered corner (backsplash or front edge angled)	EA	818	E24A	20" x 20" x 14" Bowl	EA	1778
606331	Knife rack	EA	393	E25	24" x 24" x 14" Bowl	EA	2405
E58	Hole in top for electric cord	EA	224	313304	T&S faucet upgrade	EA	720
<b>TABLE BASE MODIFICATIONS AND OPTIONS:</b>				E93	Glass Filler with faucet, trough and grate, installed	EA	1822
E15	Vertical Tray Dividers	EA	812	E94	Glass Filler only, no trough, installed	EA	895
E17	Special Height Legs	TABLE	192	E95	Ice Bin and fill faucet with trough and grate, installed	EA	3953
E19	Stainless steel gussets	EA	41	<b>FAUCETS AND ACCESSORIES:</b>			
E28	Angle slides for pans, up to six pairs	SET	713	313918	Faucet, std. splash mtd. 8"L, 8"o.c.	EA	263
E28A	Angle slides for glass racks, up to four pairs	SET	754	300716	Faucet, std. splash mtd. 12"L, 8"o.c.	EA	269
E31	1-1/2" rear upturn for undershef	TABLE	151	300804	Faucet, std. splash mtd. 14"L, 8"o.c.	EA	278
E59	Upgrade 16 ga. 304 stainless steel undershef	LIN. FT.	46	313919	Faucet, std. splash mtd. 16"L, 8"o.c.	EA	279
E35	16 ga apron front of sink or cutout	LIN. FT.	189	313920	Faucet, T&S splash mtd. 8"L, 8"o.c.	EA	704
E36	Fully welded	EA	606	340380	Faucet, T&S splash mtd. 10"L, 8"o.c.	EA	719
E36A	Welded base only	EA	407	313293	Faucet, T&S splash mtd. 12"L, 8"o.c.	EA	722
<b>DRAWER MODIFICATIONS AND OPTIONS:</b>				313294	Faucet, T&S splash mtd. 14"L, 8"o.c.	EA	729
-L	Lock assembly	EA	178				
E84	Hasp for padlock	EA	329				
NTD3I	Three Drawers integral to table	EA	4220				

\* - for GFI receptacle, add "-GFI" to E number (example: E18.1-GFI) and \$48 to list price.

\*\* - applicable to wall mount shelves and pot racks

## For Tables, Sinks, and Dishtables (continued)

Please note: Suffixes are typically indicated by the dash ("-") preceding numbers and/or letters.

model # or suffix	description	unit	list	model # or suffix	description	unit	list
<b>PRERINSE FAUCETS AND ACCESSORIES:</b>				<b>SINK COMPARTMENT MODIFICATIONS AND OPTIONS (continued):</b>			
300719	Prerinse Faucet, std. splash mtd. 8"o.c.	EA	1348	E43	Stand pipe w/corner guard	EA	264
300718	Prerinse Faucet, std. deck mtd.	EA	1344	E47	Sink cover holder, upper/lower track (for s/s or poly)	SLOT	812
301189	Prerinse Faucet 12" Add-on Spout	EA	357	E50	Provision for water pump	EA	1822
301190	Prerinse Wall Bracket, std.	EA	89	<b>SINK BASE MODIFICATIONS AND OPTIONS:</b>			
313116	Prerinse Hose, 36"L, std.	EA	257	E54	Working height revision	TABLE	354
313323	Prerinse Spray Valve, std.	EA	221	E36	Fully welded	EA	606
313296	Prerinse Faucet, T&S splash mtd. 8"o.c.	EA	1764	E36A	Welded base	EA	407
313295	Prerinse Faucet, T&S deck mtd.	EA	1662	E108	Field joint, bolted or ready for field welding by others	EA	320
313297	Prerinse 12" Add-on Faucet	EA	439	E96	Control Panel Bracket 6x9	EA	287
<b>DRAINS AND ACCESSORIES:</b>				E96A	Control Panel Bracket 9x12	EA	433
300720	Lever drains, 1.5"	EA	279	300692	Bullet feet, stainless steel	EA	22
300721	Lever drains, 2"	EA	279	313835	Flanged bullet feet, stainless steel	EA	32
300722	Lever drains, 2" with overflow	EA	573	311772	Legs and crossbrace assembly	EA	223
341189	Twist handle drains, 1.5"	EA	294	<b>DISHTABLE BACKSPLASH MODIFICATIONS AND OPTIONS:</b>			
336002	Twist handle drains, 2"	EA	294	E101	Splash 10" per linear ft. (dishtable only)	LIN. FT.	74
341190	Twist handle drains, 2" with overflow	EA	665	E101A	Turn down backsplash (with z-clips)	TABLE	292
-TB	Twist drain handle bracket	EA	35	E30	End splash - per end, all heights	EA	375
313834	Backflow Preventer	EA	247	<b>DISHTABLE TOP MODIFICATIONS AND OPTIONS:</b>			
300789	P-Trap, Nickel Plated	EA	109	E100	Additional length NSF Construction	LIN. FT.	424
300791	Tail Piece	EA	20	E102	Pass-thru shelf max. 12" up to 3 lin. ft.	LIN. FT.	2439
313832	Anti-Siphon Vacuum Breaker	EA	212	E102A	additional over 36" for pass-thru shelf	LIN. FT.	812
300287	Crumb Cup Strainer	EA	25	E106	Rack guide curved 2x1/4 s/s flat bar (requires E112)	EA	426
<b>SINK COVERS / CUTTING BOARDS:</b>				E107	Corner turn 90 degrees	EA	1639
313207	Polyboard, 10" x 14"	EA	161	E108	Field joint, bolted or ready for field welding by others	EA	320
351584	Polyboard, 16" x 20"	EA	182	E109	Cutout for pipes, columns	EA	801
335377	Polyboard, 18" x 20"	EA	188	E112	Mitered Corner	EA	818
326267	Polyboard, 20" x 20"	EA	192	E119	Landing shelf 12"W integral with top	LIN. FT.	288
313204	Polyboard, 22" x 22"	EA	197	E120	Limit switch	EA	213
326268	Polyboard, 18" x 24"	EA	193	E97	Provision for side loader	EA	895
313205	Polyboard, 24" x 24"	EA	213	E98	Modify for custom machine opening	EA	374
326269	Polyboard, 20" x 28"	EA	212	<b>DISHTABLE SCRAPPING MODIFICATIONS AND OPTIONS:</b>			
321555	Stainless steel, 10" x 14"	EA	199	E115	Scrapping Trough 6"x4" deep—up to 60"	LIN. FT.	1989
351585	Stainless steel, 16" x 20"	EA	226	E115A	additional over 60"	LIN. FT.	340
346175	Stainless steel, 18" x 20"	EA	239	E115B	Mitered angle in scrapping trough	EA	862
305428	Stainless steel, 20" x 20"	EA	241	E116	Scrap Block installed (Rubber)	EA	433
321557	Stainless steel, 22" x 22"	EA	254	300691	Replacement rubber scrap block	EA	122
326270	Stainless steel, 18" x 24"	EA	246	<b>DISHTABLE SINK WELDMENT MODIFICATIONS AND OPTIONS:</b>			
321558	Stainless steel, 24" x 24"	EA	311	E105	Prerinse sink 20" x 20" x 5"	EA	1243
326271	Stainless steel, 20" x 28"	EA	249	E105A	for each additional 2" in depth	EA	151
<b>SINK SPLASH MODIFICATIONS AND OPTIONS:</b>				E110	Sink 24" x 26 1/2" x 14"	EA	2251
E101A	Turn down backsplash (with z-clips)	TABLE	292	E117	Soak sink 16" x 20" x 13 1/2"	EA	1611
E30	End splash - per end, all heights	EA	375	E122	Faucet Holes	EA	200
E44	Faucet Hole Revision (adding or moving)	EA	198	E20A	10" x 14" x 5" sink	EA	1297
E46	Scrap Block Installed (Rubber)	EA	433	E20	10" x 14" x 9.5" sink	EA	1297
E48	Stainless steel apron to cover sink bowls (2 or 3)	SET	1300	E24A	20" x 20" x 14" sink bowl	EA	1778
E48A	additional compartments over 3	EA	217	<b>DISHTABLE BASE MODIFICATIONS AND OPTIONS:</b>			
E52	High backsplash up to 13"	LIN. FT.	209	E111	Undershelving stainless steel, per linear foot	LIN. FT.	299
E53	High backsplash up to 18"	LIN. FT.	374	E113	Brackets for booster heater, installation only, brackets by others	EA	166
E56	Overflow Holes	EA	52	E118	Crossbracing left-to-right, stainless steel	LIN. FT.	98
<b>SINK DRAINBOARD MODIFICATIONS AND OPTIONS:</b>				<b>DISHTABLE RACK SHELF MODIFICATIONS AND OPTIONS:</b>			
E41A	Disposal provision package, cone	EA	882	E103	Rack shelf, back splash mounted	FT.	603
E45	Drain trough installed in drainboard or dishtable	EA	1081	E104	Drain, bleeder type	EA	151
E49	Undershelf under drainboard 24" long	EA	699	E-DRS60	Tubular rack unit, 60" long, with shelf	EA	5906
E49A	additional charge over 24" long	LIN. FT.	306	E-DRS60-NS	Tubular rack unit, 60" long, no shelf	EA	5192
E51	Optional size drainboard	LIN. FT.	403	E-DRS96	Tubular rack unit, 96" long, with shelf	EA	7205
E55	Drainboard corner turn	EA	1639	E-DRS96-NS	Tubular rack unit, 96" long, no shelf	EA	6316
<b>SINK COMPARTMENT MODIFICATIONS AND OPTIONS:</b>							
E40	Provision for sink heater	EA	213				
E41	Disposal provision package, collar	EA	882				
E41B	Provision for scrap collector and troughveyor	EA	1639				

# CUSTOM OPTIONS / ACCESSORIES

## For Underbar

model #	description	1800 Series list price	2200 Series list price	model #	description	1800 Series list price	2200 Series list price
E60	Workboards (minimum 4' 0") per linear foot	427	520	300712	Towel bar, 24" (610mm)-long, stainless steel - shipped loose	111	111
Sinks:				300670	Sliding s/s ice cover for 15½" x 19¾" bowl (non NSF)	488	488
E61	- hand sink 10" x 14" x 5" w/drain faucet	400	400	300325	Rack for round bottle wells	177	177
E61A	- sink bowl 10" x 14" x 9½" w/drain, faucet & overflow	466	466	300491	Bottle holder, individual	47	47
E61B	- sink bowl 12" x 14" x 9½" w/drain, faucet & overflow	581	581	300805	Bottle holder trays (not installed) hold 4 bottles each	86	86
Cocktail units 15½" x 19¾" bowls:				326636	Poly cutting board 15" x 15" x ½" (not attached) poly-plastic	194	194
E62	- 24" unit, 6 bottle wells, inside liner, no cover	1602	1758	303365	Faucet - 10" spout, splash mount	209	209
E62A	- 36" unit, 8 bottle wells, outside liner, sliding s/s cover	2109	2266	E76	Divider for ice chest (removable), installed at factory	435	435
E63	Ice chest 15½" x 19¾" x 8" deep	2052	2928	300713	- Bottle opener and	75	75
E64	Ice chest w/sliding s/s cover 15½" x 19¾" x 8" deep	1566	1724	300819	- Cap catcher (not attached)	75	75
E65	Higher backsplash up to 9" high per linear foot	124	124	E77	Duplex GFCI receptacle, installed	376	376
Blender step unit w/liquid waste chute, faucet, electrical outlet:				359032	Post-mix cold plate for 15½" x 19¾" bowl, 7-circuit, sealed-in (NSF)	1853	1853
E66	- 12" wide single station	1506	1747	E78	Glass rack storage, holds (2) 20" x 20" racks	1617	1617
E66A	- 14" wide double station	1619	1855	E79	Dipperwell with faucet	872	872
E67	Blender recess 12" (305mm) wide with electrical GFCI outlets	1092	1205	Pass-thru ice chests:			
E68	Open waste chute installed	487	487	E80	- 18" x 36" x 8"	3078	3078
E69	Liquid waste chute installed	584	584	E80A	- 24" x 36" x 8"	3473	3473
E70	Glass filler	403	403	E81	Stainless steel leg, each	53	53
E71	Cutout in back (2200 Series only)	-	169	300293	Plastic bullet foot, each	2	2
E72	End splash per end	682	697	E83	NSF sprayed-on sound deadening, up to 12' (3658mm) length - for each additional foot	777	777
E73	"L" shape corner welded per corner (except sink bowls)	price upon application		Modular Angle Fillers and Corner Drainboards—front and rear sections			
E74	Pass-thru	894	1063	see page 293 for models and list prices			
E75	Blender shelf 12" (305mm) wide, removable hook-on type	492	492	Double speed rail			
				see page 296 for models and list prices			

## For Ventilation Hoods

model #	description	unit	list	model #	description	unit	list
E150	3" Air Space - on front side of unit	LIN. FT.	87	E164	Stainless Steel Trim Strips - on right side of unit	LIN. FT.	36
E151	3" Air Space - on left side of unit	PER SIDE	371	E165	Extra Collars -exhaust collar	EA	674
E152	3" Air Space - on right side of unit	PER SIDE	371	E166	Extra Collars - supply collar	EA	674
E153	Insulated Back - on front side of unit	LIN. FT.	87	E167	Extra Supply Fire Damper	EA	443
E154	Insulated Back - on back side of unit	LIN. FT.	87	E168	Filter Frames	EA	140
E155	Insulated Back - on left side of unit	LIN. FT.	87	E169	Light Switch	EA	303
E156	Insulated Back - on right side of unit	LIN. FT.	87	E170	Extra Bullet Lights	EA	422
E157	Stainless Steel Furring Channel - on front side of unit	LIN. FT.	179	E174	Enclosure Panels	LIN. FT.	286
E158	Stainless Steel Furring Channel - on back side of unit	LIN. FT.	179	E175	Insulated Make-Up Air Plenum	LIN. FT.	335
E159	Stainless Steel Furring Channel - on left side of unit	LIN. FT.	179	361269	Add'l Mounting Channel	LIN. FT.	45
E160	Stainless Steel Furring Channel - on right side of unit	LIN. FT.	179	331677	Extra Grease Cups	EA	122
E161	Stainless Steel Trim Strips - on front side of unit	LIN. FT.	36	332493	Extra Grease Filters - aluminum	EA	102
E162	Stainless Steel Trim Strips - on back side of unit	LIN. FT.	36	332494	Extra Grease Filters - steel	EA	178
E163	Stainless Steel Trim Strips - on left side of unit	LIN. FT.	36				

# SpecFAB® Custom Fabrications

Chef's Counter .....	380	Ozone Prep Station .....	379	Sport Complex Project Management.....	378
Custom Refrigeration .....	380	Premium Modular Counters .....	379	The SpecFAB® Division .....	374
Elite Series Counters.....	379	Shelf Select™ .....	376	Uni-Wall® Concession Counters .....	378
Merchandising Solutions .....	377	Spec-Bar Select™ .....	375		

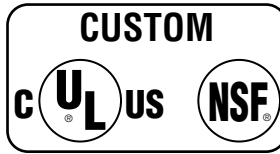

## CUSTOM GRAPHICS AVAILABLE!!

### Laser-Cutting and Custom Decal Services!

Put  
**YOUR LOGO**  
here.  
*(laser-cut shown)*

#### Laser-Cutting...

- Offers a "high-tech" look.
- Creates smooth curves along text/artwork.
- Choose from various plastic laminates, woods, stainless steel, designer aluminum, magnetic sheets...more.



#### Decals...

- Industrial-strength, factory-applied, yet more economical.
- Image is printed on vinyl material with adhesive backing.

*Eagle provides a 3D rendering of your logo or design prior to production.*



Quality Stainless & Millwork Fabrication



Quality Stainless & Millwork Fabrication

**EAGLE GROUP's SpecFAB® Division fills the gap between standard equipment and high-cost, highly customized equipment. Depending on the custom need, configurations can be designed from pre-fab pieces by using existing components, or designed completely from scratch to match exacting consultant and architect's plans and details. This flexibility means custom equipment can be delivered faster and at a lower cost directly to the job site.**

## Frequently Asked Questions about Project Quotations:

### How do I request a Quote?

- Standard or modified product using listed 'E' numbers from the catalog:
  - Email requests to the Customer Service Representative for your geographical area or [custserv@eaglegrp.com](mailto:custserv@eaglegrp.com)
  - Telephone (800) 441-8440 and ask for the Customer Service Representative for your city and state.
  - Fax (302) 653-2065
  - Eagle Group, ATTN: Customer Service, 100 Industrial Blvd., Clayton, DE 19938
- Custom products not found in the catalog:
  - Email requests to [quotes@eaglegrp.com](mailto:quotes@eaglegrp.com)
  - Fax (302) 653-2065
  - Eagle Group, ATTN: Project Quotations, 100 Industrial Blvd., Clayton, DE 19938

### What to include with your request?

- Your Name and Dealer Name
- Projected Installation Date and Timeline
- Job or Project Name
- Consultant Name when Applicable
- Required Date for Quote
- Plans and Specs related to the Project
- Bid Date for Project
- Special Considerations

### How long will it take to process my request for a custom quote?

- Typical lead time of 72 hours for most new incoming projects.
- Large scale projects will carry longer lead times. Please be sure to communicate required bid dates.

### How can I find out the status of my custom quote request?

- Customer Service - The Customer Service representative for your area can access information regarding the status of your request via email or call (800) 441-8440.
- SpecFAB® Customer Service.
- SpecFAB® Quote Coordinator - call (800) 441-8440 and ask for the Quote Coordinator.
- Outgoing email signatures for quotes sent from SpecFAB® highlight the primary points of contact.

## Frequently Asked Questions about Project Submittals:

### How do I get a Submittal Drawing?

- Submit a purchase order for the project with plans and specifications if not previously provided to the Quotations Department.
- Provide a letter of intent for the project.
- Request quote drawings via [quotes@eaglegrp.com](mailto:quotes@eaglegrp.com).
- Shelf Select™ and SpecBAR Select™ requests through [quotes@eaglegrp.com](mailto:quotes@eaglegrp.com).

### How long will it take to receive drawings?

- Typical requests for drawings are addressed within 72-hours.
- Large scale projects will carry longer lead times. Please be sure to communicate required bid dates.
- To contact Project Submittals regarding your drawings, contact the Submittals Manager, Bruce Moffett at [bmoffett@eaglegrp.com](mailto:bmoffett@eaglegrp.com) or (800) 441-8440, ext. 3158.
- Outgoing email signatures for drawings sent from SpecFAB® highlight the primary points of contact.



# Spec-Bar Select™

***A No-Cost Design & Layout Service for Bar Equipment.***



## Provide Us With:

- Scaled floor plan.
- Required number of service stations.
- Any additional specific or pertinent working requirements.

## And We'll Provide You With:

- **Plan View**  
Underbar equipment layout makes the most efficient utilization of your space available.
  - **Elevation View\***  
Illustrates the proposed equipment assembled in the available space.
  - **Quote\***  
Includes model numbers, net prices and shipping weights for all components in specified job.
- \* Will be provided after plan view is approved.

Spec-Bar® is available in numerous colors and patterns, along with high profile hardwoods and composites to fit the decor of any room or theme.

**For more information about Spec-Bar Select™, request Spec-Bar Select™ service announcement EG8202**

*Simply*

**Email: [quotes@eaglegrp.com](mailto:quotes@eaglegrp.com)  
Fax: 302-653-2065**

in your request and our trained staff will begin planning, layout and quotation upon receipt.

A completed Spec-Bar Select™ custom layout and quotation will be mailed, emailed or faxed back to you within 48 hours.

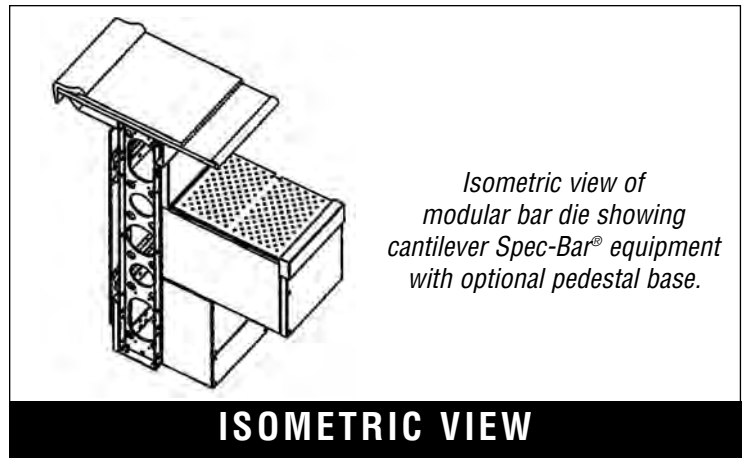
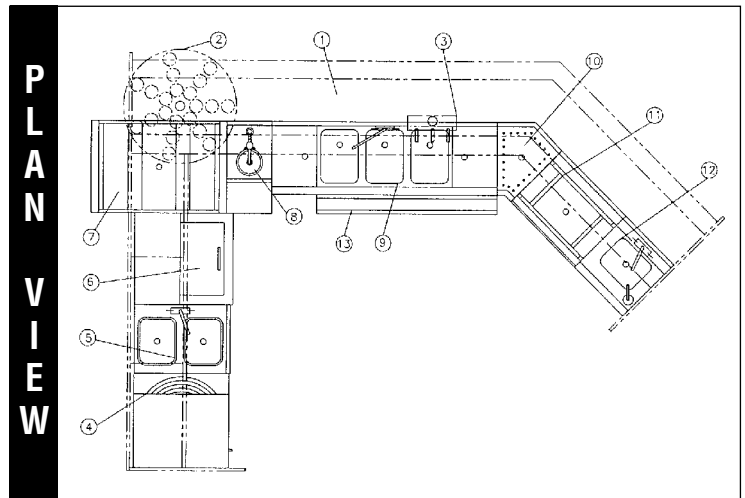

**FINAL OUTCOME!**

# Shelf Select™

***A No-Cost Design & Layout Service for Shelving Products.***



***Typical Shelf Select™ applications include walk-in coolers and freezers; dry storage areas; supermarkets; and department stores.***

## Provide Us With:

- Dimensions of a storage space available.
- Number of shelves per unit.
- Post heights.
- Indicate stationary, mobile or high density shelving.
- Any additional specific or pertinent storage requirements.

## And We'll Provide You With:

- **Plan View**  
Shelving system layout makes the most efficient utilization of your space available.
- **Perspective View\***  
Illustrates the proposed equipment assembled in the available space. A great tool for presentation which reduces field assembly time when provided to your installer.
- **Quote\***  
Includes model numbers, net prices and shipping weights for all components in specified job.

\* Will be provided after plan view is approved.

***For more information about Shelf Select™, request Shelf Select™ service announcement EG8027***

***Simply***

**Email: [quotes@eaglegrp.com](mailto:quotes@eaglegrp.com)**

**Fax: 302-653-2065**

in your order and our trained staff will begin planning, layout and quotation upon receipt.

A completed Shelf Select™ custom layout and quotation will be mailed, emailed or faxed back to you within 48 hours.

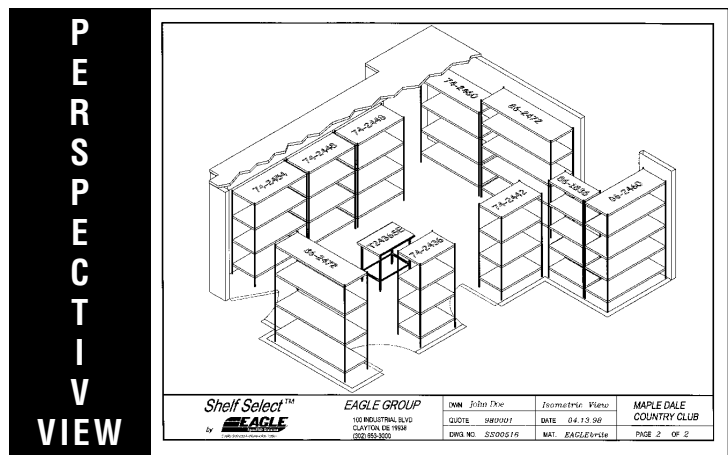
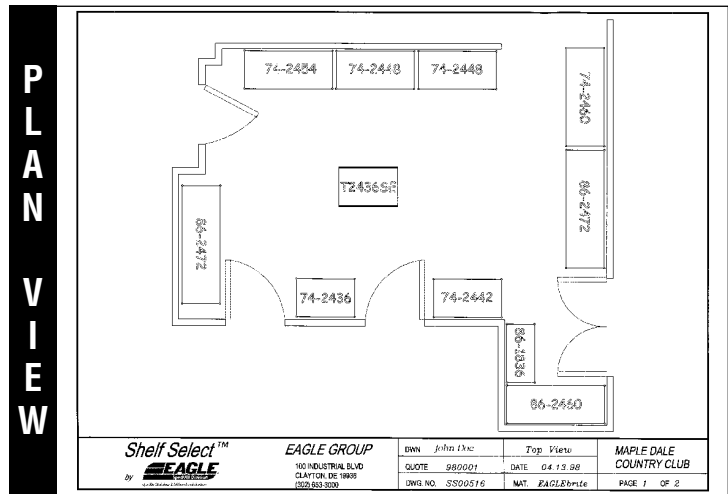

**FINAL OUTCOME!**

# Merchandising Solutions

*Using a combination of millwork, refrigeration and stainless steel*



## We Make it Easy for You

*First* – we did our homework so you don't have to. With more NSF and UL approvals than any other equipment manufacturer in the field, we make sure our equipment meets or exceeds industry standards and is manufactured with health and safety codes in mind.

*Second* – the process of submitting a quote has been streamlined to ensure the process is as quick and efficient for our customers as well as our SpecFAB® team. The process starts by a phone call or an e-mail sent to [quotes@eaglegrp.com](mailto:quotes@eaglegrp.com).

*Third* – prompt, efficient delivery. We do our best to ship your counters and bars fully assembled and crated. We work with manufacturing schedules to meet stringent deadlines and offer on-site installation services.

You will speak directly with people, not voice mail. Real-time access to the status of your order, instantaneous direct order entry, and order processing are available at the time of your call. Real-time access, whether it is about inventories, manufacturing schedule, shipping status, or delivery date.

Product details start as an idea.... ideas that we build on. Using the latest computerized tools, our Design Engineering team takes these ideas to reality in a way that ensures they'll work best for our customer and can be manufactured to the highest standards at competitive prices.

Depending on our customer's needs, we can build custom configurations from scratch, or we can design superior modular components using our standard product offering with modifications and options.

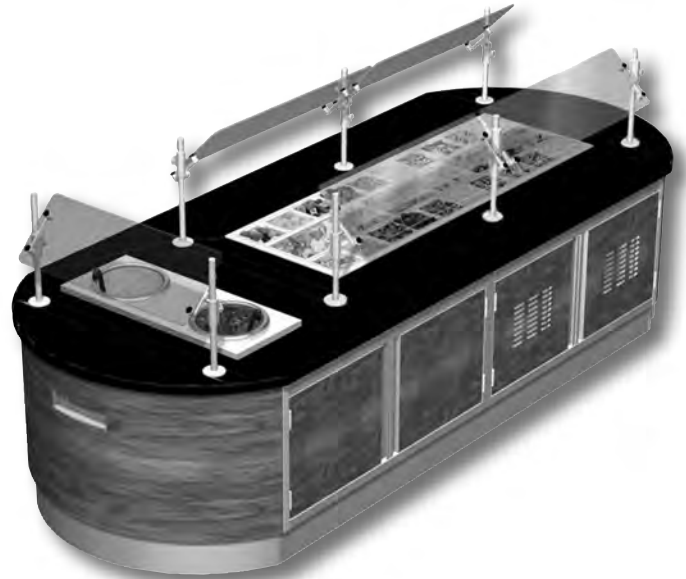

*Cold Foods • Salad Bars • Soup Stations • Olive Bars • Hot Foods • Beverage Bars*



*Simply*

**Email: [quotes@eaglegrp.com](mailto:quotes@eaglegrp.com)**

**Fax: 302-653-2065**

in your request and our trained staff will begin planning, layout and quotation upon receipt.



# Sport Complex Project Management

From project planning to closeout, you and our project management team will develop the project objectives and define the scope insuring your project is **measured by results, not just dates.**

Our sports complex resumé ranges from local neighborhood parks to the most current professional sports facilities. We provide this service for all EAGLE GROUP products from our standard catalog items to custom fabricated equipment, and include everything in one integrated package!



## Uni-Wall® Concession Counters

see product announcement **EG8131**



concession counter with tubular base rear support and open front exposing chase



concession counter stainless steel front panels - middle panel removed to expose electrical, plumbing and beverage lines

**FEATURES:**

- Utilizes 12 gauge galvanized Uni-Wall® stud framing assembly with utility and beverage line chase.
- Available in random lengths.

**FINISHES AVAILABLE:**

- Top is offered in the following finishes:
  - 14 gauge type 304 stainless steel.
  - Plastic laminate of your choice.
  - A variety of Corian® decorative patterns.
  - Elegant hardwood tones.
- Front Panels are offered in the following finishes:
  - Stainless steel.
  - Plastic laminate of your choice.
  - Elegant hardwood tones.

**REAR SUPPORT CONFIGURATIONS AVAILABLE:**

- 1 1/8" (41mm) diameter stainless steel tubular base.
- Heavy gauge stainless steel cabinet.
- Wire shelving featuring patented QuadTruss® design or heavy gauge solid shelving.



Aloha High School - Beaverton, Oregon



Each section of the Uni-Wall® is skidded before it is shipped from the factory. Each unit arrives with the necessary electrical lines run, plumbing in place and the beverage chase accessible and ready for immediate placement and hook-up when specified.

### Elite Series Counters

see product announcement **EG8116**



A new innovative way to design and build counters! The look of the counter is only limited by your imagination. The Elite Series of counters is all about the 'look' and 'functionality'. The customer can utilize many different tops, front panel material, tray slides, buy-out equipment etc. to attain just the look you want.

Heavy gauge stainless steel construction, with curb style base constructed of 16 gauge type 304 stainless steel. Solid top is offered in stainless steel or stainless steel swirl finish. Exterior Panels—available with graphics—are offered in plastic laminates, natural woods, stainless steel, powder-coated, and brushed aluminum. Tray slides with inverted "V" stainless steel are available with square or round tubing. Choice of storage solutions include drawers, work shelves, plate shelves, and cabinets.

### Ozone Prep Station

see product announcement **EG8117**



This unique prep station allows for designs to optimize the available space in all types of kitchens. All components can be brought together to combine all kinds of food prep within the area. All the different cutting boards are within reach. Ease of cleaning systems allows for quick changes between food products. Convenient positioning of refrigeration, close sorting of cut products, along with convenient disposal of waste products and thorough cleaning system, allows for smooth transition between products with minimal interruption between finishing one job, cleaning up, and being ready for the next ingredient.



### Premium Modular Counters - PMC

see product announcement **EG8118**



Premium Modular Counters afford the user complete flexibility. Sectional frame work allows for free standing equipment to be added or replaced as needed based on changing menu's, or repair issues without using tools. Roll-out the old and roll in the new.

Features include heavy gauge type 304 stainless steel top, stainless steel end panels, 4" (102mm) wide stainless steel partitions. Stationary and portable units available.

# SpecFAB® Refrigeration

see product announcement **EG8119**

Engineered and designed to be an integral part of custom fabricated chef's counters or serving counters.

One-, two-, and three-door models feature self-contained or remote refrigeration, stainless steel flat top, sandwich style, or raised rail style refrigerator. Top and front exterior constructed of heavy gauge type 304 stainless steel. Door openings are finished with ABS breaker strips. Mullion, back, and top mount evaporator coils with digital thermostatic control. Foam-in-place urethane insulation throughout. 2" (51mm) thick CFC free R-134A blown. Refrigeration system is R404A with expansion valve.

Raised rail units come sized to fit six-1/6 pans through thirty-1/6 hotel pans. Pan ledge is recessed 2" and will hold 6" (152mm) deep pans (*pans not provided*), full width NSF cutting board and stainless steel hinged night cover.

Sandwich style units come with one 12" x 20" (305 x 508mm) opening per section with recessed pan ledge to hold 6" (152mm) deep pans (*pans not provided*), full width NSF cutting board and stainless steel hinged night cover. Stainless steel hinged compressor access panel, furnished with dial thermometer mounted in front fascia.



CUSTOM



## Chef's Counter

CUSTOM



*Standard components used to create a system customized to meet your needs!*

see product announcement **EG8123**



**D**esigned by EAGLE's SpecFAB® Division, these units are engineered to provide custom configurations using pre-engineered modular components.

Among the many modular design options are open based cabinets, closed base cabinets featuring either hinged or sliding doors as well as cabinets that accept hot well and refrigerated drop-ins. Refrigerated undercounter storage and drawers can also be accommodated in all modular designs.

Island units are designed with chef and server pick-up sides at different heights. This design not only increases worker efficiency but also incorporates a unique tray-lock feature to prevent accidents and spills. If desired, the server side can also accommodate an 18" (457mm) wide wire shelving unit positioned below the tray pick up surface. Choose from either stationary or mobile design options, depending on needs.

# 2020 Foodservice Equipment Price List

## Alphanumeric Price Index

EAGLE's Alphanumeric Price Index has been developed to assist our customers in quickly locating items found in our main Price List.

**EAGLE is committed to *customer service* and *customer satisfaction* along with *quality products*.**

**If you need assistance,  
please call EAGLE's Customer Service Center at  
**1-800-441-8440.****



# ALPHANUMERIC PRICE INDEX

Part Number	List Price	Page No.	Part Number	List Price	Page No.	Part Number	List Price	Page No.	Part Number	List Price	Page No.
004026	22	141,171	1436Z	74	6	1830WGS-C	151	104	1848V63	646	24
	181,224		1442BL	98	65	1830WGS-VG	155	104	1848V63-5	783	24
	252,322		1442C	94	6	1830WGS-Z	141	104	1848V74	672	24
	334		1442E	94	6	1830Z	83	6	1848V74-5	821	24
11QCW-120	1007	269	1442R	98	65	1836-2-16/3	1874	190	1848VG	100	6
11QCW-208	1007	269	1442S	320	6	1836-2-16/4	1533	190	1848VG63	646	24
11QCW-240	1007	269	1442V	82	6	1836-3-16/3	2147	191	1848VG63-5	783	24
11QDI-120	928	273	1442VG	82	6	1836-3-16/4	1766	191	1848VG74	672	24
11QDI-120D	1009	273	1442W	98	65	1836BL	99	63	1848VG74-5	821	24
11QDI-120T	1105	273	1442Z	82	6	1836C	87	6,38	1848W	120	65
11QDI-120TD	1189	273	1448BL	100	65	1836C63	531	24	1848WGS-C	181	104
11QDI-240	928	273	1448C	96	6,45,46	1836C63-5	637	24	1848WGS-VG	186	104
11QDI-240D	1009	273	1448E	96	6,45	1836C74	540	24	1848WGS-Z	167	104
11QFW-120	904	268	1448R	100	65	1836C74-5	664	24	1848Z	100	6
11QFW-208	904	268	1448S	321	6,45	1836E	87	6	1848Z63	561	24
11QFW-240	904	268	1448V	86	6	1836E63	642	24	1848Z63-5	685	24
11QP	129	273	1448VG	86	6	1836E63-5	768	24	1848Z74	586	24
1202	792	353	1448W	100	65	1836E74	644	24	1848Z74-5	708	24
1203	873	353	1448Z	86	6	1836E74-5	805	24	1854-3-16/3	2491	191
1212	1016	353	1454BL	106	65	1836R	99	65	1854-3-16/4	2093	191
1220CWD-120	968	269	1454C	102	6	1836S	325	6	1854BL	129	65
1220CWD-208	968	269	1454E	102	6	1836V	86	6	1854C	120	6
1220CWD-240	968	269	1454R	106	65	1836V63	572	24	1854E	120	6
1220FW2-120	1680	268	1454S	399	6	1836V63-5	685	24	1854R	129	65
1220FW2-208	1680	268	1454W	106	65	1836V74	582	24	1854S	486	6
1220FW2-240	1680	268	1454V	95	6	1836V74-5	715	24	1854V	116	6
1220FWD-120	737	268	1454VG	95	6	1836VG	86	6	1854VG	116	6
1220FWD-208	737	268	1454Z	95	6	1836VG63	572	24	1854W	129	65
1220FWD-240	737	268	1460BL	120	65	1836VG63-5	685	24	1854Z	116	6
1220FWE-120	732	268	1460C	109	6,45	1836VG74	582	24	1860BL	139	65
1220FWE-208	732	268	1460E	109	6,45	1836VG74-5	715	24	1860C	123	6,38
1220FWE-240	732	268	1460R	120	65	1836W	99	65	1860C63	682	24
1290PP	3556	357	1460S	411	6,45	1836WGS-C	157	104	1860C63-5	836	24
1290WDW	4638	357	1460V	102	6	1836WGS-VG	162	104	1860C74	698	24
1292	3581	357	1460VG	102	6	1836WGS-Z	144	104	1860C74-5	866	24
1424BL	73	65	1460W	120	65	1836Z	86	6	1860E	123	6
1424C	69	6	1460Z	102	6	1836Z63	497	24	1860E63	844	24
1424E	69	6	1472BL	129	65	1836Z63-5	599	24	1860E63-5	1035	24
1424R	73	65	1472C	125	6	1836Z74	508	24	1860E74	896	24
1424S	257	6	1472E	125	6	1836Z74-5	600	24	1860E74-5	1074	24
1424V	66	6	1472R	129	65	1842BL	111	65	1860R	139	65
1424VG	66	6	1472S	461	6	1842C	102	6	1860S	492	6
1424W	73	65	1472V	119	6	1842E	102	6	1860V	119	6
1424Z	66	6	1472VG	119	6	1842R	111	65	1860VG	119	6
1430BL	77	65	1472W	129	63	1842S	382	6	1860V63	734	24
1430C	74	6,45	1472Z	119	6	1842V	96	6	1860V63-5	901	24
1430E	74	6,45	1818-1-16/3	1326	189	1842VG	96	6	1860V74	753	24
1430R	77	65	1818-1-16/4	1136	189	1842W	111	65	1860V74-5	932	24
1430S	260	6,45	1824-1-16/3	1386	189	1842Z	96	6	1860VG63	734	24
1430V	69	6	1824-1-16/4	1145	189	1848-2-16/3	2019	190	1860VG63-5	901	24
1430VG	69	6	1824BL	84	65	1848-2-16/4	1607	190	1860VG74	753	24
1430W	77	65	1824C	82	6	1848-3-16/3	2281	191	1860VG74-5	932	24
1430WGS-C	141	104	1824E	82	6	1848-3-16/4	1842	191	1860W	139	65
1430WGS-VG	145	104	1824R	84	65	1848BL	120	65	1860Z	119	6
1430WGS-Z	129	104	1824S	318	6	1848C	106	6,38	1860Z63	663	24
1430Z	69	6	1824V	81	6	1848C63	601	24	1860Z63-5	751	24
1436BL	84	65	1824VG	81	6	1848C63-5	726	24	1860Z74	651	24
1436C	82	6,45,46	1824W	84	65	1848C74	626	24	1860Z74-5	761	24
1436E	82	6,45	1824Z	81	6	1848C74-5	761	24	1872-4-16/3	3000	192
1436R	84	65	1830BL	92	65	1848E	106	6	1872-4-16/4	2406	192
1436S	262	6,45	1830C	85	6	1848E63	739	24	1872BL	167	65
1436V	74	6	1830E	85	6	1848E63-5	899	24	1872C	147	6
1436VG	74	6	1830R	92	65	1848E74	761	24	1872E	147	6
1436W	84	65	1830S	320	6	1848E74-5	933	24	1872R	167	65
1436WGS-C	146	104	1830V	83	6	1848R	120	65	1872S	583	6
1436WGS-VG	152	104	1830VG	83	6	1848S	385	6	1872V	139	6
1436WGS-Z	138	104	1830W	92	65	1848V	100	6	1872VG	139	6



# ALPHANUMERIC PRICE INDEX

Part Number	List Price	Page No.	Part Number	List Price	Page No.	Part Number	List Price	Page No.	Part Number	List Price	Page No.
1872W	167	65	2148C	120	6	2424BL	103	65	2448-2-16/3	2164	190
1872Z	139	6	2148E	120	6	2424C	102	6	2448-2-16/4	1739	190
18x18 RRDEDB	319	192	2148R	129	65	2424E	102	6	2448-2-24-16/3	3885	190
18x18 RRDEDB-16/3	534	192	2148S	432	6	2424GADJUS	213	151	2448-2-24-16/4	3236	190
18x24 RRDEDB	338	192	2148V	109	6	2424R	103	65	2448-3-16/3	2461	191
18x24 RRDEDB-16/3	561	192	2148VG	109	6	2424S	396	6	2448-3-16/4	1986	191
18x30 RRDEDB	576	192	2148W	129	65	2424SADJUS-18/3	522	151	2448BL	148	65
18x30 RRDEDB-16/3	628	192	2148Z	109	6	2424SADJUS-18/4	475	151	2448C	133	6,45,46
2118-1-16/3	1359	189	2154-3-16/3	2559	191	2424V	95	6	2448C63	715	24
2118-1-16/4	1131	189	2154-3-16/4	2100	191	2424VG	95	6	2448C63-5	882	24
2124-1-16/3	1424	189	2154-3-18-16/3	4296	191	2424W	103	65	2448C74	732	24
2124-1-16/4	1172	189	2154-3-18-16/4	3582	191	2424Z	95	6	2448C74-5	907	24
2124-1-18-16/3	3074	189	2154BL	147	65	2430BL	116	65	2448E	133	6,45
2124-1-18-16/4	2521	189	2154C	138	6	2430C	106	6,45	2448E63	878	24
2124BL	96	65	2154E	138	6	2430E	106	6,45	2448E63-5	987	24
2124C	92	6	2154R	147	65	2430GADJUS	254	151	2448E74	911	24
2124E	92	6	2154S	568	6	2430R	116	65	2448E74-5	1118	24
2124R	96	65	2154V	129	6	2430S	399	6,45	2448GADJUS	268	151
2124S	365	6	2154VG	129	6	2430SADJUS-18/3	572	151	2448R	148	65
2124V	87	6	2154W	147	65	2430SADJUS-18/4	521	151	2448S	485	6,45
2124VG	87	6	2154Z	129	6	2430V	98	6	2448SADJUS-18/3	659	151
2124W	96	65	2160-3-16/3	2659	191	2430VG	98	6	2448SADJUS-18/4	601	151
2124Z	87	6	2160-3-16/4	2171	191	2430W	116	65	2448V	121	6
2130BL	102	65	2160BL	157	65	2430Z	98	6	2448V63	768	24
2130C	100	6	2160C	140	6	2436-1-16/3	1657	189	2448V63-5	949	24
2130E	100	6	2160E	140	6	2436-1-16/4	1298	189	2448V74	785	24
2130R	102	65	2160R	157	65	2436BL	121	65	2448V74-5	978	24
2130S	368	6	2160S	572	6	2436C	109	6,45,46	2448VG	121	6
2130V	91	6	2160V	134	6	2436C63	619	24	2448VG63	768	24
2130VG	91	6	2160VG	134	6	2436C63-5	754	24	2448VG63-5	949	24
2130W	102	65	2160W	157	65	2436C74	629	24	2448VG74	785	24
2130Z	91	6	2160Z	134	6	2436C74-5	782	24	2448VG74-5	978	24
2136-1-16/3	1583	189	2172-4-16/3	3048	192	2436E	109	6,45	2448W	148	65
2136-1-16/4	1261	189	2172-4-16/4	2521	192	2436E63	744	24	2448Z	121	6
2136-2-16/3	1929	190	2172-4-18-16/3	4636	192	2436E63-5	909	24	2448Z63	652	24
2136-2-16/4	1567	190	2172-4-18-16/4	3972	192	2436E74	759	24	2448Z63-5	807	24
2136-2-18-16/3	3783	190	2172BL	183	65	2436E74-5	945	24	2448Z74	682	24
2136-2-18-16/4	3107	190	2172C	172	6	2436GADJUS	259	151	2448Z74-5	832	24
2136-3-16/3	2217	191	2172E	172	6	2436R	121	65	2454BL	165	65
2136-3-16/4	1812	191	2172R	183	65	2436S	403	6,45	2454C	153	6
2136-3-18-16/3	3755	191	2172S	677	6	2436SADJUS-18/3	599	151	2454E	153	6
2136-3-18-16/4	3175	191	2172V	161	6	2436SADJUS-18/4	548	151	2454R	165	65
2136BL	116	65	2172VG	161	6	2436V	102	6	2454S	594	6
2136C	103	6	2172W	183	65	2436V63	666	24	2454V	145	6
2136E	103	6	2172Z	161	6	2436V63-5	808	24	2454VG	145	6
2136R	116	65	21x18 RRDEDB	319	192	2436V74	677	24	2454W	165	65
2136S	371	6	21x18 RRDEDB-16/3	534	192	2436V74-5	843	24	2454Z	145	6
2136V	95	6	21x24 RRDEDB	343	192	2436VG	102	6	2460-2-16/3	2485	190
2136VG	95	6	21x24 RRDEDB-16/3	561	192	2436VG63	666	24	2460-2-16/4	2157	190
2136W	116	65	21x30 RRDEDB	643	192	2436VG63-5	808	24	2460-3-16/3	2762	191
2136Z	95	6	21x30 RRDEDB-16/3	675	192	2436VG74	677	24	2460-3-16/4	2297	191
2142BL	123	65	24108GADJUS	314	151	2436VG74-5	843	24	2460BL	177	65
2142C	118	6	24108SADJUS-18/3	1126	151	2436W	121	65	2460C	155	6,45
2142E	118	6	24108SADJUS-18/4	1039	151	2436Z	102	6	2460C63	827	24
2142R	123	65	24120GADJUS	338	151	2436Z63	569	24	2460C63-5	1001	24
2142S	427	6	24120SADJUS-18/3	1137	151	2436Z63-5	698	24	2460C74	848	24
2142V	106	6	24120SADJUS-18/4	1045	151	2436Z74	588	24	2460C74-5	1028	24
2142VG	106	6	24132GADJUS	378	151	2436Z74-5	720	24	2460E	155	6,45
2142W	123	65	24132SADJUS-18/3	1217	151	2442BL	135	65	2460E63	1000	24
2142Z	106	6	24132SADJUS-18/4	1117	151	2442C	126	6	2460E63-5	1221	24
2148-2-16/3	2038	190	24144GADJUS	417	151	2442E	126	6	2460E74	1028	24
2148-2-16/4	1585	190	24144SADJUS-18/3	1436	151	2442R	135	65	2460E74-5	1258	24
2148-3-16/3	2355	191	24144SADJUS-18/4	1323	151	2442S	483	6	2460GADJUS	279	151
2148-3-16/4	1892	191	2424-1-16/3	1495	189	2442V	119	6	2460R	177	65
2148-3-18-16/3	4042	191	2424-1-16/4	1220	189	2442VG	119	6	2460S	596	6,45
2148-3-18-16/4	3279	191	2424-1-24-16/3	3176	189	2442W	135	65	2460SADJUS-18/3	740	151
2148BL	129	65	2424-1-24-16/4	2713	189	2442Z	119	6	2460SADJUS-18/4	677	151



100 Industrial Boulevard, Clayton, DE 19938-8903 U.S.A.  
 Phone: 800-441-8440 or 302-653-3000. Fax: 302-653-2065  
<http://www.eaglegrp.com>

# ALPHANUMERIC PRICE INDEX

Part Number	List Price	Page No.	Part Number	List Price	Page No.	Part Number	List Price	Page No.	Part Number	List Price	Page No.
2460V	148	6	300691	122	326,371	301669	95	232, 266, 276	3048SADJUS-18/3	753	151
2460V63	891	24	300692	22	158,204, 328,370, 371	301757	88	266	3048SADJUS-18/4	686	151
2460V63-5	1078	24				301759	104	266	3048V	153	6
2460V74	912	24				301791	37	232,276	3048VG	153	6
2460V74-5	1103	24	300696	32	107,109, 148,156, 233	301792	35	232,276	3048Z	153	6
2460VG	148	6				302004	220	173, 199	305169	403	223
2460VG63	891	24	300698	124	158,370	302027	263	214-216, 231	305170	496	223
2460VG63-5	1078	24	300699	119	158,370				305171	649	223
2460VG74	912	24	300708	23	296				305172	707	223
2460VG74-5	1103	24	300712	111	297,372	3024GADJUS	221	151	305173	89	273
2460W	177	65	300713	75	296,297, 372	3024SADJUS-18/3	603	151	305174	113	273
2460Z	148	6				3024SADJUS-18/4	555	151	305197	53	274
2460Z63	766	24	300716	269	205,370	3030C	141	6.45	305198	57	274
2460Z63-5	944	24	300718	1344	206,328, 371	3030E	141	6.45	305259	649	223
2460Z74	794	24				3030GADJUS	268	151	305300	71	232,276
2460Z74-5	967	24	300719	1348	206,328, 371	3030S	487	6.45	305313	739	223
2472-3-16/3	2923	191				3030SADJUS-18/3	652	151	305314	964	223
2472-3-16/4	2353	191	300720	279	158,204, 328,371	3030SADJUS-18/4	596	151	305315	665	223
2472-3-24-16/3	4923	191				3030V	122	6	305316	1218	223
2472-3-24-16/4	3865	191	300721	279	158,204, 328,371	3030VG	122	6	305428	241	204,329, 371
2472-4-16/3	3189	192				3030Z	122	6			
2472-4-16/4	2591	192	300722	573	158,204, 371	303365	209	295,297, 372	3060C	227	6.45
2472BL	209	65							3060E	227	6.45
2472C	183	6	300765	89	329	303560	584	199	3060GADJUS	285	151
2472E	183	6	300789	109	174,205, 295,371	303561	661	199	3060S	694	6.45
2472GADJUS	283	151				303562	659	199	3060SADJUS-18/3	861	151
2472R	209	65	300791	20	174,205, 371	3036C	144	6.45	3060SADJUS-18/4	786	151
2472S	744	6				3036E	144	6.45	3060V	201	6
2472SADJUS-18/3	832	151	300804	278	205,370	3036GADJUS	271	151	3060VG	201	6
2472SADJUS-18/4	758	151	300805	86	296,297, 372	3036S	516	6.45	3060Z	201	6
2472V	173	6				3036SADJUS-18/3	687	151	306134	643	169
2472VG	173	6	300819	75	296,297, 372	3036SADJUS-18/4	631	151	306495	414	173
2472W	209	65				3036V	124	6	307105	584	143
2472Z	173	6	300886	16	175,295	3036VG	124	6	307106	654	143
2484GADJUS	285	151	300887	31	295	3036Z	124	6	307107	725	143
2484SADJUS-18/3	923	151	300889	3	295	303775	116	232,276	307108	799	143
2484SADJUS-18/4	845	151	300966	5	175,295	303974	29	232,276	307109	936	143
2496GADJUS	303	151	301001	651	205	303987	199	173	307110	1072	143
2496SADJUS-18/3	998	151	301002	659	205	304018	24	232,276	307120	124	173
2496SADJUS-18/4	912	151	301003	731	205	304019	51	232,276	3072C	260	6
24x18 RRDEDB	329	192	301004	606	205	304020	89	232,276	3072E	260	6
24x18 RRDEDB-16/3	526	192	301005	372	205	304021	136	232,276	3072GADJUS	303	151
24x24 RRDEDB	356	192	301036	11	79,158, 328,370	304025	43	232,276	3072S	811	6
24x24 RRDEDB-16/3	580	192	30108GADJUS	359	151	304026	52	232,276	3072SADJUS-18/3	961	151
24x30 RRDEDB	631	192	30108SADJUS-18/3	1332	151	304027	43	232,276	3072SADJUS-18/4	879	151
24x30 RRDEDB-16/3	665	192	30108SADJUS-18/4	1194	151	304028	52	232,276	3072V	236	6
2B2136C	444	47	301124	339	328	304041	47	232,276	3072VG	236	6
2B2148C	519	47	301189	357	206,328, 371	304042	52	232,276	3072Z	236	6
300287	25	175,176, 204,371				304049	51	232,276	307543	104	270
300293	2	158,204, 231,297, 328,370, 372	301190	89	206,328, 371	304050	55	232,276	307546	104	270
300315	38	204				304051	71	232,276	3084GADJUS	312	151
300325	177	296, 297,372	30120GADJUS	382	151	304052	47	232,276	3084SADJUS-18/3	1063	151
300489	331	195	30120SADJUS-18/3	1405	151	304053	59	232,276	3084SADJUS-18/4	973	151
300490	209	199,326	30120SADJUS-18/4	1327	151	304054	43	232,276	309197	43	270
300491	47	296, 297,372	301248	197	173,199	304055	52	232,276	3096GADJUS	314	151
300600	226	176	30132GADJUS	411	151	304056	94	232,276	3096SADJUS-18/3	1182	151
300602	37	174	30132SADJUS-18/3	1547	151	304057	51	232,276	3096SADJUS-18/4	1081	151
300604	449	174	30132SADJUS-18/4	1469	151	304058	37	232,276	309781	138	270
300670	488	297,372	301440	227	199	304059	47	232,276	309796	83	204
			30144GADJUS	455	151	304060	142	232,276	310-10-3-12	3579	195
			30144SADJUS-18/3	1729	151	304141	142	214-216, 231	310-10-3-18	3669	195
			30144SADJUS-18/4	1592	151				310-10-3-24	3734	195
			301628	47	266	304146	120	205	311772	223	329,371
			301630	546	328	3048C	171	6.45	311915	29	148
						3048E	171	6.45	312-12-3-12	3797	195
						3048GADJUS	279	151	312-14-3-12	4067	195
						3048S	601	6.45	312007	5	295

# ALPHANUMERIC PRICE INDEX

Part Number	List Price	Page No.	Part Number	List Price	Page No.	Part Number	List Price	Page No.	Part Number	List Price	Page No.
312162	403	173	314-18-1-24	4203	178	314-24-4-18	10717	181	353986	1038	229
312688	226	196	314-18-1-24L	3864	178	314-24-4-18L	10495	181	353987	1177	229
312689	217	196	314-18-1-24R	3864	178	314-24-4-18R	10495	181	353988	1477	229
312690	633	196	314-18-2	4212	179	314-24-4-24	11236	181	353996	471	230
313075	194	173,205	314-18-2-18	5673	179	314-24-4-24L	11009	181	353997	516	230
313116	257	206,371	314-18-2-18L	5517	179	314-24-4-24R	11009	181	353998	595	230
313204	197	204,371	314-18-2-18R	5517	179	316660	213	329	354066	879	230
313205	213	204,371	314-18-2-24	5733	179	316743	41	328	354562	40	107
313207	161	204,371	314-18-2-24L	5549	179	317635	162	158,370	354563	48	107
313293	722	205,370	314-18-2-24R	5549	179	317636	162	158,370	354564	55	107
313294	729	205,370	314-18-3	5560	180	318495	698	173	354565	77	107
313295	1662	206,328,371	314-18-3-18	7144	180	318496	344	174	354566	91	107
313296	1764	206,371	314-18-3-18L	6977	180	319931	94	175	355196	1546	229
313297	439	206,328,371	314-18-3-18R	6977	180	319932	43	175	355994	449	174
313302	707	295	314-18-3-24	7267	180	321555	199	204,371	356128	2016	173
313303	524	199	314-18-3-24L	7001	180	321557	254	204,371	356902	111	107
313304	720	158,205,370	314-18-3-24R	7001	180	321558	311	204,371	356903	129	107
313305	641	169	314-18-4	7054	181	321561	331	196	357068	34	365
313306	507	199	314-18-4-18	8831	181	324074	144	174	357071	38	365
313307	525	199	314-18-4-18L	8675	181	326014	1882	173	357074	34	365
313308	525	199	314-18-4-18R	8675	181	326015	114	174,176	357077	38	365
313323	221	206,371	314-18-4-24	8928	181	326267	192	204,371	357080	34	365
313481	600	174	314-18-4-24L	8703	181	326268	193	204,371	357083	38	365
313832	212	205,328,371	314-18-4-24R	8703	181	326269	212	204,371	358114	47	106
313834	247	205,371	314-22-1	3047	178	326270	246	204,371	358115	49	106
313835	32	158,204,370,371	314-22-1-18	4297	178	326271	249	204,371	359032	1853	297,372
313918	263	205,370	314-22-1-18L	3949	178	326272	566	173	359106	1186	251
313919	279	205,370	314-22-1-18R	3949	178	326636	194	297,372	359107	1264	251
313920	704	205,370	314-22-1-24	4332	178	326696	753	173	359108	1318	251
313970	520	143	314-22-1-24L	3977	178	330010	6	79	359109	1352	251
314-16-1	2617	178	314-22-1-24R	3977	178	331006	722	211	359110	1531	251
314-16-1-18	3672	178	314-22-2	4337	179	331160	220	271	359111	1564	251
314-16-1-18L	3514	178	314-22-2-18	5959	179	331677	122	334,371	359112	1620	251
314-16-1-18R	3514	178	314-22-2-18L	5787	179	332130	36	263	359113	1899	251
314-16-1-24	3783	178	314-22-2-18R	5787	179	332493	102	334,371	359114	2087	251
314-16-1-24L	3557	178	314-22-2-24	6021	179	332494	178	334,371	359115	1438	251
314-16-1-24R	3557	178	314-22-2-24L	5818	179	335377	188	204,371	359116	1516	251
314-16-2	3513	179	314-22-2-24R	5818	179	336002	294	158,204,371	359117	1541	251
314-16-2-18	4952	179	314-22-3	5823	180	336976	884	211	359118	1620	251
314-16-2-18L	4586	179	314-22-3-18	7578	180	336992	773	211	359119	1797	251
314-16-2-18R	4586	179	314-22-3-18L	7392	180	340380	719	205,370	359120	1819	251
314-16-2-24	5034	179	314-22-3-18R	7392	180	340859	68	270	359121	1842	251
314-16-2-24L	4848	179	314-22-3-24	7759	180	340992	669	211	359122	2223	251
314-16-2-24R	4848	179	314-22-3-24L	7422	180	341109	800	211	359123	2442	251
314-16-3	4394	180	314-22-3-24R	7422	180	341109	800	211	359124	2652	251
314-16-3-18	6042	180	314-24-1	3253	178	341110	660	211	359125	2800	251
314-16-3-18L	5899	180	314-24-1-18	4688	178	341113	707	211	359126	2847	251
314-16-3-18R	5899	180	314-24-1-18L	4583	178	341117	561	211	359127	3037	251
314-16-3-24	6127	180	314-24-1-18R	4583	178	341123	612	211	359128	3258	251
314-16-3-24L	5940	180	314-24-1-24	4856	178	341169	440	211	359129	3385	251
314-16-3-24R	5940	180	314-24-1-24L	4649	178	341189	294	158,204,371	359130	3552	251
314-16-4	6209	181	314-24-1-24R	4649	178	341190	665	158,204,371	359131	3929	251
314-16-4-18	7652	181	314-24-2	4996	179	341330	621	211	359132	4339	251
314-16-4-18L	7384	181	314-24-2-18	6694	179	342938	38	174	360332	63	266
314-16-4-18R	7384	181	314-24-2-18L	6426	179	342938	38	174	361269	45	335,372
314-16-4-24	7759	181	314-24-2-18R	6426	179	345934	839	211	361673	82	270
314-16-4-24L	7427	181	314-24-2-24	6988	179	346175	239	204,371	361993	163	265,266
314-16-4-24R	7427	181	314-24-2-24L	6856	179	347771	264	175	362188	31	199
314-18-1	3029	178	314-24-3	6492	180	349921	83	173	362647	165	211
314-18-1-18	4165	178	314-24-3-18	8224	180	350037	9	295	362648	139	211
314-18-1-18L	3838	178	314-24-3-18L	8298	180	351572	858	211	362649	165	211
314-18-1-18R	3838	178	314-24-3-18R	8298	180	351584	182	204,371	362650	139	211
			314-24-3-24	8891	180	351585	226	204,329,371	362651	217	211
			314-24-3-24L	8645	180	351738	600	174	362652	178	211
			314-24-3-24R	8645	180	353985	977	229	362653	271	211
			314-24-4	8516	181				362654	218	211
									3636C	161	6



100 Industrial Boulevard, Clayton, DE 19938-8903 U.S.A.  
 Phone: 800-441-8440 or 302-653-3000. Fax: 302-653-2065  
<http://www.eaglegrp.com>

# ALPHANUMERIC PRICE INDEX

Part Number	List Price	Page No.	Part Number	List Price	Page No.	Part Number	List Price	Page No.	Part Number	List Price	Page No.
3636E	161	6	381138	2040	251	411248	438	147	414-18-2-24R	4927	179
3636S	576	6	381139	2077	251	411260	471	147	414-18-3	4744	180
3636V	145	6	381140	2822	251	411272	539	147	414-18-3-18	6261	180
3636VG	145	6	381141	2387	251	411284	600	147	414-18-3-18L	6102	180
3636Z	145	6	381142	2448	251	411296	649	147	414-18-3-18R	6102	180
3648C	189	6	381143	2457	251	412-16-1	2013	178	414-18-3-24	6417	180
3648E	189	6	381144	2832	251	412-16-1-18	2994	178	414-18-3-24L	6126	180
3648S	682	6	381145	3555	251	412-16-1-18L	2823	178	414-18-3-24R	6126	180
3648V	174	6	381146	4414	251	412-16-1-18R	2823	178	414-18-4	5994	181
3648VG	174	6	381147	4462	251	412-16-1-24	3001	178	414-18-4-18	7689	181
3648Z	174	6	381148	4462	251	412-16-1-24L	2845	178	414-18-4-18L	7567	181
3660C	263	6	381149	5106	251	412-16-1-24R	2845	178	414-18-4-18R	7567	181
3660E	263	6	381167	3446	250	412-16-2	2752	179	414-18-4-24	7779	181
3660S	794	6	381250	425	251,252	412-16-2-18	3769	179	414-18-4-24L	7762	181
3660V	235	6	381251	432	251,252	412-16-2-18L	3648	179	414-18-4-24R	7762	181
3660VG	235	6	381252	442	251,252	412-16-2-18R	3648	179	414-22-1	2880	178
3660Z	235	6	381253	453	251,252	412-16-2-24	3828	179	414-22-1-18	4152	178
366456	126	246	382444	3446	250	412-16-2-24L	3685	179	414-22-1-18L	3811	178
366457	58	246	383390	3446	250	412-16-2-24R	3685	179	414-22-1-18R	3811	178
366458	98	246	383671	677	328	412-16-3	3489	180	414-22-1-24	4186	178
3672C	303	6	383949	86	261	412-16-3-18	3817	180	414-22-1-24L	3837	178
3672E	303	6	384794	392	206	412-16-3-18L	3687	180	414-22-1-24R	3837	178
3672S	944	6	384795	392	206	412-16-3-18R	3687	180	414-22-2	3979	179
3672V	278	6	384796	246	174	412-16-3-24	3882	180	414-22-2-18	5622	179
3672VG	278	6	388075	778	230	412-16-3-24L	3725	180	414-22-2-18L	5451	179
3672Z	278	6	3B2136C	528	47	412-16-3-24R	3725	180	414-22-2-18R	5451	179
368421	35	173,205,295	3B2148C	622	47	414-16-1	2314	178	414-22-2-24	5686	179
369370	538	367	3TF1836-BL	88	36	414-16-1-18	3319	178	414-22-2-24L	5480	179
369371	369	367	3TF1836-C	83	36	414-16-1-18L	3171	178	414-22-2-24R	5480	179
369653	474	204	3TF1836-V	88	36	414-16-1-18R	3171	178	414-22-3	5274	180
370000	172	211	3TF1836-VG	88	36	414-16-1-24	3426	178	414-22-3-18	7054	180
370001	209	211	3TF1836-Z	51	36	414-16-1-24L	3208	178	414-22-3-18L	6867	180
370002	226	211	3TF1848-BL	98	36	414-16-1-24R	3208	178	414-22-3-18R	6867	180
370003	179	211	3TF1848-C	91	36	414-16-2	3169	179	414-22-3-24	7236	180
370004	220	211	3TF1848-V	98	36	414-16-2-18	4356	179	414-22-3-24L	6894	180
370005	229	211	3TF1848-VG	98	36	414-16-2-18L	4192	179	414-22-3-24R	6894	180
370006	285	211	3TF1848-Z	55	36	414-16-2-18R	4192	179	414-24-1	2920	178
370007	353	211	3TF1860-BL	109	36	414-16-2-24	4436	179	414-24-1-18	4382	178
370008	291	211	3TF1860-C	102	36	414-16-2-24L	4258	179	414-24-1-18L	4211	178
370009	366	211	3TF1860-V	109	36	414-16-2-24R	4258	179	414-24-1-18R	4211	178
373030	176	211	3TF1860-VG	112	36	414-16-3	3841	180	414-24-1-24	4448	178
373206	267	211	3TF1860-Z	59	36	414-16-3-18	4989	180	414-24-1-24L	4254	178
373848	2556	173	4004	669	355	414-16-3-18L	4858	180	414-24-1-24R	4254	178
374015	145	211	4005	742	355	414-16-3-18R	4858	180	414-24-2	4397	179
374018	175	211	4006	817	355	414-16-3-24	5067	180	414-24-2-18	6111	179
374021	185	211	4008	779	355	414-16-3-24L	4896	180	414-24-2-18L	5914	179
374044	145	211	4009	869	355	414-16-3-24R	4896	180	414-24-2-18R	5914	179
374047	175	211	4010	958	355	414-16-4	5186	181	414-24-2-24	6300	179
374073	188	211	4027	1052	355	414-16-4-18	6562	181	414-24-2-24L	6042	179
374076	227	211	4065	1234	355	414-16-4-18L	6301	181	414-24-2-24R	6042	179
374079	284	211	411010	683	147	414-16-4-18R	6301	181	414-24-3	5755	180
374102	229	211	411012	738	147	414-16-4-24	6661	181	414-24-3-18	7594	180
374105	287	211	411013	799	147	414-16-4-24L	6343	181	414-24-3-18L	7589	180
374136	51	64	411014	857	147	414-16-4-24R	6343	181	414-24-3-18R	7589	180
374955	41	174	411030	380	147	414-18-1	2709	178	414-24-3-24	7929	180
375612	406	174	411036	384	147	414-18-1-18	3792	178	414-24-3-24L	7696	180
375952	19	263	411048	415	147	414-18-1-18L	3488	178	414-24-3-24R	7696	180
376509	211	168	411060	453	147	414-18-1-18R	3488	178	414-24-4	7387	181
376740	66	173	411072	513	147	414-18-1-24	3827	178	414-24-4-18	9552	181
377430	522	199	411084	573	147	414-18-1-24L	3514	178	414-24-4-18L	9077	181
377455	315	174	411096	631	147	414-18-1-24R	3514	178	414-24-4-18R	9077	181
377456	315	174	411210	722	147	414-18-2	3646	179	414-24-4-24	9987	181
377563	1131	173	411212	805	147	414-18-2-18	5043	179	414-24-4-24L	9766	181
379769	6	148,233	411213	862	147	414-18-2-18L	4897	179	414-24-4-24R	9766	181
381136	1902	251	411214	919	147	414-18-2-18R	4897	179	418002	193	147
381137	1842	251	411230	384	147	414-18-2-24	5100	179	418012	200	233
			411236	403	147	414-18-2-24L	4927	179	418202	165	147

# ALPHANUMERIC PRICE INDEX

Part Number	List Price	Page No.	Part Number	List Price	Page No.	Part Number	List Price	Page No.	Part Number	List Price	Page No.
421002	528	233	4TF1860-VG	100	36	606331	393	158,370	812482	119	74
421003	555	233	4TF1860-Z	81	36	606376	657	339	812483	119	74
421004	585	233	500772	336	152	606377	783	339	812484	119	74
421005	743	233	500778	123	296	606378	632	339	812485	119	74
421006	865	233	500779	157	296	606396	259	175	812486	119	74
421010	789	147	500780	201	296	606434	672	328	814361	112	74
421012	841	147	501045	285	296	606479	1036	328	814362	112	74
421013	902	147	501571	474	153	606480	1154	328	814363	112	74
421014	981	147	501572	862	154	606481	1334	328	814364	112	74
421030	415	147	501585	532	231,276	606570	126	354	814365	112	74
421036	427	147	501600	146	232,262	606587	155	354	814366	112	74
421048	472	147	501883	235	296	606588	165	354	814481	124	74
421060	529	147	501884	313	296	606589	89	354	814482	124	74
421072	593	147	501885	412	296	606590	106	354	814483	124	74
421084	651	147	501886	621	296	606593	104	354	814484	124	74
421096	737	147	501912	146	232,262	606594	71	354	814485	124	74
421210	846	147	501913	146	232,262	606595	80	354	814486	124	74
421212	909	147	501914	146	232,262	606598	77	354	816361	118	74
421213	967	147	501915	146	232,262	606599	88	354	816362	118	74
421214	1024	147	502808	1580	231	606641	1323	327	816363	118	74
421230	427	147	502809	853	231	606642	1411	327	816364	118	74
421236	478	147	502941	292	152	606643	1541	327	816365	118	74
421248	499	147	502942	434	153	606644	1632	327	816366	118	74
421260	556	147	502943	828	154	606826	288	154	816481	126	74
421272	629	147	502946	894	154	607560	412	175	816482	126	74
421284	705	147	502947	853	154	608115	229	154	816483	126	74
421296	788	147	502948	344	155	608116	229	154	816484	126	74
421502	754	233	502949	412	155	608117	279	154	816485	126	74
421503	788	233	502950	501	155	608118	241	154	816486	126	74
421504	820	233	502956	241	296	608119	323	154	818361	125	74
421505	1066	233	502957	516	296	609539	137	144,145	818362	125	74
421506	1224	233	502971	1385	154			146	818363	125	74
430002	247	147	502972	1339	154	609540	137	144,146	818364	125	74
430012	257	233	502975	254	152	609541	123	144,146	818365	125	74
430202	181	147	502976	214	152	609542	123	144,146	818366	125	74
4330	3215	355	503006	254	152	609543	142	145,146	818481	137	74
4331	2725	355	503007	214	152	609544	142	146	818482	137	74
4333	2425	355	503010	254	152	611869	259	175	818483	137	74
4337	2532	356	503011	214	152	7QDI-120	891	273	818484	137	74
4338	3022	356	503095	636	196	7QDI-120D	995	273	818485	137	74
4339	3444	356	503096	636	196	7QDI-120T	1069	273	818486	137	74
4340	2720	356	503097	1002	196	7QDI-120TD	1174	273	820361	135	74
448002	326	147	503098	673	196	7QDI-240	891	273	820362	135	74
448012	349	233	503099	673	196	7QDI-240D	995	273	820363	135	74
448202	221	147	503100	1098	196	7QFW-120	828	268	820364	135	74
451CWB-19	788	306	605371	654	328	7QFW-208	828	268	820365	135	74
451CWB-24	968	306	605372	795	328	7QFW-240	828	268	820366	135	74
450CWB-19	788	306	605373	985	328	7QP	120	273	820481	141	74
450CWB-24	968	306	605374	839	328	810361	102	74	820482	141	74
4635	3175	357	605375	935	328	810362	102	74	820483	141	74
4637	4007	357	605376	1156	328	810363	102	74	820484	141	74
4640	3718	357	605380	1323	327	810364	102	74	820485	141	74
4642	4698	357	605381	1411	327	810365	102	74	820486	141	74
4PEK	106	59	605382	1541	327	810366	102	74	901CWB-19	1235	306
4TF1836-BL	81	36	605383	2909	327	810481	107	74	901CWB-24	1268	306
4TF1836-C	76	36	606215	582	175	810482	107	74	900CWB-19	1235	306
4TF1836-V	81	36	606294	1632	327	810483	107	74	900CWB-24	1268	306
4TF1836-VG	81	36	606295	2998	327	810484	107	74	912991	208	62,63
4TF1836-Z	69	36	606296	1049	327	810485	107	74	A1422BL	96	36
4TF1848-BL	87	36	606297	1174	327	810486	107	74	A1422R	96	36
4TF1848-C	83	36	606298	1267	327	812361	108	74	A1422V	96	36
4TF1848-V	87	36	606299	1339	327	812362	108	74	A1422VG	96	36
4TF1848-VG	87	36	606300	1155	327	812363	108	74	A1422W	96	36
4TF1848-Z	76	36	606301	1293	327	812364	108	74	A1424BL	88	36
4TF1860-BL	100	36	606302	1392	327	812365	108	74	A1424R	88	36
4TF1860-C	92	36	606303	1472	327	812366	108	74	A1424V	88	36
4TF1860-V	100	36	606329	269	158,370	812481	119	74	A1424VG	88	36



100 Industrial Boulevard, Clayton, DE 19938-8903 U.S.A.  
 Phone: 800-441-8440 or 302-653-3000. Fax: 302-653-2065  
<http://www.eaglegrp.com>

# ALPHANUMERIC PRICE INDEX

Part Number	List Price	Page No.	Part Number	List Price	Page No.	Part Number	List Price	Page No.	Part Number	List Price	Page No.
A1424W	.88	36	A206218	.13	42	A223748	.21	42	A4-63-1848VG	.577	19
A1430BL	.91	36	A206219	.16	42	A223749	.21	42	A4-63-1848Z	.488	19
A1430R	.91	36	A206220	.18	42	A225208	.23	42	A4-63-1860C	.586	19
A1430V	.91	36	A206221	.22	42	A225494	.6	25	A4-63-1860E	.721	19
A1430VG	.91	36	A206222	.25	42	A225512	.11	25	A4-63-1860S	2162	19
A1436BL	.94	22,36,73	A207016	.52	112	A225513	.13	25	A4-63-1860V	.649	19
A1436C	.91	21,46,71,73	A207199	.27	51	A225514	.18	25	A4-63-1860VG	.649	19
A1436R	.94	22,36,73	A207351	.10	59	A225515	.31	25	A4-63-1860Z	.565	19
A1436V	.94	36	A207562	.39	14	A225516	.33	25	A4-63-1872C	.683	19
A1436VG	.94	36	A208505	.86	55	A225517	.57	25	A4-63-1872E	.808	19
A1436W	.94	22,36,73	A208506	.118	55,348	A225518	.59	25	A4-63-1872S	2528	19
A1436Z	.82	22,73	A208507	.107	55	A225519	.62	25	A4-63-1872V	.766	19
A1448BL	.109	22,73	A208508	.102	55	A226093	.29	51	A4-63-1872VG	.766	19
A1448C	.106	22,46,73	A208513	.60	55,348	A226096	.38	51	A4-63-1872Z	.642	19
A1448R	.109	22,73	A208627	.37	51	A226104	.27	51	A4-63-2124C	.461	19
A1448W	.109	22,73	A208746	.3	42	A226105	.29	51	A4-63-2124E	.563	19
A1448Z	.94	22,73	A208747	.9	42	A227763	.20	42	A4-63-2124S	1652	19
A1836BL	.99	22,73	A208749	.13	42	A227764	.20	42	A4-63-2124V	.481	19
A1836C	.96	22,73	A208750	.16	42	A227841	.29	42	A4-63-2124VG	.481	19
A1836R	.99	22,73	A208751	.18	42	A227842	.29	42	A4-63-2124Z	.440	19
A1836W	.99	22,73	A208752	.22	42	A228162	.15	112	A4-63-2130C	.491	19
A1836Z	.95	22,73	A208753	.25	42	A2436BL	.122	22,73	A4-63-2130E	.577	19
A1848BL	.119	22,73	A208891	.13	21,74	A2436C	.119	22,46,73	A4-63-2130S	1667	19
A1848C	.116	22,73	A208903	.18	66	A2436R	.122	22,73	A4-63-2130V	.499	19
A1848R	.119	22,73	A208904	.20	66	A2436W	.122	22,73	A4-63-2130VG	.499	19
A1848W	.119	22,73	A208905	.32	66	A2436Z	.111	22,73	A4-63-2130Z	.455	19
A1848Z	.109	22,73	A208906	.39	66	A2448BL	.143	22,73	A4-63-2136C	.499	19
A1860BL	.138	22	A208908	.35	51	A2448R	.143	22,73	A4-63-2136E	.586	19
A1860C	.134	22	A208909	.20	51	A2448W	.143	22,73	A4-63-2136S	1677	19
A1860R	.138	22	A210075	.25	71	A2448Z	.129	22,73	A4-63-2136V	.558	19
A1860W	.138	22	A210098	.23	50	A2460BL	.173	22	A4-63-2136VG	.558	19
A1860Z	.125	22	A210109	.49	71	A2460C	.167	22,46	A4-63-2136Z	.469	19
A200012	.3	51	A210115	.115	71	A2460R	.173	22	A4-63-2142C	.563	19
A200019	.4	14	A212494	.23	42	A2460W	.173	22	A4-63-2142E	.655	19
A200868	.3	59	A213096	.20	42	A2460Z	.156	22	A4-63-2142S	1907	19
A201007	.29	14	A213261	.7	14	A230612	.38	51	A4-63-2142V	.593	19
A201008	.34	14	A2136BL	.116	22,73	A230624	.29	51	A4-63-2142VG	.593	19
A201009	.35	14	A2136C	.112	22,73	A230625	.29	51	A4-63-2142Z	.513	19
A201706	.23	14	A2136R	.116	22,73	A4-63-1824C	.419	19	A4-63-2148C	.573	19
A203078	.33	16	A2136W	.116	22,73	A4-63-1824E	.499	19	A4-63-2148E	.664	19
A203568	.3	51	A2136Z	.103	22,73	A4-63-1824S	.464	19	A4-63-2148S	1916	19
A203841	.4	54	A214169	.17	51	A4-63-1824V	.434	19	A4-63-2148V	.615	19
A203842	.5	54	A2148BL	.133	22,73	A4-63-1824VG	.434	19	A4-63-2148VG	.615	19
A203843	.6	54	A2148C	.126	22,73	A4-63-1824Z	.411	19	A4-63-2148Z	.526	19
A203844	.6	54	A2148R	.133	22,73	A4-63-1830C	.434	19	A4-63-2160C	.649	19
A203845	.5	54	A2148W	.133	22,73	A4-63-1830E	.511	19	A4-63-2160E	.779	19
A203846	.6	54	A2148Z	.119	22,73	A4-63-1830S	.1474	19	A4-63-2160S	2479	19
A203877	.21	105	A2160BL	.155	22	A4-63-1830V	.466	19	A4-63-2160V	.725	19
A203879	.28	105	A2160C	.151	22	A4-63-1830VG	.466	19	A4-63-2160VG	.725	19
A204237	.24	105	A2160R	.155	22	A4-63-1830Z	.421	19	A4-63-2160Z	.618	19
A204318	.2	28	A2160W	.155	22	A4-63-1836C	.442	19	A4-63-2172C	.775	19
A204331	.3	42	A2160Z	.141	22	A4-63-1836E	.534	19	A4-63-2172E	.928	19
A204795	.37	14	A216649	.54	55	A4-63-1836S	1494	19	A4-63-2172S	2904	19
A204942	.7	66	A216650	.46	55	A4-63-1836V	.491	19	A4-63-2172V	.832	19
A205340	.98	155	A216651	.49	55	A4-63-1836VG	.491	19	A4-63-2172VG	.832	19
A205341	.111	155	A217621	.23	42	A4-63-1836VG	.491	19	A4-63-2172Z	.734	19
A205342	.21	155	A217638	.60	54	A4-63-1836Z	.436	19	A4-63-2424C	.495	19
A206196	.9	42	A217760	.6	54	A4-63-1842C	.495	19	A4-63-2424E	.601	19
A206197	.13	42	A217763	.7	54	A4-63-1842E	.606	19	A4-63-2424S	1772	19
A206198	.16	42	A217764	.5	54	A4-63-1842S	1724	19	A4-63-2424V	.506	19
A206199	.18	42	A217765	.47	54	A4-63-1842V	.539	19	A4-63-2424VG	.506	19
A206200	.22	42	A217766	.4	54	A4-63-1842VG	.539	19	A4-63-2424Z	.469	19
A206201	.25	42	A218017	.15	112	A4-63-1842Z	.474	19	A4-63-2430C	.515	19
A206216	.3	42	A219236	.9	51	A4-63-1848C	.515	19	A4-63-2430E	.611	19
A206217	.9	42	A222144	.29	42	A4-63-1848E	.621	19	A4-63-2430S	1787	19
			A223747	.21	42	A4-63-1848S	1739	19	A4-63-2430V	.558	19
						A4-63-1848V	.577	19	A4-63-2430VG	.558	19

# ALPHANUMERIC PRICE INDEX

Part Number	List Price	Page No.	Part Number	List Price	Page No.	Part Number	List Price	Page No.	Part Number	List Price	Page No.
A4-63-2430Z	479	19	A4-74-1872C	689	19	A4-74-2442E	734	19	A5-74-2124S	2048	21
A4-63-2436C	528	19	A4-74-1872E	815	19	A4-74-2442S	2144	19	A5-74-2124V	593	21
A4-63-2436E	626	19	A4-74-1872S	2548	19	A4-74-2442V	635	19	A5-74-2124VG	593	21
A4-63-2436S	1806	19	A4-74-1872V	771	19	A4-74-2442VG	635	19	A5-74-2124Z	545	21
A4-63-2436V	582	19	A4-74-1872VG	771	19	A4-74-2442Z	573	19	A5-74-2130C	607	21
A4-63-2436VG	582	19	A4-74-1872Z	649	19	A4-74-2448C	624	19	A5-74-2130E	714	21
A4-63-2436Z	493	19	A4-74-2124C	469	19	A4-74-2448E	753	19	A5-74-2130S	2066	21
A4-63-2442C	601	19	A4-74-2124E	569	19	A4-74-2448S	2156	19	A5-74-2130V	615	21
A4-63-2442E	725	19	A4-74-2124S	1674	19	A4-74-2448V	698	19	A5-74-2130VG	615	21
A4-63-2442S	2124	19	A4-74-2124V	486	19	A4-74-2448VG	698	19	A5-74-2130Z	563	21
A4-63-2442V	631	19	A4-74-2124VG	486	19	A4-74-2448Z	582	19	A5-74-2136C	619	21
A4-63-2442VG	631	19	A4-74-2124Z	448	19	A4-74-2460C	719	19	A5-74-2136E	724	21
A4-63-2442Z	565	19	A4-74-2130C	497	19	A4-74-2460E	867	19	A5-74-2136S	2078	21
A4-63-2448C	615	19	A4-74-2130E	584	19	A4-74-2460S	2598	19	A5-74-2136V	687	21
A4-63-2448E	746	19	A4-74-2130S	1688	19	A4-74-2460V	808	19	A5-74-2136VG	687	21
A4-63-2448S	2134	19	A4-74-2130V	506	19	A4-74-2460VG	808	19	A5-74-2136Z	581	21
A4-63-2448V	694	19	A4-74-2130VG	506	19	A4-74-2460Z	694	19	A5-74-2142C	698	21
A4-63-2448VG	694	19	A4-74-2130Z	461	19	A4-74-2472C	835	19	A5-74-2142E	809	21
A4-63-2448Z	575	19	A4-74-2136C	508	19	A4-74-2472E	999	19	A5-74-2142S	2366	21
A4-63-2460C	713	19	A4-74-2136E	595	19	A4-74-2472S	3195	19	A5-74-2142V	731	21
A4-63-2460E	861	19	A4-74-2136S	1698	19	A4-74-2472V	938	19	A5-74-2142VG	731	21
A4-63-2460S	2576	19	A4-74-2136V	563	19	A4-74-2472VG	938	19	A5-74-2142Z	635	21
A4-63-2460V	804	19	A4-74-2136VG	563	19	A4-74-2472Z	784	19	A5-74-2148C	709	21
A4-63-2460VG	804	19	A4-74-2136Z	477	19	A5-74-1824C	517	21	A5-74-2148E	821	21
A4-63-2460Z	685	19	A4-74-2142C	569	19	A5-74-1824E	617	21	A5-74-2148S	2379	21
A4-63-2472C	827	19	A4-74-2142E	662	19	A5-74-1824S	1814	21	A5-74-2148V	759	21
A4-63-2472E	991	19	A4-74-2142S	1929	19	A5-74-1824V	531	21	A5-74-2148VG	759	21
A4-63-2472S	3173	19	A4-74-2142V	597	19	A5-74-1824VG	531	21	A5-74-2148Z	654	21
A4-63-2472V	933	19	A4-74-2142VG	597	19	A5-74-1824Z	509	21	A5-74-2160C	806	21
A4-63-2472VG	933	19	A4-74-2142Z	520	19	A5-74-1830C	536	21	A5-74-2160E	965	21
A4-63-2472Z	777	19	A4-74-2148C	580	19	A5-74-1830E	629	21	A5-74-2160S	3083	21
A4-74-1824C	425	19	A4-74-2148E	671	19	A5-74-1830S	1825	21	A5-74-2160V	898	21
A4-74-1824E	508	19	A4-74-2148S	1938	19	A5-74-1830V	574	21	A5-74-2160VG	898	21
A4-74-1824S	1487	19	A4-74-2148V	621	19	A5-74-1830VG	574	21	A5-74-2160Z	768	21
A4-74-1824V	438	19	A4-74-2148VG	621	19	A5-74-1830Z	521	21	A5-74-2172C	962	21
A4-74-1824VG	438	19	A4-74-2148Z	534	19	A5-74-1836C	547	21	A5-74-2172E	1153	21
A4-74-1824Z	419	19	A4-74-2160C	657	19	A5-74-1836E	660	21	A5-74-2172S	3612	21
A4-74-1830C	440	19	A4-74-2160E	786	19	A5-74-1836S	1849	21	A5-74-2172V	1032	21
A4-74-1830E	517	19	A4-74-2160S	2502	19	A5-74-1836V	603	21	A5-74-2172VG	1032	21
A4-74-1830S	1496	19	A4-74-2160V	732	19	A5-74-1836VG	603	21	A5-74-2172Z	912	21
A4-74-1830V	472	19	A4-74-2160VG	732	19	A5-74-1836Z	539	21	A5-74-2424C	613	21
A4-74-1830VG	472	19	A4-74-2160Z	626	19	A5-74-1842C	613	21	A5-74-2424E	743	21
A4-74-1830Z	427	19	A4-74-2172C	782	19	A5-74-1842E	749	21	A5-74-2424S	2198	21
A4-74-1836C	451	19	A4-74-2172E	935	19	A5-74-1842S	2138	21	A5-74-2424V	622	21
A4-74-1836E	542	19	A4-74-2172S	2924	19	A5-74-1842V	664	21	A5-74-2424VG	622	21
A4-74-1836S	1516	19	A4-74-2172V	837	19	A5-74-1842VG	664	21	A5-74-2424Z	581	21
A4-74-1836V	495	19	A4-74-2172VG	837	19	A5-74-1842Z	586	21	A5-74-2430C	637	21
A4-74-1836VG	495	19	A4-74-2172Z	741	19	A5-74-1848C	637	21	A5-74-2430E	755	21
A4-74-1836Z	442	19	A4-74-2424C	502	19	A5-74-1848E	768	21	A5-74-2430S	2216	21
A4-74-1842C	502	19	A4-74-2424E	608	19	A5-74-1848S	2157	21	A5-74-2430V	687	21
A4-74-1842E	613	19	A4-74-2424S	1794	19	A5-74-1848V	713	21	A5-74-2430VG	687	21
A4-74-1842S	1747	19	A4-74-2424V	511	19	A5-74-1848VG	713	21	A5-74-2430Z	594	21
A4-74-1842V	544	19	A4-74-2424VG	511	19	A5-74-1848Z	604	21	A5-74-2436C	656	21
A4-74-1842VG	544	19	A4-74-2424Z	477	19	A5-74-1860C	726	21	A5-74-2436E	774	21
A4-74-1842Z	481	19	A4-74-2430C	522	19	A5-74-1860E	894	21	A5-74-2436S	2241	21
A4-74-1848C	522	19	A4-74-2430E	618	19	A5-74-1860S	2685	21	A5-74-2436V	718	21
A4-74-1848E	628	19	A4-74-2430S	1808	19	A5-74-1860V	802	21	A5-74-2436VG	718	21
A4-74-1848S	1760	19	A4-74-2430V	563	19	A5-74-1860VG	802	21	A5-74-2436Z	611	21
A4-74-1848V	582	19	A4-74-2430VG	563	19	A5-74-1860Z	701	21	A5-74-2442C	746	21
A4-74-1848VG	582	19	A4-74-2430Z	486	19	A5-74-1872C	847	21	A5-74-2442E	899	21
A4-74-1848Z	495	19	A4-74-2436C	537	19	A5-74-1872E	1002	21	A5-74-2442S	2637	21
A4-74-1860C	595	19	A4-74-2436E	633	19	A5-74-1872S	3142	21	A5-74-2442V	778	21
A4-74-1860E	729	19	A4-74-2436S	1827	19	A5-74-1872V	946	21	A5-74-2442VG	778	21
A4-74-1860S	2185	19	A4-74-2436V	586	19	A5-74-1872VG	946	21	A5-74-2442Z	701	21
A4-74-1860V	655	19	A4-74-2436VG	586	19	A5-74-1872Z	797	21	A5-74-2448C	762	21
A4-74-1860VG	655	19	A4-74-2436Z	499	19	A5-74-2124C	572	21	A5-74-2448E	924	21
A4-74-1860Z	573	19	A4-74-2442C	608	19	A5-74-2124E	696	21	A5-74-2448S	2649	21



100 Industrial Boulevard, Clayton, DE 19938-8903 U.S.A.  
Phone: 800-441-8440 or 302-653-3000. Fax: 302-653-2065  
<http://www.eaglegrp.com>

# ALPHANUMERIC PRICE INDEX

Part Number	List Price	Page No.	Part Number	List Price	Page No.	Part Number	List Price	Page No.	Part Number	List Price	Page No.
A5-74-2448V	857	21	A5-86-2130VG	635	21	A5-86-2460Z	867	21	ASFT-1896-SG	9339	208
A5-74-2448VG	857	21	A5-86-2130Z	580	21	A5-86-2472C	1045	21	ASFT-1860-FG	4683	208
A5-74-2448Z	714	21	A5-86-2136C	636	21	A5-86-2472E	1231	21	ASFT-1860-SG	6746	208
A5-74-2460C	884	21	A5-86-2136E	724	21	A5-86-2472S	3948	21	ASFT-1872-FG	5234	208
A5-74-2460E	1068	21	A5-86-2136S	2078	21	A5-86-2472V	1177	21	ASFT-1872-SG	7451	208
A5-74-2460S	3203	21	A5-86-2136V	707	21	A5-86-2472VG	1177	21	ASFT-24120-FG	8520	208
A5-74-2460V	995	21	A5-86-2136VG	707	21	A5-86-2472Z	982	21	ASFT-24120-SG	13174	208
A5-74-2460VG	995	21	A5-86-2136Z	598	21	ADD-A-CLAMP	13	12,23	ASFT-2424-FG	3279	208
A5-74-2460Z	853	21	A5-86-2142C	715	21	ADD-A-CLAMP-BL	17	12,23	ASFT-2424-SG	4800	208
A5-74-2472C	1029	21	A5-86-2142E	809	21	APS2	507	143	ASFT-2430-FG	3697	208
A5-74-2472E	1231	21	A5-86-2142S	2366	21	APS3	574	143	ASFT-2430-SG	5560	208
A5-74-2472S	3948	21	A5-86-2142V	749	21	APS4	631	143	ASFT-2436-FG	3984	208
A5-74-2472V	1157	21	A5-86-2142VG	749	21	APS5	699	143	ASFT-2436-SG	5774	208
A5-74-2472VG	1157	21	A5-86-2142Z	652	21	APS6	761	143	ASFT-2448-FG	4677	208
A5-74-2472Z	965	21	A5-86-2148C	725	21	APS7	953	143	ASFT-2448-SG	6752	208
A5-86-1824C	534	21	A5-86-2148E	821	21	APS8	1103	143	ASFT-2460-FG	5359	208
A5-86-1824E	617	21	A5-86-2148S	2379	21	ASFT-12120-FG	6287	208	ASFT-2460-SG	7629	208
A5-86-1824S	1814	21	A5-86-2148V	779	21	ASFT-12120-SG	10838	208	ASFT-2472-FG	5412	208
A5-86-1824V	551	21	A5-86-2148VG	779	21	ASFT-1218-FG	2577	208	ASFT-2472-SG	8893	208
A5-86-1824VG	551	21	A5-86-2148Z	669	21	ASFT-1218-SG	3574	208	ASFT-2484-FG	6741	208
A5-86-1824Z	525	21	A5-86-2160C	823	21	ASFT-1224-FG	2796	208	ASFT-2484-SG	9773	208
A5-86-1830C	552	21	A5-86-2160E	965	21	ASFT-1224-SG	3589	208	ASFT-2496-FG	7373	208
A5-86-1830E	629	21	A5-86-2160S	3083	21	ASFT-1230-FG	3069	208	ASFT-2496-SG	10842	208
A5-86-1830S	1825	21	A5-86-2160V	918	21	ASFT-1230-SG	3754	208	ASWTFT-1215-FGG	12933	210
A5-86-1830V	594	21	A5-86-2160VG	918	21	ASFT-1236-FG	3214	208	ASWTFT-1215-SG	14174	210
A5-86-1830VG	594	21	A5-86-2160Z	784	21	ASFT-1236-SG	3919	208	ASWTFT-1218-FGG	13224	210
A5-86-1830Z	538	21	A5-86-2172C	979	21	ASFT-1248-FG	3688	208	ASWTFT-1218-SG	14264	210
A5-86-1836C	564	21	A5-86-2172E	1153	21	ASFT-1248-SG	4879	208	ASWTFT-1224-FGG	13454	210
A5-86-1836E	660	21	A5-86-2172S	3612	21	ASFT-1260-FG	3994	208	ASWTFT-1224-SG	14283	210
A5-86-1836S	1849	21	A5-86-2172V	1049	21	ASFT-1260-SG	5875	208	ASWTFT-1230-FGG	13739	210
A5-86-1836V	624	21	A5-86-2172VG	1049	21	ASFT-1272-FG	4514	208	ASWTFT-1230-SG	14454	210
A5-86-1836VG	624	21	A5-86-2172Z	928	21	ASFT-1272-SG	6783	208	ASWTFT-1236-FGG	13891	210
A5-86-1836Z	556	21	A5-86-2424C	631	21	ASFT-1284-FG	4938	208	ASWTFT-1236-SG	14627	210
A5-86-1842C	631	21	A5-86-2424E	743	21	ASFT-1284-SG	7963	208	ASWTFT-1248-FGG	14385	210
A5-86-1842E	749	21	A5-86-2424S	2198	21	ASFT-1296-FG	5388	208	ASWTFT-1248-SG	15631	210
A5-86-1842S	2138	21	A5-86-2424V	641	21	ASFT-1296-SG	8294	208	ASWTFT-1260-FGG	14705	210
A5-86-1842V	683	21	A5-86-2424VG	641	21	ASFT-15120-FG	6633	208	ASWTFT-1260-SG	16672	210
A5-86-1842VG	683	21	A5-86-2424Z	598	21	ASFT-15120-SG	11380	208	ASWTFT-1272-FGG	15247	210
A5-86-1842Z	603	21	A5-86-2430C	655	21	ASFT-1524-FG	2853	208	ASWTFT-1272-SG	17618	210
A5-86-1848C	655	21	A5-86-2430E	755	21	ASFT-1524-SG	3472	208	ASWTFT-1284-FGG	15694	210
A5-86-1848E	768	21	A5-86-2430S	2216	21	ASFT-1530-FG	3095	208	ASWTFT-1284-SG	18854	210
A5-86-1848S	2157	21	A5-86-2430V	707	21	ASFT-1530-SG	3857	208	ASWTFT-1296-FGG	16162	210
A5-86-1848V	732	21	A5-86-2430VG	707	21	ASFT-1536-FG	3242	208	ASWTFT-1296-SG	19198	210
A5-86-1848VG	732	21	A5-86-2430Z	609	21	ASFT-1536-SG	4484	208	ASWTFT-1518-FGG	13194	210
A5-86-1848Z	622	21	A5-86-2436C	672	21	ASFT-1548-FG	3733	208	ASWTFT-1518-SG	13512	210
A5-86-1860C	744	21	A5-86-2436E	774	21	ASFT-1548-SG	5397	208	ASWTFT-1524-FGG	13512	210
A5-86-1860E	894	21	A5-86-2436S	2241	21	ASFT-1560-FG	4175	208	ASWTFT-1524-SG	14160	210
A5-86-1860S	2685	21	A5-86-2436V	738	21	ASFT-1560-SG	5965	208	ASWTFT-1530-FGG	13766	210
A5-86-1860V	821	21	A5-86-2436VG	738	21	ASFT-1572-FG	4603	208	ASWTFT-1530-SG	14562	210
A5-86-1860VG	821	21	A5-86-2436Z	628	21	ASFT-1572-SG	7294	208	ASWTFT-1536-FGG	13919	210
A5-86-1860Z	718	21	A5-86-2442C	761	21	ASFT-1584-FG	5075	208	ASWTFT-1536-SG	15218	210
A5-86-1872C	864	21	A5-86-2442E	899	21	ASFT-1584-SG	8298	208	ASWTFT-1548-FGG	14434	210
A5-86-1872E	1002	21	A5-86-2442S	2637	21	ASFT-1596-FG	5480	208	ASWTFT-1548-SG	16171	210
A5-86-1872S	3142	21	A5-86-2442V	797	21	ASFT-1596-SG	9148	208	ASWTFT-1560-FGG	14893	210
A5-86-1872V	965	21	A5-86-2442VG	797	21	ASFT-18120-FG	7731	208	ASWTFT-1560-SG	16765	210
A5-86-1872VG	965	21	A5-86-2442Z	718	21	ASFT-18120-SG	12301	208	ASWTFT-1572-FGG	15343	210
A5-86-1872Z	814	21	A5-86-2448C	780	21	ASFT-1824-FG	3062	208	ASWTFT-1572-SG	17618	210
A5-86-2124C	588	21	A5-86-2448E	924	21	ASFT-1824-SG	4007	208	ASWTFT-1584-FGG	15836	210
A5-86-2124E	696	21	A5-86-2448S	2649	21	ASFT-1830-FG	3382	208	ASWTFT-1584-SG	19224	210
A5-86-2124S	2048	21	A5-86-2448V	875	21	ASFT-1830-SG	4277	208	ASWTFT-1596-FGG	16259	210
A5-86-2124V	611	21	A5-86-2448VG	875	21	ASFT-1836-FG	3622	208	ASWTFT-1596-SG	20092	210
A5-86-2124VG	611	21	A5-86-2448Z	731	21	ASFT-1836-SG	4548	208	ASWTFT-1824-FGG	13733	210
A5-86-2124Z	561	21	A5-86-2460C	900	21	ASFT-1848-FG	4194	208	ASWTFT-1824-SG	14719	210
A5-86-2130C	625	21	A5-86-2460E	1068	21	ASFT-1848-SG	5457	208	ASWTFT-1830-FGG	14065	210
A5-86-2130E	714	21	A5-86-2460S	3203	21	ASFT-1884-FG	5848	208	ASWTFT-1830-SG	15000	210
A5-86-2130S	2066	21	A5-86-2460V	1014	21	ASFT-1884-SG	9011	208	ASWTFT-1836-FGG	14317	210
A5-86-2130V	635	21	A5-86-2460VG	1014	21	ASFT-1896-FG	6382	208	ASWTFT-1836-SG	15284	210

100 Industrial Boulevard, Clayton, DE 19938-8903 U.S.A.  
 Phone: 800-441-8440 or 302-653-3000. Fax: 302-653-2065  
<http://www.eaglegrp.com>





# ALPHANUMERIC PRICE INDEX

Part Number	List Price	Page No.	Part Number	List Price	Page No.	Part Number	List Price	Page No.	Part Number	List Price	Page No.
ASWTFT-1848-FGG	14916	210	B181CPT	2684	295	B361C-24	2421	299	B5-3-L-19	3551	303
ASWTFT-1848-SG	16235	210	B181CPT-7	5139	295	B3CT-12D-18	1908	283	B5-3-L-24	3714	303
ASWTFT-1860-FGG	15426	210	B2-2-19	2367	303	B3CT-12D-18-7	3579	283	B5-3-LR-19	3634	303
ASWTFT-1860-SG	17581	210	B2-2-24	2451	303	B3CT-12D-22	1908	289	B5-3-LR-24	3784	303
ASWTFT-1872-FGG	16001	210	B201023	18	59	B3CT-12D-22-7	3579	289	B5-3-R-19	3551	303
ASWTFT-1872-SG	18317	210	B2136C	359	47	B3CT-16D-18	2458	283	B5-3-R-24	3714	303
ASWTFT-1884-FGG	16644	210	B2148C	420	47	B3CT-16D-18-7	4128	283	B5-3-R-19	3551	303
ASWTFT-1884-SG	19946	210	B241C-19	1738	299	B3CT-16D-22	2458	289	B5.5-3-L-19	3673	303
ASWTFT-1896-FGG	17201	210	B241C-24	1973	299	B3CT-16D-22-7	4128	289	B5.5-3-L-24	3859	303
ASWTFT-1896-SG	20292	210	B241CPT	2822	295	B3CT-18	1563	283	B5.5-3-R-19	3673	303
ASWTFT-2424-FGG	13959	210	B241CPT-7	5012	295	B3CT-18-7	3233	283	B5.5-3-R-24	3859	303
ASWTFT-2424-SG	15547	210	B24PTIC	2963	301	B3CT-22	1563	289	B5.5L-4-19	4143	304
ASWTFT-2430-FGG	14396	210	B281C-22	1557	290	B3CT-22-7	3233	289	B5.5L-4-24	4336	304
ASWTFT-2430-SG	16341	210	B281C-22-7	3509	290	B3L-2-18	1741	281	B5.5R-4-19	4143	304
ASWTFT-2436-FGG	14695	210	B2CT-12D-18	1574	283	B3L-2-22	1842	287	B5.5R-4-24	4336	304
ASWTFT-2436-SG	16565	210	B2CT-12D-18-7	3175	283	B3R-2-18	1741	281	B5C-18	2043	281
ASWTFT-2448-FGG	15419	210	B2CT-12D-22	1574	289	B3R-2-22	1842	287	B5C-22	2192	287
ASWTFT-2448-SG	17585	210	B2CT-12D-22-7	3175	289	B4-3-L-19	3309	303	B5L-18	2043	281
ASWTFT-2460-FGG	16131	210	B2CT-16D-18	2018	283	B4-3-L-24	3431	303	B5L-22	2192	287
ASWTFT-2460-SG	18505	210	B2CT-16D-18-7	3618	283	B4-3-R-19	3309	303	B5L-4-19	4021	304
ASWTFT-2472-FGG	16187	210	B2CT-16D-22	2018	289	B4-3-R-24	3431	303	B5L-4-24	4193	304
ASWTFT-2472-SG	19824	210	B2CT-16D-22-7	3618	289	B4-4-19	3697	304	B5R-18	2043	281
ASWTFT-2484-FGG	17576	210	B2CT-18	1296	283	B4-4-24	3838	304	B5R-22	2192	287
ASWTFT-2484-SG	20744	210	B2CT-18-7	2895	283	B40CT-12D-22	2817	289	B5R-4-19	4021	304
ASWTFT-2496-FGG	18236	210	B2CT-22	1296	289	B40CT-12D-22-7	4484	289	B5R-4-24	4193	304
ASWTFT-2496-SG	21861	210	B2CT-22-7	2895	289	B40CT-16D-22	3366	289	B6-3-L-19	3878	303
ASH2	3257	256	B21C-12D-18	1938	284	B40CT-16D-22-7	5034	289	B6-3-L-24	4073	303
ASH3	3638	256	B21C-12D-18-7	3791	284	B40CT-22	2472	289	B6-3-LR-19	3878	303
ASH4	4224	256	B21C-12D-22	1938	290	B40CT-22-7	5234	289	B6-3-LR-24	4073	303
ASH5	5476	256	B21C-12D-22-7	3791	290	B421C-12D-18	2608	284	B6-3-R-19	3878	303
ASH6	6056	256	B21C-16D-18	2382	284	B421C-12D-18-7	4461	284	B6-3-R-24	4073	303
AWT2-LP	2815	223	B21C-16D-18-7	4233	284	B421C-12D-22	2608	290	B6C-18	2159	281
AWT2-NG	2815	223	B21C-16D-22	2382	290	B421C-12D-22-7	4461	290	B6C-22	2306	287
AWT3-LP	3143	223	B21C-16D-22-7	4233	290	B421C-16D-18	3207	284	B6C-4-18	2546	281
AWT3-NG	3143	223	B21C-18	1657	284	B421C-16D-18-7	5059	284	B6C-4-22	2715	287
AWT4-LP	3977	223	B21C-18-7	3509	284	B421C-16D-22	3207	290	B6L-4-19	4263	304
AWT4-LP-1	3977	223	B21C-22	1657	290	B421C-16D-22-7	5059	290	B6L-4-24	4479	304
AWT4-NG	3977	223	B21C-22-7	3509	290	B421C-18	2229	284	B6R-4-19	4263	304
AWT4-NG-1	3977	223	B3-3-19	2981	303	B421C-18-7	4081	284	B6R-4-24	4479	304
AWT5-LP	4764	223	B3-3-24	3074	303	B421C-19	2349	299	B6R-4-19	4349	304
AWT5-NG	4764	223	B301C-12D-18	2161	284	B421C-22	2229	290	B6RL-4-24	4551	304
AWTP2-LP	3205	223	B301C-12D-18-7	4014	284	B421C-22-7	4081	290	B7-3-LR-19	4123	303
AWTP2-NG	3205	223	B301C-12D-22	2161	290	B421C-24	2644	299	B7-3-LR-24	4358	303
AWTP3-LP	3819	223	B301C-12D-22-7	4014	290	B481C-12D-18	2827	284	B7C-18	2399	281
AWTP3-NG	3819	223	B301C-16D-18	2656	284	B481C-12D-18-7	4679	284	B7C-22	2565	287
AWTP4-LP	4900	223	B301C-16D-18-7	4508	284	B481C-12D-22	2827	290	B7C-4-18	2712	281
AWTP4-LP-1	4900	223	B301C-16D-22	2656	290	B481C-12D-22-7	4679	290	B7C-4-22	2902	287
AWTP4-NG	4900	223	B301C-16D-22-7	4508	290	B481C-16D-18	3659	284	B7RL-4-19	4595	304
AWTP4-NG-1	4900	223	B301C-18	1845	284	B481C-16D-18-7	5511	284	B7RL-4-24	4838	304
AWTP5-LP	5940	223	B301C-18-7	3698	284	B481C-16D-22	3659	290	B8-3-LR-19	4366	303
AWTP5-NG	5940	223	B301C-19	1941	299	B481C-16D-22-7	5511	290	B8-3-LR-24	4642	303
B121C-12D-18	1492	284	B301C-22	1845	290	B481C-18	2417	284	B8C-18	2624	281
B121C-12D-22	1492	290	B301C-22-7	3698	290	B481C-18-7	4267	284	B8C-22	2815	287
B121C-16D-18	1837	284	B301C-24	2195	299	B481C-19	2551	299	B8C-4-18	2949	281
B121C-16D-22	1837	290	B361C-12D-18	2383	284	B481C-22	2417	290	B8C-4-22	3141	287
B121C-18	1275	284	B361C-12D-18-7	4234	284	B481C-22-7	4267	290	B8RL-4-19	4838	304
B121C-19	1328	299	B361C-12D-22	2383	290	B481C-24	2869	299	B8RL-4-24	4865	304
B121C-22	1275	290	B361C-12D-22-7	4234	290	B4C-2-18	1766	281	BBT-5	51	350
B121C-24	1524	299	B361C-16D-18	2933	284	B4C-2-22	1895	287	BBT-7	52	350
B181C-12D-18	1712	284	B361C-16D-18-7	4784	284	B4L-18	1985	281	BC-1	7253	221
B181C-12D-22	1712	290	B361C-16D-22	2933	290	B4L-2-18	1766	281	BC10-4C-22 R&L	5085	288
B181C-16D-18	2105	284	B361C-16D-22-7	4784	290	B4L-2-22	1895	287	BC10C-18L	3783	282
B181C-16D-22	2105	290	B361C-18	2038	284	B4L-22	2099	287	BC10C-18R	3783	282
B181C-18	1464	284	B361C-18-7	3889	284	B4R-18	1985	281	BC10C-22 R&L	4665	288
B181C-19	1533	299	B361C-19	2142	299	B4R-2-18	1766	281	BC10C-22L	4005	288
B181C-22	1464	290	B361C-22	2038	290	B4R-2-22	1895	287	BC10C-22R	4005	288
B181C-24	1748	299	B361C-22-7	3889	290	B4R-22	2099	287	BC7C-18L	3104	282
									BC7C-18R	3104	282



100 Industrial Boulevard, Clayton, DE 19938-8903 U.S.A.  
 Phone: 800-441-8440 or 302-653-3000. Fax: 302-653-2065  
<http://www.eaglegrp.com>

# ALPHANUMERIC PRICE INDEX

Part Number	List Price	Page No.	Part Number	List Price	Page No.	Part Number	List Price	Page No.	Part Number	List Price	Page No.
BC7C-22L	3317	288	BEV3060SEM-10BS/L	7539	136	BM62-22L	4069	291	BRW4-S	892	145
BC7C-22R	3317	288	BEV3060SEM-10BS/R	7539	136	BM62-22L-7	5740	291	BRW5	776	145
BC8-4C-22L	3920	288	BEV3072SE-10BS/L	7627	136	BM62-22R	4069	291	BRW5-S	1011	145
BC8-4C-22R	3920	288	BEV3072SE-10BS/R	7627	136	BM62-22R-7	5740	291	BRW6	792	145
BC8C-18L	3214	282	BEV3072SEM-10BS/L	8024	136	BPCP-2	4653	235	BRW6-S	1033	145
BC8C-18R	3214	282	BEV3072SEM-10BS/R	8024	136	BPCP-3	5329	235	BRW7	1040	145
BC8C-22L	3428	288	BEV3084SE-10BS/L	8848	136	BPCP-4	5649	235	BRW7-S	1354	145
BC8C-22R	3428	288	BEV3084SE-10BS/R	8848	136	BPD-1826-A	445	351	BRW8	1047	145
BC9-4C-22L	4088	288	BEV3084SEM-10BS/L	9317	136	BPDHT2-120	5573	234	BRW8-S	1364	145
BC9-4C-22R	4088	288	BEV3084SEM-10BS/R	9317	136	BPDHT2-208	5573	234	BS1-HT2	1134	228
BC9C-18L	3541	282	BEV3096SE-10BS/L	9269	136	BPDHT2-208-3	6401	234	BS1-HT2-IL	1740	228
BC9C-18R	3541	282	BEV3096SE-10BS/R	9269	136	BPDHT2-240	5573	234	BS1-HT3	1308	228
BC9C-22 R&L	4543	288	BEV3096SEM-10BS/L	9756	136	BPDHT2-240-3	6401	234	BS1-HT3-IL	1902	228
BC9C-22L	3757	288	BEV3096SEM-10BS/R	9756	136	BPDHT3-120	6273	234	BS1-HT4	1461	228
BC9C-22R	3757	288	BH-1	178	105	BPDHT3-208	6273	234	BS1-HT4-IL	2536	228
BCT24L-19	2425	300	BM1220FW-120	720	274	BPDHT3-208-3	7163	234	BS1-HT5	1595	228
BCT24R-19	2425	300	BM1220FW-120-D	777	274	BPDHT3-240	6273	234	BS1-HT5-IL	2951	228
BCT30L-19	2633	300	BM1220FW-120I	866	274	BPDHT3-240-3	7163	234	BS1-HT6	2107	228
BCT30L-24	3023	300	BM1220FW-120I-D	936	274	BPDHT4-120	7078	234	BS1-HT6-IL	3006	228
BCT30R-19	2633	300	BM1220FW-120T	717	274	BPDHT4-208	7078	234	BS14-19	1876	309
BCT30R-24	3023	300	BM1220FW-120T-D	818	274	BPDHT4-208-3	8039	234	BS14-24	2083	309
BCT36L-19	2837	300	BM1220FW-120TI	849	274	BPDHT4-240	7078	234	BS18-19	1989	309
BCT36L-24	3245	300	BM1220FW-120TI-D	936	274	BPDHT4-240-3	8039	234	BS18-24	2186	309
BCT36R-19	2837	300	BM1220FW-240	743	274	BPST-2	4049	235	BS2-HT2	1199	228
BCT36R-24	3245	300	BM1220FW-240-D	800	274	BPST-3	4446	235	BS2-HT2-IL	1820	228
BCT42L-19	3040	300	BM1220FW-240I	912	274	BPST-4	5073	235	BS2-HT3	1366	228
BCT42L-24	3469	300	BM1220FW-240I-D	978	274	BR3-19	167	299	BS2-HT3-IL	1954	228
BCT42R-19	3040	300	BM1220FW-240T	717	274	BR4-24	197	299	BS2-HT4	1517	228
BCT42R-24	3469	300	BM1220FW-240T-D	818	274	BR6-12-19	285	299	BS2-HT4-IL	2601	228
BCT48-19	3882	300	BM1220FW-240T6	717	274	BR6-18-19	285	299	BS2-HT5	1665	228
BCT48-24	4512	300	BM1220FW-240T6-D	818	274	BR6-24-19	285	299	BS2-HT5-IL	3022	228
BCT48L-19	3257	300	BM1220FW-240TI	849	274	BR6-30-19	285	299	BS2-HT6	2174	228
BCT48L-24	3697	300	BM1220FW-240TI-D	936	274	BR6-36-19	285	299	BS2-HT6-IL	3071	228
BCT48R-19	3257	300	BM1220FW-240TI6	849	274	BR6-42-19	285	299	BSH2	4336	256
BCT48R-24	3697	300	BM1220FW-240TI6-D	936	274	BR6-48-19	285	299	BSH3	4580	256
BCT54-19	4093	300	BM1220FW-277T	717	274	BR8-12-24	329	299	BSH4	4863	256
BCT54-24	4734	300	BM1220FW-277T-D	818	274	BR8-18-24	329	299	BSH5	6473	256
BCT60-19	4297	300	BM1220FW-277TI	849	274	BR8-24-24	329	299	BSH6	7705	256
BCT60-24	4961	300	BM1220FW-277TI-D	936	274	BR8-30-24	329	299	BT24108S	4306	146
BD18-19	968	308	BM3-18L	2147	285	BR8-36-24	329	299	BT24120S	4583	146
BD18-24	1074	308	BM3-18L-7	4601	285	BR8-42-24	329	299	BT2436S	1904	146
BD24-18L	1952	285	BM3-18R	2147	285	BR8-48-24	329	299	BT2448S	2295	146
BD24-18R	1952	285	BM3-18R-7	4601	285	BRC4	699	145	BT2460S	2672	146
BD24-19	1074	308	BM3-22L	2405	291	BRC4-S	909	145	BT2472S	3099	146
BD24-22L	2242	291	BM3-22L-7	5035	291	BRC5	792	145	BT2484S	3533	146
BD24-22R	2242	291	BM3-22R	2405	291	BRC5-S	1033	145	BT2496S	3986	146
BD24-24	1178	308	BM3-22R-7	5035	291	BRC6	811	145	BT30108S	4811	146
BD30-19	1178	308	BM50-18L	2913	285	BRC6-S	1056	145	BT30120S	5055	146
BD30-24	1276	308	BM50-18L-7	5368	285	BRC7	1056	145	BT3036S	2247	146
BDBS12-19	1022	309	BM50-18R	2913	285	BRC7-S	1376	145	BT3048S	2529	146
BDBS12-24	1085	309	BM50-18R-7	5368	285	BRC8	1067	145	BT3060S	3029	146
BDBS18-19	1206	309	BM50-22L	3357	291	BRC8-S	1388	145	BT3072S	3419	146
BDBS18-24	1268	309	BM50-22L-7	5527	291	BRM-24	2532	313	BT3084S	3733	146
BEV30120SE-10BS/L	13912	136	BM50-22R	3357	291	BRM-24CT	1034	313	BT3096S	4403	146
BEV30120SE-10BS/R	13912	136	BM50-22R-7	5527	291	BRM-CTLC-24	532	313	BT36108S	5538	146
BEV30120SEM-10BS/L	14643	136	BM50L-18R	2913	285	BRM-LC-24	738	313	BT36120S	6263	146
BEV30120SEM-10BS/R	14643	136	BM50L-18R-7	5368	285	BRT4	713	145	BT3636S	2420	146
BEV30144SE-10BS/L	14777	136	BM50L-22R	3357	291	BRT4-S	927	145	BT3648S	3053	146
BEV30144SE-10BS/R	14777	136	BM50L-22R-7	5527	291	BRT5	805	145	BT3660S	3604	146
BEV30144SEM-10BS/L	15556	136	BM50R-18L	2913	285	BRT5-S	1047	145	BT3672S	4014	146
BEV30144SEM-10BS/R	15556	136	BM50R-18L-7	5368	285	BRT6	819	145	BT3684S	4448	146
BEV3048SE-10BS/L	6754	136	BM50R-22L	3357	291	BRT6-S	1066	145	BT3696S	5059	146
BEV3048SE-10BS/R	6754	136	BM50R-22L-7	5527	291	BRT7	1087	145	BT4B-DT	4258	310
BEV3048SEM-10BS/L	7104	136	BM62-18L	3828	285	BRT7-S	1417	145	BT4S-DT	2293	310
BEV3048SEM-10BS/R	7104	136	BM62-18L-7	5496	285	BRT8	1089	145	BT5B-DT	4649	310
BEV3060SE-10BS/L	7163	136	BM62-18R	3828	285	BRT8-S	1419	145	BT5S-DT	2686	310
BEV3060SE-10BS/R	7163	136	BM62-18R-7	5496	285	BRW4	684	145	BW-2-120	578	266

# ALPHANUMERIC PRICE INDEX

Part Number	List Price	Page No.	Part Number	List Price	Page No.	Part Number	List Price	Page No.	Part Number	List Price	Page No.
BW-2-120I	700	266	CBH2448SE	4652	133	CC2136C-SR	897	33	CC2460Z-SRP	1182	33
BW1436BL	2880	27	CBH2448SE-BS	4683	135	CC2136C-SRP	971	33	CCP-2	4271	235
BW1436BL-SC	4366	27	CBH2460SE	4961	133	CC2136Z-S	809	33	CCP-3	4840	235
BW1436C	2794	27	CBH2460SE-BS	4995	135	CC2136Z-SB	823	33	CCP-4	4994	235
BW1436C-SC	4235	27	CBH2472SE	5264	133	CC2136Z-SBP	885	33	CCS-60-1	7412	310
BW1448BL	3686	27	CBH2472SE-BS	5313	135	CC2136Z-SP	828	33	CCS-60-2	6931	310
BW1448BL-SC	5144	27	CBH2484SE	5923	133	CC2136Z-SR	873	33	CCS-66-1	7692	310
BW1448C	3576	27	CBH2484SE-BS	5980	135	CC2136Z-SRP	945	33	CCS-66-2	7212	310
BW1448C-SC	4991	27	CBH2496SE	6353	133	CC2148C-S	954	33	CCS-66-3	7033	310
BWBS12-19	1686	309	CBH2496SE-BS	6418	135	CC2148C-SB	964	33	CCS-66-4	7675	310
BWBS12-24	1876	309	CBH30120SE	7527	133	CC2148C-SBP	1031	33	CCS-72	8480	310
BWBS14-19	1757	309	CBH30120SE-BS	7601	135	CC2148C-SP	1016	33	CCS-72-1	7957	310
BWBS14-24	1959	309	CBH3036SE	4593	133	CC2148C-SR	1015	33	CCS-72-2	7313	310
C314-10-3-12	6004	195	CBH3036SE-BS	4624	135	CC2148C-SRP	1088	33	CD-1	1271	138
C314-16-3-18	7899	195	CBH3048SE	4803	133	CC2148Z-S	902	33	CDHT2-120	4063	234
C314-22-3-18	8568	195	CBH3048SE-BS	4832	135	CC2148Z-SB	914	33	CDHT2-208	4063	234
C314-24-3-24	9260	195	CBH3060SE	5141	133	CC2148Z-SBP	979	33	CDHT2-208-3	4762	234
CA4-SB	479	130,131, 141	CBH3060SE-BS	5174	135	CC2148Z-SP	965	33	CDHT2-240	4063	234
CA6-SB	717	130,131, 141	CBH3072SE	5476	133	CC2148Z-SR	964	33	CDHT2-240-3	4762	234
CA8-SB	958	130	CBH3072SE-BS	5516	135	CC2148Z-SRP	1038	33	CDHT3-120	4753	234
CAH4-SB	635	130,131, 141,143	CBH3084SE	6078	133	CC2160C-S	1087	33	CDHT3-208	4753	234
CAH6-SB	953	130,131, 141,143	CBH3084SE-BS	6134	135	CC2160C-SB	1100	33	CDHT3-208-3	5512	234
CAH8-SB	1271	130	CBH3096SE	6594	133	CC2160C-SBP	1163	33	CDHT3-240	4753	234
CAHP4-SB	549	79,130, 131	CBH3096SE-BS	7051	135	CC2160C-SP	1153	33	CDHT3-240-3	5512	234
CAHP6-SB	825	130,131	CC-S-2	106	230	CC2160C-SR	1152	33	CDHT4-120	5661	234
CAHP8-SB	1099	130	CC-S-10	422	230	CC2160C-SRP	1203	33	CDHT4-208	5661	234
CAHW4-SB	682	79,130, 131	CC-S-60	2364	230	CC2160Z-S	1039	33	CDHT4-208-3	6498	234
CAHW6-SB	1024	130,131	CC1836C-S	749	33	CC2160Z-SB	1052	33	CDHT4-240	5661	234
CAHW8-SB	1364	130	CC1836C-SB	759	33	CC2160Z-SBP	1117	33	CDHT4-240-3	6498	234
CB24120SE	6666	133	CC1836C-SBP	827	33	CC2160Z-SP	1104	33	CDTCIL-108-14/3	6078	319
CB24120SE-BS	6742	135	CC1836C-SP	815	33	CC2160Z-SR	1103	33	CDTCIL-108-16/3	5536	319
CB2436SE	3626	133	CC1836C-SR	809	33	CC2160Z-SRP	1174	33	CDTCIL-108-16/4	5223	319
CB2436SE-BS	3811	135	CC1836C-SRP	882	33	CC2436C-S	843	33	CDTCIL-120-14/3	6872	319
CB2448SE	4056	133	CC1836Z-S	732	33	CC2436C-SB	855	33	CDTCIL-120-16/3	5826	319
CB2448SE-BS	4084	135	CC1836Z-SB	744	33	CC2436C-SBP	922	33	CDTCIL-120-16/4	5498	319
CB2460SE	4357	133	CC1836Z-SBP	807	33	CC2436C-SP	906	33	CDTCIL-48-14/3	4708	319
CB2460SE-BS	4399	135	CC1836Z-SP	795	33	CC2436C-SR	909	33	CDTCIL-48-16/3	4069	319
CB2472SE	4672	133	CC1836Z-SR	791	33	CC2436C-SRP	982	33	CDTCIL-48-16/4	3722	319
CB2472SE-BS	4721	135	CC1836Z-SRP	864	33	CC2436Z-S	817	33	CDTCIL-60-14/3	4849	319
CB2484SE	5341	133	CC1848C-S	847	33	CC2436Z-SB	828	33	CDTCIL-60-16/3	4176	319
CB2484SE-BS	5392	135	CC1848C-SB	863	33	CC2436Z-SBP	845	33	CDTCIL-60-16/4	3827	319
CB2496SE	5771	133	CC1848C-SBP	927	33	CC2436Z-SP	879	33	CDTCIL-72-14/3	5064	319
CB2496SE-BS	5826	135	CC1848C-SR	913	33	CC2436Z-SR	882	33	CDTCIL-72-16/3	4345	319
CB30120SE	6953	133	CC1848C-SP	907	33	CC2436Z-SRP	957	33	CDTCIL-72-16/4	3999	319
CB30120SE-BS	7028	135	CC1848C-SRP	980	33	CC2448C-S	982	33	CDTCIL-96-14/3	5362	319
CB3036SE	3786	133	CC1848Z-S	806	33	CC2448C-SB	998	33	CDTCIL-96-16/3	4574	319
CB3036SE-BS	3936	135	CC1848Z-SB	820	33	CC2448C-SBP	1059	33	CDTCIL-96-16/4	4231	319
CB3048SE	4208	133	CC1848Z-SBP	883	33	CC2448C-SR	1047	33	CDTCIR-108-14/3	6078	319
CB3048SE-BS	4234	135	CC1848Z-SP	872	33	CC2448C-SP	1049	33	CDTCIR-108-16/3	5536	319
CB3060SE	4541	133	CC1848Z-SR	867	33	CC2448C-SRP	1122	33	CDTCIR-108-16/4	5223	319
CB3060SE-BS	4585	135	CC1848Z-SRP	938	33	CC2448Z-S	929	33	CDTCIR-120-14/3	6872	319
CB3072SE	4879	133	CC1860C-S	986	33	CC2448Z-SB	942	33	CDTCIR-120-16/3	5826	319
CB3072SE-BS	4925	135	CC1860C-SB	1001	33	CC2448Z-SBP	1007	33	CDTCIR-120-16/4	5498	319
CB3084SE	5488	133	CC1860C-SBP	1063	33	CC2448Z-SP	994	33	CDTCIR-48-14/3	4708	319
CB3084SE-BS	5541	135	CC1860C-SP	1051	33	CC2448Z-SR	999	33	CDTCIR-48-16/3	4069	319
CB3096SE	6012	133	CC1860C-SR	1045	33	CC2448Z-SRP	1069	33	CDTCIR-48-16/4	3722	319
CB3096SE-BS	6067	135	CC1860C-SRP	1118	33	CC2460C-S	1133	33	CDTCIR-60-14/3	4849	319
CBH24120SE	7245	133	CC1860Z-S	961	33	CC2460C-SB	1145	33	CDTCIR-60-16/3	4176	319
CBH24120SE-BS	7318	135	CC1860Z-SB	973	33	CC2460C-SBP	1209	33	CDTCIR-60-16/4	3827	319
CBH2436SE	4443	133	CC1860Z-SBP	1038	33	CC2460C-SP	1198	33	CDTCIR-72-14/3	5064	319
CBH2436SE-BS	4475	135	CC1860Z-SP	1025	33	CC2460C-SR	1199	33	CDTCIR-72-16/3	4345	319
			CC1860Z-SR	1020	33	CC2460C-SRP	1269	33	CDTCIR-72-16/4	3999	319
			CC1860Z-SRP	1092	33	CC2460Z-S	1043	33	CDTCIR-96-14/3	5362	319
			CC2136C-S	835	33	CC2460Z-SB	1057	33	CDTCIR-96-16/3	4574	319
			CC2136C-SB	846	33	CC2460Z-SBP	1119	33	CDTCIR-96-16/4	4231	319
			CC2136C-SBP	912	33	CC2460Z-SP	1107	33	CDTCL-108-14/3	6789	318
			CC2136C-SP	899	33	CC2460Z-SR	1109	33	CDTCL-108-16/3	5774	318



100 Industrial Boulevard, Clayton, DE 19938-8903 U.S.A.  
 Phone: 800-441-8440 or 302-653-3000. Fax: 302-653-2065  
<http://www.eaglegrp.com>

# ALPHANUMERIC PRICE INDEX

Part Number	List Price	Page No.	Part Number	List Price	Page No.	Part Number	List Price	Page No.	Part Number	List Price	Page No.
CDTCL-108-16/4	5461	318	CDTL-96-14/3	2887	318	CF2148-E	134	58	CH30	81	38
CDTCL-120-14/3	7146	318	CDTL-96-16/3	2576	318	CF2148-S	309	58	CH3000B-208	18818	365
CDTCL-120-16/3	6078	318	CDTL-96-16/4	2261	318	CF2160-C	129	58	CH3000B-240	18818	365
CDTCL-120-16/4	5749	318	CDTR-108-14/3	3604	318	CF2160-E	157	58	CH35	11	55
CDTCL-48-14/3	4848	318	CDTR-108-16/3	2975	318	CF2160-S	365	58	CH36	86	38
CDTCL-48-16/3	4195	318	CDTR-108-16/4	2822	318	CF2172-C	181	58	CH42	92	38
CDTCL-48-16/4	3847	318	CDTR-120-14/3	3794	318	CF2172-E	222	58	CH48	99	38
CDTCL-60-14/3	4986	318	CDTR-120-16/3	3129	318	CF2172-S	403	58	CH54	100	38
CDTCL-60-16/3	4298	318	CDTR-120-16/4	2969	318	CF2424-C	103	58	CH58	12	55
CDTCL-60-16/4	3952	318	CDTR-24-14/3	1808	318	CF2424-E	124	58	CH60	106	38
CDTCL-72-14/3	5200	318	CDTR-24-16/3	1541	318	CF2424-S	291	58	CH6000B-208	27134	365
CDTCL-72-16/3	4472	318	CDTR-24-16/4	1420	318	CF2430-C	107	58	CH6000B-240	27134	365
CDTCL-72-16/4	4126	318	CDTR-30-14/3	1958	318	CF2430-E	126	58	CH6000D-208	27134	365
CDTCL-84-14/3	5444	318	CDTR-30-16/3	1643	318	CF2430-S	299	58	CH6000D-240	27134	365
CDTCL-84-16/3	4645	318	CDTR-30-16/4	1531	318	CF2436-C	109	58	CHT2424S	1698	144
CDTCL-84-16/4	4303	318	CDTR-36-14/3	2196	318	CF2436-E	133	58	CHT2430S	1820	144
CDTCL-96-14/3	5504	318	CDTR-36-16/3	1766	318	CF2436-S	305	58	CHT2436S	1973	144
CDTCL-96-16/3	4703	318	CDTR-36-16/4	1648	318	CF2442-C	111	58	CHT2448S	2195	144
CDTCL-96-16/4	4361	318	CDTR-48-14/3	2299	318	CF2442-E	134	58	CHT3030S	1927	144
CDTCR-108-14/3	6789	318	CDTR-48-16/3	1927	318	CF2442-S	319	58	CHT3036S	2138	144
CDTCR-108-16/3	5774	318	CDTR-48-16/4	1809	318	CF2448-C	115	58	CHT3048S	2420	144
CDTCR-108-16/4	5461	318	CDTR-60-14/3	2451	318	CF2448-E	137	58	CLAGGD-15-NG	2152	264
CDTCR-120-14/3	7146	318	CDTR-60-16/3	2040	318	CF2448-S	322	58	CLAGGD-24-NG	2401	264
CDTCR-120-16/3	6078	318	CDTR-60-16/4	1925	318	CF2460-C	137	58	CLAGGD-36-NG	3072	264
CDTCR-120-16/4	5749	318	CDTR-72-14/3	2586	318	CF2460-E	165	58	CLAGGD-48-NG	4142	264
CDTCR-48-14/3	4848	318	CDTR-72-16/3	2139	318	CF2460-S	372	58	CLAGGD-15-NG	2874	264
CDTCR-48-16/3	4195	318	CDTR-72-16/4	2023	318	CF2472-C	191	58	CLAGGD-24-NG	3828	264
CDTCR-48-16/4	3847	318	CDTR-84-14/3	2827	318	CF2472-E	231	58	CLAGGD-36-NG	4832	264
CDTCR-60-14/3	4986	318	CDTR-84-16/3	2375	318	CF2472-S	412	58	CLAGGD-48-NG	6259	264
CDTCR-60-16/3	4298	318	CDTR-84-16/4	2204	318	CF3036-C	118	58	CLAGGD-15-NG	3736	264
CDTCR-60-16/4	3952	318	CDTR-96-14/3	2887	318	CF3036-E	141	58	CLAGGD-24-NG	4955	264
CDTCR-72-14/3	5200	318	CDTR-96-16/3	2576	318	CF3036-S	372	58	CLAGGD-36-NG	6248	264
CDTCR-72-16/3	4472	318	CDTR-96-16/4	2261	318	CF3048-C	121	58	CLAGGD-48-NG	7872	264
CDTCR-72-16/4	4126	318	CF1824-C	99	58	CF3048-E	147	58	CLC-208-2	1793	264
CDTCR-84-14/3	5444	318	CF1824-E	118	58	CF3048-S	387	58	CLC-240-2	1793	264
CDTCR-84-16/3	4645	318	CF1824-S	261	58	CF3060-C	125	58	CLCHRB-24-NG	3575	263
CDTCR-84-16/4	4303	318	CF1830-C	102	58	CF3060-E	176	58	CLCHRB-36-NG	4931	263
CDTCR-96-14/3	5504	318	CF1830-E	123	58	CF3060-S	449	58	CLCHRB-48-NG	6839	263
CDTCR-96-16/3	4703	318	CF1830-S	291	58	CF3072-C	176	58	CLCHRL-24-NG	2588	263
CDTCR-96-16/4	4361	318	CF1836-C	103	58	CF3072-E	244	58	CLCHRL-36-NG	3580	263
CDTL-108-14/3	3604	318	CF1836-E	124	58	CF3072-S	494	58	CLCHRL-48-NG	5057	263
CDTL-108-16/3	2975	318	CF1836-S	295	58	CF3636-C	125	58	CLCW-120-2	1793	264
CDTL-108-16/4	2822	318	CF1842-C	107	58	CF3636-E	154	58	CLEF10-120	2243	265
CDTL-120-14/3	3794	318	CF1842-E	126	58	CF3636-S	384	58	CLEF10-120-1	2243	265
CDTL-120-16/3	3129	318	CF1842-S	300	58	CF3648-C	129	58	CLEF10-120M	2243	265
CDTL-120-16/4	2969	318	CF1848-C	108	58	CF3648-E	157	58	CLEF10-120M-1	2243	265
CDTL-24-14/3	1808	318	CF1848-E	127	58	CF3648-S	402	58	CLEF10-240	2667	265
CDTL-24-16/3	1541	318	CF1848-S	305	58	CF3660-E	189	58	CLEF10-240-1	2667	265
CDTL-24-16/4	1420	318	CF1860-C	122	58	CF3660-S	456	58	CLEF102-240	4837	266
CDTL-30-14/3	1958	318	CF1860-E	147	58	CF3672-E	264	58	CLEF102-240-1	4837	266
CDTL-30-16/3	1643	318	CF1860-S	353	58	CF3672-S	508	58	CLEGD-24-240	3204	265
CDTL-30-16/4	1531	318	CF1872-C	137	58	CFN2840-2-18L-48TR	10691	188	CLEGD-36-240	4046	265
CDTL-36-14/3	2196	318	CF1872-E	165	58	CFN2840-2-18R-48TL	10691	188	CLEGD-48-240	5635	265
CDTL-36-16/3	1766	318	CF1872-S	387	58	CFN2840-2-24L-48TR	10853	188	CLGF30-NG	3278	261
CDTL-36-16/4	1648	318	CF2124-C	100	58	CFN2840-2-24R-48TL	10853	188	CLGF30-LP	3278	261
CDTL-48-14/3	2299	318	CF2124-E	120	58	CFNP2840-2-48TL	10220	188	CLH-C	16	38
CDTL-48-16/3	1927	318	CF2124-S	279	58	CFNP2840-2-48TR	10220	188	CLHDWS-18120	8854	113,277
CDTL-48-16/4	1809	318	CF2130-C	103	58	CG-I-36	127	157	CLHDWS-18144	10624	113,277
CDTL-60-14/3	2451	318	CF2130-E	124	58	CG-I-48	151	157	CLHDWS-1848	3542	113,277
CDTL-60-16/3	2040	318	CF2130-S	291	58	CG-I-60	172	157	CLHDWS-1872	5313	113,277
CDTL-60-16/4	1925	318	CF2136-C	107	58	CG-I-72	189	157	CLHDWS-1896	7083	113,277
CDTL-72-14/3	2586	318	CF2136-E	126	58	CG-O-36	127	157	CLHDWS-18B	330	113,277
CDTL-72-16/3	2139	318	CF2136-S	294	58	CG-O-48	151	157	CLHDWS-21120	9320	113,277
CDTL-72-16/4	2023	318	CF2142-C	109	58	CG-O-60	172	157	CLHDWS-21144	11183	113,277
CDTL-84-14/3	2827	318	CF2142-E	133	58	CG-O-72	189	157	CLHDWS-2148	3728	113,277
CDTL-84-16/3	2375	318	CF2142-S	306	58	CH24	80	38	CLHDWS-2172	5592	113,277
CDTL-84-16/4	2204	318	CF2148-C	111	58	CH28	9	55	CLHDWS-2196	7456	113,277

100 Industrial Boulevard, Clayton, DE 19938-8903 U.S.A.  
 Phone: 800-441-8440 or 302-653-3000. Fax: 302-653-2065  
<http://www.eaglegrp.com>



# ALPHANUMERIC PRICE INDEX

Part Number	List Price	Page No.	Part Number	List Price	Page No.	Part Number	List Price	Page No.	Part Number	List Price	Page No.
CLHDWS-21B	348	113,277	CP54-S	80	13	CPSS5-250	109	14	CSC3036E	3066	44
CLHP-2-NG	1568	263	CP54-V	32	13	CR2D	201	105	CSC3036S	6586	44
CLHP-4-NG	2527	263	CP54-VG	32	13	CR4D	225	105	CSC3048	3320	44
CLHP-6-NG	3637	263	CP54-W	32	67	CRC	151	29	CSC3048E	3724	44
CLUHP-2-NG	2133	263	CP54-Z	29	13	CRC2	1806	29	CSC3048S	8036	44
CLUHP-4-NG	3043	263	CP5CB	7168	224	CRC3	2268	29	CSC3060	3585	44
CLUHP-6-NG	4417	263	CP5OB	5412	224	CRC4	2980	29	CSC3060E	4007	44
CM108APR	1542	157	CP63-BL	34	67	CRR24-C	135	47	CSC3060S	8373	44
CM108PR	2147	157	CP63-C	32	13	CS-1	2313	236	CSI-1430	86	66
CM120APR	1561	157	CP63-E	36	13	CS-CCD	548	296	CSI-1436	92	66
CM120PR	2266	157	CP63-R	34	67	CS1224-BL	80	68	CSI-1448	112	66
CM132APR	1643	157	CP63-S	83	13	CS1224-C	77	29	CSI-1460	144	66
CM132PR	2297	157	CP63-V	34	13	CS1224-R	80	68	CSI-1836	96	66
CM144APR	1677	157	CP63-VG	34	13	CS1224-S	273	29	CSI-1848	116	66
CM144PR	2620	157	CP63-W	34	67	CS1224-W	80	68	CSI-1860	134	66
CM36APR	891	157	CP63-Z	31	13	CS1230-BL	86	68	CSI-1872	153	66
CM36PR	1137	157	CP7-BL	20	67	CS1230-C	84	29	CSI-2136	102	66
CM48APR	935	157	CP7-C	18	13	CS1230-R	86	68	CSI-2148	120	66
CM48PR	1188	157	CP7-E	23	13	CS1230-S	293	29	CSI-2160	137	66
CM60APR	978	157	CP7-R	20	67	CS1230-W	86	68	CSI-2172	155	66
CM60PR	1268	157	CP7-S	39	13	CS1236-BL	98	68	CSI-2424	87	66
CM72APR	1034	157	CP7-V	20	13	CS1236-C	95	29	CSI-2430	92	66
CM72PR	1343	157	CP7-VG	20	13	CS1236-R	98	68	CSI-2436	107	66
CM84APR	1278	157	CP7-W	20	67	CS1236-S	311	29	CSI-2448	123	66
CM84PR	1634	157	CP7-Z	17	13	CS1236-W	98	68	CSI-2454	138	66
CM96APR	1319	157	CP74-BL	36	67	CS1242-BL	112	68	CSI-2460	156	66
CM96PR	1705	157	CP74-C	35	13	CS1242-C	108	29	CSI-2472	173	66
CMM49	4739	142	CP74-E	39	13	CS1242-R	112	68	CSI-3060	247	66
CMM61	5561	142	CP74-R	36	67	CS1242-S	329	29	CSI-3072	252	66
COLLAR PLUG	9	51	CP74-S	94	13	CS1242-W	112	68	CSPB5-300	88	14
CORNER GUARD-A	151	370	CP74-V	36	13	CS1248-BL	115	68	CSR5-300	60	14
CORNER GUARD-B	224	370	CP74-VG	36	13	CS1248-C	111	29	CSR5P-300	62	14
CP-3	1978	225	CP74-W	36	67	CS1248-R	115	68	CSR5PS-300	198	14
CP-4	2426	225	CP74-Z	34	13	CS1248-S	344	29	CSR5S-200	157	14
CP-5	2799	225	CP86-BL	46	67	CS1248-W	115	68	CSS4-125	39	14
CP14-BL	24	67	CP86-C	43	13	CS1254-BL	121	68	CSS5-125	47	14
CP14-C	23	13	CP86-E	47	13	CS1254-C	118	29	CSS5-300	54	14
CP14-E	27	13	CP86-R	46	67	CS1254-R	121	68	CSS5P-300	55	14
CP14-R	24	67	CP86-S	113	13	CS1254-S	368	29	CSS5PS-300	235	14
CP14-S	43	13	CP86-V	46	13	CS1254-W	121	68	CSS5S-200	191	14
CP14-V	24	13	CP86-VG	46	13	CS1260-BL	129	68	CT24108S	3205	144
CP14-VG	24	13	CP86-W	46	67	CS1260-C	125	29	CT24108S-BS	3296	144
CP14-W	24	67	CP86-Z	41	13	CS1260-R	129	68	CT24120S	3464	144
CP14-Z	21	13	CPB5-200	40	15	CS1260-S	408	29	CT24120S-BS	3493	144
CP18-C	24	13	CPB5-250	64	15	CS1260-W	129	68	CT2436S	1531	144
CP18-E	28	13	CPB5P-300	62	15	CS42-32L	10743	310	CT2436S-BS	1541	144
CP18-S	51	13	CPB5P-500	119	15	CS42-32R	10743	310	CT2448S	1698	144
CP18-V	25	13	CPB5S-300	251	15	CSB5-300	64	14	CT2448S-BS	1715	144
CP18-VG	25	13	CPB6-500	125	15	CSB5P-300	60	14	CT2460S	1849	144
CP18-Z	23	13	CPB6P-600	108	15	CSB5PS-300	263	14	CT2460S-BS	1873	144
CP33-BL	27	67	CPB8P-700	141	15	CSB5S-200	218	14	CT2472S	2474	144
CP33-C	25	13	CPR5-200	40	15	CSC2430	1722	44	CT2472S-BS	2494	144
CP33-E	32	13	CPR5-250	64	15	CSC2430E	2109	44	CT2484S	2755	144
CP33-R	27	67	CPR5P-300	62	15	CSC2430S	4212	44	CT2484S-BS	2858	144
CP33-S	68	13	CPR5P-500	119	15	CSC2436	1914	44	CT2496S	3036	144
CP33-V	27	13	CPR6-500	125	15	CSC2436E	2343	44	CT2496S-BS	3113	144
CP33-VG	27	13	CPR6P-600	108	15	CSC2436S	4679	44	CT30108S	3382	144
CP33-W	27	67	CPR8P-700	141	15	CSC2448	2304	44	CT30108S-BS	3509	144
CP33-Z	24	13	CPS5-200	35	15	CSC2448E	2843	44	CT30120S	3556	144
CP3CB	6055	224	CPS5-250	58	15	CSC2448S	5706	44	CT30120S-BS	3594	144
CP3OB	4727	224	CPS5P-300	58	15	CSC2460	2712	44	CT3036S	1632	144
CP4CB	6754	224	CPS5P-500	103	15	CSC2460E	3063	44	CT3036S-BS	1648	144
CP4OB	5124	224	CPS5S-300	213	15	CSC2460S	5904	44	CT3048S	1812	144
CP54-BL	32	67	CPS6-500	111	15	CSC3030	2475	44	CT3048S-BS	1831	144
CP54-C	31	13	CPS6P-600	86	15	CSC3030E	2760	44	CT3060S	1981	144
CP54-E	33	13	CPS8P-700	125	15	CSC3030S	5928	44	CT3060S-BS	2001	144
CP54-R	32	67	CPSBS-250	118	14	CSC3036	2749	44	CT3072S	2618	144



100 Industrial Boulevard, Clayton, DE 19938-8903 U.S.A.  
 Phone: 800-441-8440 or 302-653-3000. Fax: 302-653-2065  
<http://www.eaglegrp.com>

# ALPHANUMERIC PRICE INDEX

Part Number	List Price	Page No.	Part Number	List Price	Page No.	Part Number	List Price	Page No.	Part Number	List Price	Page No.
CT3072S-BS	2662	144	CWS4-18R	1854	283	CZ-86-2436-T	499	34	D1448C	109	22,73
CT3084S	3011	144	CWS4-18R-7	3520	283	CZ-86-2448	346	34	D1448R	113	22,73
CT3084S-BS	3116	144	CWS4-22L	1978	289	CZ-86-2448-T	526	34	D1448W	113	22,73
CT3096S	3151	144	CWS4-22L-7	3646	289	CZ-86-2460	351	34	D1448Z	96	22,73
CT3096S-BS	3346	144	CWS4-22R	1978	289	CZ-86-2460-T	576	34	D16	43	75
CV-54-1836	233	34	CWS4-22R-7	3646	289	CZ-86-2472	364	34	D18	47	75
CV-54-1848	233	34	CWS5-18L	2055	283	CZ-86-2472-T	593	34	D1836BL	103	22,73
CV-54-1860	261	34	CWS5-18L-7	4489	283	CZC-54-1836	292	34	D1836C	100	22,73
CV-54-2148	284	34	CWS5-18R	2055	283	CZC-54-1848	298	34	D1836R	103	22,73
CV-54-2160	298	34	CWS5-18R-7	4489	283	CZC-54-1860	311	34	D1836W	103	22,73
CV-54-2424	252	34	CWS5-22L	2251	289	CZC-54-2148	335	34	D1836Z	98	22,73
CV-54-2436	264	34	CWS5-22L-7	4513	289	CZC-54-2160	357	34	D1848BL	122	22,73
CV-54-2448	265	34	CWS5-22R	2251	289	CZC-54-2436	357	34	D1848C	119	22,73
CV-54-2460	284	34	CWS5-22R-7	4513	289	CZC-54-2448	364	34	D1848R	122	22,73
CV-54-2472	301	34	CZ-54-1836	233	34	CZC-54-2460	366	34	D1848W	122	22,73
CV-63-1836	263	34	CZ-54-1836-T	338	34	CZC-54-2472	404	34	D1848Z	112	22,73
CV-63-1848	263	34	CZ-54-1848	233	34	CZC-63-1836	293	34	D20	54	75
CV-63-1860	267	34	CZ-54-1848-T	357	34	CZC-63-1848	304	34	D2136BL	121	22,73
CV-63-2148	299	34	CZ-54-1860	261	34	CZC-63-1860	319	34	D2136C	118	22,73
CV-63-2160	318	34	CZ-54-1860-T	376	34	CZC-63-2148	357	34	D2136R	121	22,73
CV-63-2424	300	34	CZ-54-2148	265	34	CZC-63-2160	366	34	D2136W	121	22,73
CV-63-2436	318	34	CZ-54-2148-T	397	34	CZC-63-2436	364	34	D2136Z	108	22,73
CV-63-2448	325	34	CZ-54-2160	284	34	CZC-63-2448	371	34	D2148BL	137	22,73
CV-63-2460	329	34	CZ-54-2160-T	441	34	CZC-63-2460	379	34	D2148C	133	22,73
CV-63-2472	322	34	CZ-54-2424	277	34	CZC-63-2472	412	34	D2148R	137	22,73
CV-74-2148	325	34	CZ-54-2424-T	364	34	CZC-54-2424	338	34	D2148W	137	22,73
CV-74-2160	340	34	CZ-54-2436	292	34	CZC-63-2424	344	34	D2148Z	121	22,73
CV-74-2436	333	34	CZ-54-2436-T	427	34	CZC-63-2436	364	34	D2436BL	124	22,73
CV-74-2448	346	34	CZ-54-2448	284	34	CZC-63-2448	371	34	D2436C	121	22,73
CV-74-2460	340	34	CZ-54-2448-T	440	34	CZC-63-2460	379	34	D2436R	124	22,73
CV-74-2472	372	34	CZ-54-2460	292	34	CZC-63-2472	412	34	D2436W	124	22,73
CV-86-2436	338	34	CZ-54-2460-T	452	34	CZC-74-2148	376	34	D2436Z	116	22,73
CV-86-2448	352	34	CZ-54-2472	301	34	CZC-74-2160	386	34	D2448BL	148	22,73
CV-86-2460	353	34	CZ-54-2472-T	501	34	CZC-74-2436	371	34	D2448C	144	22,73
CV-86-2472	382	34	CZ-63-1836	238	34	CZC-74-2448	386	34	D2448R	148	22,73
CVC-54-1836	292	34	CZ-63-1836-T	349	34	CZC-74-2460	393	34	D2448W	148	22,73
CVC-54-1848	293	34	CZ-63-1848	263	34	CZC-74-2472	419	34	D2448Z	134	22,73
CVC-54-1860	304	34	CZ-63-1848-T	380	34	CZC-86-2436	378	34	DA6-BL	33	66
CVC-54-2148	357	34	CZ-63-1860	266	34	CZC-86-2448	397	34	DA6-C	32	66
CVC-54-2160	366	34	CZ-63-1860-T	401	34	CZC-86-2460	419	34	DA6-R	33	66
CVC-54-2424	340	34	CZ-63-2148	318	34	CZC-86-2472	424	34	DA6-W	33	66
CVC-54-2436	359	34	CZ-63-2148-T	422	34	D10	36	75	DA6-Z	31	66
CVC-54-2448	365	34	CZ-63-2160	318	34	D12	39	75	DB	136	105
CVC-54-2460	366	34	CZ-63-2160-T	469	34	D14	41	75	DC2-ES	321	258
CVC-54-2472	426	34	CZ-63-2424	308	34	D1422BL	102	36	DC2-FS	1217	258
CVC-63-1836	296	34	CZ-63-2424-T	378	34	D1422R	102	36	DC2-RS	346	258
CVC-63-1848	298	34	CZ-63-2436	325	34	D1422V	102	36	DC2-RSU	872	256
CVC-63-1860	311	34	CZ-63-2436-T	434	34	D1422VG	102	36	DC2-RSUL	1177	256
CVC-63-2148	362	34	CZ-63-2448	296	34	D1422W	102	36	DC2-SO-DT	6238	255
CVC-63-2160	371	34	CZ-63-2448-T	444	34	D1424BL	102	36	DC2-SO-ST	2871	255
CVC-63-2424	352	34	CZ-63-2460	318	34	D1424R	102	36	DC2-TS-SRS	1758	253
CVC-63-2436	371	34	CZ-63-2460-T	459	34	D1424V	102	36	DC2-TS-TS	1169	253
CVC-63-2448	373	34	CZ-63-2472	341	34	D1424VG	102	36	DC2-TS-TSR	1169	253
CVC-63-2460	378	34	CZ-63-2472-T	512	34	D1424W	102	36	DC2-TS-MT	1104	255
CVC-63-2472	427	34	CZ-74-2148	320	34	D1430BL	94	36	DC2-TS-PT	1072	255
CVC-74-2148	386	34	CZ-74-2148-T	444	34	D1430R	94	36	DC2-TS-RL	1245	255
CVC-74-2160	386	34	CZ-74-2160	379	34	D1430V	94	36	DC2-TS-ST	1121	255
CVC-74-2436	386	34	CZ-74-2160-T	493	34	D1430VG	94	36	DC24-TS-SRS	968	246
CVC-74-2448	386	34	CZ-74-2436	311	34	D1430W	94	36	DC24-TS-TS	968	246
CVC-74-2460	399	34	CZ-74-2436-T	474	34	D1436BL	96	22,36,73	DC24-TS-TSR	968	246
CVC-74-2472	437	34	CZ-74-2448	340	34	D1436C	94	22,73	DC24-TS-MT	972	246
CVC-86-2436	393	34	CZ-74-2448-T	499	34	D1436R	96	22,36,73	DC24-TS-PT	893	246
CVC-86-2448	400	34	CZ-74-2460	346	34	D1436V	96	36	DC24-TS-ST	935	246
CVC-86-2460	419	34	CZ-74-2460-T	547	34	D1436VG	96	36	DC2436V	1528	70
CVC-86-2472	445	34	CZ-74-2472	346	34	D1436W	96	22,36,73	DC2448V	1592	70
CWS4-18L	1854	283	CZ-74-2472-T	561	34	D1436Z	85	22,73	DC2460V	1780	70
CWS4-18L-7	3520	283	CZ-86-2436	322	34	D1448BL	113	22,73	DC24E-RSU	767	246

# ALPHANUMERIC PRICE INDEX

Part Number	List Price	Page No.	Part Number	List Price	Page No.	Part Number	List Price	Page No.	Part Number	List Price	Page No.
DC24E-RSUL	1034	246	DCOC-WS-MT	339	248	DCS3-HCFU-A	26436	244	DCS6-HCFU-C	34277	244
DC24I-RSU	767	246	DCOC-WS-ST	297	248	DCS3-SS-RHDL	2330	260	DCS6-HFU-B	16131	240
DC24I-RSUL	1034	246	DCS-CUEL-24	5814	246	DCS3-SS-RHDL-L	2362	260	DCS6-HFU-B-3	16479	240
DC3-FS	1264	258	DCS-CUEL-36	9071	246	DCS3-SS-RHHL	2587	260	DCS6-HFU-C	16131	240
DC3-RS	384	258	DCS-CUER-24	5814	246	DCS3-SS-RHHL-H	2601	260	DCS6-HFU-C-3	16479	240
DC3-RSU	977	256	DCS-CUER-36	9071	246	DCS3-SS-RHHL-L	2835	260	DCS6-HS	12397	243
DC3-RSUL	1277	256	DCS-CUI-24	5814	246	DCS3-SS-RHHL-L-H	2906	260	DCS6-SS-RHDL	2678	260
DC3-SO-DT	6499	255	DCS-CUI-36	9071	246	DCS3030-TSND	13615	248	DCS6-SS-RHDL-L	2728	260
DC3-SO-ST	3171	255	DCS-PUD-2T	7278	252	DCS4-BDU	8596	247	DCS6-SS-RHHL	2898	260
DC3-TS-SRS	1887	253	DCS-PUD-2TH	10580	252	DCS4-BSU	7017	247	DCS6-SS-RHHL-H	2906	260
DC3-TS-TS	1257	253	DCS-PUD-3T	8109	252	DCS4-CFUI	8593	242	DCS6-SS-RHHL-L	3420	260
DC3-TS-TSR	1257	253	DCS-PUD-3TH	12675	252	DCS4-CFUR	12614	241	DCS6-SS-RHHL-L-H	3519	260
DC3-WS-MT	1188	255	DCS-PUD-4T	9338	252	DCS4-CFURN	14014	241	DCS6-STU	7168	243
DC3-WS-PT	1231	255	DCS-PUD-4TH	15419	252	DCS4-DSG-BDT	10394	257	DCSC-CTU-IC	3543	248
DC3-WS-RL	1435	255	DCS-PUD-5T	12092	252	DCS4-DSG-BST	7385	257	DCSC-CTU-IM	3727	248
DC3-WS-ST	1295	255	DCS-PUD-5TH	18700	252	DCS4-DSG-CDT	10241	257	DCSC-CTU-OC	3543	248
DC36E-RSU	919	246	DCS-PUDT-CS	7218	252	DCS4-DSG-CST	4812	257	DCSC-CTU-OM	3727	248
DC36E-RSUL	1240	246	DCS-PUDT-CSH	10403	252	DCS4-FTU	13322	247	DDFT-10	1783	63
DC4-FS	1295	258	DCS1620TD	6384	250	DCS4-HCFU-B	29403	244	DDFT-11	1937	63
DC4-RS	422	258	DCS1620TDS	8428	250	DCS4-HCFU-C	29403	244	DDFT-12	2095	63
DC4-RSU	1169	256	DCS2-BDU	6609	247	DCS4-HFU-B	11685	240	DDFT-13	2251	63
DC4-RSUL	1469	256	DCS2-BSU	5515	247	DCS4-HFU-B-3	12034	240	DDFT-14	2405	63
DC4-SO-DT	7840	255	DCS2-CFUI	6575	242	DCS4-HFU-C	11685	240	DDFT-15	2562	63
DC4-SO-ST	4222	255	DCS2-CFUR	9999	241	DCS4-HFU-C-3	12034	240	DDFT-16	2717	63
DC4-TS-SRS	2031	253	DCS2-CFURN	11625	241	DCS4-HS	10547	243	DDFT-17	2875	63
DC4-TS-TS	1349	253	DCS2-CSU	11506	245	DCS4-SS-RHDL	2424	260	DDFT-18	3031	63
DC4-TS-TSR	1349	253	DCS2-DSG-BDT	8244	257	DCS4-SS-RHDL-L	2461	260	DDFT-19	3183	63
DC4-WS-MT	1276	255	DCS2-DSG-BST	5867	257	DCS4-SS-RHHL	2630	260	DDFT-20	3341	63
DC4-WS-PT	1392	255	DCS2-DSG-CDT	8072	257	DCS4-SS-RHHL-H	2640	260	DDFT-21	3496	63
DC4-WS-RL	1616	255	DCS2-DSG-CST	3905	257	DCS4-SS-RHHL-L	2959	260	DDFT-22	3660	63
DC4-WS-ST	1458	255	DCS2-FTU	10753	247	DCS4-SS-RHHL-L-H	3036	260	DDFT-23	3813	63
DC5-FS	1391	258	DCS2-HCFU-A	24634	244	DCS4-STU	5392	243	DDFT-24	3969	63
DC5-RS	509	258	DCS2-HFU-A	8040	240	DCS4-STURB	22087	243	DDFT-25	4126	63
DC5-RSU	1402	256	DCS2-HFU-B	8040	240	DCS5-BDU	9507	247	DDFT-26	4282	63
DC5-RSUL	1706	256	DCS2-HFU-B-3	8389	240	DCS5-BSU	7821	247	DDFT-27	4439	63
DC5-SO-DT	9125	255	DCS2-HFU-C	8040	240	DCS5-CFUI	9717	242	DDFT-28	4595	63
DC5-SO-ST	4717	255	DCS2-HFU-C-3	8389	240	DCS5-CFUR	13969	241	DDFT-29	4751	63
DC5-TS-SRS	2234	253	DCS2-ICU	12643	244	DCS5-CFURN	15721	241	DDFT-30	4905	63
DC5-TS-TS	1484	253	DCS2-SS-RHDL	2232	260	DCS5-DSG-BDT	15389	257	DDFT-6	1161	63
DC5-TS-TSR	1484	253	DCS2-SS-RHDL-L	2259	260	DCS5-DSG-BST	10771	257	DDFT-7	1317	63
DC5-WS-MT	1404	255	DCS2-SS-RHHL	2542	260	DCS5-DSG-CDT	14988	257	DDFT-8	1471	63
DC5-WS-PT	1546	255	DCS2-SS-RHHL-H	2556	260	DCS5-DSG-CST	6678	257	DDFT-9	1627	63
DC5-WS-RL	1801	255	DCS2-SS-RHHL-L	2710	260	DCS5-FTU	14549	247	DSDK-18	1385	63
DC5-WS-ST	1614	255	DCS2-SS-RHHL-L-H	2773	260	DCS5-HCFU-B	31707	244	DSDK-21	1423	63
DC6-FS	1594	258	DCS2-STU	4218	243	DCS5-HCFU-C	31707	244	DSDK-24	1476	63
DC6-RS	719	258	DCS2-TPU	4394	249	DCS5-HFU-B	13688	240	DSDK-30	1620	63
DC6-RSU	1660	256	DCS2-TSU	9167	249	DCS5-HFU-B-3	14039	240	DSDK-36	2064	63
DC6-RSUL	1964	256	DCS2020RD	6546	250	DCS5-HFU-C	13688	240	DSDKATB-S	484	63
DC6-SO-DT	10242	255	DCS2020RDS	7440	250	DCS5-HFU-C-3	14039	240	DF1836-A	463	42
DC6-SO-ST	5456	255	DCS3-BDU	7589	247	DCS5-HS	11113	243	DF1836-C	823	42
DC6-TS-SRS	2719	253	DCS3-BSU	6274	247	DCS5-SS-RHDL	2599	260	DF1842-A	493	42
DC6-TS-TS	1823	253	DCS3-CFUI	7416	242	DCS5-SS-RHDL-L	2645	260	DF1842-C	848	42
DC6-TS-TSR	1823	253	DCS3-CFUR	11099	241	DCS5-SS-RHHL	2798	260	DF1848-A	506	42
DC6-WS-MT	1724	255	DCS3-CFURN	12779	241	DCS5-SS-RHHL-H	2807	260	DF1848-C	876	42
DC6-WS-PT	1897	255	DCS3-DSG-BDT	9581	257	DCS5-SS-RHHL-L	3241	260	DF1860-A	560	42
DC6-WS-RL	2208	255	DCS3-DSG-BST	6632	257	DCS5-SS-RHHL-L-H	3330	260	DF1860-C	931	42
DC6-WS-ST	1981	255	DCS3-DSG-CDT	9231	257	DCS5-STU	6093	243	DF1872-A	644	42
DCE-TS-SRS	1467	253	DCS3-DSG-CST	4357	257	DCS6-CFUI	11137	242	DF1872-C	991	42
DCE-TS-TS	968	253	DCS3-FTU	12027	247	DCS6-CFUR	15674	241	DF2136-A	493	42
DCE-TS-TSR	968	253	DCS3-HFU-A	9695	240	DCS6-CFURN	17437	241	DF2136-C	853	42
DCE-WS-MT	924	255	DCS3-HFU-B	9695	240	DCS6-DSG-BDT	18069	257	DF2142-A	513	42
DCE-WS-PT	893	255	DCS3-HFU-B-3	10043	240	DCS6-DSG-BST	12286	257	DF2142-C	882	42
DCE-WS-RL	1040	255	DCS3-HFU-C	9695	240	DCS6-DSG-CDT	17364	257	DF2148-A	527	42
DCE-WS-ST	935	255	DCS3-HFU-C-3	10043	240	DCS6-DSG-CST	7385	257	DF2148-C	914	42
DCOC-TS-SRS	2476	248	DCS3-HS	9563	243	DCS6-HCFU-B	34277	244	DF2160-A	572	42
DCOC-TS-TR	1652	248	DCS3-ICU	14695	244	DCS6-FTU	16997	247	DF2160-C	965	42
DCOC-TS-TS	1652	248	DCS3-STU	4767	243				DF2172-A	606	42



100 Industrial Boulevard, Clayton, DE 19938-8903 U.S.A.  
 Phone: 800-441-8440 or 302-653-3000. Fax: 302-653-2065  
<http://www.eaglegrp.com>

# ALPHANUMERIC PRICE INDEX

Part Number	List Price	Page No.	Part Number	List Price	Page No.	Part Number	List Price	Page No.	Part Number	List Price	Page No.
DF2172-C	1109	42	DOS1096-16/3	2436	150	DR2136-C	400	39	DSI-1836	69	66
DF2436-A	498	42	DOS1096-16/4	2062	150	DR2136-E	491	39	DSI-1848	80	66
DF2436-C	848	42	DOS12108-14/3	2935	150	DR2148-C	443	39	DSI-1860	87	66
DF2442-A	516	42	DOS12108-16/3	2667	150	DR2148-E	527	39	DSI-1872	98	66
DF2442-C	873	42	DOS12108-16/4	2379	150	DR2160-C	507	39	DSI-2136	77	66
DF2448-A	542	42	DOS12120-14/3	3084	150	DR2160-E	598	39	DSI-2148	85	66
DF2448-C	909	42	DOS12120-16/3	2801	150	DR2424-C	376	39	DSI-2160	99	66
DF2460-A	583	42	DOS12120-16/4	2423	150	DR2424-E	471	39	DSI-2172	106	66
DF2460-C	965	42	DOS12132-14/3	3426	150	DR2430-C	389	39	DSI-2424	66	66
DF2472-A	685	42	DOS12132-16/3	3113	150	DR2430-E	484	39	DSI-2430	76	66
DF2472-C	1100	42	DOS12132-16/4	2601	150	DR2436-C	412	39	DSI-2436	80	66
DHT2-120	2117	214	DOS12144-14/3	3516	150	DR2436-E	494	39	DSI-2448	91	66
DHT2-208	2117	214	DOS12144-16/3	3199	150	DR2436-S	1071	39	DSI-2454	102	66
DHT2-208-3	2460	214	DOS12144-16/4	2644	150	DR2448-C	455	39	DSI-2460	111	66
DHT2-240	2117	214	DOS1236-14/3	1849	150	DR2448-E	545	39	DSI-2472	119	66
DHT2-240-3	2460	214	DOS1236-16/3	1594	150	DR2448-S	1361	39	DSI-3060	115	66
DHT3-120	2386	214	DOS1236-16/4	1433	150	DR2460-C	527	39	DSI-3072	125	66
DHT3-208	2386	214	DOS1248-14/3	1985	150	DR2460-E	629	39	DSP-1024	291	103
DHT3-208-3	2732	214	DOS1248-16/3	1715	150	DS1824-C	199	39	DSP-1030	303	103
DHT3-240	2386	214	DOS1248-16/4	1472	150	DS1824-E	258	39	DSP-1036	320	103
DHT3-240-3	2732	214	DOS1260-14/3	2136	150	DS1830-C	218	39	DSP-1224	298	103
DHT4-120	3243	214	DOS1260-16/3	1842	150	DS1830-E	265	39	DSP-1230	314	103
DHT4-208	3243	214	DOS1260-16/4	1588	150	DS1836-C	227	39	DSP-1236	335	103
DHT4-208-3	3588	214	DOS1272-14/3	2293	150	DS1836-E	275	39	DSR-1024	438	103
DHT4-240	3243	214	DOS1272-16/3	1973	150	DS1836-S	739	39	DSR-1030	499	103
DHT4-240-3	3588	214	DOS1272-16/4	1701	150	DS1848-C	263	39	DSR-1036	566	103
DHT5-208	4077	214	DOS1284-14/3	2463	150	DS1848-E	316	39	DSR-12	354	312
DHT5-208-3	4422	214	DOS1284-16/3	2162	150	DS1848-S	896	39	DSR-1224	475	103
DHT5-240	4077	214	DOS1284-16/4	1808	150	DS1860-C	299	39	DSR-1230	478	103
DHT5-240-3	4422	214	DOS1296-14/3	2732	150	DS1860-E	362	39	DSR-1236	643	103
DIC1420	1603	301	DOS1296-16/3	2560	150	DS1860-S	1052	39	DSR-13	354	312
DIC1626	2023	301	DOS1296-16/4	2197	150	DS2124-C	209	39	DSR-14	354	312
DIC2014	1603	301	DP-10	985	174	DS2124-E	262	39	DSR-15	354	312
DIC2616	2023	301	DP-20	2051	174	DS2130-C	224	39	DSR-16	354	312
DOS-HT2	1629	227	DP1826-W	40	347	DS2130-E	277	39	DSR-17	354	312
DOS-HT3	1795	227	DP30	284	47	DS2136-C	235	39	DSR-18	431	312
DOS-HT4	1846	227	DP48	319	47	DS2136-E	292	39	DSR-19	431	312
DOS-HT5	2379	227	DPB-5	5082	314	DS2148-C	275	39	DSR-20	431	312
DOS-HT6	2477	227	DPB-5-V	5590	314	DS2148-E	320	39	DSR-21	431	312
DOS10108-14/3	2892	150	DPB-5-W	5336	314	DS2160-C	314	39	DSR-22	431	312
DOS10108-16/3	2631	150	DPB-5L	5102	314	DS2160-E	371	39	DSR-23	431	312
DOS10108-16/4	2208	150	DPB-5L-V	5612	314	DS2424-C	214	39	DSR-24	511	312
DOS10120-14/3	2984	150	DPB-5L-W	5357	314	DS2424-E	278	39	DSR-25	511	312
DOS10120-16/3	2715	150	DPB-5LR	5288	314	DS2430-C	227	39	DSR-26	511	312
DOS10120-16/4	2253	150	DPB-5LR-V	5817	314	DS2430-E	287	39	DSR-27	511	312
DOS10132-14/3	3204	150	DPB-5LR-W	5552	314	DS2436-C	241	39	DSR-28	511	312
DOS10132-16/3	2913	150	DPB-5R	5102	314	DS2436-E	296	39	DSR-29	511	312
DOS10132-16/4	2402	150	DPB-5R-V	5612	314	DS2436-S	805	39	DSR-30	585	312
DOS10144-14/3	3287	150	DPB-5R-W	5357	314	DS2448-C	278	39	DSR-31	585	312
DOS10144-16/3	2987	150	DPRK1216C	35	352	DS2448-E	338	39	DSR-32	585	312
DOS10144-16/4	2446	150	DPRK1725C	65	352	DS2448-S	969	39	DSR-33	585	312
DOS1036-14/3	1668	150	DR1824-C	358	39	DS2460-C	331	39	DSR-34	585	312
DOS1036-16/3	1517	150	DR1824-E	444	39	DS2460-E	399	39	DSR-35	585	312
DOS1036-16/4	1354	150	DR1830-C	379	39	DS2460-S	1162	39	DSR-36	664	312
DOS1048-14/3	1757	150	DR1830-E	461	39	DS4-CP74-2448C	1229	40	DSR-37	664	312
DOS1048-16/3	1595	150	DR1836-C	386	39	DS4-CP74-2448E	1252	40	DSR-38	664	312
DOS1048-16/4	1397	150	DR1836-E	471	39	DS4-CP74-2448Z	1087	40	DSR-39	664	312
DOS1060-14/3	1915	150	DR1836-S	964	39	DS4-P74-2448C	1088	40	DSR-40	664	312
DOS1060-16/3	1740	150	DR1848-C	427	39	DS4-P74-2448E	1115	40	DSR-41	664	312
DOS1060-16/4	1502	150	DR1848-E	516	39	DS4-P74-2448Z	949	40	DSR-42	742	312
DOS1072-14/3	2067	150	DR1848-S	1242	39	DSG-2	4844	236	DSR-43	742	312
DOS1072-16/3	1881	150	DR1860-C	479	39	DSG-3	5038	236	DSR-44	742	312
DOS1072-16/4	1595	150	DR1860-E	578	39	DSG-4	5302	236	DSR-45	742	312
DOS1084-14/3	2216	150	DR2124-C	366	39	DSI-1430	59	66	DSR-46	742	312
DOS1084-16/3	2015	150	DR2124-E	455	39	DSI-1436	62	66	DSR-47	742	312
DOS1084-16/4	1688	150	DR2130-C	385	39	DSI-1448	71	66	DSR-48	817	312
DOS1096-14/3	2681	150	DR2130-E	473	39	DSI-1460	80	66	DSR-49	817	312



# ALPHANUMERIC PRICE INDEX

Part Number	List Price	Page No.	Part Number	List Price	Page No.	Part Number	List Price	Page No.	Part Number	List Price	Page No.
DSR-50	.817	312	DSS-1024	.340	103	DT2448-CS	1600	37	DTF2430-S	.296	57
DSR-51	.817	312	DSS-1030	.346	103	DT2448-CSB	1618	37	DTF2436-C	.120	57
DSR-52	.817	312	DSS-1036	.363	103	DT2448-CSBP	1614	37	DTF2436-E	.144	57
DSR-53	.817	312	DSS-1224	.343	103	DT2448-CSP	1600	37	DTF2436-S	.306	57
DSR-54	.896	312	DSS-1230	.362	103	DT2448-ZS	1546	37	DTF2442-C	.121	57
DSR-55	.896	312	DSS-1236	.372	103	DT2448-ZSB	1559	37	DTF2442-E	.145	57
DSR-56	.896	312	DSSP-HT2	1944	228	DT2448-ZSBP	1557	37	DTF2442-S	.319	57
DSR-57	.896	312	DSSP-HT3	1998	228	DT2448-ZSP	1546	37	DTF2448-C	.123	57
DSR-58	.896	312	DSSP-HT4	2145	228	DT2460-CS	1765	37	DTF2448-E	.148	57
DSR-59	.896	312	DSSP-HT5	2586	228	DT2460-CSB	1780	37	DTF2448-S	.322	57
DSR-60	.965	312	DSSP-HT6	2633	228	DT2460-CSBP	1777	37	DTF2460-C	.148	57
DSR-61	.965	312	DT1836-CS	1320	37	DT2460-CSP	1765	37	DTF2460-E	.179	57
DSR-62	.965	312	DT1836-CSB	1335	37	DT2460-ZS	1723	37	DTF2460-S	.373	57
DSR-63	.965	312	DT1836-CSBP	1329	37	DT2460-ZSB	1737	37	DTF2472-C	.208	57
DSR-64	.965	312	DT1836-CSP	1320	37	DT2460-ZSBP	1734	37	DTF2472-E	.251	57
DSR-65	.965	312	DT1836-ZS	1308	37	DT2460-ZSP	1723	37	DTF2472-S	.412	57
DSR-66	1.051	312	DT1836-ZSB	1320	37	DT3660SE	8235	142	DTF3036-C	.126	57
DSR-67	1.051	312	DT1836-ZSBP	1318	37	DT3672SE	9696	142	DTF3036-E	.153	57
DSR-68	1.051	312	DT1836-ZSP	1308	37	DTC-48LR-16/3	8115	319	DTF3036-S	.373	57
DSR-69	1.051	312	DT1848-CS	1445	37	DTC-48RL-16/3	8115	319	DTF3048-C	.133	57
DSR-70	1.051	312	DT1848-CSB	1456	37	DTF1824-C	.108	57	DTF3048-E	.160	57
DSR-71	1.051	312	DT1848-CSBP	1454	37	DTF1824-E	.126	57	DTF3048-S	.389	57
DSR-72	1.128	312	DT1848-CSP	1445	37	DTF1824-S	.278	57	DTF3060-C	.138	57
DSR-73	1.128	312	DT1848-ZS	1409	37	DTF1830-C	.111	57	DTF3060-E	.191	57
DSR-74	1.128	312	DT1848-ZSB	1422	37	DTF1830-E	.135	57	DTF3060-S	.449	57
DSR-75	1.128	312	DT1848-ZSBP	1420	37	DTF1830-S	.291	57	DTF3072-C	.191	57
DSR-76	1.128	312	DT1848-ZSP	1409	37	DTF1836-C	.115	57	DTF3072-E	.266	57
DSR-77	1.128	312	DT1860-CS	1585	37	DTF1836-E	.137	57	DTF3072-S	.494	57
DSR-78	1.206	312	DT1860-CSB	1599	37	DTF1836-S	.295	57	DTF3636-C	.138	57
DSR-79	1.206	312	DT1860-CSBP	1597	37	DTF1842-C	.118	57	DTF3636-E	.167	57
DSR-80	1.206	312	DT1860-CSP	1585	37	DTF1842-E	.139	57	DTF3636-S	.384	57
DSR-81	1.206	312	DT1860-ZS	1552	37	DTF1842-S	.299	57	DTF3648-C	.143	57
DSR-82	1.206	312	DT1860-ZSB	1567	37	DTF1848-C	.119	57	DTF3648-E	.174	57
DSR-83	1.206	312	DT1860-ZSBP	1560	37	DTF1848-E	.141	57	DTF3648-S	.399	57
DSR-84	1.282	312	DT1860-ZSP	1552	37	DTF1848-S	.306	57	DTF3660-C	.231	57
DSRLC-12	.378	312	DT2136-CS	1428	37	DTF1860-C	.134	57	DTF3660-E	.207	57
DSRLC-13	.378	312	DT2136-CSB	1443	37	DTF1860-E	.160	57	DTF3660-S	.456	57
DSRLC-14	.378	312	DT2136-CSBP	1439	37	DTF1860-S	.353	57	DTF3672-C	.276	57
DSRLC-15	.378	312	DT2136-CSP	1428	37	DTF1872-C	.148	57	DTF3672-E	.288	57
DSRLC-16	.378	312	DT2136-ZS	1379	37	DTF1872-E	.179	57	DTF3672-S	.507	57
DSRLC-17	.378	312	DT2136-ZSB	1392	37	DTF1872-S	.389	57	DTRA-24	.257	329
DSRLC-18	.488	312	DT2136-ZSBP	1388	37	DTF2124-C	.109	57	DTSC2430	2186	45
DSRLC-19	.488	312	DT2136-ZSP	1379	37	DTF2124-E	.129	57	DTSC2430E	3057	45
DSRLC-20	.488	312	DT2148-CS	1533	37	DTF2124-S	.282	57	DTSC2430S	5705	45
DSRLC-21	.488	312	DT2148-CSB	1546	37	DTF2130-C	.115	57	DTSC2436	2427	45
DSRLC-22	.488	312	DT2148-CSBP	1542	37	DTF2130-E	.137	57	DTSC2436E	3402	45
DSRLC-23	.488	312	DT2148-CSP	1533	37	DTF2130-S	.291	57	DTSC2436S	6338	45
DSRLC-24	.632	312	DT2148-ZS	1477	37	DTF2136-C	.118	57	DTSC2448	2852	45
DSRLC-25	.632	312	DT2148-ZSB	1493	37	DTF2136-E	.139	57	DTSC2448E	4052	45
DSRLC-26	.632	312	DT2148-ZSBP	1489	37	DTF2136-S	.294	57	DTSC2448S	7521	45
DSRLC-27	.632	312	DT2148-ZSP	1477	37	DTF2142-C	.120	57	DTSC2460	3285	45
DSRLC-28	.632	312	DT2160-CS	1675	37	DTF2142-E	.144	57	DTSC2460E	4468	45
DSRLC-29	.632	312	DT2160-CSB	1685	37	DTF2142-S	.308	57	DTSC2460S	7722	45
DSRLC-30	.746	312	DT2160-CSBP	1683	37	DTF2148-C	.121	57	DVE-50	.318	274
DSRLC-31	.746	312	DT2160-CSP	1675	37	DTF2148-E	.145	57	DVE-75	.318	274
DSRLC-32	.746	312	DT2160-ZS	1637	37	DTF2148-S	.311	57	DVS-48	1618	325,333
DSRLC-33	.746	312	DT2160-ZSB	1653	37	DTF2160-C	.143	57	DVS-60	1774	325,333
DSRLC-34	.746	312	DT2160-ZSBP	1648	37	DTF2160-E	.174	57	DVS-72	1908	325,333
DSRLC-35	.746	312	DT2160-ZSP	1637	37	DTF2160-S	.364	57	DW12-24	.858	311
DSRLC-36	.876	312	DT2436-CS	1453	37	DTF2172-C	.199	57	DW18-19	.858	311
DSRLC-37	.876	312	DT2436-CSB	1466	37	DTF2172-E	.240	57	DW18-24	.994	311
DSRLC-38	.876	312	DT2436-CSBP	1463	37	DTF2172-S	.402	57	DWB14-C	.80	13,112
DSRLC-39	.876	312	DT2436-CSP	1453	37	DTF2424-C	.115	57	DWB14-S	.192	13,112
DSRLC-40	.876	312	DT2436-ZS	1411	37	DTF2424-E	.137	57	DWB14-VG	.81	13,112
DSRLC-41	.876	312	DT2436-ZSB	1424	37	DTF2424-S	.291	57	DWB18-C	.82	13,112
DSRLC-42	1.007	312	DT2436-ZSBP	1421	37	DTF2430-C	.118	57	DWB18-S	.203	13,112
DSS	.121	105	DT2436-ZSP	1411	37	DTF2430-E	.139	57	DWB18-VG	.83	13,112

# ALPHANUMERIC PRICE INDEX

Part Number	List Price	Page No.	Part Number	List Price	Page No.	Part Number	List Price	Page No.	Part Number	List Price	Page No.
DWB21-C	.82	13,112	DWS4-74-1860VG	.846	26	ET24-BL	.33	67	F2QA2-74-1836Z	.554	8
DWB21-S	208	13,112	DWS4-74-1860Z	.751	26	ET24-R	.33	67	F2QA2-74-1848C	.628	8
DWB21-VG	.83	13,112	DWS4-74-2436V	.751	26	ET24-W	.33	67	F2QA2-74-1848E	.748	8
DWB24-C	.83	13,112	DWS4-74-2436VG	.751	26	EU2-1824C	.537	30	F2QA2-74-1848S	2056	8
DWB24-S	217	13,112	DWS4-74-2436Z	.644	26	EU2-1824S	1171	30	F2QA2-74-1848V	.689	8
DWB24-VG	.85	13,112	DWS4-74-2448V	.865	26	EU2-1824Z	.483	30	F2QA2-74-1848VG	.689	8
DWN-1-120	.3515	271	DWS4-74-2448VG	.865	26	EU2-1830C	.546	30	F2QA2-74-1848Z	.606	8
DWN-1-240	.3515	271	DWS4-74-2448Z	.746	26	EU2-1830S	1177	30	F2QA2-74-1860C	.700	8
DWN-1BI-120	.3515	271	DWS4-74-2460V	1005	26	EU2-1830Z	.496	30	F2QA2-74-1860E	.839	8
DWN-1BI-240	.3515	271	DWS4-74-2460VG	1005	26	EU2-1836C	.572	30	F2QA2-74-1860S	2504	8
DWN-2-120	.5735	271	DWS4-74-2460Z	.881	26	EU2-1836S	1185	30	F2QA2-74-1860V	.766	8
DWN-2-240	.5735	271	DWW-1-120	.3515	271	EU2-1836Z	.509	30	F2QA2-74-1860VG	.766	8
DWN-2BI-120	.5735	271	DWW-1-240	.3515	271	EU2-2136C	.595	30	F2QA2-74-1860Z	.673	8
DWN-2BI-240	.5735	271	DWW-1BI-120	.3515	271	EU2-2136S	1319	30	F2QA2-74-1872C	.794	8
DWN-3-120	.7779	271	DWW-1BI-240	.3515	271	EU2-2136Z	.531	30	F2QA2-74-1872E	.931	8
DWN-3-240	.7779	271	DWW-2-120	.5735	271	EU2-2436C	.634	30	F2QA2-74-1872S	2891	8
DWN-3BI-120	.7779	271	DWW-2-240	.5735	271	EU2-2436S	1393	30	F2QA2-74-1872V	.881	8
DWN-3BI-240	.7779	271	DWW-2BI-120	.5735	271	EU2-2436Z	.569	30	F2QA2-74-1872VG	.881	8
DWP-1L-120	.4116	269	DWW-2BI-240	.5735	271	EU3-1824C	.622	30	F2QA2-74-1872Z	.759	8
DWP-1L-240	.4116	269	DWW-3-120	.7779	271	EU3-1824CS	.896	30	F2QA2-74-2436C	.644	8
DWP-1R-120	.4116	269	DWW-3-240	.7779	271	EU3-1824S	1523	30	F2QA2-74-2436E	.753	8
DWP-1R-240	.4116	269	DWW-3BI-120	.7779	271	EU3-1824Z	.561	30	F2QA2-74-2436S	2128	8
DWS1836V	.125	26	DWW-3BI-240	.7779	271	EU3-1830C	.639	30	F2QA2-74-2436V	.696	8
DWS1836VG	.125	26	E1854-C	.108	28	EU3-1830CS	.922	30	F2QA2-74-2436VG	.696	8
DWS1836Z	.107	26	E1854-S	.209	28	EU3-1830S	1531	30	F2QA2-74-2436Z	.611	8
DWS1848V	.145	26	E1863-C	.113	28	EU3-1830Z	.583	30	F2QA2-74-2448C	.734	8
DWS1848VG	.145	26	E1863-S	.218	28	EU3-1836C	.672	30	F2QA2-74-2448E	.873	8
DWS1848Z	.126	26	E1874-C	.118	28	EU3-1836CS	.984	30	F2QA2-74-2448S	2473	8
DWS1860V	.176	26	E1874-S	.235	28	EU3-1836S	1544	30	F2QA2-74-2448V	.804	8
DWS1860VG	.176	26	E1886-C	.182	28	EU3-1836Z	.601	30	F2QA2-74-2448VG	.804	8
DWS1860Z	.154	26	E1886-S	.259	28	EU3-2030-P	.944	32	F2QA2-74-2448Z	.689	8
DWS2436V	.152	26	E2454-C	.127	28	EU3-2136C	.719	30	F2QA2-74-2460C	.825	8
DWS2436VG	.152	26	E2454-S	.252	28	EU3-2136S	1731	30	F2QA2-74-2460E	.985	8
DWS2436Z	.126	26	E2463-C	.135	28	EU3-2136Z	.641	30	F2QA2-74-2460S	2942	8
DWS2448V	.180	26	E2463-S	.273	28	EU3-2436C	.755	30	F2QA2-74-2460V	.917	8
DWS2448VG	.180	26	E2474-C	.142	28	EU3-2436S	1841	30	F2QA2-74-2460VG	.917	8
DWS2448Z	.153	26	E2474-S	.286	28	EU3-2436Z	.680	30	F2QA2-74-2460Z	.799	8
DWS2460V	.215	26	E2486-C	.206	28	EUHC-A	.7208	360	F2QA2-74-2472C	.943	8
DWS2460VG	.215	26	E2486-S	.309	28	EUHC-B	.8196	360	F2QA2-74-2472E	1117	8
DWS2460Z	.186	26	EF10-120	1753	270	EUHC-C	.8259	360	F2QA2-74-2472S	3569	8
DWS4-63-1836V	.639	26	EF10-120-1	1998	270	EUHC-D	.9251	360	F2QA2-74-2472V	1048	8
DWS4-63-1836VG	.639	26	EF10-120M	1753	270	EUHC-E	.7327	360	F2QA2-74-2472VG	1048	8
DWS4-63-1836Z	.548	26	EF10-120M-1	1998	270	EUHC-F	.8316	360	F2QA2-74-2472Z	.893	8
DWS4-63-1848V	.717	26	EF10-240	2043	270	EUHC-G	.8376	360	FB12-19	.869	307
DWS4-63-1848VG	.717	26	EF10-240-1	2043	270	EUHC-H	.9367	360	FB12-24	.968	307
DWS4-63-1848Z	.631	26	EF102-240	4351	270	EUHPC-A	.7336	362	FB18-19	.968	307
DWS4-63-1860V	.837	26	EF102-240-1	4351	270	EUHPC-B	.8325	362	FB18-24	1074	307
DWS4-63-1860VG	.837	26	EH14-C	.123	59	EUHPC-C	.8388	362	FB24-19	1074	307
DWS4-63-1860Z	.737	26	EH14-S	.148	59	EUHPC-D	.9376	362	FB24-24	1178	307
DWS4-63-2436V	.741	26	EH18-C	.126	59	EUHPC-E	.7454	362	FB30-19	1178	307
DWS4-63-2436VG	.741	26	EH18-S	.163	59	EUHPC-F	.8442	362	FB30-24	1276	307
DWS4-63-2436Z	.631	26	EH21-C	.127	59	EUHPC-G	.8507	362	FB36-19	1276	307
DWS4-63-2448V	.857	26	EH21-S	.174	59	EUHPC-H	.9494	362	FB36-24	1380	307
DWS4-63-2448VG	.857	26	EH24-C	.129	59	F1916	1766	196	FB42-19	1388	307
DWS4-63-2448Z	.732	26	EH24-S	.183	59	F1916-12	1829	196	FB42-24	1492	307
DWS4-63-2460V	.997	26	EH30-C	.134	59	F1916-VSCS	.6569	197	FB48-19	1492	307
DWS4-63-2460VG	.997	26	EH30-S	.217	59	F1916-VSCS-DL	.7504	197	FB48-24	1594	307
DWS4-63-2460Z	.865	26	EH36-C	.135	59	F1916-VSCS-DR	.7504	197	FB6-19	.775	307
DWS4-74-1836V	.649	26	EH36-S	.236	59	F2820	2021	196	FB6-24	.879	307
DWS4-74-1836VG	.649	26	EP74-C	.223	60	F2820-12	2245	196	FB60-19	1594	307
DWS4-74-1836Z	.563	26	EP74-E	.244	60	F2QA2-74-1836C	.558	8	FB60-24	1698	307
DWS4-74-1848V	.725	26	EP74-Z	.209	60	F2QA2-74-1836E	.657	8	FBGR12-18	1476	285
DWS4-74-1848VG	.725	26	EP86-C	.236	60	F2QA2-74-1836S	1792	8	FBGR12-22	1476	291
DWS4-74-1848Z	.644	26	EP86-E	.260	60	F2QA2-74-1836V	.606	8	FBGR18-18	1554	285
DWS4-74-1860V	.846	26	EP86-Z	.217	60	F2QA2-74-1836VG	.606	8	FBGR18-22	1554	291

# ALPHANUMERIC PRICE INDEX

Part Number	List Price	Page No.	Part Number	List Price	Page No.	Part Number	List Price	Page No.	Part Number	List Price	Page No.
FBGR24-18	1634	285	FDI-16-19-13.5-4	2082	202	FN2036-2-18R-14/3	5644	183	FN2840-2-24-14/3	7165	183
FBGR24-22	1634	291	FDI-16-19-8-1	598	201	FN2036-2-24-14/3	5922	183	FN2840-2-24L-14/3	6873	183
FCM1424BL	263	69	FDI-16-19-8-2	1156	201	FN2036-2-24L-14/3	5714	183	FN2840-2-24R-14/3	6873	183
FCM1424C	257	69	FDI-16-19-8-3	1668	202	FN2036-2-24R-14/3	5714	183	FN2860-3-14/3	7859	184
FCM1424R	263	69	FDI-16-19-8-4	2017	202	FN2040-2-14/3	5098	183	FN2860-3-24-14/3	9091	184
FCM1424V	263	69	FDI-18-24-13.5-1	732	201	FN2040-2-24-14/3	5922	183	FN2860-3-24L-14/3	8784	184
FCM1424VG	263	69	FDI-18-24-13.5-2	1388	201	FN2040-2-24L-14/3	5714	183	FN2860-3-24R-14/3	8784	184
FCM1424W	263	69	FDI-18-24-13.5-3	2017	202	FN2040-2-24R-14/3	5714	183	FN2880-4-14/3	10033	185
FCM1430BL	277	69	FDI-18-24-13.5-4	2373	202	FN2048-3-14/3	5739	184	FN2880-4-24-14/3	10978	185
FCM1430C	267	69	FDI-20-20-5-1	468	201	FN2048-3-18-14/3	6124	184	FN2880-4-24L-14/3	10673	185
FCM1430R	277	69	FDI-22-22-13.5-1	854	201	FN2048-3-18L-14/3	5978	184	FN2880-4-24R-14/3	10673	185
FCM1430V	277	69	FDI-22-22-13.5-2	1646	201	FN2048-3-18R-14/3	5978	184	FNP2820-1-18L-48TR	8941	187
FCM1430VG	277	69	FDI-22-22-13.5-3	2286	202	FN2048-3-24-14/3	6248	184	FNP2820-1-18R-48TL	8941	187
FCM1430W	277	69	FDI-22-22-13.5-4	2774	202	FN2048-3-24L-14/3	6038	184	FNP2820-1-24L-48TR	9100	187
FCM1436BL	294	69	FDI-24-24-13.5-1	891	201	FN2048-3-24R-14/3	6038	184	FNP2820-1-24R-48TL	9100	187
FCM1436C	284	69	FDI-24-24-13.5-2	1716	201	FN2054-3-14/3	6560	184	FNP2820-1-48TL	8467	187
FCM1436R	294	69	FDI-24-24-13.5-3	2385	202	FN2054-3-18-14/3	7213	184	FNP2820-1-48TR	8467	187
FCM1436V	294	69	FDI-24-24-13.5-4	2887	202	FN2054-3-18L-14/3	7049	184	FNP2840-2-18L-48TR	10126	187
FCM1436VG	294	69	FFN2736-2-24-14/3	13227	193	FN2054-3-18R-14/3	7049	184	FNP2840-2-18R-48TL	10126	187
FCM1436W	294	69	FFN2736-2-30-14/3	14805	193	FN2054-3-24-14/3	7423	184	FNP2840-2-24L-48TR	10287	187
FCM1442BL	322	69	FFN2740-2-24-14/3	13837	193	FN2054-3-24L-14/3	7098	184	FNP2840-2-24R-48TL	10287	187
FCM1442C	312	69	FFN2740-2-30-14/3	15407	193	FN2054-3-24R-14/3	7098	184	FNP2840-2-48TL	9655	187
FCM1442R	322	69	FFN2748-2-24-14/3	15048	193	FN2060-3-14/3	6560	184	FNP2840-2-48TR	9655	187
FCM1442V	322	69	FFN2748-2-30-14/3	16625	193	FN2060-3-24-14/3	7423	184	FNP2860-3-18L-48TR	11558	188
FCM1442VG	322	69	FFN2754-3-24-14/3	15957	193	FN2060-3-24L-14/3	7098	184	FNP2860-3-18R-48TL	11558	188
FCM1442W	322	69	FFN2754-3-30-14/3	17776	193	FN2060-3-24R-14/3	7098	184	FNP2860-3-24L-48TR	11718	188
FCM1448BL	328	69	FFN2760-2-24-14/3	16871	193	FN2064-4-14/3	7338	185	FNP2860-3-24R-48TL	11718	188
FCM1448C	319	69	FFN2760-2-30-14/3	18440	193	FN2064-4-18-14/3	7664	185	FNP2860-3-48TL	11085	188
FCM1448R	328	69	FFN2760-3-24-14/3	16871	193	FN2064-4-18L-14/3	7391	185	FNP2860-3-48TR	11085	188
FCM1448V	328	69	FFN2760-3-30-14/3	18691	193	FN2064-4-18R-14/3	7391	185	FNWNF-12-14-8-1	861	202
FCM1448VG	328	69	FFN2772-3-24-14/3	18691	193	FN2064-4-24-14/3	7807	185	FNWNF-14-16-8-1	902	202
FCM1448W	328	69	FFN2772-3-30-14/3	20506	193	FN2064-4-24L-14/3	7458	185	FNWNF-18-18-10-1	807	202
FCM1454BL	341	69	FFN2790-3-24-14/3	21419	193	FN2064-4-24R-14/3	7458	185	FNWNF-18-18-12-1	818	202
FCM1454C	333	69	FFN2790-3-30-14/3	23240	193	FN2072-4-14/3	8244	185	FNWNF-20-20-10-1	854	202
FCM1454R	341	69	FL-2	1914	236	FN2072-4-18-14/3	8944	185	FNWNF-20-20-12-1	897	202
FCM1454V	341	69	FL-3	2028	236	FN2072-4-18L-14/3	8724	185	FNWNF-20-20-14-1	945	202
FCM1454VG	341	69	FL-4	2078	236	FN2072-4-18R-14/3	8724	185	FNWNF-20-27-6-1	807	202
FCM1454W	341	69	FN2016-1-14/3	3471	182	FN2072-4-24-14/3	9028	185	FNWNF-20.5-20.5-5-1	742	202
FCM1460BL	363	69	FN2016-1-18-14/3	3840	182	FN2072-4-24L-14/3	8774	185	FNWNF-20.5-20.5-8-1	814	202
FCM1460C	351	69	FN2016-1-18L-14/3	3696	182	FN2072-4-24R-14/3	8774	185	FNWNF-24-24-12-1	998	202
FCM1460R	363	69	FN2016-1-18R-14/3	3696	182	FN2080-4-14/3	8244	185	FNWNF-24-24-14-1	1048	202
FCM1460V	363	69	FN2016-1-24-14/3	3991	182	FN2080-4-24-14/3	9028	185	FNWNF-9-12-6-1	788	202
FCM1460VG	363	69	FN2016-1-24L-14/3	3757	182	FN2080-4-24L-14/3	8774	185	FNWNF-9-14-8-1	836	202
FCM1460W	363	69	FN2016-1-24R-14/3	3757	182	FN2080-4-24R-14/3	8774	185	FOOT PLATE	16	51
FCR-10-9A	1566	346	FN2018-1-14/3	3912	182	FN2424-1-14/3	4187	182	FOOT PLATE-BL	16	51
FD-FG	1826	211	FN2018-1-18-14/3	4216	182	FN2424-1-24-14/3	4988	182	FOOT PLATE-S	32	51
FD-SG	2433	211	FN2018-1-18L-14/3	4052	182	FN2424-1-24L-14/3	4714	182	FSHC-A	7224	359
FDI-10-14-5-1	383	201	FN2018-1-18R-14/3	4052	182	FN2424-1-24R-14/3	4714	182	FSHC-B	8277	359
FDI-10-14-9.5-1	425	201	FN2018-1-24-14/3	4351	182	FN2448-2-14/3	6060	183	FSHC-C	9233	359
FDI-10-14-9.5-2	818	201	FN2018-1-24L-14/3	4121	182	FN2448-2-24-14/3	7119	183	FSHC-D	10286	359
FDI-10-14-9.5-3	1222	202	FN2018-1-24R-14/3	4121	182	FN2448-2-24L-14/3	6873	183	FSHC-E	7454	359
FDI-10-14-9.5-4	1469	202	FN2020-1-14/3	3912	182	FN2448-2-24R-14/3	6873	183	FSHC-F	8508	359
FDI-12-14-9.5-1	443	201	FN2020-1-24-14/3	4351	182	FN2472-3-14/3	7629	184	FSHC-G	9459	359
FDI-12-14-9.5-2	883	201	FN2020-1-24L-14/3	4121	182	FN2472-3-24-14/3	8856	184	FSHC-H	10515	359
FDI-12-14-9.5-3	1234	202	FN2020-1-24R-14/3	4121	182	FN2472-3-24L-14/3	8628	184	FSHPC-A	7302	361
FDI-12-14-9.5-4	1642	202	FN2032-2-14/3	4642	183	FN2472-3-24R-14/3	8628	184	FSHPC-B	8353	361
FDI-12-20-6.5-1	463	201	FN2032-2-18-14/3	5162	183	FN2496-4-14/3	9485	185	FSHPC-C	9311	361
FDI-14-16-6-1	475	201	FN2032-2-18L-14/3	4988	183	FN2496-4-24-14/3	10671	185	FSHPC-D	10363	361
FDI-14-16-9.5-1	488	201	FN2032-2-18R-14/3	4988	183	FN2496-4-24L-14/3	10381	185	FSHPC-E	7531	361
FDI-14-16-9.5-2	951	201	FN2032-2-24-14/3	5287	183	FN2496-4-24R-14/3	10381	185	FSHPC-F	8583	361
FDI-14-16-9.5-3	1385	202	FN2032-2-24L-14/3	5075	183	FN2820-1-14/3	4618	182	FSHPC-G	9542	361
FDI-14-16-9.5-4	1704	202	FN2032-2-24R-14/3	5075	183	FN2820-1-24-14/3	5038	182	FSHPC-H	10594	361
FDI-16-19-13.5-1	603	201	FN2036-2-14/3	5098	183	FN2820-1-24L-14/3	4817	182	FT-12120-FG	5596	207
FDI-16-19-13.5-2	1188	201	FN2036-2-18-14/3	5533	183	FN2820-1-24R-14/3	4817	182	FT-12120-SG	9621	207
FDI-16-19-13.5-3	1740	202	FN2036-2-18L-14/3	5644	183	FN2840-2-14/3	6071	183	FT-1218-FG	2295	207



# ALPHANUMERIC PRICE INDEX

Part Number	List Price	Page No.	Part Number	List Price	Page No.	Part Number	List Price	Page No.	Part Number	List Price	Page No.
FT-1218-SG	3191	207	FT-2484-FG	5998	207	GRS1836C	487	38	HDFCM1460W	322	69
FT-1224-FG	2488	207	FT-2484-SG	8922	207	GRS1848C	536	38	HDR-10-24-120	1653	275
FT-1224-SG	3346	207	FT-2496-FG	6563	207	GRS1860C	613	38	HDS1836SE	554	77
FT-1230-FG	2732	207	FT-2496-SG	9871	207	GS17	176	105	HDS1836SF	502	76
FT-1230-SG	3449	207	G1436BL	82	73	GWB1436C	137	111	HDS1836SL	554	78
FT-1236-FG	2861	207	G1436C	80	73	GWB1436V	139	111	HDS1836VE	299	77
FT-1236-SG	3555	207	G1436R	82	73	GWB1436VG	139	111	HDS1836VF	293	76
FT-1248-FG	3284	207	G1436W	82	73	GWB1448C	152	111	HDS1836VGE	299	77
FT-1248-SG	4393	207	G1436Z	71	73	GWB1448V	155	111	HDS1836VGF	293	76
FT-1260-FG	3556	207	G1448BL	94	73	GWB1448VG	155	111	HDS1836VGL	301	78
FT-1260-SG	5268	207	G1448C	91	73	GWB1836C	144	111	HDS1836VL	301	78
FT-1272-FG	4017	207	G1448R	94	73	GWB1836V	155	111	HDS1842SE	613	77
FT-1272-SG	6054	207	G1448W	94	73	GWB1836VG	155	111	HDS1842SF	544	76
FT-1284-FG	4394	207	G1448Z	82	73	GWB1848C	161	111	HDS1842SL	613	78
FT-1284-SG	7116	207	G1836BL	89	73	GWB1848V	176	111	HDS1842VE	314	77
FT-1296-FG	4795	207	G1836C	87	73	GWB1848VG	176	111	HDS1842VF	304	76
FT-1296-SG	7319	207	G1836R	89	73	HD612FW-S	1707	275	HDS1842VGE	314	77
FT-15120-FG	5902	207	G1836W	89	73	HD612FW-SH	1791	275	HDS1842VGF	304	76
FT-15120-SG	10357	207	G1836Z	83	73	HDBW-10-24	884	275	HDS1842VGL	318	78
FT-1524-FG	2539	207	G1848BL	112	73	HDC3636	3156	325,334	HDS1842VL	318	78
FT-1524-SG	3558	207	G1848C	108	73	HDC3642	3541	325,334	HDS1848SE	672	77
FT-1530-FG	2758	207	G1848R	112	73	HDC3648	3736	325,334	HDS1848SF	589	76
FT-1530-SG	3643	207	G1848W	112	73	HDC4242	4015	325,334	HDS1848SL	672	78
FT-1536-FG	2885	207	G1848Z	99	73	HDC48-120NYF	17624	275	HDS1848VE	321	77
FT-1536-SG	4139	207	G2136BL	107	73	HDC4848	4648	325,334	HDS1848VF	316	76
FT-1548-FG	3323	207	G2136C	103	73	HDC4860	5254	325,334	HDS1848VGE	321	77
FT-1548-SG	5038	207	G2136R	107	73	HDFCM1424BL	235	69	HDS1848VGF	316	76
FT-1560-FG	3712	207	G2136W	107	73	HDFCM1424C	228	69	HDS1848VGL	326	78
FT-1560-SG	5899	207	G2136Z	91	73	HDFCM1424R	235	69	HDS1848VL	326	78
FT-1572-FG	4096	207	G2148BL	123	73	HDFCM1424V	235	69	HDS1854SE	702	77
FT-1572-SG	6785	207	G2148C	120	73	HDFCM1424VG	235	69	HDS1854SF	644	76
FT-1584-FG	4519	207	G2148R	123	73	HDFCM1424W	235	69	HDS1854SL	702	78
FT-1584-SG	7673	207	G2148W	123	73	HDFCM1430BL	248	69	HDS1854VE	344	77
FT-1596-FG	4877	207	G2148Z	107	73	HDFCM1430C	240	69	HDS1854VF	318	76
FT-1596-SG	8505	207	G2436BL	113	73	HDFCM1430R	248	69	HDS1854VGE	344	77
FT-18120-FG	6881	207	G2436C	109	73	HDFCM1430V	248	69	HDS1854VGF	318	76
FT-18120-SG	11088	207	G2436R	113	73	HDFCM1430VG	248	69	HDS1854VGL	337	78
FT-1824-FG	2725	207	G2436W	113	73	HDFCM1430W	248	69	HDS1854VL	337	78
FT-1824-SG	3762	207	G2436Z	100	73	HDFCM1436BL	261	69	HDS1860SE	740	77
FT-1830-FG	3009	207	G2448BL	135	73	HDFCM1436C	253	69	HDS1860SF	702	76
FT-1830-SG	3972	207	G2448C	129	73	HDFCM1436R	261	69	HDS1860SL	740	78
FT-1836-FG	3224	207	G2448R	135	73	HDFCM1436V	261	69	HDS1860VE	356	77
FT-1836-SG	4183	207	G2448W	135	73	HDFCM1436VG	261	69	HDS1860VF	347	76
FT-1848-FG	3733	207	G2448Z	119	73	HDFCM1436W	261	69	HDS1860VGE	356	77
FT-1848-SG	4973	207	GBP15-C	98	105	HDFCM1442BL	288	69	HDS1860VGF	347	76
FT-1860-FG	4169	207	GDI-2-240	2331	273	HDFCM1442C	279	69	HDS1860VGL	351	78
FT-1860-SG	6137	207	GDI-3-240	2787	273	HDFCM1442R	288	69	HDS1860VL	351	78
FT-1872-FG	4660	207	GDI-4-240	3560	273	HDFCM1442V	288	69	HDS2436SE	664	77
FT-1872-SG	6718	207	GDI-5-240	4011	273	HDFCM1442VG	288	69	HDFS2436SF	625	76
FT-1884-FG	5201	207	GLIDES	3	51	HDFCM1442W	288	69	HDS2436SL	664	78
FT-1884-SG	8159	207	GPS24-C	87	105	HDFCM1448BL	294	69	HDS2436VE	320	77
FT-1896-FG	5681	207	GPWB	27	105	HDFCM1448C	284	69	HDS2436VF	311	76
FT-1896-SG	8367	207	GR12-18	1167	285	HDFCM1448R	294	69	HDS2436VGE	320	77
FT-24120-FG	7983	207	GR12-22	1167	291	HDFCM1448V	294	69	HDS2436VGF	311	76
FT-24120-SG	11957	207	GR18-18	1227	285	HDFCM1448VG	294	69	HDS2436VGL	322	78
FT-2424-FG	2917	207	GR18-19	1268	313	HDFCM1448W	294	69	HDS2436VL	322	78
FT-2424-SG	4556	207	GR18-22	1227	291	HDFCM1454BL	304	69	HDS2442SE	719	77
FT-2430-FG	3287	207	GR18-24	1472	313	HDFCM1454C	296	69	HDS2442SF	702	76
FT-2430-SG	4743	207	GR1836C	352	38	HDFCM1454R	304	69	HDS2442SL	719	78
FT-2436-FG	3544	207	GR1848C	382	38	HDFCM1454V	304	69	HDS2442VE	333	77
FT-2436-SG	5408	207	GR24-18	1293	285	HDFCM1454VG	304	69	HDS2442VF	326	76
FT-2448-FG	4161	207	GR24-19	1472	313	HDFCM1454W	304	69	HDS2442VGE	333	77
FT-2448-SG	6263	207	GR24-22	1293	291	HDFCM1460BL	322	69	HDS2442VGF	326	76
FT-2460-FG	4771	207	GR24-24	1686	313	HDFCM1460C	312	69	HDS2442VGL	335	78
FT-2460-SG	7022	207	GR1860C	431	38	HDFCM1460R	322	69	HDS2442VL	335	78
FT-2472-FG	4814	207	GRD-2020-A	522	352	HDFCM1460V	322	69	HDS2448SE	762	77
FT-2472-SG	8162	207	GRDH-2020-A	726	352	HDFCM1460VG	322	69	HDS2448SF	759	76

# ALPHANUMERIC PRICE INDEX

Part Number	List Price	Page No.	Part Number	List Price	Page No.	Part Number	List Price	Page No.	Part Number	List Price	Page No.
HDS2448SL	785	78	HEF96-54	9807	332	HG1836R	113	72	HSA-10-FE-B-DS	3256	166
HDS2448VE	343	77	HEF96-60	14424	332	HG1836W	113	72	HSA-10-FE-B-NB-MG	3319	166
HDS2448VF	336	76	HEF96-66	14434	332	HG1848BL	129	72	HSA-10-FE-B-T-NB-MG	4091	166
HDS2448VGE	343	77	HEF96-72	16765	332	HG1848C	125	72	HSA-10-FK	1561	167
HDS2448VGF	336	76	HEF96-78	16776	332	HG1848R	129	72	HSA-10-FKP	1740	167
HDS2448VGL	346	78	HEF96-84	18615	332	HG1848W	129	72	HSA-10-FL	1031	163
HDS2448VL	346	78	HEF96-90	18785	332	HG2136BL	121	72	HSA-10-FLDP	1820	164
HDS2454SE	854	77	HEF96-96	18960	332	HG2136C	118	72	HSA-10-FO	854	163
HDS2454SF	828	76	HEIA96-102	22284	333	HG2136R	121	72	HSA-10-FODP	1860	164
HDS2454SL	854	78	HEIA96-108	23575	333	HG2136W	121	72	HSA-10-FODPE	3767	165
HDS2454VE	372	77	HEIA96-114	24897	333	HG2148BL	138	72	HSA-10-FOE	2755	165
HDS2454VF	365	76	HEIA96-120	26198	333	HG2148C	134	72	HSA-10-FTWS	1136	170
HDS2454VGE	372	77	HEIA96-126	27511	333	HG2148R	138	72	HSA-10-FTWS-LRS	1688	170
HDS2454VGF	365	76	HEIA96-132	28819	333	HG2148W	138	72	HSA-10-FW	832	167
HDS2454VGL	379	78	HEIA96-138	31361	333	HG2436BL	126	72	HSA-10-FWLDP-LRS	2456	164
HDS2454VL	379	78	HEIA96-144	33914	333	HG2436C	123	72	HSA-SSK	176	175
HDS2460SE	912	77	HEIA96-48	10483	333	HG2436R	126	72	HSA-WM-48	5314	169
HDS2460SF	861	76	HEIA96-54	11806	333	HG2436W	126	72	HSA-WM-60	5566	169
HDS2460SL	912	78	HEIA96-60	13107	333	HG2448BL	144	72	HSA-WM-72	5583	169
HDS2460VE	383	77	HEIA96-66	14405	333	HG2448C	141	72	HSA-WM-96	6480	169
HDS2460VF	378	76	HEIA96-72	15732	333	HG2448R	144	72	HSAD-10-F	665	172
HDS2460VGE	383	77	HEIA96-78	17029	333	HG2448W	144	72	HSAE-10-FA	801	172
HDS2460VGF	378	76	HEIA96-84	18352	333	HGK18	37	72	HSAN-10-F	857	171
HDS2460VGL	387	78	HEIA96-90	19651	333	HGK21	43	72	HSAN-10-F-DS	1093	171
HDS2460VL	387	78	HEIA96-96	20973	333	HGK24	52	72	HSAN-10-F-LRS	1408	170
HDSCP14-S	64	79	HES96-102	12706	332	HGML18	37	72	HSAN-10-FE-B-DS	3647	166
HDSCP33-S	88	79	HES96-108	13436	332	HGML21	43	72	HSAND-10-F	715	171
HDSCP54-S	95	79	HES96-114	14194	332	HGML24	52	72	HSANT-FS	1012	171
HDSCP63-S	109	79	HES96-120	14933	332	HGP18	37	72	HSAP-14-ADA-FE-B	5749	166,169
HDSCP74-S	125	79	HES96-126	15654	332	HGP21	43	72	HSAP-14-ADA-FW	4917	169
HDSP14-S	64	79	HES96-132	16426	332	HGP24	52	72	HSAP-14-FW	2073	169
HDSP33-S	88	79	HES96-138	17139	332	HGR18	37	72	HSAP-SSK	214	175
HDSP54-S	95	79	HES96-144	17887	332	HGR21	43	72	HSD12-24	2177	302
HDSP63-S	109	79	HES96-48	5978	332	HGR24	52	72	HSD18-19	2211	302
HDSP74-S	125	79	HES96-54	6735	332	HGS18	37	72	HSD18-24	2287	302
HDT518-C	242	56	HES96-60	7473	332	HGS21	43	72	HSHC-A	6489	360
HDT518-E	251	56	HES96-66	8901	332	HGS24	52	72	HSHC-B	7478	360
HDT524-C	258	56	HES96-72	8972	332	HGU18	37	72	HSHC-C	7541	360
HDT524-E	278	56	HES96-78	9706	332	HGU21	43	72	HSHC-D	8531	360
HEB96-102	13813	332	HES96-84	10466	332	HGU24	52	72	HSHC-E	6606	360
HEB96-108	14565	332	HES96-90	11201	332	HS12-19	1632	302	HSHC-F	7595	360
HEB96-114	15404	332	HES96-96	11958	332	HS12-24	1697	302	HSHC-G	7659	360
HEB96-120	16158	332	HESFA96-102	18341	332	HS18-19	1733	302	HSHC-H	8648	360
HEB96-126	16997	332	HESFA96-108	20549	332	HS18-24	1806	302	HSHP-C	6617	362
HEB96-132	17748	332	HESFA96-114	20581	332	HSA-10	615	163	HSHP-B	7606	362
HEB96-138	18588	332	HESFA96-120	22793	332	HSA-10-1FK	1561	167	HSHP-C	7668	362
HEB96-144	19338	332	HESFA96-126	22821	332	HSA-10-8	597	172	HSHP-D	8659	362
HEB96-48	6762	332	HESFA96-132	25032	332	HSA-10-8F	767	172	HSHP-E	6735	362
HEB96-54	7538	332	HESFA96-138	25062	332	HSA-10-F	720	163	HSHP-F	7723	362
HEB96-60	8293	332	HESFA96-144	27275	332	HSA-10-F-DS	947	164	HSHP-G	7785	362
HEB96-66	9040	332	HESFA96-48	9366	332	HSA-10-F-LRS	1273	170	HSHP-H	8774	362
HEB96-72	9881	332	HESFA96-54	9398	332	HSA-10-FA	760	163	HSR-12	254	313
HEB96-78	10631	332	HESFA96-60	11607	332	HSA-10-FA-1P	1593	167	HSR-18	261	313
HEB96-84	11474	332	HESFA96-66	11618	332	HSA-10-FA-P	1593	167	HSR-24	303	313
HEB96-90	12223	332	HESFA96-72	13848	332	HSA-10-FA-PE	3488	165	HSR-30	341	313
HEB96-96	13063	332	HESFA96-78	13856	332	HSA-10-FAW	968	163,170	HSR-36	380	313
HEF96-102	21126	332	HESFA96-84	16088	332	HSA-10-FDP	1516	164	HT2-LP	2147	216
HEF96-108	21364	332	HESFA96-90	16099	332	HSA-10-FDP-T	2209	172	HT2-NG	2147	216
HEF96-114	21503	332	HESFA96-96	18142	332	HSA-10-FDPE	3751	165	HT2CB-120	5577	218
HEF96-120	23817	332	HFH	62	105	HSA-10-FDPE-LRS	4302	170	HT2CB-208	5577	218
HEF96-126	23845	332	HFL-5000	5046	162	HSA-10-FDPEE	4108	165	HT2CB-208-3	6094	218
HEF96-132	26492	332	HFL-5000-LRS	5346	162	HSA-10-FDPEE-B-T	5766	166	HT2CB-240	5577	218
HEF96-138	26931	332	HFL-5000-S	4499	162	HSA-10-FDPK	2391	167	HT2CB-240-3	6094	218
HEF96-144	28503	332	HG1836BL	113	72	HSA-10-FDPS	2314	164	HT2CB-LP	5383	220
HEF96-48	9778	332	HG1836C	109	72	HSA-10-FE	2620	165	HT2CB-NG	5383	220

# ALPHANUMERIC PRICE INDEX

Part Number	List Price	Page No.	Part Number	List Price	Page No.	Part Number	List Price	Page No.	Part Number	List Price	Page No.
HT20B-120	5025	218	IC3-12	80	299	L14-4BL	29	67	L30-4W	39	67
HT20B-208	5025	218	IC3-18	87	299	L14-4C	25	53	L36-1BL	34	67
HT20B-208-3	5544	218	IC3-24	99	299	L14-4E	32	53	L36-1C	33	53
HT20B-240	5025	218	IC3-30	109	299	L14-4R	29	67	L36-1R	34	67
HT20B-240-3	5544	218	IC3-36	119	299	L14-4S	52	53	L36-1S	58	53
HT20B-LP	5220	220	IC3-42	127	299	L14-4V	29	53	L36-1V	34	53
HT20B-NG	5220	220	IC3-48	139	299	L14-4VG	29	53	L36-1VG	34	53
HT3-LP	2574	216	IC4-12	85	299	L14-4W	29	67	L36-1W	34	67
HT3-NG	2574	216	IC4-18	98	299	L18-1BL	24	67	L36-4BL	49	67
HT3CB-120	6824	218	IC4-24	111	299	L18-1C	23	53	L36-4C	47	53
HT3CB-208	6824	218	IC4-30	123	299	L18-1R	24	67	L36-4E	51	53
HT3CB-208-3	7341	218	IC4-36	137	299	L18-1S	33	53	L36-4R	49	67
HT3CB-240	6824	218	IC4-42	148	299	L18-1V	24	53	L36-4S	104	53
HT3CB-240-3	7341	218	IC4-48	162	299	L18-1VG	24	53	L36-4V	49	53
HT3CB-LP	6152	220	ICWB-19/19	1185	306	L18-1W	24	67	L36-4VG	49	53
HT3CB-NG	6152	220	ICWB-19/24L	1217	306	L18-4BL	32	67	L36-4W	49	67
HT3OB-120	5773	218	ICWB-19/24R	1217	306	L18-4C	29	53	L42-1BL	37	67
HT3OB-208	5773	218	ICWB-19/30L	1235	306	L18-4E	34	53	L42-1C	36	53
HT3OB-208-3	6288	218	ICWB-19/30R	1235	306	L18-4R	32	67	L42-1R	37	67
HT3OB-240	5773	218	ICWB-24/24	1235	306	L18-4S	55	53	L42-1S	67	53
HT3OB-240-3	6288	218	ICWB-24/30L	1268	306	L18-4V	32	53	L42-1V	37	53
HT3OB-LP	5966	220	ICWB-24/30R	1268	306	L18-4VG	32	53	L42-1VG	37	53
HT3OB-NG	5966	220	IL-2	1879	236	L18-4W	32	67	L42-1W	37	67
HT4-LP	3147	216	IL-3	2162	236	L21-1BL	27	67	L42-4BL	58	67
HT4-NG	3147	216	IL-4	2416	236	L21-1C	25	53	L42-4C	51	53
HT4CB-120	8383	218	K10	52	75	L21-1R	27	67	L42-4E	60	53
HT4CB-208	8383	218	K12	55	75	L21-1S	35	53	L42-4R	58	67
HT4CB-208-3	8899	218	K14	59	75	L21-1V	27	53	L42-4S	118	53
HT4CB-240	8383	218	K16	66	75	L21-1VG	27	53	L42-4V	58	53
HT4CB-240-3	8899	218	K18	69	75	L21-1W	27	67	L42-4VG	58	53
HT4CB-LP	7205	220	K20	73	75	L21-4BL	33	67	L42-4W	58	67
HT4CB-NG	7205	220	KBD-1	334	48,50	L21-4C	31	53	L48-1BL	38	67
HT4OB-120	7095	218	KBD-1/SS	431	48,50	L21-4E	35	53	L48-1C	37	53
HT4OB-208	7095	218	KBD-2	289	50	L21-4R	33	67	L48-1R	38	67
HT4OB-208-3	7612	218	KBD-2/SS	454	50	L21-4S	68	53	L48-1S	68	53
HT4OB-240	7095	218	KP12-A	25	64	L21-4V	33	53	L48-1V	38	53
HT4OB-240-3	7612	218	KP34-A	36	64	L21-4VG	33	53	L48-1VG	38	53
HT4OB-LP	6987	220	KP48-A	37	64	L21-4W	33	67	L48-1W	38	67
HT4OB-NG	6987	220	KP54-A	41	64	L24-1BL	31	67	L48-4BL	60	67
HT5-LP	3792	216	KP68-A	52	64	L24-1C	29	53	L48-4C	54	53
HT5-NG	3792	216	KP72-A	55	64	L24-1R	31	67	L48-4E	62	53
HT5CB-208	9063	218	KP76-A	58	64	L24-1S	37	53	L48-4R	60	67
HT5CB-208-3	9579	218	KP84-A	67	64	L24-1V	31	53	L48-4S	133	53
HT5CB-240	9063	218	KR1842A	933	64	L24-1VG	31	53	L48-4V	60	53
HT5CB-240-3	9579	218	KR1860A	1257	64	L24-1W	31	67	L48-4VG	60	53
HT5CB-LP	8612	220	KR1880A	1445	64	L24-4BL	35	67	L48-4W	60	67
HT5CB-NG	8612	220	KR1893A	1721	64	L24-4C	33	53	L54-1BL	40	67
HT5OB-208	8364	218	KRB1842A	125	64	L24-4E	37	53	L54-1C	39	53
HT5OB-208-3	8880	218	KRB1860A	145	64	L24-4R	35	67	L54-1R	40	67
HT5OB-240	8364	218	KRB1880A	155	64	L24-4S	74	53	L54-1S	78	53
HT5OB-240-3	8880	218	KRB1893A	183	64	L24-4V	35	53	L54-1V	40	53
HT5OB-LP	8353	220	KRS1842A	240	64	L24-4VG	35	53	L54-1VG	40	53
HT5OB-NG	8353	220	KRS1860A	378	64	L24-4W	35	67	L54-1W	40	67
HT6CB-208	7235	218	KRS1880A	456	64	L30-1BL	32	67	L54-4BL	66	67
HT6CB-240	10069	218	KRS1893A	540	64	L30-1C	31	53	L54-4C	55	53
HT6CB-240-3	10643	218	KSR-12	363	313	L30-1R	32	67	L54-4E	67	53
HT6CB-LP	10065	220	KSR-18	366	313	L30-1S	53	53	L54-4R	66	67
HT6CB-NG	10065	220	KSR-24	387	313	L30-1V	32	53	L54-4S	151	53
HT6OB-208	9294	218	KSR-30	399	313	L30-1VG	32	53	L54-4V	66	53
HT6OB-240	9294	218	KSR-36	416	313	L30-1W	32	67	L54-4VG	66	53
HT6OB-240-3	9866	218	L14-1BL	22	67	L30-4BL	39	67	L54-4W	66	67
HT6OB-LP	9760	220	L14-1C	21	53	L30-4C	39	53	L60-1BL	46	67
HT6OB-NG	9760	220	L14-1R	22	67	L30-4E	47	53	L60-1C	43	53
HWB-E	3022	168	L14-1S	32	53	L30-4R	39	67	L60-1R	46	67
HWB-T	3284	168	L14-1V	22	53	L30-4S	87	53	L60-1S	85	53
HWC-E	2888	168	L14-1VG	22	53	L30-4V	39	53	L60-1V	46	53
HWC-T	3153	168	L14-1W	22	67	L30-4VG	39	53	L60-1VG	46	53

# ALPHANUMERIC PRICE INDEX

Part Number	List Price	Page No.	Part Number	List Price	Page No.	Part Number	List Price	Page No.	Part Number	List Price	Page No.
L60-1W	46	67	LR36-C	40	35	M1860V-4	909	35	MC1424-74-6VG	807	36
L60-4BL	69	67	LR36-R	47	68	M1860VG	185	35	MC1424-74-6W	807	36
L60-4C	59	53	LR36-V	47	35	M1860VG-4	909	35	MC1430-48-4BL	677	36
L60-4E	71	53	LR36-VG	47	35	M1860Z	173	35	MC1430-48-4R	677	36
L60-4R	69	67	LR36-W	47	68	M1860Z-4	843	35	MC1430-48-4V	677	36
L60-4S	152	53	LR36-Z	31	35	M18BL	59	35	MC1430-48-4VG	677	36
L60-4V	69	53	LR42-BL	51	68	M18C	53	35	MC1430-48-4W	677	36
L60-4VG	69	53	LR42-R	51	68	M18V	59	35	MC1430-54-4BL	704	36
L60-4W	69	67	LR42-W	51	68	M18VG	59	35	MC1430-54-4R	704	36
L72-1BL	52	67	LR48-BL	54	35,68	MA1-18	708	294	MC1430-54-4V	704	36
L72-1C	51	53	LR48-C	52	35	MA1-22	752	294	MC1430-54-4VG	704	36
L72-1R	52	67	LR48-R	54	68	MA2-18	843	293	MC1430-54-4W	704	36
L72-1S	91	53	LR48-V	54	35	MA2-22	906	293	MC1430-63-5BL	717	36
L72-1V	52	53	LR48-VG	54	35	MA4-18	881	294	MC1430-63-5R	717	36
L72-1VG	52	53	LR48-W	54	68	MA4-22	931	294	MC1430-63-5V	717	36
L72-1W	52	67	LR48-Z	33	35	MA5-18	742	294	MC1430-63-5VG	717	36
L72-4BL	73	67	LR54-BL	57	68	MA5-22	785	294	MC1430-63-5W	717	36
L72-4C	71	53	LR54-R	57	68	MA5-18	1047	294	MC1430-74-6BL	821	36
L72-4E	81	53	LR54-W	57	68	MA5-22	1122	294	MC1430-74-6R	821	36
L72-4R	73	67	LR60-BL	60	35,68	MA6-18	667	294	MC1430-74-6V	821	36
L72-4S	189	53	LR60-C	58	35	MA6-22	707	294	MC1430-74-6VG	821	36
L72-4V	73	53	LR60-R	60	68	MA7-18	1095	294	MC1430-74-6W	821	36
L72-4VG	73	53	LR60-V	60	35	MA7-22	1127	294	MC1436-48-4BL	682	36
L72-4W	73	67	LR60-VG	60	35	MAB12-18	827	294	MC1436-48-4R	682	36
LD12-24	1347	311	LR60-W	60	68	MAB12-22	893	294	MC1436-48-4V	682	36
LD18-24	1584	311	LR60-Z	35	35	MAB18-18	960	294	MC1436-48-4VG	682	36
LD24-18	1425	286	LR66-BL	66	68	MAB18-22	1037	294	MC1436-48-4W	682	36
LD24-22	1508	292	LR66-R	66	68	MAWB12-18	593	294	MC1436-54-4BL	712	36
LD24-24	1820	311	LR66-W	66	68	MAWB12-22	633	294	MC1436-54-4R	712	36
LD30-24	2052	311	LR72-BL	77	68	MC1422-48-4BL	695	36	MC1436-54-4V	712	36
LD36-24	2287	311	LR72-R	77	68	MC1422-48-4R	695	36	MC1436-54-4VG	712	36
LDDR12-19	1551	311	LR72-W	77	68	MC1422-48-4V	695	36	MC1436-54-4W	712	36
LDDR18-19	1820	311	M1824BL	151	35	MC1422-48-4VG	695	36	MC1436-63-5BL	721	36
LDDR24-19	2083	311	M1824BL-4	692	35	MC1422-48-4W	695	36	MC1436-63-5R	721	36
LDDR30-19	2349	311	M1824C	145	35	MC1422-54-4BL	722	36	MC1436-63-5V	721	36
LDDR36-19	2613	311	M1824C-4	659	35	MC1422-54-4R	722	36	MC1436-63-5VG	721	36
LDH	11	105	M1824V	151	35	MC1422-54-4V	722	36	MC1436-63-5W	721	36
LDH-BL	33	69	M1824V-4	692	35	MC1422-54-4VG	722	36	MC1436-74-6BL	827	36
LDH-C	33	69	M1824VG	151	35	MC1422-54-4W	722	36	MC1436-74-6R	827	36
LDSR12-19	1347	311	M1824VG-4	692	35	MC1422-63-5BL	735	36	MC1436-74-6V	827	36
LDSR12-24	1551	311	M1824Z	123	35	MC1422-63-5R	735	36	MC1436-74-6VG	827	36
LDSR18-19	1584	311	M1824Z-4	638	35	MC1422-63-5V	735	36	MC1436-74-6W	827	36
LDSR18-24	1820	311	M1836BL	155	35	MC1422-63-5VG	735	36	MCWS2424C	1174	48
LDSR24-19	1820	311	M1836BL-4	725	35	MC1422-63-5W	735	36	MCWS2424C-P	1180	48
LDSR24-24	2083	311	M1836C	153	35	MC1422-74-6BL	847	36	MCWS2424S	2085	48
LDSR30-19	2052	311	M1836C-4	694	35	MC1422-74-6R	847	36	MCWS2424S-P	2266	48
LDSR30-24	2349	311	M1836V	155	35	MC1422-74-6V	847	36	MCWS3030C	1280	48
LDSR36-19	2287	311	M1836V-4	725	35	MC1422-74-6VG	847	36	MCWS3030C-P	1286	48
LDSR36-24	2613	311	M1836VG	155	35	MC1422-74-6W	847	36	MCWS3030S	2188	48
LDUS12	75	105	M1836VG-4	725	35	MC1424-48-4BL	666	36	MCWS3030S-P	2368	48
LEVELING FOOT	2	51	M1836Z	134	35	MC1424-48-4R	666	36	MD2436	1474	48
LH	7	105	M1836Z-4	672	35	MC1424-48-4V	666	36	MD2448	1596	48
LH-BL	20	69	M1848BL	173	35	MC1424-48-4W	666	36	MDH-10	25	105
LH-C	16	69	M1848BL-4	837	35	MC1424-54-4BL	695	36	MDH-12	28	105
LLD24-18	1513	286	M1848C	161	35	MC1424-54-4R	695	36	MDH-4	17	105
LLD24-22	1652	292	M1848C-4	789	35	MC1424-54-4V	695	36	MDH-6	18	105
LR24-BL	37	35,68	M1848V	173	35	MC1424-54-4W	695	36	MDH-8	24	105
LR24-C	35	35	M1848V-4	837	35	MC1424-63-5BL	701	36	MDR1824-C	546	40
LR24-R	37	68	M1848Z	155	35	MC1424-63-5R	701	36	MDR1824-E	635	40
LR24-V	37	35	M1848Z-4	775	35	MC1424-63-5V	701	36	MDR1830-C	572	40
LR24-VG	37	35	M1860BL	185	35	MC1424-63-5VG	701	36	MDR1830-E	651	40
LR24-W	37	68	M1860BL-4	909	35	MC1424-63-5W	701	36	MDR1836-C	577	40
LR24-Z	29	35	M1860C	178	35	MC1424-74-6BL	807	36	MDR1836-E	662	40
LR30-BL	43	68	M1860C-4	855	35	MC1424-74-6R	807	36	MDR1836-S	1561	40
LR30-R	43	68	M1860V	185	35	MC1424-74-6V	807	36	MDR1848-C	621	40
LR30-W	43	68							MDR1848-E	708	40
LR36-BL	47	35,68							MDR1848-S	1657	40



100 Industrial Boulevard, Clayton, DE 19938-8903 U.S.A.  
 Phone: 800-441-8440 or 302-653-3000. Fax: 302-653-2065  
<http://www.eaglegrp.com>

# ALPHANUMERIC PRICE INDEX

Part Number	List Price	Page No.	Part Number	List Price	Page No.	Part Number	List Price	Page No.	Part Number	List Price	Page No.
MDR1860-C	.668	40	MMBB/A-12	.1171	82	MMCB/A6-R	.43	82	MMNSBB-8	.916	82
MDR1860-E	.769	40	MMBB/A-4	.431	82	MMCBSS-6-L	.68	82	MMNSBB-9	1032	82
MDR2124-C	.554	40	MMBB/A-5	.487	82	MMCBSS-6-R	.68	82	MMNSBB/FC-10	.601	82
MDR2124-E	.639	40	MMBB/A-6	.581	82	MMDB-K-14	.127	83	MMNSBB/FC-12	.747	82
MDR2130-C	.576	40	MMBB/A-7	.683	82	MMDB-K-18	.151	83	MMNSBB/FC-4	.236	82
MDR2130-E	.665	40	MMBB/A-8	.778	82	MMDB-K-21	.167	83	MMNSBB/FC-5	.296	82
MDR2136-C	.591	40	MMBB/A-9	.878	82	MMDB-K-24	.174	83	MMNSBB/FC-6	.357	82
MDR2136-E	.680	40	MMBB/FC-10	.689	82	MMDB-K/A-14	.126	83	MMNSBB/FC-7	.417	82
MDR2148-C	.634	40	MMBB/FC-12	.712	82	MMDB-K/A-18	.167	83	MMNSBB/FC-8	.481	82
MDR2148-E	.717	40	MMBB/FC-4	.218	82	MMDB-K/A-21	.177	83	MMNSBB/FC-9	.542	82
MDR2160-C	.695	40	MMBB/FC-5	.269	82	MMDB-K/A-24	.186	83	MMNSBBSS-10	2838	82
MDR2160-E	.789	40	MMBB/FC-6	.329	82	MMDBC-K-18	.145	85	MMNSBBSS-12	3401	82
MDR2424-C	.566	40	MMBB/FC-7	.385	82	MMDBC-K-21	.163	85	MMNSBBSS-4	1124	82
MDR2424-E	.662	40	MMBB/FC-8	.443	82	MMDBC-K-24	.173	85	MMNSBBSS-5	1417	82
MDR2430-C	.580	40	MMBB/FC-9	.499	82	MMDBC-K/A-18	.133	85	MMNSBBSS-6	1707	82
MDR2430-E	.672	40	MMBB/FC/A-10	.689	82	MMDBC-K/A-21	.152	85	MMNSBBSS-7	1985	82
MDR2436-C	.598	40	MMBB/FC/A-12	.712	82	MMDBC-K/A-24	.163	85	MMNSBBSS-8	2268	82
MDR2436-E	.685	40	MMBB/FC/A-4	.218	82	MMDBCSS-K-18	.247	85	MMNSBBSS-9	2555	82
MDR2436-S	1496	40	MMBB/FC/A-5	.269	82	MMDBCSS-K-21	.284	85	MMNSBBSS/FC-10	2083	82
MDR2448-C	.639	40	MMBB/FC/A-6	.329	82	MMDBCSS-K-24	.316	85	MMNSBBSS/FC-12	2498	82
MDR2448-E	.735	40	MMBB/FC/A-7	.385	82	MMDBSS-K-14	.227	83	MMNSBBSS/FC-4	.838	82
MDR2448-S	1766	40	MMBB/FC/A-8	.443	82	MMDBSS-K-18	.316	83	MMNSBBSS/FC-5	1054	82
MDR2460-C	.717	40	MMBB/FC/A-9	.499	82	MMDBSS-K-21	.380	83	MMNSBBSS/FC-6	1252	82
MDR2460-E	.819	40	MMBBSS-10	.2472	82	MMDBSS-K-24	.414	83	MMNSBBSS/FC-7	1461	82
MET2430S	2256	142	MMBBSS-12	.2978	82	MMDFB-K-14	.201	84	MMNSBBSS/FC-8	1666	82
MF30-18	.819	293	MMBBSS-4	.980	82	MMDFB-K-18	.261	84	MMNSBBSS/FC-9	1873	82
MF30-22	.853	293	MMBBSS-5	1234	82	MMDFB-K-21	.291	84	MMNSBC-K-18-L	.94	85
MF45-18	.819	293	MMBBSS-7	1734	82	MMDFB-K-24	.298	84	MMNSBC-K-18-R	.94	85
MF45-22	.853	293	MMBBSS-8	1980	82	MMDFBSSK-149	.416	84	MMNSBC-K-21-L	.109	85
MF60-18	.819	293	MMBBSS-9	2225	82	MMDFBSSK-189	.532	84	MMNSBC-K-21-R	.109	85
MF60-22	.853	293	MMBBSS/FC-10	1808	82	MMDFBSSK-249	.712	84	MMNSBC-K-24-L	.120	85
MF90-18	.819	293	MMBBSS/FC-12	2174	82	MMFB-K-14-L	.124	84	MMNSBC-K-24-R	.120	85
MF90-22	.853	293	MMBBSS/FC-4	.732	82	MMFB-K-14-R	.124	84	MMNSBC-K/A-18-L	.88	85
MFBK-S	.129	62.63	MMBBSS/FC-5	.918	82	MMFB-K-18-L	.148	84	MMNSBC-K/A-18-R	.88	85
MFC-18	1054	293	MMBBSS/FC-6	1088	82	MMFB-K-18-R	.148	84	MMNSBC-K/A-21-L	.100	85
MFC-22	1054	293	MMBBSS/FC-7	1269	82	MMFB-K-21-L	.171	84	MMNSBC-K/A-21-R	.100	85
ML10	.52	75	MMBBSS/FC-8	1449	82	MMFB-K-21-R	.171	84	MMNSBC-K/A-24-L	.109	85
ML12	.55	75	MMBBSS/FC-9	1629	82	MMFB-K-24-L	.182	84	MMNSBC-K/A-24-R	.109	85
ML14	.59	75	MMBC-K-18-L	.88	85	MMFB-K-24-R	.182	84	MMNSBCSS-K-18-L	.173	85
ML16	.66	75	MMBC-K-18-R	.88	85	MMFBSSK-149-L	.364	84	MMNSBCSS-K-18-R	.173	85
ML18	.69	75	MMBC-K-21-L	100	85	MMFBSSK-149-R	.364	84	MMNSBCSS-K-21-L	.221	85
ML20	.73	75	MMBC-K-21-R	100	85	MMFBSSK-189-L	.484	84	MMNSBCSS-K-21-R	.221	85
MMB-K-14-L	.74	83	MMBC-K-24-L	115	85	MMFBSSK-189-R	.484	84	MMNSBCSS-K-24-L	.260	85
MMB-K-14-R	.74	83	MMBC-K-24-R	115	85	MMFBSSK-249-L	.625	84	MMNSBCSS-K-24-R	.260	85
MMB-K-18-L	.91	83	MMBC-K/A-18-L	.83	85	MMFBSSK-249-R	.625	84	MMNSBSS-K-14-L	.173	83
MMB-K-18-R	.91	83	MMBC-K/A-18-R	.83	85	MMNSB-K-14-L	.84	83	MMNSBSS-K-14-R	.173	83
MMB-K-21-L	102	83	MMBC-K/A-21-L	.94	85	MMNSB-K-14-R	.84	83	MMNSBSS-K-18-L	.228	83
MMB-K-21-R	102	83	MMBC-K/A-21-R	.94	85	MMNSB-K-18-L	100	83	MMNSBSS-K-18-R	.228	83
MMB-K-24-L	113	83	MMBC-K/A-24-L	100	85	MMNSB-K-18-R	100	83	MMNSBSS-K-21-L	.279	83
MMB-K-24-R	113	83	MMBC-K/A-24-R	100	85	MMNSB-K-21-L	113	83	MMNSBSS-K-21-R	.279	83
MMB-K/A-14-L	.85	83	MMBCSS-K-18-L	163	85	MMNSB-K-21-R	113	83	MMNSBSS-K-24-L	.298	83
MMB-K/A-14-R	.85	83	MMBCSS-K-18-R	163	85	MMNSB-K-24-L	122	83	MMNSBSS-K-24-R	.298	83
MMB-K/A-18-L	.95	83	MMBCSS-K-21-L	203	85	MMNSB-K-24-R	122	83	MMNSCB-6-L	.32	82
MMB-K/A-18-R	.95	83	MMBCSS-K-21-R	203	85	MMNSB-K/A-14-L	.91	83	MMNSCB-6-R	.32	82
MMB-K/A-21-L	109	83	MMBCSS-K-24-L	240	85	MMNSB-K/A-14-R	.91	83	MMNSCB/A6-L	.43	82
MMB-K/A-21-R	109	83	MMBCSS-K-24-R	240	85	MMNSB-K/A-18-L	108	83	MMNSCB/A6-R	.43	82
MMB-K/A-24-L	122	83	MMBSS-K-14-L	162	83	MMNSB-K/A-18-R	108	83	MMNSCBSS-6-L	.68	82
MMB-K/A-24-R	122	83	MMBSS-K-14-R	162	83	MMNSB-K/A-21-L	119	83	MMNSCBSS-6-R	.68	82
MMBB-10	1004	82	MMBSS-K-18-L	222	83	MMNSB-K/A-21-R	119	83	MMNSDB-K-14	.126	83
MMBB-12	1201	82	MMBSS-K-18-R	222	83	MMNSB-K/A-24-L	138	83	MMNSDB-K-18	.167	83
MMBB-4	423	82	MMBSS-K-21-L	264	83	MMNSB-K/A-24-R	138	83	MMNSDB-K-21	.182	83
MMBB-5	499	82	MMBSS-K-21-R	264	83	MMNSBB-10	1152	82	MMNSDB-K-24	.191	83
MMBB-6	600	82	MMBSS-K-24-L	286	83	MMNSBB-12	1379	82	MMNSDB-K/A-14	.141	83
MMBB-7	701	82	MMBSS-K-24-R	286	83	MMNSBB-4	481	82	MMNSDB-K/A-18	.181	83
MMBB-8	804	82	MMCB-6-L	.32	82	MMNSBB-5	.575	82	MMNSDB-K/A-21	.194	83
MMBB-9	904	82	MMCB-6-R	.32	82	MMNSBB-6	.689	82	MMNSDB-K/A-24	.207	83
MMBB/A-10	972	82	MMCB/A6-L	.43	82	MMNSBB-7	.804	82	MMNSDBK-K-18	.157	85



# ALPHANUMERIC PRICE INDEX

Part Number	List Price	Page No.	Part Number	List Price	Page No.	Part Number	List Price	Page No.	Part Number	List Price	Page No.
MMNSDBC-K-21	177	85	MMNSUSS-9	859	81	MR45-18	819	293	MT3096B	2138	131
MMNSDBC-K-24	182	85	MMT3030G	2586	142	MR45-22	853	293	MT3096B-BS	3857	131
MMNSDBC-K/A-18	145	85	MMT3030S	2885	142	MR60-18	819	293	MT3096GT	1900	131
MMNSDBC-K/A-21	162	85	MMT3036G	2646	142	MR60-22	853	293	MT3096GT-BS	3614	131
MMNSDBC-K/A-24	163	85	MMT3036S	2972	142	MR90-18	819	293	MT3096S	2616	131
MMNSDBCSS-K-18	260	85	MMU-1	31	81	MR90-22	853	293	MT3096S-BS	4593	131
MMNSDBCSS-K-21	303	85	MMU-10	258	81	MRC-18	1054	293	MT3096ST	2459	131
MMNSDBCSS-K-24	340	85	MMU-12	314	81	MRC-22	1054	293	MT3096ST-BS	4351	131
MMNSDBSS-K-14	241	83	MMU-14	368	81	MS-C	20	48	MUK18-C	545	61
MMNSDBSS-K-18	334	83	MMU-16	419	81	MS2424	1012	141	MUK18-C86	568	61
MMNSDBSS-K-21	400	83	MMU-2	54	81	MS2424S	1229	141	MUK18-E	866	61
MMNSDBSS-K-24	425	83	MMU-3	85	81	MS3024	1055	141	MUK18-E86	879	61
MMNSDFB-K-14	221	84	MMU-4	100	81	MS3024S	1291	141	MUK18-Z	491	61
MMNSDFB-K-18	293	84	MMU-5	125	81	MS3030	1175	141	MUK18-Z86	512	61
MMNSDFB-K-21	314	84	MMU-6	151	81	MS3030S	1462	141	MUK21-C	560	61
MMNSDFB-K-24	327	84	MMU-7	177	81	MS3036	1206	141	MUK21-C86	582	61
MMNSDFBSSK-149	483	84	MMU-8	203	81	MS3036S	1487	141	MUK21-E	878	61
MMNSDFBSSK-189	614	84	MMU-9	231	81	MS3636	1265	141	MUK21-E86	902	61
MMNSDFBSSK-249	815	84	MMU/A-1	31	81	MS3636S	1557	141	MUK21-Z	511	61
MMNSFB-K-14-L	139	84	MMU/A-10	258	81	MSC1436	1516	46	MUK21-Z86	528	61
MMNSFB-K-14-R	139	84	MMU/A-12	314	81	MSC1448	1904	46	MUK24-C	569	61
MMNSFB-K-18-L	163	84	MMU/A-14	353	81	MSC2436	1566	46	MUK24-C86	594	61
MMNSFB-K-18-R	163	84	MMU/A-16	419	81	MSC2448	1969	46	MUK24-E	891	61
MMNSFB-K-21-L	186	84	MMU/A-2	54	81	MSS2020	3645	325	MUK24-E86	924	61
MMNSFB-K-21-R	186	84	MMU/A-3	85	81	MSS2020SC	4000	325	MUK24-Z	515	61
MMNSFB-K-24-L	203	84	MMU/A-4	100	81	MSS2424	3713	325	MUK24-Z86	538	61
MMNSFB-K-24-R	203	84	MMU/A-5	125	81	MSS2424SC	4084	325	MUK30-C	582	61
MMNSFBSSK-149-L	419	84	MMU/A-6	151	81	MT2448B	1063	131	MUK30-C86	606	61
MMNSFBSSK-149-R	419	84	MMU/A-7	177	81	MT2448GT	944	131	MUK30-E	914	61
MMNSFBSSK-189-L	551	84	MMU/A-8	203	81	MT2448S	1279	131	MUK30-E86	948	61
MMNSFBSSK-189-R	551	84	MMU/A-9	231	81	MT2448ST	1205	131	MUK30-Z	524	61
MMNSFBSSK-249-L	714	84	MMUSS-1	102	81	MT2460B	1193	131	MUK30-Z86	545	61
MMNSFBSSK-249-R	714	84	MMUSS-10	905	81	MT2460GT	1045	131	MUK36-C	609	61
MMNSU-1	34	81	MMUSS-12	1088	81	MT2460S	1452	131	MUK36-C86	634	61
MMNSU-10	276	81	MMUSS-2	182	81	MT2460ST	1349	131	MUK36-E	942	61
MMNSU-12	338	81	MMUSS-3	278	81	MT2472B	1322	131	MUK36-E86	971	61
MMNSU-2	57	81	MMUSS-4	366	81	MT2472GT	1146	131	MUK36-Z	537	61
MMNSU-3	89	81	MMUSS-5	460	81	MT2472S	1621	131	MUK36-Z86	554	61
MMNSU-4	109	81	MMUSS-6	546	81	MT2472ST	1499	131	MWS0710-PS	92	113
MMNSU-5	138	81	MMUSS-7	636	81	MT2496B	1875	131	MWS0710-SPS	95	113
MMNSU-6	160	81	MMUSS-8	725	81	MT2496GT	1644	131	MWS0912-PS	109	113
MMNSU-7	192	81	MMUSS-9	815	81	MT2496S	2264	131	MWS0912-SPS	112	113
MMNSU-8	220	81	MMXB-48	32	83	MT2496ST	1874	131	MWS1824	583	110
MMNSU-9	249	81	MMXB-60	37	83	MT3048B	1174	131	MWS2424	665	110
MMNSU/A-1	34	81	MMXB-72	43	83	MT3048B-BS	2243	131	NDR182412-A	293	41,351
MMNSU/A-10	276	81	MMXB-84	52	83	MT3048GT	1060	131	NDR183612-A	337	41,351
MMNSU/A-12	338	81	MMXB-N-48	83	83	MT3048GT-BS	2154	131	NDR184812-A	376	41,351
MMNSU/A-14	378	81	MMXB-N-60	100	83	MT3048S	1452	131	NDR202412-A	293	41,351
MMNSU/A-16	478	81	MMXB-N-72	120	83	MT3048S-BS	2884	131	NDR203612-A	337	41,351
MMNSU/A-2	57	81	MMXB-N-84	140	83	MT3048ST	1379	131	NDR204812-A	376	41,351
MMNSU/A-3	89	81	MOS1260C	1466	151	MT3048ST-BS	2736	131	NDR242412-A	345	41,351
MMNSU/A-4	109	81	MOS1260L	1293	151	MT3060B	1334	131	NDR243612-A	384	41,351
MMNSU/A-5	138	81	MOS1260R	1293	151	MT3060B-BS	2346	131	NDR244812-A	448	41,351
MMNSU/A-6	160	81	MOS1272C	1637	151	MT3060GT	1192	131	NL1626	54	349
MMNSU/A-7	192	81	MOS1272L	1463	151	MT3060GT-BS	2194	131	NTD3	3124	153
MMNSU/A-8	220	81	MOS1272R	1463	151	MT3060S	1664	131	NTD3I	4220	370
MMNSU/A-9	248	81	MOS1284C	1754	151	MT3060S-BS	3036	131	NTD3L	3296	153
MMNSUSS-1	109	81	MOS1284L	1583	151	MT3060ST	1572	131	NUR24	35	72,75
MMNSUSS-10	954	81	MOS1284R	1583	151	MT3060ST-BS	2880	131	NUR36	37	72,75
MMNSUSS-12	1143	81	MOS1296C	1826	151	MT3072B	1492	131	NUR48	39	72,75
MMNSUSS-2	192	81	MOS1296L	1754	151	MT3072B-BS	2821	131	OB24120SE	4559	133
MMNSUSS-3	288	81	MOS1296R	1754	151	MT3072GT	1319	131	OB24120SE-BS	4636	135
MMNSUSS-4	385	81	MPR-10	1666	343	MT3072GT-BS	2636	131	OB2436SE	2840	133
MMNSUSS-5	486	81	MPR-12	1805	343	MT3072S	1876	131	OB2436SE-BS	2873	135
MMNSUSS-6	574	81	MPT3042	5427	146	MT3072S-BS	3471	131	OB2448SE	2949	133
MMNSUSS-7	669	81	MR30-18	819	293	MT3072ST	1759	131	OB2448SE-BS	2979	135
MMNSUSS-8	760	81	MR30-22	853	293	MT3072ST-BS	3382	131	OB2460SE	3156	133



100 Industrial Boulevard, Clayton, DE 19938-8903 U.S.A.  
 Phone: 800-441-8440 or 302-653-3000. Fax: 302-653-2065  
<http://www.eaglegrp.com>

# ALPHANUMERIC PRICE INDEX

Part Number	List Price	Page No.	Part Number	List Price	Page No.	Part Number	List Price	Page No.	Part Number	List Price	Page No.
OB2460SE-BS	3194	135	ORS-2620-3	1066	346	OTR-2810-A/W	1260	344	P14-BL	24	23,65,74
OB2472SE	3364	133	ORS-2630-2	1218	346	OTR-2820-A/W	1757	344	P14-C	23	13,23,74
OB2472SE-BS	3411	135	OS-HT2	962	227	OTS-128-A	1760	344	P14-E	27	13
OB2484SE	3660	133	OS-HT3	987	227	OTS-128-SR	3029	344	P14-R	24	23,65,74
OB2484SE-BS	3714	135	OS-HT4	1015	227	OTS-228-A	2277	344	P14-S	43	13
OB2496SE	3845	133	OS-HT5	1380	227	OTS-228-SR	3722	344	P14-V	24	13
OB2496SE-BS	3905	135	OS-HT6	1519	227	OUR-1052-4-A	3141	342	P14-VG	24	13
OB30120SE	4847	133	OS10108-14/3	1603	150	OUR-1052-4-B	2983	342	P14-W	24	23,65,74
OB30120SE-BS	4924	135	OS10108-16/3	1446	150	OUR-1211-5	1634	342	P14-Z	21	13,23,74
OB3036SE	2999	133	OS10108-16/4	1105	150	OUR-1218-3-SR	2704	341	P16	66	75
OB3036SE-BS	3123	135	OS10120-14/3	1748	150	OUR-1220-3	1793	342	P18	69	75
OB3048SE	3104	133	OS10120-16/3	1567	150	OUR-1236-3-SR	5795	341	P18-C	24	13
OB3048SE-BS	3133	135	OS10120-16/4	1146	150	OUR-1452-4	3206	342	P18-E	28	13
OB3060SE	3337	133	OS10132-14/3	1853	150	OUR-1807-3	1181	339	P18-S	51	13
OB3060SE-BS	3498	135	OS10132-16/3	1665	150	OUR-1807-3-SR	2228	339	P18-V	25	13
OB3072SE	3575	133	OS10132-16/4	1199	150	OUR-1810-3/W	812	340	P18-VG	25	13
OB3072SE-BS	3618	135	OS10144-14/3	1945	150	OUR-1811-5	652	338	P18-Z	23	13
OB3084SE	3818	133	OS10144-16/3	1751	150	OUR-1811-5-SR	2335	338	P20	73	75
OB3084SE-BS	3869	135	OS10144-16/4	1243	150	OUR-1812-5/W	818	340	P1916	2979	176
OB3096SE	4214	133	OS1036-14/3	923	150	OUR-1818-3	809	338	P1916FE	3988	176
OB3096SE-BS	4274	135	OS1036-16/3	835	150	OUR-1818-3-SR	2924	338	P2RC-3	271	338
OBC-3A	564	350	OS1036-16/4	689	150	OUR-1820-3	818	338	P2RC-4	271	338
OCR-10-3A	1502	346	OS1048-14/3	1014	150	OUR-1820-3-N	1440	345	P2RCW-3	375	338
OCR-10-3AP	1688	346	OS1048-16/3	913	150	OUR-1820-3-SR	3125	338	P2RCW-4	375	338
OCR-10-4A	1697	346	OS1048-16/4	735	150	OUR-1820-3/W	882	340	P33-BL	27	23,29,65,74
OCR-10-4AP	1865	346	OS1060-14/3	1113	150	OUR-1822-5	2709	342	P33-C	25	13,23,74
OCR-10-9A	2139	346	OS1060-16/3	1002	150	OUR-1822-5-SR	5517	342	P33-E	32	13
ODR-2320-3	1043	349	OS1060-16/4	779	150	OUR-1824-2	944	338	P33-R	27	23,65,74
OHT-10	1059	61	OS1072-14/3	1212	150	OUR-1824-2-SR	3214	338	P33-S	68	13
OHT-11	1141	61	OS1072-16/3	1093	150	OUR-1830-2-N	1459	345	P33-V	27	13
OHT-12	1222	61	OS1072-16/4	835	150	OUR-1830-2/W	1271	340	P33-VG	27	13
OHT-13	1298	61	OS1084-14/3	1309	150	OUR-1836-3	3168	342	P33-W	27	23,65,74
OHT-14	1373	61	OS1084-16/3	1180	150	OUR-1836-3-SR	7028	342	P33-Z	24	13,23,74
OHT-15	1667	61	OS1084-16/4	883	150	OUR-1848-2	3614	342	P54-BL	32	23,29,65,74
OHT-16	1748	61	OS1096-14/3	1562	150	OUR-1848-2-SR	8016	342	P54-C	31	13,23,74
OHT-17	1826	61	OS1096-16/3	1405	150	OUR-2006-9A	1109	340	P54-E	33	13
OHT-18	1907	61	OS1096-16/4	1078	150	OUR-2006-9SR	2124	340	P54-R	32	23,65,74
OHT-19	1985	61	OS12108-14/3	1785	150	OUR-2008-6A	1126	340	P54-S	80	13
OHT-20	2057	61	OS12108-16/3	1603	150	OUR-2008-6SR	2156	340	P54-V	32	13
OHT-21	2137	61	OS12108-16/4	1218	150	OUR-2611-5	758	339	P54-VG	32	13
OHT-6	538	61	OS12120-14/3	1873	150	OUR-2611-5-SR	3021	339	P54-W	32	23,65,74
OHT-7	598	61	OS12120-16/3	1685	150	OUR-2612-5/W	1015	340	P54-Z	29	13,23,74
OHT-8	901	61	OS12120-16/4	1260	150	OUR-2618-3	957	339	P63-BL	34	23,29,65,74
OHT-9	980	61	OS12132-14/3	2002	150	OUR-2618-3-SR	3116	339	P63-C	32	13,23,74
OLH-C	16	38	OS12132-16/3	1800	150	OUR-2620-3	968	339	P63-E	36	13
OLR-1A	638	349	OS12132-16/4	1332	150	OUR-2620-3-SR	3206	339	P63-R	34	23,65,74
OLR-2A	682	349	OS12144-14/3	2091	150	OUR-2620-3/W	1154	340	P63-S	83	13
OLR-4A	474	349	OS12144-16/3	1882	150	OUR-2624-2	1106	339	P63-V	34	13
OLR-6A	580	349	OS12144-16/4	1374	150	OUR-2624-2-SR	3295	339	P63-VG	34	13
OPL-10-10A	708	347	OS1236-14/3	967	150	OUR-2630-2/W	1222	340	P63-W	34	23,65,74
OPL-10-12A	731	347	OS1236-16/3	871	150	OUR-DB-7A	1193	348	P63-Z	31	13,23,74
OPL-10-5A	580	347	OS1236-16/4	731	150	OUR-PZ-12A	1217	348	P7-BL	20	23,65
OPL-10-6A	603	347	OS1248-14/3	1062	150	OUR-PZA-12A	1068	348	P7-C	18	13,23
OPL-12-10A	731	347	OS1248-16/3	957	150	OURR-1811-5-A	1634	345	P7-E	23	13
OPL-12-12A	756	347	OS1248-16/4	774	150	OURR-1811-5-SR	2782	345	P7-R	20	23,65
OPL-12-5A	621	347	OS1260-14/3	1163	150	OURR-1818-3-A	1791	345	P7-S	39	13
OPL-12-6A	643	347	OS1260-16/3	1047	150	OURR-1818-3-SR	3015	345	P7-V	20	13
OR-1840	3514	341	OS1260-16/4	826	150	OURR-1824-2-A	1838	345	P7-VG	20	13
ORF-1810-6	934	346	OS1272-14/3	1274	150	OURR-1824-2-SR	3478	345	P7-W	20	23,65
ORF-1812-5	987	346	OS1272-16/3	1146	150	OURR-2036-3-A	2951	345	P7-Z	17	13,23
ORF-1815-4	1028	346	OS1272-16/4	884	150	OURR-2036-3-SR	3526	345	P74-BL	36	23,29,65,74
ORF-1820-3	1180	346	OS1284-14/3	1379	150	OUS18	121	56	P74-C	35	13,23,74
ORF-1830-2	1232	346	OS1284-16/3	1238	150	OUS21	122	56	P74-E	39	13
ORO-1840	2724	341	OS1284-16/4	940	150	OUS24	124	56			
ORS-2610-6	900	346	OS1296-14/3	1662	150	P10	52	75			
ORS-2612-5	951	346	OS1296-16/3	1493	150	P12	55	75			
ORS-2615-4	973	346	OS1296-16/4	1146	150	P14	59	75			

# ALPHANUMERIC PRICE INDEX

Part Number	List Price	Page No.	Part Number	List Price	Page No.	Part Number	List Price	Page No.	Part Number	List Price	Page No.
P74-R	36	23,65,74	PCS1884SE-CS	5626	137	PH18-C	71	59	PHT60B-240	14701	219
P74-S	94	13	PCS1896SE-CS	5951	137	PH18-S	108	59	PHT60B-240-3	15046	219
P74-V	36	13	PD3622	334	40	PH21-C	73	59	PIC60R	10341	138
P74-VG	36	13	PD4822	403	40	PH21-S	120	59	PIC72R	11109	138
P74-W	36	23,65,74	PD4836	463	40	PH24-C	73	59	PIC84R	11807	138
P74-Z	34	13,23,74	PD6022	460	40	PH24-S	127	59	PIH48-120	5131	138
P86-BL	46	23,29,65,74	PDHT2-120	2608	215	PH30-C	74	59	PIH48-208	5131	138
P86-C	43	13,23,74	PDHT2-208	2608	215	PH30-S	165	59	PIH48-240	5131	138
P86-E	47	13	PDHT2-208-3	2954	215	PH36-C	76	59	PL1030	29	347
P86-R	46	23,65,74	PDHT2-240	2608	215	PH36-S	182	59	PL1224	27	347
P86-S	113	13	PDHT2-240-3	2954	215	PH3RD	63	105	PL1230	31	347
P86-V	46	13	PDHT3-120	2879	215	PHS-A-C	7339	168	PLASTIC SPLIT SLEEVES	5	51,74
P86-VG	46	13	PDHT3-208	2879	215	PHS-A-C-LB	8073	168	POST CAP	2	51
P86-W	46	23,65,74	PDHT3-208-3	3223	215	PHS-A-H	8703	168	POST CLAMP	15	51
P86-Z	41	13,23,74	PDHT3-240	2879	215	PHS-A-H-LB	9574	168	PP1813-18	37	353
P96-C	51	13	PDHT3-240-3	3223	215	PHS-S-C	6120	168	PP1826-18	43	353
P96-S	119	13	PDHT4-120	3948	215	PHS-S-C-LB	6854	168	PR12VU	57	104
PB-5	4093	314	PDHT4-208	3948	215	PHS-S-H	7556	168	PR14B	125	104
PB-5-V	4502	314	PDHT4-208-3	4295	215	PHS-S-H-LB	7677	168	PR18B	137	104
PB-5-W	4298	314	PDHT4-240	3948	215	PHS-S3-C	6318	168	PR21B	141	104
PBH	46	105	PDHT4-240-3	4295	215	PHS-S3-C-LB	6949	168	PR2448SE14	4185	80
PC15120SE-CS	4961	137	PDHT5-208	4854	215	PHS-S3-H	7954	168	PR2448SE16	4065	80
PC15144SE-CS	6087	137	PDHT5-208-3	5197	215	PHS-S3-H-LB	9041	168	PR2448VE14	2191	80
PC1548SE-CS	3038	137	PDHT5-240	4854	215	PHT2CB-120	8718	219	PR2448VE16	2120	80
PC1560SE-CS	3245	137	PDHT5-240-3	5197	215	PHT2CB-208	8718	219	PR2448VGE14	2191	80
PC1572SE-CS	3607	137	PDS1872BL	320	29	PHT2CB-208-3	9064	219	PR2448VGE16	2120	80
PC1584SE-CS	3761	137	PDWB14C	83	112	PHT2CB-240	8718	219	PR2460SE14	4967	80
PC1596SE-CS	4080	137	PDWB14S	262	112	PHT2CB-240-3	9064	219	PR2460SE16	4659	80
PC18120SE-CS	5636	137	PDWB14VG	83	112	PHT2OB-120	7259	219	PR2460VE14	2375	80
PC18144SE-CS	6762	137	PDWB18C	86	112	PHT2OB-208	7259	219	PR2460VE16	2278	80
PC1848SE-CS	3242	137	PDWB18S	269	112	PHT2OB-208-3	7602	219	PR2460VGE14	2375	80
PC1860SE-CS	3505	137	PDWB18VG	86	112	PHT2OB-240	7259	219	PR2460VGE16	2278	80
PC1872SE-CS	4296	137	PDWB21C	89	112	PHT2OB-240-3	7602	219	PR24B	181	104
PC1884SE-CS	4633	137	PDWB21S	282	112	PHT3CB-120	10128	219	PR30VU	94	104
PC1896SE-CS	4961	137	PDWB21VG	89	112	PHT3CB-208	10128	219	PR45VU	117	104
PCH15120SE-CS	5996	137	PDWB24C	92	112	PHT3CB-208-3	10476	219	PRT108-C	217	148
PCH15144SE-CS	7125	137	PDWB24S	286	112	PHT3CB-240	10128	219	PRT120-C	224	148
PCH1548SE-CS	4075	137	PDWB24VG	92	112	PHT3CB-240-3	10476	219	PRT132-C	242	148
PCH1560SE-CS	4281	137	PF1824-C	162	38	PHT3OB-120	8988	219	PRT144-C	263	148
PCH1572SE-CS	4645	137	PF1824-E	193	38	PHT3OB-208	8988	219	PRT2-C	89	233
PCH1584SE-CS	4814	137	PF1824-Z	161	38	PHT3OB-240	8988	219	PRT3-C	109	233
PCH1596SE-CS	5116	137	PF1830-C	167	38	PHT3OB-240-3	9334	219	PRT30-C	88	148
PCH18120SE-CS	6675	137	PF1830-E	197	38	PHT3OB-240-3	9334	219	PRT36-C	104	148
PCH18144SE-CS	7801	137	PF1830-Z	163	38	PHT4CB-120	11568	219	PRT4-C	138	233
PCH1848SE-CS	4278	137	PF1836-C	172	38	PHT4CB-208	11568	219	PRT48-C	115	148
PCH1860SE-CS	4543	137	PF1836-E	200	38	PHT4CB-208-3	11914	219	PRT5-C	169	233
PCH1872SE-CS	5331	137	PF1836-Z	171	38	PHT4CB-240	11568	219	PRT6-C	221	233
PCH1884SE-CS	5668	137	PF2124-C	178	38	PHT4CB-240-3	11914	219	PRT60-C	135	148
PCH1896SE-CS	5996	137	PF2124-E	208	38	PHT4OB-120	10198	219	PRT72-C	157	148
PCP-3	2100	225	PF2124-Z	172	38	PHT4OB-208	10198	219	PRT84-C	182	148
PCP-4	2505	225	PF2130-C	181	38	PHT4OB-240	10198	219	PRT96-C	214	148
PCP-5	3334	225	PF2130-E	211	38	PHT4OB-208-3	10542	219	PST-3	2017	226
PCPL5-250	85	15	PF2130-Z	174	38	PHT4OB-240-3	10542	219	PST-4	2263	226
PCPS5-250	82	15	PF2136-C	183	38	PHT5CB-208	14652	219	PST-5	2684	226
PCS15120SE-CS	5951	137	PF2136-E	213	38	PHT5CB-208-3	14996	219	PT 3072	4962	137
PCS15144SE-CS	7078	137	PF2136-Z	177	38	PHT5CB-240	14652	219	PT 3072-R	4962	137
PCS1548SE-CS	4033	137	PF2424-C	182	38	PHT5CB-240-3	14996	219	PT 3084	5476	137
PCS1560SE-CS	4238	137	PF2424-E	217	38	PHT5OB-208	12969	219	PT 3084-R	5476	137
PCS1572SE-CS	4598	137	PF2424-Z	177	38	PHT5OB-208-3	13317	219	PT 3096	5866	137
PCS1584SE-CS	4755	137	PF2430-C	185	38	PHT5OB-240	12969	219	PT 3096-R	5866	137
PCS1596SE-CS	5071	137	PF2430-E	221	38	PHT5OB-240-3	13317	219	PT-1826-A	684	352
PCS18120SE-CS	6629	137	PF2430-Z	179	38	PHT6CB-208	16700	219	PTS-18108	1742	110
PCS18144SE-CS	7758	137	PF2436-C	191	38	PHT6CB-208-3	17046	219	PTS-18120	1778	110
PCS1848SE-CS	4233	137	PF2436-E	224	38	PHT6CB-240	16700	219	PTS-18132	1940	110
PCS1860SE-CS	4497	137	PF2436-Z	182	38	PHT6CB-240-3	17046	219	PTS-18144	2211	110
PCS1872SE-CS	5286	137	PH14-C	69	59	PHT6OB-208	14701	219	PTS-1824	641	110
			PH14-S	95	59	PHT6OB-208-3	15046	219	PTS-1836	777	110



100 Industrial Boulevard, Clayton, DE 19938-8903 U.S.A.  
 Phone: 800-441-8440 or 302-653-3000. Fax: 302-653-2065  
<http://www.eaglegrp.com>

# ALPHANUMERIC PRICE INDEX

Part Number	List Price	Page No.	Part Number	List Price	Page No.	Part Number	List Price	Page No.	Part Number	List Price	Page No.
PTS-1848	1402	110	PWE21-1C	226	111	PWM24-3S	1019	111	QA1836C	125	7
PTS-1884	1616	110	PWE21-1S	641	111	PWM24-3VG	365	111	QA1836E	145	7
PTS-1896	1677	110	PWE21-1VG	226	111	PWM24-4C	454	111	QA1836S	397	7
PTS-1860	1511	110	PWE21-2C	368	111	PWM24-4S	1285	111	QA1836V	138	7
PTS-1872	1562	110	PWE21-2S	1148	111	PWM24-4VG	454	111	QA1836VG	138	7
PTS-2	1865	236	PWE21-2VG	368	111	PWTFT-1215	11433	206	QA1836Z	124	7
PTS-24108	2376	110	PWE21-3C	514	111	PZD-Z	177	52	QA1842C	140	7
PTS-24120	2405	110	PWE21-3S	1481	111	QA1424C	113	7	QA1842E	163	7
PTS-24132	2629	110	PWE21-3VG	514	111	QA1424E	124	7	QA1842S	461	7
PTS-24144	2821	110	PWE21-4C	625	111	QA1424S	322	7	QA1842V	148	7
PTS-2424	698	110	PWE21-4S	1813	111	QA1424V	108	7	QA1842VG	148	7
PTS-2436	960	110	PWE21-4VG	625	111	QA1424VG	108	7	QA1842Z	135	7
PTS-2448	1753	110	PWE24-1C	226	111	QA1424Z	103	7	QA1848C	143	7
PTS-2460	1885	110	PWE24-1S	654	111	QA1430C	118	7	QA1848E	171	7
PTS-2472	2019	110	PWE24-1VG	226	111	QA1430E	127	7	QA1848S	466	7
PTS-2484	2211	110	PWE24-2C	372	111	QA1430S	327	7	QA1848V	157	7
PTS-2496	2364	110	PWE24-2S	1173	111	QA1430V	115	7	QA1848VG	157	7
PTS-3	1964	236	PWE24-2VG	372	111	QA1430VG	115	7	QA1848Z	139	7
PTS-4	2129	236	PWE24-3C	521	111	QA1430Z	108	7	QA1854C	157	7
PW14C	62	112	PWE24-3S	1516	111	QA1436C	120	7	QA1854E	186	7
PW14S	176	112	PWE24-3VG	521	111	QA1436E	134	7	QA1854S	577	7
PW14VG	62	112	PWE24-4C	631	111	QA1436S	329	7	QA1854V	171	7
PW33C	78	112	PWE24-4S	1873	111	QA1436V	122	7	QA1854VG	171	7
PW33S	282	112	PWE24-4VG	631	111	QA1436VG	122	7	QA1854Z	154	7
PW33VG	78	112	PWM14-1C	142	111	QA1436Z	112	7	QA1860C	161	7
PW54C	98	112	PWM14-1S	397	111	QA1442C	133	7	QA1860E	192	7
PW54S	286	112	PWM14-1VG	142	111	QA1442E	147	7	QA1860S	584	7
PW54VG	98	112	PWM14-2C	241	111	QA1442S	393	7	QA1860V	177	7
PW63C	100	112	PWM14-2S	719	111	QA1442V	137	7	QA1860VG	177	7
PW63S	293	112	PWM14-2VG	241	111	QA1442VG	137	7	QA1860Z	156	7
PW63VG	100	112	PWM14-3C	340	111	QA1442Z	120	7	QA1872C	183	7
PWB14C	53	112	PWM14-3S	959	111	QA1448C	135	7	QA1872E	214	7
PWB14S	173	112	PWM14-3VG	340	111	QA1448E	154	7	QA1872S	686	7
PWB14VG	53	112	PWM14-4C	422	111	QA1448S	394	7	QA1872V	206	7
PWB18C	54	112	PWM14-4S	1201	111	QA1448V	139	7	QA1872VG	206	7
PWB18S	176	112	PWM14-4VG	422	111	QA1448VG	139	7	QA1872Z	177	7
PWB18VG	54	112	PWM18-1C	144	111	QA1448Z	124	7	QA2124C	135	7
PWB21C	55	112	PWM18-1S	409	111	QA1454C	140	7	QA2124E	154	7
PWB21S	186	112	PWM18-1VG	144	111	QA1454E	157	7	QA2124S	443	7
PWB21VG	55	112	PWM18-2C	242	111	QA1454S	483	7	QA2124V	127	7
PWB24C	58	112	PWM18-2S	749	111	QA1454V	143	7	QA2124VG	127	7
PWB24S	192	112	PWM18-2VG	242	111	QA1454VG	143	7	QA2124Z	125	7
PWB24VG	58	112	PWM18-3C	345	111	QA1454Z	134	7	QA2130C	139	7
PWE14-1C	221	111	PWM18-3S	993	111	QA1460C	147	7	QA2130E	156	7
PWE14-1S	593	111	PWM18-3VG	345	111	QA1460E	163	7	QA2130S	448	7
PWE14-1VG	221	111	PWM18-4C	425	111	QA1460S	493	7	QA2130V	140	7
PWE14-2C	357	111	PWM18-4S	1156	111	QA1460V	157	7	QA2130VG	140	7
PWE14-2S	1093	111	PWM18-4VG	425	111	QA1460VG	157	7	QA2130Z	127	7
PWE14-2VG	357	111	PWM21-1C	148	111	QA1460Z	140	7	QA2136C	141	7
PWE14-3C	495	111	PWM21-1S	416	111	QA1472C	163	7	QA2136E	159	7
PWE14-3S	1405	111	PWM21-1VG	148	111	QA1472E	182	7	QA2136S	451	7
PWE14-3VG	495	111	PWM21-2C	258	111	QA1472S	551	7	QA2136V	154	7
PWE14-4C	598	111	PWM21-2S	756	111	QA1472V	171	7	QA2136VG	154	7
PWE14-4S	1723	111	PWM21-2VG	258	111	QA1472VG	171	7	QA2136Z	134	7
PWE14-4VG	598	111	PWM21-3C	362	111	QA1472Z	156	7	QA2142C	155	7
PWE18-1C	223	111	PWM21-3S	1007	111	QA1824C	120	7	QA2142E	177	7
PWE18-1S	636	111	PWM21-3VG	362	111	QA1824E	139	7	QA2142S	514	7
PWE18-1VG	223	111	PWM21-4C	452	111	QA1824S	389	7	QA2142V	161	7
PWE18-2C	357	111	PWM21-4S	1241	111	QA1824V	119	7	QA2142VG	161	7
PWE18-2S	1141	111	PWM21-4VG	452	111	QA1824VG	119	7	QA2142Z	143	7
PWE18-2VG	357	111	PWM24-1C	151	111	QA1824Z	119	7	QA2148C	157	7
PWE18-3C	497	111	PWM24-1S	420	111	QA1830C	123	7	QA2148E	179	7
PWE18-3S	1471	111	PWM24-1VG	151	111	QA1830E	141	7	QA2148S	516	7
PWE18-3VG	497	111	PWM24-2C	258	111	QA1830S	393	7	QA2148V	171	7
PWE18-4C	600	111	PWM24-2S	759	111	QA1830V	129	7	QA2148VG	171	7
PWE18-4S	1813	111	PWM24-2VG	258	111	QA1830VG	129	7	QA2148Z	147	7
PWE18-4VG	600	111	PWM24-3C	365	111	QA1830Z	121	7	QA2154C	176	7

# ALPHANUMERIC PRICE INDEX

Part Number	List Price	Page No.	Part Number	List Price	Page No.	Part Number	List Price	Page No.	Part Number	List Price	Page No.
QA2154E	203	7	QAR1424S	341	8	QAR2448V	199	8	QP-DR1830VG-GL	441	11
QA2154S	668	7	QAR1424V	115	8	QAR2448VG	199	8	QP-DR1830VG-GS	444	11
QA2154V	181	7	QAR1424VG	115	8	QAR2448Z	171	8	QP-DR1836E-GL	508	11
QA2154VG	181	7	QAR1424Z	111	8	QDR2436-E	349	12	QP-DR1836E-GS	512	11
QA2154Z	171	7	QAR1436C	126	8	QDR2436-VG	327	12	QP-DR1836VG-GL	464	11
QA2160C	178	7	QAR1436E	141	8	QDR2448-E	371	12	QP-DR1836VG-GS	468	11
QA2160E	207	7	QAR1436S	349	8	QDR2448-VG	340	12	QP-DR1848E-GL	573	11
QA2160S	672	7	QAR1436V	129	8	QDR2460-E	396	12	QP-DR1848E-GS	578	11
QA2160V	183	7	QAR1436VG	129	8	QDR2460-VG	362	12	QP-DR1848VG-GL	520	11
QA2160VG	183	7	QAR1436Z	119	8	QL18W-1E	52	12	QP-DR1848VG-GS	525	11
QA2160Z	173	7	QAR1448C	143	8	QL18W-1VG	39	12	QP-DR1860E-GL	640	11
QA2172C	208	7	QAR1448E	162	8	QL18W-4E	54	12	QP-DR1860E-GS	647	11
QA2172E	244	7	QAR1448S	420	8	QL18W-4VG	41	12	QP-DR1860VG-GL	569	11
QA2172S	789	7	QAR1448V	148	8	QL21W-1E	58	12	QP-DR1860VG-GS	575	11
QA2172V	223	7	QAR1448VG	148	8	QL21W-1VG	43	12	QP-DR2124E-GL	493	11
QA2172VG	223	7	QAR1448Z	126	8	QL21W-4E	60	12	QP-DR2124E-GS	496	11
QA2172Z	200	7	QAR1824C	126	8	QL21W-4VG	46	12	QP-DR2124VG-GL	448	11
QA2424C	140	7	QAR1824E	148	8	QL24L-1E	62	12	QP-DR2124VG-GS	451	11
QA2424E	162	7	QAR1824S	415	8	QL24L-1VG	45	12	QP-DR2130E-GL	511	11
QA2424S	477	7	QAR1824V	125	8	QL24L-4E	64	12	QP-DR2130E-GS	515	11
QA2424V	141	7	QAR1824VG	125	8	QL24L-4VG	46	12	QP-DR2130VG-GL	460	11
QA2424VG	141	7	QAR1824Z	125	8	QL24W-1E	62	12	QP-DR2130VG-GS	464	11
QA2424Z	134	7	QAR1836C	135	8	QL24W-1VG	45	12	QP-DR2136E-GL	538	11
QA2430C	143	7	QAR1836E	155	8	QL24W-4E	64	12	QP-DR2136E-GS	542	11
QA2430E	165	7	QAR1836S	422	8	QL24W-4VG	46	12	QP-DR2136VG-GL	482	11
QA2430S	481	7	QAR1836V	145	8	QL30L-1E	63	12	QP-DR2136VG-GS	486	11
QA2430V	154	7	QAR1836VG	145	8	QL30L-1VG	52	12	QP-DR2148E-GL	609	11
QA2430VG	154	7	QAR1836Z	134	8	QL30L-4E	73	12	QP-DR2148E-GS	615	11
QA2430Z	137	7	QAR1848C	153	8	QL30L-4VG	57	12	QP-DR2148VG-GL	542	11
QA2436C	147	7	QAR1848E	179	8	QL36L-1E	65	12	QP-DR2148VG-GS	548	11
QA2436E	172	7	QAR1848S	496	8	QL36L-1VG	60	12	QP-DR2160E-GL	679	11
QA2436S	486	7	QAR1848V	167	8	QL36L-4E	82	12	QP-DR2160E-GS	686	11
QA2436V	159	7	QAR1848VG	167	8	QL36L-4VG	67	12	QP-DR2160VG-GL	587	11
QA2436VG	159	7	QAR1848Z	148	8	QL42L-1E	67	12	QP-DR2160VG-GS	595	11
QA2436Z	140	7	QAR2124C	143	8	QL42L-1VG	63	12	QP-DR2424E-GL	511	11
QA2442C	165	7	QAR2124E	162	8	QL42L-4E	84	12	QP-DR2424E-GS	514	11
QA2442E	196	7	QAR2124S	472	8	QL42L-4VG	69	12	QP-DR2424VG-GL	469	11
QA2442S	573	7	QAR2124V	139	8	QL48L-1E	68	12	QP-DR2424VG-GS	472	11
QA2442V	174	7	QAR2124VG	139	8	QL48L-1VG	64	12	QP-DR2430E-GL	533	11
QA2442VG	174	7	QAR2124Z	135	8	QL48L-4E	85	12	QP-DR2430E-GS	538	11
QA2442Z	156	7	QAR2136C	152	8	QL48L-4VG	71	12	QP-DR2430VG-GL	471	11
QA2448C	172	7	QAR2136E	171	8	QL54L-1E	74	12	QP-DR2430VG-GS	476	11
QA2448E	200	7	QAR2136S	479	8	QL54L-1VG	71	12	QP-DR2436E-GL	553	11
QA2448S	576	7	QAR2136V	162	8	QL54L-4E	89	12	QP-DR2436E-GS	558	11
QA2448V	185	7	QAR2136VG	162	8	QL54L-4VG	74	12	QP-DR2436VG-GL	497	11
QA2448VG	185	7	QAR2136Z	141	8	QL60L-1E	87	12	QP-DR2436VG-GS	508	11
QA2448Z	159	7	QAR2148C	167	8	QL60L-1VG	78	12	QP-DR2448E-GL	637	11
QA2454C	191	7	QAR2148E	191	8	QL60L-4E	105	12	QP-DR2448E-GS	644	11
QA2454E	224	7	QAR2148S	548	8	QL60L-4VG	83	12	QP-DR2448VG-GL	566	11
QA2454S	697	7	QAR2148V	179	8	QL72L-1E	99	12	QP-DR2448VG-GS	573	11
QA2454V	204	7	QAR2148VG	179	8	QL72L-1VG	85	12	QP-DR2460E-GL	704	11
QA2454VG	204	7	QAR2148Z	156	8	QL72L-4E	116	12	QP-DR2460E-GS	713	11
QA2454Z	182	7	QAR2424C	151	8	QL72L-4VG	89	12	QP-DR2460VG-GL	619	11
QA2460C	193	7	QAR2424E	175	8	QM2962-4-A/D	4027	350	QP-DR2460VG-GS	627	11
QA2460E	228	7	QAR2424S	508	8	QM2962-5-A/D	4288	350	QP-MDR1824E-GL	628	11
QA2460S	700	7	QAR2424V	152	8	QM2962-6-A/D	4888	350	QP-MDR1824E-GS	631	11
QA2460V	214	7	QAR2424VG	152	8	QM2966-4-SR/D	4963	350	QP-MDR1824VG-GL	591	11
QA2460VG	214	7	QAR2424Z	141	8	QM2966-5-SR/D	5472	350	QP-MDR1824VG-GS	593	11
QA2460Z	185	7	QAR2436C	156	8	QM2966-6-SR/D	6369	350	QP-MDR1830E-GL	647	11
QA2472C	223	7	QAR2436E	180	8	QM2975-5-A/D	5603	350	QP-MDR1830E-GS	650	11
QA2472E	261	7	QAR2436S	516	8	QM2977-5-SR/D	6416	350	QP-MDR1830VG-GL	602	11
QA2472S	864	7	QAR2436V	171	8	QP-DR1824E-GL	470	11	QP-MDR1830VG-GS	605	11
QA2472V	248	7	QAR2436VG	171	8	QP-DR1824E-GS	472	11	QP-MDR1836E-GL	667	11
QA2472VG	248	7	QAR2436Z	151	8	QP-DR1824VG-GL	430	11	QP-MDR1836E-GS	671	11
QA2472Z	209	7	QAR2448C	180	8	QP-DR1824VG-GS	432	11	QP-MDR1836VG-GL	625	11
QAR1424C	120	8	QAR2448E	212	8	QP-DR1830E-GL	488	11	QP-MDR1836VG-GS	629	11
QAR1424E	134	8	QAR2448S	613	8	QP-DR1830E-GS	491	11	QP-MDR1848E-GL	732	11



100 Industrial Boulevard, Clayton, DE 19938-8903 U.S.A.  
 Phone: 800-441-8440 or 302-653-3000. Fax: 302-653-2065  
<http://www.eaglegrp.com>

# ALPHANUMERIC PRICE INDEX

Part Number	List Price	Page No.	Part Number	List Price	Page No.	Part Number	List Price	Page No.	Part Number	List Price	Page No.
QP-MDR1848E-GS	737	11	QPAF-QA2436E	204	10	QPF-1830VG-GS	125	9	QPF-2436VG-GL	145	9
QP-MDR1848VG-GL	681	11	QPAF-QA2436VG	182	10	QPF-1836E-GL	134	9	QPF-2436VG-GS	154	9
QP-MDR1848VG-GS	686	11	QPAF-QA2442E	209	10	QPF-1836E-GS	140	9	QPF-2442E-GL	198	9
QP-MDR1860E-GL	799	11	QPAF-QA2442VG	186	10	QPF-1836VG-GL	120	9	QPF-2442E-GS	208	9
QP-MDR1860E-GS	806	11	QPAF-QA2448E	224	10	QPF-1836VG-GS	125	9	QPF-2442VG-GL	178	9
QP-MDR1860VG-GL	730	11	QPAF-QA2448VG	191	10	QPF-1842E-GL	160	9	QPF-2442VG-GS	186	9
QP-MDR1860VG-GS	736	11	QPAF-QA2454E	227	10	QPF-1842E-GS	171	9	QPF-2448E-GL	198	9
QP-MDR2124E-GL	652	11	QPAF-QA2454VG	194	10	QPF-1842VG-GL	144	9	QPF-2448E-GS	208	9
QP-MDR2124E-GS	655	11	QPAF-QA2460E	231	10	QPF-1842VG-GS	153	9	QPF-2448VG-GL	178	9
QP-MDR2124VG-GL	609	11	QPAF-QA2460VG	195	10	QPF-1848E-GL	160	9	QPF-2448VG-GS	186	9
QP-MDR2124VG-GS	613	11	QPAF-QA2472E	241	10	QPF-1848E-GS	171	9	QPF-2454E-GL	234	9
QP-MDR2130E-GL	670	11	QPAF-QA2472VG	201	10	QPF-1848VG-GL	144	9	QPF-2454E-GS	247	9
QP-MDR2130E-GS	673	11	QPAF-1824E	92	10	QPF-1848VG-GS	153	9	QPF-2454VG-GL	211	9
QP-MDR2130VG-GL	621	11	QPAF-1824VG	78	10	QPF-1854E-GL	192	9	QPF-2454VG-GS	222	9
QP-MDR2130VG-GS	625	11	QPAF-1830E	96	10	QPF-1854E-GS	201	9	QPF-2460E-GL	234	9
QP-MDR2136E-GL	697	11	QPAF-1830VG	81	10	QPF-1854VG-GL	173	9	QPF-2460E-GS	247	9
QP-MDR2136E-GS	701	11	QPAF-1836E	100	10	QPF-1854VG-GS	180	9	QPF-2460VG-GL	211	9
QP-MDR2136VG-GL	643	11	QPAF-1836VG	83	10	QPF-1860E-GL	192	9	QPF-2460VG-GS	222	9
QP-MDR2136VG-GS	648	11	QPAF-1842E	105	10	QPF-1860E-GS	201	9	QPF-2472E-GL	275	9
QP-MDR2148E-GL	768	11	QPAF-1842VG	85	10	QPF-1860VG-GL	173	9	QPF-2472E-GS	288	9
QP-MDR2148E-GS	774	11	QPAF-1848E	109	10	QPF-1860VG-GS	180	9	QPF-2472VG-GL	247	9
QP-MDR2148VG-GL	703	11	QPAF-1848VG	87	10	QPF-1872E-GL	217	9	QPF-2472VG-GS	260	9
QP-MDR2148VG-GS	709	11	QPAF-1854E	116	10	QPF-1872E-GS	228	9	QPF-QA1824E-GL	148	9
QP-MDR2160E-GL	838	11	QPAF-1854VG	88	10	QPF-1872VG-GL	196	9	QPF-QA1824E-GS	156	9
QP-MDR2160E-GS	845	11	QPAF-1860E	121	10	QPF-1872VG-GS	206	9	QPF-QA1824VG-GL	135	9
QP-MDR2160VG-GL	748	11	QPAF-1860VG	91	10	QPF-2124E-GL	144	9	QPF-QA1824VG-GS	141	9
QP-MDR2160VG-GS	756	11	QPAF-1872E	124	10	QPF-2124E-GS	153	9	QPF-QA1830E-GL	156	9
QP-MDR2424E-GL	670	11	QPAF-1872VG	95	10	QPF-2124VG-GL	129	9	QPF-QA1830E-GS	163	9
QP-MDR2424E-GS	673	11	QPAF-2424E	106	10	QPF-2124VG-GS	138	9	QPF-QA1830VG-GL	141	9
QP-MDR2424VG-GL	630	11	QPAF-2424VG	88	10	QPF-2130E-GL	151	9	QPF-QA1830VG-GS	147	9
QP-MDR2424VG-GS	633	11	QPAF-2430E	113	10	QPF-2130E-GS	157	9	QPF-QA1836E-GL	156	9
QP-MDR2430E-GL	692	11	QPAF-2430VG	92	10	QPF-2130VG-GL	135	9	QPF-QA1836E-GS	163	9
QP-MDR2430E-GS	696	11	QPAF-2436E	118	10	QPF-2130VG-GS	141	9	QPF-QA1836VG-GL	141	9
QP-MDR2430VG-GL	633	11	QPAF-2436VG	98	10	QPF-2136E-GL	151	9	QPF-QA1836VG-GS	147	9
QP-MDR2430VG-GS	637	11	QPAF-2442E	124	10	QPF-2136E-GS	157	9	QPF-QA1842E-GL	189	9
QP-MDR2436E-GL	712	11	QPAF-2442VG	100	10	QPF-2136VG-GL	135	9	QPF-QA1842E-GS	199	9
QP-MDR2436E-GS	717	11	QPAF-2448E	137	10	QPF-2136VG-GS	141	9	QPF-QA1842VG-GL	171	9
QP-MDR2436VG-GL	665	11	QPAF-2448VG	106	10	QPF-2142E-GL	176	9	QPF-QA1842VG-GS	179	9
QP-MDR2436VG-GS	670	11	QPAF-2454E	138	10	QPF-2142E-GS	183	9	QPF-QA1848E-GL	189	9
QP-MDR2448E-GL	796	11	QPAF-2454VG	107	10	QPF-2142VG-GL	157	9	QPF-QA1848E-GS	199	9
QP-MDR2448E-GS	803	11	QPAF-2460E	140	10	QPF-2142VG-GS	165	9	QPF-QA1848VG-GL	171	9
QP-MDR2448VG-GL	728	11	QPAF-2460VG	107	10	QPF-2148E-GL	176	9	QPF-QA1848VG-GS	179	9
QP-MDR2448VG-GS	734	11	QPAF-2472E	154	10	QPF-2148E-GS	183	9	QPF-QA1854E-GL	224	9
QP-MDR2460E-GL	863	11	QPAF-2472VG	119	10	QPF-2148VG-GL	157	9	QPF-QA1854E-GS	236	9
QP-MDR2460E-GS	871	11	QPB1816E-6	268	10	QPF-2148VG-GS	165	9	QPF-QA1854VG-GL	203	9
QP-MDR2460VG-GL	780	11	QPB1816E-9	288	10	QPF-2154E-GL	206	9	QPF-QA1854VG-GS	213	9
QP-MDR2460VG-GS	788	11	QPB1816VG-6	258	10	QPF-2154E-GS	215	9	QPF-QA1860E-GL	224	9
QPAF-QA1824E	177	10	QPB1816VG-9	277	10	QPF-2154VG-GL	183	9	QPF-QA1860E-GS	236	9
QPAF-QA1824VG	165	10	QPB1822E-6	304	10	QPF-2154VG-GS	196	9	QPF-QA1860VG-GL	203	9
QPAF-QA1830E	180	10	QPB1822E-9	323	10	QPF-2160E-GL	206	9	QPF-QA1860VG-GS	213	9
QPAF-QA1830VG	169	10	QPB1822VG-6	286	10	QPF-2160E-GS	215	9	QPF-QA1872E-GL	257	9
QPAF-QA1836E	183	10	QPB1822VG-9	306	10	QPF-2160VG-GL	183	9	QPF-QA1872E-GS	267	9
QPAF-QA1836VG	169	10	QPB2416E-6	281	10	QPF-2160VG-GS	196	9	QPF-QA1872VG-GL	231	9
QPAF-QA1842E	189	10	QPB2416E-9	299	10	QPF-2172E-GL	251	9	QPF-QA1872VG-GS	241	9
QPAF-QA1842VG	172	10	QPB2416VG-6	267	10	QPF-2172E-GS	263	9	QPF-QA2124E-GL	172	9
QPAF-QA1848E	197	10	QPB2416VG-9	287	10	QPF-2172VG-GL	226	9	QPF-QA2124E-GS	179	9
QPAF-QA1848VG	174	10	QPB2422E-6	315	10	QPF-2172VG-GS	238	9	QPF-QA2124VG-GL	154	9
QPAF-QA1854E	200	10	QPB2422E-9	336	10	QPF-2424E-GL	159	9	QPF-QA2124VG-GS	161	9
QPAF-QA1854VG	178	10	QPB2422VG-6	298	10	QPF-2424E-GS	167	9	QPF-QA2130E-GL	176	9
QPAF-QA1860E	209	10	QPB2422VG-9	318	10	QPF-2424VG-GL	143	9	QPF-QA2130E-GS	183	9
QPAF-QA1860VG	181	10	QPF-1824E-GL	125	9	QPF-2424VG-GS	152	9	QPF-QA2130VG-GL	157	9
QPAF-QA1872E	214	10	QPF-1824E-GS	134	9	QPF-2430E-GL	161	9	QPF-QA2130VG-GS	167	9
QPAF-QA1872VG	182	10	QPF-1824VG-GL	115	9	QPF-2430E-GS	172	9	QPF-QA2136E-GL	176	9
QPAF-QA2424E	192	10	QPF-1824VG-GS	120	9	QPF-2430VG-GL	145	9	QPF-QA2136E-GS	183	9
QPAF-QA2424VG	175	10	QPF-1830E-GL	133	9	QPF-2430VG-GS	154	9	QPF-QA2136VG-GL	157	9
QPAF-QA2430E	196	10	QPF-1830E-GS	140	9	QPF-2436E-GL	161	9	QPF-QA2136VG-GS	167	9
QPAF-QA2430VG	179	10	QPF-1830VG-GL	120	9	QPF-2436E-GS	172	9	QPF-QA2142E-GL	207	9

# ALPHANUMERIC PRICE INDEX

Part Number	List Price	Page No.	Part Number	List Price	Page No.	Part Number	List Price	Page No.	Part Number	List Price	Page No.
QPF-QA2142E-GS	217	9	QPMU2460E-G5-74	1692	10	RDBSR24-24	1276	305	RHHL-120-240-R	1618	267
QPF-QA2142VG-GL	185	9	QPMU2460VG-G5-74	1545	10	RDBSR30-19	1276	305	RHHL-132-208	1236	267
QPF-QA2142VG-GS	196	9	QPSD18-E	85	12	RDBSR30-24	1380	305	RHHL-132-208-H	1252	267
QPF-QA2148E-GL	207	9	QPSD18-VG	84	12	RDBSR36-19	1380	305	RHHL-132-208-H-L	2275	267
QPF-QA2148E-GS	217	9	QPSD21-E	87	12	RDBSR36-24	1483	305	RHHL-132-208-H-L-R	2747	267
QPF-QA2148VG-GL	185	9	QPSD21-VG	86	12	RDW48CB	3659	70	RHHL-132-208-H-R	1725	267
QPF-QA2148VG-GS	196	9	QPSD24-E	89	12	RETAINING CLAMP	4	51	RHHL-132-208-L	2261	267
QPF-QA2154E-GL	241	9	QPSD24-VG	88	12	RGP-2	1705	263	RHHL-132-208-L-R	2735	267
QPF-QA2154E-GS	254	9	QPSU1836E-G5-74	891	10	RHDL-18-I	464	268	RHHL-132-208-R	1713	267
QPF-QA2154VG-GL	217	9	QPSU1836VG-G5-74	804	10	RHDL-18-I-R	492	268	RHHL-132-240	1236	267
QPF-QA2154VG-GS	228	9	QPSU1848E-G5-74	1045	10	RHDL-24-I	492	268	RHHL-132-240-H	1252	267
QPF-QA2160E-GL	241	9	QPSU1848VG-G5-74	941	10	RHDL-24-I-R	519	268	RHHL-132-240-H-L	2275	267
QPF-QA2160E-GS	254	9	QPSU1860E-G5-74	1214	10	RHDL-30-I	514	268	RHHL-132-240-H-L-R	2747	267
QPF-QA2160VG-GL	217	9	QPSU1860VG-G5-74	1096	10	RHDL-30-I-R	540	268	RHHL-132-240-H-R	1725	267
QPF-QA2160VG-GS	228	9	QPSU2136E-G5-74	983	10	RHDL-36-I	597	268	RHHL-132-240-L	2261	267
QPF-QA2172E-GL	295	9	QPSU2136VG-G5-74	882	10	RHDL-36-I-R	622	268	RHHL-132-240-L-R	2735	267
QPF-QA2172E-GS	309	9	QPSU2148E-G5-74	1128	10	RHDL-42-I	621	268	RHHL-132-240-R	1713	267
QPF-QA2172VG-GL	264	9	QPSU2148VG-G5-74	1014	10	RHDL-42-I-R	644	268	RHHL-144-208	1331	267
QPF-QA2172VG-GS	279	9	QPSU2160E-G5-74	1296	10	RHDL-48-I	698	268	RHHL-144-208-H	1344	267
QPF-QA2424E-GL	186	9	QPSU2160VG-G5-74	1163	10	RHDL-48-I-R	720	268	RHHL-144-208-H-L	2457	267
QPF-QA2424E-GS	198	9	QPSU2436E-G5-74	1051	10	RHDL-54-I	719	268	RHHL-144-208-H-L-R	2932	267
QPF-QA2424VG-GL	171	9	QPSU2436VG-G5-74	946	10	RHDL-54-I-R	743	268	RHHL-144-208-H-R	1819	267
QPF-QA2424VG-GS	178	9	QPSU2448E-G5-74	1257	10	RHDL-60-I	800	268	RHHL-144-208-L	2449	267
QPF-QA2430E-GL	191	9	QPSU2448VG-G5-74	1126	10	RHDL-60-I-R	826	268	RHHL-144-208-L-R	2920	267
QPF-QA2430E-GS	200	9	QPSU2460E-G5-74	1456	10	RHDL-66-I	826	268	RHHL-144-208-R	1804	267
QPF-QA2430VG-GL	172	9	QPSU2460VG-G5-74	1309	10	RHDL-66-I-R	849	268	RHHL-144-240	1331	267
QPF-QA2430VG-GS	180	9	QTR24361-E	267	12	RHDL-72-I	904	268	RHHL-144-240-H	1344	267
QPF-QA2436E-GL	191	9	QTR24361-VG	247	12	RHDL-72-I-R	929	268	RHHL-144-240-H-L	2457	267
QPF-QA2436E-GS	200	9	QTR24363-E	263	12	RHHL-108-120	1049	267	RHHL-144-240-H-L-R	2932	267
QPF-QA2436VG-GL	172	9	QTR24363-VG	242	12	RHHL-108-120-H	1063	267	RHHL-144-240-H-R	1819	267
QPF-QA2436VG-GS	180	9	QTR24481-E	287	12	RHHL-108-120-H-L	1900	267	RHHL-144-240-L	2449	267
QPF-QA2442E-GL	233	9	QTR24481-VG	259	12	RHHL-108-120-H-L-R	2374	267	RHHL-144-240-L-R	2920	267
QPF-QA2442E-GS	244	9	QTR24483-E	283	12	RHHL-108-120-H-R	1537	267	RHHL-144-240-R	1804	267
QPF-QA2442VG-GL	209	9	QTR24483-VG	256	12	RHHL-108-120-L	1887	267	RHHL-18-208	349	267
QPF-QA2442VG-GS	220	9	QTR24601-E	311	12	RHHL-108-120-L-R	2361	267	RHHL-18-208-H	362	267
QPF-QA2448E-GL	233	9	QTR24601-VG	276	12	RHHL-108-120-R	1523	267	RHHL-18-208-H-L	548	267
QPF-QA2448E-GS	244	9	QTR24603-E	305	12	RHHL-108-208	1049	267	RHHL-18-208-H-L-R	1020	267
QPF-QA2448VG-GL	209	9	QTR24603-VG	269	12	RHHL-108-208-H	1063	267	RHHL-18-208-H-R	835	267
QPF-QA2448VG-GS	220	9	R10	52	75	RHHL-108-208-H-L	1900	267	RHHL-18-208-L	538	267
QPF-QA2454E-GL	276	9	R12	55	75	RHHL-108-208-H-L-R	2374	267	RHHL-18-208-L-R	1012	267
QPF-QA2454E-GS	291	9	R14	59	75	RHHL-108-208-H-R	1537	267	RHHL-18-208-R	825	267
QPF-QA2454VG-GL	248	9	R16	66	75	RHHL-108-208-L	1887	267	RHHL-24-120	374	267
QPF-QA2454VG-GS	261	9	R18	69	75	RHHL-108-208-L-R	2361	267	RHHL-24-120-H	384	267
QPF-QA2460E-GL	276	9	R20	73	75	RHHL-108-208-R	1523	267	RHHL-24-120-H-L	573	267
QPF-QA2460E-GS	291	9	R54-C	37	28,51	RHHL-108-240	1049	267	RHHL-24-120-H-L-R	1045	267
QPF-QA2460VG-GL	248	9	R54-S	55	28,51	RHHL-108-240-H	1063	267	RHHL-24-120-H-R	859	267
QPF-QA2460VG-GS	261	9	R63-C	40	28,51	RHHL-108-240-H-L	1900	267	RHHL-24-120-L	556	267
QPF-QA2472E-GL	322	9	R63-S	58	28,51	RHHL-108-240-H-L-R	2374	267	RHHL-24-120-L-R	1031	267
QPF-QA2472E-GS	338	9	R74-C	48	28,51	RHHL-108-240-H-R	1537	267	RHHL-24-120-R	846	267
QPF-QA2472VG-GL	291	9	R74-S	69	28,51	RHHL-108-240-L	1887	267	RHHL-24-208	374	267
QPF-QA2472VG-GS	304	9	R86-C	53	28,51	RHHL-108-240-L-R	2361	267	RHHL-24-208-H	384	267
QPMU1836E-G5-74	1125	10	R86-S	76	28,51	RHHL-108-240-R	1523	267	RHHL-24-208-H-L	573	267
QPMU1836VG-G5-74	1039	10	RDB12-24	968	305	RHHL-120-208	1146	267	RHHL-24-208-H-L-R	1045	267
QPMU1848E-G5-74	1280	10	RDB18-24	1074	305	RHHL-120-208-H	1155	267	RHHL-24-208-H-R	859	267
QPMU1848VG-G5-74	1177	10	RDB24-24	1178	305	RHHL-120-208-H-L	2085	267	RHHL-24-208-L	556	267
QPMU1860E-G5-74	1449	10	RDB30-24	1276	305	RHHL-120-208-H-L-R	2560	267	RHHL-24-208-L-R	1031	267
QPMU1860VG-G5-74	1333	10	RDB36-24	1309	305	RHHL-120-208-H-R	1629	267	RHHL-24-208-R	846	267
QPMU2136E-G5-74	1220	10	RDBDR12-19	1074	305	RHHL-120-208-L	2076	267	RHHL-24-240	374	267
QPMU2136VG-G5-74	1118	10	RDBDR18-19	1178	305	RHHL-120-208-L-R	2548	267	RHHL-24-240-H	384	267
QPMU2148E-G5-74	1365	10	RDBDR24-19	1276	305	RHHL-120-208-R	1618	267	RHHL-24-240-H-L	573	267
QPMU2148VG-G5-74	1248	10	RDBDR30-19	1380	305	RHHL-120-240	1146	267	RHHL-24-240-H-L-R	1045	267
QPMU2160E-G5-74	1531	10	RDBDR36-19	1483	305	RHHL-120-240-H	1155	267	RHHL-24-240-H-R	859	267
QPMU2160VG-G5-74	1401	10	RDBSR12-19	968	305	RHHL-120-240-H-L	2085	267	RHHL-24-240-L	556	267
QPMU2436E-G5-74	1286	10	RDBSR12-24	1074	305	RHHL-120-240-H-L-R	2560	267	RHHL-24-240-L-R	1031	267
QPMU2436VG-G5-74	1182	10	RDBSR18-19	1074	305	RHHL-120-240-H-R	1629	267	RHHL-24-240-R	846	267
QPMU2448E-G5-74	1492	10	RDBSR18-24	1178	305	RHHL-120-240-L	2076	267	RHHL-30-120	396	267
QPMU2448VG-G5-74	1362	10	RDBSR24-19	1178	305	RHHL-120-240-L-R	2548	267	RHHL-30-120-H	408	267



100 Industrial Boulevard, Clayton, DE 19938-8903 U.S.A.  
 Phone: 800-441-8440 or 302-653-3000. Fax: 302-653-2065  
<http://www.eaglegrp.com>

# ALPHANUMERIC PRICE INDEX

Part Number	List Price	Page No.	Part Number	List Price	Page No.	Part Number	List Price	Page No.	Part Number	List Price	Page No.
RHHL-30-120-H-L	642	267	RHHL-42-240-L	769	267	RHHL-60-240	539	267	RHHL-84-208-H-L-R	1908	267
RHHL-30-120-H-L-R	1116	267	RHHL-42-240-L-R	1243	267	RHHL-60-240-H	549	267	RHHL-84-208-H-R	1257	267
RHHL-30-120-H-R	883	267	RHHL-42-240-R	917	267	RHHL-60-240-H-L	1014	267	RHHL-84-208-L	1423	267
RHHL-30-120-L	629	267	RHHL-48-120	466	267	RHHL-60-240-H-L-R	1488	267	RHHL-84-208-L-R	1898	267
RHHL-30-120-L-R	1103	267	RHHL-48-120-H	478	267	RHHL-60-240-H-R	1022	267	RHHL-84-208-R	1247	267
RHHL-30-120-R	869	267	RHHL-48-120-H-L	849	267	RHHL-60-240-L	1006	267	RHHL-84-240	774	267
RHHL-30-208	396	267	RHHL-48-120-H-L-R	1323	267	RHHL-60-240-L-R	1480	267	RHHL-84-240-H	783	267
RHHL-30-208-H	408	267	RHHL-48-120-H-R	953	267	RHHL-60-240-R	1013	267	RHHL-84-240-H-L	1436	267
RHHL-30-208-H-L	642	267	RHHL-48-120-L	839	267	RHHL-66-120	583	267	RHHL-84-240-H-L-R	1908	267
RHHL-30-208-H-L-R	1116	267	RHHL-48-120-L-R	1314	267	RHHL-66-120-H	596	267	RHHL-84-240-H-R	1257	267
RHHL-30-208-H-R	883	267	RHHL-48-120-R	941	267	RHHL-66-120-H-L	1105	267	RHHL-84-240-L	1423	267
RHHL-30-208-L	629	267	RHHL-48-208	466	267	RHHL-66-120-H-L-R	1580	267	RHHL-84-240-L-R	1898	267
RHHL-30-208-L-R	1103	267	RHHL-48-208-H	478	267	RHHL-66-120-H-R	1068	267	RHHL-84-240-H	1247	267
RHHL-30-208-R	869	267	RHHL-48-208-H-L	849	267	RHHL-66-120-L	1098	267	RHHL-96-120	862	267
RHHL-30-240	396	267	RHHL-48-208-H-L-R	1323	267	RHHL-66-120-L-R	1569	267	RHHL-96-120-H	879	267
RHHL-30-240-H	408	267	RHHL-48-208-H-R	953	267	RHHL-66-120-R	1058	267	RHHL-96-120-H-L	1619	267
RHHL-30-240-H-L	642	267	RHHL-48-208-L	839	267	RHHL-66-208	583	267	RHHL-96-120-H-L-R	2095	267
RHHL-30-240-H-L-R	1116	267	RHHL-48-208-L-R	1314	267	RHHL-66-208-H	596	267	RHHL-96-120-H-R	1352	267
RHHL-30-240-H-R	883	267	RHHL-48-208-R	941	267	RHHL-66-208-H-L	1105	267	RHHL-96-120-L	1607	267
RHHL-30-240-L	629	267	RHHL-48-240	466	267	RHHL-66-208-H-L-R	1580	267	RHHL-96-120-L-R	2080	267
RHHL-30-240-L-R	1103	267	RHHL-48-240-H	478	267	RHHL-66-208-H-R	1068	267	RHHL-96-120-R	1337	267
RHHL-30-240-R	869	267	RHHL-48-240-H-L	849	267	RHHL-66-208-L	1098	267	RHHL-96-208	862	267
RHHL-36-120	422	267	RHHL-48-240-H-L-R	1323	267	RHHL-66-208-L-R	1569	267	RHHL-96-208-H	879	267
RHHL-36-120-H	434	267	RHHL-48-240-H-R	953	267	RHHL-66-208-R	1058	267	RHHL-96-208-H-L	1619	267
RHHL-36-120-H-L	713	267	RHHL-48-240-L	839	267	RHHL-66-240	583	267	RHHL-96-208-H-L-R	2095	267
RHHL-36-120-H-L-R	1185	267	RHHL-48-240-L-R	1314	267	RHHL-66-240-H	596	267	RHHL-96-208-H-R	1352	267
RHHL-36-120-H-R	906	267	RHHL-48-240-R	941	267	RHHL-66-240-H-L	1105	267	RHHL-96-208-L	1607	267
RHHL-36-120-L	702	267	RHHL-54-120	489	267	RHHL-66-240-H-L-R	1580	267	RHHL-96-208-L-R	2080	267
RHHL-36-120-L-R	1177	267	RHHL-54-120-H	499	267	RHHL-66-240-H-R	1068	267	RHHL-96-208-R	1337	267
RHHL-36-120-R	895	267	RHHL-54-120-H-L	922	267	RHHL-66-240-L	1098	267	RHHL-96-240	862	267
RHHL-36-208	422	267	RHHL-54-120-H-L-R	1394	267	RHHL-66-240-L-R	1569	267	RHHL-96-240-H	879	267
RHHL-36-208-H	434	267	RHHL-54-120-H-R	973	267	RHHL-66-240-R	1058	267	RHHL-96-240-H-L	1619	267
RHHL-36-208-H-L	713	267	RHHL-54-120-L	909	267	RHHL-72-120	667	267	RHHL-96-240-H-L-R	2095	267
RHHL-36-208-H-L-R	1185	267	RHHL-54-120-L-R	1382	267	RHHL-72-120-H	677	267	RHHL-96-240-H-R	1352	267
RHHL-36-208-H-R	906	267	RHHL-54-120-R	963	267	RHHL-72-120-H-L	1234	267	RHHL-96-240-L	1607	267
RHHL-36-208-L	702	267	RHHL-54-208	489	267	RHHL-72-120-H-L-R	1707	267	RHHL-96-240-L-R	2080	267
RHHL-36-208-L-R	1177	267	RHHL-54-208-H	499	267	RHHL-72-120-H-R	1152	267	RHHL-96-240-R	1337	267
RHHL-36-208-R	895	267	RHHL-54-208-H-L	922	267	RHHL-72-120-L	1224	267	RLB-2	621	230
RHHL-36-240	422	267	RHHL-54-208-H-L-R	1394	267	RHHL-72-120-L-R	1698	267	RLB-3	774	230
RHHL-36-240-H	434	267	RHHL-54-208-H-R	973	267	RHHL-72-120-R	1141	267	RLB-4	831	230
RHHL-36-240-H-L	713	267	RHHL-54-208-L	909	267	RHHL-72-208	667	267	RLB-5	1001	230
RHHL-36-240-H-L-R	1185	267	RHHL-54-208-L-R	1382	267	RHHL-72-208-H	677	267	RLB-6	1323	230
RHHL-36-240-H-R	906	267	RHHL-54-208-R	963	267	RHHL-72-208-H-L	1234	267	RM1436BL	87	25
RHHL-36-240-L	702	267	RHHL-54-240	489	267	RHHL-72-208-H-L-R	1707	267	RM1436C	85	25
RHHL-36-240-L-R	1177	267	RHHL-54-240-H	499	267	RHHL-72-208-H-R	1152	267	RM1436R	87	25
RHHL-36-240-R	895	267	RHHL-54-240-H-L	922	267	RHHL-72-208-L	1224	267	RM1436W	87	25
RHHL-42-120	441	267	RHHL-54-240-H-L-R	1394	267	RHHL-72-208-L-R	1698	267	RM1436Z	77	25
RHHL-42-120-H	458	267	RHHL-54-240-H-R	973	267	RHHL-72-208-R	1141	267	RM1448BL	103	25
RHHL-42-120-H-L	783	267	RHHL-54-240-L	909	267	RHHL-72-240	667	267	RM1448C	100	25
RHHL-42-120-H-L-R	1257	267	RHHL-54-240-L-R	1382	267	RHHL-72-240-H	677	267	RM1448R	103	25
RHHL-42-120-H-R	932	267	RHHL-54-240-R	963	267	RHHL-72-240-H-L	1234	267	RM1448W	103	25
RHHL-42-120-L	769	267	RHHL-60-120	539	267	RHHL-72-240-H-L-R	1707	267	RM1448Z	87	25
RHHL-42-120-L-R	1243	267	RHHL-60-120-H	549	267	RHHL-72-240-H-R	1152	267	RM1836BL	94	25
RHHL-42-120-R	917	267	RHHL-60-120-H-L	1014	267	RHHL-72-240-L	1224	267	RM1836C	91	25
RHHL-42-208	441	267	RHHL-60-120-H-L-R	1488	267	RHHL-72-240-L-R	1698	267	RM1836R	94	25
RHHL-42-208-H	458	267	RHHL-60-120-H-R	1022	267	RHHL-72-240-R	1141	267	RM1836W	94	25
RHHL-42-208-H-L	783	267	RHHL-60-120-L	1006	267	RHHL-84-120	774	267	RM1836Z	88	25
RHHL-42-208-H-L-R	1257	267	RHHL-60-120-L-R	1480	267	RHHL-84-120-H	783	267	RM1848BL	113	25
RHHL-42-208-H-R	932	267	RHHL-60-120-R	1013	267	RHHL-84-120-H-L	1436	267	RM1848C	109	25
RHHL-42-208-L	769	267	RHHL-60-208	539	267	RHHL-84-120-H-L-R	1908	267	RM1848R	113	25
RHHL-42-208-L-R	1243	267	RHHL-60-208-H	549	267	RHHL-84-120-H-R	1257	267	RM1848W	113	25
RHHL-42-208-R	917	267	RHHL-60-208-H-L	1014	267	RHHL-84-120-L	1423	267	RM1848Z	103	25
RHHL-42-240	441	267	RHHL-60-208-H-L-R	1488	267	RHHL-84-120-L-R	1898	267	RM2136BL	112	25
RHHL-42-240-H	458	267	RHHL-60-208-H-R	1022	267	RHHL-84-120-R	1247	267	RM2136C	108	25
RHHL-42-240-H-L	783	267	RHHL-60-208-L	1006	267	RHHL-84-208	774	267	RM2136R	112	25
RHHL-42-240-H-L-R	1257	267	RHHL-60-208-L-R	1480	267	RHHL-84-208-H	783	267	RM2136W	112	25
RHHL-42-240-H-R	932	267	RHHL-60-208-R	1013	267	RHHL-84-208-H-L	1436	267	RM2136Z	98	25



# ALPHANUMERIC PRICE INDEX

Part Number	List Price	Page No.	Part Number	List Price	Page No.	Part Number	List Price	Page No.	Part Number	List Price	Page No.
RM2148BL	126	25	S14-20-3-18L-SL	4461	194	S4-63-1842Z	506	18	S4-63-2430C	548	18
RM2148C	123	25	S14-20-3-18R-SL	4461	194	S4-63-1848C	548	18	S4-63-2430E	655	18
RM2148R	126	25	S14-20-3-24-SL	4898	194	S4-63-1848E	664	18	S4-63-2430S	1925	18
RM2148W	126	25	S14-20-3-24L-SL	4651	194	S4-63-1848S	1876	18	S4-63-2430V	597	18
RM2148Z	112	25	S14-20-3-24R-SL	4651	194	S4-63-1848V	615	18	S4-63-2430VG	597	18
RM2424BL	109	25	S14-28-3-18-SL	5946	194	S4-63-1848VG	615	18	S4-63-2430Z	511	18
RM2424C	106	25	S16	66	75	S4-63-1848Z	520	18	S4-63-2436C	563	18
RM2424R	109	25	S16-20-1	1714	194	S4-63-1860C	621	18	S4-63-2436E	668	18
RM2424W	109	25	S16-20-2-18	3133	194	S4-63-1860E	766	18	S4-63-2436S	1943	18
RM2424Z	98	25	S16-20-2-18L	2977	194	S4-63-1860S	2300	18	S4-63-2436V	621	18
RM2436BL	116	25	S16-20-2-18R	2977	194	S4-63-1860V	687	18	S4-63-2436VG	621	18
RM2436C	112	25	S16-20-3-18	4131	194	S4-63-1860VG	687	18	S4-63-2436Z	524	18
RM2436R	116	25	S16-20-3-18L	3924	194	S4-63-1860Z	597	18	S4-63-2442C	635	18
RM2436W	116	25	S16-20-3-18R	3924	194	S4-63-1872C	717	18	S4-63-2442E	771	18
RM2436Z	106	25	S16-20-3-24	4308	194	S4-63-1872E	853	18	S4-63-2442S	2261	18
RM2448BL	139	25	S16-20-3-24L	4094	194	S4-63-1872S	2664	18	S4-63-2442V	668	18
RM2448C	135	25	S16-20-3-24R	4094	194	S4-63-1872V	804	18	S4-63-2442VG	668	18
RM2448R	139	25	S16-28-3-18	5228	194	S4-63-1872VG	804	18	S4-63-2442Z	597	18
RM2448W	139	25	S18	69	75	S4-63-1872Z	673	18	S4-63-2448C	649	18
RM2448Z	124	25	S2-3B-SSW1824C	208	108	S4-63-2124C	495	18	S4-63-2448E	788	18
RS4-63-A1436BL	668	23	S2-3B-SSW1830C	239	108	S4-63-2124E	606	18	S4-63-2448S	2271	18
RS4-63-A1436C	657	23	S2-3B-SSW1836C	258	108	S4-63-2124S	1789	18	S4-63-2448V	732	18
RS4-63-A1448BL	715	23	S2-3B-SSW1842C	293	108	S4-63-2124V	520	18	S4-63-2448VG	732	18
RS4-63-A1448C	700	23	S2-3B-SSW1848C	308	108	S4-63-2124VG	520	18	S4-63-2448Z	606	18
RS4-63-A1836BL	717	23	S2-3B-SSW1860C	371	108	S4-63-2124Z	472	18	S4-63-2460C	746	18
RS4-63-A1836C	702	23	S20	73	75	S4-63-2130C	524	18	S4-63-2460E	904	18
RS4-63-A1848BL	776	23	S3-3B-SSW1824C	279	108	S4-63-2130E	621	18	S4-63-2460S	2714	18
RS4-63-A1848C	758	23	S3-3B-SSW1830C	323	108	S4-63-2130S	1804	18	S4-63-2460V	842	18
RS4-63-A2136BL	739	23	S3-3B-SSW1836C	353	108	S4-63-2130V	539	18	S4-63-2460VG	842	18
RS4-63-A2136C	722	23	S3-3B-SSW1842C	407	108	S4-63-2130VG	539	18	S4-63-2460Z	717	18
RS4-63-A2148BL	813	23	S3-3B-SSW1848C	427	108	S4-63-2130Z	486	18	S4-63-2472C	861	18
RS4-63-A2148C	797	23	S3-3B-SSW1860C	523	108	S4-63-2136C	534	18	S4-63-2472E	1035	18
RS4-63-A2436BL	783	23	S3-5B-SSW1824C	303	108	S4-63-2136E	631	18	S4-63-2472S	3311	18
RS4-63-A2436C	768	23	S3-5B-SSW1830C	347	108	S4-63-2136S	1814	18	S4-63-2472V	972	18
RS4-63-A2448BL	894	23	S3-5B-SSW1836C	378	108	S4-63-2136V	597	18	S4-63-2472VG	972	18
RS4-63-A2448C	875	23	S3-5B-SSW1842C	431	108	S4-63-2136VG	597	18	S4-63-2472Z	808	18
RS4-74-A1436BL	714	23	S3-5B-SSW1848C	453	108	S4-63-2136Z	499	18	S4-74-1824C	466	18
RS4-74-A1436C	699	23	S3-5B-SSW1860C	547	108	S4-63-2142C	597	18	S4-74-1824E	558	18
RS4-74-A1448BL	757	23	S4-5B-SSW1824C	372	108	S4-63-2142E	698	18	S4-74-1824S	1645	18
RS4-74-A1448C	743	23	S4-5B-SSW1830C	436	108	S4-63-2142S	2045	18	S4-74-1824V	481	18
RS4-74-A1836BL	759	23	S4-5B-SSW1836C	473	108	S4-63-2142V	631	18	S4-74-1824VG	481	18
RS4-74-A1836C	746	23	S4-5B-SSW1842C	546	108	S4-63-2142VG	631	18	S4-74-1824Z	457	18
RS4-74-A1848BL	818	23	S4-5B-SSW1848C	574	108	S4-63-2142Z	544	18	S4-74-1830C	481	18
RS4-74-A1848C	801	23	S4-5B-SSW1860C	700	108	S4-63-2148C	606	18	S4-74-1830E	567	18
RS4-74-A2136BL	782	23	S4-63-1824C	453	18	S4-63-2148E	707	18	S4-74-1830S	1654	18
RS4-74-A2136C	766	23	S4-63-1824E	544	18	S4-63-2148S	2054	18	S4-74-1830V	515	18
RS4-74-A2148BL	854	23	S4-63-1824S	1602	18	S4-63-2148V	655	18	S4-74-1830VG	515	18
RS4-74-A2148C	837	23	S4-63-1824V	472	18	S4-63-2148VG	655	18	S4-74-1830Z	466	18
RS4-74-A2436BL	824	23	S4-63-1824VG	472	18	S4-63-2148Z	558	18	S4-74-1836C	491	18
RS4-74-A2436C	807	23	S4-63-1824Z	442	18	S4-63-2160C	683	18	S4-74-1836E	593	18
RS4-74-A2448BL	933	23	S4-63-1830C	466	18	S4-63-2160E	823	18	S4-74-1836S	1674	18
RS4-74-A2448C	916	23	S4-63-1830E	554	18	S4-63-2160S	2617	18	S4-74-1836V	539	18
S-HOOKS-SK	13	51	S4-63-1830S	1612	18	S4-63-2160V	766	18	S4-74-1836VG	539	18
S1-3B-SSW1824C	137	108	S4-63-1830V	506	18	S4-63-2160VG	766	18	S4-74-1836Z	481	18
S1-3B-SSW1830C	153	108	S4-63-1830VG	506	18	S4-63-2160Z	649	18	S4-74-1842C	544	18
S1-3B-SSW1836C	162	108	S4-63-1830Z	453	18	S4-63-2172C	808	18	S4-74-1842E	664	18
S1-3B-SSW1842C	177	108	S4-63-1836C	477	18	S4-63-2172E	972	18	S4-74-1842S	1905	18
S1-3B-SSW1848C	186	108	S4-63-1836E	577	18	S4-63-2172S	3039	18	S4-74-1842V	586	18
S1-3B-SSW1860C	218	108	S4-63-1836S	1632	18	S4-63-2172V	871	18	S4-74-1842VG	586	18
S10	52	75	S4-63-1836V	528	18	S4-63-2172VG	871	18	S4-74-1842Z	520	18
S12	55	75	S4-63-1836VG	528	18	S4-63-2172Z	766	18	S4-74-1848C	563	18
S14	59	75	S4-63-1836Z	466	18	S4-63-2424C	528	18	S4-74-1848E	679	18
S14-20-1-SL	1946	194	S4-63-1842C	528	18	S4-63-2424E	644	18	S4-74-1848S	1919	18
S14-20-2-18-SL	3558	194	S4-63-1842E	649	18	S4-63-2424S	1909	18	S4-74-1848V	626	18
S14-20-2-18L-SL	3382	194	S4-63-1842S	1862	18	S4-63-2424V	544	18	S4-74-1848VG	626	18
S14-20-2-18R-SL	3382	194	S4-63-1842V	577	18	S4-63-2424VG	544	18	S4-74-1848Z	534	18
S14-20-3-18-SL	4695	194	S4-63-1842VG	577	18	S4-63-2424Z	499	18	S4-74-1860C	635	18



100 Industrial Boulevard, Clayton, DE 19938-8903 U.S.A.  
 Phone: 800-441-8440 or 302-653-3000. Fax: 302-653-2065  
<http://www.eaglegrp.com>

# ALPHANUMERIC PRICE INDEX

Part Number	List Price	Page No.	Part Number	List Price	Page No.	Part Number	List Price	Page No.	Part Number	List Price	Page No.
S4-74-1860E	779	18	S4-74-2436S	1986	18	S5-74-1860V	836	20	S5-74-2436VG	752	20
S4-74-1860S	2343	18	S4-74-2436V	631	18	S5-74-1860VG	836	20	S5-74-2436Z	639	20
S4-74-1860V	698	18	S4-74-2436VG	631	18	S5-74-1860Z	731	20	S5-74-2442C	777	20
S4-74-1860VG	698	18	S4-74-2436Z	539	18	S5-74-1872C	879	20	S5-74-2442E	941	20
S4-74-1860Z	611	18	S4-74-2442C	649	18	S5-74-1872E	1042	20	S5-74-2442S	2787	20
S4-74-1872C	732	18	S4-74-2442E	784	18	S5-74-1872S	3292	20	S5-74-2442Z	812	20
S4-74-1872E	865	18	S4-74-2442S	2304	18	S5-74-1872V	980	20	S5-74-2442Z	812	20
S4-74-1872S	2708	18	S4-74-2442V	679	18	S5-74-1872VG	980	20	S5-74-2442Z	731	20
S4-74-1872V	813	18	S4-74-2442VG	679	18	S5-74-1872Z	826	20	S5-74-2448C	795	20
S4-74-1872VG	813	18	S4-74-2442Z	611	18	S5-74-2124C	602	20	S5-74-2448E	964	20
S4-74-1872Z	687	18	S4-74-2448C	664	18	S5-74-2124E	737	20	S5-74-2448S	2799	20
S4-74-2124C	511	18	S4-74-2448E	804	18	S5-74-2124S	2197	20	S5-74-2448V	891	20
S4-74-2124E	621	18	S4-74-2448S	2314	18	S5-74-2124V	626	20	S5-74-2448VG	891	20
S4-74-2124S	1833	18	S4-74-2448V	741	18	S5-74-2124VG	626	20	S5-74-2448Z	742	20
S4-74-2124V	528	18	S4-74-2448VG	741	18	S5-74-2124Z	574	20	S5-74-2460C	916	20
S4-74-2124VG	528	18	S4-74-2448Z	621	18	S5-74-2130C	638	20	S5-74-2460E	1108	20
S4-74-2124Z	486	18	S4-74-2460C	759	18	S5-74-2130E	754	20	S5-74-2460S	3352	20
S4-74-2130C	539	18	S4-74-2460E	919	18	S5-74-2130S	2215	20	S5-74-2460V	1029	20
S4-74-2130E	635	18	S4-74-2460S	2757	18	S5-74-2130V	649	20	S5-74-2460VG	1029	20
S4-74-2130S	1846	18	S4-74-2460V	853	18	S5-74-2130VG	649	20	S5-74-2460Z	881	20
S4-74-2130V	548	18	S4-74-2460VG	853	18	S5-74-2130Z	593	20	S5-74-2472C	1059	20
S4-74-2130VG	548	18	S4-74-2460Z	732	18	S5-74-2136C	651	20	S5-74-2472E	1271	20
S4-74-2130Z	499	18	S4-74-2472C	875	18	S5-74-2136E	767	20	S5-74-2472S	4098	20
S4-74-2136C	548	18	S4-74-2472E	1048	18	S5-74-2136S	2227	20	S5-74-2472V	1191	20
S4-74-2136E	644	18	S4-74-2472S	3353	18	S5-74-2136V	721	20	S5-74-2472VG	1191	20
S4-74-2136S	1857	18	S4-74-2472V	981	18	S5-74-2136VG	721	20	S5-74-2472Z	995	20
S4-74-2136V	606	18	S4-74-2472VG	981	18	S5-74-2136Z	609	20	S5-86-1824C	582	20
S4-74-2136VG	606	18	S4-74-2472Z	823	18	S5-74-2142C	729	20	S5-86-1824E	686	20
S4-74-2136Z	515	18	S5-5B-SSW1824C	441	108	S5-74-2142E	849	20	S5-86-1824S	2040	20
S4-74-2142C	611	18	S5-5B-SSW1830C	522	108	S5-74-2142S	2515	20	S5-86-1824V	603	20
S4-74-2142E	713	18	S5-5B-SSW1836C	568	108	S5-74-2142V	762	20	S5-86-1824VG	603	20
S4-74-2142S	2087	18	S5-5B-SSW1842C	660	108	S5-74-2142VG	762	20	S5-86-1824Z	572	20
S4-74-2142V	639	18	S5-5B-SSW1848C	695	108	S5-74-2142Z	664	20	S5-86-1830C	600	20
S4-74-2142VG	639	18	S5-5B-SSW1860C	853	108	S5-74-2148C	741	20	S5-86-1830E	699	20
S4-74-2142Z	558	18	S5-74-1824C	548	20	S5-74-2148E	862	20	S5-86-1830S	2052	20
S4-74-2148C	621	18	S5-74-1824E	659	20	S5-74-2148S	2528	20	S5-86-1830V	645	20
S4-74-2148E	721	18	S5-74-1824S	1963	20	S5-74-2148V	794	20	S5-86-1830VG	645	20
S4-74-2148S	2098	18	S5-74-1824V	565	20	S5-74-2148Z	794	20	S5-86-1830Z	583	20
S4-74-2148V	664	18	S5-74-1824VG	565	20	S5-74-2160C	682	20	S5-86-1836C	612	20
S4-74-2148VG	664	18	S5-74-1824Z	538	20	S5-74-2160E	837	20	S5-86-1836E	729	20
S4-74-2148Z	573	18	S5-74-1830C	566	20	S5-74-2160S	1006	20	S5-86-1836S	2076	20
S4-74-2160C	698	18	S5-74-1830E	669	20	S5-74-2160V	3232	20	S5-86-1836V	675	20
S4-74-2160E	837	18	S5-74-1830S	1975	20	S5-74-2160Z	932	20	S5-86-1836Z	675	20
S4-74-2160S	2660	18	S5-74-1830V	607	20	S5-74-2172C	994	20	S5-86-1842C	601	20
S4-74-2160V	775	18	S5-74-1830VG	607	20	S5-74-2172E	1193	20	S5-86-1842E	679	20
S4-74-2160VG	775	18	S5-74-1830Z	549	20	S5-74-2172S	3760	20	S5-86-1842E	819	20
S4-74-2160Z	664	18	S5-74-1836C	578	20	S5-74-2172V	1065	20	S5-86-1842S	2364	20
S4-74-2172C	823	18	S5-74-1836E	700	20	S5-74-2172VG	1065	20	S5-86-1842Z	737	20
S4-74-2172E	985	18	S5-74-1836S	1999	20	S5-74-2172Z	941	20	S5-86-1848C	702	20
S4-74-2172S	3084	18	S5-74-1836V	637	20	S5-74-2424C	644	20	S5-86-1848E	837	20
S4-74-2172V	881	18	S5-74-1836VG	637	20	S5-74-2424E	784	20	S5-86-1848S	2383	20
S4-74-2172VG	881	18	S5-74-1836Z	567	20	S5-74-2424S	2347	20	S5-86-1848V	784	20
S4-74-2172Z	779	18	S5-74-1842C	644	20	S5-74-2424V	656	20	S5-86-1848VG	784	20
S4-74-2424C	544	18	S5-74-1842E	789	20	S5-74-2424VG	656	20	S5-86-1848Z	667	20
S4-74-2424E	660	18	S5-74-1842S	2286	20	S5-74-2424Z	609	20	S5-86-1860C	792	20
S4-74-2424S	1953	18	S5-74-1842V	698	20	S5-74-2430C	668	20	S5-86-1860E	963	20
S4-74-2424V	554	18	S5-74-1842VG	698	20	S5-74-2430E	796	20	S5-86-1860S	2912	20
S4-74-2424VG	554	18	S5-74-1842Z	615	20	S5-74-2430S	2365	20	S5-86-1860V	874	20
S4-74-2424Z	515	18	S5-74-1848C	668	20	S5-74-2430V	721	20	S5-86-1860VG	874	20
S4-74-2430C	563	18	S5-74-1848E	808	20	S5-74-2430VG	721	20	S5-86-1860Z	762	20
S4-74-2430E	668	18	S5-74-1848S	2305	20	S5-74-2436C	622	20	S5-86-1872C	913	20
S4-74-2430S	1967	18	S5-74-1848V	746	20	S5-74-2436E	814	20	S5-86-1872E	1072	20
S4-74-2430V	606	18	S5-74-1848VG	746	20	S5-74-2436S	2389	20	S5-86-1872S	3368	20
S4-74-2430VG	606	18	S5-74-1848Z	634	20	S5-74-2436Z	752	20	S5-86-1872V	1018	20
S4-74-2430Z	524	18	S5-74-1860C	758	20				S5-86-1872VG	1018	20
S4-74-2436C	577	18	S5-74-1860E	934	20						
S4-74-2436E	683	18	S5-74-1860S	2835	20						

# ALPHANUMERIC PRICE INDEX

Part Number	List Price	Page No.	Part Number	List Price	Page No.	Part Number	List Price	Page No.	Part Number	List Price	Page No.
S5-86-1872Z	.860	20	S5-86-2448C	.828	20	SC2430S	.4212	44	SD36-C	.80	52
S5-86-2124C	.636	20	S5-86-2448E	.994	20	SC2436	.1603	44	SD36-R	.76	67
S5-86-2124E	.766	20	S5-86-2448S	.2876	20	SC2436E	.2047	44	SD36-S	.186	52
S5-86-2124S	.2275	20	S5-86-2448V	.928	20	SC2436S	.4679	44	SD36-V	.76	52
S5-86-2124V	.664	20	S5-86-2448VG	.928	20	SC2448	.1989	44	SD36-VG	.76	52
S5-86-2124VG	.664	20	S5-86-2448Z	.776	20	SC2448E	.2546	44	SD36-W	.76	67
S5-86-2124Z	.607	20	S5-86-2460C	.948	20	SC2448S	.5706	44	SDFT-10	1188	62
S5-86-2130C	.672	20	S5-86-2460E	1.137	20	SC2460	.2387	44	SDFT-11	1294	62
S5-86-2130E	.783	20	S5-86-2460S	.3428	20	SC2460E	.2767	44	SDFT-12	1394	62
S5-86-2130S	.2292	20	S5-86-2460V	.1067	20	SC2460S	.5904	44	SDFT-13	1501	62
S5-86-2130V	.687	20	S5-86-2460VG	.1067	20	SC3030	.2111	44	SDFT-14	1603	62
S5-86-2130VG	.687	20	S5-86-2460Z	.914	20	SC3030E	.2405	44	SDFT-15	1708	62
S5-86-2130Z	.626	20	S5-86-2472C	1.093	20	SC3030S	.5928	44	SDFT-16	1812	62
S5-86-2136C	.684	20	S5-86-2472E	1.300	20	SC3036	.2344	44	SDFT-17	1915	62
S5-86-2136E	.795	20	S5-86-2472S	.4175	20	SC3036E	.2675	44	SDFT-18	2019	62
S5-86-2136S	.2304	20	S5-86-2472V	1.229	20	SC3036S	.6586	44	SDFT-19	2124	62
S5-86-2136V	.759	20	S5-86-2472VG	1.229	20	SC3048	.2918	44	SDFT-20	2226	62
S5-86-2136VG	.759	20	S5-86-2472Z	1.029	20	SC3048E	.3354	44	SDFT-21	2331	62
S5-86-2136Z	.643	20	SFP10-1	.216	17	SC3048S	.8036	44	SDFT-22	2437	62
S5-86-2142C	.761	20	SFP10-2	.365	17	SC3060	.3142	44	SDFT-23	2543	62
S5-86-2142E	.879	20	SFP10-4	.334	17	SC3060E	.3608	44	SDFT-24	2647	62
S5-86-2142S	.2593	20	SB-1	.349	149	SC3060S	.8373	44	SDFT-25	2752	62
S5-86-2142V	.802	20	SB1014	.214	304	SC00P10-VG	.73	105	SDFT-26	2855	62
S5-86-2142VG	.802	20	SBH-1/3	.123	231,251	SCP-3	.2328	225	SDFT-27	2959	62
S5-86-2142Z	.698	20	SBH-1/6	.111	231,251	SCP-4	.2831	225	SDFT-28	3063	62
S5-86-2148C	.775	20	SBPR-108-A	.625	107,156	SCP-5	.3294	225	SDFT-29	3167	62
S5-86-2148E	.892	20	SBPR-108-S	.812	107,156	SCRAP TROUGH	1.068	328	SDFT-30	3271	62
S5-86-2148S	.2604	20	SBPR-120-A	.643	107,156	SD14-BL	.47	67	SDFT-6	.775	62
S5-86-2148V	.832	20	SBPR-120-S	.852	107,156	SD14-C	.32	52	SDFT-7	.876	62
S5-86-2148VG	.832	20	SBPR-24-A	.188	107,156	SD14-E	.54	52	SDFT-8	.982	62
S5-86-2148Z	.716	20	SBPR-24-S	.254	107,156	SD14-R	.47	67	SDFT-9	1085	62
S5-86-2160C	.871	20	SBPR-36-A	.286	107,156	SD14-S	.85	52	SDG2424R	.483	69
S5-86-2160E	1.036	20	SBPR-36-S	.359	107,156	SD14-V	.47	52	SDHT2-120	2376	214
S5-86-2160S	.3309	20	SBPR-48-A	.304	107,156	SD14-VG	.47	52	SDHT2-208	2376	214
S5-86-2160V	.971	20	SBPR-48-S	.403	107,156	SD14-W	.47	67	SDHT2-208-3	2720	214
S5-86-2160VG	.971	20	SBPR-60-A	.327	107,156	SD18-BL	.54	67	SDHT2-240	2376	214
S5-86-2160Z	.829	20	SBPR-60-S	.446	107,156	SD18-C	.41	52	SDHT2-240-3	2720	214
S5-86-2172C	1.028	20	SBPR-72-A	.451	107,156	SD18-E	.64	52	SDHT3-120	2674	214
S5-86-2172E	1.222	20	SBPR-72-S	.582	107,156	SD18-R	.54	67	SDHT3-208	2674	214
S5-86-2172S	.3838	20	SBPR-84-A	.468	107,156	SD18-S	.99	52	SDHT3-208-3	3018	214
S5-86-2172V	1.103	20	SBPR-84-S	.621	107,156	SD18-V	.54	52	SDHT3-240	2674	214
S5-86-2172VG	1.103	20	SBPR-96-A	.584	107,156	SD18-VG	.54	52	SDHT3-240-3	3018	214
S5-86-2172Z	.975	20	SBPR-96-S	.751	107,156	SD18-W	.54	67	SDHT4-120	3631	214
S5-86-2424C	.679	20	SC-18/22-12	.136	284,290	SD21-BL	.58	67	SDHT4-208	3631	214
S5-86-2424E	.813	20	SC-18/22-18	.167	284,290	SD21-C	.47	52	SDHT4-208-3	3977	214
S5-86-2424S	.2424	20	SC-18/22-24	.181	284,290	SD21-E	.67	52	SDHT4-240	3631	214
S5-86-2424V	.695	20	SC-18/22-28	.183	284,290	SD21-R	.58	67	SDHT4-240-3	3977	214
S5-86-2424VG	.695	20	SC-18/22-30	.206	284,290	SD21-S	.112	52	SDHT5-208	4567	214
S5-86-2424Z	.643	20	SC-18/22-36	.244	284,290	SD21-V	.58	52	SDHT5-208-3	4914	214
S5-86-2430C	.702	20	SC-18/22-42	.296	284,290	SD21-VG	.58	52	SDHT5-240	4567	214
S5-86-2430E	.825	20	SC-18/22-42	.296	284,290	SD21-W	.58	67	SDHT5-240-3	4914	214
S5-86-2430S	.2442	20	SC-18/22-48	.354	284,290	SD24-BL	.68	67	SDM1436C	1491	71
S5-86-2430V	.759	20	SC-18/22-48	.354	284,290	SD24-C	.51	52	SDM1436C-L	.466	71
S5-86-2430VG	.759	20	SC1430	.1412	44	SD24-E	.76	52	SDM1436C-P	145	71
S5-86-2430Z	.656	20	SC1430E	1.688	44	SD24-R	.68	67	SDM1436C-W	.117	71
S5-86-2436C	.720	20	SC1430S	.4189	44	SD24-S	.122	52	SDMB36-C	.246	71
S5-86-2436E	.843	20	SC1436	1.567	44	SD24-V	.68	52	SDSK-18	.761	62
S5-86-2436S	.2466	20	SC1436E	1.877	44	SD24-VG	.68	52	SDSK-21	.789	62
S5-86-2436V	.789	20	SC1436S	.4657	44	SD24-W	.68	67	SDSK-24	.824	62
S5-86-2436VG	.789	20	SC1448	1.949	44	SD30-BL	.74	67	SDSK-30	.920	62
S5-86-2436Z	.673	20	SC1448E	2.283	44	SD30-C	.62	52	SDSK-36	1.215	62
S5-86-2442C	.811	20	SC1448S	.5629	44	SD30-R	.74	67	SDSKATB-S	.339	62
S5-86-2442E	.969	20	SC1460	2.320	44	SD30-S	.153	52	SDTCIL-108-14/3	8174	322
S5-86-2442S	.2863	20	SC1460E	2.613	44	SD30-V	.74	52	SDTCIL-108-16/3	6857	322
S5-86-2442V	.849	20	SC1460S	.5784	44	SD30-VG	.74	52	SDTCIL-108-16/4	6369	322
S5-86-2442VG	.849	20	SC2430	1.444	44	SD30-W	.74	67	SDTCIL-120-14/3	8659	322
S5-86-2442Z	.762	20	SC2430E	1.841	44	SD36-BL	.76	67	SDTCIL-120-16/3	7387	322



100 Industrial Boulevard, Clayton, DE 19938-8903 U.S.A.  
 Phone: 800-441-8440 or 302-653-3000. Fax: 302-653-2065  
<http://www.eaglegrp.com>

# ALPHANUMERIC PRICE INDEX

Part Number	List Price	Page No.	Part Number	List Price	Page No.	Part Number	List Price	Page No.	Part Number	List Price	Page No.
SDTCIL-120-16/4	6879	322	SDTL-108-14/3	5796	320	SDTLR-96-16/3	7259	323	SECM1860FC	758	43
SDTCIL-60-14/3	6925	322	SDTL-108-16/3	4160	320	SDTLR-96-16/4	6802	323	SECM1860FE	801	43
SDTCIL-60-16/3	5882	322	SDTL-108-16/4	4019	320	SDTPL-124-14/3	11258	324	SECM1860FS	1883	43
SDTCIL-60-16/4	5355	322	SDTL-120-14/3	6101	320	SDTPL-124-16/3	9288	324	SECM1860FVG	790	43
SDTCIL-72-14/3	7129	322	SDTL-120-16/3	4380	320	SDTPL-124-16/4	7971	324	SECM1860FZ	596	43
SDTCIL-72-16/3	6039	322	SDTL-120-16/4	4231	320	SDTPR-124-14/3	11258	324	SECM1860G	1648	43
SDTCIL-72-16/4	5514	322	SDTL-30-14/3	3076	320	SDTPR-124-16/3	9288	324	SECM1860VG	778	43
SDTCIL-84-14/3	7385	322	SDTL-30-16/3	2592	320	SDTPR-124-16/4	7971	324	SECM1860Z	519	43
SDTCIL-84-16/3	6213	322	SDTL-30-16/4	2421	320	SDTR-108-14/3	5796	320	SECM2130C	627	43
SDTCIL-84-16/4	5691	322	SDTL-36-14/3	4218	320	SDTR-108-16/3	4160	320	SECM2130E	662	43
SDTCIL-96-14/3	7444	322	SDTL-36-16/3	2896	320	SDTR-108-16/4	4019	320	SECM2130FC	668	43
SDTCIL-96-16/3	6268	322	SDTL-36-16/4	2792	320	SDTR-120-14/3	6101	320	SECM2130FE	703	43
SDTCIL-96-16/4	5746	322	SDTL-48-14/3	4362	320	SDTR-120-16/3	4380	320	SECM2130FS	1782	43
SDTCIR-108-14/3	8174	322	SDTL-48-16/3	2993	320	SDTR-120-16/4	4231	320	SECM2130FVG	696	43
SDTCIR-108-16/3	6857	322	SDTL-48-16/4	2888	320	SDTR-30-14/3	3076	320	SECM2130FZ	561	43
SDTCIR-108-16/4	6369	322	SDTL-60-14/3	4504	320	SDTR-30-16/3	2592	320	SECM2130S	1531	43
SDTCIR-120-14/3	8659	322	SDTL-60-16/3	3092	320	SDTR-30-16/4	2421	320	SECM2130VG	653	43
SDTCIR-120-16/3	7387	322	SDTL-60-16/4	2989	320	SDTR-36-14/3	4218	320	SECM2130Z	481	43
SDTCIR-120-16/4	6879	322	SDTL-72-14/3	4715	320	SDTR-36-16/3	2896	320	SECM2136C	637	43
SDTCIR-60-14/3	6925	322	SDTL-72-16/3	3252	320	SDTR-36-16/4	2792	320	SECM2136E	669	43
SDTCIR-60-16/3	5882	322	SDTL-72-16/4	3144	320	SDTR-48-14/3	4362	320	SECM2136FC	679	43
SDTCIR-60-16/4	5355	322	SDTL-84-14/3	4968	320	SDTR-48-16/3	2993	320	SECM2136FE	716	43
SDTCIR-72-14/3	7129	322	SDTL-84-16/3	3487	320	SDTR-48-16/4	2888	320	SECM2136FS	1808	43
SDTCIR-72-16/3	6039	322	SDTL-84-16/4	3329	320	SDTR-60-14/3	4504	320	SECM2136FVG	707	43
SDTCIR-72-16/4	5514	322	SDTL-96-14/3	5033	320	SDTR-60-16/3	3092	320	SECM2136FZ	572	43
SDTCIR-84-14/3	7385	322	SDTL-96-16/3	3802	320	SDTR-60-16/4	2989	320	SECM2136S	1563	43
SDTCIR-84-16/3	6213	322	SDTL-96-16/4	3384	320	SDTR-72-14/3	4715	320	SECM2136VG	664	43
SDTCIR-84-16/4	5691	322	SDTLL-108-14/3	8958	323	SDTR-72-16/3	3252	320	SECM2136Z	492	43
SDTCIR-96-14/3	7444	322	SDTLL-108-16/3	7825	323	SDTR-72-16/4	3144	320	SECM2148C	680	43
SDTCIR-96-16/3	6268	322	SDTLL-108-16/4	7088	323	SDTR-84-14/3	4968	320	SECM2148E	717	43
SDTCIR-96-16/4	5746	322	SDTLL-120-14/3	10747	323	SDTR-84-16/3	3487	320	SECM2148FC	717	43
SDTCL-108-14/3	8353	321	SDTLL-120-16/3	9238	323	SDTR-84-16/4	3329	320	SECM2148FE	753	43
SDTCL-108-16/3	7201	321	SDTLL-120-16/4	8748	323	SDTR-96-14/3	5033	320	SECM2148FS	1905	43
SDTCL-108-16/4	6719	321	SDTLL-66-14/3	6563	323	SDTR-96-16/3	3802	320	SECM2148FVG	747	43
SDTCL-120-14/3	8794	321	SDTLL-66-16/3	5531	323	SDTR-96-16/4	3384	320	SECM2148FZ	599	43
SDTCL-120-16/3	7580	321	SDTLL-66-16/4	4880	323	SECM1830C	621	43	SECM2148S	1681	43
SDTCL-120-16/4	7072	321	SDTLL-72-14/3	8235	323	SECM1830E	652	43	SECM2148VG	708	43
SDTCL-60-14/3	7063	321	SDTLL-72-16/3	7033	323	SECM1830FC	664	43	SECM2148Z	526	43
SDTCL-60-16/3	6007	321	SDTLL-72-16/4	6519	323	SECM1830FE	698	43	SECM2160C	757	43
SDTCL-60-16/4	5483	321	SDTLL-78-14/3	8424	323	SECM1830FS	1759	43	SECM2160E	799	43
SDTCL-72-14/3	7274	321	SDTLL-78-16/3	7206	323	SECM1830FVG	692	43	SECM2160FC	772	43
SDTCL-72-16/3	6163	321	SDTLL-78-16/4	6694	323	SECM1830FZ	557	43	SECM2160FE	811	43
SDTCL-72-16/4	5638	321	SDTLL-84-14/3	8485	323	SECM1830S	1505	43	SECM2160FS	1927	43
SDTCL-84-14/3	7523	321	SDTLL-84-16/3	7235	323	SECM1830VG	647	43	SECM2160FVG	804	43
SDTCL-84-16/3	6336	321	SDTLL-84-16/4	6749	323	SECM1830Z	473	43	SECM2160FZ	609	43
SDTCL-84-16/4	5819	321	SDTLL-96-14/3	8545	323	SECM1836C	628	43	SECM2160S	1697	43
SDTCL-96-14/3	7584	321	SDTLL-96-16/3	7259	323	SECM1836E	663	43	SECM2160VG	789	43
SDTCL-96-16/3	6394	321	SDTLL-96-16/4	6802	323	SECM1836FC	669	43	SECM2160Z	536	43
SDTCL-96-16/4	5874	321	SDTLR-108-14/3	8958	323	SECM1836FE	704	43	SECM2430C	635	43
SDTCR-108-14/3	8353	321	SDTLR-108-16/3	7825	323	SECM1836FS	1785	43	SECM2430E	667	43
SDTCR-108-16/3	7201	321	SDTLR-108-16/4	7088	323	SECM1836FVG	697	43	SECM2430FC	677	43
SDTCR-108-16/4	6719	321	SDTLR-120-14/3	10747	323	SECM1836FZ	563	43	SECM2430FE	713	43
SDTCR-120-14/3	8794	321	SDTLR-120-16/3	9238	323	SECM1836S	1536	43	SECM2430FS	1801	43
SDTCR-120-16/3	7580	321	SDTLR-120-16/4	8748	323	SECM1836VG	654	43	SECM2430FVG	705	43
SDTCR-120-16/4	7072	321	SDTLR-66-14/3	6563	323	SECM1836Z	483	43	SECM2430FZ	569	43
SDTCR-60-14/3	7063	321	SDTLR-66-16/3	5531	323	SECM1848C	665	43	SECM2430S	1555	43
SDTCR-60-16/3	6007	321	SDTLR-66-16/4	4880	323	SECM1848E	699	43	SECM2430VG	661	43
SDTCR-60-16/4	5483	321	SDTLR-72-14/3	8235	323	SECM1848FC	702	43	SECM2430Z	488	43
SDTCR-72-14/3	7274	321	SDTLR-72-16/3	7033	323	SECM1848FE	741	43	SECM2436C	680	43
SDTCR-72-16/3	6163	321	SDTLR-72-16/4	6519	323	SECM1848FS	1872	43	SECM2436E	716	43
SDTCR-72-16/4	5638	321	SDTLR-78-14/3	8424	323	SECM1848FVG	731	43	SECM2436FC	713	43
SDTCR-84-14/3	7523	321	SDTLR-78-16/3	7206	323	SECM1848FZ	589	43	SECM2436FE	749	43
SDTCR-84-16/3	6336	321	SDTLR-78-16/4	6694	323	SECM1848S	1644	43	SECM2436FS	1846	43
SDTCR-84-16/4	5819	321	SDTLR-84-14/3	8485	323	SECM1848VG	693	43	SECM2436FVG	743	43
SDTCR-96-14/3	7584	321	SDTLR-84-16/3	7235	323	SECM1848Z	514	43	SECM2436FZ	583	43
SDTCR-96-16/3	6394	321	SDTLR-84-16/4	6749	323	SECM1860C	747	43	SECM2436S	1611	43
SDTCR-96-16/4	5874	321	SDTLR-96-14/3	8545	323	SECM1860E	785	43	SECM2436VG	708	43

100 Industrial Boulevard, Clayton, DE 19938-8903 U.S.A.  
 Phone: 800-441-8440 or 302-653-3000. Fax: 302-653-2065  
<http://www.eaglegrp.com>



# ALPHANUMERIC PRICE INDEX

Part Number	List Price	Page No.	Part Number	List Price	Page No.	Part Number	List Price	Page No.	Part Number	List Price	Page No.
SECM2436Z	506	43	SHDS1836SE	573	77	SHDS2448VF	356	76	SHT4-LP	3498	216
SECM2448C	772	43	SHDS1836SF	523	76	SHDS2448VGE	363	77	SHT4-NG	3498	216
SECM2448E	811	43	SHDS1836SL	573	78	SHDS2448VGF	356	76	SHT40B-120	7883	221
SECM2448FC	780	43	SHDS1836VE	311	77	SHDS2448VGL	366	78	SHT40B-208	7883	221
SECM2448FE	821	43	SHDS1836VF	303	76	SHDS2448VL	366	78	SHT40B-208-3	8458	221
SECM2448FS	1937	43	SHDS1836VGE	311	77	SHDS2454SE	889	77	SHT40B-240	7883	221
SECM2448FVG	813	43	SHDS1836VGF	303	76	SHDS2454SF	904	76	SHT40B-240-3	8458	221
SECM2448FZ	611	43	SHDS1836VGL	316	78	SHDS2454SL	889	78	SHT5-208	7674	217
SECM2448S	1720	43	SHDS1836VL	316	78	SHDS2454VE	391	77	SHT5-208-3	8019	217
SECM2448VG	804	43	SHDS1842SE	635	77	SHDS2454VF	385	76	SHT5-240	7674	217
SECM2448Z	539	43	SHDS1842SF	583	76	SHDS2454VGE	391	77	SHT5-240-3	8019	217
SECM2460C	861	43	SHDS1842SL	635	78	SHDS2454VGF	385	76	SHT5CB-208	10069	221
SECM2460E	906	43	SHDS1842VE	327	77	SHDS2454VGL	399	78	SHT5CB-208-3	10643	221
SECM2460FC	853	43	SHDS1842VF	320	76	SHDS2454VL	399	78	SHT5CB-240	10069	221
SECM2460FE	896	43	SHDS1842VGE	327	77	SHDS2460SE	989	77	SHT5CB-240-3	10643	221
SECM2460FS	2031	43	SHDS1842VGF	320	76	SHDS2460SF	967	76	SHT5-LP	4212	216
SECM2460FVG	889	43	SHDS1842VGL	329	78	SHDS2460SL	989	78	SHT5-NG	4212	216
SECM2460FZ	637	43	SHDS1842VL	329	78	SHDS2460VE	408	77	SHT5OB-208	9294	221
SECM2460S	1829	43	SHDS1848SE	689	77	SHDS2460VF	400	76	SHT5OB-208-3	9866	221
SECM2460VG	897	43	SHDS1848SF	635	76	SHDS2460VGE	408	77	SHT5OB-240	9294	221
SECM2460Z	572	43	SHDS1848SL	689	78	SHDS2460VGF	400	76	SHT5OB-240-3	9866	221
SFN2832-2-14/3	5904	194	SHDS1848VE	335	77	SHDS2460VGL	414	78	SKATB-S	85	62,63
SFN2832-2-18-14/3	7274	194	SHDS1848VF	329	76	SHDS2460VL	414	78	SL14-1C	24	53
SFN2832-2-18L-14/3	6644	194	SHDS1848VGE	335	77	SHT2-120	3852	217	SL14-1S	43	53
SFN2832-2-18R-14/3	6644	194	SHDS1848VGF	329	76	SHT2-208	3852	217	SL14-4C	37	53
SFN3052-3-14/3	7567	194	SHDS1848VGL	338	78	SHT2-208-3	4195	217	SL14-4S	60	53
SFN3052-3-18-14/3	8400	194	SHDS1848VL	338	78	SHT2-240	3852	217	SL18-1C	25	53
SFN3052-3-18L-14/3	8191	194	SHDS1854SE	742	77	SHT2-240-3	4195	217	SL18-1S	52	53
SFN3052-3-18R-14/3	8191	194	SHDS1854SF	694	76	SHT2CB-120	6197	221	SL18-4C	41	53
SFN3242-3-14/3	7885	194	SHDS1854SL	742	78	SHT2CB-208	6197	221	SL18-4S	64	53
SFN3242-3-18-14/3	8421	194	SHDS1854VE	363	77	SHT2CB-208-3	6771	221	SL21-1C	29	53
SFN3242-3-18L-14/3	8129	194	SHDS1854VF	353	76	SHT2CB-240	6197	221	SL21-1S	53	53
SFN3242-3-18R-14/3	8129	194	SHDS1854VGE	363	77	SHT2CB-240-3	6771	221	SL21-4C	43	53
SGDI-1-120T	2787	272	SHDS1854VGF	353	76	SHT2-LP	2384	216	SL21-4S	74	53
SGDI-1-120T-D	3098	272	SHDS1854VGL	346	78	SHT2-NG	2384	216	SL2136C	121	52
SGDI-1-240T	2787	272	SHDS1854VL	346	78	SHT2OB-120	5584	221	SL2136E	144	52
SGDI-1-240T-D	3098	272	SHDS1860SE	788	77	SHT2OB-208	5584	221	SL2136Z	111	52
SGDI-1-240T6	2793	272	SHDS1860SF	744	76	SHT2OB-208-3	6159	221	SL2148C	157	52
SGDI-1-240T6-D	3105	272	SHDS1860SL	788	78	SHT2OB-240	5584	221	SL2148E	191	52
SGDI-2-120T	3777	272	SHDS1860VE	373	77	SHT2OB-240-3	6159	221	SL2148Z	144	52
SGDI-2-120T-D	4317	272	SHDS1860VF	368	76	SHT3-120	5100	217	SL2160C	172	52
SGDI-2-240T	3777	272	SHDS1860VGE	373	77	SHT3-208	5100	217	SL2160E	221	52
SGDI-2-240T-D	4317	272	SHDS1860VGF	368	76	SHT3-208-3	5444	217	SL2160Z	154	52
SGDI-2-240T6	3789	272	SHDS1860VGL	380	78	SHT3-240	5100	217	SL24-1C	35	53
SGDI-2-240T6-D	4331	272	SHDS1860VL	380	78	SHT3-240-3	5444	217	SL24-1S	57	53
SGDI-3-120T	4622	272	SHDS2436SE	714	77	SHT3CB-120	7582	221	SL24-4C	43	53
SGDI-3-120T-D	5313	272	SHDS2436SF	682	76	SHT3CB-208	7582	221	SL24-4S	82	53
SGDI-3-240T	4622	272	SHDS2436SL	714	78	SHT3CB-208-3	8157	221	SL2436C	152	52
SGDI-3-240T-D	5313	272	SHDS2436VE	334	77	SHT3CB-240	7582	221	SL2436E	179	52
SGDI-3-240T6	4639	272	SHDS2436VF	327	76	SHT3CB-240-3	8157	221	SL2436Z	137	52
SGDI-3-240T6-D	5652	272	SHDS2436VGE	334	77	SHT3-LP	2859	216	SL2448C	176	52
SGDI-4-240T	5517	272	SHDS2436VGF	327	76	SHT3-NG	2859	216	SL2448E	213	52
SGDI-4-240T-D	6306	272	SHDS2436VGL	336	78	SHT3OB-120	6415	221	SL2448Z	160	52
SGDI-4-240T6	5540	272	SHDS2436VL	336	78	SHT3OB-208	6415	221	SL2460C	183	52
SGDI-4-240T6-D	6332	272	SHDS2442SE	735	77	SHT3OB-208-3	6987	221	SL2460E	226	52
SGDI-5-240T	6383	272	SHDS2442SF	746	76	SHT3OB-240	6415	221	SL2460Z	174	52
SGDI-5-240T-D	7322	272	SHDS2442SL	735	78	SHT3OB-240-3	6987	221	SL30-1C	36	53
SGDI-5-240T6	6414	272	SHDS2442VE	347	77	SHT4-120	6257	217	SL30-1S	76	53
SGDI-5-240T6-D	7767	272	SHDS2442VF	341	76	SHT4-208	6257	217	SL30-4C	55	53
SGDI-6-240T	7168	272	SHDS2442VGE	347	77	SHT4-208-3	6601	217	SL30-4S	92	53
SGDI-6-240T-D	8229	272	SHDS2442VGF	341	76	SHT4-240	6257	217	SL36-1C	39	53
SGDI-6-240T6	7192	272	SHDS2442VGL	352	78	SHT4-240-3	6601	217	SL36-1S	86	53
SGDI-6-240T6-D	8265	272	SHDS2442VL	352	78	SHT4CB-120	9315	221	SL36-4C	66	53
SH	4	105	SHDS2448SE	794	77	SHT4CB-208	9315	221	SL36-4S	115	53
SH-BL	16	69	SHDS2448SF	836	76	SHT4CB-208-3	9888	221	SL42-1C	48	53
SH-C	16	69	SHDS2448SL	794	78	SHT4CB-240	9315	221	SL42-1S	95	53
SHDR-10-24	506	275	SHDS2448VE	363	77	SHT4CB-240-3	9888	221	SL42-4C	69	53



100 Industrial Boulevard, Clayton, DE 19938-8903 U.S.A.  
 Phone: 800-441-8440 or 302-653-3000. Fax: 302-653-2065  
<http://www.eaglegrp.com>

# ALPHANUMERIC PRICE INDEX

Part Number	List Price	Page No.	Part Number	List Price	Page No.	Part Number	List Price	Page No.	Part Number	List Price	Page No.
SL42-4S	125	53	SPDHT4-120	4422	215	SPST-4	2639	226	SS1424G	195	16
SL48-1C	51	53	SPDHT4-208	4422	215	SPST-5	3126	226	SS1424S	321	16
SL48-1S	96	53	SPDHT4-208-3	4767	215	SR10-14-5-1	581	198	SS1424V	215	16
SL48-4C	81	53	SPDHT4-240	4422	215	SR10-14-5-1-ND	529	200	SS1424VG	215	16
SL48-4S	141	53	SPDHT4-240-3	4767	215	SR10-14-9.5-1	637	198	SS1430G	199	16
SL54-1C	52	53	SPDHT5-208	5433	215	SR10-14-9.5-1-ND	696	200	SS1430S	326	16
SL54-1S	112	53	SPDHT5-208-3	5776	215	SR10-14-9.5-2	1349	198	SS1430V	221	16
SL54-4C	83	53	SPDHT5-240	5433	215	SR10-14-9.5-2-ND	1317	200	SS1430VG	221	16
SL54-4S	157	53	SPDHT5-240-3	5776	215	SR10-14-9.5-3	1804	199	SS1436G	212	16
SL60-1C	55	53	SPHT2-120	3977	217	SR10-14-9.5-3-ND	1403	200	SS1436S	328	16
SL60-1S	124	53	SPHT2-208	3977	217	SR12-14-9.5-1	857	198	SS1436V	227	16
SL60-4C	84	53	SPHT2-208-3	4322	217	SR12-14-9.5-1-ND	838	200	SS1436VG	227	16
SL60-4S	163	53	SPHT2-240	3977	217	SR12-14-9.5-2	1484	198	SS1442G	215	16
SL72-1C	62	53	SPHT2-240-3	4322	217	SR12-14-9.5-2-ND	1521	200	SS1442S	391	16
SL72-1S	137	53	SPHT2CB-120	6973	221	SR12-14-9.5-3	2177	199	SS1442V	238	16
SL72-4C	99	53	SPHT2CB-208	6973	221	SR12-14-9.5-3-ND	2094	200	SS1442VG	238	16
SL72-4S	180	53	SPHT2CB-208-3	7546	221	SR14	77	105	SS1448G	218	16
SLS1836C	108	56	SPHT2CB-240	6973	221	SR14-10-5-1	581	198	SS1448S	399	16
SMPT30108	10235	136	SPHT2CB-240-3	7546	221	SR14-10-9.5-1	832	198	SS1448V	240	16
SMPT30120	10840	136	SPHT2OB-120	6359	221	SR14-12-9.5-1	847	198	SS1448VG	240	16
SMPT30144	12041	136	SPHT2OB-208	6359	221	SR14-16-9.5-1	998	198	SS1454G	235	16
SMPT3096	9637	136	SPHT2OB-208-3	6934	221	SR14-16-9.5-1-ND	953	200	SS1454S	412	16
SNSW1224C	133	107	SPHT2OB-240	6359	221	SR14-16-9.5-2	1582	198	SS1454V	263	16
SNSW1224E	154	107	SPHT2OB-240-3	6934	221	SR14-16-9.5-2-ND	1627	200	SS1454VG	263	16
SNSW1224V	139	107	SPHT3-120	5264	217	SR14-16-9.5-3	2222	199	SS1460G	238	16
SNSW1224VG	139	107	SPHT3-208	5264	217	SR14-16-9.5-3-ND	2246	200	SS1460S	475	16
SNSW1236C	174	107	SPHT3-240	5264	217	SR16-14-9.5-1	998	198	SS1460V	268	16
SNSW1236E	199	107	SPHT3-208-3	5608	217	SR16-19-13.5-1	1069	198	SS1460VG	268	16
SNSW1236V	183	107	SPHT3-240-3	5608	217	SR16-19-13.5-1-ND	944	200	SS1824G	195	16
SNSW1236VG	183	107	SPHT3CB-120	8358	221	SR16-19-13.5-2	1863	198	SS1824S	363	16
SNSW1248C	217	107	SPHT3CB-208	8358	221	SR16-19-13.5-2-ND	1466	200	SS1824V	221	16
SNSW1248E	242	107	SPHT3CB-208-3	8932	221	SR16-19-13.5-3	2443	199	SS1824VG	221	16
SNSW1248V	227	107	SPHT3CB-240	8358	221	SR16-19-13.5-3-ND	2023	200	SS1830G	204	16
SNSW1248VG	227	107	SPHT3CB-240-3	8932	221	SR16-19-8-1	854	198	SS1830S	367	16
SNSW1260C	235	107	SPHT3OB-120	7189	221	SR16-19-8-1-ND	858	200	SS1830V	225	16
SNSW1260E	265	107	SPHT3OB-208	7189	221	SR16-19-8-2	1774	198	SS1830VG	225	16
SNSW1260V	247	107	SPHT3OB-208-3	7762	221	SR16-19-8-2-ND	1295	200	SS1836G	204	16
SNSW1260VG	247	107	SPHT3OB-240	7189	221	SR16-19-8-3	2308	199	SS1836S	372	16
SNSW1272C	301	107	SPHT3OB-240-3	7762	221	SR16-19-8-3-ND	1823	200	SS1836V	232	16
SNSW1272E	333	107	SPHT4-120	6349	217	SR18-24-13.5-1	1133	198	SS1836VG	232	16
SNSW1272V	318	107	SPHT4-208	6349	217	SR18-24-13.5-1-ND	1006	200	SS1842G	221	16
SNSW1272VG	318	107	SPHT4-208-3	6694	217	SR18-24-13.5-2	2136	198	SS1842S	452	16
SP1813-18	24	353	SPHT4-240	6349	217	SR18-24-13.5-2-ND	1760	200	SS1842V	242	16
SP1826-16	43	353	SPHT4-240-3	6694	217	SR18-24-13.5-3	2964	199	SS1842VG	242	16
SP1826-18	32	353	SPHT4CB-120	10088	221	SR18-24-13.5-3-ND	2431	200	SS1848G	225	16
SP1826-G	53	353	SPHT4CB-208	10088	221	SR19-16-13.5-1	1069	198	SS1848S	456	16
SP1826-N	85	353	SPHT4CB-208-3	10663	221	SR19-16-8-1	998	198	SS1848V	242	16
SP1826-NCA	102	353	SPHT4CB-240	10088	221	SR20-12-6.5-1	1078	198	SS1848VG	242	16
SP74-CS	37	45	SPHT4CB-240-3	10663	221	SR22-22-13.5-1	1796	198	SS1854G	241	16
SP74-ES	36	45	SPHT4OB-120	8660	221	SR22-22-13.5-1-ND	1738	200	SS1854S	474	16
SP74-SS	119	45	SPHT4OB-208	8660	221	SR22-22-13.5-2	3198	198	SS1854V	268	16
SP86-CS	47	45	SPHT4OB-208-3	9233	221	SR22-22-13.5-2-ND	3231	200	SS1854VG	268	16
SP86-ES	46	45	SPHT4OB-240	8660	221	SR24	82	105	SS1860G	246	16
SP86-SS	140	45	SPHT4OB-240-3	9233	221	SR24-18-13.5-1	1041	198	SS1860S	536	16
SPCP-3	2948	225	SPHT5-208	8057	217	SR24-24-13.5-1	1364	198	SS1860V	275	16
SPCP-4	3467	225	SPHT5-240	8057	217	SR24-24-13.5-1-ND	1102	200	SS1860VG	275	16
SPCP-5	3920	225	SPHT5-208-3	8402	217	SR24-24-13.5-2	2882	198	SS2124G	209	16
SPDHT2-120	2920	215	SPHT5-240-3	8402	217	SR24-24-13.5-2-ND	1860	200	SS2124S	404	16
SPDHT2-208	2920	215	SPHT5CB-208	10844	221	SRU14-10-5-1	1096	198	SS2124V	229	16
SPDHT2-208-3	3267	215	SPHT5CB-208-3	11418	221	SS-2	303	236	SS2124VG	229	16
SPDHT2-240	2920	215	SPHT5CB-240	10844	221	SS-3	368	236	SS2130G	215	16
SPDHT2-240-3	3267	215	SPHT5CB-240-3	11418	221	SS-4	401	236	SS2130S	407	16
SPDHT3-120	3220	215	SPHT5OB-208	10069	221	SS-HT2	922	227	SS2130V	238	16
SPDHT3-208	3220	215	SPHT5OB-208-3	10643	221	SS-HT3	1033	227	SS2130VG	238	16
SPDHT3-208-3	3565	215	SPHT5OB-240	10069	221	SS-HT4	1105	227	SS2136G	227	16
SPDHT3-240	3220	215	SPHT5OB-240-3	10643	221	SS-HT5	1414	227	SS2136S	411	16
SPDHT3-240-3	3565	215	SPST-3	2355	226	SS-HT6	1460	227	SS2136V	253	16

# ALPHANUMERIC PRICE INDEX

Part Number	List Price	Page No.	Part Number	List Price	Page No.	Part Number	List Price	Page No.	Part Number	List Price	Page No.
SS2136VG	253	16	SSP-HT6	1664	227	SSR-78	602	312	SWS1224-16/4	287	106
SS2142G	232	16	SSR-12	197	312	SSR-79	602	312	SWS1224TR-16/4	303	107
SS2142S	516	16	SSR-13	197	312	SSR-80	602	312	SWS1236-14/3	466	106
SS2142V	261	16	SSR-14	197	312	SSR-81	602	312	SWS1236-16/3	437	106
SS2142VG	261	16	SSR-15	197	312	SSR-82	602	312	SWS1236-16/4	311	106
SS2148G	240	16	SSR-16	197	312	SSR-83	602	312	SWS1236TR-16/4	338	107
SS2148S	520	16	SSR-17	197	312	SSR-84	642	312	SWS1248-14/3	521	106
SS2148V	266	16	SSR-18	229	312	SSRLC-12	209	312	SWS1248-16/3	484	106
SS2148VG	266	16	SSR-19	229	312	SSRLC-13	209	312	SWS1248-16/4	382	106
SS2154G	260	16	SSR-20	229	312	SSRLC-14	209	312	SWS1248TR-16/4	427	107
SS2154S	540	16	SSR-21	229	312	SSRLC-15	209	312	SWS1260-14/3	563	106
SS2154V	292	16	SSR-22	229	312	SSRLC-16	209	312	SWS1260-16/3	528	106
SS2154VG	292	16	SSR-23	229	312	SSRLC-17	209	312	SWS1260-16/4	406	106
SS2160G	264	16	SSR-24	257	312	SSRLC-18	244	312	SWS1260TR-16/4	471	107
SS2160S	603	16	SSR-25	257	312	SSRLC-19	244	312	SWS1272-14/3	713	106
SS2160V	294	16	SSR-26	257	312	SSRLC-20	244	312	SWS1272-16/3	651	106
SS2160VG	294	16	SSR-27	257	312	SSRLC-21	244	312	SWS1272-16/4	502	106
SS2424G	213	16	SSR-28	257	312	SSRLC-22	244	312	SWS1272TR-16/4	581	107
SS2424S	438	16	SSR-29	257	312	SSRLC-23	244	312	SWS1296TR-16/4	747	107
SS2424V	232	16	SSR-30	294	312	SSRLC-24	314	312	SWS1524-14/3	411	106
SS2424VG	232	16	SSR-31	294	312	SSRLC-25	314	312	SWS1524-14/304-VMAR	534	106
SS2430G	220	16	SSR-32	294	312	SSRLC-26	314	312	SWS1524-14/316-VMAR	596	106
SS2430S	442	16	SSR-33	294	312	SSRLC-27	314	312	SWS1524-16/3	378	106
SS2430V	239	16	SSR-34	294	312	SSRLC-28	314	312	SWS1524-16/304-VMAR	524	106
SS2430VG	239	16	SSR-35	294	312	SSRLC-29	314	312	SWS1524-16/4	311	106
SS2436G	229	16	SSR-36	334	312	SSRLC-30	375	312	SWS1524-16/430-VMAR	466	106
SS2436S	444	16	SSR-37	334	312	SSRLC-31	375	312	SWS1536-14/3	508	106
SS2436V	256	16	SSR-38	334	312	SSRLC-32	375	312	SWS1536-14/304-VMAR	559	106
SS2436VG	256	16	SSR-39	334	312	SSRLC-33	375	312	SWS1536-14/316-VMAR	689	106
SS2442G	239	16	SSR-40	334	312	SSRLC-34	375	312	SWS1536-16/3	451	106
SS2442S	540	16	SSR-41	334	312	SSRLC-35	375	312	SWS1536-16/304-VMAR	583	106
SS2442V	266	16	SSR-42	372	312	SSRLC-36	439	312	SWS1536-16/4	320	106
SS2442VG	266	16	SSR-43	372	312	SSRLC-37	439	312	SWS1536-16/430-VMAR	506	106
SS2448G	248	16	SSR-44	372	312	SSRLC-38	439	312	SWS1548-14/3	618	106
SS2448S	543	16	SSR-45	372	312	SSRLC-39	439	312	SWS1548-14/304-VMAR	726	106
SS2448V	273	16	SSR-46	372	312	SSRLC-40	439	312	SWS1548-14/316-VMAR	857	106
SS2448VG	273	16	SSR-47	372	312	SSRLC-41	439	312	SWS1548-16/3	548	106
SS2454G	266	16	SSR-48	411	312	SSRLC-42	503	312	SWS1548-16/304-VMAR	698	106
SS2454S	560	16	SSR-49	411	312	SST-3	1766	226	SWS1548-16/4	385	106
SS2454V	297	16	SSR-50	411	312	SST-4	2048	226	SWS1548-16/430-VMAR	597	106
SS2454VG	297	16	SSR-51	411	312	SST-5	2542	226	SWS1560-14/3	636	106
SS2460G	273	16	SSR-52	411	312	SSW1824C	73	108	SWS1560-14/304-VMAR	808	106
SS2460S	642	16	SSR-53	411	312	SSW1830C	88	108	SWS1560-14/316-VMAR	963	106
SS2460V	305	16	SSR-54	452	312	SSW1836C	99	108	SWS1560-16/3	601	106
SS2460VG	305	16	SSR-55	452	312	SSW1842C	119	108	SWS1560-16/304-VMAR	766	106
SSD14-C	36	52	SSR-56	452	312	SSW1848C	124	108	SWS1560-16/4	419	106
SSD14-S	113	52	SSR-57	452	312	SSW1860C	159	108	SWS1560-16/430-VMAR	641	106
SSD18-C	43	52	SSR-58	452	312	SSW18B3-C	107	108	SWS1572-14/3	846	106
SSD18-S	121	52	SSR-59	452	312	SSW18B5-C	126	108	SWS1572-14/304-VMAR	957	106
SSD21-C	51	52	SSR-60	488	312	ST-3	1513	226	SWS1572-14/316-VMAR	1129	106
SSD21-S	129	52	SSR-61	488	312	ST-4	1756	226	SWS1572-16/3	749	106
SSD24-C	59	52	SSR-62	488	312	ST-5	2181	226	SWS1572-16/304-VMAR	897	106
SSD24-S	134	52	SSR-63	488	312	ST3CB	6662	225	SWS1572-16/4	512	106
SSD30-C	74	52	SSR-64	488	312	ST3OB	5281	225	SWS1572-16/430-VMAR	754	106
SSD30-S	159	52	SSR-65	488	312	ST4CB	7833	225	SWT2-208	6954	222
SSD36-C	86	52	SSR-66	526	312	ST4OB	6153	225	SWT2-240	6954	222
SSD36-S	161	52	SSR-67	526	312	ST5CB	8913	225	SWT3-208	7595	222
SSENCBKT	73	28	SSR-68	526	312	ST5OB	7614	225	SWT3-240	7595	222
SSH2	2833	256	SSR-69	526	312	STR2430A	537	47	SWT4-208	8628	222
SSH3	3167	256	SSR-70	526	312	STR2430B	817	47	SWT4-240	8628	222
SSH4	3672	256	SSR-71	526	312	STR2448A	638	47	SWT5-208	9116	222
SSH5	4760	256	SSR-72	566	312	STR2448B	989	47	SWT5-240	9116	222
SSH6	5265	256	SSR-73	566	312	SW-1	917	227	T24108B	2651	118
SSP-HT2	1067	227	SSR-74	566	312	SWS1212TR-16/4	242	107	T24108B-BS	3020	126
SSP-HT3	1127	227	SSR-75	566	312	SWS1218TR-16/4	264	107	T24108E	2774	118
SSP-HT4	1246	227	SSR-76	566	312	SWS1224-14/3	366	106	T24108E-BS	3341	126
SSP-HT5	1614	227	SSR-77	566	312	SWS1224-16/3	345	106	T24108EB	2833	118



100 Industrial Boulevard, Clayton, DE 19938-8903 U.S.A.  
 Phone: 800-441-8440 or 302-653-3000. Fax: 302-653-2065  
<http://www.eaglegrp.com>





# ALPHANUMERIC PRICE INDEX

Part Number	List Price	Page No.	Part Number	List Price	Page No.	Part Number	List Price	Page No.	Part Number	List Price	Page No.
T2448STB	1516	121	T2472GTB	1264	120	T2496EB	1962	118	T30120EB-BS	3487	126
T2448STB-BS	1934	129	T2472GTB-BS	1604	128	T2496EB-BS	2282	126	T30120EM	3811	118
T2448STE	1772	121	T2472GTE	1514	120	T2496EM	2642	118	T30120EM-BS	4433	126
T2448STE-BS	2175	129	T2472GTE-BS	1860	128	T2496EM-BS	3209	126	T30120GTB	2905	120
T2448STEB	1638	121	T2472GTB-BS	1423	120	T2496GS	2048	143	T30120GTB-BS	3402	128
T2448STEB-BS	2042	129	T2472GTB-BS	1806	128	T2496GTB	1766	120	T30120GTE	3386	120
T2448STEM	2376	121	T2472GTB-BS	1806	128	T2496GTB-BS	2142	128	T30120GTE-BS	3741	128
T2448STEM-BS	2954	129	T2472GTE	2195	120	T2496GTE	2148	120	T30120GTB-BS	3229	120
T2460B	1049	118	T2472GTE-BS	2821	128	T2496GTE-BS	2479	128	T30120GTB-BS	3633	128
T2460B-BS	1385	126	T2472SB	1597	119	T2496GTEB	2107	120	T30120GTEB	3958	120
T2460E	1268	118	T2472SB-BS	2017	127	T2496GTEB-BS	2402	128	T30120GTEB-BS	4703	128
T2460E-BS	1603	126	T2472SE	1925	119	T2496GTEB-BS	2783	120	T30120STEM	3731	119
T2460EB	1181	118	T2472SE-BS	2347	127	T2496GTEB-BS	3454	128	T30120SB	4151	127
T2460EB-BS	1558	126	T2472SE-BS-HA	6642	155	T2496GTEB-BS	2118	119	T30120SE	4400	119
T2460EBW	1274	50,140	T2472SE-HA	5880	155	T2496SB	2534	127	T30120SE-BS	4827	127
T2460EBW-1	1578	50,140	T2472SEB	1755	119	T2496SB-BS	2821	119	T30120SEB	4067	119
T2460EBW-2	1734	50,140	T2472SEB-BS	2186	127	T2496SE	3205	127	T30120SEB-BS	4497	127
T2460EM	1928	118	T2472SEB-BS-HA	5718	155	T2496SEB	2581	119	T30120SEB-BS	4802	119
T2460EM-BS	2481	126	T2472SEB-HA	2588	119	T2496SEB-BS	2985	127	T30120STEM	5326	127
T2460EW	1449	50,140	T2472SEM	3106	127	T2496SEM	3375	119	T30120STB	3871	121
T2460EW-1	1726	50,140	T2472SEM-BS	1887	143	T2496SEM-BS	3893	127	T30120STB-BS	4292	129
T2460EW-2	1883	50,140	T2472SGS	1887	143	T2496SGS	2404	143	T30120STE	4541	121
T2460F	777	139	T2472STB	1738	121	T2496STB	2260	121	T30120STE-BS	4973	129
T2460F-US	960	139	T2472STB-BS	2157	129	T2496STB-BS	2673	129	T30120STEB	4212	121
T2460F-USS	1048	139	T2472STE	2069	121	T2496STEB	2960	121	T30120STEB-BS	4552	129
T2460GS	1511	143	T2472STE-BS	2488	129	T2496STEB-BS	3348	129	T30120STEM	4943	121
T2460GTB	1188	120	T2472STE-BS	1901	121	T2496STEM	2732	121	T30120STEM-BS	5475	129
T2460GTB-BS	1525	128	T2472STB	2329	129	T2496STEM-BS	3124	129	T30132B	2905	118
T2460GTE	1408	120	T2472STB-BS	2736	121	T2496STEM	3589	121	T30132B-BS	3460	126
T2460GTE-BS	1749	128	T2472STEM	3253	129	T2496STEM-BS	4038	129	T30132E	3351	118
T2460GTEB	1323	120	T2484B	1433	118	T30108B	2677	118	T30132E-BS	3822	126
T2460GTEB-BS	1698	128	T2484B-BS	1796	126	T30108B-BS	3181	126	T30132EB	3260	118
T2460GTEM	2074	120	T2484E	1873	118	T30108E	3159	118	T30132EB-BS	3688	126
T2460GTEM-BS	2694	128	T2484E-BS	2188	126	T30108E-BS	3514	126	T30132EM	4036	118
T2460SB	1489	119	T2484EB	1829	118	T30108EB	3001	118	T30132EM-BS	4667	126
T2460SB-BS	1904	127	T2484EB-BS	2115	126	T30108EB-BS	3398	126	T30132GTB	2954	120
T2460SE	1776	119	T2484EM	2498	118	T30108EM	3729	118	T30132GTB-BS	3597	128
T2460SE-BS	2188	127	T2484EM-BS	3060	126	T30108EM-BS	4351	126	T30132GTE	3492	120
T2460SE-BS-HA	6491	155	T2484GS	1995	143	T30108GTB	2822	120	T30132GTE-BS	3849	128
T2460SE-HA	5738	155	T2484GTB	1569	120	T30108GTB-BS	3325	128	T30132GTB	3313	120
T2460SEB	1626	119	T2484GTB-BS	1934	128	T30108GTE	3298	120	T30132GTB-BS	3726	128
T2460SEB-BS	2042	127	T2484GTE	2019	120	T30108GTE-BS	3656	128	T30132GTEB	4179	120
T2460SEB-BS-HA	5993	155	T2484GTE-BS	2332	128	T30108GTEB	3141	120	T30132GTEB-BS	4943	128
T2460SEB-HA	5596	155	T2484GTEB	1976	120	T30108GTEB-BS	3444	128	T30132STEM	4719	120
T2460SEM	2437	119	T2484GTEB-BS	2263	128	T30108GTEB-BS	3871	120	T30132STEM-BS	5265	121
T2460SEM-BS	2959	127	T2484GTEB-BS	2644	120	T30108GTEB-BS	4621	128	T30132SB	3963	119
T2460SGS	1744	143	T2484GTEB-BS	3296	128	T30108GTEB-BS	3647	119	T30132SB-BS	4381	127
T2460STB	1626	121	T2484GTEM	2644	120	T30108SB	4065	127	T30132SE	4721	119
T2460STB-BS	2041	129	T2484GTEM-BS	3296	128	T30108SB-BS	4313	119	T30132SE-BS	5169	127
T2460STE	1919	121	T2484SB	1973	119	T30108SE	4740	127	T30132SEB	4347	119
T2460STE-BS	2332	129	T2484SB-BS	2391	127	T30108SE-BS	4409	127	T30132SEB-BS	4802	127
T2460STEB	1766	121	T2484SE	2631	119	T30108SE-BS	4740	127	T30132SEM	5118	119
T2460STEB-BS	2186	129	T2484SE-BS	3005	127	T30108SEB	3982	119	T30132SEM-BS	5645	127
T2460STEM	2580	121	T2484SEB	2414	119	T30108SEB-BS	4409	127	T30132STB	3984	121
T2460STEM-BS	3105	129	T2484SEB-BS	2803	127	T30108SEB-BS	4717	119	T30132STB-BS	4393	129
T2472B	1123	118	T2484SEM	3193	119	T30108SEM	5241	127	T30132STE	4729	121
T2472B-BS	1464	126	T2484SEM-BS	3708	127	T30108SEM-BS	3785	121	T30132STE-BS	5313	129
T2472E	1375	118	T2484SGS	2354	143	T30108STB	4208	129	T30132STEB	4361	121
T2472E-BS	1721	126	T2484STB	2109	121	T30108STB-BS	4455	121	T30132STEB-BS	4943	129
T2472EB	1279	118	T2484STB-BS	2526	129	T30108STE	4883	129	T30132STEM	5265	121
T2472EB-BS	1662	126	T2484STE	2769	121	T30108STE-BS	4123	121	T30132STEM-BS	5791	129
T2472EM	2046	118	T2484STE-BS	3148	129	T30108STEB	4501	129	T30144B	2991	118
T2472EM-BS	2599	126	T2484STEB	2561	121	T30108STEM	4861	121	T30144B-BS	3541	126
T2472F	887	139	T2484STEB-BS	2947	129	T30108STEM-BS	5387	129	T30144E	3537	118
T2472F-US	1017	139	T2484STEM	3335	121	T30120B	2766	118	T30144E-BS	3909	126
T2472F-USS	1125	139	T2484STEM-BS	3849	129	T30120B-BS	3267	126	T30144EB	3284	118
T2472GS	1634	143	T2496B	1629	118	T30120E	3244	118	T30144EB-BS	3775	126
			T2496B-BS	2004	126	T30120E-BS	3600	126	T30144EM	4121	118
			T2496E	2012	118	T30120EB	3089	118	T30144EM-BS	4744	126
			T2496E-BS	2334	126						



100 Industrial Boulevard, Clayton, DE 19938-8903 U.S.A.  
Phone: 800-441-8440 or 302-653-3000. Fax: 302-653-2065  
<http://www.eaglegrp.com>

# ALPHANUMERIC PRICE INDEX

Part Number	List Price	Page No.	Part Number	List Price	Page No.	Part Number	List Price	Page No.	Part Number	List Price	Page No.
T30144GTB	3125	120	T3036EB-BS	1460	126	T3048SE-BS-HA	6455	155	T3072B-BS	1532	126
T30144GTB-BS	3688	128	T3036EBW	1109	50,140	T3048SE-HA	5717	155	T3072E	1471	118
T30144GTE	3678	120	T3036EBW-1	1354	50,140	T3048SEB	1603	119	T3072E-BS	1822	126
T30144GTE-BS	3935	128	T3036EBW-2	1473	50,140	T3048SEB-BS	2004	127	T3072EB	1375	118
T30144GTB	3498	120	T3036EM	1837	118	T3048SEB-BS-HA	5957	155	T3072EB-BS	1758	126
T30144GTB-BS	3809	128	T3036EM-BS	2291	126	T3048SEB-HA	5574	155	T3072EM	2156	118
T30144GTEM	4264	120	T3036EW	1243	50,140	T3048SEM	2406	119	T3072EM-BS	2708	126
T30144GTEM-BS	5033	128	T3036EW-1	1493	50,140	T3048SEM-BS	2932	127	T3072F	919	139
T30144SB	4046	119	T3036EW-2	1613	50,140	T3048SGS	1715	143	T3072F-US	1051	139
T30144SB-BS	4464	127	T3036GS	1321	143	T3048STB	1609	121	T3072F-USS	1147	139
T30144SE	4808	119	T3036GTB	1136	120	T3048STB-BS	2025	129	T3072GS	1758	143
T30144SE-BS	5252	127	T3036GTB-BS	1453	128	T3048STE	1899	121	T3072GTB	1339	120
T30144SEB	4436	119	T3036GTE	1317	120	T3048STE-BS	2308	129	T3072GTB-BS	1671	128
T30144SEB-BS	4888	127	T3036GTE-BS	1644	128	T3048STEB	1749	121	T3072GTE	1615	120
T30144SEM	5203	119	T3036GTB	1254	128	T3048STEB-BS	2147	129	T3072GTE-BS	1967	128
T30144SEM-BS	5734	127	T3036GTB-BS	1602	120	T3048STEM	2558	121	T3072GTB	1514	120
T30144STB	4185	121	T3036GTEM	1978	120	T3048STEM-BS	3081	129	T3072GTB-BS	1905	128
T30144STB-BS	4469	129	T3036GTEM-BS	2580	128	T3060B	1107	118	T3072GTE	2300	120
T30144STE	4952	121	T3036SB	1412	119	T3060B-BS	1436	126	T3072GTE-BS	2933	128
T30144STE-BS	5397	129	T3036SB-BS	1831	127	T3060BA-BS-HGD	2191	132	T3072SB	1740	119
T30144STEB	4574	121	T3036SE	1654	119	T3060BA-BS-SLD	2405	132	T3072SB-BS	2152	127
T30144STEB-BS	5033	129	T3036SE-BS	2045	127	T3060E	1344	118	T3072SE	2112	119
T30144STEM	5349	121	T3036SEB	1525	119	T3060E-BS	1685	126	T3072SE-BS	2532	127
T30144STEM-BS	5877	129	T3036SEB-BS	1919	127	T3060EB	1254	118	T3072SE-BS-HA	6818	155
T3024GS	1179	143	T3036SEM	2314	119	T3060EB-BS	1629	126	T3072SE-HA	6057	155
T3024SGS	1376	143	T3036SEM-BS	2835	127	T3060EBW	1449	50,140	T3072SEB	1925	119
T3030B	924	118	T3036SGS	1544	143	T3060EBW-1	1726	50,140	T3072SEB-BS	2351	127
T3030B-BS	1241	126	T3036STB	1551	121	T3060EBW-2	1882	50,140	T3072SEB-BS-HA	6284	155
T3030E	1098	118	T3036STB-BS	1972	129	T3060EM	2020	118	T3072SEB-HA	5880	155
T3030E-BS	1423	126	T3036STE	1797	121	T3060EM-BS	2648	126	T3072SEM	2861	119
T3030EB	1033	118	T3036STE-BS	2193	129	T3060EW	1649	50,140	T3072SEM-BS	3291	127
T3030EB-BS	1384	126	T3036STEB	1668	121	T3060EW-1	1931	50,140	T3072SGS	2064	143
T3030EM	1756	118	T3036STEB-BS	2064	129	T3060EW-2	2089	50,140	T3072STB	1880	121
T3030EM-BS	2278	126	T3036STEM	2457	121	T3060F	866	139	T3072STB-BS	2300	129
T3030GTB	1065	120	T3036STEM-BS	2982	129	T3060F-US	985	139	T3072STE	2256	121
T3030GTB-BS	1380	128	T3048B	1013	118	T3060F-USS	1066	139	T3072STE-BS	2674	129
T3030GTE	1242	120	T3048B-BS	1338	126	T3060GS	1613	143	T3072STEB	2069	121
T3030GTE-BS	1564	128	T3048BA-BS-HGD	2042	132	T3060GTB	1247	120	T3072STEB-BS	2498	129
T3030GTB	1175	120	T3048BA-BS-SLD	2247	132	T3060GTB-BS	1574	128	T3072STEM	3005	121
T3030GTB-BS	1523	128	T3048E	1220	118	T3060GTE	1492	120	T3072STEM-BS	3437	129
T3030GTEM	1902	120	T3048E-BS	1557	126	T3060GTE-BS	1826	128	T3084B	1502	118
T3030GTEM-BS	2504	128	T3048EB	1141	118	T3060GTB	1397	120	T3084B-BS	1879	126
T3030SB	1320	119	T3048EB-BS	1506	126	T3060GTB-BS	1772	128	T3084E	1976	118
T3030SB-BS	1757	127	T3048EBW	1252	50,140	T3060GTE	2164	120	T3084E-BS	2291	126
T3030SE	1575	119	T3048EBW-1	1521	50,140	T3060GTE-BS	2788	128	T3084EB	1858	118
T3030SE-BS	1968	127	T3048EBW-2	1663	50,140	T3060GTEM-BS	2888	128	T3084EB-BS	2213	126
T3030SEB	1453	119	T3048EM	1883	118	T3060GS	1613	143	T3084EM	2607	118
T3030SEB-BS	1843	127	T3048EM-BS	2502	126	T3060GTB	1247	120	T3084EM-BS	3268	126
T3030SEM	2238	119	T3048EW	1426	50,140	T3060GTE	1492	120	T3084GS	2742	143
T3030SEM-BS	2758	127	T3048EW-1	1689	50,140	T3060GTE-BS	1826	128	T3084GTB	1639	120
T3030SEM-ST	2966	139	T3048EW-2	1842	50,140	T3060GTEB	1397	120	T3084GTB-BS	2021	128
T3030SEM-ST-CAH	3559	139	T3048F	809	139	T3060GTB-BS	1574	128	T3084GTE	2116	120
T3030STB	1476	121	T3048F-US	914	139	T3060GTE	1492	120	T3084GTE-BS	2436	128
T3030STB-BS	1898	129	T3048F-USS	983	139	T3060GTE-BS	1826	128	T3084GTEB	2002	120
T3030STE	1721	121	T3048GS	1466	143	T3060GTEB	1397	120	T3084GTEB-BS	2355	128
T3030STE-BS	2112	129	T3048GTB	1155	120	T3060GTB	1247	120	T3084GTEM	2751	120
T3030STEB	1595	121	T3048GTB-BS	1472	128	T3060GTE	1492	120	T3084GTEM-BS	3411	128
T3030STEB-BS	1986	129	T3048GTE	1364	120	T3060GTE-BS	1826	128	T3084SB	2045	119
T3030STEM	2382	121	T3048GTE-BS	1695	128	T3060GTEB	1397	120	T3084SB-BS	2463	127
T3030STEM-BS	2902	129	T3048GTB	1280	120	T3060GTEB-BS	1772	128	T3084SE	2747	119
T3036B	998	118	T3048GTB-BS	1648	128	T3060GTEM-BS	2788	128	T3084SE-BS	3121	127
T3036B-BS	1316	126	T3048GTE	1364	120	T3060GS	1613	143	T3084SEB	2521	119
T3036BA-BS-HGD	1913	132	T3048GTE-BS	1695	128	T3060GTB	1247	120	T3084SEB-BS	2909	127
T3036BA-BS-SLD	2105	132	T3048GTB	1280	120	T3060GTE	1492	120	T3084SEM	3302	119
T3036E	1173	118	T3048GTB-BS	1472	128	T3060GTE-BS	1826	128	T3084SEM-BS	3827	127
T3036E-BS	1498	126	T3048GTE	1364	120	T3060GTEB	1397	120	T3084SGS	3159	143
T3036EB	1107	118	T3048GTE-BS	1695	128	T3060GTB	1247	120	T3084STB	2191	121
			T3048GTB	1280	120	T3060GTE	1492	120			
			T3048GTB-BS	1648	128	T3060GTE-BS	1826	128			
			T3048GTE	1364	120	T3060GTEB	1397	120			
			T3048GTE-BS	1695	128	T3060GTB	1247	120			
			T3048GTB	1280	120	T3060GTE	1492	120			
			T3048GTB-BS	1648	128	T3060GTE-BS	1826	128			
			T3048GTE	1364	120	T3060GTEB	1397	120			
			T3048GTE-BS	1695	128	T3060GTB	1247	120			
			T3048GTB	1280	120	T3060GTE	1492	120			
			T3048GTB-BS	1648	128	T3060GTE-BS	1826	128			
			T3048GTE	1364	120	T3060GTEB	1397	120			
			T3048GTE-BS	1695	128	T3060GTB	1247	120			
			T3048GTB	1280	120	T3060GTE	1492	120			
			T3048GTB-BS	1648	128	T3060GTE-BS	1826	128			
			T3048GTE	1364	120	T3060GTEB	1397	120			
			T3048GTE-BS	1695	128	T3060GTB	1247	120			
			T3048GTB	1280	120	T3060GTE	1492	120			
			T3048GTB-BS	1648	128	T3060GTE-BS	1826	128			
			T3048GTE	1364	120	T3060GTEB	1397	120			
			T3048GTE-BS	1695	128	T3060GTB	1247	120			
			T3048GTB	1280	120	T3060GTE	1492	120			
			T3048GTB-BS	1648	128	T3060GTE-BS	1826	128			
			T3048GTE	1364	120	T3060GTEB	1397	120			
			T3048GTE-BS	1695	128	T3060GTB	1247	120			
			T3048GTB	1280	120	T3060GTE	1492	120			
			T3048GTB-BS	1648	128	T3060GTE-BS	1826	128			
			T3048GTE	1364	120	T3060GTEB	1397	120			
			T3048GTE-BS	1695	128	T3060GTB	1247	120			
			T3048GTB	1280	120	T3060GTE	1492	120			
			T3048GTB-BS	1648	128	T3060GTE-BS	1826	128			
			T3048GTE	1364	120	T3060GTEB	1397	120			
			T3048GTE-BS	1695	128	T3060GTB					

# ALPHANUMERIC PRICE INDEX

Part Number	List Price	Page No.	Part Number	List Price	Page No.	Part Number	List Price	Page No.	Part Number	List Price	Page No.
T3084STB-BS	2603	129	T36108SEM	5438	119	T36132STB-BS	5119	129	T3648STEB	2037	121
T3084STE	2891	121	T36108SEM-BS	5947	127	T36132STE	5455	121	T3648STEB-BS	2502	129
T3084STE-BS	3265	129	T36108STB	4356	121	T36132STE-BS	6162	129	T3648STEM	2953	121
T3084STEB	2665	121	T36108STB-BS	4900	129	T36132STEB	5241	121	T3648STEM-BS	3189	129
T3084STEB-BS	3048	129	T36108STE	5154	121	T36132STEB-BS	5574	129	T3660B	1421	118
T3084STEM	3454	121	T36108STE-BS	5677	129	T36132STEM	6034	121	T3660B-BS	1882	126
T3084STEM-BS	3972	129	T36108STEB	4823	121	T36132STEM-BS	6558	129	T3660E	1603	118
T3096B	1739	118	T36108STEB-BS	5139	129	T36144B	3574	118	T3660E-BS	2143	126
T3096B-BS	2125	126	T36108STEM	5578	121	T36144B-BS	4022	126	T3660EB	1558	118
T3096E	2159	118	T36108STEM-BS	6095	129	T36144E	4145	118	T3660EB-BS	2074	126
T3096E-BS	2485	126	T36120B	3302	118	T36144E-BS	4557	126	T3660EM	2442	118
T3096EB	2025	118	T36120B-BS	3836	126	T36144EB	3894	118	T3660EM-BS	3007	126
T3096EB-BS	2400	126	T36120E	3775	118	T36144EB-BS	4400	126	T3660GTB	1562	120
T3096EM	2789	118	T36120E-BS	4208	126	T36144EM	4742	118	T3660GTB-BS	2024	128
T3096EM-BS	3472	126	T36120EB	3688	118	T36144EM-BS	5396	126	T3660GTE	1754	120
T3096GS	2796	143	T36120EB-BS	4071	126	T36144GTB	3709	120	T3660GTE-BS	2286	128
T3096GTB	1879	120	T36120EM	4394	118	T36144GTB-BS	4155	128	T3660GTB	1698	120
T3096GTB-BS	2263	128	T36120EM-BS	5033	126	T36144GTE	4167	120	T3660GTB-BS	2217	128
T3096GTE	2304	120	T36120GTB	3445	120	T36144GTE-BS	4562	128	T3660GTEM	2581	120
T3096GTE-BS	2624	128	T36120GTB-BS	3973	128	T36144GTB	4154	120	T3660GTEM-BS	3236	128
T3096GTB	2167	120	T36120GTE	3920	120	T36144GTB-BS	4412	128	T3660GSB	1875	119
T3096GTB-BS	2542	128	T36120GTE-BS	4352	128	T36144GTEB	4888	120	T3660GSB-BS	2292	127
T3096GTEB	2935	120	T36120GTEB	3833	120	T36144GTEB-BS	5695	128	T3660SE	2203	119
T3096GTEB-BS	3625	128	T36120GTB-BS	4217	128	T36144SEM	4797	119	T3660SE-BS	2853	127
T3096SB	2292	119	T36120GTEB-BS	4540	120	T36144SB	5224	127	T3660SEB	2074	119
T3096SB-BS	2709	127	T36120GTEB-BS	4963	121	T36144SB-BS	5564	119	T3660SEB-BS	2659	127
T3096SE	3043	119	T36120GTEB-BS	5322	128	T36144SE	6102	127	T3660SEM	3023	119
T3096SE-BS	3435	127	T36120SB	4427	119	T36144SE-BS	6102	127	T3660SEM-BS	3548	127
T3096SEB	2788	119	T36120SB-BS	4843	127	T36144SEB	5248	119	T3660STB	2014	121
T3096SEB-BS	3193	127	T36120SE	5100	119	T36144SEB-BS	5513	127	T3660STB-BS	2428	129
T3096SEM	3437	119	T36120SE-BS	5620	127	T36144SEM	5982	119	T3660STE	2348	121
T3096SEM-BS	4111	127	T36120SEB	4814	119	T36144SEM-BS	6504	127	T3660STE-BS	2998	129
T3096SGS	3213	143	T36120SEB-BS	5228	127	T36144STB	4797	121	T3660STEB	2217	121
T3096STB	2428	121	T36120SEM	5517	119	T36144STB-BS	5199	129	T3660STEB-BS	2797	129
T3096STB-BS	2852	129	T36120SEM-BS	6035	127	T36144STE	5714	121	T3660STEM	3169	121
T3096STE	3193	121	T36120STB	4564	121	T36144STE-BS	6256	129	T3660STEM-BS	3581	129
T3096STE-BS	3574	129	T36120STB-BS	4984	129	T36144STEB	5393	121	T3672B	1556	118
T3096STEB	2933	121	T36120STE	5241	121	T36144STEB-BS	5653	129	T3672B-BS	1999	126
T3096STEB-BS	3335	129	T36120STE-BS	5758	129	T36144STEM	6123	121	T3672E	1748	118
T3096STEM	3579	121	T36120STEB	4963	121	T36144STEM-BS	6644	129	T3672E-BS	2295	126
T3096STEM-BS	4259	129	T36120STEB-BS	5376	129	T3648B	1262	118	T3672EB	1689	118
T3224RCB	702	139	T36120STEM	5661	121	T3648B-BS	1739	126	T3672EB-BS	2216	126
T3224RCB-BS	1043	139	T36120STEM-BS	6180	129	T3648E	1431	118	T3672EM	2601	118
T3424RCB	707	139	T36132B	3386	118	T3648E-BS	1865	126	T3672EM-BS	3174	126
T3424RCB-BS	1049	139	T36132B-BS	3942	126	T3648EB	1388	118	T3672GTB	1694	120
T36108B	3231	118	T36132E	3943	118	T3648EB-BS	1813	126	T3672GTB-BS	2071	128
T36108B-BS	3754	126	T36132E-BS	4466	126	T3648EM	2266	118	T3672GTE	1892	120
T36108E	3688	118	T36132EB	3811	118	T3648EM-BS	2829	126	T3672GTE-BS	2437	128
T36108E-BS	4121	126	T36132EB-BS	4191	126	T3648GTB	1404	120	T3672GTEB	1829	120
T36108EB	3603	118	T36132EM	4653	118	T3648GTB-BS	1879	128	T3672GTEB-BS	2356	128
T36108EB-BS	3986	126	T36132EM-BS	5313	126	T3648GTE	1749	120	T3672GTEM	2747	120
T36108EM	4308	118	T36132GTB	3520	120	T3648GTE-BS	2013	128	T3672GTEM-BS	3409	128
T36108EM-BS	4952	126	T36132GTB-BS	4078	128	T3648GTB	1531	120	T3672SB	2051	119
T36108GTB	3267	120	T36132GTE	4084	120	T3648GTB-BS	1954	128	T3672SB-BS	2475	127
T36108GTB-BS	3780	128	T36132GTE-BS	4479	128	T3648GTEB	2406	120	T3672SE	2405	119
T36108GTE	3833	120	T36132GTEB	3951	120	T3648GTEB-BS	3051	128	T3672SE-BS	3057	127
T36108GTE-BS	4264	128	T36132GTB	4328	128	T3648SB	1694	119	T3672SEB	2264	119
T36108GTB	3638	120	T36132GTB-BS	4078	128	T3648SB-BS	2109	127	T3672SEB-BS	2852	127
T36108GTB-BS	4014	128	T36132GTE	4084	120	T3648SE	2001	119	T3672SEM	3241	119
T36108GTEB	4454	120	T36132GTE-BS	4479	128	T3648SE-BS	2531	127	T3672SEM-BS	3765	127
T36108GTEB-BS	5239	128	T36132GTB	3520	120	T3648SEB	1892	119	T3672STB	2193	121
T36108SB	4339	119	T36132GTB-BS	4078	128	T3648SEB-BS	2355	127	T3672STB-BS	2607	129
T36108SB-BS	4760	127	T36132GTE	4084	120	T3648SEB-BS	2811	119	T3672STE	2556	121
T36108SE	5013	119	T36132GTE-BS	4479	128	T3648SEB-BS	3338	127	T3672STE-BS	3206	129
T36108SE-BS	5532	127	T36132GTB	3520	120	T3648STB	1837	121	T3672STEB	2405	121
T36108SEB	4731	119	T36132GTB-BS	4078	128	T3648STB-BS	2247	129	T3672STEB-BS	2994	129
T36108SEB-BS	5146	127	T36132GTE	4084	120	T3648STE	2143	121	T3672STEM	3385	121
			T36132GTE-BS	4479	128	T3648STE-BS	2673	129			



100 Industrial Boulevard, Clayton, DE 19938-8903 U.S.A.  
 Phone: 800-441-8440 or 302-653-3000. Fax: 302-653-2065  
<http://www.eaglegrp.com>

# ALPHANUMERIC PRICE INDEX

Part Number	List Price	Page No.	Part Number	List Price	Page No.	Part Number	List Price	Page No.	Part Number	List Price	Page No.
T3672STEM-BS	3912	129	T48108GTE	8837	120	T4896SEM	7934	119	TM48APR	1151	156
T3684B	2138	118	T48108GTEM	9954	120	T4896STE	6957	121	TM48PR	1397	156
T3684B-BS	2361	126	T48108SE	9941	119	T4896STEM	8068	121	TM48PRS	582	156
T3684E	2339	118	T48108SEM	11060	119	TB1016-3	37	54	TM60APR	1189	156
T3684E-BS	2688	126	T48108STE	10100	121	TB1016-6	39	54	TM60PR	1472	156
T3684EB	2295	118	T48108STEM	11197	121	TB1722-3	71	54,56	TM60PRS	625	156
T3684EB-BS	2594	126	T48120E	8800	118	TB1722-6	82	54,56	TM72APR	1245	156
T3684EM	3137	118	T48120EM	9896	118	TB1722-9	95	54,56	TM72PR	1549	156
T3684EM-BS	3731	126	T48120GTE	8936	120	TB30108S	5418	145	TM72PRS	673	156
T3684GTB	2276	120	T48120GTEM	10039	120	TB30120S	5733	145	TM84APR	1485	156
T3684GTB-BS	2501	128	T48120SE	10028	119	TB3036S	2454	145	TM84PR	1831	156
T3684GTE	2503	120	T48120SEM	11141	119	TB3048S	2795	145	TM84PRS	722	156
T3684GTE-BS	2835	128	T48120STE	10168	121	TB3060S	3363	145	TM96APR	1531	156
T3684GTB	2437	120	T48120STEM	11278	121	TB3072S	3821	145	TM96PR	1907	156
T3684GTB-BS	2744	128	T48132E	9558	118	TB3084S	4203	145	TM96PRS	800	156
T3684GTEM	3284	120	T48132EM	10659	118	TB3096S	4944	145	TMP	173	274
T3684GTEM-BS	3983	128	T48132GTE	9701	120	TB36108S	6144	145	TMS2424	1012	141
T3684SB	2835	119	T48132GTEM	10796	120	TB36120S	6935	145	TMS2424S	1229	141
T3684SB-BS	3251	127	T48132SE	10783	119	TB3636S	2621	145	TMS3024	1055	141
T3684SE	3258	119	T48132SEM	11895	119	TB3648S	3322	145	TMS3024S	1291	141
T3684SE-BS	3643	127	T48132STE	10937	121	TB3660S	3935	145	TMS3030	1175	141
T3684SEB	3077	119	T48132STEM	12035	121	TB3672S	4415	145	TMS3030S	1462	141
T3684SEB-BS	3389	127	T48144E	9627	118	TB3684S	4916	145	TMS3036	1206	141
T3684SEM	3953	119	T48144EM	10744	118	TB3696S	5595	145	TMS3036S	1487	141
T3684SEM-BS	4480	127	T48144GTE	9782	120	TC6-19	564	311	TMS3636	1265	141
T3684STB	2977	121	T48144GTEM	10879	120	TC6-24	643	311	TMS3636S	1557	141
T3684STB-BS	3387	129	T48144SE	10863	119	TC6-18	715	294	TR10	62	105
T3684STE	3398	121	T48144SEM	11979	119	TC6-22	753	294	TR18BL	80	55
T3684STE-BS	3792	129	T48144STEM	10997	121	TD2448-BSP	1477	41	TR18C	80	55
T3684STB	3213	121	T48144STEM	12117	121	TD2448-SP	1273	41	TS-DB-HT2	827	229
T3684STB-BS	3537	129	T4848E	3336	118	TD2460-BSP	1681	41	TS-DB-HT3	997	229
T3684STEM	4099	121	T4848EM	4445	118	TD2460-SP	1478	41	TS-DB-HT4	1302	229
T3684STEM-BS	4626	129	T4848GTE	3474	120	TD3	2916	153	TS-DB-HT5	1634	229
T3696B	2273	118	T4848GTEM	4562	120	TD3L	3292	153	TS-DB-HT6	1665	229
T3696B-BS	2654	126	T4848SE	3867	119	TEP74-C	223	63	TS-HT2	755	229
T3696E	2502	118	T4848SEM	4980	119	TEP74-E	244	63	TS-HT3	924	229
T3696E-BS	3022	126	T4848STE	4158	121	TEP74-Z	209	63	TS-HT4	1227	229
T3696EB	2433	118	T4848STEM	5120	121	TEP86-C	236	63	TS-HT5	1525	229
T3696EB-BS	2918	126	T4860E	3729	118	TEP86-E	260	63	TS-HT6	1611	229
T3696EM	3287	118	T4860EM	4840	118	TEP86-Z	217	63	TS1417	155	54
T3696EM-BS	3883	126	T4860GTE	3875	120	TM108APR	1857	156	TS18-C	120	56
T3696GTB	2385	120	T4860GTEM	4980	120	TM108PR	2306	156	TS18-E	160	56
T3696GTB-BS	2703	128	T4860SE	4278	119	TM108PRS	1998	156	TS2021	162	54
T3696GTE	2645	120	T4860SEM	5396	119	TM120APR	1913	156	TS24-C	126	56
T3696GTE-BS	3167	128	T4860STE	4418	121	TM120PR	2402	156	TS24-E	165	56
T3696GTB	2575	120	T4860STEM	5539	121	TM120PRS	2018	156	TS2517	153	54
T3696GTB-BS	3057	128	T4872E	4048	118	TM1220FW-120	762	274	TSB2460Z	2436	49
T3696GTEM	3436	120	T4872EM	5162	118	TM1220FW-120-D	826	274	TSC3036Z	987	49
T3696GTEM-BS	4143	128	T4872GTE	4193	120	TM1220FW-120T	815	274	TSC02460Z	1380	49
T3696SB	3056	119	T4872GTEM	5402	120	TM1220FW-120T-D	894	274	TSD3660Z	1304	49
T3696SB-BS	3469	127	T4872SE	4672	119	TM1220FW-240	788	274	TSL-DB-HT2	695	229
T3696SE	3503	119	T4872SEM	5789	119	TM1220FW-240-D	848	274	TSL-DB-HT3	820	229
T3696SE-BS	3904	127	T4872STE	4812	121	TM1220FW-240T	815	274	TSL-DB-HT4	1083	229
T3696SEB	3298	119	T4872STEM	5924	121	TM1220FW-240T-D	894	274	TSL-DB-HT5	1373	229
T3696SEB-BS	3628	127	T4884E	5498	118	TM1220FW-240T6	815	274	TSL-DB-HT6	1458	229
T3696SEM	4195	119	T4884EM	6606	118	TM1220FW-240T6-D	894	274	TSL-HT2	615	229
T3696SEM-BS	4725	127	T4884GTE	5643	120	TM1220FW-277T	815	274	TSL-HT3	742	229
T3696STB	3195	121	T4884GTEM	6746	120	TM1220FW-277T-D	894	274	TSL-HT4	1006	229
T3696STB-BS	3614	129	T4884SE	6317	119	TM132APR	1969	156	TSL-HT5	1253	229
T3696STE	3643	121	T4884SEM	7428	119	TM132PR	2522	156	TSL-HT6	1323	229
T3696STE-BS	4047	129	T4884STE	6466	121	TM132PRS	2107	156	TSM3048C	2369	49
T3696STB	3445	121	T4884STEM	7572	121	TM144APR	2036	156	TSP1448Z	1124	49
T3696STB-BS	3773	129	T4896E	5814	118	TM144PR	2569	156	TSP2460Z	2019	49
T3696STEM	4345	121	T4896EM	6926	118	TM144PRS	2131	156	TSSP1436Z	697	49
T3696STEM-BS	4869	129	T4896GTE	5949	120	TM36APR	1106	156	TU-1	2291	227
T48108E	8699	118	T4896GTEM	7068	120	TM36PR	1322	156	U10	52	75
T48108EM	9817	118	T4896SE	6818	119	TM36PRS	539	156	U12	55	75

100 Industrial Boulevard, Clayton, DE 19938-8903 U.S.A.  
 Phone: 800-441-8440 or 302-653-3000. Fax: 302-653-2065  
<http://www.eaglegrp.com>



# ALPHANUMERIC PRICE INDEX

Part Number	List Price	Page No.	Part Number	List Price	Page No.	Part Number	List Price	Page No.	Part Number	List Price	Page No.
U14.....	59	75	UARR-64-SR.....	3426	345	UOB3096SE.....	4214	134	UT24144GTB.....	2997	124
U16.....	66	75	UB-24.....	284	149	UR-501.....	820	141	UT24144GTE.....	3468	124
U18.....	69	75	UB-30.....	363	149	UR1836C.....	568	38	UT24144GTB.....	3301	124
U2-1836C.....	581	31	UC-311.....	774	32	UR1848C.....	609	38	UT24144SB.....	3897	123
U2-1836C-RP.....	403	25	UC-322.....	801	32	UR1860C.....	659	38	UT24144SE.....	4583	123
U2-1836S.....	1308	31	UC-411.....	789	32	URS1836C.....	747	38	UT24144SEB.....	4228	123
U2-1836Z.....	519	31	UC-422.....	818	32	URS1848C.....	819	38	UT24144STB.....	3846	125
U2-1842C.....	604	31	UCB24120SE.....	6666	134	URS1860C.....	935	38	UT24144STE.....	4725	125
U2-1842S.....	1456	31	UCB2436SE.....	3626	134	US-2.....	323	236	UT24144STEB.....	4252	125
U2-1842Z.....	651	31	UCB2448SE.....	4056	134	US-3.....	372	236	UT2415STE.....	1049	132
U2-2136C.....	649	31	UCB2460SE.....	4357	134	US-4.....	427	236	UT2415STEB.....	965	132
U2-2136S.....	1423	31	UCB2472SE.....	4672	134	US0824-16/3.....	707	196	UT2418STE.....	1096	132
U2-2136Z.....	578	31	UCB2484SE.....	5341	134	US0836-16/3.....	813	196	UT2418STEB.....	1009	132
U2-2142C.....	672	31	UCB2496SE.....	5771	134	US0848-16/3.....	1029	196	UT2424B.....	938	122
U2-2142S.....	1558	31	UCB30120SE.....	6953	134	US18-S.....	95	56	UT2424E.....	1072	122
U2-2142Z.....	602	31	UCB3036SE.....	3786	134	US21-S.....	115	56	UT2424EB.....	1031	122
U2-2148C.....	702	31	UCB3048SE.....	4208	134	US24-S.....	122	56	UT2424GTB.....	1077	124
U2-2148S.....	1564	31	UCB3060SE.....	4541	134	US30-S.....	138	56	UT2424GTE.....	1321	124
U2-2148Z.....	624	31	UCB3072SE.....	4879	134	US3CB.....	6383	226	UT2424GTB.....	1174	124
U2-2436C.....	606	31	UCB3084SE.....	5488	134	US3OB.....	5060	226	UT2424SB.....	1278	123
U2-2436S.....	1505	31	UCB3096SE.....	6012	134	US4CB.....	7507	226	UT2424SE.....	1454	123
U2-2436Z.....	586	31	UCBH24120SE.....	7245	134	US4OB.....	5897	226	UT2424SEB.....	1354	123
U2-2442C.....	641	31	UCBH2436SE.....	4443	134	US5CB.....	8991	226	UT2424STB.....	1439	125
U2-2442S.....	1686	31	UCBH2448SE.....	4652	134	US5OB.....	7297	226	UT2424STE.....	1595	125
U2-2442Z.....	622	31	UCBH2460SE.....	4961	134	USS24-S.....	161	56	UT2424STEB.....	1495	125
U2-2448C.....	671	31	UCBH2472SE.....	5264	134	USS30-S.....	196	56	UT2430B.....	1012	122
U2-2448S.....	1697	31	UCBH2484SE.....	5923	134	UT24108B.....	2752	122	UT2430E.....	1175	122
U2-2448Z.....	627	31	UCBH2496SE.....	6353	134	UT24108E.....	3000	122	UT2430EB.....	1107	122
U2-2460C.....	741	31	UCBH30120SE.....	7527	134	UT24108EB.....	2857	122	UT2430GTB.....	1151	124
U2-2460S.....	1957	31	UCBH3036SE.....	4593	134	UT24108GTB.....	2808	124	UT2430GTE.....	1381	124
U2-2460Z.....	684	31	UCBH3048SE.....	4803	134	UT24108GTE.....	3137	124	UT2430GTB.....	1253	124
U20.....	73	75	UCBH3060SE.....	5141	134	UT24108GTEB.....	2999	124	UT2430SE.....	1380	123
U3-1836C.....	694	31	UCBH3072SE.....	5476	134	UT24108SB.....	3546	123	UT2430SEB.....	1602	123
U3-1836C-RP.....	488	25	UCBH3084SE.....	6078	134	UT24108SE.....	4145	123	UT2430STB.....	1480	123
U3-1836S.....	1685	31	UCBH3096SE.....	6594	134	UT24108SEB.....	3833	123	UT2430STEB.....	1519	125
U3-1836Z.....	618	31	UDT-4L-14/3.....	2880	324	UT24108STB.....	3581	125	UT2430STE.....	1748	125
U3-1842C.....	725	31	UDT-4L-16/3.....	2588	324	UT24108STE.....	4291	125	UT2430STEB.....	1626	125
U3-1842S.....	1906	31	UDT-4L-16/4.....	2262	324	UT24108STEB.....	3867	125	UT2436B.....	1081	122
U3-1842Z.....	651	31	UDT-4R-14/3.....	2880	324	UT24120B.....	2808	122	UT2436E.....	1254	122
U3-2136C.....	778	31	UDT-4R-16/3.....	2588	324	UT24120E.....	3175	122	UT2436EB.....	1182	122
U3-2136CS.....	1032	30	UDT-4R-16/4.....	2262	324	UT24120EB.....	3027	122	UT2436GTB.....	1224	124
U3-2136S.....	1858	31	UDT-5L-14/3.....	3181	324	UT24120GTB.....	2980	124	UT2436GTE.....	1404	124
U3-2136Z.....	699	31	UDT-5L-16/3.....	2803	324	UT24120GTE.....	3313	124	UT2436GTB.....	1327	124
U3-2142C.....	815	31	UDT-5L-16/4.....	2421	324	UT24120GTEB.....	3171	124	UT2436SB.....	1453	123
U3-2142S.....	2059	31	UDT-5R-14/3.....	3181	324	UT24120SB.....	3628	123	UT2436SE.....	1679	123
U3-2142Z.....	732	31	UDT-5R-16/3.....	2803	324	UT24120SE.....	4231	123	UT2436SEB.....	1561	123
U3-2148C.....	860	31	UDT-5R-16/4.....	2421	324	UT24120SEB.....	3920	123	UT2436STB.....	1595	125
U3-2148S.....	2068	31	UH.....	15	105	UT24120STB.....	3767	125	UT2436STE.....	1822	125
U3-2148Z.....	760	31	UH18-C.....	69	31	UT24120STB.....	4380	125	UT2436STEB.....	1701	125
U3-2436C.....	738	31	UH18-S.....	139	31	UT24120STEB.....	4064	125	UT2448B.....	1099	122
U3-2436CS.....	1048	30	UH21-C.....	83	31	UT2412STE.....	1025	132	UT2448E.....	1276	122
U3-2436S.....	1979	31	UH21-S.....	140	31	UT2412STEB.....	943	132	UT2448EB.....	1205	122
U3-2436Z.....	696	31	UH24-C.....	87	31	UT24132B.....	2836	122	UT2448GTB.....	1241	124
U3-2442C.....	786	31	UH24-S.....	143	31	UT24132E.....	3344	122	UT2448GTE.....	1472	124
U3-2442S.....	2252	31	UOB24120SE.....	4559	134	UT24132EB.....	3085	122	UT2448GTB.....	1346	124
U3-2442Z.....	744	31	UOB2436SE.....	2840	134	UT24132GTB.....	2985	124	UT2448SB.....	1492	123
U3-2448C.....	836	31	UOB2448SE.....	2949	134	UT24132GTE.....	3386	124	UT2448SE.....	1748	123
U3-2448S.....	2260	31	UOB2460SE.....	3156	134	UT24132GTEB.....	3221	124	UT2448SEB.....	1611	123
U3-2448Z.....	753	31	UOB2472SE.....	3364	134	UT24132SB.....	3704	123	UT2448STB.....	1628	125
U3-2460C.....	940	31	UOB2484SE.....	3660	134	UT24132SE.....	4363	123	UT2448STE.....	1892	125
U3-2460S.....	2653	31	UOB2496SE.....	3845	134	UT24132SEB.....	4144	123	UT2448STEB.....	1755	125
U3-2460Z.....	841	31	UOB30120SE.....	4847	134	UT24132STB.....	3843	125	UT2460B.....	1162	122
UAR-64-A.....	2878	343	UOB3036SE.....	2999	134	UT24132STE.....	4504	125	UT2460E.....	1381	122
UAR-64-SR.....	3298	343	UOB3048SE.....	3104	134	UT24132STEB.....	4165	125	UT2460EB.....	1296	122
UAR-70-A.....	2924	343	UOB3060SE.....	3337	134	UT24144B.....	2853	122	UT2460GTB.....	1299	124
UAR-70-SR.....	3601	343	UOB3072SE.....	3569	134	UT24144E.....	3444	122	UT2460GTE.....	1521	124
UARR-64-A.....	2887	345	UOB3084SE.....	3818	134	UT24144EB.....	3261	122	UT2460GTB.....	1440	124



100 Industrial Boulevard, Clayton, DE 19938-8903 U.S.A.  
 Phone: 800-441-8440 or 302-653-3000. Fax: 302-653-2065  
<http://www.eaglegrp.com>

# ALPHANUMERIC PRICE INDEX

Part Number	List Price	Page No.	Part Number	List Price	Page No.	Part Number	List Price	Page No.	Part Number	List Price	Page No.
UT2460SB	1597	123	UT30120SE	4517	123	UT3048EB	1253	122	UT36108GTB	3476	124
UT2460SE	1897	123	UT30120SEB	4180	123	UT3048GTB	1264	124	UT36108GTE	3838	124
UT2460SEB	1738	123	UT30120STB	3982	125	UT3048GTE	1478	124	UT36108GTB	3754	124
UT2460STB	1738	125	UT30120STE	4653	125	UT3048GTB	1394	124	UT36108SB	4451	123
UT2460STE	2038	125	UT30120STEB	4325	125	UT3048SB	1578	123	UT36108SE	5127	123
UT2460STEB	1881	125	UT3012STE	1107	132	UT3048SE	1863	123	UT36108SEB	4704	123
UT2472B	1235	122	UT3012STEB	1018	132	UT3048SEB	1721	123	UT36108STB	4461	125
UT2472E	1487	122	UT30132B	3013	122	UT3048STB	1721	125	UT36108STE	5271	125
UT2472EB	1392	122	UT30132E	3462	122	UT3048STE	2012	125	UT36108STEB	4845	125
UT2472GTB	1376	124	UT30132EB	3292	122	UT3048STEB	1860	125	UT36120B	3422	122
UT2472GTE	1629	124	UT30132GTB	3068	124	UT3060B	1218	122	UT36120E	3891	122
UT2472GTB	1541	124	UT30132GTE	3708	124	UT3060E	1461	122	UT36120EB	3806	122
UT2472SB	1705	123	UT30132GTB	3432	124	UT3060EB	1375	122	UT36120GTB	3559	124
UT2472SE	2042	123	UT30132SB	3960	123	UT3060GTB	1356	124	UT36120GTE	4036	124
UT2472SEB	1865	123	UT30132SE	4837	123	UT3060GTE	1603	124	UT36120GTB	3949	124
UT2472STB	1848	125	UT30132SEB	4329	123	UT3060GTEB	1514	124	UT36120SB	4539	123
UT2472STB	1848	125	UT30132SEB	4329	123	UT3060GTEB	1514	124	UT36120SE	5216	123
UT2472STE	2186	125	UT30132STB	4092	125	UT3060SB	1716	123	UT36120SEB	4931	123
UT2472STEB	2013	125	UT30132STB	4092	125	UT3060SE	2046	123	UT36120STB	4675	125
UT2484B	1539	122	UT30132STE	4980	125	UT3060SEB	1881	123	UT36120STB	4675	125
UT2484E	1991	122	UT30132STEB	4472	125	UT3060STB	1857	125	UT36120STB	4675	125
UT2484EB	1952	122	UT30144B	3099	122	UT3060STE	2195	125	UT36120STEB	5073	125
UT2484GTB	1680	124	UT30144E	3372	122	UT3060STEB	2025	125	UT3612STE	1180	132
UT2484GTE	2136	124	UT30144GTB	3148	124	UT3072B	1312	122	UT3612STEB	1086	132
UT2484GTB	2093	124	UT30144GTE	3802	124	UT3072E	1588	122	UT36132B	3494	122
UT2484SB	2082	123	UT30144GTEB	3514	124	UT3072EB	1487	122	UT36132E	4057	122
UT2484SE	2746	123	UT30144SB	4038	123	UT3072GTB	1449	124	UT36132EB	3922	122
UT2484SEB	2531	123	UT30144SE	4926	123	UT3072GTE	1729	124	UT36132GTB	3629	124
UT2484STB	2223	125	UT30144SEB	4543	123	UT3072GTEB	1629	124	UT36132GTE	4194	124
UT2484STB	2223	125	UT30144SEB	4543	123	UT3072GTEB	1629	124	UT36132GTEB	4064	124
UT2484STE	2885	125	UT30144STB	4178	125	UT3072SB	1856	123	UT36132SB	4824	123
UT2484STEB	2673	125	UT30144STB	4178	125	UT3072SE	2228	123	UT36132SE	5431	123
UT2496B	1740	122	UT30144STEB	4688	125	UT3072SEB	2042	123	UT36132SEB	5131	123
UT2496E	2122	122	UT30155STE	1131	132	UT3072STB	1989	125	UT36132SEB	5131	123
UT2496EB	2078	122	UT30155STEB	1041	132	UT3072STB	1989	125	UT36132STB	4820	125
UT2496GTB	1880	124	UT3018STE	1195	132	UT3072STE	2373	125	UT36132STE	5547	125
UT2496GTE	2266	124	UT3018STEB	1099	132	UT3072STEB	2186	125	UT36132STEB	5267	125
UT2496GTB	2222	124	UT3030B	1037	122	UT3084B	1613	122	UT36144B	3684	122
UT2496SB	2231	123	UT3030E	1208	122	UT3084E	2093	122	UT36144E	4140	122
UT2496SE	2933	123	UT3030EB	1147	122	UT3084E	1973	122	UT36144EB	4007	122
UT2496SEB	2694	123	UT3030GTB	1174	124	UT3084GTB	1754	124	UT36144GTB	3712	124
UT2496STB	2366	125	UT3030GTE	1354	124	UT3084GTE	2238	124	UT36144GTE	4278	124
UT2496STB	2366	125	UT3030GTE	1354	124	UT3084GTEB	2115	124	UT36144GTE	4278	124
UT2496STE	3082	125	UT3030GTB	1292	124	UT3084SB	2162	123	UT36144GTB	4151	124
UT2496STEB	2843	125	UT3030SB	1449	123	UT3084SE	2861	123	UT36144SB	4916	123
UT30108B	2788	122	UT3030SE	1689	123	UT3084SEB	2635	123	UT36144SE	5681	123
UT30108E	3274	122	UT3030SEB	1564	123	UT3084STB	2300	125	UT36144SEB	5368	123
UT30108EB	3113	122	UT3030STB	1592	125	UT3084STB	2300	125	UT36144STB	4905	125
UT30108GTB	2852	124	UT3030STB	1592	125	UT3084STE	3005	125	UT36144STB	4905	125
UT30108GTB	2852	124	UT3030STE	1829	125	UT3084STEB	2782	125	UT36144STE	5660	125
UT30108GTE	3412	124	UT3030STE	1829	125	UT3096B	1849	122	UT36144STEB	5511	125
UT30108GTB	3412	124	UT3030STEB	1713	125	UT3096E	2273	122	UT3615STE	1216	132
UT30108GTB	3412	124	UT3030STEB	1713	125	UT3096E	2273	122	UT3615STEB	1120	132
UT30108GTB	3412	124	UT3030STEB	1713	125	UT3096EB	2142	122	UT3618STE	1264	132
UT30108SB	3760	123	UT3036B	1107	122	UT3096EB	2142	122	UT3618STEB	1162	132
UT30108SE	4433	123	UT3036E	1284	122	UT3096GTB	1988	124	UT3648B	1375	122
UT30108SEB	4096	123	UT3036EB	1224	122	UT3096GTB	1988	124	UT3648E	1547	122
UT30108SEB	4096	123	UT3036EB	1224	122	UT3096GTE	2416	124	UT3648EB	1506	122
UT30108STB	3791	125	UT3036GTB	1247	124	UT3096GTE	2416	124	UT3648GTB	1513	124
UT30108STE	4572	125	UT3036GTE	1431	124	UT3096GTEB	2284	124	UT3648GTE	1689	124
UT30108STE	4572	125	UT3036GTE	1431	124	UT3096GTEB	2284	124	UT3648GTB	1648	124
UT30108STEB	4239	125	UT3036GTB	1367	124	UT3096SB	2401	123	UT3648SB	1804	123
UT30120B	2869	122	UT3036GTB	1367	124	UT3096SE	3159	123	UT3648SE	2113	123
UT30120E	3359	122	UT3036SB	1522	123	UT3096SEB	2909	123	UT3648SEB	2002	123
UT30120EB	3204	122	UT3036SE	1762	123	UT3096SEB	2909	123	UT3648STB	1941	125
UT30120GTB	3005	124	UT3036SEB	1644	123	UT3096STB	2540	125			
UT30120GTE	3503	124	UT3036STB	1665	125	UT3096STB	2540	125			
UT30120GTE	3503	124	UT3036STB	1665	125	UT3096STE	3298	125			
UT30120GTB	3005	124	UT3036STB	1665	125	UT3096STE	3298	125			
UT30120GTB	3005	124	UT3036STB	1665	125	UT3096STEB	3048	125			
UT30120GTE	3503	124	UT3036STE	1907	125	UT3096STEB	3048	125			
UT30120GTE	3503	124	UT3036STE	1907	125	UT36108B	3337	122			
UT30120GTB	3346	124	UT3036STEB	1788	125	UT36108E	3699	122			
UT30120SB	3844	123	UT3048B	1123	122	UT36108E	3699	122			
			UT3048E	1331	122	UT36108EB	3585	122			

# ALPHANUMERIC PRICE INDEX

Part Number	List Price	Page No.	Part Number	List Price	Page No.	Part Number	List Price	Page No.	Part Number	List Price	Page No.
UT3648STE	2262	125	UWT3072SEB	1073	115	WBCB24-24	2297	307	WCH-84	8668	109,149
UT3648STEB	2145	125	UWT3072SEM	1954	115	WBCB30-19	2305	307	WCH-90	9160	109,149
UT3660B	1533	122	VS-2	256	236	WBCB30-24	2551	307	WCH-96	9444	109,149
UT3660E	1721	122	VS-3	309	236	WBCB36-19	2542	307	WCH4-24C-L	4496	197
UT3660EB	1668	122	VS-4	337	236	WBCB36-24	2807	307	WCH4-24C-LL	4800	197
UT3660GTB	1674	124	W1436BL	161	27	WBCB42-19	2776	307	WCH4-24C-R	4496	197
UT3660GTE	1860	124	W1436C	156	27	WBCB42-24	3062	307	WCH4-24C-RL	4800	197
UT3660GTB	1815	124	W1448BL	183	27	WBCB48-19	3009	307	WCO-24	3960	109,149
UT3660SB	1983	123	W1448C	179	27	WBCB48-24	3318	307	WCO-30	3964	109,149
UT3660SE	2318	123	W1916	3384	176	WBGR12-18	1588	285	WCO-36	4111	109,149
UT3660SEB	2195	123	W1916-FA	1766	176	WBGR12-22	1588	291	WCO-48	4736	109,149
UT3660STB	2125	125	WAL-1-1836	415	104	WBGR18-18	1669	285	WCO-60	5182	109,149
UT3660STE	2461	125	WAL-1-1848	459	104	WBGR18-22	1669	291	WCO-72	5499	109,149
UT3660STEB	2334	125	WAL-2-1836	759	104	WBGR18-24	1686	303	WCO-84	5802	109,149
UT3672B	1666	122	WAL-2-1848	847	104	WBGR24-18	1757	285	WCO-96	6497	109,149
UT3672E	1858	122	WB	40	105	WBGR24-22	1757	291	WCS-120	10775	109,149
UT3672EB	1806	122	WB-DB-HT2	817	230	WBGR24-24	1901	303	WCS-24	4479	109,149
UT3672GTB	1804	124	WB-DB-HT3	862	230	WBIC15-19	583	306	WCS-30	5458	109,149
UT3672GTE	2002	124	WB-DB-HT4	941	230	WBIC15-24	724	306	WCS-36	5627	109,149
UT3672GTB	1952	124	WB-DB-HT5	1299	230	WBIC30-19	583	306	WCS-42	5654	109,149
UT3672SB	2165	123	WB-DB-HT6	1724	230	WBIC30-24	724	306	WCS-48	6164	109,149
UT3672SE	2522	123	WB-HT2	471	230	WBIC45-19	583	306	WCS-54	6279	109,149
UT3672SEB	2382	123	WB-HT3	516	230	WBIC45-24	724	306	WCS-60	7128	109,149
UT3672STB	2306	125	WB-HT4	595	230	WBIC60-19	583	306	WCS-72	7984	109,149
UT3672STE	2666	125	WB-HT5	778	230	WBIC60-24	724	306	WCS-84	8191	109,149
UT3672STEB	2522	125	WB-HT6	977	230	WBIC75-19	726	306	WCS-90	8674	109,149
UT3684B	2247	122	WB12-19	869	305	WBIC75-24	892	306	WCS-96	8943	109,149
UT3684E	2476	122	WB12-24	968	305	WBOB24-19	1686	307	WDR203608-A	305	41,351
UT3684EB	2405	122	WB14-C	53	13,112	WBOB24-24	1901	307	WDR203612-A	305	41,351
UT3684GTB	2391	124	WB14-S	126	13,112	WBOB30-19	1876	307	WDR204808-A	354	41,351
UT3684GTE	2617	124	WB14-VG	54	13,112	WBOB30-24	2113	307	WDR204812-A	354	41,351
UT3684GTB	2556	124	WB18-19	968	305	WBOB36-19	2066	307	WDR206008-A	400	41,351
UT3684SB	2944	123	WB18-24	1074	305	WBOB36-24	2329	307	WDR206012-A	400	41,351
UT3684SE	3374	123	WB18-C	54	13,112	WBOB42-19	2267	307	WDR243608-A	344	41,351
UT3684SEB	3193	123	WB18-S	135	13,112	WBOB42-24	2542	307	WDR243612-A	344	41,351
UT3684STB	3085	125	WB18-VG	55	13,112	WBOB48-19	2458	307	WDR244808-A	386	41,351
UT3684STE	3514	125	WB2-18	940	286	WBOB48-24	2758	307	WDR244812-A	386	41,351
UT3684STEB	3335	125	WB2-22	1001	292	WBOC15-19	583	306	WDR246008-A	448	41,351
UT3696B	2382	122	WB21-C	54	13,112	WBOC15-24	724	306	WDR246012-A	448	41,351
UT3696E	2616	122	WB21-S	138	13,112	WBOC30-19	583	306	WGR18-C	43	27
UT3696EB	2545	122	WB21-VG	55	13,112	WBOC30-24	724	306	WGR18-Z	39	27
UT3696GTB	2521	124	WB24-19	1074	305	WBOC45-19	583	306	WGR24-C	49	27
UT3696GTE	2760	124	WB24-24	1178	305	WBOC45-24	724	306	WGR24-Z	46	27
UT3696GTB	2688	124	WB24-C	55	13,112	WBOC60-19	583	306	WM108APR	766	157
UT3696SB	3167	123	WB24-S	142	13,112	WBOC60-24	724	306	WM108PR	1051	157
UT3696SE	3625	123	WB24-VG	57	13,112	WBOC75-19	726	306	WM120APR	775	157
UT3696SEB	3412	123	WB3-18	1196	286	WBOC75-24	892	306	WM120PR	1113	157
UT3696STB	3301	125	WB3-22	1267	292	WBS1836C	129	42	WM132APR	897	157
UT3696STE	3761	125	WB30-19	1178	305	WCH-24	5373	109,149	WM132PR	1129	157
UT3696STEB	3558	125	WB30-24	1276	305	WCH-24C-L	4982	197	WM144APR	963	157
UUC-311	812	32	WB36-19	1276	305	WCH-24C-LL	5286	197	WM144PR	1420	157
UUC-322	841	32	WB36-24	1380	305	WCH-24C-R	4982	197	WM1836	99	104
UUC-411	829	32	WB4-18	1472	286	WCH-24C-RL	5286	197	WM1848	127	104
UUC-422	859	32	WB4-22	1563	292	WCH-30	5955	109,149	WM1860	127	104
UWT3048SE	1156	115	WB42-19	1380	305	WCH-36	6058	109,149	WM2448	151	104
UWT3048SEB	817	115	WB42-24	1483	305	WCH-42	6367	109,149	WM2472	174	104
UWT3048SEM	1621	115	WB48-19	1483	305	WCH-48	6563	109,149	WM2484	208	104
UWT3060SE	1319	115	WB48-24	1584	305	WCH-54	6712	109,149	WM2496	220	104
UWT3060SEB	957	115	WBC1836C-1B1W	463	32	WCH-60	7526	109,149	WM3354	254	104
UWT3060SEM	1731	115	WBC1836C-2B	408	32	WCH-66	7580	109,149	WM36APR	321	157
UWT3072SE	1542	115	WBCB24-19	1837	307	WCH-72	8432	109,149	WM36PR	371	157



100 Industrial Boulevard, Clayton, DE 19938-8903 U.S.A.  
 Phone: 800-441-8440 or 302-653-3000. Fax: 302-653-2065  
<http://www.eaglegrp.com>

# ALPHANUMERIC PRICE INDEX

Part Number	List Price	Page No.	Part Number	List Price	Page No.	Part Number	List Price	Page No.	Part Number	List Price	Page No.
WM4848	246	104	WS1084-16/4	714	108	WSP1296	1257	109	WTFT-1248-SG	15122	209
WM48APR	336	157	WS1096-14/3	1279	108	WSP15108	2216	109	WTFT-1260-FGG	14248	209
WM48PR	448	157	WS1096-16/3	1163	108	WSP15120	2252	109	WTFT-1260-SG	16038	209
WM60APR	383	157	WS1096-16/4	826	108	WSP15132	2420	109	WTFT-1272-FGG	14729	209
WM60PR	478	157	WS12-19	1603	304	WSP15144	2460	109	WTFT-1272-SG	16858	209
WM72APR	491	157	WS12-24	1669	304	WSP1536	1349	109	WTFT-1284-FGG	15123	209
WM72PR	607	157	WS12108-14/3	1519	108	WSP1548	1378	109	WTFT-1284-SG	17966	209
WM84APR	516	157	WS12108-16/3	1384	108	WSP1560	1567	109	WTFT-1296-FGG	15544	209
WM84PR	660	157	WS12108-16/4	1000	108	WSP1572	1701	109	WTFT-1296-SG	18180	209
WM96APR	634	157	WS12120-14/3	1609	108	WSP1584	1948	109	WTFT-1518-FGG	12580	209
WM96PR	936	157	WS12120-16/3	1462	108	WSP1596	2041	109	WTFT-1518-SG	13741	209
WPR-FL-36	1154	347	WS12120-16/4	1041	108	WSP18108	2581	109	WTFT-1524-FGG	13183	209
WPR-SL-36	1232	347	WS1224-14/3	754	108	WSP18120	2621	109	WTFT-1524-SG	14251	209
WR-39	192	138	WS1224-16/3	684	108	WSP18132	2672	109	WTFT-1530-FGG	13412	209
WR14-BL	31	68	WS1224-16/4	588	108	WSP18144	2714	109	WTFT-1530-SG	14338	209
WR14-R	31	68	WS1224TL	257	110	WSP1836	1615	109	WTFT-1536-FGG	13547	209
WR14-W	31	68	WS1236-14/3	843	108	WSP1848	1642	109	WTFT-1536-SG	14858	209
WR18-BL	33	35,68	WS1236-16/3	769	108	WSP1860	1727	109	WTFT-1548-FGG	14004	209
WR18-C	32	35	WS1236-16/4	632	108	WSP1872	1849	109	WTFT-1548-SG	15796	209
WR18-R	33	68	WS1236TL	278	110	WSP1884	2006	109	WTFT-1560-FGG	14356	209
WR18-V	33	35	WS1248-14/3	906	108	WSP1896	2124	109	WTFT-1560-SG	16698	209
WR18-VG	33	35	WS1248-16/3	824	108	WSS14-15	1211	302	WTFT-1572-FGG	14812	209
WR18-W	33	68	WS1248-16/4	646	108	WSSDI12-15	869	302	WTFT-1572-SG	17622	209
WR18-Z	28	35	WS1248TL	314	110	WSW18-24	2511	304	WTFT-1584-FGG	15254	209
WR1840C	1320	70	WS1260-14/3	998	108	WT2-208	6325	222	WTFT-1584-SG	18549	209
WR24-BL	34	68	WS1260-16/3	909	108	WT2-240	6325	222	WTFT-1596-FGG	15627	209
WR24-R	34	68	WS1260-16/4	688	108	WT3-208	6905	222	WTFT-1596-SG	19418	209
WR24-W	34	68	WS1260TL	351	110	WT3-240	6905	222	WTFT-1824-FGG	13381	209
WR30-BL	35	68	WS1272-14/3	1089	108	WT3048SE	982	115	WTFT-1824-SG	14463	209
WR30-R	35	68	WS1272-16/3	994	108	WT3048SE-BS	1228	115	WTFT-1830-FGG	13675	209
WR30-W	35	68	WS1272-16/4	737	108	WT3048SEB	695	115	WTFT-1830-SG	14682	209
WR36-BL	37	68	WS1284-14/3	1186	108	WT3048SEB-BS	866	115	WTFT-1836-FGG	13900	209
WR36-R	37	68	WS1284-16/3	1078	108	WT3048SEM	1380	115	WTFT-1836-SG	14902	209
WR36-W	37	68	WS1284-16/4	779	108	WT3048SEM-BS	1725	115	WTFT-1848-FGG	14434	209
WS10108-14/3	1405	108	WS1296-14/3	1297	108	WT3060SE	1122	115	WTFT-1848-SG	16382	209
WS10108-16/3	1276	108	WS1296-16/3	1180	108	WT3060SE-BS	1403	115	WTFT-1860-FGG	14889	209
WS10108-16/4	898	108	WS1296-16/4	914	108	WT3060SEB	813	115	WTFT-1860-SG	16944	209
WS10120-14/3	1584	108	WS14-15	1211	302	WT3060SEB-BS	1016	115	WTFT-1872-FGG	15968	209
WS10120-16/3	1441	108	WS18-19	1704	304	WT3060SEM	1471	115	WTFT-1872-SG	18409	209
WS10120-16/4	942	108	WS18-24	1780	304	WT3060SEM-BS	1839	115	WTFT-1884-FGG	15968	209
WS1024-14/3	705	108	WSC12-24	2271	304	WT3072SE	1312	115	WTFT-1884-SG	19057	209
WS1024-16/3	641	108	WSD14-15	1692	302	WT3072SE-BS	1639	115	WTFT-1896-FGG	16468	209
WS1024-16/4	547	108	WSP10108	1615	109	WT3072SEB	912	115	WTFT-1896-SG	20405	209
WS1024TL	239	110	WSP10120	1652	109	WT3072SEB-BS	1138	115	WTFT-2424-FGG	13581	209
WS1036-14/3	797	108	WSP10132	1751	109	WT3072SEM	1662	115	WTFT-2424-SG	15294	209
WS1036-16/3	723	108	WSP10144	1788	109	WT3072SEM-BS	2076	115	WTFT-2430-FGG	13966	209
WS1036-16/4	588	108	WSP1036	995	109	WT4-208	7846	222	WTFT-2430-SG	15489	209
WS1036TL	256	110	WSP1048	1016	109	WT4-240	7846	222	WTFT-2436-FGG	14235	209
WS1048-14/3	844	108	WSP1060	1060	109	WT5-208	8288	222	WTFT-2436-SG	16185	209
WS1048-16/3	772	108	WSP1072	1098	109	WT5-240	8288	222	WTFT-2448-FGG	14881	209
WS1048-16/4	595	108	WSP1084	1152	109	WTFT-1215-FGG	12311	209	WTFT-2448-SG	17076	209
WS1048TL	292	110	WSP1096	1231	109	WTFT-1215-SG	13563	209	WTFT-2460-FGG	15519	209
WS1060-14/3	934	108	WSP12108	1716	109	WTFT-1218-FGG	12929	209	WTFT-2460-SG	17871	209
WS1060-16/3	853	108	WSP12120	1756	109	WTFT-1218-SG	13864	209	WTFT-2472-FGG	15562	209
WS1060-16/4	635	108	WSP12132	1846	109	WTFT-1224-FGG	13133	209	WTFT-2472-SG	19060	209
WS1060TL	329	110	WSP12144	1880	109	WTFT-1224-SG	14028	209	WTFT-2484-FGG	16799	209
WS1072-14/3	1019	108	WSP1236	1033	109	WTFT-1230-FGG	13385	209	WTFT-2484-SG	19855	209
WS1072-16/3	931	108	WSP1248	1069	109	WTFT-1230-SG	14137	209	WTFT-2496-FGG	17391	209
WS1072-16/4	677	108	WSP1260	1120	109	WTFT-1236-FGG	13522	209	WTFT-2496-SG	20845	209
WS1084-14/3	1105	108	WSP1272	1162	109	WTFT-1236-SG	14246	209	WTS A30	212	132
WS1084-16/3	1009	108	WSP1284	1229	109	WTFT-1248-FGG	13963	209			



## - Terms and Conditions -

### PRICES

All merchandise will be billed at our current published list prices in effect at the time of shipment.

### PERFORMANCE

All shipping dates are approximate. Fulfillment is always subject to availability of material and to conditions affecting shipment that are beyond our control. EAGLE shall not be held liable for any delay in performance due to reasons beyond our control.

### SHORTAGE

All claims for shortage must be brought to our attention within five (5) business days from date merchandise is received. Please be certain that you receive the number of packages signed for.

### CANCELLATIONS

Cancellations are not accepted on orders in transit or on custom items. Standard orders that are cancelled while already in production will be subject to up to a 30% restocking charge based upon product ordered.

### RETURNS

**Custom and modified standard equipment is non-returnable.**

Authorization Policy for Standard Returns:

- ✓ Previously written approval from EAGLE's Customer Service is mandatory on all returns.
- ✓ Return authorization must be requested within 60 days from date of shipment.
- ✓ Authorized return shipments, in which merchandise is not defective and orders have been properly filled, must be shipped prepaid and properly packaged to prevent merchandise damage.
- ✓ Each return authorization number (*located on the upper right hand corner of the form*), must be written on the outside of each carton returned to EAGLE.
- ✓ No credits will be processed for a return until we have confirmation that the item has been received, has been inspected and it is confirmed that item is in unused and new, sellable condition.

Restocking:

- ✓ Restocking and equipment repair fees for merchandise damaged during return shipment to EAGLE will be withheld from issued credit.
- ✓ Returns of made-to-stock merchandise are subject to a 30% restocking fee.

Restocking (continued):

- ✓ Returns of standard made-to-order merchandise are subject to a 50% restocking fee.
- ✓ \$75 net minimum on merchandise returns.

### PRINTS & DRAWINGS

All prints and drawings submitted with orders are accepted as a final approval in the custom order process. Errors that arise due to incorrect submittals are the responsibility of the customer. There are no cancellations on custom orders.

### DAMAGES

EAGLE's responsibility ceases immediately upon our retaining receipt of pickup from our dock by the transportation company, unless the merchandise is refused by the consignee. If a container shows rough handling, do not give the carrier a clear delivery receipt and inspect the merchandise immediately. Note the damage on the delivery receipt/bill of lading while the driver is there. If you sign your name on the freight bill without noting any damages, then you are stating you have received your order/shipment in acceptable condition. Upon finding damage while unpacking the product, call the carrier without further unpacking, ask for an inspection, and follow through by filing a claim with the carrier immediately.

### ORDER APPROVAL

All orders are subject to final approval by EAGLE's home office. Acceptance and/or performance shall be at all times subject to the approval of EAGLE's Credit Department. Minimum order \$50.00 net.

### TERMS

Discount and discount date are clearly marked at the bottom of each invoice should you be entitled to any discount, subject to current status of your account.

### FOB

All orders ship FOB Origin freight collect unless otherwise specified. All orders shipped prepaid/add will receive a 20% administrative surcharge added to the freight charge. Shipper is not responsible for any unauthorized accessorial charges. These charges will be billed back to the customer after shipment in the form of a separate invoice.

### UPS

All UPS shipments will be charged a minimum of \$25.00.

- MONETARY VALUES ARE BASED ON U.S. CURRENCY. -

## Distribution Locations (in U.S. only)

For orders/sales, call 1-800-441-8440. The phone numbers of the following distribution points are for pickup information only.

#### In Delaware (corporate office):

##### EAGLE GROUP

100 Industrial Blvd.

Clayton, DE 19938

Toll Free Ph: 1-800-441-8440

#### In Texas:

##### Dallas Distribution

c/o Storage Equipment Co. Inc.

1258 Titan Drive

Dallas, TX 75247

Ph: 214-630-9221

#### In California:

##### Cerritos Distribution

c/o Displays By Jack

12930-12950 Alondra Blvd.

Cerritos, CA 90703

Toll Free Ph: 1-800-441-8440

All orders are to be sent to our corporate office. Please call our corporate office to place your order. All addresses are subject to change.



100 Industrial Boulevard, Clayton, DE 19938-8903 U.S.A.

Phone: 800-441-8440 or 302-653-3000. Fax: 302-653-2065

<http://www.eaglegrp.com>





# Check these out...

Mop Sink Splash Kits  
— page 196



Chemical Storage  
Wall Cabinets  
— page 197



Q-LEVER® Heavy Duty  
Cantilever Shelving  
Systems — pages 86 through 99

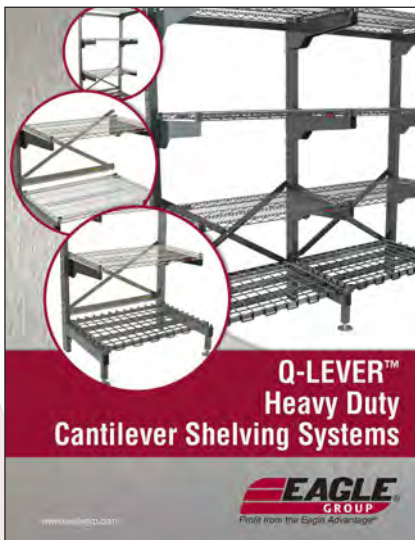

Spec-SHIELD™ Food Guards  
with **NEW** Lighting Options  
— pages 254 and 260



For the latest on our latest, visit the [Eagle Group News website](http://www.eaglegrpnews.com) at...

[www.eaglegrpnews.com](http://www.eaglegrpnews.com)



**EAGLE**<sup>™</sup>  
Foodservice Equipment Division  
Profit from the Eagle Advantage®

Rev 12/19 EG9064

100 Industrial Blvd. Clayton DE, 19938  
Toll Free: 1-800-441-8440 • Fax: 302-653-2065  
[www.eaglegrp.com](http://www.eaglegrp.com)

© 2019 EAGLE GROUP. Profit From The EAGLE Advantage® is a registered trademark of EAGLE GROUP.

Although every attempt has been made to ensure the accuracy of the data in this publication, we cannot be responsible for printing or typographical errors or omissions.