



MASTER

PRODUCT CATALOGUE

The Marine Specialist



MASTER

PRODUCT CATALOGUE

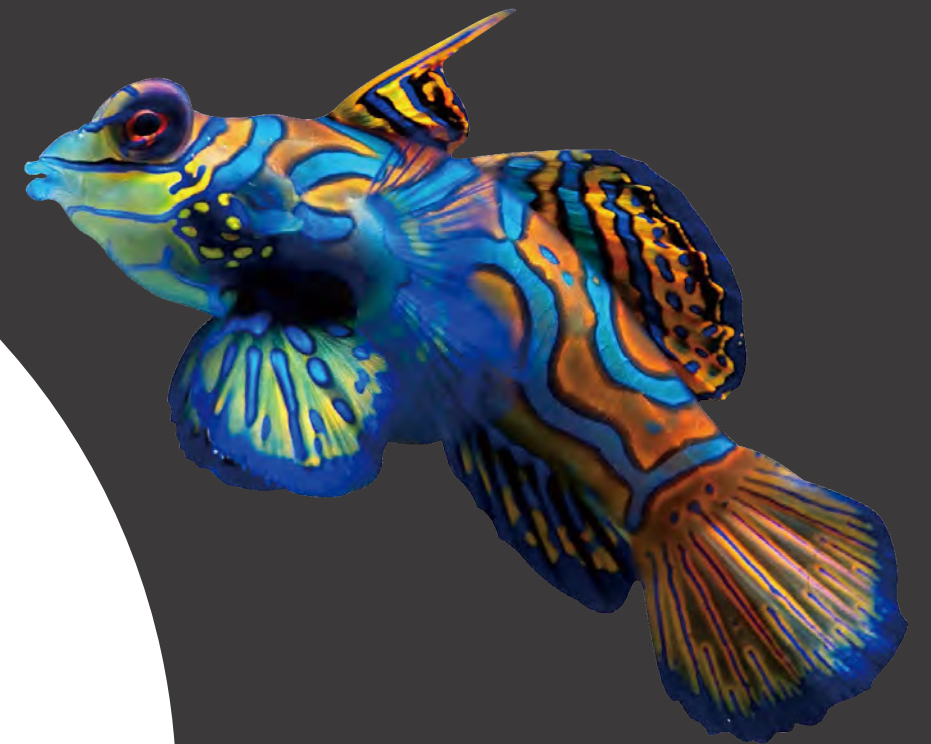
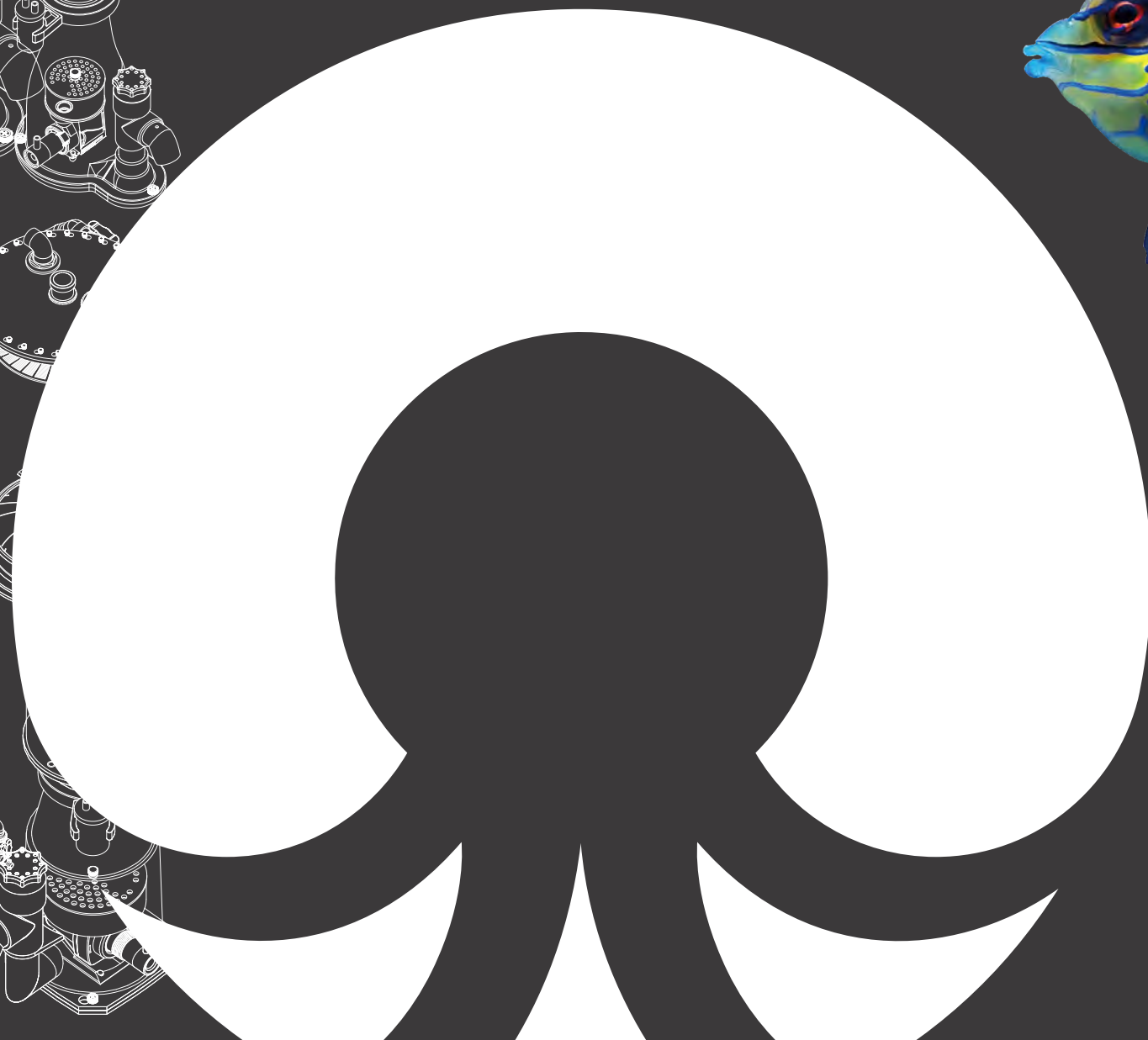
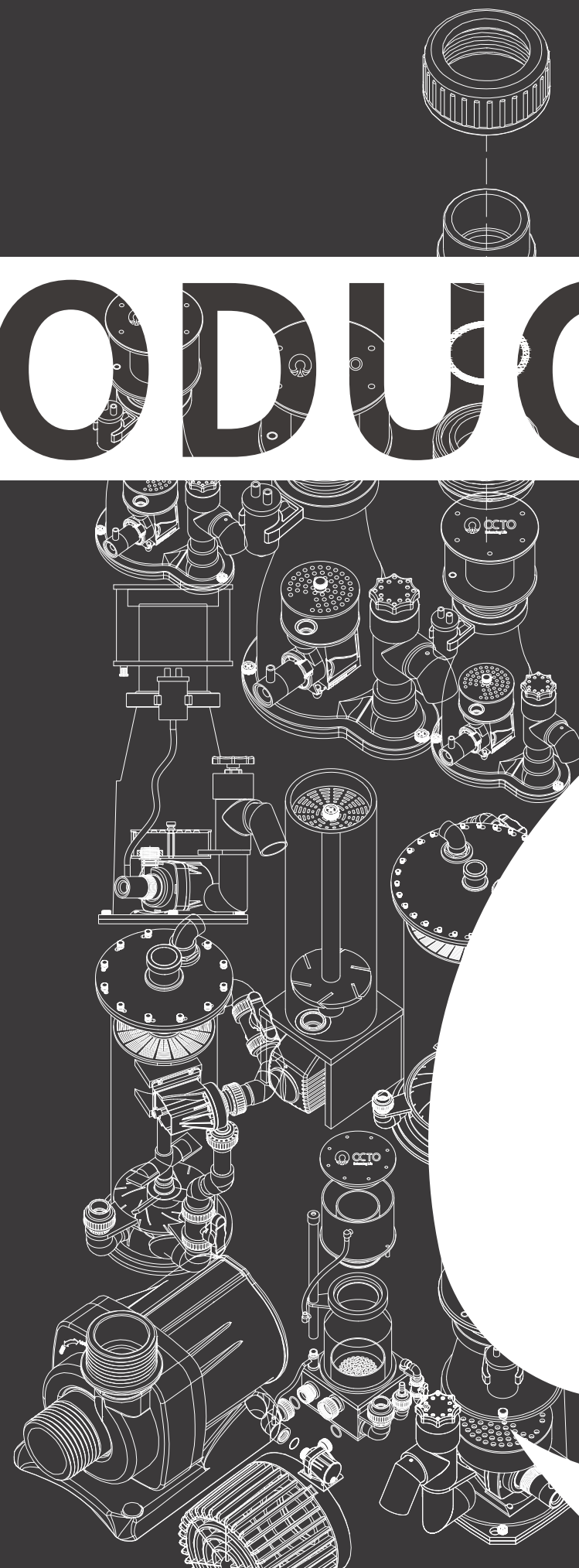



ABOUT US

Company Background

Founded in 2005, Honya Co. Ltd started with a vision to produce high quality products for the marine industry. After more than a decade, we now have one of the widest range of protein skimmers under the brand OCTO, which is globally recognised by hobbyists and professionals alike for its product quality and reliability.

In our effort to enhance the efficiency and reliability of our protein skimmers, we took the bold step to design and produce our own BLDC skimmer pumps, specifically engineered to meet the high demands of a protein skimmer. Consequently becoming the first skimmer manufacturer in the world to produce our skimmers and pump completely in-house.

Started as a manufacturer of home aquarium protein skimmers, with the recognition of our product quality and efficiency in the market, we now also design and produce commercial skimmers for public aquariums and aquaculture projects.

Product Development

Driven by a shared passion for marine life amongst our management and employees, we actively engage in research and development (R&D) to continuously improve our products as well as develop new ones; with the goal of creating a thriving marine ecosystem in an enclosed environment.

In addition to our core business in marine aquarium products, we are also involved in the commercial aquaculture sector using our customised water purification system which produces a higher yield without the need of supplements.

Vision

To be THE marine specialist producing high quality, innovative and user-centred designed aquatic products.

Mission

To ensure the sustainability of the natural marine ecosystem for the future generation, by enhancing the living environment for marine organisms while creating a sense of joy and tranquillity for human beings.



Concept of Our Logo

Octopus is a Cephalopod mollusc of the order Octopoda. The octopus' characteristics of being one of the most intelligent and behaviourally flexible of all invertebrates signifies our vision to develop intelligent and user-centred designed (UCD) products, while being flexible to adapt to the market environment.

The octopus' 8 tentacles represent our product development philosophy to meet and exceed the diverse needs of customers globally.

Evolution of Our Logo

Our logo has evolved along with the growth of the company – from a live octopus to a graphical design with a new font portraying a cleaner, modern and high quality image, which echoes our current outlook on product development. This also symbolises our leap to the next decade; in the direction towards manufacturing contemporary and user-centred designed (UCD) products, which can be witnessed with the launch of the OCTO series.



Our New Logo

Our logo illustrates an octopus hugging the globe with its tentacles, 4 at the front and 4 hidden at the back, reflecting our mission of embracing the world and its ocean and to ensure its long term sustainability even in areas not obvious to the eye.

The red colour signifies Honya' s vibrancy and shared passion in producing quality products.

The slogan "Enhancing Life" represents our philosophy in the company; to enhance the life of the marine organisms within the aquarium and at the same time enhance the life of individuals, by creating a sense of joy and tranquillity when they see a stunning and fascinating habitat within an aquarium, with the use of our products.

Over a decade of proven reliability

Featuring a small footprint, the OCTO series Classic Space Saving Skimmer is an in-sump protein skimmer ideal for aquarium with limited sump space. It is run by our very own AQ pump, encased in a solid acrylic body, can be easily disassembled for maintenance and does not require a feed pump as it draws water directly from the sump.

Available in 4 models – Classic 110-S and Classic 150-S features a straight body with a vented valve output whilst Classic 152-S and Classic 202-S features a wine-shaped smooth cone body with a precision control gate valve.

FEATURES & BENEFITS

- Ultra compact, superior performance
- AQ pumps specifically made for protein skimmers
- Easy maintenance
- Output designed for bubble-free outflow
- Quiet operation
- High quality hand-made acrylic construction
- **Sleek wine-shaped smooth cone body
- Trusted by Professionals and Hobbyists

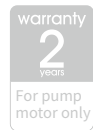

DID YOU KNOW?
We are the first protein skimmer manufacturer in the world that designs and produces our own skimmer pumps. Our skimmer pumps have been specifically engineered to enhance and increase the efficiency of our protein skimmer.

OCTO Classic Space Saving Skimmer



Classic 110-S



Classic 150-S



Classic 152-S



Classic 202-S

Dimension

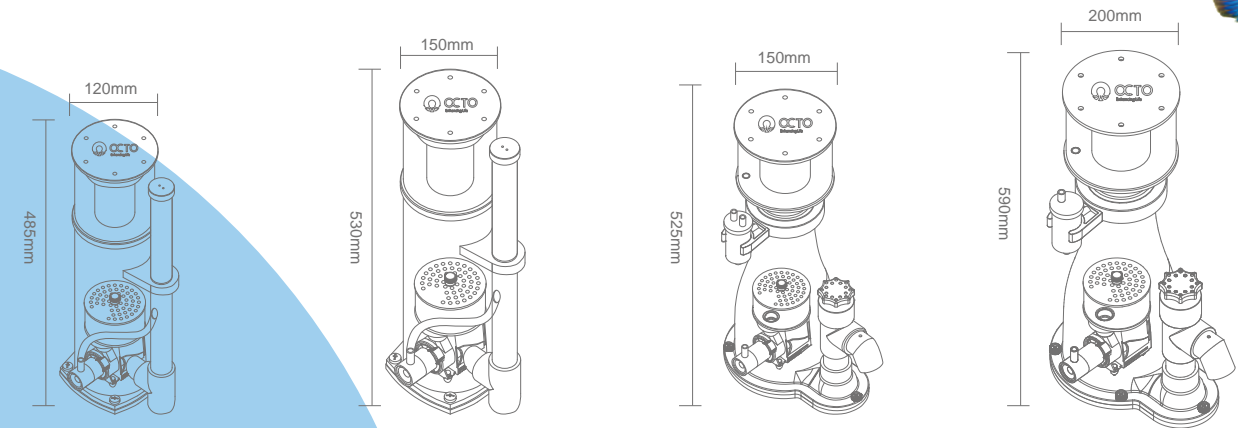

OCTO Classic Space Saving Skimmer

Item No.	Product	Wet/Dry	Pump Power		Cup Diameter		Neck Diameter		Footprint		Height		Output Size	Tank Volume			
			W	W	mm	inch	mm	inch	mm	inch	mm	inch		L	US Gal		
120101	Classic 110-S	Wet	8	9	120	4.7	60	2.4	200	155	7.9	6.1	485	19.1	Φ 32 mm (1")	500	132
120102	Classic 150-S	Wet	17	18	150	5.9	80	3.2	240	185	9.5	7.3	530	20.9	Φ 40 mm (1 - 1/4")	800	211
120103	Classic 152-S	Wet	10	11	150	5.9	80	3.2	265	205	10.4	8.1	525	20.7	Φ 40 mm (1 - 1/4")	600	158
120104	Classic 202-S	Wet	35	35	200	7.9	120	4.7	315	255	12.4	10	590	23.2	Φ 40 mm (1 - 1/4")	1000	264

Skimmer Pump

Product	Model No.	Wet/Dry	Air Intake				Power		Maximum Flow Rate				Connection Size (outlet)
			50Hz		60Hz		50Hz	60Hz	50Hz		60Hz		
			LPH	Gph	LPH	Gph	W	W	LPH	Gph	LPH	Gph	
Classic 110-S	AQ-1000S	Both	420	111	454	120	8	9	350	92	350	92	Φ25 (3/4")
Classic 150-S	AQ-2000S	Both	720	190	719	190	17	18	750	198	750	198	Φ25 (3/4")
Classic 152-S	AQ-1800S	Both	480	127	511	135	10	11	530	140	530	140	Φ25 (3/4")
Classic 202-S	AQ-3000S	Both	880	232	871	230	35	35	800	211	800	211	Φ32 (1")

Over a decade of proven reliability

OCTO Classic Hang-On Back Classic skimmers are a proverbial favourite. With its unique design, the pump is mounted externally and under the actual skimmer body (90-HOB, 1000-HOB and 2000-HOB) allowing for much less room needed behind the aquarium and less heat-to-water exchange.

The OCTO Classic series HOB is constructed of high-quality acrylic and equipped with the new highly efficient AQ pinwheel pump that produces an ideal mix of water and air for optimal waste removal.

Available in 5 models – Classic 90-HOB, 1000-HOB, 2000-HOB, 100-HOB and NS-80.

FEATURES & BENEFITS

- Low profile body
- Air Silencers
- Single output
- Solid Acrylic Construction
- Adaptive Surface Water Degreasing function
- Powered by our very own AQ pump
- Dual Chamber Reaction for specific models



warranty
2
years
For pump motor only

Defoaming Device



DID YOU KNOW?

We are the first protein skimmer manufacturer in the world that designs and produces our own skimmer pumps. Our skimmer pumps have been specifically engineered to enhance and increase the efficiency of our protein skimmer.

Pump Mounted Externally



Adjustable Surface Skimmer



OCTO Classic Hang-On Back Skimmer



Dimension

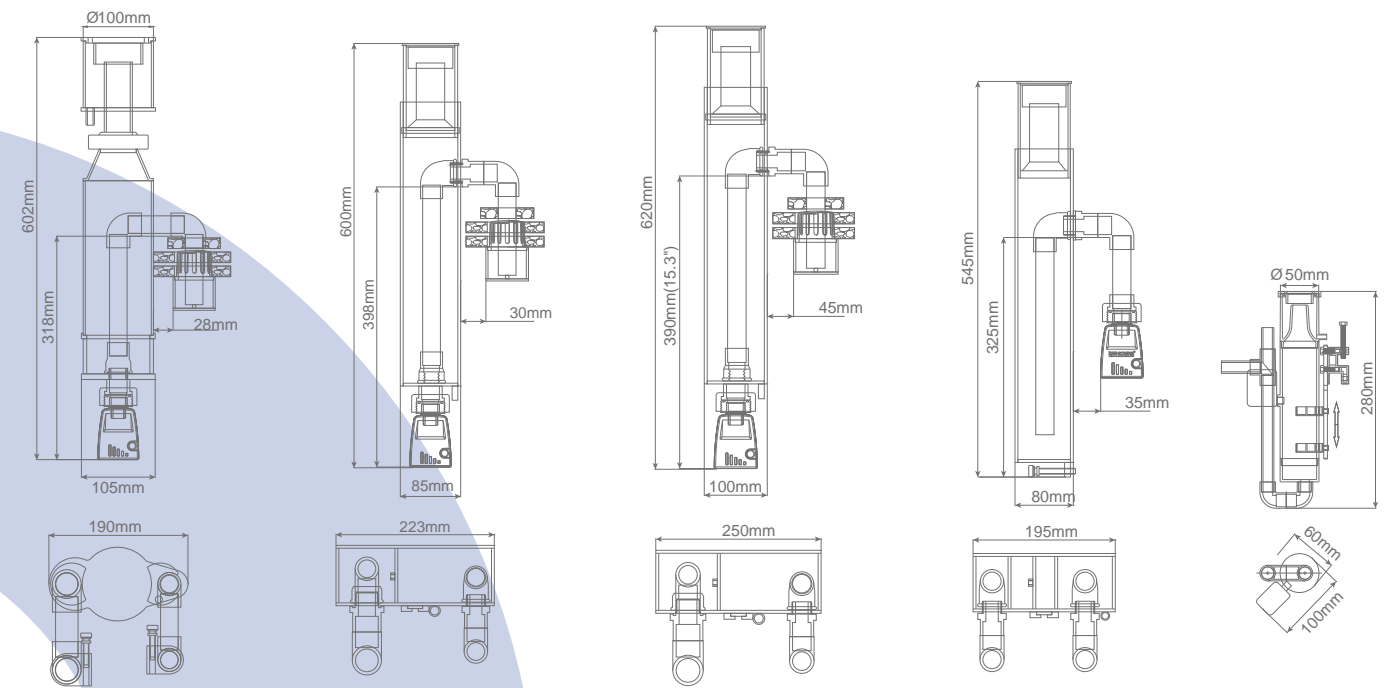

OCTO Classic Hang-On Back Skimmer

Item No.	Product	Wet/Dry	Fit Pump	Air Intake		Power		Maximum Flow Rate				Output Size	Tank Volume			
				50Hz LPH	60Hz GPH	50Hz W	60Hz W	50Hz LPH	60Hz GPH	50Hz LPH	60Hz GPH		L	US Gal		
120114	Classic 90-HOB	Dry	AQ-1000S	420	111	454	120	8	9	350	92	350	92	Φ32mm	300-500	79-132
120112	Classic 1000-HOB	Dry	AQ-1000S	420	111	454	120	8	9	350	92	350	92	Φ32mm	300-500	79-132
120113	Classic 2000-HOB	Dry	AQ-2000S	720	190	719	190	17	18	750	198	750	198	Φ40mm	500-800	132-211
120111	Classic 100-HOB	Wet	AQ-1000S	420	111	454	120	8	9	350	92	350	92	Φ25mm	50-400	13-105
120116	Classic NS-80	Wet	OTP-200S	-	-	-	-	5	5	200	52.8	200	52.8	Φ16mm	0-100	0-26

Silent, Reliable and Controllable

Featuring a small footprint, the OCTO series Regal space saving skimmer (Regal-S) is an in-sump protein skimmer ideal for aquarium with limited sump space. Regal-S further features high-quality cast acrylic body construction, easy disassembly for maintenance, a precision control gate valve and a hybrid conical body which helps to naturally stabilise and concentrate the organic rich foam as it rises.

In addition, Regal-S is run by our very own controllable VarioS skimmer pump which features a pinwheel impeller, a detachable controller, high quality ceramic shaft and bearing to reduce wear and tear, and the latest variable speed flow technology for refined control, enhanced performance, energy-efficiency and safer operations.

Unlike the vast majority of circulation pumps which uses alternating current (AC), our VarioS pump boasts several key advantages over traditional AC pump, namely, higher energy efficiency, safer operations at a working voltage of 24V and most notably, the variable speed control to adjust the ideal mix of air and water flow into the skimmer.

Enhanced Control

With the VarioS controller, users have control over the flow rates by selecting amongst five preset speed settings; indicated by five lit LEDs. A 15 or 60 minutes feed mode can also be engaged or disengaged with the push of a button.

In addition, a rotatable volute allows users to adjust the output orientation horizontally or vertically (up or down), depending on their needs.

Under normal usage, VarioS pump has an expected lifespan/product life expectancy of 10 years.

Available in 4 models – Regal 150-S, Regal 200-S, Regal 250-S and Regal 300-S.

FEATURES & BENEFITS

- Ultra compact, superior performance
- VarioS DC Pump specifically made for protein skimmers
- High quality hand-made solid cast acrylic construction
- Controllable and variable speed DC pump for energy-efficient and silent operations
- Float switch monitor
- Hybrid conical body for better foam fractionation
- Over Sized collection Cup with Drain
- High volume air intake
- Easy Maintenance

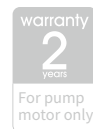

DID YOU KNOW?
We are the first protein skimmer manufacturer in the world that designs and produces our own skimmer pumps. Our skimmer pumps have been specifically engineered to enhance and increase the efficiency of our protein skimmer.

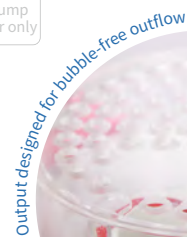

Float switch monitor

Quiet operation

Anti-Splash Gated Valve

OCTO Regal Space Saving Skimmer



Dimension

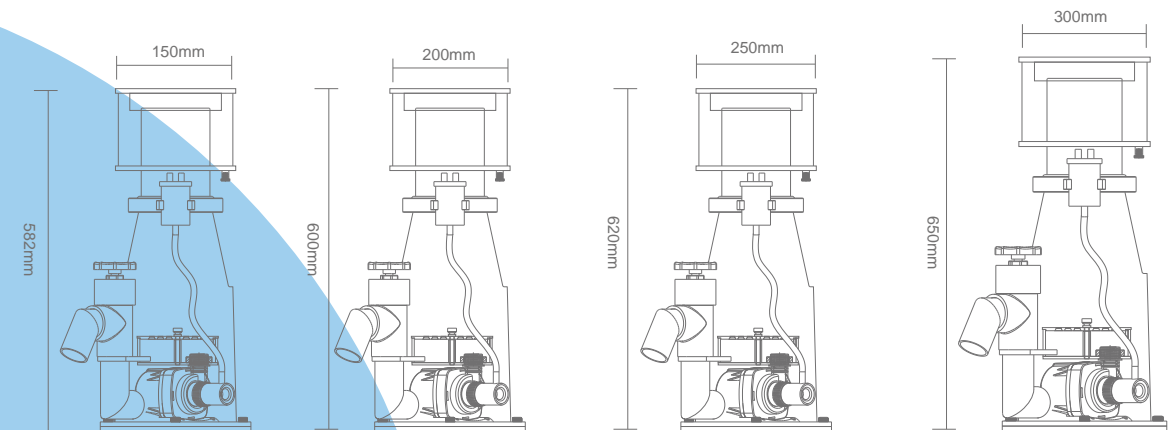

OCTO Regal Space Saving Skimmer

Item No.	Product	Wet/Dry	Pump Power	Cup Diameter		Neck Diameter		Footprint		Height		Output Size	Tank Volume			
				mm	inch	mm	inch	mm	inch	mm	inch		L	US Gal		
120201	Regal 150-S	Wet	30	150	5.9	80	3.2	230	190	9.1	7.5	582	22.9	Φ 40 mm (1-1/4")	800	211
120202	Regal 200-S	Wet	40	200	7.9	120	4.7	295	245	11.6	9.7	600	23.6	Φ 50 mm (1-1/2")	1500	396
120203	Regal 250-S	Wet	70	250	9.9	140	5.5	350	295	13.8	11.6	620	24.4	Φ 50 mm (1-1/2")	2400	634
120204	Regal 300-S	Wet	70	300	11.8	170	6.7	385	330	15.2	13.0	650	25.6	Φ 50 mm (1-1/2")	2800	739

Skimmer Pump

Product	Model No.	Wet/Dry	Power	Max Air Intake		Maximum Flow Rate		Connection Size (outlet)
				LPH	Gph	LPH	Gph	
Regal 150-S	VarioS 2-S	Both	25	900	238	900	238	Φ32 (1")
Regal 200-S	VarioS 4-S	Both	40	1500	396	1600	422	Φ32 (1")
Regal 250-S	VarioS 6-S	Both	70	2400	634	2000	528	Φ40 (1-1/4")
Regal 300-S	VarioS 6-S	Both	70	2400	634	2000	528	Φ40 (1-1/4")

Featuring a small footprint, the OCTO series Elite space saving skimmer (Elite-S) is an in-sump protein skimmer ideal for aquarium with limited sump space.

Elite-S further features high-quality cast acrylic and PVC construction, an underwater outflow for even quieter/near to silent operation, easy disassembly for maintenance with its unique "twist and lift" collection cup, a vented valve output with adjustment dial for precision control, a wine bottle shaped body which aids natural stabilisation and concentration of the organic rich foam as it rises and a professional open volute for enhanced performance.

Elite-S is run by our very own controllable VarioS skimmer pump, which features a pinwheel impeller, a detachable controller, high quality ceramic shaft and bearing to reduce wear and tear, and the latest variable speed flow technology for refined control, enhanced performance, energy-efficiency and safer operations.

Unlike the vast majority of circulation pumps which uses alternating current (AC), our VarioS pump boasts several key advantages over traditional AC pump, namely, higher energy efficiency, safer operations at a working voltage of 24V and most notably, the variable speed control to adjust the ideal mix of air and water flow into the skimmer.

Enhanced Control

With the VarioS controller, users have control over the flow rates by selecting amongst five preset speed settings; indicated by five lit LEDs. A 15 or 60 minutes feed mode can also be engaged or disengaged with the push of a button.

In addition, a rotatable volute allows users to adjust the output orientation horizontally or vertically (up or down), depending on their needs.

Under normal usage, VarioS pump has an expected lifespan/product life expectancy of 10 years.

Available in 3 models – Elite 150-S, Elite 200-S and Elite 220-S.

FEATURES & BENEFITS

- Ultra compact, superior performance
- VarioS DC Pump specifically made for protein skimmers
- High quality hand-made solid cast acrylic and machined PVC construction
- Controllable and variable speed DC pump for energy-efficient and silent operations
- Float switch monitor
- Easy Maintenance
- Open Volute optimise reaction within chamber
- Sleek wine-shaped smooth cone body
- Vented valve output with adjustments dial for precision control
- Oversized air intake silencer for quieter operation
- "Twist & Lift" collection cup with Drain

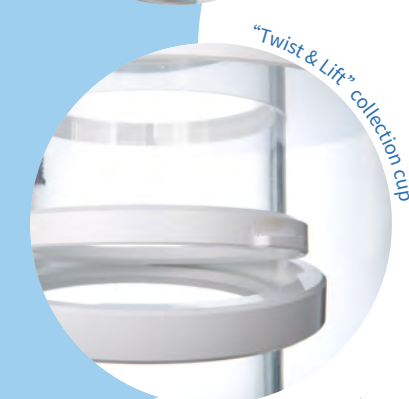
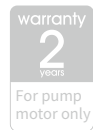

DID YOU KNOW?
We are the first protein skimmer manufacturer in the world that designs and produces our own skimmer pumps. Our skimmer pumps have been specifically engineered to enhance and increase the efficiency of our protein skimmer.



Elite 150-S



Elite 200-S



Elite 220-S

Dimension

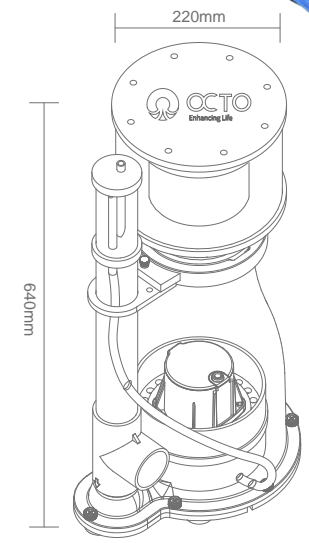
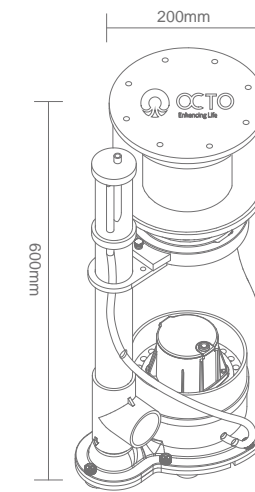
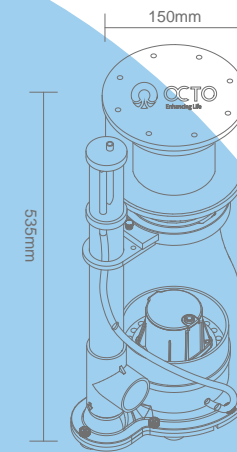

OCTO ELITE Space Saving Skimmer

Item No.	Product	Wet/ Pump		Cup Diameter		Neck Diameter		Footprint		Height		Output Size		Tank Volume		
		Dry	Power	W	mm	inch	mm	inch	mm	inch	mm	inch	mm	inch	L	US Gal
120301	Elite 150-S	Wet	25	150	5.9	80	3.2	265	195	10.4	7.7	535	21.1	Φ 40 mm (1-1/4")	800	211
120302	Elite 200-S	Wet	40	200	7.9	120	4.7	325	255	12.8	10.0	600	23.6	Φ 50 mm (1-1/2")	1500	396
120303	Elite 220-S	Wet	70	220	8.7	120	4.7	345	285	13.6	11.2	640	25.2	Φ 50 mm (1-1/2")	2000	528

Skimmer Pump

Product	Model No.	Wet/Dry	Power	Max Air Intake		Maximum Flow Rate		Connection Size (outlet)
				LPH	Gph	LPH	Gph	
Elite 150-S	VarioS 2-S	Both	25	900	238	900	238	Φ32 (1")
Elite 200-S	VarioS 4-S	Both	40	1500	396	1600	422	Φ32 (1")
Elite 220-S	VarioS 6-S	Both	70	2400	634	2000	528	Φ40 (1-1/4")



BioReact is an in-ump Bio Reactor, designed for hobbyists. It helps to accelerate the growth of beneficial bacteria, and helps to ensure water clarity. It is ideal to control the Phosphate (PO₄) and Nitrate (NO₃) level.

Powered by our very own and reliable Aquatrance (BioReact 150 use DC pump), which is both energy efficient and quiet, the BioReact is easy to set-up and allows you full flow control to the media. With a space saving footprint, it allows you more space within the sump for more products.

Made from a high quality cast acrylic body, it has a specially designed water inlet bottom chamber which prevents the media from entering the pump during a power off. A rigid sieve plate at the top cover acts to prevent the pellets from escaping through the outlet connection.

Due to the unique design of having no pipe in the middle of the chamber, it is easy to replace the cover after refilling the pellet media.

For best results, it is highly recommended to use our Bio Spheres media.

Available in 3 models OCTO BioReact 90, 120 and 150.

FEATURES & BENEFITS

- Complete with our very own recirculation pump
- Unique designed for quick and easy refilling of media
- Sieve Plate to retain media in chamber
- Cyclone "churn" style motion which ensure maximises bacteria colonisation
- Quad Directions Top plate for easy placement
- Easy Maintenance
- High quality hand-made acrylic construction



warranty
2
years
For pump motor only



OCTO BioReact



Dimension

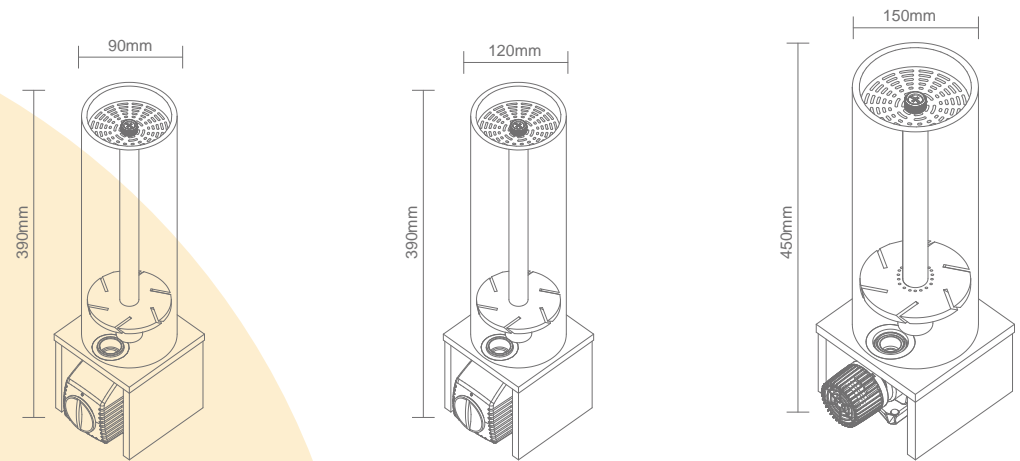

OCTO BioReact

Item No.	Product	Wet/ Dry	Pump Power		Diameter		Footprint		Height		Max Bio Sphere		Tank Volume			
			W	W	mm	inch	mm	inch	mm	inch	L	US Gal	L	US Gal		
			50Hz	60Hz												
130201	BioReact 90	Wet	6	7	90	3.5	120	100	4.7	3.9	390	15.4	0.4	0.11	400	106
130202	BioReact 120	Wet	10	15	120	4.7	140	130	5.5	5.1	390	15.4	0.7	0.18	700	185
130203	BioReact 150	Wet	30	30	150	5.9	185	160	7.3	6.3	450	17.7	2.0	0.53	2000	528

Circulation Pump

Product	Model No.	Wet/Dry	Power		Max Head Height				Maximum Flow Rate			
			50Hz	60Hz	50Hz		60Hz		50Hz		60Hz	
			w	w	m	Ft.	m	Ft.	LPH	Gph	LPH	Gph
BioReact 90	AQ-800	Both	6	7	0.8	2.6	0.9	3	880	232	908	240
BioReact 120	AQ-1200	Both	10	15	1.1	3.6	1.3	4.3	1300	343	1287	340
BioReact 150	VarioS 2	Both	30	30	4.0	13.1	4.0	13.1	3000	792	3000	792

Controllable, Reliable and Silent

OCTO VarioS Circulation Pump

Similar to the DC Skimmer Pump, this OCTO series DC circulation pump, OCTO VarioS features an all new controller with a 0-10V port, higher maximum delivery head, high quality ceramic shaft and bearing to reduce wear and tear and the latest variable speed flow technology for refined control, enhanced performance, energy-efficiency and safer operations.

Unlike the vast majority of circulation pumps which uses alternating current (AC), our OCTO VarioS pump boasts several key advantages over traditional AC pump, namely, higher energy efficiency, safer operations at a working voltage of 24V (VarioS 6 and VarioS 8 uses DC36V), less heat produced with every volume of water flow and most notably, the variable speed control to adjust the water flow rates.

Enhanced Control

With the bespoke controller, users have full control over the flow rates by selecting amongst five preset speed settings; indicated by five lit LEDs. A 15 or 60 minutes feed mode can also be engaged or disengaged with the push of a button.

In addition, a rotatable volute allows users to adjust the output orientation horizontally or vertically (up or down), depending on their needs.

Under normal usage, OCTO VarioS has an expected lifespan/product life expectancy of 10 years.

Note: This is not a pressure-rated pump. This pump is not for second floor applications or to feed Beckett or downdraft skimmers where constant pressure is required.

Available in 4 models – OCTO VarioS 2, OCTO VarioS 4, OCTO VarioS 6 and OCTO VarioS 8.

FEATURES & BENEFITS

- Ultra quiet operation
- High quality ceramic shaft and bearing for a more durable and quieter operation
- In-built circulating and intricate cooling mechanism for prevention of overheating of the rotor and pump
- Auto shutdown system upon detection of electric circuit abnormalities
- With Float Switch Control



warranty
2
years
For pump motor only



OCTO VarioS Circulation Pump



VarioS 2

VarioS 4

VarioS 6

VarioS 8

Neodymium Magnet

Dimension

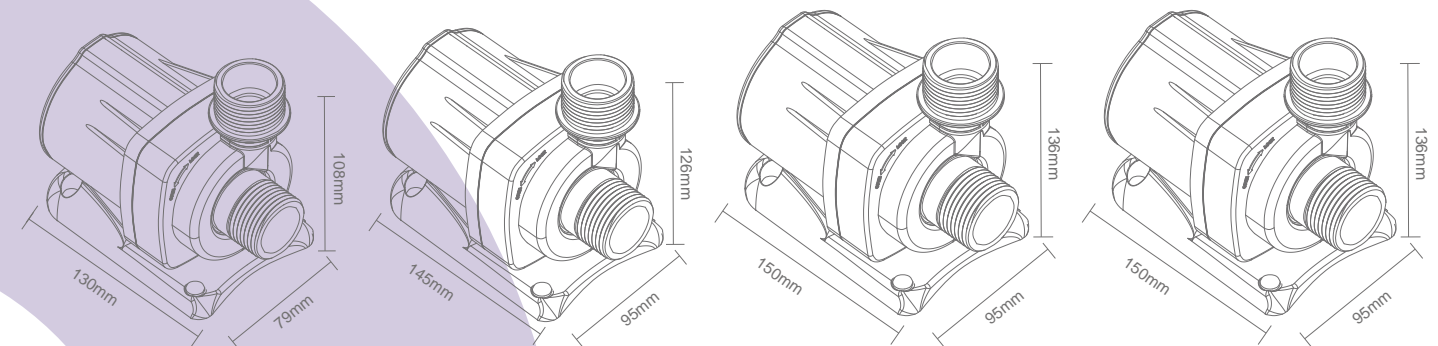

VarioS Circulation Pump

Item No.	Product	Power	Wet/Dry	Power	Max Head Height		Maximum Flow Rate		Connection Size		Fresh Water / Marine
					W	m	Ft.	LPH	Gph	Inlet	
110101	VarioS 2	DC24V	Both	25	4.0	13.1	3000	792	Φ32 (1")	Φ32 (1")	Both
110102	VarioS 4	DC24V	Both	40	4.5	14.7	4000	1056	Φ40 (1-1/4")	Φ32 (1")	Both
110103	VarioS 6	DC36V	Both	70	4.9	16.0	6500	1720	Φ40 (1-1/4")	Φ40 (1-1/4")	Both
110107	VarioS 8 *	DC36V	Both	98	5.7	18.7	10000	2646	Φ40 (1-1/4")	Φ40 (1-1/4")	Both

* Uses Neodymium Magnet

Affordable and reliable

AQ Skimmer Pump

Affordable and reliable

One of the most cost effective and reliable Skimmer Pump in the market today. Low wattage, compact in size and high in flow rate.

Specifically engineered to run on Protein Skimmers, it is highly efficient and durable compared to other skimmer pumps.

AQ Water Pump

Affordable and reliable

One of the most cost effective Wet/Dry Water Circulation Pump in the market today. Low wattage, compact in size and high in flow rate.



warranty
2
years
For pump
motor only

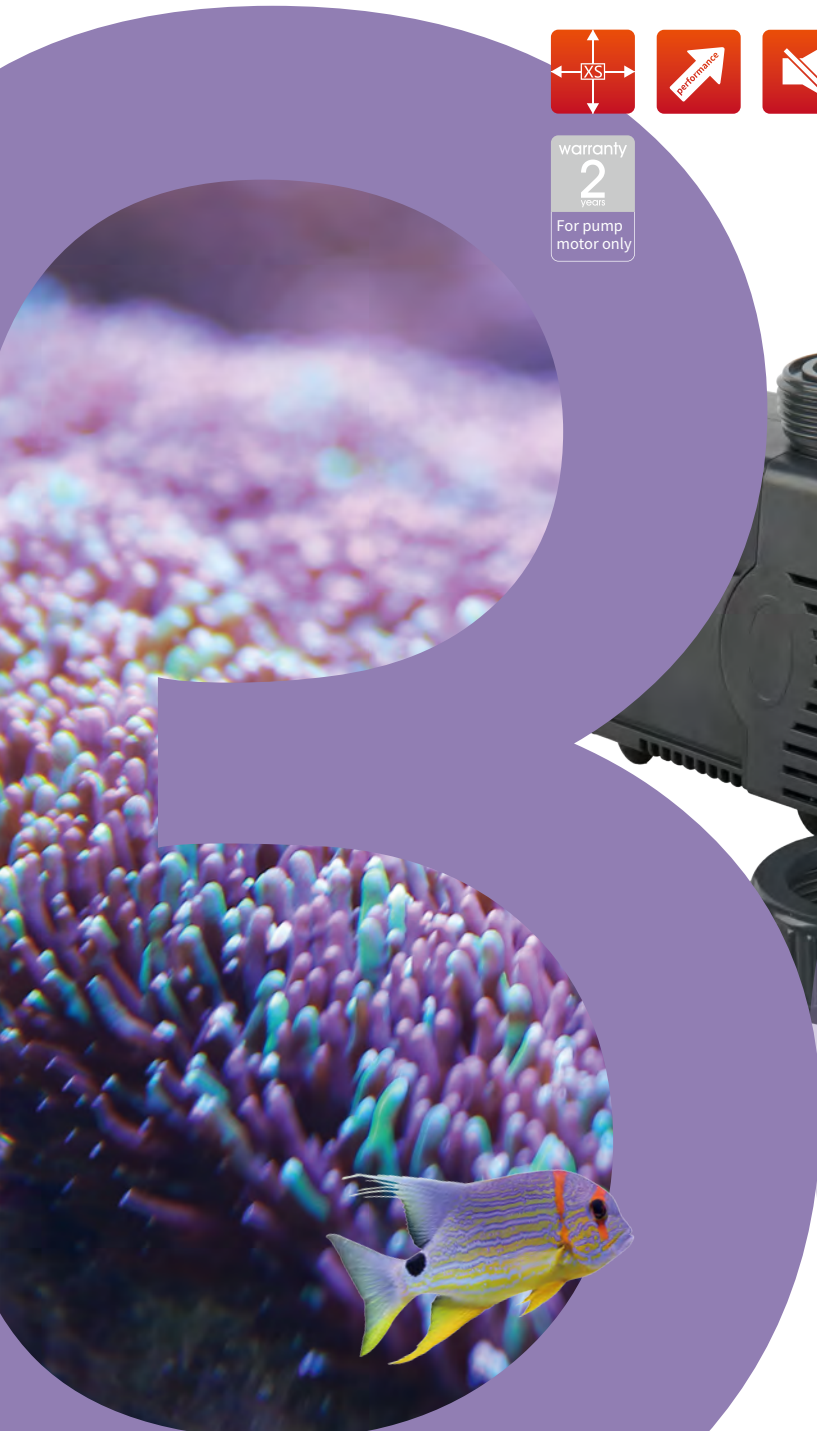

OCTO AQ pump



Skimmer Pump

Item No.	Model No.	Wet/Dry	Air Intake				Power		Maximum Flow Rate				Connection Size (outlet)
			50Hz		60Hz		50Hz	60Hz	50Hz		60Hz		
			LPH	Gph	LPH	Gph	W	W	LPH	Gph	LPH	Gph	
110208	AQ-1000S	Both	420	111	454	120	8	9	350	92	350	92	Φ25 (3/4")
110209	AQ-1800S*	Both	480	127	511	135	10	11	530	140	530	140	Φ25 (3/4")
110210	AQ-2000S	Both	720	190	720	190	17	18	750	198	750	198	Φ25 (3/4")
110211	AQ-3000S*	Both	880	232	871	230	35	35	800	211	800	211	Φ32 (1")

Water Pump

Item No.	Model No.	Wet/Dry	Power		Max Head Height				Maximum Flow Rate				Connection Size (outlet)	Fresh Water / Marine
			50Hz	60Hz	50Hz		60Hz		50Hz		60Hz			
			W	W	m	Ft.	m	Ft.	LPH	Gph	LPH	Gph		
110201	AQ-800	Both	6	7	0.8	2.6	0.9	3.0	880	232	908	240	Φ20 (1/2")	Both
110202	AQ-1000	Both	8	11	1.0	3.3	1.1	3.6	1150	304	1136	300	Φ20 (1/2")	Both
110203	AQ-1200	Both	10	15	1.1	3.6	1.3	4.3	1300	343	1287	340	Φ20 (1/2")	Both
110204	AQ-1500	Both	15	18	1.4	4.6	1.5	4.9	1500	396	1476	390	Φ20 (1/2")	Both
110205	AQ-1800*	Both	23	25	1.9	6.2	2.0	6.6	1850	488	1798	475	Φ20 (1/2")	Both
110206	AQ-2000	Both	42	45	2.0	6.5	2.1	6.9	2000	528	2203	582	Φ25 (3/4")	Both
110207	AQ-3000*	Both	62	65	2.8	9.2	2.8	9.2	3300	871	3501	925	Φ25 (3/4")	Both

* Uses Neodymium Magnet

The marine specialist!

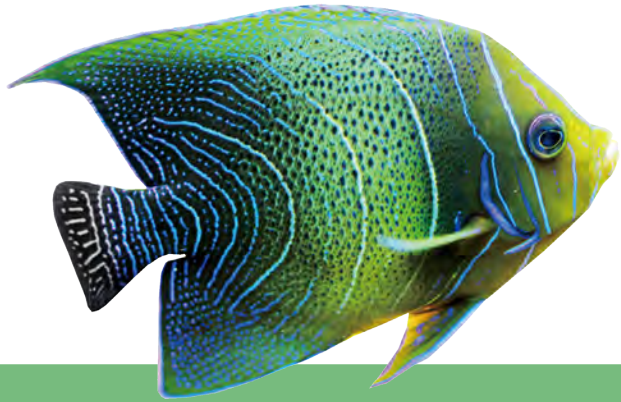

Aquarium Fan
AF-80 180209
AF-120 180210



Filter Sock Bracket
FB-200
 990202

Extra strong outer magnet Mount
 Max Glass Thickness: 21mm / 0.83"
 Suitable for Both OP-2 and OP-4
 Item No.: 117166



Filter Sock
200 Micron-Felt
 990204



Filter Sock
200 Micron-Mesh
 990205



OCTO General Accessories

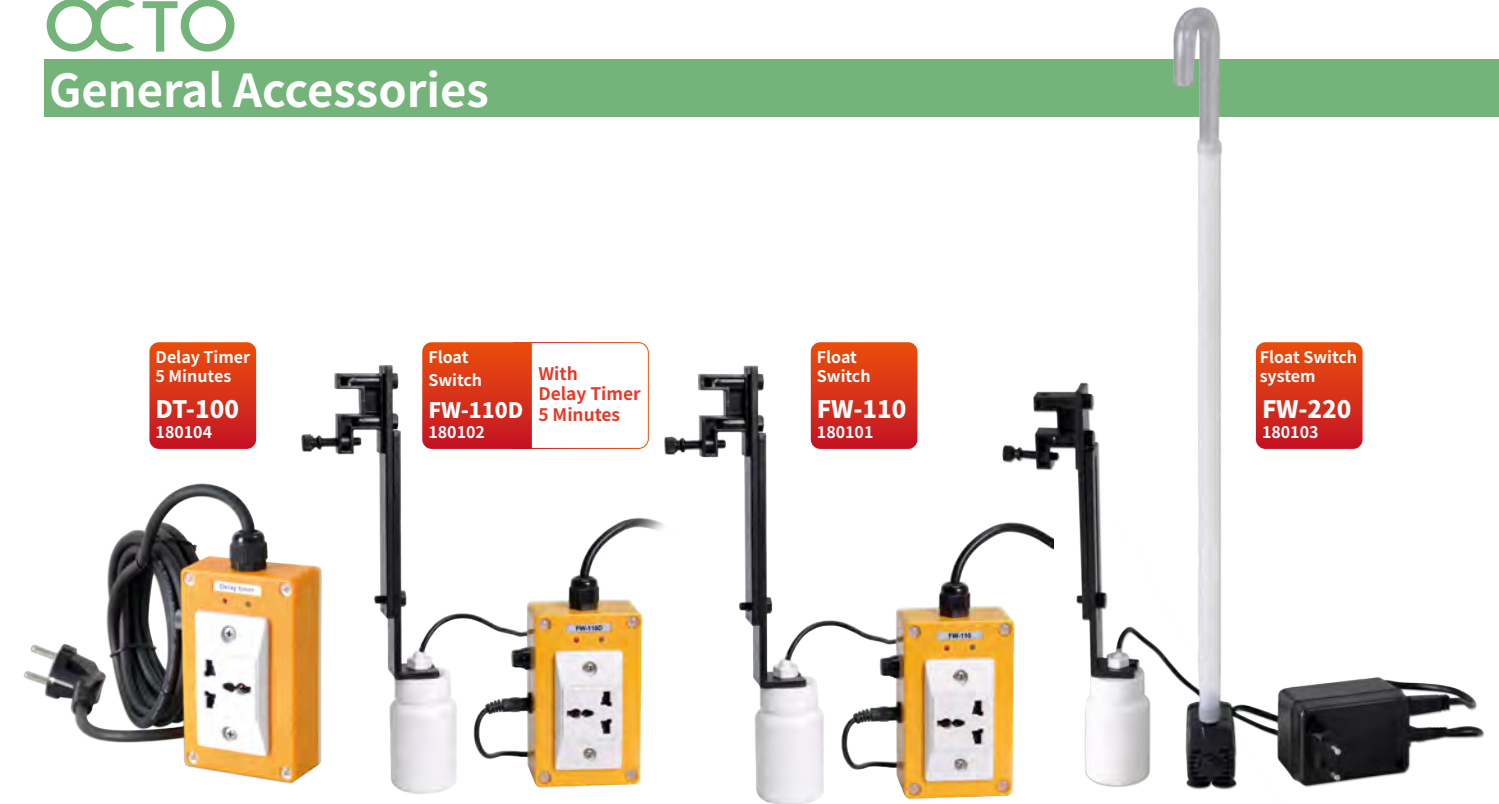

Delay Timer
5 Minutes
DT-100
 180104

Float Switch
FW-110D
 180102

With Delay Timer
5 Minutes

Float Switch
FW-110
 180101

Float Switch system
FW-220
 180103

VP-S



VP-E

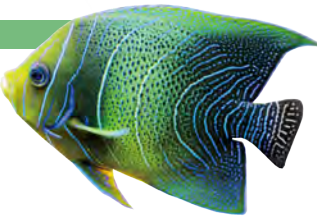

Bulkhead

Item No.	Product	Items	Glass/Acrylic Hole
997101	VP 16-S	20mm	Φ29-32mm
		1/2"	
997102	VP 20-S	25mm	Φ32-34mm
		3/4"	
997103	VP 25-S	32mm	Φ42-43mm
		1"	
997104	VP 30-S	40mm	Φ48-50mm
		1-1/4"	
997105	VP 40-S	50mm	Φ60-62mm
		1-1/2"	
997106	VP 50-S	63mm	Φ72-75mm
		2"	
997107	VP 20-E	3/4"	Φ35-38mm
		25mm	
997108	VP 25-E	1"	Φ43-47mm
		32mm	
997111	VP 40-E	1-1/2"	Φ60-66mm
		50mm	

The marine specialist!

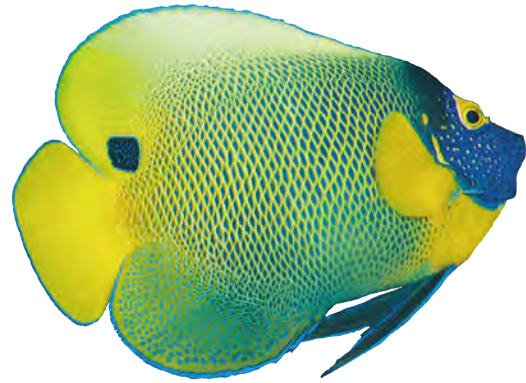

Bio-spheres

Bio-Spheres are specifically encapsulated pellets with a 100% pure biological polymer solid carbon. These pellets when use with our Bio-Churn Reactor, will slowly release the polymer carbon within the marine water which will encourage the growth of beneficial bacteria and enzymes on the pellets surface.

Bio-Spheres provides a food source required for beneficial bacteria to reproduce and reduce nitrates and phosphates.

Available in 1000ml(264 US gal) box.



Bio-spheres
1000ml/box
160202



OCTO
Salt & Bio-spheres

Salt

Provided by Mother Nature, perfected by Us.

Our marine salt is extracted through an evaporation process to ensure that its properties are as close as possible to natural sea water.

The unprocessed salt then goes through a very stringent quality inspection and tests in our laboratory to ensure that they are pollutant free.

Once the quality is ascertained, to further enhance the nutrient level, so that fishes and invertebrates can thrive better, proportionate amount of trace elements are added.

Dissolves quickly and easily.

Available in Carton Box in 6.7Kg (14.77 pounds) or 20Kg (44 pounds) Bucket.

6.7Kg (14.77 pounds) for 189 litres / 50 USGal
20Kg (44 pounds) for 605 litres / 150 USGal

Dosing

OCTO Reef Salt is recommended for use with Reverse Osmosis (RO) water or soft water with calcium level lower than 30 mg/l.

As the calcium content in OCTO Reef Salt is already enhanced to 420 mg/l, mixing it with tap water, which might contain additional calcium, may raise the concentration level above the recommended range, thus causing calcium precipitation.

RO water also does not contain elements like phosphate and nitrate, thus limiting the growth of algae in the aquarium.

Mixing

Using a clean container:

- 1) Add 1 Kg of OCTO Reef Salt to 27.5 litres of water (1 Lb to 2.9 USGal)
- 2) Mix well until all of the salt is dissolved and the solution is clear.
- 3) To ensure that salt water is well mixed, it is recommended that you aerate the water for 2-4 hours
- 4) Ensure mixed solution is similar to the temperature of your aquarium.
- 5) Check the S.G. (Specific Gravity), which is the density of the water, before adding the mixed content to the aquarium. Where necessary, add more salt or water to obtain the correct S.G.

* Remember that S.G. changes with temperature.

We recommend the use of a portable refractometer for accurate and consistent measurement of the S.G. level in your salt solution.



6.7kg/box
160301
20kg/Bucket
160303

Salt



Compact and Effective.

The Overflow Box is a great alternative for aquariums without a built-in overflow system. It effectively skims the organically rich water from the aquarium surface to the filtration system.

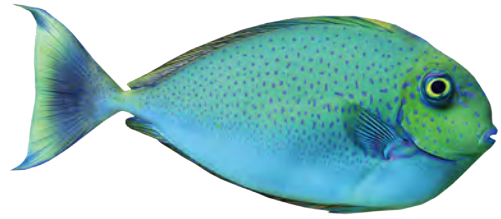

FEATURES & BENEFITS

- A reliable alternative to Build- In Overflows
- Precise machine welded cast acrylic construction
- Silent Operation
- Black top reduces light intake to reduce algae growth



OCTO Overflow Box



OB 300S

Dimension

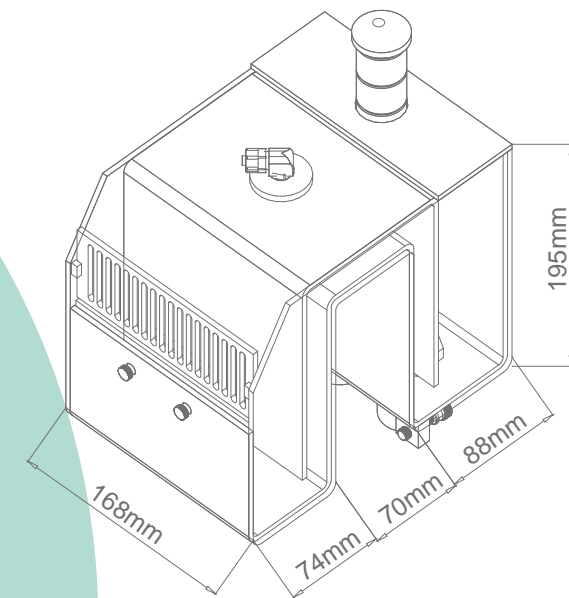

OCTO Overflow Box

Item No.	Product	L1		L2		L3		W		H		Output Drain	Max Water Flow Rate	
		mm	inch	mm	inch	mm	inch	mm	inch	mm	inch		mm(inch)	LPH
990102	OB-300S	74	2.92	70	2.76	88	3.47	168	6.62	195	7.68	32(1")x1	7000	1850

Loaded with Innovations.

10 over years of cumulative experience in the design and manufacturing of Skimmers, our S-130 are loaded with innovative human centric features.

16 Steps Water Outlet Adjustments to ensure that fine tuning of water output adjustments is possible. Design with special slanting cut grooves to ensure an even outflow which minimises splashes.

25 Angled Grooves + Apertures on the Bubble Plate for maximising constant micro air bubbling, with a Vortex churn effect which extends reaction time.

4 Quick Releases at the Base Plate of the Skimmer allow User to quickly and conveniently access the inner body of the Skimmer, no Screwdriver needed.

4 Ultra Durable Silicon Rubber Base Attachments (Feet) are attached to the Base Plate, effectively reduces vibration and noise.



warranty
2
years
For pump motor only

FEATURES & BENEFITS

- Twist & Lift Collection Cup for Easy Maintenance
- Quieter Operation with Integrated Detachable Silencer Collar
- Dome Bubble Chamber with Angled Apertures for Extended Reaction Time
- Quick Release Tabs Offer Convenient Access to the Inner Body
- 360° Submerged Water Output Provides a Quiet Splash-Free Discharge
- Calibrated Click Dial Water Output Adjustment
- Elegant Full Tapered Wine-Shaped Body
- Remarkably Compact Footprint
- Quiet, Reliable and Efficient AQ Pinwheel Pump

DID YOU KNOW?

We are the first protein skimmer manufacturer in the world that designs and produces our own skimmer pumps. Our skimmer pumps have been specifically engineered to enhance and increase the efficiency of our protein skimmer.

"Twist & Lift" Collection Cup



Dome Bubble Chamber



Calibrated 16 step



Quick Release Tabs

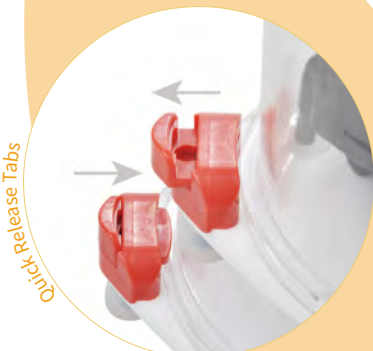

OCTO eSsence 130



eSsence 130



Dimension

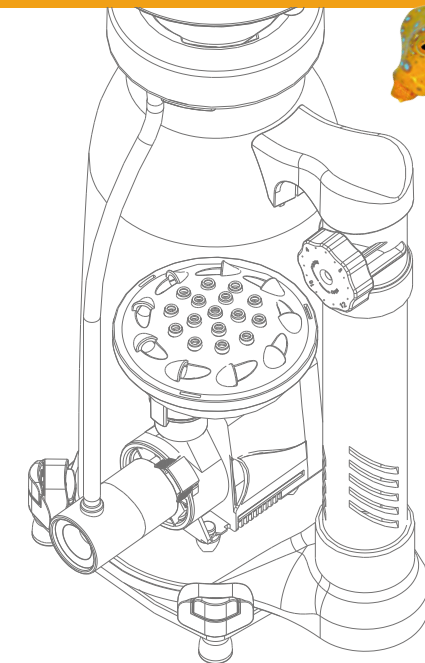
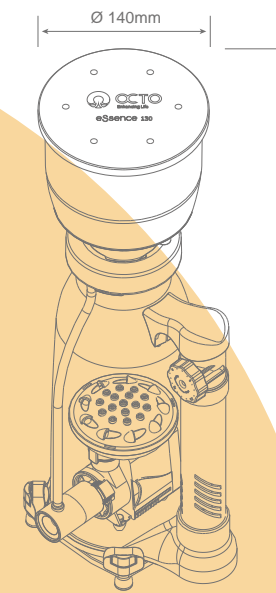

OCTO eSsence 130 Space Saving Skimmer

Item No.	Product	Wet/ Dry	Pump Power		Cup Diameter		Neck Diameter		Footprint		Height		Output Size	Tank Volume			
			W	60Hz	mm	inch	mm	inch	mm	inch	mm	inch		L	US Gal		
120501	S-130	Wet	10	11	140	5.5	60	2.4	210	175	8.2	6.8	520	20.5	Φ 40 mm (1-1/4")	600	160

Skimmer Pump

Product	Model No.	Wet/Dry	Air Intake				Power		Maximum Flow Rate				Connection Size (outlet)
			50Hz		60Hz		50Hz	60Hz	50Hz		60Hz		
			LPH	GPH	LPH	GPH	W	W	LPH	GPH	LPH	GPH	
S-130	AQ-1800S	Both	480	127	511	135	10	11	530	140	530	140	Φ25 (3/4")

Generates Massive Water Movement.

Introducing our new OCTO series Direct Current (DC) Wave Pump, OCTO Pulse features a Multiple Angle Adjustment, an all new controller with a 0-10V port, 4 pre-program pulsing patterns, high quality ceramic shaft and bearing to reduce wear and tear, and the latest variable speeds flow technology for refined control, enhanced performance, energy-efficiency and safer operations.

With the bespoke controller, users have full control over the flow rates by selecting amongst eight preset speed settings; indicated by eight lit LEDs. A 15 or 60 minutes feed mode can also be engaged or disengaged with the push of a button.

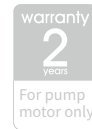

FEATURES & BENEFITS

- 360° Range of Adjustment
- Low-profile Magnetic Mount
- Strong Rare-earth Magnet Impeller
- Compact & Durable Construction
- Silent Operation
- 4 Preprogrammed Flow Patterns
- Dual Feed Mode - 15 or 60 min
- 0-10V External Controller Connection



DID YOU KNOW?
We are the first protein skimmer manufacturer in the world that designs and produces our own skimmer pumps. Our skimmer pumps have been specifically engineered to enhance and increase the efficiency of our protein skimmer.



OCTO OCTO Pulse

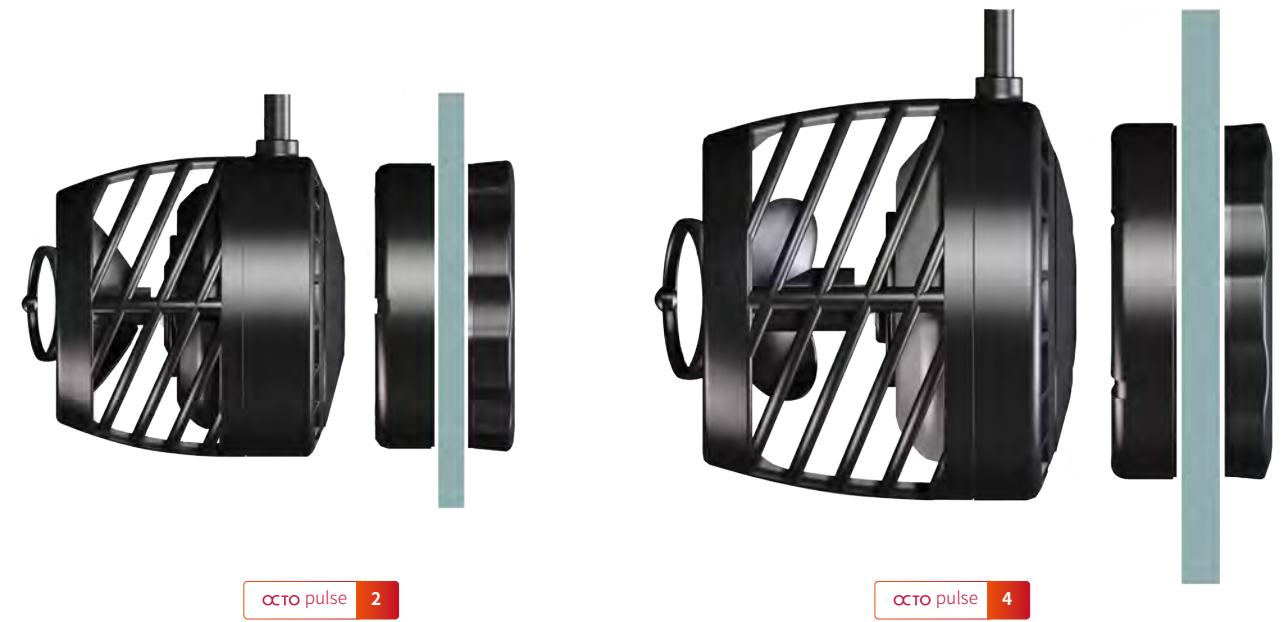

Dimension

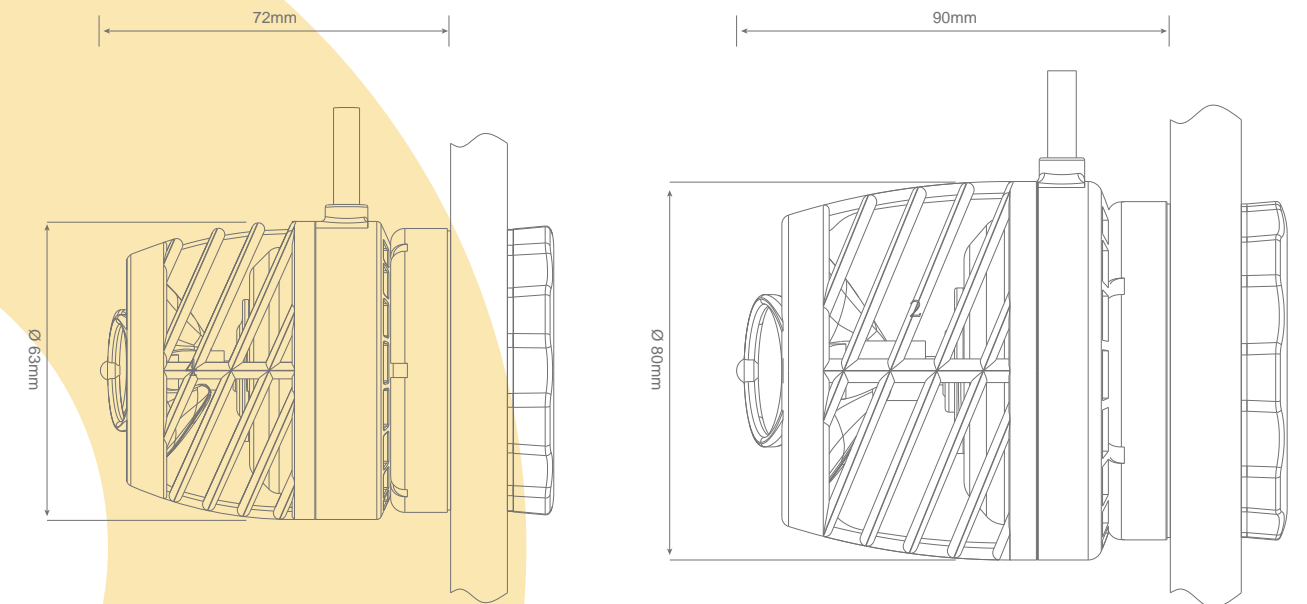

OCTO Pulse Wave Pump

Item No.	Product	Power	Max Flow Rate		Power	Tank Water Volume		Suggested Tank size		Max Wall Thickness	
			LPH	GPH		L	US GAL	cm	in	mm	in
110401	OP-2	DC24V	6000	1585	5-10	80-300	21-80	40-100	16-40	12	1/2
110402	OP-4	DC24V	17000	4490	11-32	300-1800	80-475	100-180	40-71	15	5/8

