

590 A 1.2kV Class (HTN) Molded 5/8" Tri-Clamp Secondary Bushing



ECI, ERMCO Components Inc.
 1607 Industrial Road
 Greeneville, TN 37745
 Phone: (423) 638-2302
 Toll Free: (877) 267-1855
 Fax (423) 636-6492

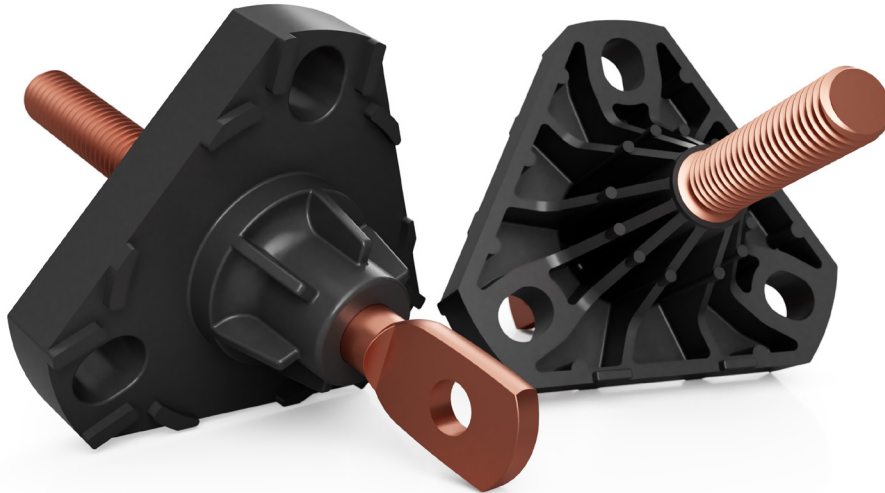

Table 1

Voltage Ratings and Characteristics

Description	kV
Standard Voltage Class	1.2
AC 60 Hz 1 Minute Withstand	10
BIL and Full Wave Crest	30

Table 2

Current Ratings and Characteristics

Description	Amperes Continuous
5/8 Inch Copper Stud	590 A rms in Transformer Oil

Current ratings and characteristics are in accordance with IEEE Std. C57.12.00™ standard

BEYOND THE STANDARD

Ordering Information

Table 1

Tri-Clamp

Catalog Number	Description
9U10BAA002	w/ Gasket and Nut (200 per barrel)
9U10BAA003	w/ Gasket
9U10BAA004	w/ Gasket and Nut
9U10BAA005	w/ Gasket and Nut

Table 2

Replacement Parts

Catalog Number	Description
9U10PRT005	Mounting Gasket
4391ZR1599	5/8"-11 Brass Hex Jam Nut 3/8" Thick

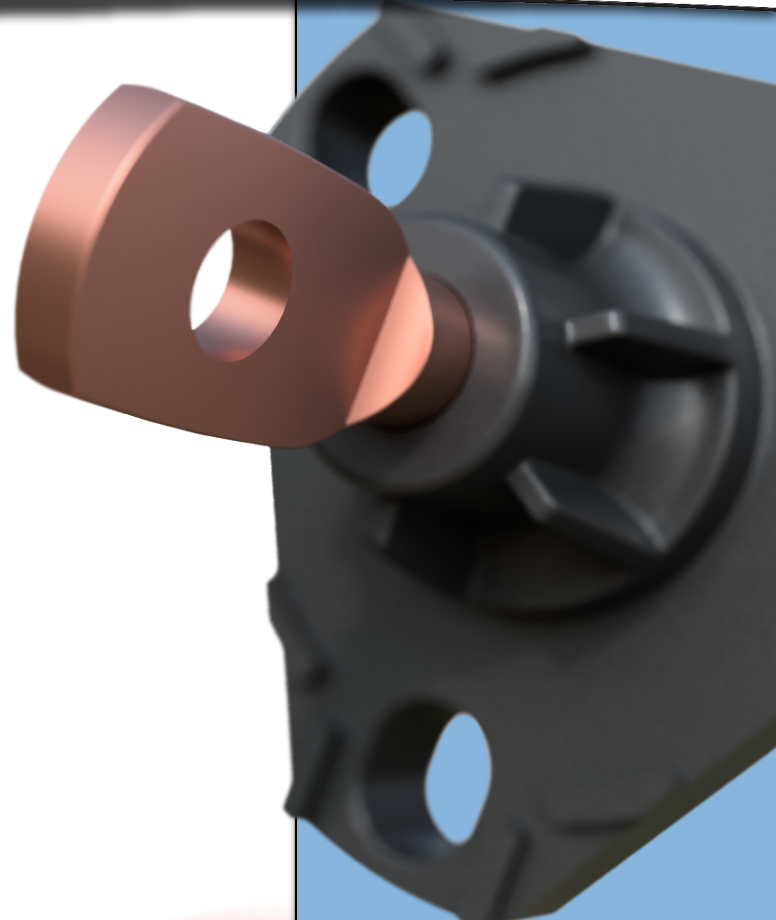

For more information about the secondary bushing, contact your Ermco Components representative or call (877) 267-1855

Dimensions and Details

Catalog Number	A	B
9U10BAA002	6.73"	1.75"
9U10BAA003	6.73"	1.75"
9U10BAA004	6.73"	1.75"
9U10BAA005	7.24"	2.19"

PRIMARY DIMENSIONS ARE INCHES
SECONDARY DIMENSIONS [] ARE MM

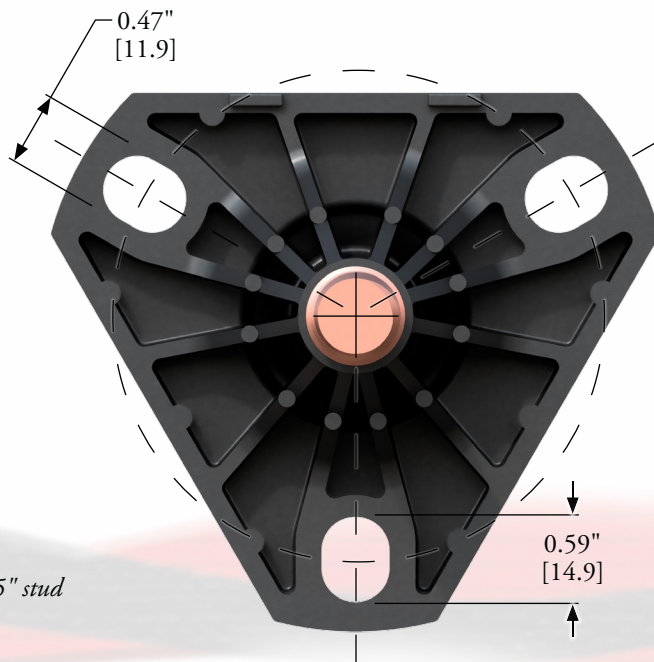
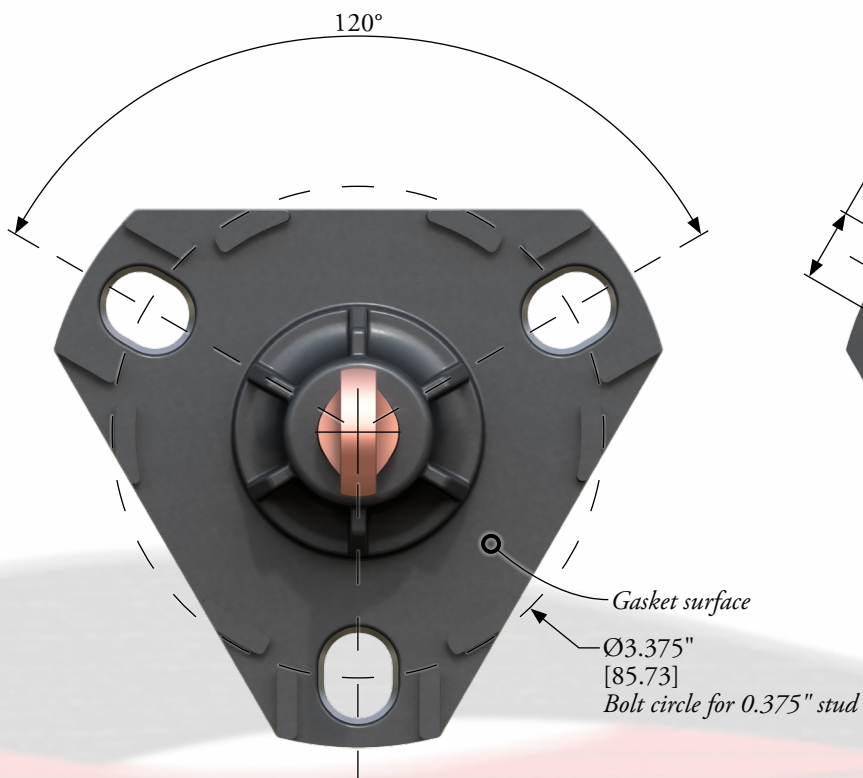
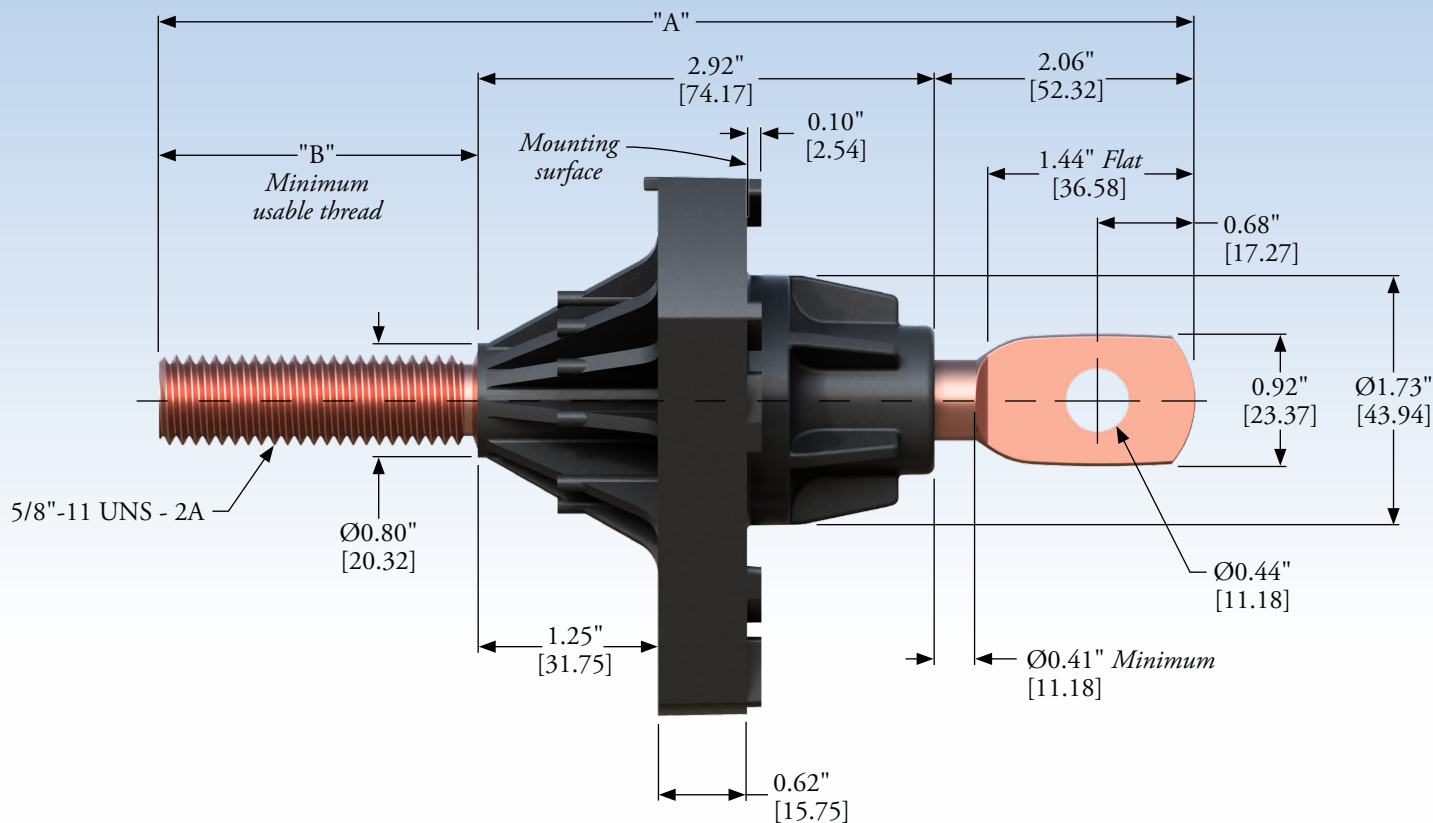

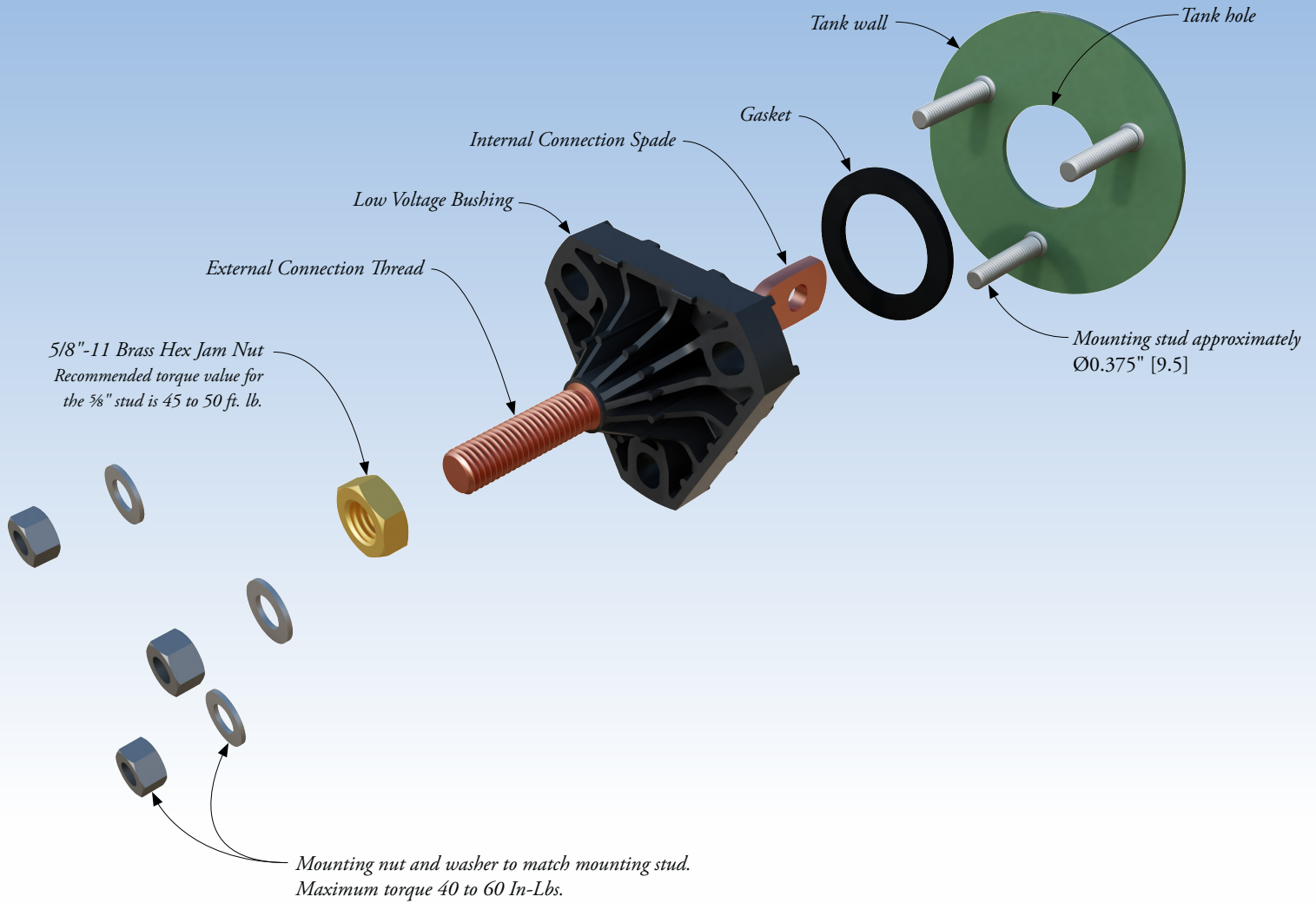

Figure 1
Mounting

PRIMARY DIMENSIONS ARE INCHES
SECONDARY DIMENSIONS [] ARE MM

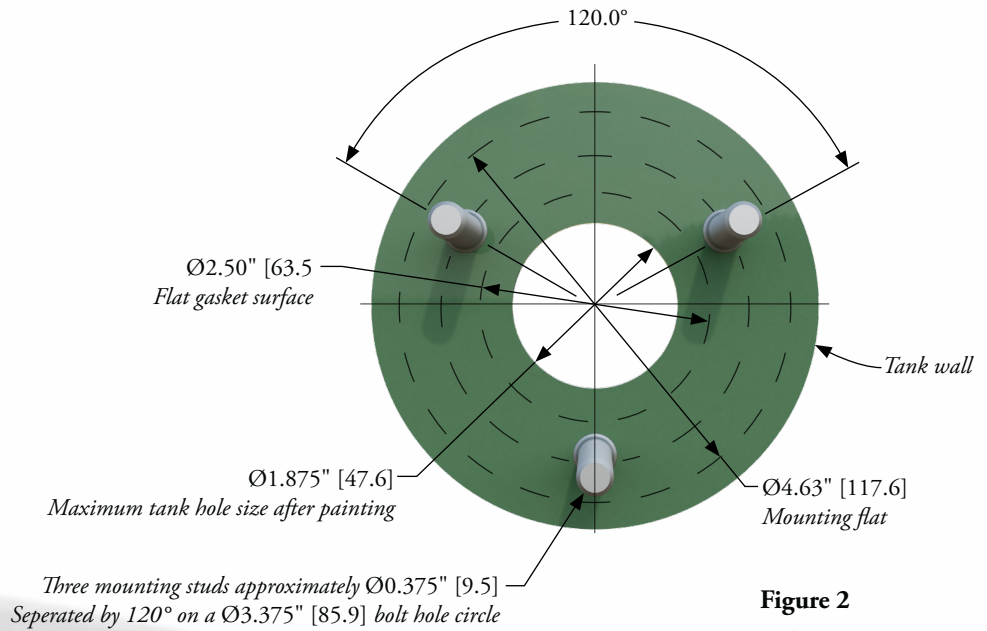

Figure 2
Bolt Pattern

PRIMARY DIMENSIONS ARE INCHES
SECONDARY DIMENSIONS [] ARE MM

ERMCO Components Inc.
1607 Industrial Road
Greeneville, TN 37745



Phone: (423) 638-2302
Toll Free: (877) 267-1855
Fax (423) 636-6492