



Installation Instructions

CDUB - Symbio™ 800 Control Upgrade Kit

For Tracer CH530/CH531 DynaView™ Display



Model Numbers: CVRD, CH531, CVHE, CVHF, CVHG, CH530

This document applies to service offering applications only.

Distribution/use of this document is limited to the Trane sales and service organization in support of Symbio™ 800 and is not intended for independent third party use or for use apart from the Symbio™ 800 AdaptiView display upgrade for Tracer CH530/CH531 DynaView display.

⚠ SAFETY WARNING

Only qualified personnel should install and service the equipment. The installation, starting up, and servicing of heating, ventilating, and air-conditioning equipment can be hazardous and requires specific knowledge and training. Improperly installed, adjusted or altered equipment by an unqualified person could result in death or serious injury. When working on the equipment, observe all precautions in the literature and on the tags, stickers, and labels that are attached to the equipment.



Introduction

Read this manual thoroughly before operating or servicing this unit.

Warnings, Cautions, and Notices

Safety advisories appear throughout this manual as required. Your personal safety and the proper operation of this machine depend upon the strict observance of these precautions.

The three types of advisories are defined as follows:

- WARNING** Indicates a potentially hazardous situation which, if not avoided, could result in death or serious injury.
- CAUTION** Indicates a potentially hazardous situation which, if not avoided, could result in minor or moderate injury. It could also be used to alert against unsafe practices.
- NOTICE** Indicates a situation that could result in equipment or property-damage only accidents.

Important Environmental Concerns

Scientific research has shown that certain man-made chemicals can affect the earth's naturally occurring stratospheric ozone layer when released to the atmosphere. In particular, several of the identified chemicals that may affect the ozone layer are refrigerants that contain Chlorine, Fluorine and Carbon (CFCs) and those containing Hydrogen, Chlorine, Fluorine and Carbon (HCFCs). Not all refrigerants containing these compounds have the same potential impact to the environment. Trane advocates the responsible handling of all refrigerants.

Important Responsible Refrigerant Practices

Trane believes that responsible refrigerant practices are important to the environment, our customers, and the air conditioning industry. All technicians who handle refrigerants must be certified according to local rules. For the USA, the Federal Clean Air Act (Section 608) sets forth the requirements for handling, reclaiming, recovering and recycling of certain refrigerants and the equipment that is used in these service procedures. In addition, some states or municipalities may have additional requirements that must also be adhered to for responsible management of refrigerants. Know the applicable laws and follow them.

WARNING

Proper Field Wiring and Grounding Required!

Failure to follow code could result in death or serious injury. All field wiring **MUST** be performed by qualified personnel. Improperly installed and grounded field wiring poses **FIRE** and **ELECTROCUTION** hazards. To avoid these hazards, you **MUST** follow requirements for field wiring installation and grounding as described in **NEC** and your local/state/national electrical codes.

WARNING

Personal Protective Equipment (PPE) Required!

Failure to wear proper PPE for the job being undertaken could result in death or serious injury. Technicians, in order to protect themselves from potential electrical, mechanical, and chemical hazards, **MUST** follow precautions in this manual and on the tags, stickers, and labels, as well as the instructions below:

- Before installing/servicing this unit, technicians **MUST** put on all PPE required for the work being undertaken (Examples; cut resistant gloves/sleeves, butyl gloves, safety glasses, hard hat/bump cap, fall protection, electrical PPE and arc flash clothing). **ALWAYS** refer to appropriate Safety Data Sheets (SDS) and OSHA guidelines for proper PPE.
- When working with or around hazardous chemicals, **ALWAYS** refer to the appropriate SDS and OSHA/GHS (Global Harmonized System of Classification and Labeling of Chemicals) guidelines for information on allowable personal exposure levels, proper respiratory protection and handling instructions.
- If there is a risk of energized electrical contact, arc, or flash, technicians **MUST** put on all PPE in accordance with OSHA, NFPA 70E, or other country-specific requirements for arc flash protection, **PRIOR** to servicing the unit. **NEVER PERFORM ANY SWITCHING, DISCONNECTING, OR VOLTAGE TESTING WITHOUT PROPER ELECTRICAL PPE AND ARC FLASH CLOTHING. ENSURE ELECTRICAL METERS AND EQUIPMENT ARE PROPERLY RATED FOR INTENDED VOLTAGE.**

⚠ WARNING**Follow EHS Policies!**

Failure to follow instructions below could result in death or serious injury.

- All Trane personnel must follow the company's Environmental, Health and Safety (EHS) policies when performing work such as hot work, electrical, fall protection, lockout/tagout, refrigerant handling, etc. Where local regulations are more stringent than these policies, those regulations supersede these policies.
- Non-Trane personnel should always follow local regulations.

Copyright

This document and the information in it are the property of Trane, and may not be used or reproduced in whole or in part without written permission. Trane reserves the right to revise this publication at any time, and to make changes to its content without obligation to notify any person of such revision or change.

Trademarks

All trademarks referenced in this document are the trademarks of their respective owners.

Revision History

Document updated to reflect CDUB error.



Table of Contents

General Information	5	Install Options	23
About This Manual	5	LON Option Installation	23
Unit Model Number	5	Communication Option	23
Other Required Manuals	5	Communication Device Mounting	24
Required Tools	5	Water Flow Measurement Options	25
Field-Provided Material	6	Energy Meter Option Installation	26
Model Number Descriptions	7	Expansion Module Option	27
Getting Started	8	Before Restoring System Power	28
Nameplate	8	Restoring System Power	28
Symbio 800 AdaptiView Display Upgrade Kit Contents	8	Programming	29
Running the IPC Bus	9	Programming the Symbio 800	29
Installation	11	Start-Up	33
Check the Configuration and Setpoints in the DynaView Display	11	Wiring Diagrams	34
Save the DynaView Configuration and Setpoints	11		
Remove Existing Control Panel Door	12		
Install New Control Panel Door and Symbio 800 Controller	12		
Choosing Display Arm Mounting Location	13		
Mounting Display Arm	14		
Adjusting the Tracer AdaptiView Display Arm	15		
Install Power Supplies and Hardware	16		
Install 1A2 Power Supply – CH530 If Not Already Present	16		
Install 1A2 Power Supply - CH531 Prebuilt Panels	16		
Install Quad Relay Output LLID—CH530 If Using Chiller Control Sequence 1	17		
Install Communication Cable Between 1A1 and 1A2 Power Supplies	17		
Connect Input Power Wiring to 1A2 Power Supply	18		
Routing New Wire Into and Out of the Control Panel Enclosure	18		
Wiring Connections to the Display and Symbio 800 Controller	18		
Solid State Oil Heater Relay Installation	21		
Mounting Location	21		
Installation	22		



General Information

About This Manual

The step-by-step instructions outlined in this manual describe the procedures required to successfully upgrade an older Tracer™ CH530 DynaView equipped CVHE, CVGF, CVHF, CVHG, CDHF, or CDHG CenTraVac™ chiller to a Symbio 800 AdaptiView display system. This manual also provides instructions and describes the procedures required to upgrade a CH531 prebuilt panel retrofit-equipped chiller to a Symbio 800 AdaptiView display system.

Installation instructions in this manual are divided into the following general topic areas:

- Check the configuration and setpoints in the DynaView display.
- Save the DynaView display configuration and setpoints.
- Shut down power.
- Remove the old control panel door.
- Install new control panel door and Symbio 800 controller.
- Choosing display arm mounting location.
- Mount display arm and new display.
- Install 1A2 power supply (if not already present).
- Install 1A2 power supply on CH531 prebuilt panels.
- Install quad relay output LLID (required if using chiller control sequence 1).
- Install communication cable between the 1A1 and 1A2 power supplies.
- Connect input power wiring to the 1A2 power supply.
- Routing new wire into and out of the control panel enclosure.
- Wiring connections to the Tracer AdaptiView display and the Symbio 800 controller.
- Before restoring system power.
- Restoring system power.
- Programming the Tracer AdaptiView display.
- Full page schematic wiring diagrams.

Unit Model Number

For service purposes, Trane Model CDUB Symbio 800 AdaptiView display upgrade packages are assigned a multiple character alphanumeric model number to identify each unit.

Use the service model number to define the operation, components and options for any specific unit.

Refer to the model number printed on the nameplate when ordering replacement parts or requesting service.

Other Required Manuals

This manual must be used with the recent versions of the following publications:

- *CenTraVac™ Water-cooled Chillers Models CVHE, CVHF, and CVHG With Symbio™ Controls - Installation, Operation, and Maintenance* (CVHE-SVX005*-EN¹).
- *CenTraVac™ Water-Cooled Chillers AdaptiView™ Display with Symbio™ Controls - User Guide* (CTV-SVU004*-EN¹).
- *Tracer® TU Service Tool For Water-Cooled CenTraVac™ Chillers with Symbio™ Controls - Programming Guide* (CTV-SVP004*-EN¹).
- *CenTraVac™ Water-cooled Chillers with Symbio™ Controls Diagnostic Descriptions, Troubleshooting Tables, and Control Component Overview - Diagnostics Manual* (CTV-SVD005*-EN¹).
- *Tracer® TU Service Tool - User Guide* - (BAS-SVU047*-EN¹).
- *Symbio™ Panel Upgrade - Programming Guide* (SO-SVP002*-EN).

Required Tools

Normal service tools are required to perform the majority of the work. A service technician with a well stocked tool chest should have the right tools to perform the job.

In addition to the normal service tools and hardware, the following is a partial list of specific field supplied hardware/software components and special tools also required to perform the display retrofit:

- An RS-232 male DB9 to female DB9 pin to pin serial cable to connect the DynaView to a PC or laptop computer.
Note: *The cable must not be a null-modem cable. The cable must be less than 50 feet in length.*
- Type A to Type B USB cable to connect the Symbio 800 controller to a PC or laptop computer.

¹ A copy of this manual is shipped with the upgrade kit.



General Information

- A PC or laptop computer equipped with the following:
 - TechView™ service software, version 12.1 or newer.
 - Tracer TU service software, version 2.02 or newer.
 - Rover™ service software (only required if the chiller is equipped with a LonTalk® Comm5 board).
- South pole magnet screwdriver (TOL01343).
- Electronics vacuum.

Field-Provided Material

Some field provided material will be required to perform the display retrofit. Technicians should note the list below to plan ahead and avoid material shortages at the job site.

- Control wire - red and green #16 AWG. This is required to make connections between the power supply and existing transformer.
- Wire connectors.
- Wire wrap or other form of wire protection for areas that wiring runs may come into contact with sharp edges.
- Cable ties to help clean up wiring runs.
- If the unit is located outside, a cover is required for the display.
- The Trane part number for this cover is COV03916.



Model Number Descriptions

Digit 1, 2, 3 — Unit Function

CDU = Color, Display, Upgrade

Digit 4 — Development Sequence

B = Symbio 800 Chiller Controller

Digit 5 — Control Upgrade¹

- 1 = CH530 Simplex
- 2 = CH530 Duplex
- 3 = CH530 Gear Drive
- 4 = CH531
- 5 = UC800 CVRE
- 6 = UC800 CDUA
- 7 = UC800 CTV Simplex
- 8 = UC800 CTV Duplex
- 9 = UC800 ECTV
- A = UC800 Agility
- B = UC800 CVHS
- C = UC800 CVHM

Digit 6 — Global Connector Kit

- 0 = No Global Connector Kit Option
- A = With Global Connector Kit Option

Digit 7 — Chiller/Tower Water Flow Display

- 0 = No Chilled/Tower Water Flow Display
- 1 = Dual Pressure Sensors
- 2 = Flow Meter Customer Provided

Digit 8 — Solid State Oil Relay Control

- 0 = No Solid State Relay
- A = Solid State Relay Only
- B = Solid State Relay W/ELM01116
- C = Solid State Relay W/ELM08119

Digit 9 — Tracer Interface Control Module

- 0 = Without Communication Module
- 2 = With Generic BAS
- 5 = LonTalk Communication

Digit 10, 11— Design Sequence

AA = Symbio 800 Upgrade Release

Digit 12 — Heat Recovery/Auxiliary Condenser

- 0 = No
- 1 = Yes

Digit 13 — Air-Fi Operation

- 0 = No
- 1 = Yes

Digit 14 — Wi-Fi Operation

- 0 = No
- 1 = Yes

Digit 15 — LTE Operation

- 0 = No
- 1 = Yes

Digit 16 — NEMA 4 Communication Box

- 0 = Without Box
- 1 = Small Box
- 2 = Large Box

Digit 17 — Energy Meter Operation

- 0 = No
- A = Energy Meter, 480V and Low
- B = Energy Meter, 575V and 600V
- C = Energy Meter, Medium Voltage, 100A CT
- D = Energy Meter, Medium Voltage, 100A CT
- E = Energy Meter, Medium Voltage, 400A CT

Digit 18 — Head Pressure Control

- 0 = No
- 1 = Yes

Digit 19 — Expansion Module

- 0 = No
- 1 = Expansion Module XM30
- 2 = Expansion Module XM32
- 3 = Expansion Module XM70
- 4 = Expansion Module XM30+XM32

¹ Digit 5 does not affect the kit contents. It is strictly for record keeping.



Getting Started

To properly install an Symbio™ 800 AdaptiView display upgrade kit, the technician must have good knowledge of the Symbio 800 control systems. Training in Symbio 800 controls is highly recommended before beginning this upgrade.

Nameplate

A Symbio™ 800 AdaptiView display upgrade nameplate is included in the kit to be installed near the original nameplate on the control panel. Always provide the model number and serial number information from the nameplate when making inquiries, ordering parts, or literature for the Symbio 800 AdaptiView display system.

Symbio 800 AdaptiView Display Upgrade Kit Contents

Figure 1. Symbio™ 800 AdaptiView display upgrade nameplate example

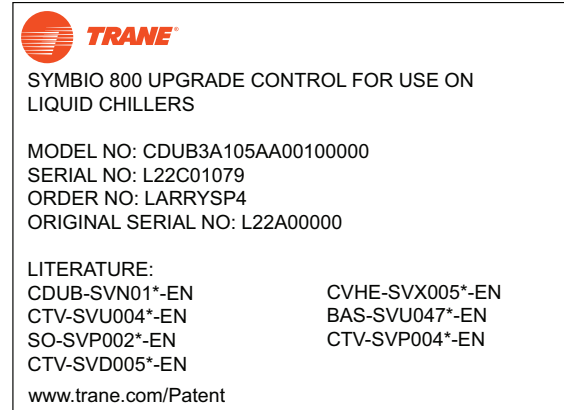

Table 1. Basic bill of material for Symbio™ 800 control upgrade kit

Description	Qty.	Part Number ^(a)	Mnemonic Part Number ^(a)
Display arm	1	X45091462010	ARM00848
Symbio AdaptiView color display	1	X13760359001	MOD03183
Symbio 800 controller	1	X13651678020	MOD02979
Harness; Modbus distribution	1	453730970001	WIR10397
Four plug Phoenix type terminal connector	2	X19220085030	CON00431
DIN Rail end stop	2	X13492732001	
Ethernet cable for Symbio 800 to display connection, 3700 mm in length (See, Figure 2, p. 9)	1	X19070632020	CAB01206
Male to Female wire harness extension, 1 meter in length (See, Figure 3, p. 9)	1	X19051623010	CAB01149
Wire harness extension, Female connector to stripped end, 1 meter in length (Refer to Figure 3, p. 9)	1	X19051625020	CAB01155
2-conductor power supply communication cable, 8 inches in length (See, Figure 4, p. 9)	1	X19051243010	CAB00974
USB Type B service port cable (See, Figure 5, p. 9)	1	X19140818010	CAB01260
USB Type B service port cap	1	X19201118010	CAP01053
Bushing, 0.88 inch diameter	2	X19100013000	BUS00866
Power supply (for installation as 1A2 power supply)	1	X13650737060	BRD02102
Power supply mounting bracket	1	X19090702010	BRK03306
10-32 x 0.50-inch screw	4	X25330033410	SCR00889
5/16-18 x 1 inch hex head cap screw	4	X25012400000	SCR01839
5/16-inch lockwasher	4	X22020400000	
5/16-inch hex nut	4	X28020700000	
Serialized nameplate decal	1	X39001817010	
Nameplate protector	1	X39001166030	
10-32 x 1.00-inch screw	1	X25330033450	SCR01014
Quad relay output	1	X13650806050	BRD04879
Bracket; CH531 sub panel	1	507104470100	BRK05365
Bracket; AdaptiView display Mt.	1	X05010050010	BRK04345
Hex HD screw; 7/16-20*1	3	42250080710	
Lockwasher, Helical spring; 7/16	3	X22020026060	
Normar size flatwasher; 7/16	3	X22050232150	

Table 1. Basic bill of material for Symbio™ 800 control upgrade kit (continued)

Description	Qty.	Part Number ^(a)	Mnemonic Part Number ^(a)
Nut Hex; 7/16-20	3	X28020003110	
Door assembly	1	506898140100	

(a) All part number information in this table is subject to change at any time.

Figure 2. Ethernet cable for Symbio 800 controller to display connection



Figure 3. Wire harness extensions: M to F connectors and F connector to stripped



Figure 4. Two-conductor power supply communication cable



Notes:

- Bk Black wire
- R Red wire

Figure 5. USB Type B service port cable



Running the IPC Bus

There are several ways to string the IPC communication bus on the chiller. The Symbio™ 800 AdaptiView display upgrade kit includes a general wire kit that has several different types

of wires. An example of a wiring layout can be seen in the below figure. Each application will vary depending on the options. If extra cables are needed, order through the local Trane Parts Center. Use the latest version of *General Service Bulletin - Tracer® CH530/CH531 Pluggable Connector System (PART-SVB16*-EN)* (Tracer CH530/CH531 Pluggable Connector System) for identification of individual cables.

⚠ WARNING

Hazardous Voltage w/Capacitors!

Failure to disconnect power and discharge capacitors before servicing could result in death or serious injury. Disconnect all electric power, including remote disconnects and discharge all motor start/run capacitors before servicing. Follow proper lockout/tagout procedures to ensure the power cannot be inadvertently energized. For variable frequency drives or other energy storing components provided by Trane or others, refer to the appropriate manufacturer's literature for allowable waiting periods for discharge of capacitors. Verify with a CAT III or IV voltmeter rated per NFPA 70E that all capacitors have discharged.

⚠ WARNING

PPE for Arc/Flash Required!

Failure to wear appropriate PPE could result in death or serious injury. On this unit, if the handle shield is cracked the circuit breaker could arc/flash when reset. To avoid being injured, technicians **MUST** put on all necessary Personal Protective Equipment (PPE), in accordance with NFPA70E for arc/flash protection, **PRIOR** to entering the starter panel cabinet.

Figure 6. Sample of IPC cable routing

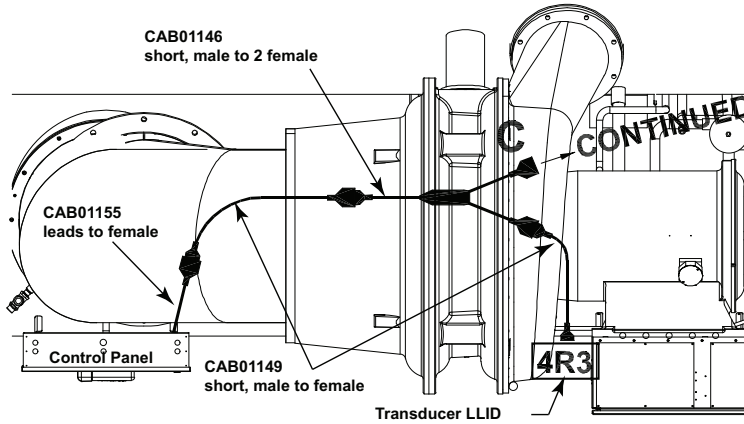

To connect the IPC bus to the control panel LLIDs, thread the bus into the control panel via a knockout or other entry. The CAB01155 connector has a female plug on one end and four stripped leads on the other end. Attach the four stripped leads to the power supply in the control panel.

Figure 7. Connecting the stripped leads to the power supply

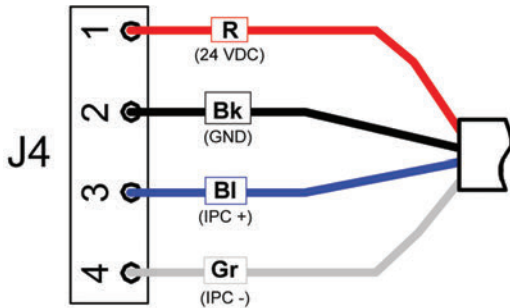

Notes:

- R - Red wire for 24 Volts direct current
- Bk - Black wire for ground
- Bl - Blue wire for IPC+ connection
- Gr - Gray wire for IPC- connection

Confirm all devices and LLIDs are connected together in some way. Use correct cables so no open plugs are available when finished. Avoid placing wire ties directly over plug connectors. This may press on the lock mechanism and over time the plugs may release.

Table 2. Cables shipped for various options

	CAB01146 branch M ^(a) to 2 F 500 mm	CAB01147 branch M to 2F 1000 mm	CAB01148 branch M to 3F 500 mm	CAB01149 extension M to F 1000 mm	CAB01150 extension M to F 2000 mm	CAB01152 extension M to leads 1000 mm	CAB01154 extension M to receptacle 1 M	CAB01155 extension F to leads 1000 mm
Standard panel cables	5	5	5	10	9	1	2	2
Actuator-stepper		1						
Oil protection—full, low pressure or high pressure		1		1				
Heat recovery/aux condenser		1	1		1			
Hot gas bypass—electric actuator		1		1				
Hot gas bypass—pulse actuator		1	1					
Cold water reset		1			8			
Enhanced protection	1	2	1	3				

(a) The letters M and F represent male and female connectors.



Installation

Check the Configuration and Setpoints in the DynaView Display

Important: Verify CH530 firmware is upgraded to the most recent version before creating the chiller service report for conversion to Symbio. The conversion utility is only designed to work with the most recent version of CH530 firmware.

1. Check the current configuration of the DynaView and confirm that all settings are correct. Make any necessary changes.

2. Check all of the current chiller setpoints programmed into the DynaView and confirm that they are all correct for the unit. Make any necessary changes.

Save the DynaView Configuration and Setpoints

Using KestrelView™ on a PC or laptop computer:

1. Generate a Chiller Service report from the DynaView with Level 4 active.

Figure 8. KestrelView screenshot—accessing chiller service report

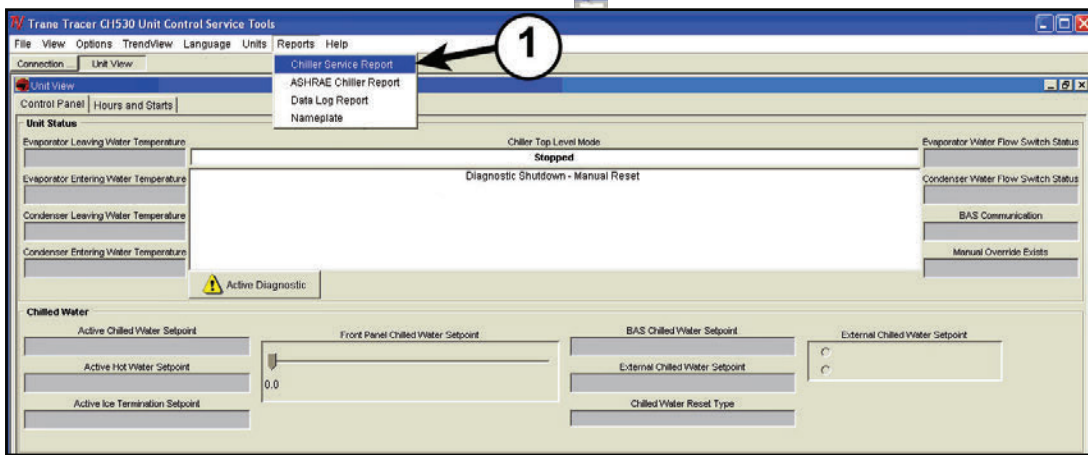

2. Check all of the boxes to confirm that you get a complete report.

Select reports	
<input checked="" type="checkbox"/> Chiller Status	<input checked="" type="checkbox"/> TechView Configuration
<input checked="" type="checkbox"/> Chiller Configuration	<input checked="" type="checkbox"/> PC Environment
<input checked="" type="checkbox"/> Chiller Setpoints	<input checked="" type="checkbox"/> Diagnostics
<input checked="" type="checkbox"/> LLID Binding	

⚠ WARNING

Hazardous Voltage w/Capacitors!

Failure to disconnect power and discharge capacitors before servicing could result in death or serious injury. Disconnect all electric power, including remote disconnects and discharge all motor start/run capacitors before servicing. Follow proper lockout/tagout procedures to ensure the power cannot be inadvertently energized. For variable frequency drives or other energy storing components provided by Trane or others, refer to the appropriate manufacturer's literature for allowable waiting periods for discharge of capacitors. Verify with a CAT III or IV voltmeter rated per NFPA 70E that all capacitors have discharged.

Shutdown Power

1. Using lock out tag out safety procedures, shutdown the chiller's main power.
2. Open all starter and control panel disconnect switches and secure them in the open position.
3. Confirm power is off to the control panel of the chiller.

Remove Existing Control Panel Door

Figure 9. Existing door removal, steps 1 and 2

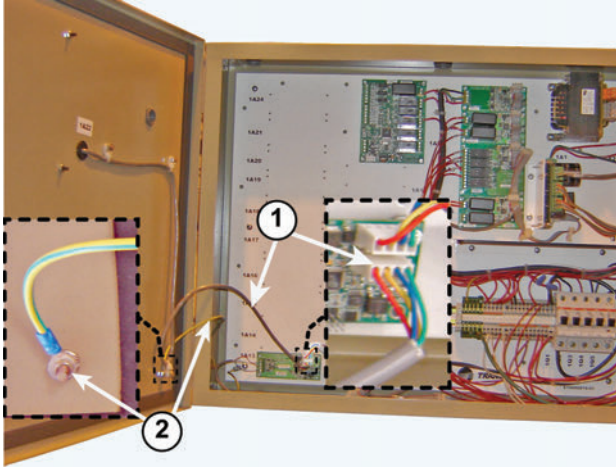

1. Unplug the wire feeding the DynaView on the existing control panel door. This may require cutting some wire ties.
2. Disconnect the equipment ground wire from the door.

Figure 10. Existing door removal, step 3



3. While supporting the door to prevent it from twisting or falling, remove the two hinge pins using a small punch and a set of pliers.
4. Set the door aside.

Install New Control Panel Door and Symbio 800 Controller

1. Set the new control panel door in place and install the hinge pins.

Figure 11. Mounting new control panel door



2. Connect the equipment ground wire to the weld-stud on the door using the 10-32 hex lock nut with star washer provided.

Figure 12. Equipment ground wire connected to new door

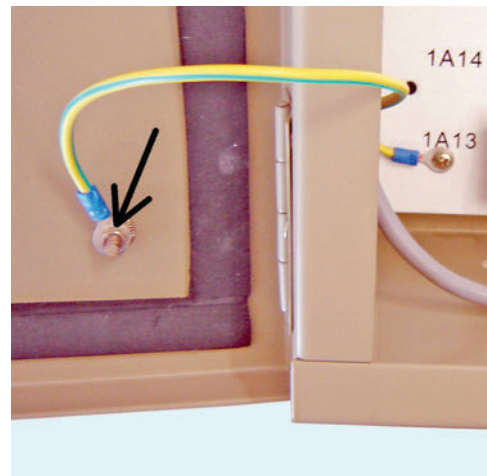

3. Clip the Symbio 800 controller onto the DIN rail secured to the back side of the door.

Important: Note the correct orientation of the Symbio 800 controller as shown in the following figure.

- a. Install DIN rail end stops on each side of the Symbio 800 controller.
- b. Tighten the center screw on each stop to lock it in position to prevent the Symbio 800 controller from moving.

Figure 13. Mounting Symbio 800 controller onto new control panel door

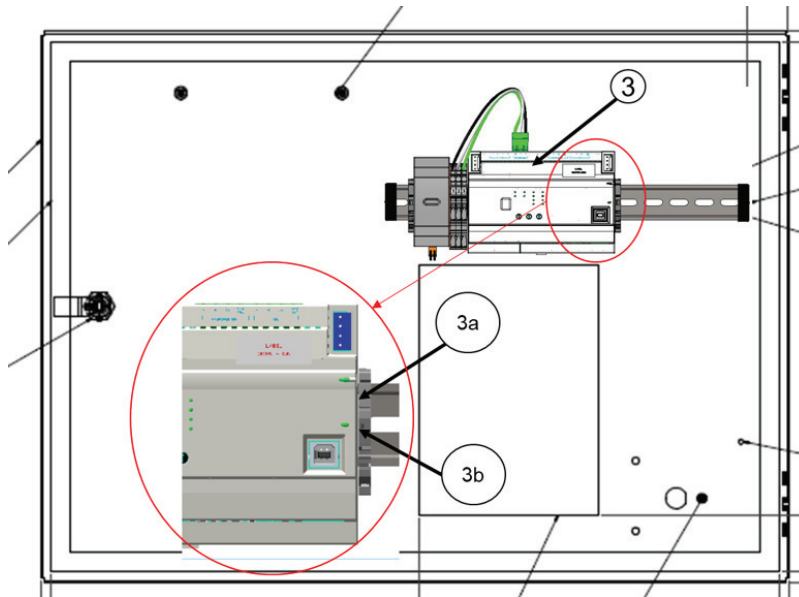

4. Install the round end of the USB Type B service port cable into the cut-out on the door and secure it with the plastic nut.
 - a. Remove the rubber protective plug from the inside of the weld nut.
 - b. Secure the dust cover to the outside of the door by inserting the #4-40 x 0.25-inch machine screw provided through the shackle on the end of the cap chain, and then threading the screw into the weld nut.
 - c. Plug the opposite end of the USB cable into the appropriate port in the Symbio 800 controller.

Figure 14. Installation of the USB service port cable

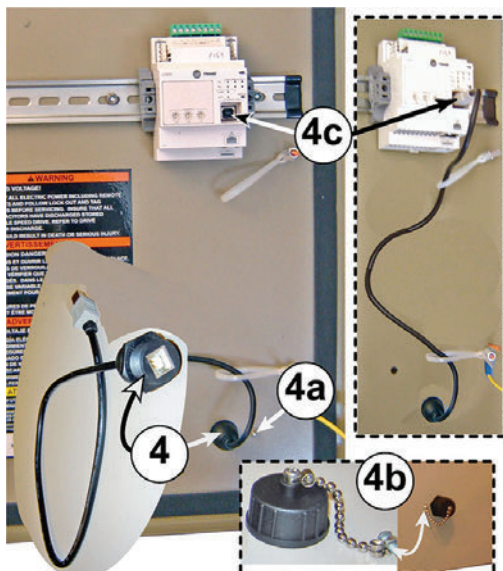

Choosing Display Arm Mounting Location

Recommended mounting location

The display arm assembly is designed to be secured to the side of the control panel or to one of the two mounting brackets underneath the control panel enclosure.

Notes:

- A production display arm bracket (BRK04345) is provided. Where applicable, this can be mounted to the existing right hand side control panel mounting arm.
- If used, plug the holes on the unused side.
- Secure the arm to the right-hand mounting bracket, located at the opposite end of the control panel enclosure from the door hinges.

Figure 15. Production arm bracket



Figure 16. Recommended mounting location on right-hand control panel bracket

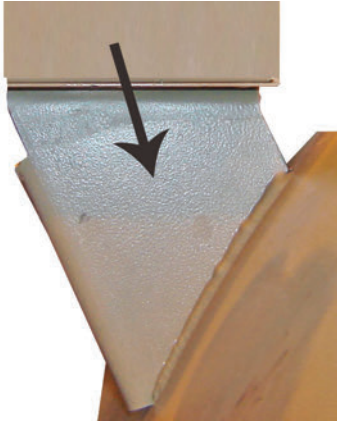

Before using the alternate mounting location and drilling the display arm mounting holes through the side of the control enclosure, note the following to prevent damaging any electrical components inside of the enclosure:

- Carefully position the template to confirm for all four mounting holes the installed mounting bolts will not come into contact with any electrical components.
- Before drilling, confirm all electrical components are adequately protected from metal filings.
 - Temporarily remove components if necessary.
 - Failure to prevent metal filings from lodging against or inside of electrical components can cause failure when re-energized.
- Before and during drilling, confirm all electrical cables and wires are not in line with the path of the drill bit. Failure to prevent damage to these components can cause electrical shorts and/or sparks to occur when the system is re-energized.
- After all four mounting holes are drilled, use an electronics vacuum to remove any dirt, debris, or metal filings that may have accumulated inside of the control enclosure.
- Confirm any components temporarily removed during the drilling process are properly reinstalled.

Alternate mounting location

If the control panel mounting brackets are obstructed by thick layers of insulation, electrical conduits, etc., in order to effectively install the display arm in the recommended mounting location, mount the display arm onto the side of the control panel enclosure shown below.

- It is recommended securing the arm to the right-hand end of the control panel enclosure, at the opposite end of the cabinet from the door hinges.
- If a retrofit requires mounting the display arm on the left-hand end of the enclosure, note that all of the cables provided within the display upgrade kit are long enough for this installation location.

Important: *If an alternate mounting location is selected, validate no electrical components are inside the control panel.*

Figure 17. Alternative mounting location chosen due to retrofitted insulation layers



Figure 18. Arm/display assembly mounted at alternate location



Mounting Display Arm

1. Using the template provided, mark the location of the 4 mounting holes required on the chosen mounting bracket.
2. Use a 3/8-inch bit to drill the holes.

Figure 19. Display arm mounting holes drilled through right-hand panel bracket



- Secure the arm to the control panel bracket using the 5/16 - 18 x 1-inch hex bolts, 5/16-inch lock washers, and 5/16 - 18 hex nuts provided.

Note: The production arm bracket (included) can also be bolted to the panel mounting bracket.

Figure 20. Production arm bracket



- Securely fasten the Tracer AdaptiView display to the mounting plate on the end of the display arm with the hardware provided.

Figure 21. Attaching Tracer AdaptiView display to arm

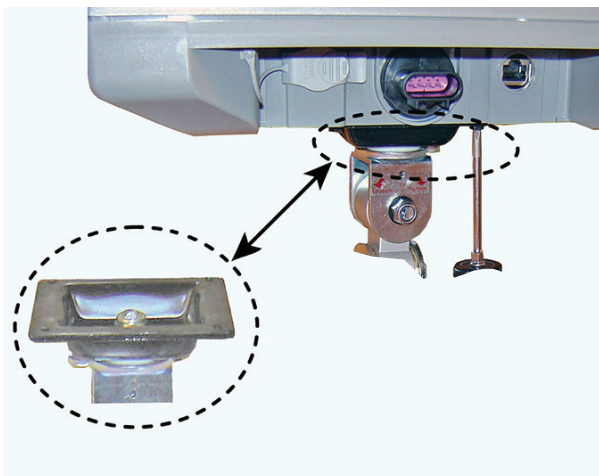

- After the display is attached, recheck the arm tension. The arm tension should be set so that the display does not spring up or sag down out of the position it is moved to by the operator.

CAUTION

Tension in Display Support Arm!

Failure to follow instructions below could result in unexpected movement of the spring-loaded support arm which could result in minor to moderate injury. Ensure that the support arm is in the full upright position when removing the Tracer AdaptiView display from the support arm.

Adjusting the Tracer AdaptiView Display Arm

The Tracer AdaptiView display arm may be too loose or too tight. To adjust the tension on the display arm:

- There are three joints on the display arm that allow the Tracer AdaptiView display to be positioned at a variety of heights and angles (refer to items labeled 1, 2, and 3 in the below figure). At each joint in the display arm there is either a hex bolt (1 and 2) or hex screw (3). Turn the hex bolt or screw in the proper direction to increase or decrease tension.

Note: Each hex bolt or screw is labeled with 'loosen'/'tighten', or '+/'-' indicators.

Figure 22. Joint locations on the display arm

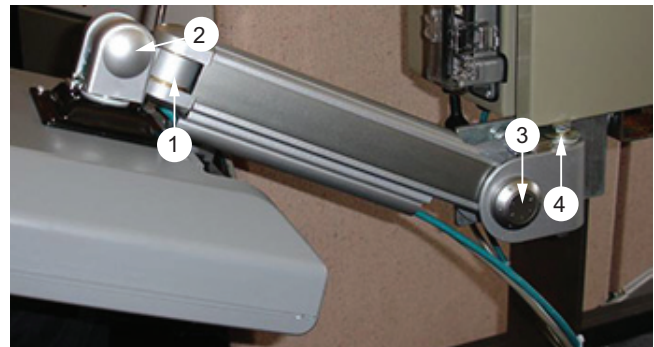

- Joint 3 has a 6 mm hex screw controlling the tension on a gas spring, which allows the Tracer AdaptiView display to tilt up and down.
- Joints 1 and 2 are covered by a plastic cap. Remove the plastic cap to access the hex bolt. Adjust using a 13 mm wrench as necessary.
- To adjust the swivel of the Tracer AdaptiView display (the spin right and left similar to the steering wheel on a car), adjust the hex bolt located inside the display arm back plate. Make the adjustment BEFORE attaching the display. Use a 9/16-inch or 14 mm wrench.
- Use a 13 mm wrench to adjust the bolt (item labeled 4 in the above figure) to allow the entire display arm to swivel to the left and right.

Install Power Supplies and Hardware

Install 1A2 Power Supply – CH530 If Not Already Present

Note: Proceed directly to the next stage of the installation process:

- for CH531 applications, or
- If there are already two power supplies (1A1 and 1A2) in place from the previous CH530 control system.

1. Find the factory-drilled mounting holes on the inner back wall of the control panel enclosure to the right of the existing power supply.
2. Attach the power supply to the mounting bracket with the hardware provided.
3. Attach the power supply assembly to the back wall of the enclosure using the 10-32 x 0.50-inch screws provided.

Note: In all subsequent manual pages, this new power supply will be referred to as the 1A2 power supply, while the preexisting power supply from the original control system will be referred to as the 1A1 power supply.

Figure 23. Installation of second power supply

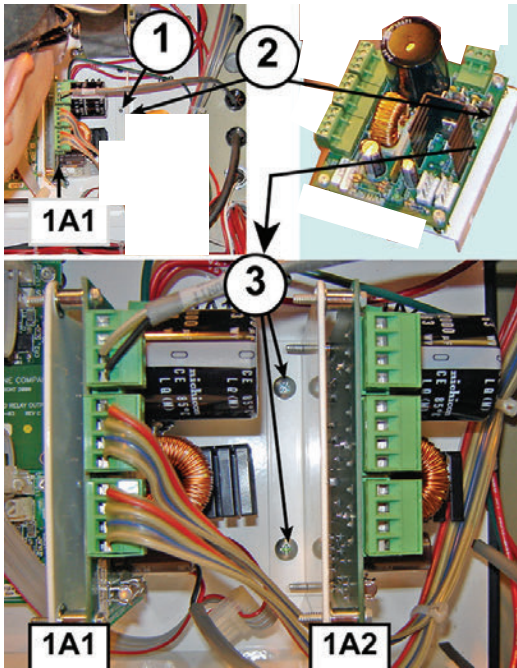

Install 1A2 Power Supply - CH531 Prebuilt Panels

1. Locate and remove the vent line solenoid time delay relay and base.

Note: Do not unwire the base. The wires should be long enough to reach the new location. Use caution when removing the timer because the center alignment post is very fragile.

2. Locate and remove the 1A1 power supply LLID and bracket.

Note: Do not unwire the 1A1 power supply LLID. The wires should be long enough to reach the new location.

3. Locate and remove the middle back panel securing screw on the right side.
4. Install the new sub back panel provided with the kit.
 - a. Secure the left side of the bracket using two #10-32 by 1/2-inch screws and the holes emptied by the removal of the power supply bracket.
 - b. Secure the right side of the bracket using one 10-32 x 1.00-inch screw and the hole emptied by the removal of the back panel securing screw.
5. Using the screws that were removed in [Step 2](#), attach the existing power supply LLID onto the new panel in the holes labeled 1A1.
6. Using the screws that were removed in [Step 1](#), attach the vent line solenoid time delay relay and base in the holes labeled 1K20.

Important: The timer must be aligned correctly with the base.

7. With the hardware provided, attach the new power supply to the mounting bracket.
8. Using 10-32 x 0.50-inch screws provided, attach the power supply assembly to the new panel in the holes labeled 1A2.

Note: In all subsequent manual pages, this new power supply will be referred to as the 1A2 power supply, while the preexisting power supply from the original control system will be referred to as the 1A1 power supply.

Figure 24. Installation of 1A2 power supply

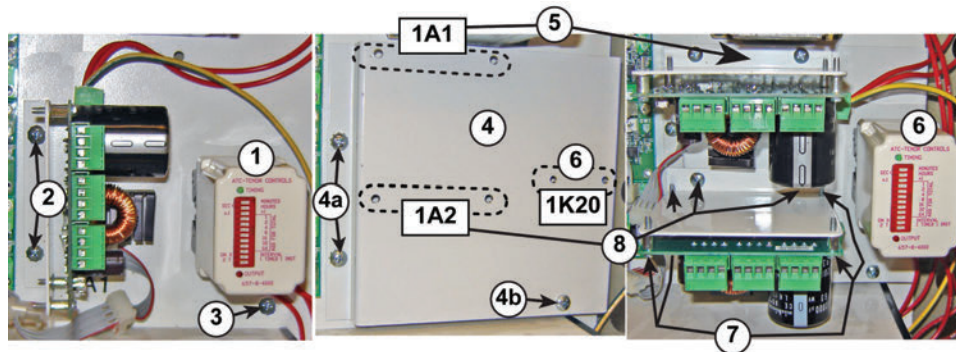

Install Quad Relay Output LLID—CH530 If Using Chiller Control Sequence 1

Notes:

- If the DynaView had CTV software and was using control sequence 1, then installing the quad relay output LLID is required. To determine this, examine the chiller service report that was saved earlier. In the configuration section, look for Connected to and in the CH530 section, look for Control Sequence. If these items are CTV and 1, respectively, then adding the quad relay output LLID is required. If not, then skip this procedure.
- If the quad relay output LLID is added, it also needs to be bound in the programming phase of the Symbio™ 800.

1. Remove LLIDs 1A3 dual relay, 1A5 dual relay, and 1A10 dual relay output from the control panel. Refer to Figure 67, p. 35.
2. Install the quad relay output LLID in an open space in the control panel, as close as possible to where the 1A3 LLID was formerly located.

Note: This may also require moving some of the other LLIDs to different control panel locations.

3. Connect the wires from the previously removed LLIDs to the quad relay output LLID terminals as shown in Figure 67, p. 35.

Install Communication Cable Between 1A1 and 1A2 Power Supplies

Note: Proceed directly to the installation section “Routing New Wire Into and Out of the Control Panel Enclosure,” p. 18, if the 1A2 power supply was already in place as part of the previous CH530 control system.

1. Connect the power supplies together at the J1 terminals using the 2-conductor power supply communication cable provided.

Note: If the J1 terminals are already being used, the communication cable can instead be connected to the J11 terminals on both power supplies.

Figure 25. Communication cable install between 1A1 and 1A2 power supplies

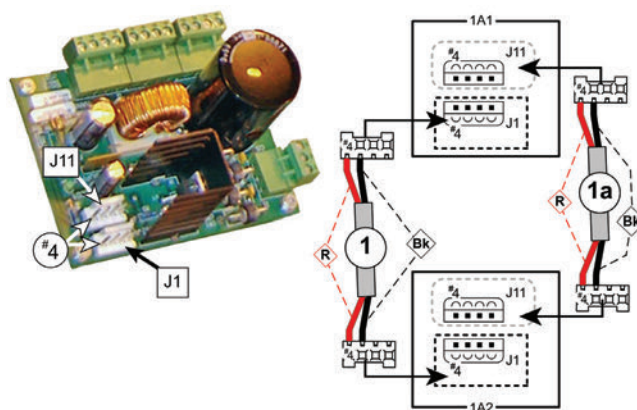

Notes:

- Bk - Black wire
- R - Red wire

Connect Input Power Wiring to 1A2 Power Supply

Notes:

- Proceed directly to the next stage of the installation process if the 1A2 power supply was already in place as part of the previous CH530 control system.
- The full schematic wiring diagram can be found in [Figure 69, p. 37](#) of this manual.

⚠ WARNING

Proper Field Wiring and Grounding Required!

Failure to follow code could result in death or serious injury. All field wiring **MUST** be performed by qualified personnel. Improperly installed and grounded field wiring poses **FIRE** and **ELECTROCUTION** hazards. To avoid these hazards, you **MUST** follow requirements for field wiring installation and grounding as described in NEC and your local/state/national electrical codes.

1. Attach a Red 16 AWG wire between J2-1 on the 1A2 power supply and 1T1-X2.
2. Attach a Red 16 AWG wire between J2-2 on the 1A2 power supply and 1T1-X1.
3. Attach a Green 16 AWG wire between J2-3 on the 1A2 power supply and any available ground terminal on the 1X1 terminal block.

Figure 26. Input power wiring to the 1A2 power supply

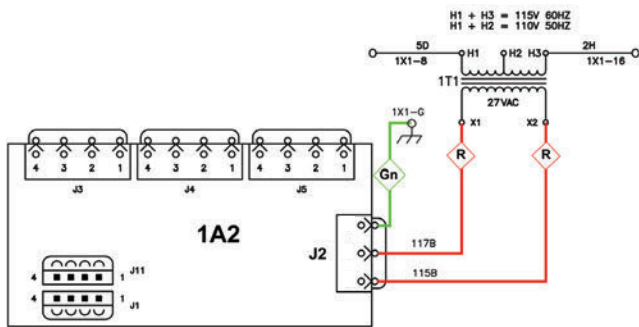

Notes:

- Gn Green wire
- R Red wire

Routing New Wire Into and Out of the Control Panel Enclosure

- Use the spare factory knock-outs available on the right-hand end of the control enclosure, to route required wiring runs from the Symbio 800 controller and the 1A2 power supply out to the connection points on the display.
- Plastic grommets are provided in the upgrade kit to line the edges of the knock-outs used.

- If a retrofit requires mounting the display arm on the left-hand panel bracket or the left hand end of the enclosure, note that all of the cables provided within the display upgrade kit are long enough to use the spare factory knock outs on the back of the control panel enclosure.

Figure 27. Example of pre-existing spare factory knock-outs on control enclosure

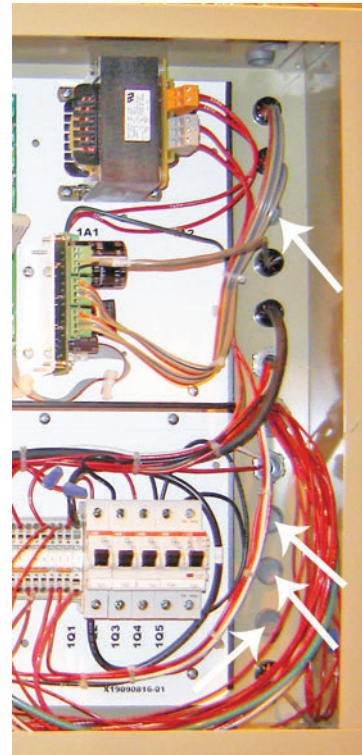

Wiring Connections to the Display and Symbio 800 Controller

Note: Also refer to the full schematic wiring diagram located in [Figure 69, p. 37](#) of this manual.

1. Ethernet communication cable installation:
 - a. Attach the head of the Ethernet cable to the display.
 - b. Route the cable through the wire channel on the display arm.

Important: Leave enough slack in the cable to allow the display arm to be moved through its full range of motion without placing a strain on the cable or the terminal connections.

- c. Take the cable around the back side of the control enclosure and feed it into the cabinet through one of the spare factory provided cable knock-outs.
- d. Insert the cable end into the Ethernet port on the Symbio 800 controller.

Figure 28. Ethernet cable installation between the display and Symbio 800 controller

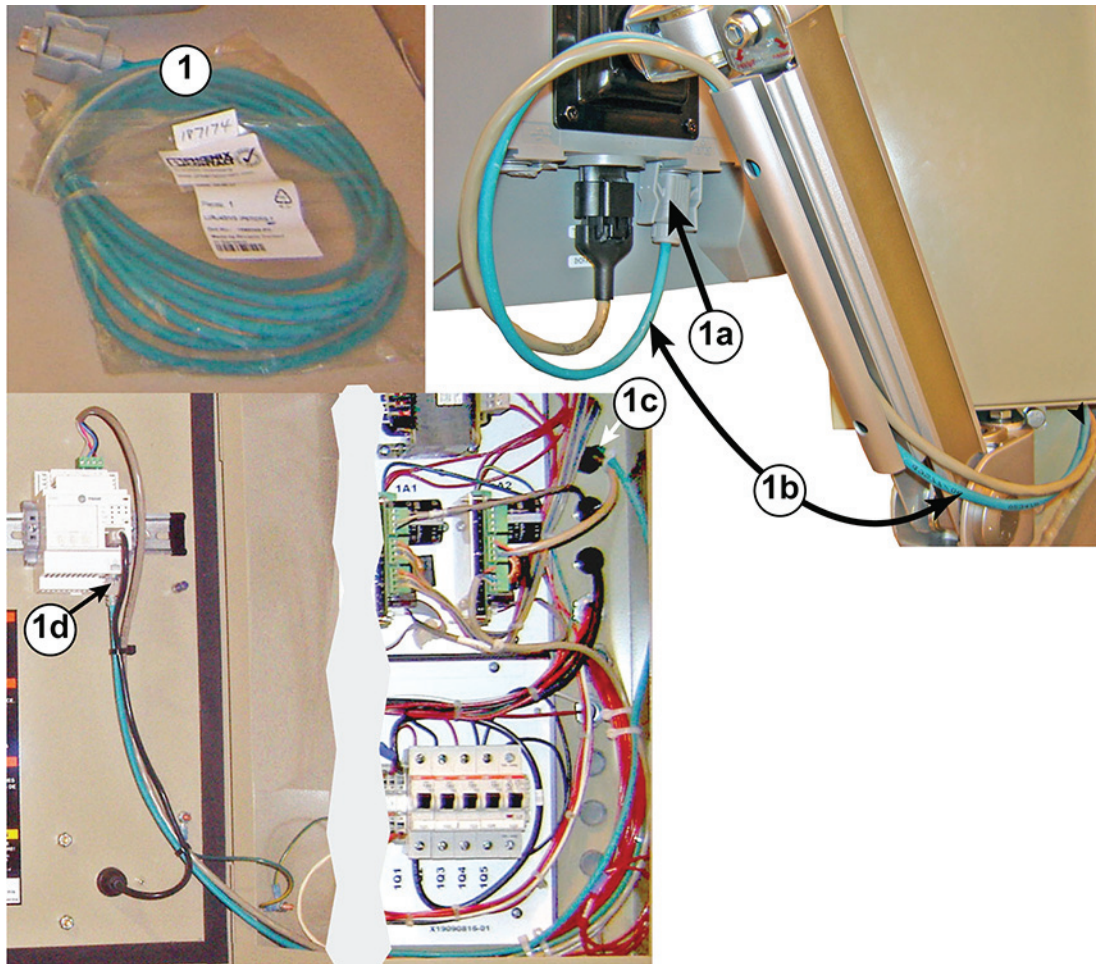

2. Install the female connector to stripped end wire harness extension to the 1A2 power supply (the first half of the power supply run to the display).
 - a. Route the stripped end of this wire harness through the same cabinet knock-out used for the Ethernet cable if possible, otherwise use one of the other spare factory made knock-outs provided.
 - b. Connect each of the four individual wires to the correct terminal of the removable J4 terminal plug on the 1A2 power supply.

Figure 29. Female to bare end wire harness install from outside cabinet in to 1A2

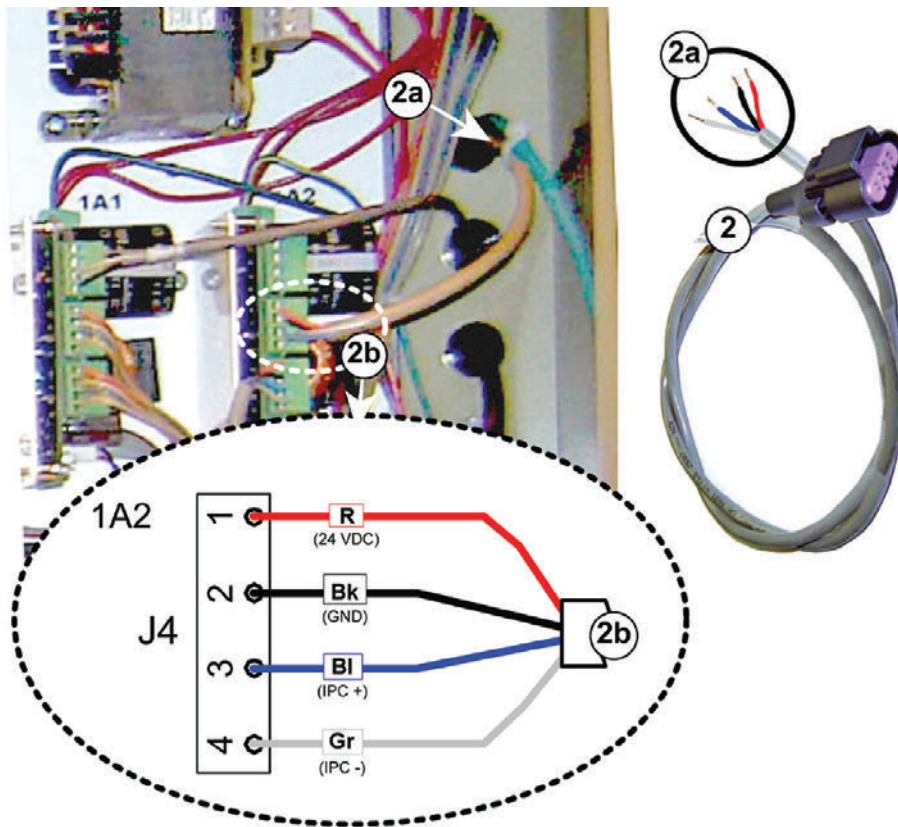

Notes:

- R. Red wire for 24 Volts direct current
 - Bk. Black wire for ground
 - Bl. Blue wire for IPC+ connection (not actually used by Tracer AdaptiView but connect anyway)
 - Gr. Gray wire for IPC- connection (not actually used by Tracer AdaptiView but connect anyway)
3. Complete the power supply connection to the display using the male to female wire harness extension:
- a. Connect the male end of this cable to the female connector on the cable installed in [Step 2](#).
 - b. Route the cable harness through the wire channel on the display arm and connect the female end to the male receptacle on the display unit.

Important: Leave enough slack in the cable to allow for the display arm to be moved through its full range of motion without placing a strain on the cable or the terminal connections.

Figure 30. Completion of power supply connection to the display

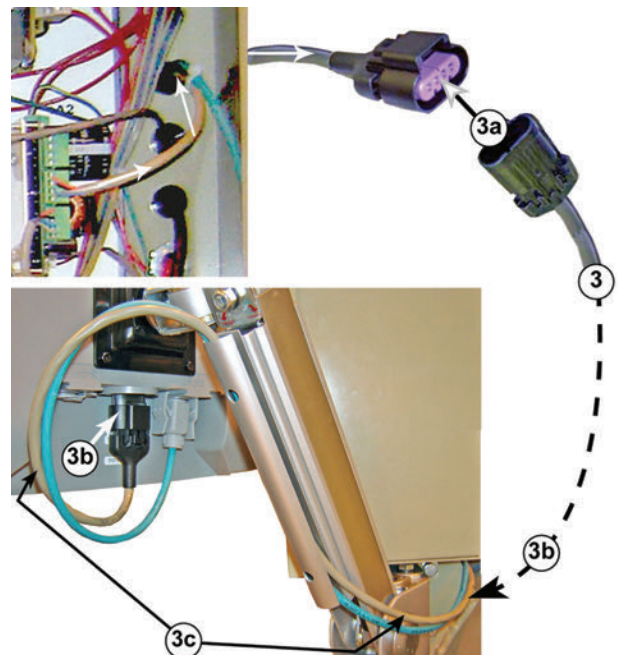

4. Connect the Symbio 800 controller to the 1A2 power supply using the length of 4-conductor cable provided:
 - a. Connect each of the four individual wires on one end of the cable to the correct terminal of the removable J5 terminal plug on the 1A2 power supply.
 - b. Route the other end of the cable inside of the cabinet over to the Symbio 800 controller and connect each of the four individual wires to the correct terminals on the controller.

Figure 31. Wire connections from 1A2 power supply J5 to Symbio 800 controller

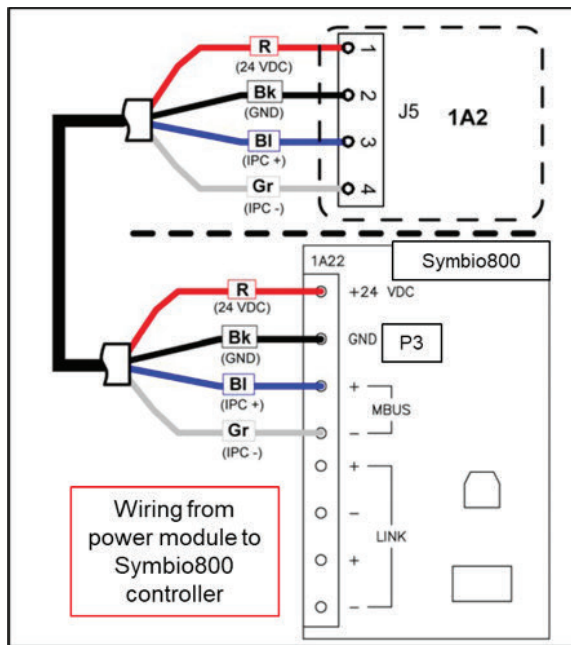

Notes:

- R. Red wire for 24 Volts direct current
- Bk. Black wire for ground
- Bl. Blue wire for IPC+ connection
- Gr. Gray wire for IPC-connection

5. Secure all cables in the wire channel on the display arm with cable ties:

There are two factory-drilled holes provided in the wire channel to aid in neatly securing the cables with cable ties.

Important: Wire protection may be required at both ends of the wire channel and at the door hinge opening on the control panel enclosure due to the potential presence of sharp edges that could abrade or cut the wires.

Figure 32. Neatly secure and protect cables in display arm wire channel

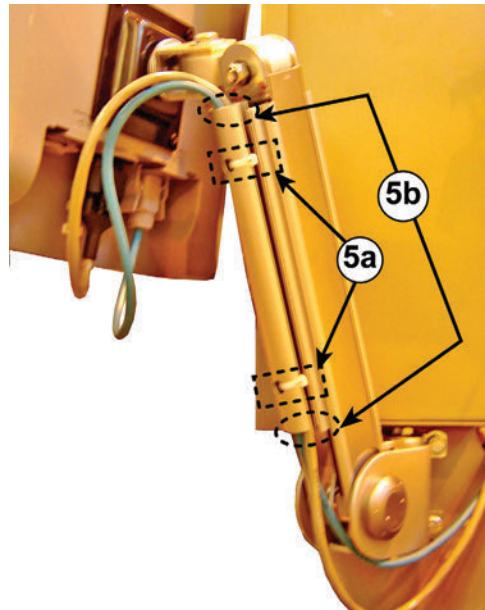

6. Use cable ties to clean up and secure wiring runs inside of the control panel enclosure.

Solid State Oil Heater Relay Installation

Note: This procedure does not apply to new chillers operating with R514A refrigerant. Chillers with R514A refrigerant have solid-state relay for heater control installed and configured by the factory.

Relay RLY02909 is provided for upgrading chillers with R-123 refrigerant. This relay will operate with a 120V 15mA signal, yet it will safely and quickly switch 120V loads up to 25 amps. The oil heater's amp draw is 6.25 amps at 120V, which is well within the capacity of RLY02909.

Mounting Location

The RLY02909 must be mounted directly onto a flat steel face of the control panel, either on a side wall of the enclosure, or on the back-plane panel. The mounting surface acts as a heat sink for the relay, so the relay should be securely bolted to the mounting surface.

Notes:

- Instructions included with the relay may require removal of paint from the mounting surface, and the use of a heat conductive paste between the relay and the mounting surface.
- Trane's lab testing indicates these additional steps are not needed for the low 6 or 7 amp draw that our heater will apply to the relay. Securely mounting the relay to any steel surface in the control panel is adequate for our application.

Installation

Note: Use 12ga wire.

1. At quad relay output LLID 1A5 in the unit control panel, disconnect wire 42A from terminal 7.
2. Connect wire 42A to RLY02909 terminal 2.
3. Install a wire between LLID 1A5 terminal 7 and RLY02909 terminal 3.
4. Install a wire from RLY02909 terminal 4 and a common terminal (1X1-17 is typical).
5. Install a wire from a 120v source terminal (1X1-10 is typical) that is downstream of breaker 1Q4, to RLY02909 terminal 1.

Figure 33. Installed solid state relay



Figure 34. Completed schematic

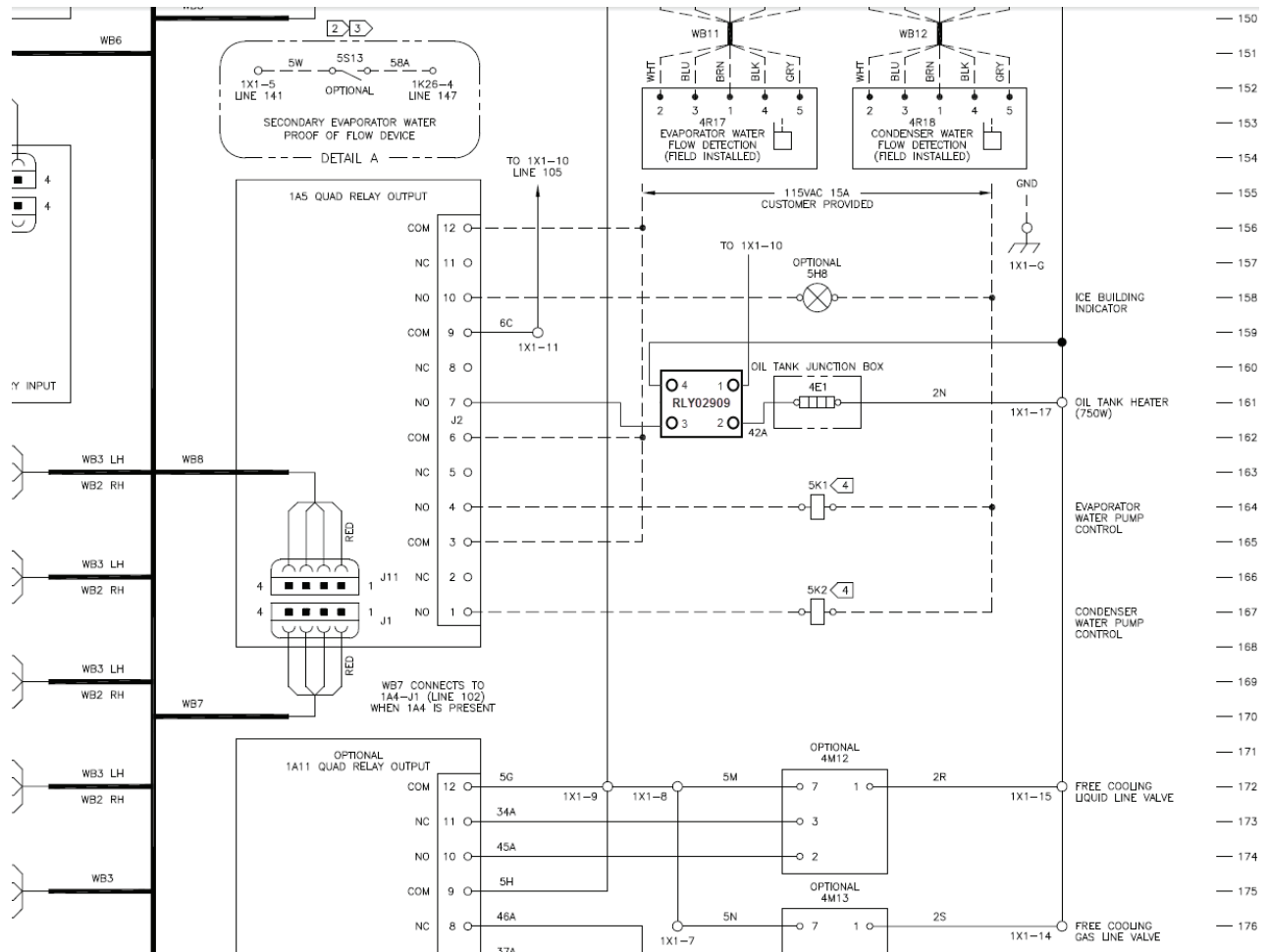

Install Options

LON Option Installation

Symbio 800 system use a U60 LON module through the USB connection instead of the LCI-C LLID.

1. Install the U60 LON module (MOD02977) on the DIN rail on the door, put it at left side of Symbio 800.
2. Connect U60 LON module to Symbio800 by USB cable which provide by module, this cable could be connect to any one of the four USB ports under the Symbio 800 controller.
3. Connect U60 LON module to BAS by shield cable and terminal, the terminal is provided by module also.

Figure 35. LON



Figure 36. LON wiring, ref. 50712792

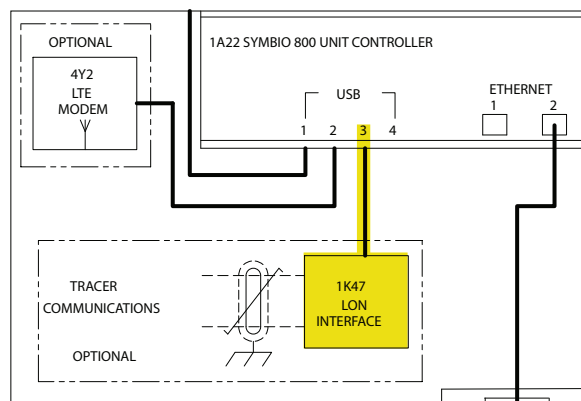

Communication Option

Symbio 800 system supports up to three wireless interfaces at same time, these are:

- Wi-Fi mobile APP for BAS interface
- Air-Fi BACnet via Zigbee for component interface
- LTE 4G modem interface for remote communications

Wi-Fi Installation

Refer to *Trane® Wi-Fi Module - Installation Instructions (BAS-SVN042*-EN)* for more information. For mounting and wiring of Wi-Fi module (MOD03122):

1. Drill a 1.36 inch holes on the top of polycarbonate box, securely fasten the Wi-Fi module by gasket and nut which provided by module.
2. Connect Wi-Fi module to Symbio 800 by USB cable which provide by module, plug USB MICRO-B side to bottom of Wi-Fi module and USB-A side to any one of the four USB ports under the Symbio 800 controller.

Figure 37. Wi-Fi wiring, ref. 50712792

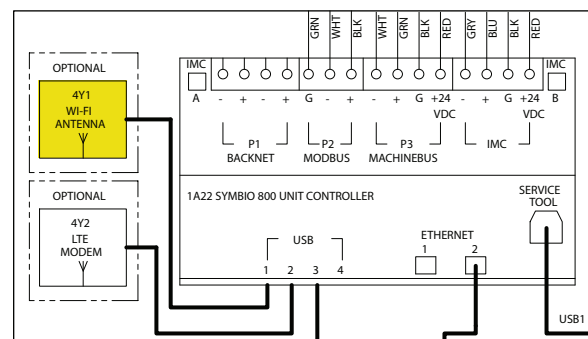

Air-Fi Installation

Refer to *Air-Fi® Wireless System - Installation, Operation, and Maintenance (BAS-SVX40*-EN)* for more information. For mounting and wiring of Air-Fi module (0185-0424-0100):

1. Drill a 0.87 inch holes on the top of polycarbonate box, align this hole with thread hole on the module, securely fasten the Air-Fi module by M4 screw.
2. Connect Air-Fi module to Symbio 800 by Modbus cable.
3. Remove the cover of module, connect 4 wires cable into 4 hosing connector and plug in Air-Fi module, connect other side of cable into 2 hosing connector and plug in IMC terminal on the Symbio 800 controller.

Figure 38. Air-Fi connecting wiring harness

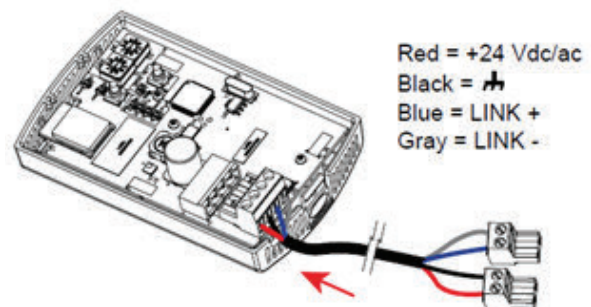

Figure 39. Air-Fi terminal

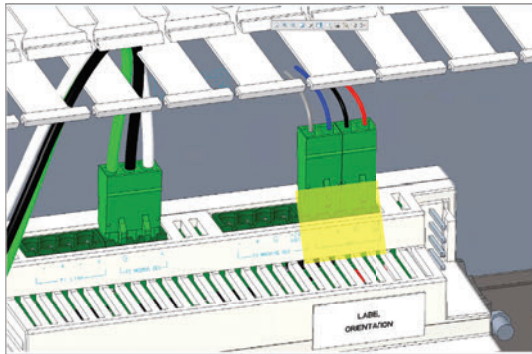
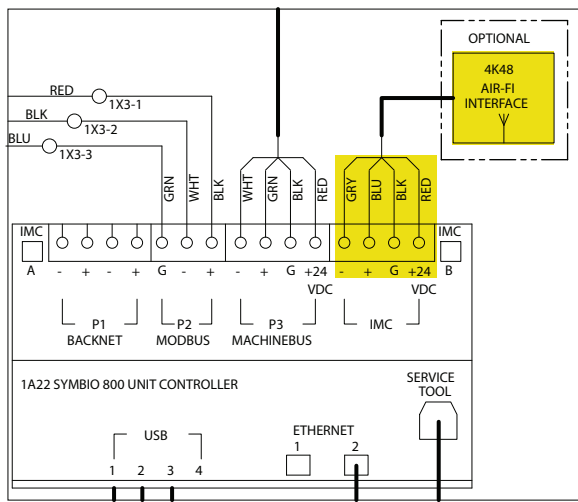

Figure 40. Air-Fi wiring, ref. 50712792



LTE Modem Installation

Modem part is MOD03184, MODULE; CELLULABLE USB 2.9 METER CABLE. Refer to provided literature for setup and operation details.

1. Drill a 1.36 inch holes on the top of polycarbonate box, securely fasten the LTE modem by gasket and nut which provided by modem.
2. Connect LTE modem to Symbio800 by USB cable which provide by module, plug USB MICRO-B side to bottom of LTE modem and USB-A side to any one of the four USB ports under the Symbio800 controller.

Figure 43. Single box (LTE, Air-Fi and Wi-Fi)



LTE

Air-Fi

WiFi

Figure 41. LTE modem wiring

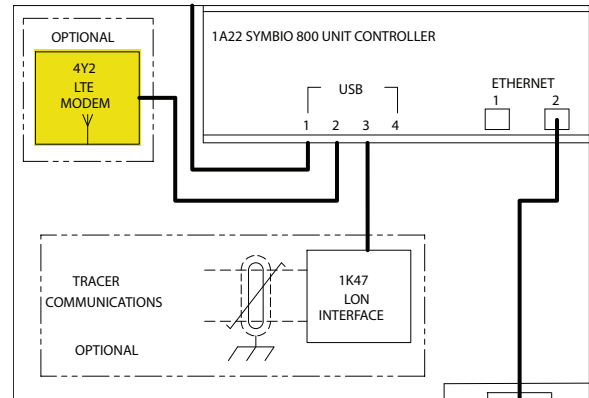

Communication Device Mounting

These devices are intended to be mounted on polycarbonate boxes. There are two installation approaches:

- Each device is mounted independently on a small box (0185-0426-0100).
- Multiple devices are mounted on a large box (0185-0427-0100).

All devices connect Symbio 800 by standard USB or Modbus cable. For installation, standard application need to field drill an 1.09-inch hole on side of box for a snap bushing. This bush can be replaced as field straight connector and conduit (3/4 inch size) as NEMA 4 applications.

The boxes have magnets for flexible attachment to the Symbio panel.

Figure 42. Polycarbonate box with magnets

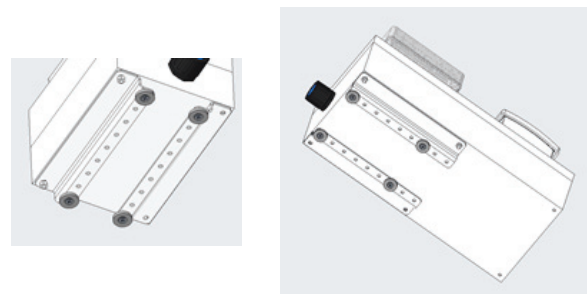

The single box is 7-inch Long x 5-inch Wide x 5-inch Tall.

Figure 44. Box mounting

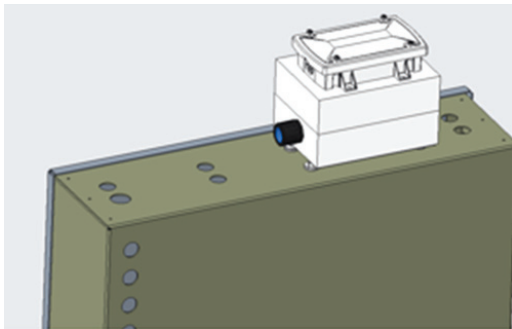

The triple box is 15.5-inch Long x 6-inch Wide x 4-inch Tall.

Figure 45. Triple box

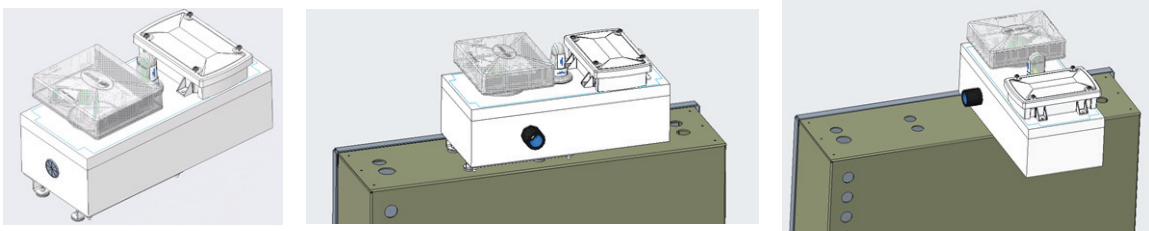

Water Flow Measurement Options

Standard Accuracy Option

Water flow is determined by measuring pressure drop across heat exchanger using water pressure transducer LLID's. Standard flow measurement transducers can be ordered for condenser, evaporator and auxiliary/heat recovery heat exchangers. The standard accuracy part is (0185-3475-0100), there are two transducer (0185-3475-0100) provided per heat exchanger. Field connect by male to 2 female 1000mm branch cable (CAB01147) which provided in package.

Figure 46. Standard accuracy package

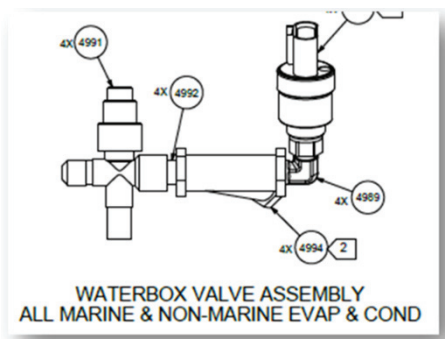

Mount transducers on the entering and leaving side water box locations with the transducer facing upwards and connect to unit control buss. After system is filled, loosen the transducer in its threaded fitting. Then crack the isolation valve until water starts dripping from threads. Close the valve and re-tighten the transducer, and then re-open the valve for use.

Figure 47. Standard accuracy flow meter wiring, ref. 50712792

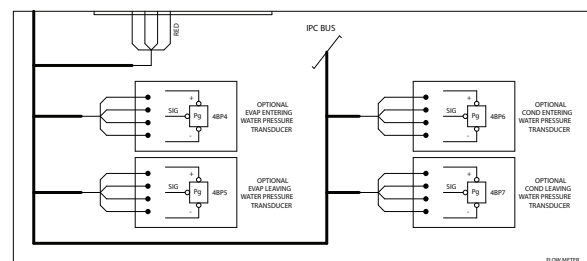

High Accuracy Customer Meter Option

The high accuracy customer meter option provides an analog input/output LLID to monitor a customer provided high accuracy meter 0-10 Vdc or 4 – 20 mA outputs. (Rosemont, etc.) This option allows monitoring of condenser, evaporator flow and auxiliary heat exchangers.

Install needed DAIO LLID(s) (BRD04875) in CVRF control panel:

1. LLID (1A21) is needed for EVAP and COND water flow. Connect flow meter wires to 1A21-J2-1 and 1A21-J2-1 for EVAP, 1A21-J2-4 and 1A21-J2-5 for COND.
2. LLID (1A28) is need for HR Aux/COND water flow. Connect flow meter wires 1A28-J2-1 and 1A28-J2-1 for HR flow or Aux COND.

Figure 48. High accuracy customer meter flow meter wiring, ref. 50712792

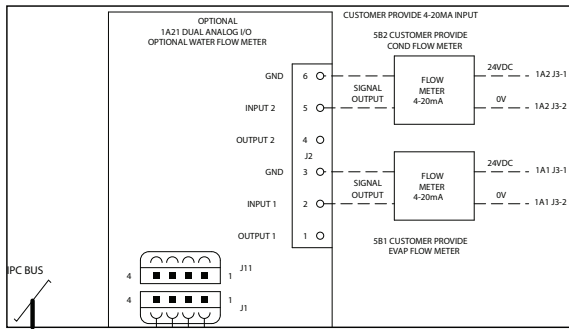

Heat Recovery/Aux COND Option

When heat recovery/Aux COND option is selected, a DHVBI LLID (BRD04874) is required as 1A29 and wires matrix show as following:

Table 3. Wire matrix

Wire #	AWG	From	To
14B	16	1A29-J3-2	1X1-21
2K	16	1A29-J3-1	1X2-10

Figure 49. Heat recovery/Aux COND flow switch wiring

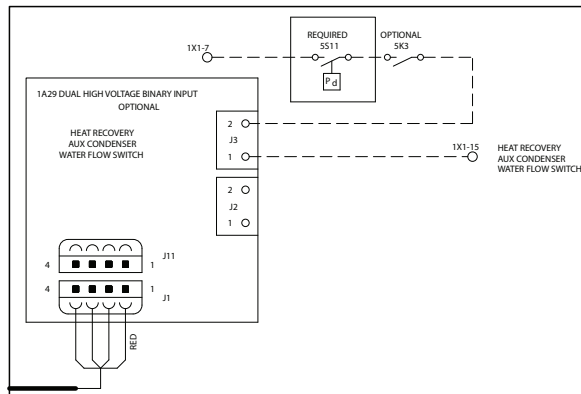

Energy Meter Option Installation

The Trane energy meter provides instrument grade accuracy power, volts and amps monitoring of Symbio controls installations. It has 1% accuracy for measuring both real power and energy and reactive power and energy. All data measured by the meter is communicated via Modbus to Symbio control system. For more detail information, refer to *Energy Meter For CTV Symbio 800 Upgrade Systems - Installation Instructions* (BAS-SVN224*-EN).

Figure 50. Energy meter

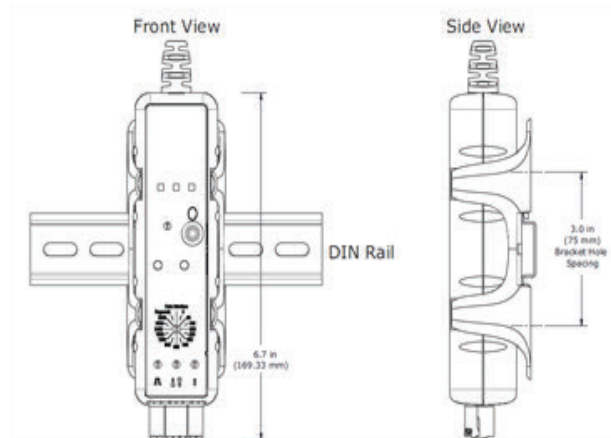

Figure 51. Rogowski CTs



The meter is connected to line voltage of up to 480 volts and should be mounted within the starter cabinet. It is provided with a mounting bracket that can either be mounted on DIN rail or directly to cabinet wall. It is mountable using the provided bracket.

Figure 52. Mount energy meter with strap tunnel on rail



The meter is connected to Modbus communications and is self-powered by the unit voltage potential inputs. Review meter literature for setup and operation details.

Modbus communications is by shielded 14 – 26 AWG cable from meter to Symbio module. Install 120 OHM resistors at first and last modules on Modbus daisy chain.

Figure 53. Shielded cable

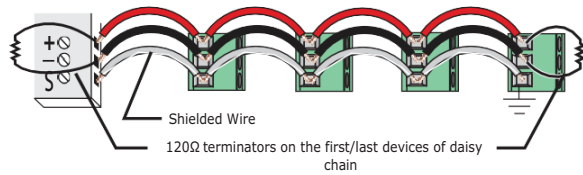

The communications wiring will be terminated at the Modbus distribution terminal (1X3) beside Symbio 800 using the 3 poles connector which provide in energy meter kits.

Figure 54. Modbus distribution terminal

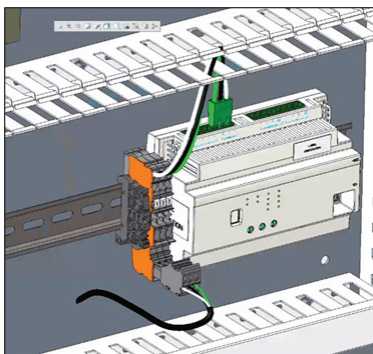
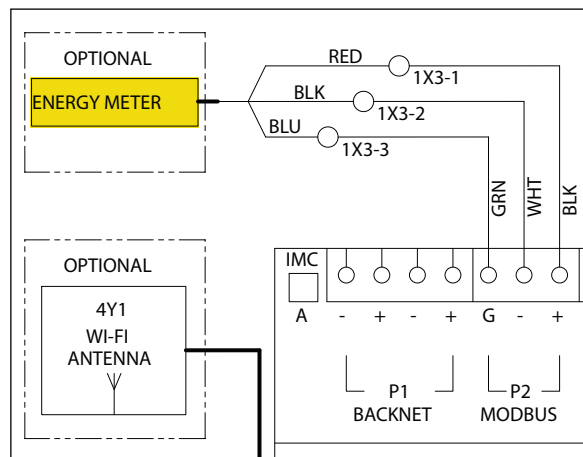

Figure 55. Communication wiring, ref. 50712792



480 Volts and Lower Installations

POTENTIAL INPUT – Install provided fused inputs to line voltage per schematic.

CURRENT INPUT – Install provided Rogowski CTs per schematic.

Figure 56. 480V Energy meter wiring, ref. 50712756

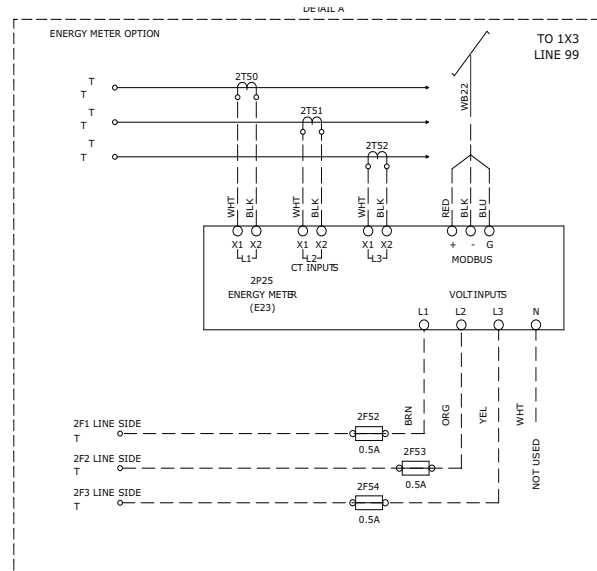

Expansion Module Option

CDUB retrofit panel reserve place of expansion module beside Symbio 800 controller. There are few configurations that depend on I/O requirements and din rail length. Currently din rail in CDUB panel is 13.9 inch, could add one XM32 or two XM30 at most. If XM70 is selected, a 20-inch din rail is required, in 0185-3495-0100. For detailed I/O information, refer to 50712794.

Figure 57. XM32 expansion module mounting

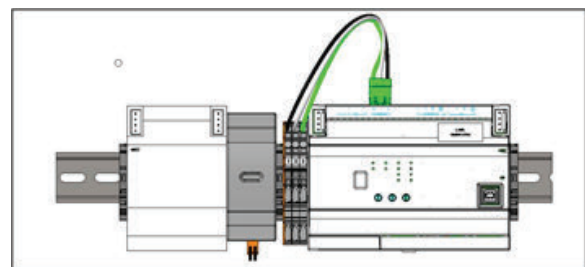

Figure 58. Two XM30 expansion module mounting

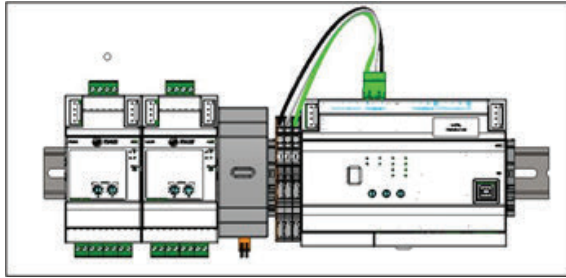
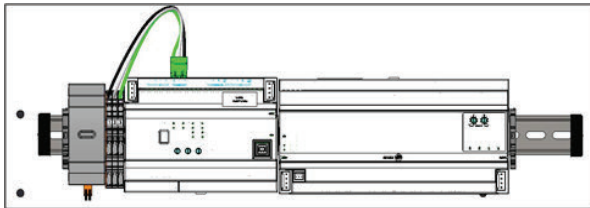

Figure 59. XM70 expansion module mounting



Before Restoring System Power

⚠ CAUTION

Unsafe Practices!
 Failure to follow these instructions could result in minor or moderate injury.
 Do not restore system power without first having completed all of the tasks specified within this installation section.

NOTICE

Unexpected Chiller Start Up!
 Failure to follow these instructions could result in minor or moderate injury.
 Do not restore system power without first having completed all of the tasks specified within this installation section.

1. To prevent an unexpected chiller start up when system power is first restored, implement the appropriate preventative measure from the list below:
 - a. If the chiller is equipped with an external Auto Stop button, disconnect the wire from terminal J2-1 on the 1A13 LLID.
 - b. If the chiller is not equipped with an external Auto Stop button, disconnect the factory installed jumper wire end from terminal J2-1 on the 1A13 LLID.

Figure 60. Preventing unexpected chiller start up before restoring system power

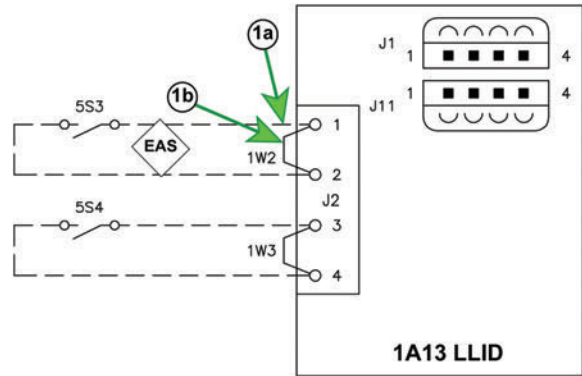

Note: EAS = External Auto Stop circuit.

2. Perform a final inspection of the control panel enclosure before restoring system power.
 - a. Remove any tools and use a shop vacuum to remove any dirt or debris that may have been created during the installation process.
 - b. Confirm that all upgrade kit wiring has been correctly routed and that all terminal connections have been properly made.
 - c. Inspect the rest of the electrical wiring and components within the enclosure to ensure that no wiring connections were accidentally loosened or disconnected during the kit installation process.
 - d. Close and latch the control panel door.

Restoring System Power

⚠ WARNING

Unsafe Practices!
 Failure to follow these instructions could result in minor or moderate injury or could result in equipment or property damage.
 Do not restore system power without first having completed the tasks specified in the previous installation section, "Before restoring system power."

1. Remove all lockout/tagout devices used at the power supply panels for the chiller equipment.
2. Warn all personnel in the area that system power is about to be restored.
3. Energize the system according to all applicable standard safety procedures.



Programming

Programming the Symbio 800

Note: For more information regarding the use of the Tracer TU service tool, installation, operation and programming of the Symbio 800 controller, operation of the control system, and a guide to the diagnostics and troubleshooting of the control system, refer to the latest version of the following manuals:

- *Tracer® TU Service Tool - User Guide (BAS-SVU047*-EN).*
- *Tracer® TU Service Tool For Water-Cooled CenTraVac™ Chillers with Symbio™ Controls - Programming Guide (CTV-SVP004*-EN).*
- *CenTraVac™ Water-cooled Chillers Models CVHE, CVHF, and CVHG With Symbio™ Controls - Installation, Operation, and Maintenance (CVHE-SVX005*-EN)*
- *Symbio™ Panel Upgrade - Programming Guide (SO-SVP002*-EN)*
- *CenTraVac™ Water-Cooled Chillers AdaptiView™ Display with Symbio™ Controls - User Guide (CTV-SVU004*-EN)*
- *CenTraVac™ Water-cooled Chillers with Symbio™ Controls Diagnostic Descriptions, Troubleshooting Tables, and Control Component Overview - Diagnostics Manual (CTV-SVD005*-EN)*

NOTICE

Separate AC Power Required for Computers when Working on Symbio 800!

When doing any service work on a Symbio 800 control system that requires connecting a laptop computer running Tracer TU service tool software to the Symbio 800 controller, the laptop must be operated from a SEPARATE AC power source AT ALL TIMES. NEVER run the laptop on internal battery power alone while connected to a Symbio 800 controller! Should the computer's internal battery die or malfunction while connected to a Symbio 800, fatal corruptions could occur to the electronic files within the controller that will render it completely inoperable and unable to accept new programming, requiring it to be replaced with new Symbio 800. Damaging a Symbio 800 controller in this manner is not covered under any warranty!

1. Obtain a working AC power adaptor with which to power the technician's laptop.
2. Connect the computer with the Tracer TU service tool software to the service port of the Symbio 800 controller with a USB type A/B cable.
3. Open Tracer TU.
Note: *Tracer TU not scheduled to have feature used in [Step 6](#) before August 2022. If not available, the unit parameters will need to be manually loaded from saved chiller service report.*
4. Obtain the latest Symbio™ 800 firmware from the Trane software download site.
5. Upgrade controller firmware as follows:
 - a. In the Utilities menu, select **File Transfer Utility**.
 - b. In the File Transfer dialog box, select **Symbio 800 controller**, and click **Next**.
 - c. Browse to the firmware file and click **Next**.
 - d. Click **Start**.
 - e. When upgrade is complete, click **Finish**.

Figure 61. Application software download



6. Follow the instructions below while also referring to [Figure 62, p. 30](#) and [Figure 63, p. 30](#):
 - a. Click the **Equipment Utility** tab (the wrench symbol on the right-hand side of the screen).
 - b. Click the **Configuration** tab.
 - c. Click the **Open File** button on the bottom of the **Configuration** screen.
 - d. Browse to the location of the Chiller Service Report file saved from the DynaView display at the start of upgrade kit installation, highlight it, and then click **Open**.
7. After completing all of [Step 6](#), the Tracer TU **Configuration** tab screen should now be populated with the values from the Chiller Service Report.
8. Verify the configuration and then click **Save**.
Clicking **Save** sends the values from this Chiller Service Report directly to the Symbio 800 controller.

Figure 62. Navigating within the equipment utility configuration tab in Tracer TU

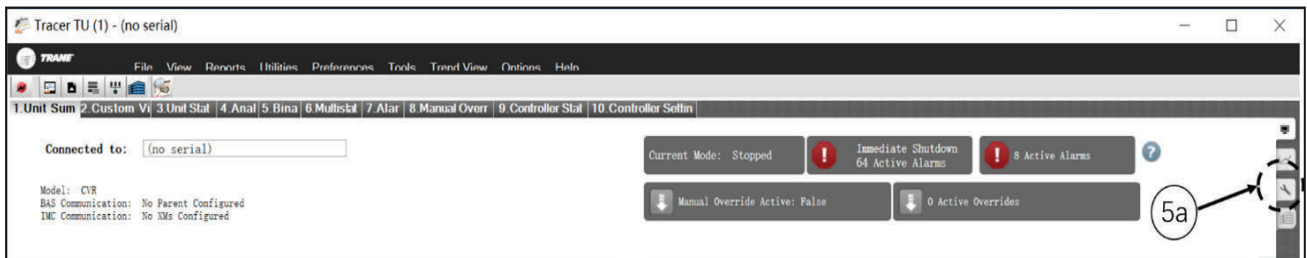
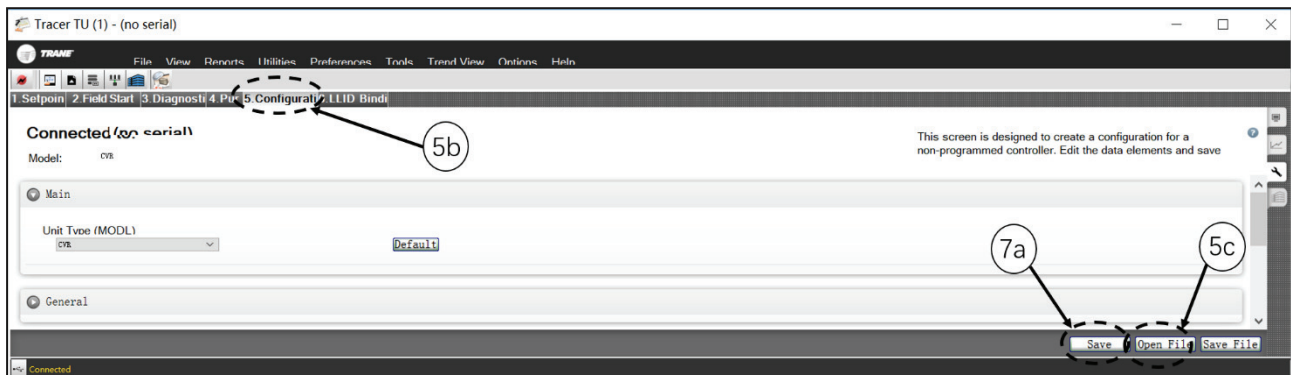
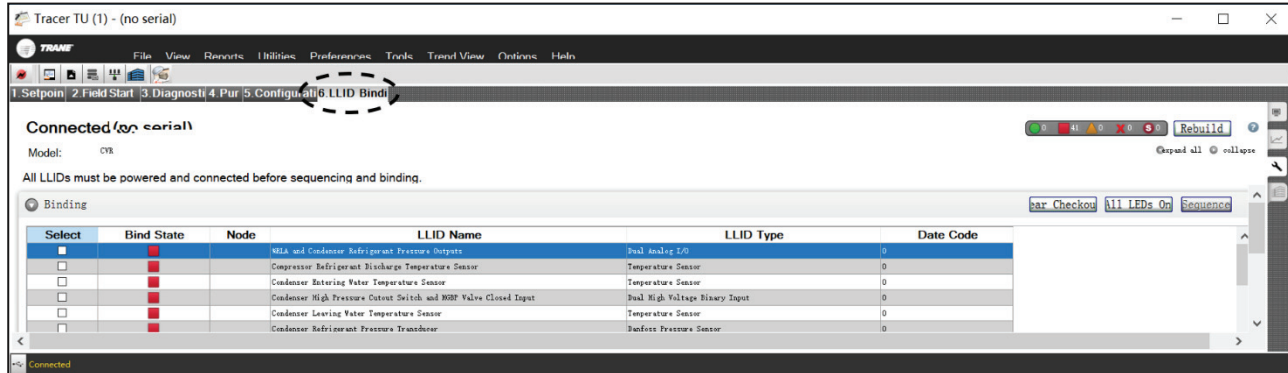

Figure 63. Location of the equipment utility tab in Tracer TU



9. After the configuration is saved, Tracer TU will automatically proceed to LLID Binding view. Check to see if any of the listed devices need to be bound, indicated by a red box. If the quad relay LLID was installed, it will have to be bound now.

Figure 64. Binding view of quad relay LLID



10. Once all LLIDs are bound, verify that the settings in the Service Setpoints, Field Startup, and Purge tabs are correct.
11. In Tracer TU, save a copy of the **Chiller Service Report**.
 - a. From the **Reports** drop-down menu, select and open **Chiller Service Report** (see the below figure).
 - b. Save a copy of **Chiller Service Report** in the folder that was created in **My Documents**.

Figure 65. Chiller service report (Tracer TU)

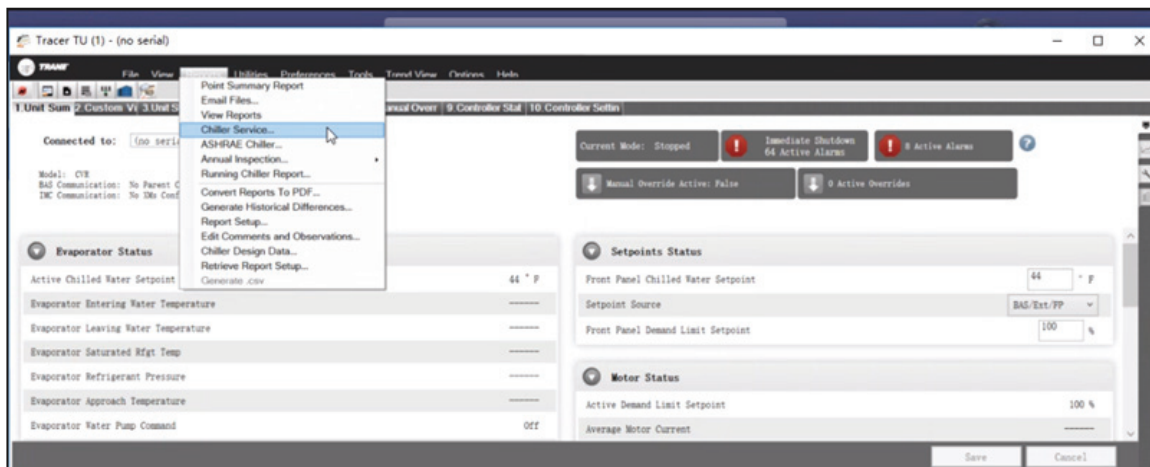

12. Save the current chiller configuration in the existing firmware version in the Symbio 800.

Note: This step produces backup configuration data in the case the Symbio 800 configuration becomes corrupt.

 - a. Access the **Equipment Utilities** section of Tracer TU by clicking the wrench symbol on the right-hand side of the screen.
 - b. Click the **Configuration** tab (see the below figure).
 - c. At the bottom of the screen, click the **Save File** button (not shown in below figure).

Figure 66. Chiller configuration (Tracer TU, simplex chiller shown)

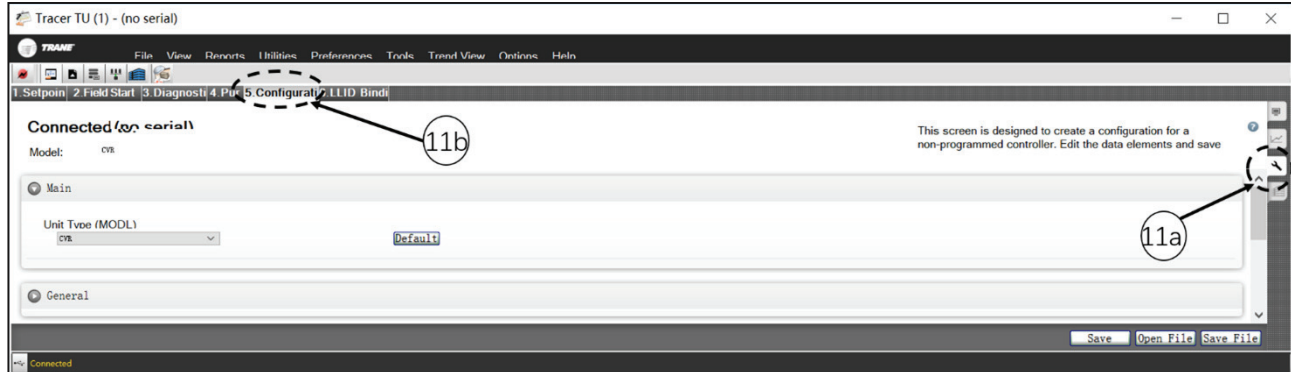

- d. In the **Browse for Folder** window, click **Make New Folder**.

A folder will be created with the name **New Folder**; this can be renamed later. The path to the folder will be:

C:\Programs\Trane\Tracer TU\Program\Plugins\UCDataBaseDAL\New Folder

- e. Select the **New Folder** file.

- f. Click the **OK** button.

The chiller configuration file will now be saved in the **New Folder**.



Start-Up

1. When the programming is completed and saved, shut down power to the control panel and disconnect the USB cable from the door of the control panel.
2. Reconnect the wire removed from the J2-1 on the 1A13 LLID.
3. Restore power to the control panel.

The chiller is now ready for normal startup and checkout procedures.

If you have further questions, contact Trane Global Parts Technical Services. To contact them, send a message to ATechnicalService@trane.com.



Wiring Diagrams

Notes:

- All of the schematic wiring diagrams displayed within this section of the installation manual are proprietary. These diagrams shall not be copied or their contents disclosed to outside parties without the written consent of Trane.
- The following hazard notifications apply to all of the electrical circuits depicted in each of the schematic wiring diagrams included within this section of the installation manual.

⚠ WARNING

Hazardous Voltage w/Capacitors!

Failure to disconnect power and discharge capacitors before servicing could result in death or serious injury. Disconnect all electric power, including remote disconnects and discharge all motor start/run capacitors before servicing. Follow proper lockout/tagout procedures to ensure the power cannot be inadvertently energized. For variable frequency drives or other energy storing components provided by Trane or others, refer to the appropriate manufacturer’s literature for allowable waiting periods for discharge of capacitors. Verify with a CAT III or IV voltmeter rated per NFPA 70E that all capacitors have discharged.

⚠ WARNING

Proper Field Wiring and Grounding Required!

Failure to follow code could result in death or serious injury. All field wiring **MUST** be performed by qualified personnel. Improperly installed and grounded field wiring poses **FIRE** and **ELECTROCUTION** hazards. To avoid these hazards, you **MUST** follow requirements for field wiring installation and grounding as described in NEC and your local/state/national electrical codes.

NOTICE

Use Copper Conductors Only!

Failure to use copper conductors could result in equipment damage as the equipment was not designed or qualified to accept other types of conductors.

Table 4. Package and diagram matrix

Description	CADE	UPGRADE KIT	LITERATURE	DIAGRAM
CH530-SIMPLEX	CCDU	018534930100 and 018534990100	5071-2798	5071-2792
				5071-2794
CH530-DUPLEX	DCUA	018534930100, 018534990100, and BRD04879	5071-2798	5071-2792
				5071-2794
CH530-GEAR	GEAR	018534930100 and 018534990100	5071-2798	5071-2792
				5071-2794
CH531	C531	018534930100 and 018535000100	5071-2797	5071-2791
				5071-2794

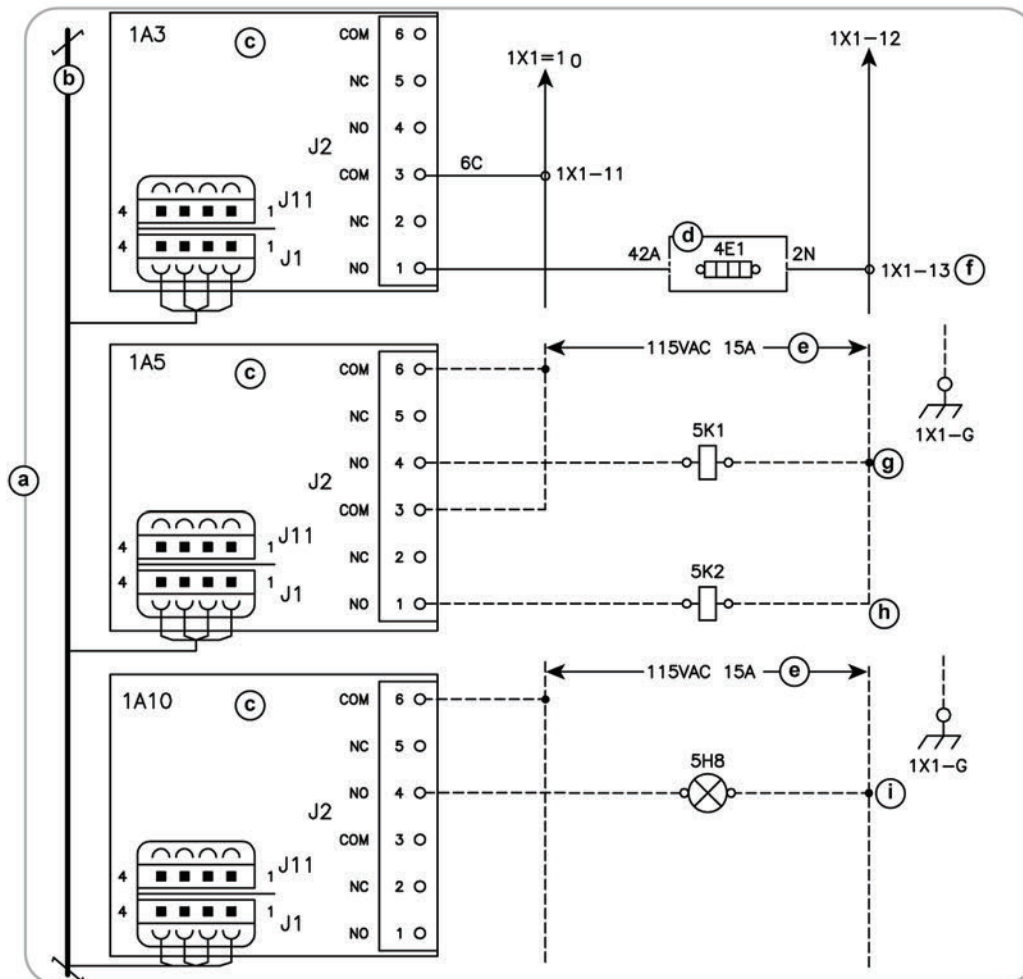
Figure 67. Existing LLIDs to remove before installing quad relay LLID

a	All notes and hazard notifications listed in "Wiring Diagrams," p. 34 of this manual apply to this drawing
b	IPC BUS
c	Dual relay LLID to remove (its functions will be replaced by the Quad Relay)
d	Oil tank junction box
e	Customer provided
f	Oil tank heater
g	Evaporator water pump (optional)
h	Condenser water pump (required)
i	Ice building indicator (optional)

Figure 68. Quad relay LLID installation

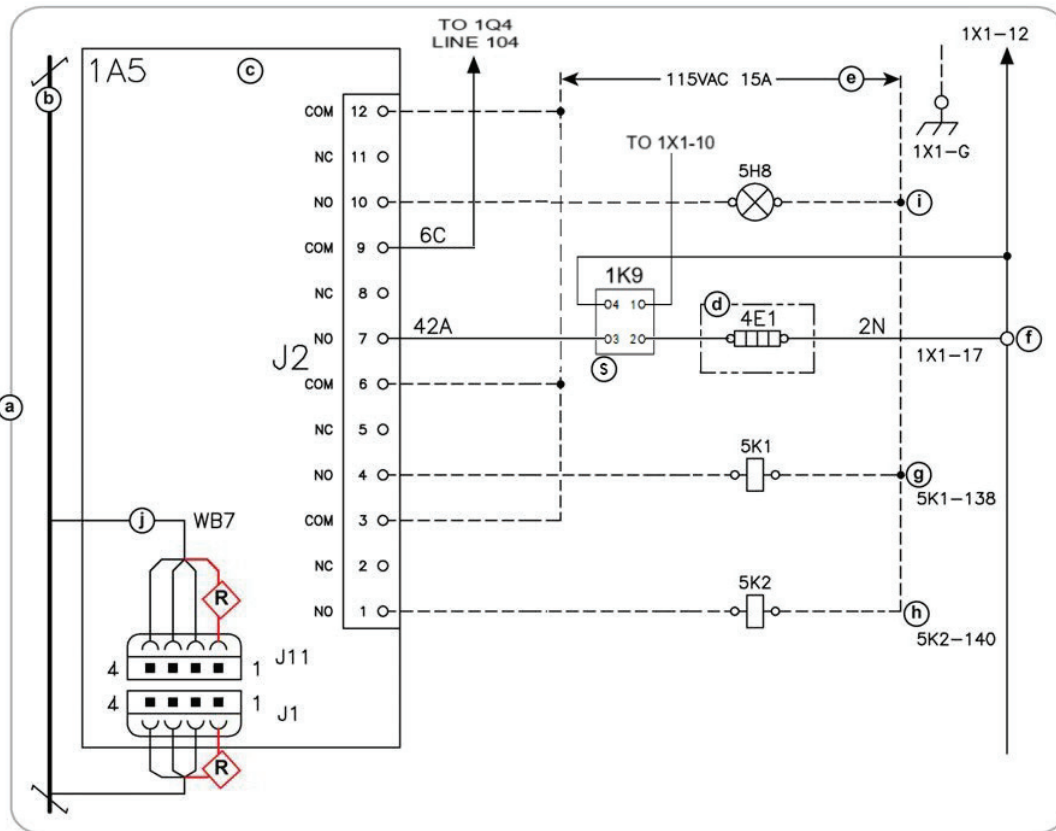

a	All notes and hazard notifications listed in "Wiring Diagrams," p. 34 of this manual apply to this drawing
b	IPC BUS
c	Quad Relay output
d	Oil tank junction box
e	Customer provided
f	Oil tank heater
g	Evaporator water pump (optional)
h	Condenser water pump (required)
i	Ice building indicator (optional)
j	WB7 connects to 1A4-J11 (Line 101) when 1A4 is present
R	Red wire (proper orientation of connector for plugging into this terminal block is with the connector end terminal holding the red wire being lined up with block terminal number 1)
S	Solid state oil heater relay

Figure 69. Full schematic wiring diagram for a standard Symbio 800 upgrade kit

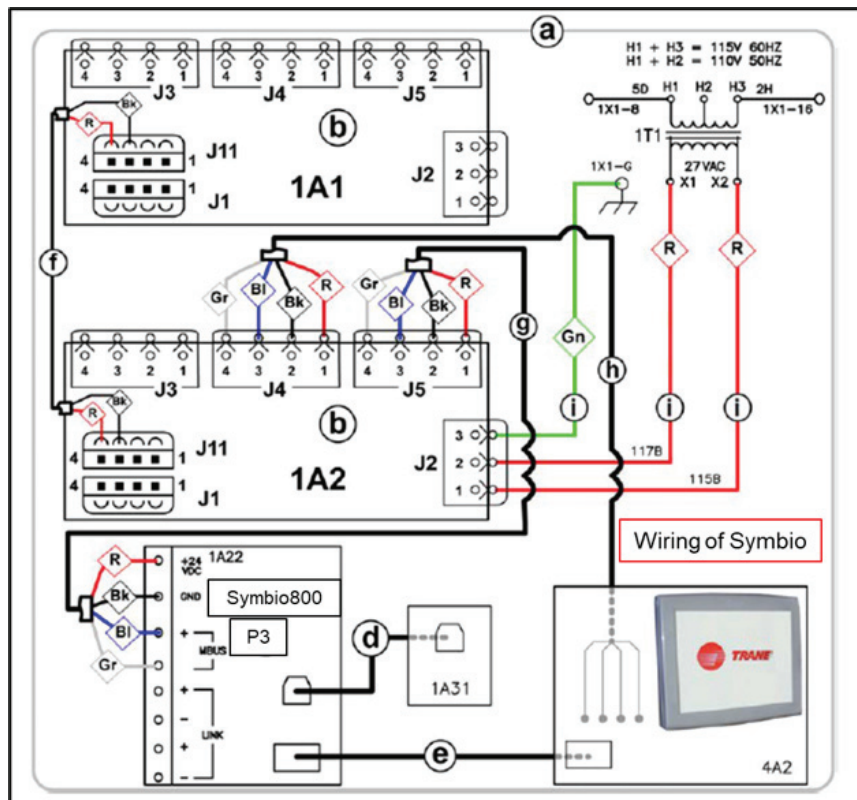

a	All notes and hazard notifications listed in "Wiring Diagrams," p. 34 of this manual apply to this drawing
b	Power Supply
c	Symbio 800 controller
d	USB Type B service port cable from Symbio 800 controller receptacle to control panel door
e	Ethernet cable connection between Symbio 800 Ethernet port and Symbio 800 display
f	2-conductor communication cable (It could also be connected between J1 terminals)
g	4-conductor cable
h	Female to bare end wire harness to Male to Female wire harness extension to display
i	Field provided 16 AWG control wire
Bl	Blue wire
Bk	Black wire
Gn	Green wire
Gr	Gray wire



Notes

Trane - by Trane Technologies (NYSE: TT), a global climate innovator - creates comfortable, energy efficient indoor environments for commercial and residential applications. For more information, please visit trane.com or tranetechnologies.com.

Trane has a policy of continuous product and product data improvement and reserves the right to change design and specifications without notice. We are committed to using environmentally conscious print practices.