

LED

Light-Emitting Diode (LED) Design Guide

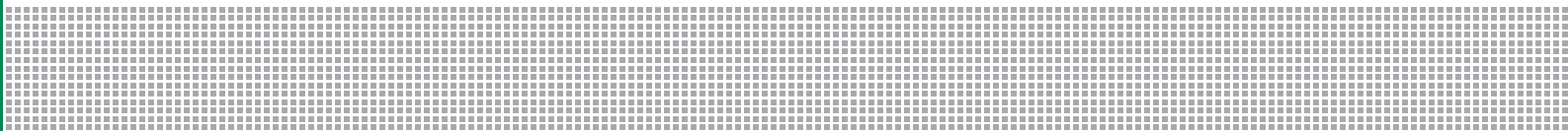
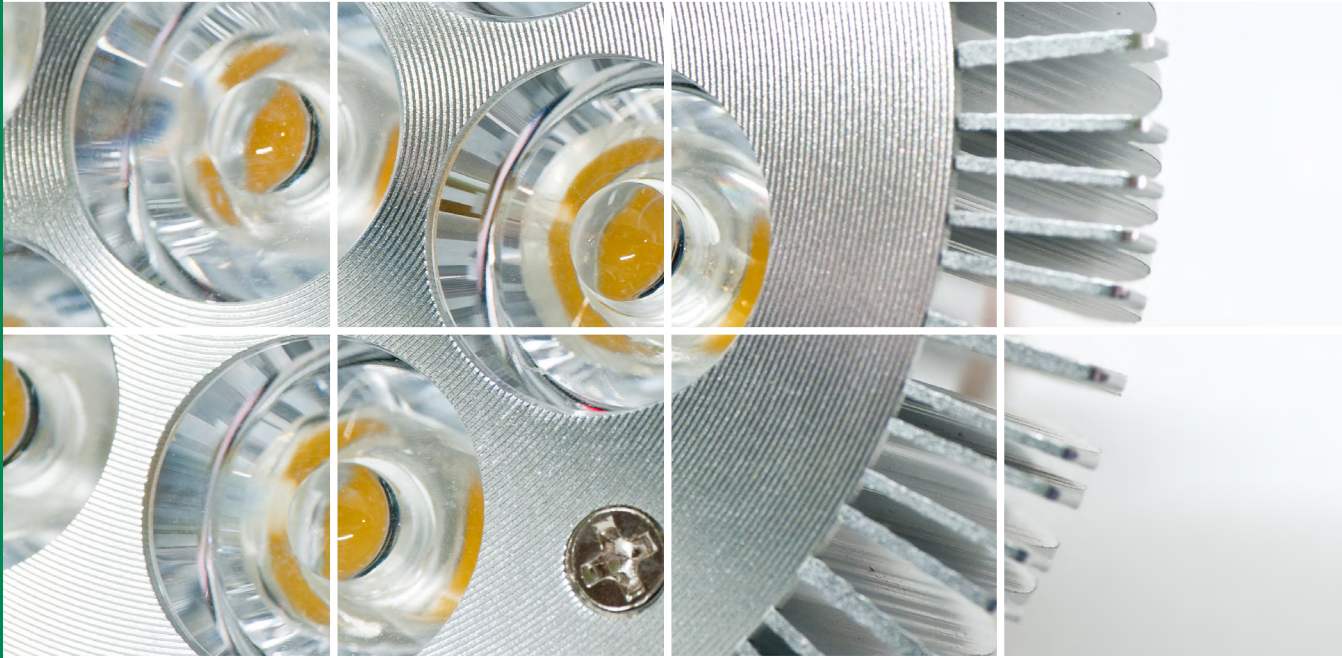

Expertise Applied | Answers Delivered

LED Light-Emitting Diode (LED) Design Guide

Table of Contents		Page
Introduction		3-4
Safety and Reliability of LED Bulbs		5-7
Surge Immunity Requirements for Consumer LED Lighting/ Retrofit Lamps		8-10
Part Selection Matrix for LED Lamp Protection		11
LED Lighting Compliance with Global Standards		12-15
Part Selection Guide		16-17
Design Considerations in MOV Selection		18-19
Surge Protection Modules and MOV Coordination		20-21
Protecting Against Temporary Overvoltage		22
Design Considerations in Fuse Selection to Withstand Surges		23
Design Considerations for TVS Diodes		24-25
Design Considerations for PLED Protectors		26-28
Potential Problems with Alternative LED Lamp Overcurrent Protection Technologies		29-33
Conclusions		34
References		34
Legal Disclaimers		35

Introduction

Introduction

The first LED lamps were introduced in the late 1990s. Since then, the unit costs have been steadily declining by double-digit percentages, making LED lighting technology viable for commercial, industrial and outdoor lighting applications. In addition, large strides have been made in improving the efficiency, lumen output and performance of LED lights. The global LED lighting market is estimated to be \$16B in 2012 and expected to reach nearly \$40B by 2014 (**Figure 1**). The US market CAGR for commercial and outdoor LED lighting alone is expected to grow 26-30% through 2016.

Market Share by Region, 2010

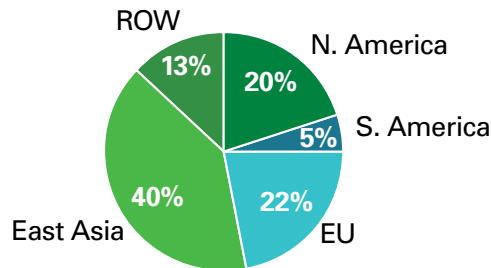

- Global LED Lighting market to reach \$16.5B in 2012, 11.3% share of total lighting
- 60% Comm, 25% Residl, 15% Indl/Instl
- Key luminaire drivers: traffic lights, roadways, parking lots, and other outdoors

Source: Green Market Research

LED share of lighting market to exceed 25% by 2014

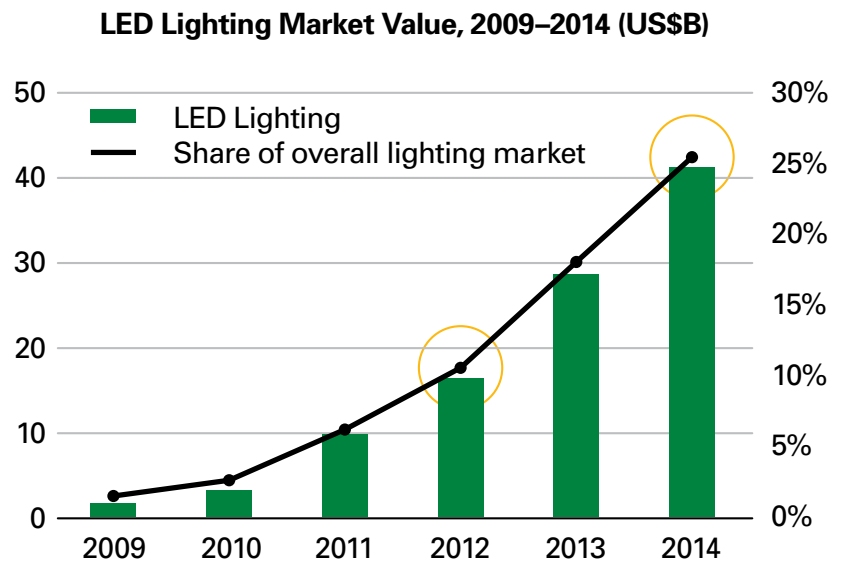

Figure 1. Global market for LED lighting
 Source: Digitimes

In the commercial sectors, the business case is not only justified from double digit energy savings but also large maintenance and labor cost reductions. Utility rebates and government financial incentives for energy efficiency further help reduce the initial cost of LED lamp and luminaire installations. As most LED lamps are specified to last around 50,000 hours versus 1000 hours for incandescent and 8,000 hours for CFLs, fewer maintenance staff hours are required to replace lamps in large facilities. Further, reduction in CO₂ emissions by going to LED alternatives is also a key driving factor near and dear to government environmental agencies. A single 100W incandescent bulb for example, that is on four hours a day produces 139 pounds of carbon per year. Switching to a 12 watt LED lamp which has the equivalent light output of a 75W incandescent will emit only 7.33 lbs. of carbon per year.

Introduction (continued)



Over the next couple of years, LED lighting adoption will be highest in retail accent lighting and cold storage followed by street, highway, parking lot and public structure illumination, and niche applications in commercial building lighting. Street lighting energy efficiency measures have been initiated by many local cities and municipalities around the world seeking to replace high pressure sodium (HPS) lamps with LED lights. For parking lots and parking garages, HPS, metal halides and fluorescents are the main targets for replacement.

The United States is leading the way for establishing uniform performance and safety standards for certain indoor commercial lighting as well as roadway, parking lot and garage illumination. The EPA's Energy Star® specifications apply to LED replacement bulbs for residential and certain commercial applications. The US Dept of Energy's Municipal Solid State Street Lighting Consortium's LED Roadway model spec, and the Commercial Building Energy Alliance Parking Lot and Structure Outdoor LED lighting performance spec are examples of important documents released in late 2011 and early 2012 respectively. A Littelfuse video, **Circuit Protection and Reliability Solutions for the LED Lighting Market**, provides an overview of global standards for circuit protection of LED lighting.

Littelfuse describes the market and circuit protection needed for LED lighting.

To view the video, visit: <https://vimeo.com/50692101>

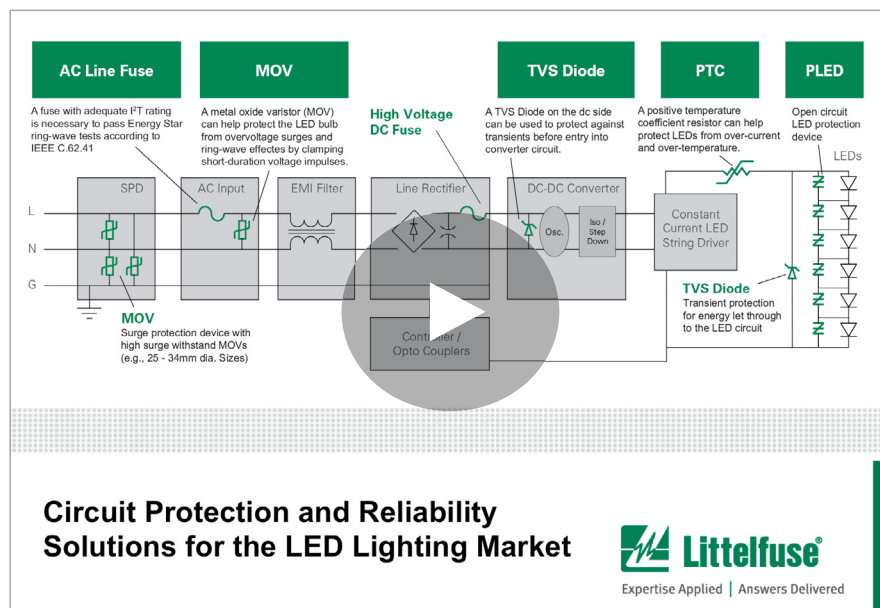

Safety and Reliability of LED Bulbs

Safety and Reliability of LED Bulbs

An LED lamp contains power conversion electronics (AC/DC), driver IC for the LEDs, a heat sink for thermal management and optics to optimize light quality. Since LED bulbs are intended to be form factor-compatible with current incandescent and CFL bulbs, they will have an AC/DC power supply circuit so they can operate from standard bulb “sockets.” (See **Figure 2**.)

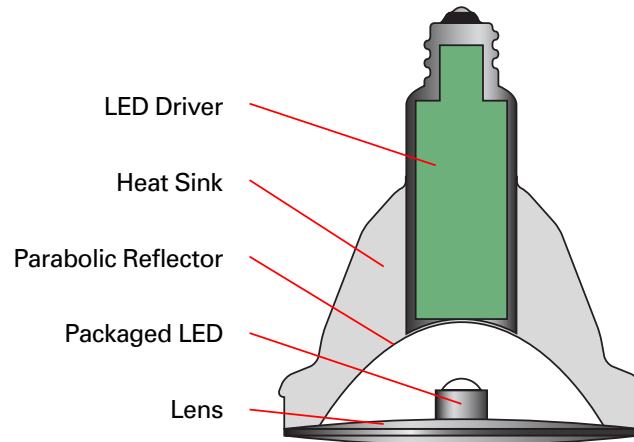

Figure 2. Typical residential LED lamp construction.

Equipment that is directly connected to AC mains (e.g. 120/220VAC) can be damaged by short circuit and overload conditions caused by component and/or circuit failures inside the bulb. In addition, lightning surges or load switching transients (originating outside the bulb) can create voltage spikes or ring waves that can stress and ultimately damage components, and render the bulb dead. Given that the value proposition for LED bulbs is not only lower energy usage, but longer lifetimes, it will be crucial that transient voltage protection is taken into account to eliminate field failures driven by the electrical environment.

To view the video, visit:
<https://vimeo.com/39714285>



Usha Patel, who leads Littelfuse's LED initiatives, describes how to use circuit protection devices to increase LED lighting reliability and safety.

Safety and Reliability of LED Bulbs (continued)

Click/toggle the green boxes below to view our product lines.



Equipment that is directly connected to AC mains (100 to 240VAC) can be damaged by short circuit overload conditions, lightning surges or load switching transients that create voltage spikes or ring waves

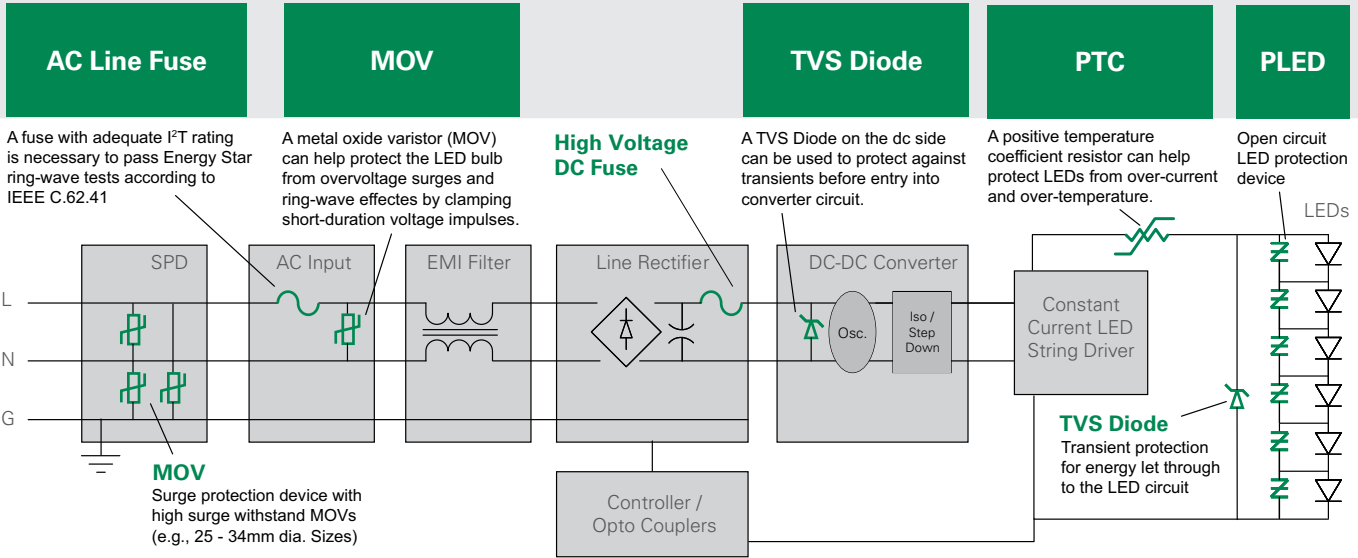

Figure 3. Typical LED luminaire driver circuit with transient and surge energy protection devices

Littelfuse offers complete AC line interface protection as well as transient protection on the DC side. Its LED Lighting Design video discusses reliability and safety issues that need to be addressed in selecting protective devices for LED retrofit bulbs and luminaires to meet industry standards. Refer to **Figure 3** for an overview of the various components and systems within the power and control circuits inside an LED lighting assembly.

As shown in **Figure 3**, a Littelfuse AC fuse in series with the line will provide safety protection against short circuit and overload conditions. They are available in a wide range of form factors, amperage ratings, voltage ratings, breaking capacity and mounting options to provide design flexibility to the design engineer.

The AC/DC power conversion circuit can use either isolated or non-isolated topologies. Transient protection is not only critical for the DC side electronics but more importantly the LED load. The ICs can be protected by nature of isolated bias windings and filtering elements. However, insufficient spacing on the PCB, flashover of physically small components, or unintentional coupling through transformers and opto couplers can fail due to inadequate transient protection. A well designed surge protection scheme will limit the peak voltage and current envelopes to avoid coupling through unintentional paths.

Safety and Reliability of LED Bulbs (continued)

In the case of non-isolated LED drivers which are prominent in many retrofit lamps and lower power applications, the LEDs themselves can be damaged by the surge energy as there is no transformer isolation between the AC input and the LEDs on the DC side. Isolated circuits, such as flyback converters, are more robust since their transformers provide some degree of isolation and surge protection. Nevertheless, protection is still required to limit higher surge events, especially in outdoor lamp and luminaire environments. High energy surge events, such as those caused by nearby lightning strikes can flash over from the primary to the secondary side.

The MOV across the AC power input in **Figure 3** is the key to providing surge clamping protection against lightning related transients. An MOV in this location is a cost-effective way to minimize transient energy that could make its way into downstream electronics. MOV selection is based on a number of parameters, including voltage rating, peak pulse current, energy rating, disk size and lead configuration. Littelfuse provides varistors with disk diameter down to 5mm (ZA series), which allows them to be used in the space-constrained power supply section of an LED lamp. **Littelfuse Application Note 9767** provides a detailed explanation of MOV technology.

The MOV and the fuse must be a coordinated solution so that energy needed to melt the fuse element (also referred to as “ i^2t ” value) is high enough to allow the MOV to operate under surge conditions without causing the fuse to open (also known as nuisance opening). In other words, during clamping and dissipation of surge energy, the fuse should not open. It should only open when an overload or short circuit condition occurs.

There will be instances when the circuit is not able to survive surge events, even with a varistor on the AC input. In these cases, a TVS diode can be added at the input of the power converter stage. Referring again to **Figure 3**, the TVS diode provides secondary protection against transients. The “let through” energy from the varistor will be further clamped by the TVS diode to a level that the circuit can survive.

Littelfuse has many options for fuses, MOVs and TVS diodes, based on form factor, space constraints, electrical parameters and cost. (See embedded links in the green boxes of **Figure 3**.)



Surge Immunity Requirements for Consumer LED Lighting/Retrofit Lamps

Surge Immunity Requirements for Consumer LED Lighting/Retrofit Lamps

Fuses, MOVs and TVS diodes from Littelfuse are critical in helping the lamp manufacturer pass important regulatory and safety standards. The United States is leading the way for establishing uniform performance and safety standards for certain indoor commercial lighting as well as roadway, parking lot and garage illumination. EPA’s Energy Star surge specifications apply to the PAR30, PAR38, A-19, MR16, Candelabra, G-globe, and R-reflector types of LED retrofit lamps.



Some IEC Requirements. With the exception of the US, which uses other standards, overvoltage transient surge testing per IEC 61000-4-5 is a global requirement for LED lighting assemblies. In addition, part of IEC61547, “Equipment for General Lighting Purposes” requires EMC immunity testing. **Figure 4** shows two waveforms that define rise time and duration of the test voltage and current.

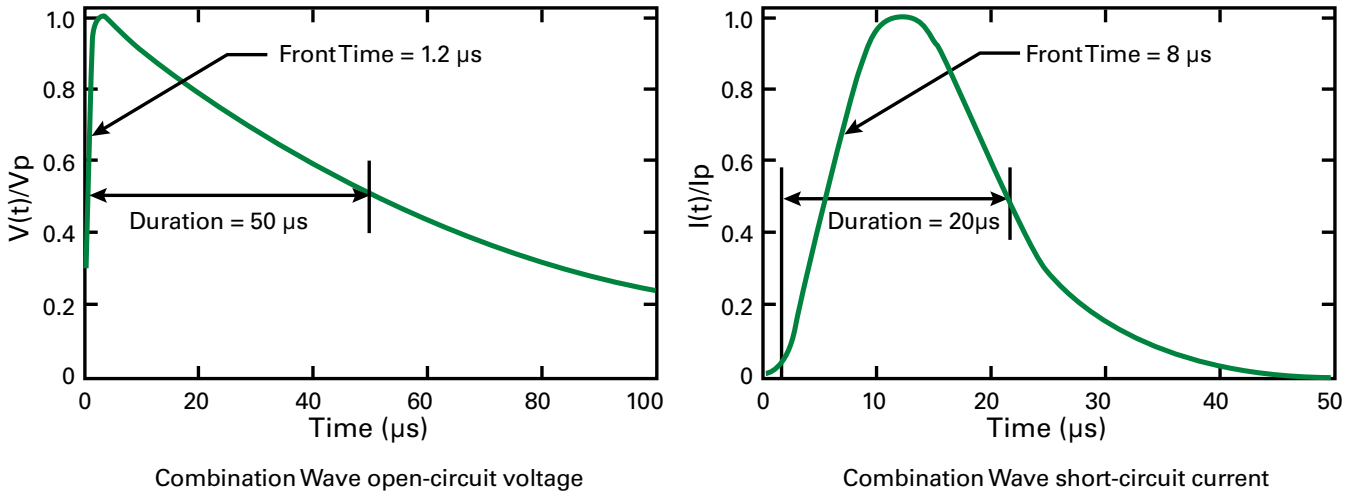

Figure 4. IEC 61000-4-5 surge immunity test waveforms: 1.2x50μs open circuit voltage and 8x20μs short circuit current.

Surge Immunity Requirements for Consumer LED Lighting/Retrofit Lamps (continued)

Additional test requirements include:

- For **self-ballasted lamps and luminaires < 25W**, 500V/250A: Apply 500V L-L with 2 ohm source impedance and 1kV L-G with 12 ohms impedance.
- For **luminaire > 25W**, 1000V/500A: Apply 1kV L-L with 2 ohm source impedance and 2kV L-G with 12 ohms impedance.
- Number of surges: 10 strikes, 5+ and 5- at phase angles 90/270, 1 minute between each strike.



In the US, manufacturers generally must meet Energy Star transient voltage surge specifications for LED replacement bulb assemblies used in residential and certain commercial applications. For example, Version 1.4 of the Energy Star program requirements define a ring wave transient test for integral LED lamps (**Figure 5**).

Other test requirements include:

- Test Level: 2.5kV/83A, line-to-line (ANSI/IEEE C.62.41-1991, Class A operation).
- Number of surges: 7 strikes in common mode and 7 in differential mode, 1 minute between each strike.

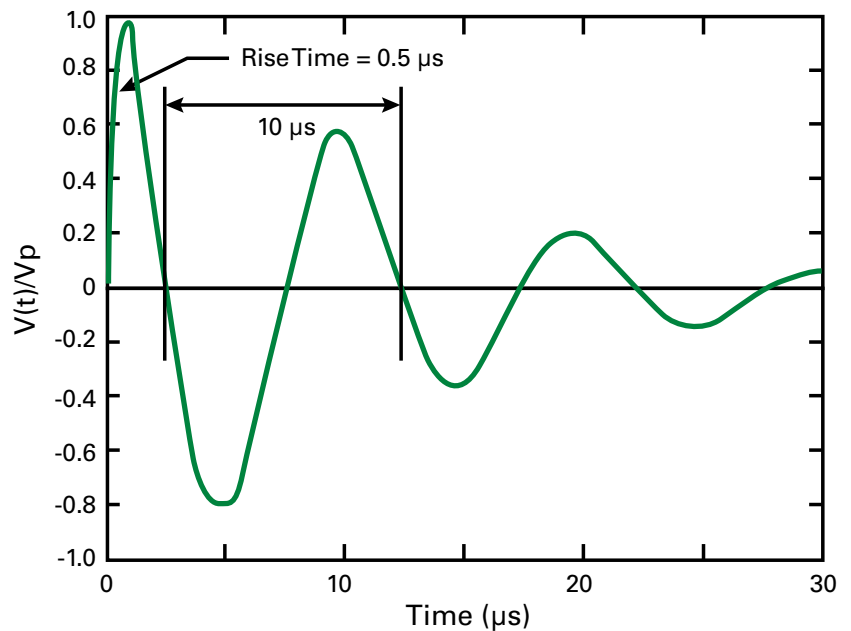

Figure 5. Energy Star transient voltage immunity test waveform: 0.5 μs rise time \times 10 μs duration (100kHz) ring wave.

The 100 kHz Ring Wave (voltage and current)

Surge Immunity Requirements for Consumer LED Lighting/Retrofit Lamps (continued)

It is often the case that engineers will want to test the robustness of their application and their protection scheme during the qualification process. For those that lack in-house surge test equipment, Littelfuse offers the use of lab facilities to verify the design of their application. This testing can identify problems at a stage early enough that they can be corrected before field issues occur. **Figure 6** illustrates the voltage and current waveforms for an Energy Star surge test conducted by Littelfuse on an LED bulb assembly. The circuitry for this A19 lamp assembly included the Littelfuse 0451/0453 series fuse installed on the lamp driver board. The LED was lit and was fully operational before and after application of the surge, thus passing Energy Star requirements.

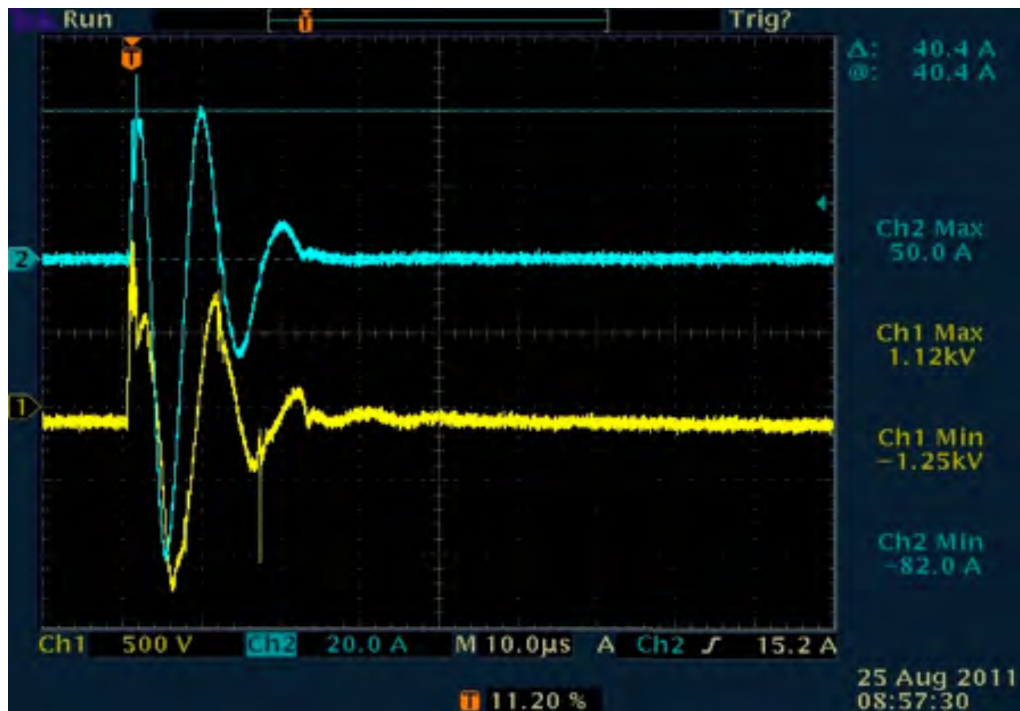

Figure 6. Typical waveform of 2.5kV, 100kHz ring wave surge test.

Part Selection Matrix for LED Lamp Protection

Part Selection Matrix for LED Lamp Protection

It's important for engineers to avoid the trap of trying to use the same protection devices for every LED lamp assembly they design. Each application should be evaluated based on the operating environment, circuit operating parameters, and the pertinent surge protection specifications. **Table 1** lists several Littelfuse part numbers for fuses, MOVs, and TVS diodes that could fit many of these applications and their associated surge test requirements.

Transient Surge Spec	Fuse Options	MOV Options	TVS Diode
ENERGY STAR® Program Requirements for Integral LED Lamps (for USA)			
1. ANSI/IEEE C.62.41-1991, Class A operation. 0.5µs 100kHz Ring Wave, 2.5kV, 7 strikes common and differential modes	047001.5 (1.5A SMT 1206 125V) 0453001 (1A SMT 2410 125V) 0454001 (1A SMT 2410 125V) 0473001 (1A Pico 125V) 39211000000 (TE5 250V 1A) 38211000000 (TR5 250V 1A)	V150LA2P V175LA2P V240ZA05P V240CH8	P6KE300CA SMAJ400A SMAJ440A SMBJ400A SMBJ440A 1.5KE400A 1.5KE440CA
IEC 61547 Equipment for general lighting purposes - EMC immunity requirements (for Europe/ Asia / Australia)			
1. IEC 61000-4-5 Surge Immunity Test. For lamps < 25W: 1.2×50µs/8×20µs combination wave 500V/250A line-to-line test (10 strikes, 5+ at phase angles 90, 5- at phase angle 270)	087601.6 (3.6x10 250V 1.6A) 39211000000 (TE5 250V 1A) 38211000000 (TR5 250V 1A) 0476003 (SMT 2410 250V 3A) 0465001 (SMT 4818 250V 1A)	V300LA2P V320LA7P V430CH8	P6KE300CA SMAJ400A SMAJ440A SMBJ400A SMBJ440A 1.5KE400A 1.5KE440CA
2. IEC 61000-4-5 Surge Immunity Test. For lamps > 25W: 1.2×50µs/8×20µs combination wave 1000V/500A line-to-line test (10 strikes, 5+ at phase angles 90, 5- at phase angle 270)	0877002 (2A 250V 3.6x10) 39211600000 (TE5 250V 1.6A) 38211600000 (TR5 250V 1.6A) 046501.6 (250V SMT 4818 1.6A)	V300LA10P V320LA10P V300SM7 V320SM7	P6KE300CA SMAJ400A SMAJ440A SMBJ400A SMBJ440A 1.5KE400A 1.5KE440CA

NOTE: MOVs were tested with 1.2×50µs open circuit voltage waveform and 8×20µs short circuit current waveform forming a combo waveform with 2 ohm source impedance. Standard method was used for testing the MOVs per datasheet specifications which consisted of driving relevant surge current through the part with the generated combination wave. In real world events, actual peak current through the lamp with typical circuit impedance path will likely be lower. Littelfuse has tested the above part selections to a more stringent level as it complies with our internal testing standards.

Table 1. A sampling of Littelfuse devices designed for LED lamp surge protection.

LED Lighting Compliance with Global Standards

LED Lighting Compliance with Global Standards

Many countries are in the midst of developing protection standards for LED lighting. As this lighting technology matures, these requirements are in a state of flux and may become more stringent. **Table 2** is a matrix of current safety and surge standards prevalent in key geographic areas of the world.

	United States	Europe S. America	Japan	Taiwan	China	Korea
Surge Immunity (Combo wave) 1.2x50µs Voc/ 8x20µs Isc Integrated LED light bulbs (E27 Base Europe/E26 Base USA) (LED retrofit lamps and indoor commercial)	Energy Star (Based on IEEE C62.41.2) Ring wave 2.5kV 100kHz Class A	IEC/EN 61547 IEC/EN 61000-4-5 500V/250A 1kV/500A	JIS C 61000-4-5 (Based on IEC/EN 61000-4-5) 500V/250A 1kV/500A	CNS 14676-5 (Based on IEC/EN 61000-4-5) 500V/250A 1kV/500A	GB/T 18595 (Based on IEC/EN 61547) 500V/250A 1kV/500A	K61547 (Based on IEC/EN 61547) 500V/250A 1kV/500A
Surge Immunity (Combo wave) 1.2x50µs Voc/ 8x20µs Isc LED Outdoor Luminaires (Street Lighting, Parking Lot Lighting)	DOE (Based on IEEE C.62.41.2) Category C-Low 6kV/3kA Category C-High 20kV/10kA ANSI/NEMA (spec. no. TBD)	IEC/EN 61547 IEC/EN 61000-4-5 4kV/2kA 6kV/3kA 10kV/5kA	JIS C 61000-4-5 (Based on IEC/EN 61000-4-5) 4kV/2kA	CNS 14676-5 (Based on IEC/EN 61000-4-5) 4kV/2kA	GB/T 17626.5 (Based on IEC/EN 61000-4-5) 4kV/2kA	KS C IEC61000-4-5 (Based on IEC/EN 61000-4-5) 4kV/2kA
Safety	UL 8750, UL 1310, UL 1993, UL 1598	IEC/EN 62560 bulb IEC/EN 60598 Luminaire IEC/EN 61347 driver IEC/EN 62031 LED array/module	DENAN standards JEL 801	CNS standards	GB24819-2009/ IEC62031 LED Module for general lighting-safety	KS standards

Table 2. Summary matrix of global protection standards for LED lighting

Safety refers to overcurrent protection, particularly short circuit and overload protection. In North America, UL8750 is the Standard for Safety of LED Equipment, which pertains to residential LED lamps and outdoor luminaire assemblies. The purpose of this requirement is to minimize the risk of shock and fire. It calls out the use of an overcurrent protection device to interrupt or limit the current during a short circuit or overload condition. Fuses are the most widely used and reliable protection technology to protect against such conditions. Outside the US, the IEC/EN 61347 LED driver (power supply) specification and IEC/EN 62031 for LED arrays/modules contain safety requirements for these power supplies.

In Europe and other countries outside the United States, the surge immunity requirements are referenced in documents such as IEC/EN 61547 that references IEC/EN 61000-4-5, which delineates different surge testing levels based on 8x20µs short circuit current combination waveform. For outdoor lighting applications, these levels can range from 4kV/2kA in many Asian countries up to 10kV/5kA in Europe.

LED Lighting Compliance with Global Standards (continued)

In the US, ANSI/IEEE C.62.41-2002 is a very important specification to consider, because it is either the primary or secondary reference for surge immunity testing. This standard defines four lighting location categories and associated transient surge testing requirements. The categories correspond to the physical location of the LED luminaire whether located indoors or outdoors. For instance, the outdoors luminaires that fall into Category C (high or low test requirements) are far more susceptible to lightning strikes and hence will be subject to the most stringent surge immunity testing. **Figure 7** illustrates these locations. **Table 3** is a summary of the IEEE C.62.41-2002 surge levels and where they apply.

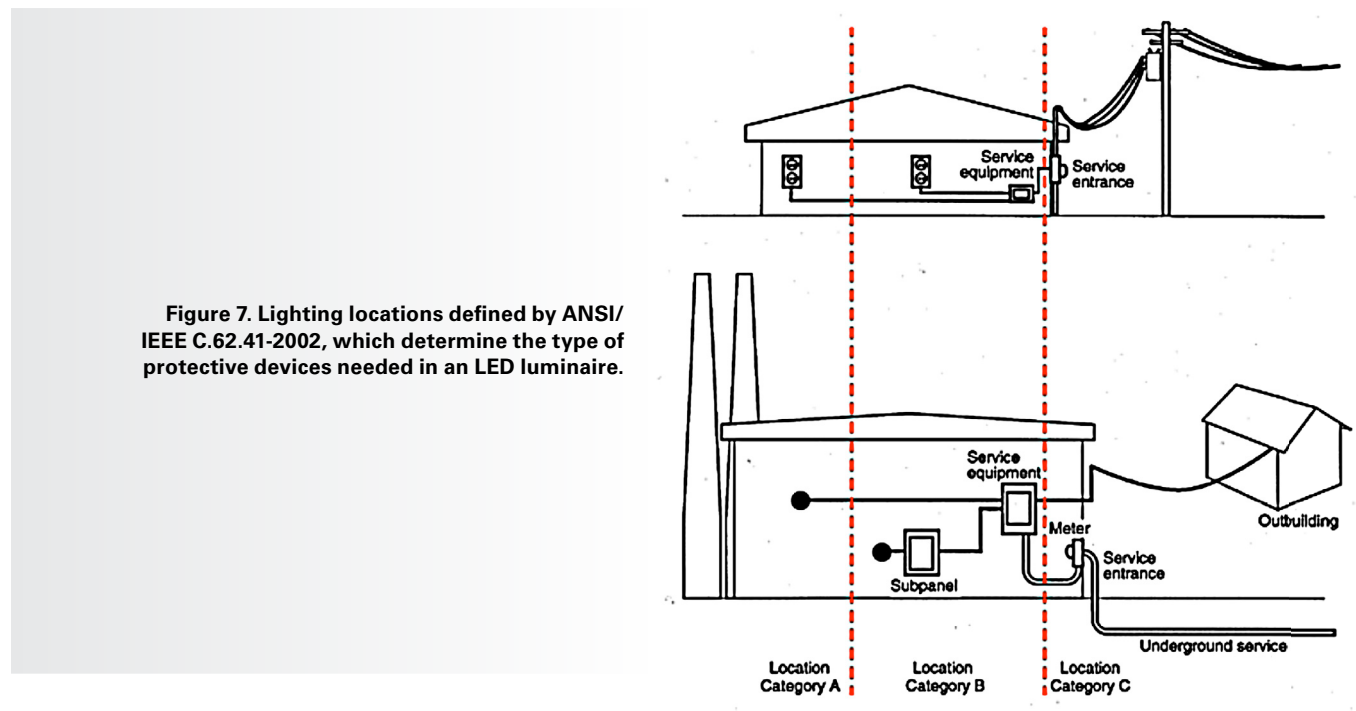

Figure 7. Lighting locations defined by ANSI/IEEE C.62.41-2002, which determine the type of protective devices needed in an LED luminaire.

Location Category	Pk Voltage (kV)	Pk Current (kA)	Source	Application
Waveform	1.2/50μs	8/20μs	Impedance (Ohms)	
A (Indoors)	6	0.5	12	Indoor Commercial Bldg/ Offices/ Retail
B	6	3	2	Lighting near Service Entrance
C Low	6	3	2	Commercial/ Industrial/ Parking Garage
C High (Outdoors)*	20	10	2	Street/ Hwy/ Parking Lot/ Area Flood/ Outdoor
Location Category	Pk Voltage (kV)	Pk Current (kA)	Source	
Waveform	0.5μs 100kHz Ring Wave		Impedance (Ohms)	
A (Indoors)	6	0.2	30	
B	6	0.5	12	
C Low or High	6	0.5	12	

*A combination waveform where specified peak current is calibrated on the tester by shorting the output together prior to connection to the luminaire. Single phase modes: L-N L-G N-G. Polyphase Modes: L-L L-N L's-G

Table 3. IEEE C.62.41-2002 test requirements for LED luminaires.

LED Lighting Compliance with Global Standards (continued)

LED luminaires today are over two times the cost of the incumbent HPS lighting assemblies. However, LEDs are expected to last nearly 100,000 hours – about three to four times that of HPS luminaires, while consuming 80% less energy. The US has established uniform performance and safety standards for Outdoor lighting including roadway, parking lot and garage illumination.



UL 1598 is the Standard for Safety of Luminaires which garners compliance from a majority of outdoor lighting manufacturers in N. America. This specification covers requirements for overcurrent protective devices such as fuses that are used for overload and short circuit protection in luminaires. These requirements are similar to those in UL 60950. In addition, UL 8750 - the Standard for LED Equipment for use in Lighting Products also calls out the use of overcurrent protective devices such as fuses.

The US Department of Energy’s (DOE) Municipal Solid-State Street Lighting Consortium (MSSSLC) has released a model specification for LED roadway luminaires for use by cities and municipalities when specifying LED lighting requirements. This DOE specification is projected to become an ANSI/NEMA C136.x requirement in the near future. The DOE’s goal is to protect LED luminaire investments by establishing strong safety and surge standards, so light fixtures will require minimal maintenance and are able to last a minimum of five years without service disruption. These will be important characteristics as cities and municipalities begin lighting replacement and retrofit programs, which will involve large capital investments. To support this initiative, funding and subsidy programs such as the American Recovery and Reinvestment Act (ARRA) are helping many cities reduce the initial cost of these LED lighting projects

The DOE specification details performance, safety and surge immunity requirements. Excerpts from this specification are listed in **Table 4** and **Table 5**.

Parameter	Test Level/ Configuration
1.2/50µs Open Circuit Voltage Peak	Low: 6 kV. High: 10kV*
8/20µs Short Circuit Current Peak	Low: 3 kA. High: 10kA
Coupling Modes	L1 to PE, L2 to PE, L1 to 72
Polarity and Phase Angle	Positive at 90° and Negative at 270°
Test Strikes	5 for each Coupling Mode and Polarity/Phase Angle combination
Time Between Strikes	1 minute
Total Number of Strikes	= 5 strikes × 3 coupling modes × 2 polarity/phase angles = 30 total strikes

*This is a MINIMUM requirement. Note that for most combination wave generators, which have a source impedance of 2Ω, the generator charging voltage will need to be raised above the specified level (to somewhere in the vicinity of 20kV) to obtain the specified current peak.

Table 4. DOE MSSSLC 1.2/50µs Combination Wave Test Specification

LED Lighting Compliance with Global Standards (continued)

Parameter	Test Level/ Configuration
Short Circuit Current Peak	0.5kA
Open Circuit Voltage Peak	6kV
Coupling Modes	L1 to PE, L2 to PE, L1 to L2
Polarity and Phase Angle	Positive at 90° and Negative at 270°
Test Strikes	5 for each Coupling Mode and Polarity/Phase Angle combination
Time between Strikes	1 minute
Total Number of Strikes	= 5 strikes × 3 coupling modes × 2 polarity/phase angles = 30 total strikes

Table 5. DOE MSSSLC 0.5µs Rise Time – 100kHz Ring Wave Test Specification

The DOE requirements are similar to those in IEEE C.62.41-2002, IEEE’s Recommended Practice on Characterization of Surge in Low Voltage (1000V or less) in AC Power Circuits, with a couple of small differences. DOE’s MSSSLC calls out a combination wave and not separate and successive application of the 10kV/10kA surge levels as stated in IEEE C.62.41-2002.

The DOE MSSSLC waveform is a combination 1.2/50µs open circuit voltage and 8/20µs short circuit current waveform (**Table 4**). To perform this test the specified peak current is calibrated on the tester by shorting the output to ground prior to connection to the luminaire. The actual current that gets driven through the luminaire is a result of the combination wave and will likely be lower based on the effective impedance of the luminaire. In turn, the actual current that would run through the MOVs (at the AC input of **Figure 3**, or elsewhere) will probably be less than the total current that enters the luminaire, based on available current paths and their effective impedances. This test setup is depicted in **Figure 8**.

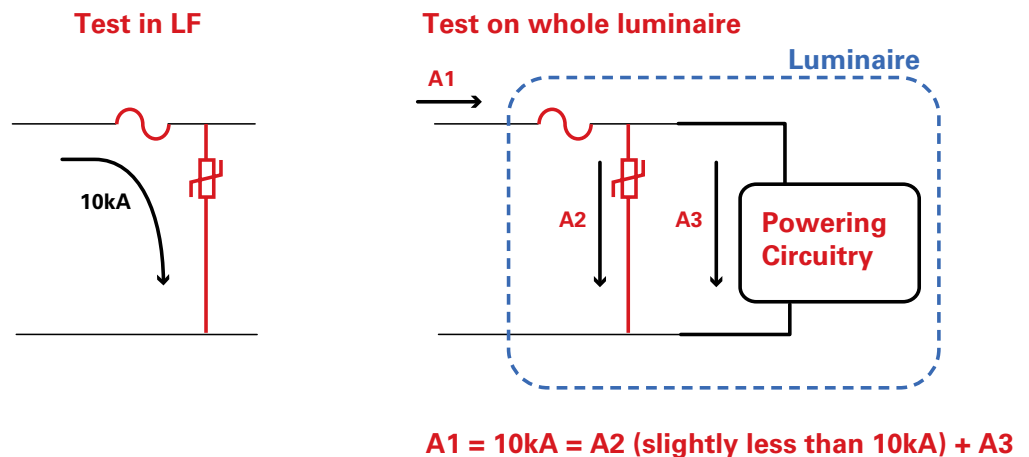

Figure 8. Littelfuse MOVs tested with 2-ohm source impedance per MSSSLC combination waveform.

Part Selection Guide

The peak voltage in this test was adjusted to a bit higher than the specified 20kV in order to drive exactly 10kA of peak current. In real world events, actual peak current through an MOV at the AC input will likely be lower than the total current that enters the luminaire, depending on available current paths. Littelfuse has tested the parts listed in **Table 1** part selections to a more stringent level as it complies with our internal testing standards.

To summarize, the DOE 10kA combination wave is a less stringent test than the Category “C-High” portion of the C62.41-2002 requirement. However, it still requires a 30-strike total with strikes spaced a minute apart (i.e., each MOV will experience 10 hits). Also, the IEEE C.62.41-2002 spec for the C-high portion specifies that the 6kV/0.5kA (12-ohm source impedance) ring wave (0.5 μ s/100kHz) test is optional. However in the DOE model specification, this is mandatory. This level is low energy and easier to pass but nonetheless requires testing.

Part Selection Guide

Littelfuse is committed to helping LED lighting manufacturers meet or exceed these specifications by providing robust coordinated overcurrent and overvoltage protection solutions for all surge levels. Littelfuse has performed extensive testing on the suggested components and in most cases at more stringent levels than what the above specifications outline. For companies not equipped to do their own testing, Littelfuse can assist with the testing.

Part Selection Guide (continued)

Table 6 is a comprehensive part selection guide for commercial and outdoor lighting systems organized by surge level that needs to be met. It provides both overcurrent and overvoltage component recommendations that will pass both safety and surge standards respectively.

Indoor - IEC / IEEE	Fuse Options	MOV Options	TVS Diode (DC)	PLED (Bypass for Open LED String Protection)		
IEC 61000-4-5 Installation Class 3						
1.2x50µs Voltage 8x20µs Current Combination Wave 2kV 1kA (2ohm), 40 strikes, 5+ and 5- at phase angles 0/90/180/270	443002 (2A 250V) 20901.5 (1.5A 350V) 219001 (1A 250V) 3831250 (2.5A 300V) 3921160 (1.6A, 250V) 3961250 (2.5A 125V) 8041100 (1A 250V)	V14E300P (14mm 300V) V14E320P (14mm 320V)	P6KE300CA SMAJ400A SMAJ440A SMBJ400A SMBJ440A 1.5KE400A 1.5KE440CA	PLED6S (I _{LED} =1A MAX; DO-214AA Pkg) PLED6Q12 (I _{LED} =1A MAX; 3x3mm QFN Pkg) PLED5Q12 (I _{LED} =0.5A MAX; 2x2mm QFN Pkg) PLED5HT (I _{LED} =0.7A MAX; SOT-89 Pkg)		
ANSI/IEEE C62.41.2-2002 Location Category A						
0.5µs 100kHz Ring Wave 6kV 0.2kA (30ohm)	45402.5 (2.5A 125V) 443002 (2A 250V) 473003 (3A 125V) 20901.5 (1.5A 350V) 219001 (1A 250V) 3831250 (2.5A 300V) 3921160 (1.6A, 250V)	V300LA10P (10mm 300V) V320LA10P (10mm 320V)				
1.2x50µs Voltage 8x20µs Current Combination Wave 6kV 0.5kA (12ohm)						
ANSI/IEEE C62.41.2-2002 Location Category B						
0.5µs 100kHz Ring Wave 6kV 0.5kA (12ohm)	8071630 (6.3A 300V) 219005 (5A 250V) 209007 (7A 350V)	V300LA20AP (14mm 300V) V320LA20AP (14mm 320V)				
1.2x50µs Voltage 8x20µs Current Combination Wave 6kV 3kA (2ohm)						
Outdoor - IEC / IEEE / US Department of Energy (DOE)						
- MSSLC Roadway Luminaires (Street Lighting)						
- CBEA High Efficiency Parking Structure Lighting						
- CBEA LED Site (Parking Lot) Lighting						
IEC 61000-4-5 Installation Class 4						
1.2x50µs Voltage 8x20µs Current Combination Wave 4kV 2kA (2ohm), 40 strikes, 5+ and 5-- at phase angles 0/90/180/270	8071400 (4A 300V) 219004 (4A 250V) 209005 (5A 350V) 477008 (8A 500V)	V20E300P (20mm 300V) V20E320P (20mm 320V)	P6KE300CA SMAJ400A SMAJ440A SMBJ400A SMBJ440A 1.5KE400A 1.5KE440CA	PLED6S (I _{LED} =1A MAX; DO-214AA Pkg) PLED6Q12 (I _{LED} =1A MAX; 3x3mm QFN Pkg) PLED5Q12 (I _{LED} =0.5A MAX; 2x2mm QFN Pkg)		
DOE Basic Requirement (IEEE C62.41.2 Location Category C Low)						
0.5µs 100kHz Ring Wave 10 strikes per line, 6kV 0.5kA (12ohm)	8071630 (6.3A 300V) 219005 (5A 250V) 209007 (7A 350V) 477010 (10A 500V)	V300LA20AP (14mm 300V) V320LA20AP (14mm 320V)				
1.2x50µs Voltage 8x20µs Current Combination Wave 10 strikes per line, 6kV 3kA (2ohm)						
DOE Elevated Requirement (IEEE C62.41.2 Location Category C High)						
0.5µs 100kHz Ring Wave 10 strikes per line, 6kV 0.5kA (12ohm)	328021 (21A 300V)	V25S300P (25mm 300V) V25S320P(25mm 320V) TMOV25SP300M (25mm 300V) TMOV25SP320M (25mm 320V) V321HB34 (34mm 320V)				
1.2x50µs Voltage 8x20µs Current Combination Wave 10 strikes per line, 20kV 10kA (2ohm)						

NOTE: MOVs were tested with 1.2x50µs open circuit voltage waveform and 8x20µs short circuit current waveform forming a combo waveform with 2 ohm source impedance. Standard method was used for testing the MOVs per datasheet specifications which consisted of driving 10kA through the part with the generated combination wave. Peak voltage was adjusted to a bit higher than 20kV in order to drive exactly 10kA of peak current. In real world events, actual peak current through the luminaire with typical circuit impedance path will likely be lower. Littelfuse has tested the above part selections to a more stringent level as it complies with our internal testing standards. The TVS diodes and PLED options were not tested due to the custom nature of each commercial lighting design. **The parts highlighted in green are design-registrable.**

Table 6. LED lighting circuit protection for compliance with IEC 61000-4-5 and IEEE C.62.41-2002.

Design Considerations in MOV Selection



Design Considerations in MOV Selection

To properly select the right MOV for the AC circuitry of an LED luminaire, you normally need to know:

1. The maximum system RMS voltage.
2. The MOV continuous voltage at 10% above maximum system voltage. For example, for an LED luminaire rated 277Vac, a 320Vac MOV is recommended.
3. The worst-case transient energy that will need to be absorbed: the surge level (max. voltage/current) and number of surges.
4. Consideration of MOV degradation and indication.

Especially in outdoor LED lighting applications, the MOV is continuously exposed to AC mains voltage transients which can cause degradation in the MOV. Once the MOV degrades, it becomes more conductive. Continuous degradation will reduce the resistance, and in turn increase the leakage current in the MOV to ultimately cause thermal runaway. In contrast, thermally protected varistors (TMOVs) protect against thermal runaway. As they heat up due to degradation, they have the ability to disconnect from the power source, and thereby avoid catastrophic failure that results in the creation of smoke or fire.

In a typical outdoor lighting application, TMOVs or multiple TMOVs in parallel are placed across each of the conductive pairs, L-N, L-G and N-G (**Figure 9**). This is the best case protection configuration for meeting surge suppression requirements.

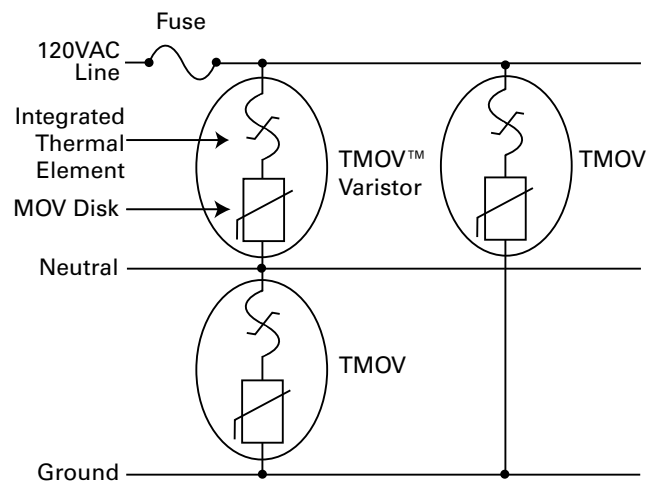

Figure 9. TMOV® varistor offline protection scheme.

Design Considerations in MOV Selection (continued)

How does one know if and when the thermal element has cleared? The Littelfuse iTMOV[®] varistor series adds an additional third indicator lead that provides access to the connection between the thermal element and the MOV electrode. Having access to this point of the circuit makes indication of the thermal element a simple procedure. **Figure 10** shows a simple application circuit with indication.

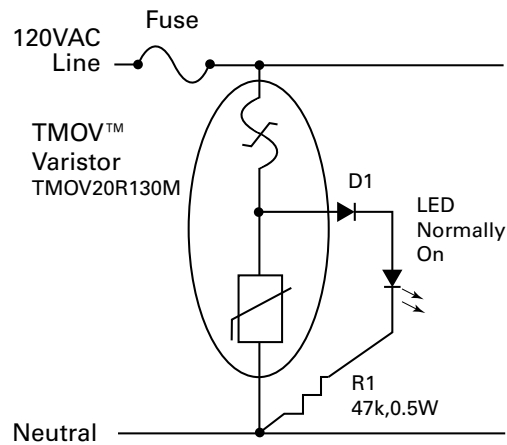

Figure 10. Indicator circuit using the Littelfuse iTMOV[®] varistor (LED normally on).

In **Figure 10**, an iTMOV[®] varistor is used to protect the L-N connection of a typical U.S. 120Vac line. An AC rated LED is placed across the iTMOV[®] varistor's indicator lead and the Neutral line. See the TMOV[®] and iTMOV[®] Varistor Series datasheet for more detail on these Littelfuse products.

Surge Protection Modules and MOV Coordination

Surge Protection Modules and MOV Coordination

Generally, most LED power supplies are a constant current type, and are often referred to as LED drivers. These can be purchased as off-the-shelf assemblies containing MOVs to meet lower level surge requirements. Typically, drivers are rated to handle surges in the range of 1-4kV. The varistor (MOV2 in **Figure 11**) is usually located after the fuse on the AC mains, and can range from 7-14mm in diameter. However, to provide higher level surge immunity, outdoor lighting OEMs may want to add surge protection devices (SPDs) on the AC input lines of their luminaires ahead of the LED driver. Typically, compliance testing of luminaires involves 20kV/10kA surges in North America and up to 10kV/5kA¹ in Europe.

Click the green boxes below for more information.

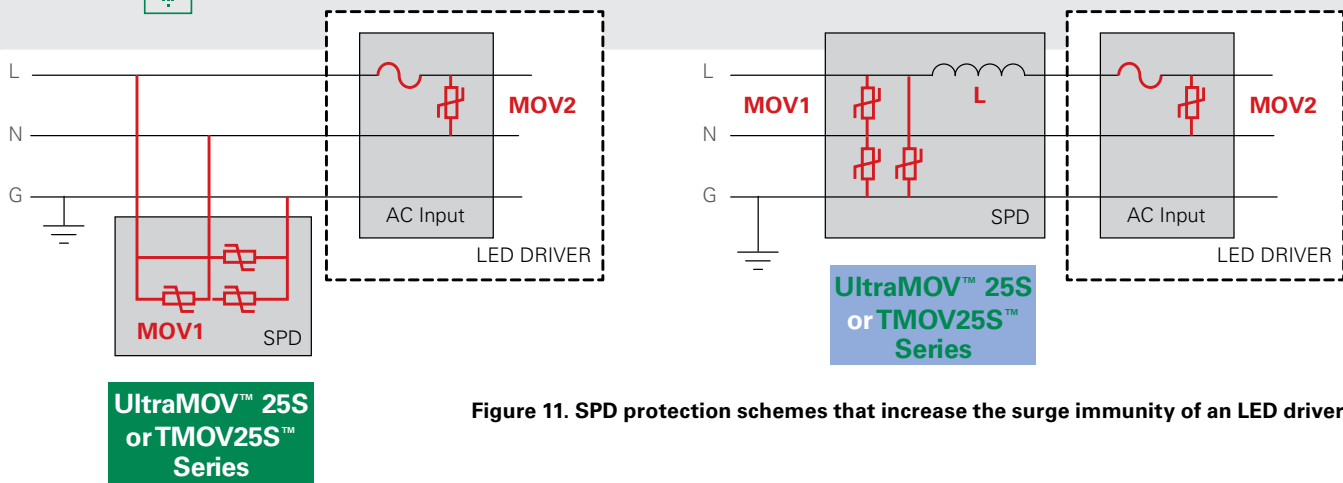

Figure 11. SPD protection schemes that increase the surge immunity of an LED driver.

SPD modules are responsible for protecting luminaires against these high surge levels, which can occur in outdoor lighting environments. The SPDs use 3-4 parallel or series connected high-surge withstand (e.g. 25mm or 34mm diameter) MOVs across the AC lines, as shown in the green MOV1 block of **Figure 11**. As shown in that figure, the MOVs are installed from line to ground, neutral to ground and line to neutral. For installations in regions with severe lightning exposure, it is common to use parallel connected MOVs for the line to neutral leg. This will increase differential mode surge capability and the reliability of a luminaire.

When adding this supplemental protection in front of the LED driver, it is very important to select (MOV1) characteristics that coordinate with those of the existing (MOV2) device in the driver. The coordination criterion for MOV1 selection is to make sure these larger disc MOVs in the SPD module clamp first, thereby taking the brunt of the surge energy before the smaller (MOV2) disc turns on. This will avoid catastrophic current through the driver MOV and premature opening of the fuse, which happens if the driver MOV turns on first. Therefore, The MOVs in the SPD module should have a lower max continuous operating voltage rating than the MOV in the driver.

¹ Although North American luminaire standards characterize immunity testing as a 10kV/10kA requirement, the test setup calls for a 2Ω source impedance, and it is actually a 20kV/10kA requirement.

Surge Protection Modules and MOV Coordination (continued)

A certain amount of impedance between the primary SPD and the driver can be beneficial; perhaps a few microHenries will help ensure proper coordination. For example, a longer length of cable between the primary SPD and the driver may be sufficient due to the characteristic impedance of the wire. On the other hand, lead wires on the input side of the SPD should be minimized to prevent increased clamping voltage in the SPD module due to the characteristic impedance of those wires.

The following steps summarize a design process that helps ensure enough inductance is present between the SPD MOVs and the one in the driver:

1. MOV1 and MOV2 need to be coordinated so that most of surge current/energy flows through MOV1.
2. Select MOVs with V_M of MOV1 \leq V_M of MOV2, where V_M is the Maximum Continuous Operating Voltage.
3. Select MOVs with V_C of MOV1 \leq V_C of MOV2, where V_C is the Maximum Clamping Voltage.
4. $V_{MOV1} = V_{MOV2} + L (di/dt)$
5. Inductance L may be added in series with (ahead of) the SPD. Increasing inductance L will result in better coordination as MOV1 absorbs the higher surge energy
6. Refer to the embedded links in the SPD blocks of **Figure 11** for MOV technical information. See the Littelfuse Varistor Ordering Information Diagram for details on constructing a part number.

The Littelfuse Application Team has years of expertise in such coordination requirements and has helped many customers optimize their circuit reliability while meeting surge immunity requirements.



Protecting Against Temporary Overvoltage

Protecting Against Temporary Overvoltage (TOV, IEC 61643) and Limited Current Abnormal Overvoltage (UL1449) by Using Thermally Protected MOVs

In AC line applications, the loss of a Neutral-Ground connection may occur in such a way that there exists a risk that a sustained over-voltage may be applied to an MOV that is rated for a much lower continuous voltage. In an unlimited current condition the MOV will first fail to a low impedance (a few Ohms), but due to the high amount of energy available, it most often ruptures instantaneously. If, however, there are loads tied to the AC line that limit current flow, the MOV can overheat and potentially cause the SPD device to overheat resulting in smoke, out-gassing and eventually fire.

For example, in a standard U.S. 120V AC Line application, two 120V AC power lines (180 degrees out of phase) are commonly fed from a center-tapped 240V transformer (**Figure 12**). Let's assume an MOV rated at 150V is present in the top 120V circuit, and some load exists on the bottom 120V circuit. Both the MOV and load share the center tap which is the Neutral-Ground Connection. If a break occurs on the center tap (X—X in **Figure 12**), then the load in the bottom phase acts as a current limiter and the line fuse may not clear.

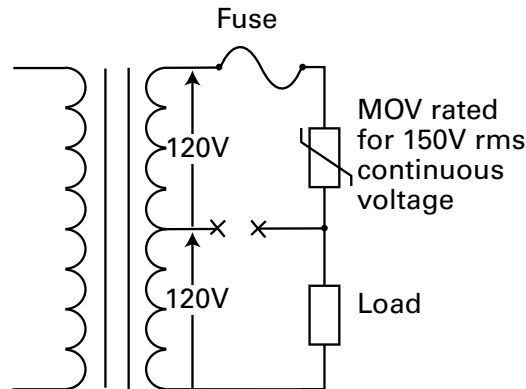

Figure 12. Possible fault conditions that could cause a limited current abnormal over-voltage event.

In this scenario, the 150V rated MOV is subjected to 240V at a limited current, potentially resulting in thermal run away for the MOV. This potential condition is specifically identified and addressed in the UL1449 and IEC 61643 Surge Protective Device Standards. As mentioned earlier in this document, new TMOV technology has been developed that will aid the designer in protecting against thermal overload in varistors. This in turn provides protection against:

- Temporary over-voltage (TOV) conditions as described in IEC 61643
- Sustained abnormal over-voltage with limited current as described in UL1449.

Design Considerations in Fuse Selection to Withstand Surges

Littelfuse technology provides a fully integrated, thermally self-protected MOV in its TMOV Varistor Series. These new devices use a patent-pending thermal element internal to the MOVs in direct contact with the metal oxide disks, allowing for optimum heat transfer. Because of the proximity of the thermal element to the MOV body, a higher opening temperature element can be used. This allows the thermally self-protected MOV to be wave soldered, and thereby simplifies OEM assembly processes. This construction method also allows a new device to perform to standard MOV ratings with regards to peak current, peak energy, voltage clamp levels, etc., while providing the safety of a thermally protected device.

Figure 13 illustrates the integrated components of a TMOV.

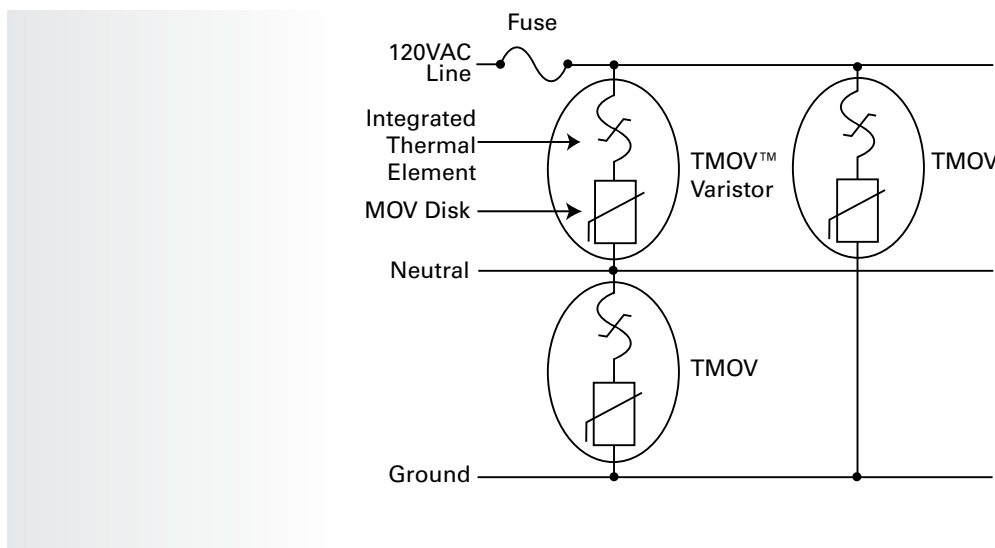

Figure 13. TMOV[®] varistor offline protection scheme.

Design Considerations in Fuse Selection to Withstand Surges

Fuses are devices whose function is to provide protection for components and complete circuits by reliably and predictably melting under current overload conditions. They are intended to be the weak links in the electrical circuit.

Lab tests are run on each fuse design to determine the amount of energy required to melt the fusing element; this is called the nominal I^2t rating and is measured in A^2s . Often, the nominal I^2t method of fuse selection is meant for applications in which the fuse must endure large current pulses of short duration. Surge immunity testing for LED lighting applications requires complying with $8 \times 20\mu s$ combination waveforms. Different fuse constructions may not react the same way to a surge, even if their nominal I^2t rating exceeds that of the waveform energy. Electrical surge pulses produce thermal cycling that can fatigue the fuse mechanically and shorten its life.

Design Considerations for TVS Diodes

Application testing is strongly recommended in order to establish whether or not the selected fuse can withstand the energy under a relevant waveform. If your lab does not have this type of test capabilities, contact Littelfuse about its Testing Services.



Design Considerations for TVS Diodes

In order to adequately protect sensitive circuits and components in LED drivers, transient voltage suppression must be part of the initial design process – not merely an afterthought. To ensure effective transient suppression, the device chosen must dissipate the impulse energy of the transient at a sufficiently low voltage so that driver circuit capabilities are not affected. The most successful type of suppression device used is the avalanche or transient voltage suppression (TVS) diode.

Some transients may be created in the circuit due to intentional inductive load switching, commutation voltage spikes, or relay operation, etc. These transients are easy to suppress since their energy content is known or can be readily calculated. It is the transients generated external to the circuit and coupled into it that require specific analysis. These can be caused by the discharge of electromagnetic energy, lightning, adjacent inductive loads, or electrostatic discharge. These transients can be more difficult to identify, measure and suppress. Regardless of their source, transients have one thing in common; all of them can be destructive. The destruction potential of transients is defined by their peak voltage, the follow-on current, and the time duration of the current flow.

The time required for a transient suppressor to begin functioning is extremely important when it is used to protect sensitive components like driver ICs and LEDs. If the suppressor is slow acting and a fast-rise transient spike appears on the system, the voltage across the protected load can rise to damaging levels before suppression begins. A TVS diode is specifically designed to protect electronic circuits against transient over voltage events. Being a silicon avalanche device, it is available in both uni-directional and bi-directional configurations. In the uni-directional version, the specified clamping characteristic is only apparent in one direction, with the other direction exhibiting a forward voltage, V_F , characteristic similar to a conventional rectifier diode. (All electrical characteristics are specified at 25°C.)

LED lighting power supplies (drivers) typically need TVS diodes at one or more locations in their circuits. When selecting a TVS diode the important parameters to be considered are:

- Reverse Standoff Voltage (V_R)
- Peak Pulse Current (I_{PP})
- Maximum Clamping Voltage (V_C)

Design Considerations for TVS Diodes (continued)

The most important of these is V_R , which should be equal to, or greater than, the peak operating level of the circuit (or the part of the circuit) to be protected. This will ensure that the TVS does not clip the circuit drive voltage. I_{PP} is the maximum current the TVS can withstand without damage and is usually stated in reference to an exponential waveform such as $10 \times 1000 \mu s$. The required I_{PP} can only be determined by dividing the peak transient voltage by the source impedance. The maximum clamping voltage (V_C) is the peak voltage that will appear across the TVS device when subjected to the Peak Pulse Current (I_{PP}), based on the referenced exponential waveform. Keep in mind that the failure mechanism in a TVS diode is a short circuit. Therefore, if the TVS fails due to a transient, the circuit it's in will still be protected. **Figure 14** illustrates some Littelfuse TVS diode package configurations, which will fit in a wide range of applications.



Figure 14. Littelfuse TVS diodes are available in a wide range of sizes, configurations, and ratings.

When selecting a TVS diode, the first step is to define the operating parameters of the circuit to be protected, whether it's an LED driver or something else. **Table 7** lists the most important circuit parameters to be considered.

Design Considerations for PLED Protectors

Normal Operating Voltage Type, DC or AC	
Device Type Required: Uni-Directional or Bi-Directional + Normal Operating Voltage, V	
Maximum Transient Current (Ipp)	
Maximum Clamping Voltage (Vc)	
Required Peak Reverse Surge Power Rating, W	
Product Mounting Type (Package)	
Operating Temperature Range	

Table 7. This fill-in form for circuit operating parameters is the first step in selecting a TVS diode.

Design Considerations for PLED Protectors

Applications for PLED protection devices are found in LED versions of traffic lights, roadway lighting, parking lot lights, airport lighting, billboard illumination, commercial signage, at railroad crossings, and in medical / surgical lighting. All these applications require high reliability, which means high up-time with little to no maintenance. To ensure maximum reliability, high brightness LEDs must be protected against wire bond failures, ESD/EFT events, lightning surges, and reverse power connections.

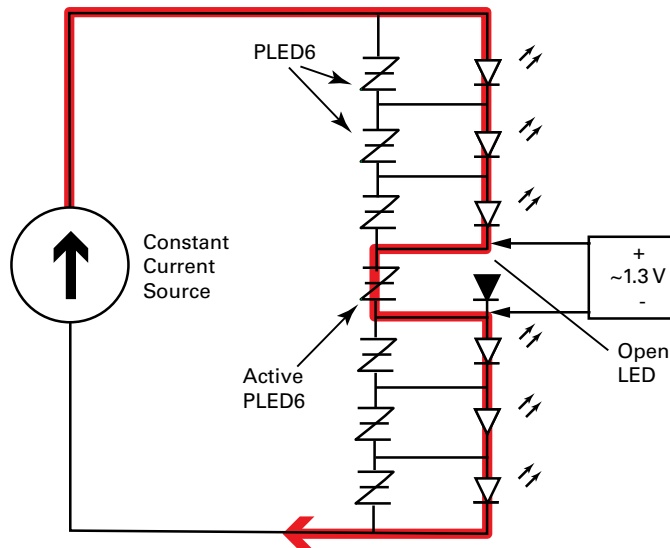

Figure 15. PLEDs protect series wired LED strings should one fail as an open circuit, the most common failure mode.

Design Considerations for PLED Protectors (continued)

While fuses, MOVs, and TVS diodes are critical devices that protect LEDs against these threats, PLEDs perform a different kind of function. They are used in series wired strings of LEDs where a single LED failure (open-circuit) would cause an entire LED string to go dark. Such events can't be tolerated in high reliability applications, and can be very costly in terms of product returns, warranty expense, and ruined customer relations.

In a typical application LED's are connected in series and driven by a constant current source as shown in **Figure 15**. The constant current source has a maximum (open circuit) output voltage called the "compliance voltage," which appears across an LED that has an open failure. This will trigger the PLED device to turn on and conduct current around the open LED. The remaining LEDs stay illuminated, and in many applications, the failure of a single LED is not critical or even noticeable. The PLED power dissipation is lower than the LED, thus lowering total system power.

Additionally, PLED devices can also protect against reverse polarity (**Figure 16**). If the power supply voltage is reversed, the PLED5 for example will switch on and bypass the LEDs with only a diode drop needed to turn it on. The reverse current passes through the PLED devices and prevents damage to the LEDs. In this case, the LEDs will not turn on while bypassed, but once normal power polarity is restored, the PLED devices turn off and the LED string will function normally.

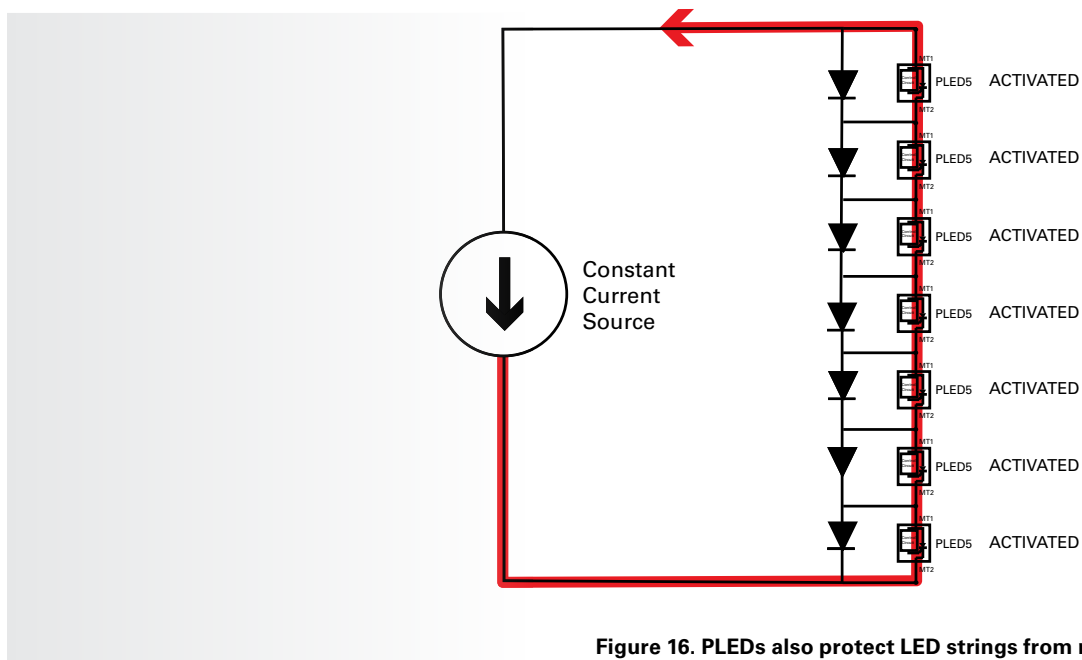

Figure 16. PLEDs also protect LED strings from reverse polarity situations.

Design Considerations for PLED Protectors (continued)

Littelfuse provides online reference designs for protection of series wired LED strings. One example is **Bypass protection for 4 LEDs up to 1000mA (PLED18)**. (See **Table 8** for a listing of Littelfuse PLED characteristics.) In general, the steps required for PLED selection are:

1. Define V_F (forward voltage), I_F (forward current), and the connection scheme of the LEDs.
2. Define the number of LEDs in the LED string and understand the constant current source value and compliance voltage of the power supply.
3. Determine the PLED device to fit for V_F , I_F and the PLED protection ratio, as follows:
 - PLED switching current must be less than constant current source value
 - PLED turn-on voltage must be less than power supply compliance voltage.
 - Choose how many LEDs in the string (1, 2 or 3) are to be protected by a single PLED. A Littelfuse PLED6, which triggers at 6 volts, protects one LED; a PLED9, which triggers at 9 volts, can be used across two LEDs; and a PLED13 can be used with three LEDs. (Note that when a single PLED is wired across multiple LEDs, a failure of one of those LEDs will cause the other one or two to go out).
4. Determine the package of the PLED device to fit the lighting environment.
5. Define the ambient temperature of the PLED environment and provide adequate heat sinking if required.
6. Perform testing on the PLEDs by shunting with the protected LEDs.

Part Number	V_{DRM} / Trigger Voltage	Typical # of LEDs Protected	By-pass Current (Maximum)	By-pass Voltage (Maximum)	Bypass Function/ Open LED Protection	ESD Protection	Reverse Battery Protection	Package Option
PLED5	5V	1	500mA 700mA	1.4V 1.8V	Yes	Yes	Yes	QFN2x2 SOT-89
PLED6	6V	1	1000mA	1.2V	Yes	No	No	D0214AA, QFN3x3
PLED9	9V	2	1000mA	1.2V	Yes	No	No	D0214AA, QFN3x3
PLED13	13V	3	1000mA	1.2V	Yes	No	No	D0214AA, QFN3x3
PLED18	18V	4	1000mA	1.2V	Yes	No	No	D0214AA, QFN3x3

Table 8. Littelfuse PLED product characteristics.

Potential Problems with Alternative LED Lamp Overcurrent Protection Technologies

Potential Problems with Alternative LED Lamp Overcurrent Protection Technologies

Fuses are the “gold standard” for overcurrent protection, particularly in LED bulb and luminaire assemblies. In some applications, circuit designers have for various reasons turned to fusible resistors or fusible circuit board traces for overcurrent protection. These solutions may end up posing unsafe failure modes such as fire, as explained below.

Fusible Resistors. These resistors are manufactured using high temperature alloys that have low thermal coefficients of resistance. This results in stable resistance across a wide temperature range, which is an important characteristic in resistors. In contrast, fuses that offer good overcurrent protection utilize a low temperature alloy with a higher thermal coefficient of resistance. This characteristic of fuses results in a sharp increase in resistance as the fuse element experiences an overcurrent situation, which is highly desirable for quickly bringing the fuse element to its melting temperature. Fusible resistors are effective at limiting current but waste energy and do not perform well on low-level overloads. In addition, because their resistance wires melt at 1300°C to 1400°C, this makes them a potential fire hazard (**Figure 17**).

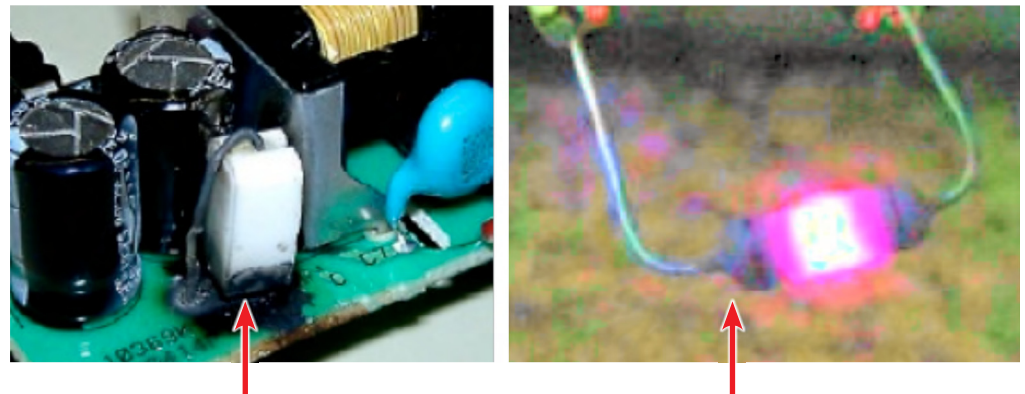

Potential fire hazard resulting from high temperature alloys that do not fuse well

Material	Typical Use	Melting Temperature (°C)
Copper	Fuse Element	1083
Silver		962
Nichrome	Resistor Element	1400

Figure 17. Using fusible resistors for overload protection can pose a fire hazard.



Potential Problems with Alternative LED Lamp Overcurrent Protection Technologies (continued)

A series of tests were performed by Littelfuse to demonstrate the differences in overcurrent protection provided by fusible resistors and fuses. Overload and surge immunity tests were run on a 22ohm, 240V, 2W fusible resistor of the type sometimes used in retrofit LED bulb assemblies. The first test involved emulating a soft overload condition using 1.65A of constant current for the fusible resistor, equivalent to 60W minimum fusing power of that device. In a comparison test, Littelfuse TR5 and TE5 fuses were subjected to 3.2A and 4A of constant current. A step current test was conducted where the current was gradually increased by 0.165A every 5 minutes starting from 0.33A (at 2W rated power). **Table 9** presents the results of these two sets of overcurrent tests.



		Fusing Resistor				Fuse #382 1.6A		Fuse #392 1.6A	
Overcurrent		Gradual 0.33A-0.825A	Constant 1.65A	Constant 3.2A	Constant 4A	Constant 3.2A	Constant 4A	Constant 3.2A	Constant 4A
Fusing Time		16 min.	5 sec.	0.8 sec.	0.4 sec.	7 sec.	1.7 sec.	8.9 sec.	2.9 sec.
During Fusing	Smoke		■	■	■				
	Glowing	■	■	■	■				
	Fire		■	■	■				
	Spark		■	■	■				
	Explode				■				
After Fusing	Discoloration	■	■	■	■				
	Crack			■					
	Rupture				■				
Risk of Fire			YES	YES	YES	NO	NO	NO	NO

Table 9. Overcurrent testing results for a fusible resistor and two different fuses made by Littelfuse.



Potential Problems with Alternative LED Lamp Overcurrent Protection Technologies (continued)

Additional tests on fusible resistors were performed according to IEC 61000-4-5 and the Energy Star surge immunity test standards. Results are detailed below.

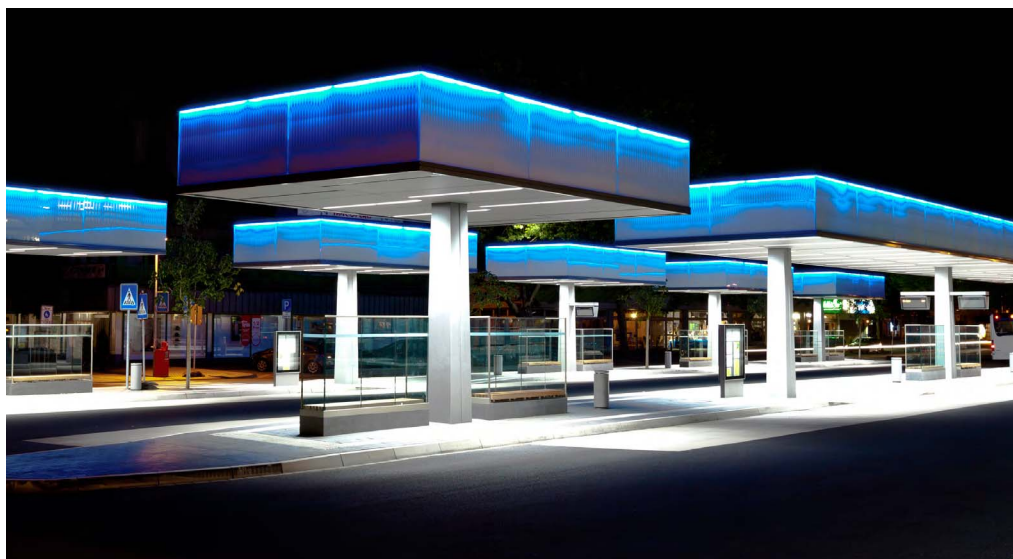
IEC Surge Test Results:

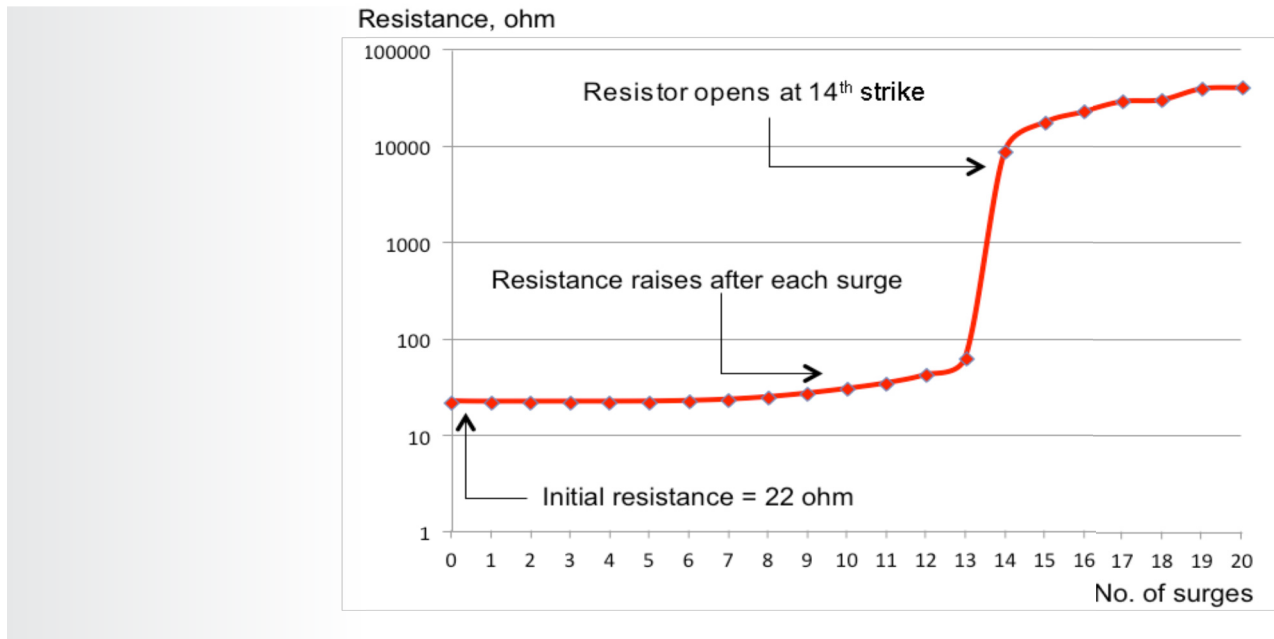

Figure 18. IEC 61000-4-5 testing on a fusible resistor.

As shown in **Figure 18**, the fusible resistor was not able to withstand 40 strikes required by IEC 61000-4-5 standard. High resistance fusible resistors dissipate excessive heat when subjected to surge current that is applied in minute intervals. Heat accumulates, which in turn raises resistor body temperature and resistance. As a result, the fusible resistor opens before the required 40 surges.

Energy Star test results: Again, fusible resistors were not able to withstand seven strikes required by the Energy Star standard (**Figure 19**). Littelfuse test results revealed that fusing resistors can catch fire, spark, and even explode under abnormal overcurrent conditions, hence rendering them unsafe. These components generate excessive heat in transient surge testing causing them to open before the required number of surges are applied, for both IEC and Energy Star test methods. In a retrofit LED bulb, once the fusible resistor opens, the bulb will be disconnected from the power source, thus resulting in the failure of EMC testing. Moreover, the bulb is rendered useless.

Potential Problems with Alternative LED Lamp Overcurrent Protection Technologies (continued)

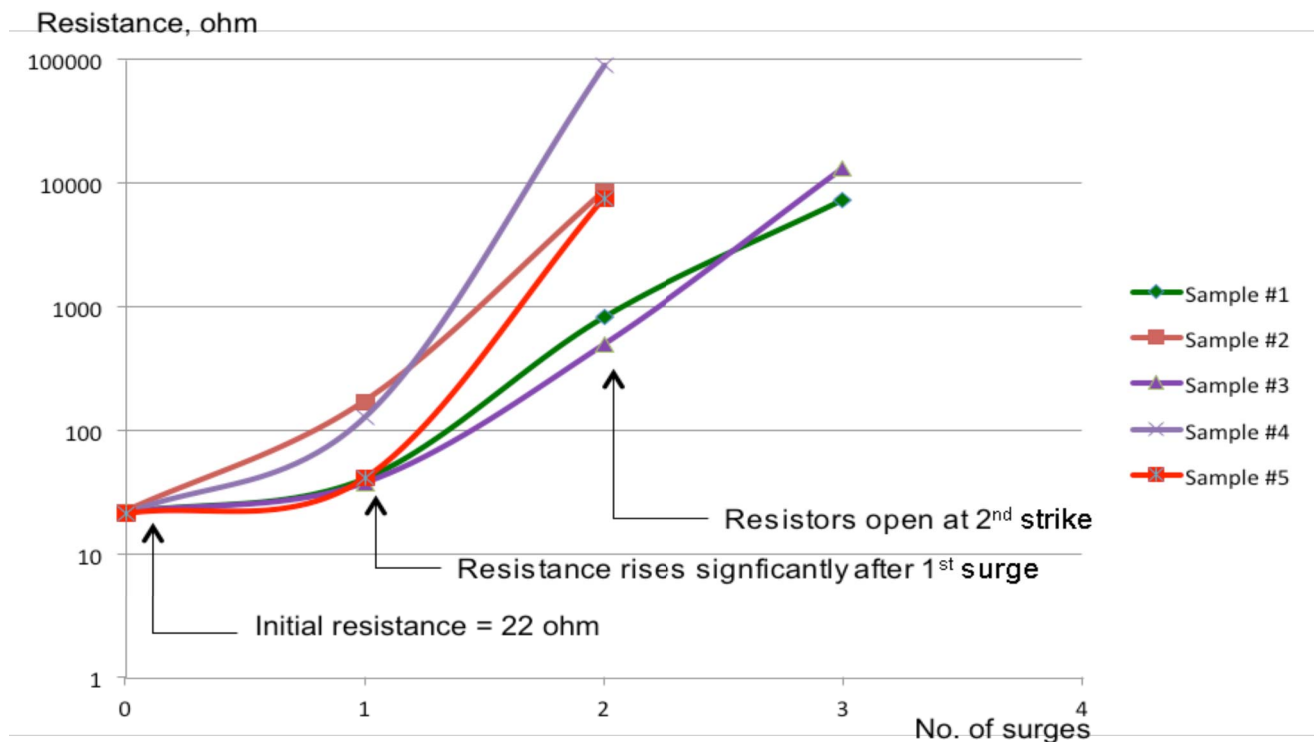

Figure 19. Energy Star surge immunity testing on five different fusible resistors.

The same tests were conducted on 10 and 100 ohm fusible resistors that had nominal 1W ratings. This was done to determine if their lower 16W fusing power rating would produce better results. These resistors also failed the IEC and Energy Star tests, and as shown in **Table 10**, they also produced a bright glow, generated sparks, and created a fire hazard.

		Fusing Resistor 100-ohm 1W				Fusing Resistor 10-ohm 1W			
Overcurrent		Gradual 0.1A-0.3A	Constant 0.4A	Constant 0.57A	Constant 0.8A	Gradual 0.32A-1.28A	Constant 1.26A	Constant 1.79A	Constant 2.53A
Fusing Time		2.1 min.	0.35 sec.	0.007 sec.	0.4 sec.	3.3 min.	11 sec.	2 sec.	0.008 sec.
During Fusing	Smoke						■	■	■
	Glowing	■	■	■	■	■	■	■	■
	Fire								
	Spark						■	■	■
	Explode								
After Fusing	Discoloration	■				■	■	■	■
	Crack	■				■	■	■	■
	Rupture								
Risk of Fire							YES	YES	YES
Note			Rated fusing power (16W)	32W	64W		Rated fusing power (16W)	32W	64W

Table 10. Overcurrent testing results for 1W 10Ω and 100Ω fusible resistors (16W fusing power rating).

Potential Problems with Alternative LED Lamp Overcurrent Protection Technologies (continued)

Fusible Traces. FR4 and other common circuit board compositions are organic based materials that contain high amounts of carbon. They generally have very low ignition temperatures relative to the melting temperature of copper. Because of this, the combination of copper and epoxy based materials can form a very unpredictable fuse package. Copper circuit traces have a melting temperature of 1083°C and are made using a lamination process that embeds dendrites into uncured epoxy. The high melting temperature and low dielectric strength created by the trapped dendrites creates a potential fire hazard (**Figure 20**) during interruption of overcurrent conditions, especially evident during low overload operation.

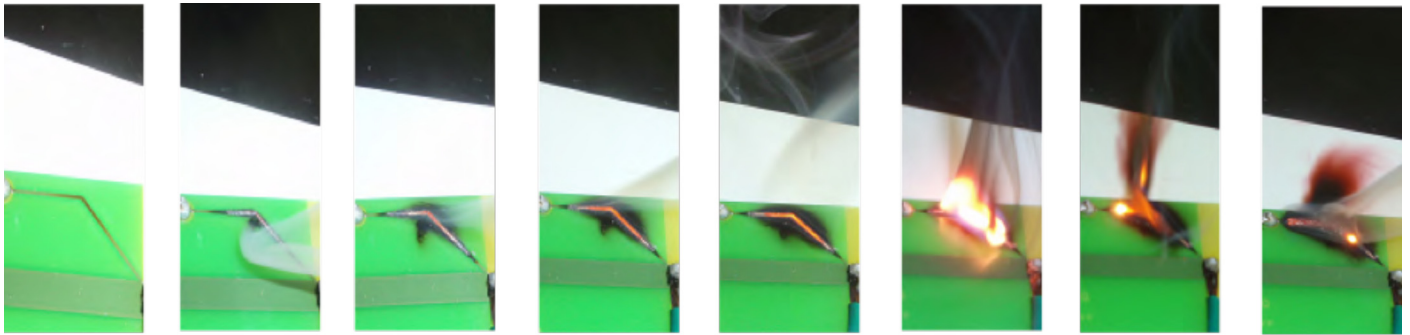

Figure 20. Progressive destruction of fusible circuit trace intended for overcurrent protection; it ends up igniting the PCB laminate material.

Conclusions and References

Conclusions

The future is bright for LED lighting technology. As efficiencies increase, thermal management issues are overcome, quality of light output impresses consumers and initial costs continue to decline, the technology will continue to proliferate over the next several years. Double digit growth, both unit shipments and market value are forecasted over the next five years.

Littelfuse is committed to supporting all facets of the LED lighting market with innovative solutions that not only meet regulatory standards but also increase equipment safety and reliability. To help protect end users, we work closely with many LED driver IC suppliers, to ensure their evaluation boards and reference designs comply with safety and surge immunity requirements. We also assist LED lighting power supply manufacturers in designing optimal protection schemes for their driver modules. At the OEM level we cooperate with luminaire and lamp manufacturers to ensure their products are optimally designed for robust surge immunity protection. When needed we also provide testing services to confirm that designs pass overcurrent and overvoltage regulatory requirements. We offer a large number of support tools, including low power consumer lighting protection sample kits, outdoor LED lighting kits, white papers, application notes, and part selection guides. When requested, our exceptional application engineering team will supply protection recommendations based on customer-specific designs.

References

1. Surge Protective Devices - UL1449, April 19, 2010
2. Littelfuse Datasheet on Thermally Protected Metal Oxide Varistor (TMOV[®] Varistor), March 2001
3. Littelfuse Application Note EC635: Designing with Thermally Protected TMOV[®] Varistors in SPD and AC Line Applications
4. IEEE C.62.41 specifications
5. IEC61000-4-5 specifications
6. Energy Star surge immunity specification
7. DOE MSSSLC LED Roadway Model Spec
8. Temporary Overvoltages Following Transformer Energizing- Daniel W. Durbak, Sept 2006
9. Electronic Systems Protection via Advanced Surge Protective Devices- Alan Chiste and Dalibor Kladar

Legal Disclaimers

Liability

Littelfuse, Inc. its affiliates, agents, and employees, and all persons acting on its or their behalf (collectively, "Littelfuse"), disclaim any and all liability for any errors, inaccuracies or incompleteness contained here or in any other disclosure relating to any product. Littelfuse disclaims any and all liability arising out of the use or application of any product described herein or of any information provided herein to the maximum extent permitted by law. The product specifications do not expand or otherwise modify Littelfuse terms and conditions of purchase, including but not limited to the warranty expressed therein, which apply to these products.

Right to Make Changes

Littelfuse reserves the right to make any and all changes to the products described herein without notice.

Not Intended for Use in Life Support or Life Saving Applications

The products shown herein are not designed for use in life sustaining or life saving applications unless otherwise expressly indicated. Customers using or selling Littelfuse products not expressly indicated for use in such applications do so entirely at their own risk and agree to fully indemnify Littelfuse for any damages arising or resulting from such use or sale. Please contact authorized Littelfuse personnel to obtain terms and conditions regarding products designed for such applications.

Intellectual Property

No license, express or implied, by estoppel or otherwise, to any intellectual property rights is granted by this document or by any conduct of Littelfuse. Product names and markings noted herein may be registered trademarks of their respective owners. Littelfuse makes no representations or warranties of non-infringement or misappropriation of any third party intellectual property rights unless specifically provided for herein.

Disclaimer

Specifications, descriptions and data contained in this document are believed to be accurate. However, users should independently evaluate each product for the particular application. Littelfuse reserves the right to change any information contained herein without notice and may, at its sole discretion, change the design, manufacture or construction of any product. Visit www.littelfuse.com for the most up-to-date information. Littelfuse's only obligations for any of its products are specified in its Standard Terms and Conditions and Littelfuse shall not be liable for any indirect, consequential or incidental damages from any sale or use of any of its products.



Expertise Applied | Answers Delivered

littelfuse.com
circuitprotection@littelfuse.com