

## APPLICATION

- For medium cinemas
- Passive 2-way screen channel loudspeaker
- Requires only one amplifier channel and no external crossover

## PRODUCT INFORMATION

The CB259X two-way passive screen loudspeaker system fills medium-sized theaters with all the high-impact, full-range sound encoded on today's digital soundtracks while reproducing voices clearly and naturally.

The two component system includes a BV253C vented dual 15-in low frequency unit and a HK294 high frequency system - a medium format 90°x40° HF horn loading a large diaphragm 2-in exit compression driver.

The HK294's constant directivity horn assures even distribution of high frequency information to every seat in the house. Its shortened horn throat minimizes horn throat distortion, eliminating the 700 Hz "honk" that has plagued cinema HF horns.

The BV253C's optimally vented enclosure uses the enclosure's resonance to increase LF response while limiting driver excursion. This method produces less distortion and minimizes driver strain while extending LF response to the lowest octaves.

The sections are integrated via an internal passive crossover/filter network. EAW's complex, computer-designed passive filter networks are tightly aligned to the loudspeakers they control and go beyond merely dividing the signal, performing critical equalization functions.

The adjustable steel bracket attaching the HF horn to the LF enclosure can be positioned at one of three mounting points for optimum front/rear HF horn placement. The bracket allows the HF horn to be aimed independently of the LF section in both the horizontal and vertical planes and can be locked once it is positioned.

The LF section includes a barrier strip that accommodates bare wire, tinned leads or spade lugs. A jumper cable is supplied to extend the signal chain to the HF component. The input connector is located on the side of the enclosure for convenient access in cramped installation areas. HF component connection is made directly on the compression driver.

## DESCRIPTIVE DATA

Part Number	999356
LF Subsystem & Loading	2x15-in vented
HF Subsystem & Loading	1x2-in exit compression driver on CD horn



## DESCRIPTIVE DATA contined

Configuration	2-way	
Powering Mode	Passive	
Recommended High-Pass Frequency (24 dB/Octave)	30 Hz	
Cabinet Type (shape)	Rectangular with externally mounted horn/driver assembly	
Enclosure Materials	3/4-in Medium Density Fiberboard with 15 mm baltic birch baffle	
Finish	Textured black	
Connectors	2 terminal barrier strip	
Dimensions	inches	millimeters
	Height	54.19 1376
	Width	24.44 621
	Depth (min.)	17.75 451
	Depth (max.)	24.94 633
Weights	pounds	kilograms
	Net Weight	160.5 73.0
	Shipping Weight	177.5 80.8



# TECHNICAL SPECIFICATIONS CB259X

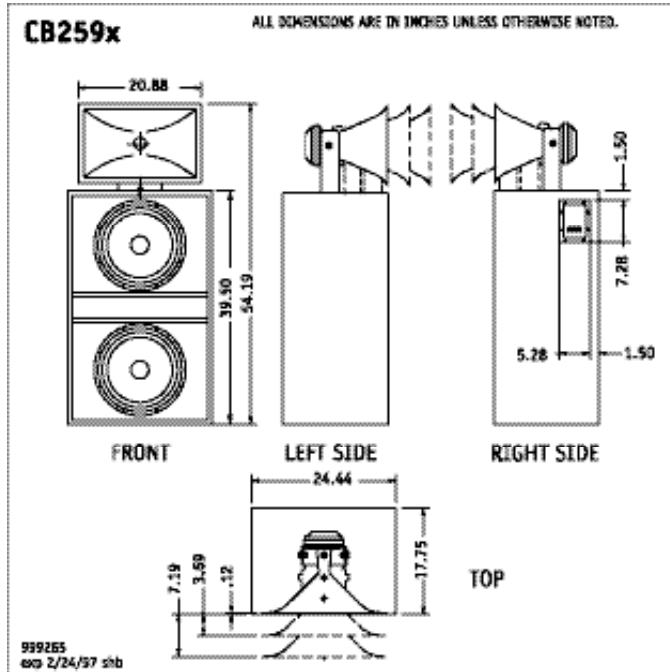

## COMPONENTS & CONSTRUCTION

The CB259X is a two way, high-output, passive, full range loud-speaker system intended for use in cinema applications. It features dual 15-in low frequency transducers mounted in a vented enclosure and a titanium diaphragm compression driver mounted to a large, 2-in throat, 90°x40° coverage pattern, constant directivity horn.

The CB259X requires no external active electronic crossover. An internal passive crossover/filter network integrates the LF and HF sections. EAW's complex, computer-designed passive filter networks are tightly aligned to the loudspeakers they control and go beyond merely dividing the signal, performing critical equalization functions.

The input connector is a 2-terminal barrier strip located on the side of the LF section for convenient access in cramped installation areas. A jumper cable is provided to extend the signal chain to the HF component.

The low frequency enclosure is constructed of 3/4-in thick Medium Density Fiberboard (MDF) with the exception of the baffle which is

## COMPONENTS & CONSTRUCTION continued

15 mm void-free, gross-grain-laminated birch plywood. Extensive internal bracing is employed to minimize panel resonances resulting from the large acoustical energies generated within the enclosures.

The high frequency horn is constructed from a specially formulated compound which is non-resonant, lightweight and non-reflective.

The LF enclosure has 3 mounting points to allow optimum front/rear positioning of the HF component. The adjustable steel bracket attaching the HF horn to the LF enclosure allow the HF horn to be aimed independently at the LF section in both the horizontal and vertical planes and can be locked once it is positioned.

All components feature a textured black finish to eliminate the reflection of light through perforated cinema screens.

## NOMINAL DATA

### Frequency Response

±3 dB 42 Hz - 17 kHz

### Axial Sensitivity (dB SPL, 1 Watt @ 1m)

Full Range 101

### Impedance (Ohms)

Full Range 4

### Power Handling, AES Standard (Watts)

Full Range 500

### Calculated Maximum Output (dB SPL @ 1m)

Full Range Peak 134.0

Full Range Long Term 128.0

### Nominal Coverage Angle/-6 dB points (degrees)

Horizontal 90

Vertical 40

