

# Proportional pressure-limiting valve type PMVE

## Product documentation



Operating pressure  $p_{\max}$ :

420 bar

Flow rate  $Q_{\max}$ :

10 lpm



© by HAWE Hydraulik SE.

The reproduction and distribution of this document, as well as the use and communication of its contents to others without explicit authorization, is prohibited.

Offenders will be held liable for the payment of damages.

All rights reserved in the event of patent or utility model applications.

Brand names, product names and trademarks are not specifically indicated. In particular with regard to registered and protected names and trademarks, usage is subject to legal provisions.

HAWE Hydraulik respects these legal provisions in all cases.

HAWE Hydraulik cannot provide individual guarantees that the stated circuits or procedures (including in part) are not subject to the intellectual property rights of third parties.

Printing date / document generated on: 2023-02-17

## Table of Contents

<b>1</b>	<b>Overview of proportional pressure-limiting valve type PMVE.....</b>	<b>4</b>
<b>2</b>	<b>Available versions.....</b>	<b>5</b>
2.1	Screw-in valve.....	5
2.1.1	Basic type and size.....	5
2.1.2	Circuit symbol.....	5
2.1.3	Pressure range.....	5
2.1.4	Pressure setting.....	6
2.1.5	Solenoid voltage and connector.....	6
2.2	Single valve for pipe connection or manifold mounting.....	7
2.2.1	Block configuration.....	7
2.2.2	Additional element.....	7
<b>3</b>	<b>Parameters.....</b>	<b>8</b>
3.1	General data.....	8
3.2	Pressure and volumetric flow.....	8
3.3	Weight.....	9
3.4	Characteristic lines.....	9
3.5	Electrical data.....	15
3.5.1	Standard solenoid.....	15
3.5.2	Solenoid for potentially explosive atmospheres.....	15
<b>4</b>	<b>Dimensions.....</b>	<b>16</b>
4.1	Screw-in valve.....	16
4.2	Single valve for pipe connection.....	18
4.3	Single valve for manifold mounting.....	18
<b>5</b>	<b>Installation, operation and maintenance information.....</b>	<b>19</b>
5.1	Intended use.....	19
5.2	Assembly information.....	19
5.2.1	Creating the mounting hole.....	19
5.3	Operating instructions.....	19
5.4	Maintenance information.....	20
<b>6</b>	<b>Other information.....</b>	<b>21</b>
6.1	Accessories, spare and individual parts.....	21
6.1.1	Tapped plugs.....	21
6.1.2	Orifices.....	21
6.1.3	Seal kits.....	22

**1****Overview of proportional pressure-limiting valve type PMVE**

Proportional pressure-limiting valves are a type of pressure control valve. They remotely control the pressure in hydraulic systems continuously and electrically.

The proportional pressure-limiting valve type PMVE is a combination of a seated valve and spool valve with direct actuation. The pressure can be set to up to 420 bar.

The PMVE is available either as a screw-in valve or a single valve for pipe connection or manifold mounting. It is particularly suitable as a pilot valve for limiting LS or pilot pressures.

**Features and advantages**

- Rising and falling characteristic line
- Excellent repeatability and control tuning
- Low dynamic pressure
- Various block and solenoid versions
- For general purpose use

**Intended applications**

- Loading cranes
- Lifting platforms
- Municipal trucks
- Construction machines
- Drilling equipment
- Machines for forestry and agricultural purposes
- Oil and gas extraction
- Wind turbines
- Industrial hydraulics



*Proportional pressure-limiting valve type PMVE*

## 2 Available versions

### 2.1 Screw-in valve

#### Ordering example

PMVE 1	R	G	/320	-AMP 24
				2.1.5 "Solenoid voltage and connector"
				2.1.4 "Pressure setting"
				2.1.3 "Pressure range"
				2.1.2 "Circuit symbol"
				2.1.1 "Basic type and size"

#### 2.1.1 Basic type and size

Type	Flow rate $Q_{\max}$ (lpm)	Pressure $p_{\max}$ (bar)
PMVE 1	10	420

#### 2.1.2 Circuit symbol

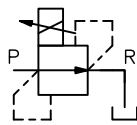
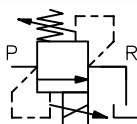
Coding	Description	Circuit symbol
S	Rising characteristic line	
R	Falling characteristic line	

#### 2.1.3 Pressure range

Coding	Description
A	Up to 50 bar
B	Up to 100 bar
C	Up to 150 bar
D	Up to 200 bar
E	Up to 250 bar
F	Up to 300 bar
G	Up to 350 bar
H	Up to 420 bar

## 2.1.4 Pressure setting

Coding	Description
Without coding	Without additional mechanical pressure setting. The set value results from the pressure range (see Chapter 2.1.3, "Pressure range") in conjunction with the flow rate and the current value (see Chapter 3.4, "Characteristic lines").
/...	With additional mechanical $p_{\max}$ setting. Only in conjunction with circuit symbol coding R. <ul style="list-style-type: none"> <li>Adjustment range: 75 to 100% of the pressure range from Chapter 2.1.3, "Pressure range".</li> <li>Default set value: <math>p_{\max}</math> (see Chapter 2.1.3, "Pressure range") at 2.5 lpm.</li> </ul>

### NOTICE

The return pressure in port R / A is added to the set value.

## 2.1.5 Solenoid voltage and connector

Coding	Electrical connection	Nominal voltage	Protection class (IEC 60529)
X 12 X 24	EN 175 301-803 A	12 V DC 24 V DC	IP 65
G 12 G 24	EN 175 301-803 A	12 V DC 24 V DC	IP 65
AMP 12 AMP 24	AMP Junior Timer	12 V DC 24 V DC	IP 67
DT 12 DT 24	GERMAN (DT 04-2P)	12 V DC 24 V DC	IP 69k

### Solenoid version for potentially explosive atmospheres

Coding	Description
X 24 EX 55 FM	Explosion-proof solenoid in terminal box. For additional details, see the operating instructions B ATEX.

## 2.2 Single valve for pipe connection or manifold mounting

### Ordering example

PMVE 1 S G -AMP 24	-1/4	-B 0,8
		2.2.2 "Additional element"
		2.2.1 "Block configuration"
		2.1 "Screw-in valve"

### 2.2.1 Block configuration

Coding	Description	Port P and R	Circuit symbol
-1/4	Connection block for pipe connection	G 1/4	<p>PMVE 1 S</p>
-3/8		G 3/8	
-P	Connection block for manifold mounting	--	
			<p>PMVE 1 R</p>

### 2.2.2 Additional element

Coding	Description	Circuit symbol
Without coding	Without additional element	
B 0.5 B 0.6 B 0.8 B 1.1 B 1.3 B 1.5	Orifice in port B with orifice $\varnothing$ between 0.5 and 1.5 mm according to coding	

## 3 Parameters

### 3.1 General data

Designation	Proportional pressure-limiting valve
Design	Directly controlled, combination of seated valve and spool valve
Model	Screw-in valve
Material	Steel, surface gas nitrided, functional inner parts hardened and ground
Tightening torque	see Chapter 4, "Dimensions"
Installation position	As desired
Ports/connections	<ul style="list-style-type: none"> <li>▪ P, B = pump pressure, system pressure</li> <li>▪ R, A = reflux, tank</li> </ul>
Flow direction	<ul style="list-style-type: none"> <li>▪ P → R</li> <li>▪ B → A</li> </ul>
Hydraulic fluid	<p>Hydraulic fluid, according to DIN 51 524 Parts 1 to 3; ISO VG 10 to 68 according to DIN ISO 3448</p> <p>Viscosity range: 4 - 1500 mm<sup>2</sup>/s</p> <p>Optimal operating range: approx. 10 - 500 mm<sup>2</sup>/s</p> <p>Also suitable for biologically degradable hydraulic fluids type HEPG (polyalkylene glycol) and HEES (synthetic ester) at operating temperatures up to approx. +70°C.</p> <p>Not suitable for HETG such as rapeseed oil and water-glycol solutions, e.g. HFA and HFC.</p>
Cleanliness level	<p><b>ISO 4406</b></p> <hr style="width: 20%; margin-left: 0;"/> <p>20/17/14</p>
Temperatures	<p>Environment: approx. -40 to +80 °C, hydraulic fluid: -25 to +80 °C, pay attention to the viscosity range.</p> <p>Start temperature: down to -40 °C is permissible (take account of the start viscosities!), as long as the steady-state temperature is at least 20 K higher during subsequent operation.</p> <p>Biologically degradable hydraulic fluids: note manufacturer specifications. With consideration for the seal compatibility, not above +70°C.</p> <div style="border: 1px solid black; padding: 5px; margin-top: 10px;"> <p> <b>NOTICE</b> Note restrictions on explosion-proof solenoid.</p> </div>

### 3.2 Pressure and volumetric flow

Operating pressure	$p_{\max} = 420 \text{ bar}$
Flow rate	$Q_{\max} = 10 \text{ lpm}$



### 3.3 Weight

Screw-in valve	Type	
	PMVE 1	= 0.5 kg
Single connection blocks for pipe connection or manifold mounting	Type	
	PMVE 1 S(R). -... -1/4(3/8)	= 0.6 kg
	PMVE 1 S(R). -... -P	= 0.6 kg

### 3.4 Characteristic lines

Viscosity of the hydraulic fluid approx. 60 mm<sup>2</sup>/s

**Minimum pressure setting depending on pressure range coding (with R = 0 bar and PMVE 1 S with I = 0% or PMVE 1 R with I = 100%)**

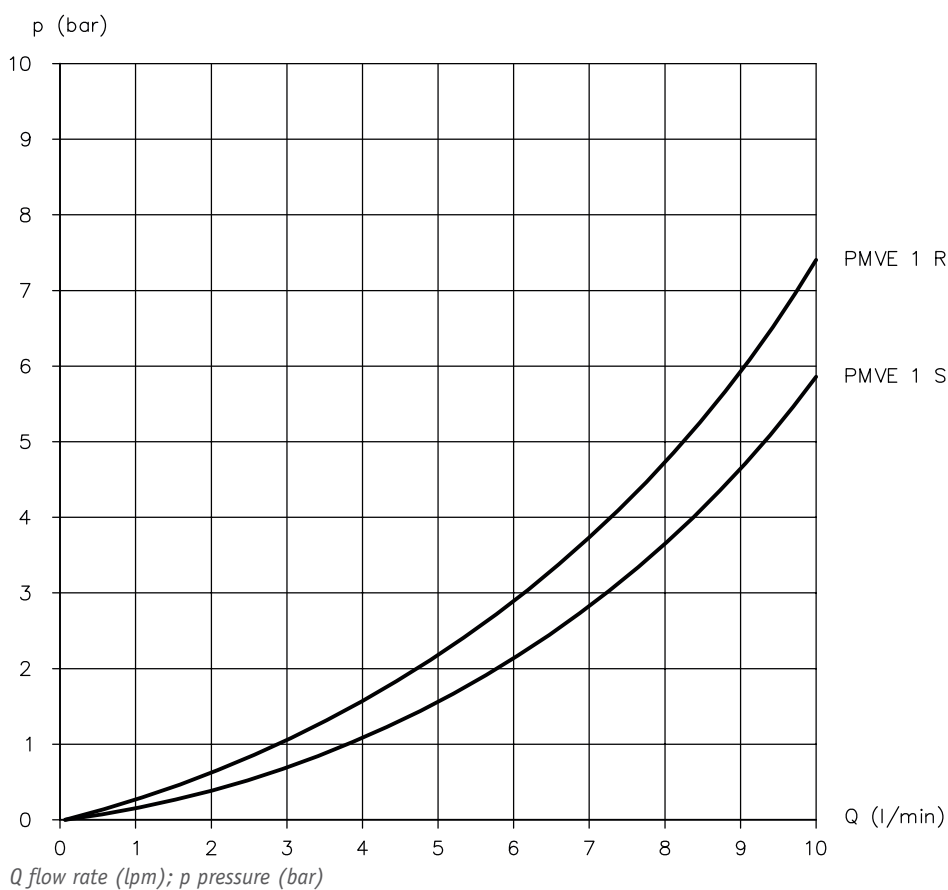

**p-I characteristic line (measured at 2.5 lpm)**

**PMVE 1 S**

Coding **F** (300 bar)

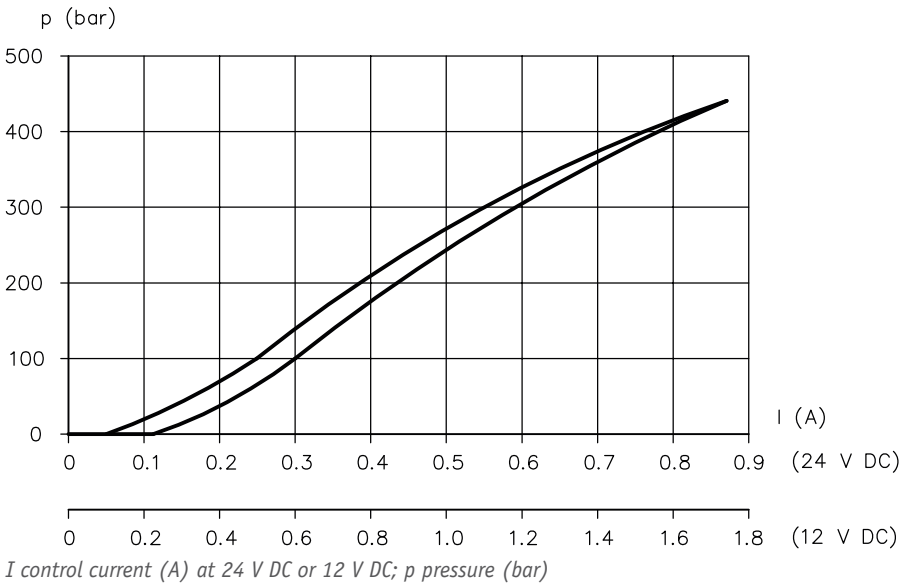

Coding **G** (350 bar)

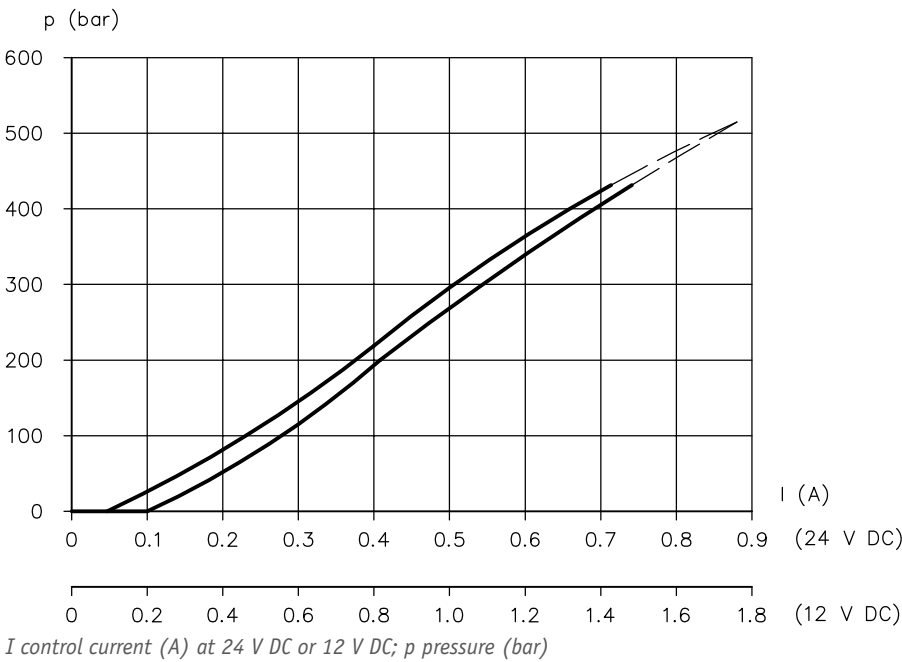

Coding **H** (420 bar)

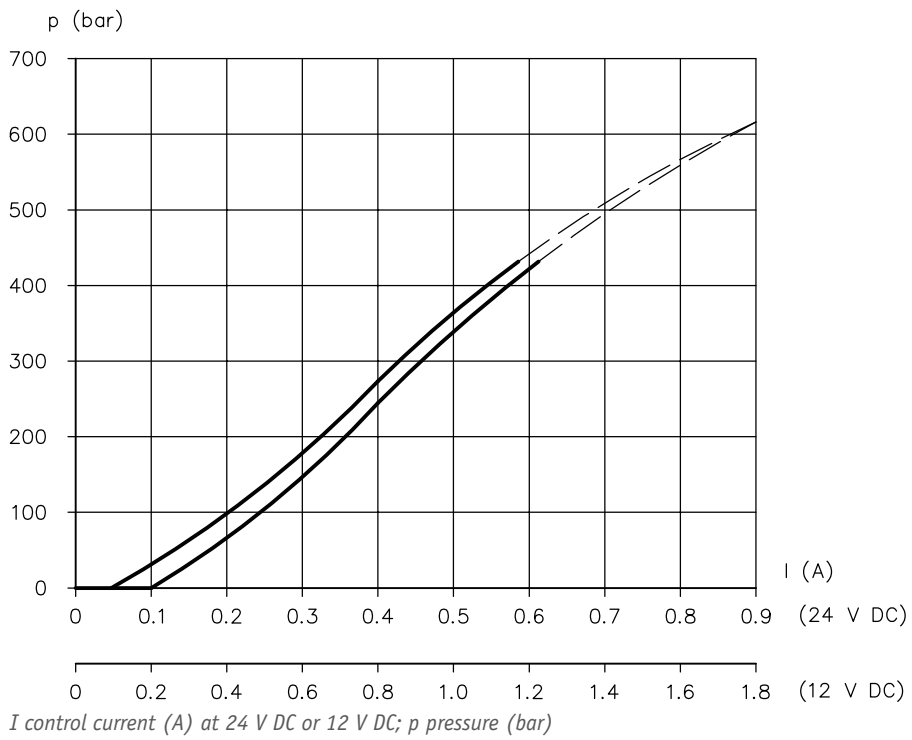

**PMVE 1 R**

Coding **F** (300 bar)

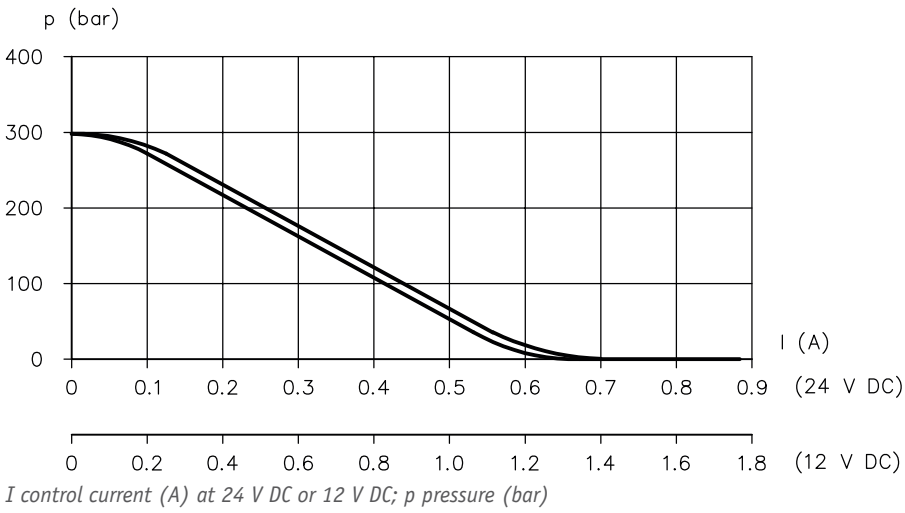

Coding **G** (350 bar)

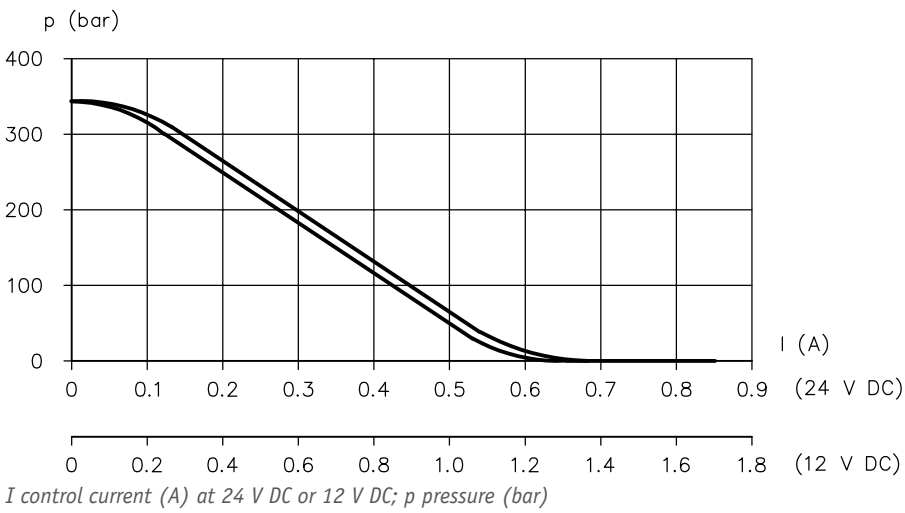

Coding **H** (420 bar)

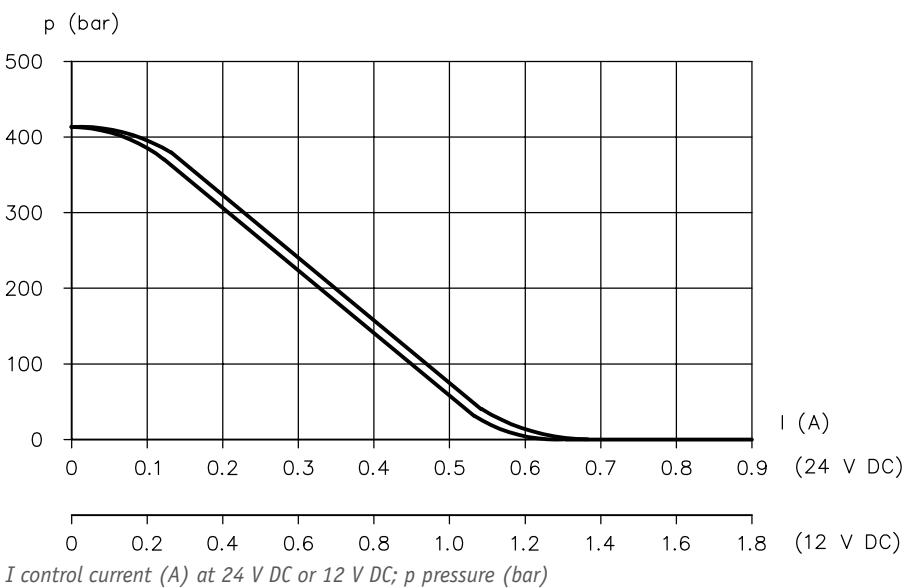

**Pressure depending on flow rate (measured at R = 0 bar)**

**PMVE 1 S**

Coding F (300 bar)

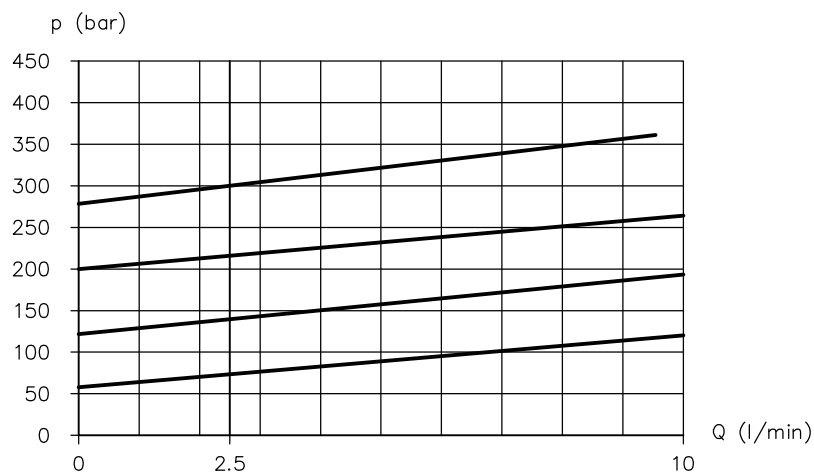

Q flow rate (lpm); p pressure (bar)

Coding G (350 bar)

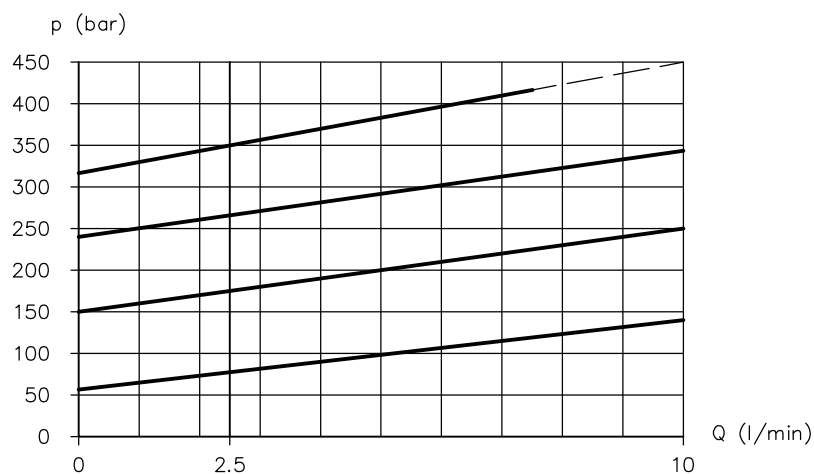

Q flow rate (lpm); p pressure (bar)

Coding H (420 bar)

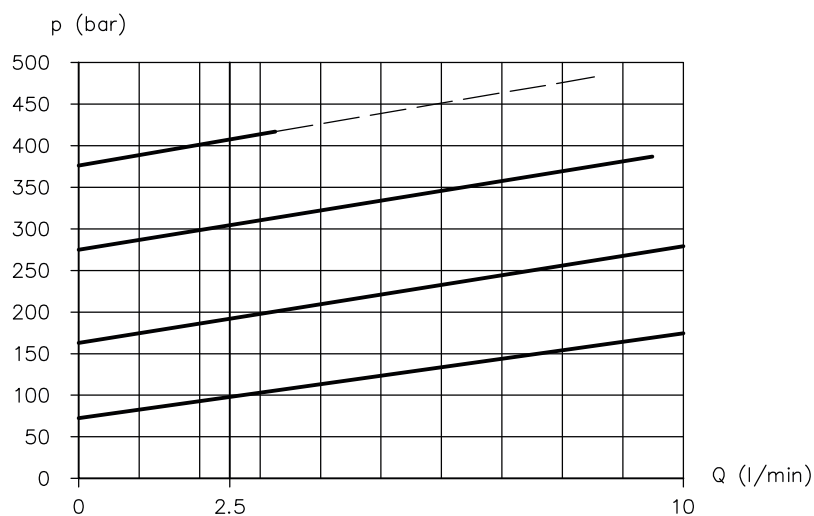

Q flow rate (lpm); p pressure (bar)

**PMVE 1 R**

Coding F (300 bar)

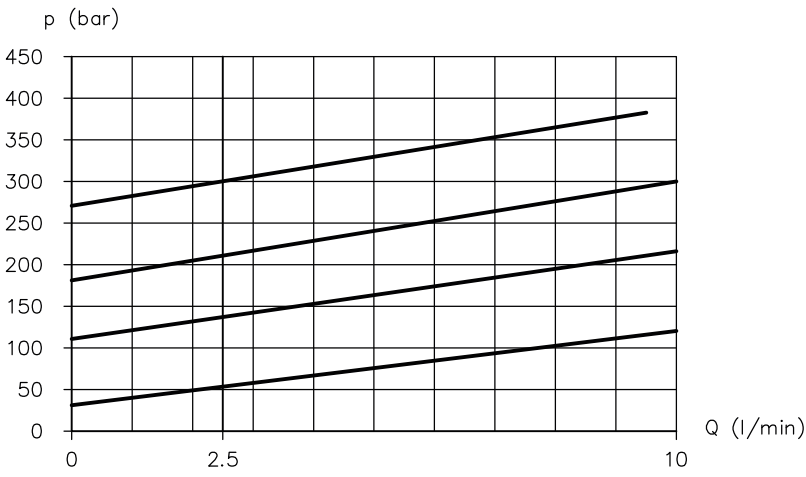

Q flow rate (lpm); p pressure (bar)

Coding G (350 bar)

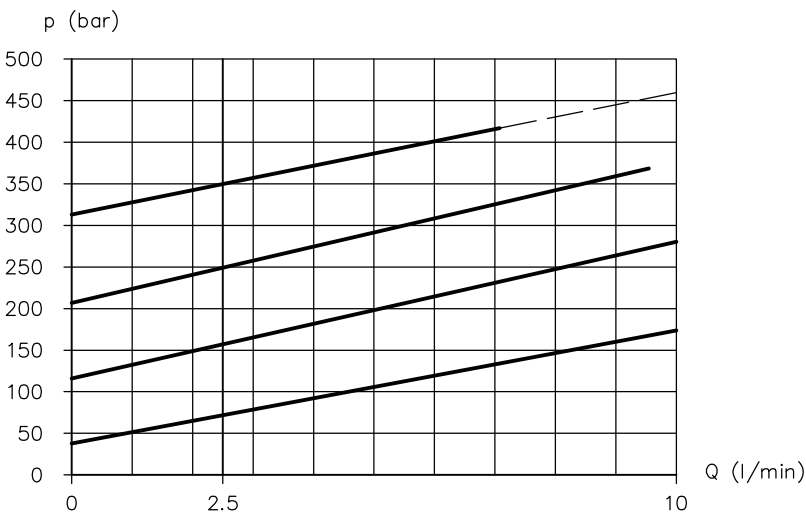

Q flow rate (lpm); p pressure (bar)

Coding H (420 bar)

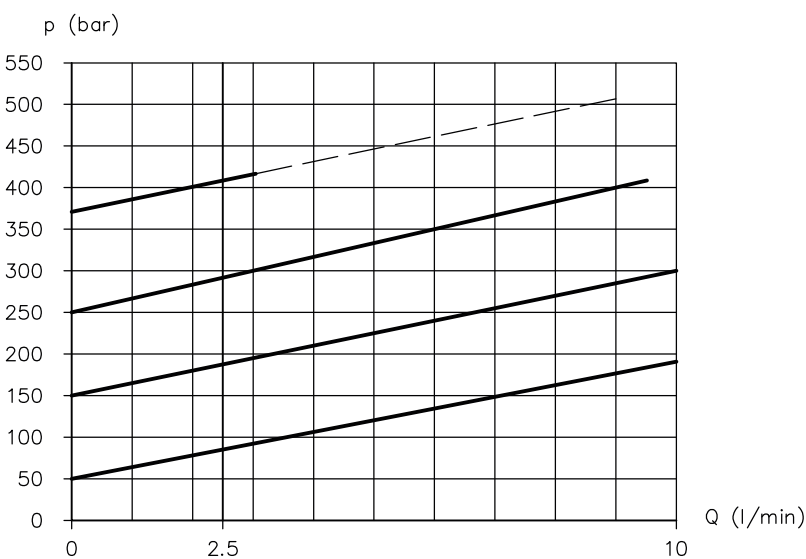

Q flow rate (lpm); p pressure (bar)

### 3.5 Electrical data

#### 3.5.1 Standard solenoid

Nominal voltage	12 V DC	24 V DC
Resistance R <sub>20</sub>	5.5 Ω	22 Ω
Current, cold I <sub>20</sub>	2.2 A	1.1 A
Limit current I <sub>G</sub>	1.28 A	0.64 A
Cooling power P <sub>20</sub>	26 W	26 W
Limit power P <sub>G</sub>	15 W	15 W
Cut-off energy W <sub>Δ</sub>	≤ 0.3 Ws	≤ 0.3 Ws
Duty cycle	S1 (100%)	
Dither frequency	100 to 200 Hz (recommended value: 100 Hz)	
Dither amplitude $A_D(\%) = \frac{I_{Peak} - I_{Peak}}{I_G} \cdot 100$	10% ≤ A <sub>D</sub> ≤ 30% (recommended value 20%)	

#### Electrical connection

	<b>X 12, X 24</b> <b>G 12, G 24</b>	<b>AMP 12</b> <b>AMP 24</b>	<b>DT 12</b> <b>DT 24</b>
Coil a (1), coil b (2)	EN 175 301-803 A IP 65 (IEC 60529)	AMP Junior Timer IP 67 (IEC 60529)	German (DT 04-2P) IP 69k (IEC 60529)

The specifications regarding the IP protection class apply for versions featuring a properly assembled male connector.

#### 3.5.2 Solenoid for potentially explosive atmospheres

**NOTICE**

When using solenoids for potentially explosive atmospheres: observe operating instructions **B ATEX** and the separate operating instructions for the respective solenoid.

Refer to the applicable operating instructions for operating thresholds, classifications, electrical parameters and electrical connections.

Coding	Operating instructions with declaration of conformity
X 24 EX 55 FM	<ul style="list-style-type: none"> <li>▪ B ATEX</li> <li>▪ B 40/2017</li> </ul>

## 4 Dimensions

All dimensions in mm, subject to change.

### 4.1 Screw-in valve

PMVE 1 S

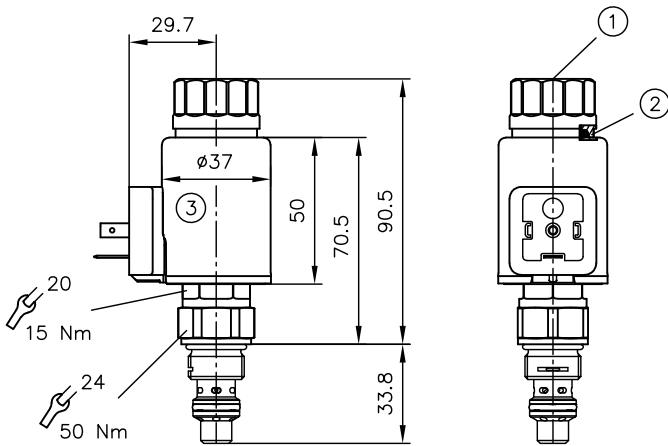

- 1 Manual override
- 2 Sealing between coil and nut
- 3 Can be rotated

PMVE 1 R

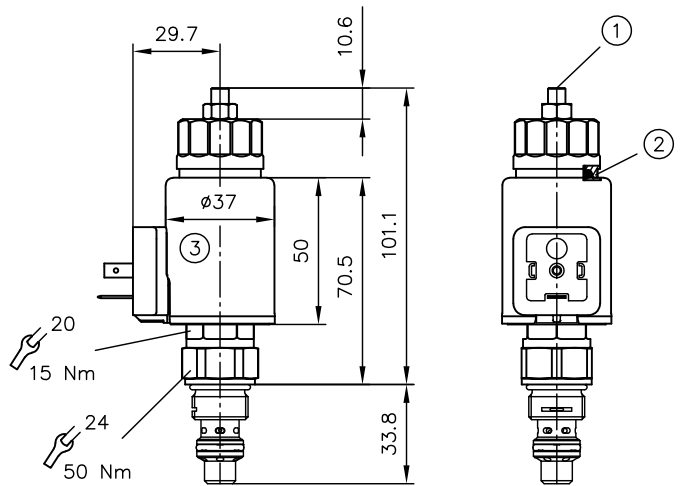

- 1 Adjusting screw for pmax setting
- 2 Sealing between coil and nut
- 3 Can be rotated

### Solenoid versions

X 12, X 24

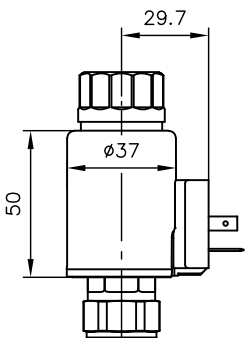

G 12, G 24

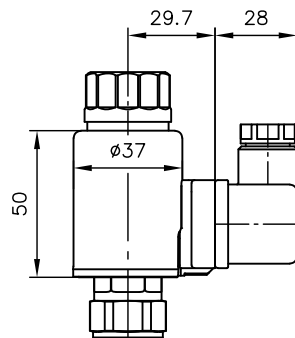

AMP 12, AMP 24

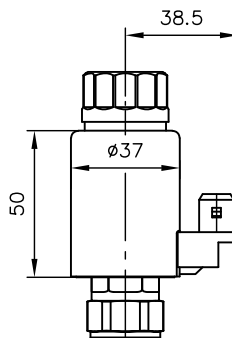

DT 12, DT 24

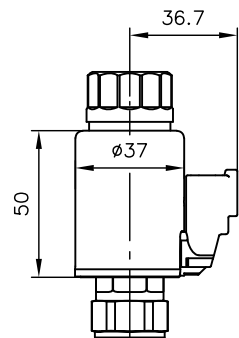



**Mounting hole for PMVE 1 S and PMVE 1 R**

**Variant 1: B port on side**

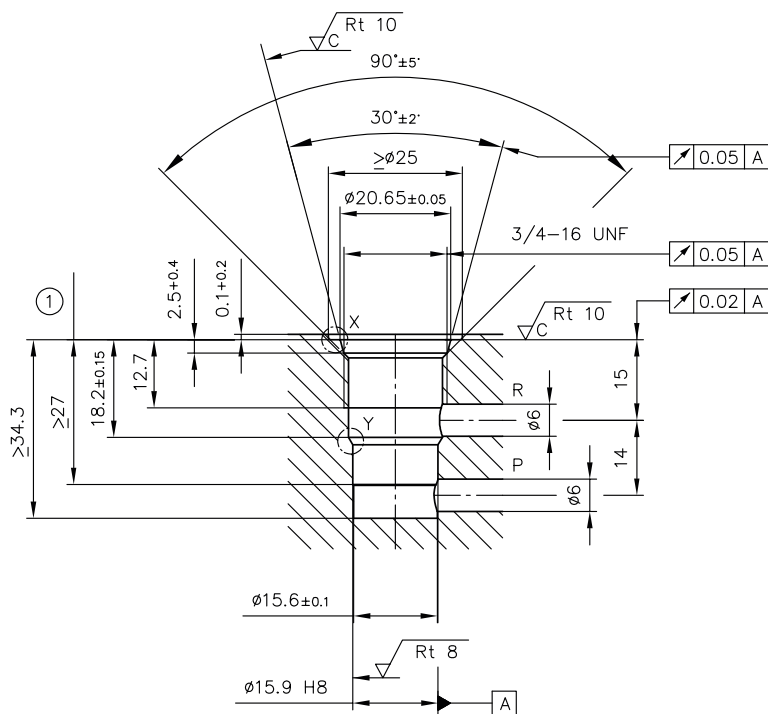

1 Reaming depth

**Detail X**

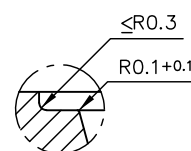

**Variant 2: B port below**

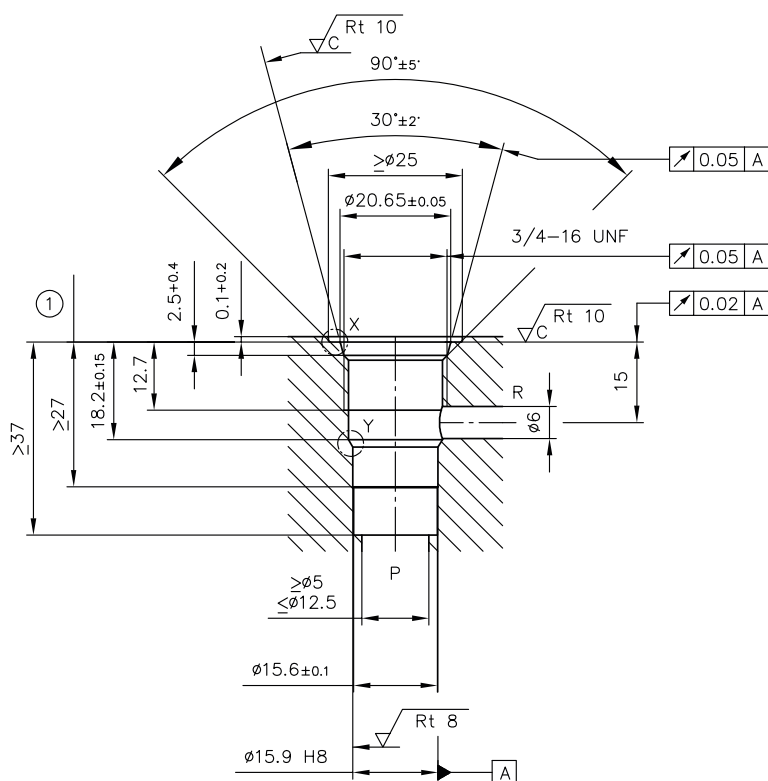

1 Reaming depth

**Detail Y**

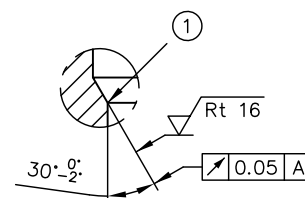

1 Round off edge max. R0.2

## 4.2 Single valve for pipe connection

PMVE 1 S. -... -1/4  
PMVE 1 S. -... -3/8

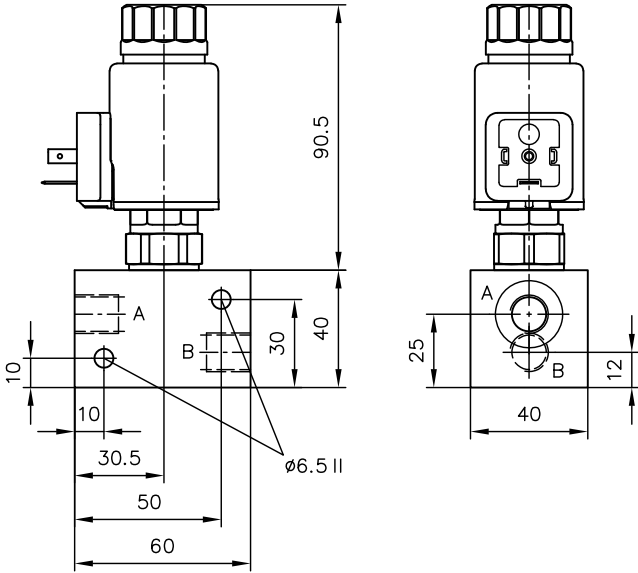

PMVE 1 R. -... -1/4  
PMVE 1 R. -... -3/8

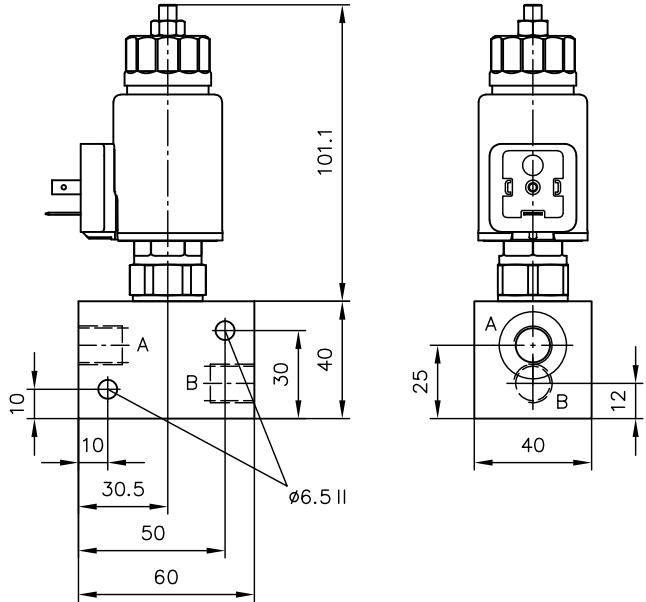

Coding	Ports (ISO 228-1) A, B
-1/4	G 1/4
-3/8	G 3/8

## 4.3 Single valve for manifold mounting

PMVE 1 S. -... -P

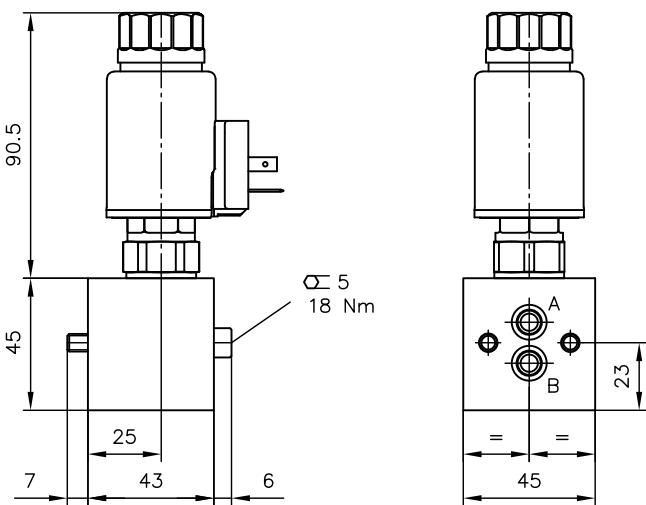

PMVE 1 R. -... -P

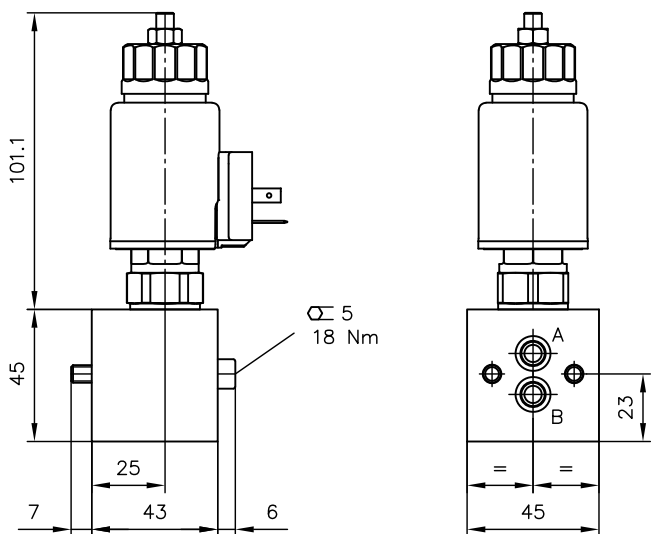

## 5 Installation, operation and maintenance information

Observe the document B 5488 "General operating instructions for assembly, commissioning, and maintenance."

### 5.1 Intended use

This product is intended exclusively for hydraulic applications (fluid technology).

The user must observe the safety measures and warnings in this document.

#### Essential requirements for the product to function correctly and safely:

- ▶ All information in this documentation must be observed. This applies in particular to all safety measures and warnings.
- ▶ The product must only be assembled and put into operation by specialist personnel.
- ▶ The product must only be operated within the specified technical parameters described in detail in this document.
- ▶ All components must be suitable for the operating conditions when using an assembly.
- ▶ The operating instructions for the components, assemblies and the specific complete system must also always be observed.

#### If the product can no longer be operated safely:

1. Remove the product from operation and mark it accordingly.
  - ✓ It is then not permitted to continue using or operating the product.

### 5.2 Assembly information

The product must only be installed in the complete system with standard and compliant connection components (screw fittings, hoses, pipes, fixtures etc.).

The product must be shut down correctly prior to disassembly (in particular in combination with hydraulic accumulators).



#### DANGER

##### Sudden movement of the hydraulic drives when disassembled incorrectly

Risk of serious injury or death

- ▶ Depressurise the hydraulic system.
- ▶ Perform safety measures in preparation for maintenance.

#### 5.2.1 Creating the mounting hole

see Chapter 4.1, "Screw-in valve"

### 5.3 Operating instructions

Observe product configuration and pressure/flow rate.

The statements and technical parameters in this document must be strictly observed.

The instructions for the complete technical system must also always be followed.



#### NOTICE

- ▶ Read the documentation carefully before usage.
- ▶ The documentation must be accessible to the operating and maintenance staff at all times.
- ▶ Keep documentation up to date after every addition or update.

**⚠ CAUTION****Overloading components due to incorrect pressure settings.**

Risk of minor injury.

- Pay attention to the maximum operating pressure of the pump, valves and fittings.
- Always monitor the pressure gauge when setting and changing the pressure.

**Purity and filtering of the hydraulic fluid**

Fine contamination can significantly impair the function of the product. Contamination can cause irreparable damage.

**Examples of fine contamination include:**

- Swarf
- Rubber particles from hoses and seals
- Dirt due to assembly and maintenance
- Mechanical debris
- Chemical ageing of the hydraulic fluid

**! NOTICE****New hydraulic fluid from the manufacturer may not have the required purity.**

Damage to the product is possible.

- ▶ Filter new hydraulic fluid to a high quality when filling.
- ▶ Do not mix hydraulic fluids. Always use hydraulic fluid that is from the same manufacturer, of the same type, and with the same viscosity properties.

For smooth operation, pay attention to the cleanliness level of the hydraulic fluid (cleanliness level [see Chapter 3, "Parameters"](#)).

Additionally applicable document: [D 5488/1](#) Oil recommendations

**5.4 Maintenance information**

Check regularly (at least once a year) by visual inspection whether the hydraulic connections are damaged. If external leakages are found, shut down and repair the system.

Clean the surface of the device regularly (at least once a year) (dust deposits and dirt).

## 6 Other information

### 6.1 Accessories, spare and individual parts

To purchase spare parts, please see [HAWE Hydraulik interactive contact map](#).

#### 6.1.1 Tapped plugs

The mounting holes can be sealed with tapped plugs if necessary; for example, if the assembly of standardised basic bodies is to be carried out with or without screw-in valves as required.

##### Tapped plug (passage open)

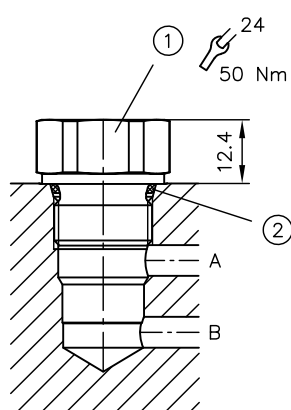

- 1 Tapped plug
- 2 O-ring 17.17x1.78-TPU 90/P 5001

##### Locking tapped plug (passage blocked)

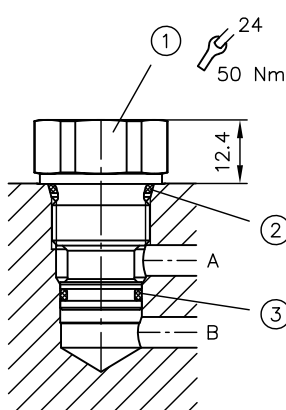

- 1 Locking tapped plug
- 2 O-ring 17.17x1.78-TPU 90/P 5001
- 3 Profile seal 13.2x15.9x1.9-TPU 90/P 6000

Tapped plug incl. O-ring	Locking tapped plug incl. O-ring	SW	Tightening torque (Nm)
7750 191	7750 181	24	50

SW = Wrench size

#### 6.1.2 Orifices

Coding	Orifice diameter Ø (mm)	Order coding		
		G 1/4	G 3/8	P
Without coding	Undrilled	7406 012 A	7400 003 A	7785 018
B 0.5	0,5	7406 012 G	7400 003 L	--
B 0.6	0,6	7406 012 B	7400 003 D	--
B 0.8	0,8	7406 012 C	7400 003 E	7785 018 A
B 1.0	1,0	--	--	7785 018 B
B 1.1	1,1	7406 012 D	7400 003 G	--
B 1.2	1,2	--	--	7785 018 C
B 1.3	1,3	7406 012 F	7400 003 H	--
B 1.4	1,4	--	--	7785 018 D
B 1.5	1,5	7406 012 H	7400 003 C	--

### 6.1.3 Seal kits

Type	Order coding
PMVE 1 seal kit	8143 005-1

## References

### Additional versions

- Proportional pressure-limiting valve type PMV and PMVP: D 7485/1
- Proportional pressure-limiting valve type NPMVP: D 7485 N
- Proportional pressure-limiting valve type PDV and PDM: D 7486
- Directional seated valve type BVE: D 7921
- Proportional-Druckregelventil Typ PM und PMZ: D 7625
- Proportional pressure-reducing valve type PDM and PDMP: D 7584/1

