

## NFPA STEEL CYLINDERS

<b>Series J 1-1/2" to 12" Bore Cylinder Features</b> . . . . .	70
Series J Technical Features . . . . .	71
<b>Series EJ 1-1/2" to 12" Bore Cylinder Features</b> . . . . .	72
Series EJ Impact Dampening Seals . . . . .	73
Series EJ Technical Features . . . . .	75
General Technical Information . . . . .	76

### Code NFPA Bore Sizes Description

01	MS4	1-1/2" - 12"	Side Tapped	. . . . .	80
03	MF1	1-1/2" - 6"	Head Rectangular Flange	. . . . .	84
03	ME3	7" - 12"	Head Square Flange	. . . . .	86
04	ME4	7" - 12"	Cap Square Flange	. . . . .	86
04	MF2	1-1/2" - 6"	Cap Rectangular Flange	. . . . .	88
05	MX0	1-1/2" - 12"	Basic	. . . . .	90
06	MX1	1-1/2" - 12"	4 Tie Rods Both Ends	. . . . .	94
6C	MX2	1-1/2" - 12"	Cap Tie Rods	. . . . .	94
6R	MX3	1-1/2" - 12"	Head Tie Rods	. . . . .	94
6B	MX4	1-1/2" - 12"	2 Tie Rods Both Ends	. . . . .	94
07	MT1	1-1/2" - 12"	Head Trunnion	. . . . .	98
08	MT2	1-1/2" - 12"	Cap Trunnion	. . . . .	102
09	MS2	1-1/2" - 12"	Side Lugs	. . . . .	106
10	MT4	1-1/2" - 12"	Intermediate Center Trunnion	. . . . .	110
11	MS1	1-1/2" - 12"	Side End Angles	. . . . .	114
12	MP1	1-1/2" - 12"	Cap Fixed Clevis	. . . . .	118
15	MS7	1-1/2" - 8"	Side End Lugs	. . . . .	122
16	N/A	1-1/2" - 6"	Sleeve Nut Construction Universal	. . . . .	124
20	MF5	1-1/2" - 6"	Head Square Flange	. . . . .	126
21	MF6	1-1/2" - 6"	Cap Square Flange	. . . . .	128
22	MP2	1-1/2" - 8"	Detachable Cap Clevis	. . . . .	130
32	MP3	1-1/2" - 12"	Cap Fixed Eye	. . . . .	132
42	MP4	1-1/2" - 8"	Detachable Cap Eye	. . . . .	136
52	N/A	1-1/2" - 8"	Spherical Bearing	. . . . .	138

Series DJ & EDJ Double Rod End Cylinders . . . . .	140
Series J & EJ 1-1/2" to 12" Cylinder Accessories . . . . .	144
Series J & EJ Optional Features & Custom Cylinders . . . . .	146
Stroke Signal Valve/Pneumatic Valve . . . . .	148
Reed & Solid State Switch Information . . . . .	150
Flow Controls . . . . .	152
Rod Alignment Coupler . . . . .	154
Air-Oil Tank . . . . .	154
Series J & EJ Standard and Special Options . . . . .	155
Series J & EJ 1-1/2" to 12" Order Information . . . . .	156

Seal Replacement Kits for Series A, EA, J & EJ . . . . .	157
Warning and Warranty . . . . .	158

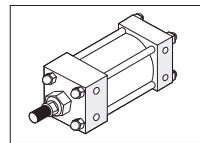

Page 80  
Cylinder with  
01 (MS4)  
Side Tapped

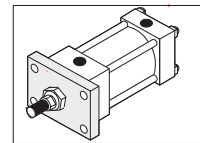

Page 84  
Cylinder with  
03 (MF1) Head  
Rectangular Flange

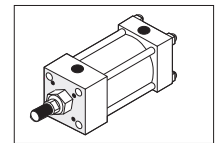

Page 86  
Cylinder with  
03 (ME3) Head  
Square Flange

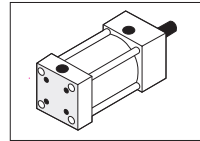

Page 86  
Cylinder with  
04 (ME4) Cap  
Square Flange

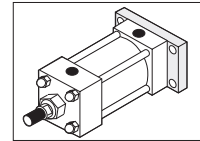

Page 88  
Cylinder with  
04 (MF2) Cap  
Rectangular Flange

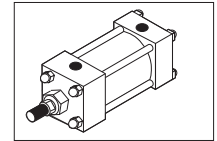

Page 90  
Cylinder with  
05 (MX0) Basic

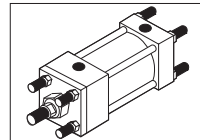

Page 94  
Cylinder with  
06 (MX1) Tie Rod-4,  
6C (MX2) Cap, 6R (MX3)  
Head, 6B (MX4) Tie Rod-2

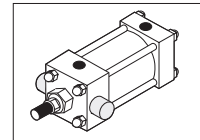

Page 98  
Cylinder with  
07 (MT1)  
Head Trunnion

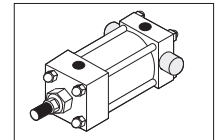

Page 102  
Cylinder with  
08 (MT2)  
Cap Trunnion

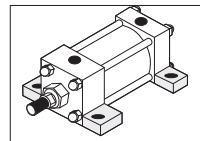

Page 106  
Cylinder with  
09 (MS2)  
Side Lugs

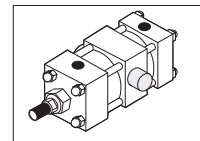

Page 110  
Cylinder with  
10 (MT4) Intermediate  
Center Trunnion

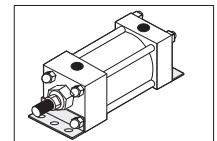

Page 114  
Cylinder with  
11 (MS1)  
Side End Angles

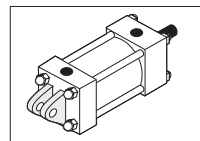

Page 118  
Cylinder with  
12 (MP1) Cap  
Fixed Clevis

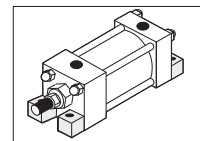

Page 122  
Cylinder with  
15 (MS7)  
Side End Lugs

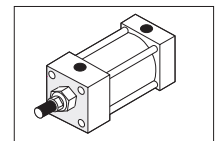

Page 124  
Cylinder with 16  
Sleeve Nut Construction  
Side Tapped (Universal)

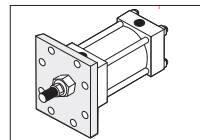

Page 126  
Cylinder with  
20 (MF5) Head  
Square Flange

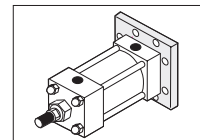

Page 128  
Cylinder with  
21 (MF6) Cap  
Square Flange

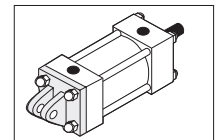

Page 130  
Cylinder with  
22 (MP2) Detachable  
Clevis

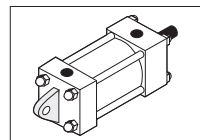

Page 132  
Cylinder with  
32 (MP3) Cap  
Fixed Eye

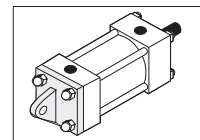

Page 136  
Cylinder with  
42 (MP4) Detachable  
Cap Eye

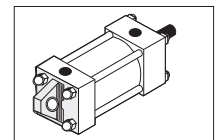

Page 138  
Cylinder with  
52 Spherical Bearing

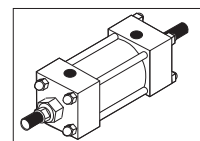

Page 140  
Double Rod End Cylinders

NFPA - National Fluid Power Association



### Series J Cylinders are constructed with the finest materials for each component!

**1 Piston Rod:** Hard chrome plated high-tensile steel, ground and polished.

**2 Rod Bearing:** External removable threaded steel bearing housing (black oxide finish), with an oil-impregnated sintered iron rod bearing.

**3 Rod Seal:** Nitrile lip-type seal is pressure energized and wear compensating for durability and long life.

**4 Head/Cap:** Precision machined from steel, then black oxide finished 1-1/2" to 2-1/2" bores. Painted black finish on 3-1/4" to 12" bores.

**5 Ultra Cushion® Seals:** Advanced design features a unique, one-piece, compound seal of nitrile\* captured within a precision machined groove. Linear and radial "float" of the cushion seals eliminates misalignment. Ultra Cushions provide exceptionally fast "out of cushion" stroke reversal. (Head and Cap Cushions are optional.)

\*Nitrile seals on the 5/8" & 1" rod diameter. For rod sizes 1-3/8" and larger, urethane seals are standard.

**6 O-Ring Tube Seal:** Buna is standard. (Viton is optional.)

**7 Tie Rods:** High-strength steel maintains uniform compression on tube end seals.

**8 Piston:** Machined solid steel, for high strength. (Threaded piston is installed with high strength threadlocker adhesive, then staked to the piston rod.)

**9 Adjustable Captive Cushion Needle:** One-piece stainless steel cushion needle with fine threads is held captive by a stainless steel press-in retaining washer. This allows for safe and precise adjustment of the cushion.

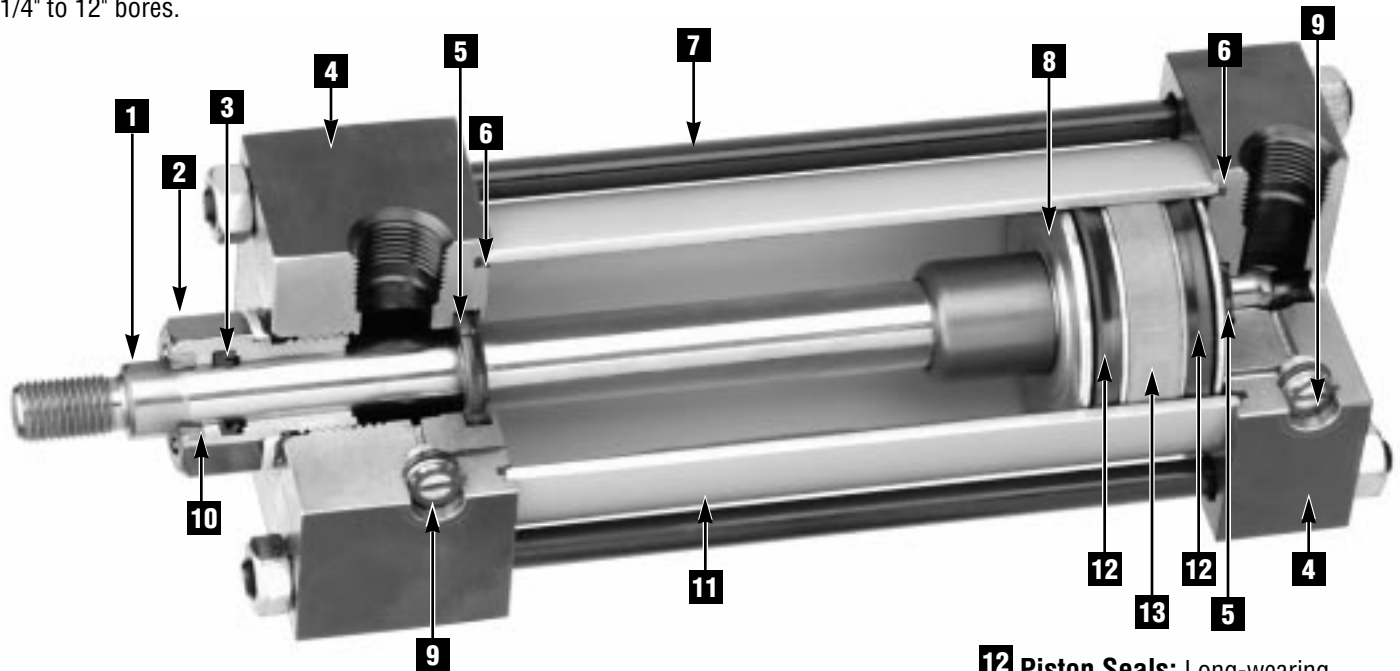

**10 Wiper Seal:** Lip-type urethane wiper seal keeps contaminants from getting into cylinder by aggressively wiping foreign materials from the piston rod, enhancing the rod seal life.

**11 Cylinder Tube:** High-strength aluminum alloy 1-1/2", 2", 2-1/2" bore anodized on the O.D. and hard coat I.D. Steel cylinder tube hard chrome plated I.D. 3-1/4" to 12" bore.

**12 Piston Seals:** Long-wearing nitrile seals.

**13 Wear Ring:** Reinforced Teflon® compounded with polyphenylene sulfide provides supreme wear and excellent bearing support.

#### Application Information

Series J NFPA interchangeable steel air cylinders are offered with a variety of accessories, standard and optional equipment to meet your application needs.

The addition of a Teflon® wear ring to the outer perimeter of the piston permits us to guarantee its operation against failure due to lack of lubrication for ONE FULL YEAR, regardless of cycles! See page 158 for complete warranty.

Standard non-cushioned Series J cylinders are recommended for applications that require full bottoming of the piston and where the noise emitted by the metal-to-metal impact between the piston and cylinder end caps is tolerable. We recommend that optional non-adjustable cushions be added for piston speeds (moving light tools) ranging from 15 to 30 in/sec. For speeds exceeding 30 in/sec, the cylinders should be equipped with adjustable air cushions.

**Operating Temperatures:**

Series J -20°F to 200°F  
 (-29°C to 93°C)  
 with Viton® Seals -20°F to 400°F  
 (-29°C to 204°C)

**Operating Pressure:**

250 PSIG Air (17.2 Bar)  
 400 PSIG Hydraulic (27.6 Bar)  
 Bore Sizes: 1-1/2", 2", 2-1/2", 3-1/4",  
 4", 5", 6", 7", 8", 10", 12"

**Supply:**

Filtered compressed air to 250 PSI  
 Petroleum based hydraulic fluid to 400 PSI

**Lubrication:**

None required  
 Norgren Air Cylinders are rated for "no lube added" service. All internal components are lubricated at time of assembly with a Teflon® based grease.

**Materials:**

Head and End Caps: precision machined steel  
 Tube: 6063-T832 aluminum, clear anodized O.D., hard coat anodized I.D.  
 Rod: hard chrome plated steel  
 Piston: machined high-strength aluminum alloy  
 Rod Bearing: oil impregnated sintered iron  
 Seals: nitrile rod seal, urethane rod wiper, nitrile piston seals, nitrile tube end seals  
 Tie Rods: high-tensile strength steel

**Side Loading:**

Cylinders are specifically designed to push and pull. Side loading (misalignment) of the piston rod should be avoided to ensure maximum operating performance and life.

Care should be taken during installation to properly align the load to be moved with the center line of the cylinder.

The use of a rod alignment coupler (see page 154) is strongly recommended whenever possible.

**Air Cylinder Selection:**

The proper application and selection of an air cylinder requires full consideration of the following: the fluid medium, operating pressures, mounting style, length of stroke, type of rod connection to the load, thrust or mounting tension on the rod, mounting attitude, speed of the stroke and how the load motion will be stopped.

The data that follows provides the necessary information in the evaluation of

an average application and will help you in selecting the proper cylinder model and size for your particular application.

**Note:** 1-1/2", 2", 2-1/2", 3-1/4", 4" and 5" bore cylinders with stroke lengths of 1/2" and less than 2" will be furnished with a short head cushion sleeve and short cap cushion spear. Only available on 5/8" and 1" rods.

The above specification applies to Series J cylinders with optional non-adjustable or adjustable cushions.

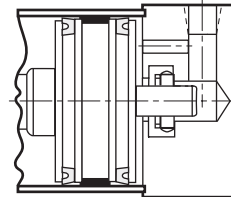
**Series J Fixed Cushions**

*Piston and rod assembly for 1-1/2" thru 5" bore cylinders with stroke lengths of 1/2" and less than 2".*

**Ultra Cushion®****A Major Design and Performance Breakthrough in Air Cylinder Cushioning Systems!**

Norgren's advanced design features a unique, one-piece, nitrile compound seal that is captured within a precision machined groove. This allows both linear and radial "float" of the cushion seal which virtually eliminates problems associated with misalignment. Integral flow paths molded in the periphery of the seal provide exceptionally fast "out of cushion" stroke reversal without the use of ball checks.

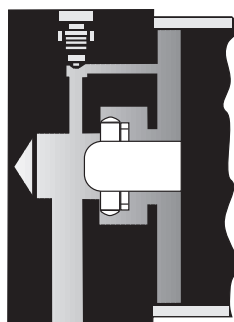

Figure 1

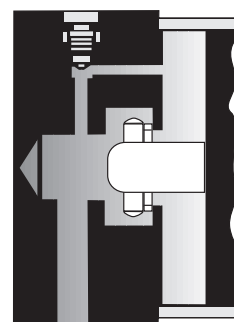

Figure 2 shows spear exiting cushion seal.



# Series EJ Ecology Cylinders are constructed with the finest materials for each component!

**1 Ultra Cushion® Seals:** Advanced design features a unique, one-piece, compound seal of nitrile\* captured within a precision machined groove. Linear and radial “float” of the cushion seals eliminates misalignment. Ultra Cushions provide exceptionally fast “out of cushion” stroke reversal. (Head and Cap Cushions are optional.)

\*Nitrile seals on the 5/8" & 1" rod diameter.  
For rod sizes 1-3/8" and larger, urethane seals are standard.

**2 Impact Dampening Piston Seals:** Our patented impact dampening piston seals, in conjunction with our advanced cushion design, decelerate and reduce end-of-stroke noise.

**3 Piston:** Machined solid steel, for high strength. (Threaded piston is installed with high strength threadlocker adhesive, then staked to the piston rod.)

**4 O-Ring Tube Seal:** Buna is standard. (Viton is optional.)

**5 Adjustable Captive Cushion Needle (not shown):** Fine thread allows for safe and precision adjustment of cushion. (See page 70.)

**6 Wiper Seal:** Lip-type urethane wiper seal keeps contaminants from getting into cylinder by aggressively wiping foreign materials from the piston rod, enhancing the rod seal life.

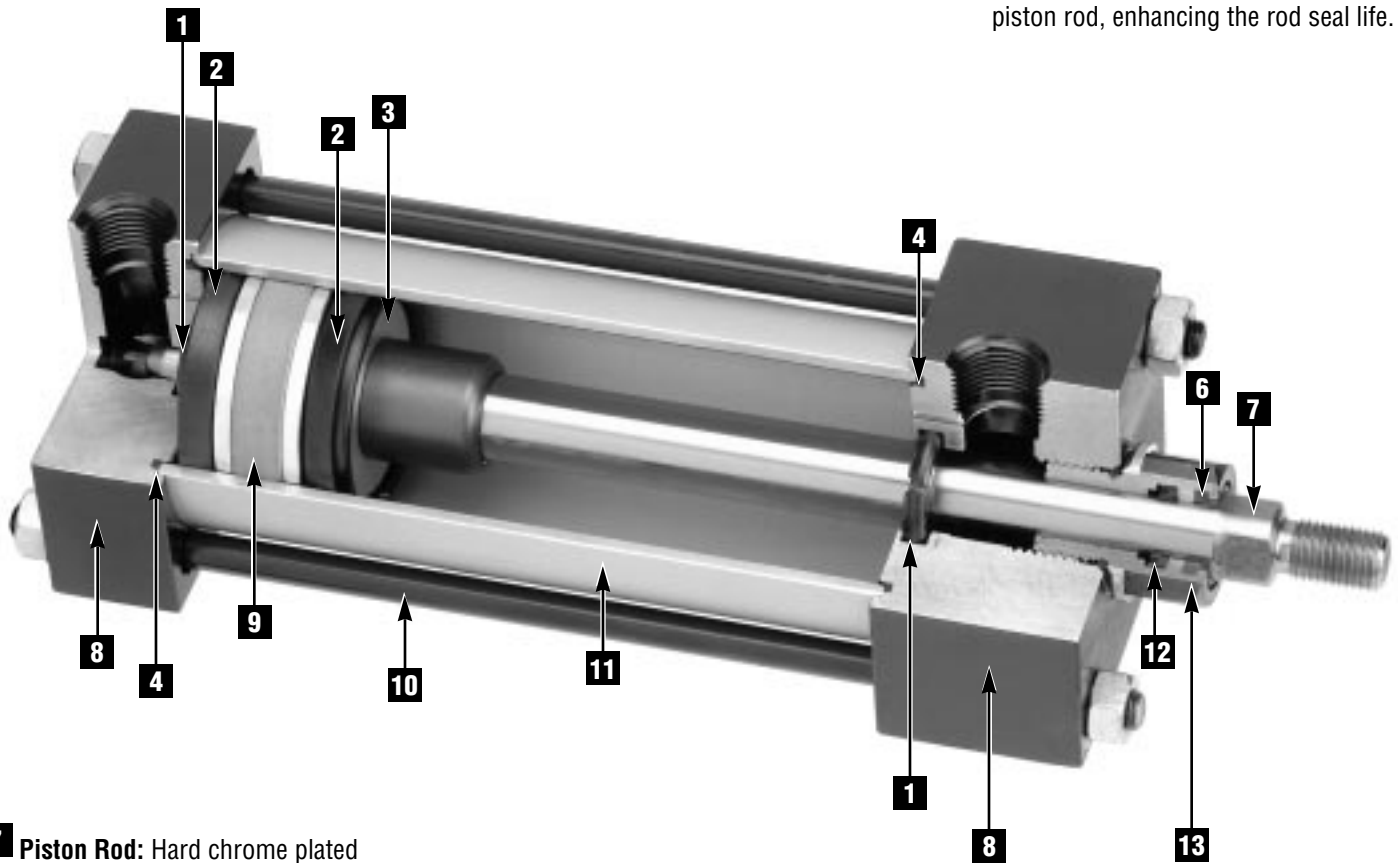

**7 Piston Rod:** Hard chrome plated high-tensile steel, ground and polished.

**8 Head/Cap:** Precision machined from steel, then black oxide finished 1-1/2" to 2-1/2" bores. Painted black finish 3-1/4" to 12" bores.

**9 Wear Ring:** Reinforced Teflon® compounded with polyphenylene sulfide provides supreme wear and excellent bearing support.

**10 Tie Rods:** High-strength steel maintains uniform compression on tube end seals.

**11 Cylinder Tube:** High-strength aluminum alloy 1-1/2", 2", 2-1/2" bore anodized on the O.D. and hard coat I.D. Steel cylinder tube hard chrome plated I.D. 3-1/4" to 12" bore.

**12 Rod Seal:** Nitrile lip-type seal is pressure energized and wear compensating for durability and long life.

**13 Rod Bearing:** External removable steel bearing housing (black oxide finish), with an oil-impregnated sintered iron rod bearing.



# Norgren Ecology Cylinders offer these advantages:

## 1 Norgren Guarantees Non-lubricated Operation for a Full Year!

The piston rod is self-lubricated by the oil-impregnated rod bearing during operation. Lubrication between piston and cylinder barrel is derived from the polishing qualities of the reinforced Teflon® wear ring.

The low friction surfaces extend the life of the seals beyond normal expectations, permitting Norgren to unconditionally guarantee non-lubricated operation for one full year. See page 158 for complete warranty.

Series EJ cylinders are NFPA interchangeable and are available in many different mounting styles.

## 2 Operates Quietly to Meet OSHA Specifications.

Series EJ cylinders provide substantial reductions in impact noise, which reduces overall machine noise and helps meet government regulations.

The summary of sound decibels chart illustrates the operating sound levels.

The impact dampening qualities of the Piston Seals\* are guaranteed for ONE FULL YEAR!

\*Patented Impact Dampening Piston Seals (No. 3,913,460)

### Summary of Sound Levels in Decibels

PSI Air Sound Pressure Level+	Cylinder Model	Cylinder Model			
		J133B3 5" x 6"	EJ155B3 5" x 6"	J1133A3 2" x 6"	EJ1155A3 2" x 6"
95 PSI+	End++	108	73	110	74
	Side++	112	84	110	81
50 PSI+	End++	108	73	113	74
	Side++	113	85	110	81

+ Peak sound pressure is given in decibels (dB) re: 2 x 10<sup>5</sup> N/m<sup>2</sup>.

++End position of mike was 3' on centerline from end of cylinder; side position of mike was 3' perpendicular to centerline abeam of end of cylinder.

Note: At 5 feet, cylinder sound levels would be less by 9 dB from side figure and 13 dB from end figure. The total noise emitted will depend on the structure to which the cylinder is attached. If it is mounted on a thin flat plate of considerable area, the noise will be increased by a sounding board effect.

## 3 Energy Absorption Capacity of the Patented Impact Dampening Seals\*

The patented impact-dampening Piston Seals in the Series EJ cylinder allow for guaranteed, repeatable cushioning. The compressive qualities of the piston seals are predictable. The degree of seal compression at various supply pressures is documented. (See Energy Absorption Chart.) This allows you to compute the exact cylinder size required by knowing the weight (pounds) you are stopping at a given speed.

\* Patent No. 3,913,460

Series EJ cylinders have a patented impact dampening piston seal that accomplishes 80% of the actual load stopping. The air cushion accounts for only 20%. (A conventional air cushioning cylinder depends 100% on the compressibility of air to do the stopping.) The EJ seal absorbs high impact loads allowing the effect of the air cushion to be reduced by using a larger air cushion bleed orifice. As a result the piston can move at a faster speed for a longer period of time before the EJ seal does the final stopping.

### Energy Absorption Capacity of the Patented Impact Dampening Seals

\*Usable Pounds Stoppable at the Following Piston Speeds

This chart features the energy absorption capacity of the patented impact dampening Piston Seals with a **Non-Adjustable** cushions. **Increase ratings by 80% on cylinders with Adjustable cushions.** For higher loads and velocities please refer to the Decel-Air Catalog.

In/Sec	Cylinder Bore										
	1 1/2	2	2 1/2	3 1/4	4	5	6	7	8	10	12
6	155.6	275.5	499.8	969.3	1505.4	2603.2	4159.8	5794.2	8067.6	12,242	20,139
12	38.4	68.1	123.4	239.7	372.6	644.8	1030.2	1435.8	2000.4	3026	4971
18	16.7	29.7	53.7	104.6	162.8	282.1	450.6	628.7	876.8	1319.3	2162.1
24	9.2	16.3	29.4	57.3	89.4	155.2	247.8	346.2	483.6	722	1179
30	5.6	10.0	18.1	35.4	55.4	96.4	153.9	215.4	301.6	445.5	724
36	3.7	6.7	11.9	23.5	37.0	64.5	102.9	144.4	202.7	295.3	476.8
42	2.6	4.6	8.2	16.3	25.8	45.3	72.2	101.6	143.1	204.8	327.7
48	1.8	3.2	5.8	11.7	18.6	32.8	52.2	73.8	104.4	146	231
54	1.3	2.4	4.2	8.5	13.6	24.2	38.5	54.7	77.9	105.7	164.7
60	1.0	1.8	3.0	6.2	10.1	18.1	28.7	41.1	58.9	76.9	117.2

\*The weight of the cylinder piston has been deducted from the figures shown above.

Note: The use of Viton® Seals limits the absorption of the impact dampening seals by 50%.

### Effect of Impact Dampening Seals on Total Stroke of Cylinders

PSI	Cylinder Bore										
	1 1/2	2	2 1/2	3 1/4	4	5	6	7	8	10	12
0	.14	.15	.17	.19	.22	.25	.28	.32	.32	.36	.40
20	.10	.10	.12	.14	.16	.18	.20	.22	.22	.24	.26
40	.07	.07	.08	.09	.10	.12	.13	.14	.14	.15	.16
60	.04	.04	.05	.05	.06	.07	.07	.08	.08	.09	.10
80	.02	.02	.02	.02	.03	.03	.03	.04	.04	.04	.04
100	0	0	0	0	0	0	0	0	0	0	0

Note: These figures are for new cylinders. The impact dampening seals will take some compression set during operation of the cylinder and the stroke loss will decrease. Also, the pressure at zero stroke loss will decrease to about 80 psi.

At pressures above those of zero stroke loss, a slight clicking sound may be produced during impact.

To determine the stroke loss for either the head or cap end, divide the value shown by 2.



As the cushion spear enters the cushion cavity, the exhaust port becomes sealed off creating an air brake. This provides the initial deceleration in piston speed. The oversized air cushion bleed orifice permits the cushion pressure to exhaust with minimal restriction. This allows the piston to move quickly and smoothly through the cushion length.



As the piston continues its travel to the point of impact with the end caps, the compressive qualities of the EJ seal provide the final decelerating force. This action compresses the EJ seal and absorbs the remaining kinetic shock vibration and noise created by the impact.



On the reverse stroke the EJ seal releases its compressive energy to propel the piston away from the end caps, producing an immediate breakaway.



# Tests by the Milwaukee School of Engineering confirm Ecology Cylinder Cushions are more efficient, faster acting and bounce less!

## NORGREN ECOLOGY CYLINDERS with Non-Adjustable Cushions

### 2" Bore Rod End Cushion Test

Average deceleration force = 15 G's  
Time consumed during cushioning = 0.030 sec.  
Number of bounces: 1 Pneumatic – 1 Metallic

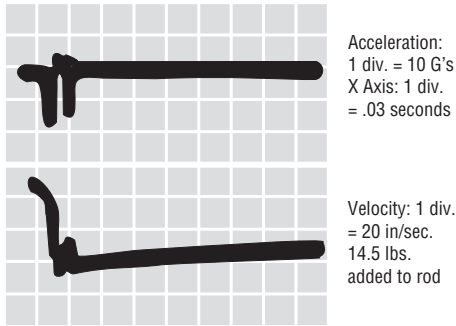

### 2" Bore Cap End Cushion Test

Average deceleration force = 17.5 G's  
Time consumed during cushioning = 0.025 sec.  
Number of bounces: 1 Pneumatic – 1 Metallic

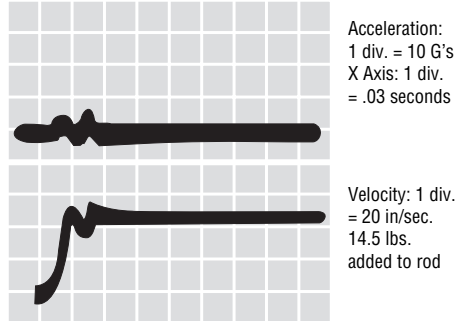

## NORGREN ECOLOGY CYLINDERS with Adjustable Cushions

### 2" Bore Rod End Cushion Test

Average deceleration force = 20 G's  
Time consumed during cushioning = 0.015 sec.  
Number of bounces: 1/2 Pneumatic – 0 Metallic

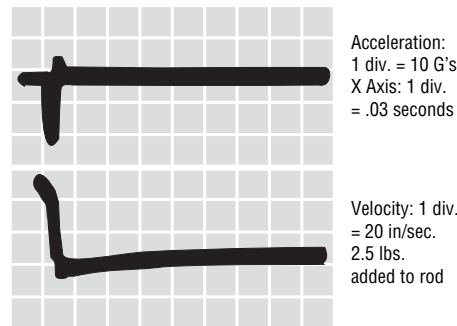

### 2" Bore Cap End Cushion Test

Average deceleration force = 10 G's  
Time consumed during cushioning = 0.020 sec.  
Number of bounces: 1/2 Pneumatic – 0 Metallic

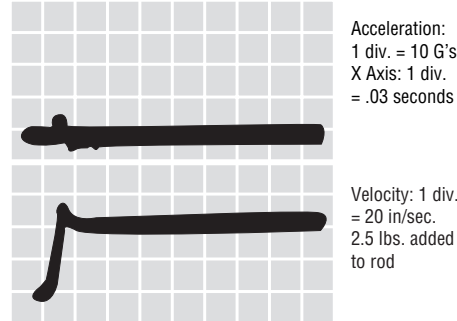

## COMPETITIVE CYLINDERS with Adjustable Cushions

### 2" Bore Rod End Cushion Test

Average deceleration force = 78 G's  
Time consumed during cushioning = 0.120 sec.  
Number of bounces: 2 Pneumatic – 4 Metallic

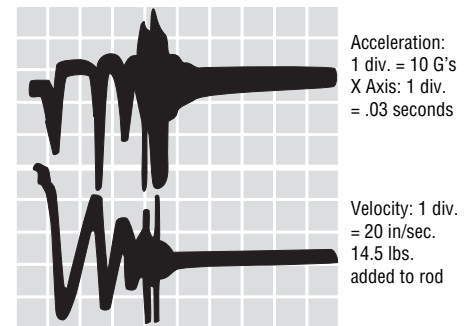

### 2" Bore Cap End Cushion Test

Average deceleration force = 60 G's  
Time consumed during cushioning = 0.120 sec.  
Number of bounces: 3 Pneumatic – 4 Metallic

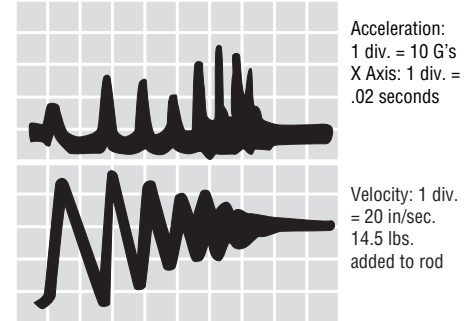

## 2" Bore Cylinder Tests Results

Figures shown are average and not the result of each individual test. Piston velocity was regulated at 45 in/sec.

Cylinders with Cushions	Weight attached to Piston Rod (lbs)	Cushion Efficiency (G's* Created)	Cushioning Time (Ms)	Bounce Cycles During Cushioning
Norgren Ecology Adjustable	8.5	14.50	25.00	1.00
Norgren Ecology Non-Adjustable	8.5	17.50	26.25	1.75
Competitor A Adjustable	8.5	48.00	107.50	7.25
Competitor B Adjustable	8.5	32.75	102.50	6.50
Competitor C Adjustable	8.5	50.50	81.25	9.25

\*Measured in G's of deceleration force created. All cylinders tested were NFPA types, front flange mounting, 6" stroke with standard diameter piston rods.

## 4" Bore Cylinder Tests Results

Figures shown are average and not the result of each individual test. Piston velocity was regulated at 25 in/sec.

Cylinders with Cushions	Weight attached to Piston Rod (lbs)	Cushion Efficiency (G's* Created)	Cushioning Time (Ms)	Bounce Cycles During Cushioning
Norgren Ecology Adjustable	54	5.25	40.00	3.25
Norgren Ecology Non-Adjustable	54	12.00	28.75	2.75
Competitor A Adjustable	54	11.50	92.50	6.75
Competitor B Adjustable	54	8.00	77.50	5.25
Competitor C Adjustable	54	6.50	67.50	6.25

\*Measured in G's of deceleration force created. All cylinders tested were NFPA types, front flange mounting, 6" stroke with standard diameter piston rods.



**Operating Temperatures:**

Series EJ -20°F to 200°F  
 (-29°C to 93°C)  
 with Viton® Seals -20°F to 400°F  
 (-29°C to 204°C)

**Operating Pressure:**

250 PSIG Air (10 Bar)  
 EJ Cylinders cannot be used  
 in hydraulic applications.  
 Bore Sizes: 1-1/2", 2", 2-1/2", 3-1/4",  
 4", 5", 6", 7", 8", 10", 12"

**Supply:**

Filtered compressed air to 250 PSI

**Lubrication:**

None required  
 Norgren Air Cylinders are rated for "no  
 lube added" service. All internal  
 components are lubricated at time of  
 assembly with a Teflon® based grease.

**Materials:**

Head and End Caps: precision  
 machined steel  
 Tube: 6063-T832 aluminum, clear  
 anodized O.D., hardcoat anodized I.D.  
 Rod: hard chrome plated steel  
 Piston: machined high-strength  
 aluminum alloy  
 Rod Bearing: oil impregnated sintered iron  
 Seals: nitrile rod seal, urethane rod wiper,  
 nitrile piston seals, nitrile tube  
 end seals  
 Tie Rods: high-tensile strength steel

**Side Loading:**

Cylinders are specifically designed to push  
 and pull. Side loading (misalignment)  
 of the piston rod should be avoided to  
 ensure maximum operating performance  
 and life.

Care should be taken during installation  
 to properly align the load to be moved  
 with the center line of the cylinder.  
 The use of a rod alignment coupler (see  
 page 154) is strongly recommended  
 whenever possible.

**Air Cylinder Selection:**

The proper application and selection of an  
 air cylinder requires full consideration of  
 the following: the fluid medium, operating  
 pressures, mounting style, length of  
 stroke, type of rod connection to the load,  
 thrust or mounting tension on the rod,  
 mounting attitude, speed of the stroke and  
 how the load motion will be stopped.

The data that follows provides the  
 necessary information in the evaluation of

an average application and will help you in  
 selecting the proper cylinder model and  
 size for your particular application.

**Note:** 1-1/2", 2", 2-1/2", 3-1/4", 4" and 5"  
 bore cylinders with stroke lengths of 1/2"  
 and less than 2" will be furnished with a  
 short head cushion sleeve and short cap  
 cushion spear. Only available on 5/8" and  
 1" rods.

The above specification applies to Series  
 EJ cylinders with standard non-adjustable  
 or optional adjustable cushions.

**Series EJ Fixed Cushions**

*Piston and rod assembly  
 for 1-1/2" thru 5"  
 bore cylinders with  
 less than 1/2" stroke,  
 and 6" thru 8"  
 bore cylinders  
 with less than 2" stroke.*

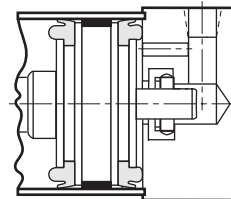
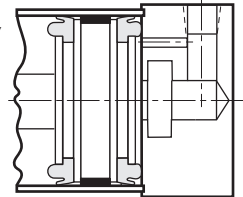

*Piston and rod  
 assembly for  
 1-1/2" thru 5" bore  
 cylinders with stroke  
 lengths of 1/2" and  
 less than 2".*

**Ultra Cushion®**

**A Major Design and Performance Breakthrough in Air Cylinder Cushioning Systems!**

Norgren's advanced cushion design  
 features a unique, one-piece, nitrile compound  
 seal that is captured within a precision  
 machined groove. This allows both linear  
 and radial "float" of the cushion seal which  
 virtually eliminates problems associated  
 with misalignment. Integral flow paths  
 molded in the periphery of the seal provide  
 exceptionally fast "out of cushion" stroke  
 reversal without the use of ball checks.

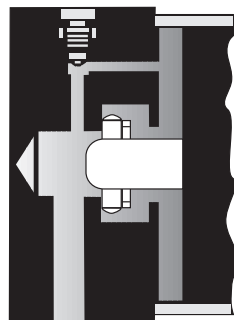

Figure 1

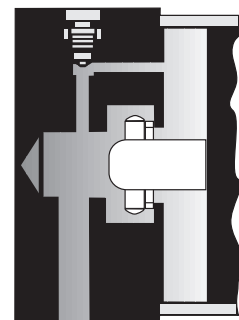
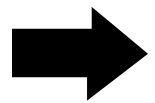

Figure 2 shows spear  
 exiting cushion seal.





**Piston Rod Diameter Selection:**

Applications requiring long extend (push) strokes may require oversized piston rod diameters to prevent buckling.

To determine the correct rod diameter for your application follow these simple steps:

1. Select the thrust from the **Cylinder Force and Volume Chart** (page 78) that is required for your application.  
Thrust = Piston Surface Area x Operating Pressure
2. From the **Cylinder Mounting Diagram Chart** (page 77) select the mounting style being used.
3. With the piston rod fully extended, calculate the value of **L** (in inches). Multiply cylinder stroke by appropriate stroke factor located in **Cylinder Mounting Diagram Chart** to obtain effective length **L**.

4. Locate the value of **L** (in inches) from the **Determining Adequate Rod Diameter Chart**.

5. **Selecting Stop Tubes:** Stop tubes enhance the transverse load carrying capability of a long stroke cylinder by increasing the distance between the piston and rod bearing at full extension (Refer to page 147). When the value of **L** (calculated from the **Adequate Rod Diameter Chart**) is less than 40", a stop tube is **not** required. However, if **L** is 40" or more, 1" of stop tube is recommended for every 10" (or fraction thereof) over 40".

6. **Recommended Mounting Styles for Maximum Stroke and Thrust Load:**

- Multiply cylinder stroke by appropriate stroke factor to obtain effective length **L**.
- If cylinder has extra rod extension, add this extension to the stroke length before obtaining effective length.

**Determining Adequate Rod Diameter Chart**

Extended Force (lbs)	Maximum effective length "L" recommended for rod diameters					
	5/8"	1"	1-3/8"	1-3/4"	2"	2-1/2"
50	95	-	-	-	-	-
100	65	170	-	-	-	-
150	50	135	260	-	-	-
200	43	115	220	-	-	-
300	34	93	180	300	-	-
500	25	70	135	250	-	-
750	20	56	110	185	250	-
1000	17	48	94	160	220	-
1500	13	38	80	130	170	260
2000	11	33	64	110	140	225
3000	9	26	51	90	115	180
4000	7	22	44	75	100	155
5000	-	20	39	66	88	140
6000	-	18	35	60	79	125
8000	-	15	30	52	68	110
10000	-	12	26	46	60	95
12500	-	10	22	41	52	86
15000	-	-	19	37	48	79
20000	-	-	14	29	41	68

**Note:** In some cases it may be necessary to use a larger bore cylinder than is required for force in order to obtain an adequate rod diameter.

**Tie Rod Tightening:**

In order to reduce the possibility of cylinder binding or damage, tighten to quarter unit increments of the final torque value in the following order: **#1, #2, #3, #4**.

Then torque fully to the recommended foot pounds in the same order.

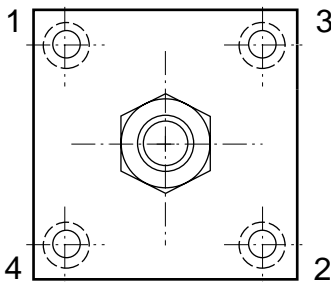

**Recommended Torques for Tightening Tie Rods**

Cylinder Bore	Standard Steel Tie Rods	Stainless Steel Tie Rods
1-1/2"	6.6 ft. lbs.	3.75 ft. lbs.
2"	11 ft. lbs.	7.5 ft. lbs.
2-1/2"	13 ft. lbs.	7.5 ft. lbs.
3-1/4"	20 ft. lbs.	13-14 ft. lbs.
4"	24 ft. lbs.	13-14 ft. lbs.
5"	40 ft. lbs.	33 ft. lbs.
6"	48 ft. lbs.	33 ft. lbs.
7" & 8"	100 ft. lbs.	65 ft. lbs.
10"	150 ft. lbs.	75 ft. lbs.
12"	175 ft. lbs.	87.5 ft. lbs.





**Cylinder Mounting Diagram Chart**

Cylinder Mounting	Rod End Connection	Example	Stroke Factor
Side Tapped, Head or Cap Flange, Tie Rod, Center or Side Lug	Fixed and Rigidly Guided		.50
Side Tapped, Head or Cap Flange, Tie Rod, Center or Side Lug	Pivoted and Rigidly Guided		.70
Side Tapped, Head or Cap Flange, Tie Rod, Center or Side Lug	Supported but not Rigidly Guided		2.00
Side Tapped, Head or Cap Flange, Tie Rod, Center or Side Lug	None		5.00
Head Trunnion	Pivoted and Rigidly Guided		1.00
Center Trunnion	Pivoted and Rigidly Guided		1.50
Cap Trunnion or Clevis	Pivoted and Rigidly Guided		2.00

**Tie Rod Supports:**

For long strokes, tie rod supports are provided. These supports are of the same envelope dimensions as the cylinder end caps.

**NOTE:** See chart for number of tie rod supports required.

**Number of Tie Rod Supports Required**

Cylinder Bore	Cylinder Stroke (in)				
	60	75	95	115	135
1-1/2"	1	1	2	2	3
2"	-	1	1	2	2
2-1/2"	-	-	1	1	1
3-1/4"	-	-	-	1	1
4"	-	-	-	-	1
5" and over	-	-	-	-	-



# Series J & EJ, NFPA Steel Air Cylinders, Technical Information

All Dimensions in Inches (mm)  
All Forces in Pounds (Newtons)

## Cylinder Force and Volume Charts

Extend Forces in pounds (newtons)

Bore	Piston Area	PSI (bar)								Volume Cu Ft (cm <sup>3</sup> ) Displacement Per Inch
		40 (3)	60 (4)	80 (6)	100 (7)	150 (10)	200 (14)			
1 1/2"	1.77 (11.40)	71 (315)	106 (472)	142 (629)	177 (786)	266 (1179)	353 (1570)	.00102 (29)		
2"	3.14 (20.27)	126 (559)	189 (839)	251 (1119)	314 (1398)	471 (2097)	628 (2793)	.00182 (52)		
2 1/2"	4.91 (31.67)	196 (874)	295 (1311)	393 (1748)	491 (2185)	737 (3277)	982 (4368)	.00284 (80)		
3 1/4"	8.30 (53.32)	332 (1477)	498 (2215)	664 (2953)	830 (3692)	1245 (5538)	1659 (7379)	.00480 (136)		
4"	12.57 (81.07)	503 (2237)	754 (3355)	1005 (4473)	1257 (5592)	1886 (8388)	2513 (11178)	.00727 (206)		
5"	19.64 (126.71)	785 (3491)	1178 (5240)	1571 (6988)	1964 (8736)	2946 (13104)	3928 (17472)	.01137 (322)		
6"	28.27 (182.39)	1130 (5026)	1696 (7544)	2262 (10061)	2827 (12574)	4240 (18860)	5654 (25149)	.01636 (463)		
7"	38.49 (247.91)	1540 (6831)	2309 (10242)	3079 (13658)	3849 (17074)	5774 (25613)	7698 (34148)	.02227 (631)		
8"	50.26 (324.26)	2010 (8940)	3015 (13411)	4020 (17881)	5026 (22356)	7539 (33533)	10052 (44711)	.02909 (829)		
10"	78.54 (506.74)	3141 (13974)	4712 (20961)	6283 (27948)	7854 (34935)	11781 (52402)	15700 (69834)	.04545 (1282)		
12"	113.10 (729.72)	4524 (20123)	6786 (30184)	9048 (40246)	11310 (50307)	16965 (75460)	22620 (100614)	.06545 (1852)		

## Deduct these Forces for Retract Strokes

Rod	Rod Area	PSI (bar)								Volume Cu Ft (cm <sup>3</sup> ) Displacement Per Inch
		40 (3)	60 (4)	80 (6)	100 (7)	150 (10)	200 (14)			
5/8"	.307 (1.98)	12 (53)	18 (80)	25 (111)	31 (138)	46 (205)	61 (271)	.00018 (5)		
1"	.785 (5.06)	31 (138)	47 (209)	63 (280)	78 (351)	118 (525)	157 (698)	.00045 (13)		
1 3/8"	1.485 (9.58)	59 (262)	89 (396)	119 (529)	149 (663)	222 (997)	297 (1321)	.00086 (24)		
1 3/4"	2.404 (15.51)	96 (423)	144 (641)	192 (854)	240 (1068)	360 (1601)	480 (2135)	.00139 (39)		
2"	3.142 (20.16)	126 (559)	189 (839)	251 (1118)	314 (1398)	471 (2096)	628 (2795)	.00182 (52)		
2 1/2"	4.909 (31.67)	196 (873)	295 (1310)	393 (1747)	491 (2184)	736 (3275)	981 (4367)	.00284 (80)		

### Bore Size Selection:

Use the following formulas in the selection of the proper bore size:

- Extended force in pounds =  
Bore area (in<sup>2</sup>) *times*  
pressure to cap in psig.
- Retract force in pounds =  
Bore area *minus* rod area (in<sup>2</sup>)  
*times* pressure to head in psig.

### Bore Areas

Cylinder Bore	Area (sq. in.)
1-1/2"	1.77
2"	3.14
2-1/2"	4.91
3-1/4"	8.30
4"	12.57
5"	19.64
6"	28.27
7"	38.49
8"	50.26
10"	78.54
12"	113.10

### Rod Areas

Rod Diameter	Area (sq. in.)
5/8"	.31
1"	.78
1-3/8"	1.49
1-3/4"	2.41
2"	3.14
2-1/2"	4.91



**Cylinder Weights**  
In pounds (kilograms)

Bore Inch (mm)	Mounting Code											Add Per Inch of Stroke
	Rod Inch (mm)	01, 05, 16	03	04	06	07, 08, 09	11	12	15	20, 21, 22, 32	10, 42, 52	
1 1/2" (38.10)	5/8" (15.88)	3.1 (1.42)	3.7 (1.67)	3.7 (1.67)	3.2 (1.48)	3.8 (1.73)	4.9 (2.24)	3.9 (1.76)	3.1 (1.42)	4.1 (1.87)	4.9 (2.24)	.18 (.08)
2" (50.80)	5/8" (15.88)	5.0 (2.27)	5.9 (2.67)	5.9 (2.67)	5.2 (2.35)	5.7 (2.58)	7.6 (3.46)	5.8 (2.61)	5.0 (2.27)	6.2 (2.82)	7.6 (3.46)	.28 (.13)
	1" (25.40)	5.1 (2.33)	6.0 (2.73)	6.0 (2.73)	5.3 (2.42)	5.8 (2.64)	7.8 (3.52)	5.9 (2.67)	5.1 (2.33)	6.4 (2.89)	7.8 (3.52)	.42 (.19)
2 1/2" (63.50)	5/8" (15.88)	7.2 (3.26)	8.1 (3.68)	8.1 (3.68)	7.4 (3.35)	7.9 (3.57)	10.3 (4.68)	7.9 (3.60)	7.2 (3.26)	9.3 (4.20)	10.3 (4.68)	.40 (.18)
	1" (25.40)	7.3 (3.32)	8.3 (3.75)	8.3 (3.75)	7.5 (3.41)	8.0 (3.64)	10.5 (4.74)	8.1 (3.66)	7.3 (3.32)	9.4 (4.26)	10.5 (4.74)	.54 (.25)
3 1/4" (82.55)	1" (25.40)	11.1 (5.02)	14.3 (6.50)	14.3 (6.50)	11.4 (5.16)	11.7 (5.30)	16.8 (7.63)	12.6 (5.70)	11.1 (5.02)	16.0 (7.26)	16.8 (7.63)	.72 (.33)
	1 3/8" (34.93)	11.3 (5.11)	14.5 (6.59)	14.5 (6.59)	11.6 (5.25)	11.9 (5.39)	17.0 (7.72)	12.8 (5.79)	11.3 (5.11)	16.2 (7.35)	17.0 (7.72)	.92 (.42)
4" (101.60)	1" (25.40)	20.3 (9.22)	24.9 (11.29)	24.9 (11.29)	20.6 (9.36)	20.8 (9.45)	27.4 (12.43)	21.8 (9.90)	20.3 (9.22)	26.9 (12.20)	27.4 (12.43)	.81 (.37)
	1 3/8" (34.93)	20.5 (9.31)	25.1 (11.38)	25.1 (11.38)	20.8 (9.45)	21.0 (9.54)	27.6 (12.52)	22.0 (9.99)	20.5 (9.31)	27.1 (12.29)	27.6 (12.52)	1.1 (.50)
5" (127.00)	1" (25.40)	34.6 (15.72)	40.4 (18.33)	40.4 (18.33)	35.2 (15.97)	38.0 (17.25)	43.2 (19.60)	36.3 (16.49)	34.6 (15.72)	43.2 (19.60)	43.2 (19.60)	.98 (.45)
	1 3/8" (34.93)	34.8 (15.81)	40.6 (18.42)	40.5 (18.42)	35.4 (16.06)	38.2 (17.34)	43.4 (19.69)	36.5 (16.58)	34.8 (15.81)	43.4 (19.69)	43.4 (19.69)	1.18 (.54)
6" (152.40)	1 3/8" (34.93)	53.1 (24.09)	63.9 (29.02)	63.9 (29.02)	54.3 (24.66)	56.4 (25.59)	65.3 (29.65)	57.1 (25.93)	53.1 (24.09)	68.1 (30.91)	65.3 (29.65)	1.68 (.76)
	1 3/4" (44.45)	53.3 (24.21)	64.2 (31.41)	64.2 (31.41)	54.6 (24.78)	56.7 (25.72)	65.6 (29.77)	57.4 (26.05)	53.3 (24.21)	68.1 (30.93)	65.6 (29.77)	1.94 (.88)
7" (177.80)	1 3/8" (34.93)	73.0 (33.14)	73.0 (33.14)	73.0 (33.14)	74.0 (33.60)	76.5 (34.73)	96.0 (43.58)	85.0 (38.59)	73.0 (33.14)	—	96.0 (43.58)	1.75 (.80)
	1 3/4" (44.45)	73.3 (33.26)	73.3 (33.26)	73.3 (33.26)	74.3 (33.71)	76.8 (34.85)	96.3 (43.70)	85.3 (38.71)	73.3 (33.26)	—	96.3 (43.70)	2.01 (.91)
8" (203.20)	1 3/8" (34.93)	92.3 (41.88)	92.3 (41.88)	92.3 (41.88)	93.6 (42.50)	95.8 (43.47)	120.0 (54.48)	97.8 (44.41)	92.3 (41.88)	—	120.0 (54.48)	2.18 (.99)
	1 3/4" (44.45)	92.5 (42.00)	92.5 (42.00)	92.5 (42.00)	93.9 (42.62)	96.0 (43.59)	120.3 (54.60)	98.1 (44.52)	92.5 (42.00)	—	120.3 (54.60)	2.44 (1.11)
10" (254.00)	1 3/4" (44.45)	179.9 (81.66)	179.9 (81.66)	179.9 (81.66)	181.6 (82.46)	184.3 (83.65)	228.0 (103.51)	186.1 (84.50)	179.9 (81.66)	—	228.0 (103.51)	3.43 (1.56)
	2" (50.80)	180.0 (81.72)	180.1 (81.76)	180.1 (81.76)	181.8 (82.55)	184.5 (83.74)	228.2 (103.61)	186.3 (84.59)	180.1 (81.76)	—	228.2 (103.61)	3.64 (1.65)
12" (304.80)	2" (50.80)	288.0 (130.75)	288.0 (130.75)	288.0 (130.75)	289.0 (131.21)	293.0 (133.02)	380.0 (172.52)	297.0 (134.84)	288.0 (130.75)	—	380.0 (172.52)	4.12 (1.87)
	2 1/2" (63.50)	288.5 (130.98)	288.5 (130.98)	288.5 (130.98)	289.5 (131.43)	293.5 (133.25)	380.5 (172.75)	297.5 (135.20)	288.5 (130.98)	—	380.5 (172.75)	4.62 (2.10)

**Breakaway Pressures**

An average of 5 pounds (psig) is necessary to breakaway non-cushioned Series J air cylinders when mounted horizontally with no load on the piston rod. Double rod end cylinders require an average of 7 pounds (psig).

An average of 6 pounds (psig) is required to breakaway single rod and Series J and Series EJ air cylinders equipped with optional non-adjustable air cushions. Double rod end cylinders require an average of 8 pounds (psig).

These figures are for non-cushioned cylinders with strokes of 6 inches or less with factory lubrication. Consult the factory if your application requires a lower breakaway pressure or a guaranteed minimum breakaway.

Series J cylinders with 3-1/4" thru 12" diameter pistons are counterbored to provide a larger area for the pressure to act upon.

Listed are the average breakaway pressures in PSI for all Series J & EJ Cylinders. If your application requires a lower breakaway pressure than indicated for a particular bore size, consult the factory.

**Breakaway Pressures in PSI**

Bore	Series J		Low Friction Seals (LF)	
	Extend	Retract	Extend	Retract
1 1/2", 2", 2 1/2"	5	6	3	4
3 1/4", 4"	4	5	2	3
5", 6", 7", 8"	3	4	1	2
10"	3	4	1	2
12"	3	4	1	2

Note: Breakaway pressures were established with the cylinders mounted horizontally and no load on the piston rod.

- **NFPA (MS4) 01 Side Tapped Mount** for 1-1/2" to 6" bore sizes.
- **Series J Cylinders** rated to 250 PSI air, 400 PSI hydraulic (non-shock).  
**Series EJ Cylinders** rated to 250 PSI air only.
- **Designed for non-lube service.**
- **Switches available on all bore sizes.** (See pages 150 & 151 for ordering information.)



### Cylinder Order Information

**01** - - - -

J	Series J Cylinder
EJ	Series EJ Cylinder

Bore and Stroke (write out)

Mounting Options	
01	Side Tapped (MS4)
03	Head Rectangular Flange (MF1)
03	Head Square (ME3)–7" to 12" Bores
04	Cap Rectangular Flange (MF2)
04	Cap Square (ME4)–7" to 12" Bores
05	Basic Cylinder No Mounting (MX0)
06	Both Ends (4) Tie Rods Ext. (MX1)
6B	Both Ends (2) Tie Rods Ext. (MX4)
6C	Cap Tie Rods Ext. (MX2)
6R	Head Tie Rods Ext. (MX3)
07	Head Trunnion (MT1)
08	Cap Trunnion (MT2)
09	Side Lugs (MS2)
10	Center Trunnion (MT4)
11	Side End Angles (MS1)
12	Cap Fixed Clevis (MP1)
15	Side End Lugs (MS7)
16	Sleeve Nut Construction (Universal)
20	Head Square Flange (MF5)
21	Cap Square Flange (MF6)
22	Detachable Cap Clevis (MP2)
32	Cap Fixed Eye (MP3)
42	Detachable Cap Eye (MP4)
52	Spherical Bearing

Cushion in Head	
3	None
5 <sup>†</sup>	Non-Adjustable Cushion
7	Adjustable Cushion (Position 2)

<sup>†</sup>Standard with EJ

Cushion in Cap	
3	None
5 <sup>†</sup>	Non-Adjustable Cushion
7	Adjustable Cushion (Position 2)

<sup>†</sup>Standard with EJ

Additional Options – order alphabetically – More on page 155	
HR	Case Hardened (45 Rc)
L(-)	Port Location position 1 standard: L(Head Cap) (specify position 1 thru 4 for head and/or cap)
MS	Metal Rod Scraper
N(-)	Cushion Adjust Screw Location position 2 standard: N(Head Cap) (specify position 1 thru 4 for head and/or cap)
P(-)*	Non-Standard Port Sizes: [specify port size for P(-)H head only, P(-)C cap only, or P(-) both head & cap]
PS	Magnetic Piston – includes aluminum tube option
RS	Rod Stud Type 1 (5/8" – 1 3/4" øRod) Type 2 (5/8" & 1" øRod)
RX	Rod Extensions (specify length of additional rod extension)
SC	Single Acting Spring Extend (Cap End)–See page 155
SR	Single Acting Spring Retract (Rod End)–See page 155
SS	303 Stainless Steel (Hard Chrome Plated)
ST(-)C	Stop Tube (Cap End) (specify stop tube length)
ST(-)R	Stop Tube (Rod End) (specify stop tube length)
T	Special Rod Threads (specify rod thread)
TX	Thread Extensions (specify length of thread extension)
V	Viton® Seals

\*1½", 2", 2½" bore cylinders have 3/8" NPT Standard, 1/2" NPT oversize.  
3¼", 4", 5" bore cylinders have 1/2" NPT Standard, 3/4" NPT oversize.  
This will add 1/8" to the overall cylinder length.

Piston Rod Threads Type	
1	Small Male (Solid)
2	Intermediate Thread Male (Solid)
3	Female
6	Full Thread Male (Solid)
7	Plain Rod End

Piston Rod Diameters		
A	5/8"	Standard on 1½", 2", 2½"
B	1"	Standard on 3¼", 4", 5" Oversized on 1½", 2", 2½"
C	1 3/8"	Standard on 6", 7", 8" Oversized on 3¼", 4", 5"
D	1 3/4"	Standard on 10" Oversized on 6", 7", 8"
E	2"	Standard on 12" Oversized on 10"
F	2½"	Oversized on 10", 12"

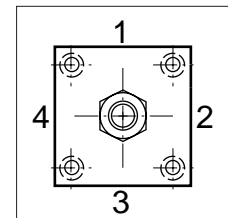

**Port and Cushion Adjustment Positions** (As viewed from rod end: Port standard position 1, Cushion Adjustment standard position 2.)  
NOTE: A Port and a Cushion Adjustment cannot be in the same position.

See page 156 for complete instructions on how to order cylinders.

# Series J & EJ, NFPA Steel Air Cylinder with 01 (MS4) Side Tapped

All Dimensions in Inches (mm)

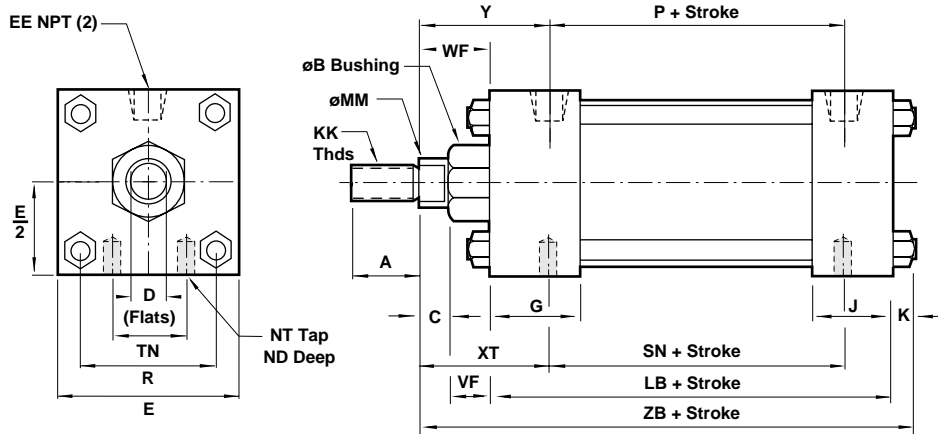

## Standard & Optional Rod Ends

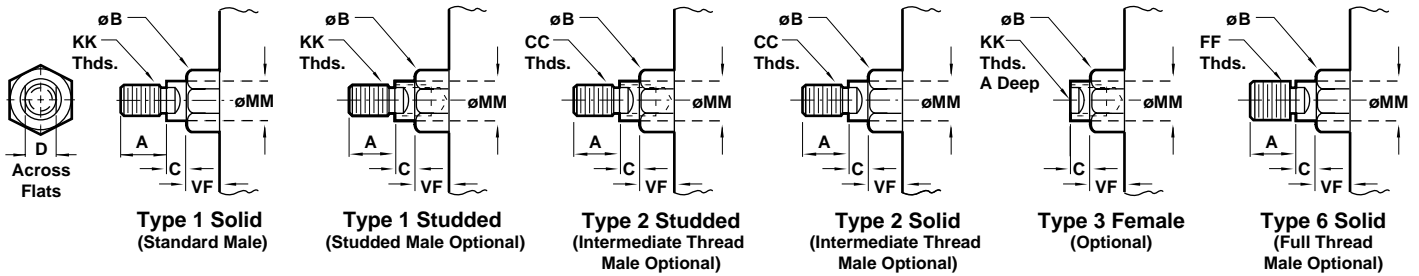

Dimension		1 1/2" Bore (38.10)	2" Bore (50.80)	2 1/2" Bore (63.50)	3 1/4" Bore (82.55)	4" Bore (101.60)	5" Bore (127.00)	6" Bore (152.40)
ø Rod	Std.	5/8" (15.88)	5/8" (15.88)	5/8" (15.88)	1" (25.40)	1" (25.40)	1" (25.40)	1 3/8" (34.93)
	O.S.	1" (25.40)	1" (25.40)	1" (25.40)	1 3/8" (34.93)	1 3/8" (34.93)	1 3/8" (34.93)	1 3/4" (44.45)
A	Std.	.750 (19.05)	.750 (19.05)	.750 (19.05)	1.125 (28.58)	1.125 (28.58)	1.125 (28.58)	1.625 (41.28)
	O.S.	1.125 (28.58)	1.125 (28.58)	1.125 (28.58)	1.625 (41.28)	1.625 (41.28)	1.625 (41.28)	2.000 (50.80)
B +.000 -.002	Std.	1.124 (28.55)	1.124 (28.55)	1.124 (28.55)	1.499 (38.08)	1.499 (38.08)	1.499 (38.08)	1.999 (50.78)
	O.S.	1.499 (38.08)	1.499 (38.08)	1.499 (38.08)	1.999 (50.78)	1.999 (50.78)	1.999 (50.78)	2.374 (60.30)
C	Std.	.375 (9.53)	.375 (9.53)	.375 (9.53)	.500 (12.70)	.500 (12.70)	.500 (12.70)	.625 (15.88)
	O.S.	.500 (12.70)	.500 (12.70)	.500 (12.70)	.625 (15.88)	.625 (15.88)	.625 (15.88)	.750 (19.05)
CC	Std.	1/2 - 20	1/2 - 20	1/2 - 20	7/8 - 14	7/8 - 14	7/8 - 14	1 1/4 - 12
	O.S.	7/8 - 14	7/8 - 14	7/8 - 14	1 1/4 - 12	1 1/4 - 12	1 1/4 - 12	1 1/2 - 12
D	Std.	.500 (12.70)	.500 (12.70)	.500 (12.70)	.813 (20.64)	.813 (20.64)	.813 (20.64)	1.125 (28.58)
	O.S.	.813 (20.64)	.813 (20.64)	.813 (20.64)	1.125 (28.58)	1.125 (28.58)	1.125 (28.58)	1.500 (38.10)
E		2.000 (50.80)	2.500 (63.50)	3.000 (76.20)	3.750 (95.25)	4.500 (114.30)	5.500 (139.70)	6.500 (165.10)
EE		.375 (9.53)	.375 (9.53)	.375 (9.53)	.500 (12.70)	.500 (12.70)	.500 (12.70)	.750 (19.05)
FF	Std.	5/8 - 18	5/8 - 18	5/8 - 18	1 - 14	1 - 14	1 - 14	1 3/8 - 12
	O.S.	1 - 14	1 - 14	1 - 14	1 3/8 - 12	1 3/8 - 12	1 3/8 - 12	1 3/4 - 12
G		1.500 (38.10)	1.500 (38.10)	1.500 (38.10)	1.750 (44.45)	1.750 (44.45)	1.750 (44.45)	2.000 (50.80)
J		1.000 (25.40)	1.000 (25.40)	1.000 (25.40)	1.250 (31.75)	1.250 (31.75)	1.250 (31.75)	1.500 (38.10)
K		.250 (6.35)	.313 (7.94)	.313 (7.94)	.375 (9.53)	.375 (9.53)	.438 (11.11)	.438 (11.11)
KK	Std.	7/16 - 20	7/16 - 20	7/16 - 20	3/4 - 16	3/4 - 16	3/4 - 16	1 - 14
	O.S.	3/4 - 16	3/4 - 16	3/4 - 16	1 - 14	1 - 14	1 - 14	1 1/4 - 12
LB		3.625 (92.08)	3.625 (92.08)	3.750 (95.25)	4.250 (107.95)	4.250 (107.95)	4.500 (114.30)	5.000 (127.00)
MM	Std.	.625 (15.88)	.625 (15.88)	.625 (15.88)	1.000 (25.40)	1.000 (25.40)	1.000 (25.40)	1.375 (34.93)
	O.S.	1.000 (25.40)	1.000 (25.40)	1.000 (25.40)	1.375 (34.93)	1.375 (34.93)	1.375 (34.93)	1.750 (44.45)
ND		.375 (9.53)	.375 (9.53)	.500 (12.70)	.750 (19.05)	.750 (19.05)	.938 (23.81)	1.125 (28.58)
NT		1/4 - 20	5/16 - 18	3/8 - 16	1/2 - 13	1/2 - 13	5/8 - 11	3/4 - 10
P		2.313 (58.74)	2.313 (58.74)	2.438 (61.91)	2.625 (66.68)	2.625 (66.68)	2.875 (73.03)	3.125 (79.38)
R		1.428 (36.27)	1.838 (46.68)	2.192 (55.67)	2.758 (70.05)	3.323 (84.40)	4.101 (104.16)	4.879 (123.92)
SN		2.250 (57.15)	2.250 (57.15)	2.375 (60.33)	2.625 (66.68)	2.625 (66.68)	2.875 (73.03)	3.125 (79.38)
TN		.625 (15.88)	.875 (22.23)	1.250 (31.75)	1.500 (38.10)	2.063 (52.37)	2.688 (68.28)	3.250 (82.55)
VF	Std.	.625 (15.88)	.625 (15.88)	.625 (15.88)	.875 (22.23)	.875 (22.23)	.875 (22.23)	1.000 (25.40)
	O.S.	.875 (22.23)	.875 (22.23)	.875 (22.23)	1.000 (25.40)	1.000 (25.40)	1.000 (25.40)	1.125 (28.58)
WF	Std.	1.000 (25.40)	1.000 (25.40)	1.000 (25.40)	1.375 (34.93)	1.375 (34.93)	1.375 (34.93)	1.625 (41.28)
	O.S.	1.375 (34.93)	1.375 (34.93)	1.375 (34.93)	1.625 (41.28)	1.625 (41.28)	1.625 (41.28)	1.875 (47.63)
XT	Std.	1.938 (49.21)	1.938 (49.21)	1.938 (49.21)	2.438 (61.91)	2.438 (61.91)	2.438 (61.91)	2.813 (71.44)
	O.S.	2.313 (58.74)	2.313 (58.74)	2.313 (58.74)	2.688 (68.26)	2.688 (68.26)	2.688 (68.26)	3.063 (77.79)
Y	Std.	1.875 (47.63)	1.875 (47.63)	1.875 (47.63)	2.438 (61.91)	2.438 (61.91)	2.438 (61.91)	2.813 (71.44)
	O.S.	2.250 (57.15)	2.250 (57.15)	2.250 (57.15)	2.688 (68.26)	2.688 (68.26)	2.688 (68.26)	3.063 (77.79)
ZB	Std.	4.875 (123.83)	4.938 (125.41)	5.063 (128.59)	6.000 (152.40)	6.000 (152.40)	6.313 (160.34)	7.063 (179.39)
	O.S.	5.250 (133.35)	5.313 (134.94)	5.438 (138.11)	6.250 (158.75)	6.250 (158.75)	6.563 (166.69)	7.313 (185.74)

## Cylinder with 01 (MS4) Side Tapped

- NFPA (MS4) 01 Side Tapped Mount for 7" to 12" bore sizes.
- Series J Cylinders rated to 250 PSI air, 400 PSI hydraulic (non-shock). Series EJ Cylinders rated to 250 PSI air only.
- Designed for non-lube service.
- Switches available on all bore sizes. (See pages 150 & 151 for ordering information.)



### Cylinder Order Information

01 - - - -

J	Series J Cylinder
EJ	Series EJ Cylinder

Bore and Stroke (write out)

Mounting Options	
01	Side Tapped (MS4)
03	Head Rectangular Flange (MF1)
03	Head Square (ME3)-7" to 12" Bores
04	Cap Rectangular Flange (MF2)
04	Cap Square (ME4)-7" to 12" Bores
05	Basic Cylinder No Mounting (MX0)
06	Both Ends (4) Tie Rods Ext. (MX1)
6B	Both Ends (2) Tie Rods Ext. (MX4)
6C	Cap Tie Rods Ext. (MX2)
6R	Head Tie Rods Ext. (MX3)
07	Head Trunnion (MT1)
08	Cap Trunnion (MT2)
09	Side Lugs (MS2)
10	Center Trunnion (MT4)
11	Side End Angles (MS1)
12	Cap Fixed Clevis (MP1)
15	Side End Lugs (MS7)
16	Sleeve Nut Construction (Universal)
20	Head Square Flange (MF5)
21	Cap Square Flange (MF6)
22	Detachable Cap Clevis (MP2)
32	Cap Fixed Eye (MP3)
42	Detachable Cap Eye (MP4)
52	Spherical Bearing

Cushion in Head	
3	None
5 <sup>†</sup>	Non-Adjustable Cushion
7	Adjustable Cushion (Position 2)

<sup>†</sup>Standard with EJ

Cushion in Cap	
3	None
5 <sup>†</sup>	Non-Adjustable Cushion
7	Adjustable Cushion (Position 2)

<sup>†</sup>Standard with EJ

Additional Options – order alphabetically – More on page 155	
HR	Case Hardened (45 Rc)
L(- -)	Port Location position 1 standard: L(Head Cap) (specify position 1 thru 4 for head and/or cap)
MS	Metal Rod Scraper
N(- -)	Cushion Adjust Screw Location position 2 standard: N(Head Cap) (specify position 1 thru 4 for head and/or cap)
P(-)*	Non-Standard Port Sizes: [specify port size for P(-H) head only, P(-C) cap only, or P(-) both head & cap]
PS	Magnetic Piston – includes aluminum tube option
RS	Rod Stud Type 1 (5/8" – 1¾" øRod) Type 2 (5/8" & 1" øRod)
RX	Rod Extensions (specify length of additional rod extension)
SC	Single Acting Spring Extend (Cap End)–See page 155
SR	Single Acting Spring Retract (Rod End)–See page 155
SS	303 Stainless Steel (Hard Chrome Plated)
ST(-C)	Stop Tube (Cap End) (specify stop tube length)
ST(-R)	Stop Tube (Rod End) (specify stop tube length)
T	Special Rod Threads (specify rod thread)
TX	Thread Extensions (specify length of thread extension)
V	Viton® Seals

\*1½", 2", 2½" bore cylinders have 3/8" NPT Standard, 1/2" NPT oversize. 3¼", 4", 5" bore cylinders have 1/2" NPT Standard, 3/4" NPT oversize. This will add 1/8" to the overall cylinder length.

Piston Rod Threads Type	
1	Small Male (Solid)
2	Intermediate Thread Male (Solid)
3	Female
6	Full Thread Male (Solid)
7	Plain Rod End

Piston Rod Diameters		
A	5/8"	Standard on 1½", 2", 2½"
B	1"	Standard on 3¼", 4", 5" Oversized on 1½", 2", 2½"
C	1⅜"	Standard on 6", 7", 8" Oversized on 3¼", 4", 5"
D	1¾"	Standard on 10" Oversized on 6", 7", 8"
E	2"	Standard on 12" Oversized on 10"
F	2½"	Oversized on 10", 12"

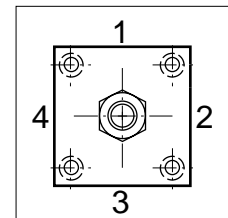

**Port and Cushion Adjustment Positions** (As viewed from rod end: Port standard position 1, Cushion Adjustment standard position 2.)  
NOTE: A Port and a Cushion Adjustment cannot be in the same position.

See page 156 for complete instructions on how to order cylinders.

# Series J & EJ, NFPA Steel Air Cylinder with 01 (MS4) Side Tapped

All Dimensions in Inches (mm)

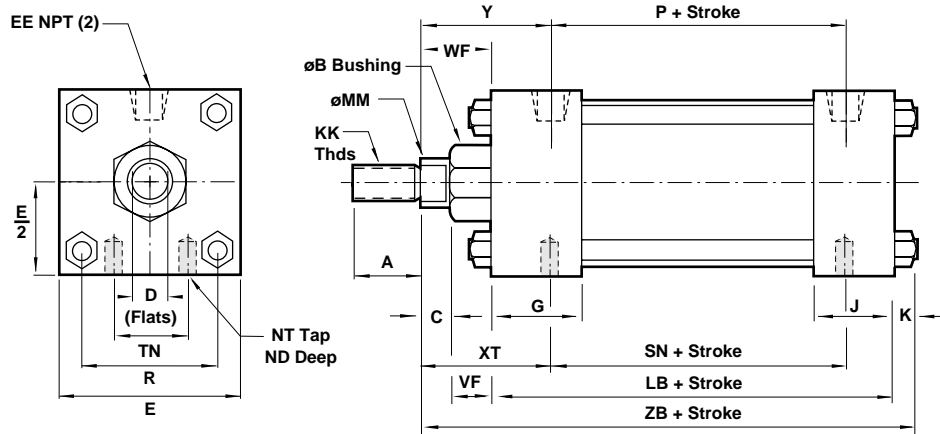

## Standard & Optional Rod Ends

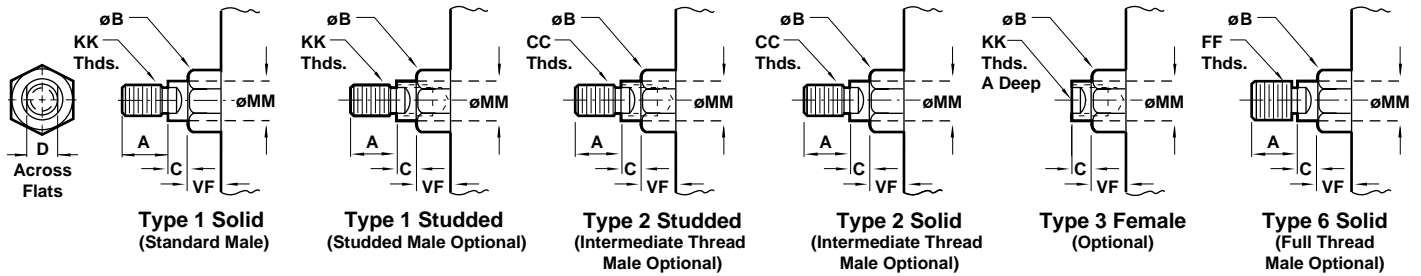

Dimension		7" Bore (177.80)	8" Bore (203.20)	10" Bore (254.00)	12" Bore (304.80)
ø Rod	Std.	1 3/8" (34.93)	1 3/8" (34.93)	1 3/4" (44.45)	2" (50.80)
	O.S.	1 3/4" (44.45)	1 3/4" (44.45)	2" (50.80)	2 1/2" (63.50)
A	Std.	1.625 (41.28)	1.625 (41.28)	2.000 (50.80)	2.250 (57.15)
	O.S.	2.000 (50.80)	2.000 (50.80)	2.250 (57.15)	3.000 (76.20)
B +.000 -.002	Std.	1.999 (50.78)	1.999 (50.78)	2.374 (60.30)	2.624 (66.65)
	O.S.	2.374 (60.30)	2.374 (60.30)	2.624 (66.65)	3.124 (79.35)
C	Std.	.625 (15.88)	.625 (15.88)	.750 (19.05)	.875 (22.23)
	O.S.	.750 (19.05)	.750 (19.05)	.875 (22.23)	1.000 (25.40)
CC	Std.	1 1/4 - 12	1 1/4 - 12	1 1/2 - 12	1 3/4 - 12
	O.S.	1 1/2 - 12	1 1/2 - 12	1 3/4 - 12	2 1/4 - 12
D	Std.	1.125 (28.58)	1.125 (28.58)	1.500 (38.10)	1.688 (42.86)
	O.S.	1.500 (38.10)	1.500 (38.10)	1.688 (42.86)	2.063 (52.39)
E		7.500 (190.50)	8.500 (215.90)	10.625 (269.88)	12.750 (323.85)
EE		.750 (19.05)	.750 (19.05)	1.000 (25.40)	1.000 (25.40)
FF	Std.	1 3/8 - 12	1 3/8 - 12	1 3/4 - 12	2 - 12
	O.S.	1 3/4 - 12	1 3/4 - 12	2 - 12	2 1/2 - 12
G		2.000 (50.80)	2.000 (50.80)	2.250 (57.15)	2.250 (57.15)
J		1.500 (38.10)	1.500 (38.10)	2.000 (50.80)	2.000 (50.80)
K		.563 (14.29)	.563 (14.29)	.688 (17.46)	.688 (17.46)
KK	Std.	1 - 14	1 - 14	1 1/4 - 12	1 1/2 - 12
	O.S.	1 1/4 - 12	1 1/4 - 12	1 1/2 - 12	1 7/8 - 12
LB		5.125 (130.18)	5.125 (130.18)	6.375 (161.93)	6.875 (174.63)
MM	Std.	1.375 (34.93)	1.375 (34.93)	1.750 (44.45)	2.000 (50.80)
	O.S.	1.750 (44.45)	1.750 (44.45)	2.000 (50.80)	2.500 (63.50)
ND		1.125 (28.58)	1.125 (28.58)	1.500 (38.10)	1.500 (38.10)
NT		3/4 - 10	3/4 - 10	1 - 8	1 - 8
P		3.250 (82.55)	3.250 (82.55)	4.125 (104.78)	4.625 (117.48)
R		5.730 (145.54)	6.442 (163.63)	7.969 (202.41)	9.406 (238.92)
SN		3.250 (82.55)	3.250 (82.55)	4.125 (104.78)	4.625 (117.48)
TN		3.500 (88.90)	4.500 (114.30)	5.500 (139.70)	7.250 (184.15)
VF	Std.	1.000 (25.40)	1.000 (25.40)	1.125 (28.58)	1.125 (28.58)
	O.S.	1.125 (28.58)	1.125 (28.58)	1.125 (28.58)	1.250 (31.75)
WF	Std.	1.625 (41.28)	1.625 (41.28)	1.875 (47.63)	2.000 (50.80)
	O.S.	1.875 (47.63)	1.875 (47.63)	2.000 (50.80)	2.250 (57.15)
XT	Std.	2.813 (71.44)	2.813 (71.44)	3.125 (79.38)	3.250 (82.55)
	O.S.	3.063 (77.79)	3.063 (77.79)	3.250 (82.55)	3.500 (88.90)
Y	Std.	2.813 (71.44)	2.813 (71.44)	3.125 (79.38)	3.250 (82.55)
	O.S.	3.063 (77.79)	3.063 (77.79)	3.250 (82.55)	3.500 (88.90)
ZB	Std.	7.313 (185.74)	7.313 (185.74)	8.938 (227.01)	9.563 (242.89)
	O.S.	7.563 (192.10)	7.563 (192.10)	9.063 (230.19)	9.813 (249.24)

## Cylinder with 03 (MF1) Head Rectangular Flange

- NFPA (MF1) 03 Head Rectangular Flange Mount for 1-1/2" to 6" bore sizes.
- Series J Cylinders rated to 250 PSI air, 400 PSI hydraulic (non-shock). Series EJ Cylinders rated to 250 PSI air only.
- Designed for non-lube service.
- Switches available on all bore sizes. (See pages 150 & 151 for ordering information.)



### Cylinder Order Information

**03** - - - -

J	Series J Cylinder
EJ	Series EJ Cylinder

Mounting Options	
01	Side Tapped (MS4)
<b>03</b>	<b>Head Rectangular Flange (MF1)</b>
03	Head Square (ME3)-7" to 12" Bores
04	Cap Rectangular Flange (MF2)
04	Cap Square (ME4)-7" to 12" Bores
05	Basic Cylinder No Mounting (MX0)
06	Both Ends (4) Tie Rods Ext. (MX1)
6B	Both Ends (2) Tie Rods Ext. (MX4)
6C	Cap Tie Rods Ext. (MX2)
6R	Head Tie Rods Ext. (MX3)
07	Head Trunnion (MT1)
08	Cap Trunnion (MT2)
09	Side Lugs (MS2)
10	Center Trunnion (MT4)
11	Side End Angles (MS1)
12	Cap Fixed Clevis (MP1)
15	Side End Lugs (MS7)
16	Sleeve Nut Construction (Universal)
20	Head Square Flange (MF5)
21	Cap Square Flange (MF6)
22	Detachable Cap Clevis (MP2)
32	Cap Fixed Eye (MP3)
42	Detachable Cap Eye (MP4)
52	Spherical Bearing

Cushion in Head	
3	None
5 <sup>†</sup>	Non-Adjustable Cushion
7	Adjustable Cushion (Position 2)

<sup>†</sup>Standard with EJ

Cushion in Cap	
3	None
5 <sup>†</sup>	Non-Adjustable Cushion
7	Adjustable Cushion (Position 2)

<sup>†</sup>Standard with EJ

Bore and Stroke (write out)

Additional Options – order alphabetically – More on page 155	
HR	Case Hardened (45 Rc)
L(-)	Port Location position 1 standard: L(Head Cap) (specify position 1 thru 4 for head and/or cap)
MS	Metal Rod Scraper
N(-)	Cushion Adjust Screw Location position 2 standard: N(Head Cap) (specify position 1 thru 4 for head and/or cap)
P(-)*	Non-Standard Port Sizes: [specify port size for P(-H) head only, P(-C) cap only, or P(-) both head & cap]
PS	Magnetic Piston – includes aluminum tube option
RS	Rod Stud Type 1 (5/8" – 1 3/4" øRod) Type 2 (5/8" & 1" øRod)
RX	Rod Extensions (specify length of additional rod extension)
SC	Single Acting Spring Extend (Cap End)–See page 155
SR	Single Acting Spring Retract (Rod End)–See page 155
SS	303 Stainless Steel (Hard Chrome Plated)
ST(-C)	Stop Tube (Cap End) (specify stop tube length)
ST(-R)	Stop Tube (Rod End) (specify stop tube length)
T	Special Rod Threads (specify rod thread)
TX	Thread Extensions (specify length of thread extension)
V	Viton® Seals

\*1½", 2", 2½" bore cylinders have 3/8" NPT Standard, 1/2" NPT oversize. 3¼", 4", 5" bore cylinders have 1/2" NPT Standard, 3/4" NPT oversize. This will add 1/8" to the overall cylinder length.

Piston Rod Threads Type	
1	Small Male (Solid)
2	Intermediate Thread Male (Solid)
3	Female
6	Full Thread Male (Solid)
7	Plain Rod End

Piston Rod Diameters		
A	5/8"	Standard on 1½", 2", 2½"
B	1"	Standard on 3¼", 4", 5" Oversized on 1½", 2", 2½"
C	1 3/8"	Standard on 6", 7", 8" Oversized on 3¼", 4", 5"
D	1 3/4"	Standard on 10" Oversized on 6", 7", 8"
E	2"	Standard on 12" Oversized on 10"
F	2½"	Oversized on 10", 12"

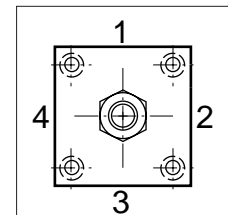

**Port and Cushion Adjustment Positions** (As viewed from rod end: Port standard position 1, Cushion Adjustment standard position 2.)  
NOTE: A Port and a Cushion Adjustment cannot be in the same position.

See page 156 for complete instructions on how to order cylinders.



# Series J & EJ, NFPA Steel Air Cylinder with 03 (MF1) Head Rectangular Flange

All Dimensions in Inches (mm)

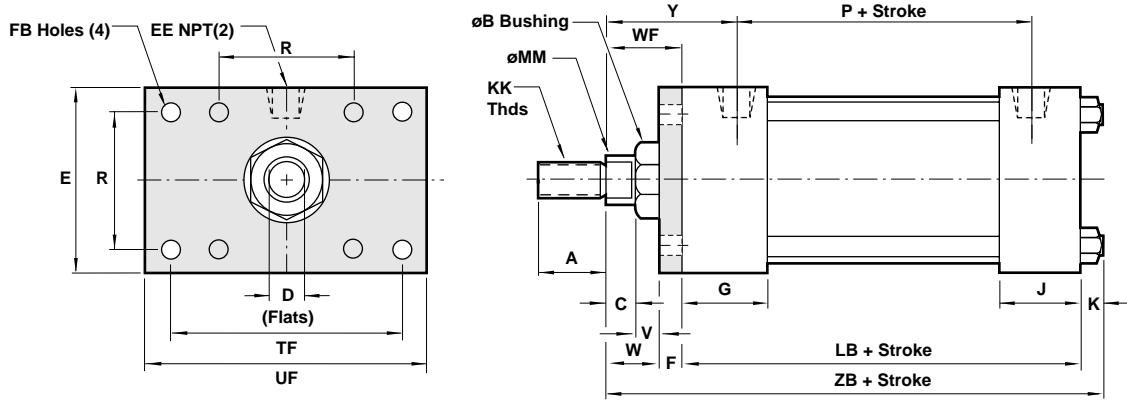

## Standard & Optional Rod Ends

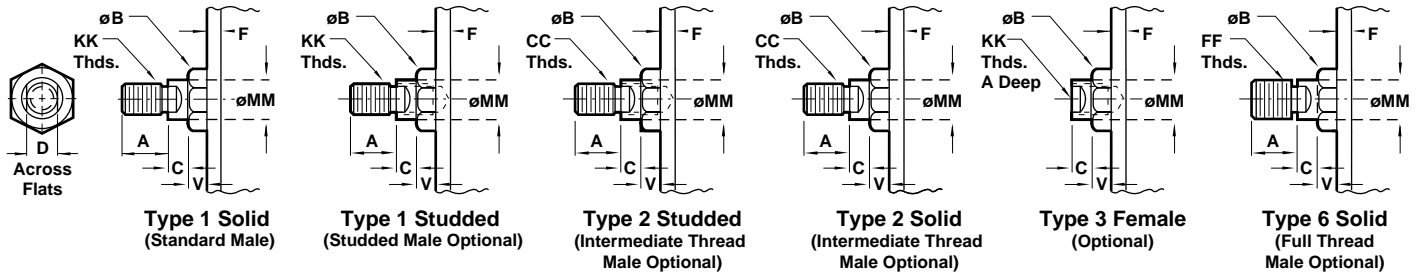

Dimension		1 1/2" Bore (38.10)	2" Bore (50.80)	2 1/2" Bore (63.50)	3 1/4" Bore (82.55)	4" Bore (101.60)	5" Bore (127.00)	6" Bore (152.40)
ø Rod	Std.	5/8" (15.88)	5/8" (15.88)	5/8" (15.88)	1" (25.40)	1" (25.40)	1" (25.40)	1 3/8" (34.93)
	O.S.	1" (25.40)	1" (25.40)	1" (25.40)	1 3/8" (34.93)	1 3/8" (34.93)	1 3/8" (34.93)	1 3/4" (44.45)
A	Std.	.750 (19.05)	.750 (19.05)	.750 (19.05)	1.125 (28.58)	1.125 (28.58)	1.125 (28.58)	1.625 (41.28)
	O.S.	1.125 (28.58)	1.125 (28.58)	1.125 (28.58)	1.625 (41.28)	1.625 (41.28)	1.625 (41.28)	2.000 (50.80)
B <sup>+0.00</sup> -0.002	Std.	1.124 (28.55)	1.124 (28.55)	1.124 (28.55)	1.499 (38.08)	1.499 (38.08)	1.499 (38.08)	1.999 (50.78)
	O.S.	1.499 (38.08)	1.499 (38.08)	1.499 (50.78)	1.999 (50.78)	1.999 (50.78)	1.999 (60.30)	2.374 (60.30)
C	Std.	.375 (9.53)	.375 (9.53)	.375 (9.53)	.500 (12.70)	.500 (12.70)	.500 (12.70)	.625 (15.88)
	O.S.	.500 (12.70)	.500 (12.70)	.500 (12.70)	.625 (15.88)	.625 (15.88)	.625 (15.88)	.750 (19.05)
CC	Std.	1/2 - 20	1/2 - 20	1/2 - 20	7/8 - 14	7/8 - 14	7/8 - 14	1 1/4 - 12
	O.S.	7/8 - 14	7/8 - 14	7/8 - 14	1 1/4 - 12	1 1/4 - 12	1 1/4 - 12	1 1/2 - 12
D	Std.	.500 (12.70)	.500 (12.70)	.500 (12.70)	.813 (20.64)	.813 (20.64)	.813 (20.64)	1.125 (28.58)
	O.S.	.813 (20.64)	.813 (20.64)	.813 (20.64)	1.125 (28.58)	1.125 (28.58)	1.125 (28.58)	1.500 (38.10)
E		2.000 (50.80)	2.500 (63.50)	3.000 (76.20)	3.750 (95.25)	4.500 (114.30)	5.500 (139.70)	6.500 (165.10)
EE		.375 (9.53)	.375 (9.53)	.375 (9.53)	.500 (12.70)	.500 (12.70)	.500 (12.70)	.750 (19.05)
F		.375 (9.53)	.375 (9.53)	.375 (9.53)	.625 (15.88)	.625 (15.88)	.625 (15.88)	.750 (19.05)
FB		.313 (7.94)	.375 (9.53)	.375 (9.53)	.438 (11.11)	.438 (11.11)	.563 (14.29)	.563 (14.29)
FF	Std.	5/8 - 18	5/8 - 18	5/8 - 18	1 - 14	1 - 14	1 - 14	1 3/8 - 12
	O.S.	1 - 14	1 - 14	1 - 14	1 3/8 - 12	1 3/8 - 12	1 3/8 - 12	1 3/4 - 12
G		1.500 (38.10)	1.500 (38.10)	1.500 (38.10)	1.750 (44.45)	1.750 (44.45)	1.750 (44.45)	2.000 (50.80)
J		1.000 (25.40)	1.000 (25.40)	1.000 (25.40)	1.250 (31.75)	1.250 (31.75)	1.250 (31.75)	1.500 (38.10)
K		.250 (6.35)	.313 (7.94)	.313 (7.94)	.375 (9.53)	.375 (9.53)	.438 (11.11)	.438 (11.11)
KK	Std.	7/16 - 20	7/16 - 20	7/16 - 20	3/4 - 16	3/4 - 16	3/4 - 16	1 - 14
	O.S.	3/4 - 16	3/4 - 16	3/4 - 16	1 - 14	1 - 14	1 - 14	1 1/4 - 12
LB		3.625 (92.08)	3.625 (92.08)	3.750 (95.25)	4.250 (107.95)	4.250 (107.95)	4.500 (114.30)	5.000 (127.00)
MM	Std.	.625 (15.88)	.625 (15.88)	.625 (15.88)	1.000 (25.40)	1.000 (25.40)	1.000 (25.40)	1.375 (34.93)
	O.S.	1.000 (25.40)	1.000 (25.40)	1.000 (25.40)	1.375 (34.93)	1.375 (34.93)	1.375 (34.93)	1.750 (44.45)
P		2.313 (58.74)	2.313 (58.74)	2.438 (61.91)	2.625 (66.68)	2.625 (66.68)	2.875 (73.03)	3.125 (79.38)
R		1.428 (36.27)	1.838 (46.68)	2.192 (55.67)	2.758 (70.05)	3.323 (84.40)	4.101 (104.16)	4.879 (123.92)
TF		2.750 (69.85)	3.375 (85.73)	3.875 (98.43)	4.688 (119.06)	5.438 (138.11)	6.625 (168.28)	7.625 (193.68)
UF		3.375 (85.73)	4.125 (104.78)	4.625 (117.48)	5.500 (139.70)	6.250 (158.75)	7.625 (193.68)	8.625 (219.08)
V	Std.	.250 (6.35)	.250 (6.35)	.250 (6.35)	.250 (6.35)	.250 (6.35)	.250 (6.35)	.250 (6.35)
	O.S.	.500 (12.70)	.500 (12.70)	.500 (12.70)	.375 (9.53)	.375 (9.53)	.375 (9.53)	.375 (9.53)
W	Std.	.625 (15.88)	.625 (15.88)	.625 (15.88)	.750 (19.05)	.750 (19.05)	.750 (19.05)	.875 (22.23)
	O.S.	1.000 (25.40)	1.000 (25.40)	1.000 (25.40)	1.000 (25.40)	1.000 (25.40)	1.000 (25.40)	1.125 (28.58)
WF	Std.	1.000 (25.40)	1.000 (25.40)	1.000 (25.40)	1.375 (34.93)	1.375 (34.93)	1.375 (34.93)	1.625 (41.27)
	O.S.	1.375 (34.93)	1.375 (34.93)	1.375 (34.93)	1.625 (41.27)	1.625 (41.27)	1.625 (41.27)	1.875 (47.63)
Y	Std.	1.875 (47.63)	1.875 (47.63)	1.875 (47.63)	2.438 (61.91)	2.438 (61.91)	2.438 (61.91)	2.813 (71.44)
	O.S.	2.250 (57.15)	2.250 (57.15)	2.250 (57.15)	2.688 (68.26)	2.688 (68.26)	2.688 (68.26)	3.063 (77.79)
ZB	Std.	4.875 (123.83)	4.938 (125.41)	5.063 (128.59)	6.000 (152.40)	6.000 (152.40)	6.313 (160.34)	7.063 (179.39)
	O.S.	5.250 (133.35)	5.313 (134.94)	5.438 (138.11)	6.250 (158.75)	6.250 (158.75)	6.563 (166.69)	7.313 (185.74)

- **NFPA (ME3) 03 Head Square Mount and NFPA (ME4) 04 Cap Square Mount for 7" to 12" bore sizes only.**
- **Series J Cylinders rated to 250 PSI air, 400 PSI hydraulic (non-shock). Series EJ Cylinders rated to 250 PSI air only.**
- **Designed for non-lube service.**
- **Switches available on all bore sizes. (See pages 150 & 151 for ordering information.)**

## Cylinder with 03 (ME3) Head Square and Cylinder with 04 (ME4) Cap Square



### Cylinder Order Information

03 - - - -

04

J	Series J Cylinder		Bore and Stroke (write out)
EJ	Series EJ Cylinder		

Mounting Options	
01	Side Tapped (MS4)
03	Head Rectangular Flange (MF1)
<b>03</b>	<b>Head Square (ME3)–7" to 12" Bores</b>
04	Cap Rectangular Flange (MF2)
<b>04</b>	<b>Cap Square (ME4)–7" to 12" Bores</b>
05	Basic Cylinder No Mounting (MX0)
06	Both Ends (4) Tie Rods Ext. (MX1)
6B	Both Ends (2) Tie Rods Ext. (MX4)
6C	Cap Tie Rods Ext. (MX2)
6R	Head Tie Rods Ext. (MX3)
07	Head Trunnion (MT1)
08	Cap Trunnion (MT2)
09	Side Lugs (MS2)
10	Center Trunnion (MT4)
11	Side End Angles (MS1)
12	Cap Fixed Clevis (MP1)
15	Side End Lugs (MS7)
16	Sleeve Nut Construction (Universal)
20	Head Square Flange (MF5)
21	Cap Square Flange (MF6)
22	Detachable Cap Clevis (MP2)
32	Cap Fixed Eye (MP3)
42	Detachable Cap Eye (MP4)
52	Spherical Bearing

Cushion in Head	
3	None
5 <sup>†</sup>	Non-Adjustable Cushion
7	Adjustable Cushion (Position 2)

<sup>†</sup>Standard with EJ

Cushion in Cap	
3	None
5 <sup>†</sup>	Non-Adjustable Cushion
7	Adjustable Cushion (Position 2)

<sup>†</sup>Standard with EJ

Additional Options – order alphabetically – More on page 155	
HR	Case Hardened (45 Rc)
L(-)	Port Location position 1 standard: L(Head Cap) (specify position 1 thru 4 for head and/or cap)
MS	Metal Rod Scraper
N(-)	Cushion Adjust Screw Location position 2 standard: N(Head Cap) (specify position 1 thru 4 for head and/or cap)
P(-)*	Non-Standard Port Sizes: [specify port size for P(-)H head only, P(-)C cap only, or P(-) both head & cap]
PS	Magnetic Piston – includes aluminum tube option
RS	Rod Stud Type 1 (5/8" – 1 3/4" øRod) Type 2 (5/8" & 1" øRod)
RX	Rod Extensions (specify length of additional rod extension)
SC	Single Acting Spring Extend (Cap End)–See page 155
SR	Single Acting Spring Retract (Rod End)–See page 155
SS	303 Stainless Steel (Hard Chrome Plated)
ST(-)C	Stop Tube (Cap End) (specify stop tube length)
ST(-)R	Stop Tube (Rod End) (specify stop tube length)
T	Special Rod Threads (specify rod thread)
TX	Thread Extensions (specify length of thread extension)
V	Viton® Seals

Piston Rod Threads Type	
1	Small Male (Solid)
2	Intermediate Thread Male (Solid)
3	Female
6	Full Thread Male (Solid)
7	Plain Rod End

Piston Rod Diameters		
A	5/8"	Standard on 1 1/2", 2", 2 1/2"
B	1"	Standard on 3 1/4", 4", 5" Oversized on 1 1/2", 2", 2 1/2"
C	1 3/8"	Standard on 6", 7", 8" Oversized on 3 1/4", 4", 5"
D	1 3/4"	Standard on 10" Oversized on 6", 7", 8"
E	2"	Standard on 12" Oversized on 10"
F	2 1/2"	Oversized on 10", 12"

**Port and Cushion Adjustment Positions** (As viewed from rod end: Port standard position 1, Cushion Adjustment standard position 2.)  
 NOTE: A Port and a Cushion Adjustment cannot be in the same position.

See page 156 for complete instructions on how to order cylinders.

# Series J & EJ Cylinder with 03 (ME3) Head Square & 04 (ME4) Cap Square



All Dimensions in Inches (mm)

## 03 (ME3)

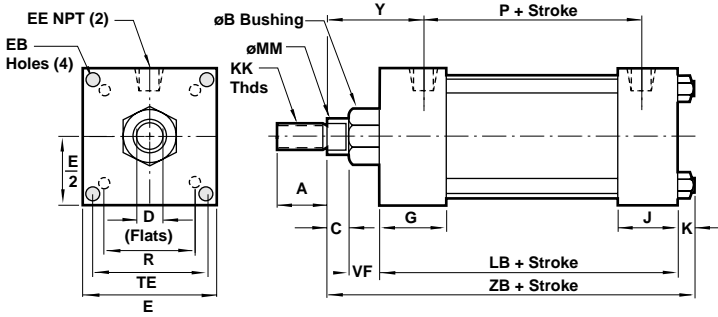

## 04 (ME4)

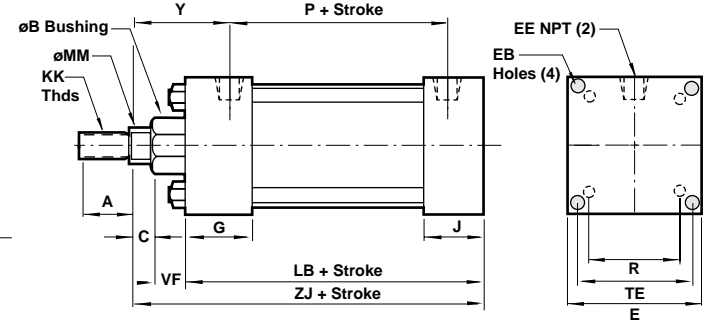

## Standard & Optional Rod Ends

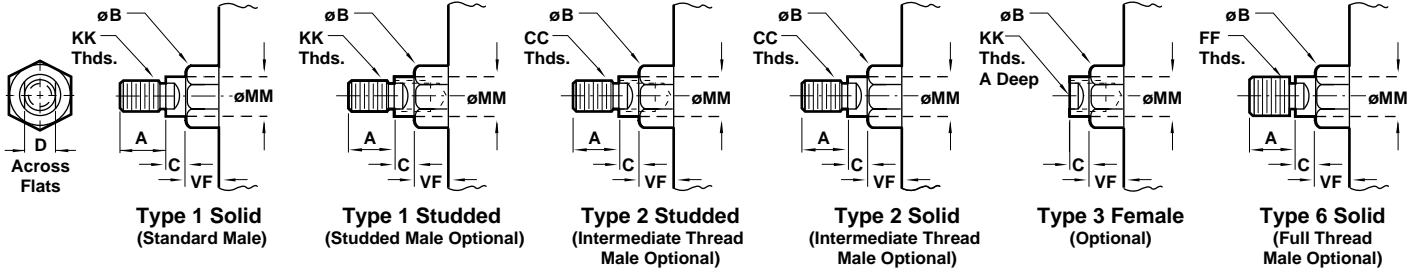

Dimension	03 (ME3) Head Square				04 (ME4) Cap Square				
	7" Bore (177.80)	8" Bore (203.20)	10" Bore (254.00)	12" Bore (304.80)	7" Bore (177.80)	8" Bore (203.20)	10" Bore (254.00)	12" Bore (304.80)	
ø Rod	Std.	1 3/8" (34.93)	1 3/8" (34.93)	1 3/4" (44.45)	2" (50.80)	1 3/8" (34.93)	1 3/8" (34.93)	1 3/4" (44.45)	2" (50.80)
	O.S.	1 3/4" (44.45)	1 3/4" (44.45)	2" (50.80)	2 1/2" (63.50)	1 3/4" (44.45)	1 3/4" (44.45)	2" (50.80)	2 1/2" (63.50)
A	Std.	1.625 (41.28)	1.625 (41.28)	2.000 (50.80)	2.250 (57.15)	1.625 (41.28)	1.625 (41.28)	2.000 (50.80)	2.250 (57.15)
	O.S.	2.000 (50.80)	2.000 (50.80)	2.250 (57.15)	3.000 (76.20)	2.000 (50.80)	2.000 (50.80)	2.250 (57.15)	3.000 (76.20)
B <sup>+0.000</sup> -0.002	Std.	1.999 (50.78)	1.999 (50.78)	2.374 (60.30)	2.624 (66.65)	1.999 (50.78)	1.999 (50.78)	2.374 (60.30)	2.624 (66.65)
	O.S.	2.374 (60.30)	2.374 (60.30)	2.624 (66.65)	3.124 (79.35)	2.374 (60.30)	2.374 (60.30)	2.624 (66.65)	3.124 (79.35)
C	Std.	.625 (15.88)	.625 (15.88)	.750 (19.05)	.875 (22.23)	.625 (15.88)	.625 (15.88)	.750 (19.05)	.875 (22.23)
	O.S.	.750 (19.05)	.750 (19.05)	.875 (22.23)	1.000 (25.40)	.750 (19.05)	.750 (19.05)	.875 (22.23)	1.000 (25.40)
CC	Std.	1 1/4 - 12	1 1/4 - 12	1 1/2 - 12	1 3/4 - 12	1 1/4 - 12	1 1/4 - 12	1 1/2 - 12	1 3/4 - 12
	O.S.	1 1/2 - 12	1 1/2 - 12	1 3/4 - 12	2 1/4 - 12	1 1/2 - 12	1 1/2 - 12	1 3/4 - 12	2 1/4 - 12
D	Std.	1.125 (28.58)	1.125 (28.58)	1.500 (38.10)	1.688 (42.86)	1.125 (28.58)	1.125 (28.58)	1.500 (38.10)	1.688 (42.86)
	O.S.	1.500 (38.10)	1.500 (38.10)	1.688 (42.86)	2.063 (52.39)	1.500 (38.10)	1.500 (38.10)	1.688 (42.86)	2.063 (52.39)
E		7.500 (190.50)	8.500 (215.90)	10.625 (269.88)	12.750 (323.85)	7.500 (190.50)	8.500 (215.90)	10.625 (269.88)	12.750 (323.85)
EB		.563 (14.29)	.688 (17.46)	.813 (20.64)	.813 (20.64)	.563 (14.29)	.688 (17.46)	.813 (20.64)	.813 (20.64)
EE		.750 (19.05)	.750 (19.05)	1.000 (25.40)	1.000 (25.40)	.750 (19.05)	.750 (19.05)	1.000 (25.40)	1.000 (25.40)
FF	Std.	1 3/8 - 12	1 3/8 - 12	1 3/4 - 12	2 - 12	1 3/8 - 12	1 3/8 - 12	1 3/4 - 12	2 - 12
	O.S.	1 3/4 - 12	1 3/4 - 12	2 - 12	2 1/2 - 12	1 3/4 - 12	1 3/4 - 12	2 - 12	2 1/2 - 12
G		2.000 (50.80)	2.000 (50.80)	2.250 (57.15)	2.250 (57.15)	2.000 (50.80)	2.000 (50.80)	2.250 (57.15)	2.250 (57.15)
J		1.500 (38.10)	1.500 (38.10)	2.000 (50.80)	2.000 (50.80)	1.500 (38.10)	1.500 (38.10)	2.000 (50.80)	2.000 (50.80)
K		.563 (14.29)	.563 (14.29)	.688 (17.46)	.688 (17.46)	.563 (14.29)	.563 (14.29)	.688 (17.46)	.688 (17.46)
KK	Std.	1 - 14	1 - 14	1 1/4 - 12	1 1/2 - 12	1 - 14	1 - 14	1 1/4 - 12	1 1/2 - 12
	O.S.	1 1/4 - 12	1 1/4 - 12	1 1/2 - 12	1 7/8 - 12	1 1/4 - 12	1 1/4 - 12	1 1/2 - 12	1 7/8 - 12
LB		5.125 (130.18)	5.125 (130.18)	6.375 (161.93)	6.875 (174.63)	5.125 (130.18)	5.125 (130.18)	6.375 (161.93)	6.875 (174.63)
MM	Std.	1.375 (34.93)	1.375 (34.93)	1.750 (44.45)	2.000 (50.80)	1.375 (34.93)	1.375 (34.93)	1.750 (44.45)	2.000 (50.80)
	O.S.	1.750 (44.45)	1.750 (44.45)	2.000 (50.80)	2.500 (63.50)	1.750 (44.45)	1.750 (44.45)	2.000 (50.80)	2.500 (63.50)
P		3.250 (82.55)	3.250 (82.55)	4.125 (104.78)	4.625 (117.48)	3.250 (82.55)	3.250 (82.55)	4.125 (104.78)	4.625 (117.48)
R		5.730 (145.54)	6.442 (163.63)	7.969 (202.41)	9.406 (238.92)	5.730 (145.54)	6.442 (163.63)	7.969 (202.41)	9.406 (238.92)
TE		6.750 (171.45)	7.570 (192.27)	9.406 (238.92)	11.109 (282.18)	6.750 (171.45)	7.570 (192.27)	9.406 (238.92)	11.109 (282.18)
VF	Std.	1.000 (25.40)	1.000 (25.40)	1.125 (28.58)	1.125 (28.58)	1.000 (25.40)	1.000 (25.40)	1.125 (28.58)	1.125 (28.58)
	O.S.	1.125 (28.58)	1.125 (28.58)	1.125 (28.58)	1.250 (31.75)	1.125 (28.58)	1.125 (28.58)	1.125 (28.58)	1.250 (31.75)
WF	Std.	1.625 (41.28)	1.625 (41.28)	1.875 (47.63)	2.000 (50.80)	1.625 (41.28)	1.625 (41.28)	1.875 (47.63)	2.000 (50.80)
	O.S.	1.875 (47.63)	1.875 (47.63)	2.000 (50.80)	2.250 (57.15)	1.875 (47.63)	1.875 (47.63)	2.000 (50.80)	2.250 (57.15)
Y	Std.	2.813 (71.44)	2.813 (71.44)	3.125 (79.38)	3.250 (82.55)	2.813 (71.44)	2.813 (71.44)	3.125 (79.38)	3.250 (82.55)
	O.S.	3.063 (77.79)	3.063 (77.79)	3.250 (82.55)	3.500 (88.90)	3.063 (77.79)	3.063 (77.79)	3.250 (82.55)	3.500 (88.90)
ZB	Std.	7.313 (185.74)	7.313 (185.74)	8.938 (227.01)	9.563 (242.89)	-	-	-	-
	O.S.	7.563 (192.09)	7.563 (192.09)	9.063 (230.19)	9.813 (249.24)	-	-	-	-
ZJ	Std.	-	-	-	-	6.750 (171.45)	6.750 (171.45)	8.250 (209.55)	8.875 (225.43)
	O.S.	-	-	-	-	7.000 (177.80)	7.000 (177.80)	8.375 (212.73)	9.125 (231.78)

## Cylinder with 04 (MF2) Cap Rectangular Flange

- NFPA (MF2) 04 Cap Rectangular Flange Mount for 1-1/2" to 6" bore sizes.
- Series J Cylinders rated to 250 PSI air, 400 PSI hydraulic (non-shock). Series EJ Cylinders rated to 250 PSI air only.
- Designed for non-lube service.
- Switches available on all bore sizes. (See pages 150 & 151 for ordering information.)



### Cylinder Order Information

04 - - - -

J	Series J Cylinder
EJ	Series EJ Cylinder

Bore and Stroke (write out)

Mounting Options	
01	Side Tapped (MS4)
03	Head Rectangular Flange (MF1)
03	Head Square (ME3)-7" to 12" Bores
<b>04</b>	<b>Cap Rectangular Flange (MF2)</b>
04	Cap Square (ME4)-7" to 12" Bores
05	Basic Cylinder No Mounting (MX0)
06	Both Ends (4) Tie Rods Ext. (MX1)
6B	Both Ends (2) Tie Rods Ext. (MX4)
6C	Cap Tie Rods Ext. (MX2)
6R	Head Tie Rods Ext. (MX3)
07	Head Trunnion (MT1)
08	Cap Trunnion (MT2)
09	Side Lugs (MS2)
10	Center Trunnion (MT4)
11	Side End Angles (MS1)
12	Cap Fixed Clevis (MP1)
15	Side End Lugs (MS7)
16	Sleeve Nut Construction (Universal)
20	Head Square Flange (MF5)
21	Cap Square Flange (MF6)
22	Detachable Cap Clevis (MP2)
32	Cap Fixed Eye (MP3)
42	Detachable Cap Eye (MP4)
52	Spherical Bearing

Cushion in Head	
3	None
5 <sup>†</sup>	Non-Adjustable Cushion
7	Adjustable Cushion (Position 2)

<sup>†</sup>Standard with EJ

Cushion in Cap	
3	None
5 <sup>†</sup>	Non-Adjustable Cushion
7	Adjustable Cushion (Position 2)

<sup>†</sup>Standard with EJ

Additional Options – order alphabetically – More on page 155	
HR	Case Hardened (45 Rc)
L(- -)	Port Location position 1 standard: L(Head Cap) (specify position 1 thru 4 for head and/or cap)
MS	Metal Rod Scraper
N(- -)	Cushion Adjust Screw Location position 2 standard: N(Head Cap) (specify position 1 thru 4 for head and/or cap)
P(-)*	Non-Standard Port Sizes: [specify port size for P(-H) head only, P(-C) cap only, or P(-) both head & cap]
PS	Magnetic Piston – includes aluminum tube option
RS	Rod Stud Type 1 (5/8" – 1¾" øRod) Type 2 (5/8" & 1" øRod)
RX	Rod Extensions (specify length of additional rod extension)
SC	Single Acting Spring Extend (Cap End)–See page 155
SR	Single Acting Spring Retract (Rod End)–See page 155
SS	303 Stainless Steel (Hard Chrome Plated)
ST(-C)	Stop Tube (Cap End) (specify stop tube length)
ST(-R)	Stop Tube (Rod End) (specify stop tube length)
T	Special Rod Threads (specify rod thread)
TX	Thread Extensions (specify length of thread extension)
V	Viton® Seals

\*1½", 2", 2½" bore cylinders have 3/8" NPT Standard, ½" NPT oversize. 3¼", 4", 5" bore cylinders have ½" NPT Standard, ¾" NPT oversize. This will add 1/8" to the overall cylinder length.

Piston Rod Threads Type	
1	Small Male (Solid)
2	Intermediate Thread Male (Solid)
3	Female
6	Full Thread Male (Solid)
7	Plain Rod End

Piston Rod Diameters		
A	5/8"	Standard on 1½", 2", 2½"
B	1"	Standard on 3¼", 4", 5" Oversized on 1½", 2", 2½"
C	1⅜"	Standard on 6", 7", 8" Oversized on 3¼", 4", 5"
D	1¾"	Standard on 10" Oversized on 6", 7", 8"
E	2"	Standard on 12" Oversized on 10"
F	2½"	Oversized on 10", 12"

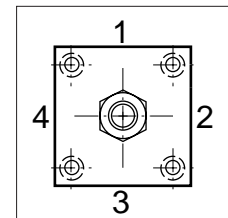

Port and Cushion Adjustment Positions (As viewed from rod end: Port standard position 1, Cushion Adjustment standard position 2.)  
NOTE: A Port and a Cushion Adjustment cannot be in the same position.

See page 156 for complete instructions on how to order cylinders.

# Series J & EJ, NFPA Steel Air Cylinder with 04 (MF2) Cap Rectangular Flange

All Dimensions in Inches (mm)

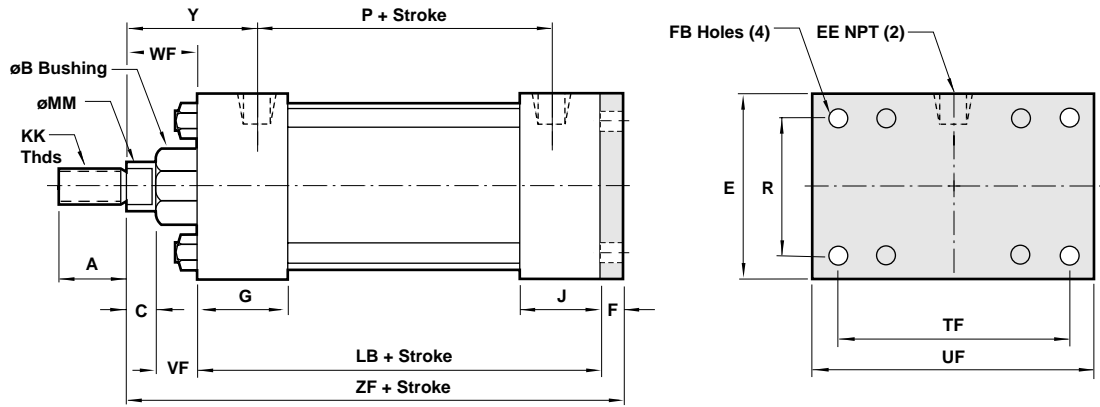

## Standard & Optional Rod Ends

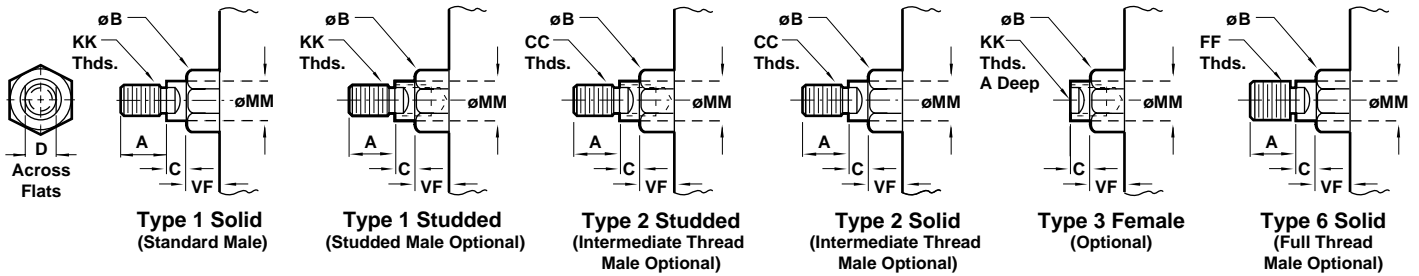

Dimension	1 1/2" Bore (38.10)	2" Bore (50.80)	2 1/2" Bore (63.50)	3 1/4" Bore (82.55)	4" Bore (101.60)	5" Bore (127.00)	6" Bore (152.40)
ø Rod	Std. 5/8" (15.88)	5/8" (15.88)	5/8" (15.88)	1" (25.40)	1" (25.40)	1" (25.40)	1 3/8" (34.93)
	O.S. 1" (25.40)	1" (25.40)	1" (25.40)	1 3/8" (34.93)	1 3/8" (34.93)	1 3/8" (34.93)	1 3/4" (44.45)
A	Std. .750 (19.05)	.750 (19.05)	.750 (19.05)	1.125 (28.58)	1.125 (28.58)	1.125 (28.58)	1.625 (41.28)
	O.S. 1.125 (28.58)	1.125 (28.58)	1.125 (28.58)	1.625 (41.28)	1.625 (41.28)	1.625 (41.28)	2.000 (50.80)
B <sup>+0.000</sup> -0.002	Std. 1.124 (28.55)	1.124 (28.55)	1.124 (28.55)	1.499 (38.08)	1.499 (38.08)	1.499 (38.08)	1.999 (50.78)
	O.S. 1.499 (38.08)	1.499 (38.08)	1.499 (38.08)	1.999 (50.78)	1.999 (50.78)	1.999 (50.78)	2.374 (60.30)
C	Std. .375 (9.53)	.375 (9.53)	.375 (9.53)	.500 (12.70)	.500 (12.70)	.500 (12.70)	.625 (15.88)
	O.S. .500 (12.70)	.500 (12.70)	.500 (12.70)	.625 (15.88)	.625 (15.88)	.625 (15.88)	.750 (19.05)
CC	Std. 1/2 - 20	1/2 - 20	1/2 - 20	7/8 - 14	7/8 - 14	7/8 - 14	1 1/4 - 12
	O.S. 7/8 - 14	7/8 - 14	7/8 - 14	1 1/4 - 12	1 1/4 - 12	1 1/4 - 12	1 1/2 - 12
D	Std. .500 (12.70)	.500 (12.70)	.500 (12.70)	.813 (20.64)	.813 (20.64)	.813 (20.64)	1.125 (28.58)
	O.S. .813 (20.64)	.813 (20.64)	.813 (20.64)	1.125 (28.58)	1.125 (28.58)	1.125 (28.58)	1.500 (38.10)
E	2.000 (50.80)	2.500 (63.50)	3.000 (76.20)	3.750 (95.25)	4.500 (114.30)	5.500 (139.70)	6.500 (165.10)
EE	.375 (9.53)	.375 (9.53)	.375 (9.53)	.500 (12.70)	.500 (12.70)	.500 (12.70)	.750 (19.05)
F	.375 (9.53)	.375 (9.53)	.375 (9.53)	.625 (15.88)	.625 (15.88)	.625 (15.88)	.750 (19.05)
FB	.313 (7.94)	.375 (9.53)	.375 (9.53)	.438 (11.11)	.438 (11.11)	.563 (14.29)	.563 (14.29)
FF	Std. 5/8 - 18	5/8 - 18	5/8 - 18	1 - 14	1 - 14	1 - 14	1 3/8 - 12
	O.S. 1 - 14	1 - 14	1 - 14	1 3/8 - 12	1 3/8 - 12	1 3/8 - 12	1 3/4 - 12
G	1.500 (38.10)	1.500 (38.10)	1.500 (38.10)	1.750 (44.45)	1.750 (44.45)	1.750 (44.45)	2.000 (50.80)
J	1.000 (25.40)	1.000 (25.40)	1.000 (25.40)	1.250 (31.75)	1.250 (31.75)	1.250 (31.75)	1.500 (38.10)
K	.250 (6.35)	.313 (7.94)	.313 (7.94)	.375 (9.53)	.375 (9.53)	.438 (11.11)	.438 (11.11)
KK	Std. 7/16 - 20	7/16 - 20	7/16 - 20	3/4 - 16	3/4 - 16	3/4 - 16	1 - 14
	O.S. 3/4 - 16	3/4 - 16	3/4 - 16	1 - 14	1 - 14	1 - 14	1 1/4 - 12
LB	3.625 (92.08)	3.625 (92.08)	3.750 (95.25)	4.250 (107.95)	4.250 (107.95)	4.500 (114.30)	5.000 (127.00)
MM	Std. .625 (15.88)	.625 (15.88)	.625 (15.88)	1.000 (25.40)	1.000 (25.40)	1.000 (25.40)	1.375 (34.93)
	O.S. 1.000 (25.40)	1.000 (25.40)	1.000 (25.40)	1.375 (34.93)	1.375 (34.93)	1.375 (34.93)	1.750 (44.45)
P	2.313 (58.74)	2.313 (58.74)	2.438 (61.91)	2.625 (66.68)	2.625 (66.68)	2.875 (73.03)	3.125 (79.38)
R	1.428 (36.27)	1.838 (46.68)	2.192 (55.67)	2.758 (70.05)	3.323 (84.40)	4.101 (104.16)	4.879 (123.93)
TF	2.750 (69.85)	3.375 (85.73)	3.875 (98.43)	4.687 (119.05)	5.438 (138.11)	6.625 (168.28)	7.625 (193.68)
UF	Std. 3.375 (85.73)	4.125 (104.78)	4.625 (117.48)	5.500 (139.70)	6.250 (158.75)	7.625 (193.68)	8.625 (219.08)
	O.S. .625 (15.88)	.625 (15.88)	.625 (15.88)	.875 (22.23)	.875 (22.23)	.875 (22.23)	1.000 (25.40)
VF	Std. .875 (22.23)	.875 (22.23)	.875 (22.23)	1.000 (25.40)	1.000 (25.40)	1.000 (25.40)	1.125 (28.58)
	O.S. 1.000 (25.40)	1.000 (25.40)	1.000 (25.40)	1.375 (34.93)	1.375 (34.93)	1.375 (34.93)	1.625 (41.27)
WF	Std. 1.375 (34.93)	1.375 (34.93)	1.375 (34.93)	1.625 (41.27)	1.625 (41.27)	1.625 (41.27)	1.875 (47.63)
	O.S. 1.875 (47.63)	1.875 (47.63)	1.875 (47.63)	2.438 (61.91)	2.438 (61.91)	2.438 (61.91)	2.813 (71.44)
Y	Std. 2.250 (57.15)	2.250 (57.15)	2.313 (57.15)	2.688 (68.26)	2.688 (68.26)	2.688 (68.26)	3.063 (77.79)
	O.S. 5.000 (127.00)	5.000 (127.00)	5.125 (130.18)	6.250 (158.75)	6.250 (158.75)	6.500 (165.10)	7.375 (187.33)
ZF	Std. 5.375 (136.53)	5.375 (136.53)	5.500 (139.70)	6.500 (165.10)	6.500 (165.10)	6.750 (171.45)	7.625 (193.68)
	O.S. 5.375 (136.53)	5.375 (136.53)	5.500 (139.70)	6.500 (165.10)	6.500 (165.10)	6.750 (171.45)	7.625 (193.68)

- NFPA (MX0) 05 Basic Mount, for 1-1/2" to 6" bore sizes.
- Series J Cylinders rated to 250 PSI air, 400 PSI hydraulic (non-shock). Series EJ Cylinders rated to 250 PSI air only.
- Designed for non-lube service.
- Switches available on all bore sizes. (See pages 150 & 151 for ordering information.)



### Cylinder Order Information

05 - - - -

J	Series J Cylinder
EJ	Series EJ Cylinder

Bore and Stroke (write out)

Mounting Options	
01	Side Tapped (MS4)
03	Head Rectangular Flange (MF1)
03	Head Square (ME3)-7" to 12" Bores
04	Cap Rectangular Flange (MF2)
04	Cap Square (ME4)-7" to 12" Bores
<b>05</b>	<b>Basic Cylinder No Mounting (MX0)</b>
06	Both Ends (4) Tie Rods Ext. (MX1)
6B	Both Ends (2) Tie Rods Ext. (MX4)
6C	Cap Tie Rods Ext. (MX2)
6R	Head Tie Rods Ext. (MX3)
07	Head Trunnion (MT1)
08	Cap Trunnion (MT2)
09	Side Lugs (MS2)
10	Center Trunnion (MT4)
11	Side End Angles (MS1)
12	Cap Fixed Clevis (MP1)
15	Side End Lugs (MS7)
16	Sleeve Nut Construction (Universal)
20	Head Square Flange (MF5)
21	Cap Square Flange (MF6)
22	Detachable Cap Clevis (MP2)
32	Cap Fixed Eye (MP3)
42	Detachable Cap Eye (MP4)
52	Spherical Bearing

Cushion in Head	
3	None
5 <sup>†</sup>	Non-Adjustable Cushion
7	Adjustable Cushion (Position 2)

<sup>†</sup>Standard with EJ

Cushion in Cap	
3	None
5 <sup>†</sup>	Non-Adjustable Cushion
7	Adjustable Cushion (Position 2)

<sup>†</sup>Standard with EJ

Additional Options – order alphabetically – More on page 155	
HR	Case Hardened (45 Rc)
L(-)	Port Location position 1 standard: L(Head Cap) (specify position 1 thru 4 for head and/or cap)
MS	Metal Rod Scraper
N(-)	Cushion Adjust Screw Location position 2 standard: N(Head Cap) (specify position 1 thru 4 for head and/or cap)
P(-)*	Non-Standard Port Sizes: [specify port size for P(-H) head only, P(-C) cap only, or P(-) both head & cap]
PS	Magnetic Piston – includes aluminum tube option
RS	Rod Stud Type 1 (5/8" – 1¾" øRod) Type 2 (5/8" & 1" øRod)
RX	Rod Extensions (specify length of additional rod extension)
SC	Single Acting Spring Extend (Cap End)–See page 155
SR	Single Acting Spring Retract (Rod End)–See page 155
SS	303 Stainless Steel (Hard Chrome Plated)
ST(-C)	Stop Tube (Cap End) (specify stop tube length)
ST(-R)	Stop Tube (Rod End) (specify stop tube length)
T	Special Rod Threads (specify rod thread)
TX	Thread Extensions (specify length of thread extension)
V	Viton® Seals

\*1½", 2", 2½" bore cylinders have 3/8" NPT Standard, ½" NPT oversize. 3¼", 4", 5" bore cylinders have ½" NPT Standard, ¾" NPT oversize. This will add 1/8" to the overall cylinder length.

Piston Rod Threads Type	
1	Small Male (Solid)
2	Intermediate Thread Male (Solid)
3	Female
6	Full Thread Male (Solid)
7	Plain Rod End

Piston Rod Diameters		
A	5/8"	Standard on 1½", 2", 2½"
B	1"	Standard on 3¼", 4", 5" Oversized on 1½", 2", 2½"
C	1⅜"	Standard on 6", 7", 8" Oversized on 3¼", 4", 5"
D	1¾"	Standard on 10" Oversized on 6", 7", 8"
E	2"	Standard on 12" Oversized on 10"
F	2½"	Oversized on 10", 12"

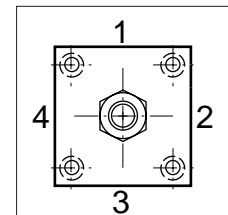

**Port and Cushion Adjustment Positions** (As viewed from rod end: Port standard position 1, Cushion Adjustment standard position 2.)  
NOTE: A Port and a Cushion Adjustment cannot be in the same position.

See page 156 for complete instructions on how to order cylinders.

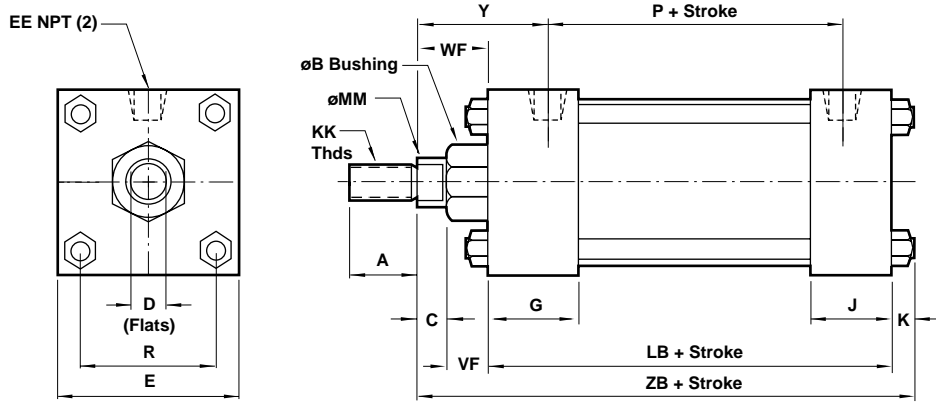

**Standard & Optional Rod Ends**

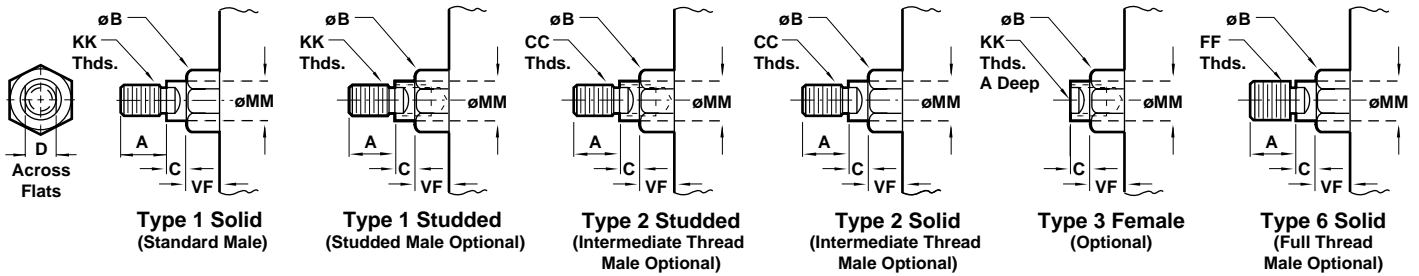

Dimension	1 1/2" Bore (38.10)	2" Bore (50.80)	2 1/2" Bore (63.50)	3 1/4" Bore (82.55)	4" Bore (101.60)	5" Bore (127.00)	6" Bore (152.40)
ø Rod	Std. 5/8" (15.88)	5/8" (15.88)	5/8" (15.88)	1" (25.40)	1" (25.40)	1" (25.40)	1 3/8" (34.93)
	O.S. 1" (25.40)	1" (25.40)	1" (25.40)	1 3/8" (34.93)	1 3/8" (34.93)	1 3/8" (34.93)	1 3/4" (44.45)
A	Std. .750 (19.05)	.750 (19.05)	.750 (19.05)	1.125 (28.58)	1.125 (28.58)	1.125 (28.58)	1.625 (41.28)
	O.S. 1.125 (28.58)	1.125 (28.58)	1.125 (28.58)	1.625 (41.28)	1.625 (41.28)	1.625 (41.28)	2.000 (50.80)
B +.000 -.002	Std. 1.124 (28.55)	1.124 (28.55)	1.124 (28.55)	1.499 (38.08)	1.499 (38.08)	1.499 (38.08)	1.999 (50.78)
	O.S. 1.499 (38.08)	1.499 (38.08)	1.499 (38.08)	1.999 (50.78)	1.999 (50.78)	1.999 (50.78)	2.374 (60.30)
C	Std. .375 (9.53)	.375 (9.53)	.375 (9.53)	.500 (12.70)	.500 (12.70)	.500 (12.70)	.625 (15.88)
	O.S. .500 (12.70)	.500 (12.70)	.500 (12.70)	.625 (15.88)	.625 (15.88)	.625 (15.88)	.750 (19.05)
CC	Std. 1/2 - 20	1/2 - 20	1/2 - 20	7/8 - 14	7/8 - 14	7/8 - 14	1 1/4 - 12
	O.S. 7/8 - 14	7/8 - 14	7/8 - 14	1 1/4 - 12	1 1/4 - 12	1 1/4 - 12	1 1/2 - 12
D	Std. .500 (12.70)	.500 (12.70)	.500 (12.70)	.813 (20.64)	.813 (20.64)	.813 (20.64)	1.125 (28.58)
	O.S. .813 (20.64)	.813 (20.64)	.813 (20.64)	1.125 (28.58)	1.125 (28.58)	1.125 (28.58)	1.500 (38.10)
E	2.000 (50.80)	2.500 (63.50)	3.000 (76.20)	3.750 (95.25)	4.500 (114.30)	5.500 (139.70)	6.500 (165.10)
EE	.375 (9.53)	.375 (9.53)	.375 (9.53)	.500 (12.70)	.500 (12.70)	.500 (12.70)	.750 (19.05)
FF	Std. 5/8 - 18	5/8 - 18	5/8 - 18	1 - 14	1 - 14	1 - 14	1 3/8 - 12
	O.S. 1 - 14	1 - 14	1 - 14	1 3/8 - 12	1 3/8 - 12	1 3/8 - 12	1 3/4 - 12
G	1.500 (38.10)	1.500 (38.10)	1.500 (38.10)	1.750 (44.45)	1.750 (44.45)	1.750 (44.45)	2.000 (50.80)
J	1.000 (25.40)	1.000 (25.40)	1.000 (25.40)	1.250 (31.75)	1.250 (31.75)	1.250 (31.75)	1.500 (38.10)
K	.250 (6.35)	.313 (7.94)	.313 (7.94)	.375 (9.53)	.375 (9.53)	.438 (11.11)	.438 (11.11)
KK	Std. 7/16 - 20	7/16 - 20	7/16 - 20	3/4 - 16	3/4 - 16	3/4 - 16	1 - 14
	O.S. 3/4 - 16	3/4 - 16	3/4 - 16	1 - 14	1 - 14	1 - 14	1 1/4 - 12
LB	3.625 (92.08)	3.625 (92.08)	3.750 (95.25)	4.250 (107.95)	4.250 (107.95)	4.500 (114.30)	5.000 (127.00)
MM	Std. .625 (15.88)	.625 (15.88)	.625 (15.88)	1.000 (25.40)	1.000 (25.40)	1.000 (25.40)	1.375 (34.93)
	O.S. 1.000 (25.40)	1.000 (25.40)	1.000 (25.40)	1.375 (34.93)	1.375 (34.93)	1.375 (34.93)	1.750 (44.45)
P	2.313 (58.74)	2.313 (58.74)	2.438 (61.91)	2.625 (66.68)	2.625 (66.68)	2.875 (73.03)	3.125 (79.38)
R	1.428 (36.27)	1.838 (46.68)	2.192 (55.67)	2.758 (70.05)	3.323 (84.40)	4.101 (104.16)	4.879 (123.92)
VF	Std. .625 (15.88)	.625 (15.88)	.625 (15.88)	.875 (22.23)	.875 (22.23)	.875 (22.23)	1.000 (25.40)
	O.S. .875 (22.23)	.875 (22.23)	.875 (22.23)	1.000 (25.40)	1.000 (25.40)	1.000 (25.40)	1.125 (28.58)
WF	Std. 1.000 (25.40)	1.000 (25.40)	1.000 (25.40)	1.375 (34.93)	1.375 (34.93)	1.375 (34.93)	1.625 (41.28)
	O.S. 1.375 (34.93)	1.375 (34.93)	1.375 (34.93)	1.625 (41.28)	1.625 (41.28)	1.625 (41.28)	1.875 (47.63)
Y	Std. 1.875 (47.63)	1.875 (47.63)	1.875 (47.63)	2.438 (61.91)	2.438 (61.91)	2.438 (61.91)	2.813 (71.44)
	O.S. 2.250 (57.15)	2.250 (57.15)	2.250 (57.15)	2.688 (68.26)	2.688 (68.26)	2.688 (68.26)	3.063 (77.79)
ZB	Std. 4.875 (123.83)	4.938 (125.41)	5.063 (128.59)	6.000 (152.40)	6.000 (152.40)	6.313 (160.34)	7.063 (179.39)
	O.S. 5.250 (133.35)	5.313 (134.94)	5.438 (138.11)	6.250 (158.75)	6.250 (158.75)	6.563 (166.69)	7.313 (185.74)

- NFPA (MX0) 05 Basic Mount, for 7" to 12" bore sizes.
- Series J Cylinders rated to 250 PSI air, 400 PSI hydraulic (non-shock). Series EJ Cylinders rated to 250 PSI air only.
- Designed for non-lube service.
- Switches available on all bore sizes. (See pages 150 & 151 for ordering information.)



### Cylinder Order Information

05 - - - -

J	Series J Cylinder
EJ	Series EJ Cylinder

Bore and Stroke (write out)

Mounting Options	
01	Side Tapped (MS4)
03	Head Rectangular Flange (MF1)
03	Head Square (ME3)–7" to 12" Bores
04	Cap Rectangular Flange (MF2)
04	Cap Square (ME4)–7" to 12" Bores
<b>05</b>	<b>Basic Cylinder No Mounting (MX0)</b>
06	Both Ends (4) Tie Rods Ext. (MX1)
6B	Both Ends (2) Tie Rods Ext. (MX4)
6C	Cap Tie Rods Ext. (MX2)
6R	Head Tie Rods Ext. (MX3)
07	Head Trunnion (MT1)
08	Cap Trunnion (MT2)
09	Side Lugs (MS2)
10	Center Trunnion (MT4)
11	Side End Angles (MS1)
12	Cap Fixed Clevis (MP1)
15	Side End Lugs (MS7)
16	Sleeve Nut Construction (Universal)
20	Head Square Flange (MF5)
21	Cap Square Flange (MF6)
22	Detachable Cap Clevis (MP2)
32	Cap Fixed Eye (MP3)
42	Detachable Cap Eye (MP4)
52	Spherical Bearing

Cushion in Head	
3	None
5 <sup>†</sup>	Non-Adjustable Cushion
7	Adjustable Cushion (Position 2)

<sup>†</sup>Standard with EJ

Cushion in Cap	
3	None
5 <sup>†</sup>	Non-Adjustable Cushion
7	Adjustable Cushion (Position 2)

<sup>†</sup>Standard with EJ

Additional Options – order alphabetically – More on page 155	
HR	Case Hardened (45 Rc)
L(- -)	Port Location position 1 standard: L(Head Cap) (specify position 1 thru 4 for head and/or cap)
MS	Metal Rod Scraper
N(- -)	Cushion Adjust Screw Location position 2 standard: N(Head Cap) (specify position 1 thru 4 for head and/or cap)
P(-)*	Non-Standard Port Sizes: [specify port size for P(-H) head only, P(-C) cap only, or P(-) both head & cap]
PS	Magnetic Piston – includes aluminum tube option
RS	Rod Stud Type 1 (5/8" – 1¾" øRod) Type 2 (5/8" & 1" øRod)
RX	Rod Extensions (specify length of additional rod extension)
SC	Single Acting Spring Extend (Cap End)–See page 155
SR	Single Acting Spring Retract (Rod End)–See page 155
SS	303 Stainless Steel (Hard Chrome Plated)
ST(-C)	Stop Tube (Cap End) (specify stop tube length)
ST(-R)	Stop Tube (Rod End) (specify stop tube length)
T	Special Rod Threads (specify rod thread)
TX	Thread Extensions (specify length of thread extension)
V	Viton® Seals

\*1½", 2", 2½" bore cylinders have ¾" NPT Standard, ½" NPT oversize. 3¼", 4", 5" bore cylinders have ½" NPT Standard, ¼" NPT oversize. This will add 1/8" to the overall cylinder length.

Piston Rod Threads Type	
1	Small Male (Solid)
2	Intermediate Thread Male (Solid)
3	Female
6	Full Thread Male (Solid)
7	Plain Rod End

Piston Rod Diameters		
A	5/8"	Standard on 1½", 2", 2½"
B	1"	Standard on 3¼", 4", 5" Oversized on 1½", 2", 2½"
C	1⅜"	Standard on 6", 7", 8" Oversized on 3¼", 4", 5"
D	1¾"	Standard on 10" Oversized on 6", 7", 8"
E	2"	Standard on 12" Oversized on 10"
F	2½"	Oversized on 10", 12"

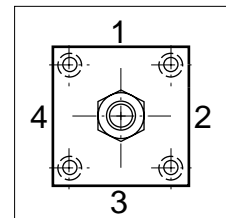

**Port and Cushion Adjustment Positions** (As viewed from rod end: Port standard position 1, Cushion Adjustment standard position 2.)  
NOTE: A Port and a Cushion Adjustment cannot be in the same position.

See page 156 for complete instructions on how to order cylinders.



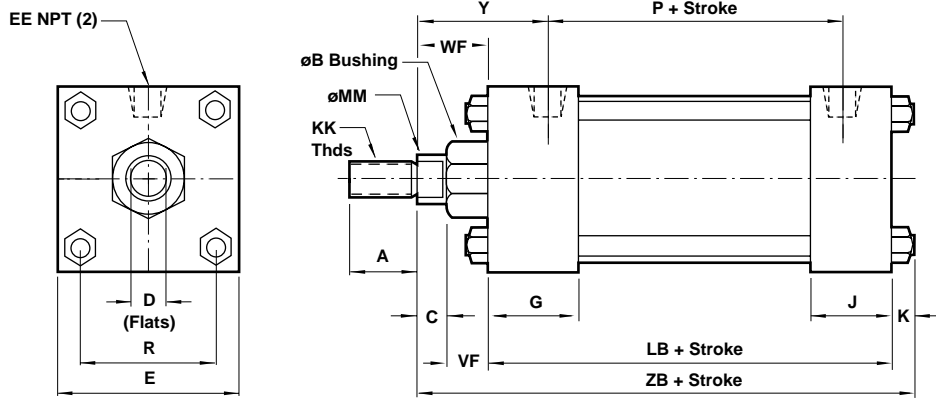

**Standard & Optional Rod Ends**

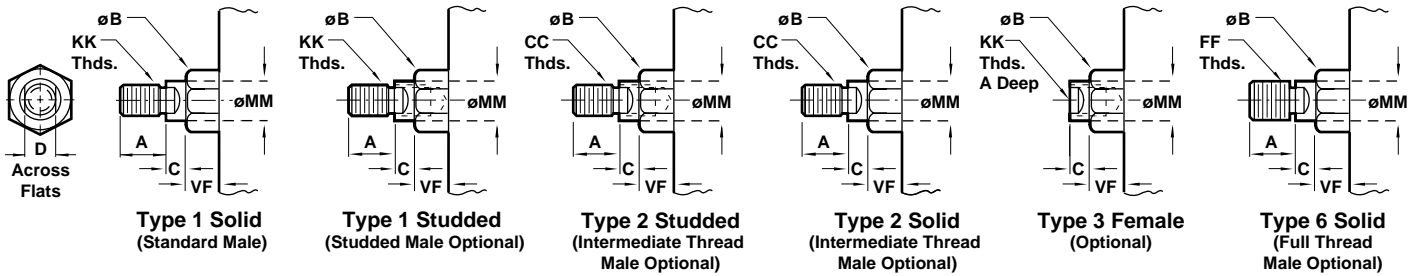

Dimension		7" Bore (177.80)		8" Bore (203.20)		10" Bore (254.00)		12" Bore (304.80)	
ø Rod	Std.	1 3/8"	(34.93)	1 3/8"	(34.93)	1 3/4"	(44.45)	2"	(50.80)
	O.S.	1 3/4"	(44.45)	1 3/4"	(44.45)	2"	(50.80)	2 1/2"	(63.50)
A	Std.	1.625	(41.28)	1.625	(41.28)	2.000	(50.80)	2.250	(57.15)
	O.S.	2.000	(50.80)	2.000	(50.80)	2.250	(57.15)	3.000	(76.20)
B +.000 -.002	Std.	1.999	(50.78)	1.999	(50.78)	2.374	(60.30)	2.624	(66.65)
	O.S.	2.374	(60.30)	2.374	(60.30)	2.624	(66.65)	3.124	(79.35)
C	Std.	.625	(15.88)	.625	(15.88)	.750	(19.05)	.875	(22.23)
	O.S.	.750	(19.05)	.750	(19.05)	.875	(22.23)	1.000	(25.40)
CC	Std.	1 1/4 - 12		1 1/4 - 12		1 1/2 - 12		1 3/4 - 12	
	O.S.	1 1/2 - 12		1 1/2 - 12		1 3/4 - 12		2 1/4 - 12	
D	Std.	1.125	(28.58)	1.125	(28.58)	1.500	(38.10)	1.688	(42.86)
	O.S.	1.500	(38.10)	1.500	(38.10)	1.688	(42.86)	2.063	(52.39)
E		7.500	(190.50)	8.500	(215.90)	10.625	(269.88)	12.750	(323.85)
EE		.750	(19.05)	.750	(19.05)	1.000	(25.40)	1.000	(25.40)
FF	Std.	1 3/8 - 12		1 3/8 - 12		1 3/4 - 12		2 - 12	
	O.S.	1 3/4 - 12		1 3/4 - 12		2 - 12		2 1/2 - 12	
G		2.000	(50.80)	2.000	(50.80)	2.250	(57.15)	2.250	(57.15)
J		1.500	(38.10)	1.500	(38.10)	2.000	(50.80)	2.000	(50.80)
K		.563	(14.29)	.563	(14.29)	.688	(17.46)	.688	(17.46)
KK	Std.	1 - 14		1 - 14		1 1/4 - 12		1 1/2 - 12	
	O.S.	1 1/4 - 12		1 1/4 - 12		1 1/2 - 12		1 7/8 - 12	
LB		5.125	(130.18)	5.125	(130.18)	6.375	(161.93)	6.875	(174.63)
MM	Std.	1.375	(34.93)	1.375	(34.93)	1.750	(44.45)	2.000	(50.80)
	O.S.	1.750	(44.45)	1.750	(44.45)	2.000	(50.80)	2.500	(63.50)
P		3.250	(82.55)	3.250	(82.55)	4.125	(104.78)	4.625	(117.48)
R		5.730	(145.54)	6.442	(163.63)	7.969	(202.41)	9.406	(238.92)
VF	Std.	1.000	(25.40)	1.000	(25.40)	1.125	(28.58)	1.125	(28.58)
	O.S.	1.125	(28.58)	1.125	(28.58)	1.125	(28.58)	1.250	(31.75)
WF	Std.	1.625	(41.28)	1.625	(41.28)	1.875	(47.63)	2.000	(50.80)
	O.S.	1.875	(47.63)	1.875	(47.63)	2.000	(50.80)	2.250	(57.15)
Y	Std.	2.813	(71.44)	2.813	(71.44)	3.125	(79.38)	3.250	(82.55)
	O.S.	3.063	(77.79)	3.063	(77.79)	3.250	(82.55)	3.500	(88.90)
ZB	Std.	7.313	(185.74)	7.313	(185.74)	8.938	(227.01)	9.563	(242.89)
	O.S.	7.563	(192.09)	7.563	(192.09)	9.063	(230.19)	9.813	(249.24)



# Series J & EJ, NFPA Steel Air Cylinder Combinations with Extended Tie Rods



All Dimensions in Inches (mm)

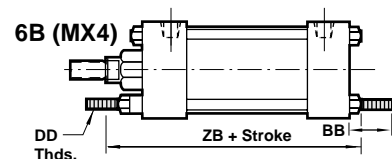
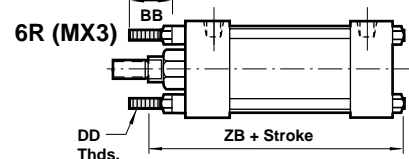
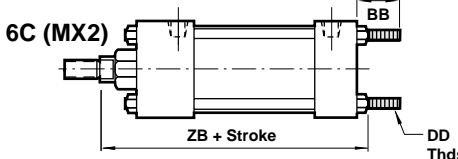
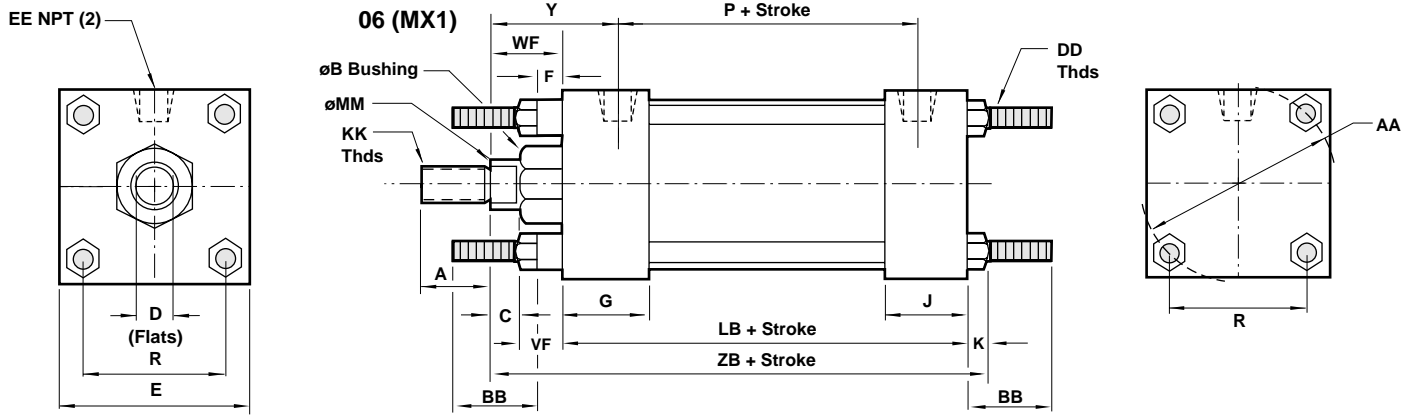

## Standard & Optional Rod Ends

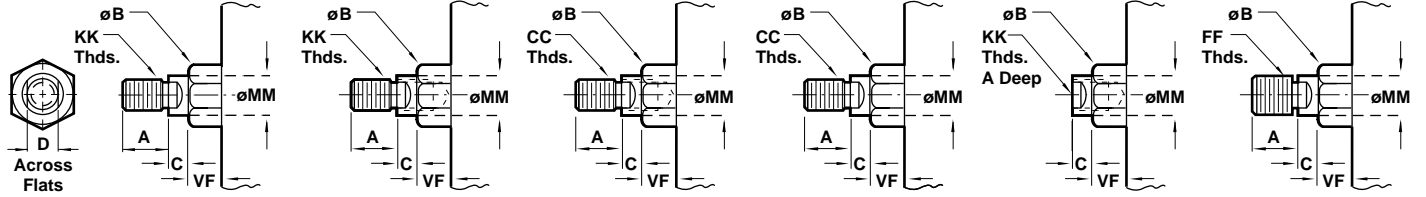

**Type 1 Solid (Standard Male)**      **Type 1 Studded (Studded Male Optional)**      **Type 2 Studded (Intermediate Thread Male Optional)**      **Type 2 Solid (Intermediate Thread Male Optional)**      **Type 3 Female (Optional)**      **Type 6 Solid (Full Thread Male Optional)**

Dimension	1 1/2" Bore (38.10)	2" Bore (50.80)	2 1/2" Bore (63.50)	3 1/4" Bore (82.55)	4" Bore (101.60)	5" Bore (127.00)	6" Bore (152.40)
ø Rod	Std. 5/8" (15.88)	5/8" (15.88)	5/8" (15.88)	1" (25.40)	1" (25.40)	1" (25.40)	1 3/8" (34.93)
	O.S. 1" (25.40)	1" (25.40)	1" (25.40)	1 3/8" (34.93)	1 3/8" (34.93)	1 3/8" (34.93)	1 3/4" (44.45)
A	Std. .750 (19.05)	.750 (19.05)	.750 (19.05)	1.125 (28.58)	1.125 (28.58)	1.125 (28.58)	1.625 (41.28)
	O.S. 1.125 (28.58)	1.125 (28.58)	1.125 (28.58)	1.625 (41.28)	1.625 (41.28)	1.625 (41.28)	2.000 (50.80)
AA	2.020 (51.31)	2.600 (66.04)	3.100 (78.74)	3.900 (99.06)	4.700 (119.38)	5.800 (147.32)	6.900 (175.26)
B +.000 -.002	Std. 1.124 (28.55)	1.124 (28.55)	1.124 (28.55)	1.499 (38.08)	1.499 (38.08)	1.499 (38.08)	1.999 (50.78)
	O.S. 1.499 (38.08)	1.499 (38.08)	1.499 (38.08)	1.999 (50.78)	1.999 (50.78)	1.999 (50.78)	2.374 (60.30)
BB	1.000 (25.40)	1.125 (28.58)	1.125 (28.58)	1.375 (34.93)	1.375 (34.93)	1.813 (46.04)	1.813 (46.04)
C	Std. .375 (9.53)	.375 (9.53)	.375 (9.53)	.500 (12.70)	.500 (12.70)	.500 (12.70)	.625 (15.88)
	O.S. .500 (12.70)	.500 (12.70)	.500 (12.70)	.625 (15.88)	.625 (15.88)	.625 (15.88)	.750 (19.05)
CC	Std. 1/2 - 20	1/2 - 20	1/2 - 20	7/8 - 14	7/8 - 14	7/8 - 14	1 1/4 - 12
	O.S. 7/8 - 14	7/8 - 14	7/8 - 14	1 1/4 - 12	1 1/4 - 12	1 1/4 - 12	1 1/2 - 12
D	Std. .500 (12.70)	.500 (12.70)	.500 (12.70)	.813 (20.64)	.813 (20.64)	.813 (20.64)	1.125 (28.58)
	O.S. .813 (20.64)	.813 (20.64)	.813 (20.64)	1.125 (28.58)	1.125 (28.58)	1.125 (28.58)	1.500 (38.10)
DD	1/4 - 28	5/16 - 24	5/16 - 24	3/8 - 24	3/8 - 24	1/2 - 20	1/2 - 20
E	2.000 (50.80)	2.500 (63.50)	3.000 (76.20)	3.750 (95.25)	4.500 (114.30)	5.500 (139.70)	6.500 (165.10)
EE	.375 (9.53)	.375 (9.53)	.375 (9.53)	.500 (12.70)	.500 (12.70)	.500 (12.70)	.750 (19.05)
F	.375 (9.53)	.375 (9.53)	.375 (9.53)	.625 (15.88)	.625 (15.88)	.625 (15.88)	.750 (19.05)
FF	Std. 5/8 - 18	5/8 - 18	5/8 - 18	1 - 14	1 - 14	1 - 14	1 3/8 - 12
	O.S. 1 - 14	1 - 14	1 - 14	1 3/8 - 12	1 3/8 - 12	1 3/8 - 12	1 3/4 - 12
G	1.500 (38.10)	1.500 (38.10)	1.500 (38.10)	1.750 (44.45)	1.750 (44.45)	1.750 (44.45)	2.000 (50.80)
J	1.000 (25.40)	1.000 (25.40)	1.000 (25.40)	1.250 (31.75)	1.250 (31.75)	1.250 (31.75)	1.500 (38.10)
K	.250 (6.35)	.313 (7.94)	.313 (7.94)	.375 (9.53)	.375 (9.53)	.438 (11.11)	.438 (11.11)
KK	Std. 7/16 - 20	7/16 - 20	7/16 - 20	3/4 - 16	3/4 - 16	3/4 - 16	1 - 14
	O.S. 3/4 - 16	3/4 - 16	3/4 - 16	1 - 14	1 - 14	1 - 14	1 1/4 - 12
LB	3.625 (92.08)	3.625 (92.08)	3.750 (95.25)	4.250 (107.95)	4.250 (107.95)	4.500 (114.30)	5.000 (127.00)
MM	Std. .625 (15.88)	.625 (15.88)	.625 (15.88)	1.000 (25.40)	1.000 (25.40)	1.000 (25.40)	1.375 (34.93)
	O.S. 1.000 (25.40)	1.000 (25.40)	1.000 (25.40)	1.375 (34.93)	1.375 (34.93)	1.375 (34.93)	1.750 (44.45)
P	2.313 (58.74)	2.313 (58.74)	2.438 (61.91)	2.625 (66.68)	2.625 (66.68)	2.875 (73.03)	3.125 (79.38)
R	1.428 (36.27)	1.838 (46.68)	2.192 (55.67)	2.758 (70.05)	3.323 (84.40)	4.101 (104.16)	4.879 (123.92)
VF	Std. .625 (15.88)	.625 (15.88)	.625 (15.88)	.875 (22.23)	.875 (22.23)	.875 (22.23)	1.000 (25.40)
	O.S. .875 (22.23)	.875 (22.23)	.875 (22.23)	1.000 (25.40)	1.000 (25.40)	1.000 (25.40)	1.125 (28.58)
WF	Std. 1.000 (25.40)	1.000 (25.40)	1.000 (25.40)	1.375 (34.93)	1.375 (34.93)	1.375 (34.93)	1.625 (41.28)
	O.S. 1.375 (34.93)	1.375 (34.93)	1.375 (34.93)	1.625 (41.28)	1.625 (41.28)	1.625 (41.28)	1.875 (47.63)
Y	Std. 1.875 (47.63)	1.875 (47.63)	1.875 (47.63)	2.438 (61.91)	2.438 (61.91)	2.438 (61.91)	2.813 (71.44)
	O.S. 2.250 (57.15)	2.250 (57.15)	2.250 (57.15)	2.688 (68.26)	2.688 (68.26)	2.688 (68.26)	3.063 (77.79)
ZB	Std. 4.875 (123.83)	4.938 (125.41)	5.063 (128.59)	6.000 (152.40)	6.000 (152.40)	6.313 (160.34)	7.063 (179.39)
	O.S. 5.250 (133.35)	5.313 (134.94)	5.438 (138.11)	6.250 (158.75)	6.250 (158.75)	6.563 (166.69)	7.313 (185.74)



# Series J & EJ, NFPA Steel Air Cylinder Combinations with Extended Tie Rods

All Dimensions in Inches (mm)

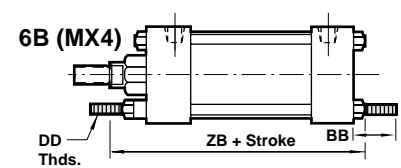
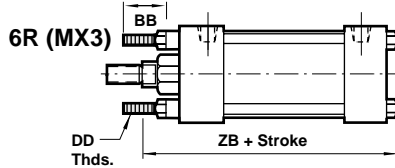
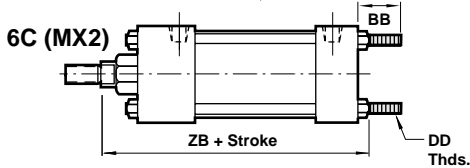
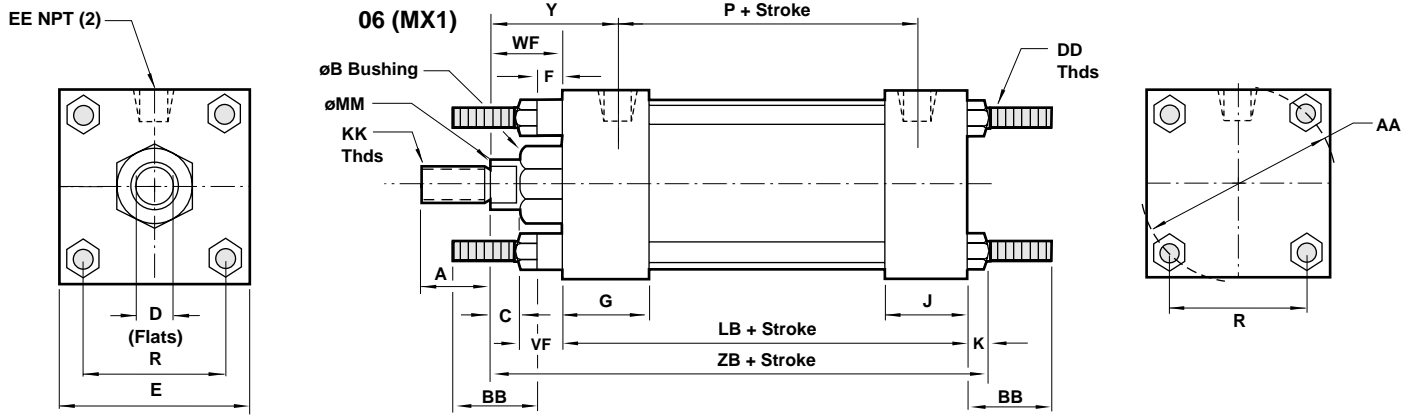

## Standard & Optional Rod Ends

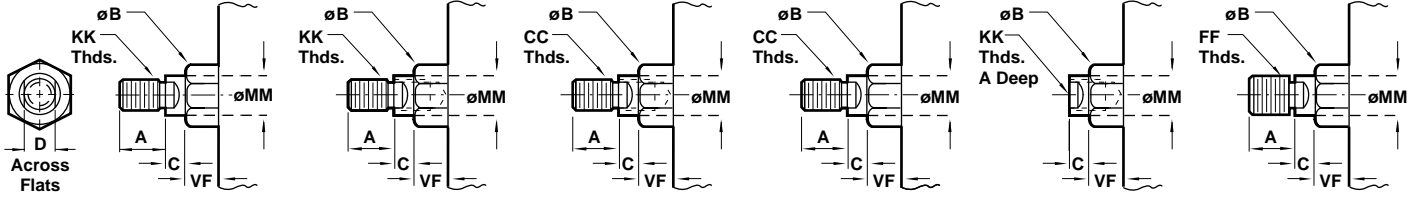

Dimension		7" Bore (177.80)	8" Bore (203.20)	10" Bore (254.00)	12" Bore (304.80)
$\phi$ Rod	Std.	1 3/8" (34.93)	1 3/8" (34.93)	1 3/4" (44.45)	2" (50.80)
	O.S.	1 3/4" (44.45)	1 3/4" (44.45)	2" (50.80)	2 1/2" (63.50)
A	Std.	1.625 (41.28)	1.625 (41.28)	2.000 (50.80)	2.250 (57.15)
	O.S.	2.000 (50.80)	2.000 (50.80)	2.250 (57.15)	3.000 (76.20)
AA		8.100 (205.74)	9.100 (231.14)	11.313 (287.34)	13.313 (338.14)
B <sup>+0.000</sup> -0.002	Std.	1.999 (50.78)	1.999 (50.78)	2.374 (60.30)	2.624 (66.65)
	O.S.	2.374 (60.30)	2.374 (60.30)	2.624 (66.65)	3.124 (79.35)
BB		2.313 (58.74)	2.313 (58.74)	2.688 (68.26)	2.688 (68.26)
C	Std.	.625 (15.88)	.625 (15.88)	.750 (19.05)	.875 (22.23)
	O.S.	.625 (19.05)	.750 (19.05)	.875 (22.23)	1.000 (25.40)
CC	Std.	1 1/4 - 12	1 1/4 - 12	1 1/2 - 12	1 3/4 - 12
	O.S.	1 1/2 - 12	1 1/2 - 12	1 3/4 - 12	2 1/4 - 12
D	Std.	1.125 (28.58)	1.125 (28.58)	1.500 (38.10)	1.688 (42.86)
	O.S.	1.500 (38.10)	1.500 (38.10)	1.688 (42.86)	2.063 (52.39)
DD		5/8 - 18	5/8 - 18	3/4 - 16	3/4 - 16
E		7.500 (190.50)	8.500 (215.90)	10.625 (269.88)	12.750 (323.85)
EE		.750 (19.05)	.750 (19.05)	1.000 (25.40)	1.000 (25.40)
F		.750 (19.05)	.750 (19.05)	—	—
FF	Std.	1 3/8 - 12	1 3/8 - 12	1 3/4 - 12	2 - 12
	O.S.	1 3/4 - 12	1 3/4 - 12	2 - 12	2 1/2 - 12
G		2.000 (50.80)	2.000 (50.80)	2.250 (57.15)	2.250 (57.15)
J		1.500 (38.10)	1.500 (38.10)	2.000 (50.80)	2.000 (50.80)
K		.563 (14.29)	.563 (14.29)	.688 (17.46)	.688 (17.46)
KK	Std.	1 - 14	1 - 14	1 1/4 - 12	1 1/2 - 12
	O.S.	1 1/4 - 12	1 1/4 - 12	1 1/2 - 12	1 7/8 - 12
LB		5.125 (130.18)	5.125 (130.18)	6.375 (161.93)	6.875 (174.63)
MM	Std.	1.375 (34.93)	1.375 (34.93)	1.750 (44.45)	2.000 (50.80)
	O.S.	1.750 (44.45)	1.750 (44.45)	2.000 (50.80)	2.500 (63.50)
P		3.250 (82.55)	3.250 (82.55)	4.125 (104.78)	4.625 (117.48)
R		5.730 (145.54)	6.442 (163.63)	7.969 (202.41)	9.406 (238.92)
VF	Std.	1.000 (25.40)	1.000 (25.40)	1.125 (28.58)	1.125 (28.58)
	O.S.	1.125 (28.58)	1.125 (28.58)	1.125 (28.58)	1.250 (31.75)
WF	Std.	1.625 (41.28)	1.625 (41.28)	1.875 (47.63)	2.000 (50.80)
	O.S.	1.875 (47.63)	1.875 (47.63)	2.000 (50.80)	2.250 (57.15)
Y	Std.	2.813 (71.44)	2.813 (71.44)	3.125 (79.38)	3.250 (82.55)
	O.S.	3.063 (77.79)	3.063 (77.79)	3.250 (82.55)	3.500 (88.90)
ZB	Std.	7.313 (185.74)	7.313 (185.74)	8.938 (227.01)	9.563 (242.89)
	O.S.	7.563 (192.09)	7.563 (192.09)	9.063 (230.19)	9.813 (249.24)



# Series J & EJ, NFPA Steel Air Cylinder with 07 (MT1) Head Trunnion

All Dimensions in Inches (mm)

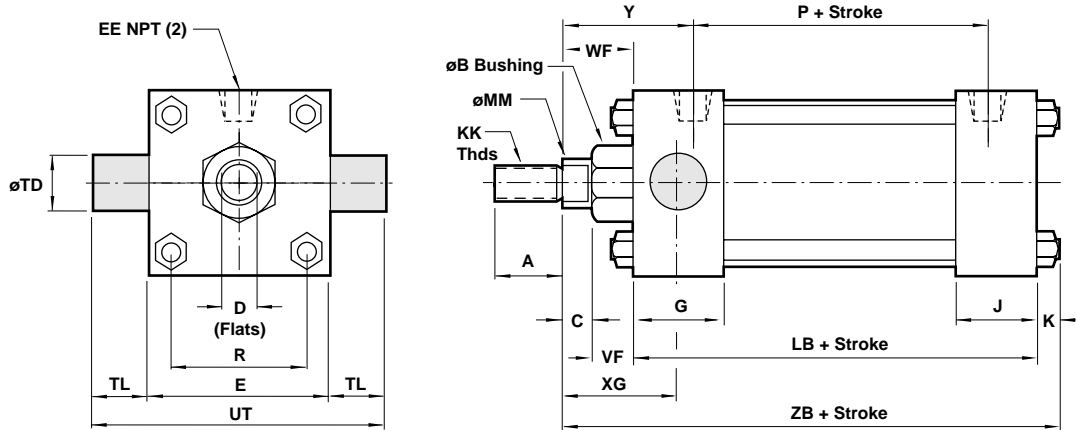

## Standard & Optional Rod Ends

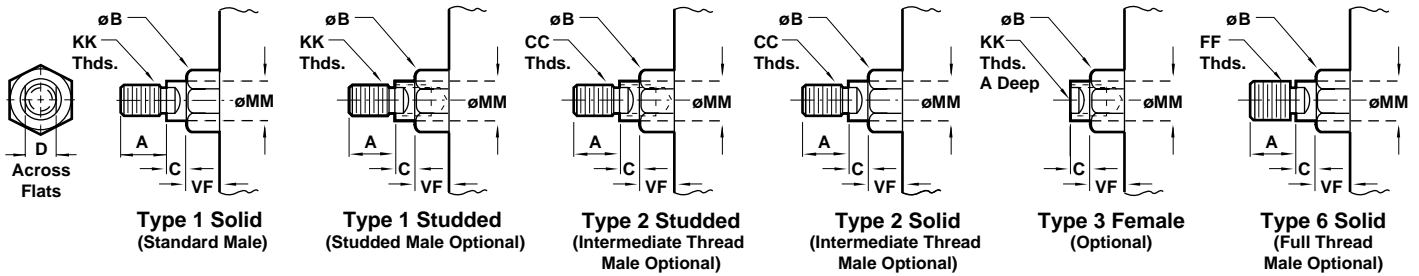

Dimension		1 1/2" Bore (38.10)	2" Bore (50.80)	2 1/2" Bore (63.50)	3 1/4" Bore (82.55)	4" Bore (101.60)	5" Bore (127.00)	6" Bore (152.40)
ø Rod	Std.	5/8" (15.88)	5/8" (15.88)	5/8" (15.88)	1" (25.40)	1" (25.40)	1" (25.40)	1 3/8" (34.93)
	O.S.	1" (25.40)	1" (25.40)	1" (25.40)	1 3/8" (34.93)	1 3/8" (34.93)	1 3/8" (34.93)	1 3/4" (44.45)
A	Std.	.750 (19.05)	.750 (19.05)	.750 (19.05)	1.125 (28.58)	1.125 (28.58)	1.125 (28.58)	1.625 (41.28)
	O.S.	1.125 (28.58)	1.125 (28.58)	1.125 (28.58)	1.625 (41.28)	1.625 (41.28)	1.625 (41.28)	2.000 (50.80)
B +.000 -.002	Std.	1.124 (28.55)	1.124 (28.55)	1.124 (28.55)	1.499 (38.08)	1.499 (38.08)	1.499 (38.08)	1.999 (50.78)
	O.S.	1.499 (38.08)	1.499 (38.08)	1.499 (38.08)	1.999 (50.78)	1.999 (50.78)	1.999 (50.78)	2.374 (60.30)
C	Std.	.375 (9.53)	.375 (9.53)	.375 (9.53)	.500 (12.70)	.500 (12.70)	.500 (12.70)	.625 (15.88)
	O.S.	.500 (12.70)	.500 (12.70)	.500 (12.70)	.625 (15.88)	.625 (15.88)	.625 (15.88)	.750 (19.05)
CC	Std.	1/2 - 20	1/2 - 20	1/2 - 20	7/8 - 14	7/8 - 14	7/8 - 14	1 1/4 - 12
	O.S.	7/8 - 14	7/8 - 14	7/8 - 14	1 1/4 - 12	1 1/4 - 12	1 1/4 - 12	1 1/2 - 12
D	Std.	.500 (12.70)	.500 (12.70)	.500 (12.70)	.875 (22.23)	.875 (22.23)	.875 (22.23)	1.125 (28.58)
	O.S.	.875 (22.23)	.875 (22.23)	.875 (22.23)	1.125 (28.58)	1.125 (28.58)	1.125 (28.58)	1.500 (38.10)
E		2.000 (50.80)	2.500 (63.50)	3.000 (76.20)	3.750 (95.25)	4.500 (114.30)	5.500 (139.70)	6.500 (165.10)
EE		.375 (9.53)	.375 (9.53)	.375 (9.53)	.500 (12.70)	.500 (12.70)	.500 (12.70)	.750 (19.05)
FF	Std.	5/8 - 18	5/8 - 18	5/8 - 18	1 - 14	1 - 14	1 - 14	1 3/8 - 12
	O.S.	1 - 14	1 - 14	1 - 14	1 3/8 - 12	1 3/8 - 12	1 3/8 - 12	1 3/4 - 12
G		1.500 (38.10)	1.500 (38.10)	1.500 (38.10)	1.750 (44.45)	1.750 (44.45)	1.750 (44.45)	2.000 (50.80)
J		1.000 (25.40)	1.000 (25.40)	1.000 (25.40)	1.250 (31.75)	1.250 (31.75)	1.250 (31.75)	1.500 (38.10)
K		.250 (6.35)	.313 (7.94)	.313 (7.94)	.375 (9.53)	.375 (9.53)	.438 (11.11)	.438 (11.11)
KK	Std.	7/16 - 20	7/16 - 20	7/16 - 20	3/4 - 16	3/4 - 16	3/4 - 16	1 - 14
	O.S.	3/4 - 16	3/4 - 16	3/4 - 16	1 - 14	1 - 14	1 - 14	1 1/4 - 12
LB		3.625 (92.08)	3.625 (92.08)	3.750 (95.25)	4.250 (107.95)	4.250 (107.95)	4.500 (114.30)	5.000 (127.00)
MM	Std.	.625 (15.88)	.625 (15.88)	.625 (15.88)	1.000 (25.40)	1.000 (25.40)	1.000 (25.40)	1.375 (34.93)
	O.S.	1.000 (25.40)	1.000 (25.40)	1.000 (25.40)	1.375 (34.93)	1.375 (34.93)	1.375 (34.93)	1.750 (44.45)
P		2.313 (58.74)	2.313 (58.74)	2.438 (61.91)	2.625 (66.68)	2.625 (66.68)	2.875 (73.03)	3.125 (79.38)
R		1.428 (36.27)	1.838 (46.68)	2.192 (55.67)	2.758 (70.05)	3.323 (84.40)	4.101 (104.16)	4.879 (123.92)
TD +.000 -.001		1.000 (25.40)	1.000 (25.40)	1.000 (25.40)	1.000 (25.40)	1.000 (25.40)	1.000 (25.40)	1.375 (34.93)
TL		1.000 (25.40)	1.000 (25.40)	1.000 (25.40)	1.000 (25.40)	1.000 (25.40)	1.000 (25.40)	1.375 (34.93)
UT		4.000 (101.60)	4.500 (114.30)	5.000 (127.00)	5.750 (146.05)	6.500 (165.10)	7.500 (190.50)	9.250 (234.95)
VF	Std.	.625 (15.88)	.625 (15.88)	.625 (15.88)	.875 (22.23)	.875 (22.23)	.875 (22.23)	1.000 (25.40)
	O.S.	.875 (22.23)	.875 (22.23)	.875 (22.23)	1.000 (25.40)	1.000 (25.40)	1.000 (25.40)	1.125 (28.58)
WF	Std.	1.000 (25.40)	1.000 (25.40)	1.000 (25.40)	1.375 (34.93)	1.375 (34.93)	1.375 (34.93)	1.625 (41.28)
	O.S.	1.375 (34.93)	1.375 (34.93)	1.375 (34.93)	1.625 (41.28)	1.625 (41.28)	1.625 (41.28)	1.875 (47.63)
XG	Std.	1.750 (44.45)	1.750 (44.45)	1.750 (44.45)	2.250 (57.15)	2.250 (57.15)	2.250 (57.15)	2.625 (66.68)
	O.S.	2.125 (53.98)	2.125 (53.98)	2.125 (53.98)	2.500 (63.50)	2.500 (63.50)	2.500 (63.50)	2.875 (73.03)
Y	Std.	1.875 (47.63)	1.875 (47.63)	1.875 (47.63)	2.438 (61.91)	2.438 (61.91)	2.438 (61.91)	2.813 (71.44)
	O.S.	2.250 (57.15)	2.250 (57.15)	2.250 (57.15)	2.688 (68.26)	2.688 (68.26)	2.688 (68.26)	3.063 (77.79)
ZB	Std.	4.875 (123.83)	4.938 (125.41)	5.063 (128.59)	6.000 (152.40)	6.000 (152.40)	6.313 (160.34)	7.063 (179.39)
	O.S.	5.250 (133.35)	5.313 (134.94)	5.438 (138.11)	6.250 (158.75)	6.250 (158.75)	6.563 (166.69)	7.313 (185.74)

## Cylinder with 07 (MT1) Head Trunnion

- NFPA (MT1) 07 Head Trunnion Mount for 7" to 12" bore sizes.
- Series J Cylinders rated to 250 PSI air, 400 PSI hydraulic (non-shock). Series EJ Cylinders rated to 250 PSI air only.
- Designed for non-lube service.
- Switches available on all bore sizes. (See page 150 & 151 for ordering information.)
- Head Trunnions are removable.



### Cylinder Order Information

**07** - - - -

J	Series J Cylinder
EJ	Series EJ Cylinder

Bore and Stroke (write out)

Mounting Options	
01	Side Tapped (MS4)
03	Head Rectangular Flange (MF1)
03	Head Square (ME3)-7" to 12" Bores
04	Cap Rectangular Flange (MF2)
04	Cap Square (ME4)-7" to 12" Bores
05	Basic Cylinder No Mounting (MX0)
06	Both Ends (4) Tie Rods Ext. (MX1)
6B	Both Ends (2) Tie Rods Ext. (MX4)
6C	Cap Tie Rods Ext. (MX2)
6R	Head Tie Rods Ext. (MX3)
<b>07</b>	<b>Head Trunnion (MT1)</b>
08	Cap Trunnion (MT2)
09	Side Lugs (MS2)
10	Center Trunnion (MT4)
11	Side End Angles (MS1)
12	Cap Fixed Clevis (MP1)
15	Side End Lugs (MS7)
16	Sleeve Nut Construction (Universal)
20	Head Square Flange (MF5)
21	Cap Square Flange (MF6)
22	Detachable Cap Clevis (MP2)
32	Cap Fixed Eye (MP3)
42	Detachable Cap Eye (MP4)
52	Spherical Bearing

Additional Options – order alphabetically – More on page 155	
HR	Case Hardened (45 Rc)
L(-)	Port Location position 1 standard: L(Head Cap) (specify position 1 thru 4 for head and/or cap)
MS	Metal Rod Scraper
N(-)	Cushion Adjust Screw Location position 2 standard: N(Head Cap) (specify position 1 thru 4 for head and/or cap)
P(-)*	Non-Standard Port Sizes: [specify port size for P(-H) head only, P(-C) cap only, or P(-) both head & cap]
PS	Magnetic Piston – includes aluminum tube option
RS	Rod Stud Type 1 (5/8" – 1¾" øRod) Type 2 (5/8" & 1" øRod)
RX	Rod Extensions (specify length of additional rod extension)
SC	Single Acting Spring Extend (Cap End)–See page 155
SR	Single Acting Spring Retract (Rod End)–See page 155
SS	303 Stainless Steel (Hard Chrome Plated)
ST(-C)	Stop Tube (Cap End) (specify stop tube length)
ST(-R)	Stop Tube (Rod End) (specify stop tube length)
T	Special Rod Threads (specify rod thread)
TX	Thread Extensions (specify length of thread extension)
V	Viton® Seals

\*1½", 2", 2½" bore cylinders have 3/8" NPT Standard, 1/2" NPT oversize. 3¼", 4", 5" bore cylinders have 1/2" NPT Standard, 3/4" NPT oversize. This will add 1/8" to the overall cylinder length.

Piston Rod Threads Type	
1	Small Male (Solid)
2	Intermediate Thread Male (Solid)
3	Female
6	Full Thread Male (Solid)
7	Plain Rod End

Piston Rod Diameters		
A	5/8"	Standard on 1½", 2", 2½"
B	1"	Standard on 3¼", 4", 5" Oversized on 1½", 2", 2½"
C	1⅜"	Standard on 6", 7", 8" Oversized on 3¼", 4", 5"
D	1¾"	Standard on 10" Oversized on 6", 7", 8"
E	2"	Standard on 12" Oversized on 10"
F	2½"	Oversized on 10", 12"

Cushion in Head	
3	None
5 <sup>†</sup>	Non-Adjustable Cushion
7	Adjustable Cushion (Position 2)

<sup>†</sup>Standard with EJ

Cushion in Cap	
3	None
5 <sup>†</sup>	Non-Adjustable Cushion
7	Adjustable Cushion (Position 2)

<sup>†</sup>Standard with EJ

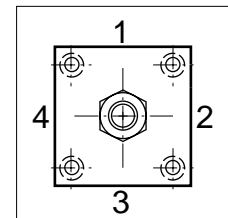

#### Port and Cushion Adjustment

**Positions** (As viewed from rod end: Port standard position 1, Cushion Adjustment standard position 2.)

NOTE: A Port and a Cushion Adjustment cannot be in the same position. Port or cushion cannot be located in position 2 or 4 on the head end.

See page 156 for complete instructions on how to order cylinders.



# Series J & EJ, NFPA Steel Air Cylinder with 07 (MT1) Head Trunnion

All Dimensions in Inches (mm)

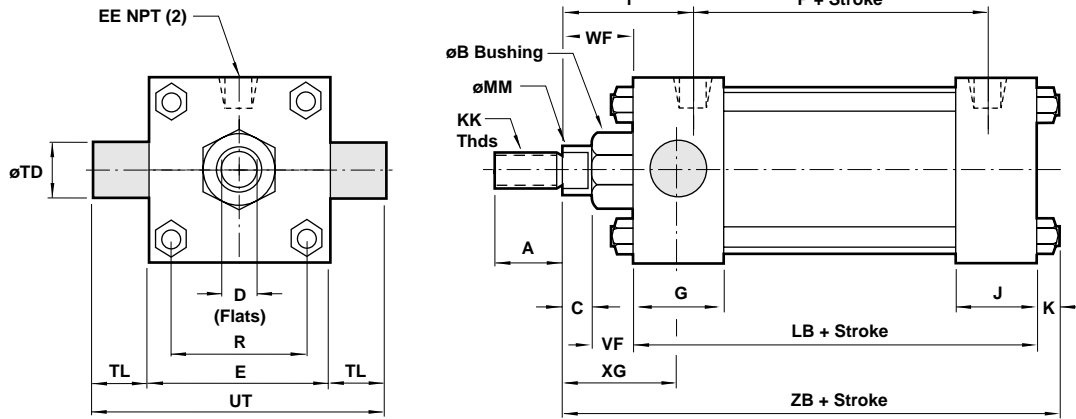

## Standard & Optional Rod Ends

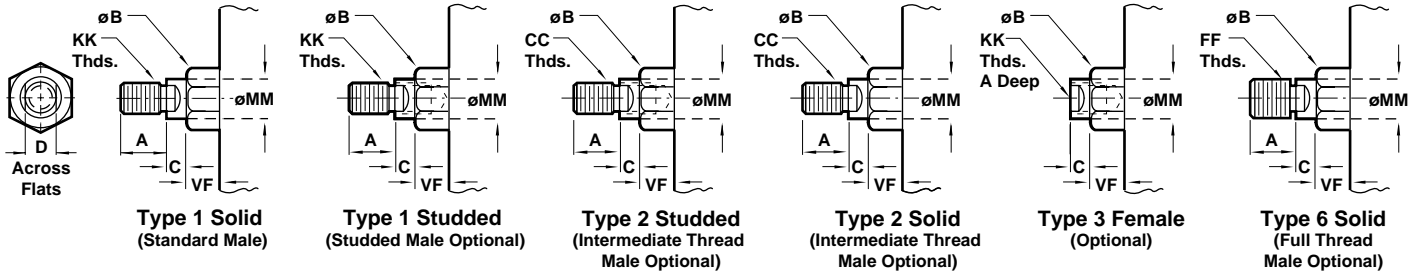

Dimension	7" Bore (177.80)		8" Bore (203.20)		10" Bore (254.00)		12" Bore (304.80)		
	Std.	(mm)	Std.	(mm)	Std.	(mm)	Std.	(mm)	
ø Rod	1 3/8"	(34.93)	1 3/8"	(34.93)	1 3/4"	(44.45)	2"	(50.80)	
	O.S.	1 3/4"	(44.45)	O.S.	1 3/4"	(44.45)	O.S.	2 1/2"	(63.50)
A	Std.	1.625	(41.28)	Std.	1.625	(41.28)	2.000	(50.80)	
	O.S.	2.000	(50.80)	O.S.	2.000	(50.80)	2.250	(57.15)	
B +.000 -.002	Std.	1.999	(50.78)	Std.	1.999	(50.78)	2.374	(60.30)	
	O.S.	2.374	(60.30)	O.S.	2.374	(60.30)	2.624	(66.65)	
C	Std.	.625	(15.88)	Std.	.625	(15.88)	.750	(19.05)	
	O.S.	.750	(19.05)	O.S.	.750	(19.05)	.875	(22.23)	
CC	Std.	1 1/4 - 12		Std.	1 1/4 - 12		1 1/2 - 12		
	O.S.	1 1/2 - 12		O.S.	1 1/2 - 12		1 3/4 - 12		
D	Std.	1.125	(28.58)	Std.	1.125	(28.58)	1.500	(38.10)	
	O.S.	1.500	(38.10)	O.S.	1.500	(38.10)	1.688	(42.86)	
E	Std.	7.500	(190.50)	Std.	8.500	(215.90)	10.625	(269.88)	
	O.S.	7.500	(190.50)	O.S.	8.500	(215.90)	10.625	(269.88)	
EE	Std.	.750	(19.05)	Std.	.750	(19.05)	1.000	(25.40)	
	O.S.	.750	(19.05)	O.S.	.750	(19.05)	1.000	(25.40)	
FF	Std.	1 3/8 - 12		Std.	1 3/8 - 12		1 3/4 - 12		
	O.S.	1 3/4 - 12		O.S.	1 3/4 - 12		2 - 12		
G	Std.	2.000	(50.80)	Std.	2.000	(50.80)	2.250	(57.15)	
	O.S.	2.000	(50.80)	O.S.	2.000	(50.80)	2.250	(57.15)	
J	Std.	1.500	(38.10)	Std.	1.500	(38.10)	2.000	(50.80)	
	O.S.	1.500	(38.10)	O.S.	1.500	(38.10)	2.000	(50.80)	
K	Std.	.563	(14.29)	Std.	.563	(14.29)	.688	(17.46)	
	O.S.	.563	(14.29)	O.S.	.563	(14.29)	.688	(17.46)	
KK	Std.	1 - 14		Std.	1 - 14		1 1/4 - 12		
	O.S.	1 1/4 - 12		O.S.	1 1/4 - 12		1 1/2 - 12		
LB	Std.	5.125	(130.18)	Std.	5.125	(130.18)	6.375	(161.93)	
	O.S.	5.125	(130.18)	O.S.	5.125	(130.18)	6.375	(161.93)	
MM	Std.	1.375	(34.93)	Std.	1.375	(34.93)	1.750	(44.45)	
	O.S.	1.750	(44.45)	O.S.	1.750	(44.45)	2.000	(50.80)	
P	Std.	3.250	(82.55)	Std.	3.250	(82.55)	4.125	(104.78)	
	O.S.	3.250	(82.55)	O.S.	3.250	(82.55)	4.125	(104.78)	
R	Std.	5.730	(145.54)	Std.	6.435	(163.44)	7.969	(202.41)	
	O.S.	5.730	(145.54)	O.S.	6.435	(163.44)	7.969	(202.41)	
TD +.000 -.001	Std.	1.375	(34.93)	Std.	1.375	(34.93)	1.750	(44.45)	
	O.S.	1.375	(34.93)	O.S.	1.375	(34.93)	1.750	(44.45)	
TL	Std.	1.375	(34.93)	Std.	1.375	(34.93)	1.750	(44.45)	
	O.S.	1.375	(34.93)	O.S.	1.375	(34.93)	1.750	(44.45)	
UT	Std.	10.250	(260.35)	Std.	11.250	(285.75)	14.125	(358.78)	
	O.S.	10.250	(260.35)	O.S.	11.250	(285.75)	14.125	(358.78)	
VF	Std.	1.000	(25.40)	Std.	1.000	(25.40)	1.125	(28.58)	
	O.S.	1.125	(28.58)	O.S.	1.125	(28.58)	1.125	(28.58)	
WF	Std.	1.625	(41.28)	Std.	1.625	(41.28)	1.875	(47.63)	
	O.S.	1.875	(47.63)	O.S.	1.875	(47.63)	2.000	(50.80)	
XG	Std.	2.625	(66.68)	Std.	2.625	(66.68)	3.000	(76.20)	
	O.S.	2.875	(73.03)	O.S.	2.875	(73.03)	3.125	(79.38)	
Y	Std.	2.813	(71.44)	Std.	2.813	(71.44)	3.125	(79.38)	
	O.S.	3.063	(77.79)	O.S.	3.063	(77.79)	3.250	(82.55)	
ZB	Std.	7.313	(185.74)	Std.	7.313	(185.74)	8.938	(227.01)	
	O.S.	7.563	(192.09)	O.S.	7.563	(192.09)	9.063	(230.19)	

## Cylinder with 08 (MT2) Cap Trunnion

- NFPA (MT2) 08 Cap Trunnion Mount for 1-1/2" to 6" bore sizes.
- Series J Cylinders rated to 250 PSI air, 400 PSI hydraulic (non-shock). Series EJ Cylinders rated to 250 PSI air only.
- Designed for non-lube service.
- Switches available on all bore sizes. (See pages 150 & 151 for ordering information.)
- Cap Trunnions are removable.



### Cylinder Order Information

08 - - - -

J	Series J Cylinder		Bore and Stroke (write out)
EJ	Series EJ Cylinder		

Mounting Options	
01	Side Tapped (MS4)
03	Head Rectangular Flange (MF1)
03	Head Square (ME3)–7" to 12" Bores
04	Cap Rectangular Flange (MF2)
04	Cap Square (ME4)–7" to 12" Bores
05	Basic Cylinder No Mounting (MX0)
06	Both Ends (4) Tie Rods Ext. (MX1)
6B	Both Ends (2) Tie Rods Ext. (MX4)
6C	Cap Tie Rods Ext. (MX2)
6R	Head Tie Rods Ext. (MX3)
07	Head Trunnion (MT1)
<b>08</b>	<b>Cap Trunnion (MT2)</b>
09	Side Lugs (MS2)
10	Center Trunnion (MT4)
11	Side End Angles (MS1)
12	Cap Fixed Clevis (MP1)
15	Side End Lugs (MS7)
16	Sleeve Nut Construction (Universal)
20	Head Square Flange (MF5)
21	Cap Square Flange (MF6)
22	Detachable Cap Clevis (MP2)
32	Cap Fixed Eye (MP3)
42	Detachable Cap Eye (MP4)
52	Spherical Bearing

Cushion in Head	
3	None
5 <sup>†</sup>	Non-Adjustable Cushion
7	Adjustable Cushion (Position 2)

<sup>†</sup>Standard with EJ

Cushion in Cap	
3	None
5 <sup>†</sup>	Non-Adjustable Cushion
7	Adjustable Cushion (Position 2)

<sup>†</sup>Standard with EJ

Additional Options – order alphabetically – More on page 155	
HR	Case Hardened (45 Rc)
L(-)	Port Location position 1 standard: L(Head Cap) (specify position 1 thru 4 for head and/or cap)
MS	Metal Rod Scraper
N(-)	Cushion Adjust Screw Location position 2 standard: N(Head Cap) (specify position 1 thru 4 for head and/or cap)
P(-)*	Non-Standard Port Sizes: [specify port size for P(-H) head only, P(-C) cap only, or P(-) both head & cap]
PS	Magnetic Piston – includes aluminum tube option
RS	Rod Stud Type 1 (5/8" – 1¾" øRod) Type 2 (5/8" & 1" øRod)
RX	Rod Extensions (specify length of additional rod extension)
SC	Single Acting Spring Extend (Cap End)–See page 155
SR	Single Acting Spring Retract (Rod End)–See page 155
SS	303 Stainless Steel (Hard Chrome Plated)
ST(-C)	Stop Tube (Cap End) (specify stop tube length)
ST(-R)	Stop Tube (Rod End) (specify stop tube length)
T	Special Rod Threads (specify rod thread)
TX	Thread Extensions (specify length of thread extension)
V	Viton® Seals

Piston Rod Threads Type	
1	Small Male (Solid)
2	Intermediate Thread Male (Solid)
3	Female
6	Full Thread Male (Solid)
7	Plain Rod End

Piston Rod Diameters		
A	5/8"	Standard on 1½", 2", 2½"
B	1"	Standard on 3¼", 4", 5" Oversized on 1½", 2", 2½"
C	1⅜"	Standard on 6", 7", 8" Oversized on 3¼", 4", 5"
D	1¾"	Standard on 10" Oversized on 6", 7", 8"
E	2"	Standard on 12" Oversized on 10"
F	2½"	Oversized on 10", 12"

  

**Port and Cushion Adjustment Positions** (As viewed from rod end: Port standard position 1, Cushion Adjustment standard position 2.)  
 NOTE: A Port and a Cushion Adjustment cannot be in the same position. Port or cushion cannot be located in position 2 or 4 on the cap end.

See page 156 for complete instructions on how to order cylinders.

# Series J & EJ, NFPA Steel Air Cylinder with 08 (MT2) Cap Trunnion

All Dimensions in Inches (mm)

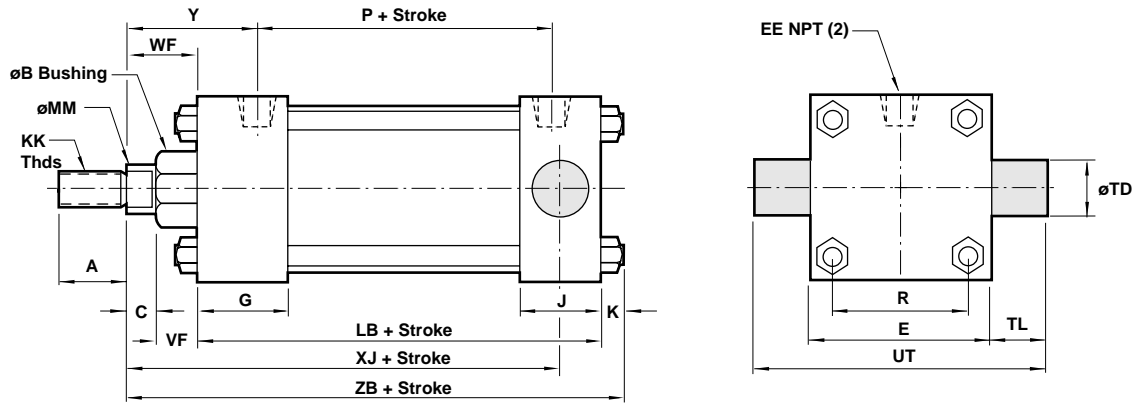

## Standard & Optional Rod Ends

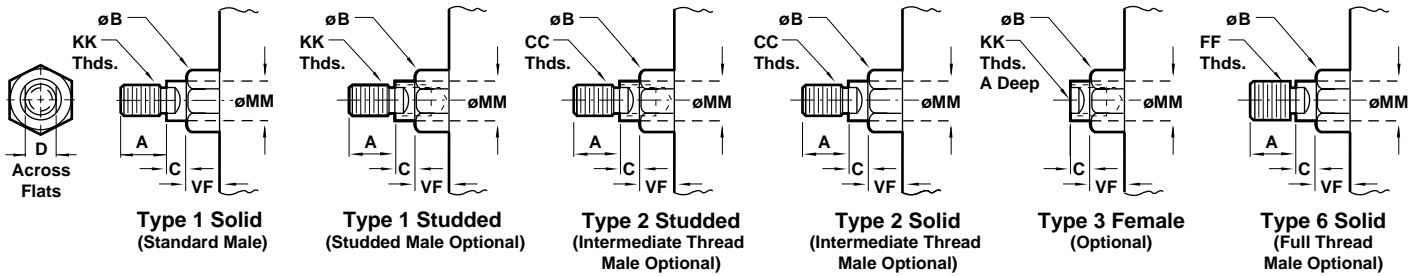

Dimension		1 1/2" Bore (38.10)	2" Bore (50.80)	2 1/2" Bore (63.50)	3 1/4" Bore (82.55)	4" Bore (101.60)	5" Bore (127.00)	6" Bore (152.40)
ø Rod	Std.	5/8" (15.88)	5/8" (15.88)	5/8" (15.88)	1" (25.40)	1" (25.40)	1" (25.40)	1 3/8" (34.93)
	O.S.	1" (25.40)	1" (25.40)	1" (25.40)	1 3/8" (34.93)	1 3/8" (34.93)	1 3/8" (34.93)	1 3/4" (44.45)
A	Std.	.750 (19.05)	.750 (19.05)	.750 (19.05)	1.125 (28.58)	1.125 (28.58)	1.125 (28.58)	1.625 (41.28)
	O.S.	1.125 (28.58)	1.125 (28.58)	1.125 (28.58)	1.625 (41.28)	1.625 (41.28)	1.625 (41.28)	2.000 (50.80)
B +.000 -.002	Std.	1.124 (28.55)	1.124 (28.55)	1.124 (28.55)	1.499 (38.08)	1.499 (38.08)	1.499 (38.08)	1.999 (50.78)
	O.S.	1.499 (38.08)	1.499 (38.08)	1.499 (38.08)	1.999 (50.78)	1.999 (50.78)	1.999 (50.78)	2.374 (60.30)
C	Std.	.375 (9.53)	.375 (9.53)	.375 (9.53)	.500 (12.70)	.500 (12.70)	.500 (12.70)	.625 (15.88)
	O.S.	.500 (12.70)	.500 (12.70)	.500 (12.70)	.625 (15.88)	.625 (15.88)	.625 (15.88)	.750 (19.05)
CC	Std.	1/2 - 20	1/2 - 20	1/2 - 20	7/8 - 14	7/8 - 14	7/8 - 14	1 1/4 - 12
	O.S.	7/8 - 14	7/8 - 14	7/8 - 14	1 1/4 - 12	1 1/4 - 12	1 1/4 - 12	1 1/2 - 12
D	Std.	.500 (12.70)	.500 (12.70)	.500 (12.70)	.875 (22.23)	.875 (22.23)	.875 (22.23)	1.125 (28.58)
	O.S.	.875 (22.23)	.875 (22.23)	.875 (22.23)	1.125 (28.58)	1.125 (28.58)	1.125 (28.58)	1.500 (38.10)
E		2.000 (50.80)	2.500 (63.50)	3.000 (76.20)	3.750 (95.25)	4.500 (114.30)	5.500 (139.70)	6.500 (165.10)
EE		.375 (9.53)	.375 (9.53)	.375 (9.53)	.500 (12.70)	.500 (12.70)	.500 (12.70)	.750 (19.05)
FF	Std.	5/8 - 18	5/8 - 18	5/8 - 18	1 - 14	1 - 14	1 - 14	1 3/8 - 12
	O.S.	1 - 14	1 - 14	1 - 14	1 3/8 - 12	1 3/8 - 12	1 3/8 - 12	1 3/4 - 12
G		1.500 (38.10)	1.500 (38.10)	1.500 (38.10)	1.750 (44.45)	1.750 (44.45)	1.750 (44.45)	2.000 (50.80)
J		1.000 (25.40)	1.000 (25.40)	1.000 (25.40)	1.250 (31.75)	1.250 (31.75)	1.250 (31.75)	1.500 (38.10)
K		.250 (6.35)	.313 (7.94)	.313 (7.94)	.375 (9.53)	.375 (9.53)	.438 (11.11)	.438 (11.11)
KK	Std.	7/16 - 20	7/16 - 20	7/16 - 20	3/4 - 16	3/4 - 16	3/4 - 16	1 - 14
	O.S.	3/4 - 16	3/4 - 16	3/4 - 16	1 - 14	1 - 14	1 - 14	1 1/4 - 12
LB		3.625 (92.08)	3.625 (92.08)	3.750 (95.25)	4.250 (107.95)	4.250 (107.95)	4.500 (114.30)	5.000 (127.00)
MM	Std.	.625 (15.88)	.625 (15.88)	.625 (15.88)	1.000 (25.40)	1.000 (25.40)	1.000 (25.40)	1.375 (34.93)
	O.S.	1.000 (25.40)	1.000 (25.40)	1.000 (25.40)	1.375 (34.93)	1.375 (34.93)	1.375 (34.93)	1.750 (44.45)
P		2.313 (58.74)	2.313 (58.74)	2.438 (61.91)	2.625 (66.68)	2.625 (66.68)	2.875 (73.03)	3.125 (79.38)
R		1.428 (36.27)	1.838 (46.68)	2.192 (55.67)	2.758 (70.05)	3.323 (84.40)	4.101 (104.16)	4.879 (123.92)
TD +.000 -.001		1.000 (25.40)	1.000 (25.40)	1.000 (25.40)	1.000 (25.40)	1.000 (25.40)	1.000 (25.40)	1.375 (34.93)
TL		1.000 (25.40)	1.000 (25.40)	1.000 (25.40)	1.000 (25.40)	1.000 (25.40)	1.000 (25.40)	1.375 (34.93)
UT		4.000 (101.60)	4.500 (114.30)	5.000 (127.00)	5.750 (146.05)	6.500 (165.10)	7.500 (190.50)	9.250 (234.95)
VF	Std.	.625 (15.88)	.625 (15.88)	.625 (15.88)	.875 (22.23)	.875 (22.23)	.875 (22.23)	1.000 (25.40)
	O.S.	.875 (22.23)	.875 (22.23)	.875 (22.23)	1.000 (25.40)	1.000 (25.40)	1.000 (25.40)	1.125 (28.58)
WF	Std.	1.000 (25.40)	1.000 (25.40)	1.000 (25.40)	1.375 (34.93)	1.375 (34.93)	1.375 (34.93)	1.625 (41.28)
	O.S.	1.375 (34.93)	1.375 (34.93)	1.375 (34.93)	1.625 (41.28)	1.625 (41.28)	1.625 (41.28)	1.875 (47.63)
XJ	Std.	4.125 (104.78)	4.125 (104.78)	4.250 (107.95)	5.000 (127.00)	5.000 (127.00)	5.250 (133.35)	5.875 (149.23)
	O.S.	4.500 (114.30)	4.500 (114.30)	4.625 (117.48)	5.250 (133.35)	5.250 (133.35)	5.500 (139.70)	6.125 (155.58)
Y	Std.	1.875 (47.63)	1.875 (47.63)	1.875 (47.63)	2.438 (61.91)	2.438 (61.91)	2.438 (61.91)	2.813 (71.44)
	O.S.	2.250 (57.15)	2.250 (57.15)	2.250 (57.15)	2.688 (68.26)	2.688 (68.26)	2.688 (68.26)	3.063 (77.79)
ZB	Std.	4.875 (123.83)	4.938 (125.41)	5.063 (128.59)	6.000 (152.40)	6.000 (152.40)	6.313 (160.34)	7.063 (179.39)
	O.S.	5.250 (133.35)	5.313 (134.94)	5.438 (138.11)	6.250 (158.75)	6.250 (158.75)	6.563 (166.69)	7.313 (185.74)

## Cylinder with 08 (MT2) Cap Trunnion

- NFPA (MT2) 08 Cap Trunnion Mount for 7" to 12" bore sizes.
- Series J Cylinders rated to 250 PSI air, 400 PSI hydraulic (non-shock). Series EJ Cylinders rated to 250 PSI air only.
- Designed for non-lube service.
- Switches available on all bore sizes. (See pages 150 & 151 for ordering information.)
- Cap Trunnions are removable.



### Cylinder Order Information

08 - - - -

J	Series J Cylinder
EJ	Series EJ Cylinder

Bore and Stroke (write out)

Mounting Options	
01	Side Tapped (MS4)
03	Head Rectangular Flange (MF1)
03	Head Square (ME3)–7" to 12" Bores
04	Cap Rectangular Flange (MF2)
04	Cap Square (ME4)–7" to 12" Bores
05	Basic Cylinder No Mounting (MX0)
06	Both Ends (4) Tie Rods Ext. (MX1)
6B	Both Ends (2) Tie Rods Ext. (MX4)
6C	Cap Tie Rods Ext. (MX2)
6R	Head Tie Rods Ext. (MX3)
07	Head Trunnion (MT1)
<b>08</b>	<b>Cap Trunnion (MT2)</b>
09	Side Lugs (MS2)
10	Center Trunnion (MT4)
11	Side End Angles (MS1)
12	Cap Fixed Clevis (MP1)
15	Side End Lugs (MS7)
16	Sleeve Nut Construction (Universal)
20	Head Square Flange (MF5)
21	Cap Square Flange (MF6)
22	Detachable Cap Clevis (MP2)
32	Cap Fixed Eye (MP3)
42	Detachable Cap Eye (MP4)
52	Spherical Bearing

Additional Options – order alphabetically – More on page 155	
HR	Case Hardened (45 Rc)
L(-)	Port Location position 1 standard: L(Head Cap) (specify position 1 thru 4 for head and/or cap)
MS	Metal Rod Scraper
N(-)	Cushion Adjust Screw Location position 2 standard: N(Head Cap) (specify position 1 thru 4 for head and/or cap)
P(-)*	Non-Standard Port Sizes: [specify port size for P(-H) head only, P(-C) cap only, or P(-) both head & cap]
PS	Magnetic Piston – includes aluminum tube option
RS	Rod Stud Type 1 (5/8" – 1¾" øRod) Type 2 (5/8" & 1" øRod)
RX	Rod Extensions (specify length of additional rod extension)
SC	Single Acting Spring Extend (Cap End)–See page 155
SR	Single Acting Spring Retract (Rod End)–See page 155
SS	303 Stainless Steel (Hard Chrome Plated)
ST(-C)	Stop Tube (Cap End) (specify stop tube length)
ST(-R)	Stop Tube (Rod End) (specify stop tube length)
T	Special Rod Threads (specify rod thread)
TX	Thread Extensions (specify length of thread extension)
V	Viton® Seals

\*1½", 2", 2½" bore cylinders have 3/8" NPT Standard, 1/2" NPT oversize. 3¼", 4", 5" bore cylinders have 1/2" NPT Standard, 3/4" NPT oversize. This will add 1/8" to the overall cylinder length.

Piston Rod Threads Type	
1	Small Male (Solid)
2	Intermediate Thread Male (Solid)
3	Female
6	Full Thread Male (Solid)
7	Plain Rod End

Piston Rod Diameters		
A	5/8"	Standard on 1½", 2", 2½"
B	1"	Standard on 3¼", 4", 5" Oversized on 1½", 2", 2½"
C	1⅜"	Standard on 6", 7", 8" Oversized on 3¼", 4", 5"
D	1¾"	Standard on 10" Oversized on 6", 7", 8"
E	2"	Standard on 12" Oversized on 10"
F	2½"	Oversized on 10", 12"

Cushion in Head	
3	None
5 <sup>†</sup>	Non-Adjustable Cushion
7	Adjustable Cushion (Position 2)

<sup>†</sup>Standard with EJ

Cushion in Cap	
3	None
5 <sup>†</sup>	Non-Adjustable Cushion
7	Adjustable Cushion (Position 2)

<sup>†</sup>Standard with EJ

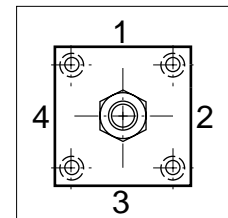

#### Port and Cushion Adjustment

**Positions** (As viewed from rod end: Port standard position 1, Cushion Adjustment standard position 2.)

NOTE: A Port and a Cushion Adjustment cannot be in the same position. Port or cushion cannot be located in position 2 or 4 on the cap end.

See page 156 for complete instructions on how to order cylinders.

# Series J & EJ, NFPA Steel Air Cylinder with 08 (MT2) Cap Trunnion

All Dimensions in Inches (mm)

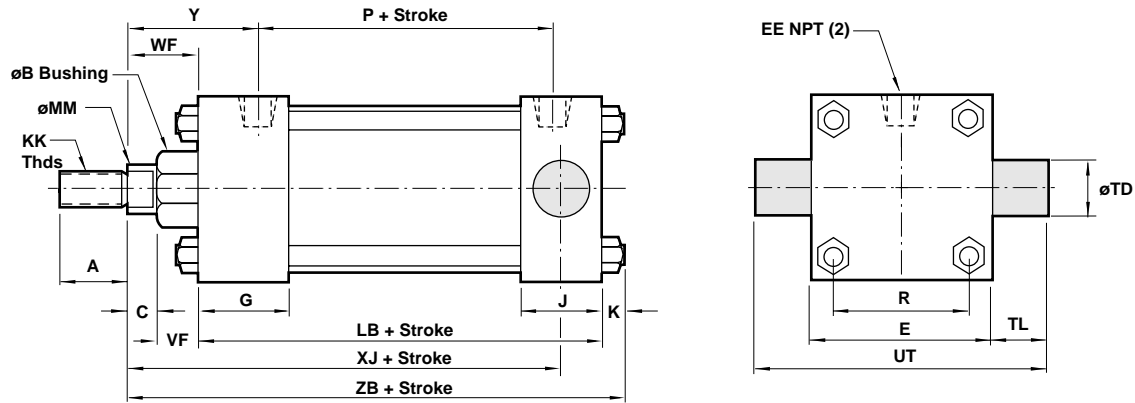

## Standard & Optional Rod Ends

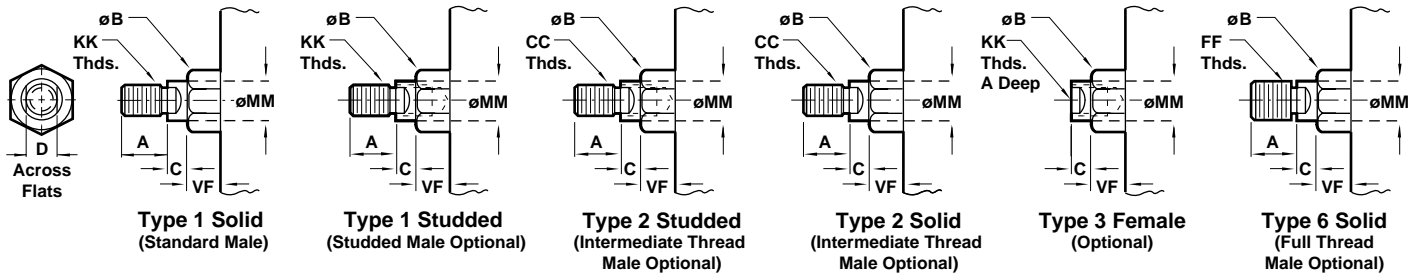

Dimension		7" Bore (177.80)		8" Bore (203.20)		10" Bore (254.00)		12" Bore (304.80)	
ø Rod	Std.	1 3/8"	(34.93)	1 3/8"	(34.93)	1 3/4"	(44.45)	2"	(50.80)
	O.S.	1 3/4"	(44.45)	1 3/4"	(44.45)	2"	(50.80)	2 1/2"	(63.50)
A	Std.	1.625	(41.28)	1.625	(41.28)	2.000	(50.80)	2.250	(57.15)
	O.S.	2.000	(50.80)	2.000	(50.80)	2.250	(57.15)	3.000	(76.20)
B +.000 -.002	Std.	1.999	(50.78)	1.999	(50.78)	2.374	(60.30)	2.624	(66.65)
	O.S.	2.374	(60.30)	2.374	(60.30)	2.624	(66.65)	3.124	(79.35)
C	Std.	.625	(15.88)	.625	(15.88)	.750	(19.05)	.875	(22.23)
	O.S.	.750	(19.05)	.750	(19.05)	.875	(22.23)	1.000	(25.40)
CC	Std.	1 1/4 - 12		1 1/4 - 12		1 1/2 - 12		1 3/4 - 12	
	O.S.	1 1/2 - 12		1 1/2 - 12		1 3/4 - 12		2 1/4 - 12	
D	Std.	1.125	(28.58)	1.125	(28.58)	1.500	(38.10)	1.688	(42.86)
	O.S.	1.500	(38.10)	1.500	(38.10)	1.688	(42.86)	2.063	(52.39)
E		7.500	(190.50)	8.500	(215.90)	10.625	(269.88)	12.750	(323.85)
EE		.750	(19.05)	.750	(19.05)	1.000	(25.40)	1.000	(25.40)
FF	Std.	1 3/8 - 12		1 3/8 - 12		1 3/4 - 12		2 - 12	
	O.S.	1 3/4 - 12		1 3/4 - 12		2 - 12		2 1/2 - 12	
G		2.000	(50.80)	2.000	(50.80)	2.250	(57.15)	2.250	(57.15)
J		1.500	(38.10)	1.500	(38.10)	2.000	(50.80)	2.000	(50.80)
K		.563	(14.29)	.563	(14.29)	.688	(17.46)	.688	(17.46)
KK	Std.	1 - 14		1 - 14		1 1/4 - 12		1 1/2 - 12	
	O.S.	1 1/4 - 12		1 1/4 - 12		1 1/2 - 12		1 7/8 - 12	
LB		5.125	(130.18)	5.125	(130.18)	6.375	(161.93)	6.875	(174.63)
MM	Std.	1.375	(34.93)	1.375	(34.93)	1.750	(44.45)	2.000	(50.80)
	O.S.	1.750	(44.45)	1.750	(44.45)	2.000	(50.80)	2.500	(63.50)
P		3.250	(82.55)	3.250	(82.55)	4.125	(104.78)	4.625	(117.48)
R		5.730	(145.54)	6.435	(163.44)	7.969	(202.41)	9.406	(238.92)
TD +.000 -.001		1.375	(34.93)	1.375	(34.93)	1.750	(44.45)	1.750	(44.45)
TL		1.375	(34.93)	1.375	(34.93)	1.750	(44.45)	1.750	(44.45)
UT		10.250	(260.35)	11.250	(285.75)	14.125	(358.78)	16.250	(412.75)
VF	Std.	1.000	(25.40)	1.000	(25.40)	1.125	(28.58)	1.125	(28.58)
	O.S.	1.125	(28.58)	1.125	(28.58)	1.125	(28.58)	1.250	(31.75)
WF	Std.	1.625	(41.28)	1.625	(41.28)	1.875	(47.63)	2.000	(50.80)
	O.S.	1.875	(47.63)	1.875	(47.63)	2.000	(50.80)	2.250	(57.15)
XJ	Std.	6.000	(152.40)	6.000	(152.40)	7.250	(184.15)	7.875	(200.03)
	O.S.	6.250	(158.75)	6.250	(158.75)	7.375	(187.33)	8.125	(206.38)
Y	Std.	2.813	(71.44)	2.813	(71.44)	3.125	(79.38)	3.250	(82.55)
	O.S.	3.063	(77.79)	3.063	(77.79)	3.250	(82.55)	3.500	(88.90)
ZB	Std.	7.313	(185.74)	7.313	(185.74)	8.938	(227.01)	9.563	(242.89)
	O.S.	7.563	(192.09)	7.563	(192.09)	9.063	(230.19)	9.813	(249.24)

- NFPA (MS2) 09 Side Lug Mount for 1-1/2" to 6" bore sizes.
- Series J Cylinders rated to 250 PSI air, 400 PSI hydraulic (non-shock). Series EJ Cylinders rated to 250 PSI air only.
- Designed for non-lube service.
- Switches available on all bore sizes. (See pages 150 & 151 for ordering information.)



### Cylinder Order Information

09 - - - -

J	Series J Cylinder		Bore and Stroke (write out)
EJ	Series EJ Cylinder		

Mounting Options	
01	Side Tapped (MS4)
03	Head Rectangular Flange (MF1)
03	Head Square (ME3)–7" to 12" Bores
04	Cap Rectangular Flange (MF2)
04	Cap Square (ME4)–7" to 12" Bores
05	Basic Cylinder No Mounting (MX0)
06	Both Ends (4) Tie Rods Ext. (MX1)
6B	Both Ends (2) Tie Rods Ext. (MX4)
6C	Cap Tie Rods Ext. (MX2)
6R	Head Tie Rods Ext. (MX3)
07	Head Trunnion (MT1)
08	Cap Trunnion (MT2)
<b>09</b>	<b>Side Lugs (MS2)</b>
10	Center Trunnion (MT4)
11	Side End Angles (MS1)
12	Cap Fixed Clevis (MP1)
15	Side End Lugs (MS7)
16	Sleeve Nut Construction (Universal)
20	Head Square Flange (MF5)
21	Cap Square Flange (MF6)
22	Detachable Cap Clevis (MP2)
32	Cap Fixed Eye (MP3)
42	Detachable Cap Eye (MP4)
52	Spherical Bearing

Cushion in Head	
3	None
5 <sup>†</sup>	Non-Adjustable Cushion
7	Adjustable Cushion (Position 2)

<sup>†</sup>Standard with EJ

Cushion in Cap	
3	None
5 <sup>†</sup>	Non-Adjustable Cushion
7	Adjustable Cushion (Position 2)

<sup>†</sup>Standard with EJ

Additional Options – order alphabetically – More on page 155	
HR	Case Hardened (45 Rc)
L(-)	Port Location position 1 standard: L(Head Cap) (specify position 1 thru 4 for head and/or cap)
MS	Metal Rod Scraper
N(-)	Cushion Adjust Screw Location position 2 standard: N(Head Cap) (specify position 1 thru 4 for head and/or cap)
P(-)*	Non-Standard Port Sizes: [specify port size for P(-H) head only, P(-C) cap only, or P(-) both head & cap]
PS	Magnetic Piston – includes aluminum tube option
RS	Rod Stud Type 1 (5/8" – 1 3/4" øRod) Type 2 (5/8" & 1" øRod)
RX	Rod Extensions (specify length of additional rod extension)
SC	Single Acting Spring Extend (Cap End)–See page 155
SR	Single Acting Spring Retract (Rod End)–See page 155
SS	303 Stainless Steel (Hard Chrome Plated)
ST(-C)	Stop Tube (Cap End) (specify stop tube length)
ST(-R)	Stop Tube (Rod End) (specify stop tube length)
T	Special Rod Threads (specify rod thread)
TX	Thread Extensions (specify length of thread extension)
V	Viton® Seals

Piston Rod Threads Type	
1	Small Male (Solid)
2	Intermediate Thread Male (Solid)
3	Female
6	Full Thread Male (Solid)
7	Plain Rod End

Piston Rod Diameters		
A	5/8"	Standard on 1½", 2", 2½"
B	1"	Standard on 3¼", 4", 5" Oversized on 1½", 2", 2½"
C	1 3/8"	Standard on 6", 7", 8" Oversized on 3¼", 4", 5"
D	1 3/4"	Standard on 10" Oversized on 6", 7", 8"
E	2"	Standard on 12" Oversized on 10"
F	2½"	Oversized on 10", 12"

\*1½", 2", 2½" bore cylinders have 3/8" NPT Standard, 1/2" NPT oversize.  
3¼", 4", 5" bore cylinders have 1/2" NPT Standard, 3/4" NPT oversize.  
This will add 1/8" to the overall cylinder length.

Port and Cushion Adjustment Positions	
1	Port standard position 1, Cushion Adjustment standard position 2.)
2	Port standard position 1, Cushion Adjustment standard position 2.)
3	Port standard position 1, Cushion Adjustment standard position 2.)
4	Port standard position 1, Cushion Adjustment standard position 2.)

**Port and Cushion Adjustment Positions** (As viewed from rod end: Port standard position 1, Cushion Adjustment standard position 2.)  
NOTE: A Port and a Cushion Adjustment cannot be in the same position.

See page 156 for complete instructions on how to order cylinders.

# Series J & EJ, NFPA Steel Air Cylinder with 09 (MS2) Side Lugs



All Dimensions in Inches (mm)

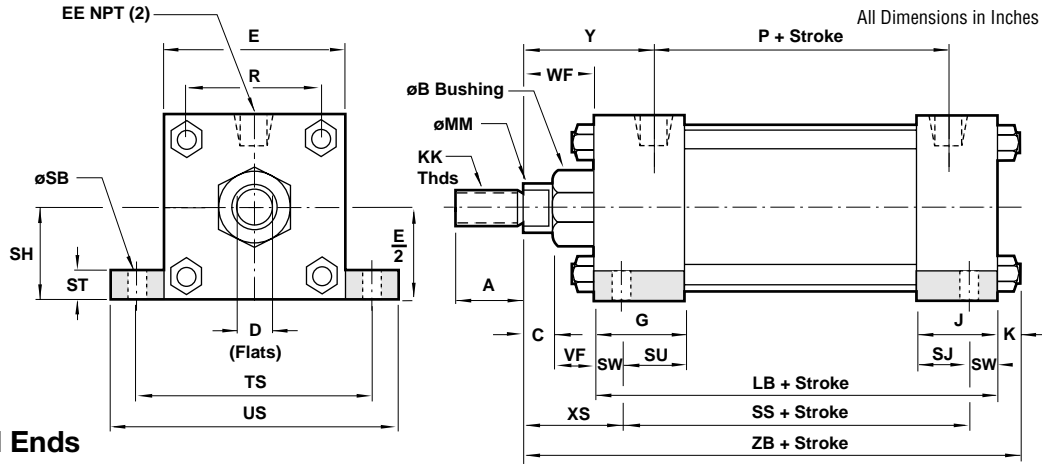

## Standard & Optional Rod Ends

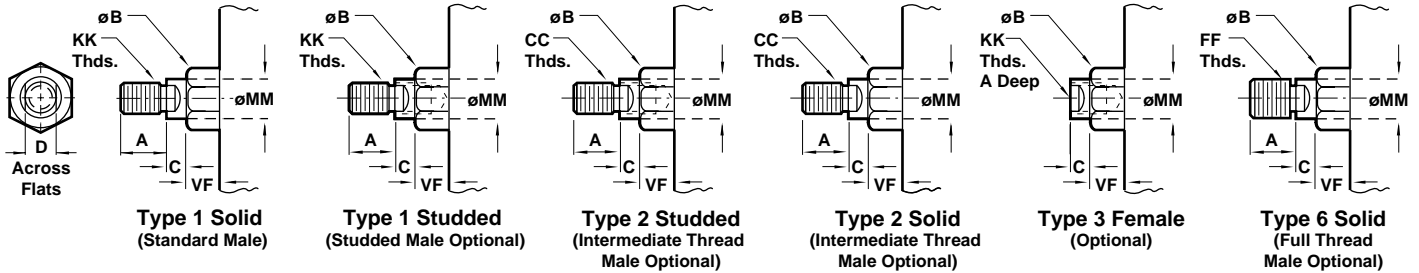

Dimension	1 1/2" Bore (38.10)	2" Bore (50.80)	2 1/2" Bore (63.50)	3 1/4" Bore (82.55)	4" Bore (101.60)	5" Bore (127.00)	6" Bore (152.40)
ø Rod	Std. 5/8" (15.88)	5/8" (15.88)	5/8" (15.88)	1" (25.40)	1" (25.40)	1" (25.40)	1 3/8" (34.93)
	O.S. 1" (25.40)	1" (25.40)	1" (25.40)	1 3/8" (34.93)	1 3/8" (34.93)	1 3/8" (34.93)	1 3/4" (44.45)
A	Std. .750 (19.05)	.750 (19.05)	.750 (19.05)	1.125 (28.58)	1.125 (28.58)	1.125 (28.58)	1.625 (41.28)
	O.S. 1.125 (28.58)	1.125 (28.58)	1.125 (28.58)	1.625 (41.28)	1.625 (41.28)	1.625 (41.28)	2.000 (50.80)
B +.000 -.002	Std. 1.124 (28.55)	1.124 (28.55)	1.124 (28.55)	1.499 (38.08)	1.499 (38.08)	1.499 (38.08)	1.999 (50.78)
	O.S. 1.499 (38.08)	1.499 (38.08)	1.499 (38.08)	1.999 (50.78)	1.999 (50.78)	1.999 (50.78)	2.374 (60.30)
C	Std. .375 (9.53)	.375 (9.53)	.375 (9.53)	.500 (12.70)	.500 (12.70)	.500 (12.70)	.625 (15.88)
	O.S. .500 (12.70)	.500 (12.70)	.500 (12.70)	.625 (15.88)	.625 (15.88)	.625 (15.88)	.750 (19.05)
CC	Std. 1/2 - 20	1/2 - 20	1/2 - 20	7/8 - 14	7/8 - 14	7/8 - 14	1 1/4 - 12
	O.S. 7/8 - 14	7/8 - 14	7/8 - 14	1 1/4 - 12	1 1/4 - 12	1 1/4 - 12	1 1/2 - 12
D	Std. .500 (12.70)	.500 (12.70)	.500 (12.70)	.813 (20.64)	.813 (20.64)	.813 (20.64)	1.125 (28.58)
	O.S. .813 (20.64)	.813 (20.64)	.813 (20.64)	1.125 (28.58)	1.125 (28.58)	1.125 (28.58)	1.500 (38.10)
E	2.000 (50.80)	2.500 (63.50)	3.000 (76.20)	3.750 (95.25)	4.500 (114.30)	5.500 (139.70)	6.500 (165.10)
EE	.375 (9.53)	.375 (9.53)	.375 (9.53)	.500 (12.70)	.500 (12.70)	.500 (12.70)	.750 (19.05)
FF	Std. 5/8 - 18	5/8 - 18	5/8 - 18	1 - 14	1 - 14	1 - 14	1 3/8 - 12
	O.S. 1 - 14	1 - 14	1 - 14	1 3/8 - 12	1 3/8 - 12	1 3/8 - 12	1 3/4 - 12
G	1.500 (38.10)	1.500 (38.10)	1.500 (38.10)	1.750 (44.45)	1.750 (44.45)	1.750 (44.45)	2.000 (50.80)
J	1.000 (25.40)	1.000 (25.40)	1.000 (25.40)	1.250 (31.75)	1.250 (31.75)	1.250 (31.75)	1.500 (38.10)
K	.250 (6.35)	.313 (7.94)	.313 (7.94)	.375 (9.53)	.375 (9.53)	.438 (11.11)	.438 (11.11)
KK	Std. 7/16 - 20	7/16 - 20	7/16 - 20	3/4 - 16	3/4 - 16	3/4 - 16	1 - 14
	O.S. 3/4 - 16	3/4 - 16	3/4 - 16	1 - 14	1 - 14	1 - 14	1 1/4 - 12
LB	3.625 (92.08)	3.625 (92.08)	3.750 (95.25)	4.250 (107.95)	4.250 (107.95)	4.500 (114.30)	5.000 (127.00)
MM	Std. .625 (15.88)	.625 (15.88)	.625 (15.88)	1.000 (25.40)	1.000 (25.40)	1.000 (25.40)	1.375 (34.93)
	O.S. 1.000 (25.40)	1.000 (25.40)	1.000 (25.40)	1.375 (34.93)	1.375 (34.93)	1.375 (34.93)	1.750 (44.45)
P	2.313 (58.74)	2.313 (58.74)	2.438 (61.91)	2.625 (66.68)	2.625 (66.68)	2.875 (73.03)	3.125 (79.38)
R	1.428 (36.27)	1.838 (46.68)	2.192 (55.67)	2.758 (70.05)	3.323 (84.40)	4.101 (104.16)	4.879 (123.92)
SB	.438 (11.11)	.438 (11.11)	.438 (11.11)	.563 (14.29)	.563 (14.29)	.813 (20.64)	.813 (20.64)
SH	1.000 (25.40)	1.250 (31.75)	1.500 (38.10)	1.875 (47.63)	2.250 (57.15)	2.750 (69.85)	3.250 (82.55)
SJ	.625 (15.88)	.625 (15.88)	.625 (15.88)	.750 (19.05)	.750 (19.05)	.813 (20.64)	.813 (20.64)
SS	2.875 (73.03)	2.875 (73.03)	3.000 (76.20)	3.250 (82.55)	3.250 (82.55)	3.125 (79.38)	3.625 (92.08)
ST	.500 (12.70)	.500 (12.70)	.500 (12.70)	.750 (19.05)	.750 (19.05)	1.000 (25.40)	1.000 (25.40)
SU	1.125 (28.58)	1.125 (28.58)	1.125 (28.58)	1.250 (31.75)	1.250 (31.75)	1.063 (26.99)	1.313 (33.34)
SW	.375 (9.53)	.375 (9.53)	.375 (9.53)	.500 (12.70)	.500 (12.70)	.688 (17.46)	.688 (17.46)
TS	2.750 (69.85)	3.250 (82.55)	3.750 (95.25)	4.750 (120.65)	5.500 (139.70)	6.875 (174.63)	7.875 (200.03)
US	3.500 (88.90)	4.000 (101.60)	4.500 (114.30)	5.750 (146.05)	6.500 (165.10)	8.250 (209.55)	9.250 (234.95)
VF	Std. .625 (15.88)	.625 (15.88)	.625 (15.88)	.875 (22.23)	.875 (22.23)	.875 (22.23)	1.000 (25.40)
	O.S. .875 (22.23)	.875 (22.23)	.875 (22.23)	1.000 (25.40)	1.000 (25.40)	1.000 (25.40)	1.125 (28.58)
WF	Std. 1.000 (25.40)	1.000 (25.40)	1.000 (25.40)	1.375 (34.93)	1.375 (34.93)	1.375 (34.93)	1.625 (41.28)
	O.S. 1.375 (34.93)	1.375 (34.93)	1.375 (34.93)	1.625 (41.28)	1.625 (41.28)	1.625 (41.28)	1.875 (47.63)
XS	Std. 1.375 (34.93)	1.375 (34.93)	1.375 (34.93)	1.875 (47.63)	1.875 (47.63)	2.062 (52.37)	2.313 (58.74)
	O.S. 1.750 (44.45)	1.750 (44.45)	1.750 (44.45)	2.125 (53.98)	2.125 (53.98)	2.313 (58.74)	2.562 (65.07)
Y	Std. 1.875 (47.63)	1.875 (47.63)	1.875 (47.63)	2.438 (61.91)	2.438 (61.91)	2.438 (61.91)	2.813 (71.44)
	O.S. 2.250 (57.15)	2.250 (57.15)	2.250 (57.15)	2.688 (68.26)	2.688 (68.26)	2.688 (68.26)	3.063 (77.79)
ZB	Std. 4.875 (123.83)	4.938 (125.41)	5.063 (128.59)	6.000 (152.40)	6.000 (152.40)	6.313 (160.34)	7.063 (177.39)
	O.S. 5.250 (133.35)	5.313 (134.94)	5.438 (138.11)	6.250 (158.75)	6.250 (158.75)	6.563 (166.69)	7.313 (185.74)





# Series J & EJ, NFPA Steel Air Cylinder with 09 (MS2) Side Lugs



All Dimensions in Inches (mm)

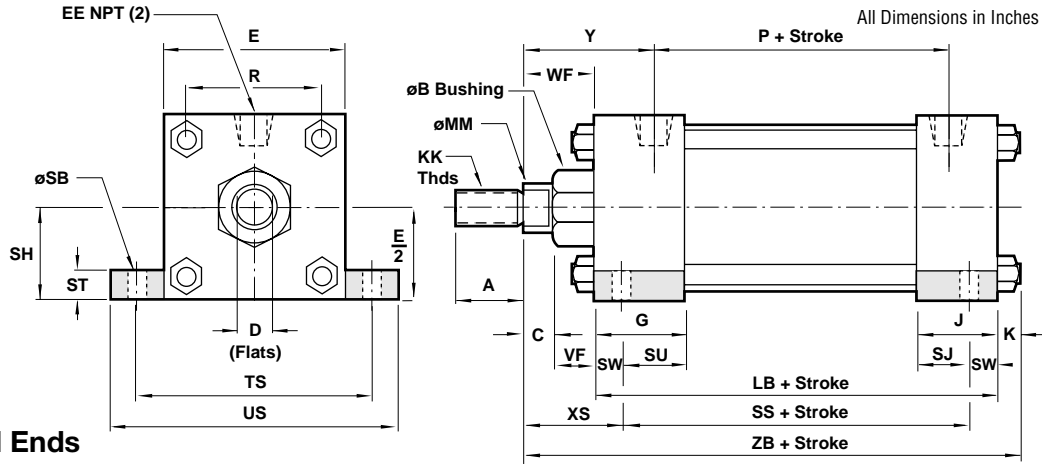

## Standard & Optional Rod Ends

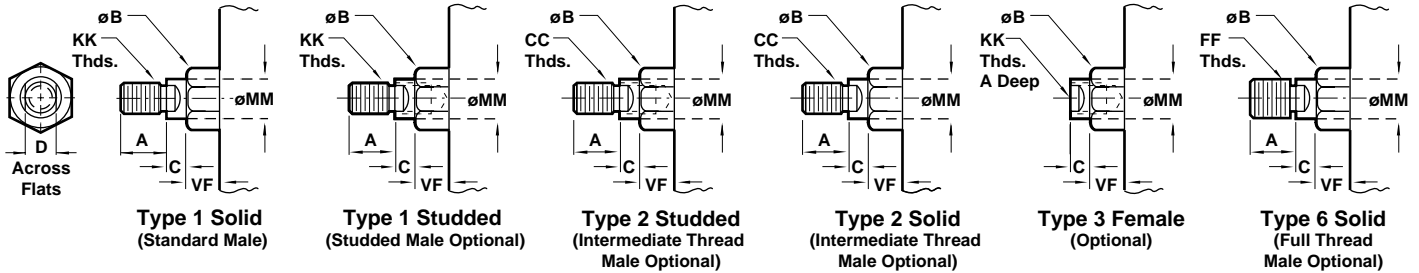

Dimension		7" Bore (177.80)	8" Bore (203.20)	10" Bore (254.00)	12" Bore (304.80)
ø Rod	Std.	1 3/8" (34.93)	1 3/8" (34.93)	1 3/4" (44.45)	2" (50.80)
	O.S.	1 3/4" (44.45)	1 3/4" (44.45)	2" (50.80)	2 1/2" (63.50)
A	Std.	1.625 (41.28)	1.625 (41.28)	2.000 (50.80)	2.250 (57.15)
	O.S.	2.000 (50.80)	2.000 (50.80)	2.250 (57.15)	3.000 (76.20)
B +.000 -.002	Std.	1.999 (50.78)	1.999 (50.78)	2.374 (60.30)	2.624 (66.65)
	O.S.	2.374 (60.30)	2.374 (60.30)	2.624 (66.65)	3.124 (79.35)
C	Std.	.625 (15.88)	.625 (15.88)	.750 (19.05)	.875 (22.23)
	O.S.	.750 (19.05)	.750 (19.05)	.875 (22.23)	1.000 (25.40)
CC	Std.	1 1/4 - 12	1 1/4 - 12	1 1/2 - 12	1 3/4 - 12
	O.S.	1 1/2 - 12	1 1/2 - 12	1 3/4 - 12	2 1/4 - 12
D	Std.	1.125 (28.58)	1.125 (28.58)	1.500 (38.10)	1.688 (42.86)
	O.S.	1.500 (38.10)	1.500 (38.10)	1.688 (42.86)	2.063 (52.39)
E		7.500 (190.50)	8.500 (215.90)	10.625 (269.88)	12.750 (323.85)
EE		.750 (19.05)	.750 (19.05)	1.000 (25.40)	1.000 (25.40)
FF	Std.	1 3/8 - 12	1 3/8 - 12	1 3/4 - 12	2 - 12
	O.S.	1 3/4 - 12	1 3/4 - 12	2 - 12	2 1/2 - 12
G		2.000 (50.80)	2.000 (50.80)	2.250 (57.15)	2.250 (57.15)
J		1.500 (38.10)	1.500 (38.10)	2.000 (50.80)	2.000 (50.80)
K		.563 (14.29)	.563 (14.29)	.688 (17.46)	.688 (17.46)
KK	Std.	1 - 14	1 - 14	1 1/4 - 12	1 1/2 - 12
	O.S.	1 1/4 - 12	1 1/4 - 12	1 1/2 - 12	1 7/8 - 12
LB		5.125 (130.18)	5.125 (130.18)	6.375 (161.93)	6.875 (174.63)
MM	Std.	1.375 (34.93)	1.375 (34.93)	1.750 (44.45)	2.000 (50.80)
	O.S.	1.750 (44.45)	1.750 (44.45)	2.000 (50.80)	2.500 (63.50)
P		3.250 (82.55)	3.250 (82.55)	4.125 (104.78)	4.625 (117.48)
R		5.730 (145.54)	6.442 (163.63)	7.969 (202.41)	9.406 (238.92)
SB		.813 (20.64)	.813 (20.64)	1.063 (26.99)	1.063 (26.99)
SH		3.750 (95.25)	4.250 (107.95)	5.313 (134.94)	6.375 (161.93)
SJ		.813 (20.64)	.813 (20.64)	2.000 (50.80)	2.000 (50.80)
SS		3.750 (95.25)	3.750 (95.25)	4.625 (117.48)	5.125 (130.18)
ST		1.000 (25.40)	1.000 (25.40)	1.250 (31.75)	1.250 (31.75)
SU		1.563 (39.69)	1.563 (39.69)	2.000 (50.80)	2.000 (50.80)
SW		.688 (17.46)	.688 (17.46)	.875 (22.23)	.875 (22.23)
TS		8.875 (225.43)	9.875 (250.83)	12.375 (314.33)	14.500 (368.30)
US		10.250 (260.35)	11.250 (285.75)	14.125 (358.78)	16.250 (412.75)
VF	Std.	1.000 (25.40)	1.000 (25.40)	1.125 (28.58)	1.125 (28.58)
	O.S.	1.125 (28.58)	1.125 (28.58)	1.125 (28.58)	1.250 (31.75)
WF	Std.	1.625 (41.28)	1.625 (41.28)	1.875 (47.63)	2.000 (50.80)
	O.S.	1.875 (47.63)	1.875 (47.63)	2.000 (50.80)	2.250 (57.15)
XS	Std.	2.313 (58.74)	2.313 (58.74)	2.750 (69.85)	2.875 (73.03)
	O.S.	2.563 (65.09)	2.563 (65.09)	2.875 (73.03)	3.125 (79.38)
Y	Std.	2.813 (71.44)	2.813 (71.44)	3.125 (79.38)	3.250 (82.55)
	O.S.	3.063 (77.79)	3.063 (77.79)	3.250 (82.55)	3.500 (88.90)
ZB	Std.	7.313 (185.74)	7.313 (185.74)	8.938 (227.01)	9.563 (242.89)
	O.S.	7.563 (192.09)	7.563 (192.09)	9.063 (230.19)	9.813 (249.24)

**Cylinder with 10 (MT4) Center Trunnion**

- **NFPA(MT4) 10 Center Trunnion Mount for 1-1/2" to 6" bore sizes.**
- **Series J Cylinders rated to 250 PSI air, 400 PSI hydraulic (non-shock). Series EJ Cylinders rated to 250 PSI air only.**
- **Designed for non-lube service.**
- **Switches available on all bore sizes. (See page 150 & 151 for ordering information.)**

**Cylinder Order Information**

10 - - - -

J	Series J Cylinder					
EJ	Series EJ Cylinder					Bore and Stroke (write out)

Mounting Options	
01	Side Tapped (MS4)
03	Head Rectangular Flange (MF1)
03	Head Square (ME3)–7" to 12" Bores
04	Cap Rectangular Flange (MF2)
04	Cap Square (ME4)–7" to 12" Bores
05	Basic Cylinder No Mounting (MX0)
06	Both Ends (4) Tie Rods Ext. (MX1)
6B	Both Ends (2) Tie Rods Ext. (MX4)
6C	Cap Tie Rods Ext. (MX2)
6R	Head Tie Rods Ext. (MX3)
07	Head Trunnion (MT1)
08	Cap Trunnion (MT2)
09	Side Lugs (MS2)
<b>10</b>	<b>Center Trunnion (MT4)</b>
11	Side End Angles (MS1)
12	Cap Fixed Clevis (MP1)
15	Side End Lugs (MS7)
16	Sleeve Nut Construction (Universal)
20	Head Square Flange (MF5)
21	Cap Square Flange (MF6)
22	Detachable Cap Clevis (MP2)
32	Cap Fixed Eye (MP3)
42	Detachable Cap Eye (MP4)
52	Spherical Bearing

Cushion in Head	
3	None
5 <sup>†</sup>	Non-Adjustable Cushion
7	Adjustable Cushion (Position 2)
<sup>†</sup> Standard with EJ	

Cushion in Cap	
3	None
5 <sup>†</sup>	Non-Adjustable Cushion
7	Adjustable Cushion (Position 2)
<sup>†</sup> Standard with EJ	

Additional Options – order alphabetically – More on page 155	
HR	Case Hardened (45 Rc)
L(- -)	Port Location position 1 standard: L(Head Cap) (specify position 1 thru 4 for head and/or cap)
MS	Metal Rod Scraper
N(- -)	Cushion Adjust Screw Location position 2 standard: N(Head Cap) (specify position 1 thru 4 for head and/or cap)
P(-)*	Non-Standard Port Sizes: [specify port size for P(-H) head only, P(-C) cap only, or P(-) both head & cap]
PS	Magnetic Piston – includes aluminum tube option
RS	Rod Stud Type 1 (5/8" – 1¾" øRod) Type 2 (5/8" & 1" øRod)
RX	Rod Extensions (specify length of additional rod extension)
SC	Single Acting Spring Extend (Cap End)–See page 155
SR	Single Acting Spring Retract (Rod End)–See page 155
SS	303 Stainless Steel (Hard Chrome Plated)
ST(-C)	Stop Tube (Cap End) (specify stop tube length)
ST(-R)	Stop Tube (Rod End) (specify stop tube length)
T	Special Rod Threads (specify rod thread)
TX	Thread Extensions (specify length of thread extension)
V	Viton® Seals

Piston Rod Threads Type	
1	Small Male (Solid)
2	Intermediate Thread Male (Solid)
3	Female
6	Full Thread Male (Solid)
7	Plain Rod End

Piston Rod Diameters		
A	5/8"	Standard on 1½", 2", 2½"
B	1"	Standard on 3¼", 4", 5" Oversized on 1½", 2", 2½"
C	1⅜"	Standard on 6", 7", 8" Oversized on 3¼", 4", 5"
D	1¾"	Standard on 10" Oversized on 6", 7", 8"
E	2"	Standard on 12" Oversized on 10"
F	2½"	Oversized on 10", 12"

\*1½", 2", 2½" bore cylinders have 3/8" NPT Standard, 1/2" NPT oversize. 3¼", 4", 5" bore cylinders have 1/2" NPT Standard, 3/4" NPT oversize. This will add 1/8" to the overall cylinder length.

Piston Rod Threads Type	
1	Small Male (Solid)
2	Intermediate Thread Male (Solid)
3	Female
6	Full Thread Male (Solid)
7	Plain Rod End

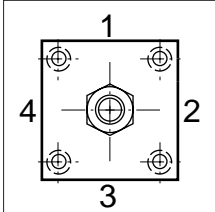

**Port and Cushion Adjustment Positions** (As viewed from rod end: Port standard position 1, Cushion Adjustment standard position 2.)

NOTE: A Port and a Cushion Adjustment cannot be in the same position.

Customer must specify XI dimension when ordering. If a rod extension is specified, the XI (min) dimension will be increased the length of the rod extension.

**See page 156 for complete instructions on how to order cylinders.**

# Series J & EJ, NFPA Steel Air Cylinder 10 (MT4) with Center Trunnion

All Dimensions in Inches (mm)

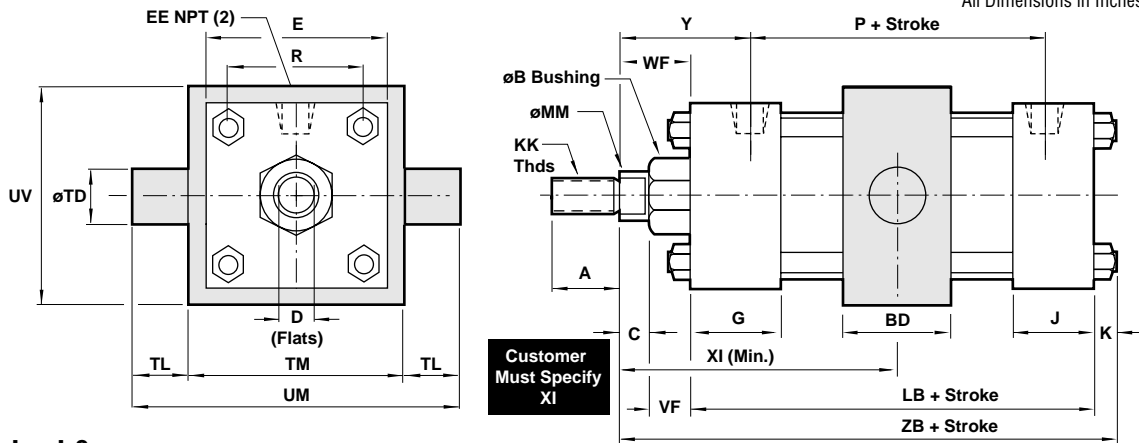

Customer Must Specify XI

## Standard & Optional Rod Ends

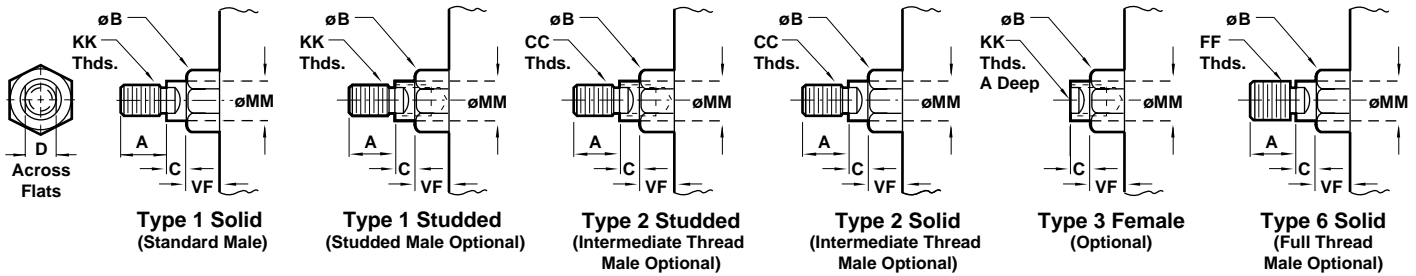

Dimension	1 1/2" Bore (38.10)	2" Bore (50.80)	2 1/2" Bore (63.50)	3 1/4" Bore (82.55)	4" Bore (101.60)	5" Bore (127.00)	6" Bore (152.40)
ø Rod	Std. 5/8" (15.88)	5/8" (15.88)	5/8" (15.88)	1" (25.40)	1" (25.40)	1" (25.40)	1 3/8" (34.93)
	O.S. 1" (25.40)	1" (25.40)	1" (25.40)	1 3/8" (34.93)	1 3/8" (34.93)	1 3/8" (34.93)	1 3/4" (44.45)
A	Std. .750 (19.05)	.750 (19.05)	.750 (19.05)	1.125 (28.58)	1.125 (28.58)	1.125 (28.58)	1.625 (41.28)
	O.S. 1.125 (28.58)	1.125 (28.58)	1.125 (28.58)	1.625 (41.28)	1.625 (41.28)	1.625 (41.28)	2.000 (50.80)
B <sup>+0.000</sup> <sub>-0.002</sub>	Std. 1.124 (28.55)	1.124 (28.55)	1.124 (28.55)	1.499 (38.08)	1.499 (38.08)	1.499 (38.08)	1.999 (50.78)
	O.S. 1.499 (38.08)	1.499 (38.08)	1.499 (38.08)	1.999 (50.78)	1.999 (50.78)	1.999 (50.78)	2.374 (60.30)
BD	1.250 (31.75)	1.500 (38.10)	1.500 (38.10)	2.000 (50.80)	2.000 (50.80)	2.000 (50.80)	2.500 (63.50)
C	Std. .375 (9.53)	.375 (9.53)	.375 (9.53)	.500 (12.70)	.500 (12.70)	.500 (12.70)	.625 (15.88)
	O.S. .500 (12.70)	.500 (12.70)	.500 (12.70)	.625 (15.88)	.625 (15.88)	.625 (15.88)	.750 (19.05)
CC	Std. 1/2 - 20	1/2 - 20	1/2 - 20	7/8 - 14	7/8 - 14	7/8 - 14	1 1/4 - 12
	O.S. 7/8 - 14	7/8 - 14	7/8 - 14	1 1/4 - 12	1 1/4 - 12	1 1/4 - 12	1 1/2 - 12
D	Std. .500 (12.70)	.500 (12.70)	.500 (12.70)	.813 (20.64)	.813 (20.64)	.813 (20.64)	1.125 (28.58)
	O.S. .813 (20.64)	.813 (20.64)	.813 (20.64)	1.125 (28.58)	1.125 (28.58)	1.125 (28.58)	1.500 (38.10)
E	2.000 (50.80)	2.500 (63.50)	3.000 (76.20)	3.750 (95.25)	4.500 (114.30)	5.500 (139.70)	6.500 (165.10)
EE	.375 (9.53)	.375 (9.53)	.375 (9.53)	.500 (12.70)	.500 (12.70)	.500 (12.70)	.750 (19.05)
FF	Std. 5/8 - 18	5/8 - 18	5/8 - 18	1 - 14	1 - 14	1 - 14	1 3/8 - 12
	O.S. 1 - 14	1 - 14	1 - 14	1 3/8 - 12	1 3/8 - 12	1 3/8 - 12	1 3/4 - 12
G	1.500 (38.10)	1.500 (38.10)	1.500 (38.10)	1.750 (44.45)	1.750 (44.45)	1.750 (44.45)	2.000 (50.80)
J	1.000 (25.40)	1.000 (25.40)	1.000 (25.40)	1.250 (31.75)	1.250 (31.75)	1.250 (31.75)	1.500 (38.10)
K	.250 (6.35)	.313 (7.94)	.313 (7.94)	.375 (9.53)	.375 (9.53)	.438 (11.11)	.438 (11.11)
KK	Std. 7/16 - 20	7/16 - 20	7/16 - 20	3/4 - 16	3/4 - 16	3/4 - 16	1 - 14
	O.S. 3/4 - 16	3/4 - 16	3/4 - 16	1 - 14	1 - 14	1 - 14	1 1/4 - 12
LB	3.625 (92.08)	3.625 (92.08)	3.750 (95.25)	4.250 (107.95)	4.250 (107.95)	4.500 (114.30)	5.000 (127.00)
MM	Std. .625 (15.88)	.625 (15.88)	.625 (15.88)	1.000 (25.40)	1.000 (25.40)	1.000 (25.40)	1.375 (34.93)
	O.S. 1.000 (25.40)	1.000 (25.40)	1.000 (25.40)	1.375 (34.93)	1.375 (34.93)	1.375 (34.93)	1.750 (44.45)
P	2.313 (58.74)	2.313 (58.74)	2.438 (61.91)	2.625 (66.68)	2.625 (66.68)	2.875 (73.03)	3.125 (79.38)
R	1.428 (36.27)	1.838 (46.68)	2.192 (55.67)	2.758 (70.05)	3.323 (84.83)	4.101 (104.16)	4.879 (123.92)
TD <sup>+0.000</sup> <sub>-0.001</sub>	1.000 (25.40)	1.000 (25.40)	1.000 (25.40)	1.000 (25.40)	1.000 (25.40)	1.000 (25.40)	1.375 (34.93)
TL	1.000 (25.40)	1.000 (25.40)	1.000 (25.40)	1.000 (25.40)	1.000 (25.40)	1.000 (25.40)	1.375 (34.93)
TM	2.500 (63.50)	3.000 (76.20)	3.500 (88.90)	4.500 (114.30)	5.250 (133.35)	6.250 (158.75)	7.625 (193.68)
UM	4.500 (114.30)	5.000 (127.00)	5.500 (139.70)	6.500 (165.10)	7.250 (184.15)	8.250 (209.55)	10.375 (263.53)
UV	2.500 (63.50)	3.000 (76.20)	3.500 (88.90)	4.250 (107.95)	5.000 (127.00)	6.000 (152.40)	7.000 (177.80)
VF	Std. .625 (15.88)	.625 (15.88)	.625 (15.88)	.875 (22.23)	.875 (22.23)	.875 (22.23)	1.000 (25.40)
	O.S. .875 (22.23)	.875 (22.23)	.875 (22.23)	1.000 (25.40)	1.000 (25.40)	1.000 (25.40)	1.125 (28.58)
WF	Std. 1.000 (25.40)	1.000 (25.40)	1.000 (25.40)	1.375 (34.93)	1.375 (34.93)	1.375 (34.93)	1.625 (41.28)
	O.S. 1.375 (34.93)	1.375 (34.93)	1.375 (34.93)	1.625 (41.28)	1.625 (41.28)	1.625 (41.28)	1.875 (47.63)
XI min.	Std. 3.125 (79.38)	3.250 (82.55)	3.250 (82.55)	4.125 (104.78)	4.125 (104.78)	4.125 (104.78)	4.625 (117.48)
	O.S. 3.500 (88.90)	3.625 (92.08)	3.625 (92.08)	4.375 (111.13)	4.375 (111.13)	4.375 (111.13)	4.875 (123.83)
Y	Std. 1.875 (47.63)	1.875 (47.63)	1.875 (47.63)	2.438 (61.91)	2.438 (61.91)	2.438 (61.91)	2.813 (71.46)
	O.S. 2.250 (57.15)	2.250 (57.15)	2.250 (57.15)	2.688 (68.26)	2.688 (68.26)	2.688 (68.26)	3.063 (77.79)
ZB	Std. 4.875 (123.83)	4.938 (125.41)	5.063 (128.59)	6.000 (152.40)	6.000 (152.40)	6.313 (160.34)	7.063 (179.39)
	O.S. 5.250 (133.35)	5.313 (134.94)	5.438 (138.11)	6.250 (158.75)	6.250 (158.75)	6.563 (166.69)	7.313 (185.74)

## Cylinder with 10 (MT4) Center Trunnion

- **NFPA(MT4) 10 Center Trunnion Mount for 7" to 12" bore sizes.**
- **Series J Cylinders rated to 250 PSI air, 400 PSI hydraulic (non-shock). Series EJ Cylinders rated to 250 PSI air only.**
- **Designed for non-lube service.**
- **Switches available on all bore sizes. (See page 150 & 151 for ordering information.)**



### Cylinder Order Information

**10 - - - -**

<b>J</b>	Series J Cylinder		Bore and Stroke (write out)
<b>EJ</b>	Series EJ Cylinder		

Mounting Options	
01	Side Tapped (MS4)
03	Head Rectangular Flange (MF1)
03	Head Square (ME3)-7" to 12" Bores
04	Cap Rectangular Flange (MF2)
04	Cap Square (ME4)-7" to 12" Bores
05	Basic Cylinder No Mounting (MX0)
06	Both Ends (4) Tie Rods Ext. (MX1)
6B	Both Ends (2) Tie Rods Ext. (MX4)
6C	Cap Tie Rods Ext. (MX2)
6R	Head Tie Rods Ext. (MX3)
07	Head Trunnion (MT1)
08	Cap Trunnion (MT2)
09	Side Lugs (MS2)
<b>10</b>	<b>Center Trunnion (MT4)</b>
11	Side End Angles (MS1)
12	Cap Fixed Clevis (MP1)
15	Side End Lugs (MS7)
16	Sleeve Nut Construction (Universal)
20	Head Square Flange (MF5)
21	Cap Square Flange (MF6)
22	Detachable Cap Clevis (MP2)
32	Cap Fixed Eye (MP3)
42	Detachable Cap Eye (MP4)
52	Spherical Bearing

Cushion in Head	
3	None
5 <sup>†</sup>	Non-Adjustable Cushion
7	Adjustable Cushion (Position 2)

<sup>†</sup>Standard with EJ

Cushion in Cap	
3	None
5 <sup>†</sup>	Non-Adjustable Cushion
7	Adjustable Cushion (Position 2)

<sup>†</sup>Standard with EJ

Additional Options – order alphabetically – More on page 155		
HR	Case Hardened (45 Rc)	
L(-)	Port Location position 1 standard: L(Head Cap) (specify position 1 thru 4 for head and/or cap)	
MS	Metal Rod Scraper	
N(-)	Cushion Adjust Screw Location position 2 standard: N(Head Cap) (specify position 1 thru 4 for head and/or cap)	
P(-)*	Non-Standard Port Sizes: [specify port size for P(-)H head only, P(-)C cap only, or P(-) both head & cap]	
PS	Magnetic Piston – includes aluminum tube option	
RS	Rod Stud Type 1 (5/8" – 1 3/4" øRod) Type 2 (5/8" & 1" øRod)	
RX	Rod Extensions (specify length of additional rod extension)	
SC	Single Acting Spring Extend (Cap End)–See page 155	
SR	Single Acting Spring Retract (Rod End)–See page 155	
SS	303 Stainless Steel (Hard Chrome Plated)	
ST(-)C	Stop Tube (Cap End) (specify stop tube length)	
ST(-)R	Stop Tube (Rod End) (specify stop tube length)	
T	Special Rod Threads (specify rod thread)	
TX	Thread Extensions (specify length of thread extension)	
V	Viton® Seals	

Piston Rod Threads Type	
1	Small Male (Solid)
2	Intermediate Thread Male (Solid)
3	Female
6	Full Thread Male (Solid)
7	Plain Rod End

Piston Rod Diameters		
A	5/8"	Standard on 1 1/2", 2", 2 1/2"
B	1"	Standard on 3 1/4", 4", 5" Oversized on 1 1/2", 2", 2 1/2"
C	1 3/8"	Standard on 6", 7", 8" Oversized on 3 1/4", 4", 5"
D	1 3/4"	Standard on 10" Oversized on 6", 7", 8"
E	2"	Standard on 12" Oversized on 10"
F	2 1/2"	Oversized on 10", 12"

**Port and Cushion Adjustment Positions** (As viewed from rod end: Port standard position 1, Cushion Adjustment standard position 2.)  
NOTE: A Port and a Cushion Adjustment cannot be in the same position.

\*1 1/2", 2", 2 1/2" bore cylinders have 3/8" NPT Standard, 1/2" NPT oversize. 3 1/4", 4", 5" bore cylinders have 1/2" NPT Standard, 3/4" NPT oversize. This will add 1/8" to the overall cylinder length.

Customer must specify XI dimension when ordering. If a rod extension is specified, the XI (min) dimension will be increased the length of the rod extension.

**See page 156 for complete instructions on how to order cylinders.**

# Series J & EJ, NFPA Steel Air Cylinder 10 (MT4) with Center Trunnion

All Dimensions in Inches (mm)

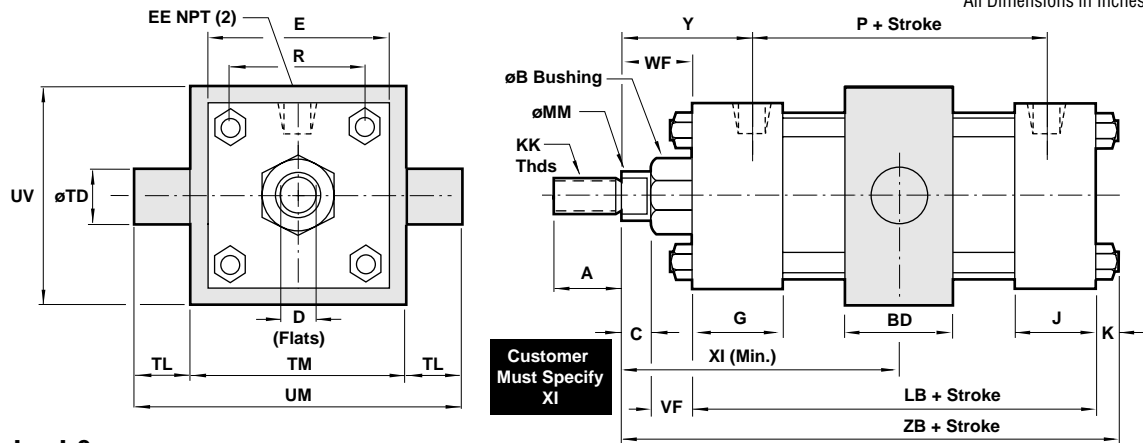

## Standard & Optional Rod Ends

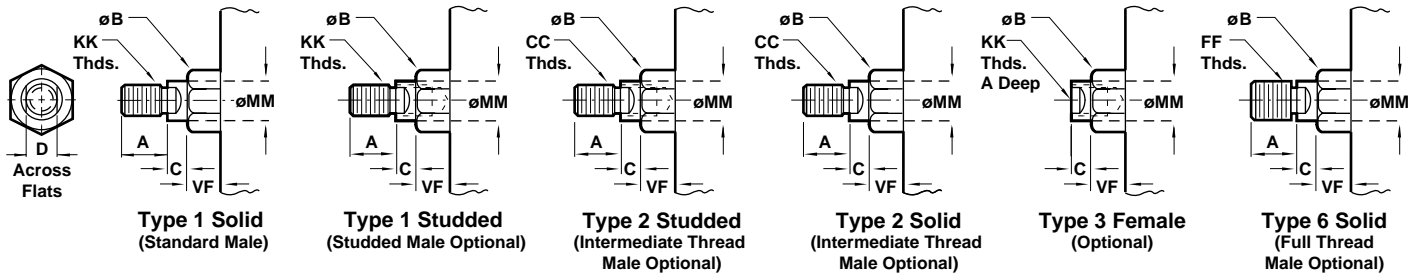

Dimension		7" Bore (177.80)	8" Bore (203.20)	10" Bore (254.00)	12" Bore (304.80)
ø Rod	Std.	1 3/8" (34.93)	1 3/8" (34.93)	1 3/4" (44.45)	2" (50.80)
	O.S.	1 3/4" (44.45)	1 3/4" (44.45)	2" (50.80)	2 1/2" (63.50)
A	Std.	1.625 (41.28)	1.625 (41.28)	2.000 (50.80)	2.250 (57.15)
	O.S.	2.000 (50.80)	2.000 (50.80)	2.250 (57.15)	3.000 (76.20)
B +.000 -.002	Std.	1.999 (50.78)	1.999 (50.78)	2.374 (60.30)	2.624 (66.65)
	O.S.	2.374 (60.30)	2.374 (60.30)	2.624 (66.65)	3.124 (79.35)
BD		2.500 (63.50)	2.500 (63.50)	3.000 (76.20)	3.000 (76.20)
C	Std.	.625 (15.88)	.625 (15.88)	.750 (19.05)	.875 (22.23)
	O.S.	.750 (19.05)	.750 (19.05)	.875 (22.23)	1.000 (25.40)
CC	Std.	1 1/4 - 12	1 1/4 - 12	1 1/2 - 12	1 3/4 - 12
	O.S.	1 1/2 - 12	1 1/2 - 12	1 3/4 - 12	2 1/4 - 12
D	Std.	1.125 (28.58)	1.125 (28.58)	1.500 (38.10)	1.688 (42.86)
	O.S.	1.500 (38.10)	1.500 (38.10)	1.688 (42.86)	2.063 (52.39)
E		7.500 (190.50)	8.500 (215.90)	10.625 (269.88)	12.750 (323.85)
EE		.750 (19.05)	.750 (19.05)	1.000 (25.40)	1.000 (25.40)
FF	Std.	1 3/8 - 12	1 3/8 - 12	1 3/4 - 12	2 - 12
	O.S.	1 3/4 - 12	1 3/4 - 12	2 - 12	2 1/2 - 12
G		2.000 (50.80)	2.000 (50.80)	2.250 (57.15)	2.250 (57.15)
J		1.500 (38.10)	1.500 (38.10)	2.000 (50.80)	2.000 (50.80)
K		.563 (14.29)	.563 (14.29)	.688 (17.46)	.688 (17.46)
KK	Std.	1 - 14	1 - 14	1 1/4 - 12	1 1/2 - 12
	O.S.	1 1/4 - 12	1 1/4 - 12	1 1/2 - 12	1 7/8 - 12
LB		5.125 (130.18)	5.125 (130.18)	6.375 (161.93)	6.375 (174.63)
MM	Std.	1.375 (34.93)	1.375 (34.93)	1.750 (44.45)	2.000 (50.80)
	O.S.	1.750 (44.45)	1.750 (44.45)	2.000 (50.80)	2.500 (63.50)
P		3.250 (82.55)	3.250 (82.55)	4.125 (104.78)	4.625 (117.48)
R		5.730 (145.54)	6.435 (163.44)	7.969 (202.41)	9.406 (238.92)
TD +.000 -.001		1.375 (34.93)	1.375 (34.93)	1.750 (44.45)	1.750 (44.45)
TL		1.375 (34.93)	1.375 (34.93)	1.750 (44.45)	1.750 (44.45)
TM		8.750 (222.25)	9.750 (247.65)	12.000 (304.80)	14.000 (355.60)
UM		11.500 (292.10)	12.500 (317.50)	15.500 (393.70)	17.500 (444.50)
UV		8.500 (215.90)	9.500 (241.30)	11.750 (298.45)	13.750 (349.25)
VF	Std.	1.000 (25.40)	1.000 (25.40)	1.125 (28.58)	1.125 (28.58)
	O.S.	1.125 (28.58)	1.125 (28.58)	1.125 (28.58)	1.250 (31.75)
WF	Std.	1.625 (41.28)	1.625 (41.28)	1.875 (47.63)	2.000 (50.80)
	O.S.	1.875 (47.63)	1.875 (47.63)	2.000 (50.80)	2.250 (57.15)
XI min.	Std.	4.875 (123.83)	4.875 (123.83)	5.625 (142.88)	5.750 (146.05)
	O.S.	5.125 (130.18)	5.125 (130.18)	5.750 (146.05)	6.000 (152.40)
Y	Std.	2.813 (71.46)	2.813 (71.46)	3.125 (79.38)	3.250 (82.55)
	O.S.	3.063 (77.79)	3.063 (77.79)	3.250 (82.55)	3.500 (88.90)
ZB	Std.	7.313 (185.74)	7.313 (185.74)	8.938 (227.01)	9.563 (242.89)
	O.S.	7.563 (192.10)	7.563 (192.10)	9.063 (230.19)	9.813 (249.24)

## Cylinder with 11 (MS1) Side End Angles

- **NFPA (MS1) 11 Side End Angle Mount** for 1-1/2" to 6" bore sizes.
- **Series J Cylinders** rated to 250 PSI air, 400 PSI hydraulic (non-shock).  
**Series EJ Cylinders** rated to 250 PSI air only.
- **Designed for non-lube service.**
- **Switches available on all bore sizes.** (See page 150 & 151 for ordering information.)

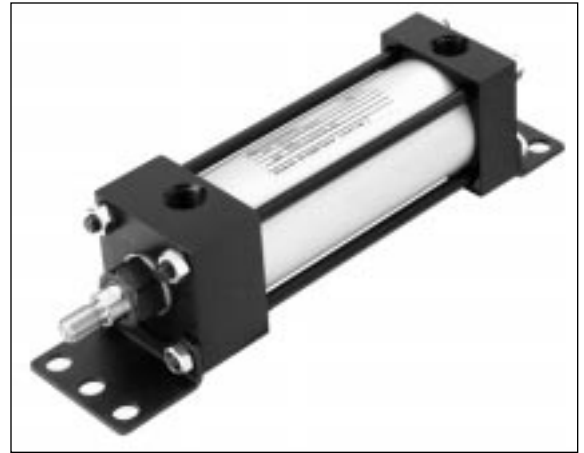

### Cylinder Order Information

11 - - - -

J	Series J Cylinder		Bore and Stroke (write out)
EJ	Series EJ Cylinder		

Mounting Options	
01	Side Tapped (MS4)
03	Head Rectangular Flange (MF1)
03	Head Square (ME3)–7" to 12" Bores
04	Cap Rectangular Flange (MF2)
04	Cap Square (ME4)–7" to 12" Bores
05	Basic Cylinder No Mounting (MX0)
06	Both Ends (4) Tie Rods Ext. (MX1)
6B	Both Ends (2) Tie Rods Ext. (MX4)
6C	Cap Tie Rods Ext. (MX2)
6R	Head Tie Rods Ext. (MX3)
07	Head Trunnion (MT1)
08	Cap Trunnion (MT2)
09	Side Lugs (MS2)
10	Center Trunnion (MT4)
<b>11</b>	<b>Side End Angles (MS1)</b>
12	Cap Fixed Clevis (MP1)
15	Side End Lugs (MS7)
16	Sleeve Nut Construction (Universal)
20	Head Square Flange (MF5)
21	Cap Square Flange (MF6)
22	Detachable Cap Clevis (MP2)
32	Cap Fixed Eye (MP3)
42	Detachable Cap Eye (MP4)
52	Spherical Bearing

Cushion in Head	
3	None
5 <sup>†</sup>	Non-Adjustable Cushion
7	Adjustable Cushion (Position 2)

<sup>†</sup>Standard with EJ

Cushion in Cap	
3	None
5 <sup>†</sup>	Non-Adjustable Cushion
7	Adjustable Cushion (Position 2)

<sup>†</sup>Standard with EJ

Additional Options – order alphabetically – More on page 155	
HR	Case Hardened (45 Rc)
L(-)	Port Location position 1 standard: L(Head Cap) (specify position 1 thru 4 for head and/or cap)
MS	Metal Rod Scraper
N(-)	Cushion Adjust Screw Location position 2 standard: N(Head Cap) (specify position 1 thru 4 for head and/or cap)
P(-)*	Non-Standard Port Sizes: [specify port size for P(-H) head only, P(-C) cap only, or P(-) both head & cap]
PS	Magnetic Piston – includes aluminum tube option
RS	Rod Stud Type 1 (5/8" – 1¾" øRod) Type 2 (5/8" & 1" øRod)
RX	Rod Extensions (specify length of additional rod extension)
SC	Single Acting Spring Extend (Cap End)–See page 155
SR	Single Acting Spring Retract (Rod End)–See page 155
SS	303 Stainless Steel (Hard Chrome Plated)
ST(-C)	Stop Tube (Cap End) (specify stop tube length)
ST(-R)	Stop Tube (Rod End) (specify stop tube length)
T	Special Rod Threads (specify rod thread)
TX	Thread Extensions (specify length of thread extension)
V	Viton® Seals

Piston Rod Threads Type	
1	Small Male (Solid)
2	Intermediate Thread Male (Solid)
3	Female
6	Full Thread Male (Solid)
7	Plain Rod End

Piston Rod Diameters		
A	5/8"	Standard on 1½", 2", 2½"
B	1"	Standard on 3¼", 4", 5" Oversized on 1½", 2", 2½"
C	1⅜"	Standard on 6", 7", 8" Oversized on 3¼", 4", 5"
D	1¾"	Standard on 10" Oversized on 6", 7", 8"
E	2"	Standard on 12" Oversized on 10"
F	2½"	Oversized on 10", 12"

  

**Port and Cushion Adjustment Positions** (As viewed from rod end: Port standard position 1, Cushion Adjustment standard position 2.)  
NOTE: A Port and a Cushion Adjustment cannot be in the same position.

See page 156 for complete instructions on how to order cylinders.

# Series J & EJ, NFPA Steel Air Cylinder with 11 (MS1) Side End Angles

All Dimensions in Inches (mm)

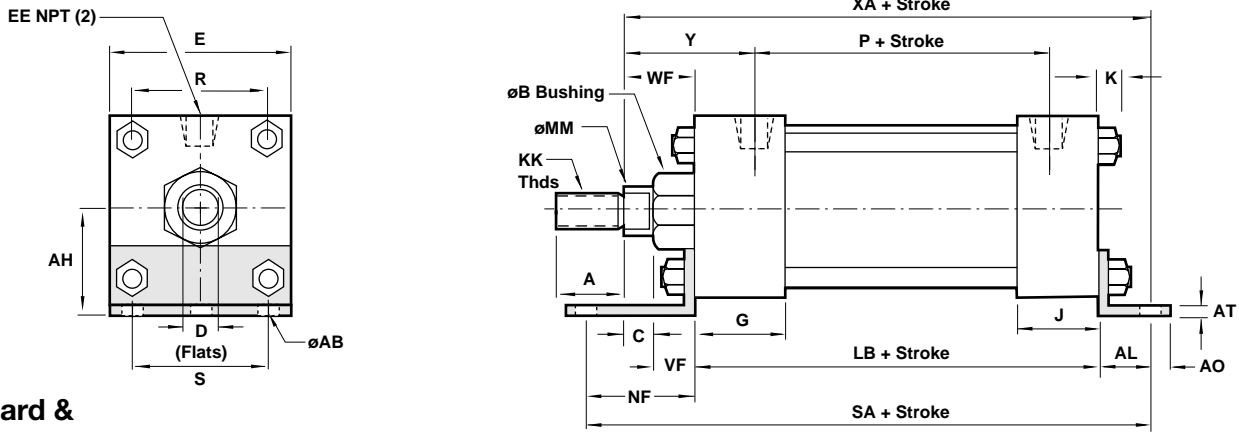

## Standard & Optional Rod Ends

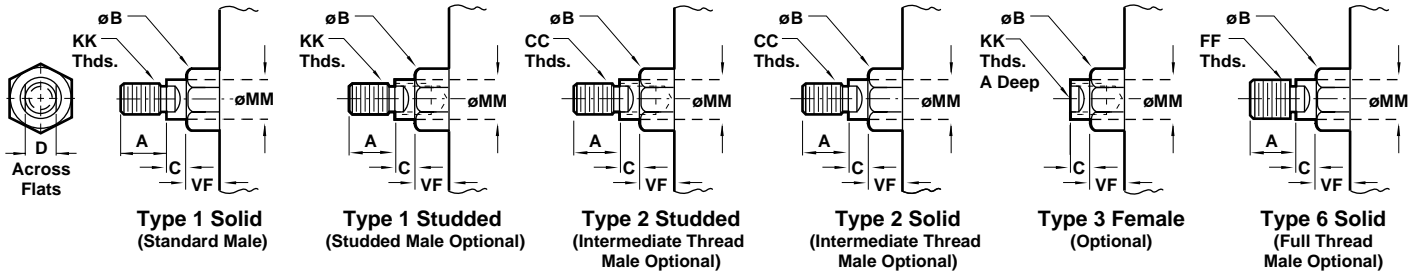

Dimension		1 1/2" Bore (38.10)	2" Bore (50.80)	2 1/2" Bore (63.50)	3 1/4" Bore (82.55)	4" Bore (101.60)	5" Bore (127.00)	6" Bore (152.40)
ø Rod	Std.	5/8" (15.88)	5/8" (15.88)	5/8" (15.88)	1" (25.40)	1" (25.40)	1" (25.40)	1 3/8" (34.93)
	O.S.	1" (25.40)	1" (25.40)	1" (25.40)	1 3/8" (34.93)	1 3/8" (34.93)	1 3/8" (34.93)	1 3/4" (44.45)
A	Std.	.750 (19.05)	.750 (19.05)	.750 (19.05)	1.125 (28.58)	1.125 (28.58)	1.125 (28.58)	1.625 (41.28)
	O.S.	1.125 (28.58)	1.125 (28.58)	1.125 (28.58)	1.625 (41.28)	1.625 (41.28)	1.625 (41.28)	2.000 (50.80)
AB		.438 (11.11)	.438 (11.11)	.438 (11.11)	.563 (14.29)	.563 (14.29)	.688 (17.46)	.813 (20.64)
AH		1.188 (30.16)	1.438 (36.51)	1.625 (41.28)	1.938 (49.21)	2.250 (57.15)	2.750 (69.85)	3.250 (82.55)
AL		1.000 (25.40)	1.000 (25.40)	1.000 (25.40)	1.250 (31.75)	1.250 (31.75)	1.375 (34.93)	1.375 (34.93)
AO		.375 (9.53)	.375 (9.53)	.375 (9.53)	.500 (12.70)	.500 (12.70)	.625 (15.88)	.625 (15.88)
AT		.125 (3.18)	.125 (3.18)	.125 (3.18)	.125 (3.18)	.125 (3.18)	.187 (4.75)	.187 (4.75)
B	Std.	1.124 (28.55)	1.124 (28.55)	1.124 (28.55)	1.499 (38.08)	1.499 (38.08)	1.499 (38.08)	1.999 (50.78)
	O.S.	1.499 (38.08)	1.499 (38.08)	1.499 (38.08)	1.999 (50.78)	1.999 (50.78)	1.999 (50.78)	2.374 (60.30)
C	Std.	.375 (9.53)	.375 (9.53)	.375 (9.53)	.500 (12.70)	.500 (12.70)	.500 (12.70)	.625 (15.88)
	O.S.	.500 (12.70)	.500 (12.70)	.500 (12.70)	.625 (15.88)	.625 (15.88)	.625 (15.88)	.750 (19.05)
CC	Std.	1/2 - 20	1/2 - 20	1/2 - 20	7/8 - 14	7/8 - 14	7/8 - 14	1 1/4 - 12
	O.S.	7/8 - 14	7/8 - 14	7/8 - 14	1 1/4 - 12	1 1/4 - 12	1 1/4 - 12	1 1/2 - 12
D	Std.	.500 (12.70)	.500 (12.70)	.500 (12.70)	.813 (20.64)	.813 (20.64)	.813 (20.64)	1.125 (28.58)
	O.S.	.813 (20.64)	.813 (20.64)	.813 (20.64)	1.125 (28.58)	1.125 (28.58)	1.125 (28.58)	1.500 (38.10)
E		2.000 (50.80)	2.500 (63.50)	3.000 (76.20)	3.750 (95.25)	4.500 (114.30)	5.500 (139.70)	6.500 (165.10)
EE		.375 (9.53)	.375 (9.53)	.375 (9.53)	.500 (12.70)	.500 (12.70)	.500 (12.70)	.750 (19.05)
FF	Std.	5/8 - 18	5/8 - 18	5/8 - 18	1 - 14	1 - 14	1 - 14	1 3/8 - 12
	O.S.	1 - 14	1 - 14	1 - 14	1 3/8 - 12	1 3/8 - 12	1 3/8 - 12	1 3/4 - 12
G		1.500 (38.10)	1.500 (38.10)	1.500 (38.10)	1.750 (44.45)	1.750 (44.45)	1.750 (44.45)	2.000 (50.80)
J		1.000 (25.40)	1.000 (25.40)	1.000 (25.40)	1.250 (31.75)	1.250 (31.75)	1.250 (31.75)	1.500 (38.10)
K		.250 (6.35)	.313 (7.94)	.313 (7.94)	.375 (9.53)	.375 (9.53)	.438 (11.11)	.438 (11.11)
KK	Std.	7/16 - 20	7/16 - 20	7/16 - 20	3/4 - 16	3/4 - 16	3/4 - 16	1 - 14
	O.S.	3/4 - 16	3/4 - 16	3/4 - 16	1 - 14	1 - 14	1 - 14	1 1/4 - 12
LB		3.625 (92.08)	3.625 (92.08)	3.750 (95.25)	4.250 (107.95)	4.250 (107.95)	4.500 (114.30)	5.000 (127.00)
MM	Std.	.625 (15.88)	.625 (15.88)	.625 (15.88)	1.000 (25.40)	1.000 (25.40)	1.000 (25.40)	1.375 (34.93)
	O.S.	1.000 (25.40)	1.000 (25.40)	1.000 (25.40)	1.375 (34.93)	1.375 (34.93)	1.375 (34.93)	1.750 (44.45)
NF		1.375 (34.93)	1.375 (34.93)	1.375 (34.93)	1.875 (47.63)	1.875 (47.63)	2.000 (50.80)	2.125 (53.98)
P		2.313 (58.74)	2.313 (58.74)	2.438 (61.91)	2.625 (66.68)	2.625 (66.68)	2.875 (73.03)	3.125 (79.38)
R		1.428 (36.27)	1.838 (46.68)	2.192 (55.67)	2.758 (70.05)	3.323 (84.40)	4.101 (104.16)	4.879 (123.92)
S		1.250 (31.75)	1.750 (44.45)	2.250 (57.15)	2.750 (69.85)	3.500 (88.90)	4.250 (107.95)	5.250 (133.35)
SA		6.000 (152.40)	6.000 (152.40)	6.125 (155.58)	7.375 (187.33)	7.375 (187.33)	7.875 (200.03)	8.500 (215.90)
VF	Std.	.625 (15.88)	.625 (15.88)	.625 (15.88)	.875 (22.23)	.875 (22.23)	.875 (22.23)	1.000 (25.40)
	O.S.	.875 (22.23)	.875 (22.23)	.875 (22.23)	1.000 (25.40)	1.000 (25.40)	1.000 (25.40)	1.125 (28.58)
WF	Std.	1.000 (25.40)	1.000 (25.40)	1.000 (25.40)	1.375 (34.93)	1.375 (34.93)	1.375 (34.93)	1.625 (41.28)
	O.S.	1.375 (34.93)	1.375 (34.93)	1.375 (34.93)	1.625 (41.28)	1.625 (41.28)	1.625 (41.28)	1.875 (47.63)
XA	Std.	5.625 (142.88)	5.625 (142.88)	5.750 (146.05)	6.875 (174.63)	6.875 (174.63)	7.250 (184.15)	8.000 (203.20)
	O.S.	6.000 (152.40)	6.000 (152.40)	6.125 (155.58)	7.125 (180.98)	7.125 (180.98)	7.500 (190.50)	8.250 (209.55)
Y	Std.	1.875 (47.63)	1.875 (47.63)	1.875 (47.63)	2.438 (61.91)	2.438 (61.91)	2.438 (61.91)	2.813 (71.44)
	O.S.	2.250 (57.15)	2.250 (57.15)	2.250 (57.15)	2.688 (68.26)	2.688 (68.26)	2.688 (68.26)	3.063 (77.79)

## Cylinder with 11 (MS1) Side End Angles

- **NFPA (MS1) 11 Side End Angle Mount for 7" to 12" bore sizes.**
- **Series J Cylinders rated to 250 PSI air, 400 PSI hydraulic (non-shock). Series EJ Cylinders rated to 250 PSI air only.**
- **Designed for non-lube service.**
- **Switches available on all bore sizes. (See page 150 & 151 for ordering information.)**



### Cylinder Order Information

**11** - - - -

J	Series J Cylinder
EJ	Series EJ Cylinder

Bore and Stroke (write out)

Mounting Options	
01	Side Tapped (MS4)
03	Head Rectangular Flange (MF1)
03	Head Square (ME3)–7" to 12" Bores
04	Cap Rectangular Flange (MF2)
04	Cap Square (ME4)–7" to 12" Bores
05	Basic Cylinder No Mounting (MX0)
06	Both Ends (4) Tie Rods Ext. (MX1)
6B	Both Ends (2) Tie Rods Ext. (MX4)
6C	Cap Tie Rods Ext. (MX2)
6R	Head Tie Rods Ext. (MX3)
07	Head Trunnion (MT1)
08	Cap Trunnion (MT2)
09	Side Lugs (MS2)
10	Center Trunnion (MT4)
<b>11</b>	<b>Side End Angles (MS1)</b>
12	Cap Fixed Clevis (MP1)
15	Side End Lugs (MS7)
16	Sleeve Nut Construction (Universal)
20	Head Square Flange (MF5)
21	Cap Square Flange (MF6)
22	Detachable Cap Clevis (MP2)
32	Cap Fixed Eye (MP3)
42	Detachable Cap Eye (MP4)
52	Spherical Bearing

Cushion in Head	
3	None
5 <sup>†</sup>	Non-Adjustable Cushion
7	Adjustable Cushion (Position 2)

<sup>†</sup>Standard with EJ

Cushion in Cap	
3	None
5 <sup>†</sup>	Non-Adjustable Cushion
7	Adjustable Cushion (Position 2)

<sup>†</sup>Standard with EJ

Additional Options – order alphabetically – More on page 155	
HR	Case Hardened (45 Rc)
L(- -)	Port Location position 1 standard: L(Head Cap) (specify position 1 thru 4 for head and/or cap)
MS	Metal Rod Scraper
N(- -)	Cushion Adjust Screw Location position 2 standard: N(Head Cap) (specify position 1 thru 4 for head and/or cap)
P(-)*	Non-Standard Port Sizes: [specify port size for P(-H) head only, P(-C) cap only, or P(-) both head & cap]
PS	Magnetic Piston – includes aluminum tube option
RS	Rod Stud Type 1 (5/8" – 1¾" øRod) Type 2 (5/8" & 1" øRod)
RX	Rod Extensions (specify length of additional rod extension)
SC	Single Acting Spring Extend (Cap End)–See page 155
SR	Single Acting Spring Retract (Rod End)–See page 155
SS	303 Stainless Steel (Hard Chrome Plated)
ST(-C)	Stop Tube (Cap End) (specify stop tube length)
ST(-R)	Stop Tube (Rod End) (specify stop tube length)
T	Special Rod Threads (specify rod thread)
TX	Thread Extensions (specify length of thread extension)
V	Viton® Seals

\*1½", 2", 2½" bore cylinders have 3/8" NPT Standard, 1/2" NPT oversize. 3¼", 4", 5" bore cylinders have 1/2" NPT Standard, 3/4" NPT oversize. This will add 1/8" to the overall cylinder length.

Piston Rod Threads Type	
1	Small Male (Solid)
2	Intermediate Thread Male (Solid)
3	Female
6	Full Thread Male (Solid)
7	Plain Rod End

Piston Rod Diameters		
A	5/8"	Standard on 1½", 2", 2½"
B	1"	Standard on 3¼", 4", 5" Oversized on 1½", 2", 2½"
C	1⅜"	Standard on 6", 7", 8" Oversized on 3¼", 4", 5"
D	1¾"	Standard on 10" Oversized on 6", 7", 8"
E	2"	Standard on 12" Oversized on 10"
F	2½"	Oversized on 10", 12"

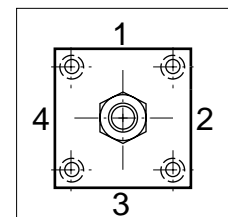

**Port and Cushion Adjustment Positions** (As viewed from rod end: Port standard position 1, Cushion Adjustment standard position 2.)  
NOTE: A Port and a Cushion Adjustment cannot be in the same position.

See page 156 for complete instructions on how to order cylinders.



# Series J & EJ, NFPA Steel Air Cylinder with 11 (MS1) Side End Angles

All Dimensions in Inches (mm)

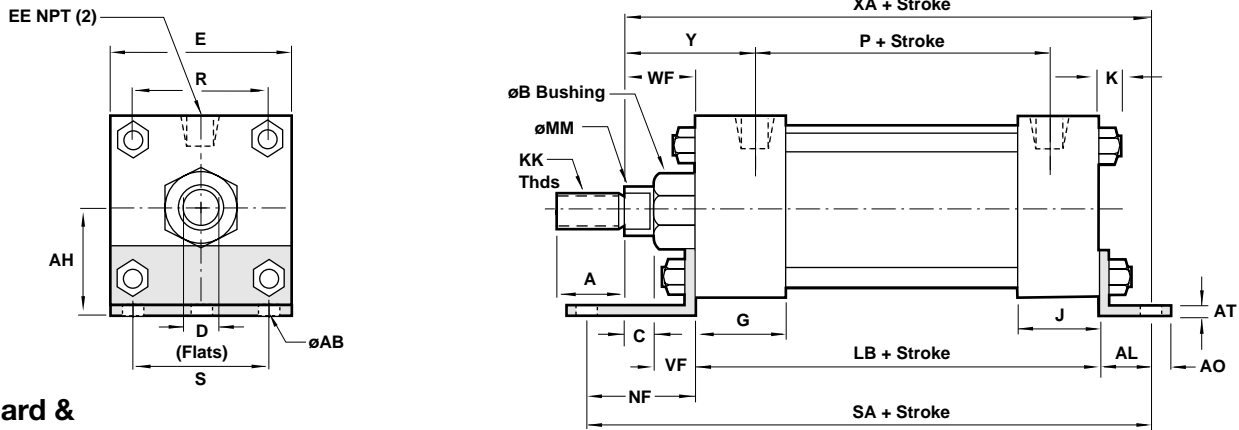

## Standard & Optional Rod Ends

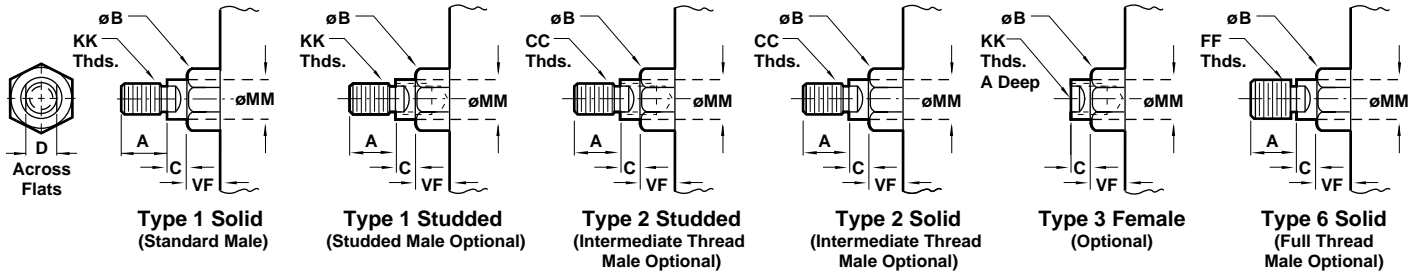

Dimension		7" Bore (177.80)	8" Bore (203.20)	10" Bore (254.00)	12" Bore (304.80)
ø Rod	Std.	1 3/8" (34.93)	1 3/8" (34.93)	1 3/4" (44.45)	2" (50.80)
	O.S.	1 3/4" (44.45)	1 3/4" (44.45)	2" (50.80)	2 1/2" (63.50)
A	Std.	1.625 (41.28)	1.625 (41.28)	2.000 (50.80)	2.250 (57.15)
	O.S.	2.000 (50.80)	2.000 (50.80)	2.250 (57.15)	3.000 (76.20)
AB		.813 (20.64)	.813 (20.64)	1.063 (26.99)	1.063 (26.99)
AH		3.750 (95.25)	4.250 (107.95)	5.313 (134.94)	6.375 (161.93)
AL		1.813 (46.04)	1.813 (46.04)	2.125 (53.98)	2.125 (53.98)
AO		.688 (17.46)	.688 (17.46)	.875 (22.23)	.875 (22.23)
AT		.250 (6.35)	.250 (6.35)	.250 (6.35)	.250 (6.35)
B	Std.	1.999 (50.78)	1.999 (50.78)	2.374 (60.30)	2.624 (66.65)
	O.S.	2.374 (60.30)	2.374 (60.30)	2.624 (66.65)	3.124 (79.35)
C	Std.	.625 (15.88)	.625 (15.88)	.750 (19.05)	.875 (22.23)
	O.S.	.750 (19.05)	.750 (19.05)	.875 (22.23)	1.000 (25.40)
CC	Std.	1 1/4 - 12	1 1/4 - 12	1 1/2 - 12	1 3/4 - 12
	O.S.	1 1/2 - 12	1 1/2 - 12	1 3/4 - 12	2 1/4 - 12
D	Std.	1.125 (28.58)	1.125 (28.58)	1.500 (38.10)	1.688 (42.86)
	O.S.	1.500 (38.10)	1.500 (38.10)	1.688 (42.86)	2.063 (52.39)
E		7.500 (190.50)	8.500 (215.90)	10.625 (269.88)	12.750 (323.85)
EE		.750 (19.05)	.750 (19.05)	1.000 (25.40)	1.000 (25.40)
FF	Std.	1 3/8 - 12	1 3/8 - 12	1 3/4 - 12	2 - 12
	O.S.	1 3/4 - 12	1 3/4 - 12	2 - 12	2 1/2 - 12
G		2.000 (50.80)	2.000 (50.80)	2.250 (57.15)	2.250 (57.15)
J		1.500 (38.10)	1.500 (38.10)	2.000 (50.80)	2.500 (50.80)
K		.563 (14.29)	.563 (14.29)	.688 (17.46)	.688 (17.46)
KK	Std.	1 - 14	1 - 14	1 1/4 - 12	1 1/2 - 12
	O.S.	1 1/4 - 12	1 1/4 - 12	1 1/2 - 12	1 7/8 - 12
LB		5.125 (130.18)	5.125 (130.18)	6.375 (161.93)	6.875 (174.63)
MM	Std.	1.375 (34.93)	1.375 (34.93)	1.750 (44.45)	2.000 (50.80)
	O.S.	1.750 (44.45)	1.750 (44.45)	2.000 (50.80)	2.500 (63.50)
NF		1.813 (46.04)	1.813 (46.04)	1.813 (46.04)	1.813 (46.04)
P		3.250 (82.55)	3.250 (82.55)	4.125 (104.78)	4.625 (117.48)
R		5.730 (145.54)	6.442 (163.63)	7.969 (202.41)	9.406 (238.92)
S		6.125 (155.58)	7.125 (180.98)	8.825 (225.43)	11.000 (279.40)
SA		8.750 (222.25)	8.750 (222.25)	10.625 (269.53)	11.125 (282.58)
VF	Std.	1.000 (25.40)	1.000 (25.40)	1.125 (28.58)	1.125 (28.58)
	O.S.	1.125 (28.58)	1.125 (28.58)	1.125 (28.58)	1.250 (31.75)
WF	Std.	1.625 (41.28)	1.625 (41.28)	1.875 (47.63)	2.000 (50.80)
	O.S.	1.875 (47.63)	1.875 (47.63)	2.000 (50.80)	2.250 (57.15)
XA	Std.	8.562 (217.47)	8.562 (217.47)	10.375 (263.53)	11.000 (279.40)
	O.S.	8.813 (223.84)	8.813 (223.84)	10.500 (266.70)	11.250 (285.75)
Y	Std.	2.813 (71.44)	2.813 (71.44)	3.125 (79.38)	3.250 (82.55)
	O.S.	3.063 (77.79)	3.063 (77.79)	3.250 (82.55)	3.500 (88.90)

## Cylinder with 12 (MP1) Cap Fixed Clevis

- NFPA (MP1) 12 Cap Fixed Clevis Mount for 1-1/2" to 6" steel bore sizes.
- Series J Cylinders rated to 250 PSI air, 400 PSI hydraulic (non-shock). Series EJ Cylinders rated to 250 PSI air only.
- Designed for non-lube service.
- Switches available on all bore sizes. (See pages 150 & 151 for ordering information.)



### Cylinder Order Information

12 - - - -

J	Series J Cylinder		Bore and Stroke (write out)
EJ	Series EJ Cylinder		

Mounting Options	
01	Side Tapped (MS4)
03	Head Rectangular Flange (MF1)
03	Head Square (ME3) – 7" to 12" Bores
04	Cap Rectangular Flange (MF2)
04	Cap Square (ME4) – 7" to 12" Bores
05	Basic Cylinder No Mounting (MX0)
06	Both Ends (4) Tie Rods Ext. (MX1)
6B	Both Ends (2) Tie Rods Ext. (MX4)
6C	Cap Tie Rods Ext. (MX2)
6R	Head Tie Rods Ext. (MX3)
07	Head Trunnion (MT1)
08	Cap Trunnion (MT2)
09	Side Lugs (MS2)
10	Center Trunnion (MT4)
11	Side End Angles (MS1)
<b>12</b>	<b>Cap Fixed Clevis (MP1)</b>
15	Side End Lugs (MS7)
16	Sleeve Nut Construction (Universal)
20	Head Square Flange (MF5)
21	Cap Square Flange (MF6)
22	Detachable Cap Clevis (MP2)
32	Cap Fixed Eye (MP3)
42	Detachable Cap Eye (MP4)
52	Spherical Bearing

Additional Options – order alphabetically – More on page 155	
HR	Case Hardened (45 Rc)
L(- -)	Port Location position 1 standard: L(Head Cap) (specify position 1 thru 4 for head and/or cap)
MS	Metal Rod Scraper
N(- -)	Cushion Adjust Screw Location position 2 standard: N(Head Cap) (specify position 1 thru 4 for head and/or cap)
P(-)*	Non-Standard Port Sizes: [specify port size for P(-H) head only, P(-C) cap only, or P(-) both head & cap]
PS	Magnetic Piston
RS	Rod Stud Type 1 (5/8" – 1 3/4" øRod) Type 2 (5/8" & 1" øRod)
RX	Rod Extensions (specify length of additional rod extension)
SC	Single Acting Spring Extend (Cap End)–See page 155
SR	Single Acting Spring Retract (Rod End)–See page 155
SS	303 Stainless Steel (Hard Chrome Plated)
ST(-C)	Stop Tube (Cap End) (specify stop tube length)
ST(-R)	Stop Tube (Rod End) (specify stop tube length)
T	Special Rod Threads (specify rod thread)
TX	Thread Extensions (specify length of thread extension)
V	Viton® Seals

Piston Rod Threads Type	
1	Small Male (Solid)
2	Intermediate Thread Male (Solid)
3	Female
6	Full Thread Male (Solid)
7	Plain Rod End

Piston Rod Diameters		
A	5/8"	Standard on 1 1/2", 2", 2 1/2" Standard on 3 1/4", 4", 5"
B	1"	Oversized on 1 1/2", 2", 2 1/2" Standard on 6", 7", 8"
C	1 3/8"	Oversized on 3 1/4", 4", 5"
D	1 3/4"	Oversized on 6", 7", 8"
E	2"	Standard on 12" Oversized on 10"
F	2 1/2"	Oversized on 10", 12"

Cushion in Head	
3	None
5 <sup>†</sup>	Non-Adjustable Cushion
7	Adjustable Cushion (Position 2)

<sup>†</sup>Standard with EJ

Cushion in Cap	
3	None
5 <sup>†</sup>	Non-Adjustable Cushion
7	Adjustable Cushion (Position 2)

<sup>†</sup>Standard with EJ

  

**Port and Cushion Adjustment Positions** (As viewed from rod end: Port standard position 1, Cushion Adjustment standard position 2.)  
NOTE: A Port and a Cushion Adjustment cannot be in the same position.

See page 156 for complete instructions on how to order cylinders.

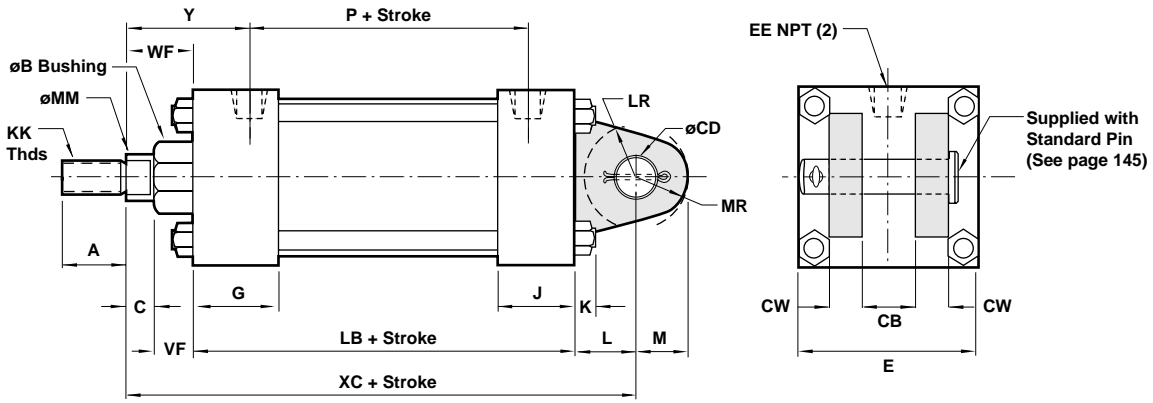

Standard & Optional Rod Ends

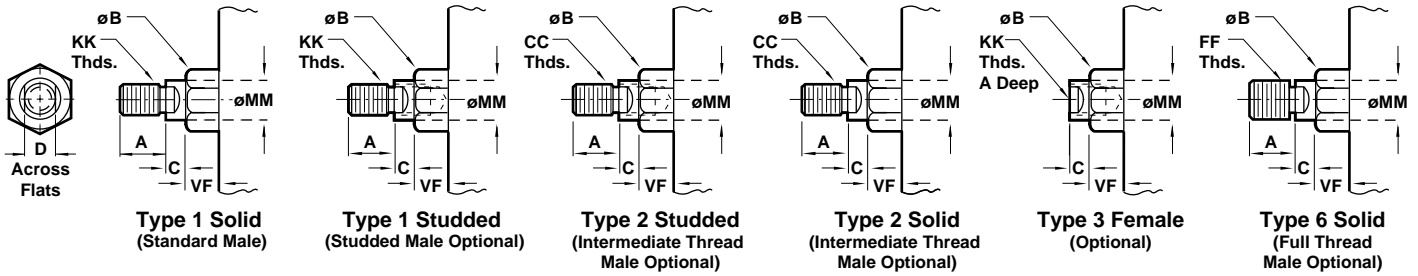

Dimension		1 1/2" Bore (38.10)	2" Bore (50.80)	2 1/2" Bore (63.50)	3 1/4" Bore (82.55)	4" Bore (101.60)	5" Bore (127.00)	6" Bore (152.40)
ø Rod	Std.	5/8" (15.88)	5/8" (15.88)	5/8" (15.88)	1" (25.40)	1" (25.40)	1" (25.40)	1 3/8" (34.93)
	O.S.	1" (25.40)	1" (25.40)	1" (25.40)	1 3/8" (34.93)	1 3/8" (34.93)	1 3/8" (34.93)	1 3/4" (44.45)
A	Std.	.750 (19.05)	.750 (19.05)	.750 (19.05)	1.125 (28.58)	1.125 (28.58)	1.125 (28.58)	1.625 (41.28)
	O.S.	1.125 (28.58)	1.125 (28.58)	1.125 (28.58)	1.625 (41.28)	1.625 (41.28)	1.625 (41.28)	2.000 (50.80)
B +.000 -.002	Std.	1.124 (28.55)	1.124 (28.55)	1.124 (28.55)	1.499 (38.08)	1.499 (38.08)	1.499 (38.08)	1.999 (50.78)
	O.S.	1.499 (38.08)	1.499 (38.08)	1.499 (38.08)	1.999 (50.78)	1.999 (50.78)	1.999 (50.78)	2.374 (60.30)
C	Std.	.375 (9.53)	.375 (9.53)	.375 (9.53)	.500 (12.70)	.500 (12.70)	.500 (12.70)	.625 (15.88)
	O.S.	.500 (12.70)	.500 (12.70)	.500 (12.70)	.625 (15.88)	.625 (15.88)	.625 (15.88)	.750 (19.05)
CB		.750 (19.05)	.750 (19.05)	.750 (19.05)	1.250 (31.75)	1.250 (31.75)	1.250 (31.75)	1.500 (38.10)
CC	Std.	1/2 - 20	1/2 - 20	1/2 - 20	7/8 - 14	7/8 - 14	7/8 - 14	1 1/4 - 12
	O.S.	7/8 - 14	7/8 - 14	7/8 - 14	1 1/4 - 12	1 1/4 - 12	1 1/4 - 12	1 1/2 - 12
CD		.500 (12.70)	.500 (12.70)	.500 (12.70)	.750 (19.05)	.750 (19.05)	.750 (19.05)	1.000 (25.40)
CW		.500 (12.70)	.500 (12.70)	.500 (12.70)	.625 (15.88)	.625 (15.88)	.625 (15.88)	.750 (19.05)
D	Std.	.500 (12.70)	.500 (12.70)	.500 (12.70)	.813 (20.64)	.813 (20.64)	.813 (20.64)	1.125 (28.58)
	O.S.	.813 (20.64)	.813 (20.64)	.813 (20.64)	1.125 (28.58)	1.125 (28.58)	1.125 (28.58)	1.500 (38.10)
E		2.000 (50.80)	2.500 (63.50)	3.000 (76.20)	3.750 (95.25)	4.500 (114.30)	5.500 (139.70)	6.500 (165.10)
EE		.375 (9.53)	.375 (9.53)	.375 (9.53)	.500 (12.70)	.500 (12.70)	.500 (12.70)	.750 (19.05)
FF	Std.	5/8 - 18	5/8 - 18	5/8 - 18	1 - 14	1 - 14	1 - 14	1 3/8 - 12
	O.S.	1 - 14	1 - 14	1 - 14	1 3/8 - 12	1 3/8 - 12	1 3/8 - 12	1 3/4 - 12
G		1.500 (38.10)	1.500 (38.10)	1.500 (38.10)	1.750 (44.45)	1.750 (44.45)	1.750 (44.45)	2.000 (50.80)
J		1.000 (25.40)	1.000 (25.40)	1.000 (25.40)	1.250 (31.75)	1.250 (31.75)	1.250 (31.75)	1.500 (38.10)
K		.250 (6.35)	.313 (7.94)	.313 (7.94)	.375 (9.53)	.375 (9.53)	.438 (11.11)	.438 (11.11)
KK	Std.	7/16 - 20	7/16 - 20	7/16 - 20	3/4 - 16	3/4 - 16	3/4 - 16	1 - 14
	O.S.	3/4 - 16	3/4 - 16	3/4 - 16	1 - 14	1 - 14	1 - 14	1 1/4 - 12
L		.750 (19.05)	.750 (19.05)	.750 (19.05)	1.250 (31.75)	1.250 (31.75)	1.250 (31.75)	1.500 (38.10)
LB		3.625 (92.08)	3.625 (92.08)	3.750 (95.25)	4.250 (107.95)	4.250 (107.95)	4.500 (114.30)	5.000 (127.00)
LR		.750 (19.05)	.750 (19.05)	.750 (19.05)	1.250 (31.75)	1.250 (31.75)	1.250 (31.75)	1.500 (38.10)
M		.500 (12.70)	.500 (12.70)	.500 (12.70)	.750 (19.05)	.750 (19.05)	.750 (19.05)	1.000 (25.40)
MM	Std.	.625 (15.88)	.625 (15.88)	.625 (15.88)	1.000 (25.40)	1.000 (25.40)	1.000 (25.40)	1.375 (34.93)
	O.S.	1.000 (25.40)	1.000 (25.40)	1.000 (25.40)	1.375 (34.93)	1.375 (34.93)	1.375 (34.93)	1.750 (44.45)
MR		.625 (15.88)	.625 (15.88)	.625 (15.88)	.938 (23.81)	.938 (23.81)	.938 (23.81)	1.188 (30.16)
P		2.313 (58.74)	2.313 (58.74)	2.438 (61.91)	2.625 (66.68)	2.625 (66.68)	2.875 (73.03)	3.125 (79.38)
VF	Std.	.625 (15.88)	.625 (15.88)	.625 (15.88)	.875 (22.23)	.875 (22.23)	.875 (22.23)	1.000 (25.40)
	O.S.	.875 (22.23)	.875 (22.23)	.875 (22.23)	1.000 (25.40)	1.000 (25.40)	1.000 (25.40)	1.125 (28.58)
WF	Std.	1.000 (25.40)	1.000 (25.40)	1.000 (25.40)	1.375 (34.93)	1.375 (34.93)	1.375 (34.93)	1.625 (41.28)
	O.S.	1.375 (34.93)	1.375 (34.93)	1.375 (34.93)	1.625 (41.28)	1.625 (41.28)	1.625 (41.28)	1.875 (47.63)
XC	Std.	5.375 (136.53)	5.375 (136.53)	5.500 (139.70)	6.875 (174.63)	6.875 (174.63)	7.125 (180.98)	8.125 (206.38)
	O.S.	5.750 (146.05)	5.750 (146.05)	5.875 (149.23)	7.125 (180.98)	7.125 (180.98)	7.375 (187.33)	8.375 (212.73)
Y	Std.	1.875 (47.63)	1.875 (47.63)	1.875 (47.63)	2.438 (61.91)	2.438 (61.91)	2.438 (61.91)	2.813 (71.44)
	O.S.	2.250 (57.15)	2.250 (57.15)	2.250 (57.15)	2.688 (68.26)	2.688 (68.26)	2.688 (68.26)	3.063 (77.79)

## Cylinder with 12 (MP1) Cap Fixed Clevis

- **NFPA (MP1) 12 Cap Fixed Clevis Mount** for 7" to 12" steel bore sizes.
- **Series J Cylinders** rated to 250 PSI air, 400 PSI hydraulic (non-shock).  
**Series EJ Cylinders** rated to 250 PSI air only.
- **Designed for non-lube service.**
- **Switches available on all bore sizes.**  
(See pages 150 & 151 for ordering information.)



### Cylinder Order Information

**12** - - - -

J	Series J Cylinder
EJ	Series EJ Cylinder

Bore and Stroke (write out)

Mounting Options	
01	Side Tapped (MS4)
03	Head Rectangular Flange (MF1)
03	Head Square (ME3) – 7" to 12" Bores
04	Cap Rectangular Flange (MF2)
04	Cap Square (ME4) – 7" to 12" Bores
05	Basic Cylinder No Mounting (MX0)
06	Both Ends (4) Tie Rods Ext. (MX1)
6B	Both Ends (2) Tie Rods Ext. (MX4)
6C	Cap Tie Rods Ext. (MX2)
6R	Head Tie Rods Ext. (MX3)
07	Head Trunnion (MT1)
08	Cap Trunnion (MT2)
09	Side Lugs (MS2)
10	Center Trunnion (MT4)
11	Side End Angles (MS1)
<b>12</b>	<b>Cap Fixed Clevis (MP1)</b>
15	Side End Lugs (MS7)
16	Sleeve Nut Construction (Universal)
20	Head Square Flange (MF5)
21	Cap Square Flange (MF6)
22	Detachable Cap Clevis (MP2)
32	Cap Fixed Eye (MP3)
42	Detachable Cap Eye (MP4)
52	Spherical Bearing

Additional Options – order alphabetically – More on page 155	
HR	Case Hardened (45 Rc)
L(- -)	Port Location position 1 standard: L(Head Cap) (specify position 1 thru 4 for head and/or cap)
MS	Metal Rod Scraper
N(- -)	Cushion Adjust Screw Location position 2 standard: N(Head Cap) (specify position 1 thru 4 for head and/or cap)
P(-)*	Non-Standard Port Sizes: [specify port size for P(-H) head only, P(-C) cap only, or P(-) both head & cap]
PS	Magnetic Piston
RS	Rod Stud Type 1 (5/8" – 1¾" øRod) Type 2 (5/8" & 1" øRod)
RX	Rod Extensions (specify length of additional rod extension)
SC	Single Acting Spring Extend (Cap End)–See page 155
SR	Single Acting Spring Retract (Rod End)–See page 155
SS	303 Stainless Steel (Hard Chrome Plated)
ST(-C)	Stop Tube (Cap End) (specify stop tube length)
ST(-R)	Stop Tube (Rod End) (specify stop tube length)
T	Special Rod Threads (specify rod thread)
TX	Thread Extensions (specify length of thread extension)
V	Viton® Seals

\*1½", 2", 2½" bore cylinders have ¾" NPT Standard, ½" NPT oversize.  
3¼", 4", 5" bore cylinders have ½" NPT Standard, ¾" NPT oversize.  
This will add ⅛" to the overall cylinder length.

Piston Rod Threads Type	
1	Small Male (Solid)
2	Intermediate Thread Male (Solid)
3	Female
6	Full Thread Male (Solid)
7	Plain Rod End

Piston Rod Diameters		
A	5/8"	Standard on 1½", 2", 2½"
B	1"	Standard on 3¼", 4", 5"
		Oversized on 1½", 2", 2½"
C	1¾"	Standard on 6", 7", 8"
		Oversized on 3¼", 4", 5"
D	1¾"	Standard on 10"
		Oversized on 6", 7", 8"
E	2"	Standard on 12"
		Oversized on 10"
F	2½"	Oversized on 10", 12"

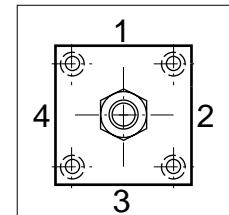

**Port and Cushion Adjustment Positions** (As viewed from rod end:  
Port standard position 1, Cushion Adjustment standard position 2.)  
NOTE: A Port and a Cushion Adjustment cannot be in the same position.

Cushion in Head	
3	None
5 <sup>†</sup>	Non-Adjustable Cushion
7	Adjustable Cushion (Position 2)

<sup>†</sup>Standard with EJ

Cushion in Cap	
3	None
5 <sup>†</sup>	Non-Adjustable Cushion
7	Adjustable Cushion (Position 2)

<sup>†</sup>Standard with EJ

See page 156 for complete instructions on how to order cylinders.

# Series J & EJ, NFPA Steel Air Cylinder with 12 (MP1) Cap Fixed Clevis

All Dimensions in Inches (mm)

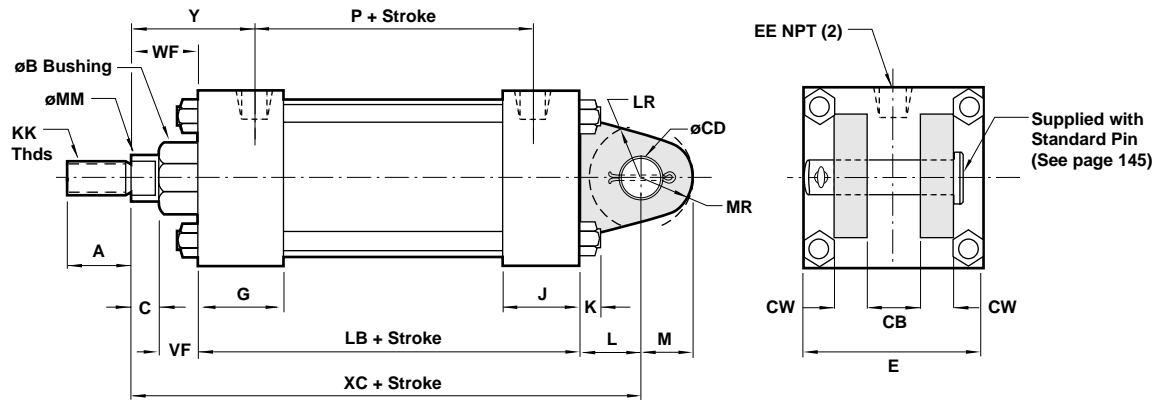

## Standard & Optional Rod Ends

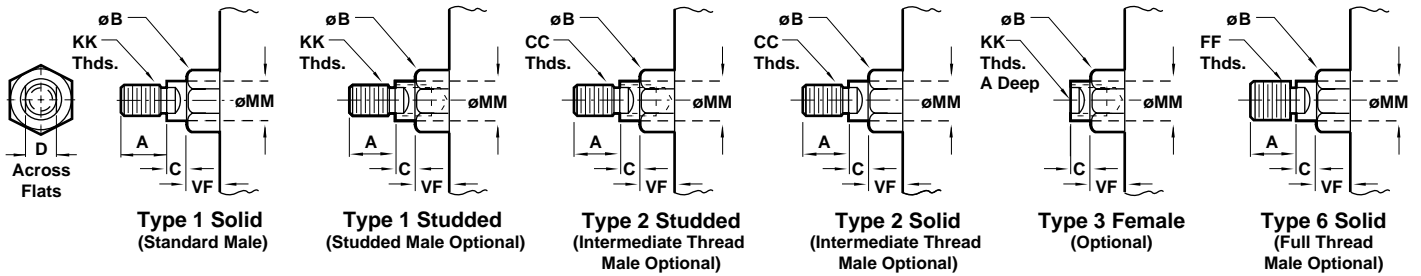

Dimension		7" Bore (177.80)	8" Bore (203.20)	10" Bore (254.00)	12" Bore (304.80)
ø Rod	Std.	1 3/8" (34.93)	1 3/8" (34.93)	1 3/4" (44.45)	2" (50.80)
	O.S.	1 3/4" (44.45)	1 3/4" (44.45)	2" (50.80)	2 1/2" (63.50)
A	Std.	1.625 (41.28)	1.625 (41.28)	2.000 (50.80)	2.250 (57.15)
	O.S.	2.000 (50.80)	2.000 (50.80)	2.250 (57.15)	3.000 (76.20)
B +.000 -.002	Std.	1.999 (50.78)	1.999 (50.78)	2.374 (60.30)	2.624 (66.65)
	O.S.	2.374 (60.30)	2.374 (60.30)	2.624 (66.65)	3.124 (79.35)
C	Std.	.625 (15.88)	.625 (15.88)	.750 (19.05)	.875 (22.23)
	O.S.	.750 (19.05)	.750 (19.05)	.875 (22.23)	1.000 (25.40)
CB		1.500 (38.10)	1.500 (38.10)	2.000 (50.80)	2.500 (63.50)
CC	Std.	1 1/4 - 12	1 1/4 - 12	1 1/2 - 12	1 3/4 - 12
	O.S.	1 1/2 - 12	1 1/2 - 12	1 3/4 - 12	2 1/4 - 12
CD		1.000 (25.40)	1.000 (25.40)	1.375 (34.93)	1.750 (44.45)
CW		.750 (19.05)	.750 (19.05)	1.000 (25.40)	1.250 (31.75)
D	Std.	1.125 (28.58)	1.125 (28.58)	1.500 (38.10)	1.688 (42.86)
	O.S.	1.500 (38.10)	1.500 (38.10)	1.688 (42.86)	2.063 (52.39)
E		7.500 (190.50)	8.500 (215.90)	10.625 (269.88)	12.750 (323.85)
EE		.750 (19.05)	.750 (19.05)	1.000 (25.40)	1.000 (25.40)
FF	Std.	1 3/8 - 12	1 3/8 - 12	1 3/4 - 12	2 - 12
	O.S.	1 3/4 - 12	1 3/4 - 12	2 - 12	2 1/2 - 12
G		2.000 (50.80)	2.000 (50.80)	2.250 (57.15)	2.250 (57.15)
J		1.500 (38.10)	1.500 (38.10)	2.000 (50.80)	2.000 (50.80)
K		.563 (14.29)	.563 (14.29)	.688 (17.46)	.688 (17.46)
KK	Std.	1 - 14	1 - 14	1 1/4 - 12	1 1/2 - 12
	O.S.	1 1/4 - 12	1 1/4 - 12	1 1/2 - 12	1 7/8 - 12
L		1.500 (38.10)	1.500 (38.10)	2.125 (53.98)	2.250 (57.15)
LB		5.125 (130.18)	5.125 (130.18)	6.375 (161.93)	6.875 (174.63)
LR		1.500 (38.10)	1.500 (38.10)	1.875 (47.63)	2.125 (53.98)
M		1.000 (25.40)	1.000 (25.40)	1.375 (34.93)	1.750 (44.45)
MM	Std.	1.375 (34.93)	1.375 (34.93)	1.750 (44.45)	2.000 (50.80)
	O.S.	1.750 (44.45)	1.750 (44.45)	2.000 (50.80)	2.500 (63.50)
MR		1.188 (30.16)	1.188 (30.16)	1.625 (41.28)	2.125 (53.98)
P		3.250 (82.55)	3.250 (82.55)	4.125 (104.78)	4.625 (117.48)
VF	Std.	1.000 (25.40)	1.000 (25.40)	1.125 (28.58)	1.125 (28.58)
	O.S.	1.125 (28.58)	1.125 (28.58)	1.125 (28.58)	1.250 (31.75)
WF	Std.	1.625 (41.28)	1.625 (41.28)	1.875 (47.63)	2.000 (50.80)
	O.S.	1.875 (47.63)	1.875 (47.63)	2.000 (50.80)	2.250 (57.15)
XC	Std.	8.250 (209.55)	8.250 (209.55)	10.375 (263.53)	11.125 (282.58)
	O.S.	8.500 (215.90)	8.500 (215.90)	10.500 (266.70)	11.375 (288.93)
Y	Std.	2.813 (71.44)	2.813 (71.44)	3.125 (79.38)	3.250 (82.55)
	O.S.	3.063 (77.79)	3.063 (77.79)	3.250 (82.55)	3.500 (88.90)

## Cylinder with 15 (MS7) Side End Lugs

- **NFPA (MS7) 15 End Lug Mount** for 1-1/2" to 8" bore sizes.
- **Series J Cylinders** rated to 250 PSI air, 400 PSI hydraulic (non-shock).  
**Series EJ Cylinders** rated to 250 PSI air only.
- **Designed for non-lube service.**
- **Switches available on all bore sizes.**  
(See pages 150 & 151 for ordering information.)



### Cylinder Order Information

15 - - - -

J	Series J Cylinder
EJ	Series EJ Cylinder

Bore and Stroke (write out)

Mounting Options	
01	Side Tapped (MS4)
03	Head Rectangular Flange (MF1)
03	Head Square (ME3) – 7" to 12" Bores
04	Cap Rectangular Flange (MF2)
04	Cap Square (ME4) – 7" to 12" Bores
05	Basic Cylinder No Mounting (MX0)
06	Both Ends (4) Tie Rods Ext. (MX1)
6B	Both Ends (2) Tie Rods Ext. (MX4)
6C	Cap Tie Rods Ext. (MX2)
6R	Head Tie Rods Ext. (MX3)
07	Head Trunnion (MT1)
08	Cap Trunnion (MT2)
09	Side Lugs (MS2)
10	Center Trunnion (MT4)
11	Side End Angles (MS1)
12	Cap Fixed Clevis (MP1)
<b>15</b>	<b>Side End Lugs (MS7)</b>
16	Sleeve Nut Construction (Universal)
20	Head Square Flange (MF5)
21	Cap Square Flange (MF6)
22	Detachable Cap Clevis (MP2)
32	Cap Fixed Eye (MP3)
42	Detachable Cap Eye (MP4)
52	Spherical Bearing

Additional Options – order alphabetically – More on page 155	
HR	Case Hardened (45 Rc)
L(- -)	Port Location position 1 standard: L(Head Cap) (specify position 1 thru 4 for head and/or cap)
MS	Metal Rod Scraper
N(- -)	Cushion Adjust Screw Location position 2 standard: N(Head Cap) (specify position 1 thru 4 for head and/or cap)
P(-)*	Non-Standard Port Sizes: [specify port size for P(-H) head only, P(-C) cap only, or P(-) both head & cap]
PS	Magnetic Piston
RS	Rod Stud Type 1 (5/8" – 1¾" øRod) Type 2 (5/8" & 1" øRod)
RX	Rod Extensions (specify length of additional rod extension)
SC	Single Acting Spring Extend (Cap End)–See page 155
SR	Single Acting Spring Retract (Rod End)–See page 155
SS	303 Stainless Steel (Hard Chrome Plated)
ST(-C)	Stop Tube (Cap End) (specify stop tube length)
ST(-R)	Stop Tube (Rod End) (specify stop tube length)
T	Special Rod Threads (specify rod thread)
TX	Thread Extensions (specify length of thread extension)
V	Viton® Seals

\*1½", 2", 2½" bore cylinders have 3/8" NPT Standard, 1/2" NPT oversize.  
3¼", 4", 5" bore cylinders have 1/2" NPT Standard, 3/4" NPT oversize.  
This will add 1/8" to the overall cylinder length.

Piston Rod Threads Type	
1	Small Male (Solid)
2	Intermediate Thread Male (Solid)
3	Female
6	Full Thread Male (Solid)
7	Plain Rod End

Piston Rod Diameters		
A	5/8"	Standard on 1½", 2", 2½"
B	1"	Standard on 3¼", 4", 5"
		Oversized on 1½", 2", 2½"
C	13/8"	Standard on 6", 7", 8"
		Oversized on 3¼", 4", 5"
D	13/4"	Standard on 10"
		Oversized on 6", 7", 8"
E	2"	Standard on 12"
		Oversized on 10"
F	2½"	Oversized on 10", 12"

Cushion in Head	
3	None
5 <sup>†</sup>	Non-Adjustable Cushion
7	Adjustable Cushion (Position 2)

<sup>†</sup>Standard with EJ

Cushion in Cap	
3	None
5 <sup>†</sup>	Non-Adjustable Cushion
7	Adjustable Cushion (Position 2)

<sup>†</sup>Standard with EJ

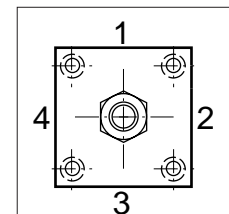

**Port and Cushion Adjustment Positions** (As viewed from rod end: Port standard position 1, Cushion Adjustment standard position 2.)  
NOTE: A Port and a Cushion Adjustment cannot be in the same position.

See page 156 for complete instructions on how to order cylinders.

# Series J & EJ, NFPA Steel Air Cylinder with 15 (MS7) Side End Lugs



All Dimensions in Inches (mm)

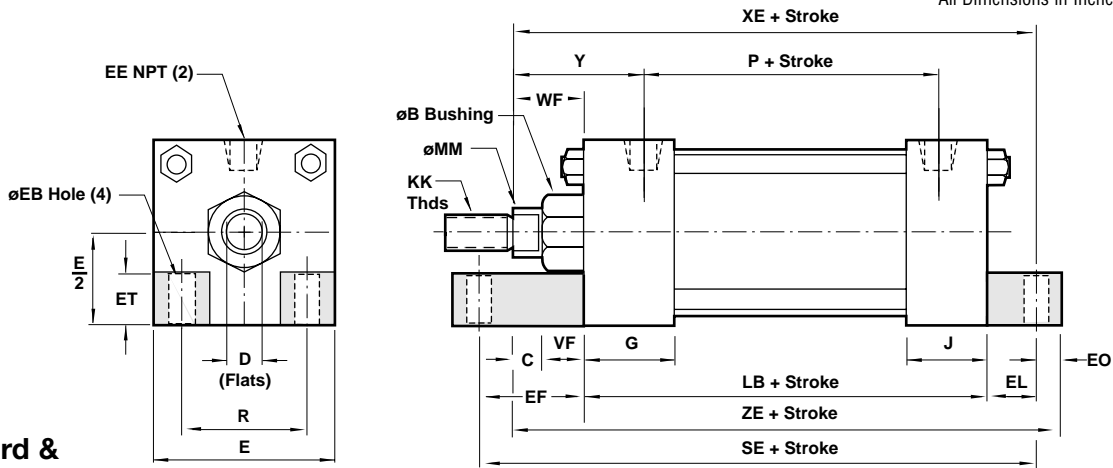

## Standard & Optional Rod Ends

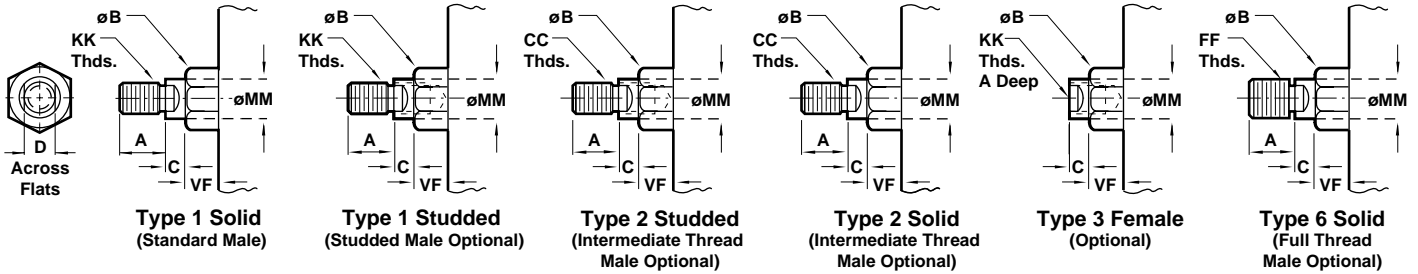

Dimension	1 1/2" Bore (38.10)	2" Bore (50.80)	2 1/2" Bore (63.50)	3 1/4" Bore (82.55)	4" Bore (101.60)	5" Bore (127.00)	6" Bore (152.40)	7" Bore (177.80)	8" Bore (203.20)
ø Rod	Std. 5/8" (15.88)	5/8" (15.88)	5/8" (15.88)	1" (25.40)	1" (25.40)	1" (25.40)	1 3/8" (34.93)	1 3/8" (34.93)	1 3/8" (34.93)
	O.S. 1" (25.40)	1" (25.40)	1" (25.40)	1 3/8" (34.93)	1 3/8" (34.93)	1 3/8" (34.93)	1 3/4" (44.45)	1 3/4" (44.45)	1 3/4" (44.45)
A	Std. .750 (19.05)	.750 (19.05)	.750 (19.05)	1.125 (28.58)	1.125 (28.58)	1.125 (28.58)	1.625 (41.28)	1.625 (41.28)	1.625 (41.28)
	O.S. 1.125 (28.58)	1.125 (28.58)	1.125 (28.58)	1.625 (41.28)	1.625 (41.28)	1.625 (41.28)	2.000 (50.80)	2.000 (50.80)	2.000 (50.80)
B +.000 -.002	Std. 1.124 (28.55)	1.124 (28.55)	1.124 (28.55)	1.499 (38.08)	1.499 (38.08)	1.499 (38.08)	1.999 (50.78)	1.999 (50.78)	1.999 (50.78)
	O.S. 1.499 (38.08)	1.499 (38.08)	1.499 (38.08)	1.999 (50.78)	1.999 (50.78)	1.999 (50.78)	2.374 (60.30)	2.374 (60.30)	2.374 (60.30)
C	Std. .375 (9.53)	.375 (9.53)	.375 (9.53)	.500 (12.70)	.500 (12.70)	.500 (12.70)	.625 (15.88)	.625 (15.88)	.625 (15.88)
	O.S. .500 (12.70)	.500 (12.70)	.500 (12.70)	.625 (15.88)	.625 (15.88)	.625 (15.88)	.750 (19.05)	.750 (19.05)	.750 (19.05)
CC	Std. 1/2 - 20	1/2 - 20	1/2 - 20	7/8 - 14	7/8 - 14	7/8 - 14	1 1/4 - 12	1 1/4 - 12	1 1/4 - 12
	O.S. 7/8 - 14	7/8 - 14	7/8 - 14	1 1/4 - 12	1 1/4 - 12	1 1/4 - 12	1 1/2 - 12	1 1/2 - 12	1 1/2 - 12
D	Std. .500 (12.70)	.500 (12.70)	.500 (12.70)	.813 (20.64)	.813 (20.64)	.813 (20.64)	1.125 (28.58)	1.125 (28.58)	1.125 (28.58)
	O.S. .813 (20.64)	.813 (20.64)	.813 (20.64)	1.125 (28.58)	1.125 (28.58)	1.125 (28.58)	1.500 (38.10)	1.500 (38.10)	1.500 (38.10)
E	2.000 (50.80)	2.500 (63.50)	3.000 (76.20)	3.750 (95.25)	4.500 (114.30)	5.500 (139.70)	6.500 (165.10)	7.500 (190.50)	8.500 (215.90)
EB	.313 (7.94)	.375 (9.53)	.375 (9.53)	.438 (11.11)	.438 (11.11)	.563 (14.29)	.563 (14.29)	.688 (17.46)	.688 (17.46)
EE	.375 (9.53)	.375 (9.53)	.375 (9.53)	.500 (12.70)	.500 (12.70)	.500 (12.70)	.750 (19.05)	.750 (19.05)	.750 (19.05)
EF	1.125 (28.58)	1.313 (33.34)	1.438 (36.51)	1.500 (38.10)	1.625 (41.28)	1.688 (42.88)	1.750 (44.45)	1.750 (44.45)	1.750 (44.45)
EL	.750 (19.05)	.938 (23.81)	1.063 (26.99)	.875 (22.23)	1.000 (25.40)	1.063 (26.99)	1.000 (25.40)	1.125 (28.58)	1.125 (28.58)
EO	.250 (6.35)	.313 (7.94)	.313 (7.94)	.375 (9.53)	.375 (9.53)	.500 (12.70)	.500 (12.70)	.625 (15.88)	.625 (15.88)
ET	.500 (12.70)	.750 (19.05)	.750 (19.05)	1.000 (25.40)	1.250 (31.75)	1.500 (38.10)	1.500 (38.10)	1.750 (44.45)	2.063 (52.39)
FF	Std. 5/8 - 18	5/8 - 18	5/8 - 18	1 - 14	1 - 14	1 - 14	1 3/8 - 12	1 3/8 - 12	1 3/8 - 12
	O.S. 1 - 14	1 - 14	1 - 14	1 3/8 - 12	1 3/8 - 12	1 3/8 - 12	1 3/4 - 12	1 3/4 - 12	1 3/4 - 12
G	1.500 (38.10)	1.500 (38.10)	1.500 (38.10)	1.750 (44.45)	1.750 (44.45)	1.750 (44.45)	2.000 (50.80)	2.000 (50.80)	2.000 (50.80)
J	1.000 (25.40)	1.000 (25.40)	1.000 (25.40)	1.250 (31.75)	1.250 (31.75)	1.250 (31.75)	1.500 (38.10)	1.500 (38.10)	1.500 (38.10)
KK	Std. 7/16 - 20	7/16 - 20	7/16 - 20	3/4 - 16	3/4 - 16	3/4 - 16	1 - 14	1 - 14	1 - 14
	O.S. 3/4 - 16	3/4 - 16	3/4 - 16	1 - 14	1 - 14	1 - 14	1 1/4 - 12	1 1/4 - 12	1 1/4 - 12
LB	3.625 (92.08)	3.625 (92.08)	3.750 (95.25)	4.250 (107.95)	4.250 (107.95)	4.500 (114.30)	5.000 (127.00)	5.125 (130.18)	5.125 (130.18)
MM	Std. .625 (15.88)	.625 (15.88)	.625 (15.88)	1.000 (25.40)	1.000 (25.40)	1.000 (25.40)	1.375 (34.93)	1.375 (34.93)	1.375 (34.93)
	O.S. 1.000 (25.40)	1.000 (25.40)	1.000 (25.40)	1.375 (34.93)	1.375 (34.93)	1.375 (34.93)	1.750 (44.45)	1.750 (44.45)	1.750 (44.45)
P	2.313 (58.74)	2.313 (58.74)	2.438 (61.91)	2.625 (66.68)	2.625 (66.68)	2.875 (73.03)	3.125 (79.38)	3.250 (82.55)	3.250 (82.55)
R	1.428 (36.27)	1.838 (46.68)	2.192 (55.67)	2.758 (70.05)	3.323 (84.40)	4.101 (104.16)	4.879 (123.92)	5.730 (145.54)	6.442 (163.63)
SE	5.500 (139.70)	5.875 (149.23)	6.250 (158.75)	6.625 (168.28)	6.875 (174.63)	7.250 (184.15)	7.750 (196.85)	8.000 (203.20)	8.000 (203.20)
VF	Std. .625 (15.88)	.625 (15.88)	.625 (15.88)	.875 (22.23)	.875 (22.23)	.875 (22.23)	1.000 (25.40)	1.000 (25.40)	1.000 (25.40)
	O.S. .875 (22.23)	.875 (22.23)	.875 (22.23)	1.000 (25.40)	1.000 (25.40)	1.000 (25.40)	1.125 (28.58)	1.125 (28.58)	1.125 (28.58)
WF	Std. 1.000 (25.40)	1.000 (25.40)	1.000 (25.40)	1.375 (34.93)	1.375 (34.93)	1.375 (34.93)	1.625 (41.28)	1.625 (41.28)	1.625 (41.28)
	O.S. 1.375 (34.93)	1.375 (34.93)	1.375 (34.93)	1.625 (41.28)	1.625 (41.28)	1.625 (41.28)	1.875 (47.63)	1.875 (47.63)	1.875 (47.63)
XE	Std. 5.375 (136.53)	5.563 (141.29)	5.813 (147.64)	6.500 (165.10)	6.625 (168.28)	6.938 (176.21)	7.625 (193.68)	7.875 (200.03)	7.875 (200.03)
	O.S. 5.750 (146.05)	5.938 (150.81)	6.188 (157.16)	6.750 (171.45)	6.875 (174.63)	7.188 (182.56)	7.875 (200.03)	8.125 (206.38)	8.125 (206.38)
Y	Std. 1.875 (47.63)	1.875 (47.63)	1.875 (47.63)	2.438 (61.91)	2.438 (61.91)	2.438 (61.91)	2.813 (71.44)	2.813 (71.44)	2.813 (71.44)
	O.S. 2.250 (57.15)	2.250 (57.15)	2.250 (57.15)	2.688 (68.26)	2.688 (68.26)	2.688 (68.26)	3.063 (77.79)	3.063 (77.79)	3.063 (77.79)
ZE	Std. 5.625 (142.88)	5.875 (149.23)	6.125 (155.58)	6.875 (174.63)	7.000 (177.80)	7.438 (188.91)	8.125 (206.38)	8.500 (215.90)	8.500 (215.90)
	O.S. 6.000 (152.40)	6.250 (158.75)	6.500 (165.10)	7.125 (180.98)	7.250 (184.15)	7.688 (195.26)	8.375 (212.73)	8.750 (222.25)	8.750 (222.25)

## Cylinder 16 Sleeve Nut Construction Side Tapped (Universal)

- **16 Sleeve Nut Construction Side Tapped (Universal Mount) for 1-1/2" to 6" bore sizes.**
- **Series J Cylinders rated to 250 PSI air, 400 PSI hydraulic (non-shock). Series EJ Cylinders rated to 250 PSI air only.**
- **Designed for non-lube service.**
- **Switches available on all bore sizes. (See pages 150 & 151 for ordering information.)**



### Cylinder Order Information

16 - - - -

J	Series J Cylinder		Bore and Stroke (write out)
EJ	Series EJ Cylinder		

Mounting Options	
01	Side Tapped (MS4)
03	Head Rectangular Flange (MF1)
03	Head Square (ME3) –7" to 12" Bores
04	Cap Rectangular Flange (MF2)
04	Cap Square (ME4) –7" to 12" Bores
05	Basic Cylinder No Mounting (MX0)
06	Both Ends (4) Tie Rods Ext. (MX1)
6B	Both Ends (2) Tie Rods Ext. (MX4)
6C	Cap Tie Rods Ext. (MX2)
6R	Head Tie Rods Ext. (MX3)
07	Head Trunnion (MT1)
08	Cap Trunnion (MT2)
09	Side Lugs (MS2)
10	Center Trunnion (MT4)
11	Side End Angles (MS1)
12	Cap Fixed Clevis (MP1)
15	Side End Lugs (MS7)
<b>16</b>	<b>Sleeve Nut Construction (Universal)</b>
20	Head Square Flange (MF5)
21	Cap Square Flange (MF6)
22	Detachable Cap Clevis (MP2)
32	Cap Fixed Eye (MP3)
42	Detachable Cap Eye (MP4)
52	Spherical Bearing

Additional Options – order alphabetically – More on page 155	
HR	Case Hardened (45 Rc)
L(- -)	Port Location position 1 standard: L(Head Cap) (specify position 1 thru 4 for head and/or cap)
MS	Metal Rod Scraper
N(- -)	Cushion Adjust Screw Location position 2 standard: N(Head Cap) (specify position 1 thru 4 for head and/or cap)
P(-)*	Non-Standard Port Sizes: [specify port size for P(-H) head only, P(-C) cap only, or P(-) both head & cap]
PS	Magnetic Piston
RS	Rod Stud Type 1 (5/8" – 1¾" øRod) Type 2 (5/8" & 1" øRod)
RX	Rod Extensions (specify length of additional rod extension)
SC	Single Acting Spring Extend (Cap End)–See page 155
SR	Single Acting Spring Retract (Rod End)–See page 155
SS	303 Stainless Steel (Hard Chrome Plated)
ST(-C)	Stop Tube (Cap End) (specify stop tube length)
ST(-R)	Stop Tube (Rod End) (specify stop tube length)
T	Special Rod Threads (specify rod thread)
TX	Thread Extensions (specify length of thread extension)
V	Viton® Seals

Piston Rod Threads Type	
1	Small Male (Solid)
2	Intermediate Thread Male (Solid)
3	Female
6	Full Thread Male (Solid)
7	Plain Rod End

Piston Rod Diameters		
A	5/8"	Standard on 1½", 2", 2½"
B	1"	Standard on 3¼", 4", 5"
		Oversized on 1½", 2", 2½"
C	1¾"	Standard on 6", 7", 8"
		Oversized on 3¼", 4", 5"
D	1¾"	Standard on 10"
		Oversized on 6", 7", 8"
E	2"	Standard on 12"
		Oversized on 10"
F	2½"	Oversized on 10", 12"

Cushion in Head	
3	None
5 <sup>†</sup>	Non-Adjustable Cushion
7	Adjustable Cushion (Position 2)

<sup>†</sup>Standard with EJ

Cushion in Cap	
3	None
5 <sup>†</sup>	Non-Adjustable Cushion
7	Adjustable Cushion (Position 2)

<sup>†</sup>Standard with EJ

**Port and Cushion Adjustment Positions** (As viewed from rod end: Port standard position 1, Cushion Adjustment standard position 2.)  
 NOTE: A Port and a Cushion Adjustment cannot be in the same position.

See page 156 for complete instructions on how to order cylinders.



# Series J & EJ Cylinder with 16 Sleeve Nut Construction Side Tapped (Universal)

All Dimensions in Inches (mm)



## 16 Sleeve Nut Construction Basic Cylinder Side Tapped (Universal)

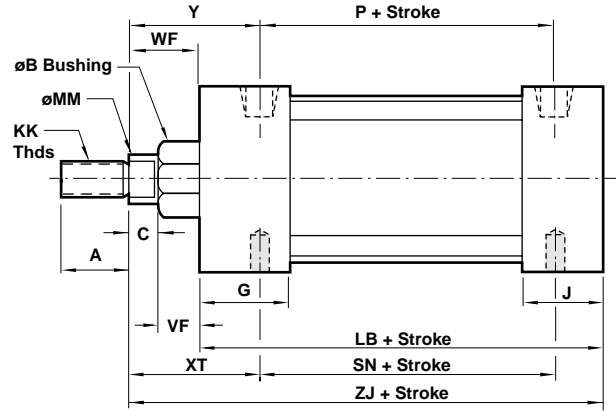
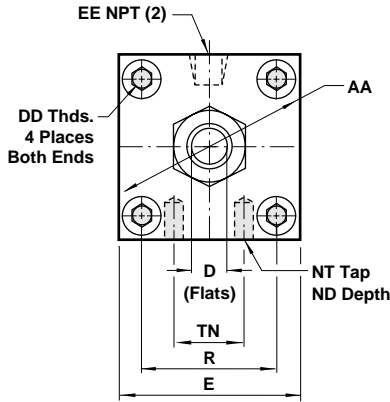

## Standard & Optional Rod Ends

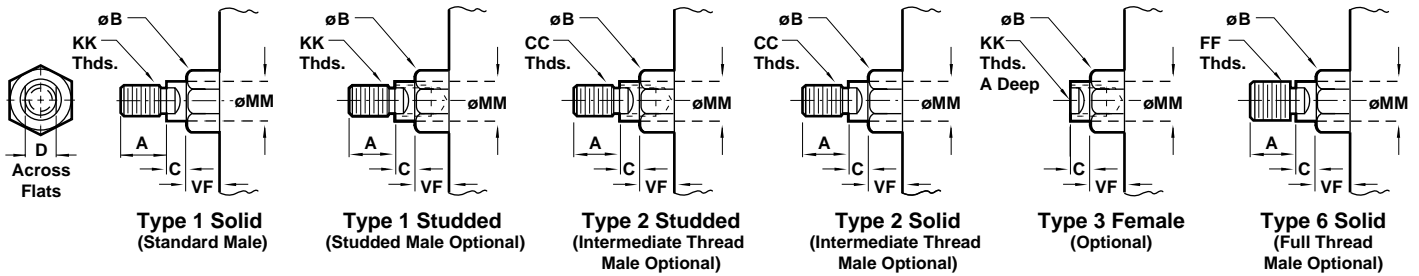

Dimension		1 1/2" Bore (38.10)	2" Bore (50.80)	2 1/2" Bore (63.50)	3 1/4" Bore (82.55)	4" Bore (101.60)	5" Bore (127.00)	6" Bore (152.40)
ø Rod	Std.	5/8" (15.88)	5/8" (15.88)	5/8" (15.88)	1" (25.40)	1" (25.40)	1" (25.40)	1 3/8" (34.93)
	O.S.	1" (25.40)	1" (25.40)	1" (25.40)	1 3/8" (34.93)	1 3/8" (34.93)	1 3/8" (34.93)	1 3/4" (44.45)
A	Std.	.750 (19.05)	.750 (19.05)	.750 (19.05)	1.125 (28.58)	1.125 (28.58)	1.125 (28.58)	1.625 (41.28)
	O.S.	1.125 (28.58)	1.125 (28.58)	1.125 (28.58)	1.625 (41.28)	1.625 (41.28)	1.625 (41.28)	2.000 (50.80)
AA	Std.	2.020 (51.31)	2.600 (66.04)	3.100 (78.74)	3.900 (99.06)	4.700 (119.38)	5.800 (147.32)	6.900 (175.26)
	O.S.	1.124 (28.55)	1.124 (28.55)	1.124 (28.55)	1.499 (38.08)	1.499 (38.08)	1.499 (38.08)	1.999 (50.78)
B <sup>+0.000</sup> -0.002	Std.	1.499 (38.08)	1.499 (38.08)	1.499 (38.08)	1.999 (50.78)	1.999 (50.78)	1.999 (50.78)	2.374 (60.30)
	O.S.	.375 (9.53)	.375 (9.53)	.375 (9.53)	.500 (12.70)	.500 (12.70)	.500 (12.70)	.625 (15.88)
C	Std.	.500 (12.70)	.500 (12.70)	.500 (12.70)	.625 (15.88)	.625 (15.88)	.625 (15.88)	.750 (19.05)
	O.S.	1/2 - 20	1/2 - 20	1/2 - 20	7/8 - 14	7/8 - 14	7/8 - 14	1 1/4 - 12
CC	Std.	7/8 - 14	7/8 - 14	7/8 - 14	1 1/4 - 12	1 1/4 - 12	1 1/4 - 12	1 1/2 - 12
	O.S.	.500 (12.70)	.500 (12.70)	.500 (12.70)	.813 (20.64)	.813 (20.64)	.813 (20.64)	1.125 (28.58)
D	Std.	.813 (20.64)	.813 (20.64)	.813 (20.64)	1.125 (28.58)	1.125 (28.58)	1.125 (28.58)	1.500 (38.10)
	O.S.	1/4 - 28	5/16 - 24	5/16 - 24	3/8 - 24	3/8 - 24	1/2 - 20	1/2 - 20
DD	Std.	2.000 (50.80)	2.500 (63.50)	3.000 (76.20)	3.750 (95.25)	4.500 (114.30)	5.500 (139.70)	6.500 (165.10)
	O.S.	.375 (9.53)	.375 (9.53)	.375 (9.53)	.500 (12.70)	.500 (12.70)	.500 (12.70)	.750 (19.05)
EE	Std.	5/8 - 18	5/8 - 18	5/8 - 18	1 - 14	1 - 14	1 - 14	1 3/8 - 12
	O.S.	1 - 14	1 - 14	1 - 14	1 3/8 - 12	1 3/8 - 12	1 3/8 - 12	1 3/4 - 12
FF	Std.	1.500 (38.10)	1.500 (38.10)	1.500 (38.10)	1.750 (44.45)	1.750 (44.45)	1.750 (44.45)	2.000 (50.80)
	O.S.	1.000 (25.40)	1.000 (25.40)	1.000 (25.40)	1.250 (31.75)	1.250 (31.75)	1.250 (31.75)	1.500 (38.10)
GG	Std.	7/16 - 20	7/16 - 20	7/16 - 20	3/4 - 16	3/4 - 16	3/4 - 16	1 - 14
	O.S.	3/4 - 16	3/4 - 16	3/4 - 16	1 - 14	1 - 14	1 - 14	1 1/4 - 12
LB	Std.	3.625 (92.08)	3.625 (92.08)	3.750 (95.25)	4.250 (107.95)	4.250 (107.95)	4.500 (114.30)	5.000 (127.00)
	O.S.	.625 (15.88)	.625 (15.88)	.625 (15.88)	1.000 (25.40)	1.000 (25.40)	1.000 (25.40)	1.375 (34.93)
MM	Std.	1.000 (25.40)	1.000 (25.40)	1.000 (25.40)	1.375 (34.93)	1.375 (34.93)	1.375 (34.93)	1.750 (44.45)
	O.S.	1/4 - 20	5/16 - 18	3/8 - 16	1/2 - 13	1/2 - 13	5/8 - 11	3/4 - 10
NT	Std.	.375 (9.53)	.375 (9.53)	.500 (12.70)	.750 (19.05)	.750 (19.05)	.938 (23.81)	1.125 (28.58)
	O.S.	2.313 (58.74)	2.313 (58.74)	2.438 (61.91)	2.625 (66.68)	2.625 (66.68)	2.875 (73.03)	3.125 (79.38)
P	Std.	1.428 (36.27)	1.838 (46.68)	2.192 (55.67)	2.758 (70.05)	3.323 (84.40)	4.101 (104.16)	4.879 (123.92)
	O.S.	2.250 (57.15)	2.250 (57.15)	2.375 (60.33)	2.625 (66.68)	2.625 (66.68)	2.875 (73.03)	3.125 (79.38)
R	Std.	.625 (15.88)	.875 (22.23)	1.250 (31.75)	1.500 (38.10)	2.063 (52.39)	2.688 (68.26)	3.250 (82.55)
	O.S.	.625 (15.88)	.625 (15.88)	.625 (15.88)	.875 (22.23)	.875 (22.23)	.875 (22.23)	1.000 (25.40)
VF	Std.	1.000 (25.40)	1.000 (25.40)	1.000 (25.40)	1.375 (34.93)	1.375 (34.93)	1.375 (34.93)	1.625 (41.28)
	O.S.	1.375 (34.93)	1.375 (34.93)	1.375 (34.93)	1.625 (41.28)	1.625 (41.28)	1.625 (41.28)	1.875 (47.63)
WF	Std.	1.938 (49.21)	1.938 (49.21)	1.938 (49.21)	2.438 (61.91)	2.438 (61.91)	2.438 (61.91)	2.813 (71.44)
	O.S.	2.313 (58.74)	2.313 (58.74)	2.313 (58.74)	2.688 (68.26)	2.688 (68.26)	2.688 (68.26)	3.063 (77.79)
XT	Std.	1.875 (47.63)	1.875 (47.63)	1.875 (47.63)	2.438 (61.91)	2.438 (61.91)	2.438 (61.91)	2.813 (71.44)
	O.S.	2.250 (57.15)	2.250 (57.15)	2.250 (57.15)	2.688 (68.26)	2.688 (68.26)	2.688 (68.26)	3.063 (77.79)
Y	Std.	4.625 (117.48)	4.625 (117.48)	4.750 (120.65)	5.625 (142.88)	5.625 (142.88)	5.625 (142.88)	6.625 (168.28)
	O.S.	5.000 (127.00)	5.000 (127.00)	5.125 (130.18)	5.875 (149.23)	5.875 (149.23)	5.875 (149.23)	6.875 (174.63)
ZJ	Std.	5.000 (127.00)	5.000 (127.00)	5.125 (130.18)	5.875 (149.23)	5.875 (149.23)	5.875 (149.23)	6.875 (174.63)
	O.S.							



# Series J & EJ, NFPA Steel Air Cylinder with 20 (MF5) Head Square Flange

All Dimensions in Inches (mm)

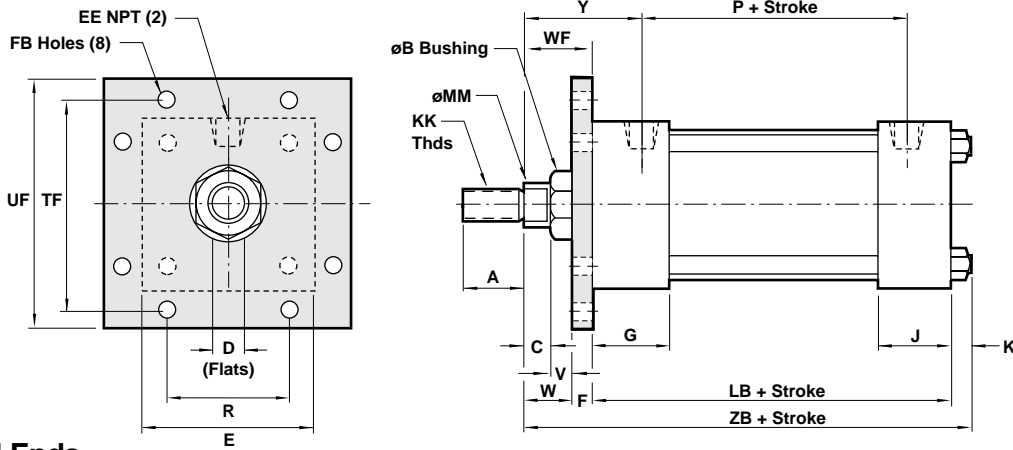

## Standard & Optional Rod Ends

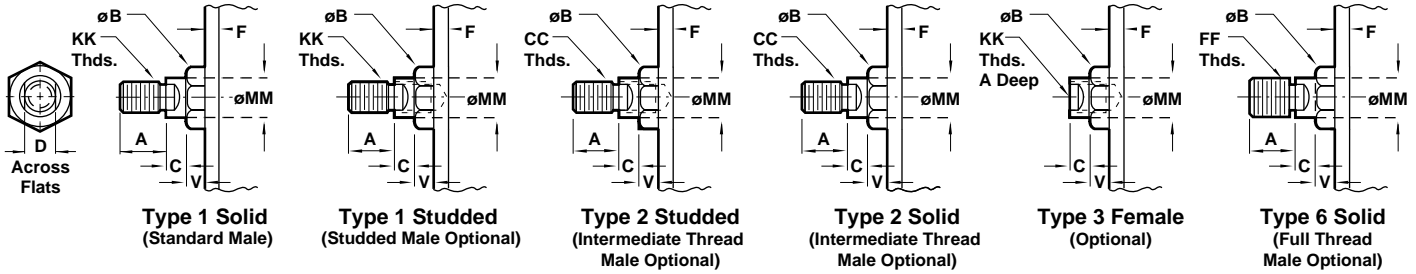

Dimension		1 1/2" Bore (38.10)	2" Bore (50.80)	2 1/2" Bore (63.50)	3 1/4" Bore (82.55)	4" Bore (101.60)	5" Bore (127.00)	6" Bore (152.40)
ø Rod	Std.	5/8" (15.88)	5/8" (15.88)	5/8" (15.88)	1" (25.40)	1" (25.40)	1" (25.40)	1 3/8" (34.93)
	O.S.	1" (25.40)	1" (25.40)	1" (25.40)	1 3/8" (34.93)	1 3/8" (34.93)	1 3/8" (34.93)	1 3/4" (44.45)
A	Std.	.750 (19.05)	.750 (19.05)	.750 (19.05)	1.125 (28.58)	1.125 (28.58)	1.125 (28.58)	1.625 (41.28)
	O.S.	1.125 (28.58)	1.125 (28.58)	1.125 (28.58)	1.625 (41.28)	1.625 (41.28)	1.625 (41.28)	2.000 (50.80)
B <sup>+0.00</sup> -0.002	Std.	1.124 (28.55)	1.124 (28.55)	1.124 (28.55)	1.499 (38.08)	1.499 (38.08)	1.499 (38.08)	1.999 (50.78)
	O.S.	1.499 (38.08)	1.499 (38.08)	1.499 (38.08)	1.999 (50.78)	1.999 (50.78)	1.999 (50.78)	2.374 (60.30)
C	Std.	.375 (9.53)	.375 (9.53)	.375 (9.53)	.500 (12.70)	.500 (12.70)	.500 (12.70)	.625 (15.88)
	O.S.	.500 (12.70)	.500 (12.70)	.500 (12.70)	.625 (15.88)	.625 (15.88)	.625 (15.88)	.750 (19.05)
CC	Std.	1/2 - 20	1/2 - 20	1/2 - 20	7/8 - 14	7/8 - 14	7/8 - 14	1 1/4 - 12
	O.S.	7/8 - 14	7/8 - 14	7/8 - 14	1 1/4 - 12	1 1/4 - 12	1 1/4 - 12	1 1/2 - 12
D	Std.	.500 (12.70)	.500 (12.70)	.500 (12.70)	.813 (20.64)	.813 (20.64)	.813 (20.64)	1.125 (28.58)
	O.S.	.813 (20.64)	.813 (20.64)	.813 (20.64)	1.125 (28.58)	1.125 (28.58)	1.125 (28.58)	1.500 (38.10)
E		2.000 (50.80)	2.500 (63.50)	3.000 (76.20)	3.750 (95.25)	4.500 (114.30)	5.500 (139.70)	6.500 (165.10)
EE		.375 (9.53)	.375 (9.53)	.375 (9.53)	.500 (12.70)	.500 (12.70)	.500 (12.70)	.750 (19.05)
F		.375 (9.53)	.375 (9.53)	.375 (9.53)	.625 (15.88)	.625 (15.88)	.625 (15.88)	.750 (19.05)
FB		.313 (7.94)	.375 (9.53)	.375 (9.53)	.438 (11.11)	.438 (11.11)	.563 (14.29)	.563 (14.29)
FF	Std.	5/8 - 18	5/8 - 18	5/8 - 18	1 - 14	1 - 14	1 - 14	1 3/8 - 12
	O.S.	1 - 14	1 - 14	1 - 14	1 3/8 - 12	1 3/8 - 12	1 3/8 - 12	1 3/4 - 12
G		1.500 (38.10)	1.500 (38.10)	1.500 (38.10)	1.750 (44.45)	1.750 (44.45)	1.750 (44.45)	2.000 (50.80)
J		1.000 (25.40)	1.000 (25.40)	1.000 (25.40)	1.250 (31.75)	1.250 (31.75)	1.250 (31.75)	1.500 (38.10)
K		.250 (6.35)	.313 (7.94)	.313 (7.94)	.375 (9.53)	.375 (9.53)	.438 (11.11)	.438 (11.11)
KK	Std.	7/16 - 20	7/16 - 20	7/16 - 20	3/4 - 16	3/4 - 16	3/4 - 16	1 - 14
	O.S.	3/4 - 16	3/4 - 16	3/4 - 16	1 - 14	1 - 14	1 - 14	1 1/4 - 12
LB		3.625 (92.08)	3.625 (92.08)	3.750 (95.25)	4.250 (107.95)	4.250 (107.95)	4.500 (114.30)	5.000 (127.00)
MM	Std.	.625 (15.88)	.625 (15.88)	.625 (15.88)	1.000 (25.40)	1.000 (25.40)	1.000 (25.40)	1.375 (34.93)
	O.S.	1.000 (25.40)	1.000 (25.40)	1.000 (25.40)	1.375 (34.93)	1.375 (34.93)	1.375 (34.93)	1.750 (44.45)
P		2.313 (58.74)	2.313 (58.74)	2.438 (61.91)	2.625 (66.68)	2.625 (66.68)	2.875 (73.03)	3.125 (79.38)
R		1.428 (36.27)	1.838 (46.68)	2.192 (55.67)	2.758 (70.05)	3.323 (84.40)	4.101 (104.16)	4.879 (123.92)
TF		2.750 (69.85)	3.375 (85.73)	3.875 (98.43)	4.688 (119.06)	5.438 (138.11)	6.625 (168.28)	7.625 (193.68)
UF		3.375 (85.73)	4.125 (104.78)	4.625 (117.48)	5.500 (139.70)	6.250 (158.75)	7.625 (193.68)	8.625 (219.08)
V	Std.	.250 (6.35)	.250 (6.35)	.250 (6.35)	.250 (6.35)	.250 (6.35)	.250 (6.35)	.250 (6.35)
	O.S.	.500 (12.70)	.500 (12.70)	.500 (12.70)	.375 (9.53)	.375 (9.53)	.375 (9.53)	.375 (9.53)
W	Std.	.625 (15.88)	.625 (15.88)	.625 (15.88)	.750 (19.05)	.750 (19.05)	.750 (19.05)	.875 (22.23)
	O.S.	1.000 (25.40)	1.000 (25.40)	1.000 (25.40)	1.000 (25.40)	1.000 (25.40)	1.000 (25.40)	1.125 (28.58)
WF	Std.	1.000 (25.40)	1.000 (25.40)	1.000 (25.40)	1.375 (34.92)	1.375 (34.92)	1.375 (34.92)	1.625 (41.27)
	O.S.	1.375 (34.92)	1.375 (34.92)	1.375 (34.92)	1.625 (41.27)	1.625 (41.27)	1.625 (41.27)	1.875 (47.63)
Y	Std.	1.875 (47.63)	1.875 (47.63)	1.875 (47.63)	2.438 (61.91)	2.438 (61.91)	2.438 (61.91)	2.813 (71.44)
	O.S.	2.250 (57.15)	2.250 (57.15)	2.250 (57.15)	2.688 (68.26)	2.688 (68.26)	2.688 (68.26)	3.063 (77.79)
ZB	Std.	4.875 (123.83)	4.938 (125.41)	5.063 (128.59)	6.000 (152.40)	6.000 (152.40)	6.313 (160.34)	7.063 (179.39)
	O.S.	5.250 (133.35)	5.313 (134.94)	5.438 (138.11)	6.250 (158.75)	6.250 (158.75)	6.563 (166.69)	7.313 (185.74)

## Cylinder with 21 (MF6) Cap Square Flange

- NFPA (MF6) 21 Cap Square Flange Mount for 1-1/2" to 6" bore sizes.
- Series J Cylinders rated to 250 PSI air, 400 PSI hydraulic (non-shock). Series EJ Cylinders rated to 250 PSI air only.
- Designed for non-lube service.
- Switches available on all bore sizes. (See pages 150 & 151 for ordering information.)



### Cylinder Order Information

21 - - - -

J	Series J Cylinder		Bore and Stroke (write out)
EJ	Series EJ Cylinder		

Mounting Options	
01	Side Tapped (MS4)
03	Head Rectangular Flange (MF1)
03	Head Square (ME3) –7" to 12" Bores
04	Cap Rectangular Flange (MF2)
04	Cap Square (ME4) –7" to 12" Bores
05	Basic Cylinder No Mounting (MX0)
06	Both Ends (4) Tie Rods Ext. (MX1)
6B	Both Ends (2) Tie Rods Ext. (MX4)
6C	Cap Tie Rods Ext. (MX2)
6R	Head Tie Rods Ext. (MX3)
07	Head Trunnion (MT1)
08	Cap Trunnion (MT2)
09	Side Lugs (MS2)
10	Center Trunnion (MT4)
11	Side End Angles (MS1)
12	Cap Fixed Clevis (MP1)
15	Side End Lugs (MS7)
16	Sleeve Nut Construction (Universal)
20	Head Square Flange (MF5)
<b>21</b>	<b>Cap Square Flange (MF6)</b>
22	Detachable Cap Clevis (MP2)
32	Cap Fixed Eye (MP3)
42	Detachable Cap Eye (MP4)
52	Spherical Bearing

Additional Options – order alphabetically – More on page 155	
HR	Case Hardened (45 Rc)
L(- -)	Port Location position 1 standard: L(Head Cap) (specify position 1 thru 4 for head and/or cap)
MS	Metal Rod Scraper
N(- -)	Cushion Adjust Screw Location position 2 standard: N(Head Cap) (specify position 1 thru 4 for head and/or cap)
P(-)*	Non-Standard Port Sizes: [specify port size for P(-H) head only, P(-C) cap only, or P(-) both head & cap]
PS	Magnetic Piston
RS	Rod Stud Type 1 (5/8" – 1¾" øRod) Type 2 (5/8" & 1" øRod)
RX	Rod Extensions (specify length of additional rod extension)
SC	Single Acting Spring Extend (Cap End)–See page 155
SR	Single Acting Spring Retract (Rod End)–See page 155
SS	303 Stainless Steel (Hard Chrome Plated)
ST(-C)	Stop Tube (Cap End) (specify stop tube length)
ST(-R)	Stop Tube (Rod End) (specify stop tube length)
T	Special Rod Threads (specify rod thread)
TX	Thread Extensions (specify length of thread extension)
V	Viton® Seals

\*1½", 2", 2½" bore cylinders have 3/8" NPT Standard, 1/2" NPT oversize.  
3¼", 4", 5" bore cylinders have 1/2" NPT Standard, 3/4" NPT oversize.  
This will add 1/8" to the overall cylinder length.

Piston Rod Threads Type	
1	Small Male (Solid)
2	Intermediate Thread Male (Solid)
3	Female
6	Full Thread Male (Solid)
7	Plain Rod End

Piston Rod Diameters		
A	5/8"	Standard on 1½", 2", 2½"
B	1"	Standard on 3¼", 4", 5"
		Oversized on 1½", 2", 2½"
C	13/8"	Standard on 6", 7", 8"
		Oversized on 3¼", 4", 5"
D	13/4"	Standard on 10"
		Oversized on 6", 7", 8"
E	2"	Standard on 12"
		Oversized on 10"
F	2½"	Oversized on 10", 12"

Cushion in Head	
3	None
5 <sup>†</sup>	Non-Adjustable Cushion
7	Adjustable Cushion (Position 2)

<sup>†</sup>Standard with EJ

Cushion in Cap	
3	None
5 <sup>†</sup>	Non-Adjustable Cushion
7	Adjustable Cushion (Position 2)

<sup>†</sup>Standard with EJ

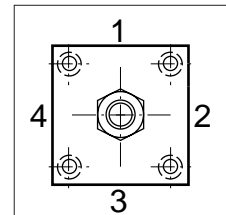

**Port and Cushion Adjustment Positions** (As viewed from rod end: Port standard position 1, Cushion Adjustment standard position 2.)  
NOTE: A Port and a Cushion Adjustment cannot be in the same position.

See page 156 for complete instructions on how to order cylinders.

# Series J & EJ, NFPA Steel Air Cylinder with 21 (MF6) Cap Square Flange

All Dimensions in Inches (mm)

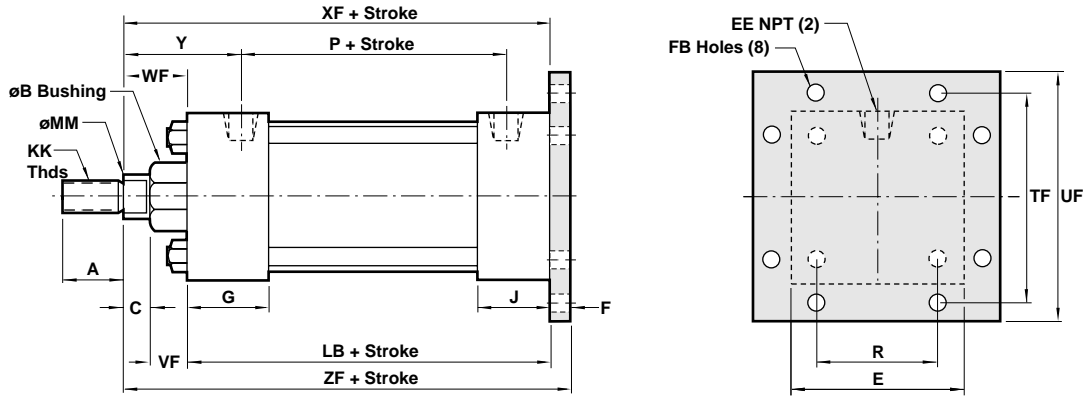

## Standard & Optional Rod Ends

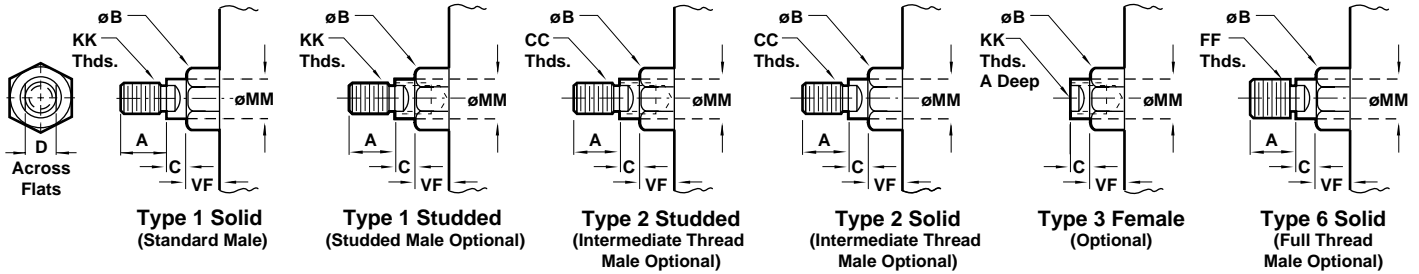

Dimension	1 1/2" Bore (38.10)	2" Bore (50.80)	2 1/2" Bore (63.50)	3 1/4" Bore (82.55)	4" Bore (101.60)	5" Bore (127.00)	6" Bore (152.40)
ø Rod	Std. 5/8" (15.88)	5/8" (15.88)	5/8" (15.88)	1" (25.40)	1" (25.40)	1" (25.40)	1 3/8" (34.93)
	O.S. 1" (25.40)	1" (25.40)	1" (25.40)	1 3/8" (34.93)	1 3/8" (34.93)	1 3/8" (34.93)	1 3/4" (44.45)
A	Std. .750 (19.05)	.750 (19.05)	.750 (19.05)	1.125 (28.58)	1.125 (28.58)	1.125 (28.58)	1.625 (41.28)
	O.S. 1.125 (28.58)	1.125 (28.58)	1.125 (28.58)	1.625 (41.28)	1.625 (41.28)	1.625 (41.28)	2.000 (50.80)
B <sup>+0.000</sup> <sub>-0.002</sub>	Std. 1.124 (28.55)	1.124 (28.55)	1.124 (28.55)	1.499 (38.08)	1.499 (38.08)	1.499 (38.08)	1.999 (50.78)
	O.S. 1.499 (38.08)	1.499 (38.08)	1.499 (38.08)	1.999 (50.78)	1.999 (50.78)	1.999 (50.78)	2.374 (60.30)
C	Std. .375 (9.53)	.375 (9.53)	.375 (9.53)	.500 (12.70)	.500 (12.70)	.500 (12.70)	.625 (15.88)
	O.S. .500 (12.70)	.500 (12.70)	.500 (12.70)	.625 (15.88)	.625 (15.88)	.625 (15.88)	.750 (19.05)
CC	Std. 1/2 - 20	1/2 - 20	1/2 - 20	7/8 - 14	7/8 - 14	7/8 - 14	1 1/4 - 12
	O.S. 7/8 - 14	7/8 - 14	7/8 - 14	1 1/4 - 12	1 1/4 - 12	1 1/4 - 12	1 1/2 - 12
D	Std. .500 (12.70)	.500 (12.70)	.500 (12.70)	.813 (20.64)	.813 (20.64)	.813 (20.64)	1.125 (28.58)
	O.S. .813 (20.64)	.813 (20.64)	.813 (20.64)	1.125 (28.58)	1.125 (28.58)	1.125 (28.58)	1.500 (38.10)
E	2.000 (50.80)	2.500 (63.50)	3.000 (76.20)	3.750 (95.25)	4.500 (114.30)	5.500 (139.70)	6.500 (165.10)
EE	.375 (9.53)	.375 (9.53)	.375 (9.53)	.500 (12.70)	.500 (12.70)	.500 (12.70)	.750 (19.05)
F	.375 (9.53)	.375 (9.53)	.375 (9.53)	.625 (15.88)	.625 (15.88)	.625 (15.88)	.750 (19.05)
FB	.313 (7.94)	.375 (9.53)	.375 (9.53)	.438 (11.11)	.438 (11.11)	.563 (14.29)	.563 (14.29)
FF	Std. 5/8 - 18	5/8 - 18	5/8 - 18	1 - 14	1 - 14	1 - 14	1 3/8 - 12
	O.S. 1 - 14	1 - 14	1 - 14	1 3/8 - 12	1 3/8 - 12	1 3/8 - 12	1 3/4 - 12
G	1.500 (38.10)	1.500 (38.10)	1.500 (38.10)	1.750 (44.45)	1.750 (44.45)	1.750 (44.45)	2.000 (50.80)
J	1.000 (25.40)	1.000 (25.40)	1.000 (25.40)	1.250 (31.75)	1.250 (31.75)	1.250 (31.75)	1.500 (38.10)
K	.250 (6.35)	.313 (7.94)	.313 (7.94)	.375 (9.53)	.375 (9.53)	.438 (11.11)	.438 (11.11)
KK	Std. 7/16 - 20	7/16 - 20	7/16 - 20	3/4 - 16	3/4 - 16	3/4 - 16	1 - 14
	O.S. 3/4 - 16	3/4 - 16	3/4 - 16	1 - 14	1 - 14	1 - 14	1 1/4 - 12
LB	3.625 (92.08)	3.625 (92.08)	3.750 (95.25)	4.250 (107.95)	4.250 (107.95)	4.500 (114.30)	5.000 (127.00)
MM	Std. .625 (15.88)	.625 (15.88)	.625 (15.88)	1.000 (25.40)	1.000 (25.40)	1.000 (25.40)	1.375 (34.93)
	O.S. 1.000 (25.40)	1.000 (25.40)	1.000 (25.40)	1.375 (34.93)	1.375 (34.93)	1.375 (34.93)	1.750 (44.45)
P	2.313 (58.74)	2.313 (58.74)	2.438 (61.91)	2.625 (66.68)	2.625 (66.68)	2.875 (73.03)	3.125 (79.38)
R	1.428 (36.27)	1.838 (46.68)	2.192 (55.67)	2.758 (70.05)	3.323 (84.40)	4.101 (104.16)	4.879 (123.92)
TF	2.750 (69.85)	3.375 (85.73)	3.875 (98.43)	4.688 (119.06)	5.438 (138.11)	6.625 (168.28)	7.625 (193.68)
UF	3.375 (85.73)	4.125 (104.78)	4.625 (117.48)	5.500 (139.70)	6.250 (158.75)	7.625 (193.68)	8.625 (219.08)
VF	Std. .625 (15.88)	.625 (15.88)	.625 (15.88)	.875 (22.23)	.875 (22.23)	.875 (22.23)	1.000 (25.40)
	O.S. .875 (22.23)	.875 (22.23)	.875 (22.23)	1.000 (25.40)	1.000 (25.40)	1.000 (25.40)	1.125 (28.58)
WF	Std. 1.000 (25.40)	1.000 (25.40)	1.000 (25.40)	1.375 (34.92)	1.375 (34.92)	1.375 (34.92)	1.625 (41.27)
	O.S. 1.375 (34.92)	1.375 (34.92)	1.375 (34.92)	1.625 (41.27)	1.625 (41.27)	1.625 (41.27)	1.875 (47.63)
XF	Std. 4.625 (117.48)	4.625 (117.48)	4.750 (120.65)	5.625 (142.88)	5.625 (142.88)	5.875 (149.23)	6.625 (168.27)
	O.S. 5.000 (127.00)	5.000 (127.00)	5.125 (130.18)	5.875 (149.23)	5.875 (149.23)	6.125 (155.58)	6.875 (174.63)
Y	Std. 1.875 (47.63)	1.875 (47.63)	1.875 (47.63)	2.438 (61.91)	2.438 (61.91)	2.438 (61.91)	2.813 (71.44)
	O.S. 2.250 (57.15)	2.250 (57.15)	2.250 (57.15)	2.688 (68.26)	2.688 (68.26)	2.688 (68.26)	3.063 (77.79)
ZF	Std. 5.000 (127.00)	5.000 (127.00)	5.125 (130.18)	6.250 (158.75)	6.250 (158.75)	6.500 (165.10)	7.375 (187.33)
	O.S. 5.375 (136.53)	5.375 (136.53)	5.500 (139.70)	6.500 (165.10)	6.500 (165.10)	6.750 (171.45)	7.625 (193.68)



# Series J & EJ, NFPA Steel Air Cylinder with 22 (MP2) Detachable Cap Clevis

All Dimensions in Inches (mm)

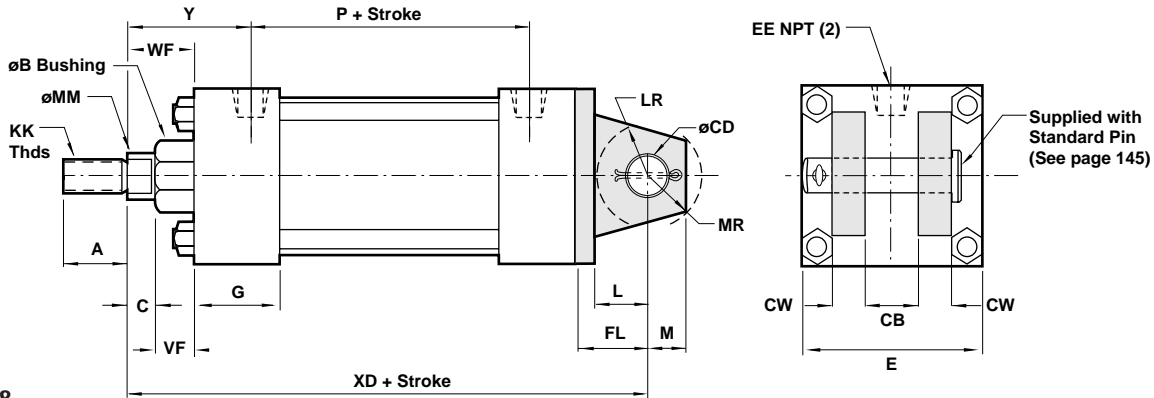

Supplied with Standard Pin (See page 145)

## Standard & Optional Rod Ends

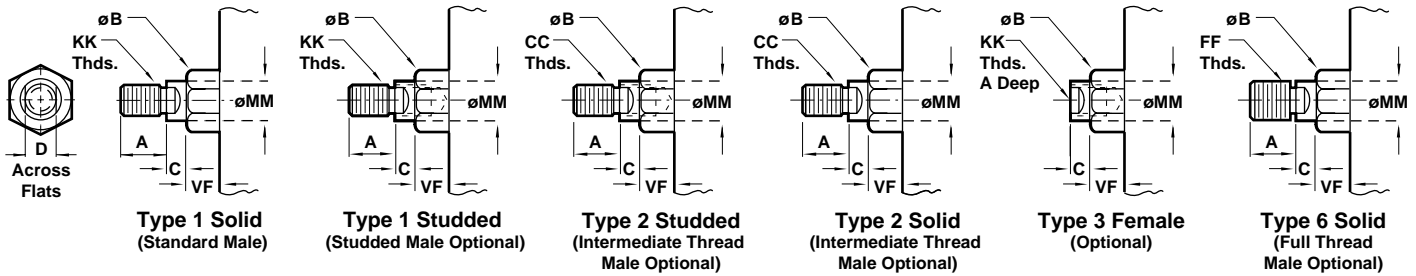

Dimension		1 1/2" Bore (38.10)	2" Bore (50.80)	2 1/2" Bore (63.50)	3 1/4" Bore (82.55)	4" Bore (101.60)	5" Bore (127.00)	6" Bore (152.40)	7" Bore (177.80)	8" Bore (203.20)
ø Rod	Std.	5/8" (15.88)	5/8" (15.88)	5/8" (15.88)	1" (25.40)	1" (25.40)	1" (25.40)	1 3/8" (34.93)	1 3/8" (34.93)	1 3/8" (34.93)
	O.S.	1" (25.40)	1" (25.40)	1" (25.40)	1 3/8" (34.93)	1 3/8" (34.93)	1 3/8" (34.93)	1 3/4" (44.45)	1 3/4" (44.45)	1 3/4" (44.45)
A	Std.	.750 (19.05)	.750 (19.05)	.750 (19.05)	1.125 (28.58)	1.125 (28.58)	1.125 (28.58)	1.625 (41.28)	1.625 (41.28)	1.625 (41.28)
	O.S.	1.125 (28.58)	1.125 (28.58)	1.125 (28.58)	1.625 (41.28)	1.625 (41.28)	1.625 (41.28)	2.000 (50.80)	2.000 (50.80)	2.000 (50.80)
B <sup>+0.000</sup> <sub>-0.002</sub>	Std.	1.124 (28.55)	1.124 (28.55)	1.124 (28.55)	1.499 (38.08)	1.499 (38.08)	1.499 (38.08)	1.999 (50.78)	1.999 (50.78)	1.999 (50.78)
	O.S.	1.499 (38.08)	1.499 (38.08)	1.499 (38.08)	1.999 (50.78)	1.999 (50.78)	1.999 (50.78)	2.374 (60.30)	2.374 (60.30)	2.374 (60.30)
C	Std.	.375 (9.53)	.375 (9.53)	.375 (9.53)	.500 (12.70)	.500 (12.70)	.500 (12.70)	.625 (15.88)	.625 (15.88)	.625 (15.88)
	O.S.	.500 (12.70)	.500 (12.70)	.500 (12.70)	.625 (15.88)	.625 (15.88)	.625 (15.88)	.750 (19.05)	.750 (19.05)	.750 (19.05)
CB		.750 (19.05)	.750 (19.05)	.750 (19.05)	1.250 (31.75)	1.250 (31.75)	1.250 (31.75)	1.500 (38.10)	1.500 (38.10)	1.500 (38.10)
CC	Std.	1/2 - 20	1/2 - 20	1/2 - 20	7/8 - 14	7/8 - 14	7/8 - 14	1 1/4 - 12	1 1/4 - 12	1 1/4 - 12
	O.S.	7/8 - 14	7/8 - 14	7/8 - 14	1 1/4 - 12	1 1/4 - 12	1 1/4 - 12	1 1/2 - 12	1 1/2 - 12	1 1/2 - 12
CD		.500 (12.70)	.500 (12.70)	.500 (12.70)	.750 (19.05)	.750 (19.05)	.750 (19.05)	1.000 (25.40)	1.000 (25.40)	1.000 (25.40)
CW		.500 (12.70)	.500 (12.70)	.500 (12.70)	.625 (15.88)	.625 (15.88)	.625 (15.88)	.750 (19.05)	.750 (19.05)	.750 (19.05)
D	Std.	.500 (12.70)	.500 (12.70)	.500 (12.70)	.813 (20.64)	.813 (20.64)	.813 (20.64)	1.125 (28.58)	1.125 (28.58)	1.125 (28.58)
	O.S.	.813 (20.64)	.813 (20.64)	.813 (20.64)	1.125 (28.58)	1.125 (28.58)	1.125 (28.58)	1.500 (38.10)	1.500 (38.10)	1.500 (38.10)
E		2.000 (50.80)	2.500 (63.50)	3.000 (76.20)	3.750 (95.25)	4.500 (114.30)	5.500 (139.70)	6.500 (165.10)	7.500 (190.50)	8.500 (215.90)
EE		.375 (9.53)	.375 (9.53)	.375 (9.53)	.500 (12.70)	.500 (12.70)	.500 (12.70)	.750 (19.05)	.750 (19.05)	.750 (19.05)
FF	Std.	5/8 - 18	5/8 - 18	5/8 - 18	1 - 14	1 - 14	1 - 14	1 3/8 - 12	1 3/8 - 12	1 3/8 - 12
	O.S.	1 - 14	1 - 14	1 - 14	1 3/8 - 12	1 3/8 - 12	1 3/8 - 12	1 3/4 - 12	1 3/4 - 12	1 3/4 - 12
FL		1.125 (28.58)	1.125 (28.58)	1.125 (28.58)	1.875 (47.63)	1.875 (47.63)	1.875 (47.63)	2.250 (57.15)	2.250 (57.15)	2.250 (57.15)
G		1.500 (38.10)	1.500 (38.10)	1.500 (38.10)	1.750 (44.45)	1.750 (44.45)	1.750 (44.45)	2.000 (50.80)	2.000 (50.80)	2.000 (50.80)
J		1.000 (25.40)	1.000 (25.40)	1.000 (25.40)	1.250 (31.75)	1.250 (31.75)	1.250 (31.75)	1.500 (38.10)	1.500 (38.10)	1.500 (38.10)
K		.250 (6.35)	.313 (7.94)	.313 (7.94)	.375 (9.53)	.375 (9.53)	.438 (11.11)	.438 (11.11)	.563 (14.29)	.563 (14.29)
KK	Std.	7/16 - 20	7/16 - 20	7/16 - 20	3/4 - 16	3/4 - 16	3/4 - 16	1 - 14	1 - 14	1 - 14
	O.S.	3/4 - 16	3/4 - 16	3/4 - 16	1 - 14	1 - 14	1 - 14	1 1/4 - 12	1 1/4 - 12	1 1/4 - 12
L		.750 (19.05)	.750 (19.05)	.750 (19.05)	1.250 (31.75)	1.250 (31.75)	1.250 (31.75)	1.500 (38.10)	1.500 (38.10)	1.500 (38.10)
LB		3.625 (92.08)	3.625 (92.08)	3.750 (95.25)	4.250 (107.95)	4.250 (107.95)	4.500 (114.30)	5.000 (127.00)	5.125 (130.18)	5.125 (130.18)
LR		.750 (19.05)	.750 (19.05)	.750 (19.05)	1.250 (31.75)	1.250 (31.75)	1.250 (31.75)	1.500 (38.10)	1.500 (38.10)	1.500 (38.10)
M		.500 (12.70)	.500 (12.70)	.500 (12.70)	.750 (19.05)	.750 (19.05)	.750 (19.05)	1.000 (25.40)	1.000 (25.40)	1.000 (25.40)
MM	Std.	.625 (15.88)	.625 (15.88)	.625 (15.88)	1.000 (25.40)	1.000 (25.40)	1.000 (25.40)	1.375 (34.93)	1.375 (34.93)	1.375 (34.93)
	O.S.	1.000 (25.40)	1.000 (25.40)	1.000 (25.40)	1.375 (34.93)	1.375 (34.93)	1.375 (34.93)	1.750 (44.45)	1.750 (44.45)	1.750 (44.45)
MR		.625 (15.88)	.625 (15.88)	.625 (15.88)	.938 (23.81)	.938 (23.81)	.938 (23.81)	1.188 (30.16)	1.188 (30.16)	1.188 (30.16)
P		2.313 (58.74)	2.313 (58.74)	2.438 (61.91)	2.625 (66.68)	2.625 (66.68)	2.875 (73.03)	3.125 (79.38)	3.250 (82.55)	3.250 (82.55)
VF	Std.	.625 (15.88)	.625 (15.88)	.625 (15.88)	.875 (22.23)	.875 (22.23)	.875 (22.23)	1.000 (25.40)	1.000 (25.40)	1.000 (25.40)
	O.S.	.875 (22.23)	.875 (22.23)	.875 (22.23)	1.000 (25.40)	1.000 (25.40)	1.000 (25.40)	1.125 (28.58)	1.125 (28.58)	1.125 (28.58)
WF	Std.	1.000 (25.40)	1.000 (25.40)	1.000 (25.40)	1.375 (34.93)	1.375 (34.93)	1.375 (34.93)	1.625 (41.28)	1.625 (41.28)	1.625 (41.28)
	O.S.	1.375 (34.93)	1.375 (34.93)	1.375 (34.93)	1.625 (41.28)	1.625 (41.28)	1.625 (41.28)	1.875 (47.62)	1.875 (47.62)	1.875 (47.62)
XD	Std.	5.750 (146.05)	5.750 (146.05)	5.875 (149.23)	7.500 (190.50)	7.500 (190.50)	7.750 (196.85)	8.875 (225.43)	9.000 (228.60)	9.000 (228.60)
	O.S.	6.125 (155.58)	6.125 (155.58)	6.250 (158.75)	7.750 (196.85)	7.750 (196.85)	8.000 (203.20)	9.125 (231.78)	9.250 (234.95)	9.250 (234.95)
Y	Std.	1.875 (47.63)	1.875 (47.63)	1.875 (47.63)	2.438 (61.91)	2.438 (61.91)	2.438 (61.91)	2.813 (71.44)	2.813 (71.44)	2.813 (71.44)
	O.S.	2.250 (57.15)	2.250 (57.15)	2.250 (57.15)	2.688 (68.26)	2.688 (68.26)	2.688 (68.26)	3.063 (77.79)	3.063 (77.79)	3.063 (77.79)

## Cylinder with 32 (MP3) Cap Fixed Eye

- **NFPA (MP3) 32 Cap Fixed Eye** for 1-1/2" to 6" bore sizes.
- **Series J Cylinders** rated to 250 PSI air, 400 PSI hydraulic (non-shock).  
**Series EJ Cylinders** rated to 250 PSI air only.
- **Designed for non-lube service.**
- **Switches available on all bore sizes.**  
(See pages 150 & 151 for ordering information.)



### Cylinder Order Information

32 - - - -

J	Series J Cylinder		Bore and Stroke (write out)
EJ	Series EJ Cylinder		

Mounting Options	
01	Side Tapped (MS4)
03	Head Rectangular Flange (MF1)
03	Head Square (ME3) –7" to 12" Bores
04	Cap Rectangular Flange (MF2)
04	Cap Square (ME4) –7" to 12" Bores
05	Basic Cylinder No Mounting (MX0)
06	Both Ends (4) Tie Rods Ext. (MX1)
6B	Both Ends (2) Tie Rods Ext. (MX4)
6C	Cap Tie Rods Ext. (MX2)
6R	Head Tie Rods Ext. (MX3)
07	Head Trunnion (MT1)
08	Cap Trunnion (MT2)
09	Side Lugs (MS2)
10	Center Trunnion (MT4)
11	Side End Angles (MS1)
12	Cap Fixed Clevis (MP1)
15	Side End Lugs (MS7)
16	Sleeve Nut Construction (Universal)
20	Head Square Flange (MF5)
21	Cap Square Flange (MF6)
22	Detachable Cap Clevis (MP2)
<b>32</b>	<b>Cap Fixed Eye (MP3)</b>
42	Detachable Cap Eye (MP4)
52	Spherical Bearing

Cushion in Head	
3	None
5 <sup>1</sup>	Non-Adjustable Cushion
7	Adjustable Cushion (Position 2)

<sup>1</sup>Standard with EJ

Cushion in Cap	
3	None
5 <sup>1</sup>	Non-Adjustable Cushion
7	Adjustable Cushion (Position 2)

<sup>1</sup>Standard with EJ

Additional Options – order alphabetically – More on page 155	
HR	Case Hardened (45 Rc)
L(- -)	Port Location position 1 standard: L(Head Cap) (specify position 1 thru 4 for head and/or cap)
MS	Metal Rod Scraper
N(- -)	Cushion Adjust Screw Location position 2 standard: N(Head Cap) (specify position 1 thru 4 for head and/or cap)
P(-)*	Non-Standard Port Sizes: [specify port size for P(-H) head only, P(-C) cap only, or P(-) both head & cap]
PS	Magnetic Piston
RS	Rod Stud Type 1 (5/8" – 1 3/4" øRod) Type 2 (5/8" & 1" øRod)
RX	Rod Extensions (specify length of additional rod extension)
SC	Single Acting Spring Extend (Cap End)–See page 155
SR	Single Acting Spring Retract (Rod End)–See page 155
SS	303 Stainless Steel (Hard Chrome Plated)
ST(-C)	Stop Tube (Cap End) (specify stop tube length)
ST(-R)	Stop Tube (Rod End) (specify stop tube length)
T	Special Rod Threads (specify rod thread)
TX	Thread Extensions (specify length of thread extension)
V	Viton® Seals

Piston Rod Threads Type	
1	Small Male (Solid)
2	Intermediate Thread Male (Solid)
3	Female
6	Full Thread Male (Solid)
7	Plain Rod End

Piston Rod Diameters		
A	5/8"	Standard on 1 1/2", 2", 2 1/2" Standard on 3 1/4", 4", 5"
B	1"	Oversized on 1 1/2", 2", 2 1/2" Standard on 6", 7", 8"
C	1 3/8"	Oversized on 3 1/4", 4", 5"
D	1 3/4"	Oversized on 6", 7", 8"
E	2"	Standard on 12" Oversized on 10"
F	2 1/2"	Oversized on 10", 12"

**Port and Cushion Adjustment Positions** (As viewed from rod end: Port standard position 1, Cushion Adjustment standard position 2.)  
NOTE: A Port and a Cushion Adjustment cannot be in the same position.

See page 156 for complete instructions on how to order cylinders.



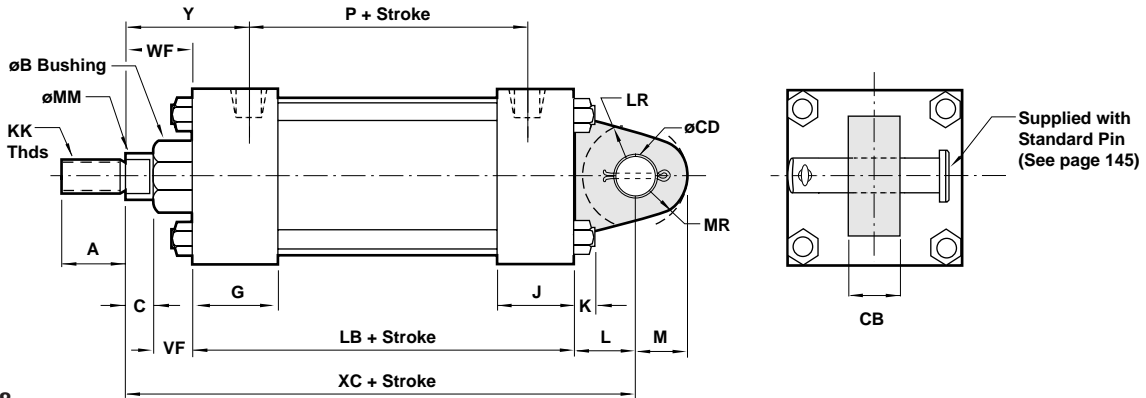

Standard & Optional Rod Ends

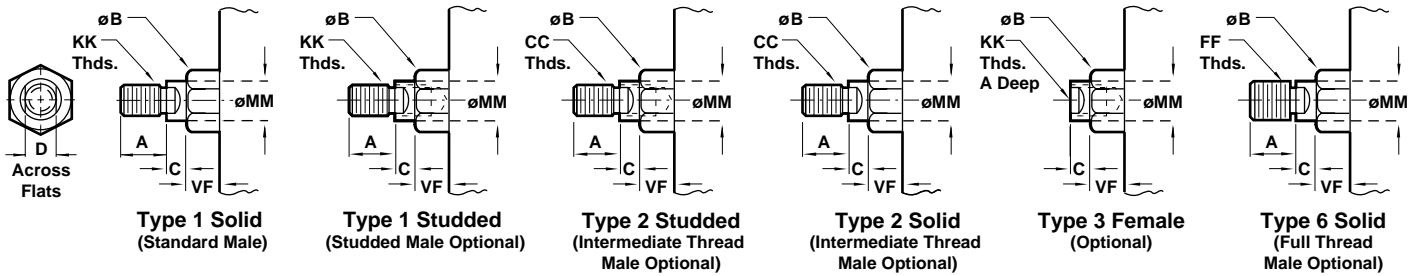

Dimension	1 1/2" Bore (38.10)	2" Bore (50.80)	2 1/2" Bore (63.50)	3 1/4" Bore (82.55)	4" Bore (101.60)	5" Bore (127.00)	6" Bore (152.40)
ø Rod	Std. 5/8" (15.88)	5/8" (15.88)	5/8" (15.88)	1" (25.40)	1" (25.40)	1" (25.40)	1 3/8" (34.93)
	O.S. 1" (25.40)	1" (25.40)	1" (25.40)	1 3/8" (34.93)	1 3/8" (34.93)	1 3/8" (34.93)	1 3/4" (44.45)
A	Std. .750 (19.05)	.750 (19.05)	.750 (19.05)	1.125 (28.58)	1.125 (28.58)	1.125 (28.58)	1.625 (41.28)
	O.S. 1.125 (28.58)	1.125 (28.58)	1.125 (28.58)	1.625 (41.28)	1.625 (41.28)	1.625 (41.28)	2.000 (50.80)
B +.000 -.002	Std. 1.124 (28.55)	1.124 (28.55)	1.124 (28.55)	1.499 (38.08)	1.499 (38.08)	1.499 (38.08)	1.999 (50.78)
	O.S. 1.499 (38.08)	1.499 (38.08)	1.499 (38.08)	1.999 (50.78)	1.999 (50.78)	1.999 (50.78)	2.374 (60.30)
C	Std. .375 (9.53)	.375 (9.53)	.375 (9.53)	.500 (12.70)	.500 (12.70)	.500 (12.70)	.625 (15.88)
	O.S. .500 (12.70)	.500 (12.70)	.500 (12.70)	.625 (15.88)	.625 (15.88)	.625 (15.88)	.750 (19.05)
CB	.750 (19.05)	.750 (19.05)	.750 (19.05)	1.250 (31.75)	1.250 (31.75)	1.250 (31.75)	1.500 (38.10)
CC	Std. 1/2 - 20	1/2 - 20	1/2 - 20	7/8 - 14	7/8 - 14	7/8 - 14	1 1/4 - 12
	O.S. 7/8 - 14	7/8 - 14	7/8 - 14	1 1/4 - 12	1 1/4 - 12	1 1/4 - 12	1 1/2 - 12
CD	.500 (12.70)	.500 (12.70)	.500 (12.70)	.750 (19.05)	.750 (19.05)	.750 (19.05)	1.000 (25.40)
D	Std. .500 (12.70)	.500 (12.70)	.500 (12.70)	.813 (20.64)	.813 (20.64)	.813 (20.64)	1.125 (28.58)
	O.S. .813 (20.64)	.813 (20.64)	.813 (20.64)	1.125 (28.58)	1.125 (28.58)	1.125 (28.58)	1.500 (38.10)
E	2.000 (50.80)	2.500 (63.50)	3.000 (76.20)	3.750 (95.25)	4.500 (114.30)	5.500 (139.70)	6.500 (165.10)
EE	.375 (9.53)	.375 (9.53)	.375 (9.53)	.500 (12.70)	.500 (12.70)	.500 (12.70)	.750 (19.05)
FF	Std. 5/8 - 18	5/8 - 18	5/8 - 18	1 - 14	1 - 14	1 - 14	1 3/8 - 12
	O.S. 1 - 14	1 - 14	1 - 14	1 3/8 - 12	1 3/8 - 12	1 3/8 - 12	1 3/4 - 12
G	1.500 (38.10)	1.500 (38.10)	1.500 (38.10)	1.750 (44.45)	1.750 (44.45)	1.750 (44.45)	2.000 (50.80)
J	1.000 (25.40)	1.000 (25.40)	1.000 (25.40)	1.250 (31.75)	1.250 (31.75)	1.250 (31.75)	1.500 (38.10)
K	.250 (6.35)	.313 (7.94)	.313 (7.94)	.375 (9.53)	.375 (9.53)	.438 (11.11)	.438 (11.11)
KK	Std. 7/16 - 20	7/16 - 20	7/16 - 20	3/4 - 16	3/4 - 16	3/4 - 16	1 - 14
	O.S. 3/4 - 16	3/4 - 16	3/4 - 16	1 - 14	1 - 14	1 - 14	1 1/4 - 12
L	.750 (19.05)	.750 (19.05)	.750 (19.05)	1.250 (31.75)	1.250 (31.75)	1.250 (31.75)	1.500 (38.10)
LB	3.625 (92.08)	3.625 (92.08)	3.750 (95.25)	4.250 (107.95)	4.250 (107.95)	4.500 (114.30)	5.000 (127.00)
LR	.750 (19.05)	.750 (19.05)	.750 (19.05)	1.250 (31.75)	1.250 (31.75)	1.250 (31.75)	1.500 (38.10)
M	.500 (12.70)	.500 (12.70)	.500 (12.70)	.750 (19.05)	.750 (19.05)	.750 (19.05)	1.000 (25.40)
MM	Std. .625 (15.88)	.625 (15.88)	.625 (15.88)	1.000 (25.40)	1.000 (25.40)	1.000 (25.40)	1.375 (34.93)
	O.S. 1.000 (25.40)	1.000 (25.40)	1.000 (25.40)	1.375 (34.93)	1.375 (34.93)	1.375 (34.93)	1.750 (44.45)
MR	.625 (15.88)	.625 (15.88)	.625 (15.88)	.938 (23.81)	.938 (23.81)	.938 (23.81)	1.188 (30.16)
P	2.313 (58.74)	2.313 (58.74)	2.438 (61.91)	2.625 (66.68)	2.625 (66.68)	2.875 (73.03)	3.125 (79.38)
VF	Std. .625 (15.88)	.625 (15.88)	.625 (15.88)	.875 (22.23)	.875 (22.23)	.875 (22.23)	1.000 (25.40)
	O.S. .875 (22.23)	.875 (22.23)	.875 (22.23)	1.000 (25.40)	1.000 (25.40)	1.000 (25.40)	1.125 (28.58)
WF	Std. 1.000 (25.40)	1.000 (25.40)	1.000 (25.40)	1.375 (34.93)	1.375 (34.93)	1.375 (34.93)	1.625 (41.28)
	O.S. 1.375 (34.93)	1.375 (34.93)	1.375 (34.93)	1.625 (41.28)	1.625 (41.28)	1.625 (41.28)	1.875 (47.63)
XC	Std. 5.375 (136.53)	5.375 (136.53)	5.500 (139.70)	6.875 (174.63)	6.875 (174.63)	7.125 (180.98)	8.125 (206.38)
	O.S. 5.750 (146.05)	5.750 (146.05)	5.875 (149.23)	7.125 (180.98)	7.125 (180.98)	7.375 (187.33)	8.375 (212.73)
Y	Std. 1.875 (47.63)	1.875 (47.63)	1.875 (47.63)	2.438 (61.91)	2.438 (61.91)	2.438 (61.91)	2.813 (71.44)
	O.S. 2.250 (57.15)	2.250 (57.15)	2.250 (57.15)	2.688 (68.26)	2.688 (68.26)	2.688 (68.26)	3.063 (77.79)

## Cylinder with 32 (MP3) Cap Fixed Eye

- **NFPA (MP3) 32 Cap Fixed Eye** for 7" to 12" bore sizes.
- **Series J Cylinders** rated to 250 PSI air, 400 PSI hydraulic (non-shock).  
**Series EJ Cylinders** rated to 250 PSI air only.
- **Designed for non-lube service.**
- **Switches available on all bore sizes.**  
(See pages 150 & 151 for ordering information.)

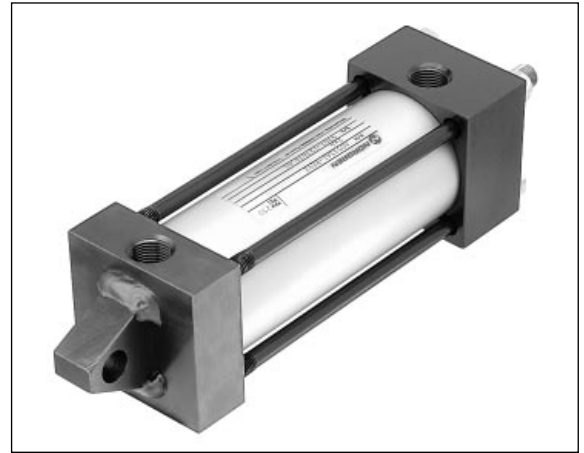

### Cylinder Order Information

32 - - - -

J	Series J Cylinder		Bore and Stroke (write out)
EJ	Series EJ Cylinder		

Mounting Options	
01	Side Tapped (MS4)
03	Head Rectangular Flange (MF1)
03	Head Square (ME3) - 7" to 12" Bores
04	Cap Rectangular Flange (MF2)
04	Cap Square (ME4) - 7" to 12" Bores
05	Basic Cylinder No Mounting (MX0)
06	Both Ends (4) Tie Rods Ext. (MX1)
6B	Both Ends (2) Tie Rods Ext. (MX4)
6C	Cap Tie Rods Ext. (MX2)
6R	Head Tie Rods Ext. (MX3)
07	Head Trunnion (MT1)
08	Cap Trunnion (MT2)
09	Side Lugs (MS2)
10	Center Trunnion (MT4)
11	Side End Angles (MS1)
12	Cap Fixed Clevis (MP1)
15	Side End Lugs (MS7)
16	Sleeve Nut Construction (Universal)
20	Head Square Flange (MF5)
21	Cap Square Flange (MF6)
22	Detachable Cap Clevis (MP2)
<b>32</b>	<b>Cap Fixed Eye (MP3)</b>
42	Detachable Cap Eye (MP4)
52	Spherical Bearing

Additional Options - order alphabetically - More on page 155	
HR	Case Hardened (45 Rc)
L(- -)	Port Location position 1 standard: L(Head Cap) (specify position 1 thru 4 for head and/or cap)
MS	Metal Rod Scraper
N(- -)	Cushion Adjust Screw Location position 2 standard: N(Head Cap) (specify position 1 thru 4 for head and/or cap)
P(-)*	Non-Standard Port Sizes: [specify port size for P(-H) head only, P(-C) cap only, or P(-) both head & cap]
PS	Magnetic Piston
RS	Rod Stud Type 1 (5/8" - 1 3/4" øRod) Type 2 (5/8" & 1" øRod)
RX	Rod Extensions (specify length of additional rod extension)
SC	Single Acting Spring Extend (Cap End)-See page 155
SR	Single Acting Spring Retract (Rod End)-See page 155
SS	303 Stainless Steel (Hard Chrome Plated)
ST(-C)	Stop Tube (Cap End) (specify stop tube length)
ST(-R)	Stop Tube (Rod End) (specify stop tube length)
T	Special Rod Threads (specify rod thread)
TX	Thread Extensions (specify length of thread extension)
V	Viton® Seals

Piston Rod Threads Type	
1	Small Male (Solid)
2	Intermediate Thread Male (Solid)
3	Female
6	Full Thread Male (Solid)
7	Plain Rod End

Piston Rod Diameters		
A	5/8"	Standard on 1 1/2", 2", 2 1/2"
B	1"	Standard on 3 1/4", 4", 5"
C	1 3/8"	Oversized on 1 1/2", 2", 2 1/2"
		Standard on 6", 7", 8"
D	1 3/4"	Oversized on 3 1/4", 4", 5"
		Standard on 10"
E	2"	Oversized on 6", 7", 8"
		Standard on 12"
F	2 1/2"	Oversized on 10", 12"

Cushion in Head	
3	None
5 <sup>1</sup>	Non-Adjustable Cushion
7	Adjustable Cushion (Position 2)

<sup>1</sup>Standard with EJ

Cushion in Cap	
3	None
5 <sup>1</sup>	Non-Adjustable Cushion
7	Adjustable Cushion (Position 2)

<sup>1</sup>Standard with EJ

  

**Port and Cushion Adjustment Positions** (As viewed from rod end:  
Port standard position 1, Cushion Adjustment standard position 2.)  
NOTE: A Port and a Cushion Adjustment cannot be in the same position.

See page 156 for complete instructions on how to order cylinders.

# Series J & EJ, NFPA Steel Air Cylinder with 32 (MP3) Cap Fixed Eye

All Dimensions in Inches (mm)

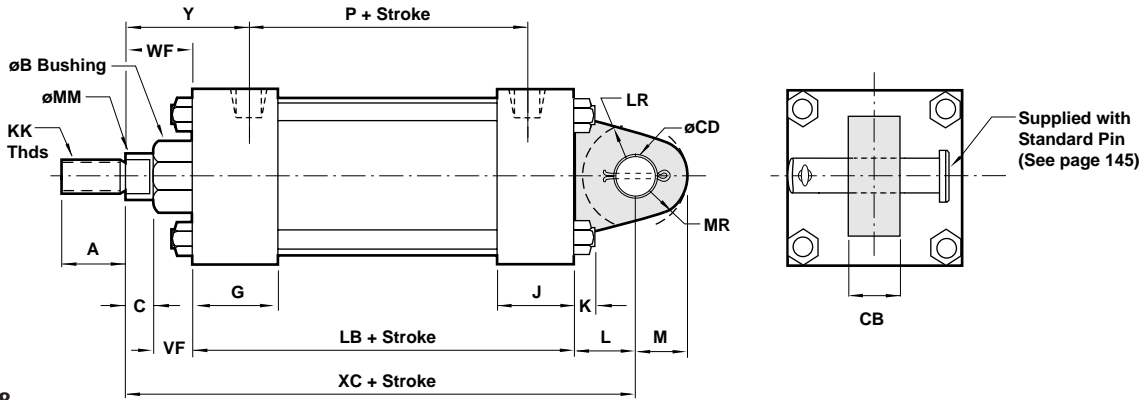

## Standard & Optional Rod Ends

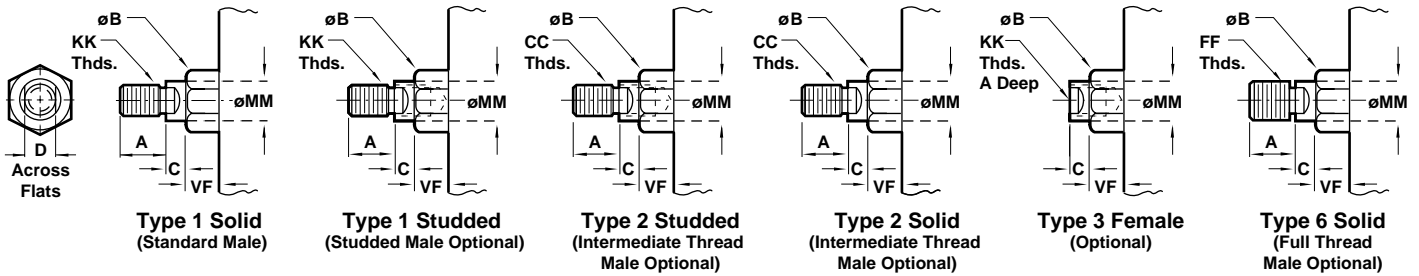

Dimension		7" Bore (177.80)		8" Bore (203.20)		10" Bore (254.00)		12" Bore (304.80)	
ø Rod	Std.	1 3/8"	(34.93)	1 3/8"	(34.93)	1 3/4"	(44.45)	2"	(50.80)
	O.S.	1 3/4"	(44.45)	1 3/4"	(44.45)	2"	(50.80)	2 1/2"	(63.50)
A	Std.	1.625	(41.28)	1.625	(41.28)	2.000	(50.80)	2.250	(57.15)
	O.S.	2.000	(50.80)	2.000	(50.80)	2.250	(57.15)	3.000	(76.20)
B +.000 -.002	Std.	1.999	(50.78)	1.999	(50.78)	2.374	(60.30)	2.724	(66.65)
	O.S.	2.374	(60.30)	2.374	(60.30)	2.624	(66.65)	3.124	(79.35)
C	Std.	.625	(15.88)	.625	(15.88)	.750	(19.05)	.875	(22.23)
	O.S.	.750	(19.05)	.750	(19.05)	.875	(22.23)	1.000	(25.40)
CB		1.500	(38.10)	1.500	(38.10)	2.000	(50.80)	2.500	(63.50)
CC	Std.	1 1/4 - 12		1 1/4 - 12		1 1/2 - 12		1 3/4 - 12	
	O.S.	1 1/2 - 12		1 1/2 - 12		1 3/4 - 12		2 1/4 - 12	
CD		1.000	(25.40)	1.000	(25.40)	1.375	(34.93)	1.750	(44.45)
D	Std.	1.125	(28.58)	1.125	(28.58)	1.500	(38.10)	1.688	(42.86)
	O.S.	1.500	(38.10)	1.500	(38.10)	1.688	(42.86)	2.063	(52.39)
E		7.500	(190.50)	8.500	(215.90)	10.625	(269.88)	12.750	(323.85)
EE		.750	(19.05)	.750	(19.05)	1.000	(25.40)	1.000	(25.40)
FF	Std.	1 3/8 - 12		1 3/8 - 12		1 3/4 - 12		2 - 12	
	O.S.	1 3/4 - 12		1 3/4 - 12		2 - 12		2 1/2 - 12	
G		2.000	(50.80)	2.000	(50.80)	2.250	(57.15)	2.250	(57.15)
J		1.500	(38.10)	1.500	(38.10)	2.000	(50.80)	2.000	(50.80)
K		.563	(14.29)	.563	(14.29)	.688	(17.46)	.688	(17.46)
KK	Std.	1 - 14		1 - 14		1 1/4 - 12		1 1/2 - 12	
	O.S.	1 1/4 - 12		1 1/4 - 12		1 1/2 - 12		1 7/8 - 12	
L		1.500	(38.10)	1.500	(38.10)	2.125	(53.98)	2.250	(57.15)
LB		5.125	(130.18)	5.125	(130.18)	6.375	(161.93)	6.875	(174.63)
LR		1.500	(38.10)	1.500	(38.10)	1.875	(47.63)	2.125	(53.98)
M		1.000	(25.40)	1.000	(25.40)	1.375	(34.93)	1.750	(44.45)
MM	Std.	1.375	(34.93)	1.375	(34.93)	1.750	(44.45)	2.000	(50.80)
	O.S.	1.750	(44.45)	1.750	(44.45)	2.000	(50.80)	2.500	(63.50)
MR		1.188	(30.16)	1.188	(30.16)	1.625	(41.28)	2.125	(53.98)
P		3.250	(82.55)	3.250	(82.55)	4.125	(104.78)	4.625	(117.48)
VF	Std.	1.000	(25.40)	1.000	(25.40)	1.125	(28.58)	1.125	(28.58)
	O.S.	1.125	(28.58)	1.125	(28.58)	1.125	(28.58)	1.250	(31.75)
WF	Std.	1.625	(41.28)	1.625	(41.28)	1.875	(47.63)	2.000	(50.80)
	O.S.	1.875	(47.63)	1.875	(47.63)	2.000	(50.80)	2.250	(57.15)
XC	Std.	8.250	(209.55)	8.250	(209.55)	10.375	(263.53)	11.125	(282.58)
	O.S.	8.500	(215.90)	8.500	(215.90)	10.500	(266.70)	11.375	(288.93)
Y	Std.	2.813	(71.44)	2.813	(71.44)	3.125	(79.38)	3.250	(82.55)
	O.S.	3.063	(77.79)	3.063	(77.79)	3.250	(82.55)	3.500	(88.90)

## Cylinder with 42 (MP4) Detachable Cap Eye

- **NFPA (MP4) 42 Detachable Cap Eye Mount** for 1-1/2" to 8" bore sizes.
- **Series J Cylinders** rated to 250 PSI air, 400 PSI hydraulic (non-shock).  
**Series EJ Cylinders** rated to 250 PSI air only.
- **Designed for non-lube service.**
- **Switches available on all bore sizes.**  
(See pages 150 & 151 for ordering information.)



### Cylinder Order Information

42 - - - -

J	Series J Cylinder		Bore and Stroke (write out)
EJ	Series EJ Cylinder		

Mounting Options	
01	Side Tapped (MS4)
03	Head Rectangular Flange (MF1)
03	Head Square (ME3) –7" to 12" Bores
04	Cap Rectangular Flange (MF2)
04	Cap Square (ME4) –7" to 12" Bores
05	Basic Cylinder No Mounting (MX0)
06	Both Ends (4) Tie Rods Ext. (MX1)
6B	Both Ends (2) Tie Rods Ext. (MX4)
6C	Cap Tie Rods Ext. (MX2)
6R	Head Tie Rods Ext. (MX3)
07	Head Trunnion (MT1)
08	Cap Trunnion (MT2)
09	Side Lugs (MS2)
10	Center Trunnion (MT4)
11	Side End Angles (MS1)
12	Cap Fixed Clevis (MP1)
15	Side End Lugs (MS7)
16	Sleeve Nut Construction (Universal)
20	Head Square Flange (MF5)
21	Cap Square Flange (MF6)
22	Detachable Cap Clevis (MP2)
32	Cap Fixed Eye (MP3)
<b>42</b>	<b>Detachable Cap Eye (MP4)</b>
52	Spherical Bearing

Additional Options – order alphabetically – More on page 155	
HR	Case Hardened (45 Rc)
L(- -)	Port Location position 1 standard: L(Head Cap) (specify position 1 thru 4 for head and/or cap)
MS	Metal Rod Scraper
N(- -)	Cushion Adjust Screw Location position 2 standard: N(Head Cap) (specify position 1 thru 4 for head and/or cap)
P(-)*	Non-Standard Port Sizes: [specify port size for P(-H) head only, P(-C) cap only, or P(-) both head & cap]
PS	Magnetic Piston
RS	Rod Stud Type 1 (5/8" – 1¾" øRod) Type 2 (5/8" & 1" øRod)
RX	Rod Extensions (specify length of additional rod extension)
SC	Single Acting Spring Extend (Cap End)–See page 155
SR	Single Acting Spring Retract (Rod End)–See page 155
SS	303 Stainless Steel (Hard Chrome Plated)
ST(-C)	Stop Tube (Cap End) (specify stop tube length)
ST(-R)	Stop Tube (Rod End) (specify stop tube length)
T	Special Rod Threads (specify rod thread)
TX	Thread Extensions (specify length of thread extension)
V	Viton® Seals

Piston Rod Threads Type	
1	Small Male (Solid)
2	Intermediate Thread Male (Solid)
3	Female
6	Full Thread Male (Solid)
7	Plain Rod End

Piston Rod Diameters		
A	5/8"	Standard on 1½", 2", 2½"
B	1"	Standard on 3¼", 4", 5"
		Oversized on 1½", 2", 2½"
C	1¾"	Standard on 6", 7", 8"
		Oversized on 3¼", 4", 5"
D	1¾"	Standard on 10"
		Oversized on 6", 7", 8"
E	2"	Standard on 12"
		Oversized on 10"
F	2½"	Oversized on 10", 12"

Cushion in Head	
3	None
5 <sup>1</sup>	Non-Adjustable Cushion
7	Adjustable Cushion (Position 2)

<sup>1</sup>Standard with EJ

Cushion in Cap	
3	None
5 <sup>1</sup>	Non-Adjustable Cushion
7	Adjustable Cushion (Position 2)

<sup>1</sup>Standard with EJ

  

**Port and Cushion Adjustment Positions** (As viewed from rod end: Port standard position 1, Cushion Adjustment standard position 2.)  
NOTE: A Port and a Cushion Adjustment cannot be in the same position.

See page 156 for complete instructions on how to order cylinders.

# Series J & EJ, NFPA Steel Air Cylinder with 42 (MP4) Detachable Cap Eye

All Dimensions in Inches (mm)

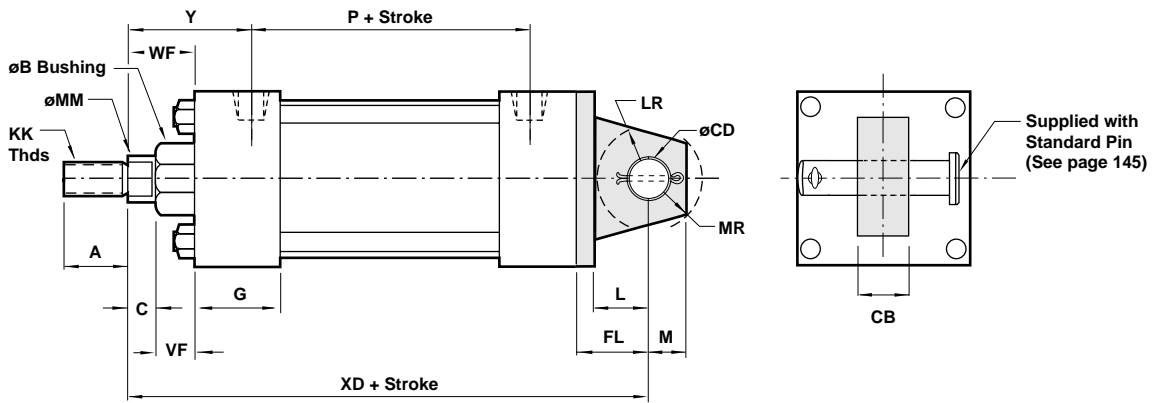

## Standard & Optional Rod Ends

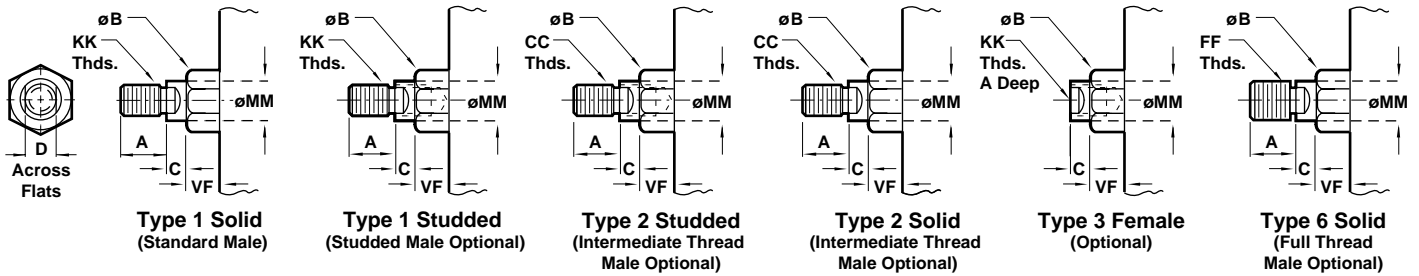

Dimension	1 1/2" Bore (38.10)	2" Bore (50.80)	2 1/2" Bore (63.50)	3 1/4" Bore (82.55)	4" Bore (101.60)	5" Bore (127.00)	6" Bore (152.40)	7" Bore (177.80)	8" Bore (203.20)
ø Rod	Std. 5/8" (15.88)	5/8" (15.88)	5/8" (15.88)	1" (25.40)	1" (25.40)	1" (25.40)	1 3/8" (34.93)	1 3/8" (34.93)	1 3/8" (34.93)
	O.S. 1" (25.40)	1" (25.40)	1" (25.40)	1 3/8" (34.93)	1 3/8" (34.93)	1 3/8" (34.93)	1 3/4" (44.45)	1 3/4" (44.45)	1 3/4" (44.45)
A	Std. .750 (19.05)	.750 (19.05)	.750 (19.05)	1.125 (28.58)	1.125 (28.58)	1.125 (28.58)	1.625 (41.28)	1.625 (41.28)	1.625 (41.28)
	O.S. 1.125 (28.58)	1.125 (28.58)	1.125 (28.58)	1.625 (41.28)	1.625 (41.28)	1.625 (41.28)	2.000 (50.80)	2.000 (50.80)	2.000 (50.80)
B <sup>+0.000</sup> -0.002	Std. 1.124 (28.55)	1.124 (28.55)	1.124 (28.55)	1.499 (38.08)	1.499 (38.08)	1.499 (38.08)	1.999 (50.78)	1.999 (50.78)	1.999 (50.78)
	O.S. 1.499 (38.08)	1.499 (38.08)	1.499 (38.08)	1.999 (50.78)	1.999 (50.78)	1.999 (50.78)	2.374 (60.30)	2.374 (60.30)	2.374 (60.30)
C	Std. .375 (9.53)	.375 (9.53)	.375 (9.53)	.500 (12.70)	.500 (12.70)	.500 (12.70)	.625 (15.88)	.625 (15.88)	.625 (15.88)
	O.S. .500 (12.70)	.500 (12.70)	.500 (12.70)	.625 (15.88)	.625 (15.88)	.625 (15.88)	.750 (19.05)	.750 (19.05)	.750 (19.05)
CB	.750 (19.05)	.750 (19.05)	.750 (19.05)	1.250 (31.75)	1.250 (31.75)	1.250 (31.75)	1.500 (38.10)	1.500 (38.10)	1.500 (38.10)
CC	Std. 1/2 - 20	1/2 - 20	1/2 - 20	7/8 - 14	7/8 - 14	7/8 - 14	1 1/4 - 12	1 1/4 - 12	1 1/4 - 12
	O.S. 7/8 - 14	7/8 - 14	7/8 - 14	1 1/4 - 12	1 1/4 - 12	1 1/4 - 12	1 1/2 - 12	1 1/2 - 12	1 1/2 - 12
CD	Std. .500 (12.70)	.500 (12.70)	.500 (12.70)	.750 (19.05)	.750 (19.05)	.750 (19.05)	1.000 (25.40)	1.000 (25.40)	1.000 (25.40)
	O.S. .813 (20.64)	.813 (20.64)	.813 (20.64)	1.125 (28.58)	1.125 (28.58)	1.125 (28.58)	1.500 (38.10)	1.500 (38.10)	1.500 (38.10)
D	Std. .500 (12.70)	.500 (12.70)	.500 (12.70)	.813 (20.64)	.813 (20.64)	.813 (20.64)	1.125 (28.58)	1.125 (28.58)	1.125 (28.58)
	O.S. .813 (20.64)	.813 (20.64)	.813 (20.64)	1.125 (28.58)	1.125 (28.58)	1.125 (28.58)	1.500 (38.10)	1.500 (38.10)	1.500 (38.10)
E	2.000 (50.80)	2.500 (63.50)	3.000 (76.20)	3.750 (95.25)	4.500 (114.30)	5.500 (139.70)	6.500 (165.10)	7.500 (190.50)	8.500 (215.90)
EE	.375 (9.53)	.375 (9.53)	.375 (9.53)	.500 (12.70)	.500 (12.70)	.500 (12.70)	.750 (19.05)	.750 (19.05)	.750 (19.05)
FF	Std. 5/8 - 18	5/8 - 18	5/8 - 18	1 - 14	1 - 14	1 - 14	1 3/8 - 12	1 3/8 - 12	1 3/8 - 12
	O.S. 1 - 14	1 - 14	1 - 14	1 3/8 - 12	1 3/8 - 12	1 3/8 - 12	1 3/4 - 12	1 3/4 - 12	1 3/4 - 12
FL	1.125 (28.58)	1.125 (28.58)	1.125 (28.58)	1.875 (47.63)	1.875 (47.63)	1.875 (47.63)	2.250 (57.15)	2.250 (57.15)	2.250 (57.15)
G	1.500 (38.10)	1.500 (38.10)	1.500 (38.10)	1.750 (44.45)	1.750 (44.45)	1.750 (44.45)	2.000 (50.80)	2.000 (50.80)	2.000 (50.80)
J	1.000 (25.40)	1.000 (25.40)	1.000 (25.40)	1.250 (31.75)	1.250 (31.75)	1.250 (31.75)	1.500 (38.10)	1.500 (38.10)	1.500 (38.10)
K	.250 (6.35)	.313 (7.94)	.313 (7.94)	.375 (9.53)	.375 (9.53)	.438 (11.11)	.438 (11.11)	.563 (14.29)	.563 (14.29)
KK	Std. 7/16 - 20	7/16 - 20	7/16 - 20	3/4 - 16	3/4 - 16	3/4 - 16	1 - 14	1 - 14	1 - 14
	O.S. 3/4 - 16	3/4 - 16	3/4 - 16	1 - 14	1 - 14	1 - 14	1 1/4 - 12	1 1/4 - 12	1 1/4 - 12
L	.750 (19.05)	.750 (19.05)	.750 (19.05)	1.250 (31.75)	1.250 (31.75)	1.250 (31.75)	1.500 (38.10)	1.500 (38.10)	1.500 (38.10)
LB	3.625 (92.08)	3.625 (92.08)	3.750 (95.25)	4.250 (107.95)	4.250 (107.95)	4.500 (114.30)	5.000 (127.00)	5.125 (130.18)	5.125 (130.18)
LR	.750 (19.05)	.750 (19.05)	.750 (19.05)	1.250 (31.75)	1.250 (31.75)	1.250 (31.75)	1.500 (38.10)	1.500 (38.10)	1.500 (38.10)
M	.500 (12.70)	.500 (12.70)	.500 (12.70)	.750 (19.05)	.750 (19.05)	.750 (19.05)	1.000 (25.40)	1.000 (25.40)	1.000 (25.40)
MM	Std. .625 (15.88)	.625 (15.88)	.625 (15.88)	1.000 (25.40)	1.000 (25.40)	1.000 (25.40)	1.375 (34.93)	1.375 (34.93)	1.375 (34.93)
	O.S. 1.000 (25.40)	1.000 (25.40)	1.000 (25.40)	1.375 (34.93)	1.375 (34.93)	1.375 (34.93)	1.750 (44.45)	1.750 (44.45)	1.750 (44.45)
MR	.625 (15.88)	.625 (15.88)	.625 (15.88)	.938 (23.81)	.938 (23.81)	.938 (23.81)	1.188 (30.16)	1.188 (30.16)	1.188 (30.16)
P	2.313 (58.74)	2.313 (58.74)	2.438 (61.91)	2.625 (66.68)	2.625 (66.68)	2.875 (73.03)	3.125 (79.38)	3.250 (82.55)	3.250 (82.55)
VF	Std. .625 (15.88)	.625 (15.88)	.625 (15.88)	.875 (22.23)	.875 (22.23)	.875 (22.23)	1.000 (25.40)	1.000 (25.40)	1.000 (25.40)
	O.S. .875 (22.23)	.875 (22.23)	.875 (22.23)	1.000 (25.40)	1.000 (25.40)	1.000 (25.40)	1.125 (28.58)	1.125 (28.58)	1.125 (28.58)
WF	Std. 1.000 (25.40)	1.000 (25.40)	1.000 (25.40)	1.375 (34.93)	1.375 (34.93)	1.375 (34.93)	1.625 (41.28)	1.625 (41.28)	1.625 (41.28)
	O.S. 1.375 (34.93)	1.375 (34.93)	1.375 (34.93)	1.625 (41.28)	1.625 (41.28)	1.625 (41.28)	1.875 (47.62)	1.875 (47.62)	1.875 (47.62)
XD	Std. 5.750 (146.05)	5.750 (146.05)	5.875 (149.23)	7.500 (190.50)	7.500 (190.50)	7.750 (196.85)	8.875 (225.43)	9.000 (228.60)	9.000 (228.60)
	O.S. 6.125 (155.58)	6.125 (155.58)	6.250 (158.75)	7.750 (196.85)	7.750 (196.85)	8.000 (203.20)	9.125 (231.78)	9.250 (234.95)	9.250 (234.95)
Y	Std. 1.875 (47.63)	1.875 (47.63)	1.875 (47.63)	2.438 (61.91)	2.438 (61.91)	2.438 (61.91)	2.813 (71.44)	2.813 (71.44)	2.813 (71.44)
	O.S. 2.250 (57.15)	2.250 (57.15)	2.250 (57.15)	2.688 (68.26)	2.688 (68.26)	2.688 (68.26)	3.063 (77.79)	3.063 (77.79)	3.063 (77.79)

## Cylinder with 52 (Not NFPA) Spherical Bearing

- 52 (Not NFPA) Spherical Bearing Mount for 1-1/2" to 8" bore sizes.
- Series J Cylinders rated to 250 PSI air, 400 PSI hydraulic (non-shock). Series EJ Cylinders rated to 250 PSI air only.
- Designed for non-lube service.
- Switches available on all bore sizes. (See pages 150 & 151 for ordering information.)



### Cylinder Order Information

**52** - - - -

J	Series J Cylinder
EJ	Series EJ Cylinder

Bore and Stroke (write out)

Mounting Options	
01	Side Tapped (MS4)
03	Head Rectangular Flange (MF1)
03	Head Square (ME3) -7" to 12" Bores
04	Cap Rectangular Flange (MF2)
04	Cap Square (ME4) -7" to 12" Bores
05	Basic Cylinder No Mounting (MX0)
06	Both Ends (4) Tie Rods Ext. (MX1)
6B	Both Ends (2) Tie Rods Ext. (MX4)
6C	Cap Tie Rods Ext. (MX2)
6R	Head Tie Rods Ext. (MX3)
07	Head Trunnion (MT1)
08	Cap Trunnion (MT2)
09	Side Lugs (MS2)
10	Center Trunnion (MT4)
11	Side End Angles (MS1)
12	Cap Fixed Clevis (MP1)
15	Side End Lugs (MS7)
16	Sleeve Nut Construction (Universal)
20	Head Square Flange (MF5)
21	Cap Square Flange (MF6)
22	Detachable Cap Clevis (MP2)
32	Cap Fixed Eye (MP3)
42	Detachable Cap Eye (MP4)
<b>52</b>	<b>Spherical Bearing</b>

Additional Options – order alphabetically – More on page 155	
HR	Case Hardened (45 Rc)
L(-)	Port Location position 1 standard: L(Head Cap) (specify position 1 thru 4 for head and/or cap)
MS	Metal Rod Scraper
N(-)	Cushion Adjust Screw Location position 2 standard: N(Head Cap) (specify position 1 thru 4 for head and/or cap)
P(-)*	Non-Standard Port Sizes: [specify port size for P(-H) head only, P(-C) cap only, or P(-) both head & cap]
PS	Magnetic Piston
RS	Rod Stud Type 1 (5/8" – 1¾" øRod) Type 2 (5/8" & 1" øRod)
RX	Rod Extensions (specify length of additional rod extension)
SC	Single Acting Spring Extend (Cap End)–See page 155
SR	Single Acting Spring Retract (Rod End)–See page 155
SS	303 Stainless Steel (Hard Chrome Plated)
ST(-C)	Stop Tube (Cap End) (specify stop tube length)
ST(-R)	Stop Tube (Rod End) (specify stop tube length)
T	Special Rod Threads (specify rod thread)
TX	Thread Extensions (specify length of thread extension)
V	Viton® Seals

\*1½", 2", 2½" bore cylinders have 3/8" NPT Standard, 1/2" NPT oversize.  
3¼", 4", 5" bore cylinders have 1/2" NPT Standard, 3/4" NPT oversize.  
This will add 1/8" to the overall cylinder length.

Piston Rod Threads Type	
1	Small Male (Solid)
2	Intermediate Thread Male (Solid)
3	Female
6	Full Thread Male (Solid)
7	Plain Rod End

Piston Rod Diameters		
A	5/8"	Standard on 1½", 2", 2½"
B	1"	Standard on 3¼", 4", 5"
		Oversized on 1½", 2", 2½"
C	13/8"	Standard on 6", 7", 8"
		Oversized on 3¼", 4", 5"
D	13/4"	Standard on 10"
		Oversized on 6", 7", 8"
E	2"	Standard on 12"
		Oversized on 10"
F	2½"	Oversized on 10", 12"

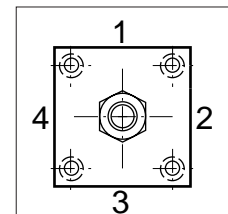

**Port and Cushion Adjustment Positions** (As viewed from rod end:  
Port standard position 1, Cushion Adjustment standard position 2.)  
NOTE: A Port and a Cushion Adjustment cannot be in the same position.

Cushion in Head	
3	None
5 <sup>1</sup>	Non-Adjustable Cushion
7	Adjustable Cushion (Position 2)

<sup>1</sup>Standard with EJ

Cushion in Cap	
3	None
5 <sup>1</sup>	Non-Adjustable Cushion
7	Adjustable Cushion (Position 2)

<sup>1</sup>Standard with EJ

See page 156 for complete instructions on how to order cylinders.

# Series J & EJ Steel Air Cylinder with 52 (Not NFPA) Spherical Bearing



All Dimensions in Inches (mm)

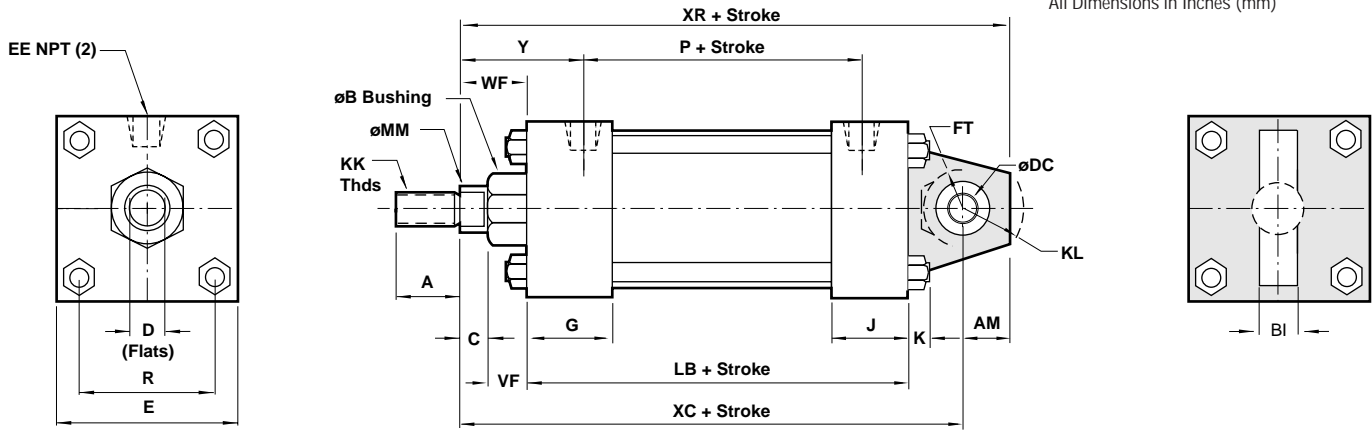

## Standard & Optional Rod Ends

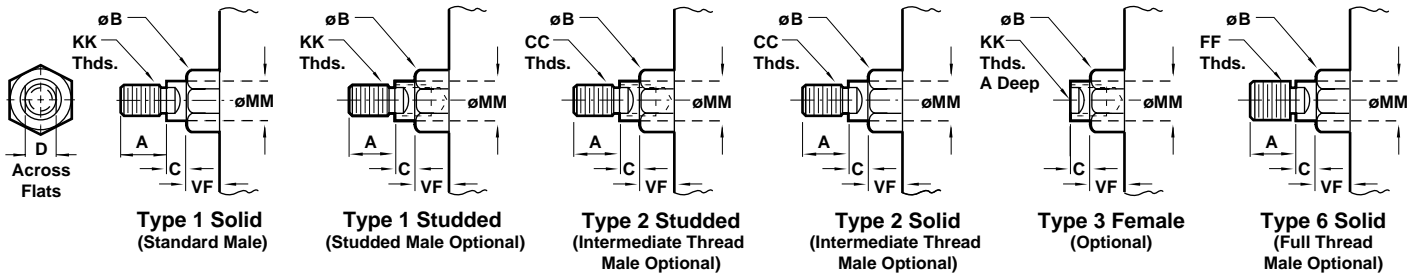

Dimension	1 1/2" Bore (38.10)	2" Bore (50.80)	2 1/2" Bore (63.50)	3 1/4" Bore (82.55)	4" Bore (101.60)	5" Bore (127.00)	6" Bore (152.40)	7" Bore (177.80)	8" Bore (203.20)
ø Rod	Std. 5/8" (15.88)	5/8" (15.88)	5/8" (15.88)	1" (25.40)	1" (25.40)	1" (25.40)	1 3/8" (34.93)	1 3/8" (34.93)	1 3/8" (34.93)
	O.S. 1" (25.40)	1" (25.40)	1" (25.40)	1 3/8" (34.93)	1 3/8" (34.93)	1 3/8" (34.93)	1 3/4" (44.45)	1 3/4" (44.45)	1 3/4" (44.45)
A	Std. .750 (19.05)	.750 (19.05)	.750 (19.05)	1.125 (28.58)	1.125 (28.58)	1.125 (28.58)	1.625 (41.28)	1.625 (41.28)	1.625 (41.28)
	O.S. 1.125 (28.58)	1.125 (28.58)	1.125 (28.58)	1.625 (41.28)	1.625 (41.28)	1.625 (41.28)	2.000 (50.80)	2.000 (50.80)	2.000 (50.80)
AM	.750 (19.05)	.750 (19.05)	.750 (19.05)	1.000 (25.40)	1.000 (25.40)	1.000 (25.40)	1.250 (31.75)	1.250 (31.75)	1.250 (31.75)
B +.000 / -.002	Std. 1.124 (28.55)	1.124 (28.55)	1.124 (28.55)	1.499 (38.08)	1.499 (38.08)	1.499 (38.08)	1.999 (50.78)	1.999 (50.78)	1.999 (50.78)
	O.S. 1.499 (38.08)	1.499 (38.08)	1.499 (38.08)	1.999 (50.78)	1.999 (50.78)	1.999 (50.78)	2.374 (60.30)	2.374 (60.30)	2.374 (60.30)
BI	.438 (11.11)	.438 (11.11)	.438 (11.11)	.656 (16.67)	.656 (16.67)	.656 (16.67)	.875 (22.23)	.875 (22.23)	.875 (22.23)
C	Std. .375 (9.53)	.375 (9.53)	.375 (9.53)	.500 (12.70)	.500 (12.70)	.500 (12.70)	.625 (15.88)	.625 (15.88)	.625 (15.88)
	O.S. .500 (12.70)	.500 (12.70)	.500 (12.70)	.625 (15.88)	.625 (15.88)	.625 (15.88)	.750 (19.05)	.750 (19.05)	.750 (19.05)
CC	Std. 1/2 - 20	1/2 - 20	1/2 - 20	7/8 - 14	7/8 - 14	7/8 - 14	1 1/4 - 12	1 1/4 - 12	1 1/4 - 12
	O.S. 7/8 - 14	7/8 - 14	7/8 - 14	1 1/4 - 12	1 1/4 - 12	1 1/4 - 12	1 1/2 - 12	1 1/2 - 12	1 1/2 - 12
D	Std. .500 (12.70)	.500 (12.70)	.500 (12.70)	.875 (22.23)	.875 (22.23)	.875 (22.23)	1.125 (28.58)	1.125 (28.58)	1.125 (28.58)
	O.S. .813 (20.64)	.813 (20.64)	.813 (20.64)	1.125 (28.58)	1.125 (28.58)	1.125 (28.58)	1.500 (38.10)	1.500 (38.10)	1.500 (38.10)
DC +.000 / -.001	.500 (12.70)	.500 (12.70)	.500 (12.70)	.750 (19.05)	.750 (19.05)	.750 (19.05)	1.000 (25.40)	1.000 (25.40)	1.000 (25.40)
E	2.000 (50.80)	2.500 (63.50)	3.000 (76.20)	3.750 (95.25)	4.500 (114.30)	5.500 (139.70)	6.500 (165.10)	7.500 (190.50)	8.500 (215.90)
EE	.375 (9.53)	.375 (9.53)	.375 (9.53)	.500 (12.70)	.500 (12.70)	.500 (12.70)	.750 (19.05)	.750 (19.05)	.750 (19.05)
FF	Std. 5/8 - 18	5/8 - 18	5/8 - 18	1 - 14	1 - 14	1 - 14	1 3/8 - 12	1 3/8 - 12	1 3/8 - 12
	O.S. 1 - 14	1 - 14	1 - 14	1 3/8 - 12	1 3/8 - 12	1 3/8 - 12	1 3/4 - 12	1 3/4 - 12	1 3/4 - 12
FT	.625 (15.88)	.625 (15.88)	.625 (15.88)	1.000 (25.40)	1.000 (25.40)	1.000 (25.40)	1.250 (31.75)	1.250 (31.75)	1.250 (31.75)
G	1.500 (38.10)	1.500 (38.10)	1.500 (38.10)	1.750 (44.45)	1.750 (44.45)	1.750 (44.45)	2.000 (50.80)	2.000 (50.80)	2.000 (50.80)
J	1.000 (25.40)	1.000 (25.40)	1.000 (25.40)	1.250 (31.75)	1.250 (31.75)	1.250 (31.75)	1.500 (38.10)	1.500 (38.10)	1.500 (38.10)
K	.250 (6.35)	.313 (7.94)	.313 (7.94)	.375 (9.53)	.375 (9.53)	.438 (11.11)	.438 (11.11)	.563 (14.29)	.563 (14.29)
KK	Std. 7/16 - 20	7/16 - 20	7/16 - 20	3/4 - 16	3/4 - 16	3/4 - 16	1 - 14	1 - 14	1 - 14
	O.S. 3/4 - 16	3/4 - 16	3/4 - 16	1 - 14	1 - 14	1 - 14	1 1/4 - 12	1 1/4 - 12	1 1/4 - 12
KL	.969 (24.61)	.969 (24.61)	.969 (24.61)	1.406 (35.71)	1.406 (35.71)	1.406 (35.71)	1.719 (43.66)	1.719 (43.66)	1.719 (43.66)
LB	3.625 (92.08)	3.625 (92.08)	3.750 (95.25)	4.250 (107.95)	4.250 (107.95)	4.500 (114.30)	5.000 (127.00)	5.125 (130.18)	5.125 (130.18)
MM	Std. .625 (15.88)	.625 (15.88)	.625 (15.88)	1.000 (25.40)	1.000 (25.40)	1.000 (25.40)	1.375 (34.93)	1.375 (34.93)	1.375 (34.93)
	O.S. 1.000 (25.40)	1.000 (25.40)	1.000 (25.40)	1.375 (34.93)	1.375 (34.93)	1.375 (34.93)	1.750 (44.45)	1.750 (44.45)	1.750 (44.45)
P	2.313 (58.74)	2.313 (58.74)	2.438 (61.91)	2.625 (66.68)	2.625 (66.68)	2.875 (73.03)	3.125 (79.38)	3.250 (82.55)	3.250 (82.55)
R	1.428 (36.27)	1.838 (46.68)	2.192 (55.67)	2.758 (70.05)	3.323 (84.40)	4.101 (104.16)	4.879 (123.92)	5.730 (145.54)	6.435 (163.44)
VF	Std. .625 (15.88)	.625 (15.88)	.625 (15.88)	.875 (22.23)	.875 (22.23)	.875 (22.23)	1.000 (25.40)	1.000 (25.40)	1.000 (25.40)
	O.S. .875 (22.23)	.875 (22.23)	.875 (22.23)	1.000 (25.40)	1.000 (25.40)	1.000 (25.40)	1.125 (28.58)	1.125 (28.58)	1.125 (28.58)
WF	Std. 1.000 (25.40)	1.000 (25.40)	1.000 (25.40)	1.375 (34.93)	1.375 (34.93)	1.375 (34.93)	1.625 (41.28)	1.625 (41.28)	1.625 (41.28)
	O.S. 1.375 (34.93)	1.375 (34.93)	1.375 (34.93)	1.625 (41.28)	1.625 (41.28)	1.625 (41.28)	1.875 (47.62)	1.875 (47.62)	1.875 (47.62)
XC	Std. 5.375 (136.53)	5.375 (136.53)	5.500 (139.70)	6.875 (174.63)	6.875 (174.63)	7.125 (180.98)	8.125 (206.38)	8.250 (209.55)	8.250 (209.55)
	O.S. 5.750 (146.05)	5.750 (146.05)	5.875 (149.23)	7.125 (180.98)	7.125 (180.98)	7.375 (187.33)	8.375 (212.73)	8.500 (215.90)	8.500 (215.90)
XR	Std. 6.125 (155.58)	6.125 (155.58)	6.250 (158.75)	7.875 (200.03)	7.875 (200.03)	8.125 (206.38)	9.375 (238.13)	9.500 (241.30)	9.500 (241.30)
	O.S. 6.500 (165.10)	6.500 (165.10)	6.625 (168.28)	8.125 (206.38)	8.125 (206.38)	8.375 (212.73)	9.625 (244.48)	9.750 (247.65)	9.750 (247.65)
Y	Std. 1.875 (47.63)	1.875 (47.63)	1.875 (47.63)	2.438 (61.91)	2.438 (61.91)	2.438 (61.91)	2.813 (71.44)	2.813 (71.44)	2.813 (71.44)
	O.S. 2.250 (57.15)	2.250 (57.15)	2.250 (57.15)	2.688 (68.26)	2.688 (68.26)	2.688 (68.26)	3.063 (77.79)	3.063 (77.79)	3.063 (77.79)

**Double Rod End Cylinder with 05 (MX0) Basic**

- NFPA (MX0) 05 Basic with Double Rod End Cylinder for 1-1/2" thru 6" bore sizes.
- Series DJ & EDJ Cylinders rated to 250 PSI air, 400 PSI hydraulic (non-shock). Series EDJ Cylinders rated to 250 PSI air only.
- Designed for non-lube service.
- Switches available on all bore sizes. (See pages 150 & 151 for ordering information.)



**Cylinder Order Information**

**05** - - - -

DJ	Series DJ Double Rod End Cylinder
EDJ	Series EDJ Double Rod End Cylinder

Bore and Stroke (write out)

Mounting Options	
01	Side Tapped (MS4)
03	Head Rectangular Flange (MF1)
03	Head Square (ME3) – 7" to 12" Bores
<b>05</b>	<b>Basic Cylinder No Mounting (MX0)</b>
06	Both Ends (4) Tie Rods Ext. (MX1)
6B	Both Ends (2) Tie Rods Ext. (MX4)
6R	Head Tie Rods Ext. (MX3)
07	Head Trunnion (MT1)
09	Side Lugs (MS2)
10	Center Trunnion (MT4)
11	Side End Angles (MS1)
15	Side End Lugs (MS7)
16	Sleeve Nut Construction (Universal)
20	Head Square Flange (MF5)

Additional Options – order alphabetically – More on page 155	
HR	Case Hardened (45 Rc)
L(- -)	Port Location position 1 standard: L(Head Cap) (specify position 1 thru 4 for head and/or cap)
MS	Metal Rod Scraper
N(- -)	Cushion Adjust Screw Location position 2 standard: N(Head Cap) (specify position 1 thru 4 for head and/or cap)
P(-)*	Non-Standard Port Sizes: [specify port size for P(-H) head only, P(-C) cap only, or P(-) both head & cap]
PS	Magnetic Piston – includes aluminum tube option
RS	Rod Stud Type 1 (5/8" – 1¾" øRod) Type 2 (5/8" & 1" øRod)
RX	Rod Extensions (specify length of additional rod extension)
SC	Single Acting Spring Extend (Cap End)–See page 155
SR	Single Acting Spring Retract (Rod End)–See page 155
SS	303 Stainless Steel (Hard Chrome Plated)
ST(-C)	Stop Tube (Cap End) (specify stop tube length)
ST(-R)	Stop Tube (Rod End) (specify stop tube length)
T	Special Rod Threads (specify rod thread)
TX	Thread Extensions (specify length of thread extension)
V	Viton® Seals

\*1½", 2", 2½" bore cylinders have 3/8" NPT Standard, ½" NPT oversize.  
3¼", 4", 5" bore cylinders have ½" NPT Standard, ¾" NPT oversize.  
This will add 1/8" to the overall cylinder length.

Cushion in Head	
3	None
5 <sup>†</sup>	Non-Adjustable Cushion
7	Adjustable Cushion (Position 2)

<sup>†</sup>Standard with EDA

Piston Rod Threads Type	
1	Small Male (Solid)
2	Intermediate Thread Male (Solid)
3	Female
6	Full Thread Male (Solid)
7	Plain Rod End

Cushion in Cap	
3	None
5 <sup>†</sup>	Non-Adjustable Cushion
7	Adjustable Cushion (Position 2)

<sup>†</sup>Standard with EDA

Piston Rod Diameters	
A	5/8" Standard on 1½", 2", 2½"
B	1" Standard on 3¼", 4", 5" Oversized on 1½", 2", 2½"
C	13/8" Standard on 6", 7", 8" Oversized on 3¼", 4", 5"
D	13/4" Standard on 10" Oversized on 6", 7", 8"
E	2" Standard on 12" Oversized on 10"
F	2½" Oversized on 10", 12"

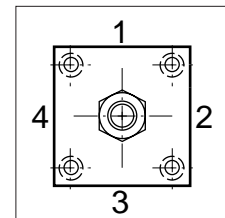

**Port and Cushion Adjustment Positions** (As viewed from rod end: Port standard position 1, Cushion Adjustment standard position 2.)  
NOTE: A Port and a Cushion Adjustment cannot be in the same position.

**NOTE: Double Rod End cylinders have a (Head Rod End) and the opposite end cap is considered the (Cap Rod End). See page 156 for complete instructions on how to order cylinders.**



# Series DJ & EDJ, NFPA Steel Double Rod End Air Cylinder with 05 (MX0) Basic



All Dimensions in Inches (mm)

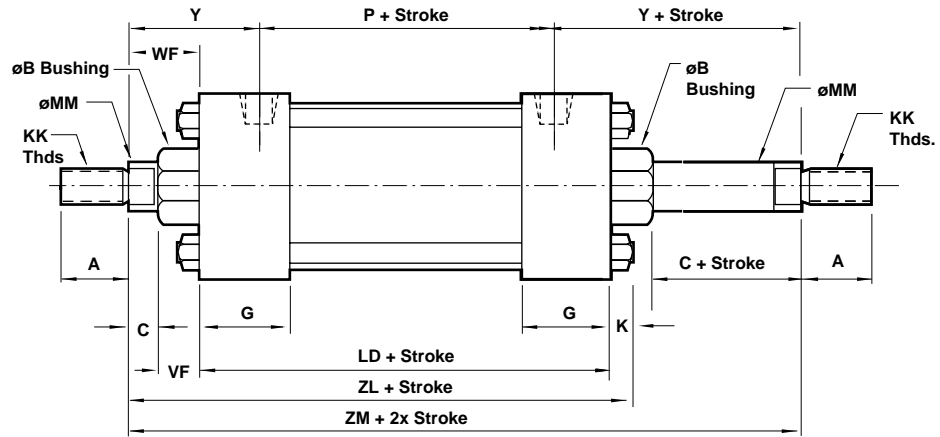
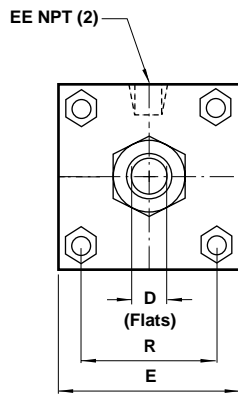

## Standard & Optional Rod Ends

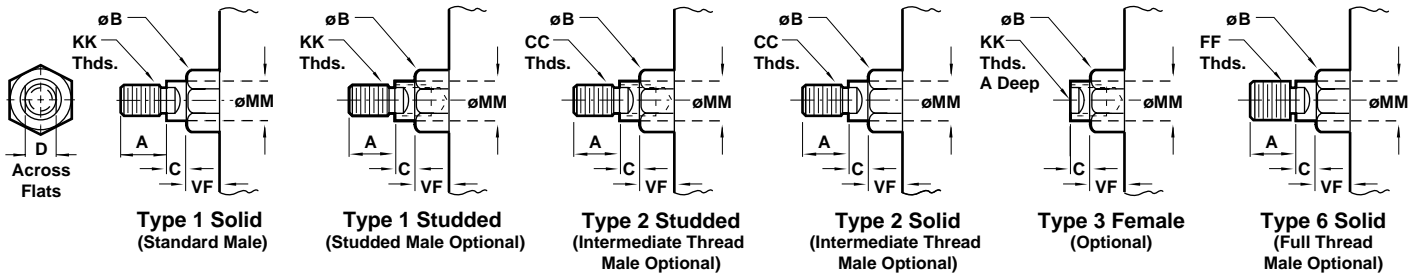

Dimension	1 1/2" Bore (38.10)	2" Bore (50.80)	2 1/2" Bore (63.50)	3 1/4" Bore (82.55)	4" Bore (101.60)	5" Bore (127.00)	6" Bore (152.40)
ø Rod	Std. 5/8" (15.88)	5/8" (15.88)	5/8" (15.88)	1" (25.40)	1" (25.40)	1" (25.40)	1 3/8" (34.93)
	O.S. 1" (25.40)	1" (25.40)	1" (25.40)	1 3/8" (34.93)	1 3/8" (34.93)	1 3/8" (34.93)	1 3/4" (44.45)
A	Std. .750 (19.05)	.750 (19.05)	.750 (19.05)	1.125 (28.58)	1.125 (28.58)	1.125 (28.58)	1.625 (41.28)
	O.S. 1.125 (28.58)	1.125 (28.58)	1.125 (28.58)	1.625 (41.28)	1.625 (41.28)	1.625 (41.28)	2.000 (50.80)
B <sup>+0.000</sup> <sub>-0.002</sub>	Std. 1.124 (28.55)	1.124 (28.55)	1.124 (28.55)	1.499 (38.08)	1.499 (38.08)	1.499 (38.08)	1.999 (50.78)
	O.S. 1.499 (38.08)	1.499 (38.08)	1.499 (38.08)	1.999 (50.78)	1.999 (50.78)	1.999 (50.78)	2.374 (60.30)
C	Std. .375 (9.53)	.375 (9.53)	.375 (9.53)	.500 (12.70)	.500 (12.70)	.500 (12.70)	.625 (15.88)
	O.S. .500 (12.70)	.500 (12.70)	.500 (12.70)	.625 (15.88)	.625 (15.88)	.625 (15.88)	.750 (19.05)
CC	Std. 1/2 - 20	1/2 - 20	1/2 - 20	7/8 - 14	7/8 - 14	7/8 - 14	1 1/4 - 12
	O.S. 7/8 - 14	7/8 - 14	7/8 - 14	1 1/4 - 12	1 1/4 - 12	1 1/4 - 12	1 1/2 - 12
D	Std. .500 (12.70)	.500 (12.70)	.500 (12.70)	.875 (22.23)	.875 (22.23)	.875 (22.23)	1.125 (28.58)
	O.S. .875 (22.23)	.875 (22.23)	.875 (22.23)	1.125 (28.58)	1.125 (28.58)	1.125 (28.58)	1.500 (38.10)
E	2.000 (50.80)	2.500 (63.50)	3.000 (76.20)	3.750 (95.25)	4.500 (114.30)	5.500 (139.70)	6.500 (165.10)
EE	.375 (9.53)	.375 (9.53)	.375 (9.53)	.500 (12.70)	.500 (12.70)	.500 (12.70)	.750 (19.05)
FF	Std. 5/8 - 18	5/8 - 18	5/8 - 18	1 - 14	1 - 14	1 - 14	1 3/8 - 12
	O.S. 1 - 14	1 - 14	1 - 14	1 3/8 - 12	1 3/8 - 12	1 3/8 - 12	1 3/4 - 12
G	1.500 (38.10)	1.500 (38.10)	1.500 (38.10)	1.750 (44.45)	1.750 (44.45)	1.750 (44.45)	2.000 (50.80)
K	.250 (6.35)	.313 (7.94)	.313 (7.94)	.375 (9.53)	.375 (9.53)	.438 (11.11)	.438 (11.11)
KK	Std. 7/16 - 20	7/16 - 20	7/16 - 20	3/4 - 16	3/4 - 16	3/4 - 16	1 - 14
	O.S. 3/4 - 16	3/4 - 16	3/4 - 16	1 - 14	1 - 14	1 - 14	1 1/4 - 12
LD	4.125 (92.08)	4.125 (92.08)	4.250 (95.25)	4.750 (107.95)	4.750 (107.95)	5.000 (127.00)	5.500 (139.70)
MM	Std. .625 (15.88)	.625 (15.88)	.625 (15.88)	1.000 (25.40)	1.000 (25.40)	1.000 (25.40)	1.375 (34.93)
	O.S. 1.000 (25.40)	1.000 (25.40)	1.000 (25.40)	1.375 (34.93)	1.375 (34.93)	1.375 (34.93)	1.750 (44.45)
P	2.313 (58.74)	2.313 (58.74)	2.438 (61.91)	2.625 (66.68)	2.625 (66.68)	2.875 (73.03)	3.125 (79.38)
R	1.428 (36.27)	1.838 (46.68)	2.192 (55.67)	2.758 (70.05)	3.323 (84.40)	4.101 (104.16)	4.879 (123.92)
VF	Std. .625 (15.88)	.625 (15.88)	.625 (15.88)	.875 (22.23)	.875 (22.23)	.875 (22.23)	1.000 (25.40)
	O.S. .875 (22.23)	.875 (22.23)	.875 (22.23)	1.000 (25.40)	1.000 (25.40)	1.000 (25.40)	1.125 (28.58)
WF	Std. 1.000 (25.40)	1.000 (25.40)	1.000 (25.40)	1.375 (34.93)	1.375 (34.93)	1.375 (34.93)	1.625 (41.28)
	O.S. 1.375 (34.93)	1.375 (34.93)	1.375 (34.93)	1.625 (41.28)	1.625 (41.28)	1.625 (41.28)	1.875 (47.63)
Y	Std. 1.875 (47.63)	1.875 (47.63)	1.875 (47.63)	2.438 (61.91)	2.438 (61.91)	2.438 (61.91)	2.813 (71.44)
	O.S. 2.250 (57.15)	2.250 (57.15)	2.250 (57.15)	2.688 (68.26)	2.688 (68.26)	2.688 (68.26)	3.063 (77.79)
ZL	Std. 5.375 (136.53)	5.438 (138.11)	5.563 (141.29)	6.500 (165.10)	6.500 (165.10)	6.813 (174.04)	7.563 (192.09)
	O.S. 5.750 (146.05)	5.813 (147.64)	5.938 (150.81)	6.750 (171.45)	6.750 (171.45)	7.063 (178.47)	7.813 (198.44)
ZM	Std. 6.125 (155.58)	6.125 (155.58)	6.250 (158.75)	7.500 (190.50)	7.500 (190.50)	7.500 (190.50)	8.750 (222.25)
	O.S. 6.875 (174.63)	6.875 (174.63)	7.000 (177.80)	8.000 (203.20)	8.000 (203.20)	8.000 (203.20)	9.250 (234.95)

**Double Rod End Cylinder with 05 (MX0) Basic**

- NFPA (MX0) 05 Basic with Double Rod End Cylinder available in 7" thru 12" bore sizes.
- Series DJ & EDJ Cylinders rated to 250 PSI air, 400 PSI hydraulic (non-shock). Series EDJ Cylinders rated to 250 PSI air only.
- Designed for non-lube service.
- Switches available on all bore sizes. (See pages 150 & 151 for ordering information.)



**Cylinder Order Information**

**05** - - - -

DJ	Series DJ Double Rod End Cylinder
EDJ	Series EDJ Double Rod End Cylinder

Bore and Stroke (write out)

Mounting Options	
01	Side Tapped (MS4)
03	Head Rectangular Flange (MF1)
03	Head Square (ME3) – 7" to 12" Bores
<b>05</b>	<b>Basic Cylinder No Mounting (MX0)</b>
06	Both Ends (4) Tie Rods Ext. (MX1)
6B	Both Ends (2) Tie Rods Ext. (MX4)
6R	Head Tie Rods Ext. (MX3)
07	Head Trunnion (MT1)
09	Side Lugs (MS2)
10	Center Trunnion (MT4)
11	Side End Angles (MS1)
15	Side End Lugs (MS7)
16	Sleeve Nut Construction (Universal)
20	Head Square Flange (MF5)

Cushion in Head	
3	None
5 <sup>†</sup>	Non-Adjustable Cushion
7	Adjustable Cushion (Position 2)

<sup>†</sup>Standard with EDA

Cushion in Cap	
3	None
5 <sup>†</sup>	Non-Adjustable Cushion
7	Adjustable Cushion (Position 2)

<sup>†</sup>Standard with EDA

Additional Options – order alphabetically – More on page 155	
HR	Case Hardened (45 Rc)
L(- -)	Port Location position 1 standard: L(Head Cap) (specify position 1 thru 4 for head and/or cap)
MS	Metal Rod Scraper
N(- -)	Cushion Adjust Screw Location position 2 standard: N(Head Cap) (specify position 1 thru 4 for head and/or cap)
P(-)*	Non-Standard Port Sizes: [specify port size for P(-H) head only, P(-C) cap only, or P(-) both head & cap]
PS	Magnetic Piston – includes aluminum tube option
RS	Rod Stud Type 1 (5/8" – 1¾" øRod) Type 2 (5/8" & 1" øRod)
RX	Rod Extensions (specify length of additional rod extension)
SC	Single Acting Spring Extend (Cap End)–See page 155
SR	Single Acting Spring Retract (Rod End)–See page 155
SS	303 Stainless Steel (Hard Chrome Plated)
ST(-C)	Stop Tube (Cap End) (specify stop tube length)
ST(-R)	Stop Tube (Rod End) (specify stop tube length)
T	Special Rod Threads (specify rod thread)
TX	Thread Extensions (specify length of thread extension)
V	Viton® Seals

\*1½", 2", 2½" bore cylinders have 3/8" NPT Standard, ½" NPT oversize.  
3¼", 4", 5" bore cylinders have ½" NPT Standard, ¾" NPT oversize.  
This will add 1/8" to the overall cylinder length.

Piston Rod Threads Type	
1	Small Male (Solid)
2	Intermediate Thread Male (Solid)
3	Female
6	Full Thread Male (Solid)
7	Plain Rod End

Piston Rod Diameters	
A	5/8" Standard on 1½", 2", 2½"
B	1" Standard on 3¼", 4", 5" Oversized on 1½", 2", 2½"
C	13/8" Standard on 6", 7", 8" Oversized on 3¼", 4", 5"
D	13/4" Standard on 10" Oversized on 6", 7", 8"
E	2" Standard on 12" Oversized on 10"
F	2½" Oversized on 10", 12"

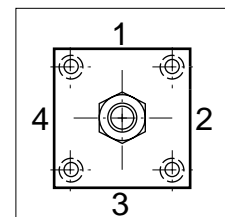

**Port and Cushion Adjustment Positions** (As viewed from rod end: Port standard position 1, Cushion Adjustment standard position 2.)  
NOTE: A Port and a Cushion Adjustment cannot be in the same position.

**NOTE: Double Rod End cylinders have a (Head Rod End) and the opposite end cap is considered the (Cap Rod End). See page 156 for complete instructions on how to order cylinders.**

# Series DJ & EDJ, NFPA Steel Double Rod End Air Cylinder with 05 (MX0) Basic



All Dimensions in Inches (mm)

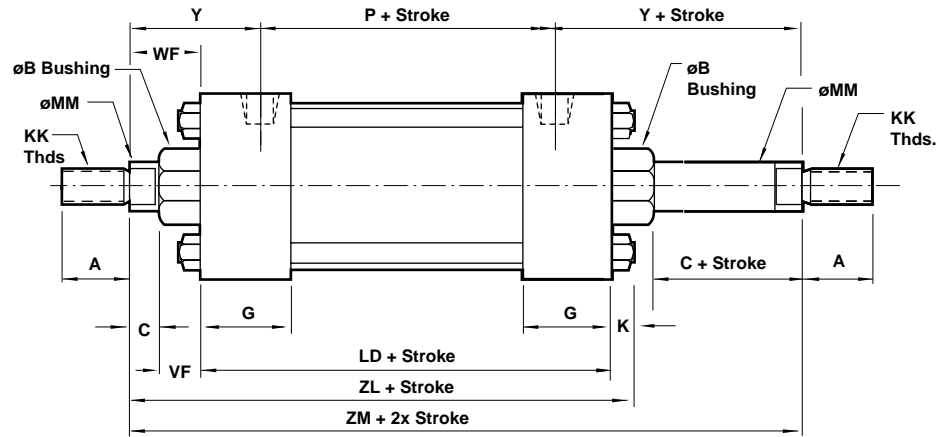
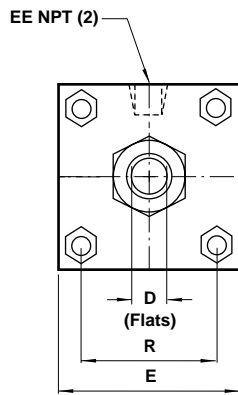

## Standard & Optional Rod Ends

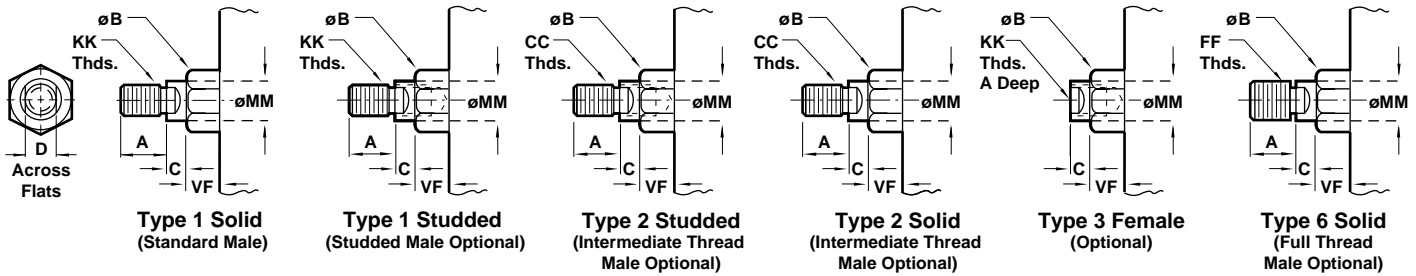

Dimension		7" Bore (177.80)		8" Bore (203.20)		10" Bore (254.00)		12" Bore (304.80)	
ø Rod	Std.	1 3/8"	(34.93)	1 3/8"	(34.93)	1 3/4"	(44.45)	2"	(50.80)
	O.S.	1 3/4"	(44.45)	1 3/4"	(44.45)	2"	(50.80)	2 1/2"	(63.50)
A	Std.	1.625	(41.28)	1.625	(41.28)	2.000	(50.80)	2.250	(57.15)
	O.S.	2.000	(50.80)	2.000	(50.80)	2.250	(57.15)	3.000	(76.20)
B +.000 -.002	Std.	1.999	(50.78)	1.999	(50.78)	2.374	(60.30)	2.624	(66.65)
	O.S.	2.374	(60.30)	2.374	(60.30)	2.624	(66.65)	3.124	(79.35)
C	Std.	.625	(15.88)	.625	(15.88)	.750	(19.05)	.875	(22.23)
	O.S.	.750	(19.05)	.750	(19.05)	.875	(22.23)	1.000	(25.40)
CC	Std.	1 1/4 - 12		1 1/4 - 12		1 1/2 - 12		1 3/4 - 12	
	O.S.	1 1/2 - 12		1 1/2 - 12		1 3/4 - 12		2 1/4 - 12	
D	Std.	1.125	(28.58)	1.125	(28.58)	1.500	(38.10)	1.688	(42.86)
	O.S.	1.500	(38.10)	1.500	(38.10)	1.688	(42.86)	2.063	(52.39)
E		7.500	(190.50)	8.500	(215.90)	10.625	(269.88)	12.750	(323.85)
EE		.750	(19.05)	.750	(19.05)	1.000	(25.40)	1.000	(25.40)
FF	Std.	1 3/8 - 12		1 3/8 - 12		1 3/4 - 12		2 - 12	
	O.S.	1 3/4 - 12		1 3/4 - 12		2 - 12		2 1/2 - 12	
G		2.000	(50.80)	2.000	(50.80)	2.250	(57.15)	2.250	(57.15)
K		.563	(14.29)	.563	(14.29)	.688	(17.46)	.688	(17.46)
KK	Std.	1 - 14		1 - 14		1 1/4 - 12		1 1/2 - 12	
	O.S.	1 1/4 - 12		1 1/4 - 12		1 1/2 - 12		1 7/8 - 12	
LD		5.625	(142.88)	5.625	(142.88)	6.625	(168.28)	7.125	(180.98)
MM	Std.	1.375	(34.93)	1.375	(34.93)	1.750	(44.45)	2.000	(50.80)
	O.S.	1.750	(44.45)	1.750	(44.45)	2.000	(50.80)	2.500	(63.50)
P		3.250	(82.55)	3.250	(82.55)	4.125	(104.78)	4.625	(117.48)
R		5.730	(145.54)	6.442	(163.63)	7.969	(202.41)	9.406	(238.92)
VF	Std.	1.000	(25.40)	1.000	(25.40)	1.125	(28.58)	1.125	(28.58)
	O.S.	1.125	(28.58)	1.125	(28.58)	1.125	(28.58)	1.250	(31.75)
WF	Std.	1.625	(41.28)	1.625	(41.28)	1.875	(47.63)	2.000	(50.80)
	O.S.	1.875	(47.63)	1.875	(47.63)	2.000	(50.80)	2.250	(57.15)
Y	Std.	2.813	(71.44)	2.813	(71.44)	3.125	(79.38)	3.250	(82.55)
	O.S.	3.063	(77.79)	3.063	(77.79)	3.250	(82.55)	3.500	(88.90)
ZL	Std.	7.813	(198.44)	7.813	(198.44)	10.375	(263.53)	11.125	(282.58)
	O.S.	8.125	(206.38)	8.125	(206.38)	10.625	(269.88)	11.625	(295.28)
ZM	Std.	8.875	(225.43)	8.875	(225.43)	9.250	(234.95)	9.675	(245.83)
	O.S.	9.375	(238.13)	9.375	(238.13)	9.375	(238.13)	10.375	(263.53)



# Series J & EJ, NFPA Steel Air Cylinders (ø 1 1/2" to 12") Accessories

All Dimensions in Inches (mm)

## NFPA Rod Clevis

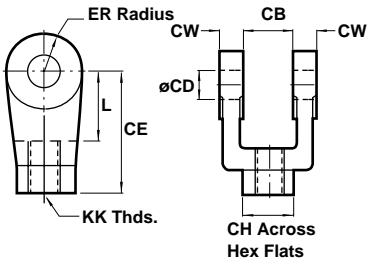

Rod Clevis	Rod Clevis Assy.	KK	CB	CD	CE	CH	CW	ER	L
49028	49028A	7/16 - 20	.750 (19.05)	.500 (12.70)	1.500 (38.10)	1.000 (25.40)	.500 (12.70)	.500 (12.70)	.750 (19.05)
49029	49029A	1/2 - 20	.750 (19.05)	.500 (12.70)	1.500 (38.10)	1.000 (25.40)	.500 (12.70)	.500 (12.70)	.750 (19.05)
49097	49097A	5/8 - 18	.750 (19.05)	.500 (12.70)	1.500 (38.10)	1.000 (25.40)	.500 (12.70)	.500 (12.70)	.750 (19.05)
49030	49030A	3/4 - 16	1.250 (31.75)	.750 (19.05)	2.375 (60.33)	1.250 (31.75)	.625 (15.88)	.750 (19.05)	1.250 (31.75)
49098	49098A	7/8 - 14	1.250 (31.75)	.750 (19.05)	2.375 (60.33)	1.250 (31.75)	.625 (15.88)	.750 (19.05)	1.250 (31.75)
49032	49032A	1 - 14	1.500 (38.10)	1.000 (25.40)	3.125 (79.38)	1.500 (38.10)	.750 (19.05)	1.000 (25.40)	1.500 (38.10)
49033	49033A	1 1/4 - 12	2.000 (50.80)	1.375 (34.93)	4.125 (104.78)	2.000 (50.80)	1.000 (25.40)	1.375 (34.93)	2.125 (53.98)
49099	49099A	1 3/8 - 12	2.000 (50.80)	1.375 (34.93)	4.125 (104.78)	2.000 (50.80)	1.000 (25.40)	1.000 (25.40)	2.125 (53.98)
49034	49034A	1 1/2 - 12	2.500 (63.50)	1.750 (44.45)	4.500 (114.30)	2.375 (60.33)	1.250 (31.75)	1.750 (44.45)	2.250 (57.15)
49100	49100A	1 3/4 - 12	2.500 (63.50)	1.750 (44.45)	4.500 (114.30)	2.375 (60.33)	1.250 (31.75)	1.750 (44.45)	2.250 (57.15)
49036	49036A	1 7/8 - 12	2.500 (63.50)	2.000 (50.80)	5.500 (139.70)	2.937 (74.60)	1.250 (31.75)	2.000 (50.80)	2.500 (63.50)
49101	49101A	2 - 12	2.500 (63.50)	2.000 (50.80)	5.500 (139.70)	2.937 (74.60)	1.250 (31.75)	2.000 (50.80)	2.500 (63.50)
49102	49102A	2 1/4 - 12	3.000 (76.20)	2.500 (63.50)	6.500 (165.10)	3.500 (88.90)	1.500 (38.10)	2.750 (69.85)	3.000 (76.20)
49103	49103A	2 1/2 - 12	3.000 (76.20)	3.000 (76.20)	6.750 (171.45)	3.875 (98.45)	1.500 (38.10)	2.750 (69.85)	3.250 (82.55)

Note: Rod Clevis Assembly 49102A and 49103A are supplied with NFPA Pin. All others are with Standard Pin

## Small Rod Clevis & Jam Nut

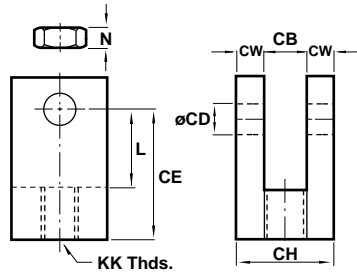

Rod Clevis	Rod Clevis Assy.	KK	CB	CD	CE	CH	CW	L	N
49218	49218A	1/2 - 20	.500 (12.70)	.500 (12.70)	1.375 (34.93)	1.000 (25.40)	.250 (6.35)	.750 (19.05)	.375 (9.53)
49219	49219A	3/4 - 16	.750 (19.05)	.750 (19.05)	1.750 (44.45)	1.500 (38.10)	.375 (9.53)	1.000 (25.40)	.500 (12.70)

Note: Rod Clevis Assembly is supplied with Jam Nut and Standard Pin.

## Rod Jam Nut

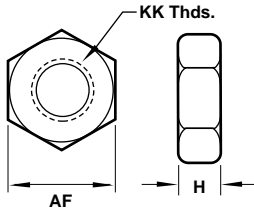

	52025	52026	52027	52010	52029	52030	52085
KK	7/16 - 20	1/2 - 20	5/8 - 18	3/4 - 16	7/8 - 14	1 - 14	1 1/4 - 12
AF	.688 (17.46)	.750 (19.05)	.938 (23.81)	1.125 (28.58)	1.313 (33.34)	1.500 (38.10)	1.875 (47.63)
H	.250 (6.35)	.313 (7.94)	.375 (9.53)	.422 (10.72)	.484 (12.30)	.547 (13.89)	.719 (18.26)

	52092	52068	52082	52070	52093	52083	52075
KK	1 3/8 - 12	1 1/2 - 12	1 3/4 - 12	1 7/8 - 12	2 - 12	2 1/4 - 12	2 1/2 - 12
AF	2.063 (53.39)	2.250 (57.15)	2.625 (66.68)	2.938 (74.61)	3.125 (79.38)	3.500 (88.90)	3.875 (98.43)
H	.781 (19.84)	.844 (21.43)	.969 (24.61)	1.031 (26.19)	1.094 (27.78)	1.203 (30.56)	1.453 (36.91)

## NFPA Rod Eye

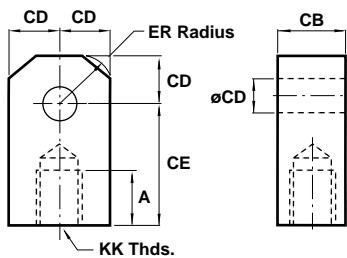

Note: Rod Eye Assembly 49062A and 49096A are supplied with NFPA Pin. All others are supplied with Standard Pin

Rod Eye	Rod Eye Assy.	KK	A	CB	CD	CE	ER
49015	49015A	7/16 - 20	.750 (19.05)	.750 (19.05)	.500 (12.70)	1.500 (38.10)	.563 (14.29)
49014	49014A	1/2 - 20	.750 (19.05)	.750 (19.05)	.500 (12.70)	1.500 (38.10)	.563 (14.29)
49091	49091A	5/8 - 18	.750 (19.05)	1.250 (31.75)	.750 (19.05)	2.063 (52.39)	.500 (12.70)
49013	49013A	3/4 - 16	1.125 (28.58)	1.250 (31.75)	.750 (19.05)	2.063 (52.39)	.938 (23.81)
49092	49092A	7/8 - 14	1.125 (28.58)	1.250 (31.75)	.750 (19.05)	2.063 (52.39)	.750 (19.05)
49011	49011A	1 - 14	1.625 (41.28)	1.500 (38.10)	1.000 (25.40)	2.813 (71.44)	1.125 (28.58)
49010	49010A	1 1/4 - 12	2.000 (50.80)	2.000 (50.80)	1.375 (34.93)	3.438 (87.31)	1.563 (39.69)
49093	49093A	1 3/8 - 12	1.625 (41.28)	2.000 (50.80)	1.375 (34.93)	3.438 (87.31)	1.375 (34.93)
49009	49009A	1 1/2 - 12	2.250 (57.15)	2.500 (63.50)	1.750 (44.45)	4.000 (101.60)	2.500 (63.50)
49094	49094A	1 3/4 - 12	2.250 (57.15)	2.500 (63.50)	1.750 (44.45)	4.000 (101.60)	2.500 (63.50)
49007	49007A	1 7/8 - 12	3.000 (76.20)	2.500 (63.50)	2.000 (50.80)	5.000 (127.00)	2.875 (73.00)
49095	49095A	2 - 12	2.250 (57.15)	2.500 (63.50)	2.000 (50.80)	5.000 (127.00)	2.875 (73.00)
49062	49062A	2 1/4 - 12	3.000 (76.20)	3.000 (76.20)	2.500 (63.50)	5.813 (147.64)	3.250 (82.55)
49096	49096A	2 1/2 - 12	3.000 (76.20)	3.000 (76.20)	3.000 (76.20)	6.125 (155.58)	3.250 (82.55)

## Spherical Rod Eye

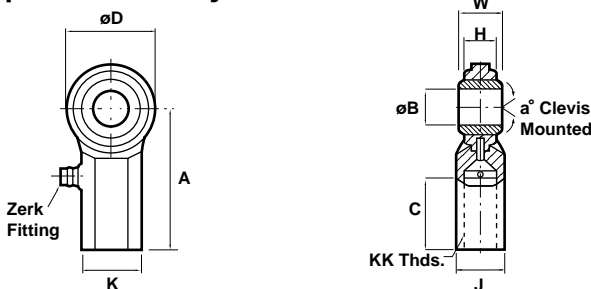

Note: Spherical Rod Eye Assembly is supplied with NFPA Pin.

Spherical Rod Eye		49220	49221	49222
Spherical Rod Eye Assy.		49220A	49221A	49222A
Bore		1 1/2, 2 & 2 1/2	3 1/4, 4 & 5	6 & 8
KK	UNF-2B	1/2 - 20	3/4 - 16	1 - 14
a°	Misalignment Angle	12	14	14
A	± .015	2.125 (53.98)	2.875 (73.03)	4.125 (104.78)
B	+ .0025 / -.0005	.500 (12.70)	.750 (19.05)	1.000 (25.40)
C	+ .062 / -.031	1.063 (26.99)	1.563 (39.69)	2.125 (53.98)
D	± .010	1.313 (33.34)	1.750 (44.45)	2.750 (69.85)
H	Reference	.453 (11.49)	.593 (15.06)	1.000 (25.40)
J	± .010	.750 (19.05)	1.000 (25.40)	1.500 (38.10)
K	± .010	.875 (22.23)	1.125 (28.58)	1.625 (41.28)
W	+ .000 / -.005	.625 (15.88)	.875 (22.23)	1.375 (34.93)



All Dimensions in Inches (mm)

**NFPA Eye Bracket**

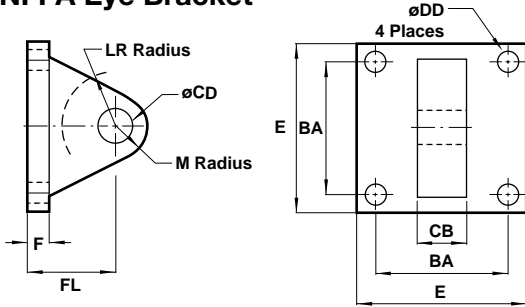

Note: NFPA Eye Bracket Assembly is supplied with Standard Pin.

NFPA Eye Bracket	49021	49020	49019	49016	49017	49018
Eye Bracket Assembly	49021A	49020A	49019A	49016A	49017A	49018A
BA	1.625 (41.28)	2.563 (65.08)	3.250 (82.55)	3.813 (96.84)	4.937 (125.40)	5.750 (146.05)
CB	.750 (19.05)	1.250 (31.75)	1.500 (38.10)	2.000 (50.80)	2.500 (63.50)	2.500 (63.50)
CD	.500 (12.70)	.750 (19.05)	1.000 (25.40)	1.375 (34.93)	1.750 (44.45)	2.000 (50.80)
DD	.406 (10.32)	.531 (13.49)	.656 (16.67)	.656 (16.67)	.906 (23.02)	1.026 (26.06)
E	2.500 (63.50)	3.500 (88.90)	4.500 (114.30)	5.000 (127.00)	6.500 (165.10)	7.500 (190.50)
F	.375 (9.53)	.625 (15.88)	.750 (19.05)	.875 (22.23)	.875 (22.23)	1.000 (25.40)
FL	1.125 (28.58)	1.875 (47.63)	2.250 (57.15)	3.000 (76.20)	3.125 (79.38)	3.500 (88.90)
LR	.750 (19.05)	1.250 (31.75)	1.500 (38.10)	2.125 (53.98)	2.250 (57.15)	2.500 (63.50)
M	.500 (12.70)	.750 (19.05)	1.000 (25.40)	1.375 (34.93)	1.750 (44.45)	2.000 (50.80)

**Norgren Eye Bracket**

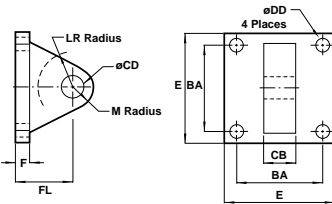

Note: Norgren Eye Bracket Assembly is supplied with Standard Pin.

Norgren Eye Bracket	49240	49241	49242	49243	49244	49019	49016	49017	49018
Eye Bracket Assembly	49240A	49241A	49242A	49243A	49244A	49019A	49016A	49017A	49018A
BA	1.438 (36.51)	1.844 (46.83)	2.188 (55.56)	2.938 (74.61)	3.563 (90.49)	3.250 (82.55)	3.813 (96.84)	4.950 (125.73)	5.730 (145.54)
CB	.750 (19.05)	.750 (19.05)	.750 (19.05)	1.250 (31.75)	1.250 (31.75)	1.500 (38.10)	2.000 (50.80)	2.500 (63.50)	2.500 (63.50)
CD	.500 (12.70)	.500 (12.70)	.500 (12.70)	.750 (19.05)	.750 (19.05)	1.000 (25.40)	1.375 (34.93)	1.750 (44.45)	2.000 (50.80)
DD	.281 (7.14)	.344 (8.73)	.344 (8.73)	.469 (11.91)	.469 (11.91)	.656 (16.67)	.656 (16.67)	.906 (23.01)	1.062 (26.98)
E	2.000 (50.80)	2.500 (63.50)	3.000 (76.20)	3.750 (95.25)	4.500 (114.30)	4.500 (114.30)	5.000 (127.00)	6.500 (165.10)	7.500 (190.50)
F	.375 (9.53)	.375 (9.53)	.375 (9.53)	.500 (12.70)	.500 (12.70)	.750 (19.05)	.875 (22.23)	.875 (22.23)	1.000 (25.40)
FL	1.125 (28.58)	1.125 (28.58)	1.125 (28.58)	1.750 (44.45)	1.750 (44.45)	2.250 (57.15)	3.000 (76.20)	3.125 (79.38)	3.500 (88.90)
LR	.563 (14.29)	.563 (14.29)	.563 (14.29)	1.000 (25.40)	1.000 (25.40)	1.500 (38.10)	2.125 (53.98)	2.250 (57.15)	2.500 (63.50)
M	.625 (15.88)	.625 (15.88)	.625 (15.88)	.875 (22.23)	.875 (22.23)	1.000 (25.40)	1.375 (34.93)	1.750 (44.45)	2.000 (50.80)

**NFPA Clevis Bracket**

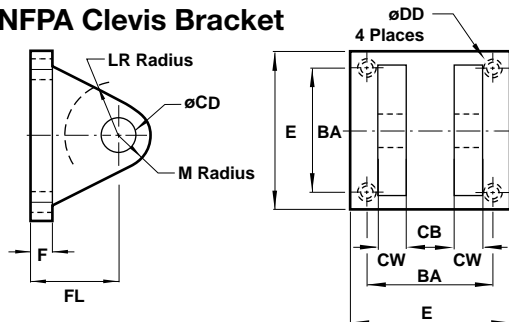

Note: NFPA Clevis Bracket Assembly is supplied with Standard Pin.

NFPA Clevis Bracket	49250	49251	49252
Clevis Bracket Assembly	49250A	49251A	49252A
BA	1.625 (41.28)	2.563 (65.09)	3.250 (82.55)
CB	.750 (19.05)	1.250 (31.75)	1.500 (38.10)
CD	.500 (12.70)	.750 (19.05)	1.000 (25.40)
CW	.500 (12.70)	.625 (15.88)	.750 (19.05)
DD	3/8 - 24	1/2 - 20	5/8 - 18
E	2.500 (63.50)	3.500 (88.90)	4.500 (114.30)
F	.375 (9.53)	.625 (15.88)	.750 (19.05)
FL	1.125 (28.58)	1.875 (47.63)	2.250 (57.15)
LR	.750 (19.05)	1.250 (31.75)	1.500 (38.10)
M	.500 (12.70)	.813 (20.64)	1.000 (25.40)

**Norgren Clevis Bracket**

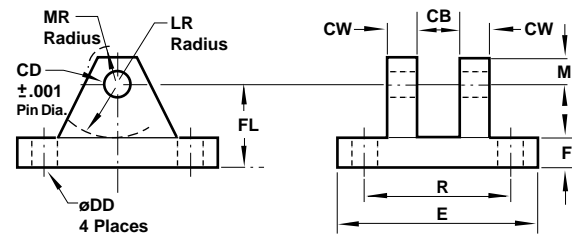

Note: Norgren Clevis Bracket Assembly is supplied with Standard Pin.

Norgren Clevis Bracket	49022	49023	49024	49027	49025	49026
Clevis Bracket Assembly	49022A	49023A	49024A	49027A	49025A	49026A
CB	.750 (19.05)	1.250 (31.75)	1.500 (38.10)	2.000 (50.80)	2.500 (63.50)	2.500 (63.50)
CD	.500 (12.70)	.750 (19.05)	1.000 (25.40)	1.375 (34.93)	1.750 (44.45)	2.000 (50.80)
CW	.500 (12.70)	.625 (15.88)	.750 (19.05)	.750 (19.05)	1.250 (31.75)	1.500 (38.10)
DD	.406 (10.32)	.531 (13.49)	.656 (16.67)	.656 (16.67)	.906 (23.02)	1.026 (26.06)
E	3.500 (88.90)	5.000 (127.00)	6.500 (165.10)	8.000 (203.20)	10.000 (254.00)	12.000 (304.80)
F	.500 (12.70)	.625 (15.88)	.750 (19.05)	.875 (22.23)	.875 (22.23)	1.000 (25.40)
FL	1.500 (38.10)	1.875 (47.63)	2.250 (57.15)	3.000 (76.20)	3.625 (92.08)	4.520 (114.94)
LR	.750 (19.05)	1.188 (30.16)	1.500 (38.10)	2.000 (50.80)	2.750 (69.85)	3.188 (80.96)
M	.500 (12.70)	.750 (19.05)	1.000 (25.40)	1.375 (34.93)	1.750 (44.45)	2.250 (57.15)
MR	.625 (15.88)	.906 (23.02)	1.250 (28.58)	1.656 (42.07)	2.219 (56.36)	2.781 (70.64)
R	2.547 (64.69)	3.828 (97.23)	4.953 (125.81)	5.734 (145.65)	7.500 (190.50)	9.938 (252.41)

**NFPA Pin**

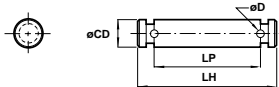

Note: ø.500, .750, 1.000 are Retainer type design ø1.375 and larger are Cotter Pin design.

NFPA Pin	49006-R	49005-R	49004-R	49003	49002	49001	49000	49126	49127
CD	.500 (12.70)	.750 (19.05)	1.000 (12.70)	1.375 (34.93)	1.750 (44.45)	2.000 (50.80)	2.000 (50.80)	2.500 (63.50)	3.000 (76.20)
LH	2.219 (56.30)	3.125 (79.38)	3.750 (95.25)	4.750 (120.65)	5.812 (147.62)	5.812 (147.62)	6.312 (160.33)	6.875 (174.60)	6.875 (174.60)
LP	1.875 (47.63)	2.750 (69.85)	3.250 (82.55)	4.250 (107.95)	5.250 (133.35)	5.281 (134.14)	5.770 (146.56)	6.312 (160.33)	6.344 (161.14)
D	-	-	-	.173 (4.39)	.173 (4.39)	.204 (5.18)	.204 (5.18)	.219 (5.56)	.250 (6.35)

**Standard Pin**

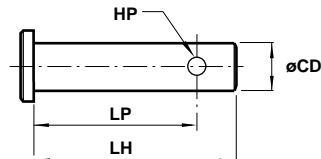

Std. Pin	49207*	49208*	49206	49205	49204	49203	49202	49201
CD	.500 (12.70)	.750 (19.05)	.500 (12.70)	.750 (19.05)	1.000 (25.40)	1.375 (34.93)	1.750 (44.45)	2.000 (50.80)
HP	.156 (3.97)	.156 (3.97)	.156 (3.97)	.156 (3.97)	.203 (5.16)	.250 (6.35)	.250 (6.35)	.250 (6.35)
LH	1.421 (36.09)	2.000 (50.80)	2.250 (57.15)	3.000 (76.20)	3.500 (88.90)	5.000 (127.00)	6.000 (152.40)	6.000 (152.40)
LP	1.266 (32.16)	1.843 (46.83)	2.093 (53.16)	2.843 (72.22)	3.297 (83.74)	4.500 (114.30)	5.500 (139.70)	5.500 (139.70)

\*For small rod clevis only, see page 144.



## Series J & EJ Optional Features & Custom Cylinders

All Dimensions in Inches (mm)

### Adjustable Stroke

Provides variable reduction of the retract stroke and serves as a positive stop for the cylinder piston. Consists of a threaded stud located in the cap end of the cylinder. Milled wrench flats on the end of the adjustment stud allow for simple yet precise positioning to accommodate varying retract stroke requirements.

TO ORDER: Enter option code **A(-)**.  
Specify adjustable stroke length.

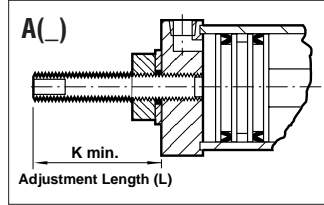

### Adjustable Stroke with Piston

Provides variable reduction of the retract stroke and serves as a positive stop for the cylinder piston. Consists of an adjustable stop piston attached to a threaded stud located in the cap end of the cylinder. Milled wrench flats on the end of the adjustment stud allow for simple yet precise positioning of the stop piston to accommodate varying retract stroke requirements.

TO ORDER: Enter option code **AA(-)**. Specify adjustable stroke length.

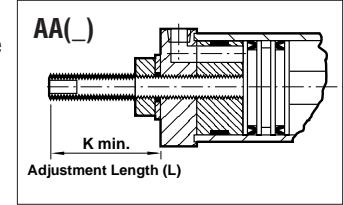

### Maximum Adjustable Stroke Length

Bore	1 1/2" (38.10)	2" (50.80)	2 1/2" (63.50)	3 1/4" (82.55)	4" (101.60)	5" (127.00)	6" (152.40)	7" (177.80)	8" (203.20)
<b>K min.</b>	1 (25.40)	1 (25.40)	1.375 (34.93)	1.375 (34.93)	1.375 (34.93)	1.625 (41.28)	1.625 (41.28)	2 (50.80)	2 (50.80)
<b>A (L max.)</b>	5 (127.00)	5 (127.00)	8 (203.20)	8 (203.20)	8 (203.20)	9 (228.60)	9 (228.60)	12 (304.80)	12 (304.80)
<b>AA (L max.)</b>	10 (254.00)	10 (254.00)	16 (406.40)	16 (406.40)	16 (406.40)	18 (457.20)	18 (457.20)	20 (508.00)	20 (508.00)

### Metallic Rod Scraper

Aggressively scrapes the exposed portion of the piston rod free of weld spatter, paint spray, abrasive powders or many other foreign materials that could damage the rod seal.

TO ORDER: Enter option code **MS**.

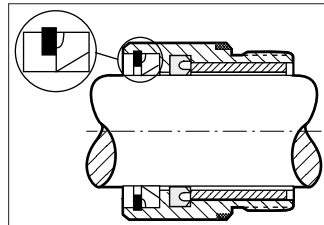

### Piston Rod Seal O-Ring Loaded

Pre-loaded lip seal has a very low leakage at low pressure. Excellent for low pressure hydraulic applications. TO ORDER, enter: Option code **H** – Rod seal only.

Option code **PP** – Rod and piston seals.

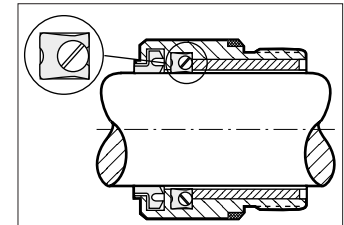

### Piston Rod Stud

Reduces the chance for piston rod failure.

The rod stud can be installed with different thread locker. TO ORDER, enter:

Option code **BL** – removable adhesive sealant.

Option code **RS** – high strength thread locker adhesive.

NOTE: Type 2 studded rod shown.

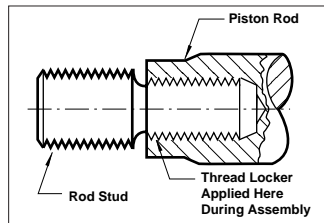

### Cushion Adjust Screw Optional Locations

Option code **N(-)**

Specify optional location.

Example: **N(4 2)** cushion location 4 Head end, standard position 2 Cap end.

When using option code **N**, head and cap locations must be specified 1, 2, 3, or 4.

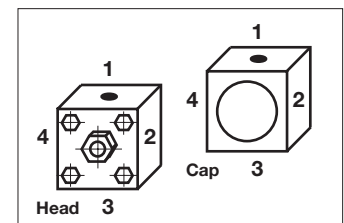

### Pinned Piston to Rod

Norgren will supply a full size piston rod to piston joint, in addition to pinning the piston to the rod, for severe applications. If under normal operating conditions, the pinned piston and rod become detached, Norgren will replace the piston and rod assembly free of charge.

TO ORDER: Enter option code **PN**.

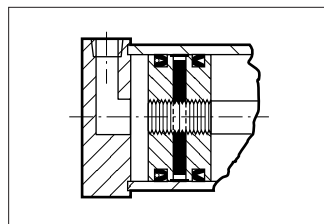

### Magnetic Piston (No Wear Ring)

When position sensing of the cylinder rod is required, a "magnetic piston" must be specified.

A magnetic band is placed at the center of the piston which creates a magnetic field to actuate Norgren's reed, solid state or hall effect switch.

NOTE: We cannot guarantee the operation of other manufacturers' switches.

TO ORDER: Enter option code **PS**.

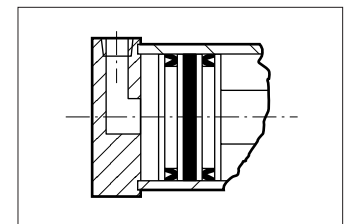

### Single Acting Spring Extend

Available on Cap End of Cylinder for 1 1/2", 2", and 2 1/2" bore sizes, 12" maximum stroke.

NOTE: Standard spring extend cylinder has 12 lbs. force pre-load, 30 lbs. force compressed. For other spring forces, bore sizes or longer strokes, consult factory.

TO ORDER: Enter option code **SC**.

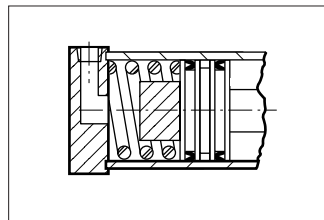

### Single Acting Spring Retract

Available on Rod End of Cylinder for 1 1/2", 2", and 2 1/2" bore sizes, 12" maximum stroke.

NOTE: Standard spring retract cylinder has 12 lbs. force pre-load, 30 lbs. force compressed. For other spring forces, bore sizes or longer strokes, consult factory.

TO ORDER: Enter option code **SR**.

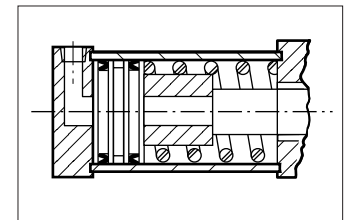

### Additional Female Thread Depth

Piston rod thread depth can be ordered over standard.

TO ORDER: Enter option code **TF(-)** and specify additional "A" depth.

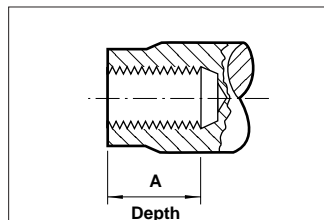

### Additional Male Thread Length

Piston rod thread extension can be ordered over standard.

TO ORDER: Enter option code **TX(-)** and specify additional "A" length.

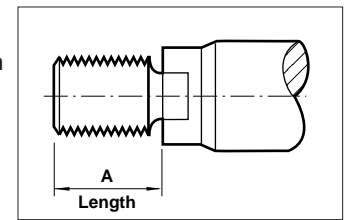



**Stop Tube**

Enhances the transverse load carrying capability of a long stroke cylinder by increasing the distance between the piston and rod bearing at full extension when placed on head end. Ideal for those applications requiring longer strokes or where additional rod stability is desired. TO ORDER: Enter option code **ST(-C)** Cap End or **ST(-R)** Rod End. Specify stop tube length. **NOTE: ST(-R)** Alternate design: the stop tube rod end design changes when the stop tube exceeds **J** lengths in the chart.

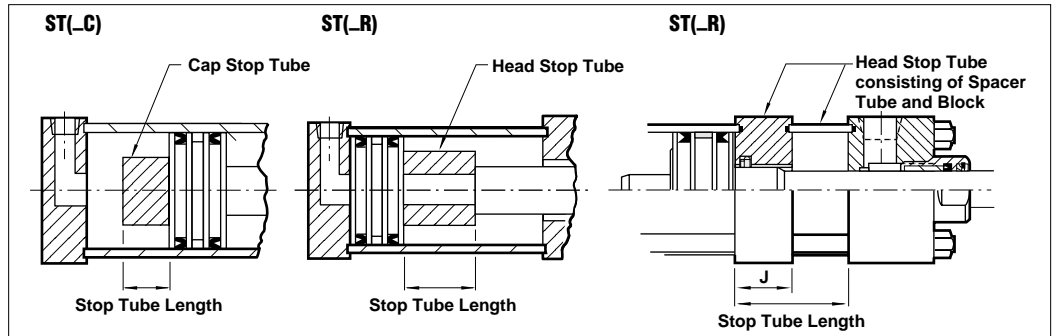

Bore	1 1/2" (38.10)	2" (50.80)	2 1/2" (63.50)	3 1/4" (82.55)	4" (101.60)	5" (127.00)	6" (152.40)	7" (177.80)	8" (203.20)
J	1 (25.40)	1 (25.40)	1 (25.40)	1.250 (31.75)	1.250 (31.75)	1.250 (31.75)	1.500 (38.10)	1.500 (38.10)	1.500 (38.10)

**Norgren's Standard Thrust Key Plate**

Thrust key plates eliminate the use of fitted bolts or dowel pins on side mountings. They prevent movement of the cylinder under shock loading, which might otherwise occur due to normal clearance between mounting holes and bolt diameters. Option code **TK** available on 01(MS4), 09(MS2) and 15(MS7) mounts. **NOTE:** Other manufacturers' thrust key plates can vary. Consult factory for information.

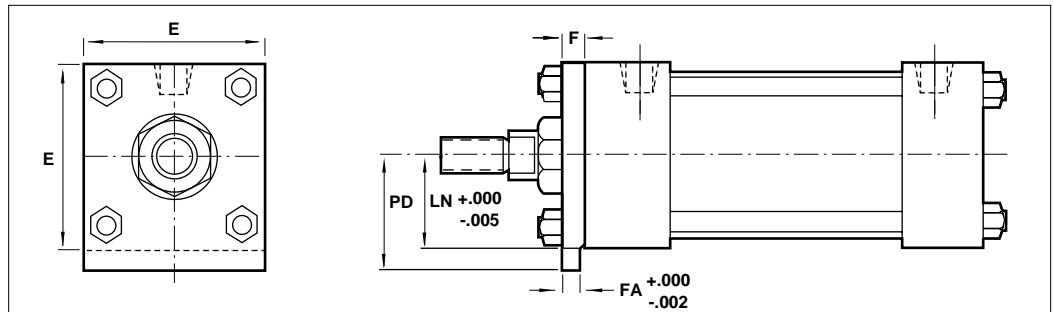

Bore	1 1/2" (38.10)	2" (50.80)	2 1/2" (63.50)	3 1/4" (82.55)	4" (101.60)	5" (127.00)	6" (152.40)
E	2.000 (50.80)	2.500 (63.50)	3.000 (76.20)	3.750 (95.25)	4.500 (114.30)	5.500 (139.70)	6.500 (165.10)
F	.375 (9.53)	.375 (9.53)	.375 (9.53)	.625 (15.88)	.625 (15.88)	.625 (15.88)	.750 (19.05)
FA	.313 (7.94)	.313 (7.94)	.313 (7.94)	.563 (14.29)	.563 (14.29)	.563 (14.29)	.688 (17.46)
LN	1.000 (25.40)	1.250 (31.75)	1.500 (38.10)	1.875 (47.63)	2.250 (57.15)	2.750 (69.85)	3.250 (82.55)
PD	1.188 (30.18)	1.438 (36.53)	1.688 (42.88)	2.188 (57.58)	2.563 (65.10)	3.063 (77.80)	3.625 (92.08)

**NOTE:** Care should be taken in machining the keyway slot for a tight fit. Only one keyway should be used per cylinder.

**Valve In Head**

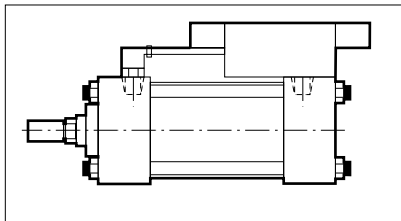

**Integral Shock Absorber**

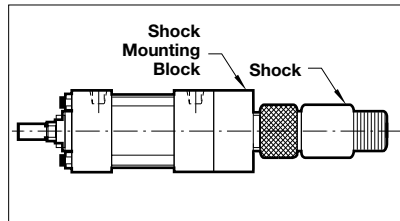

**Multi-Position Duplex**

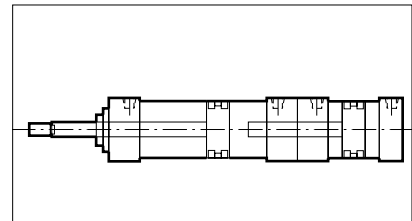

**Multi-Position Back-to-Back**

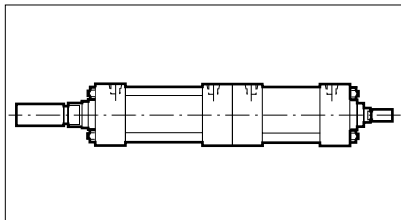

**Oversize Piston Rod**

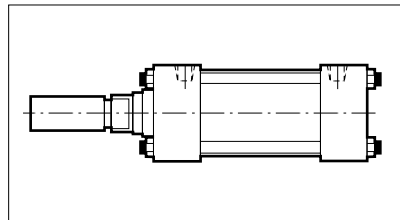

**Protective Rod Boot**

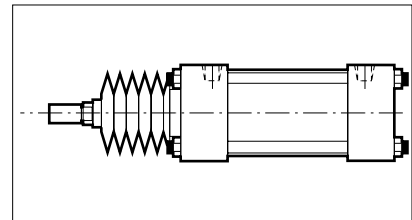

**Air to Air Booster/Pump**

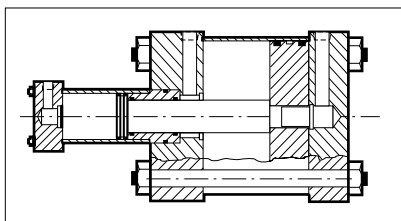

**Force Multiplication Tandem**

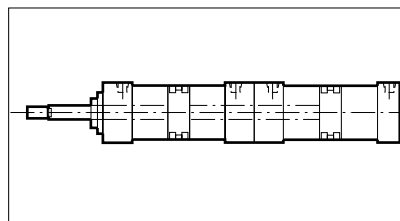

**Other Custom Cylinders:**

Norgren designs and manufactures literally hundreds of specialty cylinders. We welcome the opportunity to provide you with a customized cylinder that meets the specific requirements of your application. For more information on how to order custom cylinders consult factory.

## Pneumatic & Pneumatic Valves Shown



### Stroke Signal Valve

Stroke Signal Valves emit a positive pneumatic signal to indicate the position of the piston at each end of the cylinder stroke. It can be used to energize other air or electrical mechanisms in a control circuit.

This patented\* design involves a three-way normally closed poppet valve that uses the same pressure that drives the cylinder piston to provide a pneumatic signal.

Stroke Signal Valves are positioned on either or both ends of the cylinder according to your specifications. Each cylinder bore has minimum stroke limitations (See page 149.) The standard Signal Valve begins to give a pneumatic signal when the cylinder piston is within 1/8" of the end of the stroke. For signal distances less than 1/8", consult factory.

\*Patent No. 3,648,568

### Pneumatic Valve

Pneumatic valves incorporate a single-pole, double-throw electric conversion switch with a Stroke Signal Valve. (Optional double-pole, double-throw switches are available.)

The electric conversion switch screws directly into the outlet port of the Stroke Signal Valve, enabling the Pneumatic Valve to convert air pulses into electrical signals without the need of complicated electro-pneumatic circuitry.

### How to Order Stroke Signal Valves

Add suffix SV ( ) after cylinder model number.  
 Indicate in ( ) Stroke Signal Valve location: list head position first, cap position last.  
 Valve position on head and/or cap should be indicated by position number 1, 2, 3 or 4.  
 Example: J333A1-SV(02) – Bore x Stroke = Stroke Signal Valve mounted on cap end only, position 2.

### How to Order Pneumatic Valves

Add suffix EV after cylinder model number.  
 Example: J333A1-EV(42S)\*\* – Bore x Stroke = Pneumatic Valve mounted on head end, position 4 and cap end, position 2, with single-pole – Double-throw.

\*\* S = Single-pole – Double-throw switch  
 D = Double-pole – Double-throw switch

### How the Valve Works

■ SUPPLY PRESSURE  
 □ EXHAUST PRESSURE

#### Start of the Stroke

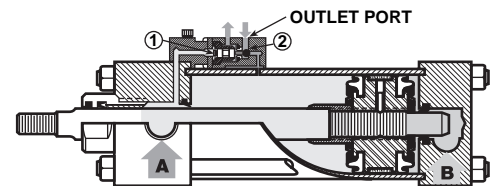

At the start of the stroke, the stroke signal valve is closed because areas (1) and (2) are equally pressurized (A), with area (1) being several times greater than area (2). Outlet port is vented to atmosphere.

#### Mid-Stroke

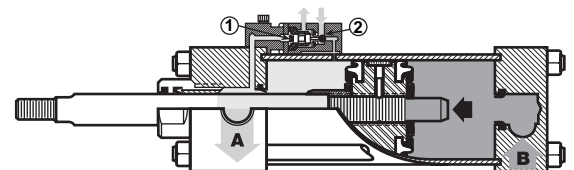

The same condition exists at mid-stroke with the exception that a greater pressure (B) has been applied to drive the piston.

#### End of the Stroke†

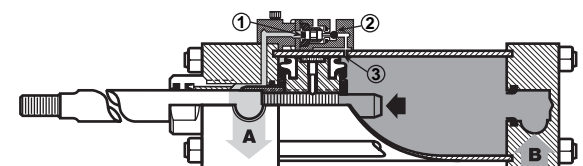

At the end of the stroke the piston seal has passed the inboard air hole (3), supplying full pressure against area (2) When air has exhausted through (A) the valve stem shifts and pressure is supplied to the outlet port of the signal valve.

† 1/8" from bottoming.





**Dimensions and Mountings: Pneumatic Valve**

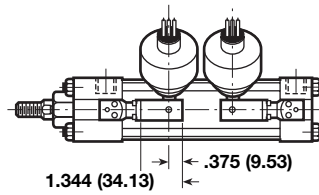
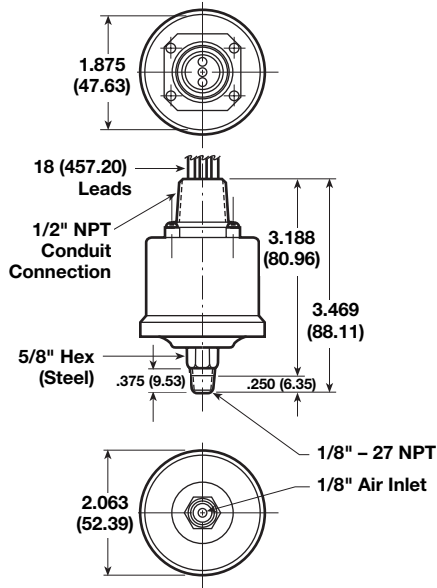

Two Valves Mounted on the Same Side (Type F)

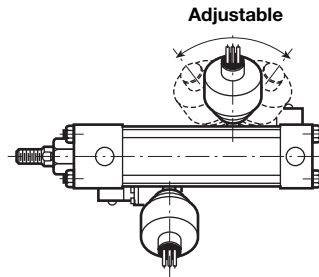

One or Two Valves Mounted on Different Sides (Type E)

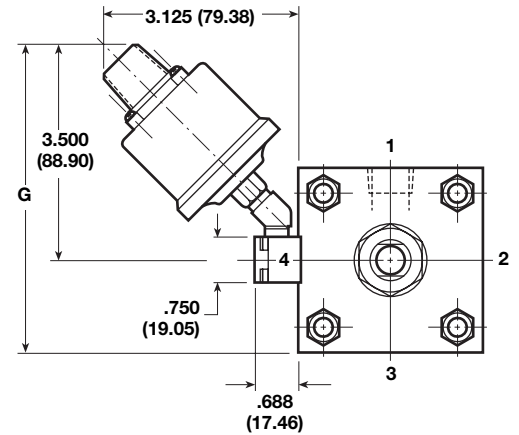

Stroke signal valves cannot be mounted on same side as port location or cushion adjustment location.

**Minimum Stroke**

Minimum Stroke	Cylinder Bore									
	1 1/2"	2"	2 1/2"	3 1/4"	4"	5"	6"	7"	8"	
Type E	.813 (20.64)	.813 (20.64)	.688 (17.46)	.688 (17.46)	.688 (17.48)	.438 (11.11)	.438 (11.11)	.688 (17.46)	.688 (17.46)	
Type F	2.750 (69.85)	2.750 (69.85)	2.625 (66.68)	2.625 (66.68)	2.625 (66.68)	2.375 (60.33)	2.375 (60.33)	3.000 (76.20)	3.000 (76.20)	
G	4.500 (114.30)	4.750 (120.65)	5.000 (127.00)	5.375 (136.53)	5.750 (146.05)	6.250 (158.75)	6.750 (171.45)	7.250 (184.15)	7.750 (196.85)	

**Mounting Specifications**

Position 4 Standard on Mounting Styles 1, 3, 4, 5, 6, 9, 11, 12, 15, 16, 20, 21, 22, 32, 42, 52 & 60.

Position 3 Standard on Mounting Styles 7\*, 8\* & 10.

\*SV or EV cannot be specified with cushion (adjustable) on same end (head or cap).

Stroke signal valves cannot be mounted on same side as port location or cushion adjustment location.

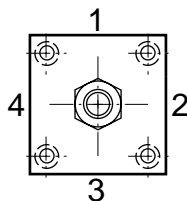

**Design Features**

Electrical Ratings:

- 10 amp 110-220 v-ac
- 10 amp 28 v-dc

Pressure Ratings: Actuation – 30 psig

Modes of Operation:

- Single-pole – Double-throw
- Double-pole – Double-throw

Single-pole – Double-throw is standard.

(For Double-pole – Double-throw specify DP-DT.)

Lead Lengths: 18" standard

Maximum Pressure: 250 psi

Minimum Pressure: 20 psi

Ambient Temperature Rating:

- 40°F to 250°F
- (-40°C to 121°C)

3 Wire Switch:

- Black = Common
- Red = N.O. Contact
- Green = N.C. Contact

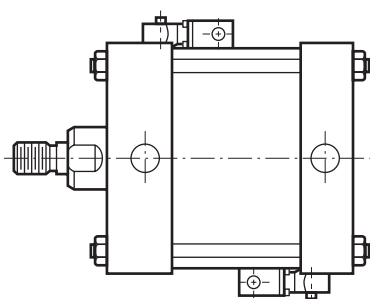

**Type E**  
One or Two Stroke Signal Valves Mounted on Opposite Sides

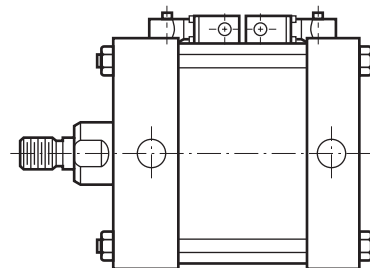

**Type F**  
Two Stroke Signal Valves Mounted on the Same Side

- Magnetically operated, non-contact sensing system.
- Consists of a magnet in the piston, and a sensing switch clamped on the cylinder tie rod.
- One or more switches may be mounted to provide an indication of piston position or to control or initiate any sequence function.
- Adjustable mounting brackets allow for switches to be securely positioned anywhere along the range of piston travel.
- LED indicator light facilitates installation and troubleshooting.
- Mounting brackets standard with switches.

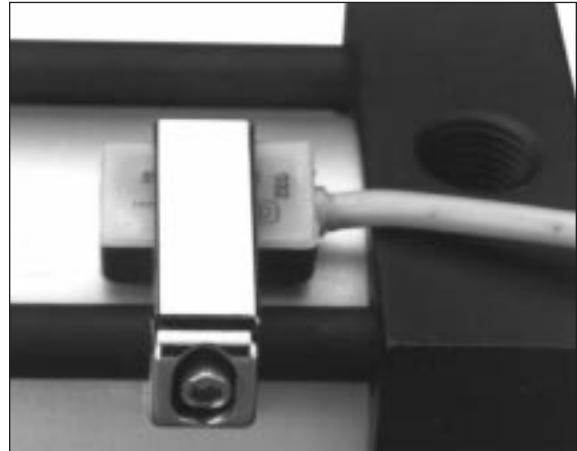

### Specifications

\*Metal Oxide Varistor Surge Suppression. **NOTE:** All CS8 Series Switches are supplied with 9 foot leads.

Switch Model	CS8-2-04 Reed	CS8-2-31 Solid State	CS8-2-32 Solid State
Bore Sizes	1 1/2" thru 2 1/2"	1 1/2" thru 2 1/2"	1 1/2" thru 2 1/2"
Switch Type	Reed Switch *MOV & Light	Solid State & Light, Sourcing PNP	Solid State & Light, Sinking NPN
Function	SPST Normally Open	Normally Open	Normally Open
Switching Voltage	5-120 VDC/VAC 50/60 Hz	6-24 VDC	6-24 VDC
Switching Current	.5 Amp Max .005 Amp Min	.5 Amp Max	.5 Amp Max
Switching Power	10 VA	12 Watts Max	12 Watts Max
Max Voltage Drop	3.5 Volts	.5 Volts	.5 Volts
Magnetic Sensitivity	85 Gauss	85 Gauss	85 Gauss
Enclosure Classification	NEMA 6 & CSA Approved	NEMA 6 & CSA Approved	NEMA 6 & CSA Approved
Temperature Range	-22°F to +176°F	-22°F to +176°F	-22°F to +176°F

Wiring Diagrams	CS8-2-04 Reed	CS8-2-31 Solid State	CS8-2-32 Solid State

### Switch & Mounting Bracket Dimensions

#### CS8-2 Series

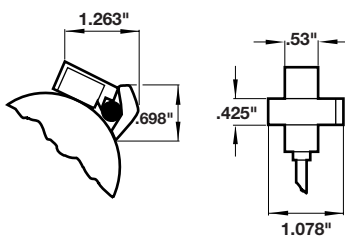

#### NOTE:

**1-1/2" to 2-1/2" bore steel cylinder is supplied with an aluminum tube as standard. If a 3-1/4" to 12" bore steel cylinder requires switches, the aluminum tube and magnetic piston options must be selected.**



### Reed Switch Working Principle

Reed switch sensors contain hermetically sealed reed elements (mechanical contacts) which are open in their normal state. When a magnetic field moves within proximity of the switch, magnetism is induced into the leads and forces the contacts to close.

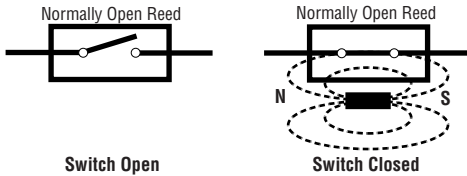

### Solid State/Magnetostrictive Working Principle

The solid state (no moving parts) magnetostrictive sensor responds to a parallel magnetic pole by providing a digital signal to the output control circuit. This technique enables the sensing of weak magnetic fields, with no limit to the maximum strength of the magnetic field. Norgren solid state switches are similar to the Hall effect switch.

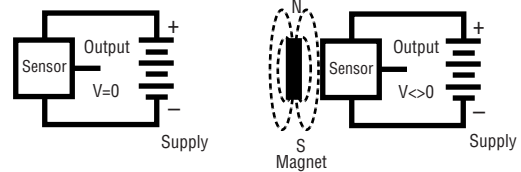

### Application Recommendations and Precautions

To provide maximum reliability.

1. Always stay within the specifications and power rating limitations of the unit installed.
2. Primary and control circuit wiring should not be mixed in the same conduit. Motors will produce high pulses that will be introduced into the control wiring if the wiring is carried in the same conduit.
3. Never connect the switch without a load present. The switch will be destroyed.
4. Some electrical loads may be capacitive. Capacitive loading may occur due to distributed capacity in cable runs over 25 feet. Use switch Model CS7-24 whenever capacitive loading may occur.

In order to obtain optimum performance and long life, magnetically operated limit switches should not be subjected to: (1) strong magnetic fields, (2) extreme temperature, and (3) excessive ferrous filing or chip buildup.

Improper wiring may damage or destroy the switch. The wiring diagram, along with the listed power ratings, must be carefully observed before connecting power to the switch.

Lower power switches are designed for signaling electronic circuits. Do not use on relay loads or with incandescent bulbs. Resistive loads only.

CS7-04 Reed	CS7-24 Reed	CS7-31 Solid State	CS7-32 Solid State
2" thru 8"	2" thru 8"	2" thru 8"	2" thru 8"
Reed Switch *MOV & Light	Reed Switch *MOV & Light, 3 Wire	Solid State & Light, Sourcing PNP	Solid State & Light, Sinking NPN
Normally Open	Normally Open	Normally Open	Normally Open
5-240 VDC/VAC 50/60 Hz	24-240 VAC 50/60 Hz	6-24 VDC	6-24 VDC
1 Amp Max	4 Amp Max 50 Amp Inrush	1 Amp Max	1 Amp Max
30 Watts Max	100 Watts Max	24 Watts Max	24 Watts Max
3 Volts	N/A	.5 Volts	.5 Volts
85 Gauss Parallel	85 Gauss Parallel	85 Gauss Parallel	85 Gauss Parallel
NEMA 6 & CSA Approved -22°F to +176°F	NEMA 6 & CSA Approved -22°F to +176°F	NEMA 6 & CSA Approved -22°F to +176°F	NEMA 6 & CSA Approved -22°F to +176°F

NOTE: For 8" bore add 9 to part number. Example: CS7-9-04. For 10" and 12" bore, consult the factory.

### CS7 Series

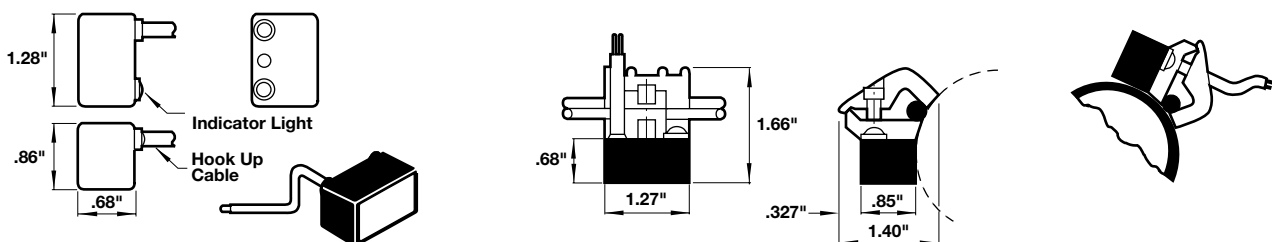

## Right Angle (Banjo) Flow Controls

- 360° rotation of the banjo body around the bolt allows for ideal positioning of tubing.
- Low profile and reduced physical size provide space saving installations, while internal configuration provides the flow capacity of much bulkier designs.
- Tapered adjustment needles with large adjustment ranges provide linear flows and greater precision.
- Knurled adjustment knobs (w/screw driver slot) and lock nuts on 12 VA0 and 10 TA0 series provide finger tip adjustment. Tamper resistance on the 10 K51 is provided by a slotted adjustment screw covered by a protective plastic cap.
- Direct mounting of flow controls on pneumatic actuators minimizes the adjustment problems encountered due to the compressibility of air in long tubing runs between the actuator and control valving. Additionally, direct mounted flow controls end the confusion over which actuator in a circuit is being controlled.
- Metallic components are limited to nickel plated all brass construction, eliminating the potential problems encountered with products constructed of dissimilar metals.
- Adjustment needles and banjo bodies are retained, preventing accidental loss of the needle or lock nut.



### Operation

Flow Controls are checked adjustable controls of the meter out type. Compressed air passes freely into the push-in fitting portion of the flow control, flowing past the check seal and entering the connected component. In reverse flow conditions, air passes back into the flow control and energizes the check seal. Air must now flow through the metered passage controlled by the tapered adjustment needle of the flow control, and finally exits through the push-in fitting end.

### Specifications

Fluid: Compressed air. *For other types of compressed gases, please consult factory.*

Working Pressure: 0 to 150 psig (0 to 10 bar)

Temperature Range: 0° to 175°F (-20° to 80°C)

### Materials of Construction

Banjo bolt, collet, adjustment knob and lock nut: Nickel plated brass

Tapered adjusting needle: Brass

Banjo Body 10 TA0 and 12 VA0 XXXX: Thermoplastic  
10 K51 XXXX: Nickel plated brass

O-rings and check-seal: Silicone free Nitrile

Sealing washer: Thermoplastic (ISO G and 10-32 UNF)

Tubing: Nylon 11 or 12, 95 durometer polyurethane.

Thread Sealant: Thread sealant is applied to the full circumference of tapered male threads.

### Options

Special versions of the flow controls are available, including meter-out and bi-directional control configurations. *Please consult factory with specific quantities and requirements.*

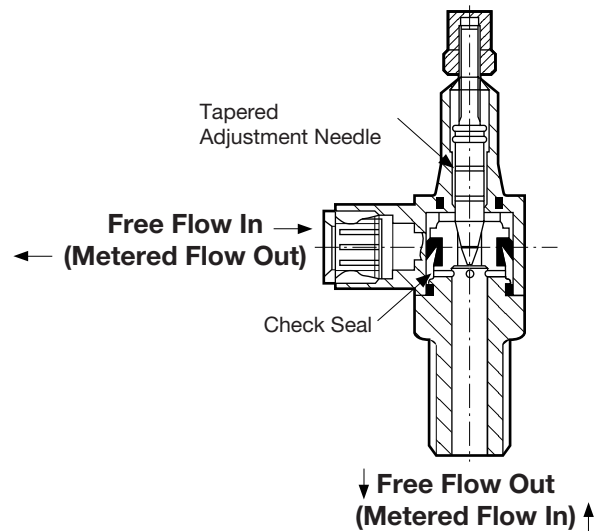

### Pneumatic Symbol

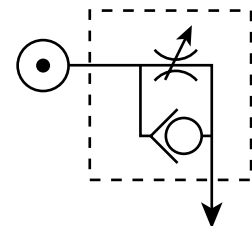



VAO Series

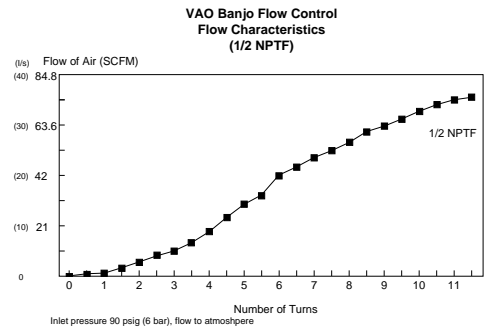
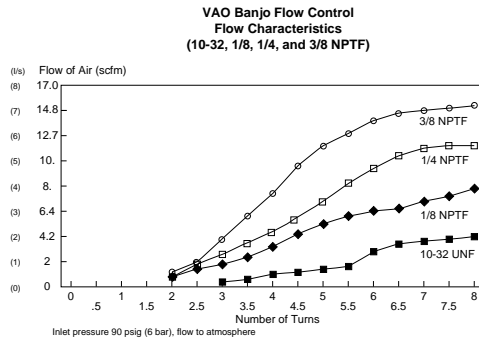
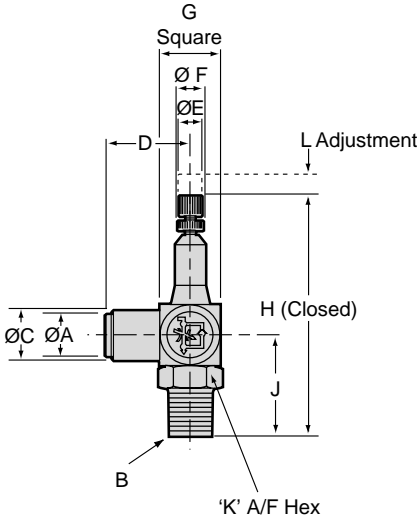

A Tube O.D.	B NPTF or UNF Thread	Part Number	C	D	E	F	G	H	J	K A/F	L ADJ
5/32"	10-32 UNF	12 VAO 0210	0.31 (7.87)	0.37 (9.40)	1.04 (26.41)	0.16 (4.06)	0.74 (18.80)	0.10 (2.54)	-	-	-
	1/8	12 VAO 0218	0.30 (7.62)	0.45 (11.43)	0.87 (22.10)	0.31 (7.87)	0.35 (8.89)	0.63 (16.00)	2.09 (53.09)	0.89 (22.61)	9/16"
1/4"	1/8	12 VAO 0418	0.43 (10.93)	0.51 (12.95)	0.91 (23.11)	0.31 (7.87)	0.35 (8.89)	0.63 (16.00)	2.09 (53.09)	0.89 (22.61)	9/16"
	1/4	12 VAO 0428	0.43 (10.93)	0.53 (13.46)	1.00 (25.4)	0.39 (9.90)	0.43 (10.93)	0.79 (20.07)	2.64 (67.06)	1.16 (29.46)	11/16"
3/8"	1/4	12 VAO 0628	0.57 (14.48)	0.77 (19.56)	0.24 (6.10)	0.39 (9.90)	0.43 (10.93)	0.79 (20.07)	2.64 (67.06)	1.16 (29.46)	11/16"
	3/8	12 VAO 0638	0.57 (14.48)	0.77 (19.56)	1.28 (32.51)	0.47 (11.94)	0.51 (12.95)	0.87 (22.09)	3.07 (77.97)	1.30 (33.02)	3/4"
1/2"	1/2	12 VAO 0748	0.71 (18.03)	0.91 (23.11)	1.50 (38.10)	0.63 (16.00)	0.71 (18.03)	1.06 (26.92)	3.66 (92.97)	1.65 (41.91)	7/8"

K51 Series

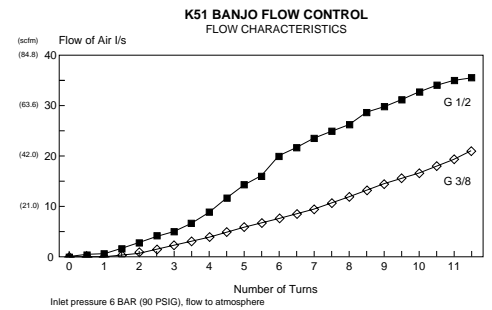
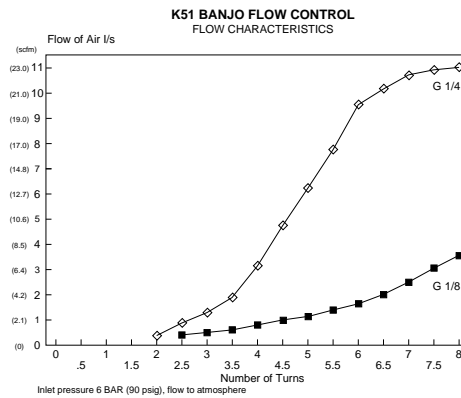
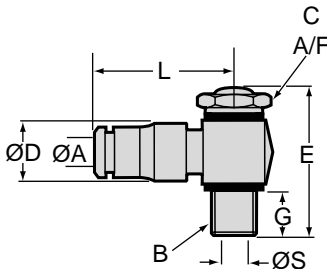

A Tube O.D.	B ISO G or Metric Thread	Part Number	C A/F	D	E	G	L	S
4"	M5 X .8	10 K51 0405	0.31 (7.87)	0.37 (9.40)	1.04 (26.41)	0.16 (4.06)	0.74 (18.80)	0.10 (2.54)
	1/8	10 K51 0418	0.55 (13.97)	0.43 (10.92)	1.34 (34.03)	0.26 (6.60)	0.81 (20.57)	0.20 (5.08)
5"	M5 X .8	10 K51 0505	0.31 (7.87)	0.43 (10.92)	1.04 (26.41)	0.16 (4.06)	0.80 (20.32)	0.10 (2.54)
	1/8	10 K51 0518	0.55 (13.97)	0.45 (11.43)	1.34 (34.04)	0.26 (6.60)	0.85 (21.59)	0.20 (5.08)
6"	M5 X .8	10 K51 0605	0.31 (7.87)	0.49 (12.45)	1.04 (26.41)	0.16 (4.06)	0.87 (22.10)	0.10 (2.54)
	1/8	10 K51 0618	0.55 (13.97)	0.49 (12.45)	1.34 (34.04)	0.26 (6.60)	0.93 (23.62)	0.20 (5.08)
8"	1/4	10 K51 0628	0.67 (17.01)	0.51 (12.95)	1.44 (36.57)	0.28 (7.11)	0.95 (24.13)	0.33 (8.38)
	1/4	10 K51 0828	0.67 (17.01)	0.55 (13.97)	1.44 (36.57)	0.28 (7.11)	0.97 (24.64)	0.33 (8.38)
10"	3/8	10 K51 0838	0.87 (22.10)	0.65 (16.51)	2.03 (51.56)	0.43 (10.92)	1.05 (26.67)	0.39 (9.90)
	3/8	10 K51 1038	0.87 (22.10)	0.67 (17.01)	2.03 (51.56)	0.43 (10.92)	1.23 (31.24)	0.39 (9.90)
12"	1/2	10 K51 1248	1.06 (26.92)	0.69 (17.53)	2.26 (57.40)	0.39 (9.91)	1.50 (38.10)	-



# Rod Alignment Coupler & Air-Oil Tank

All Dimensions in Inches (mm)

## Rod Alignment Coupler

The Rod Alignment Coupler allows 1/16" of radial float and 2° of spherical movement. This prevents cylinder binding due to misalignment thus extending bearing and seal life, and permits greater tolerance between the centerline of the cylinder and mating part for simplified installation.

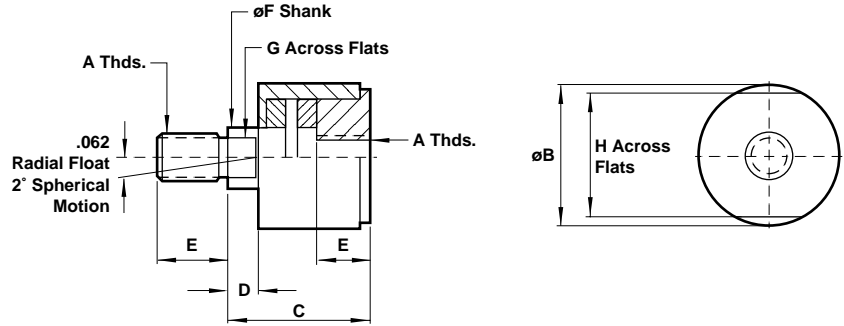

## Rod Alignment Coupler Dimensions

	CC-1-07 7/16 - 20	CC-1-08 1/2 - 20	CC-1-10 5/8 - 18	CC-1-12 3/4 - 16	CC-1-14 7/8 - 14	CC-1-16 1 - 14	CC-1-20 1 1/4 - 12	CC-1-24 1 1/2 - 12	CC-1-28 1 3/4 - 12
A									
B	1.250 (31.75)	1.250 (31.75)	1.250 (31.75)	1.750 (44.45)	1.750 (44.45)	2.500 (63.50)	2.500 (63.50)	3.250 (82.50)	3.250 (82.50)
C	2.000 (50.80)	2.000 (50.80)	2.000 (50.80)	2.312 (58.72)	2.312 (58.72)	2.937 (74.60)	2.937 (74.60)	4.375 (111.13)	4.375 (111.13)
D	.500 (12.70)	.500 (12.70)	.500 (12.70)	.500 (12.70)	.500 (12.70)	.500 (12.70)	.500 (12.70)	.812 (20.62)	.812 (20.62)
E	.750 (19.05)	.750 (19.05)	.750 (19.05)	1.125 (28.58)	1.125 (28.58)	1.625 (41.28)	1.625 (41.28)	2.250 (57.15)	2.250 (57.15)
F	.625 (28.58)	.625 (28.58)	.625 (28.58)	.969 (24.61)	.969 (24.61)	1.375 (34.93)	1.375 (34.93)	1.750 (44.45)	1.750 (44.45)
G	.500 (12.70)	.500 (12.70)	.500 (12.70)	.812 (20.62)	.812 (20.62)	1.156 (29.36)	1.156 (29.36)	1.500 (38.10)	1.500 (38.10)
H	1.125 (28.58)	1.125 (28.58)	1.125 (28.58)	1.500 (38.10)	1.500 (38.10)	2.250 (57.15)	2.250 (57.15)	3.000 (76.20)	3.000 (76.20)
Max Pull (lbs.)	10,000	14,000	19,000	34,000	39,000	64,000	78,000	134,000	134,000

## Air-Oil Tank

Available in 5 practical bore sizes: 1 1/8", 2", 3 1/4", 5", and 8", the Air-Oil Tank includes a translucent fiberglass tube which permits viewing of the tank oil level from any position, internal baffles that reduce foaming and aeration of the system oil resulting in maximum cylinder control, and standard angle mounting brackets (except 1 1/8" bore) easily removed for convenient fluid port positioning.

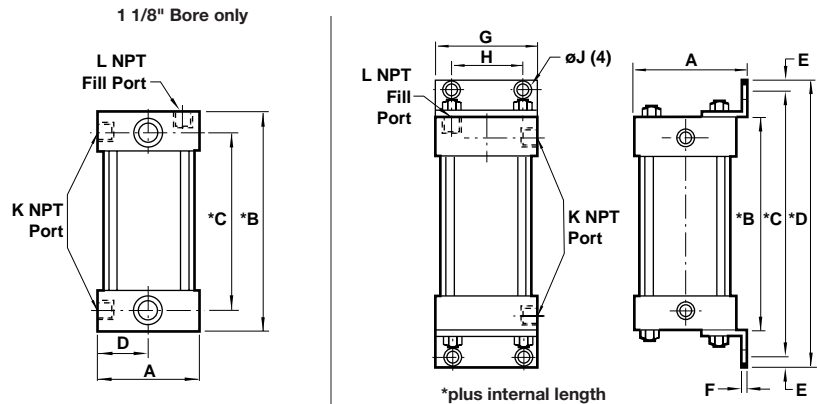

## How to Figure Length of Volume

The following equations are given to help you in selecting the right air/oil tank volume for your particular application.

- Volume of Cylinder: • Cap End Cylinder Bore Area x Stroke = Volume
- Head End Cylinder Bore Area - (Piston Rod Area\*) x Stroke = Volume \*Reference Page 78 for Areas.

Length of Tank =  $\frac{\text{Volume of Cylinder} \times 1.3^{**}}{\text{Tank Bore Area}}$  (See chart below.) \*\*30% minimum recommended reserve working volume.

Final Length of Volume of Tank = Working length of tank + 2" minimum safety factor to prevent aeration of oil.

Note: Length must be at least 3".

## Air-Oil Tank Dimensions

Bore	1-1/8"	2"	3-1/4"	5"	8"
	AOT-225	AOT-04	AOT-065	AOT-10	AOT-16
A	1.500 (38.10)	2.687 (68.25)	4.000 (101.60)	5.625 (142.88)	8.625 (219.08)
B	1.250 (31.75)	2.000 (50.80)	2.500 (63.50)	2.500 (63.50)	3.000 (76.20)
C	.750 (19.05)	4.000 (101.60)	5.000 (127.00)	5.000 (127.00)	6.625 (168.28)
D	.750 (19.05)	4.750 (120.65)	6.000 (152.40)	6.000 (152.40)	8.000 (203.20)
E	-	.375 (9.53)	.500 (12.70)	.500 (12.70)	.687 (17.45)
F	-	.125 (3.18)	.187 (4.75)	.187 (4.75)	.250 (6.35)
G	-	2.500 (63.50)	3.750 (95.25)	5.500 (139.70)	8.500 (215.90)
H	-	1.750 (44.45)	2.750 (69.85)	4.250 (107.95)	7.125 (180.98)
øJ	-	.437 (11.10)	.562 (14.27)	.562 (14.27)	.812 (20.62)
K	.125 (3.18)	.375 (9.53)	.500 (12.70)	.500 (12.70)	.750 (19.05)
L	.125 (3.18)	.250 (6.35)	.375 (9.53)	.375 (9.53)	.500 (12.70)

Note: Maximum operating pressure 250 PSI.

## Air-Oil Tank Volumes (cubic inches)

Bore	1-1/8"	2"	3-1/4"	5"	8"
Area	.995 sq."	3.14 sq."	8.30 sq."	19.64 sq."	50.26 sq."
6"	5.9	18.6	49.8	117.8	301.5
8"	7.9	25.1	66.4	157.1	402.0
10"	9.9	31.4	83.0	196.4	502.6
12"	11.9	37.6	99.6	235.6	603.1
14"	13.9	43.9	116.2	274.9	703.6
16"	15.9	50.2	132.8	314.2	804.1
18"	17.9	56.5	149.4	353.5	904.5
20"	19.9	62.8	166.0	392.8	1005.2

How to Order: Specify air-oil tank part number and internal length.  
Example: 2" bore with 6" internal length = AOT-04 x 6



Option Code	Description
A(-)	Stroke Adjustment Single Piston (specify adjustment length) – see page 146
AA(-)	Stroke Adjustment Double Piston (specify adjustment length) – see page 146
AN	Acorn Tie Rod Nuts (Stainless Steel)
AP	Air/Oil Piston (Piston supplied with O-ring hooded U-cup on cap end for air/oil operation)
BL	Removable Piston Rod Stud (installed with removable adhesive sealant)
EN	Electroless Nickel Plated Cylinder
EV(- _)	Pneumatic Stroke Signal Valve(s): EV(Head Cap) (specify position) – see pages 148-149
FG	Black Fiberglass Cylinder Tube
H	Piston Rod Seals O-ring loaded U-cups – see page 146
HR	Case Hardened Piston Rod
L(- _)	Non-Standard Port Location position 1 standard: L(Head Cap) (specify position 1 thru 4 for head and/or cap)
LF	Low Friction Cylinder (Nitrile compounded with Teflon® rod and piston seals) (not available with Ecology Series)
MS	Metal Scraper – see page 146
N(- _)	Cushion Adjust Screw Location position 2 standard: N(Head Cap) (specify position 1 thru 4 for head and/or cap)
NW	No Wearstrip in Cylinder
P(-)	Non-Standard Port Sizes – [specify port size for P(-H) head only, P(-C) cap only, or P(-) both head & cap]
PP	Seals in Cylinder O-ring loaded U-cups (rod and piston seals) – see page 146
PN	Pinned Piston and Rod Assembly – see page 146
PS	Magnetic Piston Modification (no wearstrip) – see page 146
RS	Studded Male Piston Rod End
RT	Removable Trunnion Pins
RX(-)	Piston Rod Extension Over Standard (specify additional "C" length)
S	303/304 Stainless Steel Tie Rods & Nuts
SB	Stainless Steel Rod Bushing Nut
SC†	Single Acting Spring Extend Cap End of Cylinder – see page 146
SL	Steel Cylinder Tubing
SR†	Single Acting Spring Retract Rod End of Cylinder – see page 146
SS	303 Stainless Steel Piston Rod
ST(-C)	Stop Tube on Cap End (C) of Cylinder: ST(stop tube length C) – see page 147
ST(-R)	Stop Tube on Rod End (R) of Cylinder: ST(stop tube length R) – see page 147
SV(- _)	Stroke Signal Valve(s): SV(Head Cap) – see pages 148-149
T(-)	Non-Standard Piston Rod Thread (specify thread)
TF(-)	Piston Rod Thread Depth Over Standard (Female) (specify additional "A" length) – see page 146
TX(-)	Piston Rod Thread Extension Over Standard (Male) (specify additional "A" length) – see page 146
V	Viton® Seals in Cylinder
XI(-)	Type #10 Trunnion Set Dimension (MT4 Model Only) (customer must specify length)

\*Standard available for 1½", 2", 2½" bores, 12" max stroke. (Stroke length doubles – 24" max); 12 lbs. force preload, 30 lbs. force compressed. Cushions not available on spring end. For other spring forces, bore sizes or longer strokes, consult factory.

**Consult Factory for These Options:**

Option Code	Description
AS	Airsaver Stroke Adjustment
BB	Cylinders Mounted Back to Back
BP	British Standard Pipe Cylinder Ports (Parallel) (BSPP)
BT	British Standard Pipe Cylinder Ports (Tapered) (BSPT)
CT	Close Tolerance on Cylinder Stroke
EX	Ecology Piston Seal on Rod End of Cylinder
LA	Low Friction Cylinder (Pak-Lap™ style seals)
NI	Nituff® Coated Cylinder
NS	No Silicone Used in Cylinder Assembly
NT	Nicotef® Coated Cylinder
OE	Zero Stroke/Pneumatic Stroke Signal Valve(s)
OV	Zero Stroke/Stroke Signal Valve(s)
PB	Piston Seal O-ring loaded deep U-cup shape
RB	Rod Boot over Piston Rod
SA	SAE Cylinder Ports (Straight Thread)
SM	Stroke Signal Valve (Mounting Only)
TE	Nituff® Coated Cylinder Tubing
TK	Thrust Key Plate Mounting – see page 147
VM	Valve Mounting Only
XE	Ecology Piston Seal on Cap End of Cylinder



Cylinder Order Information

**EJ 01 - 7 7 - A 1 - HR-L(14)-MS-P(1/4)-V - 2" X 6"**

J	Series J Cylinder
DJ	Series J Double Rod End Cylinder
EJ	Series EJ Cylinder
EDJ	Series EJ Double Rod End Cylinder

Mounting Options	
01	Side Tapped (MS4)
03	Head Rectangular Flange (MF1)
03	Head Square (ME3) – 7" & 8" Bores
04	Cap Rectangular Flange (MF2)
04	Cap Square (ME4) – 7" & 8" Bores
05	Basic Cylinder No Mounting (MX0)
06	Both Ends (4) Tie Rods Ext. (MX1)
6B	Both Ends (2) Tie Rods Ext. (MX4)
6C	Cap Tie Rods Ext. (MX2)
6R	Head Tie Rods Ext. (MX3)
07	Head Trunnion (MT1)
08	Cap Trunnion (MT2)
09	Side Lugs (MS2)
10	Center Trunnion (MT4)
11	Side End Angles (MS1)
12	Cap Fixed Clevis (MP1)
15	Side End Lugs (MS7)
16	Sleeve Nut Construction (Universal)
20	Head Square Flange (MF5)
21	Cap Square Flange (MF6)
22	Detachable Cap Clevis (MP2)
32	Cap Fixed Eye (MP3)
42	Detachable Cap Eye (MP4)
52	Spherical Bearing

Cushion in Head	
3	None
5 <sup>†</sup>	Non-Adjustable Cushion
7	Adjustable Cushion (Position 2)

<sup>†</sup>Standard with EJ

Cushion in Cap	
3	None
5 <sup>†</sup>	Non-Adjustable Cushion
7	Adjustable Cushion (Position 2)

<sup>†</sup>Standard with EJ

Bore and Stroke (write out)

Additional Options – order alphabetically – More on page 155	
HR	Case Hardened (45 Rc)
L(-)	Port Location position 1 standard: L(Head Cap) (specify position 1 thru 4 for head and/or cap)
MS	Metal Rod Scraper
N(-)	Cushion Adjust Screw Location position 2 standard: N(Head Cap) (specify position 1 thru 4 for head and/or cap)
P(-)*	Non-Standard Port Sizes: [specify port size for P(-)H head only, P(-)C cap only, or P(-) both head & cap]
PS	Magnetic Piston – includes aluminum tube option
RS	Rod Stud Type 1 (5/8" – 1 3/4" øRod) Type 2 (5/8" & 1" øRod)
RX	Rod Extensions (specify length of additional rod extension)
SC	Single Acting Spring Extend (Cap End)–See page 155
SR	Single Acting Spring Retract (Rod End)–See page 155
SS	303 Stainless Steel (Hard Chrome Plated)
ST(-)C	Stop Tube (Cap End) (specify stop tube length)
ST(-)R	Stop Tube (Rod End) (specify stop tube length)
T	Special Rod Threads (specify rod thread)
TX	Thread Extensions (specify length of thread extension)
V	Viton® Seals

\*1 1/2", 2", 2 1/2" bore cylinders have 3/8" NPT Standard, 1/2" NPT oversize. 3 1/4", 4", 5" bore cylinders have 1/2" NPT Standard, 3/4" NPT oversize. This will add 1/8" to the overall cylinder length.

Piston Rod Threads Type	
1	Small Male (Solid)
2	Intermediate Thread Male (Solid)
3	Female
6	Full Thread Male (Solid)
7	Plain Rod End

Piston Rod Diameters		
A	5/8"	Standard on 1 1/2", 2", 2 1/2"
B	1"	Standard on 3 1/4", 4", 5"
		Oversized on 1 1/2", 2", 2 1/2"
C	1 3/8"	Standard on 6", 7", 8"
		Oversized on 3 1/4", 4", 5"
D	1 3/4"	Standard on 10"
		Oversized on 6", 7", 8"
E	2"	Standard on 12"
		Oversized on 10"
F	2 1/2"	Oversized on 10", 12"

**Port and Cushion Adjustment Positions**

(As viewed from rod end: Port standard position 1, Cushion Adjustment standard position 2.)

NOTE: A Port and a Cushion Adjustment cannot be in the same position.

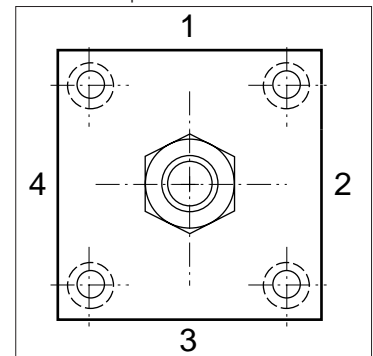

**EXAMPLE:** Series EJ Cylinder – MS4 side tapped mount – Adjustable cushion in head (Position 2) – Adjustable cushion in cap (Position 2) – 5/8" piston rod diameter – Small male (solid) piston rod thread – Case hardened rod – Head port location at 1 – Cap port location at 4 – Metal rod scraper option – 1/4" special port size – Viton seals option – 2" X 6" bore and stroke.

**IMPORTANT:** Write out bore and stroke completely as shown in example.

**Reed & Solid State Switches**

Available on all bore sizes – order separately. See pages 150 & 151 for specifications.

**NOTE:** Consult factory when using **competitive** position sensing devices.





**Piston Seal Kits** (Includes: 2 piston seals, 1 wear ring and 2 tube end seals.)

Bore Inches (mm)	Series A & J		Series EA & EJ	
	Buna N	Viton	Buna N	Viton
1-1/2" (38.10)	AJK-153	VAJK-153	EJK-153	VEJK-153
2" (50.80)	AJK-203	VAJK-203	EJK-203	VEJK-203
2-1/2" (63.50)	AJK-253	VAJK-253	EJK-253	VEJK-253
3-1/4" (82.55)	AJK-323	VAJK-323	EJK-323	VEJK-323
4" (101.80)	AJK-403	VAJK-403	EJK-403	VEJK-403
5" (127.00)	AJK-503	VAJK-503	EJK-503	VEJK-503
6" (152.40)	AJK-603	VAJK-603	EJK-603	VEJK-603
7" (177.80)	AJK-703	VAJK-703	EJK-703	Consult Factory
8" (203.20)	AJK-803	VAJK-803	EJK-803	Consult Factory
10" (254.00)	AJK-1003	VAJK-1003	EJK-1003	Consult Factory
12" (304.80)	AJK-1203	VAJK-1203	EJK-1203	Consult Factory

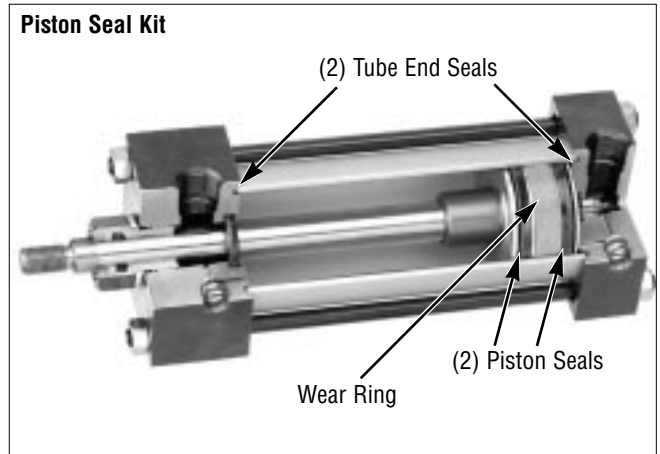

**Rod Bearing Kits for Series A, EA, J & EJ**

(Includes: Bearing Assembly, Rod Seal, Wiper & O-Ring.)

Rod Diameter	5/8" (15.88)	1" (25.40)	1-3/8" (34.93)	1-3/4" (44.45)	2" (50.80)	2-1/2" (63.50)
Buna N	RBK-15	RBK-25	RBK-35	RBK-45	RBK-55	RBK-65
Viton	VRBK-15	VRBK-25	VRBK-35	VRBK-45	VRBK-55	VRBK-65

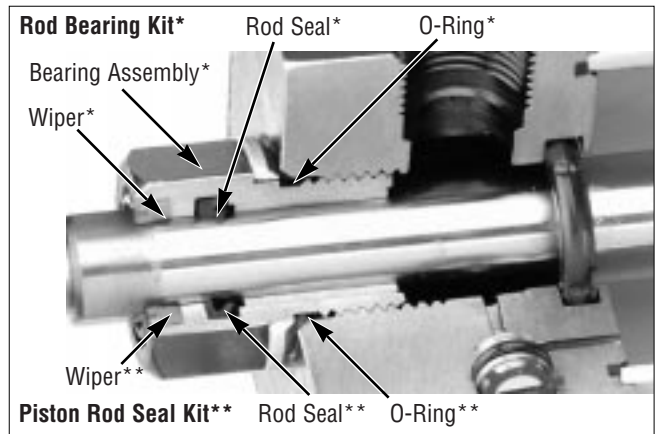

**Piston Rod Seal Kits for Series A, EA, J & EJ**

(Includes: Rod Seal, Wiper & O-Ring.)

Rod Diameter	5/8" (15.88)	1" (25.40)	1-3/8" (34.93)	1-3/4" (44.45)	2" (50.80)	2-1/2" (63.50)
Buna N	SWK-15	SWK-25	SWK-35	SWK-45	SWK-55	SWK-65
Viton	VSWK-15	VSWK-25	VSWK-35	VSWK-45	VSWK-55	VSWK-65

**Cushion Seal Kits for Series A, EA, J & EJ** (Single Rod End includes: 1 head and 1 cap cushion seal.)

Rod	Bore	1-1/2" (38.10)	2" (50.80)	2-1/2" (63.50)	3-1/4 - 5" (82.55 - 127.00)	6" - 8" (152.40 - 203.20)	10" - 12" (254.00 - 304.80)
5/8"	Buna N	CSK-15-13	CSK-15-13	CSK-15-13			
	Viton	VCSK-15-13	VCSK-15-13	VCSK-15-13			
1"	Buna N	CSK-25-43	CSK-25-13	CSK-25-13	CSK-25-23		
	Viton	VCSK-25-43	VCSK-25-13	VCSK-25-13	VCSK-25-23		
1-3/8"	Buna N		CSK-35-53	CSK-35-13	CSK-35-23	CSK-35-33	
	Viton		VCSK-35-53	VCSK-35-13	VCSK-35-23	VCSK-35-33	
1-3/4"	Buna N			CSK-45-13	CSK-45-23	CSK-45-33	CSK-65-23
	Viton			VCSK-45-13	VCSK-45-23	VCSK-45-33	VCSK-65-23
2"	Buna N				CSK-55-23	CSK-55-33	CSK-55-33
	Viton				VCSK-55-23	VCSK-55-33	VCSK-55-33
2-1/2"	Buna N				CSK-65-23	CSK-65-33	CSK-65-33
	Viton				VCSK-65-23	VCSK-65-33	VCSK-65-33

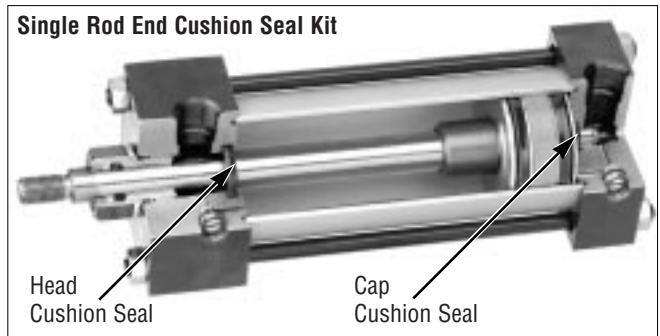

**Cushion Seal Kits for Series A, EA, J & EJ** (Double Rod End includes: 2 head cushion seals.)

Rod	Bore	1-1/2" (38.10)	2" (50.80)	2-1/2" (63.50)	3-1/4 - 5" (82.55 - 127.00)	6" - 8" (152.40 - 203.20)	10" - 12" (254.00 - 304.80)
5/8"	Buna N	CSK-15-23	CSK-15-23	CSK-15-23			
	Viton	VCSK-15-23	VCSK-15-23	VCSK-15-23			
1"	Buna N	CSK-25-63	CSK-25-53	CSK-25-53	CSK-25-53		
	Viton	VCSK-25-63	VCSK-25-53	VCSK-25-53	VCSK-25-53		
1-3/8"	Buna N		CSK-35-63	CSK-35-43	CSK-35-43	CSK-35-43	
	Viton		VCSK-35-63	VCSK-35-43	VCSK-35-43	VCSK-35-43	
1-3/4"	Buna N			CSK-45-43	CSK-45-43	CSK-45-43	CSK-45-43
	Viton			VCSK-45-43	VCSK-45-43	VCSK-45-43	VCSK-45-43
2"	Buna N				CSK-55-43	CSK-55-43	CSK-55-43
	Viton				VCSK-55-43	VCSK-55-43	VCSK-55-43
2-1/2"	Buna N				CSK-65-43	CSK-65-43	CSK-65-43
	Viton				VCSK-65-43	VCSK-65-43	VCSK-65-43

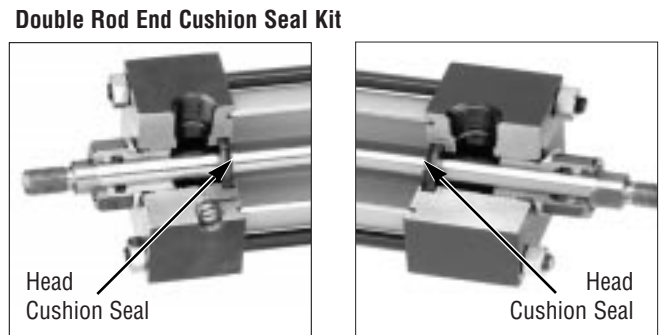

**NOTE:** When ordering repair kits for Series A, EA, J and EJ cylinders, please specify the type of kit, the cylinder model number, and the cylinder bore. This will ensure that you receive the proper repair kit(s).



## WARNING

These products are intended for use in industrial compressed air systems only. Do not use these products where pressures and temperatures can exceed those listed under **Technical Information**.

Before using these products with fluids other than those specified, for nonindustrial applications, life-support systems, or other applications not within published specifications, consult NORGREN.

Through misuse, age, or malfunction, components used in fluid power systems can fail in various modes. The system designer is warned to consider the failure modes of all component parts used in fluid power systems and to provide adequate safeguards to prevent personal injury or damage to equipment in the event of such failure modes. **System designers must provide a warning to end users in the system instructional manual if protection against a failure mode cannot be adequately provided.**

System designers and end users are cautioned to review specific warnings found in instruction sheets packed and shipped with these products. System designers should also provide for all OSHA requirements including Title 29 CFR 1910.147 Lockout/Tagout.

It should be recognized that warnings are valid for any product, regardless of manufacturer, and are not restricted to products manufactured by NORGREN. NORGREN's reputation for product quality and performance is well established. We feel we have the additional obligation to provide information or warnings to customers to assist them in applying our products in a reasonable and safe manner.

## WARRANTY

### Limited Warranty, Disclaimer & Limitation of Remedies

Items sold by NORGREN are warranted to be free from defects in materials and workmanship for a period of two years from the date of manufacture, provided said items are used according to NORGREN's recommended usages. NORGREN's liability is limited to the repair of, refund of purchase price paid for, or replacement in kind of, at NORGREN's sole option, any items proved defective, provided the allegedly defective items are returned to NORGREN prepaid. The warranties expressed above are in lieu of and exclusive of all other warranties.

**There are no other warranties, expressed or implied, except as stated herein. There are no implied warranties of merchantability or fitness for a particular purpose, which are specifically disclaimed. NORGREN's liability for breach of warranty as herein stated is the exclusive remedy, and in no event shall NORGREN be liable or responsible for incidental or consequential damages, even if the possibility of such incidental or consequential damages has been made known to NORGREN.**

NORGREN reserves the right to discontinue manufacture of any product or change product materials, design, or specifications without notice.