



Perfect choice for home and office

The ProLite B2083HSD is a 19,5" 1600x900 LED-backlit monitor with a Height Adjustable Stand supporting Screen Rotation, ensuring perfect posture and optimal viewing comfort. It features 5msec black-to-black response time and 12 000 000 : 1 Advanced Contrast Ratio assuring very good picture quality. The monitor is TCO6 and Energy Star Certified. A perfect solution for education, local government, business and finance markets.

Available also with fixed stand: [ProLite E2083HSD-B1](#)



Flicker-free + Blue light

The ultimate solution for the comfort and health of your eyes. Flicker-free monitors with the blue light reducer function substantially reduce the strain and fatigue caused by flickering and blue light emittance of regular monitors.

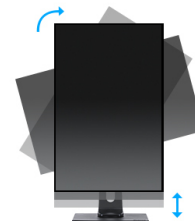

HAS + Pivot

With a height adjustable stand you will create an ergonomic work posture and position that meets all health and safety requirements. This will not only prevent any health issues but will also increase your productivity. The pivot function allows the screen to rotate from landscape to portrait orientation. This functionality can be useful if the application requires more height than width.

01 DISPLAY CHARACTERISTICS

Diagonal	19.5", 49.4cm
Panel	TN LED, matte finish
Native resolution	1600 x 900 (1.4 megapixel)
Aspect ratio	16:9
Brightness	250 cd/m ² typical
Static contrast	1000:1 typical
Advanced contrast	12M:1
Response time	5ms
Viewing zone	horizontal/vertical: 170°/160°, right/left: 85°/85°, up/down: 80°/80°
Colour support	16.7mIn 8bit (6bit + Hi-FRC) (sRGB: 99%; NTSC: 72%)
Horizontal Sync	30 - 80KHz
Vertical Sync	55 - 75Hz
Viewable area W x H	433.9 x 236.3mm, 17.1 x 9.3"
Pixel pitch	0.27mm
Colour	matte, black

02 INTERFACES / CONNECTORS / CONTROLS

Signal input	VGA x1 DVI x1
HDCP	yes
Headphone connector	yes

03 FEATURES

Blue light reducer	yes
Flicker free	yes
OSD languages	EN, DE, FR, ES, IT, CN, RU, JP, NL, PL
Control buttons	Power, Menu/ Select, Scroll up/Volume, Scroll down/ECO, Exit, Auto
User controls	auto adjust, luminance (brightness, contrast), geometry (H. position, V. position, clock, phase), colour, OSD (H. position, V. position, timeout), language, recall, miscellaneous (sharpness, DDC/CI, display information, ACR, display mode, opening logo), input select, audio adjust (volume, mute)
Speakers	2 x 1W

04 MECHANICAL

Display position adjustments	height, pivot (rotation), swivel, tilt
Height adjustment	130mm
Rotation (PIVOT function)	90°
Swivel stand	90°; 45° left; 45° right
Tilt angle	22° up; 5° down
VESA mounting	100 x 100mm

05 ACCESSORIES INCLUDED

Cables	power, DVI, Audio
Other	quick start guide, safety guide

06 POWER MANAGEMENT

Power supply unit	internal
Power supply	AC 100 - 240V, 50/60Hz
Power usage	15W typical, 0.5W stand by, 0.5W off mode

07 SUSTAINABILITY

Regulations	TCO, CE, TÜV-GS, EAC, VCCI-B, Energy Star , EPEAT
EPEAT Silver	EPEAT is a comprehensive environmental rating that helps identify greener computers and other electronic equipment. The Silver certification means the monitor meets all required criteria plus at least 50% of the optional requirements. EPEAT Silver is valid in countries where iiyama registers the product. Please visit www.epeat.net for the registration status in your country.
Other	REACH SVHC above 0.1%: Lead

08 DIMENSIONS / WEIGHT

Product dimensions W x H x D	469.5 x 348 (478) x 210mm
Weight (without box)	4.3kg
EAN code	4948570112760

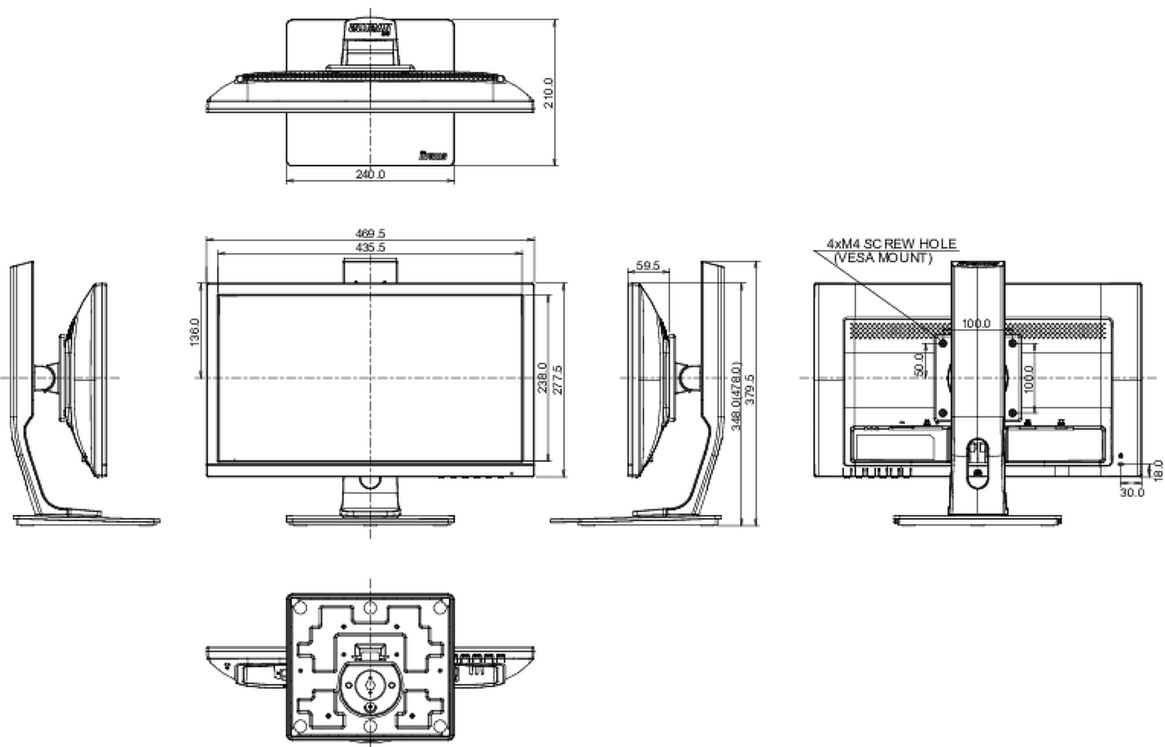

10 EU ENERGY EFFICIENCY LABEL

Power in OFF Mode	0.5W off mode
-------------------	---------------

