



## **Pushbutton Transmitter Device PTM 200**

User Manual V1.2  
November 2005

## Revision History

---

The following major modifications and improvements have been made to the first version of this document (User Manual PTM 200, V1.0):

No	Major Changes
V1.1	<ul style="list-style-type: none"> <li>• Dimensions of rocker adjusted (chapter 1.4, fig. 5 and fig. 8)</li> <li>• Note added, that simultaneously operating of 2 buttons can be differentiated, but not of 3 or 4 buttons (Chapter 2.2)</li> <li>• No. of packets defined to 3-5 depending on residual energy (chapter 1.3 and 2.3)</li> <li>• Chapter "Rocker Model" replaced by "The EnOcean Universal Switch Insert" (chapter 3.1)</li> <li>• FCC/IC Approval Requirements added (chapter 3.6)</li> <li>• US version of Evaluation Kit added (chapter 4.1)</li> </ul>
V1.2	<ul style="list-style-type: none"> <li>• Operating force adjusted to 7N (chapter 1.4)</li> </ul>

Published by EnOcean GmbH, Kolpingring 18a, 82041 Oberhaching, Germany  
[www.enocean.com](http://www.enocean.com), [info@enocean.com](mailto:info@enocean.com), phone ++49 (89) 6734 6890

© EnOcean GmbH  
 All Rights Reserved

### Important!

This information describes the type of component and shall not be considered as assured characteristics. No responsibility is assumed for possible omissions or inaccuracies. Circuitry and specifications are subject to change without notice. For the latest product specifications, refer to the EnOcean website: <http://www.enocean.com>.

As far as patents or other rights of third parties are concerned, liability is only assumed for devices, not for the described applications, processes and circuits.

EnOcean does not assume responsibility for use of devices described and limits its liability to the replacement of devices determined to be defective due to workmanship. Devices or systems containing RF components must meet the essential requirements of the local legal authorities. The approval requirements described in this document are of best knowledge without any warranty.

The devices must not be used in any relation with equipment that supports, directly or indirectly, human health or life or with applications that can result in danger for people, animals or real value.

Components of the devices are considered and should be disposed of as hazardous waste. Local government regulations are to be observed.

Packing: Please use the recycling operators known to you. By agreement we will take packing material back if it is sorted. You must bear the costs of transport. For packing material that is returned to us unsorted or that we are not obliged to accept, we shall have to invoice you for any costs incurred.

## Table of Contents

---

Revision History	2
Table of Contents	3
<b>1. GENERAL DESCRIPTION</b>	<b>4</b>
1.1 Functional Principle	4
1.2 Typical Applications	5
1.3 Features Overview	5
1.4 Mechanical Interface	6
1.5 Environmental Conditions	9
1.6 Ordering Information	10
<b>2. FUNCTIONAL DESCRIPTION</b>	<b>11</b>
2.1 Block Diagram	11
2.2 Contact Nipples Designation	12
2.3 PTM 200 Radio Telegram	13
2.4 PTM 200 Serial Data Communication via Receiver Device RCM 120	15
2.5 Basic Switching Features via Receiver Devices RCM 110 and RCM 120	15
2.6 Learning of PTM 200 to RCM 110/120 Receivers	16
<b>3. APPLICATIONS INFORMATION</b>	<b>17</b>
3.1 The EnOcean Universal Switch Insert PTM 250	17
3.2 Construction of application specific Switch Rockers	19
3.3 Device Mounting	19
3.4 Transmission Range	19
3.5 CE Approval Requirements	20
3.6 FCC/IC Approval Requirements	21
<b>4. DEVELOPMENT TOOLS</b>	<b>22</b>
4.1 Evaluation Kit EVA 100/105	22
4.2 Field Intensity Meter EPM 100	22
<b>5. DECLARATION OF CONFORMITY</b>	<b>23</b>

## 1. GENERAL DESCRIPTION

The radio transmitter device PTM 200 from EnOcean enables the implementation of wireless remote controls without batteries. Power is provided by a built-in electro-dynamic power generator.

The PTM 200 device serves the 868 MHz air interface protocol of EnOcean. Together with the receiver devices RCM 110 or RCM 120, this device can be easily integrated in operation and control units for the implementation of different application-specific system solutions.

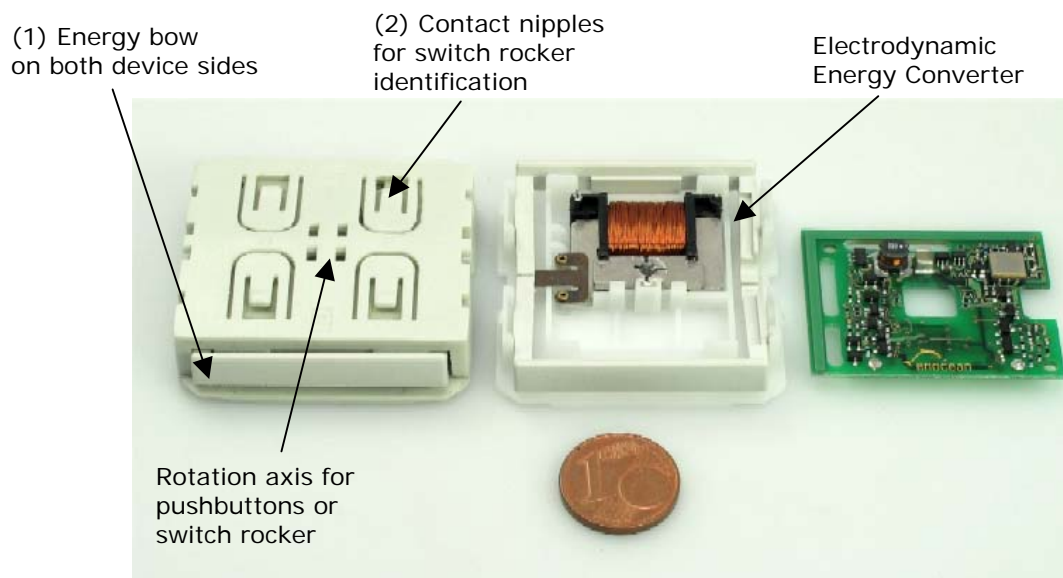


Figure 1: Electro-dynamic powered radio transmitter device PTM 200

### 1.1 Functional Principle

A common electro-dynamic energy transducer is actuated by a bow (1), which can be pushed from outside the device on the left or right by an appropriate pushbutton or switch rocker. When the energy bow is pushed down, electrical energy is created and an RF telegram is transmitted including a 32-bit device ID. Releasing the energy bow generates different telegram data, so every PTM telegram contains the information that the bow was pressed or released.

**“Long” or “Short” pushbutton operation (the time between pushing and releasing the pushbutton) can be easily detected by the receiver. By doing that, applications such as dimming control or jalousie control including slat action are simple to implement.**



In addition, the PTM telegram transmits the operating status of the contact nipples (2) when pressing the bow. This enables the identification of up to 2 appropriate switch rockers or up to 4 pushbuttons.

## 1.2 Typical Applications

---

- **Building installation**
- **Industrial automation**
- **Consumer electronics**

Key applications are wall-mounted flat rocker switches with 1 or 2 rockers (with medial position), as well as handheld remote controls with up to 4 single pushbuttons.

The PTM 200 device is part of a powerful RF system solution from EnOcean for operation and control applications. Because the RF transmitters are self-powered (no batteries), maintenance-free RF systems are possible. The RCM devices operate together with the following EnOcean components: RCM (general-purpose radio receivers), STM (solar-powered wireless sensors), CTM (remote control) and TCM (bi-directional IT interfaces and repeater).

## 1.3 Features Overview

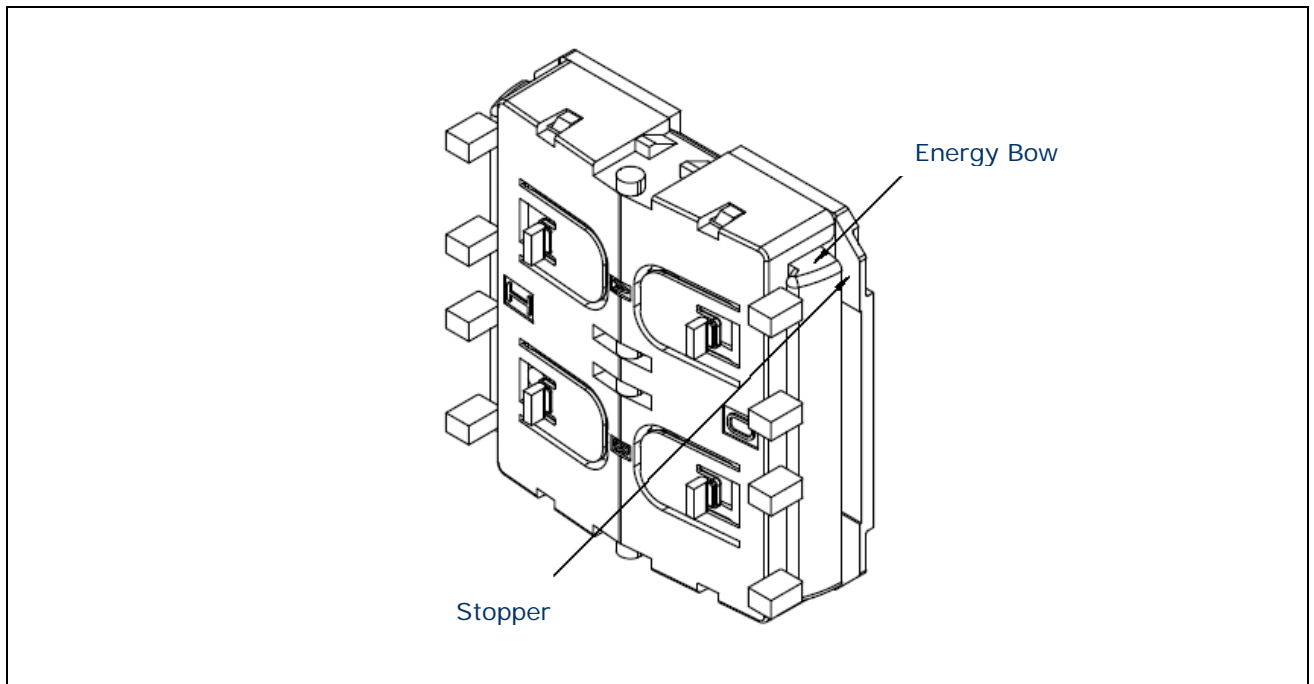
---

<b>Power supply:</b> .....	Electro-dynamic Power Generator (power generation by rocker pressing)
<b>Frequency / transmission power:</b> .....	868.3 MHz / 10 mW max.
<b>Modulation type / data rate / channel bandwidth:</b> .....	ASK / 120 kbps / 280 kHz
<b>Antenna:</b> .....	integrated
<b>Transmission range:</b> .....	approx. 300 m free field
<b>Telegram packet length (sub-telegram):</b> .....	0.7 ms +/-5%
<b>No. of (redundant) packets:</b> .....	3 – 5 (depending on residual energy), 3 packets within about 20 ms, delay effected at random
<b>Number of channels:</b> .....	2 channels with 4 action states each (upper/lower contact nipple is pressed/released)
<b>Telegram type:</b> .....	RPS of type 2 (allows interpretation of operating two buttons simultaneously)
<b>Device identifier:</b> .....	individual 32-bit ID (factory programmed)

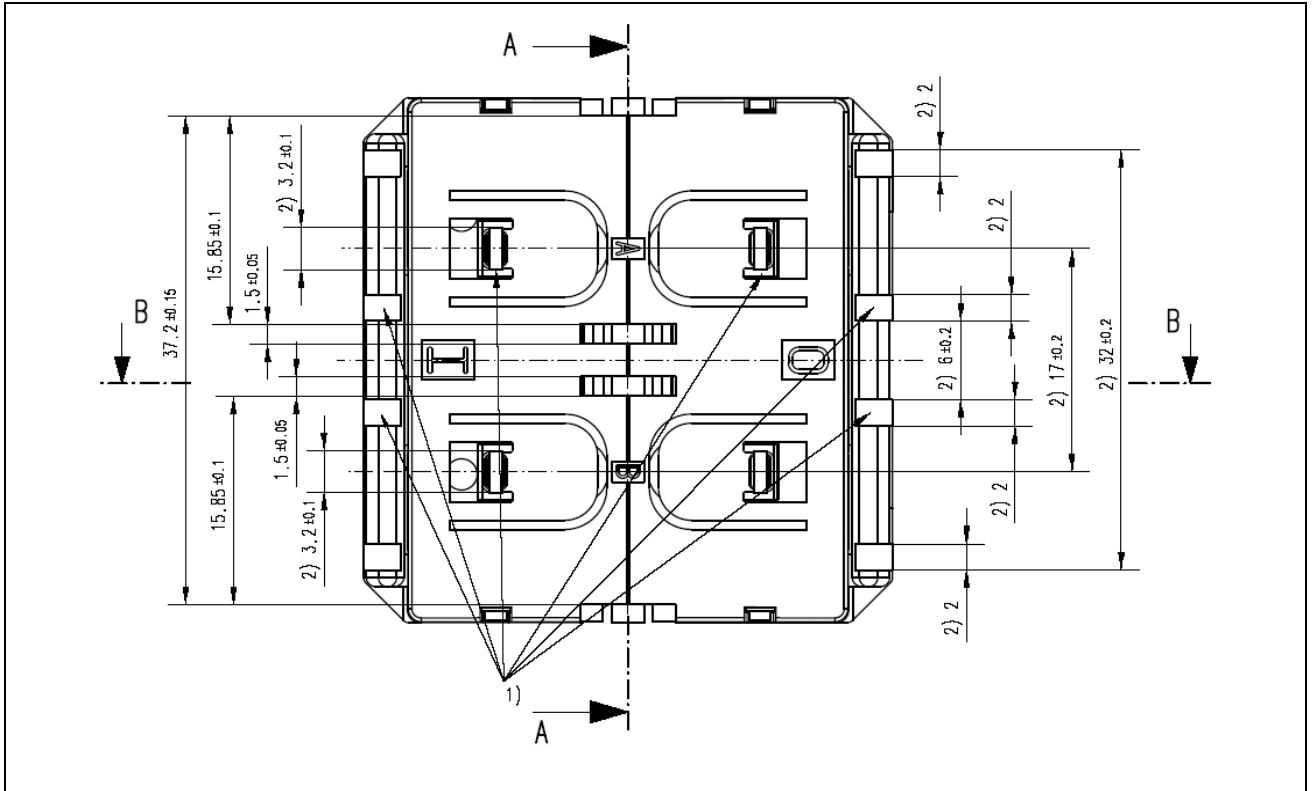
## 1.4 Mechanical Interface

---

**Device dimensions:** ..... 40.0 x 40.0 x 11.2 mm  
**Device weight:** ..... 20 g ± 1g  
**Energy bow travel / operating force:** ..... 1.8 mm / approx. 7 N \*)  
 \*) at room temperature  
**Number of operations:** ..... > 50.000 actuations tested according to VDE 0632 / EN 60669  
**Cover material:** ..... Hostaform (POM)  
**Energy bow material:** ..... PBT (50% GV)

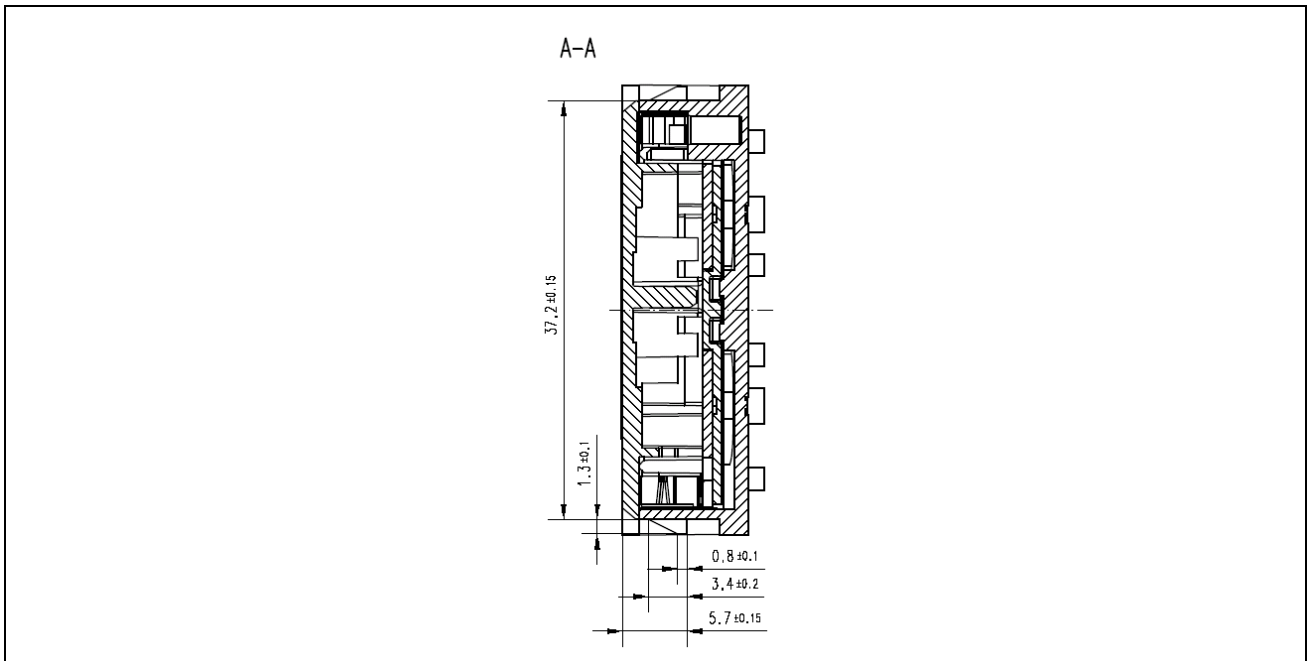


**Figure 2: PTM 200, tilted view (including rocker catwalks)**

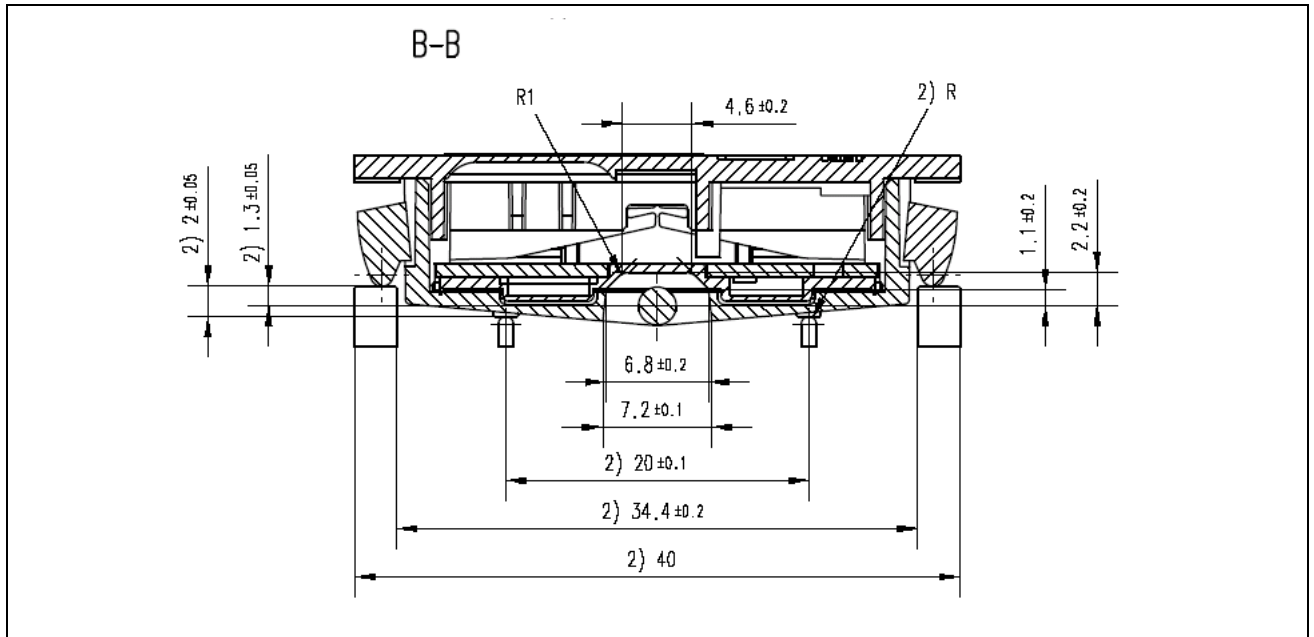


1) this catwalks are not needed when using one single rocker only    2) dimensions of rocker part

**Figure 3: PTM 200, top view (note cut A, B and C marking)**

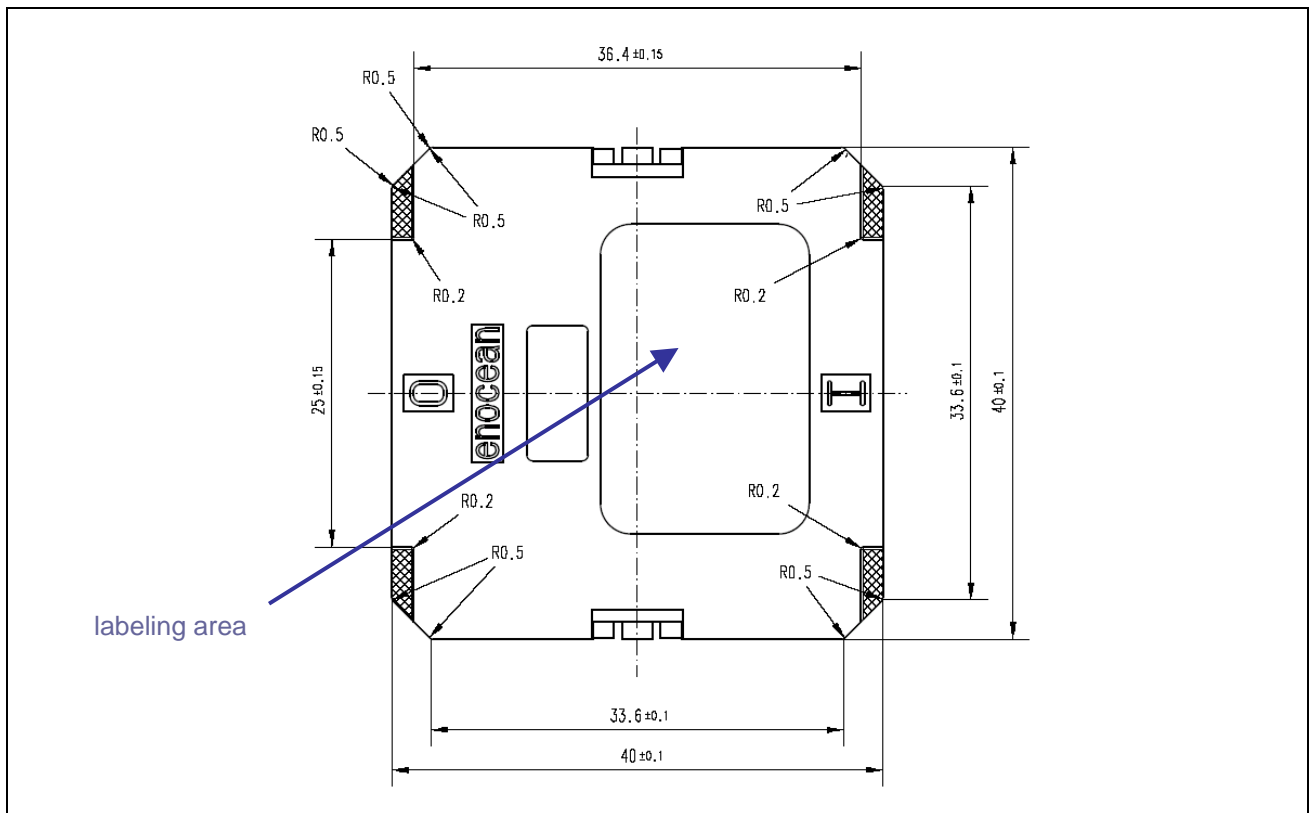


**Figure 4: PTM 200, cut A**



2) dimensions of rocker part

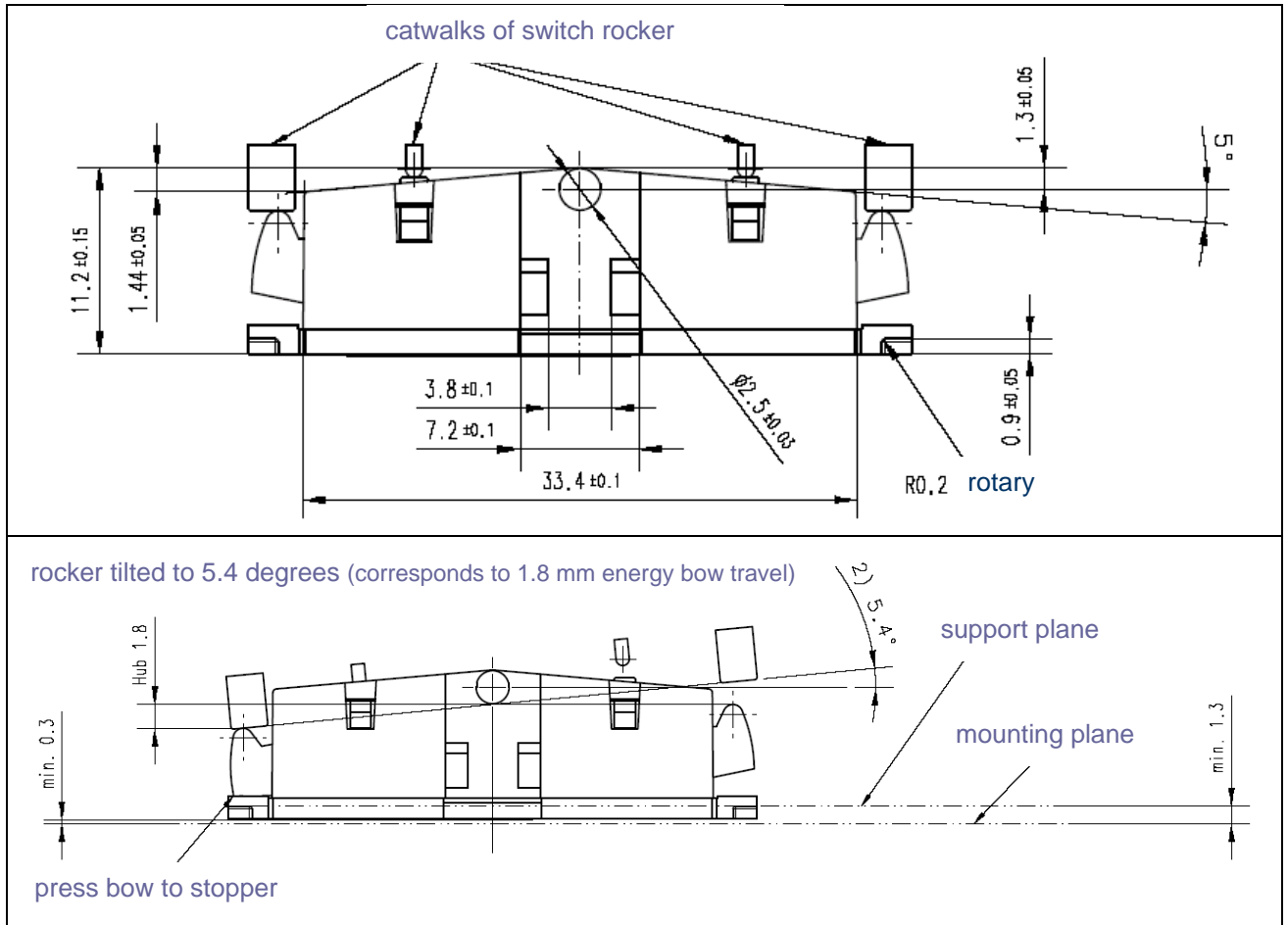
**Figure 5: PTM 100, cut B and C**



Hatched areas: support planes

**Figure 6: PTM 200, rear view**





2) dimensions of rocker part

Figure 7 and 8: PTM 200, side view

## 1.5 Environmental Conditions

**Operating temperature:** ..... -25 up to +65 °C

**Storage temperature:** ..... -40 up to +85 °C, +85 up to +100 °C for 1h max.

**Humidity:** ..... 0 % to 95 % r.h.

## 1.6 Ordering Information

---

Type	Ordering Information
<b>PTM 200 Pushbutton Transmitter Device</b>	EnOcean Ordering Code: <b>S3001-A200</b>
<b>Universal Switch Insert</b>	<b>"EnOcean easyfit PTM 250"</b> in volume production: For ordering codes see chapter 3.1
<b>Support for mounting the PTM 200 into an application specific casement</b>	IGS Data of PTM 200 device case (see Chapter 3.3): Please send an Email to <a href="mailto:info@enocean.com">info@enocean.com</a>
<b>Support for construction of application specific switch rocker</b>	IGS Data of PTM 250 switch rocker (see Chapter 3.2): Please send an Email to <a href="mailto:info@enocean.com">info@enocean.com</a>

## 2. FUNCTIONAL DESCRIPTION

### 2.1 Block Diagram

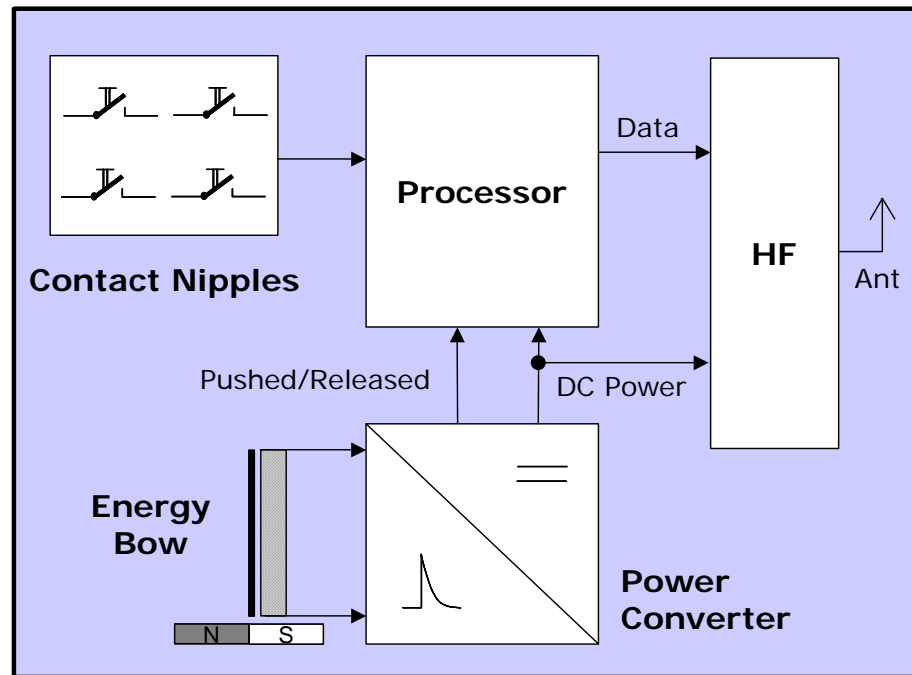


Figure 9: Block diagram of PTM 200

#### Energy Bow / Power Generator

Converts pressure on the energy bow into electrical energy.

#### Power Converter

Electronic converter unit for generating the device DC power supply

#### Processor

Converts the contact nipples' status and pushed/released data from the power generator into a reliable and energy-efficient serial telegram structure.

#### HF transmitter

Sends the data in the form of a series of short radio signals.

## 2.2 Contact Nipples Designation

---

With 4 contact nipples, the PTM 200 offers 2 channels with 4 action states each (upper/lower nipple is pressed/released when activating the energy bow). The nipples' designation is as follows:

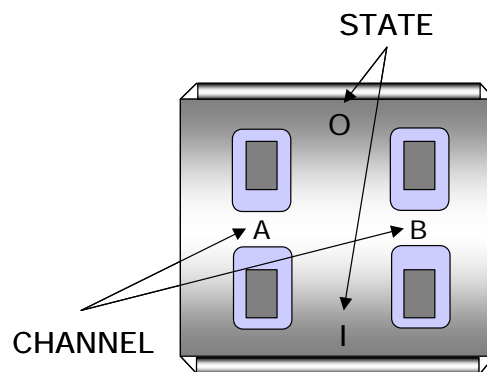


Figure 10: Contact nipple designation

Radio signals of the PTM 200 device are event-controlled (energy bow is pressed/released) with contact nipple code (channel/state) and unique device identification (fixed 32-bit ID). When operating more than one nipple at the same time, note that PTM 200 sends multiple-button code combinations (switch device of Type 2, unlike PTM 100):

- **N-message: One or two contact nipples have been pressed** when activating the energy generator → Message with nipple code and pressed/released event status of the energy bow is sent.
- **U-message: No contact nipple was pressed** when activating the energy generator, **or 3 or 4 nipples have been pressed** → Message with pressed/released event status of the energy bow is sent and the information if either none or more than two nipples have been pressed. Note that it can't be differentiated if 3 or if 4 nipples have been pressed.

**Note: Due to the mechanical hysteresis of the energy bow, in most rocker switch device implementations, pressing the rocker sends an N-message and releasing the rocker sends a U-message!**

## 2.3 PTM 200 Radio Telegram

---

For the transmission of the telemetric signals, EnOcean has defined a new dynamic radio data telegram that is adapted to the individual application. It is optimized to the essential features of energy autarkic radio sensors:

- Minimal energy demand
- Possibility of operating hundred of senders within the same radio cell
- Maximum transmission reliability
- Wide transmission range
- Easy extensibility
- Suitable for uni- and bi-directional communication
- Flexibility for adaptation of different data structures and data quantities
- Data encryption option

### 2.3.1 Frequency range

The EnOcean technology operates the 868.3 MHz radio channel (868.0 – 868.6 MHz), which is exclusively released for short-time data transmission in Europe. Timing conditions can be found in chapter 3.5 of this paper.

Because of the very low radiated field strength on average, the 868.3 MHz EnOcean radio technology can be operated in the USA and in Canada. Timing conditions can be found in chapter 3.6 of this paper.

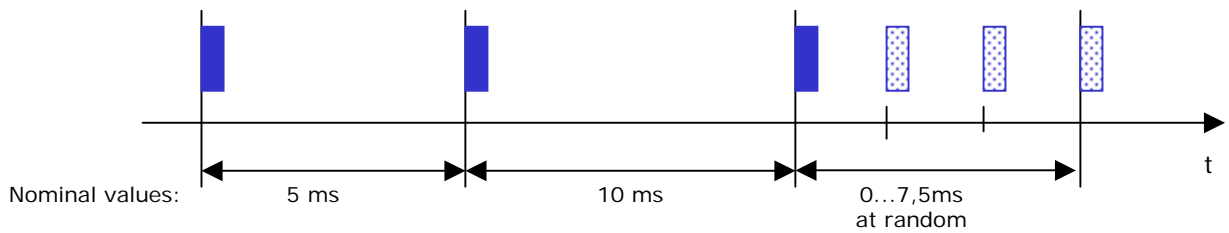
### 2.3.2 Modulation process

As modulation process, EnOcean uses incoherent amplitude modulation (ASK). Digital amplitude modulation enables the implementation of very efficient energy-saving transmitters because only the "1"-bits are transferred. At the same interference signal level, the transmission security of the alternative FSK method is identical to that of the ASK method (Reference: Pehl, Digitale und analoge Nachrichtenübertragung, Hüthig 2001).

### 2.3.3 Transmission timing

The transmission timing of the radio device PTM 200 has been developed to avoid possible collisions with data packages of other EnOcean transmitters as well as disturbances from the environment.

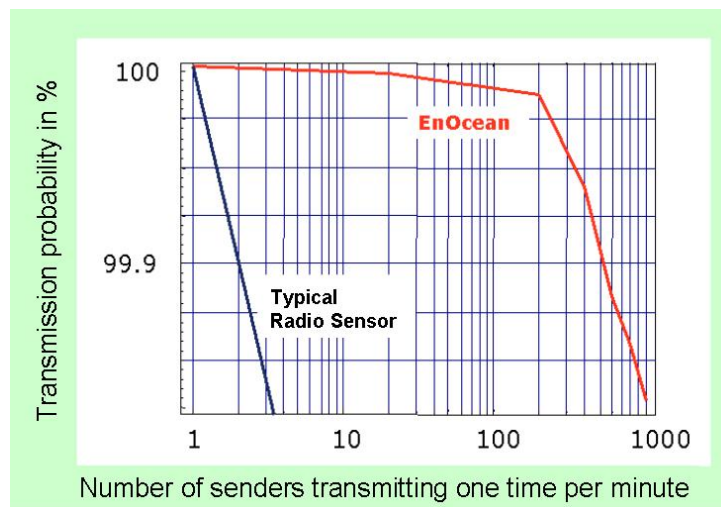
With each transmission cycle, at least three identical subtelegrams are transmitted. The transmission of a subtelegram lasts approximately 0.7 ms. To optimize data security, each telegram is repeated twice within about 20 ms, whereas the delay between the second and the third transmission burst is effected at random. If some residual energy is available after transmission of three subtelegrams, up to 2 further subtelegrams are sent.



**Figure 11: PTM 200 radio timing**

### 2.3.4 Reliable radio transmission within systems operating many sensors

The very short telegrams of EnOcean transmitters enable the operating of a large number of senders within the same radio cell; the error rate caused by telegram collisions remains extremely low. Statistically viewed, the transmission reliability is still greater than 99.99% in the case of 100 radio sensors that transmit once every minute. This means that even large office buildings and also huge industrial facilities can be equipped with a large number of sensors of this kind of radio technology.



**Figure 12: Probability of transmission failure caused by radio data collision for EnOcean light switch transmitter PTM 100**

## 2.4 PTM 200 Serial Data Communication via Receiver Device RCM 120

---

The **RCM 120 Receiver Device** of EnOcean enables standard asynchronous communication to a microcontroller or personal computer with a decompressed and simple data structure (9600 bps, 1 start bit, 8-bit data byte with LSB first, 1 stop bit).

When the RCM 120 receiver is set to Mode 0 "Serial Interface", it transfers out data blocks of information from all received EnOcean radio telegrams (from PTM-, STM-, TCM- and CTM-radio devices). For a complete transmitter message, a telegram of 14 data bytes is transferred via the serial link.

**The data block format is explained in detail in the RCM 110/120 User Manual.**



**Figure 13: Receiver devices RCM 110 and RCM 120**

## 2.5 Basic Switching Features via Receiver Devices RCM 110 and RCM 120

---

The multifunctional **RCM 110 and RCM 120 Radio Receiver Devices** are used to receive and process PTM-telegrams generated and transmitted by EnOcean radio transmitters. Via functional control outputs ("open collector"), these devices can be easily integrated into control and switching units for the implementation of different application-specific system solutions.

### **RCM 110 output switching functionalities (controlled by PTM radio signals)**

- Basic signal output functions "switching" (On/Off): 1, 2 or 4 channels
- Basic signal output function "dimming": On/Off (pushbutton operated quickly) and PWM 50 kHz (pushbutton pressed for a longer time) with switch-off value memory
- Scene selection control: ALL On/Off, 6 scene memories
- Learning procedure for EnOcean transmitters, easy to operate

### **RCM 120 output switching functionalities (controlled by PTM radio signals)**

- Basic signal output function "pushbutton": 1 channel
- Basic signal output function "tubular motor control" (UP/DOWN with slat action): 1 or 2 channel



- Learning procedure for EnOcean transmitters, easy to operate

**Any further switching functions can be simply and flexibly implemented using the serial interface output of the RCM 120 that is connected to a low-priced microcontroller. The required output control logic can be easily programmed by the user.**

## **2.6 Learning of PTM 200 to RCM 110/120 Receivers**

---

The PTM 200 can be easily made known to the receiver RCM 110 or RCM 120 that has been set into learn mode through triggering a PTM 200 radio signal by operating the energy bow when pressing either the O-rod or the I-rod of the desired channel A or B.

If the RCM 120 receiver is operated in mode 0 "Serial Interface", telegrams from learned PTM transmitters are signed (see RCM 110/120 User Manual).



### 3. APPLICATIONS INFORMATION

#### 3.1 The EnOcean Universal Switch Insert PTM 250

For evaluating the PTM 200, the EnOcean universal switch insert PTM 250 can be used.

EnOcean easyfit PTM 250 is a multi-purpose, very flat installation switch insert based on the PTM 200 radio module. A base plate of format 71x71mm is adhered or screwed straight to the mounting surface. The insert is compatible to numerous frame systems of 55 x 55 mm format:

BERKER	S1, B1, B3, B7 Glas
GIRA	Standard55, E2, Event, Esprit
JUNG	A500, Aplus
MERTEN	M-Smart, M-Arc, M-Plan

The design frame is held by an intermediate frame that comes with sophisticated spring construction to compensate for different frame heights and cutouts, and securely fixes the PTM200 in place. The most common rocker colors – white, anthracite and aluminum – add the design variety. Available are single and double rockers with light or roller blind signs.

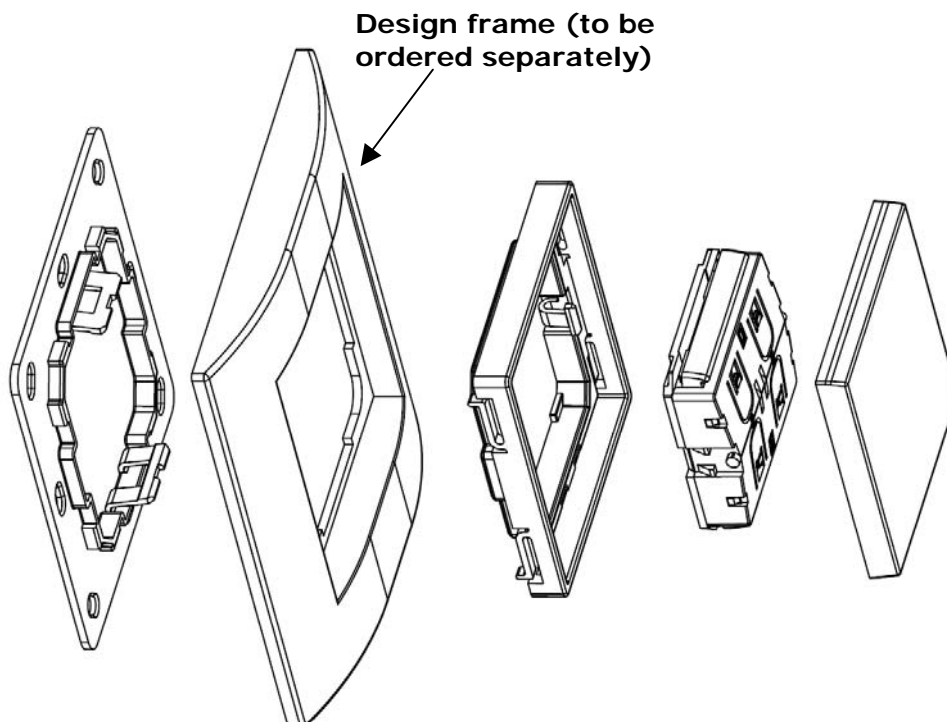


Figure 14: Universal switch insert “EnOcean easyfit PTM 250”



Figure 15: PTM 250 combines EnOcean functionality with multiple switch designs

Type	Color	Ordering No.
2-channel light	White	H5001-A210
	Anthracite	H5001-A211
	Aluminum varnished	H5001-A212
4-channel light	White	H5001-A230
	Anthracite	H5001-A231
	Aluminum varnished	H5001-A232
2-channel roller blinds	White	H5001-A220
	Anthracite	H5001-A221
	Aluminum varnished	H5001-A222
4-channel roller blinds	White	H5001-A240
	Anthracite	H5001-A241
	Aluminum varnished	H5001-A242

Table 1: Variants of PTM 250 universal switch insert

**Notes: Delivery is without design frame, this have to be ordered from the desired manufacturer program separately. Please note that pressing the rocker sends a N-message, and releasing the rocker sends a U-message.**

## 3.2 Construction of application specific Switch Rockers

---

For CAD system development support, 3D construction data of the universal switch insert PTM 250 in Chapter 3.1 are available from EnOcean (IGS data). Using this data, the mechanical interface is fixed, and the shape and surface of the rocker(s) can be changed according to requirements. Recommendation for suitable rocker material is Ultradur B 4520 with a surface roughness of min. Ra 1.0  $\mu\text{m}$ .

**Please note that the rockers should be of non metal for best transmission range.**

## 3.3 Device Mounting

---

For mounting the PTM 200 device into an application-specific case, the package outline drawings of the device are roughly dimensioned in 1.4 Mechanical Interface. **If more detailed dimensioning data of the PTM 200 device case is necessary, 3D construction data is available from EnOcean (IGS data).**

**Please note that mounting the module back side on metal surfaces directly or mounting the module into metal frames can lead to up to typical 30% loss of transmission range within a building.**

## 3.4 Transmission Range

---

The main factors that influence the system transmission range are type and location of the antennas of the receiver and the transmitter, type of terrain and degree of obstruction of the link path, sources of interference affecting the receiver, and “dead” spots caused by signal reflections from nearby conductive objects. Since the expected transmission range strongly depends on this system conditions, range tests should categorically be performed before notification of a particular range that will be attainable by a particular application.

The following figures for expected transmission range are considered by using a PTM, a STM or a TCM radio transmitter device and the RCM or the TCM radio receiver device with preinstalled whip antenna and may be used as a rough guide only:

- **Line-of-sight connections:** Typically 30m range in corridors, up to 100m in halls
- **Plasterboard walls / dry wood:** Typically 30m range, through max. 5 walls
- **Brick walls / aerated concrete:** Typically 20m range, through max. 3 walls
- **Ferroconcrete walls / ceilings:** Typically 10m range, through max. 1 ceiling
- **Fire-safety walls, elevator shafts, staircases and supply areas should be considered as screening.**

The angle at which the transmitted signal hits the wall is very important. The effective wall thickness – and with it the signal attenuation – varies according to this angle. Signals should

be transmitted as directly as possible through the wall. Wall niches should be avoided. Other factors restricting transmission range:

- **Switch mounted on metal surfaces or into metal frames (up to 30% loss of indoor transmission range)**
- **Hollow lightweight walls filled with insulating wool on metal foil**
- **False ceilings with panels of metal or carbon fiber**
- **Lead glass or glass with metal coating, steel furniture**

The distance between EnOcean receivers and other transmitting devices such as computers, audio and video equipment that also emit high-frequency signals should be at least 0.5m

**Please note for use in the US and in Canada:** In the US, 868 MHz frequency range is used by Trunk Radio. Since a reduction of transmission range is to be expected near a trunk radio station, range tests at the system's target location should categorically be performed before notification of a particular range in the US and in Canada!

### **3.5 CE Approval Requirements**

---

The devices bear the EC conformity marking CE and conform to the R&TTE EU-directive on radio equipment. The assembly conforms to the European and national requirements of electromagnetic compatibility. The conformity has been proven and the corresponding documentation has been deposited at EnOcean. **The PTM devices can be operated without notification and free of charge in the area of the European Union, in Switzerland, in Croatia, in Cyprus, in Czech, in Estonia, in Hungary, in Latvia, in Lithuania, in Malta, in Poland, in Romania and in Slovenia.** The following provisos apply:

- EnOcean RF devices must not be modified or used outside their specification limits.
- EnOcean RF devices may only be used to transfer digital or digitized data. Analog speech and/or music are not permitted.
- The final product incorporating EnOcean RF devices must itself meet the essential requirement of the R&TTE Directive and a CE marking must be affixed on the final product and on the sales packaging each. Operating instructions containing a Declaration of Conformity has to be attached.
- If transmitters are used according to the regulations of the 868.3 MHz band, a so-called "Duty Cycle" of 1% per hour for each transmitter must not be exceeded. Permanent transmitters such as radio earphones are not allowed. For conventional applications, it must be ensured that the PTM 200 radio device is **not operated more than 6000 times within one hour** (one operation: energy bow is pressed and released). Within this calculation, the extraordinary short telegram length is considered including three subtelegrams (see Chapter 2.3.3). Also a tolerance of 5% in the telegram length is included.

### 3.6 FCC/IC Approval Requirements

---

This device complies with Part 15 of the FCC Rules and with RSS-210 of Industry Canada. If this device is operated in compliance with the following requirements **it can be operated without notification and free of charge in the area of the United States of America and in Canada**. Operation is subject to the following two conditions:

- (1) this device may not cause harmful interference, and
- (2) this device must accept any interference received, including interference that may cause undesired operation.

Trade Name: PTM 200  
Model No: PTM 200

FCC ID: SZV-PTM200  
IC: 5713A-PTM200



This device complies with Part 15 of the FCC Rules and with RSS-210 of Industry Canada. Operation is subject to the following two conditions. (1) this device may not cause harmful interference, and (2) this device must accept any interference received, including interference that may cause undesired operation.

**Warning: Changes or modifications made to this equipment not expressly approved by EnOcean may void the FCC authorization to operate this equipment.**

This equipment has been tested and found to comply with the limits for a Class B digital device, pursuant to Part 15 of the FCC Rules. These limits are designed to provide reasonable protection against harmful interference in a residential installation.

This equipment generates, uses and can radiate radio frequency energy and, if not installed and used in accordance with the instructions, may cause harmful interference to radio communications.

However, there is no guarantee that interference will not occur in a particular installation. If this equipment does cause harmful interference to radio or television reception, which can be determined by turning the equipment off and on, the user is encouraged to try to correct the interference by one or more of the following measures:

- Reorient or relocate the receiving antenna.
- Increase the separation between the equipment and receiver.
- Connect the equipment into an outlet on a circuit different from that to which the receiver is connected.
- Consult the dealer or an experienced radio/TV technician for help.

Due to FCC 15.231 operational and timing requirements the PTM 200 switch device **must not be operated more than 1088 times per hour** (pushed or released as one operation each):

- Total duration of transmissions must not exceed more than two seconds per hour
- PTM 200 packet length is 0.7 ms, max. 5 redundant packets, tolerance of 5% in packet length, 50% on average packet Ton/Toff ratio

**ATTENTION: Please be aware of the possibility of reduced transmission range when using EnOcean 868 MHz system near a US trunk radio station!**

## 4. DEVELOPMENT TOOLS

### 4.1 Evaluation Kit EVA 100/105

EVA 100 is an evaluation kit to support a simple setting-up operation of the receiver side when the EnOcean transmitter device PTM 200 is evaluated. EVA 100 supports a quick evaluation of all RCM 110 and RCM 120 receiver operation modes and supports the fast development of applications.



Type	EnOcean Ordering Code	Scope of supply
<b>EVA 100</b>	<b>H3004-G100</b>	<ul style="list-style-type: none"> <li>Evaluation board EVA-PCB</li> <li>EnOcean radio devices STM 100, PTM 100, RCM 110 and RCM 120</li> <li>CD with RS232 PC-link monitor software and detailed kit documentation</li> <li>230V wall power supply for EVA-PCB</li> <li>Convenient equipment case</li> </ul>
<b>EVA 105</b>	<b>H3004-G105</b>	<ul style="list-style-type: none"> <li>US version (120V wall power supply)</li> </ul>

### 4.2 Field Intensity Meter EPM 100

The EPM100 is a mobile field-intensity meter that helps the engineer to find the best installation positions for sensor and receiver. It can also be used to check disturbances in links to already installed equipment. The EPM100 displays the field intensity of received radio telegrams and interfering radio signals in the 868MHz range.

The simplest procedure for determining the best installation positions for the radio sensor/receiver:

- Person 1 operates the radio sensor and generates pushbutton radio telegrams.
- Person 2 checks the received field intensity on the meter display to find the optimal installation position.



## 5. DECLARATION OF CONFORMITY



**EnOcean GmbH**  
**Kolpingring 18a**  
**D 82041 Oberhaching**  
**www.enocean.com**

### Declaration of Conformity



**We:** **EnOcean GmbH**  
**Kolpingring 18a**  
**D 82041 Oberhaching**  
**Germany**

**Declare:** under our sole responsibility that the following labeled products:

**Transmitter: PTM100, STM100, STM250, PTM200**

**Receiver: RCM110, RCM120, RCM121**

**Transceiver: TCM110, TCM120**

to which this declaration relates, are, when used according to specification, in conformity with the technical requirements of the standards and the provisions of the essential requirements of the Directives detailed below.

**Directives: Electromagnetic Compatibility Directive 89/336/EC**

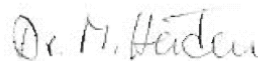
**Radio and Telecommunications Terminal Equipment Directive R&TTE 1999/5/EC**

**Standards: ETSI EN 301 489-1: 2001-09, ETSI EN 301 489-3: 2001-11 (class 2)**

**ETSI EN 61000-6-2: 2002-08**

**ETSI EN 300 220-3: 2000-09**

Place of issue: Oberhaching  
Quality Manager:  
Dr. Matthias Heiden  
Signature:



Date of issue: 13. May 2005  
General Manager:  
Markus Brehler  
Signature:

