

**Oracle® Communications
Performance Intelligence Center
Hardware Installation Guidelines**

Release 10.3.0

E98794-01

December 2018

Hardware Installation Guidelines

Oracle Communications Performance Intelligence Center Hardware Installation Guidelines, Release 10.3.0

Copyright © 2003, 2018, Oracle and/or its affiliates. All rights reserved.

This software and related documentation are provided under a license agreement containing restrictions on use and disclosure and are protected by intellectual property laws. Except as expressly permitted in your license agreement or allowed by law, you may not use, copy, reproduce, translate, broadcast, modify, license, transmit, distribute, exhibit, perform, publish, or display any part, in any form, or by any means. Reverse engineering, disassembly, or decompilation of this software, unless required by law for interoperability, is prohibited.

The information contained herein is subject to change without notice and is not warranted to be error-free. If you find any errors, please report them to us in writing.

If this is software or related documentation that is delivered to the U.S. Government or anyone licensing it on behalf of the U.S. Government, the following notices are applicable:

U.S. GOVERNMENT END USERS: Oracle programs, including any operating system, integrated software, any programs installed on the hardware, and/or documentation, delivered to U.S. Government end users are "commercial computer software" pursuant to the applicable Federal Acquisition Regulation and agency-specific supplemental regulations. As such, use, duplication, disclosure, modification, and adaptation of the programs, including any operating system, integrated software, any programs installed on the hardware, and/or documentation, shall be subject to license terms and license restrictions applicable to the programs. No other rights are granted to the U.S. Government.

This software or hardware is developed for general use in a variety of information management applications. It is not developed or intended for use in any inherently dangerous applications, including applications that may create a risk of personal injury. If you use this software or hardware in dangerous applications, then you shall be responsible to take all appropriate fail-safe, backup, redundancy, and other measures to ensure its safe use. Oracle Corporation and its affiliates disclaim any liability for any damages caused by use of this software or hardware in dangerous applications.

Oracle and Java are registered trademarks of Oracle and/or its affiliates. Other names may be trademarks of their respective owners.

Intel and Intel Xeon are trademarks or registered trademarks of Intel Corporation. All SPARC trademarks are used under license and are trademarks or registered trademarks of SPARC International, Inc. AMD, Opteron, the AMD logo, and the AMD Opteron logo are trademarks or registered trademarks of Advanced Micro Devices. UNIX is a registered trademark of The Open Group.

This software or hardware and documentation may provide access to or information about content, products, and services from third parties. Oracle Corporation and its affiliates are not responsible for and expressly disclaim all warranties of any kind with respect to third-party content, products, and services unless otherwise set forth in an applicable agreement between you and Oracle. Oracle Corporation and its affiliates will not be responsible for any loss, costs, or damages incurred due to your access to or use of third-party content, products, or services, except as set forth in an applicable agreement between you and Oracle.

My Oracle Support (MOS) (<https://support.oracle.com>) is your initial point of contact for all product support and training needs. A representative at Customer Access Support (CAS) can assist you with MOS registration.

Call the CAS main number at 1-800-223-1711 (toll-free in the US), or call the Oracle Support hotline for your local country from the list at <http://www.oracle.com/us/support/contact/index.html>.

See more information on MOS in the Appendix section.

Hardware Installation Guidelines

TABLE OF CONTENTS

1	INTRODUCTION	9
1.1	Purpose.....	9
1.2	Target audience	9
1.3	Acronyms and Terminology	9
1.4	References.....	10
1.5	Foreword.....	10
2	PERFORMANCE INTELLIGENCE CENTER MANAGEMENT	11
2.1	Hardware options for Performance Intelligence Center Management server	11
2.2	Networking guidelines for Performance Intelligence Center Management server	11
3	PERFORMANCE INTELLIGENCE CENTER MEDIATION AND STORAGE	13
3.1	Hardware options for Mediation servers	14
3.2	Networking guidelines for Performance Intelligence Center Mediation	14
3.3	Hardware options for Packet Data Unit Storage server.....	16
3.4	Networking guidelines for Packet Data Unit Storage servers.....	16
3.5	Hardware options for Data Record Storage server.....	18
3.6	Networking guidelines for Data Record Storage server.....	18
4	INTEGRATED ACQUISITION FOR EAGLE MONITORING	20
4.1	Hardware options for Eagle Integrated acquisition	20
4.2	Networking guidelines for EAGLE Integrated Acquisition.....	21
4.2.1	Default configuration	22
4.2.2	Alternate configuration	24
4.3	Networking guidelines for standard configuration.....	25
4.4	IP addressing.....	26
5	PROBED ACQUISITION	27
5.1	Hardware options for Probed acquisition servers	27
5.2	Networking guidelines for Probed acquisition.....	27
6	INTEGRATED ACQUISITION FOR DSR MONITORING	29
6.1	Hardware options for integrated acquisition servers for OCSDR monitoring	29
6.2	Networking guidelines for Integrated Acquisition for OCSDR monitoring.....	29
7	VIRTUAL MACHINE	31
8	PRE-PACKAGED OPTION FOR DSR MONITORING	32
8.1	Hardware options Pre-Packaged servers for DSR monitoring	32
8.2	Networking guidelines for Pre-Packaged option for OCSDR monitoring.....	33
9	HARDWARE CONFIGURATION SETS	35
9.1	Configuration set 1 (Oracle X6-2 8 HDD)	35
9.2	Configuration set 2 (Oracle X5-2)	36
9.3	Configuration set 3 (Oracle Netra X5-2)	37
9.4	Configuration set 4 (HP DL380 Gen9 v2)	38
9.5	Configuration set 5 (HP DL380 Gen9 v1)	40
9.6	Configuration set 6 (Oracle X6-2 2 HDD)	41
9.7	Configuration set 7 (Oracle X5-2)	42

Hardware Installation Guidelines

9.8	Configuration set 8 (Oracle Netra X5-2)	44
9.9	Configuration set 9 (HP DL360 Gen9 v2)	45
9.10	Configuration set 10 (HP DL360 Gen9 v1)	47
9.11	Configuration set 11 (HP DL360 Gen8 v2)	48
9.12	Configuration set 12 (HP DL360 Gen8 v1)	49
9.13	Configuration set 13 (Oracle ZFS)	51
9.14	Configuration set 14 (Oracle X6-2L 14 HDD)	52
9.15	Configuration set 15 (HP DL380 Gen9 v2)	54
9.16	Configuration set 16 (HP DL380 Gen9 v1)	56
9.17	Configuration set 17 (Oracle Database Appliance)	58
9.18	Configuration set 18 (Oracle E5-APP-B)	59
9.19	Configuration set 19 (Oracle X6-2)	60
9.20	Configuration set 20 (Oracle X5-2)	62
9.21	Configuration set 21 (Oracle Netra X5-2)	64
9.22	Configuration set 22 (HP DL360 Gen9 v2)	66
9.23	Configuration set 23 (HP DL360 Gen9 v1)	68
9.24	Configuration set 24 (HP DL360 Gen8 v2)	70
9.25	Configuration set 25 (HP DL360 Gen8 v1)	72
9.26	Configuration set 26 (Oracle X6-2 for Pre-package)	75
9.27	Configuration set 27 (Oracle X5-2 for Pre-package)	77
9.28	Configuration set 28 (Oracle Netra X5-2 for Pre-package)	79
9.29	Configuration set 29 (Oracle X6-2L 26 HDD)	81
9.30	Configuration set 30 (Oracle X7-2 8 HDD for virtual PIC))	82
9.31	Configuration set 31 (Oracle X7-2 2 HDD for virtual PIC)	83
9.32	Configuration set 32 (Oracle X7-2L 6 HDD for virtual PIC))	84
9.33	Configuration set 33 (Oracle X7-2 for virtual PIC)	86
9.34	SFP(+) modules	88
10	ANNEXES	90
10.1	Port identification on HP server Gen8 v1 & v2:	90
10.2	Port identification on HP server DL360 Gen9	91
10.3	Port identification on HP server DL380 Gen9:	91
10.4	Port identification on ODA X5-2	93
10.5	Port identification on Oracle X5-2	94
10.6	Port identification on Oracle Netra X5-2	94
10.7	Port identification on X6-2	96
10.8	Port identification on X6-2L	97
10.9	Port identification on ZFS ZS3-2	99
10.10	RAID configurations	101
10.11	Cable specification for Falco (SS7 to Sigtran converter)	102
10.12	Cisco Switch	104
10.13	Cisco basic knowledge	104
10.13.1	Configure and access the serial console on TPD	105
10.13.2	Configure and access the serial console on TVOE	105
10.13.3	4948&4948EF Reset to factory defaults	106
10.13.4	Assign an IP address on a 3020	107
10.13.5	2950 & 3020 Reset to factory defaults	107
10.13.6	Configure telnet access on a 3020	108
10.13.7	Configure SSH access	110
10.13.8	Recover a switch from rommon prompt	111
10.13.9	Upgrade IOS software	112
10.13.10	Backup the switch config on a server	113

Hardware Installation Guidelines

10.13.11	Configure Cisco 4948/4948E/4948E-F/9372TX switch	113
10.13.12	Configure Cisco 3020 switch	114
10.13.13	Flush ARP table	115
10.14	Mediation switch configuration template	116
10.14.1	Switch port allocation	116
10.14.2	Control Frame Switch for 4948 / 4949EF	116
10.14.3	Extension Frame Switch for Cisco 4948 / 4948EF	119
10.14.4	Control Frame Switch for 9372TX	123
10.15	Blade mediation switch configuration template	130
10.15.1	Switch port allocation	131
10.15.2	Aggregation Switch	132
10.15.3	Enclosure Switch	139
10.16	Integrated Acquisition switch configuration template	141
10.16.1	Switch port allocation	141
10.16.2	Yellow-sw1-1 Switch 4948 & 4948E-F (Layer 3)	141
10.16.3	Blue-sw1-1 Switch 4948 & 4948E-F (Layer 3)	147
10.16.4	Yellow-sw2-1 Switch 4948 & 4948E-F (Layer 3)	152
10.16.5	Blue-sw2-1 Switch 4948 & 4948E-F (Layer 3)	156
10.16.6	Yellow-sw3-1 Switch 4948 & 4948E-F (Layer 3)	160
10.16.7	Blue-sw3-1 Switch 4948 & 4948E-F (Layer 3)	162
10.16.8	Single Switch yellow-blue-sw1-1 4948 & 4948E-F	165
10.16.9	Yellow-sw1-1 Switch 9372TX (Layer 2)	168
10.16.10	Blue-sw1-1 Switch 9372TX (Layer 2)	177
10.16.11	Yellow-sw2-1 Switch 9372TX (Layer 2)	185
10.16.12	Blue-sw2-1 Switch 9372TX (Layer 2)	193
10.16.13	RMS Layer 2 switch configurations (Performance Intelligence Center 9.x and earlier)	201
10.16.14	IMF on E5-AppB	222
10.17	My Oracle Support (MOS)	232
10.18	Locate Product Documentation on the Oracle Help Center Site	233

List of Tables

Table 1: Acronyms and Terminology.....	9
Table 2: configuration set 1 with Oracle X6-2 8 SFF.....	35
Table 3: configuration set 2 with Oracle X5-2 8 SFF.....	36
Table 4: configuration set 3 with Oracle Netra X5-2 8 SFF.....	37
Table 5: Configuration set 4 with HP DL380 Gen9 v2 8 SFF.....	39
Table 6: Configuration set 5 with HP DL380 Gen9 v1 8 SFF.....	40
Table 7: configuration set 6 with Oracle X6-2 2 SFF.....	41
Table 8: configuration set 7 with Oracle X5-2.....	42
Table 9: configuration set 8 with Oracle Netra X5-2 2 SFF.....	44
Table 10: Configuration set 9 with HP DL360 Gen9 v2 2 SFF.....	45
Table 11: Configuration set 10 with HP DL360 Gen9 v1.....	47
Table 12: Configuration set 11 with HP DL360 Gen8 v2.....	48
Table 13: Configuration set 12 with HP DL360 Gen8 v1.....	49
Table 14: Configuration set 13 with ZFS.....	51
Table 15: Configuration for ZFS additional storage array.....	51
Table 16: Configuration set 14 with Oracle X6-2L with 14 HDD.....	52
Table 17: Configuration set 15 with HP DL380 Gen9 v2 24+2 SFF.....	54
Table 18: Configuration set 16 with HP DL380 Gen9 v1 24+2 SFF.....	56
Table 19: Configuration set 17 with ODA.....	58
Table 20: Configuration for additional storage enclosure with ODA.....	58
Table 21: configuration set 19 with Oracle X6-2 copper RJ45 interfaces.....	60
Table 22: configuration set 19 with Oracle X6-2 SFP+ interfaces.....	60
Table 23: configuration set 20 with Oracle X5-2 copper RJ45 interfaces.....	62
Table 24: configuration set 20 with Oracle X5-2 SFP+ interfaces.....	62
Table 25: configuration set 21 with Oracle Netra X5-2 copper RJ45 interfaces.....	64
Table 26: configuration set 21 with Oracle Netra X5-2 SFP+ interfaces.....	65
Table 27: configuration set 22 with HP Gen9 v2 with SFP+ card.....	66
Table 28: configuration set 24 with HP Gen8 v2 with SFP+ card.....	70
Table 29: configuration set 25 with HP Gen8 v1 with SFP+ card.....	72
Table 30: configuration set 25 with HP Gen8 v1 with 1G RJ45 card (NEBS).....	73
Table 31: configuration set 25 with HP Gen8 v1 with 1G RJ45 card (non NEBS).....	73
Table 32: configuration set 26 with Oracle X6-2 copper RJ45 interfaces for virtual machines hosting.....	75
Table 33: configuration set 26 with Oracle X6-2 SFP+ interfaces for virtual machines hosting.....	75
Table 34: configuration set 27 with Oracle X5-2 copper RJ45 interfaces for virtual machines hosting.....	77
Table 35: configuration set 27 with Oracle X5-2 SFP+ interfaces for virtual machines hosting.....	77
Table 36: configuration set 28 with Oracle Netra X5-2 copper RJ45 interfaces.....	79
Table 37: configuration set 28 with Oracle Netra X5-2 SFP+ interfaces.....	80
Table 38: Configuration set 29 with Oracle X6-2L with 26 HDD.....	81
Table 39: configuration set 30 with Oracle X7-2 8 SFF for virtual PIC.....	82
Table 40: configuration set 31 with Oracle X7-2 2 SFF for virtual PIC.....	84
Table 41: configuration set 32 with Oracle X7-2L 6 SFF for virtual PIC.....	85
Table 42: configuration set 33 with Oracle X7-2 copper RJ45 interfaces.....	86
Table 43: configuration set 33 with Oracle X7-2 QSFP interfaces.....	87
Table 44: SFP+ modules available on HP Intel X520 card.....	88
Table 45: SFP+ modules available on HP Intel X560 card.....	88
Table 46: Qualified SFP(+) modules on Oracle hardware Sun Dual 10GbE SFP+ card.....	88
Table 47: Cable for Falco: sample configuration for unprotected links.....	104
Table 48: Cisco 4948E-F configuration.....	104

Hardware Installation Guidelines

List of Figures

Figure 1 : Rear view for HP DL360 server Gen8 v1 & v2 used for Mediation.....90

Figure 2 : Rear view for HP DL360 server Gen8 v1 & v2 used for Probed acquisition.....90

Figure 3 : Rear view for HP DL360 server Gen9.....91

Figure 4 : Front view for HP DL38 Gen991

Figure 5 : Rear view for HP DL380 Gen9.....91

Figure 6- Front view of Oracle Database Appliance (storage shelf connections)93

Figure 7- Rear view of Oracle Database Appliance (power and network connections)93

Figure 8- Rear view of Oracle X5-2 Server94

Figure 9- Front view of Oracle Netra X5-2 Server95

Figure 10- Rear view of Oracle Netra X5-2 Server95

Figure 11- Front view of Oracle X6-2 server96

Figure 12- Front view of Oracle X6-2 server97

Figure 13- Front view of Oracle X6-2L server97

Figure 14- Rear view of Oracle X6-2L server98

Figure 15- Front view of Oracle ZFS ZS3-2 Controller.....99

Figure 16- Rear view of Oracle ZFS ZS3-2 Controller99

Figure 17- Front view of Oracle DE2-24P drive enclosure.....100

Figure 18- Rear view of Oracle DE2-24P drive enclosure100

Figure 19- SS7 line inputs to Falco102

Figure 20- Cable for Falco: sample configuration for unprotected links.....103

Hardware Installation Guidelines

1 Introduction

1.1 Purpose

Purpose of this document is to provide detailed guidelines to Oracle CGBU consulting team as well as to value-added reseller consulting teams, relating to the installation services of servers and any further Hardware required to support the Performance Intelligence Center 10.3 software.

Moreover, this document delivers Guidelines to support the implementation of the Performance Intelligence Center Software.

It is divided in 5 sections:

- Performance Intelligence Center management
- Performance Intelligence Center Mediation and Storage
- Performance Intelligence Center integrated acquisition
- Performance Intelligence Center probed acquisition
- Annex

Any BOM provided in the document are Oracle recommended configurations to be used with the Performance Intelligence Center 10.3 version. This hardware is qualified to work with Performance Intelligence Center for the usage defined in each section. Some adaptations are still possible and are documented at the end of each section when available.

 CAUTION	This document provides generic guidelines for Performance Intelligence Center supported hardware as well as rules and recommendations to build a setup compatible with Performance Intelligence Center installation. This document can't be use to replace the installation guides provided by the manufacturers of the hardware depict in this document. It is particularly true for safety rules and recommendations present in these documents.
--	--

1.2 Target audience

This guide is intended for technical personnel who are responsible for installing, configuring, and maintaining the hardware. Users should be familiar with hardware from HP, Oracle, Cisco switches, and shall have networking concepts understanding.

This document present high level rules for successful implementation of Performance Intelligence Center. Users are expected to read the manufacturer documentations for the selected hardware. Performance Intelligence Center software installation is covered in the installation Guide.

1.3 Acronyms and Terminology

PIC	Performance Intelligence Center
ILOM	Oracle Integrated Lights Out Manager
ILO	HP Integrated Lights Out
ODA	Oracle Database Appliance software
BOM	Bill Of Materials
RMS	Rack Mount Server
O&M	Operation and Maintenance

Table 1: Acronyms and Terminology

1.4 References

- Installation reference documentations : <http://eis.us.oracle.com/>
- Performance Intelligence Center 10.3.0 documentations: http://docs.oracle.com/communications/E98787_01/index.htm
- Tekelec Platform 7.0 documentations : http://docs.oracle.com/cd/E57832_01/index.htm
- Oracle ODA documentations: http://docs.oracle.com/cd/E22693_01/index.htm
- Oracle X5-2 documentations: http://docs.oracle.com/cd/E41059_01/
- Oracle ZFS documentations: http://docs.oracle.com/cd/E56021_01/index.html
- Oracle X6-2 documentations: http://docs.oracle.com/cd/E62159_01/
- Oracle X6-2L documentations: http://docs.oracle.com/cd/E62172_01/
- Oracle X7-2 documentations: http://docs.oracle.com/cd/E72435_01/
- Oracle X7-2L documentations: http://docs.oracle.com/cd/E72463_01/
- Oracle Netra X5-2 documentations: http://docs.oracle.com/cd/E53596_01
- HP Product Bulletin site: http://h71069.www7.hp.com/productbulletin/download/hppb_installer.exe
- Network Critical site: www.networkcritical.com
- Microtel Innovation site (converter): <http://microtelinnovation.com/>

1.5 Foreword

This document provides server BOMs, global guidelines to connect equipment together, and requirements for successful Performance Intelligence Center implementation. It doesn't supersede Manufacturer's documentations for the equipment. Some References are provided but it doesn't constitute the complete list.

In addition to servers and switches, other equipment may be required like racks, power distribution units, installation kits, cable management kits, cage nuts, screw, power cables, data cables, floor mounting kit, clamps, labels They are not depicted in this document. They shall be defined by the customer according to his setup or by a 3 party vendor/installer. Oracle can offer an additional service to define with the customer the installation design and additional items. This operation is performed by Oracle Consulting. Note that this may require a site survey.

When mixing AC and DC power supplies in the same plant, electrical best practice safety rules shall be strictly applied. For instance, Oracle strongly recommends that no AC powered cabinet shall be installed within 7 Ft. of DC powered equipment due to safety reasons. This may create a shock or current loop that can be severely hazardous to personnel. Exception may be granted if Telcordia reference GR1275-CORE-i08 below are fulfilled.

R19-5 [864] All elements of the integrated ground plane (MBN) (auxiliary framing, cable rack, vent ducts, pipes, etc.) within a minimum of 6 feet of an isolated ground plane (IBN) (analog or digital) shall be bonded to the Main Ground Bus (MGB) (SPCB) in the GW (SPCW) with a minimum #6 AWG stranded copper conductor.

R19-22 [880] All equipment, such as printers, terminals, stand alone units, etc., that are metallicly connected to the isolated ground plane (IBN) equipment shall be:

- Insulated from contact with integrated ground plane (MBN) members.
- Powered from sources within the isolated ground plane (IBN) or AC power that has been routed through and bonded to the MGB (SPCB).

Hardware Installation Guidelines

2 Performance Intelligence Center Management

2.1 Hardware options for Performance Intelligence Center Management server

Performance Intelligence Center Management software can be installed on:

- Oracle Hardware
- HP RMS

Performance Intelligence Center Management server	
Oracle Hardware	HP
X7-2 (virtual mode AC only)	HP Gen9 v1 & v2
X6-2 (AC only)	
Netra X5-2	
X5-2 (AC only)	

Performance Intelligence Center Management supports following hardware configurations:

- [Configuration set 30 \(X7-2 8 HDD for virtual PIC\)](#)
- [Configuration set 1 \(X6-2 8 HDD\)](#)
- [Configuration set 2 \(X5-2\)](#)
- [Configuration set 3 \(Netra X5-2\)](#)
- [Configuration set 4 \(HP Gen9 v2\)](#)
- [Configuration set 5 \(HP Gen9 v1\)](#)

2.2 Networking guidelines for Performance Intelligence Center Management server

Synthesis:

Management server requires:

- On HP and Oracle hardware: One Ethernet access for management
- Number of network ports for web access and downlink is variable (see details bellow)

Number of port is variable according to server configuration. Both Management port (for server management) and Network ports (for backbone connectivity) shall be connected to customer network.

Please refer to annex section for network ports identification

Management ports:

1 port per HP server (named ILO)
Or 1 port for Oracle hardware (named ILOM).

All servers shall have their management port (ILO for HP or ILOM for Oracle hardware) connected to the network and configured for remote access:

- Server management port is a 1000 Base-T RJ45 Ethernet compatible
- Server management port is untagged.

Hardware Installation Guidelines

- Initial Network Connection configuration shall be performed by the customer to allow remote connection to ILO(M). Please refer to Oracle documentation for ILOM initial configuration, or to HP ILO configuration and setup for HP servers.
- Static IP configuration for management port (ILO or ILOM) can be freely allocated (DHCP is not recommended).

Network ports:

All HP Ethernet network ports are RJ45 1000 Base-T compatible

Oracle Ethernet network ports are RJ45 1000 Base-T and 10G Base-T compatible.

Management server can be installed using 1 or 2 network ports:

- 1 network port: Eth01 network port used for both frontend, backend and alarms output.
- 2 network ports (recommended option): 2 ports are used to differentiate frontend and backend: :
 - Eth02: port for frontend (web access to GUI)
 - Eth01: port for backend (acquisition and mediation servers and alarms output)
- In case of 2 network ports, default route shall be on Eth02 (Web GUI access) and static routes to Performance Intelligence Center mediation and acquisition servers shall be added on Eth01.
- IP addresses can be freely allocated (in different subnets for the 2 network case).

In case of presence of a Firewall, some TCP/UDP ports shall be opened. The list of ports to open is available in Performance Intelligence Center Security guide on Oracle Technology Network site.

By default, all network ports are untagged (VLAN if needed are configured on customer switch)

Switch template configurations and cabling are available in the appendix section of this document.

Hardware Installation Guidelines

3 Performance Intelligence Center Mediation and storage

Performance Intelligence Center Mediation is a set of servers being logically grouped to create a subsystem (logical entity of servers). It is composed of

- Base server to create xDR and KPI
- Data Record storage supporting database instances
- Packet Data Unit storage servers

Performance Intelligence Center Mediation can be installed on:

- Oracle Hardware
- HP RMS

Mediation base		Data Record Storage		Packet Data Unit Storage	
Oracle Hardware	HP	Oracle Hardware	HP	Oracle Hardware	HP
X7-2 (virtual PIC AC only)	HP Gen9 v1&v2	X7-2L (virtual PIC AC only)	HP Gen9 v1&v2	X7-2L (virtual PIC AC only)	HP Gen9 v1&v2
X6-2	HP Gen8 v1&v2	X6-2L		X6-2L	
X5-2		ODA		ZFS	
Netra X5-2					

More information is provided in the following sections.

Local switches to interconnect servers together are strongly recommended.

3.1 Hardware options for Mediation servers

Performance Intelligence Center Mediation supports following configurations:

- [Configuration set 31 \(X7-2 2 HDD virtual PIC\)](#)
- [Configuration set 6 \(X6-2 2 HDD\)](#)
- [Configuration set 7 \(X5-2\)](#)
- [Configuration set 8 \(Netra X5-2\)](#)
- [Configuration set 9 \(HP Gen9 v2\)](#)
- [Configuration set 10 \(HP Gen9 v1\)](#)
- [Configuration set 11 \(HP Gen8 v2\)](#)
- [Configuration set 12 \(HP Gen8 v1\)](#)

Mixing servers is allowed in the same subsystem.

3.2 Networking guidelines for Performance Intelligence Center Mediation

Synthesis:

Each Mediation server requires:

- One Ethernet access for management
- One Ethernet access for uplink

Both Management port (for server management) and Network ports (for backbone connectivity) shall be connected to customer network.

Please refer to annex section for network ports identification.

For management ports:

All servers shall have their management port (ILO for HP or ILOM for Oracle hardware) connected to the network and configured for remote access:

- Server management port is a 1000 Base-T RJ45 Ethernet compatible
- Server management port is untagged.
- Initial Network Connection configuration shall be performed by the customer to allow remote connection to ILO(M). Please refer to Oracle documentation for ILOM initial configuration, or to HP ILO configuration and setup for HP servers.
- Static IP configuration for management port (ILO or ILOM) can be freely allocated (DHCP is not recommended).

For network ports:

All HP Ethernet network ports are RJ45 1000 Base-T compatible

Oracle Ethernet network ports are RJ45 1000 Base-T and 10G Base-T compatible.

All ports are native (VLAN if needed are configured on customer switch).

Hardware Installation Guidelines

All IP addresses shall be routable to allow remote access (including for support). In case of presence of a Firewall, some TCP/UDP ports shall be opened. The list of ports to open is available in Performance Intelligence Center security guide.

Mediation server can be installed using 1 or 2 network ports:

- 1 network port: Eth01 network port used for all
- 2 network ports: Eth1 & Eth02 used in bound mode.

It is recommended to allocate IP addresses of network ports in the same subnet using static IP addresses for all servers in a subsystem. For performance reasons, it is recommended to have high throughput performance and low latency between the mediation and the storage servers. Typically a switch (or 2 switches with path redundancy) shall be used to interconnect mediation and storage servers of a subsystem.

If production and management traffic separation is requested, IP addresses shall be allocated in different subnets for production and management. Other IP addresses (for management and ILO) can be allocated in the same or different subnets using static IP addresses.

Switch template configuration and cabling are available in appendix of this document.

3.3 Hardware options for Packet Data Unit Storage server

Performance Intelligence Center Packet Data Unit Storage server supports following configurations:

- [Configuration set 32 \(X7-2L 6 HDD virtual PIC\)](#)
- [Configuration set 29 \(X6-2L 26 HDD\)](#)
- [Configuration set 13 \(ZFS\)](#)
- [Configuration set 15 \(HP Gen9 v2\)](#)
- [Configuration set 16 \(HP Gen9 v1\)](#)

Mixing servers with different storage size is not allowed in the same subsystem.

3.4 Networking guidelines for Packet Data Unit Storage servers

Synthesis:

Each packet data unit server requires:

- On HP: One Ethernet access for management
- On ZFS: One Ethernet access for management
- On Other Oracle hardware: One Ethernet access for management
- Number of network ports for storage is variable (see details bellow)

Number of port is variable according to server type and configuration. Both Management port (for server management) and Network port (for backbone connectivity) shall be connected to customer network.

Please refer to annex section for network ports identification.

For management ports:

All servers shall have their management port (ILO for HP or ILOM for Oracle hardware) connected to the network and configured for remote access:

- Server management port is a 1000 Base-T RJ45 Ethernet compatible
- Server management port is untagged.
- Initial Network Connection configuration shall be performed by the customer to allow remote connection to ILO(M). Please refer to Oracle documentation for ILOM initial configuration, or to HP ILO configuration and setup for HP servers.
- Static IP configuration for management port (ILO or ILOM) can be freely allocated (DHCP is not recommended).

For network ports:

ZFS and HP RMS Ethernet network ports are RJ45 1000 Base-TX compatible.

X6-2L Ethernet network ports are RJ45 1000 Base-T and 10G Base-T compatible.

Please refer to annex section for network ports identification.

All ports are native (VLAN if needed are configured on customer switch).

All IP addresses shall be routable to allow remote access (including for support). In case of presence of a Firewall, some TCP/UDP ports shall be opened. The list of ports to open is available in Performance Intelligence Center security guide.

Hardware Installation Guidelines

It is recommended to allocate IP addresses of network ports in the same subnet using static IP addresses for all servers in a subsystem. For performance reasons, it is recommended to have high throughput performance and low latency between the mediation and the storages. Typically a switch (or 2 switches with path redundancy) shall be used to interconnect mediation and storage servers of a subsystem.

If production and management traffic separation is requested, IP addresses shall be allocated in different subnets for production and management. Other IP addresses (for management and ILO) can be allocated in the same or different subnets using static IP addresses.

Switch template configuration and cabling are available in appendix of this document.

Eth01 and Eth02 bonding is supported on all servers.

3.5 Hardware options for Data Record Storage server

Performance Intelligence Center Data Record storage server supports following configurations:

- [Configuration set 32 \(X7-2L 6 HDD virtual PIC\)](#)
- [Configuration set 29 \(X6-2L 26 HDD\)](#)
- [Configuration set 17 \(ODA\)](#)
- [Configuration set 15 \(HP Gen9 v2\)](#)
- [Configuration set 16 \(HP Gen9 v1\)](#)

Note that ODA (Configuration set 17) can be shared by Management server function and Data Record Storage, or support two Data Record Storage instance.

Mixing servers with different storage size is not allowed in the same subsystem.

Note that customer shall have Oracle Enterprise Edition 12c and partitioning option licenses, or Oracle Technology Foundation for Monitoring Applications license for each Data Record Storage instance, before starting the installation.

3.6 Networking guidelines for Data Record Storage server

Synthesis:

Each Mediation server requires:

- One Ethernet access for management
- One Ethernet access for uplink

Each storage server (for packet or data unit) requires:

- On HP: One Ethernet access for management
- On ODA: Two Ethernet access for management
- On other Oracle hardware: One Ethernet access for management
- Number of network ports for storage is variable (see details bellow)

Number of port is variable according to server type and configuration. Both Management port (for server management) and Network port (for backbone connectivity) shall be connected to customer network.

Please refer to annex section for network ports identification.

For management ports:

All servers shall have their management port (ILO for HP or ILOM for Oracle hardware) connected to the network and configured for remote access:

- Server management port is a 1000 Base-T RJ45 Ethernet compatible
- Server management port is untagged.
- Port is native (VLAN if needed are configured on customer switch).
- Initial Network Connection configuration shall be performed by the customer to allow remote connection to ILO(M). Please refer to Oracle documentation for ILOM initial configuration, or to HP ILO configuration and setup for HP servers.
- Static IP configuration for management port (ILO or ILOM) can be freely allocated (DHCP is not recommended).

Hardware Installation Guidelines

For network ports:

HP RMS Ethernet network ports are RJ45 1000 Base-TX compatible.

ODA and X6-2L Ethernet network ports are RJ45 1000 Base-T and 10G Base-T compatible

All ports are native (VLAN if needed are configured on customer switch).

Eth01 and Eth02 bonding is supported on all servers.

All IP addresses shall be routable to allow remote access (including for support). In case of presence of a Firewall, some TCP/UDP ports shall be opened. The list of ports to open is available in Performance Intelligence Center security guide.

It is recommended to allocate IP addresses of network ports in the same subnet using static IP addresses for all servers in a subsystem. For performance reasons, it is recommended to have high throughput performance and low latency between the mediation and the storages. Typically a switch (or 2 switches with path redundancy) shall be used to interconnect mediation and storage servers of a subsystem.

If production and management traffic separation is requested, IP addresses shall be allocated in different subnets for production and management. Other IP addresses (for management and ILO) can be allocated in the same or different subnets using static IP addresses.

Switch template configuration and cabling are available in appendix of this document.

4 Integrated Acquisition for Eagle monitoring

All Eagle integrated acquisition servers, are grouped inside a logical entity called a subsystem. Inside the subsystem, they exchange management and surveillance information. Only one subsystem can be connected to an EAGLE. And an EAGLE can be monitored by only one Integrated Acquisition subsystem.

Integrated acquisition can be installed on:

- E5-APP-B cards (installed in Eagle frame)
- Oracle RMS server
- HP RMS server

Integrated Acquisition	
Oracle Hardware	HP
X7-2 (virtual PIC AC only)	HP Gen9 v1 & v2
X6-2 (AC only)	HP Gen8 v1&v2
X5-2 (AC only)	
Netra X5-2	
E5-APP-B	

More information is provided in the following sections.

4.1 Hardware options for Eagle Integrated acquisition

Performance Intelligence Center Mediation supports following configurations:

- [Configuration set 31 \(X7-2 2 HDD virtual PIC\)](#)
- [Configuration set 6 \(X6-2 2 HDD\)](#)
- [Configuration set 7 \(X5-2\)](#)
- [Configuration set 8 \(Netra X5-2\)](#)
- [Configuration set 9 \(HP Gen9 v2\)](#)
- [Configuration set 10 \(HP Gen9 v1\)](#)
- [Configuration set 11 \(HP Gen8 v2\)](#)
- [Configuration set 12 \(HP Gen8 v1\)](#)
- [Configuration set 18 \(E5-APP-B\)](#)

Oracle HW can be mixed with HP RMS servers in the same subsystem. But performance of each server in the subsystem shall be aligned to the server with the lowest performance.

No mixed configuration is allowed in a subsystem with E5-APP-B (E5-APP-B cards can't be mixed with Oracle or HP RMS).

Mixing AC and DC equipment within the same cabinet is not allowed for safety rules.

Eagle power supply is DC only. Some Oracle hardware is available in AC only. Therefore, electrical best practice safety rules shall be strictly applied. For instance, Oracle strongly recommends that no AC powered cabinet shall be installed within 7 Ft. of DC powered equipment due to safety reasons. This may create a shock or current loop that can be severely hazardous to personnel. Exception may be granted if Telcordia reference GR1275-CORE-i08 below are fulfil.

Hardware Installation Guidelines

R19-5 [864] All elements of the integrated ground plane (MBN) (auxiliary framing, cable rack, vent ducts, pipes, etc.) within a minimum of 6 feet of an isolated ground plane (IBN) (analog or digital) shall be bonded to the Main Ground Bus (MGB) (SPCB) in the GW (SPCW) with a minimum #6 AWG stranded copper conductor.

R19-22 [880] All equipment, such as printers, terminals, stand alone units, etc., that are metallicly connected to the isolated ground plane (IBN) equipment shall be:

- Insulated from contact with integrated ground plane (MBN) members.
- Powered from sources within the isolated ground plane (IBN) or AC power that has been routed through and bonded to the MGB (SPCB).

4.2 Networking guidelines for EAGLE Integrated Acquisition

Synthesis:

Switches are mandatory (1 or more according to equipment to connect)

Each Integrated acquisition server requires

- One Ethernet access for management
- Two Ethernet access for uplink

In addition, STC and Fast copy Eagle cards are dual attached to the switches.

Switches are connected to customer network through one or 2 ports.

At least management ports of 2 servers (for server management) shall be connected directly to customer network. Network ports (for backbone connectivity) and management ports of other servers are connected to the switch(es). Switch(es) shall be connected to customer network.

Please refer to annex section for network ports identification

For management ports:

All servers shall have their management port (ILO for HP or ILOM for Oracle hardware) connected to the network and configured for remote access:

- Server management port is a 1000 Base-T RJ45 Ethernet compatible
- Server management port is untagged.
- Initial Network Connection configuration shall be performed by the customer to allow remote connection to ILO(M). Please refer to Oracle documentation for ILOM initial configuration, or to HP ILO configuration and setup for HP servers.
- Static IP configuration for management port (ILO or ILOM) can be freely allocated (DHCP is not recommended).

For network ports:

- All Ethernet network ports are RJ45 1000 Base-TX compatible.
- Please refer to annex section for network ports identification.

For Eagle cards

All Eagle cards connected to switches (fast copy ports or STC ports) are:

- Native untagged RJ45 100 Base-T compliant.
- Tagging shall be done on the switch according to the selected configuration (see below)

When Fast copy is activated on the Eagle, switch shall support jumbo frame (minimum size 1530 bytes).

Switches are part of the integrated acquisition architecture. They are mandatory. One or more switches are required according to number of servers and Eagle cards to connect. For new systems it is recommended to use the configuration described in the following chapter and assuming the system is installed in accordance with the switch port allocation described in section 6.13.1

If requested by customer an alternate configuration can be used and is described in section 4.2.2 and in this case you have to configure the switch as for the default and then add the few lines described in this section.

The Layer 3 configuration described in section 6.13.2 to 6.13.7 for RMS Servers and 6.13.10.2 to 6.13.10.3 for E5-AppB cards are designed for the CISCO 49448EF switch but is keeping also some commands in order to remain compatible with the previous CISCO 4948.

In case of switch installed to extend existing systems it is recommended the same Layer 2 configuration used in the previous Performance Intelligence Center releases and remembered in section:

1. 6.13.19 for HP RMS
2. 6.13.10.4 for E5-AppB

Layer 2 configurations can still be used even if you have Cisco Nexus 9372TX, a 4948EF instead of 4948 switches, if you don't want to use Layer 3 configuration for a new system installation. The template configuration may be customized as long as you respect the constraints described in the following section.



CAUTION:

In case of switch reconfiguration, the communication to IMF server may be lost.

It is recommended, to avoid any communication lost during switch reconfiguration, to change interface status to down state on all IMF sub-system servers before starting switch reconfiguration:

- For yellow switch reconfiguration, use “ifdown eth01”
- For blue switch reconfiguration, use “ifdown eth03”

After switch reconfiguration, don't forget to restart the interface using ifdup command.

Use this procedure only if you really need to avoid any communication lost.

4.2.1 Default configuration

The interfaces to customer switch are configured in native mode. If customer uses vlans they must be configured on his switch (transparent for Oracle) :

1. Vlan 100 172.21.49.0 255.255.255.0

vlan can't be changed and is transparent to the customer

IP can't be changed and shall not be used for servers communicating with IMF (NSP&IXP&VPN)

2. Vlan 101 172.22.49.0 255.255.255.0

Vlan can't be changed and is transparent to the customer

IP can't be changed and shall not be used for servers communicating with IMF (NSP&IXP&VPN)

Hardware Installation Guidelines

- Vlan 200 192.168.0.0 255.255.255.224 internal network minimum size for largest configuration

IP must be changed according values customer provided

Vlan can't be changed and is transparent to the customer

In the following config 192.168.0.1 is reserved and shall be used as default route for the IMF servers. 192.168.0.2 & 192.168.0.3 are reserved for switch IP

- Vlan 300 192.168.10.0 255.255.255.224 iLO network

IP must be changed according values customer provided

- Vlan 400 192.168.20.0 255.255.255.240 external network (demarcation)

IP must be changed according values customer provided

Note: the commands "switchport trunk encapsulation dot1q" and "media-type rj45" will fail on the 4948EF switch but it is kept this config for compatibility with the previous 4948

Note: While the configuration you may receive warnings like the one bellow, but this is expected.

%Warning: portfast should only be enabled on ports connected to a single

Warning: portfast should only be enabled on ports connected to a singleb

Warning: portfast should only be enabled on ports connecy bridging loops.

Warning: portfast should only be enabled on ports connecy bridging loops.t this is

expected. 4948vers. 192.168.0.2 & 192.168.0.3 are reserved for switch IPwhen portfast is

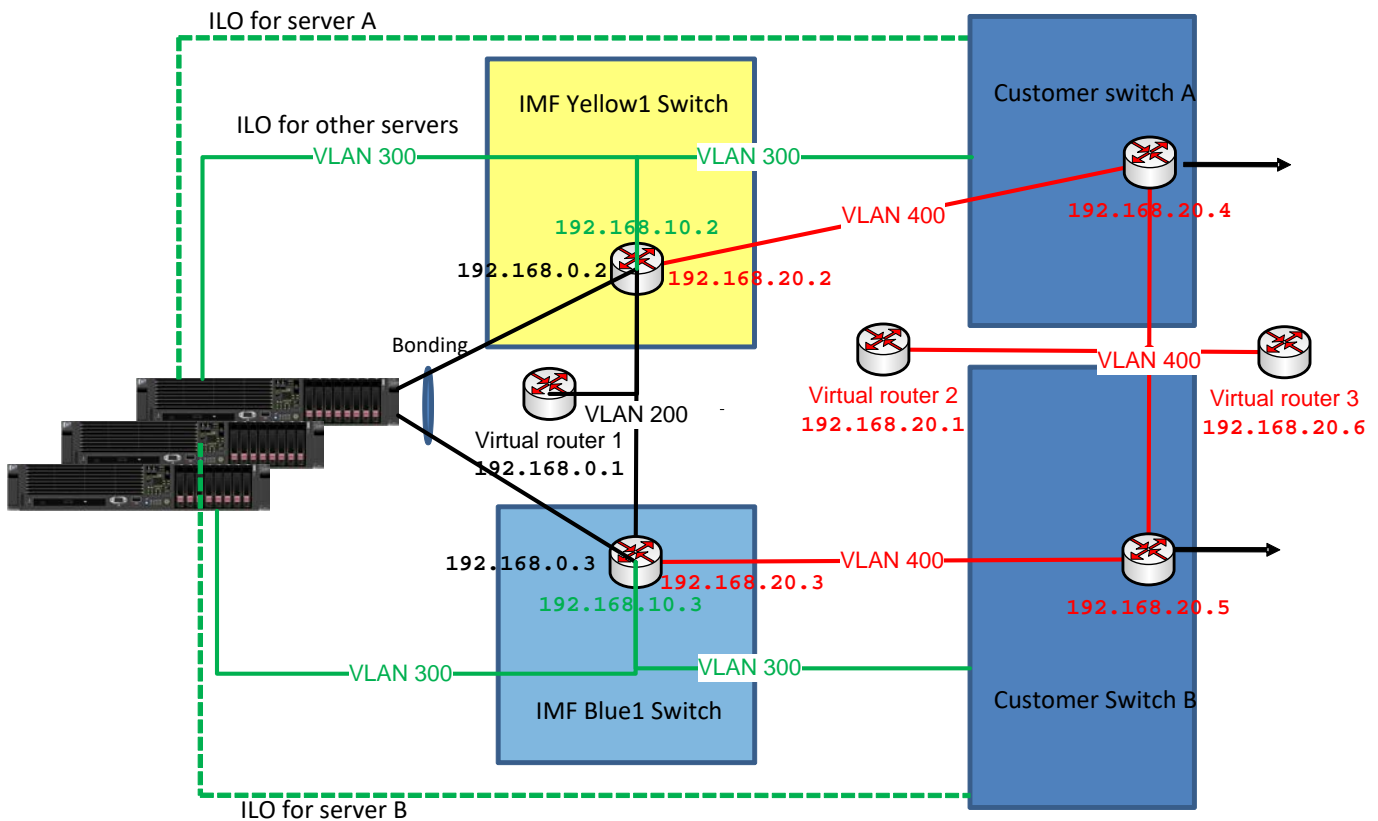

4.2.2 Alternate configuration

If the customer wants to configure on Oracle switches, we can use the alternate config below just by adding the few lines below to the default config.



This configuration can be dangerous, because customer must guarantee there is no link between the two switch access, otherwise it would make a loop and his network may crash.

```
interface Port-channell
  switchport trunk allowed vlan 100,101,200,300,400
interface GigabitEthernet 1/1
  switchport trunk allowed vlan 100,101,200,300,400
interface GigabitEthernet 1/2
  switchport trunk allowed vlan 100,101,200,300,400
no track 1 int gigabitEthernet 1/47 line-protocol
track 1 interface port-channel 1 line-protocol
```

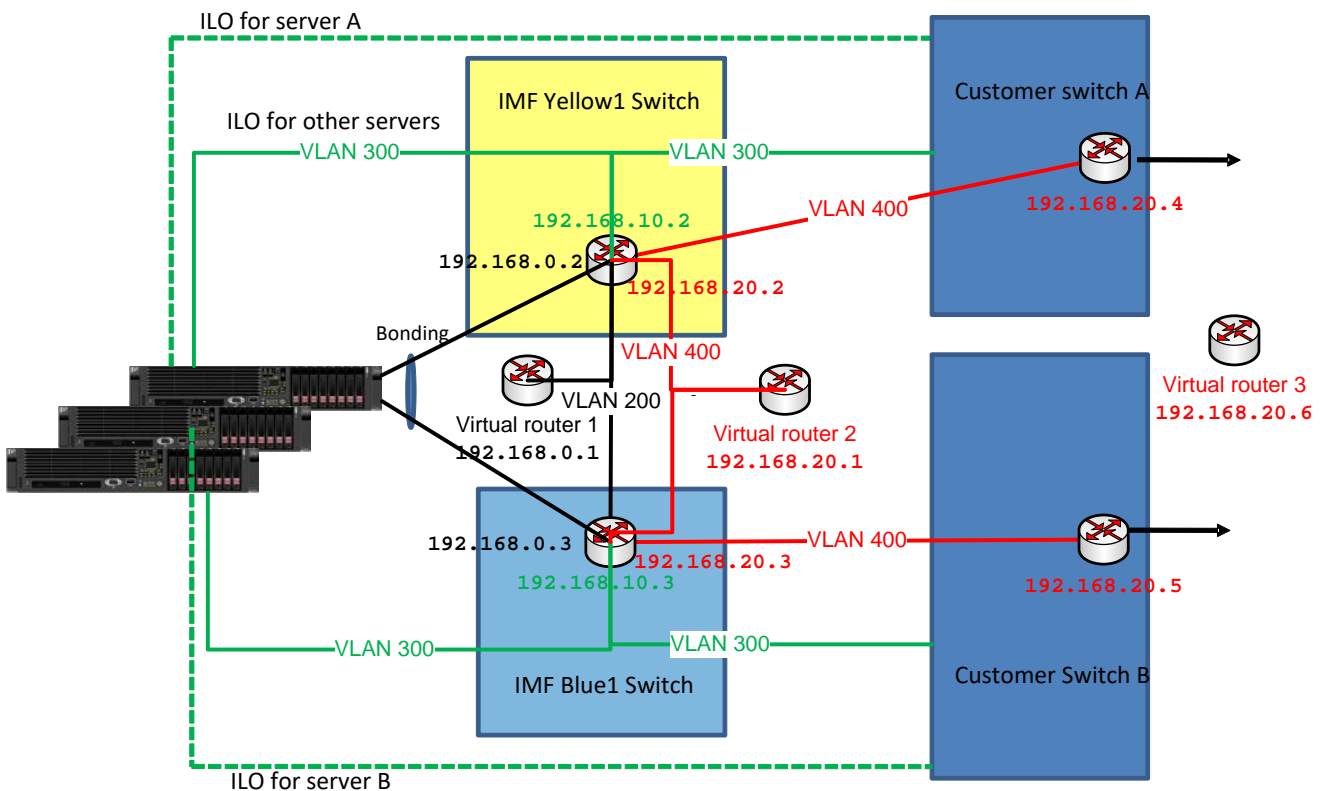

Hardware Installation Guidelines

4.3 Networking guidelines for standard configuration

According to the number of cards and servers to connect, more than one switch may be necessary. In that case, it is recommended to build a fully redundant network topology and to distribute the port from each server/card to 2 different switches connected in redundant way.

Following connection and port configuration shall be done:

- Eagle cards:
 - For all cards for which Fast copy is enable,
 1. Connect port C of the Fast Copy card, and port A for the STC cards to the switch.
In the switch, port shall be configured as untagged native port (mode access) and shall belong to VLAN 100.
 2. Connect port D of the Fast Copy card, and port B for the STC cards to the switch.
In the switch, port shall be configured as untagged native port (mode access) and shall belong to VLAN 101
- Integrated servers:
 1. Connect port Eth01 of IMF servers to a switch.
In the switch, port shall be configured as 802.1.Q tagged port (mode trunk). Vlan 100, 101 and 200 shall be allowed on the port.
 2. Connect port Eth03 of IMF servers to another switch (according to the redundant topology)..
In the switch, port shall be configured as 802.1.Q tagged port (mode trunk). Vlan 100, 101 and 200 shall be allowed on the port.
 3. It is recommended to
 - i. connect the ILO port of HP server, or the ILOM port for X5-2 of the first server to a customer switch to allow remote access even when Performance Intelligence Center switch configuration is not done
 - ii. connect the serial port of the same server on the console port of the switch (for initial configuration and troubleshooting)
 4. The other ILO/ILOM port can be connected to any switch with available ports.
In the switch, port shall be configured as untagged native port (mode access) and shall belong to VLAN 300 or any other VLAN number suitable for the customer (except 100 and 101).
- Connection to customer network:
 - According to customer will, one, two or more ports can be reserved to connect to customer network. These ports are freely configured by the customer.
 - One or more of these ports shall belong to VLAN 200 for integrated server access to the customer network.
 - One or more of these ports shall belong to the VLAN selected for the management (300 or any other vlan number except 100 and 101).
 - IP routing in the switch can be used too.

Following VLAN numbers are reserved. They can't be changed:

- VLAN 100: internal yellow network (Path 1 between Eagle and integrated servers)
- VLAN 101: internal bleu network (Path 2 between Eagle and integrated servers)
- VLAN 200: integrated servers to customer network

VLAN 100 and 101 are local and shall not be transmitted to customer backbone.

A specific VLAN number can be allocated for Management (access to ILO or ILOM).

Each VLAN shall belong to the same broadcasting domain.

4.4 IP addressing

VLAN 100 and 101 are using a specific subnets 172.21.48.00/23 and to 172.22.48.00/23 respectively. These addresses are reserved and shall not be used in Performance Intelligence Center whole system. But as they are internal, they can be used by the customer for any servers not interconnected with Performance Intelligence Center.

All integrated servers shall be in the same subnet on VLAN 200. Subnet can be freely set. It is recommended to use a subnet large enough to allow future extension. Static IP configuration shall be used (DHCP shall not be used).

For management ILO/ILOM ports:

Static IP configuration for management port (ILO or ILOM) can be freely allocated (DHCP is not recommended).

Hardware Installation Guidelines

5 Probed Acquisition

Probed acquisition can be installed on:

- Oracle server
- HP RMS

Probed Acquisition	
Oracle Hardware	HP
X7-2 (virtual PIC AC only)	HP Gen9 v1 & v2
X6-2 (AC only)	HP Gen8 v1&v2
X5-2 (AC only)	
Netra X5-2	

More information is provided in the following sections.

5.1 Hardware options for Probed acquisition servers

Performance Intelligence Center Probed acquisition supports the following configurations:

- [Configuration set 33 \(Oracle X7-2 virtual PIC\)](#)
- [Configuration set 19 \(X6-2\)](#)
- [Configuration set 20 \(X5-2\)](#)
- [Configuration set 21 \(Netra X5-2\)](#)
- [Configuration set 22 \(HP Gen9 v2\)](#)
- [Configuration set 23 \(HP Gen9 v1\)](#)
- [Configuration set 24 \(HP Gen8 v2\)](#)
- [Configuration set 25 \(HP Gen8 v1\)](#)

In addition for network acquisition cards with SFP(+) slots, they shall be populated with the SFP(+) modules according to network technology. See [SFP\(+\) module section](#) for recommended ones.

5.2 Networking guidelines for Probed acquisition

Synthesis:

Each probe server requires:

- One Ethernet access for management
- One to four Ethernet access for uplink

In addition, probe is connected to customer network links/switches for acquisition.

Both Management port (for server management) and Network ports (for backbone connectivity) shall be connected to customer network.

Please refer to annex section for network ports identification.

For management ports:

Hardware Installation Guidelines

All servers shall have their management port (ILO for HP or ILOM for Oracle hardware) connected to the network and configured for remote access:

- Server management port is a 1000 Base-T RJ45 Ethernet compatible
- Server management port is untagged.
- Initial Network Connection configuration shall be performed by the customer to allow remote connection to ILO(M). Please refer to Oracle documentation for ILOM initial configuration, or to HP ILO configuration and setup for HP servers.
- Static IP configuration for management port (ILO or ILOM) can be freely allocated (DHCP is not recommended).

For network ports:

All Ethernet network ports are RJ45 1000 Base-TX compatible.

In addition, Oracle hardware is 10G Base-T compatible for network ports

For uplink, probe implementation requires from 1 to 4 Ethernet ports according to customer option:

- One Ethernet link only:
 - Eth01: it is used for production and management traffic.
 - Other ports are unused
- Network ports aggregation for production and/or management traffic separation:
 - Eth01: it is reserved for management only when management and production traffic shall be separated. It is unused if no traffic separation.
 - Eth02: it is used for production traffic (and for management when no management/production separation).
 - Eth03 & Eth04: they are used with a bond grouping Eth02, Eth03 and Eth04 in case redundant path or aggregated (if more than 1 Gb/s output) are requested. Unused if not.
- Server needs several IP addresses:
 - One for Eth02 port only or for the eth02 to Eth04 bound
 - Optionally, one for Eth01 port when management and production traffic shall be separated

All Probe servers are independent. IP addresses can be freely allocated to probe ports.

All ports are native (VLAN if needed are configured on customer switch).

All IP addresses shall be routable to allow remote access (including for support). In case of presence of a Firewall, some TCP/UDP ports shall be opened. The list of ports to open is available in Performance Intelligence Center security guide..

Static IP configuration shall be used (DHCP shall not be used).

On acquisition side, customer shall copy network traffic to the probe. Port mirroring and tapping are supported. It is the responsibility of the customer to provide the Taps or to configure the switch. When using optical passive taps, particular attention shall be done on power budget. Probe receiver sensitivity is SFP module selection dependent.

Hardware Installation Guidelines

6 Integrated Acquisition for DSR monitoring

Integrated acquisition for DSR monitoring can be installed on:

- Oracle server
- HP RMS

Integrated Acquisition for DSR monitoring	
Oracle Hardware	HP
X7-2 (virtual PIC AC only)	HP Gen9 v1 & v2
X6-2	
X5-2 (AC only)	
Netra X5-2	

More information is provided in the following sections.

6.1 Hardware options for integrated acquisition servers for OCSDR monitoring

Performance Intelligence Center Integrated Acquisition for DSR monitoring supports the following configurations:

- [Configuration set 33 \(Oracle X7-2 virtual PIC\)](#)
- [Configuration set 19 \(X6-2\)](#)
- [Configuration set 20 \(X5-2\)](#)
- [Configuration set 21 \(Netra X5-2\)](#)
- [Configuration set 22 \(HP Gen9 v2\)](#)
- [Configuration set 23 \(HP Gen9 v1\)](#)

In addition for network acquisition cards with SFP(+) slots, they shall be populated with the SFP(+) modules according to network technology. See [SFP\(+\) module section](#) for recommended ones.

6.2 Networking guidelines for Integrated Acquisition for OCSDR monitoring

Synthesis:

Each integrated acquisition server for DSR monitoring requires:

- One Ethernet access for management
- One to four Ethernet access for uplink

In addition, probe is connected to customer network links/switches for acquisition.

Both Management port (for server management) and Network ports (for backbone connectivity) shall be connected to customer network.

Please refer to annex section for network ports identification.

For management ports:

All servers shall have their management port (ILO for HP or ILOM for Oracle hardware) connected to the network and configured for remote access:

- Server management port is a 1000 Base-T RJ45 Ethernet compatible
- Server management port is untagged.

Hardware Installation Guidelines

- Initial Network Connection configuration shall be performed by the customer to allow remote connection to ILO(M). Please refer to Oracle documentation for ILOM initial configuration, or to HP ILO configuration and setup for HP servers.
- Static IP configuration for management port (ILO or ILOM) can be freely allocated (DHCP is not recommended).

For network ports:

All Ethernet network ports are RJ45 1000 Base-TX compatible.

In addition, Oracle hardware is 10G Base-T compatible for network ports

For uplink, probe implementation requires from 1 to 4 Ethernet ports according to customer option:

- One Ethernet link only:
 - Eth01: it is used for production and management traffic.
 - Other ports are unused
- Network ports aggregation for production and/or management traffic separation:
 - Eth01: it is reserved for management only when management and production traffic shall be separated. It is unused if no traffic separation.
 - Eth02: it is used for production traffic (and for management when no management/production separation).
 - Eth03 & Eth04: they are used with a bond grouping Eth02, Eth03 and Eth04 in case redundant path or aggregated (if more than 1 Gb/s output) are requested. Unused if not.
- Server needs several IP addresses:
 - One for Eth02 port only or for the eth02 to Eth04 bound
 - Optionally, one for Eth01 port when management and production traffic shall be separated
- One of the network port shall have connectivity to the VIP of the DSR's SOAM

All Probe servers are independent. IP addresses can be freely allocated to probe ports.

All ports are native (VLAN if needed are configured on customer switch).

All IP addresses shall be routable to allow remote access (including for support). In case of presence of a Firewall, some TCP/UDP ports shall be opened. The list of ports to open is available in Performance Intelligence Center security guide..

Static IP configuration shall be used (DHCP shall not be used).

On acquisition side, the network traffic to and from the DSR shall be copied to the probe. According to DSR topology and available ports on the switch when available, port mirroring or tapping can be used. Document "Topology Specific Interconnections for Non-standard Port Mirroring" (CGBU_017238) can be provided to customer on request for configuration of the aggregation switch provided with the DSR, when port mirroring implementation is possible and desired. For the other cases, it is the responsibility of the customer to provide the Taps. When using optical passive taps, particular attention shall be done on power budget. Probe receiver sensitivity is SFP module selection dependent.

Hardware Installation Guidelines

7 Virtual machine

The virtualization allows to share a same server for multiple Performance Intelligence Center components.

The supported components for the virtualization on the same server are:

- 1 MGMT server,
- Up to N Mediation servers, according to the hardware capacity
- 1 Acquisition server, if the appropriate cards for the traffic capture are settled in the host.

The server must be chosen among the recommended ones for Mediation and Probed Acquisition hardware. Virtualization is supported and documented for all PIC components. Virtualization for storage is under control of the customer.

Performance Intelligence Center has been tested on X7-2/HP Gen9 RMS server with:

- KVM hypervisor version 1.5.3 or more (Oracle Linux 7.4 or more)
- VMware ESXi version 5.5

Technical description	Minimum Requirements
Architecture	i386 64 bits
Virtual CPU	minimum 4 cores
Virtual Memory	minimum 16 GB
Virtual Disk storage	1 virtual disk Minimum disk size 300GB Configured in IDE mode
Virtual CDROM	1
Ethernet Interface for acquisition	1 to 8 ports without any IP add configured Mode direct or PCI pass-through is recommended for high throughput ports (specifically for acquisition port) Virtio driver compatible
Ethernet Interface for production and management network access	1 to 4 ports* NAT is not supported IP addresses shall be accessible from network Virtio driver compatible
Virtual graphical interface	vnc interface compatibility for remote console access

Installation and virtual machine configuration are detailed in Performance Intelligence Center 10.3 Installation guide available on Oracle Technology Network site

8 Pre-Packaged option for DSR monitoring

The Pre-Packaged option for OCSDR monitoring can include Acquisition + Mediation + Management in the same server. More information are available on Performance Intelligence Center planning guide available on Oracle Technology Network site.

Pre-Packaged for DSR monitoring can be installed on:

- X7-2 oracle server
- X5-2 oracle server

In addition for the xDR storage option, an additional server is required:

- X7-2L oracle server
- X6-2L oracle server

Pre-Packaged DSR
X7-2 (virtual PIC AC only)
X6-2 (AC only)
X5-2 (AC only)
Netra X5-2
+
xDR storage option
X7-2L (virtual PIC AC only)
X6-2L (AC only)

More information is provided in the following sections.

Pre-Packaged solution uses a pre-defined virtualization setup including the management, the acquisition and the mediation virtual machines.

8.1 Hardware options Pre-Packaged servers for DSR monitoring

Performance Intelligence Center Pre-Packaged for DSR monitoring, with integrated acquisition, mediation and management, supports the following configurations:

- [Configuration set 30 \(X7-2 8 HDD for virtual PIC\)](#)
- [Configuration set 26 \(Oracle X6-2 for Pre-package\)](#)
- [Configuration set 27 \(X5-2\)](#)
- [Configuration set 28 \(Netra X5-2\)](#)

In addition for network acquisition cards with SFP(+) slots, they shall be populated with the SFP(+) modules according to network technology. See [SFP\(+\) module section](#) for recommended ones.

Optionally, xDR and PDU storage can be added. The xDR storage is done on an additional server and the PDU storage is performed on the Pre-Packaged DSR server. The additional xDR Storage server supports the following configurations:

Hardware Installation Guidelines

- [Configuration set 14 \(X6-2L 14 HDD\)](#)

Number of disk can be adapted to customer needs with 14 disks or 26 disks.

Note that Oracle Enterprise Edition 12c and partitioning option licenses, or Oracle Technology Foundation for Monitoring Applications license for each Data Record Storage instance, is included in the Pre-Packaged.

8.2 Networking guidelines for Pre-Packaged option for OCSDR monitoring

Synthesis:

Each Prepackage server requires:

- One IP in VLAN used for management (ILOM)
- One /28 VLAN for backend bridge
- One /29 VLAN for Storage bridge even when option is not used

In addition, server is connected to customer network links/switches for acquisition, and there are three Production VLAN which are not intended to be visible from customer network.

- On the first site one /30 VLAN for frontend bridge (web browser access) is also required

Optionally, xDR storage server requires:

- One IP in VLAN for management (ILOM)
- One IP in VLAN for Storage

IP addresses for each port shall be allocated in different subnets.

Static IP configuration shall be used (DHCP shall not be used).

Both Management port (for server management) and Network ports (for backbone connectivity) shall be connected to customer network.

Please refer to annex section for network ports identification and to the installation guide pre-package for a sample implementation.

Management ports on Prepackage server and xDR storage (option) :

1 port per server (named ILOM).

Each server shall have its ILOM port connected to the customer network and configured to allow remote access (including for support). :

- Server management port is a 1000 Base-T RJ45 Ethernet compatible
- Server management port is untagged.
- Initial Network Connection configuration shall be performed by the customer to allow remote connection .
- Please refer to Oracle documentation for ILOM initial configuration
- A fix IP address is recommended to identify uniquely the server

Network ports on Prepackage server:

Network ports are RJ45 1000 Base-T and 10G Base-T compatible.

Hardware Installation Guidelines

Please refer to annex section for network ports identification.

All IP addresses shall be routable to allow remote access (including for support).

On the first Site:

Net0: is used for backend.

Net1: is used for access to the frontend GUI

Net2: is used for xDR export and access to external database(when present).

All ports are native (VLAN if needed are configured on customer switch).

On other sites:

Net0: is used for backend.

Net1: is used for xDR export and access to external database(when present).

All ports are native (VLAN if needed are configured on customer switch).

For network ports on xDR storage (option):

X6-2L Ethernet network ports are RJ45 1000 Base-T and 10G Base-T compatible.

Port is native and for performance reasons, it is recommended to have high throughput performance and low latency between the Prepackaged server and the xDR storage server.

On acquisition side, customer shall copy network traffic to the Prepackage server. Port mirroring and tapping are supported. It is the responsibility of the customer to provide the Taps or to configure the switch. When using optical passive taps, particular attention shall be done on power budget. Receiver sensitivity is SFP module selection dependent.

Hardware Installation Guidelines

9 Hardware configuration sets

9.1 Configuration set 1 (Oracle X6-2 8 HDD)

Oracle X6-2 is available in AC only

Oracle SKU	Technical description	Qty (AC only)
7113252	Oracle Server X6-2: 1 RU base chassis with motherboard, internal 12 Gb SAS RAID HBA, 2 PSUs, slide rail kit, and cable management arm	1
7113237	One Intel® Xeon® E5-2690 v4 14-core 2.6 GHz processor	2
7110350	Heat sink for 1U	2
7113240	One 16 GB DDR4-2400 registered DIMM	4
7110339	Eight 2.5 inch drive slots, 1 DVD-RW drive slot and disk cage for 1U	1
7111107	One 1.2 TB 10000 rpm 2.5-inch SAS-3 HDD with marlin bracket	8
7110359	DVD filler panel	1
7102748	PCIe filler panel	3

Table 2: configuration set 1 with Oracle X6-2 8 SFF

Warning: an USB flash drive (8GB) will be required for initial installation or disaster recovery

In addition, 2 power cords shall be ordered according to installation country or Power distribution unit installed in the frame.

Customer can perform following adaptations on previous BOM:

- CPU: other CPUs are supported.
Pre-requisite: 10 cores minimum (on 1 or 2 processors)
Note that Ethernet ports Eth03 and Eth04 (NET2 and NET3) are non-functional in single-processor systems.
- Memory: Other memory allocation is supported.
Pre-requisite: 64 GB minimum.
- Disk type and size: other disks are supported
Pre-requisite: 8 disks minimum
all disks shall have same storage capacity
600 GB disk storage capacity (per disk) minimum.

Note that customer changes can affect server and system performances and ability to upgrade in future releases.

For server size, weight, BTU, power information... Documentations are available at http://docs.oracle.com/cd/E62159_01/

Please refer to Setup and Installation section for Oracle hardware installation. This document will drive you through the initial installation steps:

- Server installation in the rack.
- Attaching network and power Cables
- Booting Up the First Time
- Launching Oracle System Assistant to configure:
 - Server's network connection

Hardware Installation Guidelines

- Install latest server firmware
- Configure Oracle ILOM and BIOS,
- Configure hardware

OS and Performance Intelligence Center software installation on Oracle hardware server are provided in Performance Intelligence Center 10.3 Installation guide available on Oracle Technology Network site.

9.2 Configuration set 2 (Oracle X5-2)

Oracle X5-2 is available in AC only

Oracle SKU	Technical description	Qty (AC only)
7112843	Oracle Server X5-2 for Communications: 1 RU base chassis with motherboard,	1
7110339	XATO,DISK_CAGE,2.5" X 8HDD	1
7110346	ATO,E5-2699 V3,2.3G,145W,18 CORE,C-1 (SR1XD),CPU	2
7110350	XATO,HEATSINK,CPU,1U	2
7110360	XATO,OSA 8 GB MLC USB FLASH DRIVE	1
7110359	ATO,DVD,GEN5,BLANK FILLER PANEL,1U/2U	1
7102748	ATO PCIe FILLER,VENTED,LOW PROFILE	3
7110353	XATO,DIMM,16GB,DDR4,2133	8
7111107	1.2 TB 10000 rpm 2.5-inch SAS-3 HDD with marlin bracket (for factory installation)	8

Table 3: configuration set 2 with Oracle X5-2 8 SFF

In addition, 2 power cords shall be ordered according to installation country or Power distribution unit installed in the frame.

Customer can perform following adaptations on previous BOM:

- CPU: other CPUs are supported.
Pre-requisite: 8 cores minimum (on 1 or 2 processors)
- Memory: Other memory allocation is supported.
Pre-requisite: 64 GB minimum.
- Disk type and size: other disks are supported
Pre-requisite: 8 disks minimum
all disks shall have same storage capacity
600 GB disk storage capacity (per disk) minimum.

Note that customer changes can affect server and system performances and ability to upgrade in future releases.

For server size, weight, BTU, power information... Documentations are available at http://docs.oracle.com/cd/E41059_01/

Please refer to Setup and Installation section for Oracle hardware installation. This document will drive you through the initial installation steps:

- Server installation in the rack.

Hardware Installation Guidelines

- Attaching network and power Cables
- Booting Up the First Time
- Launching Oracle System Assistant to configure:
 - Server's network connection
 - Install latest server firmware
 - Configure Oracle ILOM and BIOS,
 - Configure hardware

OS and Performance Intelligence Center software installation on Oracle hardware server are provided in Performance Intelligence Center 10.3 Installation guide available on Oracle Technology Network site.

9.3 Configuration set 3 (Oracle Netra X5-2)

Oracle Netra X5-2 is available in AC and DC
 Oracle Netra X5-2 is NEBS compliant.

Oracle SKU	Technical description	Qty DC	Qty AC
7111082	Netra Server X5-2: 2 RU AC base chassis with motherboard and 8 HDDs	-	1
7111083	Netra Server X5-2: 2 RU DC base chassis with motherboard and 8 HDDs	1	-
7110346	Intel® Xeon® E5-2699 v3 18-core 2.3 GHz processor	2	2
7102981	Heat sink	2	2
7111036	One 16 GB DDR4-2133 DIMM	8	8
7111043	Memory filler panels	16	16
7111107	One 1.2 TB 10000 rpm 2.5-inch SAS-3 HDD with marlin bracket	8	8
7110116	Oracle Storage 12 Gb SAS PCIe RAID HBA, internal: 8 port and 1 GB memory	1	1
5394A	PCIe filler panel	5	5
7901A-4	19-inch 2-post rackmount kit	1	1
7111044	SAS cable kit	1	1
7111052	OSA 8 GB USB stick	1	1

Table 4: configuration set 3 with Oracle Netra X5-2 8 SFF

In addition, 2 power cords shall be ordered according to installation country or Power distribution unit installed in the frame.

Customer can perform following adaptations on previous BOM:

- CPU: other CPUs are supported.
Pre-requisite: 8 cores minimum (on 1 or 2 processors)
- Memory: Other memory allocation is supported.
Pre-requisite: 64 GB minimum.
- Disk type and size: other disks are supported
Pre-requisite: 8 disks minimum

Hardware Installation Guidelines

all disks shall have same storage capacity
600 GB disk storage capacity (per disk) minimum.

Note that customer changes can affect server and system performances and ability to upgrade in future releases.

For server size, weight, BTU, power information... Documentations are available at http://docs.oracle.com/cd/E53596_01/

Please refer to Setup and Installation section for Oracle hardware installation. This document will drive you through the initial installation steps:

- Server installation in the rack.
- Attaching network and power Cables
- Booting Up the First Time
- Launching Oracle System Assistant to configure:
 - Server's network connection
 - Install latest server firmware
 - Configure Oracle ILOM and BIOS,
 - Configure hardware

OS and Performance Intelligence Center software installation on Oracle hardware server are provided in Performance Intelligence Center 10.3 Installation guide available on Oracle Technology Network site.

9.4 Configuration set 4 (HP DL380 Gen9 v2)

HP DL380 Gen9 v2 is available in AC and DC

HP P/N	Technical description	Qty AC	Qty DC
719064-B21	HP ProLiant DL380 Gen9 8SFF	1	1
817951-L21	HPE DL380 Gen9 Intel® Xeon® E5-2680v4 (2.4GHz/14-core/35MB/120W) FIO Processor Kit	1	1
817951-B21	HPE DL380 Gen9 Intel® Xeon® E5-2680v4 (2.4GHz/14-core/35MB/120W) Processor Kit	1	1
805349-B21	HP 16GB (1x16GB) Single Rank x4 DDR4-2400 CAS-17-17-17 Registered Memory Kit	4	4
749974-B21	HP Smart Array P440ar/2GB FBWC 12Gb 2-ports Int FIO SAS Controller	1	1
720479-B21	HP 800 W Flex Slot Platinum Hot Plug Power Supply Kit	2	-
720480-B21	HP 800 W Flex Slot-48VDC Hot Plug Power Supply Kit	-	2
512485-B21	HP iLO Advanced including 1yr 24x7 Technical Support and Updates Single Server License	1	1
720863-B21	HP 2U Small Form Factor Ball Bearing Rail Kit	1	1
720865-B21	HP 2U Cable Management Arm for Ball Bearing Rail Kit	1	1
768900-B21	HP DL380 Gen9 Systems Insight Display Kit	1	1
758959-B22	HP LEGACY FIO MODE SETTING	1	1
719070-B21	HP DL380 G9 Chassis NEBS Conversion Kit	1	1

Hardware Installation Guidelines

719079-B21	HP DL380 Gen9 High Performance Fan Kit	1	1
785069-B21	HP 900GB 12G SAS 10K rpm SFF (2.5-inch) SC Ent 3yr Warranty Hard Drive	8	8

Table 5: Configuration set 4 with HP DL380 Gen9 v2 8 SFF

In addition, for each HP server, 2 power cords shall be ordered according to installation country or Power distribution unit installed in the frame.

For AC, all pre-configured servers with standard AC power supply option kit, ship with one standard 6-foot IEC C-13/C-14 jumper cord per power supply (for HP Gen9: reference A0K02A). If a different power cord is required, please check HP web site

Customer can perform following adaptations on previous BOM:

- CPU: other CPUs are supported.
Pre-requisite: 8 cores minimum (on 1 or 2 processors)
- Memory: Other memory allocation is supported.
Pre-requisite: 64 GB minimum.
- Disk type and size: other disks are supported
Pre-requisite: 8 disks minimum
all disks shall have same storage capacity
600 GB disk storage capacity (per disk) minimum.

Note that customer changes can affect server and system performances and ability to upgrade in future releases.

Internal disks shall be connected to SAS A.

Documentation on HP servers & storage array is available on HP web site or using Product bulletin tool. It includes server size, weight, BTU, power information.... The HP Product Bulletin is a free application that only takes a few minutes to download. The download site is located at

http://h71069.www7.hp.com/productbulletin/download/hppb_installer.exe

Required HP power for a cabinet can be estimated using HP Power advisor tool available on HP web site:

<http://www8.hp.com/us/en/products/servers/solutions.html?compURI=1439951#.UxSoL7QUdtk>

OS and Performance Intelligence Center management software installation and configuration on HP, are provided in Performance Intelligence Center 10.3 Installation guide available on Oracle Technology Network site. Note that customer shall have Weblogic 12c and Oracle Enterprise Edition 12c and partitioning option licenses, or Oracle Technology Foundation for Monitoring Applications license for this server, before starting the installation.

9.5 Configuration set 5 (HP DL380 Gen9 v1)

HP DL380 Gen9 v1 is available in AC and DC

HP P/N	Technical description	Qty AC	Qty DC
719064-B21	HP ProLiant DL380 Gen9 8SFF	1	1
762766-L21	HP DL380 Gen9 Intel® Xeon® E5-2680v3 (2.5GHz/12-core/30MB/120W) FIO Processor Kit	1	1
762766-B21	HP DL380 Gen9 Intel® Xeon® E5-2680v3 (2.5GHz/12-core/30MB/120W) FIO Processor Kit	1	1
726719-B21	HP 16GB (1x16GB) Dual Rank x4 DDR4-2133 CAS-15-15-15 Reg Memory Kit	4	4
749974-B21	HP Smart Array P440ar/2GB FBWC 12Gb 2-ports Int FIO SAS Controller	1	1
720479-B21	HP 800 W Flex Slot Platinum Hot Plug Power Supply Kit	2	-
720480-B21	HP 800 W Flex Slot-48VDC Hot Plug Power Supply Kit	-	2
512485-B21	HP iLO Advanced including 1yr 24x7 Technical Support and Updates Single Server License	1	1
720863-B21	HP 2U Small Form Factor Ball Bearing Gen8 Rail Kit with CMA	1	1
720865-B21	HP 2U Cable Management Arm for Ball Bearing Rail Kit	1	1
768900-B21	HP DL380 Gen9 Systems Insight Display Kit	1	1
758959-B22	HP LEGACY FIO MODE SETTING	1	1
719070-B21	HP DL380 G9 Chassis NEBS Conversion Kit	1	1
719079-B21	HP DL380 Gen9 High Performance Fan Kit	1	1
785069-B21	HP 900GB 12G SAS 10K rpm SFF (2.5-inch) SC Ent 3yr Warranty Hard Drive	8	8

Table 6: Configuration set 5 with HP DL380 Gen9 v1 8 SFF

In addition, for each HP server, 2 power cords shall be ordered according to installation country or Power distribution unit installed in the frame.

For AC, all pre-configured servers with standard AC power supply option kit, ship with one standard 6-foot IEC C-13/C-14 jumper cord per power supply (for HP Gen9: reference A0K02A). If a different power cord is required, please check HP web site

Customer can perform following adaptations on previous BOM:

- CPU: other CPUs are supported.
Pre-requisite: 8 cores minimum (on 1 or 2 processors)
- Memory: Other memory allocation is supported.
Pre-requisite: 64 GB minimum.
- Disk type and size: other disks are supported
Pre-requisite: 8 disks minimum
all disks shall have same storage capacity
600 GB disk storage capacity (per disk) minimum.

Note that customer changes can affect server and system performances and ability to upgrade in future releases.

Hardware Installation Guidelines

Internal disks shall be connected to SAS A.

Documentation on HP servers & storage array is available on HP web site or using Product bulletin tool. It includes server size, weight, BTU, power information.... The HP Product Bulletin is a free application that only takes a few minutes to download. The download site is located at

http://h71069.www7.hp.com/productbulletin/download/hppb_installer.exe

Required HP power for a cabinet can be estimated using HP Power advisor tool available on HP web site:

<http://www8.hp.com/us/en/products/servers/solutions.html?compURI=1439951#.UxSoL7QUdtk>

OS and Performance Intelligence Center management software installation and configuration on HP, are provided in Performance Intelligence Center 10.3 Installation guide available on Oracle Technology Network site. Note that customer shall have Weblogic 12c and Oracle Enterprise Edition 12c and partitioning option licenses, or Oracle Technology Foundation for Monitoring Applications license for this server, before starting the installation.

9.6 Configuration set 6 (Oracle X6-2 2 HDD)

Oracle X6-2 is available in AC only

Oracle SKU	Technical description	Qty (AC only)
7113252	Oracle Server X6-2: 1 RU base chassis with motherboard, internal 12 Gb SAS RAID HBA, 2 PSUs, slide rail kit, and cable management arm	1
7113237	One Intel® Xeon® E5-2690 v4 14-core 2.6 GHz processor	2
7110350	Heat sink for 1U	2
7113240	One 16 GB DDR4-2400 registered DIMM	4
7110339	Eight 2.5 inch drive slots, 1 DVD-RW drive slot and disk cage for 1U	1
7111107	One 1.2 TB 10000 rpm 2.5-inch SAS-3 HDD with marlin bracket	2
7110359	DVD filer panel	1
7102748	PCIe filler panel	3
6331A-N	2.5-inch HDD filler panel	6

Table 7: configuration set 6 with Oracle X6-2 2 SFF

Warning: an USB flash drive (8GB) will be required for initial installation or disaster recovery

In addition, 2 power cords shall be ordered according to installation country or Power distribution unit installed in the frame.

Customer can perform following adaptations on previous BOM:

- CPU: other CPUs are supported.
Pre-requisite: 10 cores minimum (on 1 or 2 processors)
Note that Ethernet ports Eth03 and Eth04 (NET2 and NET3) are non-functional in single-processor systems.
- Memory: Other memory allocation is supported.
Pre-requisite: 64 GB minimum.
- Disk type and size: other disks are supported
Pre-requisite: 2 disks minimum
all disks shall have same storage capacity
600 GB disk storage capacity (per disk) minimum.

Note that customer changes can affect server and system performances and ability to upgrade in future releases.

For server size, weight, BTU, power information... Documentations are available at http://docs.oracle.com/cd/E62159_01/

Please refer to Setup and Installation section for Oracle hardware installation. This document will drive you through the initial installation steps:

- Server installation in the rack.
- Attaching network and power Cables
- Booting Up the First Time
- Launching Oracle System Assistant to configure:
 - Server’s network connection
 - Install latest server firmware
 - Configure Oracle ILOM and BIOS,
 - Configure hardware

OS and Performance Intelligence Center software installation on Oracle hardware server are provided in Performance Intelligence Center 10.3.0 Installation guide available on Oracle Technology Network site.

9.7 Configuration set 7 (Oracle X5-2)

Oracle X5-2 is available in AC only

Oracle SKU	Technical description	Qty (AC only)
7112843	Oracle Server X5-2 for Communications: 1 RU base chassis with motherboard,	1
7110339	XATO,DISK_CAGE,2.5” X 8HDD	1
7110346	ATO,E5-2699 V3,2.3G,145W,18 CORE,C-1 (SR1XD),CPU	2
7110350	XATO,HEATSINK,CPU,1U	2
7110360	XATO,OSA 8 GB MLC USB FLASH DRIVE	1
7110359	ATO,DVD,GEN5,BLANK FILLER PANEL,1U/2U	1
7102748	ATO PCIe FILLER,VENTED,LOW PROFILE	3
7110353	XATO,DIMM,16GB,DDR4,2133	8
7111107	1.2 TB 10000 rpm 2.5-inch SAS-3 HDD with marlin bracket (for factory installation)	2

Table 8: configuration set 7 with Oracle X5-2

In addition, 2 power cords shall be ordered according to installation country or Power distribution unit installed in the frame.

Customer can perform following adaptations on previous BOM:

- CPU: other CPUs are supported.
Pre-requisite: 8 cores minimum (on 1 or 2 processors)
- Memory: Other memory allocation is supported.
Pre-requisite: 16GB minimum.
- Disk type and size: other disks are supported

Hardware Installation Guidelines

Pre-requisite: 2 disks minimum
all disks shall have same storage capacity
600 GB disk storage capacity (per disk) minimum.

Note that customer changes can affect server and system performances and ability to upgrade in future releases.

For server size, weight, BTU, power information... Documentations are available at
http://docs.oracle.com/cd/E41059_01/

Please refer to Setup and Installation section for Oracle hardware installation. This document will drive you through the initial installation steps:

- Server installation in the rack.
- Attaching network and power Cables
- Booting Up the First Time
- Launching Oracle System Assistant to configure:
 - Server's network connection
 - Install latest server firmware
 - Configure Oracle ILOM and BIOS,
 - Configure hardware

OS and Performance Intelligence Center software installation on Oracle hardware server are provided in Performance Intelligence Center 10.3 Installation guide available on Oracle Technology Network site.

9.8 Configuration set 8 (Oracle Netra X5-2)

Oracle Netra X5-2 is available in AC and DC
 Oracle Netra X5-2 is NEBS compliant.

Oracle SKU	Technical description	Qty DC	Qty AC
7111082	Netra Server X5-2: 2 RU AC base chassis with motherboard and 8 HDDs	-	1
7111083	Netra Server X5-2: 2 RU DC base chassis with motherboard and 8 HDDs	1	-
7110346	Intel® Xeon® E5-2699 v3 18-core 2.3 GHz processor	2	2
7102981	Heat sink	2	2
7111036	One 16 GB DDR4-2133 DIMM	8	8
7111043	Memory filler panels	16	16
7111107	One 1.2 TB 10000 rpm 2.5-inch SAS-3 HDD with marlin bracket	2	2
7110116	Oracle Storage 12 Gb SAS PCIe RAID HBA, internal: 8 port and 1 GB memory	1	1
5394A	PCIe filler panel	5	5
7901A-4	19-inch 2-post rackmount kit	1	1
7111044	SAS cable kit	1	1
7111052	OSA 8 GB USB stick	1	1

Table 9: configuration set 8 with Oracle Netra X5-2 2 SFF

In addition, 2 power cords shall be ordered according to installation country or Power distribution unit installed in the frame.

Customer can perform following adaptations on previous BOM:

- CPU: other CPUs are supported.
Pre-requisite: 8 cores minimum (on 1 or 2 processors)
- Memory: Other memory allocation is supported.
Pre-requisite: 16 GB minimum.
- Disk type and size: other disks are supported
Pre-requisite: 2 disks minimum
all disks shall have same storage capacity
600 GB disk storage capacity (per disk) minimum.

Note that customer changes can affect server and system performances and ability to upgrade in future releases.

For server size, weight, BTU, power information... Documentations are available at http://docs.oracle.com/cd/E53596_01/

Please refer to Setup and Installation section for Oracle hardware installation. This document will drive you through the initial installation steps:

Hardware Installation Guidelines

- Server installation in the rack.
- Attaching network and power Cables
- Booting Up the First Time
- Launching Oracle System Assistant to configure:
 - Server's network connection
 - Install latest server firmware
 - Configure Oracle ILOM and BIOS,
 - Configure hardware

OS and Performance Intelligence Center software installation on Oracle hardware server are provided in Performance Intelligence Center 10.3 Installation guide available on Oracle Technology Network site.

9.9 Configuration set 9 (HP DL360 Gen9 v2)

HP DL360 Gen9 v2 is available in AC and DC

HP P/N	Technical description	Qty AC	Qty DC
755258-B21	HP ProLiant DL360 Gen9 8SFF Configure-to-order Server	1	1
818184-B21	HPE DL360 Gen9 Intel® Xeon® E5-2680v4 (2.4GHz/14-core/35MB/120W) Processor Kit	1	1
818184-L21	HPE DL360 Gen9 Intel® Xeon® E5-2680v4 (2.4GHz/14-core/35MB/120W) FIO Processor Kit	1	1
805349-B21	HP 16GB (1x16GB) Single Rank x4 DDR4-2400 CAS-17-17-17 Registered Memory Kit	4	4
785069-B21	HP 900GB 12G SAS 10K rpm SFF (2.5-inch) SC Enterprise 3yr Warranty Hard Drive (Install in Drive Bays 1 and 2)	2	2
749974-B21	HP Smart Array P440ar/2GB FBWC 12Gb 2-ports Int FIO SAS Controller	1	1
720479-B21	HP 800W Flex Slot Platinum Hot Plug Power Supply Kit - AC	2	-
720480-B21	HP 800 W Flex Slot-48VDC Hot Plug Power Supply Kit	-	2
512485-B21	HP iLO Advanced incl 1yr 24x7 Tech Support and Updates Single Server License	1	1
663201-B21	HP 1U Small Form Factor Ball Bearing Rail	1	1
764636-B21	HP DL360 Gen9 SFF Systems Insight Display Kit	1	1
758959-B22	HP LEGACY FIO MODE SETTING	1	1
764646-B21	HP DL360 Gen9 Rear Serial Port and Enablement Kit	1	1

Table 10: Configuration set 9 with HP DL360 Gen9 v2 2 SFF

Note: Optionally to access to switch console port, a serial cable shall be added.

In addition, for each HP server, 2 power cords shall be ordered according to installation country or Power distribution unit installed in the frame.

For AC, all pre-configured servers with standard AC power supply option kit, ship with one standard 6-foot IEC C-13/C-14 jumper cord per power supply (for HP Gen9: reference A0K02A). If a different power cord is required, please check HP web site

Hardware Installation Guidelines

Customer can perform following adaptations on previous BOM:

- CPU: other CPUs are supported.
Pre-requisite: 8 cores minimum (on 1 or 2 processors)
- Memory: Other memory allocation is supported.
Pre-requisite: 16 GB minimum.
- Disk type and size: other disks are supported
Pre-requisite: 2 disks minimum
all disks shall have same storage capacity
600 GB disk storage capacity (per disk) minimum.

Note that customer changes can affect server and system performances and ability to upgrade in future releases.

Internal disks shall be connected to SAS A.

Documentation on HP servers & storage array is available on HP web site or using Product bulletin tool. It includes server size, weight, BTU, power information.... The HP Product Bulletin is a free application that only takes a few minutes to download. The download site is located at

http://h71069.www7.hp.com/productbulletin/download/hppb_installer.exe

Required HP power for a cabinet can be estimated using HP Power advisor tool available on HP web site:

<http://www8.hp.com/us/en/products/servers/solutions.html?compURI=1439951#.UxSoL7QUdtk>

OS and Performance Intelligence Center management software installation and configuration on HP, are provided in Performance Intelligence Center 10.3 Installation guide available on Oracle Technology Network site. Note that customer shall have Weblogic 12c and Oracle Enterprise Edition 12c and partitioning option licenses, or Oracle Technology Foundation for Monitoring Applications license for this server, before starting the installation.

Hardware Installation Guidelines

9.10 Configuration set 10 (HP DL360 Gen9 v1)

HP DL360 Gen9 v1 is available in AC and DC

HP P/N	Technical description	Qty AC	Qty DC
755258-B21	HP ProLiant DL360 Gen9 8SFF Configure-to-order Server	1	1
755394-L21	E5-2680v3 HP DL360 Gen9 Intel® Xeon® E5-2680v3 (2.5GHz/12-core/30MB/120W) Processor Kit	1	1
755394-B21	E5-2680v3 HP DL360 Gen9 Intel® Xeon® E5-2680v3 (2.5GHz/12-core/30MB/120W) Processor Kit	1	1
726719-B21	HP 16GB (1x16GB) Dual Rank x4 DDR4-2133 CAS-15-15-15 Registered Memory Kit	4	4
785069-B21	HP 900GB 12G SAS 10K rpm SFF (2.5-inch) SC Enterprise 3yr Warranty Hard Drive (Install in Drive Bays 1 and 2)	2	2
749974-B21	HP Smart Array P440ar/2GB FBWC 12Gb 2-ports Int FIO SAS Controller	1	1
720479-B21	HP 800W Flex Slot Platinum Hot Plug Power Supply Kit - AC	2	-
720480-B21	HP 800 W Flex Slot-48VDC Hot Plug Power Supply Kit	-	2
512485-B21	HP iLO Advanced incl 1yr 24x7 Tech Support and Updates Single Server License	1	1
663201-B21	HP 1U Small Form Factor Ball Bearing Rail	1	1
764636-B21	HP DL360 Gen9 SFF Systems Insight Display Kit	1	1
758959-B22	HP LEGACY FIO MODE SETTING	1	1
764646-B21	HP DL360 Gen9 Rear Serial Port and Enablement Kit	1	1

Table 11: Configuration set 10 with HP DL360 Gen9 v1

Note: Optionally to access to switch console port, a serial cable shall be added.

In addition, for each HP server, 2 power cords shall be ordered according to installation country or Power distribution unit installed in the frame.

For AC, all pre-configured servers with standard AC power supply option kit, ship with one standard 6-foot IEC C-13/C-14 jumper cord per power supply (for HP Gen9: reference A0K02A). If a different power cord is required, please check HP web site

Customer can perform following adaptations on previous BOM:

- CPU: other CPUs are supported.
Pre-requisite: 8 cores minimum (on 1 or 2 processors)
- Memory: Other memory allocation is supported.
Pre-requisite: 16 GB minimum.
- Disk type and size: other disks are supported
Pre-requisite: 2 disks minimum
all disks shall have same storage capacity
600 GB disk storage capacity (per disk) minimum.

Note that customer changes can affect server and system performances and ability to upgrade in future releases.

Internal disks shall be connected to SAS A.

Hardware Installation Guidelines

Documentation on HP servers & storage array is available on HP web site or using Product bulletin tool. It includes server size, weight, BTU, power information.... The HP Product Bulletin is a free application that only takes a few minutes to download. The download site is located at

http://h71069.www7.hp.com/productbulletin/download/hppb_installer.exe

Required HP power for a cabinet can be estimated using HP Power advisor tool available on HP web site:

<http://www8.hp.com/us/en/products/servers/solutions.html?compURI=1439951#.UxSoL7QUdtk>

OS and Performance Intelligence Center management software installation and configuration on HP, are provided in Performance Intelligence Center 10.3 Installation guide available on Oracle Technology Network site. Note that customer shall have Weblogic 12c and Oracle Enterprise Edition 12c and partitioning option licenses, or Oracle Technology Foundation for Monitoring Applications license for this server, before starting the installation.

9.11 Configuration set 11 (HP DL360 Gen8 v2)

HP DL360 Gen8 v2 is available in AC only

HP P/N	Technical description	Qty (AC only)
654081-B21	HP ProLiant DL360p Gen8 8 SFF Configure-to-order Server	1
708641-B21	HP 16GB 2Rx4 PC3-14900R-13 Kit	4
652241-B21	HP 9.5mm SATA DVD RW JackBlack Optical Drive	1
684208-B21	HP Ethernet 1Gb 4-port 331FLR FIO Adapter	1
631679-B21	HP 1GB P-series Smart Array Flash Backed Write Cache	1
512485-B21	HP iLO Advanced including 1yr 24x7 Technical Support and Updates Single Server License	1
712506-L21	HP DL360p Gen8 Intel Xeon E5-2680v2 (2.8GHz/10-core/25MB/115W) Processor Kit	1
712506-B21	HP DL360p Gen8 Intel Xeon E5-2680v2 (2.8GHz/10-core/25MB/115W) FIO Processor Kit	1
652583-B21	HP 600GB 6G SAS 10K rpm SFF (2.5-inch) SC Enterprise 3yr Warranty Hard Drive	2
734807-B21	HP 1U Small Form Factor Easy Install Rail Kit	1
656363-B21	HP 750W Common Slot Platinum Plus Hot Plug Power Supply Kit	2

Table 12: Configuration set 11 with HP DL360 Gen8 v2

Note : This BOM is intended for Performance Intelligence Center 10.1.x. For older release of Performance Intelligence Center, please use only 32GB of RAM: 2 x 708641-B21 (HP 16GB 2Rx4 PC3-14900R-13 Kit)

In addition, for each HP server, 2 power cords shall be ordered according to installation country or Power distribution unit installed in the frame.

For AC, all pre-configured servers with standard AC power supply option kit, ship with one standard 6-foot IEC C-13/C-14 jumper cord per power supply (for HP Gen9: reference A0K02A). If a different power cord is required, please check HP web site

Customer can perform following adaptations on previous BOM:

- CPU: other CPUs are supported.

Hardware Installation Guidelines

Pre-requisite: 8 cores minimum (on 1 or 2 processors)

- Memory: Other memory allocation is supported.

Pre-requisite: 16 GB minimum.

- Disk type and size: other disks are supported

Pre-requisite: 2 disks minimum

all disks shall have same storage capacity

600 GB disk storage capacity (per disk) minimum.

Note that customer changes can affect server and system performances and ability to upgrade in future releases.

Internal disks shall be connected to SAS A.

Documentation on HP servers & storage array is available on HP web site or using Product bulletin tool. It includes server size, weight, BTU, power information.... The HP Product Bulletin is a free application that only takes a few minutes to download. The download site is located at

http://h71069.www7.hp.com/productbulletin/download/hppb_installer.exe

Required HP power for a cabinet can be estimated using HP Power advisor tool available on HP web site:

<http://www8.hp.com/us/en/products/servers/solutions.html?compURI=1439951#.UxSoL7QUDtk>

OS and Performance Intelligence Center management software installation and configuration on HP, are provided in Performance Intelligence Center 10.3 Installation guide available on Oracle Technology Network site. Note that customer shall have Weblogic 12c and Oracle Enterprise Edition 12c and partitioning option licenses, or Oracle Technology Foundation for Monitoring Applications license for this server, before starting the installation.

9.12 Configuration set 12 (HP DL360 Gen8 v1)

HP DL360 Gen8 v1 is available in AC only

HP P/N	Technical description	Qty (AC only)
655651-B21	HP DL360p Gen8 4-LFF CTO Server	1
647899-B21	HP 8GB 1Rx4 PC3-12800R-11 Kit	4
652238-B21	HP 9.5mm SATA DVD ROM Jb Kit	1
684208-B21	HP Ethernet 1GbE 4P 331FLR FIO Adptr	1
661069-B21	HP 512MB FWC for P series smart array	1
512485-B21	HP iLO Advanced including 1yr 24x7 Technical Support and Updates Single Server License	1
654768-L21	HP DL360p Gen 8 E52630 FIO kit	1
654768-B21	HP DL360p Gen 8 E52630 kit	1
652620-B21	HP 600GB 6G SAS 15K 3.5in SC ENT HDD	2
663202-B21	HP 1U LFF BB Gen8 Rail Kit	1
503296-B21	HP 460W CS Gold Ht Plg Pwr Supply Kit	2

Table 13: Configuration set 12 with HP DL360 Gen8 v1

In addition, for each HP server, 2 power cords shall be ordered according to installation country or Power distribution unit installed in the frame.

Hardware Installation Guidelines

For AC, all pre-configured servers with standard AC power supply option kit, ship with one standard 6-foot IEC C-13/C-14 jumper cord per power supply (for HP Gen9: reference A0K02A). If a different power cord is required, please check HP web site

Customer can perform following adaptations on previous BOM:

- CPU: other CPUs are supported.
Pre-requisite: 8 cores minimum (on 1 or 2 processors)
- Memory: Other memory allocation is supported.
Pre-requisite: 16 GB minimum.
- Disk type and size: other disks are supported
Pre-requisite: 2 disks minimum
all disks shall have same storage capacity
600 GB disk storage capacity (per disk) minimum.

Note that customer changes can affect server and system performances and ability to upgrade in future releases.

Internal disks shall be connected to SAS A.

Documentation on HP servers & storage array is available on HP web site or using Product bulletin tool. It includes server size, weight, BTU, power information.... The HP Product Bulletin is a free application that only takes a few minutes to download. The download site is located at

http://h71069.www7.hp.com/productbulletin/download/hppb_installer.exe

Required HP power for a cabinet can be estimated using HP Power advisor tool available on HP web site:

<http://www8.hp.com/us/en/products/servers/solutions.html?compURI=1439951#.UxSoL7QUdtk>

OS and Performance Intelligence Center management software installation and configuration on HP, are provided in Performance Intelligence Center 10.3 Installation guide available on Oracle Technology Network site. Note that customer shall have Weblogic 12c and Oracle Enterprise Edition 12c and partitioning option licenses, or Oracle Technology Foundation for Monitoring Applications license for this server, before starting the installation.

Hardware Installation Guidelines

9.13 Configuration set 13 (Oracle ZFS)

ZFS ZS3-2 is available in AC only

Oracle SKU	Technical description	Qty (AC only)
7106195	Oracle ZFS Storage ZS3-2 appliance...	1
7103796	Oracle ZFS Storage ZS3-2: model family...	1
7103829	Oracle ZFS Storage ZS3-2: controller	1
7102984	One 16 GB DDR3-1600 registered DIMM	16
5394A	PCIe filler panel	4
6331A-N	2.5-inch HDD filler panel	4
7103898	Oracle Storage Drive Enclosure DE2-24P: model...	1
7103910	Oracle Storage Drive Enclosure DE2-24P: base chassis	1
7103912	One 900 GB 10000 rpm 2.5 inch SAS-2 HDD with evo bracket	24

Table 14: Configuration set 13 with ZFS

In addition, 2 power cords shall be ordered according to installation country or Power distribution unit installed in the frame. Example for international: Power cord International, 4 meters, IEC309-I... is 333R-40-10-309.

Two additional storage array can be added if more storage capacity is required.

Oracle SKU	Technical description	Qty (AC only)
7103910	Oracle Storage Drive Enclosure DE2-24P: base chassis (for factory installation)	1
7103912	One 900 GB 10000 rpm 2.5 inch SAS-2 HDD with evo bracket (for factory installation)	24

Table 15: Configuration for ZFS additional storage array

Two additional power cords shall be added for each additional storage array.

For server size, weight, BTU, power information... documentation is available at:

http://docs.oracle.com/cd/E56021_01/index.html

The documentation will drive you through the Oracle hardware installation steps and information:

- Hardware Overview
 - Controller Overview
 - Physical Specifications
 - Electrical Specifications
 - Acoustic Noise Emissions
 - Internal Components
 - Motherboard, Memory, and PCIe Cards
 - Optional Cable Management Arm
 - Attached Storage

- ZS3-2 Controller Installation Tasks
- Cabling
- Powering On and Configuring the System
 - Connecting to ILOM
 - Powering On the Appliance
 - Completing Configuration

It is strongly recommended to refer to Performance Intelligence Center 10.3 Installation guide available on Oracle Technology Network site before starting installation of ZFS. More specific details are provided for installation of ZS3-2 ZFS for Performance Intelligence Center PDU storage.

9.14 Configuration set 14 (Oracle X6-2L 14 HDD)

Oracle X6-2L is available in AC only

Oracle SKU	Technical description	Qty (AC only)
7113278	Oracle Server X6-2L: 2 RU base chassis with motherboard, internal 12 Gb SAS RAID HBA, 2 PSUs, slide rail kit, and cable management arm	1
7113239	One Intel® Xeon® E5-2630 v4 10-core 2.2 GHz processor	2
7110351	Heat sink for 2U	2
7113240	One 16 GB DDR4-2400 registered DIMM	4
7113280	Twenty-four 2.5-inch drive slots disk cage and two 2.5-inch drive rear slots disk cage	1
7111107	One 1.2 TB 10000 rpm 2.5-inch SAS-3 HDD with marlin bracket	14
6331A-N	2.5-inch HDD filler panel	12
7110359	DVD filer panel	1
7102748	PCIe filler panel	5

Table 16: Configuration set 14 with Oracle X6-2L with 14 HDD

Warning: an USB flash drive (8GB) will be required for initial installation or disaster recovery

In addition, 2 power cords shall be ordered according to installation country or Power distribution unit installed in the frame.

Customer can perform following adaptations on previous BOM:

- CPU: other CPUs are supported.
Pre-requisite: 10 cores minimum (on 1 or 2 processors)
Note that Ethernet ports Eth03 and Eth04 (NET2 and NET3) are non-functional in single-processor systems.
- Memory: Other memory allocation is supported.
Pre-requisite: 24 GB minimum.
- Disk type and size: other disks are supported
Pre-requisite: 10 disks minimum, 26 disks maximum
all disks shall have same storage capacity

Hardware Installation Guidelines

600 GB disk storage capacity (per disk) minimum.

Note that customer changes can affect server and system performances and ability to upgrade in future releases.

For server size, weight, BTU, power information... documentation is available at http://docs.oracle.com/cd/E62172_01/index.html

The documentation will drive you through the Oracle hardware installation steps and information:

- Hardware Overview
 - Controller Overview
 - Physical Specifications
 - Electrical Specifications
 - Acoustic Noise Emissions
 - Internal Components
 - Motherboard, Memory, and PCIe Cards
 - Optional Cable Management Arm
 - Attached Storage
- Cabling
- Powering On and Configuring the System
 - Connecting to ILOM
 - Powering On the Appliance
 - Completing Configuration

It is strongly recommended to refer to Performance Intelligence Center 10.3 Installation guide available on Oracle Technology Network site before starting installation of X6-2L.

9.15 Configuration set 15 (HP DL380 Gen9 v2)

HP DL380 Gen9 v2 is available in AC and DC

HP P/N	Technical description	Qty AC	Qty DC
767032-B21	HP ProLiant DL380 Gen9 24SFF	1	1
817951-L21	HPE DL380 Gen9 Intel® Xeon® E5-2680v4 (2.4GHz/14-core/35MB/120W) FIO Processor Kit	1	1
817951-B21	HPE DL380 Gen9 Intel® Xeon® E5-2680v4 (2.4GHz/14-core/35MB/120W) Processor Kit	1	1
805349-B21	HP 16GB (1x16GB) Single Rank x4 DDR4-2400 CAS-17-17-17 Registered Memory Kit	4	4
749974-B21	HP Smart Array P440ar/2GB FBWC 12Gb 2-ports Int FIO SAS Controller	1	1
720479-B21	HP 800 W Flex Slot Platinum Hot Plug Power Supply Kit	2	-
720480-B21	HP 800 W Flex Slot-48VDC Hot Plug Power Supply Kit	-	2
512485-B21	HP iLO Advanced including 1yr 24x7 Technical Support and Updates Single Server License	1	1
720863-B21	HP 2U Small Form Factor Ball Bearing Gen8 Rail Kit	1	1
720865-B21	HP 2U Cable Management Arm for Ball Bearing Rail Kit	1	1
768900-B21	HP DL380 Gen9 Systems Insight Display Kit	1	1
758959-B22	HP LEGACY FIO MODE SETTING	1	1
724864-B21	HP DL380 Gen9 2SFF Front/Rear SAS/SATA Kit	1	1
727250-B21	HP 12Gb SAS Expander Card with Cables for DL380 GEN9 (Install in Slot 2)	1	1
785069-B21	HP 900GB 12G SAS 10K rpm SFF (2.5-inch) SC Ent 3yr Warranty Hard Drive	26	26

Table 17: Configuration set 15 with HP DL380 Gen9 v2 24+2 SFF

In addition, for each HP server, 2 power cords shall be ordered according to installation country or Power distribution unit installed in the frame.

For AC, all pre-configured servers with standard AC power supply option kit, ship with one standard 6-foot IEC C-13/C-14 jumper cord per power supply (for HP Gen9: reference A0K02A). If a different power cord is required, please check HP web site

Customer can perform following adaptations on previous BOM:

- CPU: other CPUs are supported.
Pre-requisite: 8 cores minimum (on 1 or 2 processors)
- Memory: Other memory allocation is supported.
Pre-requisite: 24 GB minimum.
- Disk type and size: other disks are supported
Pre-requisite: 10 disks minimum
all disks shall have same storage capacity
600 GB disk storage capacity (per disk) minimum.

Note that customer changes can affect server and system performances and ability to upgrade in future releases.

Internal disks shall be connected to SAS A.

Hardware Installation Guidelines

Documentation on HP servers & storage array is available on HP web site or using Product bulletin tool. It includes server size, weight, BTU, power information.... The HP Product Bulletin is a free application that only takes a few minutes to download. The download site is located at

http://h71069.www7.hp.com/productbulletin/download/hppb_installer.exe

Required HP power for a cabinet can be estimated using HP Power advisor tool available on HP web site:

<http://www8.hp.com/us/en/products/servers/solutions.html?compURI=1439951#UxSoL7QUdtk>

OS and Performance Intelligence Center management software installation and configuration on HP, are provided in Performance Intelligence Center 10.3 Installation guide available on Oracle Technology Network site. Note that customer shall have Weblogic 12c and Oracle Enterprise Edition 12c and partitioning option licenses, or Oracle Technology Foundation for Monitoring Applications license for this server, before starting the installation.

9.16 Configuration set 16 (HP DL380 Gen9 v1)

HP DL380 Gen9 v1 is available in AC and DC

HP P/N	Technical description	Qty AC	Qty DC
767032-B21	HP ProLiant DL380 Gen9 24SFF Configure-to-order Server	1	1
762766-L21	HP DL380 Gen9 Intel® Xeon® E5-2680v3 (2.5GHz/12-core/30MB/120W) FIO Processor Kit	1	1
762766-B21	HP DL380 Gen9 Intel® Xeon® E5-2680v3 (2.5GHz/12-core/30MB/120W) FIO Processor	1	1
726719-B21	HP 16GB (1x16GB) Dual Rank x4 DDR4-2133 CAS-15-15-15 Reg Memory Kit	4	4
749974-B21	HP Smart Array P440ar/2GB FBWC 12Gb 2-ports Int FIO SAS Controller	1	1
720479-B21	HP 800 W Flex Slot Platinum Hot Plug Power Supply Kit	2	-
720480-B21	HP 800 W Flex Slot-48VDC Hot Plug Power Supply Kit	-	2
512485-B21	HP iLO Advanced including 1yr 24x7 Technical Support and Updates Single Server License	1	1
720863-B21	HP 2U Small Form Factor Ball Bearing Gen8 Rail Kit with CMA	1	1
720865-B21	HP 2U Cable Management Arm for Ball Bearing Rail Kit	1	1
768900-B21	HP DL380 Gen9 Systems Insight Display Kit	1	1
758959-B22	HP LEGACY FIO MODE SETTING	1	1
724864-B21	HP DL380 Gen9 2SFF Front/Rear SAS/SATA Kit	1	1
727250-B21	HP 12Gb SAS Expander Card with Cables for DL380 Gen9 (Install in Slot 2)	1	1
785069-B21	HP 900GB 12G SAS 10K rpm SFF (2.5-inch) SC Ent 3yr Warranty Hard Drive	26	26

Table 18: Configuration set 16 with HP DL380 Gen9 v1 24+2 SFF

In addition, for each HP server, 2 power cords shall be ordered according to installation country or Power distribution unit installed in the frame.

For AC, all pre-configured servers with standard AC power supply option kit, ship with one standard 6-foot IEC C-13/C-14 jumper cord per power supply (for HP Gen9: reference A0K02A). If a different power cord is required, please check HP web site

Customer can perform following adaptations on previous BOM:

- CPU: other CPUs are supported.
Pre-requisite: 8 cores minimum (on 1 or 2 processors)
- Memory: Other memory allocation is supported.
Pre-requisite: 24 GB minimum.
- Disk type and size: other disks are support
Pre-requisite: 10 disks minimum
all disks shall have same storage capacity
600 GB disk storage capacity (per disk) minimum.

Hardware Installation Guidelines

- Server Disk type and size: other disks are supported
Pre-requisite: 2 disks minimum
both disks shall have same storage capacity
600 GB disk storage capacity (per disk) minimum.

Note that customer changes can affect server and system performances and ability to upgrade in future releases.

Internal disks shall be connected to SAS A.

Documentation on HP servers & storage array is available on HP web site or using Product bulletin tool. It includes server size, weight, BTU, power information.... The HP Product Bulletin is a free application that only takes a few minutes to download. The download site is located at

http://h71069.www7.hp.com/productbulletin/download/hppb_installer.exe

Required HP power for a cabinet can be estimated using HP Power advisor tool available on HP web site:

<http://www8.hp.com/us/en/products/servers/solutions.html?compURI=1439951#.UxSoL7QUDtk>

OS and Performance Intelligence Center management software installation and configuration on HP, are provided in Performance Intelligence Center 10.3 Installation guide available on Oracle Technology Network site. Note that customer shall have Weblogic 12c and Oracle Enterprise Edition 12c and partitioning option licenses, or Oracle Technology Foundation for Monitoring Applications license for this server, before starting the installation.

9.17 Configuration set 17 (Oracle Database Appliance)

ODA X5-2 is available in AC only

Oracle SKU	Technical description	Qty (AC only)
7110250	Oracle Database Appliance X5-2: model family...	1
7110252	Oracle Database Appliance X5-2	1

Table 19: Configuration set 17 with ODA

In addition, 6 power cords shall be ordered according to installation country or Power Distribution Unit installed in the frame.

An additional storage enclosure extension can be added to the ODA to obtain more disk capacity:

Oracle SKU	Technical description	Qty (AC only)
7110281	Oracle Database Appliance X5-2 Storage Expansion	1

Table 20: Configuration for additional storage enclosure with ODA

Two additional power cords shall be ordered for the extension.

For server size, weight, BTU, power information.... documentation is available at http://docs.oracle.com/cd/E22693_01/index.htm

Please refer to documentation for initial installation of the server. This document will drive you through the initial installation steps:

- Attaching Supplied Cables
- Attaching Storage Expansion Shelf
- Attaching Peripheral Devices
- Booting Up the First Time
- Configuring Oracle Integrated Lights Out Manager.
- Configuring Initial Network Connection
- Validating Oracle Appliance Manager Software Version

It is strongly recommended to refer to Performance Intelligence Center 10.3 Installation guide available on Oracle Technology Network site before starting installation. For Oracle Database appliance, refer to the specific section for ODA configuration.

Hardware Installation Guidelines

9.18 Configuration set 18 (Oracle E5-APP-B)

E5-APP-B is an Eagle card directly installed inside a heavy duty Eagle frame.

E5-APP-B installation may include

- Provisioning of the Eagle card and installation in the Eagle frame
- Provisioning of the Terminal server (if not present) and installation in the Eagle frame
- Provisioning of the switches (one or 2 switches) and installation in the Eagle frame
- Connection of the E5-APP-B cards, to the terminal server and the switch(es)
- Connection of the Fast copy card (if option selected) to the switch(es)
- Connection of the switch console port to Terminal server
- Connection of the Terminal server to the customer network (1 port RJ45 Ethernet 1000Base-TX)
- Connection of the switch(es) in the Eagle frame to the customer network (1 port RJ45 Ethernet 1000Base-TX per switch)

E5-APP-B documentation can be found at https://docs.oracle.com/cd/E58681_01/docs.461/E58719_rev_2.pdf

9.19 Configuration set 19 (Oracle X6-2)

Oracle X6-2 is available in AC only

There are 2 options for traffic acquisition:

- One for acquisition of 1G/10G traffic on RJ45 copper links
- One for acquisition of 1G/10G traffic on optical fiber links

No mix is allowed.

This affect only the acquisition ports, not the management and network (to mediation) ports.

With 1G/10 RJ45 copper acquisition interfaces:

Oracle SKU	Technical description	Qty (AC only)
7113252	Oracle Server X6-2: 1 RU base chassis with motherboard, internal 12 Gb SAS RAID HBA, 2 PSUs, slide rail kit, and cable management arm	1
7113237	One Intel® Xeon® E5-2690 v4 14-core 2.6 GHz processor	2
7110350	Heat sink for 1U	2
7113240	One 16 GB DDR4-2400 registered DIMM	4
7110339	Eight 2.5 inch drive slots, 1 DVD-RW drive slot and disk cage for 1U	1
7111107	One 1.2 TB 10000 rpm 2.5-inch SAS-3 HDD with marlin bracket	2
7110359	DVD filer panel	1
7102748	PCIe filler panel	1
7100563	Sun Dual Port 10GBase-T Adapter (for factory installation)	2
6331A-N	2.5-inch HDD filler panel	6

Table 21: configuration set 19 with Oracle X6-2 copper RJ45 interfaces

With 1G/10 fiber SFP+ acquisition interfaces:

Oracle SKU	Technical description	Qty (AC only)
7113252	Oracle Server X6-2: 1 RU base chassis with motherboard, internal 12 Gb SAS RAID HBA, 2 PSUs, slide rail kit, and cable management arm	1
7113237	One Intel® Xeon® E5-2690 v4 14-core 2.6 GHz processor	2
7110350	Heat sink for 1U	2
7113240	One 16 GB DDR4-2400 registered DIMM	4
7110339	Eight 2.5 inch drive slots, 1 DVD-RW drive slot and disk cage for 1U	1
7111107	One 1.2 TB 10000 rpm 2.5-inch SAS-3 HDD with marlin bracket	2
7110359	DVD filer panel	1
7102748	PCIe filler panel	1
1109A-Z	ASSY,2X10GbE SFP+,X8PCIe 2.0,LP,Lead Free (Niantic)	2
6331A-N	2.5-inch HDD filler panel	6

Table 22: configuration set 19 with Oracle X6-2 SFP+ interfaces

In addition, SPF(+) modules according to network type shall be ordered.

Each acquisition card has 2 SPF(+) slots. 2 cards per server.

Total: 4 SFP+ acquisition ports for the server.

Warning: an USB flash drive (8GB) will be required for initial installation or disaster recovery

In addition, 2 power cords shall be ordered according to installation country or Power distribution unit installed in the frame.

Hardware Installation Guidelines

Customer can perform following adaptations on previous BOMs:

- CPU: other CPUs are supported.
Pre-requisite: 8 cores minimum (on 1 or 2 processors)
- Memory: Other memory allocation is supported.
Pre-requisite: 16 GB minimum.
- Disk type and size: other disks are supported
Pre-requisite: 2 disks minimum
all disks shall have same storage capacity
600 GB disk storage capacity (per disk) minimum.

Note that customer changes can affect server and system performances and ability to upgrade in future releases.

For server size, weight, BTU, power information.... Documentations are available at http://docs.oracle.com/cd/E62159_01/

Please refer to Setup and Installation section for Oracle hardware installation. This document will drive you through the initial installation steps:

- Server installation in the rack.
- Attaching network and power Cables
- Booting Up the First Time
- Launching Oracle System Assistant to configure:
 - Server's network connection
 - Install latest server firmware
 - Configure Oracle ILOM and BIOS,
 - Configure hardware

OS and Performance Intelligence Center software installation on Oracle hardware server are provided in Performance Intelligence Center 10.3.0 Installation guide available on Oracle Technology Network site.

9.20 Configuration set 20 (Oracle X5-2)

Oracle X5-2 is available in AC only.

There are 2 options for traffic acquisition:

- One for acquisition of 1G/10G traffic on RJ45 copper links
- One for acquisition of 1G/10G traffic on optical fiber links

No mix is allowed.

This affect only the acquisition ports, not the management and network (to mediation) ports.

With 1G/10 RJ45 copper acquisition interfaces:

Oracle SKU	Technical description	Qty (AC only)
7112843	ATO,BASE,CONFIG,1U	1
7110339	XATO,DISK_CAGE,2.5" X 8HDD	1
7110346	ATO,E5-2699 V3,2.3G,145W,18 CORE,C-1 (SR1XD),CPU	2
7110350	XATO,HEATSINK,CPU,1U	2
7110360	XATO,OSA 8 GB MLC USB FLASH DRIVE	1
7110359	ATO,DVD,GEN5,BLANK FILLER PANEL,1U/2U	1
7102748	ATO PCIe FILLER,VENTED,LOW PROFILE	1
6331A-N	ASSY,HDD,MARLIN-FILLER PANEL	6
7110353	XATO,DIMM,16GB,DDR4,2133	8
7111107	1.2 TB 10000 rpm 2.5-inch SAS-3 HDD with marlin bracket (for factory installation)	2
7100563	Sun Dual Port 10GBase-T Adapter (for factory installation)	2

Table 23: configuration set 20 with Oracle X5-2 copper RJ45 interfaces

With 1G/10 fiber SFP+ acquisition interfaces:

Oracle SKU	Technical description	Qty (AC only)
7112843	Oracle Server X5-2 for Communications: 1 RU base chassis with motherboard,	1
7110339	XATO,DISK_CAGE,2.5" X 8HDD	1
7110346	ATO,E5-2699 V3,2.3G,145W,18 CORE,C-1 (SR1XD),CPU	2
7110350	XATO,HEATSINK,CPU,1U	2
7110360	XATO,OSA 8 GB MLC USB FLASH DRIVE	1
7110359	ATO,DVD,GEN5,BLANK FILLER PANEL,1U/2U	1
7102748	ATO PCIe FILLER,VENTED,LOW PROFILE	1
6331A-N	ASSY,HDD,MARLIN-FILLER PANEL	6
7110353	XATO,DIMM,16GB,DDR4,2133	8
7111107	1.2 TB 10000 rpm 2.5-inch SAS-3 HDD with marlin bracket (for factory installation)	2
1109A-Z	ASSY,2X10GbE SFP+,X8PCIe 2.0,LP,Lead Free (Niantic)	2

Table 24: configuration set 20 with Oracle X5-2 SFP+ interfaces

In addition, SPF(+) modules according to network type shall be ordered.

Each acquisition card has 2 SPF(+) slots. 2 cards per server.

Total: 4 SFP+ acquisition ports for the server.

Hardware Installation Guidelines

In addition, 2 power cords shall be ordered according to installation country or Power distribution unit installed in the frame.

Customer can perform following adaptations on previous BOMs:

- CPU: other CPUs are supported.
Pre-requisite: 8 cores minimum (on 1 or 2 processors)
- Memory: Other memory allocation is supported.
Pre-requisite: 16 GB minimum.
- Disk type and size: other disks are supported
Pre-requisite: 2 disks minimum
all disks shall have same storage capacity
600 GB disk storage capacity (per disk) minimum.

Note that customer changes can affect server and system performances and ability to upgrade in future releases.

For server size, weight, BTU, power information.... Documentations are available at http://docs.oracle.com/cd/E41059_01/

Please refer to Setup and Installation section for Oracle hardware installation. This document will drive you through the initial installation steps:

- Server installation in the rack.
- Attaching network and power Cables
- Booting Up the First Time
- Launching Oracle System Assistant to configure:
 - Server's network connection
 - Install latest server firmware
 - Configure Oracle ILOM and BIOS,
 - Configure hardware

OS and Performance Intelligence Center software installation on Oracle hardware server are provided in Performance Intelligence Center 10.3 Installation guide available on Oracle Technology Network site.

9.21 Configuration set 21 (Oracle Netra X5-2)

Oracle Netra X5-2 is available in AC and DC. It is NEBS compliant. There are 2 options for traffic acquisition:

- One for acquisition of 1G/10G traffic on RJ45 copper links
- One for acquisition of 1G/10G traffic on optical fiber links

No mix is allowed.

This affect only the acquisition ports, not the management and network (to mediation) ports.

With 1G/10 RJ45 copper acquisition interfaces:

Oracle SKU	Technical description	Qty DC	Qty AC
7111082	Netra Server X5-2: 2 RU AC base chassis with motherboard and 8 HDDs	-	1
7111083	Netra Server X5-2: 2 RU DC base chassis with motherboard and 8 HDDs	1	-
7110346	Intel® Xeon® E5-2699 v3 18-core 2.3 GHz processor	2	2
7102981	Heat sink	2	2
7111036	One 16 GB DDR4-2133 DIMM	8	8
7111043	Memory filler panels	16	16
7111107	One 1.2 TB 10000 rpm 2.5-inch SAS-3 HDD with marlin bracket	2	2
6331A-N	2.5-inch HDD filler panel	6	6
7100563	Sun Dual Port 10GBase-T Adapter	2	2
7110116	Oracle Storage 12 Gb SAS PCIe RAID HBA, internal: 8 port and 1 GB memory	1	1
5394A	PCIe filler panel	3	3
7901A-4	19-inch 2-post rackmount kit	1	1
7111044	SAS cable kit	1	1
7111052	OSA 8 GB USB stick	1	1

Table 25: configuration set 21 with Oracle Netra X5-2 copper RJ45 interfaces

Each acquisition card has 2 RJ5 ports each. 2 cards per server.
Total: 4 acquisition ports for the server.

With 1G/10 fiber SFP+ acquisition interfaces:

Oracle SKU	Technical description	Qty DC	Qty AC
7111082	Netra Server X5-2: 2 RU AC base chassis with motherboard and 8 HDDs	-	1
7111083	Netra Server X5-2: 2 RU DC base chassis with motherboard and 8 HDDs	1	-
7111083	Netra Server X5-2: 2 RU DC base chassis with motherboard	1	1
7110346	Intel® Xeon® E5-2699 v3 18-core 2.3 GHz processor	2	2
7102981	Heat sink	2	2
7111036	One 16 GB DDR4-2133 DIMM	8	8
7111043	Memory filler panels	16	16

Hardware Installation Guidelines

7111107	One 1.2 TB 10000 rpm 2.5-inch SAS-3 HDD with marlin bracket	2	2
6331A-N	2.5-inch HDD filler panel	6	6
1109A-Z	Sun Dual 10GbE SFP+ PCIe Low Profile Adapter	2	2
7110116	Oracle Storage 12 Gb SAS PCIe RAID HBA, internal: 8 port and 1 GB memory	1	1
5394A	PCIe filler panel	3	3
7901A-4	19-inch 2-post rackmount kit	1	1
7111044	SAS cable kit	1	1
7111052	OSA 8 GB USB stick	1	1

Table 26: configuration set 21 with Oracle Netra X5-2 SFP+ interfaces

In addition, SPF(+) modules according to network type shall be ordered.
 Each acquisition card has 2 SPF(+) slots . 2 cards per server.
 Total: 4 SFP+ acquisition ports for the server.

In addition, 2 power cords shall be ordered according to installation country or Power distribution unit installed in the frame.

Customer can perform following adaptations on previous BOMs:

- CPU: other CPUs are supported.
Pre-requisite: 8 cores minimum (on 1 or 2 processors)
- Memory: Other memory allocation is supported.
Pre-requisite: 16 GB minimum.
- Disk type and size: other disks are supported
Pre-requisite: 2 disks minimum
all disks shall have same storage capacity
600 GB disk storage capacity (per disk) minimum.

Note that customer changes can affect server and system performances and ability to upgrade in future releases.

For server size, weight, BTU, power information.... Documentations are available at http://docs.oracle.com/cd/E53596_01/

Please refer to Setup and Installation section for Oracle hardware installation. This document will drive you through the initial installation steps:

- Server installation in the rack.
- Attaching network and power Cables
- Booting Up the First Time
- Launching Oracle System Assistant to configure:
 - Server's network connection
 - Install latest server firmware
 - Configure Oracle ILOM and BIOS,
 - Configure hardware

OS and Performance Intelligence Center software installation on Oracle hardware server are provided in Performance Intelligence Center 10.3 Installation guide available on Oracle Technology Network site.

9.22 Configuration set 22 (HP DL360 Gen9 v2)

HP DL360 Gen9 v2 is available in AC and DC
 HP Gen9 v2 has 4 SFP+ ports which can be used for 1G/10G on

- RJ45 copper links
- and optical fiber links

Mix is allowed.

HP P/N	Technical description	Qty AC	Qty DC
755258-B21	HP ProLiant DL360 Gen9 8SFF Configure-to-order Server	1	1
818184-B21	HPE DL360 Gen9 Intel® Xeon® E5-2680v4 (2.4GHz/14-core/35MB/120W) Processor Kit	1	1
818184-L21	HPE DL360 Gen9 Intel® Xeon® E5-2680v4 (2.4GHz/14-core/35MB/120W) FIO Processor Kit	1	1
805349-B21	HP 16GB (1x16GB) Single Rank x4 DDR4-2400 CAS-17-17-17 Registered Memory Kit	4	4
785069-B21	HP 900GB 12G SAS 10K rpm SFF (2.5-inch) SC Enterprise 3yr Warranty Hard Drive (Install in Drive Bays 1 and 2)	2	2
629135-B22	HP Ethernet 1Gb 4-port 331FLR Adapter (Flex LOM)	1	1
749974-B21	HP Smart Array P440ar/2GB FBWC 12Gb 2-ports Int FIO SAS Controller	1	1
720479-B21	HP 800W Flex Slot Platinum Hot Plug Power Supply Kit - AC	2	-
720480-B21	HP 800 W Flex Slot-48VDC Hot Plug Power Supply Kit	-	2
512485-B21	HP iLO Advanced incl 1yr 24x7 Tech Support and Updates Single Server License	1	1
663201-B21	HP 1U Small Form Factor Ball Bearing Rail	1	1
764636-B21	HP DL360 Gen9 SFF Systems Insight Display Kit	1	1
758959-B22	HP LEGACY FIO MODE SETTING	1	1
665249-B21	HP Ethernet 10Gb Dual Port 560SFP+ Adapter (Install cards in Slot 1 and slot 2)	2	2

Table 27: configuration set 22 with HP Gen9 v2 with SFP+ card

Note : HP Ethernet 1Gb 4-port 331FLR Adapter (Flex LOM) P/N 629135-B22 is not used in Performance Intelligence Center 10.3 but is planned for future use.

In addition, SPF(+) modules according to network type shall be ordered.
 Each acquisition card has 2 SPF(+) slots . 2 cards per server.
 Total: 4 SFP+ acquisition ports for the server.

In addition, for each HP server, 2 power cords shall be ordered according to installation country or Power distribution unit installed in the frame.
 For AC, all pre-configured servers with standard AC power supply option kit, ship with one standard 6-foot IEC C-13/C-14 jumper cord per power supply (for HP Gen9: reference A0K02A). If a different power cord is required, please check HP web site

Customer can perform following adaptations on previous BOM:

- CPU: other CPU is supported.
 Pre-requisite: 8 cores minimum. (on 1 or 2 processors)

Hardware Installation Guidelines

- Memory: Other memory allocation is supported.
Pre-requisite: 16 GB minimum.
- Disk type and size: other disks are supported
Pre-requisite: 2 disks minimum
all disks shall have same storage capacity
600 GB disk storage capacity (per disk) minimum

Customer changes can affect server and system performances and ability to upgrade in future releases.

Internal disks shall be connected to SAS A.

Documentation on HP servers & storage array is available on HP web site or using Product bulletin tool. It includes server size, weight, BTU, power information.... The HP Product Bulletin is a free application that only takes a few minutes to download. The download site is located at

http://h71069.www7.hp.com/productbulletin/download/hppb_installer.exe

Required HP power for a cabinet can be estimated using HP Power advisor tool available on HP web site:

<http://www8.hp.com/us/en/products/servers/solutions.html?compURI=1439951#.UxSoL7QUdtk>

OS and Performance Intelligence Center management software installation and configuration on HP, are provided in Performance Intelligence Center 10.3 Installation guide available on Oracle Technology Network site. Note that customer shall have Weblogic 12c and Oracle Enterprise Edition 12c and partitioning option licenses, or Oracle Technology Foundation for Monitoring Applications license for this server, before starting the installation.

9.23 Configuration set 23 (HP DL360 Gen9 v1)

HP DL360 Gen9 v1 is available in AC and DC
 HP Gen9 v1 has 4 SFP+ ports which can be used for 1G/10G on

- RJ45 copper links
- and optical fiber links

Mix is allowed.

HP P/N	Technical description	Qty DC	Qty AC
755258-B21	HP ProLiant DL360 Gen9 8SFF Configure-to-order Server	1	1
755394-L21	E5-2680v3 HP DL360 Gen9 Intel® Xeon® E5-2680v3 (2.5GHz/12-core/30MB/120W) Processor Kit	1	1
755394-B21	E5-2680v3 HP DL360 Gen9 Intel® Xeon® E5-2680v3 (2.5GHz/12-core/30MB/120W) Processor Kit	1	1
726719-B21	HP 16GB (1x16GB) Dual Rank x4 DDR4-2133 CAS-15-15-15 Registered Memory Kit	4	4
785069-B21	HP 900GB 12G SAS 10K rpm SFF (2.5-inch) SC Enterprise 3yr Warranty Hard Drive (Install in Drive Bays 1 and 2)	2	2
629135-B22	HP Ethernet 1Gb 4-port 331FLR Adapter (Flex LOM)	1	1
749974-B21	HP Smart Array P440ar/2GB FBWC 12Gb 2-ports Int FIO SAS Controller	1	1
720479-B21	HP 800W Flex Slot Platinum Hot Plug Power Supply Kit - AC	-	2
720480-B21	HP 800 W Flex Slot-48VDC Hot Plug Power Supply Kit	2	-
512485-B21	HP iLO Advanced incl 1yr 24x7 Tech Support and Updates Single Server License	1	1
663201-B21	HP 1U Small Form Factor Ball Bearing Rail Kit	1	1
764636-B21	HP DL360 Gen9 SFF Systems Insight Display Kit	1	1
758959-B22	HP LEGACY FIO MODE SETTING	1	1
665249-B21	HP Ethernet 10Gb Dual Port 560SFP+ Adapter (Install cards in Slot 1 and slot 2)	2	2

Table additional storage enclosure: configuration set 23 with HP Gen9 v1 with SFP+ card

Note : HP Ethernet 1Gb 4-port 331FLR Adapter (Flex LOM) P/N 629135-B22 is not used in Performance Intelligence Center 10.3 but is planned for future use.

In addition, SPF(+) modules according to network type shall be ordered.
 Each acquisition card has 2 SPF(+) slots . 2 cards per server.
 Total: 4 SFP+ acquisition ports for the server.

In addition, for each HP server, 2 power cords shall be ordered according to installation country or Power distribution unit installed in the frame.
 For AC, all pre-configured servers with standard AC power supply option kit, ship with one standard 6-foot IEC C-13/C-14 jumper cord per power supply (for HP Gen9: reference A0K02A). If a different power cord is required, please check HP web site

Hardware Installation Guidelines

Customer can perform following adaptations on previous BOMs:

- CPU: other CPU is supported.
Pre-requisite: 8 cores minimum. (on 1 or 2 processors)
- Memory: Other memory allocation is supported.
Pre-requisite: 16 GB minimum.
- Disk type and size: other disks are supported
Pre-requisite: 2 disks minimum
all disks shall have same storage capacity
600 GB disk storage capacity (per disk) minimum

Customer changes can affect server and system performances and ability to upgrade in future releases.

Internal disks shall be connected to SAS A.

Documentation on HP servers & storage array is available on HP web site or using Product bulletin tool. It includes server size, weight, BTU, power information.... The HP Product Bulletin is a free application that only takes a few minutes to download. The download site is located at

http://h71069.www7.hp.com/productbulletin/download/hppb_installer.exe

Required HP power for a cabinet can be estimated using HP Power advisor tool available on HP web site:

<http://www8.hp.com/us/en/products/servers/solutions.html?compURI=1439951#.UxSoL7QUdtk>

OS and Performance Intelligence Center management software installation and configuration on HP, are provided in Performance Intelligence Center 10.3 Installation guide available on Oracle Technology Network site. Note that customer shall have Weblogic 12c and Oracle Enterprise Edition 12c and partitioning option licenses, or Oracle Technology Foundation for Monitoring Applications license for this server, before starting the installation.

9.24 Configuration set 24 (HP DL360 Gen8 v2)

HP DL360 Gen8 v2 is available in AC and DC
 HP Gen8 v2 has 4 SFP+ ports which can be used for 1G/10G on

- RJ45 copper links
- and optical fiber links

Mix is allowed.

HP P/N	Technical description	Qty DC	Qty AC
654081-B21	HP ProLiant DL360p Gen8 8 SFF Configure-to-order Server	1	1
708641-B21	HP 16GB 2Rx4 PC3-14900R-13 Kit	4	4
652241-B21	HP 9.5mm SATA DVD RW JackBlack Optical Drive	1	1
684208-B21	HP Ethernet 1Gb 4-port 331FLR FIO Adapter	1	1
631679-B21	HP 1GB P-series Smart Array Flash Backed Write Cache	1	1
512485-B21	HP iLO Advanced including 1yr 24x7 Technical Support and Updates Single Server License	1	1
712506-L21	HP DL360p Gen8 Intel Xeon E5-2680v2 (2.8GHz/10-core/25MB/115W) Processor Kit	1	1
712506-B21	HP DL360p Gen8 Intel Xeon E5-2680v2 (2.8GHz/10-core/25MB/115W) FIO Processor Kit	1	1
652583-B21	HP 600GB 6G SAS 10K rpm SFF (2.5-inch) SC Enterprise 3yr Warranty Hard Drive	2	2
734807-B21	HP 1U Small Form Factor Easy Install Rail Kit	1	1
656363-B21	HP 750W Common Slot Platinum Plus Hot Plug Power Supply Kit	-	2
636673-B21	HP 750W Common Slot -48VDC Hot Plug Power Supply Kit	2	-
665249-B21	HP Ethernet 10Gb 2-port 560SFP+ Adapter	2	2

Table 28: configuration set 24 with HP Gen8 v2 with SFP+ card

Note : This BOM is intended for Performance Intelligence Center 10.1.x. For older release of Performance Intelligence Center, please use only 32GB of RAM: 2 x 708641-B21 (HP 16GB 2Rx4 PC3-14900R-13 Kit)

In addition, SPF(+) modules according to network type shall be ordered.
 Each acquisition card has 2 SPF(+) slots . 2 cards per server.
 Total: 4 SFP+ acquisition ports for the server.

In addition, for each HP server, 2 power cords shall be ordered according to installation country or Power distribution unit installed in the frame.
 For AC, all pre-configured servers with standard AC power supply option kit, ship with one standard 6-foot IEC C-13/C-14 jumper cord per power supply (for HP Gen9: reference A0K02A). If a different power cord is required, please check HP web site

Customer can perform following adaptations on previous BOMs:

- CPU: other CPU is supported.
 Pre-requisite: 8 cores minimum. (on 1 or 2 processors)

Hardware Installation Guidelines

- Memory: Other memory allocation is supported.
Pre-requisite: 16 GB minimum.
- Disk type and size: other disks are supported
Pre-requisite: 2 disks minimum
all disks shall have same storage capacity
600 GB disk storage capacity (per disk) minimum

Customer changes can affect server and system performances and ability to upgrade in future releases.

Internal disks shall be connected to SAS A.

Documentation on HP servers & storage array is available on HP web site or using Product bulletin tool. It includes server size, weight, BTU, power information.... The HP Product Bulletin is a free application that only takes a few minutes to download. The download site is located at

http://h71069.www7.hp.com/productbulletin/download/hppb_installer.exe

Required HP power for a cabinet can be estimated using HP Power advisor tool available on HP web site:

<http://www8.hp.com/us/en/products/servers/solutions.html?compURI=1439951#.UxSoL7QUDtk>

OS and Performance Intelligence Center management software installation and configuration on HP, are provided in Performance Intelligence Center 10.3 Installation guide available on Oracle Technology Network site. Note that customer shall have Weblogic 12c and Oracle Enterprise Edition 12c and partitioning option licenses, or Oracle Technology Foundation for Monitoring Applications license for this server, before starting the installation.

9.25 Configuration set 25 (HP DL360 Gen8 v1)

HP DL360 Gen8 v1 is available in AC and DC.

There are 3 options for traffic acquisition:

- One for acquisition of 1G/10G traffic on SFP+ interfaces (for copper and fiber links)
- One for NEBS acquisition of 1G traffic on copper links
- One for acquisition of 1G traffic on copper links

With 1G/10G copper or fiber SFP+ acquisition interfaces (NEBS version):

HP P/N	Technical description	Qty DC	Qty AC
655651-B21	HP DL360p Gen8 4-LFF CTO Server	1	1
647899-B21	HP 8GB 1Rx4 PC3-12800R-11 Kit	4	4
652238-B21	HP 9.5mm SATA DVD ROM Jb Kit	1	1
684208-B21	HP Ethernet 1GbE 4P 331FLR FIO Adptr	1	1
661069-B21	HP 512MB FWC for P series smart array	1	1
512485-B21	HP iLO Advanced including 1yr 24x7 Technical Support and Updates Single Server License	1	1
654786-L21	HP DL360p Gen8 E5-2670 FIO Kit	1	1
654786-B21	HP DL360p Gen8 E5-2670 Kit	1	1
652620-B21	HP 600GB 6G SAS 15K 3.5in SC ENT HDD	2	2
663202-B21	HP 1U LFF BB Gen8 Rail Kit	1	1
503296-B21	HP 460W CS Gold Ht Plg Pwr Supply Kit	-	2
636673-B21	HP 750W-48V DC Common Slot Power Supply	2	-
C3N52AA (Intel E10G42BTDA)	HP X520 10GbE Dual Port Adapter	2	2

Table 29: configuration set 25 with HP Gen8 v1 with SFP+ card

Note: This Configuration is NEBS compliant.

This configuration has 4 SFP+ ports which can be used for 1G/10G on

- RJ45 copper links
- and optical fiber links

Mix is allowed.

In addition, SPF(+) modules according to network type shall be ordered.

Each acquisition card has 2 SPF(+) slots . 2 cards per server.

Total: 4 SFP+ acquisition ports for the server.

With 1G copper acquisition interfaces (NEBS):

HP P/N	Technical description	Qty DC	Qty AC
654081-B21	HP DL360p Gen8 8-SFF CTO Server	1	1
647899-B21	HP 8GB 1Rx4 PC3-12800R-11 Kit	4	4
652241-B21	HP 9.5mm SATA DVD RW JackBlack Optical Drive	1	1

Hardware Installation Guidelines

684208-B21	HP Ethernet 1GbE 4P 331FLR FIO Adptr	1	1
661069-B21	HP 512MB FWC for P series smart array	1	1
512485-B21	HP iLO Advanced including 1yr 24x7 Technical Support and Updates Single Server License	1	1
654786-L21	HP DL360p Gen8 E5-2670 FIO Kit	1	1
654786-B21	HP DL360p Gen8 E5-2670 Kit	1	1
652583-B21	HP 600GB 6G SAS 10K 2.5in SC ENT HDD	2	2
663201-B21	HP 1U SFF BB Gen8 Rail Kit	1	1
656363-B21	HP 750W CS Plat PL Ht Plg Pwr Supply Kit	-	2
636673-B21	HP 750W-48V DC Common Slot Power Supply	2	-
647594-B21	HP Ethernet 1Gb 4-port 331T	2	2

Table 30: configuration set 25 with HP Gen8 v1 with 1G RJ45 card (NEBS)

Note: This configuration has 8 RJ45 acquisition 1G Ethernet ports

With 1G copper acquisition interfaces (non NEBS):

HP P/N	Technical description	Qty DC	Qty AC
655651-B21	HP DL360p Gen8 4-LFF CTO Server	1	1
647899-B21	HP 8GB 1Rx4 PC3-12800R-11 Kit	4	4
652238-B21	HP 9.5mm SATA DVD ROM Jb Kit	1	1
684208-B21	HP Ethernet 1GbE 4P 331FLR FIO Adptr	1	1
661069-B21	HP 512MB FWC for P series smart array	1	1
512485-B21	HP iLO Advanced including 1yr 24x7 Technical Support and Updates Single Server License	1	1
654786-L21	HP DL360p Gen8 E5-2670 FIO Kit	1	1
654786-B21	HP DL360p Gen8 E5-2670 Kit	1	1
652620-B21	HP 600GB 6G SAS 15K 3.5in SC ENT HDD	2	2
663202-B21	HP 1U LFF BB Gen8 Rail Kit	1	1
503296-B21	HP 460W CS Gold Ht Plg Pwr Supply Kit	-	2
636673-B21	HP 750W-48V DC Common Slot Power Supply	2	-
593722-B21	HP NC365T 4-port Ethernet Server Adapter	2	2

Table 31: configuration set 25 with HP Gen8 v1 with 1G RJ45 card (non NEBS)

Note: This configuration has 8 RJ45 acquisition 1G Ethernet ports

In addition, for each HP server, 2 power cords shall be ordered according to installation country or Power distribution unit installed in the frame.

For AC, all pre-configured servers with standard AC power supply option kit, ship with one standard 6-foot IEC C-13/C-14 jumper cord per power supply (for HP Gen9: reference A0K02A). If a different power cord is required, please check HP web site

Customer can perform following adaptations on previous BOMs:

Hardware Installation Guidelines

- CPU: other CPU is supported.
Pre-requisite: 8 cores minimum. (on 1 or 2 processors)
- Memory: Other memory allocation is supported.
Pre-requisite: 16 GB minimum.
- Disk type and size: other disks are supported
Pre-requisite: 2 disks minimum
all disks shall have same storage capacity
600 GB disk storage capacity (per disk) minimum

Customer changes can affect server and system performances and ability to upgrade in future releases.

Internal disks shall be connected to SAS A.

Documentation on HP servers & storage array is available on HP web site or using Product bulletin tool. It includes server size, weight, BTU, power information.... The HP Product Bulletin is a free application that only takes a few minutes to download. The download site is located at

http://h71069.www7.hp.com/productbulletin/download/hppb_installer.exe

Required HP power for a cabinet can be estimated using HP Power advisor tool available on HP web site:

<http://www8.hp.com/us/en/products/servers/solutions.html?compURI=1439951#.UxSoL7QUdtk>

OS and Performance Intelligence Center management software installation and configuration on HP, are provided in Performance Intelligence Center 10.3 Installation guide available on Oracle Technology Network site. Note that customer shall have Weblogic 12c and Oracle Enterprise Edition 12c and partitioning option licenses, or Oracle Technology Foundation for Monitoring Applications license for this server, before starting the installation.

Hardware Installation Guidelines

9.26 Configuration set 26 (Oracle X6-2 for Pre-package)

Oracle X6-2 is available in AC only

There are 2 options for traffic acquisition:

- One for acquisition of 1G/10G traffic on RJ45 copper links
- One for acquisition of 1G/10G traffic on optical fiber links

No mix is allowed.

This affect only the acquisition ports, not the management and network (to mediation) ports.

With 1G/10 RJ45 copper acquisition interfaces:

Oracle SKU	Technical description	Qty (AC only)
7113252	Oracle Server X6-2: 1 RU base chassis with motherboard, internal 12 Gb SAS RAID HBA, 2 PSUs, slide rail kit, and cable management arm	1
7113235	1 Intel Xeon E5-2699 v4 22-core 2.2 GHz processor	2
7110350	Heat sink for 1U	2
7113240	One 16 GB DDR4-2400 registered DIMM	8
7110339	Eight 2.5 inch drive slots, 1 DVD-RW drive slot and disk cage for 1U	1
7111107	One 1.2 TB 10000 rpm 2.5-inch SAS-3 HDD with marlin bracket	8
7110359	DVD filer panel	1
7102748	PCIe filler panel	1
7100563	Sun Dual Port 10GBase-T Adapter (for factory installation)	2

Table 32: configuration set 26 with Oracle X6-2 copper RJ45 interfaces for virtual machines hosting

With 1G/10 fiber SFP+ acquisition interfaces:

Oracle SKU	Technical description	Qty (AC only)
7113252	Oracle Server X6-2: 1 RU base chassis with motherboard, internal 12 Gb SAS RAID HBA, 2 PSUs, slide rail kit, and cable management arm	1
7113235	1 Intel Xeon E5-2699 v4 22-core 2.2 GHz processor	2
7110350	Heat sink for 1U	2
7113240	One 16 GB DDR4-2400 registered DIMM	8
7110339	Eight 2.5 inch drive slots, 1 DVD-RW drive slot and disk cage for 1U	1
7111107	One 1.2 TB 10000 rpm 2.5-inch SAS-3 HDD with marlin bracket	8
7110359	DVD filer panel	1
7102748	PCIe filler panel	1
1109A-Z	ASSY,2X10GbE SFP+,X8PCIe 2.0,LP,Lead Free (Niantic)	2

Table 33: configuration set 26 with Oracle X6-2 SFP+ interfaces for virtual machines hosting

In addition, SPF(+) modules according to network type shall be ordered.

Each acquisition card has 2 SPF(+) slots. 2 cards per server.

Total: 4 SFP+ acquisition ports for the server.

Warning: an USB flash drive (8GB) will be required for initial installation or disaster recovery

In addition, 2 power cords shall be ordered according to installation country or Power distribution unit installed in the frame.

Hardware Installation Guidelines

For server size, weight, BTU, power information... Documentations are available at http://docs.oracle.com/cd/E62159_01/

Please refer to Setup and Installation section for Oracle hardware installation. This document will drive you through the initial installation steps:

- Server installation in the rack.
- Attaching network and power Cables
- Booting Up the First Time
- Launching Oracle System Assistant to configure:
 - Server's network connection
 - Install latest server firmware
 - Configure Oracle ILOM and BIOS,
 - Configure hardware

OS and Performance Intelligence Center software installation on Oracle hardware server are provided in Performance Intelligence Center 10.3.0 Installation guide available on Oracle Technology Network site.

Hardware Installation Guidelines

9.27 Configuration set 27 (Oracle X5-2 for Pre-package)

Oracle X5-2 is available in AC only.

There are 2 options for traffic acquisition:

- One for acquisition of 1G/10G traffic on RJ45 copper links
- One for acquisition of 1G/10G traffic on optical fiber links

No mix is allowed.

This affect only the acquisition ports, not the management and network ports.

With 1G/10 RJ45 copper acquisition interfaces:

Oracle SKU	Technical description	Qty (AC only)
7112843	ATO,BASE,CONFIG,1U	1
7110339	XATO,DISK_CAGE,2.5" X 8HDD	1
7110346	ATO,E5-2699 V3,2.3G,145W,18 CORE,C-1 (SR1XD),CPU	2
7110350	XATO,HEATSINK,CPU,1U	2
7110360	XATO,OSA 8 GB MLC USB FLASH DRIVE	1
7110359	ATO,DVD,GEN5,BLANK FILLER PANEL,1U/2U	1
7102748	ATO PCIe FILLER,VENTED,LOW PROFILE	1
7110353	XATO,DIMM,16GB,DDR4,2133	8
7111107	1.2 TB 10000 rpm 2.5-inch SAS-3 HDD with marlin bracket (for factory installation)	8
7100563	Sun Dual Port 10GBase-T Adapter (for factory installation)	2

Table 34: configuration set 27 with Oracle X5-2 copper RJ45 interfaces for virtual machines hosting

With 1G/10 fiber SFP+ acquisition interfaces:

Oracle SKU	Technical description	Qty (AC only)
7112843	Oracle Server X5-2 for Communications: 1 RU base chassis with motherboard,	1
7110339	XATO,DISK_CAGE,2.5" X 8HDD	1
7110346	ATO,E5-2699 V3,2.3G,145W,18 CORE,C-1 (SR1XD),CPU	2
7110350	XATO,HEATSINK,CPU,1U	2
7110360	XATO,OSA 8 GB MLC USB FLASH DRIVE	1
7110359	ATO,DVD,GEN5,BLANK FILLER PANEL,1U/2U	1
7102748	ATO PCIe FILLER,VENTED,LOW PROFILE	1
7110353	XATO,DIMM,16GB,DDR4,2133	8
7111107	1.2 TB 10000 rpm 2.5-inch SAS-3 HDD with marlin bracket (for factory installation)	8
1109A-Z	ASSY,2X10GbE SFP+,X8PCIe 2.0,LP,Lead Free (Niantic)	2

Table 35: configuration set 27 with Oracle X5-2 SFP+ interfaces for virtual machines hosting

In addition, SPF(+) modules according to network type shall be ordered.

Each acquisition card has 2 SPF(+) slots . 2 cards per server.

Total: 4 SFP+ acquisition ports for the server.

In addition, 2 power cords shall be ordered according to installation country or Power distribution unit installed in the frame.

Hardware Installation Guidelines

For server size, weight, BTU, power information... Documentations are available at http://docs.oracle.com/cd/E41059_01/

Please refer to Setup and Installation section for Oracle hardware installation. This document will drive you through the initial installation steps:

- Server installation in the rack.
- Attaching network and power Cables
- Booting Up the First Time
- Launching Oracle System Assistant to configure:
 - Server's network connection
 - Install latest server firmware
 - Configure Oracle ILOM and BIOS,
 - Configure hardware

OS and Performance Intelligence Center software installation on Oracle hardware server are provided in Performance Intelligence Center 10.3 Installation guide available on Oracle Technology Network site.

Hardware Installation Guidelines

9.28 Configuration set 28 (Oracle Netra X5-2 for Pre-package)

Oracle Netra X5-2 is available in AC and DC. It is NEBS compliant.

There are 2 options for traffic acquisition:

- One for acquisition of 1G/10G traffic on RJ45 copper links
- One for acquisition of 1G/10G traffic on optical fiber links

No mix is allowed.

This affect only the acquisition ports, not the management and network (to mediation) ports.

With 1G/10 RJ45 copper acquisition interfaces:

Oracle SKU	Technical description	Qty DC	Qty AC
7111082	Netra Server X5-2: 2 RU AC base chassis with motherboard and 8 HDDs	-	1
7111083	Netra Server X5-2: 2 RU DC base chassis with motherboard and 8 HDDs	1	-
7110346	Intel® Xeon® E5-2699 v3 18-core 2.3 GHz processor	2	2
7102981	Heat sink	2	2
7111036	One 16 GB DDR4-2133 DIMM	8	8
7111043	Memory filler panels	16	16
7111107	One 1.2 TB 10000 rpm 2.5-inch SAS-3 HDD with marlin bracket	8	8
7100563	Sun Dual Port 10GBase-T Adapter	2	2
7110116	Oracle Storage 12 Gb SAS PCIe RAID HBA, internal: 8 port and 1 GB memory	1	1
5394A	PCIe filler panel	3	3
7901A-4	19-inch 2-post rackmount kit	1	1
7111044	SAS cable kit	1	1
7111052	OSA 8 GB USB stick	1	1

Table 36: configuration set 28 with Oracle Netra X5-2 copper RJ45 interfaces

Each acquisition card has 2 RJ5 ports each. 2 cards per server.

Total: 4 acquisition ports for the server.

With 1G/10 fiber SFP+ acquisition interfaces:

Oracle SKU	Technical description	Qty DC	Qty AC
7111082	Netra Server X5-2: 2 RU AC base chassis with motherboard and 8 HDDs	-	1
7111083	Netra Server X5-2: 2 RU DC base chassis with motherboard and 8 HDDs	1	-
7111083	Netra Server X5-2: 2 RU DC base chassis with motherboard	1	1
7110346	Intel® Xeon® E5-2699 v3 18-core 2.3 GHz processor	2	2
7102981	Heat sink	2	2
7111036	One 16 GB DDR4-2133 DIMM	8	8
7111043	Memory filler panels	16	16

Hardware Installation Guidelines

7111107	One 1.2 TB 10000 rpm 2.5-inch SAS-3 HDD with marlin bracket	8	8
1109A-Z	Sun Dual 10GbE SFP+ PCIe Low Profile Adapter	2	2
7110116	Oracle Storage 12 Gb SAS PCIe RAID HBA, internal: 8 port and 1 GB memory	1	1
5394A	PCIe filler panel	3	3
7901A-4	19-inch 2-post rackmount kit	1	1
7111044	SAS cable kit	1	1
7111052	OSA 8 GB USB stick	1	1

Table 37: configuration set 28 with Oracle Netra X5-2 SFP+ interfaces

In addition, SPF(+) modules according to network type shall be ordered.

Each acquisition card has 2 SPF(+) slots . 2 cards per server.

Total: 4 SFP+ acquisition ports for the server.

In addition, 2 power cords shall be ordered according to installation country or Power distribution unit installed in the frame.

For server size, weight, BTU, power information.... Documentations are available at http://docs.oracle.com/cd/E53596_01/

Please refer to Setup and Installation section for Oracle hardware installation. This document will drive you through the initial installation steps:

- Server installation in the rack.
- Attaching network and power Cables
- Booting Up the First Time
- Launching Oracle System Assistant to configure:
 - Server's network connection
 - Install latest server firmware
 - Configure Oracle ILOM and BIOS,
 - Configure hardware

OS and Performance Intelligence Center software installation on Oracle hardware server are provided in Performance Intelligence Center 10.3 Installation guide available on Oracle Technology Network site.

Hardware Installation Guidelines

9.29 Configuration set 29 (Oracle X6-2L 26 HDD)

Oracle X6-2L is available in AC only

Oracle SKU	Technical description	Qty (AC only)
7113278	Oracle Server X6-2L: 2 RU base chassis with motherboard, internal 12 Gb SAS RAID HBA, 2 PSUs, slide rail kit, and cable management arm	1
7113239	One Intel® Xeon® E5-2630 v4 10-core 2.2 GHz processor	2
7110351	Heat sink for 2U	2
7113240	One 16 GB DDR4-2400 registered DIMM	4
7113280	Twenty-four 2.5-inch drive slots disk cage and two 2.5-inch drive rear slots disk cage	1
7111107	One 1.2 TB 10000 rpm 2.5-inch SAS-3 HDD with marlin bracket	26
7110359	DVD filler panel	1
7102748	PCIe filler panel	5

Table 38: Configuration set 29 with Oracle X6-2L with 26 HDD

Warning: an USB flash drive (8GB) will be required for initial installation or disaster recovery

In addition, 2 power cords shall be ordered according to installation country or Power distribution unit installed in the frame.

Customer can perform following adaptations on previous BOM:

- CPU: other CPUs are supported.
Pre-requisite: 10 cores minimum (on 1 or 2 processors)
Note that Ethernet ports Eth03 and Eth04 (NET2 and NET3) are non-functional in single-processor systems.
- Memory: Other memory allocation is supported.
Pre-requisite: 24 GB minimum.
- Disk type and size: other disks are supported
Pre-requisite: 14 disks minimum, 26 disks maximum
all disks shall have same storage capacity
600 GB disk storage capacity (per disk) minimum.

Note that customer changes can affect server and system performances and ability to upgrade in future releases.

For server size, weight, BTU, power information.... documentation is available at http://docs.oracle.com/cd/E62172_01/index.html

The documentation will drive you through the Oracle hardware installation steps and information:

- Hardware Overview
 - Controller Overview
 - Physical Specifications
 - Electrical Specifications
 - Acoustic Noise Emissions
 - Internal Components

- Motherboard, Memory, and PCIe Cards
- Optional Cable Management Arm
- Attached Storage
- Cabling
- Powering On and Configuring the System
 - Connecting to ILOM
 - Powering On the Appliance
 - Completing Configuration

It is strongly recommended to refer to Performance Intelligence Center 10.3 Installation guide available on Oracle Technology Network site before starting installation of X6-2L.

9.30 Configuration set 30 (Oracle X7-2 8 HDD for virtual PIC))

Oracle X7-2 is available in AC only
 PIC is available on X7-2 in virtual mode only.

Oracle SKU	Technical description	Qty (AC only)
7115194	Oracle Server X7-2: 1 RU base chassis with motherboard, eight 2.5-inch drive slots disk cage, 2 PSUs, slide rail kit, and cable management arm	1
7115207	1 Intel® Xeon® Platinum 8160 24-core 2.1 GHz processor (for factory installation)	2
7115200	One 32 GB DDR4-2666 registered DIMM (for factory installation)	8
7111107	One 1.2 TB 10000 rpm 2.5-inch SAS-3 HDD with marlin bracket (for factory installation)	8
7115197	Short heat sink (for factory installation)	2
7102748	PCIe filler panel (for factory installation)	3
7116456	Processor clip (for factory installation)	2
7117125	Oracle Storage 12 Gb SAS PCIe RAID HBA, internal: 16 port and 2 GB memory (for factory installation)	1
7117386	SAS cables for 1U (for factory installation)	1

Table 39: configuration set 30 with Oracle X7-2 8 SFF for virtual PIC

Warning: an USB flash drive (8GB) will be required for initial installation or disaster recovery

In addition, 2 power cords shall be ordered according to installation country or Power distribution unit installed in the frame.

Customer can perform following adaptations on previous BOM:

- CPU: other CPUs are supported.
 Pre-requisite: 10 cores minimum (on 1 or 2 processors)
 Note that Ethernet ports Eth03 and Eth04 (NET2 and NET3) are non-functional in single-processor systems.
- Memory: Other memory allocation is supported.
 Pre-requisite: 64 GB minimum.
- Disk type and size: other disks type and size are supported

Hardware Installation Guidelines

Pre-requisite: 8 disks minimum
600 GB disk storage capacity (per disk) minimum.

- Virtual disks: it is recommended for performance reasons to distribute the virtual disks on the physical hard disks with maximum preallocated capacity. All virtual disks shall have same configured capacity with minimum 600GB.

Note that customer changes can affect server and system performances and ability to upgrade in future releases.

For server size, weight, BTU, power information... Documentations are available at https://docs.oracle.com/cd/E72435_01/index.html

Please refer to Setup and Installation section for Oracle hardware installation. This document will drive you through the initial installation steps:

- Server installation in the rack.
- Attaching network and power Cables
- Booting Up the First Time
- Launching Oracle System Assistant to configure:
 - Server's network connection
 - Install latest server firmware
 - Configure Oracle ILOM and BIOS,
 - Configure hardware

OS and Performance Intelligence Center software installation in the virtual machine and virtual machine configuration are provided in Performance Intelligence Center 10.3 Installation guide available on Oracle Technology Network site.

9.31 Configuration set 31 (Oracle X7-2 2 HDD for virtual PIC)

Oracle X7-2 is available in AC only
PIC is available on X7-2 in virtual mode only.

Oracle SKU	Technical description	Qty (AC only)
7115194	Oracle Server X7-2: 1 RU base chassis with motherboard, eight 2.5-inch drive slots disk cage, 2 PSUs, slide rail kit, and cable management arm	1
7115207	1 Intel® Xeon® Platinum 8160 24-core 2.1 GHz processor (for factory installation)	2
7115200	One 32 GB DDR4-2666 registered DIMM (for factory installation)	8
7111107	One 1.2 TB 10000 rpm 2.5-inch SAS-3 HDD with marlin bracket (for factory installation)	2
7111182	Oracle Quad Port 10GBase-T Adapter (for factory installation)	0
7115197	Short heat sink (for factory installation)	2
6331A-N	2.5-inch HDD filler panel (for factory installation)	6
7102748	PCIe filler panel (for factory installation)	3
7116456	Processor clip (for factory installation)	2
7117125	Oracle Storage 12 Gb SAS PCIe RAID HBA, internal: 16 port and 2	1

Hardware Installation Guidelines

	GB memory (for factory installation)	
7117386	SAS cables for 1U (for factory installation)	1

Table 40: configuration set 31 with Oracle X7-2 2 SFF for virtual PIC

Warning: an USB flash drive (8GB) will be required for initial installation or disaster recovery

In addition, 2 power cords shall be ordered according to installation country or Power distribution unit installed in the frame.

Customer can perform following adaptations on previous BOM:

- CPU: other CPUs are supported.
Pre-requisite: 10 cores minimum (on 1 or 2 processors)
Note that Ethernet ports Eth03 and Eth04 (NET2 and NET3) are non-functional in single-processor systems.
- Memory: Other memory allocation is supported.
Pre-requisite: 64 GB minimum.
- Disk type and size: other disks type and size are supported
Pre-requisite: 2 disks minimum
600 GB disk storage capacity (per disk) minimum.
- Virtual disks: it is recommended for performance reasons to distribute the virtual disks on the physical hard disks with maximum preallocated capacity. All virtual disks shall have same configured capacity with minimum 600GB.

Note that customer changes can affect server and system performances and ability to upgrade in future releases.

For server size, weight, BTU, power information.... Documentations are available at https://docs.oracle.com/cd/E72435_01/index.html

Please refer to Setup and Installation section for Oracle hardware installation. This document will drive you through the initial installation steps:

- Server installation in the rack.
- Attaching network and power Cables
- Booting Up the First Time
- Launching Oracle System Assistant to configure:
 - Server's network connection
 - Install latest server firmware
 - Configure Oracle ILOM and BIOS,
 - Configure hardware

OS and Performance Intelligence Center software installation in the virtual machine and virtual machine configuration are provided in Performance Intelligence Center 10.3 Installation guide available on Oracle Technology Network site.

9.32 Configuration set 32 (Oracle X7-2L 6 HDD for virtual PIC))

Oracle X7-2L is available in AC only
PIC is available on X7-2L in virtual mode only.

Hardware Installation Guidelines

Oracle SKU	Technical description	Qty (AC only)
7115162	Oracle Server X7-2L: 2 RU base chassis with motherboard, twelve 3.5-inch drive slots disk cage, 2 PSUs, slide rail kit, and cable management arm	1
7115207	1 Intel® Xeon® Platinum 8160 24-core 2.1 GHz processor (for factory installation)	2
7115200	One 32 GB DDR4-2666 registered DIMM (for factory installation)	8
7115449	One 10 TB 7200 rpm 3.5-inch SAS-3 HDD with coral bracket (for factory installation)	6
7117125	Oracle Storage 12 Gb SAS PCIe RAID HBA, internal: 16 port and 2 GB memory (for factory installation)	1
7117387	SAS cable for 2U (for factory installation)	1
7113128	3.5-inch disk drive filler panel (for factory installation)	6
7102748	PCIe filler panel (for factory installation)	10
7116456	Processor clip (for factory installation)	2
7115185	Tall heat sink (for factory installation)	2

Table 41: configuration set 32 with Oracle X7-2L 6 SFF for virtual PIC

Warning: an USB flash drive (8GB) will be required for initial installation or disaster recovery

In addition, 2 power cords shall be ordered according to installation country or Power distribution unit installed in the frame.

Customer can perform following adaptations on previous BOM:

- CPU: other CPUs are supported.
Pre-requisite: 10 cores minimum (on 1 or 2 processors)
Note that Ethernet ports Eth03 and Eth04 (NET2 and NET3) are non-functional in single-processor systems.
- Memory: Other memory allocation is supported.
Pre-requisite: 64 GB minimum.
- Disk type and size: other disks type and size are supported
Pre-requisite: 6 disks minimum
600 GB disk storage capacity (per disk) minimum.
- Virtual disks: it is recommended for performance reasons to distribute the virtual disks on the physical hard disks with maximum preallocated capacity. All virtual disks shall have same configured capacity with minimum 600GB.

Note that customer changes can affect server and system performances and ability to upgrade in future releases.

For server size, weight, BTU, power information.... Documentations are available at https://docs.oracle.com/cd/E72463_01/index.html

Please refer to Setup and Installation section for Oracle hardware installation. This document will drive you through the initial installation steps:

- Server installation in the rack.
- Attaching network and power Cables
- Booting Up the First Time

- Launching Oracle System Assistant to configure:
 - Server’s network connection
 - Install latest server firmware
 - Configure Oracle ILOM and BIOS,
 - Configure hardware

OS and Performance Intelligence Center software installation in the virtual machine and virtual machine configuration are provided in Performance Intelligence Center 10.3 Installation guide available on Oracle Technology Network site.

9.33 Configuration set 33 (Oracle X7-2 for virtual PIC)

Oracle X7-2 is available in AC only

There are 2 options for traffic acquisition:

- One for acquisition of 1G/10G traffic on RJ45 copper links
- One for acquisition of 1G/10G traffic on optical fiber links

No mix is allowed.

This affect only the acquisition ports, not the management and network (to mediation) ports.

With 1G/10 RJ45 copper acquisition interfaces:

Oracle SKU	Technical description	Qty (AC only)
7115194	Oracle Server X7-2: 1 RU base chassis with motherboard, eight 2.5-inch drive slots disk cage, 2 PSUs, slide rail kit, and cable management arm	1
7115207	1 Intel® Xeon® Platinum 8160 24-core 2.1 GHz processor (for factory installation)	2
7115200	One 32 GB DDR4-2666 registered DIMM (for factory installation)	8
7111107	One 1.2 TB 10000 rpm 2.5-inch SAS-3 HDD with marlin bracket (for factory installation)	2
7111182	Oracle Quad Port 10GBase-T Adapter (for factory installation)	2
7115197	Short heat sink (for factory installation)	2
6331A-N	2.5-inch HDD filler panel (for factory installation)	6
7102748	PCIe filler panel (for factory installation)	1
7116456	Processor clip (for factory installation)	2
7117125	Oracle Storage 12 Gb SAS PCIe RAID HBA, internal: 16 port and 2 GB memory (for factory installation)	1
7117386	SAS cables for 1U (for factory installation)	1

Table 42: configuration set 33 with Oracle X7-2 copper RJ45 interfaces

With 1G/10 fiber SFP+ acquisition interfaces:

Oracle SKU	Technical description	Qty (AC only)
7115194	Oracle Server X7-2: 1 RU base chassis with motherboard, eight 2.5-inch drive slots disk cage, 2 PSUs, slide rail kit, and cable management arm	1
7115207	1 Intel® Xeon® Platinum 8160 24-core 2.1 GHz processor (for	2

Hardware Installation Guidelines

	factory installation)	
7115200	One 32 GB DDR4-2666 registered DIMM (for factory installation)	8
7111107	One 1.2 TB 10000 rpm 2.5-inch SAS-3 HDD with marlin bracket (for factory installation)	2
7114148	Oracle Quad 10Gb or Dual 40Gb Ethernet Adapter(for factory installation)	2
7115197	Short heat sink (for factory installation)	2
6331A-N	2.5-inch HDD filler panel (for factory installation)	6
7102748	PCIe filler panel (for factory installation)	1
7116456	Processor clip (for factory installation)	2
7117125	Oracle Storage 12 Gb SAS PCIe RAID HBA, internal: 16 port and 2 GB memory (for factory installation)	1
7117386	SAS cables for 1U (for factory installation)	1
2124A	QSFP parallel fiber optics short wave transceiver	4

Table 43: configuration set 33 with Oracle X7-2 QSFP interfaces

In addition, QSPF modules and SFP modules for lower speed shall be ordered according to network type. Each acquisition card has 2 QSPF slots. 2 cards per server.
Total: 4 QSFP acquisition ports for the server.

Warning: an USB flash drive (8GB) will be required for initial installation or disaster recovery

In addition, 2 power cords shall be ordered according to installation country or Power distribution unit installed in the frame.

Customer can perform following adaptations on previous BOMs:

- CPU: other CPUs are supported.
Pre-requisite: 8 cores minimum (on 1 or 2 processors)
- Memory: Other memory allocation is supported.
Pre-requisite: 16 GB minimum.
- Disk type and size: other disks are supported
Pre-requisite: 2 disks minimum
all disks shall have same storage capacity
600 GB disk storage capacity (per disk) minimum.

Note that customer changes can affect server and system performances and ability to upgrade in future releases.

For server size, weight, BTU, power information.... Documentations are available at https://docs.oracle.com/cd/E72435_01/index.html

Please refer to Setup and Installation section for Oracle hardware installation. This document will drive you through the initial installation steps:

- Server installation in the rack.
- Attaching network and power Cables
- Booting Up the First Time
- Launching Oracle System Assistant to configure:
 - Server's network connection
 - Install latest server firmware

- Configure Oracle ILOM and BIOS,
- Configure hardware

OS and Performance Intelligence Center software installation in the virtual machine and virtual machine configuration are provided in Performance Intelligence Center 10.3 Installation guide available on Oracle Technology Network site.

9.34 SFP(+) modules

SFP modules tested by Performance Intelligence Center and qualified to work with the HP INTEL X520 card are:

Interface	Tested SFP+ modules
1000 Base-T adapter	FINISAR PN: FCLF8521-3
Dual 1000 Base LX / 10GE base LR adapter	SUN X2129A PN:530-4449 AVAGO PN:AFBR-709DMZ-SN1
Dual 1000 Base SX / 10GE base SR adapter	AVAGO PN:AFBR-703SDZ FINISAR PN:FTLX8571D3BCL SUN X2129A PN:530-4449* AVAGO PN:AFBR-703SDDZ-SN1*
10GE base SR adapter	SUN X2129A PN:530-4449 AVAGO PN:AFBR-703SDZ

Table 44: SFP+ modules available on HP Intel X520 card

Note *: not hot swappable (reboot required for SFP module recognition)

on HP INTEL X560 SFP+ card:

Interface	Tested SFP+ modules
1000 Base-T adapter	FINISAR PN: FCLF8521-3
Dual 1000 Base SX / 10GE base SR adapter	SUN X5562A PN:135-1205 AVAGO PN:AFCT-701SDDZ-SN1
Dual 1000 Base SX / 10GE base SR adapter	SUN X2129A PN:530-4449 AVAGO PN:AFBR-703SDDZ-SN1
10GE base SR adapter	AVAGO PN:AFBR-703SDZ FINISAR PN:FTLX8571D3BCL
Dual 1000 Base LX / 10GE base LR adapter	SUN X5562A PN:135-1205 AVAGO PN:AFCT-701SDDZ-SN1

Table 45: SFP+ modules available on HP Intel X560 card

on Sun Dual 10GbE SFP+ PCIe Low Profile card:

Oracle SKU	Technical description
5562A-Z	Sun SFP+ to Dual 1000 Base LX/10GE base LR adapter
2129A	Sun SFP+ to Dual 1000 Base SX/10GE base SR adapter

Table 46: Qualified SFP(+) modules on Oracle hardware Sun Dual 10GbE SFP+ card.

on Oracle Quad 10Gb or Dual 40Gb Ethernet Adapter:

- QSFP parallel fiber optics short range transceiver

Hardware Installation Guidelines

- 2124A, Factory installed
- X2124A-N, Xoption
- QSFP+ parallel fiber optics long range transceiver
 - 7110598, Factory installed
 - 7114094, Xoption

This list is by no means exhaustive. Selected cards are compliant with the standards and shall be compatible with almost all brands of SFP/SFP+/QSFP. But no commitment can be taken.

10 ANNEXES

10.1 Port identification on HP server Gen8 v1 & v2:

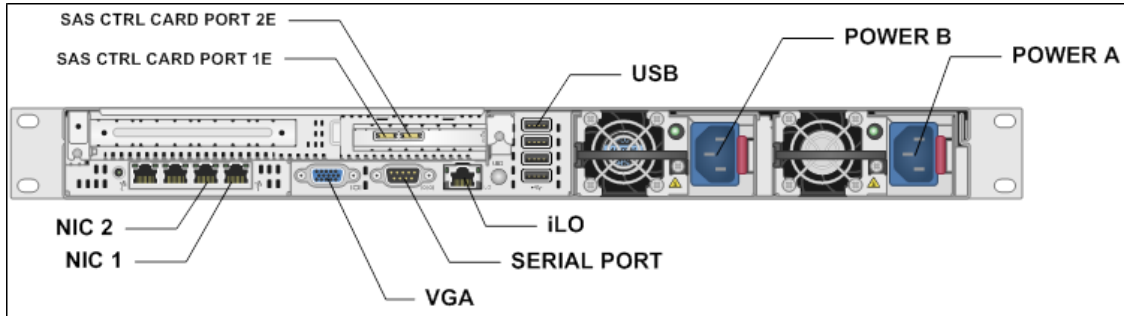

Figure 1 : Rear view for HP DL360 server Gen8 v1 & v2 used for Mediation

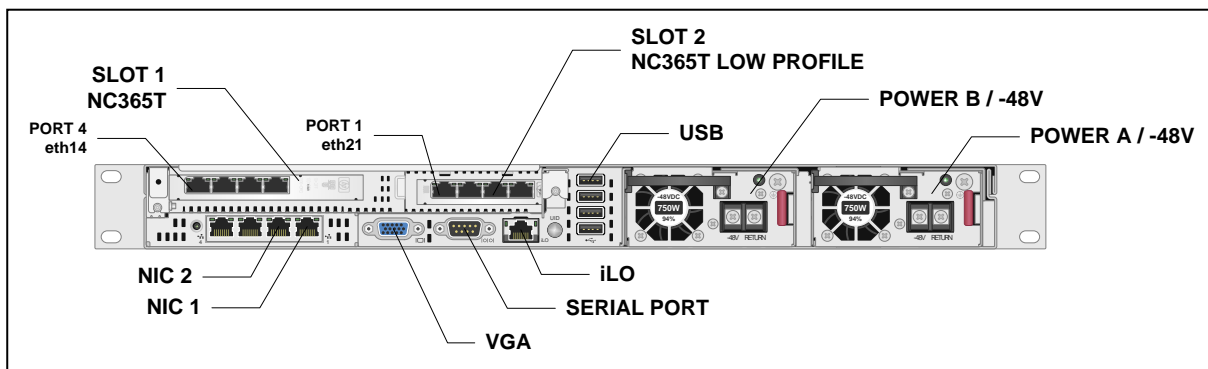

Figure 2 : Rear view for HP DL360 server Gen8 v1 & v2 used for Probed acquisition

Note: Slot and network port used for acquisition are similar for the 1Gb 4-port NC365T Adapter and 10Gb 2-port 560SFP+ Adapter, as well as for Gen9 in the following section.

Hardware Installation Guidelines

10.2 Port identification on HP server DL360 Gen9

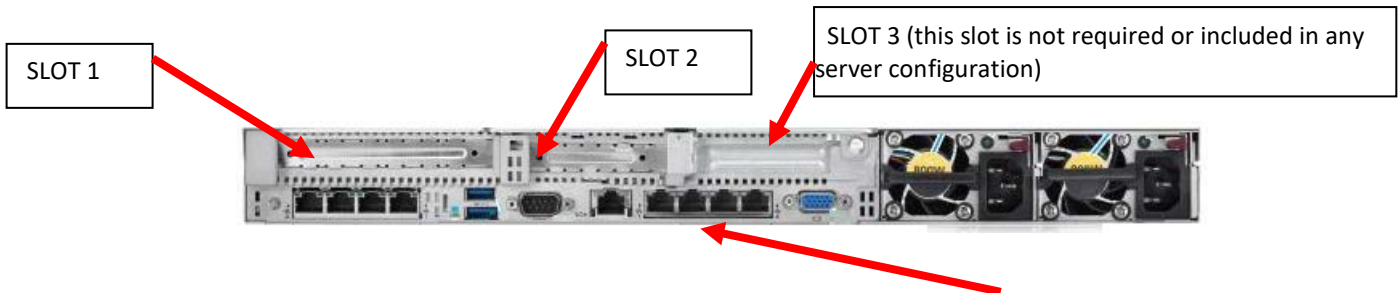

Figure 3 : Rear view for HP DL360 server Gen9

Embedded 4 x 1GbE Network Adapter
Eth01, Eth02, Eth03, Eth04

10.3 Port identification on HP server DL380 Gen9:

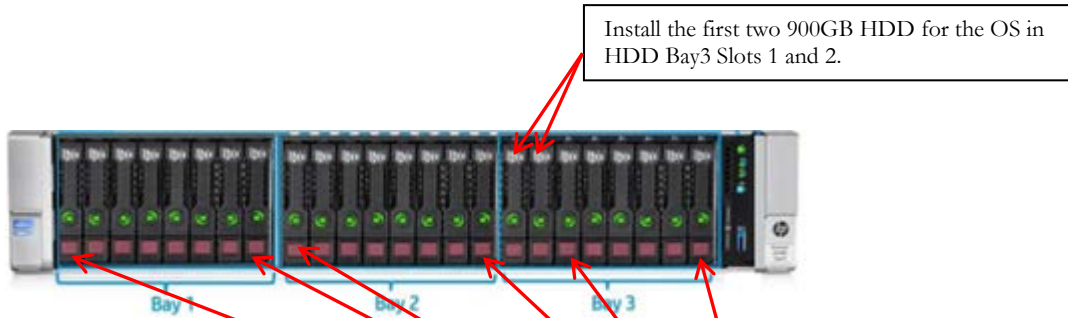

Figure 4 : Front view for HP DL38 Gen9

Install the first two 900GB HDD for the OS in
HDD Bay3 Slots 1 and 2.

After installing the 900GB HDD in Bay 3 slots 1 and 2 for the OS, install the 900GB hard drives in the remaining HDD slots in Bay 3 then start filling up BAY 2 starting with slot 1 with any remaining 900GB HDD, then start filling up BAY 1 starting with slot 1 with any remaining 900GB HDD.

Install any remaining 900GB HDD in the rear
HDD slots 25 and 26



Figure 5 : Rear view for HP DL380 Gen9

Hardware Installation Guidelines

10.4 Port identification on ODA X5-2

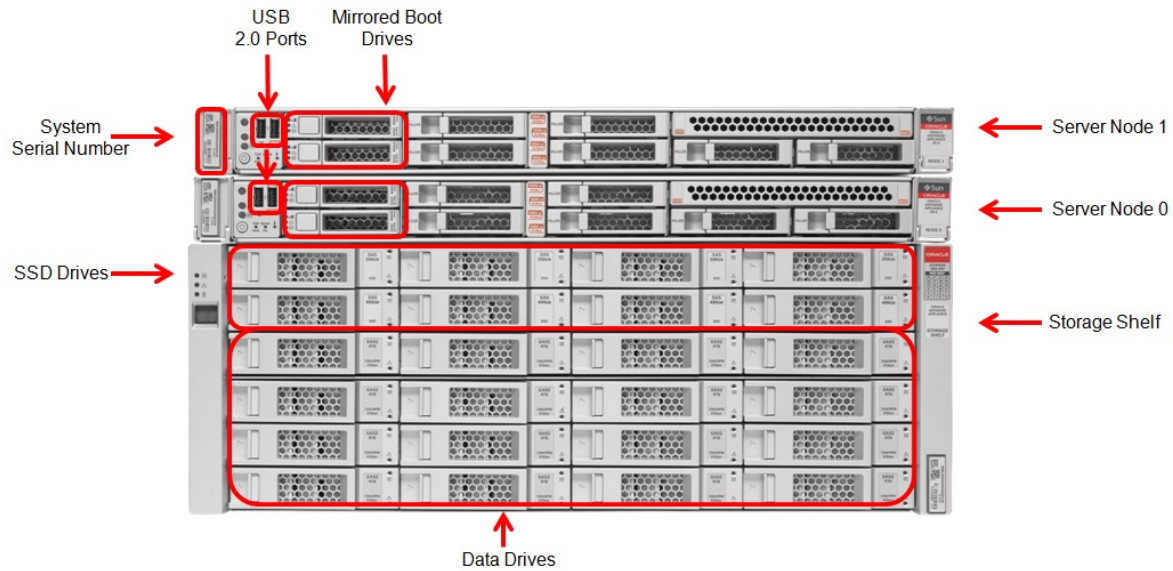

Figure 6- Front view of Oracle Database Appliance (storage shelf connections)

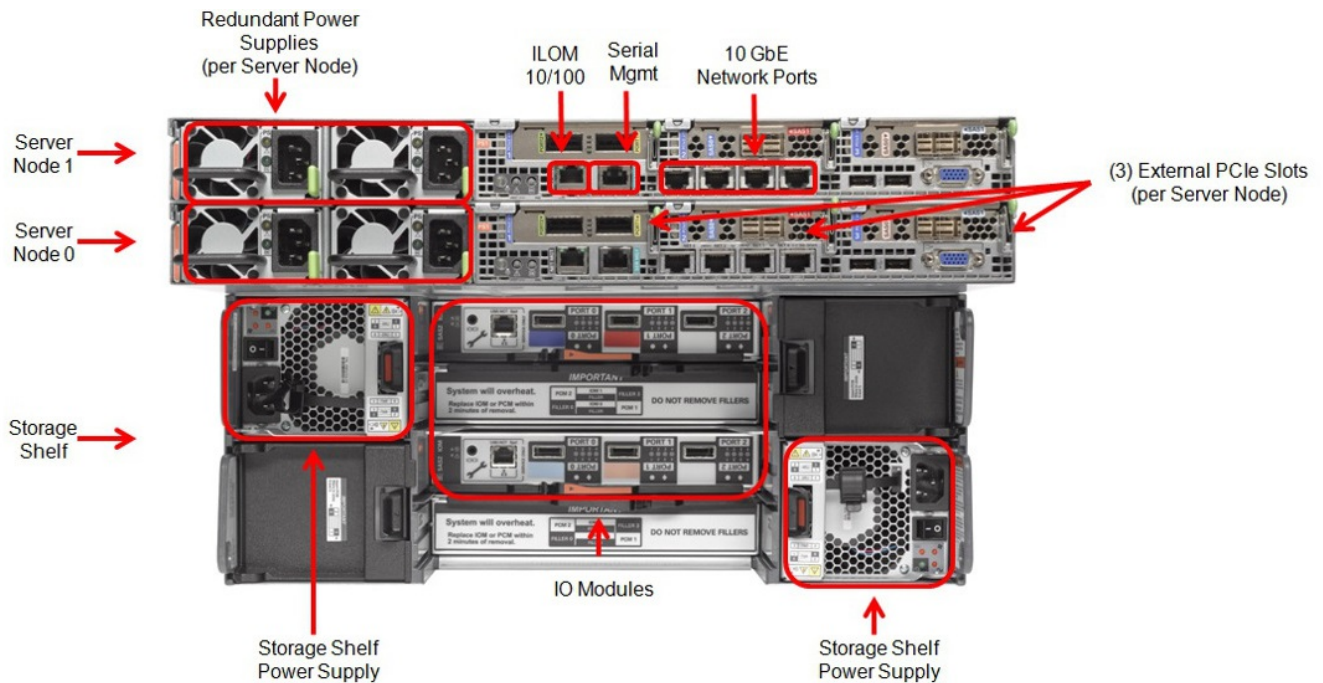

Figure 7- Rear view of Oracle Database Appliance (power and network connections)

10.5 Port identification on Oracle X5-2

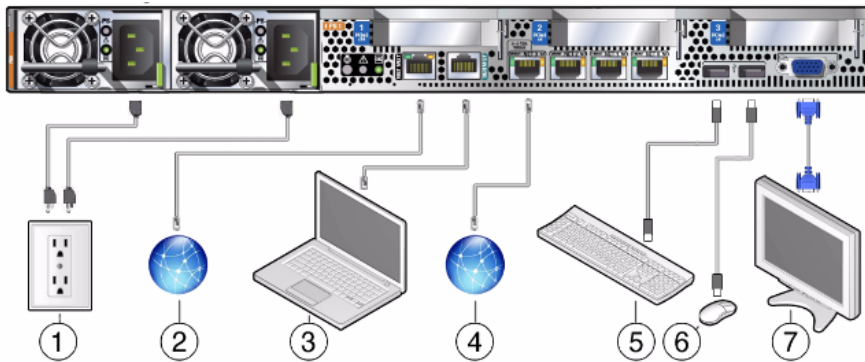
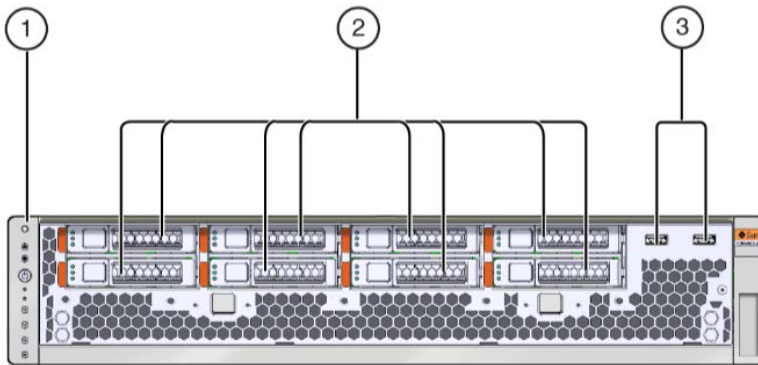

Figure Legend

- | | |
|--|--------------------|
| 1 Power supply 0 input power
Power supply 1 input power | 5 USB port (USB 0) |
| 2 Network management port (NET MGT) | 6 USB port (USB 1) |
| 3 Serial management port (SER MGT) | 7 Video port (VGA) |
| 4 Ethernet ports (NET3, NET2, NET1, NET0) | |

Figure 8- Rear view of Oracle X5-2 Server

10.6 Port identification on Oracle Netra X5-2



No.	Description
1	Indicators and switches, top to bottom:
2	Eight SAS drive slots or four SAS drive slots and four NMVe slots
3	Two USB 2.0 connectors

Hardware Installation Guidelines

Figure 9- Front view of Oracle Netra X5-2 Server

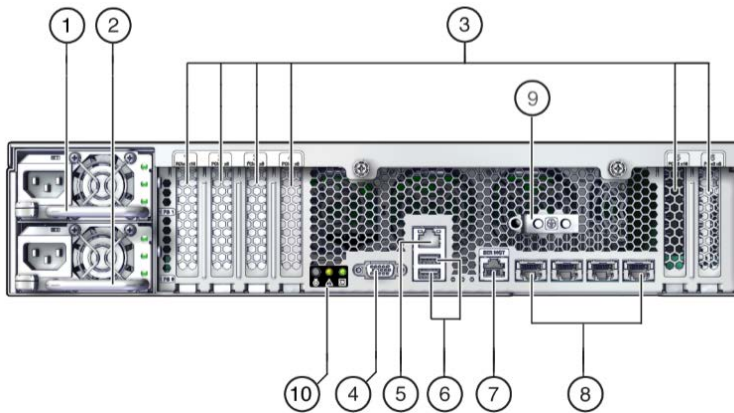

No.	Description
1	Hot-swappable power supply (AC or DC), PS1
2	Hot-swappable power supply (AC or DC), PS0
3	The number of available PCIe slots depends on the CPU configuration. <ul style="list-style-type: none"> ■ Single Processor – Two PCIe 3.0 low-profile card slots (slot 5 and slot 6) ■ Dual Processor – Six PCIe 3.0 low-profile card slots
4	SP 15-pin VGA video port
5	SP NET MGT port
6	Two USB 3.0 ports
7	SP SER MGT port
8	Four 10 Gigabit Ethernet ports (left to right: NET 3, NET 2, NET 1, NET 0)
9	Chassis ground posts
10	Chassis Status LEDs: <ul style="list-style-type: none"> ■ Locator LED and button ■ Service Required LED ■ Main Power OK LED

Figure 10- Rear view of Oracle Netra X5-2 Server

10.7 Port identification on X6-2

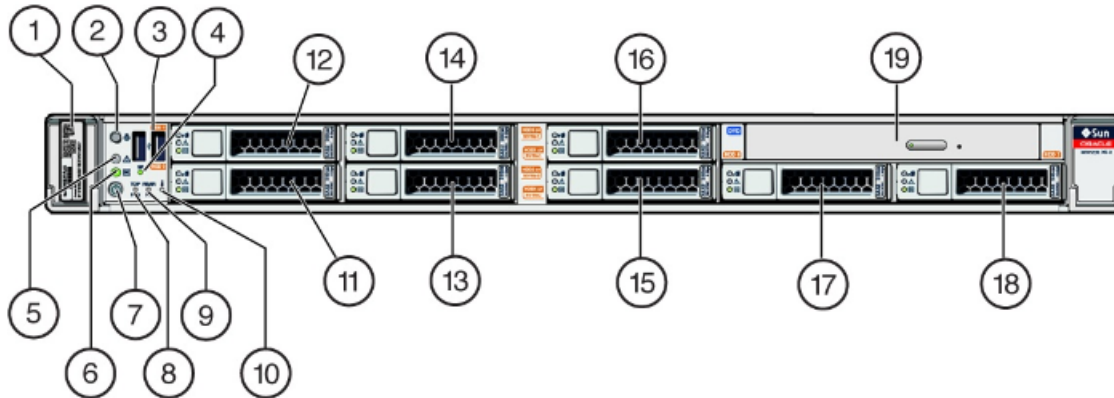

Figure 11- Front view of Oracle X6-2 server

- ① Product Serial Number (PSN) label and Radio Frequency Identification (RFID) tag
- ② Locator LED/button: white
- ③ USB 2.0 connectors (2)
- ④ SP OK LED: green
- ⑤ Service Required LED: amber
- ⑥ Power/OK LED: green
- ⑦ Power button
- ⑧ Service Required LED: Top: Fan Module (amber)
- ⑨ Service Required LED: Rear: Power Supply (amber)
- ⑩ Service Required LED: Overtemp Icon: System Over Temperature Warning (amber)
- ⑪ Storage drive 0
- ⑫ Storage drive 1
- ⑬ Storage drive 2
- ⑭ Storage drive 3
- ⑮ Storage drive 4
- ⑯ Storage drive 5
- ⑰ Storage drive 6
- ⑱ Storage drive 7
- ⑲ Optional SATA DVD Drive

Hardware Installation Guidelines

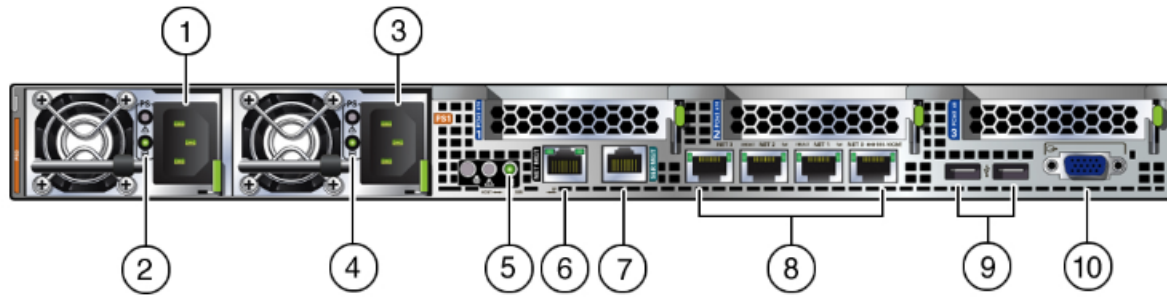

Figure 12- Front view of Oracle X6-2 server

- ① AC inlet 0
- ② AC OK Led
- ③ AC inlet 1
- ④ AC OK Led
- ⑤ Power OK Led
- ⑥ Ethernet MGT port (iLOM)
- ⑦ Serial Management port
- ⑧ Ethernet ports Net0-3 (Eth01 to Eth04)
- ⑨ USB ports
- ⑩ VGA video ports

10.8 Port identification on X6-2L

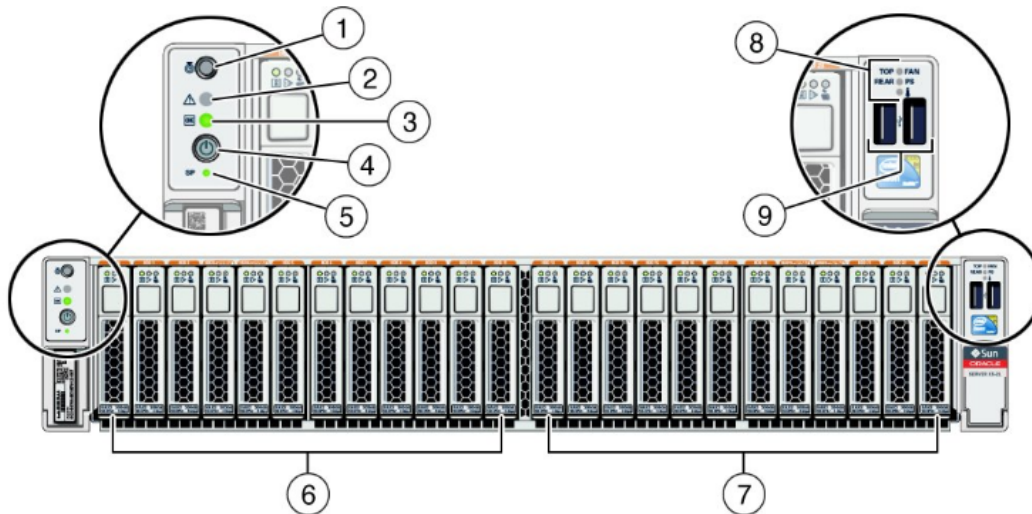

Figure 13- Front view of Oracle X6-2L server

- ① Locator LED/Locator button: white
- ② Service Required LED: amber

- ③ Power/OK LED: green
- ④ Power button
- ⑤ SP OK LED: green
- ⑥ Storage drives 0 through 11
- ⑦ Storage drives 12 through 23
- ⑧ Service Required LEDs (3): Top: Fan Module (amber); Rear: Power Supply (amber); Overtemp Icon: System Over Temperature Warning (amber)
- ⑨ USB 2.0 connectors (2)

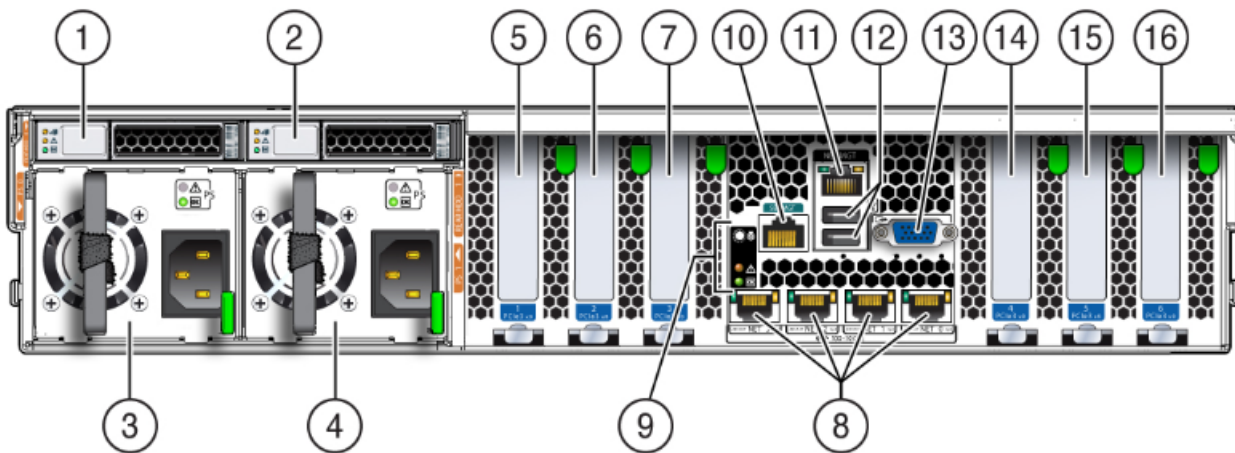

Figure 14- Rear view of Oracle X6-2L server

- ① Rear storage drive 0
- ② Rear storage drive 1
- ③ Power supply unit 0 (PSU0)
- ④ Power supply unit 0 (PSU1)
- ⑤ PCIe slot 1
- ⑥ PCIe slot 2
- ⑦ PCIe slot 3
- ⑧ Ethernet ports Net3-0 (Eth04 to Eth01)
- ⑨ System status LEDs: Locator/Button: white; Service Required: amber; Power/OK: green)
- ⑩ Serial management (SER MGT)/RJ-45 serial port
- ⑪ Oracle Integrated Lights Out Manager (ILOM) service processor (SP) network management (NET MGT) 10/100/1000BASE-T port
- ⑫ USB 2.0 ports (2)
- ⑬ DB-15 video connector
- ⑭ PCIe slot 4
- ⑮ PCIe slot 5
- ⑯ PCIe slot 6

Hardware Installation Guidelines

10.9 Port identification on ZFS ZS3-2

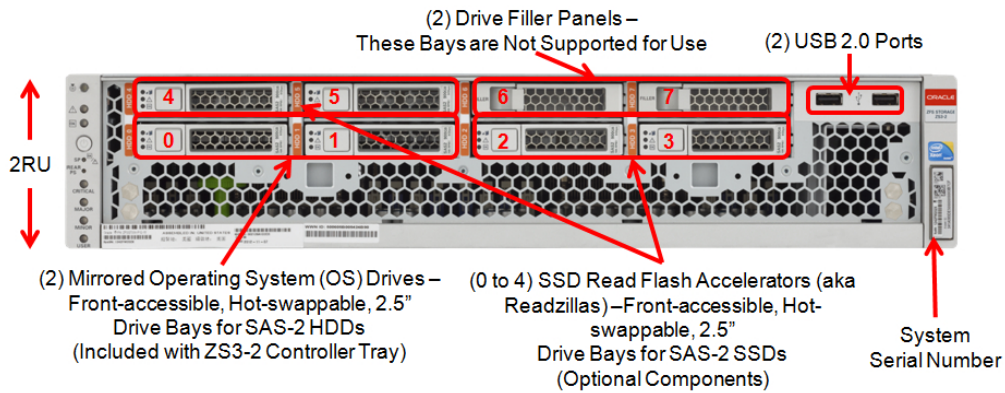

Figure 15- Front view of Oracle ZFS ZS3-2 Controller

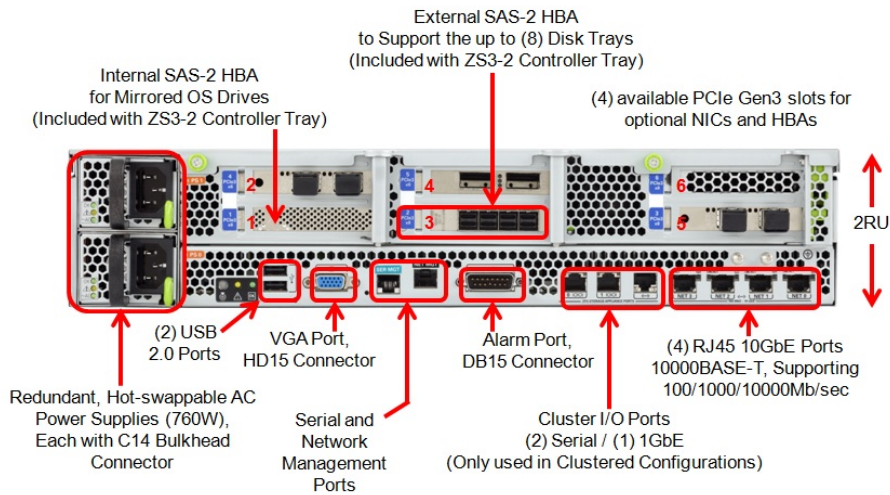

Figure 16- Rear view of Oracle ZFS ZS3-2 Controller

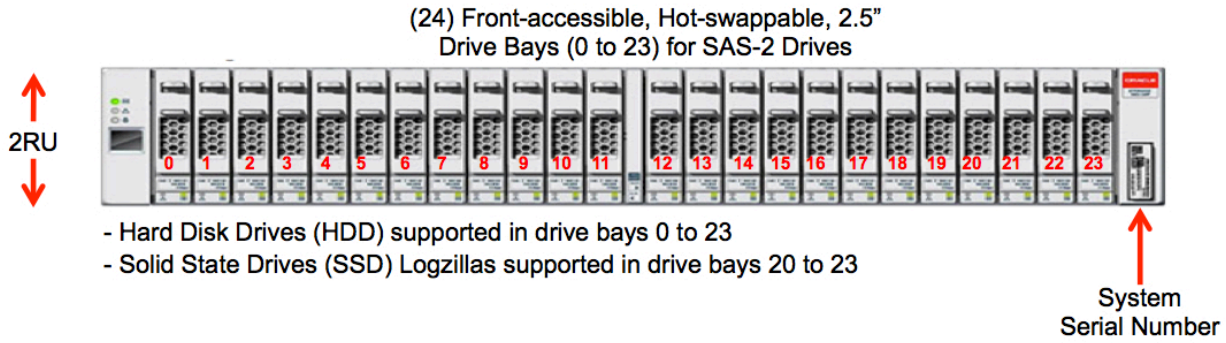

Figure 17- Front view of Oracle DE2-24P drive enclosure

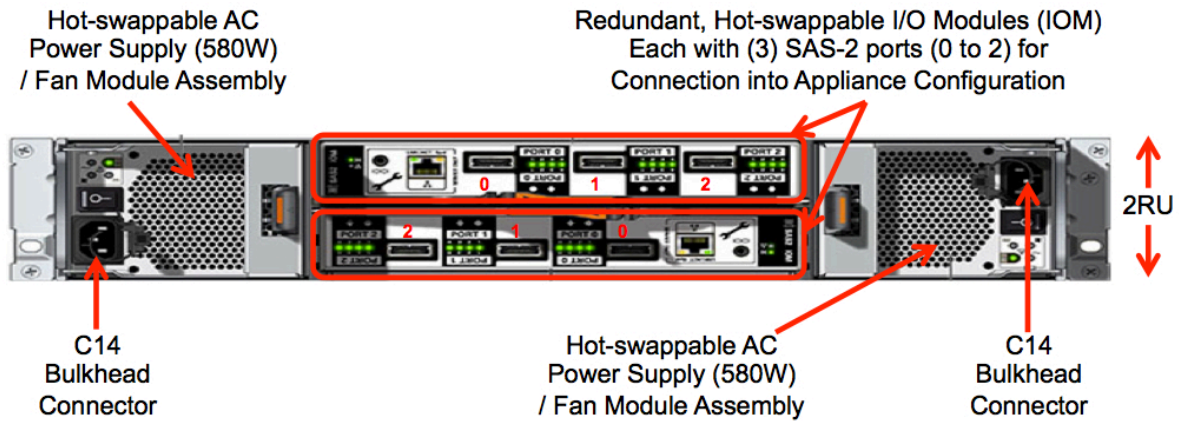

Figure 18- Rear view of Oracle DE2-24P drive enclosure

Hardware Installation Guidelines

10.10 RAID configurations

Raid configuration is provided for information.

For management server on HP Gen8 servers:

Server internal disks:

- Disk 1 & 2 are configured in a RAID 1 (system)

Storage array disks:

- Disk 1 to 6 are configured in a RAID 10 (data)
- Disk 7 to 8 are configured in a RAID 1 (redo)
- Disk 9 to 10 are configured in a RAID 1 (backup)

For management server on Gen9, X5-2, and X6-2 servers:

Server internal disks:

- Disk 1 & 2 are configured in a RAID 1 (system)
- Disk 3 to 6 are configured in a RAID 10 (data)
- Disk 7 to 8 are configured in a RAID 1 (Backup)

For Data Record storage on HP Gen8 servers:

Server internal disks:

- Disk 1 & 2 are configured in a RAID 1

Storage array disks:

- Disk 1 to 4 are configured in a RAID 5 (ASM disk 1)
- Disk 5 to 8 are configured in a RAID 5 (ASM disk 2)
- Disk 9 to 12 are configured in a RAID 5 (ASM disk 3)
- Disk 13 to 16 are configured in a RAID 5 (ASM disk 4)
- Disk 17 to 20 are configured in a RAID 5 (ASM disk 5)
- Disk 21 to 24 are configured in a RAID 5 (ASM disk 6)

For Data Record storage on HP on HP Gen9 and X6-2L servers:

Server internal disks:

- Disk 25 & 26 are configured in a RAID 1
- Disk 1 to 24 are configured in a RAID 10 (ASM disk 1)

For Packet Data storage on HP Gen8 servers:

Server internal disks:

- Disk 1 & 2 are configured in a RAID 1

Storage array disks:

- Disk 1 to 12 are configured in a RAID 5 (pdu_1 disk)
- Disk 13 to 24 are configured in a RAID 5 (pdu_2 disk)

For Packet Data storage on HP Gen9 and X6-2L servers:

Server internal disks:

- Disk 25 & 26 are configured in a RAID 1
- Disk 1 to 24 are configured in a RAID 10 (pdu_0 disk)

For mediation and acquisition on servers:

Server internal disks:

- Disk 1 & 2 are configured in a RAID 1

10.11 Cable specification for Falco (SS7 to Sigtran converter)

Ethernet ports:

Falco shall be directly connected to the probe through a cross Ethernet male cable.

An additional RJ45 Ethernet port connected to the network is required for remote O&M.

SS7 line inputs:

For connection to DDF, customer shall provide cables from its DDF to the line inputs of the Falco.

On Falco side, a patch panel provides the RJ45 female interface to connect inputs line:

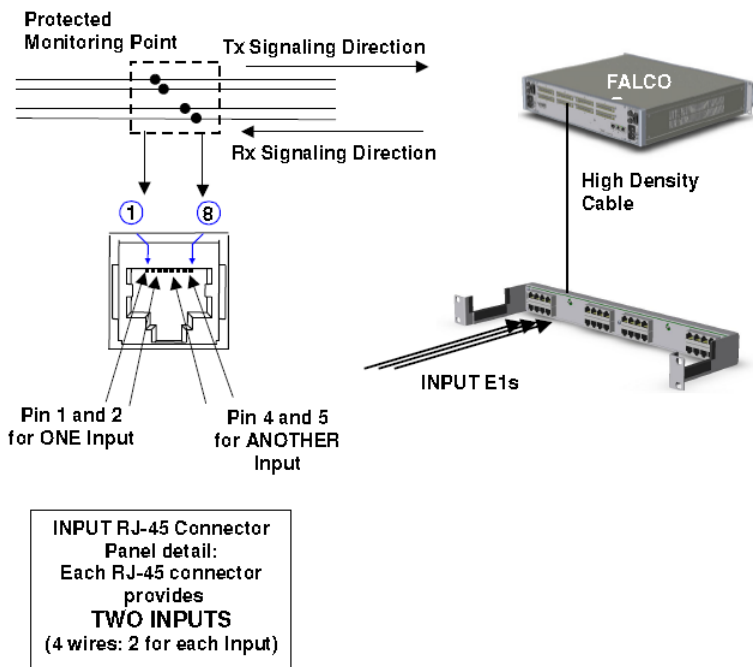

Figure 19- SS7 line inputs to Falco

Each RJ-45 Connector transports two Rx's.

On pins 1 and 2 there are the odd E1 Inputs (1, 3, 5...127)

On pins 4 and 5 there are the even E1 Inputs (2, 4, 6...128)

A Protected Monitoring Point is required, as per ITU G.772. If not, external protection by resistors on the cable to the DDF is always required.

It is strongly recommended to have shielded cables to limit electrical noise interferences from external environment.

- Cable termination sample configuration for unprotected E1

Cable termination is wrapped. Customer shall adapt termination to its specific DDF case.

Hardware Installation Guidelines

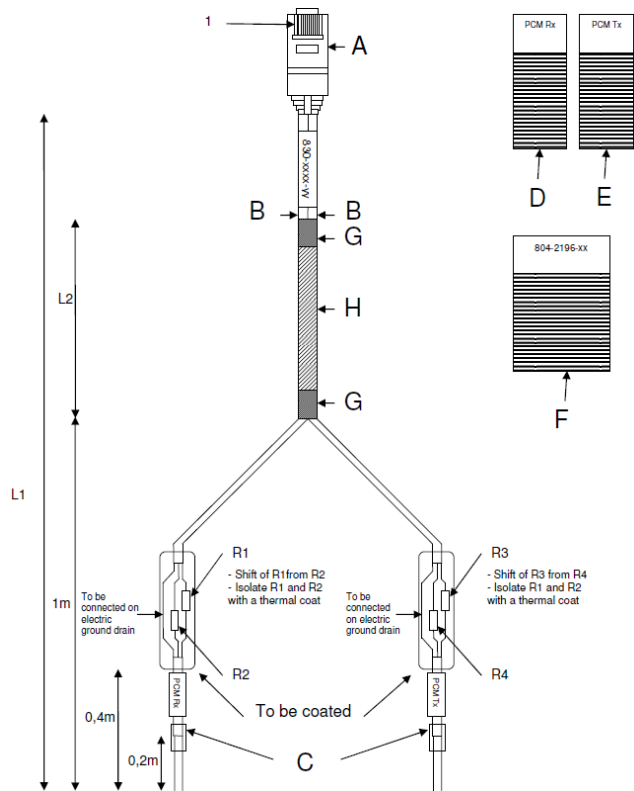

Figure 20- Cable for Falco: sample configuration for unprotected links

CABLE SPECIFICATIONS

Pair	Function	A	Remarks
Pair 1	PCM Rx-	1	
	PCM Rx+	2	
	Drain		Connected on A metallic body
Pair 2	PCM Tx-	4	
	PCM Tx+	5	
	Drain		Connected on A metallic body

Quantity	Reference	Label
1	RJ45 male 8 contacts.	A
1	Grey cover for RJ45 connector.	A
2	Shielded 1 pair cable 1 120Ω, length L1.	B
2	HELAVIA black sleeve type A2-C black L=25mm for 3,5 to 6mm wire's diameter.	C
2	Polyester label.	D-E
1	Polyester label.	F
4	560 ohms resistor 1% 1/2W.	R1, R2, R3, R4

2	Black sleeve for 6,0 wire's diameter. Length 20mm	G
1	Gray polyamide plaited insulation, diameter 8mm, length L2	H

Table 47: Cable for Falco: sample configuration for unprotected links

b) Sample configuration for unprotected T1

Same configuration and network diagram applies for T1. Only the resistors (R1 to R4) value shall be changed to 470 ohms.

c) Configuration for protected links

Cable shall not be equipped with resistors

10.12 Cisco Switch

Performance Intelligence Center is supporting Cisco 4948E-F switch and Cisco nexus 9372TX.

Cisco 4948E-F Switches shall be mounted on the rear of the cabinet. This installation simplifies the Ethernet cables connections as most of the equipment to connect on the switches has their Ethernet ports on the rear.

Note from Cisco install guide: If you are installing the Catalyst 4948E-F switch chassis in a data center that is configured as hot isle and cold isle, you might need to install the Panduit Air Duct kit, Model CDE2. The kit extends the air intake from the rear of the chassis to the front of the equipment rack allowing the system to draw in cool air from the cool isle. To install the air duct assembly, refer to the installation note that ships with the kit.

Qualified BOMs for Cisco 4948E-F is the following:

	P/N	Description	Qty
Cisco	WS-C4948E-F	CISCO 4948E-F_48 PORT_10GBE_SWITCH_ROHS	1
Power DC	PWR-C49-300DC-F	CISCO_4948E-F_DC POWER SUPPLY	1
Software	S49EIPBK9-12254WO(=)	CISCO_4948E-F_IOS SOFTWARE_IP BASE_3DE	1
redundant power	PWR-C49-300DC-F/2	CISCO 4948E-F_DC REDUNDANT POWER SUPPLY	1
Software	WS-C4900-SW-LIC	CISCO 4948E_IP BASE UPGRADE LICENSE	1

Table 48: Cisco 4948E-F configuration

Customer can choose a Cisco 4948E instead for front mounting.

Other version of IOS can be selected by the customer. IP Base is recommended minimum version.

10.13 Cisco basic knowledge

enable to move from user mode to privileged mode

disable to move from privileged mode to user mode

show running-config to display the current configuration in RAM

show startup-config to display the saved configuration in NVRAM

configure terminal to move from privileged mode to config mode

interface gil/1 to move from config mode to an interface config

Hardware Installation Guidelines

copy running-config startup-config save the current configuration

show interfaces display the interfaces status

reload to reboot the switch

show version to display the ROM and IOS information

show tech-support to display a full switch status report. It should be captured in a file because it is long and takes a few minutes

10.13.1 Configure and access the serial console on TPD

Setup minicom access for 4948/4948E switches. This procedure is generic and can be used on any Performance Intelligence Center server running TPD and connected to a switch console through a serial cable.

Determine whether needed minicom files are already available by issuing the following command:

```
# ls /etc/minirc.*
```

The minicom configuration name is: "minirc.<name_of_configuration>".

If the minicom configuration file is not already present, proceed with the rest of this step, otherwise skip to the next step:

Setup the serial connections for a switch by issuing the following command:

```
# remoteConsole --add --name=<name_of_configuration> --bps=9600 --parity=N --databits=8  
--handshake=none --port=<switch_serial_port>
```

Note:

- The default switch_serial_port should be /dev/ttyS1
- The name_of_configuration depends on the user's choice (ex: switch, yellow-sw1-1, blue-sw1-1...)

Connect serially to switch by issuing the following command as root on the management server:

```
# minicom <name_of_configuration>
```

Press RETURN to get started.

Press **Enter**

If the "autoinstall" line below does not appear, the switch may not be in factory default condition, continue with the step, disregarding this line:

```
Would you like to terminate autoinstall? [yes]:Enter
```

```
Switch> enable
```

```
Switch#
```

If "enable" command above prompts for a password, the switch is not in factory default configuration. This may be due to a previous configuration attempt. This procedure is for initial install.

To exit from the console, enter **<ctrl-a><q>** and you will be returned to the server prompt.

10.13.2 Configure and access the serial console on TVOE

From TVOE server: Setup conserver serial access a switch and open the firewall to allow for future tftp use in this procedure.

From management server, configure the conserver service to enable serial access to the switches:

```
# conserverAdm --addConsole --name=switch_console --device=/dev/ttyS4
```

Open the conserver port on the firewall of the TVOE management server:

```
# iptables -I INPUT -s <pmac_mgmtVLAN_ip_address>/255.255.255.255 -p all -j ACCEPT
```

```
# service iptables save
```

Note: The default devices should be /dev/ttyS4 and /dev/ttyS5 for PM&C

Connect serially to switch by issuing the following command from the PM&C server or any other servers you open the port on the firewall.

```
# console -M <TVOE_server_mgmtVLAN_ip_address> -l platcfg switch_console
Enter platcfg@pmac5000101's password: <platcfg_password>
[Enter '^Ec?' for help]
Press Enter
Switch>
```

Depending on the switch config you might have to provide also the appropriate password to access the switch console after having provided the platcfg password.

To exit from the console, enter <ctrl-E><c><. > and you will be returned to the server prompt.

10.13.3 4948&4948EF Reset to factory defaults



Using this procedure you might lose the network connectivity.
It is advice to not do it with a remote connection
In privileged mode type

```
Switch#write erase
Erasing the nvram filesystem will remove all configuration files! Continue? [confirm]
[OK]
Erase of nvram: complete
*May 23 07:28:47.754: %SYS-7-NV_BLOCK_INIT: Initialized the geometry of nvram
Switch#erase cat4000_flash:
Erasing the cat4000_flash filesystem will remove all files! Continue? [confirm]
[OK]
Erase of cat4000_flash: complete
Switch#reload
System configuration has been modified. Save? [yes/no]: <- if the question is asked the
answer to this question is no
Proceed with reload? [confirm]
```

Once the switch rebooted you might receive the following question before to get the prompt

```
Press RETURN to get started!
 00:00:01: %C4K_IOSSYS-3-BLANKSTARTUPCONFIG: Blank or invalid startup-config, bo
s00:00:17: %SPANTREE-5-EXTENDED_SYSID: Extended SysId enabled for type vlan
 00:00:18: %C4K_IOSMODPORTMAN-6-MODULEONLINE: Module 1 (WS-C4948 S/N: FOX11450NC
e00:00:37: %SYS-5-RESTART: System restarted --
Cisco IOS Software, Catalyst 4500 L3 Switch Software (cat4500-IPBASEK9-M), Vers
)Technical Support: http://www.cisco.com/techsupport
Copyright (c) 1986-2008 by Cisco Systems, Inc.
Compiled Tue 29-Jul-08 12:15 by tinhuang

Would you like to terminate autoinstall? [yes]: <- if the question is asked the answer
to this question is yes
```

Configure the switch to boot properly by verifying that the bootvar is showing the correct configuration, from 0-IPBASEK9-M), V# dir bootflash:

determine from the output the latest image (check the version at cisco website if necessary)

if the width of the screen does not permit to see the complete output, use the following (the question mark Number", and if it # show file info bootflash:?

```
# show bootvar
```

if how b variablebootflash:oes not permit to /or config register is not 0x2102:

basically follow:

```
# config terminal
(config)# boot system flash bootflash:<name of image with latest version>
(config)# config-register 0x2102
(config)# end
# write memory
# show bootvar
```

Hardware Installation Guidelines

10.13.4 Assign an IP address on a 3020

Refer to E53486 Oracle Communications Tekelec Platform 7.0.x Configuration Guide, section 3.5.2 Configure initial OA settings via configuration wizard step 8 OA GUI: EBIPA settings

10.13.5 2950 & 3020 Reset to factory defaults



Using this procedure you might lose the network connectivity.
It is advice to not do it with a remote connection
In privileged mode type

```
Switch#write erase
Erasing the nvram filesystem will remove all configuration files! Continue? [confirm]
[OK]
Erase of nvram: complete
*May 23 07:28:47.754: %SYS-7-NV_BLOCK_INIT: Initialized the geometry of nvram
Switch#delete flash:vlan.dat
Delete filename [vlan.dat]?
Delete flash:vlan.dat? [confirm]
Switch#reload
System configuration has been modified. Save? [yes/no]: <- if the question is asked the
answer to this question is no
Proceed with reload? [confirm]
```

10.13.6 Configure telnet access on a 3020

Connect on the OA from the enclosure, and Navigate to the Interconnect Bays. Open the management URL. Take care if you reset the switch the password is back to the default value.

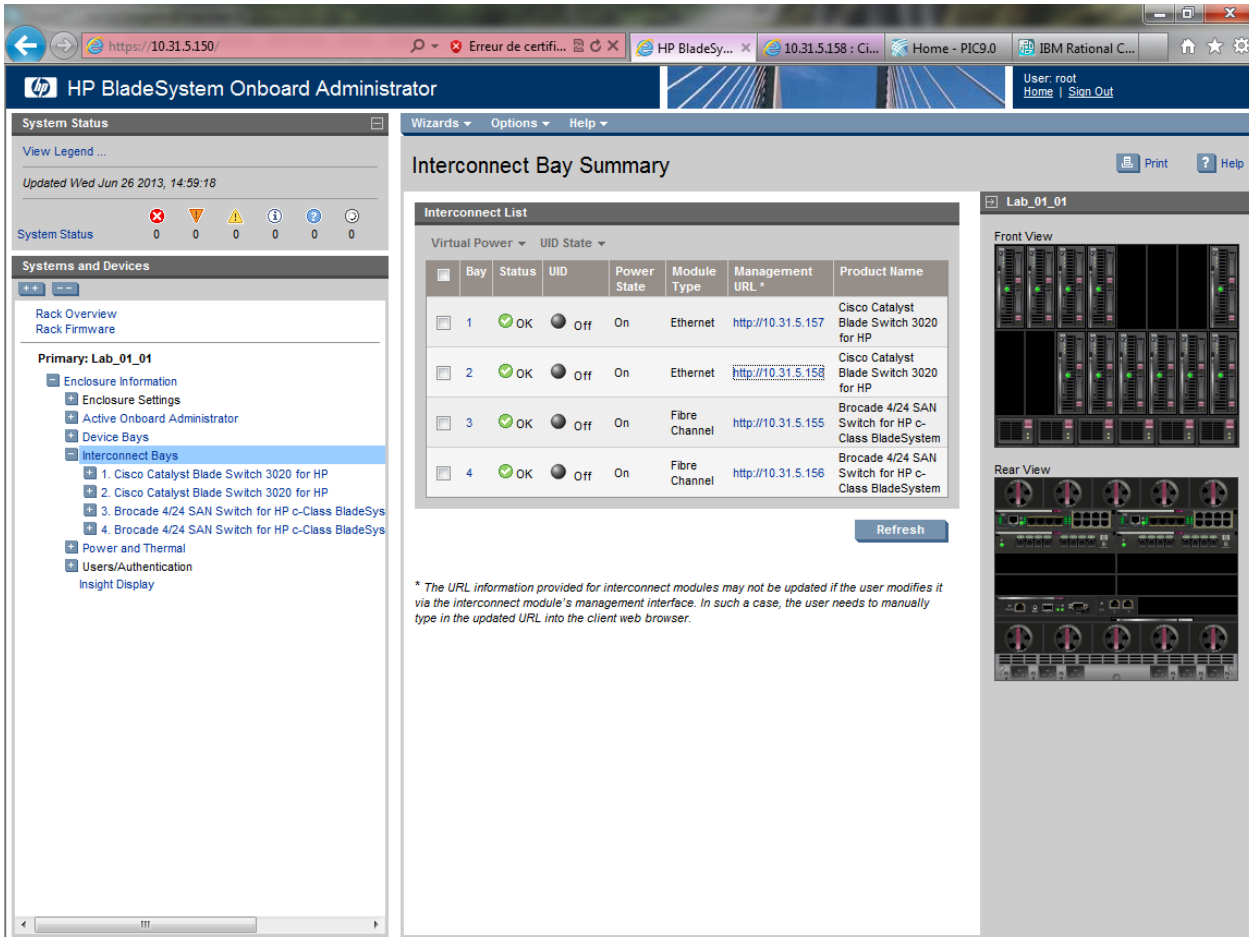

If it is the first access the web interface will open directly on the express setup, otherway you can access it from the configure menu.

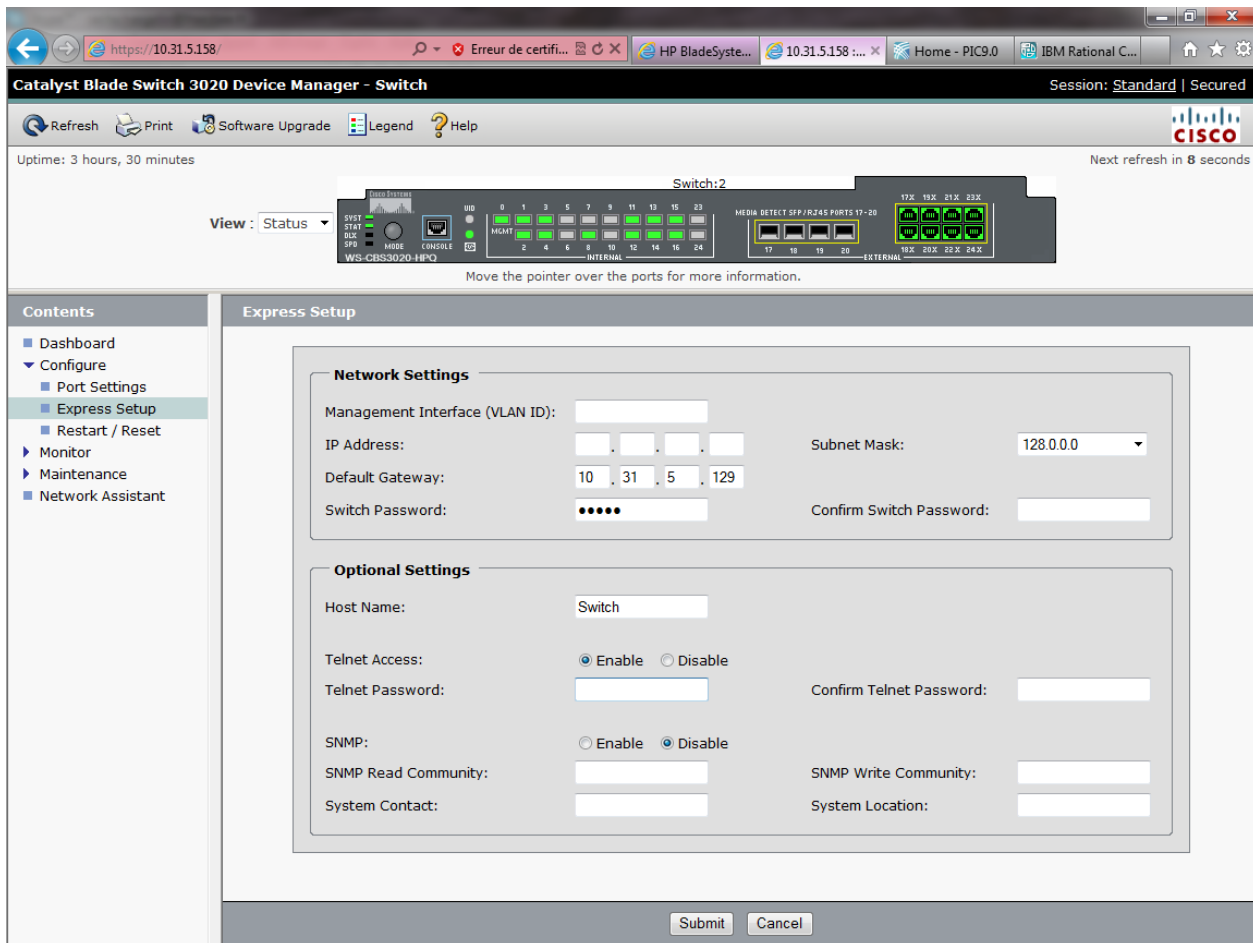

From there you can enable the telnet access and define the password. You will have also to specify the VLAN ID to 1 and an IP in this VLAN, but don't configure the gateway. The IP will be removed while the switch config, and all configuration will be done using telnet on the EBIPA address.

10.13.7 Configure SSH access

In order to configure the SSH access you must have an IOS supporting the encryption. To check you must ensure the IOS file name contain "K9"

Move from the user mode to privileged mode.

```
Switch#enable
Switch#show version | include cat4500
Cisco IOS Software, Catalyst 4500 L3 Switch Software (cat4500e-ENTSERVICESK9-M), Version 12.2(54)WO, RELEASE SOFTWARE (fc1)
```

System image file is "bootflash:cat4500e-entservicesk9-mz.122-54.WO.bin"

If it is the case than you can proceed with the following commands once you moved to the config mode:

```
Switch# configure terminal
username root password 0 ***** ! <----- replace ***** with password
specified in password dragon as Cisco SSH
ip domain-name tekelec.com
crypto key generate rsa
```

Hardware Installation Guidelines

```
% You already have RSA keys defined named switch1B.tekelec.com.
% Do you really want to replace them? [yes/no]: yes
Choose the size of the key modulus in the range of 360 to 2048 for your
  General Purpose Keys. Choosing a key modulus greater than 512 may take
  a few minutes.
How many bits in the modulus [512]: 1024
% Generating 1024 bit RSA keys, keys will be non-exportable...[OK]
ip ssh version 2
line vty 0 15
  login local
  transport input ssh
end
```

10.13.8 Recover a switch from rommon prompt

In case the switch configuration failed and the switch would be in rommon follow this procedure to boot the switch.

Note: This is a generic procedure and the ios file name might be different depending on version running on your switch.

```
rommon 6 >dir bootflash:
  File size                Checksum                File name
  -----
12632100 bytes (0xc0c024)  0x8136853a            cat4500-ipbasek9-mz.122-31.SGA8.bin
 456060 bytes (0x6f57c)    0x66d8b2a7            cat4500-ios-promupgrade-122_31r_SGA1
Total space = 60817408 bytes, Available = 47728992 bytes
```

```
rommon 8 >confreg
Configuration Summary :
=> console baud: 9600
=> autoboot from: commands specified in 'BOOT' environment variable
do you wish to change the configuration? y/n [n]: y
enable "diagnostic mode"? y/n [n]: n
enable "use net in IP bcast address"? y/n [n]:
enable "load rom after netboot fails"? y/n [n]:
enable "use all zero broadcast"? y/n [n]:
enable "break/abort has effect"? y/n [n]: y
enable "ignore system config info"? y/n [n]:
change console baud rate? y/n [n]:
change the boot characteristics? y/n [n]: y
enter to boot:
0 = disable autoboot
1 = the first file from internal flash device
2 = commands specified in 'BOOT' environment variable
[2]:
Configuration Summary :
=> break/abort has effect
=> console baud: 9600
=> autoboot from: commands specified in 'BOOT' environment variable

do you wish to save this configuration? y/n [n]: y
You must reset or power cycle for new configuration to take effect
rommon 10 >boot bootflash:cat4500-ipbasek9-mz.122-31.SGA8.bin
Rommon reg: 0xE2004180
#####
k2diags version 5.2_c
Switch> enable
Switch# config t
```

Hardware Installation Guidelines

Modify the configuration to boot using the new software and no more the previous one.

```
Switch#configure terminal
Enter configuration commands, one per line.  End with CNTL/Z.
Switch(config)#boot system flash bootflash:cat4500-ipbasek9-mz.122-53.SG2.bin
Switch(config)#no boot system flash bootflash:cat4500-ipbase-mz.122-46.SG.bin
Switch(config)#config-register 0x2102
Switch(config)#exit
Switch #copy running-config startup-config
Switch #reload
```

After reloading, verify that the switch is booting to the expected version:

```
Switch# #show version | include bootflash
System image file is "bootflash:cat4500-ipbasek9-mz.122-53.SG2.bin"
```

10.13.10 Backup the switch config on a server

Use the following command to backup a switch configuration on a server.

```
blue-sw1-1#copy running-config scp:
Address or name of remote host []? 172.22.49.10
Destination username [root]?
Destination filename [blue-sw1-1-config]?
Writing blue-sw1-1-config
Password:
!!
9314 bytes copied in 14.292 secs (652 bytes/sec)
blue-sw1-1#
```

10.13.11 Configure Cisco 4948/4948E/4948E-F/9372TX switch

This procedure describes how to configure the Cisco switches.

Configure the switches from the applicable server as follows:

Note: Not all the switches listed may be applicable for your particular configuration.

- Yellow-sw1-1 from IMF-1A server
- Blue-sw1-1 from IMF-1B server
- Yellow-sw2-1 from IMF-1C server
- Blue-sw2-1 from IMF-1D server
- Yellow-sw3-1 from IMF-1E server
- Blue-sw3-2 from IMF-1F server

In case there are more switches required than IMF servers, the console port of the additional switch will have to be moved on one of the servers or configured using a laptop.

For an estimated time for this procedure, refer to the IMF flowcharts in Installation Overview.

Mediation switch are connected to the first MEDIATION server from the cabinet.

Note: In case in the procedure would failed, refer to section 6.10.8 in order to recover the switch from rommon prompt.

- A. Configure and access the serial console from the server (PM&C, IMF or IXP) on the switches
 - a. Refer to section 6.10.1 or 6.10.2
- B. Reset the switch to factory default
 - a. If you are reconfiguring a switch backup the current config in a file using the command
- C. Configure the switch using the appropriate template
 - a. Refer to following sections to select the appropriate configuration template and adapt it to the customer IP network.
 - i. Section 6.11 for mediation
 - ii. Section 6.12 for Blades
 - iii. Section 6.13 for Intergrated Acquisition
 - b. As there is no log file for the following steps it is recomanded to enable the log feature from your terminal in case something would not work as expected and assistance is required.
 - c. Move from the user mode to priviledge mode and then to config mode

```
Switch# enable
```

```
Switch# configure terminal
```

Note : if you reset the switch to factory default no password should be requested to connect on it and move to enable mode.

- d. Adapt the template configuration to your network. The lines you need to customize are hilighted with Yellow comments. Paste the command in block and not necessary one by one but don't do it with too much commands at a time in order to take care if an error message would appear.
- e. Once the config is in place you can check it is matching your expectation using the command

```
Switch# show running-config
```

- f. If the configuration is fine then you can save it in the flash in order to have it automatically reloaded if the switch reboot

```
Switch# copy running-config startup-config
```

- g. If there is an issue in your config you can can reboot the switch without saving and then restart the config from the step a

```
Switch# reload
```

- h. Finally to configure the SSH access to the switch refer to section 6.10.7
- i. Once the config is in place you can check it is matching your expectation using the command

```
Switch# show running-config
```

- j. If the configuration is fine then you can save it in the flash in order to have it automatically reloaded if the switch reboot

```
Switch# copy running-config startup-config
```

- k. If there is an issue in your config you can can reboot the switch without saving and then restart the config from the step h

```
Switch# reload
```

10.13.12 Configure Cisco 3020 switch

- A. Assign IP addresses to the switches
 - a. Refer to E53486 Oracle Communications Tekelec Platform 7.0.x Configuration Guide, section 3.5.2 Configure initial OA settings via configuration wizard step 8 OA GUI: EBIPA settings if this was not done earlier
- B. Reset the switch to factory default
 - a. If you are reconfiguring a switch backup the current config in a file using the command

Hardware Installation Guidelines

```
Switch# show running-config
```

- b. Refer to section 6.10.5 to reset the switch. Take care to only erase the vlan.dat and not the whole content of the flash.
- C. Reconfigure the telnet access
 - a. Refer to section 6.10.6.
- D. Configure the switch using the appropriate template
 - a. Refer to the following section 6.12.3.
 - b. As there is no log file for the following steps it is recommended to enable the log feature from your terminal in case something would not work as expected and assistance is required.
 - c. Open a telnet session on the switch and then move from the user mode to privileged mode and then to config mode

```
Switch# enable
```

```
Switch# configure terminal
```

Note : if you reset the switch to factory default no password should be requested to connect on it and move to enable mode.

- d. Paste all the commands from the template config you have adapted to your network. The lines you need to customize are highlighted with yellow comments. You can paste the command in block and not necessarily one by one but don't do it with too many commands at a time in order to take care if an error message would appear.
- e. Once the config is in place you can check it is matching your expectation using the command

```
Switch# show running-config
```

- f. If the configuration is fine then you can save it in the flash in order to have it automatically reloaded if the switch reboots

```
Switch# copy running-config startup-config
```

- g. If there is an issue in your config you can reboot the switch without saving and then restart the config from step a

```
Switch# reload
```

10.13.13 Flush ARP table

- A. Check VIP address mapping on the Switch (in enable mode)

```
Switch #show arp
```

Protocol	Address	Age (min)	Hardware Addr	Type	Interface
Internet	172.21.49.10	1	0010.1326.a103	ARPA	Vlan100
Internet	172.21.49.11	0	001e.6700.c9a4	ARPA	Vlan100

Use the ifconfig command on the Master IMF server to get the MAC address of its interfaces:

```
bond0.200 Link encap:Ethernet HWaddr 00:10:13:26:A1:03
          inet addr:10.31.2.101 Bcast:10.31.2.255 Mask:255.255.255.0
          inet6 addr: fe80::210:13ff:fe26:a103/64 Scope:Link
```

Compare the **Hardware Addr** with the **HWaddr** (be careful in this example 0010.1326.a103 is equal to 00:10:13:26:A1:03).

If the values are equal or if no entry matches the VIP address, then it is not necessary to flush the ARP table of the Cisco switch.

If the VIP address is associated to a wrong MAC address, then continue the procedure.

- B. Flush the ARP table on the Switch (in enable mode)

```
Switch# clear arp-cache
```

10.14 Mediation switch configuration template

The VLAN values must be customized according customer requirement

10.14.1 Switch port allocation

The first IXP Server iLO are directly connected to customer network. Server E in the control frame and server A in the extension frames

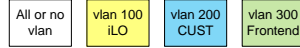

Ctrl Frame RM	Port 1 ServerA iLO	Port 3 ServerB iLO	Port 5 Free	Port 7 Free	Port 9 Free	Port 11 ServerF iLO	Port 13 ServerG iLO	Port 15 ServerH iLO	Port 17 ServerI iLO	Port 19 ServerJ iLO	Port 21 ServerK iLO	Port 23 ServerL iLO	Port 25 Next Frame	Port 27 Next Frame	Port 29 Next Frame	Port 31 Next Frame	Port 33 Next Frame	Port 35 Next Frame	Port 37 Next Frame	Port 39 Next Frame	Port 41 Cust Net iLO	Port 43 ServerA eth4	Port 45 ServerB eth4	Port 47 Cust Net SW A
	Port 2 ServerA eth2	Port 4 ServerB eth2	Port 6 ServerA eth3	Port 8 ServerB eth3	Port 10 ServerE eth1	Port 12 ServerF eth1	Port 14 ServerG eth1	Port 16 ServerH eth1	Port 18 ServerI eth1	Port 20 ServerJ eth1	Port 22 ServerK eth1	Port 24 ServerL eth1	Port 26 Next Frame	Port 28 Next Frame	Port 30 Next Frame	Port 32 Next Frame	Port 34 Next Frame	Port 36 Next Frame	Port 38 Next Frame	Port 40 Next Frame	Port 42 Cust Net Frontend	Port 44 ServerA eth5	Port 46 ServerB eth5	Port 48 Cust Net SW B
Ext Frame RM 7.1 and higher	Port 1 Free	Port 3 ServerB iLO	Port 5 ServerC iLO	Port 7 ServerD iLO	Port 9 ServerE iLO	Port 11 ServerF iLO	Port 13 ServerG iLO	Port 15 ServerH iLO	Port 17 ServerI iLO	Port 19 ServerJ iLO	Port 21 ServerK iLO	Port 23 ServerL iLO	Port 25 Free	Port 27 Free	Port 29 Free	Port 31 Free	Port 33 Free	Port 35 Free	Port 37 Free	Port 39 Free	Port 41 Free	Port 43 Free	Port 45 Free	Port 47 iLO Ctrl Frame
	Port 2 ServerA eth1	Port 4 ServerB eth1	Port 6 ServerC eth1	Port 8 ServerD eth1	Port 10 ServerE eth1	Port 12 ServerF eth1	Port 14 ServerG eth1	Port 16 ServerH eth1	Port 18 ServerI eth1	Port 20 ServerJ eth1	Port 22 ServerK eth1	Port 24 ServerL eth1	Port 26 Free	Port 28 Free	Port 30 Free	Port 32 Free	Port 34 Free	Port 36 Free	Port 38 Free	Port 40 Free	Port 42 Free	Port 44 Free	Port 46 Free	Port 48 Eth Ctrl Frame
Ext Frame RM 7.0 and lower	Port 1 Free	Port 3 ServerB iLO	Port 5 ServerC iLO	Port 7 ServerD iLO	Port 9 ServerE iLO	Port 11 Free	Port 13 Free	Port 15 Free	Port 17 Free	Port 19 Free	Port 21 ServerF iLO	Port 23 ServerG iLO	Port 25 ServerH iLO	Port 27 ServerI iLO	Port 29 ServerJ iLO	Port 31 ServerK iLO	Port 33 ServerL iLO	Port 35 Free	Port 37 Free	Port 39 Free	Port 41 Free	Port 43 Free	Port 45 Free	Port 47 iLO Ctrl Frame
	Port 2 ServerA eth1	Port 4 ServerB eth1	Port 6 ServerC eth1	Port 8 ServerD eth1	Port 10 ServerE eth1	Port 12 Free	Port 14 Free	Port 16 Free	Port 18 Free	Port 20 Free	Port 22 ServerF eth1	Port 24 ServerG eth1	Port 26 ServerH eth1	Port 28 ServerI eth1	Port 30 ServerJ eth1	Port 32 ServerK eth1	Port 34 ServerL eth1	Port 36 Free	Port 38 Free	Port 40 Free	Port 42 Free	Port 44 Free	Port 46 Free	Port 48 Eth Ctrl Frame

10.14.2 Control Frame Switch for 4948 / 4949EF

Note: The command “spanning-tree portfast trunk” will return the following warning, you can ignore:

```
%Warning: portfast should only be enabled on ports connected to a single host.
Connecting hubs, concentrators, switches, bridges, etc... to this interface
when portfast is enabled, can cause temporary bridging loops.
Use with CAUTION
```

Note: the commands “switchport trunk encapsulation dot1q” and “media-type rj45” will fail on the 4948EF switch but it is kept this config for compatibility with the previous 4948

```
!
no service pad
service timestamps debug uptime
service timestamps log uptime
service password-encryption
service compress-config
!
hostname Switch
!
enable secret ***** ! <----- replace ***** with password specified in password dragon as Cisco enable
!
no aaa new-model
ip subnet-zero
no ip source-route
no ip domain-lookup
```

Hardware Installation Guidelines

```
!  
vtp mode transparent  
!  
!  
!  
power redundancy-mode redundant  
no file verify auto  
!  
spanning-tree mode rapid-pvst  
no spanning-tree optimize bpdu transmission  
spanning-tree extend system-id  
!  
vlan internal allocation policy ascending  
!  
!  
vlan 100          ! <----- replace VLAN with customer value  
  name iLO  
!  
vlan 200          ! <----- replace VLAN with customer value  
  name CUST  
!  
vlan 300          ! <----- replace VLAN with customer value  
  name NSP_Front  
!  
Interface range Gi1/1 ,Gi1/3 ,Gi1/5 ,Gi1/7 ,Gi1/9  
  description Server iLO Access  
  switchport access vlan 100  ! <----- replace VLAN with customer value  
  switchport mode access  
  spanning-tree portfast  
!  
Interface range Gi1/11 ,Gi1/13 ,Gi1/15 ,Gi1/17 ,Gi1/19  
  description Server iLO Access  
  switchport access vlan 100  ! <----- replace VLAN with customer value  
  switchport mode access  
  spanning-tree portfast  
!  
Interface range Gi1/21 ,Gi1/23 ,Gi1/25 ,Gi1/27 ,Gi1/29  
  description Server iLO Access  
  switchport access vlan 100  ! <----- replace VLAN with customer value  
  switchport mode access  
  spanning-tree portfast  
!  
Interface range Gi1/31 ,Gi1/33 ,Gi1/35 ,Gi1/37 ,Gi1/39  
  description Server iLO Access  
  switchport access vlan 100  ! <----- replace VLAN with customer value  
  switchport mode access
```

```
spanning-tree portfast
!
Interface range Gi1/41
description Server iLO Access
switchport access vlan 100 ! <----- replace VLAN with customer value
switchport mode access
spanning-tree portfast
!
interface range Gi1/2 ,Gi1/4 ,Gi1/6 ,Gi1/8 ,Gi1/10
description Server CUST Access
switchport access vlan 200 ! <----- replace VLAN with customer value
switchport mode access
spanning-tree portfast
!
interface range Gi1/12 ,Gi1/14 ,Gi1/16 ,Gi1/18 ,Gi1/20
description Server CUST Access
switchport access vlan 200 ! <----- replace VLAN with customer value
switchport mode access
spanning-tree portfast
!
interface range Gi1/22 ,Gi1/24 ,Gi1/26 ,Gi1/28 ,Gi1/30
description Server CUST Access
switchport access vlan 200 ! <----- replace VLAN with customer value
switchport mode access
spanning-tree portfast
!
interface range Gi1/32 ,Gi1/34 ,Gi1/36 ,Gi1/38 ,Gi1/40
description Server CUST Access
switchport access vlan 200 ! <----- replace VLAN with customer value
switchport mode access
spanning-tree portfast
!
interface range GigabitEthernet1/42 - 46
description NSP NIC2 CUST Ethernet Access
switchport access vlan 300 ! <----- replace VLAN with customer value
switchport mode access
spanning-tree portfast
!
interface GigabitEthernet1/47
description 802.1Q trunk link to backbone SWA
switchport trunk encapsulation dot1q
switchport mode trunk
media-type rj45
!
interface GigabitEthernet1/48
description 802.1Q trunk link to backbone SWB
```

Hardware Installation Guidelines

```
switchport trunk encapsulation dot1q
switchport mode trunk
media-type rj45
spanning-tree cost 20
!
interface Vlan1
no ip address
shutdown
!
interface Vlan100      ! <----- replace VLAN with customer value
description Optional Switch Virtual Interface (SVI) for iLO Subnet - switch management
no ip address
shutdown
!
interface Vlan200     ! <----- replace VLAN with customer value
description Optional Switch Virtual Interface (SVI) for CUST Subnet - switch management
no ip address
shutdown
!
no ip http server
!
!
!
no cdp run
!
control-plane
!
!
line con 0
password ***** ! <----- replace ***** with password specified in password dragon as Cisco telnet
exec-timeout 30 0
logging synchronous
stopbits 1
!
end
```

10.14.3 Extension Frame Switch for Cisco 4948 / 4948EF

Note: The command “spanning-tree portfast trunk” will return the following warning, you can ignore:

```
%Warning: portfast should only be enabled on ports connected to a single host.
Connecting hubs, concentrators, switches, bridges, etc... to this interface
when portfast is enabled, can cause temporary bridging loops.
```

Use with CAUTION

Hardware Installation Guidelines

Note: the commands “switchport trunk encapsulation dot1q” and “media-type rj45” will fail on the 4948EF switch but it is kept this config for compatibility with the previous 4948

```
!  
no service pad  
service timestamps debug uptime  
service timestamps log uptime  
service password-encryption  
service compress-config  
!  
hostname Switch  
!  
enable secret ***** ! <----- replace ***** with password specified in password dragon as Cisco enable  
!  
no aaa new-model  
ip subnet-zero  
no ip source-route  
no ip domain-lookup  
!  
vtp mode transparent  
!  
!  
power redundancy-mode redundant  
no file verify auto  
!  
spanning-tree mode rapid-pvst  
no spanning-tree optimize bpdu transmission  
spanning-tree extend system-id  
!  
vlan internal allocation policy ascending  
!  
!  
vlan 100 ! <----- replace VLAN with customer value  
  name iLO  
!  
vlan 200 ! <----- replace VLAN with customer value  
  name CUST  
!  
Interface range Gi1/1 ,Gi1/3 ,Gi1/5 ,Gi1/7 ,Gi1/9  
  description Server iLO Access  
  switchport access vlan 100 ! <----- replace VLAN with customer value  
  switchport mode access  
  spanning-tree portfast  
!  
Interface range Gi1/11 ,Gi1/13 ,Gi1/15 ,Gi1/17 ,Gi1/19
```

Hardware Installation Guidelines

```
description Server iLO Access
switchport access vlan 100 ! <----- replace VLAN with customer value
switchport mode access
spanning-tree portfast
!
Interface range Gil/21 ,Gil/23 ,Gil/25 ,Gil/27 ,Gil/29
description Server iLO Access
switchport access vlan 100 ! <----- replace VLAN with customer value
switchport mode access
spanning-tree portfast
!
Interface range Gil/31 ,Gil/33 ,Gil/35 ,Gil/37 ,Gil/39
description Server iLO Access
switchport access vlan 100 ! <----- replace VLAN with customer value
switchport mode access
spanning-tree portfast
!
Interface range Gil/41 ,Gil/43 ,Gil/45
description Server iLO Access
switchport access vlan 100 ! <----- replace VLAN with customer value
switchport mode access
spanning-tree portfast
!
interface range Gil/2 ,Gil/4 ,Gil/6 ,Gil/8 ,Gil/10
description Server CUST Access
switchport access vlan 200 ! <----- replace VLAN with customer value
switchport mode access
spanning-tree portfast
!
interface range Gil/12 ,Gil/14 ,Gil/16 ,Gil/18 ,Gil/20
description Server CUST Access
switchport access vlan 200 ! <----- replace VLAN with customer value
switchport mode access
spanning-tree portfast
!
interface range Gil/22 ,Gil/24 ,Gil/26 ,Gil/28 ,Gil/30
description Server CUST Access
switchport access vlan 200 ! <----- replace VLAN with customer value
switchport mode access
spanning-tree portfast
!
interface range Gil/32 ,Gil/34 ,Gil/36 ,Gil/38 ,Gil/40
description Server CUST Access
switchport access vlan 200 ! <----- replace VLAN with customer value
switchport mode access
spanning-tree portfast
```

```
!  
interface range Gi1/42 ,Gi1/44 ,Gi1/46  
  description Server CUST Access  
  switchport access vlan 200 ! <----- replace VLAN with customer value  
  switchport mode access  
  spanning-tree portfast  
!  
interface GigabitEthernet1/47  
  description Connection to Control Frame Switch on iLO VLAN  
  switchport access vlan 100 ! <----- replace VLAN with customer value  
  switchport mode access  
  spanning-tree portfast  
!  
interface GigabitEthernet1/48  
  description Connection to Control Frame Switch on CUST VLAN  
  switchport access vlan 200 ! <----- replace VLAN with customer value  
  switchport mode access  
  spanning-tree portfast  
!  
!  
interface Vlan1  
  no ip address  
  shutdown  
!  
interface Vlan100 ! <----- replace VLAN with customer value  
  description Optional Switch Virtual Interface (SVI) for iLO Subnet - switch management  
  no ip address  
  shutdown  
!  
interface Vlan200 ! <----- replace VLAN with customer value  
  description Optional Switch Virtual Interface (SVI) for CUST Subnet - switch management  
  no ip address  
  shutdown  
!  
no ip http server  
!  
!  
!  
no cdp run  
!  
control-plane  
!  
!  
line con 0  
  password ***** ! <----- replace ***** with password specified in password dragon as Cisco telnet  
  exec-timeout 30 0
```

Hardware Installation Guidelines

```
logging synchronous
stopbits 1
!
End
```

10.14.4 Control Frame Switch for 9372TX

Note : for simplicity the port allocation on the 9372TX is identical to the one for 4948. Vlan numbers can be freely assigned. Configuration is saved using command: copy running-config startup-config
write erase command can be used to reset to factory default (this command shall be used with caution as a risk of being disconnected with no possibility to reconnect exists)

```
version 7.0(3)I4(5)
hostname Control-sw
vdc Control-sw id 1
  limit-resource vlan minimum 16 maximum 4094
  limit-resource vrf minimum 2 maximum 4096
  limit-resource port-channel minimum 0 maximum 511
  limit-resource u4route-mem minimum 248 maximum 248
  limit-resource u6route-mem minimum 96 maximum 96
  limit-resource m4route-mem minimum 58 maximum 58
  limit-resource m6route-mem minimum 8 maximum 8

feature privilege
feature bash-shell
feature scp-server
feature vrrp
feature pim
feature interface-vlan
feature hsrp
feature lacp
feature lldp
clock protocol ntp vdc 1
feature sflow
feature evmed

no password strength-check
username admin password My_password role network-admin ! <----- Specify new username password
ip domain-lookup
crypto key param rsa label P5-Switch1 modulus 1024
system jumbomt 9198
copp profile strict
ntp server X.X.X.X ! <----- Specify NTP server IP add (optional)
ntp authenticate ! <----- optional
ntp authentication-key 135 md5 swwxoomi 7 ! <----- Change Password if needed (optional)
ntp trusted-key 135
```

```
ntp logging
login on-success log

vlan 1,100,200,300

vlan 100
  name oobm_or_ilo
vlan 200
  name IXP_internal_(backend)
vlan 300
  name Fronted

spanning-tree vlan 1 priority 0
vrf context management
hardware access-list tcam region vpc-convergence 0
hardware access-list tcam region arp-ether 256

interface Ethernet1/1
  description ILO(M) port
  switchport access vlan 100
  spanning-tree port type edge

interface Ethernet1/2
  description IXP server port
  switchport access vlan 200
  spanning-tree port type edge

interface Ethernet1/3
  description ILO(M) port
  switchport access vlan 100
  spanning-tree port type edge

interface Ethernet1/4
  description IXP server port
  switchport access vlan 200
  spanning-tree port type edge

interface Ethernet1/5
  description Free port

interface Ethernet1/6
  description IXP server port
  switchport access vlan 200
  spanning-tree port type edge
```

Hardware Installation Guidelines

```
interface Ethernet1/7
  description Free port

interface Ethernet1/8
  description IXP server port
  switchport access vlan 200
  spanning-tree port type edge

interface Ethernet1/9
  description Free port

interface Ethernet1/10
  description IXP server port
  switchport access vlan 200
  spanning-tree port type edge

interface Ethernet1/11
  description ILO(M) port
  switchport access vlan 100
  spanning-tree port type edge

interface Ethernet1/12
  description IXP server port
  switchport access vlan 200
  spanning-tree port type edge

interface Ethernet1/13
  description ILO(M) port
  switchport access vlan 100
  spanning-tree port type edge

interface Ethernet1/14
  description IXP server port
  switchport access vlan 200
  spanning-tree port type edge

interface Ethernet1/15
  description ILO(M) port
  switchport access vlan 100
  spanning-tree port type edge

interface Ethernet1/16
  description IXP server port
  switchport access vlan 200
  spanning-tree port type edge
```

Hardware Installation Guidelines

```
interface Ethernet1/17
  description ILO(M) port
  switchport access vlan 100
  spanning-tree port type edge
```

```
interface Ethernet1/18
  description IXP server port
  switchport access vlan 200
  spanning-tree port type edge
```

```
interface Ethernet1/19
  description ILO(M) port
  switchport access vlan 100
  spanning-tree port type edge
```

```
interface Ethernet1/20
  description IXP server port
  switchport access vlan 200
  spanning-tree port type edge
```

```
interface Ethernet1/21
  description ILO(M) port
  switchport access vlan 100
  spanning-tree port type edge
```

```
interface Ethernet1/22
  description IXP server port
  switchport access vlan 200
  spanning-tree port type edge
```

```
interface Ethernet1/23
  description ILO(M) port
  switchport access vlan 100
  spanning-tree port type edge
```

```
interface Ethernet1/24
  description IXP server port
  switchport access vlan 200
  spanning-tree port type edge
```

```
interface Ethernet1/25
  description ILO(M) port
  switchport access vlan 100
  spanning-tree port type edge
```

```
interface Ethernet1/26
```

Hardware Installation Guidelines

```
description IXP server port
switchport access vlan 200
spanning-tree port type edge
```

```
interface Ethernet1/27
description ILO(M) port
switchport access vlan 100
spanning-tree port type edge
```

```
interface Ethernet1/28
description IXP server port
switchport access vlan 200
spanning-tree port type edge
```

```
interface Ethernet1/29
description ILO(M) port
switchport access vlan 100
spanning-tree port type edge
```

```
interface Ethernet1/30
description IXP server port
switchport access vlan 200
spanning-tree port type edge
```

```
interface Ethernet1/31
description ILO(M) port
switchport access vlan 100
spanning-tree port type edge
```

```
interface Ethernet1/32
description IXP server port
switchport access vlan 200
spanning-tree port type edge
```

```
interface Ethernet1/33
description ILO(M) port
switchport access vlan 100
spanning-tree port type edge
```

```
interface Ethernet1/34
description IXP server port
switchport access vlan 200
spanning-tree port type edge
```

```
interface Ethernet1/35
description ILO(M) port
```

Hardware Installation Guidelines

```
switchport access vlan 100
spanning-tree port type edge

interface Ethernet1/36
description IXP server port
switchport access vlan 200
spanning-tree port type edge

interface Ethernet1/37
description ILO(M) port
switchport access vlan 100
spanning-tree port type edge

interface Ethernet1/38
description IXP server port
switchport access vlan 200
spanning-tree port type edge

interface Ethernet1/39
description ILO(M) port
switchport access vlan 100
spanning-tree port type edge

interface Ethernet1/40
description IXP server port
switchport access vlan 200
spanning-tree port type edge

interface Ethernet1/41
description ILO(M) port
switchport access vlan 100
spanning-tree port type edge

interface Ethernet1/42
description NSP NIC2 CUST Ethernet Access
switchport access vlan 300

interface Ethernet1/43
description NSP NIC2 CUST Ethernet Access
switchport access vlan 300

interface Ethernet1/44
description NSP NIC2 CUST Ethernet Access
switchport access vlan 300

interface Ethernet1/45
```

Hardware Installation Guidelines

```
description NSP NIC2 CUST Ethernet Access
switchport access vlan 300

interface Ethernet1/46
description NSP NIC2 CUST Ethernet Access
switchport access vlan 300

interface GigabitEthernet1/47
description 802.1Q trunk link to backbone SWA
switchport access vlan 300
!
interface GigabitEthernet1/48
description 802.1Q trunk link to backbone SWB
switchport access vlan 300

bbbbbbbbbbbbbbbbbbbbbbbbbbbbbbbbbbbbbbbbbbbbbbbbbbbbbbbbbbbbbbbbbbbbbbbbbbbbbbbb

interface GigabitEthernet1/47
description 802.1Q trunk link to backbone SWA
switchport mode trunk
switchport trunk allowed vlan 100,200,300
!
interface GigabitEthernet1/48
description 802.1Q trunk link to backbone SWB
switchport trunk encapsulation dot1q

interface mgmt0
description oobm
vrf member management
ip address X.X.X.X/24      ! <----- Specify switch IP add
ipv6 address 2000::1/64
clock timezone UTC -4 0
line console
line vty
boot nxos bootflash:/nxos.7.0.3.I4.5.bin
ip route 0.0.0.0/0 X.X.X.X  ! <----- Specify default route
ipv6 switch-packets
logging server X.X.X.X     ! <----- Specify remote logging server (optional)
```

10.15 Blade mediation switch configuration template

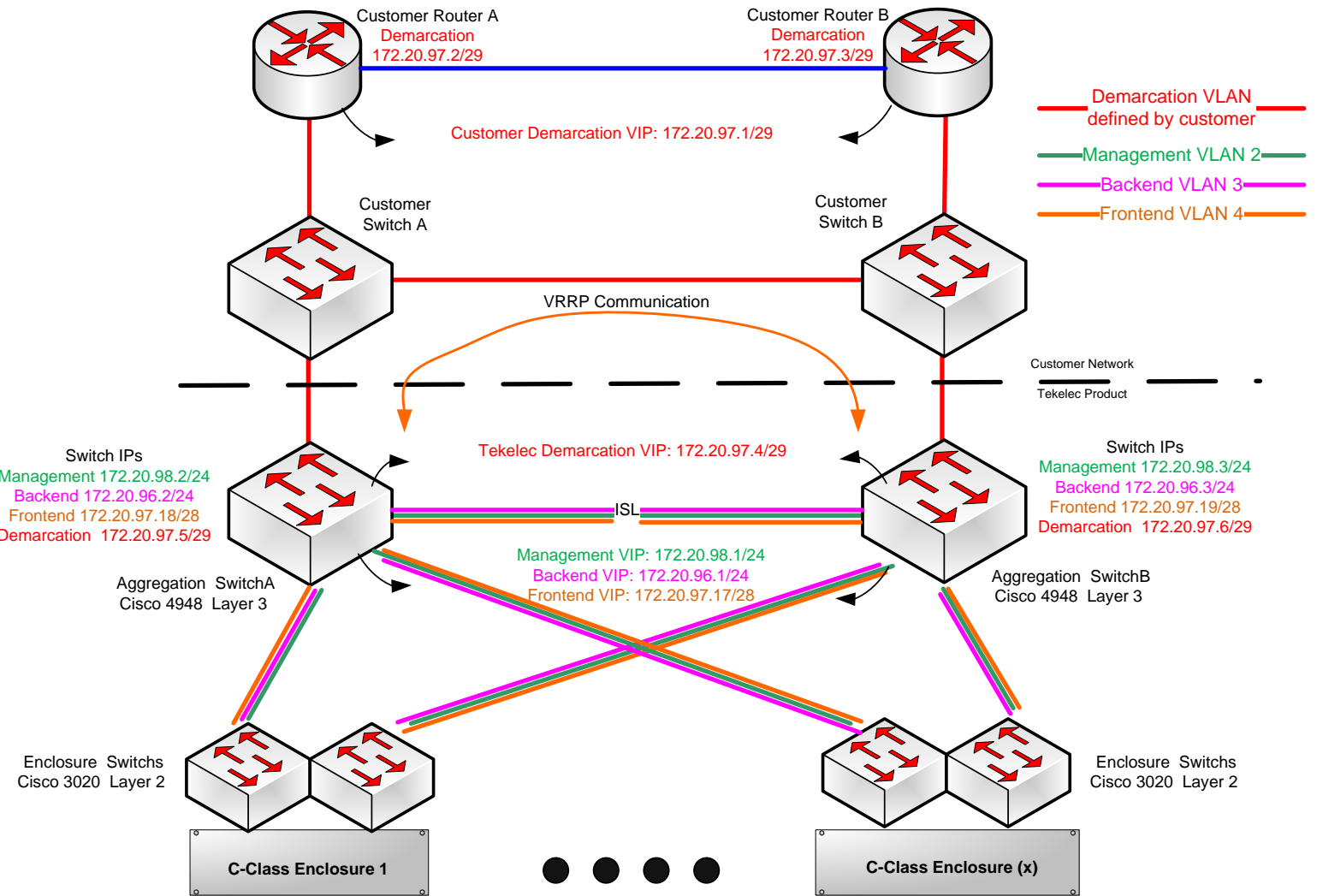

Hardware Installation Guidelines

10.15.1 Switch port allocation

All the following information assume the cabling has been done according the Tekelec System Interconnect diagrams 893-0103-XX to be used for G8 servers with P2000 storage arrays

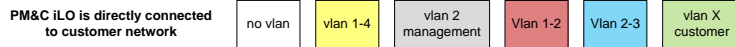

Encosure 7 Switch1

Port 1 Server1 eth2	Port 3 Server3 eth2	Port 5 Server5 eth2	Port 7 Server7 eth2	Port 9 Server9 eth2	Port 11 Server11 eth2	Port 13 Server13 eth2	Port 15 Server15 eth2	Port 17 Agg SW A P29	Port 19 Agg SW A P31	Port 21 SAN contr1	Port 23 SAN contr3
Port 2 Server2 eth2	Port 4 Server4 eth2	Port 6 Server6 eth2	Port 8 Server8 eth2	Port 10 Server10 eth2	Port 12 Server12 eth2	Port 14 Server14 eth2	Port 16 Server16 eth2	Port 18 Agg SW A P30	Port 20 Agg SW A P32	Port 22 SAN contr2	Port 24 SAN contr4

Encosure 1 Switch1

Port 1 Server1 eth2	Port 3 Server3 eth2	Port 5 Server5 eth2	Port 7 Server7 eth2	Port 9 Server9 eth2	Port 11 Server11 eth2	Port 13 Server13 eth2	Port 15 Server15 eth2	Port 17 Agg SW A P5	Port 19 Agg SW A P7	Port 21 SAN contr1	Port 23 SAN contr3
Port 2 Server2 eth2	Port 4 Server4 eth2	Port 6 Server6 eth2	Port 8 Server8 eth2	Port 10 Server10 eth2	Port 12 Server12 eth2	Port 14 Server14 eth2	Port 16 Server16 eth2	Port 18 Agg SW A P6	Port 20 Agg SW A P8	Port 22 SAN contr2	Port 24 SAN contr4

Aggregation SwitchA

Port 1 Agg SW B P1	Port 3 Agg SW B P3	Port 5 Enc1 SW1 P17	Port 7 Enc1 SW1 P19	Port 9 Enc2 SW1 P17	Port 11 Enc2 SW1 P19	Port 13 Enc3 SW1 P17	Port 15 Enc3 SW1 P19	Port 17 Enc4 SW1 P17	Port 19 Enc4 SW1 P19	Port 21 Enc5 SW1 P17	Port 23 Enc5 SW1 P19	Port 25 Enc6 SW1 P17	Port 27 Enc6 SW1 P19	Port 29 Enc7 SW1 P17	Port 31 Enc7 SW1 P19	Port 33 Enc1 OA1	Port 35 Enc3 OA1	Port 37 Enc5 OA1	Port 39 Enc7 OA1	Port 41 Free	Port 43 Free	Port 45 For Laptop	Port 47 Free
Port 2 Agg SW B P2	Port 4 Agg SW B P4	Port 6 Enc1 SW1 P18	Port 8 Enc1 SW1 P20	Port 10 Enc2 SW1 P18	Port 12 Enc2 SW1 P20	Port 14 Enc3 SW1 P18	Port 16 Enc3 SW1 P20	Port 18 Enc4 SW1 P18	Port 20 Enc4 SW1 P20	Port 22 Enc5 SW1 P18	Port 24 Enc5 SW1 P20	Port 26 Enc6 SW1 P18	Port 28 Enc6 SW1 P20	Port 30 Enc7 SW1 P18	Port 32 Enc7 SW1 P20	Port 34 Enc2 OA1	Port 36 Enc4 OA1	Port 38 Enc6 OA1	Port 40 PM&C Eth1	Port 42 Free	Port 44 Free	Port 46 For Laptop	Port 48 Cust Net eth

Port 1 Agg SW A P1	Port 3 Agg SW A P3	Port 5 Enc1 SW2 P17	Port 7 Enc1 SW2 P19	Port 9 Enc2 SW2 P17	Port 11 Enc2 SW2 P19	Port 13 Enc3 SW2 P17	Port 15 Enc3 SW2 P19	Port 17 Enc4 SW2 P17	Port 19 Enc4 SW2 P19	Port 21 Enc5 SW2 P17	Port 23 Enc5 SW2 P19	Port 25 Enc6 SW2 P17	Port 27 Enc6 SW2 P19	Port 29 Enc7 SW2 P17	Port 31 Enc7 SW2 P19	Port 33 Enc1 OA2	Port 35 Enc3 OA2	Port 37 Enc5 OA2	Port 39 Enc7 OA2	Port 41 Free	Port 43 Free	Port 45 For Laptop	Port 47 Free
Port 2 Agg SW A P2	Port 4 Agg SW A P4	Port 6 Enc1 SW2 P18	Port 8 Enc1 SW2 P20	Port 10 Enc2 SW2 P18	Port 12 Enc2 SW2 P20	Port 14 Enc3 SW2 P18	Port 16 Enc3 SW2 P20	Port 18 Enc4 SW2 P18	Port 20 Enc4 SW2 P20	Port 22 Enc5 SW2 P18	Port 24 Enc5 SW2 P20	Port 26 Enc6 SW2 P18	Port 28 Enc6 SW2 P20	Port 30 Enc7 SW2 P18	Port 32 Enc7 SW2 P20	Port 34 Enc2 OA2	Port 36 Enc4 OA2	Port 38 Enc6 OA2	Port 40 PM&C Eth2	Port 42 Free	Port 44 Free	Port 46 For Laptop	Port 48 Cust Net eth

Aggregation SwitchB

Encosure 1 Switch2

Port 1 Server1 eth2	Port 3 Server3 eth2	Port 5 Server5 eth2	Port 7 Server7 eth2	Port 9 Server9 eth2	Port 11 Server11 eth2	Port 13 Server13 eth2	Port 15 Server15 eth2	Port 17 Agg SW B P5	Port 19 Agg SW B P7	Port 21 SAN contr1	Port 23 SAN contr3
Port 2 Server2 eth2	Port 4 Server4 eth2	Port 6 Server6 eth2	Port 8 Server8 eth2	Port 10 Server10 eth2	Port 12 Server12 eth2	Port 14 Server14 eth2	Port 16 Server16 eth2	Port 18 Agg SW B P6	Port 20 Agg SW B P8	Port 22 SAN contr2	Port 24 SAN contr4

Encosure 7 Switch2

Port 1 Server1 eth2	Port 3 Server3 eth2	Port 5 Server5 eth2	Port 7 Server7 eth2	Port 9 Server9 eth2	Port 11 Server11 eth2	Port 13 Server13 eth2	Port 15 Server15 eth2	Port 17 Agg SW B P29	Port 19 Agg SW B P31	Port 21 SAN contr1	Port 23 SAN contr3
Port 2 Server2 eth2	Port 4 Server4 eth2	Port 6 Server6 eth2	Port 8 Server8 eth2	Port 10 Server10 eth2	Port 12 Server12 eth2	Port 14 Server14 eth2	Port 16 Server16 eth2	Port 18 Agg SW B P30	Port 20 Agg SW B P32	Port 22 SAN contr2	Port 24 SAN contr4

10.15.2 Aggregation Switch

Note: The command “spanning-tree portfast trunk” will return the following warning, you can ignore:

```
%Warning: portfast should only be enabled on ports connected to a single host.
Connecting hubs, concentrators, switches, bridges, etc... to this interface
when portfast is enabled, can cause temporary bridging loops.
```

Use with CAUTION

Note: the commands “switchport trunk encapsulation dot1q” and “media-type rj45” will fail on the 4948EF switch but it is kept this config for compatibility with the previous 4948

```
!
!
! Aggregation Switch configuration
! MASTER VRRP switch
!
!
hostname switchA      ! <----- replace the hostname to identify the switch
!
!
spanning-tree mode rapid-pvst
no spanning-tree optimize bpdu transmission
spanning-tree extend system-id
!
enable secret ***** ! <----- replace ***** with password specified in password dragon as Cisco enable
service password-encryption
no service pad
service timestamps debug datetime
service timestamps log datetime
no logging console
no aaa new-model
track 1 interface GigabitEthernet1/48 line-protocol
ip subnet-zero
vtp mode transparent
!
power redundancy-mode redundant
!
!
! VLAN CONFIGURATION (internal)
!
!
vlan internal allocation policy ascending
!
vlan 2
name management
```

Hardware Installation Guidelines

```
!  
vlan 3  
    name backend  
!  
vlan 4  
    name frontend  
!  
vlan 110      ! <----- Enter customer value for demarcation VLAN  
  
    name customer  
!  
!  
!   INTER switch1A to other switch ETHERCHANNEL (internal)  
!  
!  
interface Port-channel1  
    description Trunk_between_switch1A_and_Enc1SW1  
    switchport  
    switchport trunk encapsulation dot1q  
    switchport trunk allowed vlan 1-4  
    switchport mode trunk  
!  
interface Port-channel2  
    description Trunk_between_switch1A_and_Enc2SW1  
    switchport  
    switchport trunk encapsulation dot1q  
    switchport trunk allowed vlan 1-4  
    switchport mode trunk  
!  
interface Port-channel3  
    description Trunk_between_switch1A_and_Enc3SW1  
    switchport  
    switchport trunk encapsulation dot1q  
    switchport trunk allowed vlan 1-4  
    switchport mode trunk  
!  
interface Port-channel4  
    description Trunk_between_switch1A_and_Enc4SW1  
    switchport  
    switchport trunk encapsulation dot1q  
    switchport trunk allowed vlan 1-4  
    switchport mode trunk  
!  
interface Port-channel5  
    description Trunk_between_switch1A_and_Enc5SW1  
    switchport
```

```
switchport trunk encapsulation dot1q
switchport trunk allowed vlan 1-4
switchport mode trunk
!
interface Port-channel6
description Trunk_between_switch1A_and_Enc6SW1
switchport
switchport trunk encapsulation dot1q
switchport trunk allowed vlan 1-4
switchport mode trunk
!
interface Port-channel7
description Trunk_between_switch1A_and_Enc7SW1
switchport
switchport trunk encapsulation dot1q
switchport trunk allowed vlan 1-4
switchport mode trunk
!
interface Port-channel8
description Trunk_between_switch1A_and_switch1B
switchport
switchport trunk encapsulation dot1q
switchport trunk allowed vlan 1-4
switchport mode trunk
switchport nonegotiate
!
!
! INTER switch1A to other switch PORTS (internal)
!
!
interface range GigabitEthernet1/1-4
description Trunk_between_switch1A_and_switch1B
switchport trunk encapsulation dot1q
switchport trunk allowed vlan 1-4
switchport mode trunk
switchport nonegotiate
channel-group 8 mode active
!
interface range GigabitEthernet1/5-8
description Trunk_between_cxeny(en1)-sw1
switchport trunk encapsulation dot1q
switchport trunk allowed vlan 1-4
switchport mode trunk
channel-group 1 mode active
spanning-tree portfast trunk
!
```

Hardware Installation Guidelines

```
interface range GigabitEthernet1/9-12
  description ISL_to_cxeny(en2)-sw1
  switchport trunk encapsulation dot1q
  switchport trunk allowed vlan 1-4
  switchport mode trunk
  channel-group 2 mode active
  spanning-tree portfast trunk
!
interface range GigabitEthernet1/13-16
  description ISL_to_cxeny(en3)-sw1
  switchport trunk encapsulation dot1q
  switchport trunk allowed vlan 1-4
  switchport mode trunk
  channel-group 3 mode active
  spanning-tree portfast trunk
!
interface range GigabitEthernet1/17-20
  description ISL_to_cxeny(en4)-sw1
  switchport trunk encapsulation dot1q
  switchport trunk allowed vlan 1-4
  switchport mode trunk
  channel-group 4 mode active
  spanning-tree portfast trunk
!
interface range GigabitEthernet1/21-24
  description ISL_to_cxeny(en5)-sw1
  switchport trunk encapsulation dot1q
  switchport trunk allowed vlan 1-4
  switchport mode trunk
  channel-group 5 mode active
  spanning-tree portfast trunk
!
interface range GigabitEthernet1/25-28
  description ISL_to_cxeny(en6)-sw1
  switchport trunk encapsulation dot1q
  switchport trunk allowed vlan 1-4
  switchport mode trunk
  channel-group 6 mode active
  spanning-tree portfast trunk
!
interface range GigabitEthernet1/29-32
  description ISL_to_cxeny(en7)-sw1
  switchport trunk encapsulation dot1q
  switchport trunk allowed vlan 1-4
  switchport mode trunk
  channel-group 7 mode active
```

Hardware Installation Guidelines

```
spanning-tree portfast trunk
!
!
! OA PORTS
!
!
interface range GigabitEthernet1/33-39
description cxeny(enX)-OA
switchport access vlan 2
switchport mode access
spanning-tree portfast
!
!
! PM&C PORTS
!
!
interface GigabitEthernet1/40
description clmsl-nic
switchport trunk encapsulation dot1q
switchport trunk allowed vlan 1-3
switchport mode trunk
spanning-tree portfast trunk
!
interface GigabitEthernet1/41
description clmsl-iLO for compatibilty with G6 & G5, it is recomanded to connect directly on customer network
switchport access vlan 2
switchport mode access
spanning-tree portfast
!
!
! UNUSED PORTS
!
!
interface range GigabitEthernet1/42-44
description Unused
shutdown
!
interface GigabitEthernet1/47
description Unused
shutdown
!
!
! Laptop PORTS
!
!
interface range GigabitEthernet1/45-46
```

Hardware Installation Guidelines

```
description for Laptop connection
switchport access vlan 2
switchport mode access
spanning-tree portfast
no shutdown
!
!
! Customer uplink PORTS
!
!
interface GigabitEthernet1/48
description Customer_Uplink
switchport access vlan 110
switchport mode access
media-type rj45
no shutdown
!
!
! VLAN INTERFACE CONFIGURATION
!
!
interface Vlan1
ip address dhcp
no shutdown
!
interface Vlan2
description IP address, netmask, and gateway for this switch in the management VLAN
ip address 172.20.98.2 255.255.255.0! <----- Enter IP and netmask FOR management VLAN
vrrp 2 ip 172.20.98.1          ! <----- replace IP with gateway for management VLAN
vrrp 2 track 1
no shutdown
!
interface Vlan3
description IP address, netmask, and gateway for this switch in the backend VLAN
ip address 172.20.96.2 255.255.255.128      ! <----- Enter IP and netmask FOR backend VLAN
vrrp 3 ip 172.20.96.1          ! <----- replace IP with gateway for backend VLAN
vrrp 3 track 1
no shutdown
!
interface Vlan4
description IP address, netmask, and gateway for this switch in the frontend VLAN
ip address 172.20.97.18 255.255.255.240     ! <----- Enter IP and netmask for frontend VLAN
vrrp 4 ip 172.20.97.17        ! <----- replace IP with gateway for frontend VLAN
vrrp 4 track 1
no shutdown
!
```

Hardware Installation Guidelines

description VLAN ID, IP address, netmask, and gateway for this switch in the demarcation VLAN

```
interface Vlan110      ! <----- Enter customer value for demarcation VLAN
 ip address 172.20.97.5 255.255.255.248      ! <----- Enter IP and netmask for demarcation VLAN
 vrrp 5 ip 172.20.97.4      ! <----- replace IP with gateway for demarcation VLAN
 vrrp 5 track 1
 no shutdown
!
ip route 0.0.0.0 0.0.0.0 172.20.97.1 ! <----- replace IP with customer default gateway
ip route 0.0.0.0 0.0.0.0 172.20.96.3 200      ! <----- replace IP with other aggregation switch IP address in
backend vlan
no ip http server
!
!
logging 172.20.96.4      ! <----- replace IP with PM&C address
no cdp run
!
snmp-server user cfguser cfguser v1
snmp-server user cfguser cfguser v2c
snmp-server community cfguser RO
snmp-server enable traps snmp authentication linkdown linkup coldstart warmstart
snmp-server enable traps tty
snmp-server enable traps fru-ctrl
snmp-server enable traps entity
snmp-server enable traps cpu threshold
snmp-server enable traps vlancreate
snmp-server enable traps vldelete
snmp-server enable traps envmon fan shutdown supply temperature status
snmp-server enable traps config
snmp-server enable traps ipmulticast
snmp-server enable traps bridge newroot topologychange
snmp-server enable traps syslog
snmp-server enable traps vlan-membership
snmp-server host 172.20.96.132 version 2c tekelec      ! <----- replace IP with WL1 address
!
control-plane
!
!
line con 0
 password ***** ! <----- replace ***** with password specified in password dragon as Cisco telnet
 login
 stopbits 1
!
ntp clock-period 17179480
ntp server 10.27.8.4      ! <----- replace IP with NTP server address
end
```

Hardware Installation Guidelines

10.15.3 Enclosure Switch

```
!  
!  
! Enclosure Switch configuration  
!  
!  
hostname C3020A_IOBAY  
!  
no service config  
no service pad  
service timestamps debug datetime  
service timestamps log datetime  
enable secret ***** ! <----- replace ***** with password specified in password dragon as Cisco enable  
service password-encryption  
!  
link state track 1  
ip subnet-zero  
no ip domain-lookup  
!  
spanning-tree mode rapid-pvst  
no spanning-tree optimize bpdu transmission  
spanning-tree etherchannel guard misconfig  
spanning-tree extend system-id  
spanning-tree vlan 1-1024 priority 53248  
!  
!  
! VLAN CONFIGURATION (internal)  
!  
!  
vlan internal allocation policy ascending  
!  
vlan 2  
    name management  
!  
vlan 3  
    name backend  
!  
vlan 4  
    name frontend  
!  
interface Port-channel1  
    description ISL_between_4948_and_3020  
    switchport trunk allowed vlan 1-4  
    switchport mode trunk  
    link state group 1 upstream
```

Hardware Installation Guidelines

```
!  
interface range GigabitEthernet0/17-20  
  description ISL_between_4948_and_3020  
  switchport trunk allowed vlan 1-4  
  switchport mode trunk  
  channel-group 1 mode active  
  spanning-tree portfast trunk  
!  
interface FastEthernet0  
  description IP address configured in the OA interface  
! ip address dhcp          ! <----- remove the comment only in case the interface would not be already  
configured in dhcp  
!  
interface range GigabitEthernet0/1-16  
  description bay.ethx  
  switchport mode trunk  
  link state group 1 downstream  
  spanning-tree portfast trunk  
!  
interface range GigabitEthernet0/21-24  
  description P2000 SAN controller  
  switchport access vlan 2  
  switchport mode access  
  spanning-tree portfast  
!  
interface Vlan1  
  no ip address  
  shutdown  
!  
ip classless  
ip http server  
ip http secure-server  
!  
logging 172.20.96.4      ! <----- replace IP with PM&C management address  
no cdp run  
snmp-server community tekelec RO  
snmp-server enable traps snmp authentication linkdown linkup coldstart warmstart  
snmp-server enable traps tty  
snmp-server enable traps entity  
snmp-server enable traps cpu threshold  
snmp-server enable traps vlancreate  
snmp-server enable traps vlandelete  
snmp-server enable traps envmon fan shutdown supply temperature status  
snmp-server enable traps config  
snmp-server enable traps bridge newroot topologychange  
snmp-server enable traps syslog
```

Hardware Installation Guidelines

```

snmp-server enable traps vlan-membership
snmp-server host 172.20.96.132 version 2c tekelec ! <----- replace IP with WL1 backend address
!
control-plane
!
!
line con 0
 password ***** ! <----- replace ***** with password specified in password dragon as Cisco telnet
 login
line vty 0 15
 password ***** ! <----- replace ***** with password specified in password dragon as Cisco telnet
 login
!
ntp clock-period 36028892
ntp server 10.31.3.132 ! <----- replace IP with NTP server address
end

```

10.16 Integrated Acquisition switch configuration template

10.16.1 Switch port allocation

All or no vlan	vlan 100 yellow	vlan 101 blue	vlan 400 backend	vlan 300 oobm or iLO
-------------------	--------------------	------------------	---------------------	----------------------------

Yellow SW3	Port 1 Yellow1 SW P41	Port 3 Eagle Links	Port 5 Eagle Links	Port 7 Eagle Links	Port 9 Eagle Links	Port 11 Eagle Links	Port 13 Eagle Links	Port 15 Eagle Links	Port 17 Eagle Links	Port 19 Eagle Links	Port 21 Eagle Links	Port 23 Eagle Links	Port 25 Eagle Links	Port 27 Eagle Links	Port 29 Eagle Links	Port 31 Eagle Links	Port 33 Eagle Links	Port 35 Eagle Links	Port 37 Eagle Links	Port 39 Eagle Links	Port 41 Eagle Links	Port 43 Eagle Links	Port 45 Eagle Links	Port 47 Eagle Links
	Port 2 Yellow1 SW P42	Port 4 Eagle Links	Port 6 Eagle Links	Port 8 Eagle Links	Port 10 Eagle Links	Port 12 Eagle Links	Port 14 Eagle Links	Port 16 Eagle Links	Port 18 Eagle Links	Port 20 Eagle Links	Port 22 Eagle Links	Port 24 Eagle Links	Port 26 Eagle Links	Port 28 Eagle Links	Port 30 Eagle Links	Port 32 Eagle Links	Port 34 Eagle Links	Port 36 Eagle Links	Port 38 Eagle Links	Port 40 Eagle Links	Port 42 Eagle Links	Port 44 Eagle Links	Port 46 Eagle Links	Port 48 Eagle Links
Yellow SW2	Port 1 Yellow1 SW P43	Port 3 ServerG eth01	Port 5 ServerH eth01	Port 7 ServerI iLO	Port 9 ServerK eth01	Port 11 ServerL eth01	Port 13 Eagle Links	Port 15 Eagle Links	Port 17 Eagle Links	Port 19 Eagle Links	Port 21 Eagle Links	Port 23 Eagle Links	Port 25 Eagle Links	Port 27 Eagle Links	Port 29 Eagle Links	Port 31 Eagle Links	Port 33 Eagle Links	Port 35 Eagle Links	Port 37 Eagle Links	Port 39 Eagle Links	Port 41 Eagle Links	Port 43 Eagle Links	Port 45 Eagle Links	Port 47 Eagle Links
	Port 2 Yellow1 SW P44	Port 4 ServerG iLO	Port 6 ServerI eth01	Port 8 ServerJ eth01	Port 10 ServerK iLO	Port 12 Eagle Links	Port 14 Eagle Links	Port 16 Eagle Links	Port 18 Eagle Links	Port 20 Eagle Links	Port 22 Eagle Links	Port 24 Eagle Links	Port 26 Eagle Links	Port 28 Eagle Links	Port 30 Eagle Links	Port 32 Eagle Links	Port 34 Eagle Links	Port 36 Eagle Links	Port 38 Eagle Links	Port 40 Eagle Links	Port 42 Eagle Links	Port 44 Eagle Links	Port 46 Eagle Links	Port 48 Eagle Links
Yellow SW1	Port 1 Blue1 SW P1	Port 3 ServerA eth01	Port 5 ServerC eth01	Port 7 ServerD eth01	Port 9 ServerE iLO	Port 11 Eagle Links	Port 13 Eagle Links	Port 15 Eagle Links	Port 17 Eagle Links	Port 19 Eagle Links	Port 21 Eagle Links	Port 23 Eagle Links	Port 25 Eagle Links	Port 27 Eagle Links	Port 29 Eagle Links	Port 31 Eagle Links	Port 33 Eagle Links	Port 35 Eagle Links	Port 37 Eagle Links	Port 39 Eagle Links	Port 41 Yellow3 SW P1	Port 43 Yellow2 SW P1	Port 45 For Laptop	Port 47 Cust Net eth
	Port 2 Blue1 SW P2	Port 4 ServerB eth01	Port 6 ServerC iLO	Port 8 ServerE eth01	Port 10 ServerF eth01	Port 12 Eagle Links	Port 14 Eagle Links	Port 16 Eagle Links	Port 18 Eagle Links	Port 20 Eagle Links	Port 22 Eagle Links	Port 24 Eagle Links	Port 26 Eagle Links	Port 28 Eagle Links	Port 30 Eagle Links	Port 32 Eagle Links	Port 34 Eagle Links	Port 36 Eagle Links	Port 38 Eagle Links	Port 40 Eagle Links	Port 42 Yellow3 SW P2	Port 44 Yellow2 SW P2	Port 46 For Laptop	Port 48 Cust Net iLO
Blue SW1	Port 1 Yellow1 SW P1	Port 3 ServerA eth03	Port 5 ServerC eth03	Port 7 ServerD iLO	Port 9 ServerF eth03	Port 11 Eagle Links	Port 13 Eagle Links	Port 15 Eagle Links	Port 17 Eagle Links	Port 19 Eagle Links	Port 21 Eagle Links	Port 23 Eagle Links	Port 25 Eagle Links	Port 27 Eagle Links	Port 29 Eagle Links	Port 31 Eagle Links	Port 33 Eagle Links	Port 35 Eagle Links	Port 37 Eagle Links	Port 39 Eagle Links	Port 41 Blue3 SW P1	Port 43 Blue2 SW P1	Port 45 For Laptop	Port 47 Cust Net eth
	Port 2 Yellow1 SW P2	Port 4 ServerB eth03	Port 6 ServerD eth03	Port 8 ServerE eth03	Port 10 ServerF iLO	Port 12 Eagle Links	Port 14 Eagle Links	Port 16 Eagle Links	Port 18 Eagle Links	Port 20 Eagle Links	Port 22 Eagle Links	Port 24 Eagle Links	Port 26 Eagle Links	Port 28 Eagle Links	Port 30 Eagle Links	Port 32 Eagle Links	Port 34 Eagle Links	Port 36 Eagle Links	Port 38 Eagle Links	Port 40 Eagle Links	Port 42 Blue3 SW P2	Port 44 Blue2 SW P2	Port 46 For Laptop	Port 48 Cust Net iLO
Blue SW2	Port 1 Blue1 SW P43	Port 3 ServerG eth03	Port 5 ServerH iLO	Port 7 ServerJ eth03	Port 9 ServerK eth03	Port 11 ServerL iLO	Port 13 Eagle Links	Port 15 Eagle Links	Port 17 Eagle Links	Port 19 Eagle Links	Port 21 Eagle Links	Port 23 Eagle Links	Port 25 Eagle Links	Port 27 Eagle Links	Port 29 Eagle Links	Port 31 Eagle Links	Port 33 Eagle Links	Port 35 Eagle Links	Port 37 Eagle Links	Port 39 Eagle Links	Port 41 Eagle Links	Port 43 Eagle Links	Port 45 Eagle Links	Port 47 Eagle Links
	Port 2 Blue1 SW P44	Port 4 ServerH eth03	Port 6 ServerI eth03	Port 8 ServerJ iLO	Port 10 ServerK eth03	Port 12 Eagle Links	Port 14 Eagle Links	Port 16 Eagle Links	Port 18 Eagle Links	Port 20 Eagle Links	Port 22 Eagle Links	Port 24 Eagle Links	Port 26 Eagle Links	Port 28 Eagle Links	Port 30 Eagle Links	Port 32 Eagle Links	Port 34 Eagle Links	Port 36 Eagle Links	Port 38 Eagle Links	Port 40 Eagle Links	Port 42 Eagle Links	Port 44 Eagle Links	Port 46 Eagle Links	Port 48 Eagle Links
Blue SW3	Port 1 Blue1 SW P41	Port 3 Eagle Links	Port 5 Eagle Links	Port 7 Eagle Links	Port 9 Eagle Links	Port 11 Eagle Links	Port 13 Eagle Links	Port 15 Eagle Links	Port 17 Eagle Links	Port 19 Eagle Links	Port 21 Eagle Links	Port 23 Eagle Links	Port 25 Eagle Links	Port 27 Eagle Links	Port 29 Eagle Links	Port 31 Eagle Links	Port 33 Eagle Links	Port 35 Eagle Links	Port 37 Eagle Links	Port 39 Eagle Links	Port 41 Eagle Links	Port 43 Eagle Links	Port 45 Eagle Links	Port 47 Eagle Links
	Port 2 Blue1 SW P42	Port 4 Eagle Links	Port 6 Eagle Links	Port 8 Eagle Links	Port 10 Eagle Links	Port 12 Eagle Links	Port 14 Eagle Links	Port 16 Eagle Links	Port 18 Eagle Links	Port 20 Eagle Links	Port 22 Eagle Links	Port 24 Eagle Links	Port 26 Eagle Links	Port 28 Eagle Links	Port 30 Eagle Links	Port 32 Eagle Links	Port 34 Eagle Links	Port 36 Eagle Links	Port 38 Eagle Links	Port 40 Eagle Links	Port 42 Eagle Links	Port 44 Eagle Links	Port 46 Eagle Links	Port 48 Eagle Links

Server A and B iLO are directly connected to customer network

10.16.2 Yellow-sw1-1 Switch 4948 & 4948E-F (Layer 3)

! IMF YELLOW1 SWITCH configuration

Hardware Installation Guidelines

```
!  
!  
hostname yellow-sw1-1  
!  
no spanning-tree vlan 1-4094  
no spanning-tree optimize bpdu transmission  
!  
enable secret ***** ! <----- replace ***** with password specified in password dragon as Cisco enable  
service password-encryption  
no service pad  
service timestamps debug datetime  
service timestamps log datetime  
no logging console  
no aaa new-model  
track 1 interface GigabitEthernet1/47 line-protocol  
ip subnet-zero  
!  
ip multicast-routing  
!  
power redundancy-mode redundant  
!  
!  
! VLAN CONFIGURATION (internal)  
!  
!  
vlan 100  
    name internal_yellow  
!  
vlan 101  
    name internal_blue  
!  
vlan 200  
    name IMF2IXP_internal_(backend)  
!  
vlan 300  
    name oobm_or_iLO  
!  
vlan 400  
    name IMF2IXP_external_(frontend)  
!  
!  
! INTER YELLOW SW1 TO BLUE SW1 ETHERCHANNEL (internal)  
!  
!  
interface Port-channel1  
    description Trunk_between_yellow_sw1_and_blue_sw1
```

Hardware Installation Guidelines

```
switchport
switchport trunk encapsulation dot1q
switchport trunk allowed vlan 100,101,200,300
mtu 9198
no shutdown
!
!
! INTER YELLOW SW 1 TO YELLOW SW2 ETHERCHANNEL (internal)
!
!
interface Port-channel2
description Trunk_between_yellow_sw1_and_yellow_sw2
switchport
switchport trunk encapsulation dot1q
switchport trunk allowed vlan 100,101,200,300
switchport mode trunk
mtu 9198
no shutdown
!
!
! INTER YELLOW SW 1 TO YELLOW SW3 ETHERCHANNEL (internal)
!
!
interface Port-channel3
description Trunk_between_yellow_sw1_and_yellow_sw3
switchport
switchport trunk encapsulation dot1q
switchport trunk allowed vlan 100,101,200,300
switchport mode trunk
mtu 9198
no shutdown
!
!
! INTER YELLOW SW1 TO BLUE SW1 PORTS (internal)
!
!
Interface range GigabitEthernet 1/1 - 2
description ISL_between_yellow_sw1_and_blue_sw1
switchport trunk encapsulation dot1q
switchport trunk allowed vlan 100,101,200,300
switchport mode trunk
switchport nonegotiate
mtu 9198
channel-group 1 mode active
no shutdown
!
```

```
!  
! INTER yellow SW1 TO yellow SW2 PORTS (internal)  
!  
!  
Interface range GigabitEthernet 1/43 - 44  
description Trunk_between_yellow_sw1_and_yellow_sw2  
switchport trunk encapsulation dot1q  
switchport trunk allowed vlan 100,101,200,300  
switchport mode trunk  
mtu 9198  
channel-group 1 mode active  
no shutdown  
!  
!  
! INTER yellow SW1 TO yellow SW3 PORTS (internal)  
!  
!  
Interface range GigabitEthernet 1/41 - 42  
description Trunk_between_yellow_sw1_and_yellow_sw3  
switchport trunk encapsulation dot1q  
switchport trunk allowed vlan 100,101,200,300  
switchport mode trunk  
mtu 9198  
channel-group 1 mode active  
no shutdown  
!  
!  
! IMF Servers PORTS  
!  
!  
interface range GigabitEthernet 1/3 - 5  
description IMF servers ports  
switchport trunk encapsulation dot1q  
switchport mode trunk  
mtu 9198  
no shutdown  
!  
interface range GigabitEthernet 1/7 - 8  
description IMF servers ports  
switchport trunk encapsulation dot1q  
switchport mode trunk  
mtu 9198  
no shutdown  
!  
interface range GigabitEthernet 1/10  
description IMF servers ports
```

Hardware Installation Guidelines

```
switchport trunk encapsulation dot1q
switchport mode trunk
mtu 9198
no shutdown
!
!
! iLO PORTS
!
!
interface GigabitEthernet 1/6
description IMF iLO ports
switchport access vlan 300
switchport mode access
no shutdown
!
interface GigabitEthernet 1/9
description IMF iLO ports
switchport access vlan 300
switchport mode access
no shutdown
!
!
! EAGLE PORTS
!
!
interface range GigabitEthernet 1/11 - 40
description Eagle FC or STC ports
switchport access vlan 100
switchport mode access
mtu 9198
no shutdown
!
!
! PORT TO CUSTOMER SWITCH A
!
!
interface GigabitEthernet 1/47
description to customer switch A
switchport access vlan 400
switchport mode access
media-type rj45
no shutdown
!
interface GigabitEthernet 1/48
description reserved for optional direct access to ILO in case of disaster
switchport access vlan 300
```

Hardware Installation Guidelines

```
switchport mode access
media-type rj45
no shutdown
!
!
! Laptop PORTS
!
!
interface range GigabitEthernet 1/45 - 46
description for Laptop
switchport access vlan 200
switchport mode access
media-type rj45
no shutdown
!
!
! VLAN INTERFACE CONFIGURATION
!
!
interface Vlan1
no ip address
!
!
interface VLAN 100
ip address 172.21.49.1 255.255.254.0
ip pim dense-mode
no shutdown
!
!
track 1 int gigabitEthernet 1/47 line-protocol
interface Vlan200
description internal VRRP for IMF to IXP traffic. Both IP addresses and netmask must be configured according
customer network.
ip address 192.168.0.2 255.255.255.224 ! <----- replace IP with the value provided by the customer
vrrp 1 ip 192.168.0.1 ! <----- replace IP with default gateway
vrrp 1 priority 100
vrrp 1 track 1
vrrp 1 preempt
no shutdown
!
!
interface Vlan300
description oobm or iLO optional IP. IP address and netmask must be configured according customer network.
ip address 192.168.10.2 255.255.255.240 ! <----- replace IP with the value provided by the customer
no shutdown
!
```

Hardware Installation Guidelines

```
!  
interface Vlan 400  
  description external VRRP for IMF to IXP traffic to Customer switches. Both IP addresses and netmask must be  
  configured according customer network.  
  ip address 192.168.20.2 255.255.255.248 ! <----- replace IP with the value provided by the customer  
  vrrp 2 ip 192.168.20.1 ! <----- replace IP with default gateway  
  vrrp 2 priority 100  
  vrrp 2 preempt  
  no shutdown  
!  
!  
no ip http server  
no ip http secure-server  
!  
ip route 0.0.0.0 0.0.0.0 192.168.20.6 1 ! <----- replace IP with customer default gateway  
!  
!  
line con 0  
  password ***** ! <----- replace ***** with password specified in password dragon as Cisco telnet  
  login  
!  
logging 172.21.49.10  
!  
no cdp run  
!  
end
```

10.16.3 Blue-sw1-1 Switch 4948 & 4948E-F (Layer 3)

```
! IMF BLUE1 SWITCH configuration  
!  
!  
hostname blue-sw1-1  
!  
no spanning-tree vlan 1-4094  
no spanning-tree optimize bpdu transmission  
!  
enable secret ***** ! <----- replace ***** with password specified in password dragon as Cisco enable  
service password-encryption  
no service pad  
service timestamps debug datetime  
service timestamps log datetime  
no logging console  
no aaa new-model  
track 1 interface GigabitEthernet1/47 line-protocol  
ip subnet-zero
```

```
!  
ip multicast-routing  
!  
power redundancy-mode redundant  
!  
!  
! VLAN CONFIGURATION (internal)  
!  
!  
vlan 100  
    name internal_yellow  
!  
vlan 101  
    name internal_blue  
!  
vlan 200  
    name IMF2IXP_internal_(backend)  
!  
vlan 300  
    name oobm_or_iLO  
!  
vlan 400  
    name IMF2IXP_external_(frontend)  
!  
!  
! INTER YELLOW SW1 TO BLUE SW1 ETHERCHANNEL (internal)  
!  
!  
interface Port-channel1  
    description Trunk_between_yellow_sw1_and_blue_sw1  
    switchport  
    switchport trunk encapsulation dot1q  
    switchport trunk allowed vlan 100,101,200,300  
    mtu 9198  
    no shutdown  
!  
!  
! INTER BLUE SW 1 TO BLUE SW2 ETHERCHANNEL (internal)  
!  
!  
interface Port-channel2  
    description Trunk_between_ blue_sw1_and_ blue_sw2  
    switchport  
    switchport trunk encapsulation dot1q  
    switchport trunk allowed vlan 100,101,200,300  
    switchport mode trunk
```

Hardware Installation Guidelines

```
mtu 9198
no shutdown
!
!
! INTER BLUE SW 1 TO BLUE SW3 ETHERCHANNEL (internal)
!
!
interface Port-channel3
description Trunk_between_blue_sw1_and_blue_sw3
switchport
switchport trunk encapsulation dot1q
switchport trunk allowed vlan 100,101,200,300
switchport mode trunk
mtu 9198
no shutdown
!
!
! INTER BLUE SW1 TO yellow SW1 PORTS (internal)
!
!
Interface range GigabitEthernet 1/1 - 2
description ISL_between_blue_sw1_and_yellow_sw1
switchport trunk encapsulation dot1q
switchport trunk allowed vlan 100,101,200,300
switchport mode trunk
switchport nonegotiate
mtu 9198
channel-group 1 mode active
no shutdown
!
!
! INTER BLUE SW1 TO BLUE SW2 PORTS (internal)
!
!
Interface range GigabitEthernet 1/43 - 44
description Trunk_between_blue_sw1_and_blue_sw2
switchport trunk encapsulation dot1q
switchport trunk allowed vlan 100,101,200,300
switchport mode trunk
mtu 9198
channel-group 1 mode active
no shutdown
!
!
! INTER BLUE SW1 TO BLUE SW3 PORTS (internal)
!
```

Hardware Installation Guidelines

```
!  
Interface range GigabitEthernet 1/41 - 42  
description Trunk_between_blue_sw1_and_blue_sw3  
switchport trunk encapsulation dot1q  
switchport trunk allowed vlan 100,101,200,300  
switchport mode trunk  
mtu 9198  
channel-group 1 mode active  
no shutdown  
!  
!  
! IMF Servers PORTS  
!  
!  
interface range GigabitEthernet 1/3 - 6  
description IMF servers ports  
switchport trunk encapsulation dot1q  
switchport mode trunk  
mtu 9198  
no shutdown  
!  
interface range GigabitEthernet 1/8 - 9  
description IMF servers ports  
switchport trunk encapsulation dot1q  
switchport mode trunk  
mtu 9198  
no shutdown  
!  
!  
! iLO PORTS  
!  
!  
interface GigabitEthernet 1/7  
description IMF iLO ports  
switchport access vlan 300  
switchport mode access  
no shutdown  
!  
interface GigabitEthernet 1/10  
description IMF iLO ports  
switchport access vlan 300  
switchport mode access  
no shutdown  
!  
!  
! EAGLE PORTS
```

Hardware Installation Guidelines

```
!  
!  
interface range GigabitEthernet 1/11 - 40  
description Eagle FC or STC ports  
    switchport access vlan 101  
    switchport mode access  
    mtu 9198  
    no shutdown  
!  
!  
! PORT TO CUSTOMER SWITCH B  
!  
!  
interface GigabitEthernet 1/47  
description to customer switch B  
    switchport access vlan 400  
    switchport mode access  
    media-type rj45  
    no shutdown  
!  
!  
interface GigabitEthernet 1/48  
description not used to avoid loop risk on iLO VLAN.  
    switchport access vlan 300  
    switchport mode access  
    media-type rj45  
    shutdown  
!  
!  
! Laptop PORTS  
!  
!  
interface range GigabitEthernet 1/45 - 46  
description for Laptop  
    switchport access vlan 200  
    switchport mode access  
    media-type rj45  
    no shutdown  
!  
!  
! VLAN INTERFACE CONFIGURATION  
!  
!  
interface Vlan1  
    no ip address  
!
```

```

!
interface VLAN 101
 ip address 172.22.49.1 255.255.254.0
 ip pim dense-mode
 no shutdown
!
!
track 1 int gigabitEthernet 1/47 line-protocol
interface Vlan200
 description internal VRRP for IMF to IXP traffic. Both IP addresses and netmask must be configured according
 customer network.
 ip address 192.168.0.3 255.255.255.224 ! <----- replace IP with the value provided by the customer
 vrrp 1 ip 192.168.0.1 ! <----- replace IP with default gateway
 vrrp 1 priority 99
 vrrp 1 track 1
 vrrp 1 preempt
 no shutdown
!
!
interface Vlan 400
 description external VRRP for IMF to IXP traffic to Customer switches. Both IP addresses and netmask must be
 configured according customer network.
 ip address 192.168.20.3 255.255.255.248 ! <----- replace IP with the value provided by the customer
 vrrp 2 ip 192.168.20.1 ! <----- replace IP with default gateway
 vrrp 2 priority 99
 vrrp 2 preempt
 no shutdown
!
!
no ip http server
no ip http secure-server
!
ip route 0.0.0.0 0.0.0.0 192.168.20.6 1 ! <----- replace IP with customer default gateway
!
!
line con 0
 password ***** ! <----- replace ***** with password specified in password dragon as Cisco telnet
 login
!
logging 172.22.49.10
!
no cdp run
!
end

```

10.16.4 Yellow-sw2-1 Switch 4948 & 4948E-F (Layer 3)

Hardware Installation Guidelines

```
! IMF YELLOW2 SWITCH configuration
!
!
hostname yellow-sw2-1
!
no spanning-tree vlan 1-4094
no spanning-tree optimize bpdu transmission
!
enable secret ***** ! <----- replace ***** with password specified in password dragon as Cisco enable
service password-encryption
no service pad
service timestamps debug datetime
service timestamps log datetime
no logging console
no aaa new-model
track 1 interface GigabitEthernet1/47 line-protocol
ip subnet-zero
!
ip multicast-routing
!
power redundancy-mode redundant
!
!
! VLAN CONFIGURATION (internal)
!
!
vlan 100
  name internal_yellow
!
vlan 101
  name internal_blue
!
vlan 200
  name IMF2IXP_internal_(backend)
!
vlan 300
  name oobm_or_iLO
!
vlan 400
  name IMF2IXP_external_(frontend)
!
!
! INTER YELLOW SW 2 TO YELLOW SW 1 ETHERCHANNEL (internal)
!
!
interface Port-channel2
```

```
description Trunk_between_yellow_sw2_and_yellow_sw1
switchport
switchport trunk encapsulation dot1q
switchport trunk allowed vlan 100,101,200,300
switchport mode trunk
mtu 9198
no shutdown
!
!
! INTER yellow SW2 TO yellow SW1 PORTS (internal)
!
!
Interface range GigabitEthernet 1/1 - 2
description Trunk_between_yellow_sw2_and_yellow_sw1
switchport trunk encapsulation dot1q
switchport trunk allowed vlan 100,101,200,300
switchport mode trunk
mtu 9198
channel-group 1 mode active
no shutdown
!
!
! IMF Servers PORTS
!
!
interface GigabitEthernet 1/3
description IMF servers ports
switchport trunk encapsulation dot1q
switchport mode trunk
mtu 9198
no shutdown
!
interface range GigabitEthernet 1/5 - 6
description IMF servers ports
switchport trunk encapsulation dot1q
switchport mode trunk
mtu 9198
no shutdown
!
interface range GigabitEthernet 1/8 - 9
description IMF servers ports
switchport trunk encapsulation dot1q
switchport mode trunk
mtu 9198
no shutdown
!
```

Hardware Installation Guidelines

```
interface range GigabitEthernet 1/11
description IMF servers ports
 switchport trunk encapsulation dot1q
 switchport mode trunk
 mtu 9198
 no shutdown
!
!
! iLO PORTS
!
!
interface GigabitEthernet 1/4
description IMF iLO ports
 switchport access vlan 300
 switchport mode access
 no shutdown
!
interface GigabitEthernet 1/7
description IMF iLO ports
 switchport access vlan 300
 switchport mode access
 no shutdown
!
interface GigabitEthernet 1/10
description IMF iLO ports
 switchport access vlan 300
 switchport mode access
 no shutdown
!
!
! EAGLE PORTS
!
!
interface range GigabitEthernet 1/12 - 48
description Eagle FC or STC ports
 switchport access vlan 100
 switchport mode access
 mtu 9198
 no shutdown
!
!
! VLAN INTERFACE CONFIGURATION
!
!
interface Vlan1
 no ip address
```

```
!  
!  
interface VLAN 100  
  ip address 172.21.49.2 255.255.254.0  
  ip pim dense-mode  
  no shutdown!  
!  
interface Vlan200  
  description for remote access though telnet  
  ip address 192.168.0.4 255.255.255.224      ! <----- replace IP with the value provided by the  
customer  
  no shutdown  
!  
!  
no ip http server  
no ip http secure-server  
!  
ip route 0.0.0.0 0.0.0.0 192.168.0.1 1      ! <----- replace IP with VLAN 200 vrrp IP  
!  
!  
line con 0  
  password ***** ! <----- replace ***** with password specified in password dragon as Cisco telnet  
  login  
!  
logging 172.21.49.10  
!  
no cdp run  
!  
end
```

10.16.5 Blue-sw2-1 Switch 4948 & 4948E-F (Layer 3)

```
! IMF BLUE2 SWITCH configuration  
!  
!  
hostname blue-sw2-1  
!  
no spanning-tree vlan 1-4094  
no spanning-tree optimize bpdu transmission  
!  
enable secret ***** ! <----- replace ***** with password specified in password dragon as Cisco enable  
service password-encryption  
no service pad  
service timestamps debug datetime  
service timestamps log datetime  
no logging console
```

Hardware Installation Guidelines

```
no aaa new-model
track 1 interface GigabitEthernet1/47 line-protocol
ip subnet-zero
!
ip multicast-routing
!
power redundancy-mode redundant
!
!
! VLAN CONFIGURATION (internal)
!
!
vlan 100
  name internal_yellow
!
vlan 101
  name internal_blue
!
vlan 200
  name IMF2IXP_internal_(backend)
!
vlan 300
  name oobm_or_iLO
!
vlan 400
  name IMF2IXP_external_(frontend)
!
!
! INTER BLUE SW 2 TO BLUE SW 1 ETHERCHANNEL (internal)
!
!
interface Port-channel2
  description Trunk_between_ blue_sw2_and_ blue_sw1
  switchport
  switchport trunk encapsulation dot1q
  switchport trunk allowed vlan 100,101,200,300
  switchport mode trunk
  mtu 9198
  no shutdown
!
!
! INTER BLUE SW2 TO BLUE SW1 PORTS (internal)
!
!
Interface range GigabitEthernet 1/1 - 2
  description Trunk_between_blue_sw2_and_blue_sw1
```

Hardware Installation Guidelines

```
switchport trunk encapsulation dot1q
switchport trunk allowed vlan 100,101,200,300
switchport mode trunk
mtu 9198
channel-group 1 mode active
no shutdown
!
!
! IMF Servers PORTS
!
!
interface range GigabitEthernet 1/3 - 4
description IMF servers ports
switchport trunk encapsulation dot1q
switchport mode trunk
mtu 9198
no shutdown
!
interface range GigabitEthernet 1/6 - 7
description IMF servers ports
switchport trunk encapsulation dot1q
switchport mode trunk
mtu 9198
no shutdown
!
interface range GigabitEthernet 1/9 - 10
description IMF servers ports
switchport trunk encapsulation dot1q
switchport mode trunk
mtu 9198
no shutdown
!
!
! iLO PORTS
!
!
interface GigabitEthernet 1/5
description IMF iLO ports
switchport access vlan 300
switchport mode access
no shutdown
!
interface GigabitEthernet 1/8
description IMF iLO ports
switchport access vlan 300
switchport mode access
```

Hardware Installation Guidelines

```
no shutdown
!
interface GigabitEthernet 1/11
  description IMF iLO ports
  switchport access vlan 300
  switchport mode access
  no shutdown
!
!
! EAGLE PORTS
!
!
interface range GigabitEthernet 1/12 - 48
  description Eagle FC or STC ports
  switchport access vlan 101
  switchport mode access
  mtu 9198
  no shutdown
!
!
! VLAN INTERFACE CONFIGURATION
!
!
interface Vlan1
  no ip address
!
!
interface VLAN 101
  ip address 172.22.49.2 255.255.254.0
  ip pim dense-mode
  no shutdown
!
!
interface Vlan200
  description for remote access though telnet
  ip address 192.168.0.5 255.255.255.224 ! <----- replace IP with the value provided by the
customer
  no shutdown
!
!
no ip http server
no ip http secure-server
!
ip route 0.0.0.0 0.0.0.0 192.168.0.1 1 ! <----- replace IP with VLAN 200 vrrp IP
!
!
```

```
line con 0
 password ***** ! <----- replace ***** with password specified in password dragon as Cisco telnet
 login
 !
 logging 172.22.49.10
 !
 no cdp run
 !
 end
```

10.16.6 Yellow-sw3-1 Switch 4948 & 4948E-F (Layer 3)

```
! IMF YELLOW3 SWITCH configuration
!
!
hostname yellow-sw3-1
!
no spanning-tree vlan 1-4094
no spanning-tree optimize bpdu transmission
!
enable secret ***** ! <----- replace ***** with password specified in password dragon as Cisco enable
service password-encryption
no service pad
service timestamps debug datetime
service timestamps log datetime
no logging console
no aaa new-model
track 1 interface GigabitEthernet1/47 line-protocol
ip subnet-zero
!
ip multicast-routing
!
power redundancy-mode redundant
!
!
! VLAN CONFIGURATION (internal)
!
!
vlan 100
 name internal_yellow
!
vlan 101
 name internal_blue
!
vlan 200
 name IMF2IXP_internal_(backend)
```

Hardware Installation Guidelines

```
!  
vlan 300  
  name oobm_or_iLO  
!  
vlan 400  
  name IMF2IXP_external_(frontend)  
!  
!  
! INTER YELLOW SW 3 TO YELLOW SW 1 ETHERCHANNEL (internal)  
!  
!  
interface Port-channel3  
  description Trunk_between_yellow_sw3_and_yellow_sw1  
  switchport  
  switchport trunk encapsulation dot1q  
  switchport trunk allowed vlan 100,101,200,300  
  switchport mode trunk  
  mtu 9198  
  no shutdown  
!  
!  
! INTER yellow SW3 TO yellow SW1 PORTS (internal)  
!  
!  
Interface range GigabitEthernet 1/1 - 2  
  description Trunk_between_yellow_sw3_and_yellow_sw1  
  switchport trunk encapsulation dot1q  
  switchport trunk allowed vlan 100,101,200,300  
  switchport mode trunk  
  mtu 9198  
  channel-group 1 mode active  
  no shutdown  
!  
!  
! EAGLE PORTS  
!  
!  
interface range GigabitEthernet 1/3 - 48  
  description Eagle FC or STC ports  
  switchport access vlan 100  
  switchport mode access  
  mtu 9198  
  no shutdown  
!  
!  
! VLAN INTERFACE CONFIGURATION
```

Hardware Installation Guidelines

```
!  
!  
interface Vlan1  
  no ip address  
!  
!  
interface VLAN 100  
  ip address 172.21.49.3 255.255.254.0  
  ip pim dense-mode  
  no shutdown  
!  
!  
interface Vlan200  
  description for remote access though telnet  
  ip address 192.168.0.6 255.255.255.224      ! <----- replace IP with the value provided by the  
customer  
  no shutdown  
!  
!  
no ip http server  
no ip http secure-server  
!  
ip route 0.0.0.0 0.0.0.0 192.168.0.1 1      ! <----- replace IP with yellow VLAN 200 vrrp IP  
!  
!  
line con 0  
  password ***** ! <----- replace ***** with password specified in password dragon as Cisco telnet  
  login  
!  
logging 172.21.49.10  
!  
no cdp run  
!  
end
```

10.16.7 Blue-sw3-1 Switch 4948 & 4948E-F (Layer 3)

```
! IMF BLUE3 SWITCH configuration  
!  
!  
hostname blue-sw3-1  
!  
no spanning-tree vlan 1-4094  
no spanning-tree optimize bpdu transmission  
!  
enable secret ***** ! <----- replace ***** with password specified in password dragon as Cisco enable
```

Hardware Installation Guidelines

```
service password-encryption
no service pad
service timestamps debug datetime
service timestamps log datetime
no logging console
no aaa new-model
track 1 interface GigabitEthernet1/47 line-protocol
ip subnet-zero
!
ip multicast-routing
!
power redundancy-mode redundant
!
!
! VLAN CONFIGURATION (internal)
!
!
vlan 100
  name internal_yellow
!
vlan 101
  name internal_blue
!
vlan 200
  name IMF2IXP_internal_(backend)
!
vlan 300
  name oobm_or_iLO
!
vlan 400
  name IMF2IXP_external_(frontend)
!
!
! INTER BLUE SW 3 TO BLUE SW 1 ETHERCHANNEL (internal)
!
!
interface Port-channel3
  description Trunk_between_ blue_sw3_and_ blue_sw1
  switchport
  switchport trunk encapsulation dot1q
  switchport trunk allowed vlan 100,101,200,300
  switchport mode trunk
  mtu 9198
  no shutdown
!
!
```

Hardware Installation Guidelines

```
! INTER BLUE SW3 TO BLUE SW1 PORTS (internal)
!
!
Interface range GigabitEthernet 1/1 - 2
  description Trunk_between_blue_sw3_and_blue_sw1
  switchport trunk encapsulation dot1q
  switchport trunk allowed vlan 100,101,200,300
  switchport mode trunk
  mtu 9198
  channel-group 1 mode active
  no shutdown
!
!
! EAGLE PORTS
!
!
interface range GigabitEthernet 1/3 - 48
  description Eagle FC or STC ports
  switchport access vlan 101
  switchport mode access
  mtu 9198
  no shutdown
!
!
! VLAN INTERFACE CONFIGURATION
!
!
interface Vlan1
  no ip address
!
!
interface VLAN 101
  ip address 172.22.49.3 255.255.254.0
  ip pim dense-mode
  no shutdown!
!
interface Vlan200
  description for remote access though telnet
  ip address 192.168.0.7 255.255.255.224 ! <----- replace IP with the value provided by the
customer
  no shutdown
!
!
no ip http server
no ip http secure-server
!
```

Hardware Installation Guidelines

```

ip route 0.0.0.0 0.0.0.0 192.168.0.1 1      ! <----- replace IP with yellow VLAN 200 vrrp IP
!
!
line con 0
 password ***** ! <----- replace ***** with password specified in password dragon as Cisco telnet
 login
!
logging 172.22.49.10
!
no cdp run
!
end

```

10.16.8 Single Switch yellow-blue-sw1-1 4948 & 4948E-F

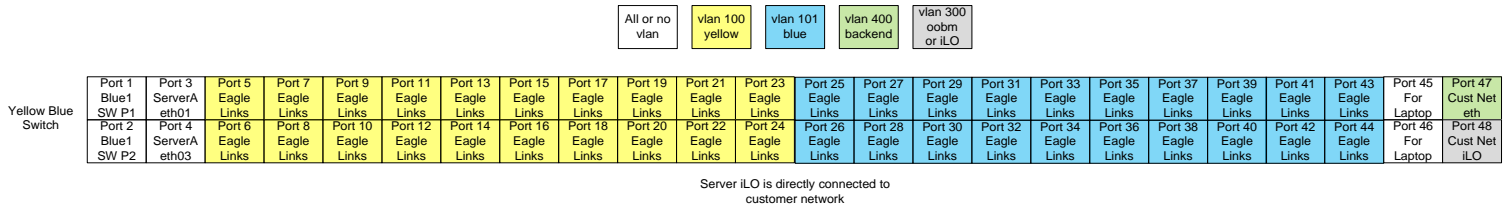

```

enable secret ***** ! <----- replace ***** with password specified in password dragon as Cisco enable
service password-encryption
no service pad
service timestamps debug uptime
service timestamps log uptime
service compress-config
!
hostname yellow-blue-sw1-1
!
no logging console
!
no aaa new-model
ip subnet-zero
!
ip multicast-routing
vtp mode transparent
!
!
!
power redundancy-mode redundant
no file verify auto
spanning-tree mode pvst

```

Hardware Installation Guidelines

```
no spanning-tree optimize bpdu transmission
spanning-tree extend system-id
!
!
! VLAN CONFIGURATION (internal)
!
!
vlan internal allocation policy ascending
!
vlan 100
  name internal_yellow
!
vlan 101
  name internal_blue
!
vlan 200
  name IMF2IXP_internal_(backend)
!
vlan 300
  name oobm_or_iLO
!
!
! INTER YELLOW SW1 TO BLUE SW1 ETHERCHANNEL (internal)
!
!
interface Port-channel1
  description Red_Wan_Trunk_between_Yellow_and_Blue (unused here but reserved)
  switchport
  switchport trunk encapsulation dot1q
  switchport mode trunk
  mtu 9198
!
!
! INTER YELLOW SW1 TO BLUE SW1 PORTS (internal)
!
!
Interface range GigabitEthernet 1/1 - 2
  description Red_Wan_Trunk_between_Yellow_and_Blue (unused here but reserved)
  switchport trunk encapsulation dot1q
  switchport mode trunk
  mtu 9198
  channel-group 1 mode active
!
!
! IMF Servers PORTS
!
```

Hardware Installation Guidelines

```
!  
interface range GigabitEthernet1/3 - 4  
  description for IMF 1A external + internal networks port  
  switchport trunk encapsulation dot1q  
  switchport trunk allowed vlan 1,100,101,200,300  
  switchport mode trunk  
  mtu 9198  
  spanning-tree portfast trunk  
!  
!  
! EAGLE PORTS  
!  
!  
interface range GigabitEthernet1/5 - 24  
  description yellow network port for Eagle connectivity  
  switchport access vlan 100  
  switchport mode access  
  mtu 9198  
  spanning-tree portfast  
!  
!  
interface range GigabitEthernet1/25-44  
  description blue network port for Eagle connectivity  
  switchport access vlan 101  
  switchport mode access  
  mtu 9198  
  spanning-tree portfast  
!  
!  
interface range GigabitEthernet1/45-46  
  description unused  
  shutdown  
!  
!  
! PORT TO CUSTOMER SWITCH A  
!  
!  
interface GigabitEthernet1/47  
  description port where customer is connected to IMF  
  switchport access vlan 200  
  switchport mode access  
  media-type rj45  
!  
interface GigabitEthernet1/48  
  description port where customer is connected to ILO  
  switchport access vlan 300  
  switchport mode access
```

```
media-type rj45
!
interface Vlan1
  no ip address
!
interface Vlan100
  ip address 172.21.49.1 255.255.254.0
  no ip route-cache cef
  no ip route-cache
  no shutdown
!
interface Vlan101
  ip address 172.22.49.1 255.255.254.0
  no ip route-cache cef
  no ip route-cache
  no shutdown
!
!
interface Vlan200
  ip address 10.27.56.166 255.255.255.240 ! <----- replace IP with an address from customer network
  no shutdown
!
no ip http server
no ip http secure-server
!
ip route 0.0.0.0 0.0.0.0 10.248.4.17 1 ! <----- replace IP with customer default gateway
!
!
logging 172.21.49.10
no cdp run
!
line con 0
  password ***** ! <----- replace ***** with password specified in password dragon as Cisco telnet
  login
!
!
!
End
```

10.16.9 Yellow-sw1-1 Switch 9372TX (Layer 2)

Note : for simplicity the port allocation on the 9372TX is identical to the one for 4948.

Configuration is saved using command: copy running-config startup-config

write erase command can be used to reset to factory default (this command shall be used with caution as a risk of being disconnected with no possibility to reconnect exists)

version 7.0(3)I4(5)

Hardware Installation Guidelines

```
hostname Yellow-sw1
vdc Yellow-sw1 id 1
  limit-resource vlan minimum 16 maximum 4094
  limit-resource vrf minimum 2 maximum 4096
  limit-resource port-channel minimum 0 maximum 511
  limit-resource u4route-mem minimum 248 maximum 248
  limit-resource u6route-mem minimum 96 maximum 96
  limit-resource m4route-mem minimum 58 maximum 58
  limit-resource m6route-mem minimum 8 maximum 8

feature privilege
feature bash-shell
feature scp-server
feature vrrp
feature pim
feature interface-vlan
feature hsrp
feature lacp
feature lldp
clock protocol ntp vdc 1
feature sflow
feature evmed

no password strength-check
username admin password My_password role network-admin ! <----- Specify new username password
ip domain-lookup
crypto key param rsa label P5-Switch1 modulus 1024
system jumbomt 9198
copp profile strict
ntp server X.X.X.X ! <----- Specify NTP server IP add (optional)
ntp authenticate ! <----- optional
ntp authentication-key 135 md5 swxoomi 7 ! <----- Change Password if needed (optional)
ntp trusted-key 135
ntp logging
login on-success log

vlan 1,100-101,200,300

vlan 100
  name internal_yellow
vlan 101
  name internal_blue
vlan 200
  name IMF2IXP_internal_(backend)
vlan 300
  name oobm_or_ilo
```

Hardware Installation Guidelines

```
spanning-tree vlan 1 priority 0
vrf context management
hardware access-list tcam region vpc-convergence 0
hardware access-list tcam region arp-ether 256

interface port-channel1
  description Trunk_between_yellow_sw1_and_blue_sw1
  switchport mode trunk
  switchport trunk allowed vlan 100-101,200,300
  mtu 9198

interface port-channel2
  description Trunk_between_yellow_sw1_and_yellow_sw2
  switchport mode trunk
  switchport trunk allowed vlan 100-101,200,300
  mtu 9198

interface port-channel3
  description Trunk_between_yellow_sw1_and_yellow_sw3
  switchport mode trunk
  switchport trunk allowed vlan 100-101,200,300
  mtu 9198

interface Ethernet1/1
  description ISL_between_yellow_sw1_and_Blue_sw1
  switchport mode trunk
  switchport trunk allowed vlan 100-101,200,300
  mtu 9198
  channel-group 1

interface Ethernet1/2
  description ISL_between_yellow_sw1_and_blue_sw1
  switchport mode trunk
  switchport trunk allowed vlan 100-101,200,300
  mtu 9198
  channel-group 1

interface Ethernet1/3
  description IMF port
  switchport mode trunk
  spanning-tree port type edge trunk
  mtu 9198

interface Ethernet1/4
```

Hardware Installation Guidelines

```
description IMF port
switchport mode trunk
spanning-tree port type edge trunk
mtu 9198
```

```
interface Ethernet1/5
description IMF port
switchport mode trunk
spanning-tree port type edge trunk
mtu 9198
```

```
interface Ethernet1/6
description ILO port
switchport access vlan 300
spanning-tree port type edge
```

```
Interface Ethernet1/7
description IMF port
switchport mode trunk
spanning-tree port type edge trunk
mtu 9198
```

```
interface Ethernet1/8
description IMF port
switchport mode trunk
spanning-tree port type edge trunk
mtu 9198
```

```
interface Ethernet1/9
description ILO port
switchport access vlan 300
spanning-tree port type edge
```

```
Interface Ethernet1/10
description IMF port
switchport mode trunk
spanning-tree port type edge trunk
mtu 9198
```

```
interface Ethernet1/11
description Eagle ports
switchport access vlan 100
spanning-tree port type edge
mtu 9198
```

```
interface Ethernet1/12
```

Hardware Installation Guidelines

```
description Eagle ports
switchport access vlan 100
spanning-tree port type edge
mtu 9198
```

```
interface Ethernet1/13
description Eagle ports
switchport access vlan 100
spanning-tree port type edge
mtu 9198
```

```
interface Ethernet1/14
description Eagle ports
switchport access vlan 100
spanning-tree port type edge
mtu 9198
```

```
interface Ethernet1/15
description Eagle ports
switchport access vlan 100
spanning-tree port type edge
mtu 9198
```

```
interface Ethernet1/16
description Eagle ports
switchport access vlan 100
spanning-tree port type edge
mtu 9198
```

```
interface Ethernet1/17
description Eagle ports
switchport access vlan 100
spanning-tree port type edge
mtu 9198
```

```
interface Ethernet1/18
description Eagle ports
switchport access vlan 100
spanning-tree port type edge
mtu 9198
```

```
interface Ethernet1/19
description Eagle ports
switchport access vlan 100
spanning-tree port type edge
mtu 9198
```

Hardware Installation Guidelines

```
interface Ethernet1/20
  description Eagle ports
  switchport access vlan 100
  spanning-tree port type edge
  mtu 9198
```

```
interface Ethernet1/21
  description Eagle ports
  switchport access vlan 100
  spanning-tree port type edge
  mtu 9198
```

```
interface Ethernet1/22
  description Eagle ports
  switchport access vlan 100
  spanning-tree port type edge
  mtu 9198
```

```
interface Ethernet1/23
  description Eagle ports
  switchport monitor
  switchport access vlan 100
  spanning-tree port type edge
  mtu 9198
```

```
interface Ethernet1/24
  description Eagle ports
  switchport access vlan 100
  spanning-tree port type edge
  mtu 9198
```

```
interface Ethernet1/25
  description Eagle ports
  switchport access vlan 100
  spanning-tree port type edge
  mtu 9198
```

```
interface Ethernet1/26
  description Eagle ports
  switchport access vlan 100
  spanning-tree port type edge
  mtu 9198
```

```
interface Ethernet1/27
  description Eagle ports
```

Hardware Installation Guidelines

```
switchport access vlan 100
spanning-tree port type edge
mtu 9198
```

```
interface Ethernet1/28
description Eagle ports
switchport access vlan 100
spanning-tree port type edge
mtu 9198
```

```
interface Ethernet1/29
description Eagle ports
switchport access vlan 100
spanning-tree port type edge
mtu 9198
```

```
interface Ethernet1/30
description Eagle ports
switchport access vlan 100
spanning-tree port type edge
mtu 9198
```

```
interface Ethernet1/31
description Eagle ports
switchport access vlan 100
spanning-tree port type edge
mtu 9198
```

```
interface Ethernet1/32
description Eagle ports
switchport access vlan 100
spanning-tree port type edge
mtu 9198
```

```
interface Ethernet1/33
description Eagle ports
switchport access vlan 100
spanning-tree port type edge
mtu 9198
```

```
interface Ethernet1/34
description Eagle ports
switchport access vlan 100
spanning-tree port type edge
mtu 9198
```

Hardware Installation Guidelines

```
interface Ethernet1/35
  description Eagle ports
  switchport access vlan 100
  spanning-tree port type edge
  mtu 9198
```

```
interface Ethernet1/36
  description Eagle ports
  switchport access vlan 100
  spanning-tree port type edge
  mtu 9198
```

```
interface Ethernet1/37
  description Eagle ports
  switchport access vlan 100
  spanning-tree port type edge
  mtu 9198
```

```
interface Ethernet1/38
  description Eagle ports
  switchport access vlan 100
  spanning-tree port type edge
  mtu 9198
```

```
interface Ethernet1/39
  description Eagle ports
  switchport access vlan 100
  spanning-tree port type edge
  mtu 9198
```

```
interface Ethernet1/40
  description Eagle ports
  switchport access vlan 100
  spanning-tree port type edge
  mtu 9198
```

```
interface Ethernet1/41
  description ISL_between_yellow_switch1_and_yellow_switch3
  switchport mode trunk
  switchport trunk allowed vlan 100-101,200,300
  mtu 9198
  channel-group 3
```

```
interface Ethernet1/42
  description ISL_between_yellow_switch1_and_yellow_switch3
  switchport mode trunk
```

Hardware Installation Guidelines

```
switchport trunk allowed vlan 100-101,200,300
mtu 9198
channel-group 3

interface Ethernet1/43
description ISL_between_yellow_switch1_and_yellow_switch2
switchport mode trunk
switchport trunk allowed vlan 100-101,200,300
mtu 9198
channel-group 2

interface Ethernet1/44
description ISL_between_yellow_switch1_and_yellow_switch2
switchport mode trunk
switchport trunk allowed vlan 100-101,200,4300
mtu 9198
channel-group 2

Interface Ethernet1/45
description Laptop native
switchport access vlan 200
spanning-tree port type edge

interface Ethernet1/46
description Laptop Trunk
switchport mode trunk
spanning-tree port type edge trunk
switchport trunk allowed vlan 1,100,101,200,300
mtu 9198

Interface Ethernet1/47
description Customer network access (backend)
switchport access vlan 200

Interface Ethernet1/47
description Customer network access for ILO
switchport access vlan 300

interface mgmt0
description oobm
vrf member management
ip address X.X.X.X/24      ! <----- Specify switch IP add
ipv6 address 2000::1/64
clock timezone UTC -4 0
line console
```

Hardware Installation Guidelines

```
line vty
boot nxos bootflash:/nxos.7.0.3.I4.5.bin
ip route 0.0.0.0/0 X.X.X.X      ! <----- Specify default route
ipv6 switch-packets
logging server X.X.X.X        ! <----- Specify remote logging server (optional)
```

10.16.10 Blue-sw1-1 Switch 9372TX (Layer 2)

Note : for simplicity the port allocation on the 9372TX is identical to the one for 4948.

Configuration is saved using command: copy running-config startup-config

write erase command can be used to reset to factory default (this command shall be used with caution as a risk of being disconnected with no possibility to reconnect exists)

```
version 7.0(3)I4(5)
hostname Blue-sw1
vdc Blue-sw1 id 1
  limit-resource vlan minimum 16 maximum 4094
  limit-resource vrf minimum 2 maximum 4096
  limit-resource port-channel minimum 0 maximum 511
  limit-resource u4route-mem minimum 248 maximum 248
  limit-resource u6route-mem minimum 96 maximum 96
  limit-resource m4route-mem minimum 58 maximum 58
  limit-resource m6route-mem minimum 8 maximum 8

feature privilege
feature bash-shell
feature scp-server
feature vrrp
feature pim
feature interface-vlan
feature hsrp
feature lacp
feature lldp
clock protocol ntp vdc 1
feature sflow
feature evmed

no password strength-check
username admin password My_password role network-admin ! <----- Specify new username password
ip domain-lookup
crypto key param rsa label P5-Switch1 modulus 1024
system jumbomtu 9198
copp profile strict
```

Hardware Installation Guidelines

```
ntp server X.X.X.X ! <----- Specify NTP server IP add (optional)
ntp authenticate ! <----- optional
ntp authentication-key 135 md5 swxoomi 7 ! <----- Change Password if needed (optional)
ntp trusted-key 135
ntp logging
login on-success log

vlan 1,100-101,200,300

vlan 100
  name internal_yellow
vlan 101
  name internal_blue
vlan 200
  name IMF2IXP_internal_(backend)
vlan 300
  name oobm_or_ilo

spanning-tree vlan 1 priority 0
vrf context management
hardware access-list tcam region vpc-convergence 0
hardware access-list tcam region arp-ether 256

interface port-channel1
  description Trunk_between_Blue_sw1_and_yellow_sw1
  switchport mode trunk
  switchport trunk allowed vlan 100-101,200,300
  mtu 9198

interface port-channel2
  description Trunk_between_Blue_sw1_and_Blue_sw2
  switchport mode trunk
  switchport trunk allowed vlan 100,101,200,300
  mtu 9198

interface port-channel3
  description Trunk_between_Blue_sw1_and_Blue_sw3
  switchport mode trunk
  switchport trunk allowed vlan 100,101,200,300
  mtu 9198

interface Ethernet1/1
  description ISL_between_blue_sw1_and_yellow_sw1
  switchport mode trunk
  switchport trunk allowed vlan 100,101,200,300
```

Hardware Installation Guidelines

```
mtu 9198
channel-group 1
```

```
interface Ethernet1/2
  description ISL_between_blue_sw1_and_yellow_sw1
  switchport mode trunk
  switchport trunk allowed vlan 100-101,200,300
  mtu 9198
  channel-group 1
```

```
interface Ethernet1/3
  description IMF port
  switchport mode trunk
  spanning-tree port type edge trunk
  mtu 9198
```

```
interface Ethernet1/4
  description IMF port
  switchport mode trunk
  spanning-tree port type edge trunk
  mtu 9198
```

```
interface Ethernet1/5
  description IMF port
  switchport mode trunk
  spanning-tree port type edge trunk
  mtu 9198
```

```
interface Ethernet1/6
  description IMF port
  switchport mode trunk
  spanning-tree port type edge trunk
  mtu 9198
```

```
Interface Ethernet1/7
  description ILO port
  switchport access vlan 300
  spanning-tree port type edge
```

```
interface Ethernet1/8
  description IMF port
  switchport mode trunk
  spanning-tree port type edge trunk
  mtu 9198
```

```
interface Ethernet1/9
```

```
description IMF port
switchport mode trunk
spanning-tree port type edge trunk
mtu 9198
```

```
Interface Ethernet1/10
description ILO port
switchport access vlan 300
spanning-tree port type edge
```

```
interface Ethernet1/11
description Eagle ports
switchport access vlan 101
spanning-tree port type edge
mtu 9198
```

```
interface Ethernet1/12
description Eagle ports
switchport access vlan 101
spanning-tree port type edge
mtu 9198
```

```
interface Ethernet1/13
description Eagle ports
switchport access vlan 101
spanning-tree port type edge
mtu 9198
```

```
interface Ethernet1/14
description Eagle ports
switchport access vlan 101
spanning-tree port type edge
mtu 9198
```

```
interface Ethernet1/15
description Eagle ports
switchport access vlan 101
spanning-tree port type edge
mtu 9198
```

```
interface Ethernet1/16
description Eagle ports
switchport access vlan 101
spanning-tree port type edge
mtu 9198
```

Hardware Installation Guidelines

```
interface Ethernet1/17
  description Eagle ports
  switchport access vlan 101
  spanning-tree port type edge
  mtu 9198
```

```
interface Ethernet1/18
  description Eagle ports
  switchport access vlan 101
  spanning-tree port type edge
  mtu 9198
```

```
interface Ethernet1/19
  description Eagle ports
  switchport access vlan 101
  spanning-tree port type edge
  mtu 9198
```

```
interface Ethernet1/20
  description Eagle ports
  switchport access vlan 101
  spanning-tree port type edge
  mtu 9198
```

```
interface Ethernet1/21
  description Eagle ports
  switchport access vlan 101
  spanning-tree port type edge
  mtu 9198
```

```
interface Ethernet1/22
  description Eagle ports
  switchport access vlan 101
  spanning-tree port type edge
  mtu 9198
```

```
interface Ethernet1/23
  description Eagle ports
  switchport monitor
  switchport access vlan 101
  spanning-tree port type edge
  mtu 9198
```

```
interface Ethernet1/24
  description Eagle ports
  switchport access vlan 101
```

```
spanning-tree port type edge
mtu 9198
```

```
interface Ethernet1/25
  description Eagle ports
  switchport access vlan 101
  spanning-tree port type edge
  mtu 9198
```

```
interface Ethernet1/26
  description Eagle ports
  switchport access vlan 101
  spanning-tree port type edge
  mtu 9198
```

```
interface Ethernet1/27
  description Eagle ports
  switchport access vlan 101
  spanning-tree port type edge
  mtu 9198
```

```
interface Ethernet1/28
  description Eagle ports
  switchport access vlan 101
  spanning-tree port type edge
  mtu 9198
```

```
interface Ethernet1/29
  description Eagle ports
  switchport access vlan 101
  spanning-tree port type edge
  mtu 9198
```

```
interface Ethernet1/30
  description Eagle ports
  switchport access vlan 101
  spanning-tree port type edge
  mtu 9198
```

```
interface Ethernet1/31
  description Eagle ports
  switchport access vlan 101
  spanning-tree port type edge
  mtu 9198
```

```
interface Ethernet1/32
```

Hardware Installation Guidelines

```
description Eagle ports
switchport access vlan 101
spanning-tree port type edge
mtu 9198
```

```
interface Ethernet1/33
description Eagle ports
switchport access vlan 101
spanning-tree port type edge
mtu 9198
```

```
interface Ethernet1/34
description Eagle ports
switchport access vlan 101
spanning-tree port type edge
mtu 9198
```

```
interface Ethernet1/35
description Eagle ports
switchport access vlan 101
spanning-tree port type edge
mtu 9198
```

```
interface Ethernet1/36
description Eagle ports
switchport access vlan 101
spanning-tree port type edge
mtu 9198
```

```
interface Ethernet1/37
description Eagle ports
switchport access vlan 101
spanning-tree port type edge
mtu 9198
```

```
interface Ethernet1/38
description Eagle ports
switchport access vlan 101
spanning-tree port type edge
mtu 9198
```

```
interface Ethernet1/39
description Eagle ports
switchport access vlan 101
spanning-tree port type edge
mtu 9198
```

Hardware Installation Guidelines

```
interface Ethernet1/40
  description Eagle ports
  switchport access vlan 101
  spanning-tree port type edge
  mtu 9198

interface Ethernet1/41
  description ISL_between_blue_switch1_and_blue_switch3
  switchport mode trunk
  switchport trunk allowed vlan 100,101,200,300
  mtu 9198
  channel-group 3

interface Ethernet1/42
  description ISL_between_blue_switch1_and_blue_switch3
  switchport mode trunk
  switchport trunk allowed vlan 100,101,200,300
  mtu 9198
  channel-group 3

interface Ethernet1/43
  description ISL_between_blue_switch1_and_blue_switch2
  switchport mode trunk
  switchport trunk allowed vlan 100,101,200,300
  mtu 9198
  channel-group 2

interface Ethernet1/44
  description ISL_between_blue_switch1_and_blue_switch2
  switchport mode trunk
  switchport trunk allowed vlan 100,101,200,300
  mtu 9198
  channel-group 2

Interface Ethernet1/45
  description Laptop native
  switchport access vlan 200
  spanning-tree port type edge

interface Ethernet1/46
  description Laptop Trunk
  switchport mode trunk
  spanning-tree port type edge trunk
  switchport trunk allowed vlan 1,100,101,300,400
  mtu 9198
```

Hardware Installation Guidelines

```
Interface Ethernet1/47
  description Customer network access (backend)
  switchport access vlan 200
```

```
Interface Ethernet1/47
  description Customer network access for ILO
  switchport access vlan 300
```

```
interface mgmt0
  description oobm
  vrf member management
  ip address X.X.X.X/24      ! <----- Specify switch IP add
  ipv6 address 2000::1/64
  clock timezone UTC -4 0
  line console
  line vty
  boot nxos bootflash:/nxos.7.0.3.I4.5.bin
  ip route 0.0.0.0/0 X.X.X.X  ! <----- Specify default route
  ipv6 switch-packets
  logging server X.X.X.X      ! <----- Specify remote logging server (optional)
```

10.16.11 Yellow-sw2-1 Switch 9372TX (Layer 2)

Configuration is save using command: copy running-config startup-config

write erase command can be used to reset to factory default (this command shall be used with caution as a risk of being disconnected with no possibility to reconnect exists)

```
version 7.0(3)I4(5)
hostname Yellow-sw2
vdc Yellow-sw2 id 1
  limit-resource vlan minimum 16 maximum 4094
  limit-resource vrf minimum 2 maximum 4096
  limit-resource port-channel minimum 0 maximum 511
  limit-resource u4route-mem minimum 248 maximum 248
  limit-resource u6route-mem minimum 96 maximum 96
  limit-resource m4route-mem minimum 58 maximum 58
  limit-resource m6route-mem minimum 8 maximum 8

feature privilege
feature bash-shell
feature scp-server
feature vrrp
feature pim
```

Hardware Installation Guidelines

```
feature interface-vlan
feature hsrp
feature lacp
feature lldp
clock protocol ntp vdc 1
feature sflow
feature evmed

no password strength-check
username admin password My_password role network-admin ! <----- Specify new username password
ip domain-lookup
crypto key param rsa label P5-Switch1 modulus 1024
system jumbomtu 9198
copp profile strict
ntp server X.X.X.X ! <----- Specify NTP server IP add (optional)
ntp authenticate ! <----- optional
ntp authentication-key 135 md5 swxoomi 7 ! <----- Change Password if needed (optional)
ntp trusted-key 135
ntp logging
login on-success log

vlan 1,100,101,200,300

vlan 100
 name internal_yellow
vlan 101
 name internal_blue
vlan 200
 name IMF2IXP_internal_(backend)
vlan 300
 name oobm_or_ilo

spanning-tree vlan 1 priority 0
vrf context management
hardware access-list tcam region vpc-convergence 0
hardware access-list tcam region arp-ether 256

interface port-channel1
 description Trunk_between_yellow_sw2_and_yellow_sw1
 switchport mode trunk
 switchport trunk allowed vlan 100-101,200,300
 mtu 9198

interface Ethernet1/1
```

Hardware Installation Guidelines

```
description ISL_between_ yellow_sw2_and_yellow_sw1
switchport mode trunk
switchport trunk allowed vlan 100-101,200,300
mtu 9198
channel-group 1
```

```
interface Ethernet1/2
description ISL_between_ yellow_sw2_and_yellow_sw1
switchport mode trunk
switchport trunk allowed vlan 100-101,200,300
mtu 9198
channel-group 1
```

```
interface Ethernet1/3
description IMF port
switchport mode trunk
spanning-tree port type edge trunk
mtu 9198
```

```
interface Ethernet1/4
description ILO port
switchport access vlan 300
spanning-tree port type edge
```

```
interface Ethernet1/5
description IMF port
switchport mode trunk
spanning-tree port type edge trunk
mtu 9198
```

```
interface Ethernet1/6
description IMF port
switchport mode trunk
spanning-tree port type edge trunk
mtu 9198
```

```
Interface Ethernet1/7
description ILO port
switchport access vlan 300
spanning-tree port type edge
```

```
interface Ethernet1/8
description IMF port
switchport mode trunk
spanning-tree port type edge trunk
mtu 9198
```

Hardware Installation Guidelines

```
interface Ethernet1/9
  description IMF port
  switchport mode trunk
  spanning-tree port type edge trunk
  mtu 9198
```

```
Interface Ethernet1/10
  description ILO port
  switchport access vlan 300
  spanning-tree port type edge
```

```
interface Ethernet1/11
  description IMF port
  switchport mode trunk
  spanning-tree port type edge trunk
  mtu 9198
```

```
interface Ethernet1/12
  description Eagle ports
  switchport access vlan 100
  spanning-tree port type edge
  mtu 9198
```

```
interface Ethernet1/13
  description Eagle ports
  switchport access vlan 100
  spanning-tree port type edge
  mtu 9198
```

```
interface Ethernet1/14
  description Eagle ports
  switchport access vlan 100
  spanning-tree port type edge
  mtu 9198
```

```
interface Ethernet1/15
  description Eagle ports
  switchport access vlan 100
  spanning-tree port type edge
  mtu 9198
```

```
interface Ethernet1/16
  description Eagle ports
  switchport access vlan 100
  spanning-tree port type edge
```

Hardware Installation Guidelines

```
mtu 9198
```

```
interface Ethernet1/17
  description Eagle ports
  switchport access vlan 100
  spanning-tree port type edge
  mtu 9198
```

```
interface Ethernet1/18
  description Eagle ports
  switchport access vlan 100
  spanning-tree port type edge
  mtu 9198
```

```
interface Ethernet1/19
  description Eagle ports
  switchport access vlan 100
  spanning-tree port type edge
  mtu 9198
```

```
interface Ethernet1/20
  description Eagle ports
  switchport access vlan 100
  spanning-tree port type edge
  mtu 9198
```

```
interface Ethernet1/21
  description Eagle ports
  switchport access vlan 100
  spanning-tree port type edge
  mtu 9198
```

```
interface Ethernet1/22
  description Eagle ports
  switchport access vlan 100
  spanning-tree port type edge
  mtu 9198
```

```
interface Ethernet1/23
  description Eagle ports
  switchport monitor
  switchport access vlan 100
  spanning-tree port type edge
  mtu 9198
```

```
interface Ethernet1/24
```

Hardware Installation Guidelines

```
description Eagle ports
switchport access vlan 100
spanning-tree port type edge
mtu 9198
```

```
interface Ethernet1/25
description Eagle ports
switchport access vlan 100
spanning-tree port type edge
mtu 9198
```

```
interface Ethernet1/26
description Eagle ports
switchport access vlan 100
spanning-tree port type edge
mtu 9198
```

```
interface Ethernet1/27
description Eagle ports
switchport access vlan 100
spanning-tree port type edge
mtu 9198
```

```
interface Ethernet1/28
description Eagle ports
switchport access vlan 100
spanning-tree port type edge
mtu 9198
```

```
interface Ethernet1/29
description Eagle ports
switchport access vlan 100
spanning-tree port type edge
mtu 9198
```

```
interface Ethernet1/30
description Eagle ports
switchport access vlan 100
spanning-tree port type edge
mtu 9198
```

```
interface Ethernet1/31
description Eagle ports
switchport access vlan 100
spanning-tree port type edge
mtu 9198
```

Hardware Installation Guidelines

```
interface Ethernet1/32
  description Eagle ports
  switchport access vlan 100
  spanning-tree port type edge
  mtu 9198
```

```
interface Ethernet1/33
  description Eagle ports
  switchport access vlan 100
  spanning-tree port type edge
  mtu 9198
```

```
interface Ethernet1/34
  description Eagle ports
  switchport access vlan 100
  spanning-tree port type edge
  mtu 9198
```

```
interface Ethernet1/35
  description Eagle ports
  switchport access vlan 100
  spanning-tree port type edge
  mtu 9198
```

```
interface Ethernet1/36
  description Eagle ports
  switchport access vlan 100
  spanning-tree port type edge
  mtu 9198
```

```
interface Ethernet1/37
  description Eagle ports
  switchport access vlan 100
  spanning-tree port type edge
  mtu 9198
```

```
interface Ethernet1/38
  description Eagle ports
  switchport access vlan 100
  spanning-tree port type edge
  mtu 9198
```

```
interface Ethernet1/39
  description Eagle ports
  switchport access vlan 100
```

Hardware Installation Guidelines

```
spanning-tree port type edge
mtu 9198
```

```
interface Ethernet1/40
  description Eagle ports
  switchport access vlan 100
  spanning-tree port type edge
  mtu 9198
```

```
interface Ethernet1/41
  description Eagle ports
  switchport access vlan 100
  spanning-tree port type edge
  mtu 9198
```

```
interface Ethernet1/42
  description Eagle ports
  switchport access vlan 100
  spanning-tree port type edge
  mtu 9198
```

```
interface Ethernet1/43
  description Eagle ports
  switchport access vlan 100
  spanning-tree port type edge
  mtu 9198
```

```
interface Ethernet1/44
  description Eagle ports
  switchport access vlan 100
  spanning-tree port type edge
  mtu 9198
```

```
interface Ethernet1/45
  description Eagle ports
  switchport access vlan 100
  spanning-tree port type edge
  mtu 9198
```

```
interface Ethernet1/46
  description Eagle ports
  switchport access vlan 100
  spanning-tree port type edge
  mtu 9198
```

```
interface Ethernet1/47
```

Hardware Installation Guidelines

```
description Eagle ports
switchport access vlan 100
spanning-tree port type edge
mtu 9198

interface Ethernet1/48
description Eagle ports
switchport access vlan 100
spanning-tree port type edge
mtu 9198

interface mgmt0
description oobm
vrf member management
ip address X.X.X.X/24      ! <----- Specify switch IP add
ipv6 address 2000::1/64
clock timezone UTC -4 0
line console
line vty
boot nxos bootflash:/nxos.7.0.3.I4.5.bin
ip route 0.0.0.0/0 X.X.X.X  ! <----- Specify default route
ipv6 switch-packets
logging server X.X.X.X     ! <----- Specify remote logging server (optional)
```

10.16.12 Blue-sw2-1 Switch 9372TX (Layer 2)

Configuration is saved using command: copy running-config startup-config
write erase command can be used to reset to factory default (this command shall be used with caution as a risk of being disconnected with no possibility to reconnect exists)

```
version 7.0(3)I4(5)
hostname Blue-sw2
vdc Blue-sw2 id 1
limit-resource vlan minimum 16 maximum 4094
limit-resource vrf minimum 2 maximum 4096
limit-resource port-channel minimum 0 maximum 511
limit-resource u4route-mem minimum 248 maximum 248
limit-resource u6route-mem minimum 96 maximum 96
limit-resource m4route-mem minimum 58 maximum 58
limit-resource m6route-mem minimum 8 maximum 8

feature privilege
feature bash-shell
feature scp-server
feature vrrp
feature pim
```

Hardware Installation Guidelines

```
feature interface-vlan
feature hsrp
feature lacp
feature lldp
clock protocol ntp vdc 1
feature sflow
feature evmed

no password strength-check
username admin password My_password role network-admin ! <----- Specify new username password
ip domain-lookup
crypto key param rsa label P5-Switch1 modulus 1024
system jumbomtu 9198
copp profile strict
ntp server X.X.X.X ! <----- Specify NTP server IP add (optional)
ntp authenticate ! <----- optional
ntp authentication-key 135 md5 swxoomi 7 ! <----- Change Password if needed (optional)
ntp trusted-key 135
ntp logging
login on-success log

vlan 1,100,101,200,300

vlan 100
 name internal_yellow
vlan 101
 name internal_blue
vlan 200
 name IMF2IXP_internal_(backend)
vlan 300
 name oobm_or_ilo

spanning-tree vlan 1 priority 0
vrf context management
hardware access-list tcam region vpc-convergence 0
hardware access-list tcam region arp-ether 256

interface port-channel1
 description Trunk_between_blue_sw2_and_blue_sw1
 switchport mode trunk
 switchport trunk allowed vlan 100-101,200,300
 mtu 9198

interface Ethernet1/1
```

Hardware Installation Guidelines

```
description ISL_between_ blue_sw2_and_blue_sw1
switchport mode trunk
switchport trunk allowed vlan 100-101,200,300
mtu 9198
channel-group 1
```

```
interface Ethernet1/2
description ISL_between_ blue_sw2_and_blue_sw1
switchport mode trunk
switchport trunk allowed vlan 100-101,200,300
mtu 9198
channel-group 1
```

```
interface Ethernet1/3
description IMF port
switchport mode trunk
spanning-tree port type edge trunk
mtu 9198
```

```
interface Ethernet1/4
description IMF port
switchport mode trunk
spanning-tree port type edge trunk
mtu 9198
```

```
interface Ethernet1/5
description ILO port
switchport access vlan 300
spanning-tree port type edge
```

```
interface Ethernet1/6
description IMF port
switchport mode trunk
spanning-tree port type edge trunk
mtu 9198
```

```
Interface Ethernet1/7
description IMF port
switchport mode trunk
spanning-tree port type edge trunk
mtu 9198
```

```
interface Ethernet1/8
description ILO port
switchport access vlan 300
spanning-tree port type edge
```

Hardware Installation Guidelines

```
interface Ethernet1/9
  description IMF port
  switchport mode trunk
  spanning-tree port type edge trunk
  mtu 9198
```

```
Interface Ethernet1/10
  description IMF port
  switchport mode trunk
  spanning-tree port type edge trunk
  mtu 9198
```

```
interface Ethernet1/11
  description ILO port
  switchport access vlan 300
  spanning-tree port type edge
```

```
interface Ethernet1/12
  description Eagle ports
  switchport access vlan 101
  spanning-tree port type edge
  mtu 9198
```

```
interface Ethernet1/13
  description Eagle ports
  switchport access vlan 101
  spanning-tree port type edge
  mtu 9198
```

```
interface Ethernet1/14
  description Eagle ports
  switchport access vlan 101
  spanning-tree port type edge
  mtu 9198
```

```
interface Ethernet1/15
  description Eagle ports
  switchport access vlan 101
  spanning-tree port type edge
  mtu 9198
```

```
interface Ethernet1/16
  description Eagle ports
  switchport access vlan 101
  spanning-tree port type edge
```

Hardware Installation Guidelines

```
mtu 9198
```

```
interface Ethernet1/17
  description Eagle ports
  switchport access vlan 101
  spanning-tree port type edge
  mtu 9198
```

```
interface Ethernet1/18
  description Eagle ports
  switchport access vlan 101
  spanning-tree port type edge
  mtu 9198
```

```
interface Ethernet1/19
  description Eagle ports
  switchport access vlan 101
  spanning-tree port type edge
  mtu 9198
```

```
interface Ethernet1/20
  description Eagle ports
  switchport access vlan 101
  spanning-tree port type edge
  mtu 9198
```

```
interface Ethernet1/21
  description Eagle ports
  switchport access vlan 101
  spanning-tree port type edge
  mtu 9198
```

```
interface Ethernet1/22
  description Eagle ports
  switchport access vlan 101
  spanning-tree port type edge
  mtu 9198
```

```
interface Ethernet1/23
  description Eagle ports
  switchport monitor
  switchport access vlan 101
  spanning-tree port type edge
  mtu 9198
```

```
interface Ethernet1/24
```

```
description Eagle ports
switchport access vlan 101
spanning-tree port type edge
mtu 9198
```

```
interface Ethernet1/25
description Eagle ports
switchport access vlan 101
spanning-tree port type edge
mtu 9198
```

```
interface Ethernet1/26
description Eagle ports
switchport access vlan 101
spanning-tree port type edge
mtu 9198
```

```
interface Ethernet1/27
description Eagle ports
switchport access vlan 101
spanning-tree port type edge
mtu 9198
```

```
interface Ethernet1/28
description Eagle ports
switchport access vlan 101
spanning-tree port type edge
mtu 9198
```

```
interface Ethernet1/29
description Eagle ports
switchport access vlan 101
spanning-tree port type edge
mtu 9198
```

```
interface Ethernet1/30
description Eagle ports
switchport access vlan 101
spanning-tree port type edge
mtu 9198
```

```
interface Ethernet1/31
description Eagle ports
switchport access vlan 101
spanning-tree port type edge
mtu 9198
```

Hardware Installation Guidelines

```
interface Ethernet1/32
  description Eagle ports
  switchport access vlan 101
  spanning-tree port type edge
  mtu 9198
```

```
interface Ethernet1/33
  description Eagle ports
  switchport access vlan 101
  spanning-tree port type edge
  mtu 9198
```

```
interface Ethernet1/34
  description Eagle ports
  switchport access vlan 101
  spanning-tree port type edge
  mtu 9198
```

```
interface Ethernet1/35
  description Eagle ports
  switchport access vlan 101
  spanning-tree port type edge
  mtu 9198
```

```
interface Ethernet1/36
  description Eagle ports
  switchport access vlan 101
  spanning-tree port type edge
  mtu 9198
```

```
interface Ethernet1/37
  description Eagle ports
  switchport access vlan 101
  spanning-tree port type edge
  mtu 9198
```

```
interface Ethernet1/38
  description Eagle ports
  switchport access vlan 101
  spanning-tree port type edge
  mtu 9198
```

```
interface Ethernet1/39
  description Eagle ports
  switchport access vlan 101
```

Hardware Installation Guidelines

```
spanning-tree port type edge
mtu 9198
```

```
interface Ethernet1/40
  description Eagle ports
  switchport access vlan 101
  spanning-tree port type edge
  mtu 9198
```

```
interface Ethernet1/41
  description Eagle ports
  switchport access vlan 101
  spanning-tree port type edge
  mtu 9198
```

```
interface Ethernet1/42
  description Eagle ports
  switchport access vlan 101
  spanning-tree port type edge
  mtu 9198
```

```
interface Ethernet1/43
  description Eagle ports
  switchport access vlan 101
  spanning-tree port type edge
  mtu 9198
```

```
interface Ethernet1/44
  description Eagle ports
  switchport access vlan 101
  spanning-tree port type edge
  mtu 9198
```

```
interface Ethernet1/45
  description Eagle ports
  switchport access vlan 101
  spanning-tree port type edge
  mtu 9198
```

```
interface Ethernet1/46
  description Eagle ports
  switchport access vlan 101
  spanning-tree port type edge
  mtu 9198
```

```
interface Ethernet1/47
```

Hardware Installation Guidelines

```
description Eagle ports
switchport access vlan 101
spanning-tree port type edge
mtu 9198

interface Ethernet1/48
description Eagle ports
switchport access vlan 101
spanning-tree port type edge
mtu 9198

interface mgmt0
description oobm
vrf member management
ip address X.X.X.X/24      ! <----- Specify switch IP add
ipv6 address 2000::1/64
clock timezone UTC -4 0
line console
line vty
boot nxos bootflash:/nxos.7.0.3.I4.5.bin
ip route 0.0.0.0/0 X.X.X.X  ! <----- Specify default route
ipv6 switch-packets
logging server X.X.X.X     ! <----- Specify remote logging server (optional)
```

10.16.13 RMS Layer 2 switch configurations (Performance Intelligence Center 9.x and earlier)

1. Yellow-sw1-1 (Layer 2)

```
!
no service pad
service timestamps debug datetime
service timestamps log datetime
service password-encryption
no logging console
!
hostname yellow-sw1-1
enable secret ***** ! <----- replace ***** with password specified in password dragon as Cisco enable
!
ip subnet-zero
vtp mode transparent
!
!
spanning-tree mode pvst
no spanning-tree optimize bpdu transmission
spanning-tree extend system-id
```

Hardware Installation Guidelines

```
spanning-tree vlan 1-1024 priority 40960
!
ip multicast-routing
!
!
! VLAN CONFIGURATION (internal)
!
!
vlan 100
  name yellow
!
vlan 101
  name blue
!
vlan 200
  name cust
!
vlan 300
  name oobm
!
!
! INTER YELLOW SW1 TO BLUE SW1 ETHERCHANNEL (internal)
!
!
interface Port-channel1
  description Red_Wan_Trunk_between_Yellow_and_Blue
  switchport
  switchport trunk encapsulation dot1q
  switchport trunk allowed vlan 1,100,101,200,300
  switchport mode trunk
  mtu 9198
  spanning-tree portfast trunk
!
!
! INTER YELLOW SW 1 TO YELLOW SW2 ETHERCHANNEL (internal)
!
!
interface Port-channel2
  description Trunk_between_Yellow_sw1_and_Yellow_sw2
  switchport
  switchport trunk encapsulation dot1q
  switchport trunk allowed vlan 1,100,101,200,300
  switchport mode trunk
  mtu 9198
  spanning-tree portfast trunk
!
```

Hardware Installation Guidelines

```
!  
!  
! INTER YELLOW SW 1 TO YELLOW SW3 ETHERCHANNEL (internal)  
!  
!  
!  
interface Port-channel3  
  description Trunk_between_Yellow_sw1_and_Yellow_sw3  
  switchport  
  switchport trunk encapsulation dot1q  
  switchport trunk allowed vlan 1,100,101,200,300  
  switchport mode trunk  
  mtu 9198  
  spanning-tree portfast trunk  
!  
!  
!  
! INTER YELLOW SW1 TO BLUE SW1 PORTS (internal)  
!  
!  
!  
interface range gigabitEthernet 1/1 - 2  
  description ISL_between_yellow_sw1_and_blue_sw1  
  switchport trunk encapsulation dot1q  
  switchport trunk allowed vlan 1,100,101,200,300  
  switchport mode trunk  
  mtu 9198  
  channel-group 1 mode active  
  spanning-tree portfast trunk  
  no shutdown  
!  
!  
!  
! INTER yellow SW1 TO yellow SW3 PORTS (internal)  
!  
!  
!  
interface range gigabitEthernet 1/41 - 42  
  description Trunk_between_yellow_sw1_and_yellow_sw3  
  switchport trunk encapsulation dot1q  
  switchport trunk allowed vlan 1,100,101,200,300  
  switchport mode trunk  
  mtu 9198  
  channel-group 3 mode active  
  spanning-tree portfast trunk  
  no shutdown  
!  
!  
!  
! INTER yellow SW1 TO yellow SW2 PORTS (internal)  
!  
!  
!  
interface range gigabitEthernet 1/43 - 44
```

Hardware Installation Guidelines

```
description Trunk_between_yellow_sw1_and_yellow_sw2
```

```
switchport trunk encapsulation dot1q
switchport trunk allowed vlan 1,100,101,200,300
switchport mode trunk
mtu 9198
channel-group 2 mode active
spanning-tree portfast trunk
no shutdown
```

```
!
!
! IMF Servers PORTS
```

```
!
!
interface range gigabitEthernet 1/3 - 5
```

```
description IMF servers ports
```

```
switchport trunk encapsulation dot1q
switchport mode trunk
mtu 9198
spanning-tree portfast trunk
no shutdown
```

```
!
interface range gigabitEthernet 1/7 - 8
```

```
description IMF servers ports
```

```
switchport trunk encapsulation dot1q
switchport mode trunk
mtu 9198
spanning-tree portfast trunk
no shutdown
```

```
!
interface gigabitEthernet 1/10
```

```
description IMF servers ports
```

```
switchport trunk encapsulation dot1q
switchport mode trunk
mtu 9198
spanning-tree portfast trunk
no shutdown
```

```
!
!
! iLO PORTS
```

```
!
!
interface gigabitEthernet 1/6
```

```
description IMF iLO ports
```

```
switchport mode access
switchport access vlan 300
spanning-tree portfast
```

Hardware Installation Guidelines

```
no shutdown
!
interface gigabitEthernet 1/9
description IMF iLO ports
switchport mode access
switchport access vlan 300
spanning-tree portfast
no shutdown
!
!
! EAGLE PORTS
!
!
interface range gigabitEthernet 1/11 - 40
description Eagle FC or STC ports
switchport mode access
switchport access vlan 100
mtu 9198
spanning-tree portfast
no shutdown
!
!
! Laptop PORTS
!
!
interface range GigabitEthernet 1/45 - 46
description for Laptop
switchport access vlan 200
switchport mode access
media-type rj45
no shutdown
!
!
! PORT TO CUSTOMER SWITCH A
!
!
interface gigabitEthernet 1/47
description to customer switch A
switchport mode access
switchport access vlan 200
media-type rj45
no shutdown
!
interface gigabitEthernet 1/48
description to customer switch A (iLO)
switchport mode access
```

```
switchport access vlan 300
media-type rj45
no shutdown
!
interface VLAN 100
 ip address 172.21.49.1 255.255.254.0
 ip pim dense-mode
 no shutdown
!
no ip route-cache
!
no ip http server
!
no cdp run
!
line con 0
 password ***** ! <----- replace ***** with password specified in password dragon as Cisco telnet
 login
!
logging 172.21.49.10
!
end
```

2. Blue-sw1-1 (Layer 2)

```
!
no service pad
service timestamps debug datetime
service timestamps log datetime
service password-encryption
no logging console
!
hostname blue-sw1-1
enable secret ***** ! <----- replace ***** with password specified in password dragon as Cisco enable
!
ip subnet-zero
vtp mode transparent
!
!
spanning-tree mode pvst
no spanning-tree optimize bpdu transmission
spanning-tree extend system-id
spanning-tree vlan 1-1024 priority 40960
!
ip multicast-routing
```

Hardware Installation Guidelines

```
!  
!  
! VLAN CONFIGURATION (internal)  
!  
!  
vlan 100  
    name yellow  
!  
vlan 101  
    name blue  
!  
vlan 200  
    name cust  
!  
vlan 300  
    name oobm  
!  
!  
! INTER YELLOW SW1 TO BLUE SW1 ETHERCHANNEL (internal)  
!  
!  
interface Port-channel1  
    description Red_Wan_Trunk_between_Yellow_and_Blue  
    switchport  
    switchport trunk encapsulation dot1q  
    switchport trunk allowed vlan 1,100,101,200,300  
    switchport mode trunk  
    mtu 9198  
    spanning-tree portfast trunk  
!  
!  
! INTER BLUE SW 1 TO BLUE SW2 ETHERCHANNEL (internal)  
!  
!  
interface Port-channel2  
    description Trunk_between_Blue_sw1_and_Blue_sw2  
    switchport  
    switchport trunk encapsulation dot1q  
    switchport trunk allowed vlan 1,100,101,200,300  
    switchport mode trunk  
    mtu 9198  
    spanning-tree portfast trunk  
!  
!  
! INTER BLUE SW 1 TO BLUE SW3 ETHERCHANNEL (internal)  
!
```

```
!  
interface Port-channel3  
  description Trunk_between_Blue_sw1_and_Blue_sw3  
  switchport  
  switchport trunk encapsulation dot1q  
  switchport trunk allowed vlan 1,100,101,200,300  
  switchport mode trunk  
  spanning-tree portfast trunk  
!  
!  
! INTER BLUE SW1 TO yellow SW1 PORTS (internal)  
!  
!  
interface range gigabitEthernet 1/1 - 2  
  description ISL_between_blue_sw1_and_yellow_sw1  
  switchport trunk encapsulation dot1q  
  switchport trunk allowed vlan 1,100,101,200,300  
  switchport mode trunk  
  mtu 9198  
  channel-group 1 mode active  
  spanning-tree portfast trunk  
  no shutdown  
!  
!  
! INTER BLUE SW1 TO BLUE SW3 PORTS (internal)  
!  
!  
interface range gigabitEthernet 1/41 - 42  
  description Trunk_between_blue_sw1_and_blue_sw3  
  switchport trunk encapsulation dot1q  
  switchport trunk allowed vlan 1,100,101,200,300  
  switchport mode trunk  
  channel-group 3 mode active  
  mtu 9198  
  spanning-tree portfast trunk  
  no shutdown  
!  
!  
! INTER BLUE SW1 TO BLUE SW2 PORTS (internal)  
!  
!  
interface range gigabitEthernet 1/43 - 44  
  description Trunk_between_blue_sw1_and_blue_sw2  
  switchport trunk encapsulation dot1q  
  switchport trunk allowed vlan 1,100,101,200,300  
  switchport mode trunk
```

Hardware Installation Guidelines

```
channel-group 2 mode active
mtu 9198
spanning-tree portfast trunk
no shutdown
!
!
! IMF Servers PORTS
!
!
interface range gigabitEthernet 1/3 - 6
description IMF servers ports
switchport trunk encapsulation dot1q
switchport mode trunk
mtu 9198
spanning-tree portfast trunk
no shutdown
!
interface range gigabitEthernet 1/8 - 9
description IMF servers ports
switchport trunk encapsulation dot1q
switchport mode trunk
mtu 9198
spanning-tree portfast trunk
no shutdown
!
!
! iLO PORTS
!
!
interface gigabitEthernet 1/7
description IMF iLO ports
switchport mode access
switchport access vlan 300
spanning-tree portfast
no shutdown
!
interface gigabitEthernet 1/10
description IMF iLO ports
switchport mode access
switchport access vlan 300
spanning-tree portfast
no shutdown
!
!
! EAGLE PORTS
!
```

Hardware Installation Guidelines

```
!  
interface range gigabitEthernet 1/11 - 40  
description Eagle FC or STC ports  
    switchport mode access  
    switchport access vlan 101  
    mtu 9198  
    spanning-tree portfast  
    no shutdown  
!  
!  
! Laptop PORTS  
!  
!  
interface range GigabitEthernet 1/45 - 46  
description for Laptop  
    switchport access vlan 200  
    switchport mode access  
    media-type rj45  
    no shutdown  
  
!  
!  
! PORT TO CUSTOMER SWITCH B  
!  
!  
interface gigabitEthernet 1/47  
description to customer switch B  
    switchport mode access  
    switchport access vlan 200  
    media-type rj45  
    no shutdown  
!  
interface gigabitEthernet 1/48  
description to customer switch B (iLO)  
    switchport mode access  
    switchport access vlan 300  
    media-type rj45  
    no shutdown  
!  
interface VLAN 101  
    ip address 172.22.49.1 255.255.254.0  
    ip pim dense-mode  
    no shutdown  
!  
no ip route-cache  
!
```

Hardware Installation Guidelines

```
no ip http server
!
no cdp run
!
line con 0
 password ***** ! <----- replace ***** with password specified in password dragon as Cisco telnet
 login
!
logging 172.22.49.10
!
end
```

3. Yellow-sw2-1 (Layer 2)

```
!
no service pad
service timestamps debug datetime
service timestamps log datetime
service password-encryption
no logging console
!
hostname yellow-sw2-1
enable secret ***** ! <----- replace ***** with password specified in password dragon as Cisco enable
!
ip subnet-zero
vtp mode transparent
!
boot-start-marker
boot system flash bootflash:cat4500-ipbasek9-mz.122-53.SG2.bin
boot-end-marker
!
!
spanning-tree mode pvst
no spanning-tree optimize bpdu transmission
spanning-tree extend system-id
spanning-tree vlan 1-1024 priority 53248
!
ip multicast-routing
!
!
! VLAN CONFIGURATION (internal)
!
!
vlan 100
 name yellow
```

Hardware Installation Guidelines

```
!  
vlan 101  
    name blue  
!  
vlan 200  
    name cust  
!  
vlan 300  
    name oobm  
!  
!  
! INTER YELLOW SW 2 TO YELLOW SW 1 ETHERCHANNEL (internal)  
!  
!  
interface Port-channel1  
    description Trunk_between_Yellow_sw2_and_Yellow_sw1  
    switchport  
    switchport trunk encapsulation dot1q  
    switchport trunk allowed vlan 1,100,101,200,300  
    switchport mode trunk  
    mtu 9198  
    spanning-tree portfast trunk  
!  
!  
! INTER yellow SW2 TO yellow SW1 PORTS (internal)  
!  
!  
interface range gigabitEthernet 1/1 - 2  
    description Trunk_between_yellow_sw2_and_yellow_sw1  
    switchport trunk encapsulation dot1q  
    switchport trunk allowed vlan 1,100,101,200,300  
    switchport mode trunk  
    mtu 9198  
    channel-group 1 mode active  
    spanning-tree portfast trunk  
    no shutdown  
!  
!  
! IMF Servers PORTS  
!  
!  
interface gigabitEthernet 1/3  
    description IMF servers ports  
    switchport trunk encapsulation dot1q  
    switchport mode trunk  
    mtu 9198
```

Hardware Installation Guidelines

```
spanning-tree portfast trunk
no shutdown
!
interface range gigabitEthernet 1/5 - 6
description IMF servers ports
switchport trunk encapsulation dot1q
switchport mode trunk
mtu 9198
spanning-tree portfast trunk
no shutdown
!
interface range gigabitEthernet 1/8 - 9
description IMF servers ports
switchport trunk encapsulation dot1q
switchport mode trunk
mtu 9198
spanning-tree portfast trunk
no shutdown
!
interface gigabitEthernet 1/11
description IMF servers ports
switchport trunk encapsulation dot1q
switchport mode trunk
mtu 9198
spanning-tree portfast trunk
no shutdown
!
!
! iLO PORTS
!
!
interface gigabitEthernet 1/4
description IMF iLO ports
switchport mode access
switchport access vlan 300
spanning-tree portfast
no shutdown
!
interface gigabitEthernet 1/7
description IMF iLO ports
switchport mode access
switchport access vlan 300
spanning-tree portfast
no shutdown
!
interface gigabitEthernet 1/10
```

```
description IMF iLO ports
switchport mode access
switchport access vlan 300
spanning-tree portfast
no shutdown
!
!
! EAGLE PORTS
!
!
interface range gigabitEthernet 1/12 - 48
description Eagle FC or STC ports
switchport mode access
switchport access vlan 100
mtu 9198
spanning-tree portfast
no shutdown
!
interface VLAN 100
ip address 172.21.49.2 255.255.254.0
ip pim dense-mode
no shutdown
!
no ip route-cache
!
no ip http server
!
no cdp run
!
line con 0
password ***** ! <----- replace ***** with password specified in password dragon as Cisco telnet
login
!
logging 172.21.49.10
!
end
```

4. Blue-sw2-1 (Layer 2)

```
!
no service pad
service timestamps debug datetime
service timestamps log datetime
service password-encryption
no logging console
```

Hardware Installation Guidelines

```
!  
hostname blue-sw2-1  
enable secret ***** ! <----- replace ***** with password specified in password dragon as Cisco enable  
!  
ip subnet-zero  
vtp mode transparent  
!  
!  
spanning-tree mode pvst  
no spanning-tree optimize bpdu transmission  
spanning-tree extend system-id  
spanning-tree vlan 1-1024 priority 53248  
!  
ip multicast-routing  
!  
!  
! VLAN CONFIGURATION (internal)  
!  
!  
vlan 100  
    name yellow  
!  
vlan 101  
    name blue  
!  
vlan 200  
    name cust  
!  
vlan 300  
    name oobm  
!  
!  
! INTER BLUE SW 2 TO BLUE SW 1 ETHERCHANNEL (internal)  
!  
!  
interface Port-channell  
    description Trunk_between_Blue_sw2_and_Blue_sw1  
    switchport  
    switchport trunk encapsulation dot1q  
    switchport trunk allowed vlan 1,100,101,200,300  
    switchport mode trunk  
    mtu 9198  
    spanning-tree portfast trunk  
!  
!  
! INTER BLUE SW2 TO BLUE SW1 PORTS (internal)
```

```
!  
!  
interface range gigabitEthernet 1/1 - 2  
description Trunk_between_blue_sw2_and_blue_sw1  
    switchport trunk encapsulation dot1q  
    switchport trunk allowed vlan 1,100,101,200,300  
    switchport mode trunk  
    mtu 9198  
    channel-group 1 mode active  
    spanning-tree portfast trunk  
    no shutdown  
!  
!  
! IMF Servers PORTS  
!  
!  
interface range gigabitEthernet 1/3 - 4  
description IMF servers ports  
    switchport trunk encapsulation dot1q  
    switchport mode trunk  
    mtu 9198  
    spanning-tree portfast trunk  
    no shutdown  
!  
interface range gigabitEthernet 1/6 - 7  
description IMF servers ports  
    switchport trunk encapsulation dot1q  
    switchport mode trunk  
    mtu 9198  
    spanning-tree portfast trunk  
    no shutdown  
!  
interface range gigabitEthernet 1/9 - 10  
description IMF servers ports  
    switchport trunk encapsulation dot1q  
    switchport mode trunk  
    mtu 9198  
    spanning-tree portfast trunk  
    no shutdown  
!  
!  
! iLO PORTS  
!  
!  
interface gigabitEthernet 1/5  
description IMF iLO ports
```

Hardware Installation Guidelines

```
switchport mode access
switchport access vlan 300
spanning-tree portfast
no shutdown
!
interface gigabitEthernet 1/8
description IMF iLO ports
switchport mode access
switchport access vlan 300
spanning-tree portfast
no shutdown
!
interface gigabitEthernet 1/11
description IMF iLO ports
switchport mode access
switchport access vlan 300
spanning-tree portfast
no shutdown
!
!
! EAGLE PORTS
!
!
interface range gigabitEthernet 1/12 - 48
description Eagle FC or STC ports
switchport mode access
switchport access vlan 101
mtu 9198
spanning-tree portfast
no shutdown
!
interface VLAN 101
ip address 172.22.49.2 255.255.254.0
ip pim dense-mode
no shutdown
!
no ip route-cache
!
no ip http server
!
no cdp run
!
line con 0
password ***** ! <----- replace ***** with password specified in password dragon as Cisco telnet
login
!
```

```
logging 172.22.49.10
!  
end
```

5. Yellow-sw3-1 (Layer 2)

```
!  
no service pad  
service timestamps debug datetime  
service timestamps log datetime  
service password-encryption  
no logging console  
!  
hostname yellow-sw3-1  
enable secret ***** ! <----- replace ***** with password specified in password dragon as Cisco enable  
!  
ip subnet-zero  
vtp mode transparent  
!  
!  
spanning-tree mode pvst  
no spanning-tree optimize bpdu transmission  
spanning-tree extend system-id  
spanning-tree vlan 1-1024 priority 53248  
!  
ip multicast-routing  
!  
!  
! VLAN CONFIGURATION (internal)  
!  
!  
vlan 100  
    name yellow  
!  
vlan 101  
    name blue  
!  
vlan 200  
    name cust  
!  
vlan 300  
    name oobm  
!  
!  
! INTER YELLOW SW 3 TO YELLOW SW 1 ETHERCHANNEL (internal)
```

Hardware Installation Guidelines

```
!  
!  
interface Port-channel1  
  description Trunk_between_Yellow_sw3_and_Yellow_sw1  
  switchport  
  switchport trunk encapsulation dot1q  
  switchport trunk allowed vlan 1,100,101,200,300  
  switchport mode trunk  
  mtu 9198  
  spanning-tree portfast trunk  
!  
!  
! INTER yellow SW3 TO yellow SW1 PORTS (internal)  
!  
!  
interface range gigabitEthernet 1/1 - 2  
  description Trunk_between_yellow_sw3_and_yellow_sw1  
  switchport trunk encapsulation dot1q  
  switchport trunk allowed vlan 1,100,101,200,300  
  switchport mode trunk  
  mtu 9198  
  channel-group 1 mode active  
  spanning-tree portfast trunk  
  no shutdown  
!  
!  
! EAGLE PORTS  
!  
!  
interface range gigabitEthernet 1/3 - 48  
  description Eagle FC or STC ports  
  switchport mode access  
  switchport access vlan 100  
  mtu 9198  
  spanning-tree portfast  
  no shutdown  
!  
interface VLAN 100  
  ip address 172.21.49.3 255.255.254.0  
  ip pim dense-mode  
  no shutdown  
!  
no ip route-cache  
!  
no ip http server  
!
```

```
no cdp run
!
line con 0
 password ***** ! <----- replace ***** with password specified in password dragon as Cisco telnet
 login
!
logging 172.21.49.10
!
end
```

6. Blue-sw3-1 (Layer 2)

```
!
no service pad
service timestamps debug datetime
service timestamps log datetime
service password-encryption
no logging console
!
hostname blue-sw3-1
enable secret ***** ! <----- replace ***** with password specified in password dragon as Cisco enable
!
ip subnet-zero
vtp mode transparent
!
!
spanning-tree mode pvst
no spanning-tree optimize bpdu transmission
spanning-tree extend system-id
spanning-tree vlan 1-1024 priority 53248
!
ip multicast-routing
!
!
! VLAN CONFIGURATION (internal)
!
!
vlan 100
 name yellow
!
vlan 101
 name blue
!
vlan 200
 name cust
```

Hardware Installation Guidelines

```
!  
vlan 300  
  name oobm  
!  
!  
! INTER BLUE SW 3 TO BLUE SW 1 ETHERCHANNEL (internal)  
!  
!  
interface Port-channel1  
  description Trunk_between_Blue_sw3_and_Blue_sw1  
  switchport  
  switchport trunk encapsulation dot1q  
  switchport trunk allowed vlan 1,100,101,200,300  
  switchport mode trunk  
  mtu 9198  
  spanning-tree portfast trunk  
!  
!  
! INTER BLUE SW3 TO BLUE SW1 PORTS (internal)  
!  
!  
interface range gigabitEthernet 1/1 - 2  
  description Trunk_between_blue_sw3_and_blue_sw1  
  switchport trunk encapsulation dot1q  
  switchport trunk allowed vlan 1,100,101,200,300  
  switchport mode trunk  
  mtu 9198  
  channel-group 1 mode active  
  spanning-tree portfast trunk  
  no shutdown  
!  
!  
! EAGLE PORTS  
!  
!  
interface range gigabitEthernet 1/3 - 48  
  description Eagle FC or STC ports  
  switchport mode access  
  switchport access vlan 101  
  mtu 9198  
  spanning-tree portfast  
  no shutdown  
!  
interface VLAN 101  
  ip address 172.22.49.3 255.255.254.0  
  ip pim dense-mode
```

Hardware Installation Guidelines

```

no shutdown
!
no ip route-cache
!
no ip http server
!
no cdp run
!
line con 0
 password ***** ! <----- replace ***** with password specified in password dragon as Cisco telnet
 login
!
logging 172.22.49.10
!
end

```

10.16.14 IMF on E5-AppB

1. Switch port allocation

All or no vian	vlan 100 yellow	vlan 101 blue	vlan 400 backend
----------------	-----------------	---------------	------------------

Yellow SW	Port 1 Blue SW P1	Port 3 ServerA eth01	Port 5 ServerC eth01	Port 7 ServerE eth01	Port 9 Eagle Links	Port 11 Eagle Links	Port 13 Eagle Links	Port 15 Eagle Links	Port 17 Eagle Links	Port 19 Eagle Links	Port 21 Eagle Links	Port 23 Eagle Links	Port 25 Eagle Links	Port 27 Eagle Links	Port 29 Eagle Links	Port 31 Eagle Links	Port 33 Eagle Links	Port 35 Eagle Links	Port 37 Eagle Links	Port 39 Eagle Links	Port 41 Eagle Links	Port 43 Eagle Links	Port 45 Eagle Links	Port 47 Cust Net eth
	Port 2 Blue SW P2	Port 4 ServerB eth01	Port 6 ServerD eth01	Port 8 ServerF eth01	Port 10 Eagle Links	Port 12 Eagle Links	Port 14 Eagle Links	Port 16 Eagle Links	Port 18 Eagle Links	Port 20 Eagle Links	Port 22 Eagle Links	Port 24 Eagle Links	Port 26 Eagle Links	Port 28 Eagle Links	Port 30 Eagle Links	Port 32 Eagle Links	Port 34 Eagle Links	Port 36 Eagle Links	Port 38 Eagle Links	Port 40 Eagle Links	Port 42 Eagle Links	Port 44 Eagle Links	Port 46 Eagle Links	Port 48 For Laptop

Blue SW	Port 1 Yellow SW P1	Port 3 ServerA eth03	Port 5 ServerC eth03	Port 7 ServerE eth03	Port 9 Eagle Links	Port 11 Eagle Links	Port 13 Eagle Links	Port 15 Eagle Links	Port 17 Eagle Links	Port 19 Eagle Links	Port 21 Eagle Links	Port 23 Eagle Links	Port 25 Eagle Links	Port 27 Eagle Links	Port 29 Eagle Links	Port 31 Eagle Links	Port 33 Eagle Links	Port 35 Eagle Links	Port 37 Eagle Links	Port 39 Eagle Links	Port 41 Eagle Links	Port 43 Eagle Links	Port 45 Eagle Links	Port 47 Cust Net eth
	Port 2 Yellow SW P2	Port 4 ServerB eth03	Port 6 ServerD eth03	Port 8 ServerF eth03	Port 10 Eagle Links	Port 12 Eagle Links	Port 14 Eagle Links	Port 16 Eagle Links	Port 18 Eagle Links	Port 20 Eagle Links	Port 22 Eagle Links	Port 24 Eagle Links	Port 26 Eagle Links	Port 28 Eagle Links	Port 30 Eagle Links	Port 32 Eagle Links	Port 34 Eagle Links	Port 36 Eagle Links	Port 38 Eagle Links	Port 40 Eagle Links	Port 42 Eagle Links	Port 44 Eagle Links	Port 46 Eagle Links	Port 48 For Laptop

Terminal server server is directly connected to customer network

Single SW	Port 1 ServerA eth01	Port 3 ServerB eth01	Port 5 ServerC eth01	Port 7 ServerD eth01	Port 9 Eagle Links	Port 11 Eagle Links	Port 13 Eagle Links	Port 15 Eagle Links	Port 17 Eagle Links	Port 19 Eagle Links	Port 21 Eagle Links	Port 23 Eagle Links	Port 25 Eagle Links	Port 27 Eagle Links	Port 29 Eagle Links	Port 31 Eagle Links	Port 33 Eagle Links	Port 35 Eagle Links	Port 37 Eagle Links	Port 39 Eagle Links	Port 41 Eagle Links	Port 43 Eagle Links	Port 45 Eagle Links	Port 47 Cust Net eth
	Port 2 ServerA eth03	Port 4 ServerB eth03	Port 6 ServerC eth03	Port 8 ServerD eth03	Port 10 Eagle Links	Port 12 Eagle Links	Port 14 Eagle Links	Port 16 Eagle Links	Port 18 Eagle Links	Port 20 Eagle Links	Port 22 Eagle Links	Port 24 Eagle Links	Port 26 Eagle Links	Port 28 Eagle Links	Port 30 Eagle Links	Port 32 Eagle Links	Port 34 Eagle Links	Port 36 Eagle Links	Port 38 Eagle Links	Port 40 Eagle Links	Port 42 Eagle Links	Port 44 Eagle Links	Port 46 Eagle Links	Port 48 For Laptop

2. Yellow-sw1-1 Switch (Layer 3)

```

! IMF YELLOW SWITCH configuration
!
!
hostname yellow-sw1-1
!
no spanning-tree vlan 1-4094
no spanning-tree optimize bpdu transmission
!
enable secret ***** ! <----- replace ***** with password specified in password dragon as Cisco enable
service password-encryption

```

Hardware Installation Guidelines

```
no service pad
service timestamps debug datetime
service timestamps log datetime
no logging console
no aaa new-model
track 1 interface GigabitEthernet1/47 line-protocol
ip subnet-zero
!
ip multicast-routing
!
power redundancy-mode redundant
!
!
! VLAN CONFIGURATION (internal)
!
!
vlan 100
  name internal_yellow
!
vlan 101
  name internal_blue
!
vlan 200
  name IMF2IXP_internal_(backend)
!
vlan 400
  name IMF2IXP_external_(frontend)
!
!
! INTER YELLOW SW1 TO BLUE SW1 ETHERCHANNEL (internal)
!
!
interface Port-channel1
  description Trunk_between_yellow_sw1_and_blue_sw1
  switchport
  switchport trunk encapsulation dot1q
  switchport trunk allowed vlan 100,101,200,300
  mtu 9198
  no shutdown

!
!
! INTER YELLOW SW1 TO BLUE SW1 PORTS (internal)
!
!
Interface range GigabitEthernet 1/1 - 2
```

Hardware Installation Guidelines

```
description ISL_between_yellow_sw1_and_blue_sw1
switchport trunk encapsulation dot1q
switchport trunk allowed vlan 100,101,200,300
switchport mode trunk
switchport nonegotiate
mtu 9198
channel-group 1 mode active
no shutdown
!
!
! IMF Servers PORTS
!
!
interface range GigabitEthernet 1/3 - 8
description IMF servers ports
switchport trunk encapsulation dot1q
switchport mode trunk
mtu 9198
no shutdown
!
!
! EAGLE PORTS
!
!
interface range GigabitEthernet 1/9 - 46
description Eagle FC or STC ports
switchport access vlan 100
switchport mode access
mtu 9198
no shutdown
!
!
! PORT TO CUSTOMER SWITCH A
!
!
interface GigabitEthernet 1/47
description to customer switch A
switchport access vlan 400
switchport mode access
media-type rj45
no shutdown
!
!
! Laptop PORTS
!
!
```

Hardware Installation Guidelines

```
interface range GigabitEthernet 1/48
  description for Laptop
  switchport access vlan 200
  switchport mode access
  media-type rj45
  no shutdown
!
!
! VLAN INTERFACE CONFIGURATION
!
!
interface Vlan1
  no ip address
!
!
interface VLAN 100
  ip address 172.21.49.1 255.255.254.0
  ip pim dense-mode
  no shutdown
!
!
track 1 int gigabitEthernet 1/47 line-protocol
interface Vlan200
  description internal VRRP for IMF to IXP traffic. Both IP addresses and netmask must be configured according
  customer network.
  ip address 192.168.0.2 255.255.255.224      ! <----- replace IP with the value provided by the customer
  vrrp 1 ip 192.168.0.1      ! <----- replace IP with default gateway
  vrrp 1 priority 100
  vrrp 1 track 1
  vrrp 1 preempt
  no shutdown
!
!
interface Vlan 400
  description external VRRP for IMF to IXP traffic to Customer switches. Both IP addresses and netmask must be
  configured according customer network.
  ip address 192.168.20.2 255.255.255.248      ! <----- replace IP with the value provided by the customer
  vrrp 2 ip 192.168.20.1      ! <----- replace IP with default gateway
  vrrp 2 priority 100
  vrrp 2 preempt
  no shutdown
!
!
no ip http server
no ip http secure-server
!
```

```
ip route 0.0.0.0 0.0.0.0 192.168.20.6 1 ! <----- replace IP with customer default gateway
!
!
line con 0
 password ***** ! <----- replace ***** with password specified in password dragon as Cisco telnet
 login
!
logging 172.21.49.10
!
no cdp run
!
end
```

3. Blue-sw1-1 Switch (Layer 3)

```
! IMF BLUE SWITCH configuration
!
!
hostname blue-sw1-1
!
no spanning-tree vlan 1-4094
no spanning-tree optimize bpdu transmission
!
enable secret ***** ! <----- replace ***** with password specified in password dragon as Cisco enable
service password-encryption
no service pad
service timestamps debug datetime
service timestamps log datetime
no logging console
no aaa new-model
track 1 interface GigabitEthernet1/47 line-protocol
ip subnet-zero
!
ip multicast-routing
!
power redundancy-mode redundant
!
!
! VLAN CONFIGURATION (internal)
!
!
vlan 100
 name internal_yellow
!
vlan 101
 name internal_blue
```

Hardware Installation Guidelines

```
!  
vlan 200  
  name IMF2IXP_internal_(backend)  
!  
vlan 400  
  name IMF2IXP_external_(frontend)  
!  
!  
! INTER YELLOW SW TO BLUE SW ETHERCHANNEL (internal)  
!  
!  
interface Port-channel1  
  description Trunk_between_yellow_sw1_and_blue_sw1  
  switchport  
  switchport trunk encapsulation dot1q  
  switchport trunk allowed vlan 100,101,200,300  
  mtu 9198  
  no shutdown  
!  
!  
! INTER BLUE SW TO YELLOW SW PORTS (internal)  
!  
!  
Interface range GigabitEthernet 1/1 - 2  
  description ISL_between_blue_sw1_and_yellow_sw1  
  switchport trunk encapsulation dot1q  
  switchport trunk allowed vlan 100,101,200,300  
  switchport mode trunk  
  switchport nonegotiate  
  mtu 9198  
  channel-group 1 mode active  
  no shutdown  
!  
!  
! IMF Servers PORTS  
!  
!  
interface range GigabitEthernet 1/3 - 8  
  description IMF servers ports  
  switchport trunk encapsulation dot1q  
  switchport mode trunk  
  mtu 9198  
  no shutdown  
!  
!  
! EAGLE PORTS
```

Hardware Installation Guidelines

```
!  
!  
interface range GigabitEthernet 1/9 - 46  
description Eagle FC or STC ports  
    switchport access vlan 101  
    switchport mode access  
    mtu 9198  
    no shutdown  
!  
!  
! PORT TO CUSTOMER SWITCH B  
!  
!  
interface GigabitEthernet 1/47  
description to customer switch B  
    switchport access vlan 400  
    switchport mode access  
    media-type rj45  
    no shutdown  
!  
!  
! Laptop PORTS  
!  
!  
interface range GigabitEthernet 1/48  
description for Laptop  
    switchport access vlan 200  
    switchport mode access  
    media-type rj45  
    no shutdown  
!  
!  
! VLAN INTERFACE CONFIGURATION  
!  
!  
interface Vlan1  
    no ip address  
!  
!  
interface VLAN 101  
    ip address 172.22.49.1 255.255.254.0  
    ip pim dense-mode  
    no shutdown  
!  
!  
track 1 int gigabitEthernet 1/47 line-protocol
```

Hardware Installation Guidelines

```
interface Vlan200
  description internal VRRP for IMF to IXP traffic. Both IP addresses and netmask must be configured according
  customer network.
  ip address 192.168.0.3 255.255.255.224      ! <----- replace IP with the value provided by the customer
  vrrp 1 ip 192.168.0.1      ! <----- replace IP with default gateway
  vrrp 1 priority 99
  vrrp 1 track 1
  vrrp 1 preempt
  no shutdown
!
!
interface Vlan 400
  description external VRRP for IMF to IXP traffic to Customer switches. Both IP addresses and netmask must be
  configured according customer network.
  ip address 192.168.20.3 255.255.255.248    ! <----- replace IP with the value provided by the customer
  vrrp 2 ip 192.168.20.1      ! <----- replace IP with default gateway
  vrrp 2 priority 99
  vrrp 2 preempt
  no shutdown
!
!
no ip http server
no ip http secure-server
!
ip route 0.0.0.0 0.0.0.0 192.168.20.6 1    ! <----- replace IP with customer default gateway
!
!
line con 0
  password ***** ! <----- replace ***** with password specified in password dragon as Cisco telnet
  login
!
logging 172.22.49.10
!
no cdp run
!
end
```

4. Single Switch yellow-blue-sw1-1 (Layer 2)

```
enable secret ***** ! <----- replace ***** with password specified in password dragon as Cisco enable
service password-encryption
no service pad
service timestamps debug uptime
service timestamps log uptime
service compress-config
```

Hardware Installation Guidelines

```
!  
hostname yellow-blue-sw1-1  
!  
no logging console  
!  
no aaa new-model  
ip subnet-zero  
!  
ip multicast-routing  
vtp mode transparent  
!  
!  
!  
power redundancy-mode redundant  
no file verify auto  
spanning-tree mode pvst  
no spanning-tree optimize bpdu transmission  
spanning-tree extend system-id  
!  
!  
! VLAN CONFIGURATION (internal)  
!  
!  
vlan internal allocation policy ascending  
!  
vlan 100  
    name internal_yellow  
!  
vlan 101  
    name internal_blue  
!  
vlan 200  
    name IMF2IXP_internal_(backend)  
!  
!  
! IMF Servers PORTS  
!  
!  
interface range GigabitEthernet1/1 - 8  
    description for IMF 1A external + internal networks port  
    switchport trunk encapsulation dot1q  
    switchport trunk allowed vlan 1,100,101,200  
    switchport mode trunk  
    mtu 9198  
    spanning-tree portfast trunk  
!
```

Hardware Installation Guidelines

```
!  
! EAGLE PORTS  
!  
!  
interface range GigabitEthernet1/9 - 27  
description yellow network port for Eagle connectivity  
switchport access vlan 100  
switchport mode access  
mtu 9198  
spanning-tree portfast  
!  
!  
interface range GigabitEthernet1/28 - 46  
description blue network port for Eagle connectivity  
switchport access vlan 101  
switchport mode access  
mtu 9198  
spanning-tree portfast  
!  
!  
! PORT TO CUSTOMER SWITCH A  
!  
!  
interface GigabitEthernet1/47  
description port where customer is connected to IMF  
switchport access vlan 200  
switchport mode access  
media-type rj45  
!  
!  
! Laptop PORTS  
!  
!  
interface range GigabitEthernet 1/48  
description for Laptop  
switchport access vlan 200  
switchport mode access  
media-type rj45  
no shutdown  
!  
!  
! VLAN INTERFACE CONFIGURATION  
!  
!  
interface Vlan1  
no ip address
```

```
!  
interface Vlan100  
  ip address 172.21.49.1 255.255.254.0  
  no ip route-cache cef  
  no ip route-cache  
  no shutdown  
!  
interface Vlan101  
  ip address 172.22.49.1 255.255.254.0  
  no ip route-cache cef  
  no ip route-cache  
  no shutdown  
!  
!  
interface Vlan200  
  ip address 10.27.56.166 255.255.255.240 ! <----- replace IP with an address from customer network  
  no shutdown  
!  
no ip http server  
no ip http secure-server  
!  
ip route 0.0.0.0 0.0.0.0 10.248.4.17 1 ! <----- replace IP with customer default gateway  
!  
!  
logging 172.21.49.10  
no cdp run  
!  
line con 0  
  password ***** ! <----- replace ***** with password specified in password dragon as Cisco telnet  
  login  
!  
!  
!  
End
```

10.17 My Oracle Support (MOS)

MOS (<https://support.oracle.com>) is your initial point of contact for all product support and training needs. A representative at Customer Access Support (CAS) can assist you with MOS registration.

Hardware Installation Guidelines

Call the CAS main number at 1-800-223-1711 (toll-free in the US), or call the Oracle Support hotline for your local country from the list at <http://www.oracle.com/us/support/contact/index.html>. When calling, make the selections in the sequence shown below on the Support telephone menu:

1. Select 2 for New Service Request
2. Select 3 for Hardware, Networking and Solaris Operating System Support
3. Select 2 for Non-technical issue

You will be connected to a live agent who can assist you with MOS registration and provide Support Identifiers. Simply mention you are a Tekelec Customer new to MOS.

MOS is available 24 hours a day, 7 days a week, 365 days a year.

10.18 Locate Product Documentation on the Oracle Help Center Site

Oracle customer documentation is available on the web at the Oracle Help Center (OTN) site, <http://docs.oracle.com>. You do not have to register to access these documents. Viewing these files requires Adobe Acrobat Reader, which can be downloaded at www.adobe.com.

1. Access the Oracle Help Center site at <http://docs.oracle.com/>.
2. Click Industries.
3. Under the Oracle Communications subheading, click the Oracle Communications documentation link. The Communications Documentation page appears.
4. Under the heading "Network Visibility and Resource Management," click on Performance Intelligence Center and then the Release Number.
A list of the entire documentation set for the release appears.
5. To download a file to your location, right-click the PDF link, select Save target as (or similar command based on your browser), and save to a local folder.