

Table of Contents

Fundamentals of BURNDY Substation Catalog Numbering System.....	L-3
BURNDY Catalog Numbering Alpha Character Designations.....	L-4
Catalog Number Conductor Identification.....	L-5
Connector Material Identification	L-6
Terminal Pad Configurations and Catalog Number Designations	L-7
Catalog Number Suffixes, Plating, Hardware, etc.	L-8
Stud Connector Catalog Numbering	L-9
Type FCB Type E-C-G; Transformer Tap Adapters.....	L-10
Type NBXR Bolted Terminals (copper pipe or cable to pad)	L-11
Type NAS Bolted Terminals (copper cable to pad).....	L-12
Type NA Bolted Terminals (copper tube to pad)	L-13
Type NAH Bolted Terminals (copper cable to pad)	L-14
Type N2AH Bolted Terminals (two copper cables to pad)	L-15
Type VVA VARILUG™ Terminals (copper cable to pad)	L-16
Type VV2A VARILUG™ Terminals (two copper cables to pad).....	L-17
Type VV3A VARILUG™ Terminals (three copper cables to pad)	L-18
Type XA Copper Expansion Terminals (copper tube to pad).....	L-19
Type NAR Aluminum Terminals (cable to pad)	L-20
Type NBC-A Aluminum T Terminals (tube to centerline tap pad).....	L-21
Type SN2A Aluminum Terminals (two cables to flat)	L-22
Type XA-A Aluminum Expansion Terminals (expansion tube to pad).....	L-23
Type NA-A Aluminum Terminals (tube to pad).....	L-24
Type STS-A-NCG Terminal Pad Cap (one piece)	L-24
Type NS Copper Bolted Couplers, (copper straight tube to tube).....	L-25
Type XP Expansion Couplers (copper tube to tube).....	L-26
Type NS-A Aluminum Couplers (aluminum tube to tube)	L-27
Type NT T-Connectors (copper tube to tube).....	L-28
Type NSNT T-Connectors (copper tube or cable to cable).....	L-29

Table of Contents

Type NHNT T-Connector Terminals (copper tube to cable)	L-30
Type VT T-Connectors (copper cable to cable)	L-31
Type NNT Aluminum T-Connectors (aluminum and copper tube to tube).....	L-32
Type NNTR Aluminum T-Connectors (cable to cable)	L-33
Type NNTR Aluminum T-Connectors (tube to cable)	L-34
Type UH Copper Bus Supports (supporting copper tube to base).....	L-35
Type UHR Copper Bus Supports (supporting copper cable or tube to base)	L-35
Type LH Bus Supports (supporting copper cable or tube to base).....	L-36
Type LHR Bus Supports (supporting copper cable or tube to insulator)	L-36
Type UHG Aluminum Bus Supports (fixed or rigid pipe to base).....	L-37
Type UHKR-A Aluminum Bus Supports (cable or tube to base)	L-38
Type LB-A Aluminum End Caps (tube end cap).....	L-39
Type NDR Copper Stud Connectors (copper stud to cable, tube, flat bar).....	L-40
Type FD Stud Connectors (copper stud to pad).....	L-41
Type VV3D-R Stud Connectors (stud to three cables - flag).....	L-42
Type SFD Stud Connectors (stud to pad)	L-43
Type CPR-A Aluminum Spacers (two cable rigid spacer)	L-44
Type S2GGBP-A Spacers (two cables rigid spacer with grounding bar).....	L-45
Type QGFL BARTAP™ Connectors (copper cable to flat).....	L-46
Type NFXR Bolted Terminals (pipe or cable to flat).....	L-47
Type HFBW Bar Clamps (copper bar to bar).....	L-48
Type HFB-P1 Bar Clamp Assembly Components (copper bar to bar)	L-49
Type HFB-N Bar Clamp Tap Pad Adapters (copper bar to pad)	L-49

**Numerous Additional Connection Options Are Available.
Contact Customer Service
or
View the BURNDY Substation Catalog for
Additional Information**

Fundamentals of BURNDY Substation Catalog Numbering System:

Over the years, BURNDY has established an alpha-numeric catalog numbering system/structure to help describe a connector's specific use/application and type or features about the connector. This resource section should be used as a catalog numbering **guideline**. Over the years there have been many exceptions made to the BURNDY Substation Catalog Number System Structure.

The basic anatomy of a catalog number is dependent on the product family, as each family of connectors has different uses / applications and types / features. Because each product family has different uses and types, each product family's numbering scheme may have different attributes to help describe the connector. Below are a few examples of the basic alpha-numeric catalog numbering structure for six different product families.

Product Family				Terminal / Tap
Family	Conductor	Pad	Suffix	
NA	19	A4	GS	
Catalog number structure				NA19A4GS

Product Family				T-Connector
Family	Run	Tap	Suffix	
NT	16	34		
Catalog number structure				NT1634

Product Family				Bus Support
Family	Conductor	Bolt Circle	Suffix	
UHG	20A	3		
Catalog number structure				UHG20A3

Product Family				Coupler
Family	Run	Tap	Suffix	
NL	14	14	8HC	
Catalog number structure				NL14148HC

Product Family				Stud Connector
Family	Stud	Conductor	Suffix	
NDR	655	34	T12	
Catalog number structure				NDR65534T12

Product Family				Spacer
Family	Conductor	Spacing	Suffix	
CP	40A	L4		
Catalog number structure				CP40AL4

BURNDY Catalog Numbering Alpha Character Designations:

Having a fundamental understanding of the alpha character designations is important when trying to interpret the product family, which typically identifies the connector's "use" and "type". Because some alpha characters are used more than once to represent different meanings or as a place holders for product differentiation, it is important that this section be used as a **guideline**. Some alpha characters have two meanings, they can represent a connector's "use" or "type". A "use" designation (white background) would indicate the application the connector would be used in. A "type" designation (blue background) would indicate features about the connector to help describe the connector's function. Some catalog numbers have both "use" and "type" letters combined.

Terminal A	Tap B	Center Pad C	Stud Module D	Inline Coupler E	Flat Bar F
					
Grounding Stud G	Bus Support H	Heavy Duty H	Cable Expansion K	Elbow L	Body & Cap N
					
Ring shape (for Bus Sup.) O	Coupler P	Range Taking R	Streamlined S	Sliding Expansion S	T-Connector T
					
U-Shape U	V-Bolt (Clamping Element) V	Vertical Bus Sup. V	Weldment (Compression) W	Expansion X	Compression Y
					

Catalog Number Conductor Identification:

Non-Range Taking Connectors:

Typically, following the product family is the conductor size. Depending on the connector family, some connectors accommodate more than one conductor and may list two conductor sizes in the catalog number.

Range Taking Connectors:

Many substation connectors have range taking features. Range taking features allow a connector to accommodate various sizes of conductors. When a connector has a range taking feature, the catalog number will identify the largest conductor that the connector can accommodate.

Examples:



NT1514 (Non-Range Taking)
N = Cap & Body
T = T-Connector
15 = 1.00" IPS
14 = 3/4" IPS



VV3A4044N (Range Taking)
VV3 = V-Bolt (accommodating 3 conductors)
A = Terminal
40 = 800 kcmil*
44N = 4" pad with 4 hole NEMA drilling
***Range is 500 - 800 kcmil**



NAS292N (Range Taking)
N = Cap & Body
A = Terminal
S = Streamline
29 = 250 kcmil*
2N = 2 hole NEMA pad
***Range is 6 AWG - 250 kcmil**



NVTT1844 (Range Taking)
N = Cap & Body
V = V-Bolt
TT = T-Connector (2 "T" for 2 V-Bolts)
18 = 2.00" IPS (Non-Range Taking)
44 = 1,000 kcmil* (Range Taking)
***Range is 750 - 1,000 kcmil**

PLEASE NOTE:

BURNDY offers Substation connectors that can accommodate aluminum or copper pipe tubing and aluminum or copper cable and in some cases both pipe and cable conductor.

For current carrying purposes, BURNDY connectors are designed to comply with the NEMA CC1.

Connector Material Identification:

Following the conductor size in the catalog number is typically the material designation. When the conductor size is followed by the letter "A", this typically indicates that the connector is made from aluminum. When the conductor is not followed by the letter "A", this indicates that the connector is made of copper or bronze material. Note that in some cases the "A" is not used in the catalog number for aluminum. BURNDY offers Substation connectors that can accommodate aluminum or copper pipe tubing and aluminum or copper cable.

Examples:



NA194N - Copper Terminal
N = Cap & Body
A = Terminal
19 = 2.50" IPS
4N = 4 hole NEMA pad



NA19A4N - Aluminum Terminal
N = Cap & Body
A = Terminal
19 = 2.50" IPS
A = Aluminum
4N = 4 hole NEMA pad



NS1414 - Copper Coupler
N = Cap & Body
S = Streamline
14 = 3/4" IPS
14 = 3/4" IPS



NS14A14A - Aluminum Coupler
N = Cap & Body
S = Streamline
14 = 3/4" IPS
A = Aluminum
14 = 3/4" IPS
A = Aluminum

Terminal Pad Configurations & Catalog Number Designations:

Typically, at the very end of the catalog number is the pad configuration, unless there is a suffix. Terminal pads also have alpha-numeric designations to describe the pad configuration. The standalone or first number describes the number of holes and the second number describes the terminal pad width. The “N” following the number(s) indicates that the pad is a NEMA drilled pad. NEMA is a standard that defines the hole diameters and hole spacing. The table shows the most common terminal pad configurations and the catalog numbering identification alpha-numeric scheme.

Pad description block (regular)	Pad description block (FDs)	Figure	Holes configuration	C - Pad width
2N	B	1	2 holes NEMA	-
4N	-	2	4 holes NEMA	-
34N	C	2	4 holes NEMA	3"
44N	D	3	4 holes NEMA	4"
6N	-	4	6 holes NEMA	-
56N	E	4	6 holes NEMA	5"
66N	F	5	6 holes NEMA	6"

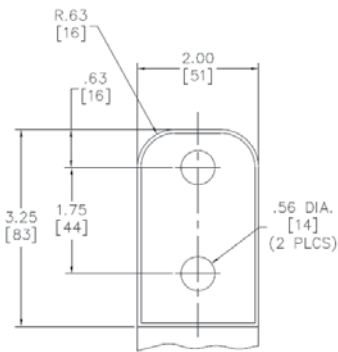

Figure 1

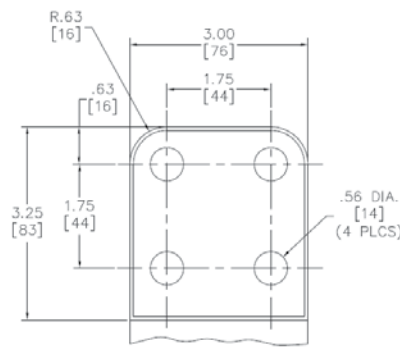

Figure 2

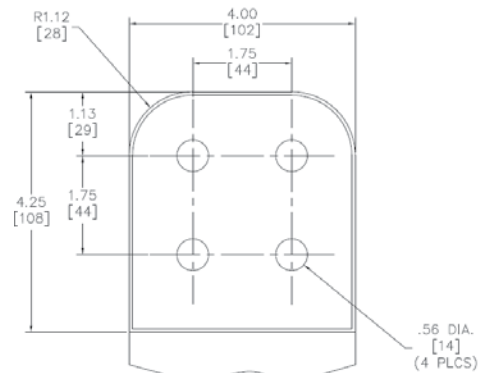

Figure 3

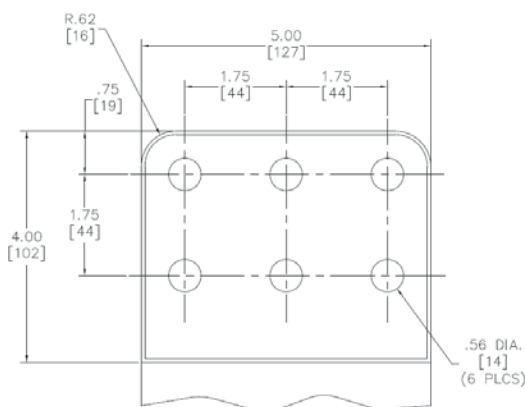

Figure 4

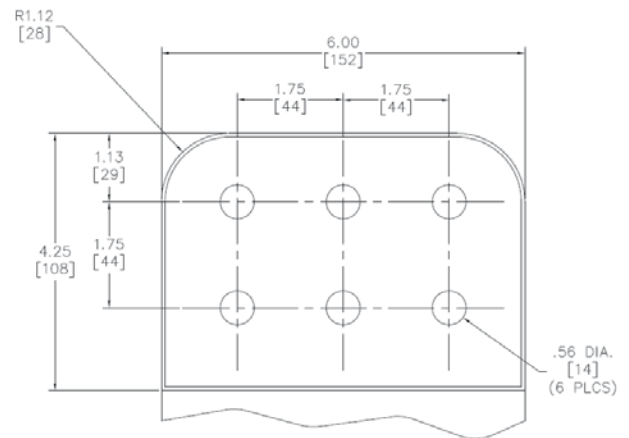

Figure 5

Catalog Number Suffixes:

Many catalog numbers have a suffix to provide additional information. The suffix could identify plating, hardware, operating voltages for streamlined connectors, etc. Below are tables listing the most common suffixes.

Plating Suffixes:

This table lists the most common plating suffixes found in the BURNDY Substation connector line.
Example: NAS292N vs. NAS292NTN (Tin plated version of the copper connector)

-TN	Electro tin plating
-BRTN	Bright electro tin plating
-W	Heavy duty electro tin plating (incl. hardware)
-SV	Silver plating
-NK	Nickel plating
-Q	Pad is finished on both sides (used in conjunction with other plating suffix)

Hardware Suffixes:

This table lists the most common hardware suffixes found in the BURNDY Substation connector offering. A catalog number with no hardware suffix will include the standard hardware for both copper and aluminum connectors.

Example: NNE14A34A vs. NNE14A34ASS (Coupler with Stainless Steel hardware)

-GS	Galvanized Steel hardware
-SS	Stainless Steel hardware
-BW	Belleville Washer
-CH	Antistatic Chatter Spring
-HC	Hex Captured hardware

Operating Voltage for Streamlined Connector Suffixes:

This table lists the most common operating voltage suffixes found in the BURNDY Substation offering.

Example: SNNE86A445A vs. SNNE86A445AS3 (S3 designates the terminal is rated for 345kV)

-S3	345kV rating
-K	cable versions for expansion items, 345kV
-S7	765V rating

G# and CG# Suffixes:

G# and CG# suffixes are used when a customer requests a connector that is similar to a product in the standard product offering, but deviates to be a standalone product within a particular family. To name these "special" connectors, BURNDY will add a G# or CG# suffix.

Example: NNE14A34AG1 or NNE14A34ACG1

Stud Connector Catalog Numbering:

Stud connectors have a different catalog numbering system in comparison to the other product families previous mentioned.

Examples:

Family	Stud Diameter	Pad Size	Pad thickness (in 1/16 of an inch)	Threads per inch of the stud (if different than 12)
FD	70	D	12	T14
Stud	3" Stud	4"x4" NEMA pad	12/16 = 3/4" thick tongue	14 threads per inch

FD70D12T14

F = Flat bar
D = Stud module
70 = 3" Stud size
D = Pad size per Pad Description block
12 = Tongue thickness (12/16" = 3/4" thick)
T14 = 14 Threads per inch



Family	Stud Diameter	Conductor	Threads per inch of the stud (if different than 12)
NDR	63	28	T13
Stud	1/2" Stud	4/0	13 threads per inch

NDR6328T13

N = Body & Cap
D = Stud module
R = Range taking
63 = 1/2" Stud size
28 = 4/0 (Range 6 AWG - 4/0)
T13 = 13 Threads per inch

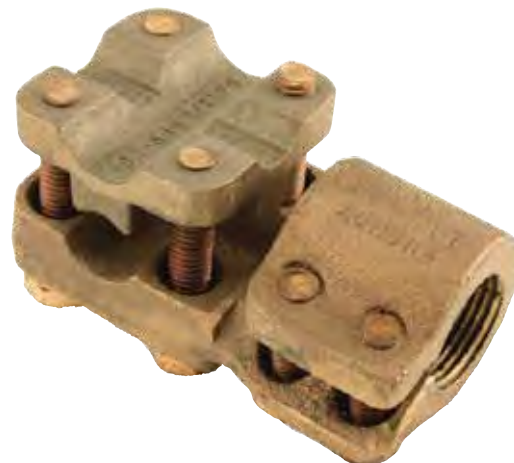

Transformer Tap Adapters, Type FCB For Copper and Aluminum Tap to Pad

Material: Copper

Cast in one piece from copper alloy. Transformer tap adapter designed to accommodate from 1 to 6 NEMA drilled copper or aluminum terminal taps from a single secondary transformer outlet. Tin-plated. Order mounting hardware and tap terminals separately.

Notes :

- Plated versions: add the required suffix to the catalog number. -TN for regular tin plating
- Please contact factory for other sizes, combinations and availability

Catalog Number	Fig. No.	A Diameter	H Ref.	L	P
FCB634N	1	0.50	5.25	3.75	2.25
FCB636N	2	0.50	5.25	5.50	2.25
FCB644N	1	0.75	5.75	4.00	2.75
FCB646N	2	0.75	5.75	5.75	2.75
FCB654N	1	1.00	7.00	4.25	4.00
FCB632NP300	Not Shown	0.50	5.00	3.50	3.00
FCB644NP50	Not Shown	0.75	9.00	5.00	5.00

NOTE: All pads are NEMA drilled.

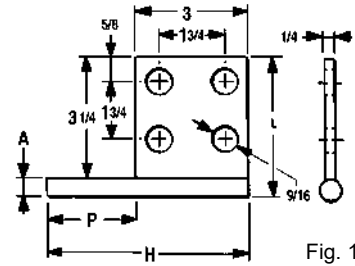

Fig. 1

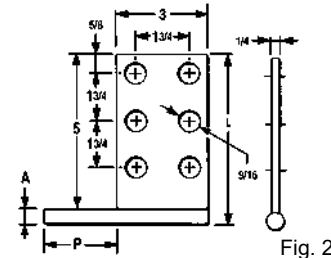

Fig. 2

Tap Adapters, Type E-C-G For Copper Cable to Tap

Material: Copper Alloy

Multi-tap, range-taking cast copper alloy connector designed to take 2, 3 or 4 conductors from a single secondary transformer outlet.

Notes :

- Plated versions: add the required suffix to the catalog number. -TN for regular tin plating
- Please contact factory for other sizes, combinations and availability

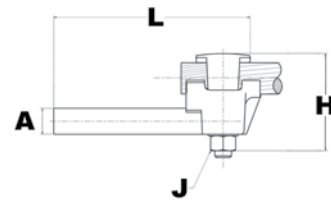
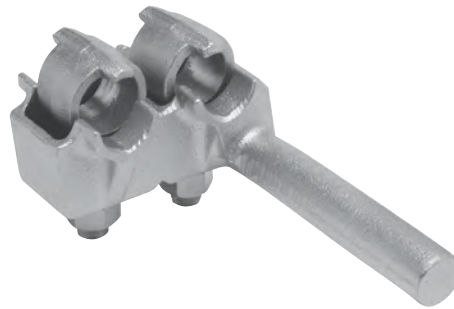

Fig.1

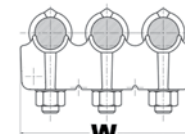

Fig.2

Catalog Number	Number of Conductors	Conductor Size	A Dia.	H	J	L	W
E2C34G1	2	1/0 -500 kcmil	0.78	3.88	1/2	6.25	3.50
E3C34G1	3						5.25
E4C34G1	4						6.88

Bolted Terminals, Type NBXR

For Copper Pipe or Cable to Pad

Material: Copper Alloy
Hardware: DURIMUM™ Silicon Bronze

One of the most versatile products available. Can be used in Terminal or Tap configuration with a large variety of cable and pipes.

Notes :

- Plated versions: add the required suffix to the catalog number. -TN for regular tin plating
- Please contact factory for other sizes, combinations and availability

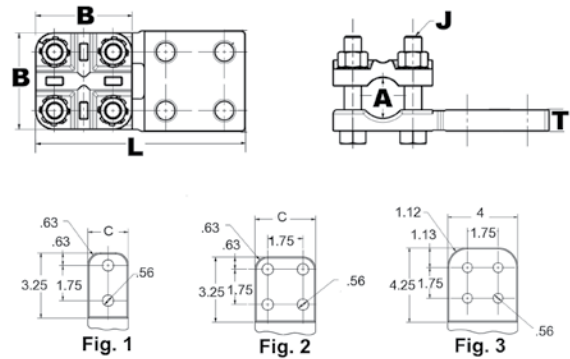

Catalog Number	Fig. #	Stranded Copper Cable	Copper Pipe (Std or EH)	B	T	L	C	J Dia.
NBXR1534NHQ	2	1/0 AWG-1250 kcmil	1/4 IPS -1 IPS	2.88	0.62	6.25	3.00	1/2
NBXR1544NHQ	3					7.19	4.00	
NBXR15CG1	2					6.25	3.00	

Bolted Terminals, Type NAS For Copper Cable to Pad

Material: Copper Alloy

Hardware: DURIMUM™ Silicon Bronze

High copper alloy reversible cap terminal for joining a wide range of cable to pads. Tongue is side formed to provide adequate clearance and terminal is designed for one-wrench installation.

Notes :

- Plated versions: add the required suffix to the catalog number. -TN for regular tin plating.
- Please contact factory for other sizes, combinations and availability.
- See NAH family for heavy duty versions.

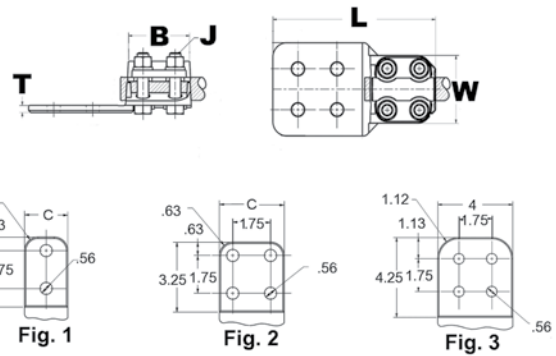
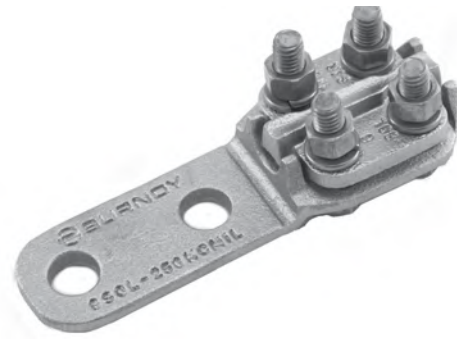

Catalog Number	Fig. #	Copper Stranded Range	Copper Solid Range	B	J Dia.	L	C	T	W
NAS292N	1	6 AWG-250 kcmil	6 AWG-4/0 AWG	2.38	3/8	5.62	1.50	0.25	2.00
NAS2934N	2			2.38	3/8	5.62	3.00	0.25	2.00
NAS29N	—			2.38	3/8	3.88	1.25	0.25	2.00
NAS342N	1	1/0 AWG-500 kcmil	1/0 AWG-4/0 AWG	2.38	3/8	5.62	2.00	0.31	2.20
NAS3434N	2			2.38	3/8	5.62	3.00	0.25	2.20
NAS34N	—			2.38	3/8	4.12	1.50	0.25	2.20
NAS40-2N	1	2/0 AWG-800 kcmil	2/0 AWG-4/0 AWG	2.62	3/8	5.88	2.00	0.38	2.44
NAS4034N	2			2.62	3/8	5.88	3.00	0.31	2.44
NAS4044N	3			2.62	3/8	6.88	4.00	0.31	2.44

Bolted Terminals, Type NA
For Copper Tube to Pad

Material: Copper Alloy

Hardware: DURIMUM™ Silicon Bronze

High copper alloy terminal for joining copper tube to a flat pad. Letter "N" on end of catalog number indicates pad drilled to NEMA standards. One-wrench installation.

Notes :

- Plated versions: add the required suffix to the catalog number. -TN for regular tin plating.
- Please contact factory for other sizes, combinations and availability.

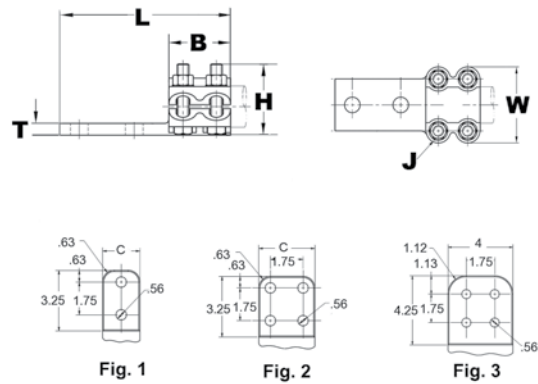

Catalog Number	Fig. #	Copper Pipe (Std or EH)	B	J Dia.	L	H	C	T	W
NA122N	1	3/8 IPS	1.38	3/8	3.75	1.50	1.50	0.25	2.13
NA132N	1	1/2 IPS	2.00		5.25	1.75	1.50	0.38	2.25
NA142N	1	3/4 IPS			5.25	2.00	1.63	0.38	2.44
NA144N	2				4.50	2.00	3.13	0.38	2.44
NA152N	1	1 IPS			5.25	2.06	1.88	0.38	2.75
NA154N	2				5.25	2.06	3.00	0.38	2.75
NA162N	1	1 1/4 IPS		2.69	1/2	5.94	2.56	2.25	0.44
NA164N	2		5.94			2.56	3.00	0.44	3.50
NA172N	1		5.94			2.75	2.50	0.50	3.94
NA1744NHQ	3	1 1/2 IPS	7.07			3.09	4.00	0.50	3.82
NA174N	2	1 1/4 IPS	5.94			2.75	3.00	0.50	3.94
NA182N	1	2 IPS	5.94			3.12	2.75	0.50	4.62
NA184N	2		5.94	3.13	3.13	0.50	4.63		
NA1944N	3	2 1/2 IPS	7.19	3.74	4.00	0.69	5.24		
NA1944NHQ	3		7.09	3.96	4.00	0.75	5.12		
NA194N	2		5.94	3.69	3.75	0.69	5.25		
NA194N90CG2	2	2 1/2 IPS	6.50	3.62	3.75	0.69	5.25		
NA204N	2	3 IPS	3.25	5/8	6.56	4.38	4.38	0.69	6.19
NA214N	2	3 1/2 IPS			6.56	4.94	4.75	0.81	6.81
NA224N	2	4 IPS			6.56	5.50	5.25	0.81	7.44

Bolted Terminals, Type NAH For Copper Cable to Pad

Material: Copper Alloy

Hardware: DURIMUM™ Silicon Bronze

Copper alloy terminal for joining a wide range of cable to equipment pads. Tongue side formed to provide adequate clearance and terminal is designed for one-wrench installation.

Notes :

- Plated versions: add the required suffix to the catalog number. -TN for regular tin plating.
- Please contact factory for other sizes, combinations and availability

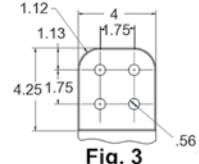
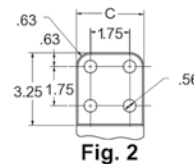
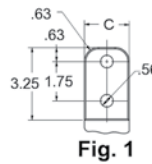
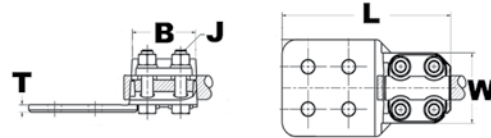

Catalog Number	Fig. #	Copper Stranded Range	Copper Solid Range	B	J Dia.	L	C	T	W					
NAH292N	1	6 AWG-250 kcmil	6 AWG-4/0 AWG	2.62	1/2	5.88	1.50	0.25	2.44					
NAH2934N	2						3.00							
NAH342N	1	1/0 -500 kcmil	1/0 AWG-4/0 AWG				2.00	0.31	2.56					
NAH3434N	2						3.00	0.25						
NAH402N	1	2/0 AWG-800 kcmil	3/0 AWG-4/0 AWG				2.88	1/2	6.88	2.00	0.38	2.81		
NAH4034N	2									3.00	0.31			
NAH4044N	3			4.00										
NAH442N	1	4/0 AWG-1000 kcmil	N/A	3.06	1/2	6.12				2.00	0.44	2.88		
NAH4434N	2									3.00	0.38			
NAH4444N	3									7.12	4.00		0.31	
NAH462N	1	1000 kcmil-1500 kcmil					N/A	3.25	1/2	6.31	2.00	0.50	3.19	
NAH4634N	2										3.00	0.41		
NAH4644N	3										7.31	4.00		0.38
NAH482N	1	500 kcmil-2000 kcmil	N/A	3.75	5/8	7.12					2.00	0.69	3.38	
NAH4834N	2										6.50	3.00		0.50
NAH4844N	3										7.50	4.00		0.44
NAH4862N	1	2000 kcmil-2500 kcmil					N/A	3.75	5/8	7.12	3.00	0.63	3.96	
NAH48634N	2													

Bolted Terminals, Type N2AH
For Two Copper Cables to Pad

Material: Copper Alloy

Hardware: DURIIUM™ Silicon Bronze

High copper alloy reversible cap terminal for joining a wide range of cable to pads. Tongue is side formed to provide adequate clearance and terminal is designed for one wrench installation.

Notes :

- Plated versions: add the required suffix to the catalog number. -TN for regular tin plating.
- Please contact factory for other sizes, combinations and availability.

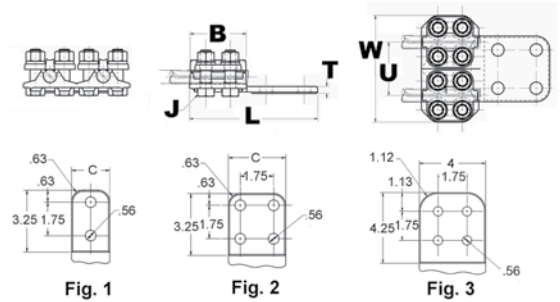

Catalog Number	Fig. #	Copper Stranded Range	Copper Solid Range	B	J Dia.	L	C	T	W	U
N2AH292N	1	6 AWG-250 kcmil	6 AWG-4/0 AWG	2.62	1/2	5.87	1.50	0.32	4.88	2.44
N2AH2934N	2	6 AWG-250 kcmil	6 AWG-4/0 AWG	2.62	1/2	5.87	3.00	0.32	4.88	2.44
N2AH342N	1	1/0 AWG-500 kcmil	1/0 AWG-4/0 AWG	2.62	1/2	5.87	2.00	0.32	5.44	2.88
N2AH3434N	2	1/0 AWG-500 kcmil	1/0 AWG-4/0 AWG	2.63	1/2	6.13	3.00	0.38	5.40	2.88
N2AH3444N	3	1/0 AWG-500 kcmil	1/0 AWG-4/0 AWG	2.63	1/2	7.00	4.00	0.38	5.38	2.88
N2AH4034N	2	2/0 AWG-800 kcmil	2/0 AWG-4/0 AWG	2.63	1/2	5.88	3.00	0.38	5.70	2.92
N2AH4434N	2	4/0 AWG-1000 kcmil	4/0 AWG	2.88	1/2	6.38	3.00	0.50	6.12	3.12
N2AH4444N	3	4/0 AWG-1000 kcmil	4/0 AWG	2.88	1/2	7.32	4.00	0.50	6.12	3.12
N2AH4444NHQ	3	4/0 AWG-1000 kcmil	4/0 AWG	2.88	1/2	7.20	4.00	0.50	6.12	3.12
N2AH4644N	3	1000 kcmil-1500 kcmil	N/A	3.07	1/2	7.46	4.00	0.75	6.50	3.36
N2AH4844N	3	1000 kcmil-1500 kcmil	N/A	3.25	1/2	7.62	4.00	0.75	9.50	4.00

VARILUG™ Terminals, Type VVA For Copper Cable to Pad

Material: Bronze Alloy

Hardware: DURIMUM™ Silicon Bronze

High copper alloy terminal for joining a wide range of cable to equipment pads or bar. Particularly suitable for use on extra flexible cable. One-wrench installation.

Notes :

- Plated versions: add the required suffix to the catalog number. -TN for regular tin plating
- Please contact factory for other sizes, combinations and availability

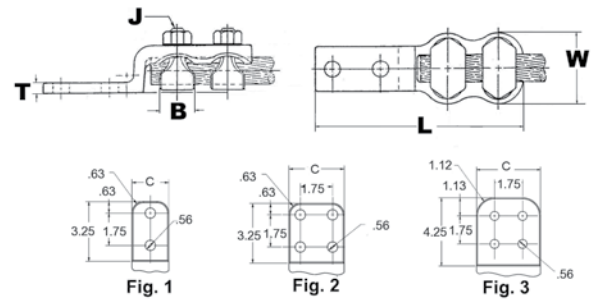

Catalog Number*	Fig. #	Copper Stranded Range	Copper Solid Range	C	B	J Dia.	L	T	W
VVA2C	—	8 AWG-2 AWG	8 AWG-2 AWG	0.81	0.81	3/8	4.06	0.25	1.00
VVA25	—	6 AWG-1/0	6 AWG-1/0 AWG	0.88	0.88	3/8	4.31	0.25	1.19
VVA252	—	1/0 AWG-4/0 AWG		0.88	0.88	3/8	5.06	0.25	1.19
VVA28	—		1.06	1.09	3/8	4.13	0.31	1.69	
VVA282N	1		1.06	1.09	3/8	6.19	0.31	1.69	
VVA30	—	300 kcmil	1/0 AWG-4/0 AWG	1.13	1.09	7/16	4.63	0.31	1.94
VVA302N	1			1.13	1.09	7/16	6.56	0.31	1.94
VVA304N	2			3.00	1.09	7/16	6.75	0.38	1.91
VVA34	—	300 kcmil-500 kcmil	N/A	1.38	1.31	1/2	5.31	0.38	2.25
VVA342N	1			1.30	1.31	1/2	6.88	0.38	2.22
VVA344	—			1.88	1.31	7/16	5.75	0.38	2.25
VVA344N	2			3.13	1.31	7/16	7.00	0.38	2.38
VVA40	—	500 kcmil-800 kcmil		1.63	1.34	9/16	6.38	0.38	2.63
VVA402N	1			1.62	1.34	9/16	7.69	0.38	2.62
VVA404N	2			3.00	1.34	9/16	7.69	0.38	2.62
VVA404NCG1	—			3.50	0.88	9/16	7.69	0.38	2.62
VVA442N	1	750 kcmil-1000 kcmil		1.88	1.41	5/8	8.12	0.50	2.88
VVA444N	2			3.00	1.41	5/8	8.06	0.50	2.88
VVA462N	1	1000 kcmil-1500 kcmil	2.25	2.00	5/8	8.69	0.56	3.25	
VVA464NCG2	—		3.50	2.00	5/8	8.75	0.56	3.25	
VVA464NCG4	—		3.50	2.00	5/8	5.50	0.56	3.23	
VVA482N	1	1500 kcmil-2000 kcmil	2.62	2.25	3/4	9.23	0.62	3.75	

* "N" indicates NEMA standard stud holes.

VARILUG™ Terminals, Type VV2A
Two Copper Cables to Pad

Material: Copper Alloy

Hardware: DURIMUM™ Silicon Bronze

Twin V elements to secure joint against vibration and flexing. Particularly recommended for use on extra flexible cables. One-wrench installation.



Notes :

- Plated versions: add the required suffix to the catalog number. -TN for regular tin plating
- Please contact factory for other sizes, combinations and availability

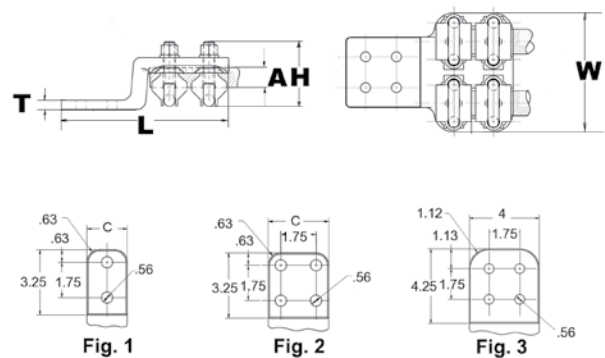

Catalog Number	Fig. #	Copper Stranded Range	L	C	T	W	H
VV2A344N	2	300 kcmil-500 kcmil	5.50	3.50	0.38	5.12	2.62
VV2A34CG1	2		5.75	3.00	0.38	5.12	2.62
VV2A4044N	3	500 kcmil-800 kcmil	9.06	4.00	0.50	5.56	1.75
VV2A46CG1	2	1000 kcmil-1500 kcmil	8.75	3.50	0.56	6.75	4.00

VARILUG™ Terminal, Type VV3A

Three Copper Cables to Pad

Material: Copper Alloy

Hardware: DURIMUM™ Silicon Bronze

Type VV3A has three V elements to secure joint against vibration and flexing. Particularly recommended for use on extra flexible cables. One-wrench installation.



Notes :

- Plated versions: add the required suffix to the catalog number. -TN for regular tin plating
- Please contact factory for other sizes, combinations and availability
- Items with -90 and -45 have oriented pad, respectively 90° and 45°

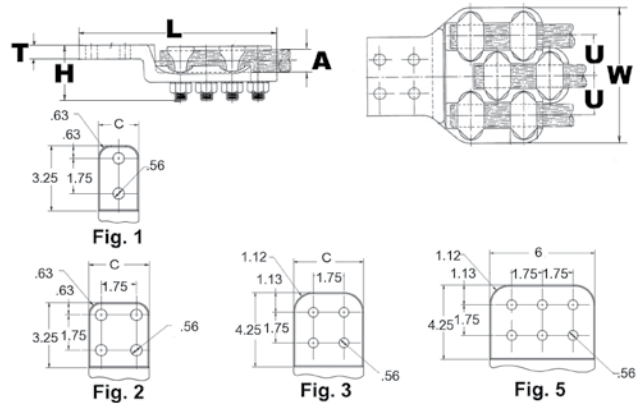

Catalog Number	Fig. #	Copper Stranded Range	T	Pad Angle	L	C	H	U	W
VV3A46CG1	2	1000 kcmil-1500 kcmil	0.84	—	8.75	3.50	3.79	3.52	10.25
VV3A46CG2	2		0.63	—	10.19	5.25	3.93	3.50	10.25
VV3A46CG3	2		1.28	90°	5.84	5.25	6.28	3.50	10.25

Copper Expansion Terminals, Type XA
For Copper Tube to Pad

Material: Copper Alloy

Hardware: DURIIUM™ Silicon Bronze

High copper alloy expansion terminal for tube to flat. Provides for longitudinal movement of tubing. Extra flexible braid carries full load of joint. One-wrench installation.

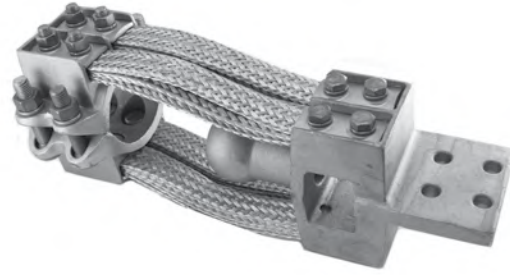

Notes :

- Plated versions: add the required suffix to the catalog number. -TN for regular tin plating.
- Please contact factory for other sizes, combinations and availability.
- Installation instructions available upon request.

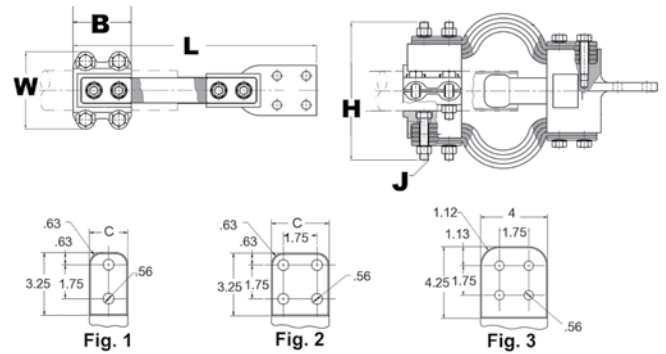

Catalog Number	Fig. #	Copper Pipe (Std)	Copper Pipe (EH)	B	C	J Dia.	L	H	W
XA132N	1	1/2 IPS	N/A	3.00	1.50	3/8	12.00	3.88	3.06
XA142N	1	3/4 IPS			1.63	3/8	12.00	4.06	3.13
XA144N	2				3.00	3/8	12.50	4.12	3.12
XA152N	1	1 IPS			1.88	3/8	12.75	4.31	3.13
XA154N	2				3.00	3/8	12.75	4.31	3.13
XA162N	1	1 1/4 IPS			2.25	1/2	14.50	5.81	4.31
XA164N	2			3.00	1/2	14.75	5.81	4.31	
XA172N	1	1 1/2 IPS		2.50	1/2	15.00	6.06	4.31	
XA174N	2			3.00	1/2	15.25	6.06	4.31	
XA184N	2	2 IPS		3.00	1/2	15.25	7.00	4.62	
XA194N	2	2 1/2 IPS		3.75	1/2	16.13	7.50	5.25	
XA204N	2	3 IPS		4.38	5/8	16.69	7.94	6.50	
XA214N	2	3 1/2 IPS		4.75	5/8	16.94	8.25	6.81	
XA224N	2	4 IPS		5.25	5/8	17.00	9.44	7.44	
XA574N	2	N/A	1 1/2 IPS	3.50	3.00	1/2	14.38	6.44	4.31
XA594N	2		2 1/2 IPS	4.00	3.75	1/2	14.75	9.56	5.25

Aluminum Terminals, Type NAR

For Cable to Pad

Material: Aluminum Alloy

Hardware: Aluminum



Aluminum alloy bolted type terminal for joining aluminum cable to copper or aluminum pads. Drilling in pad conforms to NEMA Standards. PENETROX™ joint compound recommended on contact surfaces.

Notes :

- Properly proportioned to minimize conductor corrosion due to galvanic action. When properly used, this item does not require use of bimetallic plates; Please contact BURNDY Technical Support for recommendations
- PENETROX™ A joint compound is recommended on contact surfaces
- Please contact factory for other sizes, combinations, and availability
- One wrench installation

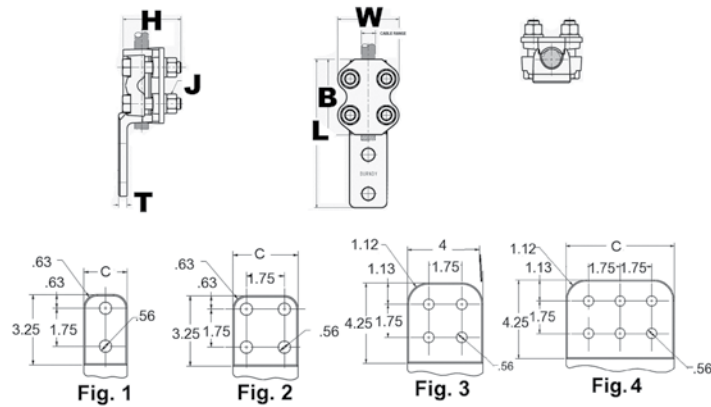

Catalog Number	Fig. #	Aluminum Stranded	Aluminum ACSR	B	J Dia.	L	H	C	T	W
NAR25A2N	1	4 AWG-1/0 AWG	4 (6/1) Swan AWG-1/0 (6/1) Raven AWG	2.00	1/2	5.10	2.72	1.25	0.31	2.28
NAR29A2N	1	1/0 AWG-250 kcmil	1/0 (6/1) Raven AWG-4/0 (6/1) Penguin AWG	2.75	1/2	6.06	2.75	1.38	0.31	2.50
NAR29A4N	2			2.88	1/2	6.06	2.75	3.00	0.31	3.00
NAR32A2N	1	250 kcmil-400 kcmil	4/0 (6/1) Penguin AWG-397.5 (30/7) Larkspur kcmil	3.00	1/2	6.31	2.88	1.63	0.38	2.63
NAR32A4N	2			3.00	1/2	6.31	2.88	3.00	0.38	3.00
NAR36A2N	1	350 kcmil-600 kcmil	336.4 (30/7) Oriole kcmil-477. (30/7) Hen kcmil	3.25	1/2	6.63	2.81	1.69	0.38	2.75
NAR36A4N	2			3.25	1/2	6.63	2.81	3.00	0.38	3.00
NAR42A2N	1	600 kcmil-900 kcmil	477. (30/7) Hen kcmil-795 (30/19) Mallard kcmil	3.50	1/2	6.81	3.31	2.00	0.50	3.00
NAR42A4N	2			3.50	1/2	6.81	3.31	3.00	0.50	3.00
NAR45A2N	1	900 kcmil-1250 kcmil	715.5 (30/19) Redwing kcmil-1113 (54/19) Finch kcmil	2.63	1/2	7.12	3.31	2.63	0.50	3.20
NAR45A4N	2			3.75	1/2	7.12	3.31	3.00	0.50	3.20
NAR46A2N	1	1250 kcmil-1600 kcmil	1113 (54/19) Finch kcmil-1431 (54/19) Plover kcmil	4.38	5/8	7.69	3.69	2.75	0.56	3.75
NAR46A4N	2			4.38	5/8	7.69	3.69	3.00	0.56	3.75
NAR48A2N	1	1500 kcmil-2000 kcmil	1272 (54/19) Pheasant kcmil-1780 (54/19) kcmil	4.50	5/8	7.88	3.94	2.75	0.69	3.88
NAR48A4N	2			4.50	5/8	7.88	3.94	3.00	0.69	3.88

Aluminum T Terminal, Type NBC-A
For Tube to Centerline Tap Pad

Material: Aluminum Alloy

Hardware: Aluminum

Aluminum alloy bolted type terminal for joining aluminum tube to copper or aluminum pads. Drilling in pad conforms to NEMA Standards. PENETROX™ joint compound recommended on contact surfaces.

Notes :

- Properly proportioned to minimize conductor corrosion due to galvanic action. When properly used, this item does not require use of bimetallic plates; Please contact BURNDY Technical Support for recommendations
- PENETROX™ A joint compound is recommended on contact surfaces
- Please contact factory for other sizes, combinations, and availability
- One wrench installation

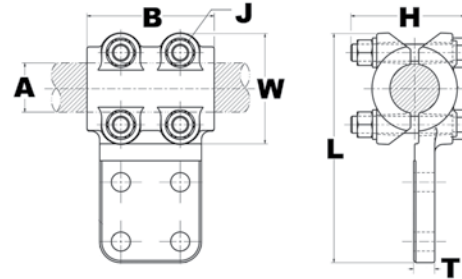

Catalog Number	Fig. #	Al tube	B	J Dia.	L	H	T
NBC14A2N	1	3/4 IPS	3.25	1/2	6.56	3.50	3/8
NBC15A2N	1	1 IPS	3.50	1/2	6.81	3.00	3/8
NBC15A34N	2		3.50	1/2	6.81	3.00	3/8
NBC16A2N	1	1 1/4 IPS	3.75	1/2	7.15	3.25	3/8
NBC16A34N	2		3.75	1/2	7.15	3.25	3/8
NBC16A44N	3		3.75	1/2	8.15	3.25	3/8
NBC17A2N	1	1 1/2 IPS	4.00	1/2	7.39	3.50	3/8
NBC17A34N	2		4.00	1/2	7.39	3.50	3/8
NBC17A44N	3		4.00	1/2	8.39	3.50	3/8
NBC18A2N	1	2 IPS	4.25	5/8	8.25	4.00	3/8
NBC18A34N	2		4.25	5/8	8.25	4.00	3/8
NBC18A44N	3		4.25	5/8	9.25	4.00	3/8
NBC19A34N	2	2 1/2 IPS	4.50	5/8	8.75	4.50	1/2
NBC19A44N	3		4.50	5/8	9.75	4.50	1/2
NBC20A2N	1	3 IPS	5.00	5/8	9.37	4.50	1/2
NBC20A34N	2		5.00	5/8	9.37	4.50	1/2
NBC20A44N	3		5.00	5/8	10.37	4.50	1/2
NBC21A44N	3	3 1/2 IPS	5.50	5/8	10.89	5.00	5/8
NBC22A2N	1	4 IPS	6.00	5/8	10.38	5.50	5/8
NBC22A34N	2		6.00	5/8	10.37	5.50	5/8
NBC22A44N	3		6.00	5/8	11.37	5.50	5/8
NBC24A2N	1	5 IPS	7.00	5/8	12.45	6.00	5/8
NBC24A34N	2		7.00	5/8	12.45	6.00	5/8
NBC24A44N	3		7.00	5/8	13.45	6.00	5/8
NBC86A44N	3	6 IPS	8.00	5/8	13.51	7.25	3/4

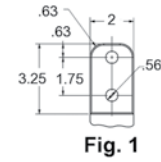

Fig. 1

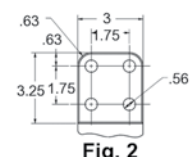

Fig. 2

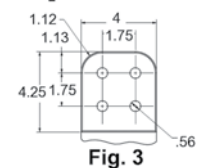

Fig. 3

Aluminum Terminal, Type SN2A

Two Cables to Flat

Material: Aluminum Alloy

Hardware: Aluminum

Aluminum alloy streamlined terminal for joining a wide range of (2) bundle aluminum cables to flat. Properly proportioned to minimize conductor corrosion due to galvanic action. Drilling in pads conforms to NEMA standards.

EHV RATED: SELF-SHIELDING UP TO 550 kV



Notes :

- PENETROX™ A joint compound is recommended on contact surfaces
- Please contact factory for other sizes, combinations and availability
- Use shielding caps for high voltage applications (STS family). Shielding caps may be purchased separately
- One-wrench installation.

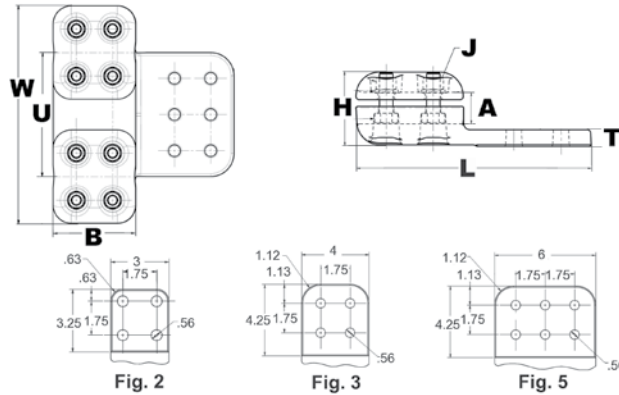

Catalog Number	Fig. #	Aluminum Stranded	Aluminum ACSR	B	J Dia.	U	L	H	T	W
SN2A445A4N	2	1033 kcmil- 1113 kcmil	954 (45/7) Rail kcmil- 1033.5 (45/7) Ortolan kcmil	3.75	1/2	4.85	7.38	2.78	.69	9.45
SN2A44A44N	3	954 kcmil	795 (54/7) Condor kcmil- 874.5 (54/7) Crane kcmil	3.75	1/2	4.77	7.38	2.74	.66	9.29
SN2A44A4N	2			3.75	1/2	4.77	7.38	2.74	.66	9.29
SN2A45A44N	3	1192 kcmil- 1272 kcmil	1033.5 (54/7) Curlew kcmil- 1192.5 (54/19) Grackle kcmil	4.88	1/2	6.00	8.62	3.28	.81	9.25
SN2A45A4N	2			3.75	1/2	5.00	7.38	2.73	.69	9.75
SN2A48A44N	3	1500 kcmil- 2000 kcmil	1272 (54/19) Pheasant kcmil- 1780 (54/19) kcmil	4.00	1/2	5.25	10.25	2.60	.81	8.75
SN2A48A4NGS	2			3.75	1/2	5.25	7.38	2.87	.81	10.25

Aluminum Expansion Terminal, Type XA-A
For Expansion Tube to Pad

Material: Aluminum Alloy

Hardware: Aluminum

Aluminum alloy expansion connector for joining tube to copper or aluminum bar or equipment pads. Flexible aluminum straps allow for longitudinal or lateral movement and carries full current load of the joint. PENETROX™ joint compound recommended on contact surfaces. Pad contact surface is on centerline of conductor.

Notes :

- PENETROX™ A joint compound is recommended on contact surfaces
- One side of pad finished on centerline of tubing; for finished pads on both sides add suffix "-Q" to catalog number

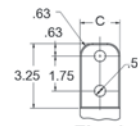
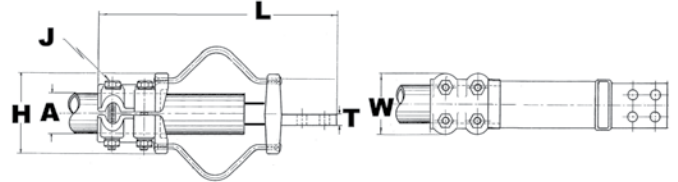
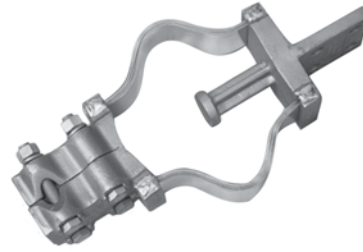

Fig. 1

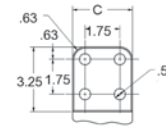

Fig. 2

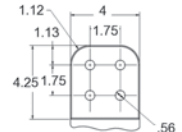

Fig. 3

Catalog Number *	Fig. #	Al tube Schd 40	C	J Dia.	L	H	T	W
XA15A4N	2	1 IPS	3.00	1/2	13.19	3.70	0.38	3.06
XA16A4N	2	1 1/4 IPS	3.00	1/2	13.62	4.00	0.44	3.41
XA18A4N	2	2 IPS	3.12	5/8	15.50	5.26	0.50	4.50
XA19A4N	2	2 1/2 IPS	3.75	5/8	16.94	5.72	0.69	5.00
XA20A4N	2	3 IPS	4.38	5/8	18.52	6.80	0.69	5.62
XA21A4N	2	3 1/2 IPS	4.75	5/8	20.00	7.60	0.81	6.12
XA22A4N	2	4 IPS	5.25	5/8	21.00	8.16	0.81	6.62
XA24A4N	2	5 IPS	6.50	5/8	24.15	9.74	0.81	7.69

* Conforms to 4-hole NEMA mounting standards.

Substation - Bolted

Aluminum Terminal, Tube to Pad; Type NA-A
Terminal Pad Cap, Type STS-A-NCG (one piece)

Aluminum Terminals, Type NA-A For Tube to Pad

Material: Aluminum Alloy

Hardware: Aluminum

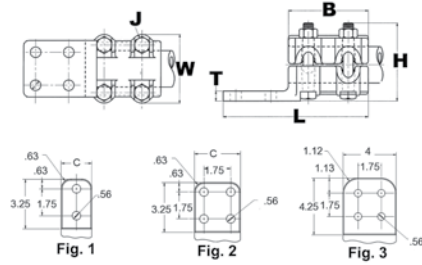

Aluminum alloy terminal for joining copper or aluminum tube to copper or aluminum pad.

Notes :

- Properly proportioned to minimize conductor corrosion due to galvanic action. When properly used, this item does not require use of bimetallic plates; Please contact BURNDY Technical Support for recommendations
- PENETROX™ A joint compound is recommended on contact surfaces
- Please contact factory for other sizes, combinations, and availability
- One wrench installation

Catalog Number	Al tube	B	C	J Dia.	L	H	T	W
NA15A2N	1 IPS	3.50	1.88	1/2	6.75	3.38	0.38	3.06
NA15A4N		3.50	3.00	1/2	6.75	3.38	0.38	3.06
NA16A2N	1 1/4 IPS	3.75	2.25	1/2	7.00	3.38	0.44	3.40
NA17A2N	1 1/2 IPS	4.00	2.50	1/2	7.50	3.88	0.50	3.64
NA17A4N		4.00	3.00	1/2	7.50	3.88	0.50	3.64
NA18A2N	2 IPS	4.25	2.75	5/8	7.50	4.47	0.50	4.50
NA18A4N		4.25	3.12	5/8	7.50	4.47	0.50	4.50
NA19A4N	2 1/2 IPS	4.50	3.75	5/8	7.75	4.97	0.69	5.00
NA20A4N	3 IPS	5.00	4.38	5/8	8.31	5.47	0.69	5.62
NA22A4N	4 IPS	6.00	5.25	5/8	9.31	6.22	0.81	6.62

Type STS-A-NCG, Single Piece Terminal Pad Cap; EHV

Bolted 1-piece terminal pad cap of cast Aluminum; Stainless Steel Hardware.

Material: Aluminum Alloy

EHV Rated: Self Shielding at operating voltages up to 500 kV

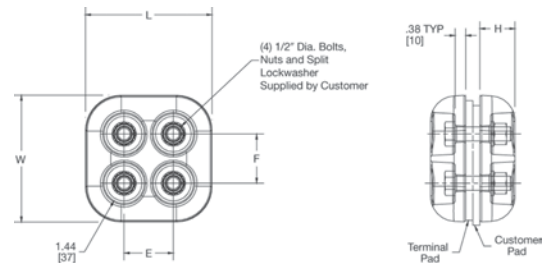

Catalog Number	E	F	H	L	W	Maximum Shielded Area
STS44ACG10	1.75 [44]	1.75 [44]	1.50 [38]	4.00 [102]	4.00 [102]	3.5 x 3.5
STS44A4NCG2	1.75 [44]	1.75 [44]	1.25 [32]	4.50 [114]	4.50 [114]	4 x 4
STS46A6NCG1	1.75 [44]	1.75 [44]	1.25 [32]	4.50 [114]	6.50 [165]	6 x 4

NOTES:

1. Dimensions in brackets [] are in millimeters.
2. Catalog number is for one shielding cap only. If more than one is required, specify total quantity.

Copper Bolted Couplers, Type NS
For Copper Straight Tube to Tube

Material: Copper Alloy

Hardware: DURIMUM™ Silicon Bronze

High copper alloy coupler for joining equal sizes of tube end to end. Slots between bolts provide independent high pressure areas of contact. One-wrench installation.

Notes :

- Plated versions: add the required suffix to the catalog number. -TN for regular tin plating; -W for extra thick tin plating (including hardware)
- Items with -HC suffix have hex head bolts; items without the suffix can be either hex head or oval shank head; both head styles are one wrench installation and offer the same clamping force and functionalities
- Please contact factory for sizes, combinations and availability

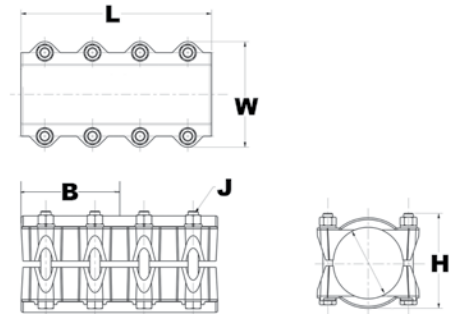

Catalog Number	Copper Conductor	B	J Dia.	L	H	W
NS1212	3/8 IPS	1.50	3/8	3.00	1.44	1.94
NS1313	1/2 IPS	1.63	3/8	3.25	1.69	2.25
NS14148HC	3/4 IPS	2.69	1/2	5.75	2.32	2.81
NS1414HC		2.69	3/8	5.38	2.32	2.81
NS1515	1 IPS	2.13	3/8	4.25	2.13	2.75
NS1515HC		2.69	1/2	5.62	2.32	3.25
NS1515HCHQ		2.69	1/2	5.63	2.36	3.22
NS1616HC	1 1/4 IPS	2.69	1/2	5.75	2.57	3.50
NS1717	1 1/2 IPS	2.88	1/2	5.75	2.75	3.94
NS1717HC		2.69	1/2	5.75	2.81	3.94
NS1717HCHQ		2.69	1/2	5.75	2.61	3.94
NS1818	2 IPS	2.88	1/2	5.75	3.31	4.63
NS1818CG2		2.69	1/2	5.36	3.06	4.62
NS1818HC		2.69	1/2	5.75	3.31	4.62
NS1919	2 1/2 IPS	2.88	1/2	5.75	3.88	5.25
NS1919HC		2.69	1/2	5.75	3.96	5.25
NS1919HCHQ		2.69	1/2	5.75	3.56	5.18
NS2020	3 IPS	3.63	5/8	7.25	4.63	6.19
NS2020HC		3.25	5/8	7.25	4.64	6.19
NS2121	3 1/2 IPS	4.00	5/8	8.00	5.19	6.81
NS2121HC		3.25	5/8	7.25	5.20	6.81
NS2222	4 IPS	4.25	5/8	8.50	5.75	7.44
NS2222HC		3.25	5/8	7.25	5.76	7.44

Expansion Couplers, Type XP For Copper Tube to Tube

Material: Copper Alloy

Hardware: DURIUM™ Silicon Bronze

High copper alloy T-connector for cable run, cable tap. V-bolt clamping elements
High alloy copper expansion coupler for joining equal size tube on end. Extra flexible
tinned copper braid allows longitudinal movement of the tube. Type XP has alignment
guide. One-wrench installation.



Notes :

- Items with “-HC” suffix have hex head bolts; items without the suffix can be either hex head or oval shank head; Both head styles are one wrench installation and offer the same clamping force and functionalities
- Installation instructions available upon request
- For other sizes or configurations, please call factory

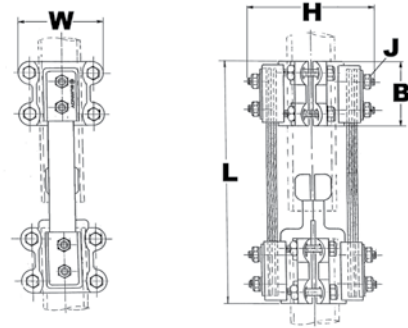

Catalog Number	Copper Pipe Size	Copper EH Pipe Size	B	J Dia.	L	H	W
XP1313	1/2 IPS	—	3.00	3/8	8.75	3.88	3.06
XP1414	3/4 IPS	—			8.75	4.06	3.13
XP1515	1 IPS	—			9.50	4.31	3.13
XP1616	1 1/4 IPS	—	3.50	1/2	11.50	5.81	4.31
XP1717	1 1/2 IPS	—			12.00	6.44	4.31
XP1818	2 IPS	—			12.00	7.00	4.63
XP1919	2 1/2 IPS	—	4.00	5/8	13.00	8.50	5.25
XP1919HC		—			13.00	8.50	5.25
XP2020	3 IPS	—			13.50	7.75	6.50
XP2121	3 1/2 IPS	—			13.63	8.00	6.81
XP2222	4 IPS	—	13.63	9.06	7.44		
XP5656	1 1/4 IPS	1 1/4 IPS	3.50	1/2	11.56	5.82	4.24

Aluminum Couplers, Type NS-A
For Aluminum Tube to Tube

Material: Aluminum Alloy

Hardware: Aluminum

Aluminum alloy coupler for joining equal sizes of tube end to end. Properly proportioned to permit use on aluminum-copper conductor combinations. One-wrench installation. PENETROX™ joint compound recommended on contact surfaces.

Notes :

- PENETROX™ A joint compound is recommended on contact surfaces
- Please contact factory for other sizes, combinations, and availability

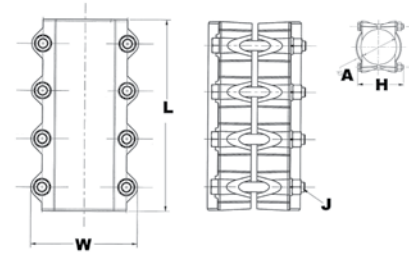

Catalog Number	A - tube	J Dia.	L	H	W
NS14A14A	3/4 IPS	1/2	6.75	2.06	2.80
NS15A15A	1 IPS		7.25	2.18	3.06
NS16A16A	1 1/4 IPS		7.75	3.50	3.41
NS17A17A	1 1/2 IPS		8.25	4.00	3.64
NS18A18A	2 IPS	5/8	8.75	4.62	4.50
NS19A19A	2 1/2 IPS		9.31	4.26	5.00
NS20A20A	3 IPS		10.25	5.62	5.63
NS21A21A	3 1/2 IPS		8.00	5.25	6.14
NS22A22A	4 IPS		12.00	5.94	6.62
NS23A23A	4 1/2 IPS		13.25	6.38	7.14
NS24A24A	5 IPS		14.38	6.94	7.70
NS86A86A	6 IPS		16.25	8.04	8.76

T-Connector, Type NT

For Copper Tube to Tube: T Application

Material: Copper Alloy

Hardware: DURIMUM™ Silicon Bronze

High copper alloy T-Connector for tubing run and tap. Slots between bolts provide independent high-pressure areas of contact. One-wrench installation.

Notes :

- Plated versions: add the required suffix to the catalog number. -TN for regular tin plating
- Items with -HC suffix have hex head bolts; items without the suffix can be either hex head or oval shank head. Both head styles are one wrench installation and offer the same clamping force and functionalities
- Please contact factory for other sizes, combinations and availability
- One-wrench installation.

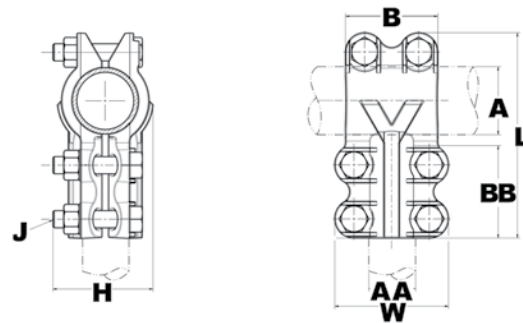

Catalog Number	A Run Copper Pipe	AA Tap Copper Pipe	B	J Dia.	BB	L	H	W
NT1313	1/2 IPS	1/2 IPS	2.00	3/8	2.00	4.13	1.94	2.44
NT1413	3/4 IPS	1/2 IPS			2.00	4.13	1.94	2.25
NT1414		3/4 IPS			2.00	4.13	1.94	2.44
NT1514	1 IPS	3/4 IPS			2.00	4.38	2.13	2.44
NT1515		1 IPS			2.00	4.44	2.13	2.75
NT1614	1 1/4 IPS	3/4 IPS			2.00	4.75	2.44	2.44
NT1615		1 IPS	2.00	4.75	2.44	2.75		
NT1616		1 1/4 IPS	2.69	5.69	2.63	3.50		
NT1714	1 1/2 IPS	3/4 IPS	2.00	3/8	2.00	5.06	2.69	2.44
NT1715		1 IPS			2.00	5.06	2.69	2.75
NT1717		1 1/2 IPS			2.69	6.06	2.75	3.94
NT1816	2 IPS	1 1/4 IPS	2.69	1/2	2.69	6.56	2.69	3.50
NT1817		1 1/2 IPS			2.69	6.63	3.25	3.94
NT1818		2 IPS			3.06	6.69	3.31	4.62
NT1919	2 1/2 IPS	2 1/2 IPS	3.63	5/8	2.69	7.25	3.88	5.25
NT2020	3 IPS	3 IPS	4.31		3.25	8.63	4.63	6.19
NT2121	3 1/2 IPS	3 1/2 IPS	4.88		3.25	9.25	5.19	6.81
NT2222	4 IPS	4 IPS	5.44		3.25	9.81	5.75	7.44

T-Connector, Type NSNT

For Copper Tube or Cable to Cable: T Application

Material: Copper Alloy

Hardware: DURSIUM™ Silicon Bronze

High copper alloy reversible T-Connector for joining a wide range of run and tap cables. Connector is designed for one-wrench installation. "S" standard 3/8 in hardware and "H" heavy duty 1/2 in hardware.

Notes :

- Plated versions: add the required suffix to the catalog number. -TN for regular tin plating.
- Please contact factory for other sizes, combinations and availability.
- One-wrench installation.

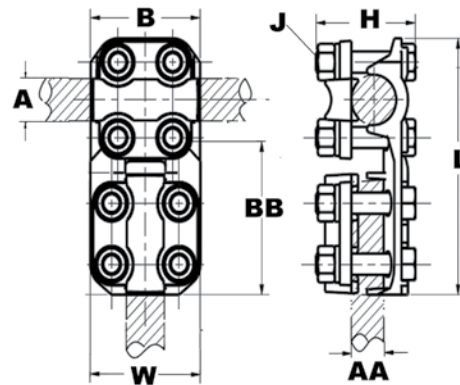

Catalog Number	A Pipe Run	A Cable Run	AA ① Cable Tap Range	B	J Dia.	BB	L	H	W
NSNT1329	1/2 IPS	N/A	6 AWG-250 kcmil	2.00	3/8	2.38	5.08	2.00	1.96
NSNT1429	3/4 IPS		6 AWG-250 kcmil	2.00	3/8	2.38	5.08	2.00	1.96
NSNT1434			1/0 AWG-500 kcmil	2.00	3/8	2.38	5.08	2.10	2.20
NSNT1529	1 IPS		6 AWG-250 kcmil	2.00	3/8	2.38	5.34	2.00	1.96
NSNT1629	1 1/4 IPS		6 AWG-250 kcmil	2.00	3/8	2.38	5.78	2.37	1.96
NSNT2929	—	6 AWG-250 kcmil	6 AWG-250 kcmil	2.38	3/8	2.38	4.60	1.75	1.96
NSNT3429		1/0 AWG-500 kcmil	6 AWG-250 kcmil	2.38	3/8	2.38	4.84	2.00	1.96
NSNT3434			1/0 AWG-500 kcmil	2.38	3/8	2.38	4.84	2.00	2.20

① Complete cable range may be accommodated by reversing cap.

Substation - Bolted

T-Connector Terminal; Copper Tube to Cable
Type NHNT

T-Connectors Terminals, Type NHNT For Copper Tube to Cable: T Application

Material: Copper Alloy

Hardware: DURIUM™ Silicon Bronze

High copper alloy reversible T-Connector for joining a wide range of run pipe and tap cables. Connector is designed for one-wrench installation.

Notes :

- Plated versions: add the required suffix to the catalog number. -TN for regular tin plating
- Please contact factory for other sizes, combinations and availability
- One-wrench installation

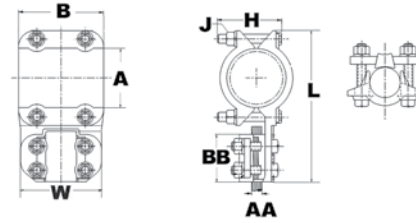

Catalog Number	A Pipe Run	AA ① Cable Tap Range	B	J Dia.	BB	L	H	W
NHNT1429	3/4 IPS	6 AWG-250 kcmil	2.25	1/2	2.62	5.82	2.32	2.44
NHNT1434		1/0 AWG-500 kcmil	2.25	1/2	2.62	5.82	2.42	2.56
NHNT1529	1 IPS	6 AWG-250 kcmil	2.25	1/2	2.62	5.92	2.57	2.44
NHNT1534		1/0 AWG-500 kcmil	2.25	1/2	2.62	5.92	2.57	2.56
NHNT1540		2/0 AWG-800 kcmil	2.25	1/2	2.62	5.92	2.60	2.78
NHNT1629	1 1/4 IPS	6 AWG-250 kcmil	2.69	1/2	2.62	6.32	2.57	2.44
NHNT1634		1/0 AWG-500 kcmil	2.69	1/2	2.62	6.32	2.60	2.56
NHNT1640		2/0 AWG-800 kcmil	2.69	1/2	2.62	6.32	2.68	2.78
NHNT1644		4/0 AWG-1000 kcmil	2.69	1/2	2.88	6.58	2.69	2.90
NHNT1729	1 1/2 IPS	6 AWG-250 kcmil	2.69	1/2	2.62	6.76	2.70	2.44
NHNT1734	1 1/2 IPS	1/0 AWG-500 kcmil	2.69	1/2	2.62	6.76	2.70	2.56
NHNT1740	1 1/2 IPS	2/0 AWG-800 kcmil	2.69	1/2	2.62	6.76	2.78	2.78
NHNT1744		4/0 AWG-1000 kcmil	2.69	1/2	2.88	7.02	2.80	2.90
NHNT1829	2 IPS	6 AWG-250 kcmil	2.69	1/2	2.62	7.44	3.06	2.44
NHNT1834		1/0 AWG-500 kcmil	2.69	1/2	2.62	7.44	3.06	2.56
NHNT1840		2/0 AWG-800 kcmil	2.69	1/2	2.62	7.44	3.06	2.78
NHNT1844		4/0 AWG-1000 kcmil	2.69	1/2	2.88	7.70	3.06	2.90
NHNT1846		1000 kcmil-1500 kcmil	2.69	1/2	3.06	7.88	3.23	3.16
NHNT1929	2 1/2 IPS	6 AWG-250 kcmil	2.69	1/2	2.62	8.06	3.64	2.44
NHNT1934		1/0 AWG-500 kcmil	2.69	1/2	2.62	8.06	3.64	2.56
NHNT1940		2/0 AWG-800 kcmil	2.69	1/2	2.62	8.06	3.64	2.78
NHNT1944		4/0 AWG-1000 kcmil	2.69	1/2	2.88	8.32	3.64	2.90
NHNT1946		1000 kcmil-1500 kcmil	2.69	1/2	3.06	8.50	3.64	3.16
NHNT2040	3 IPS	2/0 AWG-800 kcmil	2.69	1/2	2.88	8.69	4.26	2.78
NHNT2044		4/0 AWG-1000 kcmil	2.69	1/2	5.75	8.95	4.26	2.90
NHNT2229	4 IPS	6 AWG-250 kcmil	3.25	1/2	2.63	10.38	4.26	2.50

① Complete cable range may be accommodated by reversing cap.

T-Connector, Type VT

For Copper Cable to Cable: T Application

Material: Copper Alloy



Hardware: DURIIUM™ Silicon Bronze

High copper alloy T-connector for cable run, cable tap. V-bolt clamping elements accommodate large range of cable and are particularly suited for extra flexible cable. One-wrench installation.



Notes :

- Plated versions: add the required suffix to the catalog number. -TN for regular tin plating
- Please contact factory for other sizes, combinations and availability
- One-wrench installation

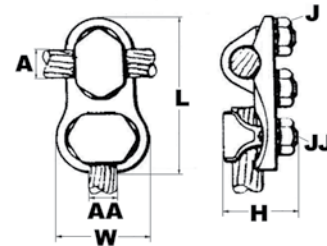

Catalog Number	A - Cable Run Range	AA - Cable Tap Range	J Dia.	JJ Dia.	L	H	W
VT2C2C	8 AWG-2 AWG	8 AWG-2 AWG	5/8	5/8	2.31	1.38	1.00
VT2525	6 AWG-1/0 AWG	6 AWG-1/0 AWG	3/4	3/4	1.37	0.38	0.56
VT2825	1/0 -4/0 AWG	6 AWG-1/0 AWG	3/8	3/4	3.12	1.62	1.25
VT2828	1/0 -4/0 AWG	1/0 -4/0 AWG	3/8	3/8	2.94	0.38	0.31
VT3028	1/0 -300 kcmil	1/0 -4/0 AWG	7/16	3/8	3.19	1.88	1.69
VT4034	500 kcmil-800 kcmil	300 kcmil-500 kcmil	9/16	1/2	4.13	2.56	2.25
VT4430	750 kcmil-1000 kcmil	1/0 -300 kcmil	5/8	7/16	4.25	2.88	1.94
VT4434		300 kcmil-500 kcmil	5/8	1/2	4.38	3.34	2.25
VT4440		500 kcmil-800 kcmil	5/8	9/16	4.75	2.88	2.63
VT4444		750 kcmil-1000 kcmil	5/8	5/8	4.88	2.88	2.88
VT4628	1000 kcmil-1500 kcmil	1/0 -4/0 AWG	5/8	3/8	4.50	3.81	1.69
VT4630		1/0 -300 kcmil	5/8	7/16	4.63	3.81	1.94
VT4640		500 kcmil-800 kcmil	5/8	9/16	5.13	3.81	2.63
VT4830	1500 kcmil-2000 kcmil	1/0 -300 kcmil	3/4	7/16	5.13	4.25	1.94
VT4840		500 kcmil-800 kcmil	3/4	9/16	5.63	4.25	2.63
VT4844		750 kcmil-1000 kcmil	3/4	5/8	5.75	4.25	2.88
VT4848		1500 kcmil-2000 kcmil	3/4	3/4	6.25	4.25	3.75

Aluminum T-Connectors, Type NNT For Aluminum and Copper Tube to Tube

Material: Aluminum Alloy

Hardware: Aluminum

Aluminum alloy T-Connector for tubing run and tap. Properly proportioned to permit use on copper-aluminum conductor combinations. Captured hex head bolts permit one-wrench installation. PENETROX™ joint compound recommended on contact surfaces.



Notes :

- PENETROX™ A joint compound is recommended on contact surfaces
- Please contact factory for other sizes, combinations and availability
- One-wrench installation

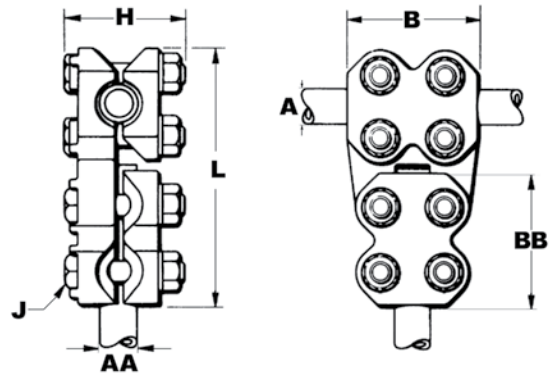

Catalog Number	A - Run tube	AA - Tap tube	B	J Dia.	BB	L	H
NNT15A15A	1 IPS	1 IPS	3.50	1/2	3.50	6.81	3.38
NNT16A16A	1 1/4 IPS	1 1/4 IPS	3.75	1/2	3.75	7.44	3.38
NNT17A17A	1 1/2 IPS	1 1/2 IPS	4.00	1/2	4.00	7.88	3.88
NNT18A18A	2 IPS	2 IPS	4.25	5/8	4.25	9.06	4.44
NNT19A19A	2 1/2 IPS	2 1/2 IPS	4.50	5/8	4.50	9.38	4.94
NNT20A20A	3 IPS	3 IPS	5.00	5/8	5.00	10.94	5.44
NNT21A20A	3 1/2 IPS	3 IPS	5.50	5/8	5.00	11.06	5.56
NNT22A22A	4 IPS	4 IPS	6.00	5/8	6.00	12.63	6.19

Aluminum T-Connectors, Type NNTR
For Cable to Cable

Material: Aluminum Alloy

Hardware: Aluminum

Aluminum alloy T-Connector for a range of cable run to range of cable tap. One-wrench installation.

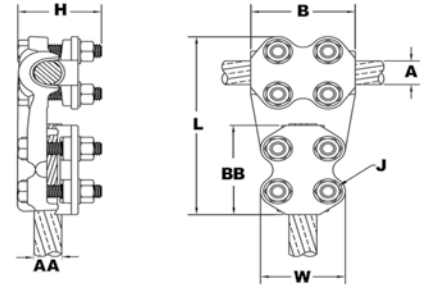

Notes :

- PENETROX™ A joint compound is recommended on contact surfaces
- Please contact factory for other sizes, combinations, and availability
- One-wrench installation

Catalog Number	A - Run Al Cable	A - Run ACSR Cable	AA - Tap Al Cable	AA - Tap ACSR Cable	B	J Dia.	BB	L	H	W
NNTR29A29A	1/0 AWG-250 kcmil	1/0 (6/1) Raven AWG-4/0 (6/1) Penquin AWG	1/0 AWG-250 kcmil	1/0 (6/1) Raven AWG-4/0 (6/1) Penquin AWG	2.75	1/2	2.75	5.56	2.56	2.50
NNTR32A25A	250 kcmil-400 kcmil	4/0 (6/1) Penquin AWG-397.5 (18/1) Chickadee kcmil	4 AWG-1/0 AWG	4 (6/1) Swan AWG-1/0 (6/1) Raven AWG	1.88	1/2	1.88	4.81	2.56	2.28
NNTR32A32A	250 kcmil-400 kcmil	4/0 (6/1) Penquin AWG-397.5 (18/1) Chickadee kcmil	250 kcmil-400 kcmil	4/0 (6/1) Penquin AWG-397.5 (18/1) Chickadee kcmil	3.00	1/2	3.00	5.94	2.56	2.63
NNTR36A29A	350 kcmil-600 kcmil	336.4 (18/1) Merlin kcmil-477.0 (18/1) Pelican kcmil	1/0 AWG-250 kcmil	1/0 (6/1) Raven AWG-4/0 (6/1) Penquin AWG	3.25	1/2	2.75	5.31	2.56	2.50
NNTR36A36A	350 kcmil-600 kcmil	336.4 (18/1) Merlin kcmil-477.0 (18/1) Pelican kcmil	350 kcmil-600 kcmil	336.4 (18/1) Merlin kcmil-477.0 (18/1) Pelican kcmil	3.25	1/2	3.25	6.31	2.56	2.75
NNTR42A32A	600 kcmil-900 kcmil	477.0 (18/1) Pelican kcmil-795 (54/7) Condor kcmil	250 kcmil-400 kcmil	4/0 (6/1) Penquin AWG-397.5 (18/1) Chickadee kcmil	3.50	1/2	3.00	6.38	3.13	2.63
NNTR42A36A	600 kcmil-900 kcmil	477.0 (18/1) Pelican kcmil-795 (54/7) Condor kcmil	350 kcmil-600 kcmil	336.4 (18/1) Merlin kcmil-477.0 (18/1) Pelican kcmil	3.50	1/2	3.25	6.63	3.13	2.75
NNTR42A42A	600 kcmil-900 kcmil	477.0 (18/1) Pelican kcmil-795 (54/7) Condor kcmil	600 kcmil-900 kcmil	477.0 (18/1) Pelican kcmil-795 (54/7) Condor kcmil	3.50	1/2	3.50	6.88	3.13	3.00
NNTR45A45A	900 kcmil-1250 kcmil	715.5 (54/7) Crow kcmil-1113 (54/19) Finch kcmil	900 kcmil-1250 kcmil	715.5 (54/7) Crow kcmil-1113 (54/19) Finch kcmil	3.75	1/2	3.75	7.31	3.25	3.19
NNTR46A42A	1250 kcmil-1600 kcmil	1113 (54/19) Finch kcmil-1431 (54/19) Plover kcmil	600 kcmil-900 kcmil	477.0 (18/1) Pelican kcmil-795 (54/7) Condor kcmil	3.75	1/2	3.50	7.25	3.44	3.00
NNTR46A46A	1250 kcmil-1600 kcmil	1113 (54/19) Finch kcmil-1431 (54/19) Plover kcmil	1250 kcmil-1600 kcmil	1113 (54/19) Finch kcmil-1431 (54/19) Plover kcmil	4.38	5/8	4.38	8.31	3.69	3.75
NNTR48A48A	1500 kcmil-2000 kcmil	1272 (54/19) Pheasant kcmil-1780 (54/19) kcmil	1500 kcmil-2000 kcmil	1272 (54/19) Pheasant kcmil-1780 (54/19) kcmil	4.50	5/8	4.50	8.63	3.81	3.88

Aluminum T-Connectors, Type NNTR

For Tube to Cable

Material: Aluminum Alloy

Hardware: Aluminum

Aluminum alloy T-Connector for tube run, range of cable tap. Properly proportioned to permit use on copper-aluminum combinations. One-wrench installation. PENETROX™ joint compound recommended on contact surfaces.

Notes :

- PENETROX™ A joint compound is recommended on contact surfaces
- Please contact factory for other sizes, combinations, and availability
- One-wrench installation

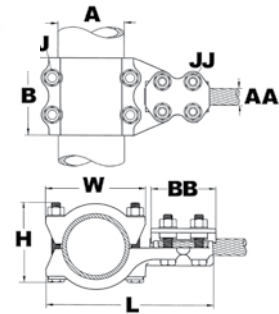

Catalog Number	A - Run Al Pipe	AA - Tap Al Cable	AA - Tap ACSR Cable	B	J Dia.	BB	L	H	JJ Dia.	W
NNTR14A29A	3/4 IPS	1/0 AWG-250 kcmil	1/0 (6/1) Raven AWG-4/0 (6/1) Penquin AWG	3.25	1/2	2.75	5.81	3.06	0.50	2.50
NNTR15A36A	1 IPS	350 kcmil-600 kcmil	336.4 (18/1) Merlin kcmil-477.0 (18/1) Pelican kcmil	3.50	1/2	3.25	6.56	3.31	0.50	2.75
NNTR15A42A	1 IPS	600 kcmil-900 kcmil	477.0 (18/1) Pelican kcmil-795 (54/7) Condor kcmil	3.50	1/2	3.50	6.81	3.31	0.50	3.00
NNTR16A29A	1 1/4 IPS	1/0 AWG-250 kcmil	1/0 (6/1) Raven AWG-4/0 (6/1) Penquin AWG	3.75	1/2	2.75	6.44	3.31	0.50	2.50
NNTR16A32A	1 1/4 IPS	250 kcmil-400 kcmil	4/0 (6/1) Penquin AWG-397.5 (18/1) Chickadee kcmil	3.75	1/2	3.12	6.69	3.31	0.50	2.63
NNTR16A42A	1 1/4 IPS	600 kcmil-900 kcmil	477.0 (18/1) Pelican kcmil-795 (54/7) Condor kcmil	3.75	1/2	3.50	7.19	3.31	0.50	3.00
NNTR17A29A	1 1/2 IPS	1/0 AWG-250 kcmil	1/0 (6/1) Raven AWG-4/0 (6/1) Penquin AWG	4.00	1/2	2.75	6.69	3.81	0.50	2.50
NNTR18A29A	2 IPS			4.00	1/2	2.75	7.56	4.44	0.50	2.50
NNTR19A42A	2 1/2 IPS	600 kcmil-900 kcmil	477.0 (18/1) Pelican kcmil-795 (54/7) Condor kcmil	4.00	5/8	3.50	8.88	5.00	0.63	3.00
NNTR20A32A	3 IPS	250 kcmil-400 kcmil	4/0 (6/1) Penquin AWG-397.5 (18/1) Chickadee kcmil	4.00	1/2	3.00	9.00	5.44	0.50	2.63
NNTR22A46A	4 IPS	1250 kcmil-1600 kcmil	1113 (54/19) Finch kcmil-1431 (54/19) Plover kcmil	6.00	5/8	4.38	11.25	6.19	0.63	3.75

Copper Bus Supports, Type UH For Supporting Copper Tube to Base

Material: Copper Alloy

Hardware: DURIMUM™ Silicon Bronze

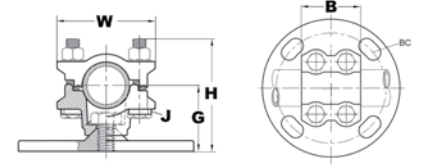

High copper alloy bus support for mounting tube on a post or pedestal type insulator. Single bolt allows rotation to any angle. Rotate cap 180° for slip or rigid fit. One wrench installation. Supplied with hardware for mounting to cap of insulator. Specify base mounting hardware, if required, by adding suffix "B" to catalog number.

Notes :

- One wrench installation
- Specify base mounting hardware, if required, by adding suffix "-B" to catalog number
- For other sizes and availability, please contact factory

Catalog Number	Copper Pipe Size	BC	G	J Dia.	B	H	W	
UH143	3/4 IPS	3	2.00	3/8	2.50	2.88	2.63	
UH153	1 IPS	3	2.00		2.50	3.00	2.88	
UH155		5	2.25		2.50	3.25	2.88	
UH163	1 1/4 IPS	3	2.25	1/2	2.69	3.44	3.50	
UH165		5	2.38		2.69	3.56	3.50	
UH173	1 1/2 IPS	3	2.50		3.00	3.81	3.81	
UH175		5	2.50		3.00	3.81	3.81	
UH183	2 IPS	3	2.75		3.00	4.31	4.63	
UH185	2 IPS	5	2.75		3.00	4.31	4.63	
UH193	2 1/2 IPS	3	3.13		3.00	5.00	5.25	
UH195		5	3.13		3.00	5.00	5.25	
UH203	3 IPS	3	3.63		5/8	3.25	5.81	6.19
UH205		5	3.63			3.25	5.81	6.19
UH225	4 IPS	5	4.50	3.25		7.25	7.50	

Copper Bus Supports, Type UHR For Supporting Copper Cable or Tube to Base

Material: Copper Alloy

Hardware: DURIMUM™ Silicon Bronze

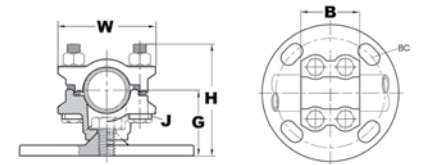

High copper alloy bus support clamp for mounting a wide range of cable or tube on post or pedestal type insulators. Single bolt allows rotation to any angle. Supplied with hardware for mounting to cap of insulator. Specify base mounting hardware, if required, by adding suffix "-B" to catalog number.

Notes :

- One wrench installation
- Specify base mounting hardware, if required, by adding suffix "-B" to catalog number
- For other sizes and availability, please contact factory

Catalog Number	Copper Stranded Range	Copper Pipe Size	BC	G	J Dia.	B	H	W
UHR133	6 AWG - 500 kcmil	1/8 IPS -	3	1.75	3/8	3.63	3.00	2.25
UHR135		1/2 IPS	5	2.13	3/8	3.63	3.38	2.25
UHR153	4/0 AWG - 1250 kcmil	1/4 IPS -	3	2.00	3/8	3.75	3.50	2.75
UHR153SS		1 IPS	3	2.00	3/8	3.75	3.50	2.75
UHR155	750 kcmil - 2500 kcmil	3/4 IPS -	5	2.25	3/8	3.75	3.75	2.75
UHR173		1 1/2 IPS	3	2.50	1/2	2.88	4.25	3.94
UHR175	N/A	1 1/4 IPS -	5	2.50	1/2	2.88	4.25	3.94
UHR183		2 IPS	3	2.75	1/2	2.81	4.75	4.63
UHR185			5	2.75	1/2	2.81	4.75	4.63

* With maximum conductor in place.

Substation - Bolted

Bus Supports, Type LH - Supporting Copper Cable or Tube to Base
Type LHR, Supporting Copper Cable or Tube to Insulator

Bus Supports, Type LH

For Supporting Copper Cable or Tube to Base

Material: Copper Alloy

Hardware: DURIUUM™ Silicon Bronze

High copper alloy, light duty bus support for mounting a wide range of cable or tube on post or pedestal type insulators. One-wrench installation. Supplied with hardware for mounting to cap of insulator. Specify base mounting hardware, if required, by adding suffix "-B" to Catalog No.

Notes :

- One wrench installation
- Specify base mounting hardware, if required, by adding suffix "-B" to catalog number
- For applications requiring heavier duty product, please see our UH product line
- For other sizes and availability, please contact factory.

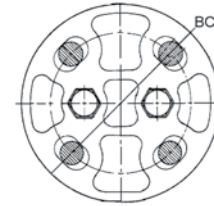
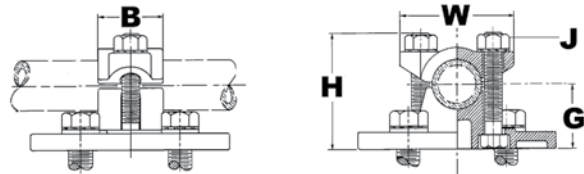

Catalog Number	Tube	Stranded Conductor	BC	G	J Dia.	B	H	W
LH283	N/A	6 AWG-4/0 AWG	3	1.25	3/8	1.69	2.62	4.25
LH343	1/4 IPS -1/2 IPS	2/0 AWG-500 kcmil	3	1.38	3/8	1.38	2.50	4.25
LH453	1/2 IPS-1 IPS	500 kcmil-1250 kcmil	3	1.50	1/2	1.62	3.19	4.44

Bus Supports, Type LHR

For Supporting Copper Cable or Tube to Insulator

Material: Copper Alloy

Hardware: DURIUUM™ Silicon Bronze

High copper alloy, bus support for mounting a wide range of cable or tube on post or pedestal type insulators. One-wrench installation. Supplied with hardware for mounting to cap of insulator.

Notes :

- One wrench installation
- Specify base mounting hardware, if required, by adding suffix "-B" to catalog number
- For applications requiring heavier duty product, please see our UH product line
- For other sizes and availability, please contact factory.

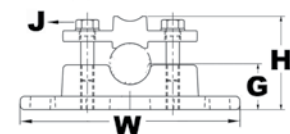
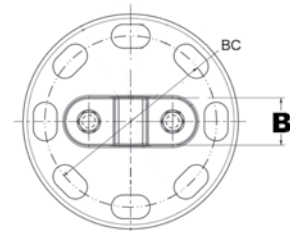

Catalog Number	Tube	Stranded Conductor	BC	G	J Dia.	B	H	W
LHR293	1/8 IPS-1/4 IPS	8 AWG-250 kcmil	3	1.23	3/8	1.00	2.03	4.25
LHR443	1/4 IPS-3/4 IPS	4/0 AWG-1000 kcmil	3	1.31	3/8	1.38	2.67	4.25
LHR445			5	1.33	3/8	1.00	2.51	6.25

Aluminum Bus Support, Type UHG
For Fixed or Rigid Pipe to Base

Material: Aluminum Alloy

Hardware: Aluminum

Aluminum alloy bus support for mounting tube on post or pedestal insulators. Properly proportioned to minimize conductor corrosion due to galvanic action. Caps are reversible for FIX or RIGID fit. One-wrench installation. Supplied with hardware for mounting to cap of insulator.

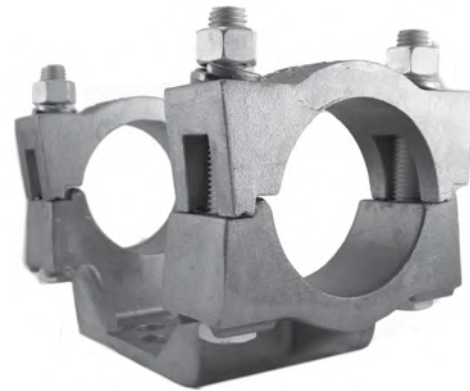

Notes :

- PENETROX™ A joint compound is recommended on contact surfaces
- Specify base mounting hardware, if required, by adding suffix "-B" to catalog number; items with suffix "-CH" include static clips

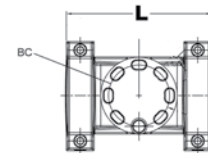
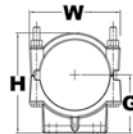
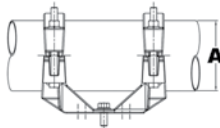

Catalog Number	A	BC	G	L	H	W	
UHG13A3CH	1/2 IPS	3.00	2.00	1.75	7.44	3.09	2.66
UHG14A3	3/4 IPS			7.44	3.50	2.94	
UHG14A3CH	3/4 IPS			7.44	3.50	2.94	
UHG15A3	1 IPS			7.44	3.88	3.06	
UHG15A3CH	1 IPS	5.00	2.25	7.44	3.88	3.19	
UHG15A5	1 IPS			9.82	3.82	3.19	
UHG15A5CH	1 IPS			9.82	3.82	3.19	
UHG16A3CH	1 1/4 IPS	3.00	2.38	7.68	3.79	3.50	
UHG16A5CH	1 1/4 IPS	5.00		10.06	3.94	3.50	
UHG17A3	1 1/2 IPS	3.00	2.50	7.68	4.06	3.66	
UHG17A3CH	1 1/2 IPS			7.68	4.06	3.66	
UHG17A5	1 1/2 IPS			10.06	4.06	3.66	
UHG17A5CH	1 1/2 IPS			10.06	4.06	3.66	
UHG18A3	2 IPS	3.00	2.75	7.68	5.25	4.12	
UHG18A3CH	2 IPS			7.68	5.25	4.12	
UHG18A5	2 IPS	5.00		10.06	4.61	4.12	
UHG18A5CH	2 IPS			10.06	4.61	4.12	
UHG19A3	2 1/2 IPS	3.00	3.12	7.68	5.23	4.62	
UHG19A3CH	2 1/2 IPS			7.68	5.23	4.62	
UHG19A5CH	2 1/2 IPS			5.00	10.56	5.23	4.62
UHG20A3CH	3 IPS	3.00	3.62	9.25	6.09	5.62	
UHG20A5	3 IPS	5.00		10.56	6.09	5.62	
UHG20A5CH	3 IPS			10.56	6.09	5.62	
UHG20A7CH	3 IPS			7.00	12.80	8.46	8.46

Catalog Number	A	BC	G	L	H	W
UHG21A3	3 1/2 IPS	3.00	4.00	8.18	6.74	6.16
UHG21A3CH	3 1/2 IPS			8.18	6.74	6.16
UHG21A5CH	3 1/2 IPS	5.00		10.56	6.74	6.16
UHG22A3CH	4 IPS	3.00		8.18	7.50	6.62
UHG22A5	4 IPS	5.00	4.50	11.34	7.50	6.62
UHG22A5CH	4 IPS			11.34	7.50	6.62
UHG24A3	5 IPS	3.00	5.25	8.68	8.86	7.70
UHG24A3CH	5 IPS			8.68	8.86	7.70
UHG24A5	5 IPS	5.00		11.56	8.86	7.70
UHG24A5CH	5 IPS			11.56	8.86	7.70
UHG83A5	8 IPS	5.00	7.16	11.56	11.84	10.12
UHG86A5CH	6 IPS		5.56	11.56	9.94	8.75

Substation - Bolted

Aluminum Bus Support, Cable or Tube to Base
Type UHKR-A

Aluminum Bus Support, Type UHKR-A For Cable or Tube to Base

Material: Aluminum Alloy

Hardware: Aluminum

Aluminum alloy bus support for mounting a wide range of cable or tube on post or pedestal type insulators. Supplied with hardware for mounting to cap of insulator.

Notes :

- PENETROX™ A joint compound is recommended on contact surfaces
- Specify base mounting hardware, if required, by adding suffix “-B” to catalog number
- Please contact factory for other sizes, combinations, and availability

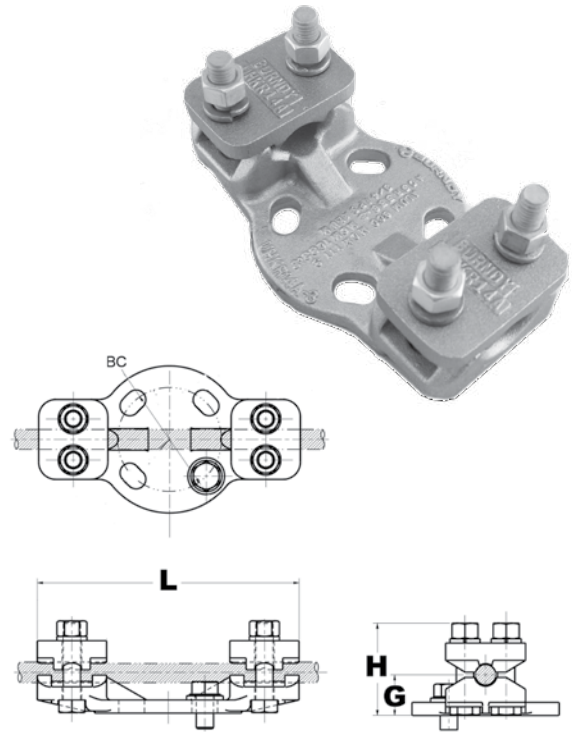

Catalog Number	Tube Size	Al Cable	ACSR Cable	BC	G*	L	H
UHKR11A3	1/4 IPS	4 AWG-4/0 AWG	6 (6/1) Turkey AWG-4/0 (6/1) Penguin AWG	3.00	1.16	7.56	2.63
UHKR11A5	1/4 IPS			5.00	1.16	8.50	2.63
UHKR13A3	3/8 IPS -1/2 IPS	250 kcmil-550 kcmil	266.8 (26/7) Owl kcmil-477. (30/7) Hen kcmil	3.00	1.32	7.56	3.88
UHKR13A5	3/8 IPS -1/2 IPS			5.00	1.32	8.88	2.88
UHKR14A3	3/4 IPS	600 kcmil-1113 kcmil	556.5 (26/7) Dove kcmil-1033.5 (54/7) Curlew kcmil	3.00	1.72	7.56	3.56
UHKR14A5	3/4 IPS			5.00	1.53	9.06	3.38
UHKR16A3	1 IPS -1 1/4 IPS	1000 kcmil-2000 kcmil	1113 (54/19) Finch kcmil-1780 (84/19) Chukar kcmil	3.00	1.97	7.56	4.06
UHKR16A5	1 IPS -1 1/4 IPS			5.00	1.80	9.25	3.88
UHKR17A3	1 1/4 IPS -1 1/2 IPS	2000 kcmil-2500 kcmil	1780 (84/19) Chukar kcmil-2156 (84/19) Bluebird kcmil	3.00	2.50	8.02	4.62
UHKR17A5	1 1/4 IPS -1 1/2 IPS			5.00	2.50	9.31	4.62

* With maximum conductor in place.

Aluminum End Cap, Type LB-A
For Use on Tube End Cap

Material: Aluminum Alloy

Hardware: Aluminum

Aluminum alloy end cap for aluminum tube. Driven into place for a secure fit. Seals out moisture, reduces electrostatic loss and eliminates hazards created by nesting birds.

Notes :

- Installation instructions available upon request
- Please contact factory for other sizes, combinations, and availability



Catalog Number	Al tube Sch 40	Al tube Sch 80	C	L
LB13A	1/2 IPS	N/A	0.38	1.25
LB14A	3/4 IPS		0.50	1.37
LB15A	1 IPS		0.50	1.35
LB16A	1 1/4 IPS		0.50	1.35
LB17A	1 1/2 IPS		0.50	1.35
LB18A	2 IPS		0.88	2.16
LB19A	2 1/2 IPS		0.88	2.24
LB20A	3 IPS		0.88	2.29
LB21A	3 1/2 IPS		0.88	2.33
LB22A	4 IPS		0.88	2.22
LB23A	4 1/2 IPS		0.88	2.28
LB24A	5 IPS		0.88	2.45
LB83A	8 OD		0.75	2.28
LB86A	6 IPS		0.88	2.57
LB88A	8 IPS		0.75	2.28
LB53A	N/A		1/2 IPS	0.38
LB54A	N/A	3/4 IPS	0.50	1.37
LB55A	N/A	1 IPS		1.35
LB56A	N/A	1 1/4 IPS		1.35
LB57A	N/A	1 1/2 IPS		1.35
LB58A	N/A	2 IPS	0.88	2.16
LB59A	N/A	2 1/2 IPS		2.24
LB90A	N/A	3 IPS	0.88	2.29
LB91A	N/A	3 1/2 IPS		2.33
LB92A	N/A	4 IPS		2.22
LB94A	N/A	5 IPS		2.45
LB96A	N/A	6 IPS		2.57

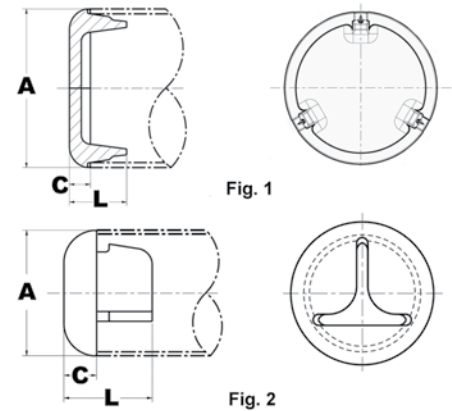

Substation - Bolted

Copper Stud Connector, Copper Stud to Cable, Tube, Flat Bar
Type NDR

Copper Stud Connectors, Type NDR For Copper Stud to Cable, Tube, Flat Bar

Material: Copper Alloy

Hardware: DURIMUM™ Silicon Bronze

High copper alloy reversible and rotatable cap stud connector joins cable, tube and flat bar in-line or at right angles to equipment studs. Accommodates a wide range of cables or tubes. One-wrench installation.

Notes :

- Plated versions: add the required suffix to the catalog number. -TN for regular tin plating
- Please contact factory for other sizes, combinations and availability
- One-wrench installation

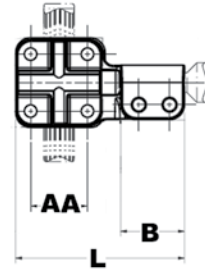

Catalog Number	Stud A	J Dia.	Threads per inch	B	AA Stranded Cable	JJ Dia.	L	H
NDR6334T13	1/2	3/8	13	1.62	6 AWG-500 kcmil	3/8	4.28	2.25
NDR6328T13			13	1.53	6 AWG-4/0 AWG	3/8	3.62	1.75
NDR6434T12	3/4		12	1.53	6 AWG-500 kcmil	3/8	4.09	2.24
NDR6434T16			16	1.53		3/8	4.09	
NDR6428T16			16	1.53	6 AWG-4/0 AWG	3/8	3.60	1.74
NDR6444T16			16	1.53	2 AWG-1000 kcmil	1/2	4.66	2.82
NDR64534T14	7/8		14	1.53	6 AWG-500 kcmil	3/8	4.16	1.91
NDR6534T12	1		12	1.53		3/8	3.96	2.24
NDR6534T14			14	1.53		3/8	3.96	
NDR6528T14			14	1.53	6 AWG-4/0 AWG	3/8	4.09	1.74
NDR6544T14			14	1.53	2 AWG-1000 kcmil	1/2	4.73	2.82
NDR65534T12	1-1/8		12	1.53	6 AWG-500 kcmil	3/8	3.97	2.24
NDR65528T12		12	1.53	6 AWG-4/0 AWG	3/8	4.12	1.75	
NDR65544T12		12	1.53	2 AWG-1000 kcmil	1/2	4.66	2.82	
NDR6748T12	1-1/2	1/2	12	2.03	4/0 AWG-2000 kcmil	1/2	5.78	3.25
NDR67548T12	1-3/4		12	2.03		1/2	6.56	2.51
NDR67544T12			12	2.03	2 AWG-1000 kcmil	1/2	6.28	3.12
NDR6848T12	2		12	2.03	4/0 AWG-2000 kcmil	1/2	6.56	2.82
NDR6844T12			12	2.03	2 AWG-1000 kcmil	1/2	6.12	2.88
NDR68544T12			2-1/4	12		2.50	1/2	6.81

Stud Connectors, Type FD
For Copper Stud to Pad

Material: Copper Alloy

Hardware: DURIIUM™ Silicon Bronze

High copper alloy stud connector allows bolting cable and tubing terminals to equipment studs. Hex head captured bolts provide one-wrench installation. One pad contact surface is on centerline of stud. Pad is finished on both sides. All pads are four hole NEMA drilled.

Notes :

- Plated versions: add the required suffix to the catalog number.
-TN for regular tin plating
- Pad is finished on both sides
- Amperage rating given is for indoor conditions
- Please contact factory for other sizes, combinations and availability
- One-wrench installation

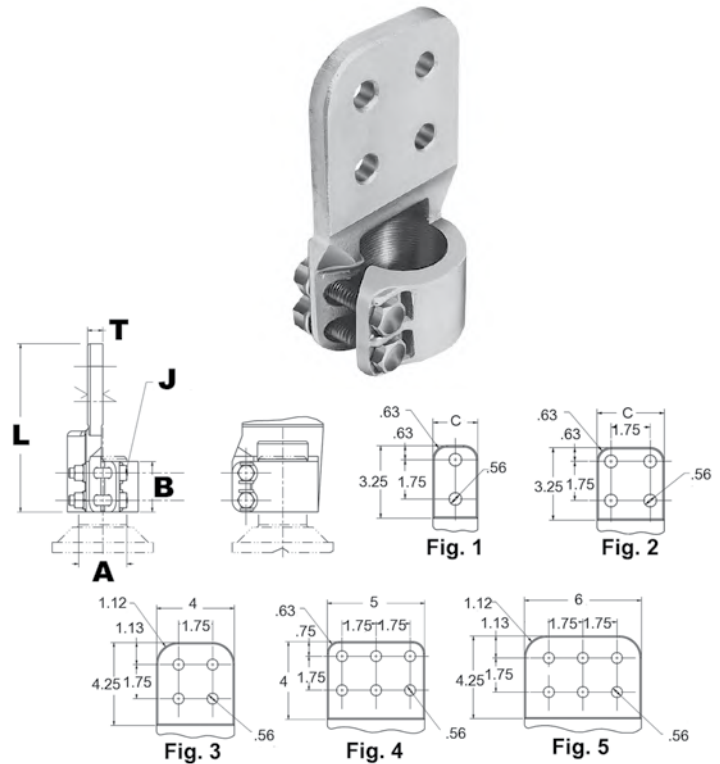

Catalog Number	Fig. #	Stud A	Threads per inch	Nominal Ampere Rating	B	J Dia.	L	T
FD64C5T16	2	3/4	16	1000	1.75	3/8	5.72	5/16
FD65C6T14	2	1	14	1075	1.75	3/8	5.72	3/8
FD655C6	2	1-1/8	12	1075	1.75	3/8	5.80	3/8
FD655D6	3		12	1300	1.75	3/8	6.86	3/8
FD66C6	2	1-1/4	12	1075	1.75	3/8	5.78	3/8
FD66D6	3		12	1300	1.75	3/8	6.84	3/8
FD675C8	2	1-3/4	12	1100	2.18	1/2	6.32	1/2
FD675D8	3		12	1450	2.18	1/2	7.39	1/2
FD68C8	2	2	12	1100	2.18	1/2	6.35	1/2
FD68D8	3		12	1450	2.18	1/2	7.42	1/2
FD68D12	3		12	2100	2.18	1/2	7.42	3/4
FD685C8	2	2-1/4	12	1100	2.50	1/2	6.71	1/2
FD685D8	3		12	1450	2.50	1/2	7.77	1/2
FD685D12	3		12	2100	2.50	1/2	7.77	3/4
FD69C8	2	2-1/2	12	1100	2.50	1/2	6.77	1/2
FD69D8	3		12	1450	2.50	1/2	8.03	1/2
FD69D12	3		12	2100	2.50	1/2	8.03	3/4
FD70D12	3	3	12	2100	2.88	5/8	8.26	3/4
FD70D16	3		12	3000	2.88	5/8	8.24	1

Copper Stud Connectors, Type VV3D-R For Copper Stud to Three Cables - Flag

Material: Copper Alloy

Hardware: DURSIUM™ Silicon Bronze

High copper alloy stud connector allows bolting (3) cables to equipment studs. The cables have a flag position to equipment stud axis.

Notes :

- Plated versions: add the required suffix to the catalog number. -TN for regular tin plating
- Please contact factory for other sizes, combinations and availability
- One-wrench installation.
- V-bolt clamping element is particularly appropriate for flexible cables

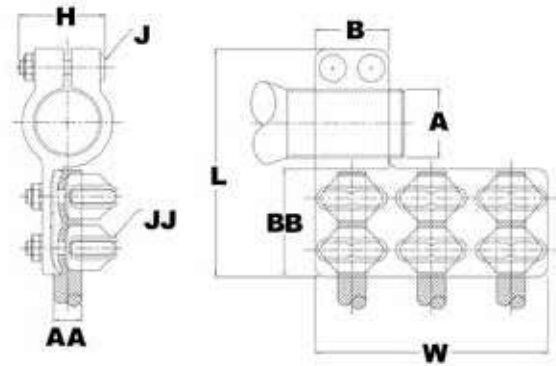

Catalog Number	Stud A	AA Stranded Cable	B	BB	J Dia.	JJ Dia.	L	H	W
VV3D6846R12	2	1000 kcmil-1500 kcmil	4.50	3.25	5/8	5/8	8.38	3.81	10.2
VV3D7046R12	3	1000 kcmil-1500 kcmil	4.50		5/8	5/8	10.0	3.81	10.2
VV3D7246R12	4	1000 kcmil-1500 kcmil	4.50		5/8	5/8	10.5	3.81	10.2

Aluminum Stud Connectors, Type SFD
For Stud to Pad

Material: Aluminum Alloy

Hardware: Aluminum
(modified by hardware suffixes)



Aluminum alloy stud connector for equipment bushing to conductor terminals. One wrench installation. Unless otherwise mentioned at the item level, this design embeds principles for self-shielding up to 550kV.

Notes :

- Properly proportioned to minimize conductor corrosion due to galvanic action. When properly used, this item does not require use of bimetallic plates. Please ask BURNDY® Technical Support for recommendations
- PENETROX™ A joint compound is recommended on contact surfaces
- Please contact factory for other sizes, combinations and availability
- Use shielding caps for high voltage applications (STS family). Shielding caps may be purchased separately
- Pad is finished on both sides

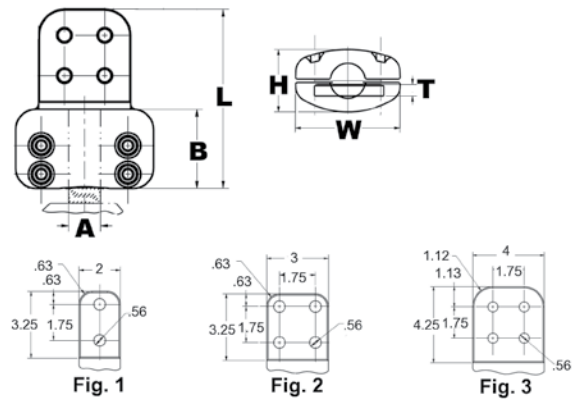

Catalog Number	Fig. #	Stud A	Threads per inch	B	H	L	W	T
SFD67D12	3	1-1/2	12	2.50	2.79	7.66	4.50	.75
SFD68AD16	3	2		3.45	3.57	8.23	6.00	1.00
SFD69AD16	3	2-1/2		3.45	3.57	8.23	6.00	1.00
SFD70AD16	3	3		3.84	4.10	8.59	7.12	1.00
SFD71AD20	3	3-1/2		3.84	4.89	8.59	7.50	1.25
SFD71AD16	3			3.84	4.89	8.59	7.50	1.00
SFD72AD20	3	4		3.84	5.37	8.58	8.12	1.25
SFD72AD18	3			3.84	5.37	8.58	8.12	1.12

Aluminum Spacer, Type CPR-A For Two Cables Rigid Spacer

Material: Aluminum Alloy

Hardware: Aluminum

Rigid spacer for large range of cables. Particularly appropriate design for short spacing (up to 6" or 8").

Notes :

- PENETROX™ A joint compound is recommended on contact surfaces
- Please contact factory for other sizes, combinations and availability
- One-wrench installation

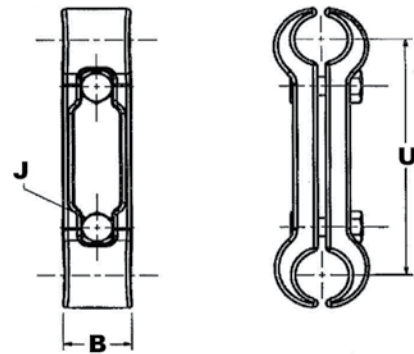

Catalog Number	Aluminum Stranded	B	J Dia.	U
CPR34A4	500 kcmil	1.75	1/2	4.00
CPR42A4	600 kcmil-900 kcmil			4.00
CPR46A4	1200 kcmil-1600 kcmil	2.13	5/8	4.00

Aluminum Spacer, Type S2GGBP-A
For Two Cables Rigid Spacer with Grounding Rod

Material: Aluminum Alloy

Hardware: Aluminum

Streamlined rigid spacer for large range of cables. The rod joining both cable modules is circular to accommodate grounding clamps.
EHV RATED: SELF-SHIELDING UP TO 550kV



Notes :

- PENETROX™ A joint compound is recommended on contact surfaces
- One wrench installation
- Please contact factory for other sizes, combinations and availability
- 1, 2 or 4 bolt designs available.

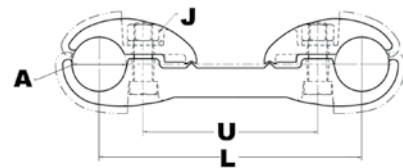
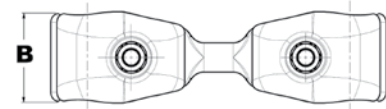

Catalog Number	Aluminum Stranded	Aluminum ACSR	B	J Dia.	U	L
S2GGBP445A12	954 kcmil- 1033 kcmil	795 (54/7) Condor kcmil- 954 (45/7) Rail kcmil	4.00	1/2	12.00	14.04
S2GGBP486A	2300 kcmil- 2500 kcmil	2156 (84/19) Bluebird kcmil- 2167 (72/7) Kiwi kcmil	3.00	5/8	18.00	20.76
S2GGBP486A9	2300 kcmil- 2500 kcmil		3.12	5/8	9.00	11.50
S2GGBP48A	1750 kcmil- 2000 kcmil	1590 (45/7) Lapwing kcmil- 1780 (54/19) kcmil	3.00	5/8	18.00	20.76
S2GGBP48A12	1750 kcmil- 2000 kcmil	1590 (54/19) Falcon kcmil- 1780 (84/19) Chukar kcmil		5/8	12.00	14.76

BARTAP™ Connectors, Type QGFL For Copper Cable to Flat

Material: Copper Alloy

High copper alloy BARTAP™ for joining a range of cable to bar or pad. One-wrench installation.

Notes :

- Can be installed side by side or in-line on NEMA drilled bar

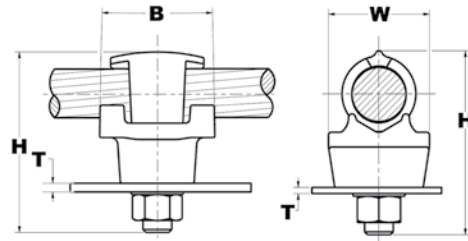

Catalog Number	Copper Conductor	B	H	J Dia.	T (Max)	W
QGFL1CB1	#10 Sol-#1 Str	1-1/8	1-7/8	3/8	1/4	1
QGFL1CB1T6	#10 Sol-#1 Str	1-1/8	2-3/8	3/8	3/4	1
QGFL26B1	#8 Sol-#2/0 Str	1-1/4	2-1/8	3/8	1/4	1-1/8
QGFL26B1T6	#8 Sol-#2/0 Str	1-1/4	2-5/8	3/8	3/4	1-1/8
QGFL26B2	#8 Sol-#2/0 Str	1-1/4	2-8/25	1/2	1/4	1-1/8
QGFL26B2T6	#8 Sol-#2/0 Str	1-1/2	2-4/5	1/2	3/4	1-1/8
QGFL29B1	#6 Str-250 kcmil	1-2/5	2-5/8	1/2	1/4	1-3/8
QGFL29B1T6	#6 Str-250 kcmil	1-5/8	3-1/8	1/2	3/4	1-3/8
QGFL31B1	2 AWG-350 kcmil	1-3/4	2-7/8	1/2	1/4	1-5/8
QGFL31B1T6	2 AWG-350 kcmil	1-3/4	3-1/4	1/2	3/4	1-5/8
QGFL34B1	1/0 -500 kcmil	2	3-1/8	1/2	1/4	1-3/4
QGFL34B1T6	1/0 -500 kcmil	2	3-5/8	1/2	3/4	1-3/4
QGFL44G3	2/0 - 1000 kcmil	1.88	4.44	1/2	3/4	2
QGFL39B1	350 kcmil-750 kcmil	2-1/4	3-1/4	1/2	1/4	1-3/4
QGFL39B1T6	350 kcmil-750 kcmil	2-1/4	3-5/8	1/2	3/4	1-3/4
QGFL44B1	750 kcmil-1000 kcmil	2-1/4	3-3/8	1/2	1/4	2-1/8
QGFL44B1T6	750 kcmil-1000 kcmil	2-1/4	4-1/8	1/2	3/4	2-1/8
QGFL46B1	1000 kcmil-1500 kcmil	2-1/4	4	1/2	1/4	2-1/2
QGFL46B1T6	1000 kcmil-1500 kcmil	2-1/4	4-1/2	1/2	3/4	2-1/2
QGFL48B1	1500 kcmil-2000 kcmil	2-1/4	4-3/4	1/2	1/4	3

Copper Bolted Terminal Type NFXR

For Pipe or Cable to Flat

Material: Copper Alloy

Hardware: DURIMUM™ Silicon Bronze

One of the most versatile products available. Can be bolted to a four-hole NEMA drilled pad. Rated for 230kV.



Notes :

- Plated versions: add the required suffix to the catalog number. -TN for regular tin plating
- Please contact factory for other sizes, combinations and availability



Catalog Number	Copper Cable	Copper Pipe (Std or EH)	H	L	W
NFXR15	1/0 -1250 kcmil	1/4 IPS-1 IPS	3.11	2.88	2.88
NFXR15CG20	1/0 -1250 kcmil		3.11	2.88	2.88
NFXR15CG24	1/0 -1250 kcmil		3.61	2.88	2.88
NFXR15CG7	1/0 -1250 kcmil		3.36	2.88	2.88
NFXR15HQ	1/0 -1250 kcmil		3.86	3.86	2.88

Bar Clamps, Type HFBW For Copper Bar to Bar

Material: Copper Alloy

The clamp assembly eliminates the need for drilling the flat bar and may be used in either indoor and outdoor applications. The open web design provides a uniform clamping pressure while minimizing the weight of the connector.

Notes :

- Please contact factory for other sizes, combinations and availability.

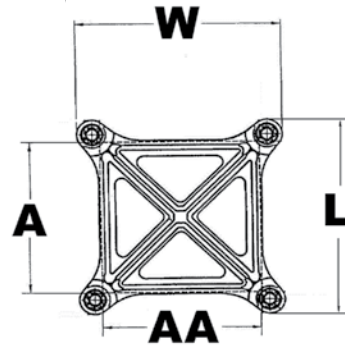
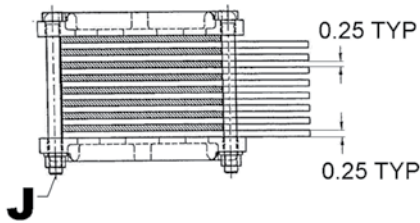

Catalog Number	A	AA	J Dia.	L	W
HFB44G30W	4.00	4.00	1/2	5.75	5.75
HFB44G31W	4.00	4.00	1/2	5.75	5.75
HFB44G32W	4.00	4.00	1/2	5.75	5.75

Bar Clamp Assembly Components, Type HFB-P1
 For Copper Bar to Bar

Material: Copper Alloy

To build your own high strength clamp assembly for multiple flat bar using type HFB-P1 bar clamps and clamping hardware, the following tables have been provided. The clamp assembly eliminates the need for drilling the flat bar and may be used in either indoor and outdoor applications. Hardware not included.



Notes :

- For other sizes and availability, please contact factory.

Catalog Number	A	AA	J Dia.	L
HFB22P1	2.00	2.00	3/8	4.38
HFB33P1	3.00	3.00	3/8	4.38
HFB42P1	4.00	2.00	3/8	5.75
HFB44P1	4.00	4.00	1/2	5.75
HFB52P1	5.00	2.00	1/2	6.75
HFB53P1	5.00	3.00	1/2	6.75
HFB54P1	5.00	4.00	1/2	6.75
HFB55P1	5.00	5.00	5/8	7.13
HFB62P1	6.00	2.00	1/2	7.75
HFB63P1	6.00	3.00	1/2	7.75
HFB64P1	6.00	4.00	1/2	7.75

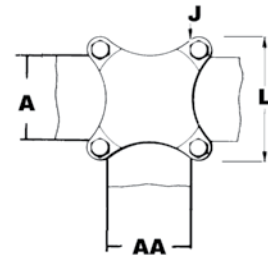

Bar Clamp Tap Pad Adapters, Type HFB-N
 For Copper Bar to Pad

Material: Copper

High conductivity copper, tap pad adapter provides a NEMA drilled contact pad when assembled to the HFB-P1 clamps (sold separately). Tap connections can be made from copper bus bar(s) without drilling, by bolting standard mechanical or compression terminal pads directly to the pre-drilled tap pad adapter.

Notes :

- **HFB-N items are only the flat drilled copper adapter pad, the HFB-P1 clamps and hardware are sold separately**
- Please contact factory for other sizes, combinations and availability

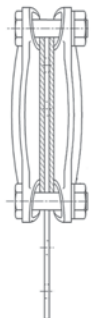
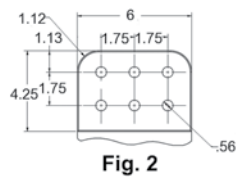
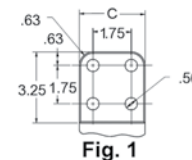
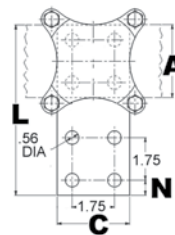

Catalog Number	Fig.	A	C	L	N
HFB334N	1	3.00	3.00	7.00	0.62
HFB444N	1	4.00	4.00	9.12	1.12
HFB666N	2	6.00	6.00	11.31	1.12