

---

## Submersible Mixer Type ABS RW 400 and 650 [NG] Submersible Recirculation Pump Type ABS RCP 400 and 500 [NG]

---

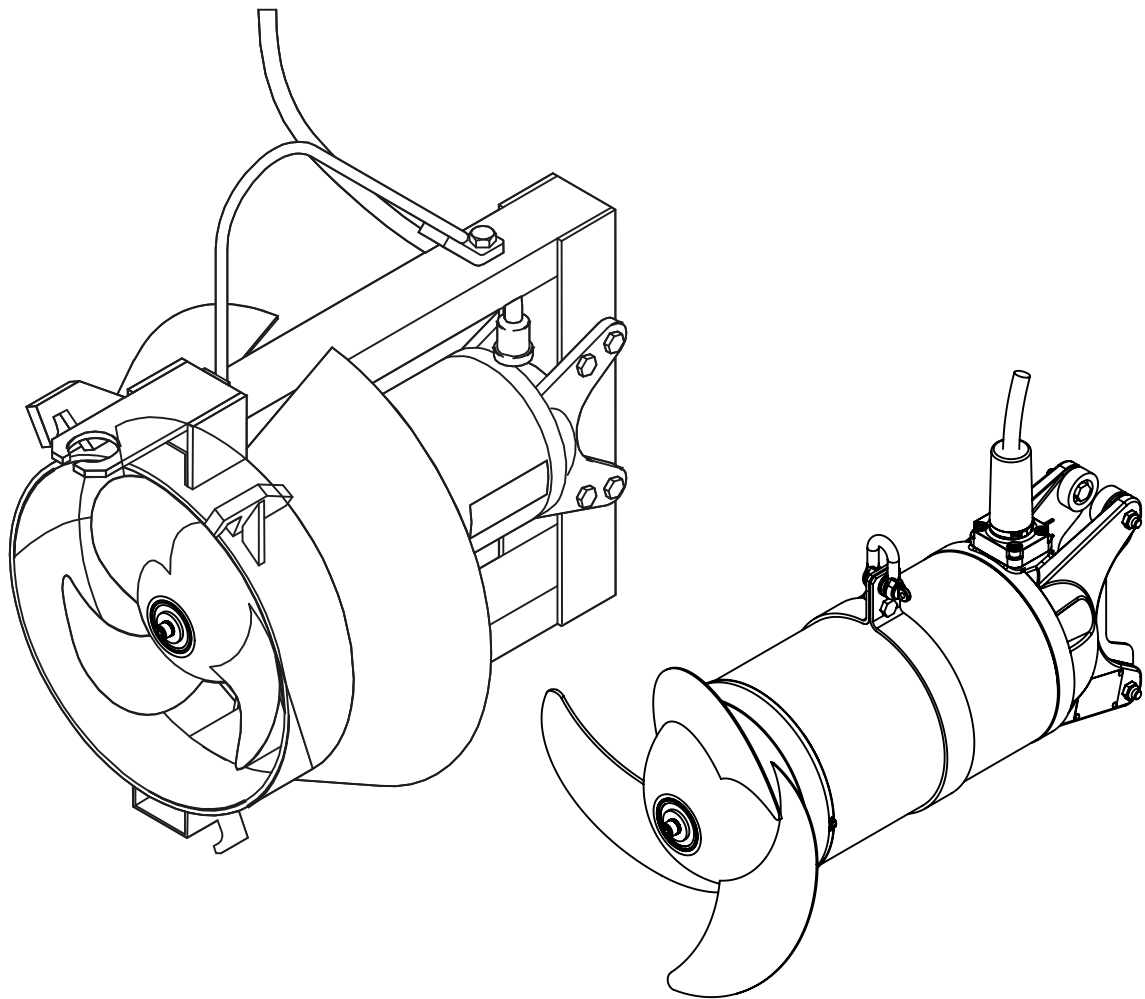

1549-01

## Installation and Operating Instructions (Original Instructions)

Submersible mixer RW [NG] and submersible recirculation pump RCP [NG]

RW 400                      RW 650  
RCP 400                    RCP 500

### Table of contents

<b>1</b>	<b>General</b> .....	<b>4</b>
1.1	Introduction .....	4
1.2	Correct usage of the products.....	4
1.3	Application restrictions of RW / RCP.....	4
1.4	Application areas .....	5
1.4.1	Application areas RW.....	5
1.4.2	Application areas RCP .....	6
1.5	Identification code .....	6
1.6	Technical data .....	6
1.6.1	Technical data RW 50 Hz.....	7
1.6.2	Technical data RW 60 Hz.....	8
1.6.3	Technical data RCP 50 Hz .....	9
1.6.4	Technical data RCP 60 Hz .....	9
1.7	Dimensions and weights .....	10
1.7.1	Dimensions RW .....	10
1.7.2	Dimensions RCP .....	11
1.7.3	Flange dimension check .....	12
1.8	Nameplate.....	13
<b>2</b>	<b>Safety</b> .....	<b>14</b>
<b>3</b>	<b>Transport and storage</b> .....	<b>14</b>
3.1	Transport.....	14
3.2	Transport securing devices .....	14
3.2.1	Motor connection cable moisture protection .....	14
3.3	Storage of the units .....	15

<b>4</b>	<b>Product description .....</b>	<b>15</b>
4.1	General description .....	15
4.2	Structural design .....	16
4.2.1	RW 400 and 650 .....	16
4.2.2	RCP 400 and 500.....	17
4.3	Operation with frequency inverters .....	18
<b>5</b>	<b>Installation .....</b>	<b>19</b>
5.1	Installation RW / RCP.....	19
5.2	Tightening torque .....	19
5.2.1	Nord-Lock® washer .....	19
5.3	Installation examples RW.....	20
5.3.1	Installation example with existing accessories .....	20
5.3.2	Installation example with alternative fixing possibilities.....	21
5.3.3	Installation example with fixed installation as flow booster .....	22
5.3.4	Fixed installation with vibration damper .....	23
5.4	Brackets RW .....	23
5.4.1	Fitting of the open bracket with vertical swivelling (option) .....	24
5.4.2	Fitting of the closed bracket with vertical swivelling (option).....	24
5.4.3	Bracket alignment on guide rail.....	26
5.5	Guide tube lengths RW (square tube) .....	26
5.6	Installation RCP .....	27
5.6.1	Installation example with Sulzer lifting unit.....	27
5.6.2	Guide tube installation.....	28
5.6.3	Securing and positioning of the motor connection cables of the RCP .....	29
5.6.4	Lowering of the RCP along the guide tube .....	30
5.7	Electrical connection .....	31
5.7.1	Standard connection diagrams. mains voltage 380 - 420 V at 50 Hz / 460 V at 60 Hz .....	32
5.7.2	Lead designations .....	33
5.7.3	Soft starter (option) .....	33
5.7.4	Checking direction of rotation.....	34
5.7.5	Changing direction of rotation .....	35
5.7.6	Connection of the seal monitoring unit to the control panel .....	35
<b>6</b>	<b>Commissioning .....</b>	<b>36</b>
6.1	Types of operation.....	37
<b>7</b>	<b>Maintenance .....</b>	<b>37</b>
7.1	General maintenance hints .....	37
7.2	Maintenance RW/RCP .....	38
7.2.1	Faults .....	38
7.3	Inspection and maintenance intervals.....	39

# 1 General

## 1.1 Introduction

These **Installation and Operating Instructions** and the separate booklet **Safety Instructions for Sulzer Products Type ABS** contain basic instructions and safety hints which must be observed during transport, installation and commissioning. For this reason it is essential that they are read by the installing technician as well as by relevant skilled operators or users. They should also be always available where the unit is installed.



Safety instructions which might cause danger to life in case of non-observance have been specifically highlighted with the general danger symbol.



The presence of a dangerous voltage is identified with this safety symbol.



This symbol indicates the danger of an explosion occurring.

**ATTENTION**      *Appears at safety instructions, the non-observance of which could damage the unit or affect its functioning.*

**NOTE**            *Used for important pieces of information.*

## 1.2 Correct usage of the products

Sulzer products have been designed and built in accordance with the latest technology and taking into account the relevant safety regulations. However, improper usage could cause a danger to life or limb of the user or a third party, or cause damage or function impairment to the unit itself and other items of value.

Sulzer units should only be used if they are in perfect technical condition, taking into account all safety requirements and conscious of the need to avoid potential dangers. The contents of the **Installation and Operating Instructions** and the **Safety Instructions for Sulzer Products Type ABS** must be applied! Any other usage (abnormal usage) or usage beyond that specified will be considered as non-compliance. The manufacturer/supplier will not accept any responsibility for damage due to this. The risk is borne by the user. In case of doubt the entire scope of the planned application must be approved by **Sulzer Pump Solutions Ireland Ltd.** (in the following called Sulzer).

In the case of any faults arising, Sulzer units should immediately be taken out of use and secured. The fault should be immediately rectified, or if necessary, contact your Sulzer Service Centre.

## 1.3 Application restrictions of RW / RCP

The RW / RCP can be supplied both in standard versions and in explosion-proof execution (ATEX II 2G Ex db IIB T4 Gb) for 50 Hz according to the standards EN ISO 12100:2010, EN 809:1998 + A1:2009 + AC:2010, EN 60079-0:2012 + A11:2018, EN 60079-1:2014, EN 80038-36:2016, or FM approval for 60 Hz (NEC 500. Class I, Division 1. Group C&D. T3C).

**Limitations:**            The ambient temperature range is 0 °C to + 40 °C (32 °F to 104 °F)  
Immersion depth maximum 20 m / (65 ft)

**ATTENTION**      *If cable length is less than 20 m / 65 ft, the max. immersion depth reduces accordingly. In special cases an immersion depth greater than 20 m / 65 ft is possible. However, the maximum number of starts according to the motor datasheet may not be exceeded. In order to do this you need written approval from the manufacturer Sulzer.*



Pumping of flammable or explosive liquids with these pumps is not allowed!



Only explosion-proof executions may be used in hazardous areas!

### **For the operation of units as explosion-proof execution the following applies:**

In hazardous areas care must be taken that during switching on and operation of the unit it is submerged or under water. Other types of operation e.g. snore operation or dry running are not allowed!

**ATTENTION** *RW / RCP mixers with Ex d IIB T4 approval are not equipped with a DI in the oil chamber.*

**ATTENTION** *RW 400 / 650 and RCP 400/500 with FM approval (NEC 500) are equipped with a DI in the oil chamber.*

### **For the operation of RW / RCP Ex the following applies:**

It must be ensured that the motor of the RW / RCP Ex is always fully submerged during start-up and operation!

The temperature monitoring of the RW / RCP Ex has to be carried out by bimetallic temperature limiters or thermistors according to DIN 44 082 connected to a suitable release device which is certified in accordance with EC directive 2014/34/EU and FM 3650.

### **For the operation of RW / RCP Ex with frequency inverter the following applies:**

Motors must have direct thermal protection devices fitted. These consist of temperature sensors (PTC DIN 44082) embedded in the windings. These must be connected to a suitable release device which is certified in accordance with EC directive 2014/34/EU and FM 3650.

Machines designated as Ex machines may never, without exception, be operated using a mains frequency that is greater than the maximum of 50 Hz or 60 Hz as indicated on the nameplate.

In the event that the pump is to be operated in explosive atmospheres using a variable speed drive, please contact your local Sulzer representative for technical advice regarding the various approvals and standards concerning thermal overload protection.

**ATTENTION** *Repair work on explosion-proof motors may only be carried out in authorized workshops by qualified personnel using original parts supplied by the manufacturer. Otherwise the Ex approvals are no longer valid. All Ex-relevant components and dimensions can be found in the modular workshop manual and the spare parts list.*

**ATTENTION** *If repair work is carried out in an unauthorized workshop and by unqualified personnel the Ex approvals are no longer valid. After such repair the unit must not be operated in hazardous areas. The Ex nameplate (see figures 7 and 8) has to be removed.*

## **1.4 Application areas**

### **1.4.1 Application areas RW**

The ABS submersible mixers RW 400 and 650, with a water pressure-tight encapsulated submersible motor, are high class quality products with the following range of applications in municipal treatment plants, in industry and in agriculture:

- Mixing
- Stirring
- Agitation

### 1.4.2 Application areas RCP

The ABS submersible recirculation pumps RCP 400 and 500 are fitted with water-pressure-tight encapsulated motors and are quality products suitable for use in the following areas:

- Pumping and recirculation of active sludge in treatment plants with nitrogen removal (nitrification/denitrification).
- Pumping of rain and surface water.

### 1.5 Identification code

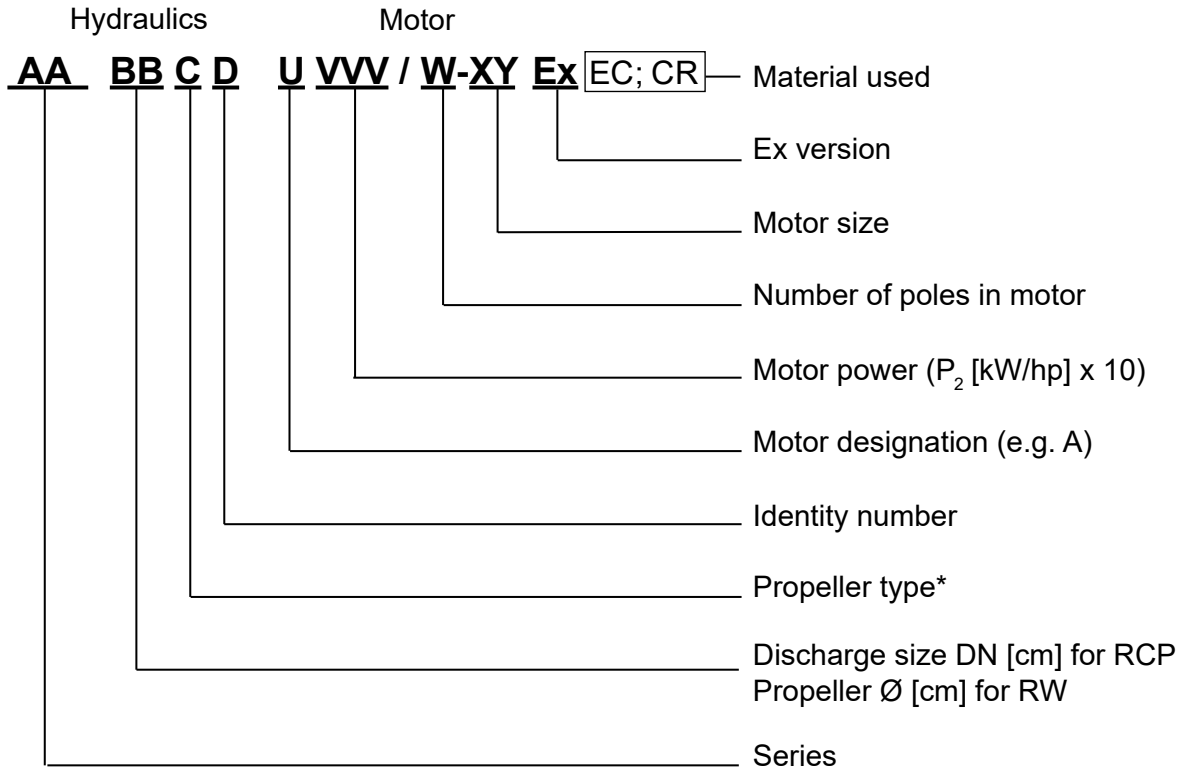

0551-0003

\*Propeller type: 1 = Mixing propeller (only without flow ring); 2 = 2-blade thrust propeller; 3 = 3-blade thrust propeller; 4 = 2-blade thrust propeller with flow ring; 5 = 3-blade thrust propeller with flow ring; 7 = 3-blade special propeller for biofilm carrier process

### 1.6 Technical data

The maximum noise level of the units of this series is  $\leq 70$  dB(A). In some types of installation it is possible that the noise level of 70 dB(A) or the measured noise level will be exceeded.

**ATTENTION**      *The maximum fluid temperature for continuous operation is 40 °C / 104 °F for a submerged unit.*

### 1.6.1 Technical data RW 50 Hz

Mixer type	Propeller			Motor (50 Hz/400 V)								Installation						
	Propeller diameter	Speed	Version with flow ring	Motor type	Rated power input P <sub>1</sub>	Rated power output P <sub>2</sub>	Starting: Direct (D.O.L)	Starting: Star/Delta	Rated current at 400 V	Starting current at 400 V	Cable type** (Ex and standard)	Temperature monitoring	Seal monitoring	Ex d IIB T4	Guide tube □ 60	Guide tube □ 100	Total weight (without flow ring)	Total weight (with flow ring)
	[mm]	[1/min]			[kW]	[kW]			[A]	[A]							[kg]	[kg]
RW 4021	400	702	○	A 30/8	4.2	3.0	●		9.3	40	1	●	●		●	○	96	107
RW 4022	400	702	○	A 30/8	4.2	3.0	●		9.3	40	1	●	●		●	○	96	107
RW 4023	400	702	○	A 30/8	4.2	3.0	●		9.3	40	1	●	●		●	○	96	107
RW 4024	400	702	○	A 30/8	4.2	3.0	●		9.3	40	1	●	●		●	○	96	107
RW 4031	400	680	○	A 40/8	5.6	4.0		●	10.9	40	2	●	●		●	○	96	107
RW 4032	400	680	○	A 40/8	5.6	4.0		●	10.9	40	2	●	●		●	○	96	107
RW 4033	400	680	○	A 40/8	5.6	4.0		●	10.9	40	2	●	●		●	○	96	107
RW 6521	580	470	○	A 50/12	7.1	5.0		●	18.2	52	2	●	●			●	155	173
RW 6522	580	470	○	A 50/12	7.1	5.0		●	18.2	52	2	●	●			●	155	173
RW 6523	650	470	○	A 50/12	7.1	5.0		●	18.2	52	2	●	●			●	155	173
RW 6524	650	470	○	A 50/12	7.1	5.0		●	18.2	52	2	●	●			●	155	173
RW 6525	650	470	○	A 50/12	7.1	5.0		●	18.2	52	2	●	●			●	155	173
RW 6531	650	462	○	A 75/12	10.3	7.5		●	24.5	54	3	●	●			●	182	200
RW 6532	650	462	○	A 75/12	10.3	7.5		●	24.5	54	3	●	●			●	182	200
RW 6533	650	470	○	A 100/12	13.3	10.0		●	31.9	91	4	●	●			●	214	232

P<sub>1</sub> = Power input ; P<sub>2</sub> = Power output

● = Standard ; ○ = Option.

\*\*Cable type: 10 m cable with free cable ends as standard: 1 = 1 x 7G 1.5, 2 = 1 x 10G 1.5, 3 = 1 x 10 G 2.5, 4 = 2 x 4G 4 + 2 x 0.75

**NOTE** *Data applies also for versions with flow ring (see section 1.5 Identification code).  
Other voltages available on request.*

1.6.2 Technical data RW 60 Hz

Mixer type	Propeller			Version with flow ring	Motor type	Motor (60 Hz/460 V)						Cable type** (Ex and standard)	Temperature monitoring	Seal monitoring	FM (NEC 500)	Installation		
	Propeller diameter	Speed				Rated power input P <sub>1</sub>	Rated power output P <sub>2</sub>	Starting: Direct (D.O.L)	Starting: Star/Delta	Rated current at 460 V	Starting current at 460 V					Guide tube □ 60	Guide tube □ 100	Total weight (without flow ring)
	[mm]	[1/min]			[kW]	[kW]			[A]	[A]							[kg]	[kg]
RW 4021	400	858	○	A 35/8	4.6	3.5	●		8.7	38	1	●	●	○	●	○	96	107
RW 4022	400	858	○	A 35/8	4.6	3.5	●		8.7	38	1	●	●	○	●	○	96	107
RW 4023	400	858	○	A 35/8	4.6	3.5	●		8.7	38	1	●	●	○	●	○	96	107
RW 4024	400	841	○	A 46/8	6.0	4.6		●	10.3	38	2	●	●	○	●	○	96	107
RW 4031	400	841	○	A 46/8	6.0	4.6		●	10.3	38	2	●	●	○	●	○	96	107
RW 6521	580	571	○	A 60/12	8.0	6.0		●	17.5	50	2	●	●	○		●	155	173
RW 6522	580	571	○	A 60/12	8.0	6.0		●	17.5	50	2	●	●	○		●	155	173
RW 6531	650	567	○	A 90/12	11.5	9.0		●	23.9	52	2	●	●	○		●	182	200
RW 6532	650	567	○	A 90/12	11.5	9.0		●	23.9	52	2	●	●	○		●	182	200
RW 6533	650	567	○	A 90/12	11.5	9.0		●	23.9	52	2	●	●	○		●	182	200
RW 6534	650	569	○	A 120/12	15.3	12.0		●	31.4	88	3	●	●	○		●	214	232
RW 6535	650	569	○	A 120/12	15.3	12.0		●	31.4	88	3	●	●	○		●	214	232

P<sub>1</sub> = Power input ; P<sub>2</sub> = Power output

● = Standard ; ○ = Option.

\*\*Cable type: 10 m cable with free cable ends as standard: 1 = 1 x 7G 1.5, 2 = 1 x 10G 1.5, 3 = 1 x 10 G 2.5, 4 = 2 x 4G 4 + 2 x 0.75

**NOTE** *Data applies also for versions with flow ring (see section 1.5 Identification code). Other voltages available on request.*



### 1.6.3 Technical data RCP 50 Hz

RCP hydraulics type	Propeller				Motor (50 Hz/400 V)											
	Propeller diameter	Propeller speed	H <sub>max</sub>	Q <sub>max</sub>	Motor type	Rated input power P <sub>1</sub>	Rated motor power P <sub>2</sub>	Starting: Direct (D.O.L)	Starting: Star/Delta	Rated current at 400 V	Starting current at 400 V	Cable type** (Ex- and standard)	Temperature monitoring	Seal monitoring	Ex d IIB T4	Total weight (Complete unit)
	[mm]	[1/min]	[m]	[l/s]		[kW]	[kW]			[A]	[A]					[kg]
RCP 4022	394	730	1.13	165	A 40/8	5.6	4.0		•	10.9	40	1	•	•	•	118
RCP 4023	394	730	1.35	195	A 40/8	5.6	4.0		•	10.9	40	1	•	•	•	118
RCP 4024	394	730	1.49	215	A 40/8	5.6	4.0		•	10.9	40	1	•	•	•	118
RCP 4031	394	730	1.67	225	A 40/8	5.6	4.0		•	10.9	40	1	•	•	•	118
RCP 4032	394	730	1.40	245	A 40/8	5.6	4.0		•	10.9	40	1	•	•	•	118
RCP 4033	394	730	1.21	280	A 40/8	5.6	4.0		•	10.9	40	1	•	•	•	118
RCP 5031	492	470	1.08	390	A 50/12	7.1	5.0		•	18.2	52	1	•	•	•	215
RCP 5032	492	470	1.30	440	A 75/12	10.3	7.5		•	24.5	54	2	•	•	•	250
RCP 5033	492	470	1.38	500	A 75/12	10.3	7.5		•	24.5	54	2	•	•	•	250
RCP 5034	492	470	1.40	550	A 75/12	10.3	7.5		•	24.5	54	2	•	•	•	250
RCP 5035	492	470	1.45	585	A 100/12	13.3	10.0		•	31.9	91	3	•	•	•	255
RCP 5036	492	470	1.27	655	A 100/12	13.3	10.0		•	31.9	91	3	•	•	•	255

P<sub>1</sub> = Power input ; P<sub>2</sub> = Power output.

• = Standard ; ◦ = Option.

\*\*Cable type: 10 m cable with free cable ends as standard: 1 = 1 x 10G 1.5, 2 = 1 x 10G 2.5, 3 = 2 x 4G 4 + 2 x 0.75

### 1.6.4 Technical data RCP 60 Hz

RCP hydraulics type	Propeller				Motor (60 Hz/460 V)											
	Propeller diameter	Propeller speed	H <sub>max</sub>	Q <sub>max</sub>	Motor type	Rated input power P <sub>1</sub>	Rated motor power P <sub>2</sub>	Starting: Direct (D.O.L)	Starting: Star/Delta	Rated current at 460 V	Starting current at 460 V	Cable type** (Ex- and standard)	Temperature monitoring	Seal monitoring	FM (NEC 500)	Total weight (Complete unit)
	[mm]	[1/min]	[m]	[l/s]		[kW]	[kW]			[A]	[A]					[kg]
RCP 4022	394	841	1.70	200	A 46/8	6.0	4.6		•	10.3	38	1	•	•	•	118
RCP 4023	394	841	1.85	245	A 46/8	6.0	4.6		•	10.3	38	1	•	•	•	118
RCP 4024	394	841	1.62	265	A 46/8	6.0	4.6		•	10.3	38	1	•	•	•	118
RCP 4031	394	841	1.36	275	A 46/8	6.0	4.6		•	10.3	38	1	•	•	•	118
RCP 5031	492	570	1.62	460	A 90/12	11.5	9.0		•	23.9	52	1	•	•	•	250
RCP 5032	492	570	1.52	515	A 120/12	15.3	12.0		•	31.4	88	2	•	•	•	255
RCP 5033	492	570	1.20	590	A 120/12	15.3	12.0		•	31.4	88	2	•	•	•	255
RCP 5034	492	570	1.14	640	A 120/12	15.3	12.0		•	31.4	88	2	•	•	•	255

P<sub>1</sub> = Power input ; P<sub>2</sub> = Power output.

• = Standard ; ◦ = Option.

\*\*Cable type: 10 m cable with free cable ends as standard: 1 = 1 x 10G 1.5, 2 = 1 x 10G 2.5

## 1.7 Dimensions and weights

**NOTE** The weights of the units can be obtained from the nameplate of the unit or from the table in section 1.6 Technical data.

### 1.7.1 Dimensions RW

Dimension	RW 400 A30/40 (50 Hz) A35/46 (60 Hz)	RW 650 A50 (50 Hz) A60 (60 Hz)	RW 650 A75 (50 Hz) A90 (60 Hz)	RW 650 A100 (50 Hz) A120 (60 Hz)
$D_1$	ø 400	ø 650	ø 650	ø 650
$D_2$	ø 560	ø 810	ø 810	ø 810
$d_1$	ø 222.5	ø 262.5	ø 262.5	ø 262.5
H □ 60	262	-	-	-
H □ 100	306	306	306	306
$h_1$	700	1100	1100	1100
$L_1$ □ 60	665	-	-	-
$L_1$ □ 100	700	830	970	970
$L_2$ □ 60	685	-	-	-
$L_2$ □ 100	720	850	990	990
$l_1$	795	925	1065	1065
$l_2$ □ 60	300	-	-	-
$l_2$ □ 100	300	400	630	530
$X_1$ □ 60	360	-	-	-
$X_1$ □ 100	280	320	420	400
$X_2$ □ 60	300	-	-	-
$X_2$ □ 100	310	330	430	410

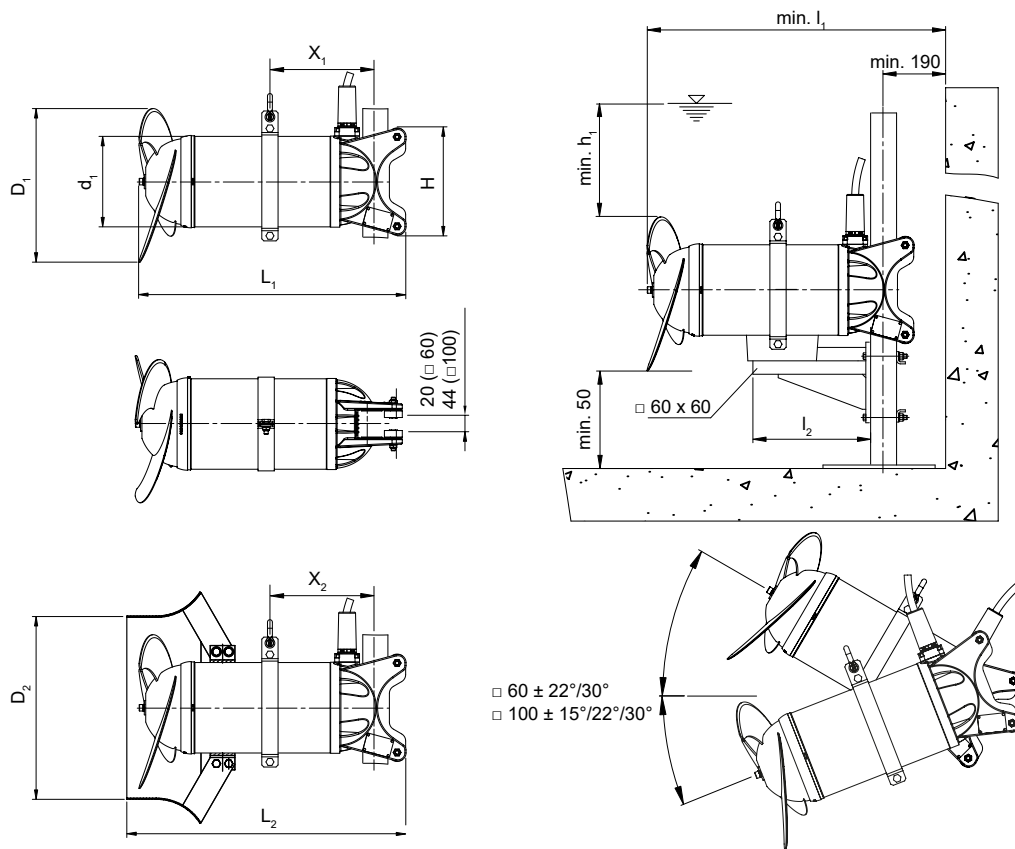

Figure 1. Dimensions RW

0552-0001



**1.7.3 Flange dimension check**

0655-0001

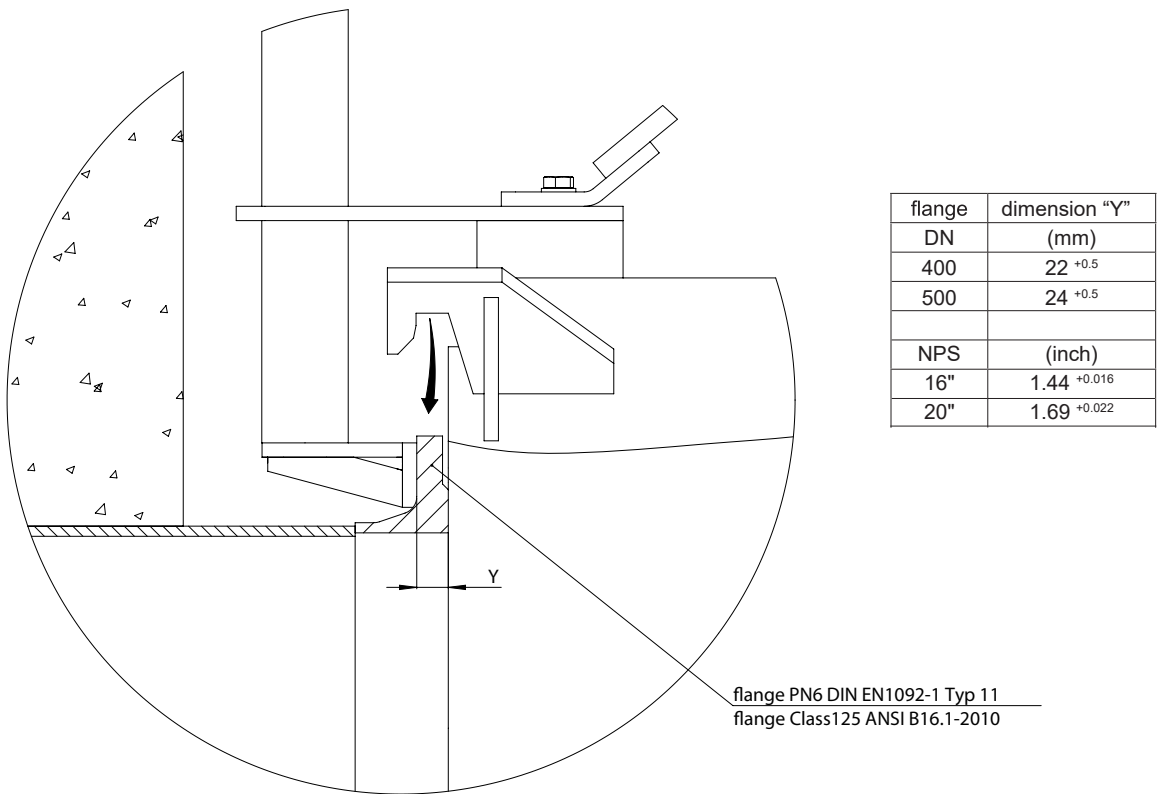

**Figure 4. Flange dimensions**

**ATTENTION** *Before installing the recirculation pump, check the "Y" dimension of the flange. Make sure that the dimensions specified in the table are adhered to, otherwise the flange will need to be reworked.*

## 1.8 Nameplate

We recommend that you record the data from the original nameplate so that you can refer to it at any time.

**NOTE** In all communication please state type of the unit, item and serial number.

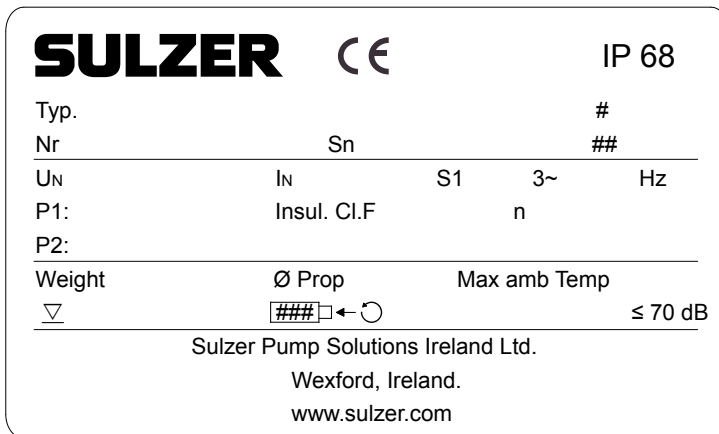

Figure 5. Nameplate 50 Hz

1555-00

Legend	
IP68	Protection type
Typ.	Type designation
#	Production date (Week/Year)
Nr	Item number
Sn	Serial number
##	Order number
Un	Nominal voltage V
In	Nominal current A
S1	Continuous operating mode
3~	Number of phases
Hz	Frequency Hz
P1	Power (consumption) kW
Insul. Cl.H	Insulation class
n	Rotation speed rpm
P2	Power (output) kW
Weight	kg
Ø Prop.	Propeller diameter mm
Max amb Temp	Maximum ambient temperature 40 °C
∇	Maximum immersion depth m
###	Motor shaft direction of rotation
≤ 70 dB	Maximum noise level



####: RW 400/RCP400 = 1034,  
RW 650/RCP500 = 1035

Figure 6. Nameplate ATEX

## 2 Safety

The general and specific health and safety instructions are described in detail in the separate booklet **Safety Instructions for Sulzer Products Type ABS**. If anything is not clear or you have any questions as to safety make certain to contact the manufacturer Sulzer.

## 3 Transport and storage

### 3.1 Transport



The unit must never be raised by the power cable.

Depending on the version, the units are fitted with a lifting hoop/eyelet, to which a chain can be fastened by means of shackles for transportation, installation or removal.



Take note of the entire weight of the unit (see nameplate Figure 2). The hoist and chain must be adequately dimensioned for the weight of the unit and must comply with the current valid safety regulations. Good technical practice must be observed.



The unit should be protected from rolling over!



The unit is prepared for transportation by placing it on an adequately strong, completely horizontal surface, taking care that it cannot topple over.



Do not stay or work in the swivel area of a suspended load!



The lifting hook height must take into consideration the entire height of the unit as well as the length of the lifting chain.

### 3.2 Transport securing devices

#### 3.2.1 Motor connection cable moisture protection

The motor connection cables are protected against the ingress of moisture along the cable by having the ends sealed at manufacture with protective covers.

**ATTENTION** *These protective covers should only be removed immediately prior to connecting the pumps electrically.*

Particular attention is necessary during storage or installation of units in locations, which could fill with water prior to laying and connection of the power cable of the motor. Please note that the cable ends, even where fitted with protective sleeves, must not be immersed in water.

**ATTENTION** *These protective covers only provide protection against water spray or similar and are not a watertight seal. The ends of the cables should not be immersed in water, otherwise moisture could enter the connection chamber of the motor.*

**NOTE** *If there is a possibility of water ingress then the cables should be secured so that the ends are above the maximum possible flood level. Take care not to damage the cable or its insulation when doing this!*

### 3.3 Storage of the units

**ATTENTION** *Sulzer products must be protected from weather influences such as UV from direct sunlight, high humidity, aggressive dust emissions, mechanical damage, frost etc. Sulzer original packaging with the relevant transport securing devices (where used) ensures optimum protection of the unit. If the units are exposed to temperatures under 0 °C / 32 °F check that there is no water in the hydraulics, cooling system, or other spaces. In the case of heavy frosts, the units and cable should not be moved if possible. When storing under extreme conditions, e.g. in tropical or desert conditions, suitable additional protective steps should be taken. We would be glad to advise you further.*

**NOTE** *Sulzer units do not generally require any particular maintenance during storage. After long storage periods (after approx. one year), the transportation locking device on the motor shaft (not with all versions) should be disassembled. By rotating the shaft several times by hand, new lubricating oil, or depending on the version, a small amount of coolant (which also serves to cool or lubricate the mechanical seals) is applied to the sealing surfaces, thus ensuring perfect operation of the mechanical seals. The bearings supporting the motor shaft are maintenance-free.*

## 4 Product description

### 4.1 General description

- Hydraulically optimized propeller with high wear resistance.
- The motor shaft is supported in lubricated-for-life, maintenance-free ball bearings.
- The shaft is sealed on the medium side by means of a high quality mechanical seal, which is independent of direction of rotation.
- The oil chamber is filled with lubricating oil (oil change is not necessary).

#### Motor

- Three phase squirrel cage motor.
- Rated voltage: 400 V 3~ 50 Hz / 460 V 3~ 60 Hz.
- Other voltages available on request.
- Insulation class F = 155 °C / 311 °F, Protection type IP68.
- Temperature of the medium for continuous operation: + 40 °C / 104 °F.

#### Motor monitoring

- All motors are fitted with temperature monitors that switch off the motor in the case of excessive temperatures. The sensors must be correctly wired into the control panel.

#### Seal monitoring

- The DI electrode carries out the seal monitoring function and signals the ingress of moisture by means of a special electronic device.

#### Operation with frequency inverters

- All RW / RCP, when **suitably selected**, can be used with frequency inverters. **Observe the EMC Directive and the installation and operating instructions of the inverter manufacturer!**

## 4.2 Structural design

### 4.2.1 RW 400 and 650

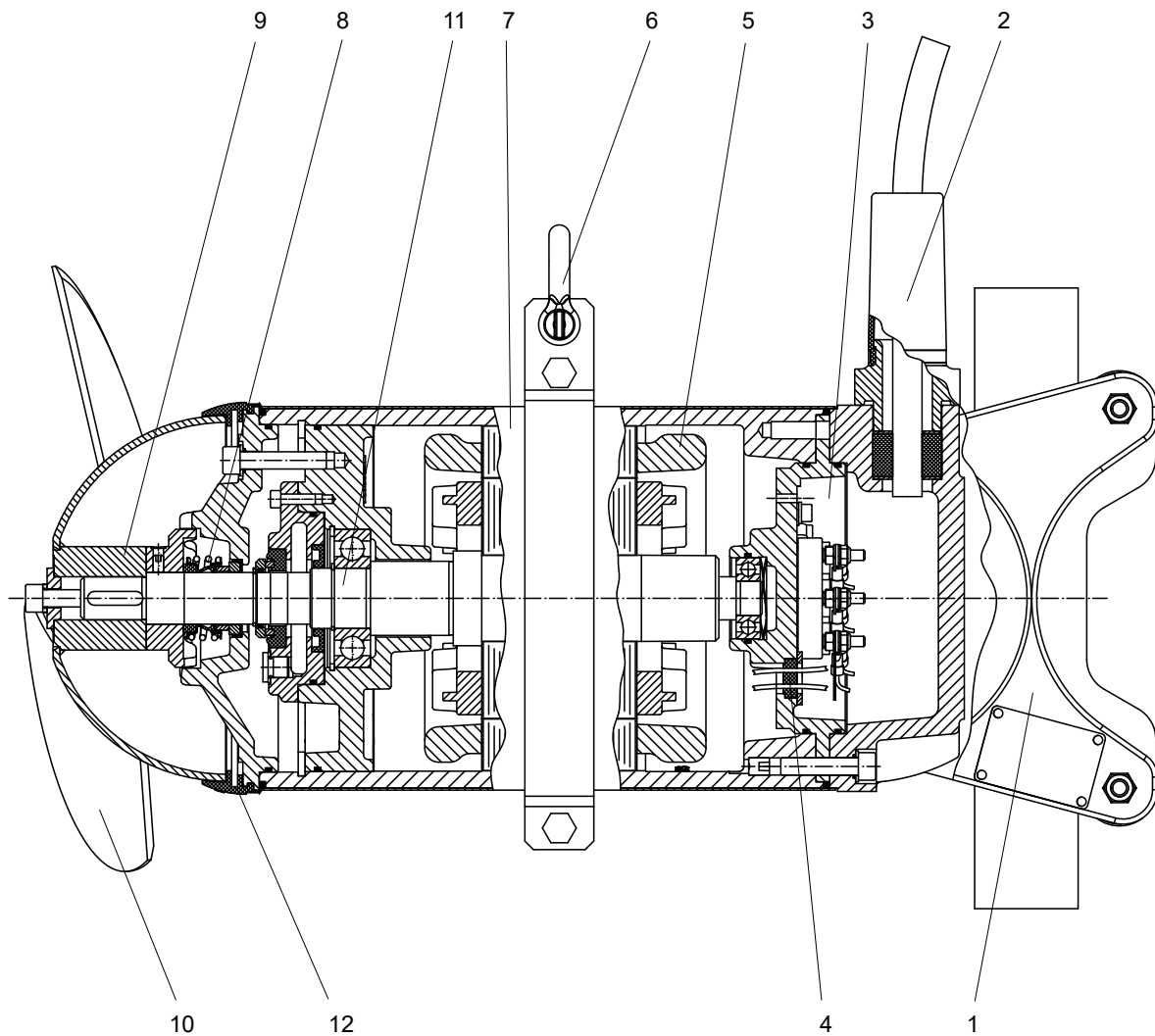

Figure 7. RW 400/650

#### Legend

- |   |                                   |    |                                    |
|---|-----------------------------------|----|------------------------------------|
| 1 | Bracket                           | 8  | Mechanical seal                    |
| 2 | Cable inlet                       | 9  | Propeller boss                     |
| 3 | Connection chamber                | 10 | Propeller                          |
| 4 | Sealing of the motor chamber      | 11 | Shaft unit with rotor and bearings |
| 5 | Stator                            | 12 | SD ring                            |
| 6 | Bracket with shackle              |    |                                    |
| 7 | Stainless steel covering (option) |    |                                    |



4.2.2 RCP 400 and 500

0557-0001

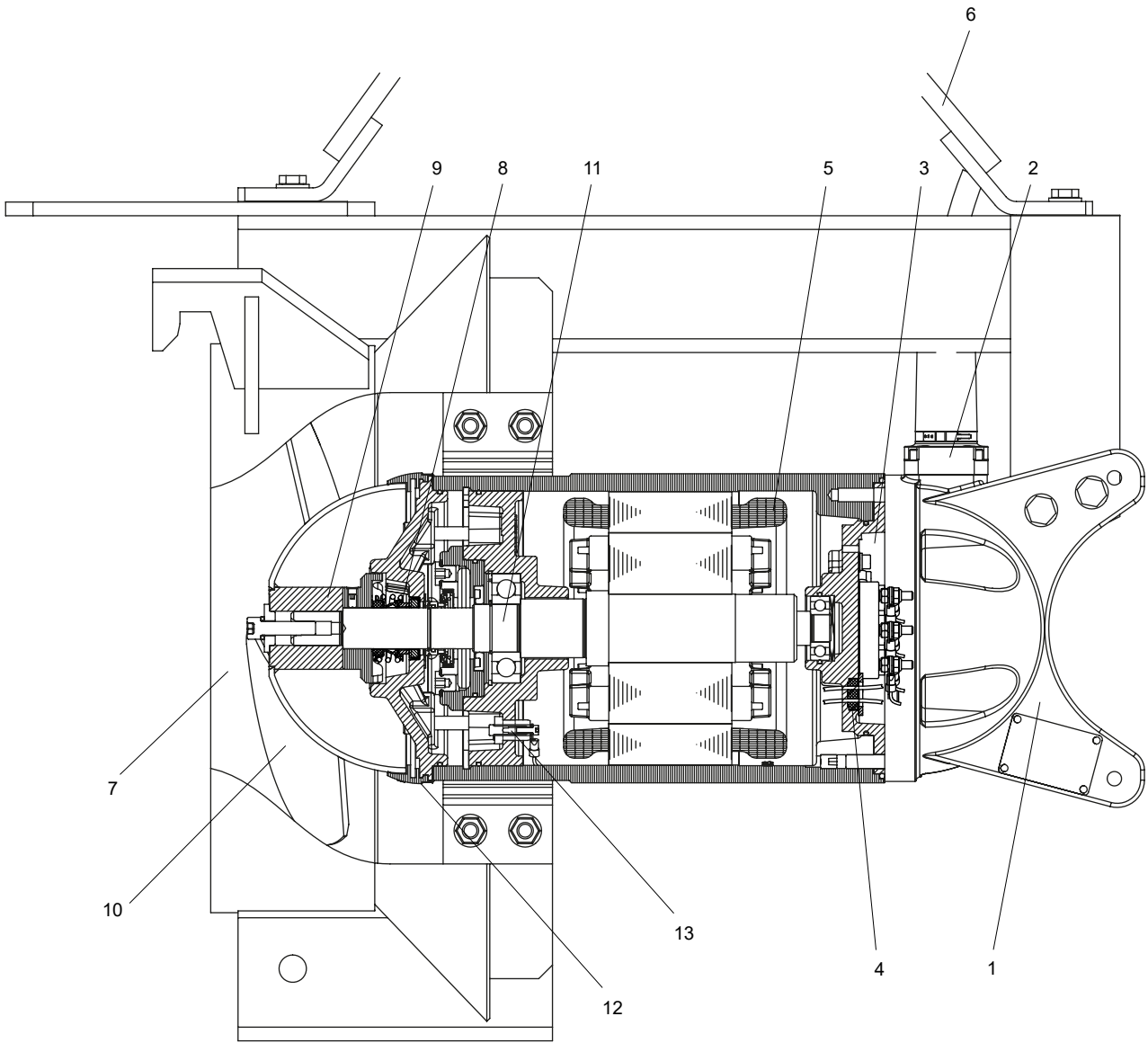

Figure 8. RCP 400/500

**Legend**

- |   |                              |    |                                    |
|---|------------------------------|----|------------------------------------|
| 1 | Bracket                      | 8  | Mechanical seal                    |
| 2 | Cable inlet                  | 9  | Propeller boss                     |
| 3 | Connection chamber           | 10 | Propeller                          |
| 4 | Sealing of the motor chamber | 11 | Shaft unit with rotor and bearings |
| 5 | Stator                       | 12 | SD ring                            |
| 6 | Lifting hook                 | 13 | DI-electrode (seal monitor)        |
| 7 | Inlet cone                   |    |                                    |

### 4.3 Operation with frequency inverters

The stator design and the insulation grade of the motors from Sulzer means that they are suitable for usage with frequency inverters. It is however essential that the following conditions are met:

- The guidelines for EMC (electromagnetic compatibility) are complied with.
- Speed/torque curves for motors driven by frequency inverters can be found in our product selection range.
- Explosion-proof motors must be equipped with thermistors (PTC temperature sensors).
- Machines designated as Ex machines may never, without exception, be operated using a mains frequency that is greater than the maximum of 50 Hz or 60 Hz as indicated on the nameplate. Make sure that the rated current specified on the nameplate is not exceeded after starting the motor. The maximum number of starts according to the motor datasheet may not be exceeded.
- Machines that are not designated as Ex machines may only be operated using the mains frequency indicated on the nameplate. Greater frequencies can be used but only after consulting with and receiving permission from the Sulzer manufacturing plant.
- For operation of Ex motors on frequency inverters special requirements in relation to the tripping times of the thermo control elements must be observed.
- The lowest frequency must be set so that it is not falling below 25 Hz.
- The maximum frequency must be set so the rated power of the motor is not exceeded.

Modern frequency inverters use higher wave frequencies and a steeper rise on the flanks of the voltage wave. This means that motor loss and motor noise is reduced. Unfortunately these inverter output signals cause higher voltage spikes in the stator. Experience has shown, that depending on rated voltage and the length of the cable between the inverter and the motor, these voltage spikes can adversely affect the life of the motor. In order to avoid this, inverters of this type must be equipped with sinus filters when used in the critical zone (see Figure 9). The sinus filter chosen must be suitable for the inverter with regard to rated voltage, inverter wave frequency, rated current of the inverter, and maximum inverter output frequency. Make sure that the rated voltage is supplied to the terminal board of the motor.

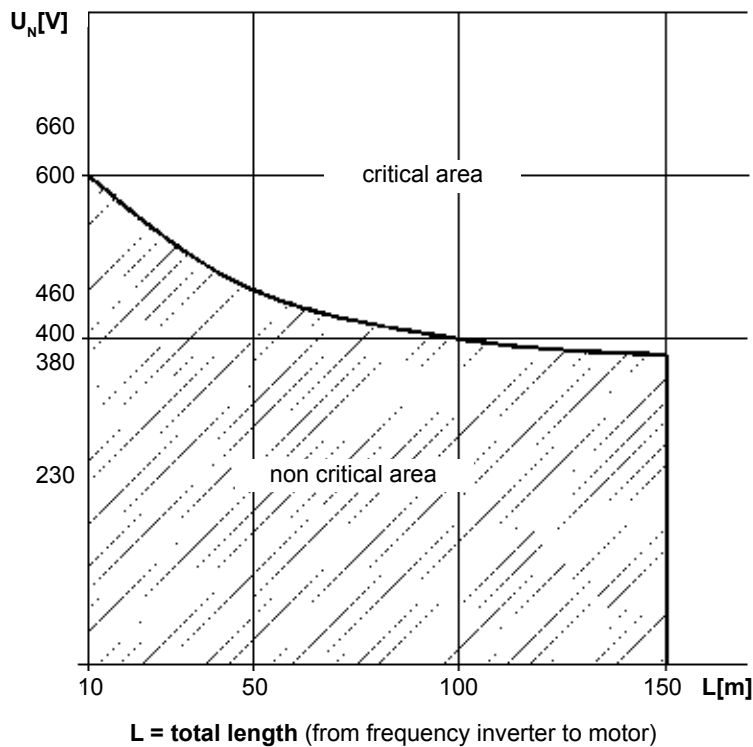

Figure 9. Critical/non critical area

1186-00

## 5 Installation



The safety instructions in the previous sections must be observed!

### 5.1 Installation RW / RCP



Care must be taken that the connection cables are positioned that they cannot get caught up in the propeller blades and that they are not subjected to tension.



The electrical connection is carried out in accordance with section 5.7 Electrical connection.

#### NOTE

*We recommend that Sulzer installation accessories be used for the installation of the RW / RCP.*

### 5.2 Tightening torque

Tightening torque for Sulzer stainless steel screws A4-70:							
Thread	M6	M8	M10	M12	M16	M20	M24
Tightening torque	6.9 Nm	17 Nm	33 Nm	56 Nm	136 Nm	267 Nm	460 Nm

#### 5.2.1 Nord-Lock® washer

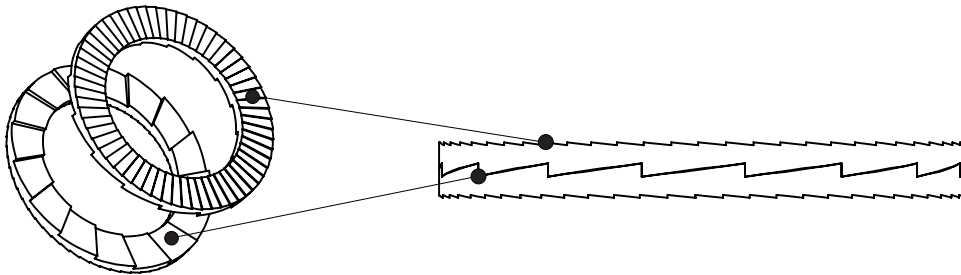

Figure 10. Correct fitting position of the Nord-Lock® securing washers

1176-00

## 5.3 Installation examples RW

### 5.3.1 Installation example with existing accessories

We recommend that the closed bracket be used for this type of installation (See Figure 17).

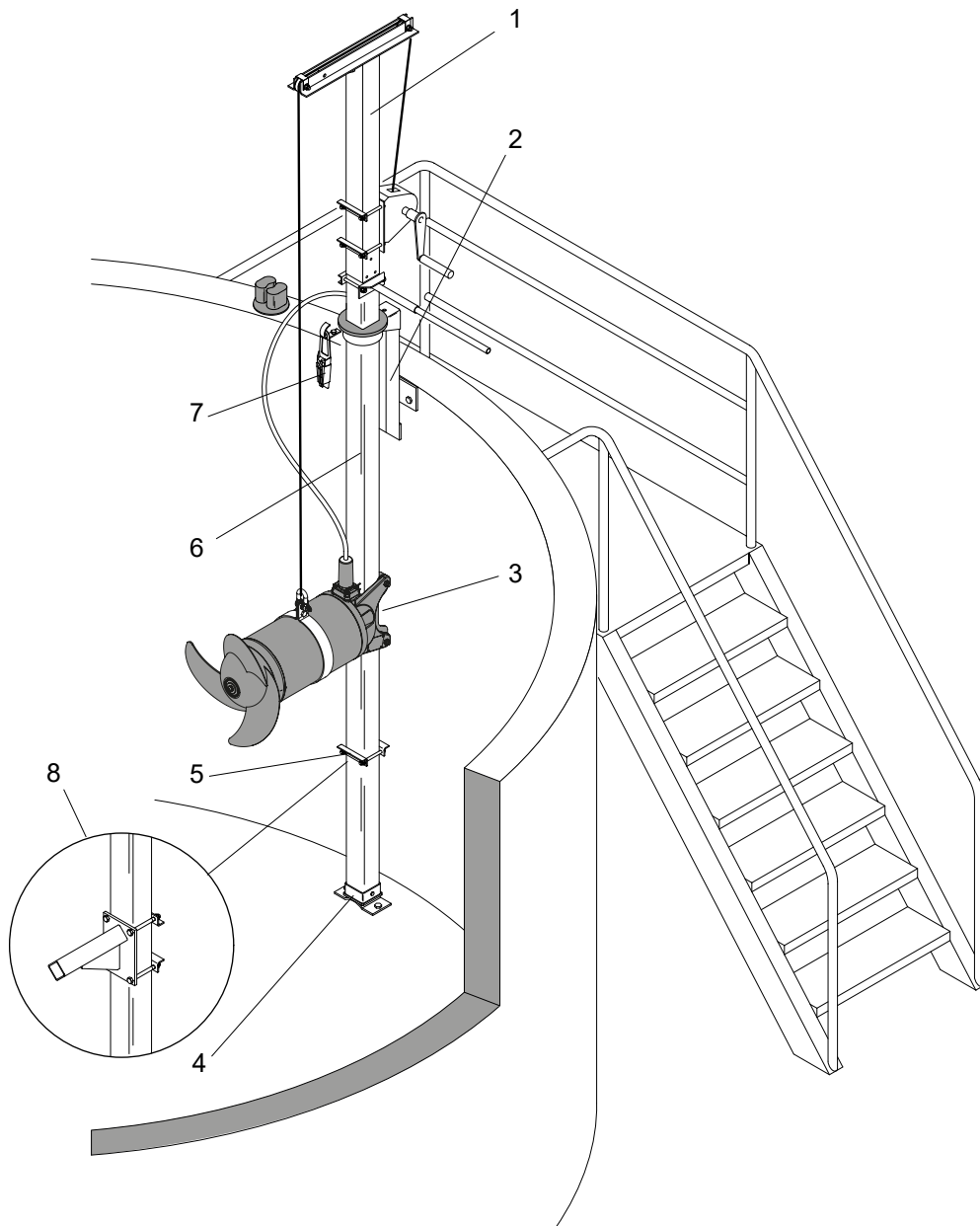

Figure 11. Installation example with existing accessories

#### Legend

- |   |                                  |   |                                    |
|---|----------------------------------|---|------------------------------------|
| 1 | Hoist with winch and rope        | 5 | Safety stop clamp                  |
| 2 | Upper bracket with locking plate | 6 | Swivelling square guide tube       |
| 3 | Closed bracket                   | 7 | Cable clamp with cable hook        |
| 4 | Bottom plate                     | 8 | Stop for vibration damper (option) |

### 5.3.2 Installation example with alternative fixing possibilities

We recommend that the open bracket be used for this type of installation (See Figure 17).

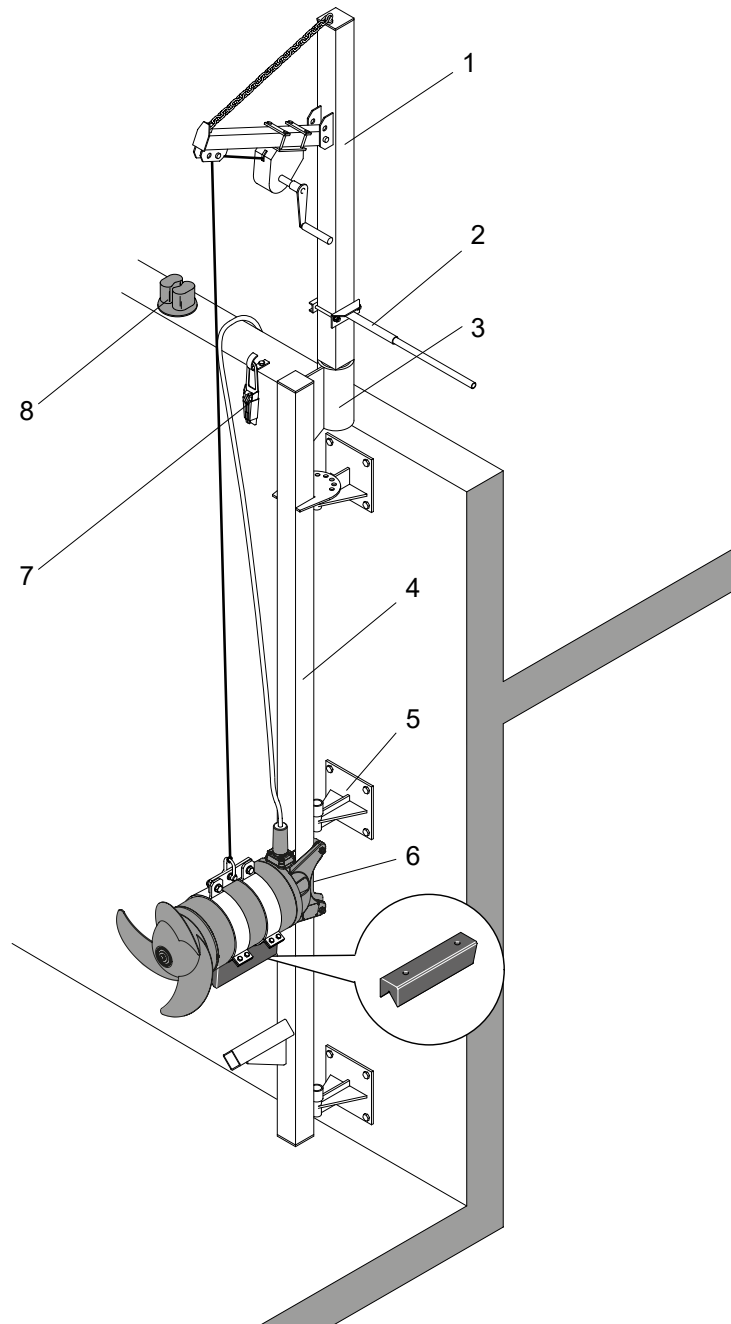

Figure 12. Installation example with alternative fixing possibilities

#### Legend

- |   |                              |   |                                 |
|---|------------------------------|---|---------------------------------|
| 1 | Transportable lifting unit   | 5 | Swivelling wall mounted bracket |
| 2 | Swivel handle                | 6 | Open bracket                    |
| 3 | Socket (fixed installed)     | 7 | Cable clamp with cable hook     |
| 4 | Swivelling square guide tube | 8 | Rope block                      |

### 5.3.3 Installation example with fixed installation as flow booster

We recommend that the open bracket be used for this type of installation (See Figure 17).

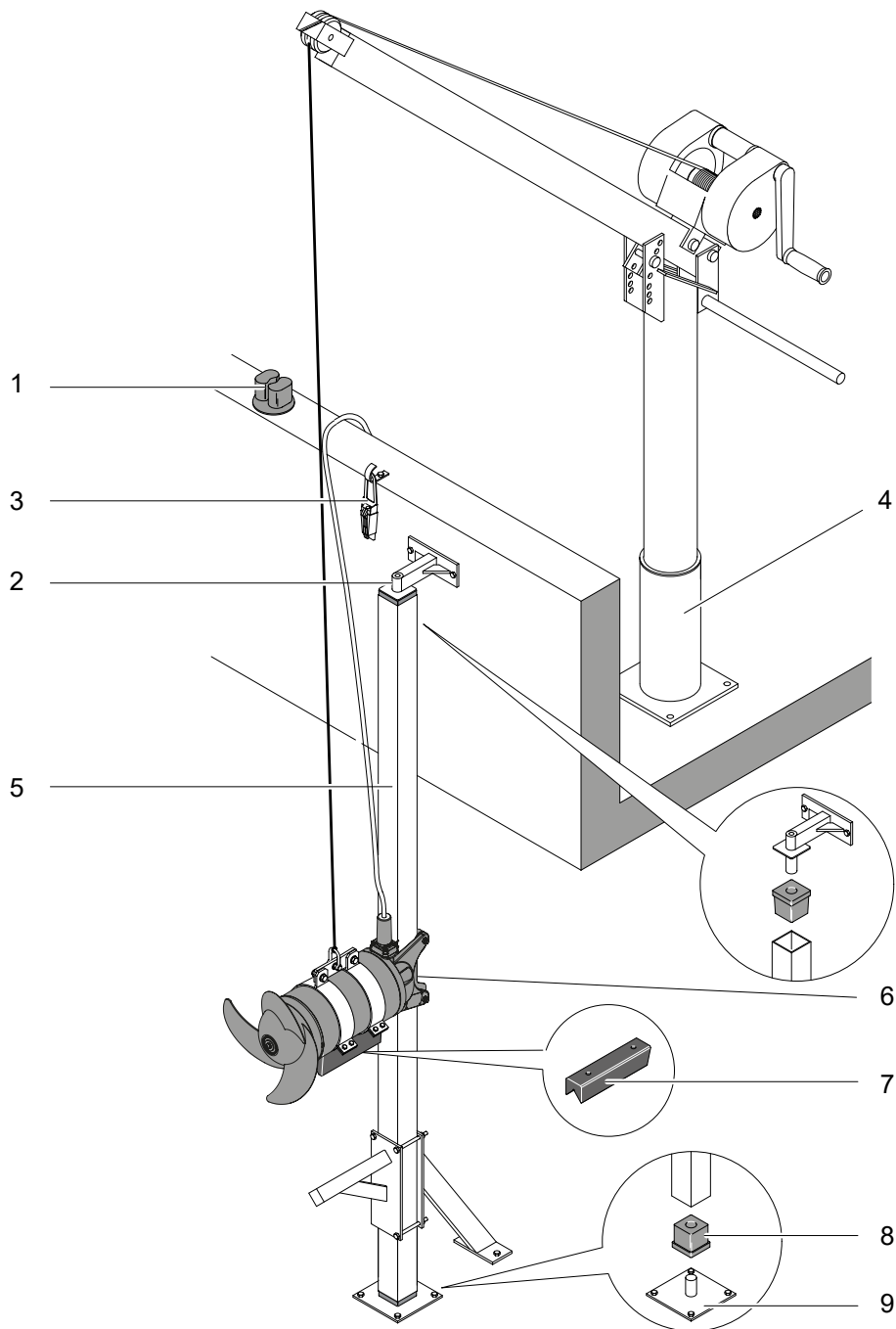

Figure 13. Installation example with fixed installation as flow booster

#### Legend

- 1 Rope block
- 2 Tube retainer
- 3 Cable clamp with cable hook
- 4 Sulzer lifting unit 5 kN
- 5 Square guide tube
- 6 Open bracket
- 7 Vibration damper
- 8 Tube connector
- 9 Bottom plate

### 5.3.4 Fixed installation with vibration damper

If the mixer is to be installed at a fixed point in the tank, then we recommend that the console with the vibration damper be used. In this case a further square tube must be used as a console at the guide tube. The vibration damper for the relevant mixer can be ordered (see table below).

#### Vibration damper listing

Mixer	Part no.
RW 400	6 162 0019
RW 650	6 162 0020 (A50/12, A 60/12). 6 162 0027 (A75/12, A 90/12, A100/12, A 120/12)

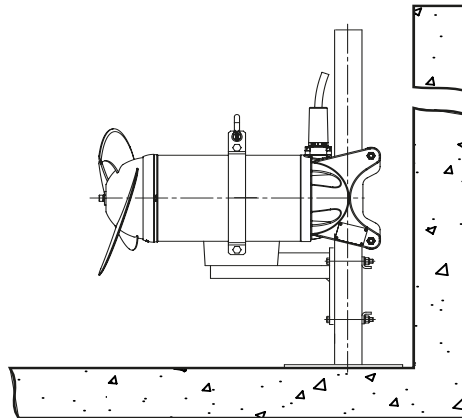

10001-0001

Figure 14. Fixed installation with vibration damper

### 5.4 Brackets RW

Brackets which can be swivelled vertically (only optional) are available for both open and closed models of the brackets for all mixers of the series.

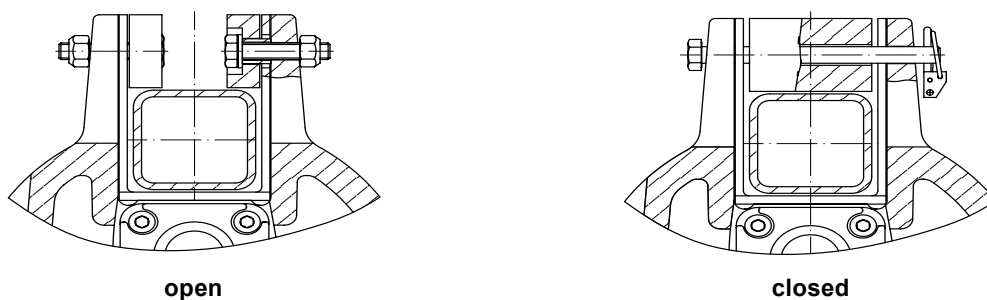

0563-0001

Figure 15. Open bracket / closed bracket

5.4.1 Fitting of the open bracket with vertical swivelling (option)

0564-0001

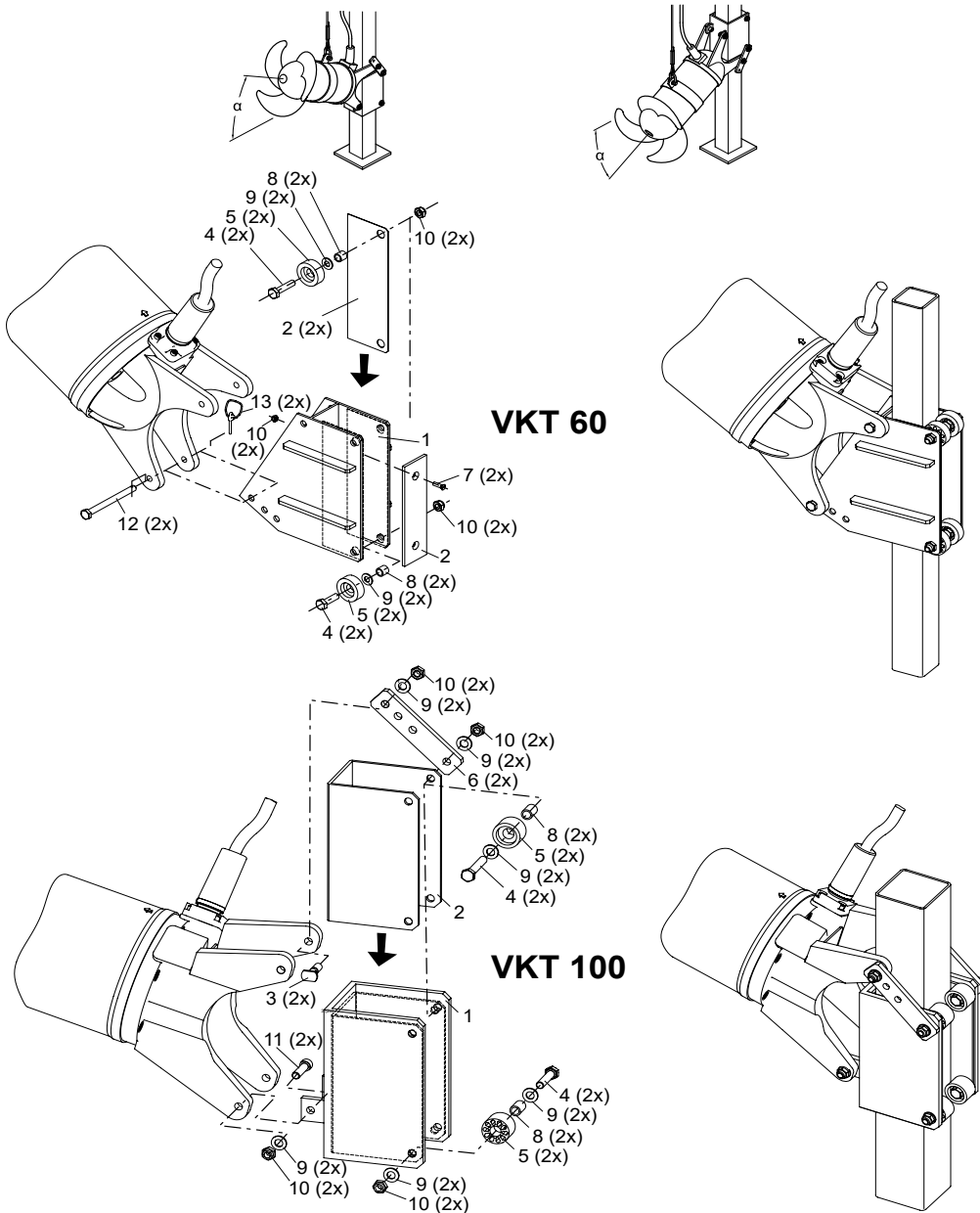

Figure 16. Open bracket with vertical swivelling

Legend

- |                    |                   |                      |
|--------------------|-------------------|----------------------|
| 1 Bracket          | 6 Strap           | 10 Hex nut           |
| 2 Cladding         | 7 Flat head screw | 11 Socket head screw |
| 3 Threaded inserts | 8 Tube            | 12 Hinge bolt        |
| 4 Hex bolts        | 9 Washer          | 13 Linchpin          |
| 5 Roller           |                   |                      |



### 5.4.2 Fitting of the closed bracket with vertical swivelling (option)

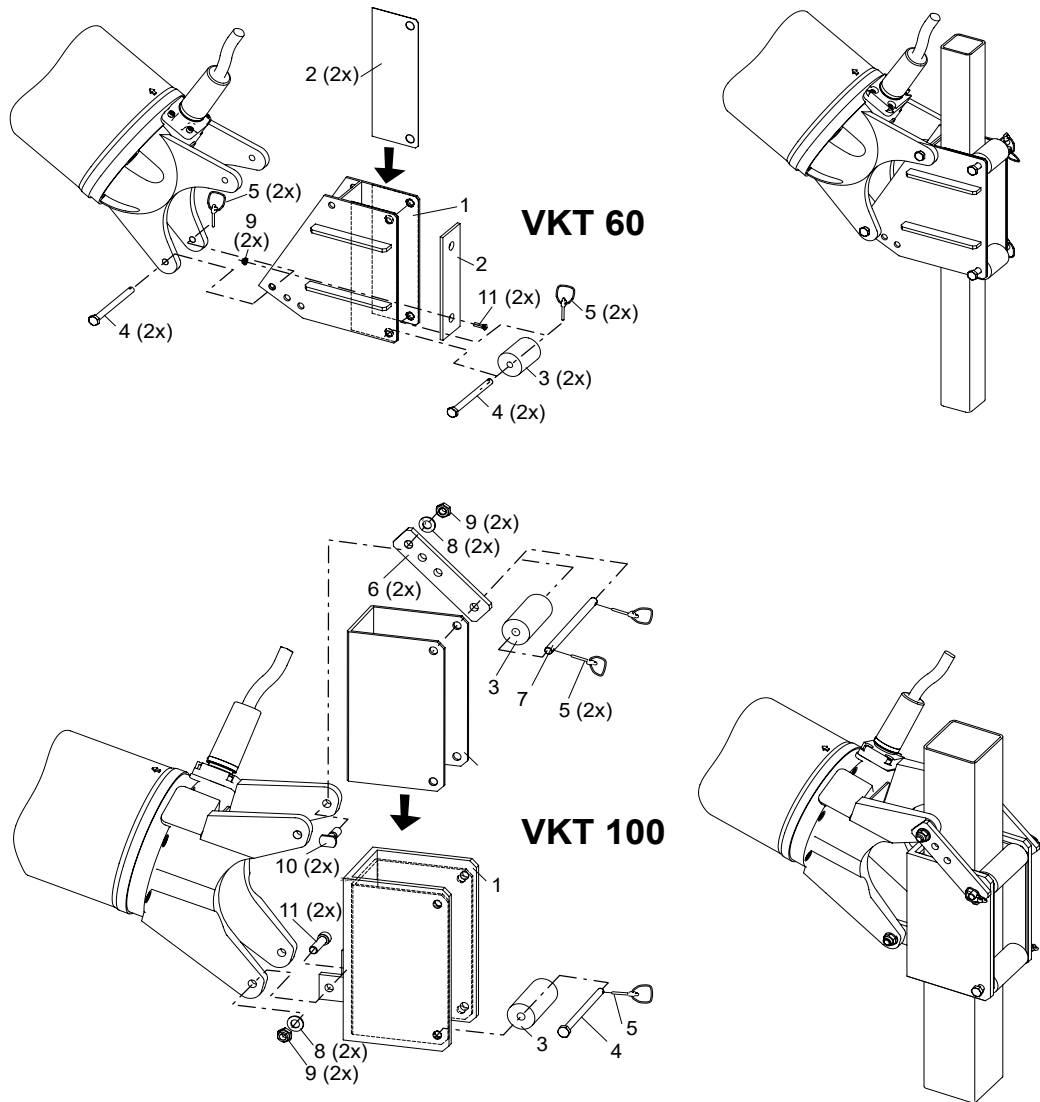

0565-0001

Figure 17. Closed bracket with vertical swivelling

#### Legend

- |              |                      |
|--------------|----------------------|
| 1 Bracket    | 7 Bolt long          |
| 2 Cladding   | 8 Washer             |
| 3 Roller     | 9 Hex nut            |
| 4 Bolt short | 10 Threaded insert   |
| 5 Linchpin   | 11 Socket head screw |
| 6 Strap      |                      |

### 5.4.3 Bracket alignment on guide rail

The mixer must be set up freely suspended with bracket fully mounted so that the bracket points vertically towards the ground. When doing this the clamp of the mixer should be moved until the desired slope of the mixer is achieved. This ensures that the mixer can slide up and down easily on the guide tube after it is fitted.

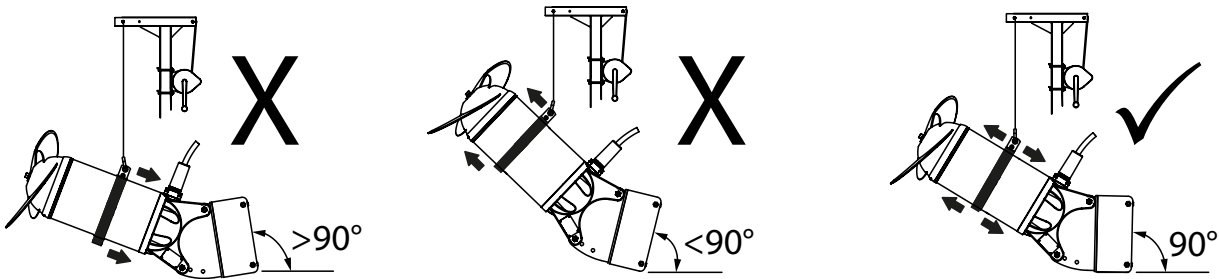

Figure 18. Setting up with fully mounted bracket

**ATTENTION** *Damage to bracket liner due to incorrect alignment setup will not be covered under warranty.*

### 5.5 Guide tube lengths RW (square tube)

The table below shows the maximum lengths of the guide tubes, based on the maximum allowable bending 1/300 th. of the length. These values have been determined in clean water of density 1000 kg/m<sup>3</sup> for the maximum thrust of the most powerful mixer.

Mixer	Maximum guide tube length (L) for an installation with square guide tube		
	with push-in type lifting unit	with separate lifting unit	guide tube with additional wall fixing
RW 400	□ 2" x 3/16". L ≤ 5 m	□ 2" x 3/16". L ≤ 5 m	□ 2" x 3/16". L ≤ 5 m
	□ 60 x 60 x 4. L ≤ 4 m	□ 60 x 60 x 4. L ≤ 5 m	□ 60 x 60 x 4. L ≤ 5 m
	□ 100 x 100 x 4. L ≤ 9 m	□ 100 x 100 x 4. L ≤ 10 m	□ 100 x 100 x 4. L ≤ 10 m
RW 650	□ 100 x 100 x 4. L ≤ 5 m	□ 100 x 100 x 4. L ≤ 6 m	□ 100 x 100 x 4. L ≤ 6 m
	□ 100 x 100 x 6. L ≤ 6 m	□ 100 x 100 x 4. L ≤ 7 m	□ 100 x 100 x 4. L ≤ 6 m
	□ 100 x 100 x 8. L ≤ 7 m	□ 100 x 100 x 4. L ≤ 8 m	□ 100 x 100 x 4. L ≤ 6 m

## 5.6 Installation RCP

### 5.6.1 Installation example with Sulzer lifting unit

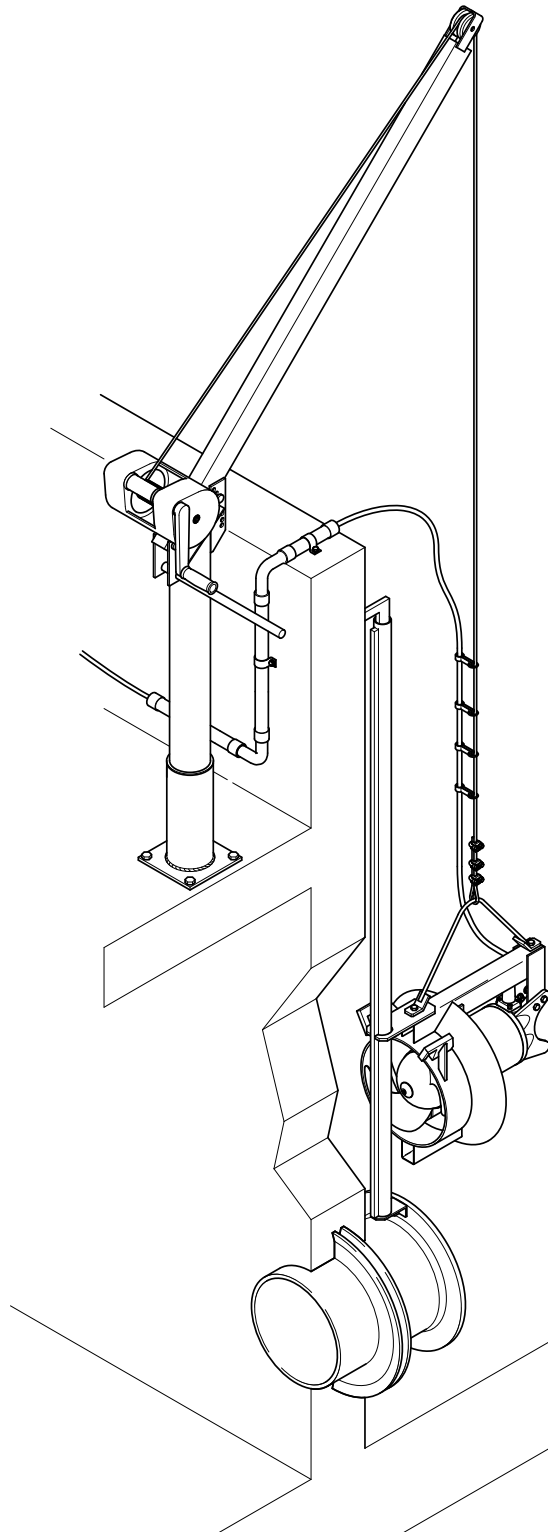

0570-0001

Figure 19. Installation example with Sulzer lifting unit 5 kN

## 5.6.2 Guide tube installation



The safety hints in the previous sections must be observed!

### ATTENTION

**The discharge line and the required flange DIN EN 1092-1 PN6 should be installed on site before starting the installation of the guide tube. The DIN flange should be installed so that none of the holes in the flange are on the axis line but are symmetrically on either side of it. Ensure that the DIN flange is securely fixed in the concrete.**

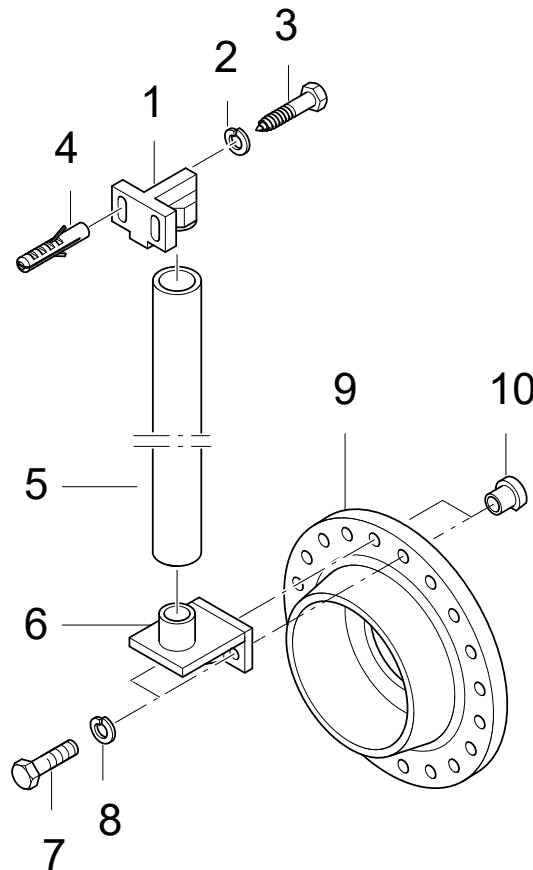

Figure 20. Guide tube installation

- Place bracket (20/6) on the DIN-flange (20/9) and fasten using hex nuts (20/7) together with spring washers (20/8) and the special nuts (20/10).

**ATTENTION**     **The flattened edge of the special nuts (20/10) must point towards the flange centre.**

- Position the tube retainer (20/1) vertically over the bracket (20/6). Mount with the aid of the wall plugs (20/4) but do not tighten yet!
- Place the guide tube (20/5) alongside the conical section of the bracket (20/6) and determine the required length. To do this measure the upper edge of the tube retainer (20/1).
- Cut the guide tube (20/5) to the required length and place it on the conical portion of the bracket (20/6).
- Press the tube retainer (20/1) into the guide tube (20/5), so that no vertical play remains. Now tighten the hex screws (20/3) using the spring washers.

### 5.6.3 Securing and positioning of the motor connection cables of the RCP



The safety hints in the previous sections must be observed!

#### NOTE

*The cable holders described here are not supplied as part of the standard execution of the RCP.*

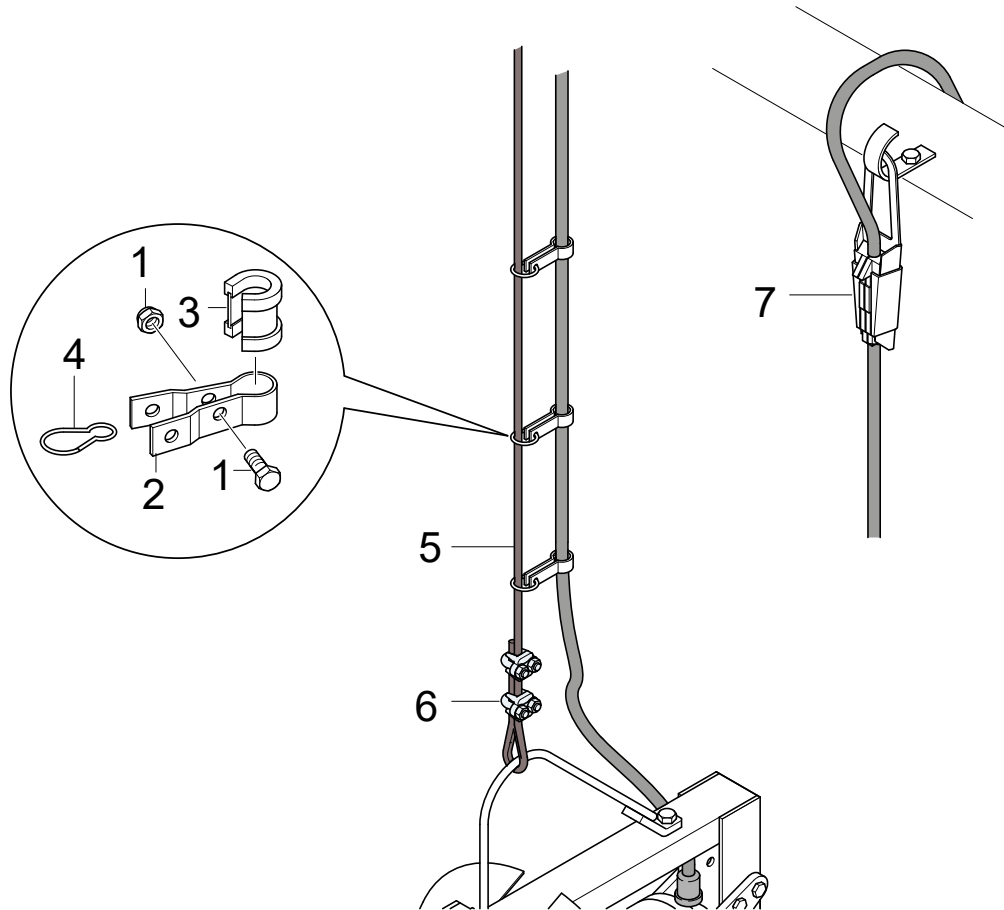

0572-0001

Figure 21. Securing and positioning of the motor connection cables of the RCP

- Place the cable holder (21/2) with rubber sleeve (21/3) on the connection cable close to the RCP itself and tighten using hex screw (21/1).
- Connect the snap hook (21/4) to the cable holder (21/2) and attach to the wire rope or chain.



Care must be taken that the connection cables are positioned that they cannot be caught up in the propeller blades and that they are not subjected to tension.

- Assemble all other cable holders in a similar manner. The spacing can be increased as the distance from the RCP increases.
- Hang the connection cable into the cable hook using the strain relief (21/7).



The electrical connection is carried out in accordance with section 5.7 Electrical connection.

#### 5.6.4 Lowering of the RCP along the guide tube



The safety hints in the previous sections must be observed!

The RCP together with the guide piece is connected onto the guide tube and lowered along it until it automatically sits in its final position (see Figure 23). When doing this, carefully feed the power cable downwards at the same time.

To ensure the RCP will tilt enough to lower correctly on the guide tube, the angle of the pump created by the lifting hook when suspended by the hoist has to be checked prior to lowering. For this purpose, begin lifting the pump from a horizontal surface and check that the rear end of the fixing support rises 2- to 4- cm from the floor before the front end begins to lift clear (see Figure 22).

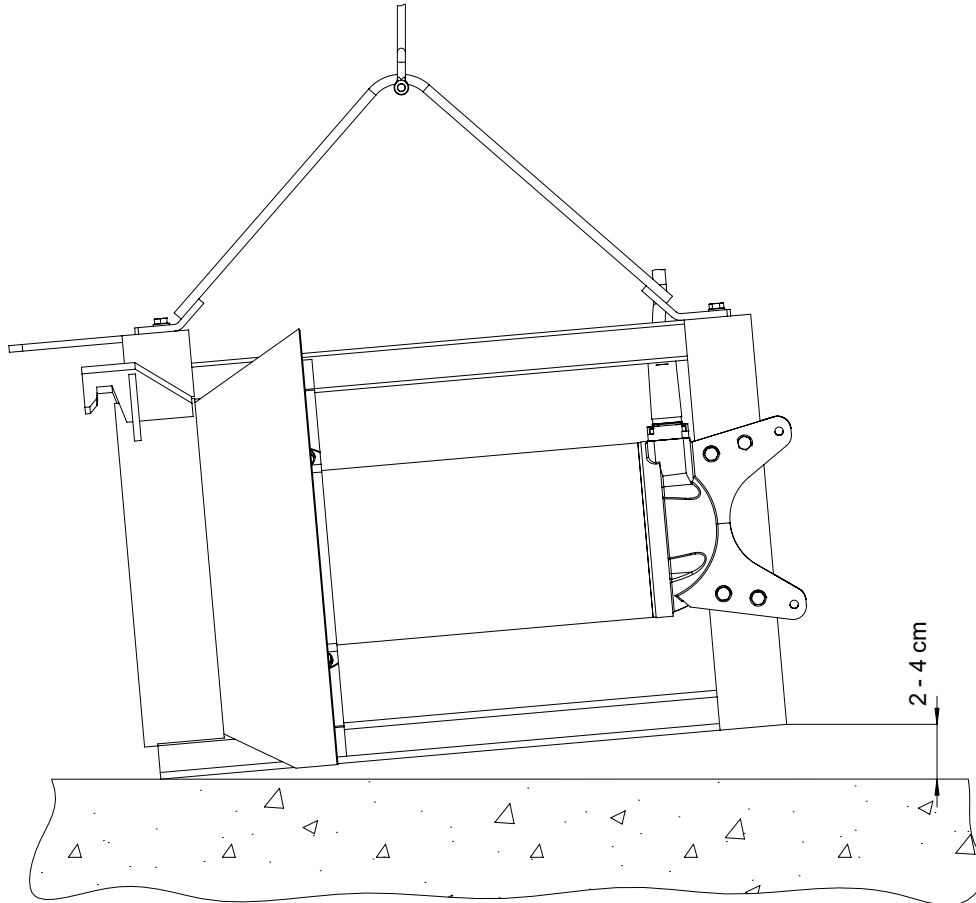

0573-0001

Figure 22. checking installation angle of pump

**ATTENTION** *The power cable should be connected to the wire rope or chain in such a manner that it cannot become entangled in the propeller and that it is not subjected to any tension.*

After lowering of the RCP the tension of the wire rope or the chain should be released.

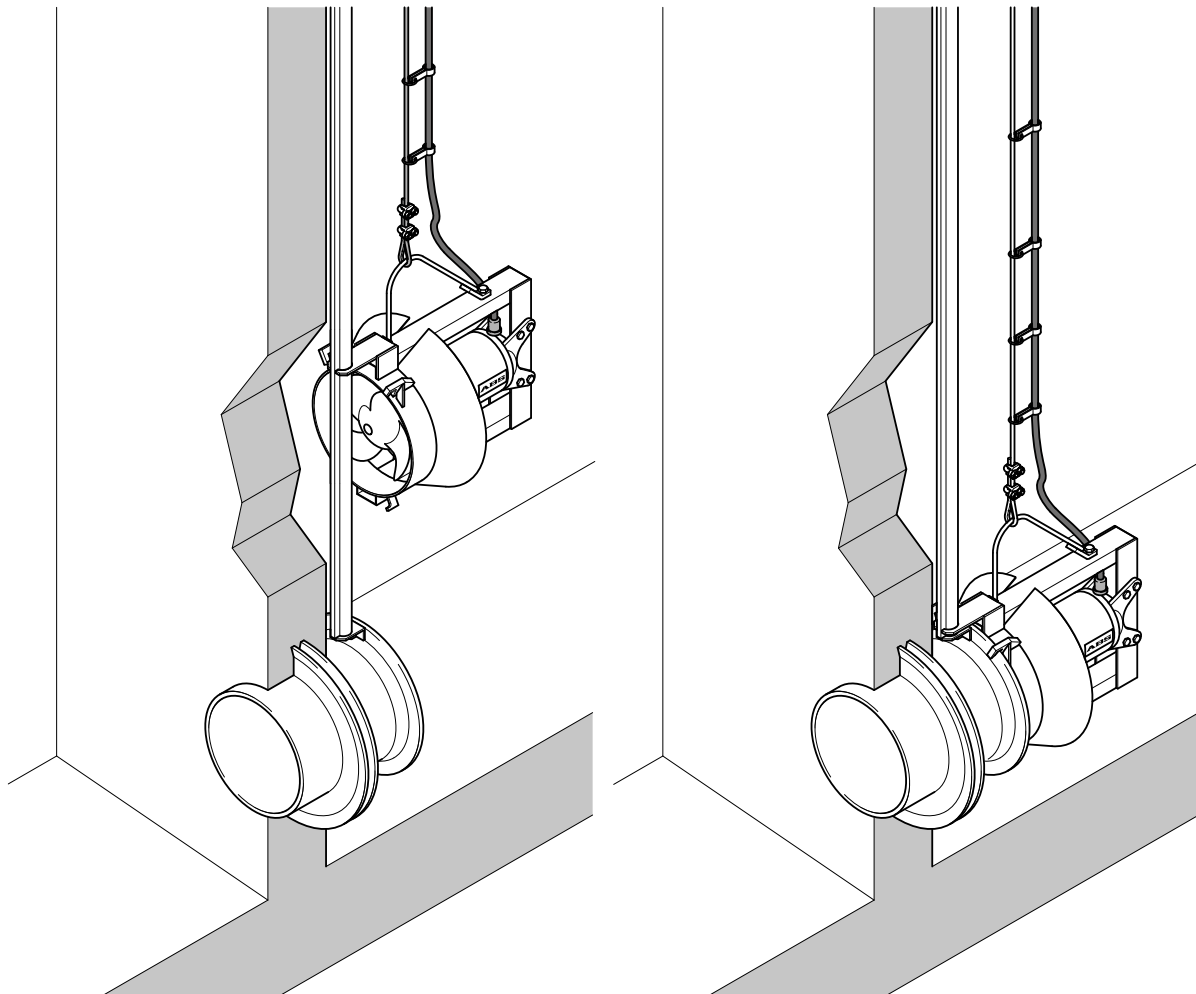

Figure 23.

RCP lowering

RCP connected

## 5.7 Electrical connection



The safety instructions in the previous sections must be observed!

Before commissioning, an expert should check that one of the necessary electrical protective devices is available. Earthing, neutral, earth leakage circuit breakers, etc. must comply with the regulations of the local electricity supply authority, and a qualified person should check that these are in perfect order.

**ATTENTION** *The power supply system on site must comply with VDE or other local regulations with regard to cross-sectional area and maximum voltage drop. The voltage stated on the nameplate of the pump must correspond to that of the mains.*



The incoming power supply as well as the connection of the unit itself to the terminals on the control panel must comply with the circuit diagram of the control panel as well as the motor connection diagrams and must be carried out by a qualified person.

The power supply cable must be protected by an adequately dimensioned slow-blow fuse corresponding to the rated power of the unit.

In pump stations/tanks potential bonding must be carried out in accordance with EN 60079-14:2014 [Ex] or IEC 60364-5-54 [non-Ex] (Regulations for the installation of pipe lines, protective measures in power plants).

In the case of units supplied with a standard control panel this must be protected from dampness and installed above flood level by means of a correctly fitted CEE earthed socket.

**ATTENTION**

*The only method of starting allowed is that specified in chapter 1.6 Technical data or on the nameplate. If you want to use other starting methods please consult the manufacturer.*

*In the case where a control panel is not supplied as standard the unit must only be operated with a motor protection switch with overload relay and thermal sensors connected.*

**5.7.1 Standard connection diagrams. mains voltage 380 - 420 V at 50 Hz / 460 V at 60 Hz**

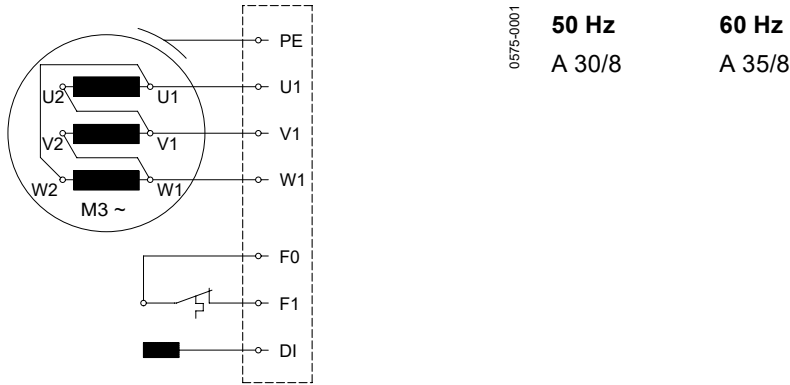

**Figure 24. One power cable with integrated control leads (internal connection in the motor only for motor < 3 kW)**

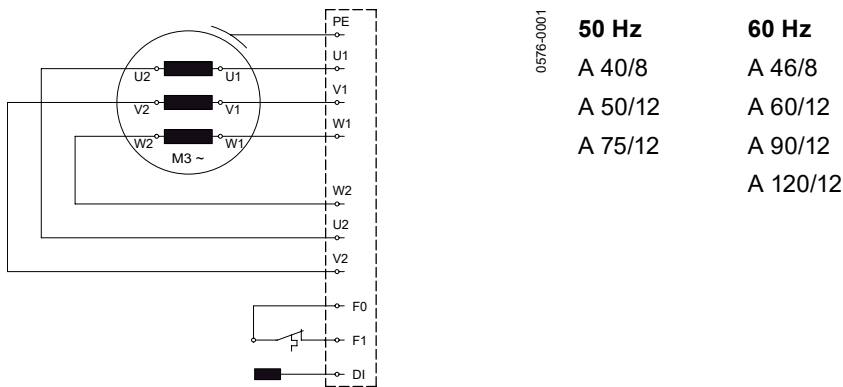

**Figure 25. One power cable with integrated control leads**

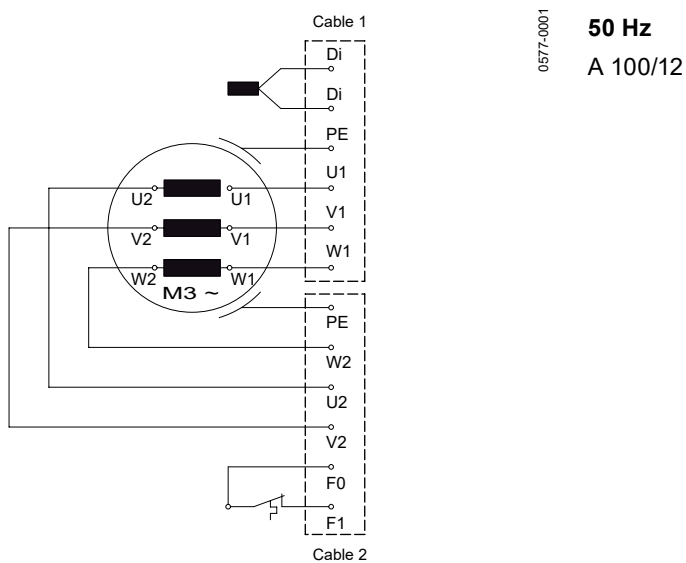
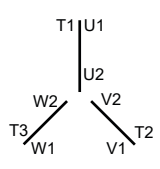

**Figure 26. Two power cables with integrated control leads**



### 5.7.2 Lead designations

Direct starting in star				
	L1	L2	L3	Join
North America	T1 (U1)*	T2 (V1)*	T3 (W1)*	-
Sulzer factory standard	U1	V1	W1	U2, V2, W2

Direct starting in delta				
	L1	L2	L3	
North America	T1 (U1)*	T2 (V1)*	T3 (W1)*	-
Sulzer factory standard	U1; W2	V1; U2	W1; V2	-

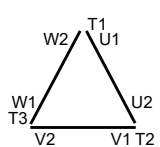

\* Alternative lead designations



The thermal monitoring circuit (F1) must be wired into the motor contactors in such a manner that a manual reset is required.

**ATTENTION** The temperature limiting switches may only be operated as specified by the manufacturer (see following table).

Operating voltage...AC	100 V to 500 V ~
Rated voltage AC	250 V
Rated current AC $\cos \varphi = 1.0$	2.5 A
Rated current AC $\cos \varphi = 0.6$	1.6 A
Max. switching current at $I_N$	5.0 A

### 5.7.3 Soft starter (option)

For units > 15 kW we recommend the use of a soft starter.

**ATTENTION** The units must be connected DOL when used with soft starters.

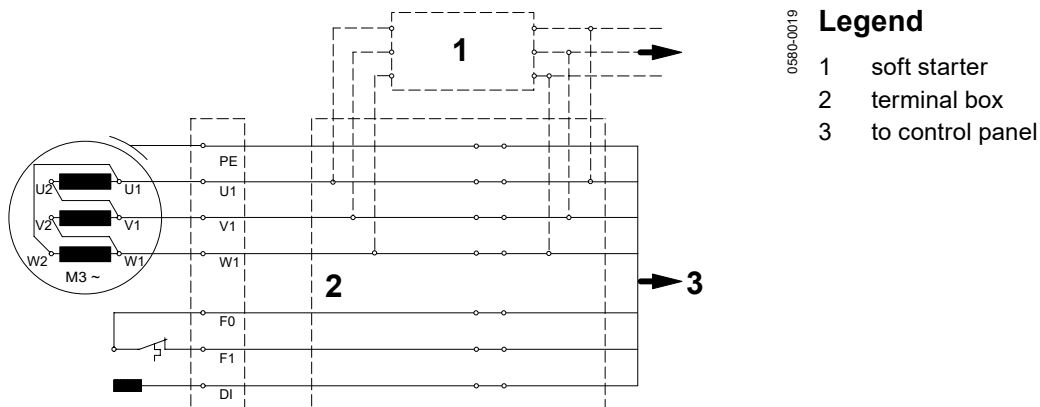

Figure 27. Wiring diagram with soft starter (option)

### Testing and adjustment of soft starter:

**ATTENTION** For the first test adjust the potentiometer in position C.

For further information consult the installation and operating instructions of the soft start manufacturer. These are supplied with the unit.

#### Test:

- First test with potentiometer setting “C”.

#### Setting:

- Set to the **lowest possible starting torque** (within the adjustment range possible).
- Set to the **longest possible starting time** (within the adjustment range possible).

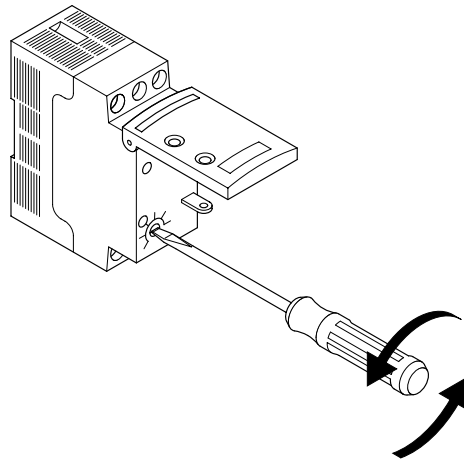

Figure 28. Testing and adjustment of soft starter

0581-0001

### 5.7.4 Checking direction of rotation

When the units are being commissioned for the first time, and also when used on a new site, the direction of rotation must be carefully checked by a qualified person.

The direction of rotation (propeller rotation) is correct if the propeller when viewed from the rear over the motor housing rotates in a clockwise manner (see arrow). This applies to all versions of the RW / RCP!

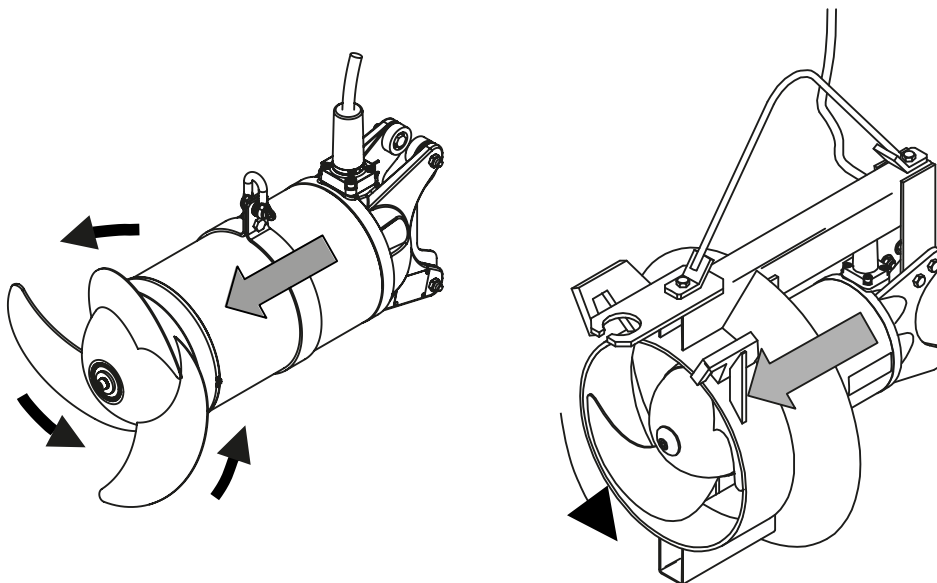

Figure 29. Checking direction of rotation

0582-0001



When checking the direction of rotation take care that no injury can be caused by the rotation of the propeller or the resulting airflow. Do not place a hand or other part of the body near the propeller or the hydraulics!



The direction of rotation should only be altered by a qualified person.



When carrying out the direction of rotation check as well as when starting the unit pay attention to the Start Reaction. This can be very powerful.

**NOTE** *If a number of units are connected to a single control panel then each unit must be individually checked.*

**ATTENTION** *The mains supply in the control panel must have a clockwise sense of rotation. If the units are connected in accordance with the wiring diagram and the lead designations the direction of rotation will be correct.*

#### 5.7.5 Changing direction of rotation



The safety instructions in the previous sections must be observed!



Changing direction of rotation must only be carried out by a qualified person.

If the direction of rotation is incorrect then this is altered by changing over two phases of the power supply cable in the control panel. The direction of rotation should then be rechecked.

**NOTE** *The direction of rotation measuring device monitors the direction of rotation of the mains supply or that of an emergency generator.*

#### 5.7.6 Connection of the seal monitoring unit to the control panel

The standard versions of the units are fitted as standard with DI seal monitors which monitor the state of the sealing. In order to integrate the DI electrode into the control panel it is necessary to fit a Sulzer DI module and connect it in accordance with the wiring diagram (Fig. 23).

**ATTENTION** *The DI seal monitoring probe in the oil chamber (60 Hz, Hazardous Location, North America only) must be connected to an intrinsically safe electrical circuit in accordance with FM (Factory Mutual) 3650.*

**ATTENTION** *The Sulzer DI module must be located outside of the hazardous location.*

**ATTENTION** *If the DI seal monitor is activated the unit must be immediately taken out of service. Please contact your Sulzer Service Centre.*

**NOTE** *Running the pump with the thermal and/or moisture sensors disconnected will invalidate any related warranty claims.*

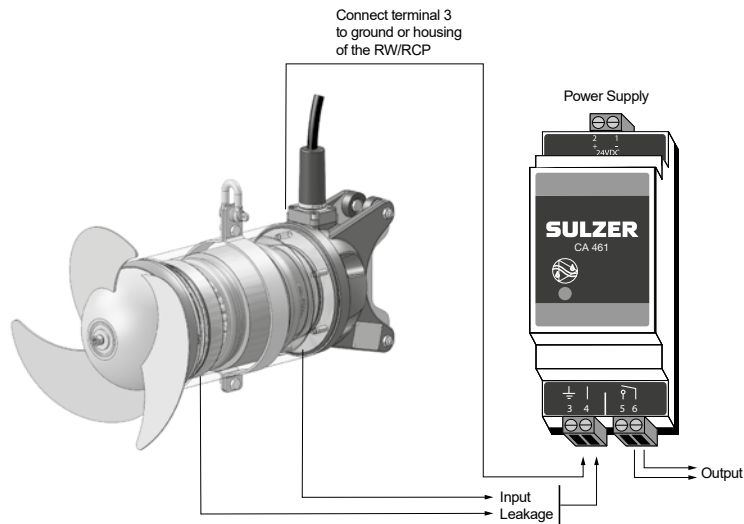

Figure 30. Electronic amplifier with collective signalling

### Electronic amplifier for 50/60 Hz

110 - 230 V AC (CSA) (Part No.: 1 690 7010)

18 - 36 V DC (CSA) (Part No.: 1 690 7011)

**ATTENTION** Maximum relay contact loading: 2 Ampere

## 6 Commissioning



The safety instructions in the previous sections must be observed!

Before commissioning, the unit should be checked and a functional test carried out. Particular attention should be paid to the following:

- Have the electrical connections been carried out in accordance with regulations?
- Have the thermal sensors/limiters been connected?
- Is the seal monitoring device (where fitted) correctly installed?
- Is the motor overload switch correctly set?
- Have the power and control circuit cables been correctly fitted?
- Has the motor connection cable been laid in such a manner that it cannot be caught up by the rotating body?
- Has the minimum submergence level been observed? (See Section 1.7 Dimensions and weights).

## 6.1 Types of operation

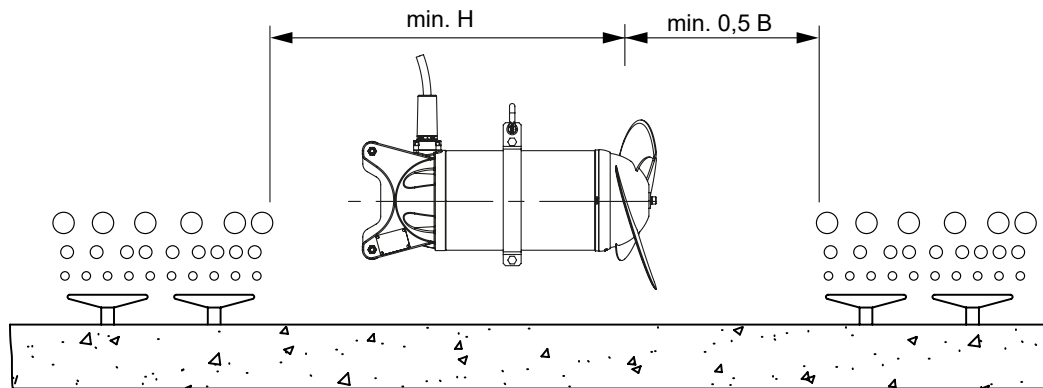

B = Tank width; H = Water depth

Figure 31. Installation example with aeration

**ATTENTION**      *The illustration is only an example. For the correct installation please contact Sulzer.*

**ATTENTION**      *Operation within the directly aerated area is not allowed!*

**ATTENTION**      *The units must work fully submerged in the fluid. During operation no air should be drawn in by the propeller. Ensure that there is a smooth medium flow. The unit should not vibrate heavily when in operation.*

**Uneven flow formation and vibrations can occur if:**

- Over-active mixing in small tanks (only for RW).
- Prevention of free inflow or outflow in the area of the flow ring if fitted (only for RW). Changing the position or direction of the mixer may assist.
- Prevention of free inflow or outflow in the area of the guide cone (only for RCP).

## 7 Maintenance



The safety instructions in the previous sections must be observed!

In particular, the advice regarding maintenance in *paragraph 3.2* of the separate booklet Safety Instructions for Sulzer Products Type ABS are to be observed.

### 7.1 General maintenance hints



Before commencing any maintenance work the unit should be completely disconnected from the mains by a qualified person and care should be taken that it cannot be inadvertently switched back on.



Servicing must only be carried out by qualified personnel.

**NOTE**              *The maintenance instructions given here are not designed for “do-it-yourself” repairs as special technical knowledge is required.*



Repair work on explosion-proof motors may only be carried out in approved workshops by approved personnel using original parts supplied by the manufacturer. Otherwise the Ex approvals no longer apply.

Sulzer units are reliable quality products, each being subjected to careful final inspection. Lubricated-for-life ball bearings, together with monitoring devices, ensure optimum reliability provided that the unit has been connected and operated in accordance with the operating instructions.

Should, nevertheless, a malfunction occur, do not improvise but ask your Sulzer Customer Service Department for assistance.

This applies particularly if the unit is continually switched off by the current overload in the control panel, by the thermal sensors/limiters of the thermo-control system, or by the seal monitoring system (DI).

**ATTENTION**      ***The lifting tools such as chains and shackles should be visually checked at regular intervals (approx. every 3 months) for wear and corrosion. These parts should be replaced if required!***

The Sulzer Service Organisation would be pleased to advise you on any applications you may have and to assist you in solving your aerating problems.

**NOTE**              ***The Sulzer warranty conditions are only valid provided that any repair work has been carried out in Sulzer approved workshops and where original Sulzer spare parts have been used.***

**ATTENTION**      ***Regular checks are highly recommended and other checks are prescribed regulations after specific intervals. This ensures a long lifetime and trouble-free operation of the units (see section 7.2 Maintenance).***

**NOTE**              ***In the case of repair work, "Table 1" from IEC60079-1 and FM 3615 may not be applied. In this case please contact Sulzer After-Sales Service!***

## **7.2 Maintenance RW/RCP**



The safety instructions in the previous sections must be observed!

Inspections carried through at regular intervals and preventive maintenance guarantee trouble-free operation. For this reason the complete unit should be cleaned thoroughly on a regular basis, maintained and inspected. For this purpose special care must be taken that all parts of the unit are in a good condition and that operational security is guaranteed. The inspection period is determined by the type of usage of the units, but should however not exceed one year.

The maintenance and inspection work must be carried through corresponding to the subsequent inspection plan. The executed work must be documented in the attached inspection list. In case of non-observance the manufacturer's warranty does not apply!

### **7.2.1 Faults**

In addition to the maintenance and inspection tasks described in section 7.3 *Inspection and maintenance intervals* an urgent check of the unit and installation should be carried out if heavy vibrations develop or uneven flow patterns occur.

#### **Possible causes:**

- Minimum liquid coverage of the RW propeller is not present.
- Aeration in the RW propeller area.
- Wrong direction of rotation of the propeller.
- Propeller is damaged.
- Restriction to the free inflow or outflow in the area of the RW flow ring.
- Restriction to the free inflow or outflow in the area of the RCP inflow cone.
- Parts of the installation, such as bracket or coupling parts, have become defective or loose.

In these cases the unit should be immediately switched off and inspected. If no fault can be found, or the fault remains after it has apparently been corrected, the unit should be left switched off. The same applies also where the current overload in the control panel regularly trips, where the DI seal monitor or the temperature sensors in the stator are activated. We recommend that in such cases you contact the local Sulzer Service Centre.

### 7.3 Inspection and maintenance intervals



The safety instructions in the previous sections must be observed!

<b>PERIOD OF TIME:</b>	<b>Regulation: once a month</b>
ACTIVITY:	Cleaning and inspection of the power and control circuit cables.
DESCRIPTION:	Once a month (more frequently - for example - in difficult application cases where the medium is heavily polluted with fibrous matter) the power and control circuit cables should be cleaned. In particular, fibrous materials must be removed. Part of the regular maintenance is also the inspection of the motor cables. These must be checked for scratches, fissures, bubbles or crushing.
MEASURE:	Damaged power and control circuit cables must be replaced in all cases. Please contact your local Sulzer Service Centre.

<b>PERIOD OF TIME:</b>	<b>Recommendation: once a month</b>
ACTIVITY:	Check the current consumption at the amp meter.
DESCRIPTION:	With normal operation the current consumption is constant; occasional current fluctuations result from the constitution of the material being mixed.
MEASURE:	If the current consumption is too high for a longer period during normal operation please contact your local Sulzer Service Centre.

<b>PERIOD OF TIME:</b>	<b>Regulation: every 3 months</b>
ACTIVITY:	Cleaning and inspection of the shackles and the lifting equipment.
DESCRIPTION:	Lift the unit out of the tank and clean it. Lifting equipment like hoists, shackles, wire ropes and wire clamps etc. must undergo a visual examination at regular intervals for wear and corrosion.
MEASURE:	Worn or damaged parts should be replaced. Please contact your local Sulzer Service Centre.
ACTIVITY:	Inspection of the propeller and the SD ring (Solids-Deflection-Ring).
DESCRIPTION:	The propeller should be inspected carefully. The propeller might show spots of rupture and wear due to strongly abrasive or aggressive mixing material. In both cases the flow formation is reduced considerably and the propeller must be replaced. The solids deflection ring must also be checked. If wear or scoring is visible on the propeller boss these parts must be replaced as well.
MEASURE:	If you find out any cases of the damage described above please contact your local Sulzer Service Centre.

<b>PERIOD OF TIME:</b>	<b>Recommendation: every 6 months</b>
ACTIVITY:	Insulation resistance check.
DESCRIPTION:	Within the scope of the maintenance work the insulation resistance of the motor winding should be measured every 4,000 hours, and/or at least once a year. If the proper insulation resistance level is not reached, moisture might have got into the motor.
MEASURE:	The unit must be taken out of operation and may not be started again. Please contact your local Sulzer Service Centre.
ACTIVITY:	Functional testing of the monitoring devices.
DESCRIPTION:	In the scope of the maintenance measures functional testing of all monitoring devices must be carried through every 4,000 hours and/or at least once a year. For these functional tests the unit must have cooled down to the ambient temperature. The electrical connecting line of the monitoring device must be disconnected at the control box. These measurements must be carried through by means of an ohmmeter at the respective cable ends.
MEASURE:	In any case of any functional problems on the monitoring devices please contact your local Sulzer Service Centre.







