

# Series MY1C

**Cam Follower Guide Type**  
ø16, ø20, ø25, ø32, ø40, ø50, ø63

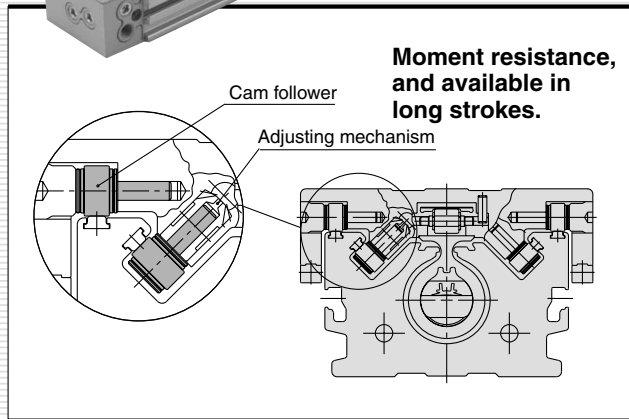
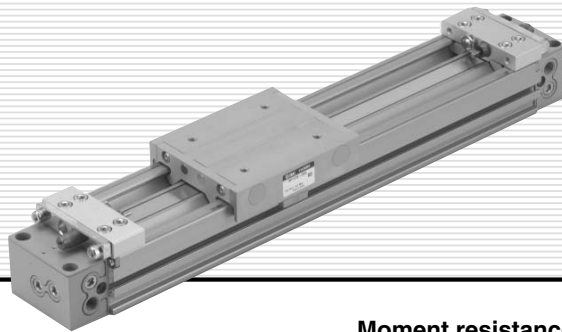

- MX
- MTS
- MY
- CY
- MG
- CX
- D-
- X
- 20-
- Data

# Series MY1C

## Before Operation

### Maximum Allowable Moment/Maximum Load Weight

Model	Bore size (mm)	Maximum allowable moment (N-m)			Maximum load weight (kg)		
		M <sub>1</sub>	M <sub>2</sub>	M <sub>3</sub>	m <sub>1</sub>	m <sub>2</sub>	m <sub>3</sub>
MY1C	16	6.0	3.0	2.0	18	7	2.1
	20	10	5.0	3.0	25	10	3
	25	15	8.5	5.0	35	14	4.2
	32	30	14	10	49	21	6
	40	60	23	20	68	30	8.2
	50	115	35	35	93	42	11.5
	63	150	50	50	130	60	16

The above values are the maximum allowable values for moment and load. Refer to each graph regarding the maximum allowable moment and maximum allowable load for a particular piston speed.

### Maximum Allowable Moment

Select the moment from within the range of operating limits shown in the graphs. Note that the maximum allowable load value may sometimes be exceeded even within the operating limits shown in the graphs. Therefore, also check the allowable load for the selected conditions.

### Load weight (kg)

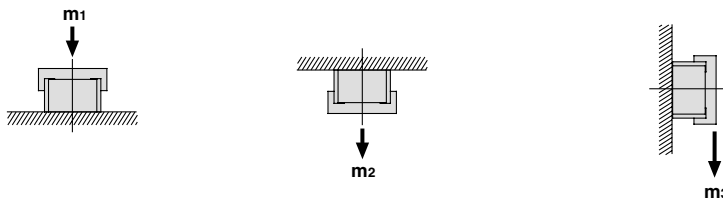

### Moment (N-m)

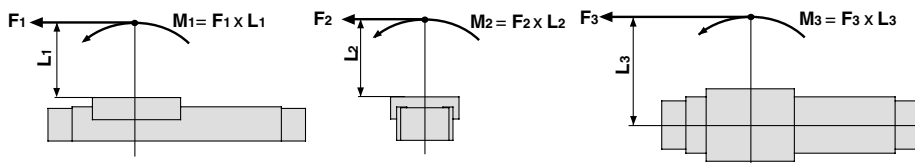

### <Calculation of guide load factor>

1. Maximum allowable load (1), static moment (2), and dynamic moment (3) (at the time of impact with stopper) must be examined for the selection calculations.

\* To evaluate, use  $\bar{v}$  (average speed) for (1) and (2), and  $v$  (collision speed  $v = 1.4\bar{v}$ ) for (3). Calculate  $m_{max}$  for (1) from the maximum allowable load graph ( $m_1, m_2, m_3$ ) and  $M_{max}$  for (2) and (3) from the maximum allowable moment graph ( $M_1, M_2, M_3$ ).

$$\text{Sum of guide load factors } \Sigma\alpha = \frac{\text{Load weight [m]}}{\text{Maximum allowable load [m}_{max}\text{]}} + \frac{\text{Static moment [M]}^{(1)}}{\text{Allowable static moment [M}_{max}\text{]}} + \frac{\text{Dynamic moment [M}_E\text{]}^{(2)}}{\text{Allowable dynamic moment [M}_{E,max}\text{]}} \leq 1$$

Note 1) Moment caused by the load, etc., with cylinder in resting condition.

Note 2) Moment caused by the impact load equivalent at the stroke end (at the time of impact with stopper).

Note 3) Depending on the shape of the workpiece, multiple moments may occur. When this happens, the sum of the load factors ( $\Sigma\alpha$ ) is the total of all such moments.

### 2. Reference formula [Dynamic moment at impact]

Use the following formulae to calculate dynamic moment when taking stopper impact into consideration.

m: Load weight (kg)

F: Load (N)

F<sub>E</sub>: Load equivalent to impact (at impact with stopper) (N)

$\bar{v}$ : Average speed (mm/s)

M: Static moment (N-m)

$v = 1.4\bar{v}$  (mm/s)  $F_E = 1.4\bar{v} \cdot \delta \cdot m \cdot g$  (Note 4)

$\therefore M_E = \frac{1}{3} \cdot F_E \cdot L_1 = 4.57\bar{v} \delta m L_1$  (N-m) (Note 5)

$v$ : Collision speed (mm/s)

L<sub>1</sub>: Distance to the load's center of gravity (m)

M<sub>E</sub>: Dynamic moment (N-m)

$\delta$ : Damper coefficient At collision:  $v = 1.4\bar{v}$

With rubber bumper = 4/100

(MY1B10, MY1H10)

With air cushion = 1/100

With shock absorber = 1/100

g: Gravitational acceleration (9.8 m/s<sup>2</sup>)

Note 4)  $1.4\bar{v}\delta$  is a dimensionless coefficient for calculating impact force.

Note 5) Average load coefficient ( $= \frac{1}{3}$ ): This coefficient is for averaging the maximum load moment at the time of stopper impact according to service life calculations.

### Maximum Load Weight

Select the load from within the range of limits shown in the graphs. Note that the maximum allowable moment value may sometimes be exceeded even within the operating limits shown in the graphs. Therefore, also check the allowable moment for the selected conditions.

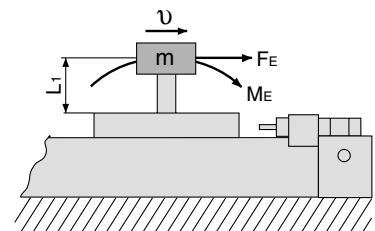

# Mechanically Jointed Rodless Cylinder Cam Follower Guide Type **Series MY1C**

**MY1C/M<sub>1</sub>**

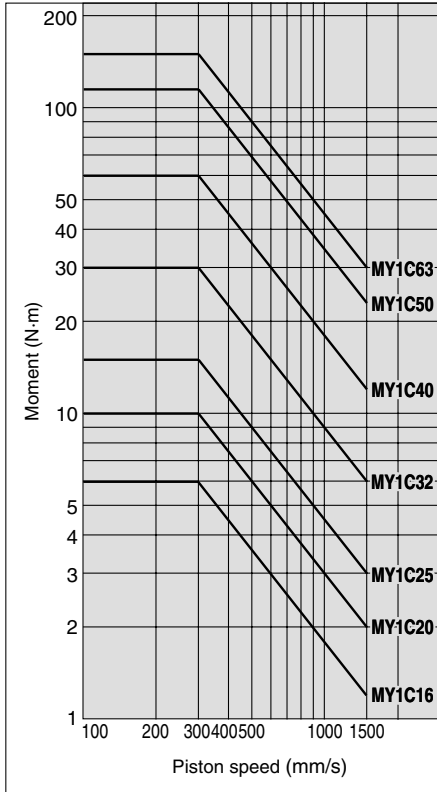

**MY1C/M<sub>2</sub>**

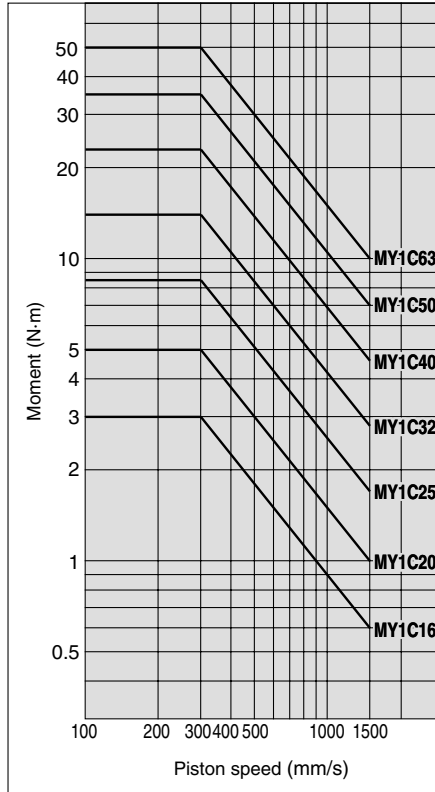

**MY1C/M<sub>3</sub>**

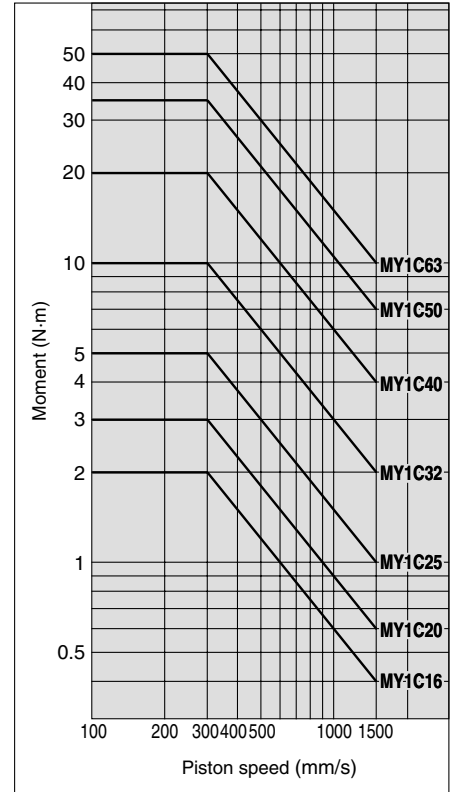

MX

MTS

MY

CY

MG

CX

D-

-X

20-

Data

**MY1C/m<sub>1</sub>**

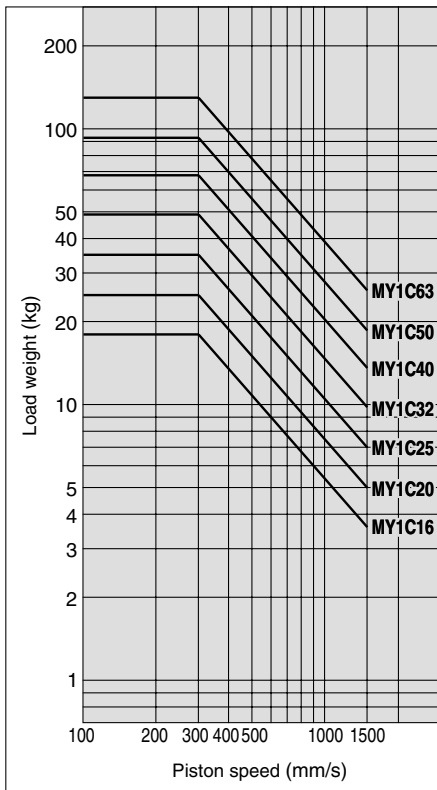

**MY1C/m<sub>2</sub>**

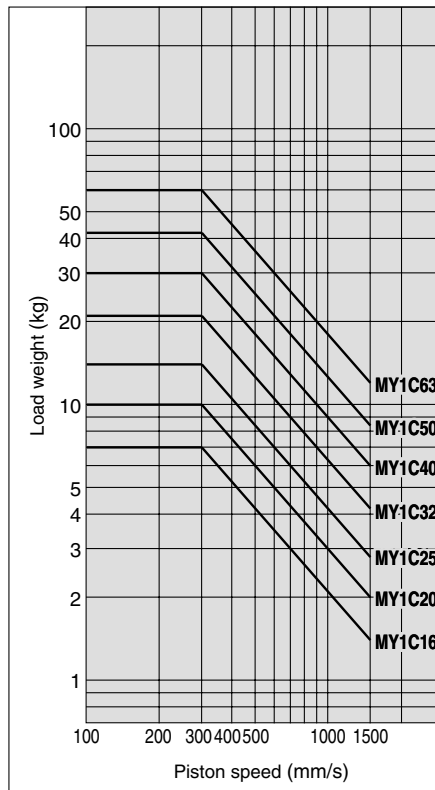

**MY1C/m<sub>3</sub>**

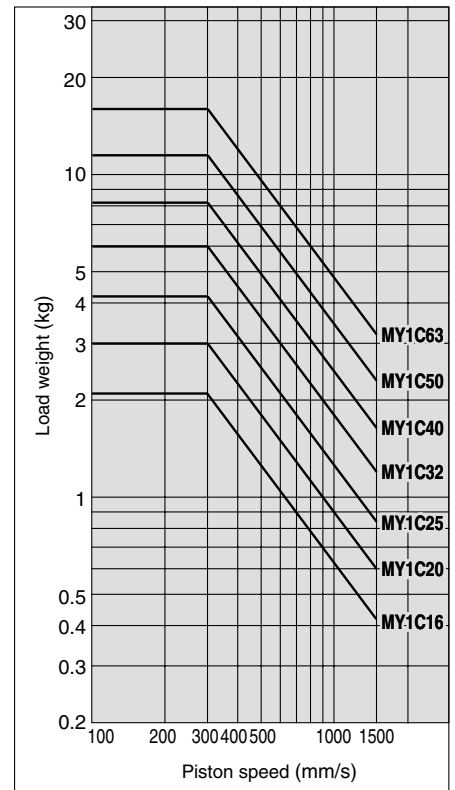

# Series MY1C Model Selection

Following are the steps for selecting the most suitable Series MY1C to your application.

## Calculation of Guide Load Factor

### 1. Operating Conditions

Cylinder..... MY1C40-500  
Average operating speed  $v_a$  ... 300 mm/s  
Mounting orientation..... Ceiling mounting  
Cushion..... Air cushion  
( $\delta = 1/100$ )

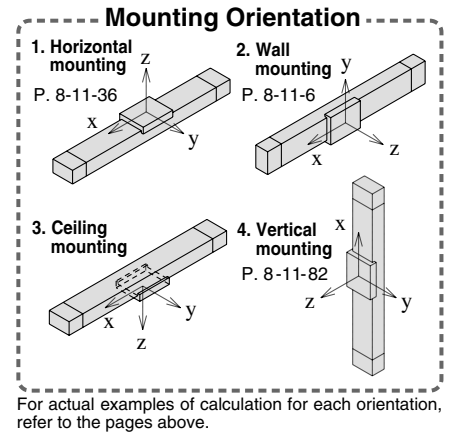
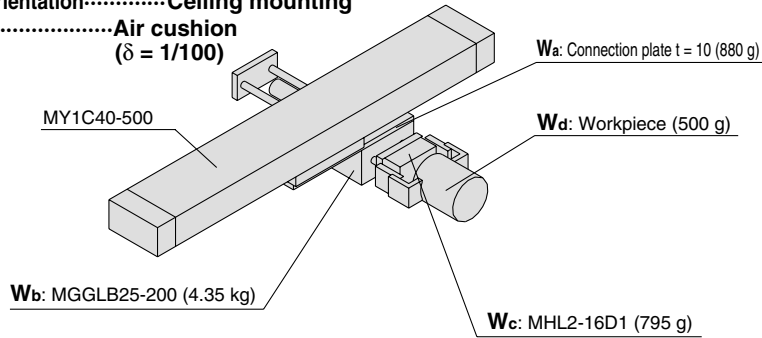

### 2. Load Blocking

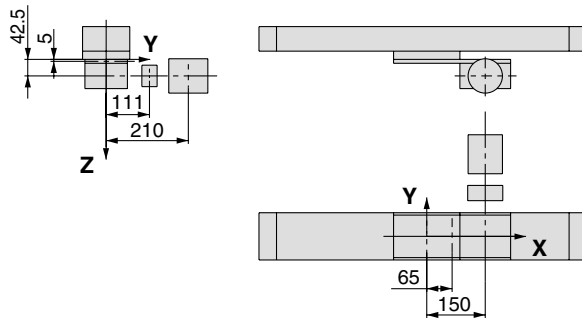

### Weight and Center of Gravity for Each Workpiece

Workpiece no. W <sub>n</sub>	Weight m <sub>n</sub>	Center of gravity		
		X-axis X <sub>n</sub>	Y-axis Y <sub>n</sub>	Z-axis Z <sub>n</sub>
W <sub>a</sub>	0.88 kg	65 mm	0 mm	5 mm
W <sub>b</sub>	4.35 kg	150 mm	0 mm	42.5 mm
W <sub>c</sub>	0.795 kg	150 mm	111 mm	42.5 mm
W <sub>d</sub>	0.5 kg	150 mm	210 mm	42.5 mm

n = a, b, c, d

### 3. Composite Center of Gravity Calculation

$$m_2 = \sum m_n$$

$$= 0.88 + 4.35 + 0.795 + 0.5 = \mathbf{6.525 \text{ kg}}$$

$$X = \frac{1}{m_2} \times \sum (m_n \times X_n)$$

$$= \frac{1}{6.525} (0.88 \times 65 + 4.35 \times 150 + 0.795 \times 150 + 0.5 \times 150) = \mathbf{138.5 \text{ mm}}$$

$$Y = \frac{1}{m_2} \times \sum (m_n \times Y_n)$$

$$= \frac{1}{6.525} (0.88 \times 0 + 4.35 \times 0 + 0.795 \times 111 + 0.5 \times 210) = \mathbf{29.6 \text{ mm}}$$

$$Z = \frac{1}{m_2} \times \sum (m_n \times Z_n)$$

$$= \frac{1}{6.525} (0.88 \times 5 + 4.35 \times 42.5 + 0.795 \times 42.5 + 0.5 \times 42.5) = \mathbf{37.4 \text{ mm}}$$

### 4. Calculation of Load Factor for Static Load

m<sub>2</sub>: Weight

m<sub>2max</sub> (from (1) of graph MY1C/m<sub>2</sub>) = 30 (kg).....

Load factor  $\alpha_1 = m_2/m_{2max} = 6.525/30 = \mathbf{0.22}$

M<sub>1</sub>: Moment

M<sub>1max</sub> (from (2) of graph MY1C/M<sub>1</sub>) = 60 (N·m).....

M<sub>1</sub> = m<sub>2</sub> × g × X = 6.525 × 9.8 × 138.5 × 10<sup>-3</sup> = 8.86 (N·m)

Load factor  $\alpha_2 = M_1/M_{1max} = 8.86/60 = \mathbf{0.15}$

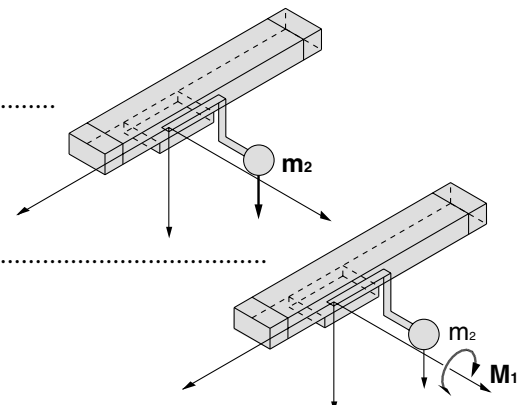

**M<sub>2</sub>: Moment**

M<sub>2max</sub> (from (3) of graph MY1C/M<sub>2</sub>) = 23.0 (N·m).....

M<sub>2</sub> = m<sub>2</sub> × g × Y = 6.525 × 9.8 × 29.6 × 10<sup>-3</sup> = 1.89 (N·m)

Load factor  $\alpha_3 = M_2/M_{2max} = 1.89/23.0 = 0.08$

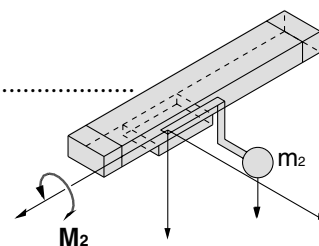

### 5. Calculation of Load Factor for Dynamic Moment

**Equivalent load F<sub>E</sub> at impact**

F<sub>E</sub> = 1.4v<sub>a</sub> × δ × m × g = 1.4 × 300 ×  $\frac{1}{100}$  × 6.525 × 9.8 = 268.6 (N)

**M<sub>1E</sub>: Moment**

M<sub>1E</sub>max (from (4) of graph MY1C/M<sub>1</sub> where 1.4v<sub>a</sub> = 420 mm/s) = 42.9 (N·m).....

M<sub>1E</sub> =  $\frac{1}{3}$  × F<sub>E</sub> × Z =  $\frac{1}{3}$  × 268.6 × 37.4 × 10<sup>-3</sup> = 3.35 (N·m)

Load factor  $\alpha_4 = M_{1E}/M_{1Emax} = 3.35/42.9 = 0.08$

**M<sub>3E</sub>: Moment**

M<sub>3E</sub>max (from (5) of graph MY1C/M<sub>3</sub> where 1.4v<sub>a</sub> = 420 mm/s) = 14.3 (N·m).....

M<sub>3E</sub> =  $\frac{1}{3}$  × F<sub>E</sub> × Y =  $\frac{1}{3}$  × 268.6 × 29.6 × 10<sup>-3</sup> = 2.65 (N·m)

Load factor  $\alpha_5 = M_{3E}/M_{3Emax} = 2.65/14.3 = 0.19$

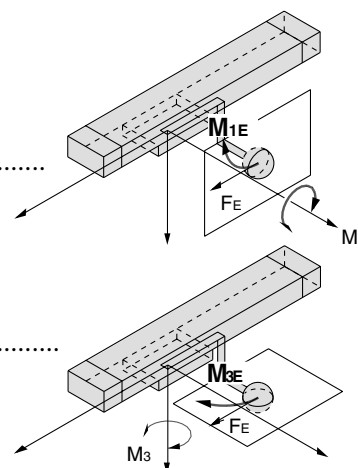

- MX
- MTS
- MY
- CY
- MG
- CX
- D-
- X
- 20-
- Data

### 6. Sum and Examination of Guide Load Factors

$$\Sigma\alpha = \alpha_1 + \alpha_2 + \alpha_3 + \alpha_4 + \alpha_5 = 0.72 \leq 1$$

The above calculation is within the allowable value, and therefore the selected model can be used.

Select a shock absorber separately.

In an actual calculation, when the total sum of guide load factors  $\Sigma\alpha$  in the formula above is more than 1, consider either decreasing the speed, increasing the bore size, or changing the product series. This calculation can be easily made using the "SMC Pneumatics CAD System".

#### Load Weight

MY1C/m<sub>2</sub>

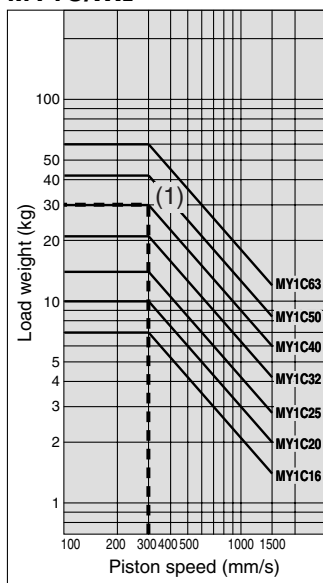

#### Allowable Moment

MY1C/M<sub>1</sub>

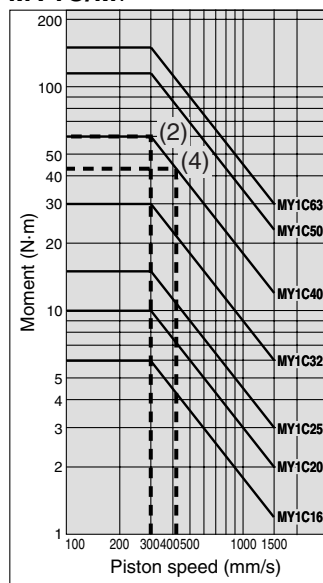

MY1C/M<sub>2</sub>

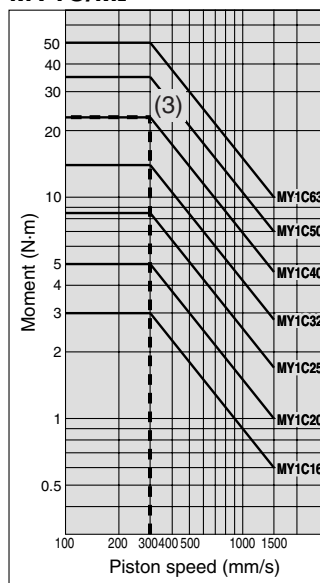

MY1C/M<sub>3</sub>

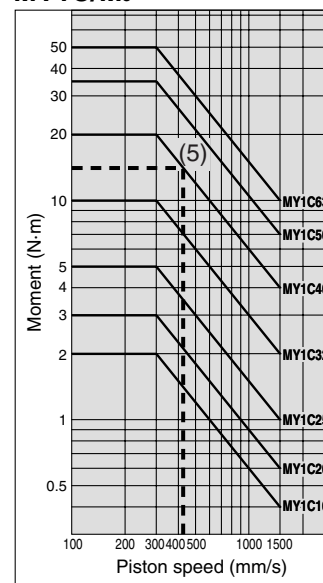

# Mechanically Jointed Rodless Cylinder Cam Follower Guide Type



## Series MY1C

ø16, ø20, ø25, ø32, ø40, ø50, ø63

### How to Order

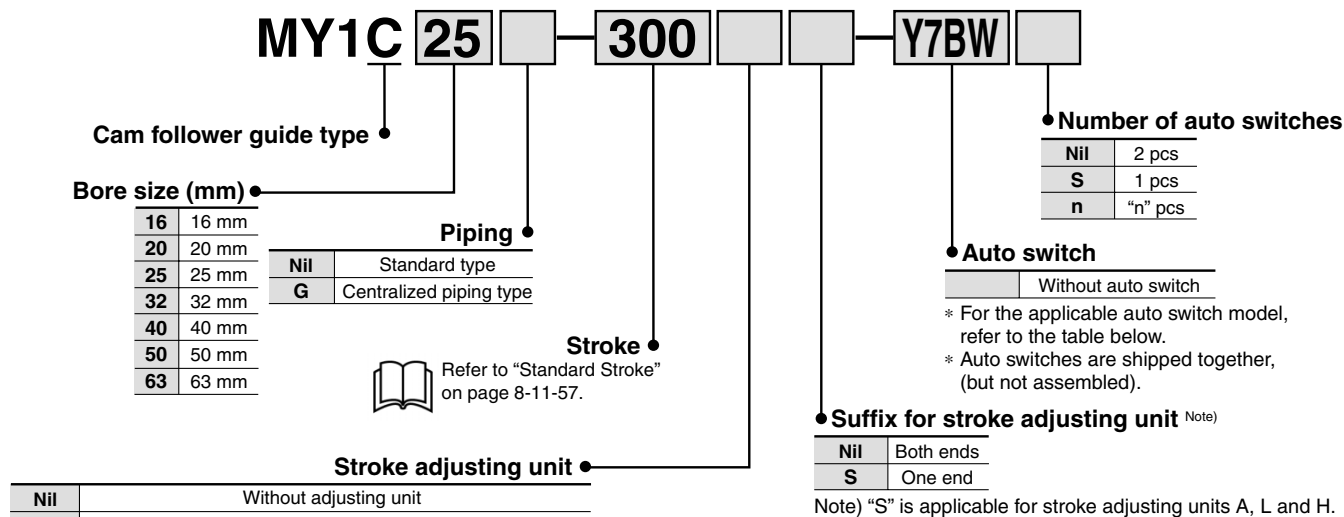

### Shock Absorbers for L and H Units

Unit type	Bore size (mm)						
	16	20	25	32	40	50	63
L unit	RB0806		RB1007		RB1412		RB2015
H unit	—	RB1007	RB1412		RB2015		RB2725

### Applicable Auto Switch/Refer to page 8-30-1 for further information on auto switches. For ø16, ø20

Type	Special function	Electrical entry	Indicator light	Wiring (Output)	Load voltage			Auto switch model		Lead wire length (m)*			Pre-wire connector	Applicable load	
					DC	AC	AC	Perpendicular	In-line	0.5 (Nil)	3 (L)	5 (Z)			
Reed switch	—	Grommet	Yes	3-wire (NPN equivalent)	—	5 V	—	<b>A96V</b>	<b>A96</b>	●	●	—	—	IC circuit	
				2-wire	24 V	12 V	100 V	<b>A93V</b>	<b>A93</b>	●	●	—	—	—	Relay, PLC
Solid state switch	—	Grommet	Yes	3-wire (NPN)	24 V	5 V, 12 V	—	<b>M9NV</b>	<b>M9N</b>	●	●	○	○	IC circuit	
				3-wire (PNP)				<b>M9PV</b>	<b>M9P</b>	●	●	○	○	—	
				2-wire				<b>M9BV</b>	<b>M9B</b>	●	●	○	○	—	
	Diagnostic indication (2-color indication)			3-wire (NPN)	24 V	5 V, 12 V	—	<b>F9NWV</b>	<b>F9NW</b>	●	●	○	○	—	IC circuit
				3-wire (PNP)				<b>F9PWV</b>	<b>F9PW</b>	●	●	○	○	—	
				2-wire				<b>F9BWV</b>	<b>F9BW</b>	●	●	○	○	—	

### For ø25, ø32, ø40, ø50, ø63

Type	Special function	Electrical entry	Indicator light	Wiring (Output)	Load voltage			Auto switch model		Lead wire length (m)*			Pre-wire connector	Applicable load	
					DC	AC	AC	Perpendicular	In-line	0.5 (Nil)	3 (L)	5 (Z)			
Reed switch	—	Grommet	Yes	3-wire (NPN equivalent)	—	5 V	—		<b>Z76</b>	●	●	—	—	IC circuit	
				2-wire	24 V	12 V	100 V		<b>Z73</b>	●	●	●	—	—	Relay, PLC
Solid state switch	—	Grommet	Yes	3-wire (NPN)	24 V	5 V, 12 V	—	<b>Y69A</b>	<b>Y59A</b>	●	●	○	○	IC circuit	
				3-wire (PNP)				<b>Y7PV</b>	<b>Y7P</b>	●	●	○	○	—	
				2-wire				<b>Y69B</b>	<b>Y59B</b>	●	●	○	○	—	
	Diagnostic indication (2-color indication)			3-wire (NPN)	24 V	5 V, 12 V	—	<b>Y7NWV</b>	<b>Y7NW</b>	●	●	○	○	—	IC circuit
				3-wire (PNP)				<b>Y7PWV</b>	<b>Y7PW</b>	●	●	○	○	—	
				2-wire				<b>Y7BWV</b>	<b>Y7BW</b>	●	●	○	○	—	

\* Lead wire length symbols: 0.5 m...Nil (Example) A93  
3 m...L (Example) Y59BL  
5 m...Z (Example) F9NWZ

\* Solid state switches marked with "○" are produced upon receipt of order.

- There are other applicable auto switches than listed above. For details, refer to page 8-11-101.
- For details about auto switches with pre-wire connector, refer to page 8-30-52.

# Mechanically Jointed Rodless Cylinder Cam Follower Guide Type Series MY1C

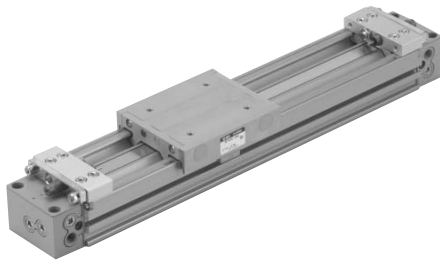

JIS Symbol

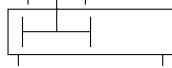

## Specifications

Bore size (mm)	16	20	25	32	40	50	63
Fluid	Air						
Action	Double acting						
Operating pressure range	0.1 to 0.8 MPa						
Proof pressure	1.2 MPa						
Ambient and fluid temperature	5 to 60°C						
Cushion	Air cushion						
Lubrication	Non-lube						
Stroke length tolerance	1000 or less $\begin{smallmatrix} +1.8 \\ 0 \end{smallmatrix}$ 1001 to 3000 $\begin{smallmatrix} +2.8 \\ 0 \end{smallmatrix}$		2700 or less $\begin{smallmatrix} +1.8 \\ 0 \end{smallmatrix}$ , 2701 to 5000 $\begin{smallmatrix} +2.8 \\ 0 \end{smallmatrix}$				
Piping port size	Front/Side port	M5 x 0.8			Rc 1/8	Rc 1/4	Rc 3/8
	Bottom port	ø4			ø5	ø6	ø8 ø10 ø11

## Stroke Adjusting Unit Specifications

Bore size (mm)	16			20			25			32			40			50			63		
Unit symbol	A	L	H	A	L	H	A	L	H	A	L	H	A	L	H	A	L	H	A	L	H
Configuration Shock absorber model	With adjusting bolt	RB 0806 with adjusting bolt	With adjusting bolt	RB 0806 with adjusting bolt	RB 1007 with adjusting bolt	With adjusting bolt	RB 1007 with adjusting bolt	RB 1412 with adjusting bolt	With adjusting bolt	RB 1412 with adjusting bolt	RB 2015 with adjusting bolt	With adjusting bolt	RB 1412 with adjusting bolt	RB 2015 with adjusting bolt	With adjusting bolt	RB 2015 with adjusting bolt	RB 2725 with adjusting bolt	With adjusting bolt	RB 2015 with adjusting bolt	RB 2725 with adjusting bolt	
Fine stroke adjustment range (mm)	0 to -5.6			0 to -6			0 to -11.5			0 to -12			0 to -16			0 to -20			0 to -25		
Stroke adjustment range	When exceeding the stroke fine adjustment range: Utilize a made-to-order specifications "-X416" and "-X417".																				

## Shock Absorber Specifications

Model	RB 0806	RB 1007	RB 1412	RB 2015	RB 2725	
Max. energy absorption (J)	2.9	5.9	19.6	58.8	147	
Stroke absorption (mm)	6	7	12	15	25	
Max. collision speed (mm/s)	1500					
Max. operating frequency (cycle/min)	80	70	45	25	10	
Spring force (N)	Extended	1.96	4.22	6.86	8.34	8.83
	Retracted	4.22	6.86	15.98	20.50	20.01
Operating temperature range (°C)	5 to 60					

## Piston Speed

Bore size (mm)	16 to 63	
Without stroke adjusting unit	100 to 1000 mm/s	
Stroke adjusting unit	A unit	100 to 1000 mm/s <sup>(1)</sup>
	L unit and H unit	100 to 1500 mm/s <sup>(2)</sup>

Note 1) Be aware that when the stroke adjusting range is increased by manipulating the adjusting bolt, the air cushion capacity decreases. Also, when exceeding the air cushion stroke ranges on page 8-11-59.

Note 2) The piston speed is 100 to 1000 mm/s for centralized piping.

Note 3) Use at a speed within the absorption capacity range. Refer to page 8-11-59.

## Made to Order Specifications (For details, refer to page 8-31-1.)

Symbol	Specifications
-XB11	Long stroke
-XC18	NPT finish piping port
-XC56	With knock pin hole
-XC67	NBR rubber lining in dust seal band
-X168	Helical insert thread specifications
-X416	Holder mounting bracket I
-X417	Holder mounting bracket II

## Standard Stroke

Bore size (mm)	Standard stroke (mm) *	Maximum manufacturable stroke (mm)
16	100, 200, 300, 400, 500, 600, 700, 800, 900, 1000, 1200, 1400, 1600, 1800, 2000	3000
20, 25, 32, 40, 50, 63		5000

\* Strokes are manufacturable in 1 mm increments, up to the maximum stroke. However, when exceeding a 2000 mm stroke, specify "-XB11" at the end of the model number.

# Series MY1C

## Theoretical Output (N)

Bore size (mm)	Piston area (mm <sup>2</sup> )	Operating pressure (MPa)							
		0.2	0.3	0.4	0.5	0.6	0.7	0.8	
16	200	40	60	80	100	120	140	160	
20	314	62	94	125	157	188	219	251	
25	490	98	147	196	245	294	343	392	
32	804	161	241	322	402	483	563	643	
40	1256	251	377	502	628	754	879	1005	
50	1962	392	588	784	981	1177	1373	1569	
63	3115	623	934	1246	1557	1869	2180	2492	

Note) Theoretical output (N) = Pressure (MPa) x Piston area (mm<sup>2</sup>)

## Weight (kg)

Bore size (mm)	Basic weight	Additional weight per each 50mm of stroke	Side support weight (per set)	Stroke adjusting unit weight (per unit)		
			Type A and B	A unit weight	L unit weight	H unit weight
16	0.67	0.12	0.01	0.03	0.04	—
20	1.06	0.15	0.02	0.04	0.05	0.08
25	1.58	0.24	0.02	0.07	0.11	0.18
32	3.14	0.37	0.04	0.14	0.23	0.39
40	5.60	0.52	0.08	0.25	0.34	0.48
50	10.14	0.76	0.08	0.36	0.51	0.81
63	16.67	1.10	0.17	0.68	0.83	1.08

Calculation: (Example) MY1C25-300A

- Basic weight ..... 1.58 kg
  - Additional weight ..... 0.24/50 st
  - Weight of A unit ..... 0.07 kg
  - Cylinder stroke.....300 st
- $1.58 + 0.24 \times 300 \div 50 + 0.07 \times 2 \approx 3.16$  kg

## Option

### Stroke Adjusting Unit Part No.

Bore size (mm)	16	20	25	32
A unit	MYM-A16A	MYM-A20A	MYM-A25A	MYM-A32A
L unit	MYM-A16L	MYM-A20L	MYM-A25L	MYM-A32L
H unit	—	MYM-A20H	MYM-A25H	MYM-A32H

Bore size (mm)	40	50	63
A unit	MYM-A40A	MYM-A50A	MYM-A63A
L unit	MYM-A40L	MYM-A50L	MYM-A63L
H unit	MYM-A40H	MYM-A50H	MYM-A63H

### Side Support Part No.

Bore size (mm)	16	20	25	32
Side support A	MY-S16A	MY-S20A	MY-S25A	MY-S32A
Side support B	MY-S16B	MY-S20B	MY-S25B	MY-S32B

Bore size (mm)	40	50	63
Side support A	MY-S40A	MY-S50A	MY-S63A
Side support B	MY-S40B	MY-S50B	MY-S63B

For details about dimensions, etc., refer to page 8-11-65.



## Cushion Capacity

### Cushion Selection

#### <Air cushion>

Air cushions are a standard feature on mechanically jointed rodless cylinders. The air cushion mechanism is incorporated to prevent excessive impact of the piston at the stroke end during high speed operation. The purpose of air cushion, thus, is not to decelerate the piston near the stroke end.

The ranges of load and speed that air cushions can absorb are within the air cushion limit lines shown in the graphs.

#### <Stroke adjusting unit with shock absorber>

Use this unit when operating with a load or speed exceeding the air cushion limit line, or when cushioning is necessary because the cylinder stroke is outside of the effective air cushion stroke range due to stroke adjustment.

#### L unit

Use this unit when the cylinder stroke is outside of the effective air cushion range even if the load and speed are within the air cushion limit line, or when the cylinder is operated in a load and speed range above the air cushion limit line or below the L unit limit line.

#### H unit

Use this unit when the cylinder is operated in a load and speed range above the L unit limit line and below the H unit limit line.

## ⚠ Caution

1. Refer to the figure below when using the adjusting bolt to perform stroke adjustment.

When the effective stroke of the shock absorber decreases as a result of stroke adjustment, the absorption capacity decreases dramatically. Secure the adjusting bolt at the position where it protrudes approximately 0.5 mm from the shock absorber.

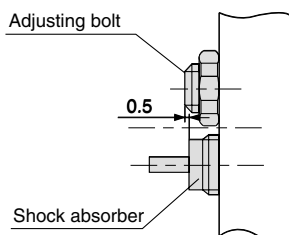

2. Do not use a shock absorber together with air cushion.

### Air Cushion Stroke

(mm)

Bore size (mm)	Cushion stroke
16	12
20	15
25	15
32	19
40	24
50	30
63	37

### Absorption Capacity of Air Cushion and Stroke Adjusting Units

MY1C16

Horizontal collision: P = 0.5 MPa

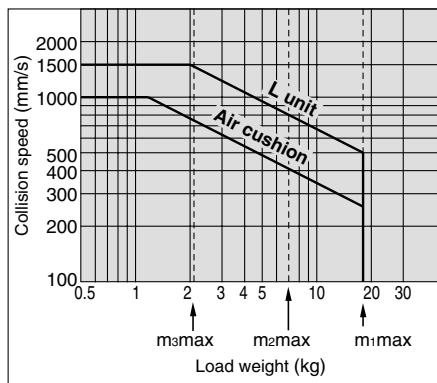

MY1C32

Horizontal collision: P = 0.5 MPa

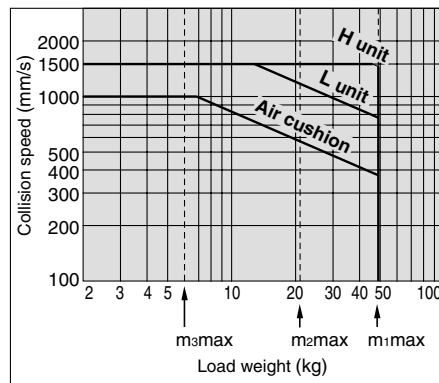

MY1C20

Horizontal collision: P = 0.5 MPa

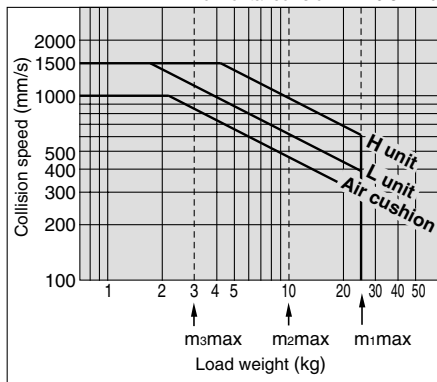

MY1C40

Horizontal collision: P = 0.5 MPa

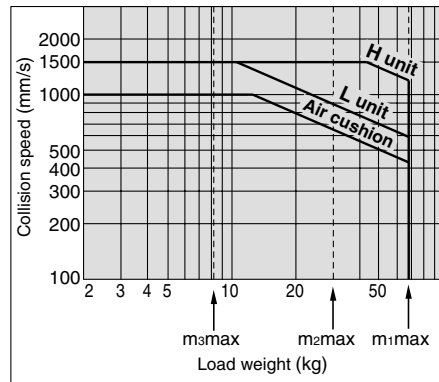

MY1C25

Horizontal collision: P = 0.5 MPa

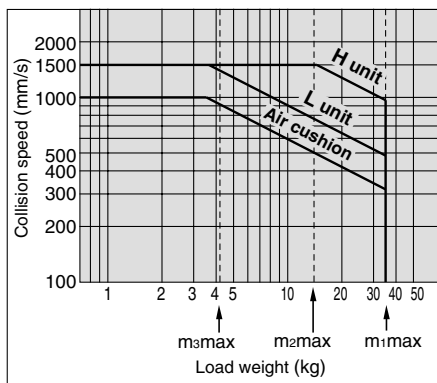

MY1C50

Horizontal collision: P = 0.5 MPa

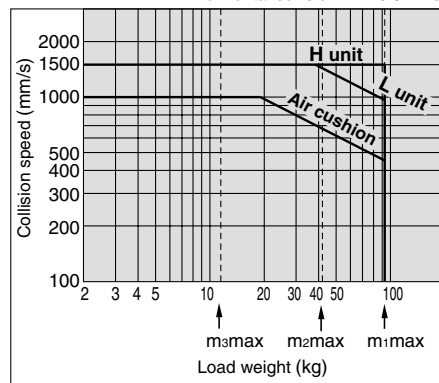

MY1C63

Horizontal collision: P = 0.5 MPa

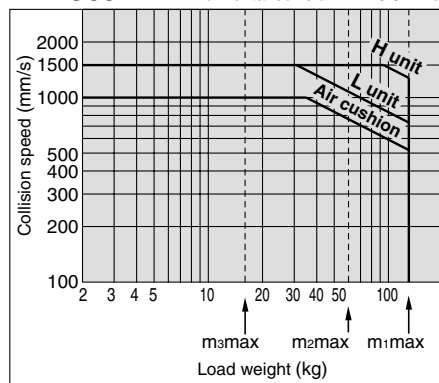

MX

MTS

MY

CY

MG

CX

D-

-X

20-

Data

# Series MY1C

## Cushion Capacity

### Tightening Torque for Stroke Adjusting Unit Holding Bolts (N·m)

Bore size (mm)	Unit	Tightening torque
16	A	0.6
	L	
20	A	1.5
	H	
25	A	3.0
	L	
	H	5.0
32	A	5.0
	L	
	H	12
40	A	12
	L	
	H	
50	A	12
	L	
	H	
63	A	24
	L	
	H	

### Tightening Torque for Stroke Adjusting Unit Lock Plate Holding Bolts (N·m)

Bore size (mm)	Unit	Tightening torque
25	L	1.2
	H	3.3
32	L	3.3
	H	10
40	L	3.3
	H	10

### Calculation of Absorbed Energy for Stroke Adjusting Unit with Shock Absorber (N·m)

Type of impact	Horizontal collision	Vertical (Downward)	Vertical (Upward)
Kinetic energy E <sub>1</sub>		$\frac{1}{2} m \cdot v^2$	
Thrust energy E <sub>2</sub>	F·s	F·s + m·g·s	F·s - m·g·s
Absorbed energy E		E <sub>1</sub> + E <sub>2</sub>	

#### Symbol

- v: Speed of impact object (m/s)
- F: Cylinder thrust (N)
- s: Shock absorber stroke (m)
- m: Weight of impact object (kg)
- g: Gravitational acceleration (9.8 m/s<sup>2</sup>)

Note) The speed of the impact object is measured at the time of impact with the shock absorber.

## ⚠ Precautions

Be sure to read before handling. For Safety Instructions and Actuator Precautions, refer to pages 8-34-3 to 8-34-6.

## ⚠ Caution

Use caution not to get your hands caught in the unit.

- When using a product with stroke adjusting unit, the space between the slide table (slider) and the stroke adjusting unit becomes narrow at the stroke end, causing a danger of hands getting caught. Install a protective cover to prevent direct contact with the human body.

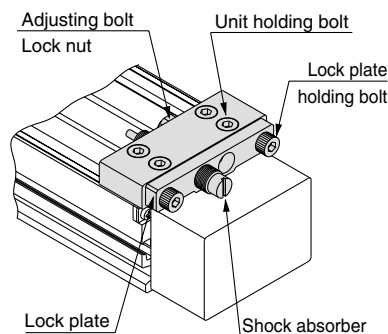

#### <Fastening of unit>

The unit can be secured by evenly tightening the four unit holding bolts.

## ⚠ Caution

Do not operate with the stroke adjusting unit fixed in an intermediate position.

When the stroke adjusting unit is fixed in an intermediate position, slippage can occur depending on the amount of energy released at the time of an impact. In such cases, the use of the adjusting bolt mounting brackets, available per made-to-order specifications -X416 and -X417, is recommended.

For other lengths, please consult with SMC (Refer to "Tightening Torque for Stroke Adjusting Unit Holding Bolts".)

#### <Stroke adjustment with adjusting bolt>

Loosen the adjusting bolt lock nut, and adjust the stroke from the lock plate side using a hexagon wrench. Retighten the lock nut.

#### <Stroke adjustment with shock absorber>

Loosen the two lock plate holding bolts, turn the shock absorber and adjust the stroke. Then, uniformly tighten the lock plate holding bolts to secure the shock absorber.

Take care not to over-tighten the holding bolts. (Except ø16, ø20, ø50, ø63) (Refer to "Tightening Torque for Stroke Adjusting Unit Lock Plate Holding Bolts".)

Note) Although the lock plate may slightly bend due to tightening of the lock plate holding bolt, this does not affect the shock absorber and locking function.

# Mechanically Jointed Rodless Cylinder Cam Follower Guide Type Series MY1C

## Standard Type/Centralized Piping Type $\phi 16, \phi 20$

Refer to page 8-11-9 regarding centralized piping port variations.

MY1C16□/20□ — Stroke

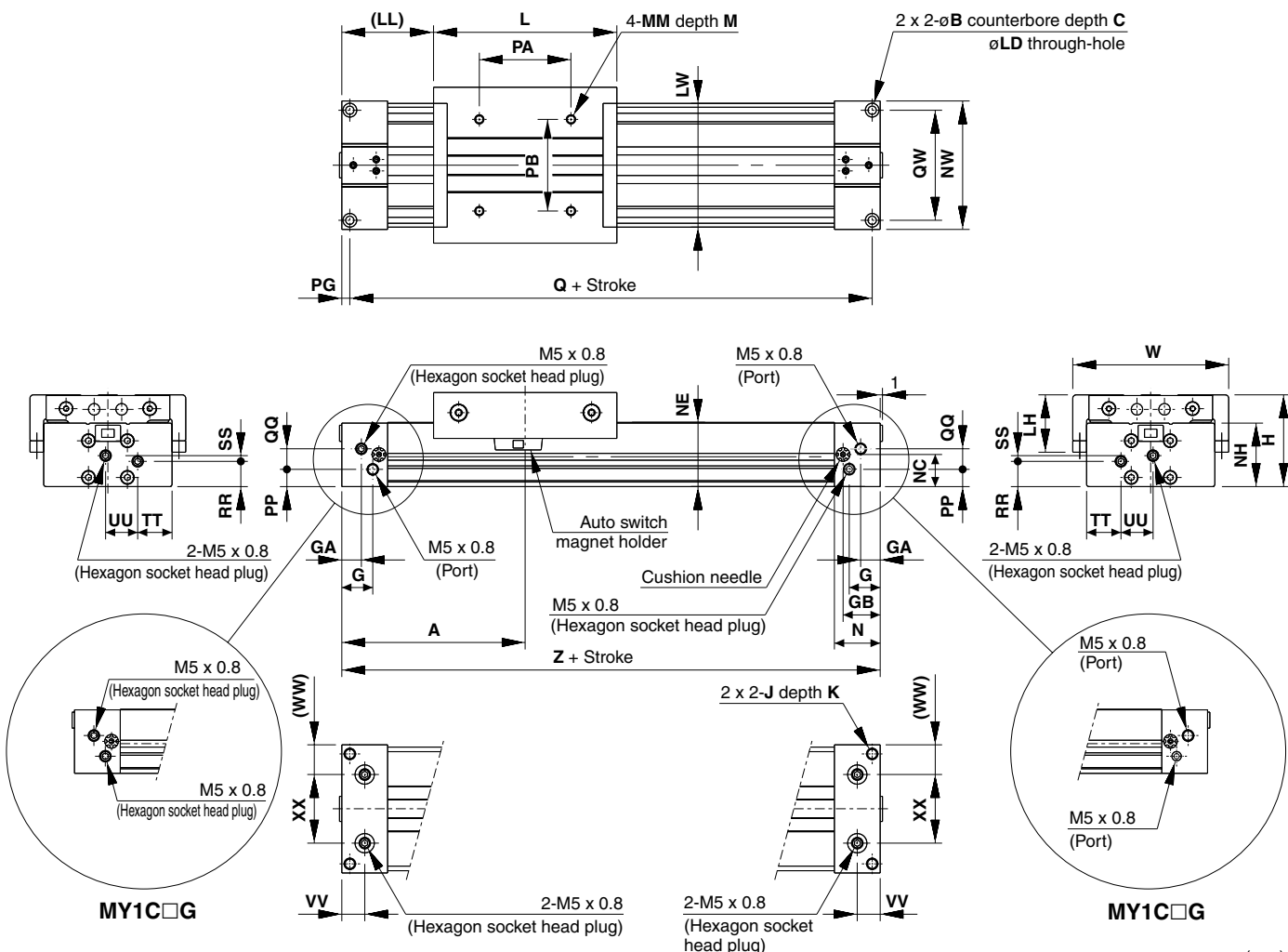

- MX□
- MTS
- MY□
- CY□
- MG□
- CX□
- D-
- X
- 20-
- Data

Model	A	B	C	G	GA	GB	H	J	K	L	LD	LH	LL	LW	M	MM	N	NC
MY1C16□	80	6	3.5	13.5	8.5	16.2	40	M5 x 0.8	10	80	3.6	22.5	40	54	6	M4 x 0.7	20	14
MY1C20□	100	7.5	4.5	12.5	12.5	20	46	M6 x 1	12	100	4.8	23	50	58	7.5	M5 x 0.8	25	17

Model	NE	NH	NW	PA	PB	PG	PP	Q	QQ	QW	RR	SS	TT	UU	VV	W	WW	XX	Z
MY1C16□	28	27.7	56	40	40	3.5	7.5	153	9	48	11	2.5	15	14	10	68	13	30	160
MY1C20□	34	33.7	60	50	40	4.5	11.5	191	10	45	14.5	5	18	12	12.5	72	14	32	200

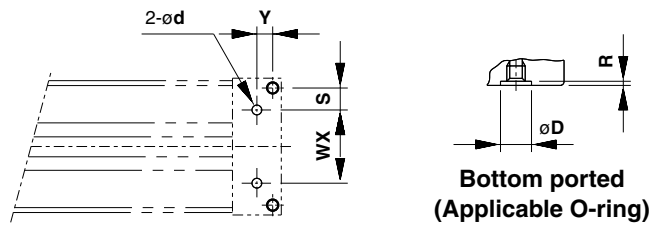

**Hole Sizes for Centralized Piping on the Bottom**

Model	WX	Y	S	d	D	R	Applicable O-ring
MY1C16□	30	6.5	9	4	8.4	1.1	C6
MY1C20□	32	8	6.5	4	8.4	1.1	

(Machine the mounting side to the dimensions below.)

# Series MY1C

**Standard Type/Centralized Piping Type  $\phi 25$ ,  $\phi 32$ ,  $\phi 40$**  Refer to page 8-11-9 regarding centralized piping port variations.

MY1C25□/32□/40□ — Stroke

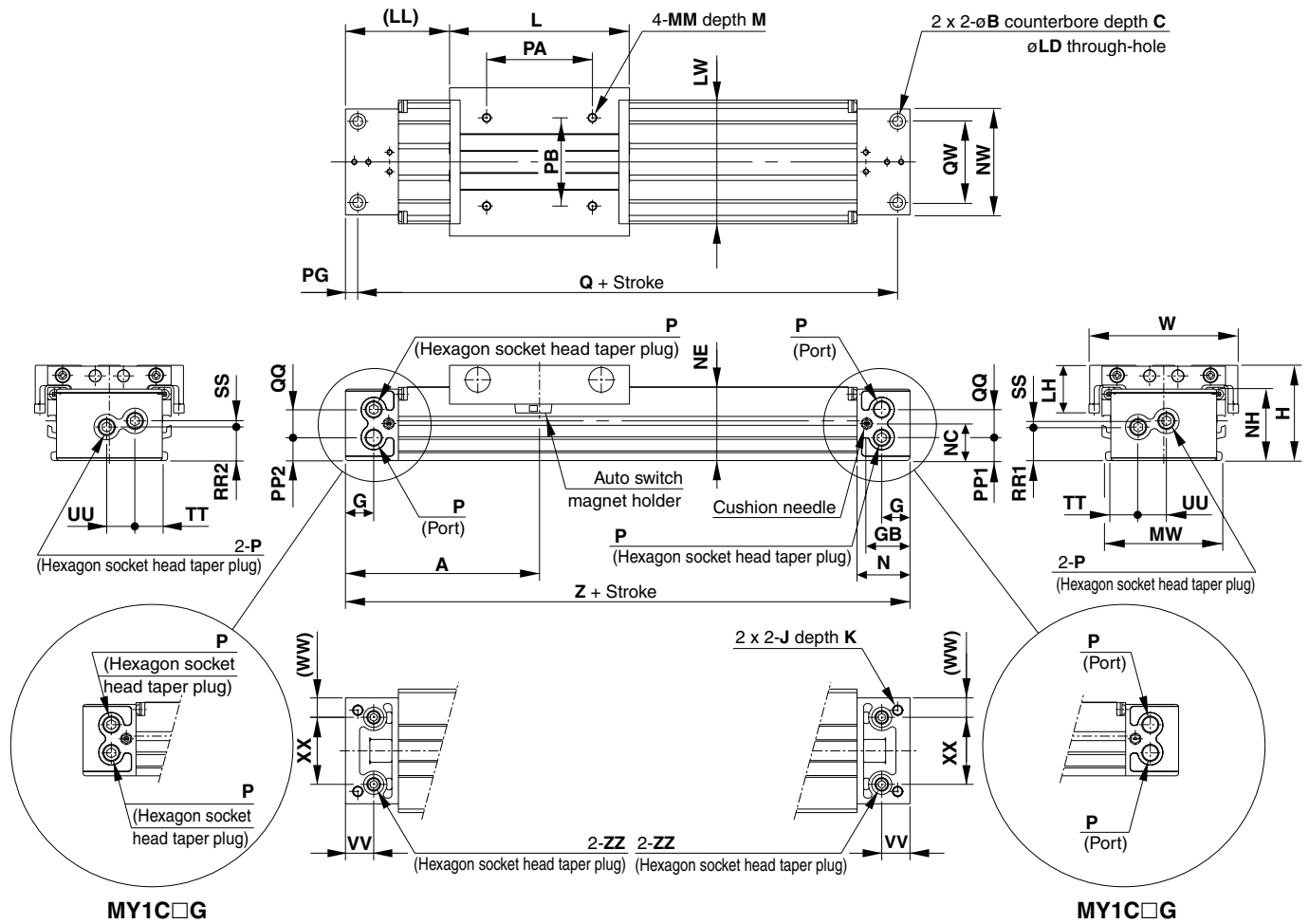

MY1C□G

MY1C□G

Model	A	B	C	G	GB	H	J	K	L	LD	LH	LL	LW	M	MM	MW	N	NC	NE	NH	NW	P	PA
MY1C25□	110	9	5.5	17	24.5	54	M6 x 1	9.5	102	5.6	27	59	70	10	M5 x 0.8	66	30	21	41.8	40.5	60	Rc 1/8	60
MY1C32□	140	11	6.5	19	30	68	M8 x 1.25	16	132	6.8	35	74	88	13	M6 x 1	80	37	26	52.3	50	74	Rc 1/8	80
MY1C40□	170	14	8.5	23	36.5	84	M10 x 1.5	15	162	8.6	38	89	104	13	M6 x 1	96	45	32	65.3	63.5	94	Rc 1/4	100

(mm)

"P" indicates cylinder supply ports.

Model	PB	PG	PP1	PP2	Q	QQ	QW	RR1	RR2	SS	TT	UU	VV	W	WW	XX	Z	ZZ
MY1C25□	50	7	12.7	12.7	206	15.5	46	18.9	17.9	4.1	15.5	16	16	84	11	38	220	Rc 1/16
MY1C32□	60	8	15.5	18.5	264	16	60	22	24	4	21	16	19	102	13	48	280	Rc 1/16
MY1C40□	80	9	17.5	20	322	26	72	25.5	29	9	26	21	23	118	20	54	340	Rc 1/8

(mm)

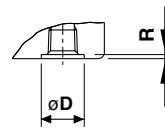
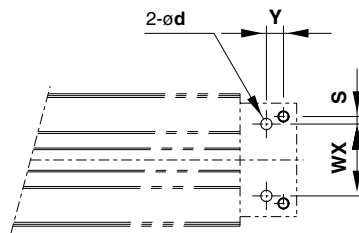

Bottom ported (ZZ)  
(Applicable O-ring)

### Hole Size for Centralized Piping on the Bottom

Model	WX	Y	S	d	D	R	Applicable O-ring
MY1C25□	38	9	4	6	11.4	1.1	C9
MY1C32□	48	11	6	6	11.4	1.1	
MY1C40□	54	14	9	8	13.4	1.1	

(Machine the mounting side to the dimensions below.)



# Series MY1C

## Stroke Adjusting Unit

With adjusting bolt

MY1C  Bore size  — Stroke  A

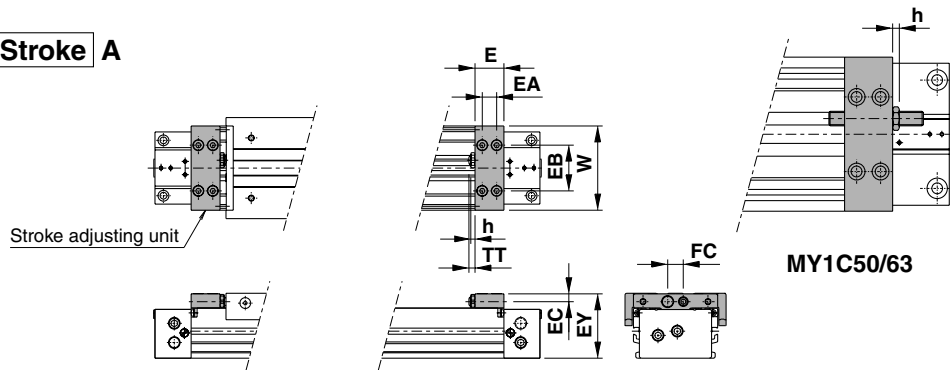

(mm)

Applicable bore size	E	EA	EB	EC	EY	FC	h	TT	W
MY1C16	14.6	7	30	5.8	39.5	14	3.6	5.4 (Max. 11)	58
MY1C20	20	10	32	5.8	45.5	14	3.6	5 (Max. 11)	58
MY1C25	24	12	38	6.5	53.5	13	3.5	5 (Max. 16.5)	70
MY1C32	29	14	50	8.5	67	17	4.5	8 (Max. 20)	88
MY1C40	35	17	57	10	83	17	4.5	9 (Max. 25)	104
MY1C50	40	20	66	14	106	26	5.5	13 (Max. 33)	128
MY1C63	52	26	77	14	129	31	5.5	13 (Max. 38)	152

With low load shock absorber + Adjusting bolt

MY1C  Bore size  — Stroke  A

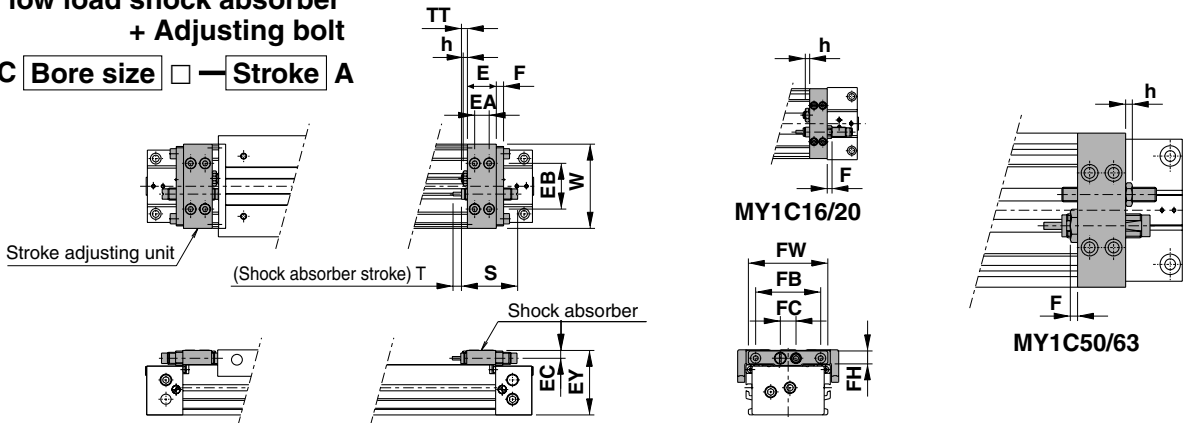

(mm)

Applicable bore size	E	EA	EB	EC	EY	F	FB	FC	FH	FW	h	S	T	TT	W	Shock absorber model
MY1C16	14.6	7	30	5.8	39.5	4	—	14	—	—	3.6	40.8	6	5.4 (Max. 11)	58	RB0806
MY1C20	20	10	32	5.8	45.5	4	—	14	—	—	3.6	40.8	6	5 (Max. 11)	58	RB0806
MY1C25	24	12	38	6.5	53.5	6	54	13	13	66	3.5	46.7	7	5 (Max. 16.5)	70	RB1007
MY1C32	29	14	50	8.5	67	6	67	17	16	80	4.5	67.3	12	8 (Max. 20)	88	RB1412
MY1C40	35	17	57	10	83	6	78	17	17.5	91	4.5	67.3	12	9 (Max. 25)	104	RB1412
MY1C50	40	20	66	14	106	6	—	26	—	—	5.5	73.2	15	13 (Max. 33)	128	RB2015
MY1C63	52	26	77	14	129	6	—	31	—	—	5.5	73.2	15	13 (Max. 38)	152	RB2015

With high load shock absorber + Adjusting bolt

MY1C  Bore size  — Stroke  A

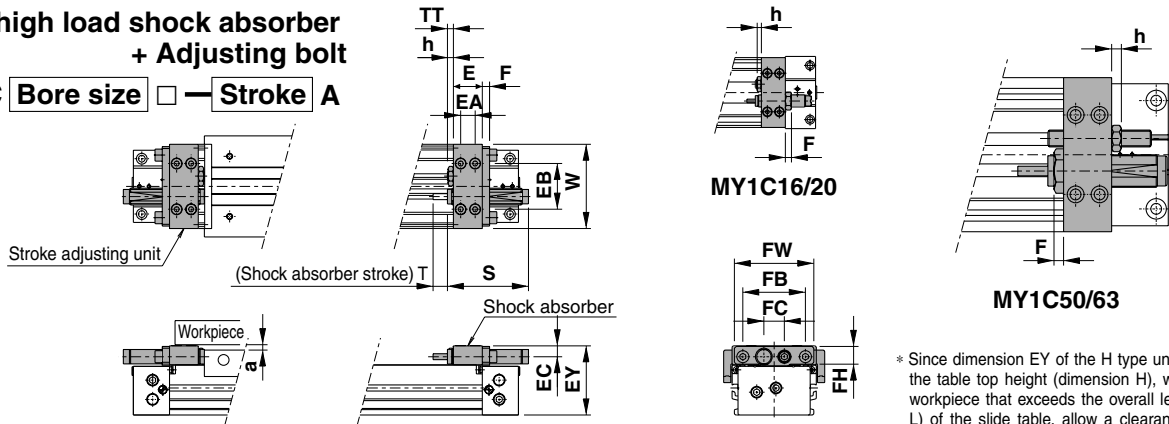

\* Since dimension EY of the H type unit is greater than the table top height (dimension H), when mounting a workpiece that exceeds the overall length (dimension L) of the slide table, allow a clearance of dimension "a" or larger on the workpiece side.

Applicable bore size	E	EA	EB	EC	EY	F	FB	FC	FH	FW	h	S	T	TT	W	Shock absorber model	a
MY1C20	20	10	32	7.7	50	5	—	14	—	—	3.5	46.7	7	5 (Max. 11)	58	RB1007	5
MY1C25	24	12	38	9	57.5	6	52	17	16	66	4.5	67.3	12	5 (Max. 16.5)	70	RB1412	4.5
MY1C32	29	14	50	11.5	73	8	67	22	22	82	5.5	73.2	15	8 (Max. 20)	88	RB2015	6
MY1C40	35	17	57	12	87	8	78	22	22	95	5.5	73.2	15	9 (Max. 25)	104	RB2015	4
MY1C50	40	20	66	18.5	115	8	—	30	—	—	11	99	25	13 (Max. 33)	128	RB2725	9
MY1C63	52	26	77	19	138.5	8	—	35	—	—	11	99	25	13 (Max. 38)	152	RB2725	9.5

## Side Support

### Side support A MY-S□□A

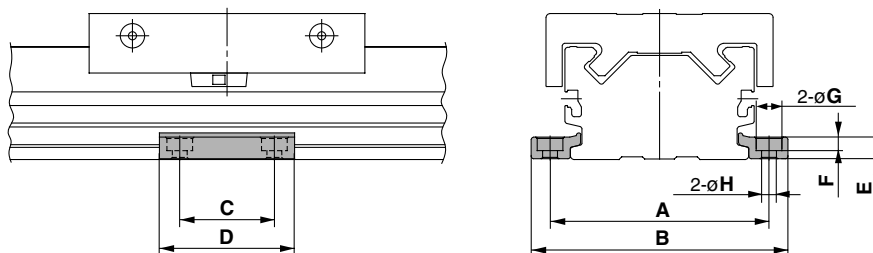

### Side support B MY-S□□B

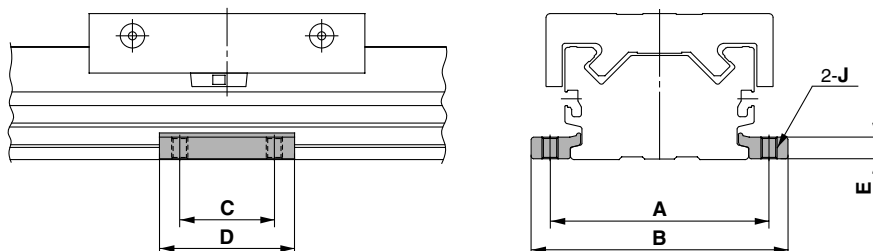

Model	Applicable bore size	A	B	C	D	E	F	G	H	J
MY-S16 <sup>A</sup> <sub>B</sub>	MY1C16	61	71.6	15	26	4.9	3	6.5	3.4	M4 x 0.7
MY-S20 <sup>A</sup> <sub>B</sub>	MY1C20	67	79.6	25	38	6.4	4	8	4.5	M5 x 0.8
MY-S25 <sup>A</sup> <sub>B</sub>	MY1C25	81	95	35	50	8	5	9.5	5.5	M6 x 1
MY-S32 <sup>A</sup> <sub>B</sub>	MY1C32	100	118	45	64	11.7	6	11	6.6	M8 x 1.25
MY-S40 <sup>A</sup> <sub>B</sub>	MY1C40	120	142	55	80	14.8	8.5	14	9	M10 x 1.5
MY-S50 <sup>A</sup> <sub>B</sub>	MY1C50	142	164							
MY-S63 <sup>A</sup> <sub>B</sub>	MY1C63	172	202	70	100	18.3	10.5	17.5	11.5	M12 x 1.75

- MX□
- MTS
- MY□
- CY□
- MG□
- CX□
- D-
- X
- 20-
- Data

## Guide for Side Support Application

For long stroke operation, the cylinder tube may be deflected depending on its own weight and the load weight. In such a case, use a side support in the middle section. The spacing ( $\ell$ ) of the support must be no more than the values shown in the graph on the right.

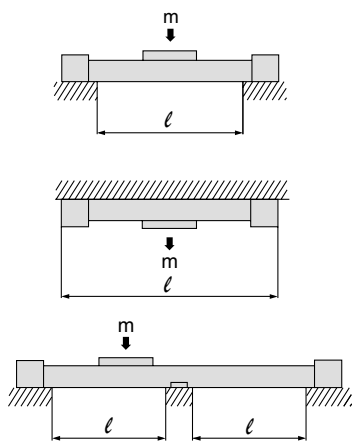

### ⚠ Caution

1. If the cylinder mounting surfaces are not measured accurately, using a side support may cause poor operation. Therefore, be sure to level the cylinder tube when mounting. Also, for long stroke operation involving vibration and impact, use of a side support is recommended even if the spacing value is within the allowable limits shown in the graph.
2. Support brackets are not for mounting; use them solely for providing support.

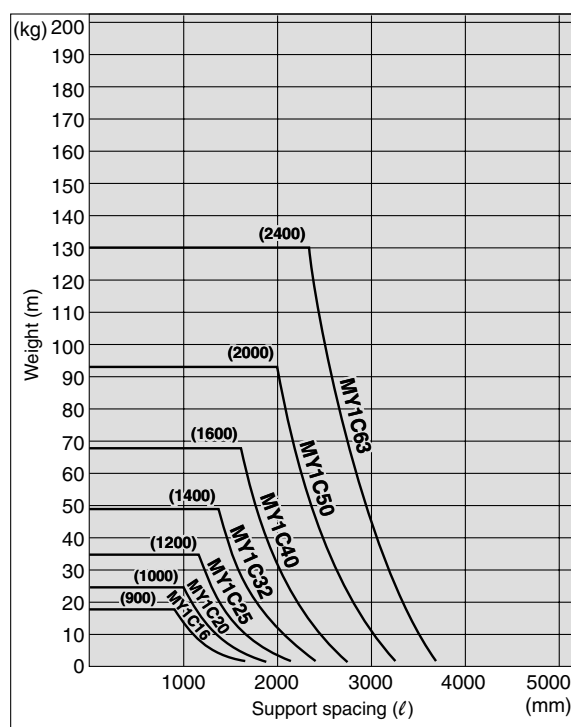



# Series MY1C

Construction:  $\varnothing 16$  to  $\varnothing 63$

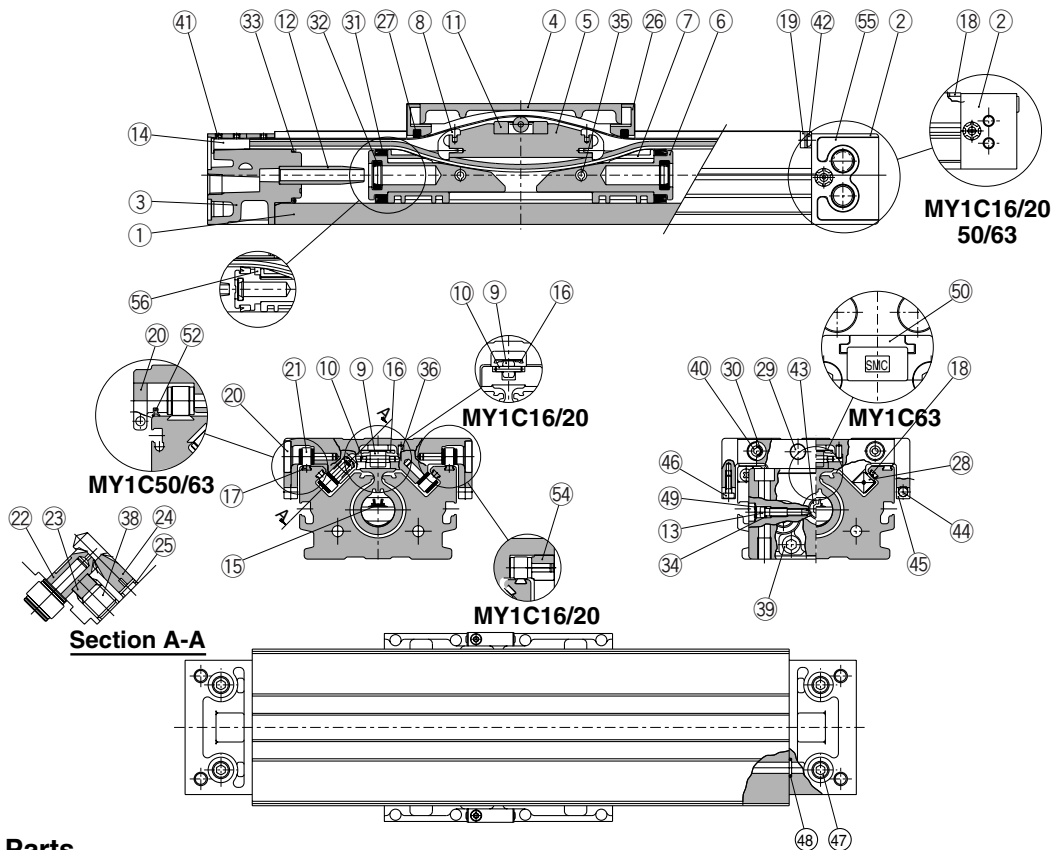

## Component Parts

No.	Description	Material	Note
①	Cylinder tube	Aluminum alloy	Hard anodized
②	Head cover WR	Aluminum alloy	Painted
③	Head cover WL	Aluminum alloy	Painted
④	Slide table	Aluminum alloy	Electroless nickel plated
⑤	Piston yoke	Aluminum alloy	Chromated
⑥	Piston	Aluminum alloy	Chromated
⑦	Wear ring	Special resin	
⑧	Belt separator	Special resin	
⑨	Guide roller	Special resin	
⑩	Guide roller shaft	Stainless steel	
⑪	Coupler	Sintered iron material	
⑫	Cushion ring	Brass	
⑬	Cushion needle	Rolled steel	Nickel plated
⑭	Belt clamp	Special resin	
⑰	Rail	Hard steel wire material	
⑱	End spacer	Special resin	
⑲	End clamp	Stainless steel	Rubber lining ( $\varnothing 25$ to $\varnothing 40$ )
⑳	Cam follower cap	Special resin	( $\varnothing 25$ to $\varnothing 40$ )
㉑	Cam follower		
㉒	Eccentric gear	Stainless steel	
㉓	Gear bracket	Stainless steel	
㉔	Adjustment gear	Stainless steel	
㉕	Snap ring	Stainless steel	

No.	Description	Material	Note
㉖	End Cover	Special resin	
㉘	Backup plate	Special resin	
㉙	Stopper	Carbon steel	Nickel plated
㉚	Spacer	Stainless steel	
㉛	Spring pin	Carbon tool steel	Black zinc chromated
㉜	Parallel pin	Stainless steel	
㉝	Hexagon socket head set screw	Chromium molybdenum steel	Black zinc chromated
㉞	Hexagon socket head cap screw	Chromium molybdenum steel	Nickel plated
㉟	Hexagon socket button head screw	Chromium molybdenum steel	Nickel plated
㊱	Hexagon socket head set screw	Chromium molybdenum steel	Black zinc chromated/Nickel plated
㊲	Round head Phillips screw	Chromium molybdenum steel	Nickel plated
㊳	Hexagon socket head taper plug	Carbon steel	Nickel plated
㊴	Magnet	Rare earth magnet	
㊵	Magnet holder	Special resin	
㊶	Hexagon socket head cap screw	Chromium molybdenum steel	Nickel plated
㊷	Hexagon socket head taper plug	Carbon steel	Nickel plated
㊸	Type CR retaining ring	Spring steel	
㊹	Head plate	Aluminum alloy	Hard anodized ( $\varnothing 63$ )
㊺	Side scraper	Special resin	( $\varnothing 50$ to $\varnothing 63$ )
㊻	Bushing	Aluminum alloy	( $\varnothing 16$ to $\varnothing 20$ )
㊼	Port cover	Special resin	( $\varnothing 25$ to $\varnothing 40$ )
㊽	Felt B	Felt	( $\varnothing 16$ to $\varnothing 20$ )

## Seal List

No.	Description	Material	Qty.	MY1C16	MY1C20	MY1C25	MY1C32	MY1C40	MY1C50	MY1C63
⑮	Seal belt	Special resin	1	MY16-16A-Stroke	MY20-16A-Stroke	MY25-16A-Stroke	MY32-16A-Stroke	MY40-16A-Stroke	MY50-16A-Stroke	MY63-16A-Stroke
⑯	Dust seal band	Stainless steel	1	MY16-16B-Stroke	MY20-16B-Stroke	MY25-16B-Stroke	MY32-16B-Stroke	MY40-16B-Stroke	MY50-16B-Stroke	MY63-16B-Stroke
㉗	Scraper	NBR	2	MYM16-15AK0500	MYM20-15AK0501	MYM25-15AA5903	MYM32-15AA5904	MYM40-15AA5905	MYM50-15AK0502	MYM63-15AK0503
㉘	Piston seal	NBR	2	GM Y16	GM Y20	GM Y25	GM Y32	GM Y40	GM Y50	GM Y63
㉙	Cushion seal	NBR	2	MYB16-15-A7163	MYB20-15-A7164	RCS-8	RCS-10	RCS-12	MC-16	MC-20
㉚	Tube gasket	NBR	2	P12	P16	TMY-25	TMY-32	TMY-40	P44	P53
㉛	O-ring	NBR	2	$\varnothing 4 \times \varnothing 1.8 \times \varnothing 1.1$	$\varnothing 5.1 \times \varnothing 3 \times \varnothing 1.05$	$\varnothing 5.1 \times \varnothing 3 \times \varnothing 1.05$	$\varnothing 7.15 \times \varnothing 3.75 \times \varnothing 1.7$	$\varnothing 8.3 \times \varnothing 4.5 \times \varnothing 1.9$	C-4	C-4
㉜	O-ring	NBR	4	$\varnothing 7 \times \varnothing 4 \times \varnothing 1.5$	$\varnothing 7 \times \varnothing 4 \times \varnothing 1.5$	C-6	C-7	C-9	C-11.2	C-14
㉝	Side scraper	Special resin	2	—	—	—	—	—	MYM50-15CK0502B	MYM63-15CK0503B

Note) Two types of dust seal bands are available. Verify the type to use, since the part number varies depending on the treatment of the hexagon socket head set screw ④. (A) Black zinc chromated → MY□□-16B-Stroke (B) Nickel plated → MY□□-16BW-Stroke



# Series MY1

## Auto Switch

### D-A90(V), D-A93(V), D-A96(V)



Applicable cylinder series

Applicable cylinder series	Bore size (mm)									
	10	16	20	25	32	40	50	63	80	100
MY1B (Basic type)	●	●	●							
MY1M (Slide bearing type)		●	●							
MY1C (Cam follower guide type)		●	●							
MY1H (High precision guide type)	●	●	●							

### D-Z73, D-Z76, D-Z80



Applicable cylinder series

Applicable cylinder series	Bore size (mm)									
	16	20	25	32	40	50	63	80	100	
MY1B (Basic type)			●	●	●	●	●	●	●	●
MY1M (Slide bearing type)			●	●	●	●	●	●	●	●
MY1C (Cam follower guide type)			●	●	●	●	●	●	●	●
MY1H (High precision guide type)			●	●	●					
MY1HT (High rigidity/High precision guide type)						●	●			

### D-M9N(V), D-M9P(V), D-M9B(V)



Applicable cylinder series

Applicable cylinder series	Bore size (mm)									
	10	16	20	25	32	40	50	63	80	100
MY1B (Basic type)	●	●	●							
MY1M (Slide bearing type)		●	●							
MY1C (Cam follower guide type)		●	●							
MY1H (High precision guide type)	●	●	●							

### D-F9NW(V), D-F9PW(V), D-F9BW(V)

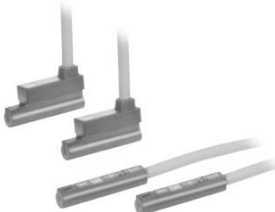

Applicable cylinder series

Applicable cylinder series	Bore size (mm)									
	10	16	20	25	32	40	50	63	80	100
MY1B (Basic type)	●	●	●							
MY1M (Slide bearing type)		●	●							
MY1C (Cam follower guide type)		●	●							
MY1H (High precision guide type)	●	●	●							

### D-Y59<sup>A</sup><sub>B</sub>, D-Y69<sup>A</sup><sub>B</sub>, D-Y7P(V)



Applicable cylinder series

Applicable cylinder series	Bore size (mm)									
	16	20	25	32	40	50	63	80	100	
MY1B (Basic type)			●	●	●	●	●	●	●	●
MY1M (Slide bearing type)			●	●	●	●	●	●	●	●
MY1C (Cam follower guide type)			●	●	●	●	●	●	●	●
MY1H (High precision guide type)			●	●	●					
MY1HT (High rigidity/High precision guide type)						●	●			

### D-Y7NW(V), D-Y7PW(V), D-Y7BW(V)

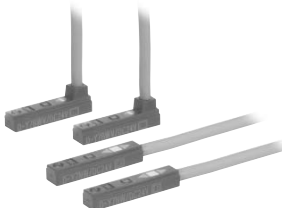

Applicable cylinder series

Applicable cylinder series	Bore size (mm)									
	16	20	25	32	40	50	63	80	100	
MY1B (Basic type)			●	●	●	●	●	●	●	●
MY1M (Slide bearing type)			●	●	●	●	●	●	●	●
MY1C (Cam follower guide type)			●	●	●	●	●	●	●	●
MY1H (High precision guide type)			●	●	●					
MY1HT (High rigidity/High precision guide type)						●	●			

Other than the applicable auto switches listed in "How to Order", the following auto switches can be mounted. For detailed specifications, refer to page 8-30-1.

Type	Model	Electrical entry (Fetching direction)	Features
Reed switch	D-A90	Grommet (In-line)	Without indicator light
	D-Z80	Grommet (In-line)	

- Normally closed (NC = b contact), solid state switch (D-F9G/F9H/Y7G/Y7H type) are also available. For details, refer to page 8-30-31 to 8-30-32.
- D-A90 cannot be mounted on Series MY1HT.

MX

MTS

MY

CY

MG

CX

D-

-X

20-

Data

# Series MY1

## Proper Auto Switch Mounting Position (Detection at stroke end) D-A9□(V)

Note) The operating range is a guide including hysteresis, but is not guaranteed. (Assuming approximately 30% dispersion.) There may be varied substantially depending on the surrounding environment.

### MY1B (Basic type)

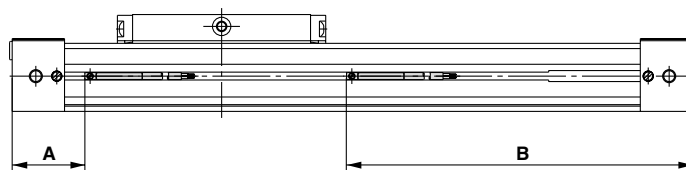

(mm)

Mounting position	ø10	ø16	ø20
<b>A</b>	20	27	35
<b>B</b>	90	133	165
Operating range $l$ (Note)	6	6.5	8.5

### MY1M (Slide bearing guide type)

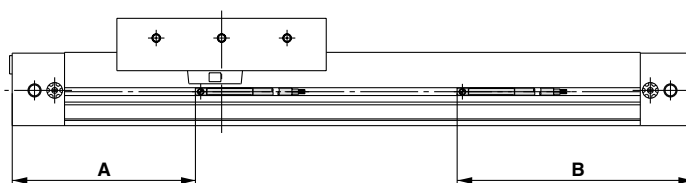

(mm)

Mounting position	ø16	ø20
<b>A</b>	70	90
<b>B</b>	90	110
Operating range $l$ (Note)	11	7.5

### MY1C (Cam follower guide type)

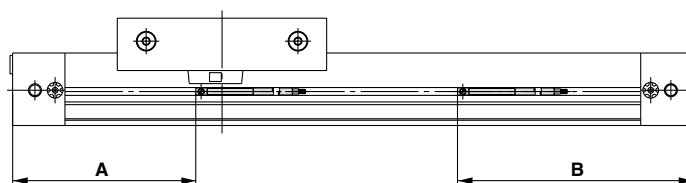

(mm)

Mounting position	ø16	ø20
<b>A</b>	70	90
<b>B</b>	90	110
Operating range $l$ (Note)	11	7.5

### MY1H (High precision guide type)

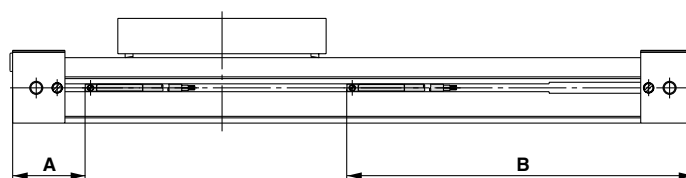

(mm)

Mounting position	ø10	ø16	ø20
<b>A</b>	20	27	35
<b>B</b>	90	133	165
Operating range $l$ (Note)	11	6.5	8.5

## Proper Auto Switch Mounting Position (Detection at stroke end) D-Z7□, D-Z80

(Note) The operating range is a guide including hysteresis, but is not guaranteed. (Assuming approximately 30% dispersion). There may be varied substantially depending on the surrounding environment.

### MY1B (Basic type)

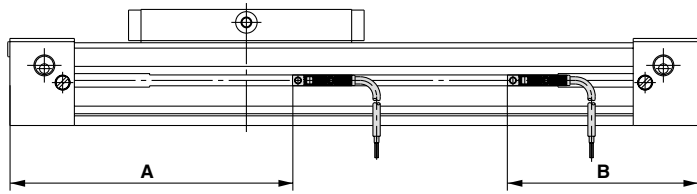

(mm)							
Mounting position	ø25	ø32	ø40	ø50	ø63	ø80	ø100
<b>A</b>	131.5	180	216	272.5	317.5	484.5	569.5
<b>B</b>	88.5	100	124	127.5	142.5	205.5	230.5
Operating range $l$ (Note)	8.5	11.5	11.5	11.5	11.5	11.5	11.5

### MY1M (Slide bearing guide type)

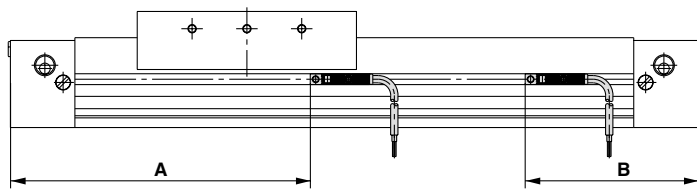

(mm)					
Mounting position	ø25	ø32	ø40	ø50	ø63
<b>A</b>	139.5	184.5	229.5	278.5	323.5
<b>B</b>	80.5	95.5	110.5	121.5	136.5
Operating range $l$ (Note)	12	12	12	11.5	11.5

### MY1C (Cam follower guide type)

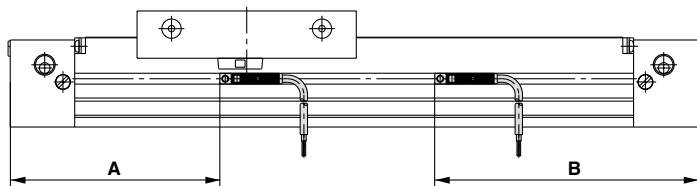

(mm)					
Mounting position	ø25	ø32	ø40	ø50	ø63
<b>A</b>	97.5	127.5	157.5	278.5	323.5
<b>B</b>	122.5	152.5	182.5	121.5	136.5
Operating range $l$ (Note)	12	12	12	11.5	11.5

### MY1H (High precision guide type)

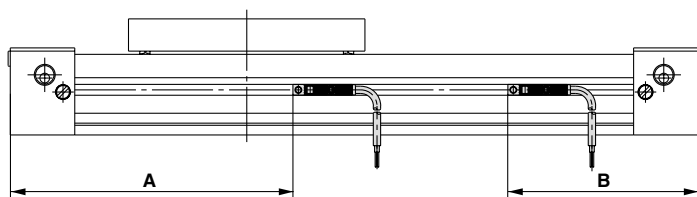

(mm)			
Mounting position	ø25	ø32	ø40
<b>A</b>	131.5	180	216
<b>B</b>	88.5	100	124
Operating range $l$ (Note)	8.5	11.5	11.5

### MY1HT (High rigidity/High precision guide type)

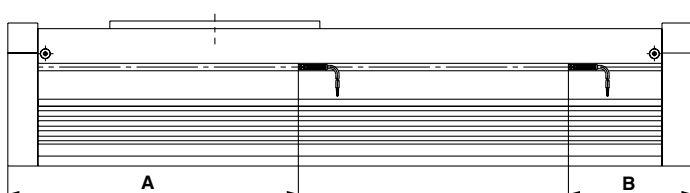

(mm)		
Mounting position	ø50	ø63
<b>A</b>	290.5	335.5
<b>B</b>	123.5	138.5
Operating range $l$ (Note)	11	11

MX□

MTS

MY□

CY□

MG□

CX□

D-

-X

20-

Data

# Series MY1

## Proper Auto Switch Mounting Position (Detection at stroke end) D-M9□, D-M9□V, D-F9□W, D-F9□WV

Note) The operating range is a guide including hysteresis, but is not guaranteed. (assuming approximately 30% dispersion.) There may be varied substantially depending on the surrounding environment.

### MY1B (Basic type)

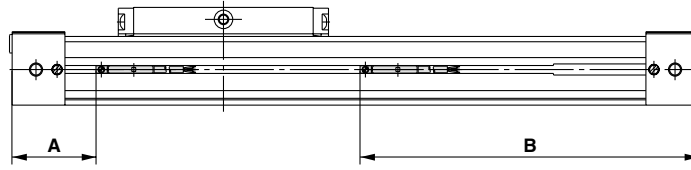

Mounting position	ø10	ø16	ø20
<b>A</b>	24	31	39
<b>B</b>	86	129	161
Operating range ℓ <sup>Note)</sup>	3 (2.5)	4 (3)	5 (3.5)

Note) Figures in parentheses are the cases for D-M9□, D-M9□V switch types.

### MY1M (Slide bearing guide type)

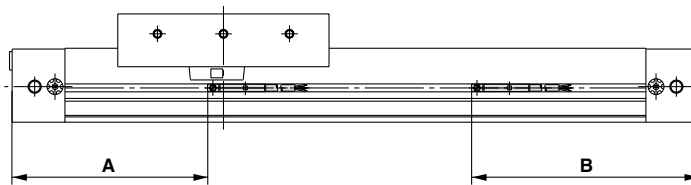

Mounting position	ø16	ø20
<b>A</b>	74	94
<b>B</b>	86	106
Operating range ℓ <sup>Note)</sup>	8.5 (6.5)	6.5 (7)

Note) Figures in parentheses are the cases for D-M9□, D-M9□V switch types.

### MY1C (Cam follower guide type)

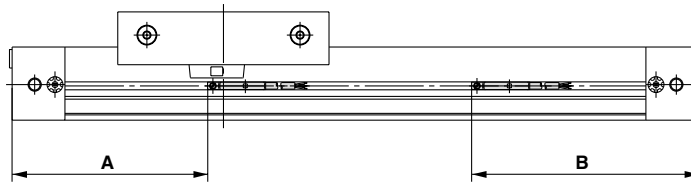

Mounting position	ø16	ø20
<b>A</b>	74	94
<b>B</b>	86	106
Operating range ℓ <sup>Note)</sup>	8.5 (6.5)	6.5 (7)

Note) Figures in parentheses are the cases for D-M9□, D-M9□V switch types.

### MY1H (High precision guide type)

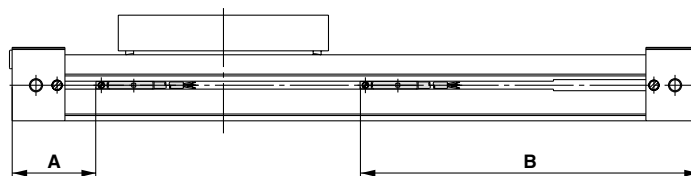

Mounting position	ø10	ø16	ø20
<b>A</b>	24	31	39
<b>B</b>	86	129	161
Operating range ℓ <sup>Note)</sup>	3 (2)	4 (3)	5 (3.5)

Note) Figures in parentheses are the cases for D-M9□, D-M9□V switch types.

## Proper Auto Switch Mounting Position (Detection at stroke end) D-Y59□, D-Y69□, D-Y7P, D-Y7PV

Note) The operating range is a guide including hysteresis, but is not guaranteed. (Assuming approximately 30% dispersion.) There may be varied substantially depending on the surrounding environment.

### MY1B (Basic type)

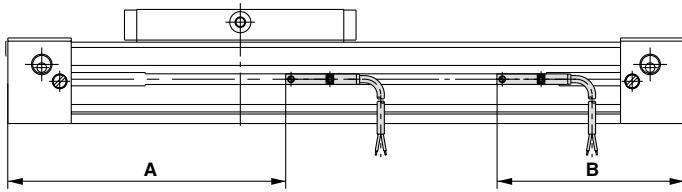

(mm)							
Mounting position	ø25	ø32	ø40	ø50	ø63	ø80	ø100
<b>A</b>	131.5	180	216	272.5	317.5	484.5	569.5
<b>B</b>	88.5	100	124	127.5	142.5	205.5	230.5
Operating range $l$ (Note)	6	9	10	3.5	3.5	3.5	3.5

### MY1M (Slide bearing guide type)

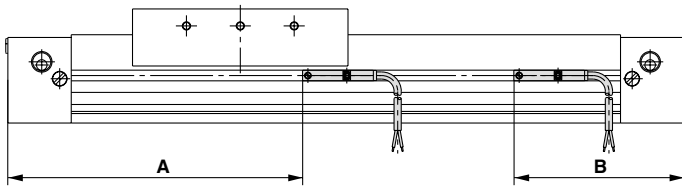

(mm)					
Mounting position	ø25	ø32	ø40	ø50	ø63
<b>A</b>	139.5	184.5	229.5	278.5	323.5
<b>B</b>	80.5	95.5	110.5	121.5	136.5
Operating range $l$ (Note)	5	5	5	5.5	5.5

### MY1C (Cam follower guide type)

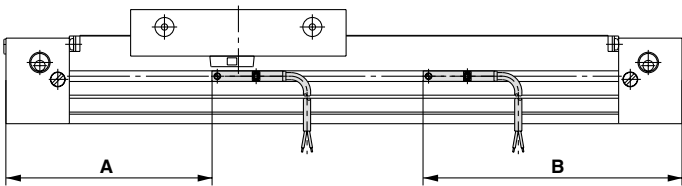

(mm)					
Mounting position	ø25	ø32	ø40	ø50	ø63
<b>A</b>	97.5	127.5	157.5	278.5	323.5
<b>B</b>	122.5	152.5	182.5	121.5	136.5
Operating range $l$ (Note)	5	5	5	5.5	5.5

### MY1H (High precision guide type)

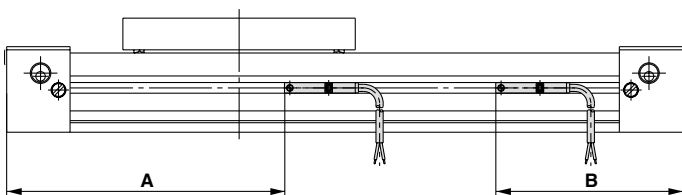

(mm)			
Mounting position	ø25	ø32	ø40
<b>A</b>	131.5	180	216
<b>B</b>	88.5	100	124
Operating range $l$ (Note)	6	9	10

### MY1HT (High rigidity/High precision guide type)

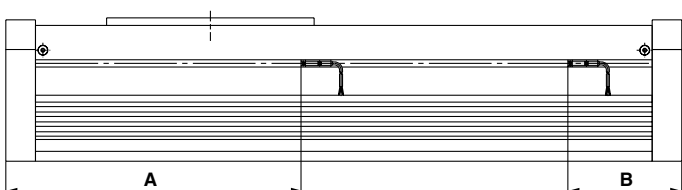

(mm)		
Mounting position	ø50	ø63
<b>A</b>	290.5	335.5
<b>B</b>	123.5	138.5
Operating range $l$ (Note)	5	5

MX□

MTS

MY□

CY□

MG□

CX□

D-

-X

20-

Data

# Series MY1

## Proper Auto Switch Mounting Position (Detection at stroke end) D-Y7□W, D-Y7□WV

Note) The operating range is a guide including hysteresis, but is not guaranteed. (Assuming approximately 30% dispersion.) There may be varied substantially depending on the surrounding environment.

### MY1B (Basic type)

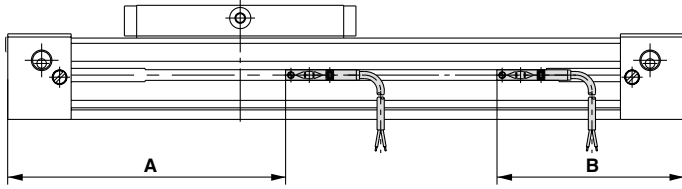

Mounting position	ø25	ø32	ø40	ø50	ø63	ø80	ø100
<b>A</b>	131.5	180	216	272.5	317.5	484.5	569.5
<b>B</b>	88.5	100	124	127.5	142.5	205.5	230.5
Operating range $l$ (Note)	6	9	10	3.5	3.5	3.5	3.5

### MY1M (Slide bearing guide type)

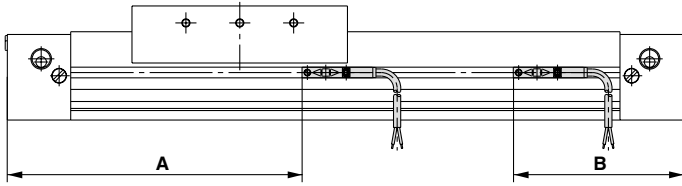

Mounting position	ø25	ø32	ø40	ø50	ø63
<b>A</b>	139.5	184.5	229.5	278.5	323.5
<b>B</b>	80.5	95.5	110.5	121.5	136.5
Operating range $l$ (Note)	5	5	5	5.5	5.5

### MY1C (Cam follower guide type)

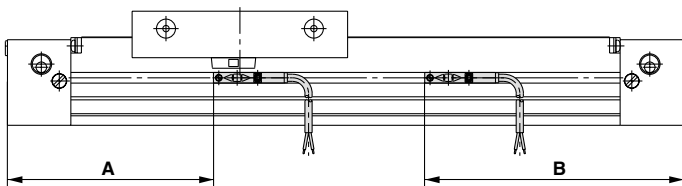

Mounting position	ø25	ø32	ø40	ø50	ø63
<b>A</b>	97.5	127.5	157.5	278.5	323.5
<b>B</b>	122.5	152.5	182.5	121.5	136.5
Operating range $l$ (Note)	5	5	5	5.5	5.5

### MY1H (High precision guide type)

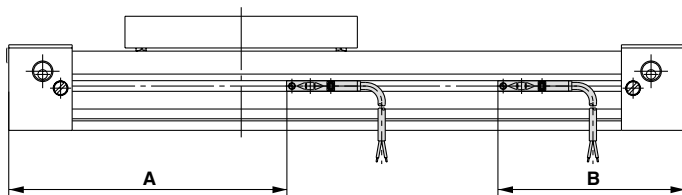

Mounting position	ø25	ø32	ø40
<b>A</b>	131.5	180	216
<b>B</b>	88.5	100	124
Operating range $l$ (Note)	6	9	10

### MY1HT (High rigidity/High precision guide type)

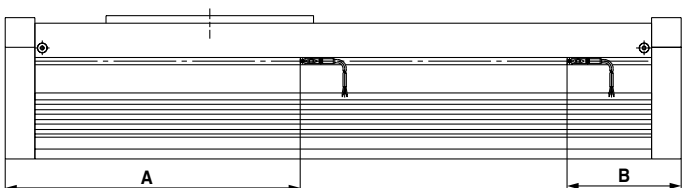

Mounting position	ø50	ø63
<b>A</b>	290.5	335.5
<b>B</b>	123.5	138.5
Operating range $l$ (Note)	5	5