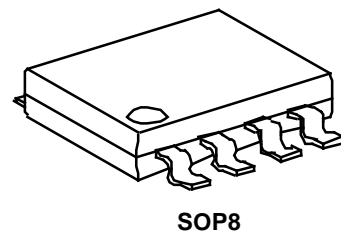
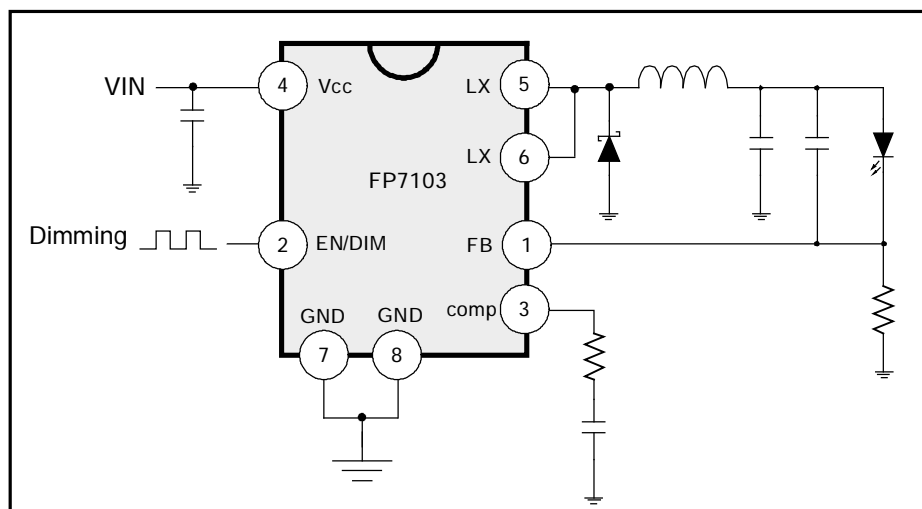

0.25V SWITCHING BUCK REGULATOR**GENERAL DESCRIPTION**

The **FP7103** is PWM control buck converter designed to provide a simple, high efficiency solution for driving high power LEDs. With a **0.25V** reference voltage feedback control to minimize power dissipation, an external resistor sets the current as needed for driving various types of LEDs. The **FP7103** includes a high current P-MOSFET, high efficiency and excellent transient characteristics. The PWM control circuit is able to the duty ratio linearly from 0 up to 100%. The features include user accessible EN/DIM pin for enabling and PWM dimming of LEDs, thermal shutdown, cycle-by cycle current limit and over current protection.

FEATURES

- Precision feedback reference voltage: 0.25V (2%)
- Wide supply voltage operating range: 3.6 to 28V
- Low current consumption: 4mA
- Internal fixed oscillator frequency: Typ. 320KHz
- Built-in P-MOSFET for 3A loading capability
- Over Current Protection
- Package: SOP8

**TYPICAL APPLICATION**

FUNCTIONAL BLOCK DIAGRAM

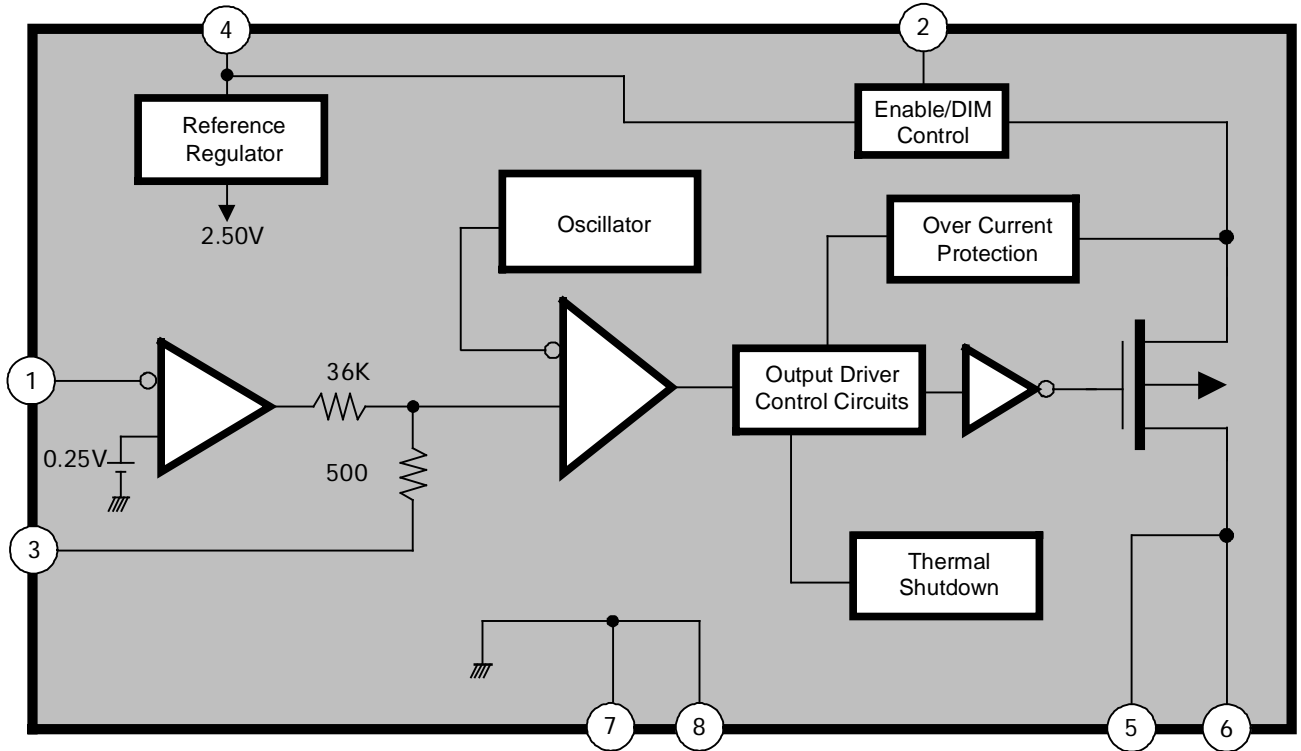

MARK VIEW

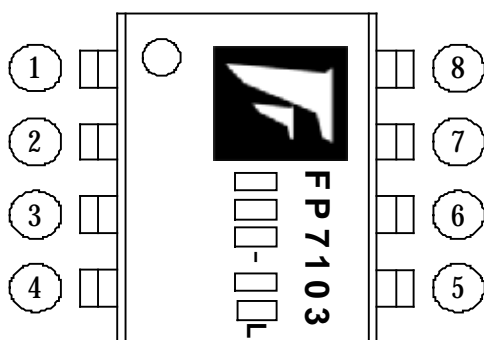

PIN DESCRIPTION

Name	No.	I/O	Description
FB	1	I	Error Amplifier Inverting Input
EN/DIM	2	I	Enable Control
COMP	3	O	Error Amplifier Compensation Output
VCC	4	P	IC Power Supply (PMOS Source)
LX	5	P	PMOS High Current Output
	6		
GND	7	O	IC Ground
	8		

ORDER INFORMATION

Part Number	Operating Temperature	Package	Description
FP7103D-LF	-25°C ~ +105°C	SOP8	Tube
FP7103DR-LF	-25°C ~ +105°C	SOP8	Tape & Reel

IC DATE CODE DISTINGUISH

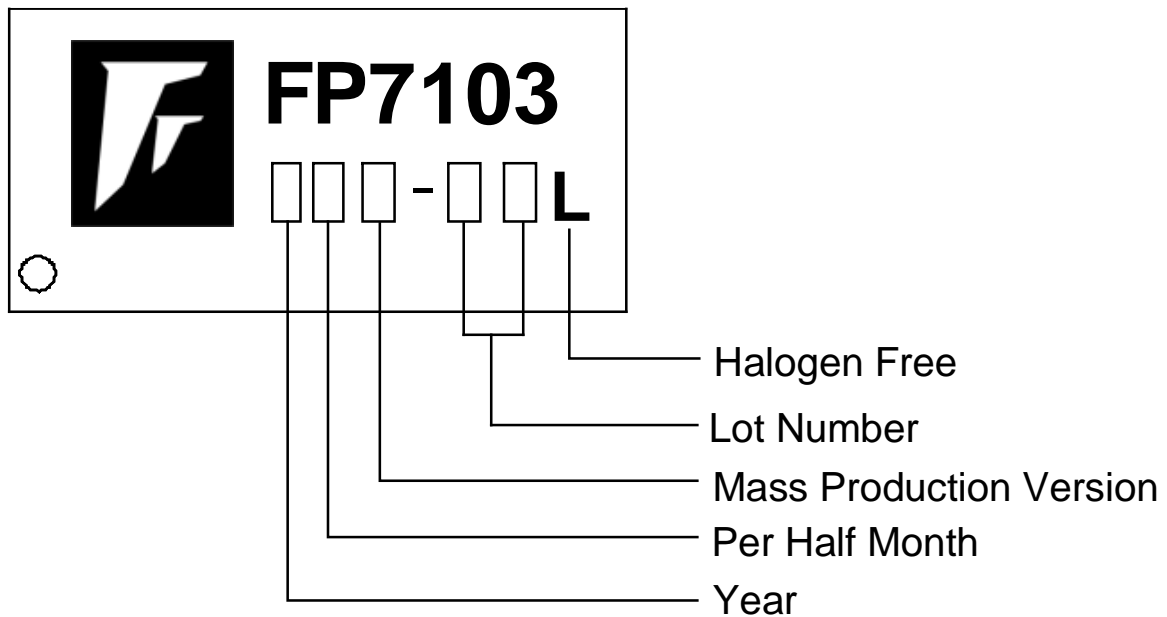

FOR EXAMPLE:

January A (Front Half Month), B (Last Half Month)
 February C, D
 March E, F -----And so on

The printing ink of the lot number is a last two numbers of one wafer lot:

For Example:

A3311C62
 └──────────▶ Lot Number

ABSOLUTE MAXIMUM RATINGS

Power supply voltage -----	+28V
Output source current -----	+3A
Error amplifier inverting input -----	-0.3V~+1.2V
Allowable dissipation	
SOP8 Ta≤+25°C -----	650mW
Thermal Resistance Junction to Ambient -----	175°C/W
Thermal Resistance Junction to Case -----	45°C/W
Operating temperature-----	-25°C ~ +105°C
ESD Susceptibility	
HBM (Human Body Mode)-----	2KV
MM (Machine Mode)-----	200V
Storage temperature-----	-55°C ~ +125°C
SOP8 Lead Temperature (soldering, 10 sec) -----	+260°C

Recommend: IR Reflow

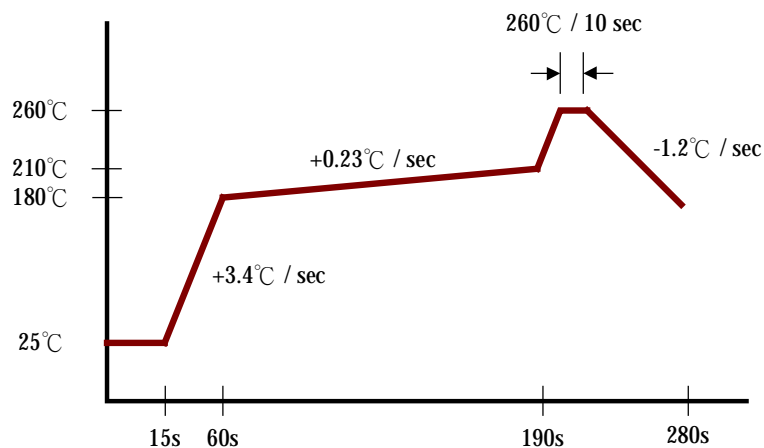

FP7103 IR Re-flow Soldering Curve

DC ELECTRICAL CHARACTERISTICS

Electrical characteristics over recommended operating free-air temperature range, $V_{CC}=6V$, (unless otherwise noted)

Reference

PARAMETER	SYMBOL	TEST CONDITIONS	MIN	TYP	MAX	UNIT
Output voltage	V_{REF}	FB connected to COMP	0.245	0.25	0.255	V
Input regulation	ΔV_{REF}	$V_{CC}=3.6V$ to 25 V	-	2	12.5	mV
Output voltage change with temperature	$\Delta V_{REF} / V_{REF}$	$T_A = -25^{\circ}C$ to $25^{\circ}C$	-	1	2	%
		$T_A = 25^{\circ}C$ to $85^{\circ}C$	-	1	2	

Oscillator section

PARAMETER	SYMBOL	TEST CONDITIONS	MIN.	TYP.	MAX.	UNIT
Oscillation frequency	f	--	-	320	-	KHz
Frequency change with voltage	$\Delta f / \Delta V$	$V_{CC}=3.6V$ to 25V	-	5	-	%
Frequency change with temperature	$\Delta f / \Delta T$	$T_a = -25^{\circ}C$ to $+85^{\circ}C$	-	5	-	%

Error Amplifier section

PARAMETER	SYMBOL	TEST CONDITIONS	MIN.	TYP.	MAX.	UNIT
Input bias current	I_B	--	-1.0	-0.2	1.0	μA
Voltage Gain	A_v	--	-	100	-	V/V
Frequency bandwidth	BW	$A_v=0$ dB	-	6	-	MHz
Output voltage Swing	Positive	V_{POS}	1.7	2	-	V
	Negative	V_{NEG}	-	0.1	0.2	
Output source current	I_{SOURCE}	$V_{comp}=200mV$	-15	-30	-	μA
Output sink current	I_{SINK}		15	30	-	μA

Idle Period Adjustment section

PARAMETER	SYMBOL	TEST CONDITIONS	MIN.	TYP.	MAX.	UNIT
Maximum duty cycle	T_{DUTY}	$V_{FB}=0.2V$	-	100	-	%

DC ELECTRICAL CHARACTERISTICS (Cont.)

Output section

PARAMETER	SYMBOL	TEST CONDITIONS	MIN.	TYP.	MAX.	UNIT
PMOS D-S voltage	V_{DSS}	$V_{COMP}=0.1V$	-	-20	-	V
PMOS source current	I_D	--	-	-3	-	A
PMOS On resistance	$R_{DS(ON)}$	$V_{CC}=4.5V, V_{FB}=0V$	-	40.5	52	$m\Omega$
		$V_{CC}=10V, V_{FB}=0V$	-	64	87	
Output leakage current	I_L	$V_{DS}=-24V, V_{GS}=0V$	-	-	-1	μA

Thermal Shutdown section

PARAMETER	SYMBOL	TEST CONDITIONS	MIN.	TYP.	MAX.	UNIT
Thermal shutdown temperature	--	--	-	150	-	$^{\circ}C$

Over Current Protection section

PARAMETER	SYMBOL	TEST CONDITIONS	MIN.	TYP.	MAX.	UNIT
PMOS OCP current	I_{OCP}	--	-	4	-	A

Total device section

PARAMETER	SYMBOL	TEST CONDITIONS	MIN.	TYP.	MAX.	UNIT
EN Input Current	I_{EN}	EN pin open	-	40	-	μA
Upper threshold voltage (EN)	V_{UPPER}	--	-	1.12	-	V
Lower threshold voltage (EN)	V_{LOW}	--	-	0.87	-	V
Hysteresis	V_{HYS}	--	210	250	-	mV
Average supply current	I_{AVE}	--	-	4	6	mA
VCC Shutdown Current	$I_{shutdown}$	--	-	15	-	μA

DETAILED DESCRIPTION

Voltage Reference

A 2.5V reference regulator supplies **FP7103** internal circuits and uses the resistive dividers to provide a **0.25V** precision reference voltage on the non-inverting terminal of error amplifier.

Setting the LED Current

FP7103 is a constant current buck regulator. The LEDs are connected between V_{OUT} and FB pin as shown in the Typical Application Circuit. The FB pin is at **0.25V** in regulation and therefore the LEDs current I_F is set by V_{FB} and the resistor R_2 from FB to ground by the following equation:

$$I_F = \frac{V_{FB}}{R_2}$$

I_F should not exceed the 3A current capability of **FP7103** and therefore R_2 minimum must be approximately 0.13Ω .

Output Voltage

The output voltage is primarily determined by the number of LEDs(n) connected from V_{OUT} to FB pin and therefore V_{OUT} can be written as:

$$V_{OUT} = ((n \times V_F) + V_{FB})$$

where V_F is the forward voltage of one LED at the set LED current level (see LED manufacturer datasheet for forward characteristics curve).

Oscillator

The fixed frequency generates from an internal oscillator, and the typical values are **320KHz**.

Thermal Protection

The thermal protection is functional due to a heavy loading drop and junction temperature achieve 150°C , then **FP7103** output turn off. When junction temperature is lower than 150°C , **FP7103** starts again and power switch turns on.

Over Current Protection

The **FP7103** uses cycle-by-cycle current limit to protect the internal power switch. During each switching cycle, a current limit comparator detects if the power switch current exceeds the internal setting current, and begins over current protection decrease the oscillator frequency to prevent thermal issue.

APPLICATION INFORMATION

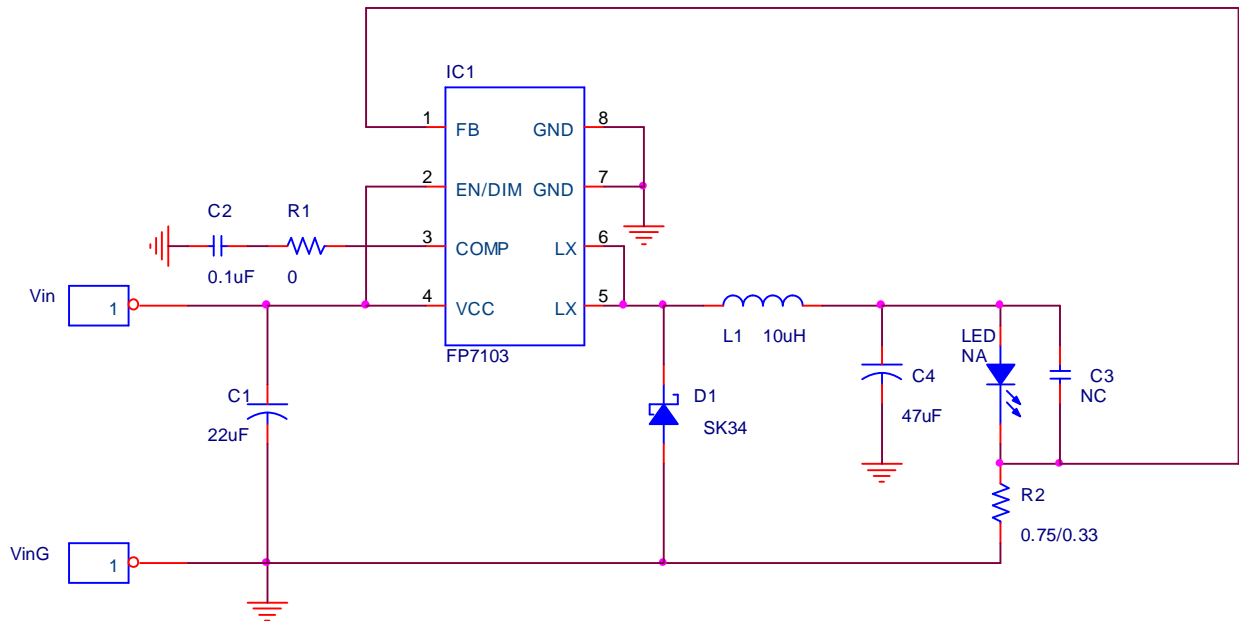

FP7103 1W/3W LED for DC Input Circuit

PACKAGE OUTLINE SOP8

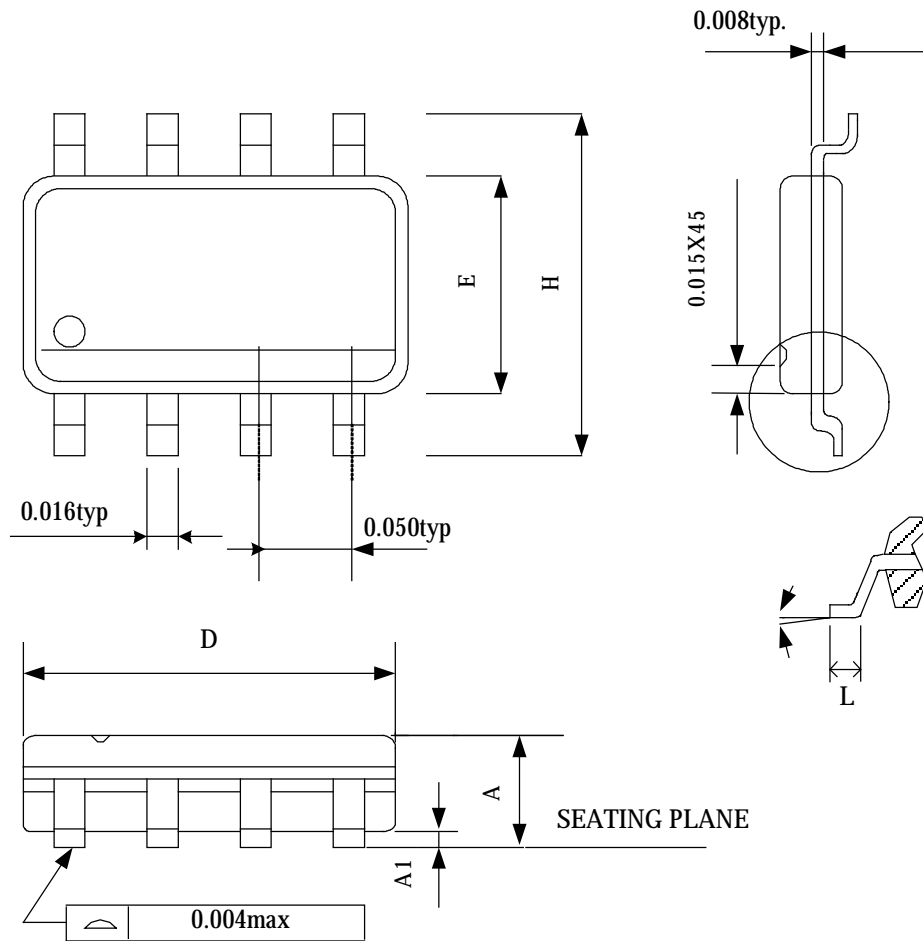

SYMBOLS	MIN	MAX
A	0.053	0.069
A1	0.004	0.010
D	0.189	0.196
E	0.150	0.157
H	0.228	0.244
L	0.016	0.050
θ°	0	8

UNIT:INCH

NOTE:

1. JEDEC OUTLINE: MS-012 AA
2. DIMENSIONS "D" DOES NOT INCLUDE MOLD FLASH, PROTRUSIONS OR GATE BURRS.MOLD FLASH, PROTRUSIONS AND GATE BURRS SHALL NOT EXCEED .15mm (.06in) PER SIDE
3. DIMENSIONS "E" DOES NOT INCLUDE INTER-LEAD FLASH, OR PROTRUSIONS. INTER-LEAD FLASH AND PROTRUSIONS SHALL NOT EXCEED .25mm (.0.10in) PER SIDE.

PACKING SPECIFICATIONS BOX DIMENSION

TUBE INSIDE BOX AND CARTON

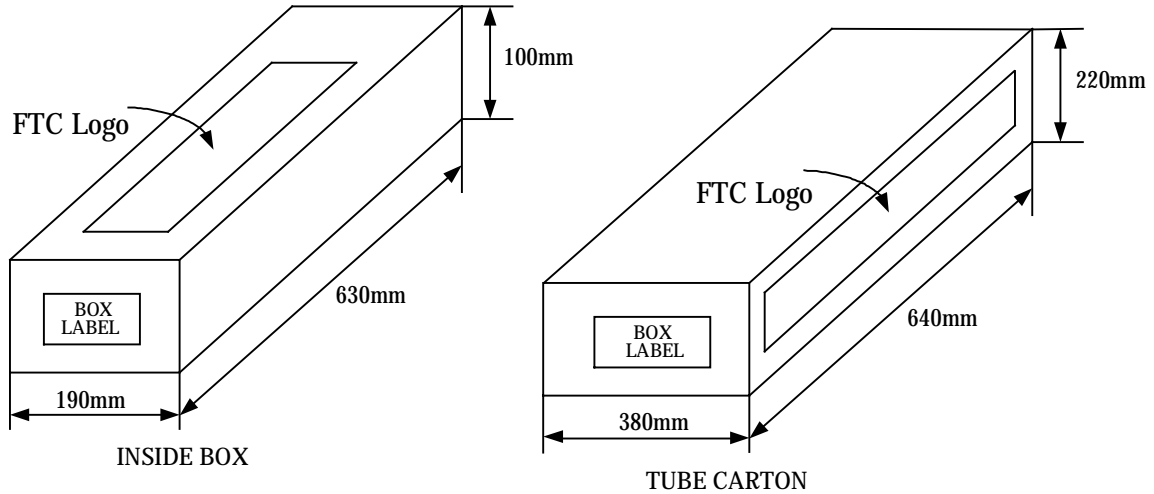

TAPE AND REEL INSIDE BOX AND CARTON

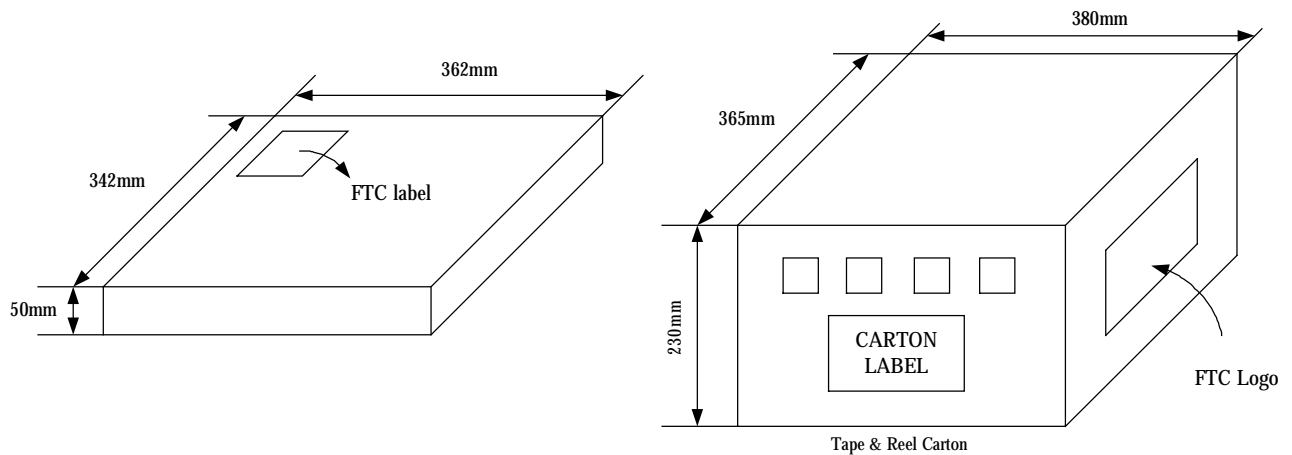

PACKING QUANTITY SPECIFICATIONS

FP7103D-LF SOP8	FP7103DR-LF SOP8
100 EA/TUBE	2500 EA / REEL
100 TUBES / INSIDE BOX	1 REEL / INSIDE BOX
4 INSIDE BOXES / CARTON	4 INSIDE BOXES / CARTON

CARRIER TAPE DIMENSIONS SOP8

APPLICATION	W	P	E	F	D	D ₁
SOP8	12.0 ^{+0.3} _{-0.1}	8.0±0.1	1.75±0.1	5.5±0.1	1.55±0.1	1.5 ^{+0.25}

APPLICATION	P ₀	P ₁	A _D	B ₀	K ₀	T
SOP8	4.0±0.1	2.0±0.1	6.4±0.1	5.20±0.1	2.1±0.10	0.30±0.013

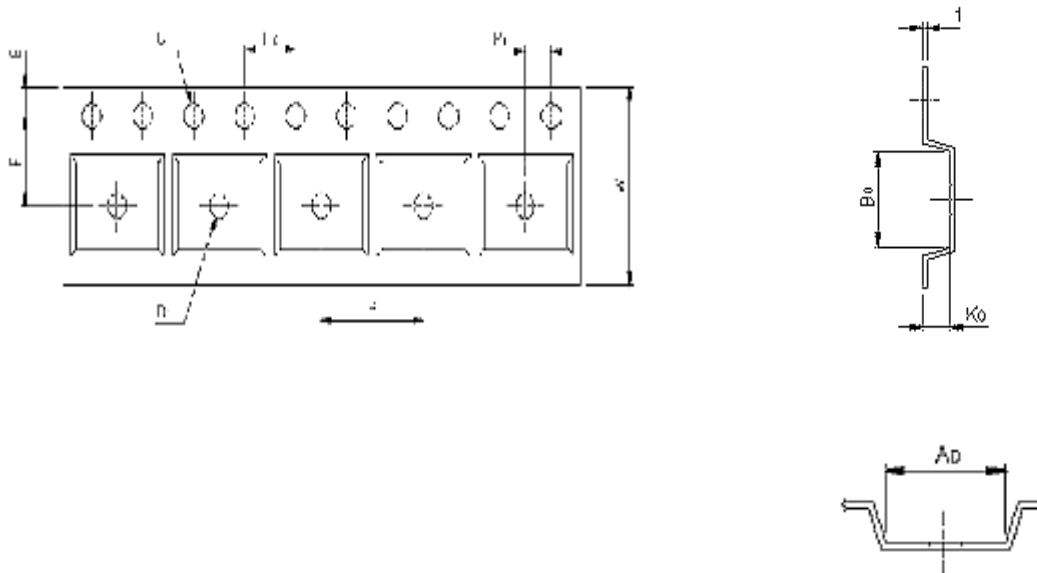

REEL DIMENSIONS

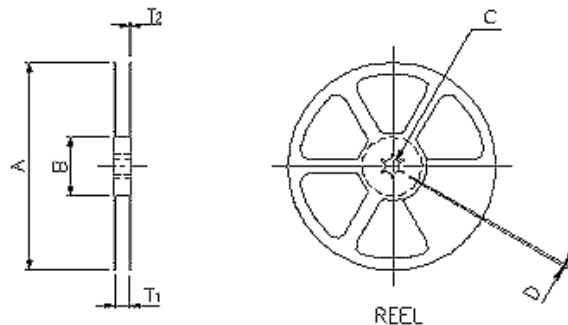

APPLICATION	MATERIAL	A	B	C	D	T ₁	T ₂
SOP8	PLASTIC REEL	330±0.1	62±1.5	12.75±0.15	2±0.6	12.4±0.2	2.0±0.2