

MAYOR
Jim Pappas

CITY OF HUNTERS CREEK VILLAGE

CITY COUNCIL
Stuart Marks
Fidel Sapien
Ken Spalding
Chip Cowell
Jay Carlton



CITY ADMINISTRATOR
Tom Fullen, MPA, CPM

Notice is hereby given of regular meeting of the City Council of Hunters Creek Village, Texas, to be held on **Tuesday, April 27, 2021 at 6:00 p.m.** in the City Hall at #1 Hunters Creek Place, for the purpose of considering the following agenda items. Members of the public may attend the meeting in person or remotely by video or audio conference. The information for attending by video or audio conference is as follows:

VIDEO

- 1) Enter the following web address:
<https://zoom.us/j/92125491501?pwd=bjhMUW90eDlmNjBBZnl5aExxNi9iZz09>
- 2) Enter the following Access Code or Meeting Number: **921 2549 1501**
- 3) Enter the following Attendee ID or Numeric Meeting Password **329623**.

AUDIO

- 1) Call the following toll free number **+1 346 248 7799 US (Houston)**
- 2) Enter the following Access Code or Meeting Number: **921 2549 1501**.
- 3) Enter the following Attendee ID or Numeric Meeting Password **329623**.

Anyone wishing to address the city council during the meeting must notify the City Administrator, Tom Fullen, before the meeting begins by: 1) emailing him at tfullen@cityofhunterscreek.com ; or 2) calling him at **713-465-2150**.

- A. Call to order and the roll of elected and appointed officers will be taken.
- B. Pledge of Allegiance.
- C. Swearing in of promoted Memorial Village Police Department officer – Certificate of Oath or Affirmation for Sergeant Richard Jarvis
- D. JOINT PUBLIC HEARING. A Joint Public Hearing will be held before the City Council and the Planning and Zoning Commission for the purpose of receiving testimony for or against proposed amendments to the Zoning Chapter of the City of Hunters Creek Village to: Define a “Porte Cochere” as a roofed structure, open on three sides and extending from an entrance to a building over an adjacent driveway for the purpose of sheltering those entering or exiting vehicles. Allow a Porte Cochere to extend into the required side yard under the following conditions; it may extend no closer than 10 feet from the nearest side property line; it must be 10 feet or less in height; it must be located at least 15 feet behind the front line of the residence to which it is attached; the area covered by its roof shall be included in the computation of the building area for purpose of applying the applicable limits on total building area; and three sides of the structure must be at least 90% open.
 - 1. Discussion and possible action to receive the final report and recommendation from the Planning and Zoning Commission. [Pgs. 1-2](#)
 - 2. Discussion and possible action to adopt an ordinance to: Define a “Porte Cochere” as a roofed structure, open on three sides and extending from an entrance to a building over an adjacent driveway for the purpose of sheltering those entering or exiting vehicles. Allow a Porte Cochere to extend into the required side yard under the following conditions; it may extend no closer than 10 feet from the nearest side property line; it must be 10 feet or less in height; it must be located at least 15 feet behind the front line of the residence to which it is attached; the area covered by its roof shall be included in the computation of the building area for purpose of applying the applicable limits on total building area; and three sides of the structure must be at least 90% open. [Pgs. 3-5](#)
- E. PUBLIC COMMENTS *At this time, any person with city-related business may speak to the Council. In compliance with the Texas Open Meetings Act, if a member of the public comments or inquires about a subject that is not specifically identified on the agenda, a member of council or a staff member may only respond by giving a statement of specific factual information or by reciting existing policy. The City Council may not deliberate or vote on the matter.*
- F. REPORTS
 - 1. City Treasurer Monthly Report [Pgs. 6-9](#)
 - 2. Police Commissioner Monthly Report [Pgs. 10-42](#)

3. Fire Commissioner Monthly Report [Pg. 43](#)
4. Building Official Monthly Report [Pgs. 44-66](#)
5. City Engineer and Public Works Report [Pgs. 67-69](#)
6. City Administrator Report
7. Mayor and Council Reports and Comments
 - Esplanade Beautification Along Voss Rd

G. CONSENT AGENDA *The following items are considered routine by the City Council and will be enacted by one motion. There will not be a separate discussion on these items unless a Councilmember requests, in which event, the item will be removed from the general order of business and considered in its normal sequence on the agenda.*

1. Approval of the Minutes of the Regular Meeting on March 23, 2021. [Pgs. 70-73](#)
2. Approval of the Cash Disbursement Journal for March, 2021. [Pgs. 74-76](#)
3. Approval of the 4th Quarter Investment Report. [Pg. 77](#)

H. REGULAR AGENDA

1. Discussion and possible action to approve the Proposed 2022 Memorial Villages Police Department Budget in the amount of \$6,299,250.00 with Hunters Creek Village's 2022 Assessment being \$2,099,750.00. [Pgs. 78-80](#)
2. Discussion and possible action to approve an amendment to the 2021 Village Fire Department's construction budget to increase the amount by \$200,000 from \$5,700,311.50 to \$5,900,311.50 with the proviso that it will not increase the cities' assessment but will be funded by other potential sources. [Pgs. 81-83](#)
3. Discussion and possible action to consider a request from Spring Branch Independent School District for approval of a Specific Use Permit for installation of Building Identification Signage and a Marquee to be constructed on the Hunters Creek Elementary School campus located at 10650 Beinhorn Road, Houston, Texas, 77024. [Pgs. 84-88](#)
4. Discussion and possible action to approve Amendment No. 67 to the engineering contract with Cobb Fendley in the amount of \$10,500.00 for Engineering Services associated with the Pavement Repairs to Timberglen Drive. [Pgs. 89-93](#)
5. Discussion and possible action to approve Change Order #3 to the contract with Main Lane Industries, Ltd.- (Close Out) in the amount of -\$509.78 for the 2020 Street Maintenance Project. [Pgs. 94-97](#)
6. Discussion and possible action to approve the purchase of playground equipment for City Hall. [Pgs. 98-100](#)
7. Discussion and possible action to approve a resolution opposing Texas Senate Bill 1661, which would require all city general elections to be held in November of even numbered years. [Pgs. 101-102](#)
8. Discussion and possible action to approve the Entry Sign Beautification design. [Pgs. 103-106](#)

9. Discussion and possible action to approve the agreement between Hunters Creek Village and Spring Branch School District to assess and collect ad valorem taxes. [Pgs. 107-110](#)
10. Discussion and possible action to approve a Network Node Deployment Agreement (which includes a list of proposed node locations) with Verizon Wireless. [Pgs. 111-159](#)
11. Consideration and possible action to adopt a resolution: a) approving an agreement with the law firm of Linebarger Goggan Blair & Sampson, LLP to act as special counsel to perform all legal services necessary to collect unpaid fines, fees and court costs as provided in Texas Code of Criminal Procedure Art. 103.0031; and b) authorizing the Mayor to sign the agreement on the City's behalf. [Pgs. 160-178](#)

REQUIRED LEGAL NOTICE

(A) The above referenced agreement is necessary for the unpaid fines, fees and court costs owed to the City of Hunters Creek Village (the "City") to be collected in the most effective manner. The City desires that such unpaid fines, fees and court costs be collected as provided in the Texas Code of Criminal Procedure.

(B) The Linebarger Goggan Blair & Sampson, LLP firm ("Linebarger") is fully qualified to provide this representation, being the largest law firm specializing in the collection of governmental receivables in the State of Texas, as well as the United States, and having been engaged in this specialized legal service for more than 40 years. In addition, Linebarger possesses infrastructure and technology, such as call center technology, that the City does not currently possess.

(C) Linebarger has represented The City of Hunters Creek Village for the past three years (beginning in 2018) with competence and professionalism, in the collection of unpaid fines, fees and court costs.

(D) The specialized legal services required by this agreement cannot be adequately performed by the attorneys and supporting personnel of the City due to the high cost of implementing the appropriate infrastructure and technology and employing sufficient in-house attorneys and staff with the level of experience and competence necessary to perform these activities.

(E) Under the agreement, Linebarger will be compensated on a contingent fee basis as provided in Texas Code of Criminal Procedure

Art. 103.0031. This Article specifically provides for an additional collection fee, in the amount of 30 percent, in certain cases to compensate collection attorneys. A contract to pay inside or outside attorneys on an hourly basis would represent an additional cost to the City.

(F) Entering into the proposed agreement is in the best interests of the residents of the City because the unpaid fines, fees and court costs will be professionally and competently collected without the additional costs to the City of implementing infrastructure and technology, and employing in-house personnel.

I. ADJOURNMENT

CERTIFICATION

I, the undersigned authority, does hereby certify that this Notice of a Meeting was posted on the bulletin board at City Hall, #1 Hunters Creek Place, a place convenient and readily accessible to the general public at all times, and said Notice was posted on the following date and time: April 23, 2021 at 4:00 p.m. and remained so posted continuously for at least 72 hours before said meeting was convened.

/s/

Tom Fullen, City Administrator
Acting City Secretary

The City Hall is wheelchair accessible and accessible parking spaces are available. Persons with disabilities who plan to attend this meeting and who may need auxiliary aids or services such as interpreters for persons who are deaf or hearing impaired, readers, or large print, are requested to contact the City Administrator's Office at 713.465.2150, by fax at 713.465.8357, or by email at tfullen@cityofhunterscreek.com. Requests should be made at least 48 hours prior to the meeting. This agenda is posted on the city's web site at <http://cityofhunterscreek.com>

**Notice of Joint Public Hearing
City of Hunters Creek Village**

A Joint Public Hearing will be held before the Hunters Creek Village City Council and Planning & Zoning Commission on Tuesday, April 27, 2021, at 6:00 p.m. for the purpose of receiving testimony for or against proposed amendments to the City's Zoning Chapter. The proposed amendments would accomplish the following:

Define a "Porte Cochere" as a roofed structure, open on three sides and extending from an entrance to a building over an adjacent driveway for the purpose of sheltering those entering or exiting vehicles.

Allow a Porte Cochere to extend into the required side yard under the following conditions; it may extend no closer than 10 feet from the nearest side property line; it must be 10 feet or less in height; it must be located at least 15 feet behind the front line of the residence to which it is attached; the area covered by its roof shall be included in the computation of the building area for purpose of applying the applicable limits on total building area; and three sides of the structure must be at least 90% open.

The preliminary report of the Planning and Zoning Commission of the City of Hunters Creek Village, Texas concerning the proposed amendments is available for inspection in the office of the City Secretary at City Hall, 1 Hunters Creek Place, Houston, Texas 77024.

PRELIMINARY REPORT ON PROPOSED AMENDMENT TO
ZONING CHAPTER TO ALLOW PORTE COCHERES IN SIDE YARDS IN
CERTAIN CIRCUMSTANCES

The Planning and Zoning Commission has considered a proposal, forwarded to it for recommendation by the city council, to amend the zoning chapter to permit the construction of porte cocheres in side yards of residences under certain circumstances. After considering the proposal at its meeting on April 5, 2021, the Commission voted to schedule a public hearing on a proposed amendment that would:

a) Define a "Porte Cochere" as "a roofed structure, open on three sides and extending from an entrance to a building over an adjacent driveway for the purpose of sheltering those entering or exiting vehicles".

b) Allow a Porte Cochere to extend into the required side yard under the following conditions:

- 1) It may extend no closer than 10 feet from the nearest side property line;
- 2) It must be 10 feet or less in height;
- 3) It must be located at least 15 feet behind the front line of the residence to which it is attached;
- 4) The area covered by its roof shall be included in the computation of the building area for purpose of applying the applicable limits on total building area; and
- 5) Three sides of the porte cochere are 90% open.

4-5-21

Date of Signature

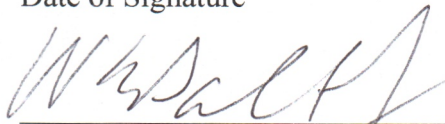

CHAIRMAN
PLANNING AND ZONING COMMISSION
CITY OF HUNTERS CREEK VILLAGE

ORDINANCE NO. _____

AN ORDINANCE AMENDING CHAPTER 44 (THE ZONING CHAPTER) OF THE CODE OF ORDINANCES OF THE CITY OF HUNTERS CREEK VILLAGE TO ALLOW A PORTE COCHERE TO EXTEND INTO A REQUIRED SIDE YARD UNDER CERTAIN CIRCUMSTANCES; AND MAKING OTHER PROVISIONS RELATED TO THE SUBJECT

WHEREAS, the City Council finds that it is in the public interest to amend the City’s zoning chapter to allow a porte cochere to extend into a required side yard under certain circumstances;

WHEREAS, the City Council finds that the amendment is consistent with the City’s comprehensive plan; and

WHEREAS, the City Council has received the final report from the Planning & Zoning Commission recommending adoption of the amendment:

* * * * *

NOW, THEREFORE, BE IT ORDAINED BY THE CITY COUNCIL OF THE CITY OF HUNTERS CREEK VILLAGE, TEXAS:

Section 1. Section 44-2 of Chapter 44 (the Zoning Chapter) of the Code of Ordinances of the City of Hunters Creek Village is amended to add the following definition:

“*Porte Cochere* means a roofed structure, open on three sides and extending from an entrance to a building over an adjacent driveway for the purpose of sheltering those entering or exiting vehicles.”

Section 2. Chapter 44 (the Zoning Chapter) of the Code of Ordinances of the City of Hunters Creek Village is amended to add a new section 44-160.1 to read as follows:

“Sec. 44-160.1. – Exception to side yard requirement for certain porte cocheres.

- (a) A porte cochere, as defined in this chapter, may extend into a required side yard if it meets all of the following conditions:
- 1) It must extend no closer than 10 feet to the nearest side property line;
 - 2) It must be 10 feet or less in height;
 - 3) It must be located at least 15 feet behind the front line of the residence to which it is attached; and
 - 4) Three sides of the structure must be at least 90% open to view.
- (b) The area covered by the roof of a porte cochere shall be included in the computation of the building area for purpose of applying the applicable limits on total building area.”

Section 3. In the event any clause, phrase, provision, sentence, or part of this Ordinance, or its application to any person or circumstance, shall for any reason be adjudged invalid or held unconstitutional by a court of competent jurisdiction, it shall not affect, impair, or invalidate this Ordinance as a whole or any part or provision hereof, other than the part declared to be invalid or unconstitutional. The City Council declares that it would have passed each and every part of this Ordinance notwithstanding the omission of any part that might be declared to be invalid or unconstitutional.

PASSED, APPROVED and ADOPTED this, the ____ day of _____, 2021.

Jim Pappas, Mayor
City of Hunters Creek Village, Texas

ATTEST:

Tom Fullen, City Administrator/acting City Secretary
City of Hunters Creek Village, Texas

DRAFT



Budget Report

Account Summary

For Fiscal: 2021 Period Ending: 03/31/2021

		Original Total Budget	Current Total Budget	Period Activity	Fiscal Activity	Variance Favorable (Unfavorable)	Percent Remaining
Fund: 100 - GENERAL GOVERNMENT (01)							
Revenue							
100-00-41000	CURRENT AD VALOREM TAXES	5,869,080.00	5,869,080.00	104,598.75	5,638,192.83	-230,887.17	3.93 %
100-00-41005	PREVIOUS AD VALOREM TAXES	15,000.00	15,000.00	-1,097.47	-1,406.59	-16,406.59	109.38 %
100-00-41010	FRANCHISE TAXES	370,000.00	370,000.00	44,766.74	94,315.40	-275,684.60	74.51 %
100-00-41015	SALES TAXES	450,000.00	450,000.00	56,707.67	177,145.78	-272,854.22	60.63 %
100-00-41020	MIXED DRINK TAX	20,000.00	20,000.00	1,821.31	3,500.29	-16,499.71	82.50 %
100-00-41040	PENALTIES/INTEREST	15,000.00	15,000.00	6,306.80	7,678.88	-7,321.12	48.81 %
100-00-42035	BUILDING PERMITS	225,000.00	225,000.00	26,709.80	85,708.48	-139,291.52	61.91 %
100-00-42044	CREDIT CARD PROCESSING FEE	2,000.00	2,000.00	347.38	760.64	-1,239.36	61.97 %
100-00-43057	CHILD SAFETY FEES	4,000.00	4,000.00	0.00	1,147.95	-2,852.05	71.30 %
100-00-43070	METRO RECEIPTS	225,000.00	225,000.00	58,834.96	88,572.90	-136,427.10	60.63 %
100-00-44025	TRAFFIC FINES	100,000.00	100,000.00	10,497.56	21,139.47	-78,860.53	78.86 %
100-00-44027	COURT TECHNOLOGY FUND	3,500.00	3,500.00	190.31	378.60	-3,121.40	89.18 %
100-00-44028	COURT SECURITY FUND	2,500.00	2,500.00	205.27	406.87	-2,093.13	83.73 %
100-00-46030	INTEREST INCOME	60,000.00	60,000.00	0.00	1,285.52	-58,714.48	97.86 %
100-00-48040	BURGLAR ALARM PERMITS	0.00	0.00	-10.00	-20.00	-20.00	0.00 %
100-00-48045	SUBD ST. LIGHTS	35,000.00	35,000.00	-3,292.90	-3,292.90	-38,292.90	109.41 %
100-00-48055	OTHER INCOME	10,000.00	10,000.00	10.21	10.21	-9,989.79	99.90 %
100-00-48056	Ice Storm Insurance Payment	0.00	0.00	29,764.80	29,764.80	29,764.80	0.00 %
	Revenue Total:	7,406,080.00	7,406,080.00	336,361.19	6,145,289.13	-1,260,790.87	17.02 %
Expense							
100-01-71000	SALARIES & WAGES	622,180.00	622,180.00	42,579.28	131,688.40	490,491.60	78.83 %
100-01-71001	LONGEVITY	5,952.00	5,952.00	0.00	0.00	5,952.00	100.00 %
100-01-71025	TMRS	118,525.00	118,525.00	8,230.43	25,443.86	93,081.14	78.53 %
100-01-71030	PAYROLL TAXES	49,612.00	49,612.00	3,322.52	11,526.31	38,085.69	76.77 %
100-01-71105	INSURANCE BENEFITS	126,787.00	126,787.00	17,306.56	38,522.70	88,264.30	69.62 %
100-01-71107	HRA	4,000.00	4,000.00	0.00	500.00	3,500.00	87.50 %
100-01-72045	NOTICES & MAILING	15,000.00	15,000.00	0.00	520.99	14,479.01	96.53 %
100-01-72055	OFFICE SUPPLIES & PRINTING	8,500.00	8,500.00	393.05	1,351.04	7,148.96	84.11 %
100-01-72060	TELEPHONE	16,500.00	16,500.00	2,032.51	3,671.83	12,828.17	77.75 %
100-01-72061	TRAVEL & TRAINING	10,000.00	10,000.00	2,357.50	3,092.54	6,907.46	69.07 %
100-01-72062	TUITION REIMBURSEMENT	5,000.00	5,000.00	0.00	0.00	5,000.00	100.00 %
100-01-72063	CERTIFICATION/LICENSE/EDUCATION	10,200.00	10,200.00	625.00	1,875.00	8,325.00	81.62 %
100-01-72065	MACHINE RENTAL MAINTENANCE	1,800.00	1,800.00	0.00	0.00	1,800.00	100.00 %
100-01-72090	MEMBERSHIPS & SUBSCRIPTIONS	3,500.00	3,500.00	1,457.00	1,712.00	1,788.00	51.09 %
100-01-72108	GEN LIABILITY/PROP/WC INS	21,850.00	21,850.00	0.00	0.00	21,850.00	100.00 %
100-01-72109	SURETY BONDS	250.00	250.00	0.00	0.00	250.00	100.00 %
100-01-72110	ELECTIONS	3,500.00	3,500.00	0.00	0.00	3,500.00	100.00 %
100-01-72111	RECORDS MANAGEMENT	500.00	500.00	0.00	0.00	500.00	100.00 %
100-01-72112	CODIFICATIONS	2,500.00	2,500.00	0.00	0.00	2,500.00	100.00 %
100-01-75040	OFFICE EQUIPMENT	5,000.00	5,000.00	0.00	0.00	5,000.00	100.00 %
100-01-76010	COMPUTER SOFTWARE SERVICES	14,000.00	14,000.00	7,717.46	7,749.42	6,250.58	44.65 %
100-01-78056	BANK FEES	1,200.00	1,200.00	0.00	47.96	1,152.04	96.00 %
100-01-78115	PUBLIC RELATIONS	23,000.00	23,000.00	682.11	1,851.93	21,148.07	91.95 %
100-02-72042	CONSULTING SERVICES	20,000.00	20,000.00	1,220.98	2,154.11	17,845.89	89.23 %
100-02-72085	TAX COLLECTOR/ASSESSOR	47,500.00	47,500.00	19,157.00	29,781.00	17,719.00	37.30 %
100-02-72120	AUDITOR	17,500.00	17,500.00	0.00	0.00	17,500.00	100.00 %
100-02-72300	LITIGATION	25,000.00	25,000.00	0.00	0.00	25,000.00	100.00 %
100-02-72310	CITY ATTORNEY	75,000.00	75,000.00	1,655.00	3,000.00	72,000.00	96.00 %
100-02-72502	CITY ENGINEER	75,000.00	75,000.00	2,347.50	4,579.00	70,421.00	93.89 %
100-02-78504	TCEQ PHIII STORMWATER PERMIT	7,500.00	7,500.00	0.00	100.00	7,400.00	98.67 %

		Original Total Budget	Current Total Budget	Period Activity	Fiscal Activity	Variance Favorable (Unfavorable)	Percent Remaining
100-03-72001	VILLAGE FIRE DEPARTMENT	1,548,892.00	1,548,892.00	258,148.72	580,834.63	968,057.37	62.50 %
100-03-72002	FIRE DEPT. COVID-19 SCAP PROGRAM...	0.00	0.00	0.00	49,171.73	-49,171.73	0.00 %
100-03-72005	MEMORIAL VILLAGES POLICE DEPT.	2,036,481.00	2,036,481.00	338,496.00	851,745.00	1,184,736.00	58.18 %
100-03-72006	POLICE DEPT. COVID-19 SCAP REIMB...	0.00	0.00	0.00	29,051.82	-29,051.82	0.00 %
100-04-72015	GARBAGE SERVICE	525,790.00	525,790.00	42,769.42	85,538.84	440,251.16	83.73 %
100-04-72021	STREET LIGHTS-CITY	60,000.00	60,000.00	9.62	3,577.36	56,422.64	94.04 %
100-04-72057	OFFICE SUPP/PRINTING - PW	2,000.00	2,000.00	115.64	115.64	1,884.36	94.22 %
100-04-72062	TRAVEL/TRAINING - PW	8,500.00	8,500.00	0.00	150.00	8,350.00	98.24 %
100-04-72070	MOSQUITO FOGGING CONTRACT	12,500.00	12,500.00	0.00	0.00	12,500.00	100.00 %
100-04-72091	MEMBERSHIPS/SUBS PW	1,000.00	1,000.00	0.00	0.00	1,000.00	100.00 %
100-04-72205	UNIFORMS-PW	3,500.00	3,500.00	151.98	455.94	3,044.06	86.97 %
100-04-72500	PW-BUILDING INSPECTIONS	60,000.00	60,000.00	2,271.98	5,351.98	54,648.02	91.08 %
100-04-72520	TRUCK MAINTENANCE	15,000.00	15,000.00	663.32	1,317.98	13,682.02	91.21 %
100-04-72530	TRAFFIC LIGHT MAINTENANCE	3,500.00	3,500.00	0.00	0.00	3,500.00	100.00 %
100-04-72540	MOWING CONTRACT	60,000.00	60,000.00	3,628.00	4,378.00	55,622.00	92.70 %
100-04-72541	CONTRACT LABOR	35,000.00	35,000.00	2,940.00	5,705.00	29,295.00	83.70 %
100-04-72560	LANDSCAPING	30,000.00	30,000.00	364.15	652.06	29,347.94	97.83 %
100-04-75510	RENTAL/PURCHASE EQUIPMENT	15,000.00	15,000.00	346.59	936.07	14,063.93	93.76 %
100-04-75550	TRAFFIC SIGNS	3,000.00	3,000.00	0.00	0.00	3,000.00	100.00 %
100-04-76500	STREET & DRAINAGE MAINTENANCE	100,000.00	100,000.00	8,658.95	14,486.16	85,513.84	85.51 %
100-04-78050	BUILDING MAINTENANCE	30,000.00	30,000.00	729.37	4,454.78	25,545.22	85.15 %
100-04-78051	JANITORIAL SERVICE BLDG MAINTEN...	9,500.00	9,500.00	1,591.72	3,183.44	6,316.56	66.49 %
100-04-78063	STORM DISASTER FUND	300,000.00	300,000.00	0.00	0.00	300,000.00	100.00 %
100-04-78064	Ice Storm Expenses 2021	0.00	0.00	11,732.08	11,732.08	-11,732.08	0.00 %
100-04-78540	URBAN FORESTER	15,000.00	15,000.00	875.00	1,585.00	13,415.00	89.43 %
100-04-78544	CREDIT CARD PROCESSING FEES	3,000.00	3,000.00	0.00	382.94	2,617.06	87.24 %
100-05-73000	JUDGES & PROSECUTORS	45,000.00	45,000.00	2,725.00	5,167.50	39,832.50	88.52 %
100-05-73020	JURY DUTY FEES	300.00	300.00	0.00	0.00	300.00	100.00 %
100-05-73025	WARRANTS ISSUED	500.00	500.00	0.00	0.00	500.00	100.00 %
100-05-73030	COURT SUPPLIES & PRINTING	2,500.00	2,500.00	116.78	116.78	2,383.22	95.33 %
100-05-73031	COURT TECHNOLOGY	1,500.00	1,500.00	0.00	0.00	1,500.00	100.00 %
100-05-73032	COURT SECURITY	1,800.00	1,800.00	299.85	599.70	1,200.30	66.68 %
100-05-73034	COURT MEMBERSHIPS & SUBSCRIPTI...	500.00	500.00	0.00	0.00	500.00	100.00 %
100-05-73035	COURT-TRAVEL & TRAINING	1,500.00	1,500.00	0.00	200.00	1,300.00	86.67 %
100-05-73044	CREDIT CARD FEES	3,000.00	3,000.00	60.19	145.37	2,854.63	95.15 %
100-05-73045	COURT TAX PD TO STATE	70,000.00	70,000.00	0.00	0.00	70,000.00	100.00 %
100-06-75041	COMPUTER EQUIP. & SOFTWARE	5,000.00	5,000.00	0.00	0.00	5,000.00	100.00 %
100-06-75065	FURNITURE & EQUIPMENT	15,000.00	15,000.00	4,407.90	12,594.00	2,406.00	16.04 %
100-06-78064	CAPITAL RESERVE	200,000.00	200,000.00	0.00	0.00	200,000.00	100.00 %
	Expense Total:	6,561,119.00	6,561,119.00	792,186.16	1,942,797.89	4,618,321.11	70.39 %
	Fund: 100 - GENERAL GOVERNMENT (01) Surplus (Deficit):	844,961.00	844,961.00	-455,824.97	4,202,491.24	3,357,530.24	-397.36 %
	Fund: 200 - CAPITAL IMPROVEMENTS (02)						
	Expense						
200-01-75038	STREET AND MAINTANANCE - RECUR...	850,000.00	850,000.00	175,804.99	191,524.89	658,475.11	77.47 %
200-01-75050	REFORESTATION	20,000.00	20,000.00	0.00	0.00	20,000.00	100.00 %
200-01-75056	TRAFFIC LIGHT MAST ARMS	330,000.00	330,000.00	109,313.16	111,073.16	218,926.84	66.34 %
200-01-75064	STREET REPLACEMENT-BEINHORN W...	2,100,000.00	2,100,000.00	0.00	0.00	2,100,000.00	100.00 %
200-01-75065	PLAYGROUND AMENITIES	12,500.00	12,500.00	0.00	0.00	12,500.00	100.00 %
	Expense Total:	3,312,500.00	3,312,500.00	285,118.15	302,598.05	3,009,901.95	90.86 %
	Fund: 200 - CAPITAL IMPROVEMENTS (02) Total:	3,312,500.00	3,312,500.00	285,118.15	302,598.05	3,009,901.95	90.86 %
	Report Surplus (Deficit):	-2,467,539.00	-2,467,539.00	-740,943.12	3,899,893.19	6,367,432.19	258.05 %

Group Summary

Account Typ...	Original Total Budget	Current Total Budget	Period Activity	Fiscal Activity	Variance Favorable (Unfavorable)	Percent Remaining
Fund: 100 - GENERAL GOVERNMENT (01)						
Revenue	7,406,080.00	7,406,080.00	336,361.19	6,145,289.13	-1,260,790.87	17.02 %
Expense	6,561,119.00	6,561,119.00	792,186.16	1,942,797.89	4,618,321.11	70.39 %
Fund: 100 - GENERAL GOVERNMENT (01) Surplus (Deficit):	844,961.00	844,961.00	-455,824.97	4,202,491.24	3,357,530.24	-397.36 %
Fund: 200 - CAPITAL IMPROVEMENTS (02)						
Expense	3,312,500.00	3,312,500.00	285,118.15	302,598.05	3,009,901.95	90.86 %
Fund: 200 - CAPITAL IMPROVEMENTS (02) Total:	3,312,500.00	3,312,500.00	285,118.15	302,598.05	3,009,901.95	90.86 %
Report Surplus (Deficit):	-2,467,539.00	-2,467,539.00	-740,943.12	3,899,893.19	6,367,432.19	258.05 %

Fund Summary

Fund	Original Total Budget	Current Total Budget	Period Activity	Fiscal Activity	Variance Favorable (Unfavorable)
100 - GENERAL GOVERNMENT (01)	844,961.00	844,961.00	-455,824.97	4,202,491.24	3,357,530.24
200 - CAPITAL IMPROVEMENTS (02)	-3,312,500.00	-3,312,500.00	-285,118.15	-302,598.05	3,009,901.95
Report Surplus (Deficit):	-2,467,539.00	-2,467,539.00	-740,943.12	3,899,893.19	6,367,432.19

2021 Municipal Court Recap

Month	Year 2019					Year 2020					Year 2021				
	Total Cases Filed	Citations vs Warnings	Revenues*	Retained by City	Remitted to State	Total Cases Filed	Citations vs Warnings	Revenues*	Retained by City	Remitted to State	Total Cases Filed	Citations vs Warnings	Revenues*	Retained by City	Remitted to State
Jan.	330	129C/201W	\$18,026	\$11,473	\$6,553	255	105C/150W	\$12,104	\$7,689	\$4,415	19	8C/11W	\$7,098	\$4,746	\$2,352
Feb.	258	90C/168W	\$14,856	\$9,823	\$5,033	264	116C/148W	\$14,774	\$9,785	\$4,989	24	4C/18W	\$3,424	\$2,226	\$1,198
March	272	122C/150W	\$22,911	\$16,008	\$6,903	38	18C/20W	\$11,245	\$7,858	\$3,387	28	15C/13W	\$11,892	\$8,005	\$3,886
April	266	113C/153W	\$15,747	\$10,757	\$4,990	4	4C/0W	\$6,487	\$4,903	\$1,583					
May	298	144C/154W	\$17,311	\$11,650	\$5,661	40	21C/19W	\$10,157	\$7,871	\$2,286					
June	270	148C/122W	\$20,249	\$13,885	\$6,364	33	19C/14W	\$5,720	\$4,219	\$1,501					
July	193	109C/84W	\$21,863	\$13,900	\$7,963	11	8C/3W	\$4,710	\$3,420	\$1,290					
Aug.	277	122C/156W	\$18,752	\$12,154	\$6,598	12	8C/4W	\$4,790	\$3,644	\$1,145					
Sept.	247	111C/136W	\$17,869	\$12,627	\$5,242	28	18C/10W	\$3,597	\$2,715	\$882					
Oct.	211	97C/114W	\$17,680	\$11,762	\$5,918	59	33C/26W	\$3,677	\$2,787	\$890					
Nov.	239	104C/135W	\$15,556	\$10,226	\$5,330	79	56C/23W	\$3,072	\$2,154	\$918					
Dec.	180	71C/109W	\$20,823	\$14,825	\$5,998	64	34C/30W	\$3,351	\$2,438	\$975					
TOTAL	3041	1360C/156W	\$221,643	\$149,089	\$72,554	887	440C/447W	\$83,682	\$59,484	\$24,261	71	27C/42W	\$22,413	\$14,978	\$7,436
Monthly Avg	253.4	107C/121W	\$18,470.27	\$12,424.08	\$6,046.20	73.917	37C/37W	\$6,973.50	\$4,956.98	\$2,021.74	5.92	2C/3W	\$1,867.78	\$395.47	\$619.64

*REVENUES INCLUDES BONDS THAT HAVE BEEN APPLIED



Memorial Villages Police Department
11981 Memorial Drive
Houston, Texas 77024
Tel. (713) 365-3701

Raymond Schultz
Chief of Police

April 12, 2021

TO: MVPD Police Commissioners

FROM: R. Schultz, Chief of Police

REF: March Monthly Report

During the month of March MVPD responded/handled a total of 7,617 calls/incidents. 6,404 House watch checks were conducted. 144 traffic stops were initiated with 159 citations being issued for 280 violations. (Note: 11 Assists in Hedwig, 68 in Houston, 2 in Spring Valley and 0 in Hillshire)

Calls/Events by Village were:

Village	Calls/YTD	House Watches/YTD	Accidents	Citations	Response Time
Bunker Hill:	2321/5241	1943/4119	5	26/35/61	3@3:07
Piney Point:	1696/3948	1378/2953	9	18/47/65	3@4:06
Hunters Creek:	3481/6970	3067/5739	2	16/13/29	4@4:51
				Cites/Warn/Total	10@4:06

Type and frequency of calls for service/citations include:

Call Type	#	Call Type	#	Citations	#
False Alarms:	161	Ord. Violations:	21	Speeding:	60
Accidents:	16	Information:	139	Exp. Registration:	25
ALPR Hits:	105	Suspicious Situations:	91	No Ins:	16
Assist Fire:	50	Welfare Checks:	10	No License	31
Assist EMS:	29			Stop Sign	27

This month the department generated a total of 85 police reports.

Crimes Against of Persons (4)

Assault	3
Crime against a Child	1

Crimes Against Property (27)

Burglary of a Motor Vehicle	6	Theft Misd.	5
Fraud/ID	15	Theft (Felony)	1

Petty/Quality of Life Crimes/Events (54)

ALPR Hits (valid)	6	ALPR Hit Investigations	6
Misc. Reports	34	Information Reports	8

Arrest Summary: Individuals Arrested (7)

Warrants	3	Felony	1
Class 3 Arrests	2	DWI	1

Budget YTD:	Expense	Budget	%
• Personnel Expense:	1,031,108	5,040,063	20.5%
• Operating Expense:	276,252	899,881	30.6%
• Total M&O Expenditures:	1,307,360	5,939,944	22.0%
• Capital Expenses:	76	169,500	0%
• Net Expenses:	1,307,436	6,109,444	21%

Follow-up on Previous Month Items/Requests from Commission

- March 2, 2021 the MVPD participated in the Bridies fore Blues Fund Raiser hosted by area residents Hunter and Harrison Lee. The event was huge success with proceeds going towards the Police Foundation.
- Commander Sission submitted his formal Letter of Intent to retire effective May 1, 2021.
- The 2020 financial audit has officially started. Victoria is providing documents to the Auditors.

Personnel Changes/Issues/Updates

- Officer Andy Lowrie started with the MVPD and is currently assigned to dayshift riding with Officer Nash.
- MVPD tested 5 applicants. All completed the written examination and physical assessment. Backgrounds have been initiated to determine eligibility.
- 5 officers completed the sergeants written examination. The top 4 scores are progressing to the assessment center scheduled for April 13, 2021.

Major/Significant Events

- The MVPD hosted a regional RAD Instructor certification class for Statewide RAD Instructors at Chapelwood. 16 instructors attended the training on how to deliver RAD in a post COVID-19 environment. Reserve Officer Michelle Owens is the State of Teas RAD Coordinator.
- 3/8/21 in the 11100 Block of Wickdale. Theft. The victim was having work done at her home and after the contractors left, she discovered that a ring was missing. As detectives began their investigation, they had contacted the employer of the contractors and had located the ring on a Pawn shop data base. Before the detectives could get to the pawn shop, the pawner/seller had retrieved the ring and then returned it to the victim by leaving it on the porch. Detectives were able to ID the employee as the thief who had taken the ring. The DA accepted charges on the suspect and the ring is now in the possession of the victim.

Status Update on any Major Projects

- Chief attended the 2021 Texas Police Chief's Association meeting in Fort Worth. This was the first in-person meeting since 2019. Workshops included discussions on Risk Reduction, Public Protests and Responses, Legislative Updates and other current topics.
- Staff received their second COVID-19 vaccinations on April 1, 2021.
- The transition from Blue Cross to United Health Care for Medical Insurance Coverage was completed and occurred at the end of March. Maureen worked many hours ensuring that there were no gaps in coverage and that all employees were moved to the new provider without interruption.

V-LINC new registrations in March: +30

BH – 1350(+12)

PP – 921 (+3)

HC – 1391 (+10)

Out of Area – 459 (+5)

March VFD Assists

Calls received directly by MVPD via 911/3700

<u>Priority Events</u>	<u>Average Response Times</u>
------------------------	-------------------------------

Total – 3	4:52
-----------	------

Fire – 0	0
----------	---

EMS – 3	4:52
---------	------

By Village

BH Fire – 0	0
-------------	---

BH EMS – 0	0
------------	---

PP Fire – 0	0
-------------	---

PP EMS – 0	0
------------	---

HC Fire -0	0
------------	---

HC EMS -3	4:52
-----------	------

Combined VFD Events (Priority + Radio)

Total – 59	3:28
------------	------

Fire – 41	3:01
-----------	------

EMS – 18	4:18
----------	------

Radio Call Events

Total – 56	3:23
------------	------

Fire- 41	3:01
----------	------

EMS- 15	4:12
---------	------

2021 Burglary Map

Address

302 Chapel Bell

Alarm

No

POE

Vacant (none)

2021 Robberies

Address

MO



Daytime Burglary



Nighttime Burglary



Robbery

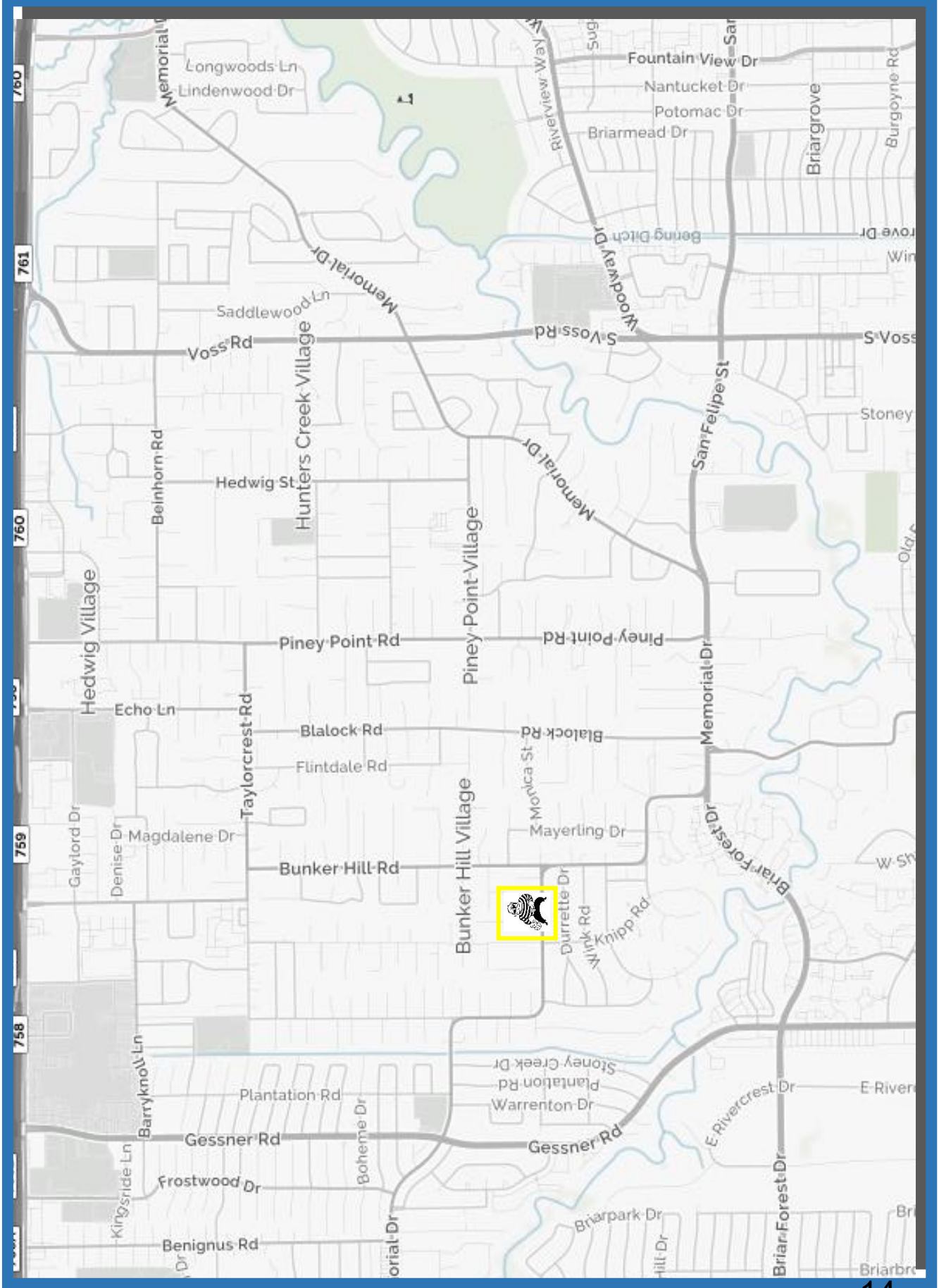

2021 Auto Burglary Map

Address	POE
10709 Memorial (Jugging)	Side Win Smash
335 Knipp	UNL Door
11931 Broken Bough	UNL Door
348 Knipp	UNL Door
512 Knipp	UNL Door
8435 Katy Fwy	Side Win Smash
11322 Surrey Oaks	UNL Door
505 Ripplecreek	Truck Bed
7627 River Point	UNL Door
11734 Flintwood	UNL Door
7630 River Point	UNL Door
907 Tarrington	UNL Door
10610 N Evers Park	UNL Door

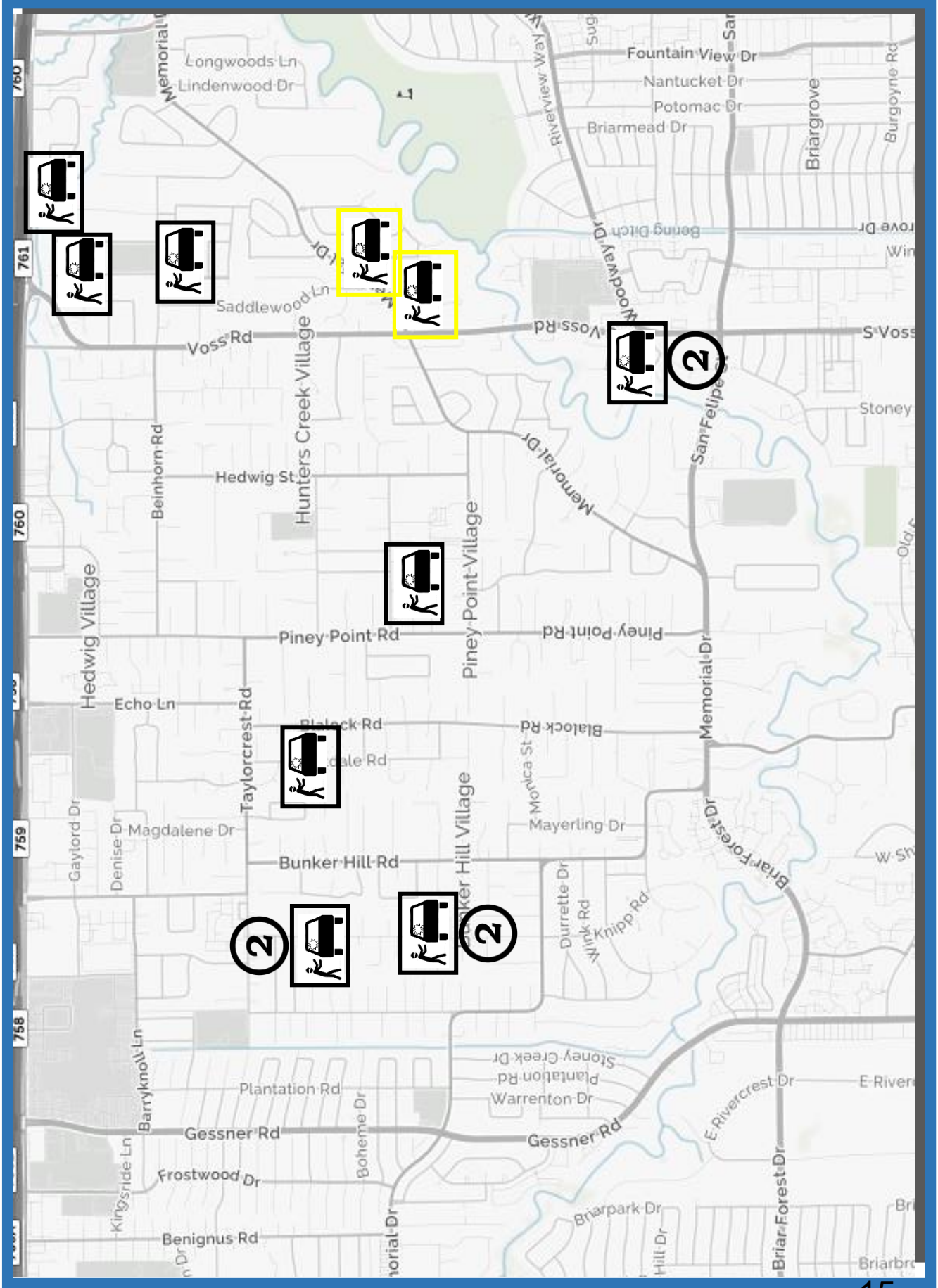

Daytime Burglary

Nighttime Burglary

- 2
- 3
- 4

2021 Total Incidents

2021	Crimes Against Persons	Crimes Against Property	Quality of Life Incidents	Total	Arrests	Incidents	House Checks	YTD BH INC	YTD BH HC	YTD PP INC	YTD PP HC	YTD HC INC	YTD HC HC
January	2	28	47	77	5	4008	3019	1377	1077	1153	876	1377	1062
February	1	26	37	64	3	4833	3411	1543	1099	1099	699	2112	1610
March	4	27	54	85	7	7617	6404	2321	1943	1696	1378	3481	3067
April													
May													
June													
July													
August													
September													
October													
November													
December													
Total	7	81	138	226	15	16458	12834	5241	4119	3948	2953	6970	5739

2020 Totals	19	269	591	879	178	96885	83432	34182	30460	25843	22003	35623	30831
Difference	0	0	0	0	0	0	0	0	0	0	0	0	0
% Change	0	0	0	0	0	0	0	0	0	0	0	0	0

2021 Officer Committed Time to Service Report

Employee Name	Jan	Feb	Mar	Apr	May	Jun	Jul	Aug	Sep	Oct	Nov	Dec	Reports	Cites
BAKER, BRIAN C	14:27:08	6:19:50	9:11:48										1	18
BEHUNKO, JOHN	23:07:01	19:19:59	14:04:18										2	18
BOGGUS, LARRY	7:55:02	20:20:04	5:40:37										1	0
BRACHT, DANIEL	17:07:03	11:15:42	9:46:04											8
BURLESON, Jason	12:12:34	18:10:56	10:39:53										3	0
CADENA, VANESSA	18:00:04	12:07:28	24:08:28										9	15
CANALES, RALPH EDWARD	16:04:00	7:27:16	14:33:16										8	26
CERNY, BLAIR C.	* 7:56:59	4:17:26	7:37:24											0
HARWOOD, NICHOLAS	18:15:14	15:46:27	14:27:52										4	18
JARVIS, RICHARD	10:46:12	28:53:18	23:27:39										7	13
JOLIVET, CHARLES	11:59:12	9:59:43	10:18:23											0
JONES, ERIC	* 0:31:48	0:06:32	0:00:00											0
KELSO JR, RONALD K	15:55:08	2:04:16	15:04:52										3	26
LERMA, FRANK	* 5:48:56													0
MICELVANY, ROBERT	15:06:05	10:55:03	7:34:12										4	1
MILLER, OSCAR	* 11:42:37	16:13:37	16:55:40										2	0
NASH, CHRISTOPHER	13:30:51	14:08:19	13:58:31										4	3
OWENS, LANE	* 4:42:45	0:12:48	2:33:47											0
PAVLOCK, JAMES ADAM	7:56:41	9:16:17	3:48:02											0
RODRIGUEZ, CHRISTOPHER	* 5:37:51	7:31:36	3:54:08											0
SCHANMEIR, CHRISTIAN	t 2:03:24	11:09:37	22:03:09										2	30
SCHULTZ, RAYMOND	* 0:00:00	0:49:06	0:00:56											0
SILLIMAN, ERIC	16:45:18	18:58:22	19:39:33										12	37
SISSON, KYLE J	* 0:58:16	0:15:03	0:00:00											0
SPRINKLE, MICHAEL	1:19:49	4:18:27	6:30:48											4
TAYLOR, CRAIG	14:41:29	12:18:05	11:35:47										3	1
TORRES, PATRICK	14:43:57	13:30:08	13:27:58										5	8
TUGGLE, JAMES	8:01:57	13:07:32	13:22:19										4	2
VALDEZ, JUAN	17:55:02	21:37:31	25:08:41										7	28
VASQUEZ, MONICA	23:38:14	15:16:42	15:32:19										1	11
WHITE, TERRY	23:35:00	19:20:08	19:55:44										3	13
* = Admin Asmt.														
t = temporary														
Dispatch Committed Time														Totals
911 Phone Calls	302	314	231											847
3700 Phone Calls	2189	3536	2566											8291
DP General Phone Calls*	54:30:49	90:01:08	62:57:40											

85 280

* This is the minimal time as all internal calls route through the 3700 number.

Hedwig
 **5**

Bunker Hill



Piney Point

Hunters Creek

Frequent Mobile Locations

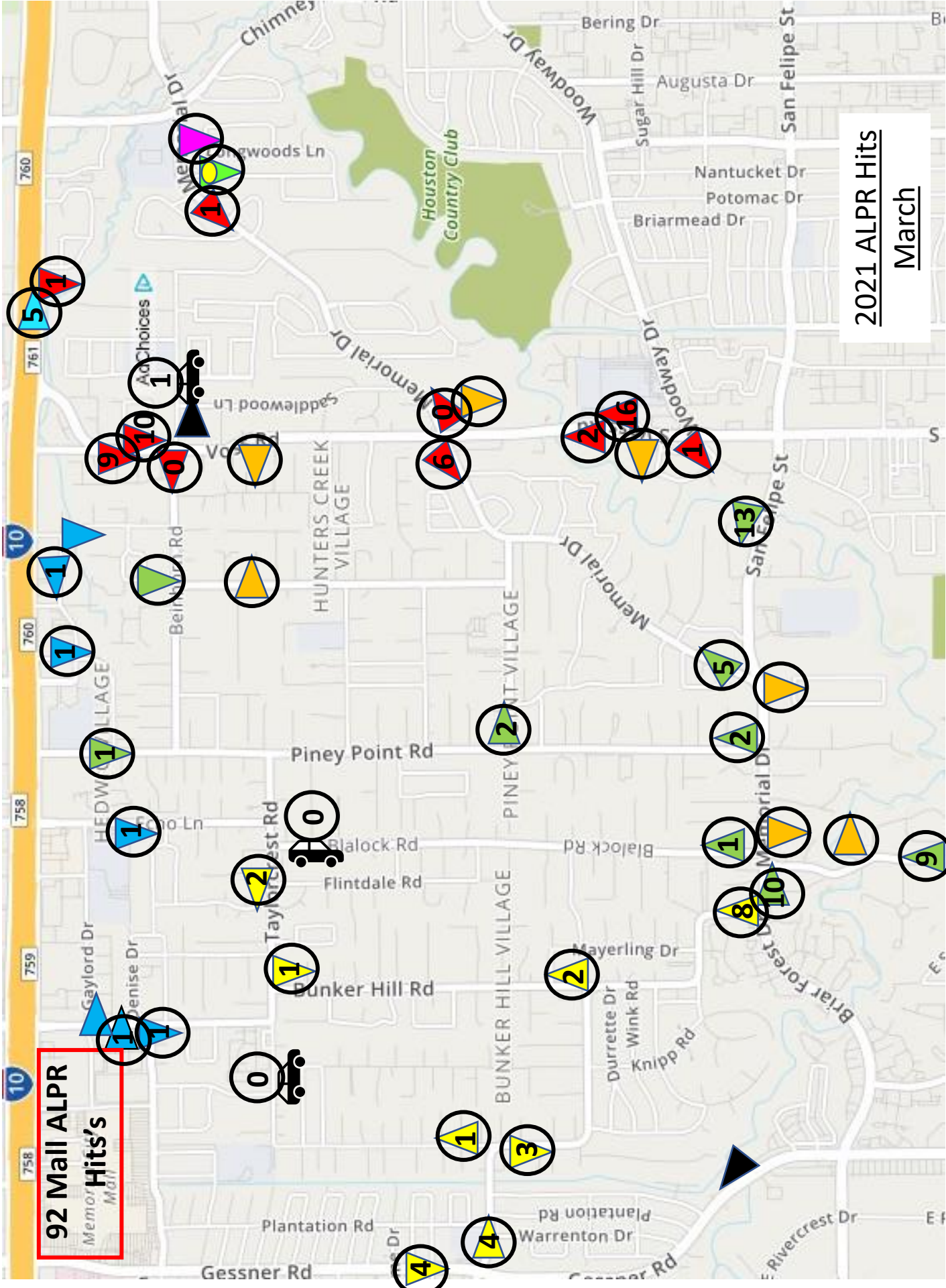

117 Total Hits
18

92 Mall ALPR Hits's



2021 ALPR Hits
March

Lindenwood HOA

Longwoods HOA

US Coins

In Process

HOA Systems

03/31/21

Hedwig



Bunker Hill



Piney Point



Hunters Creek



Frequent Mobile Locations



6



Investigative Leads



Lindenwood HOA



Longwoods HOA



US Coins



In Process



HOA Systems



2021 ALPR Recoveries
March

03/31/21

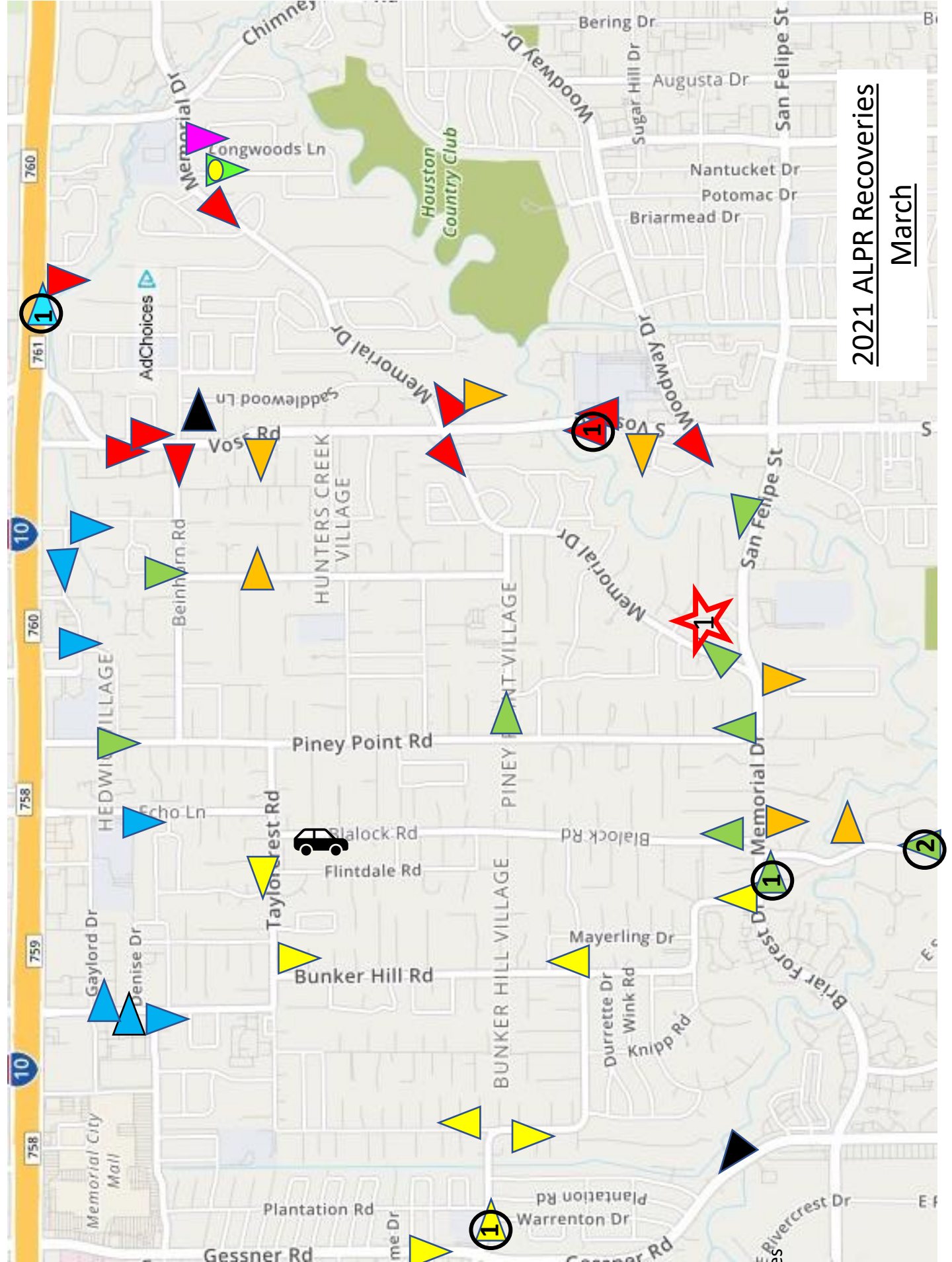

ALPR Recoveries						
Num	Plate	Vehicle	Loc	Val	Links	
1	KHM2376	Ford F350	22	\$ 48,000.00	Drugs-Meth	1/5/2021
2	MVL8705	Hyndi	10	\$ 14,000.00		11-Jan
3	GKR5588	Hond Civ	8	\$ 12,500.00	Fugitive/poss c	18-Jan
4	MWV2069	Chev Cruz	8	\$ 9,800.00	Fraud	20-Jan
5	R000293	Toy Cor	17	\$ 12,000.00	Rental/Cluck	21-Jan
6	LJP9550	Hynd SFE	19	\$ 14,000.00		28-Jan
7	DV48493	VW Jetta	14	\$ 17,500.00	Fel Warrant	29-Jan
8	MHT8564	Hond Acc	2	\$ 16,000.00	Car Jacking	31-Jan
9	9.49E+09	Chev Volt	8	\$ 38,000.00		2-Feb
10	DLJ392	Hond Acc	6	\$ 21,000.00	Fel Warrant	4-Feb
11	MPR6064	Toy Cor	12	\$ 14,000.00	Fug/Drugs	5-Feb
12	N541138	Chev Mal	8	\$ 21,000.00	Fug/Burg	8-Feb
13	BZ8K588	Ford Taur	23	\$ 8,000.00	Fraud	10-Feb
14	MNC3563	Cadi CTS	8	\$ 28,500.00		21-Feb
15	MYR3265	ToyHigh	US Coins	\$ 18,000.00	Fraud	3-Mar
16	89686F5	HYNSon	7	\$ 18,500.00	Fraud	4-Mar
17	KXS9288	Ford Focus	2	\$ 14,500.00	Fraud	11-Mar
18	MXL9491	Ford F350	22	\$ 31,000.00		18-Mar
19	NZN3882	AcuraTLX	8	\$ 24,500.00		22-Mar
20	GSC6637	Niss Alt	8	\$ 16,000.00		30-Mar
21	AW83550	Ford F150	19	\$ 24,000.00	meth/fraud	2-Apr

Plate Recoveries		
Plate Recove	Date	Links
90561S4	3/1/2021	Paper Fraud Tag

Firearm in vehicle

2021 Value	\$ 420,800.00
2020 Value	\$ 1,147,500.00
2019 Value	\$ 438,000.00
Program Total	\$ 2,006,300.00

INVESTIGATIVE LEADS

103	NVK8808	Chev Tahoe	MDE Harrassment Case	SBISD	Solved	21-Jan
18	92350G3	Jeep Cherokee	Jugger Belaire to Racquet Club		CID-Open	22-Jan
21	BXR4783	Chev Pickup	FSGI		Solved	8-Feb
WIND HOA	FDC2680	Niss Alt	Mail Thieves		Solved	16-Feb
US Coins	MPV1209	Toy	BMV Jugger		CID-Open2,	27-Feb
Strey	LYN9642	Toy Cor	Package Thief		CID-Open	27-Feb
17	CNB1734	BLK F150	FSGI		ID's	3-Mar

Plate Reads Summary

Total Plate Reads:
3,092,119

Export



Mar 2 - Mar 31

Cameras (30)

Search

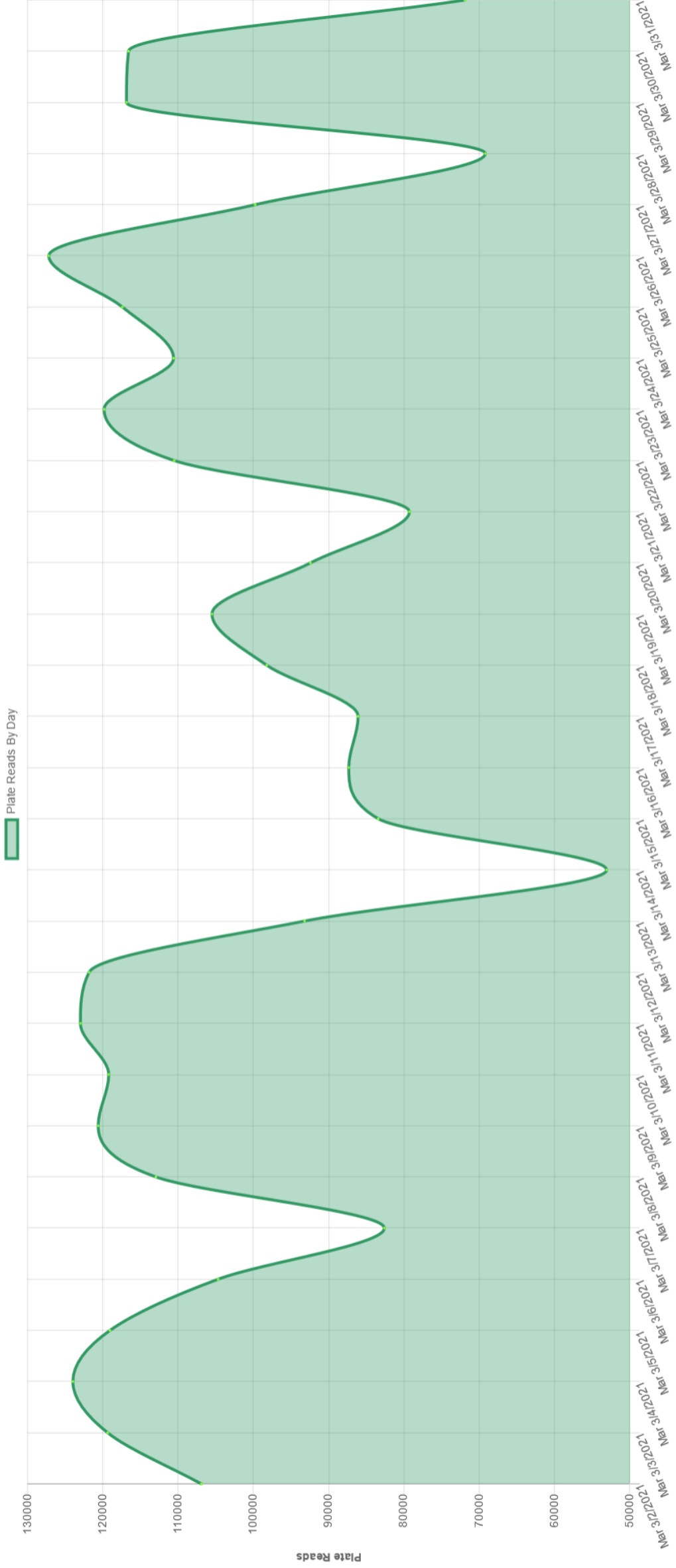

Unique Plate Reads Summary

Total Unique Plate Reads:
1,352,001

Export 

Mar 2 - Mar 31

Cameras (30) ▾

Search

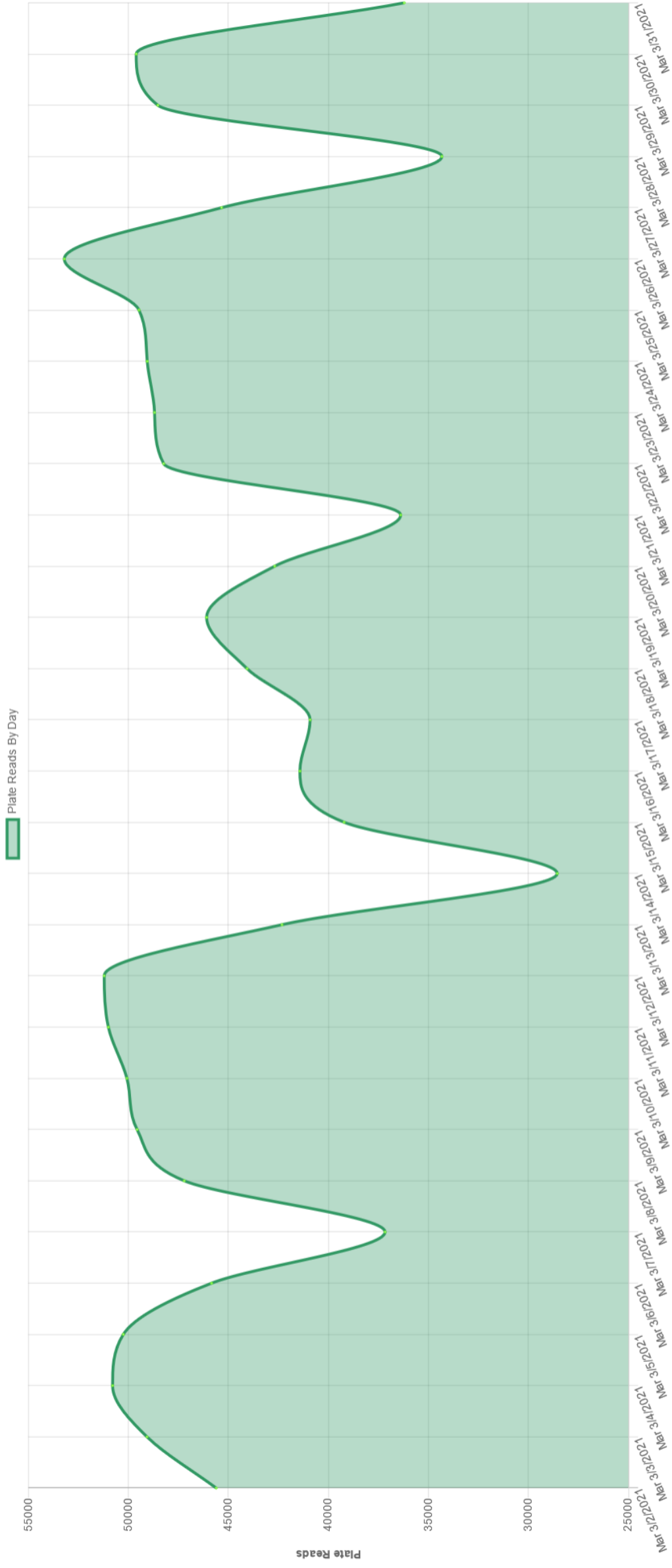

Hits Report

Total Hits:
257

Export



Mar 2 - Mar 31

Topics (13) ▾

Cameras (30) ▾

Search

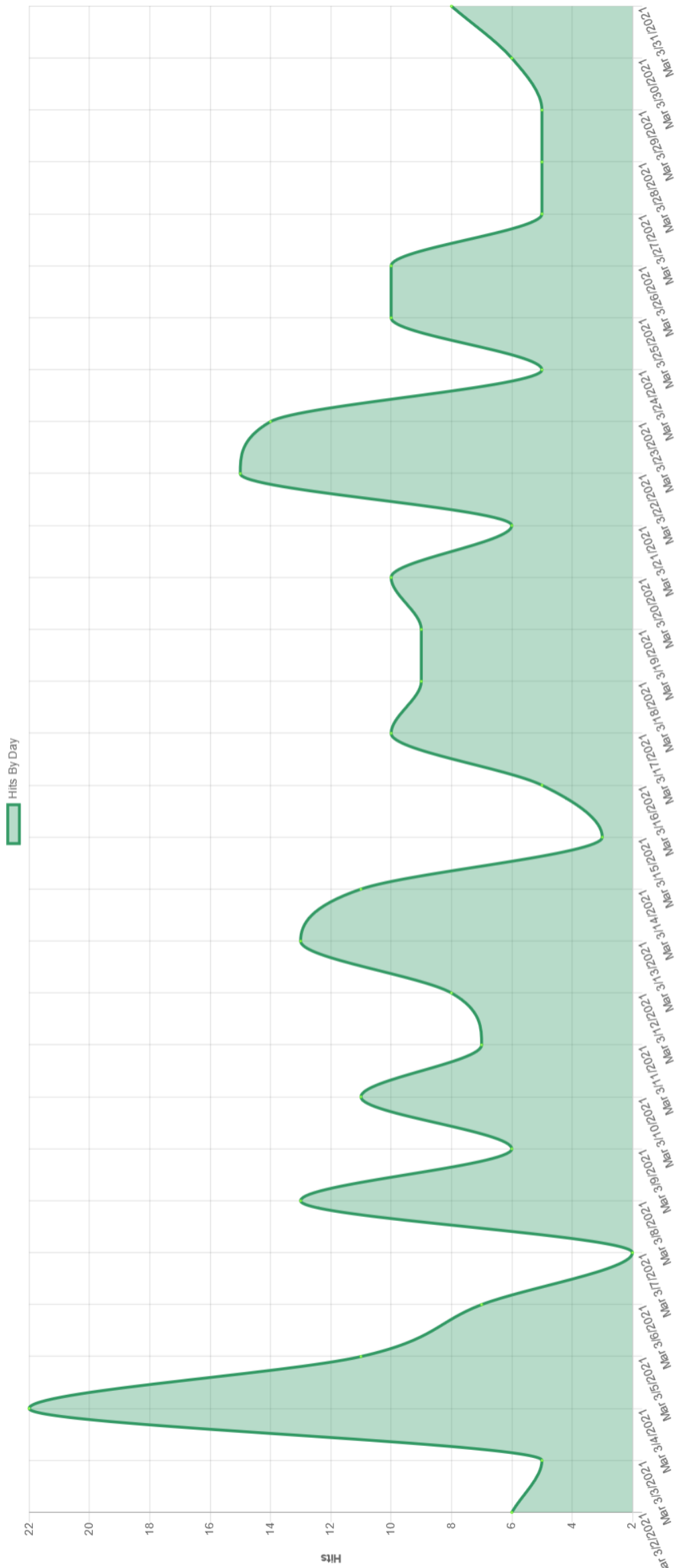

Hits Report 6 Monitored Categories

Hits Report

Total Hits:

115

Export 

Mar 2 - Mar 31

Topics (6)

Cameras (30)

Search

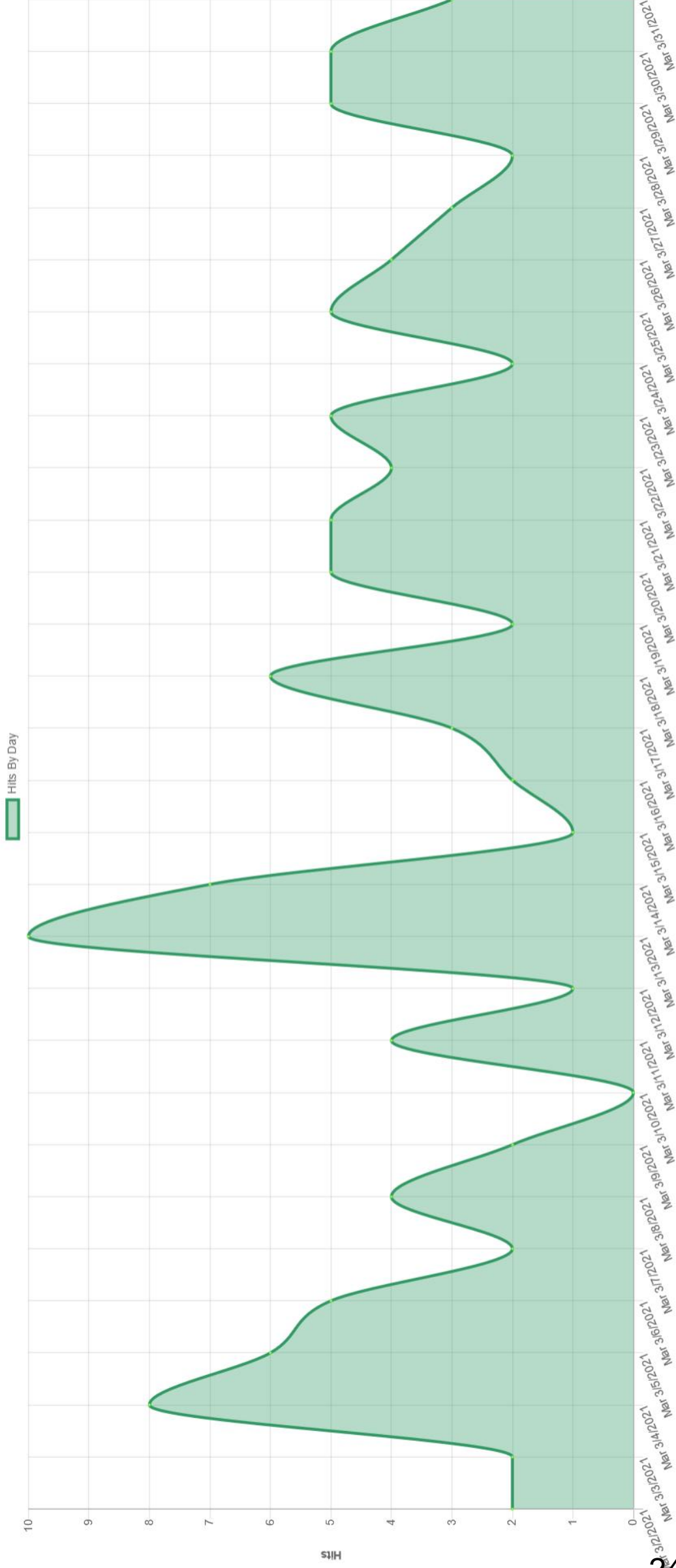

Hits Report

Sex Offenders Only

Total Hits:
11

Export 

Mar 2 - Mar 31

Topics (1) ▾

Cameras (30) ▾

Search

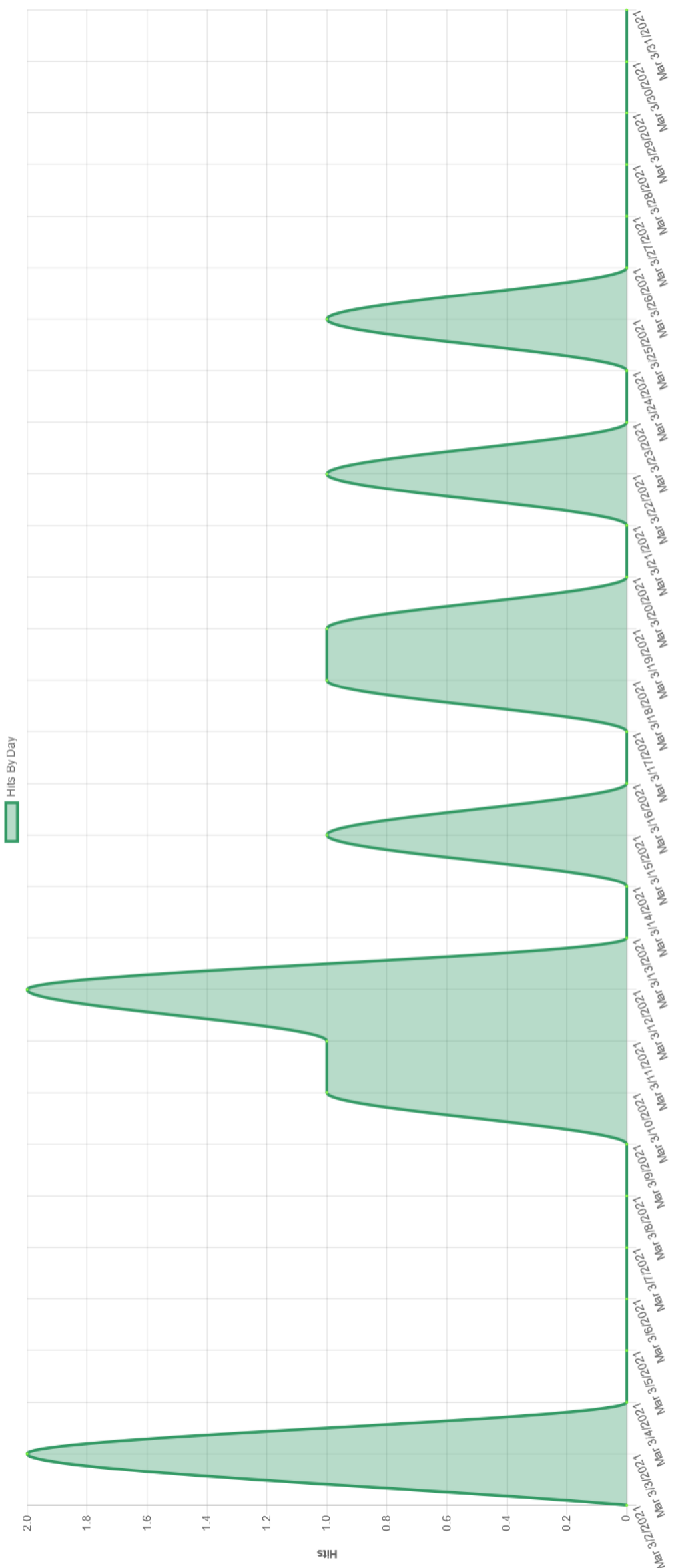

Hits Report

Total Hits: 4

Export CVV Mar 2 - Mar 31

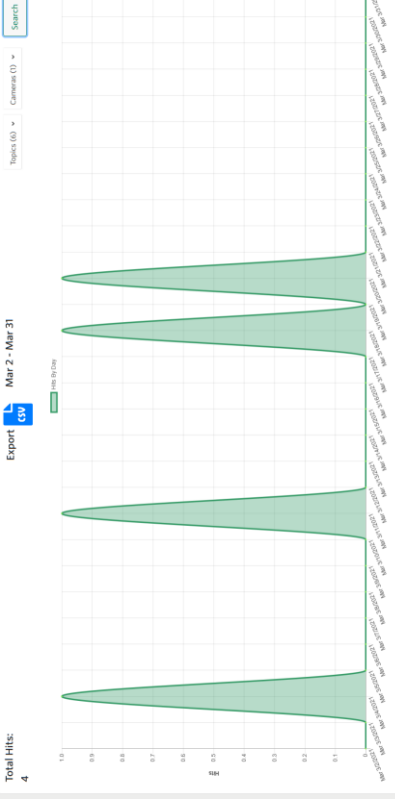

Hits Report

Total Hits: 8

Export CVV Mar 2 - Mar 31

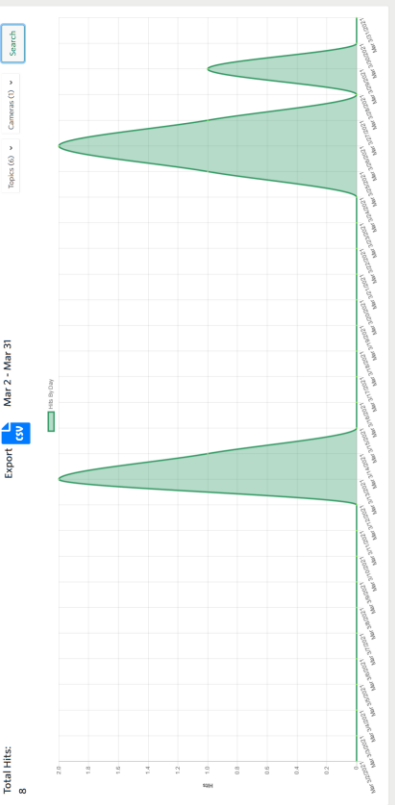

Hits Report

Total Hits: 10

Export CVV Mar 2 - Mar 31

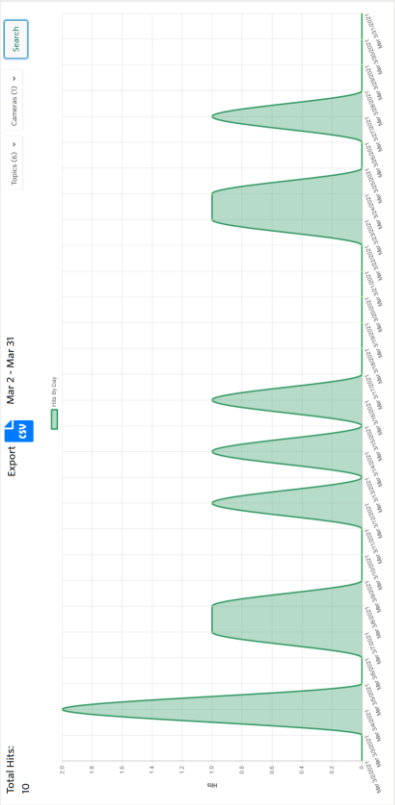

Hits Report

Total Hits: 4

Export CVV Mar 2 - Mar 31

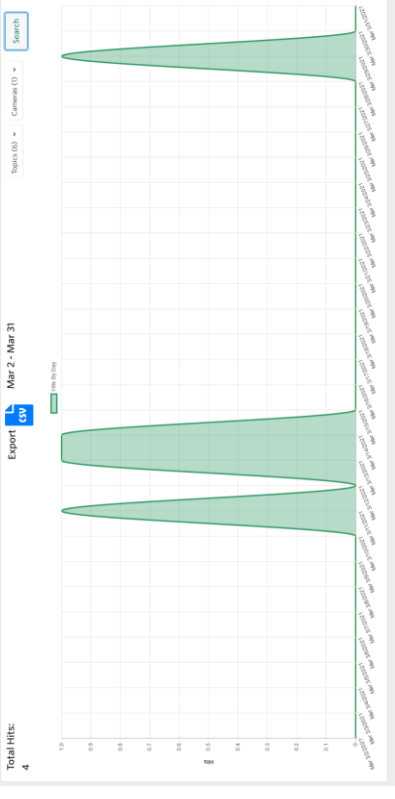

Hits Report

Total Hits: 1

Export CVV Mar 2 - Mar 31

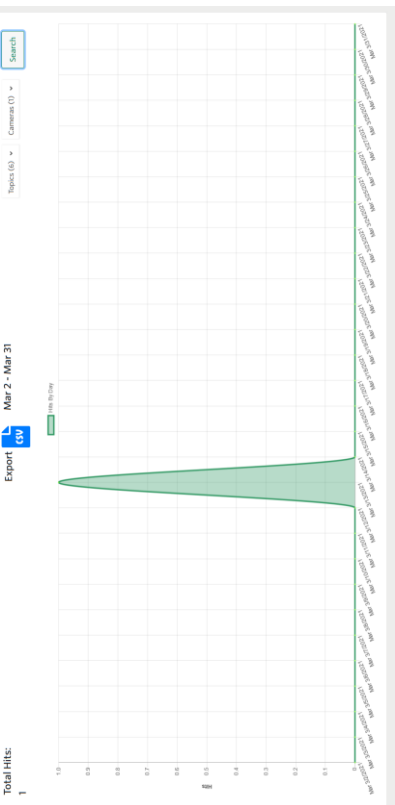

Hits Report

Total Hits: 9

Export CVV Mar 2 - Mar 31

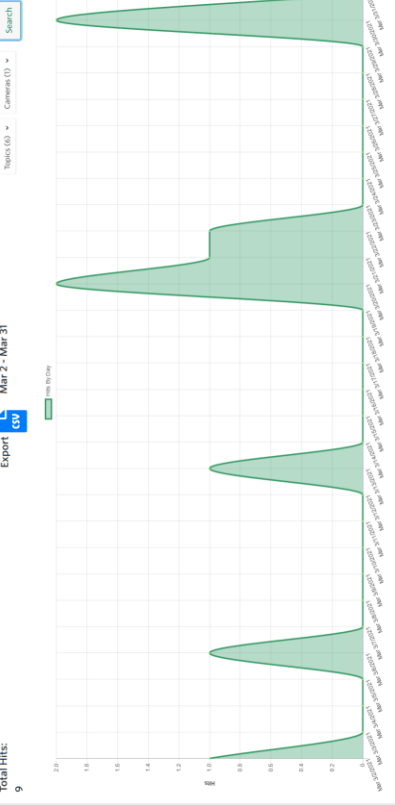

Hits Report

Total Hits: 0

Export CVV Mar 2 - Mar 31

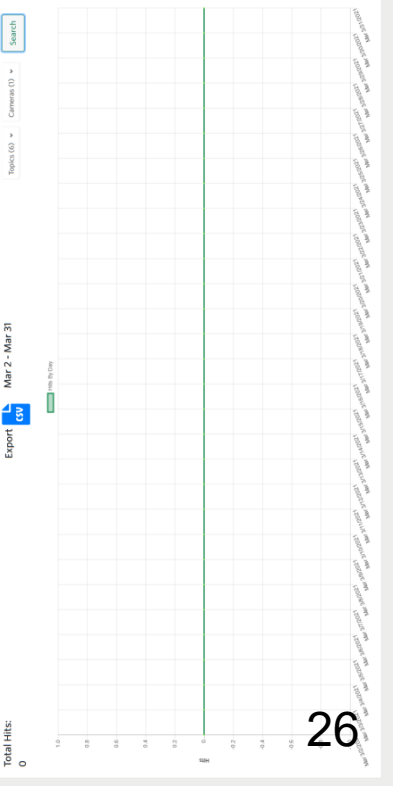

Hits Report

Total Hits: 2

Export CVV Mar 2 - Mar 31

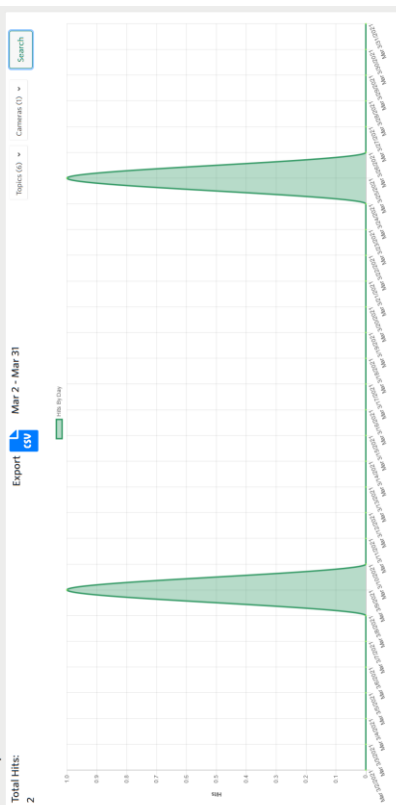

Hits Report

Total Hits: 2

Export CVV Mar 2 - Mar 31

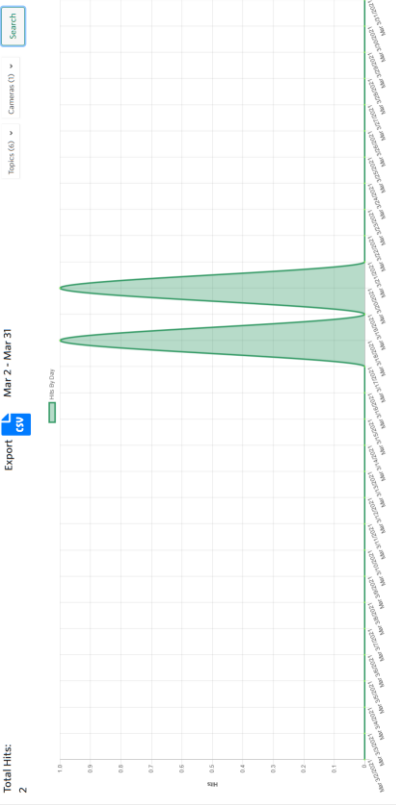

Hits Report

Total Hits: 5

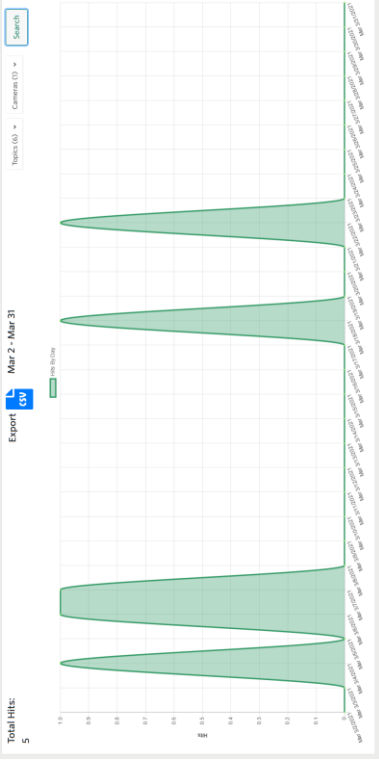

Hits Report

Total Hits: 0

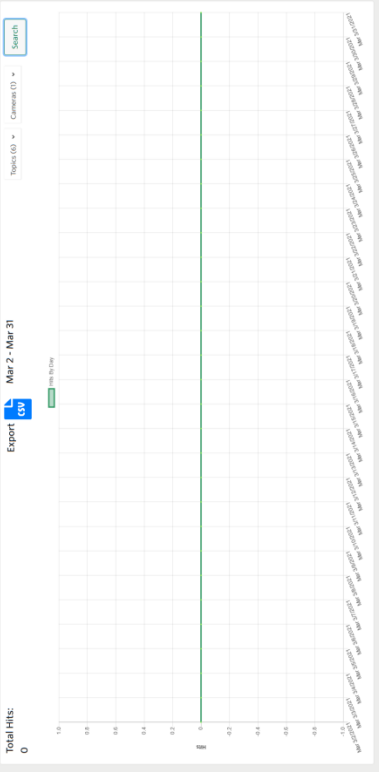

Hits Report

Total Hits: 1

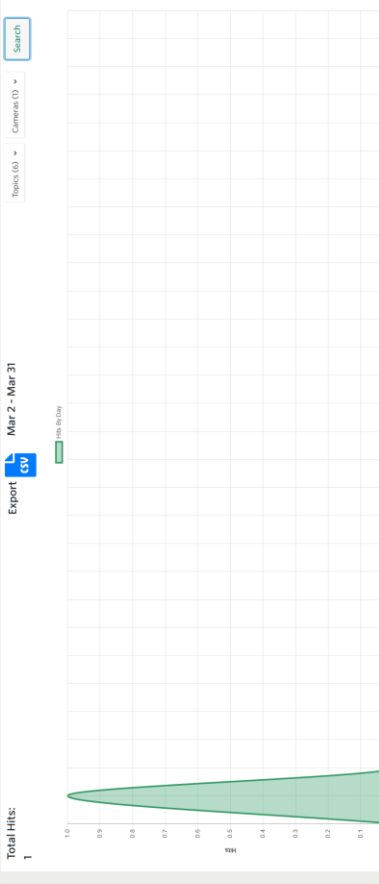

Hits Report

Total Hits: 2

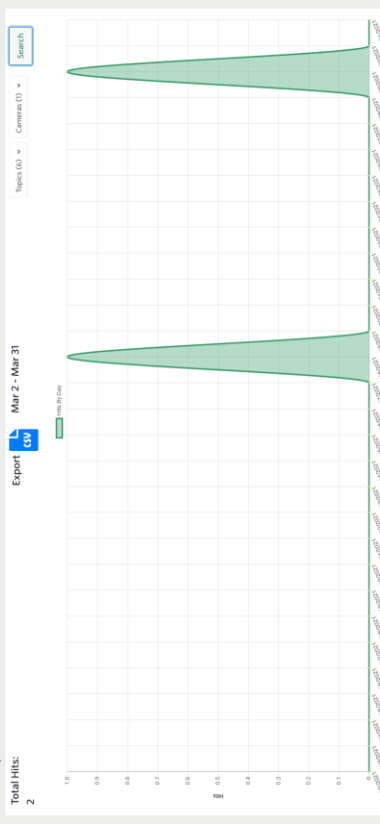

Hits Report

Total Hits: 0

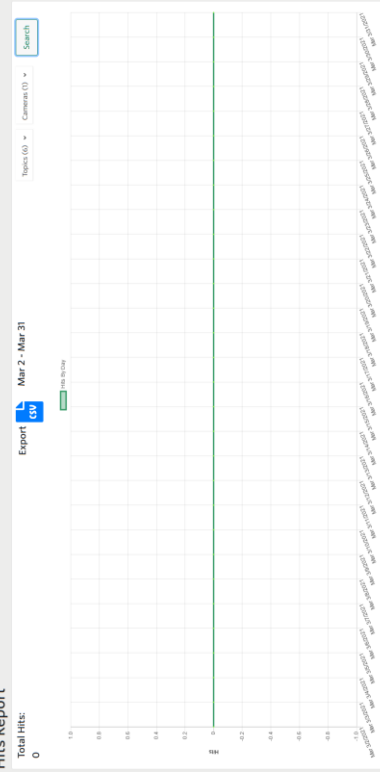

Hits Report

Total Hits: 6

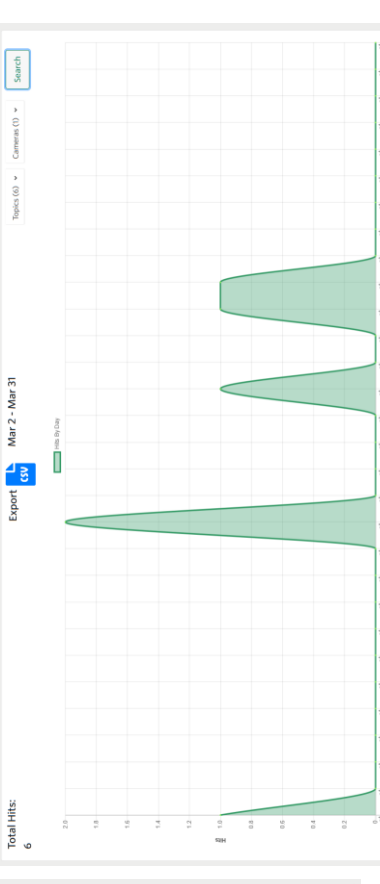

Hits Report

Total Hits: 1

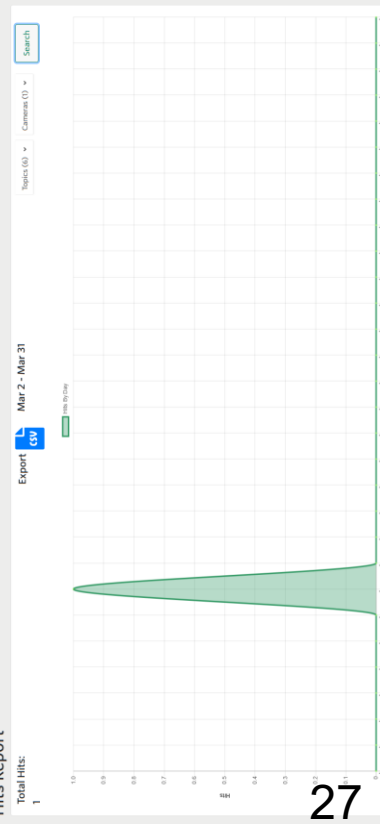

Hits Report

Total Hits: 1

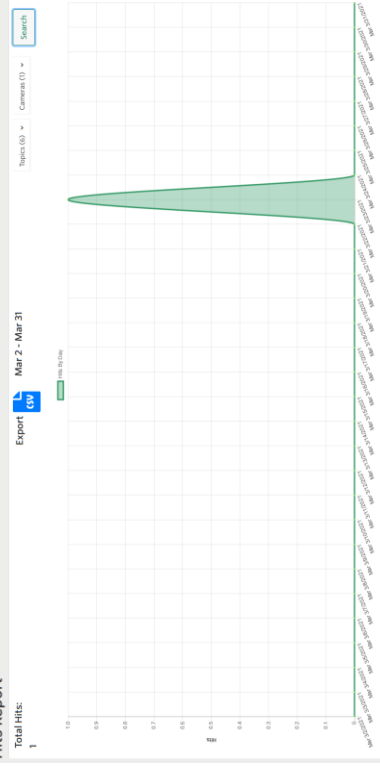

Hits Report

Total Hits: 0

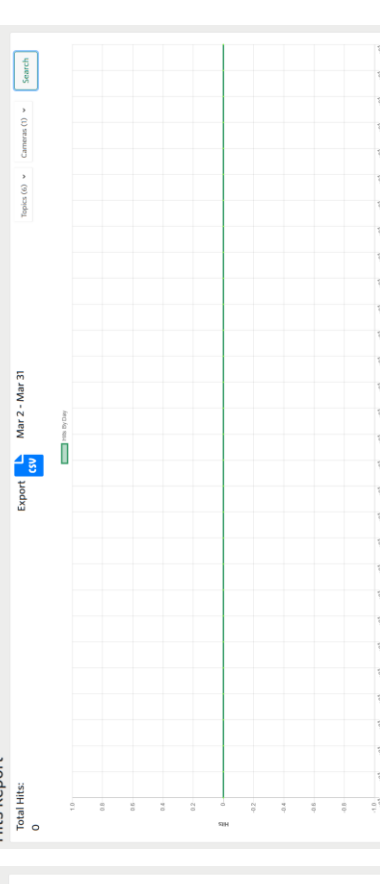

Hits Report

Total Hits: 9

Export [CSV](#)

Mar 2 - Mar 31

Topics (0) [+](#) Cameras (0) [+](#)

[Search](#)

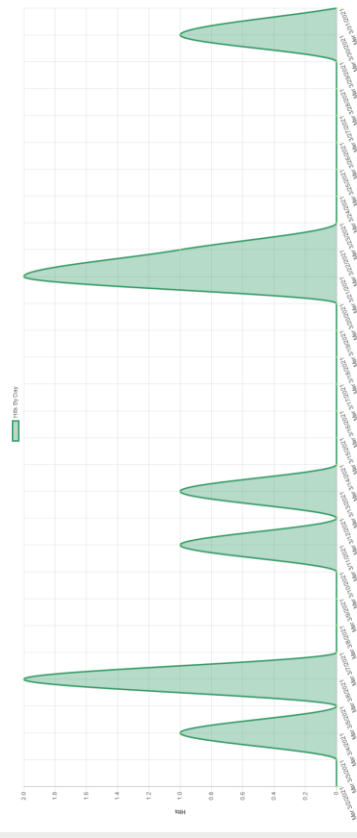

Hits Report

Total Hits: 16

Export [CSV](#)

Mar 2 - Mar 31

Topics (0) [+](#) Cameras (0) [+](#)

[Search](#)

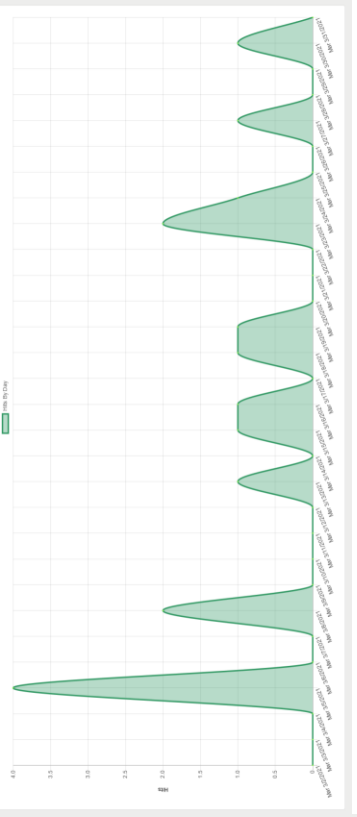

Hits Report

Total Hits: 10

Export [CSV](#)

Mar 2 - Mar 31

Topics (0) [+](#) Cameras (0) [+](#)

[Search](#)

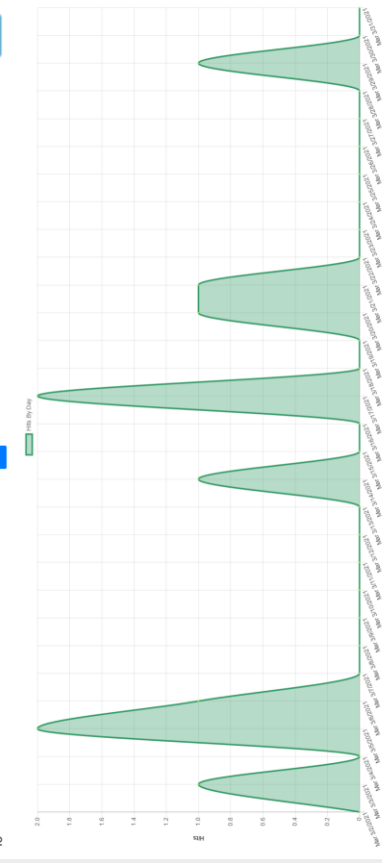

Hits Report

Total Hits: 13

Export [CSV](#)

Mar 2 - Mar 31

Topics (0) [+](#) Cameras (0) [+](#)

[Search](#)

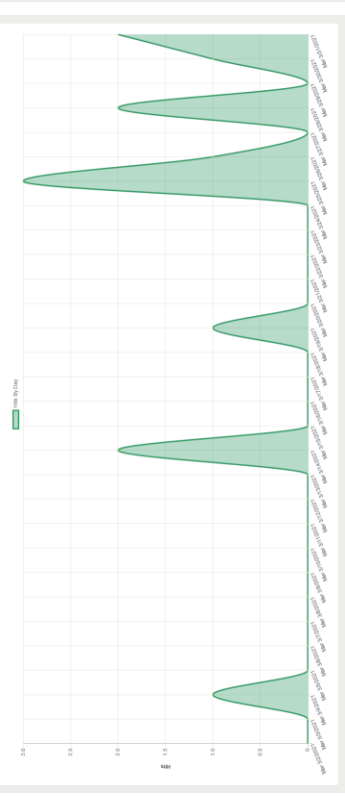

Hits Report

Total Hits: 2

Export [CSV](#)

Mar 2 - Mar 31

Topics (0) [+](#) Cameras (0) [+](#)

[Search](#)

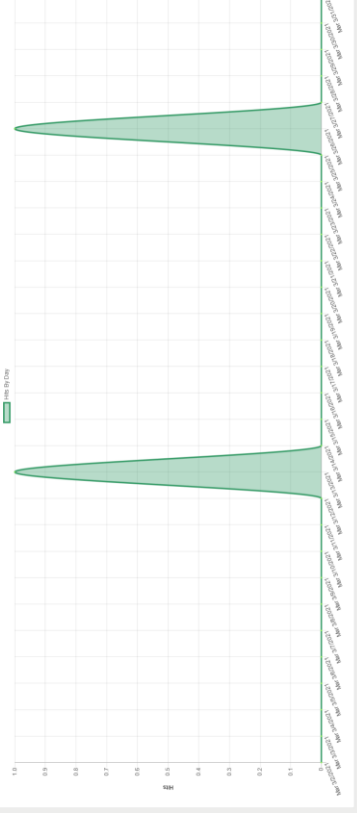

Hits Report

Total Hits: 0

Export [CSV](#)

Mar 2 - Mar 31

Topics (0) [+](#) Cameras (0) [+](#)

[Search](#)

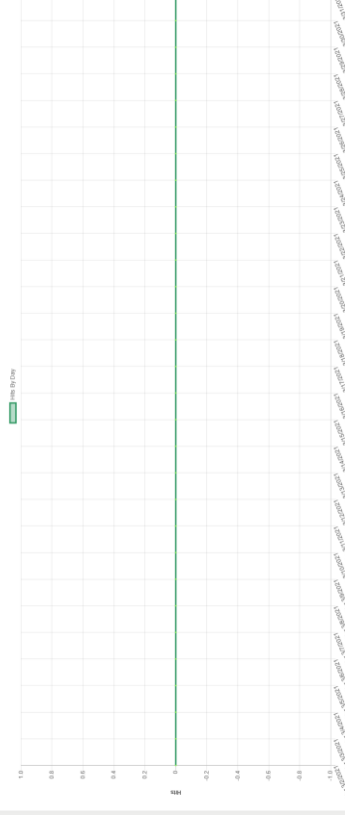

Hits Report

Total Hits: 2

Export [CSV](#)

Mar 2 - Mar 31

Topics (0) [+](#) Cameras (0) [+](#)

[Search](#)

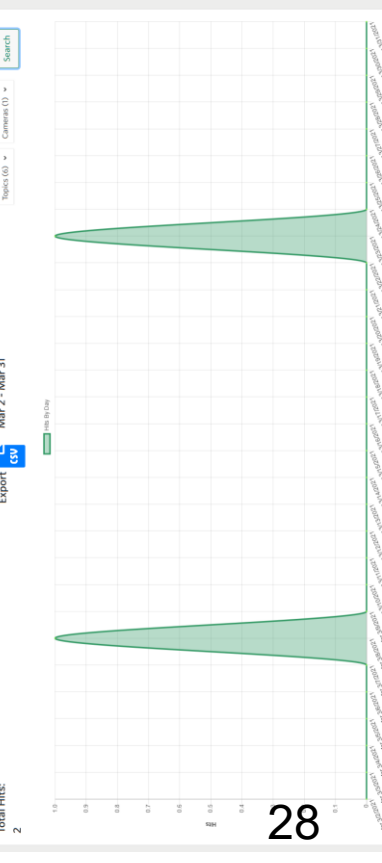

Hits Report

Total Hits: 1

Export [CSV](#)

Mar 2 - Mar 31

Topics (0) [+](#) Cameras (0) [+](#)

[Search](#)

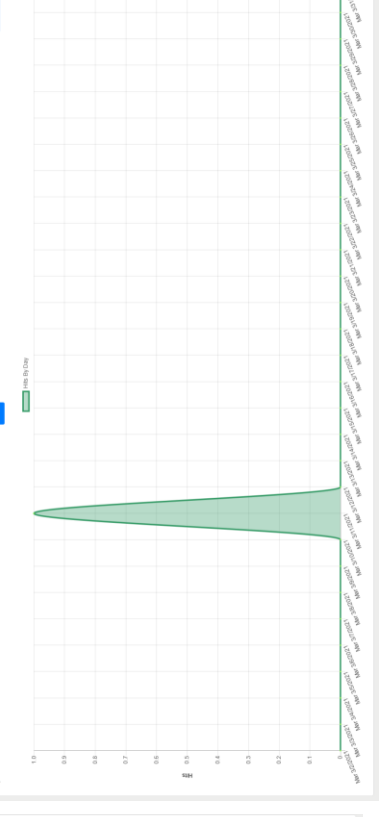

Hits Report

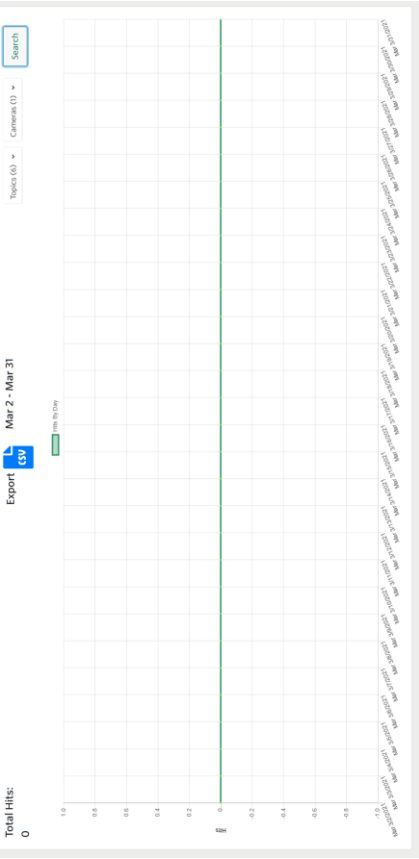

Hits Report

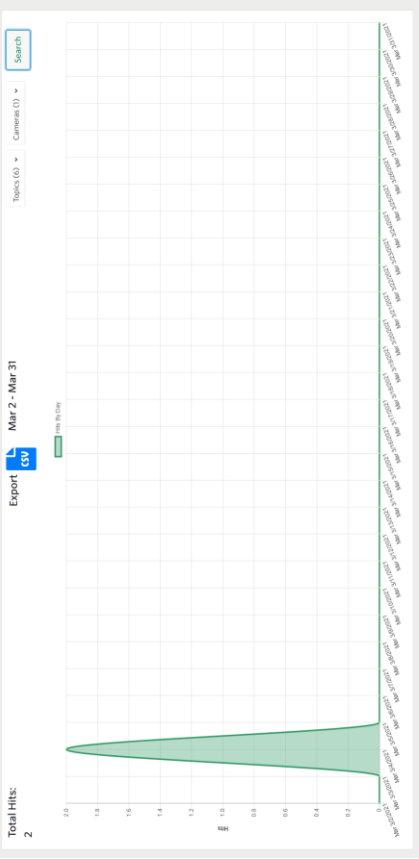

Hits Report

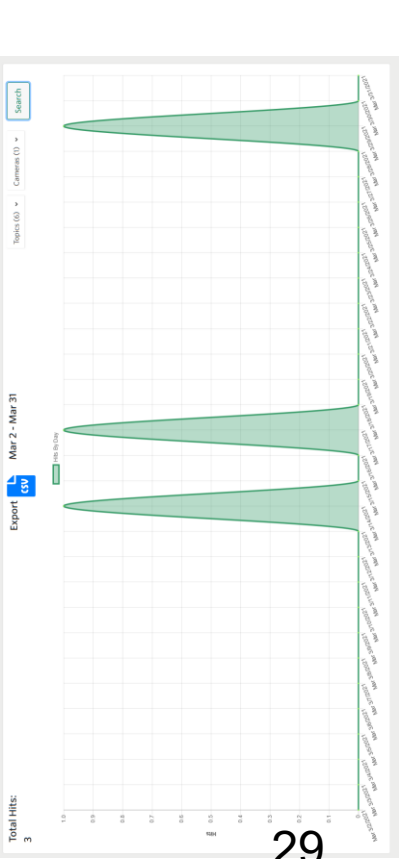

Camera Read Data						
1	114,643	16	61,120			
2	119,171	17	143,382			
3	0	18	103,695			
4	146,238	19	241,283			
5	80,546	20	169,827			
6	73,700	21	102,459			
7	218,395	22	373,228			
8	161,599	23	245,979			
9	56,870	24	46,338			
10	112,683	25	57,057			
11	28,223	26	40,840			
12	69,906	27	74,134	Unit#172		
13	0	28	0	Trailer		
14	76,309	29	47,510	Strey		
15	7,002	30	116,201	Station		

Memorial Villages Police Department

FY22 BUDGET PROPOSAL

GENERAL FUND							
Acct. No	Category	2019 Actual	2020 Unaudited Actual	2021 Adopted	2022 Requested	\$ Increase/ 2021-2022	% Increase
100							
100	Salaries	3,279,467	3,557,690	3,679,271	3,785,751	106,480	3%
110	Overtime	115,094	92,292	125,000	125,000	0	0%
115	Court/Bailiff	6,010	1,269	12,000	10,000	(2,000)	-17%
120	Retirement	379,669	430,477	450,483	459,268	8,785	2%
125	475b contribution		31,865	32,869	62,870	30,001	91%
130	Health Insurance	503,527	513,331	592,828	565,314	(27,514)	-5%
140	Workers Compensation - TML	65,000	59,982	70,500	75,000	4,500	6%
150	Life/LTD	17,847	18,946	21,709	21,982	273	1%
160	Medicare	47,252	52,046	55,403	56,911	1,508	3%
	TOTAL PERSONNEL/BENEFITS	4,413,866	4,757,898	5,040,063	5,162,098	122,035	2%
200							
	TML INTERGOVERNMENTAL RISK POOL						
200	Auto	26,604	25,201	41,100	27,500	(13,600)	-33%
210	General Liability	430	330	720	400	(320)	-44%
220	Public Official Bond	849	848	960	900	(60)	-6%
230	Professional Liability	18,858	18,998	21,400	21,000	(400)	-2%
240	Real & Personal Property	12,637	11,923	8,000	9,600	1,600	20%
	TOTAL OTHER INSURANCE	59,378	57,300	72,180	59,400	(12,780)	-18%
300							
300	Gas and Oil	66,046	69,296	70,500	81,000	10,500	15%
310	Fleet maintenance	31,154	37,949	35,000	40,000	5,000	14%
320	Tires	6,565	6,569	7,000	7,000	0	0%
	Damage Repair	5,783	5,010	10,000	10,000	0	0%
	TOTAL FLEET MAINTENANCE	109,548	118,824	122,500	138,000	15,500	13%
400							
400	General/Building Maintenance	18,848	21,849	25,000	30,000	5,000	20%
410	Janitorial Services	18,000	19,078	21,000	21,000	0	0%
420	Jail	773	299	1,000	1,000	0	0%
430	Building Furnishings	7,450	8,775	15,000	15,000	0	0%
	TOTAL BUILDING	45,070	50,001	62,000	67,000	5,000	8%
500							
500	Computers	10,640	8,521	13,000	13,000	0	0%
510	Postage/postage machine	840	1,129	1,100	1,300	200	18%
520	Office Supplies	12,063	11,974	15,000	15,000	0	0%
530	Bank/Finance Service Chgs	329	400	550	550	0	0%
540	Payroll Services	16,220	17,210	17,400	17,900	500	3%
	TOTAL OFFICE	40,093	39,233	47,050	47,750	700	1%
600							
600	Telephone	33,954	32,499	36,003	40,606	4,603	13%
610	Electric	16,051	14,704	20,000	20,000	0	0%
620	Water/Sewer	5,067	5,153	5,320	5,500	180	3%
630	Natural Gas	510	439	600	600	0	0%
	TOTAL UTILITIES	55,582	52,794	61,923	66,706	4,783	8%
700							
700	Equipment Maint. Contracts	58,797	134,984	118,340	135,950	17,610	15%
710	SETCIC fees	3,262	3,065	3,600	3,600	0	0%
720	Legal/Professional	51,406	76,802	55,000	80,660	25,660	47%
730	IT Services	98,578	100,055	101,850	102,050	200	0%
740	Software Maintenance Contracts	52,170	56,252	56,202	59,200	2,998	5%
	TOTAL CONTRACTS/SERVICES	264,214	371,159	334,992	381,460	46,468	14%
800							
800	Accreditation	0	0	1,200	1,200	0	0%
810	Uniforms	26,518	25,131	30,500	30,500	0	0%
820	Radio parts and labor	29,686	31,328	33,036	33,036	0	0%
830	Firearms Trng and Ammo	5,323	5,880	5,500	6,500	1,000	18%
	Tasers	9,656	10,122	15,000	15,000	0	0%

Memorial Villages Police Department

FY22 BUDGET PROPOSAL

GENERAL FUND CONTINUED							
Acct. No	Category	2019 Actual	2020 Unaudited Actual	2021 Adopted	2022 Requested	\$ Increase/ 2021-2022	% Increase
840	Training & Prof. Dues	38,311	23,113	58,000	58,000	0	0%
850	Travel	7,642	592	9,000	7,000	(2,000)	-22%
860	Recruiting Costs	5,154	958	5,000	5,000	0	0%
870	Criminal Investigations (CID)	3,084	3,003	3,500	3,500	0	0%
880	Contingency - Miscellaneous	13,481	4,179	25,000	25,000	0	0%
892	Small Equipment	4,182	2,255	13,500	14,100	600	4%
	COVID expenditures		47,884			0	
	TOTAL OPERATIONS	143,038	154,444	199,236	198,836	(400)	0%
	TOTAL M&O	5,130,790	5,601,654	5,939,944	6,121,250	181,306	3.05%
OTHER FUNDS							
Acct. No	Category	2019 Actual	2020 Unaudited Actual	2021 Adopted	2022 Requested	\$ Increase/ 2021-2022	% Increase
1000							
1000	Auto Replacement	158,332	165,670	153,000	160,000	7,000	5%
	Rifle Locking System						
	AEDs						
	TOTAL VEHICLE REPLACEMENT	158,332	165,670	153,000	160,000	7,000	4.58%
2000							
2880	Capital Projects Contingency	518	150				
	Radar message board			16,500		(16,500)	
	12TB Dato and Replacement Server				18,000	18,000	
	TOTAL SPECIALCAPITAL ASSETS	518	150	16,500	18,000	1,500	
	TOTAL OTHER FUNDS	158,850	165,821	169,500	178,000	8,500	5%
Category	2019 Actual	2020 Unaudited Actual	2021 Adopted	2022 Requested	\$ Increase/ 2021-2022	% Increase	
GENERAL FUND	5,130,790	5,601,654	5,939,944	6,121,250	181,306	3.05%	
OTHER FUNDS	158,850	165,821	169,500	178,000	8,500	5.01%	
COMBINED TOTALS	5,289,639	5,767,474	6,109,444	6,299,250	189,806	3.11%	



Hunters Creek



Village

FY22 Budget

Bunker Hill Village - Piney Point Village - Hunters Creek Village

Facing the Challenges of
Today, Tomorrow and Beyond

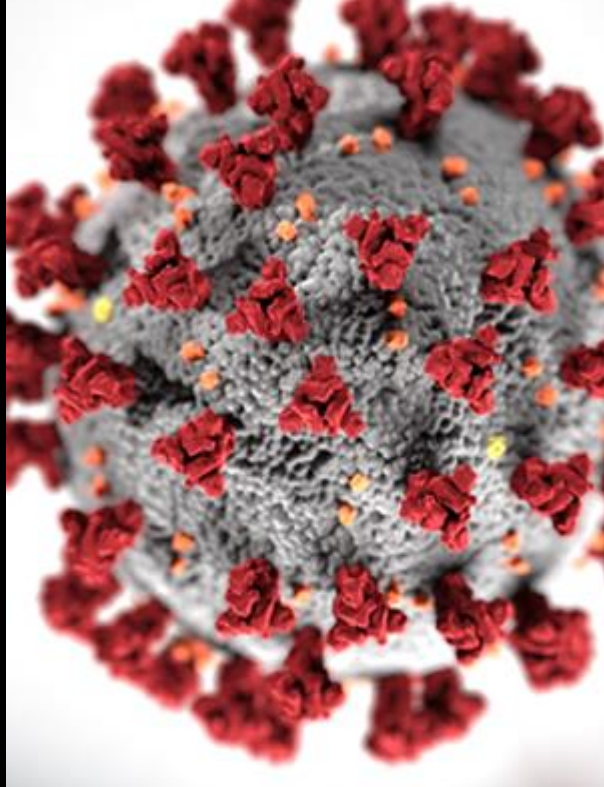



Hunters Creek



Village

FY22 Budget Goals and Objectives

Goals:

Hire, Develop and Maintain the **best qualified and experienced employees** to serve as Memorial Villages Police Department, Police Officers, Dispatchers and Professional Support Staff.

Provide and maintain the **best tools, technology and equipment** available for use by the MVPD in order to provide for a Safe Community, Free of Crime and the Fear of Crime.

Objective:

Use Village Funds in the most effective and efficient manner possible in order to hire and retain employees by providing a competitive salary and benefit package, while at the same time providing staff with the latest technology, tools, equipment and support services that will allow personnel to provide the **highest level of Police Services and Protection**.

FY22 Budget

Results from Previous Budgets

- Staffing ✓
- Building the Brand ✓
- Tackling Crime ✓
- Technology ✓
- Response Times ✓
- Officer and Community Safety ✓

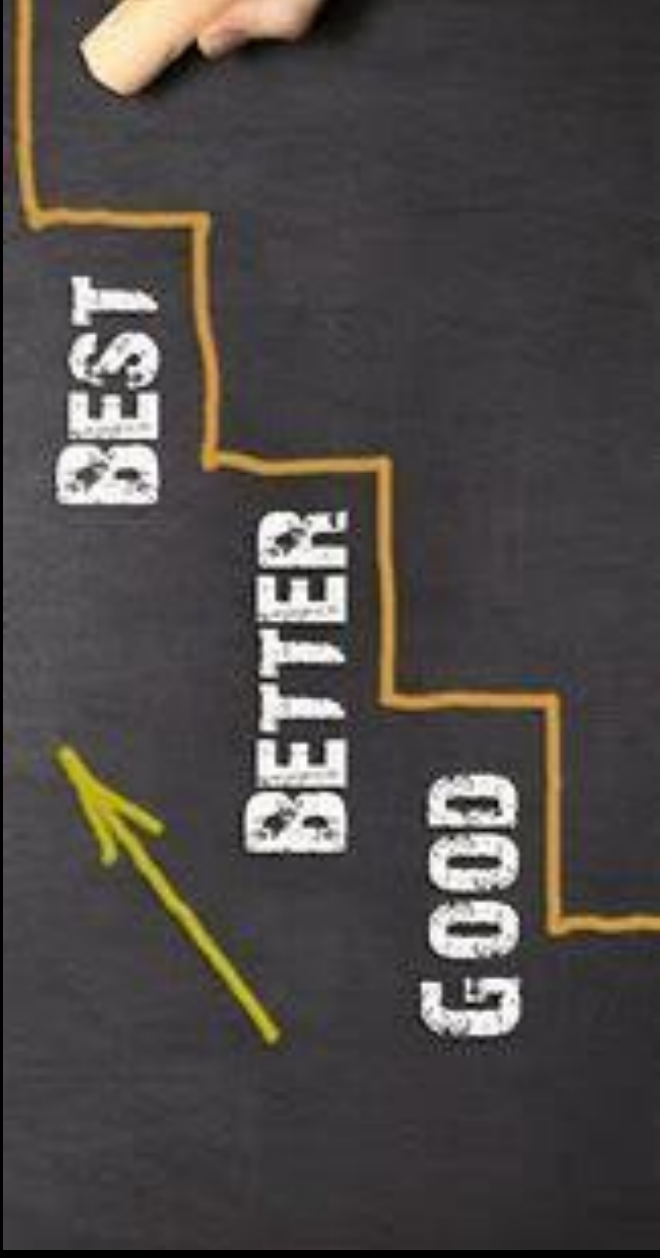

Hunters Creek



Village



Hunters Creek



Village

FY22 Budget

Investment in Personnel – Fully Staffed

Build on our Solid Base

2% Increase in Salary and Benefit Budget

- Avg Base Salary Increase – 3.5%
(1% STEP + 2.5% Salary Adjustment)
- Fully Fund 457b City contribution at 2% (+1%)

Average Salary

w/pay incentives will be:

Sergeant	\$107,205
Patrol Officer	\$87,576
Dispatcher	\$60,611

FY22 Budget

Salary Adjustments - Justification

Maintain our Competitiveness in the LE Community

If not at the Top of the Scale – Be very close

- Base Salary Increase – Recognize the quality work performed along with the additional duties and attention to detail performed by MVPD employees
- 1% STEP – Annual Individual Performance Based Pay Incentive
- Additional 1% 457b Contribution taking total to 2% – Long term savings incentive to compensate for Windfall Act Penalty, Fixed TMRS benefit and Post Employment Health Care.



Hunters Creek



Village

FY22 Budget



Technology = Efficiency + Risk Reduction

- ALPR – The Department ALPR Project has been extremely effective at pro-actively identifying criminals who are within the jurisdiction of the MVPD and as an investigative tool for Detectives. This budget adds 3 additional systems.
- Server – Computer technology touches every aspect of the department. The primary domain server is at end of life.
- Back-up System DATTO – System back-up and Security Hardware and Software is intragyral. Current equipment is at end of life. Back-up of Data will reside both on-site and in the Cloud.



Hunters Creek



Village

FY22 Budget Proposal

FY22 Budget Adjustments/Increases/Decreases

Vehicle Maintenance Adjustment +\$5,000

General Maintenance Contracts +\$5,000+

- Phone System
- Generator
- E-RAD
- Copier
- Elevator
- Fire Safety Systems

Office

- Firearms and Ammo +\$1,000
- Small Equipment +\$600

Equipment

- 3 ALPR's \$7,500
- 4 Replacement Ticket Writers \$6,800
- 4 Urban Rifles +7,300

Vehicle Replacement Budget Adjustment +\$7,000



Hunters Creek



Village

FY22 Budget Proposal



Proposed Total Budget Package for 2022

Personnel and Benefits \$5,162,098 (+2%)

Total Operations \$198,836 (-0.2%)

Total M&O \$6,121,250 (+3.05%)

Auto – \$160,000 (+5%)
(Vehicles)



Hunters Creek



Village

Proposed 2022 Budget – \$6,299,250 (+3.11%)

Cost per Village \$2,099,750

Increase of \$63,268 per village over FY21



Future Capital Projects 2022-2025

The Memorial Villages Police Department administration has identified several capital projects that will likely need Funding from participating cities over the next 1-5 years.

These projects include:

- Roof Replacement \$93,385+
- HVAC Replacement \$56,000-\$148,000+
- Radio System Upgrades \$130,000+
- CAD/RMS/ARS Replacement \$190,000-\$470,000
- Building Upgrades – \$TBD
- Gutters, Overhead Doors, Paint, Jail Fixtures

Hunters Creek



Village



Although the Memorial Villages Police Department has a fund in place to account for capital projects, this fund has not been regularly used as a vehicle to hold funds for these projects. Instead, the three cities have essentially employed a pay as you go methodology whereby the participating cities provide funding for capital projects as needed. A Capital Strategic Plan has been prepared that estimates these costs and an approximate timeline of the needed Repairs/Replacements/Improvements.

Future Capital Projects 2022-2025

5 Projects requiring attention within the next 4-5 years



Hunters Creek



Village



Roof
\$93,400 - \$110,000+



Radio System
\$130,000+



Gutters
Unknown Custom Fab



HVAC
\$56,000 - \$148,000



CAD/RMS/ARS
\$190,000 - \$400,000

**THANK YOU
FOR INVESTING IN
PUBLIC SAFETY**



Hunters Creek



Village

1	Total Number of VTD Incidents 2021														
	Life Threatening (LT) EMS Incidents					Life Threatening (LT) Fire Incidents					Life Threatening (LT) Fire Incidents				
	2	3	4	5	6	7	8	9	10	11	12	13	14	15	
Fire	EMS	Total	# LT EMS	Natl Stand. 6:30 1st Resp. Time	of 90% of 90%	Natl. Stand 10:30 ALS Resp Time	of 90%	# LT Fire	Natl Stand. 6:50 Response Time	of 90%	% of 2021 Calls are: Fire EMS	Fire Alarms	% of Fire Calls		
93	30	123	16	4:21	100%	7:07	100%	1	3:25	100%	76%	44	47%		
52	48	100	29	3:13	100%	3:13	100%	8	3:56	100%	52%	13	25%		
14	11	25	6	3:32	100%	3:56	100%	1	3:19	100%	56%	4	0%		
108	52	160	25	3:46	100%	5:38	100%	9	4:18	100%	68%	62	57%		
89	43	132	18	4:15	100%	5:00	100%	9	5:28	100%	67%	37	42%		
80	33	113	19	2:25	100%	4:04	100%	8	2:51	100%	71%	22	28%		
31	0	31													
467	217	684	113	3:35	100%	4:49	100%	36	3:53	100%	68%	182	33%		

A

Notes: ALL Response Time categories include from the receipt of the call at the Primary Dispatch to arrival on location of the responding units.

Column 1: Reflects the cities listed within the chart.

Column 2: Reflects the year to date number of "fire" type calls within each jurisdiction. Includes: fires, vehicle collisions, gas leaks, rescues, tree in roadways, and others.

Column 3: Reflects the year to date number of "EMS" calls within each jurisdiction.

Column 4: Reflects the year to date, total number of all calls within each jurisdiction.

Column 5: Reflects the year to date, number of "life threatening EMS" calls within each jurisdiction. Includes: heart attacks, strokes, seizures, cardiac arrest, seizures and others.

Column 6, Row A: Reflects the "National Standard for total response time for life threatening EMS Calls of 6 minutes 30 seconds.

Column 6: Reflects the year to date, first responder's response times for each jurisdiction.

Column 7, Row A, Reflects the National Standard of the percentage of calls which the national standard should be met: 90%

Column 7: Reflects the year to date, percentage of calls which the national standard is met during life threatening EMS calls.

Column 8 Row A: Reflects the National Standard for total response time for life threatening EMS calls for arrival of Advanced Life Support Equipment and Personnel: 10 minutes 30 seconds.

Column 8: Reflects the year to date, Advanced Life Support equipment and personnel response time for life threatening calls within each jurisdiction.

Column 9 Row A, Reflects the National Standard of the percentage of calls which the ALS standard should be met: 90%

Column 9: Reflects the year to date, percentage of calls, which the national standards is met of ALS response for each jurisdiction.

Column 10: Reflects the year to date, number of life threatening "Fire Type" calls within each jurisdiction.

Column 11: Reflects the year to date, average total response time to fire type calls within each jurisdiction.

Column 12: Reflects the year to date, percentage of life threatening fire type calls which meet or exceed the National Standard.

Column 13: Reflects the year to date, percentage of calls which our "fire type" calls.

Column 14: Reflects the year to date, percentage of call which our "EMS" calls.

Column 15: Reflects the year to date number of Fire Alarms within each jurisdiction.

Column 16: Reflects the percentage of fire type calls which are fire alarms.

Building Official Monthly Report

Prepared April 20, 2021 for the April 27, 2021 meeting.

Mayor and Council,

Please find attached the Building Officials Monthly Report for March 2021.

Thank You,

James A. Stewart, CBO
Building Official/Public Works Director

**City of Hunters Creek Village
Permit Activity Report (Issued) - 2019**

Month	Building			Electrical		Mech & Plumbing		Total		Valuation
	# Issued	\$ Fees	# New Res	# Issued	\$ Fees	# Issued	\$ Fees	# Issued	\$ Fees	\$
January	19	\$4,633	0	11	\$1,405	15	\$3,730	45	\$9,768	\$702,660
February	17	\$6,188	1	8	\$1,355	30	\$4,080	55	\$11,623	\$2,637,978
March	23	\$13,320	0	10	\$1,170	18	\$2,262	51	\$16,752	\$1,758,240
April	22	\$17,127	1	15	\$3,160	40	\$6,175	77	\$26,462	\$2,931,125
May	26	\$17,786	2	17	\$3,045	29	\$4,295	72	\$25,126	\$2,661,043
June	24	\$12,674	1	6	\$1,150	23	\$4,030	53	\$17,854	\$2,088,440
July	39	\$19,821	1	18	\$2,535	34	\$5,025	91	\$27,381	\$3,760,834
August	27	\$26,431	2	12	\$2,265	33	\$5,145	72	\$33,841	\$5,975,468
September	23	\$26,541	2	12	\$2,095	31	\$5,140	66	\$33,776	\$3,896,872
October	27	\$40,968	3	12	\$1,865	35	\$6,050	74	\$48,883	\$8,384,388
November	20	\$7,283	0	13	\$1,790	22	\$3,235	55	\$12,308	\$1,213,903
December	22	\$14,495	0	10	\$2,020	31	\$4,675	63	\$21,190	\$1,767,497
Total	289	\$207,265	13	144	\$23,855	341	\$53,842	774	\$284,962	\$37,778,448

**City of Hunters Creek Village
Permit Activity Report (Issued) - 2020**

Month	Building			Electrical		Mech & Plumbing		Total		Valuation
	# Issued	\$ Fees	# New Res	# Issued	\$ Fees	# Issued	\$ Fees	# Issued	\$ Fees	\$
January	17	\$10,267	1	12	\$2,160	18	\$2,510	47	\$14,937	\$1,779,758
February	24	\$17,887	1	10	\$1,455	21	\$3,355	55	\$22,697	\$2,970,153
March	34	\$149,084	0	17	\$3,390	32	\$6,140	83	\$158,614	\$29,896,341
April	18	\$4,866	0	15	\$2,825	29	\$4,030	62	\$11,721	\$13,646,371
May	25	\$5,817	0	13	\$2,340	26	\$4,440	64	\$12,597	\$1,032,779
June	23	\$24,680	2	18	\$3,220	35	\$5,320	76	\$33,220	\$7,849,746
July	15	\$23,330	2	23	\$4,590	29	\$5,700	67	\$33,619	\$5,221,170
August	19	\$27,662	2	14	\$2,965	20	\$4,495	53	\$35,122	\$4,849,719
September	26	\$6,996	0	13	\$2,670	34	\$4,870	73	\$14,536	\$1,362,060
October	27	\$32,322	3	8	\$1,385	24	\$4,795	59	\$38,501	\$5,800,301
November	19	\$4,856	0	13	\$1,900	24	\$4,175	56	\$10,930	\$940,466
December	27	\$4,284	0	6	\$700	12	\$1,215	45	\$6,199	\$1,174,925
Total	274	\$312,050	11	162	\$29,600	304	\$51,045	740	\$392,693	\$76,523,789

**City of Hunters Creek Village
Permit Activity Report (Issued) - 2021**

Month	Building			Electrical		Mech & Plumbing		Total		Valuation
	# Issued	\$ Fees	# New Res	# Issued	\$ Fees	# Issued	\$ Fees	# Issued	\$ Fees	\$
January	29	\$17,846	1	19	\$3,215	24	\$4,495	72	\$25,556	\$3,108,651
February	15	\$24,327	2	9	\$1,410	18	\$2,420	49	\$28,516	\$4,311,997
March	35	\$14,765	0	19	\$2,615	44	\$6,985	98	\$24,365	\$2,394,000
April										
May										
June										
July										
August										
September										
October										
November										
December										
Total	79	\$56,937		47	\$7,240	86	\$13,900	219	\$78,437	\$9,814,648

**City of Hunters Creek Village
Inspection Activity Report - 2020**

	Inspections Performed	Inspections Passed	% Passed	Inspections Failed	% Failed
Month					
January	112	100	89.0	12	11.0
February	161	134	83.2	27	16.8
March	149	137	91.9	12	8.1
April	203	171	84.2	32	15.8
May	199	165	82.9	34	17.1
June	164	138	84.1	26	15.9
July	228	193	84.6	35	15.4
August	159	140	88.1	19	11.9
September	167	138	82.6	29	17.4
October	155	127	81.9	28	18.1
November	108	89	82.4	19	17.6
December	134	110	82.1	24	17.9
Total	1939	1642	84.8	297	15.3

**City of Hunters Creek Village
Inspection Activity Report - 2021**

	Inspections Performed	Inspections Passed	% Passed	Inspections Failed	% Failed
Month					
January	147	124	84.4	23	15.6
February	98	86	87.8	12	12.2
March	172	146	84.9	26	15.1
April					
May					
June					
July					
August					
September					
October					
November					
December					
Total	417	356	85.7	61	14.3

Inspections with Odometer Readings, by Inspector and Vehicle

Apr 21, 2021 9:56 AM
James Stewart
City of Hunters Creek Village

Date Range (inclusive): **Mon Mar 01 2021 to Wed Mar 31 2021**
Inspection Department: **Building Permit Inspections**

BBG Consulting, Inc (BBG)		Address		Insp Type	Date	Reinsp?	Reinsp Result	Correction Notes
Odometer	Permit #						Fee?	
Vehicle ID:								
	201900605	10623 Fairlane Dr		Bld-Final	3/1/21		No	NC Disapproved; Construction debris in front yard; Front walkway no complete; Front entry brick work not complete; Landscaping not complete.
	202000741	10611 S Ever Park Drive		F Final	3/1/21		No	Pass
	202100055	10623 Fairlane Dr		DW Final	3/1/21		No	Pass
	202100084	10623 Fairlane Dr		I Trench	3/1/21		No	Pass
	202100084	10623 Fairlane Dr		I Final	3/1/21		No	Pass
	202100114	10650 Beinhorn Rd		I Trench	3/1/21		No	Pass
	202000488	346 HUNTERS TRAIL ST		E Underg	3/2/21		No	Pass
	202100060	10623 Fairlane Dr		E Final	3/2/21		No	Pass
	202100104	3 Cape Cod Lane		E Rough	3/2/21		No	Pass
	201900476	7511 Riverview Way		Bld-Final	3/3/21		No	Pass
	202000390	289 Bryn Mawr Cir		Frame R	3/3/21		No	NC Disapproved; Frame portal per detail on S3.2; Frame overhang for detail on 1/S3.0; Parallel trust and wall for detail 1/S4.1; Provide (4) 2 x 6 Under each side of header in family room and game room; Provide LRU28 hangers for ceiling joist in bedroom one; Provide L US to six for

													ceiling joist in game room; Provide one anchor bolt within 12 inches of end of seal plate and minimum of two anchor bolts per section of seal plate; Draft stop gable roof wall in master bedroom
	202000488	346 HUNTERS TRAIL ST	E TCI	3/3/21			No	Pass					
	202000596	346 HUNTERS TRAIL ST	P TO/Rough	3/3/21			No	PPass					Correct and proceed; Provide plate straps and stud supports for overboard plates and studs
	202000714	7511 Riverview Way	F Final	3/3/21			No	Pass					
	202100011	3 Cape Cod Lane	Frame R	3/3/21	Y		No	Pass					[Entered 2/11/2021 by BBG]: Approved - Floor Joist; h-clips and nail pattern
	202100063	10917 Roaring Brook Lane	F Post Hole	3/3/21			No	Pass					
	202100087	3 Cape Cod Lane	P TO/Rough	3/3/21	Y		No	Pass					[Entered 2/11/2021 by BBG]: Approved partial under floor
	202100091	13 Inwood Oaks	E Underg	3/3/21			No	Pass					
	202100091	13 Inwood Oaks	E Serv/ML	3/3/21			No	Pass					
	202100092	13 Inwood Oaks	E Underg	3/3/21			No	Pass					
	202100119	703 Saddlewood Lane	P Final	3/3/21			No	Pass					
	202100120	517 WELLESLEY DR	ET-Pole	3/3/21			No	Pass					
	202100077	10906 TIMBERGLEN DR	M Final	3/4/21			No	Pass					
	202100112	10709 Marsha Lane	E Final	3/4/21			No	Pass					
	202100122	609 Saddlewood Lane	E Underg	3/4/21			No	Pass					

202100122	609 Saddlewood Lane	E Serv/ML	3/4/21		No	Pass	Released to Centerpoint 3/4/21 jas
201900718	711 Hunters Grove Ln	Gas Test	3/5/21		No	Pass	
202000378	7 Hedwig Shadows Dr	Frame R	3/5/21		No	NC	Contractor Cancelled.
202000390	289 Bryn Mawr Cir	Frame R	3/5/21	Y	No	NC	Disapproved - Frame portal per detail on S3.2; Frame overhangs per detail on 1/ S3.0; Draft stop gable roof at master bedroom over garage [Entered 3/3/2021 by BBG]: Disapproved; Frame portal per detail on S3.2; Frame overhang for detail on 1/S3.0; Parallel trust and wall for detail 1/S4.1; Provide (4) 2 x 6 Under each side of header in family room and game room; Provide LRU28 hangers for ceiling joist in bedroom one; Provide L US to six for ceiling joist in game room; Provide one anchor bolt within 12 inches of end of seal plate and minimum of two anchor bolts per section of seal plate; Draft stop gable roof wall in master bedroom
202100081	289 Bryn Mawr Cir	P Steel/Piping	3/5/21		No	Pass	
202100108	819 Country Lane	Shower Pan	3/5/21		No	Pass	
202100113	7611 River Point Dr	F Post Hole	3/5/21		No	Pass	
202000452	10733 Old Coach Ln	E Underg	3/8/21	Y	No	Pass	
202000470	10733 Old Coach Ln	Shower Pan	3/8/21		No	Pass	
202000470	10733 Old Coach Ln	P UnderG	3/8/21	Y	No	Pass	
202100011	3 Cape Cod Lane	Insulation	3/8/21		No	Pass	
202100040	819 Country	Frame R	3/8/21		No	Pass	

	Lane									
202100133	711 Hunters Grove Ln	E Underg	3/8/21	No	Pass					
202100133	711 Hunters Grove Ln	E Rough	3/8/21	No	Pass					
202100049	10714 OLD COACH LN	Frame R	3/9/21	No	Pass					
202100087	3 Cape Cod Lane	Shower Pan	3/9/21	No	Pass					
202100105	10714 Old Coach Ln	E Rough	3/9/21	No	Pass					
202100122	609 Saddlewood Lane	E Final	3/9/21	No	Pass					
202100135	10714 Old Coach Ln	P TO/Rough	3/9/21	No	Pass					
202100127	10614 S Evers Park Drive	E Serv/ML	3/10/21	No	Pass					
202000729	10926 Wickline Dr	Demo F	3/11/21	No	Pass					
202100040	819 Country Lane	Frame C/I	3/11/21	No	Pass					
202100049	10714 OLD COACH LN	Insulation	3/11/21	No	Pass					
202100111	517 WELLESLEY DR	FD-Piers	3/11/21	No	P Pass	Approved pending engineer letter				
202100131	843 Country Lane	P Final	3/11/21	No	Pass					
202100144	256 Hedwig Road	P UnderG	3/11/21	No	Pass					
202100144	256 Hedwig Road	P GL & GT	3/11/21	No	Pass					
202100145	10900 Kemwood Drive	P UnderG	3/11/21	No	Pass					
202100145	10900	P Final	3/11/21	No	Pass					

	Kemwood Drive														
202100146	506 Hunterwood Drive	F Post Hole	3/11/21		No			Pass							
202000503	731 Kuhlman Rd	Bld-Final	3/12/21		No			Pass							
202100127	10614 S Evers Park Drive	E Final	3/12/21		No			NC						Disapproved - Home owner said no work done and didn't schedule inspection	
202100132	703 Saddlewood Lane	E Serv/ML	3/12/21		No			Pass							
202000102	11000 Hunters Park Drive	Shower Pan	3/15/21		No			P Pass						Approved - partial; Second floor only	
202000378	7 Hedwig Shadows Dr	Frame R	3/15/21	Y	No			Pass						Approved - Per engineers letter	
202100114	10650 Beinhorn Rd	I Trench	3/15/21		No			P Pass						[Entered 3/5/2021 by BBG]: Contractor Cancelled.	
202000452	10733 Old Coach Ln	E TCI	3/16/21		No			Pass						"Approved - partial; See sheet L4.00; NO HYDRO on mains "	
202100020	10906 Long Shadow Ln	E Final	3/16/21		No			Pass							
202100114	10650 Beinhorn Rd	I Trench	3/16/21	Y	No			Pass						"Approved - See sheet L4.00; No hydro on main lines"	
202100127	10614 S Evers Park Drive	E Final	3/16/21	Y	No			Pass						[Entered 3/15/2021 by BBG]: "Approved - partial; See sheet L4.00; NO HYDRO on mains "	
202100132	703 Saddlewood Lane	E Final	3/16/21		No			Pass						[Entered 3/12/2021 by BBG]: Disapproved - Home owner said no work done and didn't schedule inspection	
202100141	406 Ripple Creek Drive	P TO/Rough	3/16/21		No			Pass							

202100156	730 E CREEKSIDE DR	Gas Test	3/16/21	No	Pass	
202000486	346 HUNTERS TRAIL ST	Frame R	3/17/21	No	Pass	Approved - Plumber has not installed all stud supports at Laundry rooms first and second floor and at bar area on second floor; DO NOT cover these areas.
202000486	346 HUNTERS TRAIL ST	Insulation	3/17/21	No	Pass	Approved - Plumber has not installed all stud supports at Laundry rooms first and second floor and at bar area on second floor; DO NOT cover these areas.
202100148	5 Pine Grove	Re-Roof	3/17/21	No	Pass	
202000161	10706 Beinhorn Rd	Gas Test	3/18/21	No	Pass	Released.
202000390	289 Bryn Mawr Cir	Frame R	3/18/21	No	Pass	Approved; Per Engineer Letter. [Entered 3/5/2021 by James]: Everything but Garage Area. Will need reinspection for garage area. [Entered 3/5/2021 by BBG]: Disapproved - Frame portal per detail on S3.2; Frame overhangs per detail on 1/ S3.0; Draft stop gable roof at master bedroom over garage [Entered 3/3/2021 by BBG]: Disapproved; Frame portal per detail on S3.2; Frame overhang for detail on 1/S3.0; Parallel trust and wall for detail 1/S4.1; Provide (4) 2 x 6 Under each side of header in family room and game room; Provide LRU28 hangers for ceiling joist in bedroom one; Provide L US to six for ceiling joist in game room; Provide one anchor bolt within 12 inches of end of seal plate and minimum of two anchor bolts per section of seal plate; Draft stop gable roof wall in master bedroom
202000641	10529 Beinhorn Rd	Gas Test	3/18/21	No	Pass	Released.

202100147	10725 OLD COACH LN	DW Steel	3/18/21	No	NC	Disapproved - No approved plans on site.
202100165	318 Lindenwood Drive	F Post Hole	3/18/21	No	Pass	Approved - South Side
202000517	611 Shartle Cir	M Final	3/19/21	No	Pass	
202100114	10650 Beinhorn Rd	I Trench	3/19/21	Y	Pass	Approved as marked on plans, see sheet L4.00
202100150	907 Oak Valley Dr	P UnderG	3/22/21	No	Pass	
202100150	907 Oak Valley Dr	P Final	3/22/21	No	Pass	
202100162	511 Hunterwood Drive	E Rough	3/22/21	No	Pass	
202100164	1 Inwood Oaks Drive	P Final	3/22/21	No	Pass	
202000390	289 Bryn Mawr Cir	Insulation	3/23/21	No	Pass	
202000596	346 HUNTERS TRAIL ST	P TO/Rough	3/23/21	Y	Pass	[Entered 3/3/2021 by BBG]: Correct and proceed; Provide plate straps and stud supports for overboard plates and studs
202100180	10811 PINE BAYOU ST	E Underg	3/23/21	No	Pass	
202100180	10811 PINE BAYOU ST	E Rough	3/23/21	No	Pass	
202000102	11000 Hunters Park Drive	Shower Pan	3/24/21	Y	Pass	[Entered 3/15/2021 by BBG]: Approved - partial;Second floor only
202000245	5 Cape Cod Lane	Shower Pan	3/24/21	No	Pass	
202000378	7 Hedwig Shadows Dr	Insulation	3/24/21	No	Pass	
202000587	408 LINDENWOOD DR	H-Strap	3/24/21	No	Pass	
202000717	635 Saddlewood	Frame R	3/24/21	No	Pass	

	Lane											
202000735	10811 PINE BAYOU ST	Bid-Final	3/24/21	No	Pass							
202100000	10906 Long Shadow Ln	P Final	3/24/21	No	Pass							
202100009	511 Hunterwood Drive	P TO/Rough	3/24/21	No	Pass							Correct and proceed - Provide proper plates and stud shoes for all over bored plates and studs
202100009	511 Hunterwood Drive	P UnderG	3/24/21	Y	Pass							Correct and proceed - Provide proper plates and stud shoes for all over bored plates and studs [Entered 1/14/2021 by BBG]: Partially Approved; Excludes Tub
202100030	10906 Long Shadow Ln	P Final	3/24/21	No	Pass							
202100051	10606 N EVERS PARK DR	Gas Test	3/24/21	No	NC							Disapproved; No pressure or guage on system.
202100051	10606 N EVERS PARK DR	P Rgh/P-T/CBK	3/24/21	No	P Pass							Approved Vacuum Breaker; Disapproved Ptrap-Not Installed.
202100052	10606 N EVERS PARK DR	E Underg	3/24/21	No	Pass							
202100052	10606 N EVERS PARK DR	E Rough	3/24/21	No	Pass							
202100096	10926 Wickline Dr	FD-Piers	3/24/21	No	Pass							Approved Pending Engineer Letter
202100154	517 WELLESLEY DR	P UnderG	3/24/21	No	Pass							
202100154	517 WELLESLEY DR	P Sewer	3/24/21	No	Pass							
202100163	7611 River Point Dr	I Trench	3/24/21	No	Pass							
202100163	7611 River	I Final	3/24/21	No	Pass							

	Point Dr											
202100180	10811 PINE BAYOU ST	E Final	3/24/21	No	Pass							
202100184	10733 Old Coach Ln	YD Trench	3/24/21	No	PPass	Approved - Provide catch basins on east side of home as design on several drawings						
202000561	10610 S EVERS PARK DR	E Final	3/25/21	No	Pass							
202000682	10318 Memorial Dr	Gas Test	3/25/21	Y	Pass							
202000682	10318 Memorial Dr	P Rgh/P-T/V/CBK	3/25/21	Y	Pass							
202100178	10706 Beinhorn Rd	YD Trench	3/25/21	No	NC	Disapproved; Not all piping has been installed; Catch basin 1 not installed and 8 & 9 not complete.						
202100184	10733 Old Coach Ln	YD Trench	3/25/21	Y	Pass	[Entered 3/24/2021 by BBG]: Approved - Provide catch basins on east side of home as design on several drawings						
202100185	10733 Old Coach Ln	E Underg	3/25/21	No	Pass							
202100185	10733 Old Coach Ln	E Rough	3/25/21	No	Pass							
202000429	737 Camelot Lane	F Final	3/26/21	No	Pass							
202000663	10917 Roaring Brook Lane	Gas Test	3/26/21	Y	Pass	[Entered 11/11/2020 by james]: No gas line installed.						
202000686	10318 Memorial Dr	E Final	3/26/21	No	Pass							
202100051	10606 N EVERS PARK DR	Gas Test	3/26/21	Y	Pass	[Entered 3/24/2021 by BBG]: Disapproved; No pressure or guage on system.						
202100051	10606 N EVERS PARK DR	P Rgh/P-T/V/CBK	3/26/21	Y	Pass	[Entered 3/24/2021 by BBG]: Approved Vacuum Breaker; Disapproved Ptrap-Not Installed.						
202100146	506 Hunterwood Drive	F Final	3/26/21	No	Pass							

202100155	10915 Kinwick Drive	M Rough	3/26/21	No	Pass
202100179	635 Saddlewood Lane	M Rough	3/26/21	No	Pass
202100193	751 E CREEKSIDE DR	Shower Pan	3/26/21	No	Pass
202000742	10623 Fairlane Dr	E Final	3/29/21	No	Pass
202100178	10706 Beinhorn Rd	YD Trench	3/29/21	Y	Pass
202000243	10429 Memorial Dr	Foundation	3/30/21	No	Pass
202000669	730 E CREEKSIDE DR	H-Strap	3/30/21	No	NC
202100135	10714 Old Coach Ln	Shower Pan	3/30/21	No	Pass
202100137	770 Pifer Road	F Post Hole	3/30/21	No	Pass
202100183	10810 Hunters Forest Dr	P Final	3/30/21	No	Pass
202000577	10906 Long Shadow Ln	FD Steel	3/31/21	No	Pass
202000577	10906 Long Shadow Ln	E Underg	3/31/21	No	Pass
202000577	10906 Long Shadow Ln	E Rough	3/31/21	No	Pass
202000578	10906 Long Shadow Ln	P UnderG	3/31/21	No	Pass
202000578	10906 Long Shadow Ln	Gas Test	3/31/21	No	Pass
202000682	10318	P Final	3/31/21	No	Pass

		Memorial Dr										
	202100028	10529 Beinhorn Rd	M Rough	3/31/21	No	Pass						
	202100109	215 VOSS RD	Demo F	3/31/21	No	Pass						
	202100117	777 W Creekside Dr	M Final	3/31/21	No	Pass						
Inspections		Begin Odometer		End Odometer		Miles	Avg Miles per Inspection					
139					0		0.0					

Fire Marshall (FireMars)

Odometer **Permit #** **Address** **Insp Type** **Date** **Reinsp?** **Reinsp Result** **Correction Notes**
Fee?

Vehicle ID:

	202000518	346 HUNTERS TRAIL ST	Fire Marshall	3/8/21	No	P Pass	Hydro OK @ 210 psi Cover Failed
	202000518	346 HUNTERS TRAIL ST	Fire Marshall	3/15/21	Y	Pass	Hydro OK @ 210 psi Cover OK [Entered 3/8/2021 by FireMars]: Hydro OK @ 210 psi Cover Failed

Inspections

2		Begin Odometer		End Odometer		Miles	Avg Miles per Inspection
					0		0.0

James Stewart (james)

Odometer **Permit #** **Address** **Insp Type** **Date** **Reinsp?** **Reinsp Result** **Correction Notes**
Fee?

Vehicle ID:

	202000684	13 SLEEPY OAKS CIR	Demo F	3/1/21	No	Pass	
	201900552	7511 Riverview Way	Bld-Final	3/2/21	No	Pass	Via Engineer Letter.
	201900605	10623 Fairlane Dr	Bld-Final	3/2/21	Y	Pass	[Entered 3/1/2021 by BBG]: Disapproved; Construction debris in front yard; Front walkway no complete; Front entry brick work not complete; Landscaping not complete.
	202100116	10623 Fairlane	P UnderG	3/2/21	No	Pass	

	202100116	Dr	10623 Fairlane Dr	P Final	3/2/21		No	Pass				
	202100116	Dr	10623 Fairlane Dr	P GL & GT	3/2/21		No	Pass				
	202000717		635 Saddlewood Lane	Foundation	3/3/21		No	Pass				
	202000364		714 Country Ln	P Final	3/5/21		No	Pass				
	202000390		289 Bryn Mawr Cir	Frame R	3/5/21	Y	No	PPass	Everything but Garage Area. Will need reinspection for garage area. [Entered 3/5/2021 by BBG]: Disapproved - Frame portal per detail on S3.2; Frame overhangs per detail on 1/ S3.0; Draft stop gable roof at master bedroom over garage [Entered 3/3/2021 by BBG]: Disapproved; Frame portal per detail on S3.2; Frame overhang for detail on 1/S3.0; Parallel trust and wall for detail 1/S4.1; Provide (4) 2 x 6 Under each side of header in family room and game room; Provide LRU28 hangers for ceiling joist in bedroom one; Provide L US to six for ceiling joist in game room; Provide one anchor bolt within 12 inches of end of seal plate and minimum of two anchor bolts per section of seal plate; Draft stop gable roof wall in master bedroom			
	202000412		714 Country Lane	P Final	3/5/21		No	Pass				
	202000414		714 Country Lane	E Final	3/5/21		No	Pass				
	202100136		10822 Everwood Drive	P Final	3/8/21		No	Pass				
	202100140		10829 Long Shadow Ln	YD Trench	3/9/21		No	Pass	Passed per James.			

202100070	310 LINDENWOOD DR	TCI	3/10/21	No	Pass	
202100140	10829 Long Shadow Ln	YD Final	3/10/21	No	Pass	
202000612	210 TIMBERWILDE LN	TCI	3/11/21 Y	No	Pass	
202100025	902 Oak Valley Dr	DW Final	3/12/21	No	Pass	
202100068	725 1/2 Voss Rd	CALLCTHL	3/15/21	No	Pass	
202100158	3 Bridlewood Ct	DW Steel	3/16/21	No	Pass	
202000537	6 PINE GROVE CIR	P Deck S	3/17/21	No	Pass	
202100118	621 Wellesley Dr	P Layout	3/18/21	No	Pass	
202100147	10725 OLD COACH LN	DW Steel	3/18/21 Y	No	Pass	[Entered 3/18/2021 by BBG]: Disapproved - No approved plans on site.
202100027	256 Hedwig Road	TCI	3/19/21	No	Pass	
202100157	10914 Kirwick Drive	Foundation	3/19/21	No	PPass	Partial for Exterior Court Yard - Passed
202100160	13 Inwood Oaks	P UnderG	3/22/21	No	Pass	
202100160	13 Inwood Oaks	P GL & GT	3/22/21	No	Pass	
202000587	408 LINDENWOOD DR	Foundation	3/23/21 Y	No	Pass	Received Engineer Letter. [Entered 2/3/2021 by BBG]: Approved upon receipt to the city of the engineer's letter
202100118	621 Wellesley Dr	P Steel/Piping	3/26/21	No	Pass	
202100147	10725 OLD COACH LN	DW Final	3/29/21	No	Pass	

202000470	10733 Old Coach Ln	Gas Test	3/30/21	No	Pass
202100203	111 Willowend Dr	P Final	3/30/21	No	Pass
Inspections	Begin Odometer	End Odometer	Miles	Avg Miles per Inspection	
31			0	0.0	

Copyright © 2021 CityView. All rights reserved. BuildingDepartment.com and BluePrince are trademarks of Harris Computer.

HUNTERS CREEK VILLAGE - PLAN REVIEW STATUS REPORT

PROJECT ADDRESS	PROJECT TYPE	DATE SUBMITTED	REVIEW STATUS	COMMENTS
10714 Old Coach Ln.	Remodel	1/20/2021	Review Completed - 1/20/21 - Not Approved	Contractor notified of needed revisions - 1/20/21
10802 Oak Hollow St.	Residential Remodel	2/22/2021	Review Completed 2/25/21 - Not Approved - Plans Resubmitted - 3/4/21 - Received Fire Sprinkler Verification - 3/29/20 - Review Completed 3/29/20 - Approved	Contractor Notified of Needed Revisions - 2/25/21 - Contractor Notified of approval - 3/29/21
10914 Kirwick Dr.	Residential Remodel	2/22/2021	Review Completed - 3/2/21 - Approved	Contractor Notified of Approval - 3/2/21
621 Wellesley Dr.	New Pool	2/23/2021	Review Completed - 2/26/21 - Approved	Contractor Notified of Approval - 2/26/21
2 Bridlewood Court	New Residence	3/3/2021	Review Completed 3/10/21 - Not Approved - Resubmitted 3/17/21 - Resubmittal Review Completed 3/30/21 - Not Approved - Second Resubmittal 3/31/21 - Review Completed - 4/1/21 - Approved	Contractor Notified of Needed Revisions - 3/10/21 - Contractor notified of further needed revisions - 3/30/21 - Contractor Notified of approval - 4/1/21
10815 Everwood Ln.	Remodel	3/9/2021	Review Completed - 3/10/21 - Not Approved - Plans resubmitted 3/11/21 - Review Completed - 3/11/21 - Approved	Contractor notified of needed revisions. - 3/10/21 - Contractor Notified of Approval - 3/11/21
422 Thamer Ln.	Remodel	3/9/2021	Review Completed - 3/11/21 - Approved	Contractor Notified of Approval - 3/11/21
10426 Memorial Drive	New Home	3/25/2021	Review Completed - 4/6/21 - Not Approved	Contractor notified of needed revisions 4/6/21
10430 Memorial Dr.	New Pool	4/1/2021	Review Completed 4-6-21 - Not Approved - Resubmitted 4/19/21 - Review Completed 4/19/21 - Approved	Contractor Notified of Needed Revisions 4/6/21 - Contractor notified of approval - 4/19/21
11002 Huntwyck Dr.	New Pool	4/1/2021	Review Completed 4/7/21 - Not approved	Contractor notified of needed revisions 4/7/21
13 Sleepy Oaks Cir	New Home	4/5/2021	In Review	
10737 Marsh Ln	Remodel	4/6/2021	Review Completed 4/7/21 - Not Approved	Contractor Notified of needed revisions 4/7/21
34 Willowend	Remodel	4/8/2021	Review Completed 4/9/21 - Approved	Contractor notified of approval 4/9/21
773 Pifer Rd.	New Home	4/14/2021	In Review	
4 Pinewood Circle	Remodel	4/19/2021	In Review	
15 Inwood Oaks	Remodel	4/19/2021	In Review	

City of Hunters Creek Village

Certificate of Occupancy

March 5, 2021

Permit Number: 201900605

Zachary and Audrey Springer
10623 Fairlane Drive
Houston, TX 77024

The Residence Is Ready For Occupancy. All Final Building, Mechanical, Electrical and Plumbing Inspections Have Been Made And All Fees Have Been Paid. This Building Complies With The 2015 IRC.

* This Residence Has Been Equipped With An Automatic Sprinkler System

James A. Stewart, CBO
Building Official

HUNTERS CREEK VILLAGE - ANIMAL CONTROL ACTIVITY REPORT				
DATE	ADDRESS	ACTIVITY DESCRIPTION	DISPOSITION	NOTES
1/29/2019	Voss @ Beinhorn	Dead animal in roadway	Picked up and disposed	Appeared the animal was an Otter
4/9/2019	640 Pifer Rd.	Dead Animals in Roadway	Picked up and disposed	
4/10/2019	12 Inwood Oaks	Stray Dog at Residence	Picked up/Taken to Shelter	
5/10/2019	750 Pifer Rd.	Animal Trap Delivered to Resident	Trap Delivered	
6/4/2019	210 Timberwilde Ln.	Opossum in trap - Picked Up	Picked Up/Relocated	
6/7/2019	725 W. Creekside Dr	Animal Trap Delivered to Resident	Trap Delivered	
6/11/2019	737 Camelot Ln	Animal Trap Delivered to Resident	Trap Delivered	
6/24/2019	107 Timberwilde Ln	Trapped Raccoon - Pick Up/Return Trap to Resident	Picked Up/Relocated	
7/2/2019	10650 Memorial Dr.	Dead Squirrel on roadway	Picked Up/Disposed	
7/8/2019	321 Shasta	Bat inside House - Owner Caught and Froze - Rabies Test	Picked up/Took to Lab for Testing	Rabies test result was negative for R
7/8/2019	646 Hedwig Rd.	Dead Cat near street	Picked Up - Disposed	
7/11/2019	602 Wellesley	Dead Squirrel in front.	Picked up - Disposed	
7/15/2019	507 Three Corners	Large Opossum in Trap	Picked up- Relocated	
7/23/2019	507 Three Corners	Large Raccoon in Trap	Picked Up - Relocated	
8/27/2019	729 W. Creekside	Needs animal trap delivered so they can catch animals in back yard.	Delivered trap to resident	
8/28/2019	403 Thamer Ln.	Pick up trapped racoon - Return trap	Picked up Raccoon - Returned trap	
9/5/2019	10810 Oak Creek St.	Report of Dog in Street from Police Dept.	Picked up Dog - Owner Located	Dog Returned to Owner
9/13/2019	331 Hunters Trail St.	Owner Bitten by his dog - Dog Very Aggressive/Dangerous	Dog Euthanized by Owner Request - Tested	Rabies Test NEGATIVE for Rabies
9/16/2019	210 Timberwilde Ln.	Opossum in trap - Picked Up	Picked Up - Relocated	
9/27/2019	600 Blk Timberwilde	Dog at Large	Picked Up Dog - Taken to CAPS for Adoption	Enrolled for Adoption at CAPS.
9/30/2019	10914 Walwick Dr.	Dead Raccoon	Picked Up/Disposed	
10/7/2019	9 Hunters Ridge Ct.	Dead Armadillo	Picked Up/Disposed	
10/11/2019	10800 BLK Roaring Brook	Dead squirrel in road	Picked Up/Disposed	
10/14/2019	938 Boros	Deliver Animal Trap - Feral Cats	Delivered Trap to resident	
10/25/2019	10814 Jaycee Ln.	Deliver Animal Trap - Racoons	Delivered Trap to resident	
11/6/2019	10537 Gawain Ln.	Deliver trap for raccoons.	Delivered Trap to resident	
11/7/2019	Pifer at Beihorn	Dead Opossum in road	Picked Up/Disposed	
11/8/2019	Beinhorn at Pifer Rd	Dead Raccoon in Road	Picked Up/Disposed	
11/7/2019	423 Thamer Ln.	Dog Bite - UPS Driver Bitten while making delivery	Home Quarantine of Dog - Shots Current	Home Quarantine ended 11/18/19 - All OK - Rabies Vaccination Current
11/11/2019	Voss at Longshadow	Dead Raccoon in Road	Picked Up/Disposed	
11/11/2019	Memorial at Hunters Way	Dead animal in roadway	Picked Up/Disposed	
11/20/2019	Memorial at Creekside	Dead animal in roadway	Picked Up/Disposed	

1/6/2020	3 Saddlewood Estates	Animal Trap Delivered to Resident	Animal Trap Delivered to Resident	Delivered Trap to resident	
1/7/2020	5 Reynolds Ct	Animal Trap Delivered to Resident	Animal Trap Delivered to Resident	Delivered Trap to resident	
1/8/2020	Memorial near Thamer	Dead animal in roadway	Dead animal in roadway	Picked Up/Disposed	
1/8/2020	Voss at Beinhorn	Dead animal in roadway	Dead animal in roadway	Picked Up/Disposed	
1/17/2020	5 Reynolds Ct.	Pick Up Trap - No Longer Needed	Pick Up Trap - No Longer Needed	Picked Up Trap	
2/3/2020	606 Hunters Way Dr.	Animal Trap Delivered to Resident	Animal Trap Delivered to Resident	Delivered Trap to Resident	
2/19/2020	210 Timberwilde Ln.	Trapped Raccoon - Pick Up/Return Trap to Resident	Trapped Raccoon - Pick Up/Return Trap to Resident	Picked Up Raccoon - Relocated	Relocated Raccoon
2/19/2020	3 Saddlewood Estates	Animal Trap Request	Animal Trap Request	Delivered Trap to Resident	
2/21/2020	3 Saddlewood Estates	Raccoon in trap	Raccoon in trap	Picked up and relocated raccoon	Relocated Raccoon
2/26/2020	Hunters Trail St.	Stray Dog	Stray Dog	Pick Up Dog - Delivered to shelter	
2/28/2020	507 Hunters Park Ln.	2 Feral Cats in Trap	2 Feral Cats in Trap	Picked up/Relocated	Relocated Cats
3/3/2020	108 Shasta	Stray Dog on Banks Of Bayou	Stray Dog on Banks Of Bayou	Picked Up Dog	
3/5/2020	907 Creekwood Way	Stray Dog	Stray Dog	Picked up dog - Delivered to Vet Clinic	
3/6/2020	506 Hunters Park Ln.	Feral Cat in Trap	Feral Cat in Trap	Picked Up - Relocated	Relocated Cats
3/10/2020	Voss Park at Voss	Dead animal in roadway	Dead animal in roadway	Picked Up/Disposed	
3/23/2020	Saddlewood near Beinhorn	Dead Opossum in Roadway	Dead Opossum in Roadway	Picked Up/Disposed	
4/6/2020	10918 Timberglen	Deliver Trap to resident	Deliver Trap to resident	Delivered trap to resident	
4/8/2020	10918 Timberglen	Opossum in Trap - Pick Up	Opossum in Trap - Pick Up	Picked Up/Relocated	
4/13/2020	10918 Timberglen	Opossum in Trap - Pick Up	Opossum in Trap - Pick Up	Picked Up/Relocated	
4/20/2020	305 Voss	Trap Request	Trap Request	Delivered trap to resident	
4/20/2020	777 W. Creekside	Raccoon at residence - Please Pick Up	Raccoon at residence - Please Pick Up	Picked Up/Relocated	Relocated
4/23/2020	305 Voss	Raccoon in trap	Raccoon in trap	Picked Up/Relocated	Relocated Raccoon
4/27/2020	10314 Memorial Drive	Trap Request	Trap Request	Delivered trap to resident	
5/11/2020	Voss near I-10	Dead Raccoon on sidewalk	Dead Raccoon on sidewalk	Picked Up/Disposed	Disposed of Dead Raccoon
5/11/2020	802 Kuhlman	Trap Request	Trap Request	Delivered trap to resident	
5/12/2020	10705 Marsha Ln.	Trap Request	Trap Request	Delivered trap to resident	
5/14/2020	10705 Marsh Ln.	Opossum in Trap/Please Pick Up	Opossum in Trap/Please Pick Up	Picked Up/Relocated	Relocated Opossum
					Quarantine to end 5/21/20 - Spoke with dog owner and bite victim. Dog euthanized per owners request on 5/21/20.
5/14/2020	714 Creekside Ln.	Dog Bite - Food Delivery person bitten at front door.	Dog Bite - Food Delivery person bitten at front door.	Dog Quarantined at Vet - Shots Current	
5/18/2020	10807 Pine Bayou	Animal Trap Request	Animal Trap Request	Delivered trap to resident	
5/20/2020	826 Oak Valley Dr.	Animal Trap Request	Animal Trap Request	Delivered trap to resident	
5/20/2020	922 Huntington Cove	Animal in Trap - Please Pick Up	Animal in Trap - Please Pick Up	Picked Up/Relocated Raccoon	Relocated
5/22/2020	826 Oak Valley Dr.	Animal in Trap - Please Pick Up	Animal in Trap - Please Pick Up	Picked Up/Relocated Opossum	Relocated
5/22/2020	10807 Pine Bayou Dr.	Animal in Trap - Please Pick Up	Animal in Trap - Please Pick Up	Picked Up/Relocated Opossum	Relocated
5/22/2020	10619 Gawaitn Ln.	Animal Trap Request	Animal Trap Request	Delivered trap to resident	
6/2/2020	836 Kuhlman Rd.	Dog Bite - Dog owners friend bitten in back yard.	Dog Bite - Dog owners friend bitten in back yard.	Dog - Home Quarantine - Shots Current	Quarantine to end 6/13/20
6/4/2020	205 Shasta Dr.	Animal in Trap - Please Pick Up	Animal in Trap - Please Pick Up	Picked up/Relocated Raccoon	Relocated
6/10/2020	760 Pifer Rd.	Dead animal in roadway	Dead animal in roadway	Picked up and disposed of dead Opossum	Disposed

6/16/2020	10814 Roaring Brook	Animal Trap Request	Delivered trap to resident	
7/1/2020	10622 N. Evers Park	Dead Raccoon in Driveway	Picked Up/Disposed of Raccoon	Disposed
7/1/2020	1108 River Glyn	Dead Armadillo in Driveway	Picked Up/Disposed of Armadillo	Disposed
7/2/2020	Memorial Dr @ Shartle Circle	Dead Armadillo in Roadway	Picked Up/Disposed of Armadillo	Disposed
7/6/2020	Memorial Dr at Three Corners	Dead Armadillo in Roadway	Picked Up/Disposed of Armadillo	Disposed
7/7/2020	10819 Smithdale Rd.	Animal Trap Request	Delivered trap to resident	
7/9/2020	606 Hunters Way Ct.	Animal In Trap - Please Pick Up	Picked Up/Relocated Cat	Relocated
7/15/2020	606 Hunters Way Ct.	Animal In Trap - Please Pick Up	Picked Up/Relocated Cat	Relocated
7/15/2020	634 Saddlewood Ln.	Dead animal in roadway	Picked up/Disposed of Squirrel	Disposed
8/6/2020	725 W. Creekside Dr.	Animal Trap Request	Delivered trap to resident	
8/10/2020	10650 Memorial Dr.	Dead Armadillo in Roadway	Picked Up/Disposed of Armadillo	Disposed
8/10/2020	725 W. Creekside Dr.	Raccoon in Trap - Pick Up	Picked Up/Relocated Raccoon	Relocated
8/11/2020	757 W. Creekside	Stray Dog Found by Resident	Picked up Dog - Owner found	Returned Dog to Owner
8/20/2020	10819 Smithdale	Pick Up Empty Trap from Resident	Picked Up Trap	
9/9/2020	802 Flint River	Animal Trap Request	Delivered trap to resident	
9/14/2020	802 Flint River	Raccoon in Trap - Please pick up	Picked up/Relocate Raccoon	Relocated
9/14/2020	3 Saddlewood Estates	Opossum in Trash Can	Caught/Relocated Opossum	Relocated
9/15/2020	3 Saddlewood Estates	Opossum in Trap - Please pick up	Picked up\Relocated Opossum	Relocated
9/17/2020	Memorial at Thamer	Injured turtle in roadway	Picked up/Disposed of turtle	Disposed
9/17/2020	10220 Memorial Dr.	Dead animal in roadway	Picked up/Disposed of animal	Disposed
9/25/2020	525 Trails End	Animal Trap Request	Dropped trap with resident	
9/29/2020	525 Trails End	Animal in Trap - Please Pick Up	Picked up/Relocated Animal	Relocated
10/8/2020	606 Hunters Way	Animal Trap Request	Dropped trap with resident	
10/13/2020	704 Pifer Green	Feral Cat in Trap	Picked up - Relocated Cat	Relocated
10/14/2020	321 Pifer Road	Dead animal in roadway - Pick Up	Picked up-Disposed of Squirrel	Disposed
10/16/2020	Memorial Dr. @ Saddlewood	Dead animal in roadway - Pick Up	Picked up and disposed of Squirrel	Disposed
10/19/2020	Memorial Dr. @ Lindenwood	Dead Animal In roadway - Pick Up	Picked up and disposed of animal.	Disposed
11/5/2020	Memorial Dr @ Fleetway	Dead animal in roadway - Pick Up	Picked up and disposed of animal.	Disposed
11/6/2020	11007 Hunters Park Ln.	Animal Trap Request	Dropped trap with resident	
11/9/2020	315 Timberwilde	Animal Trap Request	Dropped trap with resident	
11/10/2020	629 Wellesley	Animal in Trap - Please Pick Up	Picked up/Relocated Opossum	Relocated
11/17/2020	3 Saddlewood Estates	Animal in Trash Can - Please Assist	Picked up/Relocated Opossum	Relocated
11/23/2020	10500 Beinhorn	Dead animal in roadway	Picked up/Disposed of animal	Disposed
11/23/2020	Shartle Circle @ Memorial	Dead animal in roadway	Picked up/Disposed of animal	Disposed
11/30/2020	826 Oak Valley Dr.	Animal Trap Request	Dropped trap with resident	
12/7/2020	760 Pifer Road	Dead Animal in Roadway	Picked up/Disposed of animal	Disposed
12/9/2020	11007 Hunters Park Dr.	Animal Trap Request	Delivered trap to resident	
12/11/2021	11007 Hunters Park Dr.	Animal in Trap - Please Pick Up	Picked up and Relocated Opossum	Relocated
12/16/2020	Memorial near Wickdale	Dead animal near sidewalk.	Picked up/Disposed of animal	Disposed
12/21/2020	3 Saddlewood Estates	Opossum in Trash Can	Removed Opossum from trash can.	Relocated
12/28/2020	Voos at Longshadow	Dead animal in roadway	Picked up/Disposed of animal	Disposed

1/4/2021	Roaring Brook at Voss	Dead animal in roadway	Picked up and disposed of animal.	Disposed
1/4/2021	305 Lindenwood	Animal Trap Request	Delivered trap to resident	
1/26/2021	13 Creekside Circle	Animal Trap Request	Delivered trap to resident	
1/27/2021	607 Shartle Circle	Dead animal in roadway	Picked up and disposed of animal.	Disposed
1/27/2021	13 Creekside Circle	Animal In Trap - Please Pick Up	Picked up and Relocated Opossum	Relocated
2/2/2021	10955 Beinhorn	Animal In Trap - Please Pick Up	Picked up and relocated animal	Relocated
2/4/2021	11007 Hunters Park	Animal Trap Request	Delivered Trap to resident	
2/22/2021	740 Kuhlman Rd.	Bat found in House - Pick up - to Lab for Rabies Test	Delivered to Lab for testing	Rabies Test NEGATIVE for Rabies
2/25/2021	10955 Beinhorn	Animal In Trap - Please Pick Up	Picked up and relocated animal	Relocated
3/3/2021	11007 Hunters Park	Animal In Trap - Please Pick Up	Picked up and relocated animal	Relocated
3/15/2021	10955 Beinhorn	Animal Trap Request	Delivered Trap to resident	
3/23/2021	11007 Hunters Park	Animal In Trap - Please Pick Up	Picked up and relocated animal	Relocated
3/24/2021	10314 Memorial Dr.	Animal Trap Request	Delivered Trap to resident	
3/25/2021	10906 Little Lisa	Animal Trap Request	Delivered Trap to resident	
3/25/2021	10910 Little Lisa	Animal Trap Request	Delivered Trap to resident	
3/29/2021	5 Creekside Cir.	Animal Trap Request	Delivered Trap to resident	
4/5/2021	110 Shasta	Animal Trap Request	Delivered Trap to resident	
4/5/2021	Memorial at Lindenwood	Animal Trap Request	Delivered Trap to resident	
4/7/2021	110 Shasta	Dead Animal in Roadway	Picked up and disposed of animal.	Disposed
4/8/2021	11007 Hunters Park	Animal In Trap - Please Pick Up	Picked up and relocated animal	Relocated
4/9/2021	525 Trails End	Animal Trap Request	Delivered Trap to Resident	
4/9/2021	10779 Bridgewood	Animal In Trap - Please Pick Up	Picked up and relocated animal	Relocated
4/19/2021	Memorial near Kuhlman	Dead animal in ROW	Picked up and disposed of animal.	Disposed
4/19/2021	Voss near Voss Park	Dead animal in road.	Picked up and disposed of animal.	Disposed
4/19/2021	606 Hunters Way Ct.	Dead animal in road.	Picked up and disposed of animal.	Disposed
4/19/2021		Animal Trap Request	Delivered Trap to resident	

CITY OF HUNTERS CREEK VILLAGE ENGINEER'S REPORT

Prepared April 21, 2021 for the April 27, 2021 Agenda

A. Voss at Second Baptist

1. Just Kidding. Hwy 288 near 610. But similar phenomenon.



B. Beinhorn and Voss – Traffic Signal Reconstruction

1. Waiting for Centerpoint to energize electric service. Request was made February 1st.
2. After energized, new controller can be relocated, and signals turned on. Work will take less than one week.
3. Contract amount is \$329,078.87. On Budget.
4. Check out the new bollards with the logo.

C. 2020 Street Maintenance – Memorial Drive

1. Closeout Change Order on this agenda.

D. 10 Willowend Dr. Outfall

1. Survey was completed mid-April.
2. Internal televising of the line to locate failures and defects is scheduled for next week.
3. Design is on-going following completion of the survey. Partial replacement or rehabilitation method will be finalized once CCTV is received next week. Will have a final cost estimate and plan by next meeting.
4. Plan to bid in June, pending HCFCD plan approvals.

E. Ripple Creek Repair

1. Conducted Precon already with HOA member in attendance.
2. NTP scheduled for May 3rd.

F. Timberglen Pavement Repair

1. The 'T' intersection of Timberglen and Kari Court has always had a small birdbath. Additionally, the pavement has had moderate cracking around the intersection.
2. Recently (past six months) the corner has cracked up and has failed completely.



3. This work is too large to add to Ripple Creek contract. And is anticipated to be greater than \$50k.
4. Have amendment on agenda for plan preparation, bidding and construction phase services.
5. If authorized, will have plans prepared in one week, advertise and bid, and be prepared with recommendation in May meeting.

G. Congressional Earmark – Community Project Funding

1. With two days' notice we prepared and submitted candidate projects for consideration to Congresswoman Fletchers office.
2. I submitted for Beinhorn east of Voss because it is a primary street and has the elementary school. I also submitted on a potential park because it could be a PPP, have stormwater benefits and possibly some erosion control.
3. Both projects were quickly declined by her office because they weren't considered "construction and capital improvements of public facilities".
4. I received the following response:

Amanda, I connected with our legislative team and I do not think #1 will qualify (unless it has already been included in an STIP by TXDOT) nor #2. That said, my Leg Director recommended/asked whether you have any public works projects in the queue? These can be basic upgrades/repairs to public facilities or public services. He sent a brief description which I've pasted below. **If think you have anything that falls into that category and if you can let us know by noon tomorrow that would be ideal!** I am out of the office tomorrow (but I will be checking/responding to emails relating to community project funding) but I am copying Ben Jackson here in case there are immediate questions and I am slow to respond. Department of Housing and Urban Development - [Economic Development Initiative \(EDI\)](#): Site acquisition, demolition or rehabilitation of housing or facilities, **construction and capital**

improvements of public facilities (including water and sewer facilities), and public services are eligible.

For a submission, we will also need an explanation of the request, including project site location, purpose, and why it is a valuable use of taxpayer funds.

H. Joint seal of Memorial Estates subdivision roads (aka Old Coach, Marsha Lane)

1. Recently Tom and I were looking at an unrelated issue on Old Coach and we noticed that expansion joint material (typically redwood 1"x6" boards) were missing in the area we were looking. We found that all expansion material is gone from every joint in every street in the subdivision.
2. The street is not very old and in great condition otherwise. However, anywhere the joint seal has failed runoff will easily get to the base material and fail the subgrade post haste.
3. It is my recommendation that we replace the joint seal ASAP. It is a relatively low cost, high opportunity project.

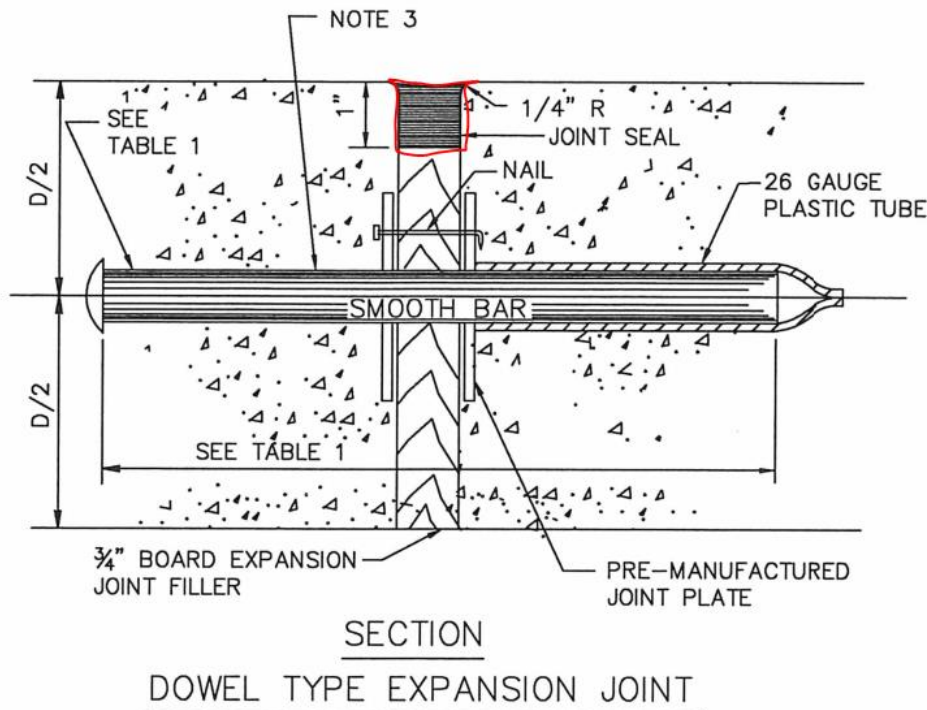

**CITY OF HUNTERS CREEK VILLAGE, TEXAS
MINUTES OF THE REGULAR
CITY COUNCIL MEETING
March 23, 2021**

The City Council of the City of Hunters Creek Village, Texas held a regular meeting on Tuesday, March 23, 2021, #1 Hunters Creek Place, Hunters Creek Village, Texas. Members of the public were invited to attend the meeting in person or by video or audio conference.

Present:	Mayor:	Jim Pappas
	Councilmembers:	Stuart Marks Ken Spalding Chip Cowell Jay Carlton Fidel Sapien
	City Attorney:	John Hightower
	City Administrator:	Tom Fullen
	Police Chief:	Ray Schultz
	Assistant to City Secretary:	Jennifer Namie (by teleconference)

With a quorum of the Council Members present, Mayor Jim Pappas called the meeting to order at 6:01 p.m. followed by the pledge of allegiance and a brief prayer by Mayor Pappas.

PUBLIC COMMENTS *At this time, any person with city-related business may speak to the Council. In compliance with the Texas Open Meetings Act, if a member of the public comments or inquires about a subject that is not specifically identified on the agenda, a member of council or a staff member may only respond by giving a statement of specific factual information or by reciting existing policy. The City Council may not deliberate or vote on the matter.*

Karen Vannerson of Linebarger Goggan Blair & Sampson, LLP introduced a new colleague.

REPORTS

Treasurer: City Administrator Tom Fullen, presented the financial report and gave a brief summary.

Police Commission: Police Commissioner Steve Reichel presented the police department report. Later in the meeting, Chief Schultz gave a presentation of the Police Department's FY2022 Budget Process.

Fire Commission: Councilmember Jay Carlton presented the fire department report. The next Commission Meeting is Wednesday, March 24, 2021. Budget is currently in line. Construction is moving along well. Average response time for Hunters Creek is 3 minutes and 14 seconds.

Building Official: Tom Fullen, City Administrator, gave a brief summary of the building report. The Project Manager and Contractor for the house at 10802 Hunters Forest Drive, gave an update on the progress of construction.

City Engineer: Tom Fullen, City Administrator, reported on ongoing public work projects.

City Administrator Report: Tom Fullen, City Administrator, presented updated designs for Entry Sign Beautification Project. The final design choice will be on April's agenda.

Mayor Report: There was no report.

CONSENT AGENDA *The following items are considered routine by the City Council and will be enacted by one motion. There will not be a separate discussion on these items unless a Councilmember requests, in which event, the item will be removed from the general order of business and considered in its normal sequence on the agenda.*

1. Approval of the Minutes of the Regular Meeting on February 23, 2021.
2. Approval of the Cash Disbursement Journal for February, 2021.

A motion was made by Councilmember Sapien to approve the consent agenda. Councilmember Spalding seconded the motion and the motion carried unanimously.

REGULAR AGENDA

1. Discussion and possible action to award a contract to Century Concrete Construction, Inc. in an amount not to exceed \$149,180.79 for the Ripple Creek Pavement Repair Project.

A motion was made by Councilmember Spalding to award a contract to Century Concrete Construction, Inc. in an amount not to exceed \$149,180.79 for the Ripple Creek Pavement Repair Project. Councilmember Cowell seconded the motion and the motion carried unanimously.

2. Discussion and possible action to approve Change Order #1 to the contract with Main Lane Industries, Ltd. in the amount of \$9,685.54 for Memorial Drive Repairs for Center Line Striping.

A motion was made by Councilmember Marks to approve Change Order #1 to the contract with Main Lane Industries, Ltd. in the amount of \$9,685.54 for

Memorial Drive Repairs for Center Line Striping. Councilmember Sapien seconded the motion and the motion carried unanimously.

3. Discussion and possible action to approve Change Order #2 to the contract with Main Lane Industries, Ltd. in the amount of \$7,470.87 for Memorial Drive Repairs for Voss Manhole Emergency Repair.

A motion was made by Councilmember Spalding to approve Change Order #2 to the contract with Main Lane Industries, Ltd. in the amount of \$7,470.87 for Memorial Drive Repairs for Voss Manhole Emergency Repair. Councilmember Marks seconded the motion and the motion carried unanimously.

4. Discussion and possible action to decide whether or not to decline the 2021 consumer price index adjustment to the City's telecommunications right-of-way access line rates.

A motion was made by Councilmember Spalding to decline the 2021 consumer price index adjustment to the City's telecommunications right-of-way access line rates. Councilmember Sapien seconded the motion and the motion carried unanimously.

5. Discussion and possible action to adopt a resolution suspending CenterPoint Energy's 2021 Annual Gas Reliability Infrastructure Program ("GRIP") rate adjustment for 45 days.

A motion was made by Councilmember Sapien to adopt a resolution suspending CenterPoint Energy's 2021 Annual Gas Reliability Infrastructure Program ("GRIP") rate adjustment for 45 days. Councilmember Cowell seconded the motion and the motion carried unanimously.

6. Discussion and possible action to approve an amendment to the Network Node Deployment Standard Agreement.

A motion was made by Councilmember Marks to approve an amendment to the Network Node Deployment Standard Agreement. Councilmember Spalding seconded the motion and the motion carried unanimously.

7. Discussion and possible action to direct Planning and Zoning to review and make a recommendation on a proposal to amend the zoning ordinance to allow the construction of Porte Cochères in a side yard under certain circumstances.

A motion was made by Councilmember Spalding to direct Planning and Zoning to review and make a recommendation on a proposal to amend the zoning ordinance to allow the construction of Porte Cochères in a side yard

under certain circumstances. Councilmember Sapien seconded the motion and the motion carried unanimously.

ADJOURNMENT

At 7:00 p.m. a motion was made by Councilmember Spalding to adjourn the meeting. The vote to approve the motion was unanimous.

The meeting was adjourned at 7:00 p.m.

These minutes were approved on the ____ day of April, 2021.

Jim Pappas, Mayor

ATTEST:

Tom Fullen, City Administrator
Acting City Secretary

DRAFT



Vendor Number	Vendor Name	Payment Date	Payment Type	Discount Amount	Payment Amount	Number
Bank Code: AP POOLED-AP POOLED						
000774	Adam Voyles	03/04/2021	Regular	0.00	300.00	32511
0647	Aflac Worldwide Headquarters	03/04/2021	Regular	0.00	358.80	32512
0458	AT&T (5019)	03/04/2021	Regular	0.00	715.81	32513
0669	C & D Janitor Service, Inc.	03/04/2021	Regular	0.00	795.86	32514
0045	CARMEN KNEZEAK	03/04/2021	Regular	0.00	420.00	32515
0010	CENTERPOINT ENERGY	03/04/2021	Regular	0.00	109.11	32516
000775	CityLynx, Inc.	03/04/2021	Regular	0.00	60,934.26	32517
0013	COWBOY TRUCKING INC	03/04/2021	Regular	0.00	95.00	32518
000796	Engie Resources	03/04/2021	Regular	0.00	4.81	32519
0150	GARY B MADDOX	03/04/2021	Regular	0.00	500.00	32520
0023	GORMAN UNIFORM SERVICE	03/04/2021	Regular	0.00	101.32	32521
000857	Guardian Repair & Parts	03/04/2021	Regular	0.00	63.90	32522
0028	HARRIS COUNTY APPRAISAL DISTRICT	03/04/2021	Regular	0.00	10,547.00	32523
0034	HOME SECURITY SYSTEMS INC	03/04/2021	Regular	0.00	299.85	32524
0431	HOOPER COMMUNICATIONS LP	03/04/2021	Regular	0.00	4,407.90	32525
0641	Mark E. Easley	03/04/2021	Regular	0.00	300.00	32526
0052	MEMORIAL VILLAGES POLICE DEPT - MAIN	03/04/2021	Regular	0.00	4,250.00	32527
0052	MEMORIAL VILLAGES POLICE DEPT - MAIN	03/04/2021	Regular	0.00	164,998.00	32528
0053	MEMORIAL VILLAGES WATER AUTHORITY	03/04/2021	Regular	0.00	981.07	32529
0065	OFFICE DEPOT CREDIT PLAN	03/04/2021	Regular	0.00	115.64	32530
0135	PITNEY BOWES GLOBAL FINANCIAL SERVICES LLC	03/04/2021	Regular	0.00	246.21	32531
0501	TCMA REGION VI	03/04/2021	Regular	0.00	50.00	32532
0103	TEXAS MUNICIPAL RETIREMENT SYSTEM - TMRS	03/04/2021	Regular	0.00	11,442.39	32533
0635	Tyler Technologies, Inc.	03/04/2021	Regular	0.00	7,701.48	32534
000789	Van Sant Landscape Management	03/04/2021	Regular	0.00	3,628.00	32535
0105	VILLAGE FIRE DEPARTMENT	03/04/2021	Regular	0.00	129,074.36	32536
0107	VILLAGES MUTUAL INSURANCE COOPERATIVE	03/04/2021	Regular	0.00	8,653.28	32537
0005	AT&T (5414)	03/15/2021	Regular	0.00	352.86	32538
000815	BBG Consulting, Inc.	03/15/2021	Regular	0.00	2,120.00	32539
0628	BRADFORD GENE HENDRICKS	03/15/2021	Regular	0.00	875.00	32540
0045	CARMEN KNEZEAK	03/15/2021	Regular	0.00	1,260.00	32541
0023	GORMAN UNIFORM SERVICE	03/15/2021	Regular	0.00	50.66	32542
0654	Lora Jean D. Lenzsch	03/15/2021	Regular	0.00	1,025.00	32543
000812	Main Lane Industries, Ltd.	03/15/2021	Regular	0.00	174,638.36	32544
0641	Mark E. Easley	03/15/2021	Regular	0.00	300.00	32545
0066	OLSON & OLSON LLP	03/15/2021	Regular	0.00	1,655.00	32546
0420	PREMIER TREE SERVICE	03/15/2021	Regular	0.00	4,000.00	32547
0152	SPRING BRANCH ISD	03/15/2021	Regular	0.00	8,610.00	32548
000803	SUNBELT RENTALS	03/15/2021	Regular	0.00	100.38	32549
0104	TEXAS MUNICIPAL LEAGUE	03/15/2021	Regular	0.00	1,337.00	32550
0362	VERIZON WIRELESS	03/15/2021	Regular	0.00	38.03	32551
0537	WCA Waste Systems Inc.	03/15/2021	Regular	0.00	42,769.42	32552
0530	xlrINT LLC	03/15/2021	Regular	0.00	1,080.00	32553
000774	Adam Voyles	03/31/2021	Regular	0.00	300.00	32554
0647	Aflac Worldwide Headquarters	03/31/2021	Regular	0.00	358.80	32555
0458	AT&T (5019)	03/31/2021	Regular	0.00	715.81	32556
0669	C & D Janitor Service, Inc.	03/31/2021	Regular	0.00	795.86	32557
0045	CARMEN KNEZEAK	03/31/2021	Regular	0.00	1,260.00	32558
0010	CENTERPOINT ENERGY	03/31/2021	Regular	0.00	188.61	32559
0445	CENTURY CONCRETE CONSTRUCTION INC	03/31/2021	Regular	0.00	1,500.00	32560
000775	CityLynx, Inc.	03/31/2021	Regular	0.00	48,378.90	32561
0012	COBB FENDLEY	03/31/2021	Regular	0.00	3,514.13	32562
000796	Engie Resources	03/31/2021	Regular	0.00	4.81	32563
0023	GORMAN UNIFORM SERVICE	03/31/2021	Regular	0.00	151.98	32564

Check Report

Date Range: 03/01/2021 - 03/31/2021

Vendor Number	Vendor Name	Payment Date	Payment Type	Discount Amount	Payment Amount	Number
0030	HARRIS COUNTY MAYORS' & COUNCILS' ASSOCIA	03/31/2021	Regular	0.00	40.00	32565
0052	MEMORIAL VILLAGES POLICE DEPT - MAIN	03/31/2021	Regular	0.00	4,250.00	32566
0052	MEMORIAL VILLAGES POLICE DEPT - MAIN	03/31/2021	Regular	0.00	164,998.00	32567
0053	MEMORIAL VILLAGES WATER AUTHORITY	03/31/2021	Regular	0.00	744.51	32568
0065	OFFICE DEPOT CREDIT PLAN	03/31/2021	Regular	0.00	206.75	32569
0420	PREMIER TREE SERVICE	03/31/2021	Regular	0.00	1,000.00	32570
000858	Servpro of Town & Country	03/31/2021	Regular	0.00	9,278.85	32571
0085	SHERWIN-WILLIAMS CO	03/31/2021	Regular	0.00	136.12	32572
000738	Texas Elite Generators, Inc.	03/31/2021	Regular	0.00	2,453.23	32573
0691	Texas Irrigation Supply	03/31/2021	Regular	0.00	98.12	32574
0103	TEXAS MUNICIPAL RETIREMENT SYSTEM - TMRS	03/31/2021	Regular	0.00	11,254.74	32575
0105	VILLAGE FIRE DEPARTMENT	03/31/2021	Regular	0.00	129,074.36	32576
0107	VILLAGES MUTUAL INSURANCE COOPERATIVE	03/31/2021	Regular	0.00	8,653.28	32577
0530	xlrINT LLC	03/31/2021	Regular	0.00	125.00	32578
0228	CITY OF BUNKER HILL VILLAGE	03/31/2021	Regular	0.00	639.32	32579
0638-JS	Payment Remittance Center	03/03/2021	Bank Draft	0.00	900.08	DFT0000287
0517-TF	PAYMENT REMITTANCE CENTER	03/03/2021	Bank Draft	0.00	958.72	DFT0000288
0638-JS	Payment Remittance Center	03/18/2021	Bank Draft	0.00	362.99	DFT0000289
0517-TF	PAYMENT REMITTANCE CENTER	03/18/2021	Bank Draft	0.00	1,323.43	DFT0000290
0127-EA	PAYMENT REMITTANCE CENTER	03/18/2021	Bank Draft	0.00	393.03	DFT0000291

Bank Code AP POOLED Summary

Payment Type	Payable Count	Payment Count	Discount	Payment
Regular Checks	78	69	0.00	1,041,426.94
Manual Checks	0	0	0.00	0.00
Voided Checks	0	0	0.00	0.00
Bank Drafts	7	5	0.00	3,938.25
EFT's	0	0	0.00	0.00
	85	74	0.00	1,045,365.19

All Bank Codes Check Summary

Payment Type	Payable Count	Payment Count	Discount	Payment
Regular Checks	78	69	0.00	1,041,426.94
Manual Checks	0	0	0.00	0.00
Voided Checks	0	0	0.00	0.00
Bank Drafts	7	5	0.00	3,938.25
EFT's	0	0	0.00	0.00
	85	74	0.00	1,045,365.19

Fund Summary

Fund	Name	Period	Amount
999	POOL	3/2021	1,045,365.19
			1,045,365.19

**CITY OF HUNTERS CREEK VILLAGE
QUARTERLY INVESTMENT REPORT
QUARTER ENDING DECEMBER 31, 2020**

Account Description	Beginning	Interest		Deposits		Withdrawal		Cash		Outstanding	Ending Book/ Market Value Balance 12/31/2020	% of Total Funds	Average Interest Rate	Maturity	3-month Average Collateral
	Bank Balance 10/1/2020	10/1/20-12/31/20	10/1/20-12/31/20	10/1/20-12/31/20	10/1/20-12/31/20	10/1/20-12/31/20	In Transit	Checks							
Wells Fargo															
Disbursement	\$296,282.38	\$153.27	\$1,324,953.47	\$1,252,455.05	\$0.00	\$0.00	\$60,398.33	\$308,535.74	3.82%	0.16	Immediate				
Public Funds	\$187,881.47	\$219.81	\$2,977,764.17	\$1,409,785.85	\$0.00	\$0.00	\$0.00	\$1,756,079.60	21.71%	0.16	Immediate				
Texas Class	\$3,424,740.06	\$956.36	\$0.00	\$0.00	\$0.00	\$0.00	\$0.00	\$3,425,696.42	42.36%	0.10	Immediate				
Tex Pool	\$2,746,426.73	\$661.33	\$0.00	\$150,000.00	\$0.00	\$0.00	\$0.00	\$2,597,088.06	32.11%	0.12	Immediate				
Total Accounts	\$6,655,330.64	\$1,990.77	\$4,302,717.64	\$2,812,240.90	\$0.00	\$0.00	\$60,398.33	\$8,087,399.82	100.00%	0.13				\$2,909,274.47	

The investment report for the 4th quarter of 2020 is in compliance with the City of Hunters Creek Village's investment policy as well as in compliance with the provisions of Chapter 2256 of the Texas Local Government Code, as required by the Public Funds Investment Act.

Reviewed and Approved by:

James S. Pappas
Mayor
Dated:

Prepared by:

Tom Fullen
City Administrator and Investment Officer
Dated: March 24, 2021



**CITY OF HUNTERS CREEK VILLAGE
AGENDA DISCUSSION FORM**

AGENDA DATE: April 27, 2021
AGENDA SUBJECT: Discussion and possible action to approve the Proposed 2022 Memorial Villages Police Department Budget in the amount of \$6,299,250.00 with Hunters Creek Village's 2022 Assessment being \$2,099,750.00.
EXHIBITS: PD FY22 Budget Proposal

Memorial Villages Police Department

FY22 BUDGET PROPOSAL

GENERAL FUND							
Acct. No	Category	2019 Actual	2020 Unaudited Actual	2021 Adopted	2022 Requested	\$ Increase/ 2021-2022	% Increase
100							
100	Salaries	3,279,467	3,557,690	3,679,271	3,785,751	106,480	3%
110	Overtime	115,094	92,292	125,000	125,000	0	0%
115	Court/Bailiff	6,010	1,269	12,000	10,000	(2,000)	-17%
120	Retirement	379,669	430,477	450,483	459,268	8,785	2%
125	475b contribution		31,865	32,869	62,870	30,001	91%
130	Health Insurance	503,527	513,331	592,828	565,314	(27,514)	-5%
140	Workers Compensation - TML	65,000	59,982	70,500	75,000	4,500	6%
150	Life/LTD	17,847	18,946	21,709	21,982	273	1%
160	Medicare	47,252	52,046	55,403	56,911	1,508	3%
	TOTAL PERSONNEL/BENEFITS	4,413,866	4,757,898	5,040,063	5,162,098	122,035	2%
200							
	TML INTERGOVERNMENTAL RISK POOL						
200	Auto	26,604	25,201	41,100	27,500	(13,600)	-33%
210	General Liability	430	330	720	400	(320)	-44%
220	Public Official Bond	849	848	960	900	(60)	-6%
230	Professional Liability	18,858	18,998	21,400	21,000	(400)	-2%
240	Real & Personal Property	12,637	11,923	8,000	9,600	1,600	20%
	TOTAL OTHER INSURANCE	59,378	57,300	72,180	59,400	(12,780)	-18%
300							
300	Gas and Oil	66,046	69,296	70,500	81,000	10,500	15%
310	Fleet maintenance	31,154	37,949	35,000	40,000	5,000	14%
320	Tires	6,565	6,569	7,000	7,000	0	0%
	Damage Repair	5,783	5,010	10,000	10,000	0	0%
	TOTAL FLEET MAINTENANCE	109,548	118,824	122,500	138,000	15,500	13%
400							
400	General/Building Maintenance	18,848	21,849	25,000	30,000	5,000	20%
410	Janitorial Services	18,000	19,078	21,000	21,000	0	0%
420	Jail	773	299	1,000	1,000	0	0%
430	Building Furnishings	7,450	8,775	15,000	15,000	0	0%
	TOTAL BUILDING	45,070	50,001	62,000	67,000	5,000	8%
500							
500	Computers	10,640	8,521	13,000	13,000	0	0%
510	Postage/postage machine	840	1,129	1,100	1,300	200	18%
520	Office Supplies	12,063	11,974	15,000	15,000	0	0%
530	Bank/Finance Service Chgs	329	400	550	550	0	0%
540	Payroll Services	16,220	17,210	17,400	17,900	500	3%
	TOTAL OFFICE	40,093	39,233	47,050	47,750	700	1%
600							
600	Telephone	33,954	32,499	36,003	40,606	4,603	13%
610	Electric	16,051	14,704	20,000	20,000	0	0%
620	Water/Sewer	5,067	5,153	5,320	5,500	180	3%
630	Natural Gas	510	439	600	600	0	0%
	TOTAL UTILITIES	55,582	52,794	61,923	66,706	4,783	8%
700							
700	Equipment Maint. Contracts	58,797	134,984	118,340	135,950	17,610	15%
710	SETCIC fees	3,262	3,065	3,600	3,600	0	0%
720	Legal/Professional	51,406	76,802	55,000	80,660	25,660	47%
730	IT Services	98,578	100,055	101,850	102,050	200	0%
740	Software Maintenance Contracts	52,170	56,252	56,202	59,200	2,998	5%
	TOTAL CONTRACTS/SERVICES	264,214	371,159	334,992	381,460	46,468	14%
800							
800	Accreditation	0	0	1,200	1,200	0	0%
810	Uniforms	26,518	25,131	30,500	30,500	0	0%
820	Radio parts and labor	29,686	31,328	33,036	33,036	0	0%
830	Firearms Trng and Ammo	5,323	5,880	5,500	6,500	1,000	18%
	Tasers	9,656	10,122	15,000	15,000	0	0%

Memorial Villages Police Department

FY22 BUDGET PROPOSAL

GENERAL FUND CONTINUED							
Acct. No	Category	2019 Actual	2020 Unaudited Actual	2021 Adopted	2022 Requested	\$ Increase/ 2021-2022	% Increase
840	Training & Prof. Dues	38,311	23,113	58,000	58,000	0	0%
850	Travel	7,642	592	9,000	7,000	(2,000)	-22%
860	Recruiting Costs	5,154	958	5,000	5,000	0	0%
870	Criminal Investigations (CID)	3,084	3,003	3,500	3,500	0	0%
880	Contingency - Miscellaneous	13,481	4,179	25,000	25,000	0	0%
892	Small Equipment	4,182	2,255	13,500	14,100	600	4%
	COVID expenditures		47,884			0	
	TOTAL OPERATIONS	143,038	154,444	199,236	198,836	(400)	0%
	TOTAL M&O	5,130,790	5,601,654	5,939,944	6,121,250	181,306	3.05%
OTHER FUNDS							
Acct. No	Category	2019 Actual	2020 Unaudited Actual	2021 Adopted	2022 Requested	\$ Increase/ 2021-2022	% Increase
1000							
1000	Auto Replacement	158,332	165,670	153,000	160,000	7,000	5%
	Rifle Locking System						
	AEDs						
	TOTAL VEHICLE REPLACEMENT	158,332	165,670	153,000	160,000	7,000	4.58%
2000							
2880	Capital Projects Contingency	518	150				
	Radar message board			16,500		(16,500)	
	12TB Dato and Replacement Server				18,000	18,000	
	TOTAL SPECIALCAPITAL ASSETS	518	150	16,500	18,000	1,500	
	TOTAL OTHER FUNDS	158,850	165,821	169,500	178,000	8,500	5%
Summary							
	Category	2019 Actual	2020 Unaudited Actual	2021 Adopted	2022 Requested	\$ Increase/ 2021-2022	% Increase
	GENERAL FUND	5,130,790	5,601,654	5,939,944	6,121,250	181,306	3.05%
	OTHER FUNDS	158,850	165,821	169,500	178,000	8,500	5.01%
	COMBINED TOTALS	5,289,639	5,767,474	6,109,444	6,299,250	189,806	3.11%



**CITY OF HUNTERS CREEK VILLAGE
AGENDA DISCUSSION FORM**

AGENDA DATE: April 27, 2021
AGENDA SUBJECT: Discussion and possible action to approve an amendment to the 2021 construction budget to increase the amount by \$200,000 from \$5,700,311.50 to \$5,900,311.50 with the proviso that it will not increase the cities' assessment but will be funded by other potential sources.

EXHIBITS: VFD Budget Amendment Request

Village Fire Department



901 Corbindale Rd
Houston, Texas 77024
(713) 468-7941
(713) 468-5039 FAX

Protecting and Serving the Cities of:

BUNKER HILL VILLAGE
HEDWIG VILLAGE
HILSHIRE VILLAGE
HUNTERS CREEK VILLAGE
PINEY POINT VILLAGE
SPRING VALLEY VILLAGE

The Honorable Brian T. Muecke

Mayor, City of Hedwig Village

The Honorable Russell Herron

Mayor, City of Hilshire Village

The Honorable Jim Pappas

Mayor, City of Hunters Creek Village

The Honorable Mark Kobelan

Mayor, City of Piney Point Village

The Honorable Marcus Vajdos

Mayor, City of Spring Valley Village

April 9, 2021

Re: Facility Renovations

Dear Mayors:

As you know, the Village Fire Commission has awarded the construction contract for renovation of the fire station and solidified the other cost elements involved in the renovation.

During a special board meeting April 8, 2021, the Village Fire Department Board of Commissioners voted unanimously for the Fire Commission to request the cities to allow them to spend an additional \$200,000 over the current construction budget of \$5,700,311.50, increasing the budget to \$5,900,311.50, with the proviso that money will not create any additional assessments to the cities. The monies will be funded by other sources: 2020 audit surplus, EMS revenue, and/or the 2021 money allocated to the capital replacement fund.

In order to confirm this, we ask that you put on your City's agenda and approve amending the 2021 construction budget from \$5,700,311.50 to \$5,900,311.50 with the proviso that it will not increase the Cities' assessment but will be funded by other potential sources.

- a. 2020 audit surplus
- b. EMS revenue to the end of 2021
- c. 2021 Capital Replacement allocation

Respectfully,

Allen Carpenter, Chairman

Village Fire Department



901 Corbindale Rd
Houston, Texas 77024
(713) 468-7941
(713) 468-5039 FAX

Protecting and Serving the Cities of:

BUNKER HILL VILLAGE
HEDWIG VILLAGE
HILSHIRE VILLAGE
HUNTERS CREEK VILLAGE
PINEY POINT VILLAGE
SPRING VALLEY VILLAGE

To: Ms. Kelly Johnson, City of Hedwig Village
Ms. Susan Blevins, City of Hilshire Village
Mr. Tom Fullen, City of Hunters Creek Village
Ms. Karen Farris, City of Piney Point Village
Ms. Julie Robinson, City of Spring Valley
Ms. Karen Glynn, City of Bunker Hill Village

CC: Village Fire Department Commissioner and Alternates

From: Marlo Longoria

Date: April 9, 2021

Re: Facility Renovations

During a special board meeting April 8, 2021, the Village Fire Department Board of Commissioners voted unanimously for the Fire Commission to request the cities to allow them to spend an additional \$200,000 over the current construction budget of \$5,700,311.50, increasing the budget to \$5,900,311.50, with the proviso that money will not create any additional assessments to the cities. The monies will be funded by other sources: 2020 audit surplus, EMS revenue, and/or the 2021 money allocated to the capital replacement fund.

In order to confirm this, we ask that you put on your City's agenda and approve amending the 2021 construction budget from \$5,700,311.50 to \$5,900,311.50 with the proviso that it will not increase the Cities' assessment but will be funded by other potential sources.

- a. 2020 audit surplus
- b. EMS revenue to the end of 2021
- c. 2021 Capital Replacement allocation

Marlo Longoria
Marlo Longoria



**CITY OF HUNTERS CREEK VILLAGE
AGENDA DISCUSSION FORM**

AGENDA DATE: April 27, 2021
AGENDA SUBJECT: Discussion and possible action to consider a request from Spring Branch Independent School District for approval of a Specific Use Permit for installation of Building Identification Signage and a Marquee to be constructed on the Hunters Creek Elementary School campus located at 10650 Beinhorn Road, Houston, Texas, 77024.

EXHIBITS: HCE Request and Map



April 09, 2021

Mayor and City Council
City of Hunters Creek Village
Attn: Crystal Dozier, City Secretary
1 Hunters Creek Place
Hunters Creek Village, Texas 77024

Re: Spring Branch ISD – Hunters Creek Elementary School Replacement, Request for Specific Use Permit from the City of Hunters Creek Village

Dear Mayor Pappas and Council Members,

We represent Spring Branch Independent School District, regarding the, currently in construction, Replacement of Hunters Creek Elementary School, located at 10650 Beinhorn Rd Houston, Texas 77024. The district desires to install Building Identification Signage and a Marquee at the replacement campus. Attached you will find the locations and elevations of the proposed signage.

We seek a Specific Use Permit, pursuant to Sections 44-188 (f) (5), of the City's Zoning Ordinance. The applicable Zoning District is R. Please set our request on the next City Council Meeting for consideration.

We enclose a check in the amount of \$500.00 to the City of Hunters Creek Village which represents the fee for this request.

Should you have any questions or concerns, please do not hesitate to contact me at 713.222.1141. Thank you in advance for your time and consideration.

Please accept this letter as Spring Branch ISD's formal request to amend a zoning district.

Sincerely,

Michael A. Martinez, AIA | Principal

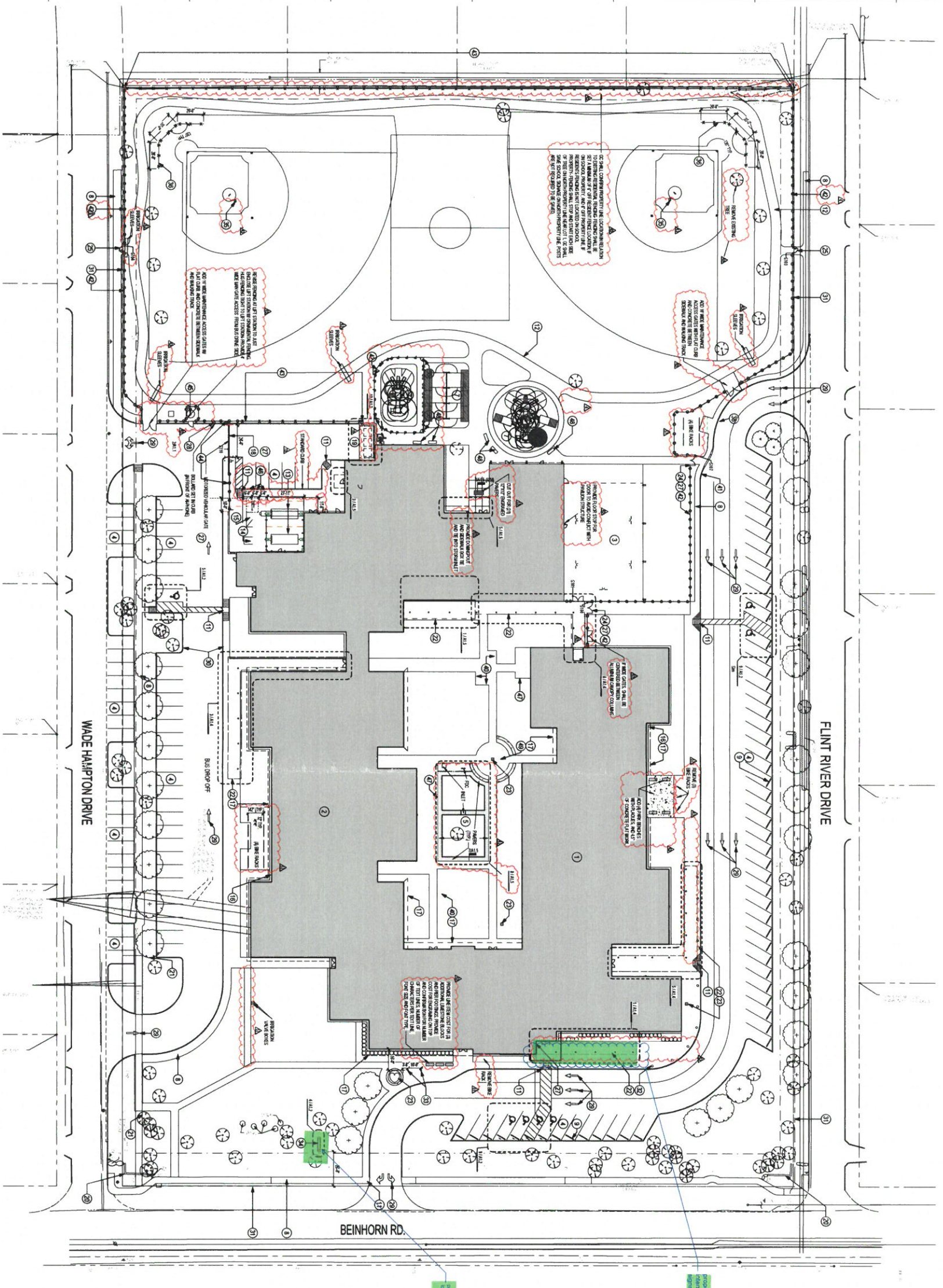

1 ARCHITECTURAL SITE PLAN
1" = 32'

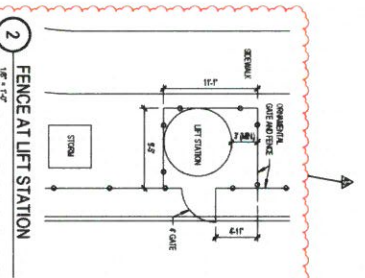

2 FENCE AT LIFT STATION
1" = 4'

TRUE PLAN
NORTH NORTH

- SITE PLAN GENERAL NOTES**
1. REFER TO ALL DIMENSIONS FOR FINISH GRADE UNLESS OTHERWISE SPECIFIED.
 2. REFER TO ALL DIMENSIONS FOR FINISH GRADE UNLESS OTHERWISE SPECIFIED.
 3. REFER TO ALL DIMENSIONS FOR FINISH GRADE UNLESS OTHERWISE SPECIFIED.
 4. REFER TO ALL DIMENSIONS FOR FINISH GRADE UNLESS OTHERWISE SPECIFIED.
 5. REFER TO ALL DIMENSIONS FOR FINISH GRADE UNLESS OTHERWISE SPECIFIED.
 6. REFER TO ALL DIMENSIONS FOR FINISH GRADE UNLESS OTHERWISE SPECIFIED.
 7. REFER TO ALL DIMENSIONS FOR FINISH GRADE UNLESS OTHERWISE SPECIFIED.
 8. REFER TO ALL DIMENSIONS FOR FINISH GRADE UNLESS OTHERWISE SPECIFIED.
 9. REFER TO ALL DIMENSIONS FOR FINISH GRADE UNLESS OTHERWISE SPECIFIED.
 10. REFER TO ALL DIMENSIONS FOR FINISH GRADE UNLESS OTHERWISE SPECIFIED.
 11. REFER TO ALL DIMENSIONS FOR FINISH GRADE UNLESS OTHERWISE SPECIFIED.
 12. REFER TO ALL DIMENSIONS FOR FINISH GRADE UNLESS OTHERWISE SPECIFIED.
 13. REFER TO ALL DIMENSIONS FOR FINISH GRADE UNLESS OTHERWISE SPECIFIED.
 14. REFER TO ALL DIMENSIONS FOR FINISH GRADE UNLESS OTHERWISE SPECIFIED.
 15. REFER TO ALL DIMENSIONS FOR FINISH GRADE UNLESS OTHERWISE SPECIFIED.
 16. REFER TO ALL DIMENSIONS FOR FINISH GRADE UNLESS OTHERWISE SPECIFIED.
 17. REFER TO ALL DIMENSIONS FOR FINISH GRADE UNLESS OTHERWISE SPECIFIED.
 18. REFER TO ALL DIMENSIONS FOR FINISH GRADE UNLESS OTHERWISE SPECIFIED.
 19. REFER TO ALL DIMENSIONS FOR FINISH GRADE UNLESS OTHERWISE SPECIFIED.
 20. REFER TO ALL DIMENSIONS FOR FINISH GRADE UNLESS OTHERWISE SPECIFIED.
 21. REFER TO ALL DIMENSIONS FOR FINISH GRADE UNLESS OTHERWISE SPECIFIED.
 22. REFER TO ALL DIMENSIONS FOR FINISH GRADE UNLESS OTHERWISE SPECIFIED.
 23. REFER TO ALL DIMENSIONS FOR FINISH GRADE UNLESS OTHERWISE SPECIFIED.
 24. REFER TO ALL DIMENSIONS FOR FINISH GRADE UNLESS OTHERWISE SPECIFIED.
 25. REFER TO ALL DIMENSIONS FOR FINISH GRADE UNLESS OTHERWISE SPECIFIED.
 26. REFER TO ALL DIMENSIONS FOR FINISH GRADE UNLESS OTHERWISE SPECIFIED.
 27. REFER TO ALL DIMENSIONS FOR FINISH GRADE UNLESS OTHERWISE SPECIFIED.
 28. REFER TO ALL DIMENSIONS FOR FINISH GRADE UNLESS OTHERWISE SPECIFIED.
 29. REFER TO ALL DIMENSIONS FOR FINISH GRADE UNLESS OTHERWISE SPECIFIED.

- SITE PLAN LEGEND**
- 1. FILL AREA - CONSTRUCTION FENCE
 - 2. FILL AREA - SITE FENCE
 - 3. FILL AREA - PERIMETER FENCE

- SITE PLAN NOTES**
1. PROVIDE PERIMETER FENCE AROUND ENTIRE SITE.
 2. PROVIDE CONSTRUCTION FENCE AROUND ENTIRE SITE.
 3. PROVIDE PERIMETER FENCE AROUND ENTIRE SITE.
 4. PROVIDE CONSTRUCTION FENCE AROUND ENTIRE SITE.
 5. PROVIDE PERIMETER FENCE AROUND ENTIRE SITE.
 6. PROVIDE CONSTRUCTION FENCE AROUND ENTIRE SITE.
 7. PROVIDE PERIMETER FENCE AROUND ENTIRE SITE.
 8. PROVIDE CONSTRUCTION FENCE AROUND ENTIRE SITE.
 9. PROVIDE PERIMETER FENCE AROUND ENTIRE SITE.
 10. PROVIDE CONSTRUCTION FENCE AROUND ENTIRE SITE.
 11. PROVIDE PERIMETER FENCE AROUND ENTIRE SITE.
 12. PROVIDE CONSTRUCTION FENCE AROUND ENTIRE SITE.
 13. PROVIDE PERIMETER FENCE AROUND ENTIRE SITE.
 14. PROVIDE CONSTRUCTION FENCE AROUND ENTIRE SITE.
 15. PROVIDE PERIMETER FENCE AROUND ENTIRE SITE.
 16. PROVIDE CONSTRUCTION FENCE AROUND ENTIRE SITE.
 17. PROVIDE PERIMETER FENCE AROUND ENTIRE SITE.
 18. PROVIDE CONSTRUCTION FENCE AROUND ENTIRE SITE.
 19. PROVIDE PERIMETER FENCE AROUND ENTIRE SITE.
 20. PROVIDE CONSTRUCTION FENCE AROUND ENTIRE SITE.
 21. PROVIDE PERIMETER FENCE AROUND ENTIRE SITE.
 22. PROVIDE CONSTRUCTION FENCE AROUND ENTIRE SITE.
 23. PROVIDE PERIMETER FENCE AROUND ENTIRE SITE.
 24. PROVIDE CONSTRUCTION FENCE AROUND ENTIRE SITE.
 25. PROVIDE PERIMETER FENCE AROUND ENTIRE SITE.
 26. PROVIDE CONSTRUCTION FENCE AROUND ENTIRE SITE.
 27. PROVIDE PERIMETER FENCE AROUND ENTIRE SITE.
 28. PROVIDE CONSTRUCTION FENCE AROUND ENTIRE SITE.
 29. PROVIDE PERIMETER FENCE AROUND ENTIRE SITE.
 30. PROVIDE CONSTRUCTION FENCE AROUND ENTIRE SITE.

pfluger
 office 713.222.1141 | fax 713.222.1174
 3411 Richardson Ave., Suite 720
 Houston, Texas 77046
 pflugarchitects.com

HUNTERS CREEK ELEMENTARY SCHOOL REPLACEMENT

10650 BEINHORN RD., HOUSTON, TEXAS 77024

SPRING BRANCH INDEPENDENT SCHOOL DISTRICT
 955 CAMPBELL RD.
 HOUSTON, TEXAS 77024



ARCHITECTURAL SITE PLAN

PROJECT: HUNTERS CREEK ELEMENTARY SCHOOL REPLACEMENT
 DATE: 03/24/2021
 SCALE: 1" = 32'
 DRAWN BY: [Name]
 CHECKED BY: [Name]
 APPROVED BY: [Name]

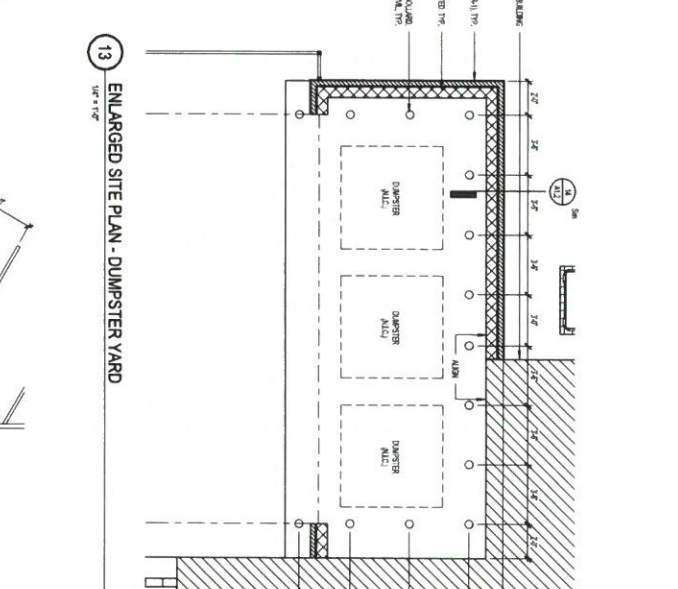
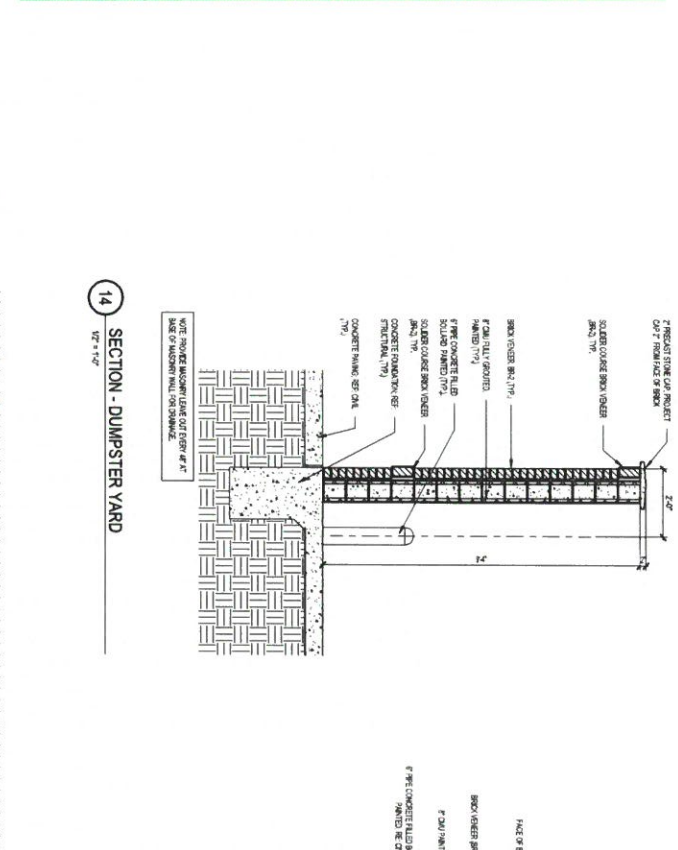
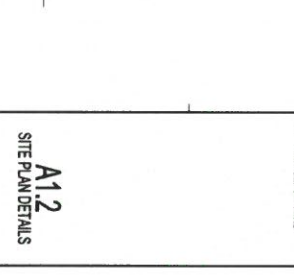
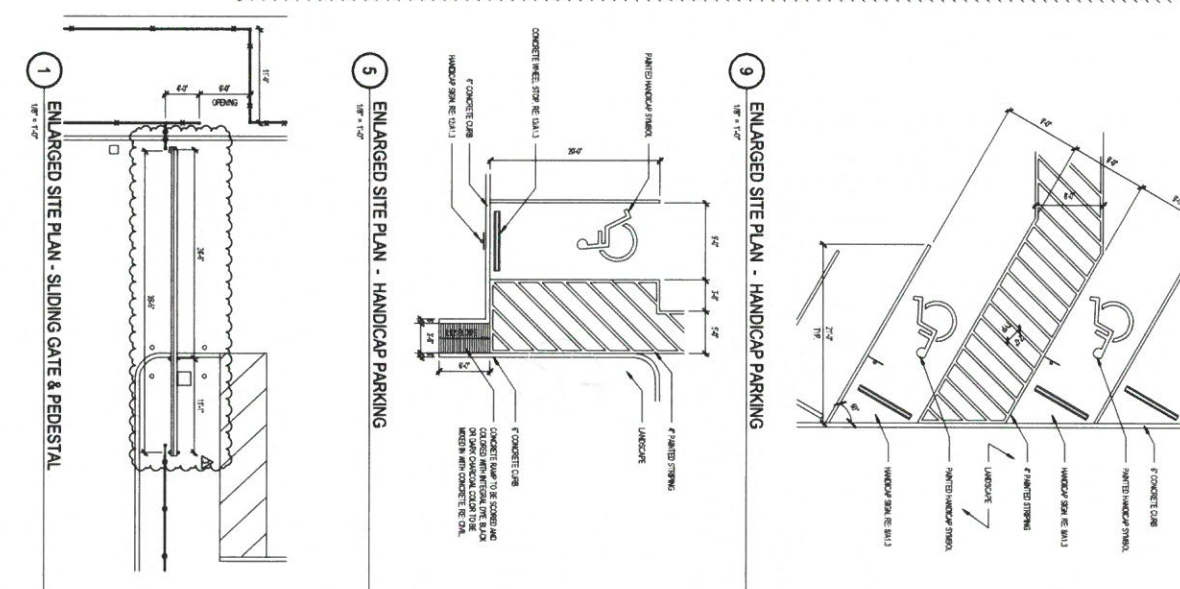
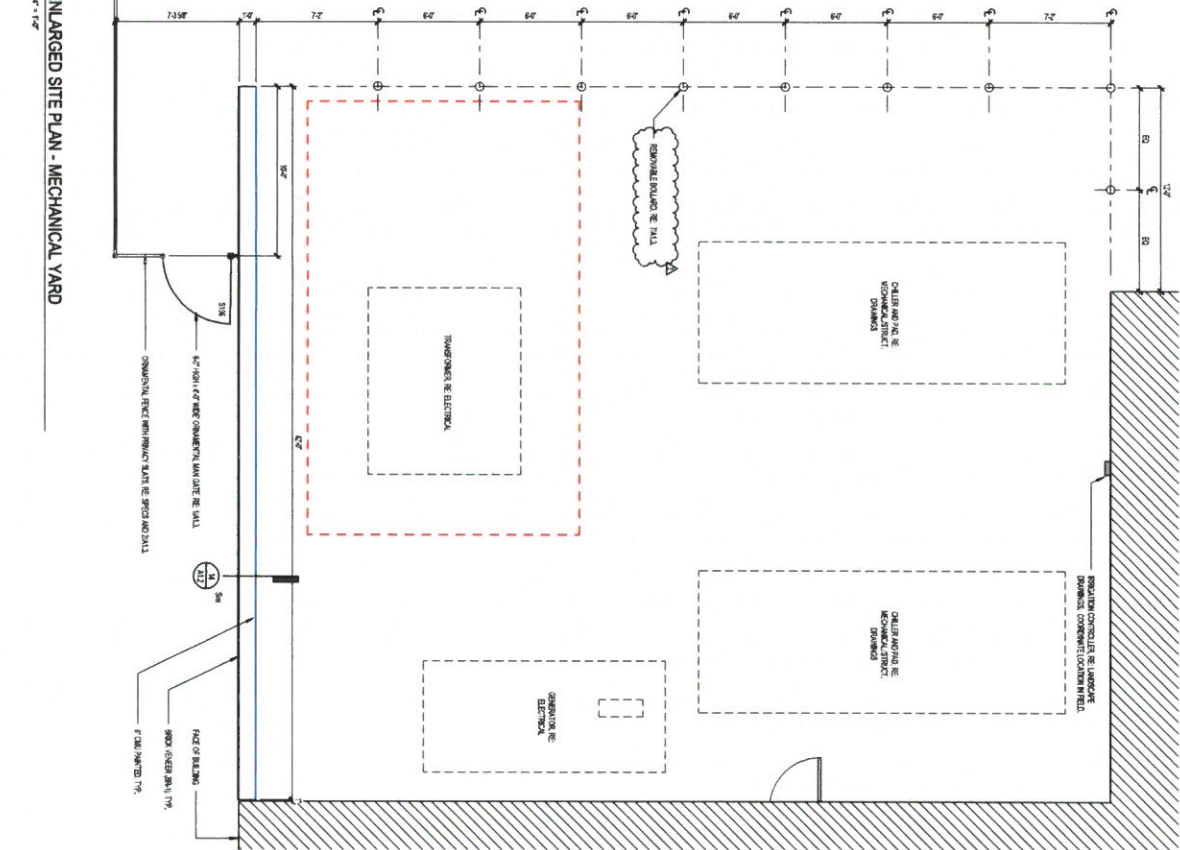
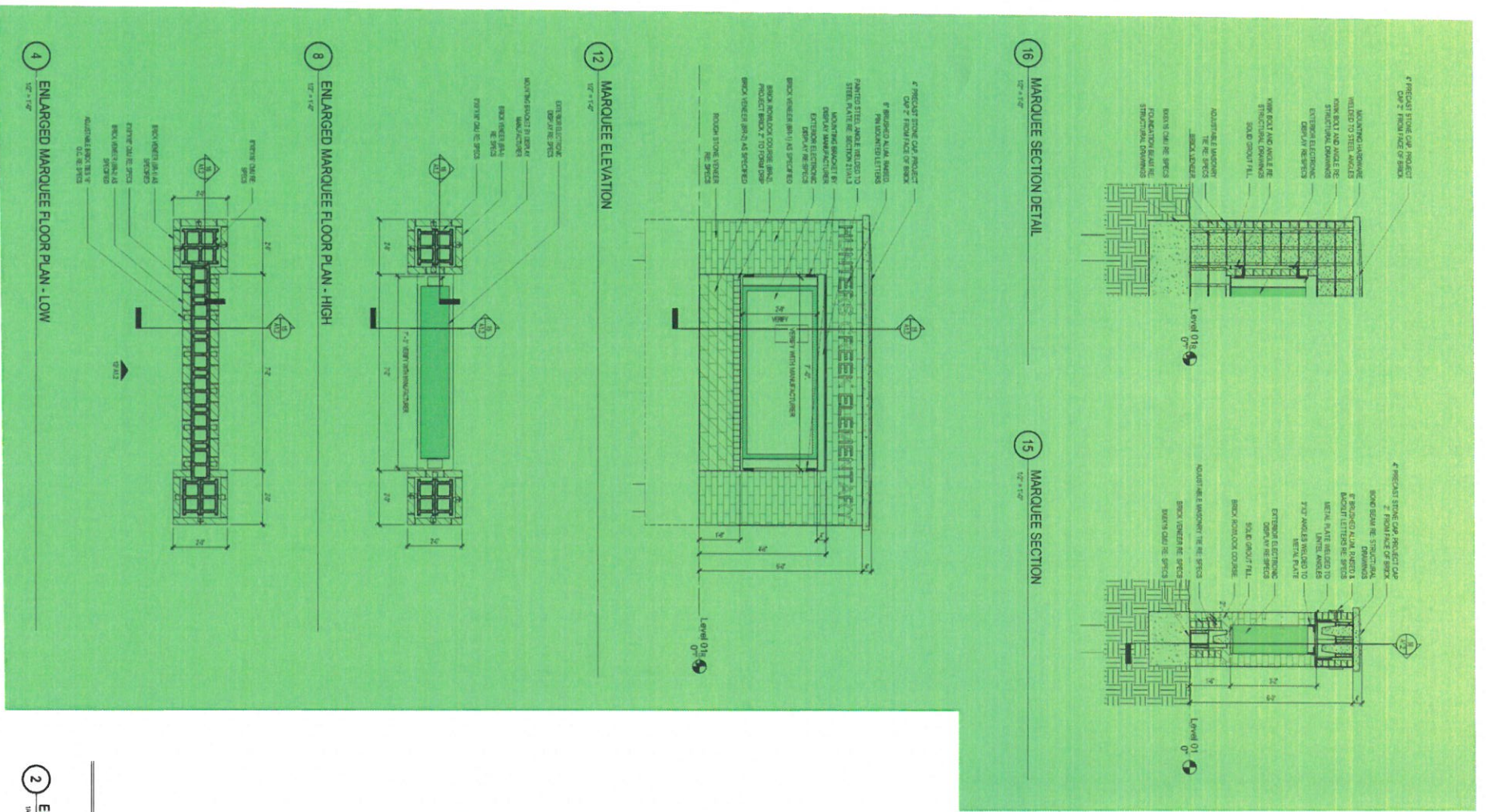

<p>A1.2 SITE PLAN DETAILS</p>		<p>PROJECT NO. 18-056</p> <p>SHEET NO. 12</p> <p>DATE 02/20/20</p>	<p>SPRING BRANCH INDEPENDENT SCHOOL DISTRICT</p> <p>955 CAMPBELL RD. HOUSTON, TEXAS 77024</p>	<p>HUNTERS CREEK ELEMENTARY SCHOOL REPLACEMENT</p> <p>10650 BEINHORN RD., HOUSTON, TEXAS 77024</p>	<p>pfluger</p> <p>office: 713.222.1141 fax: 713.222.1174 3411 Richmond Ave., Suite 725 Houston, Texas 77046 pflugarchitects.com</p>										
		<p>REVISIONS:</p> <table border="1"> <tr> <th>NO.</th> <th>DATE</th> <th>DESCRIPTION</th> </tr> <tr> <td>1</td> <td></td> <td>ISSUE FOR PERMITTING</td> </tr> <tr> <td>2</td> <td></td> <td>ISSUE FOR CONSTRUCTION</td> </tr> <tr> <td>3</td> <td></td> <td>ISSUE FOR OCCUPANCY</td> </tr> </table>	NO.	DATE	DESCRIPTION	1		ISSUE FOR PERMITTING	2		ISSUE FOR CONSTRUCTION	3		ISSUE FOR OCCUPANCY	
NO.	DATE	DESCRIPTION													
1		ISSUE FOR PERMITTING													
2		ISSUE FOR CONSTRUCTION													
3		ISSUE FOR OCCUPANCY													

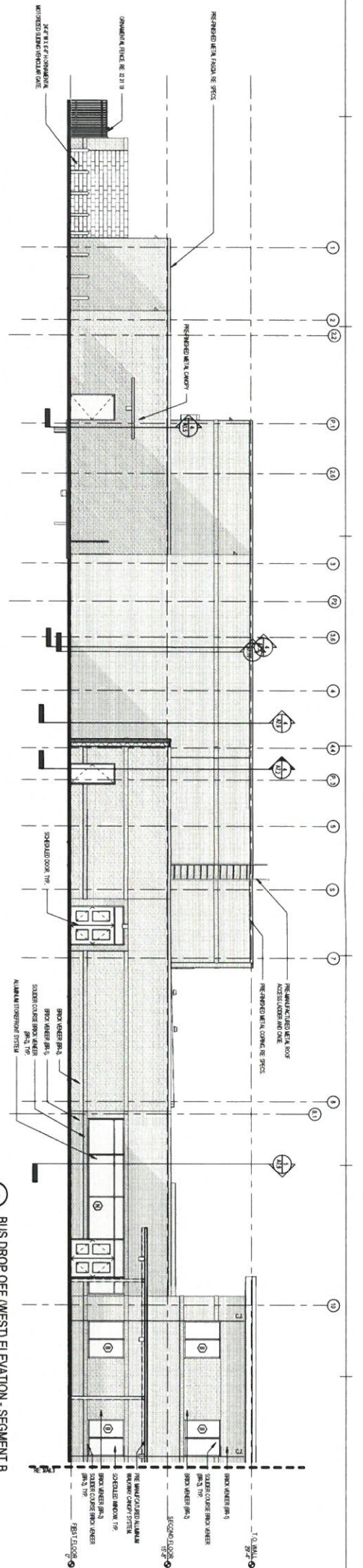

EXTERIOR MATERIAL LEGEND

	STONE VENEER
	BRICK
	CONCRETE
	METAL PANEL
	GLASS
	WOOD
	INSULATION
	GYPSUM BOARD
	DRYWALL
	STUCCO
	CONCRETE BLOCK
	METAL DECK
	STEEL DECK
	ALUMINUM SIDING
	VINYL SIDING
	FIBERGLASS SIDING
	CEMENTITIOUS SIDING
	SYNTHETIC SLATE
	ASPHALT SHINGLES
	METAL ROOFING
	CLAY TILES
	CONCRETE TILES
	SLATE TILES
	SHINGLE TILES

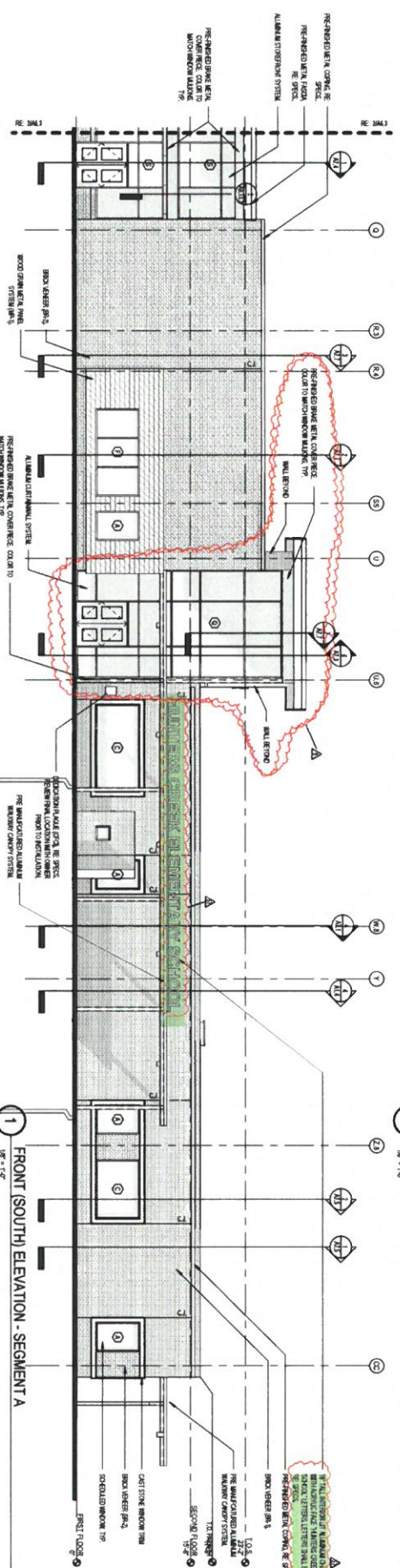
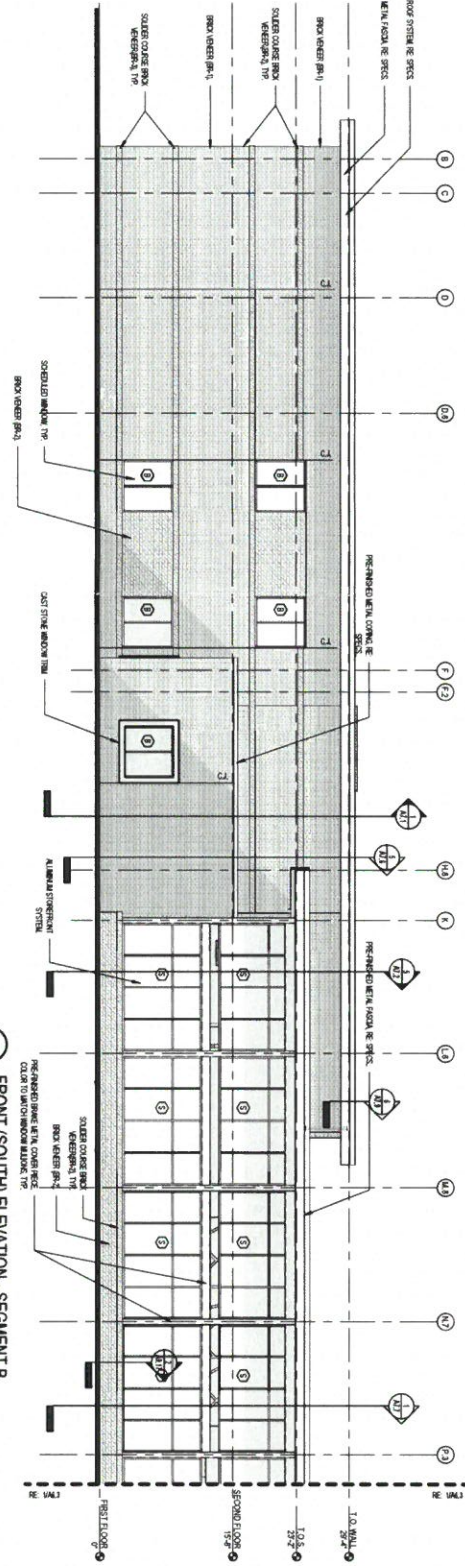
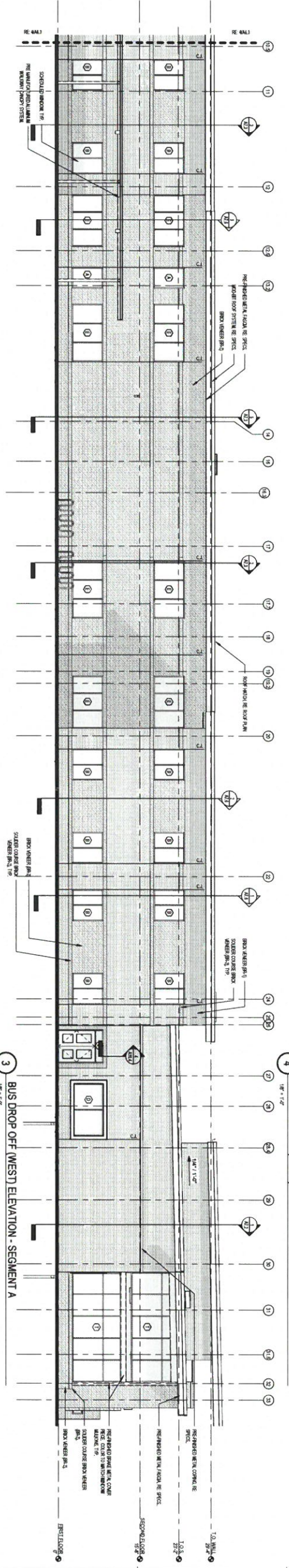

pfluger
 office: 713.222.1141 | fax: 713.222.1174
 3411 Fisherswood Ave. Suite 729
 Houston, Texas 77046
 pflugarchitects.com

HUNTERS CREEK ELEMENTARY SCHOOL REPLACEMENT
 10650 BEINHORN RD., HOUSTON, TEXAS 77024

SPRING BRANCH INDEPENDENT SCHOOL DISTRICT
 955 CAMPBELL RD. HOUSTON, TEXAS 77024



PROJECT NO: _____
 SHEET NO: _____
 DATE: _____
 DESIGNER: _____
 CHECKER: _____

A6.2
 EXTERIOR ELEVATIONS



**CITY OF HUNTERS CREEK VILLAGE
AGENDA DISCUSSION FORM**

AGENDA DATE: April 27, 2021
AGENDA SUBJECT: Cobb Fendley Amendment #67 Timberglen Drive
Pavement Repairs
PROCEEDING: Motion
EXHIBITS: Proposed Amendment

**CITY OF HUNTERS CREEK VILLAGE
STANDARD AMENDMENT TO
CONSULTANT SERVICES AGREEMENT**

AMENDMENT NO. 67

This Amendment (hereinafter "Amendment") is made between the City of Hunters Creek Village, Texas (hereinafter "City"), and Cobb, Fendley & Associates, Inc. (hereinafter "Consultant") to amend that consultant services (the "Contract") between the City and Consultant for services associated with the City Engineer Contract.

1. Amended Terms. The City and Consultant hereby agree that the Contract is amended as follows:

A. Add new task order for the **Engineering Services associated with Timberglen Drive Pavement Repairs** in the amount of **\$10,500.**

B. See Attached Exhibit A for Scope of Services for this project.

2. Contract to Remain in Force. Other than the provisions of the Contract expressly amended herein, the Contract shall remain in full force, and its enforceability shall be unaffected by this Amendment.

EXECUTED and EFFECTIVE as of the ____ day of _____, 20__.

CITY OF HUNTERS CREEK VILLAGE

Signature: _____

Name/Title: Honorable Jim Pappas/ Mayor

CONSULTANT

Signature: 

Name/Title: Charles M. Eastland, PE / Regional Manager

“EXHIBIT A”
Timberglen Drive Repairs
SCOPE OF SERVICES

The City of Hunters Creek Village (“the City”) intends to repair the intersection pavement at Timberglen Drive. The marked-out locations will be repaired full depth using materials and methods to expedite the opening of the street.

The Scope of Services, as far as practical, describes and identifies those services required to provide plan preparation, permitting, civil design, bidding and construction phase services in support of the project effort. Cobb, Fendley & Associates, Inc. (CobbFendley) shall provide those services necessary to complete the project as described herein.

The identified **Basic Services** shall include:

GENERAL

CobbFendley shall subcontract any other services not specifically offered by CobbFendley to perform the tasks described in this scope of service.

I. DESIGN & BID PHASE

1. Utilize pavement markings already made.
2. Prepare 22x34 drawings for the project showing location of project elements; and prepare contract bidding and construction documents consisting of technical specifications and contract documents outlining the construction contract requirements.
3. Include standard details for TCP.
4. Prepare bid documents and bid the project on CivCast. The City will be responsible for legal notice costs.
5. CobbFendley will conduct a Pre-Bid Meeting for prospective contractors upon advertisement of the project.

II. CONSTRUCTION PHASE

1. CobbFendley will conduct a Pre-Construction meeting with contractor and stakeholders and prepare and distribute meeting notes.
2. CobbFendley shall visit the construction site periodically to ensure that the project is proceeding in accordance with the schedule, plans and specifications.
3. CobbFendley shall provide technical interpretation of the plans and specifications to the construction contractor.
4. CobbFendley shall review and approve submittals/shop drawings from the contractor. CobbFendley shall maintain a log of submittals/shop drawings. CobbFendley shall monitor the contractor’s actual submittals against the schedule to confirm overall compliance.

5. CobbFendley shall maintain a noncompliance log throughout the course of the project. The log shall include details of noncompliance, date activity occurred, and date correction of item occurred.
6. CobbFendley shall evaluate requests for change orders in a timely manner and maintain a change order log. CobbFendley shall negotiate with the contractor and prepare the change order. CobbFendley shall provide a recommendation on approval/disapproval to the City Council.
7. CobbFendley shall review and provide a recommendation on approval/disapproval of monthly invoices submitted by the construction contractor. CobbFendley shall verify the accuracy of all quantities. CobbFendley shall submit the monthly invoices and recommendation to the City in a timely manner.
8. CobbFendley shall review all laboratory reports pertaining to the project to ensure the passing results. CobbFendley shall coordinate direction for any further testing or corrective action required by the contractor. CobbFendley shall maintain a copy of the lab results.
9. CobbFendley shall provide part-time inspection services throughout construction activities on the project.
10. CobbFendley shall contract with a materials testing firm for materials testing of soils, subgrades, and paving throughout the project in accordance with the project specifications.

EXCLUSIONS FROM THE SCOPE OF SERVICES

The services described above are the identified **Basic Services** for this assignment. Other items that may arise during the course of the project that the City may wish to add to the scope of services shall be deemed as **ADDITIONAL SERVICES**. CobbFendley shall undertake such additional services as assigned by the City upon written direction from the City. Examples of such items are as follows:

1. Reproduction of drawings, descriptions or specifications other than for CobbFendley's use in developing the project.
2. Public meetings will be billed under the general services of the City Engineering contract.
3. Any other services not specifically included within the description of the Basic Services or Other Services as described above.

EXHIBIT B
Timberglen Drive Repairs
COMPENSATION

BASIC SERVICES

The Compensation to be paid to CobbFendley for providing the BASIC SERVICES rendered under this agreement shall be based on Lump sum fees for overall phases of the work as shown below. The fees shown by task are for information only and will not be reflected on the invoices. Reimbursable items and subconsultant invoices will be subject to a 10% administration charge.

I. DESIGN & BID PHASE	
1. Construction Drawings, Project Manual (Lump Sum)	<u>\$2,000</u>
2. Bidding (Lump Sum)	<u>\$2,000</u>
TOTAL DESIGN & BID PHASE BASIC SERVICE LUMP SUM FEE	<u>\$4,000</u>

II. CONSTRUCTION PHASE	
1. Construction Phase Services	
1. Construction Administration (Lump Sum)	<u>\$2,500</u>
2. Field Observation (Hourly basis as needed)	<u>\$3,000</u>
2. Construction Materials Testing (as needed).....	<u>\$1,000</u>
TOTAL CONSTRUCTION PHASE SERVICE FEE	<u>\$6,500</u>

TOTAL BASIC SERVICES FEE INCLUDING ADDITIONAL SERVICES AND REIMBURSABLE BUDGET

DESIGN & BID PHASE Service Fee Items, Total	\$4,000
CONSTRUCTION PHASE Service Fee Items, Total	\$6,500
Reimbursable Items	\$0,000
Total Project Budget	<u>\$10,500</u>



**CITY OF HUNTERS CREEK VILLAGE
AGENDA DISCUSSION FORM**

AGENDA DATE: April 27, 2021
AGENDA SUBJECT: Discussion and possible action to approve Change Order #3 to the contract with Main Lane Industries, Ltd.- (Close Out) in the amount of -\$509.78 for the 2020 Street Maintenance Project.

EXHIBITS: Change Order No. 3

April 21, 2021

City of Hunters Creek Village
City Administrator
1 Hunters Creek Place
Houston, Texas 77024

Re: 2020 Street Maintenance Project
Change Order #3 and Final
CFA No. 2012-006-04

To Tom Fullen:

Attached is Change Order #3 and Final from Main Lane Industries, Ltd. for the above – referenced project. This Change Order is an adjustment of the contract total to match the actual as-built quantities on the project. The required adjustment to the contract total is - \$509.78. We recommend approval of this Change Order.

If you have any questions or require additional information, I can be contacted at (713) 462-3242.

Sincerely,

COBB, FENDLEY & ASSOCIATES, INC.



Thomas A. Artz, P.E.
Sr. Project Engineer

Enclosures

cc: Tom Fullen
Jackie Ramos
Steve Byington
Mark Sharpe

Change Order # 3 (FINAL)

DATE OF ISSUANCE:	April 21, 2021	EFFECTIVE DATE:	April 21, 2021
PROJECT:	2020 Street Maintenance Project	CONTRACTOR:	Main Lane Industries, Ltd.
OWNER:	City of Hunters Creek	ADDRESS:	14115 Luthe Rd.
ADDRESS:	1 Hunters Creek Place Houston, Tx 77024		Houston, TX 77039

DESCRIPTION OF CHANGES

Scope: Final contract quantity adjustment.
Justification: Adjustment of the contract total to match the as-built quantities for the project.
Adjustment: (\$ 509.78)
Time: None

EXECUTIVE SUMMARY

CONTRACT PRICE SUMMARY

Original Contract Price	\$ 297,312.00
Previous Change Orders	\$ 17,156.41
This Change Order	\$ - 509.78
Revised Contract Price	\$ 313,958.63

CONTRACT TIME SUMMARY

		DATE
Original Contract Time Substantial Completion	45	January 21, 2021
Previous Change Orders	50	
This Change Order	0	
Revised Contract Time	95	March 12, 2021
Original Contract Time Final Completion	60	February 5, 2021
Previous Change Orders	50	
This Change Order	0	
Revised Contract Time	110	March 27, 2021

Submitted by:

By:	<u>Kernon Rowman</u>		<u>4/21/21</u>
	Print Name	Signature	Date
	Main Lane Industries, Ltd		

Recommended by:

By:	<u>Thomas A. Arnt</u>		<u>4/21/21</u>
	Print Name	Signature	Date
	CobbFendley		

Approved by:

By:			
	Print Name	Signature	Date
	City of Hunters Creek Village		

2020 Street Maintenance Contract

Final Quantities

Original

Contract

Final

Item No.	Description	Unit	Quantity	Unit Price	Contract Amount	Final Quantity	Final Contract Amount
1	Mobilization	LS	1	\$12,000.00	\$12,000.00	1	\$12,000.00
2	Traffic Control	LS	1	\$12,000.00	\$12,000.00	1	\$12,000.00
3	3" HMA Asphalt	Ton	323	\$210.00	\$67,830.00	385.76	\$81,009.60
4	16" Crushed Concrete Base (Non-stab)	SY	1867	\$52.00	\$97,084.00	2037.67	\$105,958.84
5	Rem & Dispose Asphalt and Subgrade	SY	1867	\$25.00	\$46,675.00	2037.67	\$50,941.75
6	Laminated Geogrid	SY	1867	\$9.00	\$16,803.00	2037.67	\$18,339.03
7	Sodding	SY	400	\$6.00	\$2,400.00	0	\$0.00
8	Root Barrier (24" Depth)(City Furnished)	LF	620	\$15.00	\$9,300.00	467	\$7,005.00
9	16" Crushed Concrete Base (Stab)	SY	200	\$75.00	\$15,000.00	0	\$0.00
10	Remove and Replace 3" HMA	SY	100	\$65.00	\$6,500.00	0	\$0.00
11	Remove and Reinstall Traffic Pods	LS	1	\$5,000.00	\$5,000.00	0	\$0.00
12	4" Pavement Stripe (all types & Colors)	LF	1200	\$2.00	\$2,400.00	2774	\$5,548.00
13	Traffic Buttons	EA	40	\$8.00	\$320.00	0	\$0.00
14	Root Barrier (24" Depth)(Cont. Furn.)	LF	200	\$20.00	\$4,000.00		\$0.00
15	CO 1 - 4" Yellow Stripe Greenbay to Voss	LF	0	\$0.94	\$0.00	3986	\$3,746.84
16	CO 1 - 4" Solid Stripe Voss to Linden Wood	LF	0	\$0.90	\$0.00	10089	\$9,080.10
17	CO 1 -24" Yellow Striping	LF	0	\$7.95	\$0.00	108	\$858.60
18	CO 2 MH Repair on NB Voss Rd.	LS	0	\$7,470.87	\$0.00	1	\$7,470.87

ORIGINAL CONTRACT TOTAL

\$297,312.00

CHANGE ORDER 1

\$9,685.54

CHANGE ORDER 2

\$7,470.87

TOTAL CONTRACT COST

\$314,468.41

FINAL CONSTRUCTION COST \$313,958.63



**CITY OF HUNTERS CREEK VILLAGE
AGENDA DISCUSSION FORM**

AGENDA DATE: April 27, 2021
AGENDA SUBJECT: Discussion and possible action to approve the purchase of playground equipment for City Hall.
EXHIBITS: Playground Proposal



"creating playground memories filled with fun"

fun abounds, inc.
 114 Venice
 Sugar Land, TX. 77478
 855-226-8637 phone
 281-265-0043 Fax
 Leigh Walden, President
 lwalden@fabplaygrounds.com
 www.fabplaygrounds.com

Estimate	
Date	Estimate #
4/6/2021	6749

Sarah McClure
 Playground Specialist
 Greater Houston/East Texas
 sarah@fabplaygrounds.com
 832-808-9600

We are pleased to provide this estimate for

City of Hunters Creek Village
 Attn: Tom Fullen

Ship to:		
Rep	Terms	Project
Sarah	Net 30	Playground Unit

Item	Description	Qty	Rate	Total
Burke APS-Border12"	BCI Burke Playground NUIIN 2995 12" APS Playground Border with Surfacing Guide and 1 spike **Will Reuse 10 that are currently on site**	26	18,400.00 35.00	18,400.00T 910.00T
Installation	Installation		4,800.47	4,800.47
Freight	Freight		2,579.75	2,579.75T
EWF - Material Only ove...	EWF - Material only over 50 yds	52	20.46	1,063.92T
EWF - Installation Cost ...	Installation only of EWF and Geotextile (EWf pricing on separate line item)	52	31.32	1,628.64T
EWf - Freight	Freight (Truck Load 85 yds)	1	650.00	650.00T
Discount	Discount- Welcome Spring Sales Must be ordered by June 30th, 2021		-7,360.00	-7,360.00

Subtotal	
Sales Tax..	
Total	

**PLEASE NOTE: Order will be placed upon receipt of signed quote or purchase order, color selections, and down payment.
 Thank you! We appreciate the opportunity to earn your business!**

City of Houston WBE
 (Women's Business Enterprise)
 Certificate #20-2-11596

Signature

We are proud of a job well done and may spotlight your project on our website or FaceBook. If we do not have your permission to do so, please notify us. Thank you!



"creating playground memories filled with fun"

fun abounds, inc.
 114 Venice
 Sugar Land, TX. 77478
 855-226-8637 phone
 281-265-0043 Fax
 Leigh Walden, President
 lwalden@fabplaygrounds.com
 www.fabplaygrounds.com

Estimate	
Date	Estimate #
4/6/2021	6749

Sarah McClure
 Playground Specialist
 Greater Houston/East Texas
 sarah@fabplaygrounds.com
 832-808-9600

We are pleased to provide this estimate for

City of Hunters Creek Village
 Attn: Tom Fullen

Ship to:

Rep	Terms	Project
Sarah	Net 30	Playground Unit

Item	Description	Qty	Rate	Total
Note	Pricing is for the above listed equipment only, and does not include additional insured addendum, additional insurance, storage, security, or any applicable taxes, bonds, additional insurance or permits. Orders canceled after 5 days will be subject to a restocking fee and freight charges as applicable. Price valid for 30 days.		0.00	0.00T

Subtotal		\$22,672.78
Sales Tax..		\$0.00
Total		\$22,672.78

**PLEASE NOTE: Order will be placed upon receipt of signed quote or purchase order, color selections, and down payment.
 Thank you! We appreciate the opportunity to earn your business!**

City of Houston WBE
 (Women's Business Enterprise)
 Certificate #20-2-11596

Signature _____

We are proud of a job well done and may spotlight your project on our website or FaceBook. If we do not have your permission to do so, please notify us. Thank you!



**CITY OF HUNTERS CREEK VILLAGE
AGENDA DISCUSSION FORM**

AGENDA DATE: April 27, 2021
AGENDA SUBJECT: Discussion and possible action to approve a resolution opposing Texas Senate Bill 1661, which would require all city general elections to be held in November of even numbered years.

EXHIBITS: Draft Resolution Opposing Texas Senate Bill 1661

RESOLUTION NO. _____

A RESOLUTION OF THE CITY COUNCIL OF THE CITY OF HUNTERS CREEK VILLAGE, TEXAS OPPOSING TEXAS SENATE BILL 1661, WHICH WOULD REQUIRE ALL CITY GENERAL ELECTIONS TO BE HELD IN NOVEMBER OF EVEN NUMBERED YEARS.

WHEREAS, the City of Hunters Creek Village (the "City") has staggered two-year-terms for its city council members in order to promote continuity of government; and

WHEREAS, the citizens of the City have chosen to hold the City's general elections in May to avoid City election issues being placed on the bottom of a lengthy November ballot that also contains County, State and Federal election issues; and

WHEREAS, Texas Senate Bill 1661 seeks to require all cities to hold their general elections only in November of even-numbered years; and

WHEREAS, imposing such a requirement would eliminate the ability of the City to have staggered two-year-terms for its city council members and would also reduce the visibility of City's election issues by forcing them to compete for attention with Federal, State, and County election issues on the same ballot.

NOW, THEREFORE, BE IT RESOLVED, by the City Council of the City of Hunters Creek Village, Texas:

Section 1. The City Council expresses its strong opposition to the enactment of SB 1661 because it would frustrate the important choices made by the citizens of the City of Hunters Creek Village in establishing their own municipal government.

Section 2. City staff is directed to send an executed copy of this resolution to the governor, the lieutenant governor, and the state senator and state representatives whose districts are included within the City.

PASSED, APPROVED, AND RESOLVED this ____ day of _____, 2021.

Jim Pappas
Mayor

ATTEST:

Tom Fullen
Acting City Secretary



**CITY OF HUNTERS CREEK VILLAGE
AGENDA DISCUSSION FORM**

AGENDA DATE: April 27, 2021
AGENDA SUBJECT: Discussion and possible action to approve the Entry Sign Beautification design.

EXHIBITS: Entry Sign Attachments

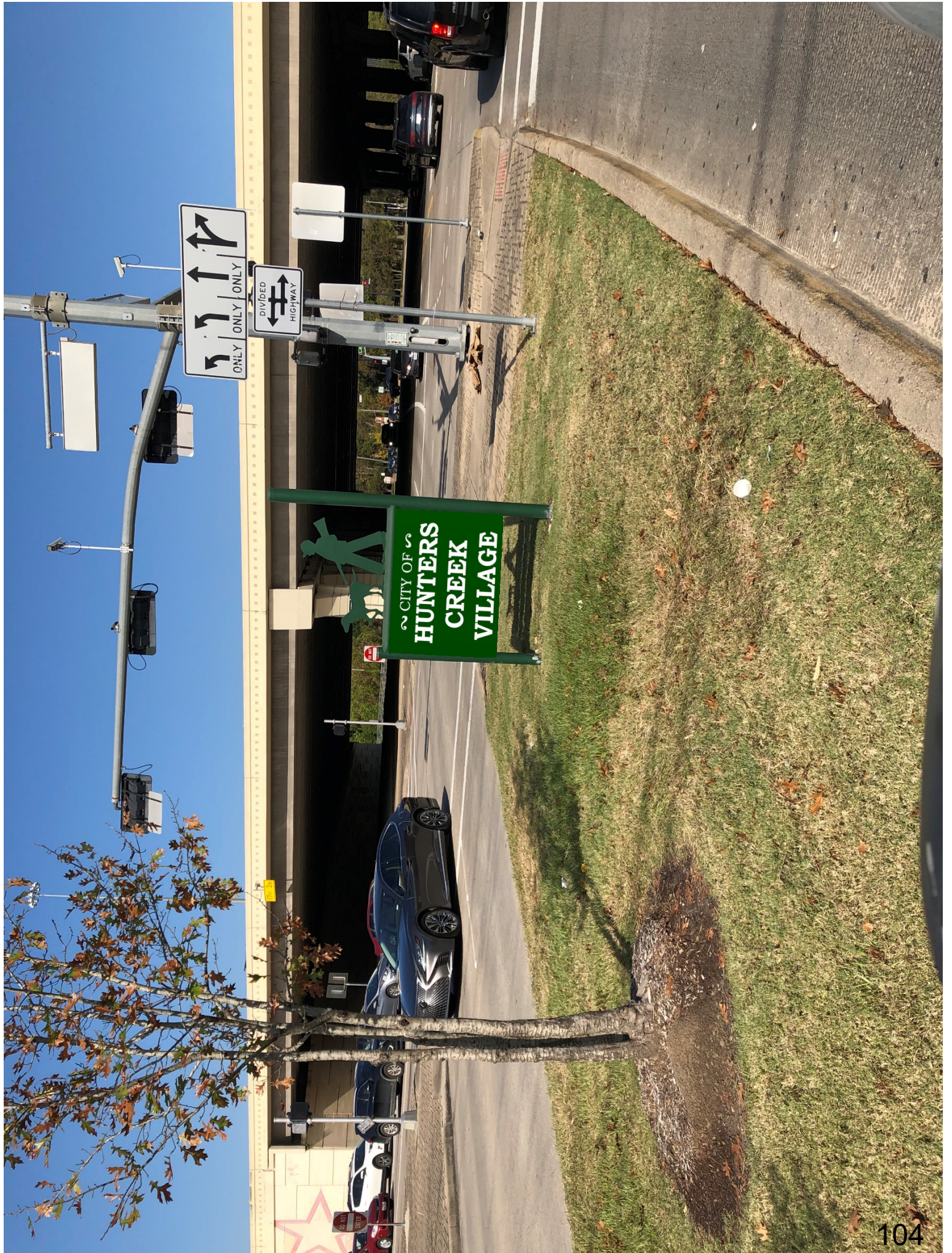





1128 Pasadena Blvd.
 Pasadena, TX 77506
 713-943-0895

Deposit Invoice

Date	Job #
4-21-21	21-0222-61544

Client Name / Address
City of Hunters Creek Village 1 Hunters Creek Place Houston, TX. 77024 Tom Fullen

Project
Neighborhood Entrance Signs

Qty.	Description	Total
9	<p>Manufacture (18) 36" x 48" x 1" primed and painted PVC panels with 1/2" routed and primed and painted PVC letters. This would be (2) 1" PVC panels mounted back to back to create a double-sided sign with 1/2" PVC copy "City of Hunters Creek" mounted to each face. Installed in existing (9) sign structures. Per a client approved layout.</p> <p>Permitting is not required on this project per Tom Fullen</p> <p>Please allow 4 to 6 weeks from time of approval / deposit received to completion of project</p> <p><i>** ADS Custom Signs appreciates the opportunity to do this project for you **</i></p>	\$16,785.00

Subtotal	\$16,785.00
Tax (8.25%)	\$1,384.76
Total	\$18,169.76
50% Deposit	\$9,084.88

 Client Acceptance

 Sales Representative

 Date

 Date



**CITY OF HUNTERS CREEK VILLAGE
AGENDA DISCUSSION FORM**

AGENDA DATE: April 27, 2021
AGENDA SUBJECT: Discussion and possible action to approve the agreement between Hunters Creek Village and Spring Branch School District to assess and collect ad valorem taxes.
EXHIBITS: SBISD Annual Contract

THE STATE OF TEXAS

KNOW ALL MEN BY THESE PRESENTS:

COUNTY OF HARRIS

This memorandum of contract is made and executed this ____ day of _____, 2021 by and between the City of Hunters Creek Village, Texas a municipal corporation of the State of Texas, hereinafter called "City," and the Spring Branch Independent School District, a body politic and corporate, hereinafter called "District";

WHEREAS, City has requested District to assess and collect ad valorem taxes for said City; and

WHEREAS, it will be to the mutual benefit of both parties to enter into such an agreement; now therefore

FOR AND IN CONSIDERATION of the premises and benefits described below, City and District hereby enter into the following agreement:

1. District agrees that its Tax Assessor-Collector will assess and collect all ad valorem taxes for City and perform all the necessary services with regard to assessment and collection of said City's taxes with the exception of legal services incidental to the collection of delinquent taxes. In the performance of such necessary services, the Tax Assessor-Collector will apply the applicable rules, regulations, and ordinances of City.

2. This contract shall be for a period of two (2) years, beginning on the 1st day of September 2021, and ending on the 31st day of August 2023.

3. District agrees to make deposits to the Depository of City of all taxes collected on behalf of City at least once each week.

4. City agrees that it will pay to District, as compensation for performing this service, a fee which shall be the sum of five dollars (\$5.00) per account for each annual tax period, plus postage expenses incurred by District on behalf of the City. District will submit a statement for the services so

rendered and payment for said services will be made to District on or before March 31. Payment for said services shall be made from current revenues available to City.

5. City and District recognize that the Harris County Appraisal District is responsible for appraising the property that is subject to taxation by City and District. City or District, separately in its own name and on its own behalf, may challenge any act or omission of the Appraisal District and any decision to make such challenge or not, by either City or District, shall not be binding on the other.

6. District will not be liable to City for any failure to collect taxes, nor shall District's Tax Assessor-Collector be liable unless such failure to collect results from the failure of the Tax Assessor-Collector to perform such duties in the manner and in accordance with the standards imposed by law. District's Tax Assessor-Collector shall furnish a bond in the sum of statutory minimum payable to and approved by City and conditioned on the faithful performance of the duties as Tax Assessor-Collector. The cost of such bond shall be paid by City.

7. District's Tax Assessor-Collector shall prepare a written monthly statement of all amounts collected for the benefit of City, and such reports of collection made in the months of October through January are due on the twenty-fifth (25th) day of the month following the month that is the subject of the report. Reports of collections made in all other months are due the fifteenth (15th) day of the month following the month that is the subject of the report. City will be permitted to audit the tax records at a reasonable time mutually agreed upon by both parties.

8. The tax office is to remain under the administrative control of the Tax Assessor-Collector of District.

9. In the event any provision of this contract is inconsistent with the statutes of the State of Texas, the statutes of the State of Texas shall control and

the District's Tax Assessor-Collector will discharge these duties in accordance therewith.

10. District agrees to furnish to City a written list of each delinquent taxpayer, the delinquent taxpayer's address, the amount of the delinquency, and the designation of the property involved, by July 1st of each year. District further agrees that by August 1st, or as soon thereafter as practical each year, the Tax Assessor-Collector will provide City with the Harris County Appraisal District's certified estimate of the total appraised value of all property in the Appraisal District that is taxable by City.

11. This agreement shall replace all prior agreements with regard to the assessing and collecting of ad valorem taxes heretofore made between the parties hereto.

ATTEST:
TEXAS

CITY OF HUNTERS CREEK VILLAGE,

Tom Fullen
Acting City Secretary

Jim Pappas
Mayor

ATTEST:

SPRING BRANCH INDEPENDENT
SCHOOL DISTRICT

Secretary
Board of Trustees

President
Board of Trustees



**CITY OF HUNTERS CREEK VILLAGE
AGENDA DISCUSSION FORM**

AGENDA DATE: April 27, 2021
AGENDA SUBJECT: Discussion and possible action to approve a Network Node Deployment Agreement (which includes a list of proposed node locations) with Verizon Wireless.

EXHIBITS: Verizon Packet and Agreement



EXISTING		PROPOSED	
3D DESIGN & ENGINEERING, INC. email: info@3ddne.com Tel: 832-431-8629 www.3ddne.com	SITE INFORMATION N/A	PHOTO SIMULATION CPE EXCEPTION EXAMPLE FRONT VIEW	VERIZON WIRELESS 14123 Cicero Rd. Houston, TX, 77095 Tel: 713-507-1618
	NEAREST ADDRESS N/A		

CPE UTILITY POLE WITH ANTENNA ARRAY ATTACHED TO POLE PER CPE REQUIREMENTS

NOTE: EXACT LOCATION OF CABINET TO BE DEPICTED IN CONSTRUCTION DRAWINGS.

VERIZON EQUIPMENT CABINET CONCEALED WITH SHRUBS

EXISTING

3D DESIGN & ENGINEERING, INC.

email: info@3ddne.com

Tel: 832-431-8629

www.3ddne.com

SITE INFORMATION

MEMORIAL_VILLAGES_SC21
29.778786, -95.501790

NEAREST ADDRESS

10734 MARSHA LN
HOUSTON, TX 77024

PHOTO SIMULATION

CPE WOOD UTILITY POLE WITH CABINET

PROPOSED



VERIZON WIRELESS
14123 Cicero Rd.
Houston, TX 77095
Tel: 713-907-1618



CPE UTILITY POLE WITH ANTENNA ARRAY ATTACHED TO POLE PER CPE REQUIREMENTS



NOTE: EXACT LOCATION OF CABINET TO BE DEPICTED IN CONSTRUCTION DRAWINGS.

VERIZON EQUIPMENT CABINET CONCEALED WITH SHRUBS

EXISTING

3D DESIGN & ENGINEERING, INC.
 email: info@3ddne.com
 Tel: 832-431-8629
www.3ddne.com

SITE INFORMATION
 MEMORIAL_VILLAGES_SC26
 29.767606, -95.498447

NEAREST ADDRESS
 500 SADDLEWOOD LN
 HOUSTON, TX 77024

PHOTO SIMULATION
 CPE WOOD UTILITY POLE WITH CABINET

PROPOSED

verizon
 VERIZON WIRELESS
 14123 Cicero Rd.
 Houston, TX 77095
 Tel: 713-907-1618



CPE UTILITY POLE WITH ANTENNA ARRAY ATTACHED TO POLE PER CPE REQUIREMENTS

NOTE: EXACT LOCATION OF CABINET TO BE DEPICTED IN CONSTRUCTION DRAWINGS.

VERIZON EQUIPMENT CABINET CONCEALED WITH SHRUBS



EXISTING		PROPOSED	
3D DESIGN & ENGINEERING, INC. email: info@3ddne.com Tel: 832-431-8629 www.3ddne.com	SITE INFORMATION MEMORIAL VILLAGES_SC27 29.774685, -95.492782	NEAREST ADDRESS 709 KUHLMAN RD HOUSTON, TX 77024	PHOTO SIMULATION CPE WOOD UTILITY POLE WITH CABINET
		verizon VERIZON WIRELESS 14123 Cicero Rd. Houston, TX 77095 Tel: 713-907-1618	



CPE UTILITY POLE WITH ANTENNA ARRAY ATTACHED TO POLE PER CPE REQUIREMENTS

NOTE: EXACT LOCATION OF CABINET TO BE DEPICTED IN CONSTRUCTION DRAWINGS.

VERIZON EQUIPMENT CABINET CONCEALED WITH SHRUBS



EXISTING

3D DESIGN & ENGINEERING, INC.
 email: info@3ddne.com
 Tel: 832-431-8629
www.3ddne.com

SITE INFORMATION
 MEMORIAL_VILLAGES_SC30
 29.760992, -95.506316

NEAREST ADDRESS
 10927 WICKLINE DR
 HOUSTON, TX 77024

PHOTO SIMULATION
 CPE WOOD UTILITY POLE WITH CABINET

PROPOSED

verizon
 VERIZON WIRELESS
 14123 Cicero Rd.
 Houston, TX 77095
 Tel: 713-907-1618



EXISTING

SITE INFORMATION
 MEMORIAL_VILLAGES_SC11
 29.777738, -95.505327

NEAREST ADDRESS
 10840 BEINHORN RD
 HOUSTON, TX 77024

PHOTO SIMULATION
 34' BLACK RAYCAP STEALTH
 POLE - BLACK

PROPOSED

verizon
 VERIZON WIRELESS
 14123 Cicero Rd.
 Houston, TX 77095
 Tel: 713-907-1618



PROPOSED 34' BLACK
RAYCAP STEALTH
POLE

EXISTING

3D DESIGN & ENGINEERING, INC.

email: info@3ddne.com
Tel: 832-431-8629
www.3ddne.com

SITE INFORMATION

MEMORIAL_VILLAGES_SC23
29.774148, -95.501408

NEAREST ADDRESS

6 SHANNON CIR
HOUSTON, TX 77024

PHOTO SIMULATION

34' BLACK RAYCAP STEALTH
POLE - BLACK

PROPOSED



VERIZON WIRELESS
14123 Cicero Rd.
Houston, TX 77095
Tel: 713-507-1618



PROPOSED 34' BLACK RAYCAP STEALTH POLE

EXISTING

3D DESIGN & ENGINEERING, INC.

email: info@3ddne.com
 Tel: 832-431-8629
www.3ddne.com

SITE INFORMATION

MEMORIAL_VILLAGES_SC24
 29.769047, -95.501311

NEAREST ADDRESS

10802 ROARING BROOK LN
 HOUSTON, TX 77024

PHOTO SIMULATION

34' BLACK RAYCAP STEALTH
 POLE - BLACK

PROPOSED

VERIZON WIRELESS

14123 Cicero Rd.
 Houston, TX 77095
 Tel: 713-507-1618





PROPOSED 34' BLACK RAYCAP STEALTH POLE



EXISTING

3D DESIGN & ENGINEERING, INC.
 email: info@3ddne.com
 Tel: 832-431-8629
www.3ddne.com

SITE INFORMATION
 MEMORIAL_VILLAGES_SC31
 29.770634, -95.495060

NEAREST ADDRESS
 515 HUNTERWOOD DR
 HOUSTON, TX 77024

PHOTO SIMULATION
 34' BLACK RAYCAP STEALTH POLE - BLACK

PROPOSED

verizon
 VERIZON WIRELESS
 14123 Cicero Rd.
 Houston, TX 77095
 Tel: 713-507-1618

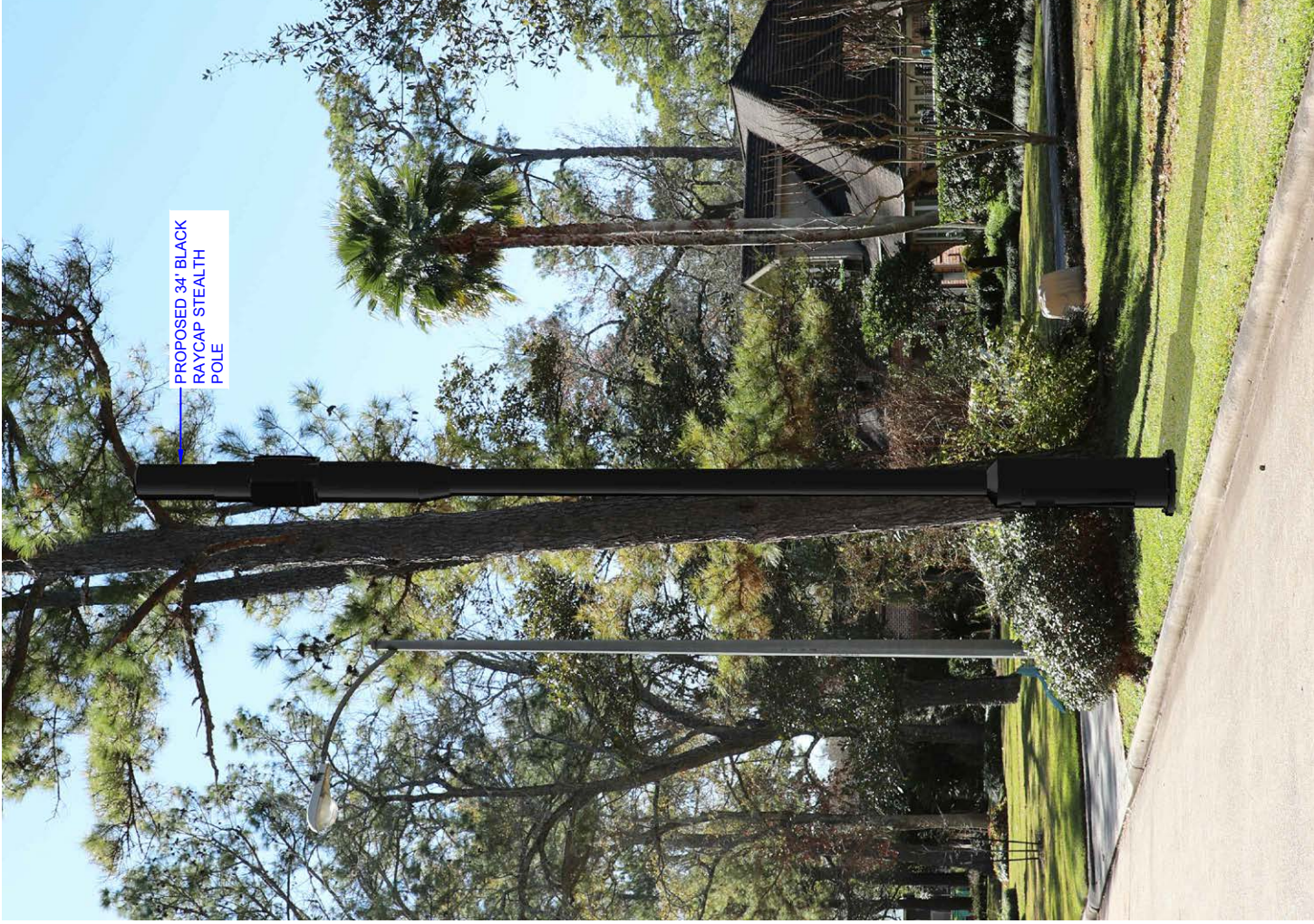

PROPOSED 34' BLACK
RAYCAP STEALTH
POLE

EXISTING

3D DESIGN & ENGINEERING, INC.

email: info@3ddne.com
Tel: 832-431-8629
www.3ddne.com

SITE INFORMATION

MEMORIAL_VILLAGES_SC34
29.774564, -95.506159

NEAREST ADDRESS

515 HUNTERS PARK LN
HOUSTON, TX 77024

PHOTO SIMULATION

34' BLACK RAYCAP STEALTH
POLE - BLACK

PROPOSED



verizon
VERIZON WIRELESS
14123 Cicero Rd.
Houston, TX 77095
Tel: 713-907-1618



PROPOSED 34' BLACK
RAYCAP STEALTH
POLE

3D DESIGN & ENGINEERING, INC.
 email: info@3ddne.com
 Tel: 832-431-8629
 www.3ddne.com

EXISTING

SITE INFORMATION
 MEMORIAL_VILLAGES_SC46
 29.770895, -95.499668

NEAREST ADDRESS
 10707 SHALLOWBROOK LN
 HOUSTON, TX 77024

PHOTO SIMULATION
 34' BLACK RAYCAP STEALTH
 POLE - BLACK

PROPOSED

verizon
VERIZON WIRELESS
 14123 Cicero Rd.
 Houston, TX 77095
 Tel: 713-907-1618

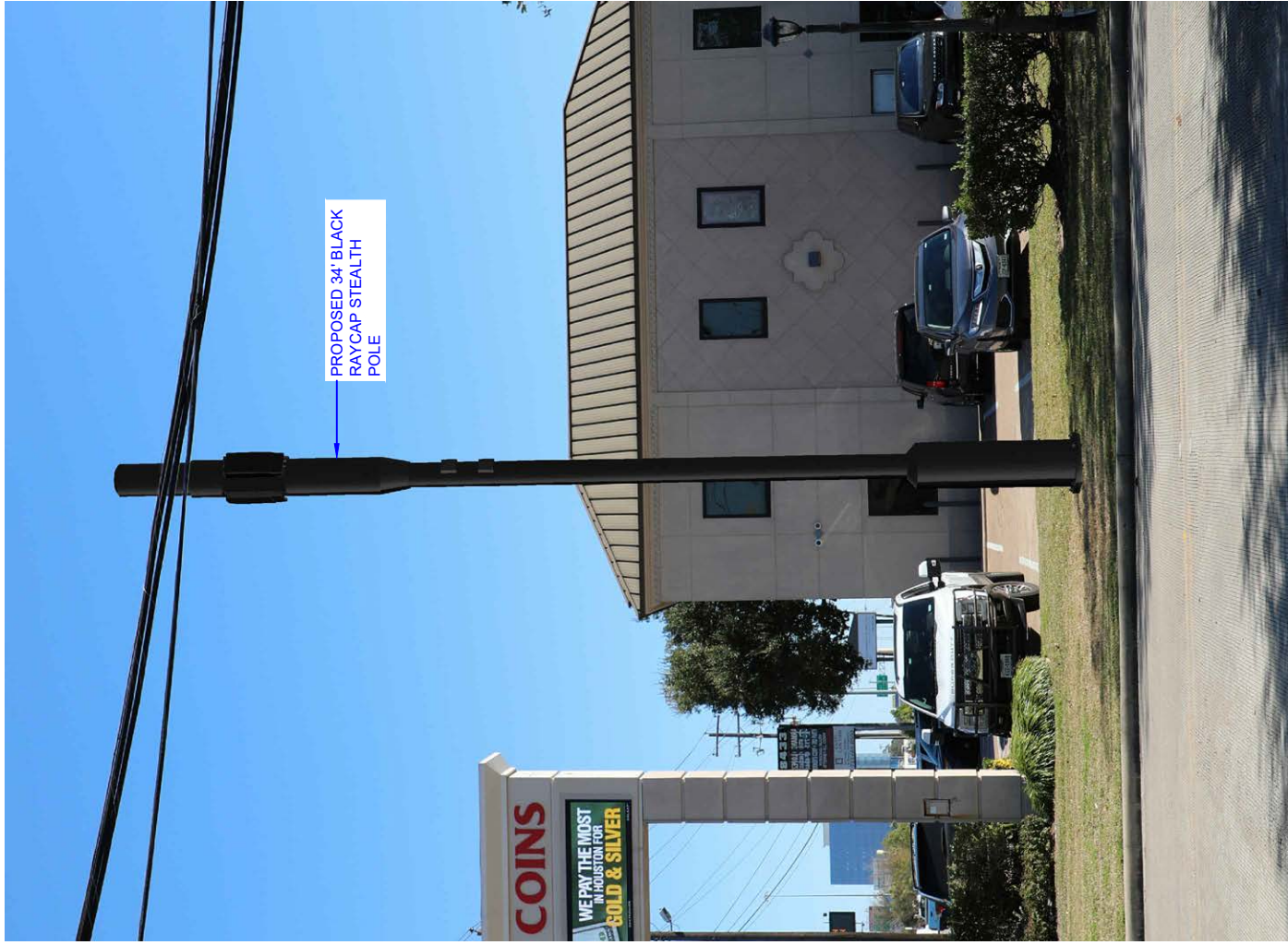

PROPOSED 34' BLACK
RAYCAP STEALTH
POLE

3D DESIGN & ENGINEERING, INC.
 email: info@3ddne.com
 Tel: 832-431-8629
 www.3ddne.com

EXISTING

SITE INFORMATION
 HOU_SPRING_BRANCH_166_TX
 29.783392, -95.492321

NEAREST ADDRESS
 8435 KATY FWY
 HOUSTON, TX 77024

PHOTO SIMULATION
 34' BLACK RAYCAP STEALTH
 POLE - BLACK

PROPOSED

verizon
 VERIZON WIRELESS
 14123 Cicero Rd.
 Houston, TX 77095
 Tel: 713-507-1618



3D DESIGN & ENGINEERING, INC.
 email: info@3ddne.com
 Tel: 832-431-8629
 www.3ddne.com

EXISTING

SITE INFORMATION
 MEMORIAL_VILLAGES_SC17
 29.768756, -95.505708

NEAREST ADDRESS
 10924 ROARING BROOK LN,
 HOUSTON, TX 77024

PHOTO SIMULATION
 EMI METAL POLE
 PAINTED TO MATCH SIGN

PROPOSED

verizon
 VERIZON WIRELESS
 14123 Cicero Rd.
 Houston, TX 77095
 Tel: 713-507-1618



PROPOSED METAL
EMI POLE WITH
STREET SIGN
(PAINTED TO MATCH
EXISTING POLE)

3D DESIGN & ENGINEERING, INC.
 email: info@3ddne.com
 Tel: 832-431-8629
www.3ddne.com

EXISTING

SITE INFORMATION
 MEMORIAL_VILLAGES_SC22
 29.775172, -95.498018

NEAREST ADDRESS
 10634 FAIRLANE DR,
 HOUSTON, TX 77024

PHOTO SIMULATION
 EMI METAL POLE
 PAINTED TO MATCH SIGN

PROPOSED

verizon
 VERIZON WIRELESS
 14123 Cicero Rd.
 Houston, TX, 77095
 Tel: 713-507-1618



CPE UTILITY POLE WITH ANTENNA ARRAY ATTACHED TO POLE PER CPE REQUIREMENTS

NOTE: EXACT LOCATION OF CABINET TO BE DEPICTED IN CONSTRUCTION DRAWINGS.

VERIZON EQUIPMENT CABINET CONCEALED WITH SHRUBS

EXISTING

3D DESIGN & ENGINEERING, INC.
 email: info@3ddne.com
 Tel: 832-431-8629
 www.3ddne.com

SITE INFORMATION
 MEMORIAL_VILLAGES_SC25
 29.764874, -95.502932

NEAREST ADDRESS
 202 CARUTHERS LN
 HOUSTON, TX 77024

PHOTO SIMULATION
 CPE WOOD UTILITY POLE WITH CABINET

PROPOSED

verizon
 VERIZON WIRELESS
 14123 Cicero Rd.
 Houston, TX 77095
 Tel: 713-507-1618



127

EXISTING

3D DESIGN & ENGINEERING, INC.
 email: info@3ddne.com
 Tel: 832-431-8629
www.3ddne.com

SITE INFORMATION
 MEMORIAL_VILLAGES_SC28
 29.777446, -95.496762

NEAREST ADDRESS
 10622 N EVERS PARK DR,
 HOUSTON, TX 77024

PHOTO SIMULATION
 CPE WOOD UTILITY POLE
 WITH CABINET

PROPOSED

verizon
 VERIZON WIRELESS
 14123 Cicero Rd.
 Houston, TX 77095
 Tel: 713-507-1618





PROPOSED METAL
EMI POLE WITH
STREET SIGN
(PAINTED TO MATCH
EXISTING POLE)

EXISTING

3D DESIGN & ENGINEERING, INC.
 email: info@3ddne.com
 Tel: 832-431-8629
www.3ddne.com

SITE INFORMATION
 MEMORIAL_VILLAGES_SC36
 29.772288, -95.504031

NEAREST ADDRESS
 10830 EVERWOOD LN,
 HOUSTON, TX 77024

PHOTO SIMULATION
 EMI METAL POLE
 PAINTED TO MATCH SIGN

PROPOSED

verizon
 VERIZON WIRELESS
 14123 Cicero Rd.
 Houston, TX 77095
 Tel: 713-507-1618



EXISTING



PROPOSED METAL
EMI POLE WITH
STREET SIGN
(PAINTED TO MATCH
EXISTING POLE)

PROPOSED

3D DESIGN & ENGINEERING, INC.

email: info@3ddne.com
Tel: 832-431-8629
www.3ddne.com

SITE INFORMATION

MEMORIAL_VILLAGES_SC47
29.767675, -95.494220

NEAREST ADDRESS

411 THAMER CIR,
HOUSTON, TX 77024

PHOTO SIMULATION

EMI METAL POLE
PAINTED TO MATCH SIGN

VERIZON WIRELESS

14123 Cicero Rd.
Houston, TX 77095
Tel: 713-507-1618



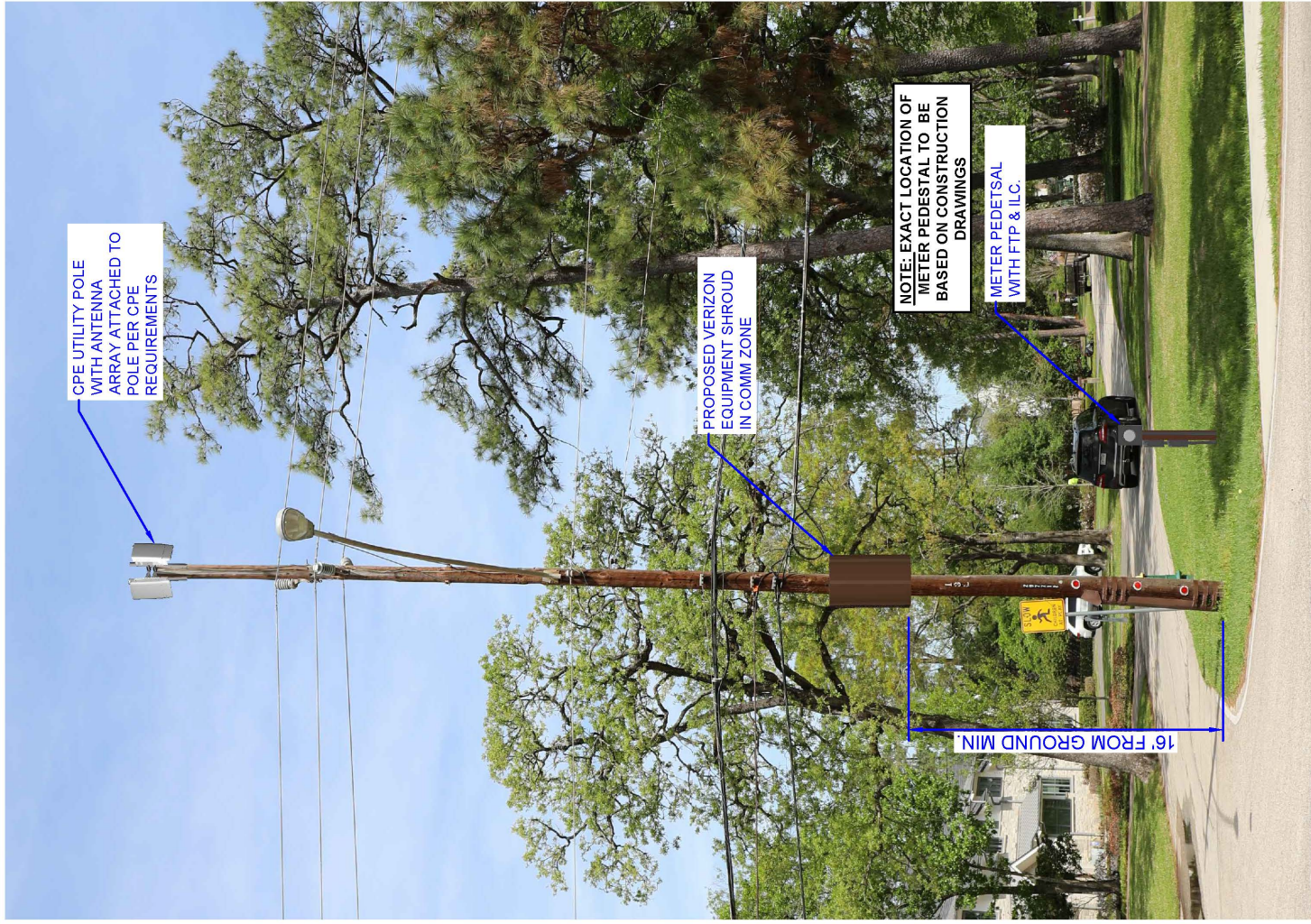

CPE UTILITY POLE WITH ANTENNA ARRAY ATTACHED TO POLE PER CPE REQUIREMENTS

PROPOSED VERIZON EQUIPMENT SHROUD IN COMM ZONE

NOTE: EXACT LOCATION OF METER PEDESTAL TO BE BASED ON CONSTRUCTION DRAWINGS

METER PEDESTAL WITH FTP & ILC.

16' FROM GROUND MIN.



EXISTING		PROPOSED	
3D DESIGN & ENGINEERING, INC. email: info@3ddne.com Tel: 832-431-8629 www.3ddne.com	NEAREST ADDRESS N/A	PHOTO SIMULATION CPE EXCEPTION EXAMPLE FRONT VIEW	VERIZON WIRELESS 14123 Cicero Rd. Houston, TX 77095 Tel: 713-507-1618

Site Name	Lat	Long	Pole Type
HOU_SPRING_BRANCH_166_TX	29.783392	-95.492321	RAYCAP STEALTH 34' 9005
MEMORIAL_VILLAGES_SC11	29.777738	-95.505327	RAYCAP STEALTH 34' 9005
MEMORIAL_VILLAGES_SC17	29.768756	-95.505708	EMI Pole (Street sign rep). Painted to match existing pole.
MEMORIAL_VILLAGES_SC21	29.778786	-95.50179	CenterPoint Energy
MEMORIAL_VILLAGES_SC22	29.775172	-95.498018	EMI Pole (Street sign rep). Painted to match existing pole.
MEMORIAL_VILLAGES_SC23	29.774148	-95.501408	RAYCAP STEALTH 34' 9005
MEMORIAL_VILLAGES_SC24	29.769047	-95.501311	RAYCAP STEALTH 34' 9005
MEMORIAL_VILLAGES_SC25	29.764874	-95.502932	CenterPoint Energy
MEMORIAL_VILLAGES_SC26	29.767606	-95.498447	CenterPoint Energy
MEMORIAL_VILLAGES_SC27	29.774685	-95.492782	CenterPoint Energy
MEMORIAL_VILLAGES_SC28	29.777446	-95.496762	CenterPoint Energy

MEMORIAL_VILLAGES_SC30	29.760992	-95.506316	CenterPoint Energy
MEMORIAL_VILLAGES_SC31	29.770634	-95.49506	RAYCAP STEALTH 34' 9005
MEMORIAL_VILLAGES_SC34	29.774564	-95.506159	RAYCAP STEALTH 34' 9005
MEMORIAL_VILLAGES_SC36	29.772288	-95.504031	EMI Pole (Street sign repl). Painted to match existing pole.
MEMORIAL_VILLAGES_SC46	29.770895	-95.499668	RAYCAP STEALTH 34' 9005
MEMORIAL_VILLAGES_SC47	29.767675	-95.49422	EMI Pole (Street sign repl)

**Connecting
our homes,
businesses &
communities.**

verizon

Why are we expanding the wireless network?

More people than ever before rely on wireless connections to manage their lives and businesses.

Verizon is expanding its wireless network to meet the growing demands of today and tomorrow.

But it takes time.

39_{GB}
of data per month

Mobile data traffic per smartphone will rise from 7 GB per month in 2018 to 39 GB per month in 2024.¹

61%
are now wireless

61.3% of adults (nearly 154 million) and 70.3% of children (approximately 51 million) lived in households that did not have a landline telephone but did have at least one wireless telephone.²

31
billion devices

It is projected that there will be 31 billion connected devices by 2023.³

1. Ericsson Mobility Report, June 2019

2. CDC's 2019 Wireless Substitution: Early Release of Estimates from the National Health Interview Survey, July-December

3. CTIA Infographics, January 2020

What it takes to keep families and businesses connected.

How does wireless service work?

Radio frequencies can carry signals from radios and televisions, to baby monitors, garage door openers, home Wi-Fi service, and cordless phones.

Cell service uses these radio frequencies to wirelessly connect a mobile device with the nearest antenna. That antenna may be hidden in a church steeple, sitting on a rooftop, attached to a building façade or mounted on a freestanding tower structure. All are known generically as cell sites.

From the cell site, the call or data session then travels through a high-speed connection to a network switching center where it is then directed to the recipient.

This all happens in fractions of a second.

The many types of wireless technologies include cellular and fixed wireless, or Wi-Fi.

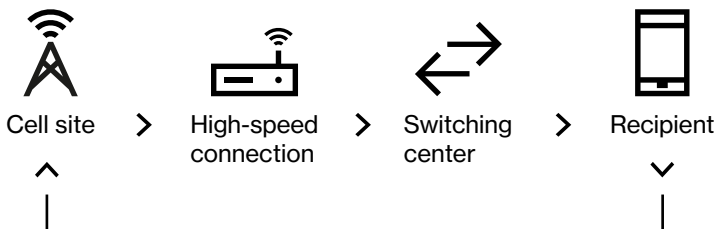

Different locations require different solutions.

Verizon uses a balanced approach to engineering the best possible network given the local community's needs.

Traditional, or macro cell sites, are most often the best choice for meeting coverage and capacity needs. Macro sites are traditional cell sites or towers that provide coverage to a broad area, up to several miles.

Small cells are just like the name implies – short range cell sites used to complement macro cell towers in a smaller geographic area ranging from a few hundred feet to upwards of 1,000 feet. These lower power antennas enhance capacity in high traffic areas, dense urban areas, suburban neighborhoods, and more. Small cells use small radios and a single antenna placed on existing structures including utility poles and street lights.

Distributed Antenna Systems (DAS) are a group of antennas in outdoor or indoor locations that connect to a base station. DAS systems are typically used in large venues including stadiums and shopping centers.

Staying ahead of demand.

A wireless network is like a highway system...

More wireless traffic needs more wireless facilities just like more vehicle traffic needs more lanes.

- Many wireless users share each cell site and congestion may result when too many try to use it at the same time.
- Wireless coverage may already exist in an area, but with data usage growth increasing exponentially each year, more capacity is needed.
- To meet capacity demands, we need to add more wireless antennas closer to users and closer to other cell sites to provide the reliable service customers have come to expect from Verizon.

In the United States, mobile data traffic will reach 5.7 exabytes per month by 2022 (the equivalent of 1 billion DVDs), up from 1.2 exabytes per month in 2017.*

Finding the right location.

To meet customer needs and expectations, wireless providers need the ability to expand and enhance their networks where users live, work, travel and play.

Verizon gathers information from many sources including customer feedback, results of our own exhaustive network testing, and data from third parties.

When an area for improvement is identified, utilizing our existing network is always our first effort. If that is not possible, we then look at adding a new site.

Steps to finding a new site

Our engineers analyze the areas that need improvement to figure out the ideal location based on customer needs, terrain and modeling results.

Using existing structures is considered first.

Network teams perform exhaustive searches in the area needing improvement to find a location that will meet our technical needs. We also look at interest from property owners.

We pick a location that has the highest likelihood of meeting technical needs and works for the community.

Guidelines for new sites

We comply fully with all requirements for community notification and review, zoning and permitting.

Potential antenna locations must meet all local, state and federal regulations.

Verizon holds Federal Communications Commission (FCC) licenses for the frequencies utilized and we strictly follow their regulations.

Wireless facilities and property values.

Cell service in and around the home has emerged as a critical factor in home-buying decisions.

National studies demonstrate that most home buyers value good cell service over many other factors including the proximity of schools when purchasing a home.

75%

More than 75% of prospective home buyers said a good cellular connection was important to them.¹

83%

The same study showed that 83% of Millennials (those born between 1982 and 2004) said cell service was the most important fact in purchasing a home.

90%

90% of U.S. households use wireless service. Citizens need access to 911 and reverse 911 and wireless may be their only connection.²

Health and safety background.

Health and safety organizations worldwide have studied potential health effects of RF emissions for decades, and studies continue.

The Federal Communications Commission (FCC) guidelines for operating wireless networks are based on the recommendations of federal health and safety agencies including:

- The Environmental Protection Agency (EPA)
- The Food and Drug Administration (FDA)
- The National Institute for Occupational Safety and Health (NIOSH)
- The Occupational Safety and Health Administration (OSHA)
- The Institute of Electrical and Electronics Engineers (IEEE)
- The National Council on Radiation Protection and Measurements (NCRP)

Wireless technology, equipment and network operations are highly regulated.

For more information go to:

Federal Communications Commission: fcc.gov

Food and Drug Administration: fda.gov

World Health Organization: who.int

American Cancer Society: cancer.org

Hundreds of times less

According to the FCC, measurements made near a typical 40 foot cell site have shown that groundlevel power densities are 100's of times less than the FCC's limits for safe exposure.



Building a wireless network you can rely on in a crisis.

The reliability of your cell phone is never more important than when crisis strikes. That's when a simple call or text message can make the difference between life and death.

We build reliability into every aspect of our wireless network to keep customers connected when you need it most. Reliability starts when we choose the safest, most secure locations for our wireless equipment. The likelihood of earthquakes, and risk from wildfires, mudslides, floods, hurricanes and more are all considered. When disaster strikes, we coordinate with first responders and can mobilize charging stations, special equipment, emergency vehicles and more to support local, state and federal agencies in all 50 states.

80%

80% of 911 calls originate from a cell phone.¹

240

240 million 911 calls are made annually. In many areas, 80% or more are from wireless devices.¹

1. National Emergency Number Association, About and FAQ
2. EMS World, April 24, 2014

Wireless connectivity is critical in schools and communities.

Wireless is a critical component in schools and for today's students.

20k

learning apps are available for iPads.

72%

of iTunes top selling educational apps are designed for preschool and elementary students.

600+

school districts replaced text books with tablets in classrooms.

77%

of parents think tablets are beneficial to kids.

74%

of school administrators feel digital content increases student engagement.

70%

of teens use cellphones to help with homework.

Wireless is a critical component in today's medical fields.

Smart pill bottles and cases can help patients and their care-givers track medication usage, ensuring medications are taken on time and correctly. This supports increased medical compliance, provides more consistent care, and enables preventative care, keeping patients in their homes longer and reducing the number of emergency visits to the doctor's office or hospital.

Wireless connected glucose monitors, blood-pressure cuffs, and EKGs can track a patient's vital signs and catch an issue before it turns into an emergency.

Pace makers and sleep apnea monitors can be tracked remotely.

Routine eye exams can be conducted with a wireless device connected to a smart phone, bringing solutions and services to low-income and remote areas that would otherwise go unsupported.

Wireless is a critical component in today's communities.

Wireless smart city solutions are being used to track available parking and minimize pollution and wasted time.

These same solutions are being used to track pedestrian and bike traffic to help planning and minimize accidents.

Smart, wireless connected lighting enables cities to control lighting remotely, saving energy and reducing energy costs by 20%.

4G technology is utilized to track and plan vehicle deliveries to minimize travel, maximize efficiency, and minimize carbon footprint.

4G technology is also used to monitor building power usage down to the circuit level remotely, preventing energy waste and supporting predictive maintenance on machines and equipment.

Wireless sensors placed in shipments are being used to track temperature-sensitive medications, equipment, and food. This is important for preventing the spread of food-borne diseases that kill 3,000 Americans each year.

Verizon is part of your community.

**Because we live
and work there too.**

We believe technology can help solve our biggest social problems. We're working with innovators, community leaders, non-profits, universities and our peers to address some of the unmet challenges in education, healthcare and energy management.

Learn more about our corporate social responsibility at www.verizon.com.



verizon^v

CONCEALED NETWORK NODE DEPLOYMENT AGREEMENT

This Agreement is entered into pursuant to Section 284.056, Section 284.201, and Section 284.301 of the Texas Local Government Code, this _____ day of _____ 2021 (“**Effective Date**”), by and between the City of Hunters Creek Village, (the “**City**”) and GTE Mobilnet of South Texas LP d/b/a Verizon Wireless, (“**Network Provider**”).

WHEREAS, Network Provider is a wireless telecommunications Network Provider as that term is defined in Section 284.002 of the Texas Local Government Code (“**Chapter 284**”); and

WHEREAS, the majority of City rights-of-way are located in design districts with decorative poles, in municipal parks, and/or adjacent to residential streets not more than 50 feet wide;

WHEREAS, the City desires to facilitate deployment of Network Nodes and related equipment in a manner that minimizes the impact on adjacent property owners and users of City rights-of-way; and

WHEREAS, a Network Provider may choose to enter into an agreement with the City to obtain advance approval of the locations, specifications and concealment measures for a uniform deployment of multiple Network Nodes within the City;

WHEREAS, pursuant to Chapter 284, the City offers this same agreement to any and all Network Providers desiring to install Network Nodes on existing utility poles or on streetlights with concealed Network Nodes and associated equipment in locations where City Poles are installed or planned to be installed in order to streamline the permitting, land use approval and registration processes; and

WHEREAS, Network Provider and the City desire to enter into this Agreement to secure authority from the City for Network Provider to install certain Network Nodes, as that term is defined in Chapter 284, and related equipment in the City’s rights-of-way, subject to the City’s Right-of-Way Management Ordinance and the terms and conditions of this Agreement;

NOW, THEREFORE, Network Provider and the City mutually agree as follows:

1. Definitions. Unless expressly provided otherwise, all terms used in this Agreement that are expressly defined in Chapter 284 and the City’s Right-of-Way Management Ordinance shall have the same meaning in this Agreement, including but not limited to: Service Poles, Network Node, Network Node Support Poles, Antenna, and Transport Facility. Terms defined in the recitals, above, shall have the meanings provided in the recitals.
 - a. “**Approved Node**” means Network Nodes, Network Node Support Poles, Network Provider Poles, ground equipment, Antennas, and any other equipment associated with operation of a Network Node expressly authorized under this Agreement and installed or

caused to be installed by Network Provider, including but not limited to any Network Nodes collocated on utility poles.

- b. **“Network Provider”** means GTE Mobilnet of South Texas LP d/b/a Verizon Wireless, its parent company, subsidiaries, affiliates, contractors, agents, subcontractors, successors, assigns, and any other party performing work on an Approved Node.
 - c. **“Network Provider Pole”** means a Pole that is also a Node Support Pole containing a concealed Network Node and concealed Network Node equipment, including but not limited to the Antenna and ground equipment, constructed in accordance with the specifications attached as Exhibit B-2, and located in an approved location, as shown on Exhibit A.
2. License granted. The City hereby grants Network Provider a nonexclusive right to construct and install Network Provider Poles in the approved locations, as shown in Exhibit A, attached and incorporated by reference for all purposes, for purposes of deploying Approved Nodes and related equipment under the terms of this Agreement.
 3. Term. The primary term of this Agreement shall be ten (10) years commencing upon the effective date first set forth above. This Agreement may be renewed for additional five (5) year terms upon mutual written approval of the Parties. Following expiration or termination of this Agreement, Approved Nodes that remain in the public right-of-way shall require annual registration in accordance with the City’s Right-of-Way Management Ordinance on the earlier of: (i) the first anniversary of the Effective Date of this agreement following termination or expiration, or (ii) the first date that registration is required under the City’s Right-of-Way Management Ordinance.
 4. Consideration. In consideration for streamlined permit processing, waiver of certain construction permit fees, pre-approval of concealment measures, and other good and valuable consideration the sufficiency of which is hereby acknowledged, Network Provider agrees to pay the City the fees required by this Agreement and to construct, install and maintain the Approved Nodes in accordance with the terms of this Agreement, notwithstanding any limitation on the regulatory conditions that may be imposed by the City under Chapter 284. The following fees shall apply to the Approved Nodes:
 - a. Application Fee for Network Node Deployment Agreement: \$1,000, one time fee covering all Approved Nodes authorized under this Agreement (This fee is in lieu of construction permits for all Approved Nodes, including Network Provider Poles), due within sixty (60) days of the Effective date of this Agreement;
 - b. Annual public right-of-way fee: \$250 per Approved Node, located in the public right-of-way, per year, due each year on or before each anniversary of the Effective Date of this Agreement;
 - c. Fiber line fee: \$28 per Approved Node per month for the associated Transport Facility, as such term is defined by Chapter 284, due each year on or before each anniversary of the Effective Date of this Agreement (this amount shall be reduced by the amount if any, of municipal fees paid by the transport Network Provider for right-of-way access under Chapter 283 of the Texas Local Government Code);

These fees shall apply only to Approved Nodes. All other Network Nodes that are not Approved Nodes under this Agreement or a substantially similar agreement shall be subject to the fees required under the City's Right-of-Way Management Ordinance and applicable law.

5. Requirements Prior to Construction. At least ten (10) days prior to construction or installation of any Approved Network Node, Network Provider shall submit or cause to be submitted an application form to the City in order to provide all necessary information for City records. Further, prior to blocking any street, cutting pavement, beginning construction or maintenance, installing a network node or pole, or any equipment associated with such network node or pole, Network Provider shall require on-site personnel, including any subcontractor, to: (1) contact the City Administrator by telephone at 713-465-2150 or email at tfullen@hunterscreekvillage.com and provide the approximate start date, end date, brief description of work, and any anticipated impact on vehicle or pedestrian traffic; and (2) maintain on their person during work within the City a copy of this Agreement or the applicable permit for any network node or pole not provided for in this Agreement. Network Provider acknowledges that all construction work requiring a permit within the City requires a copy of the permit to be maintained on site. Further, Network Provider acknowledges that failure to comply with City regulations is a violation of law that may result in a citation being issued by the Village Police Department.

6. Approved Node Specifications. Approved Nodes (including new poles, antenna and associated equipment for Approved Nodes) shall be installed, constructed and maintained in compliance with the plans and specifications, including the specific concealment measures, attached as Exhibit B (including Exhibit B-1 and Exhibit B-2) and incorporated by reference for all purposes. The City Administrator is authorized to allow modifications in the height of Approved Nodes upon written request from Network Provider; provided, however, no pole installed under this Agreement for an Approved Node shall be taller than thirty-five (35) feet and no Network Node, antenna or other equipment for an Approved Node installed under this Agreement shall be located more than thirty-five (35) feet above the ground except when collocating on utility poles. Further, the City Administrator is authorized to allow modifications in the paint color or concealment measures; provided a written request is submitted in writing by Network Provider prior to installation or construction of the Network Node that includes updated pictures and specifications of the proposed concealment measures for the Network Node, and detailed justification for the request. The Network Provider shall provide a copy of the written request to the owners of the immediately adjacent property. Network Provider acknowledges that pre-approval of the Approved Node specifications and concealment measures is an essential term of the Agreement and that the City would not have entered into this Agreement without the authority to approve these requirements for all Approved Nodes in advance of a Network Node deployment in a manner that minimizes the impact of the Approved Nodes on the surrounding property owners and users of the City's rights-of-way and allows for public input on this Agreement at a City Council meeting. Further, each Approved Node shall comply with the National Electric Code and any other requirements of Chapter 284.

7. Approved Node Locations. Approved Nodes shall be located within five (5) feet of the location shown in Exhibit A, attached and incorporated by reference for all purposes. The City Administrator is authorized to allow modifications in the location of an Approved Node of up to an additional three (3) feet; provided a written request is submitted in writing by Network Provider prior to installation or construction of the Network Node and includes an updated map showing the proposed location of the Network Node, any changes to the Network Node or pole specifications and concealment measures, and detailed justification for the request. Network Provider acknowledges that pre-approval of the Approved Node locations is an essential term of the Agreement and that the City would not have entered into this Agreement without the authority to approve the specific location of all Approved Nodes in a Network Node deployment in advance in a manner that minimizes the impact of the Approved Nodes on the surrounding property owners and users of the City's rights-of-way and allows for public input on this Agreement at a City Council meeting.
8. Duplicate Locations. In the event that the Network Provider desires to install a new Pole at a location that is within 100 feet of any existing Network Node or any Approved Node that has not yet been constructed, the Network Provider shall do one of the following:
 - a) submit a request to the City to amend Exhibit A to show an alternate location for the Network Node that is at least 100 feet from any existing Network Node or any Approved Node that has not yet been constructed, whether owned by the same Provider or not;
 - b) submit a written request to the City in the form of a Network Node Support Pole application including: (i) a visual representation of the existing location with the proposed Network Provider Pole installed, (ii) the Provider's explanation of how the proposed installation will promote uniformity of Network Node deployment within the City, minimize the visual impact on adjacent residents, and avoid interference with users of the City's Rights-of-Way, and (iii) the Provider's justification for not collocating on an existing Pole.
9. Network Provider's Maintenance Obligations. Network Provider shall own, maintain, repair, replace, modify, and operate its Network Nodes, Network Provider Poles and related equipment at its sole expense and responsibility. To facilitate Network Provider's undertaking hereunder, City grants to Network Provider a non-exclusive, non-transferable right of access to Network Provider Poles to operate and maintain the Network Nodes, Network Provider Poles and related equipment, subject to the requirements of the City's Right-of-Way Management Ordinance.
10. Removal and Relocation of Nodes. Network Provider shall relocate its Network Nodes at its own expense to an alternative location made available by the City, and acceptable to Network Provider, not later than one hundred eighty (180) days after receiving written notice from the City that removal or relocation of the Network Provider Pole is necessary due to construction, expansion, repair, relocation, or maintenance of a street or other public improvement project.

11. Amendment of Approved Nodes. Network Provider is authorized to request amendments to Exhibits A and B, including requests to delete Approved Node locations, where no Nodes were constructed at those locations or where Nodes have been removed, and to add additional Approved Node locations, at any time during the Term of this Agreement; provided, however, City Council approval shall be required for these amendments except where an additional Approved Node complies with the specification and concealment measures in Exhibit B and is proposed at a location that the City Administrator has approved and to which no adjacent property owner has objected.
12. Termination. This Agreement may be terminated prior to the expiration of its term by either Party upon written notice to the other Party, if such other Party materially breaches any provision of this Agreement and the breach is not cured within sixty (60) days after receipt of such notice of the breach from the non-breaching Party, or, if the breach cannot reasonably be remedied in such time, if the failing Party does not commence a remedy within such time and diligently pursue the cure to completion.
13. Non-compliance of Approved Nodes. In the event any Approved Node installed in the City is found to be non-compliant with the terms of this Agreement or the City's Right-of-Way Management Ordinance, the City shall provide notice of such noncompliance to Network Provider in accordance with this Agreement and Network Provider shall correct such noncompliance within 30 days or respond to the City in writing with an estimate of the time required to complete any work necessary to correct the noticed violation. Failure to correct the noticed violation(s) within 30 days from the date of the notice may result in a citation issued by law enforcement to Network Provider or other action by the City pursuant to the City's Right-of-Way Management Ordinance.
14. Collocation. Collocation on City Service Poles, to the extent such poles exist, is not authorized under this Agreement. This section is not intended to prevent collocation of the utility poles.
15. No Interference with Network Nodes. Network Provider acknowledges that it has received and reviewed the Right-of-Way Management Ordinance and that this Agreement does not waive any City Code requirements except the requirement to apply for a construction permit and land use approval under the City's Right-of-Way Management Ordinance for Approved Nodes. Pursuant to Section 284.301 of the Texas Local Government Code, Network Provider agrees that none of the provisions in this Agreement materially interfere with the use of Network Provider's Network Nodes.
16. Governmental Immunity; Limitation on Liability. This Agreement serves in lieu of certain permits and land use approvals that would otherwise be issued by the City and Network Provider agrees and acknowledges that this Agreement does not impose any liability on the City, its officers, employees or agents, for any damage to any equipment or other property owned, installed or maintained by Network Provider pursuant to this Agreement. Nothing in this Agreement is intended to waive any governmental immunity to which the City is entitled.

17. Governing Law; Venue. This Agreement shall be governed by the laws of the State of Texas and applicable federal laws. Venue shall lie exclusively in Harris County, Texas.
18. No Waiver. None of the material provisions of this Agreement may be waived or modified except expressly in writing signed by Network Provider and the City. Failure of either Party to require the performance of any term in this Agreement or the waiver by either Party of any breach thereof shall not prevent subsequent enforcement of this term and shall not be construed or deemed a waiver of any subsequent breach.
19. Notices. Notices required by this Agreement may be given by certified mail by depositing the same in the United States mail or with a commercial courier. Either Party shall have the right by giving written notice to the other, to change the address at which its notices are to be received. Until any such change is made, notices shall be delivered as follows:

If to the City:

City of Hunters Creek Village
 1 Hunters Creek Place
 Houston, TX 77024
 Attn: City Administrator

With a copy to:

Olson & Olson
 2727 Allen Pkwy, Ste 600
 Houston, TX 77019
 Attn: John Hightower

If to Network Provider:

With a copy to:

Notices shall be deemed effective upon delivery or refusal of delivery.

20. Counterparts and Electronic Copies. This Agreement may be executed by the Parties hereto in separate counterparts, each of which when so executed and delivered shall be an original for all purposes, but all such counterparts shall together constitute but one and the same instrument. A scanned or electronically reproduced copy of this fully executed Agreement shall have the same legal effect as an original signed version of this Agreement.
21. Severability. If one or more provision in this Agreement is found to be invalid, illegal or otherwise unenforceable, all other provisions will remain unaffected and shall be deemed to be in full force and effect. If any provision in this Agreement is found to be invalid, illegal or otherwise unenforceable, the Parties shall negotiate in good faith to modify this Agreement so as to effect the original intent of the Parties as closely as possible in a mutually acceptable manner in order that the transactions contemplated hereby be consummated as originally intended by the Parties.

22. Binding Effect. This Agreement shall be binding upon and shall inure to the benefit of the Parties hereto and their respective successors and permitted assigns, and shall not be modified except by an express written agreement signed by a duly authorized representative of both Parties.
23. Force Majeure. Neither Party shall be responsible for delays in the performance of its obligations caused by events beyond the Party's reasonable control, including, but not limited to, acts of God.
24. Exhibits. All exhibits to this Agreement are hereby made a part hereof as if fully set out herein.
25. Entire Agreement. This Agreement embodies the complete agreement of the Parties, superseding all oral or written previous and contemporary agreements between the Parties relating to this Agreement.
26. Authority to Execute. Any individual executing this Agreement on behalf of a Party represents and warrants that he or she is duly authorized to execute and deliver this Agreement on behalf of such Party, and this Agreement is binding upon such Party in accordance with its terms.
27. Parties in Interest. This Agreement shall be for the sole and exclusive benefit of the Parties and shall not be construed to confer any benefit or right upon any third party. This Agreement is for the sole benefit of, and may be enforced only by, the Parties to this Agreement. No other third party shall have standing to enforce any provision of this Agreement.
28. Remedies. In the event of any breach of the terms of this Agreement by the either Party, the non-breaching Party shall be entitled to pursue any and all legal and equitable rights and remedies permitted by applicable law.
29. Amendments. Subject to minor modifications by the City Administrator expressly authorized under this Agreement, this Agreement can only be amended by mutual written agreement of the Parties following approval of such amendment by City Council.
30. Assignment. Network Provider may, upon 30 days advance written notice to the City, assign or transfer its rights arising under this Agreement, provided such assignment requires the assignee to assume all the duties and obligations of Network Provider under this Agreement, to any corporation, partnership or other entity which (i) is controlled by, controlling or under common control with Network Provider, (ii) shall merge or consolidate with or into Network Provider, (iii) shall succeed to all or substantially all the assets, property and business of Network Provider to which this Agreement relate, or (iv) any affiliate or subsidiary or other party as may be required in connection with any offering, merger, acquisition, recognized security exchange or financing. Under all other circumstances, such assignment or transfer shall require the City's written consent, which consent shall not be unreasonably withheld, delayed or conditioned.

31. Relationship of the Parties. Each Party shall be considered an independent contractor, and no party nor any affiliate of any party shall be considered the agent, partner, fiduciary or employee of any other party, in its performance of any and all duties under any transactions contemplated by this Agreement. No party shall be deemed to have any fiduciary relationship to any other party.

[Signatures on following page]

IN WITNESS WHEREOF, the Parties have executed, or caused their respective duly authorized representatives to execute, this Agreement as of the day and year listed below.

CITY OF HUNTERS CREEK
VILLAGE

Mayor

ATTEST:

City Secretary

NETWORK PROVIDER

Company Name
By:
Title:

Exhibit A – Approved Node Location Listing and Map

Exhibit B – Approved Node Specifications and Concealment Measures

B-1: specifications for nodes collocated on utility poles

B-2: specifications for Network Provider Poles, including network nodes



**CITY OF HUNTERS CREEK VILLAGE
AGENDA DISCUSSION FORM**

AGENDA DATE: **April 27, 2021**
AGENDA SUBJECT: Consideration and possible action to adopt a resolution: a) approving an agreement with the law firm of Linebarger Goggan Blair & Sampson, LLP to act as special counsel to perform all legal services necessary to collect unpaid fines, fees and court costs as provided in Texas Code of Criminal Procedure Art. 103.0031; and b) authorizing the Mayor to sign the agreement on the City's behalf.

EXHIBITS: **Linebarger Packet and Resolution**

NOTICE OF A PUBLIC MEETING

Notice is hereby given that a meeting of the Hunters Creek Village City Council will be held on April 27, 2021 at Hunters Creek Village City Hall, 1 Hunters Creek Place, Houston, TX 77024, for the purpose of considering and taking action on all matters on the agenda for the meeting, including approval of an agreement with the law firm of Linebarger Goggan Blair & Sampson, LLP as special counsel to perform all legal services necessary to collect unpaid fines, fees and court costs as provided in Tx Code of Criminal Procedure Art. 103.0031 and authorizing the execution of such agreement.

The agreement to be considered is necessary for the unpaid fines, fees and court costs owed to The City of Hunters Creek Village to be collected in the most effective manner. The City of Hunters Creek Village desires that such unpaid fines, fees and court costs be collected as provided in the Texas Code of Criminal Procedure.

The Linebarger Goggan Blair & Sampson, LLP firm is fully qualified to provide this representation, being the largest law firm specializing in the collection of governmental receivables in the State of Texas, as well as the United States, and having been engaged in this specialized legal service for more than 40 years. In addition, the Linebarger Goggan Blair and Sampson, LLP firm possesses infrastructure and technology, such as call center technology, that The City Hunters Creek Village does not currently possess.

Linebarger Goggan Blair & Sampson, LLP has represented The City of Hunters Creek Village for the past three (3) years with competence and professionalism, in the collection of unpaid fines, fees and court costs beginning in 2018.

The specialized legal services required by this agreement cannot be adequately performed by the attorneys and supporting personnel of The City of Hunters Creek Village due to the high cost of implementing the appropriate infrastructure and technology and employing sufficient in-house attorneys and staff with the level of experience and competence necessary to perform these activities.

Linebarger will be compensated on a contingent fee basis as provided in Tx Code of Criminal Procedure Art. 103.0031. This Article specifically provides for an additional collection fee, in the amount of 30 percent, in certain cases to compensate collection attorneys. A contract to pay inside or outside attorneys on an hourly basis would represent an additional cost to The City of Hunters Creek Village.

Entering into the proposed agreement is in the best interests of the residents of The City of Hunters Creek Village because the unpaid fines, fees and court costs will be professionally and competently collected without the additional costs to The City of Hunters Creek Village of implementing infrastructure and technology, and employing in-house personnel or paying outside counsel on an hourly fee basis, which would otherwise be required.

RESOLUTION 2021

A RESOLUTION OF THE CITY COUNCIL OF THE CITY OF HUNTERS CREEK VILLAGE, TEXAS REGARDING LINEBARGER GOGGAN BLAIR & SAMPSON, LLP AS BEING FULLY QUALIFIED AS SPECIAL COUNCIL TO PERFORM ALL LEGAL SERVICES NECCESARY TO COLLECT UNPAID FINES, FEES, COURT COSTS, FORFEITED BONDS, AND RESTITUTION AS PROVIDED IN TEXAS CODE OF CRIMINAL PROCEDURE, ARTICLE 103.0031.

WHEREAS, providing adequate notice as required by Sec. 2254.1036 of the Texas Government Code, the consideration of a Contract for Fines and Fees Collection Services with Linebarger Goggan Blair & Sampson, LLP, and

AFTER EXCERCISING ITS DUE DILIGENCE, THE CITY OF HUNTERS CREEK VILLAGE FINDS THAT:

1. There is a substantial need for the legal services to be provided pursuant to the Contract for Fines and Fees Collection Services; and
2. These legal services cannot be adequately performed by the attorneys and supporting personnel of the City of Hunters Creek Village at a reasonable cost; and
3. These legal services cannot reasonably be obtained from attorneys in private practice under a contract providing only for the payment of hourly fees, without regard to the outcome of the matter, because of the nature of the collection fee authorized by TX Code of Criminal Procedure Art. 103.0031 and because the City of Hunters Creek Village does not have the funds to pay the estimated amounts required under a contract only for the payment of hourly fees; and
4. Linebarger Goggan Blair & Sampson, LLP, is well qualified and competent to perform the legal services required to comply with the terms of this contract; and
5. Linebarger Goggan Blair & Sampson, LLP has represented The City of Hunters Creek Village for the past three (3) years with competence and professionalism, in the collection of unpaid fines, fees and court costs beginning in 2018; and
6. The contract with Linebarger Goggan Blair & Sampson, LLP is the result of an arm's length transaction between the City of Hunters Creek Village and Linebarger Goggan Blair & Sampson, LLP and is fair and reasonable.

NOW, THEREFORE, BE IT RESOLVED BY THE CITY COUNCIL OF THE CITY OF HUNTERS CREEK VILLAGE THAT:

SECTION 1. This statement set out in the preamble to this Resolution are true and correct.

SECTION 2. The meeting at which this Resolution was approved was in all things conducted in strict compliance with the Texas Open Meetings, Texas Government Code, Chapter 551.

PASSED AND APPROVED this 27th day of April 2021.

Jim Pappas, Mayor

ATTEST:

Tom Fullen, City Administrator

Contract for Fines and Fees Collection Services

STATE OF TEXAS

COUNTY OF HARRIS

THIS CONTRACT (hereinafter "AGREEMENT") is made and entered into by and between the CITY OF HUNTERS CREEK VILLAGE, acting herein by and through its governing body, hereinafter styled "CLIENT", and Linebarger Goggan Blair & Sampson, LLP, hereinafter styled "FIRM".

Article I

Nature of Relationship and Authority for Contract

1.01 The parties hereto acknowledge that this AGREEMENT creates an attorney-client relationship between CLIENT and FIRM.

1.02 The CLIENT hereby employs the FIRM to provide the services hereinafter described for compensation hereinafter provided.

1.03 This AGREEMENT is entered into pursuant to and as authorized by Subsection (a) of ART. 103.0031, Texas Code of Criminal Procedure.

Article 2

Scope of Services

2.01 CLIENT agrees to employ and does hereby employ FIRM to provide specific legal services provided herein and enforce the collection of delinquent court fees and fines that are subject to this AGREEMENT, pursuant to the terms and conditions described herein. Such legal services shall include but not be limited to recommendations and legal advice to CLIENT to take legal enforcement action; representing CLIENT in any dispute or legal challenge over authority to collect such court fees and fines; defending CLIENT in litigation or challenges of its collection authority; and representing CLIENT in collection interests in bankruptcy matters as determined by FIRM and CLIENT. This AGREEMENT supersedes all prior oral and written agreements between the parties regarding court fees and fines, and can only be amended if done so in writing and signed by all parties. Furthermore, this contract cannot be transferred or assigned by either party without the written consent of all parties.

2.02 The CLIENT may from time-to-time specify in writing additional actions that should be taken by the FIRM in connection with the collection of the fines and fees that are subject to this AGREEMENT. CLIENT further constitutes and appoints the FIRM as CLIENT's attorneys to sign all legal instruments, pleadings, drafts, authorizations and papers as shall be reasonably necessary to pursue collection of the CLIENT's claims.

2.03 Fines and fees that are subject to this AGREEMENT are those that are more than sixty (60) days past due as of the effective date hereof and those that become more than sixty (60) days past due during the term hereof. As used in this section, "more than 60 days past due" has that meaning assigned by Subsection (f) of Art. 103.0031, Texas Code of Criminal Procedure [as amended by Senate Bill 782, 78th Legislature (2003), effective June 18, 2003]. The meaning assigned to the phrase "more than 60 days past due" shall, for the term and purposes of this AGREEMENT, survive any future amendments to, or repeal of, Article 103.0031, Texas Code of Criminal Procedure, or any parts thereof.

2.04 The CLIENT agrees to provide to the FIRM data regarding any fines and fees that are subject to this AGREEMENT. The data shall be provided by electronic medium in a file format specified by the FIRM. The CLIENT and the FIRM may from time-to-time agree in writing to modify this format. The CLIENT shall provide the data to the FIRM not less frequently than monthly.

2.05 The FIRM, in all communications seeking the collection of fines and fees, shall direct all payments directly to the CLIENT at an address designated by the CLIENT. If any fines and fees are paid to the FIRM, said payments shall be expeditiously turned over to the CLIENT.

Article 3 *Compensation*

3.01 The CLIENT agrees to pay the FIRM as compensation for the services required hereunder thirty (30%) percent of the total amount of all the fines and fees [exclusive of any collection fee assessed by the CLIENT pursuant to Subsection (b) of Article 103.0031, Texas Code of Criminal Procedure] subject to the terms of this AGREEMENT as set forth in Section 2.03 above that are collected by the CLIENT during the term of this AGREEMENT. The collection fee stated herein does not apply to an offense committed prior to June 18, 2003. All compensation shall become the property of the FIRM at the time payment of the fines and fees is made to the CLIENT.

3.02 The CLIENT shall pay the FIRM by the twentieth day of each month all compensation earned by the FIRM for the previous month as provided in this Article 3. The CLIENT shall provide an accounting showing all collections for the previous month with the remittance.

Article 4 *Intellectual Property Rights*

4.01 The CLIENT recognizes and acknowledges that the FIRM owns all right, title and interest in certain proprietary software that the FIRM may utilize in conjunction with performing the services provided in this AGREEMENT. The CLIENT agrees and hereby grants to the FIRM the right to use and incorporate any information provided by the CLIENT ("CLIENT Information") to update the databases in this proprietary software,

and, notwithstanding that CLIENT Information has been or shall be used to update the databases in this proprietary software, further stipulates and agrees that the CLIENT shall have no rights or ownership whatsoever in and to the software or the data contained therein, except that the CLIENT shall be entitled to obtain a copy of such data that directly relates to the CLIENT's accounts at any time.

4.02 The FIRM agrees that it will not share or disclose any specific confidential CLIENT Information with any other company, individual, organization or agency, without the prior written consent of the CLIENT, except as may be required by law or where such information is otherwise publicly available. It is agreed that the FIRM shall have the right to use CLIENT Information for internal analysis, improving the proprietary software and database, and generating aggregate data and statistics that may inherently contain CLIENT Information. These aggregate statistics are owned solely by the FIRM and will generally be used internally, but may be shared with the FIRM's affiliates, partners or other third parties for purposes of improving the FIRM's software and services.

Article 5

Costs

5.01 The FIRM and CLIENT recognize that certain costs may be incurred in the process of providing any additional services contemplated in Section 2.02 above or in providing any special litigation services. The CLIENT agrees that all such costs shall be billed to the CLIENT, but that the FIRM will either (i) advance such costs on behalf of the CLIENT or, (ii) when possible, arrange with the vendor or agency providing the service that the costs of services will not be paid unless and until such costs are recovered by the CLIENT from the debtor.

5.02 The CLIENT acknowledges that the FIRM may provide such services with its own employees or with other entities or individuals who may be affiliated with the FIRM, but the FIRM agrees that any charges for such services will be reasonable and consistent with what the same services would cost if obtained from a third party.

5.03 The CLIENT agrees that upon the recovery of such costs, the CLIENT will (i) pay the FIRM for any such costs that have been advanced by the FIRM or performed by the FIRM and (ii) pay any third party agency or vendor owed for performing such services.

Article 6

Term and Termination

6.01 This AGREEMENT shall be effective April 27, 2021 and shall expire on April 27, 2024 unless extended as hereinafter provided.

6.02 Unless prior to sixty (60) days before the Expiration Date, the CLIENT or the FIRM notifies the other in writing that it does not wish to continue this AGREEMENT beyond its initial term, this AGREEMENT shall be automatically extended for an additional two year period without the necessity of any further action by either party. In the absence of

any such sixty (60) day notice by either the CLIENT or the FIRM, the AGREEMENT shall continue to automatically renew for additional and successive two-year terms in the same manner at the end of each renewal period.

6.03 If, at any time during the initial term of this AGREEMENT or any extension hereof, the CLIENT determines that the FIRM's performance under this AGREEMENT is unsatisfactory, the CLIENT shall notify the FIRM in writing of the CLIENT's determination. The notice from the CLIENT shall specify the particular deficiencies that the CLIENT has observed in the FIRM's performance. The FIRM shall have sixty (60) days from the date of the notice to cure any such deficiencies. If, at the conclusion of that sixty (60) day remedial period, the CLIENT remains unsatisfied with the FIRM's performance, the CLIENT may terminate this AGREEMENT effective upon the expiration of thirty (30) days following the date of written notice to the FIRM of such termination ("Termination Date").

6.04 Whether this AGREEMENT expires or is terminated, the FIRM shall be entitled to continue to collect any items and to pursue collection of any claims that were referred to and placed with the FIRM by the CLIENT prior to the Termination Date or Expiration Date for an additional ninety (90) days following termination or expiration. The CLIENT agrees that the FIRM shall be compensated as provided by Article 3 for any such item or pending matters during the ninety (90) day period.

6.05 The CLIENT agrees that the FIRM shall be reimbursed for any costs advanced and shall be paid for any services performed pursuant to Article 5 when such costs are recovered by or on behalf of the CLIENT, regardless of the date recovered. It is expressly agreed that neither the expiration nor the termination of this AGREEMENT constitutes a waiver by the FIRM of its entitlement to be reimbursed for such costs and to be paid for such services. It is further expressly agreed that the expiration of any ninety (90) day period under Section 6.04 does not constitute any such waiver by the FIRM.

Article 7 *Miscellaneous*

7.01 Subcontracting. The FIRM may from time-to-time obtain co-counsel or subcontract some of the services provided for herein to other law firms or entities. In such cases, the FIRM will retain supervisory control and responsibility for any services provided by such co-counsel or subcontractors and shall be responsible to pay any compensation due to any such co-counsel or subcontractor.

7.02 Arbitration. Any controversy between the parties to this AGREEMENT involving the construction or application of any of the terms, covenants, or conditions of this AGREEMENT shall, on the written request of one party served on the other, be submitted to arbitration, and such arbitration shall comply with and be governed by the provisions of the Texas General Arbitration Act.

7.03 Integration. This AGREEMENT contains the entire AGREEMENT between the parties hereto and may only be modified in a written amendment, executed by both parties.

7.04 Representation of Other Governmental Entities. The CLIENT acknowledges and consents to the representation by the FIRM of other governmental entities that may be seeking the payment of fines and fees or other claims from the same person(s) as the CLIENT.

7.05 Notices. For purposes of sending any notice under the terms of this contract, all notices from CLIENT shall be sent to FIRM by certified United States mail, or delivered by hand or by courier, and addressed as follows:

Linebarger Goggan Blair & Sampson, LLP
Attention: Director of Client Services
The Terrace II
2700 Via Fortuna Drive
Suite 400
Austin, TX 78746

All notices from the FIRM to the CLIENT shall be sent to CLIENT by certified United States mail, or delivered by hand or by courier, and addressed as follows:

Office of the City Secretary
#1 Hunters Creek Place
Hunters Creek Village, TX 77024

7.06 *Compliance with Tx. Govt. Code §2270.002.* In order to comply with Tx. Govt. Code §2270.002, the Firm verifies that it does not boycott Israel and will not boycott Israel during the term of the contract.

EXECUTED ON the 27th day of April, 2021.

City of Hunters Creek Village

By: _____
Jim Pappas
Mayor

Linebarger Goggan Blair & Sampson, LLP

By: _____
Richard S. Hill
Capital Partner

***CITY OF HUNTERS CREEK VIL MUNICIPAL
COURT***

Fees and Fines Collection & Activity Report

As of March 31, 2021



Linebarger Goggan Blair & Sampson, LLP

**PROPRIETARY AND CONFIDENTIAL
INFORMATION**

Linebarger Goggan Blair & Sampson, LLP considers the information contained in this report to be proprietary, confidential, trade secrets of the firm. We respectfully request that no copies of this information be made and/or distributed without the prior written consent of the firm.

Collections & Activity Summary

Collection Disposition Summary - March 2021	
Citations Assigned	0
Amount Assigned	\$0
Citations Collected	1
Amount Collected	\$273
Citations Cancelled	0
Amount Cancelled	\$0
Citations Resolved	1
Amount Resolved	\$273

Collection Disposition Summary - Contract to Date	
Citations Assigned	1,141
Amount Assigned	\$399,955
Citations Adjusted	148
Amount Adjusted	(\$299)
Citations Collected	92
Amount Collected	\$32,752
Citations Cancelled	75
Amount Cancelled	\$25,045
Citations Resolved	167
Amount Resolved	\$57,798
Dollar Resolution Rate	14.5%

Collection Activity - March 2021		
Letters		0
Address/Phone Updated		5
Phone Activity	Inbound	6
	Outbound	47

Collection Activity - Contract to Date		
Letters		1,758
Address/Phone Updated		370
Phone Activity	Inbound	118
	Outbound	4,677

Status of Open Accounts

Status	Count	Amount
ACT - Active Account	932	\$325,413
ATT - Attorney Contact Only	10	\$3,494
BKR - Bankruptcy	2	\$897
DEC - Deceased No Estate Or Beyond Claim	2	\$391
PRM - Promise Payment	7	\$2,144
SKP - Skip Tracing for Phone	4	\$1,617
Total	957	\$333,957

Monthly Collection Activity Last 24 Months

Year	Month	Letters Mailed	Address/Phone Updated	Phone Activity		Dollars Collected
				Inbound	Outbound	
2021	March	0	5	6	47	\$273
	February	0	6	0	51	\$446
	January	229	25	2	71	\$0
2020	December	58	8	3	132	\$645
	November	0	14	0	221	\$811
	October	65	9	0	256	\$380
	September	254	15	10	178	\$4,625
	August	0	8	0	115	\$688
	July	0	10	0	151	\$0
	June	0	8	3	248	\$4,001
	May	0	5	2	324	\$0
	April	12	8	4	315	\$4,522
	March	64	13	10	241	\$0
	February	192	10	11	211	\$8,137
	January	122	38	6	480	\$0
2019	December	0	54	5	286	\$518
	November	112	16	8	119	\$156
	October	132	10	6	126	\$0
	September	79	10	3	126	\$0
	August	87	31	7	177	\$1,427
	July	22	16	8	197	\$3,905
	June	37	8	6	137	\$0
	May	71	11	0	187	\$0
	April	93	10	12	86	\$1,582
	March	68	3	3	42	\$637
Total*		1,697	351	115	4,524	\$32,752

***Total Amounts noted represent the last 24 months & not contract to date.**

Portfolio Analysis Outstanding Placements

	Accounts	Dollars	Acct. Pct.	Dollar Pct.	Average Balance
ALL ACCOUNTS	957	\$333,956.77	100.00%	100.00%	\$348.96
ADDRESSES					
No Mailing Address	24	\$7,822.10	2.51%	2.34%	\$325.92
Returned Mail	120	\$39,606.10	12.54%	11.86%	\$330.05
Good Address	813	\$286,528.57	84.95%	85.80%	\$352.43
OFFENSE AGE					
One Year or Less	0	\$0.00	0.00%	0.00%	\$0.00
1-2 Years	147	\$53,747.10	15.36%	16.09%	\$365.63
2-3 Years	548	\$194,307.35	57.26%	58.18%	\$354.58
+3 Years	262	\$85,902.32	27.38%	25.72%	\$327.87
PLACEMENT AGE					
One Year or Less	95	\$26,910.60	9.93%	8.06%	\$283.27
1-2 Years	628	\$221,996.62	65.62%	66.47%	\$353.50
2-3 Years	234	\$85,049.55	24.45%	25.47%	\$363.46
+3 Years	0	\$0.00	0.00%	0.00%	\$0.00

Offense Age of Placements Last 13 Months

	2014 & PRIOR	2015	2016	2017	2018	2019	2020	2021	Total Placements
March 2021	-	-	-	-	-	-	-	-	0
February 2021	-	-	-	-	-	-	-	-	0
January 2021	-	-	-	-	-	-	-	-	0
December 2020	-	-	-	-	-	-	-	-	0
November 2020	-	-	-	-	-	-	-	-	0
October 2020	67	14	8	2	1	3	-	-	95
	70.53%	14.74%	8.42%	2.11%	1.05%	3.16%			
September 2020	-	-	-	-	-	-	-	-	0
August 2020	-	-	-	-	-	-	-	-	0
July 2020	-	-	-	-	-	-	-	-	0
June 2020	-	-	-	-	-	-	-	-	0
May 2020	-	-	-	-	-	-	-	-	0
April 2020	-	-	-	-	-	-	-	-	0
March 2020	-	-	-	-	-	-	-	-	0

Placement Activity Summary Contract to Date										
Year	Month	Count #	Orig Placement \$	Cancelled \$	Adjustment \$	Net Placement \$	Collected \$	Collected %		
2021 Summary	March	0	\$0	\$0	\$0	\$0	\$0	0.00%		
	February	0	\$0	\$0	\$0	\$0	\$0	0.00%		
	January	0	\$0	\$0	\$0	\$0	\$0	0.00%		
			0	\$0	\$0	\$0	\$0	\$0	#Error	
	December	0	\$0	\$0	\$0	\$0	\$0	0.00%		
	November	0	\$0	\$0	\$0	\$0	\$0	0.00%		
	October	95	\$26,601	\$0	\$310	\$26,911	\$0	\$0	0.00%	
	September	0	\$0	\$0	\$0	\$0	\$0	\$0	0.00%	
	August	0	\$0	\$0	\$0	\$0	\$0	\$0	0.00%	
	July	0	\$0	\$0	\$0	\$0	\$0	\$0	0.00%	
2020 Summary	June	0	\$0	\$0	\$0	\$0	\$0	0.00%		
	May	0	\$0	\$0	\$0	\$0	\$0	0.00%		
	April	0	\$0	\$0	\$0	\$0	\$0	0.00%		
	March	0	\$0	\$0	\$0	\$0	\$0	0.00%		
	February	0	\$0	\$0	\$0	\$0	\$0	0.00%		
	January	97	\$32,748	\$1,057	\$642	\$32,333	\$2,196	\$2,196	6.79%	
			192	\$59,349	\$1,057	\$952	\$59,244	\$2,196	3.71%	
	December	0	\$0	\$0	\$0	\$0	\$0	\$0	0.00%	
	November	100	\$34,667	\$1,863	(\$53)	\$32,751	\$1,932	\$1,932	5.90%	
	October	1	\$407	\$0	\$39	\$446	\$0	\$0	0.00%	
2019 Summary	September	152	\$54,265	\$6,463	(\$2,629)	\$45,172	\$6,677	\$6,677	14.78%	
	August	0	\$0	\$0	\$0	\$0	\$0	\$0	0.00%	
	July	123	\$45,847	\$5,450	(\$586)	\$39,811	\$3,069	\$3,069	7.71%	
	June	78	\$29,084	\$1,251	(\$230)	\$27,603	\$5,775	\$5,775	20.92%	
	May	32	\$10,795	\$0	\$0	\$10,795	\$280	\$280	2.59%	
	April	252	\$92,906	\$8,920	(\$1,121)	\$82,864	\$4,027	\$4,027	4.86%	
	March	37	\$9,112	\$241	\$2,151	\$11,022	\$981	\$981	8.90%	
			775	\$277,082	\$24,187	(\$2,429)	\$250,465	\$22,740	9.08%	
	2018 Summary		174	\$63,525	\$3,954	\$1,178	\$60,748	\$7,816	12.87%	

Monthly Collections Last 18 Months

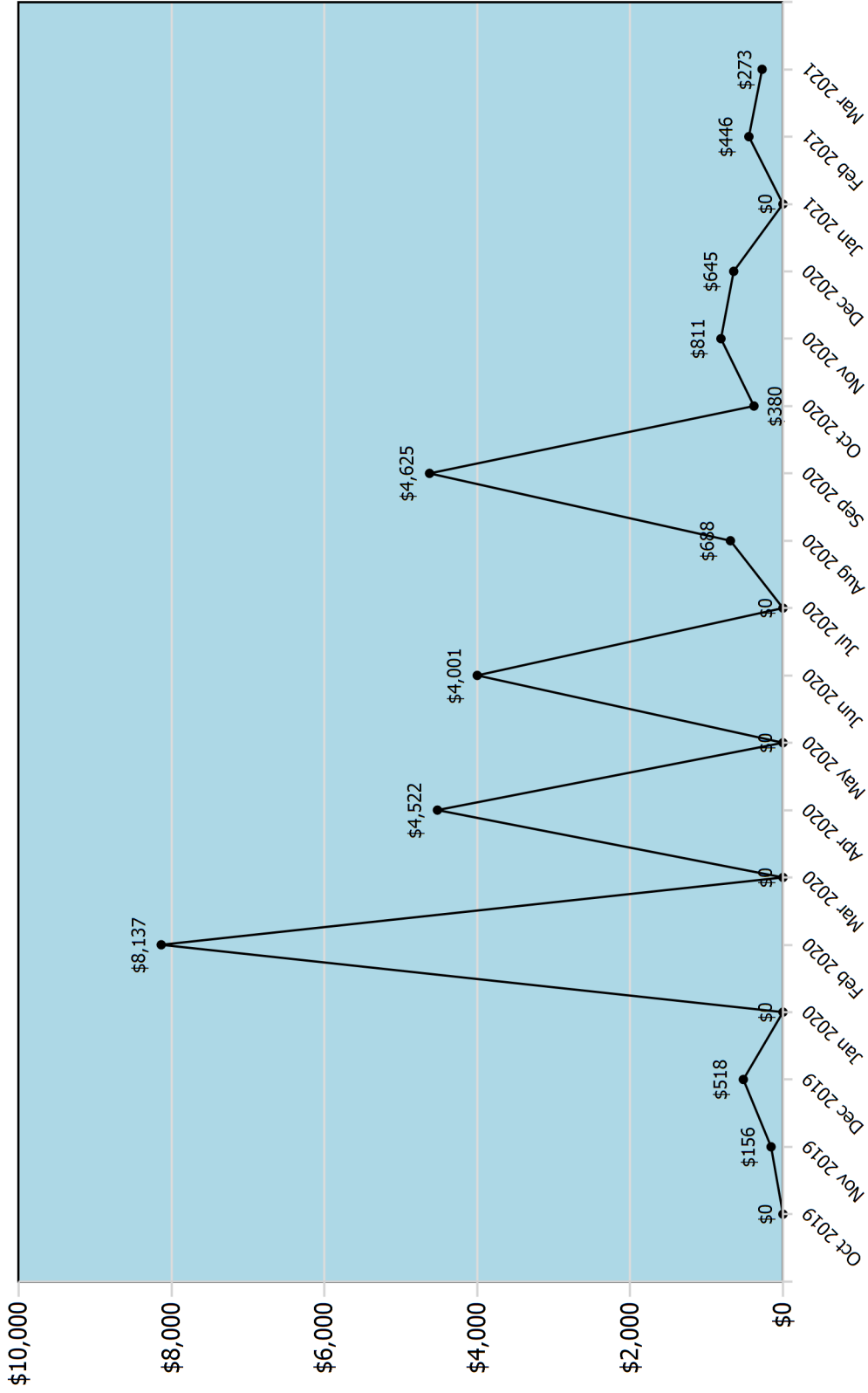

Delinquent Court Fees & Fines Annual Collections Last 6 Years

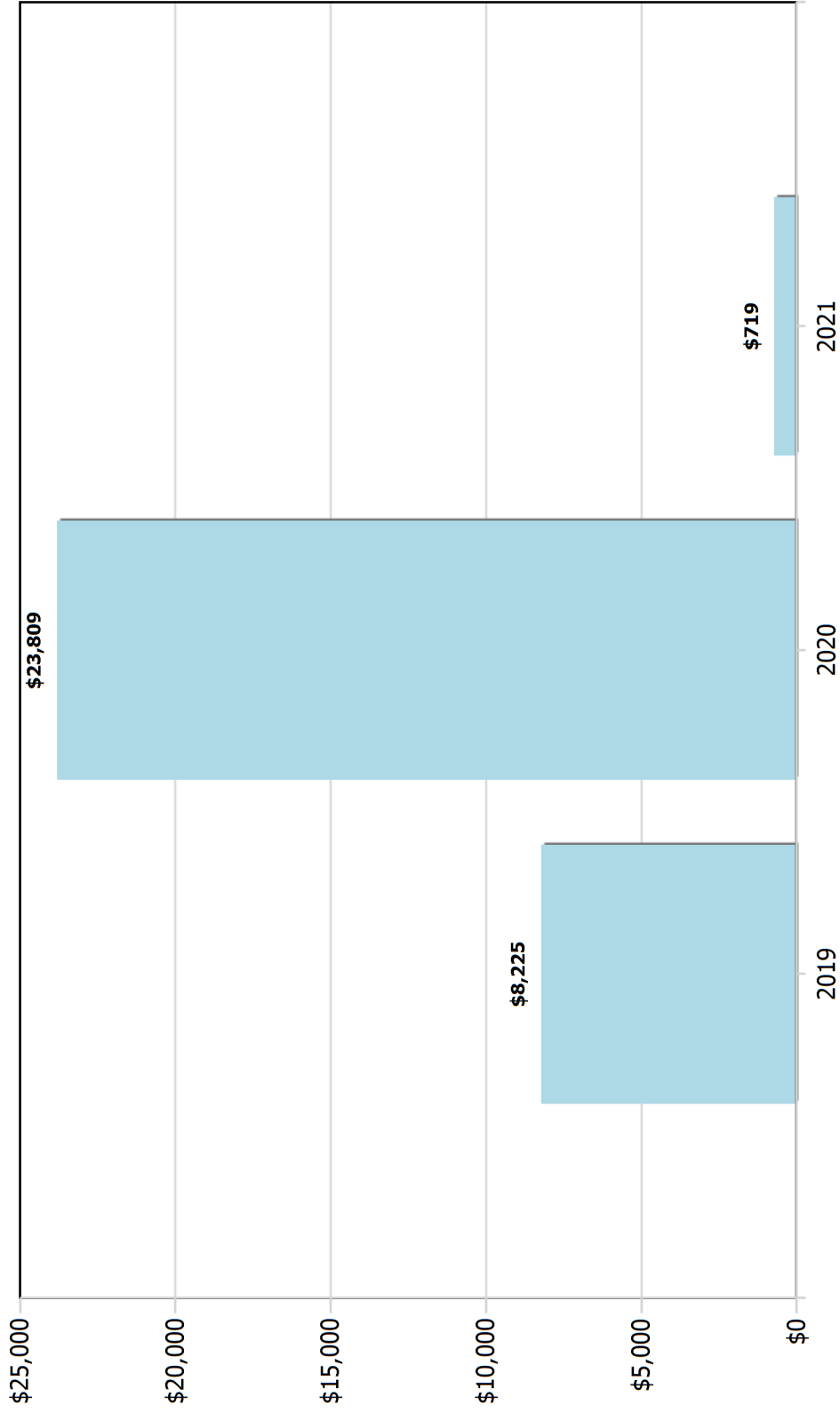

*** Current Year as of Reporting Month
*** First Placement : August 2018

Delinquent Fees & Fines Cumulative Collections

