

ASDIN ANNUAL SCIENTIFIC MEETING

J W Marriott Washington DC, Grand Salon 2-4

February 15 - 17, 2013

GES Information and Order Forms	3
General Information	4
G-1: Show Information	4
G-1a: Important Freight Information	5
G-11: General Information	6
G-10: Trade Show Tips	7
G-5: Stop. Think. Safety.	8
G-6: Show Site Work Rules	9
G-7: GES Terms & Conditions of Contract	10
G-9: Operation of All Mechanical Lifts	11
G-4: Petroleum Surcharge Information	12
L-3: Official Service Provider Information	13
SAMPLE COPY: Certificate of Liability Insurance	14
L-4: Notice of Intent to Use Exhibitor Appointed Contractor	15
Material Handling	16
R-1: Material Handling Information	16
GES Transportation Plus	17
R-2: Material Handling Order Form	18
R-5: Advance Shipping Labels	19
R-3: Pre-Printed Outbound Material Handling Request	20
R-8: GES Logistics - Domestic Shipping Quote Form	21
GES Global Transportation Plus	22
R-20: GES Logistics - International Shipping Quote Form	23
R-14: Cartload Service Order Form	24
Decorating Services	25
Q-1: Price List	25
Carpet Brochure	30
Standard Furniture Brochure	32
Specialty Furniture Brochure	34
Standard Exhibit Systems Brochure	43
I-2: Digital File Preparation	50
Custom Graphics Brochure	51
Labor Services	52
L-1: Installation & Dismantling Order Form	52
L-2: Key Information\Supervised Labor Checklist	53
J-1: Cleaning Order Form	54
Required Forms	55
G-2: Payment & Credit Card Charge Authorization	55
G-3: 3rd Party Billing Request	56
H-3: Booth Layout Form	57

All orders are governed by the GES Payment Policy and GES Terms & Conditions of Contract as specified in this Exhibitor Services Manual.

ASDIN ANNUAL SCIENTIFIC MEETING

J W Marriott Washington DC, Grand Salon 2-4

February 15 - 17, 2013

Additional Service Order Forms	58
Audio Visual Services	59
Lead Retrieval	60
Floral Services	63
Index	64



GES Information and Order Forms

All orders are governed by the GES Payment Policy and GES Terms & Conditions of Contract as specified in this Exhibitor Services Manual.

ASDIN ANNUAL SCIENTIFIC MEETING

J W Marriott Washington DC, Grand Salon 2-4
February 15 - 17, 2013

Official Service Provider

Global Experience Specialists, Inc. (GES)	Phone (in USA):	800.475.2098	International Calls:	702.515.5970
7000 Lindell Road	FAX (in USA):	866.329.1437	International Faxes:	702.263.1520
Las Vegas, NV 89118-4702	Contact us Online:	www.ges.com/chat		

GES will be onsite at your show to assist you in coordinating any last minute services, ordering additional products and answering any questions you may have.

Show Information

Booth Size: 10X10
 Backwall Drapes: Red/White/Blue
 Sidewall Drapes: White
 Facility Carpet Color: Multicolored
 Table Skirt Color: White
 Aisle Carpet Color: Multicolored
 1 - 6' Skirted Table (White Skirt)
 1 - Wastebasket
 1 - One line ID sign (7"x44") provided automatically

Important Dates *Be sure to check all order forms for additional deadlines*

Discount Deadline Date

Friday, January 25 GES orders must be received with payment by this date.

Installation

Friday, February 15 1:00 PM - 5:00 PM

Please take notice - this event moves in on overtime, all applicable surcharges will apply

Show Hours

Friday, February 15 5:30 PM - 7:00 PM
 Saturday, February 16 7:00 AM - 4:00 PM
 Sunday, February 17 7:30 AM - 11:00 AM

Dismantle

Sunday, February 17 11:00 AM - 2:00 PM

Please take notice - this event moves out on overtime, all applicable surcharges will apply

Facility Clear

Sunday, February 17 2:00 PM All exhibitor materials must be removed.

Carrier Pick Up Post-Show from Warehouse

Tuesday, February 19 10:00 AM Carrier pick-up post show from warehouse begins.
 Tuesday, February 19 4:00 PM Carrier pick-up post show from warehouse ends.

Shipping Addresses *Use Provided Shipping Labels in this Exhibitor Services Manual to Expedite Handling*

Consign all **domestic** shipments c/o GES. Please do **not** consign **international** shipments c/o GES. Contact our international division at: GESLogistic_international@ges.com.

Advance Shipments to Warehouse/Post Show Pickup:

c/o GES
 ASDIN ANNUAL SCIENTIFIC MEETING
 (Your Company Name & Booth Number)
 3636B Pennsy Drive
 Landover, MD 20785
 USA

Shipments should arrive on or between:

January 14 - February 12, 2013
 Hours for receiving are Monday - Friday, 8:00 AM - 4:30 PM

ATTENTION EXHIBITORS: All exhibit materials must be sent in advance to the GES warehouse. Direct to showsite shipments **will not** be accepted at the J W Marriott Washington DC. J W Marriott Washington DC does not have the capabilities to receive nor have adequate storage space for Exhibitor materials. Any materials shipped to the J W Marriott Washington DC will be consigned to GES and you will be billed the appropriate material handling charges by GES. Exhibitors may also be billed an additional receiving charge by the J W Marriott Washington DC for any items sent directly to the J W Marriott Washington DC. For shipments inadvertently delivered directly to the facility, a 30% (\$50.00 minimum) late arrival surcharge will apply to each shipment received not within the deadlines.



All orders are governed by the GES Payment Policy and GES Terms & Conditions of Contract as specified in this Exhibitor Services Manual.

ASDIN ANNUAL SCIENTIFIC MEETING

J W Marriott Washington DC, Grand Salon 2-4
February 15 - 17, 2013

IMPORTANT NOTE REGARDING INBOUND & OUTBOUND FREIGHT

Due to tight security and lack of adequate storage space at the J W Marriott Washington DC absolutely NO Direct Shipments are permitted to this facility.

Please make arrangements with your carrier to deliver all shipments to the GES Advanced Receiving Warehouse at 3636B Pennsy Drive, starting January 14, 2013 until February 12, 2013.

For Outbound shipments, carriers must pick up all shipments at the GES Advanced Receiving Warehouse at 3636B Pennsy Drive, starting February 19, 2013 at 10:00 AM.

**ALL SHIPMENTS MUST BE PICKED UP NO LATER THAN
February 19, 2013 by 4:00 PM
OR THEY WILL BE RE-ROUTED VIA GES LOGISTICS.**

Warehouse Hours of Operation are Monday - Friday, 8:00 AM - 4:30 PM.

If you have any questions regarding this procedure, please call the GES National Servicer or contact us: <http://www.ges.com/chat>

For shipments inadvertently delivered directly to the facility, a 30% (\$50.00 minimum) late arrival surcharge will apply to each shipment received not within the deadlines.

All orders are governed by the GES Payment Policy and GES Terms & Conditions of Contract as specified in this Exhibitor Services Manual.

ASDIN ANNUAL SCIENTIFIC MEETING

J W Marriott Washington DC, Grand Salon 2-4
February 15 - 17, 2013

We have designed this form to help you better understand the role of the Official Service Provider, the services we offer and to provide tips to maximize your cost savings.

What is an Official Service Provider?

GES has been selected as the Official Service Provider by the show organizer to design and produce your show. Because of the many areas that GES is involved in at the show, we are familiar with the key individuals managing your event. If at any time during the planning process you are unsure where to turn, just ask us – we're at your service.

Many Exhibitors are not aware of the depth and breadth of products and services offered by GES. Because we have insight into and control of the entire show process, we can generally save you time and money by assisting in your pre-show planning.

GES Show Services

Booth Furniture and Accessories

The booth furniture & accessories brochure showcases a wide variety of both standard and specialty furniture. All items rented from GES will automatically be delivered to your booth and picked up at the close of the show, with no material handling charges incurred by you.

Booth Carpet

GES offers a wide variety of carpet selections. The booth carpet brochure covers carpet choices from standard to custom color, size, grade, padding and booth cleaning.

Custom Exhibits

Let GES design and build an extraordinary custom exhibit that will deliver your marketing message. Please visit our design gallery at www.ges.com.

Rental Exhibits

Our hassle-free rental program gives you a customized look without the long-term commitment of purchasing an exhibit. Please visit our design gallery at www.ges.com.

Installation and Dismantle Services

If you already own an exhibit, or plan to purchase one, you will need to arrange for installation and dismantling of your booth. As the Official Service Provider on this show, GES provides you with the best labor and on-site personnel from move-in to move-out.

Graphics

Give visitors to your exhibit a great first impression by displaying captivating graphics and signs.

Shipping

GES can manage your transportation without a hassle. We offer simplified rates, online tracking, and single invoicing. Call to have your "shipping made easy."

Lighting and Rigging

A great way to maximize your visibility on the show floor is by creating mood and movement in your booth through lighting.

Work Zone

Customer acknowledges that the show site and surrounding areas are active work zones. Customer, its agents, employees and representatives are present at their own risk.

How Can I Order My Show Services?

Expresso is GES' new planning, ordering and management system. You can order everything you need for your tradeshow exhibits, view account order history, download the show schedule and so much more.

Step 1: Go to <https://e.ges.com/083600045/esm>

Step 2: Find your show by typing the show name into the search box and selecting it.

Step 3: Browse products and services and make your selections. When you add the first item or service to your cart, you will be prompted to sign in or create an account if you have not ordered on Expresso before.

Step 4: When you're ready to complete your order, click your shopping cart and submit the required information.

GES National Servicer®

The GES National Servicer® provides consistency and continuity of customer service for exhibitors at all GES shows, offering the following services:

- Single point of contact for all GES shows
- Coast to coast time zone coverage
- Personalized exhibitor service for all pre- and post-show orders

7050 Lindell Road
Las Vegas, NV 89118
Phone: 800.475.2098 / Fax: 866.329.1437
International Phone: 702.515.5970 / Fax: 702.263.1520
Online Chat: www.ges.com/chat

GES Servicer®

Once you are at the show, the GES Servicer® is onsite to place any last minute orders and provide show information.

Exhibitor Services

Our Exhibitor Services organization is the service team responsible for answering exhibitor questions, processing your orders and handling any special requests. They are the conduits between production, operations and your exhibiting needs. Regardless of your request, you can contact them for advice and information about the show – if they don't know the answer, they will find it!

Need Assistance?

Toll Free: 800.475.2098 | Tel: 702.515.5970 | www.ges.com/chat



All orders are governed by the GES Payment Policy and GES Terms & Conditions of Contract as specified in this Exhibitor Services Manual.

ASDIN ANNUAL SCIENTIFIC MEETING

J W Marriott Washington DC, Grand Salon 2-4
February 15 - 17, 2013

As your tradeshow partner, our goal is to provide you with hassle-free service so you can get on with your show. Even if you use an Exhibitor Appointed Contractor, you should have a basic working knowledge of the Exhibitor Services Manual contents and information.

By following the information below, you will enjoy a smooth trade show experience.

Ordering Trade Show Services

- Please include your complete customer information on each order form including address with zip code, phone and fax numbers, e-mail addresses, company, and contact name and most importantly, booth number. If you have multiple booth locations, please complete separate order forms for each location (booth, meeting room, etc.).
- Please ensure that the credit card information is complete and correct including the expiration date.
- When ordering carpet, draped tables or counters remember to select the colors you desire.
- Please make sure that the size of the carpet you order is appropriate for your booth space (e.g.; do not order a 10' x 20' carpet for a 10X10 booth).
- Keep the total square footage of your booth space in mind when you order your decorating items. Don't order more than will comfortably fit in your booth and still allow you to do business.

Inbound - Move In

- Confirm your furnishings orders with the GES National Servicenter® www.ges.com/chat. You should receive a confirmation of your order within 3-5 days of placement.
- **Confirm target dates with GES and communicate them to your carrier. Refer to the Special Handling brochure to ensure that you do not incur special handling charges. You may want to share this brochure with your carrier.**
- Keep the phone number of your carrier with you, including weekend contact and tracking numbers.
- Have your hotel information available, including phone number, address etc.
- After emptying crates, place empty labels on all sides of your crates and cases. Remember to remove old empty labels. Additionally, empty labels are sometimes color coded, so make sure you get the correct color and be sure your booth number is on each label.

Showsite

Put together a trade show survival kit to include in your freight or carry with you, including:

- Small Tool Kit
- Stapler, Scissors, Tape
- Pens & Markers for labels
- First Aid Kit
- Bottled Water

Work Zone

- Customer acknowledges that the show site and surrounding areas are active work zones. Customer, its agents, employees and representatives are present at their own risk.

Outbound - Move Out

- Keep in mind, the return of empty containers varies depending on the size of the show, so coordinate your outbound flight to accommodate this. GES does not provide security at show site. It is the Customer's responsibility to stay with their property. GES is not responsible for loss or damage to property left in the Customer's booth at any time for any reason.



All orders are governed by the GES Payment Policy and GES Terms & Conditions of Contract as specified in this Exhibitor Services Manual.

ASDIN ANNUAL SCIENTIFIC MEETING

J W Marriott Washington DC, Grand Salon 2-4
February 15 - 17, 2013

Safety is very important for everyone working in the exhibit hall.

Global Experience Specialists, Inc. (GES) values safety throughout our organization and demonstrates it in the work we perform. By following the safety guidelines below you will be doing your part in creating a safe work environment.

Safety Guidelines:

- Only authorized personnel and employees allowed, all others are prohibited.
- This is an active work zone.
- All exhibitors and attendees enter at their own risk. Do not enter the dock/yard areas.
- Stay clear of heavy machinery.
- Never stand on furniture.
- Wear closed toe shoes.
- Clean up or report spills.
- Keep aisles free and clear of any and all debris.
- Practice good housekeeping.
- Check electrical cords for damage.
- Protect valuables at show site.
- Report any fires immediately.

If you notice anything unsafe please contact a GES employee immediately.

During move in and move out individuals under the age of 18 are prohibited from being on or around the show floor. Show sites during these times are similar to a construction zone and considered to be hazardous. OSHA regulations prohibit minors from being present in a hazardous work environment.



STOP. THINK. SAFETY.



All orders are governed by the GES Payment Policy and GES Terms & Conditions of Contract as specified in this Exhibitor Services Manual.

ASDIN ANNUAL SCIENTIFIC MEETING

J W Marriott Washington DC, Grand Salon 2-4
February 15 - 17, 2013

Union Information

To assist you in planning your participation in your Washington area show, we are certain you will appreciate knowing in advance that union labor will be required for certain aspects of your exhibit handling.

Carpenter Union

The installation and dismantling of prefabricated displays comes under the jurisdiction of the Carpenter's Union. This includes signs and laying of carpet.

Teamsters Union

Members of this union claim jurisdiction on the operation of all material handling equipment, all unloading and reloading, and handling of empty containers. An exhibitor may move materials that can be carried by hand, by one person in one trip, without the use of dollies, hand trucks, or other mechanical equipment.

The Official Service Contractor shall be responsible for all matters in the Dock area. This shall include but not limited to such items as assignment of dock space and loading or unloading of all materials and equipment.

Trade and Public Shows

Two (2) full-time exhibitor employees may work without Carpenter labor for one (1) hour on the move in and one (1) hour on the move out, for booths that are larger than 10'x10'. Exhibitors may work in booths 10'x10' or smaller without the use of Union labor.

The use of power tools is not permitted. As an exhibitor, you will be pleased to know that there are no restrictions or requirements to use union labor for the unpacking and placement of your merchandise or product and equipment tuning or calibrating, provided exhibitors use full-time permanent employees.

Gratuities

Our work rules prohibit the SOLICITATION OR ACCEPTANCE of tips in cash, product or gifts in kind by any employee (union or non-union). Our employees are paid appropriate wages denoting professional status, therefore tipping of any kind is not allowed.

Work Zone

Customer acknowledges that the show site and surrounding areas are active work zones. Customer, its agents, employees and representatives are present at their own risk.

Always Honest Hotline

GES requires the highest standards of integrity from all employees. Please call our confidential Always Honest hotline at 866.225.8230 to report fraudulent or unethical behavior.



All orders are governed by the GES Payment Policy and GES Terms & Conditions of Contract as specified in this Exhibitor Services Manual.

ASDIN ANNUAL SCIENTIFIC MEETING
 J W Marriott Washington DC, Grand Salon 2-4
 February 15 - 17, 2013

GES Terms & Conditions are subject to change at GES' sole discretion without notice to any parties.

I. Definitions

GES: Global Experience Specialists, Inc., is hereinafter referred to as GES and/or GES Logistics, and/or Trade Show Electrical (a/k/a TSE) and/or Trade Show Rigging (a/k/a TSR) and their employees; **Agents:** GES' agents, sub-contractors, carriers, and the agents of each; **Customer:** Exhibitor or other party requesting Services from GES; **Goods:** Exhibits, property, and commodities of any type for which GES is requested to provide Services; **Carrier:** Motor carrier, van line, air carrier, or air or surface freight forwarder; **Shipper:** Party who tenders Goods to Carrier for transportation; **Cold Storage:** Holding of Goods in a climate controlled area; **Accessible Storage:** Holding of Goods in an area from which Goods may be removed during shows; **Services:** Warehousing, transportation, drayage, un-supervised labor, supervised labor and/or related services; **Show Site:** The venue or place where an exposition or event takes place; **Supervised Labor (OK TO PROCEED):** Union labor that is provided to a Customer to install or dismantle a booth or exhibit space, and is supervised and/or directed by GES; **Un-Supervised Labor (DO NOT PROCEED):** Union labor that is provided to a Customer to install or dismantle a booth or exhibit space and pursuant to Customer's election is not supervised and/or directed by GES. Customer assumes the responsibility and any liability arising therefrom, for the work of union labor when Customer elects to use un-supervised labor.

II. Scope

These Terms and Conditions shall be binding upon Customer, GES, and their respective Agents and Representatives, including but not limited to Customer contracted labor such as Customer Appointed Contractors and Installation and Dismantle Companies, and any other party with an interest in the Goods. Each shall have the benefit of and be bound by all provisions stated herein, including but not limited to time limits and limitations of liability.

III. Customer Obligations

a. **Payment for services.** Customer shall be liable for all unpaid charges for services performed by GES or Agents. Customer authorizes GES to charge its credit card directly for services rendered on Customer's behalf after departure, by placing an order on-line, via fax, phone or through a work order on site.
 b. **Credit Terms.** All charges are due before Services are performed unless other arrangements have been made in advance. GES has the right to require prepayment or guarantee of the charges at the time of request for Services. A failure to pay timely will result in Customer having to pay in cash in advance for future services. GES retains its right to hold Customer Goods for non-payment. If a credit card is provided to GES, GES is authorized to bill to such credit card any unpaid charges for services provided to Customer, including charges for return shipping. Any charges not paid within 30 days of delivery will be subject to interest at 1 1/2% per month until paid.

IV. Mutual Obligation Indemnification

a. **Customer to GES:** Customer shall defend, hold harmless and indemnify GES from and against any claims, lawsuits, demands, liability, costs and expenses, including reasonable attorney's fees and court costs, resulting from any injury to or death of persons, or damage to property other than Goods, relating to or arising from performance of Services herein. Customer agrees to indemnify and hold GES harmless for any and all acts of its representatives and agents, including but not limited to Customer Appointed Contractors and Installation and Dismantle Companies, any subcontractor or other user of its space or any agents or employees engaged in business on behalf of Customer or present at Customer's invitation, including supervision of labor secured through GES. Customer's obligations under this provision shall not apply to GES' own negligence and/or willful misconduct. **CUSTOMER ACKNOWLEDGES THAT THE SHOW SITE IS AN ACTIVE WORK ZONE AND CUSTOMER, ITS AGENTS, EMPLOYEES AND REPRESENTATIVES ARE PRESENT AT THEIR OWN RISK.**

b. **GES to Customer:** To the extent of GES' own negligence and/or willful misconduct, and subject to the limitations of liability below, GES shall defend, hold harmless and indemnify Customer from and against any claims, lawsuits, demands, liability, costs and expenses, including reasonable attorney's fees and court costs, resulting from any injury to or death of persons, or damage to property other than Goods. GES' obligations under this provision shall not apply to claims for bodily injury arising a) from Customer's presence in areas which have been marked as "off limits to exhibitors"; and b) when exhibitors are present in the facility prior or subsequent to the effective dates or hours of Exhibitor's space lease with show management.

V. DISCLAIMER AND LIMITATION OF LIABILITY

UNDER NO CIRCUMSTANCES WILL ANY PARTY BE LIABLE FOR SPECIAL, INCIDENTAL, CONSEQUENTIAL INDIRECT OR PUNITIVE DAMAGES, INCLUDING BUT NOT LIMITED TO LOSS OF PROFITS OR INCOME. GES SHALL BE LIABLE, SUBJECT TO THE LIMITATIONS CONTAINED HEREIN, FOR LOSS OR DAMAGE TO GOODS ONLY IF SUCH LOSS OR DAMAGE IS CAUSED BY THE DIRECT NEGLIGENCE OR WILLFUL MISCONDUCT OF GES. CLAIMS PRESENTED FOR LOSS OR DAMAGE ARISING OUT OF INCIDENTS REFERENCED IN SECTION VI HEREIN WILL BE DENIED.

VI. No Liability for Loss or Damage to Goods

a. **Condition of Goods:** GES shall not be liable for damage, loss, or delay to uncrated freight, improperly packed, glass breakage or concealed damage. GES shall not be liable for ordinary wear and tear in handling of Goods or for damage to shrink wrapped Goods. All Goods shall be able to withstand handling by heavy equipment, including but not limited to forklifts, cranes, or dollies. It is the Customer's responsibility to ensure that Goods are packaged correctly prior to shipment or movement on or off the Show floor.
 b. **Receipt of Goods:** GES shall not be liable for Goods received without receipts, freight bills, or specified piece count on receipts or freight bills, or for bulk shipments (i.e., UPS, air freight, or van lines). Such Goods shall be delivered to booth without the guarantee of piece count or condition.
 c. **Force Majeure:** GES shall not be liable for loss or damage that results from Acts of God, weather conditions, act or default of Customer, shipper, or the owner of the Goods, inherent nature of the Goods, public enemy, public authority, labor disputes, and acts of terrorism or war.
 d. **Cold Storage:** Goods requiring cold storage are stored at Customer's own risk. GES assumes no liability or responsibility for Cold Storage.
 e. **Accessible Storage:** GES assumes no liability for loss or damage to Goods while in Accessible Storage. Storage charges are for the use of space and are not a form of insurance, or a guarantee of security.
 f. **Unattended Goods:** GES assumes no liability for loss or damage to unattended Goods received at Show Site at any time from the point of receipt of inbound Goods until the loading of the outbound Goods, including the entire term of the respective show or exhibition. Customer is responsible for insuring its own Goods for any and all risk of loss.
 g. **Empty Storage:** GES assumes no liability for loss or damage to Goods or crates, or the contents therein, while containers are in Empty Storage. It is Customer's sole responsibility to affix the appropriate labels available at the GES Service Desk for empty container storage, and ensures that any pre-existing empty labels are removed.
 h. **Forced Freight:** GES is not liable for Customer Goods left on the show floor after the show closing deadline, with or without a Material Handling Services/Straight Bill of Lading signed by Customer. It is Customer's responsibility to complete accurate paperwork for shipping and to

ensure Customer Goods are properly labeled. If Customer Goods remain on the floor after the show closing deadline, GES has the right to remove the Customer Goods. GES is authorized by Customer to proceed in the manner chosen by Customer on the Order of Material Handling Services/Straight Bill of Lading, if one has been completed, or otherwise to ship Customer Goods at the discretion of GES and at Customer's expense. GES shall incur no liability for such shipment. GES retains the right to dispose of Customer Goods without liability if left on the show floor unattended, without labels or not correctly labeled.

i. **Concealed Damage:** GES shall not be liable for concealed loss or damage including but not limited to: glass, electronic equipment, prototypes, original art, uncrated Goods, or improperly packaged or labeled Goods.
 j. **Unattended Booth:** GES shall not be liable for any loss or damage occurring while the Goods are unattended in Customer's booth at any time, including, but not limited to, the time the Goods are delivered to the dock until the time the Goods are received by Customer's chosen carrier. All Material Handling Forms and/or Straight Bills of Lading covering outgoing Goods submitted to GES will be checked at the time of pickup from the booth and corrections to the count or condition will be documented where discrepancies exist.

k. **Hanging items from Booth:** Customer shall not hang any articles, merchandise, product, advertisements, or other similar items from GES supplied booth materials (this includes but is not limited to GES panels or pipe and drape), utilized in Customer's own booth set up or in areas occupied by the show organizer or third parties. If Customer does hang any prohibited items, Customer alone shall be held liable for any damages, costs, actions or injuries resulting from the hanging of such item(s). GES shall have no liability for any damages, costs, actions or injuries arising out of Customer's failure to comply with this provision.

VII. Measure of Damage

a. **Sole Relief:** If found liable for any loss, GES' sole and exclusive maximum liability for loss or damage to Customer's Goods is limited to \$.50 (USD) per pound with a maximum liability of \$100.00 (USD) per container, or \$1,500.00 (USD) per shipment whichever is less.
 b. **Labor:** GES assumes no liability for loss, damage, or bodily injury arising out of Customer's supervision of GES provided union labor. If GES supervises labor for a fee, GES shall be liable only for actions or claims arising out of its negligent supervision. Such liability shall be limited to the cost to Customer of the supervised labor or the depreciated value of the Goods, whichever is less. If Customer elects to use unsupervised labor, then Customer assumes all liability for the actions or claims that arise out of such work, including but not limited to loss, damage or bodily injury and shall provide GES and show management with an indemnity, including defense costs, for any claims that result from Customers' supervision or failure to supervise assigned labor.

VIII. Miscellaneous

a. **Insurance. GES IS NOT AN INSURANCE COMPANY AND DOES NOT OFFER OR PROVIDE INSURANCE.** It is the obligation of Customer to ensure Goods are insured at all times. Loss or theft of the Goods in storage or in transit to and from the show and or while on the show floor is the sole responsibility of Customer. GES recommends Customer arrange for all Risk Coverage.
 b. **Notice of Loss or Damage:** In order to have a valid claim, notice of loss or damage to Goods must be given to GES or its agent within 24 hours of occurrence (as evidenced in an Incident Report completed at Show Site by GES) or delivery of outbound Goods.
 c. **Filing of Claim:** Any claim for loss or damage to Goods must be in writing, containing facts sufficient to identify the Goods, asserting liability for alleged loss or damage, and making claim for the payment of a specified or determinable amount of money. Such claim must be filed with the appropriate party within the time limits specified herein. Damage reports, incident reports, inspection reports, notations of shortage or damage on freight bills or other documents, do not constitute filing of a claim. Claims for Goods alleged to be lost, stolen or damaged at the Show Site must be received in writing by GES within **thirty (30) days** after the close of the show. Claims for Goods alleged to be lost or damaged **during transit** must be received by the responsible party within nine (9) months of date of delivery of Goods. GES Logistics subcontracts the movement of Goods to third party carriers. Claims for damage in transit should be made directly with your carrier as shown on the Material Handling form/ Bill of Lading. In the event of a dispute with GES, Customer will not withhold payment or any amount due GES for Services as an offset against the amount of the alleged loss or damage. Customer agrees to pay GES prior to the close of the show for all such charges and further agrees that any claim Customer may have against GES shall be pursued independently by Customer as a separate action to be resolved on its own merits. GES retains the right to pursue collection on amounts owed after show close, without regard to any amount alleged to be owed for damage, or loss.
 d. **Filing of Suit:** Any action at law regarding loss or damage to Goods must be filed within one (1) year of the date of declaration of any part of a claim (logistics claims excluded).

IX. Jurisdiction, Choice of Forum

These Terms and Conditions of Contract shall be governed by and construed in accordance with the applicable laws of the United States or, alternatively, and depending on jurisdiction, the laws of the State of Nevada. The parties hereby submit to jurisdiction and venue in the United States Federal District Court of Nevada, or as applicable depending upon jurisdiction, the County Circuit Court in Clark County, Nevada.

X. Advanced Warehousing/Temporary Storage/Long Term Storage

All terms and conditions relative to Advanced Warehousing/Temporary Storage/Long Term Storage are contained in separate agreements titled "Storage Agreement". In the event that a Storage Agreement is not executed between the parties, the following shall apply with respect to GES' liability for Customer Goods. The responsibility of GES with respect to Customer Goods is limited to the exercise of ordinary care and diligence in handling and storing of Customer Goods. GES shall be liable only for loss or damage to Goods caused by GES' sole negligence. GES' liability is limited to \$.60 (USD) per pound with a maximum liability of \$100.00 (USD) per container, or \$1,500.00 (USD) per shipment whichever is less. In case of partial loss or damage, the maximum liability shall be prorated based on weight. GES is not responsible for any loss or damage to Goods caused by, but not limited to fire, theft, the elements, vandalism, moisture, vermin, mechanical breakdown or failure, freezing or changes in temperature, as well as any other causes beyond GES' immediate control. GES is not responsible for the marring, scratching or breakage of glass or other fragile items. GES is not liable for the mechanical functions of instruments or appliances even if such articles are packed or unpacked by GES. In no event shall GES be liable for special, incidental, indirect or consequential damages, including business loss of any kind, resulting from any damage to or loss of the Goods or from any act or failure to act. Customer pays storage fees or costs for advance warehousing for use of the space only. There is no guarantee of security or representations made by GES as to appropriateness of the conditions for Customer Goods. The risk of loss remains Customer's alone and GES recommends the Customer carry and maintain insurance in amounts sufficient to cover its risk.

08/26

Need Assistance?

Toll Free: 800.475.2098 | Tel: 702.515.5970 | www.ges.com/chat



Order Directly Online:

<https://e.ges.com/083600045/esm>

All orders are governed by the GES Payment Policy and GES Terms & Conditions of Contract as specified in this Exhibitor Services Manual.

ASDIN ANNUAL SCIENTIFIC MEETING
 J W Marriott Washington DC, Grand Salon 2-4
 February 15 - 17, 2013

ATTENTION ALL EXHIBITORS!

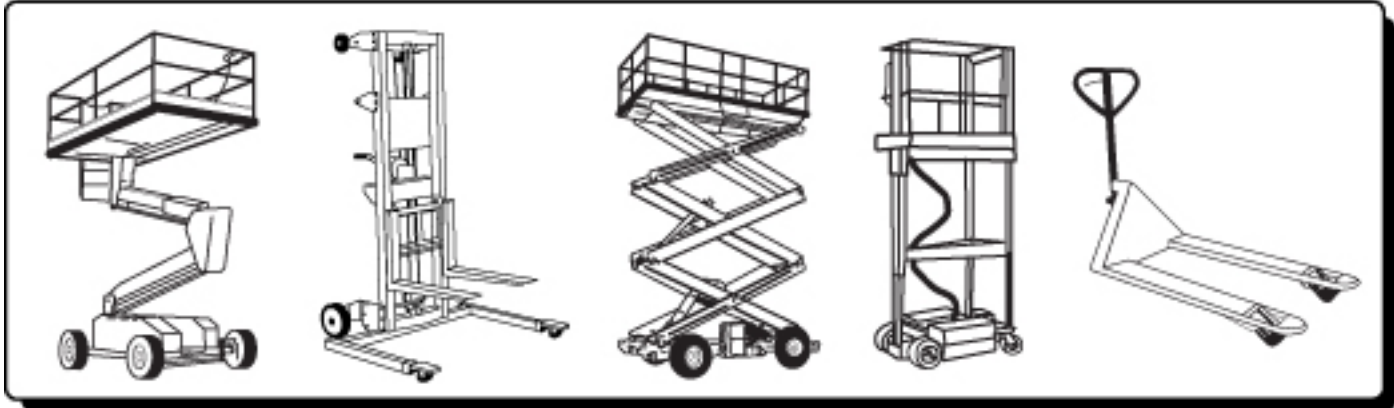

The operation or use of all motorized lifting equipment for installation of booth structures or signs is not permitted by exhibitors or their appointed contractors.

The operation or use of motorized or mechanical material handling equipment is not permitted by exhibitors or their appointed contractors. This also includes all mechanical scooters and carts.

ALL LIFTS, SCOOTERS, PALLET JACKS, DOLLIES AND MANPOWER MUST BE PROVIDED BY THE OFFICIAL SERVICE PROVIDER.

Scooters and carts may only be used by the individuals to whom the scooters and carts are issued. GES equipment is for use by GES employees only. Please **do not** take it for your use.

Customer acknowledges that the show site and surrounding areas are active work zones. Customer, its agents, employees and representatives are present at their own risk.

Thank you for your complete cooperation.

ASDIN ANNUAL SCIENTIFIC MEETING

J W Marriott Washington DC, Grand Salon 2-4

February 15 - 17, 2013

ATTENTION:

PETROLEUM SURCHARGE INFORMATION

Increased petroleum costs have impacted every facet of our business, from the cost of carpeting, plastics, visqueens, graphic substrates, propane & diesel fuel.

While the cost of gasoline has fluctuated greatly in recent months, the costs for other petroleum based products still are at record levels. GES has enacted a petroleum surcharge to partially recover the increased costs related to petroleum.

The Petroleum Surcharge will result in a 3% increase on all services published in the exhibitor services manual with the exception of GES Logistics, which already has a fuel surcharge built into the rates. These charges will be shown as a separate line item on your GES invoice.

GES thanks you for your continued support and patience during this critical time.

All orders are governed by the GES Payment Policy and GES Terms & Conditions of Contract as specified in this Exhibitor Services Manual.

ASDIN ANNUAL SCIENTIFIC MEETING

J W Marriott Washington DC, Grand Salon 2-4
February 15 - 17, 2013

Official Service Provider

Show Organizer, acting on behalf of all Exhibitors and in the best interest of the exposition, has appointed Official Service Providers to perform and provide necessary services and equipment. Official Service Providers are appointed to:

- Ensure the orderly and efficient installation and removal of the overall exposition,
- Assure the distribution of labor to all Exhibitors according to need,
- Provide sufficient labor to satisfy the requirements of Exhibitors and for the exposition itself,
- See that the proper type and limits of insurance are in force, and
- Avoid any conflict with local union and/or exhibit hall regulations and requirements.

The Official Service Providers will provide all usual trade show services, including labor. Exceptions are:

- a. Supervision may be provided by the Exhibitor.
- b. The Exhibitor may appoint an exhibit installation contractor or display builder.

In both such instances, GES shall have no liability to any party for damage or injuries caused by Exhibitor or its third party agents. Exhibitor is responsible for the actions of its third party contractors.

Exhibitor Appointed Contractors

Exhibitors may employ the service of independent contractors to install and dismantle their display, providing the Exhibitor and the installation and dismantling contractor comply with the following requirements:

1. The Exhibitor must notify Show Management in writing and Global Experience Specialists, Inc. (GES) of the intention to use an independent contractor no later than 30 days prior to the first move-in day furnishing the name, address and telephone number of the firm.
2. The Exhibitor shall provide evidence that the Exhibitor Appointed Contractor has proper insurance by submitting a certificate of insurance prepared by the "Exhibitor Appointed Contractor's" insurance agent with a minimum of coverage and limits as described below.
 - a. Commercial General Liability with limits of not less than \$1,000,000 each occurrence, \$2,000,000 general aggregate and \$2,000,000 products & completed operations aggregate.
 - b. Umbrella/Excess Liability with a limit of not less than \$1,000,000 each occurrence.
 - c. Workers Compensation, as required by law, with Employers Liability Limits of not less than \$1,000,000 each accident, \$1,000,000 disease - each employee and \$1,000,000 disease - policy limit.
 - d. Automobile Liability with a limit of not less than \$1,000,000 combined single limit - each accident.
 - e. The Commercial General Liability Policy shall name Global Experience Specialists, Inc. (GES) (Official Service Provider), American Society of Diagnostic & International Nephrology (Show Management), ASDIN ANNUAL SCIENTIFIC MEETING (Show) and J W Marriott Washington DC (Facility) as additional insureds on a primary and non-contributory basis. See attached sample certificate of insurance.
3. Any Exhibitor who has identified an Exhibitor Appointed Contractor must ensure that the Exhibitor Appointed Contractor has a current Certificate of Insurance on file with GES or Show Management evidencing the correct coverage at least 10 days prior to the first move-in date for the show or the Exhibitor Appointed Contractor will not be able to have access to the facility to perform any work.
4. Customer acknowledges that the show site and surrounding areas are active work zones. Customer, its agents, employees and representatives are present at their own risk.

For your safety, be aware of the following:

- a. Do not enter dock areas in search of empty crates. Entry into these areas is at your sole risk.
 - b. During tear down, pull all manageable structures back from aisle carpet lines. Electronics, mannequins, etc. should be placed in the center of the booth.
 - c. Be aware of vehicle traffic inside and outside of the facility. All attendees are solely responsible for their own safety in parking lots, driveways, access roads and non-exhibit hall areas.
5. For services such as electrical, plumbing, telephone, cleaning and drayage, no service provider other than the Official Service Provider will be approved. This regulation is necessary due to licensing, insurance and work done on equipment and facilities owned by parties other than the Exhibitor. Exhibitors shall provide only the material and equipment they own and is to be used in their exhibit space.
 6. Exhibitor Appointed Contractor compliances:
 - a. Must agree to abide by all rules and regulations of the show as outlined in this exhibitor kit including all union rules and regulations.
 - b. Must have all business licenses, permits and Workers Compensation Insurance required by the State and City governments and the convention facility management prior to commencing work. A certificate of insurance complying with all requirements in paragraph 2 above must be submitted to GES at least 10 days prior to the first date of move in.
 - c. Will be responsible for all reasonable costs related to its operation including, but not limited to, overtime pay for stewards and restoration of exhibit space to its initial condition.
 - d. Must furnish Show Management and Global Experience Specialists, Inc. (GES) with the names of all on-site employees who will be working on the exposition floor and see that they have and wear at all times necessary identification badges as determined by Show Management.
 - e. Shall be prepared to show evidence that it has a valid authorization from the Exhibitor for services. The Exhibitor Appointed Contractor may not solicit business on the exhibit floor.
 - f. Must confine its operations to the exhibit area of its clients. No service desks, storage areas or other work facilities will be located anywhere in the building. The show aisles and public space are not a part of the Exhibitor's booth space and must be kept clear. Exhibitors may be charged for costs related to movement of its property if the Exhibitor Appointed Contractor does not contain its operations within the confines of the booth.
 - g. Shall provide, if requested, evidence to Global Experience Specialists, Inc. (GES) that it possesses applicable and current labor contracts and must comply with all labor agreements and practices. The Exhibitor Appointed Contractor must not commit or allow to be committed by persons in its employment any acts that could lead to work stoppages, strikes or labor problems.
 - h. Must coordinate all of its activities with Global Experience Specialists, Inc. (GES).
 - i. Must comply with all reasonable rules and regulations of the venue, Show Management and/or Official Service Provider in order to create a safe work environment. A failure to do so can result in a delay or termination of your right to continue if the condition cannot be corrected.
 - j. May not move freight from one booth to another booth, or to meeting rooms. GES must provide labor.
 7. All information must be received in the Global Experience Specialists, Inc. (GES) office no later than 10 days prior to the show.



ACORD		CERTIFICATE OF LIABILITY INSURANCE				DATE (MM/DD/YY) 01/01/13	
1. PRODUCER ABC Insurance Agency Fax: (212) 555-6100 1234 Broker Lane New York, NY 10895 Attn: Joe Agent (212) 555-6102 ext. 1234		THIS CERTIFICATE IS ISSUED AS A MATTER OF INFORMATION ONLY AND CONFERS NO RIGHTS UPON THE CERTIFICATE HOLDER, THIS CERTIFICATE DOES NOT AMEND, EXTEND OR ALTER THE COVERAGE AFFORDED BY THE POLICIES BELOW. INSUREERS AFFORDING COVERAGE					
2. INSURED Big Boom Company, Inc. 1234 Corporate Lane New York, NY 10895 Attn: Joe Smith Phone: (212) 555-5349 Fax: (212) 555-9819		INSURER A: Hartford Insurance Company of Illinois INSURER B: Aetna Casualty & Surety Company INSURER C: Travelers Insurance Company INSURER D: Royal Insurance Company INSURER E:					
COVERAGES THE POLICIES OF INSURANCE LISTED BELOW HAVE BEEN ISSUED TO THE INSURED NAMED ABOVE FOR THE POLICY PERIOD INDICATED. NOTWITHSTANDING ANY REQUIREMENT, TERM OF CONDITION OF ANY CONTRACT OR OTHER DOCUMENT WITH RESPECT TO WHICH THIS CERTIFICATE MAY BE ISSUED OR MAY PERTAIN, THE INSURANCE AFFORDED BY THE POLICIES DESCRIBED HEREIN IS SUBJECT TO ALL THE TERMS, EXCLUSIONS AND CONDITIONS OF SUCH POLICIES. LIMITS SHOWN MAY HAVE BEEN REDUCED BY PAID CLAIMS.							
INSR LTR	TYPE OF INSURANCE	POLICY NUMBER	POLICY EFFECTIVE DATE (MM/DD/YY)	POLICY EXPIRATION DATE (MM/DD/YY)	LIMITS		
A	GENERAL LIABILITY <input checked="" type="checkbox"/> COMMERCIAL GENERAL LIABILITY <input type="checkbox"/> CLAIMS MADE <input checked="" type="checkbox"/> OCCUR <input type="checkbox"/> _____ <input type="checkbox"/> _____ GENERAL AGGREGATE LIMIT APPLIES PER <input type="checkbox"/> POLICY <input type="checkbox"/> PROJECT <input type="checkbox"/> LOC	000P98298-A11	01/01/13	01/01/14	EACH OCCURENCE	\$1,000,000	
	FIRE DAMAGE (Any one fire)				\$ 50,000		
	MED EXP (Any one person)				\$ 5,000		
	PERSONAL & ADV INJURY				\$1,000,000		
	GENERAL AGGRREGATE				\$2,000,000		
	PRODUCTS-COMP/OP AGG				\$2,000,000		
B	AUTOMOBILE LIABILITY <input checked="" type="checkbox"/> ANY AUTO <input type="checkbox"/> ALL OWNED AUTOS <input type="checkbox"/> SCHEDULED AUTOS <input checked="" type="checkbox"/> HIRED AUTOS <input checked="" type="checkbox"/> NON-OWNED AUTOS <input type="checkbox"/> _____ <input type="checkbox"/> _____	SKLS-029499S	01/01/13	01/01/14	COMBINED SINGLE LIMIT	\$1,000,000	
	(Ea accident)						
	BODILY INJURY				\$		
	(Per person)						
	BODILY INJURY				\$		
	(Per accident)						
	PROPERTY DAMAGE				\$		
(Per accident)							
A	GARAGE LIABILITY <input type="checkbox"/> ANY AUTO <input type="checkbox"/> _____	XL1234567	01/01/13	01/01/14	AUTO ONLY-EA ACCIDENT	\$1,000,000	
	OTHER THAN AUTO ONLY:				\$		
					\$		
					\$		
A	UMBRELLA/EXCESS LIABILITY <input checked="" type="checkbox"/> OCCUR <input type="checkbox"/> CLAIMS MADE <input type="checkbox"/> DEDUCTIBLE <input type="checkbox"/> RETENTION \$	A4145-SS-PJ37	01/01/13	01/01/14	EACH OCCURENCE	\$1,000,000	
	AGGREGATE				\$1,000,000		
					\$		
					\$		
					\$		
C	WORKERS COMPENSATION AND EMPLOYERS' LIABILITY	A4145-SS-PJ37	01/01/13	01/01/14	X WC STATU-ORY LIMITS	OTHER	
	E.L. EACH ACCIDENT				\$1,000,000		
	E.L. DISEASE-EA EMPLOYEE				\$1,000,000		
	E.L. DISEASE -POLICY LIMIT				\$1,000,000		
D	OTHER Professional Liability	000P98298-A11	01/01/13	01/01/14	Each Occurrence & Aggregate	\$1,000,000	
					\$3,000,000		
5. DESCRIPTION OF OPERATIONS/LOCATIONS/VEHICLES/EXCLUSIONS ADDED BY ENDORSEMENT/SPECIAL PROVISIONS Global Experience Specialists, Inc. (GES) (Official Service Provider), American Society of Diagnostic & International Nephrology (Show Management), J W Marriott Washington DC (Facility), and ASDIN ANNUAL SCIENTIFIC MEETING (Show) are hereby named as additional insureds, except for Workers' Compensation. Global Experience Specialists, Inc. (GES) and/or the consignor are included as Loss Payee. The insurance provided for the benefit of Global Experience Specialists, Inc. (GES), shall be primary insurance as respects any claim, loss, or liability, arising out of the Named Insured's operations for which the Named Insured is liable. Any other insurance maintained by GES shall be excess and non-contributory. Show date(s) are: February 15 - 17, 2013 at city of Washington.							
6. CERTIFICATE HOLDER		<input checked="" type="checkbox"/> ADDITIONAL INSURED; INSURER LETTER: X		CANCELLATION			
Global Experience Specialists, Inc. (GES) Exhibitor Services 3636 Pennsy Drive Landover, MD 20785				SHOULD ANY OF THE ABOVE DESCRIBED POLICIES BE CANCELLED BEFORE THE EXPIRATION DATE THEREOF, THE ISSUING COMPANY WILL ENDEAVOR TO MAIL 30 DAYS WRITTEN NOTICE TO THE CERTIFICATE HOLDER NAMED TO THE LEFT, BUT FAILURE TO DO SO SHALL IMPOSE NO OBLIGATION OR LIABILITY OF ANY KIND UPON THE INSURER, ITS AGENTS OF REPRESENTATIONS			
				AUTHORIZED REPRESENTATIVE John Smith, CIC			

- PRODUCER: Insurance Agent / Broker who issues certificate.
- NAME OF INSURED: Must be the legal name of contracting party.
- TYPES OF INSURANCE: Must include types required by contract. See Official Services Provider Information (form L-3) in this exhibitor manual).
- FORM OF COVERAGE: Must be "occurrence" form of coverage.
- NAME ADDITIONAL INSUREDS: Global Experience Specialists, Inc. (GES) (Official Service Provider), American Society of Diagnostic & International Nephrology (Show Management), ASDIN ANNUAL SCIENTIFIC MEETING (Show) and J W Marriott Washington DC (Facility) as additional insureds on a primary and non-contributory basis.
- CERTIFICATE HOLDER: Must be Global Experience Specialists, Inc. (GES)
- POLICY EFFECTIVE DATE: Must be prior to or coincidental with the first day of Exhibitor Move-In.
- POLICY EXPIRATION DATE: Must be on or after the last day of Exhibitor Move-Out.
- LIMITS OF INSURANCE: Must be the same or greater than required by contract. See Official Services Provider Information (form L-3) in this exhibitor manual.
- NOTICE OF CANCELLATION: 30 days notice must be provided.
- AUTHORIZED REPRESENTATIVE: Must be signed (not stamped) by an authorized representative of Producer.

RETURN TO: Global Experience Specialists, Inc. (GES) • 7000 Lindell Road, Las Vegas, NV 89118-4702 • Fax: 866.329.1437 or 702.263.1520 for international exhibitors
 Contact us Online: www.ges.com/chat Phone: 800.475.2098 or 702.515.5970 for international exhibitors

All orders are governed by the GES Payment Policy and GES Terms & Conditions of Contract as specified in this Exhibitor Services Manual.

ASDIN ANNUAL SCIENTIFIC MEETING

Form Deadline Date:
January 16, 2013

J W Marriott Washington DC, Grand Salon 2-4
February 15 - 17, 2013

COMPANY NAME	EMAIL ADDRESS	BOOTH NUMBER
--------------	---------------	--------------

An Exhibitor Appointed Contractor is a company other than the "general or official" service provider on the show, or third party service provider designated by the show organizer in the exhibitor manual as the provider of a specific service and requires access to your booth during installation and dismantling. The Exhibitor Appointed Contractor may only provide services in the venue, which are not designated by the venue as "exclusive" to a venue provider, or by the show organizer in a contract as an exclusive service for the "official" or "general" service provider or other third party. If an Exhibitor Appointed Contractor attempts to provide services designated to another party as "exclusive" or is discovered soliciting on the show floor or otherwise does not comply with the rules, the company may be removed from the show floor, and the Exhibitor will not be able to use that company for the remainder of the event.

Due to the necessity of coordinating all activities during the move-in and for security purposes, Exhibitors who choose to use these contractors must complete this form, comply with all rules and regulations (listed below) and supply GES with all necessary information by the deadline date indicated above.

Exhibitor Appointed Contractor _____			
Street Address _____			
City, State, Zip _____			
Phone (_____) _____	Fax (_____) _____	On-Site Phone (_____) _____	
Contact: _____		E-mail Address: _____	
Description of Proposed Service for Exhibitor: _____			

This form will only be accepted if filled out by an authorized representative of the exhibiting company. Below are the Rules and Regulations regarding Exhibitor Appointed Contractors. Everyone must abide by these rules, which are accepted industry rules that were drafted by the International Association for Expositions & Events.

Rules & Regulations

- All Exhibitor Appointed Contractors must comply with show rules and regulations, and accept appropriate liability for any negligent actions.
- The Exhibitor Appointed Contractor acknowledges that the show site and surrounding areas are active work zones and the Exhibitor Appointed Contractor, its agents, employees and representatives are present at their own risk.
- The Exhibitor Appointed Contractors shall be prepared to show evidence to the Official Service Provider that it possesses applicable and current contracts.
- The Exhibitor Appointed Contractors shall be prepared to show evidence it has authorization from the contractor.
- The Exhibitor agrees that he is ultimately responsible for all services in connection with his exhibit, including freight, drayage, rentals and labor.
- The Exhibitor Appointed Contractor shall provide certificates of insurance and must agree in writing no later than 10 days prior to show opening.
- The Exhibitor Appointed Contractor will be responsible for all reasonable costs related to its operation, including overtime pay for stewards, restoration of exhibit space to its initial condition, etc. Where applicable a one hour minimum labor charge will be charged at the appropriate steward rate of pay per day/per union to either the Exhibitor Appointed Contractor/ Exhibitor depending upon the billing arrangement set up with GES. (Based upon Exhibitor Appointed Contractor not number of booths)
- The Exhibitor Appointed Contractor will not be permitted on the exhibit floor during the show days unless provided a proper registration badge by the exhibiting company.
- The show aisles and public spaces are not part of the Exhibitor's booth. Therefore, the Exhibitor Appointed Contractor is required to confine all activities to the exhibit space of the Exhibitor who has given the valid order for services. Exhibitors may be charged for costs related to movement of its property if the Exhibitor Appointed Contractor does not contain its operations within the confines of the booth.
- Solicitation on the exhibit floor is prohibited. Any Exhibitor Appointed Contractor or Non-official contractor engaged in any solicitation on the exhibit floor including the distribution of official company literature will be removed from the exhibit floor, unless pre-approved in writing by Show Organizer or GES Management.

- During show hours Exhibitor Appointed Contractors only with exhibit badges will be permitted on the exhibit floor. No installation and dismantling crew members will be permitted on the exhibit floor during show hours without the proper Convention name badge supplied by the exhibiting company. These badges should be ordered through the complimentary allotment of registration forms sent to each exhibiting company.
- The Exhibitor Appointed Contractor shall indemnify and hold Show Management and Global Experience Specialists, Inc. (GES) harmless from and against any and all negligent acts or omissions of Exhibitor Appointed Contractor, its agents, employees and representatives.

For insurance and safety reasons, the Official Service Provider designated in this service manual must be used for services such as:

Electrical	Plumbing	Booth Cleaning	Decorator Labor
Telephone	Rigging	Millwright Work	Material Handling

No exceptions will be made

Tips to Exhibitor Appointed Contractors

- Order services required from GES and the Exhibit Hall in advance. Ordering labor or services onsite which contractors may not be prepared to provide immediately may delay the set-up of your booth or force your set-up into overtime.
- Take steps to protect your client's product in the booth by arranging for booth security and/or cages.
- Please stay out of adjacent booths during set-up. Exhibitor Appointed Contractors must stay within the confines of the booth.
- Label empty cartons and crates for storage as soon as they are ready. Holding back on "empties" only adds congestion to the aisles.
- Do not store empty cartons inside of empty crates. Cartons are returned from storage first so Exhibitors may begin packing their product.
- Keep "No Freight Aisles" clear at all times. If GES is required to rearrange any material situated in a clearly identified "No Freight Aisle," you or your client depending upon your billing arrangements with GES, will be charged a one hour minimum for forklift rental and labor.
- Turn in outbound freight bills to the service desk on a timely basis. Holding freight bills until late in the day or turning in large amounts of freight bills to the GES Servicenter at one time may delay outbound truck scheduling and subsequently force your loading out into overtime.



All orders are governed by the GES Payment Policy and GES Terms & Conditions of Contract as specified in this Exhibitor Services Manual.

ASDIN ANNUAL SCIENTIFIC MEETING

J W Marriott Washington DC, Grand Salon 2-4
February 15 - 17, 2013

Material Handling is the unloading of your exhibit materials, delivery to your booth, handling of empty containers to and from storage, and removal of your materials from your booth for reloading onto your outbound carrier. This is not to be confused with the cost to transport your exhibit material to and from the event.

Benefits of Advance Shipping to the GES Warehouse

- Storage of materials for up to 32 days prior to your show.
- Delivery of Shipments to your booth by your published set-up time.
- Some convention centers and hotels do not have facilities for receiving or storing freight.
- Saves valuable set-up time.

How to Ship in Advance to the GES Warehouse

- Remove all old shipping and empty storage labels.
- Fill out and attach enclosed Advance Shipping labels.
- Complete the enclosed Material Handling Order Form.
- Remember to confirm receipt of your shipment prior to leaving for the show.
- All shipments must have a bill of lading or delivery slip showing the number of pieces, weight, and type of merchandise.
- Certified weight tickets must accompany all shipments.
- Take the time to ensure that your display and products are packed neatly and securely.
- Do not ship uncrated materials to warehouse.
- For a rate quote please call GES Logistics at 1.888.454.4437.

Freight Carriers

Select a carrier with experience in handling exhibition materials. Make sure to give your carrier explicit information as to where and when to check in. Delivery and pick up times are often out of the range of "normal" delivery hours, make sure your carrier is committed to meeting your target dates and times. While making shipping plans to the Show, also plan for the return shipment. For a rate quote please call GES Logistics at 1.888.454.4437.

Tracking Shipments

Confirm your delivery date and time with your carrier, and have all pertinent shipping information in the hands of your representative at show site. You may also want to review the return of your Goods at the end of the show. GES Logistics domestic shipments can be tracked online by going to: www.ges.com/everything/logistics/tracking/.

Estimating Material Handling Charges

Handling charges are based on the weight of the freight. Shipments are billed by the hundred weight and rounded up to the nearest hundred. Minimum per Shipment may apply, see enclosed Material Handling Order Form for details. Please prepay all shipping charges - GES cannot accept or be responsible for collect shipments. Crated and uncrated shipments must be separated and clearly identified on separate bills of lading with separate weight tickets - otherwise GES will invoice the entire load at the Uncrated rate.

- **Crated** – Material that is skidded, or is in any type of shipping container that can be unloaded at the dock with no additional handling required.
- **Uncrated** – Material that is shipped loose or pad-wrapped, and/or unskidded machinery without proper lifting bars or hooks.
- **Special Handling** - Defined as shipments that are loaded by cubic space and/or packed in such a manner as to require special handling, such as ground loading, side door loading, constricted space loading and designated piece loading or stacked shipments. Also included are mixed shipments and shipments without proper delivery receipts.
- **Overtime Surcharges** - Shows that move-in or move-out on weekends or after 4:30 PM during the weekday, may be subject to additional overtime surcharges. See enclosed Material Handling Order Form for details.
- **Late Surcharges** – May be charged an additional overtime surcharge
 - a. If advance freight is received before or after the published deadline date for shipments to arrive at the warehouse. See enclosed Material Handling Order Form for details.
 - b. Freight shipments sent to the show after it has opened.
 - c. Freight shipments that are received at showsite that do not meet their published date & time.

Estimating Material Handling Charges, *continued*

- **Shipment Surcharges** – A surcharge will be incurred per shipment for those that are received with incomplete information on shipping labels identifying company name and booth number and/or shipments that are left on the show floor at the end of the show with no labels and no bill of lading turned in.

Machinery Labor and Equipment

Labor and equipment for uncrating, unskidding, positioning, leveling, dismantling, recrating, and reskidding machinery and/or equipment must be ordered separately. Place your order for this labor using the In-Booth Forklift & Labor Order Form. If your material requires specialized rigging equipment, please notify us promptly so that we can make arrangements. When possible, supply your own rigging equipment with shipments and pre-rig your material.

Storing Empty Containers

Properly labeled empty shipping cartons will be picked up, stored, and returned after the show. Labels are available at the **GES Servicer**® or from your GES Service Executive and are for empty storage only. Depending on the size of the show, it can take from two to twelve hours to return empty crates. Do not store any items in crates marked "empty." GES has no liability for damage to crates or items sent to empty storage in crates.

Outgoing Shipments

An OMHF (Outbound Material Handling Form / Bill of Lading) must accompany all outgoing shipments. Shipping information, outbound forms and labels will be available at the **GES Servicer**®. Exhibitors selecting non-official carriers will need to make their own arrangements for pickup. Make sure that someone from your company will be on-site to oversee the outbound shipment of your display and product.

Measure of Damage

- **Liability** – GES is liable for loss or damage to your Goods only if the loss or damage is caused by GES negligence.
- **Sole Relief** – If found liable for any loss, GES' sole and exclusive maximum liability for loss or damage to Customer's Goods is limited to \$.50 (USD) per pound with a maximum liability of \$100 (USD) per container, or \$1,500.00 (USD) per shipment, whichever is less.

Insurance

All of your Goods should be insured by your own insurance policy. Although we do our best to handle your Goods as our own, there are many variables in shipping and handling that can affect your exhibit and products. GES has published GES Terms & Conditions of Contract that are in this exhibitor service manual. Please read them carefully. It is recommended that your Goods be insured.

Work Zone

Customer acknowledges that the show site and surrounding areas are active work zones. Customer, its agents, employees and representatives are present at their own risk.



Get GES Transportation Plus and
Save 10%
On Material Handling

The banner features a teal background on the left with white text. On the right, there are two vertical panels: the top one shows a road with a truck icon, and the bottom one shows a sky with an airplane icon. A dashed white line connects the truck and the airplane, suggesting a shipping route.

With decades of tradeshow experience, GES Logistics understands your transportation needs. As the Official Services Provider for your show, we offer a variety of fully integrated services at competitive rates.

GES Transportation Plus provides:

- Online tracking 24/7
- On-site GES support team
- Consolidated invoice

Note: Round-trip shipping is required to qualify for Transportation Plus rates. Transportation Plus does not apply to shipments that are considered small package, local or shipments over 5000 lbs.

Get an instant quote today at logisticsquote.ges.com.

RETURN TO: Global Experience Specialists, Inc. (GES) • 7000 Lindell Road, Las Vegas, NV 89118-4702 • Fax: 866.329.1437 or 702.263.1520 for international exhibitors
 Contact us Online: www.ges.com/chat Phone: 800.475.2098 or 702.515.5970 for international exhibitors

All orders are governed by the GES Payment Policy and GES Terms & Conditions of Contract as specified in this Exhibitor Services Manual.

ASDIN ANNUAL SCIENTIFIC MEETING

J W Marriott Washington DC, Grand Salon 2-4
 February 15 - 17, 2013

Form Deadline Date:

January 25, 2013

Go to below link to view images and information:
<http://ges.com/ecomm/info/specialhandling.pdf>

COMPANY NAME	EMAIL ADDRESS	BOOTH NUMBER
--------------	---------------	--------------

Transportation Plus: Ship With GES Logistics To Receive A 10.00% Savings On Material Handling. To set up your savings with **Transportation Plus** for domestic shipments please call 888.454.4437, or complete the GES Logistics - Domestic Shipping Quote Form (R-8) included in this exhibitor services manual and fax it to 702.515.5972, or email us at GESLogistics@ges.com. For international shipments complete the GES Logistics - International Shipping Quote Form (R-20) in this exhibitor services manual and fax it to 866.329.1437 or 702.263.1520, or email us at GESLogistic_International@ges.com. Call 888.454.4437 for a quote for any shipments that are under 5000 lbs. **Transportation Plus does not apply to shipments that are considered Small Package, Local or shipments over 5000 lbs. Round Trip shipping is required to qualify for Transportation Plus rates.**

Price List

Important Information

Advance Shipment to Warehouse (200 lbs. minimum per shipment)

Crated Materials

Standard Rates	Transportation Plus Saving Rates
ST/ST \$ 71.00 cwt	\$ 63.90 cwt
ST/OT \$ 92.00 cwt	\$ 82.80 cwt
OT/OT \$ 113.50 cwt	\$ 102.15 cwt

Special Handling Materials

Standard Rates	Transportation Plus Saving Rates
ST/ST \$ 88.75 cwt	\$ 79.88 cwt
ST/OT \$ 115.00 cwt	\$ 103.50 cwt
OT/OT \$ 141.88 cwt	\$ 127.69 cwt

ATTENTION EXHIBITORS: All exhibit materials must be sent in advance to the GES warehouse. Direct to showsite shipments **will not** be accepted at the J W Marriott Washington DC. J W Marriott Washington DC does not have the capabilities to receive nor have adequate storage space for Exhibitor materials. Any materials shipped to the J W Marriott Washington DC will be consigned to GES and you will be billed the appropriate material handling charges by GES. Exhibitors may also be billed an additional receiving charge by the J W Marriott Washington DC for any items sent directly to the J W Marriott Washington DC. **For shipments inadvertently delivered directly to the facility, a A 30% (\$50.00 minimum) late arrival surcharge based on the above rates will apply to each shipment received not within the deadlines.**

How To Know What Rates To Use Based On Show Move-In/Move-Out:

Straight Time: Monday through Friday 8:00 AM to 4:30 PM. Trucks signing in after 2:00 PM may be charged at the overtime rate.

Overtime: All other times, Saturdays, Sundays, Holidays.

ST/ST: If freight will be handled on straight time into the show and out of the show.

ST/OT: If freight will be handled one way on straight time and one way on overtime, either into the show or out of the show.

OT/OT: If freight will be handled on overtime into the show and out of the show.

Certified Weight Tickets Are Required For All Shipments:

Drivers with inbound shipments must check in at the GES warehouse by 2:00 PM to be guaranteed same day unloading. Warehouse receiving hours are Monday - Friday, 8:00 AM - 4:30 PM; Closed 12:00 PM - 1:00 PM & Holidays. In the event of weight discrepancies or shipments received without a certified weight certificate, a \$ 21.25 fee will be charged per shipment.

Advance Shipments to Warehouse: GES will receive uncrated carpet and pad at the warehouse. A special handling charge will apply on these shipments. **Price includes:** unloading crated freight (the warehouse cannot receive uncrated shipments); storing at warehouse for up to 32 days (any materials stored beyond 32 days will incur additional costs applied to your invoice); reloading onto trucks and delivery to the exhibit site; unloading freight and delivery to your booth; picking up, storing, and returning empty shipping containers; and reloading freight for return to your specified destination from exhibit site.

Small Packages: Cartons and envelopes received without documentation will be delivered without guarantee of piece count or condition. Maximum weight is 50 lbs. per shipment, per delivery. This includes UPS and Federal Express shipments. All shipments received via air carrier that do not fall under the small package category may be subject to special handling charges.

Measure of Damage: If found liable for any loss, GES' sole and exclusive maximum liability for loss or damage to Customer's Goods is limited to \$50 (USD) per pound with a maximum liability of \$100 (USD) per container, or \$1,500.00 (USD) per shipment, whichever is less.

Arrival Dates and Surcharges for Shipments: A 30% (\$50.00 minimum) late arrival surcharge based on the above rates will apply to each shipment received not within the below deadlines.

Advance Dates:

Mon, Jan 14, 2013: Advance shipments may begin arriving at warehouse.

Tue, Feb 12, 2013: Last day for shipments to arrive at warehouse.

Please Indicate Below

Calculate Total CWT (Enter in increments of 100's only; round up to the next 100 mark if your weight is more than 8 lbs. over the previous 100 mark. **200** pound minimum per shipment.)

_____ pounds ÷ 100 = _____ Total CWT

Shipment Will Be Sent To Warehouse:

On Date: _____

By Carrier: _____

Total Number of Pieces: _____

We understand that your calculation is only an estimate. Invoicing will be done from the actual weight. Adjustments will be made accordingly.

Place Order Here

(Please Complete R-8 or R-20 for Using GES Logistics)

SMALL PACKAGE DESCRIPTION	PRICE	X QUANTITY =	TOTAL PRICE
Small Package, 1st Carton	\$ 45.00	1	\$
Small Package, Each Additional Carton	\$ 20.00		\$

MATERIAL HANDLING DESCRIPTION	PRICE	X	CWT =	TOTAL PRICE
				\$
A. Total All Items Ordered				\$
B. Petroleum Surcharge Assessment: 3%			A x 3% = B	\$
C. Payment Enclosed			A + B = C	\$

I agree in placing this order that I have accepted GES Payment Policy and GES Terms & Conditions of Contract.

Authorized Signature - Please Sign: _____ X

AUTHORIZED NAME - PLEASE PRINT	DATE
--------------------------------	------





FROM:



FROM:



TO:

FULL EXHIBITING COMPANY NAME AT SHOW

ASDIN ANNUAL SCIENTIFIC MEETING

NAME OF EXHIBITION

0830600045

BOOTH NUMBER

C/O GES
3636B Pennsy Drive
Landover, MD 20785
USA

SHIPMENT SHOULD ARRIVE ON OR BETWEEN:

Monday, Jan 14, 2013 - Tuesday, Feb 12, 2013

CERTIFIED WEIGHT TICKETS ARE REQUIRED FOR ALL SHIPMENTS. Drivers must check in by 2:00 PM to be guaranteed same day unloading. Warehouse receiving hours are Monday - Friday, 8:00 AM - 4:30 PM; Closed 12:00 PM - 1:00 PM & Holidays.

Carrier _____

Number _____ of _____ pieces



TO:

FULL EXHIBITING COMPANY NAME AT SHOW

ASDIN ANNUAL SCIENTIFIC MEETING

NAME OF EXHIBITION

0830600045

BOOTH NUMBER

C/O GES
3636B Pennsy Drive
Landover, MD 20785
USA

SHIPMENT SHOULD ARRIVE ON OR BETWEEN:

Monday, Jan 14, 2013 - Tuesday, Feb 12, 2013

CERTIFIED WEIGHT TICKETS ARE REQUIRED FOR ALL SHIPMENTS. Drivers must check in by 2:00 PM to be guaranteed same day unloading. Warehouse receiving hours are Monday - Friday, 8:00 AM - 4:30 PM; Closed 12:00 PM - 1:00 PM & Holidays.

Carrier _____

Number _____ of _____ pieces



RETURN TO: Global Experience Specialists, Inc. (GES) • 7000 Lindell Road, Las Vegas, NV 89118-4702 • Fax: 866.329.1437 or 702.263.1520 for international exhibitors
 Contact us Online: www.ges.com/chat Phone: 800.475.2098 or 702.515.5970 for international exhibitors

All orders are governed by the GES Payment Policy and GES Terms & Conditions of Contract as specified in this Exhibitor Services Manual.

ASDIN ANNUAL SCIENTIFIC MEETING
 J W Marriott Washington DC, Grand Salon 2-4
 February 15 - 17, 2013

Form Deadline Date:
 January 25, 2013

COMPANY NAME	EMAIL ADDRESS	BOOTH NUMBER
--------------	---------------	--------------

Complete this form for pre-printed outbound material handling documents (Bill of Lading) and shipping labels at the close of the show.

To take advantage of this service, please complete and return this form. If this form is not received by GES by the time of above Deadline Date, this pre-printing service will not be provided.

Step 1. Tell us the location of materials for pickup:

COMPANY/CONSIGNEE:		ATTENTION:			
STREET ADDRESS:		CITY:	STATE:	ZIP:	COUNTRY:
1331 Pennsylvania Avenue Nw		Washington	DC	20004	USA
PHONE:	FAX:			BOOTH NUMBER:	

Step 2. Tell us the location where freight should be sent:

SHIPPING DESTINATION 1:

Number of Labels Needed:

COMPANY/CONSIGNEE:		ATTENTION:			
STREET ADDRESS:		CITY:	STATE:	ZIP:	COUNTRY:
PHONE:	FAX:			BOOTH NUMBER:	

SHIPPING DESTINATION 2:

Number of Labels Needed:

COMPANY/CONSIGNEE:		ATTENTION:			
STREET ADDRESS:		CITY:	STATE:	ZIP:	COUNTRY:
PHONE:	FAX:			BOOTH NUMBER:	

Showsite Instructions: Once your shipment is packed and ready to be picked up, please return the outbound material handling order form to the **GES Servicercenter®**. Verify the piece count, weight, and that the signature is on the outbound material handling order form prior to shipping out. **Shipments without paperwork turned in will be returned to GES Warehouse or forced onto another carrier at Exhibitor's expense.**

GES does not accept responsibility for any exhibitor property left on the show floor unattended at any time for any reason.

Measure of Damage: If found liable for any loss, GES' sole and exclusive maximum liability for loss or damage to Customer's Goods is limited to \$.50 (USD) per pound with a maximum liability of \$100.00 (USD) per container, or \$1,500.00 (USD) per shipment, whichever is less.



RETURN TO: Global Experience Specialists, Inc. (GES) • 7000 Lindell Road, Las Vegas, NV 89118-4702 • Fax: 866.329.1437 or 702.263.1520 for international exhibitors
 Contact us Online: www.ges.com/chat Phone: 800.475.2098 or 702.515.5970 for international exhibitors

All orders are governed by the GES Payment Policy and GES Terms & Conditions of Contract as specified in this Exhibitor Services Manual.

ASDIN ANNUAL SCIENTIFIC MEETING

J W Marriott Washington DC, Grand Salon 2-4
 February 15 - 17, 2013

COMPANY NAME		EMAIL ADDRESS			BOOTH NUMBER:
SHOWSITE CONTACT		SHOWSITE CONTACT PHONE #		DATE/TIME OF ARRIVAL	CONTACT'S HOTEL (OPTIONAL)
Pick Up Information					
DATE:		SHIPPING / RECEIVING HOURS (4 HOUR WINDOW REQUIRED):			
STREET ADDRESS:		CITY:	STATE:	ZIP:	COUNTRY:
PICK UP CONTACT:		PHONE NUMBER:		FAX NUMBER:	
SHIPPING INSTRUCTIONS (ADDITIONAL CHARGES MAY APPLY):					MARK FOR WEEKEND PICK UP OR DELIVERY: <input type="checkbox"/> Pick Up <input type="checkbox"/> Delivery

Delivery Information					
DATE:		RECEIVING HOURS:			
DESTINATION:		EXHIBITOR NAME:			
SHOW NAME:		BOOTH NUMBER:			
STREET ADDRESS:		CITY:	STATE:	ZIP:	COUNTRY:
SHOW CONTRACTOR:		CONTACT:		PHONE NUMBER:	

Method of Shipment		
Ground: <input type="checkbox"/> Less than a Truck Load <input type="checkbox"/> Truck Load Rates (Price Per Shipment) Shipments 0-100 lbs.* Shipments 101 lbs. and up* _____ *Subject to Applicable Surcharges	Air: <input type="checkbox"/> Next Day <input type="checkbox"/> 2nd Day <input type="checkbox"/> Deferred * Dim weight or actual weight, whichever is greater, will apply to Next Day and 2nd Day.	Special Instructions (Additional Charges May Apply)

Weight & Dimensions (Final Weight Subject to Correct Weight & Dimensions)											
Mark "X" in the H/M column to designate hazardous materials as defined in Department of Transportation Regulations.											
LIST EACH PIECE	H/M	DIMENSIONS IN INCHES			EST. WEIGHT	LIST EACH PIECE	H/M	DIMENSIONS IN INCHES			EST. WEIGHT
		L x	W x	H				L x	W x	H	
		L x	W x	H				L x	W x	H	
		L x	W x	H				L x	W x	H	
		L x	W x	H				L x	W x	H	
		L x	W x	H				L x	W x	H	
		L x	W x	H				L x	W x	H	
		L x	W x	H				L x	W x	H	
		L x	W x	H				L x	W x	H	

Total Pieces:	Total Weight:	Hazardous Materials Contact Number () _____ - _____
You must read the Terms and Conditions of Contract under which GES provides transportation services to you, our valued customer. The Terms and Conditions may be downloaded by going to www.ges.com/terms/logistics.aspx . If you do not have internet capability, a copy of the Terms and Conditions may be obtained by contacting your GES Logistics representative at 1.888.454.4437.		I agree in placing this order that I have accepted GES Payment Policy and GES Terms & Conditions of Contract. <div style="border: 1px solid black; padding: 2px; display: inline-block;"> Authorized Signature - Please Sign: </div> _____ X
I have read and agree to the Terms and Conditions of Contract and have the right and authority to bind the exhibiting company referenced herein to such terms.		AUTHORIZED NAME - PLEASE PRINT _____ DATE _____

Measure of Damage: If found liable for any loss, GES' sole and exclusive maximum liability for loss or damage to Customer's Goods is limited to \$.50 (USD) per pound with a maximum liability of \$100.00 (USD) per container, or \$1,500.00 (USD) per shipment, whichever is less.

Subject to individually determined rates or contracts that have been agreed upon in writing between GES and shipper, if applicable, otherwise to the rates, classifications and rules that have been established by GES and are available to the shipper, on request; **By signing this order form, shipper agrees to be bound by all its terms and conditions.**

Need Assistance?

Toll Free: 800.475.2098 | Tel: 702.515.5970 | www.ges.com/chat



Get *GES Global Transportation Plus* and
Save 10%
On Material Handling



GES Logistics provides an integrated network of carriers that service transportation solutions to over 80 countries by land, air and sea. Documentation services include ATA Carnet and temporary import bonds for the most comprehensive worldwide support available.

GES Global Transportation Plus delivers these unique benefits:

- Save 10% on material handling when using GES Logistics round-trip shipping
- Consolidated invoicing for material handling and shipping charges
- Managed transportation to and from the show floor
- On-site customer support

Note: All international transportation services are subject to the terms, conditions, limits of liability and instructions as set forth by the carrier.

To request a quote call 702.515.5970 or contact us at logisticsquote.ges.com/international.

RETURN TO: Global Experience Specialists, Inc. (GES) • 7000 Lindell Road, Las Vegas, NV 89118-4702 • Fax: 866.329.1437 or 702.263.1520 for international exhibitors
 Contact us Online: www.ges.com/chat Phone: 800.475.2098 or 702.515.5970 for international exhibitors

All orders are governed by the GES Payment Policy and GES Terms & Conditions of Contract as specified in this Exhibitor Services Manual.

ASDIN ANNUAL SCIENTIFIC MEETING

J W Marriott Washington DC, Grand Salon 2-4
 February 15 - 17, 2013

COMPANY NAME	EMAIL ADDRESS	BOOTH NUMBER
Pick Up Information		
PICKUP DATE:	SHIPPING / RECEIVING HOURS:	
STREET ADDRESS:	CITY:	PROVINCE: POSTAL CODE: COUNTRY:
PICK UP CONTACT:	PHONE NUMBER:	FAX NUMBER:
SHIPPING INSTRUCTIONS (ADDITIONAL CHARGES MAY APPLY):		MARK FOR WEEKEND PICK UP OR DELIVERY: <input type="checkbox"/> Pick Up <input type="checkbox"/> Delivery

Please complete the following information by either checking the appropriate box or by filling in the blank. Please be as thorough as possible as this will enable us to provide you with the most accurate cost estimate possible.

Method of Shipment				
Type of Customs Entry:	<input type="checkbox"/> Permanent (Sold/Giveaways)	Value of Permanent Goods (US\$):	\$	
	<input type="checkbox"/> Temporary (To Return)	Value of Temporary Goods (US\$):	\$	
Mode of Transport:	<input type="checkbox"/> Ocean FCL	<input type="checkbox"/> Ocean LCL	<input type="checkbox"/> AirFreight	<input type="checkbox"/> Truck
Type of Equipment for FCL:	<input type="checkbox"/> 40' Container	<input type="checkbox"/> 20' Container	<input type="checkbox"/> High Cube	<input type="checkbox"/> Other:
Commodity:				
Desired Delivery Date or Targeted Move-In Date:				

Weight & Dimensions (Final Weight Subject to Actual Weight & Dimensions)					
Detailed Description of Contents (1)	Length (2) cms	Width (3) cms	Height (4) cms	Net Weight (5) kilos	Value (US\$) (6)
					\$
					\$
					\$
					\$
					\$
					\$
					\$
					\$
					\$
					\$
					\$
					\$
					\$
					\$
					\$
					\$
					\$

Use a separate piece of paper if you need to provide additional weight and dimensions.

Check this box if you would like to receive a return quote back to origin specified at the top of this form.

You must read the Terms and Conditions of Contract under which GES provides transportation services to you, our valued customer. The Terms and Conditions may be downloaded by going to www.ges.com/terms/logistics.aspx. If you do not have internet capability, a copy of the Terms and Conditions may be obtained by contacting your GES Logistics representative at 1.888.454.4437.

I agree in placing this order that I have accepted GES Payment Policy and GES Terms & Conditions of Contract.

Authorized Signature - Please Sign: X

	Total Gross Weight (7)	Total Value (8)
	kilos	\$
AUTHORIZED NAME - PLEASE PRINT		DATE

SPECIAL REQUIREMENTS (ADDITIONAL CHARGES MAY APPLY)

GES is acting as a broker only and is liable for cargo loss or damage only if it results from the negligence or willful misconduct of GES. If found liable for any loss, GES' and the transportation provider's sole and exclusive maximum liability for loss or damage to Customer's Goods is limited to \$.50 (USD) per pound per package, \$ 100.00 (USD) per package or \$ 1,500.00 (USD) per occurrence, whichever is less.

All international transportation services are subject to the terms, conditions, and limits of liability set forth by the international transportation provider. If loss or damage occurs during transit, the liability of the underlying air carrier is governed by Montreal Protocol #4 to the Warsaw Convention.

Subject to individually determined rates or contracts that have been agreed upon in writing between GES and shipper, if applicable, otherwise to the rates, classifications and rules that have been established by GES or its transportation provider and are available to the shipper on request. **By signing this order form, shipper agrees to be bound by all its terms and conditions.**

Need Assistance?

Toll Free: 800.475.2098 | Tel: 702.515.5970 | www.ges.com/chat

RETURN TO: Global Experience Specialists, Inc. (GES) • 7000 Lindell Road, Las Vegas, NV 89118-4702 • Fax: 866.329.1437 or 702.263.1520 for international exhibitors
 Contact us Online: www.ges.com/chat Phone: 800.475.2098 or 702.515.5970 for international exhibitors

All orders are governed by the **GES Payment Policy** and **GES Terms & Conditions of Contract** as specified in this Exhibitor Services Manual.

ASDIN ANNUAL SCIENTIFIC MEETING
 J W Marriott Washington DC, Grand Salon 2-4
 February 15 - 17, 2013

Form Deadline Date:
 January 25, 2013

COMPANY NAME	EMAIL ADDRESS	BOOTH NUMBER
--------------	---------------	--------------

Special Freight Services — Small Passenger Vehicles Only!

Maximum Weight 200 lbs

- To facilitate the move-in and move-out of Exhibitors with small exhibit material shipments, Global Experience Specialists, Inc. (GES) is pleased to make available for hire, one (1) laborer with one (1) pushcart, for one (1) trip. Services can be made **one way** from the dock to your booth or your booth to the dock. Charges for these services are \$82.00 each way.
- This service is for those who have **small hand carry items** all of which must fit on a 2' x 6' push cart, in one trip only. **If you arrive with a truck, van, trailer, or truck with trailer filled with exhibit material you will not qualify for this service and will be redirected.**
- A cartload is eight (8) pieces or less, weighing less than 200 lbs. total. There is one cartload allowed per booth.
- Your vehicle must unload on the receiving dock of the exhibit hall. GES personnel will direct vehicles. The cart is not authorized to enter or go to any parking structure. There must be two (2) people with the vehicle; one person to go with your product to the booth space and one person to remove your vehicle from the unloading area to the parking area.
- Freight that is too large or heavy will be charged Material Handling rates.** No personal trucks (one (1) ton & over), no rental trucks, trailers, or bobtails will be unloaded through cartload service.
- You may also order this service at the GES Servicenter at show site.



Place Order Here				
ITEM#	DESCRIPTION	PRICE	QUANTITY	TOTAL PRICE
200506	Dock to Booth	\$82.00	1	\$
200506	Booth to Dock	\$82.00	1	\$
A.	Total All items Ordered			\$
B.	Petroleum Surcharge Assessment: 3%		A x 3% = B	\$
C.	Payment Enclosed		A + B = C	\$
I agree in placing this order that I have accepted GES Payment Policy and GES Terms & Conditions of Contract.				
Authorized Signature - Please Sign: X				
AUTHORIZED NAME - PLEASE PRINT				DATE

RETURN WITH G-2: PAYMENT & CREDIT CARD CHARGE AUTHORIZATION FORM & Q-2: PRICE LIST ORDER FORM TO:

Global Experience Specialists, Inc. (GES) • 7000 Lindell Road, Las Vegas, NV 89118-4702 • Fax: 866.329.1437 or 702.263.1520 for international exhibitors

All orders are governed by the GES Payment Policy and GES Terms & Conditions of Contract as specified in this Exhibitor Services Manual.

ASDIN ANNUAL SCIENTIFIC MEETING

J W Marriott Washington DC, Grand Salon 2-4
February 15 - 17, 2013

Discount Deadline Date:

January 25, 2013

COMPANY NAME	EMAIL ADDRESS	BOOTH NUMBER
--------------	---------------	--------------

Carpet

Standard Pre-Cut Carpet

ITEM CODE	DESCRIPTION	TAX (%)	DISCOUNT (\$)	REGULAR (\$)
5001	13 oz. Standard Carpet 10'x10'	6.0	265.75	398.50
5002	13 oz. Standard Carpet 10'x20'	6.0	534.50	802.25
5003	13 oz. Standard Carpet 10'x30'	6.0	800.25	1,205.00

Custom-Cut Carpet

ITEM CODE	DESCRIPTION	TAX (%)	DISCOUNT (\$)	REGULAR (\$)
5000	13 oz. Carpet Custom-Cut, Per Sq.Ft.	6.0	6.50	9.75
5006	26 oz. Plush Carpet Custom-Cut, Per Sq.Ft.	6.0	10.05	15.10
5007	50 oz. Ultra Plush Carpet Custom-Cut, Per Sq.Ft.	6.0	11.85	17.75

Padding

ITEM CODE	DESCRIPTION	TAX (%)	DISCOUNT (\$)	REGULAR (\$)
500400	Carpet Padding, 1/2" Thick, Per Sq.Ft.	6.0	3.02	4.53

Visqueen Plastic Covering for Protection

ITEM CODE	DESCRIPTION	TAX (%)	DISCOUNT (\$)	REGULAR (\$)
500410	Carpet Plastic Covering, Per Sq.Ft.	6.000	1.52	2.29

Carpet Package

Custom Cut Package

ITEM CODE	DESCRIPTION	TAX (%)	DISCOUNT (\$)	REGULAR (\$)
400021	13 oz. Carpet Package, Per Sq.Ft. Includes 10% Off: 13 oz. Standard Custom-Cut Carpet, Padding, Visqueen and 3 Day(s) Cleaning.	6.0	9.89	14.85
400022	26 oz. Plush Carpet Package, Per Sq.Ft. Includes 10% Off: 26 oz. Plush Custom-Cut Carpet, Padding, Visqueen, and 3 Day(s) Cleaning.	6.0	13.09	19.67
400023	50 oz. Ultra Plush Carpet Package, Per Sq.Ft. Includes 10% Off: 50 oz. Ultra Plush Custom-Cut Carpet, Padding, Visqueen, and 3 Day(s) of Cleaning.	6.0	14.71	22.05

Furniture and Accessories

Chairs

ITEM CODE	DESCRIPTION	TAX (%)	DISCOUNT (\$)	REGULAR (\$)
300051	Chair, Contemporary Arm, 23"W 18"D 31"H	6.0	135.00	203.00
300052	Chair, Contemporary Side, 19.5"W 18"D 31"H	6.0	123.50	185.50
300050	Chair, Plastic Contour, 18"W 18.5"D 32"H	6.0	74.75	112.25
300053	Stool, Contemporary, 17"W 18"D 48"H	6.0	150.50	225.50

Tables

ITEM CODE	DESCRIPTION	TAX (%)	DISCOUNT (\$)	REGULAR (\$)
300057	Table, Rectangle, 24"x36"x30" High	6.0	132.75	199.75
300056	Table, Square, 24"x24"x30" High	6.0	123.50	185.50
300059	Table, Starbase, 30" Diameter x 40" High	6.0	267.75	401.75
300058	Table, Starbase, 40" Diameter x 30" High	6.0	267.75	401.75

Skirted Tables

ITEM CODE	DESCRIPTION	TAX (%)	DISCOUNT (\$)	REGULAR (\$)
3004	Table 4', Skirted 4 Sides, 24" x 30" High	6.0	156.50	234.75
3006	Table 6', Skirted 3 Sides, 24" x 30" High	6.0	199.75	299.75
3008	Table 8', Skirted 3 Sides, 24" x 30" High	6.0	243.00	364.50
3007	Table, Skirt 4th Side	6.0	84.50	126.75

Skirted Counters

ITEM CODE	DESCRIPTION	TAX (%)	DISCOUNT (\$)	REGULAR (\$)
3014	Counter 4', Skirted 4 Sides, 24" x 42" High	6.0	199.75	299.75
3016	Counter 6', Skirted 3 Sides, 24" x 42" High	6.0	243.00	364.50
3018	Counter 8', Skirted 3 Sides, 24" x 42" High	6.0	284.25	426.50
3017	Counter, Skirt 4th Side	6.0	94.25	141.00

Risers

ITEM CODE	DESCRIPTION	TAX (%)	DISCOUNT (\$)	REGULAR (\$)
300193	Riser 4', Double Tier, 48"x8"x16" High	6.0	65.25	97.75
300191	Riser 4', Single Tier, 48"x8"x8" High	6.0	46.50	70.00
300194	Riser 6', Double Tier, 72"x8"x16" High	6.0	84.50	126.75
300192	Riser 6', Single Tier, 72"x8"x8" High	6.0	65.25	97.75

Custom Booth Drape

ITEM CODE	DESCRIPTION	TAX (%)	DISCOUNT (\$)	REGULAR (\$)
3001	Drape, 3' High, Per Foot, 4' Minimum	6.0	19.45	29.00
3002	Drape, 8' High, Per Foot, 4' Minimum	6.0	23.35	35.00

Display Furniture

ITEM CODE	DESCRIPTION	TAX (%)	DISCOUNT (\$)	REGULAR (\$)
300073	Display Case 4', Corner View	6.0	672.50	1,009.50
300074	Display Case 4', Full View	6.0	654.00	981.50
300075	Display Case 4', Half View	6.0	654.00	981.50
300076	Display Case 4', Quarter View	6.0	654.00	981.50
300078	Display Case 5', Full View	6.0	672.50	1,009.50
300079	Display Case 5', Half View	6.0	672.50	1,009.50
300080	Display Case 5', Quarter View	6.0	672.50	1,009.50
300082	Display Case 6', Full View	6.0	690.00	1,040.25
300083	Display Case 6', Half View	6.0	690.00	1,040.25
300084	Display Case 6', Quarter View	6.0	690.00	1,040.25
300088	Display Case 7', Vertical	6.0	903.25	1,359.50

Accessories

ITEM CODE	DESCRIPTION	TAX (%)	DISCOUNT (\$)	REGULAR (\$)
300124	Aisle Stanchion Chain, Plastic, Per Foot	6.0	5.70	8.60
300123	Aisle Stanchion, without Chain	6.0	55.25	83.25
300103	Aluminum Easel	6.0	74.75	112.25
300111	Bag Stand	6.0	104.00	156.50
300102	Coat Rack	6.0	104.00	156.50
300104	Garment Rack	6.0	104.00	156.50
300106	Literature Rack	6.0	159.75	240.00
300201	Pegboard, White, 4'x8'	6.0	180.25	271.00
300107	Refrigerator	6.0	412.00	618.00
300131	Security Cage, Large, without Lock	6.0	575.75	864.25
300132	Security Cage, Small, without Lock	6.0	384.25	576.75
300120	Sign Holder, Bell Base	6.0	94.25	141.00
300108	Sign Holder, Chrome, 22"x28"	6.0	94.25	141.00
300211	Tackboard, 4'x8'	6.0	191.50	287.25
300112	Ticket Tumbler, Small, Table Top	6.0	160.75	241.00
300113	Wastebasket	6.0	23.35	35.00
300118	Waterfall Stand	6.0	104.00	156.50

Furniture Package

Furniture Package 1

ITEM CODE	DESCRIPTION	TAX (%)	DISCOUNT (\$)	REGULAR (\$)
400011	Furniture Package 1 Includes 10% Off: (2) Plastic Contour Chairs, (1) 6' Skirted Table 24"x30", (1) Wastebasket.	6.0	335.34	503.33

Furniture Package 2

ITEM CODE	DESCRIPTION	TAX (%)	DISCOUNT (\$)	REGULAR (\$)
400012	Furniture Package 2 Includes 10% Off: (4) Contemporary Arm Chairs, (1) Starbase Table 40"x30", (1) Wastebasket.	6.0	747.99	1,123.88

Specialty Furniture

Seating - Sofas and Loveseats

ITEM CODE	DESCRIPTION	TAX (%)	DISCOUNT (\$)	REGULAR (\$)
305066	Loveseat, Black Leather, 64"L 36"D 34"H	6.0	850.75	1,277.25
305068	Loveseat, Key West, Black, 57"L 35"D 33"H	6.0	589.25	883.75
305067	Loveseat, Newport, Charcoal Leather, 54"L 34"D 33"H	6.0	932.25	1,400.75
305118	Sectional, 3 pc., Newport, Charcoal, 113"L 34"D 33"H	6.0	1,843.75	2,770.75
305120	Sectional, South Beach, 3 pc., Platinum, 152"L 40"D 33"H	6.0	1,709.75	2,564.75
305236	Sofa, Allegro, Blue Fabric, 73"L 34.5"D 29.5"H	6.0	818.75	1,225.75
305117	Sofa, Astro, 83"L 36"D 29"H	6.0	875.50	1,318.50
305125	Sofa, Key West, Black, 85"L 35"D 33"H	6.0	661.25	992.00
305121	Sofa, Lisbon, Black Leather, 88"L 36"D 34"H	6.0	930.00	1,390.50
305116	Sofa, Marrakesh, Light Beige, 84"L 37"D 34"H	6.0	784.75	1,174.25
305124	Sofa, Memphis, 55"L 31"D 28"H	6.0	832.25	1,246.25
305226	Sofa, Mirabel, Brown Leather, 76"L 35"D 32"H	6.0	1,028.00	1,545.00
305221	Sofa, Roma, White Vinyl, 78"L 31"D 33"H	6.0	1,050.50	1,576.00
305119	Sofa, South Beach, Platinum Suede, 69"L 29"D 33"H	6.0	772.50	1,164.00

Seating - Club Chairs

ITEM CODE	DESCRIPTION	TAX (%)	DISCOUNT (\$)	REGULAR (\$)
305235	Chair, Allegro, Blue Fabric, 36"L 34.5"D 29.5"H	6.0	647.75	972.25
305081	Chair, Astro Light Beige, 36"L 36"D 29"H	6.0	591.25	886.75
305072	Chair, Barcelona, Black, 30"L 31"D 35"H	6.0	940.50	1,411.00
305073	Chair, Barcelona, White, 30"L 30"D 31"H	6.0	1,009.50	1,514.00
305074	Chair, Cappuccino, 29"L 29"D 34"H	6.0	448.00	672.50

R032112 B122 112-0810



RETURN WITH G-2: PAYMENT & CREDIT CARD CHARGE AUTHORIZATION FORM & Q-2: PRICE LIST ORDER FORM TO:

Global Experience Specialists, Inc. (GES) • 7000 Lindell Road, Las Vegas, NV 89118-4702 • Fax: 866.329.1437 or 702.263.1520 for international exhibitors

All orders are governed by the GES Payment Policy and GES Terms & Conditions of Contract as specified in this Exhibitor Services Manual.		
COMPANY NAME	EMAIL ADDRESS	BOOTH NUMBER

Tables - Conference

ITEM CODE	DESCRIPTION	TAX (%)	DISCOUNT (\$)	REGULAR (\$)
305172	Table, Conf., Gray, 96"L 36"D 29"H	6.0	715.75	1,071.25
305033	Table, Conf., Mahogany, 120"L 42"W 29"H	6.0	778.75	1,164.00
305030	Table, Conf., Mahogany, 42" Round, 42"L 42"W 29"H	6.0	439.75	660.25
305031	Table, Conf., Mahogany, 72"L 42"W 29"H	6.0	520.25	780.75
305032	Table, Conf., Mahogany, 96"L 42"W 29"H	6.0	638.50	958.00
305177	Table, Conf., Manhattan, 42" Round 29"H	6.0	392.50	589.25
305208	Table, Nova, Oval, White/Silver Legs, 71"L 35.5"D 29"H	6.0	688.00	1,030.00

Tables - Martini Bar

ITEM CODE	DESCRIPTION	TAX (%)	DISCOUNT (\$)	REGULAR (\$)
305004	Table, Bar, Martini 3 pc., 100"L 100"D 47"H	6.0	3,739.00	5,613.50
305003	Table, Bar, Martini, 50"L 50"D 47"H	6.0	1,411.00	2,121.75

Product Display

ITEM CODE	DESCRIPTION	TAX (%)	DISCOUNT (\$)	REGULAR (\$)
305002	Bookcase, Graphite, 36"L 13"D 71"H	6.0	410.00	615.00
305001	Bookcase, Mahogany, 36"L 13"D 71"H	6.0	410.00	615.00
305053	Etagere, Black, 30"L 16"D 70"H	6.0	377.00	565.50
305052	Etagere, Pewter, 30"L 16"D 70"H	6.0	377.00	565.50
305215	Pedestal, Black Plastic, 24"L 24"D 36"H	6.0	480.00	720.00
305216	Pedestal, Black Plastic, 24"L 24"D 42"H	6.0	565.50	848.75
305102	Pedestal, Graphite, 30"L 30"D 42"H	6.0	537.75	806.50
305103	Pedestal, Locking Door, Black, 24"L 24"D 42"H	6.0	558.25	837.50

Office and Utility Furniture

ITEM CODE	DESCRIPTION	TAX (%)	DISCOUNT (\$)	REGULAR (\$)
305040	Credenza, Graphite, 72"L 24"D 29"H	6.0	574.75	862.00
305039	Credenza, Mahogany, 72"L 24"D 29"H	6.0	672.50	1,009.50
305057	Desk, Executive, Graphite, 60"L 30"D 29"H	6.0	565.50	848.75
305056	Desk, Executive, Mahogany, 60"L 30"D 29"H	6.0	622.00	933.25
305138	Desk, Writing, Graphite, 48"L 24"D 30"H	6.0	377.00	565.50
305059	File, Lateral, Graphite, 36"L 20"D 29"H	6.0	484.00	726.25
305058	File, Lateral, Mahogany, 36"L 20"D 29"H	6.0	520.25	780.75
305106	Kiosk, Black/Maple, 24"L 21"D 42"H	6.0	568.50	852.75
305104	Podium, Lecturn, Cherry, 24"L 19"D 50"H	6.0	358.50	537.75
305038	Table, Computer, Graphite, 36"L 30"D 42"H	6.0	377.00	565.50
305036	Table, Training, Grey, 48"L 24"D 30"H	6.0	367.75	552.00

Lamps

ITEM CODE	DESCRIPTION	TAX (%)	DISCOUNT (\$)	REGULAR (\$)
305204	Lamp, Floor, Mason, Silver, 18" Round 55"H	6.0	255.50	383.25
305203	Lamp, Floor, Trovato, LED, White, 7"L 7"D 72"H	6.0	468.75	703.50
305205	Lamp, Table, Mason, Silver, 16" Round 26"H	6.0	348.25	522.25
305202	Lamp, Table, Trovato, White, 7"L 7"D 26"H	6.0	368.75	553.00

Convenience Packages

GEM Package

ITEM CODE	DESCRIPTION	TAX (%)	DISCOUNT (\$)	REGULAR (\$)
404200	GEM #3 10' x 10' Package Includes: (1) 10' x 10' Standard Exhibit System, (1) 10' x 10' Standard 13oz Carpet, (3) Contemporary Stools, (1) Starbase Table 30"x40", (1) Wastebasket.	6.0	4,584.60	6,881.25
404201	GEM #4 10' x 20' Package Includes: (1) 10' x 20' Standard Exhibit System, (1) 10' x 20' Standard 13oz Carpet, (2) Contemporary Stools, (1) Wastebasket.	6.0	8,749.85	13,124.00

Standard Furniture Package

ITEM CODE	DESCRIPTION	TAX (%)	DISCOUNT (\$)	REGULAR (\$)
404001	Chair Package A Includes: (2) Contemporary Arm Chairs, (1) Starbase Table 40"x30", (1) Wastebasket.	6.0	561.10	842.75
404023	Display Case Package A Includes: (2) Contemporary Stools, (1) Starbase Table 30"x40", (1) 6' Half View Display Case.	6.0	1,258.75	1,893.00
404024	Display Case Package B Includes: (2) Contemporary Arm Chairs, (1) Starbase Table 40"x30", (1) 6' Half View Display Case.	6.0	1,227.75	1,848.00
404011	Stool Package A Includes: (2) Contemporary Stools, (1) Starbase Table 30"x40", (1) Wastebasket.	6.0	592.10	887.75

Standard Furniture Package Skirt

ITEM CODE	DESCRIPTION	TAX (%)	DISCOUNT (\$)	REGULAR (\$)
404002	Chair Package B Includes: (2) Contemporary Arm Chairs, (1) 6' Skirted Table 24"x30", (1) Wastebasket.	6.0	493.10	740.75
404012	Stool Package B Includes: (2) Contemporary Stools, (1) 6' Skirted Counter 24"x42", (1) Wastebasket.	6.0	567.35	850.50

Specialty Furniture Package

ITEM CODE	DESCRIPTION	TAX (%)	DISCOUNT (\$)	REGULAR (\$)
404104	Bar Package Includes: (2) White Oslo Barstools, (1) Martini Bar.	6.0	2,111.50	3,172.25
404101	Barcelona Club Package Includes: (2) Black Barcelona Chairs, (1) Inspiration End Table.	6.0	2,245.50	3,369.00

Specialty Furniture Package

ITEM CODE	DESCRIPTION	TAX (%)	DISCOUNT (\$)	REGULAR (\$)
404103	Deluxe Chair Package Includes: (2) New York Chairs, (1) Cafe Table 36"x29".	6.0	913.50	1,372.00
404110	Newport Collection Includes: (1) 3-Piece Newport Sectional (Charcoal Leather), (1) Soho Coffee Table.	6.0	2,287.75	3,437.25
404107	Premium Chair Package Includes: (2) Black Brewer Chairs, (1) Bar Table 36"x29".	6.0	782.00	1,174.00
404105	Premium Pedestal Package Includes: (2) Black Banana Barstools, (1) Locking Pedestal.	6.0	941.25	1,412.00
404106	Premium Stool Package Includes: (2) White Banana Barstools, (1) Bar Table 30"x42".	6.0	748.75	1,123.50
404108	South Beach Club Collection Includes: (1) White Half-Round Ottoman, (1) 3-Piece South Beach Sectional (Platinum Suede).	6.0	2,202.00	3,303.25

Standard Exhibits

20x20 Exhibits

ITEM CODE	DESCRIPTION	TAX (%)	DISCOUNT (\$)	REGULAR (\$)
600005	Exhibit System GEM #5, 20'x20' Island	6.0	12,535.00	18,807.75

10x20 Exhibits

ITEM CODE	DESCRIPTION	TAX (%)	DISCOUNT (\$)	REGULAR (\$)
600004	Exhibit System GEM #4, 10'x20' Inline	6.0	8,425.50	12,638.00

10x10 Exhibits

ITEM CODE	DESCRIPTION	TAX (%)	DISCOUNT (\$)	REGULAR (\$)
600002	Exhibit System GEM #2, 10'x10' Inline	6.0	2,039.50	3,059.00
600003	Exhibit System GEM #3, 10'x10' Inline	6.0	3,842.00	5,768.00

6ft Table Display

ITEM CODE	DESCRIPTION	TAX (%)	DISCOUNT (\$)	REGULAR (\$)
600001	Exhibit System GEM #1, 6' Tabletop Display	6.0	1,915.75	2,873.75

Accessories

ITEM CODE	DESCRIPTION	TAX (%)	DISCOUNT (\$)	REGULAR (\$)
600410	Exhibit, Ad Board, 1M x 8'	6.0	662.25	994.00
600110	Exhibit, Armlight Black	6.0	98.25	147.25
600103	Exhibit, Counter, 1M Curved	6.0	915.75	1,370.00
600101	Exhibit, Counter, 1M x 1/2M x 40"H	6.0	461.50	692.25
600102	Exhibit, Counter, 2M x 1/2M x 40"H	6.0	634.50	951.75
600221	Exhibit, Light Box, Large 37"x85"	6.0	842.50	1,267.00
600222	Exhibit, Light Box, Medium 37"x56"	6.0	664.25	997.00
600223	Exhibit, Light Box, Small 37"x28"	6.0	410.00	615.00
661931	Exhibit, Panel, Slatwall, 1M x 8'	6.0	578.75	868.25
600291	Exhibit, Panel, Wirewall, 1M	6.0	566.50	849.75
600243	Exhibit, Shelf, 1M x 10' Deep	6.0	77.25	116.50

Graphics and Signage

Graphics and Signage

ITEM CODE	DESCRIPTION	TAX (%)	DISCOUNT (\$)	REGULAR (\$)
600505	Sign, 10"x60"	6.0	131.75	197.75
600506	Sign, 11"x14"	6.0	80.00	120.50
600507	Sign, 14"x22"	6.0	87.25	130.75
600509	Sign, 20"x60"	6.0	228.75	343.00
600510	Sign, 22"x28"	6.0	145.25	218.25
600512	Sign, 28"x44"	6.0	239.00	358.50
600514	Sign, 40"x60"	6.0	396.50	595.25
600501	Sign, 7"x11"	6.0	62.00	93.25
600502	Sign, 7"x44"	6.0	84.25	126.75
600534	22"W x 28"H Vertical Sign w/ Sign Holder, Double Sided	6.0	268.75	403.75
600533	22"W x 28"H Vertical Sign w/ Sign Holder, Single Sided	6.0	207.00	311.00
600535	72"W x 36"H Vinyl Banner (horizontal or vertical) w/ Silver Grommets, Single Sided	6.0	219.50	329.50
600528	Freestanding 24"W x 84"H Vertical Ad Board w/ Cardboard Base, Double Sided	6.0	396.50	595.25
600526	Freestanding 24"W x 84"H Vertical Ad Board w/ Cardboard Base, Single Sided	6.0	244.00	366.75
600529	Freestanding 38"W x 84"H Vertical Ad Board w/ Cardboard Base, Double Sided	6.0	519.00	778.75
600527	Freestanding 38"W x 84"H Vertical Ad Board w/ Cardboard Base, Single Sided	6.0	365.75	549.00
601099	Printed Cardboard Base for Freestanding Boards	6.0	23.85	35.75

Easel Back

ITEM CODE	DESCRIPTION	TAX (%)	DISCOUNT (\$)	REGULAR (\$)
600547	Easel Back	6.0	13.30	19.95

R032112 B122 112-0810



RETURN WITH G-2: PAYMENT & CREDIT CARD CHARGE AUTHORIZATION FORM & Q-2: PRICE LIST ORDER FORM TO:

Global Experience Specialists, Inc. (GES) • 7000 Lindell Road, Las Vegas, NV 89118-4702 • Fax: 866.329.1437 or 702.263.1520 for international exhibitors

All orders are governed by the GES Payment Policy and GES Terms & Conditions of Contract as specified in this Exhibitor Services Manual.		
COMPANY NAME	EMAIL ADDRESS	BOOTH NUMBER

Carpet Information

Prices include delivery, rental, and removal. Labor to install carpet is included when the carpet is installed on a flat floor space prior to exhibit installation. Labor will be charged at published rates when installation is required for stairs, platforms, risers, meeting rooms, or other installations post exhibit installation.

Precut

Custom-cut carpet is required for all booths larger than 30', or for booths configured as island or peninsula.

Custom Cut

Guaranteed to be high quality carpet, and includes visqueen plastic covering. Custom-Cut carpet orders must be received 14 days prior to move-in to guarantee delivery and color selection. Custom-Cut Carpet can be custom-dyed and we offer discounts for orders exceeding 2,000 square feet (please call for a quote). Custom dye orders require 30 days to process. A minimum of 100 square feet is required for custom-cut carpet orders.

Padding

GES offers the finest padding used in the industry, a 5/8" double-netted rebond pad. We guarantee your satisfaction.

Cancellation Policy

Custom Size Booth Carpet cancelled after being cut will be charged **100%**. All other carpet cancelled will be charged **50%** of original price after move-in begins and **100%** of original price after installation.

Furniture & Accessories Information

Prices include delivery, rental, installation, and removal. Please include Booth Layout Form (H-3) for placement of items.

Orders received within three (3) weeks prior show move-in are subject to availability and/or substitutions.

Cancellation Policy

Items cancelled will be charged **50%** of original price after move-in begins and **100%** of original price after installation.

Specialty Furniture Information

Prices include delivery, rental, installation, and removal. Please include Booth Layout Form (H-3) for placement of items. Custom orders are available. Please call for quote.

Orders received within three (3) weeks prior show move-in are subject to availability and/or substitutions.

Cancellation Policy

Items cancelled will be charged **100%** of original price after move-in begins.

Standard Exhibits Information

Prices include delivery, rental, installation, and removal. For Custom Exhibits, please send a request to email address exhibitdesign@ges.com.

Cancellation Policy

Due to material and labor costs, orders cancelled before move-in begins will be charged **50%** of original price. Similarly, orders cancelled after move-in begins will be charged **100%** of original price.

Graphics & Signage Information

We offer complete graphics services from Design to Print!

We can create custom graphics to fit any of your needs, including:

- Pressure Sensitive Vinyl (PSV) Booth Wraps (the same as vehicle wraps)
- Vinyl or Mesh Banners for use in your booth
- Backlit graphics for lightboxes and display cases
- Custom fit / contour cut / 3D graphics for eye catching effects
- Printing on specialized materials

For a quotation, please visit: <http://www.ges.com/graphics/quote/>

Digital File Submission:

You can upload your file(s) after sending in your order using the information below.

HOST	USER NAME:	PASSWORD:
ftp://csftp.ges.com/Central	gescentfp	t7od4cfz*

Please make sure your file(s) are labeled with the exhibiting company's name and the show name (e.g. EGGWHITES_COOKING SHOW.zip)

RETURN WITH G-2: PAYMENT & CREDIT CARD CHARGE AUTHORIZATION FORM TO:

Global Experience Specialists, Inc. (GES) • 7000 Lindell Road, Las Vegas, NV 89118-4702 • Fax: 866.329.1437 or 702.263.1520 for international exhibitors

All orders are governed by the GES Payment Policy and GES Terms & Conditions of Contract as specified in this Exhibitor Services Manual.

ASDIN ANNUAL SCIENTIFIC MEETING

J W Marriott Washington DC, Grand Salon 2-4
February 15 - 17, 2013

Discount Deadline Date:

January 25, 2013

COMPANY NAME	EMAIL ADDRESS	BOOTH NUMBER
--------------	---------------	--------------

Place Order Here

ITEM CODE	DESCRIPTION	COLOR CODE	PRICE EACH or PRICE/SQ.FT. X	QUANTITY or TOTAL SQ.FT. =	TOTAL (\$) X	3% PSP =	SUBTOTAL (\$) X	TAX (%)*	GRAND TOTAL (\$)
			\$		\$	3 %	\$	%	\$
			\$		\$	3 %	\$	%	\$
			\$		\$	3 %	\$	%	\$
			\$		\$	3 %	\$	%	\$
			\$		\$	3 %	\$	%	\$
			\$		\$	3 %	\$	%	\$
			\$		\$	3 %	\$	%	\$
			\$		\$	3 %	\$	%	\$
			\$		\$	3 %	\$	%	\$
			\$		\$	3 %	\$	%	\$
			\$		\$	3 %	\$	%	\$
			\$		\$	3 %	\$	%	\$
			\$		\$	3 %	\$	%	\$
			\$		\$	3 %	\$	%	\$
			\$		\$	3 %	\$	%	\$
			\$		\$	3 %	\$	%	\$
			\$		\$	3 %	\$	%	\$
			\$		\$	3 %	\$	%	\$
			\$		\$	3 %	\$	%	\$
			\$		\$	3 %	\$	%	\$

*Calculate tax only if the item is identified as having a tax on the price list.

Payment Enclosed	\$
-------------------------	----

Color Options

- 13 oz. Standard Custom-Cut Carpet Colors**
Black (41), Blue (42), Blue Jay (56), Burgundy (43), Emerald Green (44), Gray (40), Pepper (52) or Red (49). Gray will be provided if no color is indicated on your order.
- 13 oz. Standard Carpet Colors**
Black (41), Blue (42), Blue Jay (56), Burgundy (43), Emerald Green (44), Gray (40), Pepper (52) or Red (49). Gray will be provided if no color is indicated on your order.
- 26 oz. Plush Custom-Cut Carpet Colors**
Cement (70), Charcoal (71), Cobalt (72), Dove (73), Lava Rock (74), Navy (75), Onyx (76), Red (49), Royal Blue (77), Silky Beige (78), Silver (79) or Snow (80). Dove will be provided if no color is indicated on your order.
- 50 oz. Ultra Plush Custom-Cut Carpet Colors**
Bisque (81), Black (41), Cabernet (82), Graphite (83), Iceberg (84), Midnight (85), Seascape (86), Sterling (87) or Teal (55). Iceberg will be provided if no color is indicated on your order.
- Column Drrape**
Beige (54), Black (41) or White (50). Black will be provided if no color is indicated on your order.
- Table Skirt Color**
Beige (54), Black (41), Blue (42), Burgundy (43), Forest Green (45), Gold (46), Gray (40), Mauve (47), Purple (48), Red (49), Teal (55) or White (50). Gray will be provided if no color is indicated on your order.
- Standard Exhibit Panel Type and Color**
Coated: Black (C41), Coated: Oxford White (C50), Coated: Prism Blue (C42), Coated: Silver Gray (C79), Fabric: Black (F41), Fabric: Blue (F42) or Fabric: Gray (F40). Gray Fabric Panel will be provided if no color is indicated on your order.
- Standard Exhibit Trim Metal Color**
Black (41) or Silver (79). Silver will be provided if no color is indicated on your order.

Exhibit System Header Copy

**EXHIBIT
HEADER
COPY**

Signs will be black text on white background.
If Custom ID is not required, please indicate ID copy. Print or type.

**CUSTOM
ID SIGN**

Colored signs are available at additional cost, please go to http://www.ges.com/ecomm/info/exhibit_graphics.pdf for example. An EPS Vector format file, with all the fonts converted to outline, and hard copy must be received with this order to receive a Custom ID Sign. Please review "I-2: Digital File Submission Guide" within this manual for additional information and instructions.

I agree in placing this order that I have accepted GES Payment Policy, GES Terms & Conditions of Contract, and the Information as outlined by each line of business on the preceding pages.

Authorized Signature - Please Sign: X

AUTHORIZED NAME - PLEASE PRINT	DATE
--------------------------------	------

R032112_B122 112-0810

GES® offers eco-friendly and conventional carpet to enhance the look and comfort of your exhibit. Available in various colors of three carpet grades with padding option:

Ultra Plush (50 oz.) 
 50 oz. carpet is 100% recyclable and offered as a business standard for our premium grades.

Plush (26 oz.) 
 26 oz. carpet is 100% recyclable and offered as a business standard for our premium grades.

Standard (13 oz.)
 13 oz. is conventional filament nylon carpet that is re-used for pre-cut sizes and new for custom-cut orders

Padding (1/2 in.) 
 Double-netted rebound pad is 100% recyclable, made with 98% pre & post consumer content.

100% recyclable flooring solutions have the same industry tradeshow performance standards as conventional carpet and help to reduce the volume of excess materials from entering landfills.

 The leaf symbol indicates recyclable or eco-friendly materials, per manufacturers specifications.

Ultra Plush

Includes:

- 50 oz. 100% recyclable premium carpet 
- 4 mil poly covering
- anti-static treatment
- 3M Scotchgard™ protection



Bisque (81)



Black (41)



Cabernet (82)

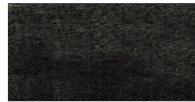

Graphite (83)

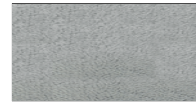

Iceberg (84)

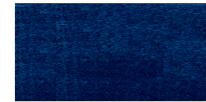

Midnight (85)

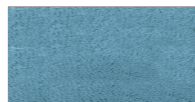

Seascape (86)

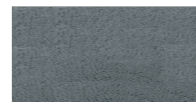

Sterling (87)



Teal (55)

Ultra Plush Color Codes

- Bisque (81)
- Cabernet (82)
- Iceberg (84)
- Seascape (86)
- Teal (55)
- Black (41)
- Graphite (83)
- Midnight (85)
- Sterling (87)

Our carpet is offered as pre-cut, custom-cut or in carpet packages that include visqueen and recycled padding. Visqueen and recycled padding are also available as upgrades.

Rental includes material handling, installation, front edge taping, and pick-up at the close of the show.

To order contact the GES National Servicer® at 800.475.2098 or fill out and fax the enclosed order form.

Plush

Includes:

- 26 oz. 100% recyclable premium carpet
- 4 mil poly covering
- anti-static treatment
- 3M Scotchgard™ protection

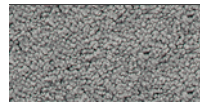

Cement (70)



Charcoal (71)

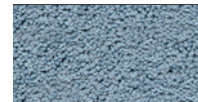

Cobalt (72)

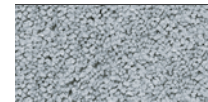

Dove (73)

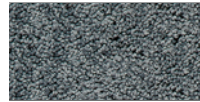

Lava Rock (74)

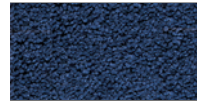

Navy (75)



Onyx (76)

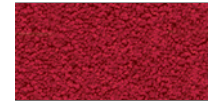

Red (49)

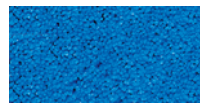

Royal Blue (77)



Silky Beige (78)

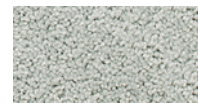

Silver (79)



Snow (80)

Standard

Includes:

- 13 oz. filament nylon carpet
- Available in pre-cut sizes (see order form for details)
- Custom-cut includes 4 mil poly covering



Black (41)



Blue (42)



Blue Jay (56)



Burgundy (43)

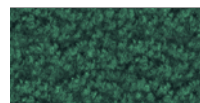

Emerald Green (44)

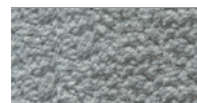

Gray (40)



Pepper (52)



Red (49)

Plush Color Codes

- | | | | |
|-------------------|--------------------|---------------|-------------|
| - Cement (70) | - Charcoal (71) | - Cobalt (72) | - Dove (73) |
| - Lava Rock (74) | - Navy (75) | - Onyx (76) | - Red (49) |
| - Royal Blue (77) | - Silky Beige (78) | - Silver (79) | - Snow (80) |

Standard Color Codes

- | | |
|----------------------|-----------------|
| - Black (41) | - Blue (42) |
| - Blue Jay (56) | - Burgundy (43) |
| - Emerald Green (44) | - Gray (40) |
| - Pepper (52) | - Red (49) |

Chairs



300051 - Chair, Contemporary Arm, 23"W 18"D 31"H



300052 - Chair, Contemporary Side, 19.5"W 18"D 31"H



300050 - Chair, Plastic Contour, 18"W 18.5"D 32"H



300053 - Stool, Contemporary, 17"W 18"D 48"H

Tables



300057 - Table, Rectangle, 24"x36"x30" High



300056 - Table, Square, 24"x24"x30" High



300059 - Table, Starbase, 30" Diameter x 40" High



300058 - Table, Starbase, 40" Diameter x 30" High

Skirted Tables



3004 - Table 4', Skirted 4 Sides, 24" x 30" High



3006 - Table 6', Skirted 3 Sides, 24" x 30" High















3008 - Table 8', Skirted 3 Sides, 24" x 30" High



3007 - Table, Skirt 4th Side

Table Skirt Colors

 Beige (54)	 Black (41)	 Blue (42)	 Burgundy (43)
 Forest Green (45)	 Gold (46)	 Gray (40)	 Mauve (47)
 Purple (48)	 Red (49)	 Teal (55)	 White (50)

Display Furniture



Full View



Half View



Quarter View



Vertical

Accessories



300124 - Aisle Stanchion Chain, Plastic, Per Foot



300123 - Aisle Stanchion, without Chain



300103 - Aluminum Easel



300111 - Bag Stand



300102 - Coat Rack



300104 - Garment Rack



300106 - Literature Rack



300201 - Pegboard, White, 4'x8'



300107 - Refrigerator



300131 - Security Cage, Large, without Lock



300132 - Security Cage, Small, without Lock



300120 - Sign Holder, Bell Base



300108 - Sign Holder, Chrome, 22"x28"



300211 - Tackboard, 4'x8'



300112 - Ticket Tumbler, Small, Table Top



300118 - Waterfall Stand

Seating - Sofas and Loveseats



305066 - Loveseat, Black Leather, 64"L 36"D 34"H



305068 - Loveseat, Key West, Black, 57"L 35"D 33"H



305067 - Loveseat, Newport, Charcoal Leather, 54"L 34"D 33"H



305118 - Sectional, 3 pc., Newport, Charcoal, 113"L 34"D 33"H



305120 - Sectional, South Beach, 3 pc., Platinum, 152"L 40"D 33"H



305236 - Sofa, Allegro, Blue Fabric, 73"L 34.5"D 29.5"H



305117 - Sofa, Astro, 83"L 36"D 29"H



305125 - Sofa, Key West, Black, 85"L 35"D 33"H



305121 - Sofa, Lisbon, Black Leather, 88"L 36"D 34"H



305116 - Sofa, Marrakesh, Light Beige, 84"L 37"D 34"H



305124 - Sofa, Memphis, 55"L 31"D 28"H



305226 - Sofa, Mirabel, Brown Leather, 76"L 35"D 32"H



305221 - Sofa, Roma, White Vinyl, 78"L 31"D 33"H



305119 - Sofa, South Beach, Platinum Suede, 69"L 29"D 33"H

Colors may vary due to facility lighting, printing limitations and dye lot differences. Some items may not be available at all locations. See order form for details. Styles of items portrayed **34** this brochure may vary in some locations.

Seating - Club Chairs



305235 - Chair, Allegro, Blue Fabric, 36\"/>



305081 - Chair, Astro Light Beige, 36\"/>



305072 - Chair, Barcelona, Black, 30\"/>



305073 - Chair, Barcelona, White, 30\"/>



305074 - Chair, Cappuccino, 29\"/>



305180 - Chair, Globus, 28\"/>



305178 - Chair, Lisbon, Black Leather, 40\"/>



305080 - Chair, Marrakesh, Light Beige, 34\"/>



305127 - Chair, Memphis, 27.25\"/>



305225 - Chair, Mirabel, Brown Leather, 36\"/>



305179 - Chair, Newport, Charcoal Leather, 24\"/>



305220 - Chair, Roma, White Vinyl, 37\"/>



305070 - Chair, Tub, Key West, Black, 31\"/>



305035 - Corner, Charcoal Leather, 34\"/>

Seating - Chairs



305152 - Chair, Altura, Guest, 25\"/>



305041 - Chair, Berlin, Black/White, 18\"/>



305042 - Chair, Berlin, Red/White, 18\"/>



305110 - Chair, Brewer, Black, 20\"/>



305109 - Chair, Brewer, Gray, 20\"/>



305217 - Chair, Casper, Clear, 21\"/>



305231 - Chair, Fusion, Clear/White, 19\"/>



305230 - Chair, Fusion, Green/White, 19\"/>



305232 - Chair, Fusion, Red/White, 19\"/>



305079 - Chair, Ice Transparent/Chrome, 17.25\"/>



305034 - Chair, Iso Mesh Black, 36\"/>



305111 - Chair, Jetson, 19\"/>



305149 - Chair, Luxor, Guest, 27\"/>



305113 - Chair, Manhattan, 26\"/>



305108 - Chair, New York, 23\"/>



305115 - Chair, Panton, White, 20\"/>



305078 - Chair, Stage, Beige, 24\"/>



305071 - Chair, Stage, Camel, 24\"/>



305077 - Chair, Stage, Onyx, 24\"/>



305075 - Chair, Stage, Red, 24\"/>



305069 - Chair, T-Vac Translucent, 25\"/>

Seating - Ottomans



305088 - Ottoman, Bench, Black, 24\"/>



305089 - Ottoman, Bench, White, 24\"/>



305085 - Ottoman, Cube, Black, 17\"/>



305093 - Ottoman, Cube, White Leather, 17\"/>



305086 - Ottoman, Half Round, Black, 72\"/>



305087 - Ottoman, Half Round, White, 72\"/>



305094 - Ottoman, Oval, Black, 52\"/>



305095 - Ottoman, Oval, White, 52\"/>



305240 - Ottoman, Puzzle Bench, White, 48\"/>



305092 - Ottoman, South Beach, Wedge, Platinum, 25\"/>



305090 - Ottoman, Square, Black, 40\"/>



305091 - Ottoman, Square, White, 40\"/>



305246 - Ottoman, Vibe Cube, Blue, Vinyl, 18\"/>



305242 - Ottoman, Vibe Cube, Champagne, Vinyl, 18\"/>



305243 - Ottoman, Vibe Cube, Gold/Bronze, Vinyl, 18\"/>



305241 - Ottoman, Vibe Cube, Green, Vinyl, 18\"/>



305244 - Ottoman, Vibe Cube, Pink, Vinyl, 18\"/>



305245 - Ottoman, Vibe Cube, Red, Vinyl, 18\"/>



305247 - Ottoman, Vibe Cube, Yellow, Vinyl, 18\"/>

Seating - Office and Utility Seating



305150 - Chair, Altura, High Back, 25\"/>



305151 - Chair, Altura, Med. Back, 25\"/>



305114 - Chair, Flex with Wheels, 24\"/>



305147 - Chair, Luxor, High Back, 27\"/>



305148 - Chair, Luxor, Med. Back, 27\"/>



305076 - Chair, Otto, Highback Black, 23\"/>



305126 - Chair, Task, 25\"/>



305112 - Chair, Tilt with Arms, Black, 26\"/>



305043 - Stool, Drafting, 25\"/>

Colors may vary due to facility lighting, printing limitations and dye lot differences. Some items may not be available at all locations. See order form for details. Styles of items portrayed **36** this brochure may vary in some locations.

Seating - Barstools



305012 - Barstool, Banana, Black, 21"L 22"D 30"H



305013 - Barstool, Banana, White, 21"L 22"D 30"H



305010 - Barstool, Gin, Maple, 16"L 16"D 29"H



305023 - Barstool, Ice, Transparent/Chrome, 16.75"L 16"D 32"H



305011 - Barstool, Jetson, Black, 18"L 19"D 29"H



305006 - Barstool, Ohio, Black, 18" Round 31"H Adj.



305007 - Barstool, Ohio, Grey, 18" Round 31"H Adj.



305005 - Barstool, Ohio, Red, 18" Round 31"H Adj.



305009 - Barstool, Oslo, Blue, 17"L 20"D 30"H



305008 - Barstool, Oslo, White, 17"L 20"D 30"H



305206 - Barstool, Shark Swivel, White/Chrome Base, 22"L 19"D 34"-44"H



305207 - Barstool, Zooney Swivel, White/Chrome Base, 15"Lx17"Dx31"-35"H

Table Surface Colors



Maple



Graphite Nebula



Grey Nebula



Metallic Silver



Brushed Red



Brushed Blue

Tables - Cafe



305162 - Table, Cafe, Blue/Black, 30" Round 29"H



305154 - Table, Cafe, Blue/Chrome, 30" Round 29"H



305164 - Table, Cafe, Graphite/Black, 30" Round 29"H



305167 - Table, Cafe, Graphite/Black, 36" Round 29"H



305156 - Table, Cafe, Graphite/Chrome, 30" Round 29"H



305159 - Table, Cafe, Graphite/Chrome, 36" Round 29"H



305166 - Table, Cafe, Grey/Black, 36" Round 29"H



305158 - Table, Cafe, Grey/Chrome, 36" Round 29"H



305165 - Table, Cafe, Maple/Black, 30" Round 29"H



305168 - Table, Cafe, Maple/Black, 36" Round 29"H



305157 - Table, Cafe, Maple/Chrome, 30" Round 29"H



305160 - Table, Cafe, Maple/Chrome, 36" Round 29"H



305161 - Table, Cafe, Red/Black, 30" Round 29"H



305153 - Table, Cafe, Red/Chrome, 30" Round 29"H



305163 - Table, Cafe, Silver/Black, 30" Round 29"H



305155 - Table, Cafe, Silver/Chrome, 30" Round 29"H

Colors may vary due to facility lighting, printing limitations and dye lot differences. Some items may not be available at all locations. See order form for details. Styles of items portrayed  this brochure may vary in some locations.

Tables - Bar



305131 - Table, Bar, Blue/Black, 30" Round 42"H



305140 - Table, Bar, Blue/Chrome, 30" Round 42"H



305133 - Table, Bar, Graphite/Black, 30" Round 42"H



305136 - Table, Bar, Graphite/Black, 36" Round 42"H



305142 - Table, Bar, Graphite/Chrome, 30" Round 42"H



305145 - Table, Bar, Graphite/Chrome, 36" Round 42"H



305135 - Table, Bar, Grey/Black, 36" Round 42"H



305144 - Table, Bar, Grey/Chrome, 36" Round 42"H



305134 - Table, Bar, Maple/Black, 30" Round 42"H



305137 - Table, Bar, Maple/Black, 36" Round 42"H



305143 - Table, Bar, Maple/Chrome, 30" Round 42"H



305146 - Table, Bar, Maple/Chrome, 36" Round 42"H



305130 - Table, Bar, Red/Black, 30" Round 42"H



305139 - Table, Bar, Red/Chrome, 30" Round 42"H



305132 - Table, Bar, Silver/Black, 30" Round 42"H



305141 - Table, Bar, Silver/Chrome, 30" Round 42"H

Tables - Cocktail



305017 - Table, Cocktail, Geo, Black, 50"L 22"D 16"H



305014 - Table, Cocktail, Geo, Chrome, 50"L 22"D 16"H



305020 - Table, Cocktail, Inspiration, 42"L 28"D 18"H



305210 - Table, Cocktail, Oliver, 47"L 27"D 19"H



305016 - Table, Cocktail, Silverado, 36" Round 17"H



305015 - Table, Cocktail, Soho, 38"L 38"D 18.5"H



305025 - Table, Cocktail, Sydney Black, 48"L 26"D 18"H



305024 - Table, Cocktail, Sydney White, 48"L 26"D 18"H

Tables - End Tables



305047 - Table, End, Geo, Black, 26"L 26"D 20"H



305044 - Table, End, Geo, Chrome, 26"L 26"D 20"H



305049 - Table, End, Inspiration, 24"L 28"D 22"H



305211 - Table, End, Oliver, 22" Round 22"H



305046 - Table, End, Silverado, 24" Round 22"H



305045 - Table, End, Soho, 26"L 26"D 27"H



305050 - Table, End, Sydney, Black, 27"L 23"D 22"H



305048 - Table, End, Sydney, White, 27"L 23"D 22"H

Conference Tables



305175 - Table, Conf., Geo, Black, 42"L 42"D 29"H



305176 - Table, Conf., Geo, Black, 60"L 36"D 29"H



305173 - Table, Conf., Geo, Chrome, 42"L 42"D 29"H



305174 - Table, Conf., Geo, Chrome, 60"L 36"D 29"H



305027 - Table, Conf., Graphite, 42" Round 29"H



305028 - Table, Conf., Graphite, 72"L 36"D 29"H



305029 - Table, Conf., Graphite, 96"L 36"D 29"H



305170 - Table, Conf., Gray, 42" Round 29"H



305171 - Table, Conf., Gray, 72"L 36"D 29"H



305172 - Table, Conf., Gray, 96\"/>



305033 - Table, Conf., Mahogany, 120\"/>



305030 - Table, Conf., Mahogany, 42\"/>



305031 - Table, Conf., Mahogany, 72\"/>



305032 - Table, Conf., Mahogany, 96\"/>



305177 - Table, Conf., Manhattan, 42\"/>



305208 - Table, Nova, Oval, White/Silver Legs, 71\"/>

Tables - Martini Bar



305004 - Table, Bar, Martini 3 pc., 100\"/>



305003 - Table, Bar, Martini, 50\"/>

Product Display



305002 - Bookcase, Graphite, 36"L 13"D 71"H



305001 - Bookcase, Mahogany, 36"L 13"D 71"H



305053 - Etagere, Black, 30"L 16"D 70"H



305052 - Etagere, Pewter, 30"L 16"D 70"H



305215 - Pedestal, Black Plastic, 24"L 24"D 36"H



305216 - Pedestal, Black Plastic, 24"L 24"D 42"H



305102 - Pedestal, Graphite, 30"L 30"D 42"H



305103 - Pedestal, Locking Door, Black, 24"L 24"D 42"H

Office and Utility Furniture



305040 - Credenza, Graphite, 72"L 24"D 29"H



305039 - Credenza, Mahogany, 72"L 24"D 29"H



305057 - Desk, Executive, Graphite, 60"L 30"D 29"H



305056 - Desk, Executive, Mahogany, 60"L 30"D 29"H



305138 - Desk, Writing, Graphite, 48"L 24"D 30"H



305059 - File, Lateral, Graphite, 36"L 20"D 29"H



305058 - File, Lateral, Mahogany, 36"L 20"D 29"H



305106 - Kiosk, Black/Maple, 24"L 21"D 42"H



305104 - Podium, Lectern, Cherry, 24"L 19"D 50"H



305038 - Table, Computer, Graphite, 36"L 30"D 42"H



305036 - Table, Training, Grey, 48"L 24"D 30"H

Lamps



305204 - Lamp, Floor,
Mason, Silver, 18" Round
55"H



305203 - Lamp, Floor,
Trovato, LED, White, 7"L
7"D 72"H



305205 - Lamp, Table,
Mason, Silver, 16" Round
26"H



305202 - Lamp, Table,
Trovato, White, 7"L 7"D
26"H

With 5 GES® standard exhibits to choose from, selecting the size and configuration that meets your tradeshow needs is easy. Our modular exhibits are hassle-free because you pay no design fees, no shipping fees, and no repair or refurbishing fees. Plus, you may customize the trim and panels, and choose from a wide variety of accessories to create a unique exhibit that reinforces your brand and marketing efforts.

All packages include rental, delivery, installation, and dismantling. For other custom furnishings, hanging signs, or graphics, chat with your GES National Servicenter® representative at www.ges.com/chat.

20x20 Exhibits

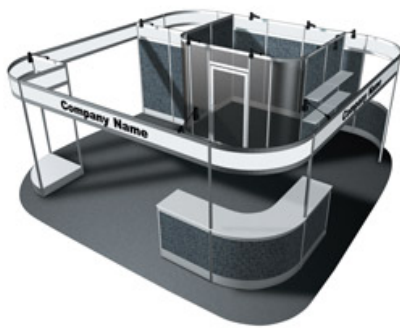

600005 - Exhibit System GEM #5, 20'x20' Island Includes:

- three digitally printed signs
- one locking office
- four shelves
- one curved counter
- two 1m counters
- ten arm lights
- one standard 20' x 20' carpet
- no padding

10x20 Exhibits



600004 - Exhibit System GEM #4, 10'x20' Inline Includes:

- one 116-7/8" x 12" digitally printed signs
- one 57-13/16" x 12" digitally printed signs
- one 2m counter
- six arm lights
- five shelves
- one standard 10' x 20' carpet
- no padding

10x10 Exhibits



600002 - Exhibit System GEM #2, 10'x10' Inline Includes:

- one custom ID sign
- two arm lights
- two shelves
- one standard 10' x 10' carpet
- no padding



600003 - Exhibit System GEM #3, 10'x10' Inline Includes:

- one custom ID sign
- three arm lights
- five shelves
- one 1m counter
- one standard 10' x 10' carpet
- no padding

6ft Table Display



600001 - Exhibit System GEM #1, 6' Tabletop Display Includes:

- one custom ID sign
- three arm lights
- two shelves
- one 6' skirted table
- no carpet and padding

Accessories



600410 - Exhibit, Ad Board, 1M x 8'



600110 - Exhibit, Armlight Black



600103 - Exhibit, Counter, 1M Curved



600101 - Exhibit, Counter, 1M x 1/2M x 40"H



600102 - Exhibit, Counter, 2M x 1/2M x 40"H



600221 - Exhibit, Light Box, Large 37"x85"



600222 - Exhibit, Light Box, Medium 37"x56"



600223 - Exhibit, Light Box, Small 37"x28"



661931 - Exhibit, Panel, Slatwall, 1M x 8'

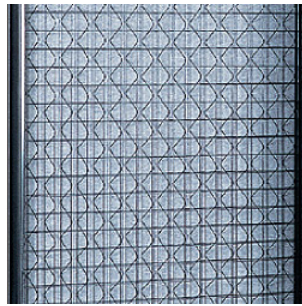







600291 - Exhibit, Panel, Wirewall, 1M



600243 - Exhibit, Shelf, 1M x 10" Deep

Trim and Panel Choices

Panel Type & Color

- | | | | |
|---|--|--|---|
|  Coated: Black (C41) |  Coated: Oxford White (C50) |  Coated: Prism Blue (C42) |  Coated: Silver Gray (C79) |
|  Fabric: Black (F41) |  Fabric: Blue (F42) |  Fabric: Gray (F40) | |

Trim Color

- | | |
|--|---|
|  Black (41) |  Silver (79) |
|--|---|

Exhibit #1, 6' Tabletop (600001)

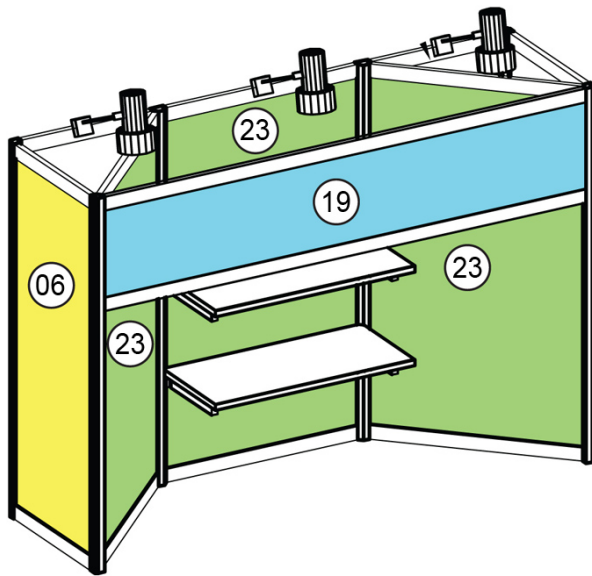

23 608323 26 9/16" wide x 45" tall

Discount Price - \$162.75 /Regular Price - \$244.00

Produced on 3/16" Thick White Foamcore

06 608306 18 7/16" wide x 45" tall

Discount Price - \$67.25 /Regular Price - \$101.00

Produced on 3/16" Thick White Foamcore

19 608319 65 15/16" wide x 12" tall

Discount Price - \$107.00 /Regular Price - \$160.75

Produced on 3/16" Thick White Foamcore

All Prices listed above are Per Panel.

Please note that pricing listed is for Graphic Panels only. GEM units are rented separately.

GES requires a form of payment on the booth graphic files in order to produce signage. Please see Digital File Preparation (1-2) for required information. Files uploaded to the GES FTP site without the required information will not be produced.

For additional questions, please contact:
Michelle Stuckert
407.370.6203



Exhibit #2, 10 x 10 (600002)

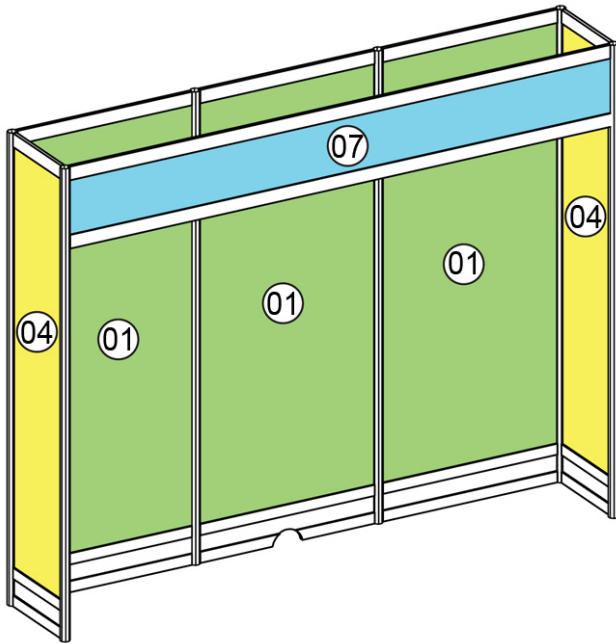

- 01** 608301 38 1/8" wide x 86 1/4" tall
Discount Price - \$445.00 /Regular Price - \$667.50
Produced on 3/16" Thick White Foamcore
- 04** 608304 18 7/16" wide x 86 1/4" tall
Discount Price - \$222.50 /Regular Price - \$333.75
Produced on 3/16" Thick White Foamcore
- 07** 608307 117" wide x 12" tall
Discount Price - \$190.50 /Regular Price - \$286.25
Produced on 3/16" Thick White Foamcore

All Prices listed above are Per Panel.

Please note that pricing listed is for Graphic Panels only. GEM units are rented separately.

GES requires a form of payment on the booth graphic files in order to produce signage. Please see Digital File Preparation (1-2) for required information. Files uploaded to the GES FTP site without the required information will not be produced.

For additional questions, please contact:
Michelle Stuckert
407.370.6203



Exhibit #3, 10 x 10 (600003)

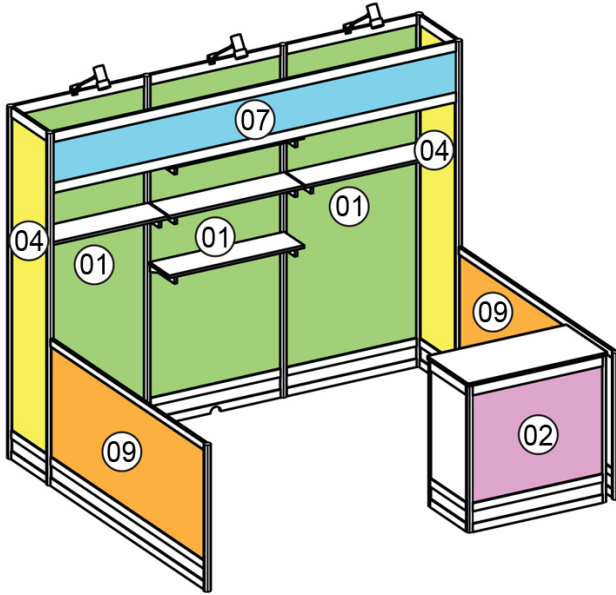

- 01** 608301 38 1/8" wide x 86 1/4" tall
Discount Price - \$445.00 /Regular Price - \$667.50
Produced on 3/16" Thick White Foamcore
- 04** 608304 18 7/16" wide x 86 1/4" tall
Discount Price - \$222.50 /Regular Price - \$333.75
Produced on 3/16" Thick White Foamcore
- 07** 608307 117" wide x 12" tall
Discount Price - \$190.50 /Regular Price - \$286.25
Produced on 3/16" Thick White Foamcore
- 02** 608302 38 1/8" wide x 30 1/4" tall
Discount Price - \$156.50 /Regular Price - \$234.75
Produced on 3/16" Thick White Foamcore
- 09** 608309 77 1/2" wide x 30 1/4" tall
Discount Price - \$317.25 /Regular Price - \$475.75
Produced on 3/16" Thick White Foamcore

All Prices listed above are Per Panel.

Please note that pricing listed is for Graphic Panels only. GEM units are rented separately.

GES requires a form of payment on the booth graphic files in order to produce signage. Please see Digital File Preparation (1-2) for required information. Files uploaded to the GES FTP site without the required information will not be produced.

For additional questions, please contact:
Michelle Stuckert
407.370.6203



Exhibit #4, 10 x 20 (600004)

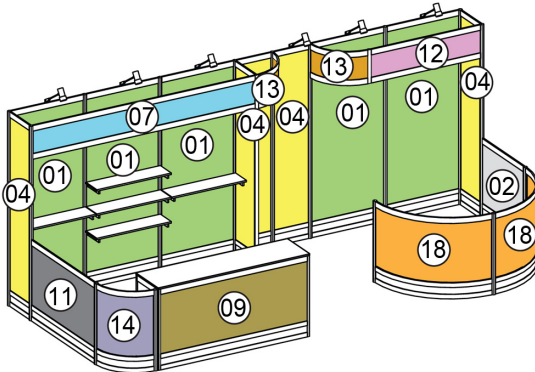

- 12** 608312 57 7/8" wide x 12" tall
Discount Price - \$97.50 /Regular Price - \$146.25
Produced on 3/16" Thick White Foamcore
- 13** 608313 29 3/4" wide x 12" tall
Discount Price - \$49.00 /Regular Price - \$73.50
Produced on 1/8" Thick White Foamacell
- 18** 608318 60 3/4" wide x 30 1/4" tall
Discount Price - \$248.25 /Regular Price - \$372.75
Produced on 1/8" Thick White Foamacell
- 09** 608309 77 1/2" wide x 30 1/4" tall
Discount Price - \$317.25 /Regular Price - \$475.75
Produced on 3/16" Thick White Foamcore
- 14** 608314 29 3/4" wide x 30 1/4" tall
Discount Price - \$121.50 /Regular Price - \$182.25
Produced on 1/8" Thick White Foamacell

- 01** 608301 38 1/8" wide x 86 1/4" tall
Discount Price - \$445.00 /Regular Price - \$667.50
Produced on 3/16" Thick White Foamcore
- 04** 608304 18 7/16" wide x 86 1/4" tall
Discount Price - \$222.50 /Regular Price - \$333.75
Produced on 3/16" Thick White Foamcore
- 11** 608311 57 7/8" wide x 30 1/4" tall
Discount Price - \$94.00 /Regular Price - \$141.00
Produced on 3/16" Thick White Foamcore
- 02** 608302 38 1/8" wide x 30 1/4" tall
Discount Price - \$156.50 /Regular Price - \$234.75
Produced on 3/16" Thick White Foamcore
- 07** 608307 117" wide x 12" tall
Discount Price - \$190.50 /Regular Price - \$286.25
Produced on 3/16" Thick White Foamcore



All Prices listed above are Per Panel.

Please note that pricing listed is for Graphic Panels only. GEM units are rented separately.

GES requires a form of payment on the booth graphic files in order to produce signage. Please see Digital File Preparation (I-2) for required information. Files uploaded to the GES FTP site without the required information will not be produced.

For additional questions, please contact:
Michelle Stuckert
407.370.6203

Exhibit #5, 20 x 20 (600005)

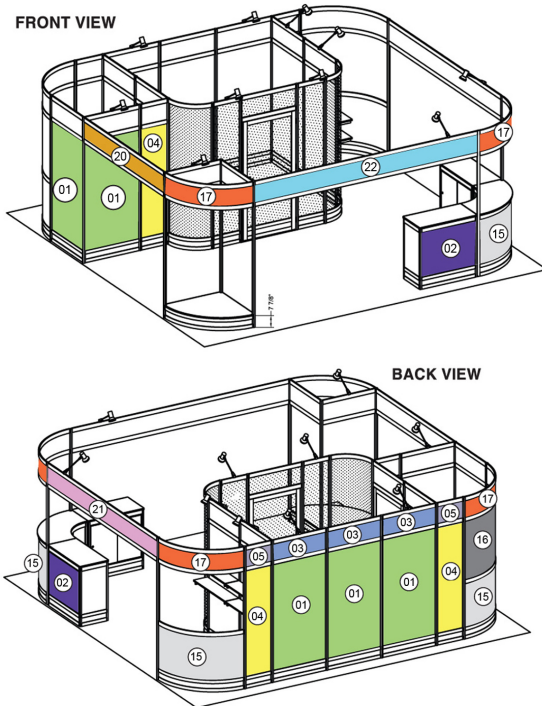

21 608321 136 9/16" wide x 12" tall
Discount Price - \$147.25 /Regular Price - \$221.50
Produced on 3/16" Thick White Foamcore

20 608320 97 3/16" wide x 12" tall
Discount Price - \$157.50 /Regular Price - \$237.00
Produced on 1/8" Thick White Foamcore

17 608317 60 11/16" wide x 12" tall
Discount Price - \$181.25 /Regular Price - \$272.00
Produced on 1/8" Thick White Foamacell

02 608302 38 1/8" wide x 30 1/4" tall
Discount Price - \$156.50 /Regular Price - \$234.75
Produced on 3/16" Thick White Foamcore

03 608303 38 1/8" wide x 12" tall
Discount Price - \$62.00 /Regular Price - \$93.25
Produced on 3/16" Thick White Foamcore

05 608305 18 7/16" wide x 12" tall
Discount Price - \$49.00 /Regular Price - \$73.50
Produced on 3/16" Thick White Foamcore

01 608301 38 1/8" wide x 86 1/4" tall
Discount Price - \$445.00 /Regular Price - \$667.50
Produced on 3/16" Thick White Foamcore

04 608304 18 7/16" wide x 86 1/4" tall
Discount Price - \$222.50 /Regular Price - \$333.75
Produced on 3/16" Thick White Foamcore

16 608316 60 11/16" wide x 40 1/4" tall
Discount Price - \$297.75 /Regular Price - \$447.00
Produced on 1/8" Thick White Foamcell

15 608315 60 11/16" wide x 30 1/4" tall
Discount Price - \$248.25 /Regular Price - \$372.75
Produced on 1/8" Thick White Foamcell

22 608322 156 1/4" wide x 12" tall
Discount Price - \$252.25 /Regular Price - \$379.00
Produced on 3/16" Thick White Foamcore

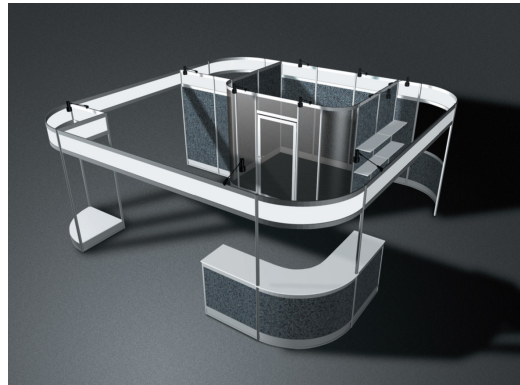

All Prices listed above are Per Panel.

Please note that pricing listed is for Graphic Panels only. GEM units are rented separately.

GES requires a form of payment on the booth graphic files in order to produce signage. Please see Digital File Preparation (I-2) for required information. Files uploaded to the GES FTP site without the required information will not be produced.

For additional questions, please contact:
Michelle Stuckert
407.370.6203

All orders are governed by the GES Payment Policy and GES Terms & Conditions of Contract as specified in this Exhibitor Services Manual.

ASDIN ANNUAL SCIENTIFIC MEETING

J W Marriott Washington DC, Grand Salon 2-4
February 15 - 17, 2013

We want your graphics and images to look their absolute best. We are committed to partnering with you in order to provide the most comprehensive and effective solutions in the trade show industry. The graphic print and production industry is continuously evolving. In order to insure the best quality graphics and images from your digital files, and to make file transfers as seamless as possible, we are pleased to provide you with guidelines for submission of your art to Graphics Production. If you are unable to provide digital artwork for your signage needs, we are capable of providing you with layout services. Additional fees will apply. Please contact GES for details.

Suitable Formats for images or logos	
Program	Preferred Format
Adobe Illustrator CS4	ai, eps
Adobe Photoshop CS4	tiff (LZW), jpeg (high quality)
Adobe InDesign CS4	indd (include all links)
Adobe Acrobat	PDF (press quality setting)
QuarkXPress 7	qxd (include all links)

Suitable Media for images or logos	
Media	Preferred Format
CD-ROM (CD-R or CD-RW)	Please send hard copy color proofs
DVD-ROM (DVD-R or DVD-RW)	Please send hard copy color proofs
Email Attachments	Limited to maximum size of 5MB
FTP	Mandatory zip or sit compression

AVOIDING ADDITIONAL COSTS:

Files obtained from the internet (.jpg or .gif) or artwork created in MS Office applications (Word, Excel, PowerPoint, etc.) are often not suitable for high quality output, and often require additional hourly charges. Artwork should be created at actual size, however, for larger files i.e., banner artwork, 10% or 25% of actual size is acceptable. Scans should be no smaller than 300dpi at quarter size. To avoid additional costs associated with these file types, please supply files in accordance with the defined herein.



gif
@ 400%



ai / eps vector
@ 400%

Vector Artwork

For the best quality, artwork should be created in **vector format (ai or vector eps)**. Logos taken from websites are generally gifs. **Gif files are not acceptable as they will not print clearly.** See Visual.

Artwork which is going to be produced in vinyl, for example; solid company logo's or text, must be supplied in a **vector format (ai or vector eps)**. Artwork created in a pixel format, i.e., TIFF and JPEG is not suitable. See Visual.



Vectors
Text @ 100%



Vectors
Outlined Text

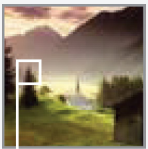

Low Resolution
(72dpi) jpeg 88 Kb



High Resolution
(300dpi) jpeg 3.52 Mb

Bitmap/Raster Artwork

JPEG - We accept this format but only if used to compress a file for ease of sending, the original artwork should have been created high resolution - **300dpi or vector eps to print at the best possible quality.** See Visual.

PDF - These are print files only and can not be altered to fit different sizes, artwork must be set up at the correct proportion and at print ready quality. Make sure images are saved at high resolution (300dpi). See Visual.

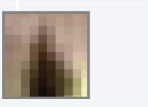

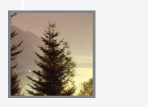



Color Set Up

If your artwork is using PANTONE Colors, please supply a Pantone color reference. Some colors are more likely to be achieved, but due to printer limitations, Pantone colors are matched to the best possible interpretation for the specific output device. Hard copies such as brochures or print outs can be used as a reference for color matching.

Fonts

Turn all fonts into outlines or convert to paths before sending the files. If you are using a program where this is not an option, **YOU MUST INCLUDE ALL FONTS** with your files.

FTP (File Transfer Protocol) Information

You can upload your file(s) after sending in your order using the information below.

	HOST	USER NAME:	PASSWORD:
Central Region Shows	ftp://csftp.ges.com/Central	gescentfp	t7od4cfz*

Please make sure your file(s) are labeled with the exhibiting company's name and the show name (e.g. EGGWHITES_COOKING SHOW.zip)



38" Ad Board

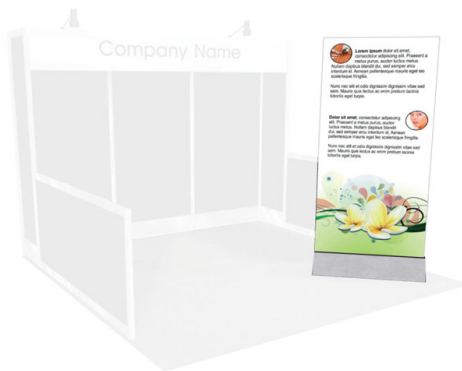

- 600527 Freestanding 38"W x 84"H Vertical Ad Board w/ Cardboard Base, Single Sided (includes cardboard base, graphic & delivery)
 - 600529 Freestanding 38"W x 84"H Vertical Ad Board w/ Cardboard Base, Double Sided
- Includes cardboard base, graphic and delivery.
Printed base available at additional cost.*

24" Ad Board

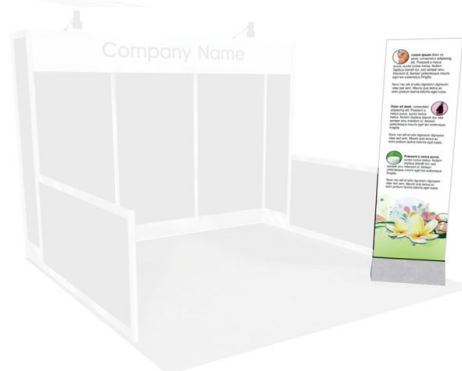

- 600526 Freestanding 24"W x 84"H Vertical Ad Board w/ Cardboard Base, Single Sided (includes cardboard base, graphic & delivery)
 - 600528 Freestanding 24"W x 84"H Vertical Ad Board w/ Cardboard Base, Double Sided
- Includes cardboard base, graphic and delivery.
Printed base available at additional cost.*

22" x 28" with Sign Holder

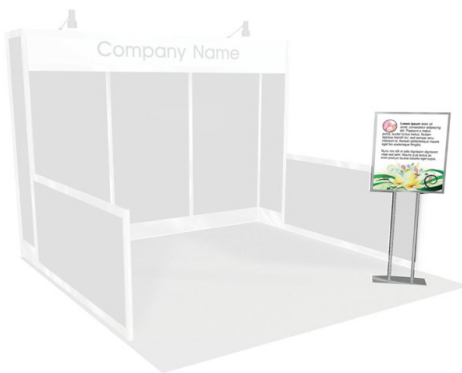

- 600533 22"W x 28"H Vertical Sign w/ Sign Holder, Single Sided
- 600534 22"W x 28"H Vertical Sign w/ Sign Holder, Double Sided

Includes sign holder rental, graphic and delivery.

6' x 3' Banner



- 600535 72"W x 36"H Vinyl Banner (horizontal or vertical) w/ Silver Grommets, Single Sided

*Banner is available horizontal or vertical.
Includes silver grommets.*

RETURN WITH G-2: PAYMENT & CREDIT CARD CHARGE AUTHORIZATION FORM TO:

Global Experience Specialists, Inc. (GES) • 7000 Lindell Road, Las Vegas, NV 89118-4702 • Fax: 866.329.1437 or 702.263.1520 for international exhibitors

All orders are governed by the GES Payment Policy and GES Terms & Conditions of Contract as specified in this Exhibitor Services Manual.

ASDIN ANNUAL SCIENTIFIC MEETING

J W Marriott Washington DC, Grand Salon 2-4
February 15 - 17, 2013

Discount Deadline Date:

January 25, 2013

Go to below link to view images and information:
<http://ges.com/ecommm/info/landD.pdf>

COMPANY NAME	EMAIL ADDRESS	BOOTH NUMBER
SHOWSITE CONTACT	SHOWSITE CONTACT PHONE #	DATE/TIME OF ARRIVAL
CONTACT'S HOTEL (OPTIONAL)		

**PLEASE COMPLETE THIS FORM FOR ALL DISPLAY LABOR NEEDED.
TO DETERMINE IF YOU NEED DISPLAY LABOR, PLEASE READ THIS FORM CAREFULLY.**

- Display Labor is required for all installation and dismantling of exhibits, including signs and floor covering installation.
- Exhibitor may unpack and place merchandise.
- Exhibitor may set up exhibit display if one person can accomplish the task in less than one-half (1/2) hour without the use of tools.

Important Information & Rates

Starting time can be guaranteed only when labor is requested for the start of the working day. All exhibit labor scheduled at the start of the working day will be dispatched to booth space. For all other starting times, check in at the labor desk one-half (1/2) hour before time requested. Labor cancelled without a 24 hour notice shall be charged a one (1) hour cancellation fee per worker. If Exhibitor fails to use the workers at the time confirmed, a one (1) hour "No-Show" charge per worker will apply.

The minimum charge for labor is one (1) hour per worker. Labor thereafter is charged in half (1/2) hour increments. Gratuities in any form, including cash, gifts, or labor hours for work not actually performed are prohibited by GES. GES requires the highest standards of integrity from all employees. Please call our confidential Always Honest hotline at 866.225.8230 to report fraudulent or unethical behavior. All rates are subject to change if necessitated by increased labor and material costs.

LABOR RATES ARE AS FOLLOWS:

Worker per Hour	Discount	Regular	Show Site
Install & Dismantle, ST Code: 705000	\$ 80.00	\$ 100.00	\$ 120.00
Install & Dismantle, OT Code: 705000	\$ 120.00	\$ 150.00	\$ 180.00
Install & Dismantle, DT Code: 705000	\$ 182.25	\$ 227.75	\$ 274.00

- Straight Time:** Monday through Friday from 8:00 AM to 4:30 PM.
- Overtime:** All other times Monday through Friday. All day Saturday.
- Double Time:** All day Sunday & Holidays.
- Discount Rate:** Rate applies to orders placed on or before the above Discount Deadline Date.
- Regular Rate:** Rate applies to orders placed after the above Discount Deadline Date, but before the first day of exhibitor move-in.
- Show Site Rate:** Rate applies to orders placed at show site

Please Indicate Service

GES Supervised (OK to Proceed)

Please complete "Key Information" form (L-2)

GES will supervise labor to:

- Unpack and install display before Exhibitor arrival at show site.
- Dismantle and pack the display after show closing.
- Subject to terms and conditions of all GES policies, including terms and conditions of contract, including but not limited to sub-paragraph VII, b., Labor.

A 25% (\$50.00 minimum) surcharge will be added to the labor rates above for this professional supervision.

LOCATION OF BOOTH/DIMENSION OF BOOTH: Use the Booth Layout Form to represent your booth, indicate from each boundary how you would like your booth placed.

Exhibitor Supervised (Do Not Proceed)

Exhibitor will supervise.

- Indicate workers needed for installation and dismantling
- GES assumes no liability for loss, damage or bodily injury arising out of the installation and/or dismantling of Exhibitor's property by GES provided union labor. Exhibitor assumes the responsibility and any liability arising therefrom, for the work performed by union labor under Exhibitor's supervision. Exhibitors must stay clear during movement of freight.

GES is responsible for the following type of booth:

- Pop-Up Two Story Custom
 Other: _____

Place Order Here

SCHEDULE DATE(S)	SCHEDULE START TIME	SCHEDULE END TIME	TOTAL # OF HOURS	TOTAL # OF WORKERS	LABOR RATE	TOTAL	3% PSP	GRAND TOTAL
	AM PM	AM PM						\$
	AM PM	AM PM						\$
I agree in placing this order that I have accepted GES Payment Policy and GES Terms & Conditions of Contract.						A.	Total Labor Ordered	\$
Authorized Signature - Please Sign:						B.	25% (\$50.00 min) GES Supervision	\$
X	AUTHORIZED NAME - PLEASE PRINT				DATE	C.	Payment Enclosed	\$

Please estimate the number of workers and hours per worker needed for installation and dismantling above. Invoice will be calculated according to actual hours worked, relative to the original estimate and based upon the date received. Additional labor required will be calculated and invoiced at the show site rate.



RETURN TO: Global Experience Specialists, Inc. (GES) • 7000 Lindell Road, Las Vegas, NV 89118-4702 • Fax: 866.329.1437 or 702.263.1520 for international exhibitors
 Contact us Online: www.ges.com/chat Phone: 800.475.2098 or 702.515.5970 for international exhibitors

All orders are governed by the GES Payment Policy and GES Terms & Conditions of Contract as specified in this Exhibitor Services Manual.

ASDIN ANNUAL SCIENTIFIC MEETING

J W Marriott Washington DC, Grand Salon 2-4
 February 15 - 17, 2013

Form Deadline Date:
 January 25, 2013

MANDATORY FORM*

COMPANY NAME _____	EMAIL ADDRESS _____	BOOTH NUMBER _____
--------------------	---------------------	--------------------

To Be Completed By Exhibitor When Order is Placed

Inbound Freight Information

Method GES Logistics Common Carrier AirFreight Vanline Other _____
 Carrier (if known) _____
 Contact _____ Phone _____
 Number of Crates _____ Shipped By _____ Date _____
 Number of Fiber Cases _____ Color _____ Pro Number _____
 Target Date _____ Loose Display _____ Crated Display _____
 Shipped To: (Check One) Warehouse

Setup Information for GES Installation

<input type="checkbox"/> Setup Drawings/Instructions Attached <input type="checkbox"/> Setup Drawings With Exhibit <input type="checkbox"/> Case/Crate Number _____ <input type="checkbox"/> Number of Workers Required for Setup _____ <input type="checkbox"/> Forklift Ordered Hrs. _____ Time _____ <input type="checkbox"/> Number of Graphics _____ Layout Provided? <input type="checkbox"/> Yes <input type="checkbox"/> No <input type="checkbox"/> Number of Lights _____ Number of Light Boxes _____	<input type="checkbox"/> Rental Carpet Color _____ <input type="checkbox"/> Own Carpet Color _____ <input type="checkbox"/> Padding _____ Approximate Time for Setup _____ Special Equipment Required _____ Description _____ Description _____
---	---

Did You Order ---

Electrical Outlets Yes No Electrical Labor/Boothwork Yes No Electrical Under Carpet Yes No
 Electrical Drawings Attached Sent to the Official Electrical Contractor With the Exhibit
 Booth Cleaning Yes No Other Items _____
 Furniture Yes No
 A/V Equipment Yes No
 Telephone/Internet Yes No

Tear-down Information for GES Dismantle

<input type="checkbox"/> Tear-down Drawings/Instructions Attached <input type="checkbox"/> Tear-down Drawings With Exhibit <input type="checkbox"/> Case/Crate Number _____ <input type="checkbox"/> Number of Workers Required for Tear- down _____ <input type="checkbox"/> Forklift Ordered Hrs. _____ Time _____ <input type="checkbox"/> Number of Graphics _____ Layout Provided? <input type="checkbox"/> Yes <input type="checkbox"/> No <input type="checkbox"/> Number of Lights _____ Number of Light Boxes _____	<input type="checkbox"/> Rental Carpet Color _____ <input type="checkbox"/> Own Carpet Color _____ <input type="checkbox"/> Padding _____ Approximate Time for Tear-down _____ Special Equipment Required _____ Description _____ Description _____
--	---

Outbound Freight Information

Outbound Freight Charges _____ Consigned To _____
 PrePaid Collect (for non-GES Logistics Shipments only) Address _____
 Bill To _____ City/State/Zip _____
 _____ Second Consignee _____
 _____ Address _____
 GES Storage _____ City/State/Zip _____
 Method GES Logistics Common Carrier AirFreight Vanline Other _____
 Carrier (if known) _____
 Contact _____ Phone _____
 Exhibitor-completed GES' Outbound Material Handling Form attached: Yes No
 Exhibitor will pack all product, prepare shipping labels and complete GES' Outbound Material Handling Form attached: Yes No

Emergency Contact Information / Showsite Contact

Name _____ Title _____
 Telephone _____ Cell Phone _____
 Other Means of Contacting This Person _____
 Contact's Hotel _____ Arrival _____ Departure _____
 Purchasing Authorization Yes No

*This Form must be returned to GES for your orders to be processed.

I agree in placing this order that I have accepted GES Payment Policy and GES Terms & Conditions of Contract.

Authorized Signature - Please Sign:

X

AUTHORIZED NAME - PLEASE PRINT _____	DATE _____
--------------------------------------	------------

Need Assistance?

Toll Free: 800.475.2098 | Tel: 702.515.5970 | www.ges.com/chat



RETURN WITH G-2: PAYMENT & CREDIT CARD CHARGE AUTHORIZATION FORM TO:

Global Experience Specialists, Inc. (GES) • 7000 Lindell Road, Las Vegas, NV 89118-4702 • Fax: 866.329.1437 or 702.263.1520 for international exhibitors

All orders are governed by the GES Payment Policy and GES Terms & Conditions of Contract as specified in this Exhibitor Services Manual.

ASDIN ANNUAL SCIENTIFIC MEETING

J W Marriott Washington DC, Grand Salon 2-4
February 15 - 17, 2013

Discount Deadline Date:
January 25, 2013

COMPANY NAME	EMAIL ADDRESS	BOOTH NUMBER
--------------	---------------	--------------

Price List

ITEM#	DESCRIPTION	DISCOUNT PRICE	REGULAR PRICE
Vacuuming			
<i>Includes emptying your wastebasket nightly.</i>			
500601	Before Show Open Only (per sq. ft.)	\$ 0.72	\$ 1.08
500600	Duration of Show (per sq. ft. per day)	\$ 0.49	\$ 0.74
500602	Per Day (per sq. ft. per day)	\$ 0.69	\$ 1.04
Shampooing			
501004	Cleaning, Carpet Shampoo Before Show Open	\$ 0.97	\$ 1.45
Mopping and Waxing			
501002	Cleaning, Damp Mop & Wax	\$ 1.26	\$ 1.88
Porter service			
<i>GES will empty wastebaskets & wipe down counters at two hour intervals, show hours only. Vacuuming not included. Calculate by your booth size.</i>			
501010	Porter Service, 0-500 sq.ft., Per Day	\$ 152.50	\$ 228.75
501010	Porter Service, 501-1500 sq.ft., Per Day	\$ 191.50	\$ 287.25
501010	Porter Service, 1501-3000 sq.ft., Per Day	\$ 228.75	\$ 343.00

To ensure your booth is show-ready, specify your requirements below. Please call us if you have a special need. GES is the exclusive cleaning contractor for your show and will handle all cleaning services on the exhibit floor. We offer discounts for orders exceeding 2,000 square feet (please call for a quote).

Cost of vacuuming, shampooing, mopping and waxing will be invoiced on the total area of your booth.

Cancellation Policy: Due to material and labor costs, orders cancelled before move-in begins will be charged **50%** of original price. Similarly, orders cancelled after move-in will be charged **100%**.

Please Indicate Service Place Order Here

Calculate Total Square Footage

Width _____ x Length _____ = _____ Square Feet

Would you like us to call you and give you a quote for hourly porter service?

Yes No

Please list dates and times Vacuuming Per Day/Periodic Porter Service is needed:

To avoid any misunderstanding regarding these services, please bring any discrepancies to our attention at the **GES Servicenter**. GES will be unable to adjust invoices after the close of the show.

ITEM#	DESCRIPTION	TOTAL SQ FT	X PRICE/SQ FT	X NO. OF DAYS	TOTAL PRICE
500600	Vacuuming Duration			3	\$
500602	Vacuuming Per Day				\$

ITEM#	DESCRIPTION	TOTAL SQ FT	X PRICE/SQ FT	TOTAL PRICE
500601	Vacuuming Before Show Only			\$
501004	Shampooing Before Show Only			\$
501002	Mop/Wax Before Show Only			\$

ITEM#	DESCRIPTION	PRICE	X NO. OF DAYS	TOTAL PRICE
	Porter service			\$
A.	Total All Items Ordered			\$
B.	Petroleum Surcharge Assessment: 3%		A x 3% = B	\$
C.	Subtotal		A + B = C	\$
D.	Labor Tax: 6%		C x 6% = D	\$
E.	Payment Enclosed		C + D = E	\$

I agree in placing this order that I have accepted GES Payment Policy and GES Terms & Conditions of Contract.

Authorized Signature - Please Sign: X

AUTHORIZED NAME - PLEASE PRINT	DATE
--------------------------------	------



Credit Card Authorization: Global Experience Specialists, Inc. (GES) • 7000 Lindell Road, Las Vegas, NV 89118-4702 • Fax: 866.329.1437 or 702.263.1520 for international exhibitors

Check Payments: Global Experience Specialists, Inc. (GES) • Bank of America P.O. Box 96174, Chicago, IL 60693

All orders are governed by the GES Payment Policy and GES Terms & Conditions of Contract as specified in this Exhibitor Services Manual.

ASDIN ANNUAL SCIENTIFIC MEETING

J W Marriott Washington DC, Grand Salon 2-4
February 15 - 17, 2013

Form Deadline Date:
January 25, 2013

MANDATORY FORM*

COMPANY NAME	EMAIL ADDRESS	BOOTH NUMBER		
STREET ADDRESS	CITY	STATE	ZIP	COUNTRY
PHONE	FAX	PURCHASE ORDER NUMBER		
BOOTH PRIMARY CONTACT NAME AND PHONE NUMBER		SHOWSITE CONTACT NAME AND PHONE NUMBER		

Payment Policy

Payment for Services — GES requires payment in full at the time services are ordered. Further, GES requires that you provide a credit card authorization with your initial order. For your convenience, we will use this authorization to charge your account for services, which may include labor, material handling, or any applicable fuel or energy surcharge.
Discount Prices — To qualify for discount pricing, orders must be received with payment on or before the discount price deadline(s).

Method of Payment — GES accepts MasterCard, Visa, American Express, check and bank wire transfer. Purchase orders are not considered payment. All payments must be made in U.S. funds drawn on a U.S. Bank. *Exhibitors will be charged a \$50.00 fee for returned NSF checks.*

Third Party Billing — Each exhibiting firm is ultimately responsible for all charges incurred on its behalf. GES reserves the right to institute collection action against the exhibitor if the authorized third party does not pay. See *Third Party Billing Request* form.

Tax Exempt — If you are tax exempt in the state in which you will be exhibiting, you must provide a Sales Tax Exemption Certificate for that state. Please send the above information to the GES office for this show. Taxes vary by location and will be added to your invoice, if you do not submit your tax exempt certificate prior to the deadline.

Adjustments and Cancellations — No adjustments to invoices will be made after the close of the show. Please refer to the individual forms for labor, etc., for cancellation fees. All orders cancelled by the Exhibitor or due to the cancellation of an event or their non-participation may be subject to cancellation fees equal to 50% - 100% of the total order, based upon the status of move-in, work performed and/or GES set-up costs or expenses. A minimum non-refundable deposit of \$25.00 will be applied towards the invoice, unless there is a cancellation of your order. Additionally, GES retains the right to implement/assess a fuel or energy surcharge on all services as necessary based upon market conditions.

Bank wire transfer payment information:

Beneficiary: Global Experience Specialists
c/o Bank of America **Account #:** 7188-1-01819
901 Main Street, TX1-492-07-14 **ABA Routing #:** 0260-0959-3
Dallas, TX 75202-3714 USA **SWIFT Address:** BOFAUS3N
Telephone # 888-715-1000 ext 50118 **CHIPS Address:** 0959

If requested, following is the physical address for routing identifiers:

Bank of America, Wire Transfer-Customer Services
2000 Clayton Road, Concord, CA 94520 USA

To properly credit your account, send the following information to the GES address listed on the order forms:

- exhibiting company name, show name, show facility, and booth number
- date and amount of wire transfer
- bank and country where transfer originated

- **If you have any questions regarding our payment policy, please call GES National Servicenter® at 800.475.2098 or visit the GES Servicenter® at the show.**
- **Please complete the information and return payment in full with this form and your orders.** You may choose to pay by credit card, check, or bank wire transfer, however, **we require your credit card charge authorization to be on file with GES.**
- All balances must be paid at the conclusion of the event. You agree to late fees up to 1.5% per month on any balance not paid at the conclusion of the event, or balance left without appropriate credit card on file.
- **For your convenience,** we will use this authorization to charge your credit card for any additional amounts ordered by your representative or services rendered to your company for this event.
- GES will charge a convenience fee for each request to reprocess payment to an alternate credit card in order to cover incremental processing costs. An alternate credit card is a credit card different than the one used to process your initial payment in accordance with GES payment policy. The convenience fee will be quoted at the time your request is made to reprocess payment. The convenience fee will be added to your account balance and settled utilizing the new credit card provided.

GES requires the highest standards of integrity from all employees. Please call our confidential Always Honest hotline at 866.225.8230 to report fraudulent or unethical behavior.

***This form must be returned to GES for your orders to be processed.**

Credit Card Charge Authorization

All information must be provided. **Your order will not be processed if any information is missing.** (i.e., Expiration Date, Account Number, Contact Information, Type of Card, Signature) **We require your credit card charge authorization to be on file with GES even if you are paying by check or bank wire transfer.**

Account Number Corporate Card Personal Card

____ - ____ - ____ - ____

PROVIDE EXPIRATION DATE MasterCard VISA American Express

____ / ____

*Signature Required Below

CARDHOLDER'S NAME PLEASE PRINT

CARDHOLDER'S BILLING ADDRESS CITY

STATE ZIP COUNTRY

Calculation of Orders

	TOTAL
Material Handling	\$
Carpet	\$
Furniture & Accessories	\$
Specialty Furniture	\$
Standard Exhibit Systems	\$
Graphics & Signage	\$
Installation & Dismantling Labor	\$
Cleaning	\$
Other GES Services (Specify)	\$
Other GES Services (Specify)	\$
Other GES Services (Specify)	\$
Other GES Services (Specify)	\$
FULL PAYMENT in U.S. funds drawn on a U.S. Bank <small>Global Experience Specialists Federal ID #59-1008863 GES is exempt from backup withholding tax.</small>	\$

To simplify payment, send a check payable to Global Experience Specialists for your entire order or note the amount to be charged to your credit card.

Charge my credit card in the amount of: \$ _____

Enclosed is a check in the amount of: \$ _____

Check Number: _____ Dated: _____

Please note payment return addresses at top of form.

I agree in placing this order that I have accepted GES Payment Policy and GES Terms & Conditions of Contract. *Credit card charge authorization signature required below.

PLEASE SIGN X _____
AUTHORIZED SIGNATURE / CARDHOLDER'S SIGNATURE

AUTHORIZED NAME - PLEASE PRINT DATE

RETURN TO: Global Experience Specialists, Inc. (GES) • 7000 Lindell Road, Las Vegas, NV 89118-4702 • Fax: 866.329.1437 or 702.263.1520 for international exhibitors
 Contact us Online: www.ges.com/chat Phone: 800.475.2098 or 702.515.5970 for international exhibitors

All orders are governed by the GES Payment Policy and GES Terms & Conditions of Contract as specified in this Exhibitor Services Manual.

ASDIN ANNUAL SCIENTIFIC MEETING
 J W Marriott Washington DC, Grand Salon 2-4
 February 15 - 17, 2013

Form Deadline Date:
 January 25, 2013

COMPANY NAME	EMAIL ADDRESS	BOOTH NUMBER
--------------	---------------	--------------

If you would like to arrange a third party to handle your display, please complete the below steps:

- **Step 1:** Fill in the appropriate information and select the services to be charged to the **Exhibiting Firm**. A signature is **required** to authorize these services.
- **Step 2:** Complete and sign the **Exhibiting Firm** Credit Card Authorization.
- **Step 3:** Fill in the appropriate information and select the services to be charged to the **Third Party**. A signature is **required** to authorize these services.
- **Step 4:** Complete and sign the **Third Party** Credit Card Authorization.

GES reserves the right to deny any Third Party Billing Request that is not complete or received by the deadline date.

It is understood and agreed that the exhibiting firm is ultimately responsible for payment of charges. If your named third party does not pay the invoice before the last day of the show, charges will revert to the exhibiting firm. All invoices are due and payable upon receipt. GES Terms & Conditions of Contract apply to both the Exhibiting Firm and Third Party Representative.

STEP 1: Exhibiting Firm - Complete Below Information	STEP 2: Exhibiting Firm Credit Card Charge Authorization
EXHIBITING FIRM	CARDHOLDER'S NAME PLEASE PRINT
STREET ADDRESS	CARDHOLDER'S BILLING ADDRESS CITY
CITY STATE ZIP	STATE ZIP COUNTRY
PHONE FAX	Account Number
<p><i>The items checked below are to be invoiced to the Exhibiting Firm:</i></p> <input type="checkbox"/> Booth Cleaning <input type="checkbox"/> Exhibit Systems <input type="checkbox"/> I & D Labor <input type="checkbox"/> Material Handling In & Out <input type="checkbox"/> Rental Carpet <input type="checkbox"/> Rental Furniture <input type="checkbox"/> Signs <input type="checkbox"/> Transportation Charges <input type="checkbox"/> Other (Please Specify) _____	<input type="text"/> - <input type="text"/> - <input type="text"/> - <input type="text"/> EXPIRATION DATE <input type="checkbox"/> MasterCard <input type="checkbox"/> Corporate Card <input type="checkbox"/> VISA <input type="checkbox"/> Personal Card <input type="checkbox"/> American Express
I agree in placing this order that I am responsible for the above selected services and that I have accepted GES Payment Policy and GES Terms & Conditions of Contract.	All information must be provided. Your order will not be processed if any information is missing. (i.e. Expiration Date, Account Number, Contact Information, Type of Card, and Signature.) We require your credit card charge authorization to be on file with GES even if you are paying by check or bank wire transfer.
PLEASE SIGN <input checked="" type="checkbox"/> _____ AUTHORIZED SIGNATURE	PLEASE SIGN <input checked="" type="checkbox"/> _____ CARDHOLDER'S SIGNATURE
_____ AUTHORIZED NAME - PLEASE PRINT DATE	_____ CARDHOLDER NAME - PLEASE PRINT DATE

Check here if the Third Party or its sub-contractors will be providing services to Exhibiting Firm at show site. (EAC Notification Form and insurance requirements must be completed for admission)

STEP 3: Third Party - Complete Below Information	STEP 4: Third Party Credit Card Charge Authorization
THIRD PARTY	CARDHOLDER'S NAME PLEASE PRINT
STREET ADDRESS	CARDHOLDER'S BILLING ADDRESS CITY
CITY STATE ZIP	STATE ZIP COUNTRY
PHONE FAX	Account Number
<p><i>The items checked below are to be invoiced to the Third Party:</i></p> <input type="checkbox"/> Booth Cleaning <input type="checkbox"/> Exhibit Systems <input type="checkbox"/> I & D Labor <input type="checkbox"/> Material Handling In & Out <input type="checkbox"/> Rental Carpet <input type="checkbox"/> Rental Furniture <input type="checkbox"/> Signs <input type="checkbox"/> Transportation Charges <input type="checkbox"/> All Services <input type="checkbox"/> Other (Please Specify) _____	<input type="text"/> - <input type="text"/> - <input type="text"/> - <input type="text"/> EXPIRATION DATE <input type="checkbox"/> MasterCard <input type="checkbox"/> Corporate Card <input type="checkbox"/> VISA <input type="checkbox"/> Personal Card <input type="checkbox"/> American Express
I agree in placing this order that I am responsible for the above selected services and that I have accepted GES Payment Policy, GES Terms & Conditions of Contract, and Agreement and Rules and Regulations between GES and EAC (L4).	All information must be provided. Your order will not be processed if any information is missing. (i.e. Expiration Date, Account Number, Contact Information, Type of Card, and Signature.) We require your credit card charge authorization to be on file with GES even if you are paying by check or bank wire transfer.
PLEASE SIGN <input checked="" type="checkbox"/> _____ AUTHORIZED SIGNATURE	PLEASE SIGN <input checked="" type="checkbox"/> _____ CARDHOLDER'S SIGNATURE
_____ AUTHORIZED NAME - PLEASE PRINT DATE	_____ CARDHOLDER NAME - PLEASE PRINT DATE

12/12/12

RETURN TO: Global Experience Specialists, Inc. (GES) • 7000 Lindell Road, Las Vegas, NV 89118-4702 • Fax: 866.329.1437 or 702.263.1520 for international exhibitors
 Contact us Online: www.ges.com/chat Phone: 800.475.2098 or 702.515.5970 for international exhibitors

All orders are governed by the GES Payment Policy and GES Terms & Conditions of Contract as specified in this Exhibitor Services Manual.

ASDIN ANNUAL SCIENTIFIC MEETING

J W Marriott Washington DC, Grand Salon 2-4
 February 15 - 17, 2013

Form Deadline Date:
 January 25, 2013

MANDATORY FORM*

COMPANY NAME	EMAIL ADDRESS	BOOTH NUMBER	
SHOWSITE CONTACT	SHOWSITE CONTACT PHONE #	DATE/TIME OF ARRIVAL	CONTACT'S HOTEL (OPTIONAL)

A unique grid must be completed for each of the following services to ensure proper placement of items in your booth. Please do not combine services onto a single grid. Print/photocopy as needed.

- Show Cases - Form Q-1
- Pegboard / Tackboard - Form Q-1
- Special Colored Drape - Form Q-1
- Standard Exhibit Systems (if exhibit size is smaller than booth size) - Form Q-1
- Pad and Carpet (if you are not carpeting your entire booth) - Form Q-1
- Installation & Dismantling - Form L-1

To use this grid:

- Use bold lines to indicate the outline of your booth.
- Indicate the scale of the grid (i.e. 1 square = 1 foot) or indicate the dimensions of your booth.
- Mark the adjacent booth numbers or aisle numbers.

Each square is _____ feet square since my booth is _____ feet wide by _____ feet long.

BACK OF BOOTH (indicate adjacent booth or aisle number: _____)

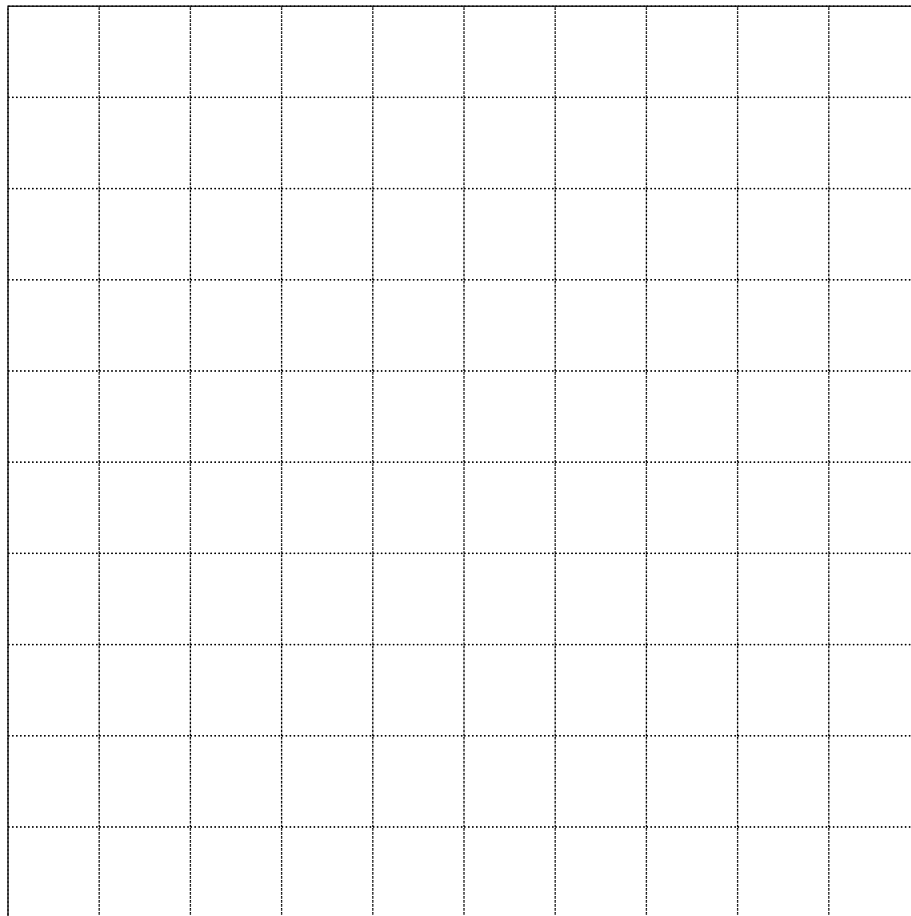

Indicate
 Adjacent
 Booth or
 Aisle Number:

Indicate
 Adjacent
 Booth or
 Aisle Number:

FRONT OF BOOTH (indicate adjacent booth or aisle number: _____)

***This form must be returned to GES for your orders to be processed.**



Additional Service Order Forms



JW MARRIOTT
WASHINGTON DC

JW Marriott Washington, DC
1331 Pennsylvania Avenue, NW
Washington, DC 20004
Phone: (202) 626-1360
Fax: (636) 680-5592



EXHIBITOR EQUIPMENT ORDER FORM

COMPUTER		QTY	TOTAL	INFORMATION				
Laptop PC w/Windows/Office	\$ 350.00			EVENT NAME				
Laser Printer	\$ 200.00							
MONITORS		QTY	TOTAL	COMPANY				
21" Flat Panel Monitor	\$ 200.00							
52" LCD TV Monitor	\$ 750.00							
70" Interactive LED Touchscreen Monitor	\$ 950.00			ADDRESS				
LCD Projector (meeting room)	\$ 850.00							
6' Tripod Screen	\$ 75.00			CITY	STATE	ZIP		
DVD/BLU RAY		QTY	TOTAL	PHONE # FAX #				
DVD Player	\$ 75.00							
Blu Ray Player	\$ 125.00							
TELEPHONE		QTY	TOTAL	MOBILE # EMAIL				
House Phone	\$ 25.00							
DID Phone Line (direct inward dial)	\$ 125.00			REPRESENTATIVE'S NAME TITLE				
Polycom Speakerphone	\$ 350.00							
INTERNET		QTY	TOTAL	REPRESENTATIVE'S SIGNATURE				
Wired Internet (per computer)	\$ 500.00							
Wireless Internet (1-5 users)	\$ 125.00			ON SITE CONTACT				
Wireless Internet (6-10 users)	\$ 195.00							
ELECTRICAL		QTY	TOTAL	ROOM BOOTH				
20 AMPS (120V, 1 Phase)	\$ 100.00							
60 AMPS (120V, 1 Phase)	\$ 250.00							
				SETUP DATE TIME				
ENGINEERING		QTY	TOTAL	REMOVAL DATE TIME				
Banner Hanging Fee (per banner)	\$ 75.00							
LIFT RENTAL		QTY	TOTAL	ACTUAL SHOW DATES TIME				
Personal Man Lift	\$ 500.00							
ELECTRICAL		QTY	TOTAL	ELECTRICAL NOTICE: Washington, DC code requires that no electrical or apparatus can be connected unless it conforms to the D.C. electrical code. Flexible cords and cables less than #14 gauge are not permitted. Only fixtures with screw-in type allowed with #14-3 SJ cord. No Spring-type clamp spot fixtures or holders will be allowed				
100 AMPS (208V, 1 Phase)	\$ 350.00							
100 AMPS (208V, 3 Phase)	\$ 475.00							
200 AMPS (208V, 1 Phase)	\$ 500.00							
SUB TOTAL			\$					
NUMBER OF DAYS NEEDED			X	PAYMENT BY CHECK				
				Please mail checks to the address posted above. Payments by check must be received 7 days prior to installation.				
				PAYMENT BY CREDIT CARD				
GRAND TOTAL			\$	CREDIT CARD NUMBER				
<p>PLEASE NOTE All charges are on a per day basis. A 6% D.C. sales tax & 22% service charge which includes set-up and teardown will be applied to all orders. Equipment cancelled within 12 hours of an event will be charged 50% of the full price. Credit or payment MUST be established before installation.**Local & Long Distance rates may apply to phone line rentals.</p> <p>All fees current as of January 2012</p>				TYPE		EXP DATE		
				CARDHOLDERS NAME				
				SIGNATURE				
				PMS # (Hotel Use Only)				



JW Marriott
Washington, DC



American Society of Diagnostic & Interventional Nephrology

February 15th – 17th, 2013

Order online: www.MyLeadRetrievalOrder.com/ASDIN

Modernize Your Booth Marketing

iLeads Cloud-Based Lead Retrieval

Improve Your Show Efficiency and Close More Deals Faster

What is the iLeads App?

The award winning iLeads is the first and most widely used exhibitor lead management app. Capture leads by typing Badge ID # or scan the QR code when available using your own iPod touch, iPhone, iPad.

(Minimum Operating System required is 4.3) Android (Minimum Operating System required is 2.1). Build a greater pipeline of qualified leads. Capture sales leads anywhere, anytime. Add action items and notes to leads. Follow up instantly by tapping attendee's telephone and email address.



- ✓ Contact Management.
- ✓ Works Offline
- ✓ Capture sales leads anywhere, any time.
- ✓ Customizable. Add action items and notes to leads.
- ✓ Live Reporting. Run real-time lead analysis reports.
- ✓ Backed up and synched on a secure website.

Marketing Extras, included, no extra charge

Attendee Notification

Bartizan e-mails each attendee with an interactive list of the booths they visited.

Lets attendees follow up on you.

QR Code for Booth

One free, print-ready custom QR code for booth marketing.

Your custom QR code can send attendees to your video, twitter page or your website.

Use the digital image file to print on your literature or premium items.

Lead Management Software

Using LeadsLightning, track the attendees who stopped by your booth. View, sort, print and download leads.

Identify best leads by filtering and prioritizing.

Access anywhere, anytime up to 6 months after the show.

Email Follow-Up Service

One optional customized, email sent within 48 hours after the event to each of your leads.

Now you can guarantee prompt follow-up before you even get back to the office.

Exhibitor Education

Copy of Bartizan's 64-page eBook of exhibitor tips.

Includes "7 Deadly Sins of Tradeshow Exhibiting."



JW Marriott
Washington, DC



American Society of Diagnostic & Interventional Nephrology

February 15th – 17th, 2013

Order online: www.MyLeadRetrievalOrder.com/ASDIN

Mobile Lead Management Packages



All Lead App Packages Include:

- ✓ **iLeads App Data Licenses for Your Booth**
- ✓ **1 Print Ready Custom QR Code** for product promotion at booth.
- ✓ **Email Follow-up Service:** One optional email sent to the leads you capture at your event
- ✓ **Exhibitor Education:** 64-page eBook with insider information.

Lead Retrieval Options	QTY	ORDER BY	ORDER BY	ONSITE	TOTAL
		1/18/2013	2/1/2013		
iLeads App: Master License Capture leads by typing Badge ID # or scan the QR code when available using your own iPod touch, iPhone, iPad. <i>(Minimum Operating System required is 4.3) Android (Minimum Operating System required is 2.1).</i>	<input type="checkbox"/>	\$200.00	\$210.00	\$220.00	_____
Additional Licenses: 1 to 2 Allow your entire team to collect leads. 2 nd and 3 rd license: Pricing based per license	<input type="checkbox"/>	\$89.00	\$99.00	\$109.00	_____
Additional Licenses: 4 plus Allow your entire team to collect leads. 4 th license +: Pricing based per license	<input type="checkbox"/>	\$49.00	\$59.00	\$69.00	_____
PLEASE NOTE: When purchasing additional licenses a Master license must always be purchased.					
iPod touch Rental: Includes iLeads lead retrieval app pre-loaded.	<input type="checkbox"/>	\$300.00	\$325.00	N/A	_____
iPad Rental: Includes iLeads lead retrieval app pre-loaded.	<input type="checkbox"/>	\$400.00	\$425.00	N/A	_____
iPad Rental with 3G Service: Includes iLeads lead retrieval app pre-loaded	<input type="checkbox"/>	\$480.00	\$505.00	N/A	_____
Additional QR Codes: For exhibitors that have ordered lead retrieval (1 per order)	<input type="checkbox"/>	\$19.00	\$29.00	N/A	_____
QR Codes: For exhibitors that have NOT ordered lead retrieval (1 per order)	<input type="checkbox"/>	\$49.00	\$59.00	N/A	_____

Company Name _____



GRAND TOTAL _____

Please Note: Upon placing this order you agree to the full Terms & Conditions on the attached document. All attendees will receive an email a few days after the show containing a list of booths that they visited, extending your reach after the show. To make the most of this free listing please log on to: www.leadslightning.com/leadslightning/ASDIN2013 to provide your info. Without your complete company contact information, the list sent to attendees will contain only your name and booth number.

Order Online: www.MyLeadRetrievalOrder.com/ASDIN or Fax to: 914-965-7746

Contact Information

COMPANY: _____ BOOTH #: _____

ADDRESS: _____

CITY: _____ STATE: _____ ZIP: _____ COUNTRY: _____

PHONE#: _____ FAX #: _____

ORDER CONTACT: _____ EMAIL: _____

ONSITE CONTACT: _____ CELL #: _____

iLeads Only:

Please provide First Name, Last Name and Email address of person to receive the Event Access Code.

Recipient will also receive the User Name & Password to access your company's leads on LeadsLightning.

Name:

Email:

ORDER ONLINE:

www.myleadretrievalorder.com/ASDIN

Email Order Form to:

customerservice@myleadretrievalorder.com

Mail Checks to:

Bartizan Connects,
 Attn: Customer Service
 217 Riverdale Avenue,
 Yonkers, NY 10705

Phone: 800.899.2278 **Order by Fax:** 914-965-7746

Please Note: Upon placing this order you agree to the full Terms & Conditions listed below. For those exhibitors who choose to rent an iPod touch® or iPad® please return device to Bartizan Connects within 4 business days using the FedEx label provided.

My Tradeshow Connections:

All attendees will receive an email a few days after the show containing a list of booths that they visited, extending your reach after the show. To make the most of this free listing please log on to:

www.leadslightning.com/leadslightning/ASDIN2013

to provide your info online. Without your complete company contact information, the list sent to attendees will contain only your name and booth number.

Payment



Check# _____

Card Number

Expiration Date

Security Code

Cardholder Name

Authorized Signature

(Card holder & signature represents above company and authorizes this credit card to be used as payment for this contract)

Terms and Conditions

1. Cancellations made 7 or more days prior to the event are subject to a \$50.00 cancellation fee. Cancellations made less than 10 days prior to the event will result in forfeiture of the entire rental fee.
2. Limitation of Liability: Bartizan bears no responsibility for any consequential damages suffered by the exhibitor. Its liability is limited to the cost of the goods and services it provides. Bartizan is not responsible for events beyond its control such as power failures, erratic electrical power, exhibitor's failure to comply with instructions or force majeure.
3. It is the Exhibitors responsibility to ensure that the device they use at the show meets the minimum requirements to run the iLeads app.
4. Exhibitor is responsible for returning the rental device to Bartizan Connects by using the pre-paid fedex airway bill and pouch provided within 4 business days from the conclusion of the event.
5. Replacement cost for lost equipment: iPod Touch: \$300.00. iPad: \$650.00



Mail or fax this form to:
Urban Jungle, Inc.
 P.O. Box 6165
 McLean, VA 22106
 703-241-8545 phone
 866-516-3716 fax
 [Tax ID #: 54-1796144]

**PLANT & FLORAL
 ORDER FORM**
 info@urbanjungleinc.com

QTY	ITEM	ADVANCE *	SHOW PRICE	TOTAL
	Floral Arrangement (approx. 12" H)	\$ 55.00	\$ 65.00	
	Floral Arrangement (approx. 18" H)	\$ 70.00	\$ 80.00	
	Custom Floral Arrangement (call for assistance)	\$ 95.00	\$ 110.00	
	Bud Vases (list color preference)	\$ 25.00	\$ 30.00	
	Carnation Boutonniere....Daily amount (_____)	\$ 8.00	\$ 10.00	
	Orchid Plants (4"_____ 6"_____)	\$ 50/75.00	\$ 60/85.00	
	➤ One-time Daily delivery charge for boutonnieres	\$ 15.00	\$ 25.00	
	Mum Plants (white_____ yellow_____ lavender_____)	\$ 25.00	\$ 30.00	
	Azaleas (red_____ pink_____ white_____)	\$ 30.00	\$ 35.00	
	Bromeliads (Red, pink, yellow, other)	\$ 30.00	\$ 35.00	
	Seasonal Plants (kalanchoe, gloxinia, cyclamen, etc.)	\$ 30.00	\$ 35.00	
	Small (6"pot) Fern_____ Ivy_____ Pothos_____	\$ 25.00	\$ 30.00	
	Large Fern_____ Ivy_____ Pothos_____	\$ 30.00	\$ 35.00	
	Glass Bowl for Cards (yours to keep)	\$ 25.00	\$ 30.00	
	Pkg A: (1) 6' Ficus topped w/ fern & blooming plant	\$ 125.00	\$ 135.00	
	Pkg B: (2) 3' plants and (1) Blooming plant	\$ 100.00	\$ 110.00	
	Pkg C: large container w/ivy and blooming plants	\$ 100.00	\$ 115.00	
	2' Green Plants	\$ 30.00	\$ 35.00	
	3' Green Plants	\$ 40.00	\$ 45.00	
	4' Green Plants	\$ 50.00	\$ 55.00	
	5' Green Plants	\$ 60.00	\$ 65.00	
	6' Green Plants	\$ 70.00	\$ 75.00	
	7' Green Plants	\$ 95.00	\$ 105.00	
	8' - 10' Ficus Trees	\$ 115.00	\$ 130.00	
Decorative Containers: White Black Wicker			SUB TOTAL	\$
♦ Call for prices on brass, chrome, terra cotta pots				
♦ Tax is based on show location			Sales Tax	\$
			MD 6%	
GNR	Call for items you may want but do not see on this list.	TOTAL AMOUNT DUE		\$

Please remit payment to URBAN JUNGLE, Inc.

Rental Price includes: Container, top-dressing, delivery and pick-up. **All orders must be paid in full.** No adjustments will be made after the show closes. All green plants are rental items and are the property of Urban Jungle, Inc. Show site cancellations will incur a 100% cancellation fee. **If tax-exempt in state of delivery, your certificate must be included with this order form.**

HAVE AN URBAN JUNGLE REP SEE US AT OUR BOOTH: Date _____ Time _____

Exhibitor: _____ Telephone #: _____
 (Third Party): _____ Fax # _____
 Address: _____ PO # _____
 City, State, ZIP: _____ e-mail **: _____

Show Name: _____ Location: _____
 Dates: _____ Booth #: _____

Payment Info: (circle one) AX VISA MC CHECK
 Credit Card #: _____ Exp. Date: _____ Security # _____
 Name on Card: _____ Signature: _____

{Overnight order form to: Urban Jungle, Inc. 1631 Dempsey St. McLean, VA 22101}

****Email is required for confirmation and final invoices.**

***Orders must be received two weeks prior to show date for advance price!**

ASDIN ANNUAL SCIENTIFIC MEETING

J W Marriott Washington DC, Grand Salon 2-4

February 15 - 17, 2013

3

3rd Party Billing Request, Page 56

A

Additional Service Order Forms, Page 58

Advance Shipping Labels, Page 19

Audio Visual Services, Page 59

B

Booth Layout Form, Page 57

C

Carpet Brochure, Page 30

Cartload Service Order Form, Page 24

Certificate of Liability Insurance: **SAMPLE COPY**, Page 14

Cleaning Order Form, Page 54

Custom Graphics Brochure, Page 51

D

Digital File Preparation, Page 50

Domestic Shipping Quote Form: GES Logistics, Page 21

E

Exhibitor Appointed Contractor: Notice of Intent to Use, Page 15

F

Floral Services, Page 63

G

General Information, Page 6

GES Global Transportation Plus, Page 22

GES Information and Order Forms, Page 3

GES Logistics - Domestic Shipping Quote Form, Page 21

GES Logistics - International Shipping Quote Form, Page 23

GES Terms & Conditions of Contract, Page 10

GES Transportation Plus, Page 17

I

Important Freight Information, Page 5

Installation & Dismantling Order Form, Page 52

International Shipping Quote Form: GES Logistics, Page 23

K

Key Information\Supervised Labor Checklist, Page 53

L

Lead Retrieval, Page 60

M

Material Handling Information, Page 16

Material Handling Order Form, Page 18

N

Notice of Intent to Use Exhibitor Appointed Contractor, Page 15

O

Official Service Provider Information, Page 13

Operation of All Mechanical Lifts, Page 11

P

ASDIN ANNUAL SCIENTIFIC MEETING

J W Marriott Washington DC, Grand Salon 2-4

February 15 - 17, 2013

**Payment & Credit Card Charge
Authorization, Page 55****Petroleum Surcharge Information, Page 12****Pre-Printed Outbound Material Handling
Request, Page 20****Price List, Page 25****S****SAMPLE COPY: Certificate of Liability
Insurance, Page 14****Shipping Labels: Advance, Page 19****Show Information, Page 4****Show Site Work Rules, Page 9****Specialty Furniture Brochure, Page 34****Standard Exhibit Systems Brochure, Page
43****Standard Furniture Brochure, Page 32****Stop. Think. Safety., Page 8****Supervised Labor Checklist & Key
Information, Page 53****T****Terms & Conditions of Contract: GES, Page
10****Trade Show Tips, Page 7**