

# Filter Driers with Replaceable Core series HTG for R32



The filter driers with replaceable core - HTG series for R32, are designed to be used as drier in liquid line and suction line of refrigerating, freezing and air conditioning system. The filter housing allows to choose different kinds of cores. It's sealed by bottom cover for an easy removal and replacement of core from the bottom. The core holder requires minimum free space to remove the core for replacement.

## Features

- High efficient in moisture absorption, filtering impurity, acid, paint remains and mud removal
- Different types of filter cores
- Durable and solid filter cores
- Filtering fineness: 20 $\mu$ m
- Corrosion resistant painting can survive salt spray test of 500 hours
- Connection type: solder

## Features of filter element

- **SH48-A80 filter element**

80% 3A desiccant and 20% activated alumina,

It provides a good desiccation ability and an acid absorption capability in a wide temperature range. The core resistance is guaranteed with high level of vibration thanks to an anti-shock design. Suggested installation position on liquid line

- **SH48-A00 filter element**

100% 3A desiccant

It provides the maximum level of desiccation ability in a wide temperature range. The core resistance is guaranteed with high level of vibration thanks to an anti-shock design. Suggested installation position on liquid line

- **SH48-A30 filter element**

30% 3A desiccant, 70% activated alumina

This solid filter element provides an excellent acid absorption together with a standard desiccation ability in a wide temperature range. The suggested installation position is on the suction line; it is suitable after compressor burnout because it removes acid, impurities and other harmful substance avoiding the damage of the new compressor.

Its design optimizes the flow passage generating low internal pressure drop. The core resistance is guaranteed with high level of vibration thanks to an anti-shock design.

- **SH48-B00 filter element**

Mechanical strainer for filtering dirt particles. Suggested installation position is on the suction line.

## General Specification

- Applicable for R32<sup>1)</sup>
- Ambient temperature min./max.: -30°C / +55°C
- Medium temperature TS min./max.: -40°C / +70°C
- Max. operating pressure PS: 5 MPa (50 bar)
- Installation position: HTG with SH48-A80 or SH48-A00 in liquid line  
HTG with SH48-A30 or SH48-B00 in suction line
- Certifications: PED declaration

### Note:

1) Please contact Sanhua for applicability with other A2L refrigerants

**Desiccant Selection Table:**

	Medium Type	30% 3A desiccant 70% active alumina	80% 3A desiccant 20% active alumina	100% 3A desiccant	Mechanical strainer
<b>Core Model</b>	-	HTG-A30-010003	HTG-A80-010003	HTG-A00-010003	HTG-B00-010005
<b>With “universal” flange gasket (suitable for standard HTG and HTG for R32): Ø115 mm x Ø121,4 mm and Ø105,6 mm x Ø115 mm</b>	-	20225028602	20225027702	20225028502	20225028702
<b>Suggested Installation position</b>	-	Suction Line	Liquid Line	Liquid Line	Suction Line
<b>Refrigerant</b>	R32	Applicable	Applicable	Suggested	Suggested
<b>Oil<sup>1)</sup></b>	Pure POE or PAG	Applicable	Applicable	Suggested	Suggested
	POE or PAG with additives	Not applicable	Not applicable	Applicable	Applicable

Note:

1) when the systems use oil with additive, it is not recommended to use a core with alumina

**Accessories and spare parts:**

Universal flange gaskets set	Model	Part Number (multi package)
	HTG-000-024006	20225027601

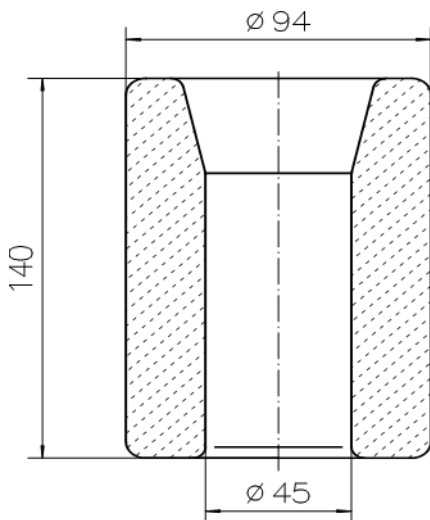

*Filter core dimensions*

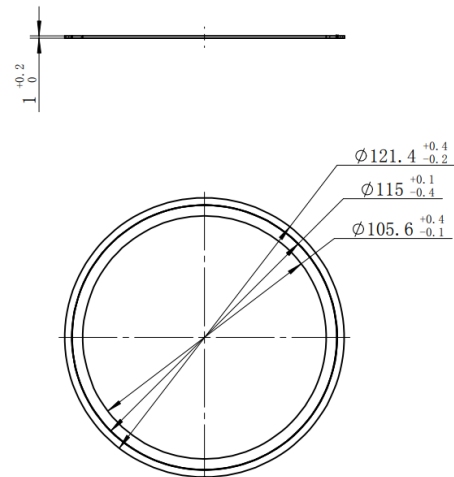

*Universal flange gaskets set*

Pos. No.	Model Designation Legend		
1	<b>Product Code</b>	<b>Filter Drier Series</b>	
	HTG	Indicates replaceable core filter drier	
2	<b>Internal volume</b>	<b>Expressed in inch<sup>3</sup></b>	<b>Expressed in cm<sup>3</sup></b>
	A48	48	787
3	<b>Connection size</b>	<b>Pos. 4 shows "0": Solder - xx/8 [inch]</b>	
	05	5/8 - (5/8" version can be used for 16 mm)	
	07	7/8 - (7/8" version can be used for 22 mm)	
	09	1 - 1/8	
	11	1 3/8" (1 3/8" version can be used for 35 mm)	
	13	1 - 5/8	
	17	2 1/8 - (2 1/8" version can be used for 54 mm)	
4	<b>Pipe Connection</b>	<b>Type</b>	
	0	Solder with inch connections	
5	<b>Version Number</b>	<b>Description</b>	
	801	Product designed for R32 (MOP = 50 bar)	

### Model Designation Example:

Position Number					According to Model Designation Legend
1	2	3	4	5	
HTG	A48	07	0	801	Replaceable core filter drier
HTG	<b>A48</b>	07	0	801	48 inch <sup>3</sup> internal volume
HTG	A48	<b>07</b>	0	801	When Pos. 4 is "0": connection size 7/8 inch
HTG	A48	07	<b>0</b>	801	Solder connection, inch
HTG	A48	07	0	<b>801</b>	Product for R32 (MOP = 50 bar)

Table 1

General Characteristics of filter												
Series	Model	Part Number (multi package) <sup>1)</sup>	Solder Connections ODF		Number of cores	Dimensions & Weight					Design Pressure (MPa)	PED category
			[ in ]	[ mm ]		A	B	L	G	Weight <sup>2)</sup>		
						[ mm ]	[ mm ]	[ mm ]	[ mm ]	[ kg ]		
HTG A48s	HTG-A48050-801	10225007902	5/8	16	1	249	163	170	97	4,66	5	Art 4.3
	HTG-A48070-801	10225008002	7/8	22		249	163	170	97	4,68	5	
	HTG-A48090-801	10225007802	1 1/8	-		253	168	170	102	4,73	5	
	HTG-A48110-801	10225008102	1 3/8	35		253	167	170	102	4,77	5	
	HTG-A48130-801	10225008202	1 5/8	-		253	168	170	122	4,91	5	
	HTG-A48170-801	10225008302	2 1/8	54		253	168	170	126	5,24	5	

Note:

- 1) Available also as industrial package. Contact Sanhua for more details
- 2) Weight of filter shell (must be added the filter core weight: 0.6 kg)

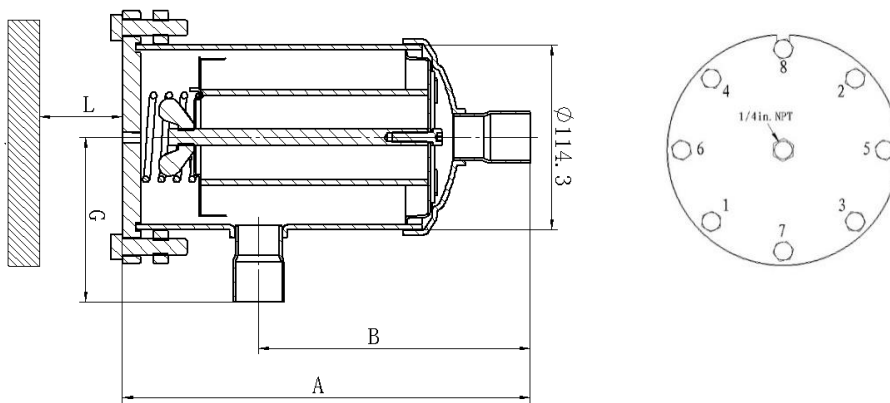

Filter shell dimensions

Table 2

Selection Table - with core SH48-A00				
Model	Acid Adsorption capacity (g)	Capacity [kW] <sup>1)</sup>	Moisture Absorption [gram H <sub>2</sub> O]	
		R32	R32	
			75°F	125°F
			23,9°C	51,7°C
HTG-A48050-801	-	126	78.93	67.52
HTG-A48070-801		225		
HTG-A48090-801		295		
HTG-A48110-801		348		
HTG-A48130-801		374		
HTG-A48170-801		402		

Table 3

Selection Table - with core SH48-A80				
Model	Acid Adsorption capacity <sup>2)</sup> (g)	Capacity [kW] <sup>1)</sup>	Moisture Absorption [gram H <sub>2</sub> O]	
		R32	R32	
			75°F	125°F
			23,9°C	51,7°C
HTG-A48050-801	10	126	63.58	53.15
HTG-A48070-801		225		
HTG-A48090-801		295		
HTG-A48110-801		348		
HTG-A48130-801		374		
HTG-A48170-801		402		

**Note:**

1) The data reported in the Table 2 and 3 are based on filter driers in a clean system at ideal conditions; with impurities accumulated in the filter, the capacity may decrease

2) Preliminary data. Adsorption capacity of oleic acid at 0.05 TAN (Total Acid Number)

**Selection Formulas:**

Filter driers for liquid line are manufactured in compliance with ARI Standard 710. Maximum flow rate of liquid refrigerant at a differential pressure of 0,07bar (1psi) is indicated by kW (ton) which is based on the temperature of liquid refrigerant 30°C (86°F), the evaporating temperature of -15°C (5°F) and the following mass flow:

- 0,235 kg/min/kW (1.8lb/min/ton) R32

Note: Data on water absorption is based on the following EPD:

- 60 ppm R32

**Suction Line Filter-Driers:**

Any pressure loss in the suction line also reduces system capacity significantly. Obtaining a low pressure drop is particularly important for energy savings on all the air conditioning and refrigeration systems. Therefore, suction line filter-driers should be sized generously on these systems. Sanhua suggests that the pressure drop across it should not exceed the values given in the table below (table 4: DP limits in metric units; table 5: DP limits in imperial units)

Table 4

Suction Line Filter Drier Maximum Recommended Pressure Drop (bar)			
System	Evaporator Saturated Suction Temperature <sup>4)</sup> (°C)	Permanent Installation	Temporary Installation
		Refrigerant	
		R32	
Air conditioning	4	0,21	0,56
Commercial	-7	0,14	0,28
Low temperature	-29	0,07	0,14

Table 5

Suction Line Filter Drier Maximum Recommended Pressure Drop (psi)			
System	Evaporator Saturated Suction Temperature <sup>5)</sup> (°F)	Permanent Installation	Temporary Installation
		Refrigerant	
		R32	R32
Air conditioning	40	3	8
Commercial	20	2	4
Low temperature	-20	1	2

Table 6

Suction Line Flow Capacity with core SH48-A30 (kW) <sup>1)</sup>				
NO.	Model	Capacity (kW)		
		Evaporation temperature (°C)		
		-40	-20	4,4
		Pressure drop (bar)		
		0,04	0,1	0,21
1	HTG-A48050-801	2.7	7.8	18.3
2	HTG-A48070-801	5.0	14.2	33.0
3	HTG-A48090-801	6.8	18.7	44.3
4	HTG-A48110-801	8.7	24.0	56.0
5	HTG-A48130-801	8.7	24.0	56.0
6	HTG-A48170-801	8.7	24.0	56.0

1) The capacities listed in the table 6 are rated at the maximum recommended pressure drop for permanent installation. Suction line Filter-Driers guarantees an acid removal and a drying capacity described in table 7:

Table 7

Drying capacity: SH48-A30 <sup>1)</sup>			
Filter Type		HTG-A48	
Number of cores		1	
Acid Adsorption capacity (g) <sup>2)</sup>		25,0	
Refrigerant	Evaporating Temp. (°C) <sup>3)</sup>	Moisture Absorption [gram H2O] <sup>3)</sup>	
R32	-40,0	36,0	
	-20,0	30,0	
	4,4	22,0	

Drying capacity is expressed during drying in:

R32: EPD = 60 ppm W

Note:

- 1) The data reported in the Table 2, 3, 6 and 7 are based on filter driers in a clean system at ideal conditions; with impurities accumulated in the filter, the capacity may decrease.
- 2) Preliminary data. Adsorption capacity of oleic acid at 0.05 TAN (Total Acid Number)
- 3) Standard Evaporating Temperature defined by ANSI. AHRI Standard 731 (SI)-2013. Preliminary data