



E-SEALS
JE, JH & JW SERIES

JETSEAL, INC.

Founded in 1988, JETSEAL began in Spokane, Washington as a small manufacturer of metallic seals to the aerospace industry. Today, JETSEAL has evolved to become an industry leader providing cost-effective sealing solutions to many industries requiring absolute dependability, reliability and performance. Our resilient metal seals are found in major industries including Aviation, Space, Automotive, Oil & Gas, Power Generation, Laser and Research & Development

Whether your company is seeking a standard metal seal or a custom metallic seal assembly, JETSEAL solves difficult sealing issues. JETSEAL resilient metallic seals comprise a complete selection of cross-sections, capable of satisfying a vast variety of sealing applications. Whether your project needs seals for high-pressure or deep-vacuum, cryogenics or extremely high temperatures, large deflections or light loadings, JETSEAL can design a seal to meet your sealing system requirements.

JETSEAL produces all of its products to the certified quality requirements of **ISO 9001:2015** and **AS 9100 Rev D** and is **NADCAP** approved for welding. JETSEAL is **ISO 14001** certified, and we are committed to protecting our employees, customers, and the environment through complete compliance with applicable laws and regulations while conducting our operations.

E-SEAL

E-Seals are used in many aerospace and ground power sealing systems requiring high-performance when sealing hot high-pressure gasses. JETSEAL's E-Seals are effective high deflection seals designed for low to moderate force conditions with high spring back. Current applications include usage in high cyclic deflection, extreme temperature, and moderate pressure environments. These seals may be plated to further reduce leak rates with a defect-free ductile material. E-Seals concentrate a substantial load on the sealing contact area to force plating material into the surface finish grooves on the cavity surface forming a solid barrier to gasses and liquids.

The engineering of the cavity for specific applications is critical to optimizing the performance of the sealing system. It is important that the cavity is precisely manufactured to engineering requirements. The cavity faces are required to be flat, parallel, and within the specified depth limits. A machined surface finish of 32 micro-inches or better and concentric to the cavity is recommended. The peaks and valleys of the cavity surface finish creates a labyrinth effect between the un-plated or plated seal and cavity.

E-Seals are available in various diameters, cross-sections, and noncircular shapes. JETSEAL's E-Seal cross-sections are not limited to those shown in the following tables. E-Seals are produced in three series JE, JH, and JW. The JE series is currently used in demanding high-cycle applications for sealing hot gasses found in aircraft, jet engines and turbo chargers. An additional version of the JE series E-Seal, JETSEAL's patented Lever Seal, is a single piece un-plated or plated design providing superior deflection capability, increased seal line load, and lower leakage rates than traditional E-Seals. The JH series has a higher stiffness and lower elastic deflection capability making it better suited for high-pressure dynamic sealing systems found in the most demanding space applications. The JW series is a taller multi-convolution seal capable of higher deflections and is used in the most demanding aerospace high temperature applications. Our application engineers will work with you and your design team to develop a custom E-Seal cross-section and cavity for your specific application.

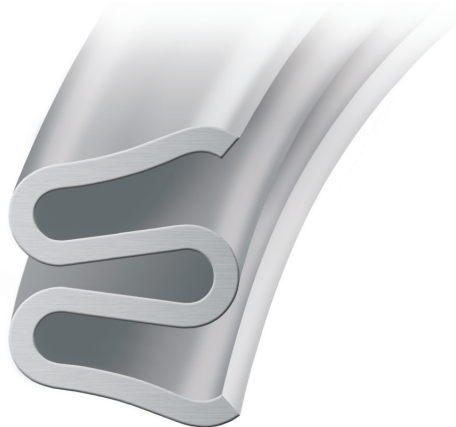

E-SEALS, JE, JH & JW SERIES

JETSEAL Intelligent Part Numbering System for Standard E-Seals

(non-standard seals are described by numerical part numbers with non-significant digits.)

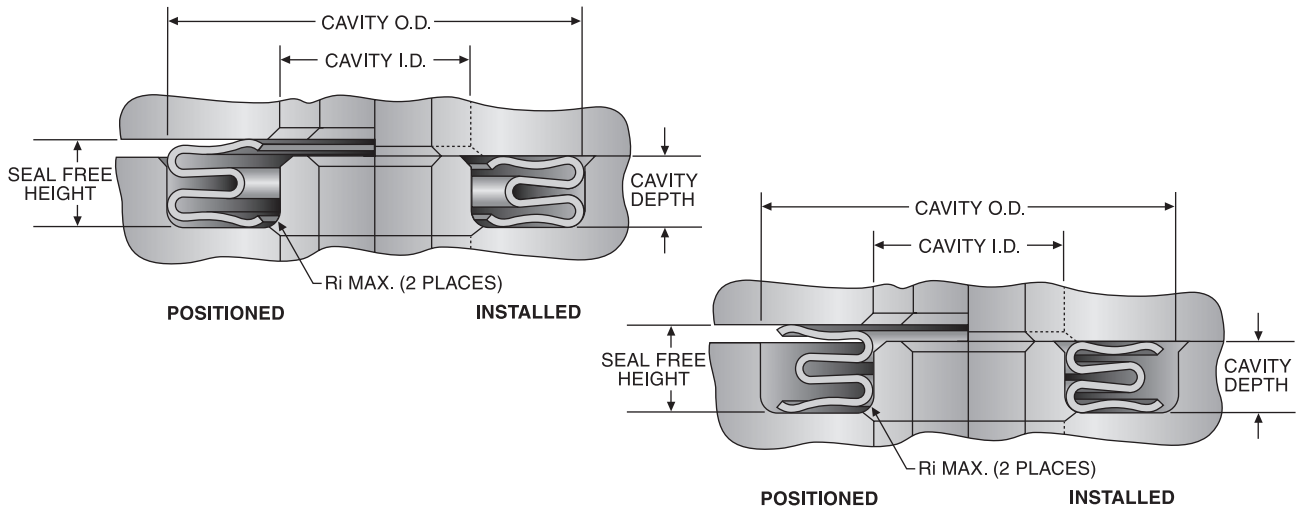

Example of Intelligent P/N (part number whose characters signify discrete properties of the product).

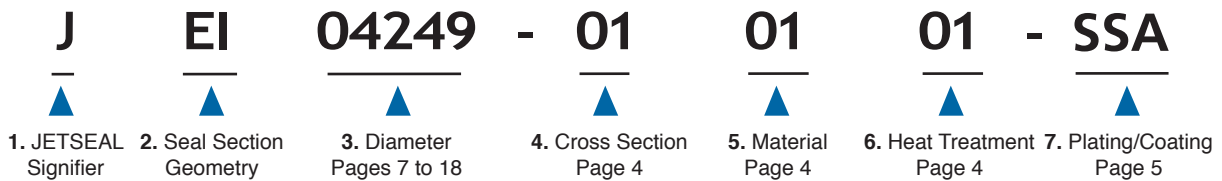

JETSEAL INTELLIGENT PART NUMBERING SYSTEM

1. **J Prefix** indicates seal P/N defines seal in English units.

2. **Seal Section Geometry:**
- EI = E-Seal, High Deflection, Internal Pressure
 - EE = E-Seal, High Deflection, External Pressure
 - HI = E-Seal, High Pressure, Internal
 - HE = E-Seal, High Pressure, External
 - WI = Two Convolution E-Seal, Internal
 - WE = Two Convolution E-Seal, External

3. **Diameter code:** Expressed in one-thousandths of an inch, e.g.

02707 = 2.707 inches
 99500 = 99.500 inches

For JEI seals, the maximum external diameter is encoded. For JEE seals, the minimum internal diameter is used. These are the most critical diameters in each case. (Non-standard seals are described by numerical part numbers with non-significant digits.)

P/N JEI 04249-010101- SSA defines an internal pressure, high deflection E-Seal, 4.249 - 4.243 outside diameter, .113 - .103 free height, .010 material thickness, Alloy 718, Solution and precipitation heat treated, unplated.

4. Cross-Section Codes:

Code	Series	Nominal Section _a	Radial Width (ref)	Free Height _a	Material Thickness/ply	Cavity Depth	Cavity Corner Radius (max)	Comments
01	JE	.108	.137	.113 .103	.010	.086 .090	.020	High Deflection
02	JE	.140	.184	.145 .135	.012	.116 .120	.030	High Deflection
03	JH	.102	.084	.104 .100	.010	.086 .088	.020	High Pressure
04	JH	.132	.115	.135 .129	.115	.116 .118	.030	High Pressure
05	JH	.218	.177	.221 .215	.020	.178 .183	.030	High Pressure
06	JW	.230	.137	.245 .235	.010	.187 .193	.020	2 convolution variant of JE
07	JW	.250	.184	.255 .245	.012	.187 .193	.030	2 convolution variant of JE

^a Free height can be adjusted to suit application. Consult JETSEAL technical support staff.

5. Material Codes:

Code	Material	Specification	Temperature Limit (°F) ¹	Remarks
01	Alloy 718	AMS 5596 AMS 5589 AMS 5662	1200	Superior performance (NACE approved Heat Treat available)
02	Alloy X-750	AMS 5598 AMS 5582 AMS 5667	1100	Excellent performance Lower load / spring back
03	Waspaloy	AMS 5544 AMS 5706 AMS 5586	1350	Superior resistance to creep / stress relaxation above 1200°F
04	Cres 304	AMS 5511 AMS 5560 AMS 5639	800	Effective within reduced temp. range. Low spring back
05	Elgiloy	AMS 5876 AMS 5833	900	Excellent H ₂ embrittlement resistance
06	Haynes 282	AMS 5951	1600	Superior for high temperature applications
07	Hastelloy X	AMS 5754 AMS 5587 AMS 5530	1500	High temperature oxidation resistance
08	Rene 41	AMS 5545 AMS 5712	1400	High temperature and corrosion resistance

¹ Temperatures may be exceeded for certain applications; especially short duration.

6. Heat Treatment Codes:

Code	Heat Treatment	Recommended Materials	Remarks
00	None	Cres 304	Strain-hardened condition and non-hardenable materials
01	Solution and Precipitation	Alloy 718 Alloy X750 Rene 41	General applications
02	Solution Only	Hastelloy X	Optimum corrosion resistance and Mechanical Properties
03	Solution and Precipitation (NACE)	Alloy 718	Special heat treat for sour gas (Hydrogen Sulfide) service
04	Solution, Stabilization and Precipitation	Waspaloy Haynes 282	Creep and relaxation resistance
05	Solution and Precipitation (H ₂)	Alloy 718	High temperature H ₂ gas service
06	Precipitation Only	Alloy 718 Alloy X-750	Static applications

7. Plating and Coating Table:

Code	Plating/Coating	Thickness
SSA	SILVER	.0005 - .0010
SSB		.0010 - .0015
SSC		.0015 - .0020
SSD		.002 - .003
SSF		.003 - .004
SAA	SILVER W/GOLD UNDERLAY	.0005 - .0010
SAB		.0010 - .0015
SAC		.0015 - .0020
SAD		.002 - .003
SAF		.003 - .004
NIA	NICKEL	.0005 - .0010
NIB		.0010 - .0015
NIC		.0015 - .0020
NID		.002 - .003
NAA	NICKEL W/GOLD UNDERLAY	.0005 - .0010
NAB		.0010 - .0015
NAC		.0015 - .0020
NAD		.002 - .003
AAA	GOLD	.0005 - .0010
AAB		.0010 - .0015
AAC		.0015 - .0020
AAD		.002 - .003
CUA	COPPER	.0005 - .0010
CUB		.0010 - .0015
CUC		.0015 - .0020
CAA	COPPER W/GOLD UNDERLAY	.0005 - .0010
CAB		.0010 - .0015
CAC		.0015 - .0020
TIN	TIN	.002 - .004
TAC	TIN W/ GOLD UNDERLAY	.002 - .004
PBC	LEAD	.0015 - .0025
PBD		.002 - .004
TFB	PTFE	.001 - .002
TFD		.002 - .003
PFB	PFA	.001 - .002
PFD		.002 - .003
TRB	TRIBALLOY T-800	.002 - .004

Specification of Geometric Tolerances:

Depending on their diameter to cross-section and material thickness ratios, JETSEAL standard metallic seal rings range from moderate to high flexibility when deflected across a diametral plane or perpendicular to such plane. It is necessary, therefore, to allow reasonably large roundness and flatness tolerances for these metallic seals in the unrestrained condition.

For example, a JEI or JEE E-Seal, twenty or more inches in diameter, becomes visibly oval when suspended from a point on its diameter, simply due to the effects of gravitational acceleration on its own mass. When laid “flat” on a surface table, this seal may arch slightly above the surface due to extremely slight variations in the symmetry of its cross-section within specified tolerances. Such “non-conformances” may be eliminated by the touch of a finger and have no bearing on the performance of the seal in its installed, restrained, state.

The tolerances shown in the following table are standard for all JETSEAL metallic seals in the unrestrained condition and are additional to feature tolerances. In the restrained condition, JETSEAL E-Seals conform to the feature size tolerances shown elsewhere in this manual.

Mean Diameter Range (in)	Roundness (in)	Flatness (in)
To 1.000	.015	.005
1.001 – 2.000	.020	.010
2.001 – 3.500	.030	.015
3.501 – 7.500	.050	.025
7.501 – 10.000	.065	.035
10.001 – 15.000	.085	.050
15.001 – 20.000	.115	.060
20.001 – 30.000	.150	.070
30.001 – 35.000	.200	.100
35.001 – 40.000	.250	.125
40.001 – 50.000	.300	.150

Seals with Non-Circular Geometry:

JETSEAL metallic seals may be supplied shaped to match the contour of virtually any groove, provided that practical constraints on corner radius form are respected. The following guidelines are considered safe for E-Seals:

Minimum Inside Corner Bend Radius											
Cross-Section	01	02	03	04	05	06	07	08	09	10	11
Radius (in.)	1.000	1.250	.750	.900	1.250	1.000	1.250	1.000	1.250	1.000	1.250

Typical Performance¹:

Cross Section	Max Operating Pressure (PSID)	Compression Inches (ref)	Seating Force ^{2,3} (lbf per inch circ)	Springback ² (inches)
01/JE	2,200	.020	25	.020
02/JE	2,000	.022	25	.022
03/JH	7,500	.015	110	.012
04/JH	9,600	.015	110	.012
05/JH	10,800	.037	120	.018
06/JW	2,200	.050	20	.040
07/JW	2,000	.060	20	.050

¹ Values listed are for Alloy 718. Use correction factors for other materials and elevated temperatures, from table in JETSEAL Guide (JETCAT No. 01).

² Seating force increases and springback may decrease for small diameter to cross-section ratios. If these parameters are critical for your application, please consult JETSEAL’s technical support staff for further information.

³ Unpressurized, at nominal deflection.

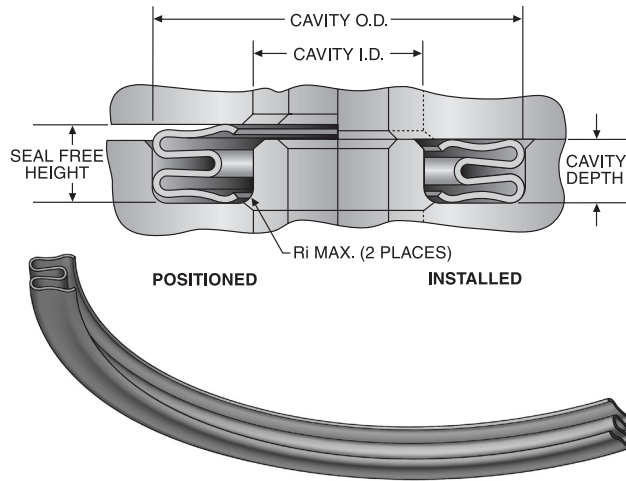

- Recommended for high temperature air systems and equipment.
- See page 4 for all dimensions and tolerances other than those for diameters.
- Average diameters are specified. Seals are out-of-round to provide snap-fit retention in inverted cavities.
- Inner cavity wall optional.
- Standard sizes are presented. Non-standard diameters may be derived by interpolation.
- Cavity sealing surface texture 32 μ-in., circular lay.

P/N: JEI

Seal type diameter code derived from seal O.D., Pages 7-9 cross-section Page 4 material Page 4 heat treatment Page 4 plating or coating Page 5

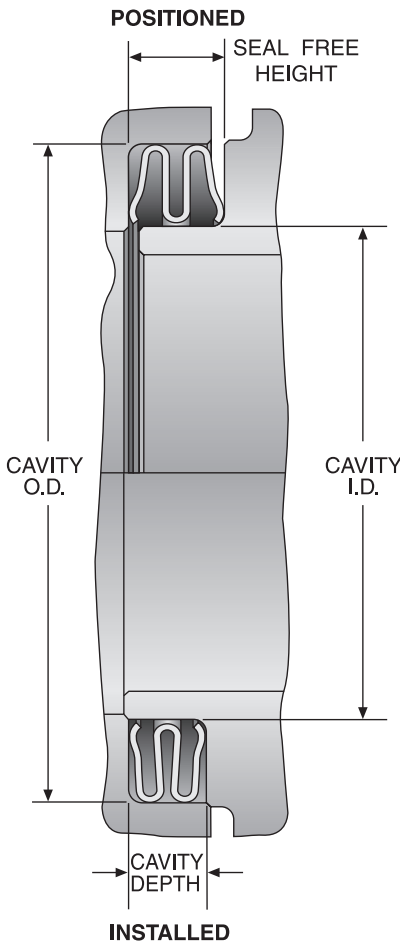

**JEI E-SEAL,
INTERNAL PRESSURE**

FREE HEIGHT: JEI .108					FREE HEIGHT: JEI .140				
SEAL DIA. CODE	CAVITY		SEAL		SEAL DIA. CODE	CAVITY		SEAL	
	I.D. (MAX)	O.D. +.003 -.000	I.D. (MIN)	O.D. +.000 -.006		I.D. (MAX)	O.D. +.003 -.000	I.D. (MIN)	O.D. +.000 -.006
01238	.937	1.240	.947	1.238	01712	1.308	1.714	1.324	1.712
01249	.965	1.251	.958	1.249	01775	1.371	1.777	1.387	1.775
01303	1.000	1.305	1.012	1.303	01837	1.433	1.839	1.449	1.837
01365	1.062	1.367	1.074	1.365	01863	1.459	1.865	1.475	1.863
01428	1.125	1.430	1.137	1.428	01900	1.496	1.902	1.512	1.900
01499	1.187	1.501	1.199	1.499	01962	1.558	1.964	1.574	1.962
01553	1.250	1.555	1.262	1.553	02025	1.621	2.027	1.637	2.025
01615	1.312	1.617	1.324	1.615	02087	1.683	2.089	1.699	2.087
01678	1.375	1.680	1.387	1.678	02113	1.709	2.115	1.725	2.113
01740	1.437	1.742	1.449	1.740	02150	1.746	2.152	1.762	2.150
01749	1.446	1.751	1.458	1.749	02212	1.808	2.214	1.824	2.212
01803	1.500	1.805	1.512	1.803	02275	1.871	2.277	1.887	2.275
01865	1.562	1.867	1.574	1.865	02337	1.933	2.339	1.949	2.337
01928	1.625	1.930	1.637	1.928	02363	1.959	2.365	1.975	2.363
01990	1.687	1.992	1.699	1.990	02402	1.998	2.404	2.014	2.402
01999	1.696	2.001	1.708	1.999	02464	2.060	2.466	2.076	2.464
02053	1.750	2.055	1.762	2.053	02527	2.123	2.529	2.139	2.527
02115	1.812	2.117	1.824	2.115	02589	2.185	2.591	2.201	2.589
02178	1.875	2.180	1.887	2.178	02614	2.210	2.616	2.226	2.614
02240	1.937	2.242	1.949	2.240	02652	2.248	2.654	2.264	2.652
02249	1.946	2.251	1.958	2.249	02714	2.310	2.716	2.326	2.714
02305	2.000	2.307	2.014	2.305	02777	2.373	2.779	2.389	2.777
02367	2.062	2.369	2.076	2.367	02839	2.435	2.841	2.451	2.839
02430	2.125	2.432	2.139	2.430	02864	2.460	2.866	2.476	2.864
02492	2.187	2.494	2.201	2.492	02902	2.498	2.904	2.514	2.902
02499	2.194	2.501	2.208	2.499	02964	2.560	2.966	2.576	2.964
02555	2.250	2.557	2.264	2.555	03027	2.623	3.029	2.639	3.027
02617	2.312	2.619	2.326	2.617	03089	2.685	3.091	2.701	3.089
02680	2.375	2.682	2.389	2.680	03114	2.710	3.116	2.726	3.114
02742	2.437	2.744	2.451	2.742	03152	2.748	3.154	2.764	3.152
02749	2.440	2.751	2.458	2.749					
02805	2.500	2.807	2.514	2.805					
02867	2.562	2.869	2.576	2.867					
02930	2.625	2.932	2.639	2.930					
02992	2.687	2.994	2.701	2.992					
02999	2.694	3.001	2.708	2.999					
03055	2.750	3.057	2.764	3.055					

Seal dimensions in inches, prior to plating or coating where applicable. Plating not generally recommended for this low load seal series.

FREE HEIGHT: JEI .108					FREE HEIGHT: JEI .140				
SEAL DIA. CODE	CAVITY		SEAL		SEAL DIA. CODE	CAVITY		SEAL	
	I.D.	O.D.	I.D.	O.D.		I.D.	O.D.	I.D.	O.D.
	(MAX)	+0.003 -0.000	(MIN)	+0.000 -0.006		(MAX)	+0.003 -0.000	(MIN)	+0.000 -0.006
03117	2.812	3.119	2.826	3.117	03152	2.748	3.154	2.764	3.152
03180	2.875	3.182	2.889	3.180	03214	2.810	3.216	2.826	3.214
03249	2.937	3.251	2.958	3.249	03277	2.873	3.279	2.889	3.277
03307	3.000	3.309	3.016	3.307	03364	2.960	3.366	2.976	3.364
03369	3.062	3.371	3.078	3.369	03404	3.000	3.406	3.016	3.404
03432	3.125	3.434	3.141	3.432	03466	3.062	3.468	3.078	3.466
03499	3.187	3.501	3.208	3.499	03529	3.125	3.531	3.141	3.529
03557	3.250	3.559	3.266	3.557	03614	3.210	3.616	3.226	3.614
03619	3.312	3.621	3.328	3.619	03654	3.250	3.656	3.266	3.654
03682	3.375	3.684	3.391	3.682	03716	3.312	3.718	3.328	3.716
03749	3.437	3.751	3.458	3.749	03779	3.375	3.781	3.391	3.779
03807	3.500	3.809	3.516	3.807	03865	3.461	3.867	3.477	3.865
03869	3.562	3.871	3.578	3.869	03904	3.500	3.906	3.516	3.904
03932	3.625	3.934	3.641	3.932	03966	3.562	3.968	3.578	3.966
03994	3.687	3.996	3.703	3.994	04029	3.625	4.031	3.641	4.029
04057	3.750	4.059	3.766	4.057	04091	3.687	4.093	3.703	4.091
04119	3.812	4.121	3.828	4.119	04154	3.750	4.156	3.766	4.154
04182	3.875	4.184	3.891	4.182	04216	3.812	4.218	3.828	4.216
04249	3.937	4.251	3.958	4.249	04279	3.875	4.281	3.891	4.279
04309	4.000	4.311	4.018	4.309	04365	3.961	4.367	3.977	4.365
04371	4.062	4.373	4.080	4.371	04406	4.002	4.408	4.018	4.406
	(MAX)	+0.004 -0.000	(MIN)	+0.000 -0.008		(MAX)	+0.004 -0.000	(MIN)	+0.000 -0.008
04434	4.125	4.436	4.143	4.434	04531	4.125	4.533	4.143	4.531
04496	4.187	4.498	4.205	4.496	04593	4.187	4.595	4.205	4.593
04559	4.250	4.561	4.268	4.559	04656	4.250	4.658	4.268	4.656
04621	4.312	4.623	4.330	4.621	04718	4.312	4.720	4.330	4.718
04684	4.375	4.686	4.393	4.684	04781	4.375	4.783	4.393	4.781
04749	4.437	4.751	4.458	4.749	04843	4.437	4.845	4.455	4.843
04809	4.500	4.811	4.518	4.809	04906	4.500	4.908	4.518	4.906
04871	4.562	4.873	4.580	4.871	04968	4.562	4.970	4.580	4.968
04934	4.625	4.936	4.643	4.934	05031	4.625	5.033	4.643	5.031
04996	4.687	4.998	4.705	4.996	05093	4.687	5.095	4.705	5.093
05059	4.750	5.061	4.768	5.059	05156	4.750	5.158	4.768	5.156
05121	4.812	5.123	4.830	5.121	05218	4.812	5.220	4.830	5.218
05184	4.875	5.186	4.893	5.184	05281	4.875	5.283	4.893	5.281
05249	4.937	5.251	4.958	5.249	05343	4.937	5.345	4.955	5.343
	(MAX)	+0.004 -0.000	(MIN)	+0.000 -0.010		(MAX)	+0.004 -0.000	(MIN)	+0.000 -0.010
05311	5.000	5.313	5.020	5.311	05408	5.000	5.410	5.020	5.408
05373	5.062	5.375	5.082	5.373	05470	5.062	5.472	5.082	5.470
05436	5.125	5.438	5.145	5.436	05533	5.125	5.535	5.145	5.533
05498	5.187	5.500	5.207	5.498	05595	5.187	5.597	5.207	5.595
05561	5.250	5.563	5.270	5.561	05658	5.250	5.660	5.270	5.658
05623	5.312	5.625	5.332	5.623	05720	5.312	5.722	5.332	5.720
05686	5.375	5.688	5.395	5.686	05783	5.375	5.785	5.395	5.783
05749	5.437	5.751	5.458	5.749	05845	5.437	5.847	5.457	5.845

Seal dimensions in inches, prior to plating or coating where applicable.
Plating not generally recommended for this low load seal series.

FREE HEIGHT: JEI .108					FREE HEIGHT: JEI .140				
SEAL DIA. CODE	CAVITY		SEAL		SEAL DIA. CODE	CAVITY		SEAL	
	I.D.	O.D.	I.D.	O.D.		I.D.	O.D.	I.D.	O.D.
	(MAX)	+0.004 -.000	(MIN)	+0.000 -.012		(MAX)	+0.004 -.000	(MIN)	+0.000 -.012
05811	5.500	5.813	5.509	5.811	05908	5.500	5.910	5.520	5.908
05871	5.562	5.875	5.569	5.873	05970	5.562	5.972	5.582	5.970
05936	5.625	5.938	5.634	5.936	06033	5.625	6.035	5.645	6.033
06061	5.750	6.063	5.759	6.061	06158	5.750	6.160	5.770	6.158
06186	5.875	6.088	5.884	6.186	06283	5.875	6.285	5.895	6.283
06249	5.937	6.251	5.947	6.249	06367	5.959	6.369	5.979	6.367
06311	6.000	6.313	6.009	6.311	06410	6.000	6.412	6.022	6.410
06436	6.125	6.438	6.134	6.436	06469	6.059	6.471	6.081	6.469
06561	6.250	6.563	6.261	6.561	06535	6.125	6.537	6.147	6.535
06686	6.375	6.688	6.384	6.686	06660	6.250	6.662	6.272	6.660
06749	6.437	6.751	6.447	6.749	06785	6.375	6.787	6.397	6.785
06811	6.500	6.813	6.509	6.811	06910	6.500	6.912	6.522	6.910
06938	6.625	6.938	6.634	6.936	07035	6.625	7.037	6.647	7.035
07061	6.750	7.063	6.759	7.061	07160	6.750	7.162	6.772	7.160
07249	6.910	7.251	6.947	7.249	07285	6.875	7.287	6.897	7.285
07311	7.000	7.313	7.009	7.311	07412	7.000	7.414	7.024	7.412
07436	7.125	7.438	7.134	7.436	07537	7.125	7.539	7.149	7.537
07561	7.250	7.563	7.259	7.561	07662	7.250	7.664	7.274	7.662
07749	7.410	7.751	7.447	7.749	07787	7.375	7.789	7.399	7.787
07811	7.500	7.813	7.509	7.811	07912	7.500	7.914	7.524	7.912
07936	7.625	7.938	7.634	7.936	08037	7.543	8.039	7.649	8.037
08061	7.750	8.063	7.759	8.061	08162	7.668	8.164	7.774	8.162
08249	7.910	8.251	7.948	8.249	08287	7.793	8.289	7.899	8.287
08311	8.000	8.313	8.009	8.311	08414	7.920	8.416	8.026	8.414
08436	8.125	8.438	8.134	8.436	08539	8.033	8.541	8.151	8.539
08561	8.250	8.563	8.259	8.561	08664	8.158	8.666	8.276	8.664
08749	8.400	8.751	8.448	8.749	08789	8.283	8.791	8.401	8.789
08811	8.500	8.813	8.509	8.811	08914	8.408	8.916	8.526	8.914
08936	8.625	8.938	8.634	8.936	09039	8.533	9.041	8.651	9.039
09061	8.750	9.063	8.759	9.061	09164	8.658	9.166	8.776	9.164
	(MAX)	+0.005 -.000	(MIN)	+0.000 -.015		(MAX)	+0.005 -.000	(MIN)	+0.000 -.015
09249	8.900	9.251	8.944	9.249	09289	8.783	9.291	8.901	9.289
09311	9.000	9.313	9.006	9.311	09416	8.910	9.418	9.028	9.416
09436	9.125	9.438	9.131	9.436	09541	9.023	9.543	9.153	9.541
09561	9.250	9.563	9.256	9.561	09666	9.148	9.668	9.278	9.666
09749	9.400	9.751	9.444	9.749	09791	9.273	9.793	9.403	9.791
09811	9.500	9.813	9.506	9.811	09916	9.398	9.918	9.528	9.916
09986	9.625	9.938	9.631	9.936	10041	9.523	10.043	9.653	10.041
10061	9.750	10.063	9.755	10.061	10166	9.648	10.168	9.778	10.166
10249	9.900	10.251	9.944	10.249	10291	9.773	10.293	9.903	10.291
10311	10.000	10.313	10.006	10.311	10418	9.900	10.420	10.030	10.418
10436	10.125	10.438	10.131	10.436	10543	10.025	10.545	10.155	10.543
10561	10.250	10.563	10.256	10.561	10668	10.150	10.670	10.280	10.668
10749	10.400	10.751	10.444	10.749	10793	10.275	10.795	10.405	10.793

Seal dimensions in inches, prior to plating or coating where applicable.
Plating not generally recommended for this low load seal series.

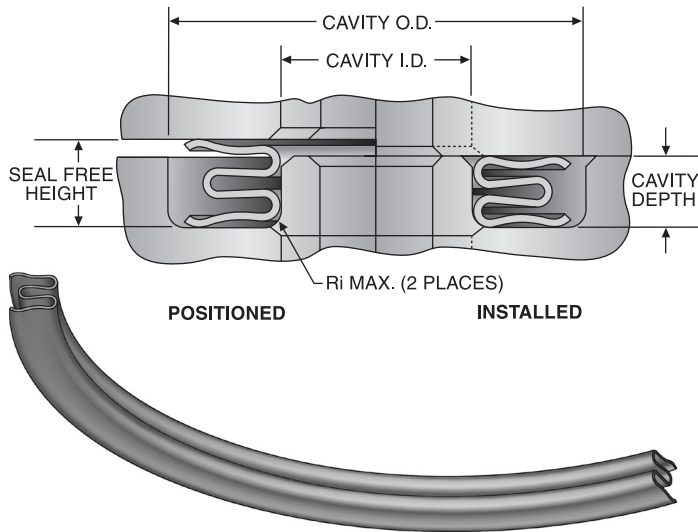

- Recommended for high temperature air systems and equipment.
- High deflection capability.
- See page 4 for all dimensions and tolerances other than those for diameters.
- Average diameters are specified. For seal out-of-roundness tolerance see Page 6.
- Outer cavity wall optional.
- Standard sizes are presented. Non-standard diameters may be derived by interpolation.
- Cavity sealing surface texture 32 μ-in., circular lay.

P/N: JEE

Seal type diameter code derived from seal I.D., Pages 10 - 12 cross-section Page 4 material Page 4 heat treatment Page 4 coating Page 5

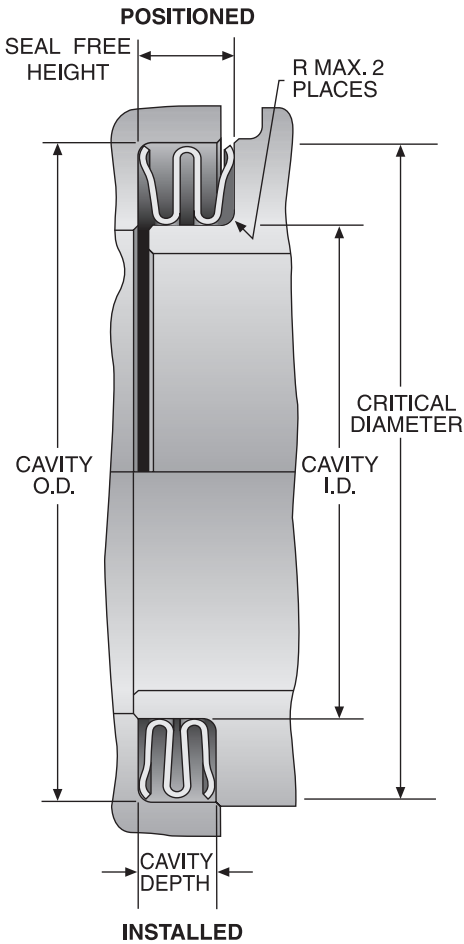

JEE E-SEAL, EXTERNAL PRESSURE

SEAL DIA. CODE	FREE HEIGHT: JEE .108				FREE HEIGHT: JEE .140			
	CAVITY		SEAL		CAVITY		SEAL	
	I.D.	O.D.	I.D.	O.D.	I.D.	O.D.	I.D.	O.D.
	+0.000	(MIN)	+0.006	(MAX)	+0.000	(MIN)	+0.006	(MAX)
	-0.003		-0.000		-0.003		-0.000	
01005	1.003	1.308	1.005	1.296				
01067	1.065	1.370	1.067	1.358				
01130	1.128	1.433	1.130	1.421				
01192	1.190	1.495	1.192	1.483				
01255	1.253	1.558	1.255	1.546				
01317	1.315	1.620	1.317	1.608				
01380	1.378	1.683	1.380	1.671	1.378	1.780	1.380	1.768
01442	1.440	1.745	1.442	1.733	1.440	1.842	1.442	1.830
01505	1.503	1.808	1.505	1.796	1.503	1.905	1.505	1.893
01567	1.565	1.870	1.567	1.858	1.565	1.967	1.567	1.955
01630	1.628	1.933	1.630	1.921	1.628	2.030	1.630	2.018
01692	1.690	1.995	1.692	1.983	1.690	2.092	1.692	2.080
01755	1.753	2.058	1.755	2.046	1.753	2.155	1.755	2.143
01817	1.815	2.120	1.817	2.108	1.815	2.217	1.817	2.205
01880	1.878	2.183	1.880	2.171	1.878	2.280	1.880	2.268
01942	1.940	2.245	1.942	2.233	1.940	2.342	1.942	2.330
02005	2.003	2.310	2.005	2.296	2.003	2.407	2.005	2.393
02067	2.065	2.372	2.067	2.358	2.065	2.469	2.067	2.455
02130	2.128	2.435	2.130	2.421	2.128	2.532	2.130	2.518
02192	2.190	2.497	2.192	2.483	2.190	2.594	2.192	2.580
02255	2.253	2.560	2.255	2.546	2.253	2.657	2.255	2.643
02317	2.315	2.622	2.317	2.608	2.315	2.719	2.317	2.705
02380	2.378	2.685	2.380	2.671	2.378	2.782	2.380	2.768
02442	2.440	2.747	2.442	2.733	2.440	2.844	2.442	2.830
02505	2.503	2.810	2.505	2.796	2.503	2.907	2.505	2.893
02567	2.565	2.872	2.567	2.858	2.565	2.969	2.567	2.955
02630	2.628	2.935	2.630	2.921	2.628	3.032	2.630	3.018
02692	2.690	2.997	2.692	2.983	2.690	3.094	2.692	3.080
02755	2.753	3.060	2.755	3.046	2.753	3.157	2.755	3.143
02817	2.815	3.122	2.817	3.108	2.815	3.219	2.817	3.205
02880	2.878	3.185	2.880	3.171	2.878	3.282	2.880	3.268
02942	2.940	3.247	2.942	3.233	2.940	3.344	2.942	3.330
03005	3.003	3.312	3.005	3.296	3.003	3.409	3.005	3.393

Seal dimensions in inches, prior to plating or coating. Plating not generally recommended for this low load seal series.

SEAL DIA. CODE	FREE HEIGHT: JEE .108				FREE HEIGHT: JEE .140			
	CAVITY		SEAL		CAVITY		SEAL	
	I.D.	O.D.	I.D.	O.D.	I.D.	O.D.	I.D.	O.D.
	+000 -003	(MIN)	+006 -000	(MAX)	+000 -003	(MIN)	+006 -000	(MAX)
03067	3.065	3.374	3.067	3.358	3.065	3.471	3.067	3.455
03130	3.128	3.437	3.130	3.421	3.128	3.534	3.130	3.518
03292	3.290	3.499	3.292	3.483	3.290	3.596	3.292	3.580
03255	3.253	3.562	3.255	3.546	3.253	3.659	3.255	3.643
03317	3.315	3.624	3.317	3.608	3.315	3.721	3.317	3.705
03380	3.378	3.687	3.380	3.671	3.378	3.784	3.380	3.768
03442	3.440	3.749	3.442	3.733	3.440	3.846	3.442	3.830
03505	3.503	3.812	3.505	3.796	3.503	3.909	3.505	3.893
03567	3.565	3.874	3.567	3.858	3.565	3.971	3.567	3.955
03630	3.628	3.937	3.630	3.921	3.628	4.034	3.630	4.018
03692	3.690	3.999	3.692	3.983	3.690	4.096	3.692	4.080
03755	3.753	4.062	3.755	4.046	3.753	4.159	3.755	4.143
03817	3.815	4.124	3.817	4.108	3.815	4.221	3.817	4.205
03880	3.878	4.187	3.880	4.171	3.878	4.284	3.880	4.268
03942	3.940	4.249	3.942	4.233	3.940	4.346	3.942	4.330
	+000 - .004	(MIN)	+008 -000	(MAX)	+000 -004	(MIN)	+008 - .000	(MAX)
04005	4.003	4.314	4.005	4.296	4.003	4.411	4.005	4.393
04067	4.065	4.376	4.067	4.358	4.065	4.473	4.067	4.455
04130	4.128	4.439	4.130	4.421	4.128	4.536	4.130	4.518
04192	4.190	4.501	4.192	4.483	4.190	4.598	4.192	4.580
04255	4.253	4.564	4.255	4.546	4.253	4.661	4.255	4.643
04317	4.315	4.626	4.317	4.608	4.315	4.723	4.317	4.705
04380	4.378	4.689	4.380	4.671	4.378	4.786	4.380	4.768
04442	4.440	4.751	4.442	4.733	4.440	4.848	4.442	4.830
04505	4.503	4.814	4.505	4.796	4.503	4.911	4.505	4.893
04567	4.565	4.876	4.567	4.858	4.565	4.973	4.567	4.955
04630	4.628	4.939	4.630	4.921	4.628	5.036	4.630	5.018
04692	4.690	5.001	4.692	4.983	4.690	5.098	4.692	5.080
04755	4.753	5.064	4.755	5.046	4.753	5.161	4.755	5.143
04817	4.815	5.126	4.817	5.108	4.815	5.223	4.817	5.205
04880	4.878	5.189	4.880	5.171	4.878	5.286	4.880	5.268
	+000 -004	(MIN)	+010 -000	(MAX)	+000 -004	(MIN)	+010 -000	(MAX)
04942	4.940	5.251	4.942	5.233	4.940	5.348	4.942	5.330
05005	5.003	5.316	5.005	5.296	5.003	5.413	5.005	5.393
05067	5.065	5.378	5.067	5.358	5.065	5.475	5.067	5.455
05130	5.128	5.441	5.130	5.421	5.128	5.538	5.130	5.518
05192	5.190	5.503	5.192	5.483	5.190	5.600	5.192	5.580
05255	5.253	5.566	5.255	5.546	5.253	5.663	5.255	5.643
05317	5.315	5.628	5.317	5.608	5.315	5.725	5.317	5.705
05380	5.378	5.691	5.380	5.671	5.378	5.788	5.380	5.768
05442	5.440	5.753	5.442	5.733	5.440	5.850	5.442	5.830
05505	5.503	5.816	5.505	5.796	5.503	5.913	5.505	5.893
05567	5.565	5.878	5.567	5.858	5.565	5.975	5.567	5.955
05630	5.628	5.941	5.630	5.921	5.628	6.038	5.630	6.018
05755	5.753	6.066	5.755	6.046	5.753	6.163	5.755	6.143
05880	5.878	6.191	5.880	6.171	5.878	6.288	5.880	6.268
06005	6.003	6.318	6.005	6.296	6.003	6.415	6.005	6.393
	+000 - .005	(MIN)	+012 - .000	(MAX)	+000 -005	(MIN)	+012 - .000	(MAX)
06130	6.128	6.454	6.130	6.432	6.128	6.540	6.130	6.518
06255	6.253	6.579	6.255	6.557	6.253	6.665	6.255	6.643
06380	6.378	6.704	6.380	6.682	6.378	6.790	6.380	6.768
06505	6.503	6.829	6.505	6.807	6.503	6.915	6.505	6.893
06630	6.628	6.954	6.630	6.932	6.628	7.040	6.630	7.018

Seal dimensions in inches, prior to plating or coating. Plating not generally recommended for this low load seal series.

SEAL DIA. CODE	FREE HEIGHT: JEE .108				FREE HEIGHT: JEE .140			
	CAVITY		SEAL		CAVITY		SEAL	
	I.D.	O.D.	I.D.	O.D.	I.D.	O.D.	I.D.	O.D.
	+0.000 -0.005	(MIN)	+0.015 -0.000	(MAX)	+0.000 -0.005	(MIN)	+0.015 -0.000	(MAX)
06755	6.753	7.079	6.755	7.057	6.753	7.165	6.755	7.143
06880	6.878	7.204	6.880	7.182	6.878	7.290	6.880	7.268
07005	7.003	7.329	7.005	7.307	7.003	7.417	7.005	7.393
07130	7.128	7.454	7.130	7.432	7.128	7.542	7.130	7.518
07255	7.253	7.579	7.255	7.557	7.253	7.667	7.255	7.643
07380	7.378	7.694	7.380	7.682	7.378	7.792	7.380	7.768
07505	7.503	7.819	7.505	7.807	7.503	7.917	7.505	7.893
07630	7.628	7.944	7.630	7.932	7.628	8.042	7.630	8.018
07755	7.753	8.069	7.755	8.057	7.753	8.167	7.755	8.143
07880	7.878	8.194	7.880	8.182	7.878	8.292	7.880	8.268
08005	8.003	8.319	8.005	8.307	8.003	8.419	8.005	8.393
08130	8.128	8.444	8.130	8.432	8.128	8.544	8.130	8.518
08255	8.253	8.569	8.255	8.557	8.253	8.669	8.255	8.643
08380	8.378	8.694	8.380	8.682	8.378	8.794	8.380	8.768
08505	8.503	8.819	8.505	8.807	8.503	8.919	8.505	8.893
08630	8.628	8.944	8.630	8.932	8.628	9.044	8.630	9.018
	+0.000 - .005	(MIN)	+0.020 - .000	(MAX)	+0.000 - .005	(MIN)	+0.020 - .000	(MAX)
08755	8.753	9.087	8.755	9.065	8.753	9.169	8.755	9.143
08880	8.878	9.212	8.880	9.190	8.878	9.294	8.880	9.268
09005	9.003	9.337	9.005	9.315	9.003	9.421	9.005	9.393
09130	9.128	9.462	9.130	9.440	9.128	9.546	9.130	9.518
09255	9.253	9.587	9.255	9.565	9.253	9.671	9.255	9.643
09380	9.378	9.712	9.380	9.690	9.378	9.796	9.380	9.768
09505	9.503	9.837	9.505	9.815	9.503	9.921	9.505	9.893
09630	9.628	9.962	9.630	9.940	9.628	10.046	9.630	10.018
09755	9.753	10.087	9.755	10.065	9.753	10.171	9.755	10.143
09880	9.878	10.212	9.880	10.190	9.878	10.296	9.880	10.268
10005	10.003	10.337	10.005	10.315	10.003	10.423	10.005	10.393
10130	10.128	10.462	10.130	10.440	10.128	10.548	10.130	10.518
10255	10.253	10.587	10.255	10.565	10.253	10.673	10.255	10.643
10380	10.378	10.712	10.380	10.690	10.378	10.798	10.380	10.768
10505	10.503	10.837	10.505	10.815	10.503	10.928	10.505	10.893
10630	10.628	10.962	10.630	10.940	10.628	11.048	10.630	11.018
10755	10.753	11.087	10.755	11.065	10.753	11.173	10.755	11.143
10880	10.878	11.212	10.880	11.190	10.878	11.298	10.880	11.268
11005	11.003	11.337	11.005	11.315	11.003	11.425	11.005	11.393
11130	11.128	11.462	11.130	11.440	11.128	11.550	11.130	11.518
11255	11.253	11.587	11.255	11.565	11.253	11.675	11.255	11.643
11380	11.378	11.712	11.380	11.690	11.378	11.800	11.380	11.768
11505	11.503	11.837	11.505	11.815	11.503	11.925	11.505	11.893
11630	11.628	11.962	11.630	11.940	11.628	12.050	11.630	12.018
11755	11.753	12.087	11.755	12.065	11.753	12.175	11.755	12.143
11880	11.878	12.212	11.880	12.190	11.878	12.300	11.880	12.268
12005	12.003	12.337	12.005	12.315	12.003	12.427	12.005	12.393
12130	12.128	12.462	12.130	12.440	12.128	12.552	12.130	12.518
12255	12.253	12.587	12.255	12.565	12.253	12.777	12.255	12.643
12380	12.378	12.712	12.380	12.690	12.378	12.802	12.380	12.768
12505	12.503	12.837	12.505	12.815	12.503	12.927	12.505	12.893
12630	12.628	12.962	12.630	12.940	12.628	13.052	12.630	13.018
12755	12.753	13.087	12.755	13.065	12.753	13.177	12.755	13.143
12880	12.878	13.212	12.880	13.190	12.878	13.302	12.880	13.268
13005	13.003	13.337	13.005	13.315	13.003	13.427	13.005	13.393
13130	13.128	13.462	13.130	13.440	13.128	13.552	13.130	13.518

Seal dimensions in inches, prior to plating or coating. Plating not generally recommended for this low load seal series.

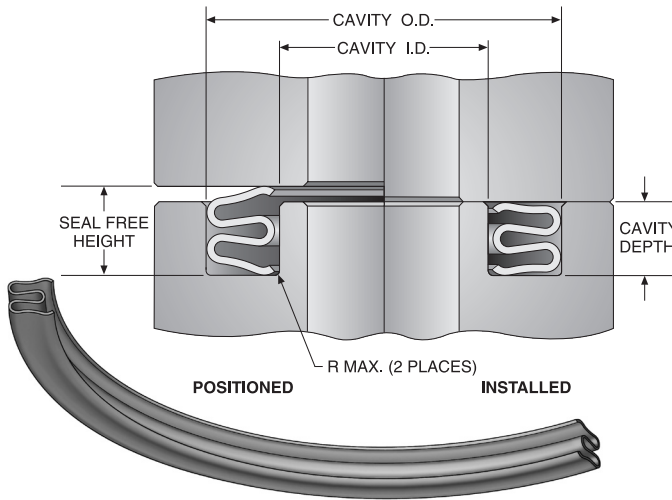

- Recommended for high pressure liquid and air systems and equipment.
- High deflection capability.
- See page 4 for all dimensions and tolerances other than those for diameters.
- Seal diameters are average. See roundness table, page 6.
- Inner cavity wall optional.
- Standard sizes are presented. Non-standard diameters may be derived by interpolation.
- Cavity sealing surface texture 32 μ-in., circular lay.

P/N: JHI

seal type diameter code cross-section material heat treatment plating or coating
 derived from seal O.D., Pages 13 - 15 Page 4 Page 4 Page 4 Page 5

FREE HEIGHT .102					FREE HEIGHT .132					FREE HEIGHT .218				
SEAL DIA. CODE	CAVITY		SEAL		SEAL DIA. CODE	CAVITY		SEAL		SEAL DIA. CODE	CAVITY		SEAL	
	I.D. (MAX)	O.D. (+.002 - .000)	I.D. (MIN)	O.D. (+.000 - .005)		I.D. (MAX)	O.D. (+.002 - .000)	I.D. (MIN)	O.D. (+.000 - .005)		I.D. (MAX)	O.D. (+.002 - .000)	I.D. (MIN)	O.D. (+.000 - .005)
00809	.625	.812	.628	.809										
00872	.687	.875	.690	.872										
00934	.750	.937	.753	.934										
00997	.812	1.000	.815	.997										
01059	.875	1.062	.878	1.059	01122	.875	1.125	.878	1.122					
01122	.937	1.125	.940	1.122	01184	.937	1.187	.940	1.184					
01184	1.000	1.187	1.003	1.184	01247	1.000	1.250	1.003	1.247					
01247	1.062	1.250	1.065	1.247	01309	1.062	1.312	1.065	1.309					
01309	1.125	1.312	1.128	1.309	01372	1.125	1.375	1.128	1.372					
01372	1.187	1.375	1.190	1.372	01434	1.187	1.437	1.190	1.434					
01434	1.250	1.437	1.253	1.434	01497	1.250	1.500	1.253	1.497					
01497	1.312	1.500	1.315	1.497	01559	1.312	1.562	1.315	1.559					
01559	1.375	1.562	1.378	1.559	01622	1.375	1.625	1.378	1.622					
01622	1.437	1.625	1.440	1.622	01684	1.437	1.687	1.440	1.684					
01684	1.500	1.687	1.503	1.684	01747	1.500	1.750	1.503	1.747					
01747	1.562	1.750	1.565	1.747	01809	1.562	1.812	1.565	1.809					
01809	1.625	1.812	1.628	1.809	01872	1.625	1.875	1.628	1.872					
01872	1.687	1.875	1.690	1.872	01934	1.687	1.937	1.690	1.934					
01934	1.750	1.937	1.753	1.934	01997	1.750	2.000	1.753	1.997					
01997	1.812	2.000	1.815	1.997	02059	1.812	2.062	1.815	2.059					
02059	1.875	2.062	1.878	2.059	02122	1.875	2.125	1.878	2.122					
02122	1.937	2.125	1.940	2.122	02184	1.937	2.187	1.940	2.184					
02184	2.000	2.187	2.003	2.184	02247	2.000	2.250	2.003	2.247					
02247	2.062	2.250	2.065	2.247	02309	2.062	2.312	2.065	2.309					
02309	2.125	2.312	2.128	2.309	02372	2.125	2.375	2.128	2.372					
02372	2.187	2.375	2.190	2.372	02434	2.187	2.437	2.190	2.434					
02434	2.250	2.437	2.253	2.434	02497	2.250	2.500	2.253	2.497					
02497	2.312	2.500	2.315	2.497	02559	2.312	2.562	2.315	2.559					
02559	2.375	2.562	2.378	2.559	02622	2.375	2.625	2.378	2.622					
02622	2.437	2.625	2.440	2.622	02684	2.437	2.687	2.440	2.684					
02684	2.500	2.687	2.503	2.684	02747	2.500	2.750	2.503	2.747					
02747	2.562	2.750	2.565	2.747	02809	2.562	2.812	2.565	2.809					
02809	2.625	2.812	2.628	2.809	02872	2.625	2.875	2.628	2.872					
02872	2.687	2.875	2.690	2.872	02934	2.687	2.937	2.690	2.934					
02934	2.750	2.937	2.753	2.934	02997	2.750	3.000	2.753	2.997					
02997	2.812	3.000	2.815	2.997	03059	2.812	3.062	2.815	3.059					
03059	2.875	3.062	2.878	3.059	03122	2.875	3.125	2.878	3.122					
03122	2.937	3.125	2.940	3.122	03184	2.937	3.187	2.940	3.184					
03184	3.000	3.187	3.003	3.184	03247	3.000	3.250	3.003	3.247	03372	3.000	3.375	3.003	3.372
03247	3.062	3.250	3.065	3.247	03309	3.062	3.312	3.065	3.309	03434	3.062	3.437	3.065	3.434

Seal dimensions in inches, prior to plating or coating where applicable.

FREE HEIGHT .102					FREE HEIGHT .132					FREE HEIGHT .218				
SEAL DIA. CODE	CAVITY		SEAL		SEAL DIA. CODE	CAVITY		SEAL		SEAL DIA. CODE	CAVITY		SEAL	
	I.D.	O.D.	I.D.	O.D.		I.D.	O.D.	I.D.	O.D.		I.D.	O.D.	I.D.	O.D.
	(MAX)	+0.004 -.000	(MIN)	+0.000 -.010		(MAX)	+0.004 -.000	(MIN)	+0.000 -.010		(MAX)	+0.004 -.000	(MIN)	+0.000 -.010
03309	3.125	3.312	3.128	3.309	03372	3.125	3.375	3.128	3.372	03497	3.125	3.500	3.128	3.497
03372	3.187	3.375	3.190	3.372	03434	3.187	3.437	3.190	3.434	03559	3.187	3.562	3.190	3.559
03434	3.250	3.437	3.253	3.434	03497	3.250	3.500	3.253	3.497	03622	3.250	3.625	3.253	3.622
03497	3.312	3.500	3.315	3.497	03559	3.312	3.562	3.315	3.559	03684	3.312	3.687	3.315	3.684
03559	3.375	3.562	3.378	3.559	03622	3.375	3.625	3.378	3.622	03747	3.375	3.750	3.378	3.747
03622	3.437	3.625	3.440	3.622	03684	3.437	3.687	3.440	3.684	03809	3.437	3.812	3.440	3.809
03684	3.500	3.687	3.503	3.684	03747	3.500	3.750	3.503	3.747	03872	3.500	3.875	3.503	3.872
03747	3.562	3.750	3.565	3.747	03809	3.562	3.812	3.565	3.809	03934	3.562	3.937	3.565	3.934
03809	3.625	3.812	3.628	3.809	03872	3.625	3.875	3.628	3.872	03997	3.625	4.000	3.628	3.997
03872	3.687	3.875	3.690	3.872	03934	3.687	3.937	3.690	3.934	04059	3.687	4.062	3.690	4.059
03934	3.750	3.937	3.753	3.934	03997	3.750	4.000	3.753	3.997	04122	3.750	4.125	3.753	4.122
03997	3.812	4.000	3.815	3.997	04059	3.812	4.062	3.815	4.059	04184	3.812	4.187	3.815	4.184
04059	3.875	4.062	3.878	4.059	04122	3.875	4.125	3.878	4.122	04247	3.875	4.250	3.878	4.247
04112	3.937	4.125	3.940	4.122	04184	3.937	4.187	3.940	4.184	04309	3.937	4.312	3.940	4.309
04184	4.000	4.187	4.003	4.184	04247	4.000	4.250	4.003	4.247	04372	4.000	4.375	4.003	4.372
04247	4.062	4.250	4.065	4.247	04309	4.062	4.312	4.065	4.309	04434	4.062	4.437	4.065	4.434
04309	4.125	4.312	4.128	4.309	04372	4.125	4.375	4.128	4.372	04497	4.125	4.500	4.128	4.497
04372	4.187	4.375	4.190	4.372	04434	4.187	4.437	4.190	4.434	04559	4.187	4.562	4.190	4.559
04434	4.250	4.437	4.253	4.434	04497	4.250	4.500	4.253	4.497	04622	4.250	4.625	4.253	4.622
04497	4.312	4.500	4.315	4.497	04559	4.312	4.562	4.315	4.559	04684	4.312	4.687	4.315	4.684
04559	4.375	4.562	4.378	4.559	04622	4.375	4.625	4.378	4.622	04747	4.375	4.750	4.378	4.747
04622	4.437	4.625	4.440	4.622	04684	4.437	4.687	4.440	4.684	04809	4.437	4.812	4.440	4.809
04684	4.500	4.687	4.503	4.684	04747	4.500	4.750	4.503	4.747	04872	4.500	4.875	4.503	4.872
04747	4.562	4.750	4.565	4.747	04809	4.562	4.812	4.565	4.809	04934	4.562	4.937	4.565	4.934
04809	4.625	4.812	4.628	4.809	04872	4.625	4.875	4.628	4.872	04997	4.625	5.000	4.628	4.997
04872	4.687	4.875	4.690	4.872	04934	4.687	4.937	4.690	4.934	05059	4.687	5.062	4.690	5.059
04934	4.750	4.937	4.753	4.934	04997	4.750	5.000	4.753	4.997	05122	4.750	5.125	4.753	5.122
04997	4.812	5.000	4.815	4.997	05059	4.812	5.062	4.815	5.059	05184	4.812	5.187	4.815	5.184
05059	4.875	5.062	4.878	5.059	05122	4.875	5.125	4.878	5.122	05247	4.875	5.250	4.878	5.247
05122	4.937	5.125	4.940	5.122	05184	4.937	5.187	4.940	5.184	05309	4.937	5.312	4.940	5.309
	(MAX)	+0.006 -.000	(MIN)	+0.000 -.012		(MAX)	+0.006 -.000	(MIN)	+0.000 -.012		(MAX)	+0.006 -.000	(MIN)	+0.000 -.012
05184	5.000	5.187	5.003	5.184	05247	5.000	5.250	5.003	5.247	05372	5.000	5.375	5.003	5.372
05247	5.062	5.250	5.065	5.247	05309	5.062	5.312	5.065	5.309	05434	5.062	5.437	5.065	5.434
05309	5.125	5.312	5.128	5.309	05372	5.125	5.375	5.128	5.372	05497	5.125	5.500	5.128	5.497
05372	5.187	5.375	5.190	5.372	05434	5.187	5.437	5.190	5.434	05559	5.187	5.562	5.190	5.559
05434	5.250	5.437	5.253	5.434	05497	5.250	5.500	5.253	5.497	05622	5.250	5.625	5.253	5.622
05497	5.312	5.500	5.315	5.497	05559	5.312	5.562	5.315	5.559	05684	5.312	5.687	5.315	5.684
05559	5.375	5.562	5.378	5.559	05622	5.375	5.625	5.378	5.622	05747	5.375	5.750	5.378	5.747
05622	5.437	5.625	5.440	5.622	05684	5.437	5.687	5.440	5.684	05809	5.437	5.812	5.440	5.809
05684	5.500	5.687	5.503	5.684	05747	5.500	5.750	5.503	5.747	05872	5.500	5.875	5.503	5.872
05747	5.562	5.750	5.565	5.747	05809	5.562	5.812	5.565	5.809	05934	5.562	5.937	5.565	5.934
05809	5.625	5.812	5.628	5.809	05872	5.625	5.875	5.628	5.872	05997	5.625	6.000	5.628	5.997
05934	5.750	5.937	5.753	5.934	05997	5.750	6.000	5.753	5.997	06122	5.750	6.125	5.753	6.122
06059	5.875	6.062	5.878	6.059	06122	5.875	6.125	5.878	6.122	06247	5.875	6.250	5.878	6.247
06184	6.000	6.187	6.003	6.184	06247	6.000	6.250	6.003	6.247	06372	6.000	6.375	6.003	6.372
06309	6.125	6.312	6.128	6.309	06372	6.125	6.375	6.128	6.372	06497	6.125	6.500	6.128	6.497
06434	6.250	6.437	6.253	6.434	06497	6.250	6.500	6.253	6.497	06622	6.250	6.625	6.253	6.622
06559	6.375	6.562	6.378	6.559	06622	6.375	6.625	6.378	6.622	06747	6.375	6.750	6.378	6.747
06684	6.500	6.687	6.503	6.684	06747	6.500	6.750	6.503	6.747	06872	6.500	6.875	6.503	6.872
06809	6.625	6.812	6.628	6.809	06872	6.625	6.875	6.628	6.872	06997	6.625	7.000	6.628	6.997
06934	6.750	6.937	6.753	6.934	06997	6.750	7.000	6.753	6.997	07122	6.750	7.125	6.753	7.122

Seal dimensions in inches, prior to plating or coating.

FREE HEIGHT .102					FREE HEIGHT .132					FREE HEIGHT .218				
SEAL DIA. CODE	CAVITY		SEAL		SEAL DIA. CODE	CAVITY		SEAL		SEAL DIA. CODE	CAVITY		SEAL	
	I.D.	O.D.	I.D.	O.D.		I.D.	O.D.	I.D.	O.D.		I.D.	O.D.	I.D.	O.D.
	(MAX)	+0.006 -0.000	(MIN)	+0.000 -0.015		(MAX)	+0.006 -0.000	(MIN)	+0.000 -0.015		(MAX)	+0.006 -0.000	(MIN)	+0.000 -0.015
07059	6.875	7.062	6.878	7.059	07122	6.875	7.125	6.878	7.122	07247	6.875	7.250	6.878	7.247
07184	7.000	7.187	7.003	7.184	07247	7.000	7.250	7.003	7.247	07372	7.000	7.375	7.003	7.372
07309	7.125	7.312	7.128	7.309	07372	7.125	7.375	7.128	7.372	07497	7.125	7.500	7.128	7.497
07434	7.250	7.437	7.253	7.434	07497	7.250	7.500	7.253	7.497	07622	7.250	7.625	7.253	7.622
07559	7.375	7.562	7.378	7.559	07622	7.375	7.625	7.378	7.622	07747	7.375	7.750	7.378	7.747
07684	7.500	7.687	7.503	7.684	07747	7.500	7.750	7.503	7.747	07872	7.500	7.875	7.503	7.872
07809	7.625	7.812	7.628	7.809	07872	7.625	7.875	7.628	7.872	07997	7.625	8.000	7.628	7.997
07934	7.750	7.937	7.753	7.934	07997	7.750	8.000	7.753	7.997	08122	7.750	8.125	7.753	8.122
08059	7.875	8.062	7.878	8.059	08122	7.875	8.125	7.878	8.122	08247	7.875	8.250	7.878	8.247
08184	8.000	8.187	8.003	8.184	08247	8.000	8.250	8.003	8.247	08372	8.000	8.375	8.003	8.372
08309	8.125	8.312	8.128	8.309	08372	8.125	8.375	8.128	8.372	08497	8.125	8.500	8.128	8.497
08434	8.250	8.437	8.253	8.434	08497	8.250	8.500	8.253	8.497	08622	8.250	8.625	8.253	8.622
08559	8.375	8.562	8.378	8.559	08622	8.375	8.625	8.378	8.622	08747	8.375	8.750	8.378	8.747
08684	8.500	8.687	8.503	8.684	08747	8.500	8.750	8.503	8.747	08872	8.500	8.875	8.503	8.872
08809	8.625	8.812	8.628	8.809	08872	8.625	8.875	8.628	8.872	08997	8.625	9.000	8.628	8.997
08934	8.750	8.937	8.753	8.934	08997	8.750	9.000	8.753	8.997	09122	8.750	9.125	8.753	9.122
09059	8.875	9.062	8.878	9.059	09122	8.875	9.125	8.878	9.122	09247	8.875	9.250	8.878	9.247
09184	9.000	9.187	9.003	9.184	09247	9.000	9.250	9.003	9.247	09372	9.000	9.375	9.003	9.372
09309	9.125	9.312	9.128	9.309	09372	9.125	9.375	9.128	9.372	09497	9.125	9.500	9.128	9.497
09434	9.250	9.437	9.253	9.434	09497	9.250	9.500	9.253	9.497	09622	9.250	9.625	9.253	9.622
09559	9.375	9.562	9.378	9.559	09622	9.375	9.625	9.378	9.622	09747	9.375	9.750	9.378	9.747
09684	9.500	9.687	9.503	9.684	09747	9.500	9.750	9.503	9.747	09872	9.500	9.875	9.503	9.872
09809	9.625	9.812	9.628	9.809	09872	9.625	9.875	9.628	9.872	09997	9.625	10.000	9.628	9.997
09934	9.750	9.937	9.753	9.934	09997	9.750	10.000	9.753	9.997	10122	9.750	10.125	9.753	10.122
10059	9.875	10.062	9.878	10.059	10122	9.875	10.125	9.878	10.122	10247	9.875	10.250	9.878	10.247
	(MAX)	+0.008 -0.000	(MIN)	+0.000 -0.020		(MAX)	+0.008 -0.000	(MIN)	+0.000 -0.020		(MAX)	+0.008 -0.000	(MIN)	+0.000 -0.020
10184	10.000	10.187	10.003	10.184	10247	10.000	10.250	10.003	10.247	10372	10.000	10.375	10.003	10.372
10309	10.125	10.312	10.128	10.309	10372	10.125	10.375	10.128	10.372	10497	10.125	10.500	10.128	10.497
10434	10.250	10.437	10.253	10.434	10497	10.250	10.500	10.253	10.497	10622	10.250	10.625	10.253	10.622
10559	10.375	10.562	10.378	10.559	10622	10.375	10.625	10.378	10.622	10747	10.375	10.750	10.378	10.747
10684	10.500	10.687	10.503	10.684	10747	10.500	10.750	10.503	10.747	10872	10.500	10.875	10.503	10.872
10809	10.625	10.812	10.628	10.809	10872	10.625	10.875	10.628	10.872	10997	10.625	11.000	10.628	10.997
10934	10.750	10.937	10.753	10.934	10997	10.750	11.000	10.753	10.997	11122	10.750	11.125	10.753	11.122
11059	10.875	11.062	10.878	11.059	11122	10.875	11.125	10.878	11.122	11247	10.875	11.250	10.878	11.247
11184	11.000	11.187	11.003	11.184	11247	11.000	11.250	11.003	11.247	11372	11.000	11.375	11.003	11.372
11309	11.125	11.312	11.128	11.309	11372	11.125	11.375	11.128	11.372	11497	11.125	11.500	11.128	11.497
11434	11.250	11.437	11.253	11.434	11497	11.250	11.500	11.253	11.497	11622	11.250	11.625	11.253	11.622
11559	11.375	11.562	11.378	11.559	11622	11.375	11.625	11.378	11.622	11747	11.375	11.750	11.378	11.747
11684	11.500	11.687	11.503	11.684	11747	11.500	11.750	11.503	11.747	11872	11.500	11.875	11.503	11.872
11809	11.625	11.812	11.628	11.809	11872	11.625	11.875	11.628	11.872	11997	11.625	12.000	11.628	11.997
11934	11.750	11.937	11.753	11.934	11997	11.750	12.000	11.753	11.997	12122	11.750	12.125	11.753	12.122
12059	11.875	12.062	11.878	12.059	12122	11.875	12.125	11.878	12.122	12247	11.875	12.250	11.878	12.247
12184	12.000	12.187	12.003	12.184	12247	12.000	12.250	12.003	12.247	12372	12.000	12.375	12.003	12.372
12309	12.125	12.312	12.128	12.309	12372	12.125	12.375	12.128	12.372	12497	12.125	12.500	12.128	12.497
12434	12.250	12.437	12.253	12.434	12497	12.250	12.500	12.253	12.497	12622	12.250	12.625	12.253	12.622
12559	12.375	12.562	12.378	12.559	12622	12.375	12.625	12.378	12.622	12747	12.375	12.750	12.378	12.747
12684	12.500	12.687	12.503	12.684	12747	12.500	12.750	12.503	12.747	12872	12.500	12.875	12.503	12.872
12809	12.625	12.812	12.628	12.809	12872	12.625	12.875	12.628	12.872	12997	12.625	13.000	12.628	12.997
12934	12.750	12.937	12.753	12.934	12997	12.750	13.000	12.753	12.997	13122	12.750	13.125	12.753	13.122
13059	12.875	13.062	12.878	13.059	13122	12.875	13.125	12.878	13.122	13247	12.875	13.250	12.878	13.247
13184	13.000	13.187	13.003	13.184	13247	13.000	13.250	13.003	13.247	13372	13.000	13.375	13.003	13.372

Seal dimensions in inches, prior to plating or coating.

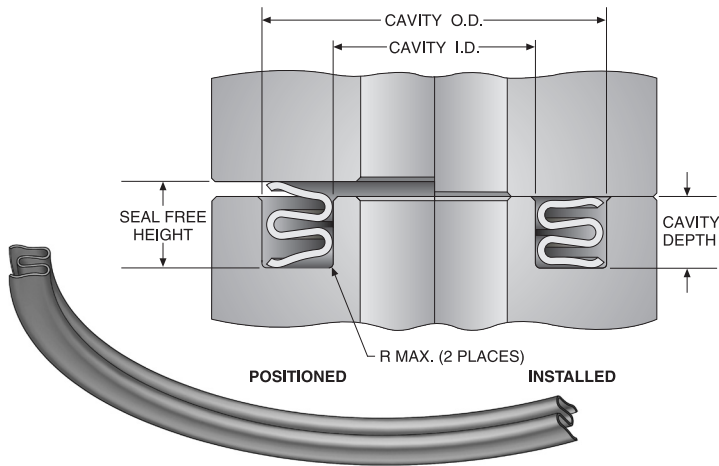

- Recommended for high pressure liquid and air systems and equipment .
- High deflection capability.
- See page 4 for all dimensions and tolerances other than those for diameters.
- Seal diameters are average. See roundness table, page 6.
- Outer cavity wall optional.
- Standard sizes are presented. Non-standard diameters may be derived by interpolation.
- Cavity sealing surface texture 32 μ-in., circ. lay.

P/N: JHE

seal type diameter code derived from seal I.D., Pages 16 - 18 cross-section Page 4 material Page 4 heat treatment Page 4 plating Page 5

FREE HEIGHT .102					FREE HEIGHT .132					FREE HEIGHT .218				
SEAL DIA. CODE	CAVITY I.D.		SEAL I.D.		SEAL DIA. CODE	CAVITY I.D.		SEAL I.D.		SEAL DIA. CODE	CAVITY I.D.		SEAL I.D.	
	+0.000 -.003	(MIN)	+0.006 -.000	(MAX)		+0.000 -.003	(MIN)	+0.006 -.000	(MAX)		+0.000 -.003	(MIN)	+0.006 -.000	(MAX)
00628	.625	.812	.628	.809										
00690	.687	.875	.690	.872										
00753	.750	.937	.753	.934										
00815	.812	1.000	.815	.997										
00878	.875	1.062	.878	1.059	00878	.875	1.125	.878	1.122					
00940	.937	1.125	.940	1.122	00940	.937	1.187	.940	1.184					
01003	1.000	1.187	1.003	1.184	01003	1.000	1.250	1.003	1.247					
01065	1.062	1.250	1.065	1.247	01065	1.062	1.312	1.065	1.309					
01128	1.125	1.312	1.128	1.309	01128	1.125	1.375	1.128	1.372					
01190	1.187	1.375	1.190	1.372	01190	1.187	1.437	1.190	1.434					
01253	1.250	1.437	1.253	1.434	01253	1.250	1.500	1.253	1.497					
01315	1.312	1.500	1.315	1.497	01315	1.312	1.562	1.315	1.559					
01378	1.375	1.562	1.378	1.559	01378	1.375	1.625	1.378	1.622					
01440	1.437	1.625	1.440	1.622	01440	1.437	1.687	1.440	1.684					
01503	1.500	1.687	1.503	1.684	01503	1.500	1.750	1.503	1.747					
01565	1.562	1.750	1.565	1.747	01565	1.562	1.812	1.565	1.809					
01628	1.625	1.812	1.628	1.809	01628	1.625	1.875	1.628	1.872					
01690	1.687	1.875	1.690	1.872	01690	1.687	1.937	1.690	1.934					
01753	1.750	1.937	1.753	1.934	01753	1.750	2.000	1.753	1.997					
01815	1.812	2.000	1.815	1.997	01815	1.812	2.062	1.815	2.059					
01878	1.875	2.062	1.878	2.059	01878	1.875	2.125	1.878	2.122					
01940	1.937	2.125	1.940	2.122	01940	1.937	2.187	1.940	2.184					
02003	2.000	2.187	2.003	2.184	02003	2.000	2.250	2.003	2.247					
02065	2.062	2.250	2.065	2.247	02065	2.062	2.312	2.065	2.309					
02128	2.125	2.312	2.128	2.309	02128	2.125	2.375	2.128	2.372					
02190	2.187	2.375	2.190	2.372	02190	2.187	2.437	2.190	2.434					
02253	2.250	2.437	2.253	2.434	02253	2.250	2.500	2.253	2.497					
02315	2.312	2.500	2.315	2.497	02315	2.312	2.562	2.315	2.559					
02378	2.375	2.562	2.378	2.559	02378	2.375	2.625	2.378	2.622					
02440	2.437	2.625	2.440	2.622	02440	2.437	2.687	2.440	2.684					
02503	2.500	2.687	2.503	2.684	02503	2.500	2.750	2.503	2.747					
02565	2.562	2.750	2.565	2.747	02565	2.562	2.812	2.565	2.809					
02628	2.625	2.812	2.628	2.809	02628	2.625	2.875	2.628	2.872					
02690	2.687	2.875	2.690	2.872	02690	2.687	2.937	2.690	2.934					
02753	2.750	2.937	2.753	2.934	02753	2.750	3.000	2.753	2.997					
02815	2.812	3.000	2.815	2.997	02815	2.812	3.062	2.815	3.059					
02878	2.875	3.062	2.878	3.059	02878	2.875	3.125	2.878	3.122					
02940	2.937	3.125	2.940	3.122	02940	2.937	3.187	2.940	3.184					
03003	3.000	3.187	3.003	3.184	03003	3.000	3.250	3.003	3.247	03003	3.000	3.375	3.003	3.372
03065	3.062	3.250	3.065	3.247	03065	3.062	3.312	3.065	3.309	03065	3.062	3.437	3.065	3.434

Seal dimensions in inches, prior to plating or coating

FREE HEIGHT .102					FREE HEIGHT .132					FREE HEIGHT .218				
SEAL DIA. CODE	CAVITY		SEAL		SEAL DIA. CODE	CAVITY		SEAL		SEAL DIA. CODE	CAVITY		SEAL	
	I.D.	O.D.	I.D.	O.D.		I.D.	O.D.	I.D.	O.D.		I.D.	O.D.	I.D.	O.D.
	+0.00 -0.05	(MIN)	+0.08 -0.00	(MAX)		+0.00 -0.05	(MIN)	+0.08 -0.00	(MAX)		+0.00 -0.05	(MIN)	+0.08 -0.00	(MAX)
03128	3.125	3.312	3.128	3.309	03128	3.125	3.375	3.128	3.372	03128	3.125	3.500	3.128	3.497
03190	3.187	3.375	3.190	3.372	03190	3.187	3.437	3.190	3.434	03190	3.187	3.562	3.190	3.559
03253	3.250	3.437	3.253	3.434	03253	3.250	3.500	3.253	3.497	03253	3.250	3.625	3.253	3.622
03315	3.312	3.500	3.315	3.497	03315	3.312	3.562	3.315	3.559	03315	3.312	3.687	3.315	3.684
03378	3.375	3.562	3.378	3.559	03378	3.375	3.625	3.378	3.622	03378	3.375	3.750	3.378	3.747
03440	3.437	3.625	3.440	3.622	03440	3.437	3.687	3.440	3.684	03440	3.437	3.812	3.440	3.809
03503	3.500	3.687	3.503	3.684	03503	3.500	3.750	3.503	3.747	03503	3.500	3.875	3.503	3.872
03565	3.562	3.750	3.565	3.747	03565	3.562	3.812	3.565	3.809	03565	3.562	3.937	3.565	3.934
03628	3.625	3.812	3.628	3.809	03628	3.625	3.875	3.628	3.872	03628	3.625	4.000	3.628	3.997
03690	3.687	3.875	3.690	3.872	03690	3.687	3.937	3.690	3.934	03690	3.687	4.062	3.690	4.059
03753	3.750	3.937	3.753	3.934	03753	3.750	4.000	3.753	3.997	03753	3.750	4.125	3.753	4.122
03815	3.812	4.000	3.815	3.997	03815	3.812	4.062	3.815	4.059	03815	3.812	4.187	3.815	4.184
03878	3.875	4.062	3.878	4.059	03878	3.875	4.125	3.878	4.122	03878	3.875	4.250	3.878	4.247
03940	3.937	4.125	3.940	4.122	03940	3.937	4.187	3.940	4.184	03940	3.937	4.312	3.940	4.309
04003	4.000	4.187	4.003	4.184	04003	4.000	4.250	4.003	4.247	04003	4.000	4.375	4.003	4.372
04065	4.062	4.250	4.065	4.247	04065	4.062	4.312	4.065	4.309	04065	4.062	4.437	4.065	4.434
04128	4.125	4.312	4.128	4.309	04128	4.125	4.375	4.128	4.372	04128	4.125	4.500	4.128	4.497
04190	4.187	4.375	4.190	4.372	04190	4.187	4.437	4.190	4.434	04190	4.187	4.562	4.190	4.559
04253	4.250	4.437	4.253	4.434	04253	4.250	4.500	4.253	4.497	04253	4.250	4.625	4.253	4.622
04315	4.312	4.500	4.315	4.497	04315	4.312	4.562	4.315	4.559	04315	4.312	4.687	4.315	4.684
04378	4.375	4.562	4.378	4.559	04378	4.375	4.625	4.378	4.622	04378	4.375	4.750	4.378	4.747
04440	4.437	4.625	4.440	4.622	04440	4.437	4.687	4.440	4.684	04440	4.437	4.812	4.440	4.809
04503	4.500	4.687	4.503	4.684	04503	4.500	4.750	4.503	4.747	04503	4.500	4.875	4.503	4.872
04565	4.562	4.750	4.565	4.747	04565	4.562	4.812	4.565	4.809	04565	4.562	4.937	4.565	4.934
04628	4.625	4.812	4.628	4.809	04628	4.625	4.875	4.628	4.872	04628	4.625	5.000	4.628	4.997
04690	4.687	4.875	4.690	4.872	04690	4.687	4.937	4.690	4.934	04690	4.687	5.062	4.690	5.059
04753	4.750	4.937	4.753	4.934	04753	4.750	5.000	4.753	4.997	04753	4.750	5.125	4.753	5.122
04815	4.812	5.000	4.815	4.997	04815	4.812	5.062	4.815	5.059	04815	4.812	5.187	4.815	5.184
04878	4.875	5.062	4.878	5.059	04878	4.875	5.125	4.878	5.122	04878	4.875	5.250	4.878	5.247
04940	4.937	5.125	4.940	5.122	04940	4.937	5.187	4.940	5.184	04940	4.937	5.312	4.940	5.309
	+0.00 -0.06	(MIN)	+0.10 -0.00	(MAX)		+0.00 -0.06	(MIN)	+0.10 -0.00	(MAX)		+0.00 -0.06	(MIN)	+0.10 -0.00	(MAX)
05003	5.000	5.187	5.003	5.184	05003	5.000	5.250	5.003	5.247	05003	5.000	5.375	5.003	5.372
05065	5.062	5.250	5.065	5.247	05065	5.062	5.312	5.065	5.309	05065	5.062	5.437	5.065	5.434
05128	5.125	5.312	5.128	5.309	05128	5.125	5.375	5.128	5.372	05128	5.125	5.500	5.128	5.497
05190	5.187	5.375	5.190	5.372	05190	5.187	5.437	5.190	5.434	05190	5.187	5.562	5.190	5.559
05253	5.250	5.437	5.253	5.434	05253	5.250	5.500	5.253	5.497	05253	5.250	5.625	5.253	5.622
05315	5.312	5.500	5.315	5.497	05315	5.312	5.562	5.315	5.559	05315	5.312	5.687	5.315	5.684
05378	5.375	5.562	5.378	5.559	05378	5.375	5.625	5.378	5.622	05378	5.375	5.750	5.378	5.747
05440	5.437	5.625	5.440	5.622	05440	5.437	5.687	5.440	5.684	05440	5.437	5.812	5.440	5.809
05503	5.500	5.687	5.503	5.684	05503	5.500	5.750	5.503	5.747	05503	5.500	5.875	5.503	5.872
05565	5.562	5.750	5.565	5.747	05565	5.562	5.812	5.565	5.809	05565	5.562	5.937	5.565	5.934
05628	5.625	5.812	5.628	5.809	05628	5.625	5.875	5.628	5.872	05628	5.625	6.000	5.628	5.997
05753	5.750	5.937	5.753	5.934	05753	5.750	6.000	5.753	5.997	05753	5.750	6.125	5.753	6.122
05878	5.875	6.062	5.878	6.059	05878	5.875	6.125	5.878	6.122	05878	5.875	6.250	5.878	6.247
06003	6.000	6.187	6.003	6.184	06003	6.000	6.250	6.003	6.247	06003	6.000	6.375	6.003	6.372
06128	6.125	6.312	6.128	6.309	06128	6.125	6.375	6.128	6.372	06128	6.125	6.500	6.128	6.497
06253	6.250	6.437	6.253	6.434	06253	6.250	6.500	6.253	6.497	06253	6.250	6.625	6.253	6.622
06378	6.375	6.562	6.378	6.559	06378	6.375	6.625	6.378	6.622	06378	6.375	6.750	6.378	6.747
06503	6.500	6.687	6.503	6.684	06503	6.500	6.750	6.503	6.747	06503	6.500	6.875	6.503	6.872
06628	6.625	6.812	6.628	6.809	06628	6.625	6.875	6.628	6.872	06628	6.625	7.000	6.628	6.997
06753	6.750	6.937	6.753	6.934	06753	6.750	7.000	6.753	6.997	06753	6.750	7.125	6.753	7.122
06878	6.875	7.062	6.878	7.059	06878	6.875	7.125	6.878	7.122	06878	6.875	7.250	6.878	7.247
07003	7.000	7.187	7.003	7.184	07003	7.000	7.250	7.003	7.247	07003	7.000	7.375	7.003	7.372
07128	7.125	7.312	7.128	7.309	07128	7.125	7.375	7.128	7.372	07128	7.125	7.500	7.128	7.497
07253	7.250	7.437	7.253	7.434	07253	7.250	7.500	7.253	7.497	07253	7.250	7.625	7.253	7.622
07378	7.375	7.562	7.378	7.559	07378	7.375	7.625	7.378	7.622	07378	7.375	7.750	7.378	7.747

Seal dimensions in inches, prior to plating or coating

FREE HEIGHT .102					FREE HEIGHT .132					FREE HEIGHT .218				
SEAL DIA. CODE	CAVITY		SEAL		SEAL DIA. CODE	CAVITY		SEAL		SEAL DIA. CODE	CAVITY		SEAL	
	I.D.	O.D.	I.D.	O.D.		I.D.	O.D.	I.D.	O.D.		I.D.	O.D.	I.D.	O.D.
	+ .000 - .008	(MIN)	+ .012 - .000	(MAX)		+ .000 - .008	(MIN)	+ .012 - .000	(MAX)		+ .000 - .008	(MIN)	+ .012 - .000	(MAX)
07503	7.500	7.687	7.503	7.684	07503	7.500	7.750	7.503	7.503	07503	7.500	7.875	7.503	7.872
07628	7.625	7.812	7.628	7.809	07628	7.625	7.875	7.628	7.628	07628	7.625	8.000	7.628	7.997
07753	7.750	7.937	7.753	7.934	07753	7.750	8.000	7.753	7.753	07753	7.750	8.125	7.753	8.122
07878	7.875	8.062	7.878	8.059	07878	7.875	8.125	7.878	7.878	07878	7.875	8.250	7.878	8.247
08003	8.000	8.187	8.003	8.184	08003	8.000	8.250	8.003	8.003	08003	8.000	8.375	8.003	8.372
08128	8.125	8.312	8.128	8.309	08128	8.125	8.375	8.128	8.128	08128	8.125	8.500	8.128	8.497
08253	8.250	8.437	8.253	8.434	08253	8.250	8.500	8.253	8.253	08253	8.250	8.625	8.253	8.622
08378	8.375	8.562	8.378	8.559	08378	8.375	8.625	8.378	8.378	08378	8.375	8.750	8.378	8.747
08503	8.500	8.687	8.503	8.684	08503	8.500	8.750	8.503	8.503	08503	8.500	8.875	8.503	8.872
08628	8.625	8.812	8.628	8.809	08628	8.625	8.875	8.628	8.628	08628	8.625	9.000	8.628	8.997
08753	8.750	8.937	8.753	8.934	08753	8.750	9.000	8.753	8.753	08753	8.750	9.125	8.753	9.122
08878	8.875	9.062	8.878	9.059	08878	8.875	9.125	8.878	8.878	08878	8.875	9.250	8.878	9.247
09003	9.000	9.187	9.003	9.184	09003	9.000	9.250	9.003	9.003	09003	9.000	9.375	9.003	9.372
09128	9.125	9.312	9.128	9.309	09128	9.125	9.375	9.128	9.128	09128	9.125	9.500	9.128	9.497
09253	9.250	9.437	9.253	9.434	09253	9.250	9.500	9.253	9.253	09253	9.250	9.625	9.253	9.622
09378	9.375	9.562	9.378	9.559	09378	9.375	9.625	9.378	9.378	09378	9.375	9.750	9.378	9.747
09503	9.500	9.687	9.503	9.684	09503	9.500	9.750	9.503	9.503	09503	9.500	9.875	9.503	9.872
09628	9.625	9.812	9.628	9.809	09628	9.625	9.875	9.628	9.628	09628	9.625	10.000	9.628	9.997
09753	9.750	9.937	9.753	9.934	09753	9.750	10.000	9.753	9.753	09753	9.750	10.125	9.753	10.122
09878	9.875	10.062	9.878	10.059	09878	9.875	10.125	9.878	9.878	09878	9.875	10.250	9.878	10.247
10003	10.000	10.187	10.003	10.184	10003	10.000	10.250	10.003	10.003	10003	10.000	10.375	10.003	10.372
10128	10.125	10.312	10.128	10.309	10128	10.125	10.375	10.128	10.128	10128	10.125	10.500	10.128	10.497
					10253	10.250	10.500	10.253	10.253	10253	10.250	10.625	10.253	10.622
					10378	10.375	10.625	10.378	10.378	10378	10.375	10.750	10.378	10.747
					10503	10.500	10.750	10.503	10.503	10503	10.500	10.875	10.503	10.872
					10628	10.625	10.875	10.628	10.628	10628	10.625	11.000	10.628	10.997
					10753	10.750	11.000	10.753	10.753	10753	10.750	11.125	10.753	11.122
					10878	10.875	11.125	10.878	10.878	10878	10.875	11.250	10.878	11.247
					11003	11.000	11.250	11.003	11.003	11003	11.000	11.375	11.003	11.372
					11128	11.125	11.375	11.128	11.128	11128	11.125	11.500	11.128	11.497
					11253	11.250	11.500	11.253	11.253	11253	11.250	11.625	11.253	11.622
					11378	11.375	11.625	11.378	11.378	11378	11.375	11.750	11.378	11.747
					11503	11.500	11.750	11.503	11.503	11503	11.500	11.875	11.503	11.872
					11628	11.625	11.875	11.628	11.628	11628	11.625	12.000	11.628	11.997
					11753	11.750	12.000	11.753	11.753	11753	11.750	12.125	11.753	12.122
					11878	11.875	12.125	11.878	11.878	11878	11.875	12.250	11.878	12.247
					12003	12.000	12.250	12.003	12.003	12003	12.000	12.375	12.003	12.372

Seal dimensions in inches, prior to plating or coating

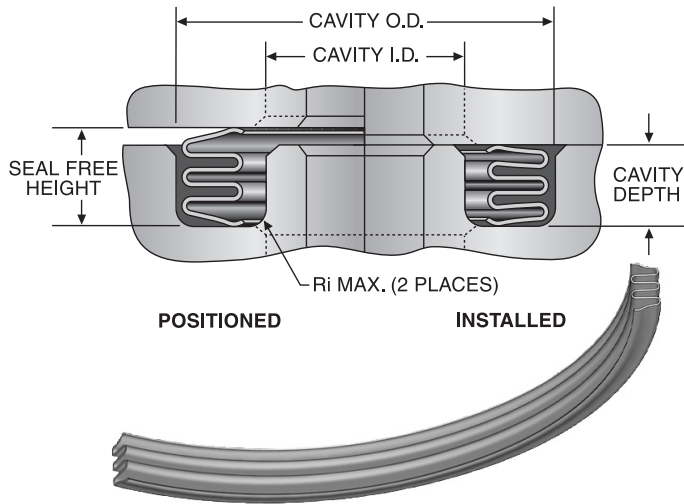

- Recommended for high temperature air systems and equipment.
- See page 4 for all dimensions and tolerances other than those for diameters.
- Average diameters are specified. Seals are out-of-round to provide snap-fit retention in inverted cavities.
- Inner cavity wall optional.
- Standard sizes are presented. Non-standard diameters may be derived by interpolation.
- Cavity sealing surface texture 32 μ-in., circular lay.

P/N: JW

Seal type diameter code derived from seal O.D., Pages 19 - 21 cross-section Page 4 material Page 4 heat treatment Page 4 plating or coating Page 5

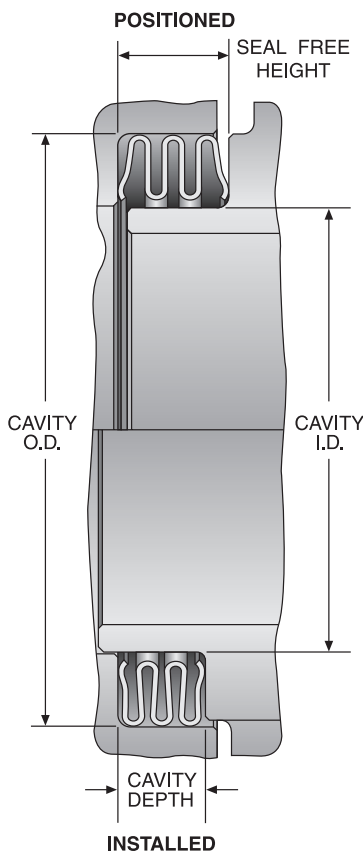

**JW E-SEAL,
INTERNAL PRESSURE**

FREE HEIGHT: JW .240					FREE HEIGHT: JW .250				
SEAL DIA. CODE	CAVITY I.D.		SEAL O.D.		SEAL DIA. CODE	CAVITY I.D.		SEAL O.D.	
	(MAX)	+0.003 -.000	(MIN)	+0.00 -.006		(MAX)	+0.003 .000	(MIN)	+0.000 -.006
01238	.937	1.240	.947	1.238	01712	1.308	1.714	1.324	1.712
01249	.965	1.251	.958	1.249	01775	1.371	1.777	1.387	1.775
01303	1.000	1.305	1.012	1.303	01837	1.433	1.839	1.449	1.837
01365	1.062	1.367	1.074	1.365	01863	1.459	1.865	1.475	1.863
01428	1.125	1.430	1.137	1.428	01900	1.496	1.902	1.512	1.900
01499	1.187	1.501	1.199	1.499	01962	1.558	1.964	1.574	1.962
01553	1.250	1.555	1.262	1.553	02025	1.621	2.027	1.637	2.025
01615	1.312	1.617	1.324	1.615	02087	1.683	2.089	1.699	2.087
01678	1.375	1.680	1.387	1.678	02113	1.709	2.115	1.725	2.113
01740	1.437	1.742	1.449	1.740	02150	1.746	2.152	1.762	2.150
01749	1.446	1.751	1.458	1.749	02212	1.808	2.214	1.824	2.212
01803	1.500	1.805	1.512	1.803	02275	1.871	2.277	1.887	2.275
01865	1.562	1.867	1.574	1.865	02337	1.933	2.339	1.949	2.337
01928	1.625	1.930	1.637	1.928	02363	1.959	2.365	1.975	2.363
01990	1.687	1.992	1.699	1.990	02402	1.998	2.404	2.014	2.402
01999	1.696	2.001	1.708	1.999	02464	2.060	2.466	2.076	2.464
02053	1.750	2.055	1.762	2.053	02527	2.123	2.529	2.139	2.527
02115	1.812	2.117	1.824	2.115	02589	2.185	2.591	2.201	2.589
02178	1.875	2.180	1.887	2.178	02614	2.210	2.616	2.226	2.614
02240	1.937	2.242	1.949	2.240	02652	2.248	2.654	2.264	2.652
02249	1.946	2.251	1.958	2.249	02714	2.310	2.716	2.326	2.714
02305	2.000	2.307	2.014	2.305	02777	2.373	2.779	2.389	2.777
02367	2.062	2.369	2.076	2.367	02839	2.435	2.841	2.451	2.839
02430	2.125	2.432	2.139	2.430	02864	2.460	2.866	2.476	2.864
02492	2.187	2.494	2.201	2.492	02902	2.498	2.904	2.514	2.902
02499	2.194	2.501	2.208	2.499	02964	2.560	2.966	2.576	2.964
02555	2.250	2.557	2.264	2.555	03027	2.623	3.029	2.639	3.027
02617	2.312	2.619	2.326	2.617	03089	2.685	3.091	2.701	3.089
02680	2.375	2.682	2.389	2.680	03114	2.710	3.116	2.726	3.114
02742	2.437	2.744	2.451	2.742	03152	2.748	3.154	2.764	3.152
02749	2.440	2.751	2.458	2.749					
02805	2.500	2.807	2.514	2.805					
02867	2.562	2.869	2.576	2.867					
02930	2.625	2.932	2.639	2.930					
02992	2.687	2.994	2.701	2.992					
02999	2.694	3.001	2.708	2.999					
03055	2.750	3.057	2.764	3.055					

Seal dimensions in inches, prior to plating or coating where applicable. Plating not generally recommended for this low load seal series.

FREE HEIGHT: JW1 .240					FREE HEIGHT: JW1 .250				
SEAL DIA. CODE	CAVITY		SEAL		SEAL DIA. CODE	CAVITY		SEAL	
	I.D.	O.D.	I.D.	O.D.		I.D.	O.D.	I.D.	O.D.
	(MAX)	+0.003 -0.000	(MIN)	+0.000 -0.006		(MAX)	+0.003 -0.000	(MIN)	+0.000 -0.006
03117	2.812	3.119	2.826	3.117	03152	2.748	3.154	2.764	3.152
03180	2.875	3.182	2.889	3.180	03214	2.810	3.216	2.826	3.214
03249	2.937	3.251	2.958	3.249	03277	2.873	3.279	2.889	3.277
03307	3.000	3.309	3.016	3.307	03364	2.960	3.366	2.976	3.364
03369	3.062	3.371	3.078	3.369	03404	3.000	3.406	3.016	3.404
03432	3.125	3.434	3.141	3.432	03466	3.062	3.468	3.078	3.466
03499	3.187	3.501	3.208	3.499	03529	3.125	3.531	3.141	3.529
03557	3.250	3.559	3.266	3.557	03614	3.210	3.616	3.226	3.614
03619	3.312	3.621	3.328	3.619	03654	3.250	3.656	3.266	3.654
03682	3.375	3.684	3.391	3.682	03716	3.312	3.718	3.328	3.716
03749	3.437	3.751	3.458	3.749	03779	3.375	3.781	3.391	3.779
03807	3.500	3.809	3.516	3.807	03865	3.461	3.867	3.477	3.865
03869	3.562	3.871	3.578	3.869	03904	3.500	3.906	3.516	3.904
03932	3.625	3.934	3.641	3.932	03966	3.562	3.968	3.578	3.966
03994	3.687	3.996	3.703	3.994	04029	3.625	4.031	3.641	4.029
04057	3.750	4.059	3.766	4.057	04091	3.687	4.093	3.703	4.091
04119	3.812	4.121	3.828	4.119	04154	3.750	4.156	3.766	4.154
04182	3.875	4.184	3.891	4.182	04216	3.812	4.218	3.828	4.216
04249	3.937	4.251	3.958	4.249	04279	3.875	4.281	3.891	4.279
04309	4.000	4.311	4.018	4.309	04365	3.961	4.367	3.977	4.365
04371	4.062	4.373	4.080	4.371	04406	4.002	4.408	4.018	4.406
	(MAX)	+0.004 -0.000	(MIN)	+0.000 -0.008		(MAX)	+0.004 -0.000	(MIN)	+0.000 -0.008
04434	4.125	4.436	4.143	4.434	04531	4.125	4.533	4.143	4.531
04496	4.187	4.498	4.205	4.496	04593	4.187	4.595	4.205	4.593
04559	4.250	4.561	4.268	4.559	04656	4.250	4.658	4.268	4.656
04621	4.312	4.623	4.330	4.621	04718	4.312	4.720	4.330	4.718
04684	4.375	4.686	4.393	4.684	04781	4.375	4.783	4.393	4.781
04749	4.437	4.751	4.458	4.749	04843	4.437	4.845	4.455	4.843
04809	4.500	4.811	4.518	4.809	04906	4.500	4.908	4.518	4.906
04871	4.562	4.873	4.580	4.871	04968	4.562	4.970	4.580	4.968
04934	4.625	4.936	4.643	4.934	05031	4.625	5.033	4.643	5.031
04996	4.687	4.998	4.705	4.996	05093	4.687	5.095	4.705	5.093
05059	4.750	5.061	4.768	5.059	05156	4.750	5.158	4.768	5.156
05121	4.812	5.123	4.830	5.121	05218	4.812	5.220	4.830	5.218
05184	4.875	5.186	4.893	5.184	05281	4.875	5.283	4.893	5.281
05249	4.937	5.251	4.958	5.249	05343	4.937	5.345	4.955	5.343
	(MAX)	+0.004 -0.000	(MIN)	+0.000 -0.010		(MAX)	+0.004 -0.000	(MIN)	+0.000 -0.010
05311	5.000	5.313	5.020	5.311	05408	5.000	5.410	5.020	5.408
05373	5.062	5.375	5.082	5.373	05470	5.062	5.472	5.082	5.470
05436	5.125	5.438	5.145	5.436	05533	5.125	5.535	5.145	5.533
05498	5.187	5.500	5.207	5.498	05595	5.187	5.597	5.207	5.595
05561	5.250	5.563	5.270	5.561	05658	5.250	5.660	5.270	5.658
05623	5.312	5.625	5.332	5.623	05720	5.312	5.722	5.332	5.720
05686	5.375	5.688	5.395	5.686	05783	5.375	5.785	5.395	5.783
05749	5.437	5.751	5.458	5.749	05845	5.437	5.847	5.457	5.845

Seal dimensions in inches, prior to plating or coating where applicable.
Plating not generally recommended for this low load seal series.

FREE HEIGHT: JW1 .240					FREE HEIGHT: JW1 .250				
SEAL DIA. CODE	CAVITY		SEAL		SEAL DIA. CODE	CAVITY		SEAL	
	I.D.	O.D.	I.D.	O.D.		I.D.	O.D.	I.D.	O.D.
	(MAX)	+0.004 -0.000	(MIN)	+0.000 -0.012		(MAX)	+0.004 -0.000	(MIN)	+0.000 -0.012
05811	5.500	5.813	5.509	5.811	05908	5.500	5.910	5.520	5.908
05871	5.562	5.875	5.569	5.873	05970	5.562	5.972	5.582	5.970
05936	5.625	5.938	5.634	5.936	06033	5.625	6.035	5.645	6.033
06061	5.750	6.063	5.759	6.061	06158	5.750	6.160	5.770	6.158
06186	5.875	6.088	5.884	6.186	06283	5.875	6.285	5.895	6.283
06249	5.937	6.251	5.947	6.249	06367	5.959	6.369	5.979	6.367
06311	6.000	6.313	6.009	6.311	06410	6.000	6.412	6.022	6.410
06436	6.125	6.438	6.134	6.436	06469	6.059	6.471	6.081	6.469
06561	6.250	6.563	6.261	6.561	06535	6.125	6.537	6.147	6.535
06686	6.375	6.688	6.384	6.686	06660	6.250	6.662	6.272	6.660
06749	6.437	6.751	6.447	6.749	06785	6.375	6.787	6.397	6.785
06811	6.500	6.813	6.509	6.811	06910	6.500	6.912	6.522	6.910
06938	6.625	6.938	6.634	6.936	07035	6.625	7.037	6.647	7.035
07061	6.750	7.063	6.759	7.061	07160	6.750	7.162	6.772	7.160
07249	6.910	7.251	6.947	7.249	07285	6.875	7.287	6.897	7.285
07311	7.000	7.313	7.009	7.311	07412	7.000	7.414	7.024	7.412
07436	7.125	7.438	7.134	7.436	07537	7.125	7.539	7.149	7.537
07561	7.250	7.563	7.259	7.561	07662	7.250	7.664	7.274	7.662
07749	7.410	7.751	7.447	7.749	07787	7.375	7.789	7.399	7.787
07811	7.500	7.813	7.509	7.811	07912	7.500	7.914	7.524	7.912
07936	7.625	7.938	7.634	7.936	08037	7.543	8.039	7.649	8.037
08061	7.750	8.063	7.759	8.061	08162	7.668	8.164	7.774	8.162
08249	7.910	8.251	7.948	8.249	08287	7.793	8.289	7.899	8.287
08311	8.000	8.313	8.009	8.311	08414	7.920	8.416	8.026	8.414
08436	8.125	8.438	8.134	8.436	08539	8.033	8.541	8.151	8.539
08561	8.250	8.563	8.259	8.561	08664	8.158	8.666	8.276	8.664
08749	8.400	8.751	8.448	8.749	08789	8.283	8.791	8.401	8.789
08811	8.500	8.813	8.509	8.811	08914	8.408	8.916	8.526	8.914
08936	8.625	8.938	8.634	8.936	09039	8.533	9.041	8.651	9.039
09061	8.750	9.063	8.759	9.061	09164	8.658	9.166	8.776	9.164
	(MAX)	+0.005 -0.000	(MIN)	+0.000 -0.015		(MAX)	+0.005 -0.000	(MIN)	+0.000 -0.015
09249	8.900	9.251	8.944	9.249	09289	8.783	9.291	8.901	9.289
09311	9.000	9.313	9.006	9.311	09416	8.910	9.418	9.028	9.416
09436	9.125	9.438	9.131	9.436	09541	9.023	9.543	9.153	9.541
09561	9.250	9.563	9.256	9.561	09666	9.148	9.668	9.278	9.666
09749	9.400	9.751	9.444	9.749	09791	9.273	9.793	9.403	9.791
09811	9.500	9.813	9.506	9.811	09916	9.398	9.918	9.528	9.916
09986	9.625	9.938	9.631	9.936	10041	9.523	10.043	9.653	10.041
10061	9.750	10.063	9.755	10.061	10166	9.648	10.168	9.778	10.166
10249	9.900	10.251	9.944	10.249	10291	9.773	10.293	9.903	10.291
10311	10.000	10.313	10.006	10.311	10418	9.900	10.420	10.030	10.418
10436	10.125	10.438	10.131	10.436	10543	10.025	10.545	10.155	10.543
10561	10.250	10.563	10.256	10.561	10668	10.150	10.670	10.280	10.668
10749	10.400	10.751	10.444	10.749	10793	10.275	10.795	10.405	10.793

Seal dimensions in inches, prior to plating or coating where applicable.
Plating not generally recommended for this low load seal series.

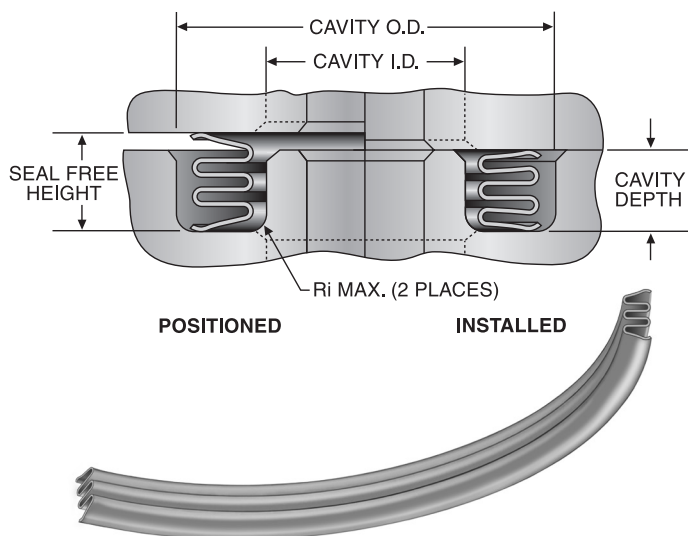

- Recommended for high temperature air systems and equipment.
- High deflection capability.
- See page 4 for all dimensions and tolerances other than those for diameters.
- Average diameters are specified. For seal out-of-roundness tolerance see Page 6.
- Outer cavity wall optional.
- Standard sizes are presented. Non-standard diameters may be derived by interpolation.
- Cavity sealing surface texture 32 μ-in., circular lay.

P/N: JWE

Seal type diameter code derived from seal I.D., Pages 22 - 24 cross-section Page 4 material Page 4 heat treatment Page 4 coating Page 5

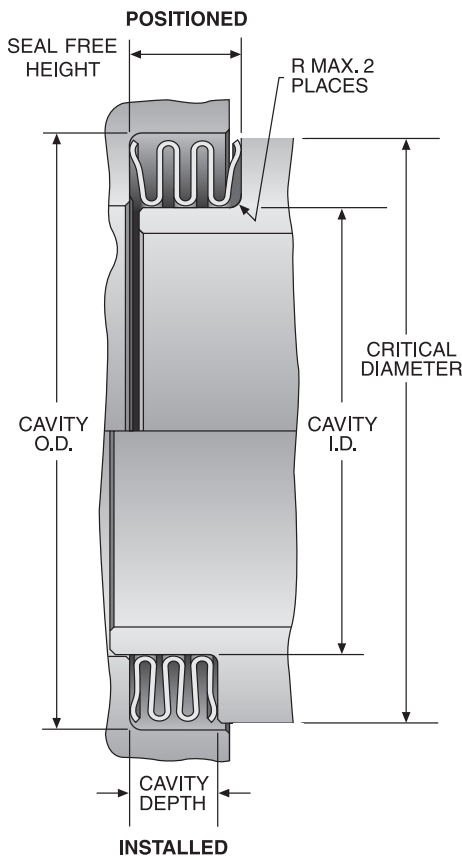

JWE E-SEAL, EXTERNAL PRESSURE

SEAL DIA. CODE	FREE HEIGHT: JWE .240				FREE HEIGHT: JWE .250			
	CAVITY		SEAL		CAVITY		SEAL	
	I.D.	O.D.	I.D.	O.D.	I.D.	O.D.	I.D.	O.D.
	+ .000	(MIN)	+ .006	(MAX)	+ .000	(MIN)	+ .006	(MAX)
	- .003		- .000		- .003		- .000	
01005	1.003	1.308	1.005	1.296				
01067	1.065	1.370	1.067	1.358				
01130	1.128	1.433	1.130	1.421				
01192	1.190	1.495	1.192	1.483				
01255	1.253	1.558	1.255	1.546				
01317	1.315	1.620	1.317	1.608				
01380	1.378	1.683	1.380	1.671	1.378	1.780	1.380	1.768
01442	1.440	1.745	1.442	1.733	1.440	1.842	1.442	1.830
01505	1.503	1.808	1.505	1.796	1.503	1.905	1.505	1.893
01567	1.565	1.870	1.567	1.858	1.565	1.967	1.567	1.955
01630	1.628	1.933	1.630	1.921	1.628	2.030	1.630	2.018
01692	1.690	1.995	1.692	1.983	1.690	2.092	1.692	2.080
01755	1.753	2.058	1.755	2.046	1.753	2.155	1.755	2.143
01817	1.815	2.120	1.817	2.108	1.815	2.217	1.817	2.205
01880	1.878	2.183	1.880	2.171	1.878	2.280	1.880	2.268
01942	1.940	2.245	1.942	2.233	1.940	2.342	1.942	2.330
02005	2.003	2.310	2.005	2.296	2.003	2.407	2.005	2.393
02067	2.065	2.372	2.067	2.358	2.065	2.469	2.067	2.455
02130	2.128	2.435	2.130	2.421	2.128	2.532	2.130	2.518
02192	2.190	2.497	2.192	2.483	2.190	2.594	2.192	2.580
02255	2.253	2.560	2.255	2.546	2.253	2.657	2.255	2.643
02317	2.315	2.622	2.317	2.608	2.315	2.719	2.317	2.705
02380	2.378	2.685	2.380	2.671	2.378	2.782	2.380	2.768
02442	2.440	2.747	2.442	2.733	2.440	2.844	2.442	2.830
02505	2.503	2.810	2.505	2.796	2.503	2.907	2.505	2.893
02567	2.565	2.872	2.567	2.858	2.565	2.969	2.567	2.955
02630	2.628	2.935	2.630	2.921	2.628	3.032	2.630	3.018
02692	2.690	2.997	2.692	2.983	2.690	3.094	2.692	3.080
02755	2.753	3.060	2.755	3.046	2.753	3.157	2.755	3.143
02817	2.815	3.122	2.817	3.108	2.815	3.219	2.817	3.205
02880	2.878	3.185	2.880	3.171	2.878	3.282	2.880	3.268
02942	2.940	3.247	2.942	3.233	2.940	3.344	2.942	3.330
03005	3.003	3.312	3.005	3.296	3.003	3.409	3.005	3.393

Seal dimensions in inches, prior to plating or coating. Plating not generally recommended for this low load seal series.

SEAL DIA. CODE	FREE HEIGHT: JWE .240				FREE HEIGHT: JWE .250			
	CAVITY		SEAL		CAVITY		SEAL	
	I.D.	O.D.	I.D.	O.D.	I.D.	O.D.	I.D.	O.D.
	+0.000 -0.003	(MIN)	+0.006 -0.000	(MAX)	+0.000 -0.003	(MIN)	+0.006 -0.000	(MAX)
03067	3.065	3.374	3.067	3.358	3.065	3.471	3.067	3.455
03130	3.128	3.437	3.130	3.421	3.128	3.534	3.130	3.518
03292	3.290	3.499	3.292	3.483	3.290	3.596	3.292	3.580
03255	3.253	3.562	3.255	3.546	3.253	3.659	3.255	3.643
03317	3.315	3.624	3.317	3.608	3.315	3.721	3.317	3.705
03380	3.378	3.687	3.380	3.671	3.378	3.784	3.380	3.768
03442	3.440	3.749	3.442	3.733	3.440	3.846	3.442	3.830
03505	3.503	3.812	3.505	3.796	3.503	3.909	3.505	3.893
03567	3.565	3.874	3.567	3.858	3.565	3.971	3.567	3.955
03630	3.628	3.937	3.630	3.921	3.628	4.034	3.630	4.018
03692	3.690	3.999	3.692	3.983	3.690	4.096	3.692	4.080
03755	3.753	4.062	3.755	4.046	3.753	4.159	3.755	4.143
03817	3.815	4.124	3.817	4.108	3.815	4.221	3.817	4.205
03880	3.878	4.187	3.880	4.171	3.878	4.284	3.880	4.268
03942	3.940	4.249	3.942	4.233	3.940	4.346	3.942	4.330
	+0.000	(MIN)	+0.008	(MAX)	+0.000	(MIN)	+0.008	(MAX)
	- .004		- .000		- .004		- .000	
04005	4.003	4.314	4.005	4.296	4.003	4.411	4.005	4.393
04067	4.065	4.376	4.067	4.358	4.065	4.473	4.067	4.455
04130	4.128	4.439	4.130	4.421	4.128	4.536	4.130	4.518
04192	4.190	4.501	4.192	4.483	4.190	4.598	4.192	4.580
04255	4.253	4.564	4.255	4.546	4.253	4.661	4.255	4.643
04317	4.315	4.626	4.317	4.608	4.315	4.723	4.317	4.705
04380	4.378	4.689	4.380	4.671	4.378	4.786	4.380	4.768
04442	4.440	4.751	4.442	4.733	4.440	4.848	4.442	4.830
04505	4.503	4.814	4.505	4.796	4.503	4.911	4.505	4.893
04567	4.565	4.876	4.567	4.858	4.565	4.973	4.567	4.955
04630	4.628	4.939	4.630	4.921	4.628	5.036	4.630	5.018
04692	4.690	5.001	4.692	4.983	4.690	5.098	4.692	5.080
04755	4.753	5.064	4.755	5.046	4.753	5.161	4.755	5.143
04817	4.815	5.126	4.817	5.108	4.815	5.223	4.817	5.205
04880	4.878	5.189	4.880	5.171	4.878	5.286	4.880	5.268
	+0.000	(MIN)	+0.010	(MAX)	+0.000	(MIN)	+0.010	(MAX)
	- .004		- .000		- .004		- .000	
04942	4.940	5.251	4.942	5.233	4.940	5.348	4.942	5.330
05005	5.003	5.316	5.005	5.296	5.003	5.413	5.005	5.393
05067	5.065	5.378	5.067	5.358	5.065	5.475	5.067	5.455
05130	5.128	5.441	5.130	5.421	5.128	5.538	5.130	5.518
05192	5.190	5.503	5.192	5.483	5.190	5.600	5.192	5.580
05255	5.253	5.566	5.255	5.546	5.253	5.663	5.255	5.643
05317	5.315	5.628	5.317	5.608	5.315	5.725	5.317	5.705
05380	5.378	5.691	5.380	5.671	5.378	5.788	5.380	5.768
05442	5.440	5.753	5.442	5.733	5.440	5.850	5.442	5.830
05505	5.503	5.816	5.505	5.796	5.503	5.913	5.505	5.893
05567	5.565	5.878	5.567	5.858	5.565	5.975	5.567	5.955
05630	5.628	5.941	5.630	5.921	5.628	6.038	5.630	6.018
05755	5.753	6.066	5.755	6.046	5.753	6.163	5.755	6.143
05880	5.878	6.191	5.880	6.171	5.878	6.288	5.880	6.268
06005	6.003	6.318	6.005	6.296	6.003	6.415	6.005	6.393
	+0.000	(MIN)	+0.012	(MAX)	+0.000	(MIN)	+0.012	(MAX)
	- .005		- .000		- .005		- .000	
06130	6.128	6.454	6.130	6.432	6.128	6.540	6.130	6.518
06255	6.253	6.579	6.255	6.557	6.253	6.665	6.255	6.643
06380	6.378	6.704	6.380	6.682	6.378	6.790	6.380	6.768
06505	6.503	6.829	6.505	6.807	6.503	6.915	6.505	6.893
06630	6.628	6.954	6.630	6.932	6.628	7.040	6.630	7.018

Seal dimensions in inches, prior to plating or coating. Plating not generally recommended for this low load seal series.

SEAL DIA. CODE	FREE HEIGHT: JWE .240				FREE HEIGHT: JWE .250			
	CAVITY		SEAL		CAVITY		SEAL	
	I.D.	O.D.	I.D.	O.D.	I.D.	O.D.	I.D.	O.D.
	+0.00 -0.05	(MIN)	+0.015 -0.000	(MAX)	+0.000 -0.005	(MIN)	+0.015 -0.000	(MAX)
06755	6.753	7.079	6.755	7.057	6.753	7.165	6.755	7.143
06880	6.878	7.204	6.880	7.182	6.878	7.290	6.880	7.268
07005	7.003	7.329	7.005	7.307	7.003	7.417	7.005	7.393
07130	7.128	7.454	7.130	7.432	7.128	7.542	7.130	7.518
07255	7.253	7.579	7.255	7.557	7.253	7.667	7.255	7.643
07380	7.378	7.694	7.380	7.682	7.378	7.792	7.380	7.768
07505	7.503	7.819	7.505	7.807	7.503	7.917	7.505	7.893
07630	7.628	7.944	7.630	7.932	7.628	8.042	7.630	8.018
07755	7.753	8.069	7.755	8.057	7.753	0.167	7.755	8.143
07880	7.878	8.194	7.880	8.182	7.878	8.292	7.880	8.268
08005	8.003	8.319	8.005	8.307	8.003	8.419	8.005	8.393
08130	8.128	8.444	8.130	8.432	8.128	8.544	8.130	8.518
08255	8.253	8.569	8.255	8.557	8.253	8.669	8.255	8.643
08380	8.378	8.694	8.380	8.682	8.378	8.794	8.380	8.768
08505	8.503	8.819	8.505	8.807	8.503	8.919	8.505	8.893
08630	8.628	8.944	8.630	8.932	8.628	9.044	8.630	9.018
	+0.000 -0.005	(MIN)	+0.020 -0.000	(MAX)	+0.000 -0.005	(MIN)	+0.020 -0.000	(MAX)
08755	8.753	9.087	8.755	9.065	8.753	9.169	8.755	9.143
08880	8.878	9.212	8.880	9.190	8.878	9.294	8.880	9.268
09005	9.003	9.337	9.005	9.315	9.003	9.421	9.005	9.393
09130	9.128	9.462	9.130	9.440	9.128	9.546	9.130	9.518
09255	9.253	9.587	9.255	9.565	9.253	9.671	9.255	9.643
09380	9.378	9.712	9.380	9.690	9.378	9.796	9.380	9.768
09505	9.503	9.837	9.505	9.815	9.503	9.921	9.505	9.893
09630	9.628	9.962	9.630	9.940	9.628	10.046	9.630	10.018
09755	9.753	10.087	9.755	10.065	9.753	10.171	9.755	10.143
09880	9.878	10.212	9.880	10.190	9.878	10.296	9.880	10.268
10005	10.003	10.337	10.005	10.315	10.003	10.423	10.005	10.393
10130	10.128	10.462	10.130	10.440	10.128	10.548	10.130	10.518
10255	10.253	10.587	10.255	10.565	10.253	10.673	10.255	10.643
10380	10.378	10.712	10.380	10.690	10.378	10.798	10.380	10.768
10505	10.503	10.837	10.505	10.815	10.503	10.928	10.505	10.893
10630	10.628	10.962	10.630	10.940	10.628	11.048	10.630	11.018
10755	10.753	11.087	10.755	11.065	10.753	11.173	10.755	11.143
10880	10.878	11.212	10.880	11.190	10.878	11.298	10.880	11.268
11005	11.003	11.337	11.005	11.315	11.003	11.425	11.005	11.393
11130	11.128	11.462	11.130	11.440	11.128	11.550	11.130	11.518
11255	11.253	11.587	11.255	11.565	11.253	11.675	11.255	11.643
11380	11.378	11.712	11.380	11.690	11.378	11.800	11.380	11.768
11505	11.503	11.837	11.505	11.815	11.503	11.925	11.505	11.893
11630	11.628	11.962	11.630	11.940	11.628	12.050	11.630	12.018
11755	11.753	12.087	11.755	12.065	11.753	12.175	11.755	12.143
11880	11.878	12.212	11.880	12.190	11.878	12.300	11.880	12.268
12005	12.003	12.337	12.005	12.315	12.003	12.427	12.005	12.393
12130	12.128	12.462	12.130	12.440	12.128	12.552	12.130	12.518
12255	12.253	12.587	12.255	12.565	12.253	12.777	12.255	12.643
12380	12.378	12.712	12.380	12.690	12.378	12.802	12.380	12.768
12505	12.503	12.837	12.505	12.815	12.503	12.927	12.505	12.893
12630	12.628	12.962	12.630	12.940	12.628	13.052	12.630	13.018
12755	12.753	13.087	12.755	13.065	12.753	13.177	12.755	13.143
12880	12.878	13.212	12.880	13.190	12.878	13.302	12.880	13.268
13005	13.003	13.337	13.005	13.315	13.003	13.427	13.005	13.393
13130	13.128	13.462	13.130	13.440	13.128	13.552	13.130	13.518

Seal dimensions in inches, prior to plating or coating. Plating not generally recommended for this low load seal series.

NOTES



DEFENSE

POWER GENERATION

JETCAT No. 01 – *Resilient Metallic Seal Design Guide*

JETCAT No. 02 – *C-Seals*

JETCAT No. 03 – *E-Seals*

JETCAT No. 04 – *V-Seals*

JETCAT No. 05 – *Omega Seals*

SPACE

AIRCRAFT ENGINES

LASER TECHNOLOGY

AVIATION

TRANSPORTATION TURBOCHARGERS & SENSORS

OIL & GAS

NUCLEAR



This document does not include technical data subject to the International Traffic in Arms Regulations (22 CFR 121-130). US Government authorization is not required to transfer this technical data to foreign persons.