

Snow Blowers

SBL2566, SBL2574, & SBL2584 with S/N 891531+

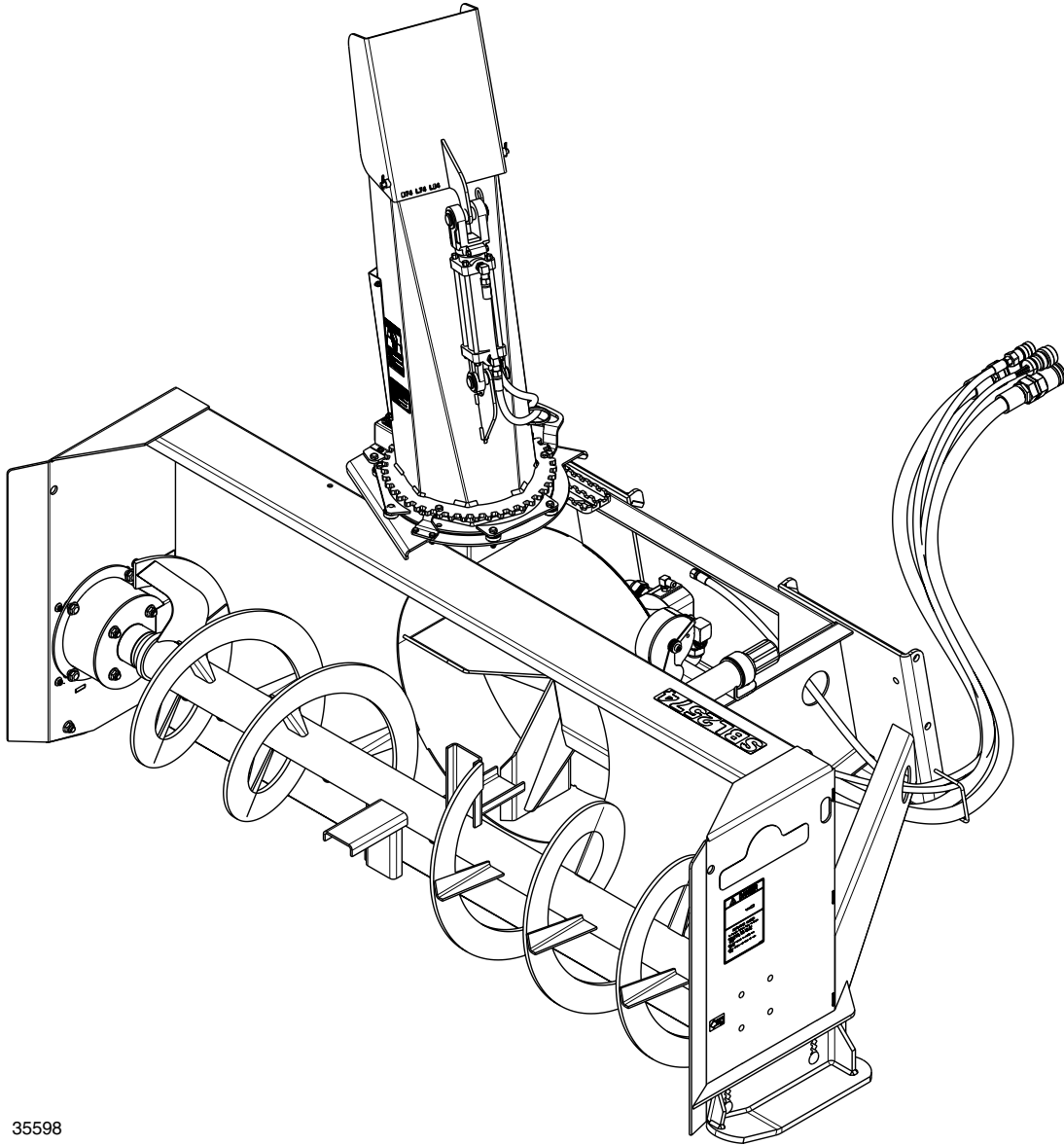

35598

370-478M Operator's Manual



Read the Operator's Manual entirely. When you see this symbol, the subsequent instructions and warnings are serious - follow without exception. Your life and the lives of others depend on it!

Cover photo may show optional equipment not supplied with standard unit.



Table of Contents

Important Safety Information	1	Section 4: Adjustments	20
Safety at All Times	1	Discharge Chute & Spout Deflector	20
Look For The Safety Alert Symbol	1	Spout Deflector Adjustment	20
Safety Labels	4	Chute Rotation Gear Alignment	20
Introduction	6	Chute Rotation Adjustment	20
Application	6	Outer Skid Shoe Adjustment	21
Using This Manual	6	Inner Skid Shoe Adjustment	21
Owner Assistance	6	Auger Speed	22
Serial Number	6	Level Run Indicator Adjustment	22
Section 1: Assembly & Set-up	7	Section 5: Operating Instructions	23
Skid Steer/Tractor Requirements	7	Introduction	23
Torque Requirements	7	Pre-Operational Safety Check	23
Loading & Unloading	7	Operational Safety Check	23
Optional Outer Skid Shoes	7	General Safety Information	24
Optional Inner Skid Shoes	7	Mounting & Dismounting Skid Steer	26
SBL2566 Chute Assembly	8	Transporting	26
SBL2574 & SBL2584 Chute Assembly	8	Leveling The Snow Blower	27
Spout Deflector, Hydraulic Cylinder	9	General Operator Instructions	27
Quick Coupler Set-up	10	Section 6: Maintenance & Lubrication	29
Section 2: Equipment Hook-up & Unhook	11	General Maintenance Information	29
Snow Blower Hook-up	11	Tractor/Skid Steer Maintenance	29
Hydraulic Hose Hook-up	12	Auger & Impeller Inspection	29
Solenoid Hook-up	12	Outer Skid Shoe Option	30
Check Equipment Clearances	13	Inner Skid Shoe Option	30
Unhooking The Snow Blower	14	Grader Blade	31
Section 3: Options	15	Long Term Storage	31
Motor Assembly	15	Ordering Replacement Parts	31
Flat Face Couplers	15	Lubrication	32
Case Drain Coupler & Cable Ties	15	Auger Flange Bearing	32
Electrical Control Harness (Optional)	16	Section 7: Specifications & Capacities	33
Control Harness With Deutsch 14 Pin Plug	16	Section 8: Features & Benefits	34
Control Harness With Deutsch 2 Pin Plug	17	Section 9: Troubleshooting	35
Tractor Control Harness With 2 Eyelets	18	Section 10: Torque Values Chart	36
Skid Steer Control Harness With 2 Eyelets	19	Section 11: Warranty	37
Outer Skid Shoes	19		
Inner Skid Shoes	19		



© Copyright 2015 All rights Reserved

Land Pride provides this publication "as is" without warranty of any kind, either expressed or implied. While every precaution has been taken in the preparation of this manual, Land Pride assumes no responsibility for errors or omissions. Neither is any liability assumed for damages resulting from the use of the information contained herein. Land Pride reserves the right to revise and improve its products as it sees fit. This publication describes the state of this product at the time of its publication, and may not reflect the product in the future.

Land Pride is a registered trademark.

All other brands and product names are trademarks or registered trademarks of their respective holders.

Printed in the United States of America.

Important Safety Information

These are common practices that may or may not be applicable to the products described in this manual.

Safety at All Times

Thoroughly read and understand the instructions given in this manual before operation. Refer to the “Safety Label” section, read all instructions noted on them.

Do not allow anyone to operate this equipment who has not fully read and comprehended this manual and who has not been properly trained in the safe operation of the equipment.

The operator must not use drugs or alcohol as they can change the alertness or coordination of that person while operating equipment. The operator should, if taking over-the-counter drugs, seek medical advice on whether he/she can safely operate the equipment.

Operator should be familiar with all functions of the unit.

Make sure all guards and shields are in place and secured before operating implement.

Start skid steer with steering levers and hydraulic controls in neutral.

Keep all persons away from equipment and work area.

Operate implement and loader arms from the driver’s seat only. Dismounting from a moving unit can cause serious injury or death.

Do not allow anyone to stand between skid steer/tractor and implement while hooking-up to implement.

Keep hands, feet, and clothing away from power-driven parts.

Watch out for objects overhead and along side such as fences, buildings, wires, trees, limbs, etc., while transporting and operating attached implement.

Detach and store implement in an area where children normally do not play. Secure implement by using blocks and supports.



Look For The Safety Alert Symbol

The SAFETY ALERT SYMBOL indicates there is a potential hazard to personal safety involved and extra safety precaution must be taken. When you see this symbol, be alert, and carefully read the message that follows it. In addition to design and configuration of equipment, hazard control, and accident prevention are dependent upon the awareness, concern, prudence, and proper training of personnel involved in the operation, transport, maintenance, and storage of equipment.

Be Aware of Signal Words

A Signal word designates a degree or level of hazard seriousness. The signal words are:

⚠ DANGER

Indicates an imminently hazardous situation which, if not avoided, will result in death or serious injury. This signal word is limited to the most extreme situations, typically for machine components that, for functional purposes, cannot be guarded.

⚠ WARNING

Indicates a potentially hazardous situation which, if not avoided, could result in death or serious injury, and includes hazards that are exposed when guards are removed. It may also be used to alert against unsafe practices.

⚠ CAUTION

Indicates a potentially hazardous situation which, if not avoided, may result in minor or moderate injury. It may also be used to alert against unsafe practices.

For Your Protection

Thoroughly read and understand the “Safety Label” section, read all instructions noted on them.

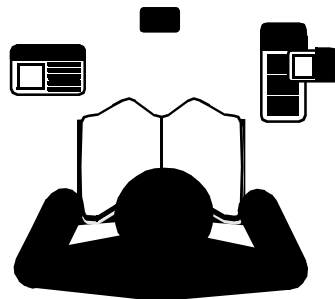

Use Safety Lights and Devices

Slow moving tractors, skid steer, self-propelled equipment, and towed implements can create a hazard when driven on public roads. They are difficult to see, especially at night.

Flashing warning lights and turn signals are recommended whenever driving on public roads.

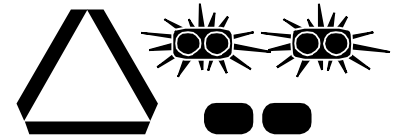

Parts Manual QR Locator

The QR (Quick Reference) code to the left will take you to the Parts Manual for this equipment. Download the appropriate App on your smart phone, open the App, point your phone on the QR code and take a picture.



Dealer QR Locator

The QR code to the left will link you to available dealers for Land Pride products. Refer to Parts Manual QR Locator on this page for detailed instructions.

These are common practices that may or may not be applicable to the products described in this manual.

Skid Steer Shutdown & Storage

Before leaving operator's seat:

- Lower lift arms and put attachment flat on the ground.
- Turn off engine.
- Engage park brake.
- If included, raise seat bar and move controls until both lock.
- Remove key to prevent unauthorized starting.
- Use steps, grab-handles and skid-resistant surfaces when getting on and off the loader.
- Detach and store implements in an area where children normally do not play. Secure implement by using blocks and supports.

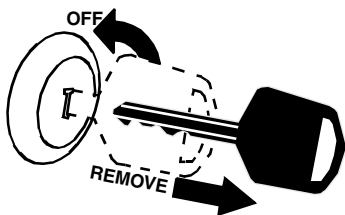

Transport Safely

- Comply with state and local laws.
- Use towing vehicle and trailer of adequate size and capacity. Secure equipment towed on a trailer with tie downs and chains.
- Sudden braking can cause a towed trailer to swerve and upset. Reduce speed if towed trailer is not equipped with brakes.
- Avoid contact with any over head utility lines or electrically charged conductors.
- Always drive with load on end of loader arms low to the ground.
- Always drive straight up and down ramps with load on "uphill" side of skid steer or tractor.
- Engage park brake when stopped on an incline.

Maximum transport speed for an attached implement is 20 mph. DO NOT EXCEED. Never travel at a speed which does not allow adequate control of steering and stopping. Some rough terrains require a slower speed.

As a guideline, use the following maximum speed weight ratios for an attached implement:

20 mph when weight of attached implement is less than or equal to the weight of machine towing the implement.

10 mph when weight of attached implement exceeds weight of machine towing implement but not more than double the weight.

IMPORTANT: Do not tow a load that is more than double the weight of the vehicle towing the load.

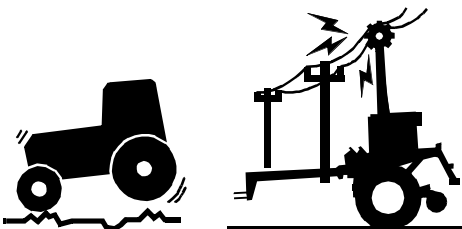

Tractor Shutdown & Storage

Before leaving operator's seat:

- If engaged, disengage PTO.
- Lower attached implement to ground or onto support blocks.
- Put tractor in park or set park brake, turn off engine, and remove switch key to prevent unauthorized starting.
- Wait for all components to come to a complete stop before leaving the operator's seat.
- Detach and store implement in an area where children normally do not play. Secure implement using blocks and supports.

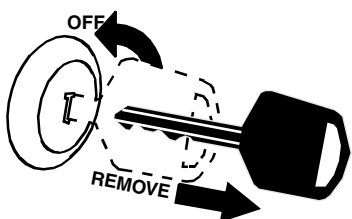

Practice Safe Maintenance

- Understand procedure before doing work. Use proper tools and equipment, refer to Operator's Manual for additional information.
- Work in a clean dry area.
- Lower attached implement to the ground and follow all shutdown procedures before leaving the operator's seat to perform maintenance.
- Allow implement to cool completely before working on it.

Disconnect battery ground cable (-) before servicing or adjusting electrical systems or before welding on implement.

Do not grease or oil implement while it is in operation.

Inspect all parts. Make sure parts are in good condition & installed properly.

Remove buildup of grease, oil, or debris.

Remove all tools and unused parts from implement before operation.



Important Safety Information

These are common practices that may or may not be applicable to the products described in this manual.

Prepare for Emergencies

Be prepared if a fire starts. Keep a first aid kit and fire extinguisher handy. Keep emergency numbers for doctor, ambulance, hospital, and fire department near phone.

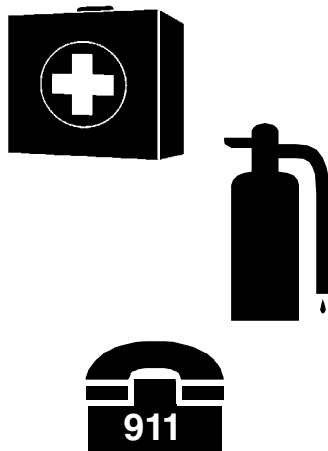

Wear Protective Equipment

Wear protective clothing and equipment appropriate for the job. Clothing should be snug fitting without fringes and pull strings to avoid entanglement with moving parts. Prolonged exposure to loud noise can cause hearing impairment or hearing loss. Wear suitable hearing protection such as earmuffs or earplugs. Operating equipment safely requires the operator's full attention. Avoid wearing radio headphones while operating machinery.



Avoid High Pressure Fluids Hazard

Escaping fluid under pressure can penetrate the skin causing serious injury. Avoid the hazard by relieving pressure before disconnecting hydraulic lines or performing work on the system. Make sure all hydraulic fluid connections are tight and all hydraulic hoses and lines are in good condition before applying pressure to the system. Use a piece of paper or cardboard, NOT BODY PARTS, to check for suspected leaks. Wear protective gloves and safety glasses or goggles when working with hydraulic systems. **DO NOT DELAY.** If an accident occurs, see a doctor familiar with this type of injury immediately. Any fluid injected into the skin or eyes must be treated within a few hours or gangrene may result.



Tire Safety

Tire changing can be dangerous and should be performed by trained personnel using the correct tools and equipment. When inflating tires, use a clip-on chuck and extension hose long enough to allow you to stand to one side and NOT in front of or over the tire assembly. Use a safety cage if available. When removing and installing wheels, use wheel handling equipment adequate for the weight involved.



Keep Riders Off Machinery

Never carry riders or use machinery as a personlift. Riders obstruct operator's view. Riders could be struck by foreign objects or thrown from the machine. Never allow children to operate equipment.

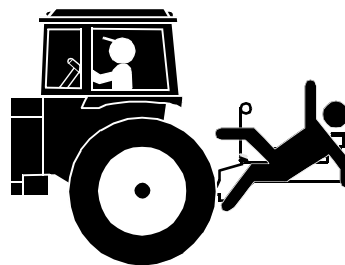

Use Seat Belt and ROPS

Operate only tractors & skid steer loaders equipped with Roll-Over Protective Structure (ROPS) and seat belt. Fasten seat belt snugly and securely to help protect operator from being thrown, crushed, or severely injured if a rollover occurs; and from falling off the tractor or skid steer loader and being ran over. Not using the seat belt can result in serious injury or death. Wearing protective equipment such as safety shoes, safety glasses, hard hat, and ear plugs is highly recommended.

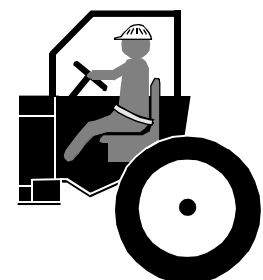

Important Safety Information

Safety Labels

Your Snow Blower comes equipped with all safety labels in place. They were designed to help you safely operate your implement. Read and follow their directions.

1. Keep all safety labels clean and legible.
2. Refer to this section for proper label placement. Replace all damaged or missing labels. Order new labels from your nearest Land Pride dealer. To find your nearest dealer, visit our dealer locator at www.landpride.com.
3. Some new equipment installed during repair requires safety labels to be affixed to the replaced component as

specified by Land Pride. When ordering new components make sure the correct safety labels are included in the request.

4. Refer to this section for proper label placement. To install new labels:
 - a. Clean surface area where label is to be placed.
 - b. Spray soapy water onto the cleaned area.
 - c. Peel backing from label and press label firmly onto the surface.
 - d. Squeeze out air bubbles with edge of a credit card or with a similar type of straight edge.

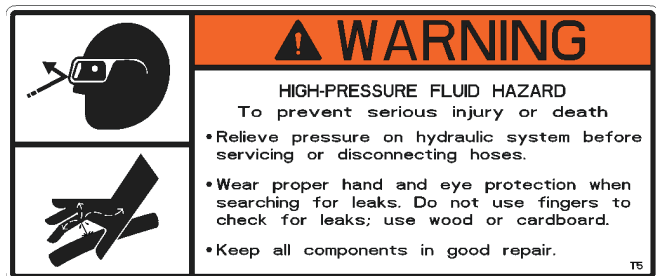
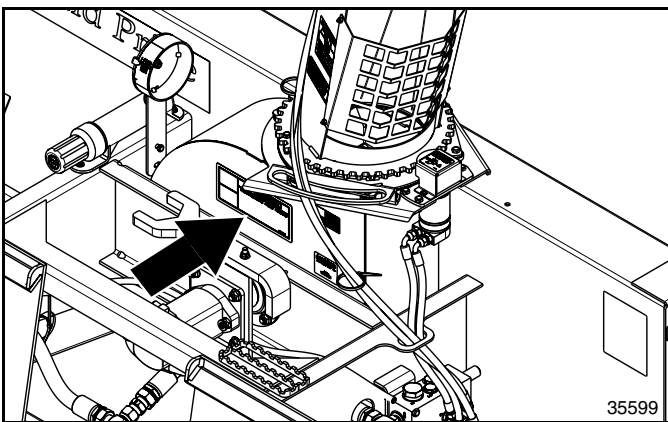
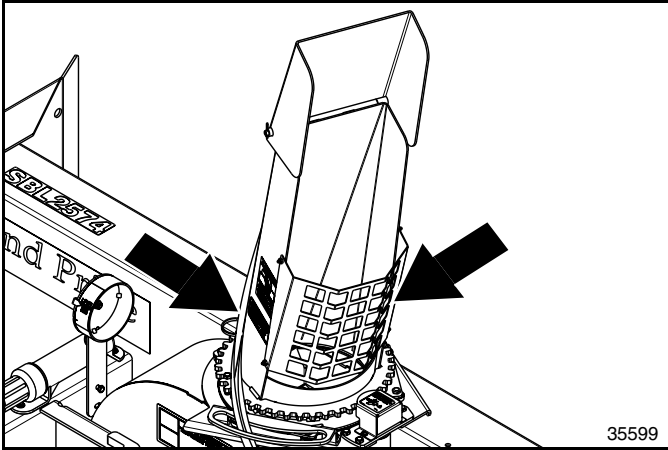
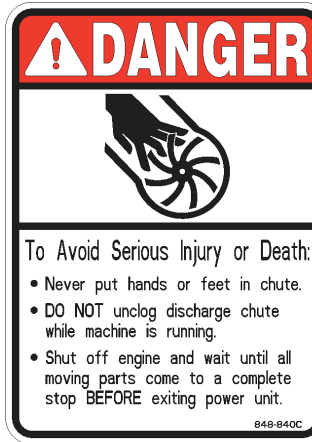
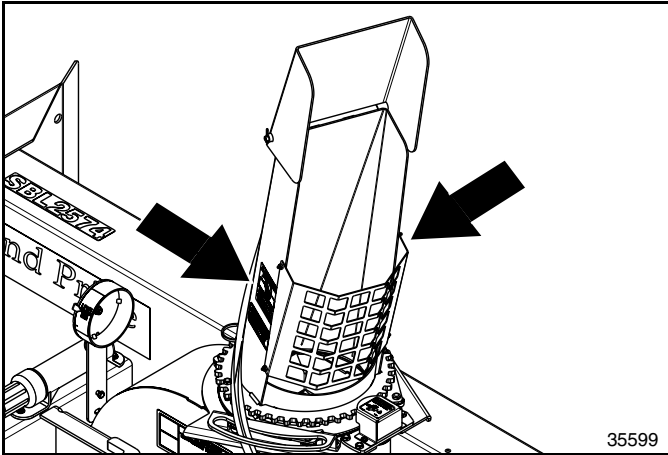

Important Safety Information

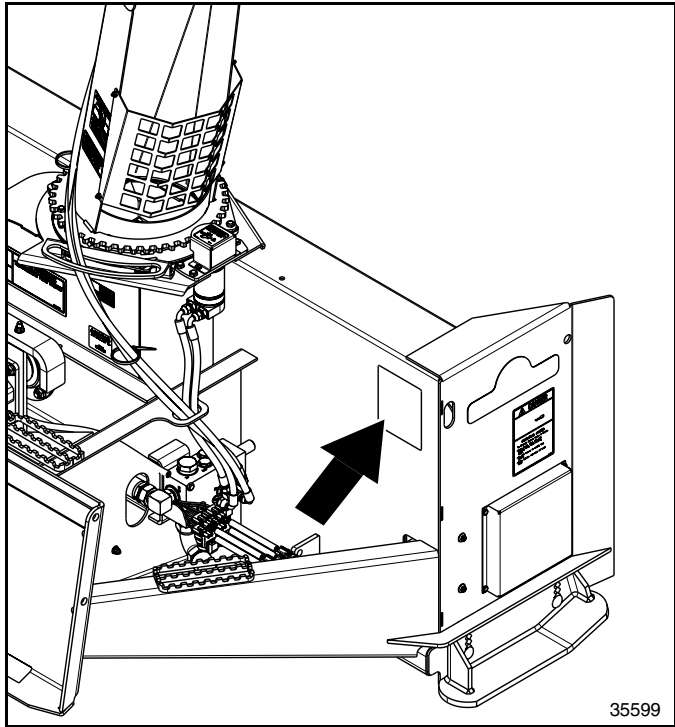

⚠ WARNING

To prevent serious injury or death:

- Read and understand Operator's Manual before using. Review annually.
- Do not permit riders on the tractor, skid steer or implement.
- Do not allow children to operate implement.
- Operate only with guards installed and in good condition.
- Keep hands, feet, hair and clothing away from moving parts. Never shake, hit or kick to dislodge material.
- Operate only with tractor or skid steer equipped with ROPS and seatbelts.
- Before operating, clear debris from working area.
- Do not operate in the raised position.
- Stop engine, set brake and wait for all moving parts to stop before dismounting.
- Support implement securely before working beneath unit.
- Transport with clean reflectors, SMV and working lights as required by federal, state, and local laws.
- Stand clear when implement is in operation.
- Always wear appropriate hand, ear and eye protection when operating equipment.

818-858C REV.G

818-858C

Warning: To Prevent Serious Injury or Death

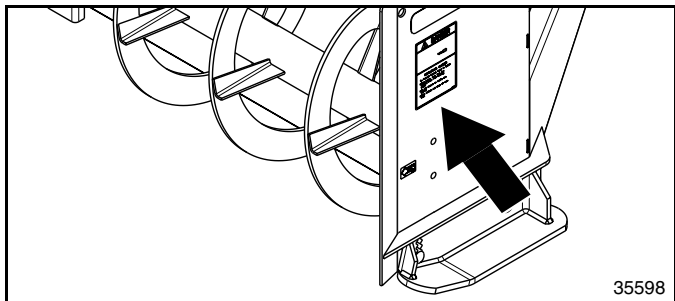

⚠ DANGER

ROTATING AUGER

To prevent serious injury or death:

- Keep hands, feet, hair and clothing away from rotating auger.
- Do not remove or modify any guards.
- Keep children well clear of work area.

818-634C

818-634C

Danger: Rotating Auger
2-Places

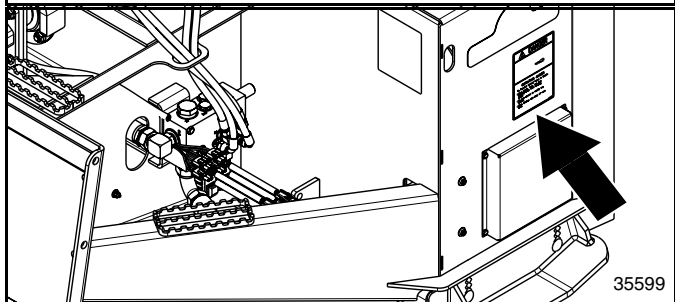

⚠ WARNING

PINCH POINT HAZARD

858-148C

858-148C

Warning: Pinch Point Hazard

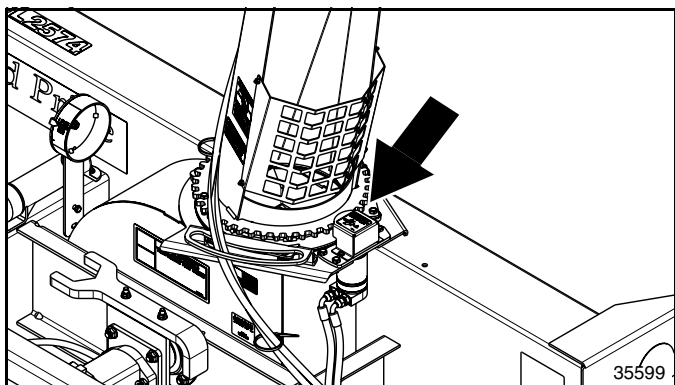



Introduction

Land Pride welcomes you to the growing family of new product owners.

This Snow Blower has been designed with care and built by skilled workers using quality materials. Proper assembly, maintenance, and safe operating practices will help you get years of satisfactory use from this machine.

Application

Land Pride offers the SBL2566, SBL2574, and SBL2584 Series of Snow Blowers ranging from 66" up to 84" in width. They are designed with a skid steer mounting plate for attaching to skid steers. The SBL2566 can also be attached to a tractor front loader with Land Pride's 3-point hydraulic reservoir system (HRS) or equivalent system mounted on the back. These Snow Blowers are designed to remove snow from parking lots, farm yards, feed lots, driveways, walking paths, and sidewalks in municipal and commercial areas.

Land Pride's unique patent-pending level run indicator provides the operator with a clear, visible indication that the Snow Blower is operating level. The auger, impeller, and chute rotation are powered with individual hydraulic motors. Adjustable skid shoes mounted on both sides can be adjusted to carry the Snow Blower above hard surfaces, loose gravel, and rocks to help increase the life of the unit.

See "**Specifications & Capacities**" on page 33 and "**Features & Benefits**" on page 34 for additional information and performance enhancing options.

Using This Manual

- This Operator's Manual is designed to help familiarize you with safety, assembly, operation, adjustments, troubleshooting, and maintenance. Read this manual and follow the recommendations to help ensure safe and efficient operation.
- The information contained within this manual was current at the time of printing. Some parts may change slightly to assure you of the best performance.
- To order a new Operator's or Parts Manual, contact your authorized dealer. Manuals can also be downloaded, free-of-charge, from our website at www.landpride.com.

Terminology

See Figure 1: "Right" or "Left" as used in this manual is determined by facing in the direction the machine will operate while in use unless otherwise stated.

Definitions

IMPORTANT: A special point of information related to the following topic. Land Pride's intention is this information must be read & noted before continuing.

NOTE: A special point of information that the operator should be aware of before continuing.

Owner Assistance

The Online Warranty Registration should be completed by the dealer at the time of purchase. This information is necessary to provide you with quality customer service.

The parts on your Snow Blower have been specially designed by Land Pride and should only be replaced with genuine Land Pride parts. Contact a Land Pride dealer if customer service or repair parts are required. Your Land Pride dealer has trained personnel, repair parts, and equipment needed to service the implement.

Serial Number

Model No. _____ Serial No. _____

For quick reference and prompt service, record model number and serial number in the spaces provided above and again on Warranty page 37. Always provide model and serial number when ordering parts and in all correspondences with your Land Pride dealer. Refer to Figure 1 for location of your serial number plate.

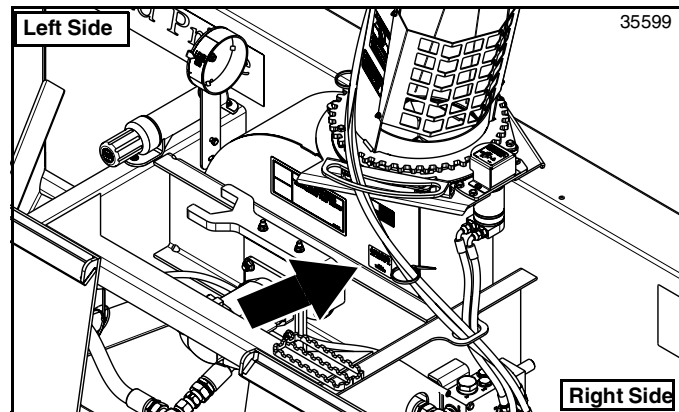

Serial Number Plate Location
Figure 1

Further Assistance

Your dealer wants you to be satisfied with your new Snow Blower. If for any reason you do not understand any part of this manual or are not satisfied with the service received, the following actions are suggested:

1. Discuss the matter with your dealership service manager making sure that person is aware of any problems you may have and has had the opportunity to assist you.
2. If you are still not satisfied, seek out the owner or general manager of the dealership, explain the problem, and request assistance.
3. For further assistance write to:

Land Pride Service Department
1525 East North Street
P.O. Box 5060
Salina, Ks. 67402-5060

E-mail address
lp servicedept@landpride.com

Section 1: Assembly & Set-up

Skid Steer/Tractor Requirements

The SBL2566, SBL2574, & SBL2584 Snow Blowers are designed to attach to skid steers. The SBL2566 can also be attach to a tractor loader with Land Pride’s 3-point mounted hydraulic reservoir system (HRS) or equivalent system mounted on the back. The skid steer and/or tractor/HRS must meet the following minimum requirements:

- SAE Lift Capacity 1200 lbs
- Hitch Type Skid steer/loader plate
- Hydraulic Pressure Rating 2500 - 3500 psi
- Low Volume Motors & Hoses 12 - 19 gpm
- Medium Volume Motor & Hoses 20 - 26 gpm
- High Volume Motor & Hoses 27 - 33 gpm
- Hydraulic Hoses 2 - Hydraulic outlets
- Case Drain Hose 1 - Hydraulic outlet

Skid Steer Weight See warning below

! WARNING

Ballast weights may be required to maintain steering control. Refer to your skid steer or tractor Operator’s Manual to determine proper ballast requirements.

IMPORTANT: The skid steer or tractor mounted hydraulic reservoir system must be equipped with a case drain system.

Torque Requirements

Refer to “**Torque Values Chart**” on page 36 to determine correct torque values for common bolts.

Loading & Unloading

Refer to Figure 1-1:

There are two lifting holes (one on each end panel). Use these holes to attach lift chains during loading/unloading and while installing skid shoes in assembly & set-up.

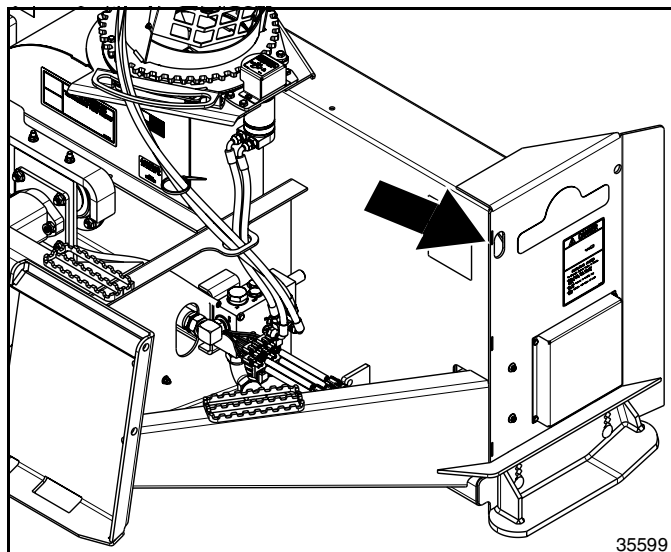

Lift Points
Figure 1-1

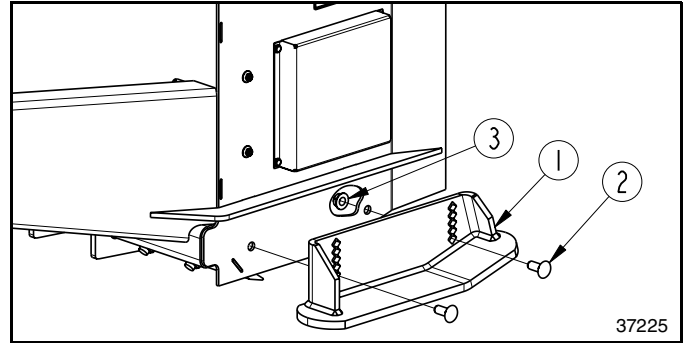

Outer Skid Shoe Assembly (Right-Hand Shown)
Figure 1-2

Optional Outer Skid Shoes

Refer to Figure 1-2:

1. Attach outer right-hand skid shoe (#1) to the right-hand side panel with 1/2"-13 x 1 1/4" GR5 carriage bolts (#2) and hex flange lock nuts (#3) using the bottom square holes as shown.
2. Tighten hex flange lock nuts (#3) to the correct torque.
3. Repeat steps 1 & 2 for the left-hand side.

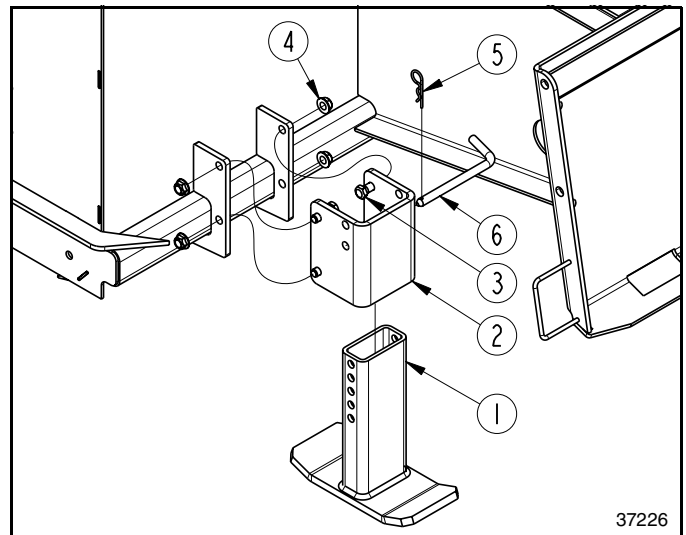

Inner Skid Shoe Assembly (Left-Hand Shown)
Figure 1-3

Optional Inner Skid Shoes

Refer to Figure 1-3:

1. Attach skid shoe mount (#2) to the back, left side of the Snow Blower with 1/2"-13 x 1 1/2" GR5 bolts (#3) and hex flange lock nuts (#4). Tighten hex flange lock nuts to the correct torque.
2. Attach inner skid shoe (#1) to skid shoe mount (#2) with bent pin (#6) as shown. Secure bent pin with hairpin cotter (#5).
3. Repeat steps 1 & 2 for the back, right side of the Snow Blower.

Section 1: Assembly & Set-up

SBL2566 Chute Assembly

Refer to Figure 1-5:

1. Remove hex nuts (#8), spring lock washers (#9), hex head bolts (#7), bearing strap (#2A), and chute bearings (#4). Keep hardware for reuse.

IMPORTANT: Position chute (#1) facing straight forward to the front as shown in Figure 1-4 before sliding base of chute over bearing ring (#10).

2. With discharge chute (#1) facing straight forward. Slide base of chute over UHMW chute bearing ring (#10) until base of chute is fully under chute rotational stop (#5), bearing strap (#2B), and engaged with sprocket (#3).
3. Reattach bearing strap (#2A) to snow blower housing with existing 3/8"-16 x 1 1/2" GR5 bolts (#7), chute bearings (#4), lock washers (#9), and nuts (#8). Tighten nuts (#8) to the correct torque.
4. Verify stop bolts (#6) are at the back as shown.

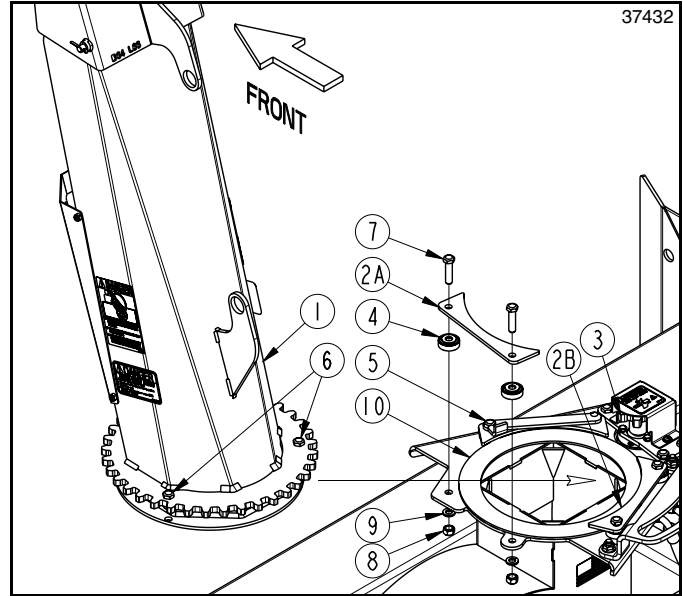

SBL2566 Chute Assembly
Figure 1-4

SBL2574 & SBL2584 Chute Assembly

Refer to Figure 1-5:

1. Remove hex nuts (#10), spring lock washers (#12), hex head bolts (#7), and rotational stop (#6). Keep hardware for reuse.
2. Remove hex nuts (#11), spring lock washers (#13), hex head bolts (#9), bearing strap (#2A), and chute bearings (#5). Keep hardware for reuse.

IMPORTANT: Position chute (#1) facing straight forward to the front as shown in Figure 1-5 before sliding base of chute over bearing ring (#14).

3. With discharge chute (#1) facing straight forward as shown. Slide base of chute over UHMW chute bearing ring (#14) until base of chute is fully under remaining bearing straps (#2B & #2C) and engaged with sprocket (#4).
4. Reattach bearing strap (#2A) to snow blower housing with existing 3/8"-16 x 1 1/2" GR5 bolts (#9), chute bearings (#5), lock washers (#13), and nuts (#11). Tighten nuts (#11) to the correct torque.
5. Reattach rotational stop (#6) to Snow Blower housing with existing 1/4"-20 x 3/4" GR5 bolts (#7), rotational stop (#6), lock washers (#12) and hex nuts (#10). Tighten nuts (#10) to the correct torque.

Refer to Figure 1-6:

6. Verify stop bolts (#8A & #8B) are left of rotational stop (#6) as shown.
7. Tighten hex bolts (#7) to the correct torque.

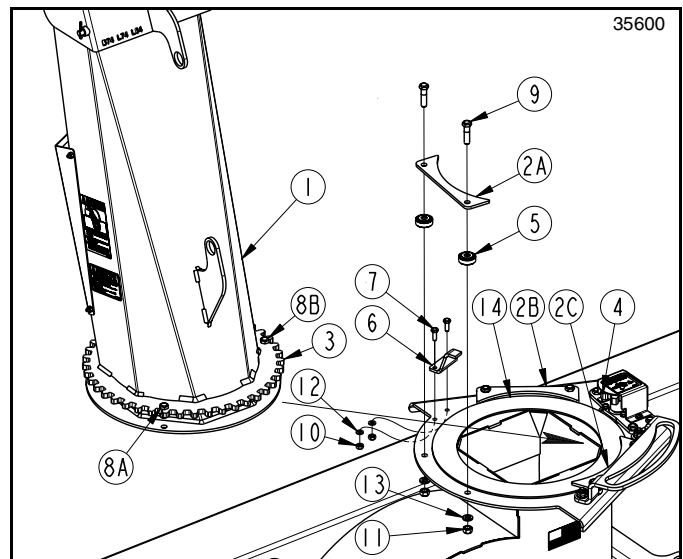

SBL2574 & SBL2584 Chute Assembly
Figure 1-5

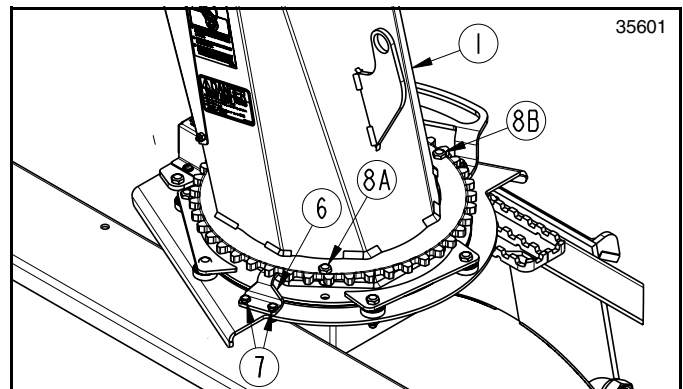

SBL2574 & SBL2584 Rotational Stop Bar Set-up
Figure 1-6

Section 1: Assembly & Set-up

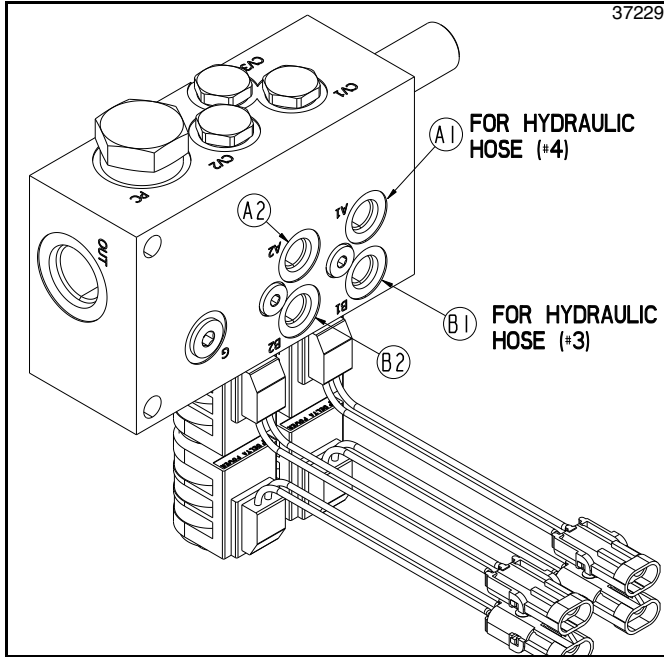

Priority Valve Ports
Figure 1-7

Spout Deflector, Hydraulic Cylinder

Refer to Figure 1-7 & Figure 1-8:

1. Route hydraulic hoses (#3 & #4) through hose guides (#6 & #7).
2. Tie hoses (#3 & #4) together below hose guide (#7) with cable tie (#8) in the locations shown.

Refer to Figure 1-9:

3. Screw o-ring end of 9/16" elbows (#2A & #2B) into cylinder ports on hydraulic cylinder (#1). Do not tighten elbows at this time.
4. Screw 1/4" x 45" short hydraulic hose (#3) to elbow (#2B) until tight.
5. Screw 1/4" x 55" long hydraulic hose (#4) to elbow (#2A) until tight.
6. Tighten elbows (#2A & #2B) to hydraulic cylinder (#1) until tight.

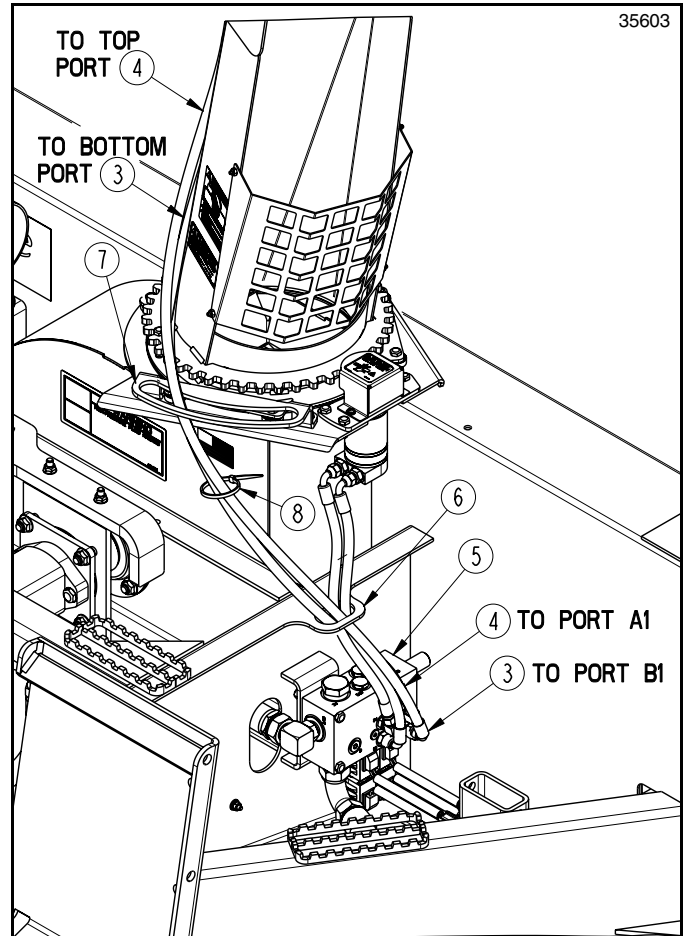

Hydraulic Hose Hook-up (Spout Deflector to Solenoid)
Figure 1-8

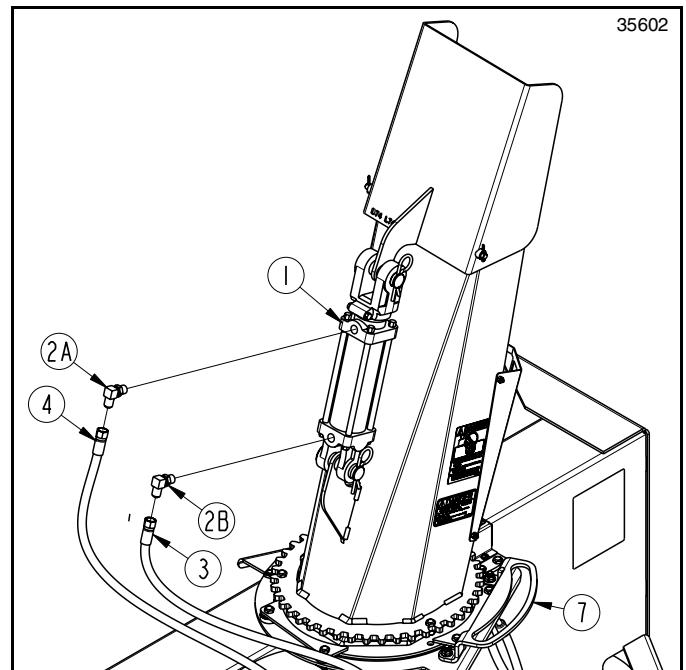

Hydraulic Cylinder Assembly For Spout Deflector
Figure 1-9

Section 1: Assembly & Set-up

Quick Coupler Set-up

Refer to Figure 1-10

Two high pressure hydraulic outlets are required for attaching hydraulic hoses (#7 & #8) and a third outlet is required for attaching case drain line (#9).

NOTE: How to identify hydraulic lines (#7, #8, & #9):

- Hydraulic pressure line (#7) attaches to port (#1) located on right-hand side of impeller motor.
- Hydraulic return line (#8) attaches to tee (#3) located beneath impeller motor.
- Case drain line (#9) attaches to port (#2) located on top of impeller motor.

1. Thread hydraulic hoses (#7, #8, & #9) through holes on the left-hand side of Snow Blower frame. Holes not shown in illustration.
2. Continue threading hoses through hose loop (#10).

Refer to Figure 1-11

NOTE: Flat face couplers (#11 & #12) and adapters (#13) are optional. They can be purchased from your local Land Pride dealer. See “**Flat Face Couplers**” on page 15 for detailed information and Land Pride’s part number.

3. Consult your skid steer Operator’s Manual or Auxiliary Hydraulic Reservoir Manual to determine which line on your machine is under pressure when locked for continuous operation.
4. If installing optional large flat face couplers, skip to step 5 below. If installing optional small flat face couplers, screw adapters (#13) to small flat face couplers (#11 & #12) until tight.
5. Remove plastic cap from hydraulic line (#7).
6. Select couplers (#11 or #12) that will mate with your machine’s coupling that is under pressure and attach that coupling to hydraulic line (#7) and tighten.
7. Remove plastic cap from hydraulic line (#8) and screw remaining coupler to line (#8) until tight.

NOTE: Coupler (#6) is optional. It can be purchased from your local Land Pride dealer. See “**Case Drain Coupler & Cable Ties**” on page 15 for detailed information and Land Pride’s part number.

8. If customer chooses to screw case drain line (#9) directly to the tank/sump, then skip step 9 and go to “**Snow Blower Hook-up**” on page 11.
9. If attaching optional coupler (#6) to case drain line (#9):
 - a. Remove plastic cap from case drain line (#9).
 - b. Wrap teflon tape around the pipe threads on the end of the case drain line.
 - c. Screw optional coupler (#6) on tight.

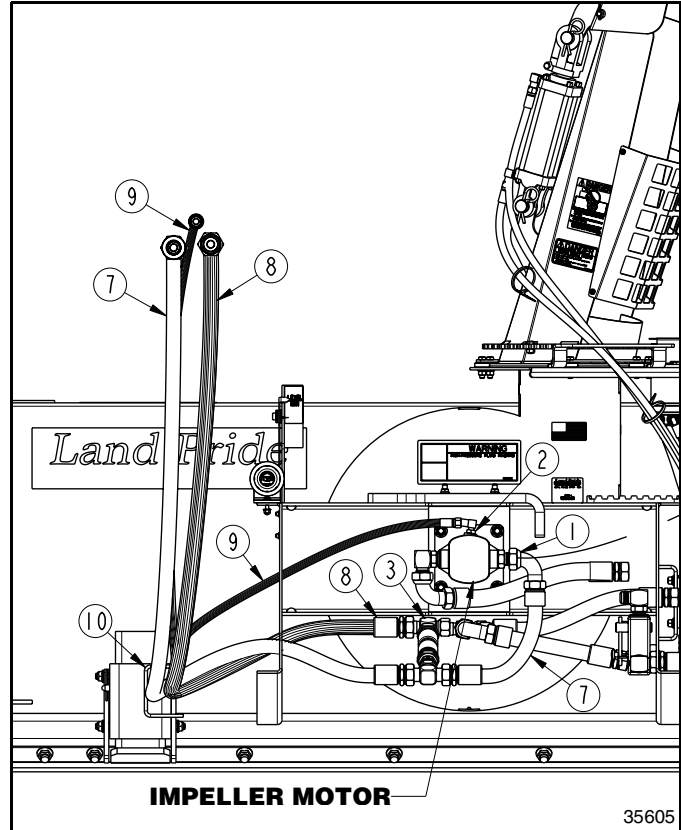

Hydraulic Hose Layout (View Without Hitch Plate)
Figure 1-10

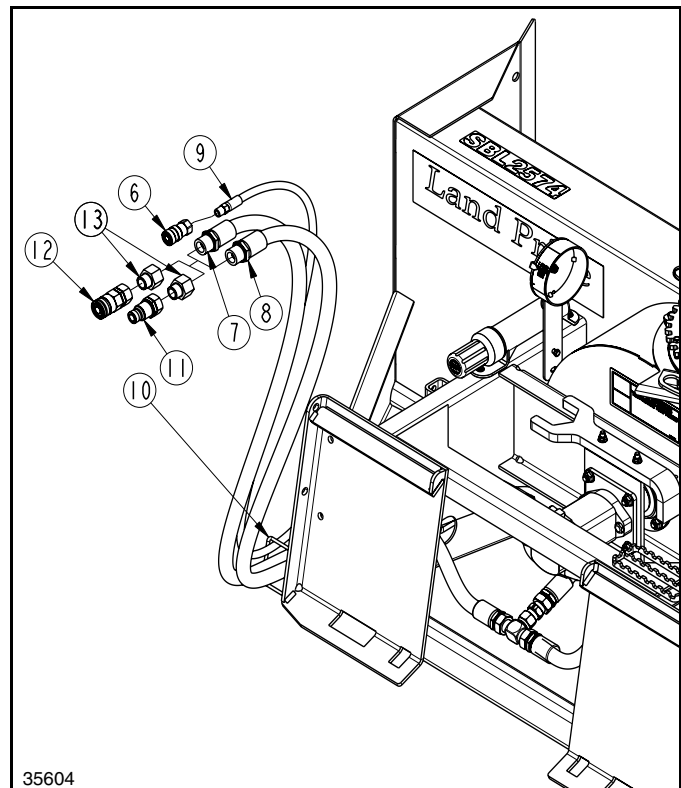

Quick Disconnect Coupling Set-up
Figure 1-11

Section 2: Equipment Hook-up & Unhook

Snow Blower Hook-up

Refer to Figure 2-1:

DANGER

A Crushing Hazard exists when hooking-up equipment. **Do not** allow anyone to stand between skid steer/tractor and implement while hooking-up to implement. **Do not** operate hydraulics while someone is near the skid steer/tractor or implement.

CAUTION

Make sure your skid steer/tractor hitch is properly attached to the Snow Blower hitch. It must be secured under the Snow Blower top angle bars and loader hitch plate lock handles must be locked down with locking pins extending fully through bottom slots in the Snow Blower hitch. An improperly attached Snow Blower can come loose and fall.

NOTE: The Snow Blowers are designed for skid steers and tractors with front mounted loaders.

Refer to Figure 2-1:

1. Check for and remove debris in the hitch point areas before hooking-up to Snow Blower.
2. Raise lock pins on loader hitch for hook-up.
3. Drive skid steer or tractor slowly to the Snow Blower hitch making sure hitch plate on the skid steer/tractor is parallel with the Snow Blower's top angle bars.
4. Rotate top of skid steer/tractor tilt arms slightly forward.
5. Position top of skid steer/tractor hitch plate under the top angled bars and slowly raise loader hitch plate up until hitch plate is seated under the top angle bars.
6. Rotate top of skid steer/tractor tilt arms back until Snow Blower makes full contact with face of hitch plate.
7. Push lock pins on the loader hitch down. Make sure lock pins go through bottom slots in the Snow Blower hitch and handles are fully locked down.

IMPORTANT: Set loader arms to float before blowing snow. The skid shoes can have increased wear if loader arms are rigid.

8. Set loader arms to float.

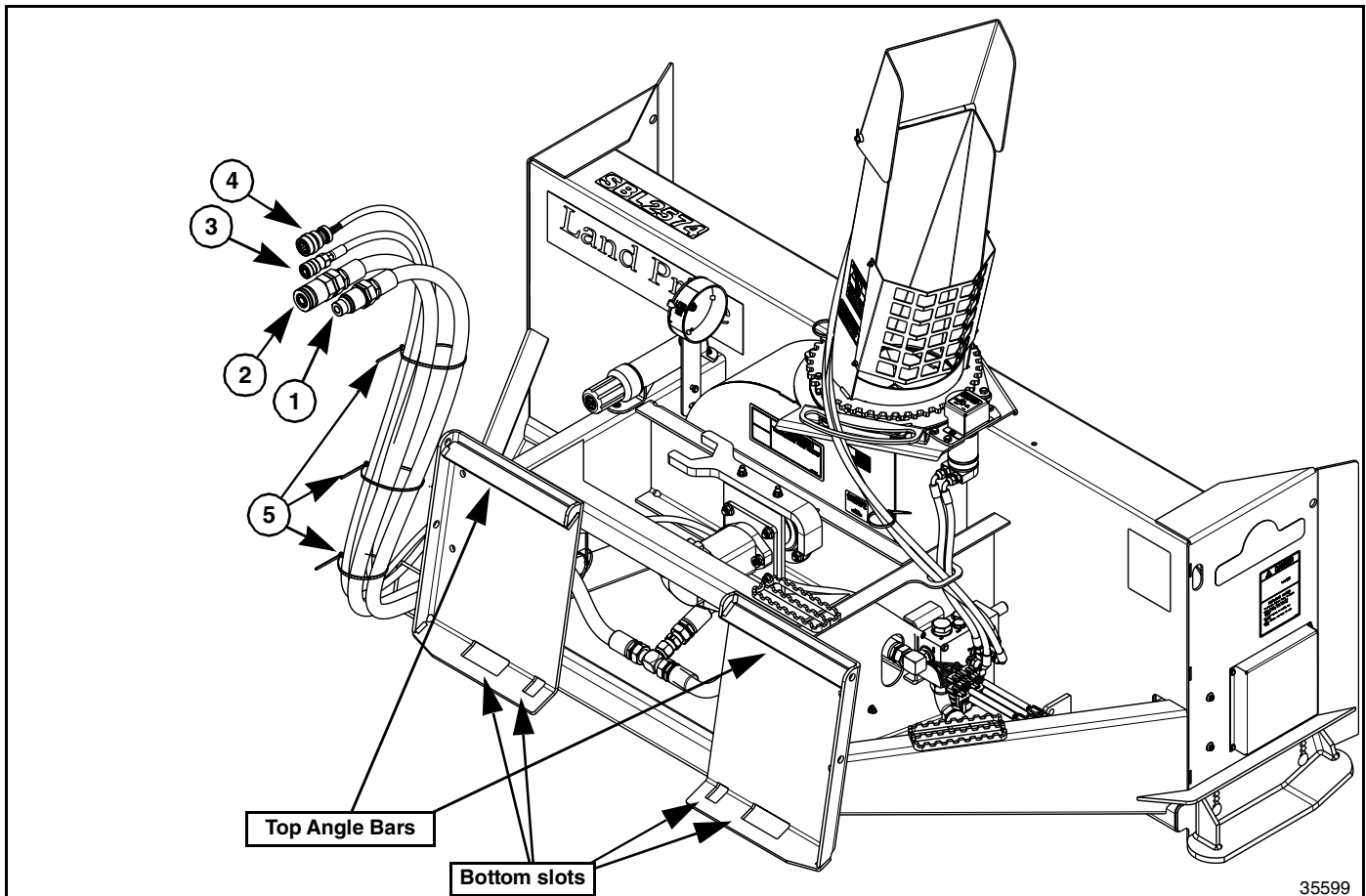

Hook-up to Snow Blower
Figure 2-1

35599

Section 2: Equipment Hook-up & Unhook

Hydraulic Hose Hook-up

DANGER

Hydraulic fluid under high pressure can penetrate skin. Wear protective gloves and safety glasses or goggles when working with hydraulic systems. Use a piece of cardboard or wood rather than hands when searching for hydraulic leaks. If hydraulic fluid is injected into the skin or eyes, it must be treated by a doctor familiar with this type of injury within a few hours or gangrene may result. **DO NOT DELAY.**

IMPORTANT: Collect and dispose all oil spills and leaks in an environmentally safe manner.

IMPORTANT: Hose routing is the responsibility of the owner/operator of the Snow Blower. Pinched and/or stretched hoses are not covered under the warranty.

IMPORTANT: Make sure all coupler fittings are clean before connecting them to skid steer couplers.

Refer to Figure 2-4 on page 13:

Two high pressure hydraulic outlets are required for the hydraulic motor and one outlet for the case drain.

1. Route hydraulic hoses along the most convenient path to access your skid steer or tractor mounted hydraulic reservoir couplings.

NOTE: If attaching to a Kubota SVL skid steer, route hydraulic hoses through Kubota's SVL Hose Stay Kit #S6689 as shown in Figure 2-2 below. Purchase **SVL Hose Stay Kit #S6689** through your nearest Kubota dealer. Refer to the SVL skid steer Operator's Manual for additional instructions.



Kubota SVL Hose Stay
Figure 2-2

2. Clean quick connect couplers of dirt and then connect couplers (#1 & #2) to the skid steer couplers or couplers at the tractor mounted hydraulic reservoir. Make sure quick connect couplers have fully engaged. If they have not, check the following:
 - a. Make sure couplers are same size and type.
 - b. Make sure hydraulic pressure has been released.
3. If case drain line is fitted with the optional coupler, then connect that coupler (#3) to the tank/sump coupler and skip to step 5 below.
4. If screwing case drain line directly to the tank/sump:
 - a. Remove plastic cap and wrap teflon tape around pipe threads on end of case drain line (#3).
 - b. Screw case drain line (#3) to your equipment's tank/sump port until tight. All required adapter fittings are supplied by customer.
5. Turn auxiliary hydraulics on to check impeller rotation. The impeller should rotate counterclockwise viewed from the operator's seat and clockwise viewed facing impeller and auger from the front. If impeller rotates incorrectly, switch male and female couplers on the hydraulic hoses and reconnect hoses.
6. Cable ties to be added at end of solenoid hook-up.

Solenoid Hook-up

Refer to Figure 2-3 on page 13:

There are six optional wiring harnesses and all connect the same way to the Snow Blower solenoids (#1 & #2) but connect differently to the skid steer or tractor. See pages 16 thru 18 for a detailed descriptions of all six.

1. Skip to step 3 if optional wire harness (#4) has a 6 pin connector. Otherwise, continue with step 2 below.
2. If solenoid harness has a 14 pin connector, attach harness to the 14 pin connector located on the end of the loader arm. Skip to step 4 on this page.
3. There are three toggle switch control harnesses available. Two are for skid steer mounted Snow Blowers and one is for tractor mounted Snow Blowers.
 - Install "**Control Harness With Deutsch 2 Pin Plug**" using instructions in manual 370-452M included with this kit. See page 17 for harness description.
 - Install "**Skid Steer Control Harness With 2 Eyelets**" using instructions in manual 370-349M included with this kit. See page 19 for harness description.
 - Install "**Tractor Control Harness With 2 Eyelets**" using "**Installation Instructions for Tractor Harness**" on page 18.

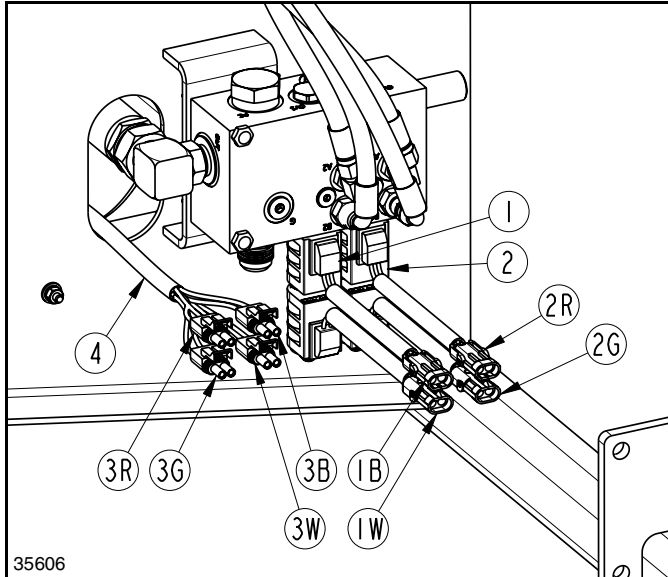

Quick Disconnect Coupling Set-up
Figure 2-3

4. Route wire harness (#4) in Figure 2-3 & Figure 2-4 along side hydraulic hoses to solenoids (#1 & #2). Do not secure wire harness (#4) with cable ties at this time.
5. At solenoid (#1), attach brown banded connector (#1B) to brown wire connector (#3B) and white banded connector (#1W) to white wire connector (#3W).
6. At solenoid (#2), attach red banded connector (#2R) to red wire connector (#3R) and green banded connector (#2G) to green wire connector (#3G).
7. Sit in the skid steer or tractor seat, fasten seat belt, start unit, turn auxiliary hydraulics “on”, and position loader arms fully down.
8. At the control box, push on the “Tilt Up/Down” toggle switch to tilt deflector spout up and pull toggle switch to tilt deflector spout down. Watch spout to make sure it moves in the proper direction.
9. At the control box, push on the “Rotate Left/Right” toggle switch to rotate chute to the left and pull toggle switch to rotate chute to the right. Watch chute to make sure it rotates in the proper direction.
10. Shut skid steer/tractor down and make any needed adjustments to the solenoid connections as follows:
 - If spout tilts opposite of what it should, change green wire connector (#3G) with red wire connector (#3R) at solenoid (#2).
 - If chute rotates in the opposite of what it should, change brown wire connector (#3B) with white wire connector (#3W) at solenoid (#1).

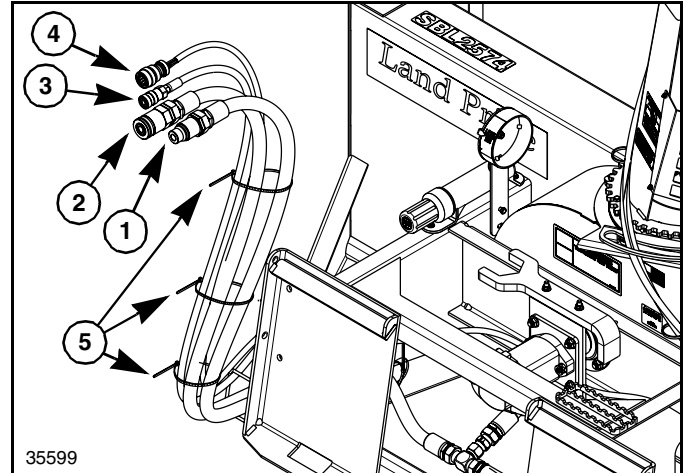

Hydraulic Hoses & Cable Ties
Figure 2-4

Refer to Figure 2-4:

11. Adjust path of hydraulic hoses (#1, #2, #3) and wire harness (#4) to suit and secure with cable ties (#5) as needed.

Check Equipment Clearances

It is important to check clearance before putting the Snow Blower into operation. Make sure hydraulic hoses and wiring harness are long enough and won't become pinched or entangled in the equipment. Also, make sure Snow Blower does not come in contact with tractor frame and tires by carefully going through its full range of motions.

1. Visually inspect hydraulic hoses for possible pinch points and shortness. If needed, make hose adjustments before putting equipment into service.
2. Visually inspect wiring harness for possible pinch points and shortness. If needed, make adjustments to the wiring harness before putting equipment into service.

IMPORTANT: Make sure hydraulic hoses and wiring harness are long enough and properly secured so that they do not become stretched or pinched through their full range of motions.

3. If necessary, have someone stand nearby that can motion for the operator to stop if a problem develops while completing steps 4 thru 6 below.
4. Start skid steer/tractor and raise loader arms high enough to tilt hitch plate fully down without Snow Blower making contact with the ground.
5. Fully extend and retract hydraulic cylinders on the end of the skid steer/tractor loader arms while watching for interferences between skid steer/tractor and Snow Blower frame.
6. Raise skid steer/tractor loader arms fully up and repeat steps 4 thru 5 above.

Section 2: Equipment Hook-up & Unhook

Unhooking The Snow Blower

Refer to Figure 2-5:

1. See “Long Term Storage” on page 31 before parking Snow Blower for long periods.
1. Park skid steer/tractor on a flat, level, solid surface, and lower Snow Blower onto the surface.
2. Place transmission in park, set park brake, shut power equipment off, and remove switch key.
3. With Snow Blower resting on the ground, release all hydraulic system pressure before dismounting skid steer or tractor. See Skid Steer Operator’s Manual for instructions on how to release skid steer hydraulic system pressure.
4. Disconnect solenoid wire harness (#4) from the front of the loader arm. Do not disconnect harness from the solenoids.
5. Disconnect hydraulic hoses (#1, #2, & #3) from skid steer or tractor mounted hydraulic reservoir.
6. Store hydraulic hoses and wire harness on the Snow Blower frame to keep dirt away from the couplings and electrical connector.
7. Raise lock pins on loader hitch. If lock pins are activated from the operator’s seat, return to the skid steer/tractor to raise lock pins.
8. From the operator’s seat, tilt top of loader hitch slightly forward towards the Snow Blower.
9. Slowly lower skid steer/tractor hitch plate until top angle bars and hitch plate have separated.
10. Back skid steer/tractor slowly away from the Snow Blower while making sure it does not interfere with the equipment.

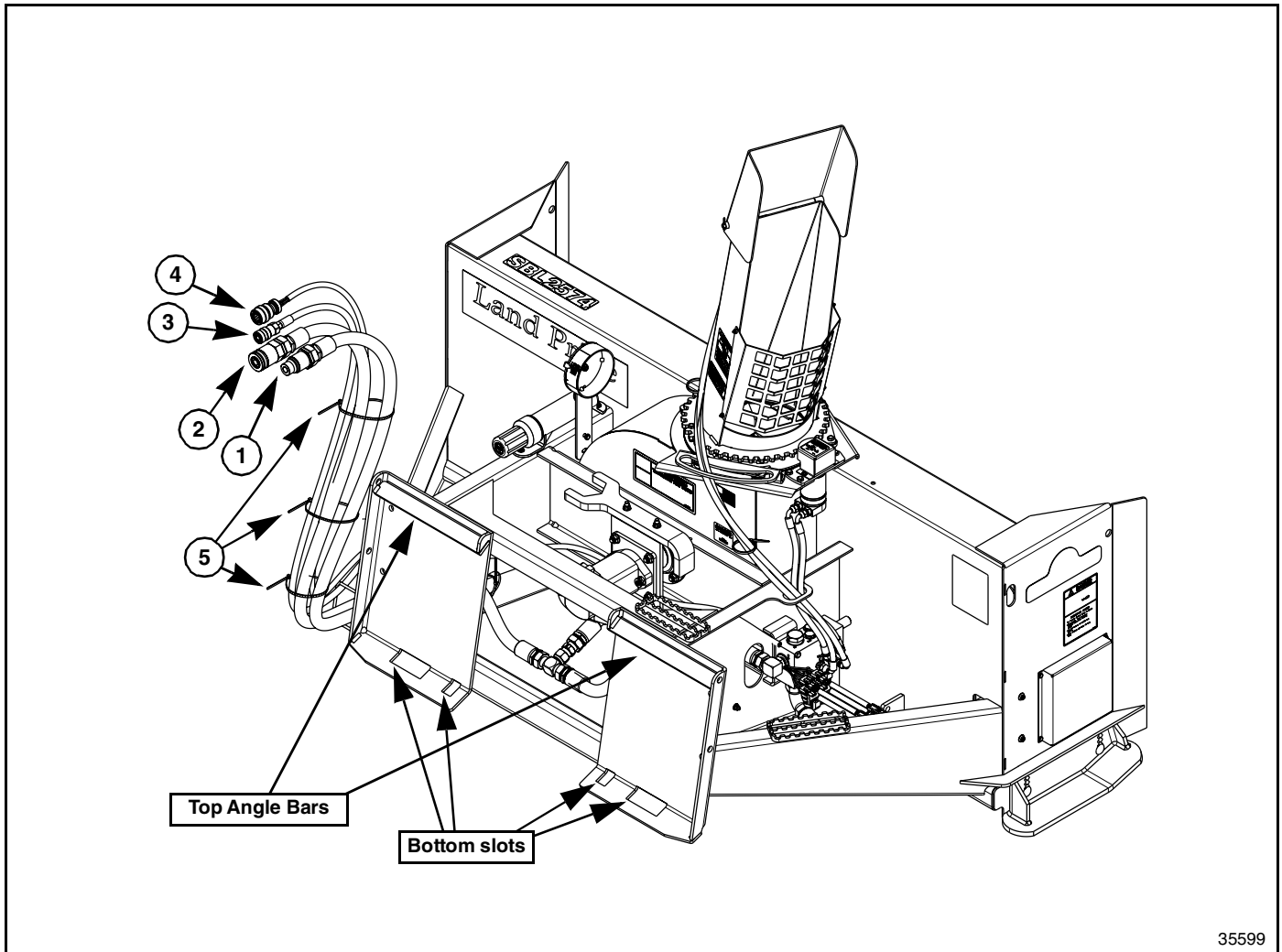

Hook-up to Snow Blower
Figure 2-5

35599

Section 3: Options

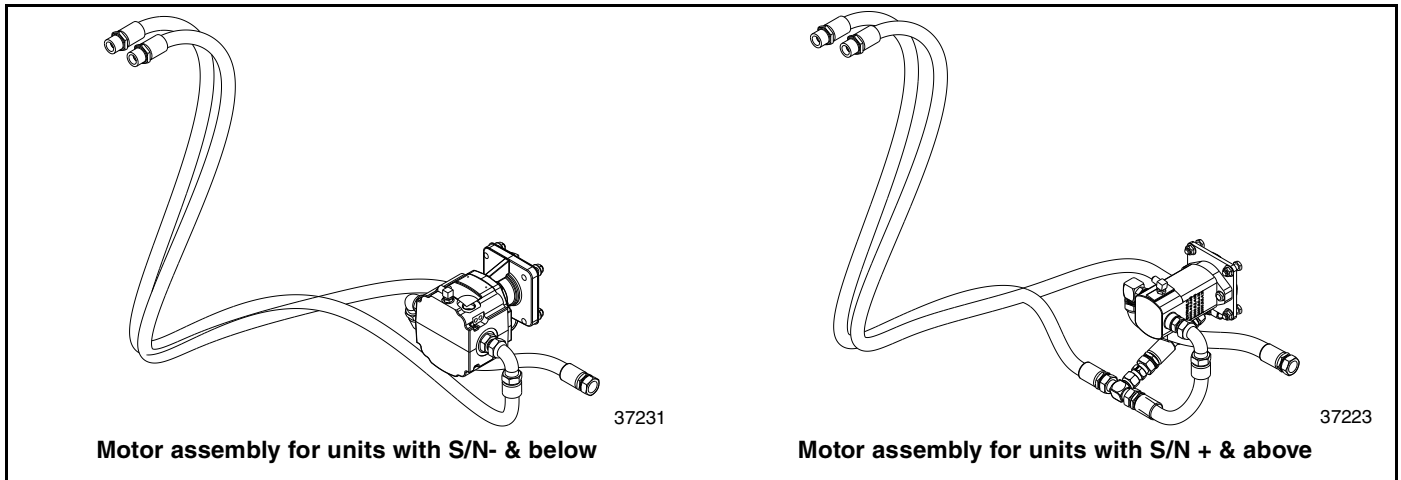

Motor Assembly
Figure 3-1

Motor Assembly

Refer to Figure 3-1:

- MOTOR BUNDLE HYD 12-19 GPM370-253A**
- MOTOR BUNDLE HYD 20-26 GPM370-254A**
- MOTOR BUNDLE HYD 27-33 GPM370-255A**

Three impeller motor assembly options are available to meet your hydraulic flow requirements. They are interchangeable and do not require adapter kits. Compare your motor’s GPM rating located on an attached decal with the GPM ratings above.

If your Snow Blower’s impeller motor is not compatible with your skid steer or tractor, you should replace it with one of the above assemblies that is compatible.

Flat Face Couplers

Refer to Figure 3-2:

The following flat face hydraulic couplers are available.

- LARGE FLAT FACE COUPLERS326-960A**

Large flat face couplers consist of one large flat face male coupler, one large flat face female coupler, and two adapters.

- SMALL FLAT FACE COUPLERS.316-290A**

Small flat face couplers consist of one small flat face male coupler, one small flat face female coupler, and two adapters.

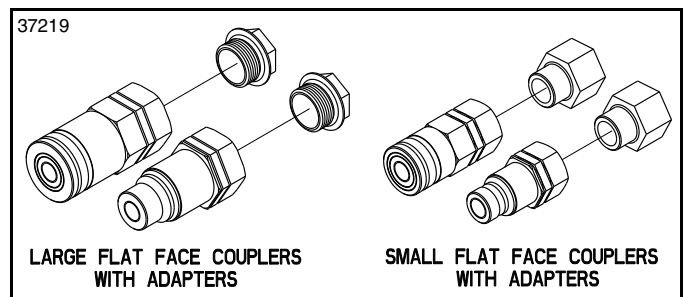

Quick Release Couplers
Figure 3-2

Case Drain Coupler & Cable Ties

Refer to Figure 3-3:

- CTL/SS COUPLER PACKAGE326-474A**

When needed, order this optional 3/8” female quick disconnect coupler for attaching to the Snow Blower’s case drain line. Included with this package are three cable ties for supporting the case drain line along its path to the tank/sump.

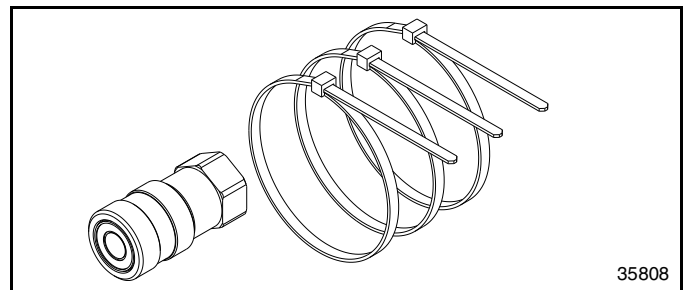

Case Drain Coupler
Figure 3-3



Section 3: Options

Electrical Control Harness (Optional)

Land Pride offers six electrical control harness. If not purchased with the Snow Blower, one may be purchased from your nearest Land Pride dealer. Additional instructions are provided on the page noted in the list below.

- Land pride Part No. 370-336A - - - - - Control harness with Deutsch 14 pin 2 function power plug.
- - - - - Refer to “**Control Harness With Deutsch 14 Pin Plug**” below.
- Land Pride Part No. 370-337A - - - - - Control harness with Deutsch 14 pin 2 function power plug.
- - - - - Refer to “**Control Harness With Deutsch 14 Pin Plug**” below.
- Land Pride Part No. 370-338A - - - - - Control harness with Deutsch 14 pin 2 function power plug.
- - - - - Refer to “**Control Harness With Deutsch 14 Pin Plug**” below.
- Land Pride Part No. 370-434A - - - - - Control harness with Deutsch 2 pin plug and control box for Skid Steers.
- - - - - Refer to “**Control Harness With Deutsch 2 Pin Plug**” on page 17.
- Land Pride Part No. 370-133A - - - - - Tractor Control harness, connects direct to a 12V power source.
- - - - - Refer to “**Tractor Control Harness With 2 Eyelets**” on page 18.
- Land Pride Part No. 370-134A - - - - - Skid Steer Control harness, connect direct to a 12V power source.
- - - - - Refer to “**Skid Steer Control Harness With 2 Eyelets**” on page 19.

Kubota offers two controllers for operating the Powered Rake attached to a Kubota compact track loader or skid steer loader. See your nearest Kubota dealer to purchase one of their controllers.

- Kubota Part No. V0511-97010 - - - - - SVL Electrical connector (2 functions)
- Kubota Part No. W/G S6699 - - - - - SVL Multifunction handle (7 functions.)

Control Harness With Deutsch 14 Pin Plug

Refer to Figure 4-3:

Three 14 pin wiring harnesses are available. They attach to the Snow Blower solenoids and skid steer 14 pin coupler. Included with the wiring harnesses are three cable ties. Pick the one that is designed for your particular skid steer.

370-336A Deutsch HD30 14 Pin 2 Function

This harness will work with the following skid steers:

- Bobcat with 14 pin coupler
- GEHL with 14 pin coupler
- Kubota with 14 pin coupler
- Komatsu with 14 pin coupler
- Mustang with 14 pin coupler
- Takeuchi with 14 pin coupler
- Volvo with 14 pin coupler

It will also work with the following skid steers by reversing the red and green wires at the solenoid:

- Case-Post 9/1/01 with 14 pin coupler
- Case-400 Series with 14 pin coupler
- New Holland with 14 pin coupler

370-337A Deutsch HGD30 14 Pin 2 Function

This harness will work with the following skid steer:

- John Deere with 14 pin coupler

370-338A Deutsch HGD30 14 Pin 2 Function

This harness will work with the following skid steer:

- John Deere “EH” with 14 pin coupler

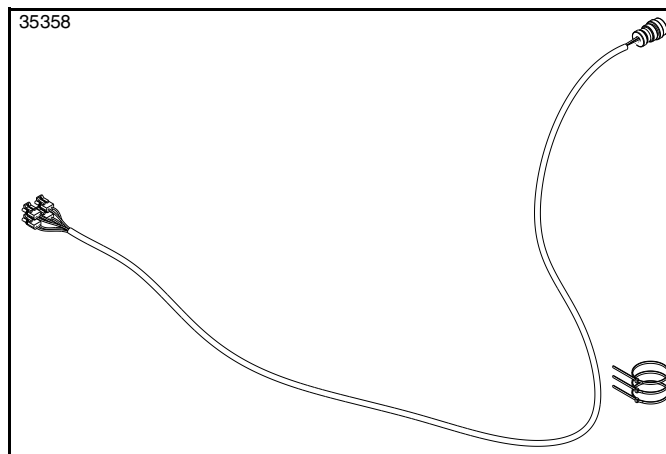

**Deutsch HGD30 14 Pin 2 Function Wiring Harness
Figure 4-3**

Section 3: Options

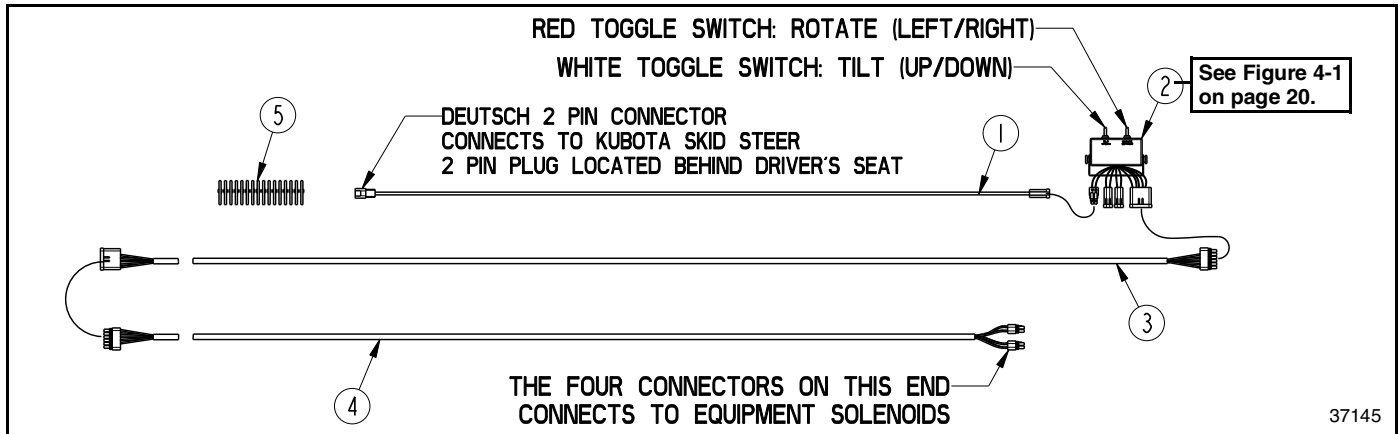

Toggle Switch Control Harness For Kubota CTL Skid Steers
Figure 3-5

Control Harness With Deutsch 2 Pin Plug

Refer to Figure 3-5:

370-434A Kubota CTL Skid Steer Control Harness

This harness is used with skid steers equipped with a Deutsch 2 pin coupler but not the Deutsch HD30 14 pin coupler. It consist of the following:

Refer to Figure 3-5:

- Power cord (#1): Attach Deutsch 2 pin plug (#1) to Kubota's CTL male plug (#7) located behind the driver's seat.

Refer to Figure 3-6:

- 10 amp Fuse (#8): Fuse (#8) is supplied by customer. Install 10 amp fuse (#8) in Kubota's fuse box slot #17 labeled "Electrical Outlet-2".

Refer to Figure 3-5:

- Power cord (#1): Attaches opposite end of the power cord (#1) to control box (#2).
- Control box (#2): Mounts in a convenient location for the operator to access from the operator's seat.
- Wire harness (#3): Attaches to control box (#2) and runs from the control box to the loader arm.
- Wiring harness (#4): Attaches to wire harness (#3) at the loader arm and at the solenoids on the Snow Blower.
- Cable ties (#5): For securing wire harnesses (#1, #3, & #4) to the skid steer and Snow Blower.
- Installation Manual 370-452M: Installation Manual, not shown, is included with the Kit.

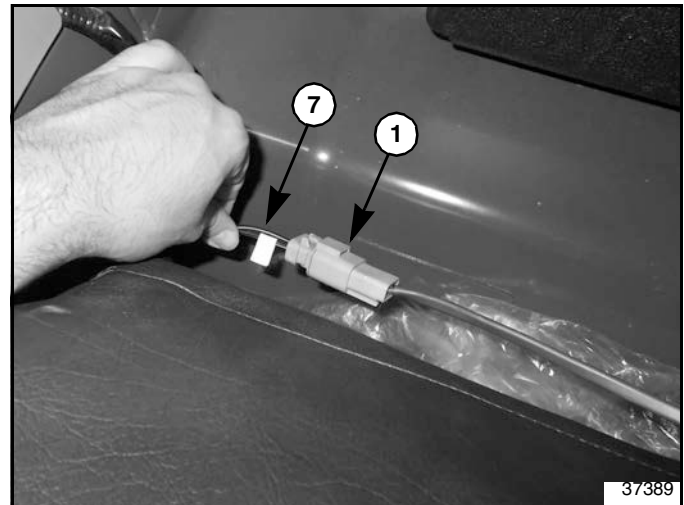

Kubota Power Connection (Located Behind Drive Seat)
Figure 3-5

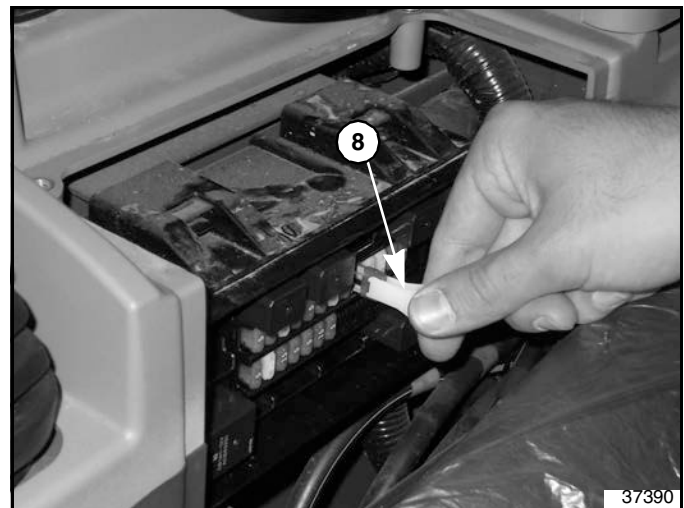

Installation of 10 amp Fuse
Figure 3-6

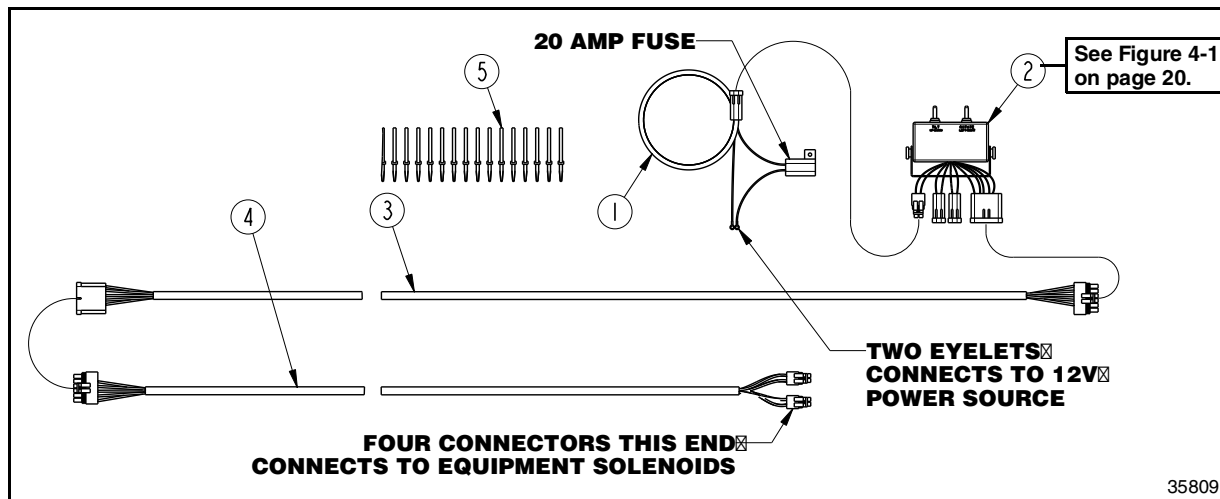

Tractor Mounted Toggle Switch Control Harness
Figure 3-4

Tractor Control Harness With 2 Eyelets

Refer to Figure 3-4:

370-133A CONTROL HARNESS TRACTOR

This harness is used only with tractor mounted Snow Blowers and consist of the following:

- Power cord (#1): Attaches to tractor battery and control box (#2).
- Control box (#2): Mounts in a convenient location for the operator to access from the seat. See also Figure 4-1 on page 20.
- Wire harness (#3): Attaches to control box (#2) and terminates at the front of one of the loader arms.
- Wiring harness (#4): Attaches to wire harness (#3) and solenoids at the Snow Blower.
- Cable ties (#5): For securing wire harnesses (#1, #3, & #4) to the tractor loader and Snow Blower.

Installation Instructions for Tractor Harness

1. Before doing anything else, determine the path power cord (#1) will travel from tractor battery to control box (#2), location of control box (#2), and path wire harness (#3) will travel from control box to the front end of the loader arm. Make sure control box is mounted in an area where the operator can operate the toggle switches easily from the tractor seat. Method of mounting the control box is to be determined by the customer.
2. Disconnect negative (-) black power cord from its battery post.
3. Attach positive (+) red wire eyelet on end of power harness (#1) to the battery's positive (+) post and tighten fastener hardware.
4. Attach negative (-) black wire eyelet on end of power harness (#1) and negative (-) black power cord to the battery's negative (-) post and tighten.
5. Route power cord (#1) from the battery to the predetermined location of control box (#2).
6. Mount toggle switch control box (#2) to the tractor using hardware furnished by customer.
7. Plug power cord (#1) and wire harness (#3) to control box (#2).
8. Route wire harness (#3) to the front end of one of the loader arms.
9. Make any final adjustments to wire harness (#3) and power cord (#1) and make sure wire harness (#4) can reach from solenoids at the Snow Blower to connector at the end of wire harness (#3).
10. Secure power cord (#1) and wire harness (#3) with cable ties (#5).
11. Connect 6 pin connector on end of wire harness (#4) to wire harness (#3).
12. Continue with step 4 under "Solenoid Hook-up" on page 12.

Section 3: Options

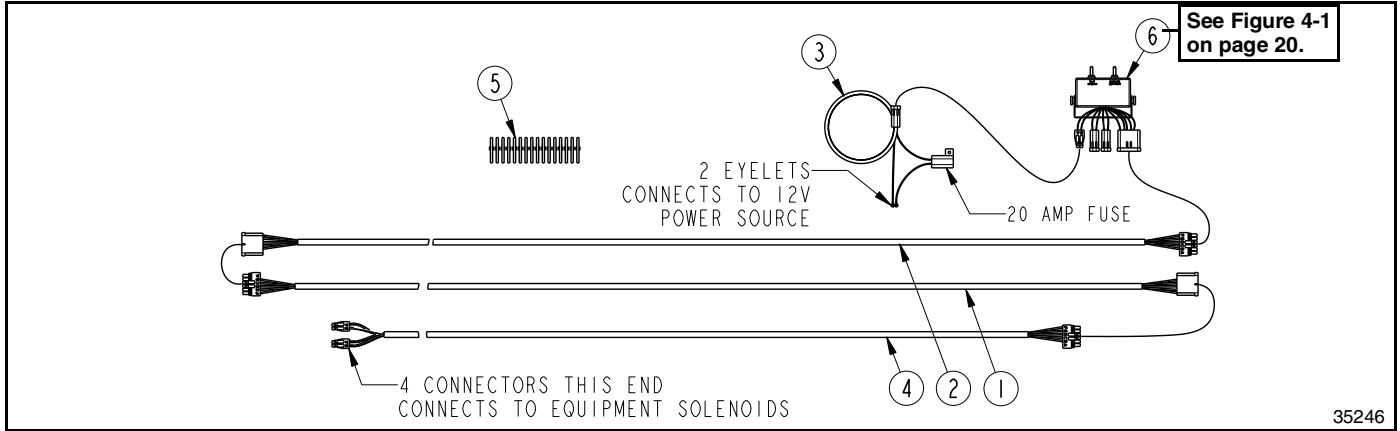

Toggle Switch Control Harness
Figure 3-7

Skid Steer Control Harness With 2 Eyelets

Refer to Figure 3-7:

370-134A Skid Steer Control Harness

This harness is used with skid steers not equipped with a Deutsch HD30 14 pin or 2 pin coupler. It consists of the following:

- Power cord (#3): Attaches to skid steer battery and control box (#6).
- Control box (#6): Mounts in a convenient location for operator to access from the seat. See also Figure 4-1 on page 20.
- Wire harness (#2): Attaches to control box (#6) and runs from control box to rear of the loader arm.
- Wire harness (#1): Attaches to wire harness (#2) at the rear of the loader arm and travels along the loader arm to the front of the loader arm.
- Wiring harness (#4): Attaches to wire harness (#1) at the loader arm and solenoids at the Snow Blower.
- Cable ties (#5): For securing wire harnesses (#1, #2, #3, & #4) to the skid steer and Snow Blower.
- Installation Manual 370-349M: (not shown)

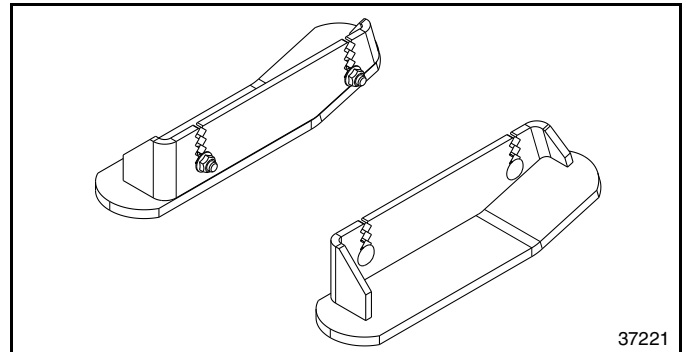

Outer Skid Shoes
Figure 3-9

Outer Skid Shoes

Refer to Figure 3-9:

Outer skid shoes are mounted on the outside of the side panels and are adjustable by unbolting them and reattaching them at a different height.

- 370-451K SBL2566 SKID SHOE BUNDLE**
- 370-438K SBL2574 & SBL2584 SKID SHOE BUNDLE**

Inner Skid Shoes

Refer to Figure 3-10:

Inner skid shoes are mounted behind the Snow Blower and are adjustable vertically by pulling a bent pin and moving the skid shoes up or down.

- 370-440K SKID SHOE BUNDLE**

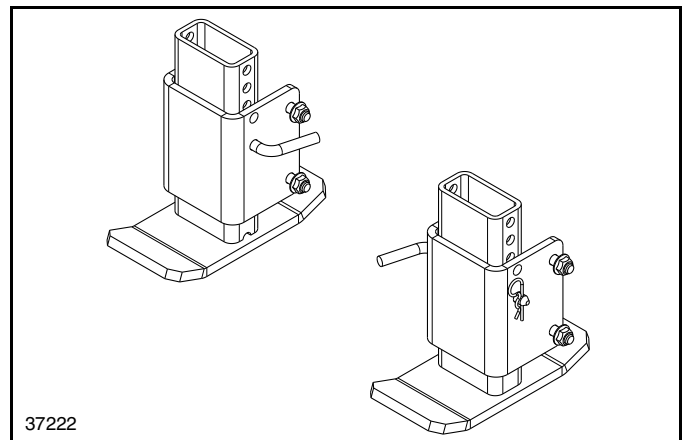

Inner Skid Shoes
Figure 3-10

Section 4: Adjustments

Discharge Chute & Spout Deflector

WARNING

Never rotate chute or spout to throw snow at the tractor, animals, or people. The Snow Blower is capable of picking up large solid objects and discharging them out the spout causing serious bodily injury or death.

IMPORTANT: Never operate a Snow Blower with chute throwing snow towards property such as vehicles, buildings, trailers etc. that can be scratched, dented or broken by thrown projectiles.

IMPORTANT: Never operate a Snow Blower that can throw snow towards the skid steer/tractor and/or operator. If this can happen, make sure the chute rotation stop is properly repaired before putting the Snow Blower back into service.

IMPORTANT: Adjustment screws on hydraulic motor are preset at the factory. Do not change factory settings. Changing factory settings can cause structural damage to the Snow Blower.

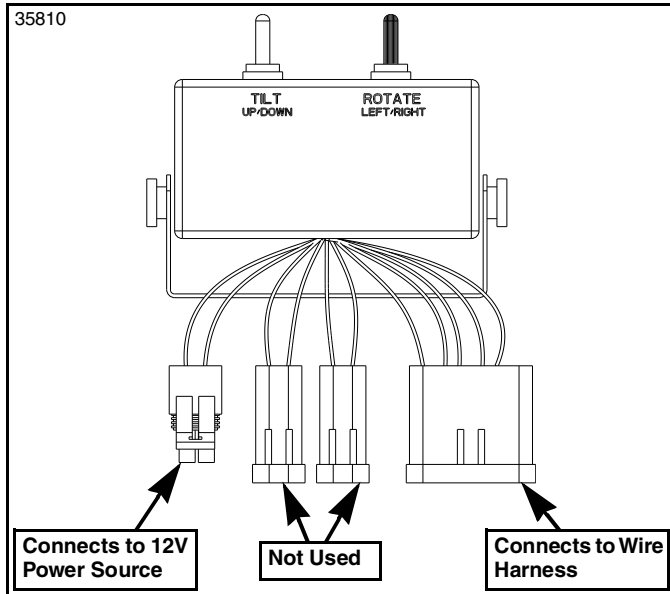

Control Switches for Chute Rotation & Spout Deflector
Figure 4-1

Spout Deflector Adjustment

Refer to Figure 4-1:

The end of the spout can be angled up or down to direct blown snow close or far away.

1. Stop skid steer/tractor and place in park before adjusting spout deflector.
2. Push on “Tilt Up/Down” toggle switch to tilt deflector spout up and pull toggle switch to tilt deflector spout down.
3. Resume snow blowing once new angle is set.

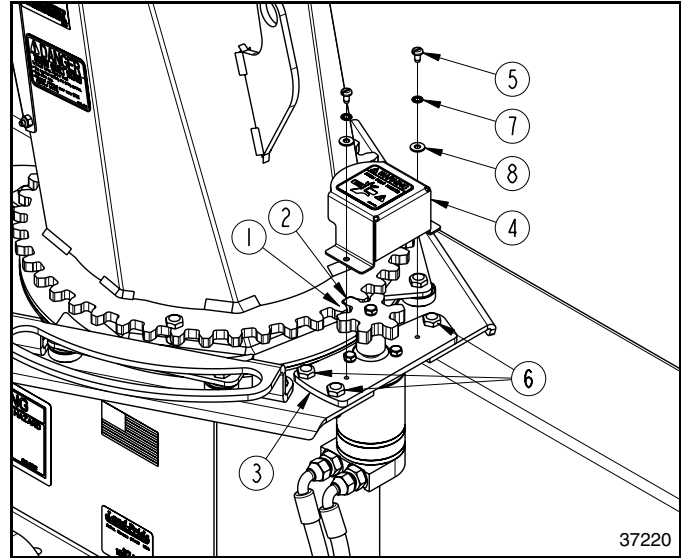

Chute Rotation Gear Adjustment
Figure 4-2

Chute Rotation Gear Alignment

Refer to Figure 4-2:

IMPORTANT: Gear guard (#4) is shown removed for clarity only. This adjustment can be made without removing the gear guard. Should the guard be removed, make certain gear guard (#4) is replaced before putting Snow Blower back into service.

1. Stop skid steer/tractor, place in park, shut engine off and remove switch key.
2. Loosen all three hex head bolts (#6). Do not remove.
3. Move hydraulic motor mount (#3) as needed until drive gear (#2) has full tooth engagement with driven gear (#1).
4. Hold hydraulic motor mount (#3) in this position and tighten all three 3/8"-16 GR5 hex head bolts (#6) to the correct torque.

If removed, be sure to replace gear guard (#4) with existing 10-24 pan screws (#5), star washer (#7), and flat washer (#8). Tighten pan screws (#5).

Chute Rotation Adjustment

Refer to Figure 4-1:

1. Stop skid steer/tractor and place in park before adjusting chute rotation angle.
2. Push on “Rotate Left/Right” toggle switch to rotate chute to the left and pull toggle switch to rotate chute to the right.
3. Resume snow blowing once new chute angle is set.

Section 4: Adjustments

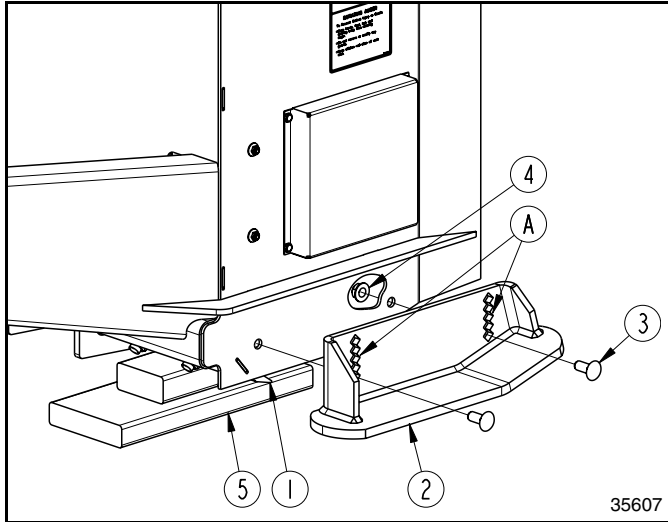

Outer Skid Shoe Assembly
Figure 4-3

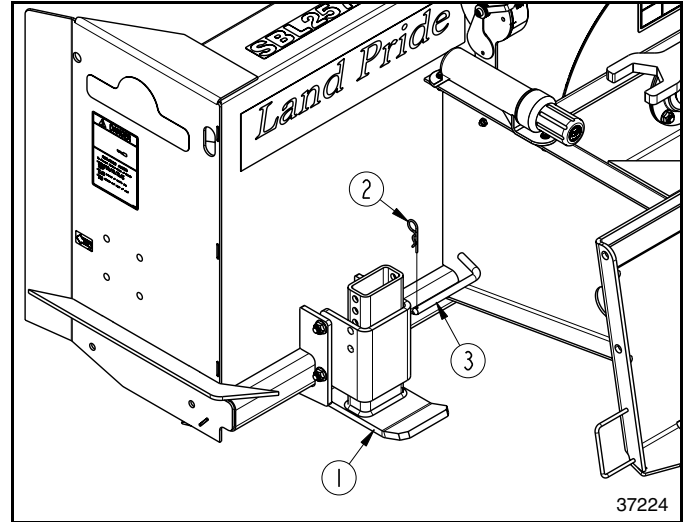

Inner Skid Shoe Assembly
Figure 4-4

Outer Skid Shoe Adjustment

Refer to Figure 4-3:

IMPORTANT: Surfaces with gravel or crushed rock will require setting the skid shoes to carry the Snow Blower higher than when on hard flat surfaces such as asphalt and concrete. Never set Snow Blower so low as to pick-up gravel and/or rock.

1. Park on a level solid surface, place skid steer/tractor in park, and lower both ends of grader blade (#1) onto support blocks (#5) that are capable of holding skid shoes (#2) off the ground several inches.
2. Shut skid steer/tractor engine off and remove switch key.
3. On the right-hand side, remove hex flange lock nuts (#4) and carriage bolts (#3).
4. Adjust skid shoe (#2) up to set grader blade closer to the ground and down to set grader blade farther away from the ground.
5. Reinsert existing 1/2"-13 GR5 carriage bolts (#3) into the square holes "A" that line up with Snow Blower frame. Secure carriage bolts (#3) with hex flange lock nuts (#4).
6. Tighten hex flange lock nuts (#4) to the correct torque.
7. Repeat steps 3 thru 6 for the left-hand side.

Inner Skid Shoe Adjustment

Refer to Figure 4-4:

IMPORTANT: Surfaces with gravel or crushed rock will require setting the skid shoes to carry the Snow Blower higher than when on hard flat surfaces such as asphalt and concrete. Never set Snow Blower so low as to pick-up gravel and/or rock.

1. Park on a level solid surface, place skid steer/tractor in park, and lower both ends of grader blade onto support blocks or jack stands that are capable of holding inner skid shoes (#1) off the ground 3 or 4 inches.
2. Shut skid steer/tractor engine off and remove switch key.
3. On the left-hand side, remove hairpin cotter (#2) and bent pin (#3).
4. Adjust skid shoe (#1) up to set grader blade closer to the ground and down to set grader blade farther away from the ground.
5. Reinsert existing bent pin (#3) and secure with hairpin cotter (#2).
6. Repeat steps 3 thru 5 for the right-hand side.

Section 4: Adjustments

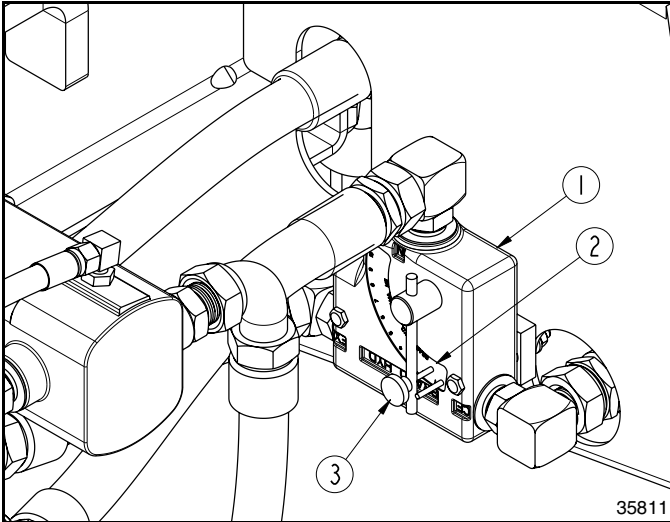

Impeller & Auger Speed
Figure 4-5

Auger Speed

Refer to Figure 4-5:

The auger speed can be changed to customer preference.

1. Park on a level solid surface, place skid steer/tractor in park or set park brake, disengage hydraulics if skid steer mounted or PTO if tractor mounted, lower loader arms and Snow Blower fully down, shut engine off, remove switch key, and wait for impeller and auger to come to a complete stop before dismantling from skid steer/tractor.
1. Loosen knob (#3) on flow control valve (#1).
2. Rotate knob (#3) to a higher number on the gradient scale (#2) to decrease auger speed and to a lower number to increase auger speed.
3. Retighten knob (#3) to keep it from moving.

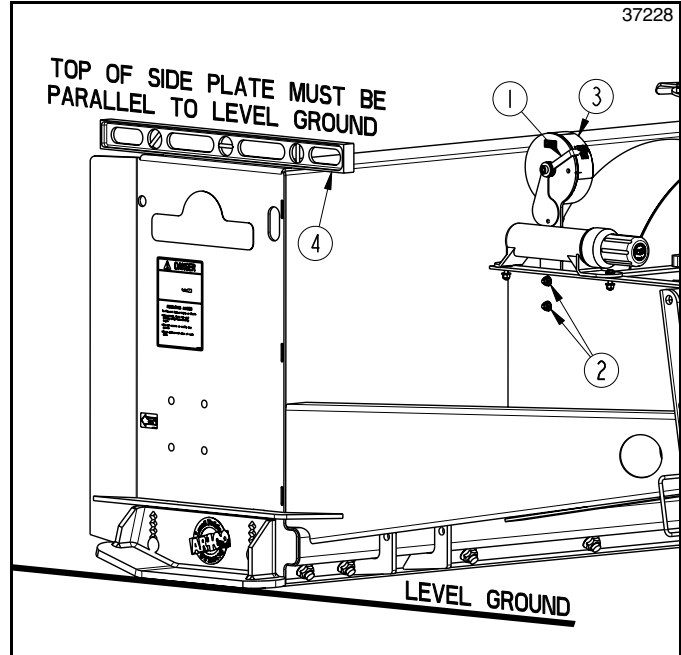

Reading Level Run Indicator
Figure 4-6

Level Run Indicator Adjustment

Refer to Figure 4-6:

IMPORTANT: In order for the level run indicator to be adjusted accurately, the skid steer or tractor with attached Snow Blower must be parked on ground that is flat and level.

1. Park skid steer/tractor on flat level ground.
2. Lower lift arms to put attachment flat on the ground.
3. Make any tilt adjustments as necessary to position top of Snow Blower side plate parallel and level with the ground. If necessary, a level (#4) can be used as shown.
4. Turn off engine, engage park brake, and remove key to prevent unauthorized starting before dismantling from skid steer or tractor.
5. If included, raise seat bar and move controls until both lock.
6. Loosen hex flange lock nuts (#2) and adjust level run indicator (#3) until indicator arrow (#1) points to "LEVEL RUN".
7. Hold level run indicator (#3) in this position and tighten hex flange lock nuts (#2) to the correct torque.

NOTE: The level run indicator should not need readjusting unless indicator has been forcibly moved, mounting hardware has come loose, or a different skid steer is hitched to the Snow Blower.

8. Repeat steps 1 thru 7 if attaching Snow Blower to a different skid steer.



Section 5: Operating Instructions

Introduction

Hazard control and accident prevention are dependent upon the awareness, concern, prudence, and proper training involved in the operation, transport, storage, and maintenance of the Snow Blower. Therefore, it is absolutely essential that no one operates the Snow Blower without first having read, fully understood, and become totally familiar with the Operator’s Manual. Make sure the operator has paid particular attention to:

- **Important Safety Information**, pages 1 to 4
- **Section 1: Assembly & Set-up**, page 7
- **Section 2: Equipment Hook-up & Unhook**, page 11
- **Section 4: Adjustments**, page 20
- **Section 5: Operating Instructions**, page 23
- **Section 6: Maintenance & Lubrication**, page 29

The following inspection should be performed before using the Snow Blower.

Operating Checklist

Check	Ref.
Make sure all guards and shields are in place. Refer to “Important Safety Information”.	Page 1
Read and follow hook-up & preparation instructions. Refer to “Snow Blower Hook-up”.	Page 11
Make all required adjustments. Refer to “Section 4: Adjustments”.	Page 20
Read and follow all operating procedures. Refer to “Section 5: Operating Instructions”.	Page 23
Read and follow all maintenance instructions. Refer to “Section 6: Maintenance & Lubrication”.	Page 29
Make sure there are no hydraulic leaks. Refer to “Avoid High Pressure Fluids Hazard”.	Page 3
Lubricate Snow Blower as needed. Refer to “Lubrication”.	Page 32
Check Snow Blower initially and periodically for loose bolts and pins. Refer to “Torque Values Chart”.	Page 36

Pre-Operational Safety Check

Make the following inspections with Snow Blower resting on the ground while attached to a skid steer or tractor. Place skid steer/tractor in park or set park brake, disengage hydraulics, disengage PTO if tractor mounted, lower loader arms fully down, remove switch key and make sure impeller and auger have come to a complete stop before dismounting skid steer or tractor:

1. Complete Operating Checklist table provided above.
2. Inspect skid steer/tractor safety equipment to make sure it is in good working condition and that all safety alert decals are visible and readable. Replace all missing and unreadable safety alert decals.
3. Inspect hitch hook-up to Snow Blower. Make sure skid steer or tractor hitch is secured under the Snow Blower’s top angle bars, lock pins extend fully through bottom slots in Snow Blower hitch, and handles are locked down.

4. Inspect wiring harness and connection points before starting the machine. Make sure wire harness and connections are not pinched, frayed, or broken and that they will not come in contact with moving parts.
5. Inspect hydraulic hoses, fittings, and valves before starting the machine. Make sure hoses are not pinched, kinked, twisted, or frayed and that they will not come in contact with moving parts.
6. Check for and remove foreign objects wrapped around auger and impeller.
7. Check for bent, broken, and extreme wear on auger flighting and impeller. Repair or replace auger and impeller as required.
8. Check skid shoes for wear. Replace skid shoes as needed. See “**Outer Skid Shoe Option**” on page 30 for replacement instructions.
9. Verify skid shoes are set at the correct height. Refer to “**Outer Skid Shoe Adjustment**” or “**Inner Skid Shoe Adjustment**” on page 21.

Operational Safety Check

The remaining inspections are made with the skid steer or tractor engine running.

1. Start skid steer or tractor and set throttle to idle or slightly above idle.
2. Operate hydraulic controls to verify control lever movements function properly and equipment movements are correct.
3. Shut skid steer or tractor down properly and make any necessary changes to the controls before continuing.
4. Operate Snow Blower loader arms through their full range of movements to check for clearances. Refer to “**Check Equipment Clearances**” on page 13.



WARNING

Stop hydraulics immediately if auger or impeller makes contact with Snow Blower housing. Wait for impeller and auger to come to a complete stop before dismounting from skid steer or tractor to check for probable causes. Make necessary repairs before continuing on.

5. With skid steer throttle set to idle or slightly above idle, slowly engage hydraulics to the Snow Blower.
6. Once Snow Blower is running smoothly, increase impeller and auger speed. Disengage hydraulics immediately if any unusual sound or vibration is noticed.
 - a. Shut skid steer or tractor down properly and investigate cause of noise.
 - b. Make repairs before putting Snow Blower back into service.
7. Shut Snow Blower down after it has been operating smoothly at full speed for several minutes.
8. This completes the operational safety checks.



Section 5: Operating Instructions

General Safety Information

 **DANGER**

The operator should be a person who is responsible, physically capable, and properly trained to operate this Snow Blower. They should read and understand all instructions in this Operator's Manual. Anyone not properly trained and all children under the age of 16 should not operate this machine.

 **DANGER**

A crushing hazard always exists around equipment attached to a skid steer or tractor with loader arms. Loader arms and hydraulic cylinders can pinch and/or crush causing serious injury or death.

- The operator must know how to control the skid steer or tractor and how to stop it and attached equipment quickly in an emergency.
- Do not drive up to anyone standing in front of a fixed object such as a wall or bench. Never assume that the brakes will stop the machine in time.
- Never allow anyone to go near the attached equipment or under the unit when arms are raised.
- When equipped, sound horn before traveling in reverse. Drive at a slower speed to compensate for blind spots.

 **DANGER**

All guards and shields must be installed and in good working condition at all times during Snow Blower operation.

 **DANGER**

Always place skid steer/tractor in park or set park brake, disengage hydraulics, disengage PTO if tractor mounted, lower loader arms fully down, shut engine off, remove switch key, and wait for impeller and auger to come to a complete stop before dismounting from the skid steer or tractor.

 **DANGER**

Always operate attached implement while seated in the skid steer/tractor cab with Roll-Over Protective Structure (ROPS) and seat belt fastened around the operator. Operator can become pinched, crushed, or entangled if not seat belted in or if operating equipment from outside the cab.

 **DANGER**

Keep people and animals away from machinery while in operation. They can become entangled in the Snow Blower auger or be ran over by the skid steer/tractor and/or Snow Blower causing serious injury or death.

 **DANGER**

Make certain the Snow Blower is resting on the ground and all hydraulic pressure is relieved before disconnecting hydraulic fittings from the Snow Blower.

 **DANGER**

Always operate Snow Blower with skid steer/tractor flashing lights turned on. Be extremely careful blowing snow at night with rear bright lights on. Approaching traffic from either direction can mistake which traffic lane you are traveling in and your direction of travel.

 **DANGER**

Always secure underside of Snow Blower with solid supports before working under the unit. Never work under equipment supported by hydraulics. Hydraulics can drop equipment if controls are actuated or if hydraulic lines burst. Either situation can drop the Snow Blower instantly even when power to hydraulics is shut off.

 **DANGER**

Do not operate and/or travel across steep inclines where a skid steer or tractor can slip or roll-over causing serious injury or death. Consult your skid steer or tractor Operator's Manual for acceptable inclines the machine is capable of traveling across.

 **DANGER**

Hydraulic fluid under high pressure can penetrate skin. Wear protective gloves and safety glasses or goggles when working with hydraulic systems. Use a piece of cardboard or wood rather than hands when searching for hydraulic leaks. If hydraulic fluid is injected into the skin or eyes, it must be treated by a doctor familiar with this type of injury within a few hours or gangrene may result. DO NOT DELAY.

 **DANGER**

Always shut down hydraulics and wait for all rotating components to come to a complete stop before cleaning out a plugged discharge chute. The impeller blades are located just below the chute and will nip off body extremities and cause serious injuries or death even when using a stick or other object to unplug the chute.

 **DANGER**

Always shut down hydraulics and wait for all rotating components to come to a complete stop before attempting to unclog built-up snow from the auger or impeller, make adjustments, perform maintenance, or clean the Snow Blower. Rotating impeller, auger, and chain drive can cause serious bodily injury or death.

 **DANGER**

Never run gravel, crushed rock, or other solid objects through the Snow Blower. Doing so will result in an expensive breakdown. The Snow Blower is also capable of throwing solid objects at high speeds causing property damage and injury or death to animals and people.

Section 5: Operating Instructions

 **DANGER**

Never allow riders including children on the skid steer/tractor or Snow Blower. They can become entangled in the machinery or fall and be ran over causing serious injury or death.

 **DANGER**

Never work around or make contact with utilities such as gas lines, electrical lines, or other hazards that can cause serious injury or death from electrocution, explosion, or fire.

 **WARNING**

Always be aware of pedestrians and vehicle traffic. Move snow during low-traffic hours. Adjust chute to correct trajectory due to wind that will not create a driving hazard for all other vehicles. Always exercise safety, courtesy, and common sense.

 **WARNING**

Always dress to stay warm in cold weather. Use a skid steer or tractor equipped with a cab to help stay warm and to protect against cold blowing snow. Never allow your body or extremities to become too cold. Go inside to warm-up if you are getting too cold.

 **WARNING**

Always travel removing snow at a speed that allows the operator to be in control at all times and always be ready to make emergency stops. Snow removal speed will vary depending on depth of snow, snow moisture, and how tight the snow is compacted.

 **WARNING**

Beware of obstacles along side the skid steer/tractor while making turns when backing up. Never swing front of tractor or tractor mounted Snow Blower into fire hydrants, mailboxes, buildings, vehicles, fences, trees, or other standing obstacles.

 **WARNING**

Clear area to be worked of debris and other unforeseen removable objects before blowing snow. Mark any potential hazards that cannot be removed such as tree stumps, posts, rocks, holes, and drop-offs with a visible flag. The Snow Blower is capable of throwing solid objects at high speeds causing property damage and serious bodily injuries, or death to animals and people.

 **WARNING**

Do not remove snow from an icy surface unless skid steer or tractor is properly equipped for working on such a surface. Always proceed with caution when traveling on ice. An icy surface covered with snow will result in loss of traction and steering control.

 **WARNING**

Dress properly for the job. Do not wear loose fitting clothing or clothing with pull strings such as hooded sweat shirts. Also, keep long hair tucked in. Loose clothing, pull strings, and long hair can become entangled in rotating parts causing serious injury or death. Wear footwear that will improve footing on slippery surfaces. Always be sure of your footing and keep a firm hold on handles. Walk, never run.

 **WARNING**

Do not abuse equipment. Incorrect use of skid steer or tractor and Snow Blower can damage equipment structurally and cause serious injury or death.

- Check hook-up points frequently to make sure tractor hitch is properly positioned under the top angle bar, locking pins are seated in their notches, handles are locked down, and equipment is in good operating condition.
- Do not carry, lift loads, or use Snow Blower as a working platform. Doing so can cause serious injury or death.
- Do not use Snow Blower for pulling objects out of the ground, for digging into the ground, for prying other objects, or for pushing and towing other equipment.
- Do not use skid steer/tractor loader arms for lifting front end of the skid steer or tractor off the ground. Doing so can damage equipment and cause injury if exceeding lift capacity of unit.
- The parts on your Snow Blower have been specially designed and should only be replaced with genuine Land Pride parts. Altering the Snow Blower can adversely affect its performance and/or reliability.

 **WARNING**

Do not operate Snow Blower with auger flighting or impeller blades that are broken or bent making contact with the housing. Broken or bent flighting and blades can break loose at high speeds causing serious injury or death.

 **WARNING**

Do not operate Snow Blower with loose pins, bolts, and nuts. Loose hardware can result in a serious breakdown causing bodily injury or death.

 **WARNING**

If required, use back-up alarm to warn others you are backing up. Always comply with all federal, state, and local laws.

 **WARNING**

Keep people and animals away while removing snow. Never operate Snow Blower with chute throwing snow toward people, animals, or operator. The Snow Blower is capable of picking up large solid objects and discharging them at high speeds causing serious bodily injury or death.

Section 5: Operating Instructions

! WARNING

Keep body extremities, loose clothing, and pull strings away from hydraulically driven chute rotation. Especially keep away from sprocket teeth that can pinch and crush fingers and hands.

! WARNING

Never operate Snow Blower without good visibility and light. Use a skid steer or tractor equipped with a cab to keep snow from being blown by the wind into the operator's face.

! WARNING

Never pile snow where it obstructs visibility of traffic. Never pile snow near fire hydrants, mailboxes, water drains, shut-off valves, electrical boxes, and handicap parking areas.

! WARNING

Never remove snow that has been plowed. Plowed snow contains foreign particles such as dirt and rocks that can damage the unit and cause serious bodily injury or death.

! WARNING

Blow only fresh snow with the Snow Blower. Blowing other materials can damage the unit and cause serious bodily injury or death.

! CAUTION

Do not exceed Snow Blower specifications for maximum hydraulic pressure rating and gallons per minute rating. Personal injury and/or machine damage can occur.

IMPORTANT: Never operate Snow Blower with chute throwing snow toward property such as vehicles and buildings that can be scratched, dented, or broken by solid objects hitting them.

IMPORTANT: Do not use Snow Blower as a Box Scraper or to blow other materials. Doing so can break the auger, impeller, and cause structural damage to the unit.

NOTE: Always check with local codes to know where snow can be legally piled. Never pile snow on someone else's property, streets, or sidewalks.

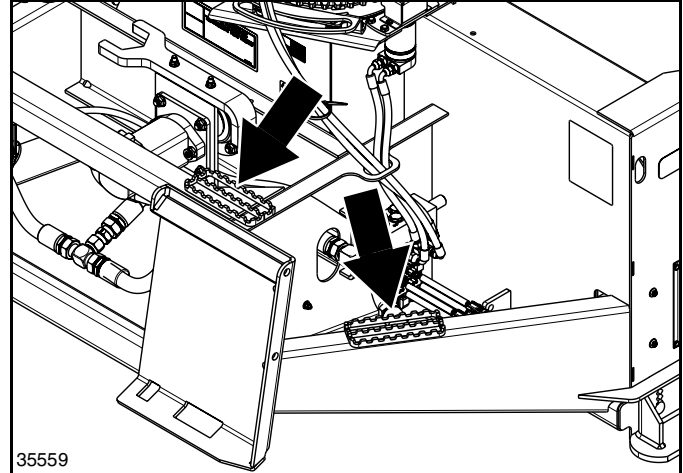

Safety Steps
Figure 5-1

Mounting & Dismounting Skid Steer

Refer to Figure 5-1:

! WARNING

Use stepping pads, grab-handles, and anti-slip surfaces when getting on or off the skid steer. Using unapproved surfaces and handles to mount and dismount can result in a falling hazard and cause serious injury or death.

Transporting

! WARNING

Follow all safety precautions when transporting. Not using safe transporting methods can damage the equipment and cause death or serious injury.

- Always transport with attached equipment low to the ground to maintain stability of the skid steer or tractor.
- Always travel straight up and straight down inclines. Make turns only on level ground.
- Keep equipment away from electrical power lines. Place an orange warning sign under overhead electrical power lines indicating type of danger above.
- Transporting loads across inclines, over ramps, grades, bumpy, soft, or slippery surfaces reduces machine stability. Transporting in these conditions is extremely dangerous.
- When traveling on public roads at night or during the day, use accessory lights and devices for adequate warning to operators of other vehicles. Comply with all federal, state, and local laws.
- When traveling on roadways, transport in such a way that faster moving vehicles may pass you safely.
- Limit maximum transport speed to 20 mph. Reduce ground speed when turning and leave enough clearance so Snow Blower does not contact obstacles such as buildings, trees, or fences.

Section 5: Operating Instructions

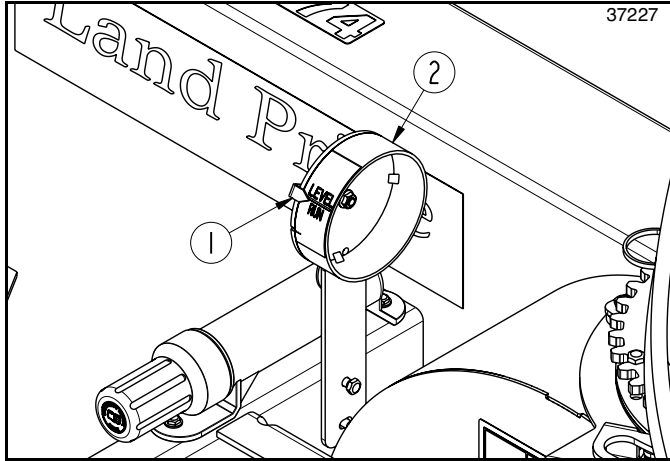

Reading Level Run Indicator
Figure 5-2

Leveling The Snow Blower

Refer to Figure 5-2:

The level run indicator (#2) helps the operator to verify the Snow Blower is operating parallel to the ground.

NOTE: Most tractor loaders have a leveling rod that can be used in lieu of the level run indicator. Refer to your tractor loader manual to properly adjust the leveling rod. Leveling rod must be adjusted to operate the Snow Blower parallel to the ground.

IMPORTANT: The level run indicator must be adjusted correctly before using it. Refer to “**Level Run Indicator Adjustment**” on page 22.

1. Stop skid steer/tractor on a flat level surface and lower loader arms until Snow Blower is close to ground.
2. Extend or retract hydraulic cylinders on the end of the skid steer/tractor loader arms until the indicator arrow (#1) points to “LEVEL RUN”
3. Lower Snow Blower until it is resting on its skid shoes and make any final adjustments necessary to make sure the indicator arrow (#1) still points to “LEVEL RUN”

IMPORTANT: The indicator arrow (#1) should point to “LEVEL RUN” when parked on flat level ground and Snow Blower is sitting on the ground. It is normal for the indicator arrow to move from “LEVEL RUN” during operation. **DO NOT** readjust hitch angle. Doing so can cause the auger to contact the ground and damage it.

4. Once set, **DO NOT** change position of the hydraulic cylinders on the end of the skid steer/tractor loader arms. See important note above.
5. Repeat steps 1 thru 4 if skid shoes are readjusted or if hydraulic cylinders on end of skid steer/tractor loader arms have been moved.

General Operator Instructions

It is important that you familiarize yourself with the Operator’s Manual, properly attach the Snow Blower to your skid steer or tractor front loader, completed the operating checklist and pre-operating safety check before running the operational safety check.

You will want to park on a flat level surface and level your Snow Blower to operate parallel to the ground before making any operational safety checks or removing snow. If you have not leveled the Snow Blower, please complete this procedure before continuing.

If you detect a malfunction in either your Snow Blower or skid steer/tractor during the operational safety check, immediately shut skid steer or tractor off, remove switch key, and make all necessary repairs and adjustments before continuing.

Before starting the skid steer or tractor, make sure your machine is in park or in neutral and the park brake is set. Turn hydraulic function off. If Snow Blower is tractor mounted and powered by a rear mounted Hydraulic Reservoir System (HRS), disengage tractor PTO to the HRS.

IMPORTANT: Set loader arms to float before blowing snow. The skid shoes can have increased wear if loader arms are rigid.

With your Snow Blower resting on the ground and loader arms set to float, start your skid steer or tractor and set engine throttle speed at a low idle. Engage PTO if tractor mounted with a rear mounted HRS. Turn hydraulics to the Snow Blower on. If everything is running smoothly at a low idle, slowly increase skid steer/tractor engine RPM until the Snow Blower reaches full operating speed. If everything is still running smoothly, return engine to low idle, turn hydraulic function to off, and when applicable, disengage PTO.

You should now be ready to transport to your snow blowing site at a safe ground speed. On roadways transport in such a manner that faster moving vehicles can easily see you and pass you safely. Reduce your speed when travelling over rough and hilly terrain. Avoid quick or sharp steering corrections. Take extra care to ensure that the Snow Blower doesn’t come into contact with obstacles such as trees, buildings, or fences. Use accessory lights and appropriate reflective devices to provide adequate warning to pedestrians and other vehicle operators when traveling on public roads and in the dark of night. Comply with all local, state, and federal laws.

It is important that you know the area where snow is to be removed and what lies beneath the snow. If possible, survey the area ahead of the snow. Remove all possible obstructions and mark any obstructions that cannot be removed with flags that project above the snow. If you are unfamiliar with the area, ask someone who can identify hidden obstructions so that you can mark them with a flag. Flag manholes, water meters, gas meters, culvert



Section 5: Operating Instructions

edges, fire hydrants, stumps, and other obstructions that are not easily seen. It really pays to inspect a new area and to develop a safe plan before moving snow.

Determine how close to the ground the Snow Blower can be operated. Set skid shoes to hold the Snow Blower off the ground at a predetermined height. Surfaces with gravel or crushed rock will require a higher setting than hard flat surfaces such as asphalt and concrete. Never set Snow Blower so low as to pick-up gravel and/or rock.

Determine wind direction and devise a removal plan that will allow wind to carry blown snow away from the operator. Snow discharged out the Snow Blower and blown back at you will obstruct your view and can totally block your vision of work.

Determine direction to blow snow that will not create a driving hazard for other vehicles and rotate chute to blow snow in that direction. To minimize work, do not blow snow over an area that has already been cleared of snow and never rotate chute to blow snow toward the skid steer/tractor and/or operator as hard objects can be thrown from the discharge chute.

Set spout deflector angle. The angle will vary depending on how far snow is to be blown, how light and fluffy the snow is, and how wet and heavy it is.

Some adjustments to the chute rotation, spout deflector angle, and skid shoe height may be necessary after traveling a few feet. If you need to get off the skid steer or tractor to make adjustments, you must stop your machine, turn hydraulic functions off, disengage PTO when applicable, place skid steer/tractor in park or in neutral with park brake set, shut engine off, remove switch key, and wait for all components to come to a complete stop before dismounting your skid steer/tractor.

It is now time to position your Snow Blower at your starting point. Once there, stop travelling and lower Snow Blower down onto its skid shoes.

Set throttle at an idle speed, engage PTO if tractor mounted, and turn hydraulic function on. Listen for unusual clicking or knocking sounds as the auger and impeller start rotating. If everything sounds fine increase engine speed to a recommended operating speed. If an unusual sound is heard, shut your machine down immediately, investigate the cause, and make necessary repairs before continuing.

Start traveling forward while blowing snow. Always blow

snow while traveling at a speed that will allow you to be in control at all times. Change speed if travel speed is too fast. Only change to a higher speed if you are certain it will be safe. The heavier and deeper the snow the slower you will need to travel. If your unit is tractor mounted and powered with a rear mount HRS, maintain recommended PTO speed and use a lower gear selection to maintain proper travel speed. If your unit is skid steer mounted, you should set your high/low gear selection in the low range and vary your engine speed to maintain proper travel speed.

Do not use rear view mirrors to view direction of travel while backing up. Instead, turn your head to look where you are traveling. It is very important that you get a full field of view to prevent an accident.

Beware of obstacles along side your machine while making turns traveling forward and backing-up. Never swing the Snow Blower into fire hydrants, mailboxes, buildings, vehicles, fences, trees, or other standing obstacles. Shift to a lower gear when possible and travel very slow when in a tight situation to allow time to react. Stop your skid steer or tractor before hitting an obstacle.

Once you have reached end of travel, stop your skid steer or tractor, raise the Snow Blower up, and return to the front of your work to make another run at blowing snow. It is not necessary to disengage hydraulics while returning to the front of your work.

Once at the front, line up your Snow Blower with your next starting point, lower unit down onto its skid shoes until all pressure is off the loader arms, and begin traveling forward blowing snow.

With a little practice you will be pleased with what you and your Land Pride Snow Blower can do. Whether you are done blowing snow, need to take a break, or just need to make a few adjustments to the Snow Blower, remember to always do the following:

- Reduce engine rpm
- Shut hydraulic functions off
- Disengage PTO if tractor mounted
- Stop on level ground and set park brake
- Turn off the engine and remove the key
- Stay on the tractor until the Snow Blower auger and rotor have come to a complete stop.

Section 6: Maintenance & Lubrication

General Maintenance Information

Proper servicing and adjustments are key to the long life of any implement. With careful inspection and routine maintenance, you can avoid costly downtime and repair.

Check all bolts after using unit for several hours to be sure they are tight. Replace any worn, damaged, or illegible safety labels by obtaining new labels from your Land Pride dealer.

The parts on your Snow Blower have been specially designed and should only be replaced with genuine Land Pride parts. Do not alter the Snow Blower in a way which will adversely affect its performance.

Tractor/Skid Steer Maintenance

One of the most important things you can do to prevent hydraulic system problems is ensure that your hydraulic oil remains free of dirt and contamination.

Use a clean cloth to wipe hose couplings before attaching them to your machine and replace hydraulic filter elements at the prescribed intervals. These simple steps will go a long way to prevent control valve and hydraulic cylinder problems.

Auger & Impeller Inspection

Refer to Figure 6-1:

1. Check 2"-12 impeller nut (#3) for tightness. If loose, tighten jam nut with wrench (#1). When finished, secure wrench to housing with flange lock nuts (#2).

Refer to Figure 6-2:

2. Check impellers (#1) for wear, structural cracks, and breakage. Repair or replace impeller before it causes structural damage to Snow Blower housing.
3. Check for bent impeller blades (#1) that are making contact or are about to make contact with Snow Blower housing. Repair or replace impeller before it causes structural damage to Snow Blower housing.
4. Check auger flighting (#3) and auger paddles (#2) for wear, structural cracks, bending, and breakage. Repair or replace auger before components break-off and are sent into the impeller or through the air.
5. Check end bearing (#5) for wear. Replace bearings that are worn excessively.
6. Lubricate bearings as required. See lubrication schedule for "**Auger Flange Bearing**" on page 32.
7. Check bearing mounting bolts (#4) for tightness. Make certain they are tightened to the correct torque.
8. **Refer to Figure 6-3:** Check motor mounting bolts (#2 & #5) for tightness. If needed, tighten bolts as follows:
 - a. Remove nuts (#4), bolts (#3), & motor cover (#1).
 - b. Tighten 1/2"-13 GR5 bolts (#2 & #5) to the correct torque as needed.
 - c. Reattach motor cover (#1) with existing 1/4"-20 GR5 bolts (#3) and hex lock nuts (#4). Tighten lock nuts to the correct torque.

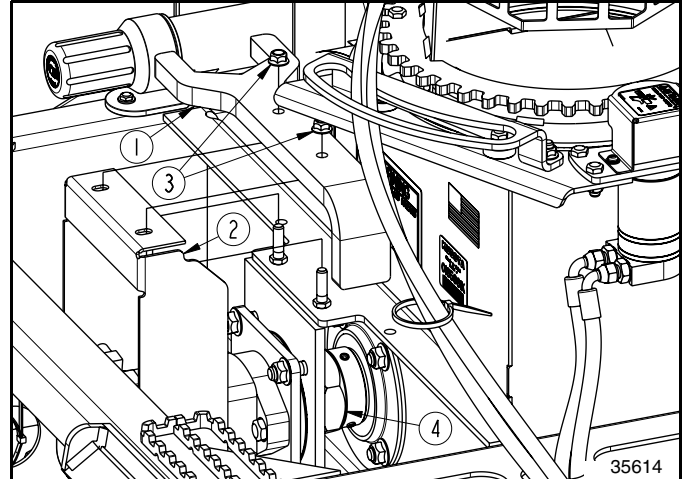

Impeller Inspection
Figure 6-1

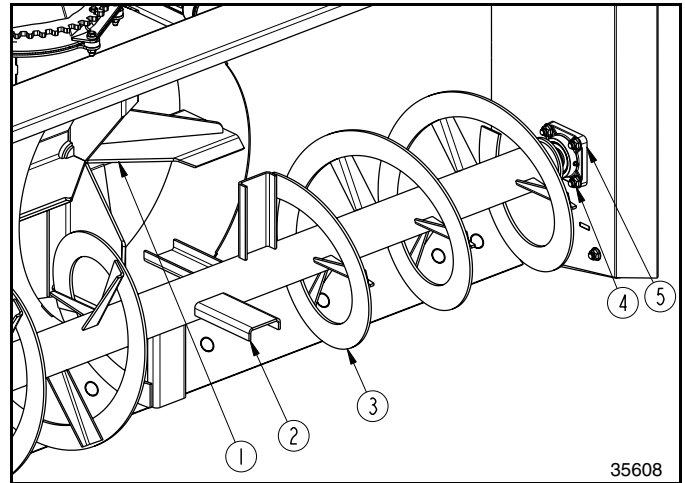

Auger & Impeller Inspection
Figure 6-2

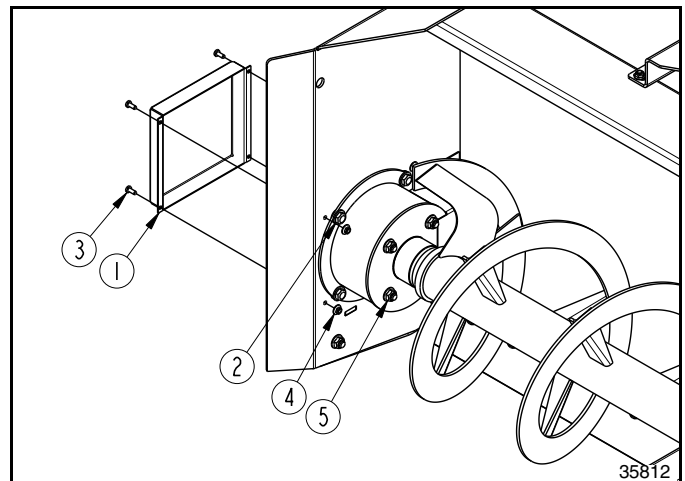

Motor Mount Inspection
Figure 6-3

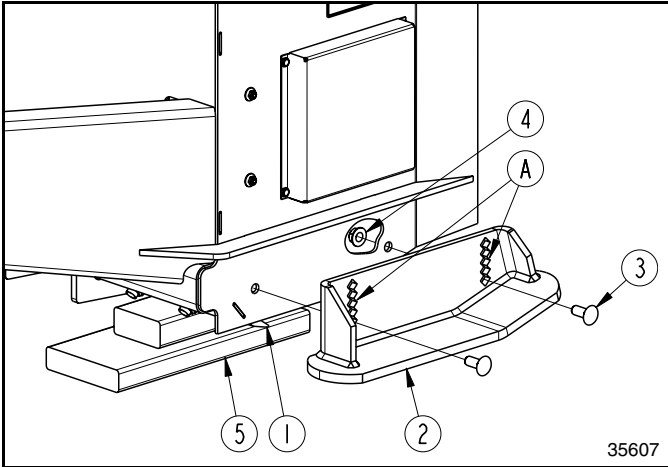

Outer Skid Shoe Replacement
Figure 6-4

Outer Skid Shoe Option

Refer to Figure 6-4:

Outer Skid Shoe Part Numbers	
Part No.	Part Description
370-436H	OUTER RIGHT-HAND SKID SHOE SBL66
370-437H	OUTER LEFT-HAND SKID SHOE SBL66
370-449H	OUTER RIGHT-HAND SKID SHOE SBL74/84
370-450H	OUTER LEFT-HAND SKID SHOE SBL74/84

Inspect outer skid shoes for wear and replace as needed.

1. Park on a level solid surface, place skid steer/tractor in park or neutral with park brake set, lower Snow Blower until it is approximately 6" above ground, disengage hydraulics, and wait for all components to stop rotating before dismounting skid steer/tractor.
2. Place 1 1/2" to 3" thick support block(s) (#5) under the grader blade (#1) near the right-hand and left-hand skid shoes (#2).
3. Return to the skid steer/tractor and lower the Snow Blower onto the support blocks (#5), shut engine off and remove switch key. Wait for all components to stop rotating before dismounting skid steer/tractor.
4. Count & record number of square holes "A" from top down to the holes carriage bolts (#3) are located.
5. Remove hex nuts (#4), carriage bolts (#3), and right-hand skid shoe (#2). Discard skid shoe and save hardware for reattachment of new skid shoe.
6. Using the recorded number in step 4 above, insert 1/2"-13 x 1 1/4" GR5 carriage bolts (#3) through square holes "A" in skid shoe (#2) and the Snow Blower side panel. Secure carriage bolts with hex flange lock nuts (#4).
7. Tighten lock nuts (#4) to the correct torque.
8. Repeat steps 4 to 7 above for left-hand skid shoe.
9. If skid shoes need readjusting, refer to "Outer Skid Shoe Adjustment" on page 21.

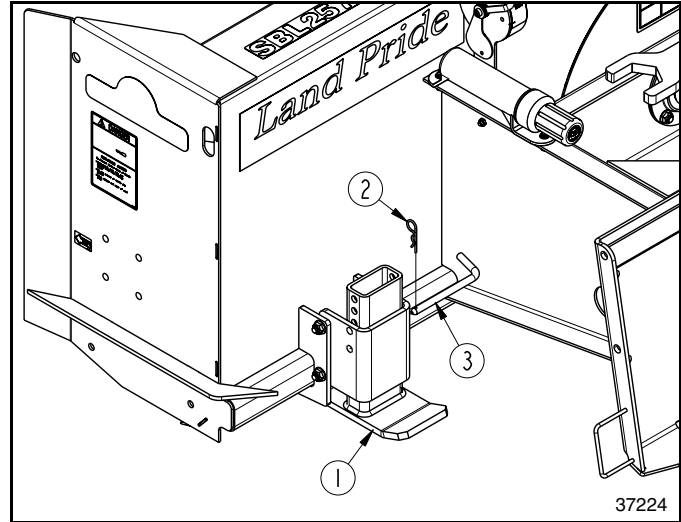

Outer Skid Shoe Assembly
Figure 6-5

Inner Skid Shoe Option

Refer to Figure 6-5:

Inner Skid Shoe Part Numbers	
Part No.	Part Description
370-439H	INNER SKID SHOE

Inspect inner skid shoes for wear and replace as needed.

1. Park on a level solid surface, place skid steer/tractor in park, and lower both ends of grader blade onto support blocks or jack stands that are, at a minimum, 8 1/2" high.
2. Shut skid steer/tractor engine off and remove switch key.
3. On the left-hand side, remove hairpin cotter (#2), bent pin (#3), and inner skid shoe (#1).
4. Reinsert new inner skid shoe (#1).
5. Insert bent pin (#3) thru the same holes in the skid shoe mount and new skid shoe that it was removed from.
6. Secure bent pin with hairpin cotter (#2).
7. Repeat steps 3 & 4 for the right-hand side.
8. If skid shoes need readjusting, refer to "Inner Skid Shoe Adjustment" on page 21.

Section 6: Maintenance & Lubrication

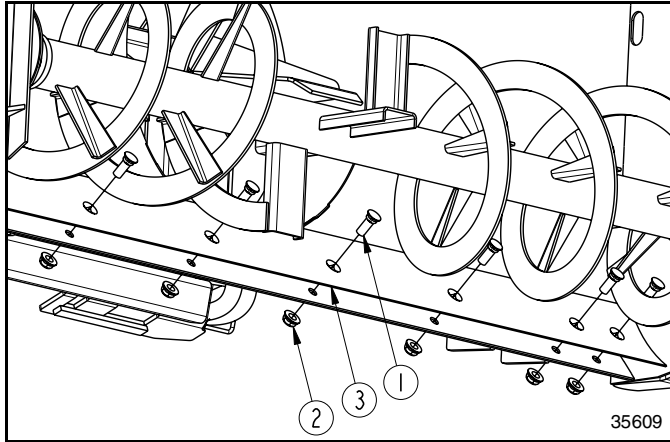

Grader Blade Replacement
Figure 6-6

Grader Blade

Refer to Figure 6-6:

Grader Blade Part Numbers		
Part No.	Part Description	
1. 802-206C	PLOW 5/8"-11 x 1 3/4" GR5	
2. 803-263C	NUT HEX FLANGE LOCK 5/8"-11 PLT	
3. 820-042C	SBL2566: GRADER BLADE 1/2" x 6" x 65 1/2"	
3. 820-477C	SBL2574: GRADER BLADE 1/2" x 6" x 73 1/2"	
3. 820-046C	SBL2584: GRADER BLADE 1/2" x 6" x 83 1/2"	

NOTE: When front edge of grader blade (#3) is worn excessively, it can be rotated 180° and reused to extend its wear life.

Inspect cutting edge of grader blade and plow bolts for wear and rotate 180° or replace as needed. Make sure grader blade is replaced before auger housing becomes exposed to wear.

1. Remove hex flange lock nuts (#2), plow bolts (#1), and grader blade (#3).
2. Attach new or rotated grader blade (#3) to bottom of Snow Blower frame with existing/new plow bolts (#1) and hex flange lock nuts (#2).
3. Tighten lock nuts to the correct torque.

Long Term Storage

Clean, inspect, service, and make necessary repairs to the Snow Blower when parking it for long periods and when parking it at the end of a working season. This will help ensure the Snow Blower is ready for field use the next time you hook-up to it.

DANGER

Always disconnect driveline from tractor PTO before servicing drive train components or underside of unit. Snow Blower can be engaged if tractor is started causing bodily injury or death.

DANGER

Always secure Snow Blower in the up position with solid supports before servicing underside of Snow Blower. Never work under equipment supported by hydraulics. Hydraulics can drop equipment if controls are actuated or if hydraulic lines burst. Either situation can drop the Snow Blower instantly even when power to hydraulics is shut off.

1. Clean off any dirt and grease that may have accumulated on the Snow Blower and moving parts, and then wash surface thoroughly with a garden hose.
2. Check impeller, auger, wear bars, and skid shoes for wear and breaks. Repair or replace if necessary. See "Auger & Impeller Inspection" on page 29.
3. Inspect for loose, damaged, or worn parts. Make adjustments, repairs, and/or replace as needed.
4. Repaint parts where paint is worn or scratched to prevent rust. Ask your Land Pride dealer for aerosol touch-up paint. Paint is also available in touch-up bottles with brush, quarts, and gallon sizes by adding TU, QT, or GL to the end of the aerosol part number.

Land Pride Aerosol Touch-up Paint

Part No.	Part Description
821-011C	PAINT LP BEIGE AEROSOL SPRAY CAN
821-002C	PAINT LP BLACK AEROSOL SPRAY CAN
821-066C	PAINT ORANGE AEROSOL SPRAY CAN

5. Replace all damaged or missing decals.
6. Lubricate as noted under "Lubrication" on page 32.
7. Apply a coating of oil to the areas without paint due to high wear to minimize oxidation.
8. Store Snow Blower on a level surface in a clean, dry place. Inside storage will reduce maintenance and make for a longer Snow Blower life.
9. Follow all "Unhooking The Snow Blower" instructions on page 14 when disconnecting Snow Blower from skid steer/tractor.

Ordering Replacement Parts

Land Pride offers equipment in factory standard beige with black highlights. Equipment may also be purchased in orange. Special attention must be given to the part number to prevent ordering the wrong color. A suffix number corresponding to one of the colors below must be added at the end of the part number. Parts ordered without the suffix number will be supplied in factory standard colors.





82 Orange

85 Black



For example, if you are ordering a replacement part with part number 555-555C and the existing part is orange, then add the suffix 82 to the end of the number to make the part number read 555-555C82.

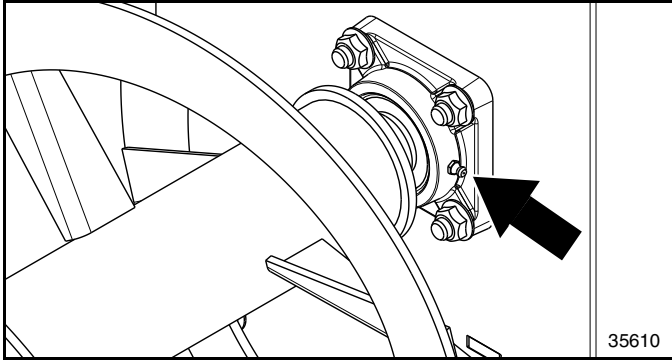

Lubrication

Lubrication Legend	 Multi-purpose spray lube	 Multi-purpose grease lube	 Multi-purpose oil lube	 50 Hrs	Intervals in hours at which lubrication is required



	 10 Hours
---	---

Auger Flange Bearing

1 - Zerk: Left Side

Type of Lubrication: Multi-purpose Grease

Quantity = As needed



SBL25 Series Snow Blowers With S/N 891531+

List	Specifications & Capacities		
Model No.	Model SBL2566	Model SBL2574	Model SBL2584
Working Width	66"	74"	84"
Overall Width	71 1/2"	79 1/2"	89 1/2"
Weight with outside skid shoes, case drain line, couplings, & hydraulic motor	816 lbs	938 lbs	988 lbs
Drive and Control System	Hydraulic motors with electric over hydraulic		
Hydraulic Requirements:			
Low Volume Motor Option	12 - 19 GPM		
Medium Volume Motor Option	20 - 26 GPM		
High Volume Motor Option	27 - 33 GPM		
Hydraulic Pressure Rating	2500 - 3500 psi		
Hitch	Skid steer/loader mounting plate		
Main Housing Material	10 Gauge		
Side Plate Material	3/16"		
Chute Opening at the Base	11"	16"	
Impeller Housing Depth	11"		11"
Impeller Diameter	24"		24"
Number of Impeller Blades	4		4
Auger Diameter	11"		16"
Number of Auger Paddles	4		4
Cutting edge	Bolt-on, reversible, and replaceable full-length cutting edge		
Skid Shoes	Bolt-on, adjustable & replaceable		
Chute Rotation	220 Degrees (Hydraulically driven sprocket)		
Spout Deflector	Hydraulic operation		
Spout Deflector Cylinder	Double acting 2" x 4" x 1 1/2" rod		

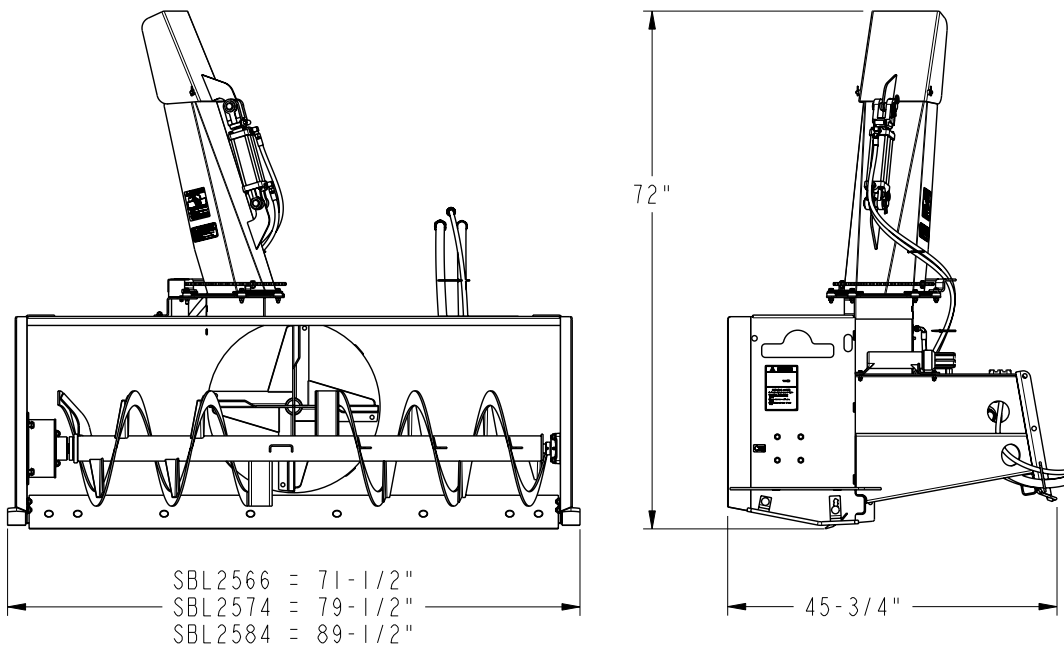



SBL25 Series Snow Blowers With S/N 891531+

Features	Benefits
Large main housing	Ability to handle large drifts.
Large impeller diameter	The ability to move and throw material farther.
Level run indicator (Patent-Pending)	Operator can visually verify the Snow Blower is properly leveled before each use. Protects against tilting the auger into concrete/paved surfaces.
Hydraulically operated deflector spout	Allows operator to change end of spout up or down from the seat to direct blown snow up close or far away.
Hydraulically operated chute rotation with sprocket drive	Allows operator to change direction of snow discharge from the seat. Sprocket drive is built to last.
Bolt-on reversible and replaceable cutting edge	Improves service life of Snow Blower by protecting the unit from bottom wear and absorbing some of the shock when hitting solid objects. The blade can be rotated 180° to double its life and can be replaced when both edges are worn out.
Greaseable auger end bearing	Less drag on the power train and extends life of unit.
Sprocket driven chute rotator	Allows operator to change chute rotation angle within a 220° discharge pattern.
3/8" Auger Flighting	Stands up to severe use.
Options	
Quality hydraulic motor available in low, medium, or high volume flow	Provides long life, durable construction. Three flow options allows this Snow Blower to fit many skid steer/tractors.
Bolted-on outer skid shoes	Supports cutting edge above paved, gravel, and rocky surfaces. They are adjustable and replaceable.
Inner skid shoes secured with a bent pin.	Supports cutting edge above paved, gravel, and rocky surfaces. Bent pin makes it easy to change skid shoe height and replace.



Troubleshooting Chart

Problem	Cause	Solution
Auger and/or impeller stalls (will not turn)	Obstacles are entangled in auger and/or blower housing.	Shut Snow Blower down and manually clear auger and impeller housing.
	Impeller jam nut is loose.	Tighten impeller jam nut.
	Quick couplings did not engage.	Reconnect quick couplings to skid steer.
	Hydraulic system is not engaged.	Engage hydraulic system.
	Hydraulic flow from skid steer or tractor rear mounted hydraulic reservoir is inadequate.	Check hydraulic flow at the Snow Blower.
	Skid steer or tractor rear mounted hydraulic reservoir is low on hydraulic fluid.	Add hydraulic oil to skid steer or tractor rear mounted hydraulic reservoir.
	Hydraulic hose has a break.	Replace hydraulic hose.
	Hydraulic hose has an obstruction.	Remove obstruction or replace hose.
	Hydraulic line is pinched.	Fix pinched line.
	Hydraulic lines have air in them.	Engage hydraulics to Snow Blower until air is purged from hydraulic lines.
Bottom of auger housing is wearing.	Grader blade is worn.	Reverse or replace grader blade.
Discharge chute won't rotate	Ice build-up around base of discharge chute.	Remove ice.
	Wire harness connections are loose.	Reconnect wire harness connections.
	Solenoid is not operating properly.	Have solenoid inspected and repaired.
	Hydraulics problems	Refer to hydraulic problems for: "Auger and/or impeller stalls"
Discharge chute is plugging	Ground speed is too fast.	Decrease ground speed.
	Auger motor speed is too fast.	Decrease motor speed at the flow control valve.
Discharge chute throws snow at the operator	Rotational stop bolts are on the wrong side of the rotational stop.	Remove rotational stop. Rotate chute to throw snow straight forward. Reattach rotational stop.
Discharge spout does not throw snow the preferred distance	Discharge spout is set at the wrong angle.	Extend hydraulic cylinder to shorten throwing distance. Retract hydraulic cylinder to lengthen throwing distance.
Impeller is throwing small amounts of snow	Not enough snow to fill the impeller.	This is normal when clearing snow fall that is not very deep.
	Auger motor speed is too slow.	Increase motor speed at the flow control valve.
	Ground speed is too slow.	Increase ground speed.
Hydraulic motor is leaking oil	Hydraulic motor seals are blown.	Have the hydraulic motor with leaky seals repaired.
Skid shoes are wearing too fast	Loader arms are not set to float.	Set loader arms in float position.
	Snow Blower is not parallel to ground.	Level Snow Blower.
Snow Blower makes intermittent clicking noise	Impeller jam nut is loose.	Tighten impeller jam nut.
	Auger flighting is bent or broken.	Repair or replace damaged auger.
	Impeller blades are bent or broken.	Repair or replace damaged impeller blades.
Snow Blower makes excessive noises or vibrates excessively	Auger is contacting the ground.	Adjust Snow Blower to operate level. (Parallel with the ground.)
	Blowing dirty snow or refrozen melted snow.	Blow only clean fresh snow.
	Picking up road gravel and/or crushed rock.	Lower skid shoes to carry grader blade above road gravel and crushed rock.
	Obstacles are entangled in auger and/or impeller housing.	Shut Snow Blower down and manually clear auger and/or impeller housing.
	End bearing is worn or damaged.	Replace end bearing.
	Auger is bent or broken.	Repair or replace damaged auger.
	Impeller blades are bent or broken.	Repair or replace damaged blades.
Snow is left on the ground	Skid shoes are set too low.	Raise skid shoes up.



Torque Values Chart for Common Bolt Sizes													
Bolt Size (inches)	Bolt Head Identification						Bolt Size (Metric)	Bolt Head Identification					
	Grade 2		Grade 5		Grade 8			Class 5.8		Class 8.8		Class 10.9	
in-tpi ¹	N · m ²	ft-lb ³	N · m	ft-lb	N · m	ft-lb	mm x pitch ⁴	N · m	ft-lb	N · m	ft-lb	N · m	ft-lb
1/4" - 20	7.4	5.6	11	8	16	12	M 5 X 0.8	4	3	6	5	9	7
1/4" - 28	8.5	6	13	10	18	14	M 6 X 1	7	5	11	8	15	11
5/16" - 18	15	11	24	17	33	25	M 8 X 1.25	17	12	26	19	36	27
5/16" - 24	17	13	26	19	37	27	M 8 X 1	18	13	28	21	39	29
3/8" - 16	27	20	42	31	59	44	M10 X 1.5	33	24	52	39	72	53
3/8" - 24	31	22	47	35	67	49	M10 X 0.75	39	29	61	45	85	62
7/16" - 14	43	32	67	49	95	70	M12 X 1.75	58	42	91	67	125	93
7/16" - 20	49	36	75	55	105	78	M12 X 1.5	60	44	95	70	130	97
1/2" - 13	66	49	105	76	145	105	M12 X 1	90	66	105	77	145	105
1/2" - 20	75	55	115	85	165	120	M14 X 2	92	68	145	105	200	150
9/16" - 12	95	70	150	110	210	155	M14 X 1.5	99	73	155	115	215	160
9/16" - 18	105	79	165	120	235	170	M16 X 2	145	105	225	165	315	230
5/8" - 11	130	97	205	150	285	210	M16 X 1.5	155	115	240	180	335	245
5/8" - 18	150	110	230	170	325	240	M18 X 2.5	195	145	310	230	405	300
3/4" - 10	235	170	360	265	510	375	M18 X 1.5	220	165	350	260	485	355
3/4" - 16	260	190	405	295	570	420	M20 X 2.5	280	205	440	325	610	450
7/8" - 9	225	165	585	430	820	605	M20 X 1.5	310	230	650	480	900	665
7/8" - 14	250	185	640	475	905	670	M24 X 3	480	355	760	560	1050	780
1" - 8	340	250	875	645	1230	910	M24 X 2	525	390	830	610	1150	845
1" - 12	370	275	955	705	1350	995	M30 X 3.5	960	705	1510	1120	2100	1550
1-1/8" - 7	480	355	1080	795	1750	1290	M30 X 2	1060	785	1680	1240	2320	1710
1-1/8" - 12	540	395	1210	890	1960	1440	M36 X 3.5	1730	1270	2650	1950	3660	2700
1-1/4" - 7	680	500	1520	1120	2460	1820	M36 X 2	1880	1380	2960	2190	4100	3220
1-1/4" - 12	750	555	1680	1240	2730	2010	¹ in-tpi = nominal thread diameter in inches-threads per inch ² N · m = newton-meters ³ ft-lb= foot pounds ⁴ mm x pitch = nominal thread diameter in millimeters x thread pitch						
1-3/8" - 6	890	655	1990	1470	3230	2380							
1-3/8" - 12	1010	745	2270	1670	3680	2710							
1-1/2" - 6	1180	870	2640	1950	4290	3160							
1-1/2" - 12	1330	980	2970	2190	4820	3560							

Torque tolerance + 0%, -15% of torquing values. Unless otherwise specified use torque values listed above.

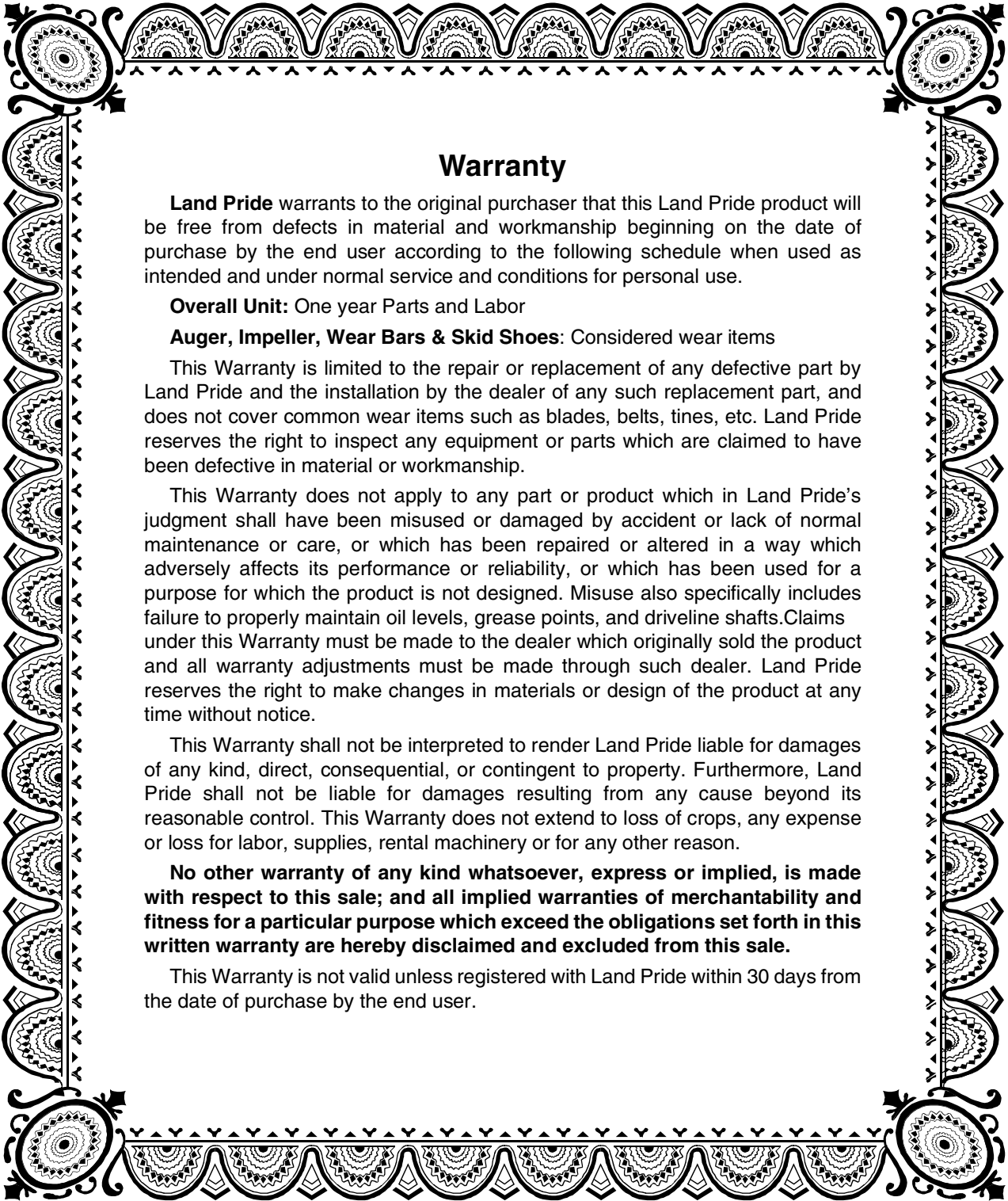

Warranty

Land Pride warrants to the original purchaser that this Land Pride product will be free from defects in material and workmanship beginning on the date of purchase by the end user according to the following schedule when used as intended and under normal service and conditions for personal use.

Overall Unit: One year Parts and Labor

Auger, Impeller, Wear Bars & Skid Shoes: Considered wear items

This Warranty is limited to the repair or replacement of any defective part by Land Pride and the installation by the dealer of any such replacement part, and does not cover common wear items such as blades, belts, tines, etc. Land Pride reserves the right to inspect any equipment or parts which are claimed to have been defective in material or workmanship.

This Warranty does not apply to any part or product which in Land Pride's judgment shall have been misused or damaged by accident or lack of normal maintenance or care, or which has been repaired or altered in a way which adversely affects its performance or reliability, or which has been used for a purpose for which the product is not designed. Misuse also specifically includes failure to properly maintain oil levels, grease points, and driveline shafts. Claims under this Warranty must be made to the dealer which originally sold the product and all warranty adjustments must be made through such dealer. Land Pride reserves the right to make changes in materials or design of the product at any time without notice.

This Warranty shall not be interpreted to render Land Pride liable for damages of any kind, direct, consequential, or contingent to property. Furthermore, Land Pride shall not be liable for damages resulting from any cause beyond its reasonable control. This Warranty does not extend to loss of crops, any expense or loss for labor, supplies, rental machinery or for any other reason.

No other warranty of any kind whatsoever, express or implied, is made with respect to this sale; and all implied warranties of merchantability and fitness for a particular purpose which exceed the obligations set forth in this written warranty are hereby disclaimed and excluded from this sale.

This Warranty is not valid unless registered with Land Pride within 30 days from the date of purchase by the end user.

IMPORTANT: The Online Warranty Registration should be completed by the dealer at the time of purchase. This information is necessary to provide you with quality customer service.

Model Number _____

Serial Number _____



Corporate Office: P.O. Box 5060
Salina, Kansas 67402-5060 USA
www.landpride.com
