

## PUC 2720 Pole silver

Article number (SKU)  
Colour

7227204  
Silver

### Key Benefits

- Cable management
- Modular

The poles are the connection between the floor base and display interface and are available in 3 different lengths, 150cm, 180cm and 200 cm. The poles are provided with a multiple cable management (CIS®) and can be combined with all Connect-it accessories. The PUC 27xx Series can only be used in combination with the floor solutions.

Vogel's Connect-it floor solutions (floor stands and trolleys) is an uniquely flexible system. With only a few standard components, you can create a solution for almost any requirement. From a single display floor stand in a shop window, a back-to-back display set-up in an airport, to a movable video conferencing set-up for corporate use, the flexible Connect-it floor solutions line fits every situation. Connect-it floor solutions can accommodate displays from small to extra large, weighing up to 160 kg. Connect-it floor modules are available in black and silver to fit any interior décor.

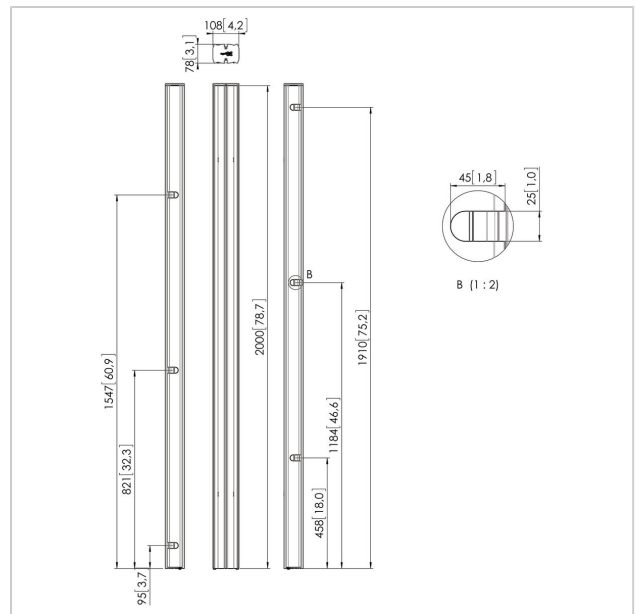



## PUC 2720 Pole silver

[www.vogels.com](http://www.vogels.com)

VOGEL'S HOLDING BV 2019 (c) All rights reserved.  
Subject to printing errors, technical and price amendments.  
Date:2019-05-10

## Specifications

Product type number	PUC 2720
Article number (SKU)	7227204
Colour	Silver
EAN single box	8712285323720
Length	2000
TÜV certified	Yes
Guarantee	5 years
Back-to-back displays	True
Connect It exceptions	2x if inches gte 65

