



# Ultra Low NOx Atmospheric Vent Water Heaters with Direct Spark Ignition and ICON CONTROL



# SERVICE MANUAL

Troubleshooting Guide  
and Instructions for Service

(To be performed ONLY by  
qualified service providers)

## Models Covered by This Manual:

UCG80H125(N,X)  
UCG(80,100)H199\*(N,X)(A)  
UCG(80,100)H270\*(N,X)(A)  
UCG(80,100)H399\*(N,X)  
(\* Denotes Warranty Years)

**Effective: February, 2021**  
**ECO 8323**



As required by the state of California Proposition 65.

# Ultra Low NOx Atmospheric Vent Water Heaters with Direct Spark Ignition

---

## Table of Contents

Serial Number Breakdown.....	3
How to Use This Manual .....	4
Tools Required for Service .....	5
Specifications .....	6
Sequence of Operation .....	9
Troubleshooting .....	13
Service Procedure I: Thermostat Circuit Testing and Replacement.....	23
Service Procedure II: Combustion System Testing and Replacement .....	27
Service Procedure III: Burner Tube Inspection and Replacement .....	31
Service Procedure IV: Gas Valve Replacement.....	33
Service Procedure V: Blower Testing and Replacement .....	34
Service Procedure VI: Flame Sensor Testing and Replacement.....	36
Service Procedure VII: Spark Rod Gap Adjustment and Replacement.....	38
Service Procedure VIII: Ignition Module/Control Board Replacement.....	40
Service Procedure IX: Blocked Vent Switch Inspection and Replacement .....	41
Service Procedure X: Anode Inspection and Replacement.....	42
Service Procedure XI: Display Module Replacement.....	43
Service Procedure XII: Transformer Replacement.....	44
Water Heater Installation Checklist.....	45
Water Heater Service Report .....	46
Notes .....	47

# Determining the Age of Your Water Heater

The first two characters of the serial number represent the year and month of manufacture. The remainder of the serial is a sequential production number, seven digits in length before December 2007 (DM), and eight digits in length after.

For example:

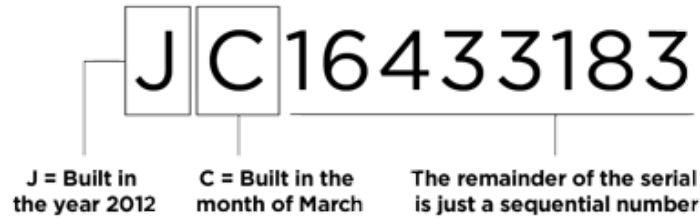

Production Year	
A = 1984 or 2004	L = 1994 or 2014
B = 1985 or 2005	M = 1995 or 2015
C = 1986 or 2006	N = 1996 or 2016
D = 1987 or 2007	P = 1997 or 2017
E = 1988 or 2008	S = 1998 or 2018
F = 1989 or 2009	T = 1999 or 2019
G = 1990 or 2010	W = 2000 or 2020
H = 1991 or 2011	X = 2001 or 2021
J = 1992 or 2012	Y = 2002 or 2022
K = 1993 or 2013	Z = 2003 or 2023

Production Month	
A = January	G = July
B = February	H = August
C = March	J = September
D = April	K = October
E = May	L = November
F = June	M = December

**For the year column, we do not use the letters: I, O, Q, R U, V**

**For the month column we do not use the letters: I & N – Z**

Due to a computer error there were some OA serial water heaters manufactured. They were built in January of 1997.

## NOTICE

This Service Manual is ONLY for ICON Control Systems (Serial Numbers XC and later for 125,199 and 270 kBTU systems,

NA37235769 and later for ). Please make sure that your water heater falls within this range.

UCG80H125(N,X)	XC and Later
UCG(80,100)H199*(N,X)(A)	XC and Later
UCG(80,100)H270*(N,X)(A)	XC and Later
UCG80H399*(N,X)	NA37235769 and Later
UCG100H399*(N,X)	LM35401146 and Later

# Introduction

---

The Bradford White Ultra Low NOx Atmospheric Vent Water Heater is designed to deliver hot water at up to 82% thermal efficiency in a quiet running unit with a top exhaust vent connection that allows for installation in existing locations. While this unit is vented atmospherically, there is no damper required to maintain heat loss during off cycle. Several technologically advanced design features are incorporated that will require additional knowledge on the part of the qualified service provider. The information in this manual will instruct service and maintenance professionals on the function, proper diagnosis, and repair of The Bradford White Ultra Low NOx Atmospheric Vent Water Heater.

This water heater uses an Ultra Low NOx premix power burner located at the top of the water heater to direct a turbulent flame down into the water backed combustion chamber. This turbulence causes a thorough mixing of gas and air for optimum combustion. The combustion gases then travel through a two pass flue system keeping the gases moving at a high velocity. The combination of high turbulence and velocity results in an optimum transfer of heat from the flue gases into the water.

Burner operation is controlled using an electronic ignition module. The module monitors the status of the electronic thermostat, blocked vent limit switch, flame sensor to control output voltage to blower motor, spark rod, and gas valve. The module contains programming which determines the sequence of operation and timings for purge periods, trial for ignition, flame sensing, and lockout. The module will also provide diagnostic information to help in determining the cause of system lockouts.

The contents in this manual are detailed informational tools to assist in the proper diagnosis of the water heater's operational faults. Please read this service manual completely and record as much information regarding the Ultra Low NOx Atmospheric Vent Water Heater operation and installation specifics related to any concerns.

## How to Use This Manual

---

It is intended for this manual to be used by qualified service personnel for the primary purpose of troubleshooting analysis and repair of the water heater. Understanding the sequence of operation section of this manual will contribute greatly to troubleshooting this product.

An Installation Checklist is shown towards the end of this manual. Compare the installation against the installation checklist to confirm all requirements are met. A Service Report is shown towards the end of this manual. Completing this form will assist in the troubleshooting efforts. Should you need to call for Technical Support, please provide the information shown on this form to the support technician to help ensure accurate troubleshooting. Troubleshooting begins with System Observation to determine failure mode as indicated by the error code on the system display. Troubleshooting continues with Failure Modes and Probable Cause directing the service provider to a series of test procedures to determine root cause of failure. Component replacement procedures directly follow the test procedures for a given component. In some difficult to diagnose conditions, it may be necessary to isolate the heater from the vent system to determine root cause.

Contact Technical Support immediately if diagnosis is not determined using the methods described in this service manual.

# Tools Required for Service

---

**Manometer:** Two types available, a liquid “U” tube type or a digital (magna-helic) type. This device is used to measure gas and/or air pressures and vacuum.

**Multi-Meter:** A digital type is strongly recommended. This device is used to measure electrical values. The meter you select must have the capability to measure volts AC, volts DC, Amps, micro-amps and ohms.

**Thermometer:** Used to measure water temperature. An accurate thermometer is recommended.

**Water Pressure Gauge:** Used to measure water supply pressure. Also used to determine tank pressure by adapting to the drain valve of the heater.

**Jumper Leads:** A length of wire (12" min.) with alligator clip at both ends.

**Various Hand Tools:** Pipe wrench, channel locks, open end wrench set, 12" crescent wrench, Allen wrench set, Torx bit set, screwdrivers (common & Philips), long reach (12") magnetic tip Philips head screwdriver #2 tip, 1/4" nut driver, pliers (common & needle nose), socket set including a 1-1/16 deep well socket, wire cutters, wire strippers, wire crimpers, torpedo level, small shop vac, step ladder, and flashlight.

## Features

---

### Features of ICON System Control

- Digital water heater display on control panel for setting and displaying the temperature setpoint. Pressing temperature UP and DOWN buttons changes the temperature setpoint. Temperature format may be displayed in °F or °C.
- Single control board with plug in wiring controls temperature, ignition, and blower operation.
- Reduced number of parts for servicing and wiring.
- Plug in wiring reduces chance of miswiring.
- Burner ignition with direct spark ignition - A high voltage spark jumps from the spark rod to the burner surface to ignite the gas. Eliminates burned out hot surface igniter replacements.
- Water heater display will show diagnostic codes in the event the water heater needs servicing. Aids in diagnosing and servicing the water heater.
- Water heater display can show previous error code history to further aid in servicing the water heater.

# Specifications

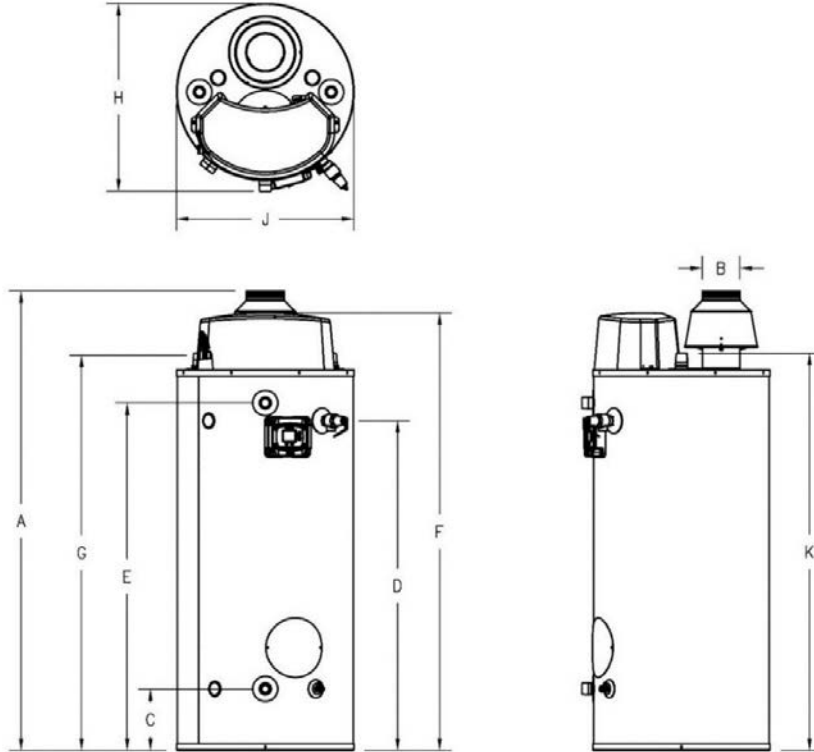

Model Description			Dimensions (INCHES)													
Model No.	Input Rate BTU/h	Storage Capacity U.S. Gallons	A Floor to Top of Vent	B Vent Dia.	C Floor to Cold Water Conn.	D Floor to T&P	E Floor to Hot Water Conn.	F Floor to Top of Water Heater	G Floor to Gas Conn.	H Depth	J Jacket Dia.	K Floor to Top Conn.	Water Conn. Dia.	Gas Conn. Dia.	Relief Valve Open	Shipping Weight (lbs)
UCG80H125	125,000	80	75 1/16	6	10	52 1/2	55 1/2	69 3/4	63 1/4	30	28 1/4	63 1/4	1 1/2	3/4	3/4	535
UCG80H199	199,000	80	66 9/16	6	10	44	47	61 5/16	54 13/16	30	28 1/4	54 13/16	1 1/2	3/4	3/4	535
UCG100H199	199,000	100	75 1/16	6	10	52 1/2	55 1/2	69 3/4	63 1/4	30	28 1/4	63 1/4	1 1/2	3/4	3/4	632
UCG80H270	270,000	80	66 9/16	6	10	44	47	61 5/16	54 13/16	30	28 1/4	54 13/16	1 1/2	3/4	1	545
UCG100H270	270,000	100	75 1/16	6	10	52 1/2	55 1/2	69 3/4	63 1/4	30	28 1/4	63 1/4	1 1/2	3/4	1	632
UCG80H399	399,000	80	68 3/4	8	10	44	47	61 1/4	55 3/4	30	28 1/4	55 3/4	1 1/2	3/4	1	545
UCG100H399	399,000	100	77 1/4	8	10	52 1/2	55 1/2	69 3/4	63 1/4	30	28 1/4	63 1/4	1 1/2	3/4	1	657

Model Description			Dimensions (millimeters)										
Model Number	Capacity (Liters)	Input kW/Hr Nat. & L.P.	A Floor to Top of Vent	B Vent Dia.	C Floor to Cold Water Conn.	D Floor to T&P	E Floor to Hot Water Conn.	F Floor to Top of Water Heater	G Floor to Gas Conn.	Water Conn. Dia.	Gas Conn. Dia.	Relief Valve	
UCG100H199	379	58.6	1861	152	254	1334	1410	1772	1607	38	19	19	
UCG100H270	379	79.1	1861	152	254	1334	1410	1772	1607	38	19	25	
UCG100H399	371	117.2	1962	203	254	1334	1410	1772	1607	38	19	25	
UCG80H125	303	36.6	1600	127	254	1118	1194	1556	1391	38	19	19	
UCG80H199	303	58.6	1899	152	254	1118	1194	1556	1391	38	19	19	
UCG80H270	303	79.1	1899	152	254	1118	1194	1556	1391	38	19	25	
UCG80H399	303	117.2	2000	203	254	1118	1194	1556	1391	38	19	25	

# Specifications

Power Supply	Dedicated 120 VAC, 60 Hz, 15A GFI
Gas Supply	Minimum 3/4" NPT (schedule 40 black iron pipe recommended)
Approved Gas Type	Natural and L.P. Unit must match gas type supplied.
Gas Pressure (Nat.)	14.0" W.C. maximum static, 4.5" W.C. minimum running (recommend 7.0" W.C. min running)
Gas Pressure (L.P.)	14.0" W.C. maximum static, 11.0" minimum static, 4.5" W.C. minimum running (recommend 7.0" W.C. min running)
Venting System	Atmospherically vented, Type B venting system or approved chimney. Follow the current National Fuel Gas Code requirements or in Canada, the Natural Gas and Propane Installation Code.
Minimum Clearance for Servicing	16" from top, 4" from front, 0" sides and rear.
Maximum Water Supply Pressure	150 PSI
Thermostat Sensor	11,900 Ohms @ 70°F, ECO opens @ 207°F (92.7°C) Max. Redundant sensor for ECO. Sensor inside well for easy replacement of sensor.
Control Display	Digital display, 24 volts. temperature Range: 70-180°F (21-82°C). Used to set tank temperature (°F or °C), show operating status, display error codes, error code history, limit maximum setpoint temperature.
Control Board	Operates from 24 volt from transformer. Controls tank temperature, ignition functions, combustion blower. See ignition timings in sequence of operation for Integrated Control.
Transformer	120 VAC primary, 24 VAC secondary, 40 VA.
Spark Rod Igniter	0.22" nominal gap to the burner surface.
Flame Sensor Output	Minimum 1 micro amp. Typical range 5 to 30 micro amps.
Gas Valve	Negative regulation, 24 VAC, 1/2" PSI max., 4.5" W.C. minimum running inlet.
Vent Safety Switch	Normally closed, opens @ 240°F (115.5°C), manual reset.
Blower	120 VAC, 60 Hz, 1.5-3.5 amps

# Specifications

## Vent Tables

(Intake Only)

Model Number	2" Max Intake Vent Length (feet)	3" Max Intake Vent Length (feet)	4" Max Intake Vent Length (feet)
UCG80H125	20	50	75
UCG(80,100)H199	20	50	75
UCG(80,100)H270	20	50	75
UCG(80,100)H399	N/A	75	20

### WARNING

The UCG(80,100)H399 model is not approved for 2 inch diameter vent pipe. Venting with 2 inch pipe may result in damage to the water heater or cause an unsafe condition. **DO NOT** use 2 inch vent air intake pipe with UCG(80,100)H399.

### Determining Required Intake Vent Length

1. Determine the total length of straight vent pipe (in feet) required for the intake.
2. Add 5 feet of venting for every 90° elbow.
3. Add 2 ½ feet of venting for every 45° elbow.
4. **Total vent length cannot exceed Max Intake Vent Length on the venting table shown above.**

### Example of Total Intake Vent Length for UCG100H399 installation:

A 3" venting system has a total of two 90-degree elbows and a total straight pipe length of 10 feet. Equivalent vent length for elbows: 2 x 5 feet = 10 feet.

**Total equivalent vent distance = 10 feet + 10 feet = 20 feet total equivalent vent length. This is below the maximum allowed distance of 25 feet for this model using 3" vent.**

### Approved Intake Venting Materials

#### For installations in the US only

- PVC Sch. 40 (ASTM D-1785, ULC 1738, ULC S636)
- DWV PVC Sch. 40 (ASTM-D2665)
- CPVC Sch. 40 (ASTM-F441, ASTM-D2846, ULC S636)
- Polypropylene (UL 1738, ULC S636)
- ABS Sch. 40 DWV (ASTM D2661)

#### For installations in CANADA

- ULC S636 approved Sch. 40 PVC and CPVC for flue gas venting rated Class II, 65°C (components provided with water heater)
- ULC S636 approved Polypropylene for flue gas venting rated Class II, 65°C

### Approved Primers and Cements

#### For installations in the US only

- PVC and CPVC Primer (ASTM F-656)
- PVC Cement (ASTM D-2564)
- CPVC Cement (ASTM F493)
- ABS Primer and Cement (ASTM D-2235)

#### For installations in CANADA

- ULC S636 approved PVC Primer and Cement for flue gas venting rated Class II, 65°C



# Sequence of Operation

---

1. Thermostat calls for heat.
2. Combustion blower starts at a 3,000 RPM “soft” start light off.
3. Blower pre-purge period of approximately 15 seconds.
4. Ignition control board runs an internal verification safety check for approximately 15 seconds.
5. Trial for ignition (approximately 5 seconds per trial, 3 trials total):
  - a. Flame establishing period (3 seconds), gas valve opens, sparks from spark rod to burner surface to ignite the gas.
  - b. Burner on, flame proving period (2 seconds). Requires a minimum of 1 microamp through the flame sense rod to prove flame.
  - c. If the blocked vent safety switch contacts (normally closed) are open, then the ignition sequence will not start and error code “67” (pressure switch failed to close/open or vent safety switch failed to close/open) will flash once on the digital display. The unit will then go into pre-purge/“Hold” while the unit is waiting for the issue to be corrected. If the issue continues to occur, the digital display with flash error code “137” (pressure switch is open, or vent safety switch is open) while the unit is waiting to restart (5 minutes) the normal sequence of operation.
6. Once the flame signal is verified, the blower will remain at the “soft” start RPM for 5 seconds to stabilize the flame.
7. Steady state operation – Burner continues to operate until:
  - a. The thermostat circuit opens, gas valve closes, and blower continues to operate for 30 second post-purge period.
  - b. If the blocked vent safety switch contacts open (normally closed) while the burner is on, then the gas valve closes, and the unit will retry a normal sequence of operation. If issue remains on restart, the unit will go into recycle as described in 5c.
8. Thermostat is satisfied.
9. Gas valve closes and burner is extinguished.
10. Blower post purge for 30 seconds at maximum RPM.

# Sequence of Operation

## Lockout Conditions

The system will go into lock out mode for the following reasons:

1. Error Code 110 (Ignition failure occurred)
  - a. Control board will go into “Soft Lockout” if the main burner cannot be lit or fails to prove flame after 3 ignition trials. The water heater display indicates a lockout condition by showing an error code number 110 with “Service Needed” in the control display window. Refer to error codes in the diagnostic section of this Service Manual. In a Soft Lockout condition, the control will wait for 15 minutes and then make 3 more attempts to light the main burners. Soft lockout reset is accomplished by depressing the lower right button under “Reset” for 3 seconds.
2. Error Code 80 (High limit overheat condition)
  - a. If the top of the tank should exceed 207°F (92.7°C), then the high limit control will shut off the burner and the water heater will go into a “Hard Lockout.” Error code 80 will be shown in the water heater display. The control can only be reset in the Service Mode, which is detailed in the Troubleshooting section (page 13).
3. Error Code 67 (ILK off)
  - a. If the vent safety switch located on the draft hood should open, the gas valve will close, the blower will post-purge and error code 67 will appear on the display. The lockout condition will reset once the problem is corrected and the switch reset. Refer to Vent Safety Switch Testing and Replacement.

## Connection/Wiring Diagram

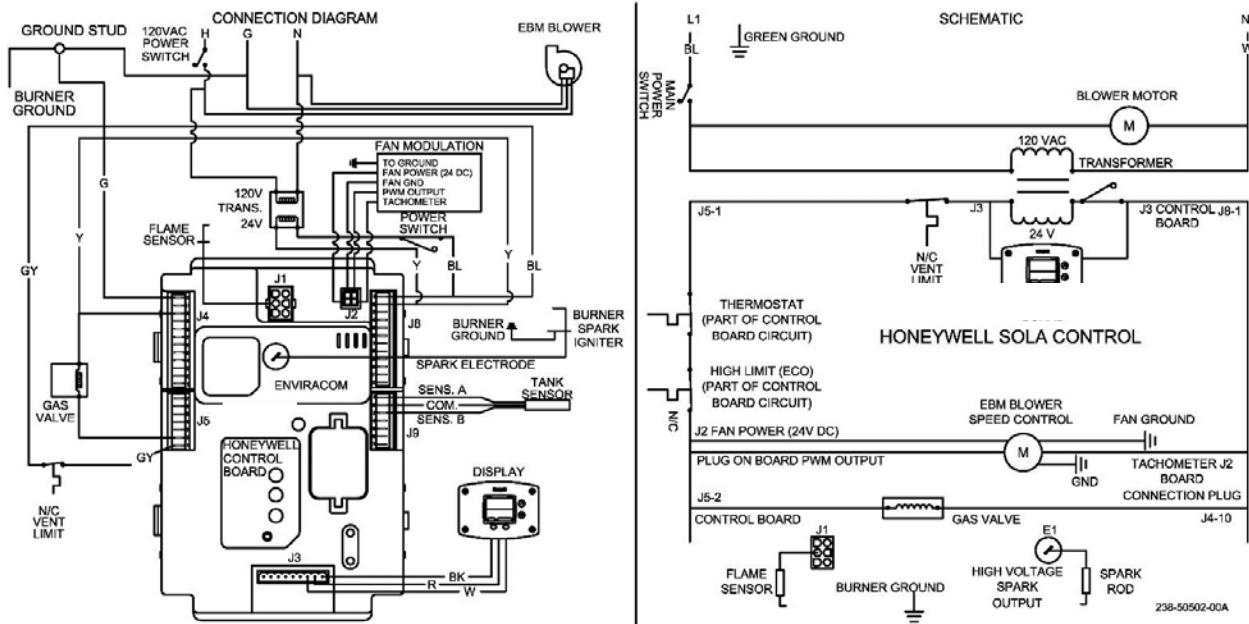

# Building Management System (BMS)

All water heaters with serial numbers after XA..... (with ICON Systems) can be equipped with a gateway kit that will facilitate a Building Management System (BMS) connection to Modbus or Bacnet®. This kit is sold separately and is not factory installed. A full installation, operation, and troubleshooting manual is provided with the gateway kit.

## BMS Mapping

Map Descriptor Name	Modbus Register	Read/Write	BACnet Object ID	Note
Demand source	00006	Read	001	Current demand source: 0 = Unknown 1 = No source demand 2 = CH 3 = DHW 4 = Lead Lag slave 5 = Lead Lag master 6 = CH frost protection 7 = DHW frost protection 8 = No demand due to burner switch (register 199) turned off 9 = DHW storage 10 = Reserved 11 = Warm weather shutdown 12 = Hot standby
Firing rate	00008	Read	002	Actual firing rate (% or RPM)
Fan speed	00009	Read	003	RPM
Flame signal	00010	Read	004	0.01V or 0.01 $\mu$ A precision (0.00-50.00V)
Tank temperature sensor	00012	Read	005	-40°-130° (0.1°C precision)
Appliance setpoint	00017	Read	006	-40°-130° (0.1°C precision)
Burner status	00032	Read	007	0 = Disabled 1 = Locked out 2-3 = Reserved 4 = Anti-short cycle 5 = Unconfigured safety data 6-33 = Reserved 34 = Standby Hold 35 = Standby Delay
Lockout code	00034	Read	008	0 = No lockout 1-4096
Appliance status	00080	Read	009	0 = Unknown 1 = Disabled 2 = Normal 3 = Suspended
DHW priority count	00082	Read	010	Countdown of time when DHW has priority over CH (secs). Applicable when DHW priority time is enabled.
Burner run time	00130/00131	Read	011	Hours
Controller cycle count	00142/00145	Read	012	0-999,999
Controller run time	00144/00145	Read	013	Hours
Alarm reason	0035	Read	014	0 = None 1 = Lockout 2 = Alert 3 = Other
DHW setpoint	0453	Read/Write	015	40°-130° (0.1°C precision)

# BMS Wiring Diagram

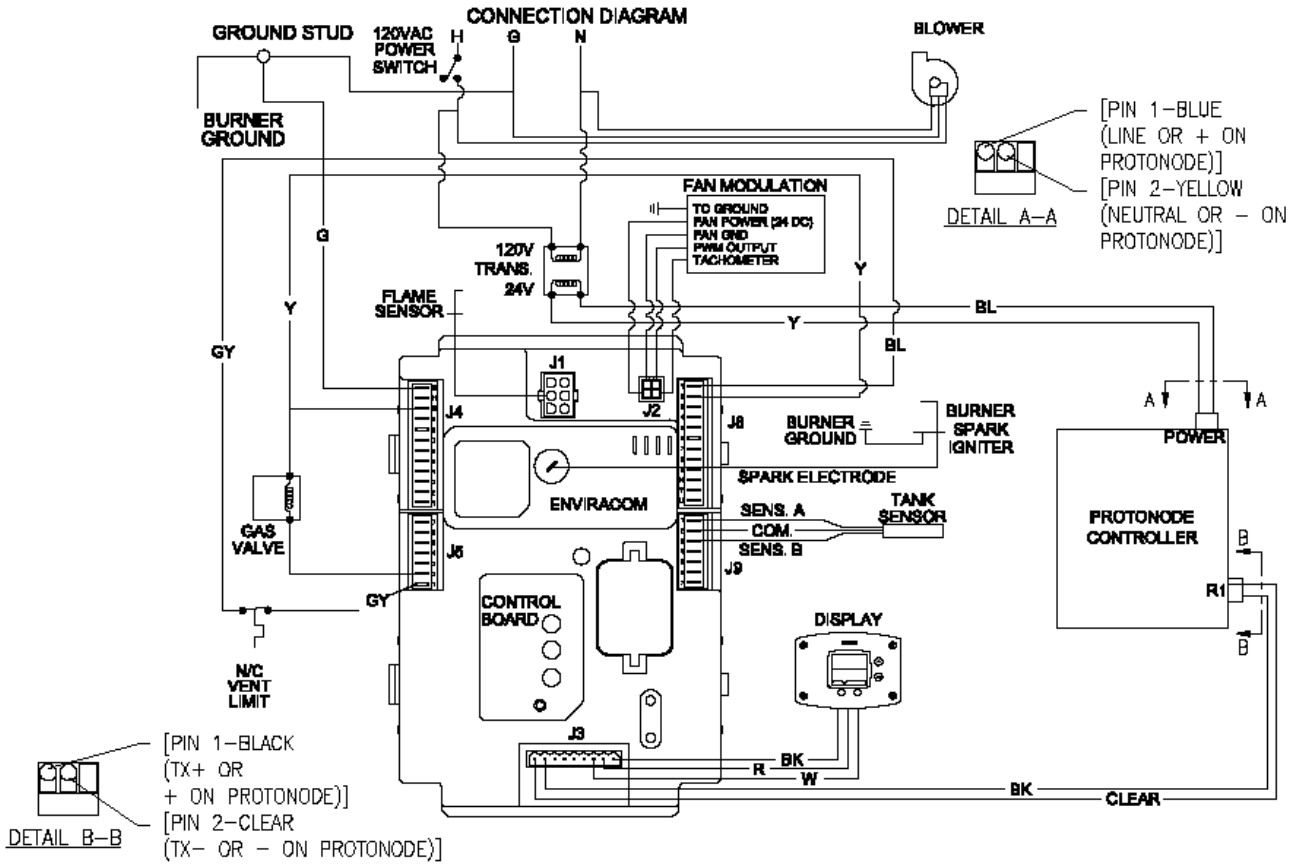

## ⚠ CAUTION

Before beginning any Troubleshooting operations listed below, please note that the gateway kit and BMS may need to be disconnected from the heater. Please ensure this has been completed before proceeding with any troubleshooting operation that may be impacted by settings in the BMS.

## NOTICE

The Building Management System (BMS) is only compatible with units that have SOLA controllers.

Part	Bradford White Part Number
BMS Gateway Installation Kit	415-53943-00

# Troubleshooting

## System Observations

**Water Heater Fault:** Water heater does not operate  
**Display Error Code:** Water heater display does not operate - blank display

Check main power supply to water heater – fuse, circuit breaker, plug receptacle, line cord or wiring to water heater.

Check to make sure switch on front of control panel is in the ON position.

Verify primary voltage at the transformer.

Refer to control board illustration. Voltage at transformer across black and white wires should be 110-120 VAC. Check line cord with volt meter. Replace line cord if defective.

Refer to control board illustration. Voltage at connector location J8 across blue and yellow wires should be 24VAC. If not, check transformer. Replace transformer if defective.

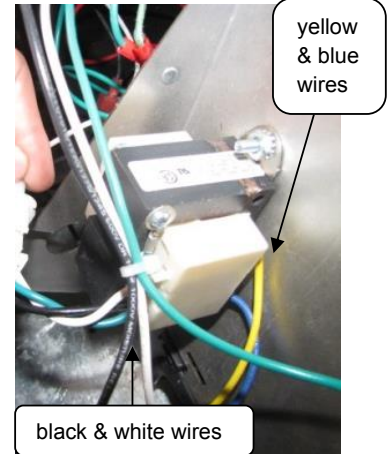

Verify secondary voltage at the control board.

Does water heater display operate? Increase thermostat setting if tank is warm.

Display operates – see next page.

Is 24VAC present between **RED** and **BLACK** wire pin connections on the back of control display?

Display operates – see next page.

Check wires for proper termination to control display. Are wire terminations connected properly to control display?

Replace control board.

Check wire harness for proper continuity.

Make proper wire terminations.

Replace control board.

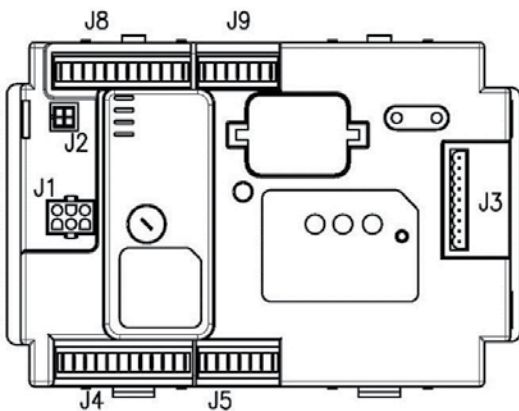

# Troubleshooting

## ⚠ CAUTION

Use caution to not damage connectors when making voltage measurements or jumping terminals

## ⚠ WARNING

120 volt potential exposure. Use caution making voltage checks to avoid personal injury.

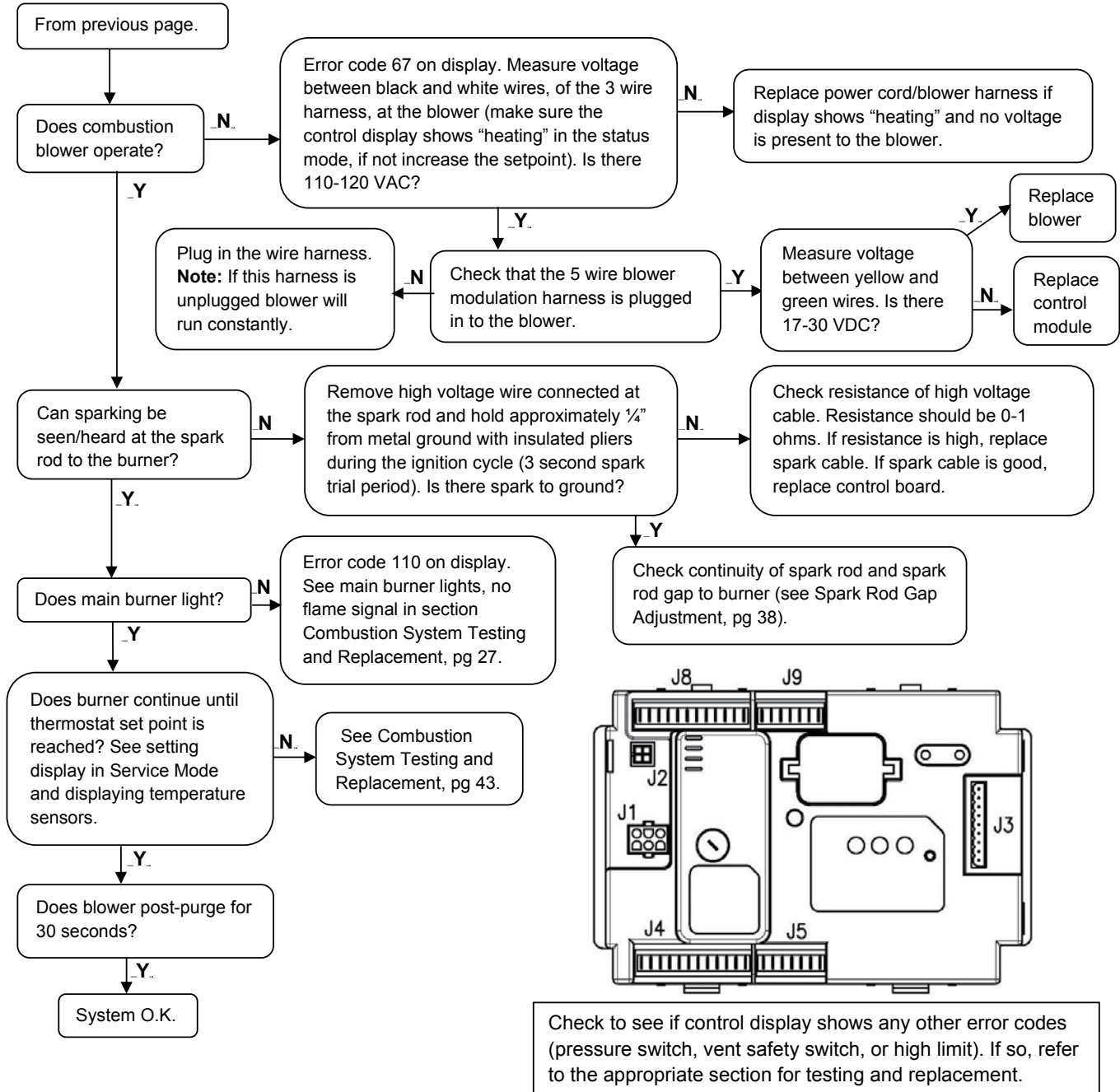

# Display Control

## Water Heater Display and Control Buttons

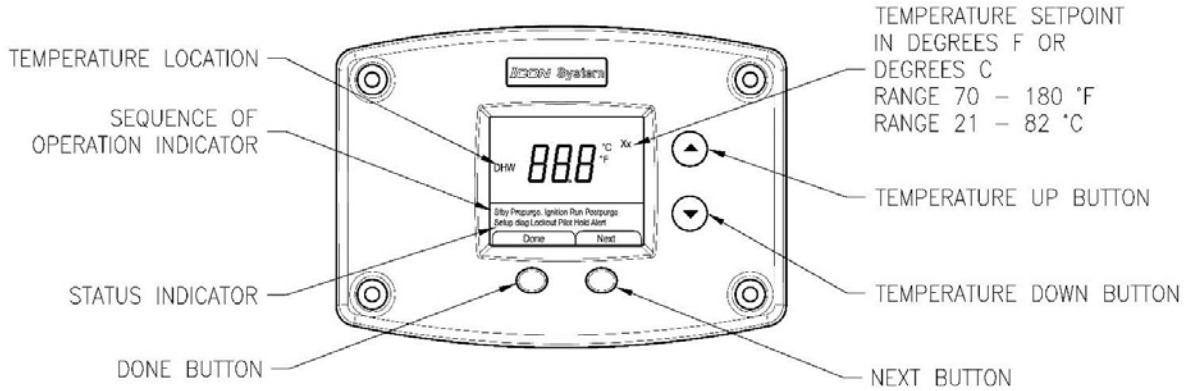

### To Increase Temperature Setpoint

**Step 1.** Press and hold “Temperature Up” button until desired setpoint temperature appears on the display.

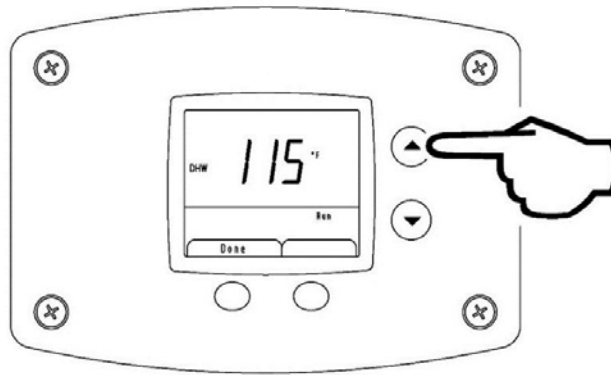

**Step 2.** Press “DONE” button for new setting to take effect immediately. If the “DONE” button is not pressed, the new temperature setting will take effect in approximately 10 seconds.

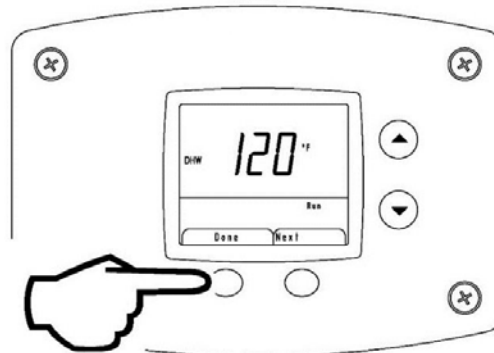

PRESS DONE BUTTON FOR SETTING TO TAKE EFFECT IMMEDIATELY

## To Decrease Temperature Setpoint

**Step 1.** Press and hold “Temperature Down” button until desired setpoint temperature appears on the display.

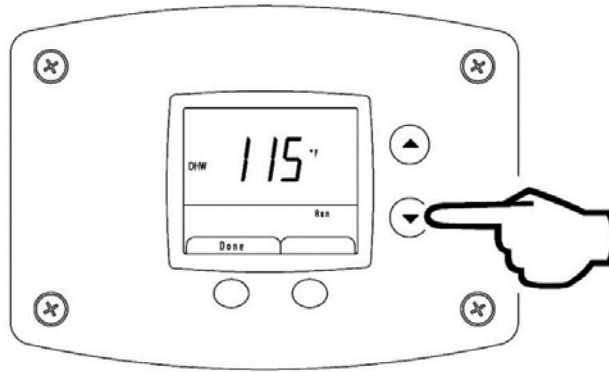

**Step 2.** Press “DONE” button for new setting to take effect immediately. If the “DONE” button is not pressed, the new temperature setting will take effect in approximately 10 seconds.

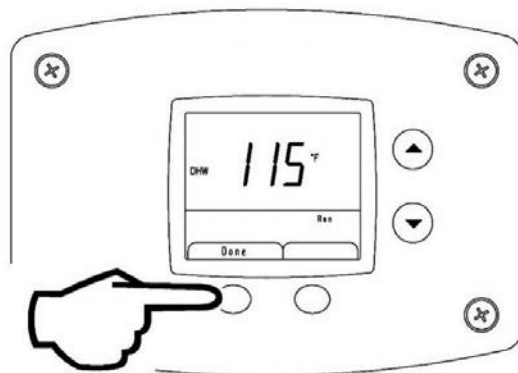

PRESS DONE FOR SETTING TO  
TO TAKE EFFECT IMMEDIATELY

## To View Combustion Rate

**Step 1.** Select Next while viewing DHW Setpoint in User Mode to access Rate screen. Rate will only be displayed while the burner is operating.

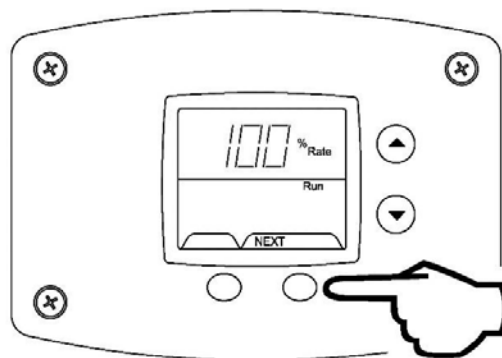

**Step 2.** Select Next to go back to the DHW Setpoint screen.



## To Change Temperature Format in Display from °F to °C or °C to °F

**Step 1.** Enter “Set-Up Mode” by pressing both UP/DOWN buttons together for 3 seconds.

**Step 2.** Use the arrows to select between °F and °C

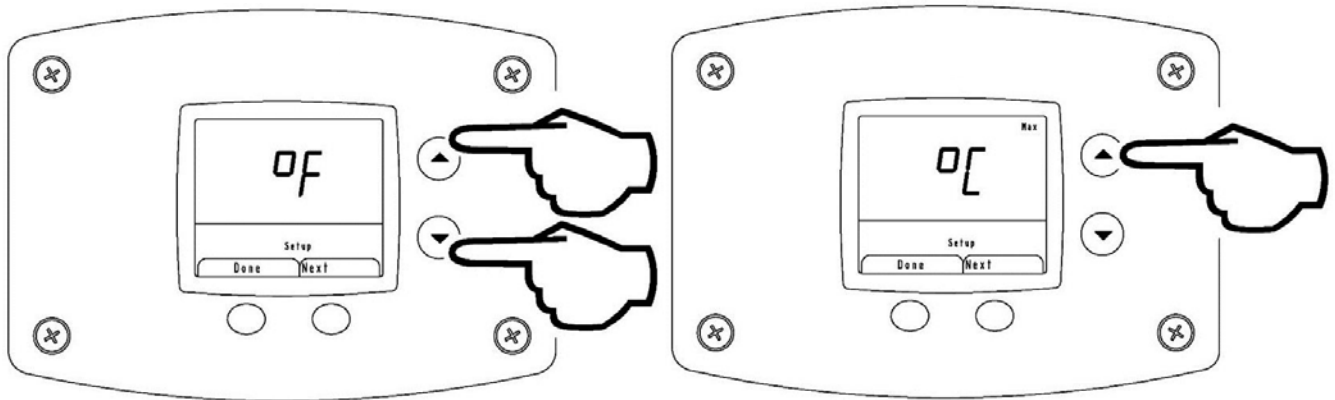

**Step 3.** Press done to return to main screen or timeout/change will occur in one minute.

An energy cut out (ECO) is incorporated in the sensor and control board which will shut off all gas supply to the burner if the water heater temperature exceeds 207°F (93°C). Should the ECO function (open), the water temperature should be reduced to approximately 120°F (49°C) and call a qualified service agent to place the water heater in operation. The water heater must have the problem corrected by a qualified service person before putting the water heater back in operation. It is recommended that all service work be performed by a qualified service agency.

If the water heater is to remain idle for 30 days or more or is subjected to freezing temperatures while shut off, the water heater and piping should be fully drained (See “To Drain the Water Heater”) and the drain valve should be left fully open.

### **WARNING**

Hydrogen gas can be produced in an operating water heater that has not had water drawn from the tank for a long period of time (generally two weeks or more). **HYDROGEN GAS IS EXTREMELY FLAMMABLE.** To prevent the possibility of injury under these conditions, we recommend the hot water faucet to be open for several minutes at the kitchen sink before you use any electrical appliance which is connected to the hot water system. If hydrogen is present, there will be an unusual sound such as air escaping through the pipes as hot water begins to flow. **DO NOT smoke or have open flame near the faucet at the time it is open.**

### **WARNING**

**DO NOT** run out of propane gas. Damage to the water heater may occur.

# Troubleshooting

## Accessing Diagnostic Mode on the Water Heater Display

(FOR SERVICE PERSONNEL ONLY)

The display has a Diagnostic Mode to access information in aiding servicing of the water heater. This procedure is for service and installation personnel only. To enter the Diagnostic Mode, follow the steps illustrated below:

### WARNING

The following procedure is for **service and installation personnel ONLY**. Resetting lockout conditions without correcting the malfunction can result in a hazardous condition.

**Step 1.** Press and hold the lower right button under “Next” in the lower right display for at least 3 seconds. You must be in user mode on the DHW temp screen to access diagnostic mode. If in user mode on the view rate screen, you cannot access diagnostic mode.

### NOTICE

The screens will stay in the Diagnostic Mode for 12.5 minutes after the last button press for viewing unless “Done” button is pressed to exit Diagnostic Mode.

**Step 2.** In the first screen of diagnostic mode the display will show the flame sense current in microamps when the burner is operating.

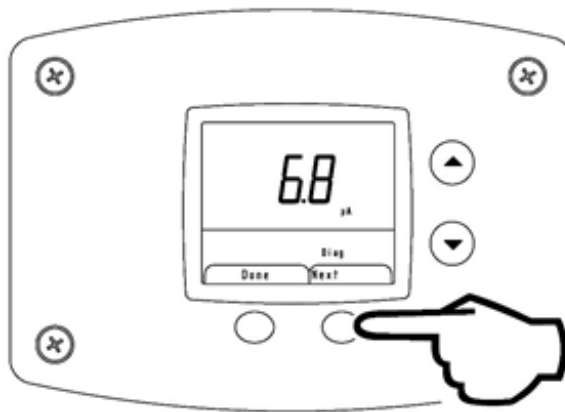

PRESS NEXT BUTTON FOR  
3 SECONDS TO ENTER

**Step 3.** Press the lower right “Next” button. The display will flash and show the number of any alert codes. These are **not** currently used.

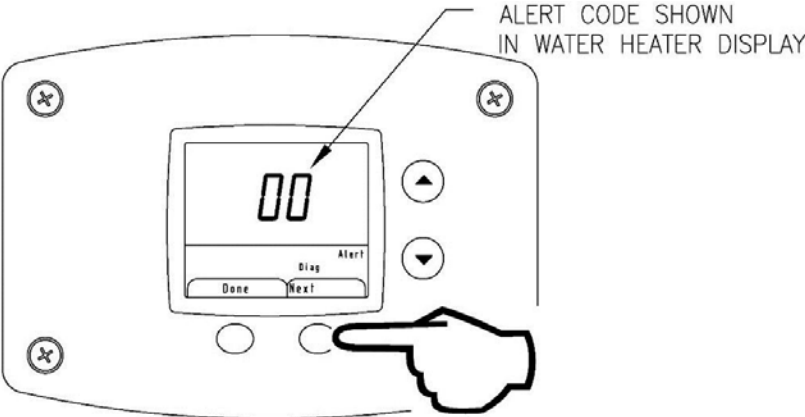

**Step 4.** Press lower right “Next” button. The display will flash and show the number of any Lockout codes. If there are no lockouts, the display will show 00. If there are multiple lockout codes “Next” will scroll through them.

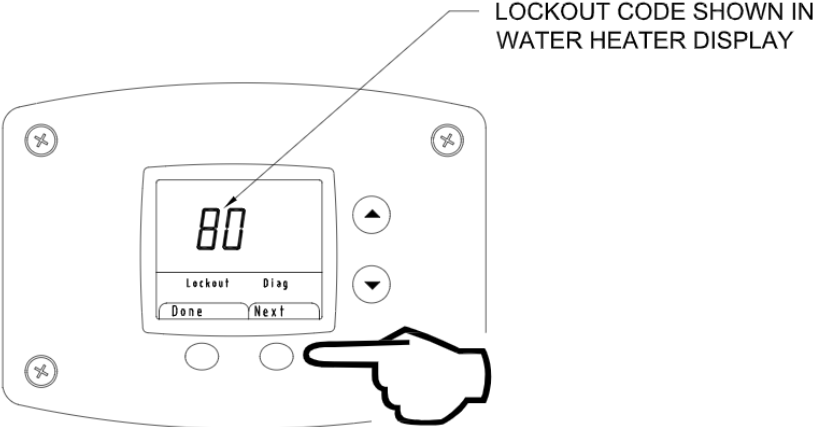

**Step 5.** Press “Next”, the display will show “DHW MAX”. This is the maximum allowable temperature that the unit can get to before a lockout occurs.

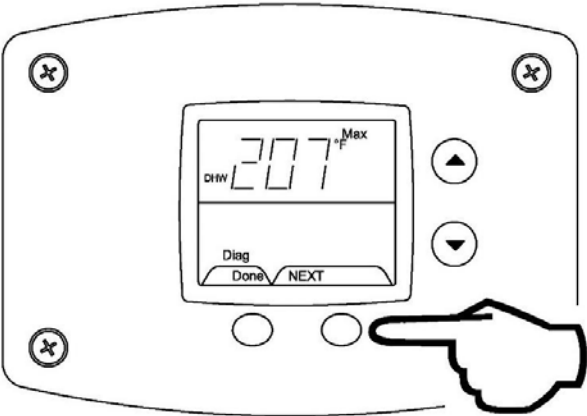

# Troubleshooting

---

**Step 6.** Press Next, display will show “DELTA T DHW”, this is the real time temperature reading of the tank.

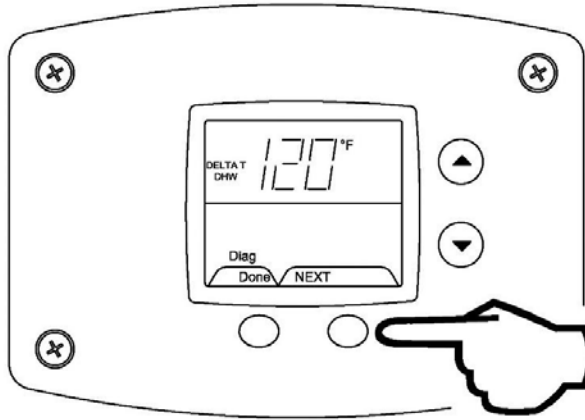

**Step 7.** Press “Done” to exit Diagnostic Mode and return to the DHW setpoint in User Mode.

## NOTICE

The ICON control system can produce soft and hard lockouts. Soft lockouts are displayed if active and are not stored in Diagnostic Mode history. The control will periodically attempt to resume normal operation when in soft lockout conditions. If the system resumes normal operation a soft lockout will clear instantly; hard lockouts will display if active and require manual reset. Up to ten previous Hard lockouts are logged chronologically (newest first) in Diagnostic Mode history.

Error Code	Definition of Code	Cause of Problem and Actions Taken to Correct
No code – blank display	No power to the unit or switch is off.	<ul style="list-style-type: none"> <li>• Check power supply to the water heater.</li> <li>• Make sure water heater is plugged in and the breaker is on.</li> <li>• Check if there is 120 volts power supply to the LINE connections on the control board.</li> <li>• Verify 24 volts at display.</li> <li>• Check for loose wires, defective transformer.</li> <li>• Check wire harness connections from display to the control board.</li> </ul>
9,22	Low flame sense signal	<ul style="list-style-type: none"> <li>• Check microamp output of flame sense</li> <li>• Inspect flame sensor and wire</li> <li>• Inspect burner for debris</li> </ul>
49	Voltage too low or high	<ul style="list-style-type: none"> <li>• Measure the incoming line voltage.</li> <li>• Voltage should be 115-125 volts.</li> <li>• If the voltage is not within this range or there is drastic fluctuation, then have the incoming power supply checked.</li> <li>• If the line voltage is satisfactory, check the output from the transformer to make sure it is 22-26 volts.</li> <li>• Replace transformer or wiring if defective.</li> </ul>
53	AC Inputs phase reversed	<ul style="list-style-type: none"> <li>• Check the module and display connections.</li> <li>• Check the module power supply and make sure that frequency, voltage and VA capacity of the transformer meet specifications.</li> <li>• Check to make sure the wiring connections on the control module from terminals J4-10 and J8-2 are connected together.</li> </ul>
62	Fan speed not proved	<ul style="list-style-type: none"> <li>• Check the pulse width modulation (PWM) wire harness connection from the blower to the control module.</li> <li>• Make sure the pin terminals make solid contact.</li> <li>• Measure the resistance of each wire in the wire harness from the terminal ends.</li> <li>• Replace wire harness if defective.</li> <li>• If value remains out of range, this hold will change to lockout 123 (defined below)</li> </ul>
67	Normally closed vent safety circuit opened	<ul style="list-style-type: none"> <li>• Check wiring to the normally closed blocked vent switch at draft hood</li> <li>• Use a voltmeter to find out if the blocked vent switch is open.</li> <li>• If so, determine the cause (vent restriction, adequate draft)</li> <li>• If limit switch is closed, check wiring for shorts.</li> <li>• Measure continuity.</li> <li>• If limit switch and wiring check O.K., replace control module.</li> </ul>
80	High Limit (Overheat Condition)	<ul style="list-style-type: none"> <li>• Check the wiring from the water temperature sensor to the control module.</li> <li>• Measure the resistance of each outside wire to the center wire. Measure the tank temperature and compare with the chart below.</li> <li>• If either outside wire has a much different resistance reading, replace the sensor.</li> <li>• Make sure the sensor is securely held inside the well with the clip.</li> <li>• If the problem persists and the sensor and wiring check O.K., then replace the control module.</li> </ul>

Error Code	Definition of Code	Cause of Problem and Actions Taken to Correct
93	Water temperature sensor fault	<ul style="list-style-type: none"> <li>• Appears after alert 172, defined below.</li> <li>• Check the water temperature sensor wire harness from the sensor to the control module.</li> <li>• Make sure there are no loose connections to the control plug.</li> <li>• Check the resistance reading from each of the outside wires to the center (common) wire. Measure the tank temperature and compare with the chart below.</li> <li>• If the ohm readings are not fairly close, replace the sensor.</li> <li>• Replace the control module if the problem persists and the sensor and wire connections are not defective.</li> </ul>
105	Flame detected out of sequence	<ul style="list-style-type: none"> <li>• Check to see if flame is present inside the combustion chamber before or after the ignition cycle.</li> <li>• If so, check to make sure the gas valve is wired correctly.</li> <li>• Check for voltage at the gas valve connection.</li> <li>• Replace the gas valve if defective.</li> <li>• If no flame is visible outside of the ignition sequence/run cycle, then make sure the flame sensor is wired to the correct terminal.</li> <li>• Make sure the ignition cable is not crossing the flame sensor wire or ignition ground wires.</li> <li>• If problem persists and all other checks have been verified, replace the control module.</li> </ul>
109, 110	Ignition Failure Occurred.	<ul style="list-style-type: none"> <li>• Burner failed to light or stay lit after 4 retries.</li> <li>• Hold condition – will reattempt ignition after 15 minute waiting period. A log will be stored in service history.</li> <li>• Check gas valve wiring and gas valve operation during the ignition cycle.</li> <li>• If burner lights but quickly goes out, check the flame sensor wire or the flame sensor.</li> <li>• If the flame sensor rod is badly corroded with deposits, clean with sandpaper or replace.</li> <li>• Check the inlet gas supply to make sure the pressure is sufficient and does not drop after the gas valve opens.</li> <li>• Make sure the combustion blower is operating during the ignition and run cycle.</li> <li>• Check the venting system to make sure the inlet and exhaust terminals and venting system is not blocked.</li> </ul>
122,123	Light-off Rate Proving Failed	<ul style="list-style-type: none"> <li>• If blower speed is not verified from the PWM (Pulse Width Modulation) signal within 5 minutes, the previously described error code "62" changes from a hold condition to this lockout code condition</li> <li>• Check the harness and pin terminals for a good connection to the control module.</li> <li>• Replace the blower or control module if the wire harness is good.</li> </ul>
137	Normally closed vent safety circuit opened	<ul style="list-style-type: none"> <li>• Refer to code 67</li> </ul>
172	Water temperature sensor resistance invalid	<ul style="list-style-type: none"> <li>• Hold 93 will be displayed if this value remains out of range</li> <li>• Measure the resistance of the water temperature sensor and compare it with the tank temperature using the chart below.</li> </ul>
NOTE		<ul style="list-style-type: none"> <li>• If there is do display, check primary/secondary voltage</li> <li>• Before troubleshooting always verify the following <ul style="list-style-type: none"> <li>○ Gas inlet pressure</li> <li>○ Static to dynamic gas pressure drop</li> <li>○ No vent and intake restrictions</li> <li>○ All wire connections are tight</li> <li>○ No grounded wires or missing grounds</li> <li>○ No water leaks</li> </ul> </li> </ul>

# Service Procedure I: Thermostat Circuit Testing and Replacement

**IMPORTANT NOTE:** This procedure assumes a cool tank.

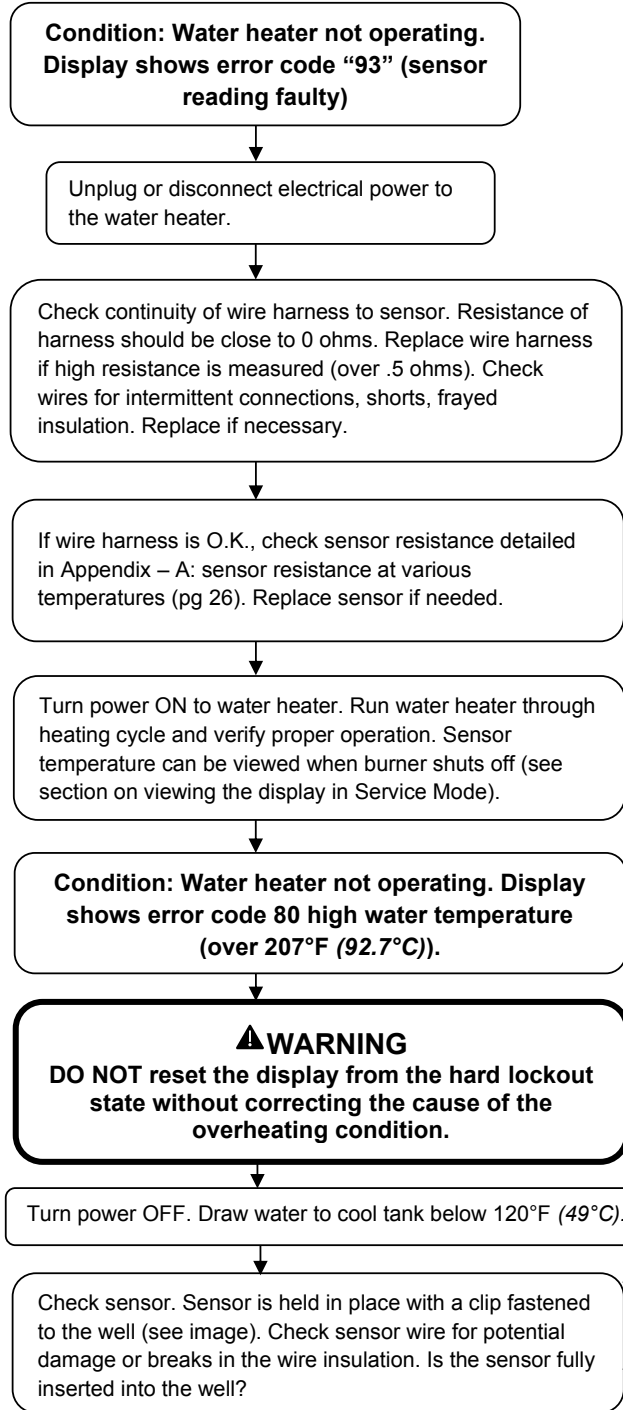

**⚠️ WARNING**  
120 volt potential exposure. Use caution making voltage checks to avoid personal injury.

**⚠️ CAUTION**  
Use caution to not damage connectors when making voltage measurements or jumping terminals.

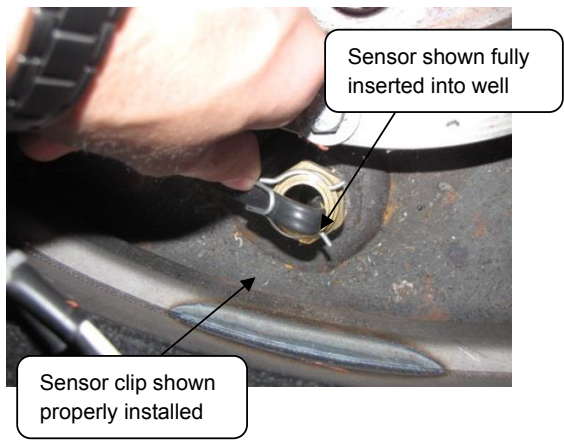
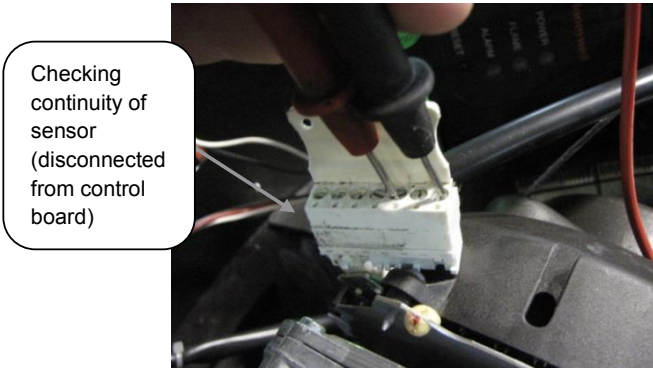

# Service Procedure I: Thermostat Circuit Testing and Replacement

**Condition: Water heater not operating. Display shows error code 80 high water temperature (over 207°F (92.7°C)) (continued from previous page).**

Once cause of overheating condition has been diagnosed and corrected, the control may be reset.

- Reconnect and switch on power to the water heater.
- Press button under "Reset" and hold for 3 seconds.
- Set thermostat to the desired setting.
- Water heater will start.
- Monitor temperatures for one complete heating cycle making sure the maximum tank temperature remains below 207°F (92.7°C).

## **WARNING**

**DO NOT** operate water heater without verifying that the overheating condition has been corrected.

This water heater is equipped with a manual reset type gas shutoff device designed to shut off the gas to the burners if excessive water temperature occurs. To reset the control, press the lower right button under "RESET" in the display for 3 seconds.

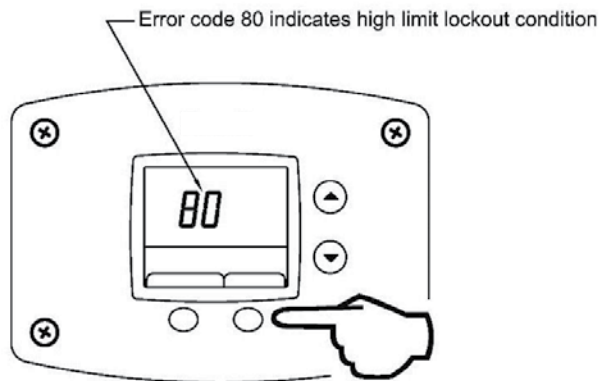

Step 1: Press for 3 seconds to reset control.



# Service Procedure I: Thermostat Circuit Testing and Replacement

## Thermostat Sensor (Thermister) Replacement Procedure

1. Position main power switch to OFF.
2. Disconnect (unplug) water heater from 120 volt power source.
3. Unlatch and remove the top surround cover from top of heater.
4. Disconnect the temperature sensor from control (see images below).
5. Unclip the sensor from well and pull sensor to remove, **do NOT** remove well (see image).
6. Install new sensor assembly into well and reinstall sensor clip.
7. Reconnect the sensor connector to the control board and route the wire harness through the same path that it was removed.
8. Restore 120 volt power supply and water supply to water heater, check and repair any leaks found. Confirm proper operation following the lighting instructions on the lighting instruction label or the lighting instruction located in the Installation and Operating Instruction Manual.
9. Replace the surround cover on the top of the water heater.

### **WARNING**

120 volt potential exposure.  
Isolate the appliance and  
reconfirm power is disconnected  
using a multi-meter.

Disconnect sensor  
harness from  
control board

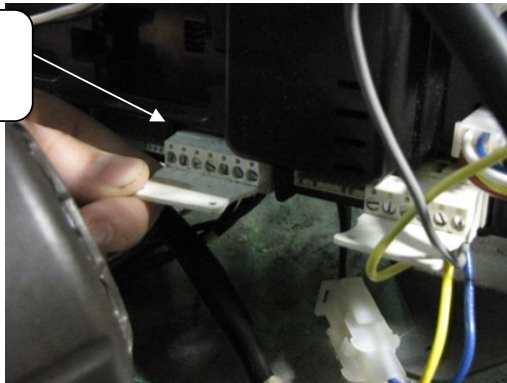

Sensor shown fully  
inserted into well

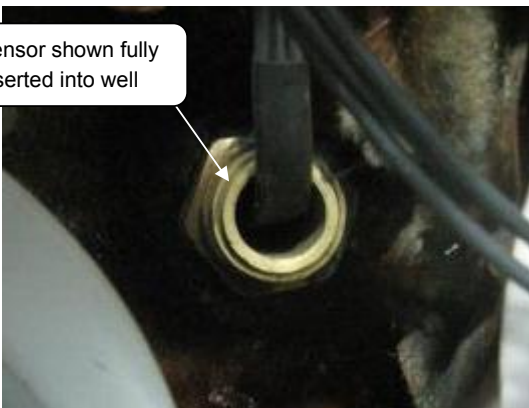

Sensor clip shown  
properly installed

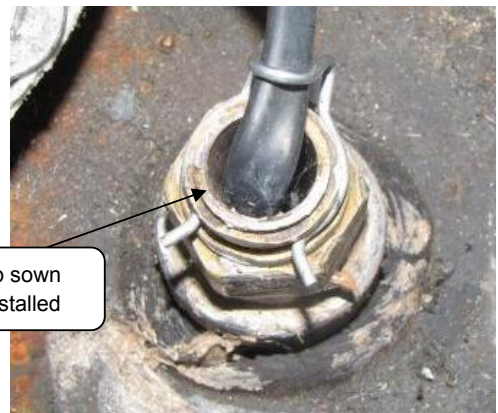

# Service Procedure I: Thermostat Circuit Testing and Replacement

---

## APPENDIX-A

### Sensor Resistance at Various Temperatures

**Be careful when making voltage measurements or jumping terminals not to damage or deform connectors or connector pins.**

Draw water from the temperature and pressure relief valve. Compare temperature with temperature ohms chart below.

Example: If the temperature is 84°F, then the resistance through the sensor would be 8449 (see shaded area).  
Note: Sensor resistance increases as the temperature falls.

In Degrees F										
°F	0	1	2	3	4	5	6	7	8	9
40	26109	25400	24712	24045	23399	22771	22163	21573	21000	20445
50	19906	19383	18876	18383	17905	17440	16990	16553	16128	15715
60	15314	14925	14548	14180	13823	13477	13140	12812	12494	12185
70	11884	11592	11308	11032	10763	10502	10248	10000	9760	9526
80	9299	9078	8862	8653	8449	8250	8057	7869	7685	7507
90	7333	7165	7000	6839	6683	6531	6383	6238	6098	5961
100	5827	5697	5570	5446	5326	5208	5094	4982	4873	4767
110	4663	4562	4464	4368	4274	4183	4094	4006	3922	3839
120	3758	3679	3602	3527	3453	3382	3312	3244	3177	3112
130	3048	2986	2925	2866	2808	2752	2697	2643	2590	2538
140	2488	2439	2391	2344	2298	2253	2209	2166	2124	2083
150	2043	2004	1966	1928	1891	1856	1820	1786	1753	1720
160	1688	1656	1625	1595	1566	1537	1509	1481	1454	1427
170	1402	1376	1351	1327	1303	1280	1257	1235	1213	1191
180	1170	1150	1129	1110	1090	1071	1053	1035	1017	999
190	982	965	949	933	917	901	886	871	857	842
200	828	814	801	788	775	762	749	737	725	713

In Degrees C										
°C	0	1	2	3	4	5	6	7	8	9
0	32648	31026	29495	28049	26682	25389	24166	23010	21915	20879
10	19898	18968	18088	17253	16461	15710	14998	14322	13680	13071
20	12492	11942	11419	10922	10450	10000	9572	9165	8778	8409
30	8057	7722	7403	7099	6808	6532	6268	6016	5775	5546
40	5327	5117	4917	4726	4543	4368	4201	4042	3889	3742
50	3602	3468	3340	3217	3099	2986	2878	2774	2675	2579
60	2488	2400	2316	2235	2157	2083	2011	1942	1876	1813
70	1752	1693	1637	1582	1530	1480	1432	1385	1340	1297
80	1256	1216	1177	1140	1105	1070	1037	1005	974	944
90	916	888	861	835	810	786	763	741	719	698

# Service Procedure II: Combustion System Testing and Replacement

Observe burner operation through the sight glass located on the combustion insert mounting flange. Normal burner operation should ignite smoothly, without evidence of coughing or huffing upon ignition. The burner flame should be a blue flame near the burner surface in a uniform flame pattern. Occasional yellow or white streaks are normal.

**Note:** On this high input model that uses metal fiber mesh burner a red glow from the burner surface is normal.

**! WARNING**

120 volt potential exposure. Use caution making voltage checks to avoid personal injury.

**! WARNING**

Removing screw from inlet gas pressure tap will immediately allow gas to flow from pressure tap.

Verify minimum gas supply piping requirements of: Minimum 3/4" NPT (schedule 40 black iron pipe recommended.)

**Y** With manometer, check inlet gas pressure. Is it stable between 7" & 14" W.C. (Nat) and 14" & 11" W.C. (L.P.) static (heater not running)? (see image).

**N** Reconfigure gas supply piping.

**Y** Does inlet gas pressure drop more than 2" W.C. during burner ignition?

**N** Is gas supply pressure regulator adjustable to maintain proper and stable setting?

**Y** Adjust gas supply regulator.

**N** Inadequately sized regulator.

**N** Can sparking be seen/heard at the spark rod to burner?

**Y** Remove high voltage wire connected at the spark rod and hold approximately 1/4" from metal ground with insulated pliers during the ignition cycle (3 second spark trial period). Is there spark to ground?

**N** Check resistance of high voltage cable. Resistance should be 0-1 Ohm. If resistance is high, replace spark cable. If spark cable is good, replace control board.

**Y** Does main burner light?

**N** Check continuity of spark rod. Is reading 0-1 Ohm?

**N** Replace spark rod (see Spark Rod Gap Inspection and Replacement, pg 38).

**Y** Proceed to next page.

**N** Check spark gap to burner (see Spark Rod Gap Inspection, pg 38).

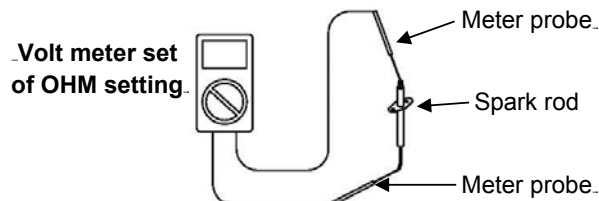
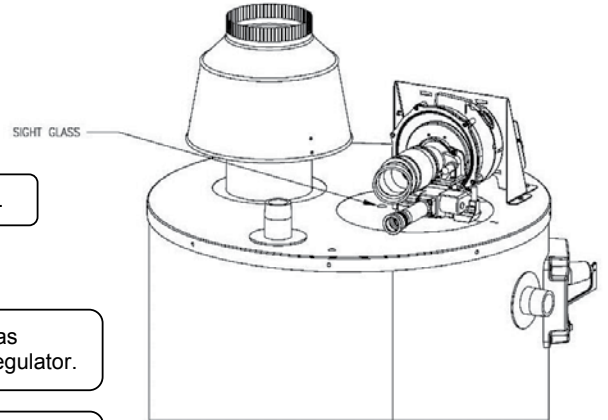

**CHECK SPARK ROD RESISTANCE**

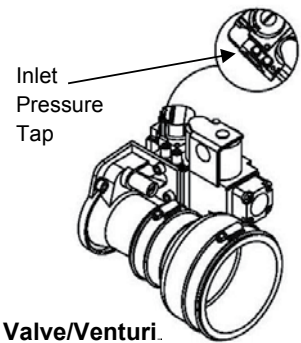

**Gas Valve/Venturi**

# Service Procedure II: Combustion System Testing and Replacement

Observe burner operation through the sight glass located on the combustion insert mounting flange. Normal burner operation should ignite smoothly, without evidence of coughing or huffing upon ignition. The burner flame should be a blue flame near the burner surface in a uniform flame pattern. Occasional yellow or white streaks are normal.

**Note:** On this high input model that uses metal fiber mesh burner a red glow from the burner surface is normal.

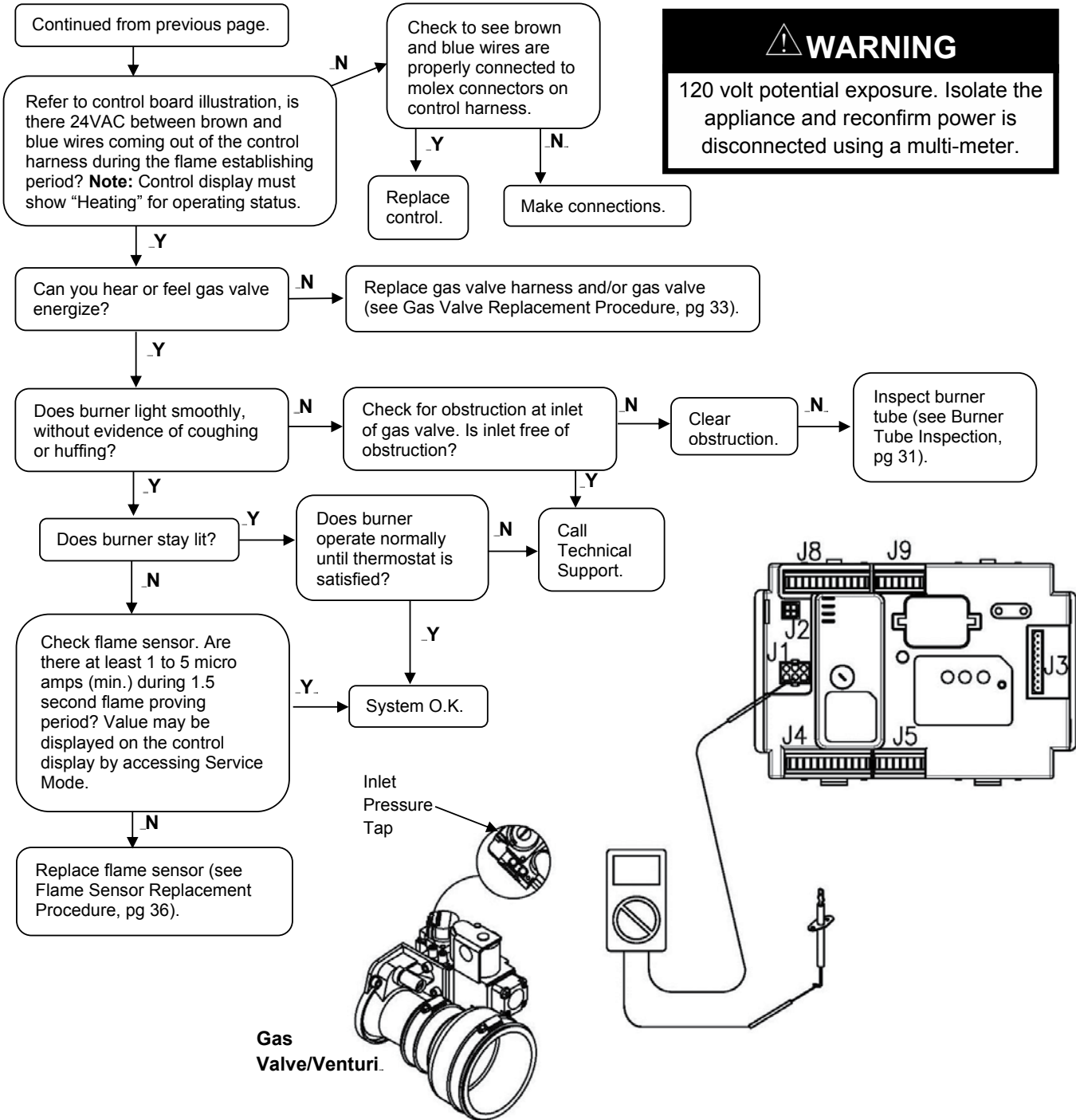

# Service Procedure II: Combustion System Testing and Replacement

## ⚠ WARNING

Heater components may be **HOT** when performing the following steps in this procedure. Take necessary precaution to prevent personal injury.

## ⚠ WARNING

120 volt potential exposure. Isolate the appliance and reconfirm power is disconnected using a multi-meter.

### Combustion System Removal Procedure

1. Position main power switch to OFF.
2. Disconnect (unplug) water heater from 120 volt power source.
3. Turn OFF gas supply to water heater.
4. Unlatch and remove surround cover from top of heater.
5. From the gas valve, disconnect the gas connection, PVC intake venting, silicone tubing, and wire harness.
6. Disconnect wire harnesses flame sensor, gas valve, and blower. Disconnect high voltage cable from spark rod connection.
7. Remove the 5 bolts (1/2" socket) holding the burner mounting insert in place.
8. Carefully remove combustion assembly with gasket from water heater.
9. See next page for combustion system installation procedure.

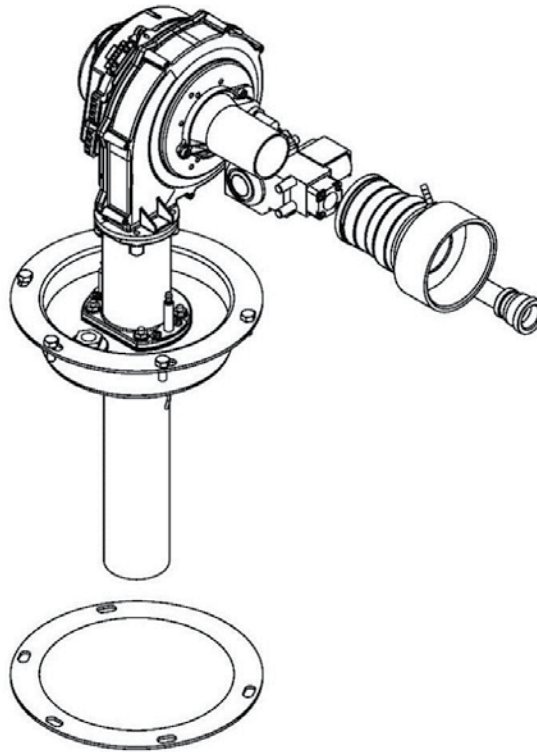

# Service Procedure II: Combustion System Testing and Replacement

---

## Combustion System Replacement Procedure

1. Fully inspect burner mounting insert gasket for the following:
  - a. Tears
  - b. Missing material
  - c. Cracks
  - d. Dirt or debris
  - e. Other imperfections that would inhibit proper seal

If gasket is NOT affected by any of the above, gasket replacement is not required.

2. Install the combustion assembly using new gasket or fully inspected gasket from Step 1. Secure combustion assembly at the burner mounting insert using screws from Step 7 on previous page. Tighten screws evenly.
3. Reconnect the high voltage cable to spark rod, flame sensor, blower and gas valve.
4. Reconnect the PVC intake venting, gas supply, and silicone tubing to gas valve. Turn ON gas supply to heater and check for gas leaks, repair any gas leaks found.
5. Restore 120 volt power supply to water heater and confirm proper operation following the lighting instructions on the lighting instruction label or the lighting instruction located in the Installation and Operating Instruction Manual.
6. Replace the surround cover on the top of the water heater.

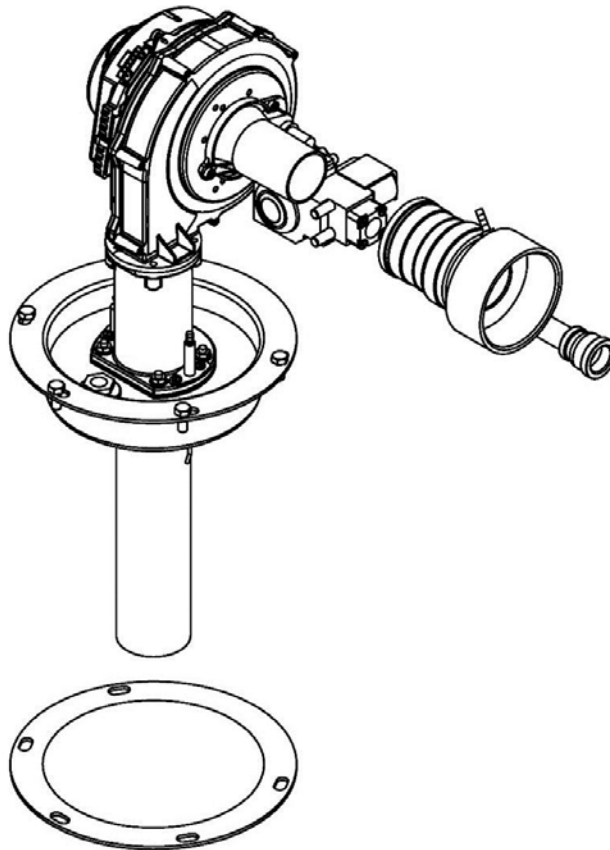



# Service Procedure III: Burner Tube Inspection and Replacement

## ⚠ WARNING

Heater components may be **HOT** when performing the following steps in this procedure. Take necessary precaution to prevent personal injury.

## ⚠ WARNING

120 volt potential exposure. Isolate the appliance and reconfirm power is disconnected using a multi-meter.

### Burner Tube Removal Procedure

1. Position main power switch to OFF.
2. Disconnect (unplug) water heater from 120 volt power source.
3. Turn OFF gas supply to water heater.
4. Unlatch and remove surround cover from top of heater.
5. From the gas valve, disconnect the PVC intake venting, gas supply connection, wire harness, and silicone tubing.
6. Disconnect wire harness from blower assembly.
7. Remove the two screws holding each the spark rod and flame sensor in place (long reach magnetic Phillips screwdriver). Carefully remove spark rod and flame sensor from combustion assembly.
8. Remove the 4 nuts (7/16" wrench) holding the burner transition in place. Lift the blower/gas valve transition assembly from burner mounting insert, remove gasket and set aside.
9. Remove burner tube from burner mounting insert. See next page for burner tube inspection procedure.

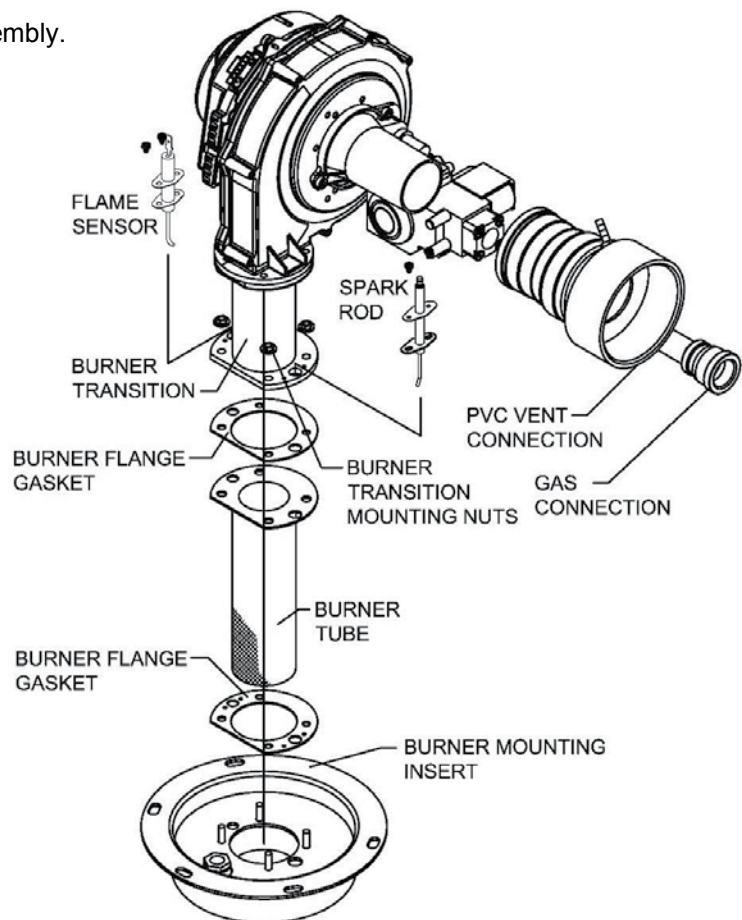

# Service Procedure III: Burner Tube Inspection and Replacement

## **WARNING**

Heater components may be **HOT** when performing the following steps in this procedure. Take necessary precaution to prevent personal injury.

### **Burner Tube Inspection**

1. **Inspect burner tube as follows (Acotech metal fiber mesh burner).**
  - a. Outer fiber mesh should be uniform with no tears or deterioration.
  - b. Gently squeeze burner tube, Burner tube should feel firm without any soft areas around the sides or at the bottom.
  - c. Visually inspect inside burner tube, Burner tube should be intact with no areas of deterioration. Ports should be free of any debris.
2. If burner tube is affected by any of the above, replacement is required. Refer to burner tube replacement procedure below.

### **Burner Tube Replacement Procedure**

**Note:** Provide the model and serial number for the correct replacement burner.

1. Fully inspect burner flange gaskets, igniter and flame sensor gaskets for the following:
  - a. Tears
  - b. Missing material
  - c. Cracks
  - d. Dirt or debris
  - e. Other imperfections that would inhibit proper seal

If gaskets are NOT affected by any of the above, gasket replacement is not required.

2. Install burner tube with gaskets into burner mounting insert. Be sure gasket surfaces are free of debris.
3. Reconnect the blower/gas valve/transition assembly to burner mounting insert. Secure using nuts from Step 8 on previous page.
4. Carefully reinstall flame sensor with gasket and spark rod with gasket and secure with screws from Step 7 on previous page. Reconnect wire harnesses to sensor and igniter.
5. Reconnect wire harnesses to blower motor and to gas valve.
6. Reconnect PVC intake venting, gas supply, and silicone tubing to gas valve. Turn ON gas to heater and check for gas leaks, repair any gas leaks found.
7. Restore 120 volt power supply to water heater and confirm proper operation following the lighting instructions on the lighting instruction label or the lighting instruction located in the Installation and Operating Instruction Manual.
8. Replace the surround cover on the top of the water heater.



# Service Procedure IV: Gas Valve Replacement

## Gas Valve Replacement Procedure

1. Position main power switch to OFF.
2. Disconnect (unplug) water heater from 120 volt power source.
3. Turn OFF gas supply to water heater.
4. Unlatch and remove surround cover from top of heater.
5. From the gas valve, disconnect the gas connection, PVC venting, wire harness, and silicone tubing.
6. Remove the 2 to 3 gas valve mounting screws (Torx bit) located as shown below on the venturi mounting flange and remove gas valve from water heater.
7. Remove any residual gasket material from blower and venturi mounting flange.
8. Install new gas valve with new gasket provided. Secure gas valve in place using screws from Step 6.
9. Reconnect PVC intake venting, gas supply, silicone tubing, and wire harness to gas valve. Turn ON gas supply to heater and check for gas leaks, repair any gas leaks found.
10. Restore 120 volt power supply to water heater and confirm proper operation following the lighting instructions on the lighting instruction label or the lighting instruction located in the Installation and Operating Instruction Manual.
11. Replace the surround cover on the top of the water heater.

### **WARNING**

120 volt potential exposure. Isolate the appliance and reconfirm power is disconnected using a multi-meter.

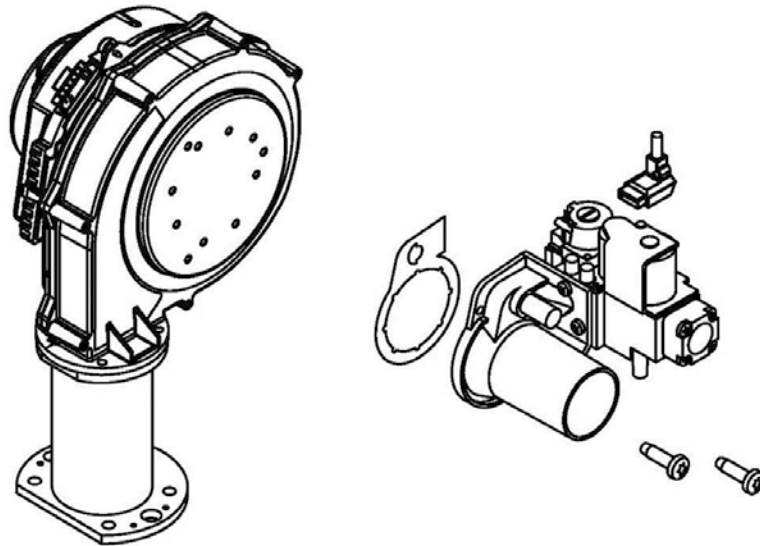

# Service Procedure V: Blower Testing and Replacement

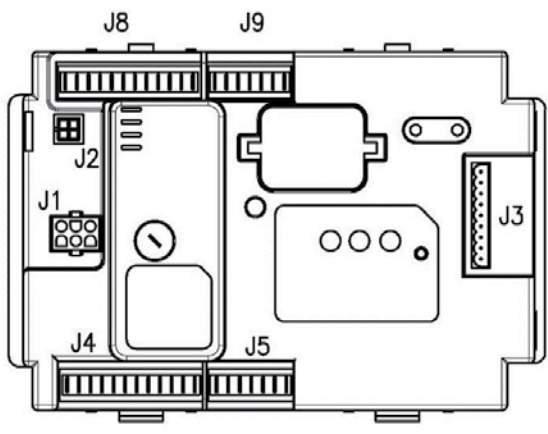
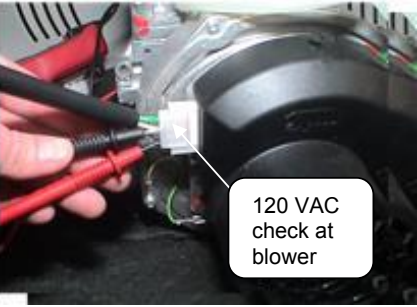
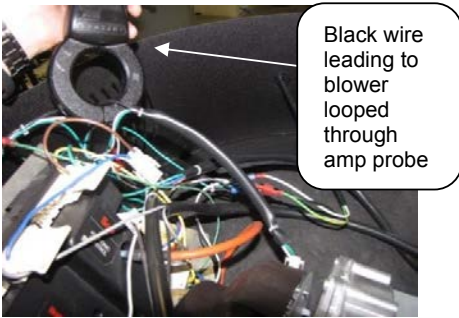
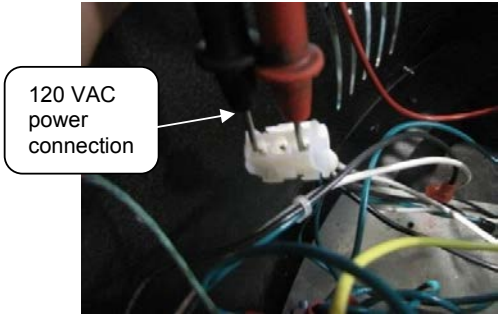
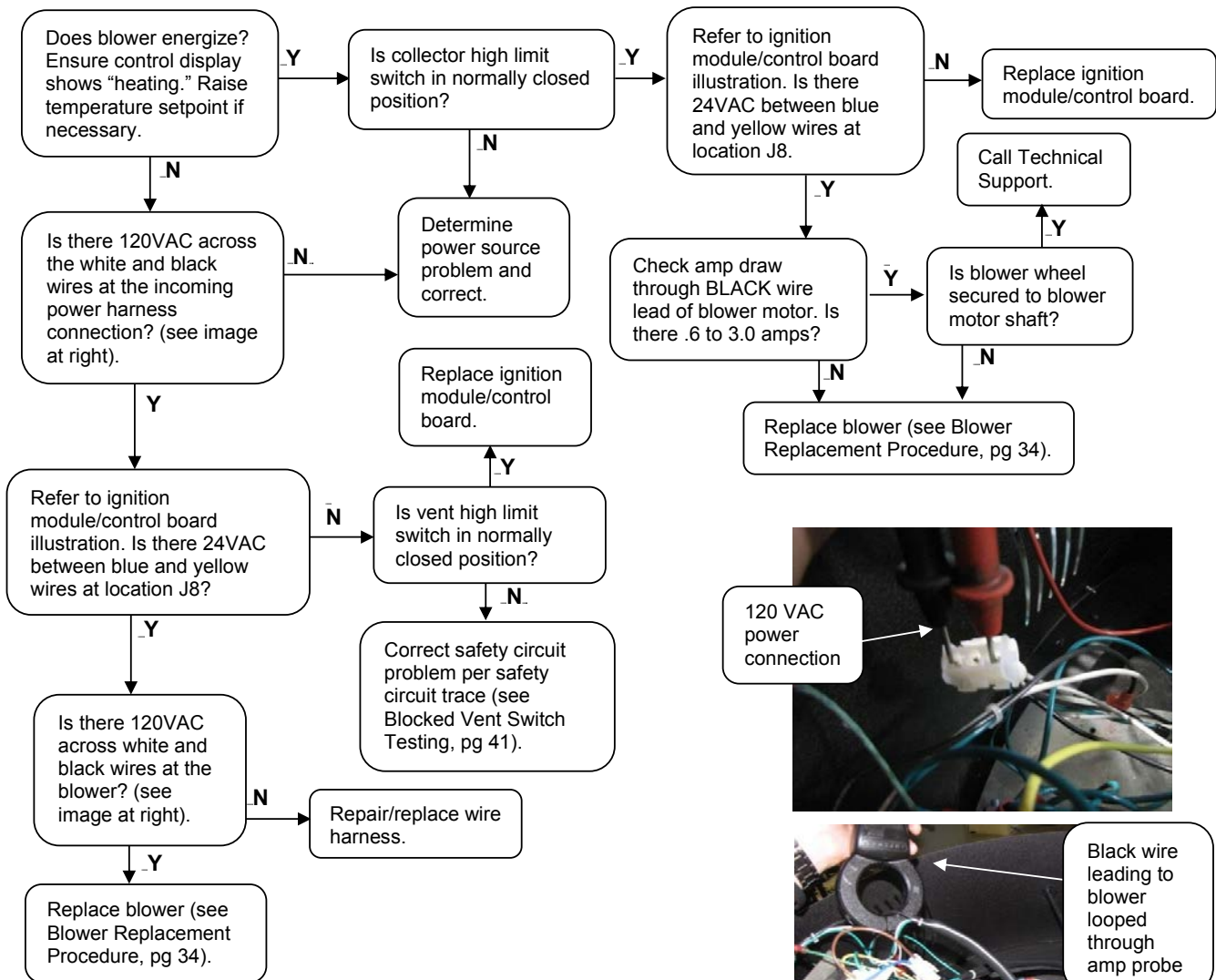

# Service Procedure V: Blower Testing and Replacement

## Blower Replacement Procedure

1. Position main power switch to OFF.
2. Disconnect (unplug) water heater from 120 volt power source.
3. Turn OFF gas supply to water heater.
4. Unlatch and remove surround cover from top of heater.
5. Disconnect the 2 wire harnesses from blower.
6. Disconnect intake vent and gas supply from gas valve assembly.
7. Remove the 2 to 3 gas valve mounting screws (Torx bit) located on the venturi mounting flange (refer to page 33 for more details.)
8. Remove the 4 blower flange mounting screws (5/32 Allen wrench) and remove blower from transition flange.
9. Remove any residual gasket material from venturi mounting flange and transition flange.
10. Install new blower with new gasket provided. Secure blower in place using screws from Step 8.
11. Reconnect gas valve assembly to blower with new gasket provided. Secure gas valve in place using screws from Step 7.
12. Reconnect intake vent and gas line to gas valve assembly and check for gas leaks repair any leaks found.
13. Reconnect the 2 wire harnesses to blower assembly, restore 120 volt power supply and gas supply to water heater and confirm proper operation following the lighting instructions on the lighting instruction label or the lighting instructions located in the Installation and Operating Instruction Manual.
14. Replace the surround cover on the top of the water heater.

### **WARNING**

120 volt potential exposure. Isolate the appliance and reconfirm power is disconnected using a multi-meter.

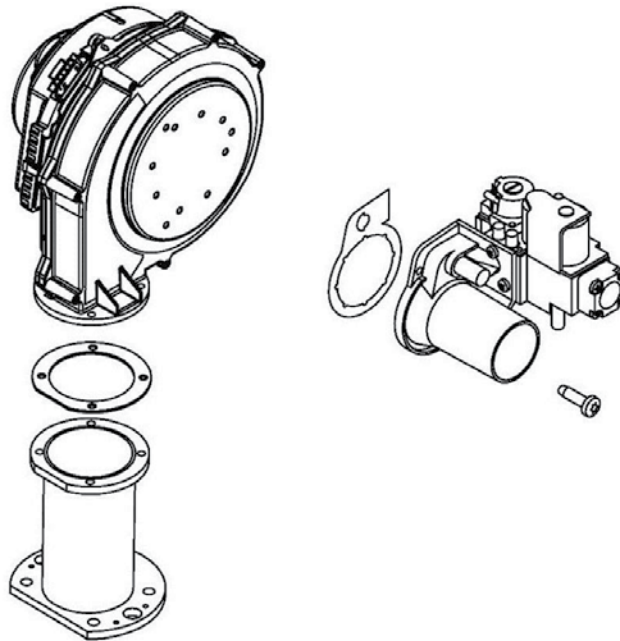

# Service Procedure VI: Flame Sensor Testing and Replacement

## Flame Sensor Testing Procedure



### WARNING

120 volt potential exposure. Use caution making voltage checks to avoid personal injury. Flame sensor may be too hot to handle, take necessary precautions.

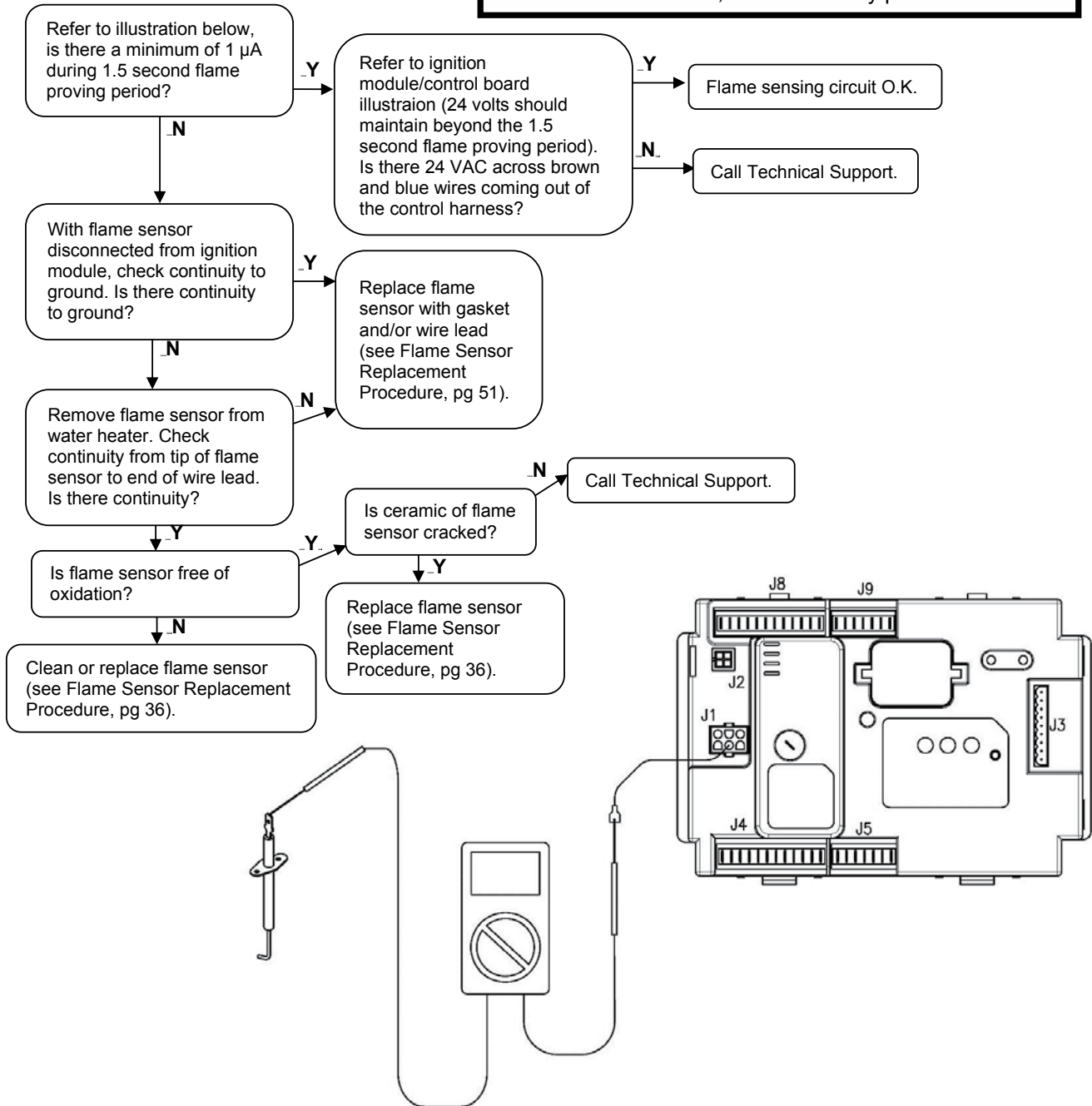

# Service Procedure VI: Flame Sensor Testing and Replacement

## Flame Sensor Replacement Procedure

1. Position main power switch to OFF.
2. Disconnect (unplug) water heater from 120 volt power source.
3. Unlatch and remove surround cover from top of heater.
4. Disconnect the wire lead from flame sensor.
5. Remove the 2 sensor mounting screws (magnetic tip, long reach Phillips screwdriver) and remove flame sensor and gasket from transition base flange.
6. Remove any residual gasket material from transition base flange.
7. Install new flame sensor with new gasket provided using screws from Step 6. Arrange flame sensor with hook towards burner.
8. Reconnect the flame sensor wire.
9. Restore 120 volt power supply to water heater and confirm proper operation following the lighting instructions on the lighting instruction label or the lighting instructions located in the Installation and Operating Instruction Manual.
10. Replace the surround cover on the top of the water heater.

### **WARNING**

120 volt potential exposure. Isolate the appliance and reconfirm power is disconnected using a multi-meter.

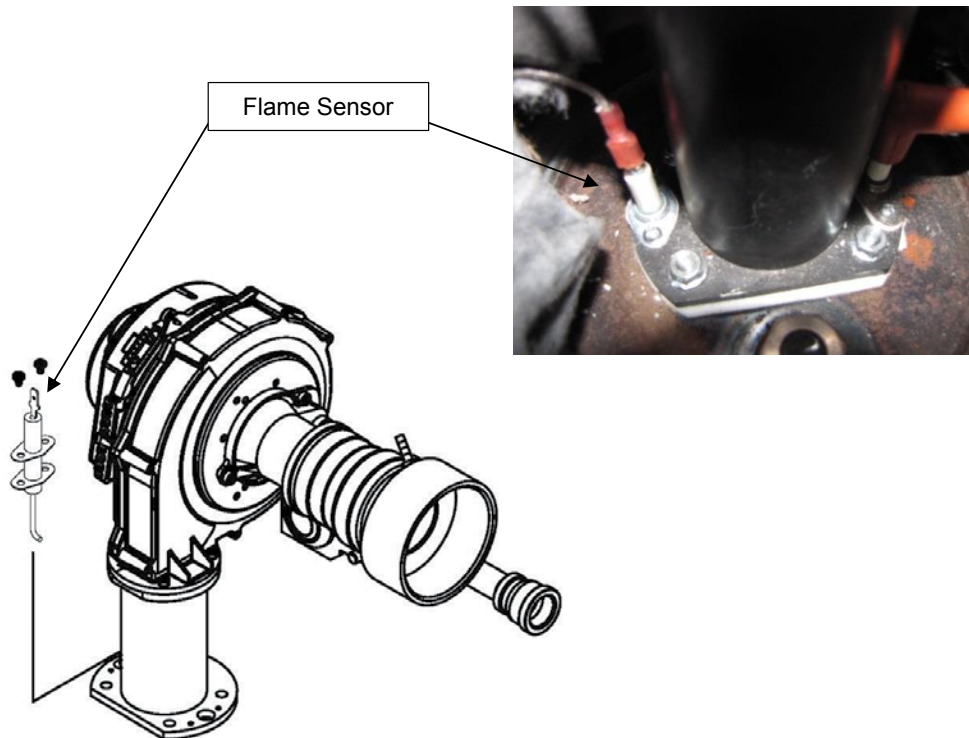



# Service Procedure VII: Spark Rod Gap Adjustment and Replacement

## Spark Rod Gap Inspection and Adjustment

1. Remove combustion system as described in Combustion System Removal Procedure, pg 27.
2. Measure spark gap between the spark rod and burner tube. Acceptable spark gap is from 3/16" to 1/4" (see image below).
3. If spark gap is not between 3/16" to 1/4", the spark rod may be carefully bent by supporting the end near the ceramic insulator with pliers and bending the end near the burner tube with needle nose pliers (see image below).
4. Re-measure and verify the spark gap is between 3/16" to 1/4" after bending.
5. Verify the integrity of all gaskets and replace where required.
6. Reinstall the combustion system per Combustion System Replacement Procedure (pg 27) and check several ignitions to ensure the burner lights smoothly.

### ⚠ WARNING

Spark gap must be set from 3/16" to 1/4". Failure to set and verify proper spark gap may result in a delayed ignition resulting in damage to the water heater.

### ⚠ CAUTION

Use caution while performing these steps to prevent stressing or cracking the ceramic insulator.

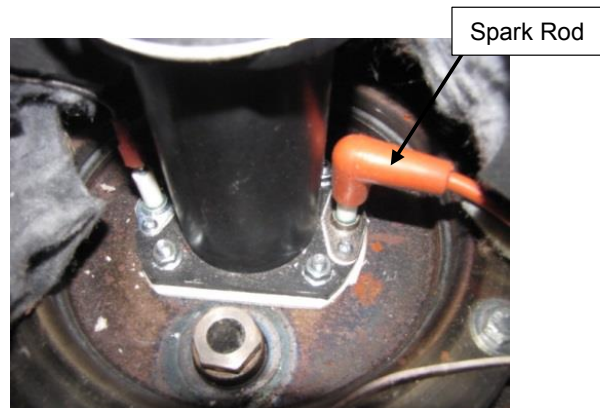
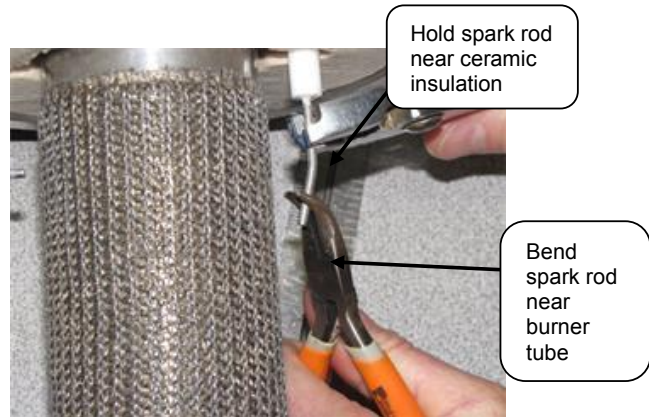
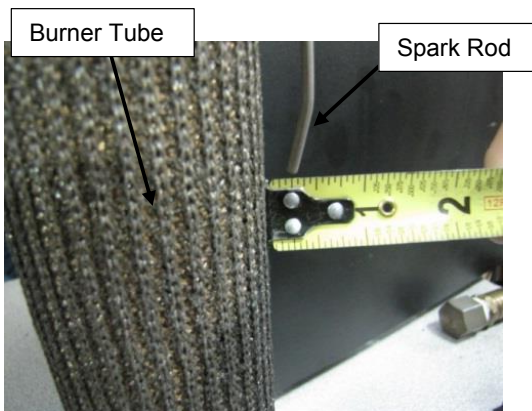

# Service Procedure VII: Spark Rod Gap Adjustment and Replacement

## Spark Rod Replacement Procedure

1. Position main power switch to OFF.
2. Disconnect (unplug) water heater from 120 volt power source.
3. Unlatch and remove surround cover from the top of the water heater.
4. Disconnect wire lead from spark rod.
5. Remove the 2 mounting screws (magnetic tip, long reach Phillips screwdriver) and remove spark rod and gasket from transition base flange.
6. Remove any residual gasket material from transition base flange.
7. Install new spark rod with new gasket provided using screws from Step 6. Arrange spark rod with hook towards burner (off-center mounting hole towards the front of the water heater).
8. Remove combustion system following Combustion System Removal Procedure (pg 27) and verify spark gap following Spark Rod Gap Inspection and Adjustment (pg 38 ). Reassemble combustion system following Combustion System Replacement Procedure (pg 27).
9. Restore 120 volt power supply to water heater and confirm proper operation following the lighting instructions on the lighting instruction label or the lighting instructions located in the Installation and Operating Instruction Manual.
10. Replace the surround cover on the top of the water heater.

### WARNING

120 volt potential exposure. Isolate the appliance and reconfirm power is disconnected using a multi-meter.

### WARNING

If the spark rod is replaced for any reason, the combustion system **MUST** be removed and the spark gap to the burner measured and adjusted properly.

### WARNING

Spark gap must be set from 3/16" to 1/4". Failure to set and verify proper spark gap may result in a delayed ignition resulting in damage to the water heater.

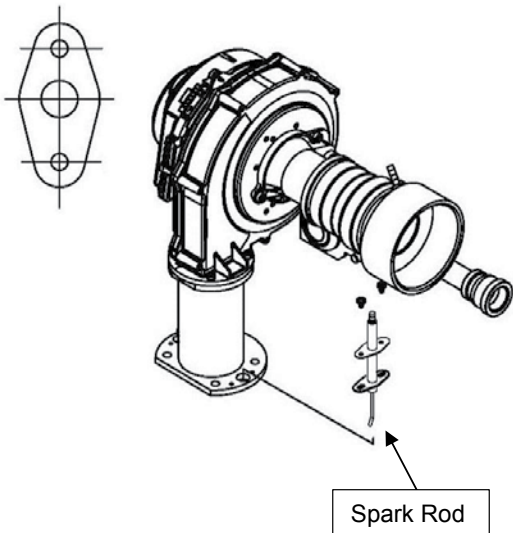

# Service Procedure VIII: Ignition Module/Control Board Replacement

## Control Board Replacement

1. Position main power switch to OFF.
2. Disconnect (unplug) water heater from 120 volt power source.
3. Unlatch and remove top surround cover from the top of the water heater.
4. Locate the control board.
5. Carefully disconnect all wire connections from the control board.  
**Note:** It may be necessary to identify wires for proper re-connection.
6. Depress the plastic tabs on the bottom side of the control board first.
7. Tilt the control panel and slide control hook tabs from slots in the control panel (see image below).
8. Replace the control board and all wire connections.
9. Restore 120 volt power supply to water heater and confirm proper operation following the lighting instructions on the lighting instruction label, or the lighting instruction located in the Installation and Operating Instruction Manual.
10. Replace the surround cover on the top of the water heater.

### **WARNING**

120 volt potential exposure. Isolate the appliance and reconfirm power is disconnected using a multi-meter.

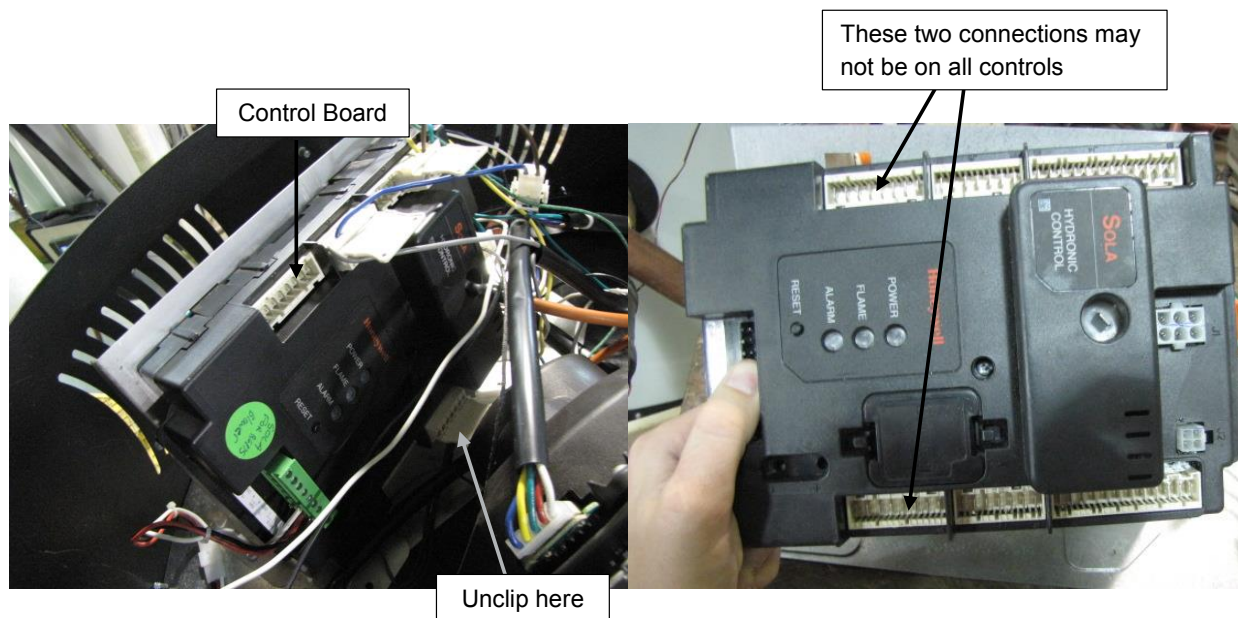



# Service Procedure IX: Blocked Vent Switch Inspection and Replacement

## Blocked Vent Switch Procedure

1. First determine if the blocked vent switch was installed correctly on the drafthood (see image to right).
2. When error code 67 is present on an ICON Control Systems Model, or error code 26 is present on an Integrated Control Model, you first must determine if there is a blocked vent condition present. If so, clear the obstruction and reset the switch then continue with normal operation.
3. If the switch is tripped and there is no obstruction in the venting, there could have been an extended down draft that tripped the switch. The down draft could have been caused by damage vent termination. Contact a plumbing professional to correct this issue.
4. When no blockage or downdraft issues are present check the continuity of the switch (see image below). If there is no continuity present, even when switch is reset, the blocked vent switch assembly needs to be replaced.
5. If blocked vent switch assembly is functioning correctly, check to see if the wire harness has any signs of damage. Replace harness if any signs of damage exist.
6. Restore water heater to use and confirm proper operation following the lighting instructions on the lighting instruction label or the lighting instruction located in the Installation and Operating Instruction Manual.

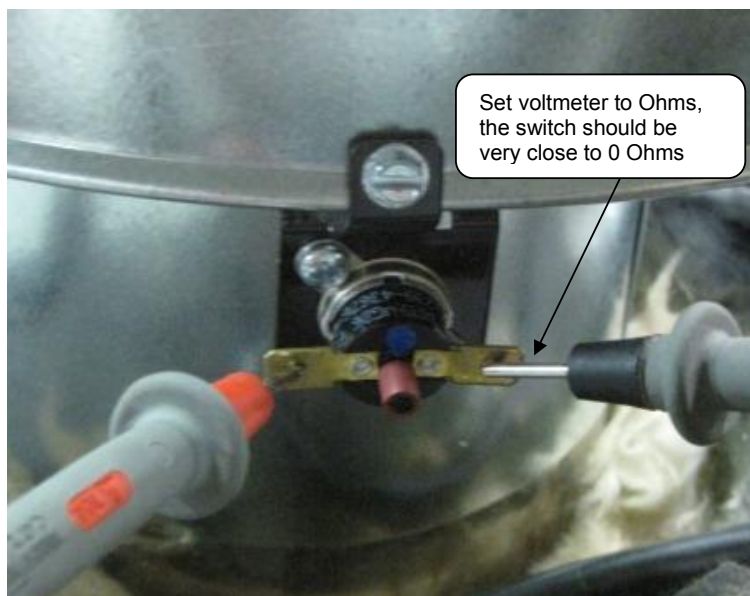

# Service Procedure X: Anode Inspection and Replacement

## Anode Replacement Procedure

1. Position main power switch to OFF.
2. Disconnect (unplug) water heater from 120 volt power source.
3. Turn OFF water supply and drain the water heater.
4. Locate (see image below) and remove anode rods from heater (1-1/16 hex socket).
5. Visually inspect anode rod. Anode rod should show signs of depletion, this is normal. If the depletion is 1/2 of the original diameter (approximately 3/4" diameter), replacement is recommended. If any of the steel core of the anode is exposed, replacement is recommended.
6. Upon completion of inspection or subsequent replacement, apply thread sealing tape or other thread compound to threads of anode and reinstall into heater. Restore the water supply and check for and repair any leaks found.
7. Restore 120 volts to water heater and verify proper heater operation following the instructions on the lighting instruction label or the lighting instruction located in the Installation and Operating Instruction Manual.

## WARNING

Heater components and stored water may be HOT when performing the following steps in this procedure. Take necessary precaution to prevent personal injury.

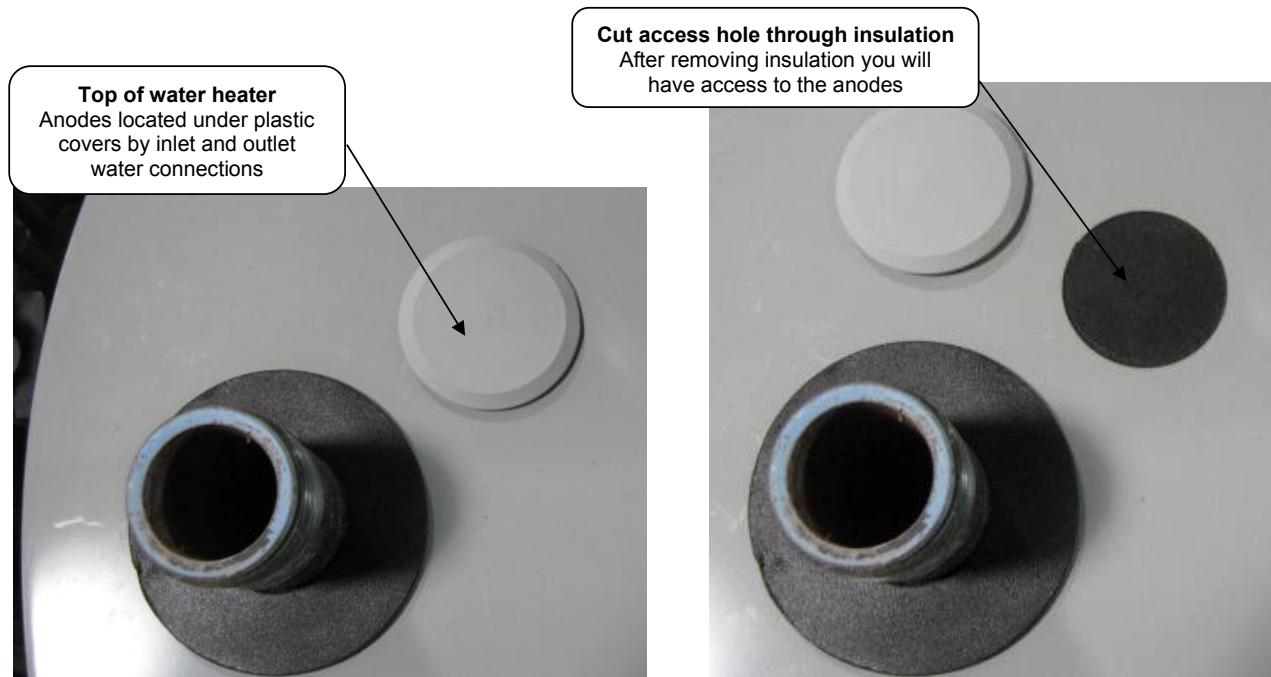

# Service Procedure XI: Display Module Replacement

## Display Module Replacement

1. Position main power switch to OFF.
2. Disconnect (unplug) water heater from 120 volt power source.
3. Remove 4 screws that hold the display into the enclosure (see image below).
4. After removing the screws pull the display out of the enclosure.
5. Once the display is removed, disconnect the two mating plugs.
6. Connect the new display and replace into the enclosure.
7. Use the 4 screws from Step 3 and reinstall the display onto the enclosure.
8. Restore 120 volt power supply to water heater and confirm proper operation following the lighting instructions on the lighting instruction label or the lighting instruction located in the Installation and Operating Instruction Manual.

### **WARNING**

120 volt potential exposure. Isolate the appliance and reconfirm power is disconnected using a multi-meter.

Display and Enclosure



Disconnect



# Service Procedure XII: Transformer Replacement

## Transformer Replacement Procedure

1. Position main power switch to OFF.
2. Disconnect (unplug) water heater from 120 volt power source.
3. Unlatch and remove surround cover from top of water heater.
4. Disconnect primary leads (black & white) and secondary leads (blue & yellow) from the transformer (connections are different sizes to prevent interchanging).
5. Remove the 2 nuts (7/16 nut driver) holding the transformer in place and remove transformer from control panel (see image below).
6. Install new transformer and secure in place with screws from Step 6.
7. Reconnect primary and secondary wires to transformer (leads are different sizes to prevent interchanging).
8. Restore 120 volt power supply to water heater and confirm proper operation following the lighting instructions on the lighting instruction label or the lighting instruction located in the Installation and Operating Instruction Manual.
9. Replace the surround cover on the top of the water heater.

### **WARNING**

120 volt potential exposure. Isolate the appliance and reconfirm power is disconnected using a multi-meter.

black & white wires

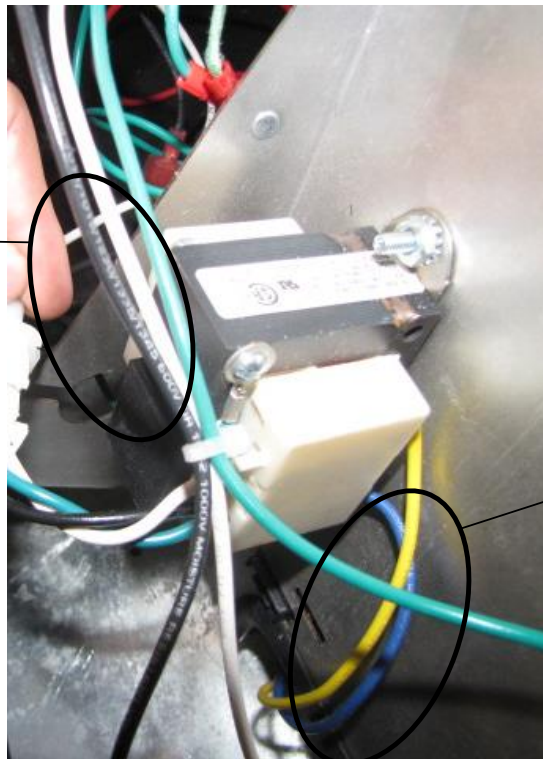

blue & yellow wire

# Water Heater Installation Checklist

<b>Product Handling</b>	Carefully uncrate the heater. Move in place with a hand truck ( <b>Do NOT</b> use the venting pipes for handles).
<b>Electrical Requirements</b>	Make sure there is 120 volts line voltage. Line voltage must be properly polarized. Adequate ground supplied to the heater.
<b>Venting Requirements</b>	All venting must stay within the required lengths and diameter (see table below). Proper support of the venting pipe is a <b>MUST</b> (every 5 ft (1.5 m) vertical and 3 ft (.92 m) horizontal). Termination must be located to prevent re-circulation of flue gases.
<b>Gas Requirements</b>	Gas piping sized adequately, 3/4". Install a properly sized regulator (if unknown, assure an adequate volume of gas is available). 7" W.C. is required when the unit is running. Gas pressure must stay below 14" W.C. static pressure. Pressure drops between static pressure and operating flow should be less than 3" W.C.
<b>Service/Mechanical Room</b>	Provide adequate space for servicing heater. Leave enough overhead room to remove the anode rods for servicing (18" min).

## Vent Tables (Intake Only)

Model Number	2" Max Intake Vent Length (feet)	3" Max Intake Vent Length (feet)	4" Max Intake Vent Length (feet)
UCG80H125	20	50	75
UCG(80,100)H199	20	50	75
UCG(80,100)H270	20	50	75
UCG(80,100)H399	N/A	75	20

### **WARNING**

The UCG(80,100)H399 model is not approved for 2 inch diameter vent pipe. Venting with 2 inch pipe may result in damage to the water heater or cause an unsafe condition. **DO NOT** use 2 inch vent air intake pipe with UCG(80,100)H399.

### Determining Required Intake Vent Length

1. Determine the total length of straight vent pipe (in feet) required for the intake.
2. Add 5 feet of venting for every 90° elbow.
3. Add 2 ½ feet of venting for every 45° elbow.
4. **Total intake vent length cannot exceed Max Intake Vent Length on the venting table shown above.**

### Example Of Total Intake Vent Length For UCG100H399 Installation:

A 3" venting system has a total of two 90-degree elbows and a total straight pipe length of 10 feet.

Equivalent vent length for elbows: 2 x 5 feet = 10 feet.

**Total equivalent intake vent distance = 10 feet + 10 feet = 20 feet total equivalent vent length. This is below the maximum allowed distance of 25 feet for this model using 3" vent.**

The "metal/atmospheric" exhaust system of this unit must follow the National Fuel Gas code.

# Water Heater Service Report

Date: \_\_\_\_\_

Service Provider: \_\_\_\_\_

Model Number: \_\_\_\_\_

Phone Number: \_\_\_\_\_

Serial Number: \_\_\_\_\_

**Intake Venting:**

Intake Vent size 3", 4" \_\_\_\_\_

Intake 45° Elbows (qty) \_\_\_\_\_

Length of Straight Pipe (Intake) \_\_\_\_\_

Intake 90° Elbows (qty) \_\_\_\_\_

Exhaust Vent Size 6", 7", 8" \_\_\_\_\_

**Gas Line:**

Size & Material \_\_\_\_\_

**Gas Pressure:**

Static \_\_\_\_\_

**Venturi:**

Setting from Bottom in Turns \_\_\_\_\_

Distance from Meter to Water Heater \_\_\_\_\_

Running Inlet \_\_\_\_\_

Manifold \_\_\_\_\_

**Electrical:**

Line Voltage \_\_\_\_\_

Low Voltage \_\_\_\_\_

Polarity \_\_\_\_\_

Flame Sense (µA) \_\_\_\_\_

Spark Gap \_\_\_\_\_

Error Codes on Control Display: \_\_\_\_\_

**Combustion:**

CO<sub>2</sub> \_\_\_\_\_

CO \_\_\_\_\_

**Installation Site Name & Address:**

\_\_\_\_\_  
\_\_\_\_\_  
\_\_\_\_\_  
\_\_\_\_\_  
\_\_\_\_\_

**Installation Site Contact Name & Phone Number**

\_\_\_\_\_  
\_\_\_\_\_  
\_\_\_\_\_  
\_\_\_\_\_  
\_\_\_\_\_

**Customer must specify complete model number and serial number when ordering service parts.**

Manufactured under one or more of the following U.S. Patents: 5,277,171; 5,341,770; 5,372,185; 5,485,879; 5,574,822; 5,596,952; 5,660,165; 5,682,666; 5,761,379; 5,943,984; 5,954,492; 5,988,117; 6,056,542; 6,142,216; 6,442,178; 6,684,821; 6,935,280; 7,063,132; 7,063,133; 7,007,748; 7,270,087; 7,334,419; 7,337,517; 7,409,925; 7,458,341; 7,559,293; 7,621,238; 7,634,976; 7,650,859; 7,665,210; 7,665,211; 7,699,026; 7,866,168; 7,900,589; 7,971,560; 7,992,526 8,082,888; 8,146,772; Other U.S. and Foreign patent applications pending. Current Canadian Patents: 2,092,105; 2,107,012; 2,108,186; 2,112,515; 2,143,031; 2,239,007; 2,262,174; 2,314,845; 2,409,271; 2,476,685; 2,504,824; 2,548,958

**Refer to the parts list on [www.bradfordwhite.com](http://www.bradfordwhite.com) for a complete parts listing and expanded views of the models covered in this manual.**







## United States

---

**Sales** 800-523-2931

**Technical Support** 800-334-3393

**Email** [techserv@bradfordwhite.com](mailto:techserv@bradfordwhite.com)

**Warranty** 800-531-2111

**Email** [warranty@bradfordwhite.com](mailto:warranty@bradfordwhite.com)

**Service Parts** 800-538-2020

**Email** [parts@bradfordwhite.com](mailto:parts@bradfordwhite.com)

## Canada

---

**Sales & Technical Support** 866-690-0961 905-03-0600

**Fax** 905-636-0666

**Warranty** [bwccwarranty@bradfordwhite.com](mailto:bwccwarranty@bradfordwhite.com)

**Technical Support** [bwccotech@bradfordwhite.com](mailto:bwccotech@bradfordwhite.com)

**Service Parts** [orders@bradfordwhitecanada.com](mailto:orders@bradfordwhitecanada.com)

**Orders** [ca.orders@bradfordwhite.com](mailto:ca.orders@bradfordwhite.com)

For U.S. and Canada field service,  
contact your professional installer or  
local Bradford White sales representative.

## International

---

**General Contact** [international@bradfordwhite.com](mailto:international@bradfordwhite.com)