



BENSHAW POWERPRO™ FAN AND PUMP (PPFP) SINGLE AC DRIVES

OPEN LOOP
FOR VARIABLE TORQUE APPLICATION

USER GUIDE

Manual Number: 890051-00-00

PREFACE

Thank you for purchasing the Benschaw PowerPro™ Fan and Pump Single AC Drive, a dedicated fan and pump drive for diverse variable torque applications such as fans, pumps, blowers and centrifugal compressors.

A variable torque application is when the required torque is less at lower motor speeds but greater at higher speeds. A typical variable torque load is proportional to the square of the speed (e.g. fans). When the speed is reduced by ½, the required torque is reduced by ¼ — thus reducing the energy consumed by the load. The drive supports V/F operations with 110% and 150% overloads for 60s and is used primarily for speed control of three-phase AC asynchronous motors. Using high-performance V/F control technology, the Benschaw PowerPro™ Fan and Pump AC Drive delivers excellent dynamic characteristics and superior overload capability. It provides user-programmable features and PC monitoring software, and it supports multiple field buses for communication.





FIRST USE

Read this manual carefully if you are using the Benschaw PowerPro™ Fan and Pump Single AC Drive for the first time. If you have questions about its functions or performance, please contact our technicians for help.

STANDARDS COMPLIANCE

Certification marks on the product template indicate compliance with the corresponding certificates and standards.

Certification	Mark	Directive Name	Standard
CE		EMC directives	2014/30/EU EN 61800-3
		LVD directives	2014/35/EU EN 61800-5-1
		RoHS directives	2011/65/EU EN 50581
UL		—	UL61800-5-1 C22.2 No.14-13

Note: The Benschaw PowerPro™ Fan and Pump Single AC Drive complies with the IEC/EN 61800-3 standard only when it is correctly installed and used with an EMC filter. For details, refer to “2 System Connection,” and for common EMC problem rectification, refer to EMC Guidelines Compliance (contact factory for details).

REVISION HISTORY

Date	Version	Change Description
Mar 2019	V0.0	N/A

MANUAL AVAILABILITY

- This manual is delivered with the product. If you want to purchase another copy, please contact your product distributor.
- Manual number: 890051-00-00. Visit the official website (<http://www.benschaw.com>) of BENSCHAW, INC. to download the PDF version.

CONTENTS

Preface	2	1
Revision History	2	
Safety Information	6	
1. Product Information	10	2
1.1 Nameplate and Model	10	
1.2 Description of Parts	11	
2. System Connection	16	3
2.1 Benshaw PowerPro™ Fan and Pump Single AC Drive System Connection Diagram	17	
2.2 Benshaw PowerPro™ Fan and Pump Single AC Drive System Composition.....	18	
3. Technical Specifications	19	4
3.1 Drive Ratings and Technical Specifications	19	
3.2 Dimensions – Outline Drawings of Benshaw PowerPro™ Fan and Pump Single AC Drive.....	24	
3.2.1 Overall Dimensions of RSI-PPFP-0001-4-3-B-IP20-IM to RSI-PPFP-0250-4-3-X-IP00-IM	24	
3.2.2 Overall Dimensions of RSI-PPFP-0300-4-3-X-IP00-IM to RSI-PPFP-0700-4-3-X-IP00-IM	26	
4. Mechanical Installation	27	5
4.1 Installation	27	
4.1.1 Installation Environment.....	27	
4.1.2 Mounting Clearance and Orientation	28	
4.1.3 Installation of RSI-PPFP-0001-4-3-B-IP20-IM to RSI-PPFP-0250-4-3-X-IP00-IM	30	
4.1.4 Mounting in Cabinet.....	31	
4.1.5 Dimensions of Bottom Mounting Bracket	33	
4.1.6 Assemble the Guide Rail (model: RSI-PPVC-AXRY-RAIL-T10_T12, optional).....	35	
4.1.7 Installing the AC drive in the cabinet.....	36	
5. Electrical Wiring	38	6
5.1 Removal and Installation of the Cover	38	
5.2 Wiring	41	
5.2.1 Standard Wiring Diagram	41	
5.2.2 Functions of Main Circuit Terminals and Precautions.....	42	
5.2.3 Cables, Breakers and Contactors.....	43	
5.2.4 Control Board.....	48	
5.2.5 Control Circuit Terminal Arrangement.....	48	
6. Panel Operation	50	7
6.1 LED Operating Panel.....	50	
6.1.1 Indicators on LED Operating Panel	51	
6.1.2 LED Display	51	
6.1.3 Keys on LED Operating Panel	52	
6.1.4 View and Modify Function Parameters.....	52	
6.1.5 Keys on LED Operating Panel	53	
6.1.6 Drive Parameter Structure.....	54	
6.1.7 Quick View Mode – Activation	54	
6.1.8 View Function Parameters	55	

CONTENTS

6.1.9	MF.K Key Function	58
6.1.10	Function and Monitoring Parameters.....	58
6.2	Parameters.....	59
6.2.1	Standard Parameter Table - F0 to FP.....	59
6.2.2	Standard Parameter Table - A0 to AC.....	78
6.2.3	Monitoring Parameters.....	84
7.	Basic Operations and Trial Run	86
7.1	Quick Commissioning Guide	86
7.2	Commissioning Flowchart	86
7.3	Checklist Before Power-on	88
7.4	Display After Power-on.....	88
7.5	Parameter Initialization.....	88
7.6	Motor Control.....	89
7.7	Start/Stop running command	89
7.7.1	Start/Stop Operating Panel.....	89
7.7.2	Start/Stop DI.....	89
7.8	Start the AC Drive.....	92
7.8.1	Start Mode.....	92
7.8.2	Start Frequency	93
7.9	View Running Status.....	94
7.9.1	Digital Output (DO).....	94
7.9.2	Analog Output (AO).....	94
7.10	Auto-tuning	95
8.	Troubleshooting and Solutions	97
8.1	Safety Information	97
8.2	Troubleshooting During Trial Run.....	98
8.3	Fault Display.....	99
8.4	Resetting Fault.....	99
8.5	Faults and Diagnostics.....	100
8.6	Symptoms and Diagnostics	104
9.	Routine Inspection and Maintenance	106
9.1	Routine Inspection.....	106
9.1.1	Routine Inspection Items	107
9.2	Periodic Inspection	107
9.2.1	Periodical Inspection Items.....	107
9.2.2	Insulation Test on Main Circuit.....	108
9.3	Replacement of Wear Parts.....	108
9.3.1	Lifetime of Wear Parts	108
9.3.2	Number of Fans on the Drive.....	109
9.3.3	Replacement of Fans	109
9.3.4	DC Bus Electrolytic Capacitors	113
9.4	Storage.....	113
9.5	Warranty.....	113

CONTENTS

Appendix A Options and Accessories	114
A.1 Braking Unit Options and Accessories.....	114
A.1.1 Selection of Resistance of Braking Resistor.....	114
A.1.2 Selection of Power of Braking Resistor.....	114
A.1.3 Selection Guidance for Braking Units.....	114
A.1.4 Appearance and Mounting Dimensions of Braking Units.....	116
A.2 Through-Hole Mounting of Benshaw PowerPro™ Fan and Pump.....	117
A.3 Overall Dimensions with Optional Through-Hole Mounting Bracket.....	119
A.4 Cable Support Bracket.....	128
A.5 AC Output Reactor.....	129
A.6 Applicable Motor.....	129
A.7 External LCD Operating Panel.....	130
Appendix B Optional Expansion Cards, and Modbus Communication Protocol	131
B.1 Optional Expansion Card Installation and Function Guidelines.....	131
B.1.1 Installation.....	131
B.1.2 Functions.....	132
B.2 Layout and Function of Terminals of RS485 Card (RSI-PPVC-AXRY-COMM-MDBS).....	133
B.3 Layout and Function of Terminals of Extended I/O and Communications Card (RSI-PPVC-AXRY-IOMOD-ADV).....	134
B.4 Layout and Function of Terminals of Extended I/O Card-02 (RSI-PPVC-AXRY-IOMOD-STD).....	136
B.5 Modbus Communication Protocol.....	140
B.5.1 Application.....	140
B.5.2 Bus Structure.....	140
B.6 Data Format.....	141
B.7 Rules for Parameter Address Marking.....	143
B.8 Group FD Communication Parameter Description.....	146

SAFETY INFORMATION

SAFETY PRECAUTIONS

Read and follow the safety precautions when installing, operating and maintaining the product.

To ensure your safety and prevent damage to equipment, follow the marks on the product and safety precautions in this manual when installing, operating and maintaining the product.

1. "CAUTION", "WARNING" and "DANGER" items in the manual do not indicate all safety precautions that need to be followed; instead, they supplement the safety precautions.
2. Use this product in environment meeting the design and specification requirements; otherwise, a fault may occur. Noncompliance-caused malfunction or damage to parts are not covered in the product quality warranty.
3. Benshaw is not legally responsible for any personal safety accident or property losses caused by improper operation of this product.

SAFETY GRADE AND DEFINITION

 **DANGER** "DANGER" indicates a safety precaution that will result in death or serious injury if not followed.

 **WARNING** "WARNING" indicates a safety precaution that may result in death or serious injury if not followed.

 **CAUTION** "CAUTION" indicates a safety precaution that may result in minor injury or equipment damage if not followed.

UNPACKING AND CHECKING

CAUTION

- Before unpacking, check whether the outer package is intact, damaged, wet, damp or deformed.
- Open the package in sequence. During unpacking, check whether the product and its accessories have any damage, corrosion or dents on the surface.
- Check the quantity of the product and accessories to ensure that it matches the packing list.

WARNING

- Do not install the product and/or its accessories if you find that the product and/or its accessories have any damage or corrosion.
- Do not install the product if there is water inside the product or any of its parts are missing or damaged.
- Do not install the product if the product name is inconsistent with that on the packing list.

DURING STORAGE AND TRANSPORTATION

CAUTION

- Store and transport the product according to its storage and transportation conditions. The storage temperature and humidity shall meet relevant requirements.
- Do not store or transport the product in places with direct sunlight, strong electric field, strong magnetic field or strong vibration or places that are wet from rain or splashing water.
- Do not store the product for more than one year. Capacitors will need to be "reformed" if they have not been used in more than a year. Take stricter prevention measures and perform the necessary inspection if the storage time is extensive. Refer to section 9.4 for further information
- Pack the product properly before transportation. The product must be placed in a sealed box for long-distance transportation.
- Do not transport the product together with any equipment or articles that may affect or impair the product.

 **WARNING**

- Be sure to use professional loading and unloading equipment to move large or heavy equipment and products.
- When moving the product by hand, grip the product case tightly to avoid dropping product parts, causing damage.
- Be sure to move the product carefully, paying attention to your step to prevent trip or fall and risk of injury to you or damage to the product.
- When the equipment is lifted by lifting gear, do not stand in the area below the lifting area.

DURING INSTALLATION

 **WARNING**

- Before installation, carefully read the product manual and safety precautions.
- Do not modify the product.
- Do not unscrew the fixing bolts or bolts with red marks.
- Do not install this product in a place with a strong electric field or strong electromagnetic interference.
- When the product is installed in a cabinet or terminal equipment, the cabinet or terminal equipment shall be provided with the corresponding protective devices such as fireproof enclosure, electrical enclosure and mechanical enclosure. The protection grade shall comply with relevant UL/IEC standards and local laws and regulations.

 **CAUTION**

- Product installation, wiring, maintenance, inspection and component replacement should only be performed by professionals trained in electrical equipment and having knowledge of electrical equipment.
- Installers must be familiar with product installation requirements and related technical data.
- When you need to install equipment creating strong electromagnetic interference, such as transformers, install the shield protection device to prevent the product from malfunction.

DURING WIRING

 **DANGER**

- Non-professionals are strictly prohibited from equipment installation, wiring, maintenance, inspection or component replacement.
- Do not perform wiring while the power is turned on. Failure to comply may result in electric shock.
- Before wiring, cut off the power to all equipment. Residual voltage remains in the internal capacitor of the equipment after the power is cut off. Wait for at least 10 minutes before wiring and other operations.
- Be sure equipment and the product are properly grounded. Failure to comply may result in electric shock.

SAFETY INFORMATION

DURING WIRING (CONTINUED)

CAUTION

- Follow the electro-static discharge (ESD) precautions and wear an ESD wrist strap to avoid damage to the equipment or circuit inside the product.
- It is prohibited to connect the input power to the output terminal of the equipment or product; otherwise, the equipment may be damaged or fire may occur.
- When connecting the drive to the motor, be sure that the phase sequence of the drive and the motor terminal are consistent, so as to avoid reverse rotation of the motor.
- The cables used for wiring must meet relevant diameter and shielding requirements, and the shielding layer of the shielding cables must be reliably grounded at a single terminal.
- After wiring is complete, be sure there are no screws or bar cables left inside the equipment and product.

DURING POWER-ON

DANGER

- Before power-on, make sure the equipment and product are installed properly, the wiring is securely connected and the motor unit is allowed to restart.
- Before power-on, make sure the power supply meets the equipment requirements to avoid damage to the equipment or fire.
- During power-on, mechanical devices of the equipment or product may suddenly move. Stay away from the mechanical devices.
- After power-on, do not open the equipment cabinet door or product protection cover; to avoid the danger of electric shock.
- It is prohibited to touch any terminal of the equipment when power is on; otherwise, there is danger of electric shock.
- It is prohibited to dismantle any device or parts of the equipment and product when the power is on; otherwise, there is danger of electric shock.

DURING RUNNING

DANGER

- It is prohibited to touch any terminal of the equipment when it is running; otherwise, there is danger of electric shock.
- It is prohibited to dismantle any device or parts of the equipment and product when the equipment is running; otherwise, there is danger of electric shock.
- It is prohibited to touch the equipment closure, fan or resistor to check the temperature; otherwise, there is danger of burns.
- Non-professional technicians are prohibited from monitoring signals when the equipment is running; otherwise, there is danger of personal injury or damage to the equipment.

WARNING

- When the equipment is running, do not drop other articles or metals into the equipment; otherwise, the equipment may be damaged.
- Do not start or stop the equipment by turning on or off the connector; otherwise, the equipment may be damaged.

DURING MAINTENANCE

DANGER

- Non-professionals are strictly prohibited from equipment installation, wiring, maintenance, inspection or component replacement.
- It is prohibited to maintain the equipment when power is on; otherwise, there is danger of electric shock.
- After the equipment power is cut off, wait for at least 10 minutes before maintaining the equipment or performing other operations.

WARNING

- Follow the equipment maintenance and repair requirements for routine and regular inspection and maintenance of the product and equipment, and maintain maintenance records.

DURING REPAIR

DANGER

- Follow Lock Out/Tag Out procedures.
- Non-professionals are strictly prohibited from equipment installation, wiring, maintenance, inspection or component replacement.
- It is prohibited to repair the equipment when power is on; otherwise, there is danger of electric shock.
- After the equipment power is cut off, wait for at least 10 minutes before inspecting or repairing the equipment or performing other operations.

CAUTION

- Repair the equipment according to the product warranty agreement.
- When the equipment has a fault or is damaged, troubleshoot and repair the equipment and product follow guidance by professionals, and maintain repair records.
- Replace the product's wearing components under the guidance of professionals.
- Do not continue to use damaged machines; otherwise, greater damage may occur.
- After replacing the equipment, recheck the equipment wiring and parameter settings again.

DURING SCRAPPING

CAUTION

- Scrap the equipment and product according to government regulations and standards to avoid property loss or personal injury.
- Recycle scrapped equipment and product according to industrial waste processing standards to avoid pollution to the environment.

SAFETY MARKS

For safe operation and maintenance of the equipment, be sure to observe the safety marks affixed to the equipment and product. Do not damage, destroy or peel off the safety marks. Safety marks are described as follows:



- Read the user manual before installing and running the equipment; otherwise, there is danger of electric shock.
- Do not dismantle the cover within 10 minutes after the power is turned off.
- After cutting off the power at the input and output terminals, wait for 10 minutes until the power indicator turns off before maintaining, inspecting or wiring the equipment.

1. PRODUCT INFORMATION

1

SAFETY INFORMATION

CAUTION

- Do not lift/carry the drive by gripping the front cover. Failure to comply may result in personal injury.
- Follow proper electrostatic discharge (ESD) procedures when operating the drive. Failure to comply will risk damaging the internal circuits of the drive.

1.1 NAMEPLATE AND MODEL

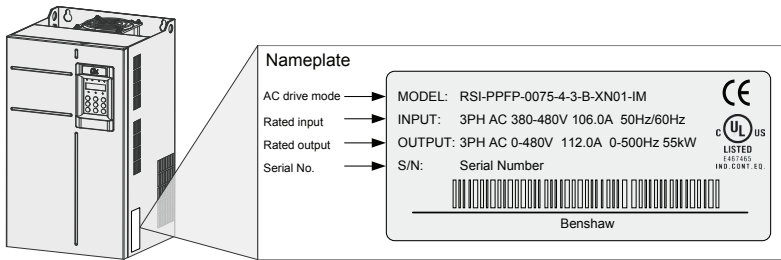

AC Drive Model

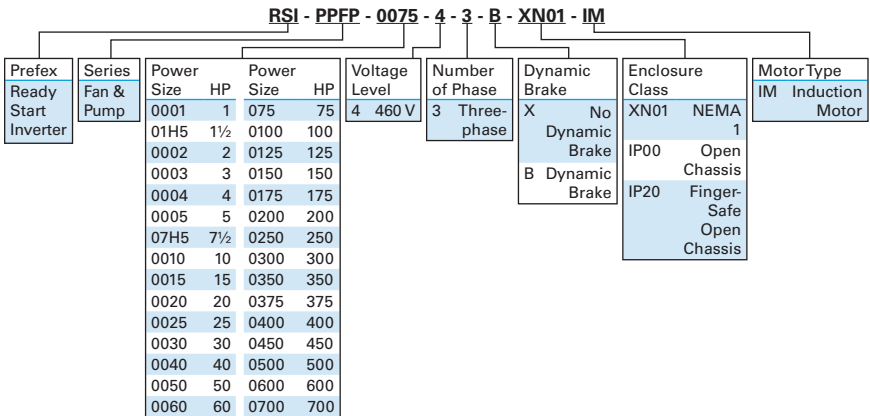

Figure 1-1 Nameplate and model number

1.2 DESCRIPTION OF PARTS

The drive may have either a plastic housing or a sheet metal housing, depending on the voltage and power rating, as shown in the following figures:

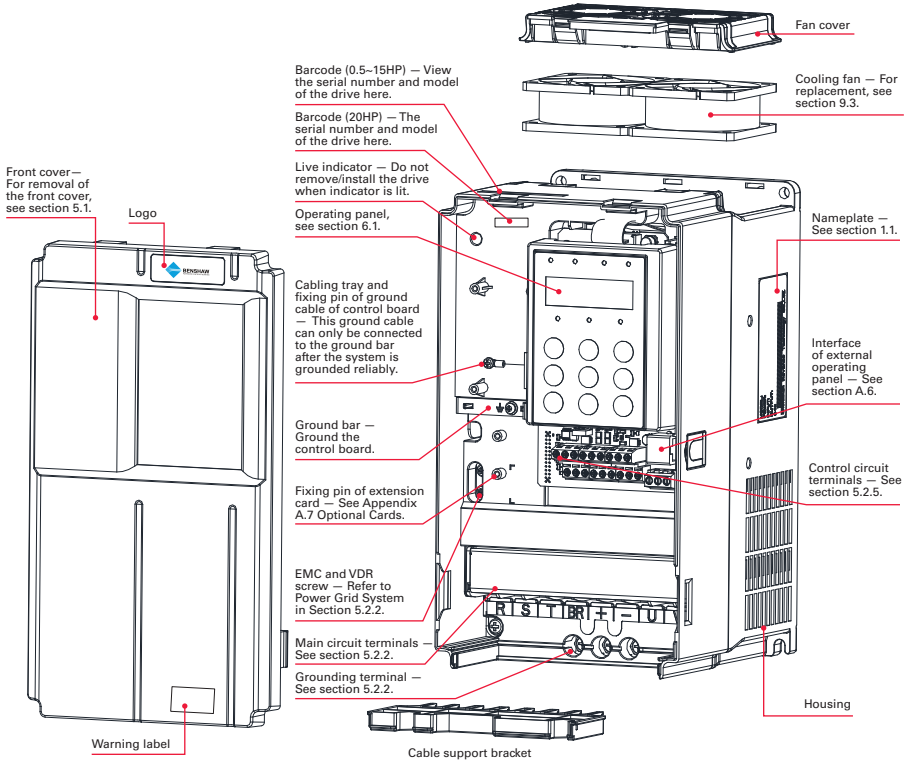

Figure 1-2a Diagram of product parts (three-phase, 380V–480V, RSI-PPFP-0001-4-3-B-IP20-IM to RSI-PPFP-0025-4-3-B-IP20-IM)

Warning label



Description

CAUTION! Read the user guide for the AC drive carefully before installation or operation.



10min

DANGER! Do not remove the front cover while the power is on or within 10 minutes after the power is turned off.

1. PRODUCT INFORMATION

1

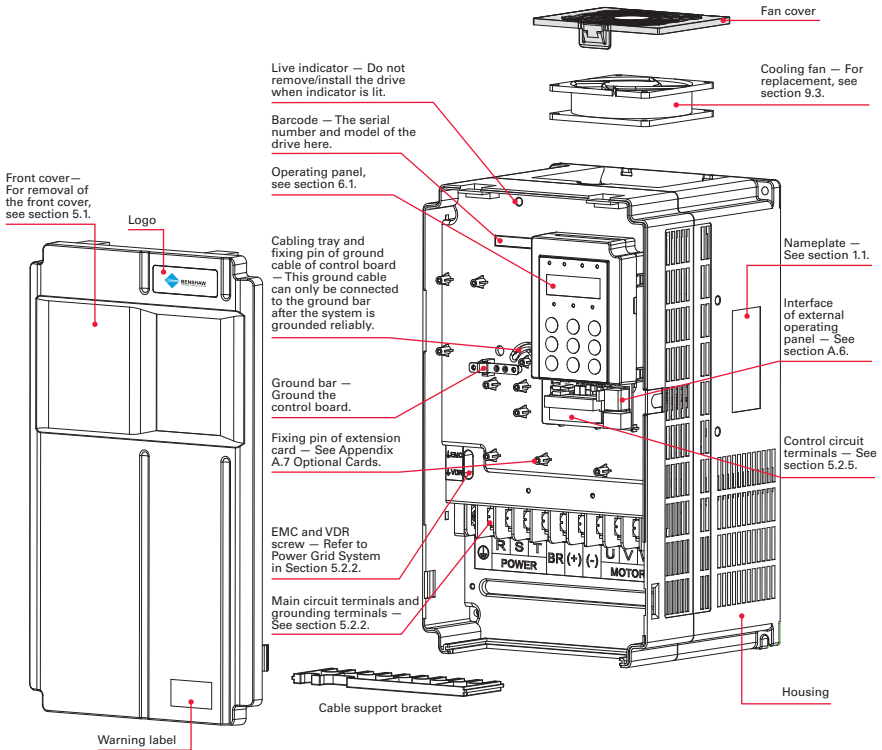

Figure 1-2b Diagram of product parts
(three-phase, 380V–480V, RSI-PPFP-0030-4-3-B-IP20-IM to RSI-PPFP-0060-4-3-B-IP20-IM)

Warning label



Description

CAUTION! Read the user guide for the AC drive carefully before installation or operation.



10min

DANGER! Do not remove the front cover while the power is on or within 10 minutes after the power is turned off.

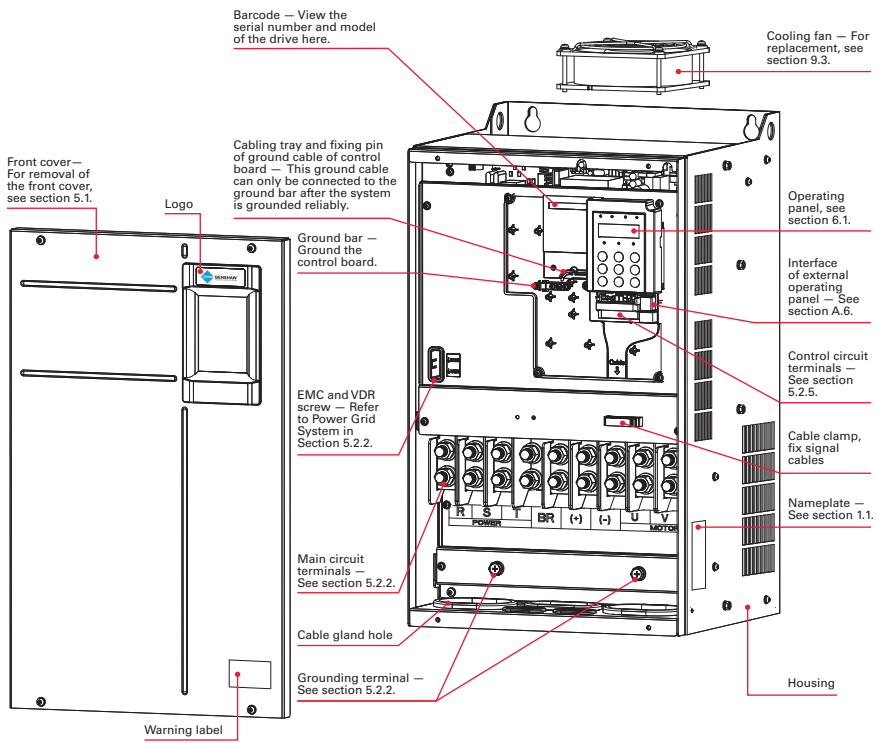

Figure 1-2c Diagram of product parts (three-phase, 380V–480V, RSI-PPFP-0075-4-3-B-XN01-IM to RSI-PPFP-0250-4-3-X-IP00-IM)

Warning label		Description
		CAUTION! Read the user guide for the AC drive carefully before installation or operation.
		DANGER! Do not remove the front cover while the power is on or within 10 minutes after the power is turned off.

1. PRODUCT INFORMATION

1

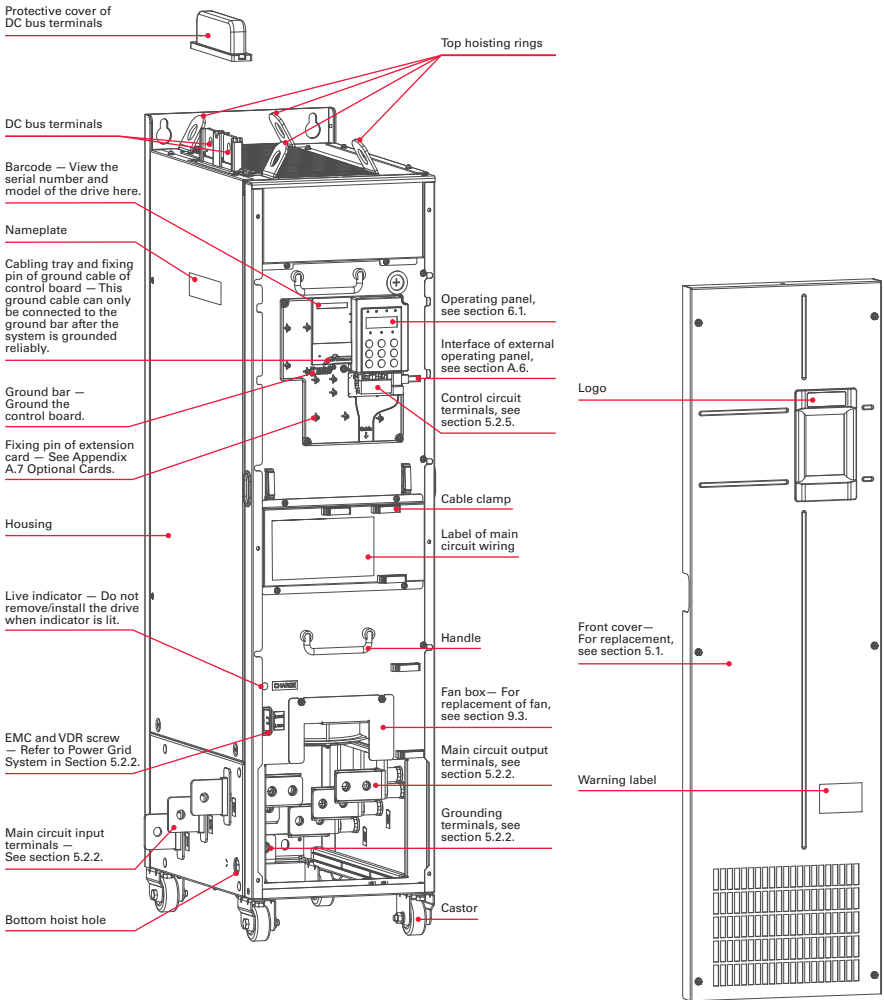

Figure 1-2d Diagram of product parts
(three-phase, 380V–480V, RSI-PPFP-0300-4-3-X-IP00-IM to RSI-PPFP-0700-4-3-X-IP00-IM)

Warning label



Description

CAUTION! Read the user guide for the AC drive carefully before installation or operation.



10min

DANGER! Do not remove the front cover while the power is on or within 10 minutes after the power is turned off.

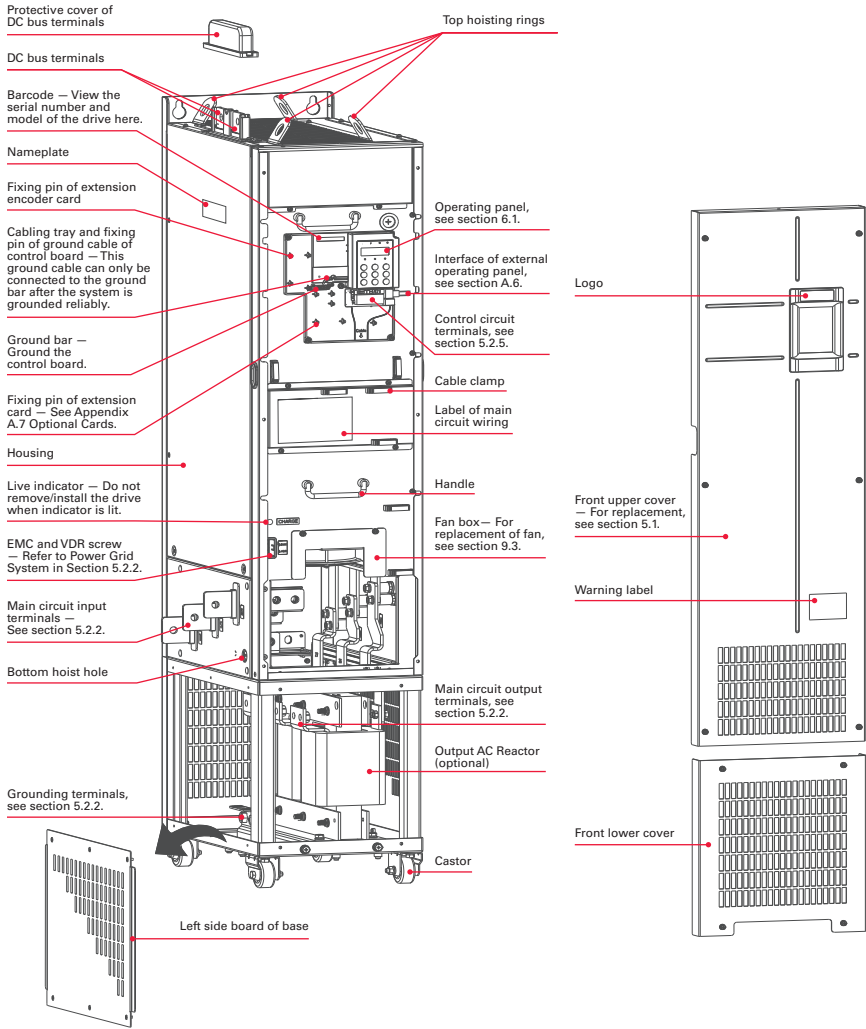





Figure 1-2e Diagram of product parts (three-phase, 380V–480V, RSI-PPFP-0300-4-3-X-IP00-IM to RSI-PPFP-0700-4-3-X-IP00-IM)

Warning label	Description
 	<p>CAUTION! Read the user guide for the AC drive carefully before installation or operation.</p>
 	<p>DANGER! Do not remove the front cover while the power is on or within 10 minutes after the power is turned off.</p>

2. SYSTEM CONNECTION

SAFETY INFORMATION

DANGER

- Do not perform any wiring with power on. Failure to comply may result in electric shock.
- Always keep breakers in OFF state.

WARNING

- When installing the drive inside an enclosed cabinet, use cooling fans or air conditioner to keep temperature below 40°C. Failure to comply may result in overheating or even a fire.

CAUTION

- Cover the top of the drive with a temporary cloth or paper during installation to prevent foreign matter such as metal shavings, oil and water from falling into the drive. If any foreign matter falls into the drive, the drive may have a fault. After the installation is completed, remove the temporary cloth or paper. If the cloth or paper is left on the drive, the drive may have abnormal heating due to poor ventilation.
 - Follow proper electrostatic discharge (ESD) procedures when operating the AC drive. Failure to comply will damage the drive due to static electricity.
 - Operating the motor at low speed reduces the cooling effect of the motor and increases motor temperature, which may result in damage to the motor.
- If the required motor speed range differs from that of the motor manufacturer, contact the motor manufacturer for advice.
 - If the torque characteristic is different with drive operation compared with operation from a commercial power supply, check the load torque characteristic of the connected machine.
 - Pay attention to the load torque characteristic when selecting the drive capacity. In addition, when there is a long distance between drive and motor, use a larger cable to minimize cable power losses.
 - If the rated current of the motor is different from a standard motor, (EX: a two-speed (pole changing) motor), check the maximum current of the motor and select an appropriate AC drive. Switch the pole after the motor stops.
 - Do not lift the AC drive while the front cover is removed. Failure to comply may result in damage to PCB and terminal block.

2.1 BENSRAW POWERPRO™ FAN AND PUMP SINGLE AC DRIVE SYSTEM CONNECTION DIAGRAM

⚠ WARNING

- Install protection devices (a fuse) at power input to the drive. The protection devices must provide protection from short-circuit, and be able to completely isolate the drive from the electrical power input. See Table 5.2.3a for required and recommended breakers, fuses and cable.

A variety of electrical devices can be installed on the input and output of the drive. Some are required for safety and protection while others are optional depending on the installation.

Connection of peripheral devices is shown below. A description of each is provided in Table 2-1. See Section 5.2.3 for recommended sizing of cable, breakers and fuses.

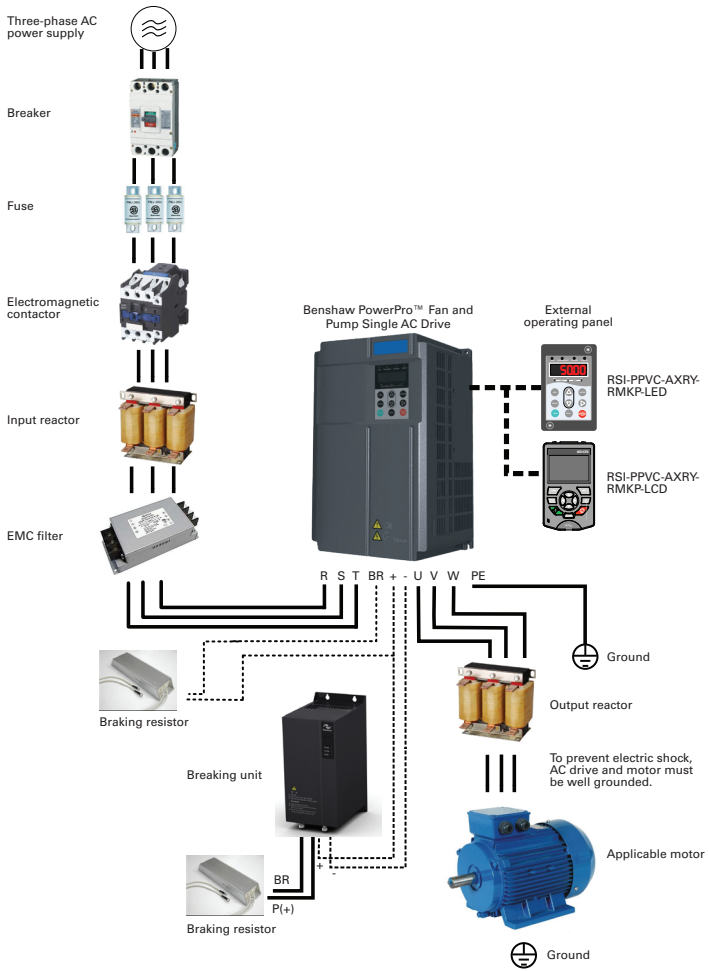

Figure 2-1 Benshaw PowerPro™ Fan and Pump Single AC Drive system composition

Note: The above figure shows a typical system connection diagram for the Benshaw PowerPro™ Fan and Pump Single AC Drive.

2. SYSTEM CONNECTION

2.2 BENSHAW POWERPRO™ FAN AND PUMP SINGLE AC DRIVE SYSTEM COMPOSITION

⚠ CAUTION

- Do not install capacitors or surge suppressors on the output side of the AC drive. Otherwise, it may damage the AC drive. If paper is left on the drive, the drive may have abnormal heating due to poor ventilation.

Table 2-2 Description of peripheral electrical devices used with AC drives. See section 5.2.3 and Appendix A for recommended sizing of these peripheral devices and accessories.

Device	Mounting Location	Function Description
Breaker	Between power and AC drive input side	MCCB: Cuts off power supply when overcurrent occurs on downstream devices. Leakage breaker: Provides protection against potential leakage current during drive operation to prevent electric shock and fire.
Fuse	Between power and AC drive input side	Provides protection in case of short circuit.
Contactors	Between breaker and AC drive input side	Switches the AC drive ON/OFF. Do not start/stop the AC drive frequently by switching contactor ON/OFF (time interval is at least one hour) nor use to directly start the AC drive.
AC reactor	AC drive input side	Improves the power factor of the drive as seen by the source. Reduces harmonics on the line side and minimizes voltage distortion. Reduces input current imbalance due to voltage imbalance.
EMC filter	AC drive input side	Reduces external conduction and radiation interference of the AC drive. Decreases conduction interference flowing from power supply to the AC drive and improves the drive's immunity to the interference.
AC reactor	AC drive input side	Improves the power factor of the drive as seen by the source. Reduces harmonics on the line side and minimizes voltage distortion. Reduces input current imbalance due to voltage imbalance.
Braking resistor	Brake IGBT included in drives 100 HP (75kW) and below. Use external resistor when required.	Dissipates regenerative energy during motor deceleration. Above 100 HP (75kW), use external brake unit and resistor, when required.
Braking unit	Above 100 HP (75kW) use external brake unit and resistor, when required.	Dissipates regenerative energy during motor deceleration.
Output reactor	Between AC drive output side and the motor, close to the AC drive	If the distance between the drive and motor is between 100 ft. and 300 ft., install an AC output reactor. Physical distance between the AC drive and connected motor causes distributed capacitance in the circuit and certain harmonics that may cause resonance in the circuit. Install an output reactor to: (a) Minimize degradation of motor insulation. (b) Reduce leakage current (c) Minimize drive nuisance trips
dV/dT reactor	AC drive output side, close to the AC drive	If the distance between the drive and the motor is greater than 300 ft. but less than 1500 ft., install a dV/dT (long lead) filter. (a) Protects motor insulation (b) Reduces motor bearing currents
Motor	AC drive output side	Select an appropriate motor.

Note: Inputs/Outputs (main circuit) of the AC drive contain harmonics, which may interfere with the communication device connected to the AC drive. Install reactors and/or other filters to minimize interference.

3. TECHNICAL SPECIFICATIONS

3.1 DRIVE RATINGS, TECHNICAL SPECIFICATIONS AND DIMENSIONS

Table 3-1a Model and technical data

Item		Specification															
Model Number		RSI-PPFP0001-4-3-B-IP20-IM	RSI-PPFP01H5-4-3-B-IP20-IM	RSI-PPFP0002-4-3-B-IP20-IM	RSI-PPFP0003-4-3-B-IP20-IM	RSI-PPFP0004-4-3-B-IP20-IM	RSI-PPFP0005-4-3-B-IP20-IM	RSI-PPFP07H5-4-3-B-IP20-IM	RSI-PPFP0010-4-3-B-IP20-IM	RSI-PPFP0015-4-3-B-IP20-IM	RSI-PPFP0020-4-3-B-IP20-IM	RSI-PPFP0025-4-3-B-IP20-IM	RSI-PPFP0030-4-3-B-IP20-IM	RSI-PPFP0040-4-3-B-IP20-IM	RSI-PPFP0050-4-3-B-IP20-IM	RSI-PPFP0060-4-3-B-IP20-IM	
Applicable motor capacity	150% overload (HP)	0.5	1	1.5	2	3	4	5	7.5	10	15	20	25	30	40	50	
	150% overload (kW)	0.4	0.7	1.1	1.5	2.2	3	3.7	5.5	7.5	11	15	18.5	22	30	37	
	110% overload (HP)	1	1.5	2	3	4	5	7.5	10	15	20	25	30	40	50	60	
	110% overload (kW)	0.7	1.1	1.5	2.2	3	3.7	5.5	7.5	11	15	18.5	22	30	37	45	
Outputs	Rated output current (A) @ 460 V — 150% overload	1.5	2.1	3.1	3.7	5.0	7.1	8.9	12.8	16.8	24.7	31.6	36.5	44.4	59.2	74	
	Rated output current (A) @ 460 V — 110% overload	2.1	3.1	3.7	5	7.1	8.9	12.8	16.8	24.7	31.6	36.5	44.4	59.2	74	89.8	
	Output voltage	Three-phase 0 to 480V (proportional to input voltage)															
	Max. output frequency	500 Hz (editable through parameter)															
	Carrier frequency	0.8 to 8.0 kHz (automatically adjusted according to the load characteristics)															
	Overload capacity	150% for 60s/110% for 60s															
Inputs	Rated input current (A) — 150% overload	1.5	2.1	3.1	3.8	5.1	7.2	9	13	17	25	32	37	45	60	75	
	Rated input current (A) — 110% overload	2.5	3.7	4.6	6.4	9.1	11.3	15.9	22.4	32.9	39.7	44	59	65.8	71	86	
Power supply	Rated voltage and frequency	AC: Three-phase 380 to 480 V, 50/60 Hz															
	Allowed voltage fluctuation	-15% to 10%, 323 to 528 VAC															
	Allowed frequency fluctuation	±5%															
	Power capacity (kVA)	2	2.8	4.1	5	9.5	9.5	12	17.5	22.8	33.4	42.8	45	54	52	63	
Thermal design	Heat Loss (W)	39	46	57	68	109	109	138	201	240	355	454	478	551	694	815	
	Air flow (CFM)	—	—	—	9	9	9	9	20	24	30	40	42	51.9	57.4	118.5	118.5

Note: All drives when used with the fuses listed in section 5.2.3 are rated for 100 kAIC SCCR.

3. TECHNICAL SPECIFICATIONS

Table 3-1a Model and technical data (continued)

Item	Specification																
Model Number	RSI-PPFP-0075-4-3-B-XN01-IM	RSI-PPFP-0100-4-3-B-XN01-IM	RSI-PPFP-0125-4-3-B-XN01-IM	RSI-PPFP-0150-4-3-X-XN01-IM	RSI-PPFP-0175-4-3-X-XN01-IM	RSI-PPFP-0200-4-3-X-XN01-IM	RSI-PPFP-0250-4-3-X-IP00-IM	RSI-PPFP-0300-4-3-X-IP00-IM	RSI-PPFP-0350-4-3-X-IP00-IM	RSI-PPFP-0375-4-3-X-IP00-IM	RSI-PPFP-0400-4-3-X-IP00-IM	RSI-PPFP-0450-4-3-X-IP00-IM	RSI-PPFP-0500-4-3-X-IP00-IM	RSI-PPFP-0600-4-3-X-IP00-IM	RSI-PPFP-0700-4-3-X-IP00-IM		
Applicable motor capacity	150% overload (HP)	60	75	100	125	150	175	200	250	300	300	350	375	400	450	500	
	150% overload (kW)	45	55	75	90	110	132	160	200	220	220	250	280	315	355	400	
	110% overload (HP)	75	100	125	150	175	200	250	300	350	375	400	450	500	600	700	
	110% overload (kW)	55	75	90	110	132	160	200	220	250	280	315	355	400	450	500	
Outputs	Rated output current (A) @ 460 V — 150% overload	89.8	110.5	148	173.6	207.1	249.6	299.9	371.9	420.2	420.2	458.7	512.9	577	641.2	715.1	
	Rated output current (A) @ 460 V — 110% overload	110.5	148	173.6	207.1	249.6	299.9	371.9	458.7	512.9	512.9	577	641.2	715.1	808.8	868	
	Output voltage	Three-phase 380 to 480V (proportional to input voltage)															
	Max. output frequency	500 Hz (editable through parameter)															
	Carrier frequency	0.8 to 8.0 kHz		0.8 to 6.0 kHz (automatically adjusted according to the load characteristics)													
	Overload capacity	150% for 60s/110% for 60s															
Inputs	Rated input current (A) — 150% overload	91	112	150	176	210	253	304	377	410	410	441	495	565	617	687	
	Rated input current (A) — 110% overload	111	143	167	198	239	295	359	410	456	507	559	624	708	782	840	
Power supply	Rated voltage and frequency	AC: Three-phase 380 to 480V, 50/60 Hz															
	Allowed voltage fluctuation	-15% to 10%, 323 to 528 VAC															
	Allowed frequency fluctuation	±5%															
	Power capacity (kVA)	81	97	127	150	220	220	263	334	375	453	404	453	517	565	629	
Thermal design	Heat Loss (W)	1010	1210	1570	1810	2850	2850	3560	4150	4550	5330	5060	5330	5690	6310	6910	
	Air flow (CFM)	122.2	122.2	218.6	287.2	547	547	627	638.4	722.5	882	789.4	882	645	860	860	

Table 3-1b Technical Specifications of Benschaw PowerPro™ Fan and Pump Single AC Drive

Item	Description	
Standard functions	Input frequency resolution	Digital setting: 0.01 Hz Analog setting: Max. frequency x 0.025%
	Control mode	Voltage/Frequency (V/F) control
	Torque boost	Customized boost 0.1 % to 30.0 %
	V/F curve	Linear V/F curve Square V/F curve Multi-point V/F curve Complete V/F separation Half V/F separation
	Ramp mode	Linear ramp Straight-line ramp S-curve ramp Four separate acceleration/deceleration time settings in the range of 0.0s to 6500.0s.
	DC injection braking	Brake frequency: 0 Hz to max. frequency Active time: 0.0s to 36.0s. Current level: 0.0% to 100.0%.
	Jog running	Frequency range: 0.00 to 50.00 Hz Acceleration/deceleration time: 0.0s to 6500.0s
	Onboard multiple preset speeds	The system implements up to 16 speeds by using simple PLC function or by using digital input signals.
	Onboard PID	The system implements the proportional integral-derivative (PID) function in the closed-loop control.
	Automatic voltage regulation (AVR)	The system maintains a constant output voltage automatically when the grid voltage changes through the permissible range.
	Overvoltage and overcurrent stall control	The system limits the output current and voltage automatically during operation to minimize overvoltage and overcurrent related faults.
	Current limiting function	The function helps to avoid frequent overcurrent faults.
	Torque limit and control	The system limits the torque automatically to prevent frequent overcurrent tripping during operation. Torque control is applied in vector control only.
	Individualized functions	Power dip ride-through
Virtual I/O		Five groups of virtual digital input/outputs (DI/DO) support simple logic control.
Timing control		Time range: 0.0 to 6500.0 minutes
Dual-motor switchover		The drive have two groups of motor parameters and can control up to two motors.
Multiple field buses		The drive supports four field buses: Modbus, PROFIBUS-DP, CANlink and CANopen.
Motor overheat protection option cards		Option: The optional input/output (I/O) extension card allows AI3 to receive a signal from the motor temperature sensor input (PT100, PT1000) to implement motor overheat protection.

3. TECHNICAL SPECIFICATIONS

Table 3-1b Technical Specifications of Benschaw PowerPro™ Fan and Pump Single AC Drive (continued)

Item		Description
Individualized functions	PC software	PC based software allows users to configure some operating parameters, and provides a virtual oscilloscope display that shows system status.
RUN	Source for run command	Allows different methods of switching between run commands: Operating panel (keypad and display); terminal I/O control; and serial communication.
	Main frequency reference setting channel	Supports up to 10 frequency reference setting channels and allows different methods of switching between frequency reference setting channels: Digital setting Analog voltage reference Analog current reference Pulse reference Communication reference
	Auxiliary frequency reference setting channel	Supports up to 10 auxiliary frequency sources, and allows fine tuning of the auxiliary frequency and main and auxiliary calculation.
	Input terminals	Standard: Five digital input (DI) terminals, one of which supports up to 100 kHz high-speed pulse inputs. Two analog input (AI) terminals, one of which supports only 0 to 10 V input, and the other supports 0 to 10 V and 0 to 20 mA current input. Available on add-on optional cards: Five digital input (DI) terminals. One AI terminal that supports -10 to 10 V voltage input and PT100/PT1000 motor temperature sensor inputs.
	Output terminals	Standard: Single high-speed pulse output terminal (open-collector) for a square-wave signal output in the frequency range 0 to 100 kHz. Single digital output (DO) terminal. Single relay output terminal. Single analog output (AO) terminal that supports either a current output in the range 0 to 20 mA or a voltage output in the range 0 to 10 V. Expanded capacity: Single digital output (DO) terminal. Single relay output terminal . Single analog output (AO) terminal that supports either a current output in the range 0 to 20 mA or a voltage output in the range 0 to 10 V. Option card
Display and operating panel	LED display	4 digit, 7 segment LED, shows parameter values.
	LCD display	Optional and shows parameters in English.
	Copy	The LCD operating panel can be used to copy parameters quickly.
	Key locking and function selection	Keys on the control panel can be locked or partially locked electronically to prevent accidental operation.

Table 3-1b Technical Specifications of Benschaw PowerPro™ Fan and Pump Single AC Drive (continued)

Item	Description	
Protections	Phase loss protection Input phase loss protection Output phase loss protection	
	Instantaneous overcurrent protection Trips when 250% of rated output current is exceeded.	
	Overvoltage protection Trips when the DC bus voltage is above 820V.	
	Undervoltage protection Trips when the DC bus voltage is below 350V.	
	Overtemperature protection Protection triggered when the AC drive becomes overheated.	
	Overload protection Trips after running at 150% of rated current for 60 seconds. Trips when 2.5 times rated current of the AC drive is exceeded.	
	Braking protection Braking unit overload protection Braking resistor short-circuit protection	
	Short-circuit protection Output phase-to-phase short-circuit protection Output phase-to-ground short-circuit protection	
	Environment	Installation location Install the AC drive indoors and protected from direct sunlight, dust, corrosive or combustible gases, oil smoke, vapor, ingress from water or any other liquid, and salt.
		Altitude Below 1000m If the altitude exceeds 1000m, de-rating by 1% per 100m increase Max. 3000m (Note: The maximum altitude for 0.5 to 4 HP drives is 2000m. For use at altitudes over 2000 m, contact Benschaw.)
Ambient temperature: -10°C to +40°C. If the ambient temperature is not in this range, de-rating by 1.5% per 1°C increase. Max. temperature: 50°C		
Humidity Less than 95% RH non-condensing		
Vibration Less than 5.9 m/s ² (0.6 g)		
Storage temperature -20°C to +60°C		

3. TECHNICAL SPECIFICATIONS

3.2 DIMENSIONS – OUTLINE DRAWINGS OF BENSHAW POWERPRO™ FAN AND PUMP SINGLE AC DRIVE

3.2.1 Overall Dimensions of RSI-PPFP-0001-4-3-B-IP20-IM to RSI-PPFP-0250-4-3-X-IP00-IM

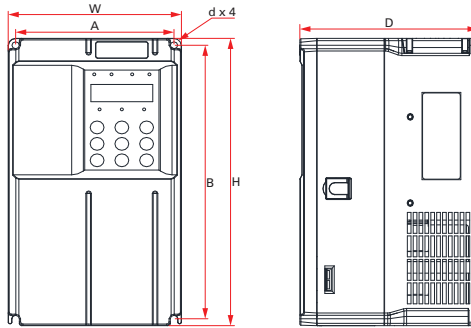

Figure 3-2-1a Mounting Dimensions of RSI-PPFP-0001-4-3-B-IP20-IM to RSI-PPFP-0250-4-3-B-IP20-IM

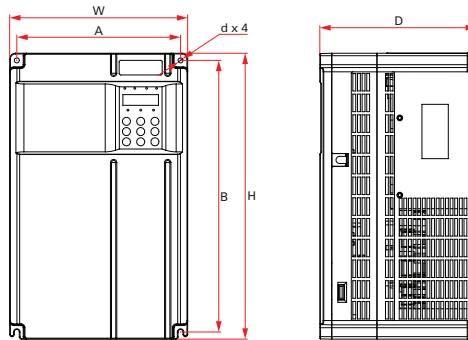

Figure 3-2-1b Mounting Dimensions of RSI-PPFP-0030-4-3-B-IP20-IM to RSI-PPFP-0060-4-3-B-IP20-IM

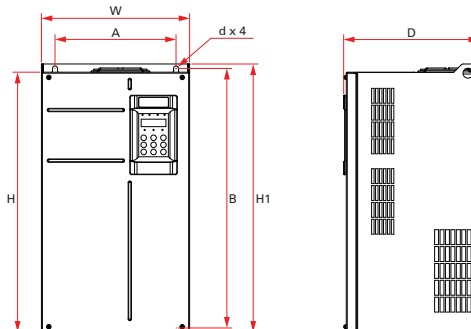

Figure 3-2-1c Mounting Dimensions of RSI-PPFP-0075-4-3-B-XN01-IM to RSI-PPFP-0250-4-3-X-IP00-IM

Table 3-2-1 Mounting Hole Dimensions of RSI-PPFP-0001-4-3-B-IP20-IM to RSI-PPFP-0250-4-3-X-IP00-IM

Frame	HP Rating	AC Drive Model	Hole Dimensions (mm)		Overall Dimensions (mm)			Hole Diameter (mm)	Weight (kg)	
			A	B	H	H1	W			D
T1	0.5	RSI-PPFP-0001-4-3-B-IP20-IM	119	189	200	—	130	152	Ø5	1.6
	1	RSI-PPFP-01H5-4-3-B-IP20-IM	119	189	200	—	130	152	Ø5	1.6
	1.5	RSI-PPFP-0002-4-3-B-IP20-IM	119	189	200	—	130	152	Ø5	1.6
	2	RSI-PPFP-0003-4-3-B-IP20-IM	119	189	200	—	130	152	Ø5	1.6
	3	RSI-PPFP-0004-4-3-B-IP20-IM	119	189	200	—	130	152	Ø5	1.6
T2	4	RSI-PPFP-0005-4-3-B-IP20-IM	119	189	200	—	130	152	Ø5	1.6
	5	RSI-PPFP-07H5-4-3-B-IP20-IM	119	189	200	—	130	162	Ø5	2.0
T3	7.5	RSI-PPFP-0010-4-3-B-IP20-IM	119	189	200	—	130	162	Ø5	2.0
	10	RSI-PPFP-0015-4-3-B-IP20-IM	128	238	250	—	140	170	Ø6	3.3
T4	15	RSI-PPFP-0020-4-3-B-IP20-IM	128	238	250	—	140	170	Ø6	3.3
	20	RSI-PPFP-0025-4-3-B-IP20-IM	166	266	280	—	180	170	Ø6	4.3
T5	25	RSI-PPFP-0030-4-3-B-IP20-IM	195	335	350	—	210	192	Ø6	7.6
	30	RSI-PPFP-0040-4-3-B-IP20-IM	195	335	350	—	210	192	Ø6	7.6
T6	40	RSI-PPFP-0050-4-3-B-IP20-IM	230	380	400	—	250	220	Ø7	17.5
	50	RSI-PPFP-0060-4-3-B-IP20-IM	230	380	400	—	250	220	Ø7	17.5
T7	60	RSI-PPFP-0075-4-3-B-XN01-IM	245	523	525	542	300	275	Ø10	35.0
	75	RSI-PPFP-0100-4-3-B-XN01-IM	245	523	525	542	300	275	Ø10	35.0
T8	100	RSI-PPFP-0125-4-3-B-XN01-IM	270	560	554	580	338	315	Ø10	51.5
	125	RSI-PPFP-0150-4-3-X-XN01-IM	270	560	554	580	338	315	Ø10	51.5
	150	RSI-PPFP-0175-4-3-X-XN01-IM	270	560	554	580	338	315	Ø10	51.5
T9	175	RSI-PPFP-0200-4-3-X-XN01-IM	320	890	874	915	400	320	Ø10	85.0
	200	RSI-PPFP-0250-4-3-X-IP00-IM	320	890	874	915	400	320	Ø10	85.0

3. TECHNICAL SPECIFICATIONS

3.2.2 Overall Dimensions of RSI-PPFP-0300-4-3-X-IP00-IM to RSI-PPFP-0700-4-3-X-IP00-IM

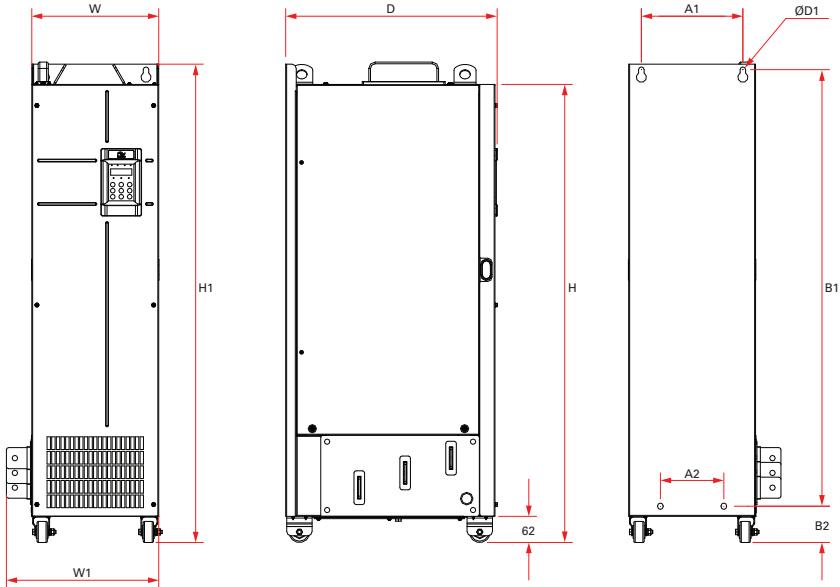

Figure 3-2-2 Mounting Dimensions of RSI-PPFP-0300-4-3-X-IP00-IM to RSI-PPFP-0700-4-3-X-IP00-IM

Table 3-2-2 Mounting Hole Dimensions of RSI-PPFP-0300-4-3-X-IP00-IM to RSI-PPFP-0700-4-3-X-IP00-IM

Frame	HP Rating	AC Drive Model	Hole Dimensions (mm)				Overall Dimensions (mm)					Hole Dia. (mm)	Weight (kg)
			A1	A2	B1	B2	H	H1	W	W1	D		
T10	250	RSI-PPFP-0300-4-3-X-IP00-IM	240	150	1035	86	1086	1134	300	360	500	Ø13	110
	300	RSI-PPFP-0350-4-3-X-IP00-IM	240	150	1035	86	1086	1134	300	360	500	Ø13	110
T11	350	RSI-PPFP-0400-4-3-X-IP00-IM	225	185	1175	97	1248	1284	330	390	545	Ø13	155
	375	RSI-PPFP-0450-4-3-X-IP00-IM	225	185	1175	97	1248	1284	330	390	545	Ø13	155
T12	400	RSI-PPFP-0500-4-3-X-IP00-IM	240	200	1280	101	1355	1405	340	400	545	Ø16	185
	450	RSI-PPFP-0600-4-3-X-IP00-IM	240	200	1280	101	1355	1405	340	400	545	Ø16	185
	500	RSI-PPFP-0700-4-3-X-IP00-IM	240	200	1280	101	1355	1405	340	400	545	Ø16	185

4. MECHANICAL INSTALLATION

4.1 INSTALLATION



4.1.1 Installation environment

1. Ambient temperature: The AC drive service life is greatly influenced by the ambient temperature. Do not operate the AC drive in a temperature exceeding the allowed temperature range (-10 °C to 40 °C).
2. Install the AC drive on a flame-retardant surface and ensure there is sufficient space around the enclosure to allow for efficient heat dissipation. The AC drive generates significant heat during operation.
3. Install the AC drive in a location not subject to strong vibration. Ensure the mounting location is not affected by levels of vibration that exceed 0.6 G. Do not install on machines with high vibration.
4. Ensure the mounting location is away from direct sunlight, dampness or water drops.
5. Ensure the mounting location is protected against corrosive, combustible or explosive gases and vapors.
6. The installation must conform to local and regional laws and regulations, and to relevant NEMA, UL and IEC requirements.

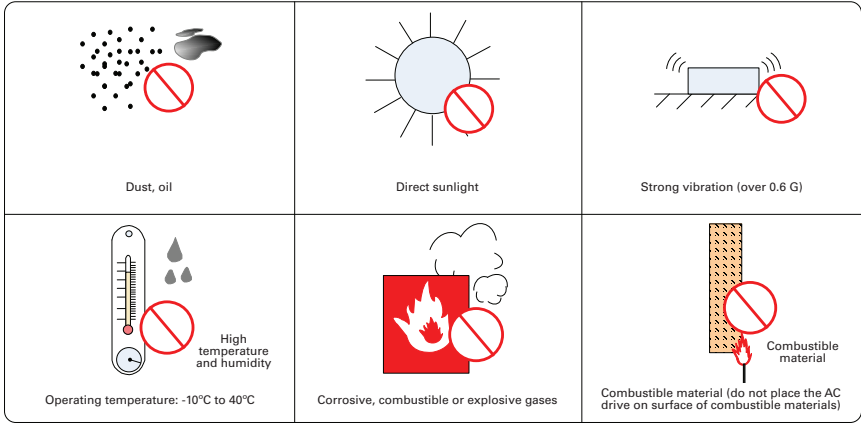

Figure 4-1-1 Installation environment requirements

4. MECHANICAL INSTALLATION

4.1.2 Mounting Clearance and Orientation

1. Mounting Clearance

2. The mounting clearance varies with the power rating of the AC drive.

Mounting of a single drive

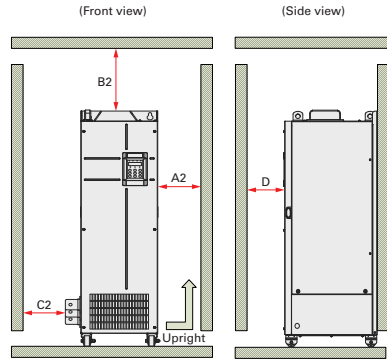
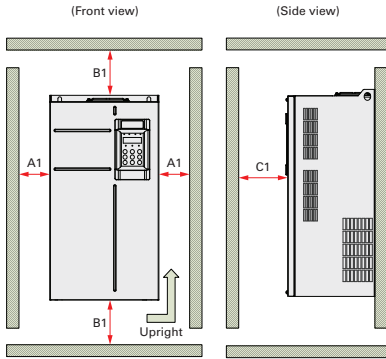

Figure 4-1-2a Mounting clearance of a single drive (RSI-PPFP-0001-4-3-B-IP20-IM to RSI-PPFP-0250-4-3-X-IP00-IM)

Figure 4-1-2b Mounting clearance of a single drive (RSI-PPFP-0300-4-3-X-IP00-IM to RSI-PPFP-0700-4-3-X-IP00-IM)

Power Rating	Clearance Requirements in. (mm)		
0.5 HP~20 HP	A1≥0.4 (10)	B1≥3.9 (100)	C1≥1.6 (40)
25 HP~30 HP	A1≥0.4 (10)	B1≥7.8 (200)	C1≥1.6 (40)
40 HP~50 HP	A1≥2.0 (50)	B1≥7.8 (200)	C1≥1.6 (40)
60 HP~200 HP	A1≥2.0 (50)	B1≥11.8 (300)	C1≥1.6 (40)

Power Rating	Clearance Requirements in. (mm)			
250 HP~	A2≥	B2≥	C2≥	D≥
900 HP	0.4 (10)	9.8 (250)	0.75 (20)	0.75 (20)

Multi-drive installation

The AC drive is designed with the cooling air flow direction from bottom to top. When installing several AC drives within a cabinet, line up the tops of the drives.

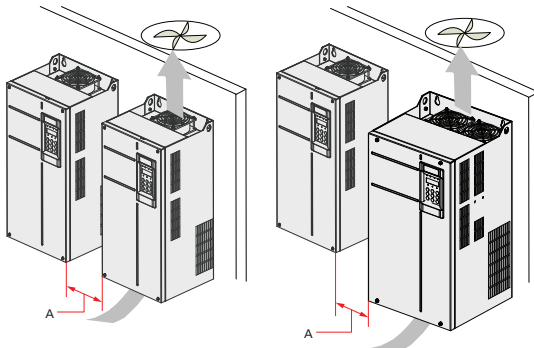

Power Rating	Clearance Requirements in. (mm)
0.5 HP~20 HP	A≥0.4 (10)
25 HP~30 HP	A≥0.4 (10)
40 HP~50 HP	A≥2.0 (50)
60 HP~200 HP	A≥2.0 (50)

Figure 4-1-2c Clearance for multi-drive installation (RSI-PPFP-0001-4-3-B-IP20-IM to RSI-PPFP-0250-4-3-X-IP00-IM)

Notes: Roll-in drives cannot be mounted sided by side; contact the manufacturer.

Installation of an air guide plate

Where an AC drive is required to be mounted directly above another AC drive, it is recommended to install an Air Guide Plate to divert exhaust cooling air from the bottom unit away from the top unit.

Note: Not applicable to 250 HP to 900 HP.

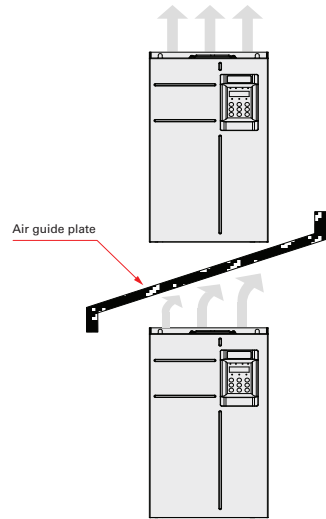

Figure 4-1-2d Installation of an air guide plate

3. Mounting Orientation

Always mount the AC drive in an upright position.

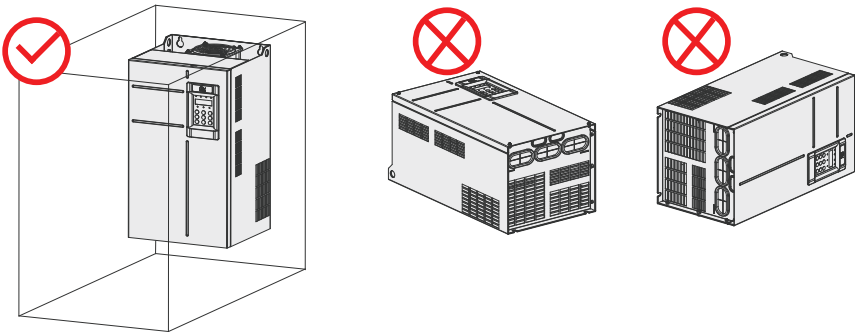

Figure 4-1-2e Mounting orientation diagram

4. MECHANICAL INSTALLATION

4.1.3 Installation of RSI-PPFP-0001-4-3-B-IP20-IM to RSI-PPFP-0250-4-3-X-IP00-IM

Drives 0.5 HP – 200 HP support backplate mounting and through-hole mounting. Follow the guidance below for specific model and application scenarios.

CAUTION

- Refer to Figure 4-1-2a and 4-1-2b for mounting clearance requirements. Ensure there is sufficient space allowed for efficient heat dissipation of the drive and the other devices in the cabinet.
- Mount the AC drive in an upright position for efficient heat dissipation. When installing several AC drives within a cabinet, line up the tops of the drives. Where an AC drive is required to be mounted directly above another AC drive, install an Air Guide Plate, as shown in Figure 4-1-2d.
- The mounting backplate must be flame retardant.
- In a location with metallic powders, mount the AC drive in a fully closed cabinet with sufficient space. It is recommended to mount the heat sink outside the cabinet.
- Mount drive using all mounting holes; otherwise, the drive may fall off or be damaged.

4

1. Backplate Mounting

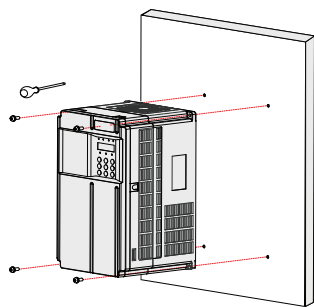

Figure 4-1-3a Backplate mounting of RSI-PPFP-0001-4-3-B-IP20-IM to RSI-PPFP-0060-4-3-B-IP20-IM, 0.5 HP – 50 HP

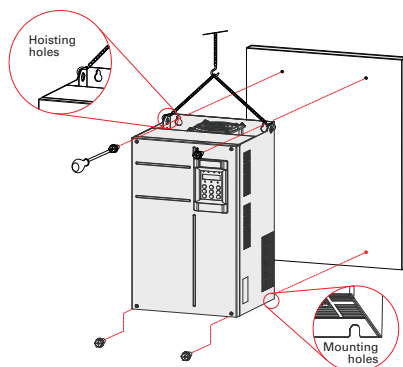

Figure 4-1-3b Backplate mounting of RSI-PPFP-0075-4-3-B-XN01-IM to RSI-PPFP-0250-4-3-X-IP00-IM, 60 HP – 200 HP

4.1.4 Mounting in Cabinet

1. Ventilation

For drives with ratings of 250 HP through 900 HP, only one drive can be mounted in a cabinet. Ventilation space must be considered when installing these drives. Follow the guidance below for specific model and application scenarios.

Direct discharging cabinet (without fan on the top)

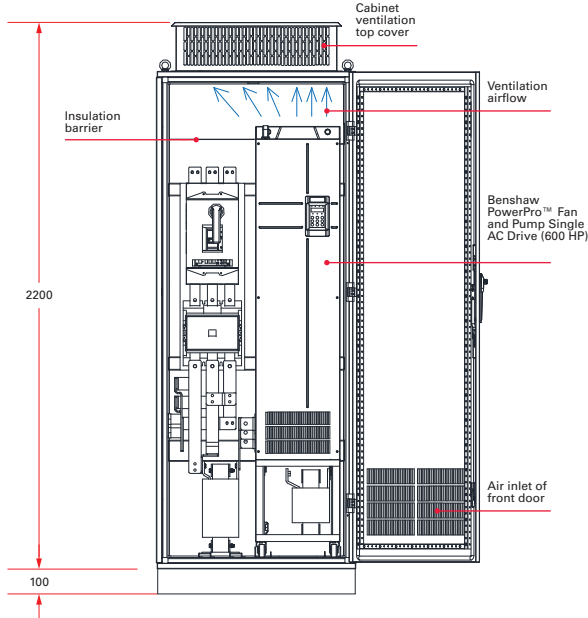

Figure 4-1-4a Direct discharging cabinet

Table 4-1-4a Specification of direct discharging cabinet

Model Number	Total Air Volume (CFM)	Effective Area of Cabinet Top Air Inlet (mm ²)	Effective Area of Cabinet Top Air Outlet (mm ²)
RSI-PPFP-0300-4-3-X-IP00-IM	586	31809	50894
RSI-PPFP-0350-4-3-X-IP00-IM	722	31809	50894
RSI-PPFP-0400-4-3-X-IP00-IM	789	47713	76341
RSI-PPFP-0450-4-3-X-IP00-IM	882	47713	76341
RSI-PPFP-0500-4-3-X-IP00-IM	644	47713	76341
RSI-PPFP-0600-4-3-X-IP00-IM	796	47713	76341
RSI-PPFP-0700-4-3-X-IP00-IM	796	47713	76341

Notes: CFM = 0.0283 m³/min

Effective area means through-hole area.

4. MECHANICAL INSTALLATION

Cabinet with fan on the top

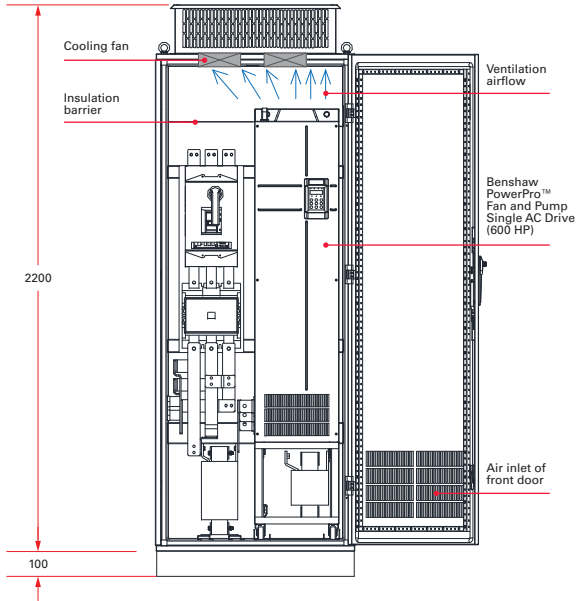

Figure 4-1-4b Cabinet with fan on the top

Table 4-1-4b Specification of cabinet with fan on the top

Model Number	Total Air Volume (CFM)	Effective Area of Cabinet Top Air Inlet (mm ²)	Max. Air Volume Required by the Top Fan (CFM)	Effective Area of Cabinet Top Air Outlet (mm ²)
RSI-PPFP-0200-4-3-X-XN01-IM	541	31809	649	$S = 0.942 \times N \times (\text{Dout2} - \text{DHUB2})$ In the preceding formula, N means the quantity of top fans, Dout means diameter of the top fan, and DHUB means diameter of the top fan center HUB.
RSI-PPFP-0250-4-3-X-IP00-IM	620	31809	744	
RSI-PPFP-0300-4-3-X-IP00-IM	586	31809	703	
RSI-PPFP-0350-4-3-X-IP00-IM	722	31809	866	
RSI-PPFP-0400-4-3-X-IP00-IM	789	47713	947	
RSI-PPFP-0450-4-3-X-IP00-IM	882	47713	1058	
RSI-PPFP-0500-4-3-X-IP00-IM	644	47713	773	
RSI-PPFP-0600-4-3-X-IP00-IM	796	47713	955	
RSI-PPFP-0700-4-3-X-IP00-IM	796	47713	955	

Notes: CFM = 0.0283 m³/min

Effective area means through-hole area.

When choosing a cabinet, be sure to select a heavy-duty enclosure that is adequately designed to handle the weight and size (including ventilation space requirements) of the drive you're installing in it.

Install the bottom mounting bracket

If your cabinet comes with mounting holes around the base, as illustrated in the figure below, use six M5 tapping screws to attach the mounting bracket to the cabinet base according to the following figure (the mounting bracket drawing is shown below and on the following page).

If your cabinet is not already equipped with mounting holes around the base, drill mounting holes for the bracket on site for the six M5 tapping screws.

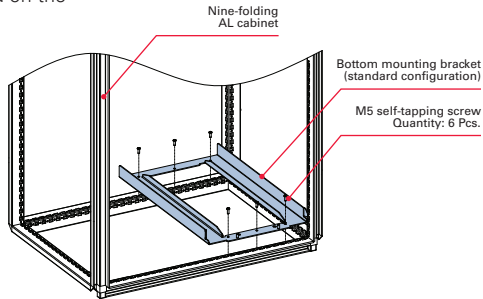
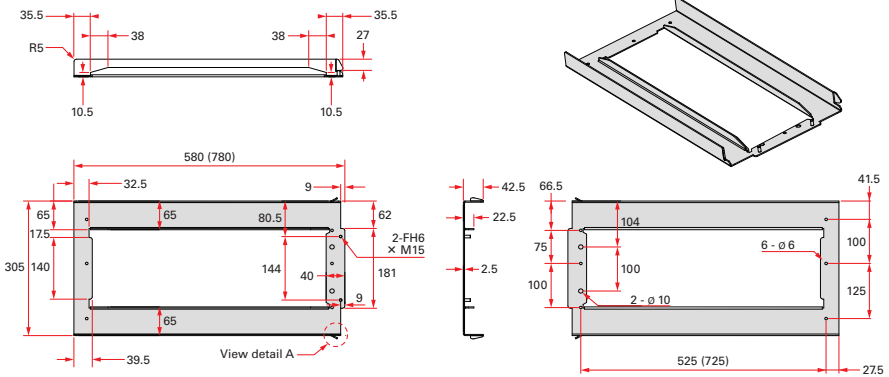

Figure 4-1-4c Installing the bottom mounting bracket

4.1.5 Dimensions of Bottom Mounting Bracket

Dimensions of mounting bracket for RSI-PPFP-0300-4-3-X-IP00-IM to RSI-PPFP-0350-4-3-X-IP00-IM



Note: This DIN rail figure is applicable to a cabinet of 800mm wide x 600mm deep or 800mm wide x 800mm deep.

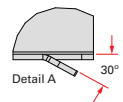
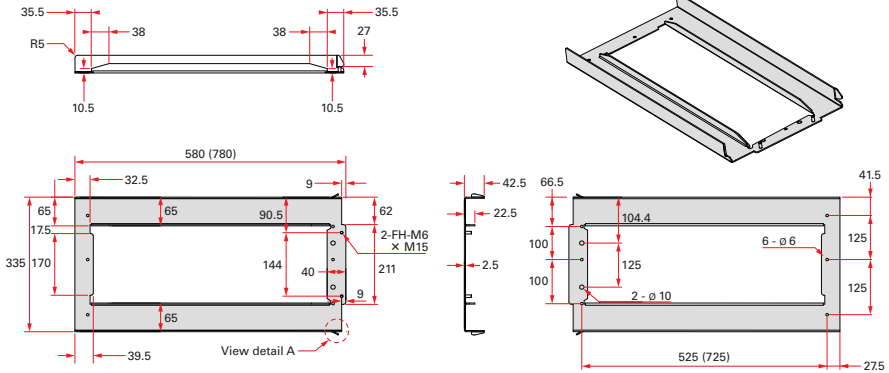

Figure 4-1-5a Dimensions of mounting bracket for RSI-PPFP-0300-4-3-X-IP00-IM to RSI-PPFP-0350-4-3-X-IP00-IM (factory standard)

4. MECHANICAL INSTALLATION

Dimensions of mounting bracket for RSI-PPFP-0400-4-3-X-IP00-IM to RSI-PPFP-0450-4-3-X-IP00-IM



Note: This DIN rail figure is applicable to a cabinet of 800mm wide x 600mm deep or 800mm wide x 800mm deep.

Figure 4-1-5b Dimensions of mounting bracket for RSI-PPFP-0400-4-3-X-IP00-IM to RSI-PPFP-0450-4-3-X-IP00-IM (factory standard)

Dimensions of mounting bracket for RSI-PPFP-0500-4-3-X-IP00-IM to RSI-PPFP-0700-4-3-X-IP00-IM

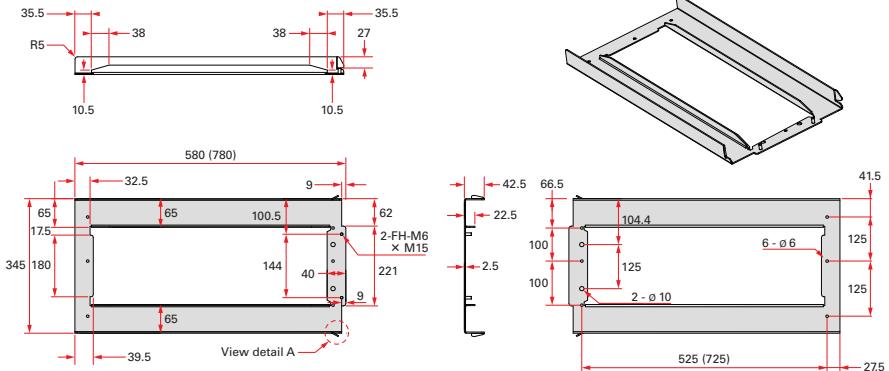

Note: This DIN rail figure is applicable to a cabinet of 800mm wide x 600mm deep or 800mm wide x 800mm deep.

Figure 4-1-5c Dimensions of mounting bracket for RSI-PPFP-0500-4-3-X-IP00-IM to RSI-PPFP-0700-4-3-X-IP00-IM (factory standard)

4.1.6 Assemble the Guide Rail (model: RSI-PPVC-AXRY-RAIL-T10_T12, optional)

As shown in Figure A, assemble the guide rail of the correct model. The assembled guide rail is shown in Figure B.

As shown in Figure C, align the two holes at the front of the guide rail with the studs of the mounting bracket, and attach them with two M6 nuts.

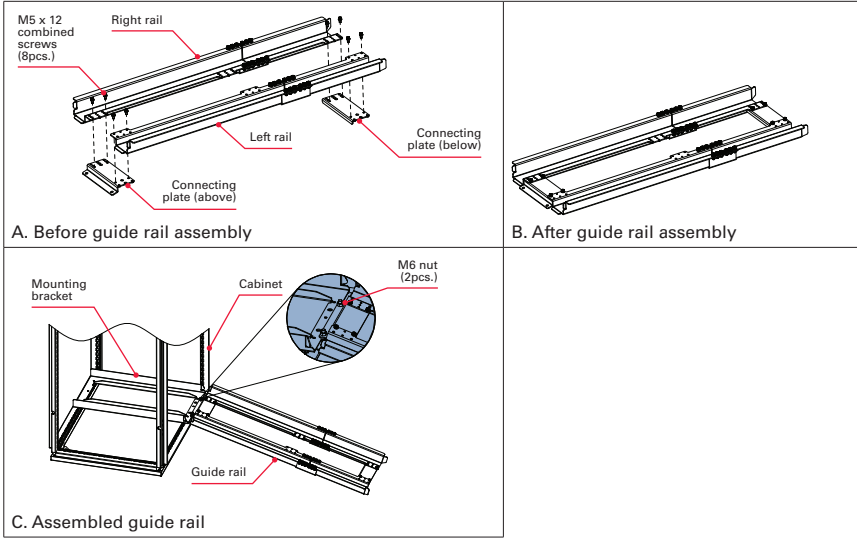

Figure 4-1-6 Assembling the guide rail in the cabinet

Notes: Carefully read the RSI-PPVC-AXRY-RAIL-T10_T12 Guide Rail Assembly Instructions before assembling the guide rail.

4. MECHANICAL INSTALLATION

4.1.7 Installing the AC drive in the cabinet

Because the center of gravity of the drive is very high, use a soft strap (with hook at both ends) during the process of installing to prevent turnover.

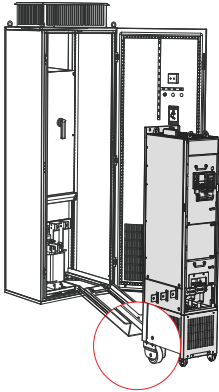

Figure 4-1-7a Align castors of the drive to the guide rail

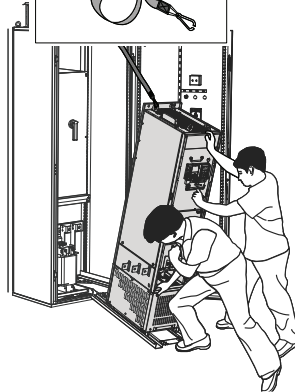

Figure 4-1-7b Push the drive into the cabinet

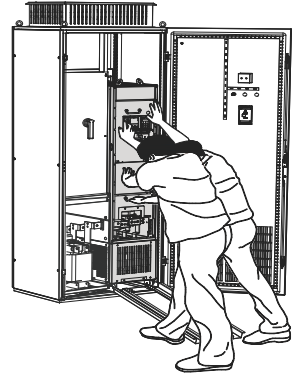

Figure 4-1-7c Installation completed

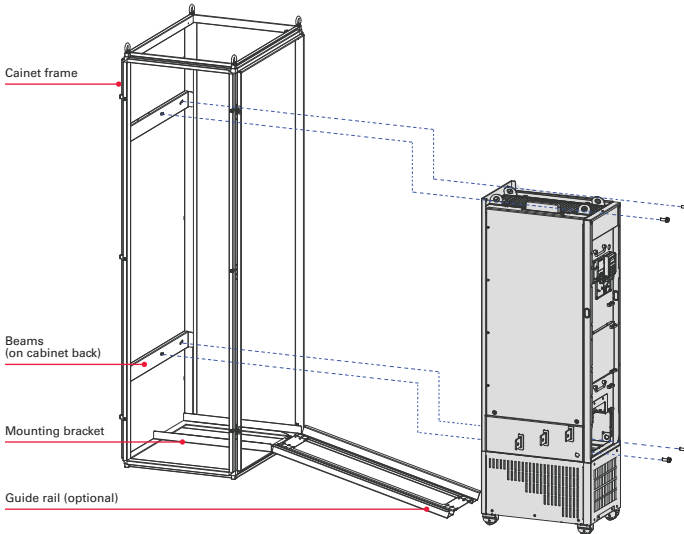
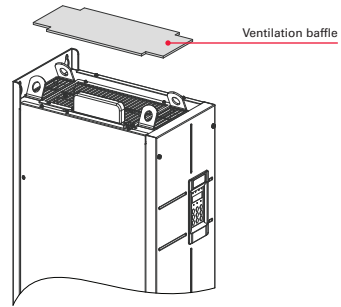

Figure 4-1-7d Mounting the AC drive to the beam by using the four mounting holes on the back of the AC drive. Removal: When removing the drive from the enclosure, follow installation steps in reverse order.

1. Precautions

Ensure the four mounting holes on the back of the drive are connected to the beams securely.

After installation is completed, remove the baffle on the top of the drive. The baffle is used to prevent foreign objects such as screws from falling into the ventilation openings while the drive is being mounted in the cabinet.



Use top hoist rings to move or hoist the drive. If it is necessary to place the drive in a horizontal position, use the top hoist ring and bottom hoist hole when you hoist the drive again. Ensure the DC bus terminals are not damaged.

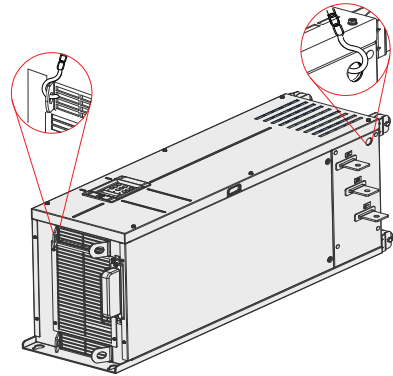

When placing the drive in an upright position, prevent stress on both sides of the drive and avoid placing the drive on an inclined floor because the drive weighs almost 441 lbs (200 kg). If inclination exceeds 5°, the drive may turn over.

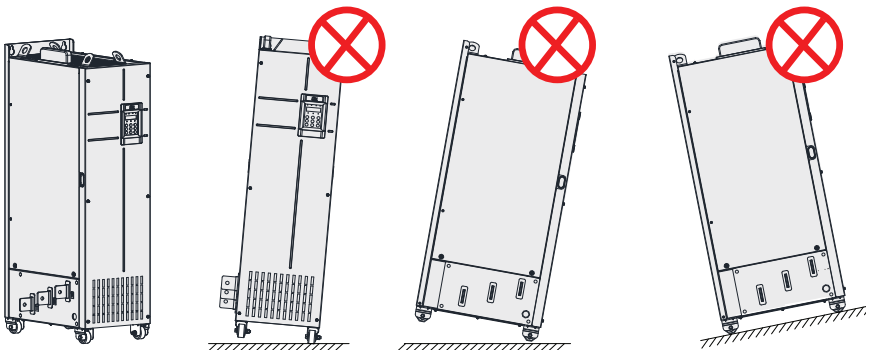

5. ELECTRICAL WIRING

5.1 REMOVAL AND INSTALLATION OF THE COVER

You need to remove the cover of the AC drive for wiring of the main circuits and control circuits.

⚠ WARNING

- Ensure the drive power-off time exceeds 10 minutes before removing the cover.

⚠ CAUTION

- Be careful when removing the front cover. A falling cover may cause personal injury.

1. Remove and Install the Cover of Drives RSI-PPFP-0001-4-3-B-IP20-IM to RSI-PPFP-0060-4-3-B-IP20-IM, 0.5 HP – 50 HP

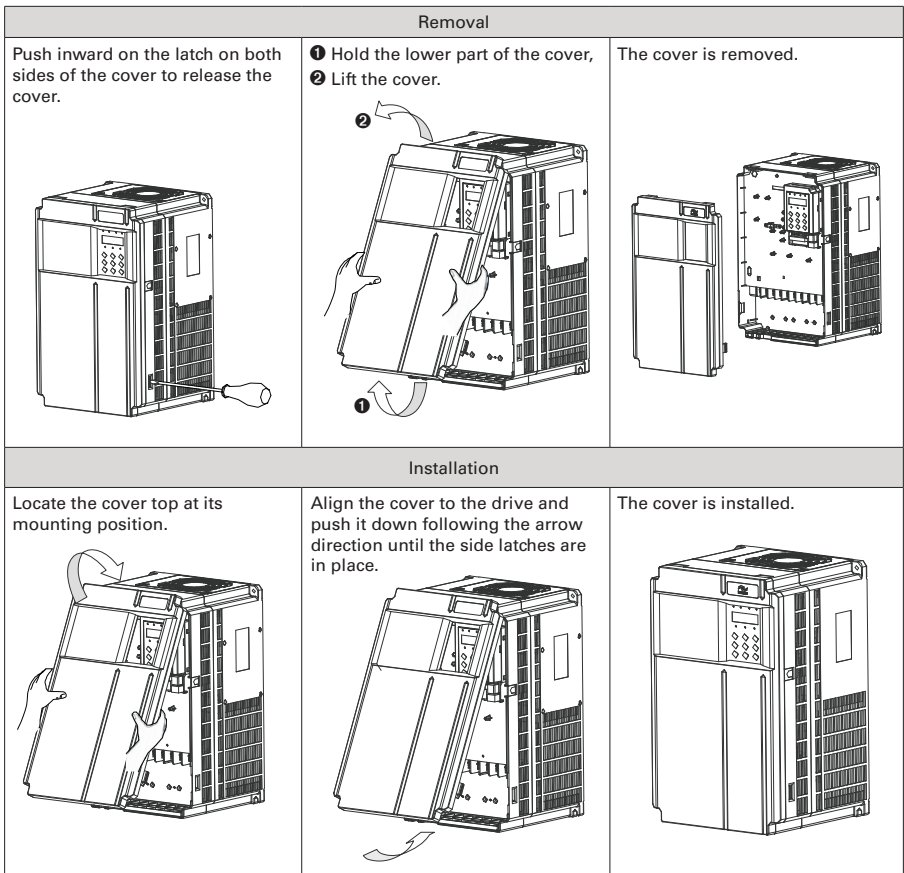

Figure 5-1a Remove and install the cover of drives RSI-PPFP-0001-4-3-B-IP20-IM to RSI-PPFP-0060-4-3-B-IP20-IM, 0.5 HP – 50 HP

2. Remove and Install the Cover of Drives RSI-PPFP-0075-4-3-B-XN01-IM to RSI-PPFP-0250-4-3-X-IP00-IM, 60 HP – 200 HP

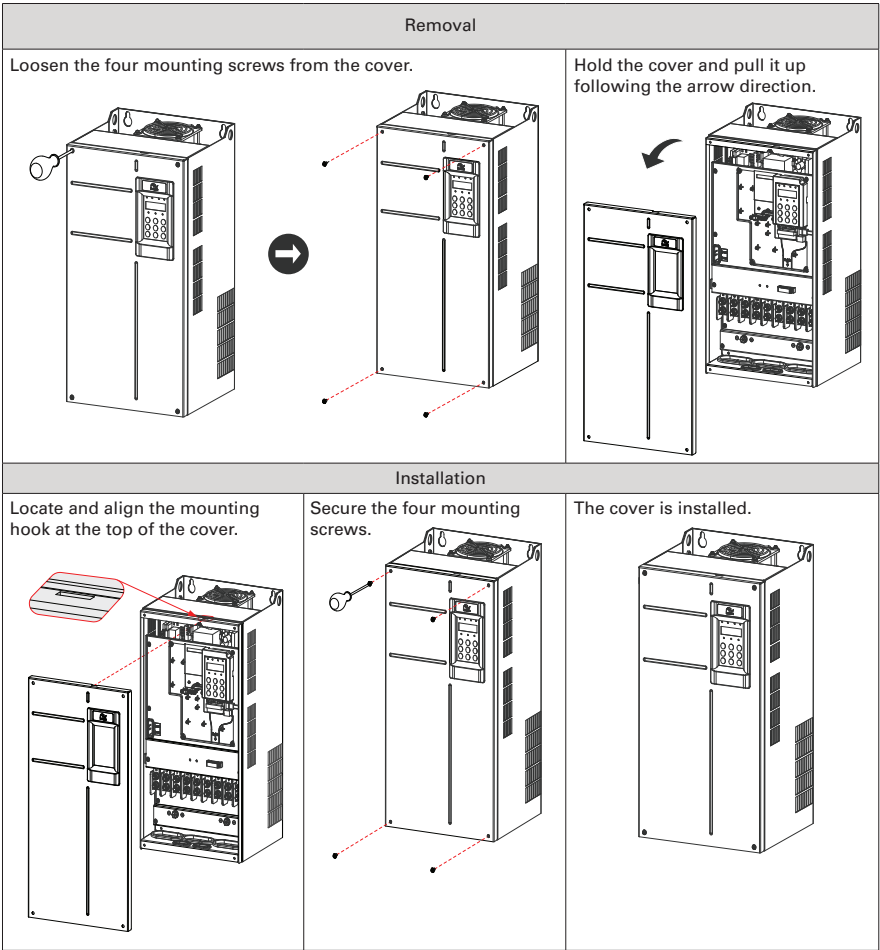

Figure 5-1b Remove and install the cover of drives RSI-PPFP-0075-4-3-B-XN01-IM to RSI-PPFP-0250-4-3-X-IP00-IM, 60 HP – 200 HP

5. ELECTRICAL WIRING

3. Remove and Install the Cover of Drives RSI-PPFP-0300-4-3-X-IP00-IM to RSI-PPFP-0700-4-3-X-IP00-IM, 250 HP – 900 HP

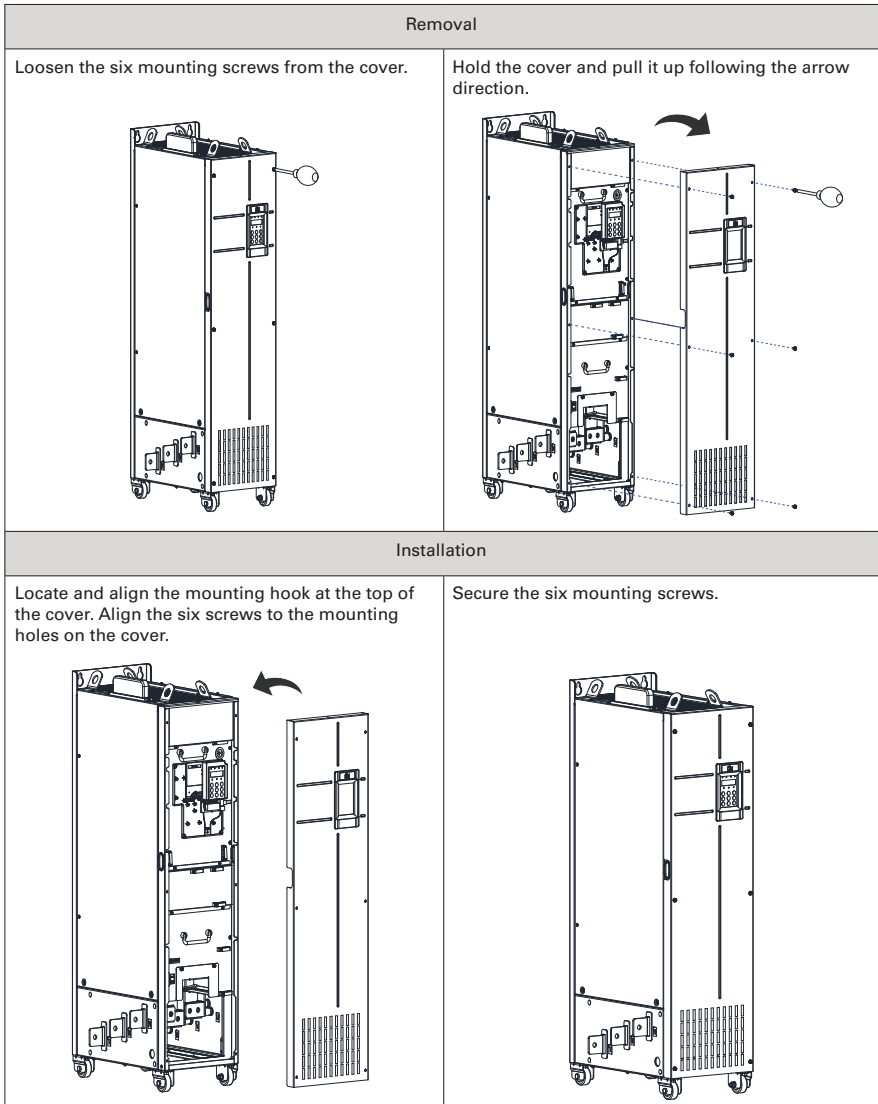
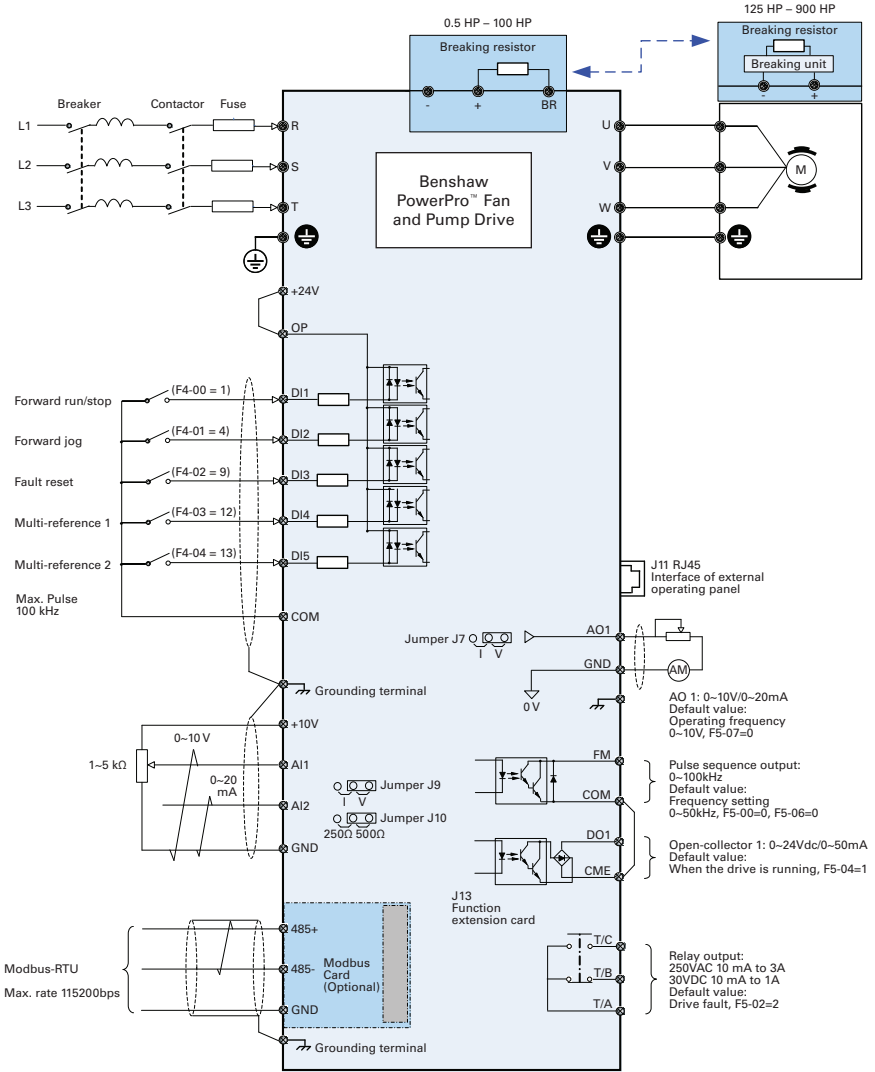

Figure 5-1c Remove and install the cover of drives RSI-PPFP-0300-4-3-X-IP00-IM to RSI-PPFP-0700-4-3-X-IP00-IM, 250 HP – 900 HP

5.2 WIRING

5.2.1 Standard Wiring Diagram



Note:  shield;  twisted pair

Figure 5-2-1 Wiring diagram of a typical three-phase 380V to 480V drive

5. ELECTRICAL WIRING

5.2.2 Functions of Main Circuit Terminals and Precautions

1. Benschaw PowerPro™ Fan and Pump Single AC Drive Main Circuit Terminals

Internal brake for up to 100 HP (75kW).

No internal brake for 125 HP, 150 HP and above (90kW, 110kW and above).

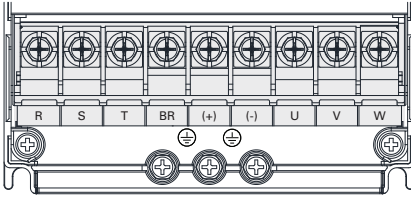

Figure 5-2-2a Terminal arrangement in RSI-PPFP-0001-4-3-B-IP20-IM to RSI-PPFP-0025-4-3-B-IP20-IM, 0.5 HP – 20 HP

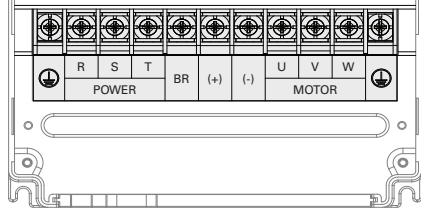

Figure 5-2-2b Terminal arrangement in RSI-PPFP-0030-4-3-B-IP20-IM to RSI-PPFP-0250-4-3-X-IP00-IM, 25 HP – 200 HP

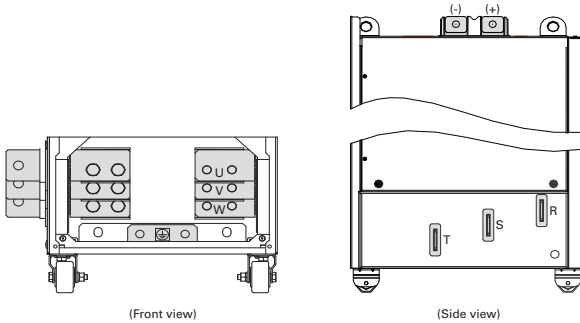



Figure 5-2-2c Terminal arrangement in RSI-PPFP-0300-4-3-X-IP00-IM to RSI-PPFP-0700-4-3-X-IP00-IM, 250 HP – 900 HP

Table 5-2-2 Description of the drive terminals

Terminal	Name	Description
R, S, T	Three-phase supply input	Connect 4 places to three-phase power supply.
(+), (-)	DC bus terminals	Connect 4 places to external braking unit with AC drive units of 125 HP (90 kW) and above.
(+), BR	Braking resistor connection	Connect 4 places to external braking resistor for AC drive units of 100 HP (75 kW) and below.
U, V, W	AC drive outputs	Connect 4 places to a three-phase motor.
	Ground (PE)	Grounding connection.

5.2.3 Cables, Breakers and Contactors

1. Power Input Protection

WARNING

- Install protection devices (a fuse and an MCCB) at power input to the drive. The protection devices must provide protection from overcurrent and short-circuit, and be able to completely isolate the drive from the electrical power input.
- Cables and protection device on the power input must be suitably rated for the power and voltage class of the drive under normal conditions, and under possible fault conditions such as system overload and short-circuit on the power input. Use recommended values in Table 5-2-3b Wire Sizing and Protection Devices.

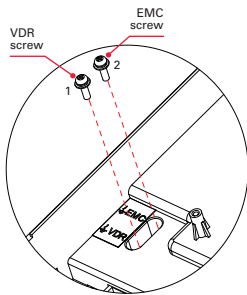

Figure 5-2-3f Drain wire of motor cable shield

Note: For main circuit terminal dimensions and cable wiring, see 4.2.3 Main Circuit Terminals and Dimensions.

2. Power Grid System

WARNING

- The drive is applicable to systems with neutral point grounded. If the drive is used in an IT power system with an ungrounded power system or a high resistance grounded [over 30 ohms] power system, it is necessary to remove both VDR and EMC screws 1 and 2 as shown in Figure 5-2-3f. Do not install a filter. Failure to comply may result in personal injury or damage to the drive.
- If a residual-current device (RCD) is used and it trips at start, remove the EMC screw 2 as shown in Figure 5-2-3f.

5. ELECTRICAL WIRING

3. Recommended Cables, Breakers and Contactors

Benshaw recommends symmetrical shielded cables as the main circuit cable, which can reduce electromagnetic radiation of the entire conductive system. If shielded cable cannot be used, the unshielded cable should be in metal conduit, grounded at both ends.

Recommended power cable: symmetrical shielded cable

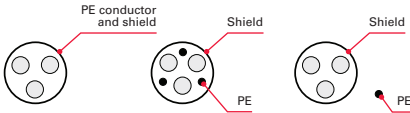

Figure 5-2-3a Recommended power cable

Non-recommended power cable



Figure 5-2-3b Non-recommended power cable

Table 5-2-3a Power Terminals

Frame Size for Ref.	Model Number	Power Cable (Input/Output) AWG or kcmil	Torque (in-lbs)	Ground Cable AWG	Torque (in-lbs)	Screw Spec
T1	RSI-PPFP-0001-4-3-B-IP20-IM	14-10	21	14-10	12	M4
T1	RSI-PPFP-01H5-4-3-B-IP20-IM	14-10	21	14-10	12	M4
T1	RSI-PPFP-0002-4-3-B-IP20-IM	14-10	21	14-10	12	M4
T1	RSI-PPFP-0003-4-3-B-IP20-IM	14-10	21	14-10	12	M4
T1	RSI-PPFP-0005-4-3-B-IP20-IM	14-10	21	14-10	12	M4
T2	RSI-PPFP-07H5-4-3-B-IP20-IM	14-10	21	14-10	12	M4
T2	RSI-PPFP-0010-4-3-B-IP20-IM	14-10	21	14-10	12	M4
T3	RSI-PPFP-0015-4-3-B-IP20-IM	10-8	49	10-6	28	M5
T3	RSI-PPFP-0020-4-3-B-IP20-IM	10-8	49	10-6	28	M5
T4	RSI-PPFP-0025-4-3-B-IP20-IM	8-6	49	10-6	28	M5
T5	RSI-PPFP-0030-4-3-B-IP20-IM	6	35	8	35	M6
T5	RSI-PPFP-0040-4-3-B-IP20-IM	4	35	8	35	M6
T6	RSI-PPFP-0050-4-3-B-IP20-IM	4	35	8	35	M6
T6	RSI-PPFP-0060-4-3-B-IP20-IM	3	35	6	35	M6
T7	RSI-PPFP-0075-4-3-B-XN01-IM	2	93	6	93	M8
T7	RSI-PPFP-0100-4-3-B-XN01-IM	1/0	93	6	93	M8

Frame Size for Ref.	Model Number	Power Cable (Input/Output) AWG or kcmil	Torque (ft-lbs)	Ground Cable AWG	Torque (ft-lbs)	Screw Spec	Bus Bar Hole Dia. (mm)
T8	RSI-PPFP-0125-4-3-B-XN01-IM	2/0	26	4	26	M12	—
T8	RSI-PPFP-0150-4-3-X-XN01-IM	3/0	26	4	26	M12	—
T9	RSI-PPFP-0200-4-3-X-XN01-IM	350	26	3	26	M12	—
T9	RSI-PPFP-0250-4-3-X-IP00-IM	3/0 (x2)	26	2	26	M12	—
T10	RSI-PPFP-0300-4-3-X-IP00-IM	350 (x2)	26	1	26	M12	13
T10	RSI-PPFP-0350-4-3-X-IP00-IM	350 (x2)	26	1	26	M12	13
T11	RSI-PPFP-0400-4-3-X-IP00-IM	600 (x2)	26	1/0	26	M12	13
T11	RSI-PPFP-0450-4-3-X-IP00-IM	600 (x2)	26	2/0	26	M12	13
T12	RSI-PPFP-0500-4-3-X-IP00-IM	700 (x2)	63	2/0	63	M16	17
T12	RSI-PPFP-0600-4-3-X-IP00-IM	700 (x2)	63	2/0	63	M16	17
T12	RSI-PPFP-0700-4-3-X-IP00-IM	700 (x2)	63	4/0	63	M16	17

Table 5-2-3b Recommended Wire Sizing and Protection Devices

Model Number	Recommended			Terminal width (mm)	Screw Specification	Recommended				
	Input IEC Cable (mm ²)*	IEC Ground Cable (mm ²)	Output IEC Cable (mm ²)			Fuse Busmann Pass UL Certification			Contactor Rated Current (A)	Breaker Rated Current (A)
						Rated Current (A)	Fuse Model Number			
Three-phase 380 to 480V, 50/60 Hz										
RSI-PPFP-0001-4-3-B-IP20-IM	3 x 0.75	0.75	3 x 0.75	10.2	M4	5	FWP-5B	9	3	
RSI-PPFP-01H5-4-3-B-IP20-IM	3 x 0.75	0.75	3 x 0.75	10.2	M4	5	FWP-5B	9	4	
RSI-PPFP-0002-4-3-B-IP20-IM	3 x 0.75	0.75	3 x 0.75	10.2	M4	10	FWP-10B	9	6	
RSI-PPFP-0003-4-3-B-IP20-IM	3 x 0.75	0.75	3 x 0.75	10.2	M4	10	FWP-10B	9	6	
RSI-PPFP-0005-4-3-B-IP20-IM	3 x 1	1	3 x 1	10.2	M4	15	FWP-15B	12	13	
RSI-PPFP-07H5-4-3-B-IP20-IM	3 x 1.5	1.5	3 x 1.5	10.2	M4	20	FWP-20B	16	16	
RSI-PPFP-0010-4-3-B-IP20-IM	3 x 2.5	2.5	3 x 2.5	10.2	M4	30	FWP-30B	26	25	
RSI-PPFP-0015-4-3-B-IP20-IM	3 x 4	4	3 x 4	13.0	M5	40	FWP-40B	26	32	
RSI-PPFP-0020-4-3-B-IP20-IM	3 x 6	6	3 x 6	13.0	M5	60	FWP-60B	38	50	
RSI-PPFP-0025-4-3-B-IP20-IM	3 x 10	10	3 x 10	14.3	M5	70	FWH-70B	50	63	
RSI-PPFP-0030-4-3-B-IP20-IM	3 x 10	10	3 x 10	15.0	M6	80	FWH-80B	65	63	
RSI-PPFP-0040-4-3-B-IP20-IM	3 x 16	16	3 x 16	15.0	M6	100	FWH-100B	65	80	
RSI-PPFP-0050-4-3-B-IP20-IM	3 x 16	16	3 x 16	18.0	M6	100	FWH-100B	65	80	
RSI-PPFP-0060-4-3-B-IP20-IM	3 x 25	16	3 x 25	18.0	M6	125	FWH-125B	80	100	
RSI-PPFP-0075-4-3-B-XN01-IM	3 x 35	16	3 x 35	26.8	M8	150	FWH-150B	95	160	
RSI-PPFP-0100-4-3-B-XN01-IM	3 x 50	25	3 x 50	26.8	M8	200	FWH-200B	115	160	
RSI-PPFP-0125-4-3-B-XN01-IM	3 x 70	35	3 x 70	30.6	M12	250	FWH-250A	150	250	
RSI-PPFP-0150-4-3-X-XN01-IM	3 x 95	50	3 x 95	30.6	M12	275	FWH-275A	170	250	
RSI-PPFP-0200-4-3-X-XN01-IM	3 x 150	95	3 x 150	*	M12	400	FWH-400A	245	400	
RSI-PPFP-0250-4-3-X-IP00-IM	3 x 185	95	3 x 185	*	M12	500	FWH-500A	300	400	
RSI-PPFP-0300-4-3-X-IP00-IM	2 x (3 x 95)	95	2 x (3 x 95)	*	M12	600	FWH-600A	410	500	
RSI-PPFP-0350-4-3-X-IP00-IM	2 x (3 x 120)	120	2 x (3 x 120)	*	M12	700	FWH-700A	410	630	
RSI-PPFP-0400-4-3-X-IP00-IM	2 x (3 x 120)	120	2 x (3 x 120)	*	M12	800	FWH-800A	475	630	
RSI-PPFP-0450-4-3-X-IP00-IM	2 x (3 x 150)	150	2 x (3 x 150)	*	M12	800	FWH-800A	620	800	
RSI-PPFP-0500-4-3-X-IP00-IM	2 x (3 x 185)	185	2 x (3 x 185)	*	M16	1000	170M5016	620	800	
RSI-PPFP-0600-4-3-X-IP00-IM	2 x (3 x 185)	185	2 x (3 x 185)	*	M16	1000	170M5016	620	800	
RSI-PPFP-0700-4-3-X-IP00-IM	2 x (3 x 240)	240	2 x (3 x 240)	*	M16	1400	170M6017	800	1000	

Notes: *Refer to 4.2.3 Main Circuit Terminals and Dimensions.

**3 x 10 indicates a three-core cable, and 2 x (3 x 95) indicates two 3-core cables.

5. ELECTRICAL WIRING

4. Circuit Breaker

Each AC drive produces more than 3.5 mA leakage current. Therefore, it must be grounded. When trip current causes the circuit breaker to trip, you should:

- Use a circuit breaker with higher rated action current or a delay-action circuit breaker.
- Reduce carrier frequency.
- Shorten length of the output cable.
- Increase current sensitivity of circuit breaker.

5. Power input R, S, T

- There are no phase sequence requirements for three-phase cable connections.
- Specification and installation of all external power cables must comply with local safety regulations and relevant national (NEC, IEC) standards.
- Refer to Table 5-2-3b for recommended wire sizing and protection devices.
- When using an EMC Filter, install filter as close as possible to the input side of the drive to keep cable length as short as possible. Connect the ground terminal of the filter and the ground terminal of the drive together to the main grounding terminal of the cabinet.

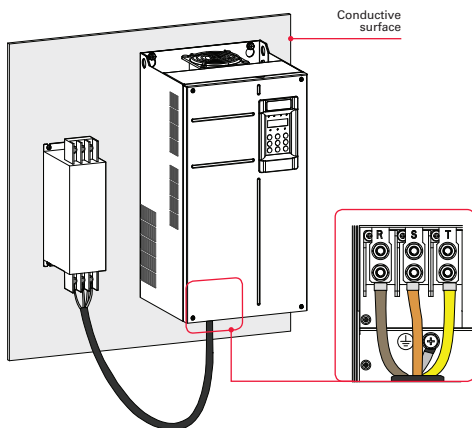

Figure 5-2-3c Mount the filter

6. DC bus terminals (+) and (-), 125 HP and above

- DC bus terminals, labeled (+) and (-), are terminals that carry a residual voltage for a certain time period after the drive has been switched off.
- To avoid risk of equipment damage or fire, when connecting an external dynamic brake module, DO NOT reverse the poles (+) and (-).
- Use a cable not exceeding 10m to connect DC bus terminals to the external braking unit. Use twisted pair wires or close pair wires for this connection.
- Fire risk! Do not connect the braking resistor directly to the DC bus.

7. Braking Resistors (+) and BR, 100 HP and below

- Braking resistor terminals (+) and BR are only for drive units up to 100 HP (75kW) that include an internal braking unit.
- To avoid risk of equipment damage, use a cable not exceeding 5m to connect an external braking resistor.
- To avoid risk of fire from the heat dissipated by the brake resistor, do not place anything combustible around the braking resistor.
- Set F6-15 (braking use ratio) and F9-08 (braking unit initial voltage) correctly according to load after connecting the braking resistor to a drive.

8. Drive Outputs UVW

- Cable specification and installation of all cables connected to the drive output U, V, W must comply with local safety regulations and relevant national (NEC, IEC) standards.
- Refer to Table 5-2-3b for proper wire sizing and protection devices.
- To avoid risk of equipment damage or operating faults, do not connect a capacitor or surge absorber to the output side of the AC drive.
- Long motor cables can contribute to electrical resonance caused by distributed capacitance and inductance. In some cases, this may cause damage to the drive, motor or cables. To avoid these problems, install an AC output reactor close to the drive. See Table A-4 in Options and Accessories for recommended cable lengths.
- Shielded cables are recommended for the motor. The shielding layer must be wound onto the cable support bracket. The drain wire must be grounded to the grounding (PE) terminal.
- Ensure the drain wire of the motor cable shield is as short as possible and its width must be no less than 1/5 of its length.

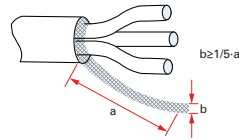



Figure 5-2-3d Drain wire of motor cable shield

9. Grounding (PE) Connection

- For personal safety and reliability of the equipment, it is important to connect ground (PE) terminal to an effective electrical ground. Resistance value of the ground cable must be less than 10 Ω.
- Do not connect the grounding (PE)  terminal of the drive to the neutral conductor of the power system.
- Refer to Table 5-2-3b for proper wire sizing and protection devices.
- Use the proper grounding cable with yellow/green insulation for the protective grounding conductor.
- Ground the shield.
- It is recommended that the drive be installed on a metal mounting surface.
- Install the filter and the drive on the same mounting surface to ensure filtering effect.

10. Main Circuit Cable Protection

- Add a heat-shrink tube to the cable lug copper tube and cable core part of the main circuit cable, and ensure the heat-shrink tube completely covers the cable conductor, as shown in the following figure.

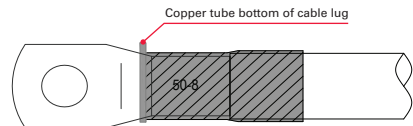

Figure 5-2-3e Heat shrink tube over cable conductor

5. ELECTRICAL WIRING

5.2.4 Control Board

The cover must be removed (see Section 5.1) to access the terminal strip of the control board and to install option cards. Figure 5-2-4 shows the location of each. (Refer to "Appendix A.7 Optional Expansion Cards" to see how to install optional cards.)

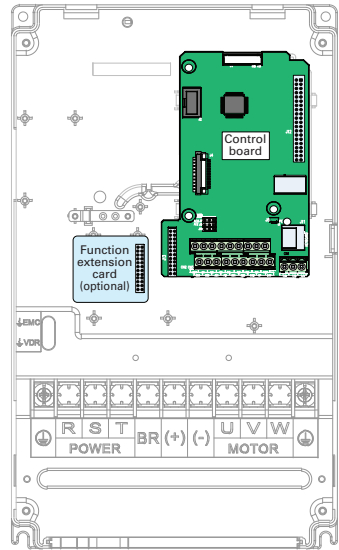

Figure 5-2-4 Control Board

5.2.5 Control Circuit Terminal Arrangement

Control circuit terminal arrangement

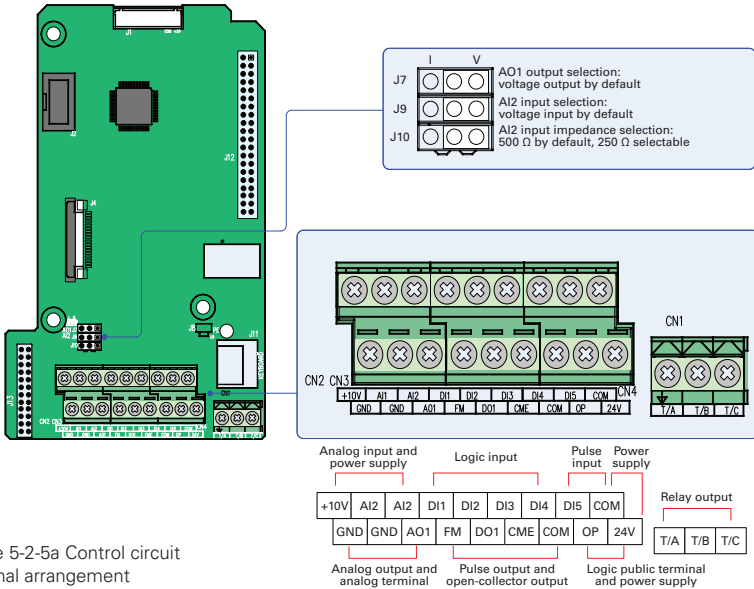

Figure 5-2-5a Control circuit terminal arrangement

Table 5-2-5a Control board terminal specification

Frame size	Model Number	Control Board Terminal	Torque (in-lbs)	Wire Range (AWG)
T1-T8	All Models	CN1	2.5	28-12
		CN2,CN3	2	26-12
T9-T12	All Models	CN1	5.5	26-16
		CN2, CN3	7	26-16

Table 5-2-5b Control circuit terminal function

Type	Terminal	Name	Description
Power supply	+10 V-GND	+10 V power supply	Provides +10 V power supply. Max. output current: 10 mA. Generally used to supply an external potentiometer of 1 to 5 k Ω
	+24 V-COM	+24 V power supply	Provides +24 V power supply. Generally used for DI/DO terminals and external switches. Max. output current: 200 mA ¹
	OP	Input terminal for external power supply	Connected to +24V by default. When DI1 to DI5 need to be driven by external signals, OP must be disconnected from + 24V and connected to an external power supply.
Analog inputs	AI1-GND	Analog input 1	Voltage range of inputs: 0 to 10 VDC Input impedance: 22 k Ω
	AI2-GND	Analog input 2	Either a voltage or a current input, determined by jumper J9 Input voltage range: 0 to 10 VDC Input current range: 0 to 20 mA Input impedance: 22 k Ω (voltage input), 500 Ω or 250 Ω (current input) determined by jumper J10 ²
Digital inputs	DI1- OP	Digital input 1	Optically coupled isolation compatible with dual-polarity inputs Input impedance: 1.39 k Ω Voltage range for inputs: 9 to 30 V In addition to having the same features as DI1 to DI4, DI5 can also be used for high speed pulse inputs. Max. input frequency: 100 kHz Input impedance: 1.03 k Ω
	DI2- OP	Digital input 2	
	DI3- OP	Digital input 3	
	DI4- OP	Digital input 4	
	DI5- OP	High-speed pulse input	
Analog outputs	AO1-GND	Analog output 1	Either a voltage or a current output, determined by jumper J7. Output voltage range: 0 to 10 V Output current range: 0 to 20mA
Digital outputs	DO1-CME	Digital output 1	Optically coupled isolation, dual-polarity open-collector output Output voltage range: 0 to 24V Output current range: 0 to 50mA Note that CME and COM are internally insulated, but are shorted externally by a jumper. In this case, DO1 is driven by +24 V by default. Remove the jumper link if you need to apply external power to DO1.
	FM- COM	High-speed pulse output	Controlled by F5-00 (FM terminal output selection). Max. output frequency: 100 kHz. When used as an open-collector output, the specification is the same as for DO1.
Relay outputs	T/A-T/B	Normally-closed (NC) terminal	Contact driving capacity: 250 VAC, 3 A, Cos Φ = 0.4 30 VDC, 1 A
	T/A-T/C	Normally-open (NO) terminal	
Auxiliary interfaces	J13	Extension card interface	Interface for the 28-pin terminal and optional cards (I/O extension card, PLC card and various bus cards)
	J4	PG card interface	Open-collector, differential and resolver are selectable options.
	J11	External operating panel interface	Connected to an external operating panel (Remote Display).
Jumpers ³	J7	AO1 output selection	Either a voltage or a current output, voltage output by default
	J9	AI2 input selection	Either a voltage or a current input, voltage input by default
	J10	AI2 input impedance selection	Either 500 Ω or 250 Ω input, 500 Ω input by default

¹ When the ambient environment is above 23°C, the output current must be derated for 1.8 mA per 1°C temperature rise. The maximum output current is 170 mA at 40°C. When OP is connected to 24 V, the current ~17mA per DI must also be considered.

² Select 500 Ω or 250 Ω input impedance according to load capacity of signal source. For example, if 500 Ω is selected, maximum output voltage of signal source must not be smaller than 10 V so that AI2 can measure 20 mA current.

³ For positions of jumpers J7, J9 and J10, refer to Figure 5-2-5a.

6. PANEL OPERATION

The AC drive has a built-in programming/operating panel with LED indicators and display. It allows you to program parameters and monitor/control system status.

The remote LED panel is the same as the built-in LED panel. For its appearance and use, refer to Section A.6.

A remote/external LED (RSI-PPVC-AXRY-RMKP-LED) or LCD (RSI-PPVC-AXRY-RMKP-LCD) operating panel is available as an option.

The LCD operating panel allows you to copy, upload and download parameters.

6.1 LED OPERATING PANEL

The LED operating panel allows you to program parameters, monitor system status, start or stop the AC drive.

Details of the operating panel are shown in the following figure:

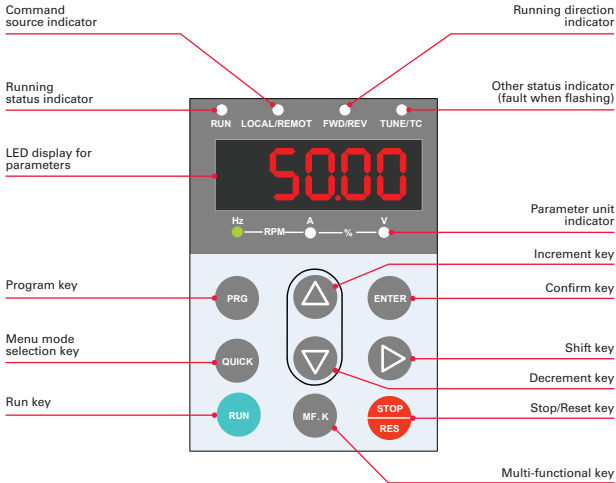

Figure 6-1 Details of the operating panel

6.1.1 Indicators on LED Operating Panel

Table 6-1-1 Indicators on the operating panel

	State	Indication
RUN Running Status indicators	RUN	OFF indicates the STOP status.
	RUN	ON indicates the RUNNING status.
LOCAL/REMOTE Running Command indicators	LOCAL/ REMOTE	OFF indicates LOCAL panel control.
	LOCAL/ REMOTE	ON indicates REMOTE (terminal) control.
	LOCAL/ REMOTE	FLASHING indicates under serial communication control.
FWD/REV Forward and reverse rotation indicators	FED/REV	OFF indicates forward motor rotation.
	FED/REV	ON indicates reverse motor rotation.
TUNE/TC Tuning, torque control and fault indicators	TUNE/TC	OFF indicates the drive is normal.
	TUNE/TC	ON indicates torque control mode.
	TUNE/TC	FLASHING SLOWLY (once a second) indicates auto-tuning status.
	TUNE/TC	FLASHING QUICKLY (four times a second) indicates a fault condition.
Hz — RPM — A — % — V	Hz for frequency	
Hz — RPM — A — % — V	A for current	
Hz — RPM — A — % — V	V for voltage	
Hz — RPM — A — % — V	RPM for motor speed	
Hz — RPM — A — % — V	Percentage	

6.1.2 LED Display

The five-digit LED data display can show the frequency reference, output frequency, monitoring information, and fault code.









Table 6-1-2 Indicators on the operating panel

LED display	Indication	LED display	Indication	LED display	Indication	LED display	Indication
0	0	6	6	C	C	n	N
1	1	7	7	c	c	P	P
2	2	8	8	d	D	r	R
3	3	9	9	E	E	f	T
4	4	A	A	F	F	U	U
5	5, S	b	B	L	L	u	u

6. PANEL OPERATION

6.1.3 Keys on LED Operating Panel

Table 6-1-3 Function of keys on the LED operating panel

Key	Key Name	Function
	Programming	Enter Level I menu, exit all other levels without saving.
	Confirm	Levels II and III menus and confirm parameter change.
	Increment	Level I - Increase Parameter Group (F0, F1, F2....) Level II - Increase Function Code (F0-01, F0-02, F0-03...) Level III - When editing a parameter value, increase the displayed value.
	Decrement	Level I - Decrease Parameter Group (F5, F4, F3....) Level II - Decrease Function Code (F0-04, F0-03, F0-02...) Level III - When editing a parameter value, decrease the displayed value.
	Shift	Select the displayed parameter in the STOP or RUNNING status. Select the digit to be modified when modifying a parameter value.
	RUN	Start the AC drive when using the operating panel control mode.
	Stop/Reset	Stop the AC drive when the drive is in the RUNNING status. The functions of this key can be restricted by using function F7-02. Perform a reset operation when the drive is in the FAULT status.
	Multifunction	Perform a function switchover as defined by the setting of F7-01. For details, refer to "6.1.9 Multifunction".
	Menu mode selection	Press to switch between menu modes as defined by the setting of FP-03.

6.1.4 View and Modify Function Parameters

The drive operating panel has three menu levels:

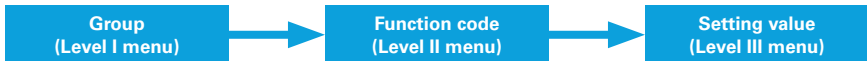

After entering each level, you can press , , or  to modify the flashing value. Operation procedure is shown in Figure 6-1-4.

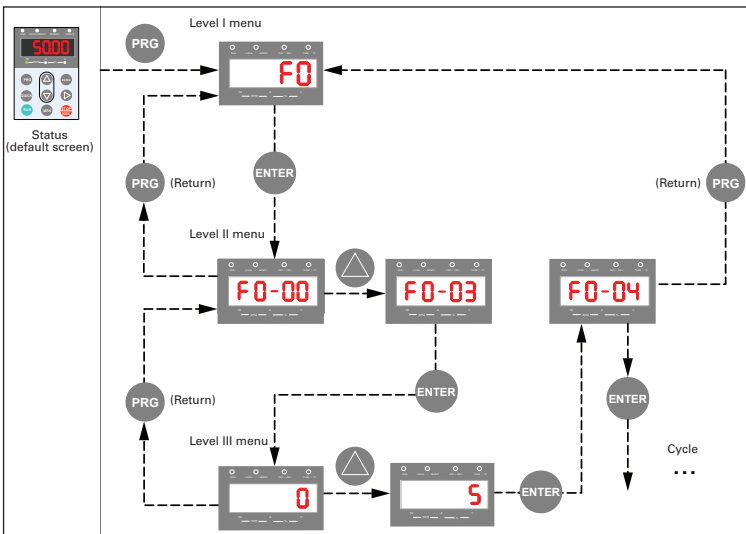

Figure 6-1-4 Operation procedure of the three levels of menu

6.1.5 Keys on LED Operating Panel

The following example shows how to modify F3-02 from 10.00 Hz to 15.00 Hz.

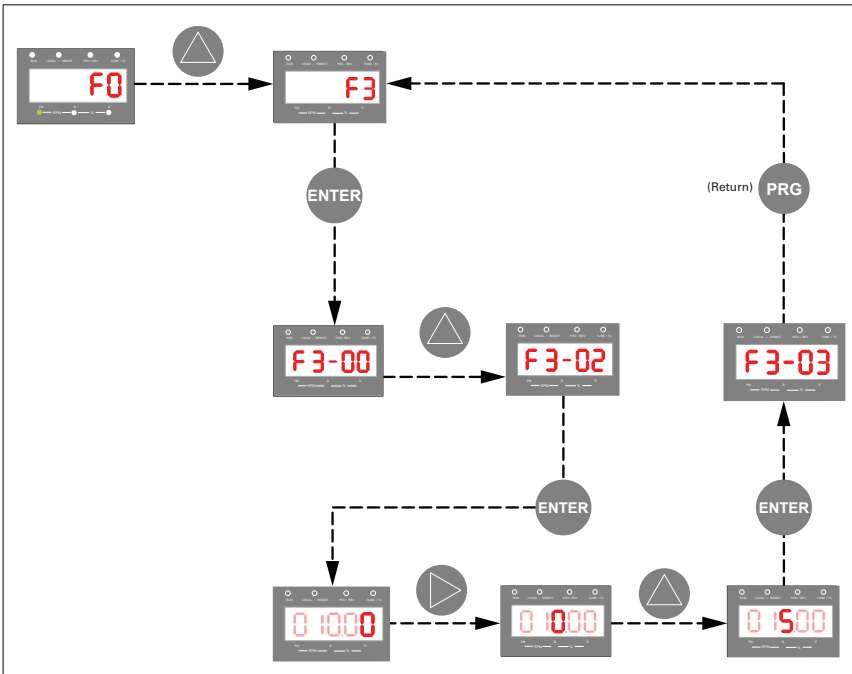

Figure 6-1-5 How to modify the parameter value

(a) Press **PRG** or **ENTER** from a Level III menu to return to a Level II menu. The difference between the two keys is:

ENTER is used to save the parameter value you have set, return to Level II menu and then select the next function parameter.

PRG is used to return to Level II menu without saving the parameter value and remain at the current function code.

(b) When operating in Level III menus, if the parameter does not include a flashing digit, then it is not possible to modify that parameter. There are two possible reasons for this:

(1) The function parameter you have selected is read-only. Examples of read only parameters are: Output Frequency, output Current, etc...

(2) The displayed function parameter cannot be modified while the AC drive is in the RUNNING status. You can modify these types of parameter only when the AC drive is in the STOP status.

6. PANEL OPERATION

6.1.6 Drive Parameter Structure

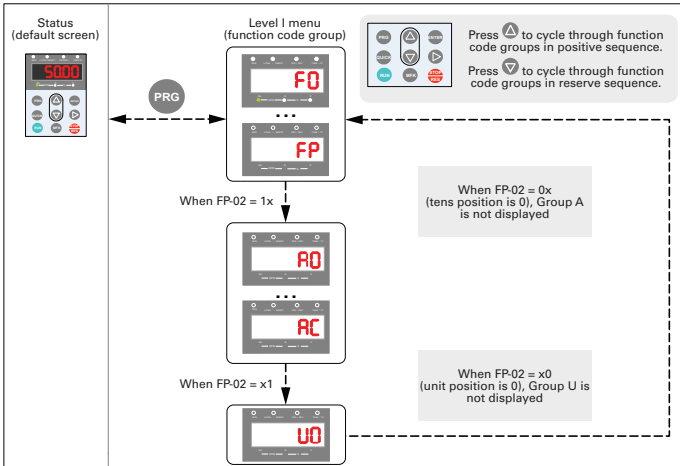

Figure 6-1-6 View the function parameter group number

6.1.7 Quick View Mode – Activation

The drive provides three display modes for viewing parameters. Base mode, user mode and modified (changed) mode. In base mode, all function parameters are shown. You can set the function code FP-03 to quick view function parameters in two other modes. A User group and a modified (changed) group can be displayed.

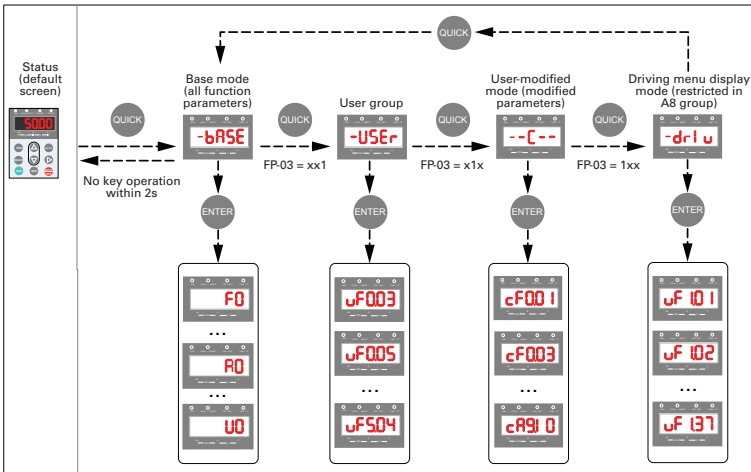



Figure 6-1-7 View the function parameters

In the figure above, in user-defined quick-view mode, the parameter is displayed as "uU3.02". It means the function parameter F3-02 can be modified in user-modified quick-view mode and base mode in the same way. Function parameter display modes are as follows:



1. Base mode

In base mode, all function parameters of the drive are shown.

You can view or edit the parameters according to section 6.1.4. Press  to cycle through three function parameter display modes. In each mode, the method you use to view and modify parameter value is the same as shown in 6.1.4.



2. Quick-view mode

To show function parameters that are defined or modified by a user, set the FP-03 value to 11.

Function Code	Definition	Default	Setting Range	Description
FP-03	Parameter display property	00	Unit's digit:  group is displayed. 0: Not displayed; 1: Displayed Ten's digit:  group is displayed. 0: Not displayed; 1: Displayed	Determine whether the operating panel displays quick-view user-defined and quick-view user modified function groups.

6.1.8 View Function Parameters

View quick-view user-defined function parameter group

Press  to enter the  mode. Then the user can view the user-defined function parameters. The user can set the function group FE (FE-00 to FE-29) to define often used function parameters. The user can define up to 30 parameters to the function group FE. The function parameters FE00 to FE-15 (16 in total) are default and can be edited by the user. If a function code in group FE is set to F0.00, it indicates that no parameter is defined by the user.





If  is displayed after you press , it indicates that the user-defined menu is empty. The following table lists the often used parameters in the user-defined menu

Table 6-1-8 Often used parameters in the user-defined menu

Function Code	User-defined Function Code	Parameter Name	Function Code	User-defined Function Code	Parameter Name
FE-00	F0-01	Control mode	FE-01	F0-02	Running command selection
FE-02	F0-03	Main frequency reference setting channel selection	FE-03	F0-07	Frequency source calculation selection
FE-04	F0-08	Preset frequency	FE-05	F0-17	Acceleration time
FE-06	F0-18	Deceleration time	FE-07	F3-00	V/F curve setting
FE-08	F3-01	Torque boost	FE-09	F4-00	DI1 function selection
FE-10	F4-01	DI2 function selection	FE-11	F4-02	DI3 function selection
FE-12	F5-04	DO1 output selection	FE-13	F5-07	AO1 output selection
FE-14	F6-00	Start mode	FE-15	F6-10	Stop mode

View user modified function parameters

Press  to enter the  mode to view function parameters that have been modified.

In this mode, you can view modified function parameters quickly. All function parameters that have been modified by a user are listed in the modified function parameter group. The current values of these parameters are different from the default values. The AC drive automatically generated a list of modified function parameters.

6. PANEL OPERATION

View status parameters

When the drive is in STOP or RUNNING state, press to switch each byte of F7-03, F7-04, an F7-05 to display multiple status parameters.

A maximum of 32 parameters in the running status can be viewed in F7-03 (running parameter 1) and F7-04 (running parameter 2) based on each bit selection in binary. At stop, a total of 13 parameters can be viewed in F7-05 (STOP parameter) based on each bit selection in binary.

You can use the operating panel to view running frequency, bus voltage, output voltage, output current, output power and PID reference.

- (1) Set each bit of F7-03 to 1 according to the mapping between each bit and the corresponding parameter.
- (2) Convert binary number to equivalent hexadecimal number. H.001F is displayed.
- (3) Press to convert each bit of F7-03. The reference is as follows:

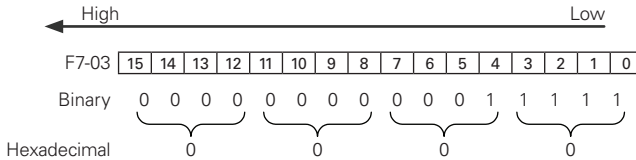

You can view the other parameters in the same way. The mapping of each bit of F7-03, F7-04, and F7-05 is shown in the following figure:

Function Code	Parameter Name	Default	Setting Range	Description																
F7-03	LED display running parameters 1	1F	0000 to FFFF	<p>If a parameter needs to be displayed during running, set corresponding bit to 1, and set F7-03 to hexadecimal equivalent.</p> <p>Lowest eight digits</p> <table border="1" style="margin-left: 20px;"> <tr> <td>7</td><td>6</td><td>5</td><td>4</td> <td>3</td><td>2</td><td>1</td><td>0</td> </tr> </table> <ul style="list-style-type: none"> Running frequency (Hz) Frequency reference (Hz) Bus voltage (V) Output voltage (V) Output current (A) Output power (kW) DI state (V) <p>Highest eight digits</p> <table border="1" style="margin-left: 20px;"> <tr> <td>15</td><td>14</td><td>13</td><td>12</td> <td>11</td><td>10</td><td>9</td><td>8</td> </tr> </table> <ul style="list-style-type: none"> DO state AI1 voltage (V) AI2 voltage (V) AI3 voltage (V) Count value Length value Load speed display PID reference <p>Note: Values with shading are default values.</p>	7	6	5	4	3	2	1	0	15	14	13	12	11	10	9	8
7	6	5	4	3	2	1	0													
15	14	13	12	11	10	9	8													

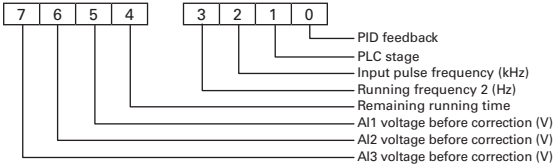
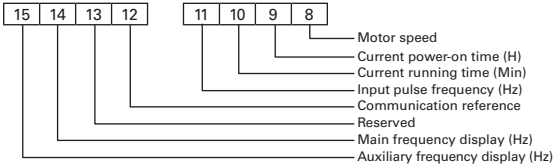
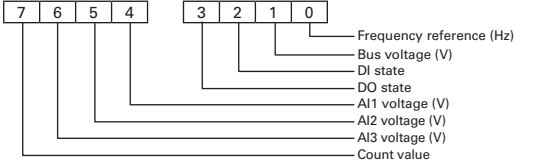
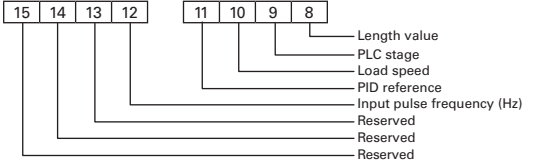
Function Code	Parameter Name	Default	Setting Range	Description
F7-04	LED display running parameters 2	0	0000 to FFFF	<p>If a parameter needs to be displayed during running, set corresponding bit to 1, and set F7-04 to hexadecimal equivalent.</p> <p>Lowest eight digits</p>  <p>Highest eight digits</p> 
F7-05	Display stop parameter	0	0000 to FFFF	<p>If a parameter needs to be displayed during stop, set corresponding bit to 1, and set F7-05 to hexadecimal equivalent.</p> <p>Lowest eight digits</p>  <p>Highest eight digits</p>  <p>Note: Values with shading are default values.</p>

Note: Once the AC drive is re-powered on after power down, the display includes the selected parameters before power down by default.

6. PANEL OPERATION

6.1.9 MFK Key Function

Function of the  key on the LED operating panel can be set via function parameter F7-01. You can switch running command or frequency reference direction of the drive and implement forward/reverse jog through this key in either STOP or RUNNING status.

Function Code	Parameter Name	Default	Setting Range	Description
F7-01	MFK key function selection	0	0: MFK disabled	The key has no function.
			1: Switchover between operating panel and terminal/communication.	F0-02 = 0, there is no effect after you press the MFK key. F0-02 = 1, running command can be switched between terminal and operating panel through the MFK key. F0-02 = 2, communication source can be switched between communication and operating panel through the MFK key.
			2: Forward/Reverse RUN switchover	Frequency reference direction can be switched through the MFK key. This function is valid only when running command is operating panel.
			3: Forward jog	Forward jog of the drive can be implemented through the MFK key. This function is valid only when running command is operating panel.
			4: Reverse jog	Reverse jog of the drive can be implemented through the MFK key. This function is valid only when running command source is operating panel.

6.1.10 Function and Monitoring Parameters

Table 6-1-10 Overall arrangement of function parameters

Function Code Group	Function Description	Description
F0 to FP	Basic function parameters	Displays parameters such as running commands, frequency commands, motor parameters, control modes
A0 to AC	Advanced parameter groups	Torque Control, Virtual I/O, Control Optimization, PLC function, Master Slave Communications, etc.
U0	Monitoring group	View only, of 78 different monitoring parameters.

Before viewing function parameters, set FP-02 (SELECTED) to see whether the function parameter group is displayed. The following figure shows how to view the function parameter group number:

Function Code	Definition	Default	Setting Range	Description
FP-02	Parameter display property	11	Unit's digit: Group U 0: Not displayed; 1: Displayed Ten's digit: Group A 0: Not displayed; 1: Displayed	The value you set for function parameter FP-02 determines whether the operating panel displays groups U and A.

6.2 PARAMETERS

When a non-zero value is set for FP-00, the user-defined password is used. In function parameter mode and function parameter editing mode, enter the password correctly. To remove password protection, set FP-00 to 0.

Password protection is not applicable to user-defined parameters.

Groups F0 through FP are standard function parameters.

For Groups A and U, see section 6.2.2 and 6.2.3.

The symbols in the parameter table are described as follows:

☆: It is possible to modify the parameter with the drive in stop and in run status.

★: It is not possible to modify the parameter with the drive in the run status.

•: The parameter is the actual measured value and cannot be modified.

*: The parameter is a factory parameter and can be set only by the manufacturer.

6.2.1 Standard Parameter Table - F0 to FP

Function Code	Name	Setting Range	Default	Change
Group F0: Standard Parameters				
F0-00	G/P type display	1: G (constant torque load) 2: P (fan or pump)	Model dependent	•
F0-01	Motor 1 control mode	0: V/F	0	★
F0-02	Running command selection	0: Operating panel 1: Terminal 2: Serial communication	0	☆
F0-03	Main frequency reference setting channel selection	0: Digital setting (revised value is not cleared after power off) 1: Digital setting (revised value is cleared after power off) 2: AI1 3: AI2 4: AI3 5: Pulse setting (DI5) 6: Multi-reference 7: Simple PLC 8: PID reference 9: Communication setting	0	★
F0-04	Auxiliary frequency reference setting channel selection	Same as F0-03	0	★
F0-05	Base value of range of auxiliary frequency reference for Main and auxiliary calculation	0: Relative to maximum frequency 1: Relative to main frequency reference	0	☆
F0-06	Range of auxiliary frequency reference for main and auxiliary calculation	0% to 150%	100%	☆

6. PANEL OPERATION

Function Code	Name	Setting Range	Default	Change
Group F0: Standard Parameters (continued)				
F0-07	Final Frequency reference setting selection	Units position: Frequency reference selection 0: Main frequency reference 1: Main and auxiliary calculation (based on tens position) 2: Switchover between main and auxiliary 3: Switchover between main and "main and auxiliary calculation" 4: Switchover between auxiliary and "main and auxiliary calculation" Tens position: main and auxiliary calculation formula 0: Main + auxiliary 1: Main - auxiliary 2: Max. (main, auxiliary) 3: Min. (main, auxiliary)	00	☆
F0-08	Preset frequency	0.00 Hz to max. frequency (F0-10)	50.00 Hz	☆
F0-09	Running direction	0: Forward (FWD/REV indicator off) 1: Reverse (FWD/REV indicator on)	0	☆
F0-10	Max. frequency	50.00 Hz to 500.00 Hz	50.00 Hz	★
F0-11	Setting channel of frequency upper limit	0: Set by F0-12 1: AI1 2: AI2 3: AI3 4: Pulse reference 5: Communication reference	0	★
F0-12	Frequency reference upper limit	Frequency lower limit (F0-14) to max. frequency (F0-10)	50.00 Hz	☆
F0-13	Frequency reference upper limit offset	0.00 Hz to max. frequency (F0-10)	0.00 Hz	☆
F0-14	Frequency reference lower limit	0.00 Hz to frequency upper limit (F0-12)	0.00 Hz	☆
F0-15	Carrier frequency	0.5kHz to 16.0kHz	Model dependent	☆
F0-16	Carrier frequency adjusted with load	0: Disabled 1: Enabled	1	☆
F0-17	Acceleration time 1	0.00s to 650.00s (F0-19 = 2) 0.0s to 6500.0s (F0-19 = 1) 0s to 65000s (F0-19 = 0)	Model dependent	☆
F0-18	Deceleration time 1	0.00s to 650.00s (F0-19 = 2) 0.0s to 6500.0s (F0-19 = 1) 0s to 65000s (F0-19 = 0)	Model dependent	☆
F0-19	Acceleration/Deceleration time unit	0: 1s 1: 0.1s 2: 0.01s	1	★
F0-21	Frequency offset of Auxiliary frequency setting channel for main and auxiliary calculation	0.00 Hz to max. frequency (F0-10)	0.00 Hz	☆
F0-22	Frequency reference resolution	2: 0.01Hz	2	★
F0-23	Retentive of digital setting frequency upon stop	0: Not retentive 1: Retentive	0	☆
F0-24	Motor parameter group selection	0: Motor parameter group 1 1: Motor parameter group 2	0	★
F0-25	Acceleration/Deceleration time base frequency	0: Maximum frequency (F0-10) 1: Frequency reference 2: 100 Hz	0	★
F0-26	Base frequency for UP/DOWN modification during running	0: Running frequency 1: Frequency reference	0	★

Function Code	Name	Setting Range	Default	Change
Group F0: Standard Parameters (continued)				
F0-27	Running command + frequency source	Units position: operating panel (keypad and display) + frequency reference setting channel 0: No function 1: Digital setting 2: AI1 3: AI2 4: AI3 5: Pulse reference (DI5) 6: Multi-reference 7: Simple PLC 8: PID reference 9: Serial communication Tens position: terminal I/O control + frequency reference setting channel Hundreds position: serial communication + frequency reference setting channel	0000	☆
F0-28	Serial port communication protocol	0: Modbus protocol 1: PROFIBUS-DP or CANopen protocol	0	★
Group F1: Motor 1 Parameters				
F1-00	Motor type selection	0: Common asynchronous motor 1: Variable frequency asynchronous motor	0	★
F1-01	Rated motor power	0.1 to 1000.0 kW	Model dependent	★
F1-02	Rated motor voltage	1 to 2000 V	Model dependent	★
F1-03	Rated motor current	0.01 to 655.35 A (AC drive power ≤ 55 kW) 0.1 to 6553.5 A (AC drive power > 55 kW)	Model dependent	★
F1-04	Rated motor frequency	0.01 Hz to max. frequency	Model dependent	★
F1-05	Rated motor speed	1 to 65535 RPM	Model dependent	★
F1-06	Stator resistance	0.001 to 65.535 Ω (AC drive power ≤ 55 kW) 0.0001 to 6.5535 Ω (AC drive power > 55 kW)	Auto-tuning parameter	★
F1-07	Rotor resistance	0.001 to 65.535 Ω (AC drive power ≤ 55 kW) 0.0001 to 6.5535 Ω (AC drive power > 55 kW)	Auto-tuning parameter	★
F1-08	Leakage inductive reactance	0.01 to 655.35 mH (AC drive power ≤ 55 kW) 0.001 to 65.535 mH (AC drive power > 55 kW)	Auto-tuning parameter	★
F1-09	Mutual inductive reactance	0.1 to 6553.5 mH (AC drive power ≤ 55 kW) 0.01 to 655.35 mH (AC drive power > 55 kW)	Auto-tuning parameter	★
F1-10	No-load current	0.01 to F1-03 (AC drive power ≤ 55 kW) 0.1 to F1-03 (AC drive power > 55 kW)	Auto-tuning parameter	★
F1-37	Auto-tuning selection	0: No auto-tuning 1: Asynchronous motor partial static auto-tuning 2: Asynchronous motor dynamic auto-tuning 3: Asynchronous motor complete static auto-tuning	0	★

6. PANEL OPERATION

Function Code	Name	Setting Range	Default	Change
Group F3: V/F Control Parameters				
F3-00	V/F curve setting	0: Linear V/F 1: Multi-point V/F 2: Squared 3-9: Reserved 10: V/F complete separation 11: V/F half separation Note: When F3-00 is set to 2 to 9, the actual linear V/F is used.	0	★
F3-01	Torque boost	0.0%: No torque boost 0.1 to 30.0 %	Model dependent	☆
F3-02	Cut-off frequency of torque boost	0.00 Hz to max. frequency	50.00 Hz	★
F3-03	Multi-point V/F frequency 1	0.00 Hz to F3-05	0.00 Hz	★
F3-04	Multi-point V/F voltage 1	0.0% to 100.0%	0.0%	★
F3-05	Multi-point V/F frequency 2	F3-03 to F3-07	0.00 Hz	★
F3-06	Multi-point V/F voltage 2	0.0% to 100.0%	0.0%	★
F3-07	Multi-point V/F frequency 3	F3-05 to rated motor frequency F1-04, Hz	0.00 Hz	★
F3-08	Multi-point V/F voltage 3	0.0% to 100.0%	0.0%	★
F3-10	V/F over-excitation gain	0 to 200	64	☆
F3-11	V/F oscillation suppression gain	0 to 100	40	☆
F3-13	Voltage source for V/F separation	0: Set by F3-14 1: AI1 2: AI2 3: AI3 4: Pulse reference (DI5) 5: Multi-reference 6: Simple PLC 7: PID reference 8: Serial comms. Note: 100.0% corresponds to the rated motor voltage	0	☆
F3-14	Digital setting of voltage for V/F separation	0V to rated motor voltage	0V	☆
F3-15	Voltage rise time of V/F separation	0.0s to 1000.0s Note: It is the time used for the voltage increases from 0V to the motor rated voltage.	0.0s	☆
F3-16	Voltage decline time of V/F separation	0.0s to 1000.0s Note: It is the time used for the voltage increases from 0V to the motor rated voltage.	0.0s	☆
F3-17	Stop mode selection for V/F separation	0: Frequency and voltage declining to 0 independently 1: Frequency declining after voltage declines to 0	0	☆
F3-18	Current limit level	50% to 200%	150%	★
F3-19	Current limit selection	0: Disabled 1: Enabled	1 (Enabled)	★
F3-20	Current limit gain	0 to 100	20	☆
F3-21	Compensation factor of speed multiplying current limit	50% to 200%	50%	★
F3-22	Voltage limit	650.0 to 800.0 V	770.0V	★
F3-23	Voltage limit selection	0: Disabled 1: Enabled	1 (Enabled)	★
F3-24	Frequency gain for voltage limit	0 to 100	30	☆
F3-25	Voltage gain for voltage limit	0 to 100	30	☆
F3-26	Frequency rise threshold during voltage limit	0 to 50 Hz	5Hz	★

Function Code	Name	Setting Range	Default	Change
Group F4: Input Terminals				
F4-00	DI1 function selection	0: No function 1: Forward RUN (FWD) 2: Reverse RUN (REV) Note: F4-11 must be set when F4-00 is set to 1 or 2. 3: Three-wire control 4: Forward JOG (FJOG) 5: Reverse JOG (RJOG) 6: Terminal UP 7: Terminal DOWN 8: Coast to stop 9: Fault reset (RESET) 10: RUN pause	1	★
F4-01	DI2 function selection	11: External fault normally open (NO) input 12: Multi-reference terminal 1 13: Multi-reference terminal 2 14: Multi-reference terminal 3 15: Multi-reference terminal 4	4	★
F4-02	DI3 function selection	16: Terminal 1 for acceleration/deceleration time selection 17: Terminal 2 for acceleration/deceleration time selection 18: Frequency source switchover 19: UP and DOWN setting clear (terminal, keypad) 20: Running command switchover terminal 1 21: Acceleration/Deceleration prohibited	9	★
F4-03	DI4 function selection	22: PID pause 23: PLC status reset 24: Swing pause 25: Counter input 26: Counter reset 27: Length count input 28: Length reset 29: Torque control prohibited 30: Pulse input (enabled only for DI5) 31: Reserved	12	★
F4-04	DI5 function selection	32: Immediate DC injection braking 33: External fault normally closed (NC) input 34: Frequency modification enabled 35: PID action direction reverse 36: External STOP terminal 1 37: Running command switchover terminal 2 38: PID integral disabled	13	★
F4-05	DI6 function selection	39: Switchover between main frequency source and preset frequency 40: Switchover between auxiliary frequency source and preset frequency 41: Motor terminal selection 42: Reserved	0	★
F4-06	DI7 function selection	43: PID parameter switchover 44: User-defined fault 1 45: User-defined fault 2 46: Speed control/Torque control switchover 47: Emergency stop	0	★
F4-07	DI8 function selection	48: External STOP terminal 2 49: Deceleration DC injection braking 50: Clear the current running time 51: Two-wire/Three-wire mode switchover 52: Reverse frequency forbidden 53-59: Reserved	0	★
F4-08	DI9 function selection		0	★
F4-09	DI10 function selection		0	★
F4-10	DI filter time	0.000s to 1.000s	0.010s	☆
F4-11	Terminal I/O control mode	0: Two-wire control mode 1 1: Two-wire control mode 2 2: Three-wire control mode 1 3: Three-wire control mode 2	0	★

6. PANEL OPERATION

Function Code	Name	Setting Range	Default	Change
Group F4: Input Terminals (continued)				
F4-12	Terminal UP/DOWN rate	0.001 to 65.535 Hz/s	1.00 Hz/s	☆
F4-13	AI curve 1 min. input	0.00 V to F4-15	0.00V	☆
F4-14	Corresponding percentage of AI curve 1 min. input	-100.0% to +100.0%	0.0%	☆
F4-15	AI curve 1 max. input	F4-13 to 10.00 V	10.00V	☆
F4-16	Corresponding percentage of AI curve 1 max. input	-100.0% to +100.0%	100.0%	☆
F4-17	AI1 filter time	0.00s to 10.00s	0.10s	☆
F4-18	AI curve 2 min. input	0.00 V to F4-20	0.00V	☆
F4-19	Corresponding percentage of AI curve 2 min. input	-100.0% to +100.0%	0.0%	☆
F4-20	AI curve 2 max. input	F4-18 to 10.00 V	10.00V	☆
F4-21	Corresponding percentage of AI curve 2 max. input	-100.0% to +100.0%	100.0%	☆
F4-22	AI2 filter time	0.00s to 10.00s	0.10s	☆
F4-23	AI3 curve min. input	-10.00V to F4-25	-10.00V	☆
F4-24	Corresponding percentage of AI curve 3 min. input	-100.0% to +100.0%	-100.0%	☆
F4-25	AI curve 3 max. input	F4-23 to 10.00 V	10.00V	☆
F4-26	Corresponding percentage of AI curve 3 max. input	-100.0% to +100.0%	100.0%	☆
F4-27	AI3 filter time	0.00s to 10.00s	0.10s	☆
F4-28	Pulse min. input	0.00kHz to F4-30	0.00kHz	☆
F4-29	Corresponding percentage of pulse min. input	-100.0% to 100.0%	0.0%	☆
F4-30	Pulse max. input	F4-28 to 100.00 kHz	50.00kHz	☆
F4-31	Corresponding percentage of pulse max. input	-100.0% to 100.0%	100.0%	☆
F4-32	Pulse filter time	0.00s to 10.00s	0.10s	☆
F4-33	AI curve selection	Units position: AI1 curve selection 1: Curve 1 (2 points, see F4-13 to F4-16) 2: Curve 2 (2 points, see F4-18 to F4-21) 3: Curve 3 (2 points, see F4-23 to F4-26) 4: Curve 4 (4 points, see A6-00 to A6-07) 5: Curve 5 (4 points, see A6-08 to A6-15) Tens position: AI2 curve selection Hundreds position: AI3 curve selection	321	☆
F4-34	Setting selection when AI less than min. input	Units position: AI1 0: Corresponding percentage of min. input 1: 0.0% Tens position: AI2 Hundreds position: AI3	000	☆
F4-35	DI1 delay	0.0s to 3600.0s	0.0s	★
F4-36	DI2 delay	0.0s to 3600.0s	0.0s	★
F4-37	DI3 delay	0.0s to 3600.0s	0.0s	★
F4-38	DI active mode selection 1	0: High level active 1: Low level active Units position: DI1 active mode Tens position: DI2 active mode Hundreds position: DI3 active mode Thousand position: DI4 active mode Ten thousands position: DI5 active mode	00000	★
F4-39	DI active mode selection 2	0: High level active 1: Low level active Units position: DI6 active mode Tens position: DI7 active mode Hundreds position: DI8 active mode Thousand position: DI9 active mode Ten thousands position: DI10 active mode	00000	★

Function Code	Name	Setting Range	Default	Change
Group F5: Output Terminals				
F5-00	FM terminal output mode	0: Pulse output (FMP) 1: Digital output (FMR)	0	☆
F5-01	FMR function selection	0: No output 1: AC Drive running 2: Fault output 3: Frequency-level detection FDT1 output 4: Frequency reached 5: Zero-speed running (no output at stop) 6: Motor overload pre-warning 7: AC drive overload pre-warning 8: Set count value reached 9: Designated count value reached 10: Length reached 11: PLC cycle completed 12: Accumulative running time reached 13: Frequency limited 14: Torque limited 15: Ready for RUN 16: AI1 > AI2	0	☆
F5-02	Control board relay function selection (T/A-T/B-T/C)	17: Frequency upper limit reached 18: Frequency lower limit reached (no output at stop) 19: Undervoltage status output 20: Communication setting 21: Reserved 22: Reserved 23: Zero-speed running 2 (having output at stop) 24: Accumulative power-on time reached 25: Frequency level detection FDT2 output	2	☆
F5-03	Extension card relay (P/A-P/B-P/C) function selection	26: Frequency 1 reached 27: Frequency 2 reached 28: Current 1 reached 29: Current 2 reached 30: Timing duration reached 31: AI1 input limit exceeded 32: Load lost 33: Reverse running 34: Zero current status 35: IGBT temperature reached 36: Software current limit exceeded 37: Frequency lower limit reached (having output at stop) 38: Alarm output 39: Motor overheat warning 40: Current running time reached 41: Fault output (no output at undervoltage)	0	☆
F5-04	DO1 function selection		1	☆
F5-05	Extension card DO2 function selection		4	☆
F5-06	FMP function selection	0: Running frequency 1: Set frequency 2: Output current 3: Output torque (absolute value, proportion to motor torque)	0	☆
F5-07	AO1 function selection	4: Output power 5: Output voltage 6: Pulse input (100.0% corresponds to 100.0kHz) 7: AI1 8: AI2	0	☆
F5-08	AO2 function selection	9: AI3 (extension card) 10: Length 11: Count value 12: Communication setting 13: Motor rotational speed 14: Output current (100.0% corresponds to 1000.0A) 15: Output voltage (100.0% corresponds to 1000.0V) 16: Output torque (actual value, proportion to motor torque)	1	☆

6. PANEL OPERATION

Function Code	Name	Setting Range	Default	Change
Group F5: Output Terminals (continued)				
F5-09	Max. FMP output frequency	0.01kHz to 100.00kHz	50.00kHz	☆
F5-10	AO1 zero offset coefficient	-100.0% to +100.0%	0.0%	☆
F5-11	AO1 gain	-10.00 to +10.00	1.00	☆
F5-12	AO2 zero offset coefficient	-100.0% to +100.0%	0.0%	☆
F5-13	AO2 gain	-10.00 to +10.00	1.00	☆
F5-17	FMR output delay	0.0s to 3600.0s	0.0s	☆
F5-18	Relay 1 output delay	0.0s to 3600.0s	0.0s	☆
F5-19	Relay 2 output delay	0.0s to 3600.0s	0.0s	☆
F5-20	DO1 output delay	0.0s to 3600.0s	0.0s	☆
F5-21	DO2 output delay	0.0s to 3600.0s	0.0s	☆
F5-22	Active mode selection of DO output terminals	0: Positive logic active 1: Negative logic active Units position: FMR active mode Tens position: Relay1 active mode Hundreds position: Relay2 active mode Thousands position: DO1 active mode Ten thousands position: DO2 active mode	00000	☆
Group F6: Start/Stop Control				
F6-00	Start mode	0: Direct start 1: Catching a spinning motor 2: Pre-excited start (AC asynchronous drive)	0	☆
F6-01	Mode of catching a spinning motor	0: From stop frequency 1: From power frequency 2: From max. frequency	0	★
F6-02	Speed of catching a spinning motor	1 to 100	20	☆
F6-03	Start frequency	0.00 Hz to 10.00 Hz	0.00 Hz	☆
F6-04	Start frequency holding time	0.0s to 100.0s	0.0s	★
F6-05	DC injection braking level/ Pre-excitation level	0% to 100%	50%	★
F6-06	DC injection braking active time/ Pre-excitation active time	0.0s to 100.0s	0.0s	★
F6-07	Acceleration/Deceleration mode	0: Linear acceleration/deceleration 1-2: S-curve acceleration/deceleration	0	★
F6-08	Time proportion of S-curve start segment	0.0% to (100.0% - F6-09)	30.0%	★
F6-09	Time proportion of S-curve end segment	0.0% to (100.0% - F6-08)	30.0%	★
F6-10	Stop mode	0: Decelerate to stop 1: Coast to stop	0	☆
F6-11	DC injection braking start frequency	0.00 Hz to max. frequency	0.00 Hz	☆
F6-12	DC injection braking delay time	0.0s to 100.0s	0.0s	☆
F6-13	DC injection braking level	0% to 100%	50%	☆
F6-14	DC injection braking active time	0.0s to 100.0s	0.0s	☆
F6-15	Braking use ratio	0% to 100%	100%	☆
F6-18	Catching a spinning motor current limit	30% to 200%	Model dependent	★
F6-23	Overexcitation selection	0: Disabled 1: Enabled during deceleration 2: Enabled in the whole process	0	☆
F6-24	Overexcitation suppression current level	0% to 150%	100%	☆
F6-25	Overexcitation gain	1.00 to 2.50	1.25	☆

Function Code	Name	Setting Range	Default	Change
Group F7: Keypad Operation and Display				
F7-00	LED default display check	0 to 1	0	☆
F7-01	MFK key function selection	0: MFK key disabled 1: Switchover from remote control (terminal or communication) to keypad control 2: Switchover between forward rotation and reverse rotation 3: Forward jog 4: Reverse jog	0	★
F7-02	STOP/RESET key function	0: STOP/RESET key enabled only in keypad control 1: STOP/RESET key enabled in any operation mode	1	☆
F7-03	LED display running parameters 1	0000 to FFFF Bit00: Running frequency 1 (Hz) Bit01: Set frequency (Hz) Bit02: Bus voltage (V) Bit03: Output voltage (V) Bit04: Output current (A) Bit05: Output power (kW) Bit06: Output torque (%) Bit07: DI state Bit08: DO state Bit09: AI1 voltage (V) Bit10: AI2 voltage (V) Bit11: AI3 voltage (V) Bit12: Count value Bit13: Length value Bit14: Load speed display Bit15: PID reference	1F	☆
F7-04	LED display running parameters 2	0000 to FFFF Bit00: PID feedback Bit01: PLC stage Bit02: Pulse reference (kHz) Bit03: Running frequency 2 (Hz) Bit04: Remaining running time Bit05: AI1 voltage before correction (V) Bit06: AI2 voltage before correction (V) Bit07: AI3 voltage before correction (V) Bit08: Motor speed Bit09: Current power-on time (H) Bit10: Current running time (Min) Bit11: Pulse reference (Hz) Bit12: Communication reference Bit13: Encoder feedback speed (Hz) Bit14: Main frequency X display (Hz) Bit15: Auxiliary frequency Y display (Hz)	0	☆
F7-05	Display stop parameters	0000 to FFFF Bit00: Frequency reference (Hz) Bit01: Bus voltage (V) Bit02: DI state Bit03: DO state Bit04: AI1 voltage (V) Bit05: AI2 voltage (V) Bit06: AI3 voltage (V) Bit07: Count value Bit08: Length value Bit09: PLC stage Bit10: Load speed Bit11: PID reference Bit12: Pulse reference (kHz)	0	☆
F7-06	Load speed display coefficient	0.0001 to 6.5000	1.0000	☆

6. PANEL OPERATION

Function Code	Name	Setting Range	Default	Change
Group F7: Keypad Operation and Display (continued)				
F7-07	Heatsink temperature of AC Drive	-20°C to 120°C	—	•
F7-08	Product number	—	—	•
F7-09	Accumulative running time	0h to 65535h	—	•
F7-10	Performance software version	—	—	•
F7-11	Function software version	—	—	•
F7-12	Number of decimal places for load speed display	Units position: Number of decimal places for U0-14 0: No decimal place 1: One decimal places 2: Two decimal places 3: Three decimal places Tens position: Number of decimal places of U0-19/U0-29 1: One decimal places 2: Two decimal places	21	☆
F7-13	Accumulative power-on time	0 to 65535 h	—	•
F7-14	Accumulative power consumption	0 to 65535 kWh	—	•
Group F8: Auxiliary Functions				
F8-00	Jog frequency reference	0.00 Hz to max. frequency	2.00 Hz	☆
F8-01	Jog acceleration time	0.0s to 6500.0s	20.0s	☆
F8-02	Jog deceleration time	0.0s to 6500.0s	20.0s	☆
F8-03	Acceleration time 2	0.0s to 6500.0s	Model dependent	☆
F8-04	Deceleration time 2	0.0s to 6500.0s	Model dependent	☆
F8-05	Acceleration time 3	0.0s to 6500.0s	Model dependent	☆
F8-06	Deceleration time 3	0.0s to 6500.0s	Model dependent	☆
F8-07	Acceleration time 4	0.0s to 6500.0s	0.0s	☆
F8-08	Deceleration time 4	0.0s to 6500.0s	0.0s	☆
F8-09	Frequency jump 1	0.00 Hz to max. frequency	0.00 Hz	☆
F8-10	Frequency jump 2	0.00 Hz to max. frequency	0.00 Hz	☆
F8-11	Frequency jump band	0.00 Hz to max. frequency	0.00 Hz	☆
F8-12	Forward/Reverse run switchover dead-zone time	0.0s to 3000.0s	0.0s	☆
F8-13	Reverse RUN selection	0: Disabled 1: Enabled	0	☆
F8-14	Running mode when frequency reference lower than frequency lower limit	0: Run at frequency reference lower limit 1: Stop 2: Run at zero speed	0	☆
F8-15	Droop rate	0.00% to 100.00%	0.00%	☆
F8-16	Accumulative power-on time threshold	0h to 65000h	0h	☆
F8-17	Accumulative running time threshold	0h to 65000h	0h	☆
F8-18	Startup protection selection	0: Disabled 1: Enabled	0	☆
F8-19	Frequency detection value 1	0.00 Hz to max. frequency	50.00 Hz	☆
F8-20	Frequency detection hysteresis 1	0.0% to 100.0% (FDT1 level)	5.0%	☆
F8-21	Detection width of target frequency reached	0.0% to 100.0% (maximum frequency)	0.0%	☆
F8-22	Jump frequency function	0: Disabled 1: Enabled	0	☆
F8-25	Switchover frequency of acceleration time 1 and acceleration time 2	0.00 Hz to max. frequency	0.00 Hz	☆

Function Code	Name	Setting Range	Default	Change
Group F8: Auxiliary Functions (continued)				
F8-26	Switchover frequency of deceleration time 1 and deceleration time 2	0.00 Hz to max. frequency	0.00 Hz	☆
F8-27	Set highest priority to terminal JOG function	0: Disabled 1: Enabled	0	☆
F8-28	Frequency detection value 2	0.00 Hz to max. frequency	50.00 Hz	☆
F8-29	Frequency detection hysteresis 2	0.0% to 100.0% (FDT2 level)	5.0%	☆
F8-30	Detection of frequency 1	0.00 Hz to max. frequency	50.00 Hz	☆
F8-31	Detection width of frequency 1	0.0% to 100.0% (maximum frequency)	0.0%	☆
F8-32	Detection of frequency 2	0.00 Hz to max. frequency	50.00 Hz	☆
F8-33	Detection width of frequency 2	0.0% to 100.0% (maximum frequency)	0.0%	☆
F8-34	Zero current detection level	0.0% to 300.0% 100.0% corresponds to rated motor current.	5.0%	☆
F8-35	Zero current detection delay	0.01s to 600.00s	0.10s	☆
F8-36	Output overcurrent threshold	0.0% (no detection) 0.1% to 300.0% (rated motor current)	200.0%	☆
F8-37	Output overcurrent detection delay	0.00s to 600.00s	0.00s	☆
F8-38	Detection level of current 1	0.0% to 300.0% (rated motor current)	100.0%	☆
F8-39	Detection width of current 1	0.0% to 300.0% (rated motor current)	0.0%	☆
F8-40	Detection level of current 2	0.0% to 300.0% (rated motor current)	100.0%	☆
F8-41	Detection width of current 2	0.0% to 300.0% (rated motor current)	0.0%	☆
F8-42	Timing function	0: Disabled 1: Enabled	0	★
F8-43	Running time setting channel	0: Set by F8-44 1: AI1 2: AI2 3: AI3 (100% of analog input corresponds to the value of F8-44)	0	★
F8-44	Running time	0.0Min to 6500.0Min	0.0Min	★
F8-45	AI1 input voltage lower limit	0.00 V to F8-46	3.10V	☆
F8-46	AI1 input voltage upper limit	F8-45 to 10.00V	6.80V	☆
F8-47	IGBT temperature threshold	0°C to 100°C	75°C	☆
F8-48	Cooling fan working mode	0: Working during drive running 1: Working continuously	0	☆
F8-49	Wakeup frequency	Hibernating frequency (F8-51) to max. frequency (F0-10)	0.00 Hz	☆
F8-50	Wakeup delay time	0.0s to 6500.0s	0.0s	☆
F8-51	Hibernating frequency	0.00 Hz to wakeup frequency (F8-49)	0.00 Hz	☆
F8-52	Hibernating delay time	0.0s to 6500.0s	0.0s	☆
F8-53	Running time threshold this time	0.0 to 6500.0 min	0.0Min	☆
F8-54	Output power correction coefficient	0.00% to 200.0%	100.0%	☆
Group F9: Fault and Protection				
F9-00	Motor overload protection	0: Disabled 1: Enabled	1	☆
F9-01	Motor overload protection gain	0.20 to 10.00	1.00	☆
F9-02	Motor overload pre-warning coefficient	50% to 100%	80%	☆
F9-03	Overvoltage protection gain	0 to 100	30	☆
F9-04	Overvoltage protection voltage	650 to 800 V	770V	☆

6. PANEL OPERATION

Function Code	Name	Setting Range	Default	Change
Group F9: Fault and Protection (continued)				
F9-07	Detection of short-circuit to ground	Units position: Detection of short-circuit to ground upon power on 0: Disabled 1: Enabled Tens position: Detection of short-circuit to ground before running 0: Disabled 1: Enabled	01	☆
F9-08	Braking unit applied voltage	650 to 800 V	760V	★
F9-09	Auto reset times	0 to 20	0	☆
F9-10	Selection of DO action during auto reset	0: Not act 1: Act	0	☆
F9-11	Delay of auto reset	0.1s to 100.0s	1.0s	☆
F9-12	Input phase loss/ pre-charge relay protection	Units position: Input phase loss protection Tens position: Pre-charge relay protection 0: Disabled 1: Enabled	11	☆
F9-13	Output phase loss protection	Units position: Output phase loss protection 0: Disabled 1: Enabled Tens position: Output phase loss protection before running 0: Disabled 1: Enabled	01	☆
F9-14	1st fault type	0: No fault 1: Reserved 2: Overcurrent during acceleration 3: Overcurrent during deceleration 4: Overcurrent at constant speed 5: Overvoltage during acceleration 6: Overvoltage during deceleration 7: Overvoltage at constant speed 8: Pre-charge resistor fault 9: Undervoltage 10: AC drive overload 11: Motor overload 12: Power input phase loss	—	•
F9-15	2nd fault type	13: Power output phase loss 14: IGBT overheat 15: External fault 16: Communication fault 17: Contactor fault 18: Current detection fault 19: Motor auto-tuning fault 20: Encoder/PG card fault 21: Parameter read and write fault 22: AC drive hardware fault 23: Motor short circuited to ground 24: Reserved 25: Reserved	—	•
F9-16	3rd (latest) fault type	26: Accumulative running time reached 27: User-defined fault 1 28: User-defined fault 2 29: Accumulative power-on time reached 30: Load lost 31: PID feedback lost during running 40: Fast current limit timeout 41: Motor switchover error during running 42: Too large speed deviation 43: Motor over-speed 45: Motor overheat 51: Initial position error 55: Slave error in master-slave control	—	•

Function Code	Name	Setting Range	Default	Change
Group F9: Fault and Protection (continued)				
F9-17	Frequency upon 3rd (latest) fault	—	—	•
F9-18	Current upon 3rd (latest) fault	—	—	•
F9-19	Bus voltage upon 3rd (latest) fault	—	—	•
F9-20	DI state upon 3rd (latest) fault	—	—	•
F9-21	DO state upon 3rd (latest) fault	—	—	•
F9-22	AC drive state upon 3rd (latest) fault	—	—	•
F9-23	Power-on time upon 3rd (latest) fault	—	—	•
F9-24	Running time upon 3rd (latest) fault	—	—	•
F9-27	Frequency upon 2nd fault	—	—	•
F9-28	Current upon 2nd fault	—	—	•
F9-29	Bus voltage upon 2nd fault	—	—	•
F9-30	DI state upon 2nd fault	—	—	•
F9-31	DO state upon 2nd fault	—	—	•
F9-32	AC drive state upon 2nd fault	—	—	•
F9-33	Power-on time upon 2nd fault	—	—	•
F9-34	Running time upon 2nd fault	—	—	•
F9-37	Frequency upon 1st fault	—	—	•
F9-38	Current upon 1st fault	—	—	•
F9-39	Bus voltage upon 1st fault	—	—	•
F9-40	DI state upon 1st fault	—	—	•
F9-41	DO state upon 1st fault	—	—	•
F9-42	AC drive state upon 1st fault	—	—	•
F9-43	Power-on time upon 1st fault	—	—	•
F9-44	Running time upon 1st fault	—	—	•
F9-47	Fault protection action selection 1	Units position: Motor overload (Err11) 0: Coast to stop 1: Stop according to the stop mode 2: Continue to run Tens position: Input phase loss (Err12) Hundreds position: Output phase loss (Err13) Thousands position: External fault (Err15) Ten thousands position: Communication fault (Err16)	00000	☆
F9-48	Fault protection action selection 2	Units position: Encoder fault (Err20) 0: Coast to stop Tens position: EEPROM read-write fault (Err21) 0: Coast to stop 1: Stop according to the stop mode Hundreds position: AC drive overload fault selection (Err10) 0: Coast to stop 1: De-rated running Thousands position: Motor overheat (Err45) Ten thousands position: Accumulative running time reached (Err26)	00000	☆

6. PANEL OPERATION

Function Code	Name	Setting Range	Default	Change
Group F9: Fault and Protection (continued)				
F9-49	Fault protection action selection 3	Units position: User-defined fault 1 (Err27) 0: Coast to stop 1: Stop according to the stop mode 2: Continue to run Tens position: User-defined fault 2 (Err28) 0: Coast to stop 1: Stop according to the stop mode 2: Continue to run Hundreds position: Accumulative power-on time reached (Err29) 0: Coast to stop 1: Stop according to the stop mode 2: Continue to run Thousands position: Load lost (Err30) 0: Coast to stop 1: Deceleration to stop 2: Continue to run at 7% of rated motor frequency and restore to the frequency reference if the load recovers Ten thousands position: PID feedback lost during drive running (Err31) 0: Coast to stop 1: Stop according to the stop mode 2: Continue to run	00000	☆
F9-54	Frequency selection for continuing to run upon fault	0: Current running frequency 1: Frequency reference 2: Frequency upper limit 3: Frequency lower limit 4: Backup frequency upon abnormality	0	☆
F9-55	Backup frequency upon fault	0.0% to 100.0% (100.0% corresponds to max. frequency (F0-10))	100.0%	☆
F9-56	Type of motor temperature sensor	0: No temperature sensor 1: PT100 2: PT1000	0	☆
F9-57	Motor overheat protection threshold	0°C to 200°C	110°C	☆
F9-58	Motor overheat pre-warning threshold	0°C to 200°C	90°C	☆
F9-59	Power dip ride-through function selection	0: Disabled 1: Bus voltage constant control 2: Decelerate to stop	0	★
F9-60	Threshold of power dip ride-through function disabled	80% to 100%	85%	★
F9-61	Judging time of bus voltage recovering from power dip	0.0s to 100.0s	0.5S	★
F9-62	Threshold of power dip ride-through function enabled	60% to 100%	80%	★
F9-63	Load lost protection	0: Disabled 1: Enabled	0	☆
F9-64	Load lost detection level	0.0% to 100.0%	10.0%	☆
F9-65	Load lost detection time	0.0 to 60.0s	1.0s	☆
F9-67	Overspeed detection level	0.0% to 50.0% (max. frequency)	20.0%	☆

Function Code	Name	Setting Range	Default	Change
Group F9: Fault and Protection (continued)				
F9-68	Overspeed detection time	0.0s: Not detected 0.1 to 60.0s	1.0s	☆
F9-69	Detection level of speed error	0.0% to 50.0% (max. frequency)	20.0%	☆
F9-70	Detection time of speed error	0.0s: Not detected 0.1 to 60.0s	5.0s	☆
F9-71	Power dip ride-through gain Kp	0 to 100	40	☆
F9-72	Power dip ride-through integral coefficient Ki	0 to 100	30	☆
F9-73	Deceleration time of power dip ride-through	0 to 300.0s	20.0s	★
Group FA: PID Function				
FA-00	PID reference setting channel	0: Set by FA-01 1: AI1 2: AI2 3: AI3 4: Pulse reference (DI5) 5: Serial comms. 6: Multi-reference	0	☆
FA-01	PID digital setting	0.0% to 100.0%	50.0%	☆
FA-02	PID feedback setting channel	0: AI1 1: AI2 2: AI3 3: AI1-AI2 4: Pulse reference (DI5) 5: Serial comms. 6: AI1 + AI2 7: Max. (AI1 , AI2) 8: Min. (AI1 , AI2)	0	☆
FA-03	PID operation direction	0: Forward 1: Reverse	0	☆
FA-04	PID reference and feedback range	0 to 65535	1000	☆
FA-05	Proportional gain Kp1	0.0 to 1000.0	20.0	☆
FA-06	Integral time Ti1	0.01s to 10.00s	2.00s	☆
FA-07	Differential time Td1	0.000s to 10.000s	0.000s	☆
FA-08	PID output limit in reverse direction	0.00 Hz to maximum frequency	0.00 Hz	★
FA-09	PID error limit	0.0% to 100.0%	0.0%	☆
FA-10	PID differential limit	0.00% to 100.00%	0.10%	☆
FA-11	PID reference change time	0.00 to 650.00s	0.00s	☆
FA-12	PID feedback filter time	0.00 to 60.00s	0.00s	☆
FA-13	PID output filter time	0.00 to 60.00s	0.00s	☆
FA-14	Reserved	—	—	☆
FA-15	Proportional gain Kp2	0.0 to 1000.0	20.0	☆
FA-16	Integral time Ti2	0.01s to 10.00s	2.00s	☆
FA-17	Differential time Td2	0.000s to 10.000s	0.000s	☆
FA-18	PID parameter switchover condition	0: No switchover 1: Switchover via DI 2: Auto switchover based on PID error 3: Auto switchover based on running frequency	0	☆
FA-19	PID error 1 for auto switchover	0.0% to FA-20	20.0%	☆
FA-20	PID error 2 for auto switchover	FA-19 to 100.0%	80.0%	☆
FA-21	PID initial value	0.0% to 100.0%	0.0%	☆
FA-22	PID initial value active time	0.00 to 650.00s	0.00s	☆
FA-23	Reserved	—	—	—
FA-24	Reserved	—	—	—

6. PANEL OPERATION

Function Code	Name	Setting Range	Default	Change
Group F9: Fault and Protection (continued)				
FA-25	PID integral property	Units position: Integral separation 0: Disabled 1: Enabled Tens position: Whether to stop integral operation when the PID output reaches the limit 0: Continue integral operation 1: Stop integral operation	00	☆
FA-26	Detection level of PID feedback loss	0.0%: No detection 0.1% to 100.0%	0.0%	☆
FA-27	Detection time of PID feedback loss	0.0s to 20.0s	0.0s	☆
FA-28	Selection of PID operation at stop	0: Disabled 1: Enabled	0	☆
Group FB: Fixed Length and Count				
FB-00	Wobble setting mode	0: Relative to the frequency reference 1: Relative to the max. frequency	0	☆
FB-01	Wobble amplitude	0.0% to 100.0%	0.0%	☆
FB-02	Wobble step	0.0% to 50.0%	0.0%	☆
FB-03	Wobble cycle	0.0s to 3000.0s	10.0s	☆
FB-04	Triangular wave rising time coefficient	0.0% to 100.0%	50.0%	☆
FB-05	Set length	0 to 65535 m	1000m	☆
FB-06	Actual length	0 to 65535 m	0m	☆
FB-07	Number of pulses per meter	0.1 to 6553.5	100.0	☆
FB-08	Set count value	1 to 65535	1000	☆
FB-09	Designated count value	1 to 65535	1000	☆
Group FC: Multi-Reference and Simple PLC Function				
FC-00	Reference 0	-100.0% to 100.0%	0.0%	☆
FC-01	Reference 1	-100.0% to 100.0%	0.0%	☆
FC-02	Reference 2	-100.0% to 100.0%	0.0%	☆
FC-03	Reference 3	-100.0% to 100.0%	0.0%	☆
FC-04	Reference 4	-100.0% to 100.0%	0.0%	☆
FC-05	Reference 5	-100.0% to 100.0%	0.0%	☆
FC-06	Reference 6	-100.0% to 100.0%	0.0%	☆
FC-07	Reference 7	-100.0% to 100.0%	0.0%	☆
FC-08	Reference 8	-100.0% to 100.0%	0.0%	☆
FC-09	Reference 9	-100.0% to 100.0%	0.0%	☆
FC-10	Reference 10	-100.0% to 100.0%	0.0%	☆
FC-11	Reference 11	-100.0% to 100.0%	0.0%	☆
FC-12	Reference 12	-100.0% to 100.0%	0.0%	☆
FC-13	Reference 13	-100.0% to 100.0%	0.0%	☆
FC-14	Reference 14	-100.0% to 100.0%	0.0%	☆
FC-15	Reference 15	-100.0% to 100.0%	0.0%	☆
FC-16	Simple PLC running mode	0: Stop after running one cycle 1: Keep final values after running one cycle 2: Repeat after running one cycle	0	☆
FC-17	Simple PLC retentive selection	Unit position: Retentive at power down 0: Not retentive 1: Retentive Tens position: Retentive at stop 0: Not retentive at stop 1: Retentive at stop	00	☆
FC-18	Running time of simple PLC reference 0	0.0s (h) to 6553.5s (h)	0.0s (h)	☆
FC-19	Acceleration/deceleration time of simple PLC reference 0	0 to 3	0	☆

Function Code	Name	Setting Range	Default	Change
Group FC: Multi-Reference and Simple PLC Function (continued)				
FC-20	Running time of simple PLC reference 1	0.0s (h) to 6553.5s (h)	0.0s (h)	☆
FC-21	Acceleration/deceleration time of simple PLC reference 1	0 to 3	0	☆
FC-22	Running time of simple PLC reference 2	0.0s (h) to 6553.5s (h)	0.0s (h)	☆
FC-23	Acceleration/deceleration time of simple PLC reference 2	0 to 3	0	☆
FC-24	Running time of simple PLC reference 3	0.0s (h) to 6553.5s (h)	0.0s (h)	☆
FC-25	Acceleration/deceleration time of simple PLC reference 3	0 to 3	0	☆
FC-26	Running time of simple PLC reference 4	0.0s (h) to 6553.5s (h)	0.0s (h)	☆
FC-27	Acceleration/deceleration time of simple PLC reference 4	0 to 3	0	☆
FC-28	Running time of simple PLC reference 5	0.0s (h) to 6553.5s (h)	0.0s (h)	☆
FC-29	Acceleration/deceleration time of simple PLC reference 5	0 to 3	0	☆
FC-30	Running time of simple PLC reference 6	0.0s (h) to 6553.5s (h)	0.0s (h)	☆
FC-31	Acceleration/deceleration time of simple PLC reference 6	0 to 3	0	☆
FC-32	Running time of simple PLC reference 7	0.0s (h) to 6553.5s (h)	0.0s (h)	☆
FC-33	Acceleration/deceleration time of simple PLC reference 7	0 to 3	0	☆
FC-34	Running time of simple PLC reference 8	0.0s (h) to 6553.5s (h)	0.0s (h)	☆
FC-35	Acceleration/deceleration time of simple PLC reference 8	0 to 3	0	☆
FC-36	Running time of simple PLC reference 9	0.0s (h) to 6553.5s (h)	0.0s (h)	☆
FC-37	Acceleration/deceleration time of simple PLC reference 9	0 to 3	0	☆
FC-38	Running time of simple PLC reference 10	0.0s (h) to 6553.5s (h)	0.0s (h)	☆
FC-39	Acceleration/deceleration time of simple PLC reference 10	0 to 3	0	☆
FC-40	Running time of simple PLC reference 11	0.0s (h) to 6553.5s (h)	0.0s (h)	☆
FC-41	Acceleration/deceleration time of simple PLC reference 11	0 to 3	0	☆
FC-42	Running time of simple PLC reference 12	0.0s (h) to 6553.5s (h)	0.0s (h)	☆
FC-43	Acceleration/deceleration time of simple PLC reference 12	0 to 3	0	☆
FC-44	Running time of simple PLC reference 13	0.0s (h) to 6553.5s (h)	0.0s (h)	☆
FC-45	Acceleration/deceleration time of simple PLC reference 13	0 to 3	0	☆
FC-46	Running time of simple PLC reference 14	0.0s (h) to 6553.5s (h)	0.0s (h)	☆
FC-47	Acceleration/deceleration time of simple PLC reference 14	0 to 3	0	☆
FC-48	Running time of simple PLC reference 15	0.0s (h) to 6553.5s (h)	0.0s (h)	☆
FC-49	Acceleration/deceleration time of simple PLC reference 15	0 to 3	0	☆
FC-50	Time unit of simple PLC running	0: s (second) 1: h (hour)	0	☆
FC-51	Reference 0 source	0: Set by FC-00 1: AI1 2: AI2 3: AI3 4: Pulse reference 5: PID 6: Set by preset frequency (F0-08), modified via terminal UP/DOWN	0	☆

6. PANEL OPERATION

Function Code	Name	Setting Range	Default	Change
Group FD: Communication				
FD-00	Baud rate	Units position (Modbus) 0: 300 bps 1: 600 bps 2: 1200 bps 3: 2400 bps 4: 4800 bps 5: 9600 bps 6: 19200 bps 7: 38400 bps 8: 57600 bps 9: 115200 bps Tens position (PROFIBUS- DP) 0: 115200 bps 1: 208300 bps 2: 256000 bps 3: 512000 bps Hundreds position: Reserved Thousands position: CANlink 0: 20 1: 50 2: 100 3: 125 4: 250 5: 500 6: 1M	5005	☆
FD-01	Modbus data format symbol	0: No check <8,N,2> 1: Even parity check <8,E,1> 2: Odd parity check <8,O,1> 3: No check, data format <8,N,1> (Valid for Modbus)	0	☆
FD-02	Local address	0: Broadcast address; 1 to 247 (Valid for Modbus, PROFIBUS-DP and CANlink)	1	☆
FD-03	Modbus response delay	0 to 20 ms (Valid for Modbus)	2	☆
FD-04	Serial port communication timeout	0.0: Disabled 0.1 to 60.0s (Valid for Modbus, PROFIBUS-DP and CANopen)	0.0	☆
FD-05	Modbus protocol selection and PROFIBUS-DP data frame	Units position: Modbus 0: Non-standard Modbus protocol 1: Standard Modbus protocol Tens position: PROFIBUS-DP 0: PPO1 format 1: PPO2 format 2: PPO3 format 3: PPO5 format	30	☆
FD-06	Current resolution read by communication	0: 0.01A (≤55 kW) 1: 0.1A	0	☆
FD-08	Profibus and CANopen communication timeout time	0.0 (Invalid) 0.1 to 60.0s	0	☆

Function Code	Name	Setting Range	Default	Change
Group FE: User-Defined Parameters				
FE-00	User-defined parameter 0	F0-00 to FP-xx	U3-17	☆
FE-01	User-defined parameter 1	A0-00 to Ax-xx	U3-18	☆
FE-02	User-defined parameter 2	U0-00 to U0-xx	F0.00	☆
FE-03	User-defined parameter 3	U3-00 to U3-xx	F0.00	☆
FE-04	User-defined parameter 4		F0.00	☆
FE-05	User-defined parameter 5		F0.00	☆
FE-06	User-defined parameter 6		F0.00	☆
FE-07	User-defined parameter 7		F0.00	☆
FE-08	User-defined parameter 8		F0.00	☆
FE-09	User-defined parameter 9		F0.00	☆
FE-10	User-defined parameter 10		F0.00	☆
FE-11	User-defined parameter 11		F0.00	☆
FE-12	User-defined parameter 12		F0.00	☆
FE-13	User-defined parameter 13		F0.00	☆
FE-14	User-defined parameter 14		F0.00	☆
FE-15	User-defined parameter 15		F0.00	☆
FE-16	User-defined parameter 16		F0.00	☆
FE-17	User-defined parameter 17		F0.00	☆
FE-18	User-defined parameter 18		F0.00	☆
FE-19	User-defined parameter 19		F0.00	☆
FE-20	User-defined parameter 20		U0-68	☆
FE-21	User-defined parameter 21		U0-69	☆
FE-22	User-defined parameter 22		F0.00	☆
FE-23	User-defined parameter 23		F0.00	☆
FE-24	User-defined parameter 24		F0.00	☆
FE-25	User-defined parameter 25		F0.00	☆
FE-26	User-defined parameter 26		F0.00	☆
FE-27	User-defined parameter 27		F0.00	☆
FE-28	User-defined parameter 28		F0.00	☆
FE-29	User-defined parameter 29		F0.00	☆
FE-30	User-defined parameter 30		F0.00	☆
FE-31	User-defined parameter 31		F0.00	☆
Group FP: Function Parameter Management				
FP-00	User password	0 to 65535	0	☆
FP-01	Parameter initialization	0: No operation 01: Restore factory parameters except motor parameters 02: Clear records 04: Back up current user parameters 501: Restore user backup parameters	0	★
FP-02	Parameter display property	Unit's digit: Group U is not displayed. 0: Not displayed 1: Displayed Tens digit: Group A is displayed. 0: Not displayed 1: Displayed	11	★
FP-03	Selection of individualized parameter display	Units position: Selection of user-defined parameter display 0: Not displayed 1: Displayed Tens position: Selection of user-modified parameter display 0: Not displayed 1: Displayed	00	☆
FP-04	Selection of parameter modification	0: Disabled 1: Enabled	0	☆

6. PANEL OPERATION

6.2.2 Standard Parameter Table - A0 to AC

Function Code	Name	Setting Range	Default	Change
Group A0: Torque Control and Limit				
A0-00	Speed/Torque control selection	0: Speed control 1: Torque control	0	★
A0-01	Torque reference source in torque control	0: Set by A0-03 1: AI1 2: AI2 3: AI3 4: Pulse reference 5: Communication reference 6: Min. (AI1, AI2) 7: Max. (AI1, AI2) Full scale of 1-7 corresponds to A0-03.	0	★
A0-03	Torque digital setting in torque control	-200.0% to 200.0%	150.0%	☆
A0-05	Forward max. frequency in torque control	0.00 Hz to max. frequency	50.00 Hz	☆
A0-06	Reverse max. frequency in torque control	0.00 Hz to max. frequency	50.00 Hz	☆
A0-07	Acceleration time in torque control	0.00s to 65000s	0.00s	☆
A0-08	Deceleration time in torque control	0.00s to 65000s	0.00s	☆
Group A1: Virtual DI/DO				
A1-00	VDI1 function selection	0 to 59	0	★
A1-01	VDI2 function selection	0 to 59	0	★
A1-02	VDI3 function selection	0 to 59	0	★
A1-03	VDI4 function selection	0 to 59	0	★
A1-04	VDI5 function selection	0 to 59	0	★
A1-05	VDI active state setting mode	Units position: VDI1 Tens position: VDI2 Hundreds position: VDI3 Thousands position: VDI4 Ten thousands position: VDI5 0: Decided by state of VDOx 1: Decided by A1-06	00000	★
A1-06	Selection of VDI active state	0: Disabled 1: Enabled Units position: VDI1 Tens position: VDI2 Hundreds position: VDI3 Thousands position: VDI4 Ten thousands position: VDI5	00000	★
A1-07	Function selection for AI1 used as DI	0 to 59	0	★
A1-08	Function selection for AI2 used as DI	0 to 59	0	★
A1-09	Function selection for AI3 used as DI	0 to 59	0	★
A1-10	Active state selection for AI used as DI	0: High level active 1: Low level active Units position: AI1 Tens position: AI2 Hundreds position: AI3	000	★
A1-11	VDO1 function selection	0: Short with physical DIx internally 1 to 41: See physical DO selection in group F5	0	☆
A1-12	VDO2 function selection	0: Short with physical DIx internally 1 to 41: See physical DO selection in group F5	0	☆
A1-13	VDO3 function selection	0: Short with physical DIx internally 1 to 41: See physical DO selection in group F5	0	☆

Function Code	Name	Setting Range	Default	Change
Group A1: Virtual DI/DO (continued)				
A1-14	VDO4 function selection	0: Short with physical DIx internally 1 to 41: See physical DO selection in group F5	0	☆
A1-15	VDO5 function selection	0: Short with physical DIx internally 1 to 41: See physical DO selection in group F5	0	☆
A1-16	VDO1 output delay	0.0s to 3600.0s	0.0s	☆
A1-17	VDO2 output delay	0.0s to 3600.0s	0.0s	☆
A1-18	VDO3 output delay	0.0s to 3600.0s	0.0s	☆
A1-19	VDO4 output delay	0.0s to 3600.0s	0.0s	☆
A1-20	VDO5 output delay	0.0s to 3600.0s	0.0s	☆
A1-21	VDO active mode selection	0: Positive logic active 1: Negative logic active Units position: VDO1 Tens position: VDO2 Hundreds position: VDO3 Thousands position: VDO4 Ten thousands position: VDO5	00000	☆
Group A2: Motor 2 Parameters				
A2-00	Motor type selection	0: Common asynchronous motor 1: Inverter duty motor	0	★
A2-01	Rated motor power	0.1 to 1000.0 kW	Model dependent	★
A2-02	Rated motor voltage	1 to 2000 V	Model dependent	★
A2-03	Rated motor current	0.01 to 655.35 A (AC drive power ≤ 55 kW) 0.1 to 6553.5 A (AC drive power > 55 kW)	Model dependent	★
A2-04	Rated motor frequency	0.01 Hz to max. frequency	Model dependent	★
A2-05	Rated motor speed	1 to 65535 RPM	Model dependent	★
A2-06	Stator resistance	0.001 to 65.535 Ω (AC drive power ≤ 55 kW) 0.0001 to 6.5535 Ω (AC drive power > 55 kW)	Model dependent	★
A2-07	Rotor resistance	0.001 to 65.535 Ω (AC drive power ≤ 55 kW) 0.0001 to 6.5535 Ω (AC drive power > 55 kW)	Model dependent	★
A2-08	Leakage inductive reactance	0.01 to 6553.5 mH (AC drive power ≤ 55 kW) 0.001 to 655.35 mH (AC drive power > 55 kW)	Model dependent	★
A2-09	Mutual inductive reactance	0.1 to 6553.5 mH (AC drive power ≤ 55 kW) 0.01 to 655.35 mH (AC drive power > 55 kW)	Model dependent	★
A2-10	No-load current	0.01 to A2-03 (AC drive power ≤ 55 kW) 0.1 to A2-03 (AC drive power > 55 kW)	Model dependent	★
A2-37	Auto-tuning selection	0: No auto-tuning 1: Asynchronous motor partial static auto-tuning 2: Asynchronous complete dynamic auto-tuning 3: Asynchronous complete static auto-tuning	0	★
A2-38	Speed loop proportional gain 1	1 to 100	30	☆
A2-39	Speed loop integral time 1	0.01s to 10.00s	0.50s	☆
A2-40	Switchover frequency 1	0.00 to A2-43	5.00 Hz	☆

6. PANEL OPERATION

Function Code	Name	Setting Range	Default	Change
Group A2: Motor 2 Parameters (continued)				
A2-41	Speed loop proportional gain 2	1 to 100	20	☆
A2-42	Speed loop integral time 2	0.01s to 10.00s	1.00s	☆
A2-43	Switchover frequency 2	A2-40 to maximum frequency	10.00 Hz	☆
A2-44	Vector control slip compensation gain)	50% to 200%	100%	☆
A2-45	Speed loop filter time constant	0.000s to 0.100s	0.000s	☆
A2-47	Torque limit source in speed control	0: Set by A2-48 1: A11 2: A12 3: A13 4: Pulse reference 5: Communication reference 6: Min. (A11, A12) 7: Max. (A11, A12) Full scale of 1-7 corresponds to A2-48.	0	☆
A2-48	Digital setting of torque limit in speed control	0.0% to 200.0%	150.0%	☆
A2-49	Torque limit source in speed control (regenerative)	0: Set by F2-10 1: A11 2: A12 3: A13 4: Pulse setting 5: Communication setting 6: Min. (A11, A12) 7: Max. (A11, A12) 8: Set by F2-12 Full scale of 1-7 corresponds to F2-12.	0	☆
A2-50	Digital setting of torque limit in speed control (regenerative)	0.0% to 200.0%	150.0%	☆
A2-51	Excitation adjustment proportional gain	0 to 20000	2000	☆
A2-52	Excitation adjustment integral gain	0 to 20000	1300	☆
A2-53	Torque adjustment proportional gain	0 to 20000	2000	☆
A2-54	Torque adjustment integral gain	0 to 20000	1300	☆
A2-55	Speed loop integral separation selection	Units position: Integral separation 0: Disabled 1: Enabled	0	☆
A2-59	Max. torque coefficient of field weakening area	50% to 200%	100%	☆
A2-60	Regenerative power limit selection	0: Disabled 1: Enabled	0	☆
A2-61	Regenerative power limit	0.0% to 200.0%	Model dependent	☆
A2-62	Motor 2 control mode	2: V/F	2	•
A2-63	Motor 2 acceleration/ deceleration time selection	0: Same to Motor 1 2: Acceleration/deceleration time selection 2 3: Acceleration/deceleration time selection 3 4: Acceleration/deceleration time selection 4	0	☆
A2-64	Motor 2 torque boost	0.0%: Automatic torque boost 0.1 to 30.0 %	Model dependent	☆
A2-66	Motor 2 oscillation suppression gain	0 to 100	40	☆

Function Code	Name	Setting Range	Default	Change
Group A5: Control Optimization				
A5-00	DPWM switchover frequency upper limit	5.00 Hz to max. frequency	8.00 Hz	☆
A5-01	PWM modulation pattern	0: Asynchronous modulation 1: Synchronous modulation	0	☆
A5-02	Dead zone compensation mode selection	0: Disabled 1: Enabled (compensation mode 1)	1	☆
A5-03	Random PWM depth	0: Random PWM invalid 1 to 10: Random PWM	0	☆
A5-04	Overcurrent fast prevention	0: Disabled 1: Enabled	1	☆
A5-05	Voltage over modulation coefficient	100 to 110%	105%	★
A5-06	Undervoltage threshold	210 to 420V	350V	☆
A5-08	Low speed frequency	0.0 to 8.0 kHz	0.0	☆
A5-09	Overvoltage threshold	200.0V to 2500.0V	Model dependent	★
A5-11	DC injection braking threshold at low speed	0.00 to 5.00 Hz	0.30 Hz	☆
Group A6: AI Curve Setting				
A6-00	AI curve 4 min. input	-10.00V to A6-02	0.00V	☆
A6-01	Corresponding percentage of AI curve 4 min. input	-100.0% to +100.0%	0.0%	☆
A6-02	AI curve 4 inflexion 1 input	A6-00 to A6-04	3.00V	☆
A6-03	Corresponding percentage of AI curve 4 inflexion 1 input	-100.0% to +100.0%	30.0%	☆
A6-04	AI curve 4 inflexion 2 input	A6-02 to A6-06	6.00V	☆
A6-05	Corresponding percentage of AI curve 4 inflexion 2 input	-100.0% to +100.0%	60.0%	☆
A6-06	AI curve 4 max. input	A6-04 to +10.00V	10.00V	☆
A6-07	Corresponding percentage of AI curve 4 max. input	-100.0% to +100.0%	100.0%	☆
A6-08	AI curve 5 min. input	-10.00V to A6-10	-10.00V	☆
A6-09	Corresponding percentage of AI curve 5 min. input	-100.0% to +100.0%	-100.0%	☆
A6-10	AI curve 5 inflexion 1 input	A6-08 to A6-12	-3.00V	☆
A6-11	Corresponding percentage of AI curve 5 inflexion 1 input	-100.0% to +100.0%	-30.0%	☆
A6-12	AI curve 5 inflexion 2 input	A6-10 to A6-14	3.00V	☆
A6-13	Corresponding percentage of AI curve 5 inflexion 2 input	-100.0% to +100.0%	30.0%	☆
A6-14	AI curve 5 max. input	A6-12 to 10.00 V	10.00V	☆
A6-15	Corresponding percentage of AI curve 5 max. input	-100.0% to +100.0%	100.0%	☆
A6-24	Jump point of AI1 input corresponding setting	-100.0% to 100.0%	0.0%	☆
A6-25	Jump amplitude of AI1 input corresponding setting	0.0% to 100.0%	0.5%	☆
A6-26	Jump point of AI2 input corresponding setting	-100.0% to 100.0%	0.0%	☆
A6-27	Jump amplitude of AI2 input corresponding setting	0.0% to 100.0%	0.5%	☆
A6-28	Jump point of AI3 input corresponding setting	-100.0% to 100.0%	0.0%	☆
A6-29	Jump amplitude of AI3 input corresponding setting	0.0% to 100.0%	0.5%	☆

6. PANEL OPERATION

Function Code	Name	Setting Range	Default	Change
Group A7: User Programmable Card				
A7-00	User programmable function selection	0: Disabled 1: Enabled	0	★
A7-01	Control board output terminal control mode selection	0: AC drive control 1: User programmable card control Units position: FMR (FM used as digital output) Tens position: Relay (T/A-T/B-TC) Hundreds position: DO1 Thousands position: FMP (FM used as pulse control) Ten thousands position: AO1	0	★
A7-02	Programmable card AIAO function selection	0: AI3 (voltage input), AO2 (voltage output) 1: AI3 (voltage input), AO2 (current output) 2: AI3 (current input), AO2 (voltage output) 3: AI3 (current input), AO2 (current output) 4: AI3 (PTC input), AO2 (voltage output) 5: AI3 (PTC input), AO2 (current output) 6: AI3 (PT100 input), AO2 (voltage output) 7: AI3 (PT100 input), AO2 (current output)	0	★
A7-03	Selection PLC program controlling the FMP output	0.0% to 100.0%	0.0%	☆
A7-04	Selection of PLC program controlling the AO1 output	0.0% to 100.0%	0.0%	☆
A7-05	Selection of PLC program controlling digital output	In decimal Units position: FMR Tens position: Relay 1 Hundreds position: DO	000	☆
A7-06	Setting frequency reference via the user programmable card	-100.00% to 100.00%	0.0%	☆
A7-08	Setting running command via the user programmable card	0: No command 1: Forward run 2: Reverse run 3: Forward jog 4: Reverse jog 5: Coast to stop 6: Decelerate to stop 7: Fault reset	0	☆
A7-09	Setting torque reference via the user programmable card	0: No fault 80 to 89: User-defined fault code	0	☆
Group A8: Point-point Communication				
A8-00	Point-point communication	0: Disabled 1: Enabled	0	☆
A8-01	Master or slave selection	0: Master 1: Slave	0	☆
A8-02	Selection of action of the slave in point-point communication	Units position: whether to follow master's command 0: No 1: Yes Tens position: whether to send fault information to master when a fault occurs 0: No 1: Yes Hundreds position: whether to alarm when it becomes off-line 0: No 1: Yes (Err16)	011	★

Function Code	Name	Setting Range	Default	Change
Group A8: Point-point Communication (continued)				
A8-03	The slave received data	0: Torque reference 1: Frequency reference	0	☆
A8-04	Zero offset of received data (torque)	-100.00% to 100.00%	0.00%	★
A8-05	Gain of received data (torque)	-10.00 to 100.00	1.00	★
A8-06	Point-point communication interruption detection time	0.0 to 10.0s	1.0s	☆
A8-07	Master data sending cycle in point-point communication	0.001 to 10.000s	0.001s	☆
A8-11	Window width	0.20 to 10.00 Hz	0.50 Hz	☆
Group AC: AI/AO Correction				
AC-00	AI1 measured voltage 1	-10.00V to 10.000V	Factory-corrected	☆
AC-01	AI1 displayed voltage 1	-10.00V to 10.000V	Factory-corrected	☆
AC-02	AI1 measured voltage 2	-10.00V to 10.000V	Factory-corrected	☆
AC-03	AI1 displayed voltage 2	-10.00V to 10.000V	Factory-corrected	☆
AC-04	AI2 measured voltage 1	-10.00V to 10.000V	Factory-corrected	☆
AC-05	AI2 displayed voltage 1	-10.00V to 10.000V	Factory-corrected	☆
AC-06	AI2 measured voltage 2	-10.00V to 10.000V	Factory-corrected	☆
AC-07	AI2 displayed voltage 2	-10.00V to 10.000V	Factory-corrected	☆
AC-08	AI3 measured voltage 1	-10.00V to 10.000V	Factory-corrected	☆
AC-09	AI3 displayed voltage 1	-10.00V to 10.000V	Factory-corrected	☆
AC-10	AI3 measured voltage 2	-10.00V to 10.000V	Factory-corrected	☆
AC-11	AI3 displayed voltage 2	-10.00V to 10.000V	Factory-corrected	☆
AC-12	AO1 target voltage 1	-10.00V to 10.000V	Factory-corrected	☆
AC-13	AO1 measured voltage 1	-10.00V to 10.000V	Factory-corrected	☆
AC-14	AO1 target voltage 2	-10.00V to 10.000V	Factory-corrected	☆
AC-15	AO1 measured voltage 2	-10.00V to 10.000V	Factory-corrected	☆
AC-16	AO2 target voltage 1	-10.00V to 10.000V	Factory-corrected	☆
AC-17	AO2 measured voltage 1	-10.00V to 10.000V	Factory-corrected	☆
AC-18	AO2 target voltage 2	-10.00V to 10.000V	Factory-corrected	☆
AC-19	AO2 measured voltage 2	-10.00V to 10.000V	Factory-corrected	☆

The user password protection is used to protect operation on the panel. If this protection has been enabled, when you finish reading or writing parameters through the keypad and exit, you need to enter the password to gain access again. Reading and writing are allowed without the password during communication operation (except FP and FF groups).

6. PANEL OPERATION

6.2.3 Monitoring Parameters

Function Code	Name	Minimum Unit	Communication Address
Group U0: Monitoring Parameters			
U0-00	Running frequency	0.01Hz	7000H
U0-01	Frequency reference	0.01Hz	7001H
U0-02	Bus voltage	0.1V	7002H
U0-03	Output voltage	1V	7003H
U0-04	Output current	0.01A	7004H
U0-05	Output power	0.1kW	7005H
U0-06	Output torque	0.1%	7006H
U0-07	DI state	1	7007H
U0-08	DO state	1	7008H
U0-09	AI1 voltage	0.01V	7009H
U0-10	AI2 voltage (V)/current (mA)	0.01V/0.01mA	700AH
U0-11	AI3 voltage	0.01V	700BH
U0-12	Count value	1	700CH
U0-13	Length value	1	700DH
U0-14	Load speed display	1	700EH
U0-15	PID reference	1	700FH
U0-16	PID feedback	1	7010H
U0-17	PLC stage	1	7011H
U0-18	Pulse reference	0.01kHz	7012H
U0-19	Feedback speed	0.01Hz	7013H
U0-20	Remaining running time	0.1Min	7014H
U0-21	AI1 voltage before correction	0.001V	7015H
U0-22	AI2 voltage (V)/ current (mA) before correction	0.001V/0.01mA	7016H
U0-23	AI3 voltage before correction	0.001V	7017H
U0-24	Linear speed	1m/Min	7018H
U0-25	Current power-on time	1Min	7019H
U0-26	Current running time	0.1Min	701AH
U0-27	Pulse reference	1Hz	701BH
U0-28	Communication reference	0.01%	701CH
U0-30	Main frequency reference	0.01Hz	701EH
U0-31	Auxiliary frequency reference	0.01Hz	701FH
U0-32	Viewing any register address value	1	7020H
U0-34	Motor temperature	1°C	7022H
U0-37	Power factor angle	0.1°	7025H
U0-39	Target voltage upon V/F separation	1V	7027H
U0-40	Output voltage upon V/F separation	1V	7028H
U0-41	DI state display	1	7029H
U0-42	DO state display	1	702AH
U0-43	DI set for function state display 1 (function 01-40)	1	702BH
U0-44	DI set for function state display 2 (function 41-80)	1	702CH
U0-45	Fault information	1	702DH
U0-59	Rated frequency	0.01%	703BH
U0-60	Running frequency	0.01%	703CH
U0-61	AC drive state	1	703DH
U0-62	Current fault code	1	703EH
U0-63	Sending torque value of point-point communication	0.01%	703FH
U0-64	Number of slaves	1	7040H

6.2.3 Monitoring Parameters

Function Code	Name	Minimum Unit	Communication Address
Group U0: Monitoring Parameters (continued)			
U0-66	Communication extension card type	100: CANOpen 200: PROFIBUS-DP 300: CANlink	7042H
U0-67	Communication extension card version	Display Range	—
U0-68	AC drive state on DP card	Bit0: AC drive running status Bit1: Running direction Bit2: Whether the drive has a fault Bit3: Target frequency reached Bit4 to Bit7: Reserved Bit8 to Bit15: Fault code	7043H
U0-69	Speed of transmitting DP/0.01 Hz	0.00 Hz to maximum frequency	7044H
U0-70	Motor speed of transmitting DP/RMP	0 to rated motor	7045H
U0-71	Communication card current display	Display Range	—
U0-72	Communication card faulty state	Display Range	—
U0-73	Motor SN	0: Motor 1 1: Motor 2	7046H
U0-74	AC drive output torque	-100% to 100%	7047H
U0-76	Low bits of accumulative power consumption	Unit: 0.1°	704CH
U0-77	High bits of accumulative power consumption	0.1°	704DH
U0-78	Linear speed	1 m/Min	704EH

7. BASIC OPERATIONS AND TRIAL RUN

This chapter describes basic operations and trial run of the AC drive, mainly including setting the frequency reference, and stopping and starting the drive.

7.1 QUICK COMMISSIONING GUIDE

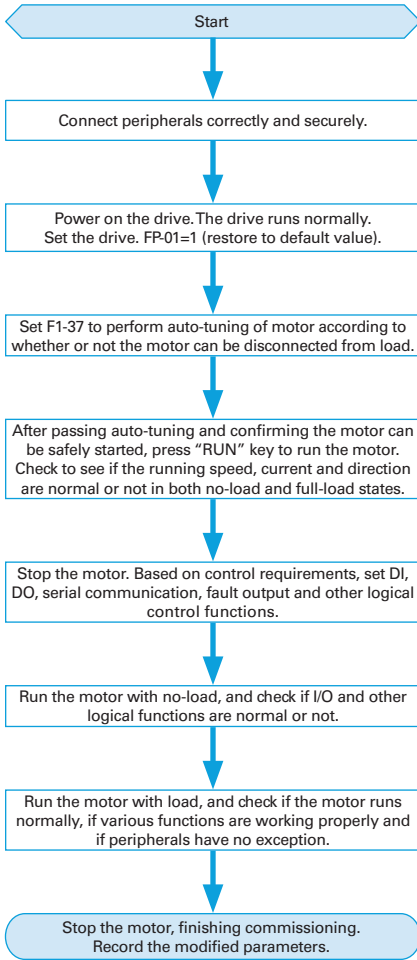

Figure 7-1 Quick commissioning steps

7.2 COMMISSIONING FLOWCHART

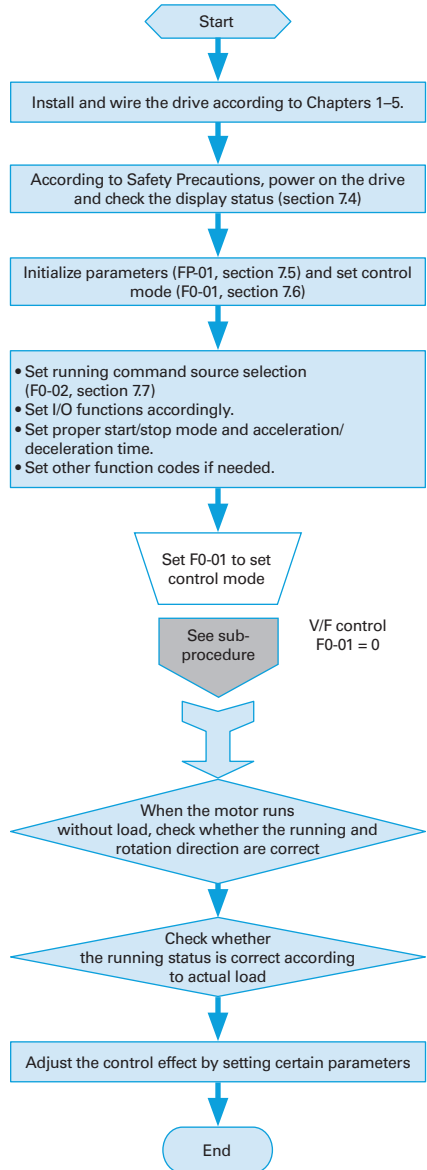

Figure 7-2a Commissioning flowchart

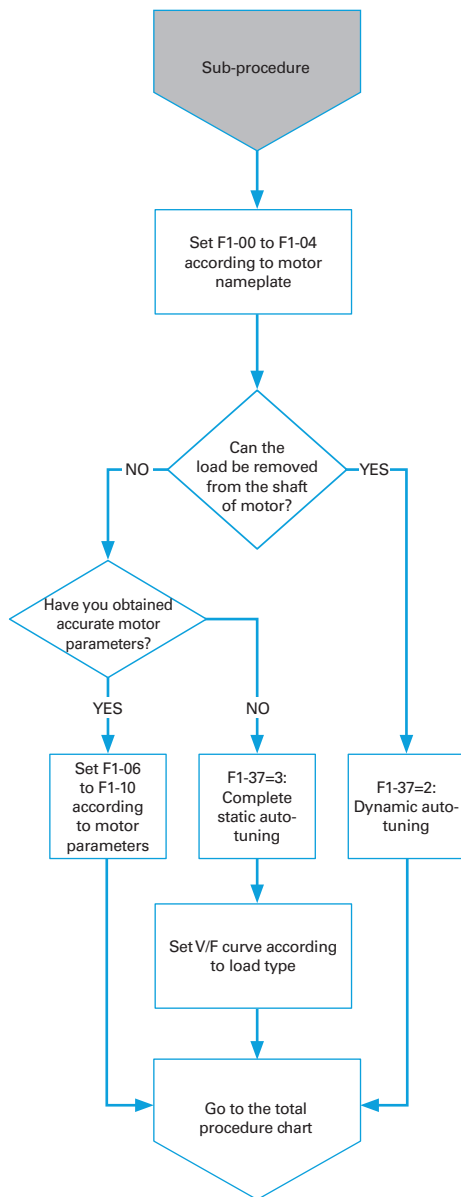

Figure 7-2b Commissioning subprocess flowchart (V/F control)

7. BASIC OPERATIONS AND TRIAL RUN



7.3 CHECKLIST BEFORE POWER-ON

Be sure to check the following items before powering on the drive.

Item	Content
Voltage	The voltage is AC 380 to 480 V and 50/60 Hz. The input terminals R, S, and T are correctly connected. The drive is connected to the motor properly.
Connection of drive output terminals and motor terminals	The drive output terminals U, V and W are securely connected to the motor terminals.
Connection of terminals in control circuit	Terminals of the control circuit are securely connected to other control devices.
Status of control terminals	All terminals of the control circuit are OFF (the drive is not running).
Load	The motor is idle and not connected to the mechanical system.

7.4 DISPLAY AFTER POWER-ON

After the drive is powered on, the display on the operating panel is described in the following table.

State	Display	Description
Normal		Default value 50.00 Hz is displayed
Fault		The drive stops and displays error code.

7.5 PARAMETER INITIALIZATION

You can restore the drive to factory parameters. After initialization, FP-01 is automatically zeroed.

FP-01	Parameter initialization	Default	0
Setting Range	0	No operation	
	1	Restore factory parameters except motor parameters	
	2	Clear records	
	4	Back up current user parameters	
	501	Restore user backup parameters	

1: Restore factory parameters except motor parameters

When FP-01 is set to 1, most of the parameters are restored to the factory default settings. However, motor parameters, frequency reference resolution (F0-22), error records, accumulative running time (F7-09), accumulative power-on time (F7-13), accumulative power consumption (F7-14), and heatsink temperature of AC drive IGBT (F7-07) cannot be restored.

2: Clear records

Error records, F7-09, F7-13, and F7-14 are cleared.

4: Back up current user parameters

Parameters set by the current user are backed up. Values of all the current function parameters are backed up for restoration after error caused by parameter adjustment.

501: Restore user backup parameters

Restore parameters backed up by setting FP-01 to 4.

7.6 MOTOR CONTROL

Function Code	Description	Scenario
F0-01: Motor control mode	F0-01 = 0: V/F	Applicable to scenarios having no requirement on load or using one drive to drive multiple motors, including fans and pumps. It is applicable to scenarios in which one drive is used to drive multiple motors.

7.7 START/STOP RUNNING COMMAND

F0-02	Running command selection	Default	0
	Setting Range	0	Operating panel (LED off)
		1	Terminal (LED on)
		2	Serial communication (LED flashing)

You can use F0-02 to select the input channel of the drive running command. The drive running commands include start, stop, forward, reverse, and jog.

F0-02 = 0: Operating panel (The LOCAL/REMOT indicator is off.)

The commands are given by pressing the RUN and STOP/RES on the operating panel.

F0-02 = 1: Terminal (The LOCAL/REMOT indicator is on.)

Commands are given by using multi-functional input terminals with functions such as FWD, REV, JOGF and JOGR.

F0-02 = 2: Serial communication (The LOCAL/REMOT indicator is flashing.)

7.7.1 Start/Stop Operating Panel

The commands are given by pressing the RUN and STOP/RES on the operating panel, and the LOCAL/REMOT indicator is off. For information about the keys, refer to Chapter 4 Panel Operations.

7.7.2 Start/Stop DI

F4-11	Terminal I/O control mode	Default	0
	Setting Range	0	Two-wire control mode 1
		1	Two-wire control mode 2
		2	Three-wire control mode 1
		3	Three-wire control mode 2

F4-11 defines the four terminal I/O control modes, in which the drive running is controlled by DI terminals.

7. BASIC OPERATIONS AND TRIAL RUN

The following example uses DI1, DI2 and DI3 to describe how to control the AC drive via DI terminals. Set F4-00 to F4-02 to select DI1, DI2 and DI3. For details, see setting ranges of F4-00 to F4-09.

F4-11 = 0: Two-wire Control Mode 1. It is the most commonly used two-wire control mode. Allocate DI1 with forward run function and DI2 with reverse run function.

The parameters are set as below:

Function Code	Parameter Name	Value	Function Description
F4-11	Terminal I/O control mode	0	Two-wire control mode 1
F4-00	DI1 function selection	1	Forward RUN (FWD)
F4-01	DI2 function selection	2	Reverse RUN (REV)

K1	K2	Running Command
1	0	Forward
0	1	Reverse
1	1	Stop
0	0	Stop

In this mode, when K1 is closed, drive rotates in forward direction. When K2 is closed, drive rotates in reverse direction. When K1 and K2 are both open or closed simultaneously, drive stops.

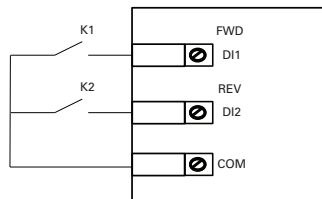

Figure 7-7-2a Two-wire control mode 1

F4-11 = 1: Two-wire Control Mode 2. In this mode, DI1 is RUN enabled terminal, and DI2 determines running direction.

The parameters are set as below:

Function Code	Parameter Name	Value	Function Description
F4-11	Terminal I/O control mode	1	Two-wire control mode 2
F4-00	DI1 function selection	1	RUN enabled
F4-01	DI2 function selection	2	Running direction

K1	K2	Running Command
1	0	Forward
1	1	Reverse
0	0	Stop
0	1	Stop

In this mode, when K1 is closed, motor rotates in forward direction with K2 open. When K1 is closed, motor rotates in reverse direction with K2 closed. When K1 is open, motor stops regardless of matter whether K2 is open or closed.

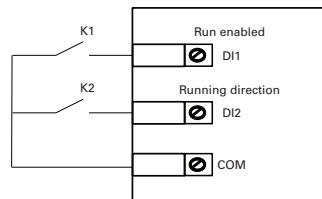

Figure 7-7-2b Two-wire control mode 2

F4-11 = 2: Three-wire Control Mode 1. In this mode, DI3 is a three-wire control terminal. DI1 is set for forward run function and DI2 is set for reverse run function. The parameters are set as below:

Function Code	Parameter Name	Value	Function Description
F4-11	Terminal I/O control mode	2	Three-wire control mode 1
F4-00	DI1 function selection	1	Forward RUN (FWD)
F4-01	DI2 function selection	2	Reverse RUN (REV)
F4-02	DI3 function selection	3	Three-wire control

In this mode, on normal condition (SW3 closed), after you press down SW1, motor rotates in forward direction. After you press down SW2, motor rotates in reverse direction. Motor stops immediately when SW3 opens. SW3 must remain closed during START sequence and during normal RUN operation. Signals from SW1 and SW2 are valid only with SW3 closed. The motor status is determined by the key that you last press.

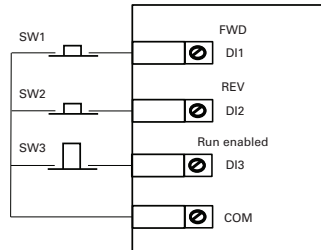

Figure 7-7-2c Three-wire control mode 1

F4-11 = 3: Three-wire Control Mode 2. In this mode, DI3 is three-wire control terminal. DI1 determines whether the RUN command is enabled and DI2 determines running direction. The parameters are set as below:

Function Code	Parameter Name	Value	Function Description
F4-11	Terminal I/O control mode	3	Three-wire control mode 2
F4-00	DI1 function selection	1	RUN enabled
F4-01	DI2 function selection	2	Reverse RUN
F4-02	DI3 function selection	3	Three-wire control

K1	Running Command
0	Forward
1	Reverse

In this mode, when SW1 is closed, after you press SW2, motor rotates in forward direction with K open and in reverse direction with K closed. Motor stops immediately when SW1 opens. SW1 must remain closed during START sequence and during normal RUN operation. Signals from SW2 are valid only with SW1 closed.

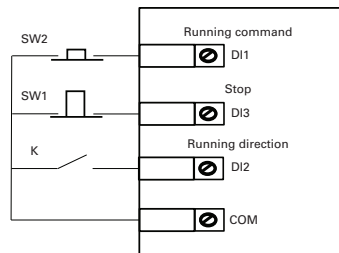

Figure Figure 7-7-2d Three-wire control mode 2

7. BASIC OPERATIONS AND TRIAL RUN

7.8 START THE AC DRIVE

7.8.1 Start Mode

F6-00	Start mode	Default	0
	Setting Range	0	Direct start
		1	Catching a spinning motor
	2	Pre-excited start	

0: Direct start

If the DC injection braking time is set to 0, the drive will start from the setting start-up frequency (F6-03). If the DC injection braking time is not set to 0, the drive will start DC braking firstly and then start from the setting start-up frequency (F6-03). This DC injection braking function is applicable to small-inertia loads that slip easily during the startup stage.

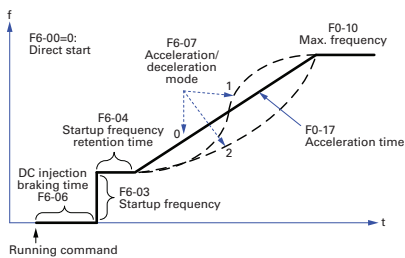

Applicable to most small-inertia loads, the frequency curve is shown in the following figure. The DC injection braking function is applicable to drive loads such as an elevator and crane. Start frequency is applicable to drive equipment requiring startup torque, such as a cement mixer.

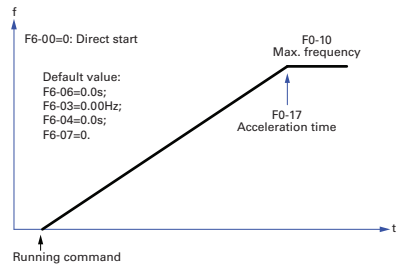

Figure 7-8-1a Direct start

7

1: Catching a spinning motor

This scenario is applicable to large-inertia loads, and the frequency curve is shown in the following figure. When the AC drive starts, the load motor is still running because of the flywheel inertia. In this case, this function can be used to avoid overcurrent during startup.

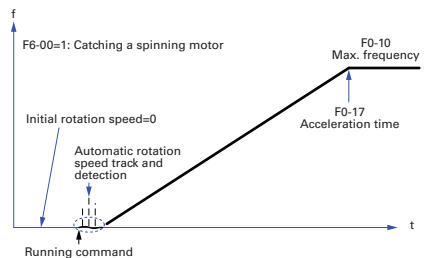
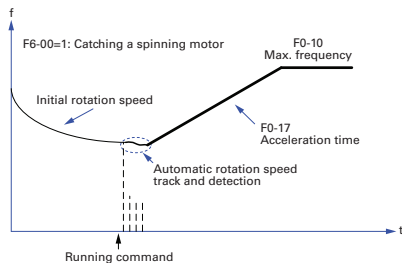

Figure 7-8-1b Catching a Spinning Motor

2: Pre-excited Start

This scenario is valid only for asynchronous motors and used for building magnetic field before motor operation. It can improve quick response of asynchronous motors and shorten acceleration time. The frequency curve is shown in the following figure.

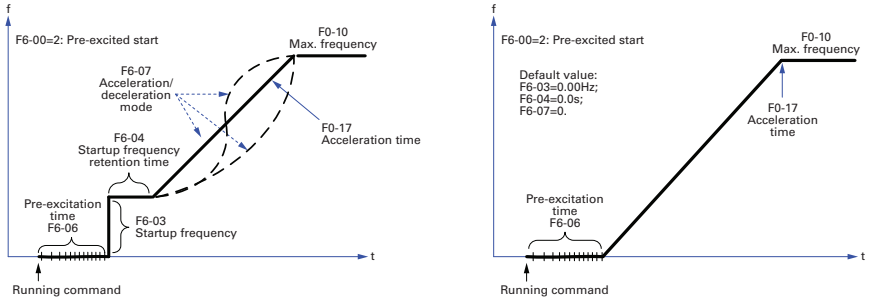

Figure 7-8-1c Pre-excited start

7.8.2 Start Frequency

Set an appropriate start frequency to ensure the motor torque when the motor starts. The start frequency needs to be retained for a period of time for full magnetic flux when the motor starts.

F6-03 has no lower frequency limit. If target frequency is smaller than start frequency, the motor does not start and is idle.

Retention time of start frequency is not counted into acceleration time but into running time of simple PLC function.

F6-03	Start frequency	Default	0.00 Hz
	Setting Range	0.00 Hz to 10.00 Hz	
F6-04	Start frequency holding time	Default	0.0s
	Setting Range	0.0s to 100.0s	

7. BASIC OPERATIONS AND TRIAL RUN

7.9 VIEW RUNNING STATUS

7.9.1 Digital Output (DO)

There are three digital output terminals on the control board. FM and DO1 are transistor outputs capable of driving a 24 VDC low-voltage circuit. TA/TB/TC is a relay capable of driving a 250 VAC control circuit.

There are two additional digital outputs on the optional I/O extension board. DO2 is a transistor output and PA/PB/PC is a relay output.

Function codes F5-01 to F5-05 define how DO terminals indicate the running status and alarm information for the AC drive. There are about 40 functions with no load available to use for these function codes.

Terminal	Corresponding Function Code	Output Feature Description
FM-COM	F5-06 when F5-00 = 0	Transistor Able to output high-speed pulses 10 Hz to 100 KHz Drive capacity: 24 VDC, 50 mA
	F5-01 when F5-00 = 1	Transistor Drive capacity: 24 VDC, 50 mA
TA-TB-TC	F5-02	Relay Drive capacity: 250 VAC, 3A
PA-PB-PC	F5-03	Extension card, relay Drive capacity: 250 VDC, 3A
DO1-CME	F5-04	Transistor Drive capacity: 24 VDC, 50 mA
DO2-CME	F5-05	Extension card, transistor Drive capacity: 24 VDC, 50 mA

When F5-00 = 0, FM terminal is a high-speed pulse output. Frequency of pulses on this DO terminal indicates the value of internal running parameters. Higher values of internal running

parameters produce higher pulse frequencies. Value 100% corresponds to a pulse frequency of 100 kHz. F5-06 indicates attributes of internal running parameters.

7.9.2 Analog Output (AO)

The drive supports a maximum of two analog output terminals. AO1 is on the control board and AO2 is on the optional extension card. F5-07 and F5-08 define how AO terminals indicate the drive's internal running parameters in analog mode.

Terminal	Input Signal Characteristics		
AO1-GND	If J7 jumps to the "V" position, AO outputs voltage signal of 0 to 10 VDC.		
AO2-GND	If J7 jumps to the "I" position, AO outputs current signal of 0 to 20 mA.		
	It is on the optional extension card. It outputs voltage signal of 0 to 10 VDC.		
F5-10	AO1 zero offset coefficient	Default	0.0%
	Setting Range	-100.0% to +100.0%	
F5-11	AO1 gain	Default	1.00
	Setting Range	-10.00 to +10.00	
F5-12	AO2 zero offset coefficient	Default	0.00%
	Setting Range	-100.0% to +100.0%	
F5-13	AO2 gain	Default	1.00
	Setting Range	-10.00 to +10.00	

These four function parameters can define required AO curve.

If “b” represents zero offset, “k” represents gain, “Y” represents actual output of the AO, and “X” represents output frequency, then the actual output is $Y=kX + b$.

Zero offset coefficient 100% of AO1 and AO2 corresponds to 10 V or 20 mA. A standard output is the value corresponding to 0 to 10 V or 0 to 20 mA without offset or gain.

For example, AO is used for output of frequency reference. To implement output of 8 V at 0 Hz and output of 4 V at 40 Hz, set F5-11 to -0.5 and set F5-10 to 80%.

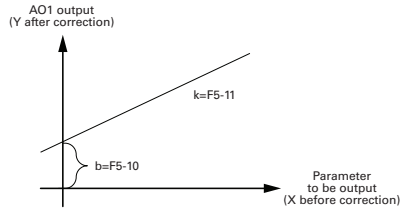

Figure 7-9-2 AO signal correction characteristic curve

7.10 AUTO-TUNING

You can obtain the parameters of a controlled motor through motor auto-tuning. Motor auto-tuning methods are dynamic auto-tuning, static auto-tuning 1, and static auto-tuning 2. You can also enter the motor parameters manually.

Auto-tuning Method	Application	Result
Dynamic auto-tuning with no-load F1-37 = 2	Applied to applications where motor can be disconnected from load.	Best
Dynamic auto-tuning with load F1-37 = 2	Applied to applications where motor cannot be disconnected from load and dynamic auto-tuning is not allowed. The load friction force is small and the motor is appropriately idle when running at a constant speed.	The effect is better with smaller friction force.
Static auto-tuning 1 F1-37 = 1	Applied to applications where the motor cannot be disconnected from the load and dynamic auto-tuning is not allowed.	OK
Static auto-tuning 2 F1-37 = 3	Applied to applications where the motor cannot be disconnected from the load and dynamic auto-tuning is not allowed. This mode is recommended for static auto-tuning. It lengthens the auto-tuning time compared to static auto-tuning 1.	Better
Manual parameter input	Applied to applications where the motor cannot be disconnected from the load. Copy parameters of motors of the same model that have been auto-tuned to F1-00 to F1-10.	Better

7. BASIC OPERATIONS AND TRIAL RUN

Auto-tuning methods are described below.

Motor 1 is used to describe motor auto-tuning methods. If you need to perform motor 2 auto-tuning, set F0-24=1.

Step 1: If the motor can be disconnected from load, cut off the power, disconnect the motor from load to let the load run in idle.

Step 2: Power on the AC drive. Set F0-02 = 0 to select the operating panel as running command.

Step 3: Input motor nameplate parameters (F1-00 to F1-05) correctly. Set the following parameters according to the motor:

Motor	Parameter
Motor 1	F1-00: Motor type selection F1-01: Rated motor power F1-02: Rated motor voltage F1-03: Rated motor current F1-04: Rated motor frequency F1-05: Rated motor speed
Motor 2	A2-00 to A2-05 have the same definition.

If there is an encoder, set F1-27, F1-28, and F1-30.

Step 4: If the motor is an asynchronous motor, set F1-37 (A2-37 in case of Motor 2) to 2 and press ENTER. TUNE is displayed, as shown in the following figure:

TUNE

Press RUN on the operating panel. The AC drive drives the motor to accelerate/ decelerate and run in forward/reverse direction. The RUN indicators becomes ON and auto-tuning lasts for about 2 minutes. After the preceding display disappears and the operating panel returns to normal parameter display state, it indicates that auto-tuning is completed.

After auto-tuning, the following motor parameters are calculated:

Motor	Parameter
Motor 1	F1-06: Stator resistance F1-07: Rotor resistance F1-08: Leakage inductive reactance F1-09: Mutual inductive reactance F1-10: No-load current
Motor 2	A2-00 to A2-05 have the same definition.

If the motor cannot be disconnected from load, set F1-37 (A2-37 in case of Motor 2) to 3 and press RUN on the operating panel. Auto-tuning begins.

8. TROUBLESHOOTING AND SOLUTIONS

8.1 SAFETY INFORMATION

DANGER

- Do not disconnect the AC drive while power is on, and keep all breakers in OFF state. Failure to comply may result in electric shock.

WARNING

- Make sure to ground the AC drive according to local laws and regulations. Failure to comply may result in electric shock or fire.
- Do not remove the front cover or touch the internal circuit while the power is on. Failure to comply may result in electric shock.
- Do not allow unqualified personnel to perform any maintenance, inspection or component replacement work. Failure to comply may result in electric shock or fire.
- When installing the drive inside an enclosed cabinet, use a cooling fan or air conditioner to keep temperature below 50°C. Failure to comply may result in overheating or even fire.

- Tighten all screws based on the specified tightening torque. Failure to comply may result in fire or electric shock.
- Always confirm input voltage is within nameplate rating. Failure to comply may result in electric shock or fire.
- Keep flammable and combustible materials away from the drive.

CAUTION

- Cover the top of the drive with a temporary cloth or paper during installation so as to prevent foreign matter such as metal shavings, oil and water from falling into the drive. If any foreign matter falls into the drive, the drive may have a fault.
- After the installation is completed, remove the temporary cloth or paper. Leaving the cloth or paper on the drive, may result in abnormal heating due to poor ventilation.
- Follow proper electrostatic discharge (ESD) procedures when operating the AC drive. Failure to comply will damage the internal circuit of the drive.

8. TROUBLESHOOTING AND SOLUTIONS

8.2 TROUBLESHOOTING DURING TRIAL RUN

1. Drive in V/F Control (F0-01 = 0)

You need only set rated motor voltage and rated motor frequency correctly.

Problem	Solutions
Motor oscillation during running	Increase the setting of F3-11 (V/F oscillation suppression gain) by 10 gradually. The permissible maximum setting here is 100.
Overcurrent during start	Decrease the setting of F3-01 (torque boost) by 0.5% gradually.
Very high current during running	Set rated motor voltage (F1-02) and rated motor frequency (F1-04) correctly. Decrease the setting of F3-01 (torque boost) by 0.5% gradually.
Motor noise too loud	Increase the setting of F0-15 (carrier frequency) by 1.0 kHz gradually. Note that increase in carrier frequency will result in an increase in the leakage current of the motor.
Overvoltage detected when heavy load is suddenly removed or during deceleration	Ensure that F3-23 (overvoltage stall enable) is enabled. Increase the setting of F3-24/ F3- 25 (overvoltage stall gain, default is 30) by 10 gradually. The permissible maximum setting here is 100. Decrease the setting of F3-22 (overvoltage stall actuating voltage, default is 770 V) by 10 V gradually. The permissible minimum setting here is 700 V.
Overcurrent detected when heavy load is suddenly added or during acceleration	Increase the setting of F3-20 (overcurrent stall gain, default is 20) by 10 gradually. The permissible maximum setting here is 100. Decrease the setting of F3-18 (overcurrent stall actuating current, default is 150%) by 10% gradually. The permissible minimum setting here is 50%.

8.3 FAULT DISPLAY

When a fault occurs during running, the AC drive stops output immediately, the fault indicator flashes, and the contact of the fault relay acts. The operating panel displays the fault code such as **Err02**, as shown in the figure at right. Solutions in the table are for reference only. Do not repair or transform the drive by yourself. If the fault persists, contact Benshaw or our agent for technical support.

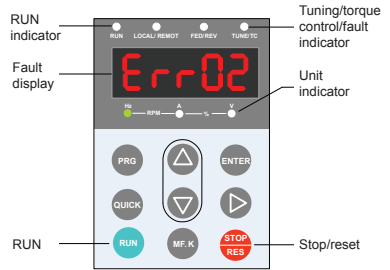

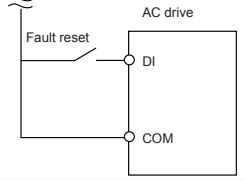
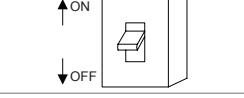



Figure 8-3 Interface

8.4 RESETING FAULT

Stage	Solution	Remark
After the fault occurs	Check the operating panel for detailed information of the most recent three faults, including fault type and frequency, current, bus voltage, DI/DO state, accumulative power-on time and accumulative running time at occurrence of the faults.	View this information via F9-14 to F9-44 
Before the fault is reset	Find and remove cause of the fault according to the fault type displayed on the operating panel. Then reset the fault.	Troubleshoot the fault according to section 8.5 "Faults and Diagnostics?"
Fault resetting method	(1) Press the STOP/RES key on operating panel. (Confirm that F7-02 = 1 (default value).)	Fault resetting via operating panel 
	(2) Allocate a DI terminal with function 9 "Fault reset (RESET)" by setting any of F4-00 to F4-09 to 9.	
	(3) Disconnect the power supply. When the fault code disappears, connect the power supply again.	
	(4) Fault resetting via host computer. Confirm that F0-02 = 2 and write "7" (fault reset) to communication address 2000H. *	

*Note: For details, refer to "Appendix B Definition of Communication Data Address and Modbus Communication Protocol".

8. TROUBLESHOOTING AND SOLUTIONS

8.5 FAULTS AND DIAGNOSTICS

Troubleshoot faults occurring during operating the drive as follows:

Fault Name	Operating Panel Display	Cause	Possible Solution
Overcurrent during acceleration	Err02	Ground fault or short circuit exists in the output circuit.	Check whether the short-circuit occurs on the motor, motor cable or contactor.
		Acceleration time is too short.	Increase acceleration time.
		The overcurrent stall prevention parameters are set improperly.	Ensure that current limit is enabled (F3-19 = 1). The setting of current limit level (F3-18) is too high. Adjust it between 120% and 150%. The setting of current limit gain (F3-20) is too low. Adjust it between 20 and 40.
		Customized torque boost or V/F curve is not appropriate.	Adjust the customized torque boost or V/F curve.
		The spinning motor is started.	Enable the catching a spinning motor function or start the motor after it stops.
Overcurrent during deceleration	Err03	Ground fault or short circuit exists in the output circuit.	Check whether the short-circuit occurs on the motor, motor cable or contactor.
		Deceleration time is too short.	Increase deceleration time.
		The overcurrent stall prevention parameters are set improperly.	Ensure that current limit is enabled (F3-19 = 1). The setting of current limit level (F3-18) is too high. Adjust it between 120% and 150%. The setting of current limit gain (F3-20) is too low. Adjust it between 20 and 40.
		Braking unit and braking resistor are not installed.	Install braking unit and braking resistor.
		The AC drive suffers external interference.	View historical fault records. If the current value is far from the overcurrent level, find interference source. If external interference does not exist, it is the drive board or hall device problem.
Overcurrent at constant speed	Err04	Ground fault or short circuit exists in the output circuit.	Check whether the short-circuit occurs on the motor, motor cable or contactor.
		The overcurrent stall prevention parameters are set improperly.	Ensure that current limit is enabled (F3-19 = 1). The setting of current limit level (F3-18) is too high. Adjust it between 120% and 150%. The setting of current limit gain (F3-20) is too low. Adjust it between 20 and 40.
		The AC drive power class is too low.	If output current exceeds rated motor current or rated output current of the AC drive during stable running, replace with a drive of higher power class.
		The AC drive suffers external interference.	View historical fault records. If the current value is far from the overcurrent level, find interference source. If external interference does not exist, it is the drive board or hall device problem.

Fault Name	Operating Panel Display	Cause	Possible Solution
Overvoltage during acceleration	Err05	Input voltage is too high.	Adjust input voltage to normal range.
		An external force drives motor during acceleration.	Cancel the external force or install a braking resistor.
		The overvoltage stall prevention parameters are set improperly.	Ensure that the voltage limit function is enabled (F3-23 = 1). The setting of voltage limit (F3-22) is too high. Adjust it between 770V and 700 V. The setting of frequency gain for voltage limit (F3-24) is too low. Adjust it between 30 and 50.
		Braking unit and braking resistor are not installed.	Install braking unit and braking resistor.
		Acceleration time is too short.	Increase acceleration time.
Overvoltage during deceleration	Err06	The overvoltage stall prevention parameters are set improperly.	Ensure that the voltage limit function is enabled (F3-23 = 1). The setting of voltage limit (F3-22) is too high. Adjust it between 770V and 700 V. The setting of frequency gain for voltage limit (F3-24) is too low. Adjust it between 30 and 50.
		An external force drives motor during deceleration.	Cancel the external force or install a braking resistor.
		Deceleration time is too short.	Increase deceleration time.
		Braking unit and braking resistor are not installed.	Install braking unit and braking resistor.
Overvoltage at constant speed	Err07	The overvoltage stall prevention parameters are set improperly.	Ensure that the voltage limit function is enabled (F3-23 = 1). The setting of voltage limit (F3-22) is too high. Adjust it between 770V and 700 V. The setting of frequency gain for voltage limit (F3-24) is too low. Adjust it between 30 and 50. The setting of frequency rise threshold during voltage limit (F3-26) is too low. Adjust it between 5 Hz and 20 Hz.
		An external force drives motor during running.	Cancel the external force or install a braking resistor.
Pre-charge resistor fault	Err08	Bus voltage fluctuates around undervoltage threshold continuously.	Contact the agent or Benshaw.
Undervoltage	Err09	Instantaneous power failure occurs.	Enable the power dip ride through function (F9-59 ≠ 0).
		The AC drive's input voltage is not within the permissible range.	Adjust the voltage to normal range.
		The bus voltage is abnormal.	Contact the agent or Benshaw.
		The rectifier bridge, the buffer resistor, the drive board or the control board are abnormal.	Contact the agent or Benshaw.
AC drive overload	Err10	Load is too heavy or locked-rotor occurs on motor.	Reduce load or check motor and mechanical conditions.
		The AC drive power class is low.	Replace with a drive of higher power class.
Motor overload	Err11	F9-01 (Motor overload protection gain) is set improperly.	Set F9-01 correctly.
		Load is too heavy or locked-rotor occurs on motor.	Reduce load or check motor and mechanical conditions.
Input phase loss	Err12	Input phase loss occurs. Drive board, lightning protection board, control board, or rectifier bridge is abnormal.	Eliminate faults in external circuitry. Contact the agent or Benshaw.





8. TROUBLESHOOTING AND SOLUTIONS

Fault Name	Operating Panel Display	Cause	Possible Solution
Input phase loss	Err 12	Input phase loss occurs. Drive board, lightning protection board, control board, or rectifier bridge is abnormal.	Eliminate faults in external circuitry. Contact the agent or Benshaw.
Output phase loss	Err 13	Motor winding is damaged. The cable connecting the AC drive and the motor is abnormal. The AC drive's three-phase outputs are unbalanced when the motor is running. The drive board or the IGBT is abnormal.	Check resistance between motor wires. Check for wiring errors and ensure the output cable is connected properly. Check whether the motor three-phase winding is normal. Contact the agent or Benshaw.
IGBT overheat	Err 14	The ambient temperature is too high. The ventilation is clogged. The fan is damaged. Thermally sensitive resistor of IGBT is damaged.	Lower the ambient temperature. Clean the ventilation. Replace the cooling fan. Replace the damaged thermally sensitive resistor.
External fault	Err 15	The AC drive IGBT is damaged. External fault signal is input via DI. External fault signal is input via virtual I/O.	Replace the AC Drive IGBT. Confirm that the mechanical condition allows restart (F8-18) and reset the operation. Confirm that the virtual I/O parameters in group A1 are set correctly and reset the operation.
Communication fault	Err 16	Host computer is in abnormal state. Communication cable is abnormal. The serial port communication protocol (F0-28) of extension communication card is set improperly. Communication parameters in group Fd are set improperly. If, after checking all the preceding,	Check the cable of host computer. Check the communication cables. Set F0-28 of extension communication card correctly. Set communication parameters in group Fd properly. the fault still exists, restore the default settings.
Contactor fault	Err 17	Drive board and power supply are abnormal. Contactor is abnormal. The lightning protection board is abnormal.	Replace drive board or power supply board. Replace contactor. Replace the lightning protection board.
Current detection fault	Err 18	The hall element is abnormal. The drive board is abnormal.	Replace the hall element. Replace the drive board.
Motor auto-tuning fault	Err 19	Motor parameters are not set according to nameplate. Motor auto-tuning times out. The encoder is abnormal.	Set motor parameters correctly according to nameplate. Check the cable connecting AC drive and motor. Check whether F1-27 (encoder pulses per revolution) is set correctly. Check whether signal lines of encoder are connected correctly and securely.
EEPROM read-write fault	Err 21	The EEPROM chip is damaged.	Replace the main control board.
Short circuit to ground	Err 23	Motor is short circuited to the ground.	Replace cable or motor.
Accumulative running time reached	Err 26	Accumulative running time reaches the setting value.	Clear the record through parameter initialization.

Fault Name	Operating Panel Display	Cause	Possible Solution
User-defined Fault 1	Err27	User-defined fault 1 is input via DI.	Reset the operation.
		User-defined fault 1 is input via virtual I/O.	Reset the operation.
User-defined Fault 2	Err28	User-defined fault 2 is input via DI.	Reset the operation.
		User-defined fault 2 is input via virtual I/O.	Reset the operation.
Accumulative power-on time reached	Err29	Accumulative power-on time reaches the setting value.	Clear the record through parameter initialization.
Load loss	Err30	The output current of AC drive is lower than F9-64 (load loss detection level).	Check whether load is disconnected or the setting of F9-64 and F9-65 (load lost detection time) satisfies actual running condition.
PID feedback lost during running Feedback loss	Err31	PID feedback is smaller than the setting value of FA- 26 (detection level of PID feedback loss).	Check PID feedback or set FA-26 properly.
Pulse-by-pulse current limit fault	Err40	Load is too heavy or locked rotor occurs on motor.	Reduce load or check motor and mechanical conditions.
		The AC drive power class is too low.	Replace with a drive of higher power class.
Motor switchover fault during running Motor winding is damaged	Err41	Motor switchover via terminal during drive running of the AC drive.	Perform motor switchover after the AC drive stops.
Speed error	Err42	Encoder parameters are set improperly.	Set encoder parameters properly.
		Motor auto-tuning is not performed.	Perform motor auto-tuning.
		F9-69 (detection level of speed error) and F9-70 (detection time of speed error) are set incorrectly.	Set F9-69 and F9-70 correctly based on actual condition.
Motor overspeed Problem	Err43	Encoder parameters are set improperly.	Set encoder parameters properly.
		Motor auto-tuning is not performed.	Perform motor auto-tuning.
		F9-67 (Overspeed detection level) and F9-68 (Overspeed detection time) are set incorrectly.	F9-67 and F9-68 correctly based on actual condition.
Motor overtemperature	Err45	Cable connection of temperature sensor becomes loose.	Check cable connection of temperature sensor.
		The motor temperature is too high.	Decrease carrier frequency or take other measures to cool the motor.
Braking unit overload	Err61	Resistance of braking resistor is too low.	Replace a braking resistor of higher resistance.
Short-circuit of braking circuit	Err62	Braking module is abnormal.	Contact the agent or Benschaw.

8. TROUBLESHOOTING AND SOLUTIONS

8.6 SYMPTOMS AND DIAGNOSTICS

SN	Fault Description	Cause	Possible Solution
1	There is no display at power-on. 	The mains voltage is not connected or too low.	Check the power supply.
		The switching power supply on drive board of the AC drive is faulty.	Check bus voltage.
		Wires between control board and drive board and between control board and operating panel are not connected.	Re-connect the 8-pin wire and 40-pin wire.
		Precharge resistor of the AC drive is damaged. Control board or operating panel is faulty. Rectifier bridge is damaged.	Contact the agent or Benschaw.
2	"HC" is displayed at power-on. 	Wires between drive board and control board have poor contact.	Re-connect the 8-pin wire and 28-pin wire.
		Related components on control board are damaged The motor or motor cable is short circuited to ground. The hall element is damaged. The mains voltage is too low.	Contact the agent or Benschaw.
		Motor or motor output cable is short circuited to ground. The AC drive is damaged.	Use a megger to measure insulation resistance of motor and motor cable. Contact the agent or Benschaw.
		The cooling fan is damaged or locked-rotor occurs.	Replace the cooling fan.
4	The display is normal at power-on. But after running, "HC" is displayed and the drive stops immediately. 	Short circuit exists in wiring of control terminals.	Eliminate short circuit fault in control circuit wiring.
		Err14 (IGBT overheat) is detected frequently. 	The setting of carrier frequency is too high. The cooling fan is damaged, or ventilation is clogged. Components inside the AC drive are damaged (thermistor or others).
6	The motor does not rotate after the AC drive runs.	There is a motor or motor cable problem.	Check that wiring between AC drive and motor is normal.
		Related AC drive and motor parameters are set improperly.	Restore the factory parameters and re-set the following parameters properly: Encoder parameters, Motor ratings, such as rate motor frequency and rated motor speed Motor 1 control mode (F0-01) and Running command selection (F0-02) F3-01 (torque boost) in V/F control under heavy-load start.
		Cable connection between drive board and control board has poor contact.	Re-connect wiring and ensure secure connection.
		The drive board is faulty.	Contact the agent or Benschaw.
7	DI terminals are disabled.	Related parameters are set incorrectly.	Check and set parameters in group F4 again.
		External signals are incorrect.	Re-connect external signal cables.
		Jumper across OP and +24 V becomes loose.	Re-confirm the jumper bar across OP and +24 V.
		The control board is faulty.	Contact the agent or Benschaw.

SN	Fault Description	Cause	Possible Solution
9	The AC drive detects overcurrent and overvoltage frequently.	Motor parameters are set improperly.	Set motor parameters or perform motor auto-tuning again.
		Acceleration/deceleration time is improper.	Set proper acceleration/deceleration time.
		Load fluctuates.	Contact the agent or Benshaw.
10	Err17 is detected upon power-on or running. 	The pre-charge relay or contactor is not closed.	Check whether the relay, contact or cable is loose. Check whether the relay or contactor is faulty. Check whether 24 V power supply of contactor is faulty. Contact the agent or Benshaw.
		The overvoltage stall protection takes effect.	If braking resistor is set, set Overvoltage Stall Enabled to Disabled (F3-23 = 0).
11	The motor stops freely or cannot be braked during deceleration or deceleration to stop.	The overvoltage stall protection takes effect.	If braking resistor is set, set Overvoltage Stall Enabled to Disabled (F3-23 = 0).

9. ROUTINE INSPECTION AND MAINTENANCE

9.1 ROUTINE INSPECTION

Safety Information

⚠ DANGER

- Do not connect or disconnect wiring while the power is on.
- Before the inspection, disconnect all power supplies. After disconnecting power to the drive, there is residual voltage in the DC capacitor in the drive, wait for several minutes until the power indicator is off. Before powering on the drive again for operation, wait for an interval specified by the drive.
- Do not modify or disconnect wiring, remove optional extension card or replace the cooling fan while the power is on.
- Make sure to connect the motor-side grounding terminal. Failure to comply may result in electric shock when touching motor housing.
- Do not allow unqualified personnel to perform repair and maintenance work.
- Installation, wiring, commissioning, repair and maintenance, and component replacement must be performed only by qualified technicians

⚠ WARNING

- Do not run the AC drive with its front cover removed.
- Drawings in the manual are sometimes shown without covers or protective guards to display details. Remember to install the covers or protective guards as specified first, and then perform operations in accordance with instructions.
- Tighten all terminal screws based on specified tightening torque.

- Ensure that input voltage is within permissible range. Incorrect input voltage of main circuit may result in abnormal operation.
- Keep combustible materials far away from the AC drive or mount the AC drive on incombustible surfaces such as a metal wall.

⚠ CAUTION

- Replace the cooling fan using correct methods as specified in this chapter. Ensure correct air outlet direction of the fan. Incorrect air direction will diminish the cooling effects.
- Do not connect or disconnect the motor while the drive is running. Failure to comply may result in electric shock and damage to the AC drive.
- Use shielded cables for control circuit wiring.
- Ground the shield to the grounding terminal reliably.
- Do not modify the drive circuitry. Failure to comply will damage the AC drive.
- Make sure to connect the output terminals of the AC drive and the motor terminals correctly.
- If it is necessary to change the motor rotation direction, exchange any two of the UVW cables of the AC drive.
- Do not operate an AC drive that has been damaged. This is to prevent further damage to external equipment.

9.1.1 Routine Inspection Items

Influence of ambient temperature, humidity, dust and vibration will cause aging of components in the AC drive, which may cause potential faults or reduce the product life. Therefore, it is necessary to perform routine and periodic maintenance. More frequent inspection will be required if it is used in harsh environments, such as: high ambient temperature; frequent starting and

stopping; fluctuations in the ac power supply or load; excessive vibrations or shock loading; dust, metal dust, salt, sulfuric acid, chlorine atmospheres; poor storage conditions.

Check the following items routinely to avoid deterioration in performance or product. Copy this checklist and sign the "Checked" column after each inspection.

Inspection Item	Inspection Points	Solutions	Checked
Motor	Inspect whether abnormal oscillation or noise exists.	Check mechanical connections. Check power phases of the motor. Tighten all loose screws.	
Fan	Inspect whether the cooling fan of the AC drive and the motor works abnormally.	Check running of the drive-side cooling fan. Check running of the motor-side cooling fan. Check whether the cooling fan is clogged or dirty. Check whether ambient temperature is within the permissible range.	
Installation environment	Inspect whether the cabinet and cable duct are abnormal.	Check for input and output cables with insulation damage. Check for vibration of hanging bracket. Check whether copper ground bars and terminals have become loose or corroded.	
Load	Inspect whether the drive output current exceeds the drive or motor rating for an extended period of time.	Check for setting of motor parameters. Check for excessive load. Check for mechanical vibration (< 0.6 g on normal condition).	
Input voltage	Check main power supply and control voltage.	Adjust the input voltage to the permissible range. Check whether start of heavy load exists.	

9.2 PERIODIC INSPECTION

9.2.1 Periodic Inspection Items

Always keep the AC drive clean. Clear away dusts, especially metal powder on the surface of the AC drive, to prevent dust from entering the drive. Clear oil and dirt from the cooling fan of the AC drive.



- Do not perform inspection while the power is on.
- Before the inspection, disconnect all power supplies and wait for 10 minutes to avoid risk caused by residual voltage in the capacitor of the drive

9. ROUTINE INSPECTION AND MAINTENANCE

Inspection Item	Inspection Points	Inspection Points	Checked
General	Inspect for wastes, dirt and dust on the surface of the AC drive.	Check that the AC drive is powered off. Use a vacuum cleaner to suck up wastes and dust to avoid direct contact. Wipe surface dirt gently with a soft cloth immersed in neutral detergent.	
Cables	Inspect power cables and connections for discoloration. Inspect wiring insulation for aging or wear.	Replace cracked cables. Replace damaged terminals.	
Peripheral devices such as relay and contactor	Inspect contactors and relays for excessive noise during operation. Inspect coils for signs of overheating such as melted or cracked insulation. Check whether the coil voltage is normal.	Replace abnormal peripheral devices.	
Ventilation	Inspect whether ventilation and heatsink are clogged. Check whether the fan is damaged.	Clean ventilation. Replace the fan.	
Control circuit	Inspect for control components with poor contact. Inspect for loose terminal screws. Inspect for control cables with cracked insulation.	Clear away foreign matter on the surface of control cables and terminals. Replace damaged or corroded control cables.	

9.2.2 Insulation Test on Main Circuit

Before measuring insulation resistance with a megameter (a 500 VDC megameter is recommended), disconnect the main circuit from the AC drive. Do not conduct the dielectric strength test using an insulation megameter. High voltage (> 500 V) test need not be performed again because it has been completed before delivery.

The measured insulation resistance must be greater than 5 MΩ.

Before test, remove the VDR screw. For positions of VDR and EMC screws, refer to Figure 5-2-3f in Electrical Wiring.

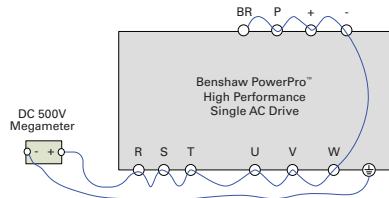

Figure 9-2-2 Test insulation on the main circuit

9.3 REPLACEMENT OF WEAR PARTS

9.3.1 Lifetime of Wear Parts

Component	Service Life
Fan	≥ 5 years
Electrolytic capacitor	≥ 5 years

You can determine when to replace these parts according to the actual operating time.

1. Ambient temperature: 40°C
2. Load rate: 80%
3. Operating rate: 24 hours per day

9.3.2 Number of Fans on the Drive

Model Number	Number of Fans
Three-phase 380 to 480 V, 50/60 Hz	
RSI-PPFP-0001-4-3-B-IP20-IM	—
RSI-PPFP-01H5-4-3-B-IP20-IM	—
RSI-PPFP-0002-4-3-B-IP20-IM	—
RSI-PPFP-0003-4-3-B-IP20-IM	1
RSI-PPFP-0005-4-3-B-IP20-IM	1
RSI-PPFP-07H5-4-3-B-IP20-IM	1
RSI-PPFP-0010-4-3-B-IP20-IM	1
RSI-PPFP-0015-4-3-B-IP20-IM	1
RSI-PPFP-0020-4-3-B-IP20-IM	2
RSI-PPFP-0025-4-3-B-IP20-IM	2
RSI-PPFP-0030-4-3-B-IP20-IM	1
RSI-PPFP-0040-4-3-B-IP20-IM	1
RSI-PPFP-0050-4-3-B-IP20-IM	1
RSI-PPFP-0060-4-3-B-IP20-IM	1

Model Number	Number of Fans
Three-phase 380to 480 V, 50/60 Hz	
RSI-PPFP-0075-4-3-B-XN01-IM	1
RSI-PPFP-0100-4-3-B-XN01-IM	1
RSI-PPFP-0125-4-3-B-XN01-IM	2
RSI-PPFP-0150-4-3-X-XN01-IM	2
RSI-PPFP-0200-4-3-X-XN01-IM	2
RSI-PPFP-0250-4-3-X-IP00-IM	2
RSI-PPFP-0300-4-3-X-IP00-IM	2
RSI-PPFP-0350-4-3-X-IP00-IM	2
RSI-PPFP-0400-4-3-X-IP00-IM	3
RSI-PPFP-0450-4-3-X-IP00-IM	3
RSI-PPFP-0500-4-3-X-IP00-IM	3
RSI-PPFP-0600-4-3-X-IP00-IM	3
RSI-PPFP-0700-4-3-X-IP00-IM	3

9.3.3 Replacement of Fans

1. Possible causes of damage: bearing worn and blade aging
2. Replacement determination criteria: Crack on the blade; abnormal vibration noise upon start-up; and blade operating abnormally.

3. Replacement method: Decompress the fan cover hook and pull the cover out. Keep air flow direction upward.

Remove the fan (RSI-PPFP-0003-4-3-B-IP20-IM to RSI-PPFP-0060-4-3-B-IP20-IM)

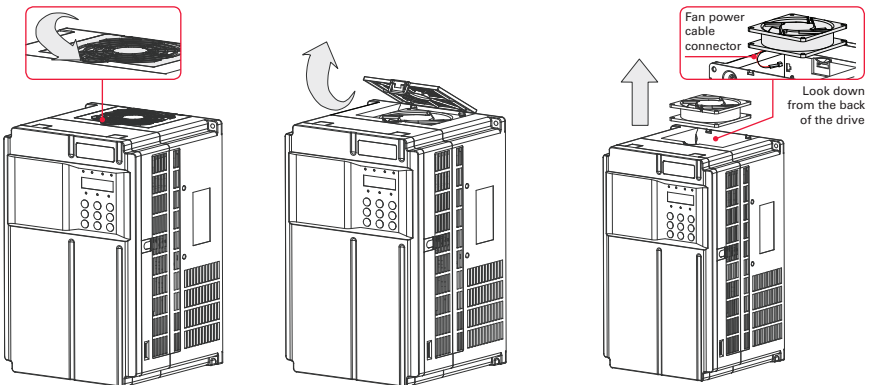

(1) Depress the fan cover hook and take the fan cover off the top of the drive.

(2) Pull the fan upward and disconnect the pluggable connector of the power cable.

9. ROUTINE INSPECTION AND MAINTENANCE

Install the fan (RSI-PPFP-0003-4-3-B-IP20-IM to RSI-PPFP-0060-4-3-B-IP20-IM)

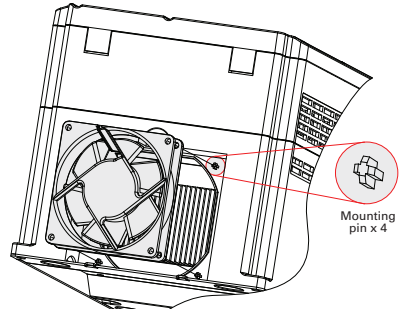
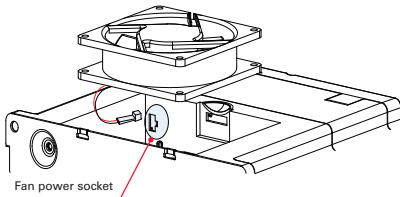

- (1) Install the fan in reverse order. Pay attention to the correct air flow direction.
- (2) Plug the fan power cable into the socket, as shown in the figure above.

- (3) Install the fan into the drive and ensure that the four mounting pins are aligned.

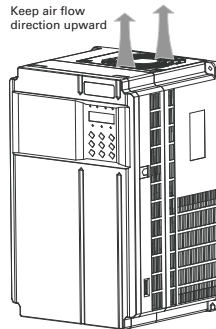
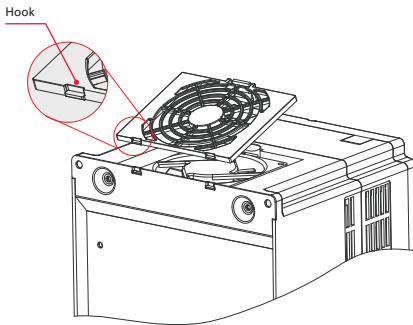

- (4) Insert the two guide pins into the square holes and then press in the hook.

Install the fan (RSI-PPFP-0003-4-3-B-IP20-IM to RSI-PPFP-0060-4-3-B-IP20-IM)

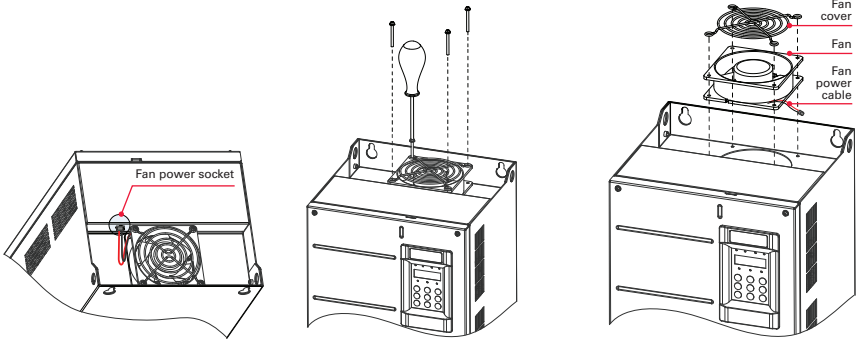

(1) Disconnect the fan cable from the drive (top view).

(2) Remove the four screws from the drive.

(3) Remove the fan and fan cover from the drive.

Install the fan (RSI-PPFP-0075-4-3-B-XN01-IM to RSI-PPFP-0250-4-3-X-IP00-IM)

- (1) Install the fan in reverse order. Pay attention to the correct air flow direction.
- (2) Install the fan cover and fan into the drive and ensure that the four mounting pins are aligned, as shown by imaginary lines in Step 3 above.
- (3) Keep air flow direction upward.

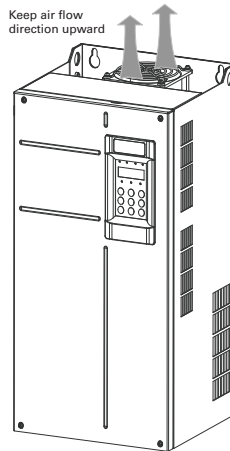

9. ROUTINE INSPECTION AND MAINTENANCE

Remove the fan (RSI-PPFP-0300-4-3-X-IP00-IM to RSI-PPFP-0700-4-3-X-IP00-IM)

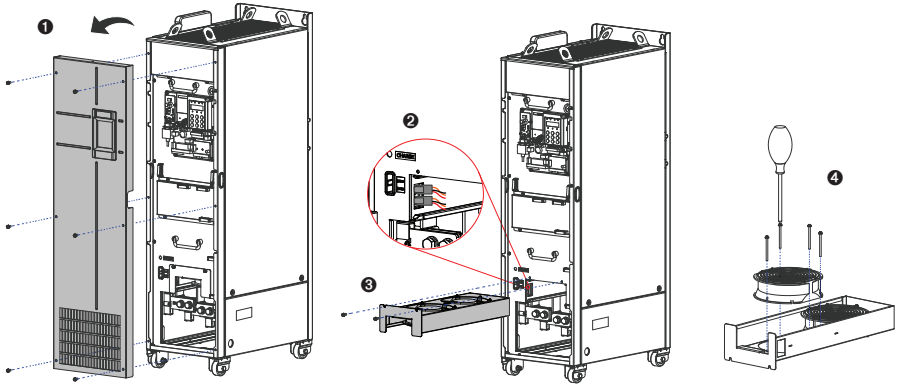

(1) Disconnect the fan cable from the drive (top view).

(2) Remove the four screws from the drive.

(3) Remove the fan and fan cover from the drive.

Install the fan (RSI-PPFP-0300-4-3-X-IP00-IM to RSI-PPFP-0700-4-3-X-IP00-IM)

- (1) Install the fan in reverse order. Pay attention to the correct air flow direction.
- (2) Align the fan box to the rail and push it into the drive.
- (3) Connect the fan power cable connectors first before fixing the fan cover. After replacement is complete, check that the air flow direction is upright.

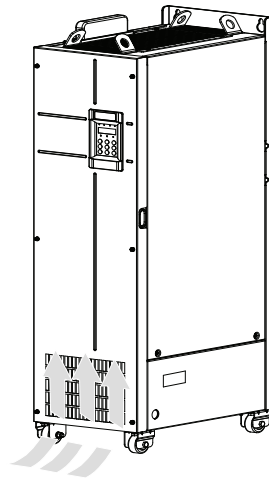

9.3.4 DC Bus Electrolytic Capacitors

1. Possible causes of damage: input power supply in poor quality; high ambient temperature; frequent load jumping; and electrolytic aging.
2. Replacement determination criteria: Whether there is liquid leakage; whether the sage valve has projected; measure the static capacitance; and measure the insulation resistance.

3. Replacement of Electrolytic Capacitor: Replacement of electrolytic capacitors by users is not advised. Please contact the factory for capacitor replacement.

9.4 STORAGE

For storage of the AC drive, pay attention to the following:

1. Pack the AC drive with the original packing box provided by Benshaw.
2. Do not expose the AC drive to moisture, high temperature or outdoor direct sunlight for an extended period.

3. The electrolytic capacitor will deteriorate after being stored for an extended period. Thus, the AC drive must be turned on once every 6 months, each time for at least 5 hours. Be sure to increase the input voltage gradually to rated value by using a voltage regulator.

9.5 WARRANTY

Free warranty only applies to the AC drive itself. Benshaw will provide a 24-month warranty from date of manufacture for failure or damage under normal use conditions. If the equipment has been used for more than 24 months, reasonable repair expenses will be charged. A reasonable repair fee will be charged for damages that occur within 24 months due to the following causes:

1. Improper operation without following the instructions.
2. Fire, flood or abnormal voltage.

3. Using the AC drive for non-recommended functions.

4. Using the AC drive without following the specifications.

5. Damage caused by force majeure, such as natural disaster, earthquake or lightning strike. The maintenance fee is charged according to Benshaw's uniform standard. If there is an agreement, the agreement prevails.

For warranty details, refer to warranty terms and conditions.

APPENDIX A

OPTIONS AND ACCESSORIES

A.1 BRAKING RESISTORS AND UNITS

A.1.1 Selection of Resistance of Braking Resistor

The AC drive transfers regenerative energy generated during braking of motor to an external braking resistor, according to formula $R = V_{dc} \times V_{dc} / P_b$.

- V_{dc} refers to braking voltage at system stable braking. (Its value varies with the system. The default braking voltage of the Benschaw PowerPro™ Fan and Pump Single AC Drive is 760 V. You can set F9-08 to change the value.)
- P_b refers to braking power

A.1.2 Selection of Power of Braking Resistor

In theory, power of braking resistor is the same as braking power. But in consideration of de-rating, power of braking resistor is calculated from the following formula: $P_r = P_b \times D / K$

- K is about 50%.
- P_r refers to power of braking resistor.
- D refers to braking frequency (Duty Cycle).



K is de-rating coefficient of braking resistor. Low K value can ensure that braking resistor does not get over-heated. The K value can be increased appropriately on the condition of good dissipation and should not exceed 50%. Failure to comply may result in a fire due to overheating of braking resistor.

Braking frequency (D) is determined by application. Typical values of braking frequency in different applications are listed in Table A-1-2.

Table A-1-2 Typical values of braking frequency in different applications

Application	Elevator	Winding & Unwinding	Centrifuge	Occasional Braking Load	General Application
Braking Frequency (Duty Cycle)	20% to 30%	20% to 30%	50% to 60%	5%	10%

A.1.3 Selection Guidance for Braking Units

Table A-2 Selection Guidance for Braking Units

Model Number	Applicable Motor (HP)	Braking Unit		125% Braking Torque (10% D, Max. 10s)		Remark	Min. Resistance of Braking Resistor (Ω)
		Model	Qty.	Specification	Qty.		
RSI-PPFP-0001-4-3-B-IP20-IM	0.5	Built-in	—	80W 1450 Ω	1	AC drive model ending with letter "B"	96
RSI-PPFP-01H5-4-3-B-IP20-IM	1			140W 800 Ω	1		96
RSI-PPFP-0002-4-3-B-IP20-IM	1.5			220W 500 Ω	1		96
RSI-PPFP-0003-4-3-B-IP20-IM	2			300W 380 Ω	1		64
RSI-PPFP-0005-4-3-B-IP20-IM	4			600W 190 Ω	1		32
RSI-PPFP-07H5-4-3-B-IP20-IM	5			740W 150 Ω	1		32
RSI-PPFP-0010-4-3-B-IP20-IM	7.5			1100W 100 Ω	1		32
RSI-PPFP-0015-4-3-B-IP20-IM	10			1500W 75 Ω	1		32
RSI-PPFP-0020-4-3-B-IP20-IM	15			2200W 50 Ω	1		20
RSI-PPFP-0025-4-3-B-IP20-IM	20			3000W 38 Ω	1		20
RSI-PPFP-0030-4-3-B-IP20-IM	25	Built-in	—	4000W 32 Ω	1	24	
RSI-PPFP-0040-4-3-B-IP20-IM	30			4500W 27 Ω	1	24	
RSI-PPFP-0050-4-3-B-IP20-IM	40			6000W 20 Ω	1	19.2	
RSI-PPFP-0060-4-3-B-IP20-IM	50			7000W 16 Ω	1	14.8	
RSI-PPFP-0075-4-3-B-XN01-IM	60			9000W 13 Ω	1	12.8	
RSI-PPFP-0100-4-3-B-XN01-IM	75			11000W 10.5 Ω	1	9.6	
RSI-PPFP-0125-4-3-B-XN01-IM	100			15000W 7.7 Ω	1	6.8	

Table A-2 Selection Guidance for Braking Units (continued)

Model Number	Applicable Motor (HP)	Braking Unit		125% Braking Torque (10% D, Max. 10s)		Remark	Min. Resistance of Braking Resistor (Ω)
		Model	Qty.	Specification	Qty.		
RSI-PPFP-0150-4-3-X-XN01-IM	125	RSI-PPVC-AXRY-DBRK-200	2	9000W 10.0 Ω	2	Input voltage \leq 440 VAC	9.3 \times 2
RSI-PPFP-0200-4-3-X-XN01-IM	175	RSI-PPVC-AXRY-DBRK-200	2	13000W 6.8 Ω	2	Input voltage \leq 440 VAC	6.2 \times 2
RSI-PPFP-0250-4-3-X-IP00-IM	200	RSI-PPVC-AXRY-DBRK-200	2	16000W 6.3 Ω	2	Input voltage \leq 440 VAC	6.2 \times 2
RSI-PPFP-0300-4-3-X-IP00-IM	250	RSI-PPVC-AXRY-DBRK-0200	2	19000W 4.5 Ω	2	Input voltage \leq 440 VAC	2.5 \times 2
	250	RSI-PPVC-AXRY-DBRK-200	2	19000W 5.8 Ω	2	Input voltage $>$ 440 VAC	3.0 \times 2
RSI-PPFP-0350-4-3-X-IP00-IM	300	RSI-PPVC-AXRY-DBRK-0200	2	21000W 4.1 Ω	2	Input voltage \leq 440 VAC	2.5 \times 2
	300	RSI-PPVC-AXRY-DBRK-200	2	21000W 5.3 Ω	2	Input voltage $>$ 440 VAC	3.0 \times 2
RSI-PPFP-0400-4-3-X-IP00-IM	350	RSI-PPVC-AXRY-DBRK-0200	2	24000W 3.6 Ω	2	Input voltage \leq 440 VAC	2.5 \times 2
	350	RSI-PPVC-AXRY-DBRK-200	2	24000W 4.6 Ω	2	Input voltage $>$ 440 VAC	3.0 \times 2
RSI-PPFP-0450-4-3-X-IP00-IM	375	RSI-PPVC-AXRY-DBRK-0200	2	27000W 3.2 Ω	2	Input voltage \leq 440 VAC	2.5 \times 2
	375	RSI-PPVC-AXRY-DBRK-200	2	27000W 4.1 Ω	2	Input voltage $>$ 440 VAC	3.0 \times 2
RSI-PPFP-0500-4-3-X-IP00-IM	400	RSI-PPVC-AXRY-DBRK-0200	3	20000W 4.3 Ω	3	Input voltage \leq 440 VAC	2.5 \times 3
	400	RSI-PPVC-AXRY-DBRK-200	3	20000W 5.5 Ω	3	Input voltage $>$ 440 VAC	3.0 \times 3
RSI-PPFP-0600-4-3-X-IP00-IM	450	RSI-PPVC-AXRY-DBRK-0200	3	23000W 3.8 Ω	3	Input voltage \leq 440 VAC	2.5 \times 3
	450	RSI-PPVC-AXRY-DBRK-200	3	23000W 4.9 Ω	3	Input voltage $>$ 440 VAC	3.0 \times 3
RSI-PPFP-0700-4-3-X-IP00-IM	500	RSI-PPVC-AXRY-DBRK-0200	3	26000W 3.4 Ω	3	Input voltage \leq 440 VAC	2.5 \times 3
	500	RSI-PPVC-AXRY-DBRK-200	3	26000W 4.3 Ω	3	Input voltage $>$ 440 VAC	3.0 \times 3

Notes: Minimum resistance supports operating condition with D of 10% and longest time for single braking of 10s.

Default initial braking voltage for built-in brake units (IGBT) is 760 V.

The preceding table is for reference only. You can select resistance and power of braking resistor based on actual needs. Resistance must not be lower than the reference value. Power may be higher than the reference value. Selection of braking resistor model is determined by horse-power of motor and is also related to system inertia, deceleration time and potential energy load. For systems with high inertia, and/or short deceleration time, and/or frequent braking, select a braking resistor with higher power and lower resistance value.

APPENDIX A

A.1.4 Appearance and Mounting Dimensions of Braking Units

1. Mounting Dimensions of Braking Unit (mm)

RSI-PPVC-AXRY-DBRK-200

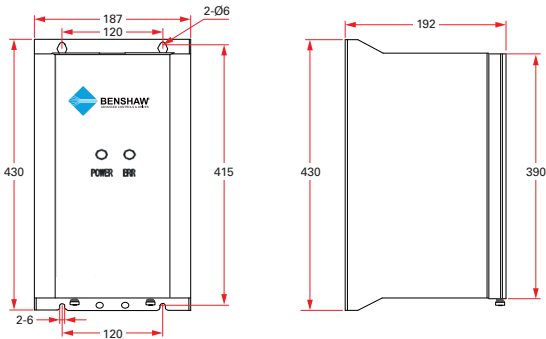

Figure A-2-1a Mounting dimensions of braking unit (mm)

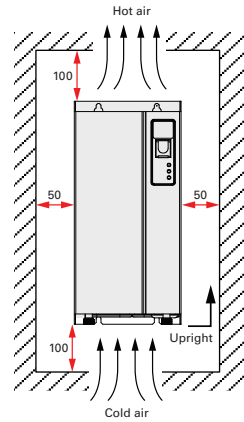

Figure A-2-1b Mounting clearance of braking unit (mm)

Notes: For use and installation of braking unit, refer to the Braking Unit User Guide.

A.2 THROUGH-HOLE MOUNTING OF BENSCHAW POWERPRO™ FAN AND PUMP AC DRIVE

1. Through-Hole Mounting

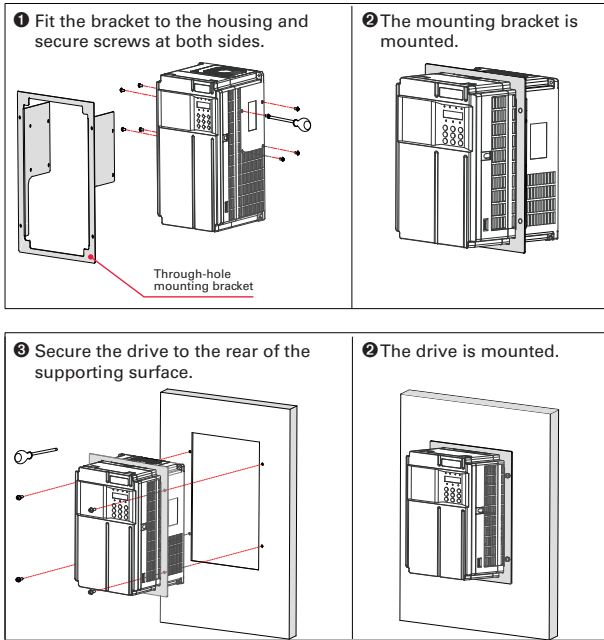

Figure A-2-2a Through-hole mounting of RSI-PPFP-0001-4-3-B-IP20-IM to RSI-PPFP-0060-4-3-B-IP20-IM

APPENDIX A

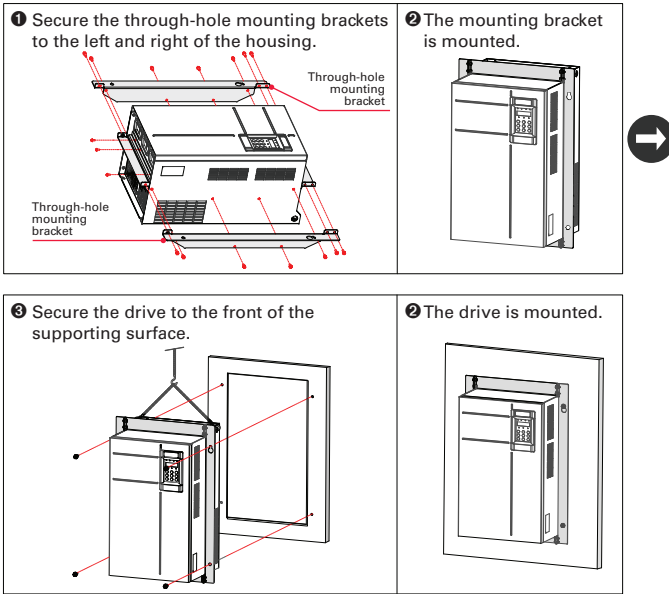

Figure A-2-2b Through-hole mounting of RSI-PPFP-0075-4-3-B-XN01-IM to RSI-PPFP-0250-4-3-X-IP00-IM

2. Through-Hole Mounting Models

Table A-2-2 Through-hole mounting models

Through-Hole Mounting Model	Applicable AC Drive Model	Through-Hole Mounting Model	Applicable AC Drive Model
RSI-PPVC-AXRY-FLNG-FRF	RSI-PPFP-0001-4-3-B-IP20-IM RSI-PPFP-01H5-4-3-B-IP20-IM RSI-PPFP-0002-4-3-B-IP20-IM	RSI-PPVC-AXRY-FLNG-FRA	RSI-PPFP-0030-4-3-B-IP20-IM RSI-PPFP-0040-4-3-B-IP20-IM
RSI-PPVC-AXRY-FLNG-FRG	RSI-PPFP-0003-4-3-B-IP20-IM RSI-PPFP-0005-4-3-B-IP20-IM	RSI-PPVC-AXRY-FLNG-FRB	RSI-PPFP-0050-4-3-B-IP20-IM RSI-PPFP-0060-4-3-B-IP20-IM
RSI-PPVC-AXRY-FLNG-FRH	RSI-PPFP-07H5-4-3-B-IP20-IM RSI-PPFP-0010-4-3-B-IP20-IM	RSI-PPVC-AXRY-FLNG-FRD	RSI-PPFP-0075-4-3-B-XN01-IM RSI-PPFP-0100-4-3-B-XN01-IM
RSI-PPVC-AXRY-FLNG-FRI	RSI-PPFP-0015-4-3-B-IP20-IM RSI-PPFP-0020-4-3-B-IP20-IM	RSI-PPVC-AXRY-FLNG-FRE	RSI-PPFP-0125-4-3-B-XN01-IM RSI-PPFP-0150-4-3-X-XN01-IM
	RSI-PPFP-0025-4-3-B-IP20-IM		RSI-PPFP-0200-4-3-X-XN01-IM RSI-PPFP-0250-4-3-X-IP00-IM

Note: For details about appearance and dimensions of through-hole mounting brackets, refer to Section A.3.

A.3 OVERALL DIMENSIONS WITH OPTIONAL THROUGH-HOLE MOUNTING BRACKET

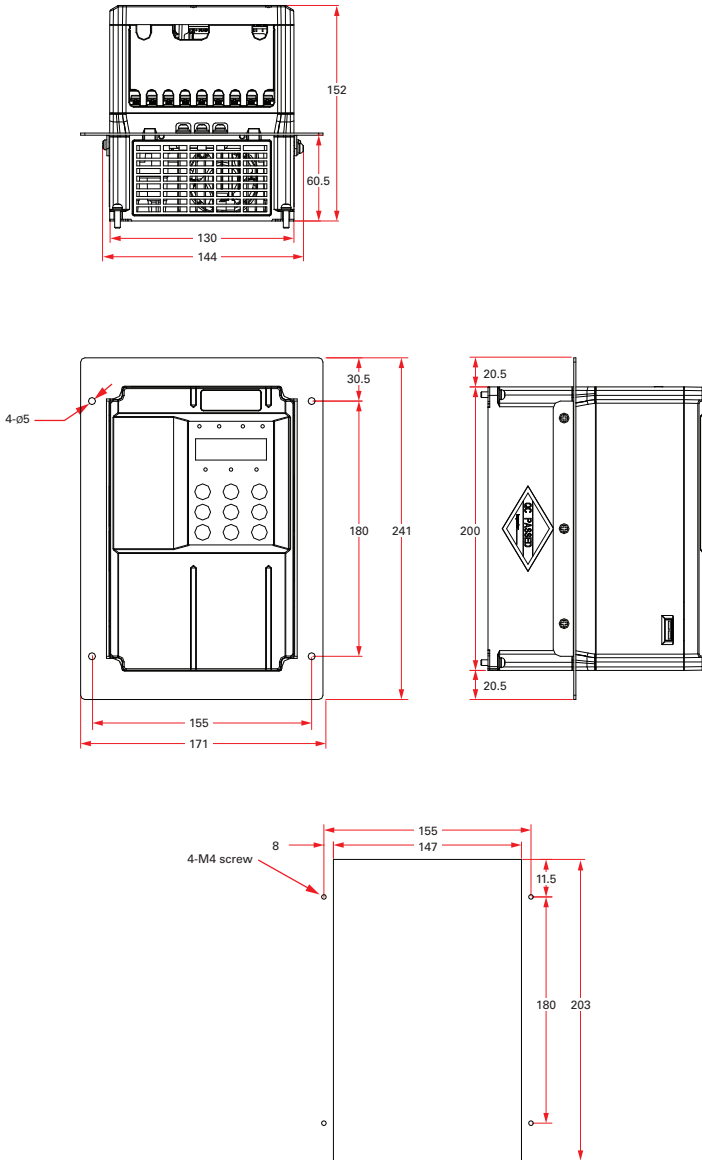

Figure A-2-3a Dimensions of through-hole mounting bracket and hole of RSI-PPFP-0001-4-3-B-IP20-IM to RSI-PPFP-0005-4-3-B-IP20-IM

APPENDIX A

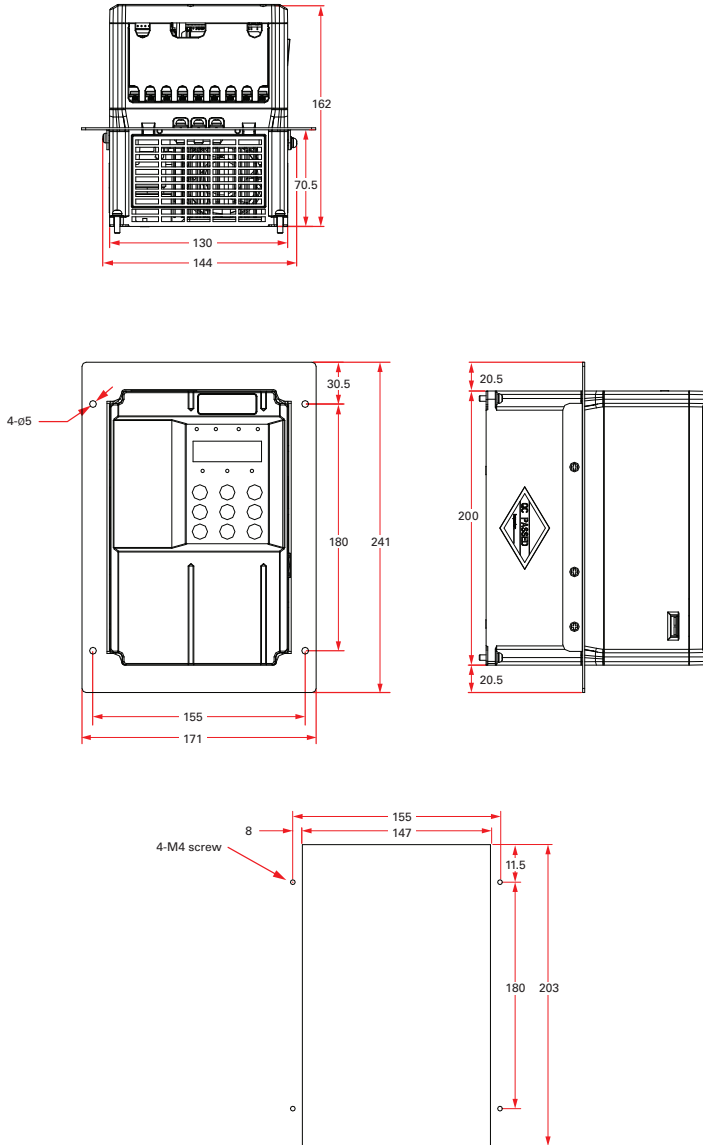

Figure A-2-3b Dimensions of through-hole mounting bracket and hole of RSI-PPFP-07H5-4-3-B-IP20-IM to RSI-PPFP-0010-4-3-B-IP20-IM

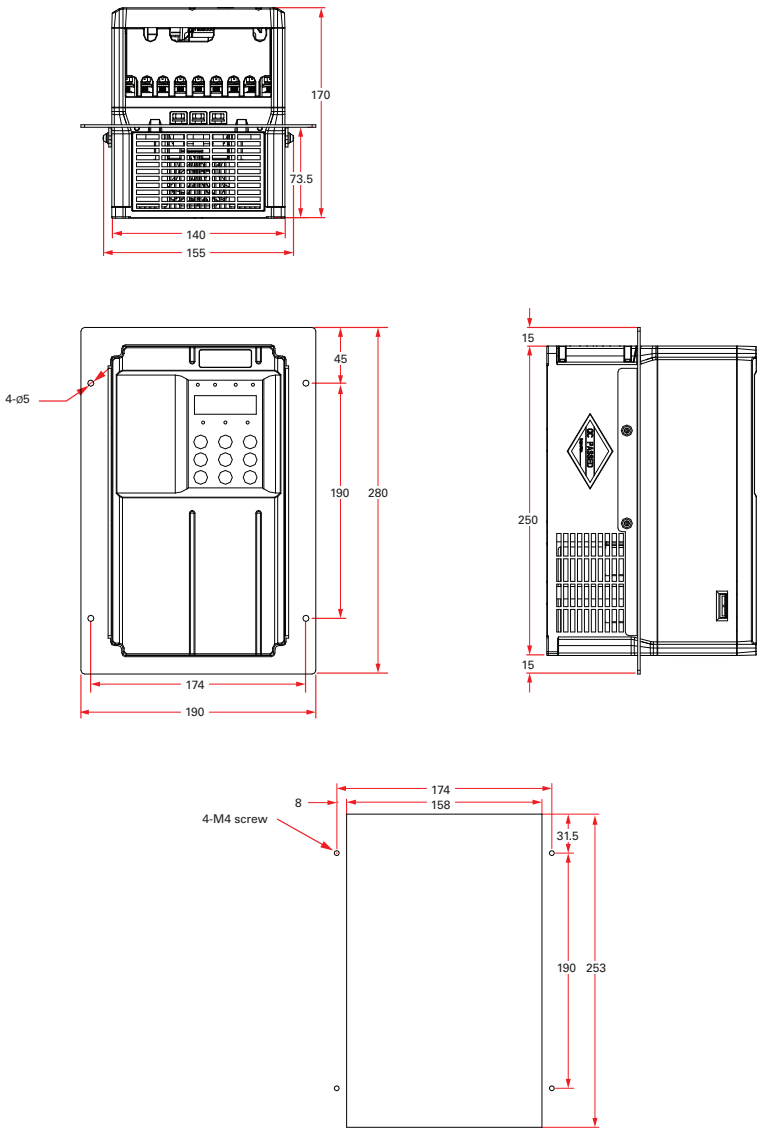

Figure A-2-3c Dimensions of through-hole mounting bracket and hole of RSI-PPFP-0015-4-3-B-IP20-IM to RSI-PPFP-0020-4-3-B-IP20-IM

APPENDIX A

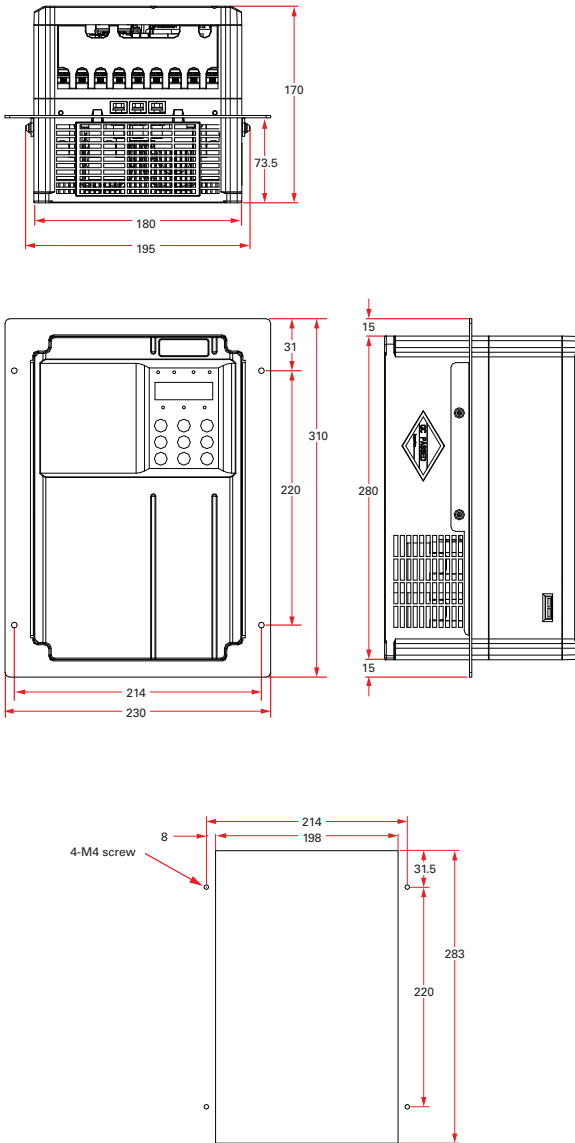

Figure A-2-3d Dimensions of through-hole mounting bracket and hole of RSI-PPFP-0025-4-3-B-IP20-IM

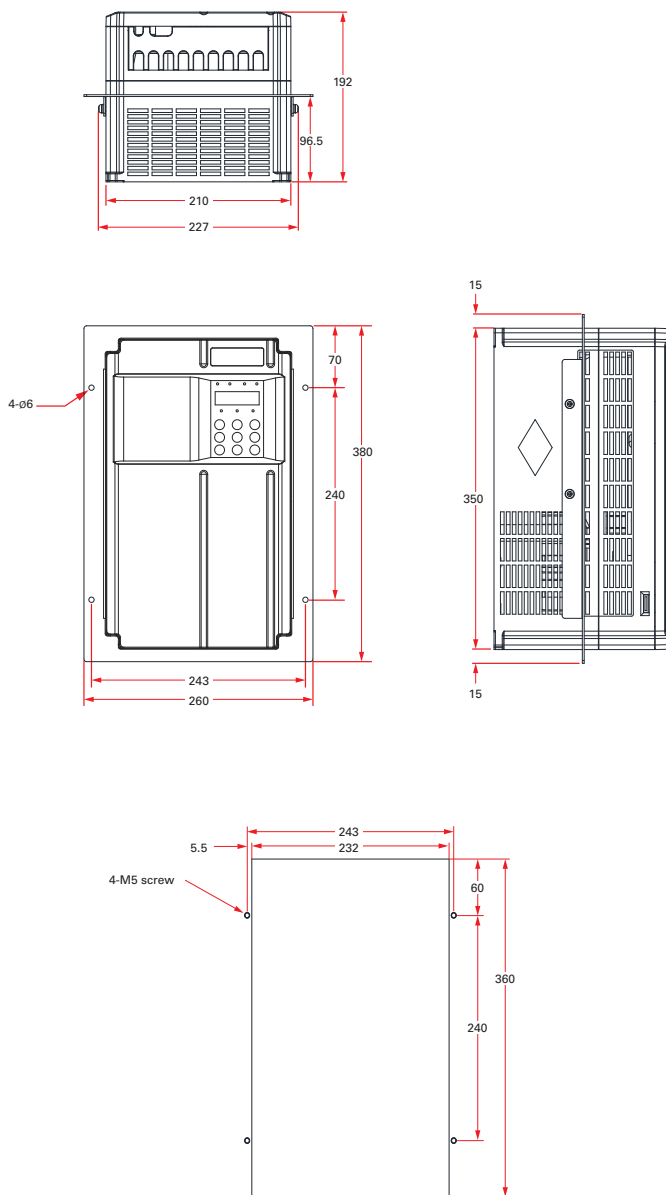

Figure A-2-3e Dimensions of through-hole mounting bracket and hole of RSI-PPFP-0030-4-3-B-IP20-IM to RSI-PPFP-0040-4-3-B-IP20-IM

APPENDIX A

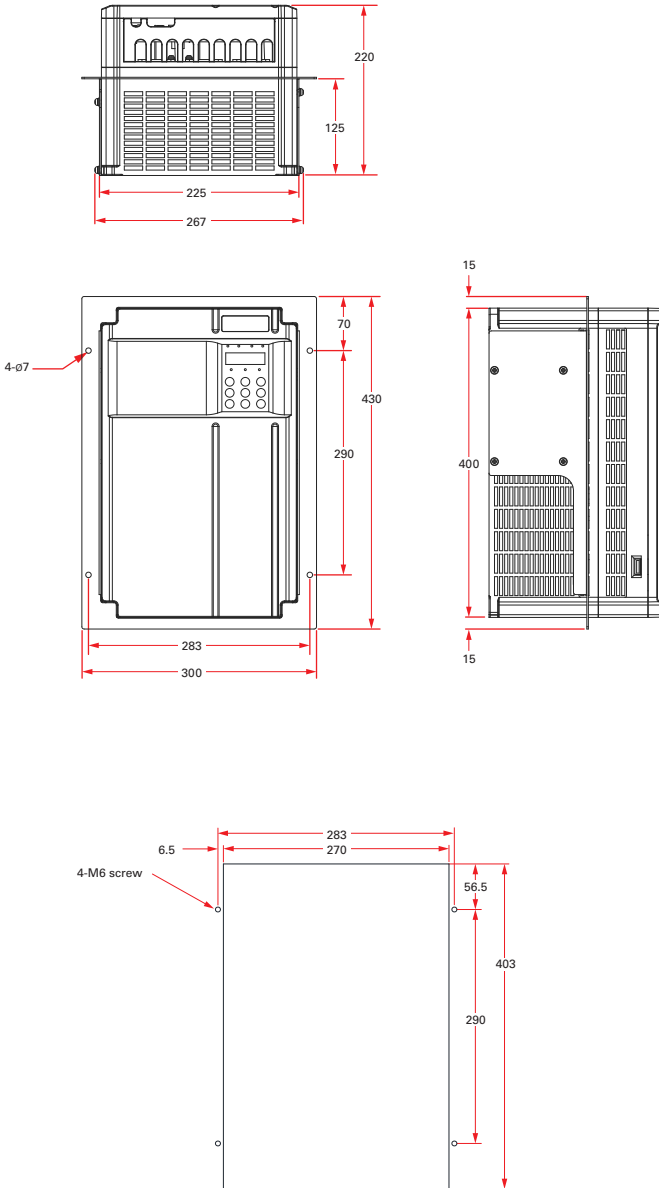

Figure A-2-3f Dimensions of through-hole mounting bracket and hole of RSI-PPFP-0050-4-3-B-IP20-IM to RSI-PPFP-0060-4-3-B-IP20-IM

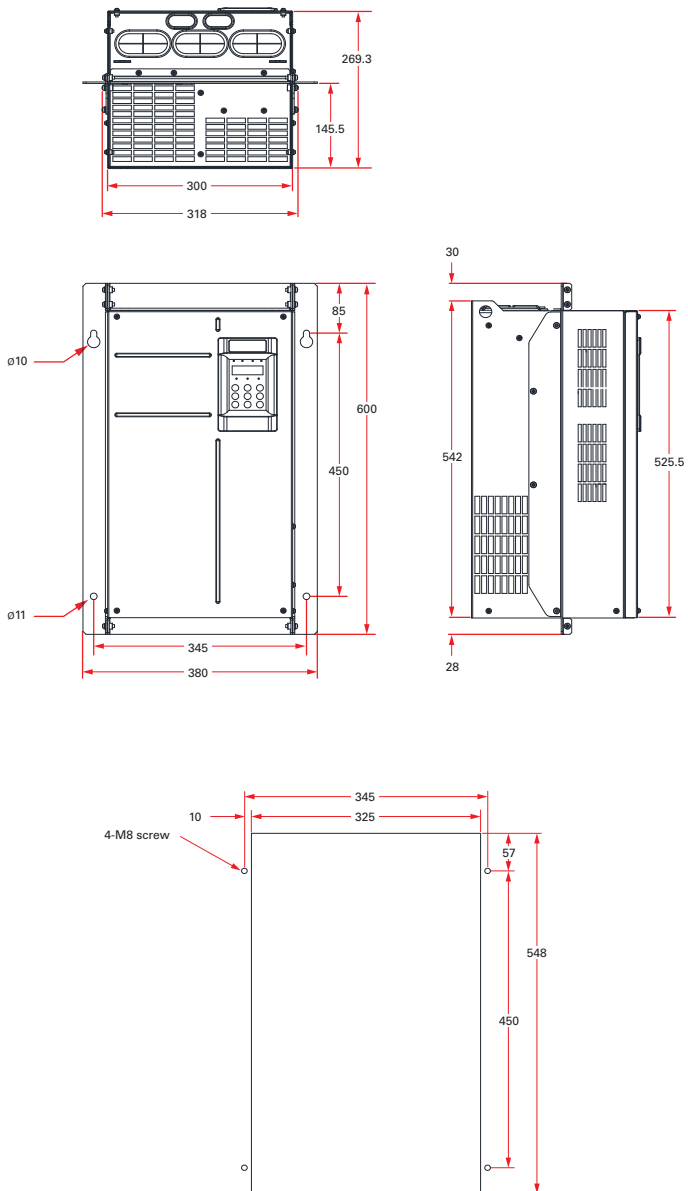

Figure A-2-3g Dimensions of through-hole mounting bracket and hole of RSI-PPFP-0075-4-3-B-XN01-IM to RSI-PPFP-0100-4-3-B-XN01-IM

APPENDIX A

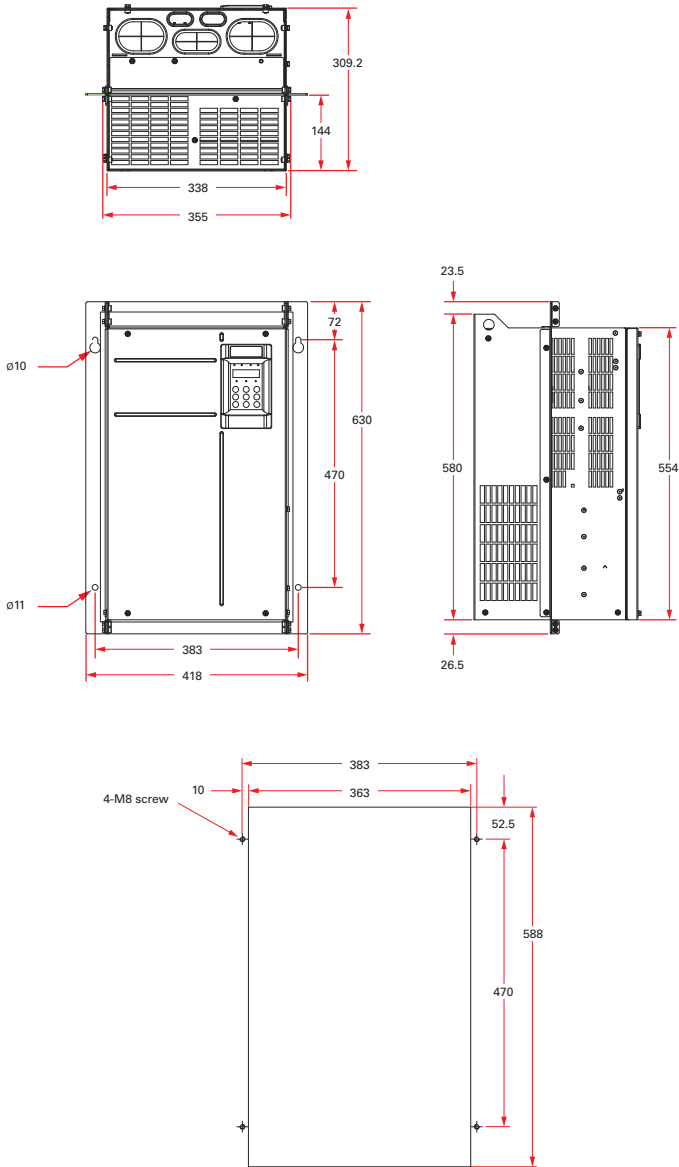

Figure A-2-3h Dimensions of through-hole mounting bracket and hole of RSI-PPFP-0125-4-3-B-XN01-IM to RSI-PPFP-0175-4-3-X-XN01-IM

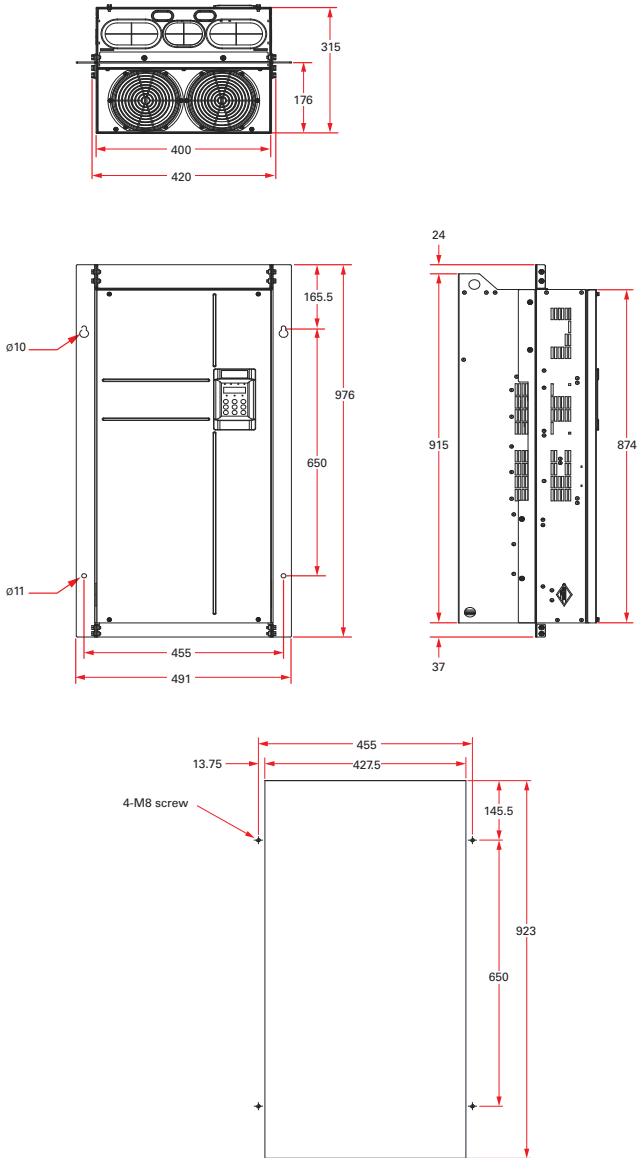

Figure A-2-3i Dimensions of through-hole mounting bracket and hole of RSI-PPFP-0200-4-3-X-XN01-IM to RSI-PPFP-0250-4-3-X-IP00-IM

APPENDIX A

A.4 CABLE SUPPORT BRACKET

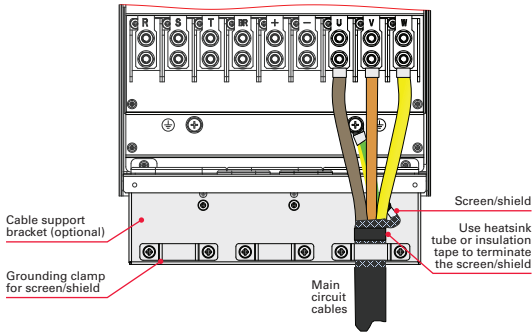

Figure A-3a Cable Support Bracket

The cable support bracket in Figure A-3a is an optional accessory. Installation of the bracket is shown below.

- (1) Remove the cover.
- (2) Unscrew two M4*12 screws on the inlet plate.
- (3) Install the cable support bracket the drive, and secure it to the position with three M4*12 screws.
- (4) Secure the two support bracket positions with two M4*12 screws.
- (5) Install the cover.

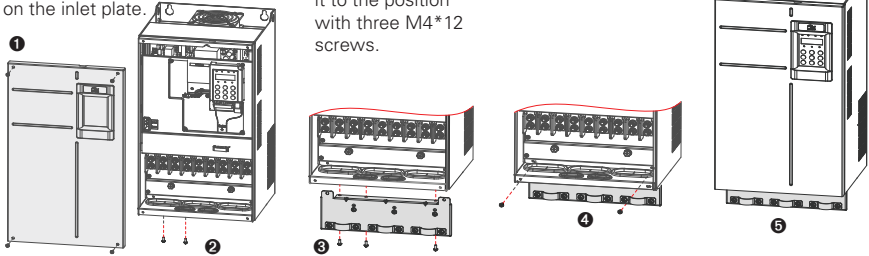

Figure A-3b Installation of cable support bracket

Table A-3 Cable support bracket models

Cable Support Bracket Model	Applicable AC Drive Model	Cable Support Bracket Model	Applicable AC Drive Model
RSI-PPVC-AXRY-RAILCBLCLM-T1	RSI-PPFP-0001-4-3-B-IP20-IM RSI-PPFP-01H5-4-3-B-IP20-IM	RSI-PPVC-AXRY-RAILCBLCLM-T5	RSI-PPFP-0030-4-3-B-IP20-IM RSI-PPFP-0040-4-3-B-IP20-IM
	RSI-PPFP-0002-4-3-B-IP20-IM RSI-PPFP-0003-4-3-B-IP20-IM RSI-PPFP-0005-4-3-B-IP20-IM	RSI-PPVC-AXRY-RAILCBLCLM-T6	RSI-PPFP-0050-4-3-B-IP20-IM RSI-PPFP-0060-4-3-B-IP20-IM
RSI-PPVC-AXRY-RAILCBLCLM-T2	RSI-PPFP-07H5-4-3-B-IP20-IM RSI-PPFP-0010-4-3-B-IP20-IM	RSI-PPVC-AXRY-RAILCBLCLM-T7	RSI-PPFP-0075-4-3-B-XN01-IM RSI-PPFP-0100-4-3-B-XN01-IM
RSI-PPVC-AXRY-RAILCBLCLM-T3	RSI-PPFP-0015-4-3-B-IP20-IM RSI-PPFP-0020-4-3-B-IP20-IM	RSI-PPVC-AXRY-RAILCBLCLM-T8	RSI-PPFP-0125-4-3-B-XN01-IM RSI-PPFP-0150-4-3-X-XN01-IM
RSI-PPVC-AXRY-RAILCBLCLM-T4	RSI-PPFP-0025-4-3-B-IP20-IM	RSI-PPVC-AXRY-RAILCBLCLM-T9	RSI-PPFP-0200-4-3-X-XN01-IM RSI-PPFP-0250-4-3-X-IP00-IM

A.5 AC OUTPUT REACTOR

The decision to install an AC output reactor on power output side depends on actual situation. The cable connecting the drive and motor should not be any longer than the value in Table A-4.

Long cable lengths cause increased capacitance and high harmonic currents resulting in drive over current trips. To minimize these problems, install an output reactor.

Table A-4 Cable length limit

AC Drive Power HP (kW)	Rated Voltage (V)	Cable Length Limit (m)	AC Drive Power HP (kW)	Rated Voltage (V)	Cable Length Limit (m)
0.5 to 5 (0.4 to 4)	200 to 500	164 (50)	20 (15)	200 to 500	410 (125)
7.5 (5.5)	200 to 500	229 (70)	25 (18.5)	200 to 500	442 (135)
10 (7.5)	200 to 500	328 (100)	≥ 30 (22)	200 to 500	492 (150)
15 (11)	200 to 500	360 (110)			

Note: Contact Benschaw for assistance in sizing the correct reactor for the drive.

A.6 APPLICABLE MOTOR

1. A four-pole squirrel-cage asynchronous induction motor is the standard motor. For non-standard motors, select an AC drive based on motor rated current. Refer to Table 3.1a, Technical Specifications for drive sizing.

2. In standard induction motors, the cooling fan is connected to the rotor shaft; therefore, the cooling effect is reduced at slower speeds and the motor may overheat. Consider using a separate cooling fan or use an inverter duty rated motor.

3. The AC drive provides standard motor parameter settings. Set the actual motor nameplate settings with parameters F1-00 through F1-05. Otherwise, the motor performance or drive protection may be affected.

4. A short circuit in the motor or the cables may damage the drive. It is recommended to perform a hi-pot or megger test after installation. Disconnect the drive during the testing.

Table A-5 Applicable motors

Model Number	Power Capacity (kVA)	Input Current (A)	Output Current (A)	Applicable Motor	
				(kW)	(HP)
Three-phase, 480V, 50–60 Hz					
RSI-PPFP-0001-4-3-B-IP20-IM	2	1.8	1.5	0.4	0.5
RSI-PPFP-01H5-4-3-B-IP20-IM	2.8	2.4	2.1	0.75	1
RSI-PPFP-0002-4-3-B-IP20-IM	4.1	3.7	3.1	1.1	1.5
RSI-PPFP-0003-4-3-B-IP20-IM	5	4.6	3.7	1.5	2
RSI-PPFP-0005-4-3-B-IP20-IM	9.5	9.0	7.1	3	4
RSI-PPFP-07H5-4-3-B-IP20-IM	12	11.4	8.9	3.7	5
RSI-PPFP-0010-4-3-B-IP20-IM	17.5	16.7	12.8	5.5	7.5
RSI-PPFP-0015-4-3-B-IP20-IM	22.8	21.9	16.8	7.5	10
RSI-PPFP-0020-4-3-B-IP20-IM	33.4	32.2	24.7	11	15
RSI-PPFP-0025-4-3-B-IP20-IM	42.8	41.3	31.6	15	20
RSI-PPFP-0030-4-3-B-IP20-IM	45	49.5	36.5	18.5	25
RSI-PPFP-0040-4-3-B-IP20-IM	54	59	44.4	22	30
RSI-PPFP-0050-4-3-B-IP20-IM	52	57	59.2	30	40
RSI-PPFP-0060-4-3-B-IP20-IM	63	69	74.0	37	50
RSI-PPFP-0075-4-3-B-XN01-IM	81	89	89.8	45	60
RSI-PPFP-0100-4-3-B-XN01-IM	97	106	110.5	55	75
RSI-PPFP-0125-4-3-B-XN01-IM	127	139	148.0	75	100
RSI-PPFP-0150-4-3-X-XN01-IM	150	164	173.6	90	125
RSI-PPFP-0200-4-3-X-XN01-IM	220	240	249.6	132	180
RSI-PPFP-0250-4-3-X-IP00-IM	263	287	299.9	160	220
RSI-PPFP-0300-4-3-X-IP00-IM	334	365	371.9	200	275
RSI-PPFP-0350-4-3-X-IP00-IM	375	410	420.2	220	300
RSI-PPFP-0400-4-3-X-IP00-IM	404	441	458.7	250	340
RSI-PPFP-0450-4-3-X-IP00-IM	453	495	512.9	280	380
RSI-PPFP-0500-4-3-X-IP00-IM	517	565	577.0	315	430
RSI-PPFP-0600-4-3-X-IP00-IM	565	617	641.2	355	485
RSI-PPFP-0700-4-3-X-IP00-IM	629	687	715.1	400	545

A.7 EXTERNAL LCD OPERATING PANEL

External LCD operating panel RSI-PPVC-AXRY-RMKP-LCD (optional) allows you to copy, download and modify parameters conveniently. The following figures show its appearance and keys.

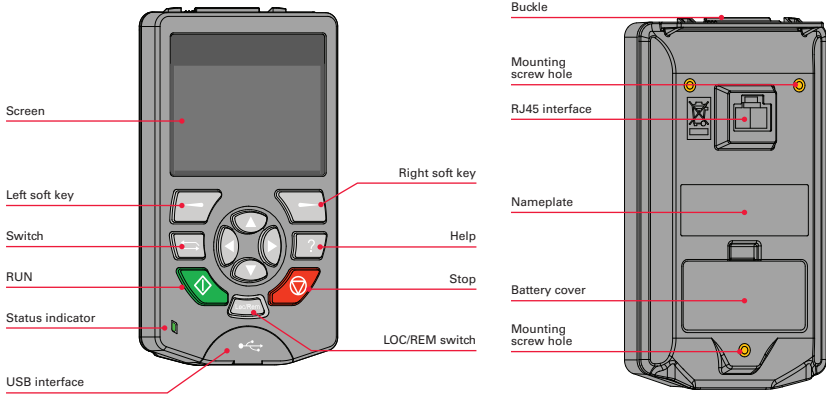

Figure A-6a Appearance of the external LCD operating panel (RSI-PPVC-AXRY-RMKP-LCD)

Note: External LCD operating panel RSI-PPVC-AXRY-RMKP-LCD supports English language.

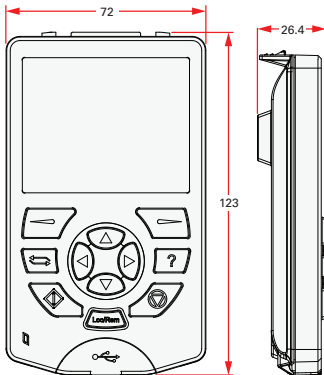

Figure A-6b Mounting dimensions

Note: The mounting base (bezel) for the external LCD operating panel is RSI-PPVC-AXRY-RMKP-MNT.

APPENDIX B

OPTIONAL EXPANSION CARDS AND MODBUS COMMUNICATION PROTOCOL

The Benschaw PowerPro™ Fan and Pump Single AC Drive supports abundant field buses and custom programming via connection with the optional expansion cards.

This chapter introduces the optional card installation guideline for PG cards, function extension cards and extension communication cards.

B.1 OPTIONAL EXPANSION CARD INSTALLATION AND FUNCTION GUIDELINES

B.1.1 Installation

The Benschaw PowerPro™ Fan and Pump Single AC Drive supports two types of I/O cards, one type of PC programming card and four types of field bus cards (Modbus-RTU, Profibus-DP2, CANLink, CANOpen). Refer to section 5.1 for cover removal before installation.

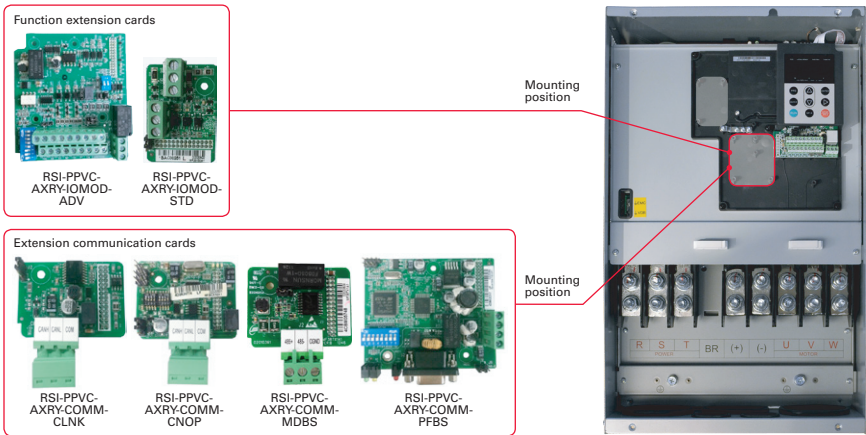

Figure B-1-1 Mounting positions of extension cards

APPENDIX B

B.1.2 Functions

Table B-1-2 Functions of extension cards

Model	Name	Function	Frequency Dividing Coefficient	Applicable Model
RSI-PPVC-AXRY-IOMOD-ADV	Multi-functional I/O extension card	Provides the following: Five extra DI terminals, an analog input, a relay output, a digital output, an analog output; supports Modbus-RTU, supports CANlink	—	Available for models of 20 HP or above
RSI-PPVC-AXRY-IOMOD-STD	Mini-I/O extension card	Provides three extra DI terminals.	—	Available for all models
RSI-PPVC-AXRY-COMM-CLNK	CANlink communication card	Supports CANlink	—	Available for all models
RSI-PPVC-AXRY-COMM-CNOP	CANopen communication card	Supports CANopen	—	Available for all models
RSI-PPVC-AXRY-COMM-MDBS	RS-485 communication extension card	Supports Modbus-RTU	—	Available for all models
RSI-PPVC-AXRY-COMM-PFBS	Profibus-DP2 communication card	Supports Profibus-DP2	—	Available for models of 20 HP or above

B.2 LAYOUT AND FUNCTION OF TERMINALS OF RS485 CARD (RSI-PPVC-AXRY-COMM-MDBS)

RSI-PPVC-AXRY-COMM-MDBS is specially designed to provide the drive with RS485 communication function. It adopts isolation scheme and electrical parameters conforming to international standards. It helps to implement control of drive operation and parameter setting through remote serial interface.

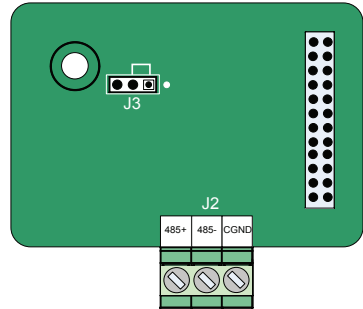

Figure B-2 Layout of RSI-PPVC-AXRY-COMM-MDBS terminals

Table B-2a Terminal descriptions of RSI-PPVC-AXRY-COMM-MDBS

Terminal	Terminal Name	Function Description	Terminal Arrangement
J2	485+	RS485 positive input	
	485-	RS485 negative input	
	CGND	RS485 Power ground	
		Isolated power	

Table B-2b Jumper descriptions of RSI-PPVC-AXRY-COMM-MDBS

Terminal	Terminal Name	Function Description	Jumper
J3	RS485 terminal resistor matching selection	Matching terminal resistor	
		Not matching terminal resistor	

Note: Setting of jumpers shown with main terminals at the bottom of the card. Jumpers are silk-screened on the card.

APPENDIX B

B.3 LAYOUT AND FUNCTION OF TERMINALS OF EXTENDED I/O AND COMMUNICATIONS CARD (RSI-PPVC-AXRY-IOMOD-ADV)

RSI-PPVC-AXRY-IOMOD-ADV is a multifunctional I/O extension card designed for Benschaw AC drives. It has five digital input (DI) terminals, an analog input (AI) terminal, a relay output terminal, a digital output (DO) terminal and an analog output (AO) terminal. It also has the RS485 communication interface and CAN communication interface for fieldbus control.

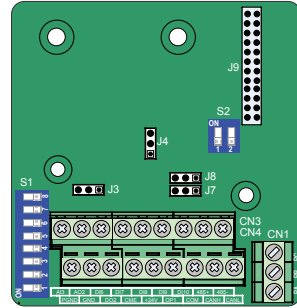
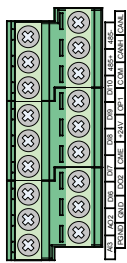
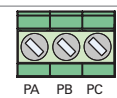
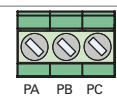











Figure B-3 Layout of RSI-PPVC-AXRY-IOMOD-ADV terminals

Table B-3a Terminal descriptions of RSI-PPVC-AXRY-IOMOD-ADV

Terminal	Terminal Name	Function Description	Terminal Arrangement
CN4	+24V/COM	External +24VDC power supply	
	OP1	Digital input power terminal	
	DO2-CME	Digital output 2	
	CANH/CANL/COM	Communication interface	
	AI3-PGND	Analog input 3	
CN3	AO2-GND	Analog output 2	
	DI6-OP1 to DI10-OP1	Five digit inputs	
	485+/485-/COM	Communication interface	
CN1	PA-PB	Normally-closed (NC) terminal	
	PA-PC	Normally-open (NO) terminal	

Note: RS485 communication terminals 485+/485-/COM and CANlink communication terminals CANH/CANL/COM are completely independent and can be used simultaneously.

Table B-3b Jumper descriptions of RSI-PPVC-AXRY-IOMOD-ADV

Terminal	Terminal Name	Function Description	Terminal Arrangement
J3	AO2 output selection: voltage or current	Voltage: 0 V to 10 V	
		Current: 0 mA to 20 mA	
J4	CAN terminal resistor matching selection	Matching terminal resistor	
		Not matching terminal resistor	
			
S2	RS485 terminal resistor matching selection	1 and 2 set to ON: matching terminal resistor	
		1 and 2 set to OFF: not matching terminal resistor	
S1	AI, PT100, PT1000 selection	AI3: 1, 2, 3 set to ON	
		PT1000: 4, 5, 6 set to ON	
		PT100: 6, 7, 8 set to ON	

Note: Setting of jumpers shown with main terminals at the bottom of the card.
Jumpers are silk-screened on the card.

APPENDIX B

B.4 LAYOUT AND FUNCTION OF TERMINALS OF EXTENDED I/O CARD-02 (RSI-PPVC-AXRY-IOMOD-STD)

The RSI-PPVC-AXRY-IOMOD-STD Extended I/O Card adds 3 digital input terminals and a 24VDC power supply for sourcing or sinking of the digital inputs.

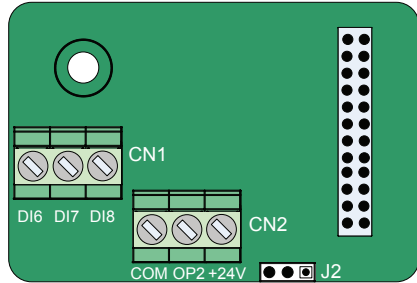

Figure B-4 Layout of RSI-PPVC-AXRY-IOMOD-STD terminals

Table B-4a Terminal descriptions of RSI-PPVC-AXRY-IOMOD-STD



Terminal	Terminal Name	Function Description	Terminal Arrangement
CN2	+24V/COM	External +24VDC power supply	 COM OP2 +24V
	OP2	Digital input power terminal	
CN1	DI6-OP2 to DI8-OP2	Three digit inputs	 DI6 DI7 DI8

Table B-4b Jumper descriptions of RSI-PPVC-AXRY-IOMOD-STD

Terminal	Terminal Name	Function Description	Jumper
J2	OP2 connecting mode selection	If DI connected in DRAIN mode, OP2 connected to +24V If DI connected in SOURCE mode, OP2 connected to COM	

Note: Setting of jumpers shown with main terminals at the bottom of the card. Jumpers are silk-screened on the card.

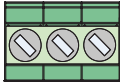
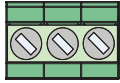
B.5 MODBUS COMMUNICATION PROTOCOL

The drive provides RS485 communication interface and supports Modbus-RTU communication protocol, so that the user can implement centralized control, such as setting running commands and function codes, and reading running status and fault information of the AC drive, by using a PC or PLC.

This protocol defines content and format of transmitted messages during serial communication, including master polling (or broadcasting) format and master coding method (function code for the action, transmission data, and error check). The slave uses the same structure in response, including action confirmation, data returning and error check. If an error occurs when the slave receives a message, or the slave cannot complete the action required by the master, the slave returns a fault message as a response to the master.

B.5.1 Application

The AC drive is connected to a “single-master multi-slave” PC/PLC control network with RS485 bus.

B.5.2 Bus Structure

1. Interface mode

The RS485 extension card RSI-PPVC-AXRY-COMM-MDBS must be inserted into the AC drive.

2. Topological structure

The system consists of a single master and multiple slaves. In the network, each communication device has a unique slave address. A device is the master (can be a PC, a PLC or an HMI) and initiates communication to perform parameter read or write operations on slaves. The other devices (slaves) provide data to respond to query or operations from the master. At the same moment, either the master or the slave transmits data and the other can only receive data.

The address range of the slaves is 1 to 247, and 0 is broadcast address. A slave address must be unique in the network.

3. Transmission mode

The asynchronous serial and half-duplex transmission mode is used. During asynchronous serial communication, data is sent frame by frame in the form of message. In Modbus-RTU protocol, an interval of at least 3.5-byte time marks the end of the previous message. A new message starts to be sent after this interval.

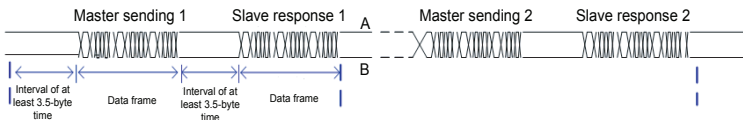

The communication protocol used by the drive is the Modbus-RTU slave communication protocol, which allows the drive to provide data to respond to “query/command” from the master or execute the action according to “query/command” from the master.

The master can be a PC, an industrial device, or a PLC. The master can communicate with a single slave or send broadcast messages to all slaves. When the master communicates with a single slave, the slave needs to return a message (response) to “query/command” from the master. For a broadcast message sent by the master, the slaves need not return a response.

APPENDIX B

B.6 DATA FORMAT

The Modbus-RTU protocol communication data format of the drive is as follows. The drive supports reading and writing of word-type parameters only. Reading command is 0x03 and writing command is 0x06. It does not support reading and writing of bytes or bits.

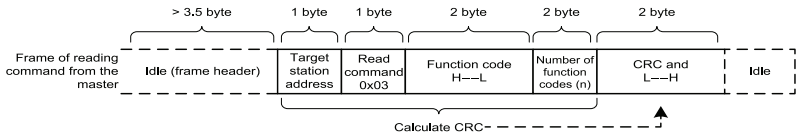

In theory, the host computer can read several consecutive parameters (n can reach up to 12) but the last parameter it reads must not jump to the next parameter group. Otherwise, an error occurs on response.

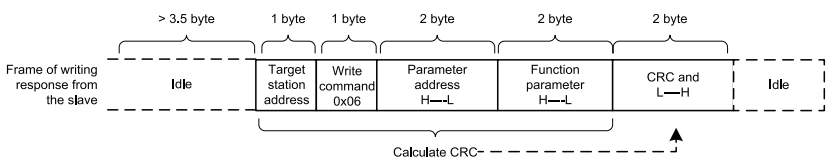
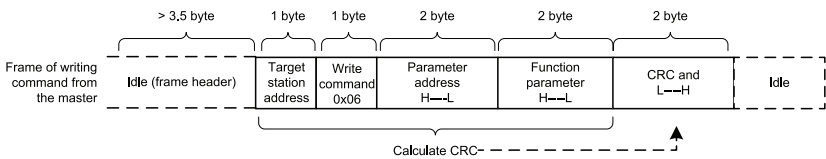
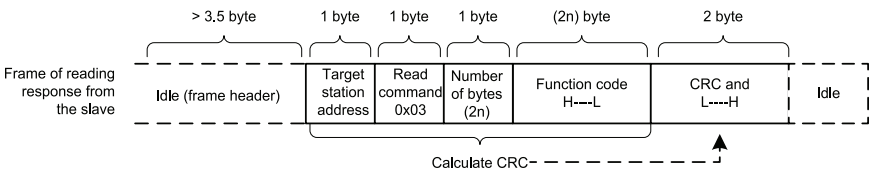

If the slave detects a reading/writing failure caused by a communication frame error or due to other reasons, an error frame will be returned.

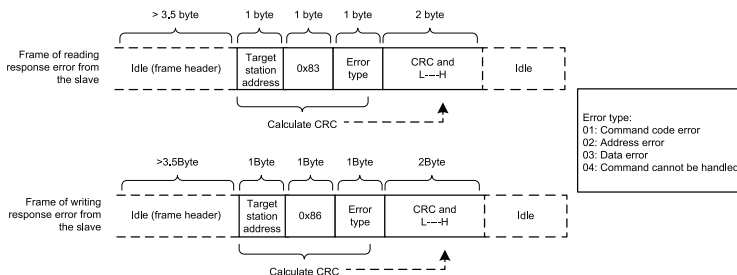

The frame format is described in the following table.

Frame header (START)	Greater than the 3.5-byte transmission idle time
Slave address (ADR)	Communication address: 1 to 247; 0: Broadcast address
Command code (CMD)	03: Read slave parameters; 06: Write slave parameters
Function code address (H)	This is the internal parameter address of the AC drive, expressed in hexadecimal format. The parameters include functional parameters and non-functional parameters (running status and running command). During transmission, low-order bytes follow the high-order bytes.
Function code address (L)	
Number of function codes (H)	This is the number of function codes read by this frame. If it is 1, it indicates that one function code is read. During transmission, low-order bytes follow the high-order bytes. In the present protocol, only one function code is read once, and this field is unavailable.
Number of function codes (L)	
Data (H)	This is the response data or data to be written. During transmission, low-order bytes follow the high-order bytes.
Data (L)	
CRC CHK low bytes	Detection value: CRC16 verification value. During transmission, low-order bytes follow the high-order bytes. For calculation method, refer to CRC Check.
CRC CHK high bytes	
END	This is 3.5-byte transmission time.

CRC Check

In Modbus-RTU mode, a message includes a CRC-based error-check field. The CRC field checks content of the entire message. The CRC field is two bytes, containing a 16-bit binary value. The CRC field is calculated by the transmitting device, and then added to the message. The receiving device recalculates a CRC value after receiving the message, and compares the calculated value with the CRC value in the received CRC field. The CRC is first stored to 0xFFFF. Then a procedure is invoked to process the successive 8-bit byte in the message and the value in the register. Only the eight bits in each character are used for the CRC. The start bit, stop bit and the parity bit do not apply to the CRC. During generation of the CRC, each eight-bit character is in exclusive-OR (XOR) with the content in the register. Then the result is shifted in the direction of the least significant bit (LSB), with a zero filled into the most significant bit (MSB) position. The LSB is extracted and examined. If the LSB was a 1, the register then performs XOR with a preset value. If the LSB was a 0, no XOR is performed. This process is repeated until eight shifts have been performed. After the last (eighth) shift, the next eight-bit byte is in XOR with the register's current value, and the process repeats for eight more shifts as described above. The final value of the register, after all the bytes of the message have been applied, is the CRC value. The CRC is added to the message from the low-order byte followed by the high-order byte. The CRC simple function is as follows.

APPENDIX B

```

unsigned int crc_chk_value(unsigned char *data_value,unsigned char length)
{
    unsigned int crc_value=0xFFFF;
    int i;
    while (length--)
    {
        crc_value^=*data_value++;
        for (i=0;i<8;i++)
        {
            if(crc_value&0x0001)
            {
                crc_value=(crc_value>>1)^0xa001;
            }
            else
            {
                crc_value=crc_value>>1;
            }
        }
    }
    return(crc_value);
}

```

Definition of Communication Parameter Addresses

Function parameters can be read and written (except those which cannot be changed because they are only for the factory use or for monitoring).

B.7 RULES FOR PARAMETER ADDRESS MARKING

Parameter group no. and parameter identifying no. are used to express parameter address.

High-order bytes: F0 to FF (groups F), A0 to AF (groups A), 70 to 7F (group U)

Low-order bytes: 00 to FF

For example, to read parameter F3-12, communication address of F3-12 is expressed as 0xF30C.

Notes: Group FF: These are factory parameters. The parameters cannot be read or changed.

Group U: These parameters can only be read.

Some parameters cannot be modified when the AC drive is running. Some parameters cannot be modified regardless of status of the AC drive. In addition, pay attention to setting range, unit and description of parameters when modifying them

Parameter Group	Visited Address	Parameter Address in RAM
F0 to FE	0xF000 to 0xFEFF	0x0000 to 0x0EFF
A0 to AC	0xA000 to 0xACFF	0x4000 to 0x4CFF
U0	0x7000 to 0x70FF	

Notes: Frequent storage to the EEPROM reduces its service life. Therefore, in communication mode, users can change values of certain parameters in RAM rather than storing the setting.

For group F parameters, users only need to change high order F of the function code address to 0. For group A parameters, users only need to change high order A of the function code address to 4. The function code addresses are expressed as follows:

High-order bytes: 00 to 0F (group F), 40 to 4F (group A)

Low-order bytes: 00 to FF

If function code F3-12 is not stored into EEPROM, the address is expressed as 030C; if function code A0-05 is not stored into EEPROM, the address is expressed as 4005; this address can only be marked as RAM. It is an invalid address when being read.

Stop/RUN Parameters

Parameter Address	Description	Parameter Address	Description
1000H	*Communication setting value (Decimal): -10000 to 10000	1010H	PID reference
1001H	Running frequency	1011H	PID feedback
1002H	Bus voltage	1012H	PLC process
1003H	Output voltage	1013H	Pulse input frequency, unit: 0.01 kHz
1004H	Output current	1014H	Feedback speed, unit 0.1Hz
1005H	Output power	1015H	Remaining running time
1006H	Output torque	1016H	AI1 voltage before correction
1007H	Running speed	1017H	AI2 voltage before correction
1008H	DI input indication	1018H	AI3 voltage before correction
1009H	DO output indication	1019H	Linear speed
100AH	AI1 voltage	101AH	Current power-on time
100BH	AI2 voltage	101BH	Current running time
100CH	AI3 voltage	101CH	Pulse input frequency, unit: 1Hz
100DH	Counting value input	101DH	Communication reference
100EH	Length value input	101EH	Actual feedback speed
100FH	Load speed	101FH	Main frequency X display
—	—	1020H	Auxiliary frequency Y display

Notes: Communication setting value indicates percentage: 10000 corresponds to 100.00%, and -10000 corresponds to -100.00%.

With regard to frequency, communication reference is a percentage of F0-10 (maximum frequency). With regard to torque, communication reference is a percentage of F2-10 and A2-48 (corresponding to motor 1 and motor 2, respectively).

Control command input to AC drive (write-only):

Command Word Address	Status Definition
2000H	0001: Forward run
	0002: Reverse run
	0003: Forward jog
	0004: Reverse jog
	0005: Coast to stop
	0006: Decelerate to stop
	0007: Fault reset

Read AC drive state (read-only):

Command Word Address	Command Word Function
3000H	0001: Forward run
	0002: Reverse run
	0003: Stop

Parameter lock password check: If the actual password is returned, it indicates that password check is passed. ("0000H" is returned when password is set to 0 (no password)).

Password Address	Password Content
1F00H	*****

APPENDIX B

DO terminal control (write-only)

Command Address	Command Content
2001H	BIT0: DO1 output control
	BIT1: DO2 output control
	BIT2: Relay1 output control
	BIT3: Relay2 output control
	BIT4: FMR output control
	BIT5: VDO1
	BIT6: VDO2
	BIT7: VDO3
	BIT8: VDO4
	BIT9: VDO5

AO1 control (write-only)

Command Address	Command Content
2002H	0 to 7FFF indicates 0% to 100%.

AO2 control (write-only)

Command Address	Command Content
2003H	0 to 7FFF indicates 0% to 100%.

Pulse output control (write-only)

Command Address	Command Content
2004H	0 to 7FFF indicates 0% to 100%.

AC drive fault description:

AC Drive Fault Address	AC Drive Fault Information	
8000H	0000: No fault	0015: Parameter read and write fault
	0001: Reserved	0016: AC drive hardware fault
	0002: Overcurrent during acceleration	0017: Motor short circuited to ground
	0003: Overcurrent during deceleration	0018: Reserved
	0004: Overcurrent at constant speed	0019: Reserved
	0005: Overvoltage during acceleration	001A: Accumulative running time reached
	0006: Overvoltage during deceleration	001B: User-defined fault 1
	0007: Overvoltage at constant speed	001C: User-defined fault 2
	0008: Buffer resistor overload	001D: Accumulative power-on time reached
	0009: Undervoltage	001E: Load lost
	000A: AC drive overload	001F: PID feedback lost during running
	000B: Motor overload	0028: Fast current limit timeout
	000C: Power input phase loss	0029: Motor switchover error during running
	000D: Power output phase loss	002A: Too large speed deviation
	000E: IGBT overheat	002B: Motor over-speed
	000F: External fault	002D: Motor overheat
	0010: Communication fault	005A: Incorrect setting of PPR of the encoder
0011: Contactor fault	005B: Not connecting the encoder	
0012: Current detection fault	005C: Initial position error	
0013: Motor auto-tuning fault	005E: Speed feedback error	

B.8 GROUP FD COMMUNICATION PARAMETER DESCRIPTION

Fd-00	Baud Rate	Default	5005
	Setting Range	Units position (Modbus)	
		0: 300 bps	5: 9600 bps
		1: 600 bps	6: 19200 bps
		2: 1200 bps	7: 38400 bps
		3: 2400 bps	8: 57600 bps
		4: 4800 bps	9: 115200 bps

This parameter is used to set transmission speed between the host computer and AC drive. Note that baud rate of host computer must be the same as that of AC drive. Otherwise, communication will fail. The higher the baud rate is, the faster communication will be.

Fd-01	Data Format	Default	0
	Setting Range	0: No check <8,N,2> 1: Even parity check <8,E,1> 2: Odd parity check <8,O,1> 3: No check, data format <8,N,1>	

Note that the data format of the host computer must be the same as that of the AC drive. Otherwise, communication will fail.

Fd-02	Local Address	Default	1
	Setting Range	1 to 247 0: Broadcast address	

When the local address is set to 0 (that is, broadcast address), the host computer broadcast is enabled.

This address is unique (except broadcast address), which is the basis for point-to-point communication between the host computer and AC drive.

Fd-03	Response Delay	Default	2 ms
	Setting Range	0 to 20 ms	

This parameter sets the interval between the AC drive receiving data and the AC drive sending data to the host computer. If response delay is shorter than system processing time, system processing time will prevail. If response delay is longer than system processing time, the system sends data to the host computer only after response delay is over.

Fd-04	Communication Timeout	Default	0.0s
	Setting Range	0.0s (invalid) 0.1s to 60.0s	

When this parameter is set to 0.0s, the system does not detect communication timeout.

When the AC drive does not receive communication signal within the time set in this parameter, it detects communication timeout fault (Err16). Generally, this parameter is set to 0.0s. In applications with continuous communication, you can use this parameter to monitor communication status.

Fd-05	Communication Protocol Selection	Default	0
	Setting Range	0: Non-standard Modbus protocol; 1: Standard Modbus protocol	

When Fd-05 = 1, standard Modbus protocol is used. For details, refer to B.3

When Fd-05 = 0, an additional byte is returned by the slave computer during read.

For other read or write operations, the number of bytes returned is the same in both standard and non-standard protocols.

Fd-06	Current Resolution Read by Communication	Default	0
	Setting Range	0: 0.01A 1: 0.1A	

This parameter is used to set the unit of output current read by communication.



Visit us online at
benshaw.com and
benshawexpress.com,
or contact:

BENSHAW, Inc.

615 Alpha Drive
Pittsburgh, PA 15238
Phone: 412.968.0100
Fax: 412.968.5415

BENSHAW Canada

550 Bright Street East
Listowel, Ontario N4W 3W3
Phone: 519.291.5112
Fax: 519.291.2595