

Service Manual

FM/AM STEREO RECEIVER

SA-200

SA-200K

(X), (XA), (XAL)

(XGH), (E), (EG)



* SA-200K is different in appearance and colour tone. (Refer to page 13)

- * The models SA-200(X) and SA-200(XA) are available in Asia, Latin America, Middle East and Africa only.
- * The model SA-200(XAL) is available in Australia only.
- * The models SA-200(XGH) and SA-200K(XGH) are available in Holland only.
- * The models SA-200(E, EG), and SA-200K(E, EG), are available in Scandinavia and European only.

TECHNICAL SPECIFICATIONS

Specifications are subject to change without notice for further improvement.

[DIN 45 500]

AMPLIFIER SECTION

1 kHz continuous power output		
both channels driven	2 x 30 W (4Ω), 2 x 27 W (8Ω)	
40 Hz ~ 16 kHz continuous power output		
both channels driven	2 x 27 W (4Ω), 2 x 25 W (8Ω)	
20 Hz ~ 20 kHz continuous power output		
both channels driven	2 x 25 W (8Ω)	
Power bandwidth		
both channels driven, -3 dB	10 Hz ~ 25 kHz (4Ω)	
Total harmonic distortion		
rated power at 1 kHz	0.04% (4Ω, 8Ω)	
rated power at 40 Hz ~ 16 kHz	0.04% (4Ω, 8Ω)	
rated power at 20 Hz ~ 20 kHz	0.04% (8Ω)	
half power at 20 Hz ~ 20 kHz	0.025% (8Ω)	
half power at 1 kHz	0.009% (8Ω)	
-26 dB power at 1 kHz	0.06% (4Ω)	
50 mW power at 1 kHz	0.2% (4Ω)	
Intermodulation distortion		
rated power at 250 Hz: 8 kHz = 4:1, 4 Ω	0.04%	
rated power at 60 Hz: 7 kHz = 4:1, SMPTE, 8Ω	0.04%	
Residual hum & noise	0.6mV	
Damping factor	16 (4Ω), 32 (8Ω)	
Input sensitivity and impedance		
PHONO	2.5 mV/47 kΩ	
AUX	150 mV/33 kΩ	
PLAYBACK (TAPE), REC/PLAY	180 mV/39 kΩ	
PHONO maximum input voltage (1 kHz, RMS)	130 mV	
S/N		
rated power at 4 Ω	PHONO 70 dB (IHF, A); 78 dB	AUX 88 dB (IHF, A); 95 dB
-26 dB power at 4 Ω	PHONO 68 dB, AUX 77 dB	
50 mW power at 4 Ω	PHONO 64 dB, AUX 65 dB	
Frequency response	PHONO RIAA standard curve	
	30Hz ~ 15kHz, ±0.5 dB	
	AUX 20 Hz ~ 20 kHz, ±0.5 dB	
	10 Hz ~ 30 kHz, -1 dB	
Tone controls	BASS 50 Hz, +10 dB ~ -10 dB	
	TREBLE 10 kHz, +10 dB ~ -10 dB	
Loudness control (volume at -30 dB)	50 Hz, +9 dB	
Output voltage and impedance	REC OUT (TAPE) 150 mV	
	REC/PLAY 30mV/80kΩ	
Channel balance (250 Hz ~ 6300 Hz), AUX	±1.0 dB	
Channel separation at 1 kHz, AUX	55 dB	
Headphones output level and impedance	330mV/330Ω	
Load impedance	MAIN or REMOTE 4 ~ 16Ω	
	MAIN + REMOTE 8 ~ 16Ω	

FM TUNER SECTION

Frequency range	88 ~ 108 MHz
Antenna impedance	300Ω (balanced), 75Ω (unbalanced)
Sensitivity (±40 kHz deviation)	
S/N 30 dB	1.9μV (300Ω), 1.3μV (75Ω)
S/N 26 dB	1.7μV (300Ω), 1.2μV (75Ω)
S/N 20 dB	1.5μV (300Ω), 0.9μV (75Ω)
IHF usable sensitivity	1.9μV (IHF '58)
IHF S/N 46 dB stereo quieting sensitivity	22μV (75Ω)
Total harmonic distortion	MONO 0.15%
	STEREO 0.3%
S/N (±40kHz deviation)	MONO 60 dB (IHF: 75 dB)
	STEREO 58 dB (IHF: 70 dB)
Frequency response	20Hz ~ 15 kHz, +1/-2 dB
	20 Hz ~ 14 kHz, ±1.5 dB
Alternate channel selectivity	70 dB
Capture ratio	1.2 dB
Image rejection at 98 MHz	70 dB
IF rejection at 98 MHz	90 dB
Spurious response rejection at 98 MHz	80 dB
AM suppression	55 dB
Stereo separation	1 kHz 45 dB, 10 kHz 35 dB
Leak carrier	19 kHz -33 dB (-40 dB, IHF)
	38 kHz -48 dB (-50 dB, IHF)
Limiting point	1.2μV
Bandwidth	IF amplifier 180 kHz
	FM demodulator 1000 kHz
Channel balance (250 Hz ~ 6300 Hz)	±1.5 dB

AM TUNER SECTION

Frequency range	525 ~ 1605 kHz
Sensitivity (S/N 20 dB)	30μV, 300μV/m
Selectivity	30 dB
Image rejection at 1000 kHz	45 dB
IF rejection at 1000 kHz	40 dB

GENERAL

Power consumption	300W
Power supply (50 Hz/60 Hz)	110V/120V/220V/240V
Dimensions (W x H x D)	430 x 142 x 300 mm
	(16 1/8" x 5 5/8" x 11 3/8")
Weight	7.2 kg (15.9 lb.)

Technics

Matsushita Electric Trading Co., Ltd.
P.O. Box 288, Central Osaka Japan

LOCATION OF CONTROLS (Front Panel)

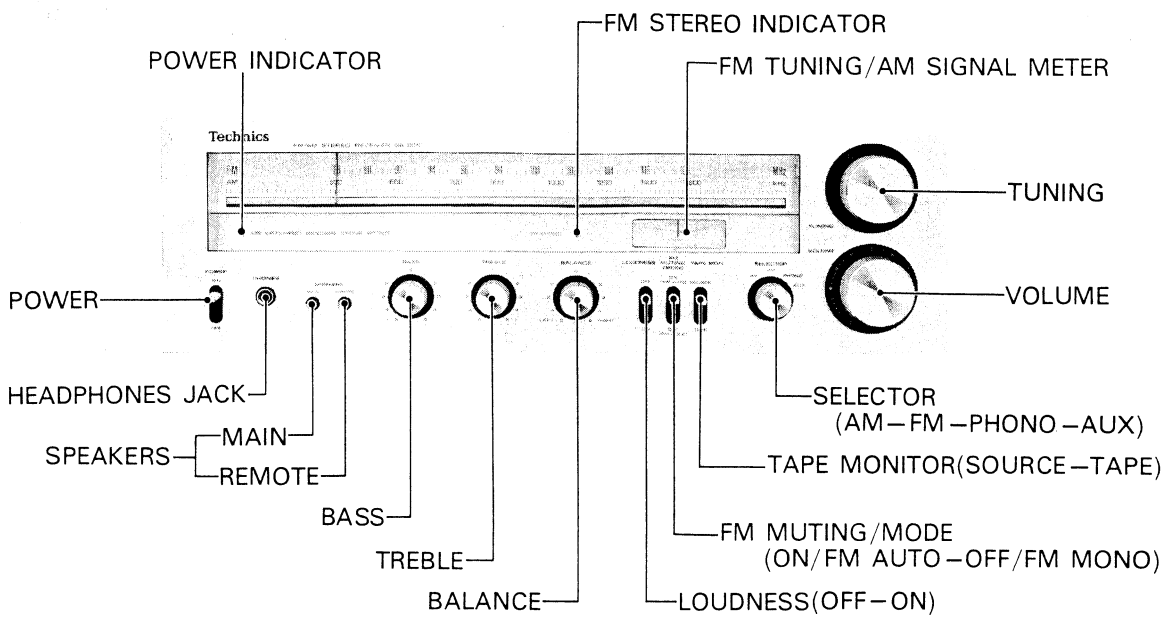

TECHNISCHE DATEN [DIN 45 500]

Spezifikationen können infolge von Verbesserungen ohne Ankündigung geändert werden.

VERSTÄRKERTEIL

Dauertonleistung bei 1 kHz beide Kanäle zusammen angesteuert	2 x 30 W (4Ω) 2 x 27 W (8Ω)
Dauertonleistung bei 40 Hz ~ 16 kHz beide Kanäle zusammen angesteuert	2 x 27 W (4Ω) 2 x 25 W (8Ω)
Dauertonleistung bei 20 Hz ~ 20 kHz beide Kanäle zusammen angesteuert	2 x 25 W (8Ω)
Leistungsbandbreite beide Kanäle zusammen angesteuert, -3 dB	10 Hz ~ 25 kHz (4Ω)
Harmonische Verzerrungen	
Nennausgangsleistung bei 1 kHz	0,04% (4Ω, 8Ω)
Nennausgangsleistung bei 40 Hz ~ 16 kHz	0,04% (4Ω, 8Ω)
Nennausgangsleistung bei 20 Hz ~ 20 kHz	0,04% (8Ω)
Halber Ausgangsleistung bei 20 Hz ~ 20 kHz	0,025% (8Ω)
Halber Ausgangsleistung bei 1 kHz	0,009% (8Ω)
-26 dB Ausgangsleistung bei 1 kHz	0,06% (4Ω)
50 mW Ausgangsleistung bei 1 kHz	0,2% (4Ω)
Intermodulationsverzerrung	
Nennausgangsleistung bei 250 Hz: 8 kHz = 4:1, 4Ω	0,04%
Nennausgangsleistung bei 60 Hz: 7 kHz = 4:1, 8Ω	0,04%
Hum & Noise	0,6 mV
Dämpfungsfaktor	16 (4Ω), 32 (8Ω)
Eingangsempfindlichkeit & Impedanz	
PHONO	2,5 mV/47 kΩ
AUX	150 mV/33 kΩ
PLAYBACK (TAPE), REC/PLAY Eingang	180 mV/39 kΩ
PHONO Maximale Eingangsspannungen (1 kHz RMS)	130 mV
Fremdspannungsabstand	
Nennausgangsleistung bei 4Ω PHONO	70 dB (IHF, A: 78 dB)
AUX	88 dB (IHF, A: 95 dB)
-26 dB Ausgangsleistung bei 4Ω PHONO	68 dB
AUX	77 dB
50 mW Ausgangsleistung bei 4Ω PHONO	64 dB
AUX	65 dB
Frequenzgang PHONO	RIAA Standardkurve
AUX	30 Hz ~ 15 kHz, ±0,5 dB
Klangregler BÄSSE	20 Hz ~ 20 kHz, ±0,5 dB
HOHEN	10 Hz ~ 30 kHz, -1 dB
	50 Hz, +10 dB ~ -10 dB
	10 kHz, +10 dB ~ -10 dB
Gehörgerechte Lautstärkekorrektur (Lautstärke bei -30 dB)	50 Hz, +9 dB
Ausgangsspannungen & Impedanz REC OUT (TAPE)	150 mV
REC/PLAY Aufnahme	30 mV/80kΩ
Kanalabweichung (250Hz ~ 6300Hz), AUX	±1,0 dB
Kanaltrennung bei 1 kHz, AUX	55 dB
Kopfhörerpegel und Ausgangsimpedanz	330 mV/330Ω

Endimpedanz	MAIN oder REMOTE	4 ~ 16Ω
	MAIN und REMOTE	8 ~ 16Ω

UKW-TUNERTEIL

Empfangsbereich	88 ~ 108 MHz
Antennenanschluss	300Ω (symmetrisch), 75Ω (asymmetrisch)
Empfindlichkeit (±40 kHz Hub)	
30 dB Fremdspannungsabstand	1,9μV (300Ω), 1,3μV (75Ω)
26 dB Fremdspannungsabstand	1,7μV (300Ω), 1,2μV (75Ω)
20 dB Fremdspannungsabstand	1,5μV (300Ω), 0,9μV (75Ω)
IHF Empfindlichkeit	1,9μV (IHF '58)
46 dB Fremdspannungsabstand Empfindlichkeit, IHF	22μV (75Ω), STEREO
Harmonische Verzerrung	
MONO	0,15%
STEREO	0,3%
Fremdspannungsabstand (±40 kHz Hub)	
MONO	60 dB (IHF: 75 dB)
STEREO	58 dB (IHF: 70 dB)
Frequenzgang	
	20 Hz ~ 15 kHz, +1
	-2
	20 Hz ~ 14 kHz, ±1,5 dB
Selektivität	70 dB
Gleichwellen-Selektion	1,2 dB
Spiegelselektion bei 98 MHz	70 dB
ZF-Festigkeit bei 98 MHz	90 dB
Unselektivitätsfestigkeit bei 98 MHz	30 dB
AM-Unterdrückung	55 dB
Stereo Übersprechdämpfung	1 kHz 45 dB, 10 kHz 35 dB
Trägerrest	19 kHz -33 dB (-40 dB, IHF)
	38 kHz -48 dB (-50 dB, IHF)
Begrenzung, Einsatzpunkt	1,2μV
Bandbreite ZF-Verstärker	180 kHz
UKW-Demodulator	1000 kHz
Kanalabweichung (250 Hz ~ 6300 Hz)	±1,5 dB

AM-TUNERTEIL

Empfangsbereich	525 ~ 1605 kHz
Empfindlichkeit (20 dB Fremdspannungsabstand)	30μV, 300μV/m
Selektivität	30 dB
Spiegelselektion bei 1000 kHz	45 dB
ZF-Festigkeit bei 1000 kHz	40 dB

ALLGEMEINE DATEN

Leistungsaufnahme	300W
Netzspannung umschaltbar (50 Hz/60Hz)	110V/120V/220V/240V
Abmessungen (B x H x T)	430 x 142 x 300mm
Gewicht	7,2 kg

SA-200/K SA-200/K

■ LOCATION OF CONTROLS (Rear Panel)

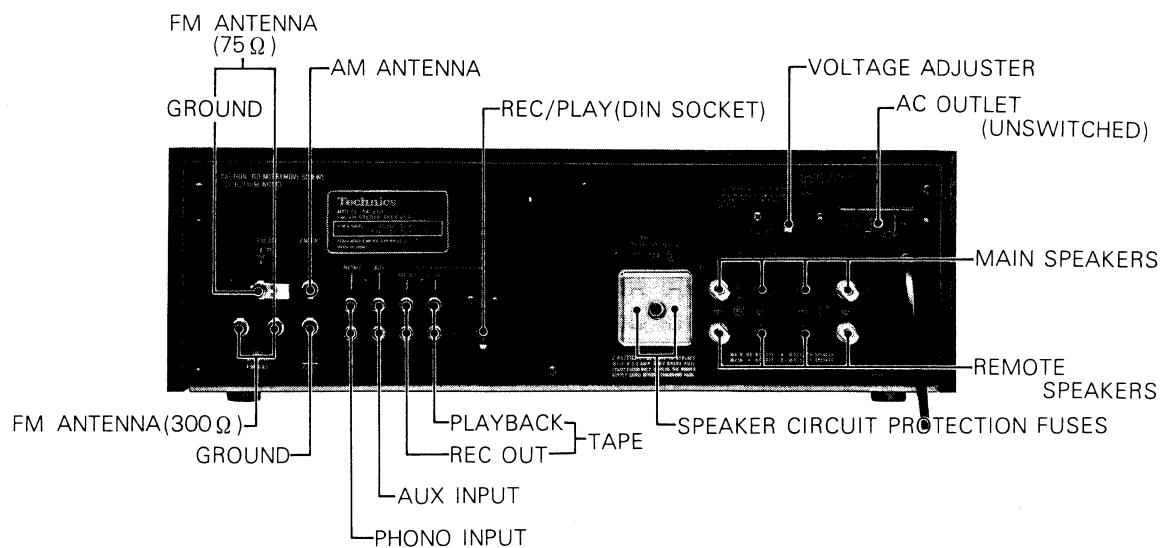

* This photo shows only the products for (X) and (XA).
* The products for other destinations except (X) and (XA) are not equipped with AC outlet.

CARACTERISTIQUES TECHIQUES (Sujet à changement sans préavis.)

[DIN 45 500]

PARTIE AMPLIFICATEUR

Puissance RMS (continue) à 1 kHz
pour l'ensemble des canaux excités 2 x 30 W (4 Ω)
2 x 27 W (8 Ω)

Puissance RMS (continue) à 40 Hz ~ 16 kHz
pour l'ensemble des canaux excités 2 x 27 W (4 Ω)
2 x 25 W (8 Ω)

Puissance RMS (continue) à 20 Hz ~ 20 kHz
pour l'ensemble des canaux excités 2 x 25 W (8 Ω)

Largeur de bande de puissance
pour l'ensemble des canaux excités, -3 dB
10 Hz ~ 25 kHz (4 Ω)

Distorsion harmonique totale
pour la puissance mesurée à 1 kHz 0,04% (4 Ω, 8 Ω)
pour la puissance mesurée à 40 Hz ~ 16 kHz 0,04% (4 Ω, 8 Ω)
pour la puissance mesurée à 20 Hz ~ 20 kHz 0,04% (8 Ω)

pour la demi-puissance mesurée à 20 Hz ~ 20 kHz 0,025% (8 Ω)
pour la puissance mesurée à 1 kHz 0,009% (8 Ω)
pour une puissance mesurée de -26 dB, 1 kHz 0,06% (4 Ω)
pour une puissance mesurée de 50 mW, 1 kHz 0,2% (4 Ω)

Distorsion d'intermodulation
pour la puissance mesurée à 250 Hz: 8 kHz=4:1, 4 Ω 0,04%
pour la puissance mesurée à 60 Hz: 7 kHz=4:1, 8 Ω 0,04%

Tension résiduelle de bruit 0,6mV
Facteur d'amortissement 16 (4 Ω), 32 (8 Ω)

Sensibilité & impédance d'entrée
PHONO 2,5 mV/47 kΩ
AUX 150 mV/33 kΩ
PLAYBACK (TAPE), REC/PLAY entrée 180 mV/39 kΩ

Voltage d'entrée maximum (PHONO, 1 kHz, RMS) 130 mV
Rapport signal/bruit
pour la puissance nominale, 4 Ω

PHONO 70 dB (IHF, A: 78 dB)
AUX 88 dB (IHF, A: 95 dB)

pour une sortie de -26 dB, 4 Ω PHONO 68 dB, AUX 77 dB
pour une sortie de 50 mW, 4 Ω PHONO 64 dB, AUX 65 dB

Réponse de fréquence
PHONO Courbe standard RIAA
30 Hz ~ 15 kHz, ±0,5 dB
AUX 20 Hz ~ 20 kHz, ±0,5 dB
10 Hz ~ 30 kHz, -1 dB

Régulation de la tonalité
BASS (graves) 50 Hz, +10 dB ~ -10 dB
TREBLE (aigus) 10 kHz, +10 dB ~ -10 dB

Correction physiologique (volume à -30 dB) 50 Hz, +9 dB
Tension de sortie & impédance REC OUT (TAPE) 150 mV
REC/PLAY 30mV/80kΩ
Equilibrage de canaux (250 Hz ~ 6300 Hz), AUX ±1,0 dB

Ecart canaux à 1 kHz, AUX 55 dB
Niveau des écouteurs et impédance de sortie 330mV/330Ω
Impédance de charge PRINCIPALE ou ELOIGNEE 4 ~ 16 Ω
PRINCIPALE + ELOIGNEE 8 ~ 16 Ω

PARTIE TUNER FM

Gamme reçue 88 ~ 108 MHz
Impédance d'antenne 300 Ω (symétrique) 75 Ω (asymétrique)
Sensibilité (± 40 kHz déviation)
Signal/bruit 30 dB 1,9 μV (300 Ω), 1,3 μV (75 Ω)
Signal/bruit 26 dB 1,7 μV (300 Ω), 1,2 μV (75 Ω)
Signal/bruit 20 dB 1,5 μV (300 Ω), 0,9 μV (75 Ω)
IHF Sensibilité 1,9 μV (IHF '58)
IHF Sensibilité pour 46 dB 22 μV (75 Ω), STEREO
Distorsion harmonique totale
MONO 0,15%
STEREO 0,3%
Signal/bruit (± 40 kHz déviation) MONO 60 dB (IHF: 75 dB)
STEREO 58 dB (IHF: 70 dB)

Réponse de fréquence
20 Hz ~ 15 kHz, +1 dB
20 Hz ~ 14 kHz, ±1,5 dB

Sélectivité alternée par canal 70 dB
Taux de capture 1,2 dB
Réjection de fréquence image à 98 MHz 70 dB
Réjection FI à 98 MHz 90 dB
Réjection de réception non sélective à 98 MHz 80 dB
Suppression AM 55 dB
Séparation stéréophonique 1 kHz 45 dB, 10 kHz 35 dB
Courant porteur de dispersion 19 kHz -33 dB (-40 dB, IHF)
38 kHz -48 dB (-50 dB, IHF)

Point limite 1,2 μV
Largeur de bande Amplificateur FI 180 kHz
Démodulateur FM 1000 kHz
Equilibrage de canaux (250 Hz ~ 6300 Hz) ±1,5 dB

PARTIE TUNER AM

Gamme reçue 525 ~ 1605 kHz
Sensibilité (Rapport S/B 20 dB) 30 μV, 300 μV/m
Sélectivité 30 dB
Réjection de fréquence image à 1000 kHz 45 dB
Réjection FI à 1000 kHz 40 dB

GENERALITES

Consommation 300W
Alimentation (50 Hz/60 Hz) 110V/120V/220V/240V
Dimensions (L x H x Pr) 430 x 142 x 300 mm
Poids 7,2 kg

■ ALIGNMENT INSTRUCTIONS ENGLISH

SIGNAL GENERATOR		DIAL SETTING	INDICATOR (AC VTVM or SCOPE) (DISTORTION METER)	ADJUSTMENT POINTS	REMARKS
CONNECTION	FREQUENCY				
AM ALIGNMENT					
1	High side through 0.001 μF to AM antenna trimmer terminal. Common to chassis.	455kHz (30% Mod. with 400Hz)	Point of non-interference	Connect VTVM or scope to TP201, through 0.1 μF	T201 (1st IFT) Z201 (2nd IFT) ● Adjust for maximum output.
2	Fashion loop of several turns of wire and radiate signal into loop of receiver	600kHz (30% Mod. with 400Hz)	600kHz	Connect VTVM or scope to speaker terminals of receiver.	L202 (OSC Coil) L201 (ANT Coil) ● Adjust for maximum output. Adjust L201 by moving coil bobbin along ferrite core.
3	Fashion loop of several turns of wire and radiate signal into loop of receiver	1500kHz (30% Mod. with 400Hz)	1500kHz	Connect VTVM or scope to speaker terminals of receiver.	CT5 (OSC Trimmer) CT4 (ANT Trimmer) ● Adjust for maximum output ● Repeat steps (2) and (3)
FM-IF ALIGNMENT					
4	No Signal	Point of non-interference	Tuning meter of set.	T101 (DISCRI IFT) (A) Orange Core	● FM muting/mode switch to ON/FM AUTO. ● Adjust for center position of tuning meter.
FM-RF ALIGNMENT					
5	Connect to FM 300 Ω antenna terminal through FM dummy antenna.	90MHz (100% Mod. with 400Hz)	90MHz	Connect scope to speaker terminals of receiver.	L5 (OSC Coil) L3 (RF-DET Coil) L1 (ANT Coil) ● FM muting/mode switch to OFF/FM MONO. ● Adjust for maximum amplitude and symmetrical curve (Refer to fig. 4).
6	Connect to FM 300 Ω antenna terminal through FM dummy antenna.	106MHz (100% Mod. with 400Hz)	106MHz	Connect scope to speaker terminals of receiver.	CT3 (OSC Trimmer) CT2 (RF DET Trimmer) CT1 (ANT Trimmer) ● Adjust for maximum amplitude and symmetrical curve. ● Repeat steps (5) and (6).
FM MONO DISTORTION ALIGNMENT					
7	Connect to FM 300 Ω antenna terminal through FM dummy antenna. Apply 60 dB to set.	100MHz (100% Mod. with 400Hz)	100MHz	Connect distortion meter to speaker terminals of receiver.	T101 (DISCRI IFT) (B) Green Core ● Adjust for minimum distortion of left output. ● Repeat steps (4) and (7).
FM MUTING LEVEL ALIGNMENT					
8	Connect to FM 300 Ω antenna terminal through FM dummy antenna. Apply 16dB (6.3 μV) to set.	100MHz (100% Mod. with 400Hz)	100MHz	Connect VTVM or scope to speaker terminals.	VR101 ● FM muting/mode switch to "ON/FM AUTO". ● Adjust so that output can be obtained.
FM MPX PILOT ALIGNMENT					
Using a frequency counter		Using alternate system			
9	1 100MHz Non-modulated mono signal applied to set. (Apply 60dB) 2 FM muting/mode switch to "ON/FM AUTO" 3 Connect frequency counter to TP301 through resistor (100k Ω) 4 Adjust VR301 to 19kHz, ±30Hz.		1 Apply stereo signal from generator or stereo station to receiver. 2 Adjust VR301 until stereo indicator lights up. Cement arm of VR301 as shown in fig. 5.		
Notes: 1 Stereo modulator ● Connect stereo modulator output to EXT MOD terminal of signal generator. 2 Pilot signal modulation to "10%" 2 FM signal generator ● Frequency approximately 100MHz/Output level to "72dB (IHF)" 3 Selector switch to "FM" ● Modulation mode to "FM" 4 FM muting/mode switch to "ON/FM AUTO"					
FM SIGNAL GENERATOR CONNECTION	STEREO MODULATOR MODE & MOD. RATE	INDICATOR (AC VTVM)	ADJUSTMENT POINT	REMARKS	
FM STEREO SEPARATION ALIGNMENT					
10	FM 300 Ω antenna terminals through FM dummy antenna.	(1kHz 30% Modulation) MODE L (and R) Pilot signal to "ON"	Connect VTVM to speaker terminals through low pass filter. (Refer to fig. 6)	VR302	● Tuning at 100MHz. ● Make adjustment so that, when the antenna input is subjected to L modulation (or R modulation) R channel output (or L channel output) becomes minimum.

ABGLEICHANWEISUNGEN DEUTSCH

(Für Deutschland)

AM/UKW MESSENDER		SKALENZEI- GEREIN- STELLUNG DES TUNER	ANZEIGE (Wechselstrom Röhrenvoltmeter oder Oszillograph bzw. Klirrfaktor-Meßgerät)	ABGLEICHS- PUNKTE	BEMERKUNGEN
AM-ABGLEICH					
Heißes Ende des Meßsenders über einen 0.001µF Kondensator an den AM Antenneneingang schließen. Kaltes Ende an Masse.	455kHz (400Hz Modul., 30%)	Kein Empfang	Röhrenvoltmeter oder Oszillograph über den Lautsprecher schließen.	T201 (1. IFT) Z201 (2. IFT)	• Auf max. Ausgang abgleichen.
Das Meßsendersignal induktiv in den Tuner speisen. Hierzu behelfsmäßig eine Rahmenantenne fertigen und an den Eingang schließen.	600kHz (400Hz Modul., 30%)	600kHz	Röhrenvoltmeter oder Oszillograph über den Lautsprecher schließen.	L202 (Osc. Spule) L201 (Ant. Spule)	• Auf max. Ausgang abgleichen. • L201 wird abgeglichen, indem die Spule am Ferritstab, entlanggeschoben wird.
Das Meßsendersignal induktiv in den Tuner speisen. Hierzu behelfsmäßig eine Rahmenantenne fertigen und an den Eingang schließen.	1500kHz (400Hz Modul., 30%)	1500kHz	Röhrenvoltmeter oder Oszillograph über den Lautsprecher schließen.	CT5 (Osc. Trimmer) CT4 (Ant. Trimmer)	• Auf max. Ausgang abgleichen. • Schritt (2) und (3) sind zu wiederholen.
UKW ZF-ABGLEICH					
	Kein Signal	Kein Empfang	Abstimmanzeige.	T101 (Diskriminator IFT) [A]	• FM Muting-Schalter auf ON stellen. • Den Abstimmungsanzeiger auf den zentrum Wert einstellen.
UKW HF-ABGLEICH					
Meßsender über eine Konstantenne an den UKW-Antenneneingang schließen.	87.5MHz (400Hz Modul., 100%)	87.5MHz (Frequenz Min.)	Röhrenvoltmeter oder Oszillograph über den Lautsprecher schließen.	L5 (Osc. Spule)	• FM Muting-Schalter auf OFF stellen. • Auf max. Ausgang abgleichen.
Meßsender über eine Konstantenne an den UKW-Antenneneingang schließen.	90MHz (400Hz Modul., 100%)	90MHz	Röhrenvoltmeter oder Oszillograph über den Lautsprecher schließen.	L3 (Det. Spule) L1 (Ant. Spule)	• Auf max. Amplitude bei entsprechender Linearität abgleichen. (Vgl. Abb. 4)
Meßsender über eine Konstantenne an den UKW-Antenneneingang schließen.	106MHz (400Hz Modul., 100%)	106MHz	Röhrenvoltmeter oder Oszillograph über den Lautsprecher schließen.	CT3 (Osc. Trimmer) CT2 (Det. Trimmer) CT1 (Ant. Trimmer)	• Auf max. Amplitude bei entsprechender Linearität abgleichen. (Vgl. Abb. 4) • Schritt (5), (6) und (7) sind zu wiederholen.
ABGLEICH AUF MIN. VERZERRUNG IN STELLUNG UKW-MONO					
Meßsender über eine Konstantenne an den UKW-Antenneneingang schließen.	100MHz (400Hz Modul., 100%)	100MHz	Klirrfaktor-Meßbrücke über den Lautsprecher schließen.	T101 (Diskriminator IFT) [B]	• Auf min. Verzerrung auf der Klirrfaktor-Meßbrücke abgleichen. • Schritt (4) und (8) sind zu wiederholen.
UKW-MUTING-ABGLEICH					
Meßsender über eine Konstantenne an den UKW-Antenneneingang schließen. Meßsender auf 16 dB (6.3µV) einstellen.	100MHz (400Hz Modul., 100%)	100MHz	Röhrenvoltmeter oder Oszillograph über den Lautsprecher schließen.	VR101	• Muting Schalter auf "ON" stellen. • So einstellen, daß ein Ausgang zu vernehmen ist.
UKW-STEREO-DEKODER-ABGLEICH					
Unter Verwendung eines Zählers			Alternativ-Meßmethode		
1. Unmoduliertes Mono-Signal 100 MHz in das Gerät speisen. 2. FM Muting-Schalter auf "ON /FM AUTO" stellen. 3. Zähler über einen Widerstand 100k ohm an TP301 schließen. 4. VR301 auf 19kHz ±30Hz einstellen.			1. Stereosignal entweder von einem Stereogenerator oder einem Sender einspeisen. 2. VR301 so einstellen, bis die Stereolampe auf leuchtet. Schleifer von VR301 sichern, wie in Abb. 5 gezeigt.		
KANALTRENNUNG-ABGLEICH					
Anmerkungen:					
1. Stereo-Modulator Ausgang des Stereo-Modulators an den Eingang EXT MOD des Meßsenders schließen. Eingebauter Oszillator 1kHz/Pilotton-Modulation 10%					
2. UKW Meßsender Auf etwa 100MHz einstellen. Ausgangspegel 72dB (IHF). Modulation FM					
3. Bereichsschalter FM					
4. Muting/Mode-Schalter ON/FM AUTO					
ANSCHLUSS DES UKW MESSENDERS	STEREO MODULATOR MODE oder MOD. RATE	ANZEIGE (Röhrenvoltmeter oder Oszillograph)	ABGLEICHS-PUNKTE	ANMERKUNGEN	
Meßsender über eine Konstantenne an den UKW-Antenneneingang schließen.	L (und R) Modulation 30%	Röhrenvoltmeter oder Oszillograph über Tiefpassfilter an den Tuner-Ausgang schließen. Vgl. Abb. 6.	VR302	• Auf min. Ausgang rechter (und linker) abgleichen.	

INSTRUCTIONS D'ALIGNEMENT FRANÇAIS

AM/FM GENERATEUR		AIGUILLE SUR LE CADRAN	INDICATEUR ELECTRONIQUE COPE OU DISTORSIONMETRE	POINTS DE REGLAGE	OBSERVATIONS
ALIGNEMENT AM					
1. Côté chaud, à travers 0.001µF, sur le trimmer de l'antenne AM, commutateur de haut-parleur de l'ampli-tuner.	455kHz (modulé à 30% par 400Hz)	Point sans signal	Branchez un voltmètre électronique ou un oscilloscope sur les bornes de haut-parleur de l'ampli-tuner.	T201 (1 transfo FI) Z201 (2 transfo FI)	• Réglez au maximum de signal de sortie.
2. Faire une boucle de quelques tours et rayonner le signal dans le cadre de l'ampli-tuner.	600kHz (modulé à 30% par 400Hz)	600kHz	Branchez un voltmètre électronique ou un oscilloscope sur les bornes de haut-parleur de l'ampli-tuner.	L202 (bobine OSC) L201 (bobine ANT)	• Réglez au maximum de signal de sortie. Réglez L201 en déplaçant la bobine le long du noyau de ferrite.
3. Faire une boucle de quelques tours et rayonner le signal dans le cadre de l'ampli-tuner.	1500kHz (modulé à 30% par 400Hz)	1500kHz	Branchez un voltmètre électronique ou un oscilloscope sur les bornes de haut-parleur de l'ampli-tuner.	CT5 (trimmer OSC) CT4 (trimmer ANT)	• Réglez au maximum de signal de sortie. • Recommencez les étapes (2) et (3).
ALIGNEMENT FI-FM					
4. Sans signal	Sans signal	point sans signal	Indicateur d'accord de l'appareil	T101 (Transfo FI discr.) [A]	• Commutateur de silencieux sur ON. • Réglez pour atteindre position médiane sur l'indicateur d'accord.
ALIGNEMENT RF-FM					
5. Branchez sur la prise d'antenne FM à travers une antenne fictive FM.	90MHz (modulé à 100% par 400Hz)	90MHz	Branchez un voltmètre électronique ou un oscilloscope sur les bornes de haut-parleur de l'ampli-tuner.	L5 (bobine OSC) L3 (bobine DET) L1 (bobine ANT)	• Commutateur de silencieux sur OFF. • Réglez au maximum d'amplitude et de symétrie. (Voir fig. 1)
6. Branchez sur la prise d'antenne FM à travers une antenne fictive FM.	106MHz (modulé à 100% par 400Hz)	106MHz	Branchez un voltmètre électronique ou un oscilloscope sur les bornes de haut-parleur de l'ampli-tuner.	CT3 (trimmer OSC) CT2 (trimmer DET) CT1 (trimmer ANT)	• Réglez au maximum d'amplitude et de symétrie. (Voir fig. 1) • Recommencez les étapes (5) et (6)
REGLAGE DE LA DISTORSION FM EN MONO					
7. Branchez sur la prise d'antenne FM à travers une antenne fictive FM.	100MHz (modulé à 100% par 400Hz)	100MHz	Branchez un distorsio mètre sur les bornes de haut-parleur de l'appareil.	T101 (Transfo FI discr.) [B]	• Réglez au minimum d'indication du distorsio-mètre. Recommencez les étapes (4) et (7).
REGLAGE DU SEUIL DU SILENCIEUX D'ACCORD					
8. Branchez sur la prise d'antenne FM à travers une antenne fictive FM. Niveau de sortie du générateur 16 dB (6.3µV).	100MHz (modulé à 100% par 400Hz)	100MHz	Branchez un voltmètre électronique ou un oscilloscope sur les bornes de haut-parleur de l'ampli-tuner.	VR101	• Commutateur de silencieux sur "ON" • Réglez pour obtenir une lecture en sortie.
ALIGNEMENT DU PILOTE MULTIPLEX FM					
Avec un fréquencemètre			Par un autre système		
1. Signal mono 100 MHz non modulé appliqué à l'appareil. 2. Commutateur de silencieux sur "ON/FM AUTO" 3. Branchez le fréquencemètre sur TP301 à travers une résistance de 100kΩ. 4. Réglez VR301 sur 19kHz ±30Hz.			1. Appliquez à l'appareil un signal stéréo provenant d'un générateur ou de la réception d'un émetteur. 2. Réglez VR301 jusqu'à ce que l'indicateur de stéréophonie s'allume. Collez le curseur de VR301 comme indiqué sur la fig. 2.		
REGLAGE DE LA SEPARATION DES CANAUX					
Notes:					
1. Modulateur stéréo Branchez sa sortie sur la prise EXT. MOD. du générateur. OSC interne 1kHz Modulation du signal pilote 10%					
2. Générateur de signal Fréquence env. 100MHz, niveau de sortie 72dB (IHF), genre de modulation sur FM.					
3. Commutateur de gamme FM					
4. Commutateur de silencieux ON/FM AUTO					
BRANCHEMENT DU GENERATEUR DE SIGNAL	MODE DU MODULATEUR STEREO ET TAUX DE MODULATION	INDICATEUR (VOLTMETRE ELECTRONIQUE OU OSCILLOSCOPE)	POINTS DE REGLAGE	OBSERVATIONS	
10. Borne d'antenne FM à travers antenne fictive.	Gauche (et droite) à 30% de modulation.	Sur les bornes de haut-parleur à travers un filtre passe-bas, voir fig. 3.	VR302	• Réglez au minimum de sortie droite (et gauche)	

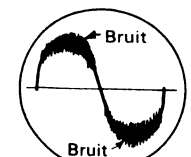

Fig. 1

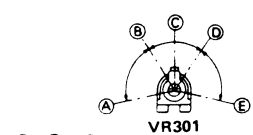

Fig. 2
A-B, D-E: Position stéréo arrêt
B-D: Position stéréo en marche (éclairage du voyant indicateur)
C: Point de réglage du circuit pilote

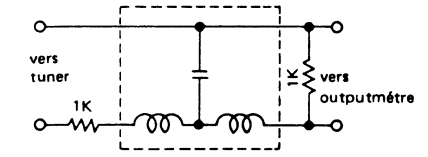
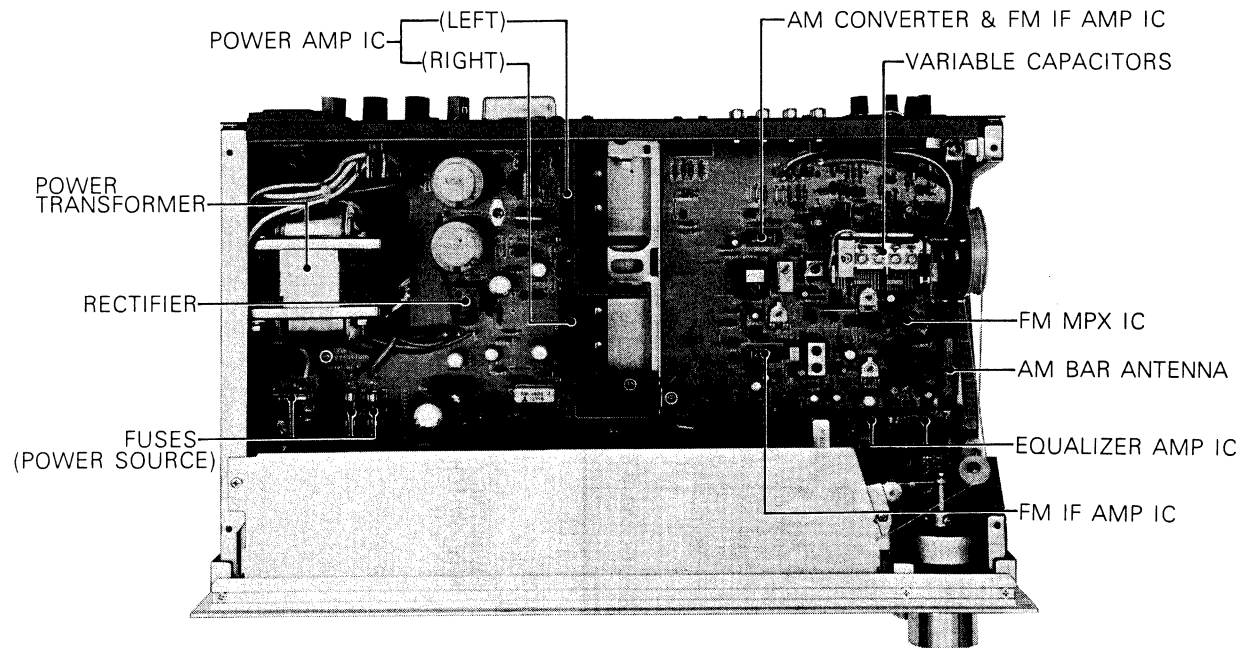

Fig. 3
FILTRE PASSE-BAS (fc = 15 kHz ~ 19 kHz)

SA-200/K SA-200/K

PRINTED CIRCUIT BOARD VIEW



NOTE

The unit is provided with the speaker circuit protection fuses at the right and left channels respectively. The fuse is to prevent the power IC from destruction, should the speaker terminals be short-circuited. Accordingly, if the unit fails to function upon completion of the speaker connections, check the speaker circuit protection fuses first of all for possible blowing.

ALIGNMENT POINTS

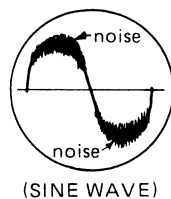
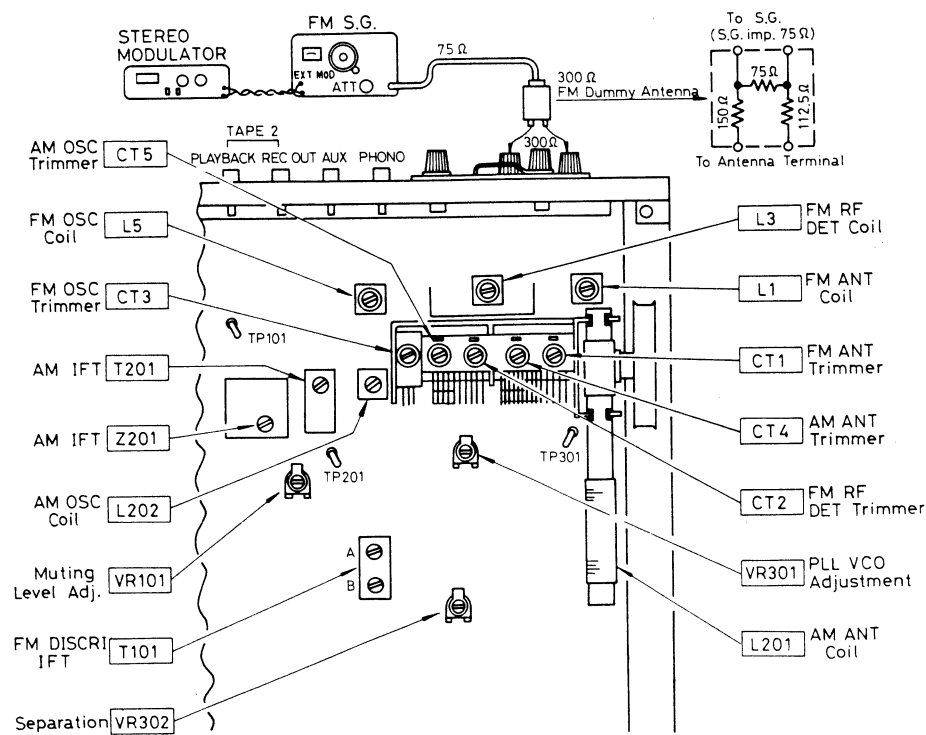

(SINE WAVE)
Fig. 4 (Abb. 4)

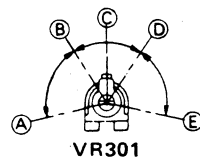

A - B, D - E: Stereo OFF Position.
B - D: Stereo ON Position (Indicator Lighting)
C: Adjust Point of Pilot Circuit.

Fig. 5 (Abb. 5)

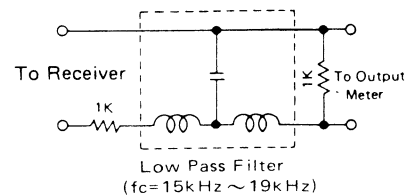
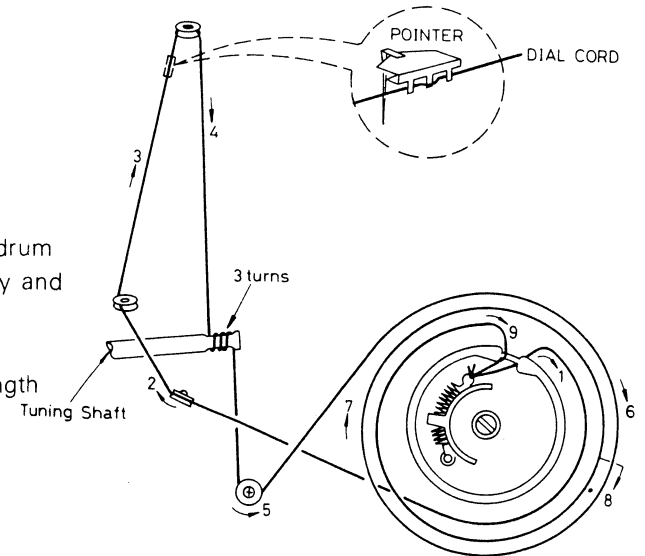

Fig. 6 (Abb. 6)

DIAL CORD INSTALLATION GUIDE

- For threading a fresh cord, proceed as follows.
 - Prepare a fresh cord more than 200cm(78-3/4") in length.
 - Bring the variable capacitor into a state where the drum is completely turned to the right (maximum capacity and lowest frequency for the variable capacitor).
 - Direct the cord in the order from 1 to 9.
 - Stretch the cord in such a tension as the spring length is elongated by 1.5 times that of the original state.
 - Fix the knot of the cord with the bond.



TO REMOVE CABINET

- Remove the two cabinet mounting screws (nos ①, ② screws in fig. 7).
- Remove the four cabinet mounting screws (nos ①~④ screws in fig. 8).
- Sliding it toward (A) direction and lifting it upward (B) direction as shown in fig. 8.
- When the cabinet is installed, insert the metal fitting of cabinet (as shown in fig. 9) into the space between the front panel and light reflector.

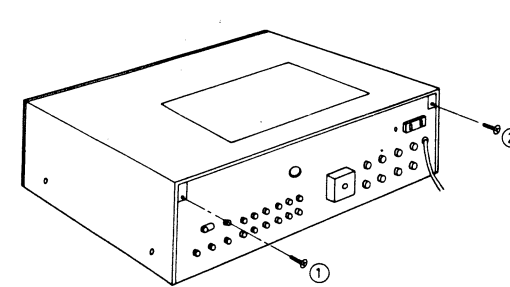

Fig. 7

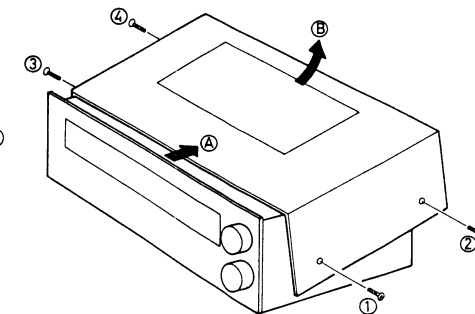

Fig. 8

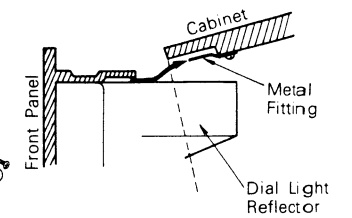

Fig. 9

THE UNIT CAN USE TWO DIFFERENT PARTS IN VOLTAGE ADJUSTER

- When using the part number ESE37200, connect as shown in fig. 10.
- When using the part number SSR53S, connect as shown in fig. 11.

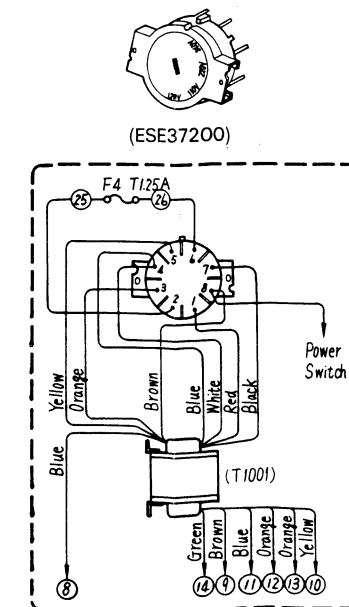

Fig. 10

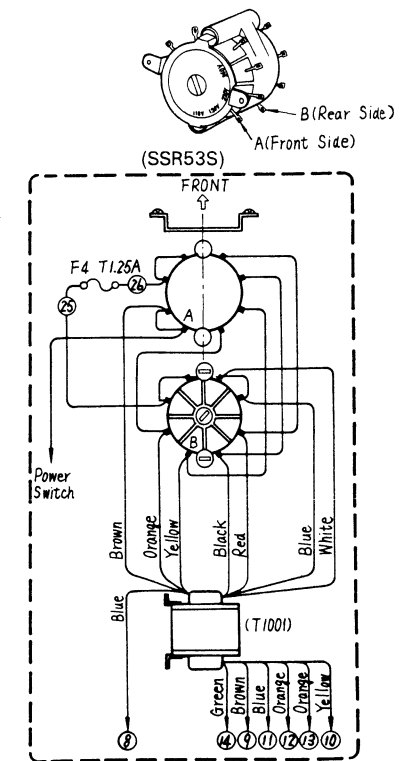

Fig. 11

FM/AM TUNER AND EQUALIZER CIRCUIT BOARD

Earth (Ground) Lines

IC201 AN217
AM CONV 5 FM/AM 1st, 2nd IF AMP

FM	AM	FM	AM
1 0V	0V	9 0.6V	7.3V
2 0V	0V	10 0.5V	1.5V
3 0.4V	0V	11 0.7V	0.8V
4 6.2V	0V	12 0.8V	7.3V
5 1.1V	0V	13 0.5V	0.7V
6 0V	0V	14 0.8V	1.1V
7 1.1V	0V	15 0.8V	7.3V
8 5.9V	0V	16 0.5V	0.7V

IC101 AN377
FM IF AMP & DET

1 2.2V	9 5.7V
2 2.2V	10 5.7V
3 2.2V	11 10.3V
4 1.0V	12 1.7V
5 1.5V	13 0.7V
6 5.8V	14 0V
7 6.0V	15 5.1V
8 5.7V	16 0V

Q101 2SC828
MUTING SWITCHING

MUTING	MUTING
E 0V	OFF
F 0.6V	0V
C 0V	11.4V

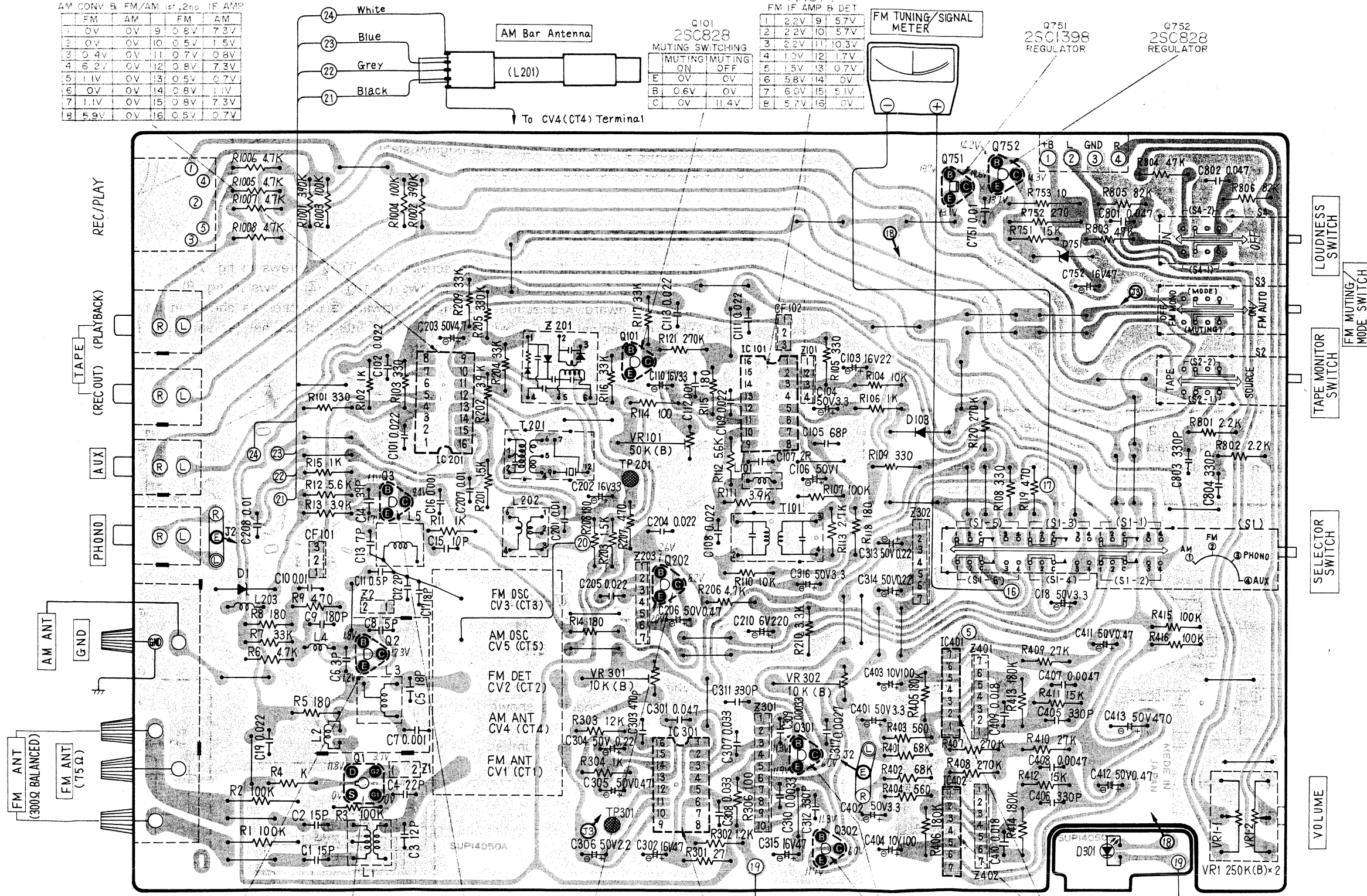

TERMINAL GUIDE OF TRANSISTOR AND IC

<p>2SA798A</p>	<p>2SA721, 2SC828 2SC1047, 2SC1675 2SC1685, 2SC1885</p>
<p>3SK40</p>	<p>2SC1398</p>
<p>AN217, AN363, AN377</p>	<p>SVISTA7129P</p>
<p>SVISTK0029</p>	<p>2SC1398</p>

Q2 2SC1047 FM MIXER	Q1 3SK40 FM RF AMP	Q3 2SC1675 FM LOCAL OSC	Q202 2SC828 4F AMP	IC301 AN363 FM MPX	Q301, 302 2SA721 4F AMP	IC401, 402 SVISTA7129P EQUALIZER AMP
1 2.7V	9 1.7V	1 2.0V	1 2.7V	1 2.7V	1 2.0V	1 2.0V
2 3.1V	10 1.9V	2 0.65V	2 2.2V	2 0.65V	2 0.65V	2 0.65V
3 5.0V	11 9V	3 0.96V	3 2.2V	3 0.96V	3 0.96V	3 0.96V
4 1.3V	12 8V	4 0V	4 1.0V	4 0V	4 0V	4 0V
5 1.3V	13 8V	5 0.59V	5 1.5V	5 0.59V	5 0.59V	5 0.59V
6 1.4V	14 8V	6 1.9 5V	6 5.8V	6 1.9 5V	6 1.9 5V	6 1.9 5V
7 0V	15 9V	7 3.6 0V	7 6.0V	7 0V	7 3.6 0V	7 3.6 0V
8 1.4V	16 3.3V		8 5.7V	8 1.4V		

■ TONE, MAIN AMPLIFIER AND POWER SUPPLY CIRCUIT BOARD

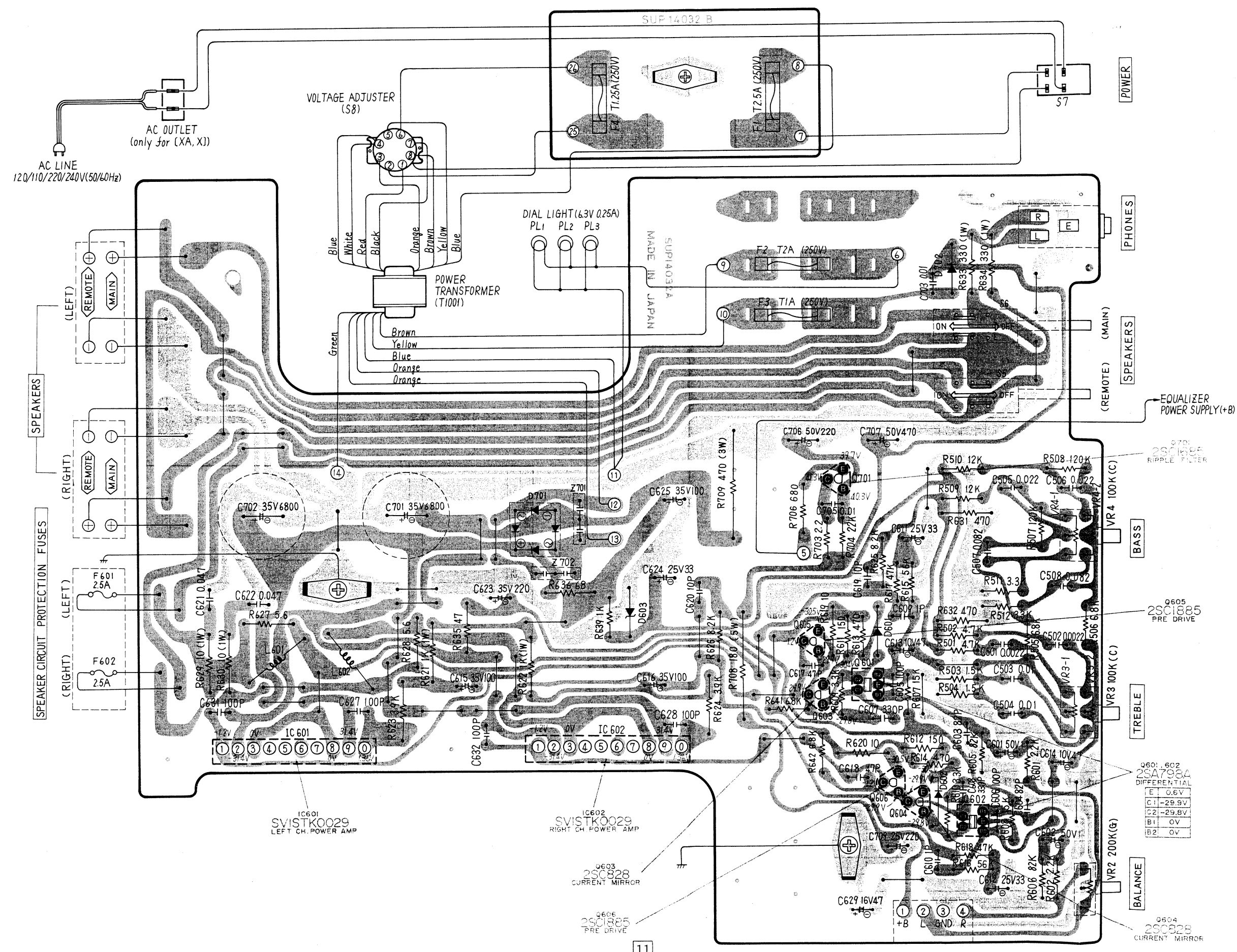

SA-200/K SA-200/K

■ BLOCK DIAGRAM

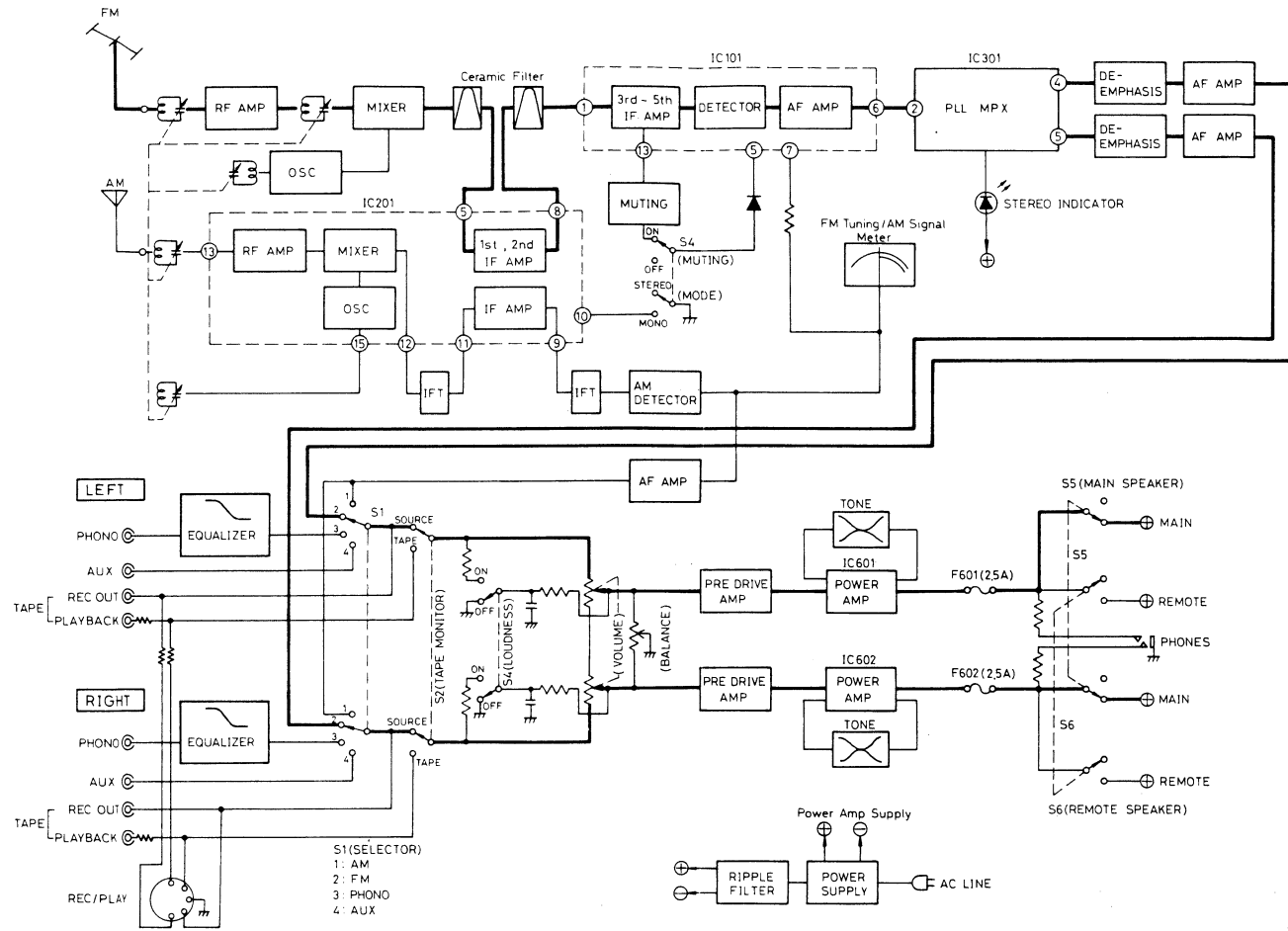

SA-200K (E),(EG),(XGH)

- * The model SA-200K(E, EG) is available in European and Scandinavia only.
- * The model SA-200K(XGH) is available in Holland only.

Note:
This parts list included only the changes of the model SA-200(E, EG) and SA-200(XGH) parts list.

Ref. No.	Change of Part No.		Part Name & Description	Per Set (Pcs.)	Remarks
	SA-200	SA-200K			
CABINET and CHASSIS PARTS					
2	SGWA200X	SGWA200KD	Panel, Front Ass'y	1	○
24	SGX6579	SGX6579-1	Bracket, Dial Scale Left Side	1	○
26	SDH461A	SDH461-1A	Plate, Dial Scale	1	○
31	SGX6577	SGX6577-1	Bracket, Dial Scale Right Side	1	○
33	SDP1129	SDP1129-1	Pointer, Dial	1	○
53(E) only	SGP1370A	SGP1370B	Rear Panel	1	○
53(EG, XGH)	SGPA200D	SGPA200KD	Rear Panel, SGP1370B with Name Plate (SGT16650)	1	○
PACKING PARTS					
P7	SPG1517	SPG1507	Carton Box	1	○

13

■ REPLACEMENT PARTS LIST Electric Parts

- NOTES 1: 1. Part numbers are indicated on most mechanical parts.
Please use this part number for parts orders.
2. indicates that only parts specified by the manufacturer be used for safety.

14

Ref. No.	Part No.	Part Name & Description	Per Set	Remarks
L601, 602	SLQY15G-3U	Coil, Power Amplifier Output	2	○
T101	SL14D513-Z	Transformer, FM IF Detector	1	
T201	SL17D101-M	Transformer, AM IF	1	
T1001 (XAL) only	SLT5P151-W	Transformer, Power Source	1	
Z1	EXRP102Z223C	COMPONENT COMBINATIONS	1	
Z2	EXRP103P102C	Component Combination, 22kΩ & 0.001μF	1	
Z101	EXF3SL04C	Component Combination, 1kΩ & 0.01μF	1	
Z201	SL19F101-Z	Component Combination, 0.01μF (X3)	1	
Z301	EXB-H85005K	Component Combination, AM Detector	1	
Z302	EXB-H8007K	Component Combination, Resistors	1	
Z401, 402	EXA6YD04CL	Component Combination, 39kΩ (X2), 100kΩ (X2), 820pF (X2)	2	
Z701, 702	EXA6SD01C	Component Combination, Equalizer	2	
Z701, 702	EXRF5203ZS	Component Combination, 0.01μF (X2)	2	
CF101, 102	SVFEI07MS8-A	CERAMIC FILTERS	each 2	
	SVFEI07MS8-B	Ceramic Filter, Red, 10.7MHz		
	SVFEI07MS8-C	Ceramic Filter, Blue, 10.67MHz		
	SVFEI07MS8-D	Ceramic Filter, Orange, 10.73MHz		
	SVFEI07MS8-E	Ceramic Filter, Black, 10.64MHz		
	SVFEI07MS8-F	Ceramic Filter, White, 10.76MHz		
		(Use pair ranks as same as CF101 and CF102.)		
VR1	EVFMKA031BF5	VARIABLE RESISTORS	1	
VR2, 4	EVHGP2F25G25	Volume Control, 250kΩ (B)	2	
VR101	EWK99AF25C15	Balance Control, 200kΩ (G)	1	
VR301	EVLS3AA00B54	Bass & Treble Control, 100kΩ (C)	1	
VR302	EVT53MA00B14	Muting Level Adjustment, 50kΩ (B)	1	
	EVLS3AA00B14	PLL VCO Adjustment, 10kΩ (B)	1	
		Separation Adjustment, 10kΩ (B)	1	
CV1~CV5 (CT1~CT5)	ECVC751K144A	VARIABLE CAPACITORS	1	
		Variable Capacitor, with Trimmer		
PL1, 2, 3	XAMR62S	LAMPS	3	
		Lamp, Dial (6.3V 0.25A)		
F1	XBA2C251RO	FUSES	1	
F2	XBA2C201RO	Fuse, T 2.5A(250V) Power Primary	1	
F3	XBA2C101RO	Fuse, T 2A(250V) Lamp	1	
F4	XBA2C121RO	Fuse, T 1A(250V) Power Secondary	1	
F601, 602	XBA2C2B5SO	Fuse, T 1.25A(250V) Power Primary	2	
S1	ESRM164F25E	SWITCHES	1	
S2	SSL121	Switch, Selector	1	
S3, 4	SSL123	Switch, Tape Monitor	2	
S5, 6	SSH223S	Switch, FM Muting & Loudness	2	
S7	ESL21191	Switch, Main & Remote Speakers	1	
S8	SSR53S	Switch, Power Source	1	
S8	ESE37200	Switch, Voltage Adjuster (See page 8)	1	

Ref. No.	Part No.	Part Name & Description	Per Set	Remarks
INTEGRATED CIRCUITS				
IC101	AN377	IC, FM IF Amplifier & FM Detector	1	
IC201	AN217P-BB	IC, FM IF Amplifier & AM Converter	1	
IC301	AN363	IC, FM Multiplex	1	
IC401, 402	SVITA7129P	IC, Equalizer Amplifier	2	
IC601, 602	SVISTK0029	IC, Power Amplifier	2	○
TRANSISTORS				
Q1	35K40-M	Transistor, FM RF Amplifier	1	
Q2	25C1047-C	Transistor, FM Mixer	1	
Q3	25C1675-L1	Transistor, FM Local Oscillator	1	
Q101, 202	25C1328-T	Transistor, Muting & AM AF Amplifier	2	
Q301, 302	25A902S-F	Transistor, FM AF Amplifier	2	
Q601, 602	25A798A-G2	Transistor, Differential Amplifier	2	
Q603, 604	25C1328-T	Transistor, Current Mirror	2	
Q605, 606	25C1885-Q	Transistor, Pre Driver	2	
Q701	25C1685-T	Transistor, Ripple Filter	1	
Q751	25C1398-Q	Transistor, Regulator	1	
Q752	25C1328-T	Transistor, Regulator	1	
DIODES				
D1	SVDMZ303BM	Diode, 3V Zener	1	
D103	OA99	Diode, Switching	1	
D301	LN259P	Light Emitting Diode, Stereo Indicator	1	
D601, 602	MA27B	Diode, Current Mirror	2	
D603	SVDMZ322	Diode, 22V Zener	1	
D701	SVDS4VB10	Rectifier	1	
D702	SM112	Rectifier	1	
D751	SVDMZ414	Diode, 14V Zener	1	
COILS and TRANSFORMERS				
L1	SLA4P25	Coil, FM Antenna	1	
L2	RLQY25S2	Coil, Choke	1	
L3	SLD4P13	Coil, FM RF Detector	1	
L4	RLQY15G5	Coil, Choke	1	
L5	SLO4P31	Coil, FM Local Oscillator	1	
L101	SLQX180-2	Coil, Choke	1	
L201	SLE2C11	Coil, AM Bar Antenna	1	
L202	SLO2C3-P	Coil, AM Local Oscillator	1	
L203	SLQX101-2D	Coil, Choke	1	

■ BLOCK DIAGRAM OF INTEGRATED CIRCUITS

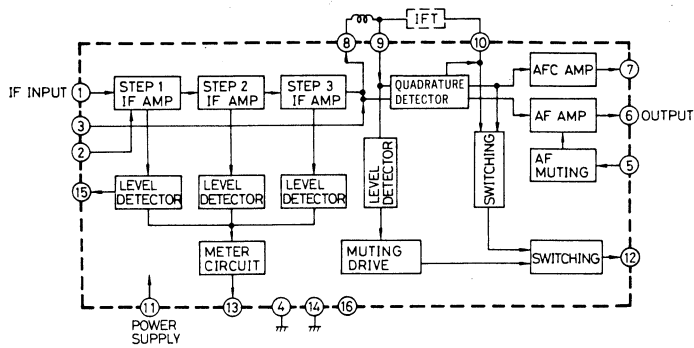

IC101 (AN377)
FM IF Amplifier & Detector

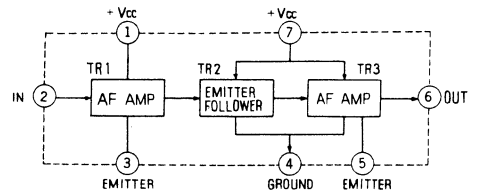

IC401, 402 (SVITA7129P)
Equalizer Amplifier

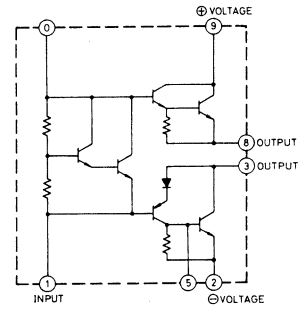

IC601, 602 (SVISTK0029)
Power Amplifier

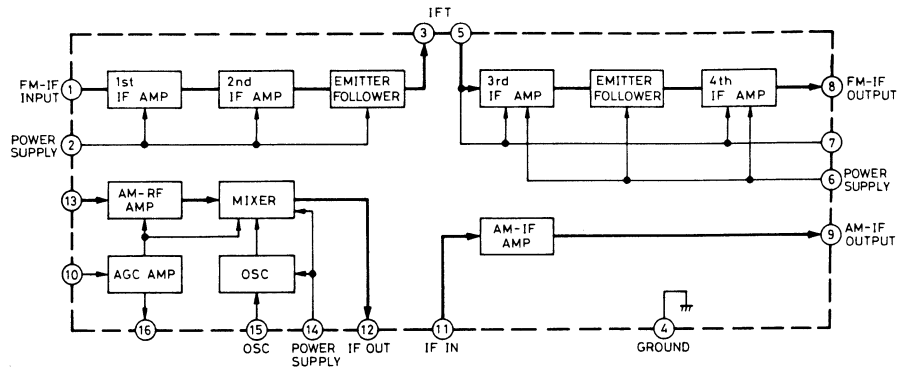

IC201 (AN217)
FM IF Amplifier & AM Converter

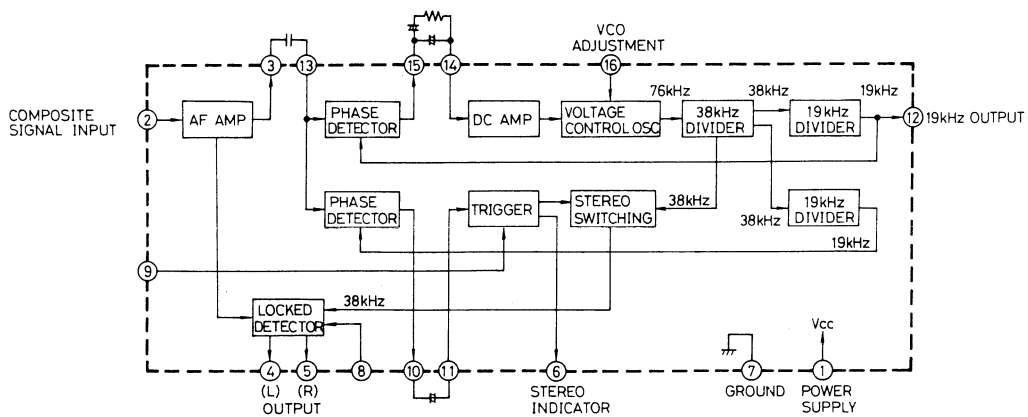

IC301 (AN363)
FM Multiplex

NOTES 2:

Guide letters of Resistor and Capacitor indicate.

Resistors

ERD Carbon ERG Metal oxide
 ERO Metal film ERX Metal film
 ERF Non-flammable

Capacitors

ECC Ceramic ECK Ceramic
 ECQM Polyester ECQS Polystyrene
 ECE Electrolytic

Ref. No.	Part No.
RESISTORS	
R1, 2 (The product for (XAL) are not provided.)	ERD50TJ104
R3	ERD25TJ104
R4	ERD25TJ563
R5	ERD25TJ181
R6	ERD25TJ472
R7	ERD25TJ333
R8	ERD25TJ181
R9	ERD25TJ471
R11	ERD25TJ102
R12	ERD25TJ562
R13	ERD25TJ392
R14	ERD25TJ181
R15	ERD25TJ102
R101	ERD25TJ331
R102	ERD25TJ102
R103	ERD25TJ331
R104	ERD25TJ103
R105	ERD25TJ331
R106	ERD25TJ102
R107	ERD25TJ104
R108, 109	ERD25TJ331
R110	ERD25TJ103
R111	ERD25TJ392
R112	ERD25TJ562
R113	ERD25TJ272
R114	ERD25TJ101
R115	ERD25TJ181
R116, 117	ERD25TJ333
R118	ERD25TJ181
R119	ERD25TJ471
R120, 121	ERD25TJ274
R201	ERD25TJ152
R202	ERD25TJ392
R203	ERD25TJ152
R204	ERD25TJ333
R205	ERD25TJ334
R206	ERD25TJ472
R207	ERD25TJ471
R208	ERD25TJ181
R209	ERD25TJ333
R210	ERD25TJ332
R301	ERD25TJ270
R302	ERD25TJ122
R303	ERD25TJ123
R304	ERD25TJ102
R306	ERD25TJ101
R401, 402	ERO25CKG6802

Ref. No.	Part No.
R403, 404	ERD25TJ561
R405, 406	ERO25CKG1803
R407, 408	ERO25CKG2703
R409, 410	ERD25TJ273
R411, 412	ERD25TJ153
R413, 414	ERD25TJ184
R415, 416	ERD25TJ104
R501, 502	ERD25TJ472
R503, 504	ERD25TJ152
R505, 506	ERD25TJ682
R507, 508	ERD25TJ124
R509, 510	ERD25TJ123
R511, 512	ERD25TJ332
R601, 602	ERD25TJ222
R605, 606	ERD25TJ823
R607, 608	ERD25TJ153
R609, 610	ERD25TJ332
R611, 612	ERD25TJ151
R613, 614	ERD25TJ471
R615, 616	ERD25TJ563
R617, 618	ERD25TJ473
R619, 620	ERD14FJ100
R621, 622	ERGIANJ102
R623, 624	ERD12FJ392
R625, 626	ERD14FJ822
R627, 628	ERD14FJ5R6
R629, 630	ERX1ANJ100
R631, 632	ERD14FJ471
R633, 634	ERGIANJ331
R635	ERD14FJ470
R636	ERD14FJ680
R639	ERD25TJ102
R641, 642	ERD25TJ682
R703	ERD18FAJ2R2
R704	ERD25TJ223
R706	ERD14FJ681
R708	ERF5SJ181
R709	ERG3ANJ471
R751	ERD25TJ153
R752	ERD12FJ271
R753	ERD12FJ100
R801, 802	ERD25TJ222
R803, 804	ERD25TJ473
R805, 806	ERD25TJ823
R1001, 1002	ERD25TJ394
R1003, 1004	ERD25TJ104
R1005~1008	ERD25TJ472

Ref. No.	Part No.
CAPACITORS	
C1, 2	ECCD1H150KC
C3	ECCD1H120KC
C4	ECCD1H220KC
C5	ECCD1H180KR
C6	ECCD1H030CC
C7	ECKD1H102MDA
C8	ECCD1H050CC
C9	ECCD1H181K
C10	ECKD1H103ZF
C11	ECCD1H0R5CC
C12	ECCD1H020CC
C13	ECCD1H070DC
C14	ECCD1H390KC
C15	ECCD1H100KC
C16	ECKD1H102MDA
C17	ECCD1H180KR
C18	ECEA50Z3R3
C19	ECKD1H223ZF
C101, 102	ECKD1H223ZF
C103	ECEA1CS220
C51, 52(XAL)only	ECKDHS101MB
C104	ECEA50Z3R3
C105	ECCD1H680K
C106	ECEA50Z1
C107	ECCD1H020CC
C108, 109	ECKD1H223ZF
C110	ECEA1CS330
C111	ECKD1H223ZF
C112	ECKD1H103ZF
C113	ECKD1H223ZF
C201	ECKD1H103MD
C202	ECEA1CS330
C203	ECEA1JS4R7
C204, 205	ECQM1H223KZ
C206	ECEA2ASR47
C207, 208	ECKD1H103ZF
C210	ECEA1AS221
C251(XAL)only	ECKDHS102MD
C301	ECQM1H473KZ
C302	ECEA1ES470
C303	ECQS05471JZ
C304	ECEA50ZR22
C305	ECEA50ZR47
C306	ECEA50M2R2R

Ref. No.	Part No.
C307, 308	ECQM1H333JZ
C309, 310	ECQM1H332KZ
C311, 312	ECKD1H331KB
C313, 314	ECEA50ZR22
C315	ECEA1ES470
C316	ECEA50Z3R3
C317	ECQM1H272KZ
C401, 402	ECEA50M3R3R
C403, 404	ECEA1AS101
C405, 406	ECKD1H331KB
C407, 408	ECQM1H472JZ
C409, 410	ECQM1H183JZ
C411, 412	ECEA50MR47R
C413	ECEA1JS471
C501, 502	ECQM1H222KZ
C503, 504	ECQM1H103KZ
C505, 506	ECQM1H223KZ
C507, 508	ECQM1H823KZ
C601, 602	ECEA50M1R
C603, 604	ECCD1H820K
C605, 606	ECCD1H101K
C607, 608	ECKD1H331KB
C609, 610	ECCD1H010C
C611, 612	ECEA1VS330
C613, 614	ECEA1ES470
C615, 616	ECEA1VS101
C617, 618	ECCD2H470K
C619, 620	ECCD1H100K
C621, 622	ECQM1H473KZ
C623	ECEA1VS221
C624	ECEA1VS330
C625	ECEA1VS101
C627, 628	ECCD1H101K
C629	ECEA1ES470
C631, 632	ECCD1H101K
C701, 702	ECET35R6800S
C703	ECKD1H103ZF
C705	ECKD1H103ZF
C706	ECEA1HS221
C707	ECEA1JS471
C709	ECEA1ES221
C751	ECKD1H103ZF
C752	ECEA1ES470
C801, 802	ECQM1H473KZ
C803, 804	ECKD1H331KB

Schematic Diagram

Model SA-200/SA-200K

Notes:

- S1-1~S1-6: Selector switch in "AM" position.
① AM → ② FM → ③ PHONO → ④ AUX
 - S2-1, S2-2: Tape monitor switch in "SOURCE" position.
 - S3: FM muting/mode switch in "ON/AUTO" position.
 - S4-1, S4-2: Loudness switch in "OFF" position.
 - S5: Remote speaker switch in "OFF" position.
 - S6: Main speaker switch in "ON" position.
 - S7: Power source switch in "ON" position.
 - S8: Voltage adjustment switch in "240V" position.
240V ↔ 220V ↔ 110V ↔ 120V
9. Indicated voltage values are the standard values for the unit measured by the DC electronic circuit tester (high-impedance) with the chassis taken as standard. Therefore, there may exist some errors in the voltage values, depending on the internal impedance of the DC circuit tester.
- Not apply signal to set and muting switch to OFF condition.
 - AM signal reception.
 - FM muting to ON condition.
 - FM stereo signal reception.
 - AF signal lines. → FM signal lines. → AM signal lines.
11. indicates that only parts specified by the manufacturer be used for safety.
12. This schematic diagram may be modified at any time with the development of new technology.

ANTENNA CAPACITORS

■ Product for Australia(XAL) only

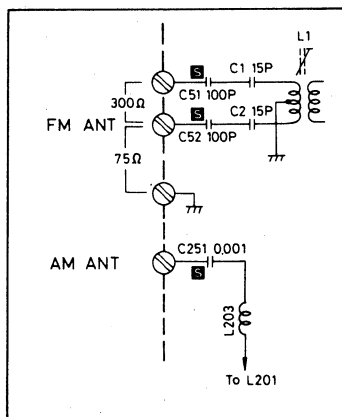

POWER SOURCE CIRCUITRY OF PRODUCTS FOR (E, EG), (XGH) & (XAL)

■ Products for Scandinavia/European(E, EG) and Holland(XGH) only

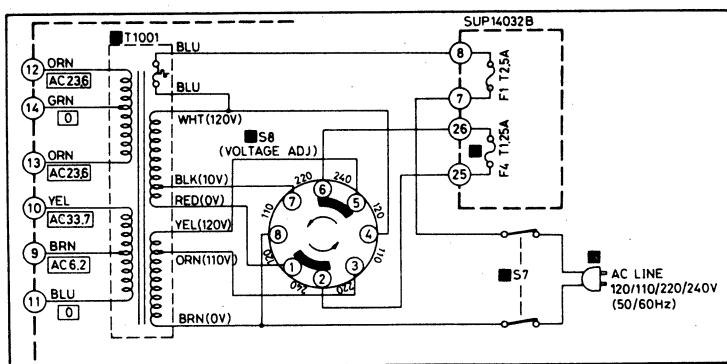

■ Product for Australia(XAL) only

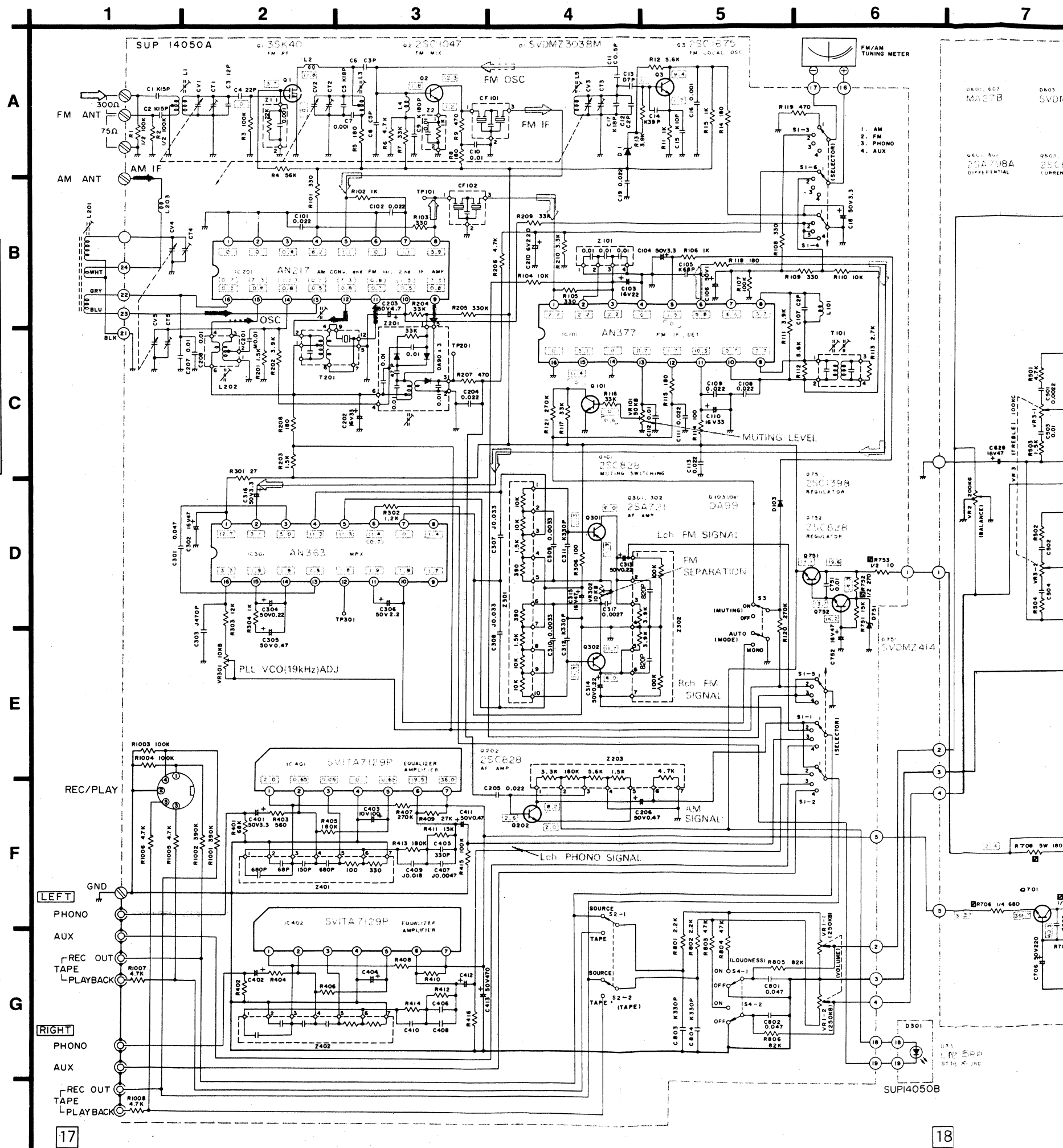
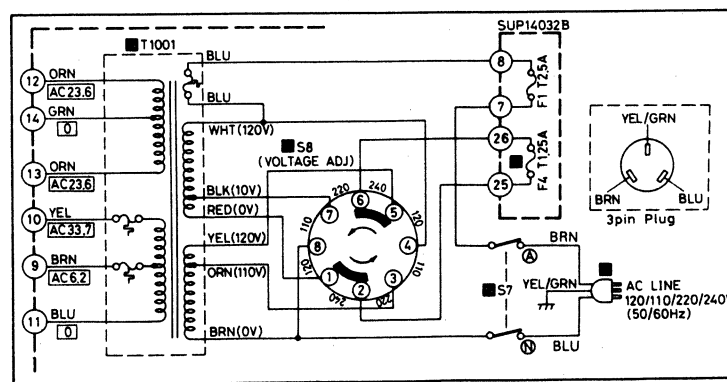

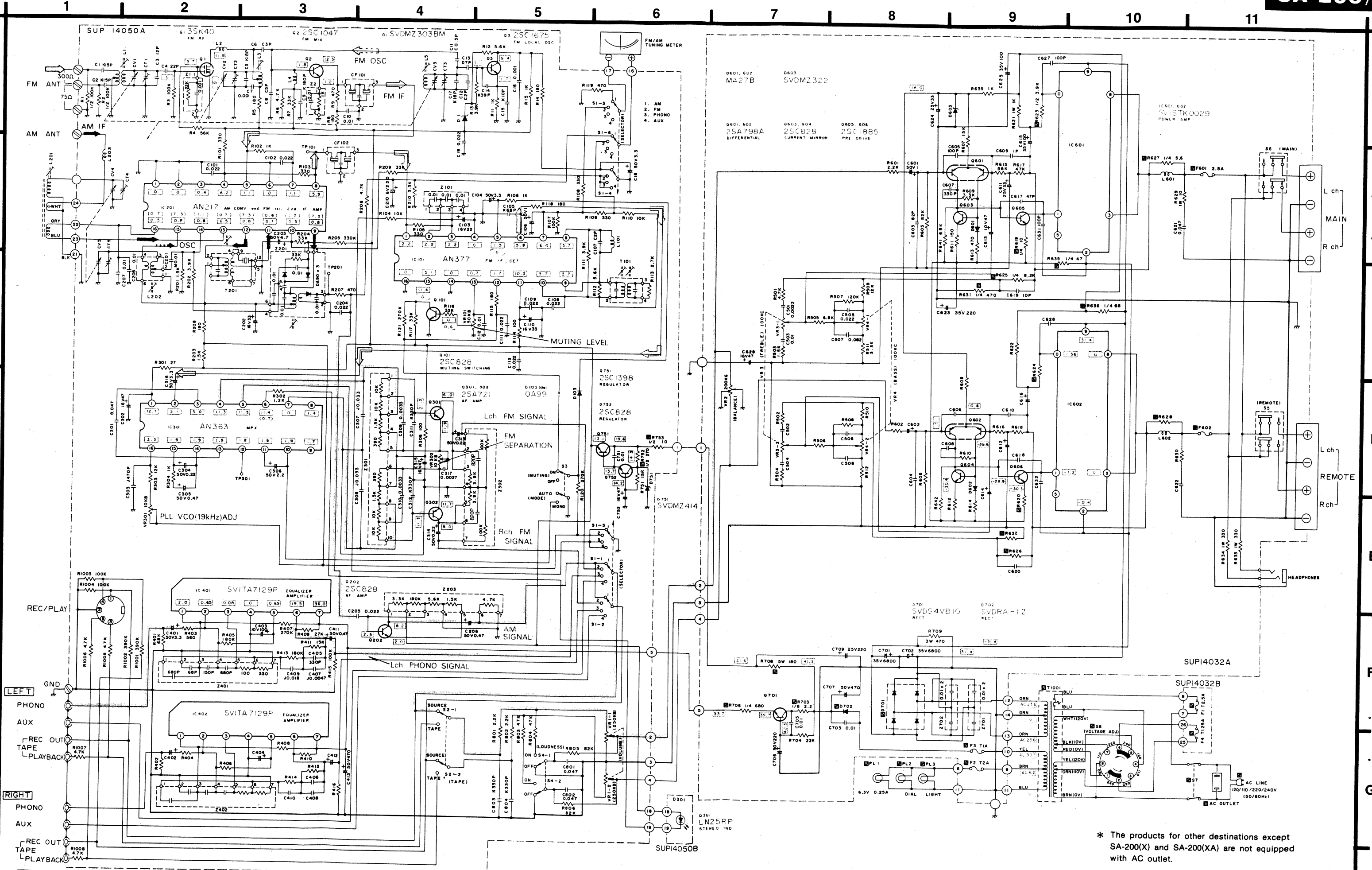

* The products for other destinations except SA-200(X) and SA-200(XA) are not equipped with AC outlet.

EXPLODED VIEW

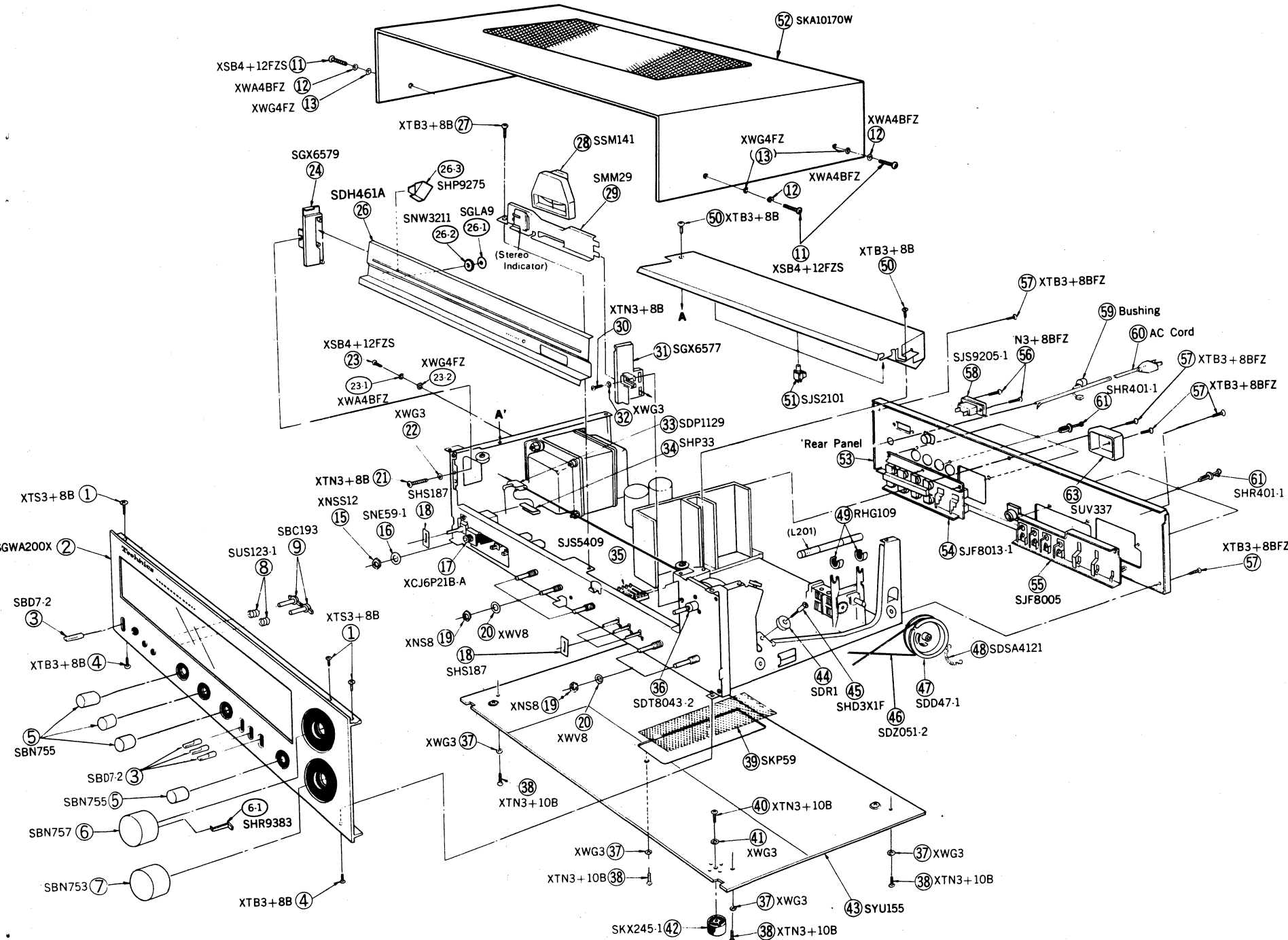

REPLACEMENT PARTS LIST

NOTES: 1. Part numbers are indicated on most mechanical parts.
Please use this part number for parts orders.
2. ■ indicates that only parts specified by the manufacturer be used for safety.

Ref. No.	Part No.	Part Name & Description	Per Set	Remarks
CABINET and CHASSIS PARTS				
1	XTS3+8B	Screw, Front Panel M'tg	3	
2	SGWA200X	Panel, Front Ass'y	1	○
3	SBD7-2	Knob, Lever Switches	4	
4	XTB3+8B	Screw, Front Panel M'tg	2	
5	SBN755	Knob, Bass, Treble, Balance & Selector	4	
6	SBN757	Knob, Tuning	1	
6-1	SHR9383	Spacer, Tuning Knob	1	
7	SBN753	Knob, Volume	1	
8	SUS123-1	Spring, Speaker Push Switches	2	
9	SBC193	Button, Speaker Switches	2	
11	XSB4+12FZS	Screw, Cabinet M'tg	4	
12	XWA4BFZ	Washer, Spring	4	
13	XWG4FZ	Washer	4	
15	XNS12	Nut, Headphones Jack M'tg	1	
16	SNE59-1	Washer, Headphones Jack	1	
17	XCJ6P21B-A	Jack, Headphones	1	
18	SHS187	Shading Cloth, Lever Switches	4	
19	XNS8	Nut, Volumes & Selector M'tg	5	
20	XWV8	Washer, Volumes & Selector	5	
21	XTN3+8B	Screw, Dial Scale Bracket Left M'tg	1	
22	XWG3	Washer, Left Bracket Screw	1	
23	XSB4+12FZS	Screw, Power Transformer M'tg	4	
23-1	XWA4BFZ	Washer, Spring	4	
23-2	XWG4FZ	Washer	4	
24	SGX6579	Bracket, Dial Scale Left Side	1	
26	SDH461A	Plate, Dial Scale	1	*
26-1	SGLA9	Panel Light, Orange	1	
26-2	SNW3211	Washer, Panel Light	1	
26-3	SHP9275	Paper, Panel Light	1	
27	XTB3+8B	Screw, Meter Bracket M'tg	1	
28	SSM141	Meter, Signal & Tuning	1	
29	SMM29	Bracket, Meter	1	*
30	XTN3+8B	Screw, Dial Scale Bracket Right M'tg	1	
31	SGX6577	Bracket, Dial Scale Right Side	1	
32	XWG3	Washer, Right Bracket Screw	1	
33	SDP1129	Pointer, Dial	1	*
34	SHP33	Sheet, Pointer Slider	1	
35	SJS5409	Connector, 4 pin	1	
36	SDT8043-2	Shaft, Tuning	1	*
37	XWG3	Washer, Bottom Board Screw	7	
38	XTN3+10B	Screw, Bottom Board M'tg	7	
39	SKP59	Ventilation Plate	1	
40	XTN3+10B	Screw, Feet M'tg	4	
41	XWG3	Washer, Feet Screw	4	
42	SKX245-1	Foot Set	4	
43	SYU155	Bottom Board	1	*
44	SDR1	Pulley, Dial Cord	4	
45	SHD3X1F	Screw, Pulley M'tg	4	*
46	SDZ051-2	Cord, Dial 200cm (78-3/4")	1roll	
47	SDD47-1	Drum, Variable Capacitor	1	
48	SDSA4121	Spring, Dial Cord	1	
49	RHG109	Rubber Cushion, AM Bar Antenna	2	
50	XTB3+8B	Screw, Reflection Cover M'tg	2	
51	SJS2101	Holder, Dial Lamp	3	
52	SKA10170W	Cabinet	1	
53(E)	SGP1370A	Rear Panel	1	○
53(EG.XGH)	SGPA200D	Rear Panel, SGP1370A with Name Plate SGT16590	1	○
53(XAL)	SGPA200L	Rear Panel, SGP1370-2A with Name Plate SGT16710	1	○
53(XA.X)	SGP1370-1A	Rear Panel	1	○
54	SJF8013-1	Terminal, Speakers	1	
55	SJF8005	Terminal, Input & Antenna	1	
56(XA.X)only	XTN3+8BFZ	Screw, AC Outlet M'tg	2	
57	XTB3+8BFZ	Screw, Rear Panel & Fuse Cover M'tg	7	
58(XA.X)only	SJS9205-1	Socket, AC Outlet	1	
59(XAL)only	SHR131	Bushing, AC Cord	1	
59	SHR127	Bushing, AC Cord	1	
60(XAL)only	QFC1207M	AC Cord, Power Source	1	
60	RJA23ZC	AC Cord, Power Source	1	
61	SHR401-1	Latch, Speaker & Input Terminal M'tg	6	
62	SUW1101S	Bracket, DIN Socket	1	*
63	SUV337	Cover, Speaker Fuses	1	
64	SJS6803	Socket, DIN (Tape deck REC/PLAY)	1	
65	XSN3+6FZS	Screw, Voltage Adjuster & DIN Socket M'tg	4	
65-1	XWA3BFZ	Washer, Spring	4	

ACCESS

PACKING

REPLACEMENT PARTS LIST

- NOTES:** 1. Part numbers are indicated on most mechanical parts.
Please use this part number for parts orders.
2. ■ indicates that only parts specified by the manufacturer be used for safety.

Ref. No.	Part No.	Part Name & Description	Per Set	Remarks
CABINET and CHASSIS PARTS				
1	XTS3+8B	Screw, Front Panel M'tg	3	
2	SGWA200X	Panel, Front Ass'y	1	○
3	SBD7-2	Knob, Lever Switches	4	
4	XTB3+8B	Screw, Front Panel M'tg	2	
5	SBN755	Knob, Bass, Treble, Balance & Selector	4	
6	SBN757	Knob, Tuning	1	
6-1	SHR9383	Spacer, Tuning Knob	1	
7	SBN753	Knob, Volume	1	
8	SUS123-1	Spring, Speaker Push Switches	2	
9	SBC193	Button, Speaker Switches	2	
11	XSB4+12FZS	Screw, Cabinet M'tg	4	
12	XWA4BFZ	Washer, Spring	4	
13	XWG4FZ	Washer	4	
15	XNSS12	Nut, Headphones Jack M'tg	1	
16	SNE59-1	Washer, Headphones Jack	1	
17	XCJ6P21B-A	Jack, Headphones	1	
18	SHS187	Shading Cloth, Lever Switches	4	
19	XNS8	Nut, Volumes & Selector M'tg	5	
20	XWV8	Washer, Volumes & Selector	5	
21	XTN3+8B	Screw, Dial Scale Bracket Left M'tg	1	
22	XWG3	Washer, Left Bracket Screw	1	
23	XSB4+12FZS	Screw, Power Transformer M'tg	4	
23-1	XWA4BFZ	Washer, Spring	4	
23-2	XWG4FZ	Washer	4	
24	SGX6579	Bracket, Dial Scale Left Side	1	
26	SDH461A	Plate, Dial Scale	1	*
26-1	SGLA9	Panel Light, Orange	1	
26-2	SNW3211	Washer, Panel Light	1	
26-3	SHP9275	Paper, Panel Light	1	
27	XTB3+8B	Screw, Meter Bracket M'tg	1	
28	SSM141	Meter, Signal & Tuning	1	
29	SMM29	Bracket, Meter	1	*
30	XTN3+8B	Screw, Dial Scale Bracket Right M'tg	1	
31	SGX6577	Bracket, Dial Scale Right Side	1	
32	XWG3	Washer, Right Bracket Screw	1	
33	SDP1129	Pointer, Dial	1	*
34	SHP33	Sheet, Pointer Slider	1	
35	SJS5409	Connector, 4 pin	1	
36	SDT8043-2	Shaft, Tuning	1	*
37	XWG3	Washer, Bottom Board Screw	7	
38	XTN3+10B	Screw, Bottom Board M'tg	7	
39	SKP59	Ventilation Plate	1	
40	XTN3+10B	Screw, Feet M'tg	4	
41	XWG3	Washer, Feet Screw	4	
42	SKX245-1	Foot Set	4	
43	SYU155	Bottom Board	1	*
44	SDR1	Pulley, Dial Cord	4	
45	SHD3X1F	Screw, Pulley M'tg	4	*
46	SDZ051-2	Cord, Dial 200cm (78-3/4")	1 roll	
47	SDD47-1	Drum, Variable Capacitor	1	
48	SDSA4121	Spring, Dial Cord	1	
49	RHG109	Rubber Cushion, AM Bar Antenna	2	
50	XTB3+8B	Screw, Reflection Cover M'tg	2	
51	SJS2101	Holder, Dial Lamp	3	
52	SKA10170W	Cabinet	1	
53(E)	SGP1370A	Rear Panel	1	○
53(EG,XGH)	SGPA200D	Rear Panel, SGP1370A with Name Plate SGT16590	1	○
53(XAL)	SGPA200L	Rear Panel, SGP1370-2A with Name Plate SGT16710	1	○
53(XA,X)	SGP1370-1A	Rear Panel	1	○
54	SJF8013-1	Terminal, Speakers	1	
55	SJF8005	Terminal, Input & Antenna	1	
56(XA,X)only	XTN3+8BFZ	Screw, AC Outlet M'tg	2	
57	XTB3+8BFZ	Screw, Rear Panel & Fuse Cover M'tg	7	
58(XA,X)only	SJS9205-1'	Socket, AC Outlet	1	
59(XAL)only	SHR131	Bushing, AC Cord	1	
59	SHR127	Bushing, AC Cord	1	
60(XAL)only	QFC1207M	AC Cord, Power Source	1	
60	RJA23ZC	AC Cord, Power Source	1	
61	SHR401-1	Latch, Speaker & Input Terminal M'tg	6	
62	SUW1101S	Bracket, DIN Socket	1	*
63	SUV337	Cover, Speaker Fuses	1	*
64	SJS6803	Socket, DIN (Tape deck REC/PLAY)	1	
65	XSN3+6FZS	Screw, Voltage Adjuster & DIN Socket	4	
65-1	XWA3BFZ	Washer, Spring	4	

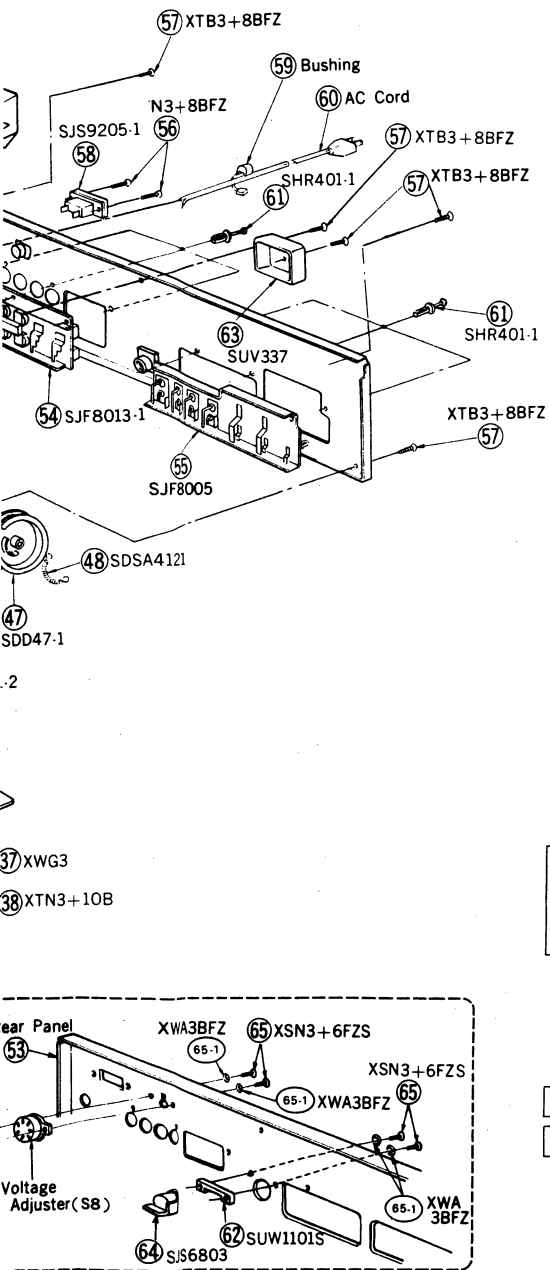

Ref. No.	Part No.	Part Name & Description	Per Set	Remarks
ACCESSORIES				
A1	SSA251	Cord, FM Indoor Antenna	1	
A2	XBA2C25SSO	Fuse, 2.5A(250V) Speaker Circuit	2	
A3(XA,X)only	SJP5213-1	Plug Adapter, AC Power	1	
PACKING PARTS				
P1	SPP495	Polyethylene Bag	1	
P2(XAL)only	SPS1591	Pad, Left Side	1	
P2	SPS1591-1	Pad, Left Side	1	
P3(XAL)only	SPS1593	Pad, Right Side	1	
P3	SPS1593-1	Pad, Right Side	1	
P4(XAL)only	SPS1651	Pad, Bottom Side	1	
P4	SPS1649	Pad, Bottom Side	1	
P5(XAL)only	SPS1657	Pad, Right Side	1	
P5	SPS1655	Pad, Right Side	1	
P6	SPS1653	Pad, Right Front Side	1	
P7(XAL)only	SPG1519	Carton Box	1	○
P7	SPG1517	Carton Box	1	○
P8(E,EG,XGH)	SQF1899	Instructions Book, Printed Matter	1	○
P8(XA,X,XAL)	SQF1901	Instructions Book, Printed Matter	1	○

- Notes:** * (X) and (XA) are available in Asia, Latin America, Middle East and Africa only.
* (XAL) is available in Australia only.
* (XGH) is available in Holland only.
* (E) and (EG) are available in Scandinavia and European only.

ACCESSORIES

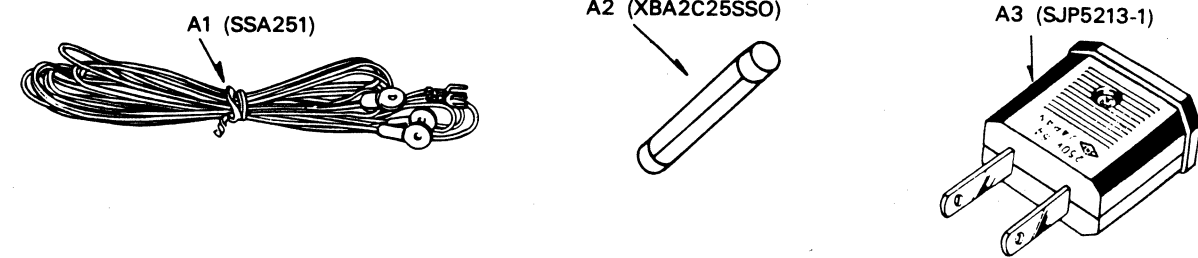

PACKINGS

