



Cisco HyperFlex HXAF240c M5 Node (All Flash)

1
2
3
4
5
6

CONTENTS

OVERVIEW	3
DETAILED VIEWS	4
Chassis Front View	4
Chassis Rear View	5
BASE NODE STANDARD CAPABILITIES and FEATURES	7
CONFIGURING the HyperFlex HXAF240c M5 Node	10
STEP 1 VERIFY SERVER SKU	11
STEP 2 SELECT RISER CARDS	12
STEP 3 SELECT CPU(s)	13
STEP 4 SELECT MEMORY	19
STEP 5 SELECT RAID CONTROLLER	24
SAS HBA (internal HDD/SSD/JBOD support)	24
STEP 6 SELECT DRIVES	25
STEP 7 SELECT PCIe OPTION CARD(s)	28
STEP 8 ORDER GPU CARDS (OPTIONAL)	30
STEP 9 SELECT ACCESSORIES	32
STEP 10 ORDER SECURITY DEVICES (OPTIONAL)	33
STEP 11 ORDER POWER SUPPLY	34
STEP 12 SELECT POWER CORD(s)	35
STEP 13 ORDER TOOL-LESS RAIL KIT AND OPTIONAL REVERSIBLE CABLE MANAGEMENT ARM	38
STEP 14 SELECT HYPERVISOR / HOST OPERATING SYSTEM	39
STEP 15 SELECT HX DATA PLATFORM SOFTWARE	40
STEP 16 SELECT INSTALLATION SERVICE	41
STEP 17 SELECT SERVICE and SUPPORT LEVEL	42
SUPPLEMENTAL MATERIAL	47
Hyperconverged Systems	47
CHASSIS	48
Block Diagram	50
Riser Card Configuration and Options	51
Serial Port Details	53
Upgrade and Servicing-Related Parts	54
KVM CABLE	56
DISCONTINUED EOL PRODUCTS	57
TECHNICAL SPECIFICATIONS	60
Dimensions and Weight	60
Power Specifications	61
Environmental Specifications	64
Extended Operating Temperature Hardware Configuration Limits	65
Compliance Requirements	66

OVERVIEW

Cisco HyperFlex™ Systems unlock the full potential of hyperconvergence. The systems are based on an end-to-end software-defined infrastructure, combining software-defined computing in the form of Cisco Unified Computing System (Cisco UCS) servers; software-defined storage with the powerful Cisco HX Data Platform and software-defined networking with the Cisco UCS fabric that will integrate smoothly with Cisco Application Centric Infrastructure (Cisco ACI™). Together with a single point of connectivity and hardware management, these technologies deliver a preintegrated and adaptable cluster that is ready to provide a unified pool of resources to power applications as your business needs dictate.

The Cisco HyperFlex HXAF240c M5 Node is shown in [Figure 1](#).

The HXAF240c M5 servers extend the capabilities of Cisco's HyperFlex portfolio in a 2U form factor with the addition of the Intel® Xeon® Processor Scalable Family, 24 DIMM slots with configuration options ranging from 128GB up to 3TB of DRAM, and an all flash footprint of cache and capacity drives for highly available, high performance storage.

The latest update includes support for 2nd Generation Intel® Xeon® Scalable Processors, 2933-MHz DDR4 memory

Figure 1 Cisco HyperFlex HXAF240c M5 Node

Front View Front View with Bezel attached



Front View Front View with Bezel removed



Rear View



DETAILED VIEWS

Chassis Front View

Figure 2 shows the front view of the Cisco HyperFlex HXAF240c M5 Node

Figure 2 Chassis Front View

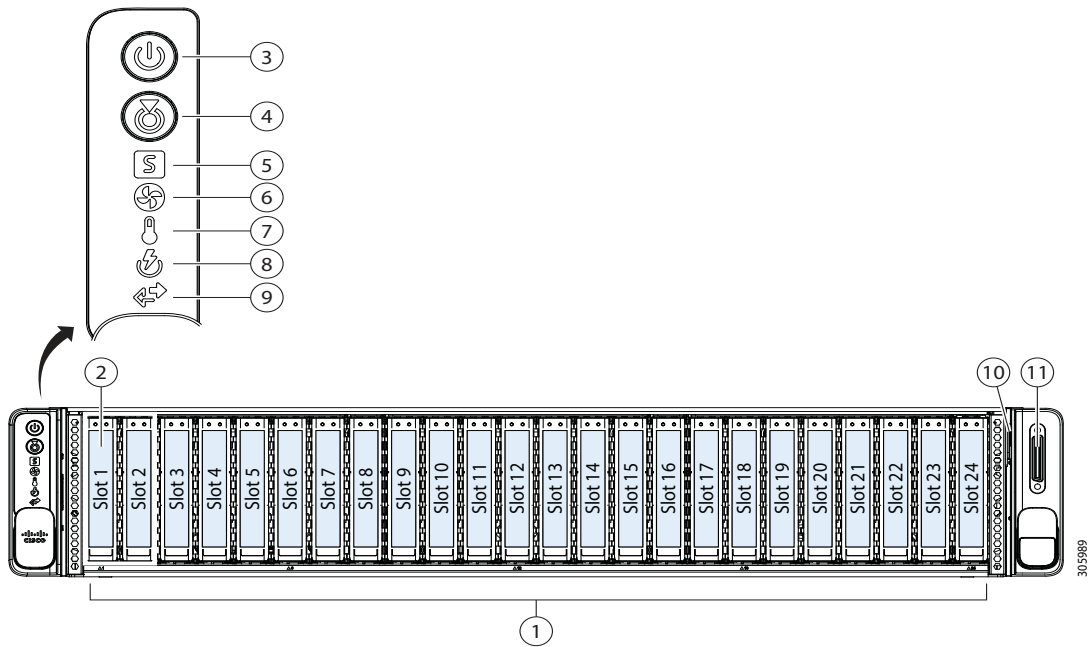

1	<p>Drive Slots:</p> <p>Slot 01 (For HyperFlex System/Log drive)</p> <ul style="list-style-type: none"> • 1 x SATA SSD <p>Slot 02 through 24 (For Capacity drives)</p> <ul style="list-style-type: none"> • Up to 23 x SATA SSD OR • Up to 23 x SED SATA SSD OR • Up to 23 x SED SAS SSD 	7	Temperature status LED
2	N/A	8	Power supply status LED
3	Power button/LED	9	Network link activity LED
4	Unit identification button/LED	10	Pull-out asset tag
5	System status LED	11	KVM connector (used with KVM cable that provides two USB 2.0, one VGA, and one serial connector)
6	Fan status LED	—	—

Chassis Rear View

Figure 3 shows the external features of the rear panel.

Figure 3 Chassis Rear View

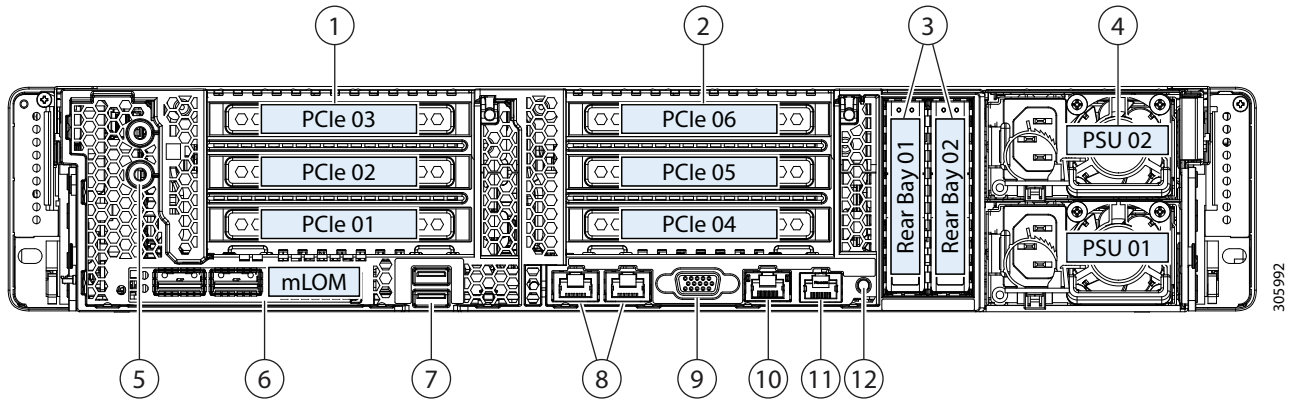

305992

1	<p>PCIe riser 1 (slots 1, 2, 3)</p> <ul style="list-style-type: none"> ■ Riser 1A <ul style="list-style-type: none"> • slot 1 (x8, CPU1 controlled, full height, 3/4 length, 230 pins) • slot 2 (x16, CPU1 controlled, Full height, full length, 230 Pins) - for GPU • slot 3 (x8, CPU2 controlled, full height, half length, 164 pins) ■ Riser 2B (Riser 1B 3PCIe slots all from CPU1) <ul style="list-style-type: none"> HX-RIS-1B-240M5 • slot 1 (x8, CPU1 controlled) • slot 2 (x8, CPU1 controlled) • slot 3(x8, CPU1 controlled) 	7	USB 3.0 ports (two)
2	<p>PCIe riser 2 (slots 4, 5, 6)</p> <ul style="list-style-type: none"> ■ Riser 2B <ul style="list-style-type: none"> • slot 4 (x8, CPU2 controlled) • slot 5 (x16, CPU2 controlled) - for GPU • slot 6 (x8, CPU2 controlled) • One x8 NVMe connector (for rear NVMe drive) from slot 4 • Use of PCIe riser 2 requires a dual CPU configuration. 	8	Dual 1/10GE ports (LAN1, LAN2) LAN1 /is left connector, LAN2 is right connector

DETAILED VIEWS

3	Rear 2.5-inch drive bays: ■ For SAS SSD/ NVMe drive for Caching	9	VGA video port (DB-15 connector)
4	Power supplies (two, redundant as 1+1)	10	1GE dedicated management port
5	Screw holes for dual-hole grounding lug	11	Serial port (RJ-45 connector)
6	Modular LAN-on-motherboard (mLOM) card slot (x16)	12	Rear Unit Identification button/LED

BASE NODE STANDARD CAPABILITIES and FEATURES

Table 1 lists the capabilities and features of the base server. Details about how to configure the server for a particular feature or capability (for example, number of processors, disk drives, or amount of memory) are provided in [CONFIGURING the HyperFlex HXAF240c M5 Node, page 10](#).

Table 1 Capabilities and Features

Capability/Feature	Description
Chassis	Two rack unit (2RU) chassis
CPU	Intel® Xeon® scalable family CPUs and 2nd Generation Intel® Xeon® scalable family CPUs
Chipset	Intel® C621 series chipset
Memory	24 slots for registered ECC DIMMs (RDIMMs), load-reduced DIMMs (LRDIMMs), or through silicon via (TSV) DIMMs
Multi-bit Error Protection	This server supports multi-bit error protection.
Video	The Cisco Integrated Management Controller (CIMC) provides video using the ASPEED Pilot 4 video/graphics controller: <ul style="list-style-type: none"> ■ Integrated 2D graphics core with hardware acceleration ■ 512MB total DDR4 memory, with 16MB dedicated to Matrox video memory ■ Supports all display resolutions up to 1920 x 1200 x 32bpp resolution at 60Hz ■ High speed Integrated 24-bit RAMDAC ■ Single lane PCI-Express Gen2 host interface ■ eSPI processor to BMC support
Power subsystem	One or two of the following hot-swappable power supplies: <ul style="list-style-type: none"> ■ 1050 W (AC) ■ 1050 W (DC) ■ 1600 W (AC) One power supply is mandatory; one more can be added for 1 + 1 redundancy.
Front Panel	A front panel controller provides status indications and control buttons.
ACPI	This server supports the advanced configuration and power interface (ACPI) 4.0 standard.
Fans	<ul style="list-style-type: none"> ■ Six hot-swappable fans for front-to-rear cooling
Expansion slots	<ul style="list-style-type: none"> ■ Dedicated RAID/JBOD controller slot (see Figure 6 on page 48) <ul style="list-style-type: none"> • An internal slot is reserved for the Cisco 12G SAS HBA. ■ Dedicated slots for Riser 1 and Riser 2 <ul style="list-style-type: none"> • For more details on riser 1 and riser 2 see the Riser options section below

Table 1 Capabilities and Features (*continued*)

Capability/Feature	Description
Internal storage devices	<p>Up to 24 Drives are installed into front-panel drive bays that provide hot-swappable access for SAS/SATA drives. 24 Drives are used as below:</p> <ul style="list-style-type: none"> • Up to 23 SATA SSD OR Up to 23 SED SATA/SAS SSD (for capacity) • One SATA SSD (System drive for HXDP Operations) <p>One rear drive slot for caching drives</p> <ul style="list-style-type: none"> • One NVMe SSD OR One SAS SSD OR One SED SAS SSD (for caching) <p>A mini-storage module connector on the motherboard for M.2 module for one M.2 SATA SSDs for following usage:</p> <ul style="list-style-type: none"> • ESXi hypervisor boot and HyperFlex storage controller VM <p>One socket for one micro-SD card on PCIe Riser 1 for following usage:</p> <ul style="list-style-type: none"> • The micro-SD card serves as a dedicated local resource for utilities such as host upgrade utility HUU. Images can be pulled from a file share (NFS/CIFS) and uploaded to the cards for future use.
I/O Interfaces	<ul style="list-style-type: none"> ■ One slot for a micro-SD card on PCIe Riser 1 (Option 1 and 1B). The micro-SD card serves as a dedicated local resource for utilities such as host upgrade utility (HUU). Images can be pulled from a file share (NFS/CIFS) and uploaded to the cards for future use. ■ Rear panel <ul style="list-style-type: none"> • One 1Gbase-T RJ-45 management port (Marvell 88E6176) • Two 10Gbase-T LOM ports (Intel X550 controller embedded on the motherboard) • One RS-232 serial port (RJ45 connector) • One DB15 VGA connector • Two USB 3.0 port connectors • One flexible modular LAN on motherboard (mLOM) slot that can accommodate various interface cards ■ Front panel <ul style="list-style-type: none"> • One KVM console connector (supplies two USB 2.0 connectors, one VGA DB15 video connector, and one serial port (RS232))
Modular LAN on Motherboard (mLOM) slot	<p>The dedicated mLOM slot on the motherboard can flexibly accommodate the following cards:</p> <ul style="list-style-type: none"> ■ Cisco 1457 Quad Port Virtual Interface Card (10GE/25GE)
	<p>NOTE:</p> <ul style="list-style-type: none"> ■ 1387 VIC natively supports 6300 series FIs. ■ To support 6200 series FIs with 1387, 10G QSAs compatible with 1387 are available for purchase. ■ Breakout cables are not supported with 1387 ■ Use of 10GE is not permitted with 6300 series FI

Table 1 Capabilities and Features (*continued*)

Capability/Feature	Description
(optional) Additional NICs	<p>PCIe slot 1 and PCIe slot 2 on the motherboard can flexibly accommodate the following cards:</p> <ul style="list-style-type: none"> ■ Intel X550-T2 dual port 10Gbase-T ■ Intel XXV710-DA2 dual port 25GE NIC ■ Intel i350 quad port 1Gbase-T ■ Intel X710-DA2 dual port 10GE NIC
Integrated management processor	<p>Baseboard Management Controller (BMC) running Cisco Integrated Management Controller (CIMC) firmware.</p> <p>Depending on your CIMC settings, the CIMC can be accessed through the 1GE dedicated management port, the 1/10 GE LOM ports, or a Cisco virtual interface card (VIC).</p> <p>CIMC manages certain components within the server, such as the Cisco 12G SAS HBA.</p>
UCSM	<p>Unified Computing System Manager (UCSM) runs in the Fabric Interconnect and automatically discovers and provisions some of the server components.</p>

CONFIGURING the HyperFlex HXAF240c M5 Node

Follow these steps to configure the Cisco HyperFlex HXAF240c M5 Node

- *STEP 1 VERIFY SERVER SKU, page 11*
- *STEP 2 SELECT RISER CARDS, page 12*
- *STEP 3 SELECT CPU(s), page 13*
- *STEP 4 SELECT MEMORY, page 19*
- *STEP 5 SELECT RAID CONTROLLER, page 24*
- *STEP 6 SELECT DRIVES, page 25*
- *STEP 7 SELECT PCIe OPTION CARD(s), page 28*
- *STEP 8 ORDER GPU CARDS (OPTIONAL), page 30*
- *STEP 9 SELECT ACCESSORIES, page 32*
- *STEP 10 ORDER SECURITY DEVICES (OPTIONAL), page 33*
- *STEP 12 SELECT POWER CORD(s), page 35*
- *STEP 13 ORDER TOOL-LESS RAIL KIT AND OPTIONAL REVERSIBLE CABLE MANAGEMENT ARM, page 38*
- *STEP 14 SELECT HYPERVISOR / HOST OPERATING SYSTEM, page 39*
- *STEP 15 SELECT HX DATA PLATFORM SOFTWARE, page 40*
- *STEP 16 SELECT INSTALLATION SERVICE, page 41*
- *STEP 17 SELECT SERVICE and SUPPORT LEVEL, page 42*
- *SUPPLEMENTAL MATERIAL, page 47*

STEP 1 VERIFY SERVER SKU

Verify the product ID (PID) of the server as shown in [Table 2](#).

Table 2 PID of the HXAF240c M5 Node

Product ID (PID)	Description
HXAF-M5S-HXDP	This major line bundle (MLB) consists of the Server Nodes (HXAF220c-M5SX and HXAF240C-M5SX) with HXDP software spare PIDs
HXAF240C-M5SX ¹	HXAF240c M5 Node, with two CPUs, memory, upto 23 SSDs for data storage, one SSD for system/HXDP logs, one SSD for caching, two power supplies, one M.2 SATA SSD, one micro-SD card, one VIC 1387 mLOM card, no PCIe cards, and no rail kit
HXAF2X0C-M5S	This major line bundle (MLB) consists of the Server Nodes (HXAF220C-M5SX and HXAF240C-M5SX), Fabric Interconnects (HX-FI-6248UP, HX-FI-6296UP, HX-FI-6332, HX-FI-6332-16UP) and HXDP software spare PIDs.

Notes:

1. This product may not be purchased outside of the approved bundles (must be ordered under the MLB).

The HXAF240c M5 Node:

- Requires configuration of one or two power supplies, one or two CPUs, recommended memory sizes, 1 SSD for Caching, 1 SSD for system logs, up to 23 data HDDs, 1 VIC mLOM card, 1 M.2 SATA SSD and 1 micro-SD card.
- Provides option to choose 10G QSAs to connect with HX-FI-6248UP and HX-FI-6296UP
- Provides option to choose rail kits.



NOTE: Use the steps on the following pages to configure the node with the components that you want to include.

STEP 2 SELECT RISER CARDS

There are two riser cards per server, riser card 1 and 2. Order one riser card 1 and one riser 2 card from [Table 3](#). Riser card 1 is the one on the left when viewed from the back of the server and riser card 2 is on the right.

Table 3 Riser 1 Options

Product ID (PID)	Description
PCIe Riser 1 options	
HX-RIS-1B-240M5	Riser 1B 3PCIe slots (x8, x8, x8); all from CPU1, For T4
HX-RIS-1-240M5	Riser 1 3PCIe slots (x8, x16, x8); slot 3 req CPU2, For T4, RTX
PCIe Riser 2 options (all slots controlled with CPU2)	
HX-RIS-2B-240M5	Riser 2B 3PCIe slot(x8,x16,x8) supports GPU+rear NVMe, For T4, RTX

For additional details, see [Riser Card Configuration and Options, page 51](#)

STEP 3 SELECT CPU(s)

The standard CPU features are:

- Intel® Xeon® processor scalable family CPUs and 2nd Generation Intel® Xeon® scalable family CPUs
- 8 cores and up required for Dual CPU
- 16 cores and up required for Single CPU
- Intel C621 series chipset
- Cache size of up to 38.5 MB

Select CPUs

The available CPUs are listed in [Table 4](#).

Table 4 Available CPUs

Product ID (PID)	Clock Freq (GHz)	Power (W)	Cache Size (MB)	Cores	UPI ¹ Links (GT/s)	Highest DDR4 DIMM Clock Support (MHz)	Workload/Processor type
Cisco Recommended CPUs (2 nd Generation Intel® Xeon® Processors)							
HX-CPU-I8276	2.2	165	38.50	28	3 x 10.4	2933	Oracle, SAP
HX-CPU-I8260	2.4	165	35.75	24	3 x 10.4	2933	Microsoft Azure Stack
HX-CPU-I6262V	1.9	135	33.00	24	3 x 10.4	2400	Virtual Server infrastructure or VSI
HX-CPU-I6248R	3.0	205	35.75	24	2 x 10.4	2933	
HX-CPU-I6248	2.5	150	27.50	20	3 x 10.4	2933	VDI, Oracle, SQL, Microsoft Azure Stack
HX-CPU-I6238R	2.2	165	38.50	28	2 x 10.4	2933	Oracle, SAP (2-Socket TDI only), Microsoft AzureStack
HX-CPU-I6238	2.1	140	30.25	22	3 x 10.4	2933	SAP
HX-CPU-I6230R	2.1	150	35.75	26	2 x 10.4	2933	Virtual Server Infrastructure, Data Protection, Big Data, Splunk, Microsoft AzureStack
HX-CPU-I6230	2.1	125	27.50	20	3 x 10.4	2933	Big Data, Virtualization
HX-CPU-I5220R	2.2	125	35.75	24	2 x 10.4	2666	Virtual Server Infrastructure, Splunk, Microsoft Azure Stack
HX-CPU-I5220	2.2	125	24.75	18	2 x 10.4	2666	HCI

Table 4 Available CPUs

Product ID (PID)	Clock Freq (GHz)	Power (W)	Cache Size (MB)	Cores	UPI ¹ Links (GT/s)	Highest DDR4 DIMM Clock Support (MHz)	Workload/Processor type
HX-CPU-I5218R	2.1	125	27.50	20	2 x 10.4	2666	Virtual Server Infrastructure, Data Protection, Big Data, Splunk, Scale-out Object Storage, Microsoft AzureStack
HX-CPU-I5218	2.3	125	22.00	16	2 x 10.4	2666	Virtualization, Microsoft Azure Stack, Splunk, Data Protection
HX-CPU-I4216	2.1	100	22.00	16	2 x 9.6	2400	Data Protection, Scale Out Storage
HX-CPU-I4214R	2.4	100	16.50	12	2 x 9.6	2400	Data Protection, Splunk, Scale-out Object Storage, Microsoft AzureStack
HX-CPU-I4214	2.2	85	16.50	12	2 x 9.6	2400	Data Protection, Scale Out Storage
HX-CPU-I4210R	2.4	100	13.75	10	2 x 9.6	2400	Virtual Server Infrastructure, Data Protection, Big Data, Splunk
HX-CPU-I4210	2.2	85	13.75	10	2 x 9.6	2400	Virtualization, Big Data, Splunk
8000 Series Processor							
HX-CPU-I8280L	2.7	205	38.50	28	3 x 10.4	2933	2 nd Gen Intel® Xeon®
HX-CPU-I8280	2.7	205	38.50	28	3 x 10.4	2933	2 nd Gen Intel® Xeon®
HX-CPU-I8276L	2.2	165	38.50	28	3 x 10.4	2933	2 nd Gen Intel® Xeon®
HX-CPU-I8276	2.2	165	38.50	28	3 x 10.4	2933	2 nd Gen Intel® Xeon®
HX-CPU-I8270	2.7	205	35.75	26	3 x 10.4	2933	2 nd Gen Intel® Xeon®
HX-CPU-I8268	2.9	205	35.75	24	3 x 10.4	2933	2 nd Gen Intel® Xeon®
HX-CPU-I8260Y	2.4	165	35.75	24/20/ 16	3 x 10.4	2933	2 nd Gen Intel® Xeon®
HX-CPU-I8260L	2.3	165	35.75	24	3 x 10.4	2933	2 nd Gen Intel® Xeon®
HX-CPU-I8260	2.4	165	35.75	24	3 x 10.4	2933	2 nd Gen Intel® Xeon®
HX-CPU-8180M	2.5	205	38.50	28	3 x 10.4	2666	Intel® Xeon®
HX-CPU-8176M	2.1	165	38.50	28	3 x 10.4	2666	Intel® Xeon®
HX-CPU-8170M	2.1	165	35.75	26	3 x 10.4	2666	Intel® Xeon®
HX-CPU-8160M	2.1	150	33.00	24	3 x 10.4	2666	Intel® Xeon®
HX-CPU-8180	2.5	205	38.50	28	3 x 10.4	2666	Intel® Xeon®
HX-CPU-8176	2.1	165	38.50	28	3 x 10.4	2666	Intel® Xeon®

Table 4 Available CPUs

Product ID (PID)	Clock Freq (GHz)	Power (W)	Cache Size (MB)	Cores	UPI ¹ Links (GT/s)	Highest DDR4 DIMM Clock Support (MHz)	Workload/Processor type
HX-CPU-8170	2.1	165	35.75	26	3 x 10.4	2666	Intel® Xeon®
HX-CPU-8168	2.7	205	33.00	24	3 x 10.4	2666	Intel® Xeon®
HX-CPU-8164	2.0	150	35.75	26	3 x 10.4	2666	Intel® Xeon®
HX-CPU-8160	2.1	150	33.00	24	3 x 10.4	2666	Intel® Xeon®
HX-CPU-8158	3.0	150	24.75	12	3 x 10.4	2666	Intel® Xeon®
HX-CPU-8153	2.0	125	22.00	16	3 x 10.4	2666	Intel® Xeon®
6000 Series Processor							
HX-CPU-I6262V	1.9	135	33.00	24	3 x 10.4	2400	2 nd Gen Intel® Xeon®
HX-CPU-I6258R	2.7	205	35.75	28	2 x 10.4	2933	2 nd Gen Intel® Xeon®
HX-CPU-I6256	3.6	205	33.00	12	2 x 10.4	2933	2 nd Gen Intel® Xeon®
HX-CPU-I6254	3.1	200	24.75	18	3 x 10.4	2933	2 nd Gen Intel® Xeon®
HX-CPU-I6252N	2.3	150	35.75	24	3 x 10.4	2933	2 nd Gen Intel® Xeon®
HX-CPU-I6252	2.1	150	35.75	24	3 x 10.4	2933	2 nd Gen Intel® Xeon®
HX-CPU-I6250	3.9	185	35.75	8	2 x 10.4	2933	2 nd Gen Intel® Xeon®
HX-CPU-I6248R	3.0	205	35.75	24	2 x 10.4	2933	2 nd Gen Intel® Xeon®
HX-CPU-I6248	2.5	150	27.50	20	3 x 10.4	2933	2 nd Gen Intel® Xeon®
HX-CPU-I6246R	3.4	205	35.75	16	2 x 10.4	2933	2 nd Gen Intel® Xeon®
HX-CPU-I6246	3.3	165	24.75	12	3 x 10.4	2933	2 nd Gen Intel® Xeon®
HX-CPU-I6244	3.6	150	24.75	8	3 x 10.4	2933	2 nd Gen Intel® Xeon®
HX-CPU-I6242R	3.1	205	35.75	20	2 x 10.4	2933	2 nd Gen Intel® Xeon®
HX-CPU-I6242	2.8	150	22.00	16	3 x 10.4	2933	2 nd Gen Intel® Xeon®
HX-CPU-I6240R	2.4	165	35.75	24	2 x 10.4	2933	2 nd Gen Intel® Xeon®
HX-CPU-I6240Y	2.6	150	24.75	18/14/ 8	3 x 10.4	2933	2 nd Gen Intel® Xeon®
HX-CPU-I6240L	2.6	150	24.75	18	3 x 10.4	2933	2 nd Gen Intel® Xeon®
HX-CPU-I6240	2.6	150	24.75	18	3 x 10.4	2933	2 nd Gen Intel® Xeon®
HX-CPU-I6238R	2.2	165	38.50	28	2 x 10.4	2933	2 nd Gen Intel® Xeon®
HX-CPU-I6238L	2.1	140	30.25	22	3 x 10.4	2933	2 nd Gen Intel® Xeon®
HX-CPU-I6238	2.1	140	30.25	22	3 x 10.4	2933	2 nd Gen Intel® Xeon®
HX-CPU-I6234	3.3	130	24.75	8	3 x 10.4	2933	2 nd Gen Intel® Xeon®
HX-CPU-I6230R	2.1	150	35.75	26	2 x 10.4	2933	2 nd Gen Intel® Xeon®
HX-CPU-I6230N	2.3	125	27.50	20	3 x 10.4	2933	2 nd Gen Intel® Xeon®
HX-CPU-I6230	2.1	125	27.50	20	3 x 10.4	2933	2 nd Gen Intel® Xeon®
HX-CPU-I6226R	2.8	150	22.00	16	2 x 10.4	2933	2 nd Gen Intel® Xeon®

Table 4 Available CPUs

Product ID (PID)	Clock Freq (GHz)	Power (W)	Cache Size (MB)	Cores	UPI ¹ Links (GT/s)	Highest DDR4 DIMM Clock Support (MHz)	Workload/Processor type
HX-CPU-I6226	2.7	125	19.25	12	3 x 10.4	2933	2 nd Gen Intel® Xeon®
HX-CPU-I6222V	1.8	115	27.50	20	3 x 10.4	2400	2 nd Gen Intel® Xeon®
HX-CPU-6142M	2.6	150	22.00	16	3 x 10.4	2666	Intel® Xeon®
HX-CPU-6140M	2.3	140	24.75	18	3 x 10.4	2666	Intel® Xeon®
HX-CPU-6134M	3.2	130	24.75	8	3 x 10.4	2666	Intel® Xeon®
HX-CPU-6154	3.0	200	24.75	18	3 x 10.4	2666	Intel® Xeon®
HX-CPU-6152	2.1	140	30.25	22	3 x 10.4	2666	Intel® Xeon®
HX-CPU-6150	2.7	165	24.75	18	3 x 10.4	2666	Intel® Xeon®
HX-CPU-6148	2.4	150	27.50	20	3 x 10.4	2666	Intel® Xeon®
HX-CPU-6146	3.2	165	24.75	12	3 x 10.4	2666	Intel® Xeon®
HX-CPU-6144	3.5	150	24.75	8	3 x 10.4	2666	Intel® Xeon®
HX-CPU-6142	2.6	150	22.00	16	3 x 10.4	2666	Intel® Xeon®
HX-CPU-6140	2.3	140	24.75	18	3 x 10.4	2666	Intel® Xeon®
HX-CPU-6138	2.0	125	27.50	20	3 x 10.4	2666	Intel® Xeon®
HX-CPU-6136	3.0	150	24.75	12	3 x 10.4	2666	Intel® Xeon®
HX-CPU-6134	3.2	130	24.75	8	3 X 10.4	2666	Intel® Xeon®
HX-CPU-6132	2.6	140	19.25	14	3 x 10.4	2666	Intel® Xeon®
HX-CPU-6130	2.1	125	22.00	16	3 x 10.4	2666	Intel® Xeon®
HX-CPU-6126	2.6	125	19.25	12	3 x 10.4	2666	Intel® Xeon®
5000 Series Processor							
HX-CPU-I5220S	2.6	125	19.25	18	2 x 10.4	2666	2 nd Gen Intel® Xeon®
HX-CPU-I5220R	2.2	150	35.75	24	2 x 10.4	2666	2 nd Gen Intel® Xeon®
HX-CPU-I5220	2.2	125	24.75	18	2 x 10.4	2666	2 nd Gen Intel® Xeon®
HX-CPU-I5218R	2.1	125	27.50	20	2 x 10.4	2666	2 nd Gen Intel® Xeon®
HX-CPU-I5218B	2.3	125	22.00	16	2 x 10.4	2933	2 nd Gen Intel® Xeon®
HX-CPU-I5218N	2.3	105	22.00	16	2 x 10.4	2666	2 nd Gen Intel® Xeon®
HX-CPU-I5218	2.3	125	22.00	16	2 x 10.4	2666	2 nd Gen Intel® Xeon®
HX-CPU-I5217	3.0	115	11.00	8	2 x 10.4	2666	2 nd Gen Intel® Xeon®
HX-CPU-I5215L	2.5	85	13.75	10	2 x 10.4	2666	2 nd Gen Intel® Xeon®
HX-CPU-I5215	2.5	85	13.75	10	2 x 10.4	2666	2 nd Gen Intel® Xeon®
HX-CPU-5120	2.2	105	19.25	14	2 x 10.4	2400	Intel® Xeon®
HX-CPU-5118	2.3	105	16.50	12	2 x 10.4	2400	Intel® Xeon®
HX-CPU-5117	2.0	105	19.25	14	2 x 10.4	2400	Intel® Xeon®
HX-CPU-5115	2.4	85	13.75	10	2 x 10.4	2400	Intel® Xeon®

Table 4 Available CPUs

Product ID (PID)	Clock Freq (GHz)	Power (W)	Cache Size (MB)	Cores	UPI ¹ Links (GT/s)	Highest DDR4 DIMM Clock Support (MHz)	Workload/Processor type
4000 Series Processor							
HX-CPU-I4216	2.1	100	22.00	16	2 x 9.6	2400	2 nd Gen Intel® Xeon®
HX-CPU-I4215R	3.2	130	11.00	8	2 x 9.6	2400	2 nd Gen Intel® Xeon®
HX-CPU-I4215	2.5	85	11.00	8	2 x 9.6	2400	2 nd Gen Intel® Xeon®
HX-CPU-I4214R	2.4	100	16.50	12	2 x 9.6	2400	2 nd Gen Intel® Xeon®
HX-CPU-I4214Y	2.2	85	16.50	12/10/8	2 x 9.6	2400	2 nd Gen Intel® Xeon®
HX-CPU-I4214	2.2	85	16.50	12	2 x 9.6	2400	2 nd Gen Intel® Xeon®
HX-CPU-I4210R	2.4	100	13.75	10	2 x 9.6	2400	2 nd Gen Intel® Xeon®
HX-CPU-I4210	2.2	85	13.75	10	2 x 9.6	2400	2 nd Gen Intel® Xeon®
HX-CPU-I4208	2.1	85	11.00	8	2 x 9.6	2400	2 nd Gen Intel® Xeon®
HX-CPU-4116	2.1	85	16.50	12	2 x 9.6	2400	Intel® Xeon®
HX-CPU-4114	2.2	85	13.75	10	2 x 9.6	2400	Intel® Xeon®
HX-CPU-4110	2.1	85	11.00	8	2 x 9.6	2400	Intel® Xeon®
HX-CPU-4108	1.8	85	11.00	8	2 x 9.6	2400	Intel® Xeon®
3000 Series Processor							
HX-CPU-I3206R	1.9	85	11.00	8	2 x 9.6	2133	2 nd Gen Intel® Xeon®
HX-CPU-3106	1.7	85	11.00	8	2 x 9.6	2133	Intel® Xeon®

Notes:

- UPI = Ultra Path Interconnect. 2-socket servers support only 2 UPI performance, even if the CPU supports 3 UPI.



CAUTION: For systems configured with 2nd Gen Intel® Xeon® 205W R-series processors, operating above 32° C [89.6° F], a fan fault or executing workloads with extensive use of heavy instructions sets like Intel® Advanced Vector Extensions 512 (Intel® AVX-512), may assert thermal and/or performance faults with an associated event recorded in the System Event Log (SEL).

- HX-CPU-I6258R - Intel 6258R 2.7GHz/205W 28C/35.75MB DDR4 2933MHz
- HX-CPU-I6248R - Intel 6248R 3.0GHz/205W 24C/35.75MB DDR4 2933MHz
- HX-CPU-I6246R - Intel 6246R 3.4GHz/205W 16C/35.75MB DDR4 2933MHz
- HX-CPU-I6242R - Intel 6242R 3.1GHz/205W 20C/35.75MB DDR4 2933MHz

Approved Configurations

(1) 1-CPU Configuration:

- Select any one CPU listed in [Table 4 on page 13](#)

- Requires 16 Core and above CPUs
- Requires HX-RIS-1B-240M5, Riser 1B 3PCIe slots (x8, x8, x8); all from CPU1
 - Supports only 3 PCIe slots for any combination of GPU, NICs, Hercules PCIe-Offload
- Does not support Riser Card 2 (from 2nd CPU).
 - No NVMe or Optane CACHE support from 1 socket configs

(2) 2-CPU Configuration:

- Select two identical CPUs from any one of the rows of [Table 4 on page 13](#).

STEP 4 SELECT MEMORY

The standard memory features are:

- DIMMs
 - Clock speed: 2666 MHz or 2933 MHz depending on CPU type



NOTE: The compatibility of Intel® Xeon® scalable processor family CPUs and 2nd Generation Intel® Xeon® Scalable CPUs with different DIMM memory speeds and production servers is as shown below:

CPU Family	DIMM Speed (MHz)	Configuration
Intel Scalable CPUs	2666	2666 MHz DIMMs are supported for all production servers
	2933	2933 MHz DIMMs are not supported for new production servers
2 nd Gen Intel Scalable CPUs	2666	2666 MHz DIMMs are only supported when upgrading from Intel Scalable CPUs to 2 nd Gen Intel Scalable CPUs
	2933	2933 MHz is the only DIMM speed supported for new production servers

- Ranks per DIMM: 1, 2, 4, or 8
 - Operational voltage: 1.2 V
 - Registered ECC DDR4 DIMMs (RDIMMs), load-reduced DIMMs (LR-DIMMs), or through-silicon-via DIMMs (TSV-DIMMs).
- Memory is organized with six memory channels per CPU, with up to two DIMMs per channel, as shown in [Figure 4](#).

Figure 4 HXAF240c M5 Node Memory Organization

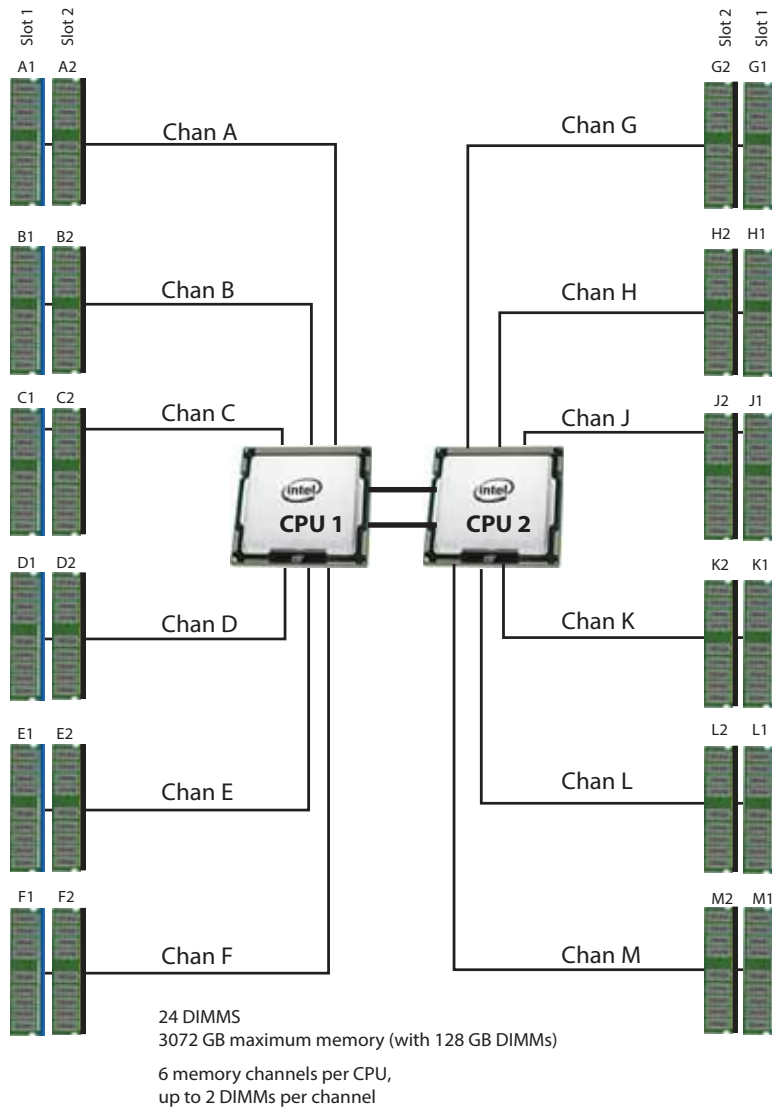

Select DIMMs

Select the memory configuration. The available memory DIMMs are listed in [Table 5](#)



NOTE: The memory mirroring feature is not supported with HyperFlex nodes.

Table 5 Available DDR4 DIMMs

Product ID (PID)	PID Description	Voltage	Ranks/ DIMM
HX-MR-128G8RS-H	128 GB DDR4-2666-MHz TSV-RDIMM/8R/x4	1.2 V	8
HX-ML-X64G4RS-H	64 GB DDR4-2666-MHz LRDIMM/4R/x4	1.2 V	4
HX-MR-X64G4RS-H	64 GB DDR4-2666-MHz TSV-RDIMM/4R/x4	1.2 V	4
HX-MR-X32G2RS-H	32 GB DDR4-2666-MHz RDIMM/2R/x4	1.2 V	2
HX-MR-X16G1RS-H	16 GB DDR4-2666-MHz RDIMM/1R/x4	1.2 V	1
HX-ML-128G4RT-H	128 GB DDR4-2933-MHz LRDIMM/4Rx4 (16Gb)	1.2 V	4
HX-ML-X64G4RT-H	64 GB DDR4-2933-MHz LRDIMM/4Rx4 (8Gb)	1.2 V	4
HX-MR-X64G2RT-H	64 GB DDR4-2933-MHz RDIMM/2Rx4 (16Gb)	1.2 V	2
HX-MR-X32G2RT-H	32GB DDR4-2933-MHz RDIMM/2Rx4 (8Gb)	1.2 V	2
HX-MR-X16G1RT-H	16 GB DDR4-2933-MHz RDIMM/1Rx4 (8Gb)	1.2 V	1
Intel® Persistent Memory Product			
HX-MP-512GS-A0	Intel Optane DC Persistent Memory, 512GB, 2666MHz		
HX-MP-256GS-A0	Intel Optane DC Persistent Memory, 256GB, 2666MHz		
HX-MP-128GS-A0	Intel Optane DC Persistent Memory, 128GB, 2666MHz		
Intel® Persistent Memory Product Operational Modes			
UCS-DCPMM-AD	Intel Optane DC Persistent Memory Operational Mode - App Di		

Approved Configurations

(1) 1-CPU configuration

- Select from 1 to 12 DIMMs.

CPU 1 DIMM Placement in Channels (for identical ranked DIMMs)	
4	(A1, B1); (D1, E1)
6	(A1, B1, C1); (D1, E1, F1)
8	(A1, A2, B1, B2); (D1, D2, E1, E2)
12	(A1, A2, B1, B2, C1, C2); (D1, D2, E1, E2, F1, F2)

(2) 2-CPU configuration.

- Select 8,12 16, or 24 identical DIMMs per CPU. The DIMMs will be placed by the factory as shown in the following table

	CPU 1 DIMM Placement in Channels (for identical ranked DIMMs)	CPU 2 DIMM Placement in Channels (for identical ranked DIMMs)
	CPU 1	CPU 2
8	(A1,B1); (D1,E1)	(G1, H1); (K1, L1)
12	(A1, B1, C1); (D1, E1, F1)	(G1, H1, J1); (K1, L1, M1)
16	(A1, A2, B1, B2); (D1, D2, E1, E2)	(G1, G2, H1, H2); (K1, K2, L1, L2)
24	(A1, A2, B1, B2, C1, C2); (D1, D2, E1, E2, F1, F2)	(G1, G2, H1, H2, J1, J2); (K1, K2, L1, L2, M1, M2)



NOTE: System performance is optimized when the DIMM type and quantity are equal for both CPUs, and when all channels are filled equally across the CPUs in the server.

Table 6 2933-MHz DIMM Memory Speeds with Different 2nd Generation Intel® Xeon® Scalable Processors

DIMM and CPU Frequencies (MHz)	DPC	LRDIMM (4Rx4)- 128 GB (MHz)	LRDIMM (4Rx4) - 64 GB (MHz)	RDIMM (2Rx4) - 64 GB (MHz)	RDIMM (2Rx4) - 32 GB (MHz)	RDIMM (1Rx4) - 16 GB (MHz)
		1.2 V	1.2 V	1.2 V	1.2 V	1.2 V
DIMM = 2933 CPU = 2933	1DPC	2933	2933	2933	2933	2933
	2DPC	2933	2933	2933	2933	2933
DIMM = 2933 CPU = 2666	1DPC	2666	2666	2666	2666	2666
	2DPC	2666	2666	2666	2666	2666
DIMM = 2933 CPU = 2400	1DPC	2400	2400	2400	2400	2400
	2DPC	2400	2400	2400	2400	2400
DIMM = 2933 CPU = 2133	1DPC	2133	2133	2133	2133	2133
	2DPC	2133	2133	2133	2133	2133

Table 7 2666-MHz DIMM Memory Speeds with Different Intel® Xeon® Scalable Processors

DIMM and CPU Frequencies (MHz)	DPC	TSV-RDIMM (8Rx4) - 128 GB (MHz)	TSV-RDIMM (4Rx4) - 64 GB (MHz)	LRDIMM (4Rx4) - 64 GB (MHz)	RDIMM (2Rx4) - 32 GB (MHz)	LRDIMM (2Rx4) - 32 GB (MHz)
		1.2 V	1.2 V	1.2 V	1.2 V	1.2 V
DIMM = 2666 CPU = 2666	1DPC	2666	2666	2666	2666	2666
	2DPC	2666	2666	2666	2666	2666
DIMM = 2666 CPU = 2400	1DPC	2400	2400	2400	2400	2400
	2DPC	2400	2400	2400	2400	2400
DIMM = 2666 CPU = 2133	1DPC	2133	2133	2133	2133	2133
	2DPC	2133	2133	2133	2133	2133

STEP 5 SELECT RAID CONTROLLER

SAS HBA (internal HDD/SSD/JBOD support)

Choose the following SAS HBA for internal drive connectivity (non-RAID):

- The Cisco 12G SAS HBA, which plugs into a dedicated RAID controller slot.

Select Controller Options

Select the following:

- Cisco 12 Gbps Modular SAS HBA (see [Table 8](#))

Table 8 Hardware Controller Options

Product ID (PID)	PID Description
Controllers for Internal Drives	
Note that the following Cisco 12G SAS HBA controller is factory-installed in the dedicated internal slot.	
HX-SAS-M5HD	Cisco 12G SAS HBA <ul style="list-style-type: none"> ■ Supports up to 26 internal SAS HDDs and SAS/SATA SSDs ■ Supports JBOD mode only (no RAID functionality. Ideal for SDS (Software Defined Storage) applications. It is also ideal for environments demanding the highest IOPs (for external SSD attach), where a RAID controller can be an I/O bottleneck.

Approved Configurations

The Cisco 12 Gbps Modular SAS HBA supports up to 26 internal drives with non-RAID support.

STEP 6 SELECT DRIVES

The standard disk drive features are:

- 2.5-inch small form factor
- Hot-pluggable
- Drives come mounted in sleds

Select Drives

The available drives are listed in [Table 9](#)



NOTE: All SED HDDs are FIPS 140-2 compliant.
FIPS compliant SED SSDs are indicated below.

Table 9 Available Hot-Pluggable Sled-Mounted HDDs and SSDs

Product ID (PID)	PID Description	Drive Type	Capacity
Capacity Drives			
HX-SD960GBHTNK9**	[FIPS Compliant] 960GB Enterprise value 12G SAS SSD (1X FWPD, SED)	SAS	960 GB
HX-SD38T2HTNK9**	[FIPS Compliant] 3.8TB Enterprise value SAS SSD (1X FWPD, SED) (HyperFlex Release 4.0(2a) and later)	SAS	3.8 TB
HX-SD960G61X-EV	960GB 2.5 Inch Enterprise Value 6G SATA SSD (1X endurance)	SATA	960 GB
HX-SD960GBE1NK9**	960GB 2.5 inch Ent. Value 6G SATA SED SSD (1X endurance)	SATA	960 GB
HX-SD960GBM2NK9**	960GB Enterprise value SATA SSD (1X, SED) (HyperFlex Release 4.0(2c) and later)	SATA	960 GB
HX-SD38T61X-EV	3.8TB 2.5 inch Enterprise Value 6G SATA SSD (1X endurance)	SATA	3.8 TB
HX-SD38TBE1NK9**	3.8TB 2.5 inch Ent. Value 6G SATA SED SSD (1X endurance) (HyperFlex Release 4.0(2c) and later)	SATA	3.8 TB
HX-SD76T61X-EV	7.6TB 2.5 inch Enterprise Value 6G SATA SSD (1X endurance) (HyperFlex Release 4.0(2a) and later)	SATA	7.6 TB
HX-SD76TBEM2NK9**	7.6TB Enterprise value SATA SSD (1X endurance, SED) (HyperFlex Release 4.0(2c) and later)	SATA	7.6 TB
Caching Drives			
HX-NVMEXPB-I375	375GB 2.5 inch Intel Optane Drive, Extreme Perf & Endurance (HyperFlex Release 3,5 (2h) or later)	NVMe	375 GB
HX-NVMEHW-H1600*	1.6TB 2.5 inch Ent. Perf. NVMe SSD (3X endurance)	NVMe	1.6 TB
HX-SD800G123X-EP ¹	800GB 2.5in Enterprise Performance 12G SAS SSD (3X endurance) (HyperFlex Release 4.0(2a) and later)	SAS	800 GB
HX-SD16T123X-EP ²	1.6TB 2.5 inch Enterprise performance 12G SAS SSD(3X endurance) (Requires upgrade to 3.5(2e) or later)	SAS	1.6 TB

Table 9 Available Hot-Pluggable Sled-Mounted HDDs and SSDs (continued)

Product ID (PID)	PID Description	Drive Type	Capacity
HX-SD800GBHMK9	[FIPS Compliant] 800GB Enterprise performance SAS SSD (10X FWP, SED) (HyperFlex Release 3.5(2g) or later)	SAS	800 GB
System / Log Drives			
HX-SD240GM1X-EV	240GB 2.5 inch Enterprise Value 6G SATA SSD (Requires upgrade to 3.5(1a) or later)	SATA	240 GB
Boot Drives			
HX-M2-240GB	240GB SATA M.2 SSD	SATA	240 GB
HX-M2-960GB	960GB SATA M.2 (HyperFlex Release 4.0(2a) and later)	SATA	960 GB

NOTE:

- Cisco uses solid state drives (SSDs) from a number of vendors. All solid state drives (SSDs) are subject to physical write limits and have varying maximum usage limitation specifications set by the manufacturer. Cisco will not replace any solid state drives (SSDs) that have exceeded any maximum usage specifications set by Cisco or the manufacturer, as determined solely by Cisco.
- ** SED drive components are not supported with Microsoft Hyper-V
- * NVMe cache drive components are not supported with Microsoft Hyper-V

Notes:

1. HX-SD800G123X-EP part can used as replacement of HX-SD400G12TX-EP cache drive or expansion of a cluster containing the HX-SD400G12TX-EP as cache drive. However this requires the cluster be upgraded to 4.0(2a) or above.
2. HX-SD16T123X-EP part can used as replacement of HX-SD400G12TX-EP cache drive or expansion of a cluster containing the HX-SD400G12TX-EP as cache drive. However this requires the cluster be upgraded to 3.5(2e) or above.

Approved Configurations

Select the following drives:

- 6 to 23 capacity drives -



NOTE:

- If you select 'SED capacity' drives, you must choose 'SED cache' drives below
- HX-SD76T61X-EV requires HXDP 4.0(2a) software release.
- For cluster scale related information please see the product [release notes](#)

- One cache drive -



NOTE: 'SED cache' drive can only be selected if you have selected 'SED capacity' drives
 NVMe Cache drive is not available for SED configurations.
 NVMe Cache drives & SED drives are not supported with Microsoft Hyper-V.

- One system drive
- One boot drive

Caveats

You must choose up to 6-23 SSD Capacity drives, one caching drive, one system drive and one boot drive.

If you select SED drives, you must adhere to the following

- You must select minimum of 6 'SED capacity' drives
- All selected 'cache' and 'capacity' drives must be SED drives

STEP 7 SELECT PCIe OPTION CARD(S)

The standard PCIe card offerings is:

- Modular LAN on Motherboard (mLOM)
- Virtual Interface Card (VIC)
- Network Interface Card (NIC)

Select PCIe Option Card

The available PCIe option card is listed in [Table 10](#).

Table 10 Available PCIe Option Cards

Product ID (PID)	PID Description	Card Height
Modular LAN on Motherboard (mLOM) ¹		
HX-MLOM-C40Q-03	Cisco VIC 1387 Dual Port 40Gb QSFP CNA MLOM	N/A
HX-MLOM-C25Q-04	Cisco UCS VIC 1457 Quad Port 10/25G SFP28 CNA MLOM (Requires HX 4.0(1a) or higher)	N/A
Virtual Interface Card (VIC)		
HX-PCIE-C40Q-03	Cisco VIC 1385 Dual Port 40Gb QSFP+ CNA w/RDMA	HHHL*
HX-PCIE-C25Q-04	Cisco UCS VIC 1455 Quad Port 10/25G SFP28 CNA PCIE (Requires HX 4.0(1a) or higher)	HHHL*
Network Interface Card (NIC)		
HX-PCIE-IRJ45	Intel i350 Quad Port 1Gb Adapter	HHHL*
HX-PCIE-ID10GF	Intel X710-DA2 dual-port 10G SFP+ NIC	HHHL*
HX-PCIE-ID10GC	Intel X550-T2 dual-port 10GBase-T NIC	HHHL*
HX-PCIE-ID25GF	Intel XXV710-DA2 10-dual-port 25G NIC	HHHL*
HX PCIe Accel Engine ²		
HX-PCIE-OFFLOAD-1	Application Acceleration Engine	
* HHHL= Half Height Half length		

Notes:

1. The mLOM card does not plug into any of the riser 1 or riser 2 card slots; instead, it plugs into a connector inside the chassis.
2.
 - Optional card offloads the compression functionality to HW acceleration card. HX-PCIE-OFFLOAD-1 uses a more computationally intensive compression algorithm. This results in lower storage space and frees up CPU cycles
 - HXDP-P Enterprise licenses are required.
 - HX-PCIE-OFFLOAD-1 works with all HXDP features, including Stretched Cluster, SED drives, T4 GPUs and more
 - Native Replication (NR) will be supported in a future release

Caveats

Other considerations for the Cisco VIC 1387 card:

- VIC 1387 natively supports 6300 series FI.
- VIC 1387 also supports Cisco QSA Modules when working with HX-FI-6248UP or HX-FI-6296UP is desired.
- Breakout cables cannot be used to connect to 6200 series fabric interconnects. Use a QSA instead.
- Cisco QSA Module is available as an option under 'Accessories -> SFP'. PID for QSA is CVR-QSFP-SFP10G
- Please order two of above QSA modules when connectivity with 6200 is desired.
- Use of 10GE is not permitted with 6300 series FI.

STEP 8 ORDER GPU CARDS (OPTIONAL)

Select GPU Options

The available GPU PCIe options are listed in [Table 11](#)

Table 11 Available PCIe Option Cards

Product ID (PID)	PID Description	Card Height
GPU PCIe Cards		
HX-GPU-M10	NVIDIA M10 GPU	Double Wide (consumes 2 slots)
HX-GPU-P4	NVIDIA P4 (PG414-200), PASSIVE, 75W, 8GB PCIe Card	Low Profile Single-Width
HX-GPU-T4-16	NVIDIA T4 PCIE 75W 16GB	Low Profile Single-Width
HX-GPU-P40	NVIDIA P40	Double Wide (consumes 2 slots)
HX-GPU-V100	NVIDIA Volta 100 PCIe	Double wide (consumes 2 slots)
HX-GPU-V100-32	NVIDIA TESLA, VOLTA 100 PCIE 32GB, 250W	Double wide (consumes 2 slots)
HX-GPU-RTX6000	NVIDIA QUADRO RTX 6000, PASSIVE, 250W TGP, 24GB	Double Wide (consumes 2 slots)
HX-GPU-RTX8000	NVIDIA QUADRO RTX 8000, PASSIVE, 250W TGP, 48GB	Double Wide (consumes 2 slots)



CAUTION: When using the GPU cards, The maximum allowable operating temperature for NVIDIA P40 GPU is 32oC (89oF)



NOTE:

- All GPU cards must be procured from Cisco as there is a unique SBIOS ID required by CIMC and UCSM
- All GPU cards require two CPUs and a minimum of two power supplies in the server. 1600 W power supplies are recommended. Use the power calculator at the following link to determine the needed power based on the options chosen (CPUs, drives, memory, and so on):
- Only T4 supported with 1 CPU, max 3 with HX-RIS-1B-240M5, Riser 1B 3PCIe slots (x8, x8, x8); all from CPU1, For T4
- HX-GPU-T4-16 or HX-GPU-P4 require special riser cards (HX-RIS-1-240M5 and HX-RIS-2B-240M5) for full configuration of 5 or 6 cards.
- Both RTX GPUs are maximum 2 per node

<http://ucspowercalc.cisco.com>

Caveats

- NVIDIA M10 GPUs can support only less than 1 TB of total memory in the server. Do not install more than fourteen 64-GB DIMMs when using an NVIDIA GPU card in this server.
- GPUs cannot be mixed.
- Slot 5 on riser card 2 is the required slot for the first GPU.
- Slot 2 on riser card 1 is the secondary slot for a second GPU.

STEP 9 SELECT ACCESSORIES

Select

1. Internal microSD Card Module HX-MSD-32G.
 - This is a required component.
 - The micro-SD card mounts internally on riser 1.
 - The micro-SD card serves as a dedicated local resource for utilities such as HUU. Images can be pulled from a file share (NFS/CIFS) and uploaded to the cards for future use.
2. Optional SFP adapter CVR-QSFP-SFP10G.
 - This is optional and only needed if connection to 6200 series FI (HX-FI-6248UP, HX-FI-6296UP) is desired
 - When choosing this option, please choose two QSAs per server.

STEP 10 ORDER SECURITY DEVICES (OPTIONAL)

A Trusted Platform Module (TPM) is a computer chip (microcontroller) that can securely store artifacts used to authenticate the platform (server). These artifacts can include passwords, certificates, or encryption keys. A TPM can also be used to store platform measurements that help ensure that the platform remains trustworthy. Authentication (ensuring that the platform can prove that it is what it claims to be) and attestation (a process helping to prove that a platform is trustworthy and has not been breached) are necessary steps to ensure safer computing in all environments.

A chassis intrusion switch gives a notification of any unauthorized mechanical access into the server.

The security device ordering information is listed in [Table 12](#).

Table 12 Security Devices

Product ID (PID)	PID Description
HX-TPM2-002	Trusted Platform Module 2.0 for UCS servers
HX-INT-SW01	C220 M5 and C240 M5 Chassis Intrusion Switch



NOTE:

- The TPM module used in this system conforms to TPM v2.0 as defined by the Trusted Computing Group (TCG). It is also SPI-based.
- TPM installation is supported after-factory. However, a TPM installs with a one-way screw and cannot be replaced, upgraded, or moved to another server. If a server with a TPM is returned, the replacement server must be ordered with a new TPM.

STEP 11 ORDER POWER SUPPLY

Power supplies share a common electrical and physical design that allows for hot-plug and tool-less installation into M5 C-series servers. Each power supply is certified for high-efficiency operation and offers multiple power output options. This allows users to “right-size” based on server configuration, which improves power efficiency, lower overall energy costs and avoids stranded capacity in the data center. Use the power calculator at the following link to determine the needed power based on the options chosen (CPUs, drives, memory, and so on):

<http://ucspowercalc.cisco.com>

Table 13 Power Supply

Product ID (PID)	PID Description
HX-PSU1-1050W	1050W AC power supply for C-Series servers
HX-PSUV2-1050DC	1050W DC power supply for C-Series servers
HX-PSU1-1600W ¹	1600W AC power supply for C-Series servers

Notes:

1. PSU supported on C220/C240/HX



NOTE: In a server with two power supplies, both power supplies must be identical.

STEP 12 SELECT POWER CORD(S)

Using [Table 14](#), select the appropriate AC power cords. You can select zero to two power cords. If you select the option R2XX-DMYMPWRCORD, no power cord is shipped with the server.

Table 14 Available Power Cords

Product ID (PID)	PID Description	Images
R2XX-DMYMPWRCORD	No power cord (dummy PID to allow for a no power cord option)	Not applicable
CAB-48DC-40A-8AWG	C-Series -48VDC PSU Power Cord, 3.5M, 3 Wire, 8AWG, 40A	
CAB-N5K6A-NA	Power Cord, 200/240V 6A, North America	
CAB-AC-L620-C13	AC Power Cord, NEMA L6-20 - C13, 2M/6.5ft	
CAB-C13-CBN	CABASY,WIRE,JUMPER CORD, 27" L, C13/C14, 10A/250V	
CAB-C13-C14-2M	CABASY,WIRE,JUMPER CORD, PWR, 2 Meter, C13/C14,10A/250V	
CAB-C13-C14-AC	CORD,PWR,JMP,IEC60320/C14,IEC60320/C13, 3.0M	

Table 14 Available Power Cords

Product ID (PID)	PID Description	Images
CAB-250V-10A-AR	Power Cord, 250V, 10A, Argentina	 <p>Plug: EL 219 (IRAM 2073)</p> <p>Cordset rating: 10 A, 250/500 V MAX Length: 8.2 ft</p> <p>Connector: EL 701 (IEC60320/C13)</p>
CAB-9K10A-AU	Power Cord, 250VAC 10A 3112 Plug, Australia	 <p>Plug: EL 210 (BS 1363A) 13 AMP fuse</p> <p>Cordset rating: 10 A, 250 V/500 V MAX Length: 2500mm</p> <p>Connector: EL 701C (EN 60320/C15)</p>
CAB-250V-10A-CN	AC Power Cord - 250V, 10A - PRC	 <p>Plug: EL 210 (BS 1363A) 13 AMP fuse</p> <p>Cordset rating: 10 A, 250 V/500 V MAX Length: 2500mm</p> <p>Connector: EL 701C (EN 60320/C15)</p>
CAB-9K10A-EU	Power Cord, 250VAC 10A CEE 7/7 Plug, EU	 <p>Plug: M2511</p> <p>Cordset rating: 10A/16 A, 250 V Length: 8 ft 2 in. (2.5 m)</p> <p>Connector: VSCC15</p>
CAB-250V-10A-ID	Power Cord, 250V, 10A, India	 <p>Plug: EL 208</p> <p>Cordset rating 16A, 250V (2500mm)</p> <p>Connector: EL 701</p>
CAB-250V-10A-IS	Power Cord, SFS, 250V, 10A, Israel	 <p>Plug: EL 212 (SI-32)</p> <p>Cordset rating 10A, 250V/500V MAX (2500 mm)</p> <p>Connector: EL 701B (IEC60320/C13)</p>
CAB-9K10A-IT	Power Cord, 250VAC 10A CEI 23-16/VII Plug, Italy	 <p>Plug: 1/3G (CEI 23-16)</p> <p>Cordset rating: 10 A, 250 V Length: 8 ft 2 in. (2.5 m)</p> <p>Connector: C15M (EN60320/C15)</p>
CAB-9K10A-SW	Power Cord, 250VAC 10A MP232 Plug, Switzerland	 <p>Plug: MP232-R</p> <p>Cordset rating: 10 A, 250 V Length: 8 ft. 2 in (2.5 m)</p> <p>Connector: IEC 60320 C15</p>

Table 14 Available Power Cords

Product ID (PID)	PID Description	Images
CAB-9K10A-UK	Power Cord, 250VAC 10A BS1363 Plug (13 A fuse), UK	
CAB-9K12A-NA ¹	Power Cord, 125VAC 13A NEMA 5-15 Plug, North America	
CAB-250V-10A-BR	Power Cord - 250V, 10A - Brazil	
CAB-C13-C14-2M-JP	Power Cord C13-C14, 2M/6.5ft Japan PSE mark	Image not available
CAB-9K10A-KOR ¹	Power Cord, 125VAC 13A KSC8305 Plug, Korea	Image not available
CAB-ACTW	AC Power Cord (Taiwan), C13, EL 302, 2.3M	Image not available
CAB-JPN-3PIN	Japan, 90-125VAC 12A NEMA 5-15 Plug, 2.4m	Image not available
CAB-48DC-40A-INT	-48VDC PSU PWR Cord, 3.5M, 3 Wire, 8AWG, 40A (INT)	Image Not available
CAB-48DC-40A-AS	-48VDC PSU PWR Cord, 3.5M, 3Wire, 8AWG, 40A (AS/NZ)	Image Not available
CAB-C13-C14-IN ²	Power Cord Jumper,C13-C14 Connectors,1.4 Meter Length, India	Image Not available
CAB-C13-C14-3M-IN ²	Power Cord Jumper, C13-C14 Connectors, 3 Meter Length, India	Image Not available

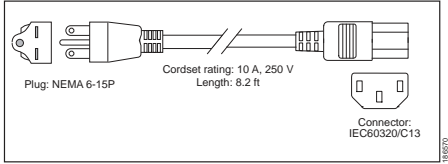
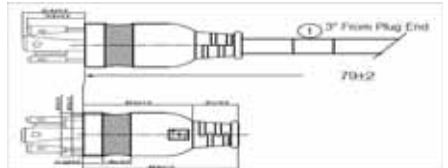
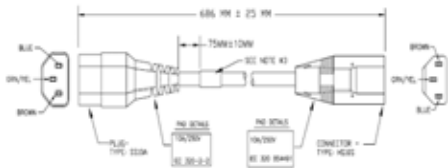
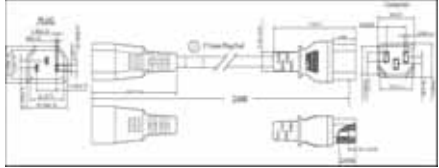
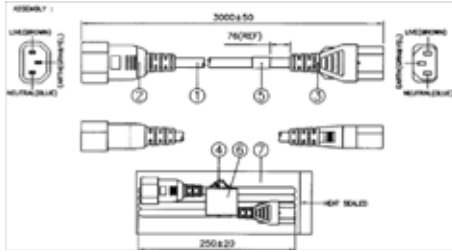
Notes:

1. This power cord is rated to 125V and only supported for PSU rated at 1050W or less
2. These new replacement parts for cards in compliance with the Dec 1st, 2020 Bureau of Indian Standards (BIS) regulatory standard for lower-power consumption products.

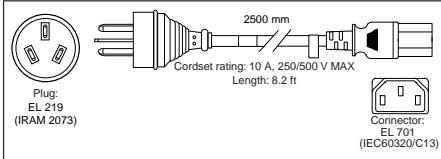
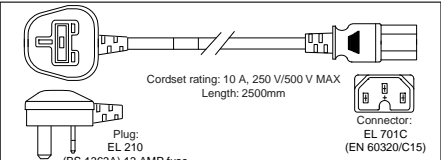
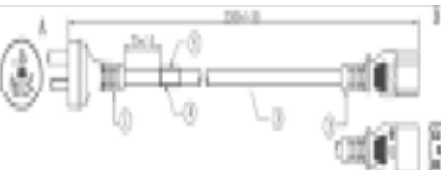
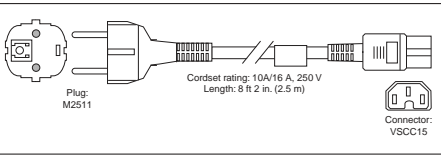
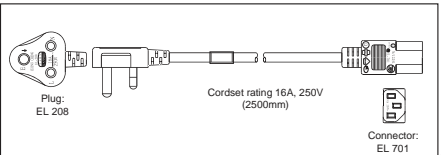
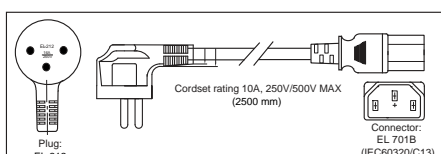
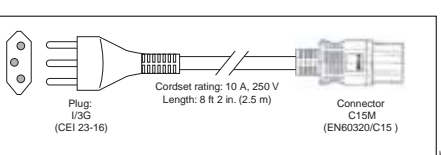
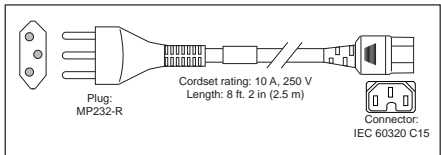
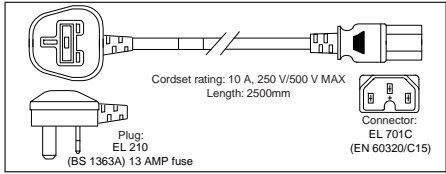
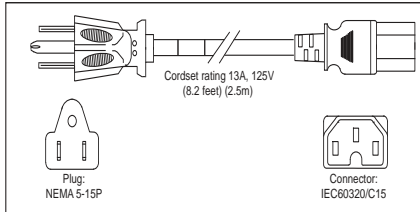
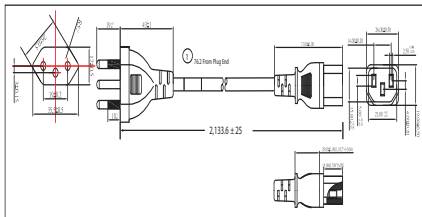
STEP 13 ORDER TOOL-LESS RAIL KIT AND OPTIONAL REVERSIBLE CABLE MANAGEMENT ARM

Select a Tool-Less Rail Kit

Select a tool-less rail kit from [Table 15](#).

Table 15 Tool-less Rail Kit Options

Product ID (PID)	PID Description
HX-RAILB-M4	Ball Bearing Rail Kit for HXAF240c M5 Rack Servers
HX-RAILF-M4	Friction Rail kit for HXAF240c M5 Rack Servers
HX-RAIL-NONE	No rail kit option

Select an Optional Reversible Cable Management Arm

The reversible cable management arm mounts on either the right or left slide rails at the rear of the server and is used for cable management. Use [Table 16](#) to order a cable management arm.

Table 16 Cable Management Arm

Product ID (PID)	PID Description
HX-CMAF-M4	Reversible CMA for tool-less HXAF240c M5 ball bearing rail kit

For more information about the tool-less rail kit and cable management arm, see the Cisco UCS C240 M5 Installation and Service Guide at this URL:

https://www.cisco.com/c/en/us/td/docs/unified_computing/ucs/c/hw/C240M5/install/C240M5.html



NOTE: If you plan to rackmount your HyperFlex HXAF240c Node, you must order a tool-less rail kit. The same rail kits and CMA's are used for M4 and M5 servers.

STEP 14 SELECT HYPERVISOR / HOST OPERATING SYSTEM

Cisco Hypervisor/Host Operating system options are available as follows. Select either VMware ESXi or Microsoft Hyper-V PIDs as desired from [Table 17](#)

Table 17 Hypervisor/Host Operating System

Product ID (PID)	PID Description
VMware	
HX-VSP-6-5-FNDR-D	Factory Installed vSphere 6.5 1-CPU End user provides License
HX-VSP-6-5-FNDR2-D	Factory Installed vSphere 6.5 2-CPU End user provides License
HX-VSP-6-7-FNDR-D	Factory Installed vSphere 6.7 1-CPU Enduser provides License
HX-VSP-6-7-FNDR2-D	Factory Installed vSphere 6.7 2-CPU Enduser provides License
VMWare PAC Licenses¹	
HX-VSP-EPL-1A	VMware vSphere 6 Ent Plus (1 CPU), 1-yr, Support Required Cisco
HX-VSP-EPL-3A	VMware vSphere 6 Ent Plus (1 CPU), 3-yr, Support Required Cisco
HX-VSP-EPL-5A	VMware vSphere 6 Ent Plus (1 CPU), 5-yr, Support Required Cisco
HX-VSP-STD-1A	VMware vSphere 6 Standard (1 CPU), 1-yr, Support Required Cisco
HX-VSP-STD-3A	VMware vSphere 6 Standard (1 CPU), 3-yr, Support Required Cisco
HX-VSP-STD-5A	VMware vSphere 6 Standard (1 CPU), 5-yr, Support Required Cisco
Microsoft Hyper-V^{2,3}	
HXDP-S001-1YR=	Cisco HyperFlex HX Data Platform SW 1 yr Subscription
Guest Operating system.⁴	
Microsoft Windows Server	
HX-19-DC16C	Windows Server 2019 Data Center (16 Cores/Unlimited VMs)
HX-19-DC16C-NS	Windows Server 2019 DC (16 Cores/Unlim VMs) - No Cisco SVC
HX-19-ST16C	Windows Server 2019 Standard (16 Cores/2 VMs)
HX-19-ST16C-NS	Windows Server 2019 Standard (16 Cores/2 VMs) - No Cisco SVC
HX-MSWS-19-ST16C	Windows Server 2019 Standard (16 Cores/2 VMs)
HX-MSWS-19-DC16C	Windows Server 2019 Data Center (16 Cores/Unlimited VMs)

Notes:

1. Choose quantity of two when choosing PAC licensing for dual CPU systems.
2. Microsoft Windows Server with Hyper-V will NOT be installed in Cisco Factory. Customers need to bring their own Windows Server ISO image that needs to be installed at deployment site.
3. To ensure the best possible Day 0 Installation experience, mandatory Installation Services are required with all Hyper-V orders. Details on PIDs can be found in HyperFlex Ordering Guide.
4. Optional guest OS licenses that may be purchased to run on top of the hypervisor

STEP 15 SELECT HX DATA PLATFORM SOFTWARE

HyperFlex Data Platform Edition & Subscription Period options are available as follows. Select as desired from [Table 18](#)

Table 18 HX Data Platform Software

Product ID (PID)	PID Description
HXDP-S001-1YR to HXDP-S001-5YR	HyperFlex Data Platform Datacenter Advantage (1 to 5) Yr
HXDP-S-SLR	HyperFlex Data Platform Datacenter Advantage SLR 1 to 10 Years
HXDP-P001-1YR To HXDP-P001-5YR	HyperFlex Data Platform Datacenter Premier (1 to 5) Yr
HXDP-P-SLR	HyperFlex Data Platform Datacenter Premier SLR 1 to 10 Years

STEP 16 SELECT INSTALLATION SERVICE

To ensure the best possible Day 0 Installation experience, mandatory Installation Services are required with all Hyper-V orders. Customers can purchase Cisco Advanced Services (AS) or Cisco Learning partner mentored Services. Select as desired from [Table 19](#)

Table 19 Installation services

Product ID (PID)	PID Description
Cisco Advanced Services	
ASF-ULT2-HPF-QSS	Quick Start Services - 1 Week
ASF-ULT2-HPF-ADS	Accelerated Deployment Services - 2 Weeks
AS-DCN-CNSLT	Advanced Services Consulting
Cisco Learning Partner Mentored Services	
TRN-CLC-004	1 Training credit. Expires in 1 yr. Team Captain required
TRN-CLC-000	10 Training credit. Expires in 1 yr. Team Captain required

STEP 17 SELECT SERVICE and SUPPORT LEVEL

A variety of service options are available, as described in this section.

Smart Net Total Care (SNTC)

For support of the entire Unified Computing System, Cisco offers the Cisco Smart Net Total Care for UCS Service. This service provides expert software and hardware support to help sustain performance and high availability of the unified computing environment. Access to Cisco Technical Assistance Center (TAC) is provided around the clock, from anywhere in the world.

For systems that include Unified Computing System Manager, the support service includes downloads of UCSM upgrades. The Cisco Smart Net Total Care for UCS Service includes flexible hardware replacement options, including replacement in as little as two hours. There is also access to Cisco's extensive online technical resources to help maintain optimal efficiency and uptime of the unified computing environment. For more information please refer to the following url: <http://www.cisco.com/c/en/us/services/technical/smart-net-total-care.html?stickynav=1>

You can choose a desired service listed in *Table 20*.

Table 20 Cisco SNTC Service (PID HXAF240C-M5SX)

Service SKU	Service Level GSP	On Site?	Description
CON-PREM-AF240CSX	C2P	Yes	SNTC 24X7X2O5
CON-UCSD8-AF240CSX	UCSD8	Yes	UC SUPP DR 24X7X2O5*
CON-C2PL-AF240CSX	C2PL	Yes	LL 24X7X2O5**
CON-OSP-AF240CSX	C4P	Yes	SNTC 24X7X4O5
CON-UCSD7-AF240CSX	UCSD7	Yes	UCS DR 24X7X4O5*
CON-C4PL-AF240CSX	C4PL	Yes	LL 24X7X4O5**
CON-USD7L-AF240CSX	USD7L	Yes	LLUCS HW DR 24X7X4O5***
CON-OSE-AF240CSX	C4S	Yes	SNTC 8X5X4O5
CON-UCSD6-AF240CSX	UCSD6	Yes	UC SUPP DR 8X5X4O5*
CON-SNCO-AF240CSX	SNCO	Yes	SNTC 8x7xNCDOS****
CON-OS-AF240CSX	CS	Yes	SNTC 8X5XNBDOS
CON-UCSD5-AF240CSX	UCSD5	Yes	UCS DR 8X5XNBDOS*
CON-S2P-AF240CSX	S2P	No	SNTC 24X7X2
CON-S2PL-AF240CSX	S2PL	No	LL 24X7X2**
CON-SNTP-AF240CSX	SNTP	No	SNTC 24X7X4
CON-SNTPL-AF240CSX	SNTPL	No	LL 24X7X4**
CON-SNTE-AF240CSX	SNTE	No	SNTC 8X5X4
CON-SNC-AF240CSX	SNC	No	SNTC 8x7xNCD****
CON-SNT-AF240CSX	SNT	No	SNTC 8X5XNBD
CON-SW-AF240CSX	SW	No	SNTC NO RMA

*Includes Drive Retention (see below for full description)

**Includes Local Language Support (see below for full description) – Only available in China and Japan

***Includes Local Language Support and Drive Retention – Only available in China and Japan

****Available in China Only

Smart Net Total Care with Onsite Troubleshooting Service

An enhanced offer over traditional Smart Net Total Care which provides onsite troubleshooting expertise to aid in the diagnostics and isolation of hardware issue within our customers' Cisco Hyper-Converged environment. It is delivered by a Cisco Certified field engineer (FE) in collaboration with remote TAC engineer and Virtual Internet working Support Engineer (VISE). You can choose a desired service listed in [Table 21](#)

Table 21 SNTC with UCS Onsite Troubleshooting Service (PID HXAF240C-M5SX)

Service SKU	Service Level GSP	On Site?	Description
CON-OSPT-AF240CSX	OSPT	Yes	24X7X4OS Trblshtg
CON-OSPTD-AF240CSX	OSPTD	Yes	24X7X4OS TrblshtgDR*
CON-OSPTL-AF240CSX	OSPTL	Yes	24X7X4OS TrblshtgLL**
CON-OPTLD-AF240CSX	OPTLD	Yes	24X7X4OS TrblshtgLLD***

*Includes Drive Retention (see below for full description)

**Includes Local Language Support (see below for full description) - Only available in China and Japan

***Includes Local Language Support and Drive Retention - Only available in China and Japan

Solution Support

Solution Support includes both Cisco product support and solution-level support, resolving complex issues in multivendor environments, on average, 43% more quickly than product support alone. Solution Support is a critical element in data center administration, to help rapidly resolve any issue encountered, while maintaining performance, reliability, and return on investment.

This service centralizes support across your multivendor Cisco environment for both our products and solution partner products you've deployed in your ecosystem. Whether there is an issue with a Cisco or solution partner product, just call us. Our experts are the primary point of contact and own the case from first call to resolution. For more information please refer to the following url:

<http://www.cisco.com/c/en/us/services/technical/solution-support.html?stickynav=1>

You can choose a desired service [Table 22](#)

Table 22 Solution Support Service (PID HXAF240C-M5SX)

Service SKU	Service Level GSP	On Site?	Description
CON-SSC2P-AF240CSX	SSC2P	Yes	SOLN SUPP 24X7X2OS
CON-SSC4P-AF240CSX	SSC4P	Yes	SOLN SUPP 24X7X4OS
CON-SSC4S-AF240CSX	SSC4S	Yes	SOLN SUPP 8X5X4OS

Table 22 Solution Support Service (PID HXAF240C-M5SX)

CON-SSCS-AF240CSX	SSCS	Yes	SOLN SUPP 8X5XNBDOS
CON-SSDR7-AF240CSX	SSDR7	Yes	SSPT DR 24X7X4OS*
CON-SSDR5-AF240CSX	SSDR5	Yes	SSPT DR 8X5XNBDOS*
CON-SSS2P-AF240CSX	SSS2P	No	SOLN SUPP 24X7X2
CON-SSSNP-AF240CSX	SSSNP	No	SOLN SUPP 24X7X4
CON-SSSNE-AF240CSX	SSSNE	No	SOLN SUPP 8X5X4
CON-SSSNC-AF240CSX	SSSNC	No	SOLN SUPP NCD**
CON-SSSNT-AF240CSX	SSSNT	No	SOLN SUPP 8X5XNBD

Includes Drive Retention (see below for description)

**Available in China only

Partner Support Service for UCS

Cisco Partner Support Service (PSS) is a Cisco Collaborative Services service offering that is designed for partners to deliver their own branded support and managed services to enterprise customers. Cisco PSS provides partners with access to Cisco's support infrastructure and assets to help them:

- Expand their service portfolios to support the most complex network environments
- Lower delivery costs
- Deliver services that increase customer loyalty

PSS options enable eligible Cisco partners to develop and consistently deliver high-value technical support that capitalizes on Cisco intellectual assets. This helps partners to realize higher margins and expand their practice.

PSS is available to all Cisco PSS partners.

PSS provides hardware and software support, including triage support for third party software, backed by Cisco technical resources and level three support. You can choose a desired service listed in [Table 23](#).

Table 23 PSS (PID HXAF240C-M5SX)

Service SKU	Service Level GSP	On Site?	Description
CON-PSJ8-AF240CSX	PSJ8	Yes	UCS PSS 24X7X2 OS
CON-PSJ7-AF240CSX	PSJ7	Yes	UCS PSS 24X7X4 OS
CON-PSJD7-AF240CSX	PSJD7	Yes	UCS PSS 24X7X4 DR*
CON-PSJ6-AF240CSX	PSJ6	Yes	UCS PSS 8X5X4 OS
CON-PSJD6-AF240CSX	PSJD6	Yes	UCS PSS 8X5X4 DR*

Table 23 PSS (PID HXAF240C-M5SX)

CON-PSJ4-AF240CSX	PSJ4	No	UCS SUPP PSS 24X7X2
CON-PSJ3-AF240CSX	PSJ3	No	UCS SUPP PSS 24X7X4
CON-PSJ2-AF240CSX	PSJ2	No	UCS SUPP PSS 8X5X4
CON-PSJ1-AF240CSX	PSJ1	No	UCS SUPP PSS 8X5XNBD
*Includes Drive Retention (see below for description)			

Combined Support Service

Combined Services makes it easier to purchase and manage required services under one contract. The more benefits you realize from the Cisco HyperFlex System, the more important the technology becomes to your business. These services allow you to:

- Optimize the uptime, performance, and efficiency of your HyperFlex System
- Protect your vital business applications by rapidly identifying and addressing issues
- Strengthen in-house expertise through knowledge transfer and mentoring
- Improve operational efficiency by allowing HyperFlex experts to augment your internal staff resources
- Enhance business agility by diagnosing potential issues before they affect your operations

You can choose a desired service listed in [Table 24](#)

Table 24 Combined Support Service (PID HXAF240C-M5SX)

Service SKU	Service Level GSP	On Site?	Description
CON-NCF2P-AF240CSX	NCF2P	Yes	CMB SVC 24X7X2OS
CON-NCF4P-AF240CSX	NCF4P	Yes	CMB SVC 24X7X4OS
CON-NCF4S-AF240CSX	NCF4S	Yes	CMB SVC 8X5X4OS
CON-NCFCS-AF240CSX	NCFCS	Yes	CMB SVC 8X5XNBDOS
CON-NCF2-AF240CSX	NCF2	No	CMB SVC 24X7X2
CON-NCFP-AF240CSX	NCFP	No	CMB SVC 24X7X4
CON-NCFE-AF240CSX	NCFE	No	CMB SVC 8X5X4
CON-NCFT-AF240CSX	NCFT	No	CMB SVC 8X5XNBD
CON-NCFW-AF240CSX	NCFW	No	CMB SVC SW

UCS Drive Retention Service

With the Cisco Drive Retention Service, you can obtain a new disk drive in exchange for a faulty drive without returning the faulty drive.

Sophisticated data recovery techniques have made classified, proprietary, and confidential information vulnerable, even on malfunctioning disk drives. The Drive Retention service enables you to retain your drives and ensures that the sensitive data on those drives is not compromised,

which reduces the risk of any potential liabilities. This service also enables you to comply with regulatory, local, and federal requirements.

If your company has a need to control confidential, classified, sensitive, or proprietary data, you might want to consider one of the Drive Retention Services listed in the above tables (where available)



NOTE: Cisco does not offer a certified drive destruction service as part of this service.

Local Language Technical Support for UCS

Where available, and subject to an additional fee, local language support for calls on all assigned severity levels may be available for specific product(s) - see tables above.

For a complete listing of available services for Cisco HyperFlex System, see the following URL:
<https://www.cisco.com/c/en/us/services/technical.html?stickynav=1>

SUPPLEMENTAL MATERIAL

Hyperconverged Systems

Cisco HyperFlex Systems let you unlock the full potential of hyperconvergence and adapt IT to the needs of your workloads. The systems use an end-to-end software-defined infrastructure approach, combining software-defined computing in the form of Cisco HyperFlex HX-Series nodes; software-defined storage with the powerful Cisco HX Data Platform; and software-defined networking with the Cisco UCS fabric that will integrate smoothly with Cisco Application Centric Infrastructure (Cisco ACI). Together with a single point of connectivity and management, these technologies deliver a preintegrated and adaptable cluster with a unified pool of resources that you can quickly deploy, adapt, scale, and manage to efficiently power your applications and your business.

Figure 5 show a small footprint cluster.

Figure 5 Small Footprint Cluster Using HXAF240c M5 Nodes

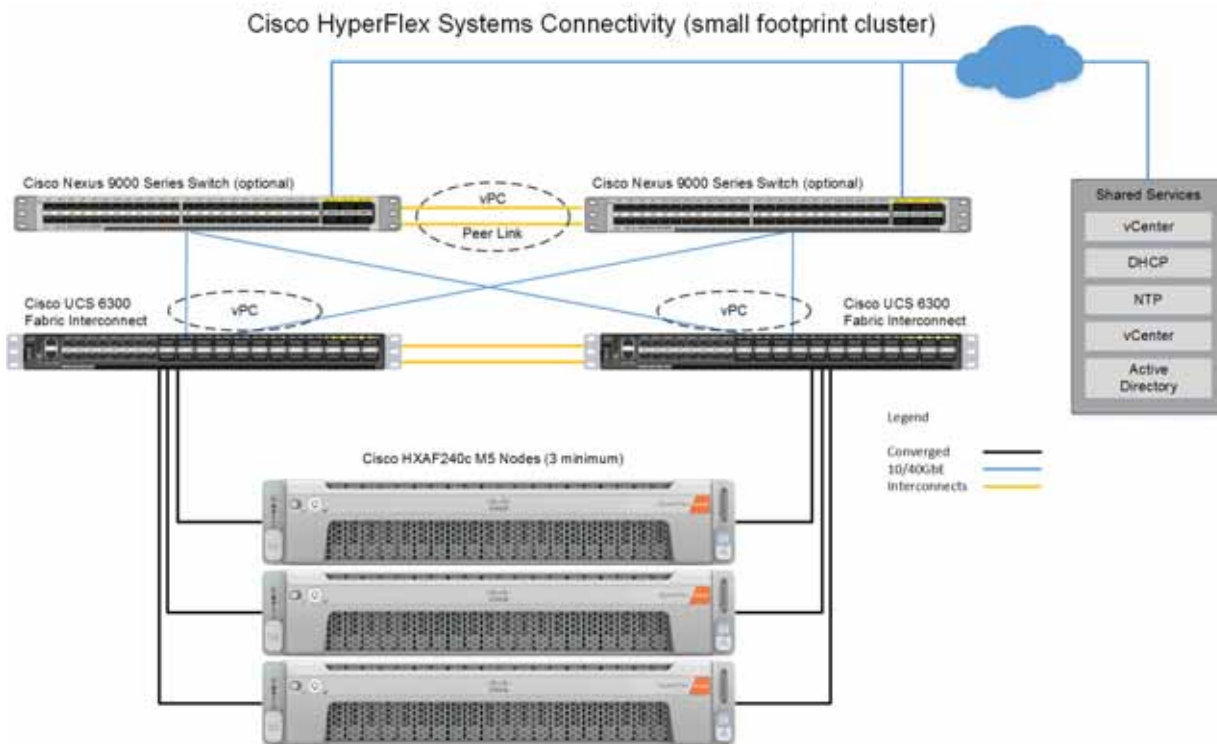

CHASSIS

An internal view of the HXAF240c M5 Node chassis with the top cover removed is shown in *Figure 6*.

Figure 6 HXAF240c M5 With Top Cover Off

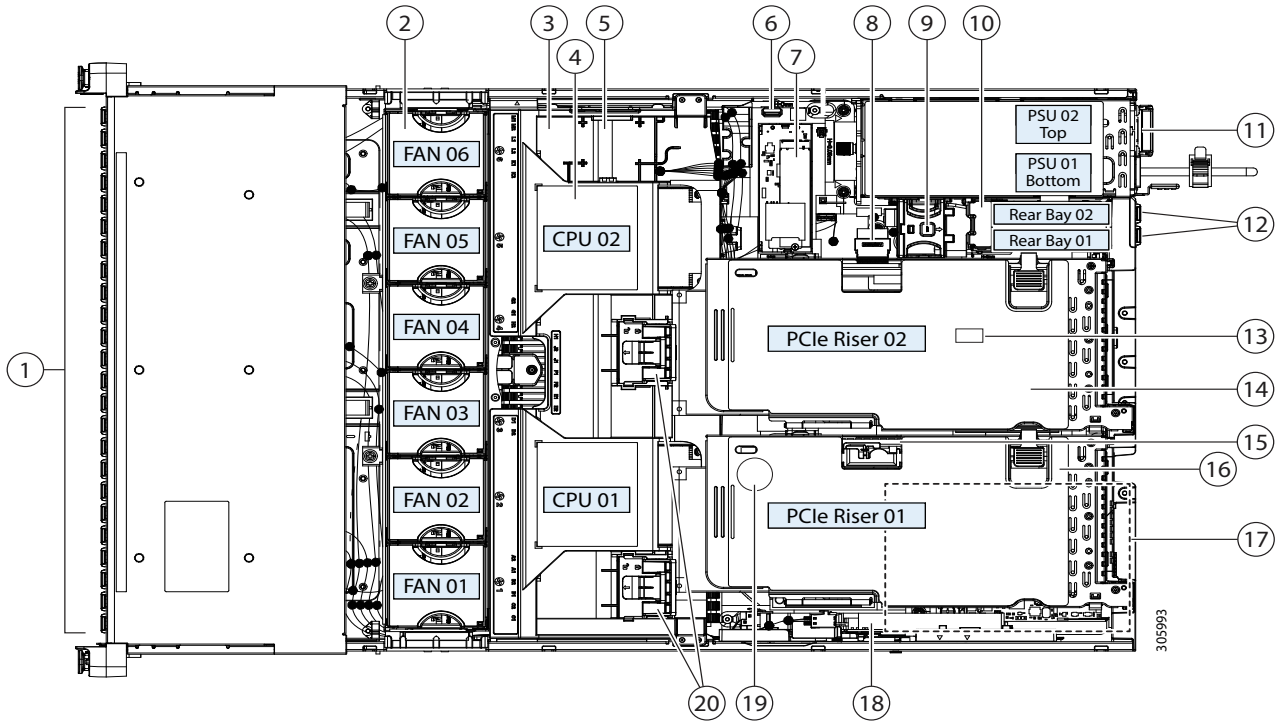

1	Front-Facing drive bays. All drive bays support SAS/SATA SSDs.	11	Power supplies (hot-swappable, redundant as 1+1).
2	Fan modules (six, hot-swappable)	12	Rear 2.5-inch drive bays: <ul style="list-style-type: none"> ■ Choice of SAS/SATA SSD OR ■ NVMe drive
3	DIMM sockets on motherboard (up to 12 per CPU; total 24). Not visible under air baffle in this view.	13	Trusted platform module (TPM) socket on motherboard (not visible in this view)
4	CPUs and heatsinks (one or two). Not visible under air baffle in this view	14	PCIe riser 2 (PCIe slots 4, 5, 6), <ul style="list-style-type: none"> ■ 2B—With slots 4 (x8), 5 (x16), and 6 (x8); includes one PCIe cable connector for rear NVMe SSDs.
5	N/A	15	Micro-SD card socket on PCIe riser 1

6	USB 3.0 slot on motherboard	16	PCIe riser 1 (PCIe slot 1, 2, 3), with the following options: <ul style="list-style-type: none"> ■ 1A—Slots 1 (x8), 2 (x16), 3 (x8); slot 2 requires CPU2.
7	Mini-storage module connector. Supports M.2 module with SATA M.2 SSD slots	17	mLOM card socket (x16) on motherboard (not visible in this view)
8	PCIe cable connectors for NVMe SSDs, with PCIe riser 2: <ul style="list-style-type: none"> ■ One connector for rear SFF NVMe SSDs 	18	Cisco modular RAID controller PCIe slot (dedicated slot)
9	Rear-drive fan module	19	RTC battery on motherboard (not visible in this view)
10	Rear-drive backplane assembly	20	Securing clips for GPU cards on air baffle

Block Diagram

Figure 7 HXAF240c M5 Block Diagram

Cisco HX 240 M5 2U Server System Block Diagram

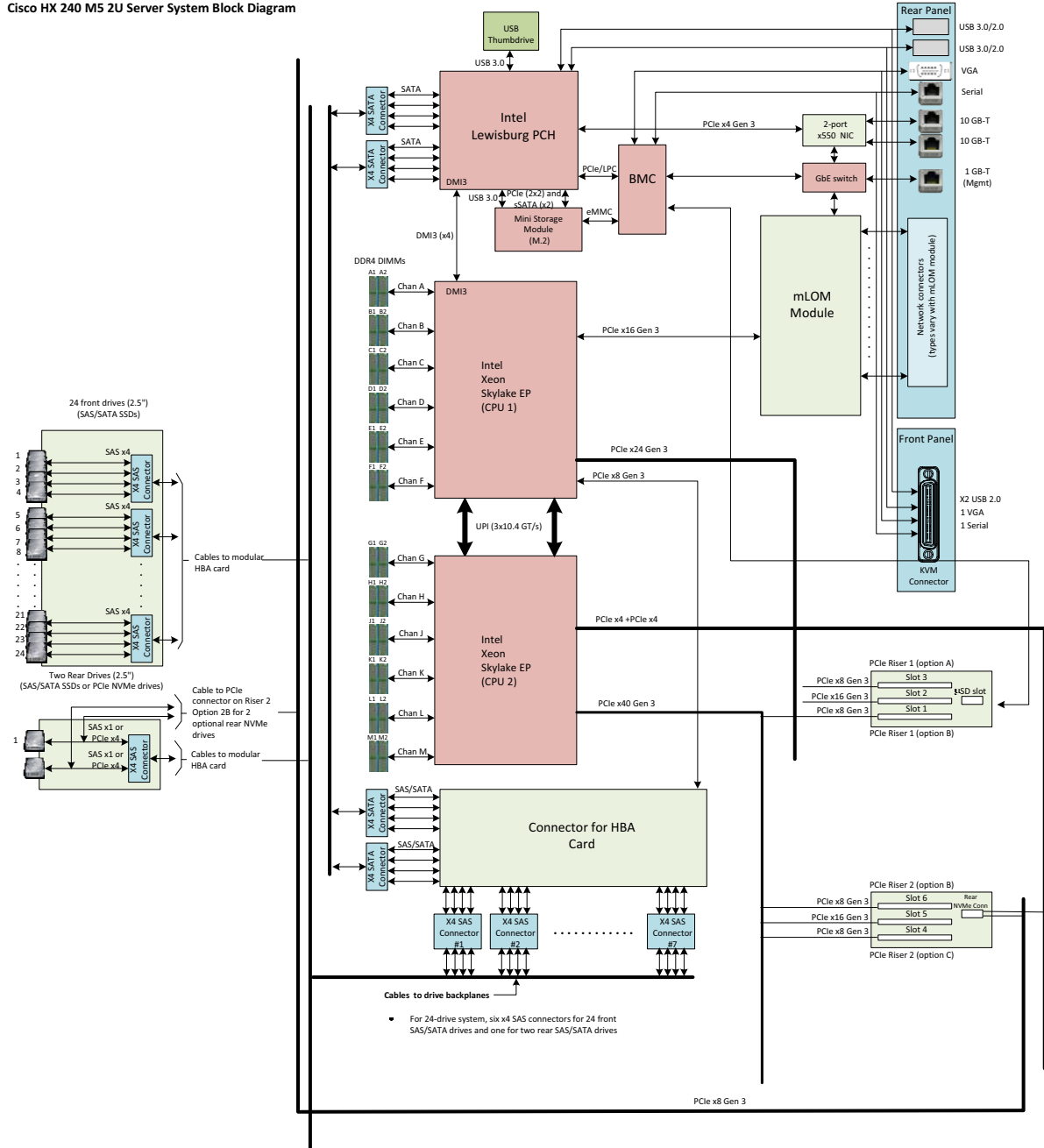

Riser Card Configuration and Options

The two riser cards are shown in *Figure 8*.

Figure 8 Riser Card 1 (slots 1, 2, and 3) and Riser Card 2 (slots 4, 5, and 6)

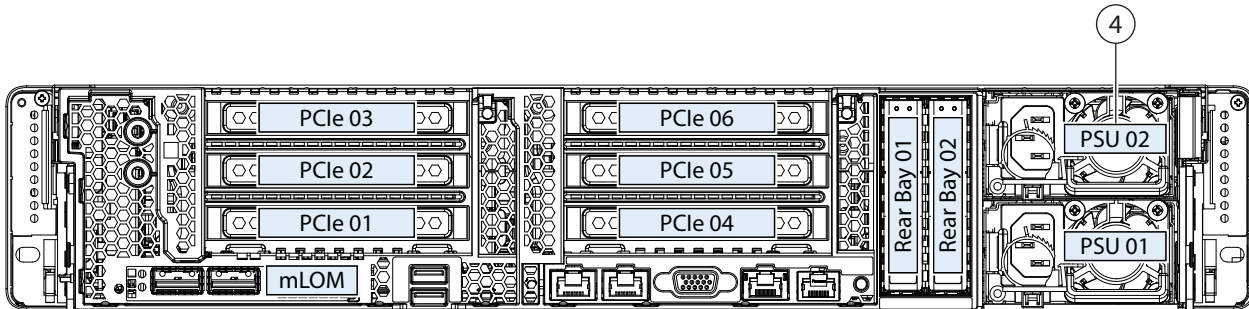

The two riser card 1 options are shown in [Table 25](#).

Table 25 Riser Card 1 and Riser Card 2 Slot Options

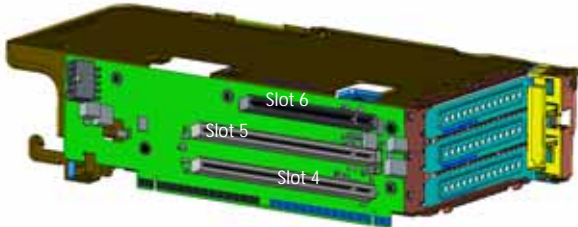
Slot #	Height	Length	Electrical	NCSI	Physical
Riser Card 1 (option 1A, PID UCSC-PCI-1-C240M5)					
					
3	Full	Half	x8	No	CPU2
2	Full	Full ¹	x16	Yes	CPU1
1	Full	Half	x8	Yes	CPU1

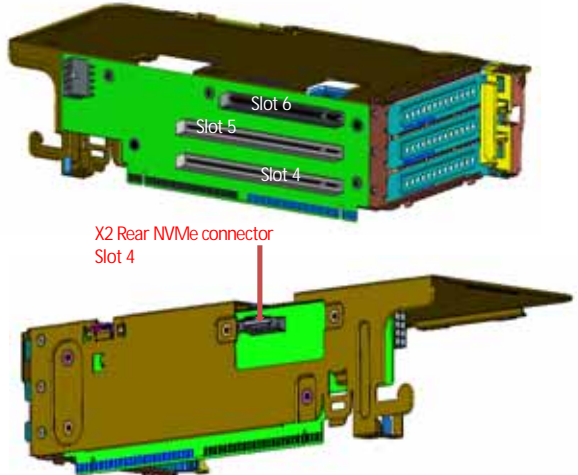
Riser Card 2 (option 2B, PID UCSC-PCI-2B-240M5)					
					
6	Full	Full	x8	No	CPU2
5	Full	Full ¹	x16	Yes ²	CPU2
4	Full	Half	x8	Yes ²	CPU2

Notes:

- 1. GPU capable slot

Serial Port Details

The pinout details of the rear RJ-45 serial port connector are shown in *Figure 9*.

Figure 9 Serial Port (Female RJ-45 Connector) Pinout

Serial Port (RJ-45 Female Connector)

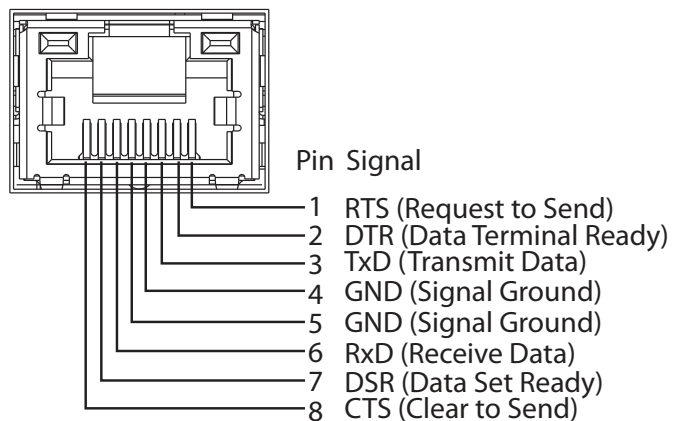

Upgrade and Servicing-Related Parts

This section lists the upgrade and servicing-related parts you may need during the life of your system. Some of these parts are configured with every system, and some may be ordered when needed or may be ordered and kept on hand as spares for future use. See [Table 26](#).

Table 26 Upgrade and Servicing-related Parts for UCS HXAF240c M5 Server

Spare Product ID (PID)	Description
UCSC-HS-C240M5=	Heat sink for UCS HXAF240c M5 rack servers 150W CPUs & below
UCSC-HS2-C240M5=	Heat sink for UCS HXAF240c M5 rack servers CPUs above 150W
UCS-CPUAT=	CPU Assembly Tool for M5 Servers
UCS-CPU-TIM=	Single CPU thermal interface material syringe for M5 server HS seal
UCSX-HSCK=	UCS Processor Heat Sink Cleaning Kit For Replacement of CPU
UCS-M5-CPU-CAR=	UCS M5 CPU Carrier
UCSC-RNVME-240M5=	HXAF240c M5 Rear NVMe cable (1) kitw/fan,riser2C,bkplnforSFF&LFF
UCSC-RSAS-C240M5=	C240 Rear UCSC-RAID-M5 SAS cbl(1)kitinclfan,bkplnforSFF&LFF C240
UCSC-RSAS-240M5X=	Rear UCS-RAID-M5HD SAS cbl(1)kitinclfan,bkpln
UCS-AMDCBL-C240M5	C240 M5 AMD 7150x2 cable
UCS-P40CBL-C240M5	C240 M5 NVIDIA P40 cable
UCS-M10CBL-C240M5	C240 M5 NVIDIA M10 cable
UCSC-BBLKD-S2=	C-Series M5 SFF drive blanking panel ¹
UCSC-PCI-1-C240M5=	Riser 1 incl 3 PCIe slots (x8, x16, x8); slot 3 requires CPU2
UCSC-PCI-2B-240M5=	Riser 2B incl 3PCleslots(x8,x16,x8); supports GPU and rear SFF NVMe
UCSC-PCIF-240M5=	C240 M5 PCIe Riser Blanking Panel
UCSC-PCIF-01H=	PCIe Low Profile blanking panel for UCS C-Series Server
UCSC-PCIF-01F=	PCIe Full Height blanking panel for UCS C-Series Server
UCSC-MLOMBLK-M5	C220 M5 and C240 M5 mLOM blanking panel
UCSC-CMAF-M4=	Reversible CMA for C220 & C240 M4 & M5 rack servers
UCSC-RAILB-M4=	Ball Bearing Rail Kit for C220 & C240 M4 & M5 rack servers
HXAF240C-BZL-M5SX	HX240 M5 Security Bezel
UCSC-FAN-C240M5=	C240 M5 Fan Module (one)
UCSC-FANR-C240M5=	C240 M5 Rear Fan Module (one)
N20-BKVM=	KVM cable for Server console port
UCSC-PSU-BLKP240=	Power Supply Blanking Panel for C220 M5 and C240 M5 Servers
UCS-MSTOR-M2=	Mini Storage Carrier for M.2 SATA
UCSC-PCIF-240M5=	C240 M5 PCIe Riser Blanking Panel

Notes:

1. A drive blanking panel must be installed if you remove a disk drive from a UCS server. These panels are required to maintain system temperatures at safe operating levels, and to keep dust away from system components.

KVM CABLE

The KVM cable provides a connection into the server, providing a DB9 serial connector, a VGA connector for a monitor, and dual USB 2.0 ports for a keyboard and mouse. With this cable, you can create a direct connection to the operating system and the BIOS running on the server.

The KVM cable ordering information is listed in [Table 27](#).

Table 27 KVM Cable

Product ID (PID)	PID Description
N20-BKVM=	KVM cable for UCS Server console port

Figure 10 KVM Cable

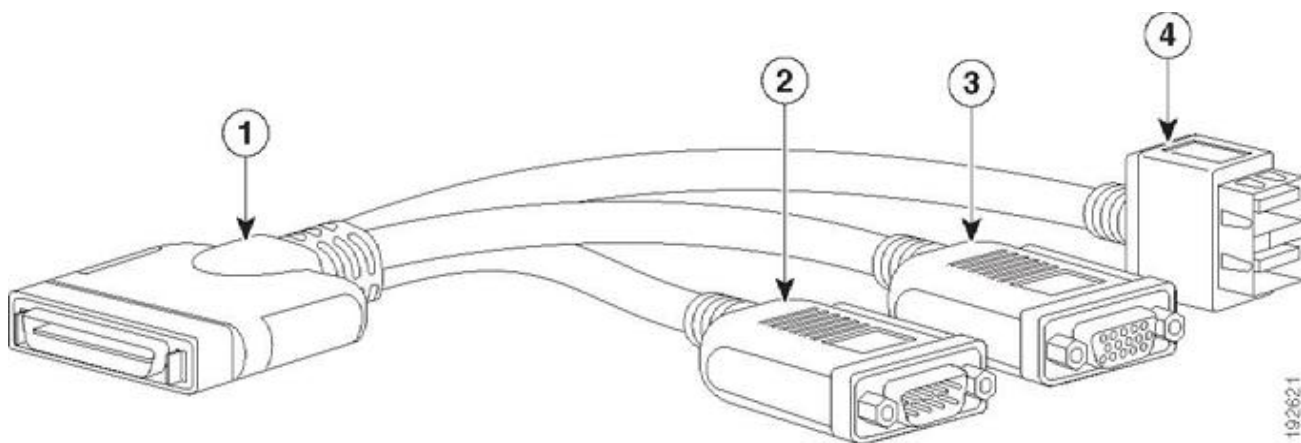

1	Connector (to server front panel)	3	VGA connector (for a monitor)
2	DB-9 serial connector	4	Two-port USB 2.0 connector (for a mouse and keyboard)

DISCONTINUED EOL PRODUCTS

Below is the list of parts were previously available for this product and are no longer sold. Please refer to the EOL Bulletin Links via the [Table 28](#) below to determine if still supported.

Table 28 EOL Products

EOS option PID	Description	EOL bulletin link
DRIVES		
Enterprise Value SSDs		
HX-SD240G61X-EV	240GB 2.5 inch Enterprise Value 6G SATA SSD	https://www.cisco.com/c/en/us/products/collateral/servers-unified-computing/ucs-b-series-blade-servers/eos-eol-notice-c51-742066.html
HX-NVMEXP-I375	Cisco 2.5" 375GB Intel Optane NVMe Extreme Performance SSD	https://www.cisco.com/c/en/us/products/collateral/servers-unified-computing/ucs-c-series-rack-servers/eos-eol-notice-c51-742509.html
HX-SD800GBENK9	800GB Enterprise performance SAS SSD (10X FWPD, SED)	https://www.cisco.com/c/en/us/products/collateral/servers-unified-computing/ucs-c-series-rack-servers/eos-eol-notice-c51-742823.html
HX-SD38TBHTNK9**	[FIPS Compliant] 3.8TB Enterprise value 12G SAS SSD (1X FWPD, SED)	https://www.cisco.com/c/en/us/products/collateral/servers-unified-computing/ucs-c-series-rack-servers/eos-eol-notice-c51-742823.html
Enterprise Performance		
HX-SD400G12TX-EP	400GB 2.5 inch Ent. Perf. 12G SAS SSD (10X endurance)	https://www.cisco.com/c/en/us/products/collateral/servers-unified-computing/ucs-c-series-rack-servers/eos-eol-notice-c51-741644.html
Host OS		
HX-VSP-ENT-D	Factory Installed - VMware vSphere6 Ent SW and Lic (2 CPU)	https://www.cisco.com/c/en/us/products/collateral/servers-unified-computing/ucs-b-series-blade-servers/eos-eol-notice-c51-740304.html
HX-VSP-ENT-DL	Factory Installed - VMware vSphere6 Enterprise SW Download	https://www.cisco.com/c/en/us/products/collateral/servers-unified-computing/ucs-b-series-blade-servers/eos-eol-notice-c51-740304.html
CPU		
HX-CPU-I8280M	Intel 8280M 2.7GHz/205W 28C/38.50MB 3DX DDR4 2TB 2933 MHz	https://www.cisco.com/c/en/us/products/collateral/servers-unified-computing/ucs-c-series-rack-servers/eos-eol-notice-c51-743832.html
HX-CPU-I8276M	Intel 8276M 2.2GHz/165W 28C/38.50MB 3DX DDR4 2TB 2933 MHz	https://www.cisco.com/c/en/us/products/collateral/servers-unified-computing/ucs-c-series-rack-servers/eos-eol-notice-c51-743832.html
HX-CPU-I8260M	Intel 8260M 2.4GHz/165W 24C/35.75MB 3DX DDR4 2TB 2933 MHz	https://www.cisco.com/c/en/us/products/collateral/servers-unified-computing/ucs-c-series-rack-servers/eos-eol-notice-c51-743832.html
HX-CPU-I6240M	Intel 6240M 2.6GHz/150W 18C/24.75MB 3DX DDR4 2TB 2933 MHz	https://www.cisco.com/c/en/us/products/collateral/servers-unified-computing/ucs-c-series-rack-servers/eos-eol-notice-c51-743832.html
HX-CPU-I6238M	Intel 6238M 2.1GHz/140W 22C/30.25MB 3DX DDR4 2TB 2933 MHz	https://www.cisco.com/c/en/us/products/collateral/servers-unified-computing/ucs-c-series-rack-servers/eos-eol-notice-c51-743832.html

Table 28 EOL Products

EOS option PID	Description	EOL bulletin link
HX-CPU-I5215M	Intel 5215M 2.5GHz/85W 10C/13.75MB 3DX DDR4 2TB 2666MHz	https://www.cisco.com/c/en/us/products/collateral/servers-unified-computing/ucs-c-series-rack-servers/eos-eol-notice-c51-743832.html
GPU		
HX-GPU-P100-12G	NVIDIA P100 12GB	https://www.cisco.com/c/en/us/products/collateral/servers-unified-computing/ucs-c-series-rack-servers/eos-eol-notice-c51-741579.html
HX-GPU-P100-16G	NVIDIA P100 16GB	https://www.cisco.com/c/en/us/products/collateral/servers-unified-computing/ucs-c-series-rack-servers/eos-eol-notice-c51-741579.html
HX-GPU-M60	UCS Rack Server M60 GPU HW - GRID 2.0 SW required for VDI	https://www.cisco.com/c/en/us/products/collateral/servers-unified-computing/ucs-c-series-rack-servers/eos-eol-notice-c51-743558.html
HX-GPU-7150x2	AMD Firepro 7150x2	https://www.cisco.com/c/en/us/products/collateral/servers-unified-computing/ucs-c-series-rack-servers/eos-eol-notice-c51-741579.html
HX-GPU-V340	AMD Radeon Pro V340, 2X16GB, 300W	https://www.cisco.com/c/en/us/products/collateral/servers-unified-computing/ucs-c-series-rack-servers/eos-eol-notice-c51-741579.html
Microsoft Windows server		
HX-16-ST16C	Windows Server 2016 Standard (16 Cores/2 VMs)	https://www.cisco.com/c/en/us/products/servers-unified-computing/ucs-c-series-rack-servers/eos-eol-notice-c51-743145.html
HX-16-ST24C	Windows Server 2016 Standard (24 Cores/2 VMs)	https://www.cisco.com/c/en/us/products/servers-unified-computing/ucs-c-series-rack-servers/eos-eol-notice-c51-743145.html
HX-16-ST16C-NS	Windows Server 2016 Standard (16 Cores/2 VMs) - No Cisco SVC	https://www.cisco.com/c/en/us/products/servers-unified-computing/ucs-c-series-rack-servers/eos-eol-notice-c51-743145.html
HX-16-ST24C-NS	Windows Server 2016 Standard (24 Cores/2 VMs) - No Cisco SVC	https://www.cisco.com/c/en/us/products/servers-unified-computing/ucs-c-series-rack-servers/eos-eol-notice-c51-743145.html
HX-16-DC16C	Windows Server 2016 Data Center (16 Cores/Unlimited VMs)	https://www.cisco.com/c/en/us/products/servers-unified-computing/ucs-c-series-rack-servers/eos-eol-notice-c51-743145.html
HX-16-DC24C	Windows Server 2016 Data Center (24 Cores/Unlimited VMs)	https://www.cisco.com/c/en/us/products/servers-unified-computing/ucs-c-series-rack-servers/eos-eol-notice-c51-743145.html
HX-16-DC16C-NS	Windows Server 2016 DC (16 Cores/Unlim VMs) - No Cisco SVC	https://www.cisco.com/c/en/us/products/servers-unified-computing/ucs-c-series-rack-servers/eos-eol-notice-c51-743145.html
HX-16-DC24C-NS	Windows Server 2016 DC (24 Cores/Unlim VMs) - No Cisco SVC	https://www.cisco.com/c/en/us/products/servers-unified-computing/ucs-c-series-rack-servers/eos-eol-notice-c51-743145.html
OS Media		

Table 28 EOL Products

EOS option PID	Description	EOL bulletin link
HX-16-ST16C-RM	Windows Server 2016 Std (16 Cores/2 VMs) - Recovery Media	https://www.cisco.com/c/en/us/products/servers-unified-computing/ucs-c-series-rack-servers/eos-eol-notice-c51-743145.html
HX-16-ST24C-RM	Windows Server 2016 Std (24 Cores/2 VMs) - Recovery Media	https://www.cisco.com/c/en/us/products/servers-unified-computing/ucs-c-series-rack-servers/eos-eol-notice-c51-743145.html
HX-16-DC16C-RM	Windows Server 2016 DC (16 Cores/Unlim VMs) - Recovery Media	https://www.cisco.com/c/en/us/products/servers-unified-computing/ucs-c-series-rack-servers/eos-eol-notice-c51-743145.html
HX-16-DC24C-RM	Windows Server 2016 DC (24 Cores/Unlim VMs) - Recovery Media	https://www.cisco.com/c/en/us/products/servers-unified-computing/ucs-c-series-rack-servers/eos-eol-notice-c51-743145.html

TECHNICAL SPECIFICATIONS

Dimensions and Weight

Table 29 HXAF240c M5 Dimensions and Weight

Parameter	Value
Height	3.43 in. (8.70 cm)
Width (including slam latches)	17.65 in. (44.8 cm) Including handles: 18.96 in (48.2 cm)
Depth	29.0 in. (73.8 cm) Including handles: 30.18 in (76.6 cm)
Front Clearance	3 in. (76 mm)
Side Clearance	1 in. (25 mm)
Rear Clearance	6 in. (152 mm)
Weight ¹	
Maximum	
(24 HDD model with 24 HDDs, 2 CPUs, 24 DIMMs, 2 1600 W power supplies)	57.5 lbs (26.1 kg)
(8 HDD model with 8 HDDs, 2 CPUs, 24 DIMMs, 2 1600 W power supplies)	45.5 lbs (20.4 kg)
Minimum	
(24 HDD model with 1 HDD, 1 CPU, 1 DIMM, 1 770 W power supply)	37.0 lbs (16.8 kg)
(8 HDD model with 1 HDD, 1 CPU, 1 DIMM, 1 770 W power supply)	41.5 lbs (18.8 kg)
Bare	
(24 HDD model with 0 HDD, 0 CPU, 0 DIMM, 1 770 W power supply)	35.5 lbs (16.1 kg)
(8 HDD model with 0 HDD, 0 CPU, 0 DIMM, 1 770 W power supply)	40.0 lbs (18.1 kg)

Notes:

1. Weight includes inner rail, which is attached to the server. Weight does not include outer rail, which is attached to the rack.

Power Specifications

The server is available with the following types of power supplies:

- 1050 W (AC) power supply (see [Table 30](#)).
- 1050 W V2 (DC) power supply (see [Table 31](#))
- 1600 W (AC) power supply (see [Table 32](#))

Table 30 HXAF240c M5 1050 W (AC) Power Supply Specifications

Parameter	Specification			
Input Connector	IEC320 C14			
Input Voltage Range (V rms)	100 to 240			
Maximum Allowable Input Voltage Range (V rms)	90 to 264			
Frequency Range (Hz)	50 to 60			
Maximum Allowable Frequency Range (Hz)	47 to 63			
Maximum Rated Output (W) ¹	800			1050
Maximum Rated Standby Output (W)			36	
Nominal Input Voltage (V rms)	100	120	208	230
Nominal Input Current (A rms)	9.2	7.6	5.8	5.2
Maximum Input at Nominal Input Voltage (W)	889	889	1167	1154
Maximum Input at Nominal Input Voltage (VA)	916	916	1203	1190
Minimum Rated Efficiency (%) ²	90	90	90	91
Minimum Rated Power Factor ²	0.97	0.97	0.97	0.97
Maximum Inrush Current (A peak)			15	
Maximum Inrush Current (ms)			0.2	
Minimum Ride-Through Time (ms) ³			12	

Notes:

1. Maximum rated output is limited to 800W when operating at low-line input voltage (100-127V)
2. This is the minimum rating required to achieve 80 PLUS Platinum certification, see test reports published at <http://www.80plus.org/> for certified values
3. Time output voltage remains within regulation limits at 100% load, during input voltage dropout

Table 31 HXAF240c M5 1050 W (DC) Power Supply Specifications

Parameter	Specification
Input Connector	Molex 42820
Input Voltage Range (V rms)	-48
Maximum Allowable Input Voltage Range (V rms)	-40 to -72
Frequency Range (Hz)	NA
Maximum Allowable Frequency Range (Hz)	NA
Maximum Rated Output (W)	1050

Table 31 HXAF240c M5 1050 W (DC) Power Supply Specifications

Maximum Rated Standby Output (W)	36
Nominal Input Voltage (V rms)	-48
Nominal Input Current (A rms)	24
Maximum Input at Nominal Input Voltage (W)	1154
Maximum Input at Nominal Input Voltage (VA)	1154
Minimum Rated Efficiency (%) ¹	91
Minimum Rated Power Factor ¹	NA
Maximum Inrush Current (A peak)	15
Maximum Inrush Current (ms)	0.2
Minimum Ride-Through Time (ms) ²	5

Notes:

1. This is the minimum rating required to achieve 80 PLUS Platinum certification, see test reports published at <http://www.80plus.org/> for certified values
2. Time output voltage remains within regulation limits at 100% load, during input voltage dropout

Table 32 UCS HXAF240c M5 1600 W (AC) Power Supply Specifications

Parameter	Specification			
Input Connector	IEC320 C14			
Input Voltage Range (V rms)	200 to 240			
Maximum Allowable Input Voltage Range (V rms)	180 to 264			
Frequency Range (Hz)	50 to 60			
Maximum Allowable Frequency Range (Hz)	47 to 63			
Maximum Rated Output (W) ¹	1600			
Maximum Rated Standby Output (W)	36			
Nominal Input Voltage (V rms)	100	120	208	230
Nominal Input Current (A rms)	NA	NA	8.8	7.9
Maximum Input at Nominal Input Voltage (W)	NA	NA	1778	1758
Maximum Input at Nominal Input Voltage (VA)	NA	NA	1833	1813
Minimum Rated Efficiency (%) ²	NA	NA	90	91
Minimum Rated Power Factor ²	NA	NA	0.97	0.97
Maximum Inrush Current (A peak)	30			
Maximum Inrush Current (ms)	0.2			
Minimum Ride-Through Time (ms) ³	12			

Notes:

1. Maximum rated output is limited to 800W when operating at low-line input voltage (100-127V)
2. This is the minimum rating required to achieve 80 PLUS Platinum certification, see test reports published at <http://www.80plus.org/> for certified values
3. Time output voltage remains within regulation limits at 100% load, during input voltage dropout

For configuration-specific power specifications, use the Cisco UCS Power Calculator at this URL:

<http://ucspowercalc.cisco.com>

Environmental Specifications

The environmental specifications for the HXAF240c M5 server are listed in [Table 33](#).

Table 33 HXAF240c M5 Environmental Specifications

Parameter	Minimum
Operating Temperature	10°C to 35°C (50°F to 95°F) with no direct sunlight Maximum allowable operating temperature de-rated 1°C/300 m (1°F/547 ft) above 950 m (3117 ft)
Extended Operating Temperature	5°C to 40°C (41°F to 104°F) with no direct sunlight Maximum allowable operating temperature de-rated 1°C/175 m (1°F/319 ft) above 950 m (3117 ft) 5°C to 45°C (41°F to 113°F) with no direct sunlight Maximum allowable operating temperature de-rated 1°C/125 m (1°F/228 ft) above 950 m (3117 ft) System performance may be impacted when operating in the extended operating temperature range. Operation above 40C is limited to less than 1% of annual operating hours. Hardware configuration limits apply to extended operating temperature range.
Non-Operating Temperature	-40°C to 65°C (-40°F to 149°F) Maximum rate of change (operating and non-operating) 20°C/hr (36°F/hr)
Operating Relative Humidity	8% to 90% and 24°C (75°F) maximum dew-point temperature, non-condensing environment
Non-Operating Relative Humidity	5% to 95% and 33°C (91°F) maximum dew-point temperature, non-condensing environment
Operating Altitude	0 m to 3050 m {10,000 ft)
Non-Operating Altitude	0 m to 12,000 m (39,370 ft)
Sound Power level, Measure A-weighted per ISO7779 LWAd (Bels) Operation at 73°F (23°C)	5.8
Sound Pressure level, Measure A-weighted per ISO7779 LpAm (dBA) Operation at 73°F (23°C)	43

Extended Operating Temperature Hardware Configuration Limits

Table 34 Cisco HXAF240c M5 Extended Operating Temperature Hardware Configuration Limits

Platform ¹	ASHRAE A3 (5°C to 40°C) ²	ASHRAE A4 (5°C to 45°C) ³
Processors:	155W+	155W+ and 105W+ (4 or 6 Cores)
Memory:	LRDIMMs	LRDIMMs
Storage:	M.2 SATA SSDs NVMe SSDs	M.2 SATA SSDs NVMe SSDs HDDs or SSDs (Rear Bays)
Peripherals:	PCIe NVMe SSDs GPUs	PCIe NVMe SSDs GPUs VICs (Slots 1 and 4) NICs (Slots 1 and 4) HBAs (Slots 1 and 4)

Notes:

1. Two PSUs are required and PSU failure is not supported
2. Non-Cisco UCS qualified peripherals and/or peripherals that consume more than 25W are not supported
3. High power or maximum power fan control policy must be applied

Compliance Requirements

The regulatory compliance requirements for C-Series servers are listed in [Table 35](#).

Table 35 UCS HX Regulatory Compliance Requirements

Parameter	Description
Regulatory Compliance	Products should comply with CE Markings per directives 2014/30/EU and 2014/35/EU
Safety	UL 60950-1 Second Edition CAN/CSA-C22.2 No. 60950-1 Second Edition EN 60950-1 Second Edition IEC 60950-1 Second Edition AS/NZS 60950-1 GB4943 2001
EMC - Emissions	47CFR Part 15 (CFR 47) Class A AS/NZS CISPR32 Class A CISPR32 Class A EN55032 Class A ICES003 Class A VCCI Class A EN61000-3-2 EN61000-3-3 KN32 Class A CNS13438 Class A
EMC - Immunity	EN55024 CISPR24 EN300386 KN35



Americas Headquarters
Cisco Systems, Inc.
San Jose, CA

Asia Pacific Headquarters
Cisco Systems (USA) Pte. Ltd.
Singapore

Europe Headquarters
Cisco Systems International BV Amsterdam,
The Netherlands

Cisco has more than 200 offices worldwide. Addresses, phone numbers, and fax numbers are listed on the Cisco Website at www.cisco.com/go/offices.

Cisco and the Cisco Logo are trademarks of Cisco Systems, Inc. and/or its affiliates in the U.S. and other countries. A listing of Cisco's trademarks can be found at www.cisco.com/go/trademarks. Third party trademarks mentioned are the property of their respective owners. The use of the word partner does not imply a partnership relationship between Cisco and any other company. (1005R)