

STX660(P)  
STX660L

SMARTMOUNT XT™

## Universal Tilt Wall Mount for 46" to 70" Flat Panel Displays

Limitless placement opportunities are delivered with speed and ease with both horizontal and vertical adjustment capability. Its slim, open wall plate architecture delivers flat panel display placement flexibility and enables hands-free behind-the-display access along with cable management. Quick and easy installation and optional IncreLok™ Tilt technology complete the ultimate secure, low profile flat panel installation.



Display size: 46"-70"



Max load: 150lb (68kg)

### FEATURES

- Open wall plate design allows for total wall access, increasing electrical and cable management options
- Pre-tensioned universal tilt adapter brackets offer up to +15/-5° of One-Touch™ tilt adjustment in one easy motion
- Optional IncreLok™ feature offers fixed tilt lock in 5° increments
- Easy-Glide™ design ensures that the display is securely attached to the wall plate
- 5° of back tilt offers 3" of space for hands-free, behind the display access
- Up to 23" of horizontal adjustment for centering display on wall
- Up to 1" of vertical adjustment on each universal display adapter bracket for post-installation leveling and height adjustment fine-tuning
- Increased security with included Master Lock 510KAD keyed-alike padlock on locking model
- Universal tilt adapter brackets easily hook onto wall plate for fast installation
- Low profile design holds display 1.69" (43mm) from the wall
- Fits displays with mounting hole patterns from 100 x 100mm (3.94"W x 3.94"H) to 805 x 433mm (31.71"W x 17.04"H)

#### POST-INSTALLATION ADJUSTMENT

±0.5" of vertical adjustment for post-installation leveling and height adjustment fine-tuning

#### VIEWING FLEXIBILITY

Up to 23" of horizontal adjustment for centering display on wall

#### EASY INSTALLATION

Universal display adapter brackets easily hook onto wall plate for fast installation

#### IDEAL VIEWING ANGLE

Pre-tensioned universal tilt adapter brackets offer up to +15/-5° of One-Touch™ tilt adjustment in one easy motion

#### OPEN ARCHITECTURE

Open wall plate architecture for flexible cable management and wall placement

#### SECURE INSTALLATION

Theft resistant screws/ padlock on secure and locking units

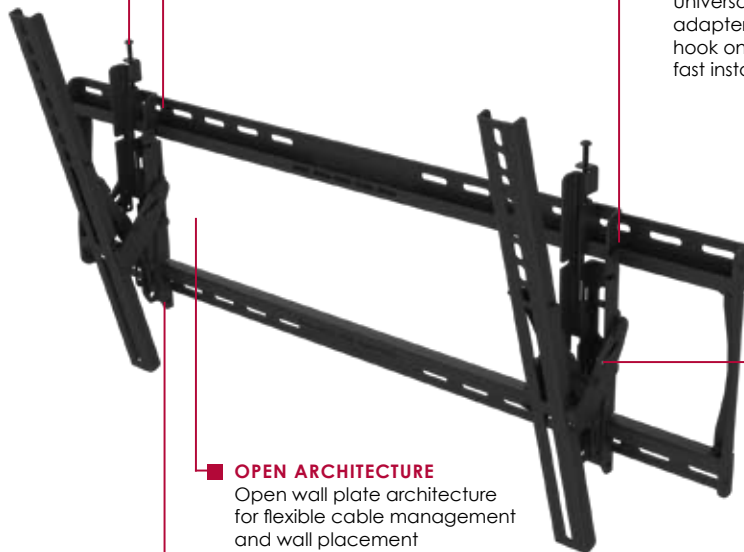

OSHDP Approval Pending



INTEGRATED  
PARTNER  
PROGRAM

Contact your Peerless-AV sales representative for more information

CLICK: [www.peerless-av.com](http://www.peerless-av.com)

CALL: 800.865.2112

FAX: 800.359.6500

peerless-AV™

<b>STX660</b>	SmartMountXT™ Universal Tilt Wall Mount for 46" to 70" Flat Panel Displays - security model
<b>STX660L</b>	SmartMountXT™ Universal Tilt Wall Mount for 46" to 70" Flat Panel Displays - security locking model
<b>STX660P</b>	SmartMountXT™ Universal Tilt Wall Mount for 46" to 70" Flat Panel Displays - standard model

Product Specifications

	DIMENSIONS (W x H x D)	PRODUCT WEIGHT	LOAD CAPACITY	FINISH	AVAILABLE COLORS
<b>STX660(P)</b> <b>STX660L</b>	34.12" x 18" x 1.69"-6.55" (867 x 457 x 43-166mm)	STX660(P): 8.63lb (3.91kg) STX660L: 9.13lb (4.14kg)	150lb (68kg)	Powder coat	Ravens Black

Package Specifications

	PACKAGE SIZE (W x H x D)	PACKAGE SHIP WEIGHT	PACKAGE UPC CODE	PACKAGE CONTENTS	UNITS IN PACKAGE
<b>STX660(P)</b> <b>STX660L</b>	10.125" x 3.5" x 35.875" (257 x 89 x 991mm)	STX660(P): 11.7lb (5.31kg) STX660L: 12.2lb (5.53kg)	STX660: 735029278979 STX660L: 735029278986 STX660P: 735029279396	Universal Tilt Wall Mount, attachment hardware, installation instructions	1

Accessories

<b>ACCXT302:</b>	SmartMountXT™ Video Conferencing Shelf accessory
<b>ACCXT400:</b>	In-Wall Cable and Power Management Accessory with AC Surge Suppressor

All dimensions = inch (mm)

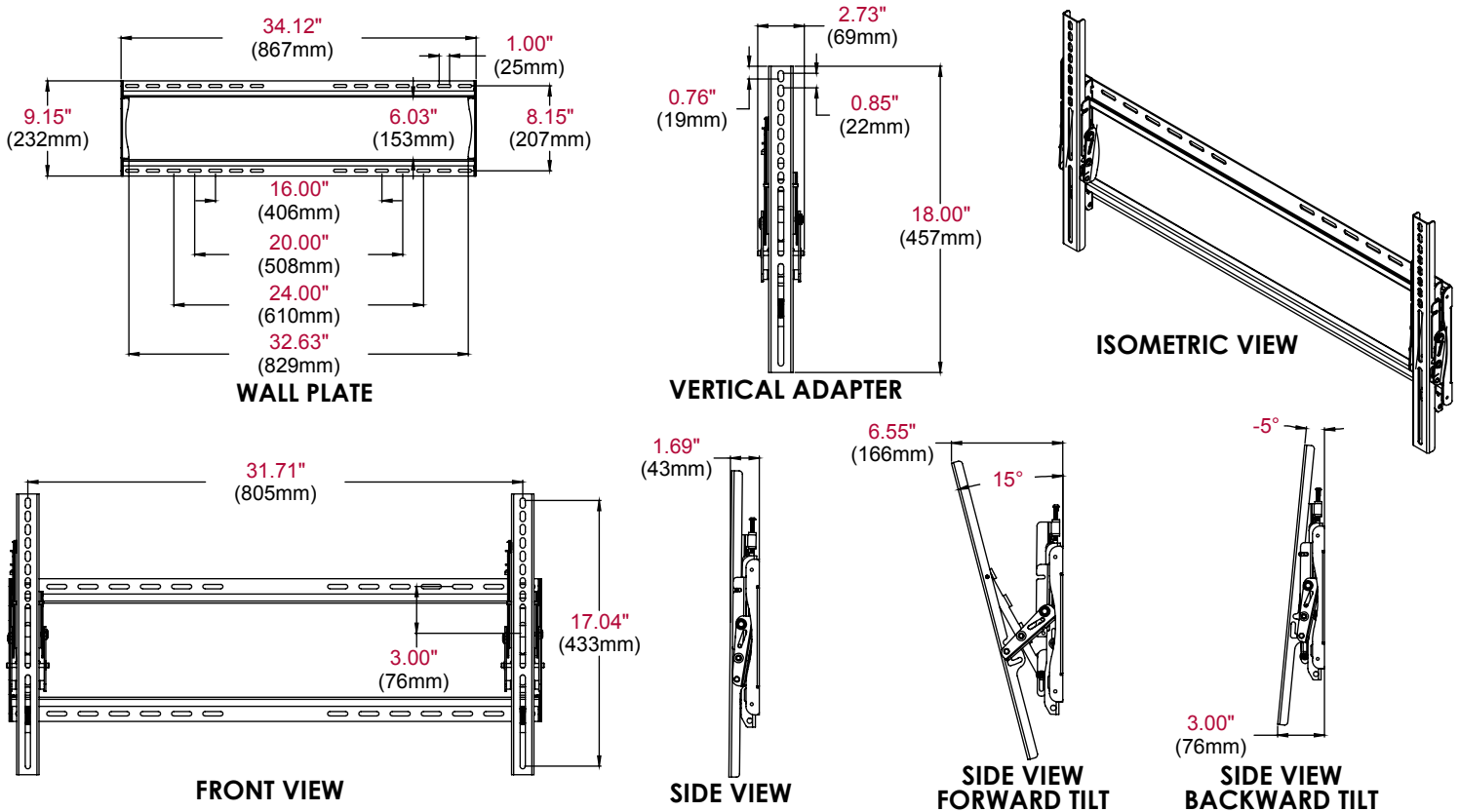

ARCHITECTS SPECIFICATIONS

The SmartmountXT™ Universal Tilt Wall Mount shall be a Peerless-AV™ model STX660, STX660L or STX660P and shall be located where indicated on the plans. It shall be constructed of heavy gauge cold rolled steel and finished with scratch resistant Black Fused Epoxy. Assembly and installation shall be done according to instructions provided by the manufacturer.

Peerless Industries, Inc. ■ 2300 White Oak Circle ■ Aurora, IL 60502 ■ (800) 865-2112 ■ (630) 375-5100 ■ Fax: (800) 359-6500 ■ www.peerless-av.com

Visit [www.peerless-av.com](http://www.peerless-av.com) to see the complete line of AV solutions from Peerless-AV, including flat panel mounts, projector mounts, carts/stands, furniture, cables, screen cleaners and a full assortment of accessories.