

U.S. FULL LINE CATALOG

IRWIN[®] TOOLS

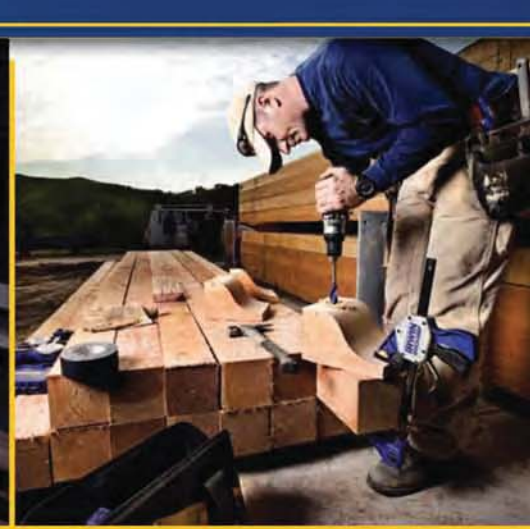

WISE-GRIP[®]

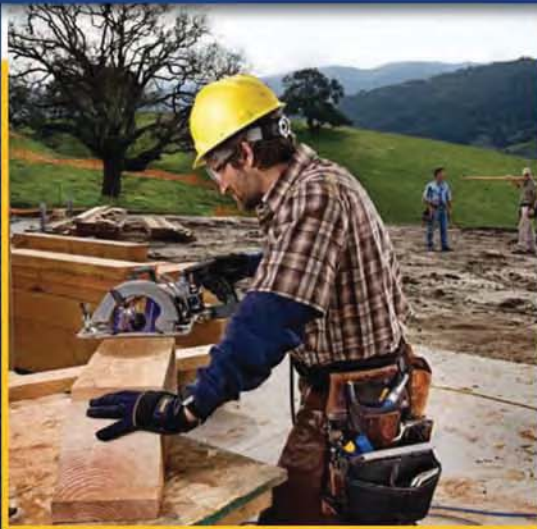

MARATHON



QUICK-GRIP



SPEEDBOR



STRAIT-LINE.



Unibit.



HANSON.

www.irwin.com

For the latest additions to the IRWIN product line,
visit our on-line catalog at irwin.com

THE HISTORY OF IRWIN TOOLS

IRWIN Tools has a long and storied history, stretching for more than a century and set against the backdrop of a young, ambitious nation. In 1885, Charles Irwin patented the Auger bit and, along with four business partners, formed the IRWIN Auger Bit Company. In 1924, William Petersen, a Danish immigrant, invented and patented VISE-GRIP locking pliers. Through innovation and a series of acquisitions, these two companies have now become IRWIN Tools.

IRWIN Tools manufactures and distributes a broad line of professional-grade hand tools and power tool accessories worldwide for trade professionals who demand superior performance and durability on the job. The IRWIN Tools brand portfolio features user-preferred category leaders such as VISE-GRIP® locking tools, MARATHON® circular saw blades, QUICK-GRIP® clamping tools, SPEEDBOR® wood drilling bits, STRAIT-LINE® marking tools, UNIBIT® step drill bits and HANSON® taps and dies.

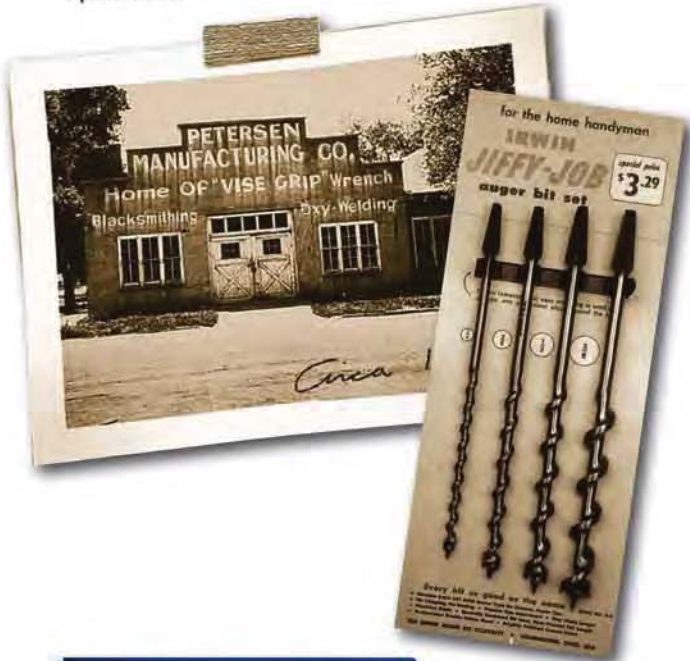

NEW PRODUCTS

IRWIN Industrial Tools' end user obsession, combined with world-class product development, enables us to produce professional-grade hand tools and power tool accessories that provide superior performance and durability on the job.

By incorporating end-user feedback with advanced engineering, we deliver innovative products that continue to surpass industry standards.

HANSON. Tap & Die Performance Threading System (Self-Aligning)



VISE-GRIP Curved Jaw Locking Pliers (Self-Energizing Lower Jaw)



INNOVATION MILESTONES

1828
MARPLES
Chisels



1885
IRWIN
Auger Bit
invented by
Charles Irwin



1914
HANSON
Taps & Dies
developed and
refined by Henry Hanson



1924
VISE-GRIP
Locking Pliers
invented by William Petersen

1954
SPEEDBOR
Wood Boring
Spade Bits
for Power Drills



1960
STRAIT-LINE
Chalk Reels



1972
UNIBIT
Step Drill Bits
invented by
Harry Oaks



SPEEDBOR.
WeldTec Augers

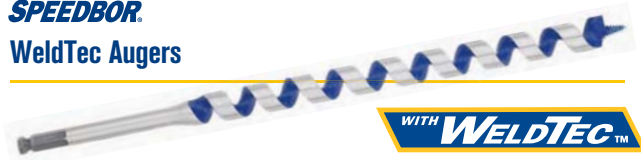

4-Point Utility Blades



SpeedHammer
Power Masonry Bits



Metal Cutting
Saw Blades



WISE-GRIP®
GrooveLock Pliers



(Available in three jaw configurations)

MARATHON.
Cordless Carbide
Saw Blades



Universal Handsaw



MARATHON.
Fiber Cement PCD
Saw Blades



1984
SPEEDBOR
Spade Bits with
Cutting Spurs



1986
QUICK-GRIP
One-Handed
Bar Clamp
invented by Joe Sorenson



MARATHON
Thin Curf Saw Blade



2003
UNIBIT
Self-Starting
Speedpoint Tip

2005
WISE-GRIP
GrooveLock Pliers



2006
SPEEDBOR
MAX Bit with
Tri-Flute Design
and Screw Tip

2007
MARATHON
WeldTec Saw Blades
with Welded Carbide Teeth



2008
UNIBIT
Cobalt Step
Drill Bit

STRAIT-LINE
Mach6
Chalk Reel



2009
HANSON
Self-Aligning
Tap & Die

ULTIMATE TRADESMAN CHALLENGE

IRWIN Tools is searching for the Ultimate Tradesman. The tradesman who can **GRIP IT, RIP IT, and DRIVE IT** faster than any other tradesman out there, will be the next IRWIN Tools Ultimate Tradesman.

IRWIN has always been passionate about tradesmen. Every tool we make starts with the tradesman in mind. We focus intently on delivering products that help the professional tradesman do his/her job better/faster/easier. The Ultimate Tradesman Challenge celebrates professional tradesmen.

The Ultimate Tradesman Challenge has been revamped for the new competition season beginning in 2010. It's all about gripping, ripping, and driving. Tools used include 10" IRWIN VISE-GRIP® GrooveLock pliers, an IRWIN QUICK-GRIP® XP600® one-handed bar clamp, the brand new IRWIN Universal Handsaw, and an IRWIN SPEEDBOR® Max Speed wood drilling bit. Speed; ability to remove pipe fittings; ability to clamp work securely; accurate marking; fast, straight cuts; and the ability to accurately drill two holes are crucial to winning the challenge.

Over 50 events will take place throughout North America, with 24 top times advancing to the North American Finals. All competitors at local events will win cool IRWIN gear, and the winner with the top time of the day will walk away with an IRWIN tool bag packed with IRWIN tools, plus genuine Cat footwear. The North American Champion will win a year's supply of Cat footwear and a custom IRWIN Tools Mustang GT Premium Pace Car – the official pace car of the 2010 IRWIN Tools Night Race at Bristol.

The North American Ultimate Tradesman will then advance to the World Finals in March of 2011, where six tradesmen from around the world will



compete to become the Worldwide IRWIN Tools Ultimate Tradesman. The tradesman with the top time will win the grand prize – a custom 2010 IRWIN Ultimate Tradesman Challenge trophy and a chance to win \$1 MILLION!

For more information, official rules, or to find an event near you, visit www.irwin.com.



NIGHT RACE AT BRISTOL MOTOR SPEEDWAY

IRWIN Tools has been a part of racing for quite a while, so we're incredibly proud to hold the title sponsorship of one of the most prestigious sporting events in the country – the IRWIN Tools Night Race at Bristol Motor Speedway. This summer classic under the lights is one of stock car racing's most popular events. With 55 consecutive sellouts, the Night Race at Bristol is affectionately known as the “toughest ticket in sports.”



SKILLSUSA®



IRWIN Tools is a proud sponsor of SkillsUSA, a national career and technical education organization, serving more than 300,000 high school and college students and professional members in technical, skilled and service

occupations. IRWIN supports the building trade students and instructors of the SkillsUSA organization with the necessary tools to learn their trade and begin their careers. SkillsUSA programs include local, state and national competitions in which students demonstrate occupational and leadership skills. For more information about SkillsUSA, visit the website at www.skillsusa.org.



IRWIN DEMAND TEAM



IRWIN is committed to investing time and resources to understand and satisfy the needs of our professional end-users. The IRWIN Tools Demand Team has multiple “feet on the street” that target key distributor partners, industrial suppliers, and high volume end-users in the Maintenance, Repair, and Operations (MRO) trade. The efforts of the Demand Team include highly-focused sales calls, end-user training, partnerships and training with local trade schools, distributor ride-a-longs, product demonstrations, product trade-outs at jobsites, and participation at key distributor events and tradeshows.

Our Demand Team routinely visits jobsites throughout the world to gain firsthand knowledge of tool technology and enhancements that professional end-users require in order to be more productive in their jobs. The Demand Team compliments IRWIN's end-user obsession by assisting with field research and helping to guarantee marketing efforts that are focused on the tradesman, in order to build and solidify loyalty for our products and our brand.

IRWIN UNIVERSITY

IRWIN Tools is committed to the pursuit of developing tools to get the job done right. Our commitment extends beyond our broad assortment of innovative IRWIN products to include the development of our employees and valued customers. We are dedicated to delivering best-in-class career and industry development opportunities through a variety of product training programs.

Instructor-led Product Training

The Newell Rubbermaid Learning and Development Center in Huntersville, NC is a state-of-the-art facility which boasts a 5,000 sq. ft. tool shop dedicated to IRWIN product training. IRWIN employees participate in a variety of multi-day training programs led by highly skilled facilitators to expand their knowledge of IRWIN hand tools and power tool accessories. These hands-on courses range from introductory product knowledge overviews to more advanced curriculum including jobsite assessment, phases of construction, and hands-on, real-world product applications.



E-Learning Tools

LearnIrwin.com is a powerful web-based training tool accessible to IRWIN employees, distributor partners, and consumers seeking greater knowledge of IRWIN Tools. Each self-guided training module is approximately 20 minutes long, and includes detailed information on product features and benefits, end-user research, common applications, and product comparisons, all set to voice narration. Join us today at www.LearnIrwin.com for interactive up-to-date product training. Be sure to check back often as new courses are added regularly.

Field Training Support

MAX Training is a field training initiative designed to enhance product knowledge of IRWIN Tools outside of the classroom. Our product trainers have over 30 years of industry experience and provide their expertise to IRWIN distributor partners with hands-on product demonstrations at select sales and marketing events across North America.



■ Pliers, Wrenches & Locking Tools	7
■ Clamping Tools	25
■ Vises	33
■ Chisels	39
■ Snips	41
■ Marking & Layout Tools	43
■ Handsaws	51
■ Utility Knives & Blades	55
■ Circular Saw Blades	59
■ Linear Edge	67
■ Fastener Drive & Screwdriving	73
■ Masonry Drilling	99
■ Metal Drilling	107
■ Wood Drilling	127
■ Taps & Dies	141
■ Extractors	183
■ Worksite Products	191
■ Index	197

IRWIN®

WISE-GRIP®

Locking Tools, Pliers & Wrenches



www.irwin.com

The Choice of Professional Tradesmen Since 1924

The IRWIN® VISE-GRIP® brand is legendary. Professional tradesmen have trusted the strength and durability of VISE-GRIP pliers since 1924. With proven performance in every turn, these are the tools that tradesmen choose first – and pass on to the next generation.

VISE-GRIP locking tools have twice the life of any other locking pliers on the market. The familiar VISE-GRIP Original™ locking tools, with the classic trigger release, continue to be a favorite. Our innovative VISE-GRIP Fast Release™ locking pliers have a one-handed, triggerless release, so they're twice as easy to open as the traditional design. Plus, anti-pinch, non-slip ProTouch™ Grips provide comfort, control, and less hand fatigue.

The newly re-engineered curved jaw (CR) locking pliers are the latest innovation in the VISE-GRIP family of locking tools. With a self-energizing lower jaw, these locking tools have three times more gripping power than traditional locking pliers, and will never slip or strip. There's no need for heavy input pressure – the jaws tighten to provide maximum grip as more torque is applied to the tool. The CR range is available in both Original and Fast Release.

VISE-GRIP GrooveLock pliers have a press-n-slide button that adjusts the jaw twice as fast as other groove joint pliers. Anti-pinch, non-slip ProTouch™ Grips provide comfort, control, and less hand fatigue. With precise jaw positioning and a multi-groove ratcheting system, GrooveLock pliers are now available in straight, smooth, and v-shaped jaws.

In addition to locking tools and groove joint pliers, VISE-GRIP offers a full line of pliers and wrenches, including traditional pliers, pipe wrenches, and specialty tools – all backed by the IRWIN VISE-GRIP Lifetime Guarantee.

IRWIN VISE-GRIP pliers and wrenches continue to set the standard for dependability, quality, and innovation... today and tomorrow. Wherever there's a need for a quality tool, IRWIN VISE-GRIP is on the job.



The Perfect Grip for Any Job

The Original SINCE 1924™

IRWIN VISE-GRIP Original locking tools, with a classic trigger release, are designed to provide maximum locking force.

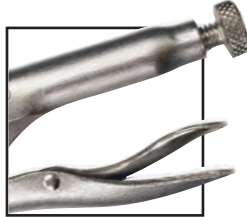

Fast Release™

IRWIN VISE-GRIP Fast Release locking pliers have a one-handed, triggerless release, so they're twice as easy to open as the traditional design. Anti-pinch, non-slip ProTouch™ Grips provide comfort, control, and less hand fatigue.



2X LONGER LIFE*

CURVED JAW LOCKING PLIERS FEATURES

1. Curved Jaw** is perfect for securely gripping and torquing multiple surface shapes, such as round pipe, square or hex bolts, and more; ideal for any application that requires maximum torque.
2. Self-Energizing Lower Jaw – pivot allows jaw to align on workpiece for maximum grip without slipping or stripping; provides maximum torque or grip without requiring heavy input pressure; jaw mechanism grips tighter, as more torque is applied to the tool.
3. Fast Release Handle for one-handed, triggerless release; no pinch points.
4. ProTouch™ Grips have molded handles for comfort, control, and less hand fatigue.
5. Hex Key Adjusting Screw offers controlled release, and draws materials together.



LOCKING TOOLS, PLIERS & WRENCHES

ProTouch™ GRIPS

3X MORE GRIPPING POWER*

*vs. traditional locking pliers
**Patent pending



Locking Tools, Pliers & Wrenches

Locking Pliers

WISE-GRIP Curved Jaw Locking Pliers



11T



4935576

- Self-energizing lower jaw provides three times more gripping power, with no slipping or stripping on any style nut or bolt head

Model	Description	Jaw Capacity	Carded Item #
Fast Release™			
10CR®	Fast Release Curved Jaw - 10" (250 mm)	1-7/8" (48 mm)	11T
7CR®	Fast Release Curved Jaw - 7" (175 mm)	1-1/2" (38 mm)	13T
5CR®	Fast Release Curved Jaw - 5" (125 mm)	1-1/8" (29 mm)	4935581
Original™			
10CR®	Original Curved Jaw - 10" (250 mm)	1-7/8" (48 mm)	4935576
7CR®	Original Curved Jaw - 7" (175 mm)	1-1/2" (38 mm)	4935578
5CR®	Original Curved Jaw - 5" (125 mm)	1-1/8" (29 mm)	4935579

WISE-GRIP Straight Jaw Locking Pliers



1T



102L3

- Straight jaw provides maximum contact on flat, square or hex materials

Model	Description	Jaw Capacity	Carded Item #
Fast Release™			
10R®	Fast Release Straight Jaw - 10" (250 mm)	1-7/8" (48 mm)	1T
7R®	Fast Release Straight Jaw - 7" (175 mm)	1-1/2" (38 mm)	3T
Original™			
10R®	Original Straight Jaw - 10" (250 mm)	1-7/8" (48 mm)	102L3
7R®	Original Straight Jaw - 7" (175 mm)	1-1/2" (38 mm)	302L3

WISE-GRIP Curved Jaw Locking Pliers with Wire Cutter



5T



502L3

- Curved jaw with built-in wire cutter great for a variety of applications and material shapes.

Model	Size	Jaw Capacity	Carded Item #
Fast Release™			
10WR®	Fast Release Curved Jaw w/ Wire Cutter 10" (250 mm)	1-7/8" (48 mm)	5T
7WR®	Fast Release Curved Jaw w/ Wire Cutter 7" (175 mm)	1-1/2" (38 mm)	7T
5WR®	Fast Release Curved Jaw w/ Wire Cutter 5" (125 mm)	1-1/8" (29 mm)	9T
Original™			
10WR®	Fast Release Curved Jaw w/ Wire Cutter 10" (250 mm)	1-7/8" (48 mm)	502L3
7WR®	Fast Release Curved Jaw w/ Wire Cutter 7" (175 mm)	1-1/2" (38 mm)	702L3
5WR®	Fast Release Curved Jaw w/ Wire Cutter 5" (125 mm)	1-1/8" (29 mm)	902L3
4WR®	Fast Release Curved Jaw w/ Wire Cutter 4" (100 mm)	1" (25 mm)	1002L3

WISE-GRIP Long Nose Locking Pliers



- Long, straight nose provides easy access in narrow, hard-to-reach places

WISE-GRIP Locking C-Clamps with Regular Tips

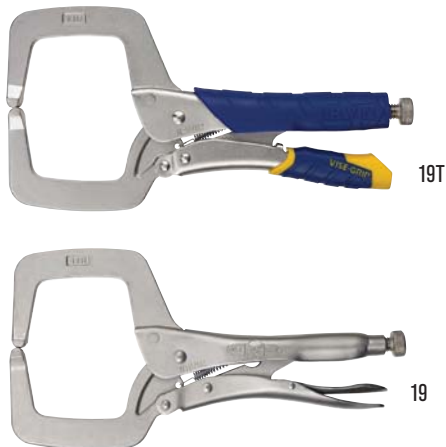

- Wide-opening jaw provides greater versatility in clamping a variety of shapes

WISE-GRIP Locking C-Clamps with Swivel Pads



- Swivel pads hold tapered work, awkward fabricating jobs and delicate projects without damaging the work surface

Model	Description	Jaw Capacity	Carded Item #
Fast Release™			
9LN®	Fast Release Long Nose - 9" (225 mm)	2-3/4" (70 mm)	15T
6LN®	Fast Release Long Nose - 6" (150 mm)	2" (51 mm)	14T
Original™			
9LN®	Original Long Nose - 9" (225 mm)	2-3/4" (70 mm)	1502L3
6LN®	Original Long Nose - 6" (150 mm)	2" (51 mm)	1402L3
4LN®	Original Long Nose - 4" (100 mm)	1-5/8" (41 mm)	1602L3

Model	Description	Jaw Capacity	Carded Item #
Fast Release™			
11R®	Fast Release Locking Clamp - 11" (275 mm)	4" (102 mm)	19T
6R®	Fast Release Locking Clamp - 6" (150 mm)	2-1/8" (54 mm)	17T
Original™			
24R™	Original Locking Clamp - 24" (605 mm)	10" (254 mm)	275
18DR™	Original Locking Clamp - 18" (455 mm)	7-1/2" (190 mm)	211ZR
18R®	Original Locking Clamp - 18" (455 mm)	8" (203 mm)	21
11R®	Original Locking Clamp - 11" (275 mm)	4" (102 mm)	19
9DR™	Original Locking Clamp - 9" (225 mm)	4-1/2" (114 mm)	30
6R®	Original Locking Clamp - 6" (150 mm)	2-1/8" (54 mm)	17

Model	Description	Jaw Capacity	Carded Item #
Original™ Handle			
24SP™	Locking Clamp w/ Swivel Pads - 24" (605 mm)	10" (254 mm)	28
18SP™	Locking Clamp w/ Swivel Pads - 18" (455 mm)	8" (203 mm)	22
11SP®	Locking Clamp w/ Swivel Pads - 11" (275 mm)	4" (102 mm)	20
9SP™	Locking Clamp w/ Swivel Pads - 9" (225 mm)	4-1/2" (114 mm)	31
6SP™	Locking Clamp w/ Swivel Pads - 6" (150 mm)	2-1/8" (54 mm)	18
4SP™	Locking Clamp w/ Swivel Pads - 4" (100 mm)	1-5/8" (41 mm)	165



- 41053
- Soft Pads fit 11SP, 18SP and 24SP

Locking Tools, Pliers & Wrenches

Locking Wrenches / Specialty Tools

WISE-GRIP® Locking Wrenches



- Heavy duty jaws lock onto three sides of a hex fastener, and won't slip or mar

Model	Description	Jaw Capacity	Carded Item #
Original™			
10LW®	Locking Wrench - 10" (250 mm)	5/8"- 1-1/8" (16 mm - 28 mm)	2
7LW®	Locking Wrench - 7" (175 mm)	7/16"- 3/4" (11 mm - 19 mm)	4
4LW®	Locking Wrench - 4" (100 mm)	1/4"- 9/16" (7 mm - 14 mm)	8

Specialty Tools

WISE-GRIP Large Jaw Locking Pliers



- Heavy-duty jaws grip all shapes; ideal for plumbers, mechanics, welders, and large jobs

WISE-GRIP Locking Panel Clamp



- Provides quick clamping and alignment of auto body panels

WISE-GRIP Locking Sheet Metal Tool



- Makes bending, forming and crimping sheet metal jobs easier

WISE-GRIP Locking Chain Clamp



- Chain holds and locks around any shape or size

WISE-GRIP Locking Welding Clamp



- U-shaped jaw provides enhanced visibility and more working space

WISE-GRIP Locking Pinch-Off Tool



- Pinches off and locks onto tubing, leaving both hands free to do other work

Model	Description	Jaw Capacity	Carded Item #
12LC®	Large Jaw Locking Pliers - 12" (300 mm)	3-1/8" (79 mm)	12L3
8R®	Locking Sheet Metal Tool - 8" (200 mm)	3-1/8" (78 mm)	23
9R®	Locking Welding Clamp - 9" (225 mm)	2-3/4" (70 mm)	25ZR
9AC®	Locking Panel Clamp - 9" (225 mm)	2-3/4" (70 mm)	251
20R®	Locking Chain Clamp - 9" (225 mm)	18" (455 mm)	27ZR
RR®	Locking Pinch-off Tool - 7" (175 mm)	1/4" (6 mm)	29

Replacement Parts & Accessories

Genuine VISE-GRIP replacement parts include springs, adjusting screws, chains and pads

Description	Item #
Adjusting Screw 5 Pc. (10R®, 10WR®, 10CR®, 20R®, 12LC®, 11R®, 11SP®, 18R®, 18SP™, 24R™, 24SP™, & 10LW® Locking Tools)	2071910
Adjusting Screw 5 Pc. (7R®, 7WR®, 7CR®, 7LW®, 9LN®, 8R®, 9R®, RR™ Locking Tools)	2071907
Adjusting Screw 5 Pc. (5WR®, 6LN®, 6R®, 6SP Locking Tools)	2071905
Adjusting Screw 5 Pc. (4WR®, 4LN®, 4SP™ and 4LW® Locking Tools)	2071904
Replacement Spring 5 Pc. (24R™, 24SP™, 18R®, 18SP™, 18DR™ Locking Tools)	4935309
Replacement Spring 5 Pc. (10R®, 10WR®, 10CR®, 11R®, 11SP, 20R®, 12LC®, and 10LW® Locking Tools)	4008
Replacement Spring 5 Pc. (9DR™ and 9SP™ Locking Tools)	4050ZR
Replacement Spring 5 Pc. (7R®, 7WR®, 7CR®, 7LW®, 9LN®, 8R®, 9R® and RR™ Locking Tools)	4022ZR
Replacement Spring 5 Pc. (5WR®, 6LN®, 6R®, and 6SP® Locking Tools)	4052ZR
Replacement Spring 5 Pc. (4WR®, 4LN®, 4SP™ and 4LW® Locking Tools)	4092
Soft Pads 4 Pc. (11SP®, 18SP®, 24SP®)	40153
Replacement Chain 18" / 455 mm For 20R® Locking Pliers	40REP
Extension Chain 18" / 455 mm For 20R® Locking Pliers	40EXT



- Replacement screw offered in quantities of five (5)
- Sizes for all locking tools
- Hex key adjust in all sizes



- Replacement springs offered in quantities of five (5)
- Sizes for all locking tools



40153

- Soft Pads offered in quantities of four (4)
- Fit 11SP, 18SP 24SP



40REP

- Replacement chain and extension for 20R (individually offered)

LOCKING TOOLS, PLIERS & WRENCHES

Locking Tools, Pliers & Wrenches

Locking Pliers Sets

Packaged Sets

Fast Release



Fast Release Locking Pliers (2-piece Set)
77T



Fast Release Locking Pliers (2-piece Set)
1771883



Fast Release Locking Pliers (2-piece Set)
214T



Fast Release Locking Pliers w/Kitbag (3-piece Set)
76KBT

The Original SINCE 1924™



The Original Locking Pliers (2-piece Set)
36



The Original Locking Pliers (2-piece Set)
37



The Original Locking Pliers (3-piece Set)
73



The Original Locking Pliers (3-piece Set)
4935580

LOCKING TOOLS, PLIERS & WRENCHES

Kitbags



Fast Release Locking Pliers (4-piece Set)
428KBT



Fast Release Locking Pliers (5-piece Set)
538KBT



Fast Release Locking Pliers (6-piece Set)
2076709



Fast Release Locking Pliers (7-piece Set)
757KBT



The Original Locking Pliers (4-piece Set)
71

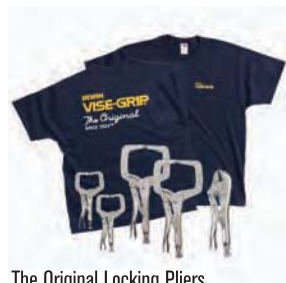

The Original Locking Pliers (5-piece Set with T-shirt)
74



The Original Locking Pliers (6-piece Set with 6 Koozies)
641



The Original Locking Pliers (7-piece Set)
757KB

Tray Sets & Other



The Original™ Locking Pliers
(5-piece Tool Bag Set)
2077704



The Original Locking Pliers (10-piece Set)
1078KB



The Original Locking Pliers (10-piece
Tray Set)
1078TRAY



Fast Release™ Locking Pliers
(10-piece Tray Set)
1078TRT

Description	Item #
2 Pc. Fast Release Locking Pliers Set (Contains: 10WR® and 6LN®)	77T
2 Pc. Fast Release Locking Pliers Set (Contains: 7CR® 9LN®)	1771883
2 Pc. Fast Release Locking Pliers Set (Contains: 10WR® and 7WR®)	214T
2 Pc. Original Locking Pliers Set (Contains: 7WR® and 6LN®)	36
2 Pc. Original Locking Pliers Set (Contains: 10WR® and 5WR®)	37
2 Pc. Original Clamping Set (Contains: (2) 9SP™ and (4) Protective Pads)	45619
3 Pc. Fast Release Locking Pliers Kitbag Set (Contains: 10WR®, 9LN® and 7R®)	76KBT
3 Pc. Original Locking Pliers Set (Contains: 10WR®, 7R® and 6LN®)	323S
3 Pc. Original Locking Pliers Kitbag Set (Contains: 10WR®, 6LN® and 5CR®)	73
3 Pc. Original Locking Pliers Set & 8-n-1 Multi-Tool (Contains: 10R®, 7CR® and 5WR®)	2077703
3 Pc. Original Locking Pliers Set In Tray Set (Contains: 10CR®, 7CR® and 5CR®)	4935580
4 Pc. Fast Release Locking Pliers Kitbag Set (Contains: 10CR®, 7R®, 6LN® & 5WR®)	428KBT
4 Pc. Original Locking Pliers Kitbag Set (Contains: 10CR®, 7R®, 6LN® & 5WR®)	71
5 Pc. Fast Release Locking Pliers Kitbag (Set Contains: 10R®, 10CR®, 7WR®, 6LN® & 5WR®)	538KBT
5 Pc. Original Locking Pliers Tool Bag Set (Contains: 10R®, 10WR®, 7CR®, 5WR® & 6LN®)	2077704
5 Pc. Original Locking Pliers Kitbag Set (Contains: 10R®, 10CR®, 7WR®, 6LN®, & 5CR®)	68
5 Pc. Original Locking Pliers and Clamps T-shirt Set (Contains: (1) 10R®, (2) 11R®, (2) 6R® & T-shirt)	74
6 Pc. Fast Release Locking Pliers Kitbag Set (Contains: 10R®, 7WR®, 6LN®, 5CR®, 11R® & 6R®)	2076709
6 Pc. Original Locking Pliers Kitbag Set (with 6 Koozie Cups, 10WR®, 9LN®, 7R®, 6LN®, 5CR® & 4WR®)	641
7 Pc. Fast Release Locking Pliers Kitbag Set (Contains: 10R®, 7R®, 10CR®, 7WR®, 6LN®, 5WR® & 9LN®)	757KBT
7 Pc. Original Locking Pliers Kitbag Set (Contains: 10CR®, 6LN®, 7R®, 10LW®, 7LW®, 5CR® & 12LC®)	757KB
8 Pc. Original Locking Clamp Set (Contains: (2) 6R®, (2) 11R®, (2) 18R® & (2) 24R™)	8107
10 Pc. Fast Release Locking Pliers Tray Set (Contains: 10R®, 10WR®, 7R®, 7WR®, 7CR®, 5WR®, 6LN®, 9LN®, 6R® & 11R®)	1078TRT
10 Pc. Original Locking Pliers Tray Set (Contains: 10R®, 10CR®, 7R®, 7WR®, 7CR®, 5WR®, 6LN®, 9LN®, 6R® & 11R®)	1078TRAY
10 Pc. Original Locking Pliers Kitbag Set (Contains: 10R®, 10CR®, 7R®, 7WR®, 7CR®, 5WR®, 6LN®, 9LN®, 6R® & 11R®)	1078KB

LOCKING TOOLS, PLIERS & WRENCHES

Locking Tools, Pliers & Wrenches

GrooveLock Pliers

IRWIN® VISE-GRIP® GrooveLock Pliers

GrooveLock
Pliers

2X FASTER*
QUICK-ADJUSTING LOWER JAW

GrooveLock Pliers
FEATURES

1. Right Angle Teeth grip in all directions for maximum bite
2. Metal Injection Molding (MIM) process for precision parts that deliver strength & exceptional performance
3. Press & Slide Button quickly adjusts lower jaw
4. ProTouch™ Grips are anti-pinch and non-slip for comfort, control, and less hand fatigue
5. Multi-Groove Ratcheting System allows for precise positioning and twice the groove positions of traditional groove joint pliers



ProTouch™
GRIPS

LOCKING TOOLS, PLIERS & WRENCHES



* vs. traditional groove joint pliers



Straight Jaw



V-Jaw



Smooth Jaw

Model	Description	Jaw Capacity	Jaw Positions	Item #
GV6	GrooveLock 6"/150 mm V-Jaw Pliers	1-1/8"	11	4935351
GV8R	GrooveLock 8"/200 mm Straight Jaw Pliers	1-3/4"	13	4935095
GV8	GrooveLock 8"/200 mm V-Jaw Pliers	1-3/4"	13	2078108
GV10R	GrooveLock 10"/250 mm Straight Jaw Pliers	2-1/4"	16	4935096
GV10	GrooveLock 10"/250 mm V-Jaw Pliers	2-1/4"	16	2078110
GV10S	GrooveLock 10"/250 mm Smooth Jaw Pliers	2-1/4"	16	4935097
GV12R	GrooveLock 12"/300 mm Straight Jaw Pliers	2-1/4"	19	4935098
GV12	GrooveLock 12"/300 mm V-Jaw Pliers	2-3/4"	19	2078112
GV12S	GrooveLock 12"/300 mm Smooth Jaw Pliers	2-3/4"	19	4935099
GV16	GrooveLock 16"/400 mm V-Jaw Pliers**	4-1/2"	21	2078116
GV20	GrooveLock 20"/500 mm V-Jaw Pliers**	6"	26	2078120

**Dipped grips

WISE-GRIP® Lineman's Pliers



2078209

- Induction-hardened cutting edge stays sharp longer
- Machined jaws for maximum gripping strength
- ProTouch™ grips provide comfort, control and less hand fatigue

Model	Size	Jaw Length	Jaw Width	Jaw Thickness	Wire Cutter	Item #
LP8	8"/200 mm	1-15/32"	1-3/16"	9/16"	YES	2078208
LP9	9.5"/240 mm	1-9/16"	1-1/4"	5/8"	YES	2078209

WISE-GRIP Long Nose Pliers



2078216

- Induction-hardened cutting edge stays sharp longer
- Machined jaws for maximum gripping strength
- ProTouch™ grips provide comfort, control and less hand fatigue

Model	Size	Jaw Length	Jaw Width	Jaw Thickness	Wire Cutter	Item #
LN6	6"/150 mm	1-7/8"	3/4"	7/16"	YES	2078216
LN8	8"/200 mm	2-7/16"	15/16"	15/32"	YES	2078218

WISE-GRIP Bent Nose Pliers



2078226

- Thin nose profile gets into tight spaces and is easy to reach around obstructions
- Induction-hardened cutting edge stays sharp longer
- ProTouch™ grips provide comfort, control and less hand fatigue

Model	Size	Jaw Length	Jaw Width	Jaw Thickness	Wire Cutter	Item #
BN6	6"/150 mm	1-9/16"	3/4"	7/16"	YES	2078226
BN8	8"/200 mm	2"	15/16"	15/32"	YES	2078228

WISE-GRIP Diagonal Cutting Pliers



2078306

- Induction-hardened cutting edge stays sharp longer
- ProTouch™ grips provide comfort, control and less hand fatigue

Model	Size	Jaw Length	Jaw Width	Jaw Thickness	Wire Cutter	Item #
DIA6	6"/150 mm	13/16"	13/16"	13/32"	YES	2078306
DIA7	7"/175 mm	13/16"	1-5/32"	1/2"	YES	2078307
DIA8	8"/200 mm	7/8"	1-1/8"	7/16"	YES	2078308

Locking Tools, Pliers & Wrenches

Pliers

WISE-GRIP® End Cutting Pliers



2078318

- Wide throat clearance allows semi-flush cutting of nails and rivets
- Induction-hardened cutting edge stays sharp longer
- ProTouch™ grips provide comfort, control and less hand fatigue

Model	Size	Jaw Length	Jaw Width	Jaw Thickness	Wire Cutter	Item #
EC8	8"/200 mm	1/2"	1-21/32"	1-1/8"	YES	2078318

WISE-GRIP Groove Joint Pliers



2078508

- Right angle teeth grip in all directions for maximum bite
- Available in ProTouch™ (6", 8", 10", 12") or dipped (16") grips for comfort, control and less hand fatigue

Model	Size	Jaw Capacity	Jaw Thickness	Jaw Positions	Item #
Straight Jaw Groove Joint Pliers					
GJR6	6"/150 mm	1"	3/8"	4	4935318
GJR8	8"/200 mm	1-1/4"	13/32"	5	4935320
GJR10	10"/250 mm	2"	13/32"	7	4935321
GJR12	12"/300 mm	2-1/4"	1/2"	7	4935322
V-Jaw Groove Joint Pliers					
GJ6	6"/150 mm	1"	3/8"	4	2078506
GJ8	8"/200 mm	1-1/4"	13/32"	5	2078508
GJ10	10"/250 mm	2"	13/32"	7	2078510
GJ12	12"/300 mm	2-1/4"	1/2"	7	2078512
GJ16	16"/400 mm	4-1/2"	17/32"	9	2078516
Smooth Jaw Groove Joint Pliers					
GJS6	6"/150 mm	1"	3/8"	4	4935317
GJS8	8"/200 mm	1-1/4"	13/32"	5	4935319
GJS10	10"/250 mm	2"	13/32"	7	2078500
GJS12	12"/300 mm	2-1/4"	1/2"	7	4935323

WISE-GRIP Cable Cutting Pliers



2078328

- Cuts up to 3/0 fine stranded copper battery cable
- Induction-hardened cutting edge stays sharp longer
- ProTouch grips provide comfort, control and less hand fatigue

Model	Size	Jaw Length	Jaw Width	Jaw Thickness	Type of Wire	Item #
CC8	8"/200 mm	13/16"	1-1/4"	19/32"	Copper & Aluminum	2078328

WISE-GRIP Slip Joint Pliers



2078406

- Machined jaws for maximum gripping strength
- ProTouch™ grips provide comfort, control and less hand fatigue

Model	Size	Jaw Length	Jaw Width	Jaw Thickness	Wire Cutter	Item #
SJ6	6"/150 mm	1-1/8"	1-5/32"	7/16"	YES	2078406
SJ8	8"/200 mm	1-5/16"	1-11/32"	7/16"	YES	2078408

WISE-GRIP Iron Workers Pliers



2078909

- Induction-hardened cutting edge stays sharp longer
- Cross-hatched teeth designed to provide aggressive grip

Model	Size	Jaw Length	Jaw Width	Jaw Thickness	Wire Cutter	Item #
IW9	9"/225 mm	1-1/2"	1-1/4"	19/32"	YES	2078909

WISE-GRIP Fencing Pliers



2078901

- The only tool needed to work on metal and wood posts
- Nickel chromium steel construction for overall strength and durability
- ProTouch grips provide comfort, control and less hand fatigue

Model	Size	Jaw Length	Jaw Width	Jaw Thickness	Wire Cutter	Item #
FP10	10-1/4"/260 mm	13/16"	3-3/16"	19/32"	YES	2078901

WISE-GRIP Concrete Nippers



2078910

- Induction-hardened cutting edge stays sharp longer
- Precision-matched jaws provide a clean cut
- ProTouch grips provide comfort, control and less hand fatigue

Model	Size	Jaw Length	Jaw Width	Jaw Thickness	Wire Cutter	Item #
CN10	10"/250 mm	3/4"	1-3/8"	15/16"	YES	2078910

Locking Tools, Pliers & Wrenches

Pliers / Adjustable Wrenches / Insulated Pliers

WISE-GRIP® Forged Crimper



2078310

- Designed for crimping insulated and non-insulated connections and terminals on 10-22 AWG wire
- ProTouch™ grips provide extra comfort, control, and less hand fatigue

Model	Size	Jaw Length	Jaw Width	Jaw Thickness	Wire Cutter	Item #
FC10	10"/250 mm	1-3/16"	1-9/32"	3/16"	YES	2078310

WISE-GRIP Adjustable Wrenches



2078608

- Inch and metric scales
- Available in ProTouch grips (6", 8", 10", 12") or solid metal handles (15", 18", 24")

Model	Adjustable Size	Jaw Capacity	Jaw Width	Jaw Thickness	Item #
AW6	6"/150 mm	15/16"	27/32"	1/4"	2078606
AW8	8"/200 mm	1-1/8"	1"	5/16"	2078608
AW10	10"/250 mm	1-1/4"	1-1/4"	3/8"	2078610
AW12	12"/300 mm	1-1/2"	1-13/32"	7/16"	2078612
AW15	15"/380 mm	1-13/16"	1-27/32"	17/32"	2078615
AW618	18"/455 mm	2-1/4"	2-3/32"	19/32"	2078618
AW24	24"/610 mm	2-5/8"	2-5/32"	3/4"	2078624

WISE-GRIP 1000V Insulated Pliers

- All 1000V tools individually tested at factory and meet ASTM, IEC, VDE and DIN specifications.



10505872NA



10505868NA



10505865NA



10507529NA



10505870NA



10505871NA

Model	Description	Size	Jaw Length	Jaw Width	Jaw Thickness	Wire Cutter	Item #
IC6	Insulated Combination - Standard	6"/150 mm	1-3/8"	1"	3/8"	YES	10505872NA
IC7	Insulated Combination - High Leverage	7"/170 mm	1-1/2"	1-1/8"	7/16"	YES	10505873NA
IC8	Insulated Combination - High Leverage	8"/200 mm	1-3/4"	1-1/8"	7/16"	YES	10505874NA
IL9	Insulated Linemen's Pliers	8.5"/215 mm	1-7/8"	1-1/16"	1/2"	YES	10507529NA
ILN6	Insulated Long Nose - Standard	6"/150 mm	2-1/8"	11/16"	11/32"	YES	10505868NA
ILN8	Insulated Long Nose - High Leverage	8"/200 mm	3"	13/16"	3/8"	YES	10505869NA
IBN8	Insulated Bent Nose - High Leverage	8"/200 mm	2-3/4"	13/16"	3/8"	YES	10505870NA
ID6	Insulated Standard Diagonal Cutter	6"/150 mm	7/8"	7/8"	7/16"	YES	10505865NA
ID7	Insulated High Leverage Diagonal Cutter	7"/170 mm	13/16"	1-1/8"	1/2"	YES	10505866NA
ID8	Insulated High Leverage Diagonal Cutter	8"/200 mm	7/8"	1-1/8"	3/8"	YES	10505867NA
IWS6	Insulated Wire Stripper	6"/150 mm	3/8"	7/8"	3/8"	NO	10505871NA

WISE-GRIP Mini Pliers

- ProTouch™ grips provide comfort, control and less hand fatigue



Model	Description	Size	Jaw Length	Jaw Width	Jaw Thickness	Spring Loaded	Wire Cutter	Item #
BN5	Bent Nose Pliers	5"/125 mm	1-1/8"	9/16"	11/32"	YES	NO	2078965
FN5	Flat Nose Pliers	5-1/4"/135 mm	1-1/4"	9/16"	11/32"	YES	NO	2078945
LN5	Long Nose Pliers	5-1/4"/135 mm	1-1/4"	9/16"	11/32"	YES	YES	2078905
EC4	End Nipper	4-1/4"/110 mm	5/16"	9/16"	11/32"	YES	YES	2078904
DC4	Standard Diagonal Pliers	4-1/2"/115 mm	17/32"	9/16"	11/32"	YES	YES	2078935
FD4	Flush Cut Diagonal Pliers	4-1/2"/115 mm	17/32"	9/16"	11/32"	YES	YES	2078925
LP4	Lineman's Pliers	4-3/4"/120 mm	5/8"	9/16"	11/32"	YES	YES	2078915
NN5	Needle Nose Pliers	5-1/2"/139 mm	1-11/16"	9/16"	11/32"	YES	NO	2078955

WISE-GRIP Wire Strippers

- Available in ProTouch (6", 7", 8", 8-1/2") or dipped (5") grips for comfort



Model	Description	Size	Jaw Length	Jaw Width	Wire Gauge	Wire Cutter	Item #
WS8	Self Adjusting	8"/200 mm	-	2"	10-24 AWG	YES	2078300
CM8	Crimper Cutter Multi-Tool	8"/200 mm	1-3/16"	1-1/4"	10-22 AWG	YES	2078309
CM7	Crimper Cutter	7"/170 mm	1-11/16"	1-1/4"	10-20 AWG	YES	2078317
WS6	Wire Stripper/Cutter	6"/150 mm	1-19/32"	1-1/4"	10-20 AWG	YES	2078316
WS5	Wire Stripper/Cutter	5"/125 mm	5/8"	3/4"	10-24 AWG	YES	2078305
CS6	Convertible Snap Ring Pliers	6"/150 mm	1-11/32"	1"	-	NO	2078900

Locking Tools, Pliers & Wrenches

Pipe Wrenches

IRWIN® VISE-GRIP® Quick Adjusting Pipe Wrench

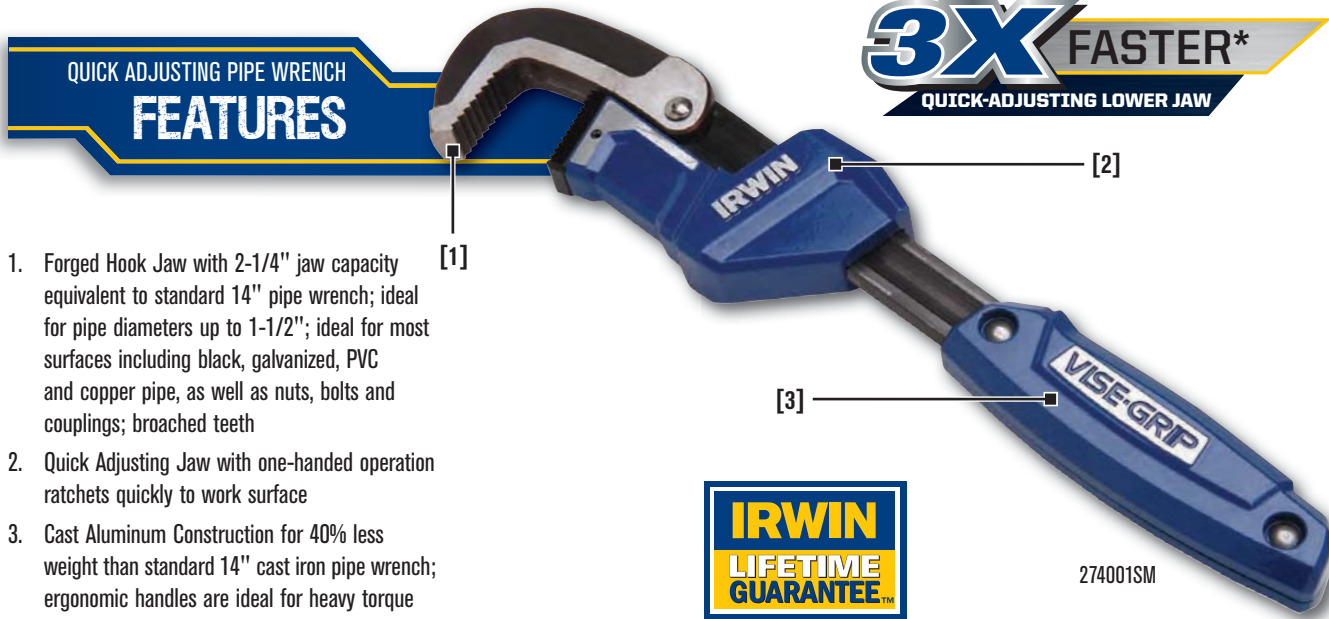

1. Forged Hook Jaw with 2-1/4" jaw capacity equivalent to standard 14" pipe wrench; ideal for pipe diameters up to 1-1/2"; ideal for most surfaces including black, galvanized, PVC and copper pipe, as well as nuts, bolts and couplings; broached teeth
2. Quick Adjusting Jaw with one-handed operation ratchets quickly to work surface
3. Cast Aluminum Construction for 40% less weight than standard 14" cast iron pipe wrench; ergonomic handles are ideal for heavy torque and maximum comfort



274001SM

*than traditional pipe wrenches

Description	Pipe Capacity	Item #
11" Quick Adjusting Pipe Wrench	1-1/2"	274001SM

LOCKING TOOLS, PLIERS & WRENCHES

VISE-GRIP Cast Aluminum Pipe Wrenches



- 40% lighter than our cast iron pipe wrenches
- Drop forged jaw is heat-treated to resist distortion or breakage
- Hardened teeth provide tremendous bite
- Easy-spin adjusting nut is heat-treated for durability
- I-Beam handle's wide design provides better weight distribution
- Unique design of hammer head provides flat surface for hammering

Description	Pipe Capacity	Item #
10" Cast Aluminum Pipe Wrench	1-1/2"	2074110
12" Cast Aluminum Pipe Wrench	2"	2074112
14" Cast Aluminum Pipe Wrench	2"	2074114
18" Cast Aluminum Pipe Wrench	2-1/2"	2074118
24" Cast Aluminum Pipe Wrench	3"	2074124
36" Cast Aluminum Pipe Wrench	5"	2074136
48" Cast Aluminum Pipe Wrench	6"	2074148

VISE-GRIP Cast Iron Pipe Wrenches



- Heavy-duty cast iron housing
- Drop forged jaw is heat-treated to resist distortion or breakage
- Hardened teeth provide tremendous bite
- Easy-spin adjusting nut is heat-treated for durability
- I-Beam handle's wide design provides better weight distribution
- Unique design of hammer head provides flat surface for hammering

Description	Pipe Capacity	Item #
8" Cast Iron Pipe Wrench	1	274105
10" Cast Iron Pipe Wrench	1-1/2"	274101
12" Cast Iron Pipe Wrench	2"	274106
14" Cast Iron Pipe Wrench	2"	274102
18" Cast Iron Pipe Wrench	2-1/2"	274103
24" Cast Iron Pipe Wrench	3"	274104
36" Cast Iron Pipe Wrench	5"	274107
48" Cast Iron Pipe Wrench	6"	274108

VICE-GRIP Packaged Sets



2-piece Traditional Pliers Set
2078701



2-piece GrooveLock Pliers Set
2078709



2-piece Traditional Pliers Set
2078702



3-piece Traditional Pliers Set
2078704



2-piece Traditional Pliers
Joint Set
2078703



2-piece Adjustable
Wrench Set
2078700

VICE-GRIP Kitbag Sets



3-piece GrooveLock Pliers Set
2078711



5-piece Pliers & Wrenches Set
2078708



8-piece Mini Pliers Set
2078714



8-piece Pliers Set
2078712

VICE-GRIP Tray Sets



3-piece GrooveLock Pliers Set
2078710



4-piece Adjustable Wrench Set
2078706



4-piece Pliers Set
2078707



3-piece Insulated Pliers Set
10505519NA



4-piece Pliers and Adjustable Wrench Set
2078705

Description	Item #
Traditional Pliers Sets	
2 Pc. Adjustable Wrench Set (Contains: 6" & 10")	2078700
2 Pc. Traditional Pliers Set (Contains: 6" Slip Joint & 10" Groove Joint)	2078701
2 Pc. Traditional Pliers Set (Contains: 6" Slip Joint & 6" Long Nose)	2078702
2 Pc. Traditional Pliers Joint Set (Contains: 6" Long Nose & 10" Groove Joint)	2078703
3 Pc. Insulated Set (Contains: 6" Diagonal, 7" Combination & 8" Long Nose)	10505519NA
3 Pc. Traditional Pliers Set (Contains: 6" Long Nose, 6" Slip Joint & 10" Groove Joint)	2078704
4 Pc. Traditional Pliers Set (Contains: 6" Long Nose, 6" Slip Joint, 10" Adj Wrench & 10" Groove Joint)	2078705
4 Pc. Adjustable Wrench Tray Set (Contains: 6", 8", 10" & 12")	2078706
4 Pc. Traditional Pliers Tray Set (Contains: 6" Diagonal, 6" Slip Joint, 8" Long Nose, 10" Groove Joint)	2078707
5 Pc. Traditional Pliers Kitbag Set (Contains: 6" Slip Joint, 6" Diagonal, 8" Lineman, 10" Adj. Wrench, 10" Groove Joint)	2078708
8 Pc. Mini Traditional Pliers Set w/Case (Contains 1 Each: 2078904, 2078945, 2078905, 2078915, 2078925, 2078935, 2078955 & 2078965)	2078714
GrooveLock Pliers Sets	
2 Pc. GrooveLock Pliers Set (Contains: GV8, GV10)	2078709
3 Pc. GrooveLock Tray Set (Contains: GV8, GV10, GV12)	2078710
3 Pc. GrooveLock Kitbag Set (Contains: GV8, GV10, GV12)	2078711
GrooveLock & Traditional Pliers Sets	
8 Pc. GrooveLock/Traditional Pliers Kitbag Set (Contains: GV8, GV10, GV12, 10" Adj. Wrench, 8" Long Nose, 8" Linemans, 6" Diagonal & 6" Slip Joint)	2078712

IRWIN®

QUICK-GRIP®

Clamping Tools



www.irwin.com

Clamping Tools

The Complete Solution for Clamping

IRWIN® QUICK-GRIP® can deliver the right fit, features and pressure for any clamping job – from the smallest craft project to large scale cabinetry. So whether you need the one-handed power of the QUICK-GRIP XP600 or the versatility of the SL300 clamp, you can be sure you will get the clamping performance you need when you reach for the clamp with the QUICK-GRIP brand.

CLAMPING TOOLS APPLICATION GUIDE

	One-Handed Bar Clamps				Handi/Spring Clamps			Traditional Clamps				Specialty Clamps	
Clamps & Specs													
	Micro Bar Clamp	Mini Bar Clamp	QUICK-GRIP QG150	QUICK-GRIP SL300	QUICK-GRIP XP600	HANDI-CLAMP	Metal & Resin Spring Clamps	C-Clamp Spring Clamps	Bar Clamp, F-Clamp (Med. Duty)	Bar Clamp, F-Clamp (Heavy Duty)	Pipe Clamp	Parallel, Box, Cabinet Clamp	Specialty Clamps
Holding Force:	40 lbs	140 lbs	150 lbs	300 lbs	600 lbs	30-60 lbs	25-65 lbs	600-1600 lbs	1000 lbs	1150 lbs	1000-1200 lbs	1150 lbs	N/A
Clamp Capacity:	4"	6"-12"	6"-12"	6"-36"	6"-50"	1-1/2"-4"	1", 2", 3"	1"-8"	6"-36"	12"-30"	Based on Pipe Length	24"-48"	N/A
Throat Depth:	1-3/16"	2-7/8"	3-1/4"	3-1/2"	3-3/4"	1-1/2"-4"	1", 2", 3"	1-3/16"-4-1/2"	3-1/8"	4-7/8"	1-1/2"-1-7/8"	3-3/4"	N/A
Crafts/Light Duty Clamping	BEST	BEST	BETTER	BETTER		BETTER	GOOD	GOOD					
Temporary hold-down quick clamping	BEST	BEST	BEST	BEST	BEST	BETTER	GOOD						
Flat panels/Solid edge wood glue up / Deep reach clamping					BETTER				BETTER	BETTER	BEST	BEST	
Irregular shape/ Multiple surface/ Corner joining			BETTER	BETTER									BEST
Installation/ Demolition/Heavy-duty clamping			GOOD	BETTER				BETTER	BETTER	BEST			
Localized pressure/ Metal working								BEST	BETTER	BETTER	GOOD		

CLAMPING TOOLS

IRWIN
QUICK-GRIP

BEST Best choice for clamping application

BETTER Better choice for clamping application

GOOD Good choice for clamping application

One-Handed Bar Clamp Life Test

An overall brand comparison is shown in this chart. Only the IRWIN QUICK-GRIP® XP600 and SL300 are able to complete the 5,000 cycle* test without showing failure.

*1 cycle = clamp to test force and release

**Failure = no longer achieving

QUICK-GRIP XP600 & SL300 Longest Life

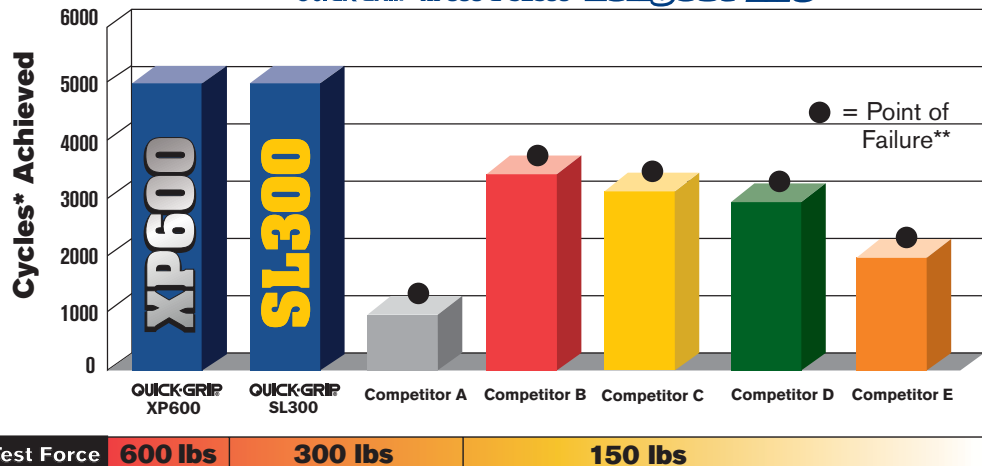

QUICK-GRIP® XP600

The IRWIN® QUICK-GRIP XP600 (Extreme Pressure) is the most powerful one-handed bar clamp available. Its 600 lbs. of hold force make it ideal for heavy-duty applications like installation, demolition, and rough glue-up. The new adjustable foot allows XP600 to rest upright on the work surface for gluing – perfect for panels and cabinetry. In addition, the full face pads distribute pressure evenly. Remove the pads to activate the swivel jaw feature, which maintains full contact to combat flexing at extreme pressure, or conforms to irregular surfaces. The IRWIN QUICK-GRIP XP600 delivers maximum power, versatility and stability – it's what you would expect from the innovator in clamping.

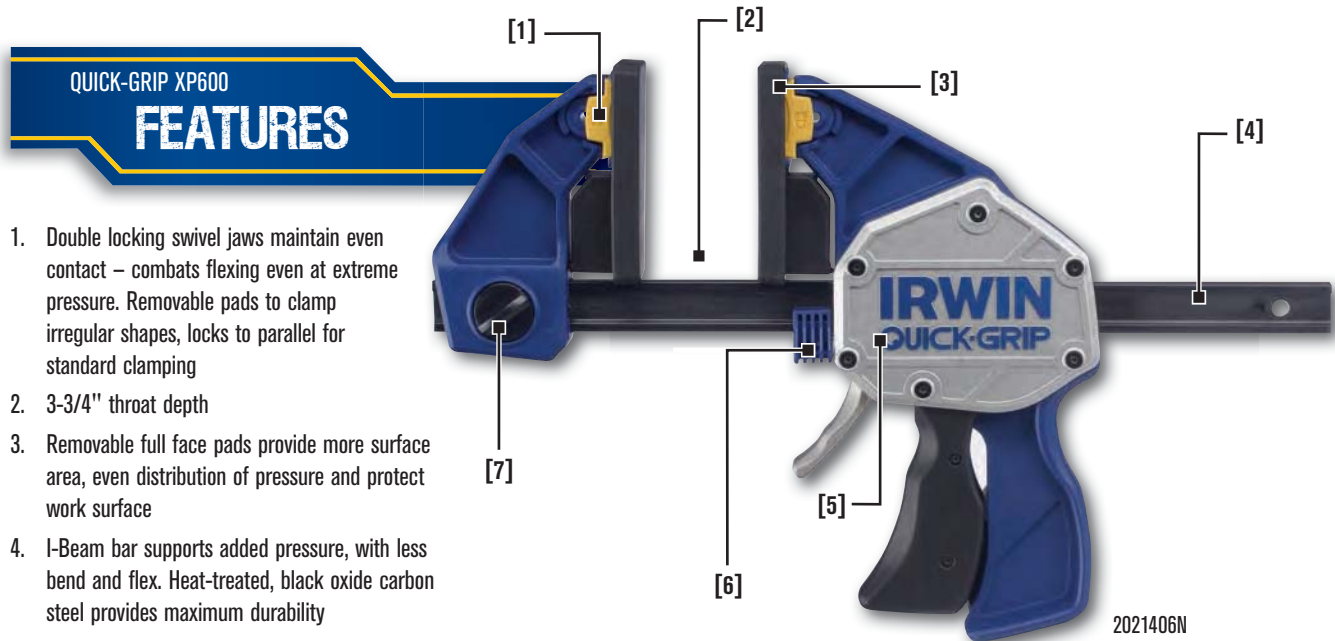

- QUICK-GRIP XP600 FEATURES**
1. Double locking swivel jaws maintain even contact – combats flexing even at extreme pressure. Removable pads to clamp irregular shapes, locks to parallel for standard clamping
 2. 3-3/4" throat depth
 3. Removable full face pads provide more surface area, even distribution of pressure and protect work surface
 4. I-Beam bar supports added pressure, with less bend and flex. Heat-treated, black oxide carbon steel provides maximum durability
 5. Patented Power Lock™ system holds more pressure longer
 6. Adjustable foot sits upright for gluing
 7. Quick Change™ screw allows for quick conversion to a spreader, affixed spring-loaded screw won't get lost

600 lbs
SUSTAINED CLAMPING FORCE

CLAMPING TOOLS

Description	Spreading Capacity	Throat Depth	Pack Qty	Item #
6" (15 cm) XP Bar Clamp/Spreader	9" - 14-5/8" (23 cm - 37 cm)	3-3/4" (95 mm)	2	2021406N
12" (30 cm) XP Bar Clamp/Spreader	9" - 20-5/8" (23 cm - 52 cm)	3-3/4" (95 mm)	2	2021412N
18" (45 cm) XP Bar Clamp/Spreader	9" - 26-5/8" (23 cm - 67 cm)	3-3/4" (95 mm)	2	2021418N
24" (60 cm) XP Bar Clamp/Spreader	9" - 32-5/8" (23 cm - 83 cm)	3-3/4" (95 mm)	2	2021424N
36" (91 cm) XP Bar Clamp/Spreader	9" - 44-5/8" (23 cm - 113 cm)	3-3/4" (95 mm)	2	2021436N
50" (127 cm) XP Bar Clamp/Spreader	9" - 58-5/8" (23 cm - 147 cm)	3-3/4" (95 mm)	2	2021450N

QUICK-GRIP® SL300

Twenty years ago, IRWIN® QUICK-GRIP revolutionized clamping with the introduction of the one-handed bar clamp. QUICK-GRIP is now taking that convenience to the next level with the SL300 (Swivel Lock). This new clamp has an I-beam bar and delivers 300 lbs. of hold force. In addition, the locking swivel jaw conforms to irregular surfaces, maintains full contact to combat flexing, or easily locks to parallel for standard clamping. The SL300 also has a Quick Change™ screw to convert easily to a spreader. The QUICK-GRIP SL300 combines one-handed convenience with unparalleled performance – it's the new generation in one-handed bar clamps.

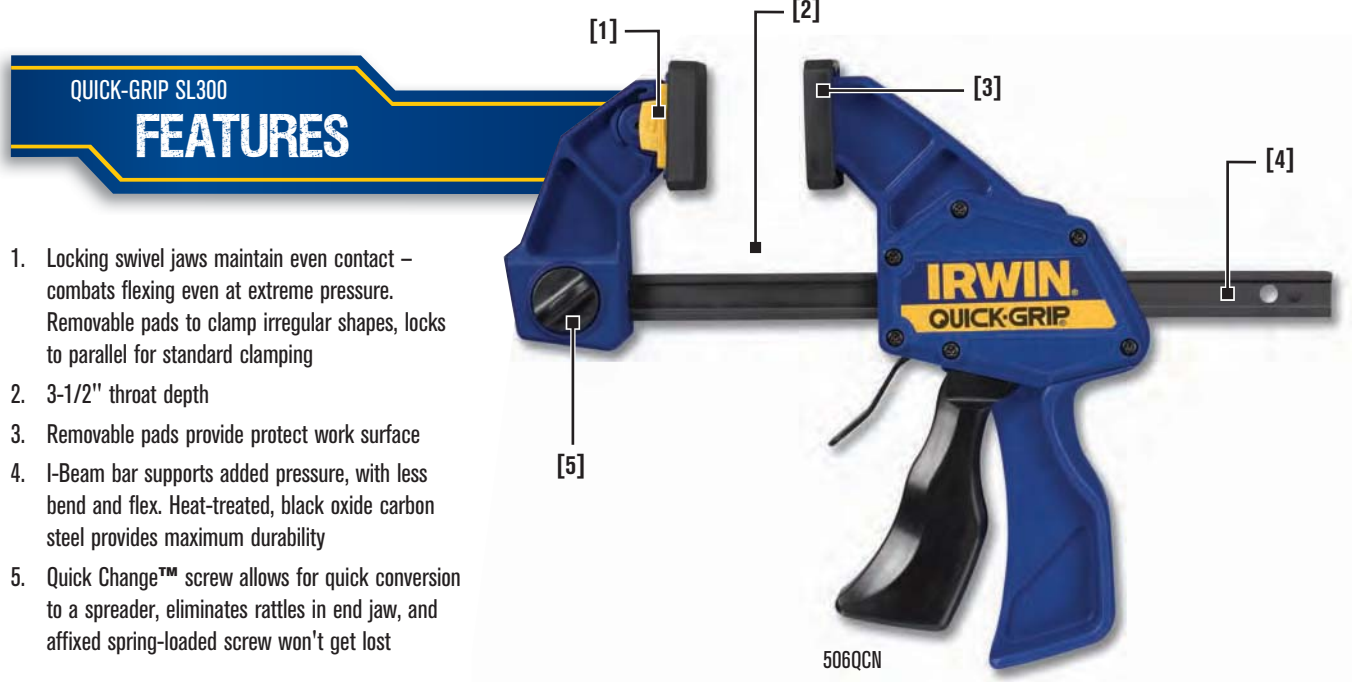

QUICK-GRIP SL300 FEATURES

1. Locking swivel jaws maintain even contact – combats flexing even at extreme pressure. Removable pads to clamp irregular shapes, locks to parallel for standard clamping
2. 3-1/2" throat depth
3. Removable pads provide protect work surface
4. I-Beam bar supports added pressure, with less bend and flex. Heat-treated, black oxide carbon steel provides maximum durability
5. Quick Change™ screw allows for quick conversion to a spreader, eliminates rattles in end jaw, and affixed spring-loaded screw won't get lost

CLAMPING TOOLS

300 lbs
SUSTAINED CLAMPING FORCE

Description	Spreading Capacity	Throat Depth	Pack Qty	Item #
6" (15 cm) SL300 Bar Clamp/Spreader	8" - 13-3/8" (200 mm - 340 mm)	3-1/4" (80 mm)	5	506QCN
12" (30 cm) SL300 Bar Clamp/Spreader	8" - 19-3/8" (200 mm - 590 mm)	3-1/4" (80 mm)	5	512QCN
18" (45 cm) SL300 Bar Clamp/Spreader	8" - 25-3/8" (200 mm - 645 mm)	3-1/4" (80 mm)	5	518QCN
24" (60 cm) SL300 Bar Clamp/Spreader	8" - 31-3/8" (200 mm - 795 mm)	3-1/4" (80 mm)	5	524QCN
36" (91 cm) SL300 Bar Clamp/Spreader	8" - 43-3/8" (1000 mm - 1120mm)	3-1/4" (80 mm)	2	536QCN

QUICK-GRIP® QG150 One-Handed Bar Clamp/Spreader



4935191

- Removable resin pads protect work surfaces
- Converts to a spreader

QUICK-GRIP Mini One-Handed Bar Clamp



5412

- Pistol grip design enhances comfort and ease of use
- QUICK-RELEASE™ trigger for fast and easy positioning

QUICK-GRIP Micro One-Handed Bar Clamp/Spreader



53006

- Perfect size for hobby and craft applications
- Converts to a spreader – 8" spreading capacity

QUICK-GRIP HANDI-CLAMP®



59200

- QUICK-RELEASE trigger allows fast and easy positioning and release

QUICK-GRIP Spring Clamps



58200

- High-tech resin construction provides strength and durability

Description	Spreading Capacity	Throat Depth	Pack Qty	Item #
6" (15 cm) QG150 Bar Clamp	7"-12-3/4" (18cm - 32 cm)	3-1/4" (80 mm)	5	4935191
12" (30 cm) QG150 Bar Clamp	7"-18-3/4" (18cm - 48 cm)	3-1/4" (80 mm)	5	4935192

Description	Throat Depth	Pack Qty	Item #
6" (15 cm) Mini Clamp	2-7/16" (62 mm)	5	5462R
6" (15 cm) Mini Clamp - 2 Pack	2-7/16" (62 mm)	5	5462
12" (30 cm) Mini Clamp	2-7/16" (62 mm)	5	5412
12" (30 cm) Mini Clamp - 2 Pack	2-7/16" (62 mm)	5	54122

Description	Spreading Capacity	Throat Depth	Pack Qty	Item #
4-1/4" (10 cm) Micro Clamp	8" (200 mm)	1-3/16" (30 mm)	10	53006
4-1/4" (10 cm) Micro Clamp - 2 Pack	8" (200 mm)	1-3/16" (30 mm)	5	530062

Description	Throat Depth	Pack Qty	Item #
1-1/2" (37 mm) HANDI-CLAMP	1-1/2" (37 mm)	5	59100
2" (50 mm) HANDI-CLAMP	2" (50 mm)	5	59200
4" (10 cm) HANDI-CLAMP	3" (75 mm)	5	59400

Description	Throat Depth	Pack Qty	Item #
1" (25 mm) Resin Spring Clamp	1" (25 mm)	10	58100
2" (50 mm) Resin Spring Clamp	2" (50 mm)	10	58200
3" (75 mm) Resin Spring Clamp	3" (75 mm)	5	58300

Clamping Tools

Hand Clamps /Traditional Clamps

QUICK-GRIP® Metal Clamps



222601

- Simple and convenient for light clamping crafts

QUICK-GRIP Bar Clamps, Medium Duty



223112

- ProTouch handle for an ergonomic grip
- I-beam bar reduces flexing and bowing
- Clutch lock for easy movement along bar
- Non-marring pads protect the workpiece

QUICK-GRIP Bar Clamps, Heavy Duty



223212

- Ergonomic ProTouch™ handle allows higher clamping pressure
- I-beam bar reduces flexing and bowing
- Non-marring pads protect the workpiece

QUICK-GRIP C-Clamps



225104

- Double-rolled thread provides greater clamping speed
- Large swivel pad reduces marring on work surface and increases stability
- Large handle for greater clamping pressure with less effort

Description	Throat Depth	Pack Qty	Item #
1" (25 mm) Metal Spring Clamp	1" (25 mm)	5	222601
2" (50 mm) Metal Spring Clamp	2" (50 mm)	5	222702
3" (75 mm) Metal Spring Clamp	3" (75 mm)	5	222803

Description	Throat Depth	Pack Qty	Item #
Medium Duty Bar Clamps (100 Series)			
6" (15 cm) Bar Clamp, Clutch Lock	3-1/8" (76 mm)	5	223106
12" (30 cm) Bar Clamp, Clutch Lock	3-1/8" (76 mm)	5	223112
18" (45 cm) Bar Clamp, Clutch Lock	3-1/8" (76 mm)	5	223118
24" (65 cm) Bar Clamp, Clutch Lock	3-1/8" (76 mm)	5	223124
30" (30 cm) Bar Clamp, Clutch Lock	3-1/8" (76 mm)	5	223130
36" (91 cm) Bar Clamp, Clutch Lock	3-1/8" (76 mm)	5	223136
Heavy Duty Bar Clamps (200 Series)			
12" (30 cm) Bar Clamp, Passive Lock	4-7/8" (12 cm)	5	223212
18" (45 cm) Bar Clamp, Passive Lock	4-7/8" (12 cm)	5	223218
24" (60 cm) Bar Clamp, Passive Lock	4-7/8" (12 cm)	5	223224
32" (75 cm) Bar Clamp, Passive Lock	4-7/8" (12 cm)	5	223230

Description	Throat Depth	Pack Qty	Item #
1" (25 mm) C-Clamp	1-3/16" (30 mm)	5	225101
2" (50 mm) C-Clamp	1-5/16" (33 mm)	5	225102
3" (75 mm) C-Clamp	2-1/4" (51 mm)	5	225103
4" (10 cm) C-Clamp	3" (75 mm)	5	225104
5" (12.5 cm) C-Clamp	3-1/4" (81 mm)	5	225105
6" (15 cm) C-Clamp	3-1/2" (87 mm)	5	225106
8" (20 cm) C-Clamp	4" (10 cm)	5	225108
2" Deep Throat C-Clamp	3-1/2" (87 mm)	5	225123
3" Deep Throat C-Clamp	4-1/2" (12 cm)	5	225134
1-1/2" (37 mm) C-Clamp	1-1/2" (37 mm)	5	2025101
2-1/2" (63 mm) C-Clamp	1-3/8" (33 mm)	5	2025102
2-1/2" (63 mm) C-Clamp	2-1/2" (63 mm)	5	2025103

QUICK-GRIP® Parallel Jaw Clamps



2026500

- Deep 3-3/4 inch jaw depth for optimized pressure distribution
- Secure locking system prevents jaws from slipping
- ProTouch handle for an ergonomic grip
- Body and jaws made of quality resin to prevent marring and glue adhesion
- Up to 1150 lbs of pressure
- Removal of end foot allows for quick conversion to a spreader
- 2" additional clamping capacity without end stop

Description	Throat Depth	Pack Qty	Item #
24" (60 cm) Parallel Jaw Box Clamp	3-3/4" (95 mm)	5	2026500
48" (121 cm) Parallel Jaw Box Clamp	3-3/4" (95 mm)	5	2026501

QUICK-GRIP Pipe Clamps



224134

- Innovative clutch system eliminates the need for threaded pipe
- Large feet offer more stability
- Greater clearance between handle and worktop
- Large clutch plates allow for easier release

Description	Throat Depth	Pack Qty	Item #
3/4" (19 mm) Pipe Clamp	1-1/2" (37 mm)	5	224134
1/2" (12 mm) Pipe Clamp	1-7/8" (47 mm)	5	224212
3/4" (19 mm) Pipe Clamp Deep Throat	2-1/2" (95 mm)	5	2024100

QUICK-GRIP Band Clamp



226100

- 1" x 15' for large and irregular shaped projects

Description	Pack Qty	Item #
Specialty Clamps		
1" x 15' Band Clamp	1	226100
3" Corner Clamp	1	226200
90° Angle Clamp	1	226410
Wooden Handscrew Clamp	1	226800

QUICK-GRIP Corner Clamp



226200

- Light-duty 3" corner clamp is perfect for picture frames and smaller projects

QUICK-GRIP 90° Angle Clamp



226410

- Designed to hold material up to 3" thick at a 90° angle

QUICK-GRIP Wooden Handscrew Clamp



226800

- Crafted from quality boxwood
- 4-1/2" jaws adjust to any angle for clamping non-parallel surfaces and odd shapes

IRWIN®

Vises



www.irwin.com

The Complete Solution for Vises

With a diverse offering that ranges from widely-used general purpose vises to the most popular specialty vises, IRWIN® vises are built to handle any job. The impressive, versatile line of vises from IRWIN is designed with the most sought-after features to fit every application, from the garage workbench to the factory floor. Whether used for cutting, screwing, drilling, planning, sanding, or just holding, there is an IRWIN vise that's perfect for the any type of holding application. Designed and manufactured to the highest standards, and built with the best available materials, IRWIN vises are available in a variety of styles, jaw widths, jaw capacities, base types, and clamping forces. Refer to the chart below to select the best vise for the job.

HOW TO SELECT A VISE																	
	Heavy Duty Workshop Vises			Light Duty Workshop Vise	Mechanics Vises			Clamp-on Vise	Drill Press Vise	Wood-workers Vise	Bench Vise	Multi-purpose Vise	Record® Mechanics Vises				
	226304ZR	226305ZR	226306ZR	4935507	4935506	4935504	226303ZR	226340	226361	2026303	4935505	1ZR	3	4ZR	5	6	8ZR
Jaw Width	4" 10 cm	5" 12 cm	6" 15 cm	4-1/2" 11 cm	6" 15 cm	4" 10 cm	3" 7 cm	4" 10 cm	6-1/2" 17 cm	4-1/2" 11 cm	5" 12 cm	3" 75 mm	4" 100 mm	4-1/2" 115 mm	5" 127mm	6" 152 mm	8" 203 mm
Jaw Capacity	3" 7 cm	4" 10 cm	5" 12 cm	3" 7 cm	4.9" 12 cm	3" 7 cm	2" 5 cm	4-1/2" 11 cm	4-1/2" 11 cm	4" 10 cm	4.9" 12 cm	3-3/4" 95 mm	4-3/4" 121 mm	5-1/2" 140 mm	6-1/2" 165 mm	8" 203 mm	9-1/4" 235 mm
Throat Depth	2.2" 5.6 cm	2.6" 6.6 cm	3" 7 cm	2-3/8" 6 cm	3" 7 cm	2-3/8" 6 cm	3" 7 cm	1/2" 1 cm	2" 5 cm	2-3/8" 6 cm	3" 7 cm	1-7/8" 48 mm	2-3/4" 70 mm	3" 75 mm	3-1/4" 82 mm	3-1/2" 90 mm	4" 100 mm
Swivel Base	360°	360°	360°	240°	120°	120°	N/A	N/A	N/A	N/A	360°	N/A	N/A	N/A	N/A	N/A	N/A
Pipe Jaw	N/A	N/A	N/A	YES	N/A	N/A	YES	N/A	N/A	YES	YES	N/A	N/A	N/A	N/A	N/A	N/A
Typical Workpiece Weight	<15 lbs.	<26 lbs.	<30 lbs.	<9 lbs.	<30 lbs.	<12 lbs.	<4 lbs.	N/A	N/A	<11 lbs.	<33 lbs.	<12	<30	<40	<50	<70	<80
General Purpose	BEST	BEST	BEST	BETTER	BEST	BEST	BETTER	NR	NR	BEST	BEST	BEST	BEST	BEST	BEST	BEST	BEST
Hobbyist	NR	NR	NR	BEST	BETTER	BETTER	BEST	NR	BEST	BEST	BETTER	BETTER	BETTER	BETTER	NR	NR	NR
Light Duty	NR	NR	NR	BEST	BETTER	BETTER	BEST	BETTER	BEST	BEST	BETTER	BETTER	BETTER	BETTER	NR	NR	NR
Drill Press	N/A	N/A	N/A	N/A	N/A	N/A	N/A	BEST	N/A	N/A	N/A	N/A	N/A	N/A	N/A	N/A	N/A
Round Stock/Pipe	BETTER	BETTER	BETTER	BEST	BETTER	BETTER	BEST	NR	NR	BEST	BEST	BETTER	BETTER	BETTER	BETTER	BETTER	BETTER
Portable	NR	NR	NR	NR	NR	NR	BEST	BEST	NR	NR	NR	NR	NR	NR	NR	NR	NR

BEST Best choice for application

BETTER Better choice for application

NR Not recommended for application

Record® Mechanics Vises

RECORD MECHANICS VISE FEATURES

1. Replaceable hardened steel jaws
2. Fused steel handle bends before vise can be overstressed
3. Machined steel mainscrew with rolled two-start acme thread for wear-resistance and smooth operation
4. Fully-machined on all load-bearing surfaces
5. Internal SG nut takes load, secures and aligns mainscrew. Can be replaced when worn, saving cost of replacement of whole vise body
6. Safety stop prevents slide from accidentally separating from body
7. Lip on back body guides filings and fragments away from the slide

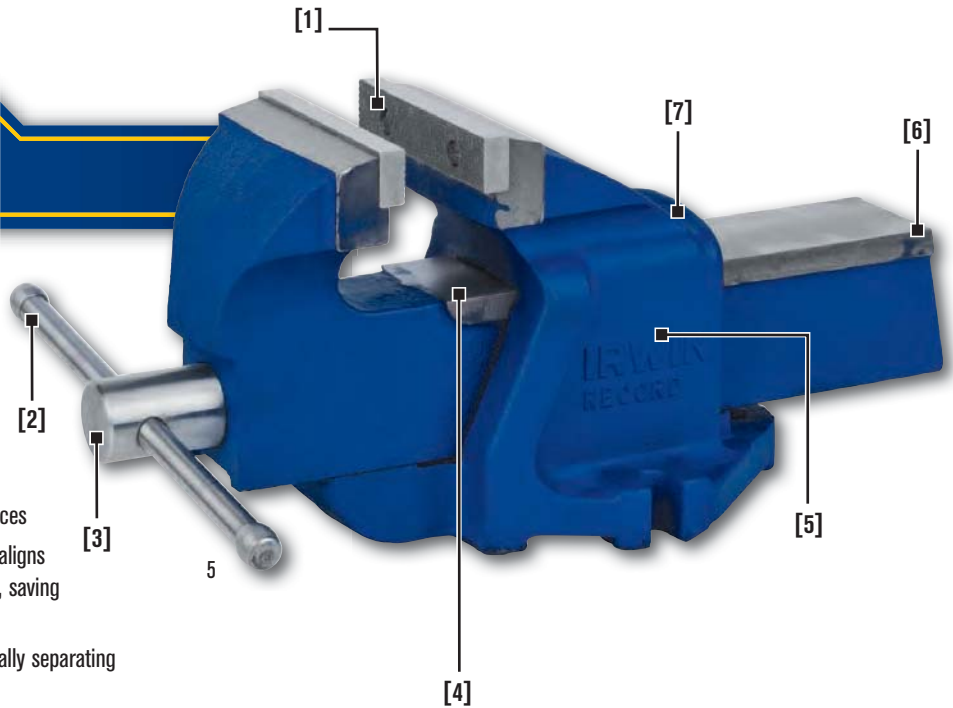

VISES

4-1/2" Record Mechanics Vise



4ZR

Description	Weight	Pack Qty	Item #
3" Mechanics Vise	12 lbs	1	1ZR
4" Mechanics Vise	33 lbs	1	3
4-1/2" Mechanics Vise T4	42 lbs	1	4ZR
5" Mechanics Vise T5	53 lbs	1	5
6" Mechanics Vise T6	70 lbs	1	6
8" Mechanics Vise T8	84 lbs	1	8ZR

6" Record Mechanics Vise



6

Vises

Record Accessories

Replacement Jaw Plates

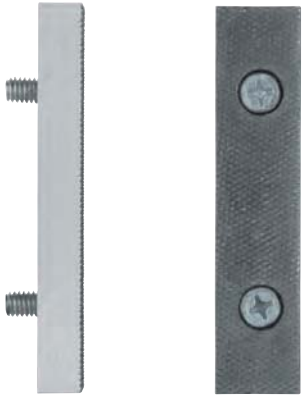

T4D

Description	Pack Qty	Item #
Pair Jaw Plates (3") & Screws for #1ZR Mechanics Vise	1	T1D
Pair Jaw Plates (4") & Screws for #3 Mechanics Vise	1	T3D
Pair Jaw Plates (4-1/2") & Screws for #4ZR Mechanics Vise 4-1/2", Pre-1996	1	T4D
Pair Jaw Plates (4-1/2") & Screws for #4 Mechanics Vise	1	T4DN
Pair Jaw Plates (5") & Screws for #5 Mechanics Vise	1	T5D
Pair Jaw Plates (6") & Screws for #6 Mechanics Vise	1	T6D
Pair Jaw Plates (8") & Screws for #8ZR Mechanics Vise	1	T8D

Replacement Mainscrew

VICES

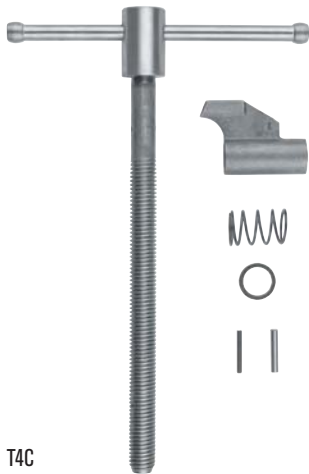

T4C

Description	Pack Qty	Item #
Mainscrew with Handle, Nut, Pin, Spring, and Washer for #1ZR Mechanics Vise	1	T1C
Mainscrew with Handle, Nut, Pin, Spring, and Washer for #3 Mechanics Vise	1	T3C
Mainscrew with Handle, Nut, Pin, Spring, and Washer for #4ZR Mechanics Vise	1	T4C
Mainscrew with Handle, Nut, Pin, Spring, and Washer for #5 Mechanics Vise	1	T5C
Mainscrew with Handle, Nut, Pin, Spring, and Washer for #6 Mechanics Vise	1	T6C
Mainscrew with Handle, Nut, Pin, Spring, and Washer for #8ZR Mechanics Vise	1	T8C

Fiber Grips



FG412

Description	Pack Qty	Item #
Swivel Base for Item #3: 4" Mechanics Vise	1	T3SB
Swivel Base for Item #4ZR: 4-1/2" Mechanics Vise	1	T4SB
Swivel Base for Item #6: 6" Mechanics Vise	1	T6SB
3" Fiber Grip Clip-On Jaws	1	FG3
3-1/2" Fiber Grip Clip-On Jaws	1	FG312
4" Fiber Grip Clip-On Jaws	1	FG4
4-1/4" Fiber Grip Clip-On Jaws	1	FG414
4-1/2" Fiber Grip Clip-On Jaws	1	FG412
5" Fiber Grip Clip-On Jaws	1	FG5
5-1/4" Fiber Grip Clip-On Jaws	1	FG514
6" Fiber Grip Clip-On Jaws	1	FG6

IRWIN Workshop Vises



226306ZR



4935507

Description	Weight	Pack Qty	Item #
Workshop Vises			
4" Heavy Duty Workshop Vise	15.7 lbs.	1	226304ZR
5" Heavy Duty Workshop Vise	26.4 lbs.	1	226305ZR
6" Heavy Duty Workshop Vise	30.6 lbs.	1	226306ZR
4-1/2" Light Duty Workshop Vise	11.22 lbs.	1	4935507

- Captured safety jaw to prevent slide from falling out on Heavy Duty
- Swivel base
- Anvil and pipe jaws incorporated
- Aggressive steel jaws

IRWIN Mechanics Vises



4935504



4935505

Description	Weight	Pack Qty	Item #
Mechanics Vises			
4" Mechanics Vise	12.1 lbs.	1	4935504
5" Multi-purpose Vise	33.1 lbs.	1	4935505
6" Mechanics Vise	30 lbs.	1	4935506

- Fused steel handle
- Swivel base
- Anvil incorporated
- Rotating pipe jaws on 5" multi-purpose vise

VICES

3" Clamp-on Vise



226303ZR

Description	Pack Qty	Item #
3" Clamp-on Vise	1	226303ZR

- Easy clamp-on feature for mobility
- 2" table thickness capacity
- Anvil shaping horn incorporated
- Integrated pipe jaws

4" Drill Press Vise



226340

Description	Pack Qty	Item #
4" Drill Press Vise	1	226340

- Slotted base for easy installation and positioning
- Textured jaws for secure gripping

6-1/2" Woodworkers Vise



226361

Description	Pack Qty	Item #
6-1/2" Woodworkers Vise	1	226361

- Toe-in toward top of jaws helps ensure firm grip on work piece
- Square body seating for easy under-bench mounting
- Provision for installing wooden cheeks to protect work pieces

4-1/2" Bench Vise



2026303

Description	Pack Qty	Item #
4-1/2" Bench Vise	1	2026303

- Fused steel handle
- Anvil incorporated
- Integrated pipe jaws

VICES

IRWIN®

Chisels



www.irwin.com

Professionals who use chisels everyday know that edge retention is key to chisel performance. That is why IRWIN® Tools manufactures its chisels from solid-forged, chrome vanadium steel. IRWIN Marples® chisels remain the world standard, incorporating the advantages that have made them an industry-leading brand for close to 200 years.



1768777

NEW IRWIN Marples
MS500 Bevel Edge Chisels

- ProTouch™ Handles for increased comfort
- Steel strike cap for use with hammers
- Solid-forged chrome vanadium steel blade for maximum edge retention

Blade Width	Item #
1/4"	1768772
3/8"	1768773
1/2"	1768774
5/8"	1768775
3/4"	1768776
1"	1768777
1-1/4"	1768778
1-1/2"	1768779
2"	1768780
Set	
3-pc Set (Wallet) 1/2", 3/4", 1"	1768781

CHISELS



M4441N

IRWIN Marples
BLUE CHIP® Bevel Edge Chisels

- Long blade and polypropylene handle for increased leverage
- Best suited for hand or mallet work
- Solid-forged chrome vanadium steel blade for maximum edge retention

Blade Width	Item #
1/8"	M44418N
1/4"	M44414N
3/8"	M44438N
1/2"	M44412N
5/8"	M44458N
3/4"	M44434N
1"	M4441N
1-1/4"	M444114N
1-1/2"	M444112N
2"	M4442N
Sets	
3-pc Set (Carded) 1/2", 3/4", 1"	1769179
4-pc Set (Carded) 1/4", 1/2", 3/4", 1"	M444S4N
6-pc Set (Boxed) 1/4", 3/8", 1/2", 5/8", 3/4", 1"	M444SB6N

Bevel Up Versus Bevel Down

The position of your chisel's bevel makes a big difference in the results you will achieve. When you use a chisel with the bevel up, the result is removal of larger chips. With the bevel down, a chisel offers you more control. The blade tends to work itself out of the wood grain, removing small shavings instead of large chips.

IRWIN®

Snips



www.irwin.com

Trust Built On Performance

IRWIN® Aviation and Offset Snips feature hot-drop forged steel blades for a sharper cutting edge and greater strength. Ergonomically designed ProTouch™ Grips and long-life spring increase leverage and optimize each cut.

Aviation Snips



2073111



2073112



2073113



2073115

- Aviation snips have multiple pivot pins that provide compound cutting action.

Offset Snips



2073212



2073211

- Offset snips have multiple pivot pins that provide compound cutting action. They also cut at a sharper angle, distancing your hands from sharp, jagged work surfaces.

Multi-Purpose Snips



21304

- Compound leverage design provides cuts up to 3-1/8"

Tinner Snips



22007



23007

- Precision-ground blade edges ensure quality cuts
- Hot-drop, forged steel blades provide maximum strength
- Double-dipped vinyl handles provide comfort

3-piece Set



2073704

SNIPS

Model	Description	Size	Length of Cut	Cutting Capacity		Carded Item #
Aviation Snips						
111	Cuts left and straight	10" (254 mm)	1-5/16" (33 mm)	Cold-Roll Steel 18 ga	Stainless Steel 23 ga	2073111
112	Cuts right and straight	10" (254 mm)	1-5/16" (33 mm)	Cold-Roll Steel 18 ga	Stainless Steel 23 ga	2073112
113	Cuts straight and wide curves	10" (254 mm)	1-5/16" (33 mm)	Cold-Roll Steel 18 ga	Stainless Steel 23 ga	2073113
115	Bulldog snips notch and trim	9" (228 mm)	3/4" (19 mm)	Cold-Roll Steel 16 ga	Stainless Steel 18 ga	2073115
Offset Snips						
SR	Cuts straight and angles or curves right	9-1/2" (241 mm)	1-5/16" (33 mm)	Cold-Roll Steel 18 ga	Stainless Steel 23 ga	2073212
SL	Cuts straight and angles or curves left	9-1/2" (241 mm)	1-5/16" (33 mm)	Cold-Roll Steel 18 ga	Stainless Steel 23 ga	2073211
Multi-Purpose Snips						
304	Extra cut snip, cut straight and curves	11-3/4" (298 mm)	3-1/8" (80 mm)	Cold-Roll Steel 24 ga	Stainless Steel 26 ga	21304
Tinner Snips – Flat Blades						
007	Cuts straight and wide curves	7" (175 mm)	1-1/2" (38 mm)	Cold-Roll Steel 24 ga	Stainless Steel 28 ga	22007
010	Cuts straight and wide curves	10" (250 mm)	2" (51 mm)	Cold-Roll Steel 22 ga	Stainless Steel 26 ga	22010
012	Cuts straight and wide curves	12-3/4" (320 mm)	2-3/4" (70 mm)	Cold-Roll Steel 20 ga	Stainless Steel 22 ga	22012
Tinner Snips – Duckbill Blades						
207	Cuts straight and tight curves	7" (175 mm)	2" (51 mm)	Cold-Roll Steel 26 ga	Stainless Steel 28 ga	23007
210	Cuts straight and tight curves	10" (250 mm)	2" (51 mm)	Cold-Roll Steel 24 ga	Stainless Steel 26 ga	23010
212	Cuts straight and tight curves	12-3/4" (320 mm)	2-3/4" (70 mm)	Cold-Roll Steel 22 ga	Stainless Steel 24 ga	23012
Sets						
3-piece set includes items 21304, 2073113 and 23007						2073704

IRWIN®

STRAIT-LINE®

Marking & Layout Tools



www.irwin.com

Marking & Layout Tools

Chalk Reels

IRWIN® STRAIT-LINE® Chalk Reels

IRWIN® STRAIT-LINE® offers a complete line of Chalk Reels. We have been manufacturing Chalk Reels that meet and exceed end-user needs for over 50 years. IRWIN STRAIT-LINE Chalk Reels focus on speed, line, and durability, the three benefits that are spoken about by nearly every end-user. In our full-line assortment, we offer reels that range from 1:1 gear ratio, up to 6:1 gear ratio, and a blended line, which is 2x stronger than traditional Chalk Reel line. IRWIN STRAIT-LINE is the leader in Chalk Reels, and will continue to be the Chalk Reel that end-users demand.



ALUMINUM Chalk Reel

- 1:1 Gear ratio
- Locking metal handle minimizes tangles
- Durable aluminum alloy construction



SPEEDLINE Chalk Reel

- 3.5:1 Gear ratio
- Locking metal handle minimizes tangles
- Polyester line delivers 5-6 strikes per pull



SPEEDLINE Pro Chalk Reel

- 3.5:1 Gear ratio
- Twist-off cap for easy refills
- Nylon/Polyester braided line for 2x durability*



MACH6™ Chalk Reel

- 6:1 Gear ratio
- EZ Access door for quick line change
- Nylon/Polyester braided line for 2x durability*



Large Capacity Chalk Reel

- 2:1 Gear ratio
- Nylon/Polyester line is 2x stronger; resists fraying and breaking*
- Durable steel crank locks securely to prevent line tangles



MARKING & LAYOUT TOOLS

Chalk Reel Features

	<i>PRECISION</i>	<i>MACH6</i>	<i>SPEEDLINE Pro</i>	<i>SPEEDLINE</i>	Aluminum Chalk Reel	Large Capacity Chalk Reel
Gear Ratio	3:5:1	6:1	3.5:1	3.5:1	1:1	2:1
Polyester Line				X	X	
Nylon/Polyester Line	Braided Premium	2x Stronger *	2x Stronger *			2x Stronger *
Case Material	Aluminum	Aluminum	Plastic & Aluminum	Plastic	Aluminum	Plastic
Steel Handle	X	X	X	X	X	X
Hook	Wide Pronged	Wide Pronged	Wide Pronged	Narrow	Narrow	Bull Ring
Chalk Fill Cap	¼ Turn	¼ Turn	¼ Turn			
Chalk Fill Side Door				Locking	Locking	Sliding
EZ Access Door	Tool-less	X				
Metal Drive Gear		X				

*as compared to traditional polyester line

IRWIN STRAIT-LINE PRECISION Chalk Reel

The IRWIN STRAIT-LINE Precision chalk reel is ideal for detail finish work. Designed with a smooth 3.5:1 gear system, this advanced chalk reel retrieves line up to 3.5 times faster than traditional models. Its metal plates and handle, plus premium thin line, provide extra strength for unrivaled durability. The tool-less EZ Access Door allows for easy entry into the back of the chalk reel to change or clean the line.

PRECISION CHALK REEL FEATURES

1. Nylon/Polyester Braided Line delivers multiple snaps of 1mm (0.040") thickness, available in 1mm or 0.5mm (0.020") thickness
2. 3.5:1 Gear Ratio rewinds 3x faster* for increased productivity
3. Aluminum Housing for increased durability and greater impact resistance
4. Large Steel Handle for increased durability and strength

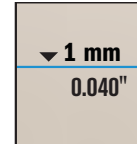

Length	Description	Item #	Bulk Item #	Pack Qty
Reels				
50'	Aluminum Chalk Line Reel - Carded (1:1)	63950	-	6
100'	Aluminum Chalk Line Reel - Carded (1:1)	64110	64111	6/24
100'	Speed-Line Chalk Reel - Carded (3.5:1)	64310	64311	6/24
100'	Speed-Line Pro Chalk Reel - Carded (3.5:1)	2031318DS	2031321B	6/24
100'	MACH6 Chalk Reel - Carded (6:1)	2031314DS	2031317B	6/24
100'	Precision Chalk Reel	2031322	-	6
150'	Large Capacity Chalk Reel (2:1)	2031311	-	2
Combos				
100'	Aluminum Reel & 4 oz. Standard Blue Chalk (1:1)	64499	-	3
100'	Aluminum Reel & 4 oz. Hi-Visibility Orange Chalk (1:1)	64497	-	3
100'	Aluminum Reel & 4 oz. Permanent Red Chalk (1:1)	64498	-	3
100'	Speed-Line Chalk Reel & 4 oz. Standard Blue Chalk (3.5:1)	64494	-	3
100'	Speed-Line Chalk Reel & 4 oz. Permanent Red Chalk (3.5:1)	64495	-	3
100'	Speed-Line Pro Chalk Reel & 4 oz. Standard Blue Chalk (3.5:1)	2031319DS	-	8
100'	Speed-Line Pro Chalk Reel & 4 oz. Permanent Red Chalk (3.5:1)	2031320DS	-	8
100'	MACH6 Chalk Reel & 4 oz. Standard Blue Chalk (6:1)	2031315DS	-	8
100'	MACH6 Chalk Reel & 4 oz. Permanent Red Chalk (6:1)	2031316DS	-	8
Replacement Lines				
50'	Replacement Line - Polyester	64550	-	6
100'	Replacement Line - Polyester	64610	-	6
100'	Speed-Line Pro and MACH6 Replacement Line - Nylon/Polyester	2031333	-	6
100'	Premium thin chalk reel replacement line - 1.0 mm Thickness	2031323	-	6
100'	Premium ultra thin chalk reel replacement line - 0.5 mm Thickness	2031324	-	6
150'	Replacement Line - Lrg. Cap. Chalk Reel (2031311) - Nylon/Polyester	2031313	-	1

*as compared to traditional chalk reels

Chalk Reels



STRAIT-LINE® Marking Chalk

Keep The Chalk Where You Want It

IRWIN® STRAIT-LINE® marking chalks have a newly engineered flip-top cap that keeps the chalk in the bottle where you want it and stops it from spilling out in areas that you don't. The flip-top cap, available on all IRWIN STRAIT-LINE chalk bottles, seals the chalk in an airtight chamber, keeping out moisture and reducing the risk of clumping.

The Right Chalk for Every Job

The IRWIN STRAIT-LINE range of category-leading marking products include Dust-off Chalk and Permanent Staining Chalk. Dust-Off Chalk is temporary chalk that can be used to mark interior walls and trim and then wiped away cleanly. Permanent Staining chalk is great for extreme outdoor conditions because it can withstand harsh weather conditions and months of jobsite wear.

In addition to Dust-Off and Permanent Staining, the range of chalk has varying levels of permanence, color and special uses. So whether working indoors or outdoors, on finished surfaces or in extreme conditions, IRWIN STRAIT-LINE has the ideal chalk for every job.

MARKING & LAYOUT TOOLS



Description	Item #	Shelf Pack
Dust-Off Marking Chalk		
8 oz. - Light Violet - Dust-Off	2032170	6
5 lb. - Light Violet - Dust-Off	2032177	4
Standard Marking Chalk		
4 oz. - Blue Chalk - Standard	64801	6
8 oz. - White Chalk - Standard	64904	6
8 oz. - Blue Chalk - Standard	64901	6
2.5 lb. - Blue Chalk - Standard	65201	6
5 lb. - White Chalk - Standard	65104	4
5 lb. - Blue Chalk - Standard	65101	4
Hi-Visibility Marking Chalk		
8 oz. - Yellow Chalk - Hi-Vis	64903	6
8 oz. - Orange Chalk - Hi-Vis	64905	6
8 oz. - Green Chalk - Hi-Vis	64907	6
2.5 lb. - Orange Chalk - Hi-Vis	65205	6
5 lb. - Yellow Chalk - Hi-Vis	65103	4
5 lb. - Orange Chalk - Hi-Vis	65105	4
5 lb. - Green Chalk - Hi-Vis	65106	4
Permanent Marking Chalk		
4 oz. - Red Chalk - Permanent	64802	6
8 oz. - Red Chalk - Permanent	64902	6
8 oz. - Black Chalk - Permanent	64908	6
2.5 lb. - Red Chalk - Permanent	65202	6
2.5 lb. - Black Chalk - Permanent	65207	6
5 lb. - Red Chalk - Permanent	65102	4
5 lb. - Black Chalk - Permanent	2032160	4
Permanent Staining Marking Chalk		
8 oz. - Indigo Blue - Permanent Staining	2032171	6
8 oz. - Crimson Red - Permanent Staining	2032172	6
6 oz. - Midnight Black - Permanent Staining	4935520	6
2.5 lb. - Indigo Blue - Permanent Staining	2032174	6
2 lb. - Crimson Red - Permanent Staining	4935522	6
2.5 lb. - Midnight Black - Permanent Staining	2032176	6
4 lb. - Indigo Blue - Permanent Staining	4935524	4
5 lb. - Crimson Red - Permanent Staining	2032179	4
5 lb. - Midnight Black - Permanent Staining	2032180	4

Marking Chalk Color Permanence & Application Guide

PERMANENCY SCALE				
Low				High
DUST-OFF 0 1 2 3 4 INDOOR • Eliminates need for priming before painting COLORS 	STANDARD 1 2 3 4 INDOOR/OUTDOOR • Temporary marking chalk COLORS 	HI-VISIBILITY 2 3 4 OUTDOOR • Low light conditions COLORS 	PERMANENT 3 4 WEEKS OUTDOORS • Weather resistant lines remain visible after weeks of weather and jobsite wear and tear COLORS 	EXTREME CONDITIONS 4 MONTHS OUTDOORS • Withstands months of weather and jobsite wear and tear COLORS

STRAIT-LINE® Lumber Crayons



66401

- For use on oily, slick, wet, cold or dry surfaces
- Ideal for lumber, concrete, ceramics, rubber, metal, paper & cardboard
- Non-toxic, waterproof

SHARPIE® China Markers



2089

- Ideal for writing on china, glass, metal or plastic
- Marks on porous and non-porous surfaces
- Fade and moisture resistant
- Write length of 2500 ft.

STRAIT-LINE Carpenter Pencils & Sharpener



66300

- 7" overall length pencil



233250

STRAIT-LINE Chalk Markers & Soapstone



2033500

- For temporary marking on metal surfaces
- Made of natural soapstone for superior marking

Hexagon Plumb Bobs



13085

- Accurately machined steel, corrosion resistant nickel plating

Description	Color	Qty.	Carded Item #	Bulk Item #
4-1/2" Wax Based Lumber Crayon	Red	12-pc	-	66401
	Blue	12-pc	-	66402
	Green	12-pc	-	66403
	Black	12-pc	-	66404
	White	12-pc	-	66405
	Yellow	12-pc	-	66406
4-1/2" Wax Based Lumber Crayon	Red	2-pc	666012	-
	Black	2-pc	666042	-
	Yellow	2-pc	666062	-
4-1/2" Wax Based Lumber Crayon	Red	6-pc	66501	-
	Yellow	6-pc	66506	-
Lumber Crayon Holder	-	-	66510	-

Description	Color	Qty.	Bulk Item #
China Marker	Red	12-pc	2059
	Black	12-pc	2089
	White	12-pc	2060

Description	Qty.	Carded Item #	Bulk Item #
Soft Lead Carpenter Pencil	12-pc	-	66301
Medium Lead Carpenter Pencil	Box of 72	-	66305SL
Medium Lead Carpenter Pencil	12-pc	-	66300
Medium Lead Carpenter Pencil	6-pc	66400	-
Hard Lead Carpenter Pencil	12-pc	-	66302
Carpenter Pencil Sharpener	25-pc	-	233250

Description	Color	Qty.	Bulk Item #
Soapstone 5" x 1/2" x 3/16"	White	144	2033500
Railroad Chalk	White	144	2032150
Half Moon Carpenter Chalk	Blue	144	2032101

Description	Weight	Qty.	Carded Item #
Hex Plumb Bob	5 oz.	5	13055
Hex Plumb Bob	8 oz.	5	13085
Plumb Bob	12 oz.	5	13125

Marking & Layout Tools

Tapes / Flags / Twine

STRAIT-LINE® Flagging Tapes



65901



66200

- **Flagging tape** is weatherproof PVC for harsh outdoor conditions
- **Barrier tape** is co-extruded polyethylene for durability and weather-resistance
- Ideal for construction, landscaping, excavating, identification of trees or hazards and locating underground cables or pipe

MARKING & LAYOUT TOOLS

STRAIT-LINE Stake Flags

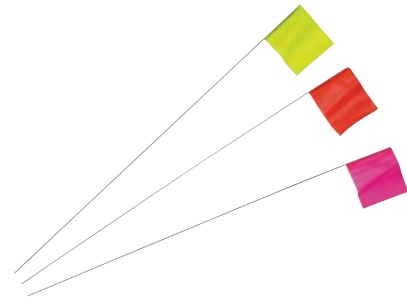

- Bright, fade resistant color for maximum visibility
- Ideal for above ground marking, even at -40°

STRAIT-LINE #18 Braided Twine



Length	Description	Qty.	Bulk Item #
Flagging Tape			
150'	Glo Red	24	65601
	Glo Orange	24	65602
	Glo Pink	24	65603
	Glo Lime	24	65604
	Glo Yellow	24	65605
300'	Red	24	65901
	Orange	24	65902
	Blue	24	65903
	White	24	65904
	Yellow	24	65905
Barrier Tape			
300' x 3"	CAUTION	8	66200
300' x 3"	DANGER - DO NOT ENTER	8	66202
300' x 3"	WET PAINT	8	66222
1000' x 3"	CAUTION - CONSTRUCTION AREA	8	66211
1000' x 3"	CAUTION	8	66231
Danger Flags Roll			
12" x 12"	Red Danger Flags	1	2034208
Floor Tape			
2" x 54'	Yellow/Black Floor Tape	12	2034300

Length	Color	Qty.	Bulk Item #
2.5" X 3.5" X 21"	Glo Orange	10x100 pc.	64100
	Glo Pink	10x100 pc.	64101
	Glo Lime	10x100 pc.	64102
	White	10x100 pc.	2034204
	Yellow	10x100 pc.	2034205
	Blue	10x100 pc.	2034206
	Glo Red	10x100 pc.	2034207

Length	Description	Qty.	Bulk Item #
100'	Orange # 18 Braided Twine	12	2034410
	Fluorescent Green # 18 Braided Twine	12	2034411
270'	Orange # 18 Braided Twine	12	2034403
	Fluorescent Green # 18 Braided Twine	12	2034408
500'	Orange # 18 Braided Twine	12	2034404
	Fluorescent Green # 18 Braided Twine	12	2034409

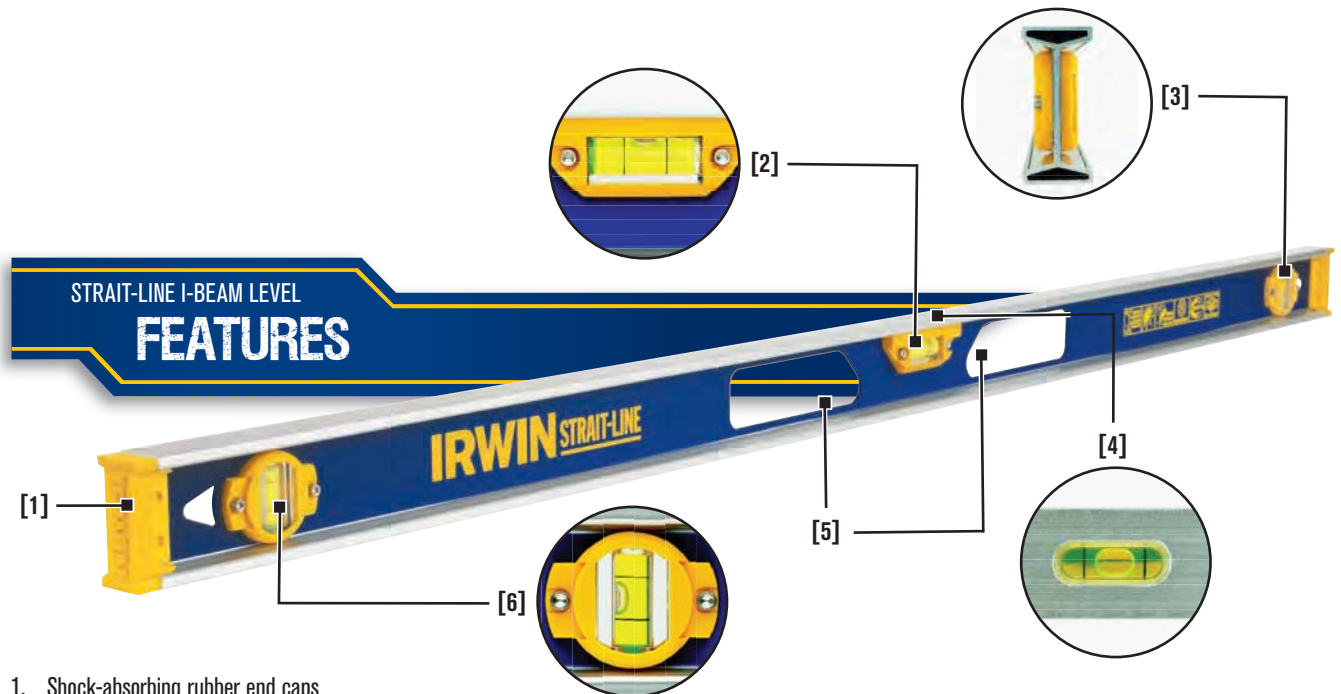

IRWIN STRAIT-LINE I-Beam Levels

Constructed of durable aluminum and featuring our patented Dual Chamber design, IRWIN STRAIT-LINE I-Beam Levels provide industry-leading strength and durability. The easy-to-read MagnaVials™ are 20% larger than standard vials, providing accurate, consistent readings. For quality, accuracy & durability, you can always count on your STRAIT-LINE I-Beam level to get the job done right.



- 1. Shock-absorbing rubber end caps
- 2. MagnaVials™ for 20% larger for easy, accurate readings
- 3. Patented Dual Chamber design resists twisting 2x more than traditional I-beams
- 4. Convenient top read window
- 5. Oversized grips for use with gloves
- 6. Impact resistant acrylic vial housings

MARKING & LAYOUT TOOLS

Length	Description	Item #
24"	I-Beam Level	2035200
 24"	Magnetic I-Beam Level	2035201
48"	I-Beam Level	2035202
 48"	Magnetic I-Beam Level	2035203
72"	I-Beam Level	2035204
 78"	Magnetic I-Beam Level	2035207

Marking & Layout Tools

Levels / Accessories

STRAIT-LINE® Box Beam Levels







2035101

- Durable box beam construction
- PlumbSite® front vial viewer
- Continuous edge center vial

LIFETIME GUARANTEE

Vials are guaranteed not to fade, fog, leak, develop a static charge or become inaccurate under normal usage

Length	Description	Item #
24"	Box Beam Level	2035101
 24"	Magnetic Box Beam Level	2035102
48"	Box Beam Level	2035103
 48"	Magnetic Box Beam Level	2035104
72"	Box Beam Level	2035105
 72"	Magnetic Box Beam Level	2035106
96"	Box Beam Level	2035107
 96"	Magnetic Box Beam Level	2035108
78" & 32"	Door Jamb Level Kit	2035400
 78" & 32"	Magnetic Door Jamb Level Kit	2035401

Cast Aluminum Torpedo Level



2035100

- Cast aluminum body for unrivaled strength and durability
- PlumbSite® front vial viewer
- V-Groove for small pipes, concave sides for use on pipes
- B tank valve key
- Inch and metric scales

Length	Description	Item #
 9"	Torpedo Level	2035100
9"	Torpedo Level Counter Display	2035100CD



Level Accessories

- RAFTERHOOK™ safely hangs the box beam level
- WOODTACS™ attach the box beam level to door jambs or timber frame wall
- Storage bag holds up to two 4 ft. levels

Description	Item #
Level RAFTERHOOK	2035600
Level WOODTACS	2035601
Level Storage Bag	2035602



2035600

RAFTERHOOK



2035601

WOODTACS



2035602

Level Storage Bag

 - magnetic

IRWIN®

Handsaws



www.irwin.com

IRWIN® Universal HandSaw

The IRWIN Universal Handsaw delivers performance and quality results that users demand on the jobsite. With a patent-pending handle design, the angle in which force is exerted converts energy into full blade strokes, cutting through virtually any material. This specially-designed handle, combined with universal triple-ground teeth, completely eliminates binding, and cuts three times faster than traditional hand saws. The Universal Handsaw provides the speed of a coarse-cutting saw, and the fine finish of a fine-cutting saw. No matter what the application, this powerful handsaw will hold up to the demands on the jobsite, proving to be the only handsaw the professional tradesman will ever need.

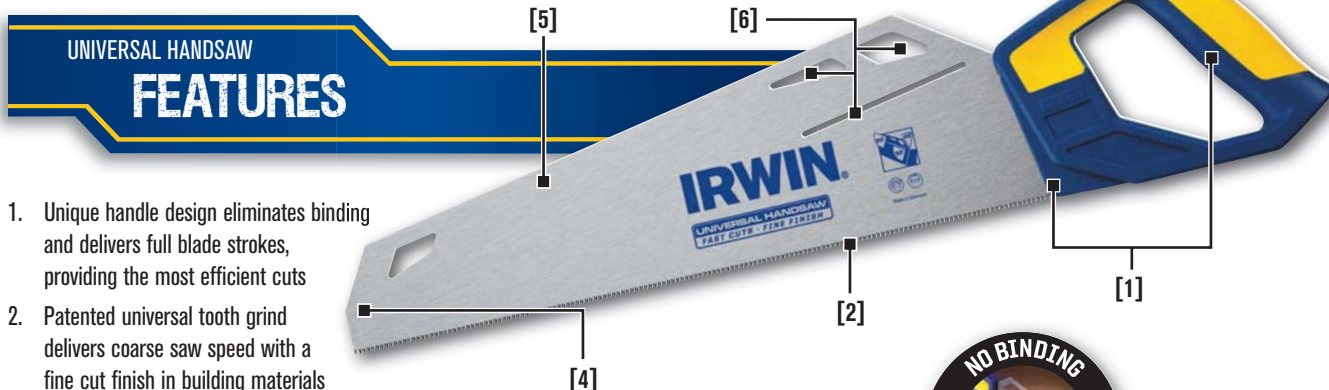

1. Unique handle design eliminates binding and delivers full blade strokes, providing the most efficient cuts
2. Patented universal tooth grind delivers coarse saw speed with a fine cut finish in building materials
3. Comfort grip handle
4. Blade profile has tapered-pitch nose for improved clearance and stability
5. .85 mm blade with water-based lacquer coating for speed and control
6. 90° & 45° marking feature



HANDSAWS

Carpenter Saws	Typical User	Common Applications
	<ul style="list-style-type: none"> ▪ General Carpenter ▪ Exterior Trim Carpenter ▪ Remodeler 	<ul style="list-style-type: none"> ▪ General utility cuts ▪ Overhead fascia and gable work ▪ Removing door plates ▪ Drywall rough-in ▪ Demolition when power tools may damage surrounding materials ▪ Making hand cuts in custom installations when the miter angle is greater than 55°

15" Universal



1773465

15" ProTouch Fine Cut



2011200

15" Standard Coarse Cut



2011102

Description	Blade Length	Blade Thickness	Tooth Count	Item #
Universal Handsaw	15" (381 mm)	.85 mm	11 pt.	1773465
	20" (508 mm)	.85 mm	11 pt.	1773466
ProTouch Coarse Cut Saw	15" (381 mm)	1 mm	9 pt.	2011201
	20" (508 mm)	1 mm	9 pt.	2011204
	24" (609 mm)	1 mm	9 pt.	2011203
ProTouch Fine Cut Saw	15" (381 mm)	1 mm	12 pt.	2011200
	24" (609 mm)	1 mm	12 pt.	2011202
Standard Coarse Cut Saw	15" (381 mm)	1 mm	9 pt.	2011102
	20" (508 mm)	1 mm	9 pt.	2011104

ProTouch™ Drywall/Jab Saw



2014100

Typical User:

Drywall Contractor, Electrician, Plumber, HVAC

Common Applications:

Roughing in drywall, Cutting out HVAC and electrical openings, Cutting ceiling tile openings for light installation

- Thick-Body™ Blade
- Aggressive Tri-Ground™ Teeth
- Ergonomic ProTouch Handle

Standard Drywall/Jab Saw



2014102

Typical User:

Drywall Contractor, Electrician, Plumber, HVAC

Common Applications:

Roughing in drywall, Cutting out HVAC and electrical openings, Cutting ceiling tile openings for light installation

- Rigid Blade
- Bi-Ground Teeth
- Hardwood Handle

ProTouch Coping Saw



2014400

Typical User:

Interior Trim Contractor, Woodworker

Common Applications:

Supplement to power tools, Cutting the curved profile on crown, base or chair rail moulding

- Flat-Bar™ Frame with 5-1/2" (140 mm) frame depth
- High Speed Steel Blade
- DuraSteel™ Pins
- Ergonomic Triangular ProTouch Handle

ProTouch Dovetail/Jamb Saw



2014450

Typical User:

Tile Contractors, Remodelers

Common Applications:

Flush cutting door jambs and millwork for tile installation/prep

- Wide-Body™ Reversible Flush-Cut™ Blade
- Spring-Loaded Pin enables blade to reverse for left or right cutting
- Ergonomic ProTouch Handle

ProTouch Multi-Saw



2015100

- Includes both Metal & Wood blades
- Ergonomic ProTouch Handle

Standard Utility Saw



2014200



- Thick-Body Blade (1 mm)
- Aggressive Tri-Ground Teeth
- Hardwood Handle

HANDSAWS

Description	Blade Length	Blade Thickness	Tooth Count	Item #
ProTouch Drywall/Jab Saw	6-1/2" (165 mm)	1.5 mm	9 pt.	2014100
Standard Drywall/Jab Saw	6-1/2" (165 mm)	1.2 mm	7 pt.	2014102
ProTouch Coping Saw	6-1/2" (165 mm)	-	17 pt.	2014400
Coping Saw Replacement Blades - Coarse 3pk	6-1/2" (165 mm)	-	17 pt.	2014500
Coping Saw Replacement Blades - Fine 3pk	6-1/2" (165 mm)	-	21 pt.	2014501
ProTouch Dovetail/Jamb Saw	10" (254 mm)	2" (50 mm)	14 pt.	2014450
ProTouch Multi-Saw Metal Blade	10" (254 mm)	-	24 pt.	2015100
Wood Blade	5-1/4" (133 mm)	-	10 pt.	-
Standard Utility Saw (Wood/Drywall)	11-1/2" (292 mm)	-	10 pt.	2014200

Pull Saw Advantages

Pull Saws do not have to withstand a pushing force, so a micro-thin blade can be used. The thin blade and precision ground teeth provide clean cuts. The pulling motion prevents binding and provides better control. Less weight, coupled with the natural pulling motion, results in less user fatigue.

Type of Saw	Typical User	Common Application
General Carpentry  Double Edge 	<ul style="list-style-type: none"> Interior Trim Contractors Exterior Trim Contractors Hardwood Flooring Contractors Traditional Woodworkers Cabinetmakers 	Woodworking <ul style="list-style-type: none"> Cutting hand-cut dovetails Creating miters on small millwork, such as shoe and quarter round moulding Flush cutting dowels Construction <ul style="list-style-type: none"> Flush cutting shims and door casings Overhead fascia and gable work Making utility trim cuts on millwork and hardwood flooring

15" General Carpentry Saw



213100

Primary use – Aggressive cross cutting

- Flexible blade for flush cuts
- User example: General Carpenter – cleaning out the 90° circular saw cut on a stair stringer and bird's mouth rafter cut

12" General Carpentry Saw



213101

Primary uses – Cross cutting and ripping

- Flexible blade for flush cut
- User example: Exterior Trim Carpenter – cutting the overhang of gable soffit

Extra Fine Cut Saw



213102

Primary uses – Fine miter or hand dovetail cuts

- Spine provides support for more control
- User example: Woodworker – cutting hand dovetails for furniture assembly

Double Edge Saw



213103

Primary uses – Utility ripping and cross cutting

- User example: General Carpenter – flush cutting door shims and remodeling – cleanout of door casing prior to laying new floor tile

Dovetail/Detail Saw



213104

Primary uses – Flush cutting dowels and fine detail cut

- User example: Interior Trim Contractor – detail work around windows and door frames

Combi-Saw



218HP-300

Primary uses – Gardening/pruning and metal cutting

- Contains both wood cutting and hacksaw blades
- ProTouch™ Grip

Description	Tooth Count	Blade Length	Handle Material	Item #
Pull Saw - Carpenter	10 pt.	15" (380 mm)	2-Polymer	213100
	14 pt.	12" (305 mm)	2-Polymer	213101
Pull Saw - Extra Fine (with spine)	19 pt.	10-5/8" (270 mm)	2-Polymer	213102
Pull Saw - Double Edge (rip/cross cut)	7 pt./17 pt.	9-1/2" (240 mm)	Polymer	213103
Pull Saw - Mini Dovetail/Detail	22 pt.	7-1/4" (185 mm)	Polymer	213104
Utility Saw - Combi-Saw	4 pt. Bow Saw Blade 24 pt. Hack Saw Blade	12" (317 mm)	ProTouch Handle	218HP-300

IRWIN®

Utility Knives & Blades



www.irwin.com

Utility Knives & Blades

Utility Blades

IRWIN® 4-Point Bi-Metal Utility Blades

The new IRWIN 4-Point Bi-Metal utility blade combines the toughness of a traditional blade with the simplicity of a snap blade. When one edge dulls, just snap the tip for another. With four cutting edges, these blades are built to last and last – up to six times longer than traditional carbon blades. Plus, these blades have IRWIN's patented Bi-Metal technology.



1. Snaps on the score for sharp tip
2. Four notches for full blade extension
3. Welded Bi-Metal for sharp edge and flexible body

Bi-Metal Utility Blades



2084100

- Welded Bi-Metal for sharp edge and flexible body
- Stay sharper 3X longer than traditional carbon blades

Bi-Metal Safety Blades



2088100

- Blunted ends inhibit puncture wounds
- Speed tip penetrates surfaces easily

4-Point Carbon Blades



1764983

- Snaps on the score for sharp tip
- Four notches for full blade extension

UTILITY KNIVES & BLADES

Traditional Carbon Blades



2083100

Large Carbon Hook Blades



2087100

- Hooked point protects surface underneath

Description	Quantity	Item #	
4-POINT Bi-Metal Utility Blades	5 Pack	1764987	
	10 Pack	1764988	
	50 Pack	1764989	
	100 pack	1764990	
BLUE BLADE Bi-Metal Utility Blades	5 Pack	2084100	
	20 Pack w/Dispenser	2084200	
	50 Pack w/Dispenser	2084300	
	70 Pack w/Dispenser	2084350	
	100 Pack w/Dispenser	2084400	
Bi-Metal Safety Blades	5 Pack	2088100	
	50 Pack	2088300	
	4-Point Carbon Blades	5 Pack	1764983
4-Point Carbon Blades	10 Pack	1764984	
	50 Pack	1764985	
	100 Pack	1764986	
	Traditional Carbon Blades	5 Pack	2083100
Traditional Carbon Blades	100 Pack	2083200	
	Carbon Hook Blades	5 Pack	2087100
	100 Pack	2087102	

ProTouch™ Retractable Utility Knife



2082200

- QUICK-CHANGE™ mechanism allows for easy blade removal & reversal without opening
- Optimized cutting angle for reduced fatigue
- ProTouch ergonomic grip
- Inside storage for 5 blades
- Includes 3 IRWIN BLUE BLADE Bi-Metal utility blades

ProTouch Fixed Utility Knife



2081200

- Optimized cutting angle for reduced fatigue
- Easy tool-free entry
- ProTouch ergonomic grip
- Inside storage for 5 blades
- Includes 3 IRWIN BLUE BLADE Bi-Metal utility blades

Standard Retractable Utility Knife



2082101

- Optimized cutting angle for reduced fatigue
- Smooth, three-position slide exposes variable blade lengths
- Screw permanently captured in casing to prevent loss
- Inside storage for 5 blades
- Includes 1 IRWIN BLUE BLADE Bi-Metal utility blade

Standard Fixed Utility Knife



2081101

- Optimized cutting angle for reduced fatigue
- Screw permanently captured in casing to prevent loss
- Inside storage for 5 blades
- Includes 1 IRWIN BLUE BLADE Bi-Metal utility blade

Hi-Vis Retractable Utility Knife



2082300

- Optimized cutting angle for reduced fatigue
- Smooth, three-position slide exposes variable blade lengths
- Screw permanently captured in casing to prevent loss
- Inside storage for 5 blades
- Includes 3 IRWIN BLUE BLADE Bi-Metal utility blades

Self-Retracting Safety Knife



2088600

- Two blade positions: 2 mm extension for box cutting & full extension for general use
- Self-retracting for safer use
- Interlocking nose
- Tool-free entry
- Ergonomic Grip
- Includes 1 IRWIN Bi-Metal safety blade

Folding Utility Knife



2089100

- Compact, rugged design
- Quick-Change Button™ for easy blade change
- Wire stripper notch for built in convenience
- Extended thumb ledge provides support and leverage while cutting
- Anchored belt clip for convenient access

Description	Case Qty.	Item #
ProTouch Retractable Utility Knife	5	2082200
ProTouch Fixed Utility Knife	5	2081200
Standard Retractable Knife	5	2082101
Standard Fixed Utility Knife	5	2081101
Hi-Vis Retractable Utility Knife	5	2082300
Self-Retracting Safety Knife	5	2088600
Folding Utility Knife	10	2089100

Utility Knives & Blades

Snap Knives & Blades

18 mm ProTouch™ Snap Knife



2086203

- ProTouch™ Handle provides secure grip and comfort
- Patented auto blade lock and auto blade load
- Internal blade storage
- Stainless steel blade guide
- Rubberized hinged end cap with snap closure
- Includes 1 Bi-Metal snap blade

9 mm ProTouch Snap Knife



2086200

- ProTouch Handle provides secure grip and comfort
- Patented auto blade lock and auto blade load
- Internal blade storage
- Stainless steel blade guide
- Rubberized hinged end cap with snap closure
- Includes 3 snap blades

Snap Blade Refill Packs



2086404

- Easy one-touch dispensing
- Convenient, durable carrying case
- Available in 3, 10, & 50 packs



18 mm Standard Snap Knife



2086102

- Patented auto blade lock
- Hinged end cap with snap closure
- Internal blade storage
- Stainless steel blade guide
- Includes 1 Bi-Metal snap blade

9 mm Standard Snap Knife



2086100

- Handle provides secure grip and comfort
- Patented auto blade lock and auto blade load
- Internal blade storage
- Stainless steel blade guide
- Rubberized hinged end cap with snap closure
- Includes 3 snap blades

Bi-Metal Snap Blades

The IRWIN® Blue Blade™ has revolutionized traditional snap blades with the introduction of Bi-Metal technology. Bi-Metal snap blades are produced through a patented process of combining two types of metal, spring steel and high speed steel, allowing the blade to bend without accidentally breaking. It also ensures that the blade snaps cleanly on the score every time.



Hi Flex Blade

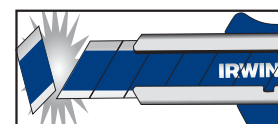

Snaps Cleanly Every Time

UTILITY KNIVES & BLADES

Description	Case Quantity	Item #
Knives & Blades		
Pro Touch Snap Knife - 9 mm Carbon Blade	5	2086200
Pro Touch Snap Knife - 18 mm Bi-Metal Blade	5	2086203
Standard Snap Knife - 9 mm Carbon Blade	5	2086100
Standard Snap Knife - 18 mm Bi-Metal Blade	5	2086102
3-Pack - 9 mm Carbon Blades	5	2086300
10-Pack - 9 mm Carbon Blades	5	2086301
Bi-Metal Snap Blades		
3-Pack Bi-Metal Snap Blades - 18 mm	25	2086403
10-Pack Bi-Metal Snap Blades - 18 mm	5	2086404
50-Pack Bi-Metal Snap Blades - 18 mm	5	2086405

IRWIN®

MARATHON®

Circular Saw Blades



www.irwin.com

The Professional Tradesman's Choice for Construction

When you're building, there's no room for error. It's a tireless pursuit to get the job done right, to produce something to be proud of. Not just any blade will do. You want the blade that helps you do the job the way it was meant to be done. That's why professional tradesmen choose the MARATHON® family of circular saw blades from IRWIN Tools®. Offering a wide variety of blades for every construction application, IRWIN is the brand of blades you can always depend on.

The Standard for Jobsite Productivity

IRWIN Tools makes MARATHON circular saw blades for a full range of saws and applications. Use the table below to match blades for your equipment with your project plans. Locate the saw type and blade diameter in the left column. The columns to the right list the recommended MARATHON blade sizes and the available number of teeth per blade.

Type of Saw	Blade Diameter	Arbor	Application	Teeth	
Cordless Circular Saws		5-3/8"	10 mm	Framing/Ripping	18, 24
		5-1/2"	10 mm	Framing/Ripping	18, 24
		6-1/2"	5/8"	Framing/Ripping Trim/Finish	18, 24 40
		7-1/4"	5/8"	Framing/Ripping	24
Corded Circular Saws		6-1/2"	5/8" Diamond	Framing/Ripping	20
		7-1/4"	5/8" and Diamond Knockout	Framing/Ripping	16, 18, 24
				Decks Trim/Finish	24 40, 60
Worm Drive Circular Saws		7-1/4"	5/8" and Diamond Knockout	Framing/Ripping	18, 24
				Decks	24
				Trim/Finish	40
Table & Miter Saws		8 - 8-1/4"	5/8" and Diamond Knockout	General Purpose	24
				Trim/Finish	40
		10"	5/8"	General Purpose	24
				Decks	40
				Trim/Finish	60, 80
Compound Miter & Sliding Compound Miter Saws		10"	5/8"	Framing/Ripping	24
				Decks	40
				Trim/Finish	60
				Trim/Finish	80
		12"	1"	General Purpose	40
				Trim/Finish	72
				Trim/Finish	80, 100
NEW Metal Circular Saws		6-3/4"	5/8"	Steel/Thin Steel	40
		7-1/4"	5/8"	Steel/Thin Steel	48, 68
		8"	5/8"	Steel/Thin Steel	50
		10"	5/8"	Steel/Thin Steel	80
		12"	1"	Steel/Thin Steel	60
		14"	1"	Steel/Thin Steel	80
NEW Corded Circular Saws: Fiber Cement Saw Blades		7-1/4"	5/8"	Ripping	4
		10"	5/8"	Ripping	6
		12"	1"	Ripping	8
Vinyl Siding	7-1/4"	5/8"	Ripping	120T	

CIRCULAR SAW BLADES

Fiber Cement Saw Blades

FIBER CEMENT SAW BLADE FEATURES

1. Ground and hardened plate body provides smooth and accurate cuts
2. Polycrystalline diamond-tipped teeth
3. 4T thin kerf blade produces less dust than continuous rim blades
4. Laser cut blade body, stronger tooth bond and greater accuracy

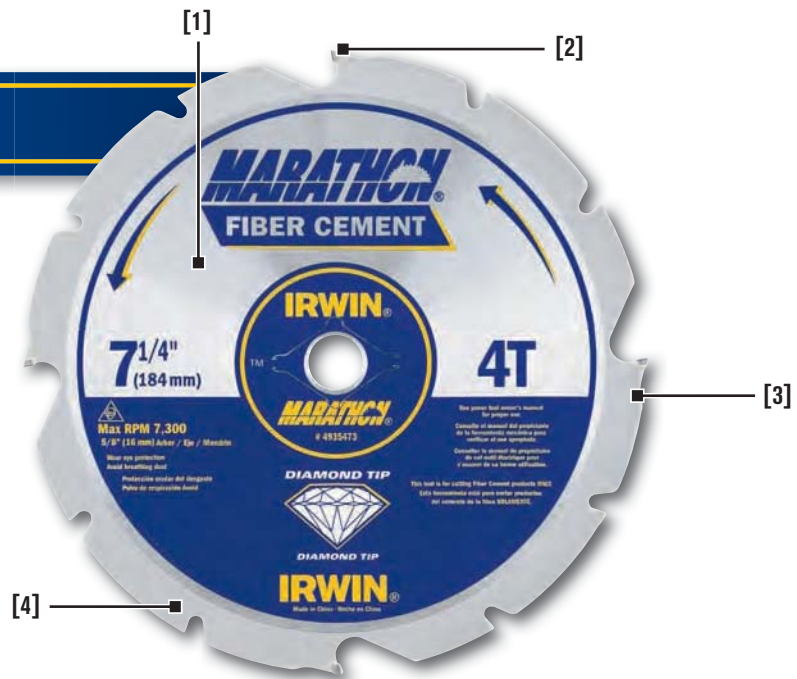

15X
LONGER CUTTING LIFE*

*Vs standard carbide fiber cement blade

CIRCULAR SAW BLADES

Metal Cutting Saw Blades

METAL CUTTING SAW BLADE FEATURES

1. Laser cut anti-vibration vents keeps the blade cool for smooth and accurate cuts
2. Anti-kickback tooth shoulder reduces dust and sparks for safer cuts
3. Metal cutting grade carbide teeth withstand impact, reduces wear and delivers long life
4. Laser cut blade body, stronger tooth bond and greater accuracy



Circular Saw Blades

WELDTEC™ Saw Blades

Made Stronger. Lasts Longer.™

IRWIN® has redefined excellence in the world of saw blades with the introduction of MARATHON® with WeldTec. This revolutionary new saw blade has WELDED carbide teeth for a 30% stronger tooth bond that gives you 50% longer life. UC2™ (sub-micro grain) carbide teeth are 70% more compact than standard carbide teeth and are sharpened to finer, more durable cutting edges that stay sharper longer. The E.O.T.™ grind technology, where every other tooth is ground thinner, makes this the FASTEST FRAMING BLADE EVER™.

WELDTEC SAW BLADE

FEATURES

1. WeldTec Technology means the carbide teeth are welded, not brazed, resulting in 30% stronger tooth bond and longest life & durability
2. UC2 Carbide with Sub-micro grain is 70% tougher than standard carbide, stays sharper longer, with best in class cut quality
3. E.O.T. Grind Technology with patented tooth design, where every other tooth is ground thinner for the FASTEST FRAMING BLADE EVER
4. Innovative heat vents & expansion slots for straighter cuts
5. Reinforced shoulder for durability



CIRCULAR SAW BLADES

Braze vs. Weld

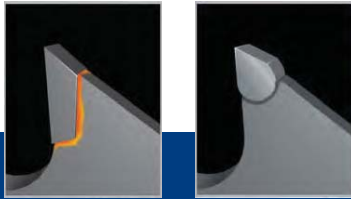

Standard brazed blades use a brazing material, which acts like a glue, to join the carbide tooth to the steel plate. This bond is only as strong as the brazing material, which softens as heat builds up during a cut and can cause tooth loss upon impact.

Marathon with WeldTec has welded carbide teeth. Welding fuses the carbide teeth to the steel plate, which makes the bond as strong as the base material. This bond is unaffected by heat build up and results in superior tooth retention.

How many weeks did this blade last?*

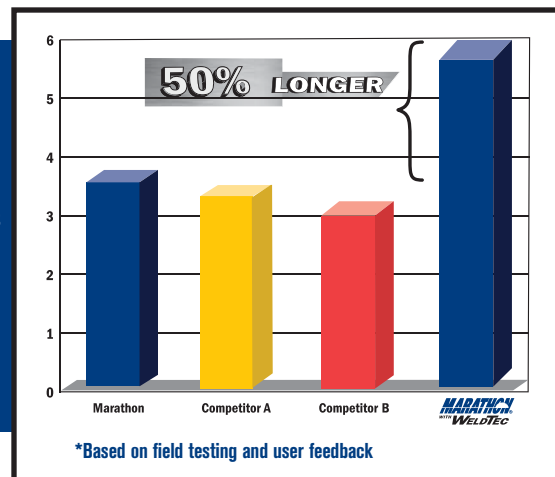



24035

MARATHON® with WeldTec Saw Blades

- Carbide teeth are welded not brazed
- Longest life & durability
- Patent pending tooth design
- Every other tooth is ground thinner for fast cuts
- Fastest Framing Blade Ever™
- 50% longer life vs. 24030



24030

MARATHON Saw Blades

- Every other tooth is ground thinner for faster cuts
- Construction grade carbide teeth for long life
- Reinforced shoulder for added durability
- Heat vent & expansion slot design reduces vibration for longer life and straighter cuts
- Fastest Framing Blade Ever™



25130

IRWIN® Classic Series Saw Blades

- Precision ground teeth for smooth, accurate cuts
- Corrosion resistant coating helps prevent rusting
- Professional performance for an economic price

Diameter	Tooth Count	Arbor	Kerf	Hook Angle	Grind	Item #	Bulk Item #	Applications
MARATHON Portable Corded Carbide Saw Blades								
6-1/2"	20	5/8" Diamond	.071"	20°	ATB	–	24021	Framing/Ripping
7-1/4"	18	5/8" Diamond	.071"	20°	ATB	14028	24028	Framing/Ripping
MARATHON w/ WeldTec 7-1/4"	24	5/8" Diamond	.071"	20°	ATB	14035	24035	Framing/Ripping
7-1/4"	24	5/8" Diamond	.071"	20°	ATB	14030	24030	Framing/Ripping
7-1/4"	40	5/8" Diamond	.071"	20°	ATB	14031	24031	Trim/Finish
IRWIN Classic Series Portable Corded Carbide Saw Blades								
7-1/4"	16	5/8" Diamond	.087"	22°	ATB	15030	25030ZR	General Purpose
7-1/4"	24	5/8" Diamond	.087"	19°	ATB	15130	25130	Framing/Ripping/Decks
7-1/4"	40	5/8" Diamond	.087"	20°	ATB	15230ZR	25230	Trim/Finish
7-1/4"	60	5/8" Diamond	.087"	18°	ATB	15530ZR	25530	Trim/Finish
IRWIN Portable Corded Steel Saw Blades								
7-1/4"	26	5/8" Diamond	.087"	28°	Top/Face	11040ZR	–	Framing/Ripping
7-1/4"	40	5/8" Diamond	.087"	18°	Top/Face	11140	–	Trim/Finish
7-1/4"	60	5/8" Diamond	.087"	5°	Top/Face	11240	–	Trim/Finish
7-1/4"	140	5/8" Diamond	.078"	5°	Top/Face	11840	21840ZR	Trim/Finish
7-1/4"	150	5/8" Diamond	.067"	5°	Top/Face Hollow Ground	11440	21440	Trim/Finish
MARATHON Portable Corded Deck Saw Blade (Pressure Treated Wood)								
7-1/4"	24	5/8" Diamond	.071"	20°	ATB	14130	24130	Deck Blade

CIRCULAR SAW BLADES

Circular Saw Blades

Material Specific Saw Blades



4935473

NEW MARATHON® Fiber Cement PCD Saw Blades

- Ground and hardened plate body provides smooth and accurate cuts
- 4T PCD polycrystalline diamond tipped teeth provide 15X longer cutting life
- Thin kerf blade produces less dust than continuous rim blades



4935555

NEW IRWIN® Metal Cutting Saw Blades

- Laser-cut blades and anti-vibration vents keep blade cool for smooth and accurate cuts
- Metal cutting grade carbide teeth withstand impact, reduce wear and deliver longer life.



11830

MARATHON Vinyl Cutting Saw Blades

- Optimized, symmetric 60° tooth design angle eliminates chipping & cracking for a fast, smooth finish when pushing or pulling through the cut
- Innovative heat vent & expansion slot designs
- Efficient chip ejection prevents binding & blade warping

CIRCULAR SAW BLADES

Diameter	Tooth Count	Arbor	Kerf	Hook Angle	Grind	Item #	Bulk Item #	Applications
NEW MARATHON Fiber Cement PCD Saw Blades								
7-1/4"	4	5/8"	1.8	10	Flat	4935473	-	Fiber Cement
10"	6	5/8"	2.0	10	Flat	4935624	-	Fiber Cement
12"	8	1"	2.2	10	Flat	4935625	-	Fiber Cement
NEW MARATHON Metal Saw Blades								
6-3/4"	40	5/8" Bushing	2.0	0	MATB	4935554		Steel/Thin Steel
7-1/4"	48	5/8" w/ KO	2.0	0	MATB	4935555	4935556	Steel/Thin Steel
7-1/4"	68	5/8" w/ KO	2.0	0	MATB	4935560		Steel/Thin Steel
8	50	5/8" w/ KO	2.0	0	MATB	4935557		Steel/Thin Steel
10	80	5/8"	2.0	0	MATB	4935561		Steel/Thin Steel
12	60	1	2.5	0	MATB	4935558		Steel/Thin Steel
14	80	1	2.8	0	MATB	4935559		Steel/Thin Steel
MARATHON Portable Corded Vinyl Saw Blade								
7-1/4"	120	5/8" Diamond	.055"	60°	Top/Face	11830	21830ZR	Vinyl/PVC
IRWIN Portable Corded Fiber Cement Saw Blade								
7-1/4"	6	5/8" Diamond	.079"	15°	ATB	15702ZR	-	Fiber Cement



14076

MARATHON® Miter/Table Saw Blades

- #400 grit diamond ground teeth for a smooth finish
- Construction grade carbide teeth for longer life
- Precision balanced for accurate smooth cuts
- Thin kerf for fast cuts and longer motor life



15370

IRWIN Classic Series Miter/Table Saw Blades

- Precision ground teeth for smooth, accurate cuts
- Corrosion resistant coating helps prevent rusting
- Professional performance for an economic price



11270

IRWIN Steel Miter/Table Saw Blades

- Precision ground teeth for smooth, accurate cuts
- Fully hardened plate runs truer longer
- Heavy gauge, high carbon steel for extended life

Diameter	Tooth Count	Arbor	Kerf	Hook Angle	Grind	Item #	Bulk Item #	Applications
MARATHON Miter/Table Carbide Saw Blades								
8-1/4"	24	5/8" Diamond	.083"	20°	ATB	14050ZR	–	General Purpose
8-1/4"	40	5/8" Diamond	.083"	15°	ATB	14053	–	Trim/Finish
10"	24	5/8"	.095"	20°	ATB	14233	24233	Framing/Ripping
10"	40	5/8"	.095"	20°	ATB	14070	24070	Decks
10"	60	5/8"	.095"	15°	ATB	14074	–	Trim/Finish
10"	80	5/8"	.095"	10°	ATB	14076	–	Trim/Finish
12"	40	1"	.095"	20°	ATB	14080	–	General Purpose
12"	72	1"	.095"	15°	ATB	14082	–	Trim/Finish
12"	80	1"	.095"	5°	ATB	14083	–	Trim/Finish
12"	100	1"	.095"	10°	ATB	14084	–	Trim/Finish
IRWIN Classic Series Miter/Table Carbide Saw Blades								
8- 8-1/4"	24	5/8" Diamond	.087"	16°	ATB	15150	–	General Purpose
8- 8-1/4"	40	5/8" Diamond	.087"	17°	ATB	15250	–	Trim/Finish
10"	24	5/8" Diamond	.102"	22°	ATB	15070	–	Framing/Ripping
10"	40	5/8" Diamond	.102"	16°	ATB	15270	–	Decks
10"	60	5/8" Diamond	.102"	12°	ATB	15370	–	Trim/Finish
IRWIN Miter/Table Saw Steel Blades								
10"	40	5/8"	.110"	18°	Top/Face	11170	–	Decks
10"	80	5/8"	.079"	6°	Top/Face	11670	–	Trim/Finish
10"	80	5/8"	.110"	6°	Top/Face Hollow Ground	11270ZR	–	Trim/Finish
10"	180	5/8"	.094"	2°	Top/Face	11870	–	Trim/Finish
IRWIN Miter Saw Laser Guides						3061001	–	Miter/Table Saw
						3061002	–	Abrasive Chop Saw

CIRCULAR SAW BLADES

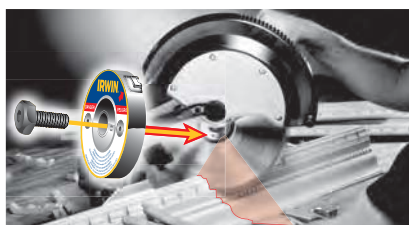

Turn Your Miter Saw into a Laser Guided Power Tool!

- Projects a clear laser line on the work for more accurate cuts.
- Self Calibrating – sits flush against the blade for an accurate line, every time!
- Save time and money. No need to remeasure. No miscuts to scrap.
- Self activating! Rotation of the blade powers the laser.

Circular Saw Blades

Cordless Saw Blades



24029C

MARATHON® Cordless Carbide Saw Blades

- Ultra thin kerf for more cuts per charge
- Face ground carbide teeth for fast, clean cuts
- Aggressive hook angle for fast cuts
- Construction grade carbide teeth for longer life



15120

IRWIN® Classic Series Cordless Carbide Saw Blades

- Corrosion resistant coating helps prevent rusting
- Precision ground teeth for smooth, accurate cuts
- Professional performance for an economic price



11220

IRWIN Classic Series Cordless Steel Saw Blades

- Precision ground teeth for smooth, accurate cuts
- Fully hardened plate runs truer longer
- Heavy gauge, high carbon steel for extended life

CIRCULAR SAW BLADES

Diameter	Tooth Count	Arbor	Kerf	Hook Angle	Grind	Item #	Bulk Item #	Applications
MARATHON Cordless Carbide Saw Blades								
5-3/8"	18	10 mm	.063"	20°	ATB	14015	–	Framing/Ripping
5-3/8"	24	10 mm	.063"	20°	ATB	14017	–	Framing/Ripping
5-1/2"	18	10 mm	.063"	25°	ATB	14027	–	Framing/Ripping
5-1/2"	24	10 mm	.063"	23°	ATB	14011	–	Framing/Ripping
6-1/2"	18	5/8"	.063"	23°	ATB	14020	24020	Framing/Ripping
6-1/2"	24	5/8"	.063"	23°	ATB	14029	24029C	Framing/Ripping
6-1/2"	40	5/8"	.063"	23°	ATB	14023	–	Trim/Finish
IRWIN Classic Series Cordless Carbide Saw Blades								
6-1/2"	24	5/8" Diamond	.087"	22°	ATB	15120	–	Framing/Ripping
6-1/2"	40	5/8" Diamond	.087"	19°	ATB	15220	–	Trim/Finish
IRWIN Cordless Steel Saw Blades								
6-1/2"	60	5/8" Diamond	.087"	5°	Top/Face	11220	–	Trim/Finish
6-1/2"	140	5/8" Diamond	.078"	4°	Top/Face	11820ZR	–	Trim/Finish

IRWIN®

Linear Edge



www.irwin.com

RECIPROCATING SAW BLADE FEATURES

1. High speed steel cutting edge with 8% cobalt stays sharper, lasts longer
2. WeldTec™ tooth design – MADE STRONGER. LASTS LONGER.™
3. Increased tang angle for optimal speed and performance
4. Spring steel backing is virtually unbreakable

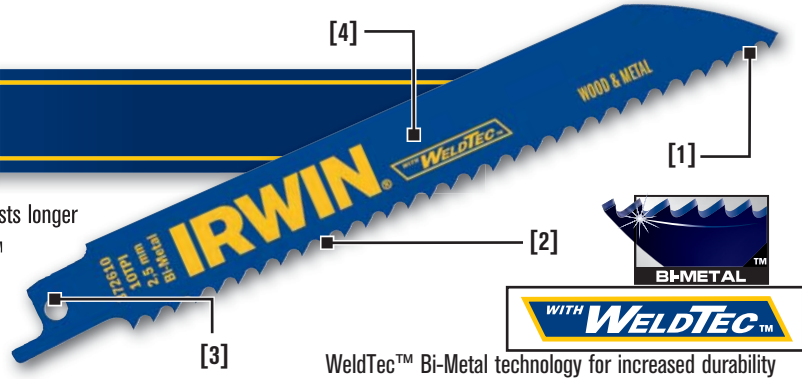

Reciprocating Saw Blade Cross Reference Guide

Application	IRWIN®#	Length	TPI	LENOX	Bosch	DeWalt	Milwaukee	Morse
Metal Cutting	372414P 372414P5	4"	14	20550-414R 20488-B414R 20551-S414R	S518B S522AF S522BF	DW4807 DW4807B	48-01-5181, 48-00-5181, 48-01-6181, 48-00-1172, 48-01-1181, 48-00-1181, 48-02-1181	RB41014P, RB41014B, RB414B, RB414P, RB414C, RH414B, RH414P
	372418P 372418P5	4"	18	20552-418R 20489-B418R	S518E S522EF	DW4810	48-01-5183, 48-00-5183, 48-01-6183, 48-01-1183, 48-02-1183, 48-00-1183, 48-00-1174	RB418P, RB418B, RB418C, RH418B, RH418P
	372424P2 372424P5	4"	24	2055-424R 20490-B424R 20555-S424R	S518EF S518G	DW4812	48-10-5185, 48-00-5185, 48-01-6185, 48-01-1185, 48-00-1185, 48-00-1176, 48-00-1185	RB424B, RB424HP, RB424C, RH424B, RH424P
	372614 372614P5 372614B	6"	14	20564-614R 20494-B614R 20565-S614R	S918BF S918B S922BF	DW4808 DW4808B	48-01-5182, 48-02-5182, 48-00-5182, 48-01-6182, 8-01-5282, 48-00-5282, 48-01-6282, 48-01-1182, 48-02-1182, 48-00-1182, 48-00-1179	RB614B, RB614P, RB614C, RH614B, RH614P
	372618 372618P5 372618B	6"	18	20566-618R 20529-B618R 20567-S618R	S918EF S918E S922EF	DW4811 DW4811B DW4878	48-01-5184, 48-02-5184, 48-00-5184, 48-01-6184, 48-01-6184, 48-01-5284, 48-00-5284, 48-01-6284, 48-01-1184, 48-02-1184, 48-00-1184, 48-00-2170	RB618B, RB618C, RB618P, RH618B, RH618P
	372624 372624P5 372624B	6"	24	20568-624R 20496-B624R 20569-S624R	S918A S922AF	DW4813	48-01-5186, 48-02-5186, 48-00-5186, 48-01-6186, 48-01-5286, 48-00-5286, 48-01-1186, 48-02-1186, 48-00-2171	RB624B, RB624P, RB624C, RH624B, RH624P
	372810 372810P5 372810B	8"	10	20580-810R 20590-B810R 20581-S810R	S1018H S1122HF	DW4865 DW4865B	48-01-5093, 48-02-5093, 48-00-5093, 48-01-6093, 48-01-5193, 48-00-5193, 48-01-6193, 48-01-3093, 48-02-3093, 48-00-2175, 48-00-5713, 48-00-8713	RB8501014B, RB8501014P, RB8501014C, RB810B, RB810P, RB81014B, RB81014P, RB81014C
	372818 372818P5 372818B	8"	18	20578-818R 20487-B818R 20563-S618R	S1122EF	DW4921	48-01-5188, 48-02-5188, 48-00-5188, 48-01-6188, 48-00-5788, 48-00-8788	RB818B, RB818P, RB814B, RB814P, RB814C
	372118P5	12"	18	21510-118R 21511B118R			48-015189	RB1218P
	Wood Cutting	372606 372606P5 372606B	6"	6	2056-606R 20492-B606R 20559-S606R	S811DF S811D S828D	DW4850	48-00-5012, 48-01-5012, 48-01-6012
372610 372610P5 372610B		6"	10	20562-610R 20493-B610R 20561-S61	S811HF S811H S922VF	DW4845 DW4806 DW4806B DW4877	48-01-5092, 48-02-5092, 48-00-5092, 48-01-6092, 48-01-3092, 48-02-3092, 48-00-1064	RB610B, RB610P, RB610C, RB61014B, RB61014P, RC610B, RC610C
372110 372110P5 372110B		12"	10	20583-110R 20491-B110R 20584-S110R	S1211H S1222VF	DW4838	48-01-5094, 48-02-5094, 48-00-5094, 48-01-6094, 48-01-5194, 48-00-5194, 48-01-6194, 48-01-3094, 48-02-3094	RB12501014B, RB12501014P, RB12501014C, RB121014P, RB121014B, RB1214P
372606C	6"	6	20596-6565RCT				RTCT606ST25, RTCT606SC	
Nail Embedded Wood Cutting	372656 372656P5 372656B	6"	6	20572-656R 20530-B656R 20573-S656R	S611DF S644D S611VF S644DF	DW4847 DW4848B DW4802 DW4802B DW4876	48-01-5031, 48-02-5031, 48-00-5031, 48-01-6031, 48-01-5035, 48-02-5035, 48-00-5035, 48-01-6035, 48-00-5015, 48-01-3031, 48-02-3031, 48-00-3031, 48-01-3035, 48-02-3035, 48-00-3035, 48-01-1012, 48-02-1012, 48-00-1031	RB63506B, RB53606P, RC606STB, RC606B, RB65006B, RB65006P, RB65006C, RC606STP
	372956 372956P5 372956B	9"	6	20582-956R 20558-B956R 20587-S956R	S1544DF S1511DF	DW4848 DW4803 DW4803B	48-01-5036, 48-02-5036, 48-00-5036, 48-01-6036, 48-00-5016, 48-00-3036, 48-01-3036, 48-00-1033, 48-02-3036	RB95006B, RB93500B, RC905B, RB95006P, RB035006P, RC905P, RB95006C, RB906B, RC900P
	372156 372156P5 372156B	12"	6	20585-156R 205495-B156R 20586-S156R	S1344D S1411DF S1344DF	DW4849 DW4804 DW4804B	48-01-5037, 48-02-5037, 48-00-5037, 48-01-6037, 48-00-5017, 48-01-3037, 48-02-3037, 48-00-3037, 48-00-1032, 48-00-1302	RB125006, RC1206C, RB125006P, RC1206P, RB125006C, RB123506B, RB123506P
	372666 372666P5	6"	6	20512-6066R 20614-B066R	-	DW4862	48-00-5021, 48-00-8021	RB66206T20, RB66206T3
372966	9"	6						
372960 372960P5	9"	10	20597-960R 20524-B960R	-	DW4865 DW4865B	-	RB96210T20, RB96210T3	
372166	12"	9						
Demolition								

LINEAR EDGE

Nail Embedded Wood Cutting



372656

- Roughing-in work and nail embedded wood
- Fast cutting for wood, composition materials and plastic
- Use with materials 3/16" (5 mm) and thicker

Length	TPI	Blade Thickness	Item #	Item # (5-pk)	Item # (25-pk)	Bulk # (25pk)	Bulk # (50-pk)
6"	6	.035	372606	372606P5	372606B	-	-
6"	6	.050"	372656	372656P5	372656B	372656B25	372656BB
9"	6	.050"	372956	372956P5	372956B	372956B25	372956BB
12"	6	.050"	372156	372156P5	372156B	372156B25	372156BB

Metal & Wood Cutting



372610

- Cuts nail embedded wood, composition materials, plastic, pipe, carbon steel and stainless steel
- Use with materials 1/8" (3.2 mm) and thicker

Length	TPI	Blade Thickness	Item #	Item # (5-pk)	Item # (25-pk)	Bulk # (25-pk)	Bulk # (50-pk)
6"	10	.035"	372610	372610P5	372610B	372610B25	372610BB
8"	10	.050"	372810	372810P5	372810B	372810B25	372810BB
12"	10/14	.050"	372110	372110P5	372110B	372110B25	372110BB

Metal Cutting



372614

- Cuts all metals including nonferrous pipe conduit, stainless and sheet metals
- Use with materials 1/8"-1/2" (3.2 -13 mm) thick

Length	TPI	Blade Thickness	Item #	Item # (5-pk)	Item # (25-pk)	Bulk # (25-pk)	Bulk # (50-pk)
4"	14	.035"	372414	372414P5	-	-	-
4"	18	.035"	372418	372418P5	-	-	-
4"	24	.035"	372424	372424P5	-	-	-
6"	14	.035"	372614	372614P5	372614B	372614B25	372614BB
6"	18	.035"	372618	372618P5	372618B	372618B25	372618BB
6"	24	.035"	372624	372624P5	372624B	372624B25	372624BB
8"	18	.035"	372818	372818P5	372818B	372818B25	372818BB
12"	18	.035"	-	372118P5	-	-	-

Demolition



372966

- For heavy duty and demolition applications in wood and metal
- Use with materials 3/16" (5 mm) and thicker

Length	TPI	Blade Thickness	Item #	Item # (5-pk)	Bulk # (50-pk)
6"	6	.062"	372666	372666P5	372666BB
9"	6	.062"	372966	372966P5	372966BB
9"	10	.062"	372960	372960P5	372960BB
12"	6	.062"	372166	372166P5	372166BB

Specialty



372606C

- Designed for specialty applications, pruning and fiber cement board

Application	Length	TPI	Blade Thickness	Item #
Hardiplank, Fiberglass & Cement Board	6"	6 Carbide	.050"	372606C
General Purpose, Wood & Metal Cutting	6"	6 Fleam	.050"	372645F
Hardiplank, Fiberglass & Cement Board	8"	3 Carbide	.050"	372803C
Pruning, Fast Wood Cutting	9"	6 Fleam	.050"	372945F

High Quality Construction For Fast Clean Cuts

Each IRWIN Hole Saw is crafted from the highest quality bi-metal. The High Speed steel teeth are welded to a carbon steel body for bi-metal construction that allows a Hole Saw to stay sharper longer.

Because IRWIN Hole Saws are engineered and manufactured for exceptional sharpness and durability, they will cut a variety of materials. These saws will cut holes in wood, aluminum, copper, iron, stainless steel and zinc.

BI-METAL HOLE SAW

FEATURES

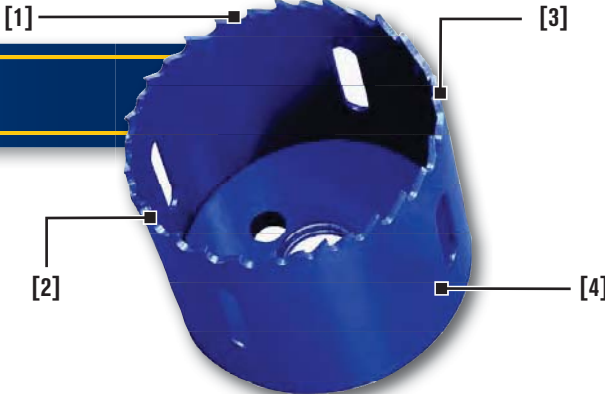

1. Variable depth gullets provide more efficient chip clearance
2. 4/6 Variable pitch teeth for reduced noise and improved performance
3. High speed steel cutting edge for stronger, longer lasting teeth
4. Bi-Metal construction for toughness and long life

Hole Saw RPM Reference Guide

LINEAR EDGE

Diameter	Mild Steel	Tool & Stainless	Cast Iron	Brass	Alum.
9/16" (14mm)	580	300	400	790	900
5/8" (16mm)	550	275	365	730	825
11/16" (17mm)	500	250	330	665	750
3/4" (19mm)	460	230	300	600	690
25/32" (20mm)	425	210	280	560	630
13/16" (21mm)	425	210	280	560	630
7/8" (22mm)	390	195	260	520	585
15/16" (24mm)	370	185	245	495	555
1" (25mm)	350	175	235	470	525
1-1/16" (27mm)	325	160	215	435	480
1-1/8" (29mm)	300	150	200	400	450
1-3/16" (30mm)	285	145	190	380	425
1-1/4" (32mm)	275	140	180	360	410
1-5/16" (33mm)	260	135	175	345	390
1-3/8" (35mm)	285	145	190	380	425
1-7/16" (37mm)	240	120	160	315	360
1-1/2" (38mm)	230	115	150	300	345
1-9/16" (40mm)	220	110	145	290	330
1-5/8" (41mm)	210	105	140	280	315
1-11/16" (43mm)	205	100	135	270	305
1-3/4" (44mm)	195	95	130	250	295
1-13/16" (46mm)	190	95	125	250	285
1-7/8" (48mm)	180	90	120	240	270
2" (51mm)	170	85	115	230	255

Diameter	Mild Steel	Tool & Stainless	Cast Iron	Brass	Alum.
2-1/16" (52mm)	165	80	110	220	245
2-1/8" (54mm)	160	80	105	210	240
2-1/4" (57mm)	150	75	100	200	225
2-5/16" (59mm)	140	70	95	190	220
2-3/8" (60mm)	140	70	95	190	220
2-1/2" (64mm)	135	65	90	180	205
2-9/16" (65mm)	130	65	85	175	200
2-5/8" (67mm)	130	65	85	170	195
2-3/4" (70mm)	125	60	80	160	185
2-7/8" (73mm)	120	60	80	160	180
3" (76mm)	115	55	75	150	170
3-1/8" (79mm)	110	55	70	140	165
3-1/4" (83mm)	105	50	70	140	155
3-3/8" (86mm)	100	50	65	130	150
3-1/2" (89mm)	95	45	65	130	145
3-5/8" (92mm)	95	45	60	120	140
3-3/4" (95mm)	90	45	60	120	135
3-7/8" (98mm)	85	40	55	110	130
4" (102mm)	85	40	55	110	130
4-1/8" (105mm)	80	40	55	110	120
4-1/4" (108mm)	80	40	55	110	120
4-3/8" (111mm)	75	35	50	100	105
4-1/2" (114mm)	75	35	50	100	105
4-3/4" (121mm)	70	35	45	90	95

Hole Saw Arbors



373002

- Tough, durable construction
- For 3/8" & 1/2" drill chucks
- Removable pilot drill for easy replacement

Shank Size	Shank Type	Fits Hole Saw Sizes	Pin Driven	Item #
3/8"	Standard Hex	9/16" - 1-3/16"	No	373001
1/2"	Standard Hex	9/16" - 1-3/16"	Yes	373002
3/8"	Standard Hex	1-1/4" - 6"	No	373003
1/2"	Standard Hex	1-1/4" - 6"	Yes	373004
1/4"	Quick Change Hex	9/16" - 1-3/16"	No	373005
N/A	—	1/4" Replacement Pilot Drill	—	373000

Bi-Metal Hole Saws

Diameter	Pipe Entrance	Pipe Tap	Recommended RPM (In Steel)	Boxed Item #
9/16"	-	-	580	373090BX
5/8"	-	-	550	373058BX
11/16"	-	-	500	373011BX
3/4"	3/8"	1/2"	460	373034BX
13/16"	-	-	425	373013BX
7/8"	1/2"	3/4"	390	373078BX
15/16"	-	-	370	373015BX
1"	-	-	350	373100BX
1-1/16"	-	-	325	373110BX
1-1/8"	3/4"	1"	300	373118BX
1-3/16"	-	-	285	373130BX
1-1/4"	-	-	275	373114BX
1-5/16"	-	-	260	373150BX
1-3/8"	1"	-	285	373138BX
1-7/16"	-	-	240	373170BX
1-1/2"	-	1-1/4"	230	373112BX
1-9/16"	-	-	220	373190BX
1-5/8"	-	-	210	373158BX
1-11/16"	-	-	205	373111BX
1-3/4"	1-1/4"	1-1/2"	195	373134BX
1-13/16"	-	-	190	373113BX
1-7/8"	-	-	180	373178BX
2"	1-1/2"	-	170	373200BX
2-1/16"	-	-	165	373210BX
2-1/8"	-	-	160	373218BX
2-1/4"	-	2"	150	373214BX
2-5/16"	-	-	140	373250BX
2-3/8"	-	-	140	373238BX
2-1/2"	2"	-	135	373212BX
2-9/16"	-	-	130	373290BX
2-5/8"	-	2-1/2"	130	373258BX
2-3/4"	-	-	125	373234BX
2-7/8"	-	-	120	373278BX
3"	2-1/2"	-	115	373300BX
3-1/8"	-	-	110	373318BX
3-1/4"	-	3"	105	373314BX
3-3/8"	-	-	100	373338BX
3-1/2"	-	-	95	373312BX
3-5/8"	3"	-	95	373358BX
3-3/4"	-	3-1/2"	90	373334BX
3-7/8"	-	-	85	373378BX
4"	-	-	80	373400BX
4-1/8"	3-1/2"	-	80	373418BX
4-1/4"	-	-	75	373414BX
4-3/8"	-	-	75	373438BX
4-1/2"	-	4-1/2"	70	373412BX
4-3/4"	-	-	65	373434BX
5"	-	-	180	373500BX
5-1/2"	-	-	60	373512BX
6"	-	-	55	373600BX

LINEAR EDGE

Bi-Metal Hole Saw Kits



3073004

- Super hard steel RC 65-66 for increased life
- 4/6 TPI reduces vibration
- Variable gullet depths provide more efficient chip removal

Description	Contents	Item #
9 pc Electrician's Kit	7/8", 1-1/8", 1-3/8", 1-3/4", 2", 2-1/2", 1/2" Hex, 3/8" Hex, Pilot Drill	3073002
9 pc Plumber's Kit	3/4", 7/8", 1-1/8", 1-1/2", 1-3/4", 2-1/4, 1/2" Hex, 3/8" Hex, Pilot Drill	3073003
17 pc General Purpose Kit	5/8", 3/4", 7/8", 1", 1-1/8", 1-1/4", 1-3/8", 1-1/2", 1-3/4", 2", 2-1/2", 3", 1/2" Hex, 1/2" Hex, Pilot Drill (3)	3073004

Linear Edge

Jigsaw Blades / Portable Band Saw Blades / Door Lock Kits

Jig Saw Blades



3071412



3072410D

- Wood cutting: Precision ground teeth for fast smooth cutting in hard & soft wood, plastics, laminate particle board and plywood
- Metal cutting: Fully hardened teeth for cutting ferrous and non-ferrous metals, aluminum and sheet steel

Blade Length	TPI	Blade Material	Tooth Design	Carded Item # (2-pk)
U-Shank				
3"	–	5/32 Carbide Grit	–	3071300
3-1/4"	10	Bi-Metal	Milled	3071314
3-1/4"	20	Bi-Metal	Milled	3071320
3-1/4"	36	Bi-Metal	Milled	3071336
4"	6	Carbon	Fleam Ground	3071406
4"	10	Carbon	Milled	3071410
4"	10	Carbon	Fleam Ground	3071412
4"	10	Carbon	Fleam Ground	3071410D
6-pc Assorted	–	–	–	3071001
T-Shank				
3"	–	5/32 Carbide Grit	–	3072300
3"	10	Bi-Metal	Milled	3072314
3"	20	Bi-Metal	Milled	3072320
3"	36	Bi-Metal	Milled	3072336
4"	6	Carbon	Fleam Ground	3072406
4"	10	Carbon	Milled	3072410
4"	10	Carbon	Fleam Ground	3072412
4"	10	Carbon	Fleam Ground	3072410D
6-pc Assortment	–	–	–	3072001

Portable Band Saw Blades

LINEAR EDGE



3074000P3

- Shatter resistant, bi-metal construction for extended life
- 8% Cobalt content for added durability
- Electron beam weld construction provides flexibility

Blade Length	TPI	Height	Blade Thickness	Item # (3-pk)	Bulk # (25-pk)
44-7/8"	10/14	1/2"	.020"	3074000P3	3074000P25
44-7/8"	14	1/2"	.020"	3074001P3	3074001P25
44-7/8"	18	1/2"	.020"	3074002P3	3074002P25
44-7/8"	24	1/2"	.020"	3074003P3	3074003P25
44-7/8"	14/18	1/2"	.020"	3074004P3	3074004P25

Portable Band Saw Matrix

Blade Length	TPI	Recommended Thickness
44-7/8"	14	1/4" to 1/2"
44-7/8"	18	1/8" to 1/4"
44-7/8"	24	3/32" to 1/8"
44-7/8"	14/18	1/8" to 1/2"

Door Lock Installation Kits



3111002

- Self centering jig fits all common door widths
- Adjustable for both 2-3/8" and 2-3/4" backsets
- Complete installation in 3 easy steps

Door Width	Backset	Door Type	Hole Saw Type	Item #
1-1/4" or 1-3/4"	2-3/8" or 2-3/4"	Wood	Carbon Steel	3111001
1-1/4" or 1-3/4"	2-3/8" or 2-3/4"	Wood or Metal	Bi-Metal	3111002

IRWIN®

Fastener Drive & Screwdriving

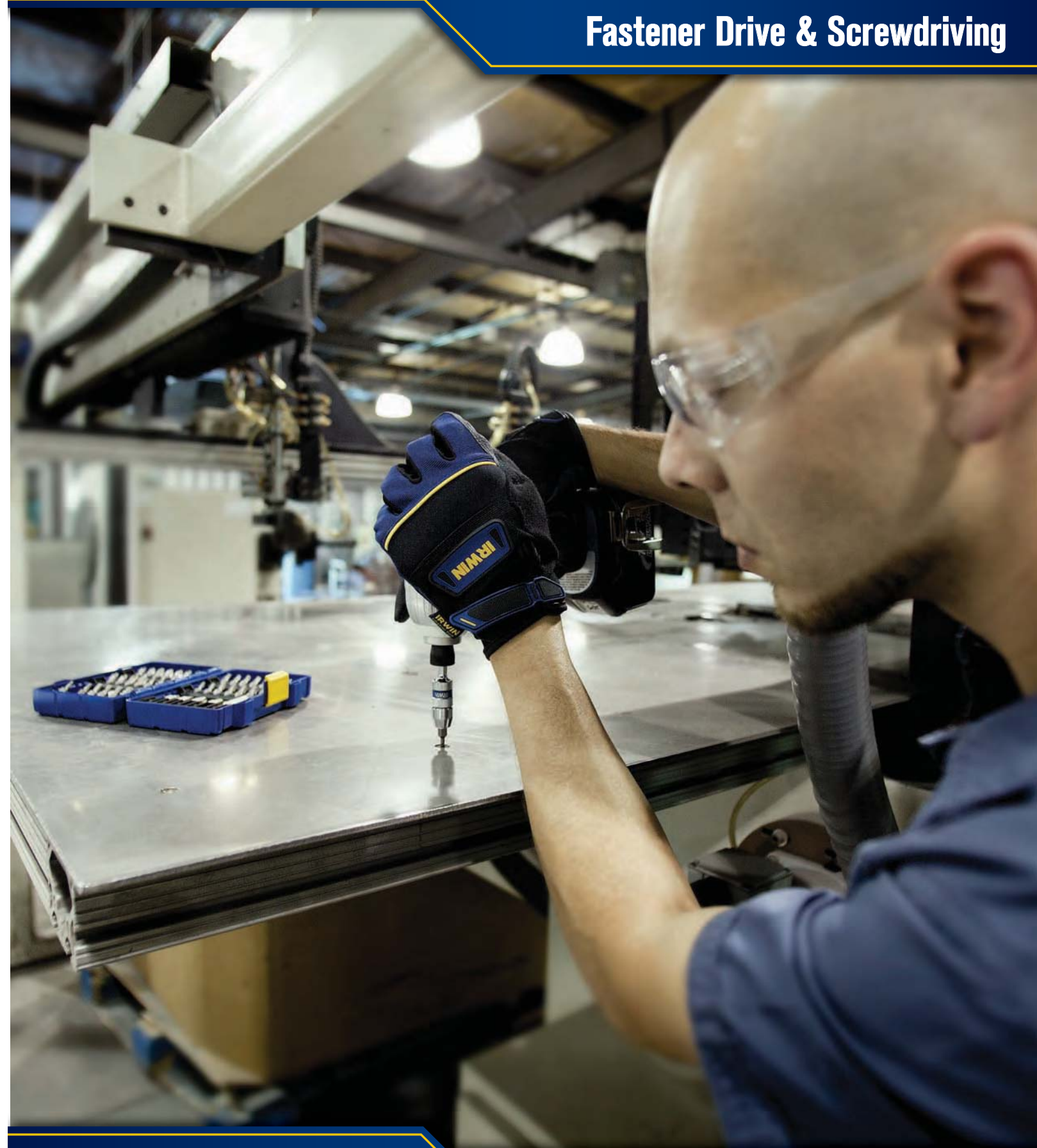

www.irwin.com

Tools Manufactured for Strength and Value

Industry-Specific Screwdriver Bits

Fastener heads are often designed for the particular needs of specific applications and industries. The table below identifies the most common fastener styles used in each industry listed. Manufactured to meet ANSI standards.

Features

- Made of high-grade S2 tool steel
- Wide variety of point sizes to fit many different applications
- IRWIN® bits are milled for a precise fit
- On the Rockwell hardness scale, IRWIN bits are between 58-62

INDUSTRY	PROFILE	Phillips®	Slotted	Square Recess	TORX®	Tamper Resistant TORX®	Hex	POZIDRIV®	TORQ-SET®	TRI-WING®	Spanner	Frearson	Clutch G	Clutch A
Appliance		•	•	•	•			•						
Automotive		•	•		•		•	•						
Aviation		•	•						•	•		•		
Cabinetry				•								•		
Construction		•	•					•						
Control Panels							•				•			
Decking		•	•	•				•						
Drywall		•		•										
Electronics		•	•		•	•	•		•	•				
Furniture		•	•	•			•							
Hobby		•	•				•					•	•	•
HVACR		•	•	•										
Machine Tools/Metal							•							
Manufactured Housing													•	•
Marine		•	•									•		
Recreation		•	•				•					•	•	•
Security				•		•	•		•	•	•			
Subfloor		•		•										

*TRI-WING, POZIDRIV, TORQ-SET, and Phillips are registered trademarks of the Phillips Screw Company.

*TORX is a registered trademark of Acument Intellectual Properties, LLC.

FASTENER DRIVE & SCREWDRIVING

Phillips Bit Selection

The chart below shows the proper Phillips bit to use for driving each type of fastener.

Find the screw type and size you are driving. The column at the far left lists the proper point size to use.

Screw Type:	APPLICATION					
	Wood			Sheet Metal	Machine	
	Flat, Oval	Round	Flat, Oval, Binding	Flat, Oval, Round, Stove, Binding	Round Fillister	Truss Brazier Button
Phillips Bit Point Size	Size			Size	Size	
0	0, 1	0, 1	0, 1	0, 1	0, 1	0, 1
1	2, 3, 4	2, 3, 4	2, 3, 4	2, 3, 4	2, 3, 4	2, 3, 4, 5
2	5, 6, 7, 8, 9	5, 6, 7, 8, 9, 10	5, 6, 7, 8, 9, 10	5, 6, 7, 8, 9, 10	5, 6, 7, 8, 9, 10	6, 8, 10
3	10, 12, 14, 16	12, 14, 16	12, 14	12, 14	12, 1/4", 5/16"	12, 1/4"
4	18, 20, 24	18, 20, 24	5/16", 3/8", 7/16", 1/2"	-	3/8", 7/16", 1/2"	5/16", 3/8", 7/16", 1/2"

Torsion Screwdriving Bit Lasts 3X Longer than Other Bits

Superior fit, increased durability and the ability to withstand high torque applications are the IRWIN Torsion difference. A unique four-hit, cold-forged manufacturing process enables better fitment into screws with less camout and is compatible with all drills and bit holders. The innovative heat-treating process provides greater durability for bit users. The IRWIN Torsion bit lasts longer and delivers professional performance that stands up to rigorous use. The Torsion bit's extreme torque output is derived from a precise cylindrical body geometry designed by IRWIN engineers to ensure the highest torque load in IRWIN history.

TORSION SCREWDRIVING BIT FEATURES

1. Forged bit reduces stripping and increases bit life
2. Heavy-duty cold-forged steel for higher torque output
3. Quick Change shank for use in all drills

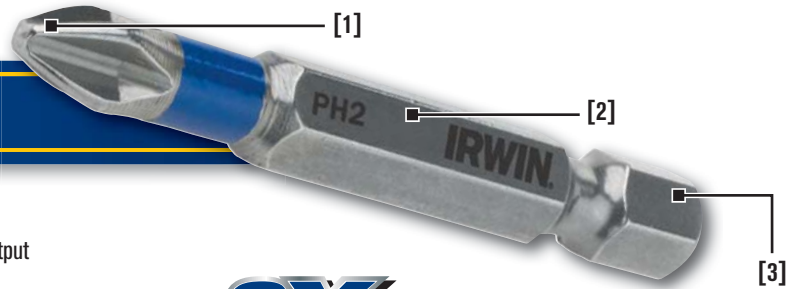

TORSION 3X LIFE

Phillips® 1" Insert Bit



3053002

Phillips 2" Power Bit

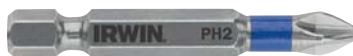

3052002

Square Recess 1" Insert Bits



3053007

Square Recess 2" Power Bits



3052005

Point Size	Shank Diameter	Overall Length	Carded Item #	Bulk Item #
Torsion Phillips Bits				
#1	1/4"	1"	3053001*	3053001B
#1	1/4"	1-15/16"	3052001*	3052001B
#1	1/4"	3"	3052038	3052038B
#1	1/4"	4"	3052041	3052041B
#1	1/4"	6"	3052044	3052044B
#2	1/4"	1"	3053002*	3053002B
#2	1/4"	1-15/16"	3052002*	3052002B
#2	1/4"	3"	3052039	3052039B
#2	1/4"	4"	3052042	3052042B
#2	1/4"	6"	3052045	3052045B
#3	1/4"	1"	3053004*	3053004B
#3	1/4"	1-15/16"	3052003*	3052003B
#3	1/4"	3"	3052040	3052040B
#3	1/4"	4"	3052043	3052043B
#3	1/4"	6"	3052046	3052046B
Torsion Phillips Drywall Bits				
#2	1/4"	1"	4935100	4935101
Torsion Square Recess Bits				
#1	1/4"	1"	3053005*	3053005B
#1	1/4"	1-15/16"	3052004*	3052004B
#1	1/4"	3"	3052047	3052047B
#1	1/4"	4"	3052050	3052050B
#1	1/4"	6"	3052053	3052053B
#2	1/4"	1"	3053006*	3053006B
#2	1/4"	1-15/16"	3052005*	3052005B
#2	1/4"	3"	3052048	3052048B
#2	1/4"	4"	3052051	3052051B
#2	1/4"	6"	3052054	3052054B
#3	1/4"	1"	3053007*	3053007B
#3	1/4"	1-15/16"	3052006*	3052006B
#3	1/4"	3"	3052049	3052049B
#3	1/4"	4"	3052052	3052052B
#3	1/4"	6"	3052055	3052055B

* 2 Pieces Per Card

FASTENER DRIVE & SCREWDRIVING

Fastener Drive & Screwdriving

Screwdriving Bits



Phillips® Bits

Phillips Insert Bits



92011

- Milled steel for high torque output

Point Size	Shank Diameter	Overall Length	Carded Item #	Bagged Item #	Bulk Item #
#0	1/4"	1"	3053008 (2-pc)	-	92001
#1	1/4"	1"	3510052C (2-pc)	-	92005
#1	1/4"	1-1/2"	-	-	92025
#1	5/16"	1-1/4"	-	-	92073
#2	1/4"	1"	3510112C (2-pc)	3510115B (5-pc)	92011
#2	1/4"	1"	3510115C (5-pc)	351011XB (10-pc)	-
#2	1/4"	1"	351011XC (10-pc)	35101125 (25-pc)	-
#2	1/4"	1-1/2"	-	-	92027
#2	5/16"	1-1/4"	-	-	92075ZR
#2	1/4"	2"	-	-	92039
#2	1/4"	2-1/2"	-	-	92045
#3	1/4"	1"	3510192C (2-pc)	-	92019
#3	1/4"	1-1/2"	-	-	92035
#3	5/16"	1-1/4"	-	-	92077
#4	5/16"	1-1/4"	-	-	92079ZR

Phillips Drywall Insert Bits



92047

Point Size	Shank Diameter	Overall Length	Carded Item #	Bagged Item #	Bulk Item #
#1	1/4"	1"	-	-	92007
#2	1/4"	1"	3510472C (2-pc)	351047XB (10-pc)	92047
#2	1/4"	1"	3510475C (5-pc)	35104725 (25-pc)	-
#2	1/4"	1"	351047XC (10-pc)	-	-
#2	1/4"	2"	-	-	92053

Phillips Drywall Screwsetter



351064

Point Size	Shank Diameter	Overall Length	Carded Item #	Bagged Item #	Bulk Item #
#2	1/4"	1"	3510641C (1-pc)	3510643B (3-pc)	351064

Phillips Power Bits



93007

Point Size	Shank Diameter	Overall Length	Carded Item # (1-pc)	Carded Item # (2-pc)	Carded Item # (5-pc)	Bagged Item # (5-pc)	Bulk Item #
#1	1/4"	2"	3520031C	3052007	-	-	93003ZR
#1	1/4"	2-3/4"	-	-	-	-	93017
#1	1/4"	3"	-	-	-	-	93043
#1	1/4"	3-1/2"	3520231C	-	-	-	93023
#1	1/4"	4"	-	-	-	-	93053
#1	1/4"	6"	-	-	-	-	93063
#2	1/4"	2"	3520071C	-	3520075C	3520075B	93007ZR
#2	1/4"	2-3/4"	-	3052009	-	-	93019
#2	1/4"	3"	-	-	-	-	93047
#2	1/4"	3-1/2"	3520251C	-	-	-	93025
#2	1/4"	4"	-	-	-	-	93057
#2	1/4"	6"	3520671C	-	-	-	93067
#3	1/4"	1-15/16"	3520111C	-	-	-	93011
#3	1/4"	2-3/4"	-	-	-	-	93021
#3	1/4"	3"	-	-	-	-	93049
#3	1/4"	3-1/2"	3520291C	-	-	-	93029
#3	1/4"	4"	-	-	-	-	93059
#3	1/4"	6"	3520691C	-	-	-	93069

Power Bit Sets

#1, #2, & #3	1/4"	2"					3521993C
--------------	------	----	--	--	--	--	----------

FASTENER DRIVE & SCREWDRIVING



Square Recess Bits

Square Recess Insert Bits



92205

- Milled one-piece construction

Point Size	Shank Diameter	Overall Length	Carded Item #	Bagged Item #	Bulk Item #
#0	1/4"	1"	-	-	92201
#1	1/4"	1"	3512032C (2-pc)	-	92203
#2	1/4"	1"	3512052C (2-pc)	3512055B (5-pc)	92205
#2	1/4"	1"	-	351205XB (10-pc)	-
#2	1/4"	1"	-	35120525 (25-pc)	-
#3	1/4"	1"	3512072C (2-pc)	-	92207

Square Recess 2-Piece Design Insert Bits



92225

- Cold-forged tip for added durability

Point Size	Shank Diameter	Overall Length	Carded Item # (2-pc)	Bulk Item #
#0	1/4"	1"	-	92221
#1	1/4"	1"	3512232C	92223
#2	1/4"	1"	3512252C	92225
#3	1/4"	1"	3512272C	92227

Square Recess Power Bits



93205

Point Size	Shank Diameter	Overall Length	Carded Item # (1-pc)	Carded Item # (5-pc)	Bulk Item #
#1	1/4"	2"	3522031C	-	93203
#1	1/4"	2-3/4"	-	-	93211
#1	1/4"	3"	93219C	-	93219
#1	1/4"	4"	-	-	93225
#1	1/4"	6"	-	-	93230ZR
#2	1/4"	2"	3522051C	3522055C	93205
#2	1/4"	2-3/4"	-	-	93213
#2	1/4"	3"	93221C	-	93221
#2	1/4"	4"	-	-	93226
#2	1/4"	6"	3522311C	-	93231
#3	1/4"	2"	3522071C	-	93207
#3	1/4"	2-3/4"	-	-	93215
#3	1/4"	3"	4935199	-	93223
#3	1/4"	4"	-	-	93227
#3	1/4"	6"	-	-	93232

Fastener Drive & Screwdriving

Screwdriving Bits

Square Recess 2-Piece Design Power Bits



93239

- Cold-forged tip for added durability

Point Size	Shank Diameter	Overall Length	Carded Item # (1-pc)	Carded Item # (5-pc)	Bulk Item #
#0	1/4"	1-15/16"	-	-	93235
#1	1/4"	1-15/16"	-	-	93237
#1	1/4"	2-3/4"	-	-	93245
#1	1/4"	3"	-	-	93253
#1	1/4"	6"	-	-	93263
#2	1/4"	1-15/16"	3522391C	3522395C	93239
#2	1/4"	2-3/4"	-	-	93247
#2	1/4"	3"	-	-	93255
#2	1/4"	6"	-	-	93265
#3	1/4"	1-15/16"	-	-	93241
#3	1/4"	2-3/4"	-	-	93249
#3	1/4"	3"	-	-	93257
#3	1/4"	6"	-	-	93267
Power Bit Set					
#1, #2 & #3	1/4"	1-15/16"	3522993C	-	-

Slotted Bits

Slotted Insert Bits



92047

Point Size	Shank Diameter	Overall Length	Carded Item # (1-pc)	Carded Item # (2-pc)	Bulk Item #
3-4	1/4"	1"	3511051C	-	92105
3-4	5/16"	1-1/2"	-	-	92163
4-5	1/4"	1-1/2"	-	-	92135
4-5	5/16"	1-1/2"	-	-	92165
6-8	1/4"	1"	3511111C	3511112C	92111
6-8	1/4"	1-1/2"	-	-	92139
6-8	5/16"	1-1/2"	-	-	92169
8-10	1/4"	1"	3511131C	3511132C	92113
8-10	1/4"	1-1/2"	-	-	92141
8-10	5/16"	1-1/2"	-	-	92171
10-12	1/4"	1"	3511151C	3511152C	92115
10-12	1/4"	1-1/2"	-	-	92143
10-12	5/16"	1-1/2"	-	-	92173
12-14	1/4"	1"	-	-	92117
12-14	1/4"	1-1/2"	-	-	92145ZR
12-14	5/16"	1-1/2"	-	-	92175
14-16	1/4"	1"	-	-	92119
14-16	1/4"	1-1/2"	-	-	92147
14-16	5/16"	1-1/2"	-	-	92177ZR

Slotted Power Bits with Finder



93193

- Assists in keeping power bit engaged with fastener

Point Size	Shank Diameter	Overall Length	Bulk Item #
4-5	1/4"	3-3/4"	93186
5-6	1/4"	2-5/32"	93191
5-6	1/4"	3-3/4"	93187
6-8	1/4"	2-5/32"	93193
6-8	1/4"	3-3/4"	93188
8-10	1/4"	3-3/4"	93189
10-12	1/4"	2-5/32"	93195

FASTENER DRIVE & SCREWDRIVING

Slotted Power Bits



93111

- Used for common round-head, oval-head and flat-head fasteners

Point Size	Shank Diameter	Overall Length	Carded Item # (1-pc)	Bulk Item #
3-4	1/4"	2"	-	93103
3-4	1/4"	2-3/4"	-	93123
3-4	1/4"	3"	-	93139
3-4	1/4"	3-1/2"	-	93155
3-4	1/4"	6"	-	93173
4-5	1/4"	2"	-	93105ZR
4-5	1/4"	2-3/4"	-	93125
4-5	1/4"	3"	-	93141
4-5	1/4"	3-1/2"	-	93157
4-5	1/4"	6"	-	93175
5-6	1/4"	2"	3052010	93107
5-6	1/4"	2-3/4"	-	93127
5-6	1/4"	3"	-	93143
5-6	1/4"	3-1/2"	-	93159
5-6	1/4"	6"	-	93177
6-8	1/4"	2"	3521091C	93109
6-8	1/4"	2-3/4"	-	93129
6-8	1/4"	3"	-	93145
6-8	1/4"	3-1/2"	-	93161
6-8	1/4"	6"	-	93179
8-10	1/4"	2"	3521111C	93111
8-10	1/4"	2-3/4"	-	93131
8-10	1/4"	3"	-	93147
8-10	1/4"	3-1/2"	-	93163
8-10	1/4"	6"	-	93181
10-12	1/4"	2"	3521131C	93113ZR
10-12	1/4"	2-3/4"	-	93133
10-12	1/4"	3"	-	93149
10-12	1/4"	3-1/2"	-	93165
10-12	1/4"	6"	-	93183
12-14	1/4"	2"	-	93115
12-14	1/4"	2-3/4"	-	93135
12-14	1/4"	3"	-	93151
12-14	1/4"	3-1/2"	-	93167
12-14	1/4"	6"	-	93185
Power Bit Set				
4-5, 6-8 & 8-10	1/4"	2"		3523993C

FASTENER DRIVE & SCREWDRIVING



TORX® Bits

TORX Insert Bits



3522993C

Point Size	Shank Diameter	Overall Length	Carded Item # (1-pc)	Carded Item # (10-pc)	Bulk Item #
T6	1/4"	1"	3053009	-	92306
T7	1/4"	1"	3513091C	-	92309
T8	1/4"	1"	3513121C	-	92312
T9	1/4"	1"	3513151C	-	92315
T10	1/4"	1"	3513181C	-	92318
T15	1/4"	1"	3513211C	-	92321
T20	1/4"	1"	3513241C	-	92324
T25	1/4"	1"	3513271C	351327XC	92327
T27	1/4"	1"	3513301C	-	92330
T30	1/4"	1"	3513331C	-	92333
T40	1/4"	1"	3513361C	-	92336
T30	5/16"	1-1/4"	-	-	92361
T40	5/16"	1-1/4"	-	-	92365
T45	5/16"	1-1/4"	-	-	92369
T50	5/16"	1-1/4"	-	-	92377
T55	5/16"	1-1/4"	-	-	92381
Insert Bit Sets					
T10 & T15	1/4"	1"	3514962C (2-pc)		
T20 & T25	1/4"	1"	3514972C (2-pc)		

FASTENER DRIVE & SCREWDRIVING



TORX Tamper-Resistant Bits

TORX Tamper-Resistant Insert Bits



92335

Point Size	Shank Diameter	Overall Length	Carded Item # (1-pc)	Bulk Item #
T7	1/4"	1"	3053019	
T8	1/4"	1"	3053021	
T9	1/4"	1"	3053022	92317
T10	1/4"	1"	3053023	92320
T15	1/4"	1"	3053024	92323
T20	1/4"	1"	3053025	92326
T25	1/4"	1"	3053026	92329
T27	1/4"	1"	3053027	92332
T30	1/4"	1"	3053028	92335
T40	1/4"	1"	3053029	92338
T45	5/16"	1-1/4"	3053058	92371
T50	5/16"	1-1/4"	3053059	92379
T55	5/16"	1-1/4"	3043060	92383
Insert Bit Set				
T10, T15, T20, T25, T27 & T30	1/4"	1"	3514996C (6-pc)	



TORX® Bits

TORX Power Bits



93336

Point Size	Shank Diameter	Overall Length	Carded Item # (1-pc)	Bulk Item #
T6	1/4"	2"	-	93306
T7	1/4"	2"	-	93309
T7	1/4"	2-3/4"	-	93337
T7	1/4"	3-1/2"	-	93356
T8	1/4"	2"	-	93312
T8	1/4"	2-3/4"	-	93339
T8	1/4"	3-1/2"	-	93357
T8	1/4"	6"	-	93366
T9	1/4"	2"	-	93315
T9	1/4"	2-3/4"	-	93340
T9	1/4"	3-1/2"	-	93358
T10	1/4"	2"	3523181C	93318
T10	1/4"	2-3/4"	-	93341
T10	1/4"	3-1/2"	-	93359
T10	1/4"	6"	3052018	93367
T15	1/4"	2"	3523211C	93321
T15	1/4"	2-3/4"	3052012	93342
T15	1/4"	3-1/2"	3052015	93360
T15	1/4"	6"	3052019	93368
T20	1/4"	2"	3523241C	93324
T20	1/4"	2-3/4"	3052013	93343
T20	1/4"	3-1/2"	3052016	93361
T20	1/4"	6"	3052020	93369
T25	1/4"	2"	3523271C	93327
T25	1/4"	2-3/4"	3052014	93344
T25	1/4"	3-1/2"	3052017	93362
T25	1/4"	6"	3052021	93370
T27	1/4"	2"	3523301C	93330
T27	1/4"	2-3/4"	-	93345
T27	1/4"	3-1/2"	-	93363
T27	1/4"	6"	-	93371
T30	1/4"	2"	3523331C	93333
T30	1/4"	2-3/4"	-	93346
T30	1/4"	3-1/2"	-	93364
T30	1/4"	6"	-	93372
T40	1/4"	2"	3052011	93336
T40	1/4"	2-3/4"	-	93347
T40	1/4"	3-1/2"	-	93365
T40	1/4"	6"	-	93373
Power Bit Set				
T15, T20 & T25	1/4"	1-15/16"	3524993C	

FASTENER DRIVE & SCREWDRIVING



POZIDRIV® Bits

POZIDRIV Insert Bits



92085

Point Size	Shank Diameter	Overall Length	Carded Item # (1-pc)	Bulk Item #
#1	1/4"	1"	3510831C	92083
#2	1/4"	1"	3510851C	92085
#3	1/4"	1"	3510871C	92087

POZIDRIV Power Bits



93079

Point Size	Shank Diameter	Overall Length	Carded Item # (1-pc)	Bulk Item #
#1	1/4"	2"		93073
#1	1/4"	3-1/2"	3052022	93036
#1	1/4"	6"		93039
#2	1/4"	2"		93077
#2	1/4"	3-1/2"	3052023	93037
#2	1/4"	6"		93040
#3	1/4"	2"		93079
#3	1/4"	3-1/2"	3052024	93038
#3	1/4"	6"		93041

- Reduces cam-out



TORQ-SET® Bits

TORQ-SET Insert Bits



92238

Point Size	Shank Diameter	Overall Length	Carded Item # (2-pc)	Bulk Item #
#0	1/4"	1"	3053037	92230
#1	1/4"	1"	3053038	92231
#2	1/4"	1"	3053039	92232
#3	1/4"	1"	3053040	92233
#4	1/4"	1"	3053041	92234
#5	1/4"	1"	3053042	92235
#6	1/4"	1"	3053043	92236
#8	1/4"	1"	3053044	92238
#10	1/4"	1"	3053045	92240

TORQ-SET Power Bits



93438

Point Size	Shank Diameter	Overall Length	Carded Item # (2-pc)	Bulk Item #
#0	1/4"	1-1/4"	3052025	93430
#1	1/4"	1-1/4"	3052026	93431
#2	1/4"	1-1/4"	3052027	93432
#3	1/4"	1-1/4"	3052028	93433
#4	1/4"	1-1/4"	3052029	93434
#5	1/4"	1-1/4"	3052030	93435
#6	1/4"	1-1/4"	3052031	93436
#8	1/4"	1-1/4"	3052032	93438
#10	1/4"	1-1/4"	3052033	93439



Hex Head Bits

Hex Head Metric Insert Bits



92531

Point Size	Shank Diameter	Overall Length	Bulk Item #
2 mm	1/4"	1-1/4"	92507
3 mm	1/4"	1-1/4"	92509
3 mm	5/16"	1-1/4"	92525
4 mm	1/4"	1-1/4"	92511
4 mm	5/16"	1-1/4"	92527
5 mm	1/4"	1-1/4"	92513
5 mm	5/16"	1-1/4"	92529
6 mm	1/4"	1-1/4"	92515
6 mm	5/16"	1-1/4"	92531
8 mm	1/4"	1-1/4"	92517
8 mm	5/16"	1-1/4"	92533

Hex Head Fractional Insert Bits



92495

Point Size	Shank Diameter	Overall Length	Carded Item # (1-pc)	Bulk Item #
.050"	1/4"	1-1/4"	-	92407
1/16"	1/4"	1-1/4"	-	92403
5/64"	1/4"	1-1/4"	3053010	92411
3/32"	1/4"	1-1/4"	3053011	92415
7/64"	1/4"	1-1/4"	3053012	92419
1/8"	1/4"	1-1/4"	3053013	92423
9/64"	1/4"	1-1/4"	3053014	92427
5/32"	1/4"	1-1/4"	3053015	92431
5/32"	5/16"	1-1/4"	-	92489
3/16"	1/4"	1-1/4"	3053016	92437
3/16"	5/16"	1-1/4"	-	92491
7/32"	1/4"	1-1/4"	3053017	92443
7/32"	5/16"	1-1/4"	-	92493
1/4"	1/4"	1-1/4"	3053018	92451
1/4"	5/16"	1-1/4"	-	92495
5/16"	1/4"	1-1/4"	-	92467
5/16"	5/16"	1-1/4"	-	92497
3/8"	1/4"	1-1/4"	-	92483
3/8"	5/16"	1-1/4"	-	92499

Insert Bit Set

3/32", 7/64", 1/8", 9/64", 5/32", 3/16" & 7/32"	1/4"	1-1/4"	3515997C (7-pc)
---	------	--------	-----------------

Hex Head Power Bits



93411

Point Size	Shank Diameter	Overall Length	Bulk Item #
1/16"	1/4"	1-15/16"	93403
5/64"	1/4"	1-15/16"	93405
3/32"	1/4"	1-15/16"	93407
7/64"	1/4"	1-15/16"	93409
1/8"	1/4"	1-15/16"	93411
9/64"	1/4"	1-15/16"	93413
5/32"	1/4"	1-15/16"	93415
3/16"	1/4"	1-15/16"	93419
7/32"	1/4"	1-15/16"	93423
1/4"	1/4"	1-15/16"	93427

Frearson Bits

Frearson Insert Bits



92595

Shank Diameter	Overall Length	Bulk Item #
1/4"	1"	92595

Frearson Power Bits



93481

Shank Diameter	Overall Length	Bulk Item #
1/4"	2"	93481

Type A Clutch Insert Bits



92545

Point Size	Shank Diameter	Overall Length	Carded Item # (1-pc)	Bulk Item #
5/32"	1/4"	1"	3053047	92545
3/16"	1/4"	1"	3053048	92549

Type G Clutch Bits

Type G Clutch Insert Bits



92543

Point Size	Shank Diameter	Overall Length	Carded Item # (1-pc)	Bulk Item #
1/8"	1/4"	1"	3053049	92543
5/32"	1/4"	1"	3053050	92547
3/16"	1/4"	1"	3053051	92551

Type G Clutch Power Bits

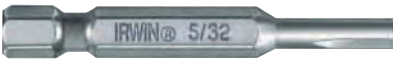

93467

Point Size	Shank Diameter	Overall Length	Carded Item # (1-pc)	Bulk Item #
1/8"	1/4"	1-15/16"	3052034	93463
5/32"	1/4"	1-15/16"	3052035	93467
3/16"	1/4"	1-15/16"	3052036	93471
5/32"	1/4"	2-3/4"	3052037	93475

TRI-WING® Insert Bits



92536

Point Size	Shank Diameter	Overall Length	Carded Item # (2-pc)	Bulk Item #
#1	1/4"	1"	3053030*	92535
#2	1/4"	1"	3053031*	92536
#3	1/4"	1"	3053032*	92537
#4	1/4"	1"	3053033*	92538
#5	1/4"	1"	3053034*	92539
#6	1/4"	1-1/4"	3053035*	92540
#7	1/4"	1-1/4"	3053036*	92599

* Note: 2 Bits per card

FASTENER DRIVE & SCREWDRIVING



Spanner Insert Bits



92567

Point Size	Shank Diameter	Overall Length	Carded Item # (1-pc)	Bulk Item #
#4	1/4"	1"	3053052	92563
#6	1/4"	1"	3053053	92565
#8	1/4"	1"	3053054	92567
#10	1/4"	1"	3053055	92569
#12	1/4"	1"	3053056	92571
#14	1/4"	1"	3053057	92573

Double End Bits*

IRWIN Double-End Bits deliver both speed and convenience by combining screwdriver bits in a durable one-piece design. These industrial quality bits are manufactured to withstand the same high-torque use as IRWIN power bits.



93525

Point Size	Shank Diameter	Overall Length	Carded Item # (2-pc)	Bagged Item # (5-pc)	Bagged Item # (3-pc)	Bulk Item #
#1 Phillips®/6-8 Slotted	1/4"	1-1/2"	3054001	-	-	93503
#2 Phillips/8-10 Slotted	1/4"	1-1/2"	3535092C	3535095B	-	93509
#3 Phillips/10-12 Slotted	1/4"	1-1/2"	3054002	-	-	93515ZR
#1 Phillips/6-8 Slotted	1/4"	2-3/8"	-	-	-	93521
#2 Phillips/8-10 Slotted	1/4"	2-3/8"	3535252C	3535255B	-	93525
#2 Phillips/#2 Phillips	1/4"	2-3/8"	3532022C	3532025B	-	353202
#3 Phillips/10-12 Slotted	1/4"	2-3/8"	-	-	-	353201
#2 Sq Recess/#2 Sq Recess	1/4"	2-3/8"	-	3532035B	-	353203
#2 Phillips/8-10 Slotted	1/4"	3-1/2"	3533012C	-	-	-
Double End Bit Set						
#1 Phillips/6-8 Slotted, #2 Phillips/8-10 Slotted & #3 Phillips/10-12 Slotted	1/4"	2-3/8"	-	-	3532993C	-

* DO NOT place double-end bits in bit holding screwdrivers, power bit holders, or quick-change chuck adapters. The retaining ring in the bit holder is designed for insert bits only.

Ceiling Tile Hanger Bits

Ceiling Tile Hanger Bits are designed for suspended ceiling installers. Their unique shape allows for faster driving of the eye hooks from which ceiling grids are hung. Designed to maintain fastener alignment during rotation.



93543

Description	Overall Length	Bulk Item #
1/4" Ceiling Tile Hanger Bit	3"	93543
5/16" Ceiling Tile Hanger Bit	3"	93545

FASTENER DRIVE & SCREWDRIVING

Screw Guides — Retracting Sleeves

Engineered to hold long fasteners in place, the screw guide sleeve retracts as the fastener is driven into the workpiece. It is especially useful in hard-to-reach applications.

Features

- Ideal for extra long fasteners
- Magnetic for secure retention of fastener
- Reduces fastener slipping and wobble
- Designed for use with insert bits only



93551

	Hex Drive	Shank Diameter	Retracted Length	Extended Length	Carded Item # (1-pc)	Bulk Item #
☞	Compact	1/4"	3-1/16"	4-11/16"	3555511C	93551
☞	Standard	1/4"	4-11/16"	7-3/8"	3555531C	93553

Insert Bit Holders

Features

- Can be used with socket wrench or socket adapter
- Available with or without magnet
- Available with or without C-ring
- Designed for insert bits only

1/4" Hex Shank Bit Holders



93718

- C-ring design contains an internal clip that fits into the retaining ring notch of the insert bit to hold the bit securely in place
- Bit holders with no internal C-ring hold the insert bit in place by magnet only
- Knurled design contains an external screw cap combined with an internal O-ring to hold the insert bit securely in place

	Point Size	Overall Length	Carded Item # (1-pc)	Bagged Item # (3-pc)	Bulk Item #
	Standard with C-Ring	2-1/4"	-	-	93711
☞	Standard with C-Ring	2-1/4"	3557121C	3557123B	93712
☞	No C-Ring	2-1/4"	-	-	93714
☞	Knurled	3"	3056002	-	93715
	Standard with C-Ring	3"	-	-	93717
☞	Standard with C-Ring	3"	3557181C	3557183B	93718
	Turned	3"	-	-	93720
☞	Turned	3"	-	-	93721
☞	No C-Ring	3"	-	-	93722
☞	Standard with C-Ring	4"	-	-	93728
☞	Standard with C-Ring	6"	-	-	93730
☞	Standard with C-Ring	8"	-	-	93732
☞	Standard with C-Ring	10"	-	-	93734
☞	Standard with C-Ring	12"	-	-	93736

1/4" Hex Shank Bit Holders For 5/16" Hex Insert Bits



93724

	Hex Drive	Overall Length	Bulk Item #
☞	Turned	3"	93723
☞	Turned	3"	93724



- magnetic

7/16" Hex Shank Bit Holders



93741

Hex Drive	Overall Length	Bulk Item #
For 1/4" Insert Bits	2-3/4"	93741

Square Drive Bit Holders



93813

Square Drive	Bit Size	Overall Length	Carded Item # (1-pc)	Bagged Item # (3-pc)	Bulk Item #
1/4"	1/4"	1"	3056003	-	93811
1/4"	1/4"	1"	4935070	-	4935072
3/8"	1/4"	1-1/4"	3558131C	3558133B	93813
3/8"	1/4"	1-1/4"	4935071	-	4935073
3/8"	5/16"	1-1/4"	-	-	93815
3/8"	5/16"	1-1/4"	-	-	4935074
1/2"	5/16"	1-1/2"	3056005	-	93817
1/2"	5/16"	1-1/2"	-	-	4935075

Nutsetters

IRWIN Nutsetters stand apart from the competition by combining unsurpassed magnetic power and high performance materials to provide total control of the fastener.



Lobular Design

- Drives the fastener on the side, instead of forcing the corners to turn
- Maintains the true shape of the fastener, dramatically reducing breakage and stripping damage
- Provides more clearance on the corners of the fastener where paint build-up can occur

Features

- Magnetic nutsetters use magnets that are 4X more powerful than common magnets
- Positive retention of the screw improves installation rate
- Universal 1/4" hex shank fits most power tools and quick-change chuck adapters

Fractional Nutsetter 1-7/8" Length - Lobular



94712

Hex Drive	Shank Diameter	Socket Body Dia.	Carded Item #	Bagged Item # (3-pc)	Bulk Item #
1/4"	1/4"	7/16"	3547121C	3547123B	94712
5/16"	1/4"	1/2"	3547321C	3547323B	94732
3/8"	1/4"	9/16"	3547521C	3547523B	94752
7/16"	1/4"	5/8"	3547721C	3547723B	94772

Fractional Nutsetter 2-9/16" Length - Lobular



94872

Hex Drive	Shank Diameter	Socket Body Dia.	Carded Item # (1-pc)	Bagged Item # (2-pc)	Bagged Item # (3-pc)	Bulk Item #
1/4"	1/4"	7/16"	3548121C	3548122B	3548123B	94812
5/16"	1/4"	1/2"	3548321C	3548322B	3548323B	94832
3/8"	1/4"	9/16"	3548521C	-	3548523B	94852
7/16"	1/4"	5/8"	3548721C	-	3548723B	94872

Nutsetter Sets - Lobular



3545984C

- magnetic

Hex Drive	Shank Diameter	Overall Length	Carded Item #
1/4", 5/16", 3/8"	1/4"	1-7/8"	3545973C (3-pc)
1/4", 5/16", 3/8", 7/16"	1/4"	1-7/8"	3545984C (4-pc)
1/4", 5/16", 3/8"	1/4"	2-9/16"	3545993C (3-pc)

Fastener Drive & Screwdriving

Nutsetters

Metric Nutsetters



94204

	Hex Drive	Shank Diameter	Socket Body Dia.	Overall Length	Bagged Item # (3-pc)	Bulk Item #
Ⓜ	6 mm	1/4"	11.1 mm	47.6 mm	3051019	94202
	8 mm	1/4"	12.7 mm	47.6 mm		94203
Ⓜ	8 mm	1/4"	12.7 mm	47.6 mm	3051020	94204ZR
Ⓜ	10 mm	1/4"	14.3 mm	47.6 mm	3051021	94206

Magnetic Insert Nutsetters



94132

- Can be used in bit holding screwdrivers or in any non-magnetic bit holders

	Hex Drive	Shank Diameter	Socket Body Dia.	Overall Length	Bulk Item #
Ⓜ	1/4"	1/4"	7/16"	1-1/2"	94112ZR
Ⓜ	5/16"	1/4"	1/2"	1-1/2"	94132
Ⓜ	3/8"	1/4"	9/16"	1-5/8"	94152
Ⓜ	7/16"	1/4"	5/8"	1-5/8"	94172ZR

Fractional Nutsetters



94212

- For use with sheet metal screws and other hexagonal head fasteners

	Hex Drive	Shank Body	Shank Diameter	Socket Body Dia.	Overall Length	Carded Item # (1-pc)	Bagged Item # (3-pc)	Bulk Item #
	3/16"	-	1/4"	7/16"	1-7/8"		3051010	94209
	1/4"	-	1/4"	7/16"	1-7/8"			94211
Ⓜ	1/4"	-	1/4"	7/16"	1-7/8"		3051011	94212
Ⓜ	1/4"	-	1/4"	1/2"	1-7/8"			94215
Ⓜ	1/4"	-	1/4"	1/2"	1-7/8"			94216
Ⓜ	1/4"	-	1/4"	7/16"	2-9/16"			94311
Ⓜ	1/4"	-	1/4"	7/16"	2-9/16"		3051012	94312
Ⓜ	1/4"	3/8"	1/4"	7/16"	2-9/16"			94316
Ⓜ	1/4"	-	1/4"	7/16"	4"	3051001		94414
Ⓜ	1/4"	-	1/4"	7/16"	6"	3051004		94416
Ⓜ	1/4"	-	1/4"	7/16"	12"	3051007		
	5/16"	-	1/4"	1/2"	1-7/8"			94231
Ⓜ	5/16"	-	1/4"	1/2"	1-7/8"		3051013	94232
Ⓜ	5/16"	5/16"	1/4"	1/2"	2-9/16"			94331ZR
Ⓜ	5/16"	5/16"	1/4"	1/2"	2-9/16"		3051014	94332
Ⓜ	5/16"	3/8"	1/4"	1/2"	2-9/16"			94335
Ⓜ	5/16"	3/8"	1/4"	1/2"	2-9/16"			94336
Ⓜ	5/16"	-	1/4"	1/2"	4"	3051002		94434
Ⓜ	5/16"	-	1/4"	1/2"	6"	3051005		94436
Ⓜ	5/16"	-	1/4"	1/2"	12"	3051008		
Ⓜ	3/8"	-	1/4"	9/16"	1-7/8"			94251ZR
Ⓜ	3/8"	-	1/4"	9/16"	1-7/8"		3051015	94252
Ⓜ	3/8"	5/16"	1/4"	9/16"	2-9/16"			94351
Ⓜ	3/8"	5/16"	1/4"	9/16"	2-9/16"		3051016	94352
Ⓜ	3/8"	3/8"	1/4"	9/16"	2-9/16"			94356ZR
Ⓜ	3/8"	-	1/4"	9/16"	4"	3051003		
Ⓜ	3/8"	-	1/4"	9/16"	6"	3051006		
Ⓜ	3/8"	-	1/4"	9/16"	12"	3051009		
	7/16"	-	1/4"	5/8"	1-7/8"			94271
Ⓜ	7/16"	-	1/4"	5/8"	1-7/8"			94272
Ⓜ	7/16"	3/8"	1/4"	5/8"	2-9/16"			94371ZR
Ⓜ	7/16"	3/8"	1/4"	5/8"	2-9/16"		3051017	94372ZR
	1/2"	-	1/4"	3/4"	1-7/8"			94291
	1/2"	-	1/4"	3/4"	2-9/16"		3051018	

Ⓜ - magnetic

▼ - tapered

Socket Adapters

SOCKET ADAPTER FEATURES

1. Bearing Groove
2. Pin lock design for production applications;
Ball retention design for quick-change application
3. Forged Socket Body
4. Shank Body

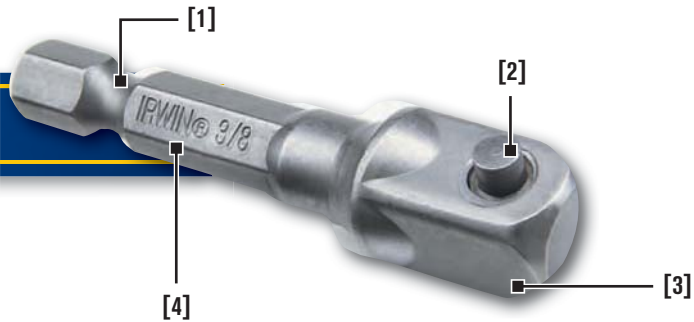

7/16" Hex Shank Square Drive Socket Adapter



93749

Square Drive	Lock Type	Overall Length	Bulk Item #
3/8"	Pin	5"	93748
1/2"	Pin	3"	93749

1/4" Square Drive Socket Adapter



93758

Square Drive	Lock Type	Overall Length	Carded Item # (1-pc)	Bulk Item #
1/4"	Pin	1-3/8"	3056004	93755
1/4"	Ball	1-3/8"	-	93756
1/4"	Pin	2"	-	93758
1/4"	Ball	2"	3567611C	93761
1/4"	Pin	3"	-	93763
1/4"	Ball	3"	-	93765
1/4"	Pin	4"	-	93771
1/4"	Pin	6"	-	93776
1/4"	Ball	6"	-	93777

3/8" Square Drive Socket Adapter



93783

Square Drive	Lock Type	Overall Length	Carded Item # (1-pc)	Bulk Item #
3/8"	Pin	1-5/8"	-	93781
3/8"	Ball	1-5/8"	-	93782
3/8"	Pin	2"	-	93783
3/8"	Ball	2"	3567841C	93784
3/8"	Pin	3"	-	93786
3/8"	Ball	3"	-	93787
3/8"	Pin	4"	-	93789
3/8"	Pin	6"	-	93792
3/8"	Ball	6"	-	93793

1/2" Square Drive Socket Adapter



93795

Square Drive	Lock Type	Overall Length	Carded Item # (1-pc)	Bulk Item #
1/2"	Ball	2"	3567951C	93795
1/2"	Ball	3"	-	93797

FASTENER DRIVE & SCREWDRIVING

Fastener Drive & Screwdriving Sets

IRWIN® PRO-PAK™



357320

Description	Item # (20-pc)
#2 TORSION Phillips® Insert Bit 1"	3053003
#2 TORSION Phillips Drywall Insert Bit 1"	4935102
#2 TORSION Square Recess Insert Bit 1"	4935103
#2 Phillips Insert Bit 1"	357320
#2 Phillips Drywall Insert Bit 1"	357120
#2 Square Recess Insert Bit 1"	357220
#2 Square 2-pc Insert Bit 1"	357220C

Torsion 6-piece Quick Change Magnetic Drive Guide Set



3057023

Contents	Quantity	Item # 3057023
#1 Phillips Power Bit	1	3052001
#2 Phillips Power Bit	2	3052002
#1 Square Recess Power Bit	1	3052004
#2 Square Recess Power Bit	1	3052005
2-1/2" Quick Change Chuck	1	90102

Torsion 14-piece Quick Change Magnetic Drive Guide Set



3057024

Contents	Quantity	Item # 3057024
#1 Phillips Insert Bit	2	3053001
#2 Phillips Insert Bit	4	3053002
#1 Square Recess Insert Bit	2	3053005
#2 Square Recess Insert Bit	4	3053006
Magnetic bit Holder 2-1/4"	1	93714
Compact Magnetic Drive Guide	1	93551

7-piece Magnetic Drive Guide Set



3057011DS

Contents	Quantity	Item # 3057011DS
#2 Phillips Insert Bit 1"	2	92011
#2 Square Recess Insert Bit 1"	2	92205
8-10 Slotted Insert Bits 1"	2	92113
Compact Magnetic Drive Guide	1	93551

- magnetic

FASTENER DRIVE & SCREWDRIVING

13-piece Magnetic Drive Guide Set



3057013DS

Contents	Quantity	Item # 3057013DS
#1 Phillips® Insert Bit 1"	1	92005
#2 Phillips Insert Bit 1"	4	92011
#3 Phillips Insert Bit 1"	1	92019
#1 Square Recess Insert Bit 1"	1	92203
#2 Square Recess Insert Bit 1"	3	92205
8-10 Slotted Insert Bit 1"	2	92113
 4-11/16" Magnetic Drive Guide	1	93553

21-piece Magnetic Drive Guide Set



3057002DS

Contents	Quantity	Item # 3057002DS
#2 Phillips Insert Bits 1"	10	92011
#2 Square Insert Bits 1"	5	92205
8-10 Slotted Insert Bits 1"	5	92113
 4-11/16" Magnetic Drive Guide	1	93553

7-piece Quick Change Bit Set



3057003DS

Contents	Quantity	Item # 3057003DS
#1 Phillips Power Bit 2"	1	93003
#2 Phillips Power Bit 2"	2	93007
#2 Square Recess Power Bit 2"	2	93205
8-10 Slotted Power Bit 2"	1	93111
2-1/2" Quick Change Chuck	1	90102

31-piece Screwdriver Bit Set with Storage



3057026

- Soft case with snap-lock closure and durable hinge for rigorous jobsite conditions
- Bit and fastener storage case included

 - magnetic



Contents	Quantity	Item # 3057026
 Magnetic Bit Holer 2-1/4"	1	93714
#1 Phillips Insert Bit 1"	2	92005
#2 Phillips Insert Bit 1"	5	92011
#3 Phillips Insert Bit 1"	3	92019
#1 Square Recess Insert Bit 1"	2	92203
#2 Square Recess Insert Bit 1"	5	92205
#3 Square Recess Insert Bit 1"	1	92207
4-5 Slotted Insert Bit 1"	1	92107
6-8 Slotted Insert Bit 1"	3	92111
8-10 Slotted Insert Bit 1"	2	92113
10-12 Slotted Insert Bit 1"	1	92115
T15 Torx® Insert Bit 1"	1	92321
T20 Torx Insert Bit 1"	1	92324
T25 Torx Insert Bit 1"	1	92327
T27 Torx Insert Bit 1"	1	92330
T30 Torx Insert Bit 1"	1	92333

31-piece SPEEDBOR® Drill/Drive Set



3057031

- Featuring SPEEDBOR spade bits with patented Blue-Groove™ point and cutting edge for faster chip removal.
- Soft case with snap-lock closure and durable hinge for rigorous jobsite conditions



Contents	Quantity	Item # 3057031
2-1/2" Quick Change Chuck	1	90102
 Magnetic bit Holder 2-1/4"	1	93714
 Compact Magnetic Screw guide 3-1/16"	1	93551
#1 PH Power Bit 2"	2	93003
#2 PH Power Bit 2"	4	93007
#3 PH Power Bit 2"	1	93011
8-10 Slotted Power Bit 2"	1	93111
10-12 Slotted Power Bit 2"	1	93113
#1 Square Recess Power Bit 2"	2	93203
#2 Square Recess Power Bit 2"	3	93205
#3 Square Recess Power Bit 2"	1	93207
#2 Square Recess Power Bit 1"	3	92205
#2 Phillips® Insert Bit 1"	4	92011
3/8"-6" BULK SPEEDBOR DRILL BIT	1	99906
1/2"-6" BULK SPEEDBOR DRILL BIT	1	99908
5/8"-6" BULK SPEEDBOR DRILL BIT	1	99910
3/4"-6" BULK SPEEDBOR DRILL BIT	1	99912
7/8"-6" BULK SPEEDBOR DRILL BIT	1	99914
1"-6" BULK SPEEDBOR DRILL BIT	1	99916

41-piece Screwdriver Bit Soft Case Set



3057041

- Soft case with snap-lock closure and durable hinge for rigorous jobsite conditions
- Includes most popular insert bits, power bits and nutsetters

Contents	Quantity	Item # 3057041
 Compact Magnetic Screw Guide 3-1/16"	1	93551
 Magnetic bit Holder 2-1/4"	1	93714
#1 Phillips Insert Bit 1"	2	92005
#2 Phillips Insert Bit 1"	6	92011
#3 Phillips Insert Bit 1"	2	92019
#1 Square Recess Insert Bit 1"	2	92203
#2 Square Recess Insert Bit 1"	4	92205
#3 Square Recess Insert Bit 1"	1	92207
6-8 Slotted Insert Bit 1"	1	92111
8-10 Slotted Insert Bit 1"	2	92113
10-12 Slotted Insert Bit 1"	1	92115
#1 PH Power Bit 2"	1	93003
#2 PH Power Bit 2"	4	93007
#3 PH Power Bit 2"	2	93003
8-10 Slotted Power Bit 2"	1	93111
10-12 Slotted Power Bit 2"	1	93113
#1 Square Recess Power Bit 2"	1	93203
#2 Square Recess Power Bit 2"	3	93205
#3 Square Recess Power Bit 2"	1	93207
#2 PH Power Bit 4"	1	93059
#2 Square Recess Power Bit 4"	1	93226
1/4" - 1-7/8" Nutsetter	1	94712
5/16" - 1-7/8" Nutsetter	1	94732

NEW 47-piece TORSION Screwdriver Bit Set



4935547

- Includes TORSION Insert Bits that last longer and fit better

NEW 26-piece TORSION Screwdriver Bit Set



4935548

- Includes TORSION Insert Bits that last longer and fit better

16-piece Screwdriver Bit Set











3057014

- Includes most popular insert bits, power bits and nutsetters

 - magnetic

Contents	Quantity	Item # 4935547
#2 TORSION Phillips® Insert Bit 1"	7	3053002B
#2 TORSION Square Insert Bit 1"	7	3053006B
#1 Phillips Insert Bit 1"	3	92005
#3 Phillips Insert Bit 1"	4	92019
#1 Square Insert Bit 1"	3	92203
#3 Square Insert Bit 1"	4	92207
8-10 Slotted Insert Bit 1"	2	92113
T20 TORX Insert Bit 1"	1	92324
T25 TORX Insert Bit 1"	3	92327
T30 TORX Insert Bit 1"	1	92333
#2 Phillips Power Bit 2"	3	93007
#2 Square Power Bit 2"	2	93205
8-10 Slotted Power Bit 2"	1	93111
T25 TORX Power Bit 2"	1	93327
 Compact Magnetic Screw Guide 3-1/16"	1	93551
 1/4" Magnetic Nutsetter 2-9/16"	1	94812
 5/16" Magnetic Nutsetter 2-9/16"	1	94832
 3/8" Magnetic Nutsetter 2-9/16"	1	94852
#2PH/#2PH Double Ended Bit 2-3/8"	1	353202

Contents	Quantity	Item # 4935548
#2 TORSION Phillips Insert Bit 1"	4	3053002B
#2 TORSION Square Insert Bit 1"	3	3053006B
#1 TORSION Phillips Power Bit 2"	1	3052001B
#2 TORSION Phillips Power Bit 2"	2	3052002B
#3 TORSION Phillips Power Bit 2"	1	3052003B
#2 TORSION Square Power Bit 2"	1	3052005B
#2 TORSION Phillips Power Bit 4"	1	3052042B
#2 TORSION Square Power Bit 4"	1	3052051B
#1 Square Power Bit 2"	1	93203
#2 Square Power Bit 2"	2	93205
#3 Square Power Bit 2"	1	93207
6-8 Slotted Power Bit 2"	1	93109
8-10 Slotted Power Bit 2"	1	93111
10-12 Slotted Power Bit 2"	1	93113
 Compact Magnetic Screw Guide 3-1/16"	1	93551
 1/4" Magnetic Nutsetter 2-9/16"	1	94812
 5/16" Magnetic Nutsetter 2-9/16"	1	94832
 3/8" Magnetic Nutsetter 2-9/16"	1	94852
1/4" Lock-N-Load Quick Change 2-1/2"	1	4935703

Contents	Quantity	Item # 3057014
 Magnetic Bit Holder 2-1/4"	1	97314
#1 Phillips® Insert Bit 1"	1	92005
#2 Phillips Insert Bit 1"	2	92011
#3 Phillips Insert Bit 1"	1	92019
#2 Square Recess Insert Bit 1"	2	92205
8-10 Slotted Insert Bit 1"	1	92113
 1/4" x 1-7/8" Nutsetter	1	94712
 5/16" x 1-1/8" Nutsetter	1	94732
 3/8" x 1-7/8" Nutsetter	1	94752
#2 Phillips Power Bit 2"	2	93007
#2 Square Recess Insert Bit 2"	1	93205
8-10 Slotted Power Bit 2"	1	93111
6-8 Slotted Power Bit 2"	1	93109

FASTENER DRIVE & SCREWDRIVING

Fastener Drive & Screwdriving Sets

24-piece Screwdriver Bit Set



3057015

- Magnetic drive guide included
- 4" power bits for increased accessibility

Contents	Quantity	Item # 3057015
#1 Phillips Insert Bit 1"	1	92005
#2 Phillips Insert Bit 1"	5	92011
#3 Phillips Insert Bit 1"	1	92019
#1 Square Recess Insert Bit 1"	1	92203
#2 Square Recess Insert Bit 1"	3	92205
#3 Square Recess Insert Bit 1"	2	92207
8-10 Slotted Insert Bit 1"	1	92113
Compact Magnetic Screw Guide 3-1/16"	1	93551
1/4" x 1-7/8" Nutsetter	1	94712
5/16" x 1-7/8" Nutsetter	1	94732
3/8" x 1-7/8" Nutsetter	1	94752
#2 Phillips Power Bit 4"	1	93057
#2 Square Recess Insert Bit 4"	1	93226
#2 Phillips Power Bit 2"	2	93007
#2 Square Recess Power Bit 2"	1	93205
8-10 Slotted Power Bit 2"	1	93111

20-piece Drill Drive Set



357020

- Includes HSS Black Oxide Drill Bits

Contents	Quantity	Item # 357020
Compact Magnetic Drive Guide	1	93551
1/4" x 2-9/16" Nutsetter	1	94812
3/8" x 2-9/16" Nutsetter	1	94852
5/16" x 2-9/16" Nutsetter	1	94832
#2/#2 Phillips Double End Bit	1	353202
#1 Phillips Insert Bit	1	92005
#2 Phillips Insert Bit	2	92011
#3 Phillips Insert Bit	1	92019
#2 Square Recess Insert Bit	2	92205
8-10 Slotted Insert Bit	1	92113
1/4" 135° Black Oxide HSS Fractional Straight Shank Jobber Length Drill Bit	1	63516
3/16" 135° Black Oxide HSS Fractional Straight Shank Jobber Length Drill Bit	1	63512
5/32" 135° Black Oxide HSS Fractional Straight Shank Jobber Length Drill Bit	1	63510
1/8" 135° Black Oxide HSS Fractional Straight Shank Jobber Length Drill Bit	2	63508
3/32" 135° Black Oxide HSS Fractional Straight Shank Jobber Length Drill Bit	1	63506
1/16" 135° Black Oxide HSS Fractional Straight Shank Jobber Length Drill Bit	2	63504

33-piece Screwdriver Bit Set



3057017

- Includes most popular insert bits, power bits and nutsetters

Contents	Quantity	Item # 3057017
Magnetic Bit Holder 2-1/4"	1	93714
#1 Phillips Insert Bit 1"	2	92005
#2 Phillips Insert Bit 1"	12	92011
#3 Phillips Insert Bit 1"	2	92019
#1 Square Recess Insert Bit 1"	1	92203
#2 Square Recess Insert Bit 1"	5	92205
#3 Square Recess Insert Bit 1"	1	92207
1/4" x 1-7/8" Nutsetter	1	94712
5/16" x 1-7/8" Nutsetter	1	94732
3/8" x 1-7/8" Nutsetter	1	94752
#2 Phillips Power Bit 2"	1	93007
6-8 Slotted Insert Bit 1"	2	92111
8-10 Slotted Insert Bit 1"	2	92113
10-12 Slotted Insert Bit 1"	1	92115

40-piece Screwdriver Bit Set



3057018

- Includes Torx and hex head insert bits

Contents	Quantity	Item # 3057018
Magnetic Bit Holder 2-1/4"	1	93714
#1 Phillips® Insert Bit 1"	2	92005
#2 Phillips Insert Bit 1"	7	92011
#3 Phillips Insert Bit 1"	2	92019
#1 Square Recess Insert Bit 1"	1	92203
#2 Square Recess Insert Bit 1"	5	92205
#3 Square Recess Insert Bit 1"	1	92207
6-8 Slotted Insert Bit 1"	1	92111
8-10 Slotted Insert Bit 1"	1	92113
10-12 Slotted Insert Bit 1"	1	92115
TORX® Insert Bits 1": T10, T15, T20, T25, T27, T30, T40	7	92318, 92321, 92324, 92327, 92330, 92333, 92336
Hex Head Insert Bits: 3/32", 7/64", 1/8", 9/64", 5/32", 3/16", 7/32"	7	92415, 92419, 92423, 92427, 92431, 92437, 92493
#2 Square Recess Power Bit 2"	1	93205
#3 Square Recess Power Bit 2"	1	93207
#2 Phillips Power Bit 2"	1	93007
#3 Phillips Power Bit 2"	1	93003

30-piece Screwdriver Set

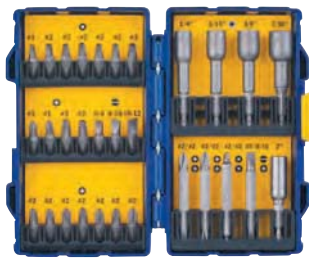

357030

Contents	Quantity	Item # 357030
#1 Phillips Insert Bit	2	92005
#2 Phillips Insert Bit	7	92011
#3 Phillips Insert Bit	2	92019
#1 Sq Recess Insert Bit	1	92203
#2 Sq Recess Insert Bit	5	92205
#3 Sq Recess Insert Bit	1	92207
6-8 Slotted Insert Bit	1	92111
8-10 Slotted Insert Bit	1	92113
10-12 Slotted Insert Bit	1	92115
2-1/4" Magnetic Bit Holder	1	93712
#2/#2 Phillips Double End Bit	2	353202
#2 Sq Recess Double End	1	353203
8-10 Slotted Double End Bit	1	93525
1/4" Magnetic Nutsetters - 2-9/16"	1	94812
5/16" Magnetic Nutsetters - 2-9/16"	1	94832
3/8" Magnetic Nutsetters - 2-9/16"	1	94852
7/16" Magnetic Nutsetters - 2-9/16"	1	94872

FASTENER DRIVE & SCREWDRIVING

16-piece Automotive & Maintenance Power Bit Set



3057016

All IRWIN® Fastener Drive Bits are manufactured from industrial-grade tool steel and tested to meet the highest standards for hardness and torque.

Contents	Quantity	Item # 3057016
#2 Phillips® Power Bit x 3-1/2"	1	93025
#3 Phillips Power Bit x 3-1/2"	1	93029
#2 POZIDRIV® Power Bit x 3-1/2"	1	93037
#1 Phillips Power Bit x 6"	1	93063
#2 Phillips Power Bit x 6"	1	93067
T15 TORX® #2 Power Bit x 3-1/2"	1	93360
T20 TORX #2 Power Bit x 3-1/2"	1	93361
T20 TORX #2 Power Bit x 6"	1	93369
T25 TORX #2 Power Bit x 6"	1	93370
T27 TORX #2 Power Bit x 6"	1	93371
T30 TORX #2 Power Bit x 6"	1	93372
1/4" Socket Adapter x 2"	1	93761
3/8" Socket Adapter x 2"	1	93784
5/16" Magnetic Nutsetter x 1-7/8"	1	94732
2" Quick Change Bit Holder	1	4935703
6" Quick Change Bit Holder	1	4935704



FASTENER DRIVE & SCREWDRIVING

34-piece Automotive & Maintenance Power Bit Set



3057034

All IRWIN Fastener Drive Bits are manufactured from industrial-grade tool steel and tested to meet the highest standards for hardness and torque.

Contents	Quantity	Item # 3057034
#1 Phillips Power Bit x 2"	1	93003
#2 Phillips Power Bit x 2"	1	93007
#3 Phillips Power Bit x 2"	1	93011
#1 POZIDRIV Power Bit x 2"	1	93073
#2 POZIDRIV Power Bit x 2"	1	93077
#3 POZIDRIV Power Bit x 2"	1	93079
T8 TORX Power Bit x 2"	1	93312
T9 TORX Power Bit x 2"	1	93315
T10 TORX Power Bit x 2"	1	93318
#1 Phillips Power Bit x 3-1/2"	1	93023
#2 Phillips Power Bit x 3-1/2"	1	93025
#3 Phillips Power Bit x 3-1/2"	1	93029
#2 POZIDRIV Power Bit x 3-1/2"	1	93037
T15 TORX Power Bit x 3-1/2"	1	93360
T20 TORX Power Bit x 3-1/2"	1	93361
T25 TORX Power Bit x 3-1/2"	1	93362
T30 TORX Power Bit x 3-1/2"	1	93364
#1 Phillips Power Bit x 6"	1	93063
#2 Phillips Power Bit x 6"	1	93067
#3 Phillips Power Bit x 6"	1	93069
#2 POZIDRIV Power Bit x 6"	1	93040
T15 TORX Power Bit x 6"	1	93368
T20 TORX Power Bit x 6"	1	93369
T25 TORX Power Bit x 6"	1	93370
T27 TORX Power Bit x 6"	1	93371
T30 TORX Power Bit x 6"	1	93372
1/4" Socket Adapter x 2"	1	93761
3/8" Socket Adapter x 2"	1	93784
1/2" Socket Adapter x 2"	1	93795
 1/2" Magnetic Nutsetter x 1-7/8"	1	94712
 5/16" Magnetic Nutsetter x 1-7/8"	1	94732
 3/8" Magnetic Nutsetter x 1-7/8"	1	94752
2" Quick Change Bit Holder	1	4935703
6" Quick Change Bit Holder	1	4935704

 - magnetic

IRWIN 9-in-1 Multi-Tool

IRWIN's 9-in-1™ Multi-Tool takes versatility and convenience to a new level. This professional-grade tool features six (6) bits and three (3) nut drivers – the most common sizes – all conveniently stored inside the tool in a unique stacking configuration. The right fastening tool will always be at your fingertips. The 9-in-1 Multi-Tool also features IRWIN's ergonomic ProTouch™ Grip, providing comfort and slip resistance for maximum torque.

9-in-1 MULTI-TOOL

FEATURES

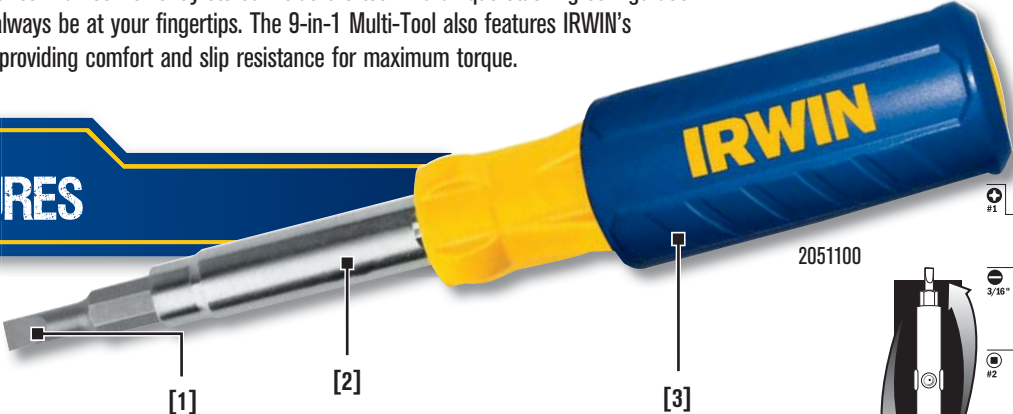

2051100

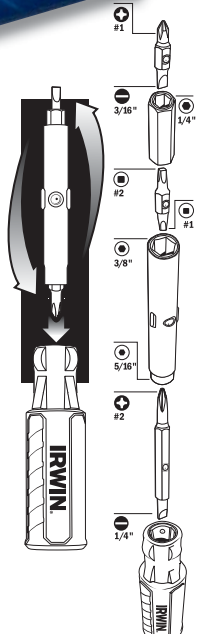

1. 9 bits & nut setters for use on a variety of fasteners
2. Internal storage keeps bits and nut setters locked in place and close at hand
3. Ergonomic ProTouch™ grip provides maximum torque, comfort, and slip resistance

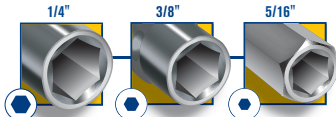

3 Nut Setters



6 Bits

ProTouch™

FASTENER DRIVE & SCREWDRIVING

IRWIN 8-in-1 Multi-Tool

The highly versatile IRWIN 8-in-1 Multi-tool is ideal for hard-to-reach areas. This professional-grade tool includes seven (7) of the most common-sized screwdriving bits, all conveniently and securely stored inside of the tool. The shank functions as a 1/4" nut driver. Plus, the shank is magnetic, so bits are held securely in place. The IRWIN 8-in-1 Multi-tool features a non-slip ProTouch™ Grip, providing maximum torque, with incredible comfort and control.

8-in-1 MULTI-TOOL

FEATURES



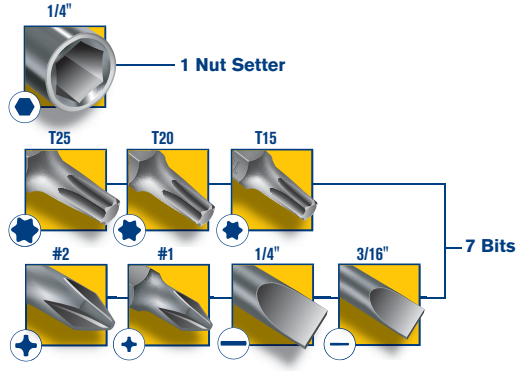

1. Magnetic shank holds bits securely in place
2. Ergonomic ProTouch™ grip provides maximum torque, comfort, and slip resistance
3. Internal storage keeps bits locked in place and close at hand

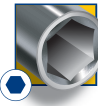

1 Nut Setter

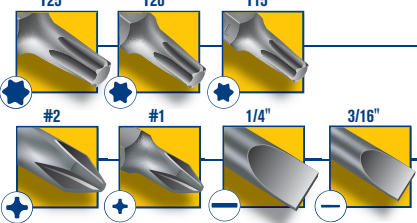

7 Bits

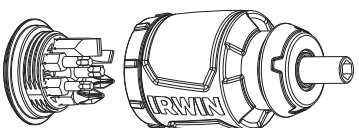

4935586

Description	Item #	Carton Qty
9-in-1 Multi-Tool	2051100	6
8-in 1 Multi-Tool	4935586	5

IRWIN®

Masonry & Specialty Drilling



www.irwin.com



Powers Through Rebar

With 125 years of experience in drill bit manufacturing, product innovation, design, and development, and a full range of products available, IRWIN® is serious about drilling. Rebar-reinforced concrete is found on most jobsites, and hitting rebar is a common obstacle in construction work. IRWIN now offers a solution for drilling through concrete with rebar – the IRWIN SpeedHammer POWER Masonry Bit.

The SpeedHammer POWER bit has a patent-pending high performance tip that's manufactured with 2X more carbide*. It easily powers through 2X more concrete and rebar than traditional masonry bits. When long life and durability are crucial, depend on the IRWIN SpeedHammer POWER Masonry Bit.

SPEEDHAMMER POWER FEATURES

1. 2X more carbide in tip longer for drilling life in rebar-reinforced concrete, optimized for cutting through rebar at high speeds
2. Maximized Flute for faster, more efficient dust removal and extended life
3. Optimal Groove Design minimizes friction for increased speed and longer life
4. Premium Steel provides improved core strength for maximum durability and extended life
5. Blue Power Ring for easier identification in the toolbox

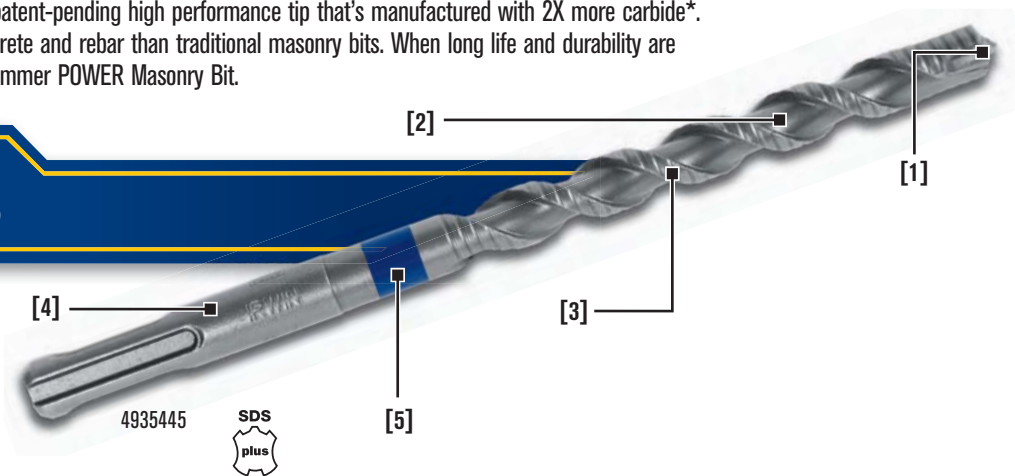

2X LONGER LIFE**

MASONRY DRILLING

Description	Pack Qty	Item #
SpeedHammer Power – 2-Cutter – Hang Tag		
3/16" X 4" X 6"	1	4935448
3/16" X 6" X 8"	1	4935449
3/16" X 10" X 12"	1	4935447
1/4" X 4" X 6"	1	4935445
1/4" X 6" X 8"	1	4935446
1/4" X 10" X 12"	1	4935444
3/8" X 4" X 6"	1	4935454
3/8" X 6" X 8"	1	4935455
3/8" X 10" X 12"	1	4935453
1/2" X 4" X 6"	1	4935442
1/2" X 6" X 8"	1	4935443
1/2" X 10" X 12"	1	4935441
5/8" X 4" X 6"	1	4935457
5/8" X 6" X 8"	1	4935458
5/8" X 10" X 12"	1	4935456
3/4" X 4" X 6"	1	4935451
3/4" X 6" X 8"	1	4935452
3/4" X 10" X 12"	1	4935450

Description	Pack Qty	Item #
SpeedHammer Power – 2-Cutter Bulk		
3/16" X 4" X 6"	25	4935461
1/4" X 4" X 6"	25	4935460
1/2" X 4" X 6"	25	4935459
3/8" X 4" X 6"	25	4935463
5/8" X 4" X 6"	25	4935464
3/4" X 4" X 6"	5	4935462
3/16" X 6" X 8"	25	4935466
1/4" X 6" X 8"	25	4935465
3/8" X 10" X 12"	5	4935469
1/2" X 10" X 12"	5	4935467
5/8" X 10" X 12"	5	4935470
3/4" X 10" X 12"	5	4935468
SpeedHammer Power – 2-Cutter Set		
5 Pc Set 6" OAL Includes: 3/16", 1/4" (2), 3/8", 1/2"	6	4935471

* Compared to IRWIN SpeedHammer Plus masonry bits
** Vs. traditional masonry bits



Speed in Clean Concrete

SPEEDHAMMER PLUS

FEATURES

1. Patented carbide tip controlled self centering when starting holes; aggressive angles for faster drilling
2. Short drill head forces drilling dust into flute
3. Patented flute design for rapid dust removal, reduces clogging and increases penetration speed
4. 140° cutting tip provides more cutting surface than competitor's tip, reduces breakout in through-hole applications; centering point prevents walking

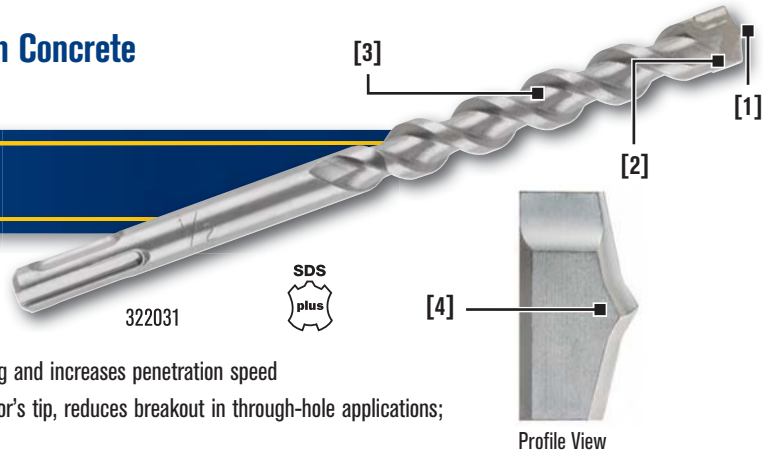

Description	Pack Qty	Item #
SpeedHammer Plus - 2-Cutter - Hang Tag		
5/32" x 2" x 4"	1	322001
5/32" x 4" x 6"	1	322002
3/16" x 2" x 4"	1	322003
3/16" x 4" x 6"	1	322004
3/16" x 6" x 8"	1	322005
3/16" x 8" x 10"	1	322006
3/16" x 10" x 12"	1	322007
7/32" x 4" x 6"	1	322013
7/32" x 6" x 8"	1	322014
7/32" x 10" x 12"	1	322015
1/4" x 2" x 4"	1	322016
1/4" x 4" x 6"	1	322017
1/4" x 6" x 8"	1	322018
1/4" x 8" x 10"	1	322019
1/4" x 10" x 12"	1	322020
1/4" x 12" x 14"	1	322021
5/16" x 4" x 6"	1	322022
5/16" x 10" x 12"	1	322023
3/8" x 4" x 6"	1	322024
3/8" x 8" x 10"	1	322025
3/8" x 10" x 12"	1	322026
3/8" x 16" x 18"	1	322027
3/8" x 22" x 24"	1	322028
7/16" x 4" x 6"	1	322029
7/16" x 10" x 12"	1	322030
1/2" x 4" x 6"	1	322031
1/2" x 8" x 10"	1	322032
1/2" x 10" x 12"	1	322033
1/2" x 16" x 18"	1	322034
1/2" x 22" x 24"	1	322035
9/16" x 4" x 6"	1	322036
9/16" x 10" x 12"	1	322037
9/16" x 16" x 18"	1	322038
5/8" x 4" x 6"	1	322041
5/8" x 6" x 8"	1	322042
5/8" x 10" x 12"	1	322043
5/8" x 16" x 18"	1	322044
5/8" x 22" x 24"	1	322045
11/16" x 6" x 8"	1	322046
3/4" x 6" x 8"	1	322047
3/4" x 10" x 12"	1	322048
3/4" x 16" x 18"	1	322049
3/4" x 22" x 24"	1	322050
7/8" x 6" x 8"	1	322051
7/8" x 10" x 12"	1	322052

Description	Pack Qty	Item #
SpeedHammer Plus - 2-Cutter - Hang Tag		
7/8" x 16" x 18"	1	322053
1 x 8 x 10	1	322054
1" x 16" x 18"	1	322055
Adapter, to SDS-Plus	1	327001
Adapter, to Spline	1	327002
SpeedHammer Plus - 2-Cutter Sets		
5 Pc. Drill Set Contains One Each: 5/32" x 6", 3/16" x 6", 1/4" x 6", 3/8" x 6", and 1/2" x 6"	6	4935077
SpeedHammer Plus - 2-Cutter Bulk		
3/16" x 4" x 7"	25	322058B25
5/32" x 4" x 6"	25	322002B25
3/16" x 2" x 4"	25	322003B25
3/16" x 4" x 6"	25	322004B25
3/16" x 6" x 8"	25	322005B25
3/16" x 8" x 10"	25	322006B25
3/16" x 10" x 12"	25	322007B25
7/32" x 4" x 6"	25	322013B25
7/32" x 6" x 8"	25	322014B25
7/32" x 10" x 12"	25	322015B25
1/4" x 2" x 4"	25	322016B25
1/4" x 4" x 6"	25	322017B25
1/4" x 6" x 8"	25	322018B25
5/16" x 4" x 6"	25	322022B25
3/8" x 4" x 6"	25	322024B25
3/8" x 10" x 12"	25	322026B25
1/2" x 4" x 6"	25	322031B25
1/2" x 10" x 12"	25	322033B25
5/8" x 6" x 8"	25	322042B25
SpeedHammer Plus - 4-Cutter - Hang Tag		
3/4" x 16" x 18"	1	322082
7/8" x 16" x 18"	1	322085
1" x 16" x 18"	1	322087
1-1/8" x 16" x 18"	1	322089
SpeedHammer Plus - Hex Drive Drill Bits - Hang Tag		
3/16" x 2" x 5"	1	322056
3/16" x 3" x 6"	1	322057
3/16" x 4" x 7"	1	322058
5/32" x 2" x 5"	1	322059
5/32" x 4" x 7"	1	322061



2-cutter Head



4-cutter Head

MASONRY DRILLING

IRWIN SDS-Max® Drill Bits



323000



2-cutter Head



4-cutter Head

- Patented tip design enhances dust removal and provides symmetrical holes
- Shot-peened double-tempered finish for increased wear resistance and extended life

Description	Pack Qty	Item #
SDS-Max - 2-Cutter - Tubed		
3/8" x 7-1/2" x 13"	1	323000
1/2" x 7-1/2" x 13"	1	323001
1/2" x 15-1/2" x 21"	1	323002
9/16" x 7-1/2" x 13"	1	323003
9/16" x 15-1/2" x 21"	1	323004
Adapter, to SDS-Max	1	327001
SDS-Max - 4-Cutter - Tubed		
5/8" x 7-1/2" x 13"	1	323005
5/8" x 15-1/2" x 21"	1	323006
5/8" x 30-1/2" x 36"	1	323007
11/16" x 15-1/2" x 21"	1	323008
3/4" x 8" x 13"	1	323009
3/4" x 17" x 21"	1	323010
3/4" x 31" x 36"	1	323011
13/16" x 17" x 21"	1	323012
7/8" x 8" x 13"	1	323014
7/8" x 17" x 21"	1	323015
1" x 8" x 13"	1	323016
1" x 17" x 21"	1	323017
1" x 31" x 36"	1	323018
1-1/8" x 12" x 17"	1	323020
1-1/8" x 17" x 21"	1	323022
1-1/4" x 10" x 15"	1	323023ZR
1-1/4" x 18" x 23"	1	323024
1-1/4" x 31" x 36"	1	323025
1-3/8" x 18" x 23"	1	323028
1-1/2" x 18" x 23"	1	323031
1-3/4" x 17" x 23"	1	323033
2" x 17" x 23"	1	323034

©SDS-Max is a registered trademark of Robert Bosch GmbH.

Spline Drill Bits



324011



2-cutter Head



4-cutter Head

- Patented tip design enhances dust removal and provides symmetrical holes
- Shot-peened double-tempered finish for increased wear resistance and extended life

Description	Pack Qty	Item #
Spline - 2-Cutter - Hang Tag		
3/8" x 5" x 10"	1	324000
3/8" x 8" x 13"	1	324001
3/8" x 11" x 16"	1	324002
1/2" x 5" x 10"	1	324003
1/2" x 8" x 13"	1	324004
1/2" x 11" x 16"	1	324005
1/2" x 17" x 22"	1	324006
1/2" x 24" x 29"	1	324007
1/2" x 31" x 36"	1	324008
9/16" x 8" x 13"	1	324009
9/16" x 17" x 23"	1	324010
5/8" x 5" x 10"	1	324011
5/8" x 11" x 16"	1	324012
5/8" x 17" x 22"	1	324013
5/8" x 31" x 36"	1	324015
3/4" x 5" x 10"	1	324017
3/4" x 8" x 13"	1	324018
3/4" x 11" x 16"	1	324019
3/4" x 17" x 22"	1	324020
3/4" x 24" x 29"	1	324021
3/4" x 31" x 36"	1	324022
7/8" x 11" x 16"	1	324025
7/8" x 17" x 22"	1	324026
7/8" x 31" x 36"	1	324027
1" x 8" x 13"	1	324028
1" x 11" x 16"	1	324029
1" x 17" x 22"	1	324030
1" x 31" x 36"	1	324031
1 1/8" x 11" x 16"	1	324033
1-1/8" x 17" x 22"	1	324034
1-1/4" x 11" x 16"	1	324035
1-1/4" x 17" x 22"	1	324036
1-1/4" x 31" x 36"	1	324037
1-3/8" x 11" x 16"	1	324038
1-3/8" x 17" x 22"	1	324039
1-1/2" x 11" x 16"	1	324040
1-1/2" x 17" x 22"	1	324041
1-3/4" x 17" x 22"	1	324043
2" x 17" x 22"	1	324044

Description	Pack Qty	Item #
Spline - 4-Cutter - Hang Tag		
5/8" x 5" x 10"	1	324050
5/8" x 11" x 16"	1	324051
5/8" x 17" x 22"	1	324052
5/8" x 24" x 29"	1	324053
5/8" x 31" x 36"	1	324054
11/16" x 11" x 16"	1	324055
3/4" x 11" x 16"	1	324056
3/4" x 5" x 10"	1	324057
3/4" x 17" x 22"	1	324058
3/4" x 24" x 29"	1	324059
3/4" x 31" x 36"	1	324060
7/8" x 11" x 16"	1	324063
7/8" x 17" x 22"	1	324064
1" x 11" x 16"	1	324065
1" x 17" x 22"	1	324066
1" x 31" x 36"	1	324067
1" x 24" x 29"	1	324068
1-1/8" x 11" x 16"	1	324070
1-1/8" x 17" x 22"	1	324071
1-1/4" x 11" x 16"	1	324072
1-1/4" x 17" x 22"	1	324073
1-1/4" x 31" x 36"	1	324074
1-3/8" x 17" x 22"	1	324076
1-1/2" x 17" x 22"	1	324078
1-3/4" x 18" x 23"	1	324080
2" x 18" x 23"	1	324081

MASONRY DRILLING

Masonry Drilling

Core Bits / Masonry Installers



325000

One-Piece HAMMER Core Spline



Description	Pack Qty	Item #
Spline – One Piece Hammer Cores – Tubed		
1-1/2" x 11-3/8"	1	325000
1-1/2" x 22"	1	325001
2" x 11-3/8"	1	325002
2" x 22"	1	325003
2-1/2" x 11-3/8"	1	325004
2-1/2" x 22"	1	325005
3-1/8" x 11-3/8"	1	325006
3-1/8" x 22"	1	325007
3-1/2" x 11-3/8"	1	325008
3-1/2" x 22"	1	325009
4" x 11-3/8"	1	325010
4" x 22"	1	325011
5" x 11-3/8"	1	325012
5" x 22"	1	325013

One-Piece HAMMER Core SDS-Max®

MASONRY DRILLING



325014

325030

325031

Description	Pack Qty	Item #
SDS-Max – One Piece Hammer Cores – Tubed		
1-1/2" x 11-3/8"	1	325014
1-1/2" x 22"	1	325015
2" x 11-3/8"	1	325016
2" x 22"	1	325017
2-1/2" x 11-3/8"	1	325018
2-1/2" x 22"	1	325019
3-1/8" x 11-3/8"	1	325020
3-1/8" x 22"	1	325021
3-1/2" x 11-3/8"	1	325022
3-1/2" x 22"	1	325023
4" x 11-3/8"	1	325024
4" x 22"	1	325025
5" x 22"	1	325026
6" x 22"	1	325027
Ejector Key	1	325030
Center Bit	1	325031



40012

Masonry Installer Bits

- Hole in flute makes it easy to pull wire through walls, ceilings, and floors
- Specially designed flute quickly clears masonry dust
- Heavy duty 118° point enters material quickly
- Carbide tip cutting edge ideal for use where masonry construction is encountered including brick, mortar joints, and cinder blocks

Diameter	Shank Size	Overall Length	Item #
1/4"	.245"	18"	40004ZR
5/16"	.250"	18"	40005
3/8"	.370"	18"	40006
1/2"	.370"	18"	40008
5/8"	.370"	18"	40010
3/4"	.370"	18"	40012

Flat Chisel



332003

- For general chiseling and breaking work in brickwork, concrete and loose stone (ex: when laying cables)

Scaling Chisel



332008

- For removing large quantities of material

Wide Scaling Chisel



332010

- For removing large areas of floor covering and reward sheeting

Scraping Chisel (Angled)



332011

- For easy removal of tiles (with ergonomically angled working end)

Mortar/Seam Tool



332012

- For the removal and cleaning of pointing in brickwork and mortar

Slotting Chisel



332013

- For brickwork repair (ex: removing pointing)

Clay Spade



332014

- For general garden and landscaping (not for use in concrete)

Pointed Spade



332014

- For digging in soil (not for use in concrete)

Asphalt Cutter



332015

- For road building when repairing road surfaces or other road maintenance, (not for use in concrete)

Moil Point



334020

- For general chiseling and breaking work in brickwork, concrete and loose stone (ex: when laying cables)

Gouge



332016

- For cutting narrow channels into concrete

Bush Tool



332017

- For roughing up concrete and asphalt prior to a surface treatment

Ground Rod Driver



332019

- For driving in ground rods (ex: telecommunications)

Tamping Plate



332020

- For compacting soil and gravel

Description	Pack Qty	Item #
SDS-Max® - Demolition Chisel Hammer Bits - Bulk		
Moil Point - 12"	1	332000
Moil Point - 18"	1	332001
Flat Chisel - 1" X 12"	1	332003
Flat Chisel - 1" X 18"	1	332004
Scaling Chisel - 1-1/2" X 12"	1	332006
Scaling Chisel - 2" X 12"	1	332008
Scaling Chisel, 3" X 12"	1	332010
Scraping Chisel - 2" X 12", Angled	1	332011
Mortar/Seam Tool - 1-1/8" X 12"	1	332012
Slotting Chisel - 1-3/8" X 12"	1	332013
Clay Spade - 4" X 16"	1	332014
Asphalt Cutter - 4-3/8" X 16"	1	332015
Gouge - 1" X 12"	1	332016
Bush Tool, 1 Pc - 1-3/4" X 9-1/2"	1	332017
Ground Rod Driver - 5/8"-3/4" X 10-1/4"	1	332019
5" x 5" Tamping Plate SDS-max®	1	332020
12" Tamping Plate SDS-max®	1	332021

Description	Pack Qty	Item #
SDS-Plus® - Demolition Chisel - Hang Tag		
Moil Point - 10"	1	331000
Flat Chisel - 3/4" X 10"	1	331001
Scaling Chisel - 1-5/8" X 10"	1	331002
5/32" x 4" x 7" Hex	1	322061
Spline - Demolition Chisel Hammer Bits - Bulk		
Moil Point - 12"	1	333000
Moil Point - 18"	1	333001
Flat Chisel - 1" x 12"	1	333003
Flat Chisel - 1" x 18"	1	333004
Scaling Chisel - 1-1/2" x 12"	1	333006
Scaling Chisel - 2" x 12"	1	333008
Scaling Chisel - 3" x 12"	1	333010
Scraping Chisel - 2" x 12", Angled	1	333011
Slotting Chisel - 1-3/8" x 12"	1	333012
Pointed Spade - 5-3/8" x 16"	1	333014
Asphalt Cutter - 4-3/8" x 16"	1	333015
Gouge - 1" x 12"	1	333016
Bush Tool, 1 pc. - 1-3/4" x 9-1/4"	1	333017
Ground Rod Driver - 5/8"-3/4" x 10-1/4"	1	333019
5" x 5" Tamping Plate Spline	1	333020
12" Tamping Plate Spline	1	333021

Masonry & Specialty Drilling

Rotary Percussion / Glass & Tile / Rotary / Multi-Material

Rotary Percussion Drill Bits



- Aggressive diamond-ground tip for fast drilling. Optimal flute design for dust removal.

Description	Pack Qty	Item #
Rotary Percussion - Tubed		
1/8" x 1-1/2" x 3"	1	326000
5/32" x 4" x 6"	1	326001
3/16" x 2" x 3-1/2"	1	326002
3/16" x 4-1/2" x 6"	1	326003
1/4" x 2" x 4"	1	326005
1/4" x 4" x 6"	1	326006
1/4" x 8" x 12"	1	326007
5/16" x 2-1/2" x 4-3/4"	1	326008
5/16" x 4" x 6"	1	326009
5/16" x 8" x 12"	1	326010
3/8" x 4" x 6"	1	326011
3/8" x 8" x 12"	1	326012
3/8" x 16" x 20"	1	326013
7/16" x 4" x 6"	1	326014
1/2" x 4" x 6"	1	326015
1/2" x 8" x 12"	1	326016
1/2" x 20" x 24"	1	326017
5/8" x 3" x 6" (1/2" Shank)	1	326019
5/8" x 8" x 12" (1/2" Shank)	1	326020
5/8" x 20" x 24" (1/2" Shank)	1	326021
3/4" x 3" x 6" (1/2" Shank)	1	326022
3/4" x 8" x 12" (1/2" Shank)	1	326023
7/8" x 3" x 6" (1/2" Shank)	1	326024
7/8" x 8" x 12" (1/2" Shank)	1	326025
1" x 3" x 6" (1/2" Shank)	1	326026
1" x 8" x 12" (1/2" Shank)	1	326027

Description	Pack Qty	Item #
Rotary Percussion Sets		
5 Pc. Hammer Drill Set Contains One Each: 5/32"x6", 3/16"x6", 1/4"x6", 3/8"x6", and 1/2"x6"	6	4935076
Rotary Percussion Bulk		
1/8" x 1-1/2" x 3"	25	326000B25
3/16" x 2" x 3-1/2"	25	326002B25
3/16" x 4-1/2" x 6"	25	326003B25
1/4" x 2" x 4"	25	326005B25
1/4" x 4" x 6"	25	326006B25
5/16" x 2-1/2" x 4-3/4"	25	326008B25
5/16" x 4" x 6"	25	326009B25
3/8" x 4" x 6"	25	326011B25
1/2" x 4" x 6"	25	326015B25

Rotary Drill Bits



5026012

Description	Pack Qty	Item #
Rotary Drill Bits - Carded		
1/8" x 3"	5	5026000
5/32" x 3"	5	5026001
3/16" x 4"	5	5026002
1/4" x 4"	5	5026003
1/4" x 13"	3	5026005
5/16" x 4"	5	5026006
5/16" x 13"	3	5026008
3/8" x 4"	5	5026009
3/8" x 13"	3	5026011
7/16" x 6"	5	5026012
7/16" x 13"	3	5026013
1/2" x 6"	5	5026015
1/2" x 13"	3	5026016
5/8" x 6"	5	5026019
5/8" x 13"	3	5026020
3/4" x 6"	5	5026021
3/4" x 13"	3	5026022
1" x 6"	5	5026023
Sets		
5 Pc Set 3/16", 1/4" (2 each), 3/8", 1/2"	1	5026024

Glass and Tile Masonry Drill Bits



50520

Description	Pack Qty	Item #
Glass and Tile Masonry Drill Bits - Carded		
1/8"	5	50508
3/16"	5	50512
1/4"	5	50516
5/16"	5	50520
3/8"	5	50524
1/2"	5	

IRWIN® Multi-Material Bits



- Designed to drill in multiple materials including brick, block, tile, metal, wood, plastic and marble



Description	Pack Qty	Item #
Multi-Material Bit		
1/8" x 3"	1	4935105
5/32" x 3-1/2"	1	4935106
3/16" x 3-3/4"	1	4935107
1/4" x 4"	1	4935108
5/16" x 4-3/4"	1	4935109
Sets		
5 Pc. Multi Material Set Contains One Each: 1/8" x 3", 5/32" x 3-1/2", 3/16" x 3-3/4", 1/4" x 4" and 5/16" x 4-3/4"	6	4935078

IRWIN®

Metal Drilling



www.irwin.com

Engineered for Controlled Precision and Speed

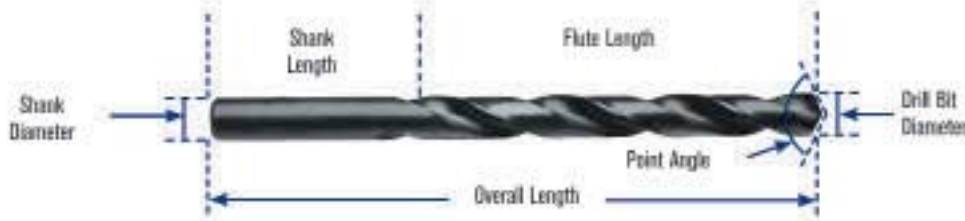

Overall Length: The length from the point to the end of the drill bit

Point Angle: The angle of the cutting edges

Drill Diameter: The cutting diameter of the drill bit

Shank Length: The end of the drill bit that is secured by the drill

Flute Length: The length from the point to the end of the flutes

Tip Geometry

METAL DRILLING

118° Conventional Point

- General use
- Not self-centering
- For stationary drills
- Performs better in softer materials than hard metal

118° Point Angle

135° Split Point

- Self-centering (won't "walk")
- For portable drills
- Requires less force than 118°

135° Point Angle

TURBOMAX® Tip

- Self-centering (won't "walk")
- Precision-ground to stay sharp longer and drill faster
- For portable drills
- Requires less force than 118°

Drill Bit Selection

Material	Point Angle	Black & Gold	TURBOMAX®	Heavy-Duty	Titanium Nitride (TiN) Coated	Cobalt	General Purpose
		(118°)	(TURBOMAX)	(135°)	(118°)	(135°)	(118°)
Wood/Drywall		●	●	●	●	●	●
Sheet Metal		●	●	●	●	●	●
Mild Steel		●	●	●	●	●	●
High Alloy Steels		●	●	●	●	●	●
Stainless Steel		●	●	●	●	●	●
Cast Iron		●	●	●	●	●	●
Aluminum, Brass & Copper		●	●	●	●	●	●
Plastic		●	●	●	●	●	●

Key: ● Recommended ● Acceptable ● Not Recommended

Cutting Speeds (by Working Material)

Speeds for High Speed Steel Drills

	SFM*
Aluminum and its Alloys	200 - 300
Brass and Bronze (Ordinary)	150 - 300
Bronze (High Tensile)	70 - 150
Die Castings (Zinc Base)	300 - 400
Iron-Cast (Soft)	100 - 150
Cast (Medium hard)	70 - 100
Hard Chilled	30 - 40
Malleable	80 - 90
Magnesium and its Alloys	250 - 400
Monel Metal or High-Nickel Steel	30 - 50
Plastics or Similar Materials (Bakelite)	100 - 300
Steel - Mild (.2 carbon to .3 carbon)	80 - 110
Steel (.4 carbon to .5 carbon)	70 - 80
Tool (1.2 carbon)	50 - 60
Forgings	40 - 50
Alloy - 300 to 400 Brinell	20 - 30
High Tensile (Heat-Treated)	
35 to 40 Rockwell C	30 - 40
40 to 45 Rockwell C	25 - 35
45 to 50 Rockwell C	15 - 25
50 to 55 Rockwell C	7 - 15
Stainless Steel	
Free Machining Grades	30 - 80
Work Hardening Grades	15 - 50
Wood	300 - 400

*Surface Feet per Minute (SFM)

$$\text{RPM} = \frac{\text{SFM} \times 3.82}{\text{Drill Diameter}}$$

TURBOMAX® Titanium HSS Fractional Jobber Length Drill Bits (Series 3015)



3015012

- Titanium Nitride coating for 6X longer life
- TURBOMAX tip for burr-free holes. Exact centering / no walking on straight and curved surfaces
- Reinforced web for added strength and durability
- 3-flatted shank on 3/16" and above for better chuck grip

Sets:

Pro Set Cases: 3018008, 3018009, 3018010, 3018011

Speeds and Feeds for Deep-Hole Drilling

Holes that qualify as "deep-hole drilling" are three or more drill bit diameters deep. When drilling this deep, the speed and feed rate must be adjusted to reduce friction. Friction creates heat, and heat build-up in the drill bit can cause failure and breakage. Lubricants help dissipate heat from the tip of the drill bit, prolonging drill life, and should always be used when deep-hole drilling.

Another technique that should be used when deep-hole drilling is "pecking". Pecking is the process whereby the user drills a short distance, then backs the drill out of the hole before progressing. Pecking lessens the possibility of chips getting lodged in the flute, and allows for the reintroduction of lubricant into the hole.

Speed and Feed Reduction (Based upon the hole depth)

Hole Depth to Dia. (times drill dia.)	Speed Reduction	Feed Reduction
3	10%	10%
4	20%	10%
5	30%	20%
6	35 - 40%	20%

Feed Per Drill Revolution

Drill Dia. Range	Light	Medium	Heavy
1/16" to 1/8"	.0005 - .0010	.0010 - .0020	.0020 - .0040
1/8" to 1/4"	.0010 - .0030	.0030 - .0050	.0040 - .0050
1/4" to 3/8"	.0030 - .0050	.0050 - .0070	.0060 - .0100
3/8" to 1/2"	.0040 - .0060	.0050 - .0080	.0080 - .0120
1/2" to 3/4"	.0050 - .0070	.0070 - .0100	.0090 - .0140
3/4" to 1"	.0070 - .0100	.0090 - .0140	.0140 - .0200

See pages 144-145 for Tap & Drill Selection Chart

Size	Decimal Equiv.	Flute Length	Overall Length	Carded Item #	Bulk Item #
1/16"	.0625	7/8"	1-7/8"	3015004*	-
5/64"	.0781	1"	2"	3015005*	-
3/32"	.0938	1-1/8"	2-1/4"	3015006*	-
7/64"	.1094	1-1/2"	2-5/8"	3015007*	-
1/8"	.1250	1-5/8"	2-3/4"	3015008	-
9/64"	.1406	1-3/4"	2-7/8"	3015009	-
5/32"	.1563	2"	3-1/8"	3015010	-
11/64"	.1719	2-1/8"	3-1/4"	3015011	-
3/16"	.1875	2-5/16"	3-1/2"	3015012	-
13/64"	.2031	2-7/16"	3-5/8"	3015013	-
7/32"	.2188	2-1/2"	3-3/4"	3015014	-
15/64"	.2344	2-5/8"	3-7/8"	3015015	-
1/4"	.2500	2-3/4"	4"	3015016	-
17/64"	.2656	2-7/8"	4-1/8"	3015017	-
9/32"	.2813	2-15/16"	4-1/4"	3015018	-
19/64"	.2969	3-1/16"	4-3/8"	3015019	-
5/16"	.3125	3-3/16"	4-1/2"	3015020	-
21/64"	.3281	3-5/16"	4-5/8"	3015021	-
11/32"	.3438	3-7/16"	4-3/4"	3015022	-
23/64"	.3594	3-1/2"	4-7/8"	3015023	-
3/8"	.3750	3-5/8"	5"	3015024	-
25/64"***	.3906	3-3/4"	5-1/8"	3015025	-
13/32"***	.4063	3-7/8"	5-1/4"	3015026	-
27/64"***	.4219	3-15/16"	5-3/8"	3015027	-
7/16"***	.4375	4-1/16"	5-1/2"	3015028	-
29/64"***	.4531	4-3/16"	5-5/8"	3015029	-
15/32"***	.4688	4-5/16"	5-3/4"	3015030	-
31/64"***	.4844	4-3/8"	5-7/8"	3015031	-
1/2"***	.5000	4-1/2"	6"	3015032	-

*Note: 2 bits per Card

**Note: 3/8" reduced shank

Metal Drilling

Jobber Length Drill Bits

TURBOMAX® HSS Fractional Straight Shank Jobber Length Drill Bits (Series 733/731)



73124

- High speed steel features a black body and gold flute
- TURBOMAX tip for burr-free holes. Exact centering / no walking on straight and curved surfaces
- 3-flatted shank on 3/16" and above for better chuck grip

Sets:

Metal Index: 73136, 73137, 73138, 73149

Pro Set Cases: 318015, 318018

Size	Decimal Equiv.	Flute Length	Overall Length	Carded Item #	Bulk Item #
1/16"	.0625	7/8"	1-7/8"	73304*	73104
5/64"	.0781	1"	2"	73305*	73105ZR
3/32"	.0938	1-1/8"	2-1/4"	73306*	73106ZR
7/64"	.1094	1-1/2"	2-5/8"	73307*	73107
1/8"	.1250	1-5/8"	2-3/4"	73308*	73108
9/64"	.1406	1-3/4"	2-7/8"	73309	73109
5/32"	.1563	2"	3-1/8"	73310	73110
11/64"	.1719	2-1/8"	3-1/4"	73311	73111
3/16"	.1875	2-5/16"	3-1/2"	73312	73112
13/64"	.2031	2-7/16"	3-5/8"	73313	73113
7/32"	.2188	2-1/2"	3-3/4"	73314	73114
15/64"	.2344	2-5/8"	3-7/8"	73315	73115
1/4"	.2500	2-3/4"	4"	73316	73116
17/64"	.2656	2-7/8"	4-1/8"	73317	73117
9/32"	.2813	2-15/16"	4-1/4"	73318ZR	73118
19/64"	.2969	3-1/16"	4-3/8"	73319	73119
5/16"	.3125	3-3/16"	4-1/2"	73320	73120
21/64"	.3281	3-5/16"	4-5/8"	73321	73121
11/32"	.3438	3-7/16"	4-3/4"	73322	73122
23/64"	.3594	3-1/2"	4-7/8"	73323	73123
3/8"	.3750	3-5/8"	5"	73324	73124
25/64"	.3906	3-3/4"	5-1/8"	73325	73125
13/32"	.4063	3-7/8"	5-1/4"	73326	73126
27/64"	.4219	3-15/16"	5-3/8"	73327	73127
7/16"	.4375	4-1/16"	5-1/2"	73328	73128
29/64"	.4531	4-3/16"	5-5/8"	73329	73129
15/32"	.4688	4-5/16"	5-3/4"	73330	73130
31/64"	.4844	4-3/8"	5-7/8"	73331	73131
1/2"	.5000	4-1/2"	6"	73332	73132

*Note: 2 bits per Card

METAL DRILLING

TURBOMAX® HSS 3/8" Reduced Shank Jobber Length Drill Bits (Series 736/734)



73432

- Standard TURBOMAX bit with 3/8" reduced shanks

Sets:

Metal Index: 3018006B

Size	Decimal Equiv.	Flute Length	Overall Length	Carded Item #	Bulk Item #
25/64"	.3906	3-3/4"	5-1/8"	73625ZR	73425
13/32"	.4063	3-7/8"	5-1/4"	73626	73426
27/64"	.4219	3-15/16"	5-3/8"	73627ZR	73427
7/16"	.4375	4-1/16"	5-1/2"	73628ZR	73428ZR
29/64"	.4531	4-3/16"	5-5/8"	73629ZR	73429ZR
15/32"	.4688	4-5/16"	5-3/4"	73630ZR	73430
31/64"	.4844	4-3/8"	5-7/8"	73631	73431ZR
1/2"	.5000	4-1/2"	6"	73632	73432ZR

Cobalt HSS Fractional Straight Shank Jobber Length Drill Bits 135° Point (Series 3016/631)



63124

- 5% Cobalt for higher heat and abrasion resistance
- Heavy-duty web construction for strength and durability
- 135° split point begins drilling immediately, minimizing bit "walk"

Applications:

Tough metal drilling, including heavy-duty abrasive alloy metal drilling on hardened steel (heat-treated)

Sets:

Pro Set Case: 316015

Metal Index: 63137, 63221, 3018002b (M42 grade)

Cobalt HSS Fractional 3/8" Reduced Shank Jobber Length Drill Bits 135° Point (Series 30160)



3016228

- Standard Cobalt bit with 3/8" reduced shanks

Applications:

Tough metal drilling, including heavy-duty abrasive alloy metal drilling on hardened steel (heat-treated)

Sets:

Pro Set Case: 316015

Metal Index: 3018002 (M35 grade)

Size	Decimal Equiv.	Flute Length	Overall Length	Carded Item #	Bulk Item #
1/16"	.0625	7/8"	1-7/8"	3016004	63104
5/64"	.0781	1"	2"	3016005	63105ZR
3/32"	.0938	1-1/8"	2-1/4"	3016006	63106
7/64"	.1094	1-1/2"	2-5/8"	3016007	63107
1/8"	.1250	1-5/8"	2-3/4"	3016008	63108
9/64"	.1406	1-3/4"	2-7/8"	3016009	63109
5/32"	.1563	2"	3-1/8"	3016010	63110
11/64"	.1719	2-1/8"	3-1/4"	3016011	63111
3/16"	.1875	2-5/16"	3-1/2"	3016012	63112ZR
13/64"	.2031	2-7/16"	3-5/8"	3016013	63113ZR
7/32"	.2188	2-1/2"	3-3/4"	3016014	63114
15/64"	.2344	2-5/8"	3-7/8"	3016015	63115
1/4"	.2500	2-3/4"	4"	3016016	63116
17/64"	.2656	2-7/8"	4-1/8"	3016017	63117
9/32"	.2813	2-15/16"	4-1/4"	3016018	63118
19/64"	.2969	3-1/16"	4-3/8"	3016019	63119
5/16"	.3125	3-3/16"	4-1/2"	3016020	63120
21/64"	.3281	3-5/16"	4-5/8"	3016021	63121
11/32"	.3438	3-7/16"	4-3/4"	3016022	63122
23/64"	.3594	3-1/2"	4-7/8"	3016023	63123
3/8"	.3750	3-5/8"	5"	3016024	63124
25/64"	.3906	3-3/4"	5-1/8"	3016125	63125
13/32"	.4063	3-7/8"	5-1/4"	3016126	63126
27/64"	.4219	3-15/16"	5-3/8"	3016127	63127
7/16"	.4375	4-1/16"	5-1/2"	3016128	63128
29/64"	.4531	4-3/16"	5-5/8"	3016129	63129
15/32"	.4689	4-5/16"	5-3/4"	3016130	63130
31/64"	.4844	4-3/8"	5-7/8"	3016131ZR	63131
1/2"	.5000	4-1/2"	6"	3016132	63132

Size	Decimal Equiv.	Flute Length	Overall Length	Carded Item #	Bulk Item #
25/64"	.3906	7/8"	1-7/8"	3016025	3016225
13/32"	.4063	1"	2"	3016026	3016226
27/64"	.4219	1-1/8"	2-1/4"	3016027	3016227
7/16"	.4375	1-1/2"	2-5/8"	3016028	3016228
29/64"	.4531	1-5/8"	2-3/4"	3016029	3016229
15/32"	.4689	1-3/4"	2-7/8"	3016030	3016230
31/64"	.4844	2"	3-1/8"	3016031ZR	3016231
1/2"	.5000	2-1/8"	3-1/4"	3016032	3016232

Metal Drilling

Jobber Length Drill Bits

Titanium Nitride (TiN) Coated HSS Fractional Straight Shank Jobber Length Drill Bits 135° Split Point (Series 639/637)



63724

- Titanium Nitride coated bits last up to six times longer than standard high speed steel drill bits
- Cutting edge stays sharper longer
- Titanium Nitride coating reduces friction
- Repetitive metal drilling with Portable Drills, Stationary Drill Press

Sets:

Metal Index: 63737, 3018003

*Note: 2 bits per Card

Size	Decimal Equiv.	Flute Length	Overall Length	Carded Item #	Bulk Item #
1/16"	.0625	7/8"	1-7/8"	63904*	63704ZR
5/64"	.0781	1"	2"	63905*	63705ZR
3/32"	.0938	1-1/8"	2-1/4"	63906*	63706ZR
7/64"	.1094	1-1/2"	2-5/8"	63907*	63707ZR
1/8"	.1250	1-5/8"	2-3/4"	63908*	63708
9/64"	.1406	1-3/4"	2-7/8"	63909	63709ZR
5/32"	.1563	2"	3-1/8"	63910	63710
11/64"	.1719	2-1/8"	3-1/4"	63911	63711ZR
3/16"	.1875	2-5/16"	3-1/2"	63912	63712
13/64"	.1563	2-7/16"	3-5/8"	63913	63713ZR
7/32"	.2188	2-1/2"	3-3/4"	63914	63714ZR
15/64"	.2344	2-5/8"	3-7/8"	63915	63715ZR
1/4"	.2500	2-3/4"	4"	63916	63716
17/64"	.2656	2-7/8"	4-1/8"	-	63717
9/32"	.2812	2-15/16"	4-1/4"	63918	63718
19/64"	.2969	3-1/16"	4-3/8"	-	63719
5/16"	.3125	3-3/16"	4-1/2"	63920	63720ZR
21/64"	.3281	3-5/16"	4-5/8"	-	63721ZR
11/32"	.3438	3-7/16"	4-3/4"	63922	63722
23/64"	.3594	3-1/2"	4-7/8"	-	63723
3/8"	.3750	3-5/8"	5"	63924	63724
25/64"	.3906	3-3/4"	5-1/8"	-	63725
13/32"	.4063	3-7/8"	5-1/4"	63926	63726
27/64"	.4219	3-15/16"	5-3/8"	-	63727
7/16"	.4375	4-1/16"	5-1/2"	63928	63728
29/64"	.4531	4-3/16"	5-5/8"	-	63729
15/32"	.4689	4-5/16"	5-3/4"	63930	63730
31/64"	.4844	4-3/8"	5-7/8"	-	63731ZR
1/2"	.5000	4-1/2"	6"	63932	63732ZR

METAL DRILLING

Black & Gold HSS Fractional Straight Shank Jobber Length Drill Bits 135° Split Point (Series 30190)



3019016B

- High Speed Steel features a black shank and gold flute
- Heavy-duty web construction for strength and durability
- 135° split point begins drilling immediately, minimizing bit "walk"
- 3-flatted shank on 3/16" and above for better chuck grip

Size	Decimal Equiv.	Flute Length	Overall Length	Carded Item #	Bulk Item #
3/64"	.0469	3/4"	1-3/4"	-	3019003B
1/16"	.0625	7/8"	1-7/8"	-	3019004B
5/64"	.0781	1"	2"	-	3019005B
3/32"	.0938	1-1/8"	2-1/4"	-	3019006B
7/64"	.1094	1-1/2"	2-5/8"	-	3019007B
1/8"	.1250	1-5/8"	2-3/4"	-	3019008B
9/64"	.1406	1-3/4"	2-7/8"	-	3019009B
5/32"	.1563	2"	3-1/8"	-	3019010B
11/64"	.1719	2-1/8"	3-1/4"	-	3019011B
3/16"	.1875	2-5/16"	3-1/2"	-	3019012B
13/64"	.2031	2-7/16"	3-5/8"	-	3019013B
7/32"	.2188	2-1/2"	3-3/4"	-	3019014B
15/64"	.2344	2-5/8"	3-7/8"	-	3019015B
1/4"	.2500	2-3/4"	4"	-	3019016B
17/64"	.2656	2-7/8"	4-1/8"	-	3019017B
9/32"	.2813	2-15/16"	4-1/4"	-	3019018B
19/64"	.2969	3-1/16"	4-3/8"	-	3019019B
5/16"	.3125	3-3/16"	4-1/2"	-	3019020B
21/64"	.3281	3-5/16"	4-5/8"	-	3019021B
11/32"	.3438	3-7/16"	4-3/4"	-	3019022B
23/64"	.3594	3-1/2"	4-7/8"	-	3019023B
3/8"	.3750	3-5/8"	5"	-	3019024B
25/64"	.3906	3-3/4"	5-1/8"	-	3019025B
13/32"	.4063	3-7/8"	5-1/4"	-	3019026B
27/64"	.4219	3-15/16"	5-3/8"	-	3019027B
7/16"	.4375	4-1/16"	5-1/2"	-	3019028B
29/64"	.4531	4-3/16"	5-5/8"	-	3019029B
15/32"	.4688	4-5/16"	5-3/4"	-	3019030B
31/64"	.4844	4-3/8"	5-7/8"	-	3019031B
1/2"	.5000	4-1/2"	6"	-	3019032B

Black & Gold HSS Fractional 3/8" Reduced Shank Jobber Length Drill Bits 135° Split Point (Series 30191)



3019128B

- Standard Black & Gold bit with 3/8" reduced shanks

Set:

Metal Index: 3018005

Size	Decimal Equiv.	Flute Length	Overall Length	Carded Item #	Bulk Item #
25/64"	.3906	3-3/4"	5-1/8"	-	3019125B
13/32"	.4063	3-7/8"	5-1/4"	-	3019126B
27/64"	.4219	3-15/16"	5-3/8"	-	3019127B
7/16"	.4375	4-1/16"	5-1/2"	-	3019128B
29/64"	.4531	4-3/16"	5-5/8"	-	3019129B
15/32"	.4688	4-5/16"	5-3/4"	-	3019130B
31/64"	.4844	4-3/8"	5-7/8"	-	3019131B
1/2"	.5000	4-1/2"	6"	-	3019132B

Black Oxide HSS Fractional Straight Shank Jobber Length Drill Bits 135° Split Point (Series 675/635)



63524ZR

- Black Oxide finish for corrosion resistance
- Heavy-duty web construction for strength and durability
- 135° split point begins drilling immediately, minimizing bit "walk"

Set:

Pro Set Cases: 314015

Size	Decimal Equiv.	Flute Length	Overall Length	Carded Item #	Bulk Item #
3/64"	.0469	3/4"	1-3/4"	-	63503
1/16"	.0625	7/8"	1-7/8"	67504*	63504
5/64"	.0781	1"	2"	67505*	63505
3/32"	.0938	1-1/8"	2-1/4"	67506*	63506
7/64"	.1094	1-1/2"	2-5/8"	67507*	63507
1/8"	.1250	1-5/8"	2-3/4"	67508*	63508
9/64"	.1406	1-3/4"	2-7/8"	67509	63509
5/32"	.1563	2"	3-1/8"	67510	63510
11/64"	.1719	2-1/8"	3-1/4"	67511	63511
3/16"	.1875	2-5/16"	3-1/2"	67512	63512
13/64"	.2031	2-7/16"	3-5/8"	67513	63513
7/32"	.2188	2-1/2"	3-3/4"	67514	63514
15/64"	.2344	2-5/8"	3-7/8"	67515	63515
1/4"	.2500	2-3/4"	4"	67516	63516
17/64"	.2656	2-7/8"	4-1/8"	67517	63517
9/32"	.2813	2-15/16"	4-1/4"	67518	63518
19/64"	.2969	3-1/16"	4-3/8"	67519	63519
5/16"	.3125	3-3/16"	4-1/2"	67520	63520ZR
21/64"	.3281	3-5/16"	4-5/8"	67521	63521ZR
11/32"	.3438	3-7/16"	4-3/4"	67522	63522ZR
23/64"	.3594	3-1/2"	4-7/8"	67523	63523ZR
3/8"	.3750	3-5/8"	5"	67524	63524ZR
25/64"	.3906	3-3/4"	5-1/8"	67525	63525ZR
13/32"	.4063	3-7/8"	5-1/4"	67526	63526ZR
27/64"	.4219	3-15/16"	5-3/8"	67527	63527ZR
7/16"	.4375	4-1/16"	5-1/2"	67528	63528ZR
29/64"	.4531	4-3/16"	5-5/8"	67529	63529ZR
15/32"	.4688	4-5/16"	5-3/4"	67530	63530
31/64"	.4844	4-3/8"	5-7/8"	67531	63531
1/2"	.5000	4-1/2"	6"	67532	63532

*Note: 2 bits per Card

Black Oxide HSS Fractional 3/8" Reduced Shank Jobber Length Drill Bits 135° Split Point (Series 678/634)



63432

- Standard Black Oxide bit with 3/8" reduced shanks

Sets:

Pro Set Case: 314018

Metal Index: 3018004

Size	Decimal Equiv.	Flute Length	Overall Length	Carded Item #	Bulk Item #
25/64"	.3906	3-3/4"	5-1/8"	67825	63425
13/32"	.4063	3-7/8"	5-1/4"	67826	63426
27/64"	.4219	3-15/16"	5-3/8"	67827	63427
7/16"	.4375	4-1/16"	5-1/2"	67828	63428
29/64"	.4531	4-3/16"	5-5/8"	67829	63429
15/32"	.4688	4-5/16"	5-3/4"	67830	63430
31/64"	.4844	4-3/8"	5-7/8"	67831	63431
1/2"	.5000	4-1/2"	6"	67832	63432

METAL DRILLING

Metal Drilling

Jobber Length Drill Bits

Black Oxide 1/4" Hex Shank Drill Bits



4935636

- 1/4" Hex Shank works in Lock-N-Load Extensions as well as all drill chucks
- Black Oxide coating to reduce corrosion

Applications:

Automotive, MRO, portable drills, stationary drill press

Sets:

5-pc Set: 4935642

12-pc Pro Set: 4935643

Size	Decimal Equiv.	Flute Length	Overall Length	Carded Item #	Bulk Item #
1/16"	0.0625	3/4"	2-5/8"	4935632	-
5/64"	0.0781	1"	2-3/4"	4935633	-
3/32"	0.0938	1-5/16"	3"	4935634	-
7/64"	0.1094	1-1/2"	3-7/16"	4935635	-
1/8"	0.1250	1-5/8"	3-1/2"	4935636	-
9/64"	0.1406	1-7/8"	3-3/16"	4935637	-
5/32"	0.1563	2-1/16"	3-15/16"	4935638	-
3/16"	0.1875	2-3/8"	4-1/4"	4935639	-
7/32"	0.2188	2-5/8"	4-1/2"	4935640	-
1/4"	0.2500	2-7/8"	4-3/4"	4935641	-

Left-Hand Heavy-Duty HSS Fractional Straight Shank Jobber Length Drill Bits (Series 623)



62324

- Black Oxide finish for corrosion resistance
- Heavy-duty web construction for strength and durability
- 135° split point begins drilling immediately, minimizing bit "walk"

Applications:

General metal drilling or creating pilot holes for screw extractors.

Size	Flute Length	Overall Length	Carded Item #	Bulk Item #
1/16"	7/8"	1-7/8"	-	62304
5/64"	1"	2"	-	62305
3/32"	1-1/8"	2-1/4"	-	62306
7/64"	1-1/2"	2-5/8"	-	62307
1/8"	1-5/8"	2-3/4"	-	62308
9/64"	1-3/4"	2-7/8"	-	62309ZR
5/32"	2"	3-1/8"	-	62310
11/64"	2-1/8"	3-1/4"	-	62311
3/16"	2-5/16"	3-1/2"	-	62312
13/64"	2-7/16"	3-5/8"	-	62313
7/32"	2-1/2"	3-3/4"	-	62314
15/64"	2-5/8"	3-7/8"	-	62315
1/4"	2-3/4"	4"	-	62316
17/64"	2-7/8"	4-1/8"	-	62317
9/32"	2-15/16"	4-1/4"	-	62318
19/64"	3-1/16"	4-3/8"	-	62319
5/16"	3-3/16"	4-1/2"	-	62320
21/64"	3-5/16"	4-5/8"	-	62321
11/32"	3-7/16"	4-3/4"	-	62322
23/64"	3-1/2"	4-7/8"	-	62323
3/8"	3-5/8"	5"	-	62324
25/64"	3-3/4"	5-1/8"	-	62325
13/32"	3-7/8"	5-1/4"	-	62326
27/64"	3-15/16"	5-3/8"	-	62327
7/16"	4-1/16"	5-1/2"	-	62328
29/64"	4-3/16"	5-5/8"	-	62329
15/32"	4-5/16"	5-3/4"	-	62330
31/64"	4-3/8"	5-7/8"	-	62331
1/2"	4-1/2"	6"	-	62332

Black Oxide HSS Metric Straight Shank Jobber Length Drill Bits (Series 681)



68950

- Black Oxide finish for corrosion resistance
- Economical High Speed Steel for general drilling
- Recommended for use in mild steel, wood, and plastic

Applications:

Automotive, MRO, portable drills, stationary drill press

Size	Decimal Equiv.	Flute Length	Overall Length	Carded Item #	Bulk Item #
1.00 mm	0.0394	11/16"	1-5/8"	-	68100
1.50 mm	0.0591	7/8"	1-7/8"	-	68150
2.00 mm	0.0787	1"	2"	-	68200
2.50 mm	0.0984	1-3/8"	2-3/8"	-	68250ZR
3.00 mm	0.1181	1-5/8"	2-3/4"	-	68300
3.50 mm	0.1378	1-3/4"	2-7/8"	-	68350
4.00 mm	0.1575	2-1/8"	3-1/4"	-	68400
4.50 mm	0.1772	2-3/16"	3-3/8"	-	68450
5.00 mm	0.1969	2-7/16"	3-5/8"	-	68500
5.50 mm	0.2165	2-1/2"	3-3/4"	-	68550ZR
6.00 mm	0.2362	2-3/4"	4"	-	68600
6.50 mm	0.2559	2-7/8"	4-1/8"	-	68650
7.00 mm	0.2756	2-7/8"	4-1/8"	-	68700
7.50 mm	0.2953	3-1/16"	4-3/8"	-	68750
8.00 mm	0.3150	3-3/16"	4-1/2"	-	68800
8.50 mm	0.3346	3-7/16"	4-3/4"	-	68850
9.00 mm	0.3543	3-1/2"	4-7/8"	-	68900
9.50 mm	0.3740	3-5/8"	5"	-	68950
10.00 mm	0.3937	3-3/4"	5-1/8"	-	69010
10.50 mm	0.4134	3-7/8"	5-1/4"	-	69015
11.00 mm	0.4331	4-1/16"	5-1/2"	-	69110ZR
11.50 mm	0.4528	4-3/16"	5-5/8"	-	69115ZR
12.00 mm	0.4724	4-3/8"	5-7/8"	-	69120ZR
12.50 mm	0.4921	4-1/2"	6"	-	69125ZR
13.00 mm	0.5118	4-1/2"	6"	-	69130ZR

General Purpose HSS Fractional Straight Shank Jobber Length Drill Bits 118° Point (Series 605/601)



60124

- Recommended for use in metal, wood & plastic
- 118° conventional point, bright finish

Applications:

Automotive, MRO, stationary drill press

Sets:

Metal Index: 60136, 60137, 60138, 60221

Size	Decimal Equiv.	Flute Length	Overall Length	Carded Item #	Bulk Item #
1/64"	.0156	3/16"	3/4"	-	60101ZR
1/32"	.0313	1/2"	1-3/8"	-	60102ZR
3/64"	.0469	3/4"	1-3/4"	-	60103ZR
1/16"	.0625	7/8"	1-7/8"	60504*	60104ZR
5/64"	.0781	1"	2"	60505*	60105
3/32"	.0938	1-1/8"	2-1/4"	60506*	60106ZR
7/64"	.1094	1-1/2"	2-5/8"	60507*	60107
1/8"	.1250	1-5/8"	2-3/4"	60508*	60108ZR
9/64"	.1406	1-3/4"	2-7/8"	60509	60109
5/32"	.1563	2"	3-1/8"	60510ZR	60110
11/64"	.1719	2-1/8"	3-1/4"	60511	60111
3/16"	.1875	2-5/16"	3-1/2"	60512	60112
13/64"	.2031	2-7/16"	3-5/8"	60513	60113
7/32"	.2188	2-1/2"	3-3/4"	60514	60114
15/64"	.2344	2-5/8"	3-7/8"	60515	60115ZR
1/4"	.2500	2-3/4"	4"	60516	60116
17/64"	.2656	2-7/8"	4-1/8"	60517	60117ZR
9/32"	.2813	2-15/16"	4-1/4"	60518	60118
19/64"	.2969	3-1/16"	4-3/8"	60519	60119
5/16"	.3125	3-3/16"	4-1/2"	60520	60120
21/64"	.3281	3-5/16"	4-5/8"	60521	60121
11/32"	.3438	3-7/16"	4-3/4"	60522	60122
23/64"	.3594	3-1/2"	4-7/8"	60523	60123
3/8"	.3750	3-5/8"	5"	60524	60124
25/64"	.3906	3-3/4"	5-1/8"	60525	60125
13/32"	.4063	3-7/8"	5-1/4"	60526	60126ZR
27/64"	.4219	3-15/16"	5-3/8"	60527	60127
7/16"	.4375	4-1/16"	5-1/2"	60528	60128
29/64"	.4531	4-3/16"	5-5/8"	60529	60129
15/32"	.4688	4-5/16"	5-3/4"	60530	60130
31/64"	.4844	4-3/8"	5-7/8"	60531	60131
1/2"	.5000	4-1/2"	6"	60532	60132

*Note: 2 bits per Card

Metal Drilling

Jobber Length Drill Bits

General Purpose HSS Fractional 3/8" Reduced Shank Jobber Length Drill Bits 118° Point (Series 738/718)



71832

- Standard general purpose bit with 3/8" reduced shanks

Applications:

Automotive, MRO, stationary drill press

Sets:

Metal Index: 60147, 60148

Size	Decimal Equiv.	Flute Length	Overall Length	Carded Item #	Bulk Item #
25/64"	.3906	3-3/4"	5-1/8"	73825	71825
13/32"	.4063	3-7/8"	5-1/4"	73826	71826
27/64"	.4219	3-15/16"	5-3/8"	73827	71827
7/16"	.4375	4-1/16"	5-1/2"	73828	71828
29/64"	.4531	4-3/16"	5-5/8"	73829	71829
15/32"	.4688	4-5/16"	5-3/4"	73830	71830
31/64"	.4844	4-3/8"	5-7/8"	73831	71831
1/2"	.5000	4-1/2"	6"	73832ZR	71832

General Purpose HSS Letter Size Straight Shank Jobber Length Drill Bits (Series 401)



40101ZR

- Lettered from A to Z (small to large)
- Used where more precisely-sized holes are required in larger sizes than number drills
- Drills exact size holes for tapping

Applications:

Automotive, MRO, portable drills, stationary drill press

Size	Decimal Equiv.	Flute Length	Overall Length	Carded Item #	Bulk Item #
Letter A	0.2340	2-5/8"	3-7/8"	-	40101ZR
Letter B	0.2380	2-3/4"	4"	-	40102
Letter C	0.2420	2-3/4"	4"	-	40103ZR
Letter D	0.2460	2-3/4"	4"	-	40104ZR
Letter E	0.2500	2-3/4"	4"	-	40105
Letter F	0.2570	2-7/8"	4-1/8"	-	40106
Letter G	0.2610	2-7/8"	4-1/8"	-	40107
Letter H	0.2660	2-7/8"	4-1/8"	-	40108ZR
Letter I	0.2720	2-7/8"	4-1/8"	-	40109ZR
Letter J	0.2770	2-7/8"	4-1/8"	-	40110ZR
Letter K	0.2810	2-15/16"	4-1/4"	-	40111ZR
Letter L	0.2900	2-15/16"	4-1/4"	-	40112
Letter M	0.2950	3-1/16"	4-3/8"	-	40113
Letter N	0.3020	3-1/16"	4-3/8"	-	40114
Letter O	0.3160	3-3/16"	4-1/2"	-	40115
Letter P	0.3230	3-5/16"	4-5/8"	-	40116
Letter Q	0.3320	3-7/16"	4-3/4"	-	40117
Letter R	0.3390	3-7/16"	4-3/4"	-	40118
Letter S	0.3480	3-1/2"	4-7/8"	-	40119ZR
Letter T	0.3580	3-1/2"	4-7/8"	-	40120
Letter U	0.3680	3-5/8"	5"	-	40121
Letter V	0.3770	3-5/8"	5"	-	40122
Letter W	0.3860	3-3/4"	5-1/8"	-	40123
Letter X	0.3970	3-3/4"	5-1/8"	-	40124
Letter Y	0.4040	3-7/8"	5-1/4"	-	40125
Letter Z	0.4130	3-7/8"	5-1/4"	-	40126

General Purpose HSS Wire Gauge Straight Shank Jobber Length Drill Bits (Series 811)



80128

- Numbered from 1 to 60 (large to small)
- Drills exact size hole for tapping
- Use where non-fractional-sized holes are required

Applications: Automotive, MRO, portable drills, stationary drill press

Sets:

Metal Index: 80181, 80183

Size	Decimal Equiv.	Flute Length	Overall Length	Carded Item #	Bulk Item #	Size	Decimal Equiv.	Flute Length	Overall Length	Carded Item #	Bulk Item #
No. 1	.2280	2-5/8"	3-7/8"	81101	80101	No. 41	.0960	1-3/8"	2-3/8"	81141	80141
No. 2	.2210	2-5/8"	3-7/8"	81102	80102ZR	No. 42	.0935	1-1/8"	2-1/4"	81142	80142
No. 3	.2130	2-1/2"	3-3/4"	81103	80103ZR	No. 43	.0890	1-1/8"	2-1/4"	81143	80143
No. 4	.2090	2-1/2"	3-3/4"	81104	80104	No. 44	.0860	1-1/8"	2-1/8"	81144	80144
No. 5	.2055	2-1/2"	3-3/4"	81105	80105	No. 45	.0820	1-1/8"	2-1/8"	81145	80145
No. 6	.2040	2-1/2"	3-3/4"	81106	80106	No. 46	.0810	1-1/8"	2-1/8"	81146	80146
No. 7	.2010	2-7/16"	3-5/8"	81107	80107	No. 47	.0785	1"	2"	81147	80147
No. 8	.1990	2-7/16"	3-5/8"	81108	80108	No. 48	.0760	1"	2"	81148	80148
No. 9	.1960	2-7/16"	3-5/8"	81109	80109	No. 49	.0730	1"	2"	81149	80149
No. 10	.1935	2-7/16"	3-5/8"	81110ZR	80110	No. 50	.0700	1"	2"	81150	80150
No. 11	.1910	2-5/16"	3-1/2"	81111	80111	No. 51	.0670	1"	2"	81151	80151
No. 12	.1890	2-5/16"	3-1/2"	81112	80112	No. 52	.0635	7/8"	1-7/8"	81152	80152ZR
No. 13	.1850	2-5/16"	3-1/2"	81113	80113	No. 53	.0595	7/8"	1-7/8"	81153ZR	80153
No. 14	.1820	2-3/16"	3-3/8"	81114	80114	No. 54	.0550	7/8"	1-7/8"	81154	80154
No. 15	.1800	2-3/16"	3-3/8"	81115	80115	No. 55	.0520	7/8"	1-7/8"	81155	80155
No. 16	.1770	2-3/16"	3-3/8"	81116	80116	No. 56	.0465	3/4"	1-3/4"	81156	80156
No. 17	.1730	2-3/16"	3-3/8"	81117	80117	No. 57	.0430	3/4"	1-3/4"	81157ZR	80157
No. 18	.1695	2-1/8"	3-1/4"	81118	80118	No. 58	.0420	11/16"	1-5/8"	81158	80158
No. 19	.1660	2-1/8"	3-1/4"	81119	80119	No. 59	.0410	11/16"	1-5/8"	81159ZR	80159
No. 20	.1610	2-1/8"	3-1/4"	81120ZR	80120	No. 60	.0400	11/16"	1-5/8"	81160	80160
No. 21	.1590	2-1/8"	3-1/4"	81121	80121	No. 61	.0390	11/16"	1-5/8"	-	80161
No. 22	.1570	2"	3-1/8"	81122ZR	80122	No. 62	.0380	5/8"	1-1/2"	-	80162
No. 23	.1540	2"	3-1/8"	81123ZR	80123	No. 63	.0370	5/8"	1-1/2"	-	80163
No. 24	.1520	2"	3-1/8"	81124ZR	80124	No. 64	.0360	5/8"	1-1/2"	-	80164
No. 25	.1495	1-7/8"	3"	81125	80125ZR	No. 65	.0350	5/8"	1-1/2"	-	80165
No. 26	.1470	1-7/8"	3"	81126	80126	No. 66	.0330	1/2"	1-3/8"	-	80166
No. 27	.1440	1-7/8"	3"	81127ZR	80127	No. 67	.0320	1/2"	1-3/8"	-	80167
No. 28	.1405	1-3/4"	2-7/8"	81128ZR	80128	No. 68	.0310	1/2"	1-3/8"	-	80168
No. 29	.1260	1-3/4"	2-7/8"	81129	80129	No. 69	.0292	1/2"	1-3/8"	-	80169
No. 30	.1285	1-5/8"	2-3/4"	81130ZR	80130	No. 70	.0280	3/8"	1-1/4"	-	80170
No. 31	.1200	1-5/8"	2-3/4"	81131	80131	No. 71	.0260	3/8"	1-1/4"	-	80171
No. 32	.1160	1-5/8"	2-3/4"	81132	80132	No. 72	.0250	5/16"	1-1/8"	-	80172
No. 33	.1130	1-1/2"	2-5/8"	81133	80133	No. 73	.0240	5/16"	1-1/8"	-	80173
No. 34	.1110	1-1/2"	2-5/8"	81134	80134	No. 74	.0225	1/4"	1"	-	80174ZR
No. 35	.1100	1-1/2"	2-5/8"	81135	80135	No. 75	.0210	1/4"	1"	-	80175
No. 36	.1065	1-7/16"	2-1/2"	81136	80136	No. 76	.0200	3/16"	7/8"	-	80176
No. 37	.1040	1-7/16"	2-1/2"	81137	80137	No. 77	.0180	3/16"	7/8"	-	80177
No. 38	.1015	1-7/16"	2-1/2"	81138	80138	No. 78	.0160	3/16"	7/8"	-	80178
No. 39	.0995	1-3/8"	2-3/8"	81139	80139	No. 79	.0145	1/8"	3/4"	-	80179
No. 40	.0980	1-3/8"	2-3/8"	81140	80140	No. 80	.0135	1/8"	3/4"	-	80180

METAL DRILLING

Metal Drilling

Mechanics Length / Screw Machine Length Drill Bits

Left-Hand Cobalt HSS Fractional Mechanics Length Drill Bits 135° Split Point (Series 305)



30524

- 8% Cobalt alloyed for higher heat and abrasion resistance
- Shorter drill for additional strength
- Heavy-duty web construction for strength and durability
- Drill into fasteners without tightening them
- Can often remove broken fasteners without an extractor

Sets:

5-Piece Set: 30520

Size	Decimal Equiv.	Flute Length	Overall Length	Carded Item #	Bulk Item #
5/64"	.0781	1"	2"	-	30505ZR
7/64"	.1094	1"	2-3/16"	-	30507
1/8"	.1250	1-1/16"	2-1/4"	-	30508
5/32"	.1563	1-1/4"	2-9/16"	-	30510
3/16"	.1875	1-1/2"	2-7/8"	-	30512ZR
7/32"	.2188	1-5/8"	3-1/8"	-	30514
1/4"	.2500	1-3/4"	3-5/16"	-	30516
9/32"	.2812	2"	3-9/16"	-	30518ZR
19/64"	.2969	2-1/16"	3-5/8"	-	30519
5/16"	.3125	2-1/8"	3-3/4"	-	31520
11/32"	.3438	2-1/4"	3-15/16"	-	30522
3/8"	.3750	2-3/8"	4-1/8"	-	30524
13/32"	.4062	2-1/2"	4-3/8"	-	30526ZR
7/16"	.4375	2-5/8"	4-9/16"	-	30528
15/32"	.4688	2-3/4"	4-3/4"	-	30530
1/2"	.5000	2-7/8"	5"	-	30532

HSS Fractional Screw Machine Length Drill Bits (Series 301)



30132

- Black Oxide finish for corrosion resistance
- Shorter length for increased strength and rigidity
- Also known as "stubbies"

Applications:

Industrial applications, MRO, automotive, machine shop

Size	Decimal Equiv.	Flute Length	Overall Length	Carded Item #	Bulk Item #
1/16"	.0625	5/8"	1-5/8"	-	30104
5/64"	.0781	11/16"	1-11/16"	-	30105
3/32"	.0938	3/4"	1-3/4"	-	30106
7/64"	.1094	13/16"	1-13/16"	-	30107
1/8"	.1250	7/8"	1-7/8"	-	30108
9/64"	.1406	15/16"	1-15/16"	-	30109
5/32"	.1562	1"	2-1/16"	-	30110
11/64"	.1719	1-1/16"	2-1/8"	-	30111
3/16"	.1875	1-1/8"	2-3/16"	-	30112ZR
13/64"	.2031	1-3/16"	2-1/4"	-	30113
7/32"	.2188	1-1/4"	2-3/8"	-	30114
15/64"	.2344	1-5/16"	2-7/16"	-	30115
1/4"	.2500	1-3/8"	2-1/2"	-	30116
17/64"	.2656	1-7/16"	2-5/8"	-	30117
9/32"	.2813	1-1/2"	2-11/16"	-	30118
19/64"	.2969	1-9/16"	2-3/4"	-	30119
5/16"	.3125	1-5/8"	2-13/16"	-	30120
21/64"	.3281	1-11/16"	2-15/16"	-	30121
11/32"	.3438	1-11/16"	3"	-	30122ZR
23/64"	.3594	1-3/4"	3-1/16"	-	30123
3/8"	.3750	1-13/16"	3-1/8"	-	30124
25/64"	.3906	1-7/8"	3-1/4"	-	30125
13/32"	.4063	1-15/16"	3-5/16"	-	30126
27/64"	.4219	2"	3-3/8"	-	30127ZR
7/16"	.4375	2-1/16"	3-7/16"	-	30128ZR
29/64"	.4531	2-1/8"	3-9/16"	-	30129ZR
15/32"	.4689	2-1/8"	3-5/8"	-	30130
31/64"	.4844	2-3/16"	3-11/16"	-	30131
1/2"	.5000	2-1/4"	3-3/4"	-	30132ZR

HSS Wire Gauge Screw Machine Length Drill Bits (Series 201)



20120

- Black Oxide finish for corrosion resistance
- Numbered from 1 to 55 (large to small)
- Drills exact size hole for tapping (used where more precisely-sized holes are required)
- Shorter length for increased strength and rigidity

Applications:

Industrial applications, MRO, automotive, machine shop

Size	Decimal Equiv.	Flute Length	Overall Length	Carded Item #	Bulk Item #
No. 1	.2280	1-5/16"	2-7/16"	-	20101ZR
No. 2	.2210	1-5/16"	2-7/16"	-	20102
No. 3	.2130	1-1/4"	2-3/8"	-	20103
No. 4	.2090	1-1/4"	2-3/8"	-	20104
No. 5	.2055	1-1/4"	2-3/8"	-	20105
No. 6	.2040	1-1/4"	2-3/8"	-	20106
No. 7	.2010	1-3/16"	2-1/4"	-	20107
No. 8	.1190	1-3/16"	2-1/4"	-	20108
No. 9	.1960	1-3/16"	2-1/4"	-	20109
No. 10	.1935	1-3/16"	2-1/4"	-	20110
No. 11	.1910	1-3/16"	2-1/4"	-	20111
No. 12	.1890	1-3/16"	2-1/4"	-	20112
No. 13	.1850	1-1/8"	2-3/16"	-	20113
No. 14	.1820	1-1/8"	2-3/16"	-	20114
No. 15	.1800	1-1/8"	2-3/16"	-	20115
No. 16	.1770	1-1/8"	2-3/16"	-	20116
No. 17	.1730	1-1/8"	2-3/16"	-	20117
No. 18	.1695	1-1/16"	2-1/8"	-	20118
No. 19	.1660	1-1/16"	2-1/8"	-	20119
No. 20	.1610	1-1/16"	2-1/8"	-	20120
No. 21	.1590	1-1/16"	2-1/8"	-	20121
No. 22	.1570	1-1/16"	2-1/8"	-	20122
No. 23	.1540	1"	2-1/16"	-	20123
No. 24	.1520	1"	2-1/16"	-	20124
No. 25	.1495	1"	2-1/16"	-	20125
No. 26	.1470	1"	2-1/16"	-	20126
No. 27	.1440	1"	2-1/16"	-	20127ZR
No. 28	.1405	15/16"	1-15/16"	-	20128ZR
No. 29	.1360	15/16"	1-15/16"	-	20129
No. 30	.1285	15/16"	1-15/16"	-	20130
No. 31	.1200	7/8"	1-7/8"	-	20131
No. 32	.1160	7/8"	1-7/8"	-	20132
No. 33	.1130	7/8"	1-7/8"	-	20133
No. 34	.1110	7/8"	1-7/8"	-	20134
No. 35	.1100	7/8"	1-7/8"	-	20135
No. 36	.1065	13/16"	1-13/16"	-	20136
No. 37	.1040	13/16"	1-13/16"	-	20137ZR
No. 38	.1015	13/16"	1-13/16"	-	20138ZR
No. 39	.0995	13/16"	1-13/16"	-	20139ZR
No. 40	.0980	13/16"	1-13/16"	-	20140
No. 41	.0960	13/16"	1-13/16"	-	20141
No. 42	.0935	3/4"	1-3/4"	-	20142ZR
No. 43	.0890	3/4"	1-3/4"	-	20143
No. 44	.0860	3/4"	1-3/4"	-	20144
No. 45	.0820	3/4"	1-3/4"	-	20145
No. 46	.0810	3/4"	1-3/4"	-	20146
No. 47	.0785	11/16"	1-11/16"	-	20147
No. 48	.0760	11/16"	1-11/16"	-	20148
No. 49	.0730	11/16"	1-11/16"	-	20149
No. 50	.0700	11/16"	1-11/16"	-	20150
No. 51	.0670	11/16"	1-11/16"	-	20151
No. 52	.0635	11/16"	1-11/16"	-	20152
No. 53	.0595	5/8"	1-5/8"	-	20153
No. 54	.0550	5/8"	1-5/8"	-	20154
No. 55	.0520	5/8"	1-5/8"	-	20155

Metal Drilling

Silver & Deming Drill Bits

Silver and Deming (S&D) HSS Fractional 1/2" Reduced Shank Drill Bits 118° Point (Series 911/901)



91148

- 6" overall length
- For use in 1/2" drill chucks
- 3-flatted shank for secure grip

Applications:

Heavy-duty metal drilling, automotive, body shop, metal fabrication

Sets:

8-Piece Set: 90108

Size	Decimal Equivalent.	Flute Length	Overall Length	Tubed Item #
33/64"	.5156	3"	6"	91133
17/32"	.5313	3"	6"	91134
35/64"	.5469	3"	6"	91135
9/16"	.5625	3"	6"	91136
37/64"	.5781	3"	6"	91137
19/32"	.5938	3"	6"	91138
39/64"	.6094	3"	6"	91139
5/8"	.6250	3"	6"	91140
41/64"	.6406	3"	6"	91141
21/32"	.6563	3"	6"	91142
43/64"	.6719	3"	6"	91143
11/16"	.6875	3"	6"	91144
45/64"	.7031	3"	6"	91145
23/32"	.7188	3"	6"	91146
47/64"	.7344	3"	6"	91147
3/4"	.7500	3"	6"	91148
49/64"	.7656	3"	6"	91149
25/32"	.7812	3"	6"	91150
51/64"	.7969	3"	6"	91151
13/16"	.8125	3"	6"	91152
53/64"	.8281	3"	6"	91153
27/32"	.8438	3"	6"	91154
55/64"	.8594	3"	6"	91155ZR
7/8"	.8750	3"	6"	91156
57/64"	.8906	3"	6"	91157
29/32"	.9062	3"	6"	91158
59/64"	.9219	3"	6"	91159
15/16"	.9375	3"	6"	91160
61/64"	.9531	3"	6"	91161
31/32"	.9688	3"	6"	91162
63/64"	.9844	3"	6"	91163
1"	1.000	3"	6"	91164
1-1/64"	1.0156	3"	6"	90165
1-1/32"	1.0313	3"	6"	90166
1-1/16"	1.0625	3"	6"	90168
1-3/32"	1.0938	3"	6"	90170
1-1/8"	1.1250	3"	6"	90172
1-5/32"	1.1563	3"	6"	90174
1-3/16"	1.1875	3"	6"	90176
1-1/4"	1.2500	3"	6"	90180
1-5/16"	1.3125	3"	6"	90184
1-3/8"	1.3750	3"	6"	90188
1-7/16"	1.4375	3"	6"	90192
1-1/2"	1.5000	3"	6"	90196

12" Longboy HSS Fractional 1/2" Reduced Shank Drill Bits (Series 604)



60448

- For use in 1/2" drill chucks
- 3-flatted shank for secure grip

Applications:

Deep drilling into wood and metal beams

Size	Decimal Equiv.	Flute Length	Overall Length	Carded Item #	Bulk Item #
1/2"	.5000	9"	12"	-	60432
9/16"	.5625	9"	12"	-	60436
5/8"	.6250	9"	12"	-	60440
11/16"	.6875	9"	12"	-	60444
3/4"	.7500	9"	12"	-	60448
13/16"	.8125	9"	12"	-	60452
7/8"	.8750	9"	12"	-	60456
15/16"	.9375	9"	12"	-	60460
1"	1.000	9"	12"	-	60464
1-1/16"	1.0625	9"	12"	-	60468
1-1/8"	1.1250	9"	12"	-	60472
1-1/4"	1.2500	9"	12"	-	60480

12" Aircraft Extension HSS Fractional Straight Shank Drill Bits 135° Split Point (Series 621/612)



61224

- Black Oxide finish for corrosion resistance
- Heavy-duty web construction for strength and durability

Size	Decimal Equiv.	Flute Length	Overall Length	Carded Item #	Bulk Item #
1/16"	.0625	7/8"	12"	62104ZR	61204
3/32"	.0938	1-1/4"	12"	-	61206
1/8"	.1250	1-5/8"	12"	62108	61208
5/32"	.1563	2"	12"	-	61210
3/16"	.1875	2-5/16"	12"	62112ZR	61212
7/32"	.2188	2-1/2"	12"	-	61214
1/4"	.2500	2-3/4"	12"	62116	61216
9/32"	.2813	2-15/16"	12"	-	61218
5/16"	.3125	3-3/16"	12"	62120	61220
11/32"	.3438	3-7/16"	12"	-	61222
3/8"	.3750	3-5/8"	12"	62124	61224
13/32"	.4063	3-7/8"	12"	-	61226
7/16"	.4375	4-1/16"	12"	62128	61228
15/32"	.4688	4-5/16"	12"	-	61230
1/2"	.5000	4-1/2"	12"	62132	61232ZR

6" Aircraft Extension HSS Fractional Straight Shank Drill Bits 135° Split Point (Series 667/666)



66624

- Black Oxide finish for corrosion resistance
- Heavy-duty web construction for strength and durability

Size	Decimal Equiv.	Flute Length	Overall Length	Carded Item #	Bulk Item #
1/16"	.0625	7/8"	6"	66704ZR	66604ZR
5/64"	.0781	1"	6"	-	66605
3/32"	.0938	1-1/4"	6"	-	66606
7/64"	.1094	1-1/2"	6"	-	66607
1/8"	.1250	1-5/8"	6"	66708	66608
9/64"	.1406	1-3/4"	6"	-	66609
5/32"	.1563	2"	6"	66710	66610
11/64"	.1719	2-1/8"	6"	-	66611
3/16"	.1875	2-5/16"	6"	66712	66612
13/64"	.2031	2-7/16"	6"	-	66613
7/32"	.2188	2-1/2"	6"	66714	66614
15/64"	.2344	2-5/8"	6"	-	66615
1/4"	.2500	2-3/4"	6"	66716	66616
17/64"	.2656	2-7/8"	6"	-	66617ZR
9/32"	.2813	2-15/16"	6"	-	66618
19/64"	.2969	3-1/16"	6"	-	66619
5/16"	.3125	3-3/16"	6"	66720ZR	66620
21/64"	.3281	3-5/16"	6"	-	66621
11/32"	.3438	3-7/16"	6"	-	66622
23/64"	.3594	3-1/2"	6"	-	66623
3/8"	.3750	3-5/8"	6"	66724	66624
25/64"	.3906	3-3/4"	6"	-	66625
13/32"	.4063	3-7/8"	6"	-	66626
27/64"	.4219	3-15/16"	6"	-	66627
7/16"	.4375	4-1/16"	6"	66728	66628
15/32"	.4688	4-5/16"	6"	-	66630
1/2"	.5000	4-1/2"	6"	66732	66632

Metal Drilling

Special Purpose Drilling

Double End HSS Drill Bits (Series 606/616)



10228

- Black Oxide finish for corrosion resistance
- Drills twice as many holes as a single end drill bit
- Heavy-duty web for strength and durability

Applications:

General metal drilling in tight spaces, drilling sheet metal for rivets and fasteners

Size	Decimal Equiv.	Flute Length	Overall Length	Carded Item #	Bulk Item #
7/64"	.1094	5/8"	1*7/8"	-	60607
1/8"	.1250	5/8"	2"	-	60608
9/64"	.1406	5/8"	2"	-	60609
5/32"	.1563	5/8"	2-1/16"	-	60610
3/16"	.1875	5/8"	2-3/16"	-	60612
7/32"	.2188	11/16"	2-3/8"	-	60614
1/4"	.2500	7/8"	2-1/2"	-	60616
#11	.1910	11/16"	2-1/4"	-	61611
#20	.1600	5/8"	2-1/8"	-	61620
#30	.1285	5/8"	2"	-	61630

High Speed Steel Countersinks



12413

- 1/4" round shank
- Milled and precision-ground to 82° for countersinking into most machinable materials
- 5 flutes

Size	Decimal Equiv.	Flute Length	Overall Length	Carded Item #	Bulk Item #
1/2"	.5000	3/8"	1-5/8"	12411	-
5/8"	.6250	7/16"	1-3/4"	12412	-
3/4"	.7500	1/2"	1-13/16"	12413	-

29-piece Metal Index Drill Bit Sets

Automatic Indexing

- For easy bit access and identification

Removable Cartridges

- Allows for easy transport to worksite

Rubber Over-Molded Case

- Protects case if dropped



3018003

3 Easy Steps to Open Case & Remove a Cartridge



Slide Latch



Open Case



Remove Cartridge

Description	Type	Contents	Point	Finish	Item #
29-pc Set	Cobalt M42 HSS Fractional	1/16" - 1/2" by 64ths	135°	Cobalt	3018002B
29-pc Set*	Cobalt M35 HSS Fractional	1/16" - 1/2" by 64ths	135°	Cobalt	3018002
29-pc Set*	TiN HSS Fractional	1/16" - 1/2" by 64ths	135°	TiN Coated	3018003
29-pc Set*	Heavy-Duty HSS Fractional	1/16" - 1/2" by 64ths	135°	Black Oxide	3018004
29-pc Set*	Black & Gold HSS Fractional	1/16" - 1/2" by 64ths	135°	Black & Gold Oxide	3018005
29-pc Set*	TURBOMAX HSS Fractional	1/16" - 1/2" by 64ths	TURBOMAX	Gold Oxide	3018006B
29-pc Set*	TURBOMAX Titanium Fractional	1/16" - 1/2" by 64ths	TURBOMAX	TiN Coated	3018011

*Note: 3/8" Reduced Shank

29-piece Metal Index Drill Bit Set



73138

21-piece Metal Index Drill Bit Set



73149

13-piece Metal Index Drill Bit Set



73136

Description	Type	Contents	Point	Finish	Item #
Straight Shank Sets					
13-pc Set	Gen. Purp. HSS Fractional	1/16" - 1/4" by 64ths	118°	Bright	60136
15-pc Set	Gen. Purp. HSS Fractional	1/16" - 1/2" by 32nds	118°	Bright	60137
21-pc Set	Gen. Purp. HSS Fractional	1/16" - 3/8" by 64ths	118°	Bright	60221
29-pc Set	Gen. Purp. HSS Fractional	1/16"-1/2" by 64ths	118°	Bright	60138
60-pc Set	Gen. Purp. HSS Wire Gauge	#1 - #60	118°	Bright	80181
20-pc Set	Gen. Purp. HSS Wire Gauge	#61 - #80	118°	Bright	80183
15-pc Set	Heavy Duty HSS Fractional	1/16" - 1/2" by 32nds	135°	Black Oxide	63537
15-pc Set	Cobalt HSS Fractional	1/16" - 1/2" by 32nds	135°	Cobalt	63137
21-pc Set	Cobalt HSS Fractional	1/16" - 3/8" by 64ths	135°	Cobalt	63221
15-pc Set	TiN HSS Fractional	1/16" - 1/2" by 32nds	135°	TiN Coated	63737
13-pc Set	TURBOMAX HSS Fractional	1/16" - 1/4" by 64ths	TURBOMAX	Gold Oxide	73136
15-pc Set	TURBOMAX HSS Fractional	1/16" - 1/2" by 32nds	TURBOMAX	Gold Oxide	73137
29-pc Set	TURBOMAX HSS Fractional	1/16" - 1/2" by 64ths	TURBOMAX	Gold Oxide	73138
21-pc Set	TURBOMAX HSS Fractional	1/16" - 3/8" by 64ths	TURBOMAX	Gold Oxide	73149
Reduced Shank Sets					
15-pc Set	Gen. Purp. HSS Fractional 3/8"	1/16" - 1/2" by 32nds	118°	Bright	60147
29-pc Set	Gen. Purp. HSS Fractional 3/8"	1/16" - 1/2" by 64ths	118°	Bright	60148
8-pc Set	Silver & Deming (S&D) HSS Fractional 1/2"	9/16" - 1" by 32nds	118°	Black Oxide & Bright	90108
1/4" Hex Shank Sets					
5-pc Set	Heavy Duty HSS Fractional	3/32", 7/64", 1/8", 6/64", & 5/32"	135°	Black Oxide	4935642

Metal Drilling

Drill Bit Sets / Gauges

Pro Set Cases



314018



318015



316015



3018009



3018010

METAL DRILLING

Description	Type	Contents	Point	Finish	Item #
15-pc Set	Black Oxide HSS Fractional Straight Shank Jobber Length	1/16" - 3/8"	135°	Black Oxide	314015
18-pc Set	Black Oxide HSS Fractional Jobber Length	1/16" - 1/2" with 3/8" Reduced Shank	135°	Black Oxide	314018
20-pc Set	Drill/Drive Set with Black Oxide HSS Drills and Screwdriver Bits	1/16" (2), 3/32", 1/8" (2), 5/32", 3/16", 1/4" Drills and 12 Screwdriver and Nutdriver Bits	135°	Black Oxide	357020
15-pc Set	Cobalt HSS Fractional Straight Shank Jobber Length	1/16" - 3/8"	135°	Cobalt	316015
15-pc Set	TURBOMAX® HSS Fractional Straight Shank Jobber	Length 1/16"-3/8"	TURBOMAX	Gold Oxide	318015
18-pc Set	TURBOMAX HSS Fractional Jobber	Length 1/16"-1/2" with 3/8" Reduced Shank	TURBOMAX	Gold Oxide	3018024SM
12-pc Set	Black Oxide HSS 1/4" Hex Shank Jobber Length	1/16", 5/64", 3/32", 7/64", 1/8" (2), 9/64", 5/32", 3/16", 7/32", 1/4" Drills and Lock-N-Load Quick Change	135°	Black Oxide	4935643
15-pc Set	Titanium Coated HSS Fractional Straight Shank Jobber	1/16"-3/8"	135°	TiN	4935607
15-pc Set	Titanium Turbomax	1/16" - 3/8"	TURBOMAX	TiN	3018009
18-pc Set	Titanium Turbomax	1/16" - 1/2"	TURBOMAX	TiN	3018010
9-pc Set	Titanium Turbomax & Unibit	1/16" - 3/8" Unibit #1 & #4	TURBOMAX	TiN	3018008

Drill Bit Gauge & Stand

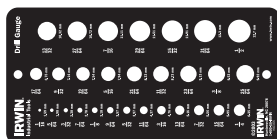

12092

Description	Carded Item #	Bulk Item #
Fractional Drill Gauge	12092	-
Drill Stand 1/16" - 1/2"	60172	-

UNIBIT® Step Drill Bits – Maximum Life in Tough Steel

UNIBIT is the most recognized brand for electrical, automotive and plumbing professionals. UNIBIT fits the IRWIN tradition of providing reliable, high-quality professional tools. IRWIN UNIBIT has been the most innovative and trusted name in step drill bits since its invention in 1972. The IRWIN UNIBIT Cobalt is the latest addition to the step drill bit category. Made of cobalt high speed steel, this step drill bit will last longer in the toughest of materials. From stainless steel to aluminum or PVC pipe, the UNIBIT Cobalt is the most versatile and longest lasting step drill bit in the market.

Comparative Life Test in Stainless Steel

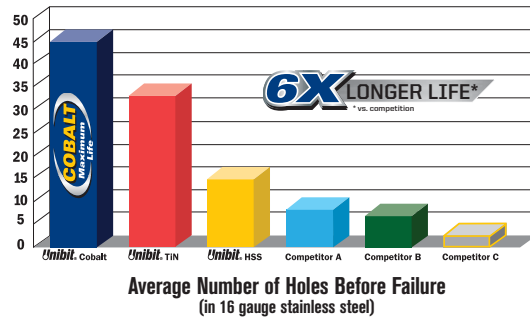

M35 Grade Cobalt HSS

- High heat & abrasion resistance
- Longest cutting edge life

Radial Concave Flute

- True round holes
- Greatest control
- Minimizes vibration

3-Flatted Shank

- Won't slip in chuck

Speedpoint® Tip

- Fast starting
- 6X faster than original Unibit

Laser Marked Sizes

- Permanent
- Won't wear off with use



METAL DRILLING

UNIBIT Cobalt HSS



10231

- M35 grade Cobalt HSS
- Longest cutting edge life
- 6X longer life*

*versus competition

Description	# of Hole Sizes	Hex Shank Size	Carded Item #
#1 1/8"-1/2" (1/32" steps)	13	1/4"	10231CB
#2 3/16"-1/2" (1/16" steps)	6	1/4"	10232CB
#3 1/4"-3/4" (1/16" steps)	9	3/8"	10233CB
#4 3/16"-7/8" (1/16" steps)	12	3/8"	10234CB
#9 7/8" and 1-1/8" for (1/2" and 3/4") KO	2	7/16"	10239CB
#20 9/16"-1" (1/16") Inc - Hole Enlarging	8	7/16"	10220CB
#1M 4 mm-12 mm (1 mm steps)	9	1/4"	11101CB
#2M 4 mm - 12 mm (2 mm steps)	5	1/4"	11102CB
#3M 6 mm - 18 mm (2 mm steps)	7	3/8"	11103CB
#4M 4 mm - 22 mm (2 mm steps)	10	3/8"	11104CB

UNIBIT® HSS Fractional Titanium Nitride (TiN) Coated



15101

- Titanium Nitride coating extends cutting edge life up to 6X
- Single-fluted cutting edge for greater control & rounder holes

Set: 15502

Description	# of Hole Sizes	Hex Shank Size	Carded Item #
#1T 1/8" - 1/2" (1/32" steps)	13	1/4"	15101ZR
#2T 3/16" - 1/2" (1/16" steps)	6	1/4"	15102ZR
#3T 1/4" - 3/4" (1/16" steps)	9	3/8"	15103ZR
#4T 3/16" - 7/8" (1/16" steps)	12	3/8"	15104
#13T 1-1/8" (single hole)	1	7/16"	15313
#20T 7/16" - 1" (hole enlarging)	8	7/16"	15200
#21T 13/16" - 1-3/8" (hole enlarging)	10	7/16"	15221

▲ - SpeedPoint™ Tip

Metal Drilling

Step Drill Bits / Sets

UNIBIT® HSS Metric Titanium Nitride (TiN) Coated



16103

- Titanium Nitride coating extends cutting edge life up to 6X
- Single-fluted cutting edge for greater control & rounder holes

UNIBIT HSS Fractional



10234

- Single-fluted cutting edge for greater control & rounder holes
- Ideal for drilling holes in thin materials such as mild steel, copper, brass, aluminum, plexiglass, wood and laminates

Sets: 10225, 10228, 10502

UNIBIT HSS Metric



11101

- Single-fluted cutting edge for greater control & rounder holes
- Ideal for drilling holes in thin materials such as mild steel, copper, brass, aluminum, plexiglass, wood and laminates

UNIBIT Sets



10502CB

▲ - SpeedPoint™ Tip

Description	# of Hole Sizes	Hex Shank Size	Carded Item #
▲ #1MT 4 mm - 12 mm (1 mm steps)	9	1/4"	16101
▲ #2MT 4 mm - 12 mm (2 mm steps)	5	1/4"	16102
▲ #3MT 6 mm - 18 mm (2 mm steps)	7	3/8"	16103
▲ #4MT 4 mm - 22 mm (2 mm steps)	10	3/8"	16104
▲ #5MT 5 mm - 35 mm (2 - 3 mm steps)	13	7/16"	16105

Description	# of Hole Sizes	Hex Shank Size	Carded Item #
▲ #1 1/8" - 1/2" (1/32" steps)	13	1/4"	10231
▲ #2 3/16" - 1/2" (1/16" steps)	6	1/4"	10232
▲ #3 1/4" - 3/4" (1/16" steps)	9	3/8"	10233
▲ #4 3/16" - 7/8" (1/16" steps)	12	3/8"	10234
▲ #5 1/4" - 1-3/8" (1/8" steps)	10	7/16"	10235
▲ #9 7/8" and 1-1/8" (1/2" and 3/4" Knock-Out)	2	7/16"	10239
#10 1/2" (single hole)	1	1/4"	10310
#11 7/8" (single hole)	1	3/8"	10311ZR
#12 3/8" (single hole)	1	1/4"	10312ZR
#13 1-1/8" (single hole)	1	7/16"	10313ZR
#14 1-7/32" (single hole)	1	7/16"	10314
#20 9/16" - 1" (hole enlarging)	8	7/16"	10220
#21 13/16" - 1-3/8" (hole enlarging)	10	7/16"	10221

Description	# of Hole Sizes	Hex Shank Size	Carded Item #
▲ #1M 4 mm - 12 mm (1 mm steps)	9	1/4"	11101ZR
▲ #2M 4 mm - 12 mm (2 mm steps)	5	1/4"	11102
▲ #3M 6 mm - 18 mm (2 mm steps)	7	3/8"	11103
▲ #4M 4 mm - 22 mm (2 mm steps)	10	3/8"	11104
▲ #5M 5 mm - 35 mm (2-3 mm steps)	13	7/16"	11105ZR
#20M 14 mm - 24 mm (hole enlarging)	6	7/16"	11580
#21M 20 mm - 34 mm (hole enlarging)	8	7/16"	11581
PG29M 5 mm - 28.3 mm	10	7/16"	11194
29 mm 5 mm - 29 mm	10	7/16"	11195

Description	Type	Contents	Item #
4-pc Set	High Speed Steel Set	#1, 2, 4 & 21	10225
4-pc Set	High Speed Steel Set w/#1 TiN	#1, 2 & 3 plus #1T	10228
3-pc Set	High Speed Steel Set	#1, 2 & 3	10502ZR
3-pc Set	Titanium Nitride Coated Set	#1T, 2T & 3T	15502
3-pc Set	Cobalt Set	#1C, 2C & 3C	10502CB
9-pc Set	Unibit/TiN Turbomax Set	#1, #4 & 7-pc TiN (1/16", 3/32", 1/8", 3/16", 7/32", 1/4", 3/8")	3018008

IRWIN®

Wood Drilling













www.irwin.com

A Century of Quality and Innovation

In 1885, the IRWIN® Auger Bit Company was formed. Over 125 years later, IRWIN is still the leading manufacturer of wood drilling bits and accessories. No matter what wood drilling project you face, IRWIN Tools makes a drill bit that performs the job better. Our mark of quality is stamped right on the shank of our full range of bits. Whether the job requires quick, clean holes, or precise finish work, IRWIN has a bit for every application and every need.

The all new IRWIN SPEEDBOR® with Weldtec™ Ship Auger Bits are MADE STRONGER and LAST LONGER. With a patent-pending WeldTec cutting edge, these bits are durable, and have twice the nail cutting life of traditional ship auger bits. The bits are fully forged, for added durability; have an aggressive screw pitch for faster drilling; and wide flutes for maximum chip removal. Only IRWIN offers the superior performance and added durability of WeldTec.

Use the chart below to determine which bit is best for the job at hand.

Bit Style	Size Range	Typical Trades	Application Benefits
 <p>Tri-Flute Bit</p>	7/16" to 1-1/2" diameter	Carpentry, Electrical, Plumbing	Fast, clean holes with reduced "break out" when through-hole drilling. Full screw-tip requires less effort.
 <p>Spade Bit</p>	1/4" to 1-1/2" diameter 4-3/4" to 16" lengths	Carpentry, Electrical, Plumbing	Fast, clean holes with reduced "break out" when through-hole drilling.
 <p>I-100 Solid Center Auger Bit</p>	1/4" to 1-1/2" diameter 7-1/2" length	Carpentry, Electrical, Plumbing	Self-feeding tip pulls bit into the work for repetitive cutting of fast clean holes with a clean exit hole. Single-spur cutting edge scribes the circumference of the hole for a smoother finish.
 <p>Ship Auger Bit</p>	3/8" to 2" diameter 7-1/2" to 29" lengths	Public Utilities, Electrical, Plumbing, Carpentry, Log Homes	Hollow center provides better chip removal for deeper holes in utility poles and logs.
 <p>Installer Bit</p>	1/4" to 3/4" diameter 12" to 30" lengths	Telecommunications, Cable/Internet, Security Systems	Wire hole near the end of the bit enables user to pull wire back through after drilling the hole.
 <p>Self-Feed Bit</p>	1" to 4-5/8" diameter	Plumbing, Electrical, General Contracting	Replaceable self-feeding tip pulls bit into the wood. For cutting larger holes with clean edges.
 <p>Forstner Bit</p>	1/4" to 2-1/8" diameter	Fine Woodworking, Cabinet Making	Precise cutting of smooth, flat-bottomed (blind) holes with clean, sharp edges.
 <p>Brad Point Bit</p>	1/8" to 1/2" diameter	Woodworking, Cabinet Making	Precise cutting of smooth through-holes with clean, sharp edges and reduced "break out."
 <p>Countersink Bit</p>	1/8" to 1/2" diameter	Woodworking, Cabinet Making	Perfect for variable-size countersink holes.
 <p>Plug Cutters</p>	1/8" to 1/2" diameter	Woodworking, Cabinet Making	Perfect for cutting dowels or plug holes.
 <p>Quick Change Extensions</p>	1/4" available in 2", 6" and 12" length 3/8" available in 2", 5-1/2" and 12" length 7/16" available in 5-1/2", 12" and 18" length	Woodworking, Cabinet Making	Lock-n-Load one-handed quick release.

SPEEDBOR® Max Speed Bits

SPEEDBOR MAX SPEED BIT FEATURES

1. Cutting spurs have three cutting edges for added durability
2. Full screw tip allows bit to self feed
3. Tri-flute design for faster chip ejection
4. Grooved hex shank prevents slipping in drill chuck or bit extension, fits all standard 1/4" quick change chucks

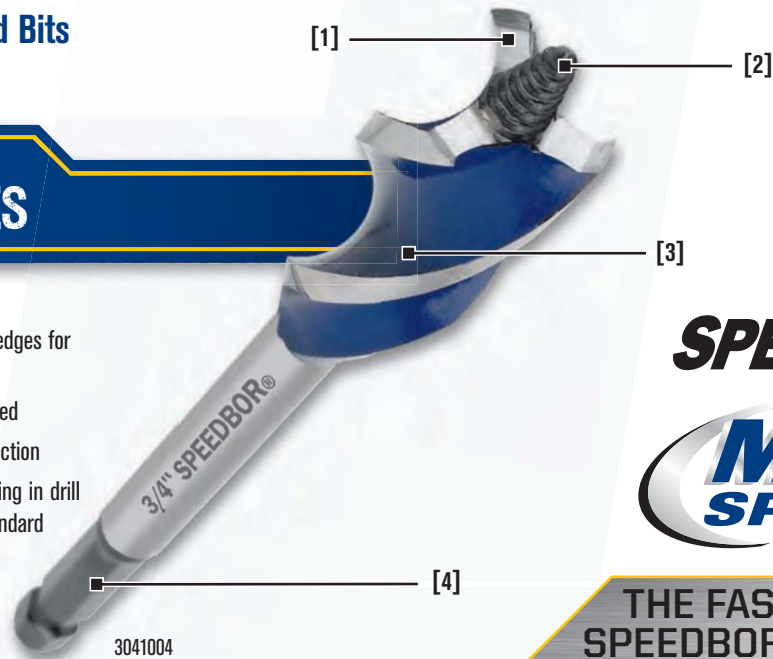

**THE FASTEST
SPEEDBOR EVER.**

6-piece SPEEDBOR MAX Speed Set



3041006

3-piece SPEEDBOR MAX Speed Set



3041003

Quick Change Extension



4935704

Diameter	Description	Shank Size	Item#	Pack Qty	Bulk Item #	Pack Qty
7/16"	7/16" x 6" SPEEDBOR MAX Speed Drill Bit	1/4" Hex	3041015	3	3041015B	6
1/2"	1/2" x 6" SPEEDBOR MAX Speed Drill Bit	1/4" Hex	3041001	3	3041001B	6
9/16"	9/16" x 6" SPEEDBOR MAX Speed Drill Bit	1/4" Hex	3041014	3	3041014B	6
5/8"	5/8" x 6" SPEEDBOR MAX Speed Drill Bit	1/4" Hex	3041002	3	3041002B	6
11/16"	7/8" x 6" SPEEDBOR MAX Speed Drill Bit	1/4" Hex	3041016	3	3041016B	6
3/4"	3/4" x 6" SPEEDBOR MAX Speed Drill Bit	1/4" Hex	3041004	3	3041004B	6
13/16"	13/16" x 6" SPEEDBOR MAX Speed Drill Bit	1/4" Hex	3041017	3	3041017B	6
7/8"	7/8" x 6" SPEEDBOR MAX Speed Drill Bit	1/4" Hex	3041005	3	3041005B	6
15/16"	15/16" x 6" SPEEDBOR MAX Speed Drill Bit	1/4" Hex	3041018	3	3041018B	6
1"	1" x 6" SPEEDBOR MAX Speed Drill Bit	1/4" Hex	3041007	3	3041007B	6
1-1/8"	1-1/8" x 6" SPEEDBOR MAX Speed Drill Bit	1/4" Hex	3041019	3	3041019B	6
1-1/4"	1-1/4" x 6" SPEEDBOR MAX Speed Drill Bit	1/4" Hex	3041009	3	3041009B	6
1-3/8"	1-3/8" x 6" SPEEDBOR MAX Speed Drill Bit	3/8" Hex	3041020	3	3041020B	6
1-1/2"	1-1/2" x 6" SPEEDBOR MAX Speed Drill Bit	3/8" Hex	3041021	3	3041021B	6
Sets						
-	3pc Set SPEEDBOR MAX Speed (5/8", 3/4", 1")		3041003	6	-	-
-	6pc Set SPEEDBOR MAX Speed (1/2", 5/8", 3/4", 7/8", 1" & 1-1/4")		3041006	6	-	-
Lock-n-Load® Quick Change Extensions						
1/4"	Quick Change Bit Holder 2" OAL (fits 7/16" - 1-1/4")		4935703	6	-	-
1/4"	Quick Change Bit Holder 6" OAL (fits 7/16" - 1-1/4")		4935704	6	-	-
1/4"	Quick Change Bit Holder 12" OAL (fits 7/16" - 1-1/4")		4935705	6	-	-
3/8"	Quick Change Bit Holder 2" OAL (fits 1-3/8" & 1-1/2")		4935651	6	-	-
3/8"	Quick Change Bit Holder 5-1/2" OAL (fits 1-3/8" & 1-1/2")		4935652	3	-	-
3/8"	Quick Change Bit Holder 12" OAL (fits 1-3/8" & 1-1/2")		4935653	3	-	-

SPEEDBOR® Spade Bits

SPEEDBOR SPADE BIT FEATURES

1. Double Cutting Spurs Scribe the outside of the hole, reducing breakout
2. Thicker Cutting Edge For longer drilling life
3. Patented BLUE-GROOVE Point & Cutting Edge for faster chip removal
4. Larger Shank for durability
5. Quick Change Shank fits all standard 1/4" quick change chucks

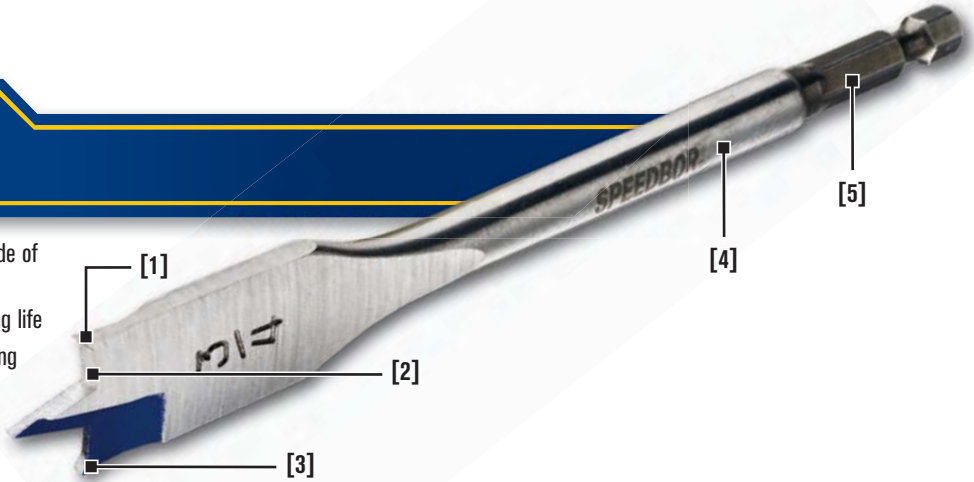

87912

4-3/4" SPEEDBOR Short Length Spade Bits

- For drilling in tight spaces



88812

6" SPEEDBOR Standard Length Spade Bits

Diameter	Length	Shank Size	Item #	Pack Qty
1/2"	4"	1/4" Hex	87908	6
5/8"	4"	1/4" Hex	87910	6
3/4"	4"	1/4" Hex	87912	6
7/8"	4"	1/4" Hex	87914	6
1"	4"	1/4" Hex	87916	6
1-1/4"	4"	1/4" Hex	87920	3
1-1/2"	4"	1/4" Hex	87924	3

Diameter	Length	Shank Size	Item #	Pack Qty	Bulk Item #	Pack Qty
1/4"	6"	1/4" Hex	88804	6	99904	24
5/16"	6"	1/4" Hex	88805	6	99905	24
3/8"	6"	1/4" Hex	88806	6	99906	24
7/16"	6"	1/4" Hex	88807	6	99907	24
1/2"	6"	1/4" Hex	88808	6	99908	24
9/16"	6"	1/4" Hex	88809	6	99909	24
5/8"	6"	1/4" Hex	88810	6	99910	24
11/16"	6"	1/4" Hex	88811	6	99911	24
3/4"	6"	1/4" Hex	88812	6	99912	24
13/16"	6"	1/4" Hex	88813	6	99913	24
7/8"	6"	1/4" Hex	88814	6	99914	24
15/16"	6"	1/4" Hex	88815	6	99915	24
1"	6"	1/4" Hex	88816	6	99916	24
1-1/8"	6"	1/4" Hex	88818	3	99918	12
1-1/4"	6"	1/4" Hex	88820	3	99920	12
1-3/8"	6"	1/4" Hex	88822	3	99922	12
1-1/2"	6"	1/4" Hex	88824	3	99924	12
Bulk 4 PC Value Packs						
5/8"	6"	1/4" Hex	1764343	6	-	-
3/4"	6"	1/4" Hex	1764344	6	-	-
1"	6"	1/4" Hex	1764345	6	-	-



88712

16" SPEEDBOR Extra-Long Spade Bits

- For extended reach
- Not for use with bit extensions or drill presses

Diameter	Length	Shank Size	Item #	Pack Qty	Bulk Item #	Pack Qty
3/8"	16"	1/4" Hex	88706	6	99706	24
1/2"	16"	1/4" Hex	88708	6	99708	24
5/8"	16"	1/4" Hex	88710	6	-	-
3/4"	16"	1/4" Hex	88712	6	99712	24
7/8"	16"	1/4" Hex	88714	6	99714	24
1"	16"	1/4" Hex	88716	6	99716	24

SPEEDBOR® Short Length Spade Bit Sets



1768411

SPEEDBOR Spade Bit Sets



88885

SPEEDBOR Pro Set



341008

- Sliding latch design provides added security

Standard Spurless Shape Bits



88012BULK

Description	Diameter	Item #	Pack Qty
Short Length Spade Bit Sets			
3-pc set	1/2", 3/4", 1"	87950	6
		87954	
6pc PRO Set w/Extension	3/4", 7/8", 15/16", 1", 1-1/8" & 6" Extension	1768411	6
	Nylon PRO Set Case		
Standard Length Spade Bit Sets			
3pc Set	1/2", 3/4", 1"	88889	6
4pc Set w/Extension	1/2", 3/4", 1", & 6" Quick Change Extension	4935687	6
5pc Set	3/8", 1/2", 5/8", 3/4", 1"	88885	6
6pc Set	3/8", 1/2", 5/8", 3/4", 7/8", 1"	88886	6
6pc Set w/Workshop Rack	3/8", 1/2", 5/8", 3/4", 7/8", 1" & Rack	88888	6
6pc Set w/Slim Case	3/8", 1/2", 5/8", 3/4", 7/8", 1" & Slim Case	88890	6
6pc Set w/Extension	3/8", 1/2", 5/8", 3/4", 1" & 6" Quick Change Extension	88898	6
8pc PRO Set Case	3/8", 1/2", 5/8", 7/8", 1", 1-1/8", 1-1/2" & PRO Set Case	341008	6
13pc Set	1/4", 5/16", 3/8", 7/16", 1/2", 9/16", 5/8", 11/16", 3/4", 13/16", 7/8", 15/16", 1"	88894	6
13pc Set w/Workshop Rack	1/4", 5/16", 3/8", 7/16", 1/2", 9/16", 5/8", 11/16", 3/4", 13/16", 7/8", 15/16", 1"	88887	6
Lock-n-Load® Quick Change Extensions			
1/4" Quick Change Bit Holder 2" OAL		4935703	6
1/4" Quick Change Bit Holder 6" OAL		4935704	6
1/4" Quick Change Bit Holder 12" OAL		4935705	6

Diameter	Length	Shank Size	Bulk Item #	Pack Qty
3/8"	6"	1/4" Hex	88006BULK	24
7/16"	6"	1/4" Hex	88007BULK	24
1/2"	6"	1/4" Hex	88008BULK	24
9/16"	6"	1/4" Hex	88009BULK	24
5/8"	6"	1/4" Hex	88010BULK	24
11/16"	6"	1/4" Hex	88011BULK	24
3/4"	6"	1/4" Hex	88012BULK	24
13/16"	6"	1/4" Hex	88013BULK	24
7/8"	6"	1/4" Hex	88014BULK	24
15/16"	6"	1/4" Hex	88015BULK	24
1"	6"	1/4" Hex	88016BULK	24
1-1/8"	6"	1/4" Hex	88018BULK	24
1-1/4"	6"	1/4" Hex	88020BULK	24
1-3/8"	6"	1/4" Hex	88022BULK	24
1-1/2"	6"	1/4" Hex	88024BULK	24

IRWIN® Lock-n-Load® Quick Change Extensions

QUICK CHANGE BIT EXTENSION FEATURES

1. Carbon steel construction sleeve and body for durability and life
2. Lock-n-Load® system for one-handed quick release
3. Patented jaw design holds bits securely on 6-flatted shanks, as well as ball detent bits
4. 1/4" Quick Change range now holds insert bits; magnetic for holding



Lock-n-Load Compatibility

WOOD DRILLING

Shank Size	Compatible Tools
1/4"	<ul style="list-style-type: none"> • SPEEDBOR Blue Groove (All Sizes) • SPEEDBOR Max Speed (Sizes 7/16" to 1-1/4") • Fastener Drive (All products) • UNIBIT® (Sizes #1, #2, #10, #12) • 1/4 Hole Saw Arbor (Sizes 9/16" to 1-3/16") • Countersinks (Sizes #4 to #12)
3/8"	<ul style="list-style-type: none"> • SPEEDBOR Max Speed (Sizes 1-3/8", 1-1/4") • UNIBIT (Sizes #3, #4, #11) • 1/4 Hole Saw Arbor (Sizes 9/16" to 6" diameter saws)
7/16"	<ul style="list-style-type: none"> • 17" Ship Augers (Sizes 9/16" and larger) • 7-1/2" Short Ship Augers (Sizes 1-1/8", 1-1/4") • Self-Feed Bits (All sizes) • UNIBIT (Sizes #5, #9, #13, #14, #20, #21)



Shank Size	Length	Item #	Pack Qty
1/4"	2" OAL	4935703	6
1/4"	6" OAL	4935704	6
1/4"	12" OAL	4935705	6
3/8"	2" OAL	4935651	6
3/8"	5-1/2" OAL	4935652	3
3/8"	12" OAL	4935653	3
7/16"	5-1/2" OAL	4935654	3
7/16"	12" OAL	4935655	3
7/16"	18" OAL	4935656	3

Ship Auger Bits

IRWIN revolutionizes cutting and drilling tools with the patent-pending WeldTec™ cutting edge. The new IRWIN SPEEDBOR® with WeldTec Ship Auger Bits are MADE STRONGER and LAST LONGER because a harder cutting edge is welded to the base material. The result is 2X longer nail cutting life versus traditional ship auger bits. The superior performance and durability of WeldTec is only available from IRWIN.

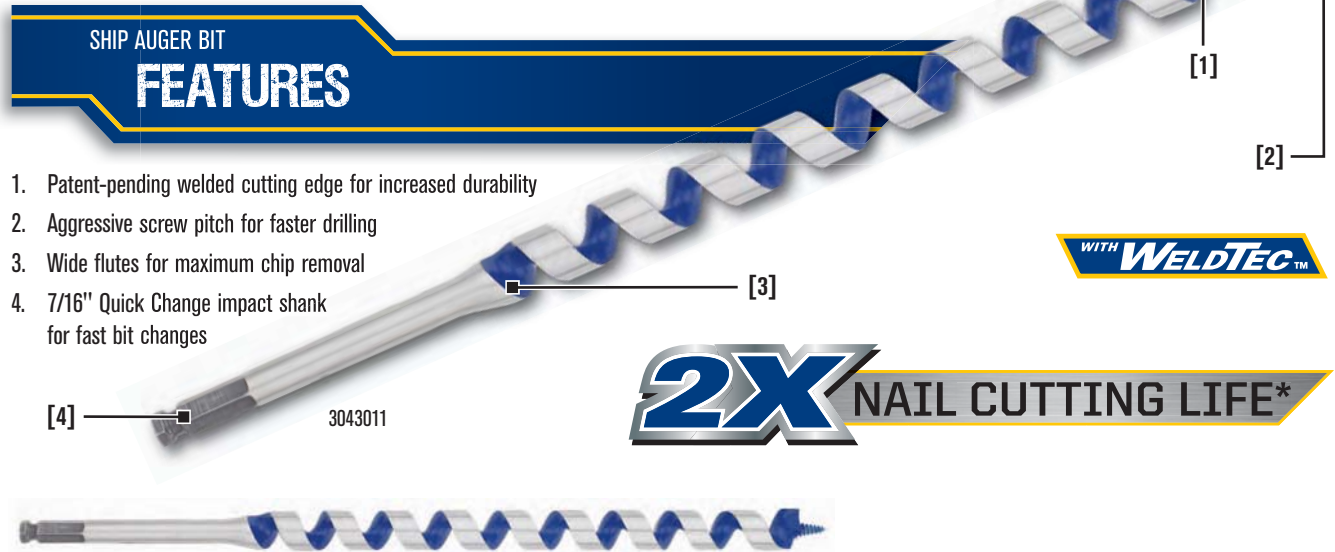

1. Patent-pending welded cutting edge for increased durability
2. Aggressive screw pitch for faster drilling
3. Wide flutes for maximum chip removal
4. 7/16" Quick Change impact shank for fast bit changes

2X NAIL CUTTING LIFE*

17" Long Ship Auger Bits with WeldTec™

- Fully forged bit** for increased durability

Diameter	Twist Length	Overall Length	Tubed Item #	Pack Qty	Bulk Item #	Pack Qty
3/8"	12"	17"	3043004	1	3043004B	6
7/16"	12"	17"	4935570	1	4935571	6
1/2"	12"	17"	3043005	1	3043005B	6
9/16"	12"	17"	3043006	1	3043006B	6
5/8"	12"	17"	3043007	1	3043007B	6
11/16"	12"	17"	3043008	1	3043008B	6
3/4"	12"	17"	3043009	1	3043009B	6
13/16"	12"	17"	3043010	1	3043010B	6
7/8"	12"	17"	3043011	1	3043011B	6
15/16"	12"	17"	3043012	1	3043012B	6
1"	12"	17"	3043013	1	3043013B	6
1-1/16"	12"	17"	4935572	1	4935573	6
1-1/8"	12"	17"	3043014	1	3043014B	6
1-1/4"	12"	17"	3043015	1	3043015B	6
1-3/8"	12"	17"	4935574	1	4935575	6
1-1/2"	12"	17"	3043016	1	3043016B	6

* Compared to standard IRWIN ship augers
** Fully forged on bits 3/4" diameter and larger



7-1/2" Short Ship Auger Bits

- Cuts through nails without damaging the bit
- Short length allows bit to be used in tight areas
- Hex shank prevents slipping in drill chuck

Diameter	Shank Size	Twist Length	Overall Length	Tubed Item #
5/8"	5/16"	5"	7-1/2"	42410
11/16"	5/16"	5"	7-1/2"	42411
3/4"	5/16"	5"	7-1/2"	42412
13/16"	5/16"	5"	7-1/2"	42413
7/8"	5/16"	5"	7-1/2"	42414
1"	5/16"	5"	7-1/2"	42416
1-1/8"	7/16"	5"	7-1/2"	42418
1-1/4"	7/16"	5"	7-1/2"	42420

WOOD DRILLING

Wood Drilling

Hollow Center Auger Bits



46616



Utility Pole Auger Bits – Hand Brace Shank

- Extra-long twist is ideal for drilling large poles, construction timbers, and for other timber applications
- Cutting spur scribes the outside of the hole during drilling for a smooth, clean hole
- Remove the taper square shank and use in an electric drill or hand brace
- Bit can be resharpened
- Medium-fast screw point ideal for general wood drilling applications

Diameter	Shank Type	Twist Length	Overall Length	Bulk Item #	Pack Qty.
3/8"	Taper square	12"	18"	46606	6
7/16"	Taper square	12"	18"	46607	6
1/2"	Taper square	12"	18"	46608	6
9/16"	Taper square	12"	18"	46609	6
5/8"	Taper square	12"	18"	46610	6
11/16"	Adapter shank	12"	18"	46611	6
3/4"	Adapter shank	12"	18"	46612	6
13/16"	Adapter shank	12"	18"	46613ZR	6
7/8"	Adapter shank	12"	18"	46614	6
15/16"	Adapter shank	12"	18"	46615	6
1"	Adapter shank	12"	18"	46616	6
1-1/16"	7/16" hex	12"	18"	46617	3
11/16"	7/16" hex	18"	24"	46711	6
13/16"	7/16" hex	18"	24"	46713ZR	6
1"	7/16" hex	18"	24"	46716	6

Adapter Shank

Fits both hand braces and power drills



Taper square shank fits hand braces



Cut off or square and use in both power drills and hand braces



47915



Utility Pole Auger Bits – Impact Shank

- Extra-long twist is ideal for drilling large poles, construction timbers, and for other timber applications
- Cutting spur scribes the outside of the hole during drilling for a smooth, clean hole
- Hex shank design for use in impact wrench drills
- Bit can be resharpened
- Medium-fast screw point ideal for general wood drilling applications

Diameter	Shank Size	Twist Length	Overall Length	Bulk Item #	Pack Qty.
13/16"	5/8"	15"	18"	48113	6
11/16"	5/8"	15"	18"	48111ZR	6
9/16"	5/8"	15"	18"	48109	6
1-1/16"	7/16"	15"	18"	47917	3
15/16"	7/16"	15"	18"	47915	6
13/16"	7/16"	15"	18"	47913	6
11/16"	7/16"	15"	18"	47911	6
9/16"	7/16"	15"	18"	47909	6
1-1/16"	5/8"	21"	24"	48317	3
15/16"	5/8"	21"	24"	48315	3
13/16"	5/8"	21"	24"	48313	6
11/16"	5/8"	21"	24"	48311	6
15/16"	7/16"	21"	24"	48215	3
13/16"	7/16"	21"	24"	48213ZR	6
11/16"	7/16"	21"	24"	48211	6



47016



Pole Auger Bits – Hex Shank

- Extra-long twist is ideal for drilling in large poles, construction timbers, and for multiple timber applications
- All bits feature 7/16" adaptable hex shank. Simply remove it to use round shank
- Bit can be resharpened
- Medium-fast screw point is ideal for general wood drilling applications
- Cutting spur scribes the outside of the hole during drilling for a smooth, clean hole

Diameter	Twist Length	Overall Length	Bulk Item #	Pack Qty
9/16"	12"	17"	46809	6
5/8"	12"	17"	46810	6
11/16"	12"	17"	46811	6
3/4"	12"	17"	46812	6
13/16"	12"	17"	46813	6
9/16"	12"	23"	46909	6
5/8"	18"	23"	46910	6
11/16"	18"	23"	46911	6
3/4"	18"	23"	46912	6
13/16"	18"	23"	46913ZR	6
7/8"	18"	23"	46914ZR	6
15/16"	18"	23"	46915ZR	3
9/16"	24"	29"	47009	6
5/8"	24"	29"	47010	6
11/16"	24"	29"	47011	6
3/4"	24"	29"	47012	6
13/16"	24"	29"	47013	6
7/8"	24"	29"	47014	6
15/16"	24"	29"	47015	3
1"	24"	29"	47016	3
1-1/16"	24"	29"	47017	3



48715



Ship Auger Bits – Impact Shank

- Hex shank design for use in impact wrench drills
- Bit can be resharpened
- Medium-fast screw point ideal for general wood drilling applications

Diameter	Shank Size	Twist Length	Overall Length	Bulk Item #
1/2"	7/16"	9"	12"	48508
9/16"	7/16"	9"	12"	48509
11/16"	7/16"	9"	12"	48511
13/16"	7/16"	9"	12"	48513
9/16"	5/8"	9"	12"	48609ZR
9/16"	7/16"	15"	18"	48709
11/16"	7/16"	15"	18"	48711
13/16"	7/16"	15"	18"	48713
15/16"	7/16"	15"	18"	48715
1-1/16"	7/16"	15"	18"	48717

WOOD DRILLING

Wood Drilling

Hollow Center / Solid Center Auger Bits



47811

1/2" Female Square Socket Impact Wrench – 51S18 Series

- Quick release button on the shank
- Medium-fast screw point is ideal for general wood drilling applications



Diameter	Twist Length	Overall Length	Bulk Item #
13/16"	15"	18"	47811



49916

Solid Center Auger with Cutting Spur – I-100 Series

- Solid center design provides extra rigidity while drilling
- Wide lands keep the bit straight as it bores through the hole. The flutes are ground behind the lands to funnel chips to the inside of the bit and away from the outside diameter, producing a faster, cleaner cut
- Single-spur cutting edge scribes the circumference of the hole for a smoother finish
- Coarse screw point provides fast drilling in hard and soft woods
- Full-length heat-treated bit guards against bending in heavy-duty applications, and strengthens the twist where the greatest strain occurs



Diameter	Shank Size	Twist Length	Overall Length	Bulk Item #	Pack Qty
1/4"	3/16"	4-1/2"	7-1/2"	49904	1
5/16"	7/32"	4-1/2"	7-1/2"	49905	1
3/8"	5/16"	4-1/2"	7-1/2"	49906	1
7/16"	5/16"	4-1/2"	7-1/2"	49907	1
1/2"	5/16"	4-1/2"	7-1/2"	49908	1
9/16"	5/16"	4-1/2"	7-1/2"	49909	1
5/8"	5/16"	4-1/2"	7-1/2"	49910	1
11/16"	5/16"	4-1/2"	7-1/2"	49911	1
3/4"	5/16"	4-1/2"	7-1/2"	49912	1
13/16"	5/16"	4-1/2"	7-1/2"	49913	1
7/8"	5/16"	4-1/2"	7-1/2"	49914	1
15/16"	5/16"	4-1/2"	7-1/2"	49915	1
1"	5/16"	4-1/2"	7-1/2"	49916	1
1-1/8"	7/16"	4-1/2"	7-1/2"	49918	1
1-1/4"	7/16"	4-1/2"	7-1/2"	49920	1
1-3/8"	7/16"	4-1/2"	7-1/2"	49922	1
1-1/2"	7/16"	4-1/2"	7-1/2"	49924	1

Solid Center Auger Bit Sets

6-pc pouched contains 1/4", 3/8", 1/2", 5/8", 3/4" & 1"	49998	1
3-pc pouched contains 1/4", 3/8", & 1/2"	49999	6

WOOD DRILLING



45516



Drilling Machine Auger Bits – 62R Series, 1/2" Round Shank

- Round shank is designed for use in power drills, drill presses, and drilling machines with 1/2" or larger chuck
- Heavy stem increases strength and rigidity while reducing vibration. Shank length is 2".
- Medium-fast screw point is ideal for general wood drilling applications

Diameter	Twist Length	Overall Length	Bulk Item #
7/16"	6"	8"	45307
1/2"	6"	8"	45308
9/16"	6"	8"	45309
11/16"	6"	8"	45311
3/4"	6"	8"	45312
13/16"	6"	8"	45313
7/8"	6"	8"	45314
1"	6"	8"	45316
3/8"	8"	10"	45406
7/16"	8"	10"	45407
9/16"	8"	10"	45409
11/16"	8"	10"	45411
3/4"	8"	10"	45412
13/16"	10"	12"	45513
1"	10"	12"	45516
3/8"	12"	14"	45606
1/2"	12"	14"	45608
11/16"	12"	14"	45611
3/4"	12"	14"	45612
13/16"	12"	14"	45613
7/8"	12"	14"	45614
1"	12"	14"	45616



43616

Hand Brace Solid Center Auger Bits – 62T Series

- Medium-fast screw point is ideal for general wood drilling applications
- Full-length heat-treated bit guards against bending in heavy-duty applications, and strengthens the twist where the greatest strain occurs
- Double spur, double cutter design leaves an extremely clean hole finish

Diameter	Shank Type	Twist Length	Overall Length	Pouched Item #	Bulk Item #
1/4"	Taper square	3-1/2"	7-1/2"	43604	–
5/16"	Taper square	3-5/8"	7-5/8"	43605	–
3/8"	Taper square	3-3/4"	7-3/4"	43606	–
7/16"	Taper square	3-7/8"	7-7/8"	43607	–
1/2"	Taper square	4"	8"	43608	–
9/16"	Taper square	4-1/8"	8-1/8"	43609	–
5/8"	Taper square	4-1/4"	8-1/4"	43610ZR	–
11/16"	Taper square	4-3/8"	8-3/8"	43611	–
3/4"	Taper square	4-1/2"	8-1/2"	43612	–
13/16"	Taper square	4-5/8"	8-5/8"	43613ZR	–
7/8"	Taper square	4-9/16"	8-3/4"	43614	–
15/16"	Taper square	4-11/16"	8-7/8"	43615	–
1"	Taper square	4-13/16"	9"	43616	–
1-1/2"	Taper square	4-7/8"	9-1/2"	–	43624
13-pc Pouch	–	–	–	–	43697

WOOD DRILLING

Wood Drilling

Installer / Adjustable Wood Bits



38912

Wood Installer Bits

- Constructed of premium alloy steel for drilling into a variety of materials including wood, plaster, and metal lath encountered while installing wire
- Special 82° point for fast drilling
- Hole in flute makes it easy to pull wire through walls, ceilings, and floors
- Ideal for installation of small wire for telephones, cable TV, computers, and security systems

Diameter	Shank Size	Overall Length	Item #	Bulk Item #			
1/4"	.230"	12"	–	38904			
5/16"	.285"	12"	–	38905			
3/8"	.370"	12"	–	38906			
1/2"	.370"	12"	–	38908			
9/16"	.370"	12"	–	38909			
5/8"	.370"	12"	–	38910			
3/4"	.370"	12"	–	38912			
1/4"	.230"	18"	39104	39004			
5/16"	.285"	18"	39105	39005			
3/8"	.370"	18"	39106	39006			
7/16"	.370"	18"	39107ZR	39007			
1/2"	.370"	18"	39108ZR	39008			
9/16"	.370"	18"	39109ZR	–			
5/8"	.370"	18"	39110	39010			
11/16"	.370"	18"	39111	–			
3/4"	.370"	18"	39112	–			
1/4"	.230"	24"	–	39404			
5/16"	.285"	24"	–	39405			
3/8"	.370"	24"	–	39406			
1/2"	.370"	24"	–	39408			
1/4"	.230"	30"	–	39604			
3/8"	.370"	30"	–	39606			
1/2"	.370"	30"	–	39608			
Installer Bit Sets							
3-pc Set 1/4", 3/8", 1/2"				–	–	–	3044001LW

WOOD DRILLING



40012

Masonry Installer Bits

- Hole in flute makes it easy to pull wire through walls, ceilings, and floors
- Specially designed flute quickly clears masonry dust
- Heavy duty 118° point enters material quickly
- Carbide tip cutting edge ideal for use where masonry construction is encountered including brick, mortar joints, and cinder blocks

Diameter	Shank Size	Overall Length	Item #
1/4"	.245"	18"	40004ZR
5/16"	.250"	18"	40005
3/8"	.370"	18"	40006
1/2"	.370"	18"	40008
5/8"	.370"	18"	40010
3/4"	.370"	18"	40012



45002

Adjustable Wood Bits

- Adjustable cutting blade bores a variety of hole sizes
- Cuts 19 hole sizes in increments of 1/8"
- Lockhead screw securely holds blade at desired drilling diameter

Diameter	Shank Size	Usage	Overall Length	Item #
5/8" - 1-3/4"	9/32"	Drill Press	5-1/2"	44801
7/8" - 3"	11/32"	Drill Press	6-1/2"	45002
7/8" - 3"	–	Hand Brace	–	44202

SPEEDBOR MAX SELF-FEED BIT FEATURES

1. Aggressive screw pitch for faster drilling
2. 3X cutting edges* extends bit life
3. 7/16" Quick Change impact shank for fast bit changes



SPEEDBOR Max Self-Feed Wood Bits

- For drilling large diameter holes in wood for pipe, conduit and other applications
- Precision-milled shank eliminates runout and wobble
- Replaceable screw tip
- Resharpenable edges

*2 cutting edges on sizes 3" and larger

Diameter	Overall Length	Pack Qty.	Item #
1"	5"	1	3046004
1-1/8"	5"	1	3046005
1-1/4"	5"	1	3046006
1-3/8"	5"	1	3046007
1-1/2"	5"	1	3046008
1-3/4"	5"	1	3046009
2"	5"	1	3046010
2-1/8"	5"	1	3046011
2-1/4"	5"	1	3046012
2-9/16"	5"	1	3046013
3"	5"	1	3046014
3-5/8"	5"	1	3046015
4-5/8"	5"	1	3046016

Lock-n-Load® Quick Change Extensions

7/16" Quick Change Bit Holder 5-1/2" OAL	3	4935654
7/16" Quick Change Bit Holder 12" OAL	3	4935655
7/16" Quick Change Bit Holder 18" OAL	3	4935656



49618

Brad Point Drill Bits & Sets

- Brad point tip provides accurate positioning for starting the hole
- Bit is precision-ground for use in furniture making, doweling, cabinetry, and other woodworking applications where an exact hole size is required
- Spur cutting edges reduce splintering and ensure a smooth, clean hole
- Wide flutes provide a fast, continuous flow of chip ejection

Diameter	Shank Size	Twist Length	Overall Length	Item #
1/8"	1/8"	1-7/16"	2-9/16"	49612
3/16"	3/16"	2-1/16"	3-3/8"	49613
1/4"	1/4"	2-1/2"	3-31/32"	49614
5/16"	5/16"	2-15/16"	4-19/32"	49615
3/8"	3/8"	3-7/16"	5-1/4"	49616
7/16"	3/8"	3-11/16"	5-19/32"	49617
1/2"	3/8"	3-31/32"	5-15/16"	49618

Brad Point Drill Bit Set

5-pc pouched set contains 3/16", 1/4", 5/16", 3/8" & 1/2" 49600

Wood Drilling

Forstner Bits / Plug Cutters / Countersinks

Forstner Bits



42916

- Reduced shank fits 3/8" portable drills and drill presses
- Brad point tip starts the bit cleanly on uneven surfaces

Forstner Bit Set



42940

Diameter	Shank Size	Item #
1/4"	3/8"	42904
3/8"	3/8"	42906
1/2"	3/8"	42908
5/8"	3/8"	42910
3/4"	3/8"	42912
7/8"	3/8"	42914
1"	3/8"	42916
1-1/8"	3/8"	42918
1-1/4"	3/8"	42920
1-3/8"	3/8"	42922
1-1/2"	3/8"	42924
1-5/8"	3/8"	42926
1-3/4"	3/8"	42928
1-7/8"	3/8"	42930
2"	3/8"	42932
2-1/8"	3/8"	42934
4" Extension	3/8"	42936
Forstner Bit Set		
4-pc Set contains 5/8", 3/4", 7/8", 1"		42940

WOOD DRILLING

Plug Cutters



43910

- Recommended for covering fastener holes in furniture, cabinetry, floors, decks, and other woodworking projects
- Constructed of hardened, high-carbon steel for added strength and durability
- Ideal for making dowels

Diameter	Shank Size	Item #
1/4"	1/4"	43904
3/8"	1/4"	43906
1/2"	1/4"	43908
5/8"	1/4"	43910

Adjustable Countersinks



90583

Description	Counterbore Diameter	Drill Bit Size	Item #
#4 - 5 Countersink	3/8"	5/64"	90581
#6 - 7 Countersink	3/8"	3/32"	90582
#8 - 9 Countersink	3/8"	7/64"	90583
#10 Countersink	3/8"	1/8"	90584
#12 Countersink	1/2"	9/64"	90585

IRWIN®

HANSON®

Taps & Dies



www.irwin.com

Driving Performance Through Innovation

IRWIN® HANSON® has been manufacturing High Carbon Steel threading tools for over 100 years, and has proven itself to be a brand you can trust. Performance, thread quality, durability, and ease of use – proven for over a century.

At IRWIN, we understand it's all about performance, and you only get out of a tool what you put into a tool. The new **Performance Threading System™** from IRWIN HANSON is a prime example. With exceptional innovation, these threading tools are now easier to use, and maintain the high thread quality and durability professionals trust. The IRWIN HANSON **Performance Threading System** includes self-aligning taps and dies for the perfect thread, every single time. New, innovative drive tools make set-up a snap. And, it's all available in handy, modular set cases that fit in the smallest drawers, have removable lids, and easy-to-read marked sizes. Professionals can choose only what they need.



PERFORMANCE THREADING SYSTEM FEATURES

1. Chip Breaking Technology (CBT) cuts chips easier
2. Tap size and recommended drill bit size are laser etched on each tool for easy identification

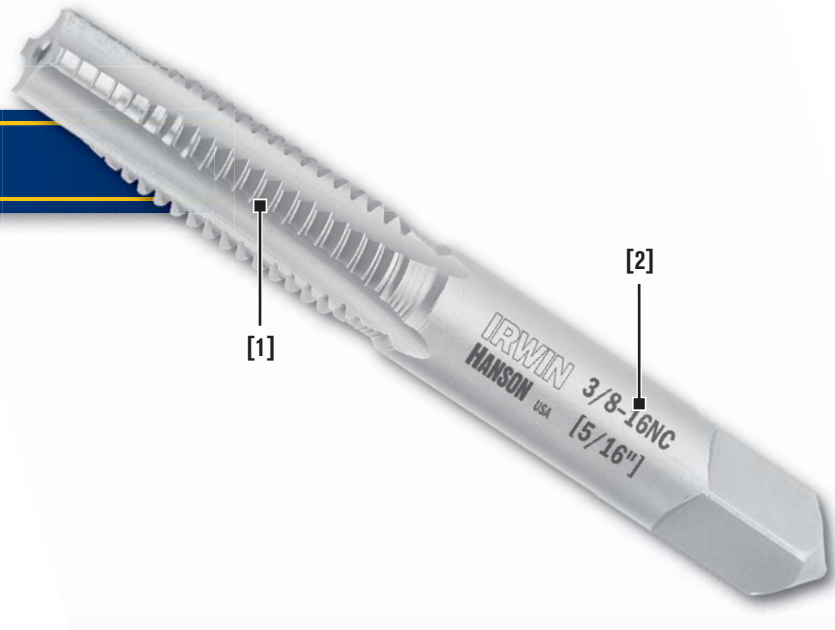

TAPS & DIES

Material Types

High Carbon Steel (HCS)

For hand tapping applications

High Speed Steel (HSS)

For machine tapping where critical dimensions are required



Tap Point Styles

Self-Aligning Taps

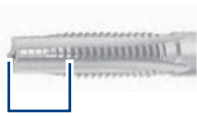

8-10 threads

- Starts straight every time
- Chip-breaking technology cuts chips easier

Plug Taps



3-5 threads

- 3 to 5 threads chamfered
- Most common chamfer
- Ideal for all general purpose threading

Taper Taps

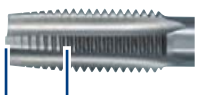

8-10 threads

- 8 to 10 threads chamfered
- Ideal for tough starting applications
- Preferred use with deep or through hole applications

Bottom Taps



1-2 threads

- 1 to 2 threads chamfered
- Shortest and least efficient standard chamfer
- Ideal for threading close to the bottom of blind holes

Die Styles

Self-Aligning Dies



Additional Strength

- Tap size and recommended drill bit size are laser etched on each tool for easy identification



1" Across Hex Flats

- Threads straight every turn
- More steel at critical points for extra strength

Hexagon Dies



5/8", 1", 1-7/16" & 1-13/16" Across Hex Flats

- Best suited for maintenance and repair work
- Recommended for use with hexagonal die stock handles
- In area with limited space, die can be used with a wrench or socket

Solid Round Dies



1" & 1-1/2" Overall Diameter

- Ideal for general purpose threading
- Fits into adjustable guide or plain die stock handles

Adjustable Round Dies



1", 1-1/2", 2" & 3" Overall Diameter

- Adjustable dies allow the user to under or over cut their threads
- Ideal for a precision threading with the adjustment of die made by set screw
- Fits into adjustable guide or plain die stock handles
- Meets Federal Specifications GGG-D-296

TAPS & DIES

Tap & Die Description Guide

10-24 NC		
Fastener Diameter	Thread Type	Applications
10 - Machine screw size 5/8" - Fractional 8 mm - Metric	NC = National Coarse (USS) NF = National Fine (SAE) NS = National Special NEF = National Extra Fine NPT = National Pipe Taper BSP = British Standard Pipe (no thread symbol required for metric fasteners)	General purpose machines and appliances Automotive parts requiring extreme pressures Special threads – either diameter or threads per inch For optical or thin wall parts For all pipe threads For all pipe threads
Thread Pitch		
Threads per inch (machine & fractional) Distance between threads (metric)		

Taps & Dies

Tap & Drill Selection Chart

TAPS & DIES

Diam/Type	Decimal Equiv.	Fractional Tap	Machine Screw Tap	Metric Tap	Screw Ext.
1/64"	.0516				
1/32"	.0312				
1.0 mm	.0394				
60	.0400				
59	.0410				
58	.0420				
57	.0430				
56	.0465				
3/64"	.0469		0 - 80 NF		
55	.0520				
54	.0550				
1.5 mm	.0591				
53	.0595		1 - 64 NC 1 - 72NF		
1/16"	.0625				
52	.0635				
51	.0670				
50	.0700		2 - 56 NC 2 - 64 NF		
49	.0730				
48	.0760				
5/64"	.0781		3 - 48 NC		EX-1
47	.0785				
2.0 mm	.0787				
46	.0810				
45	.0820		3 - 56 NF		
44	.0860		4 - 36 NS		
43	.0890		4 - 40 NC		
42	.0935				
3/32"	.0938		4 - 48 NF		
41	.0960			3 mm - 0.60	
40	.0980				
2.5 mm	.0984			3 mm - 0.50	
39	.0995			3 mm - 0.50	
38	.1015	1/8" - 40 NS	5 - 40 NC		
37	.1040		5 - 44 NF		
36	.1065		6 - 32 NC		
7/64"	.1094				EX-2
35	.1100				
34	.1110		6 - 36 NS		
33	.1130		6 - 40 NF		
32	.1160		6 - 48 NS		
3.0 mm	.1181				
31	.1200				
1/8"	.1250				
30	.1285			4 mm - 0.70 4 mm - 0.75	
29	.1360		8 - 32 NC 8 - 36 NF		
3.5 mm	.1378				
28	.1405				

Diam/Type	Decimal Equiv.	Fractional Tap	Machine Screw Tap	Metric Tap	Screw Ext.
9/64"	.1406	8 - 40 NS			ST-1
27	.1440				
26	.1470	3/16"-24 NS			
25	.1495		10 - 24 NC		
24	.1520				
23	.1540				
5/32"	.1562	3/16"-32 NS			EX-3
22	.1570				
4.0 mm	.1575				
21	.1590		10 - 32 NF		
20	.1600			5 mm - 0.90	
19	.1660			5 mm - 0.80	
18	.1695				
11/64"	.1719				
17	.1730				
16	.1770		12 - 24 NC		
4.5 mm	.1772				
15	.1800				
14	.1820		12 - 28 NEF		
13	.1850				
3/16"	.1875				ST-2
12	.1890				
11	.1910				
10	.1935		14 - 20 NS		
9	.1960				
5.0 mm	.1969			6 mm - 1.00	
8	.1990			6 mm - 1.00	
7	.2010	1/4" - 20 NC			
13/64"	.2031		14 - 24 NS		
6	.2040				
5	.2055				
4	.2090	1/4" - 24 NS			
3	.2130	1/4" - 28 NF			
5.5 mm	.2165				
7/32"	.2188	1/4" - 32 NEF			
2	.2210				
1	.2280	1/4" - 40 NS			
A	.2340				
15/64"	.2344			7 mm - 1.00	ST-3
6.0 mm	.2362			7 mm - 1.00	
B	.2380				
C	.2420				
D	.2460				
E	.2500				
1/4"	.2500				EX-4
6.5 mm	.2559				
F	.2570	5/16" - 18 NC			

Machine Screw Reference Guide

Before cutting a thread, you must know the rod diameter.

Use the chart at right to determine the appropriate machine screw size:

Machine Screw	Rod Diameter
#0	.060"
#1	.073"
#2	.086"
#3	.099"
#4	.112"
#5	.125"
#6	.138"

Machine Screw	Rod Diameter
#7	.151"
#8	.164"
#9	.179"
#10	.190"
#12	.216"
#14	.242"

Diam/Type	Decimal Equiv.	Fractional Tap	Pipe Tap	Metric Tap	Screw Ext.
G	.2610				
17/64"	.2656			8 mm - 1.25	
H	.2660				
I	.2720	5/16"-24 NF			
7.0 mm	.2756			8 mm - 1.00	
J	.2770			8 mm - 1.00	
K	.2810				
9/32"	.2812	5/16"-32 NEF			
L	.2900				
M	.2950				
7.5 mm	.2953				
19/64"	.2969				EX-5
N	.3020			9 mm - 1.25	
5/16"	.3125	3/8"- 16 NC			ST-4
8.0 mm	.3150			9 mm - 1.00	
O	.3160			9 mm - 1.00	
P	.3230			9 mm - 0.75	
21/64"	.3281		1/8" - 28 BSP		
Q	.3320	3/8"- 24 NF	1/8" - 27 NPT		
8.5 mm	.3346			10 mm - 1.50	
R	.3390			10 mm - 1.50	
11/32"	.3438			10 mm - 1.25	
S	.3480				
9.0 mm	.3543			10 mm - 1.00	
T	.3580			10 mm - 1.00	
23/64"	.3594				
U	.3680	7/16"- 14 NC			
9.5 mm	.3740			11 mm - 1.50	
3/8"	.3750			11 mm - 1.50	ST-5
V	.3770				
W	.3806				
25/64"	.3906	7/16"- 20 NF			
10.0 mm	.3937				
X	.3970				
Y	.4040				
13/32"	.4062			12 mm - 1.75	EX-6
Z	.4130			12 mm - 1.50	
10.5 mm	.4134			12 mm - 1.50	
27/64"	.4219	1/2"- 13 NC		12 mm - 1.25	
11.0 mm	.4331				
7/16"	.4375		1/4" - 18 NPT		
11.5 mm	.4528				
29/64"	.4531	1/2"-20 NF 1/2"-24 NS	1/4" - 19 BSP		
15/32"	.4688			14 mm - 2.00	ST-6
12.0 mm	.4724			14 mm - 2.00	
31/64"	.4844	9/16"- 12 NC			
12.5 mm	.4921			14 mm - 1.50	

Diam/Type	Decimal Equiv.	Fractional Tap	Pipe Tap	Metric Tap	Screw Ext.
1/2"	.5000			14 mm - 1.25 14 mm - 1.50	
13.0 mm	.5118			14 mm - 1.25	
33/64"	.5156	9/16"- 18 NF			
17/32"	.5313	5/8"- 11 NC			EX-7
35/64"	.5469			16 mm - 2.00	
9/16"	.5625		3/8" - 18 NPT		ST-7
37/64"	.5781	5/8"- 18 NF		16 mm - 1.50	
19/32"	.5938	11/16"-11 NS			
39/64"	.6094			18 mm - 2.50	
5/8"	.6250	11/16"-16 NS			
41/64"	.6406				
21/32"	.6562	3/4" - 10 NC		18 mm - 1.50	
43/64"	.6719				
11/16"	.6875	3/4" - 16 NF		20 mm - 2.50	
45/64"	.7031		1/2" - 14 NPT		
23/32"	.7188				
47/64"	.7344				
3/4"	.7500				
49/64"	.7656				
25/32"	.7812	7/8" - 9 NC			
51/64"	.7969				
13/16"	.8125	7/8" - 14 NF		22 mm - 1.50	EX-8
53/64"	.8281			24 mm - 3.00	
27/32"	.8438				
55/64"	.8594				
7/8"	.8750	1" - 8 NC		24 mm - 2.00	
57/64"	.8906				
29/32"	.9062				
59/64"	.9219	1" - 12 NF	3/4" - 14 NPT		
15/16"	.9375	1" - 14 NS			
61/64"	.9531				
31/32"	.9688				
63/64"	.9844	1-1/8"- 7 NC			
1"	1.0000				
1-1/64"	1.0156				
1-1/32"	1.0312				
1-1/16"	1.0625				EX-9
1-3/32"	1.0938				
1-1/8"	1.1250				
1-5/32"	1.1562		1" - 11-1/2" NPT		
1-3/16"	1.1875				
1-1/4"	1.2500				
1-5/16"	1.3125				
1-3/8"	1.3750				
1-7/16"	1.4375				
1-1/2"	1.5000		1-1/4" - 11-1/2" NPT		

TAPS & DIES

NC = National Coarse (USS)
 NS = National Special
 NF = National Fine (SAE)

NEF = National Extra Fine
 NPT = National Pipe Taper
 BSP = British Standard Pipe



HANSON® PTS Die Stock Handle



4935054

- Die Lock – no more set screws needed
- Simply twist to insert and remove die

HANSON Adjustable Tap Handle & Reamer Wrenches



4935052

- Versatile base, drives with die stock, 3/8" ratchet or T-handle (included)
- Adjustable jaw has two tap sockets that fit No. 4 to 1/2" or 3 mm to 12 mm

HANSON Plain Die Stock Handles



12416

- Dies easily lock in position with set screw

HANSON Offset Handle Adjustable Tap & Reamer Wrenches



12421

- Straight handle design provides greater leverage, especially when using larger diameter taps

HANSON Adjustable Tap Handle & Reamer Wrenches



12498

- Straight handle design provides greater leverage, especially when using larger diameter taps
- Designed for use with taps, reamers, screw extractors and other tools with a square shank

HANSON Adjustable Guide Die Stock Handles



12428

- Maintains alignment for accurate, straight threading

HANSON Reamers



11221

- For deburring and enlarging holes in sheet metal and similar materials
- Not for use in machine tools

Description	Usage	Carded Item #	Bulk Item #
Hanson PTS Die Stock & Tap Driver			
Tap Driver - Small	For Taps No. 4 to 1/4" (3mm to 6mm)	1766068	4935052
Tap Driver - Medium	For Taps 1/4" to 1/3" (6mm to 12mm)	1766069	4935053
Die Stock	For 1" Hexagon Dies; Accepts Small & Medium Adj. Tap Sockets to Drive Taps	1766070	4935054
HANSON Plain Die Stock Handles			
DS - 57	For 5/8" Hexagon Dies	-	12457
DS - 13	For 13/16" Round Dies	-	12416
DS - 9	For 1" Hexagon or Round Dies	12008	11008
HANSON Adj. Guide Die Stock Handles			
DS - 28	For 1" Adjustable Round Dies	-	12428
DS - 35	For 1-1/2" Adjustable Round Dies	-	12435
DS - 45	For 2" Adjustable Round Dies	-	12445
DS - 26	For 1" Hexagon or Round Dies	12026	11026
DS - 36	For 1-7/16" Hexagon Dies	-	12436
DS - 46	For 1-13/16" Hexagon Dies	-	12446
HANSON Offset Handle Adj. Tap Handle & Reamer Wrenches			
TR - 21	For Taps No. 0 to 1/2" (3 mm to 12 mm)	12021	12421
TR - 121	For Taps No. 1/4" to 1" (6 mm to 24 mm)	-	11212
HANSON Adj. Tap Handle & Reamer Wrenches			
TR - 88	For Taps No. 0 to 1/2" (3 mm to 12 mm)	12088	311088
TR - 98	For Taps 1/4" to 1" (6 mm to 24 mm)	-	12498
HANSON Reamers			
Repair Reamer (1/8" to 1/2")		11214	-
Repair Reamer Pouched (1/2" to 1")		11221	-

HANSON Tap Adaptors



3095001

- Adaptors feature a 3/8" square drive to accommodate socket wrench or extension
- Designed for use with taps, reamers, screw extractors, and other tools with a square shank
- Not recommended for cutting new threads

HANSON Metric Measuring Kit with Thread Gauges

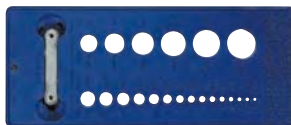

12087

- Shows 21 outside diameters (OD) in millimeters and decimals from 2.3 mm (.0906) to 24 mm (.9449)
- Measures thread pitch in millimeters from 0.35 to 3.00

HANSON T-Handle Tap Wrenches



12401

- Designed for use with taps, reamers, screw extractors and other tools with a square shank
- Adjusted and tightened to size by twisting knurled nut
- End of TR-50 & TR-73 wrench has 3/8" square drive to accommodate socket wrench or extension when desired

HANSON Thread Pitch Gauges



11016

HANSON T-Handle Ratcheting Tap Wrench



21112

21101

- Three position gear box for quick, efficient ratcheting action
- Designed for use with taps, reamers, screw extractors and other tools with a square shank

TAPS & DIES

Description	Usage	Carded Item #	Bulk Item #
HANSON Tap Adaptors			
2pc Tap Adaptor Set	2 Sizes for Taps No. 0 to 1/2"	3095001	-
Small Tap Adaptor	For Taps No. 0 to 1/4"	-	3095001A
Large Tap Adaptor	For Taps 1/4" to 1/2"	-	3095001B
HANSON T-Handle Tap Wrench			
TR - 1E	For Taps No. 0 to 1/4" (3 mm to 6 mm)	12001	12401
TR - 1-1/2E	For Taps No. 12 to 5/16"	12115	12415
TR - 2E	For Taps 1/4" to 1/2" (6 mm to 12 mm)	12002	12402
HANSON Tap Wrenches with 3/8" Drive			
TR - 50	For Taps 1/4" to 1/2" (6 mm to 12 mm)	12050	12450
TR - 73*	For Taps No. 0 to 1/4" (3 mm - 6 mm) *	12073	12473
HANSON T-Handle Ratcheting Tap Wrench			
-	For Tap Sizes No. 0 to 1/4" (3 mm to 6 mm)	21201	21101
-	For Tap Sizes 1/4" to 1/2" (6 mm to 12 mm)	21202	21102
-	10" Extended Length for Tap Sizes #0 - 1/4" (3 mm to 6 mm)	21210	21110
-	12" Extended Length for Tap Sizes 1/4" - 1/2" (6 mm to 12 mm)	21212	21112
HANSON Metric Measuring Kit w/Thread Gauges			
Metric Measuring Kit		-	12087
HANSON Thread Pitch Gauges			
16-Leaf Metric Thread Pitch Gauge		12016	11016
16-Leaf Standard and Metric Thread Pitch Gauge		12017	11017
18-Leaf Standard Thread Pitch Gauge		12018	11018

*Note: TR-73 comes with a hexagon nut

Taps & Dies

High Carbon Steel Taps

HANSON® Machine Screw Taps (HCS)



1032



1132



1232

- Self-aligning tap
- Ideal for routine maintenance, repair work and for rethreading where high accuracy and tolerance thread is not critical
- Straight flutes are ground to provide rapid chip removal for efficient threading
- Designed for hand threading work in a variety of materials
- Taps produce a class 2B thread

Description	No. of Flutes	Plug Carded Item #	Plug Bulk Item #	Taper Bulk Item #	Bottom Bulk Item #	Self Aligning Bulk Item #
0 - 80 NF	2	-	1102	1002	1202	-
1 - 64 NC	2	-	1104	1004	1204	-
1 - 72 NF	2	-	1105	1005	1205	-
2 - 56 NC	3	-	1106	1006	1206	-
2 - 64 NF	3	-	1107	1007	1207	-
3 - 48 NC	3	-	1108	1008	1208	-
3 - 56 NF	3	-	1109	1009	1209	-
4 - 36 NS	3	8011	1111	1011	1211	-
4 - 40 NC	3	8012	1112	1012	1212	4935222
4 - 48 NF	3	-	1113	1013	1213	-
5 - 40 NC	3	-	1116	1016	1216	-
5 - 44 NF	3	-	1117	1017	1217	-
6 - 32 NC	3	8018	1118	1018	1218	4935223
6 - 36 NS	3	-	1119	1019	1219	-
6 - 40 NF	3	-	1120	1020	1220	-
6 - 48 NS	3	-	1121	1021	1221	-
8 - 32 NC	4	8024	1124	1024	1224	4935224
8 - 36 NF	4	-	1125	1025	1225	-
8 - 40 NS	4	-	1126	1026	1226	-
10 - 24 NC	4	8028	1128	1028	1228	4935225
10 - 32 NF	4	8031	1131	1031	1231	4935226
12 - 24 NC	4	8032	1132	1032	1232	4935227
12 - 28 NF	4	-	1133	1033	1233	-
12 - 32 NEF	4	-	1134	1034	1234	-
14 - 20 NS	4	8035	1135	1035	1235	-
14 - 24 NS	4	-	1136	1036	1236	-

HANSON Fractional Taps (HCS)



1323



1423



1523

- Self-aligning tap
- Ideal for routine maintenance, repair work and for rethreading where high accuracy and tolerance thread is not critical
- Straight flutes are ground to provide rapid chip removal for efficient threading
- Designed for hand threading work in a variety of materials
- Taps produce a class 2B thread

Description	No. of Flutes	Plug Carded Item #	Plug Bulk Item #	Taper Bulk Item #	Bottom Bulk Item #	Self Aligning Bulk Item #
1/8" - 40 NS	3	-	1406	1306	1506	-
1/8" - 44 NS	3	-	1407	-	-	-
5/32" - 32 NS	3	-	1410	-	-	-
5/32" - 36 NS	3	-	1411	-	-	-
3/16" - 24 NS	4	-	1412	1312	1512	-
3/16" - 32 NS	4	-	1413	1313	1513	-
1/4" - 20 NC	4	8120	1420	1320	1520	4935228
1/4" - 24 NS	4	-	1421	1321	1521	-
1/4" - 28 NF	4	8123	1423	1323	1523	4935229
1/4" - 32 NEF	4	-	1424	1324	1524	-
1/4" - 40 NS	4	-	1425	1325	1525	-
5/16" - 18 NC	4	8127	1427	1327	1527	4935230
5/16" - 24 NF	4	8129	1429	1329	1529	4935231
5/16" - 32 NEF	4	-	1431	1331	1531	-
3/8" - 16 NC	4	8134	1434	1334	1534	4935232
3/8" - 24 NF	4	8136	1436	1336	1536	4935233
7/16" - 14 NC	4	8139	1439	1339	1539	4935234
7/16" - 20 NF	4	8140	1440	1340	1540	4935235
1/2" - 13 NC	4	8144	1444	1344	1544	4935236
1/2" - 20 NF	4	8145	1445	1345	1545	4935237
1/2" - 24 NS	4	-	1446	1346	1546	-
9/16" - 12 NC	4	8148	1448	1348	1548	-
9/16" - 18 NF	4	8149	1449	1349	1549	-
5/8" - 11 NC	4	8152	1452	1352	1552	-
5/8" - 18 NF	4	8154	1454	1354	1554	-
11/16" - 11 NS	4	-	1456	1356	1556	-
11/16" - 16 NS	4	-	1457	1357	1557	-
3/4" - 10 NC	4	8158	1458	1358	1558	-
3/4" - 16 NF	4	8160	1460	1360	1560	-
7/8" - 9 NC	4	-	1461	1361	1561	-
7/8" - 14 NF	4	-	1463	1363	1563	-
1" - 8 NC	4	-	1465	1365	1565	-
1" - 12 NF	4	-	1466	1366	1566	-
1" - 14 NS	4	-	1467	1367	1567	-

TAPS & DIES

HANSON Metric Taps (HCS)



1859

- Ideal for auto repair and machinery where metric threads are specified

Description	No. of Flutes	Plug Carded Item #	Plug Bulk Item #	Bottom Bulk Item #	Self Aligning Bulk Item #
3 mm - 0.50	3	8312	1712	1812	4935238
3 mm - 0.60	3	-	1713	-	-
4 mm - 0.70	4	8317	1717	1817	4935239
4 mm - 0.75	4	8318	1718	1818	4935240
5 mm - 0.80	4	8322	1722	1822	4935241
5 mm - 0.90	4	8323	1723	1823	4935242
6 mm - 1.00	4	8327	1727	1827	4935243
6.3 mm - 1.00	4	-	1729	1829	-
7 mm - 1.00	4	8331	1731	1831	4935244
8 mm - 1.00	4	8333	1733	1833	4935245
8 mm - 1.25	4	8334	1734	1834	4935246
9 mm - 0.75	4	8335	1735	-	-
9 mm - 1.00	4	8336	1736	-	4935247
9 mm - 1.25	4	8337	1737	1837	4935248
10 mm - 1.00	4	8338	1738	1838	-
10 mm - 1.25	4	8339	1739	1839	4935249
10 mm - 1.50	4	8340	1740	1840	4935250
11 mm - 1.50	4	8341	1741	-	4935251
12 mm - 1.25	4	8342	1742	1842	4935252
12 mm - 1.50	4	8343	1743	-	-
12 mm - 1.75	4	8344	1744	1844	4935253
14 mm - 1.25	4	-	1749	1849	-
14 mm - 1.50	4	-	1750	-	-
14 mm - 2.00	4	-	1752	1852	-
16 mm - 1.00	4	-	1754	-	-
16 mm - 1.50	4	-	1755	1855	-
16 mm - 2.00	4	-	1756	1856	-
18 mm - 1.50	4	-	1759	1859	-
18 mm - 2.50	4	-	1761	1861	-
20 mm - 2.50	4	-	1764	1864	-
22 mm - 1.50	4	-	1765	1865	-
24 mm - 2.00	4	-	1768	1868	-
24 mm - 3.00	4	-	1769	1869	-

HANSON Pipe Taper Taps (HCS)



1903

- Cuts internal threads in pipes
- Nominal size of the tap is that of the pipe fitting being tapped
- Available in National Pipe Taper (NPT) and British Standard Pipe Taper (BSP)
- Ideal for pipe fittings
- Tapered at a rate of 3/4" per foot

Description	No. of Flutes	Plug Carded Item #	Taper Pouched Item #	Taper Bulk Item #
1/8" - 27 NPT	4	8202	-	1902
1/4" - 18 NPT	4	8203	-	1903
3/8" - 18 NPT	4	-	1904P	1904
1/2" - 14 NPT	4	-	1905P	1905
3/4" - 14 NPT	5	-	1906P	1906
1" - 11-1/2 NPT	5	-	-	1907
1-1/4" - 11-1/2 NPT	5	-	-	1908
1-1/2" - 11-1/2 NPT	6	-	-	1909
2" - 11-1/2 NPT	6	-	-	1910
1/8" - 28 BSP	4	-	-	1911
1/4" - 19 BSP	4	-	-	1912

HANSON 6-pc Pipe Taper Tap Set (HCS)



1921

Contents	Item # 1921
1/8" - 27 NPT	1902
1/4" - 18 NPT	1903
3/8" - 18 NPT	1904
1/2" - 14 NPT	1905
3/4" - 14 NPT	1906
1" - 11-1/2 NPT	1907

Taps & Dies

High Carbon Steel Taps

HANSON Spark Plug Taps (HCS)



2459

- Available in standard and metric threads
- Ideal for threading or re-threading spark plug holes

Description	No. of Flutes	Bulk Item #
14 mm - 1.25	4	2449
18 mm - 1.50	4	2459

HANSON Tap Sets with Taper, Bottoming & Plug Point Styles

2652



- Set contains all three chamfer styles for various uses

Description	No. of Flutes	Item #
6 - 32 NC	3	2518
8 - 32 NC	4	2524
10 - 24 NC	4	2528
10 - 32 NF	4	2531
1/8" - 40 NS	3	2606
1/8" - 44 NS	3	2607
5/32" - 32 NS	4	2610
5/32" - 36 NS	4	2611
3/16" - 24 NS	4	2612
3/16" - 32 NS	4	2613ZR
1/4" - 20 NC	4	2620
1/4" - 28 NF	4	2623
5/16" - 18 NC	4	2627
5/16" - 24 NF	4	2629
3/8" - 16 NC	4	2634
3/8" - 24 NF	4	2636
7/16" - 14 NC	4	2639
7/16" - 20 NF	4	2640
1/2" - 13 NC	4	2644
1/2" - 20 NF	4	2645
9/16" - 12 NC	4	2648
9/16" - 18 NF	4	2649ZR
5/8" - 11 NC	4	2652
5/8" - 18 NF	4	2654
3/4" - 10 NC	4	2658
3/4" - 16 NF	4	2660
7/8" - 9 NC	4	2661
7/8" - 14 NF	4	2663
1" - 8 NC	4	2665
1" - 12 NS	4	2666
1" - 14 NF	4	2667
3 mm - 0.50	3	2712
5 mm - 0.80	4	2722
6 mm - 1.00	4	2727
7 mm - 1.00	4	2731
8 mm - 1.00	4	2733
8 mm - 1.25	4	2734
10 mm - 1.00	4	2738
10 mm - 1.25	4	2739
10 mm - 1.50	4	2740
12 mm - 1.25	4	2742
12 mm - 1.75	4	2744
14 mm - 2.00	4	2752
16 mm - 2.00	4	2756

TAPS & DIES

HANSON Tap (HCS) & Drill Bit (HSS)



80238

- High speed steel drill bits ensure fast, precise drilling
- High carbon steel plug taps are ideal for general purpose threading

HANSON Tap (HCS) & Drill Bit (HSS) Self Aligning Performance Threading System (PTS)



1765531



HANSON Tap (HCS) & Drill Bit (HSS) Sets



80185

- These drill and tap combinations produce a thread that is strong and easy to tap
- 135° split point HSS drill bits ensure fast, precise drilling
- High carbon steel plug taps are ideal for general purpose threading

Description	Plug Carded Item #
4 - 40 NC Tap + No. 43 Drill Bit	80209
6 - 32 NC Tap + 7/64" Drill Bit	80213
8 - 32 NC Tap + No. 29 Drill Bit	80217
10 - 24 NC Tap + No. 25 Drill Bit	80220
10 - 32 NF Tap + No. 21 Drill Bit	80221
12 - 24 NC Tap + No. 16 Drill Bit	80222
1/4" - 20 NC Tap + 13/64" Drill Bit	80230
1/4" - 28 NF Tap + No. 3 Drill Bit	80232
5/16" - 18 NC Tap + Letter G Drill Bit	80235
3/8" - 16 NC Tap + Letter O Drill Bit	80238
1/2" - 13 NC Tap + 27/64" Drill Bit	80242
1/4" - 18 NPT Tap + 7/16" Drill Bit	80260
6 mm - 1.00 Tap + 5mm Drill Bit	80327
8 mm - 1.25 Tap + 17/64" Drill Bit	80334
10 mm - 1.50 Tap + 8.5 Drill Bit	80340

Description	Self Aligning Carded Item #
6 - 32 NC Tap + No. 36 Drill Bit	1765531
8 - 32 NC Tap + No. 29 Drill Bit	1765534
10 - 24 NC Tap + No. 25 Drill Bit	1765535
10 - 32 NF Tap + No. 21 Drill Bit	1765536
12 - 24 NC Tap + No. 16 Drill Bit	1765537
1/4" - 20 NC Tap + No. 7 Drill Bit	1765538
5/16" - 18 NC Tap + Letter F Drill Bit	1765539
3/8" - 16 NF Tap + 5/16" Drill Bit	1765540

Description	Contents		Item #
13-pc Set	Lock & Hardware Drill & Tap Set		80185
Thread Size	Plug Tap Item #	Drill Bit Size	Drill Bit Item #
6 - 32 NC	1118	7/64"	30107
8 - 32 NC	1124	No. 29	20129
10 - 24 NC	1128	No. 25	20125
10 - 32 NF	1131	No. 21	20121
12 - 24 NC	1132	No. 16	20116
1/4" - 20 NC	1420	13/64"	30113
Threading Tools			Item #
T-Handle Tap Wrench			12401

Description	All-Purpose Drill & Tap Set		Item #
13-pc Set	All-Purpose Drill & Tap Set		80187
Thread Size	Plug Tap Item #	Drill Bit Size	Drill Bit Item #
4 - 40 NC	1112	No. 43	20143
6 - 32 NC	1118	No. 35	20135
8 - 32 NC	1124	No. 29	20129
10 - 24 NC	1128	No. 25	20125
10 - 32 NF	1131	No. 21	20121
1/4" - 20 NC	1420	No. 7	20107
Threading Tools			Item #
T-Handle Tap Wrench			12401

TAPS & DIES

Taps & Dies

High Carbon Steel Dies

HANSON® Self Aligning Dies (HCS) Performance Threading System (PTS)



4935027

- Threads straight every turn
- More steel at critical points for extra strength



Description	1" Across Flat Self Aligning Bulk Item #
DIE SA 4-40NC 1" HEX	4935018
DIE SA 6-32NC 1" HEX	4935019
DIE SA 8-32NC 1" HEX	4935020
DIE SA 10-24NC 1" HEX	4935021
DIE SA 10-32NF 1" HEX	4935022
DIE SA 12-24NC 1" HEX	4935023
DIE SA 1/4"-20NC 1" HEX	4935024
DIE SA 1/4"-28NF 1" HEX	4935025
DIE SA 5/16"-18NC 1" HEX	4935026
DIE SA 5/16"-24NF 1" HEX	4935027
DIE SA 3/8"-16NC 1" HEX	4935028
DIE SA 3/8"-24NF 1" HEX	4935029
DIE SA 7/16"-14NC 1" HEX	4935030
DIE SA 7/16"-20NF 1" HEX	4935031
DIE SA 1/2"-13NC 1" HEX	4935032
DIE SA 1/2"-20NF 1" HEX	4935033
DIE SA 3-0 5MM 1" HEX	4935035
DIE SA 4-0 7MM 1" HEX	4935036
DIE SA 4-0 75MM 1" HEX	4935037
DIE SA 5-0 8MM 1" HEX	4935038
DIE SA 5-0 9MM 1" HEX	4935039
DIE SA 6-1MM 1" HEX	4935040
DIE SA 7-1MM 1" HEX	4935041
DIE SA 8-1MM 1" HEX	4935042
DIE SA 8-1 25MM 1" HEX	4935043
DIE SA 9-1MM 1" HEX	4935044
DIE SA 9-1 25MM 1" HEX	4935045
DIE SA 10-1 25MM 1" HEX	4935046
DIE SA 10-1 5MM 1" HEX	4935047
DIE SA 11-1 5MM 1" HEX	4935048
DIE SA 12-1 25MM 1" HEX	4935049
DIE SA 12-1 75MM 1" HEX	4935050
DIE SA 1/8" - 28BSP 1"HEX	4935051

HANSON Hexagon Machine Screw Dies (HCS)



6432

Description	1" Across Flat Carded Item #	1" Across Flat Bulk Item #	1-7/16" Across Flat Bulk Item #	1-13/16" Across Flat Bulk Item #
Machine				
4 - 36 NS	9311	6411	-	-
4 - 40 NC	9312	6412	-	-
5 - 40 NC	-	6416	-	-
6 - 32 NC	9318	6418	-	-
8 - 32 NC	9324	6424	-	-
10 - 24 NC	9328	6428	-	-
10 - 32 NF	9331	6431	-	-
12 - 24 NC	9332	6432	-	-
14 - 20 NS	9335	6435	-	-

HANSON Hexagon Fractional Dies (HCS)



6544



8461

Description	1" Across Flat Carded Item #	1" Across Flat Bulk Item #	1-7/16" Across Flat Bulk Item #	1-13/16" Across Flat Bulk Item #
Fractional				
3/16" - 24 NS	-	6512	-	-
1/4" - 20 NC	9420	6520	-	-
1/4" - 28 NF	9423	6523	-	-
5/16" - 18 NC	9427	6527	-	-
5/16" - 24 NF	9429	6529	-	-
3/8" - 16 NC	9434	6534	-	-
3/8" - 24 NF	9436	6536	-	-
7/16" - 14 NC	9439	6539	-	-
7/16" - 20 NF	9440	6540	-	-
1/2" - 13 NC	9444	6544	-	-
1/2" - 20 NF	9445	6545	-	-
9/16" - 12 NC	-	-	6848	-
9/16" - 18 NF	-	-	6849	-
5/8" - 11 NC	-	-	6852	-
5/8" - 18 NF	-	-	6854	-
3/4" - 10 NC	-	-	6858	-
3/4" - 16 NF	-	-	6860	-
7/8" - 9 NC	-	-	-	8461
7/8" - 14 NF	-	-	-	8463
1" - 8 NC	-	-	-	8465
1" - 14 NS	-	-	-	8467

- Ideal for maintenance and repair work
- Recommended for use with hexagon die stock
- Die can be used with a wrench or socket when space is limited

TAPS & DIES

Taps & Dies

High Carbon Steel Dies

HANSON Hexagon Pipe Taper Dies (HCS)



6703



7004

- Ideal for plumbing and air applications

Description	1" Across Flat Carded Item #	1" Across Flat Bulk Item #	1-7/16" Across Flat Bulk Item #
1/8" - 27 NPT	9502	6702	-
1/4" - 18 NPT	9503	6703	-
3/8" - 18 NPT	-	-	7004
1/2" - 14 NPT	-	-	7005
1/8" - 28 BSP	-	6711	-
1/4" - 19 BSP	-	6712	-

HANSON® Hexagon Metric Dies (HCS)

TAPS & DIES



6638



6949



8569

- Ideal for automotive repair and machinery where metric threads are specified

Description	1"Across Flat Carded Item #	1" Across Flat Bulk Item #	1-7/16" Across Flat Bulk Item #	1-13/16" Across Flat Bulk Item #
3 mm - 0.50	9712	6612	-	-
3 mm - 0.60	-	6613	-	-
4 mm - 0.70	9717	6617	-	-
4 mm - 0.75	9718	6618	-	-
5 mm - 0.80	9722	6622	-	-
5 mm - 0.90	9723	6623	-	-
6 mm - 1.00	9727	6627	-	-
6.3 mm - 1.00	-	6629	-	-
7 mm - 1.00	9731	6631	-	-
8 mm - 1.00	9733	6633	-	-
8 mm - 1.25	9734	6634	-	-
9 mm - 0.75	9735	6635	-	-
9 mm - 1.00	9736	6636	-	-
9 mm - 1.25	9737	6637	-	-
10 mm - 1.00	9738	6638	-	-
10 mm - 1.25	9739	6639	-	-
10 mm - 1.50	9740	6640	-	-
11 mm - 1.50	9741	6641	-	-
12 mm - 1.25	9742	6642	-	-
12 mm - 1.50	9743	6643	-	-
12 mm - 1.75	9744	6644	-	-
14 mm - 1.25	-	-	6949	-
14 mm - 1.50	-	-	6950	-
14 mm - 2.00	-	-	6952	-
16 mm - 1.00	-	-	6954	-
16 mm - 1.50	-	-	6955	-
16 mm - 2.00	-	-	6956	-
18 mm - 1.50	-	-	6959	-
18 mm - 2.50	-	-	6961	-
20 mm - 2.50	-	-	-	8564
22 mm - 1.50	-	-	-	8565
24 mm - 2.00	-	-	-	8568
24 mm - 3.00	-	-	-	8569

HANSON Round Machine Screw Dies (HCS)



3718



3028

- Solid round dies ideal for general purpose threading
- Adjustable round dies ideal for precision threading

Description	1" Overall Diam. Screw Adj. Bulk Item #	1" Overall Diam. Solid Bulk Item #
4 - 40 NC	3712	—
4 - 48 NF	3713	—
5 - 40 NC	3716	—
5 - 44 NF	3717	—
6 - 32 NC	3718	—
6 - 36 NS	3719	—
6 - 40 NF	3720	—
6 - 48 NS	3721	—
8 - 32 NC	3724	—
8 - 36 NF	3725	—
8 - 40 NS	3726	—
10 - 24 NC	3728	3028
10 - 32 NF	3731	—
12 - 24 NC	3732	—
12 - 28 NF	3733	—
14 - 20 NS	3735	—

HANSON Round Fractional Dies (HCS)



3820



3120

- Solid round dies ideal for general purpose threading
- Adjustable round dies ideal for precision threading

Description	1" Overall Diam. Screw Adj. Bulk Item #	1" Overall Diam. Solid Bulk Item #
3/16" - 32 NS	3813	—
1/4" - 20 NC	3820	3120
1/4" - 24 NS	3821	—
1/4" - 28 NF	3823	—
1/4" - 32 NEF	3824	—
1/4" - 40 NS	3825	—
5/16" - 18 NC	3827	3127
5/16" - 24 NF	3829	—
5/16" - 32 NEF	3831	—
3/8" - 16 NC	3834	3134
3/8" - 24 NF	3836	—
7/16" - 14 NC	3839	—
7/16" - 20 NF	3840	—
1/2" - 13 NC	3844	—
1/2" - 20 NF	3845	—
1/2" - 24 NS	3846	—

TAPS & DIES

Taps & Dies

High Carbon Steel Dies

HANSON Adjustable Round Fractional Dies Right & Left-Hand (HCS)



4020



7520



7652

TAPS & DIES

- Adjustable round dies ideal for precision threading
- Left-hand dies cut threads with a left-hand rotation

Description	Right-Hand 1-1/2" O.D. Bulk Item #	Right-Hand 2" O.D. Bulk Item #	Right-Hand 3" O.D. Bulk Item #	Left-Hand 1" O.D. Bulk Item #	Left-Hand 1-1/2" O.D. Bulk Item #
1/4" - 20 NC	4020	-	-	7520	-
1/4" - 28 NF	4023	-	-	7523	-
5/16" - 18 NC	4027	-	-	7527	-
5/16" - 24 NF	4029	-	-	7529	-
3/8" - 16 NC	4034	-	-	7534	-
3/8" - 24 NF	4036	-	-	7536	-
7/16" - 14 NC	4039	-	-	7539	-
7/16" - 20 NF	4040	-	-	7540	-
1/2" - 13 NC	4044	-	-	7544	-
1/2" - 20 NF	4045	-	-	7545	-
9/16" - 12 NC	4048	-	-	-	7648
9/16" - 18 NF	4049	-	-	-	7649
5/8" - 11 NC	4052	-	-	-	7652
5/8" - 18 NF	4054	-	-	-	7654
11/16" - 11 NS	4056	-	-	-	-
11/16" - 16 NS	4057	-	-	-	-
3/4" - 10 NC	4058	-	-	-	7658
3/4" - 16 NF	4060	-	-	-	7660
7/8" - 9 NC	-	4261	-	-	-
7/8" - 14 NF	-	4263	-	-	-
1" - 8 NC	-	4265	-	-	-
1" - 12 NF	-	4266	-	-	-
1" - 14 NS	-	4267	-	-	-
1-1/8" - 7 NC	-	-	4668	-	-
1-1/8" - 12 NF	-	-	4669	-	-
1-1/4" - 7 NC	-	-	4670	-	-
1-1/4" - 12 NF	-	-	4671	-	-
1-3/8" - 6 NC	-	-	4672	-	-
1-3/8" - 12 NF	-	-	4673	-	-
1-1/2" - 6 NC	-	-	4674	-	-
1-1/2" - 12 NF	-	-	4675	-	-

HANSON Round Pipe Taper Dies (HCS)



4102

Description	1-1/2" O.D. Solid Round Bulk Item #	1-1/2" O.D. Screw Adj. Bulk Item #	1" O.D. Screw Adj. Bulk Item #	2" O.D. Screw Adj. Bulk Item #
1/8" - 27 NPT	4102	5102	502101*	-
1/4" - 18 NPT	4103	5103	-	-
3/8" - 18 NPT	4104	5104	-	-
1/2" - 14 NPT	4105	5105	-	-
1/2" - 14 NPT	-	-	-	4305
3/4" - 14 NPT	-	-	-	4306

*Note: 502101 is a High Speed Steel Die

The IRWIN HANSON Performance Threading System is available in handy modular set configurations, so professionals can choose only what they need. SAE and Metric taps and dies are available. Sizes are clearly imprinted on the cases for easier replacement and storage. Plus, sets have clear, detachable lids, and they're only 1-1/2" thick, to easily fit in the smallest drawer in the toolbox.



HANSON PTS Fractional Tap & Die Modules



4935352

4935058

Set Contents	Item # 4935056	Item # 4935352	Item # 4935060	Item # 4935058
Thread Size Fractional	Tap Item # Plug Style	Tap Item # Alignment Style	1" Solid Hex Die Item # Plug Style	1" Solid Hex Die Item # Alignment Style
4 - 40 NC	1112	4935222	6412	4935018
6 - 32 NC	1118	4935223	6418	4935019
8 - 32 NC	1124	4935224	6424	4935020
10 - 24 NC	1128	4935225	6428	4935021
10 - 32 NF	1131	4935226	6431	4935022
12 - 24 NC	1132	4935227	6432	4935023
1/4" - 20 NC	1420	4935228	6520	4935024
1/4" - 28 NF	1423	4935229	6523	4935025
5/16" - 18 NC	1427	4935230	6527	4935026
5/16" - 24 NF	1429	4935231	6529	4935027
3/8" - 16 NC	1434	4935232	6534	4935028
3/8" - 24 NF	1436	4935233	6536	4935029
7/16" - 14 NC	1439	4935234	6539	4935030
7/16" - 20 NF	1440	4935235	6540	4935031
1/2" - 13 NC	1444	4935236	6544	4935032
1/2" - 20 NF	1445	4935237	6545	4935033
1/8" - 27NPT	1902	1902	6702	6702

HANSON PTS Metric Tap & Die Modules



4935353

4935059

Set Contents	Item # 4935057	Item # 4935353	Item # 4935061	Item # 4935059
Thread Size Metric	Tap Item # Plug Style	Tap Item # Alignment Style	1" Solid Hex Die Item # Plug Style	1" Solid Hex Die Item # Alignment Style
3 - 0.50MM	1712	4935238	6612	4935035
4 - 0.70MM	1717	4935239	6617	4935036
4 - 0.75MM	1718	4935240	6618	4935037
5 - 0.80MM	1722	4935241	6622	4935038
5 - 0.90MM	1723	4935242	6623	4935039
6 - 1.00MM	1727	4935243	6627	4935040
7 - 1.00MM	1731	4935244	6631	4935041
8 - 1.00MM	1733	4935245	6633	4935042
8 - 1.25MM	1734	4935246	6634	4935043
9 - 1.00MM	1736	4935247	6636	4935044
9 - 1.25MM	1737	4935248	6637	4935045
10 - 1.25MM	1739	4935249	6639	4935046
10 - 1.50MM	1740	4935250	6640	4935047
11 - 1.50MM	1741	4935251	6641	4935048
12 - 1.25MM	1743	4935252	6642	4935049
12 - 1.75MM	1744	4935253	6644	4935050
1/8" - 28BSP	1911	1911	6711	6711

TAPS & DIES

Taps & Dies

PTS Drive Tool / Combo Sets

HANSON PTS Drive Tool Module



4935055

Threading Tools

Item # 4935055

Tap Driver - Small: Adj Tap Socket Drives Taps Sizes No. 4 (3mm) To 1/4" (6mm)	4935052
Tap Driver - Medium: Adj Tap Socket Drives Taps Sizes 1/4" (3mm) To 1/2" (12mm)	4935053
Die Stock: Drives 1" Hex Dies With And Without Alignment, Accepts Sm & Med Adj Tap Sockets	4935054
Metric Pitch Gauge	11016
SAE Pitch Gauge	11018
Die Spacer Bulk, Hex - IRWIN	1775311
T-Bar For Adj. Tap Socket Bulk - IRWIN	1775312

HANSON PTS Plug Module Combo Sets



4935354

Plug Set Contents	Item # 4935354	Item # 4935062	Item # 4935063	Item # 4935064
SAE Tap Plug Style	4935056	4935056	-	4935056
Metric Tap Plug Style	4935057	-	4935057	4935057
1" Solid Hex SAE Die Plug Style	4935060	4935060	-	-
1" Solid Hex Metric Die Plug Style	4935061	-	4935061	-
Drive Tools	4935055	4935055	4935055	4935055

HANSON PTS Alignment Module Combo Sets



4935357

Alignment Set Contents	Item # 4935355	Item # 4935356	Item # 4935357	Item # 4935358	Item # 4935359
SAE Tap Alignment Style	4935352	4935352	-	4935352	
Metric Tap Alignment Style	4935353	-	4935353	4935353	
1" Solid Hex SAE Die Alignment Style	4935058	4935058	-	-	4935058
1" Solid Hex Metric Die Alignment Style	4935059	-	4935059	-	4935059
Drive Tools	4935055	4935055	4935055	4935055	4935055



HANSON 117-piece Machine Screw/ Fractional/Metric Tap & Hex Die and Drill Bit Deluxe Set



26377

Set Contents			Set Item # 26377	
Thread Size Machine Screw	Tap Item # Plug Style	Die Item # 5/8" Hexagon	Drill Bit Size	Drill Bit Item #
4 - 40 NC	1112	6112	No. 43	80143
6 - 32 NC	1118	6118	No. 36	80136
8 - 32 NC	1124	6124	No. 29	80129
10 - 24 NC	1128	6128	No. 25	80125
10 - 32 NF	1131	6131	No. 21	80121
12 - 24 NC	1132	6132	No. 16	80116
Fractional				
		1" Hexagon		
1/4" - 20 NC	1420	6520	No. 7	80107
1/4" - 28 NF	1423	6523	No. 3	80103
5/16" - 18 NC	1427	6527	Letter F	40106
5/16" - 24 NF	1429	6529	Letter I	40109
3/8" - 16 NC	1434	6534	5/16"	60120
3/8" - 24 NF	1436	6536	Letter Q	40117
7/16" - 14 NC	1439	6539	Letter U	40121
7/16" - 24 NF	1440	6540	25/64"	60125
1/2" - 13 NC	1444	6544	27/64"	60127
1/2" - 20 NF	1445	6545	29/64"	60129
Metric				
		5/8" Hexagon		
3 mm - 0.50	1712	6312	No. 39	80139
4 mm - 0.70	1717	6317	No. 30	80130
4 mm - 0.75	1718	6318	No. 30	80130*
5 mm - 0.80	1722	6322	No. 19	90119
5 mm - 0.90	1723	6323	No. 20	80120
6 mm - 1.00	1727	6327	No. 9	80109
		1" Hexagon		
7 mm - 1.00	1731	6631	Letter B	40102
8 mm - 1.00	1733	6633	Letter J	40110
8 mm - 1.25	1734	6634	Letter H	40108
9 mm - 1.00	1736	6636	Letter O	40115
9 mm - 1.25	1737	6637	5/16"	60120*
10 mm - 1.25	1739	6639	Letter S	40119
10 mm - 1.50	1740	6640	Letter R	40118
11 mm - 1.50	1741	6641	3/8"	60124
12 mm - 1.50	1743	6643	Letter Z	40126
12 mm - 1.75	1744	6644	13/32"	60126
Pipe				
1/8" - 27 NPT	1902	6702	Letter Q	40117*
1/8" - 28 BSP	1911	6711	21/64"	60121
Spiral Flute Screw Extractor			Drill Bit Size	Item #
EX - 1			5/64"	60105
EX - 2			7/64"	60107
EX - 3			5/32"	60110
EX - 4			1/4"	60116
EX - 5			19/64"	60119
Threading Tools			Item #	
Adjustable Die Stock - 1" Dies			11026	
Plain Die Stock - 5/8" Hexagon Dies			12457	
Adj. Handle Tap Wrench - Taps No. 0 to 1/2"			311088	
Two-in-One Tap Wrench - Taps 1/4" to 1/2"			12450	
T-Handle Wrench - Taps No. 0 to 1/4"			12473	
16 Leaf Metric Thread Pitch Gauge			11016	
18 Leaf Standard Thread Pitch Gauge			11018	
Empty Plastic Case For 26377			26377MT	

* Duplicate

TAPS & DIES

Taps & Dies

High Carbon Steel Combination Sets

HANSON® 76-piece Machine Screw/ Fractional/Metric Tap & Hex Die Set



26376

TAPS & DIES

Set Contents		Item # 26376
Thread Size Machine Screw	Tap Item # Plug Style	Die Item # 5/8" Hexagon
4 - 40 NC	1112	6112
6 - 32 NC	1118	6118
8 - 32 NC	1124	6124
10 - 24 NC	1128	6128
10 - 32 NF	1131	6131
12 - 24 NC	1132	6132
Fractional		1" Hexagon
1/4" - 20 NC	1420	6520
1/4" - 28 NF	1423	6523
5/16" - 18 NC	1427	6527
5/16" - 24 NF	1429	6529
3/8" - 16 NC	1434	6534
3/8" - 24 NF	1436	6536
7/16" - 14 NC	1439	6539
7/16" - 20 NF	1440	6540
1/2" - 13 NC	1444	6544
1/2" - 20 NF	1445	6545
Metric		5/8" Hexagon
3 mm - 0.50	1712	6312
4 mm - 0.70	1717	6317
4 mm - 0.75	1718	6318
5 mm - 0.80	1722	6322
5 mm - 0.90	1723	6323
6 mm - 1.00	1727	6327
		1" Hexagon
7 mm - 1.00	1731	6631
8 mm - 1.00	1733	6633
8 mm - 1.25	1734	6634
9 mm - 1.00	1736	6636
9 mm - 1.25	1737	6637
10 mm - 1.25	1739	6639
10 mm - 1.50	1740	6640
11 mm - 1.50	1741	6641
12 mm - 1.50	1743	6643
12 mm - 1.75	1744	6644
Pipe		
1/8" - 27 NPT	1902	6702
1/8" - 28 BSP	1911	6711
Threading Tools		Item #
Adj. Die Stock - 1" Dies		11026
Plain Die Stock - 5/8" Hexagon Dies		12457
Adj. Handle Tap Wrench - Taps No. 0 to 1/2"		311088
Two-in-One Tap Wrench - Taps 1/4" to 1/2"		12450
T-Handle Wrench - Taps No. 0 to 1/4"		12473
16 Leaf Metric Thread Pitch Gauge		11016
18 Leaf Standard Thread Pitch Gauge		11018
Empty Plastic Case For 26376		26376MT

HANSON 66-piece Machine Screw/ Fractional Tap & Hex Die Set



97606

Set Contents		Item # 97606
Thread Size	Tap Item #	Die Item #
Machine Screw	Plug Style	5/8" Hexagon
4 - 40 NC	1112	6112
6 - 32 NC	1118	6118
8 - 32 NC	1124	6124
10 - 24 NC	1128	6128
10 - 32 NF	1131	6131
12 - 24 NC	1132	6132
Fractional		1" Hexagon
1/4" - 20 NC	1420	6520
1/4" - 28 NF	1423	6523
5/16" - 18 NC	1427	6527
5/16" - 24 NF	1429	6529
3/8" - 16 NC	1434	6534
3/8" - 24 NF	1436	6536
7/16" - 14 NC	1439	6539
7/16" - 20 NF	1440	6540
1/2" - 13 NC	1444	6544
1/2" - 20 NF	1445	6545
		1-7/16" Hexagon
9/16" - 12 NC	1448	6848
9/16" - 18 NF	1449	6849
5/8" - 11 NC	1452	6852
5/8" - 18 NF	1454	6854
3/4" - 10 NC	1458	6858
3/4" - 16 NF	1460	6860
		1-13/16" Hexagon
7/8" - 9 NC	1461	8461
7/8" - 14 NF	1463	8463
1" - 8 NC	1465	8465
1" - 14 NS	1467	8467
Pipe		1" Hexagon
1/8" - 27 NPT	1902	6702
1/4" - 18 NPT	1903	7003
Threading Tools		Item #
Adj. Die Stock - 1" Dies		11026
Adj. Die Stock - 1-7/16" Hexagon Dies		12436
Adj. Die Stock - 1-13/16" Hexagon Dies		12446
Plain Die Stock - 5/8" Hexagon Dies		12457
Adj. Handle Tap Wrench - Taps No. 0 to 1/2"		311088
Adj. Handle Tap Wrench - Taps 1/4" to 1"		12498
Two-in-One Tap Wrench - Taps 1/4" to 1/2"		12450
T-Handle Wrench - Taps No. 0 to 1/4"		12473
18 Leaf Standard Thread Pitch Gauge		11018

TAPS & DIES

Taps & Dies

High Carbon Steel Combination Sets

HANSON® 66-piece Metric Tap & Hex Die Set



97312

TAPS & DIES

Set Contents		Item # 97312
Thread Size Metric	Tap Item # Plug Style	Die Item # 5/8" Hexagon
3 mm - 0.50	1712	6312
4 mm - 0.70	1717	6317
4 mm - 0.75	1718	6318
5 mm - 0.80	1722	6322
5 mm - 0.90	1723	6323
6 mm - 1.00	1727	6327
		1" Hexagon
7 mm - 1.00	1731	6631
8 mm - 1.00	1733	6633
8 mm - 1.25	1734	6634
9 mm - 1.00	1736	6636
9 mm - 1.25	1737	6637
10 mm - 1.25	1739	6639
10 mm - 1.50	1740	6640
11 mm - 1.50	1741	6641
12 mm - 1.50	1743	6643
12 mm - 1.75	1744	6644
		1-7/16" Hexagon
14 mm - 1.25	2449	6949
14 mm - 1.50	1750	6950
14 mm - 2.00	1752	6952
16 mm - 1.50	1755	6955
16 mm - 2.00	1756	6956
18 mm - 1.50	1759	6959
18 mm - 2.50	1761	6961
		1-13/16" Hexagon
20 mm - 2.50	1764	8564
22 mm - 1.50	1765	8565
24 mm - 2.00	1768	8568
24 mm - 3.00	1769	8569
Pipe		1" Hexagon
1/8" - 28 BSP	1911	6711
Threading Tools		Item #
Adj. Die Stock - 1" Dies		11026
Adj. Die Stock - 1-7/16" Hexagon Dies		12436
Adj. Die Stock - 1-3/16" Hexagon Dies		12446
Plain Die Stock - 5/8" Hexagon Dies		12457
T-Handle Wrench - Taps No. 0 to 1/4"		12473
Adj. Handle Tap Wrench - Taps No. 0 to 1/2"		311088
Adj. Handle Tap Wrench - Taps 1/4" to 1"		12498
Two-in-One Tap Wrench - Taps 1/4" to 1/2"		12450
16 Leaf Metric Thread Pitch Gauge		11016

HANSON 53-piece Machine Screw/ Fractional Tap & Hex Die Set



24640

HANSON 53-piece Metric Tap & Hex Die Set



26394

Set Contents		Item # 24640
Thread Size	Tap Item #	Die Item #
Machine Screw	Plug Style	1" Hexagon
6 - 32 NC	1118	6418
8 - 32 NC	1124	6424
10 - 24 NC	1128	6428
10 - 32 NF	1131	6431
12 - 24 NC	1132	6432
Fractional		
1/4" - 20 NC	1420	6520
1/4" - 28 NF	1423	6523
5/16" - 18 NC	1427	6527
5/16" - 24 NF	1429	6529
3/8" - 16 NC	1434	6534
3/8" - 24 NF	1436	6536
7/16" - 14 NC	1439	6539
7/16" - 20 NF	1440	6540
1/2" - 13 NC	1444	6544
1/2" - 20 NF	1445	6545
		1-7/16" Hexagon
9/16" - 12 NC	1448	6848
9/16" - 18 NF	1449	6849
5/8" - 11 NC	1452	6852
5/8" - 18 NF	1454	6854
3/4" - 10 NC	1458	6858
3/4" - 16 NF	1460	6860
Pipe		
		1" Hexagon
1/8" - 27 NPT Pipe	1902	6072
1/4" - 18 NPT Pipe	1903	6703
Threading Tools		Item #
Adj. Die Stock - 1" Dies		11026
Adj. Die Stock - 1-7/16" Hexagon Dies		12436
T-Handle Wrench - Taps No. 0 to 1/4"		12473
Adj. Handle Tap Wrench - Taps No. 0 to 1/2"		311088
Adj. Handle Tap Wrench - Taps 1/4" to 1"		12498
18 Leaf Standard Thread Pitch Gauge		11018
Set Contents		Item # 26394
Thread Size	Tap Item #	Die Item #
Metric Screw	Plug Style	1" Hexagon
3 mm - 0.50	1712	6612
4 mm - 0.70	1717	6617
4 mm - 0.75	1718	6618
5 mm - 0.80	1722	6622
5 mm - 0.90	1723	6623
6 mm - 1.00	1727	6627
7 mm - 1.00	1731	6631
8 mm - 1.25	1734	6634
9 mm - 1.00	1736	6636
9 mm - 1.25	1737	6637
10 mm - 1.25	1739	6639
10 mm - 1.50	1740	6640
11 mm - 1.50	1741	6641
12 mm - 1.50	1743	6643
12 mm - 1.75	1744	6644
		1-7/16" Hexagon
14 mm - 1.25	1749	6949
14 mm - 2.00	1752	6952
16 mm - 1.50	1755	6955
16 mm - 2.00	1756	6956
18 mm - 1.50	1759	6959
18 mm - 2.50	1761	6961
Pipe		
		1" Hexagon
1/8" - 28 BSP	1911	6711
1/4" - 19 BSP	1912	6712
Threading Tools		Item #
Adj. Die Stock - 1" Dies		11026
Adj. Die Stock - Hexagon Dies		12436
T-Handle Wrench - Taps No. 0 to 1/4"		12473
T-Handle Wrench - Taps No. 0 to 1/2"		311088
Adj. Handle Tap Wrench - Taps 1/4" to 1"		12498
16 Leaf Metric Thread Pitch Gauge		11016
Empty Plastic Case		26394MT

Taps & Dies

High Carbon Steel Combination Sets

HANSON® 41-piece Machine Screw/Fractional Tap & Hex Die Set



24606

- Plastic storage case with removable tray keeps all tools organized

TAPS & DIES

HANSON 41-piece Metric Tap & Hex Die Set



26317

Set Contents		Item # 24606
Thread Size	Tap Item #	Die Item #
Machine Screw	Plug Style	5/8" Hexagon
4 - 40 NC	1112	6112
6 - 32 NC	1118	6118
8 - 32 NC	1124	6124
10 - 24 NC	1128	6128
10 - 32 NF	1131	6131
12 - 24 NC	1132	6132
Fractional		1" Hexagon
1/4" - 20 NC	1420	6520
1/4" - 28 NF	1423	6523
5/16" - 18 NC	1427	6527
5/16" - 24 NF	1429	6529
3/8" - 16 NC	1434	6534
3/8" - 24 NF	1436	6536
7/16" - 14 NC	1439	6539
7/16" - 20 NF	1440	6540
1/2" - 13 NC	1444	6544
1/2" - 20 NF	1445	6545
Pipe		1" Hexagon
1/8" - 27 NPT	1902	6702
Threading Tools		Item #
Adj. Die Stock - 1" Dies		11026
Plain Die Stock - 5/8" Hexagon Dies		12457
Adj. Handle Tap Wrench - Taps No. 0 to 1/2"		311088
T-Handle Wrench - Taps No. 0 to 1/4"		12473
Two-in-One Tap Wrench - Taps 1/4" to 1/2"		12450
18 Leaf Standard Thread Pitch Gauge		11018
Empty Plastic Case		24606MT

Set Contents		Item # 26317
Thread Size	Tap Item #	5/8" Die Item #
Metric	Plug Style	
3 mm - 0.50	1712	6312
4 mm - 0.70	1717	6317
4 mm - 0.75	1718	6318
5 mm - 0.80	1722	6322
5 mm - 0.90	1723	6323
6 mm - 1.00	1727	6327
		1" Die Item #
7 mm - 1.00	1731	6631
8 mm - 1.00	1733	6633
8 mm - 1.25	1734	6634
9 mm - 1.00	1736	6636
9 mm - 1.25	1737	6637
10 mm - 1.25	1739	6639
10 mm - 1.50	1740	6640
11 mm - 1.50	1741	6641
12 mm - 1.50	1743	6643
12 mm - 1.75	1744	6644
Pipe		Item #
1/8" - 28 BSP	1911	6711
Threading Tools		Item #
Adj. Die Stock - 1" Dies		11026
Plain Die Stock - 5/8" Hexagon Dies		12457
Adj. Handle Tap Wrench - Taps No. 0 to 1/2"		311088
T-Handle Wrench - Taps No. 0 to 1/4"		12473
Two-in-One Tap Wrench - Taps 1/4" to 1/2"		12450
16 Leaf Metric Thread Pitch Gauge		11016
Empty Plastic Case		26317MT

HANSON® 25-piece Fractional Tap & Hex Die Set



97094

Set Contents		Item # 97094
Thread Size Fractional	Tap Item # Plug Style	Die Item # 1-7/16" Hexagon
9/16" - 12 NC	1448	6848
9/16" - 18 NF	1449	6849
5/8" - 11 NC	1452	6852
5/8" - 18 NF	1454	6854
3/4" - 10 NC	1458	6858
3/4" - 16 NF	1460	6860
		1-13/16" Hexagon
7/8" - 9 NC	1461	8461
7/8" - 14 NF	1463	8463
1" - 8 NC	1465	8465
1" - 14 NS	1467	8467
Pipe		1-7/16" Hexagon
1/4" - 18 NPT	1903	7003
Threading Tools		Item #
Adj. Die Stock - 1-7/16" Hexagon Dies		12436
Adj. Die Stock - 1-13/16" Hexagon Dies		12446
Adj. Handle Tap Wrench - Taps 1/4" to 1"		12498
Empty Plastic Case		97094MT

HANSON 25-piece Metric Tap & Hex Die Set



97311

Set Contents		Item # 97311
Thread Size Metric	Tap Item # Plug Style	Die Item # 1-7/16" Hexagon
14 mm - 1.25	2449*	6949
14 mm - 1.50	1750	6950
14 mm - 2.00	1752	6952
16 mm - 1.50	1755	6955
16 mm - 2.00	1756	6956
18 mm - 1.50	1759	6959
18 mm - 2.50	1761	6961
		1-13/16" Hexagon
20 mm - 2.50	1764	8564
22 mm - 1.50	1765	8565
24 mm - 2.00	1768	8568
24 mm - 3.00	1769	8569
Threading Tools		Item #
Adj. Die Stock - 1-7/16" Hexagon Dies		12436
Adj. Die Stock - 1-13/16" Hexagon Dies		12446
Adj. Handle Tap Wrench - Taps 1/4" to 1"		12498
Empty Plastic Case		97311MT

TAPS & DIES

Taps & Dies

High Carbon Steel Combination Sets

HANSON® 41-piece Machine Screw/ Fractional/Metric Tap & Hex Die Set



26319

TAPS & DIES

HANSON 12-piece Machine Screw/ Fractional Tap & Hex Die Set



24605

HANSON 12-piece PTS Self-Aligning Machine Screw/Metric Tap & Die Set



1765541

Set Contents		Item # 26319
Thread Size	Tap Item #	Die Item #
Machine Screw	Plug Style	5/8" Hexagon
6 - 32 NC	1118	6118
8 - 32 NC	1124	6124
10 - 24 NC	1128	6128
Fractional		1" Hexagon
1/4" - 20 NC	1420	6520
5/16" - 18 NC	1427	6527
3/8" - 16 NC	1434	6534
7/16" - 14 NC	1439	6539
1/2" - 13 NC	1444	6544
1/8" - 27 NPT	1902	6702
Metric		5/8" Hexagon
4 mm - 0.75	1718	6318
5 mm - 0.80	1722	6322
6 mm - 1.00	1727	6327
		1" Hexagon
7 mm - 1.00	1731	6631
8 mm - 1.25	1734	6634
10 mm - 1.25	1739	6639
10 mm - 1.50	1740	6640
12 mm - 1.75	1744	6644
Threading Tools		Item #
Adj. Die Stock - 1" Dies		11026
Plain Die Stock - 5/8" Hexagon Dies		12457
Adj. Handle Tap Wrench - Taps No. 0 to 1/2"		311088
T-Handle Wrench - Taps No. 0 to 1/4"		12473
Two-in-One Tap Wrench - Taps 1/4" to 1/2"		12450
Standard and Metric Thread Pitch Gauge		11017

Set Contents		Item # 24605
Thread Size	Tap Item #	Die Item #
Machine Screw	Plug Style	5/8" Hexagon
6 - 32 NC	1118	6118
8 - 32 NC	1124	6124
10 - 24 NC	1128	6128
10 - 32 NF	1131	6131
Fractional		
1/4" - 20 NC	1420	6220
Threading Tools		Item #
Plain Die Stock - 5/8" Hexagon Dies		12457
T-Handle Tap Wrench - Taps No. 0 to 1/4"		12401

Set Contents		Item # 1765541
Thread Size	Tap Item #	Die Item #
Machine Screw	Plug Style	5/8" Hexagon
3mm - 0.50	1712	6312
4mm - 0.70	1717	6317
5mm - 0.80?	1722	6322
6mm - 1.00	1727	6327
7mm - 1.00	1731	6631
Threading Tools		Item #
Plain Die Stock - 5/8" Hexagon Dies		12457
T-Handle Tap Wrench - Taps No. 0 to 1/4"		12401

HANSON 24-piece Fractional Tap & Hex Die Set



24614

HANSON 24-piece Metric Tap & Hex Die Set



26313

HANSON 12-piece Fractional Tap & Hex Die Set



24612

Set Contents		Item # 24614
Thread Size Fractional	Tap Item # Plug Style	Die Item # 1" Hexagon
1/4" - 20 NC	1420	6520
1/4" - 28 NF	1423	6523
5/16" - 18 NC	1427	6527
5/16" - 24 NF	1429	6529
3/8" - 16 NC	1434	6534
3/8" - 24 NF	1436	6536
7/16" - 14 NC	1439	6539
7/16" - 20 NF	1440	6540
1/2" - 13 NC	1444	6544
1/2" - 20 NF	1445	6545
Pipe		
1/8" - 27 NPT	1902	6702
Threading Tools		Item #
Plain Die Stock - 1" Dies		11008
Offset Adj. Tap Wrench - Taps No. 0 to 1/2"		12421

Set Contents		Item # 26313
Thread Size Metric	Tap Item # Plug Style	Die Item # 1" Hexagon
3 mm - 0.50	1712	6612
4 mm - 0.70	1717	6617
5 mm - 0.80	1722	6622
6 mm - 1.00	1727	6627
7 mm - 1.00	1731	6631
8 mm - 1.25	1734	6634
9 mm - 1.25	1737	6637
10 mm - 1.50	1740	6640
12 mm - 1.50	1743	6643
12 mm - 1.75	1744	6644
Pipe		
1/8" - 28 BSP	1911	6711
Threading Tools		Item #
Plain Die Stock - 1" Dies		11008
Offset Adj. Tap Wrench - Taps No. 0 to 1/2"		12421

Set Contents		Item # 24612
Thread Size Fractional	Tap Item # Plug Style	Die Item # 1" Hexagon
1/4" - 20 NC	1420	6520
5/16" - 18 NC	1427	6527
3/8" - 16 NC	1434	6534
7/16" - 14 NC	1439	6539
1/2" - 13 NC	1444	6544
Threading Tools		Item #
Plain Die Stock - 1" Dies		11008
Offset Adj. Tap Wrench - Taps No. 0 to 1/2"		12421

TAPS & DIES

Taps & Dies

High Carbon Steel Combination Sets

HANSON® 64-piece Machine Screw/ Fractional Tap & Solid/ Adjustable Round Die Set



98614

TAPS & DIES

Set Contents		Item # 98614
Thread Size Machine Screw	Tap Item # Plug Style	Die Item # 1" Solid Round
4 - 40 NC	1112	3012
6 - 32 NC	1118	3018
8 - 32 NC	1124	3024
10 - 24 NC	1128	3028
10 - 32 NF	1131	3031
12 - 24 NC	1132	3032
Fractional		
1/4" - 20 nc	1420	3120
1/4" - 28 nf	1423	3123
5/16" - 18 nc	1427	3127
5/16" - 24 nf	1429	3129
3/8" - 16 nc	1434	3134
3/8" - 24 nf	1436	3136
7/16" - 14 nc	1439	3139
7/16" - 20 nf	1440	3140
1/2" - 13 nc	1444	3144
1/2" - 20 nf	1445	3145
1-1/2" Adj. Round		
9/16" - 12 NC	1448	4048
9/16" - 18 NF	1449	4049
5/8" - 11 NC	1452	4052
5/8" - 18 NF	1454	4054
3/4" - 10 NC	1458	4058
3/4" - 16 NF	1460	4060
2" Adj. Round		
7/8" - 9 NC	1461	4261
7/8" - 14 NF	1463	4263
1" - 8 NC	1465	4265
1" - 12 NF	1466	4266
Pipe		
		1" Solid Round
1/8" - 27 NPT	1902	3202
		1-1/2" Solid Round
1/4" - 18 NPT	1903	4103
Threading Tools		Item #
Adj. Die Stock - 1" Dies		11026
Adj. Die Stock - 1-1/2" Adj. Round Dies		12435
Adj. Die Stock - 2" Adj. Round Dies		12445
Adj. Handle Tap Wrench - Taps No. 0 to 1/2"		311088
Adj. Handle Tap Wrench - Taps 1/4" to 1"		12498
T-Handle Wrench - Taps No. 0 to 1/4"		12401
18 Leaf Standard Thread Pitch Gauge		11018

HANSON 64-piece Machine Screw/ Fractional Tap & Adjustable/Solid Round Die Set



98146

Set Contents		Item # 98146
Thread Size Machine Screw	Tap Item # Plug Style	Die Item # 1" Adj. Round
4 - 40 NC	1112	3712
6 - 32 NC	1118	3718
8 - 32 NC	1124	3724
10 - 24 NC	1128	3728
10 - 32 NF	1131	3731
12 - 24 NC	1132	3732
Fractional		
1/4" - 20 nc	1420	3820
1/4" - 28 nf	1423	3823
5/16" - 18 nc	1427	3827
5/16" - 24 nf	1429	3829
3/8" - 16 nc	1434	3834
3/8" - 24 nf	1436	3836
7/16" - 14 nc	1439	3839
7/16" - 20 nf	1440	3840
1/2" - 13 nc	1444	3844
1/2" - 20 nf	1445	3845
		1-1/2" Adj. Round
9/16" - 12 NC	1448	4048
9/16" - 18 NF	1449	4049
5/8" - 11 NC	1452	4052
5/8" - 18 NF	1454	4054
3/4" - 10 NC	1458	4058
3/4" - 16 NF	1460	4060
		2" Adj. Round
7/8" - 9 NC	1461	4261
7/8" - 14 NF	1463	4263
1" - 8 NC	1465	4265
1" - 12 NF	1466	4266
		1" Solid Round
1/8" - 27 NPT	1902	3202
		1-1/2" Solid Round
1/4" - 18 NPT	1903	4103
Threading Tools		Item #
Adj. Die Stock - 1" Adj. Round Dies		12428
Adj. Die Stock - 1-1/2" Adj. Round Dies		12435
Adj. Die Stock - 2" Adj. Round Dies		12445
Adj. Handle Tap Wrench - Taps No. 0 to 1/2"		311088
Adj. Handle Tap Wrench - Taps 1/4" to 1"		12498
T-Handle Wrench - Taps No. 0 to 1/4"		12401
18 Leaf Standard Thread Pitch Gauge		11018

TAPS & DIES

Taps & Dies

High Carbon Steel Combination Sets

HANSON® 41-piece Fractional Tap & Adjustable/Solid Round Die Set



25941

TAPS & DIES

Set Contents

Thread Size Fractional	Tap Item # Plug Style	Die Item # 1-1/2" Adj. Round
1/4" - 20 NC	1420	4020
1/4" - 28 NF	1423	4023
5/16" - 18 NC	1427	4027
5/16" - 24 NF	1429	4029
3/8" - 16 NC	1434	4034
3/8" - 24 NF	1436	4036
7/16" - 14 NC	1439	4039
7/16" - 20 NF	1440	4040
1/2" - 13 NC	1444	4044
1/2" - 20 NF	1445	4045
9/16" - 12 NC	1448	4048
9/16" - 18 NF	1449	4049
5/8" - 11 NC	1452	4052
5/8" - 18 NF	1454	4054
3/4" - 10 NC	1458	4058
3/4" - 16 NF	1460	4060
Pipe		1-1/2" Solid Round
1/8" - 27 NPT	1902	4102
1/4" - 18 NPT	1903	4103
Threading Tools		Item #
Adj. Die Stock - 1-1/2" Dies		12435
T-Handle Wrench - Taps 1/4" to 1/2"		12402
Adj. Handle Tap Wrench - Taps 1/4" to 1"		12498
18 Leaf Standard Thread Pitch Gauge		11018
Empty Plastic Case		25941MT

HANSON 39-piece Machine Screw/ Fractional Tap & Solid Round Die Set



23614

HANSON 39-piece Machine Screw/ Fractional Tap & Adjustable Round Die Set



25914

Set Contents		Item # 23614
Thread Size Machine Screw	Tap Item # Plug Style	Die Item # 1" Solid Round
4 - 40 NC	1112	3012
6 - 32 NC	1118	3018
8 - 32 NC	1124	3024
10 - 24 NC	1128	3028
10 - 32 NF	1131	3031
12 - 24 NC	1132	3032
Fractional		
1/4" - 20 NC	1420	3120
1/4" - 28 NF	1423	3123
5/16" - 18 NC	1427	3127
5/16" - 24 NF	1429	3129
3/8" - 16 NC	1434	3134
3/8" - 24 NF	1436	3136
7/16" - 14 NC	1439	3139
7/16" - 20 NF	1440	3140
1/2" - 13 NC	1444	3144
1/2" - 20 NF	1445	3145
Pipe		
1/8" - 27 NPT	1902	3202
Threading Tools		Item #
Adj. Die Stock - 1" Dies		11026
T-Handle Wrench - Taps No. 0 to 1/4"		12401
Adj. Handle Tap Wrench - Taps No. 0 to 1/2"		311088
18 Leaf Standard Thread Pitch Gauge		11018
Empty Plastic Case		23614MT

Set Contents		Item # 25914
Thread Size Machine Screw	Tap Item # Plug Style	Die Item # 1-1/2" Adj. Round
4 - 40 NC	1112	3712
6 - 32 NC	1118	3718
8 - 32 NC	1124	3724
10 - 24 NC	1128	3728
10 - 32 NF	1131	3731
12 - 24 NC	1132	3732
Fractional		
1/4" - 20 NC	1420	3820
1/4" - 28 NF	1423	3823
5/16" - 18 NC	1427	3827
5/16" - 24 NF	1429	3829
3/8" - 16 NC	1434	3834
3/8" - 24 NF	1436	3836
7/16" - 14 NC	1439	3839
7/16" - 20 NF	1440	3840
1/2" - 13 NC	1444	3844
1/2" - 20 NF	1445	3845
Pipe		
1/8" - 27 NPT	1902	3202
Threading Tools		Item #
Adj. Die Stock - 1" Adj. Round Dies		12428
T-Handle Wrench - Taps No. 0 to 1/4"		12401
Adj. Handle Tap Wrench - Taps No. 0 to 1/2"		311088
18 Leaf Standard Thread Pitch Gauge		11018
Empty Plastic Case		25914MT

TAPS & DIES

Taps & Dies

High Speed Steel Combination Sets

HANSON® 25-piece Fractional Tap & Adjustable/Solid Round Die Set



98000

Set Contents		Item # 98000
Thread Size Fractional	Tap Item # Plug Style	Die Item # 1-1/2" Adj. Round
9/16" - 12 NC	1448	4048
9/16" - 18 NF	1449	4049
5/8" - 11 NC	1452	4052
5/8" - 18 NF	1454	4054
3/4" - 10 NC	1458	4058
3/4" - 16 NF	1460	4060
		2" Adj. Round
7/8" - 9 NC	1461	4261
7/8" - 14 NF	1463	4263
1" - 8 NC	1465	4265
1" - 12 NF	1466	4266
Pipe		1-1/2" Solid Round
1/4" - 18 NPT	1903	4103
Threading Tools		Item #
Adj. Die Stock - 1-1/2" Adj. Round Dies		12435
Adj. Die Stock - 2" Adj. Round Dies		12445
Adj. Handle Tap Wrench - Taps 1/4" to 1"		12498
Empty Plastic Case		98000MT

TAPS & DIES

HANSON 24-piece Fractional Tap & Solid Round Die Set



23622

Set Contents		Item # 23622
Thread Size Fractional	Tap Item # Plug Style	Die Item # 1" Solid Round
1/4" - 20 NC	1420	3120
1/4" - 28 NF	1423	3123
5/16" - 18 NC	1427	3127
5/16" - 24 NF	1429	3129
3/8" - 16 NC	1434	3134
3/8" - 24 NF	1436	3136
7/16" - 14 NC	1439	3139
7/16" - 20 NF	1440	3140
1/2" - 13 NC	1444	3144
1/2" - 20 NF	1445	3145
Pipe		
1/8" - 27 NPT	1902	3202
Threading Tools		Item #
Plain Die Stock - 1" Dies		11008
Offset Adj. Tap Wrench - Taps No. 0 to 1/2"		12421

HANSON Cut Thread Machine Screw Taps (HSS)



400023



403025



406025

- Straight fluted, hand taps
- Taps produce a class 2B thread

HANSON Cut Thread Fractional Taps (HSS)



410022



413022



416022

- Straight fluted, hand taps
- Taps produce a class 2B thread
- Works in most materials including stainless & alloy steels

HANSON Cut Thread Pipe Taper Taps (HSS)



459002

- Cuts internal threads in pipes
- Ideal for pipe fittings
- Tapered at a rate of 3/4" per foot

Description	No. of Flutes	Plug Bulk Item #	Taper Bulk Item #	Bottom Bulk Item #
6 - 32 NC	3	403015	400015	406015
6 - 48 NS	3	403017	400017	406017
8 - 32 NC	4	403019	400019	406019
8 - 40 NS	4	403021	400021	406021
10 - 24 NC	4	403022	400022	406022
10 - 32 NF	4	403023	400023	406023
12 - 24 NC	4	403025	400025	-
14 - 20 NS	4	403028	-	-

Description	No. of Flutes	Plug Bulk Item #	Taper Bulk Item #	Bottom Bulk Item #
1/4" - 20 NC	4	413010	410010	416010
1/4" - 28 NF	4	413012	-	416012
5/16" - 18 NC	4	413015	410015	416015
5/16" - 24 NF	4	413016	-	416016
3/8" - 16 NC	4	413018	410018	416018
3/8" - 24 NF	4	413019	410019	-
7/16" - 14 NC	4	413020	410020	416020
7/16" - 20 NF	4	413021	410021	-
1/2" - 13 NC	4	413022	410022	416022
1/2" - 20 NF	4	413023	410023	-
9/16" - 12 NC	4	413024	-	-
5/8" - 11 NC	4	413026	410026	-
3/4" - 10 NC	4	-	410028	-

Description	No. of Flutes	Taper Item #
1/8" - 27 NPT	4	459001
1/4" - 18 NPT	4	459002
3/8" - 18 NPT	4	459003
1/2" - 14 NPT	4	459004
3/4" - 14 NPT	5	459005
1" - 11-1/2 NPT	5	459006
1-1/4" - 11-1/2 NPT	5	459007
1-1/2" - 11-1/2 NPT	6	459008

Taps & Dies

High Speed Steel Taps

HANSON 6-piece Cut Thread Pipe Taper Tap Set (HSS)



1924

Contents	Item # 1924
1/8" - 27 NPT	459001
1/4" - 18 NPT	459002
3/8" - 18 NPT	459003
1/2" - 14 NPT	459004
3/4" - 14 NPT	459005
1" - 11-1/2 NPT	459006

Tips

- Always use cutting fluid
- When threading a blind hole, clean the chips from the hole often and do not bottom out the tap - it can cause tap breakage.

HANSON Ground Thread Fractional Taps (HSS)



310310



313310



316310

- Ground thread taps produce a tighter thread tolerance than cut thread taps
- Designed to .0005" pitch diameter tolerance
- Straight fluted, hand taps

Description	No. of Flutes	Pitch Diameter Limits	Plug Bulk Item #	Taper Bulk Item #	Bottom Bulk Item #
1/4" - 20 NC	4	H3	313310	310310	316310
1/4" - 28 NF	4	H3	313312	310312	316312
5/16" - 18 NC	4	H3	313315	310315	316315
5/16" - 24 NF	4	H3	313316	310316	316316
3/8" - 16 NC	4	H3	313318	310318	316318
3/8" - 24 NF	4	H3	313319	310319	316319
7/16" - 14 NC	4	H3	313320	310320	316320
1/2" - 13 NC	4	H3	313322	310322	316322
1/2" - 20 NF	4	H3	313325	310323	316323
9/16" - 18 NF	4	H3	313326	-	-
5/8" - 11 NC	4	H3	313327	310327	316327
5/8" - 18 NF	4	H3	313328	310328	316328
3/4" - 10 NC	4	H3	313331	310331	316331
3/4" - 16 NF	4	H3	313332	310332	316332
7/8" - 9 NC	4	H4	313433	310433	316433
7/8" - 14 NF	4	H4	313434	310434	316434
1" - 8 NC	4	H4	313435	310435	316435
1" - 12 NF	4	H4	313436	-	-
1" - 14 NS	4	H4	313437	-	-
1-1/8" - 7 NC	4	H4	313438	310438	316438
1-1/8" - 12 NF	4	H4	313439	310439	316439
1-1/4" - 7 NC	4	H4	313440	310440	316440
1-1/4" - 12 NF	6	H4	313441	310441	316441
1-3/8" - 6 NC	4	H4	-	310442	-
1-3/8" - 12 NF	6	H4	-	310443	-
1-1/2" - 6 NC	4	H4	-	310444	316444
1-1/2" - 12 NF	6	H4	313445	-	-

HANSON Ground Thread Machine Screw Taps (HSS)



300325

- Ideal for maintenance and repair work
- Ground thread taps produce a tighter thread tolerance than cut thread taps
- Designed to .0005" pitch diameter tolerance
- Straight fluted, hand taps

Description	No. of Flutes	Pitch Diameter Limits	Plug Bulk Item #	Taper Bulk Item #	Bottom Bulk Item #
0 - 80 NF	2	H1	303101	-	-
1 - 64 NC	2	H1	303102	-	-
1 - 72 NC	2	H1	303103	-	-
2 - 56 NC	3	H2	303205	-	306205
6 - 32 NC	3	H3	-	300315	-
8 - 32 NC	4	H3	303319	300319	-
10 - 24 NC	4	H3	303322	300322	-
10 - 32 NF	4	H3	303323	300323	-
12 - 24 NC	4	H3	-	300325	-
12 - 28 NF	4	H3	-	300326	-

TAPS & DIES

HANSON Ground Thread Left-hand Fractional Plug Taps (HSS)



2120

- Left-hand taps cut threads with a left-hand rotation
- Used in applications where left-hand studs or fasteners are required

HANSON Ground Thread Pipe Taper Taps (HSS)



359003

- Ideal for pipe fittings
- Tapered at a rate of 3/4" per foot

HANSON Ground Thread Spiral Point* (Gun Taps) Chip Driver Machine Screw/Fractional Taps (HSS)



323325

- Engineered specifically for tapping of "through" holes
- Designed to .0005-inches pitch tolerance
- Cuts with a shearing action that shoots the chips ahead of the tap, producing a cleaner thread
- Recommended for production use in machine tools

Description	No. of Flutes	Pitch Diameter Limits	Bulk Item #
1/4" - 20 NC	4	H3	2120
1/4" - 28 NF	4	H3	2123
5/16" - 18 NC	4	H3	2127
5/16" - 24 NF	4	H3	2129
3/8" - 16 NC	4	H3	2134
3/8" - 24 NF	4	H3	2136
7/16" - 14 NC	4	H3	2139
7/16" - 20 NF	4	H3	2140
1/2" - 13 NC	4	H3	2144
1/2" - 20 NF	4	H3	2145
9/16" - 12 NC	4	H3	2148
9/16" - 18 NF	4	H3	2149
5/8" - 11 NC	4	H3	2152
5/8" - 18 NF	4	H3	2154
3/4" - 10 NC	4	H3	2158
3/4" - 16 NF	4	H3	2160

Description	No. of Flutes	Bulk Item #
1/16" - 27 NPT	4	359010
1/8" - 27 NPT	4	359001
1/4" - 18 NPT	4	359002
3/8" - 18 NPT	4	359003
1/2" - 14 NPT	4	359004
3/4" - 14 NPT	5	359005

Description	No. of Flutes	Pitch Diameter Limits	Taper Bulk Item #
Machine			
6 - 32 NC	2	H3	323315
8 - 32 NC	2	H3	323319
10 - 24 NC	2	H3	323322
10 - 32 NF	2	H3	323323
12 - 24 NC	2	H3	323325
14 - 20 NS	2	H3	323328
Fractional			
1/4" - 20 NC	3	H3	333310
1/4" - 28 NF	2	H3	333312
5/16" - 18 NC	2	H3	333315
3/8" - 16 NC	3	H3	333318
7/16" - 14 NC	3	H3	333320
7/16" - 20 NF	3	H3	333321
1/2" - 13 NC	3	H3	333322
1/2" - 20 NF	3	H3	333323

*Spiral Point taps should only be used on "through" hole applications

Taps & Dies

High Speed Steel Dies

HANSON Adjustable Round Machine Screw & Fractional Dies (HSS)



502024



504053

- HSS ideal for machine cutting where critical dimensions are required
- Adjustable round dies for precision threading

TAPS & DIES

Description	1" Overall Diam. Bulk Item #	2" Overall Diam. Bulk Item #
Machine		
4 - 40 NC	502009	-
6 - 32 NC	502014	-
6 - 40 NF	502015	-
8 - 32 NC	502018	-
8 - 36 NF	502019	-
10 - 24 NC	502021	-
10 - 32 NF	502022	-
12 - 24 NC	502024	-
12 - 28 NF	502025	-
Fractional		
1/4" - 20 NC	502038	-
1/4" - 28 NF	502039	-
5/16" - 18 NC	502041	-
5/16" - 24 NF	502042	-
3/8" - 16 NC	502044	-
3/8" - 24 NF	502045	-
7/16" - 14 NC	502046	-
7/16" - 20 NF	502047	-
1/2" - 13 NC	502048	-
1/2" - 20 NF	502049	-
5/8" - 11 NC	-	504053
5/8" - 18 NF	-	504054
3/4" - 10 NC	-	504057
3/4" - 16 NF	-	504058
7/8" - 9 NC	-	504059
7/8" - 14 NF	-	504060
1" - 8 NC	-	504061
1" - 12 NF	-	504062
1" - 14 NS	-	504063

HANSON 41-piece HSS Cut Thread Fractional Tap & Adjustable Die Set



543715

Set Contents		Stock # 543715
Thread Size Fractional	Tap Stock # Plug Style	Die Stock # 1-1/2" Adj. Round
1/4" - 20 NC	413010	503038
1/4" - 28 NF	413012	503039
5/16" - 18 NC	413015	503041
5/16" - 24 NF	413016	503042
3/8" - 16 NC	413018	503044
3/8" - 24 NF	413019	503045
7/16" - NC	413020	503046
7/16" - 20 NF	413021	503047
1/2" - 13 NC	413022	503048
1/2" - 20 NF	413023	503049
9/16" - 12 NC	413024	503051
9/16" - 18 NF	413025	503052
5/8" - 11 NC	413026	503053
5/8" - 18 NF	413027	503054
3/4" - 10 NC	413028	503057
3/4" - 16 NF	413029	503058
1/8" - 27 NPT	459001	503102
1/4" - 18 NPT	459002	503101
Threading Tools		Stock #
Adj. Die Stock - 1-1/2" Round Dies		12435
T-Handle Wrench - Taps No. 1/4" to 1/2"		12402
Adj. Handle Tap Wrench - Taps 1/4" to 1"		12498
18 Leaf Standard Thread Pitch Gauge		11018

HANSON 39-piece HSS Cut Thread Machine Screw/Fractional Tap & Adjustable Round Die Set



541614

Set Contents		Stock # 541614
Thread Size Machine Screw	Tap Stock # Plug Style	Die Stock # 1" Adj. Round
4 - 40 NC	403009	502009
6 - 32 NC	403015	502014
8 - 32 NC	403019	502018
10 - 24 NC	403022	502021
10 - 32 NF	403023	502022
12 - 24 NC	403025	502024
Fractional		
1/4" - 20 NC	413010	502038
1/4" - 28 NF	413012	502039
5/16" - 18 NC	413015	502041
5/16" - 24 NF	413016	502042
3/8" - 16 NC	413018	502044
3/8" - 24 NF	413019	502045
7/16" - 14 NC	413020	502046
7/16" - 20 NF	413021	502047
1/2" - 13 NC	413022	502048
1/2" - 20 NF	413023	502049
Pipe		
1/8" - 27 NPT	459001	502101
Threading Tools		Stock #
Adjustable Die Stock - 1" Adj. Round Dies		12428
T-Handle Wrench - Taps No. 0 to 1/4"		12401
Adj. Handle Tap Wrench - Taps No. 0 to 1/2"		311088
18 Leaf Standard Thread Pitch Gauge		11018

TAPS & DIES

Deep Well ThreadChaser

The IRWIN® HANSON® Deep Well ThreadChaser allows you to reach and repair threads that your current tools can't touch. Whether you're repairing wheel studs, bolts, or other fasteners, the Deep Well ThreadChaser will fix your threads quickly and correctly.

DEEP WELL THREAD CHASER FEATURES

1. Reduced profile head enables use in confined spaces
2. Rethread design repairs & cleans bent, dented, rusted, painted, or damaged threads
3. Deep well design fits over exposed studs and repairs the full length
4. Tougher than tool steel, high carbon steel ensures longer life and greater durability

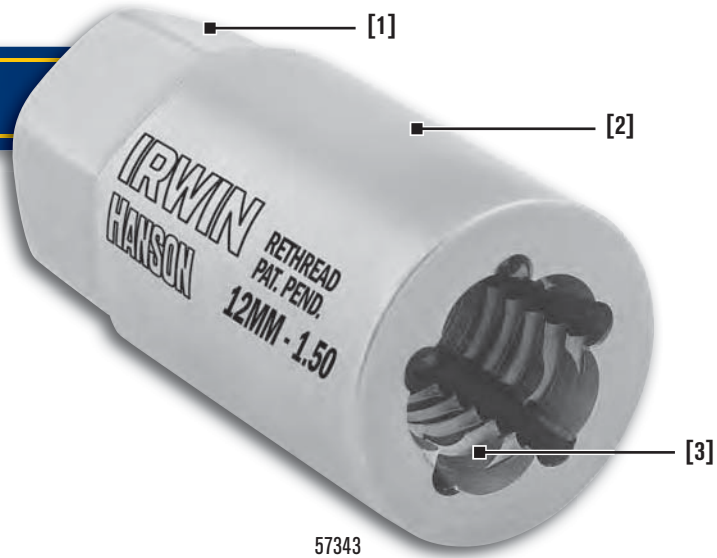

TAPS & DIES



3094102



3094104

Description	Pack Qty	Item #
3/8" - 16 NC ThreadChaser	4	57234
3/8" - 24 NF ThreadChaser	4	57236
7/16" - 14 NC ThreadChaser	4	57239
7/16" - 20 NF ThreadChaser	4	57240
1/2" - 13 NC ThreadChaser	4	57244
1/2" - 20 NF ThreadChaser	4	57245
9/16" - 12 NC ThreadChaser	4	57248
9/16" - 18 NF ThreadChaser	4	57249
5/8" - 11 NC ThreadChaser	4	57252
5/8" - 18 NF ThreadChaser	4	57254
12 mm - 1.25 ThreadChaser	4	57342
12 mm - 1.50 ThreadChaser	4	57343
14 mm - 1.50 ThreadChaser	4	57349
16 mm - 1.50 ThreadChaser	4	57355
ThreadChaser 5pc SAE Coarse Set	1	3094100
ThreadChaser 5pc SAE Fine Set	1	3094101
ThreadChaser 10pc SAE Complete Set	1	3094102
ThreadChaser 4pc Metric Set	1	3094104

HANSON® Hexagon Re-threading Pipe Taper Dies (HCS)



7403

- Ideal for repairing damaged threads on plumbing and air pipe applications

HANSON Re-threading Hexagon Metric Right & Left-hand Dies (HCS)



7349

- Ideal for repairing damaged bolts and studs where metric threads are specified

HANSON Re-threading Hexagon Fractional Right & Left-hand Dies (HCS)



7220



7720

- Designed for repairing damaged bolts and studs

Description	Width Across Hex Flats	Thickness of Hex Die	Bulk Item #
1/8" - 27 NPT	1-1/16"	3/8"	7402
1/4" - 18 NPT	1-1/4"	5/8"	7403
3/8" - 18 NPT	1-7/16"	5/8"	7404
1/2" - 14 NPT	1-5/8"	3/4"	7405
3/4" - 14 NPT	2"	3/16"	7406
1" - 11-1/2 NPT	2-3/8"	1"	7407

Description	Width Across Hex Flats	Thickness of Hex Die	Right-Hand Bulk Item #	Left-Hand Bulk Item #
14 mm - 1.25	1-1/16"	1/2"	7349	-
14 mm - 1.50	1-1/16"	1/2"	7350	-
14 mm - 2.00	1-1/16"	1/2"	7352	-
16 mm - 1.50	1-1/4"	5/8"	7355	7855
16 mm - 2.00	1-1/4"	5/8"	7356	-
18 mm - 1.00	1-7/16"	3/4"	7358	-
18 mm - 1.50	1-7/16"	3/4"	7359	7859
18 mm - 2.50	1-7/16"	3/4"	7361	-
20 mm - 2.50	1-7/16"	3/4"	7364	-
22 mm - 1.50	1-5/8"	7/8"	7365	7865
24 mm - 1.50	1-13/16"	1"	7367	-
30 mm - 1.50	2"	1"	7373	-

Description	Width Across Hex Flats	Thickness of Hex Die	Right-Hand Bulk Item #	Left-Hand Bulk Item #
1/4" - 20 NC	19/32"	1/4"	7220	7720
1/4" - 28 NF	19/32"	1/4"	7223	7723
5/16" - 18 NC	11/16"	5/16"	7227	7727
5/16" - 24 NF	11/16"	5/16"	7229	7729
3/8" - 16 NC	25/32"	3/8"	7234	7734
3/8" - 24 NF	25/32"	3/8"	7236	7736
7/16" - 14 NC	7/8"	7/16"	7239	7739
7/16" - 20 NF	7/8"	7/16"	7240	7740
1/2" - 13 NC	1-1/16"	1/2"	7244	7744
1/2" - 20 NF	1-1/16"	1/2"	7245	7745
9/16" - 12 NC	1-1/16"	1/2"	7248	7748
9/16" - 18 NF	1-1/16"	1/2"	7249	7749
5/8" - 11 NC	1-1/4"	5/8"	7252	7752
5/8" - 18 NF	1-1/4"	5/8"	7254	7754
11/16" - 11 NS	1-7/16"	3/4"	7256	7756
11/16" - 16 NS	1-7/16"	3/4"	7257	7757
3/4" - 10 NC	1-7/16"	3/4"	7258	7758
3/4" - 16 NF	1-7/16"	3/4"	7260	7760
7/8" - 9 NC	1-5/8"	7/8"	7261	7761
7/8" - 14 NF	1-5/8"	7/8"	7263	7763
1" - 8 NC	1-13/16"	1"	7265	7765
1" - 12 NF	1-13/16"	1"	7266	7766
1" - 14 NS	1-13/16"	1"	7267	7767
1-1/8" - 7 NC	2"	1"	7268	-
1-1/8" - 12 NF	2"	1"	7269	-
1-1/4" - 7 NC	2-3/16"	1"	7270	-
1-1/4" - 12 NF	2-3/16"	1"	7271	-
1-3/8" - 6 NC	2-3/8"	1"	7272	-
1-3/8" - 12 NF	2-3/8"	1"	7273	-
1-1/2" - 6 NC	2-9/16"	1"	7274	-
1-1/2" - 12 NF	2-9/16"	1"	7275	-

Taps & Dies

Re-Threading Die Sets

HANSON 10-piece Hexagon Re-threading Fractional NC Die Set (HCS)



25701

Set Contents	Item # 25701
Die Size	
1/4" - 20 NC	7220
5/16" - 18 NC	7227
3/8" - 16 NC	7234
7/16" - 14 NC	7239
1/2" - 13 NC	7244
9/16" - 12 NC	7248
5/8" - 11 NC	7252
3/4" - 10 NC	7258
7/8" - 9 NC	7261
1" - 8 NC	7265

HANSON 10-piece Hexagon Re-threading Fractional NF Die Set (HCS)



24801

Set Contents	Item # 24801
Die Size	
1/4" - 28 NF	7223
5/16" - 24 NF	7229
3/8" - 24 NF	7236
7/16" - 20 NF	7240
1/2" - 20 NF	7245
9/16" - 18 NF	7249
5/8" - 18 NF	7252
3/4" - 16 NF	7260
7/8" - 14 NF	7263
1" - 12 NF	7266

HANSON 6-piece Hexagon Re-threading Fractional Pipe Taper Die Set (HCS)

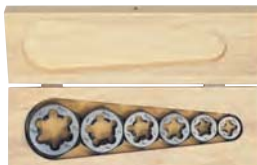

1922

Set Contents	Item # 1922
Die Size	
1/8" - 27 NPT	7402
1/4" - 18 NPT	7403
3/8" - 18 NPT	7404
1/2" - 14 NPT	7405
3/4" - 14 NPT	7406
1" - 11-1/2 NPT	7407

TAPS & DIES

HANSON 16-piece Hexagon Re-threading Fractional Die Set (HCS)



24839

Set Contents		Item # 24839
Die Size		
1/4" - 20 NC		7220
1/4" - 28 NF		7223
5/16" - 18 NC		7227
5/16" - 24 NF		7229
3/8" - 16 NC		7234
3/8" - 24 NF		7236
7/16" - 14 NC		7239
7/16" - 20 NF		7240
1/2" - 13 NC		7244
1/2" - 20 NF		7245
9/16" - 12 NC		7248
9/16" - 18 NF		7249
5/8" - 11 NC		7252
5/8" - 18 NF		7254
3/4" - 10 NC		7258
3/4" - 16 NF		7260

HANSON 12-piece Tap & Re-threading Hexagonal Pipe Die Sets (HCS) & (HSS)



1920

Set Contents			Item # 1920
Thread Size Pipe	Tap Item #	Hex Die Item #	
1/8" - 27 NPT	1902	7402	
1/4" - 18 NPT	1903	7403	
3/8" - 18 NPT	1904	7404	
1/2" - 14 NPT	1905	7405	
3/4" - 14 NPT	1906	7406	
1" - 11-1/2 NPT	1907	7407	
Empty Wooden Case		1920MT	

Set Contents			Item # 1923
Thread Size Pipe	Tap Item #	Hex Die Item #	
1/8" - 27 NPT	459001	7402	
1/4" - 18 NPT	459002	7403	
3/8" - 18 NPT	459003	7404	
1/2" - 14 NPT	459004	7405	
3/4" - 14 NPT	459005	7406	
1" - 11-1/2 NPT	459006	7407	

TAPS & DIES

IRWIN®

Extractors



www.irwin.com

Serious Solutions for Stuck Fasteners





IRWIN® Tools has the solution to deal with a stuck fastener, a rounded or broken head, a snapped stud, or a stripped screw or fitting. Five different styles of extractors give you extra gripping power to remove problem fasteners without damaging workpieces.

Remove the Guesswork in Fastener Extraction

Fasteners vary widely in composition and hardness. That's why IRWIN has many different products for removing damaged fasteners and parts. Each extraction tool is specifically designed to take into account the material involved and make removal easier. The guidelines below will help you choose the tool that will deliver the optimal results for your particular situation.

Guide for Using Screw Extractors

Drill a hole in the threaded part or fastener to be removed. Drill deep enough for the extractor to grip without bottoming out. For best results, use a left-handed drill bit. Insert the extractor and turn with a wrench or drive tool.

Extractor Type	Benefits	Fastener Size Range	Drive Tool
Straight Screw 	<ul style="list-style-type: none"> Extracts without expanding material Ideal for pipes and fittings Works on Left-hand or Right-hand threads 	3/16" - 7/8"	Tap Wrench Wrench Socket Wrench VISE-GRIP® Locking Pliers IRWIN Tap Adaptors
Spiral Screw 	<ul style="list-style-type: none"> Spiral bites into harder materials with increasing torque Flutes embed deeper with each turn 	3/32" - 2-1/2"	Tap Wrench Wrench Socket Wrench VISE-GRIP Locking Pliers IRWIN Tap Adaptors
Multi-Spline Screw 	<ul style="list-style-type: none"> Low profile enables use in confined areas Provides most torque of internal extractors Engages fastener without a deep hole 	1/8" - 7/8"	Flat Wrench Socket Wrench VISE-GRIP Locking Pliers
Bolt Extractor 	<ul style="list-style-type: none"> Engages rusted-over, painted-on, and stripped-out bolts Grips broken, worn, or stubborn fasteners Drive with a variety of tools 	1/4" - 1"	Socket Wrench Wrench VISE-GRIP Locking Pliers
POWER-GRIP™ Screw & Bolt Extractors 	<ul style="list-style-type: none"> Grips rusted, painted, stripped, and even round-head fasteners and screws Easily fits into drill or power driver with Quick Change Shank 	3/16" - 1/2"	Power Drill VISE-GRIP Locking Pliers

EXTRACTORS

HANSON® Straight Flute 536/526 Series



52605

Description	Recommended Tap Wrench	Use Drill Size	Removes Bolts & Screws	Carded Item #	Bulk Item #
ST-1	TR-88	9/64"	3/16" - 5/16", 5 mm - 8 mm, No. 10	53601	52601
ST-2	TR-88	3/16"	3/8", 10 mm	53602	52602
ST-3	TR-88	15/64"	7/16" and 1/8" NPT, 10 mm, 1/8" BSP	53603	52603
ST-4	TR-98	5/16"	1/2" - 9/16" and 1/4" NPT, 12 mm - 14 mm, 1/4" BSP	53604	52604
ST-5	TR-98	3/8"	5/8" and 3/8" NPT, 16 mm, 3/8" BSP	53605	52605
ST-6	TR-98	15/32"	3/4" and 1/2" NPT, 20 mm, 1/2" BSP	53606	52606
ST-7	TR-98	9/16"	7/8", 22 mm, 5/8" BSP	53607	52607

HANSON Straight Flute Extractor Sets 536/526 Series



53625

Description	Contents	Carded Item #	Bulk Item #
4-pc Set	ST-2 - ST-5	53625	-
5-pc Set	ST-1 - ST-5	53635	52635
6-pc Set	ST-1 - ST-6	53645	52655

HANSON 10-piece Extractor & Cobalt Drill Bit Set



11118

Description	Contents	Carded Set Item # 11118
10-pc Extractor & Cobalt Drill Bit Set in Vinyl Pouch	Straight Flute Extractors/Item #	Drill Bits/Item #
	ST-1	52601 9/64" 63109
	ST-2	52602 3/16" 63112
	ST-3	52603 15/64" 63115
	ST-4	52604 5/16" 63120
	ST-5	52605 3/8" 63124

Extractors

Spiral Flute

HANSON® Spiral Flute 534/524 Series



52405

- Designed to remove broken studs, bolts, socket screws and fittings
- Aggressive left hand spiral design for extra gripping power

Description	Recommended Tap Wrench	Use Drill Size	Removes Bolts & Screws	Carded Item #	Bulk Item #
EX-1	TR-88	5/64"	3/32" - 5/32", 2.5 mm - 4 mm, No. 3 - No. 6	53401	52401
EX-2	TR-88	7/64"	5/32" - 7/32", 4 mm - 6 mm, No. 6 - No. 12	53402	52402
EX-3	TR-88	5/32"	7/32" - 9/32", 6 mm - 8 mm, No. 12	53403	52403
EX-4	TR-88	1/4"	9/32" - 3/8", 1/8" NPT, 1/8" BSP, 8 mm - 10 mm	53404	52404
EX-5	TR-98	19/64"	3/8" - 5/8", 1/4" NPT, 1/4" BSP, 10 mm - 16 mm	53405	52405
EX-6	TR-98	13/32"	5/8" - 7/8", 3/8" NPT, 3/8" BSP, 16 mm - 22 mm	53406	52406
EX-7	TR-98	17/32"	7/8" - 1-1/8", 1/2" NPT, 1/2" BSP, 22 mm - 27 mm	53407	52407
EX-8	-	13/16"	1-1/8" - 1-3/8", 3/4" NPT, 3/4" BSP, 27 mm - 36 mm	-	52408
EX-9	-	1-1/16"	1-3/8" - 2", 1" NPT, 1" BSP, 36 mm - 52 mm	-	52409
EX-10	-	1-15/16"	2-1/8" - 2-1/2", 1-1/4" NPT, 1-1/4" BSP, 52 mm - 68 mm	-	52410

EXTRACTORS

HANSON Spiral Flute Extractor Sets 535/524 Series



53535

Description	Contents	Carded Item #	Bulk Item #
4-pc Set	EX-2 - EX-5	-	52425
5-pc Set	EX-1 - EX-5	53535	52435
6-pc Set	EX-1 - EX-6	53545	52445
9-pc Set	EX-1 - EX-9	-	52490

HANSON Spiral Extractor & Drill Bit Combo Packs 537 Series



53704

- High speed steel drill bit ensures fast, clean drilling

Description	Carded Item #
EX-1 + 5/64" Drill Bit	53701
EX-2 + 7/64" Drill Bit	53702
EX-3 + 5/32" Drill Bit	53703
EX-4 + 1/4" Drill Bit	53704
EX-5 + 19/64" Drill Bit	53705
EX-6 + 13/32" Drill Bit	53706

Description	Contents	Carded Item #	53700
6-pc Extractor & HSS Drill Bit Set in Vinyl Pouch	Straight Flute Extractors	Item #	Drill Bits
	EX-1	52401	5/64"
	EX-2	52402	7/64"
	EX-3	52403	5/32"

HANSON® 10-piece Spiral Extractor & Drill Bit Set in Metal Index



11119

HANSON 35-piece Screw Extractor & Drill Bit Set



11135

HANSON 10-piece Spiral Extractor & Drill Bit Combo Packs



11117

HANSON 48-piece Master Extractor Set



3101010

- The most complete extractor kit we produce
- For use with fasteners above, below, or flush with the work surface

Description	Contents		Item # 11119
10-pc Set in Metal Index	Spiral Flute Extractors/Item#		Drill Bits/Item #
	EX-1	52401	5/64" 30505
	EX-2	52402	7/64" 30507
	EX-3	52403	5/32" 30510
	EX-4	52404	1/4" 30516
	EX-5	52405	19/64" 30519

Description	Contents			Item # 11135
35-pc Set	Spiral Flute Extractors/Item #	Multi Spline Extractors/Item #	Left-Hand Cobalt Drill Bits/Item #	
	EX-1 52401	1/8" 53201	5/64" 30505	
	EX-2 52402	5/32" 53202	7/64" 30507	
	EX-3 52403	3/16" 53203	1/8" 30508	
	EX-4 52404	7/32" 53204	5/32" 30510	
	EX-5 52405	1/4" 53205	3/16" 30512	
	EX-6 52406	9/32" 53206	7/32" 30514	
		5/16" 53207	1/4" 30516	
		11/32" 53208	9/32" 30518	
		3/8" 53209	19/64" 30519	
		13/32" 53210	5/16" 31520	
		7/16" 53211	11/32" 30522	
		15/32" 53212	3/8" 30524	
		1/2" 53213	13/32" 30526	
			7/16" 30528	
			15/32" 30530	
			1/2" 30532	

Description	Contents		Item # 11117
10-pc Set in Metal Index	Spiral Flute Extractors/Item#		Drill Bits/Item #
	EX-1	52401	5/64" 63105
	EX-2	52402	7/64" 63107
	EX-3	52403	5/32" 63110
	EX-4	52404	1/4" 63116
	EX-5	52405	19/64" 63119

Description	Contents				Item # 3101010
48-pc Master Set	Spiral Flute Extractors/Item #	Multi Spline Extractors/Item #	Bolt Extractors/Item #	Left-Hand Cobalt Drill Bits/Item #	
	EX-1 52401	1/8" 53201	1/4" 53901	5/64" 30505	
	EX-2 52402	5/32" 53202	5/16"-8mm 53902	7/64" 30507	
	EX-3 52403	3/16" 53203	3/8" 53903	1/8" 30508	
	EX-4 52404	7/32" 53204	10mm 53904	5/32" 30510	
	EX-5 52405	1/4" 53205	7/16"-11mm 53905	3/16" 30512	
	EX-6 52406	9/32" 53206	12mm 53906	7/32" 30514	
		5/16" 53207	1/2" 53907	1/4" 30516	
		11/32" 53208	13mm 53908	9/32" 30518	
		3/8" 53209	9/16"-14mm 53909	19/64" 30519	
		13/32" 53210	5/8"-16mm 53910	5/16" 31520	
		7/16" 53211	17mm 53911	11/32" 30522	
		15/32" 53212	11/16" 53912	3/8" 30524	
		1/2" 53213	3/4"-19mm 53913	13/32" 30526	
				7/16" 30528	
				15/32" 30530	
				1/2" 30532	

EXTRACTORS

Extractors

Multi-Spline Screw

HANSON® Hex Head Multi-Spline 522/532 Series



53225

- Designed to remove broken studs, bolts, socket screws and fittings for high torque applications
- Aggressive left-hand spiral design for extra gripping power

Description	Hex Head Size	Bolt Diameter	Recommended Drill Bit Diameter	Carded Item #	Bulk Item #
1/8"	1/2"	#12	1/8"	52201	53201
5/32"	1/2"	1/4"	5/32"	52202	53202
3/16"	1/2"	5/16"	3/16"	52203	53203
7/32"	1/2"	3/8"	7/32"	52204	53204
1/4"	1/2"	7/16"	1/4"	52205	53205
9/32"	1/2"	1/2"	9/32"	52206	53206
5/16"	1/2"	9/16"	5/16"	52207	53207
11/32"	1/2"	5/8"	11/32"	52208	53208
3/8"	1/2"	11/16"	3/8"	-	53209
13/32"	1/2"	3/4"	13/32"	-	53210
7/16"	5/8"	13/16"	7/16"	-	53211
15/32"	5/8"	7/8"	15/32"	-	53212
1/2"	5/8"	15/16"	1/2"	-	53213
17/32"	3/4"	1"	17/32"	-	53214
9/16"	3/4"	1-1/16"	9/16"	-	53215
19/32"	3/4"	1-1/8"	19/32"	-	53216
5/8"	3/4"	1-3/16"	5/8"	-	53217
21/32"	7/8"	1-1/4"	21/32"	-	53218
11/16"	7/8"	1-5/16"	11/16"	-	53219
23/32"	7/8"	1-3/8"	23/32"	-	53220
3/4"	7/8"	1-7/16"	3/4"	-	53221
25/32"	1"	1-1/2"	25/32"	-	53222
13/16"	1"	1-9/16"	13/16"	-	53223
27/32"	1"	1-5/8"	27/32"	-	53224
7/8"	1"	1-11/16"	7/8"	-	53225

EXTRACTORS

HANSON Hex Head Multi-Spline Plastic Case Sets 532 Series



53226

Description	Contents	Item #
10-pc Set	1/8" through 13/32"	53226
Empty Case for 53226	-	53226MT
15-pc Set	1/8" through 9/16"	53228
Empty Case for 53228	-	53228MT
25-pc Set	1/8" through 7/8"	53227
Empty Case for 53227	-	53227MT

HANSON® Bolt Extractors



53910

- Reverse spiral flutes bite into bolt
- For use with 3/8" socket drive, VISE-GRIP® Locking Pliers, or wrench.

HANSON 9-piece Fractional Bolt Extractor Set



54009

HANSON 9-piece Metric Bolt Extractor Set



54019

HANSON 13-piece Professional's Industrial Set



54113

Removes Fractional Size Bolts	Removes Metric Size Bolts	Drive Size	Item #
1/4"	–	3/8"	53901
5/16"	8 mm	3/8"	53902
3/8"	–	3/8"	53903
–	10 mm	3/8"	53904
7/16"	11 mm	3/8"	53905
–	12 mm	3/8"	53906
1/2"	–	3/8"	53907
–	13 mm	3/8"	53908
9/16"	14 mm	3/8"	53909
5/8"	16 mm	3/8"	53910
–	17 mm	3/8"	53911
11/16"	–	3/8"	53912
3/4"	19 mm	3/8"	53913
3/4"	19 mm	1/2"	53914
13/16"	21 mm	1/2"	53915
7/8"	22 mm	1/2"	53916
15/16"	24 mm	1/2"	53917
1"	–	1/2"	53918

Removes Fractional Size Bolts	Removes Metric Size Bolts	Drive Size	Item #
1/4"	–	3/8"	53901
5/16"	8 mm	3/8"	53902
3/8"	–	3/8"	53903
7/16"	11 mm	3/8"	53905
1/2"	–	3/8"	53907
9/16"	14 mm	3/8"	53909
5/8"	16 mm	3/8"	53910
11/16"	–	3/8"	53912
3/4"	19 mm	3/8"	53913

Removes Fractional Size Bolts	Removes Metric Size Bolts	Drive Size	Item #
5/16"	8 mm	3/8"	53902
–	10 mm	3/8"	53904
7/16"	11 mm	3/8"	53905
–	12 mm	3/8"	53906
–	13 mm	3/8"	53908
9/16"	14 mm	3/8"	53909
5/8"	16 mm	3/8"	53910
–	17 mm	3/8"	53911
3/4"	19 mm	3/8"	53913

Removes Fractional Size Bolts	Removes Metric Size Bolts	Drive Size	Item #
1/4"	–	3/8"	53901
5/16"	8 mm	3/8"	53902
3/8"	–	3/8"	53903
–	10 mm	3/8"	53904
7/16"	11 mm	3/8"	53905
–	12 mm	3/8"	53906
1/2"	–	3/8"	53907
–	13 mm	3/8"	53908
9/16"	14 mm	3/8"	53909
5/8"	16 mm	3/8"	53910
–	17 mm	3/8"	53911
11/16"	–	3/8"	53912
3/4"	19 mm	3/8"	53913

EXTRACTORS

HANSON® 5-piece Lugnut Specialty Set



54125

Removes Fractional Size Bolts	Removes Metric Size Bolts	Drive Size	Item # 54125
3/4"	19 mm	1/2"	53914
13/16"	21 mm	1/2"	53915
7/8"	22 mm	1/2"	53916
15/16"	24 mm	1/2"	53917
1"	-	1/2"	53918

5-piece BOLT-GRIP® Base Set



394001

- Includes most commonly used sizes
- Engineered to grip bolts in almost any condition
- Case accommodates Expansion Set (#394002)

Removes Fractional Size Bolts	Removes Metric Size Bolts	Drive Size	Item # 394001
3/8"	-	3/8"	53903
7/16"	11 mm	3/8"	53905
1/2"	-	3/8"	53907
9/16"	14 mm	3/8"	53909
5/8"	16 mm	3/8"	53910

5-piece BOLT-GRIP Expansion Set



394002

- Provides additional diameters to address a complete range of fastener sizes

Removes Fractional Size Bolts	Removes Metric Size Bolts	Drive Size	Item # 394002
5/16"	8 mm	3/8"	53902
-	10 mm	3/8"	53904
-	13 mm	3/8"	53908
11/16"	-	3/8"	53912
3/4"	19 mm	3/8"	53913

5-piece BOLT-GRIP Deep Well Set



3094001

- Longer profile and smaller head to fit in smaller areas
- Reaches recessed fasteners and fits over exposed studs

Removes Fractional Size Bolts	Removes Metric Size Bolts	Drive Size	Item # 3094001
3/8"	-	3/8"	59903
7/16"	11 mm	3/8"	59905
1/2"	-	3/8"	59907
9/16"	14 mm	3/8"	59909
5/8"	16 mm	3/8"	59910

7-piece POWER-GRIP™ Set



394100

- Reverse spiral teeth provide maximum gripping power
- 1/4" hex shank fits most drills and Quick Change Adaptors

Removes Fractional Size Bolts	Removes Metric Size Bolts	Drive Size	Item # 394100
3/16"	-	1/4"	394100A
1/4"	-	1/4"	394101A
5/16"	8 mm	1/4"	394102A
3/8"	-	1/4"	394103A
-	10 mm	1/4"	394104A
7/16"	11 mm	1/4"	394105A
1/2"	-	1/4"	394107A

IRWIN®

Worksite Products



www.irwin.com

Worksite Products

Rigs / Aprons / Pouches

Superior Products for the Superior Tradesman

IRWIN® Tools is focused on developing products that exceed the demanding needs of the tradesman. We work directly with professionals of all trades to help us identify and develop products of superior quality and performance. Our worksite products line is just another way for IRWIN to continue to deliver this promise.

ArmorMAX™ 6pc. Polyester Construction Rig



4031049

- Triple pouch design with easy access pockets
- Includes double tane leather belt

Suede Leather 10 Pocket Carpenter's Apron



4031003

- Oversized center pocket for fasteners or tape
- Dual hammer holders
- Reinforced points of wear for greater durability
- Includes integrated nylon belt

Lightweight Cotton 2 Pocket Nail Apron



4031051

- Machine washable

WORKSITE PRODUCTS

Lightweight Cotton Machinist's Apron



4031052

- "Bib" style provides full body protection
- Machine washable

Full Grain Leather 2" Belt



4031025

- Fits all standard pouches and belt accessories
- Made of saddle leather for added durability

Oil Tanned Leather Electrician's Pouch



4031007

- Easy vertical tool access
- Includes tape holder and key fastener

Description	Item #
ArmorMAX™ 6 pc. Polyester Construction Rig	4031049
10 Pocket Suede Carpenter's Apron	4031003
2 Pocket Cotton Nail Apron	4031051
5 Pocket Cotton Machinist's Apron	4031052
2" Saddle Leather Belt	4031025
Oil Tanned Leather Electrician's Pouch	4031007

Suede Leather 10 Pocket Journeyman's Pouch



4031012

- Dual hammer holders
- Reinforced points of wear for greater durability

ArmorMAX™ 1 Pocket Maintenance Pouch



4031045

- Easy access pocket design
- Includes tape holder and multi-purpose clip

Universal Cell Phone Holder



4031022

- Holds cell phones, two-way radios and walkie talkies
- Integrated belt hook and belt loop
- Fits all standard 2" belts

Flip Phone Holder



4031024

- Holds most flip phones
- Includes belt clip
- Fits all standard 2" belts

Saddle Leather Hammer Holder



4031015

- Metal hammer capture
- Made of saddle leather for added durability
- Fits all standard 2" belts

Saddle Leather Hammer Holder



4031054

- Metal hammer capture
- Made of saddle leather for added durability
- Fits all standard 2" belts

Plier Holder



4031023

- Fits all standard pliers
- Made of saddle leather for added durability
- Fits all standard 2" belts

Saddle Leather Tape Holder



4031053

- Snap strap holds tape in place
- Made of saddle leather for added durability
- Fits all standard 2" belts

Saddle Leather Utility Knife Holder



4031018

- Holds all standard utility knives
- Made of saddle leather for added durability
- Fits all standard 2" belts

WORKSITE PRODUCTS

Description	Item #
10 Pocket Suede Journeyman's Pouch	4031012
ArmorMAX™ Polyester Maintenance Pouch	4031045
Saddle Leather Hammer Holder (Natural)	4031015
Saddle Leather Tape Holder (Black)	4031053
Saddle Leather Hammer Holder (Black)	4031054
Saddle Leather Utility Knife Holder (Black)	4031018
Universal Cell Phone Holder	4031022
Saddle Leather Plier Holder (Black)	4031023
Flip Phone Holder	4031024

18" Double-Sided Tool Bag



4402017

- 3 zippered compartments for greater organization
- Includes 3 removable pouches

16" Contractor's Bag



4402020

- Large zippered storage compartment
- Removable shoulder strap

12" Contractor's Bag



4402019

- Large zippered storage compartment
- Stay open design

Pro Bucket Tool Organizer



420001

- 56 pockets store and organize everything from screws to socket wrenches
- Easy to locate clip keeps keys and other small objects handy

Pro Large Tool Organizer



420002

- Large capacity storage
- Open at the top for quick and easy access
- False bottom provides separate storage for important items

Pro Soft Side Tool Organizer



420003

- Small, lightweight and strong
- Zippered for secure transport
- Padded handle with reinforced stitching for extra strength

Pro Utility Tool Organizer



420004

- Enough capacity to carry a broad range of tools and accessories
- Pockets and compartments designed to provide better organization

16" Utility Tote



4402016

- Open main storage compartment, side pockets, 2" level storage
- Removable shoulder strap

Electrician's Tote



4402011

- Designed for easy vertical tool access
- Includes small parts organizer

WORKSITE PRODUCTS

Description	Item #
18" Double Sided Tool Bag	4402017
16" Contractor's Bag	4402020
12" Contractor's Bag	4402019
Electrician's Tote	4402011
16" Utility Tote	4402016
Pro Bucket Tool Organizer	420001
Pro Large Tool Organizer	420002
Pro Soft Side Tool Organizer	420003
Pro Utility Tool Organizer	420004

Heavy Duty Jobsite Work Gloves



432001

- TechnoGrip® reinforced palm, thumb and fingertips for extra durability and protection
- Designed for harsh applications and rough materials
- Knuckles padded with perforated Neoprene

Carpenter Work Gloves



432003

- Open finger design, allows for better dexterity
- TechnoGrip® reinforced palm, thumb and fingertips for extra durability and protection
- Knuckles padded with perforated Neoprene

General Construction Work Gloves



432005

- Two layers of synthetic suede on palm, thumb and fingers for comfort and extended wear
- Rubberized finger tips for better gripping
- Knuckles padded with perforated Neoprene

I-Gel™ Gum Rubber Kneepads



4033005

- Skid-resistant gum rubber won't mar or scratch floors

Hard Shell Kneepads



4033014

- Exterior cap includes high density closed-cell foam providing maximum comfort
- Fully stitched cap keeps out debris
- Dual strap design for versatility

ArmorDex™ Work Gloves



4403235

- Heavy duty material protects against abrasions, cuts & punctures
- Terry cloth thumb for quick brow wipes

I-Gel Stabilizer Kneepads



4033006

- Provides great stability for roofing and HVAC use

Ultra Light Kneepads



4033016

- Ideal for wet surfaces
- Dual strap design for versatility

Description	Item #
Heavy Duty Work Gloves - L	432001
Heavy Duty Work Gloves - XL	432002
Carpenter Work Gloves - L	432003
Carpenter Work Gloves - XL	432004
General Construction Work Gloves - L	432005
General Construction Work Gloves - XL	432006
ArmorDex Work Gloves - M	4403233
ArmorDex Work Gloves - L	4403234
ArmorDex Work Gloves - XL	4403235
I-Gel Gum Rubber Kneepads	4033005
I-Gel Stabilizer Kneepads	4033006
Hard Shell Kneepads	4033014
Ultra Light Kneepads	4033016

®TechnoGrip is a registered trademark of Eastex Products, Inc.

Item #	Page	Item #	Page	Item #	Page	Item #	Page	Item #	Page	Item #	Page	Item #	Page
1002	148	10507529NA	20	11195	126	1216	148	1348	148	1436	148	1540	148
1002L3	10	10505868NA	20	1120	148	1217	148	1349	148	1439	148	1544	148
1004	148	10505869NA	20	1121	148	1218	148	1352	148	1440	148	1545	148
1005	148	10505870NA	20	11212	146	1219	148	1354	148	1444	148	1546	148
1006	148	10505865NA	20	11214	146	1220	148	1356	148	1445	148	1548	148
1007	148	10505866NA	20	11220	66	1221	148	1357	148	1446	148	1549	148
1008	148	10505867NA	20	11221	146	1224	148	1358	148	1448	148	15502	126
1009	148	10505871NA	20	1124	148	1225	148	1360	148	1449	148	1552	148
1011	148	10505519NA	23	11240	63	1226	148	1361	148	1452	148	15530ZR	63
1012	148	10502ZR	126	1125	148	1228	148	1363	148	1454	148	1554	148
1013	148	10502CB	126	1126	148	1231	148	1365	148	1456	148	1556	148
1016	148	1078TRT	15	11270ZR	65	1232	148	1366	148	1457	148	1557	148
1017	148	1078TRAY	15	1128	148	1233	148	1367	148	1458	148	1558	148
1018	148	1078KB	15	1131	148	1234	148	13T	10	1460	148	1560	148
1019	148	1T	10	1132	148	1235	148	14015	66	1461	148	1561	148
1020	148	1ZR	35	1133	148	1236	148	14017	66	1463	148	1563	148
1021	148	11008	146	1134	148	12401	147	14011	66	1465	148	1565	148
10220	126	11016	147	1135	148	12402	147	1402L3	11	1466	148	1566	148
10220CB	125	11017	147	1136	148	12416	146	14028	63	1467	148	1567	148
10221	126	11018	147	11440	63	12415	147	14027	66	14T	11	15702ZR	64
10225	126	1102	148	11580	126	12428	146	14020	66	1502L3	11	15T	11
10228	126	11026	146	11581	126	12421	146	14029	66	15030	63	1602L3	11
10231CB	125	1104	148	11670	65	12435	146	14023	66	1506	148	165	11
10232CB	125	11040ZR	63	11820ZR	66	12436	146	14035	63	15070	65	17	11
10233CB	125	1105	148	11830	64	12445	146	14030	63	15101ZR	125	1712	149
10234CB	125	1106	148	11840	63	12446	146	14031	63	15102ZR	125	1713	149
10239CB	125	1107	148	11870	65	12457	146	14050ZR	65	15103ZR	125	1717	149
10231	126	1108	148	11T	10	12450	147	14053	65	15104	125	1718	149
10232	126	1109	148	12008	146	12473	147	1406	148	15120	66	1722	149
10233	126	11101CB	125	12001	147	12498	146	14070	65	1512	148	1723	149
10234	126	11101ZR	126	12002	147	12L3	12	14074	65	15130	63	1727	149
10235	126	11102CB	125	12016	147	13055	47	14076	65	1513	148	1729	149
10239	126	11102	126	12017	147	1306	148	1407	148	15150	65	1731	149
1024	148	11103CB	125	12018	147	13085	47	14080	65	15200	125	1733	149
1025	148	11103	126	12026	146	13125	47	14082	65	1520	148	1734	149
1026	148	11104CB	125	12021	146	1312	148	14083	65	1521	148	1735	149
1028	148	11104	126	1202	148	1313	148	14084	65	15220	66	1736	149
102L3	10	11105ZR	126	1204	148	1320	148	1410	148	15221	125	1737	149
10310	126	1111	148	12050	147	1321	148	1411	148	15230ZR	63	1738	149
10311ZR	126	11117	187	1205	148	1323	148	1412	148	1523	148	1739	149
10312ZR	126	11118	185	1206	148	1324	148	14130	63	1524	148	1740	149
10313ZR	126	11119	187	12073	147	1325	148	1413	148	15250	65	1741	149
10314	126	1112	148	1207	148	1327	148	1420	148	1525	148	1742	149
1031	148	1113	148	12088	146	1329	148	1421	148	15270	65	1743	149
1032	148	11135	187	12087	147	1331	148	14233	65	1527	148	1744	149
1033	148	11140	63	1208	148	1334	148	1423	148	1529	148	1749	149
1034	148	1116	148	12092	124	1336	148	1424	148	15313	125	1750	149
1035	148	1117	148	1209	148	1339	148	1425	148	1531	148	1752	149
1036	148	11170	65	12115	147	1340	148	1427	148	1534	148	1754	149
10505872NA	20	1118	148	1211	148	1344	148	1429	148	1536	148	1755	149
10505873NA	20	1119	148	1212	148	1345	148	1431	148	15370	65	1756	149
10505874NA	20	11194	126	1213	148	1346	148	1434	148	1539	148	1759	149

Numerical Index

INDEX

Item #	Page	Item #	Page	Item #	Page	Item #	Page	Item #	Page	Item #	Page	Item #	Page
1761	149	1831	149	20111	119	20149	119	2034300	48	2078108	16	2078901	19
1764987	56	1833	149	2011102	52	20150	119	2034403	48	2078110	16	2078904	21
1764988	56	1834	149	2011104	52	2015100	53	2034404	48	2078112	16	2078905	21
1764989	56	1837	149	20112	119	20151	119	2034408	48	2078116	16	2078909	19
1764990	56	1838	149	2011201	52	20152	119	2034409	48	2078120	16	2078910	19
1764983	56	1839	149	2011204	52	20153	119	2034410	48	2078208	17	2078915	21
1764984	56	1840	149	2011203	52	20154	119	2034411	48	2078209	17	2078925	21
1764985	56	1842	149	2011200	52	20155	119	2035101	50	2078216	17	2078935	21
1764986	56	1844	149	2011202	52	2021406N	27	2035102	50	2078218	17	2078945	21
1764343	130	1849	149	20113	119	2021412N	27	2035103	50	2078226	17	2078955	21
1764344	130	1852	149	20114	119	2021418N	27	2035104	50	2078228	17	2078965	21
1764345	130	1855	149	20115	119	2021424N	27	2035105	50	2078306	17	2081101	57
1764	149	1856	149	20116	119	2021436N	27	2035106	50	2078307	17	2081200	57
1765	149	1859	149	20117	119	2021450N	27	2035107	50	2078308	17	2082101	57
1765531	151	1861	149	20118	119	2024100	31	2035108	50	2078318	18	2082200	57
1765534	151	1864	149	20119	119	2025101	30	2035100	50	2078328	18	2082300	57
1765535	151	1865	149	20120	119	2025102	30	2035100CD	50	2078300	21	2083100	56
1765536	151	1868	149	20121	119	2025103	30	2035200	49	2078305	21	2083200	56
1765537	151	1869	149	20122	119	2026303	38	2035201	49	2078309	21	2084100	56
1765538	151	19	11	20123	119	2026500	31	2035202	49	2078310	20	2084200	56
1765539	151	1902	149	20124	119	2026501	31	2035203	49	2078316	21	2084300	56
1765540	151	1903	149	20125	119	2031311	45	2035204	49	2078317	21	2084350	56
1765541	166	1904	149	20126	119	2031313	45	2035207	49	2078406	19	2084400	56
1766068	146	1904P	149	20127ZR	119	2031314DS	45	2035400	50	2078408	19	2086100	58
1766069	146	1905	149	20128ZR	119	2031315DS	45	2035401	50	2078500	18	2086102	58
1766070	146	1905P	149	20129	119	2031316DS	45	2035600	50	2078506	18	2086200	58
1768772	40	1906	149	20130	119	2031317B	45	2035601	50	2078508	18	2086203	58
1768773	40	1906P	149	20131	119	2031318DS	45	2035602	50	2078510	18	2086300	58
1768774	40	1907	149	20132	119	2031319DS	45	2051100	97	2078512	18	2086301	58
1768775	40	1908	149	20133	119	2031320DS	45	2059	47	2078516	18	2086403	58
1768776	40	1909	149	20134	119	2031321B	45	2060	47	2078606	20	2086404	58
1768777	40	1910	149	20135	119	2031322	45	2071904	13	2078608	20	2086405	58
1768778	40	1911	149	20136	119	2031323	45	2071905	13	2078610	20	2087100	56
1768779	40	1912	149	20137ZR	119	2031324	45	2071907	13	2078612	20	2087102	56
1768780	40	1920	181	20138ZR	119	2031333	45	2071910	13	2078615	20	2088100	56
1768781	40	1921	149	20139ZR	119	2032101	47	2073111	42	2078618	20	2088300	56
1768411	131	1922	180	20140	119	2032150	47	2073112	42	2078624	20	2088600	57
1768	149	1923	181	2014100	53	2032160	46	2073113	42	2078700	23	2089	47
1769179	40	1924	174	2014102	53	2032170	46	2073115	42	2078701	23	2089100	57
1769	149	19T	11	20141	119	2032171	46	2073211	42	2078702	23	21	11
1771883	15	2	12	2014200	53	2032172	46	2073212	42	2078703	23	21101	147
1773465	52	20	11	20142ZR	119	2032174	46	2073704	42	2078704	23	21102	147
1773466	52	20101ZR	119	20143	119	2032176	46	2074110	22	2078705	23	21110	147
17T	11	20102	119	20144	119	2032177	46	2074112	22	2078706	23	21112	147
18	11	20103	119	2014400	53	2032179	46	2074114	22	2078707	23	211ZR	11
1812	149	20104	119	2014450	53	2032180	46	2074118	22	2078708	23	2120	175
1817	149	20105	119	20145	119	2033500	47	2074124	22	2078714	23	21201	147
1818	149	20106	119	2014500	53	2034204	48	2074136	22	2078709	23	21202	147
1822	149	20107	119	2014501	53	2034205	48	2074148	22	2078710	23	21210	147
1823	149	20108	119	20146	119	2034206	48	2076709	15	2078711	23	21212	147
1827	149	20109	119	20147	119	2034207	48	2077703	15	2078712	23	2123	175
1829	149	20110	119	20148	119	2034208	48	2077704	15	2078900	21	2127	175

Item #	Page	Item #	Page	Item #	Page	Item #	Page	Item #	Page	Item #	Page	Item #	Page
2129	175	226100	31	2611	150	2756	150	3015014	109	3016129	111	3019031B	112
21304	42	226200	31	2612	150	27ZR	12	3015015	109	3016130	111	3019032B	112
213100	54	226303ZR	38	2613ZR	150	28	11	3015016	109	3016131ZR	111	3019125B	113
213101	54	226304ZR	37	2620	150	29	12	3015017	109	3016132	111	3019126B	113
213102	54	226305ZR	37	2623	150	3	35	3015018	109	3016225	111	3019127B	113
213103	54	226306ZR	37	2627	150	3T	10	3015019	109	3016226	111	3019128B	113
213104	54	226340	38	2629	150	30	11	3015020	109	3016227	111	3019129B	113
2134	175	226361	38	26313	167	300315	174	3015021	109	3016228	111	3019130B	113
2136	175	226410	31	26317	164	300319	174	3015022	109	3016229	111	3019131B	113
2139	175	226800	31	26319	166	300322	174	3015023	109	3016230	111	3019132B	113
2140	175	23	12	2634	150	300323	174	3015024	109	3016231	111	3028	155
2144	175	23007	42	2636	150	300325	174	3015025	109	3016232	111	302L3	10
21440	63	23010	42	26376	160	300326	174	3015026	109	3018002B	123	303101	174
2145	175	23012	42	26377	159	30104	118	3015027	109	3018002	123	303102	174
2148	175	233250	47	2639	150	30105	118	3015028	109	3018003	123	303103	174
2149	175	23614	171	26394	163	30106	118	3015029	109	3018004	123	303205	174
214T	15	23622	172	2640	150	30107	118	3015030	109	3018005	123	303319	174
2152	175	24020	66	2644	150	30108	118	3015031	109	3018006B	123	303322	174
2154	175	24021	63	2645	150	30109	118	3015032	109	3018009	124	303323	174
2158	175	24028	63	2648	150	30110	118	3016004	111	3018008	124	3041001	129
2160	175	24029C	66	2649ZR	150	30111	118	3016005	111	3018008	126	3041001B	129
218HP-300	54	24030	63	2652	150	30112ZR	118	3016006	111	3018011	123	3041002	129
21830ZR	64	24031	63	2654	150	30113	118	3016007	111	3018010	124	3041002B	129
21840ZR	63	24035	63	2658	150	30114	118	3016008	111	3018024SM	124	3041003	129
22	11	24070	65	2660	150	30115	118	3016009	111	3019003B	112	3041004	129
22007	42	24130	63	2661	150	30116	118	3016010	111	3019004B	112	3041004B	129
22010	42	24233	65	2663	150	30117	118	3016011	111	3019005B	112	3041005	129
22012	42	2449	150	2665	150	30118	118	3016012	111	3019006B	112	3041005B	129
222601	30	2459	150	2666	150	30119	118	3016013	111	3019007B	112	3041006	129
222702	30	24605	166	2667	150	30120	118	3016014	111	3019008B	112	3041007	129
222803	30	24606	164	2712	150	30121	118	3016015	111	3019009B	112	3041007B	129
223106	30	24612	167	2722	150	30122ZR	118	3016016	111	3019010B	112	3041009	129
223112	30	24614	167	2727	150	30123	118	3016017	111	3019011B	112	3041009B	129
223118	30	24640	163	2731	150	30124	118	3016018	111	3019012B	112	3041014	129
223124	30	24801	180	2733	150	30125	118	3016019	111	3019013B	112	3041014B	129
223130	30	24839	181	2734	150	30126	118	3016020	111	3019014B	112	3041015	129
223136	30	25030ZR	63	2738	150	30127ZR	118	3016021	111	3019015B	112	3041015B	129
223212	30	251	12	2739	150	30128ZR	118	3016022	111	3019016B	112	3041016	129
223218	30	25130	63	2740	150	30129ZR	118	3016023	111	3019017B	112	3041016B	129
223224	30	2518	150	274001SM	22	30130	118	3016024	111	3019018B	112	3041017	129
223230	30	25230	63	274101	22	30131	118	3016025	111	3019019B	112	3041017B	129
224134	31	2524	150	274102	22	30132ZR	118	3016026	111	3019020B	112	3041018	129
224212	31	2528	150	274103	22	3015004*	109	3016027	111	3019021B	112	3041018B	129
225101	30	2531	150	274104	22	3015005*	109	3016028	111	3019022B	112	3041019	129
225102	30	25530	63	274105	22	3015006*	109	3016029	111	3019023B	112	3041019B	129
225103	30	25701	180	274106	22	3015007*	109	3016030	111	3019024B	112	3041020	129
225104	30	25914	171	274107	22	3015008	109	3016031ZR	111	3019025B	112	3041021	129
225105	30	25941	170	274108	22	3015009	109	3016032	111	3019026B	112	3041020B	129
225106	30	25ZR	12	2742	150	3015010	109	3016125	111	3019027B	112	3041021B	129
225108	30	2606	150	2744	150	3015011	109	3016126	111	3019028B	112	3043004	133
225123	30	2607	150	275	11	3015012	109	3016127	111	3019029B	112	3043005	133
225134	30	2610	150	2752	150	3015013	109	3016128	111	3019030B	112	3043006	133

Numerical Index

Item #	Page	Item #	Page	Item #	Page	Item #	Page	Item #	Page	Item #	Page	Item #	Page
3043007	133	3051010	88	3052038B	75	3053004B	75	3053055	85	3074001P3	72	313322	174
3043008	133	3051011	88	3052039B	75	3053005	75	3053056	85	3074002P3	72	313325	174
3043009	133	3051012	88	3052030	82	3053005B	75	3053057	85	3074003P3	72	313326	174
3043004B	133	3051013	88	3052031	82	3053006	75	3053058	80	3074004P3	72	313327	174
3043005B	133	3051014	88	3052032	82	3053006B	75	3053059	80	3074000P25	72	313328	174
3043006B	133	3051015	88	3052033	82	3053007	75	30532	118	3074001P25	72	313331	174
3043007B	133	3051016	88	3052034	84	3053007B	75	3054001	85	3074002P25	72	313332	174
3043008B	133	3051017	88	3052035	84	3053008	76	3054002	85	3074003P25	72	3134	155
3043009B	133	3051018	88	3052036	84	3053009	80	3056002	86	3074004P25	72	313433	174
3043010	133	3051020	88	3052037	84	3053010	83	3056003	87	3094001	190	313434	174
3043011	133	3051021	88	3052041	75	3053011	83	3056004	89	3094100	178	313435	174
3043012	133	30512ZR	118	3052044	75	3053012	83	3056005	87	3094101	178	313436	174
3043013	133	30514	118	3052042	75	3053013	83	3057002DS	91	3094102	178	313437	174
3043014	133	30516	118	3052045	75	3053014	83	3057003DS	91	3094104	178	313438	174
3043015	133	30518ZR	118	3052040	75	3053015	83	3057011DS	90	3095001	147	313439	174
3043016	133	30519	118	3052043	75	3053016	83	3057013DS	91	3095001A	147	313440	174
3043010B	133	3052001	75	3052046	75	3053017	83	3057014	93	3095001B	147	313441	174
3043011B	133	3052002	75	3052047	75	3053018	83	3057015	94	31	11	313445	174
3043012B	133	3052003	75	3052048	75	3053019	80	3057016	96	3101010	187	314015	124
3043013B	133	3052004	75	3052049	75	3053021	80	3057017	94	310310	174	314018	124
3043014B	133	3052005	75	3052041B	75	3053022	80	3057018	95	310312	174	31520	118
3043015B	133	3052006	75	3052044B	75	3053023	80	3057023	90	310315	174	316015	124
3043016B	133	3052001B	75	3052042B	75	3053024	80	3057024	90	310316	174	316310	174
3043060	80	3052002B	75	3052045B	75	3053025	80	3057026	91	310318	174	316312	174
3044001LW	138	3052003B	75	3052040B	75	3053026	80	3057031	92	310319	174	316315	174
3046004	139	3052004B	75	3052043B	75	3053027	80	3057034	96	310320	174	316316	174
3046005	139	3052005B	75	3052047B	75	3053028	80	3057041	92	310322	174	316318	174
3046006	139	3052006B	75	3052048B	75	3053029	80	3061001	65	310323	174	316319	174
3046007	139	3052007	76	3052049B	75	3053030	84	3061002	65	310327	174	316320	174
3046008	139	3052009	76	3052050	75	3053031	84	306205	174	310328	174	316322	174
3046009	139	3052010	79	3052053	75	3053032	84	3071001	72	310331	174	316323	174
3046010	139	3052011	81	3052051	75	3053033	84	3071300	72	310332	174	316327	174
3046011	139	3052012	81	3052054	75	3053034	84	3071314	72	310433	174	316328	174
3046012	139	3052013	81	3052052	75	3053035	84	3071320	72	310434	174	316331	174
3046013	139	3052014	81	3052055	75	3053036	84	3071336	72	310435	174	316332	174
3046014	139	3052015	81	3052050B	75	3053037	82	3071406	72	310438	174	316433	174
3046015	139	3052016	81	3052053B	75	3053038	82	3071410	72	310439	174	316434	174
3046016	139	3052017	81	3052051B	75	3053039	82	3071412	72	310440	174	316435	174
30505ZR	118	3052018	81	3052054B	75	3053040	82	3071410D	72	310441	174	316438	174
30507	118	3052019	81	3052052B	75	3053041	82	3072001	72	310442	174	316439	174
30508	118	3052020	81	3052055B	75	3053042	82	3072300	72	310443	174	316440	174
30510	118	3052021	81	30522	118	3053043	82	3072314	72	310444	174	316441	174
3051001	88	3052022	82	30524	118	3053044	82	3072320	72	311088	146	316444	174
3051004	88	3052023	82	30526ZR	118	3053045	82	3072336	72	3120	155	318015	124
3051007	88	3052024	82	30528	118	3053047	84	3072406	72	3127	155	322001	101
3051002	88	3052025	82	30530	118	3053048	84	3072410	72	313310	174	322002	101
3051005	88	3052026	82	3053001	75	3053049	84	3072412	72	313312	174	322002B25	101
3051008	88	3052027	82	3053001B	75	3053050	84	3072410D	72	313315	174	322003	101
3051003	88	3052028	82	3053002	75	3053051	84	3073002	71	313316	174	322003B25	101
3051006	88	3052029	82	3053002B	75	3053052	85	3073003	71	313318	174	322004	101
3051009	88	3052038	75	3053003	90	3053053	85	3073004	71	313319	174	322004B25	101
3051019	88	3052039	75	3053004	75	3053054	85	3074000P3	72	313320	174	322005	101

Item #	Page	Item #	Page	Item #	Page	Item #	Page	Item #	Page	Item #	Page	Item #	Page
322005B25	101	322050	101	324002	103	324067	103	326007	106	333010	105	3512252C	77
322006	101	322051	101	324003	103	324068	103	326008	106	333011	105	3512272C	77
322006B25	101	322052	101	324004	103	324070	103	326008B25	106	333012	105	3513091C	80
322007	101	322053	101	324005	103	324071	103	326009	106	333014	105	3513121C	80
322007B25	101	322054	101	324006	103	324072	103	326009B25	106	333015	105	3513151C	80
322013	101	322055	101	324007	103	324073	103	326010	106	333016	105	3513181C	80
322013B25	101	322056	101	324008	103	324074	103	326011	106	333017	105	3513211C	80
322014	101	322057	101	324009	103	324076	103	326011B25	106	333019	105	3513241C	80
322014B25	101	322058	101	324010	103	324078	103	326012	106	333020	105	3513271C	80
322015	101	322058B25	101	324011	103	324080	103	326013	106	333021	105	351327XC	80
322015B25	101	322059	101	324012	103	324081	103	326014	106	333310	175	3513301C	80
322016	101	322061	101	324013	103	325000	104	326015	106	333312	175	3513331C	80
322016B25	101	322082	101	324015	103	325001	104	326015B25	106	333315	175	3513361C	80
322017	101	322085	101	324017	103	325002	104	326016	106	333318	175	3514962C	80
322017B25	101	322087	101	324018	103	325003	104	326017	106	333320	175	3514972C	80
322018	101	322089	101	324019	103	325004	104	326019	106	333321	175	3514996C	80
322018B25	101	323000	102	324020	103	325005	104	326020	106	333322	175	3515997C	83
322019	101	323001	102	324021	103	325006	104	326021	106	333323	175	3520031C	76
322020	101	323002	102	324022	103	325007	104	326022	106	341008	131	3520071C	76
322021	101	323003	102	324025	103	325008	104	326023	106	3510052C	76	3520075B	76
322022	101	323004	102	324026	103	325009	104	326024	106	35101125	76	3520075C	76
322022B25	101	323005	102	324027	103	325010	104	326025	106	3510112C	76	3520111C	76
322023	101	323006	102	324028	103	325011	104	326026	106	3510115B	76	3520231C	76
322024	101	323007	102	324029	103	325012	104	326027	106	3510115C	76	3520251C	76
322024B25	101	323008	102	324030	103	325013	104	327001	101	351011XB	76	3520291C	76
322025	101	323009	102	324031	103	325014	104	327002	101	351011XC	76	3520671C	76
322026	101	323010	102	324033	103	325015	104	331000	105	3510192C	76	3520691C	76
322026B25	101	323011	102	324034	103	325016	104	331001	105	35104725	76	3521091C	79
322027	101	323012	102	324035	103	325017	104	331002	105	3510472C	76	3521111C	79
322028	101	323014	102	324036	103	325018	104	332000	105	3510475C	76	3521131C	79
322029	101	323015	102	324037	103	325019	104	332001	105	351047XB	76	3521993C	76
322030	101	323016	102	324038	103	325020	104	332003	105	351047XC	76	3522031C	77
322031	101	323017	102	324039	103	325021	104	332004	105	351064	76	3522051C	77
322031B25	101	323018	102	324040	103	325022	104	332006	105	3510641C	76	3522055C	77
322032	101	323020	102	324041	103	325023	104	332008	105	3510643B	76	3522071C	77
322033	101	323022	102	324043	103	325024	104	332010	105	3510831C	82	3522311C	77
322033B25	101	323023ZR	102	324044	103	325025	104	332011	105	3510851C	82	3522391C	78
322034	101	323024	102	324050	103	325026	104	332012	105	3510871C	82	3522395C	78
322035	101	323025	102	324051	103	325027	104	332013	105	3511051C	78	3522993C	78
322036	101	323028	102	324052	103	325030	104	332014	105	3511111C	78	3523181C	81
322037	101	323031	102	324053	103	325031	104	332015	105	3511112C	78	3523211C	81
322038	101	323033	102	324054	103	326000	106	332016	105	3511131C	78	3523241C	81
322041	101	323034	102	324055	103	326000B25	106	332017	105	3511132C	78	3523271C	81
322042	101	323315	175	324056	103	326001	106	332019	105	3511151C	78	3523301C	81
322042B25	101	323319	175	324057	103	326002	106	332020	105	3511152C	78	3523331C	81
322043	101	323322	175	324058	103	326002B25	106	332021	105	3512032C	77	3523993C	79
322044	101	323323	175	324059	103	326003	106	333000	105	3512052C	77	3524993C	81
322045	101	323325	175	324060	103	326003B25	106	333001	105	3512055B	77	353201	85
322046	101	323328	175	324063	103	326005	106	333003	105	351205XB	77	353202	85
322047	101	323S	15	324064	103	326005B25	106	333004	105	35120525	77	3532022C	85
322048	101	324000	103	324065	103	326006	106	333006	105	3512072C	77	3532025B	85
322049	101	324001	103	324066	103	326006B25	106	333008	105	3512232C	77	353203	85

Numerical Index

Item #	Page	Item #	Page	Item #	Page	Item #	Page	Item #	Page	Item #	Page	Item #	Page
3532035B	85	37	15	372624B	69	373110BX	71	3829	155	40004ZR	104	4031025	192
3532993C	85	3712	155	372624B25	69	373111BX	71	3831	155	40005	104	4031045	193
3533012C	85	3713	155	372624BB	69	373112BX	71	3834	155	40006	104	4031049	192
3535092C	85	3716	155	372624P5	69	373113BX	71	3836	155	40008	104	4031051	192
3535095B	85	3717	155	372645F	69	373114BX	71	3839	155	40101ZR	116	4031052	192
3535252C	85	3718	155	372656	69	373118BX	71	3840	155	40102	116	4031053	193
3535255B	85	3719	155	372656B	69	373130BX	71	3844	155	40103ZR	116	4031054	193
3545973C	87	3720	155	372656B25	69	373134BX	71	3845	155	40104ZR	116	4033005	195
3545984C	87	3721	155	372656BB	69	373138BX	71	3846	155	40105	116	4033006	195
3545993C	87	372110	69	372656P5	69	373150BX	71	38904	138	40106	116	4033014	195
3547121C	87	372110P5	69	372666	69	373158BX	71	38905	138	40107	116	4033016	195
3547123B	87	372110B	69	372666BB	69	373170BX	71	38906	138	40108ZR	116	4034	156
3547321C	87	372110B25	69	372666P5	69	373178BX	71	38908	138	40109ZR	116	4036	156
3547323B	87	372110BB	69	3728	155	373190BX	71	38909	138	40110ZR	116	4039	156
3547521C	87	372118P5	69	372803C	69	3732	155	38910	138	40111ZR	116	4040	156
3547523B	87	372156	69	372810	69	373200BX	71	38912	138	40112	116	4044	156
3547721C	87	372156P5	69	372810B	69	373210BX	71	39004	138	40113	116	4045	156
3547723B	87	372156B	69	372810B25	69	373212BX	71	39005	138	40114	116	4048	156
3548121C	87	372156B25	69	372810BB	69	373214BX	71	39006	138	40115	116	4049	156
3548122B	87	372156BB	69	372810P5	69	373218BX	71	39007	138	40116	116	4050ZR	13
3548123B	87	372166	69	372818	69	373234BX	71	39008	138	40117	116	4052	156
3548321C	87	372166P5	69	372818B	69	373238BX	71	39010	138	40118	116	4052ZR	13
3548322B	87	372166BB	69	372818B25	69	373250BX	71	39104	138	40119ZR	116	4054	156
3548323B	87	3724	155	372818BB	69	373258BX	71	39105	138	40120	116	4056	156
3548521C	87	372414	69	372818P5	69	373278BX	71	39106	138	40121	116	4057	156
3548523B	87	372414P5	69	372945F	69	373290BX	71	39107ZR	138	40122	116	4058	156
3548721C	87	372418	69	372956	69	3733	155	39108ZR	138	40123	116	4060	156
3548723B	87	372418P5	69	372956B	69	373300BX	71	39109ZR	138	40124	116	406015	173
3555511C	86	372424	69	372956B25	69	373312BX	71	39110	138	40125	116	406017	173
3555531C	86	372424P5	69	372956BB	69	373314BX	71	39111	138	40126	116	406019	173
3557121C	86	3725	155	372956P5	69	373318BX	71	39112	138	40153	13	406021	173
3557123B	86	3726	155	372960	69	373334BX	71	394001	190	4020	156	406022	173
3557181C	86	372606	69	372960BB	69	373338BX	71	394002	190	4022ZR	13	406023	173
3557183B	86	372606B	69	372960P5	69	373358BX	71	39404	138	4023	156	4092	13
3558131C	87	372606C	69	372966	69	373378BX	71	39405	138	4027	156	40EXT	13
3558133B	87	372606P5	69	372966BB	69	373400BX	71	39406	138	4029	156	40REP	13
3567611C	89	372610	69	372966P5	69	373412BX	71	39408	138	403015	173	410010	173
3567841C	89	372610B	69	373000	70	373414BX	71	394100	190	403017	173	410015	173
3567951C	89	372610B25	69	373001	70	373418BX	71	39604	138	403019	173	410018	173
357020	94, 124	372610BB	69	373002	70	373434BX	71	39606	138	403021	173	410019	173
357030	95	372610P5	69	373003	70	373438BX	71	39608	138	403022	173	410020	173
357120	90	372614	69	373004	70	3735	155	4	12	403023	173	410021	173
357220	90	372614B	69	373005	70	373500BX	71	4008	13	403025	173	410022	173
357220C	90	372614B25	69	373011BX	71	373512BX	71	40010	104	403028	173	410023	173
357320	90	372614BB	69	373013BX	71	373600BX	71	400015	173	4031003	192	410026	173
359001	175	372614P5	69	373015BX	71	3813	155	400017	173	4031007	192	410028	173
359002	175	372618	69	373034BX	71	3820	155	400019	173	4031012	193	4102	156
359003	175	372618B	69	373058BX	71	3821	155	40012	104	4031015	193	4103	156
359004	175	372618B25	69	373078BX	71	3823	155	400021	173	4031018	193	4104	156
359005	175	372618BB	69	373090BX	71	3824	155	400022	173	4031022	193	4105	156
359010	175	372618P5	69	3731	155	3825	155	400023	173	4031023	193	413010	173
36	15	372624	69	373100BX	71	3827	155	400025	173	4031024	193	413012	173

INDEX

Item #	Page	Item #	Page	Item #	Page	Item #	Page	Item #	Page	Item #	Page	Item #	Page
413015	173	42940	140	45513	137	46915ZR	135	4935035	152	4935109	106	4935359	158
413016	173	4305	156	45516	137	47009	135	4935036	152	4935191	29	4935448	100
413018	173	4306	156	45606	137	47010	135	4935037	152	4935192	29	4935449	100
413019	173	432001	195	45608	137	47011	135	4935038	152	4935199	77	4935447	100
413020	173	432002	195	45611	137	47012	135	4935039	152	4935222	148	4935445	100
413021	173	432003	195	45612	137	47013	135	4935040	152	4935223	148	4935446	100
413022	173	432004	195	45613	137	47014	135	4935041	152	4935224	148	4935444	100
413023	173	432005	195	45614	137	47015	135	4935042	152	4935225	148	4935442	100
413024	173	432006	195	45616	137	47016	135	4935043	152	4935226	148	4935443	100
413026	173	43604	137	45619	15	47017	135	4935044	152	4935227	148	4935441	100
416010	173	43605	137	459001	173	47811	136	4935045	152	4935228	148	4935454	100
416012	173	43606	137	459002	173	47909	134	4935046	152	4935229	148	4935455	100
416015	173	43607	137	459003	173	47911	134	4935047	152	4935230	148	4935453	100
416016	173	43608	137	459004	173	47913	134	4935048	152	4935231	148	4935457	100
416018	173	43609	137	459005	173	47915	134	4935049	152	4935232	148	4935458	100
416020	173	43610ZR	137	459006	173	47917	134	4935050	152	4935233	148	4935456	100
416022	173	43611	137	459007	173	48109	134	4935051	152	4935234	148	4935451	100
420001	194	43612	137	459008	173	48111ZR	134	4935052	146	4935235	148	4935452	100
420002	194	43613ZR	137	46606	134	48113	134	4935053	146	4935236	148	4935450	100
420003	194	43614	137	46607	134	48211	134	4935054	146	4935237	148	4935459	100
420004	194	43615	137	46608	134	48213ZR	134	4935055	158	4935238	149	4935461	100
42410	133	43616	137	46609	134	48215	134	4935056	157	4935239	149	4935460	100
42411	133	43624	137	46610	134	48311	134	4935057	157	4935240	149	4935463	100
42412	133	43697	137	46611	134	48313	134	4935058	157	4935241	149	4935464	100
42413	133	43904	140	46612	134	48315	134	4935059	157	4935242	149	4935462	100
42414	133	43906	140	46613ZR	134	48317	134	4935060	157	4935243	149	4935466	100
42416	133	43908	140	46614	134	48508	135	4935061	157	4935244	149	4935465	100
42418	133	43910	140	46615	134	48509	135	4935062	158	4935245	149	4935469	100
42420	133	4402017	194	46616	134	48511	135	4935063	158	4935246	149	4935467	100
4261	156	4402020	194	46617	134	48513	135	4935064	158	4935247	149	4935468	100
4263	156	4402019	194	4668	156	48609ZR	135	4935070	87	4935248	149	4935473	64
4265	156	4402011	194	4669	156	48709	135	4935071	87	4935249	149	4935470	100
4266	156	4402016	194	4670	156	48711	135	4935072	87	4935250	149	4935471	100
4267	156	4403233	195	4671	156	48713	135	4935073	87	4935251	149	4935507	37
428KBT	15	4403234	195	46711	134	48715	135	4935074	87	4935252	149	4935504	37
42904	140	4403235	195	46713ZR	134	48717	135	4935075	87	4935253	149	4935505	37
42906	140	44202	138	46716	134	4935018	152	4935077	101	4935309	13	4935506	37
42908	140	44801	138	4672	156	4935019	152	4935076	106	4935318	18	4935520	46
42910	140	45002	138	4673	156	4935020	152	4935078	106	4935317	18	4935522	46
42912	140	45307	137	4674	156	4935021	152	4935095	16	4935319	18	4935524	46
42914	140	45308	137	4675	156	4935022	152	4935096	16	4935320	18	4935547	93
42916	140	45309	137	46809	135	4935023	152	4935097	16	4935321	18	4935548	93
42918	140	45311	137	46810	135	4935024	152	4935098	16	4935322	18	4935554	64
42920	140	45312	137	46811	135	4935025	152	4935099	16	4935323	18	4935555	64
42922	140	45313	137	46812	135	4935026	152	4935100	75	4935351	16	4935556	64
42924	140	45314	137	46813	135	4935027	152	4935101	75	4935352	157	4935557	64
42926	140	45316	137	46909	135	4935028	152	4935102	90	4935353	157	4935558	64
42928	140	45406	137	46910	135	4935029	152	4935103	90	4935354	158	4935559	64
42930	140	45407	137	46911	135	4935030	152	4935105	106	4935355	158	4935560	64
42932	140	45409	137	46912	135	4935031	152	4935106	106	4935356	158	4935561	64
42934	140	45411	137	46913ZR	135	4935032	152	4935107	106	4935357	158	4935576	10
42936	140	45412	137	46914ZR	135	4935033	152	4935108	106	4935358	158	4935578	10

Numerical Index

Item #	Page	Item #	Page	Item #	Page	Item #	Page	Item #	Page	Item #	Page	Item #	Page
4935579	10	49913	136	504053	176	52655	185	53645	185	58100	29	60452	121
4935570	133	49914	136	504054	176	53006	29	536QCN	28	58200	29	60456	121
4935572	133	49915	136	504057	176	530062	29	53700	186	58300	29	60460	121
4935574	133	49916	136	504058	176	53201	188	53701	186	59100	29	60464	121
4935571	133	49918	136	504059	176	53202	188	53702	186	59200	29	60468	121
4935573	133	49920	136	504060	176	53203	188	53703	186	59400	29	60472	121
4935575	133	49922	136	504061	176	53204	188	53704	186	5T	10	60504	115
4935581	10	49924	136	504062	176	53205	188	53705	186	6	35	60505	115
4935580	15	49998	136	504063	176	53206	188	53706	186	60101ZR	115	60506	115
4935586	97	49999	136	50508	106	53207	188	538KBT	15	60102ZR	115	60507	115
4935607	124	4ZR	35	50512	106	53208	188	53901	189	60103ZR	115	60508	115
4935624	64	5	35	50516	106	53209	188	53902	189	60104ZR	115	60509	115
4935625	64	502009	176	50520	106	53210	188	53903	189	60105	115	60510ZR	115
4935632	114	502014	176	50524	106	53211	188	53904	189	60106ZR	115	60511	115
4935633	114	502015	176	506QCN	28	53212	188	53905	189	60107	115	60512	115
4935634	114	502018	176	5102	156	53213	188	53906	189	60108ZR	115	60513	115
4935635	114	502019	176	5103	156	53214	188	53907	189	60109	115	60514	115
4935636	114	502021	176	5104	156	53215	188	53908	189	60110	115	60515	115
4935637	114	502022	176	5105	156	53216	188	53909	189	60111	115	60516	115
4935638	114	502024	176	512QCN	28	53217	188	53910	189	60112	115	60517	115
4935639	114	502025	176	518QCN	28	53218	188	53911	189	60113	115	60518	115
4935640	114	502038	176	52201	188	53219	188	53912	189	60114	115	60519	115
4935641	114	502039	176	52202	188	53220	188	53913	189	60115ZR	115	60520	115
4935642	123	502041	176	52203	188	53221	188	53914	189	60116	115	60521	115
4935643	124	502042	176	52204	188	53222	188	53915	189	60117ZR	115	60522	115
4935651	132	502044	176	52205	188	53223	188	53916	189	60118	115	60523	115
4935652	132	502045	176	52206	188	53224	188	53917	189	60119	115	60524	115
4935653	132	502046	176	52207	188	53225	188	53918	189	60120	115	60525	115
4935654	132	502047	176	52208	188	53226	188	54009	189	60121	115	60526	115
4935655	132	502048	176	52401	186	53226MT	188	54019	189	60122	115	60527	115
4935656	132	502049	176	52402	186	53228	188	54113	189	60123	115	60528	115
4935687	131	502101	156	52403	186	53228MT	188	5412	29	60124	115	60529	115
4935703	132	5026000	106	52404	186	53227	188	54122	29	60125	115	60530	115
4935704	132	5026001	106	52405	186	53227MT	188	54125	190	60126ZR	115	60531	115
4935705	132	5026002	106	52406	186	53401	186	541614	177	60127	115	60532	115
49600	139	5026003	106	52407	186	53402	186	543715	177	60128	115	60607	122
49612	139	5026005	106	52408	186	53403	186	5462	29	60129	115	60608	122
49613	139	5026006	106	52409	186	53404	186	546ZR	29	60130	115	60609	122
49614	139	5026008	106	52410	186	53405	186	57234	178	60131	115	60610	122
49615	139	5026009	106	52425	186	53406	186	57236	178	60132	115	60612	122
49616	139	5026011	106	52435	186	53407	186	57239	178	60136	123	60614	122
49617	139	5026012	106	52445	186	53535	186	57240	178	60137	123	60616	122
49618	139	5026013	106	52490	186	53545	186	57244	178	60138	123	61204	121
49904	136	5026015	106	524QCN	28	53601	185	57245	178	60147	123	61206	121
49905	136	5026016	106	52601	185	53602	185	57248	178	60148	123	61208	121
49906	136	5026019	106	52602	185	53603	185	57249	178	60172	124	61210	121
49907	136	5026020	106	52603	185	53604	185	57252	178	60221	123	61212	121
49908	136	5026021	106	52604	185	53605	185	57254	178	60432	121	61214	121
49909	136	5026022	106	52605	185	53606	185	57342	178	60436	121	61216	121
49910	136	5026023	106	52606	185	53607	185	57343	178	60440	121	61218	121
49911	136	5026024	106	52607	185	53625	185	57349	178	60444	121	61220	121
49912	136	502L3	10	52635	185	53635	185	57355	178	60448	121	61222	121

INDEX

Item #	Page	Item #	Page	Item #	Page	Item #	Page	Item #	Page	Item #	Page	Item #	Page
61224	121	63111	111	63523ZR	113	63915	112	65201	46	66403	47	6703	154
61226	121	63112ZR	111	63524ZR	113	63916	112	65202	46	66404	47	6711	154
61228	121	63113ZR	111	63525ZR	113	63918	112	65205	46	66405	47	6712	154
61230	121	63114	111	63526ZR	113	63920	112	65207	46	66406	47	67504	113
61232ZR	121	63115	111	63527ZR	113	63922	112	6523	153	6641	154	67505	113
61611	122	63116	111	63528ZR	113	63924	112	6527	153	6642	154	67506	113
61620	122	63117	111	63529ZR	113	63926	112	6529	153	6643	154	67507	113
61630	122	63118	111	63530	113	63928	112	6534	153	6644	154	67508	113
62104ZR	121	63119	111	63531	113	63930	112	6536	153	66501	47	67509	113
62108	121	63120	111	63532	113	63932	112	6539	153	66506	47	67510	113
62112ZR	121	63121	111	63537	123	63950	45	6540	153	66510	47	67511	113
62116	121	63122	111	63704ZR	112	641	15	6544	153	666012	47	67512	113
62120	121	63123	111	63705ZR	112	64100	48	6545	153	666042	47	67513	113
62124	121	63124	111	63706ZR	112	64101	48	65601	48	66604ZR	121	67514	113
62128	121	63125	111	63707ZR	112	64102	48	65602	48	66605	121	67515	113
62132	121	63126	111	63708	112	6411	153	65603	48	666062	47	67516	113
62304	114	63127	111	63709ZR	112	64110	45	65604	48	66606	121	67517	113
62305	114	63128	111	63710	112	64111	45	65605	48	66607	121	67518	113
62306	114	63129	111	63711ZR	112	6412	153	65901	48	66608	121	67519	113
62307	114	63130	111	63712	112	6416	153	65902	48	66609	121	67520	113
62308	114	63131	111	63713ZR	112	6418	153	65903	48	66610	121	67521	113
62309ZR	114	63132	111	63714ZR	112	6424	153	65904	48	66611	121	67522	113
62310	114	63137	123	63715ZR	112	6428	153	65905	48	66612	121	67523	113
62311	114	63221	123	63716	112	6431	153	6612	154	66613	121	67524	113
62312	114	63425	113	63717	112	64310	45	6613	154	66614	121	67525	113
62313	114	63426	113	63718	112	64311	45	6617	154	66615	121	67526	113
62314	114	63427	113	63719	112	6432	153	6618	154	66616	121	67527	113
62315	114	63428	113	63720ZR	112	6435	153	66200	48	66617ZR	121	67528	113
62316	114	63429	113	63721ZR	112	64494	45	66202	48	66618	121	67529	113
62317	114	63430	113	63722	112	64495	45	66211	48	66619	121	67530	113
62318	114	63431	113	63723	112	64497	45	6622	154	66620	121	67531	113
62319	114	63432	113	63724	112	64498	45	66222	48	66621	121	67532	113
62320	114	63503	113	63725	112	64499	45	6623	154	66622	121	67825	113
62321	114	63504	113	63726	112	64550	45	66231	48	66623	121	67826	113
62322	114	63505	113	63727	112	64610	45	6627	154	66624	121	67827	113
62323	114	63506	113	63728	112	64801	46	6629	154	66625	121	67828	113
62324	114	63507	113	63729	112	64802	46	66300	47	66626	121	67829	113
62325	114	63508	113	63730	112	64901	46	66301	47	66627	121	67830	113
62326	114	63509	113	63731ZR	112	64902	46	66302	47	66628	121	67831	113
62327	114	63510	113	63732ZR	112	64903	46	66305SL	47	66630	121	67832	113
62328	114	63511	113	63737	123	64904	46	6631	154	66632	121	68	15
62329	114	63512	113	63904	112	64905	46	6633	154	66704ZR	121	68100	115
62330	114	63513	113	63905	112	64907	46	6634	154	66708	121	68150	115
62331	114	63514	113	63906*	112	64908	46	6635	154	66710	121	68200	115
62332	114	63515	113	63907*	112	65101	46	6636	154	66712	121	68250ZR	115
63104	111	63516	113	63908*	112	65102	46	6637	154	66714	121	68300	115
63105ZR	111	63517	113	63909	112	65103	46	6638	154	66716	121	68350	115
63106	111	63518	113	63910	112	65104	46	6639	154	66720ZR	121	68400	115
63107	111	63519	113	63911	112	65105	46	6640	154	66724	121	68450	115
63108	111	63520ZR	113	63912	112	65106	46	66400	47	66728	121	6848	153
63109	111	63521ZR	113	63913	112	6512	153	66401	47	66732	121	6849	153
63110	111	63522ZR	113	63914	112	6520	153	66402	47	6702	154	68500	115

Numerical Index

INDEX

Item #	Page	Item #	Page	Item #	Page	Item #	Page	Item #	Page	Item #	Page	Item #	Page
6852	153	7252	179	73149	123	73631	110	7752	179	80137	117	80220	151
6854	153	7254	179	73304	110	73632	110	7754	179	80138	117	80221	151
68550ZR	115	7256	179	73305	110	7364	179	7756	179	80139	117	80222	151
6858	153	7257	179	73306	110	7365	179	7757	179	80140	117	80230	151
6860	153	7258	179	73307	110	7367	179	7758	179	80141	117	80232	151
68600	115	7260	179	73308	110	7373	179	7760	179	80142	117	80235	151
68650	115	7261	179	73309	110	73825	116	7761	179	80143	117	80238	151
68700	115	7263	179	73310	110	73826	116	7763	179	80144	117	8024	148
68750	115	7265	179	73311	110	73827	116	7765	179	80145	117	80242	151
68800	115	7266	179	73312	110	73828	116	7766	179	80146	117	80260	151
68850	115	7267	179	73313	110	73829	116	7767	179	80147	117	8028	148
68900	115	7268	179	73314	110	73830	116	777	15	80148	117	8031	148
68950	115	7269	179	73315	110	73831	116	7T	10	80149	117	8032	148
69010	115	7270	179	73316	110	73832ZR	116	8	12	80150	117	80327	151
69015	115	7271	179	73317	110	74	15	80101	117	80151	117	80334	151
69110ZR	115	7272	179	73318ZR	110	7402	179	80102ZR	117	80152ZR	117	80340	151
69115ZR	115	7273	179	73319	110	7403	179	80103ZR	117	80153	117	8035	148
69120ZR	115	7274	179	73320	110	7404	179	80104	117	80154	117	8107	15
69125ZR	115	7275	179	73321	110	7405	179	80105	117	80155	117	81101	117
69130ZR	115	73	15	73322	110	7406	179	80106	117	80156	117	81102	117
6949	154	73104	110	73323	110	7407	179	80107	117	80157	117	81103	117
6950	154	73105ZR	110	73324	110	7520	156	80108	117	80158	117	81104	117
6952	154	73106ZR	110	73325	110	7523	156	80109	117	80159	117	81105	117
6954	154	73107	110	73326	110	7527	156	8011	148	80160	117	81106	117
6955	154	73108	110	73327	110	7529	156	80110	117	80161	117	81107	117
6956	154	73109	110	73328	110	7534	156	80111	117	80162	117	81108	117
6959	154	73110	110	73329	110	7536	156	80112	117	80163	117	81109	117
6961	154	73111	110	73330	110	7539	156	80113	117	80164	117	81110ZR	117
7004	154	73112	110	73331	110	7540	156	80114	117	80165	117	81111	117
7005	154	73113	110	73332	110	7544	156	80115	117	80166	117	81112	117
702L3	10	73114	110	73425	110	7545	156	80116	117	80167	117	81113	117
71	15	73115	110	73426	110	757KB	15	80117	117	80168	117	81114	117
71825	116	73116	110	73427	110	757KBT	15	80118	117	80169	117	81115	117
71826	116	73117	110	73428ZR	110	7648	156	80119	117	80170	117	81116	117
71827	116	73118	110	73429ZR	110	7649	156	8012	148	80171	117	81117	117
71828	116	73119	110	73430	110	7652	156	80120	117	80172	117	81118	117
71829	116	73120	110	73431ZR	110	7654	156	80121	117	80173	117	81119	117
71830	116	73121	110	73432ZR	110	7658	156	80122	117	80174ZR	117	81120ZR	117
71831	116	73122	110	7349	179	7660	156	80123	117	80175	117	81121	117
71832	116	73123	110	7350	179	76KBT	15	80124	117	80176	117	81122ZR	117
7220	179	73124	110	7352	179	7720	179	80125ZR	117	80177	117	81123ZR	117
7223	179	73125	110	7355	179	7723	179	80126	117	80178	117	81124ZR	117
7227	179	73126	110	7356	179	7727	179	80127	117	80179	117	81125	117
7229	179	73127	110	7358	179	7729	179	80128	117	8018	148	81126	117
7234	179	73128	110	7359	179	7734	179	80129	117	80180	117	81127ZR	117
7236	179	73129	110	7361	179	7736	179	80130	117	80181	123	81128ZR	117
7239	179	73130	110	73625ZR	110	7739	179	80131	117	80183	123	81129	117
7240	179	73131	110	73626	110	7740	179	80132	117	80185	151	81130ZR	117
7244	179	73132	110	73627ZR	110	7744	179	80133	117	80187	151	81131	117
7245	179	73136	123	73628ZR	110	7745	179	80134	117	80209	151	81132	117
7248	179	73137	123	73629ZR	110	7748	179	80135	117	80213	151	81133	117
7249	179	73138	123	73630ZR	110	7749	179	80136	117	80217	151	81134	117

Item #	Page	Item #	Page	Item #	Page	Item #	Page	Item #	Page	Item #	Page	Item #	Page
81135	117	8334	149	88807	130	91148	120	92173	78	92423	83	93029	76
81136	117	8335	149	88808	130	91149	120	92175	78	92427	83	93036	82
81137	117	8336	149	88809	130	91150	120	92177ZR	78	92431	83	93037	82
81138	117	8337	149	88810	130	91151	120	92201	77	92437	83	93038	82
81139	117	8338	149	88811	130	91152	120	92203	77	92443	83	93039	82
81140	117	8339	149	88812	130	91153	120	92205	77	92451	83	93040	82
81141	117	8340	149	88813	130	91154	120	92207	77	92467	83	93041	82
81142	117	8341	149	88814	130	91155ZR	120	92221	77	92483	83	93043	76
81143	117	8342	149	88815	130	91156	120	92223	77	92489	83	93047	76
81144	117	8343	149	88816	130	91157	120	92225	77	92491	83	93049	76
81145	117	8344	149	88818	130	91158	120	92227	77	92493	83	93053	76
81146	117	8461	153	88820	130	91159	120	92230	82	92495	83	93057	76
81147	117	8463	153	88822	130	91160	120	92231	82	92497	83	93059	76
81148	117	8465	153	88824	130	91161	120	92232	82	92499	83	93063	76
81149	117	8467	153	88889	131	91162	120	92233	82	92507	83	93067	76
81150	117	8564	154	88885	131	91163	120	92234	82	92509	83	93069	76
81151	117	8565	154	88886	131	91164	120	92235	82	92511	83	93073	82
81152	117	8568	154	88888	131	92001	76	92236	82	92513	83	93077	82
81153ZR	117	8569	154	88887	131	92005	76	92238	82	92515	83	93079	82
81154	117	87908	130	88890	131	92007	76	92240	82	92517	83	93103	79
81155	117	87910	130	88894	131	92011	76	92306	80	92525	83	93105ZR	79
81156	117	87912	130	88898	131	92019	76	92309	80	92527	83	93107	79
81157ZR	117	87914	130	8ZR	35	92025	76	92312	80	92529	83	93109	79
81158	117	87916	130	90108	123	92027	76	92315	80	92531	83	9311	153
81159ZR	117	87920	130	90165	120	92035	76	92317	80	92533	83	93111	79
81160	117	87924	130	90166	120	92039	76	92318	80	92535	84	93113ZR	79
8120	148	87950	131	90168	120	92045	76	92320	80	92536	84	93115	79
8123	148	87954	131	90170	120	92047	76	92321	80	92537	84	9312	153
8127	148	88006BULK	131	90172	120	92053	76	92323	80	92538	84	93123	79
8129	148	88007BULK	131	90174	120	92073	76	92324	80	92539	84	93125	79
8134	148	88008BULK	131	90176	120	92075ZR	76	92326	80	92540	84	93127	79
8136	148	88009BULK	131	90180	120	92077	76	92327	80	92543	84	93129	79
8139	148	88010BULK	131	90184	120	92079ZR	76	92329	80	92545	84	93131	79
8140	148	88011BULK	131	90188	120	92083	82	92330	80	92547	84	93133	79
8144	148	88012BULK	131	90192	120	92085	82	92332	80	92549	84	93135	79
8145	148	88013BULK	131	90196	120	92087	82	92333	80	92551	84	93139	79
8148	148	88014BULK	131	902L3	10	92105	78	92335	80	92563	85	93141	79
8149	148	88015BULK	131	91133	120	92111	78	92336	80	92565	85	93143	79
8152	148	88016BULK	131	91134	120	92113	78	92338	80	92567	85	93145	79
8154	148	88018BULK	131	91135	120	92115	78	92361	80	92569	85	93147	79
8158	148	88020BULK	131	91136	120	92117	78	92365	80	92571	85	93149	79
8160	148	88022BULK	131	91137	120	92119	78	92369	80	92573	85	93151	79
8202	149	88024BULK	131	91138	120	92135	78	92371	80	92595	84	93155	79
8203	149	88706	130	91139	120	92139	78	92377	80	92599	84	93157	79
8312	149	88708	130	91140	120	92141	78	92379	80	93003ZR	76	93159	79
8317	149	88710	130	91141	120	92143	78	92381	80	93007ZR	76	93161	79
8318	149	88712	130	91142	120	92145ZR	78	92383	80	93011	76	93163	79
8322	149	88714	130	91143	120	92147	78	92403	83	93017	76	93165	79
8323	149	88716	130	91144	120	92163	78	92407	83	93019	76	93167	79
8327	149	88804	130	91145	120	92165	78	92411	83	93021	76	93173	79
8331	149	88805	130	91146	120	92169	78	92415	83	93023	76	93175	79
8333	149	88806	130	91147	120	92171	78	92419	83	93025	76	93177	79

Numerical Index

Item #	Page	Item #	Page	Item #	Page	Item #	Page	Item #	Page	Item #	Page
93179	79	93324	81	93439	82	93795	89	94712	87	99915	130
9318	153	93327	81	93463	84	93797	89	94732	87	99916	130
93181	79	93330	81	93467	84	93811	87	94752	87	99918	130
93183	79	93333	81	93471	84	93813	87	94772	87	99920	130
93185	79	93336	81	93475	84	93815	87	94812	87	99922	130
93186	78	93337	81	93481	84	93817	87	94832	87	99924	130
93187	78	93339	81	93503	85	94112ZR	88	94852	87	9T	10
93188	78	93340	81	93509	85	94132	88	94872	87	FG3	36
93189	78	93341	81	93515ZR	85	94152	88	9502	154	FG312	36
93191	78	93342	81	93521	85	94172ZR	88	9503	154	FG4	36
93193	78	93343	81	93525	85	9420	153	97094	165	FG414	36
93195	78	93344	81	93543	85	94202	88	9712	154	FG412	36
93203	77	93345	81	93545	85	94203	88	9717	154	FG5	36
93205	77	93346	81	93551	86	94204ZR	88	9718	154	FG514	36
93207	77	93347	81	93553	86	94206	88	9722	154	FG6	36
93211	77	9335	153	93711	86	94209	88	9723	154	M4441N	40
93213	77	93356	81	93712	86	94211	88	9727	154	M444112N	40
93215	77	93357	81	93714	86	94212	88	9731	154	M444114N	40
93219	77	93358	81	93715	86	94215	88	97311	165	M44412N	40
93219C	77	93359	81	93717	86	94216	88	97312	162	M44414N	40
93221	77	93360	81	93718	86	9423	153	9733	154	M44418N	40
93221C	77	93361	81	93720	86	94231	88	9734	154	M4442N	40
93223	77	93362	81	93721	86	94232	88	9735	154	M44434N	40
93225	77	93363	81	93722	86	94251ZR	88	9736	154	M44438N	40
93226	77	93364	81	93723	86	94252	88	9737	154	M44458N	40
93227	77	93365	81	93724	86	9427	153	9738	154	M444S4N	40
93230ZR	77	93366	81	93728	86	94271	88	9739	154	M444SB6N	40
93231	77	93367	81	93730	86	94272	88	9740	154	T1C	36
93232	77	93368	81	93732	86	9429	153	9741	154	T3C	36
93235	78	93369	81	93734	86	94291	88	9742	154	T3SB	36
93237	78	93370	81	93736	86	94311	88	9743	154	T4C	36
93239	78	93371	81	93741	87	94312	88	9744	154	T4SB	36
9324	153	93372	81	93748	89	94316	88	97606	161	T5C	36
93241	78	93373	81	93749	89	94331ZR	88	98000	172	T6C	36
93245	78	93403	83	93755	89	94332	88	98146	169	T6SB	36
93247	78	93405	83	93756	89	94335	88	98614	168	T8C	36
93249	78	93407	83	93758	89	94336	88	99706	130		
93253	78	93409	83	93761	89	9434	153	99708	130		
93255	78	93411	83	93763	89	94351	88	99712	130		
93257	78	93413	83	93765	89	94352	88	99714	130		
93263	78	93415	83	93771	89	94356ZR	88	99716	130		
93265	78	93419	83	93776	89	9436	153	99904	130		
93267	78	93423	83	93777	89	94371ZR	88	99905	130		
9328	153	93427	83	93781	89	94372ZR	88	99906	130		
93306	81	93430	82	93782	89	9439	153	99907	130		
93309	81	93431	82	93783	89	9440	153	99908	130		
9331	153	93432	82	93784	89	94414	88	99909	130		
93312	81	93433	82	93786	89	94416	88	99910	130		
93315	81	93434	82	93787	89	94434	88	99911	130		
93318	81	93435	82	93789	89	94436	88	99912	130		
9332	153	93436	82	93792	89	9444	153	99913	130		
93321	81	93438	82	93793	89	9445	153	99914	130		

INDEX

©2010

IRWIN
TOOLS®



WISE-GRIP® MARATON® QUICK-GRIP® SPEEDBOR® STRAIT-LINE® Unibit® HANSON®

Huntersville, NC 28078

Customer Service

Phone: (800) 866-5740

Fax: (800) 866-5742

IRWFL10



Mixed Sources

Product group from well-managed
forests, controlled sources and
recycled wood or fibre
www.fsc.org Cert no. SCS-COC-001247
© 1996 Forest Stewardship Council