

**CASE**  
CONSTRUCTION

**621F/721F**  
WHEEL LOADERS



**SINCE 1842**

# PRODUCTIVITY TAKES ANOTHER STEP FORWARD

## TOPNOTCH TECHNOLOGY

With a new Tier 4 Final engine using SCR (Selective Catalytic Reduction) technology, the 621F and 721F are the latest evolution of powerful-yet-efficient CASE wheel loaders. In addition to the upgraded emissions solution, these workhorses take economy even further with fuel-saving features such as auto-idle, auto-shutdown and four programmable power modes that match engine output to the task at hand. And it's all controlled from a roomy cab that gives operators an industry-leading view of all the work they're getting done.

### 621F/721F HIGHLIGHTS:

- 1 **Array of attachment options** that simplify your work.
- 2 **Three loader linkage styles:** Extended Reach (XR) for extra reach and height when loading, Tool Carrier (XT) and traditional Z-bar.
- 3 **Optional Ride Control™** provides excellent material retention and machine control over rough terrain and improves operator comfort.
- 4 One of the industry's quietest and most spacious cabs with **class-leading visibility**. An iso-mount® design, dual air filtration system and optional heated, air-ride seat help provide operators daylong comfort.
- 5 **Award-winning joystick steering** – exclusive to CASE – reduces operator fatigue and improves cycle times.
- 6 **Best-in-class rear visibility**
- 7 **Sy-Klone® ejective air pre-cleaner** gives longer life to the air filters and reduces filter change (optional).
- 8 **Many tire options available** including Radial L2, L3, solid and snow tires.
- 9 Available **five-speed transmission\*\*** with lock-up torque converter improves acceleration and hill climbing for faster cycle times.
- 10 **High-efficiency, mid-mounted cooling module** with optional auto reversing fan promotes maximum heat transfer with minimal debris buildup, making the system nearly maintenance free.
- 11 Tier 4 Final SCR technology delivers up to **20% better fuel economy** over previous Tier 3 models. No DPF\* regeneration where exhaust temperatures can be a job site hazard. No EGR, so no EGR valve, keeping your cost of operations low.



\*DPF = Diesel particulate filter \*\*Five-speed transmission not available on 621F

# THE CASE DIFFERENCE

## MAINTENANCE MADE EASY

From ground-level service checks to eye-level fluid gauges to an electric lift, tilt-up rear hood that provides complete engine access.

## SCR – EFFICIENT POWER, PROVEN PRODUCTIVITY

Because of their idle-heavy applications and variable power demands, SCR Tier 4 Final technology is the practical choice for these mid-sized wheel loaders. As an after-treatment system, SCR lets the engine run at peak performance, which provides faster throttle response while maintaining lower temperatures and delivering up to 20% better fuel efficiency over other solutions.

Best yet, SCR is simple. No DPF filters to replace, No Regeneration Exhaust Temperatures, No Regeneration downtime. Just pour and go.

## GROUND-ENGAGING EQUIPMENT

CASE offers a wide range of buckets, both pin-on and quick-coupler style. And F Series® buckets come standard with the innovative SmartFit™ bucket tooth system. These heavy-duty, self-sharpening teeth combine exceptional strength and unmatched ease of installation thanks to a hammerless fastener system with reusable locking pins. Available in a full range of styles.

**SMARTFIT™**  
BUCKET TOOTH SYSTEM



## SPECIALTY MODELS

The 621F and 721F can be configured with special tires, guarding and attachments for specialty applications such as waste/scrap handling, agriculture, lumberyards and snow removal.

\*Excludes 1221F model

## EJECTIVE AIR PRE-CLEANER

The Sy-Klone® ejective air pre-cleaner extends air filter life, lowers cost per operating hour by reducing parts, labor and downtime, extends engine life, and improves fuel efficiency.

### HERE'S HOW THE SY-KLONE WORKS:

1. Air enters the underside of the dome through screened louvers. This prevents clogging by blocking any particles larger than the ejection slot from entering the unit.
2. Curved particle-accelerator blades direct dirt against the sidewall.
3. Strakes (angled fins) along the interior surface move heavier-than-air debris towards the ejection slot.
4. Clean air continues to swirl down into the engine air inlet pipe.

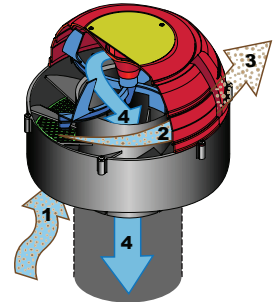

## AXLES FOR ANYWHERE

The 621F and 721F wheel loaders come standard with limited-slip axles providing outstanding traction in all conditions. Both models also offer new heavy-duty axles with locking front differential for excellent traction in the most demanding conditions and are approved for solid tires.





# SPECIFICATIONS AND DIMENSIONS

SPECIFICATIONS	621F <sup>1</sup> Z-Bar	621F <sup>1</sup> XT	621F <sup>1</sup> XR	721F <sup>2</sup> Z-Bar	721F <sup>2</sup> XT	721F <sup>2</sup> XR
<b>Engine</b>	FTPF4H- FE613W	FTPF4H- FE613W	FTPF4H- FE613W	FPTF4H- FE613T	FPTF4H- FE613T	FPTF4H- FE613T
<b>Emissions Certification</b>	Tier 4 Final	Tier 4 Final	Tier 4 Final	Tier 4 Final	Tier 4 Final	Tier 4 Final
<b>Net Peak hp – hp (kW)</b>	162 (121)	162 (121)	162 (121)	179 (133)	179 (133)	179 (133)
<b>Net Peak Torque – lb-ft (N-m)</b>	510 (692)	510 (692)	510 (692)	674 (914)	674 (914)	674 (914)
<b>Displacement/ Cylinders – in<sup>3</sup> (L)</b>	411 (6.7) / 6	411 (6.7) / 6	411 (6.7) / 6	411 (6.7) / 6	411 (6.7) / 6	411 (6.7) / 6
<b>Operating Weight – lb (kg)</b>	26,712 (12 116)	27,695 (12 562)	27,143 (12 312)	31,509 (14 292)	32,567 (14 772)	31,991 (14 511)
<b>Transmission Gears</b>	4F/3R	4F/3R	4F/3R	4 or 5F/3R	4 or 5F/3R	4 or 5F/3R
<b>Bucket Capacity – yd<sup>3</sup> (m<sup>3</sup>)</b>	2.75 (2.1)	2.5 (1.9)	2.75 (2.1)	3.25 (2.5)	3.0 (2.3)	3.25 (2.5)
<b>Bucket Cylinder Breakout Force – lb (kg)</b>	25,426 (11 533)	22,793 (10 339)	26,201 (11 885)	31,382 (14 235)	27,860 (12 637)	31,215 (14 159)
<b>Full-Turn Tipping Load, SAE – lb (kg)</b>	17,655 (8 008)	14,778 (6 703)	14,840 (6 731)	21,048 (9 547)	17,847 (8 095)	17,758 (8 055)
DIMENSIONS	621F <sup>1</sup> Z-Bar	621F <sup>1</sup> XT	621F <sup>1</sup> XR	721F <sup>2</sup> Z-Bar	721F <sup>2</sup> XT	721F <sup>2</sup> XR
<b>A. Height to Top of ROPS Cab</b>	133.7 in (3 395 mm)	133.7 in (3 395 mm)	133.7 in (3 395 mm)	133.3 in (3 385 mm)	133.3 in (3 385 mm)	133.3 in (3 385 mm)
<b>B. Wheelbase</b>	114.2 in (2 900 mm)	114.2 in (2 900 mm)	114.2 in (2 900 mm)	128.1 in (3 253 mm)	128.1 in (3 253 mm)	128.1 in (3 253 mm)
<b>C. Ground Clearance</b>	14.6 in (370 mm)	14.6 in (370 mm)	14.6 in (370 mm)	14.4 in (365 mm)	14.4 in (365 mm)	14.4 in (365 mm)
<b>D. Angle of Departure</b>	27°	27°	27°	32°	32°	31°
<b>E. Hinge Pin Height, Full Height</b>	150.8 in (3 831 mm)	155.8 in (3 958 mm)	167.1 in (4 244 mm)	156.7 in (3 979 mm)	163.8 in (4 160 mm)	172.2 in (4 374 mm)
<b>F. Overall Length, Bucket Level on Ground</b>	288.0 in (7 315 mm)	302.3 in (7 679 mm)	304.1 in (7 725 mm)	301.1 in (7 648 mm)	312.2 in (7 931 mm)	315.2 in (8 006 mm)
<b>G. Dump Height @ 45° Dump Angle, Full Height</b>	112.1 in (2 847 mm)	107.8 in (2 737 mm)	128.3 in. (3 259 mm)	115.3 in (2 930 mm)	115 in (2 921 mm)	130.9 in (3 324 mm)
<b>H. Bucket Reach @ 45° Dump Angle, Full Height</b>	38.1 in (969 mm)	51.3 in (1 304 mm)	38.7 in (984 mm)	44.3 in (1 125 mm)	50.3 in (1 279 mm)	44.3 in (1 126 mm)
<b>I. Bucket Reach @ 45° Dump Angle, 7 ft (2.13 m) Height</b>	58.8 in (1 493 mm)	70.2 in (1 782 mm)	72.8 in (1 848 mm)	65.3 in (1 658 mm)	72.1 in (1 832 mm)	77.5 in (1 968 mm)

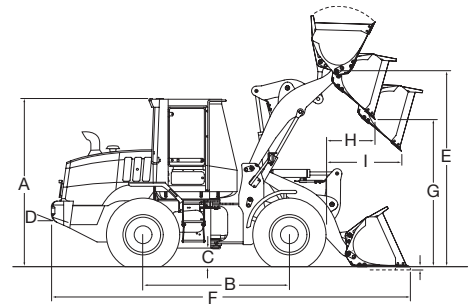

Line drawings are for illustrative purpose only and may not be exact representation of unit.

<sup>1</sup>Z-Bar and XR units equipped with 2.75 yd<sup>3</sup> (2.1 m<sup>3</sup>) general purpose pin-on bucket, XT unit 2.5 yd<sup>3</sup> (1.9 m<sup>3</sup>) coupled GP bucket on CNH XT coupler, all with bolt-on edge

<sup>2</sup>Z-Bar and XR units equipped with 3.25 yd<sup>3</sup> (2.5 m<sup>3</sup>) general purpose pin-on bucket , XT unit 3.0 yd<sup>3</sup> (2.7 m<sup>3</sup>) coupled GP bucket on CNH XT coupler, all with bolt-on edge

\*Maximum torque shown for this model



## POWERFUL PROTECTION

The 621F and 721F come standard with the industry's first all-in-one heavy machine support program that's as powerful as the equipment it protects — CASE ProCare. ProCare includes:

**3K** 3-yr./3,000-hr. Full-Machine Factory Warranty\* STANDARD

 3-yr./3,000-hr. Planned Maintenance STANDARD

 3-yr. Advanced SiteWatch™ Subscription STANDARD

\*See your dealer for the complete terms.

CaseCE.com/WL

©2016 CNH Industrial America LLC. All rights reserved. CASE is a trademark registered in the United States and many other countries, owned by or licensed to CNH Industrial N.V., its subsidiaries or affiliates. CNH Industrial Capital is a trademark in the United States and many other countries, owned by or licensed to CNH Industrial N.V., its subsidiaries or affiliates. Printed in U.S.A. Contains 10% post-consumer fiber.

Form No. CCE201604621F721F  
Replaces Form No. CCE201506621F721F

IMPORTANT: CASE Construction Equipment Inc. reserves the right to change these specifications without notice and without incurring any obligation relating to such change. Availability of some models and equipment builds vary according to the country in which the equipment is used. The illustrations and text may include optional equipment and accessories and may not include all standard equipment. Your CASE dealer/distributor will be able to give you details of the products and their specifications available in your area.



CASE Construction Equipment is biodiesel-friendly.

NOTE: All engines meet current EPA emissions regulations. All specifications are stated in accordance with SAE Standards or Recommended Practices, where applicable.



Always read the Operator's Manual before operating equipment. Inspect equipment before using it, and be sure it is operating properly. Follow the product safety signs and use any safety features provided.