

CASE
CONSTRUCTION

HYDRAULIC EXCAVATORS
C-SERIES - BRAZIL





INCREASING PRODUCTIVITY

To keep companies competitive, thorough evaluation and study of production processes are taking place. Therefore, the watchword these days is a call of the market for products with superior durability and better productivity. In line with market trends and demand, CASE introduces its new series of hydraulic excavators, maintaining the recognized quality and efficiency of its hydraulic systems. During the development of this new series, the focus was on durability and efficiency in consumption.

To this end, the new series was equipped with additional reinforcements for the implements (boom, arms, buckets and chassis), to achieve greater durability.

Hydraulic systems were optimized for better pump flow distribution in combined movements, and the entire tubing was re-dimensioned for maximum pressure loss prevention.

On the other side, the engine also was the object of adjustments to adapt to different conditions in operation and environment, by adjusting engine torque and power during operation in order to maintain production and achieve greater efficiency in consumption. This operational software flexibility ensures a 14% average reduction of consumption in comparison to the previous series, which was already recognized for its fuel efficiency.



ADVANCED ENERGY MANAGEMENT

Through the incorporation of 5 new operational functions, the excavators of this new series achieve excellent production and consumption efficiency.

BOOM ECONOMY CONTROL (BEC)

During downward movements of the boom, turning and closing the arm to attack the material, engine speed is reduced by 100 rpm, since it does not depend on hydraulic power for this action.

AUTO ENERGY SAVING (AES)

Engine speed is instantly reduced by 50 rpm on releasing the joystick. Residual pressure within the system is reduced as soon as the manipulators (joysticks) are placed in a neutral position, without any actuator demanding hydraulic flow.

SWING RELIEF CONTROL (SWC)

Hydraulic power for the turning movements is carefully managed to avoid energy waste until the inertia is overcome.

SPOOL STROKE CONTROL (SSC)

Provides automatic pressure adjustment during excavation and leveling operations. This saves fuel and, at the same time, enhances the operator's control capability during finishing work in excavations.

AUTO ECONOMY CONTROL (AEC)

All C Series excavators also come with the Auto Idle function, which reduces engine speed after 5 seconds when no hydraulic function is activated, regardless of throttle position. In addition, this function can be activated manually at any time by means of a switch on the joystick. There is also the Auto Shut Down function (programmable by the operator), which will stop the engine after 3 minutes of inactivity of the hydraulic system.

LOW CONSUMPTION AND SUPERIOR DURABILITY TIER 3 / MAR-I CERTIFICATION

The C Series models are driven by the new electronic Isuzu and FPT engines, designed to increase machine performance and optimize fuel economy. These new engines are equipped with a fuel injection system that is less sensitive to fuel with a high sulfur content, thus extending the service life of its components. By means of a new electronic regulator, the engines provide power increases to correspond to the hydraulic requirements at any time. This makes C Series excavators more productive than previous models.

Thanks to the introduction of new functions in the hydraulic system and the engine itself, fuel consumption has been improved. For example: The Shut Down system, which stops the engine if no actuator is used for 3 minutes. This function was combined with the Auto Idle function, which reduces engine speed to idle when no actuator is used for 5 seconds. The operator is able to monitor fuel consumption constantly during operation, by means of the new ECO gauge function, which displays, in real time on a scale of ten, the phases of the energy saving level being used. On the monitor, the operator can read the actual average cumulative fuel consumption. Together, all these new features will help the operator to optimize engine power. All new engines are following the latest GB3 and Tier 3 / MAR-I standards.

FIRST CLASS MAINTENANCE

All filters and regular filling points are grouped for easy access, with engine oil change intervals set at 500 hours.

A synthetic filter is used for the hydraulic system, allowing 5,000-hour oil change intervals. All pins and bushings (except the bucket pin) use the extended bushing maintenance process, allowing lubrication intervals of up to 1,000 hours.

Radiator and heat exchangers are mounted next to each other, in order to allow easy access for cleaning and better cooling, since in this mounting position all these components receive fresh air. A 100 liter/min. refueling pump with automatic shutoff is available as an option that can reduce downtime during regular refills.

CASE excavators have an enviable reputation for reliability and durability, a tradition destined to continue with the new C Series models.

FIRST CLASS ENVIRONMENT FOR THE OPERATOR

- AM/FM radio with automatic tuning, Bluetooth and MUTE switch on the joystick.
- The air conditioning system, with 9 diffusers, strategically positioned for better air distribution, provides 24% more air flow and an 8% performance increase.
- Adjustable side consoles separate from the seat for better operator ergonomics at work.
- Retractable seat belt, 50.8 mm (2") wide.
- Tempered glass windows with safety film to protect the operator's integrity in case of an accident.

The cab of the CASE C Series excavator provides 4.7% more interior space than the previous models. The internal components have been repositioned to provide 7.4% more-foot space (40 mm from the seat).

Noise levels have been reduced to standards similar to automotive standards, about 70 dBa. The operator's seat has a mechanical suspension with low-frequency springs (pneumatic suspension optional); it is fully adjustable to provide comfort.

The ROPS structure of the cabin, resting on hydraulic mounting pads, ensures the low vibration level and provides excellent visibility in all directions.



SPECIFICATIONS

SPECIFICATIONS	CX130C	CX180C
ENGINE		
Brand/Origin	ISUZU / Japan	ISUZU / Japan
Model	GJ-4JJ1X	AI-4JJ1X
Type	Water-cooled, 4-cycle diesel, high pressure Common Rail system, turbocharger, air cooled intercooler, Tier 3 certification	
Number of cylinders	4-cylinder in line	4-cylinder in line
Displacement	2.999 cc	2.999 cc
Bore/Stroke	95,4 x 104,9 mm (3,8 x 4,15 in)	95,4 x 104,9 mm (3,8 x 4,15 in)
Horsepower SAE J1349 NET	95 hp (70,9 kw) a 2.000 rpm	119,6 hp (89,2 kw) a 2.000 rpm
Maximum torque ISO 9249 NET	340 Nm (250,8 lbf.ft) a 1600 rpm	391 Nm (288,4 lbf.ft) a 1800 rpm
HYDRAULIC SYSTEM		
Max. oil flow	2 x 129 l/min (34 gpm) a 2000 rpm	2 x 142 l/min (37,5 gpm) a 2000 rpm
Pump	2 variable displacement axial piston pumps with regulating system	
Boom/Arm/Bucket circuit	343 bar (4.975 psi)	343 bar (4.975 psi)
Boom/Arm/Bucket circuit (with auto power up)	363 bar (5.265 psi)	363 bar (5.265 psi)
Swing circuit	279 bar (4.047 psi)	279 bar (4.047 psi)
Travel circuit	343 bar (4.975 psi)	343 bar (4.975 psi)
SWING		
Maximum swing speed	14,1 rpm	11,4 rpm
Swing torque	33.000 Nm (24.339,5 lbf.ft)	45.100 Nm (33.264 lbf.ft)
TRAVEL		
Travel motor	Variable displacement axial piston motor	
Max travel speed	5,6 km/h (3,5 mph)	5,2 km/h (3,2 mph)
Low travel speed	3,4 km/h (2,1 mph)	2,7 km/h (1,7 mph)
Gradeability	70% (35°)	70% (35°)
Drawbar pull	117 kN (26.303 lbf)	161 kN (33.194 lbf)
ELECTRICAL SYSTEM		
Circuit/Alternator	24 V / 50 A	
UNDERCARRIAGE		
Number of carriers rollers (each side)	2	2
Number of track rollers (each side)	7	7
Number of shoes (each side)	43	44
Type of shoe	Triple grouser shoe	
CAPACITIES		
Fuel tank	260 l (68 gal 2,7 ct)	300 l (79 gal 1 ct)
Hydraulic system	157 l (41 gal 1,9 ct)	165 l (43 gal 2,4 ct)
Cooling system	16,2 l (4 gal 1,1 ct)	16,2 l (4 gal 1,1 ct)
Engine crank Case	17 l (4 gal 2 ct)	17 l (4 gal 2 ct)
GROUND PRESSURE		
Pressure	0,28 kg/cm ² (4,1 psi)	0,41 kg/cm ² (5,8 psi)
Arm	3,01 m (9' 10,5")	2,62 m (8' 7")
Bucket	0,55 m ³ (0,72 yd ³)	0,80 m ³ (1,05 yd ³)
Shoe	600 mm (2')	600 mm (2')
WEIGHT		
Weight	13.081 kg (28.839 lb) With 3.01 m (9' 10") Arm, 0.65 m ³ (0.85 yd ³) Bucket, 600 mm (2') grouser shoe, operator 75 kg (165 lb), lubricant, coolant and full fuel tank	17.677 kg (38.971 lb) With 2.62 m (8' 7") Arm, 0.98 m ³ (1.28 yd ³) Bucket, 600 mm (2') grouser shoe, operator 75 kg (165 lb), lubricant, coolant and full fuel tank

SPECIFICATIONS

SPECIFICATIONS	CX220C S2	CX240C ME
ENGINE		
Brand/Origin	CASE / FPT / Brazil	CASE / FPT / Brazil
Model	NEF6 F4HE0687A*J101	NEF6 F4HE0687A*J101
Type	Water-cooled, 4-cycle diesel, high pressure Common Rail system, turbocharger, air cooled intercooler, Tier 3 certification	
Number of cylinders	6-cylinder in line	6-cylinder in line
Displacement	6.728 cc	6.728 cc
Bore/Stroke	104 x 132 mm (4,09 x 5,19 in)	104 x 132 mm (4,09 x 5,19 in)
Horsepower SAE J1349 NET	147,8 hp (110,2 kW) a 1.800 rpm	147,8 hp (110,2 kW) a 1.800 rpm
Maximum torque ISO 9249 NET	608 Nm (449 lbf.ft) a 1.800 rpm	608 Nm (449 lbf.ft) a 1.800 rpm
HYDRAULIC SYSTEM		
Max. oil flow	2 x 211 l/min (55,75 gpm) a 1800 rpm	2 x 211 l/min (55,75 gpm) a 1800 rpm
Pump	2 variable displacement axial piston pumps with regulating system	
Boom/Arm/Bucket circuit	343 bar (4.975 psi)	343 bar (4.975 psi)
Boom/Arm/Bucket circuit (with auto power up)	368 bar (5.337 psi)	368 bar (5.337 psi)
Swing circuit	294 bar (4.264 psi)	294 bar (4.264 psi)
Travel circuit	343 bar (4.975 psi)	343 bar (4.975 psi)
SWING		
Maximum swing speed	11,5 rpm	11,5 rpm
Swing torque	64.000 Nm (47.204 lbf.ft)	64.000 Nm (47.204 lbf.ft)
TRAVEL		
Travel motor	Variable displacement axial piston motor	
Max travel speed	5,6 km/h (3,5 mph)	5,6 km/h (3,5 mph)
Low travel speed	3,4 km/h (2,1 mph)	3,4 km/h (2,1 mph)
Gradeability	70% (35°)	70% (35°)
Drawbar pull	188 kN (42.264 lbf)	188 kN (42.264 lbf)
ELECTRICAL SYSTEM		
Circuit/Alternator	24 V / 90 A	
UNDERCARRIAGE		
Number of carriers rollers (each side)	2	2
Number of track rollers (each side)	8	8
Number of shoes (each side)	49	49
Type of shoe	Triple grouser shoe	
CAPACITIES		
Fuel tank	410 l (108 gal 1,2 ct)	410 l (108 gal 1,2 ct)
Hydraulic system	240 l (63 gal 1,6 ct)	240 l (63 gal 1,6 ct)
Cooling system	30,8 l (6 gal 3,5 ct)	30,8 l (6 gal 3,5 ct)
Engine crank Case	16 l (4 gal 0,9 ct)	16 l (4 gal 0,9 ct)
GROUND PRESSURE		
Pressure	0,45 kg/cm ² (6,5 psi)	0,49 kg/cm ² (7,1 psi)
Arm	2,94 m (9' 8")	2,45 m (8')
Bucket	1,3 m ³ (1,7 yd ³)	1,4 m ³ (1,83 yd ³)
Shoe	600 mm (2')	600 mm (2')
WEIGHT		
Weight	22.145 kg (48.821 lb) With 2.94 m (9' 8") Arm, 1.3 m ³ (1.7 yd ³) Bucket, 600 mm (2') grouser shoe, operator 75 kg (165 lb), lubricant, coolant and full fuel tank	23.468 kg (51.738 lb) With 2.45 m (8') Arm, 1.4 m ³ (1.83 yd ³) HD Bucket, 600 mm (2') grouser shoe, operator 75 kg (165 lb), lubricant, coolant and full fuel tank

SPECIFICATIONS

ESPECIFICACIONES	CX350C	CX370C ME
ENGINE		
Brand/Origin	ISUZU / Japan	ISUZU / Japan
Model	GH-6HK1XKSS	GH-6HK1XKSS
Type	Water-cooled, 4-cycle diesel, high pressure Common Rail system, turbocharger, air cooled intercooler, Tier 3 certification	
Number of cylinders	6-cylinder in line	6-cylinder in line
Displacement	7.790 cc	7790 cc
Bore/Stroke	115 x 125 mm (4,5 x 4,9 in)	115 x 125 mm (4,5 x 4,9 in)
Horsepower SAE J1349 NET	268,2 hp (200 kW) a 2.000 rpm	268,2 hp (200 kW) a 2.000 rpm
Maximum torque ISO 9249 NET	983 Nm (725 lbf.ft) a 1.500 rpm	983 Nm (725 lbf.ft) a 1.500 rpm
HYDRAULIC SYSTEM		
Max. oil flow	2 x 300 l/min (79 gpm) a 2000 rpm	2 x 300 l/min (79 gpm) a 2.000 rpm
Pump	2 variable displacement axial piston pumps with regulating system	
Boom/Arm/Bucket circuit	343 bar (4.975 psi)	343 bar (4.975 psi)
Boom/Arm/Bucket circuit (with auto power up)	373 bar (5.410 psi)	373 bar (5.410 psi)
Swing circuit	304 bar (4.410 psi)	304 bar (4.410 psi)
Travel circuit	343 bar (4.975 psi)	343 bar (4.975 psi)
SWING		
Maximum swing speed	10,0 rpm	10,0 rpm
Swing torque	112.000 Nm (82.607 lbf.ft)	112.000 Nm (82.607 lbf.ft)
TRAVEL		
Travel motor	Variable displacement axial piston motor	
Max travel speed	5,4 km/h (3,4 mph)	5,4 km/h (3,4 mph)
Low travel speed	3,4 km/h (2,1 mph)	3,4 km/h (2,1 mph)
Gradeability	70% (35°)	70% (35°)
Drawbar pull	263 kN (59.125 lbf)	263 kN (59.125 lbf)
ELECTRICAL SYSTEM		
Circuit/Alternator	24 V / 50 A	24 V / 50 A
UNDERCARRIAGE		
Number of carriers rollers (each side)	2	2
Number of track rollers (each side)	8	8
Number of shoes (each side)	48	48
Type of shoe	Triple grouser shoe	
CAPACITIES		
Fuel tank	580 l (153 gal 0,9 ct)	580 l (153 gal 0,9 ct)
Hydraulic system	350 l (92 gal 1,8 ct)	350 l (92 gal 1,8 ct)
Cooling system	32,9 l (8 gal 2,8 ct)	32,9 l (8 gal 2,8 ct)
Engine crank Case	41 l (10 gal 3 ct)	41 l (10 gal 3 ct)
GROUND PRESSURE		
Pressure	0, 53 kg/cm² (7,5 psi)	0,72 bar (10,4 psi)
Arm	3,25 m (10' 8")	2,2 m (7' 2,5")
Bucket	2,0 m³ (2,6 yd³)	2,7 m³ (3,5 yd³)
Shoe	600 mm (2')	600 mm (24")
WEIGHT		
Weight	37.910 kg (83.577 lb) With 3.25 m (10' 8") HD Arm, 2.0 m³ (2.6 yd³) HD Bucket, 600 mm (2') grouser shoe, operator 75 kg (165 lb), lubricant, coolant and full fuel tank	38.574 kg (85.041 lb) With 2.2 m (7' 2.5") Arm, 2.4 m³ (3.15 yd³) Bucket, 600 mm (2') grouser shoe, operator 75 kg (165 lb), lubricant, coolant and full fuel tank

GENERAL DIMENSIONS

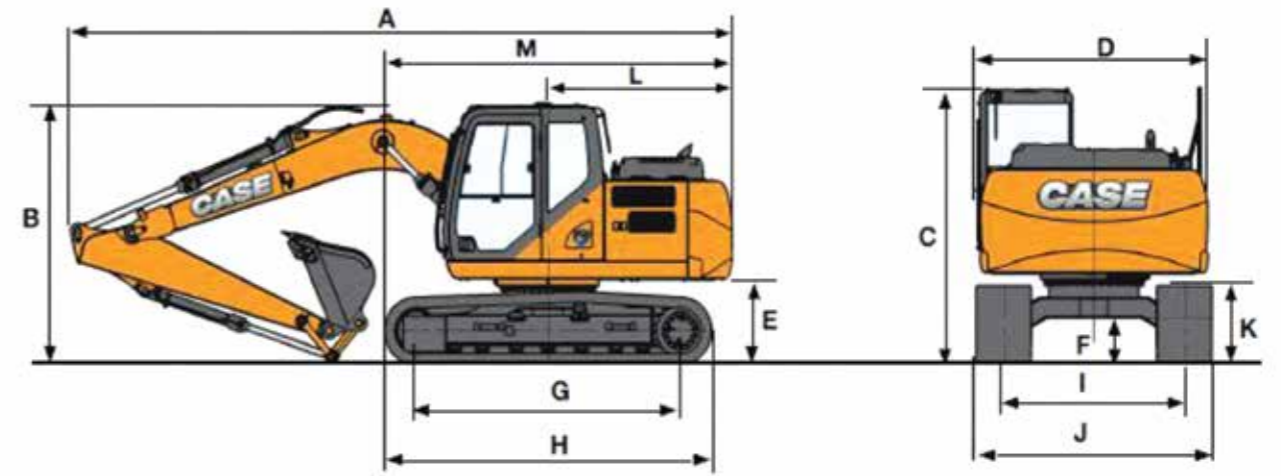

	CX130C	CX180C	CX220C S2	CX240C ME
GENERAL DIMENSIONS				
Arm	2,50 m (8' 2,5")	3,01 m (9' 10,5")	HD 2,62 m (8' 7")	HD 3,05 m (10')
A. Overall length (with attachment)	7620 mm (25')	7640 mm (25' 1")	8440 mm (27' 9")	8500 mm (27' 11")
B. Overall height (with attachment)	2810 mm (9' 3")	2820 mm (9' 3")	2960 mm (9' 9")	3130 mm (10' 4")
C. Cab height	2790 mm (9' 2")	2790 mm (9' 2")	2940 mm (9' 8")	2940 mm (9' 8")
D. Upper structure overall width	2540 mm (8' 4")	2540 mm (8' 4")	2540 mm (8' 4")	2540 mm (8' 4")
E. Clearance height under upper structure	890 mm (2' 11")	890 mm (2' 11")	1020 mm (3' 5")	1020 mm (3' 5")
F. Minimum ground clearance	440 mm (1' 6")	440 mm (1' 6")	420 mm (1' 5")	420 mm (1' 5")
G. Wheel base (Center to center of wheels)	3040 mm (10')	3040 mm (10')	3190 mm (10' 6")	3190 mm (10' 6")
H. Crawler overall length	3760 mm (12' 4")	3760 mm (12' 4")	3990 mm (13' 2")	3990 mm (13' 2")
I. Track gauge	1990 mm (6' 7")	1990 mm (6' 7")	1990 mm (6' 7")	1990 mm (6' 7")
J. Undercarriage overall width (with 600 mm shoes)	2590 mm (8' 6")	2590 mm (8' 6")	2590 mm (8' 6")	2590 mm (8' 6")
K. Crawler tracks height	790 mm (2' 8")	790 mm (2' 8")	920 mm (3' 1")	920 mm (3' 1")
L. Swing (rear end radius)	2130 mm (7')	2130 mm (7')	2450 mm (8')	2450 mm (8')
M. Overall length (without attachment)	4010 mm (13')	4010 mm (13')	4410 mm (14' 6")	4410 mm (14' 6")

	CX350C	CX370C
GENERAL DIMENSIONS		
Arm	HD 2,21 m (7' 3")	HD 3,25 m (10' 8")
A. Overall length (with attachment)	11350 mm (37' 3")	11140 mm (36' 7")
B. Overall height (with attachment)	3650 mm (12')	3420 mm (11' 3")
C. Cab height	3130 mm (10' 4")	3130 mm (10' 4")
D. Upper structure overall width	3030 mm (9' 12")	3030 mm (10')
E. Clearance height under upper structure	1200 mm (3' 12")	1200 mm (4')
F. Minimum ground clearance	480 mm (1' 7")	480 mm (1' 7")
G. Wheel base (Center to center of wheels)	4040 mm (13' 3")	4040 mm (13' 3")
H. Crawler overall length	4980 mm (16' 4")	4980 mm (16' 4")
I. Track gauge	2600 mm (8' 7")	2600 mm (8' 7")
J. Undercarriage overall width (with 600 mm shoes)	3200 mm (10' 6")	3200 mm (10' 6")
K. Crawler tracks height	1090 mm (3' 7")	1090 mm (3' 7")
L. Swing (rear end radius)	3550 mm (11' 8")	3550 mm (11' 8")
M. Overall length (without attachment)	6040 mm (19' 10")	6040 mm (19' 10")

PERFORMANCE DATA

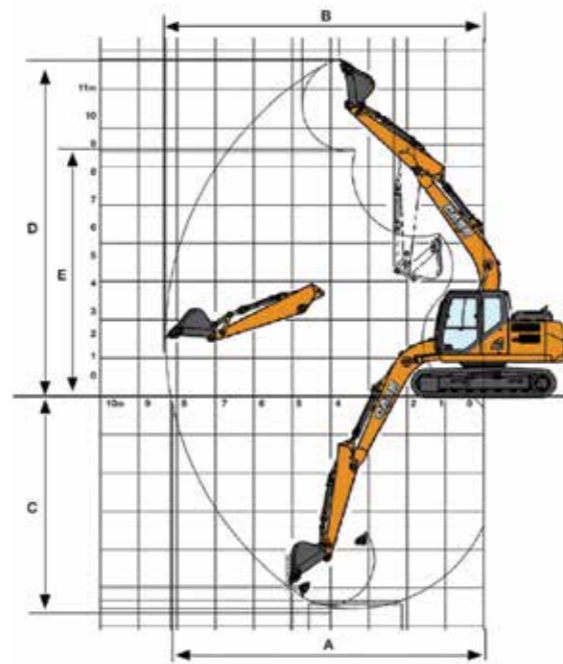

	CX130C		CX180C	
Arm	2,50 m (8' 2,5")	3,01 m (9' 10,5")	HD 2,62 m (8' 7")	HD 3,05 m (10')
Boom length	4630 mm (15' 3")	4630 mm (15' 3")	5150 mm (16' 11")	5150 mm (16' 11")
Bucket radius	1210 mm (4')	1210 mm (4')	1350 mm (4' 6")	1350 mm (4' 6")
Bucket wrist action	178°	178°	178°	178°
A. Maximum reach at GRP	8170 mm (26' 10")	8640 mm (28' 5")	8870 mm (29' 2")	9220 mm (30' 3")
B. Maximum reach	8310 mm (27' 4")	8770 mm (28' 10")	9040 mm (29' 8")	9380 mm (30' 10")
C. Max. digging depth	5540 mm (18' 3")	6050 mm (19' 11")	6060 mm (19' 11")	6490 mm (21' 4")
D. Max. digging height	8770 mm (28' 10")	9050 mm (29' 9")	9240 mm (30' 4")	9290 mm (30' 6")
E. Max. dumping height	6390 mm (21')	6680 mm (21' 11")	6610 mm (21' 9")	6690 mm (22')
Swing (rear end radius)	2130 mm (7')	2130 mm (7')	2450 mm (8' 1")	2450 mm (8' 1")

	CX220C S2		CX240C ME	
Arm	2,94 m (9' 7,8")	2,40 m (7' 10,5")	2,45 m (8')	
Boom length	5700 mm (18' 9")	5700 mm (18' 9")	5160 mm (16' 12")	
Bucket radius	1450 mm (4' 9")	1450 mm (4' 9")	1387 mm (4' 7")	
Bucket wrist action	177°	175°	169°	
A. Maximum reach at GRP	9730 mm (32')	9240 mm (30' 4")	8530 mm (27' 12")	
B. Maximum reach	9900 mm (32' 6")	9420 mm (30' 11")	8725 mm (28' 8")	
C. Max. digging depth	6650 mm (21' 10")	6110 mm (20' 1")	5702 mm (18' 9")	
D. Max. digging height	9610 mm (31' 7")	9410 mm (30' 11")	8335 mm (27' 5")	
E. Max. dumping height	6810 mm (22' 5")	6590 mm (21' 8")	5889 mm (19' 4")	
Swing (rear end radius)	2750 mm (9' 1")	2750 mm (9' 1")	2750 mm (9' 1")	

	CX350C		CX370C ME	
Arm	HD 2,21 m (7' 3")	HD 3,25 m (10' 8")	HD 2,21 m (7' 3")	
Boom length	6450 mm (21' 2")	6450 mm (21' 2")	6000 mm (19' 9")	
Bucket radius	1680 mm (5' 7")	1680 mm (5' 7")	1804 mm (5' 11")	
Bucket wrist action	173°	173°	128°	
A. Maximum reach at GRP	9990 mm (32' 9")	10980 mm (36' 1")	9771 mm (32' 1")	
B. Maximum reach	10200 mm (33' 6")	11170 mm (36' 8")	9989 mm (32' 9")	
C. Max. digging depth	6300 mm (20' 8")	7340 mm (24' 1")	6398 mm (21')	
D. Max. digging height	9850 mm (32' 4")	10370 mm (34' 1")	9445 mm (31')	
E. Max. dumping height	6770 mm (22' 3")	7230 mm (23' 9")	6284 mm (20' 8")	
Swing (rear end radius)	3550 mm (11' 8")	3550 mm (11' 8")	3545 mm (11' 7")	

EXCAVATION FORCE

	CX130C		CX180C	
Bucket (ISO 6015)	0,65 m³ (0,85 yd³)		0,55 m³ (0,72 yd³)	
Arm	2,50 m (8' 2,5")	3,01 m (9' 10,5")	HD 2,62 m (8' 7")	HD 3,05 m (10')
Arm digging force	62 kN (13939 lbf)	56 kN (12590 lbf)	79 kN (17760 lbf)	72 kN (16187 lbf)
Arm digging force with AUTO power up	66 kN (14838 lbf)	60 kN (13489 lbf)	84 kN (18884 lbf)	77 kN (17311 lbf)
Bucket digging force	90 kN (20233 lbf)	90 kN (20233 lbf)	112 kN (2473 lbf)	112 kN (25179 lbf)
Bucket digging force with AUTO power up	95 kN (21357 lbf)	95 kN (21357 lbf)	118 kN (2473 lbf)	118 kN (26528 lbf)

	CX220C S2		CX240C ME	
Bucket (ISO 6015)	1,3 m³ (1,7 yd³)		1,5 m³ (1,96 yd³) HD	
Arm	2,94 m (9' 7,8")	2,40 m (7' 10,5")	2,45 m (8')	
Arm digging force	101kN (22706 lbf)	122 kN (27427 lbf)	125 kN (28101 lbf)	
Arm digging force with AUTO power up	109 kN (24504 lbf)	130 kN (29225 lbf)	134 kN (30124 lbf)	
Bucket digging force	138 kN (31024 lbf)	138 kN (31024 lbf)	157 kN (35295 lbf)	
Bucket digging force with AUTO power up	148 kN (33272 lbf)	148 kN (33272 lbf)	168 kN (37768 lbf)	

	CX350C		CX370C ME	
Bucket (ISO 6015)	2,0 m³ (2,61 yd³) HD		HD 2,7 m³ (3,53 yd³)	
Arm	HD 2,21 m (7' 3")	HD 3,25m	HD 2,21 m (7' 3")	
Arm digging force	231 kN (51931 lbf)	167 kN (37543 lbf)	218 kN (49008 lbf)	
Arm digging force with AUTO power up	251 kN (56427 lbf)	181 kN (40690 lbf)	236,7 kN (53212 lbf)	
Bucket digging force	246 kN (55303 lbf)	246 kN (55303 lbf)	265,8 kN (59754 lbf)	
Bucket digging force with AUTO power up	267 kN (60024 lbf)	267 kN (60024 lbf)	288,6 kN (64880 lbf)	

ISO Conformity	
ROPS	12117-2:2008
FOPS level 1	10262:1998
Seat belts: performance requirements and tests	6683:2005
Operator's seat: dimensions and requirements	11112:1995
Operator seat vibration	7096:2000
Operator's controls	10968:2004
Visual display of machine operation	6011:2003
Symbols for operator controls and other displays — Common symbols	6405-1:2004
Symbols for operator controls and other displays — Specific symbols for machines, equipment and accessories	6405-2:1993
Zones of comfort and reach for control	6682:1995
Machine-control systems - Performance criteria and tests for functional safety	15998:2008
ISO Conformity	15998:2008
Operator's field of view	5006:2006 14401-1:2004 14401-2:2004
Emission sound level	Internal External
Ground pressure	6396:2008 6395:2008
Excavation force	16754:2008
Terminology and commercial specifications	6015:2006
Lift capacity	7135:2009 10567:2007

SUPPORT COMES STANDARD.

CASE Care is a unique program covering a range of services, from preventive and corrective maintenance of your machine to fleet management via satellite. The program offers free online training to operators for the entire CASE line.

Case understands the importance of greater availability of your equipment and offers SystemGard®, the fluid monitoring program for your equipment. Visit www.casece.com/latam/en-la/ to learn about the different services that CASE Care offers for your machine.



PRODUCT SUPPORT SOLUTIONS

Your CASE dealer knows how you can best maximize your equipment investment and uptime—with genuine CASE parts, expert service and a complete range of product support solutions. And only CASE dealers have exclusive access to the Electronic Service Tool (EST) that quickly pinpoints machine issues. Just ask your dealer for details.



FLEXIBLE FINANCIAL OPTIONS







Specialized finance programs and flexible leasing packages put you in the driver's seat of industry-leading CASE equipment while no-nonsense warranties and comprehensive protection plans ensure that your equipment is protected. As the only finance company dedicated to CASE in Argentina, we offer strong products and services designed around your unique needs and are the only ones supported by the helpful service professionals at your CASE dealer.





CASE customers have a direct line of communication to the brand.

This is CASE Customer Assistance, a standout service program with the flexibility you need and the quality you deserve. No matter where you are, if you need **CASE** you can contact us 24 hours a day, seven days a week. **CASE Customer Assistance**. With you wherever you are.

-  **ARGENTINA: 0800-266-1374**  **+54 11 48535831**
-  **BRASIL: 0800-727-2273**  **+55 31 2107-2045**
-  **COLÔMBIA: 01-800-944-8372**
-  **PERU: 0800-77-270**

Plants:

Contagem – Minas Gerais – Brasil

Av. General David Sarnoff, 2.237

Inconfidentes – CEP 32210-900

Tel.: +55 31 2104-3392

Sorocaba – São Paulo – Brasil

Av. Jerome Case, 1.801

Éden – CEP 18087-220

Tel.: +55 15 3334-1700

COMUNICAÇÕES AMERICA LATINA

Case reserves the right to improve designs and change specifications at any time and is under no obligation to fit them on previously sold units. The specifications, descriptions, and illustrations included in this brochure accurately reflect the details known on the publication date, but may vary from region to region and are subject to change with no advance notice. The illustrations may include optional equipment and attachments, and may not include all standard equipment.

CCEI0058 - 02/2021

CaseCe.com

