

# LEGEND SERIES SLIDE-IN COOKTOPS



# LEGEND SERIES SLIDE-IN COOKTOPS



24"

ARSCT-244  
Legend 24" cook top with  
4 sealed gas burners.  
Shown with optional 4" riser.



30"

ARSCT-304  
Legend 30" cook top with  
4 sealed gas burners.  
Shown with optional 4" riser.



36"

ARSCT-366  
Legend 36" cook top with  
6 sealed gas burners.  
Shown with optional 4" riser.

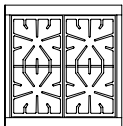

ARSCT-244

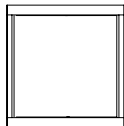

ARSCT-242GD

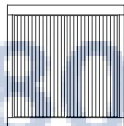

ARSCT-24X2GR

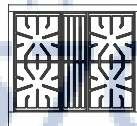

ARSCT-304



ARSCT-364GD

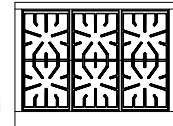

ARSCT-366

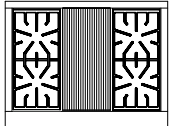

ARSCT-364GR



## RAPID HEAT OUTPUT

Rapid heat output and superior heat distribution boils water, sautes and cooks your favorite dishes, while reducing cooking time.

3 sizes of burners serve your everyday needs:

Large burner:	17,000 BTU
Medium burner:	13,000 BTU
Small burner:	9,000 BTU



# LEGEND SERIES SLIDE-IN COOKTOPS



48"

**ARSCT-486GD**  
Legend 48" cook top with  
6 sealed gas burners and 11" griddle.  
Shown with optional 4" riser.



60"

**ARSCT-606GD**  
Legend 60" cook top with  
6 sealed gas burners, with 11" grill and 11" griddle.  
Shown with optional 4" riser.

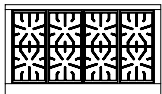

ARSCT-488

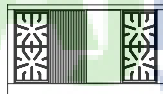

ARSCT-484GDGR



ARSCT-606GDGR

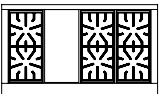

ARSCT-486GD



ARSCT-4842GD



ARSCT-6062GD

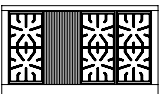

ARSCT-486GR

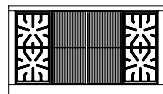

ARSCT-484X2GR

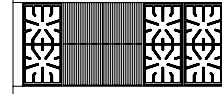

ARSCT-606X2GR



## COMMERCIAL GRADE GRILL BURNER

Constructed from Inconel® stainless steel material, a superior alloy developed to withstand high heat and abuse, the 18,000 BTU infrared broiler burner delivers broiling temperatures up to 1,800°F perfect for searing steak, fish or any food of your choice.

This respective burner is utilized in our commercial products.



## CUSTOMIZE YOUR COOK TOPS

Customize your cook tops with the configuration that best serves you.

Choose your preferred combination of burners, griddles, broilers and even a step-up burner.

Contact factory for more details.

# LEGEND SERIES SLIDE-IN COOKTOPS

## FEATURES

- 3 sizes of burners to serve your everyday needs: 17,000 BTU (lg), 13,000 BTU (med), 9,000 BTU (sm)
- Continuous and flush commercial-grade cast iron grates allow for easy transfer of pots and pans across the cooking surface
- Sealed burners deliver exceptional performance at every level setting and lift off to provide easy cleanup
- Sealed burners create simmer temperatures at minimum setting
- Variable infinite flame settings for all sealed top burners
- Fail-safe system ensures re-ignition in the event the flame goes out even on the lowest burner setting
- Sealed single piece tooled stainless steel cook top can hold more than a gallon of spills
- Analog controls provide easy, push and turn operation ensuring child safety
- Blue LED lights indicate flame and oven functions provided with every knob
- Heavy metal die-cast black satin knobs with chrome bezels

## ACCESSORIES & OPTIONS

- Mirror chrome finish griddle plates available in flat surface & grooved surfaces
- 1" standard fabricated Island back
- 1" welded Island back
- 4" Stub back
- 20" High back with shelf
- Removable griddle plate
- Griddle cover
- Grill cover
- Wok Adapter
- Bright red knobs
- Burgundy knobs

## SLIDE-IN COOKTOPS CUT-OUT DIMENSIONS

Island or peninsula installations - 10" min. clearance from back of range to combustible surface. Island trim 0" clearance to non-combustible surface. No side wall above cooking surface.

Electrical outlet - standard 3 prong 120VAC. Allow for shut off valve at gas outlet. Island peninsula installations require a 10" minimum clearance from back of range to a combustible surface. No side wall above cooking surface.

ⓐ ⓔ Location of gas and electrical supply

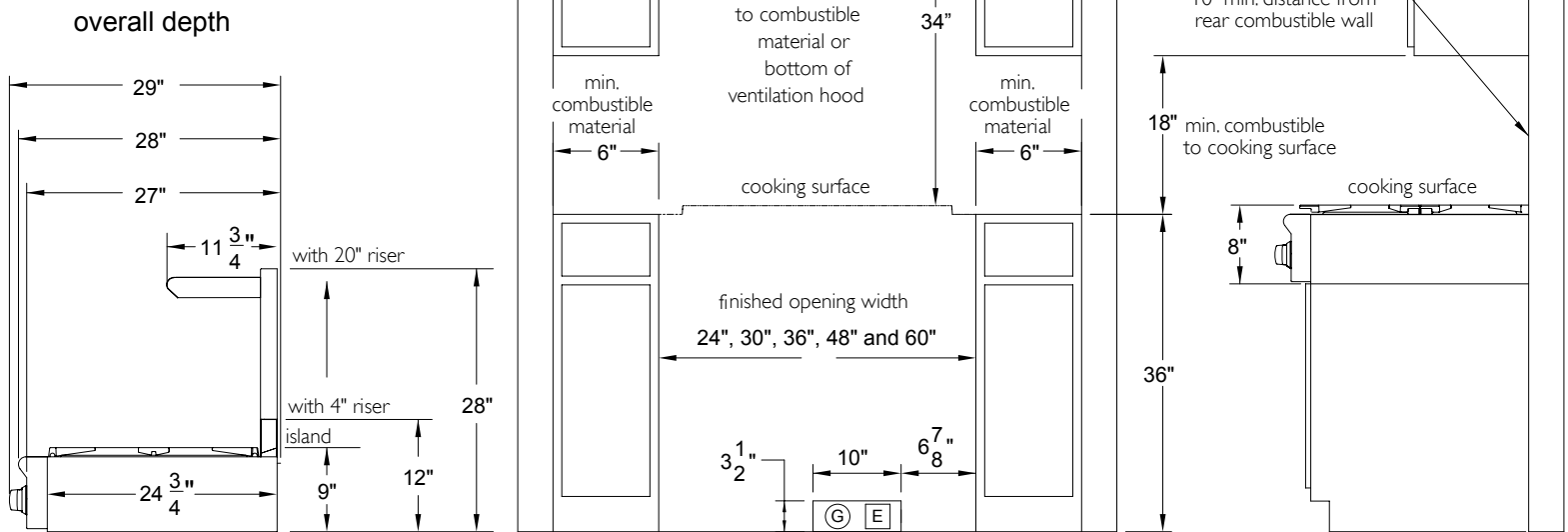

**N** = Natural Gas      Must provide **N** or **L** after model for type of gas needed.  
**L** = LP Gas            Example: AROFG-30**L**, represents unit to be built for LP gas.  
 Must specify elevation if over 1,000 ft. when ordering.

LEGEND SERIES  
SLIDE-IN COOKTOPS



24"



30"



36"

24" SLIDE IN 4 BURNER COOKTOP	
Surface Burner Rating	17,000 BTU (lg) - 13,000 BTU (md) - 9,000 BTU (sm)
Total Gas Connection Rating per model #	ARSCT-244 56,000 BTU 4 burners
Gas Supply	7" W.C. Natural, 11" W.C. Propane
Electrical Supply	120VAC 15 AMP 60 Hz Single Phase
Shipping Weight	80 Lbs

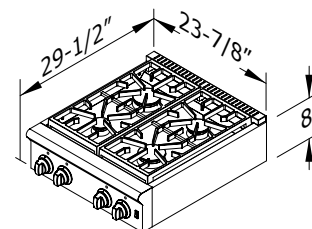

30" SLIDE IN 4 BURNER COOKTOP	
Surface Burner Rating	17,000 BTU (lg) - 13,000 BTU (md) - 9,000 BTU (sm)
Total Gas Connection Rating per model #	ARSCT-304 56,000 BTU 4 burners
Gas Supply	7" W.C. Natural, 11" W.C. Propane
Electrical Supply	120VAC 15 AMP 60 Hz Single Phase
Shipping Weight	99.5 Lbs

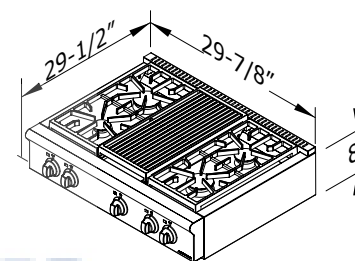

36" SLIDE IN COOKTOPS	
Surface Burner Rating	17,000 BTU (lg) - 13,000 BTU (md) - 9,000 BTU (sm)
Total Gas Connection Rating per model #	ARSCT-366 86,000 BTU 6 burners ARSCT-364GD 76,000 BTU 4 burners and griddle ARSCT-364GR 74,000 BTU 4 burners and grill
Gas Supply	7" W.C. Natural, 11" W.C. Propane
Electrical Supply	120VAC 15 AMP 60 Hz Single Phase
Shipping Weight	121.5 Lbs

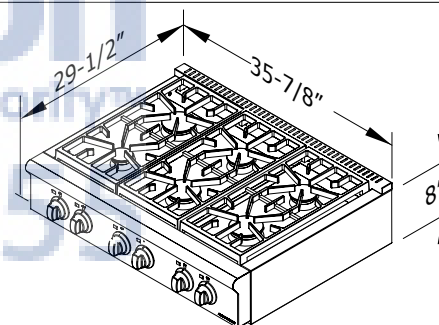

ACCESSORIES	24"	30"	36"	48"	60"
Island Back (Standard)	ARR-24SIB-L	ARR-30SIB-L	ARR-36SIB-L	ARR-48SIB-L	ARR-60SIB-L
Island Back (Welded)	ARR-24IB-L	ARR-30IB-L	ARR-36IB-L	ARR-48IB-L	ARR-60IB-L
4" Stub Back	ARR-244SB-L	ARR-304SB-L	ARR-364SB-L	ARR-484SB-L	ARR-604SB-L
20" High Back with Shelf	ARR-2421HBS-L	ARR-3021HBS-L	ARR-3621HBS-L	ARR-4821HBS-L	ARR-6021HBS
12" Grill Cover	N/A	N/A	ARR-GRCOV12-L	ARR-GRCOV12-L	ARR-GRCOV12-L
12" Griddle Cover	N/A	N/A	ARR-GDCOV12-S-L	ARR-GDCOV12-S-L	ARR-GDCOV12-S-L
24" Griddle Cover	N/A	N/A	N/A	ARR-GDCOV24-S-L	ARR-GDCOV24-S-L
12" Removable Griddle Plate	N/A	N/A	ARR-PGP12-L	ARR-PGP12-L	ARR-PGP12-L
24" Removable Griddle Plate	N/A	N/A	ARR-PGP24-L	ARR-PGP24-L	ARR-PGP24-L
Cutting Board	ARR-CUTB-12-L	ARR-CUTB-12-L	ARR-CUTB-12-L	ARR-CUTB-12-L	ARR-CUTB-12-L
Wok Adapter	ARR-WOK-L	ARR-WOK-L	ARR-WOK-L	ARR-WOK-L	ARR-WOK-L

**N** = Natural Gas      Must provide **N** or **L** after model for type of gas needed.  
**L** = LP Gas            Example: AROFG-30**L**, represents unit to be built for LP gas.  
 Must specify elevation if over 1,000 ft. when ordering.

LEGEND SERIES  
SLIDE-IN COOKTOPS



48"



60"

48" SLIDE-IN COOKTOPS																
Surface Burner Rating	17,000 BTU (lg) - 13,000 BTU (md) - 9,000 BTU (sm)															
Grill Burner Rating	18,000 BTU															
Total Gas Connection Rating per model #	<table border="0"> <tr> <td>ARSCT-486GD</td> <td>106,000 BTU</td> <td>6 burners and griddle</td> </tr> <tr> <td>ARSCT-486GR</td> <td>104,000 BTU</td> <td>6 burners and grill</td> </tr> <tr> <td>ARSCT-484GDGR</td> <td>94,000 BTU</td> <td>4 burners, grill and griddle</td> </tr> <tr> <td>ARSCT-4842GD</td> <td>96,000 BTU</td> <td>4 burners and double griddle</td> </tr> <tr> <td>ARSCT-484X2GR</td> <td>92,000 BTU</td> <td>4 burners and double grill</td> </tr> </table>	ARSCT-486GD	106,000 BTU	6 burners and griddle	ARSCT-486GR	104,000 BTU	6 burners and grill	ARSCT-484GDGR	94,000 BTU	4 burners, grill and griddle	ARSCT-4842GD	96,000 BTU	4 burners and double griddle	ARSCT-484X2GR	92,000 BTU	4 burners and double grill
ARSCT-486GD	106,000 BTU	6 burners and griddle														
ARSCT-486GR	104,000 BTU	6 burners and grill														
ARSCT-484GDGR	94,000 BTU	4 burners, grill and griddle														
ARSCT-4842GD	96,000 BTU	4 burners and double griddle														
ARSCT-484X2GR	92,000 BTU	4 burners and double grill														
Gas Supply	7" W.C. Natural, 11" W.C. Propane															
Electrical Supply	120VAC 15 AMP 60 Hz Single Phase															
Shipping Weight	170.5 Lbs															

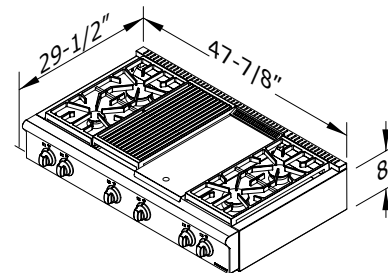

60" SLIDE-IN COOKTOPS										
Surface Burner Rating	9,000 BTU (sm), 13,000 BTU (md), 17,000 BTU (lg)									
Total Gas Connection Rating per model #	<table border="0"> <tr> <td>ARSCT-6062GD</td> <td>126,000 BTU</td> <td>6 burners and double griddle</td> </tr> <tr> <td>ARSCT-606X2GR</td> <td>122,000 BTU</td> <td>6 burners and double grill</td> </tr> <tr> <td>ARSCT-606GDGR</td> <td>124,000 BTU</td> <td>6 burners, griddle and grill</td> </tr> </table>	ARSCT-6062GD	126,000 BTU	6 burners and double griddle	ARSCT-606X2GR	122,000 BTU	6 burners and double grill	ARSCT-606GDGR	124,000 BTU	6 burners, griddle and grill
ARSCT-6062GD	126,000 BTU	6 burners and double griddle								
ARSCT-606X2GR	122,000 BTU	6 burners and double grill								
ARSCT-606GDGR	124,000 BTU	6 burners, griddle and grill								
Gas Supply	7" W.C. Natural, 11" W.C. Propane									
Gas Requirements	120VAC 15 AMP 60 Hz Single Phase									
Shipping Weight	212.5 Lbs									

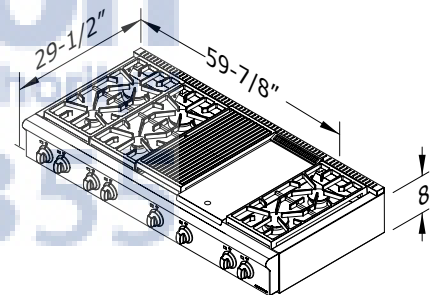

ACCESSORIES	24"	30"	36"	48"	60"
Island Back (Standard)	ARR-24SIB-L	ARR-30SIB-L	ARR-36SIB-L	ARR-48SIB-L	ARR-60SIB-L
Island Back (Welded)	ARR-24IB-L	ARR-30IB-L	ARR-36IB-L	ARR-48IB-L	ARR-60IB-L
4" Stub Back	ARR-244SB-L	ARR-304SB-L	ARR-364SB-L	ARR-484SB-L	ARR-604SB-L
20" High Back with Shelf	ARR-2421HBS-L	ARR-3021HBS-L	ARR-3621HBS-L	ARR-4821HBS-L	ARR-6021HBS
12" Grill Cover	N/A	N/A	ARR-GRCOV12-L	ARR-GRCOV12-L	ARR-GRCOV12-L
12" Griddle Cover	N/A	N/A	ARR-GDCOV12-S-L	ARR-GDCOV12-S-L	ARR-GDCOV12-S-L
24" Griddle Cover	N/A	N/A	N/A	ARR-GDCOV24-S-L	ARR-GDCOV24-S-L
12" Removable Griddle Plate	N/A	N/A	ARR-PGPI2-L	ARR-PGPI2-L	ARR-PGPI2-L
24" Removable Griddle Plate	N/A	N/A	ARR-PGP24-L	ARR-PGP24-L	ARR-PGP24-L
Cutting Board	ARR-CUTB-12-L	ARR-CUTB-12-L	ARR-CUTB-12-L	ARR-CUTB-12-L	ARR-CUTB-12-L
Wok Adapter	ARR-WOK-L	ARR-WOK-L	ARR-WOK-L	ARR-WOK-L	ARR-WOK-L

**N** = Natural Gas      Must provide **N** or **L** after model for type of gas needed.  
**L** = LP Gas            Example: AROFG-30**L**, represents unit to be built for LP gas.  
 Must specify elevation if over 1,000 ft. when ordering.



LEGEND SERIES  
SLIDE-IN STEP-UP COOKTOPS



24"



30"



36"

24" SLIDE-IN STEP-UP 4 BURNER COOKTOP	
Surface Burner Rating	17,000 BTU (lg) - 13,000 BTU (md) - 9,000 BTU (sm)
Total Gas Connection Rating	ARSCT-244SU 56,000 BTU 4 burners
Gas Supply	7" W.C. Natural, 11" W.C. Propane
Electrical Supply	120 VAC 15 AMP 60 Hz Single Phase
Shipping Weight	87 Lbs

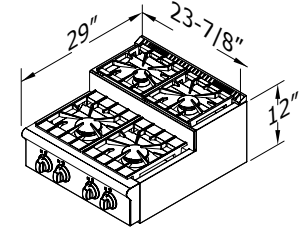

30" SLIDE-IN STEP-UP 4 BURNER COOKTOP	
Surface Burner Rating	17,000 BTU (lg) - 13,000 BTU (md) - 9,000 BTU (sm)
Total Gas Connection Rating	ARSCT-304SU 56,000 BTU 4 burners
Gas Supply	7" W.C. Natural, 11" W.C. Propane
Electrical Supply	120 VAC 15 AMP 60 Hz Single Phase
Shipping Weight	107 Lbs

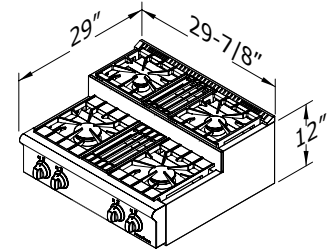

36" SLIDE-IN STEP-UP 6 BURNER COOKTOP	
Surface Burner Rating	17,000 BTU (lg) - 13,000 BTU (md) - 9,000 BTU (sm)
Total Gas Connection Rating	ARSCT-366SU 86,000 BTU 6 burners
Gas Supply	7" W.C. Natural, 11" W.C. Propane
Electrical Supply	120 VAC 15 AMP 60 Hz Single Phase
Shipping Weight	131 Lbs

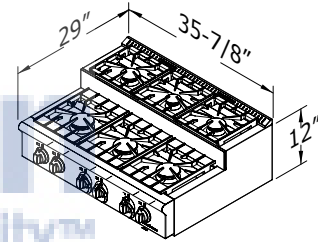

SLIDE-IN STEP-UP COOKTOPS CUT-OUT DIMENSIONS

Island or peninsula installations - 10" min. clearance from back of range to combustible surface. Island trim 0" clearance to non-combustible surface. No side wall above cooking surface.

Electrical outlet - standard 3 prong 120VAC. Allow for shut off valve at gas outlet. Island peninsula installations require a 10" minimum clearance from back of range to a combustible surface. No side wall above cooking surface.

ⓐ ⓔ Location of gas and electrical supply

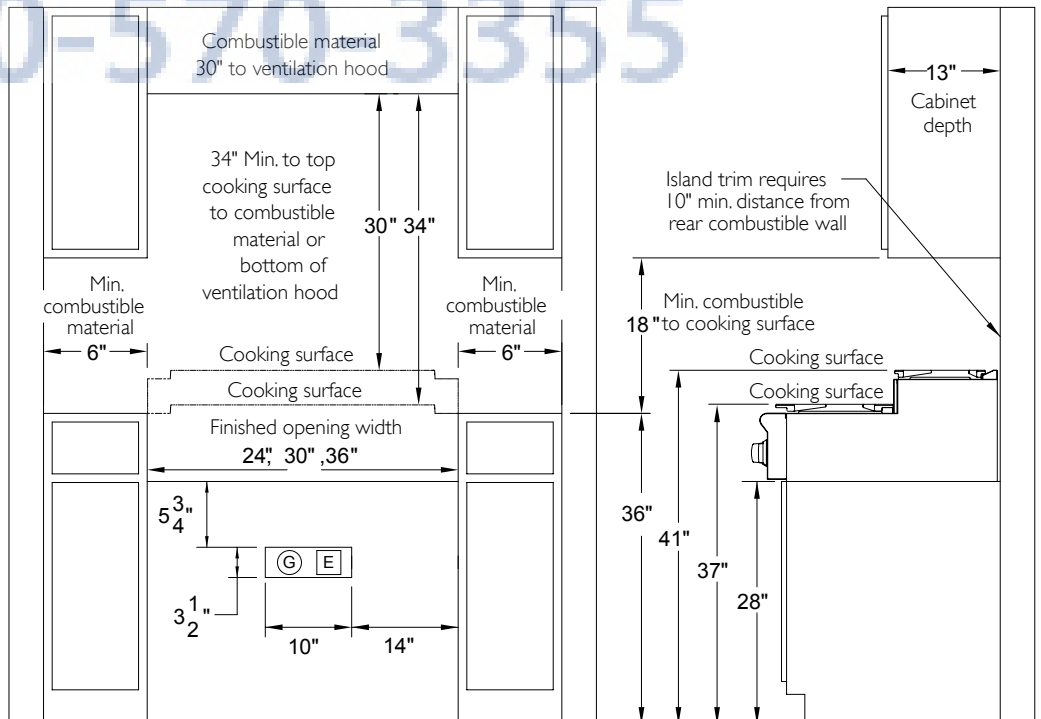
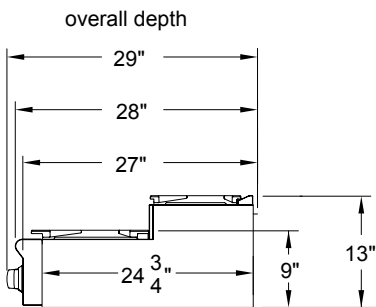

**N** = Natural Gas      Must provide **N** or **L** after model for type of gas needed.  
**L** = LP Gas          Example: AROFG-30**L**, represents unit to be built for LP gas.  
 Must specify elevation if over 1,000 ft. when ordering.