



Request For Proposal

for

Supply and installation of Cisco Electronic Equipments for AP Fiber Grid Phase I Project

RFP No. APSFL/Cisco/408/2020, Dt: 09.09.2020

Andhra Pradesh State FiberNet Limited

NTR Administrative Block, 3rd Floor, Pandit Nehru Bus Station,

Vijayawada - 520013

Web address: www.apsfl.in

Email address: apsfl@ap.gov.in

Table of Contents

Disclaimer	4
Acronyms.....	5
Definitions.....	6
1. Inviting Authority.....	7
1.1 Key Events and Dates	7
1.2 Procedure for Bid Submission.....	8
1.3 Registration with e-Procurement platform.....	9
1.4 Digital Certificate Authentication.....	9
1.5 Hard Copies.....	9
1.6 Deactivation of Bidders	9
2. Introduction.....	12
3. Scope of Work	14
3.1 Network Operation Centre.....	14
3.2 Network Infrastructure	14
4. Pre-Qualification Criteria	14
5. Schedule of Requirement.....	16
6. Instructions to the Bidder	17
6.1 General.....	17
6.2 Pre-bid Queries	18
6.3 Language of the Bid	18
6.4 Amendments	18
6.5 Clarifications by APSFL.....	18
6.6 Suppression of facts and misleading information	19
6.7 Contacting Tender Inviting Authority.....	19
6.8 Tender Validity.....	19
6.9 Hand written documents, Erasures or Alterations	19
6.10 Bid Prices	19
6.11 Firm Prices	20
6.12 Letter of Authorization	20
6.13 Conditional Bids/Offers by the Bidders	20
6.14 Late Tender Bids.....	20
6.15 Opening of Bids	20
6.16 Right to Accept or Reject Bids.....	20
6.17 Notification of Award	20
6.18 Earnest Money Deposit.....	21
6.19 Performance Bank Guarantee.....	21
6.20 Signing of Agreement	21
6.21 Rejection Criteria.....	22
6.22 Concessions permissible under statutes.....	22
6.23 Bid forms.....	22

6.24	Delivery Timelines.....	22
6.25	Delivery & Documents	22
6.26	Third Party Claims.....	23
6.27	Inspection & Test.....	23
6.28	Execution of Work Order	23
6.29	Warranty	23
6.30	Payment Terms	23
6.31	Force Majeure	23
6.32	Liquidated Damages.....	24
6.33	Termination of Contract.....	24
6.34	Arbitration and Jurisdiction	25
7.	Annexures.....	26
7.1	Checklist	26
7.2	Annexure I –Cover Letter.....	27
7.3	Annexure II – Bidder Profile.....	29
7.4	Annexure III - Financial Information.....	30
7.5	Annexure IV- Declaration of Acceptance of RFP Terms & Conditions.....	31
7.6	Annexure V - Declaration of Clean Track Record/ No Blacklisting.....	32
7.7	Annexure VI -EMD Format.....	33
7.8	Annexure VII – Performance Bank Guarantee Format	34
7.9	Annexure VIII- Manufacturer’s Authorization Form (MAF)	35
7.10	Annexure IX – Price Bid Form.....	36
7.11	Annexure X – Minimum Tech Specifications.....	38

Disclaimer

The information contained in this Request for Proposal document ("RFP") or subsequently provided to Applicants, whether verbally or in documentary or any other form by or on behalf of the APSFL or any of its employees or advisers, is provided to Applicants on the terms and conditions set out in this RFP and such other terms and conditions subject to which such information is provided.

This RFP is not an agreement and is neither an offer nor invitation by the APSFL to the prospective Applicants or any other person. The purpose of this RFP is to provide interested parties with information that may be useful to them in the preparation of their Proposals pursuant to this RFP. This RFP includes statements, which reflect various assumptions and assessments arrived at by APSFL. Such assumptions, assessments and statements do not purport to contain all the information that each Applicant may require. This RFP may not be appropriate for all persons, and it is not possible for APSFL, its employees or advisers to consider the objectives, technical expertise and particular needs of each party who reads or uses this RFP. The assumptions, assessments, statements and information contained in this RFP, may not be complete, accurate, adequate or correct. Each Applicant should, therefore, conduct its own investigations and analysis and should check the accuracy, adequacy, correctness, reliability and completeness of the assumptions, assessments and information contained in this RFP and obtain independent advice from appropriate sources.

Information provided in this RFP to the Applicants is on a wide range of matters, some of which depends upon interpretation of law. The information given is not an exhaustive account of statutory requirements and should not be regarded as a complete or authoritative statement of law. APSFL accepts no responsibility for the accuracy or otherwise for any interpretation of the law.

APSFL, its employees and advisers make no representation or warranty and shall have no liability to any person including any Applicant under any law, statute, rules or regulations or tort, principles of restitution or unjust enrichment or otherwise for any loss, damages, cost or expense which may arise from or be incurred or suffered on account of anything contained in this RFP or otherwise, including the accuracy, adequacy, correctness, reliability or completeness of the RFP and any assessment, assumption, statement or information contained therein or deemed to form part of this RFP or arising in any way in this Selection Process.

APSFL also accepts no liability of any nature whether resulting from negligence or otherwise, howsoever caused, arising from reliance of any Applicant upon the statements contained in this RFP. APSFL may in its absolute discretion, but without being under any obligation to do so, update, amend or supplement the information, assessment or assumption contained in this RFP.

Issuance of this RFP does not imply that the APSFL is bound to select an Applicant or to appoint the Selected Applicant, as the case may be, for the RFP, APSFL reserves the right to reject all or any of the Proposals without assigning any reasons whatsoever.

The applicant shall bear all its costs associated with or relating to the preparation and submission of its Proposal including but not limited to preparation, copying, postage, delivery fees, expenses associated with any demonstrations which may be required by the APSFL or any other costs incurred in connection with or relating to its Proposal. All such costs and expenses will remain with the Applicant and APSFL shall not be liable in any manner whatsoever for the same or for any other costs or other expenses incurred by an Applicant in preparation or submission of the Proposal, regardless of the conduct or outcome of the selection process

Acronyms

APSFL	Andhra Pradesh State FiberNet Limited
BG	Bank Guarantee
BNG	Broadband Network Gateway
CG NAT	Carrier Grade Network Address Translation
DD	Demand Draft
DHCP	Dynamic Host Configuration Protocol
DNS	Domain Name System
EMD	Earnest Money Deposit
FDMS	Fibre Distribution Management System
GPON	Gigabit-capable Passive Optical Networks
GST	Goods and Services Tax
INR	Indian National Rupee
IPAM	IP Address Management
IP MPLS	Internet Protocol -Multiprotocol Label Switching
IPTV	Internet Protocol Television
ISP	Internet Service Provider
LCO	Local Cable Operator
LD	Liquidated Damages
LLP	Limited Liability Partnership
LoA	Letter of Acceptance
MSO	Multiple System Operator
MTTR	Mean Time To Repair/Replace
NOC	Network Operations Centre
OEM	Original Equipment Manufacturer
PBG	Performance Bank Guarantee
PoC	Proof of Concept
PoP	Point of Presence
PSU	Public Sector Unit
SD	Security Deposit
SLA	Service Level Agreement
SOP	Standard Operating Procedure
SPOC	Single Point of Contact
USB	Universal Serial Bus
VAT	Value Added Tax
GST	Goods and Services Tax

Acronyms not defined should be interpreted as per general conventions and as per the scope of work mentioned.

Definitions

- **“Agreement”** means the Agreement to be signed between the successful bidder and APSFL including all attachments, appendices, all documents incorporated by reference thereto together with any subsequent modifications, the RFP, the bid offer, the acceptance and all related correspondences, clarifications, presentations.
- **“Authority”** refers to MD/Directors of APSFL or its nominated representatives
- **“Authorized Representative”** shall mean any person authorized by either of the parties.
- **“Bidder”** means any firm or group of firms (called consortium) offering the solution(s), service(s) and /or materials as required in the RFP. The word Bidder/ System Integrator when used in the pre-award period shall be synonymous with parties bidding for this RFP, and when used after award of the Contract shall mean the successful party with whom APSFL signs the agreement for rendering of services for implementation of this project.
- **“Contract”** is used synonymously with Agreement.
- **“Law”** shall mean any Act, notification, bye law, rules and regulations, directive, ordinance, order or instruction having the force of law enacted or issued by the Central Government and/ or Andhra Pradesh or regulatory authority or political subdivision of government agency.
- **“LoA”** means Letter of Acceptance, which shall constitute the intention of the department to place the Purchase Order with the successful bidder.
- **“Party”** means APSFL or Bidder, individually and “Parties” mean APSFL and Bidder, collectively.
- **“Proposal / Bid”** means the Pre-Qualification and Technical Proposals submitted along with the subsequent clarifications and undertakings, if any;
- **“Request for Proposal (RFP)”** means this document and its annexure etc., seeking a set of solution(s), services(s), materials and/or any combination of them.
- **“Requirements”** shall mean and include schedules, details, description, and statement of technical data, performance characteristics and standards (Indian & International) as specified in RFP.
- **“Service Level(s)”** means the performance standards, which shall apply, to the solution design, implementation & services delivered by the Empanelled Agency.

All definitions should be interpreted as per general conventions and as per the scope of work mentioned.

1. Inviting Authority

Andhra Pradesh State FiberNet Limited (APSFL) invites sealed bids from the prospective bidders for Procurement of Equipment for enhancing AP Fiber Grid Phase-1 Network. The bidders shall propose all the components as per the technical specifications mentioned in this RFP and selected bidder(s) should support APSFL in providing reliable service delivery. Selected bidder(s) should maintain supplied items with comprehensive onsite warranty for a period of **five(5)** years from the date of commissioning.

1.1 Key Events and Dates

Sl. No.	Description	Details
1.	Name of the Authority	Andhra Pradesh State FiberNet Limited
2.	Name of the Assignment	Request For Proposal for Supply and installation of Cisco Electronic Equipments for AP Fiber Grid Phase I Project
3.	RFP Number	APSFL/Cisco/408/2020, Dt: 09.09.2020
4.	RFP Publishing Date	09/09/2020
5.	Last date & time for receiving queries/clarifications	16/09/2020 at 5:00 PM
6.	Last date and time for submission of proposal (Proposal Due Date)	23/09/2020 at 3:00 PM The proposal is to be submitted on www.apecurement.gov.in on e-procurement portal.
7.	Date and time of opening of pre-qualification cum technical bids on e-procurement platform	23/09/2020 at 4:00 PM Andhra Pradesh State FiberNet Limited NTR Administrative Block, 3rd Floor, Pandit Nehru Bus Station, NH -65, Vijayawada - 520013 Web address: www.apsfl.in Email address: apsfl@ap.gov.in
8.	Date and time of opening of financial bid	Shall intimate technically qualified agencies at a later date
9.	Bid Processing Fee (Non-refundable)	INR 25,000(Rupees Twenty Five thousand Only) in the form of Demand Draft issued by one of the Nationalized / Scheduled Banks in India drawn in favour of ' Andhra Pradesh State FiberNet Ltd ', payable at Vijayawada. Original DD must be submitted in APSFL office at Vijayawada before proposal due date.
10.	Bid Security / EMD (Refundable)	INR10,00,000(INR Ten Lakh Rupees Only) in the form of Bank Guarantee issued by one of the Nationalized / Scheduled Commercial Banks in India drawn in favour of ' Andhra Pradesh State FiberNet Ltd , payable at Vijayawada. Original BG must be submitted in APSFL office at Vijayawada before proposal due date. Bid Security / EMD should be valid for a period of 210 days from Proposal Due Date. The Bid Security / EMD will be refunded to unsuccessful Applicant agencies within 30 (Thirty) days of completion of selection process.

11.	Performance Bank Guarantee	10% of the Contract Value in the form of Bank Guarantee issued by one of the Nationalized / Scheduled Commercial Banks in India drawn in favour of <u>Andhra Pradesh State FiberNet Ltd.</u> payable at Vijayawada. <ul style="list-style-type: none"> ▪ Should be valid for contract period + 3 months ▪ EMD of the successful bidder will be considered towards PBG and validity should be extended as per the contract duration.
12.	Warranty *	Comprehensive onsite warranty for a period of five years for all equipment from the date of commissioning
13.	For any enquiries and clarifications, please contact:	Executive Director –Technical, Andhra Pradesh State FiberNet Limited NTR Administrative Block, 3rd Floor, Pandit Nehru Bus Station, Vijayawada - 520013 Web address: www.apsfl.in Email: apsfl@ap.gov.in
14.	Validity of the Proposal	Bidder’s proposals shall remain valid for a period of 180 days from the Proposal due date.
15.	Method of Selection	L1

Note: *The Equipment supplied should be replaced in case of failure within warranty period

1.2 Procedure for Bid Submission

The Bidder shall submit their response through Bid submission process on e-Procurement platform at www.apecurement.gov.in by following the procedure given below:

The bidder would be required to register on the e-procurement platform www.apecurement.gov.in or <https://tender.apecurement.gov.in> and submit their bids online. Offline bids shall not be entertained by the RFP Inviting Authority for the RFPs published in e-Procurement platform.

The bidders shall submit their Pre-Qualification cum Technical bid and Price bid online in e-Procurement web site. The bidders shall upload the scanned copies of all the relevant certificates, documents etc., in support of their Pre-Qualification cum Technical bids and other certificates/documents with clear readability, in the e-Procurement web site. The bidder should sign on all the statements, documents, certificates uploaded in the e-Procurement website, owning responsibility for their correctness/authenticity.

In case any bidder is not able to upload the entire set of documents on e-procurement platform either due to space/size constraint or any other technical hitches, only in such cases, the relevant hard copies of the left over documents which could not be uploaded on e-procurement platform may be submitted in sealed covers in APSFL office located at 3rd Floor, NTR Administrative Block, Pandit Nehru Bus Station, NH-65, Vijayawada, Andhra Pradesh, before the stipulated closure time of bid submission. A self-certificate from the bidder in this regard detailing the reasons for submitting the hard copies, if any, duly bringing out issues faced in uploading them on e-procurement platform, if any, shall also be submitted. The uploaded documents on the e-procurement platform and the hard copies submitted in sealed covers, if any, together will be treated as a single set of documents under a bid and will be evaluated accordingly.

1.3 Registration with e-Procurement platform

For registration and online bid submission bidders may contact Helpdesk on www.apecurement.gov.in or <https://tender.apecurement.gov.in>

1.4 Digital Certificate Authentication

The bidder shall authenticate the bid with the agency's Digital Certificate for submitting the bid electronically on e-Procurement platform and the bids not authenticated by digital certificate of the bidder will not be accepted on the e-Procurement platform.

For obtaining Digital Certificate, you may please contact:

Andhra Pradesh Technology Services Limited, Vijayawada www.aps.gov.in/(OR)

You may please contact any Registration Authorities of Certifying Authorities in India. The list of CAs is available in the link <https://tender.apecurement.gov.in/DigitalCertificate/signature.html>

1.5 Hard Copies

All bidders should submit below documents in hard copy Original DD towards the bid processing fee & Original BG towards EMD in APSFL office at Vijayawada before proposal due date. All the bidders shall invariably upload the scanned copies of DD in e-Procurement system and this will be the primary requirement to consider the bid responsive.

- i. APSFL shall carry out the evaluation solely based on the uploaded certificates/documents, BG towards EMD in the e-Procurement system and open the price bids of the responsive bidders only.
- ii. APSFL will notify the bidders for submission of original hardcopies of the uploaded documents if required.
- iii. APSFL will not take any responsibility for any delay in receipt/non-receipt of original DD/BG towards Document Fee/ EMD before the stipulated time.

On receipt of documents, APSFL shall ensure the genuinity of the DD towards document fee, BG towards EMD and all other certificates/documents uploaded by the bidder in e-Procurement system in support of the qualification criteria before concluding the agreement.

1.6 Deactivation of Bidders

Vide Ref GO Ms. No.174 – I&CAD dated 1-9-2008, if any successful bidder fails to submit the original hard copies of uploaded certificates/documents, BG towards EMD within stipulated time or if any variation is noticed between the uploaded documents and the hardcopies submitted by the bidder, the successful bidder will be suspended from participating in the RFPs on e-Procurement platform for a period of 3 years. The e-Procurement system would deactivate the user ID of such defaulting bidder based on the trigger/recommendation by the RFP Inviting Authority in the system. Besides this, APSFL shall invoke all processes of law including criminal prosecution of such defaulting bidder as an act of extreme deterrence to avoid delays in the RFP process for execution of the development schemes taken up by the government. Other conditions as per RFP document are applicable.

The bidder is requested to get a confirmed acknowledgement from the RFP Inviting Authority a proof of Hardcopies submission to avoid any discrepancy.

a) Payment of Transaction Fee:

It is mandatory for all the participant bidders from 1st January 2006 to electronically pay a prescribed non-refundable Transaction fee to M/s. APTS, the service provider through "Payment Gateway Service on E-Procurement platform". The Electronic Payment Gateway accepts all Master and Visa Credit Cards issued by any bank and Direct Debit facility/Net Banking to facilitate the transaction. This is in compliance as per G.O.Ms. 13 dated 07.05.2006.

b) Corpus Fund:

As per GO MS No.4,user departments shall collect 0.04% of ECV (estimated project cost) with a cap of Rs.10,000 (Rupees ten thousand only) for all works with ECV upto Rs.50 Crores, and Rs.25,000/- (Rupees twenty five thousand only) for works with ECV above Rs.50 Crores, from successful bidders on e-Procurement platform before entering into agreement / issue of purchase orders, towards e-procurement fund in favour of Managing Director, APTS. There shall not be any charge towards e-Procurement fund in case of works, goods and services with ECV less than and upto Rs. 10 lakhs

c) RFP Document:

The bidder is requested to download the RFP document and read all the terms and conditions mentioned in the RFP Document and seek clarification if any from the RFP Inviting Authority. Any offline bid submission clause in the RFP document could be neglected.

The bidder has to keep track of any changes by viewing the Addendum/Corrigenda issued by the RFP Inviting Authority from time-to-time in the e-Procurement platform. The Department calling for RFPs shall not be responsible for any claims/issues arising out of this.

d) Bid Submission Acknowledgement:

The bidder shall complete all the processes and steps required for Bid submission. The system will generate an acknowledgement with a unique bid submission number after completing all the prescribed steps and processes by the bidder. Users may also note that the bids for which an acknowledgement is not generated by the e-procurement system are treated as invalid or not saved in the system. Such invalid bids are not made available to the RFP Inviting Authority for processing the bids. The Government of AP is not responsible for incomplete bid submission by users.

1. The bidders need to register on the electronic procurement market place of Government of Andhra Pradesh i.e., www.eprocurement.gov.in. On registration in the e-procurement market place they will be provided with a user ID and password by the system using which they can submit their bids on line.
2. While registering on the e-procurement market place, the bidders need to scan and upload the required documents as per the RFP requirements on to their profile. The e-procurement market place provides an online self-service registration facility to all such Contractors who are already registered with respective participating departments for supply of specified goods and services.
3. All the bidders shall invariably upload the scanned copies of DD/BG in e-Procurement system and this will be the primary requirement to consider the bid as responsive. The Department shall carry out the

Technical bid evaluation solely based on the uploaded certificates/documents, BG towards EMD in the e-procurement system and open the price bids of the eligible and responsive bidders.

4. The bidders shall furnish a declaration in online stating that the soft copies uploaded by them are genuine. Any incorrectness/deviation noticed will be viewed seriously and apart from cancelling the work duly forfeiting the EMD, criminal action will be initiated including suspension of business.

2. Introduction

Andhra Pradesh State FiberNet Limited (APSFL) has been incorporated under the Companies Act 2013 in October 2015, to undertake the works of AP Fiber Grid, its operations & maintenance and related business activities. It is a fully owned entity of the Government of AP under the control of Energy, Infrastructure & Investment (E, I&I) department. APSFL aims to provide high quality & affordable digital services to households, government departments and enterprises across the State.

Fiber Grid is one of the 5 Grids identified by the Government of Andhra Pradesh to accelerate socio-economic growth of the State. Fiber Grid is primarily aimed at harnessing the power of information resource and enabling provision of qualitative and cost-effective IT, Communication (data, voice & video) and other related services to the citizens of A.P.

Vision of AP Fiber Grid is as follows:

“To establish a highly scalable network infrastructure, accessible on a non-discriminatory basis, to provide on demand, affordable and end-to-end broadband connectivity of 15 Mbps for all households and 1 to 10 Gbps for institutions & multi-dwelling units by 2018, to enable realization of the Vision of Digital Andhra Pradesh, in partnership with the Government of India and Private Sector.” In line with the vision, a dual phased approach has been undertaken to deliver the project mandate in AP.

Phase I – Aerial Fiber Grid Network will create an aerial fiber network up-to Mandal level by leveraging assets of Electricity companies.

Phase II – Aerial Fiber network covering the entire State upto Gram Panchayat level.

Phase I of the Project (Aerial Fiber grid project), APSFL has established state-wide high speed optical fiber network infrastructure covering approximately 23,000 kms route across the 13 districts of Andhra Pradesh through 2449 PoPs being operated and controlled from Network Operations Centre (NOC) setup in Vishakhapatnam. Phase I project components include laying aerial optical Fiber across the State upto mandal level, so that the State, District, Zonal and Mandals are connected with each other using ring topology as much as possible. In addition, the last mile connectivity is to be made available through a network of MSOs/ LCOs.

APSFL has procured the required CPE (customer premise equipment) boxes in order to deliver the Triple Play Services viz., Cable TV, high-speed Broadband and Telecom. Online enrolment of MSOs/LCOs for business association with APSFL have been done and already extended Triple Play Services to thousands of customers through the CPE boxes procured.

Considering huge demand for AP FiberNet service connections from customers, APSFL has planned to upgrade the existing AP Fiber Network infrastructure by building capacities at NOC (Network Operations Centre), Network and Last Mile Infrastructure.

In this regard, APSFL intends to procure Network and support equipment as mentioned in Section -5, with specifications provided in Annexure-X, on immediate basis to enhance existing network that can cater to increasing demand from customers.

Existing Network Architecture:

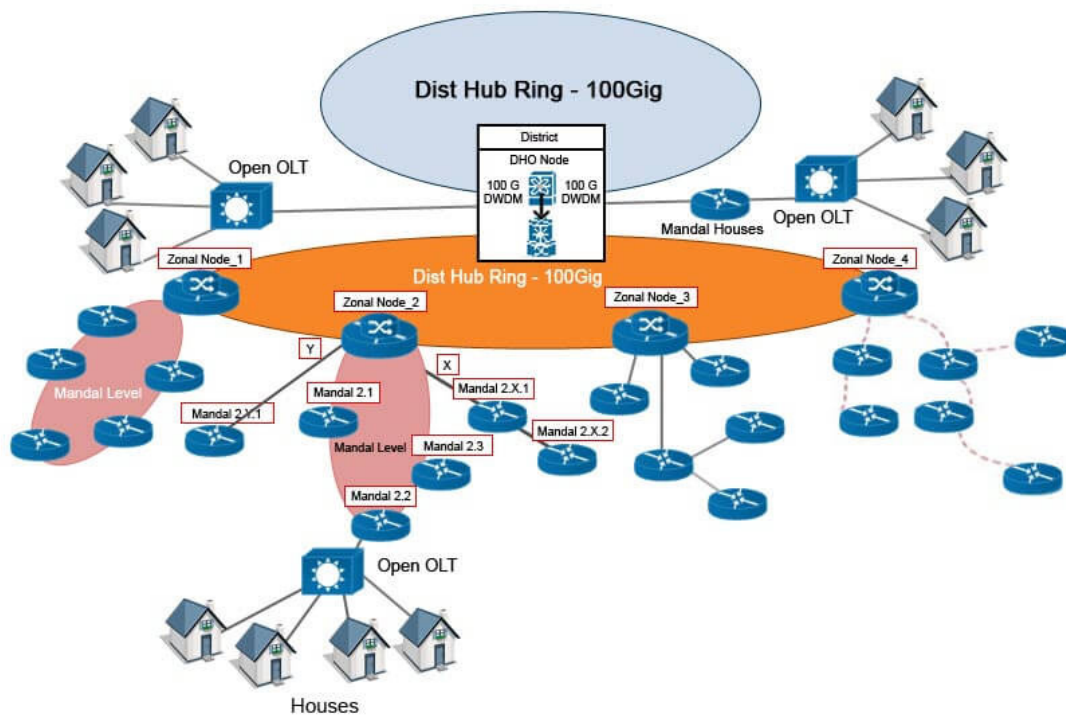
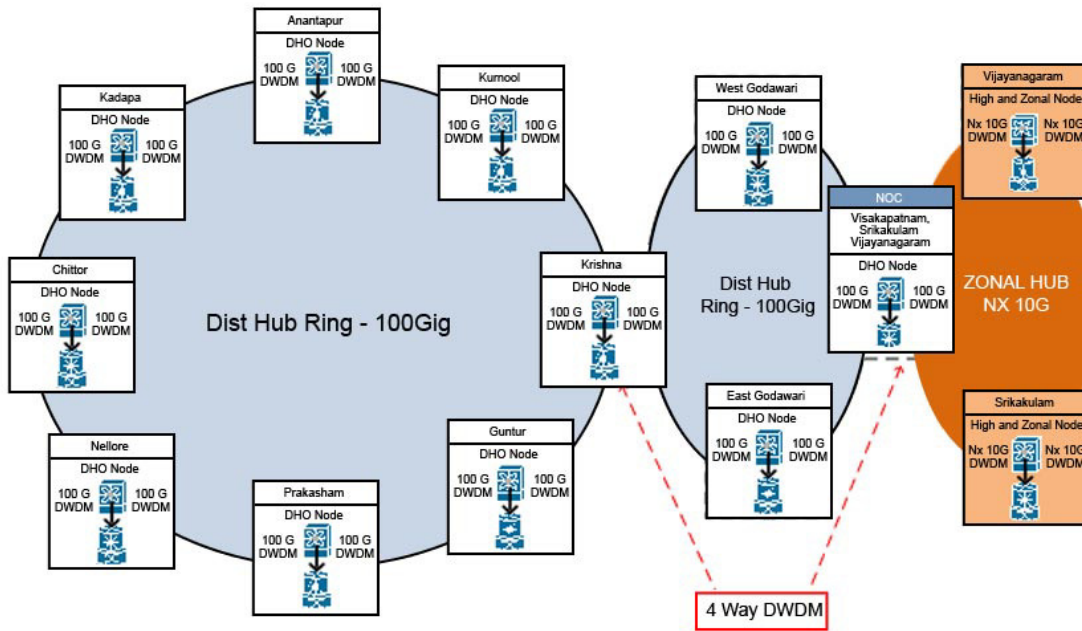

3. Scope of Work

Andhra Pradesh State FiberNet Limited intends to enhance the network capacity to provide Triple Play Services (Internet, Telephone, IPTV or CATV & other Value-Added Services) through the Fiber Network to Households and Enterprise Customers (Govt. Departments/PSU's/ Schools/Hospitals/Other Enterprises).

APSFL has planned to upgrade the existing AP Fiber Network infrastructure by building capacities at NOC (Network Operations Centre), Network and Last Mile infrastructure. The detailed scope of work is as defined below-

3.1 Network Operation Centre

The bidder shall supply, install & commission the NOC infrastructure equipment to meet the requirements mentioned in the Bill of Materials (section-5 of this document)

3.2 Network Infrastructure

APSFL proposes to upgrade the existing network infrastructure to provide seamless services to the customers across the state of Andhra Pradesh.

The bidder shall be responsible for installation, commissioning and maintenance of the supplied equipment as per BoM on existing IP/MPLS network.

Selected vendor is free to provide higher or better specifications in line with the current solution available to render smooth network operations. It is the responsibility of bidder to provide the recommendations to APSFL in case of any such modifications required and obtain approval.

4. Pre-Qualification Criteria

The prospective bidders must satisfy the following eligibility criteria for submission of their bids and provide supporting documents as proof of eligibility.

S. No.	Prequalification Criteria	Documentary Proof to be submitted
1.	<p>The Bidder/consortium members should be a Company registered in India under the Indian Companies Act 1956/2013 or a Registered Partnership Firm or a Sole Proprietary Firm or LLP.</p> <ul style="list-style-type: none"> Foreign companies can be a consortium member provided they are manufacturer/OEM of products supplied. 	<ul style="list-style-type: none"> In case the Bidder is a Registered Company in India, they should produce the copy of the Certificate of Incorporation. In case the Bidder is Registered Partnership Company / Firm, they should produce the copy of Registered Partnership Deed. In case the Bidder is a Sole Proprietary Firm, they should produce the copy of valid Tax Registration Certificate(s) Registration certificate under equivalent law abroad for foreign company A notarized or registered agreement between the Consortium members mentioning the details of Lead member and other consortium members and outline the financial strengths, technical strengths and the role and

Supply and installation of Cisco Electronic Equipments for AP Fiber Grid Phase I Project

S. No.	Prequalification Criteria	Documentary Proof to be submitted
		responsibility of each of the members of the consortium.
2.	The Bidder/ any consortium member should have atleast 3 Financial years of existence in manufacturing or supply of Equipment or similar products as on the date of bid submission.	<ul style="list-style-type: none"> • Copy of Purchase Orders/client certificate should be submitted. • In the case of authorized distributor/dealer, a Letter of Authorization from the OEM/manufacturer. • In the case of OEM, the documentary proof for manufacturing the products.
3.	The Bidder/ Consortium should have an average Annual Turnover of INR 5 Crores and above in last three audited financial years. In case of Consortium the prime bidder should contribute at least 50% of the turnover.	Copies of the Audited Balance sheets and Profit and Loss Accounts for the last 3 audited financial years (2017-18, 2018-2019, 2019-2020)
4.	Bidder/ Consortium (all partners) should have positive net worth for the last 3 audited financial years.	Certificate from the Statutory Auditor/ Practising Chartered Accountant for having positive net worth for the last 3 successive audited financial years(2017-18, 2018-2019, 2019-2020)
5.	The Bidder/ Consortium should have valid GST registration in India	Certified copy of valid GST registration certificates issued by competent authority in India. In case of consortium, this is applicable for all Indian members.
6.	Power of Attorney / Board Resolution	Power of Attorney/Board Resolution authorizing the Tender Signing Authority
7.	The Bidder/ Consortium should not have been blacklisted by any Govt or PSU in India as on the date of bid submission	Self-declaration by the bidder duly signed by the authorized signatory
8.	Technical compliance for the minimum specifications provided in scope of work	<ul style="list-style-type: none"> • The bidder shall submit all the technical leaflets/technical literature/product certifications etc. to confirm the technical compliance. • The OEM should submit the compliance confirmation for each parameter in their letterhead and also MAF • If there is any deviation, the deviation with justification should be spelt out.
9.	The bidder/ consortium shall have experience of supplying, commissioning and providing support services for similar equipment as per BOM of order value INR 3 Crore in last 3 FYs in India.	Copy of Purchase Orders/Client Certificate should be submitted
10.	Existing service centres of OEM/Authorized Distributors or Dealers in Andhra Pradesh	<ul style="list-style-type: none"> • Should have at least one service centre in AP or Undertaking to establish the same within the timelines stipulated by APSFL. • Self-certified declaration and address proof of service centres to be submitted.

Note: In case of consortium, all correspondence related to this project shall be done with /through the lead member. Consortium cannot be more than two members.

5. Schedule of Requirement

S. No	Product ID	Description	Unity of Measurement	Quantity
1	EPA-10X10GE=	Cisco ASR 1000 10x10GE Ethernet Port Adapter with 3 yrs support	Nos.	2
2	N9K-X97160YC-EX=	Nexus 9500 NX-OS line card, 48p 10G/25G with 4p (40G/100G) QSFP28	Nos.	2
3	40 DAC	QSFP-H40G-AOC 15M (40G DAC)	Nos.	6
4	NCS2K-200G-CK-C=	50G/100G/200G CPAK Multi-Rate Line Card with 3yrs support	Nos.	2
5	NCS2K-200G-CK-LIC=	200G - CPAK MR Line Card - C-Band - Licensed with 3yrs Support	Nos.	2
6	R-ISE-VMM-K9=	Cisco ISE Virtual Machine Medium with installation	Nos.	2
6.1	L-ISE-BSE-PLIC	Cisco ISE Base License - to manage 2500 devices for AAA function TECAC+	Nos.	2500
6.2	L-ISE-TACACS-ND=	Cisco ISE Device Admin Node License	Nos.	2
7	RAM Upgrade	RAM Upgrade from 128Gb to 256GB, Additional 4TB HDD For Cisco UCS C220 M5 Server	Sets	1
8	AMC	3 Years AMC for Cisco Hyperflex System	Sets	1
9	RJ45 to DB9	Rollover Console Cable for Cisco Router	Nos.	50
10	DB9 to USB	Rollover Console Cable for Cisco Router	Nos.	50
11	Ethernet Switch	12 Port 1G Switch - SG 300	Nos.	1
12	Cisco OLA	Supply of Optical Line Cmplifies NCS2006 with installation	Sets	3
12.1.1	NCS2K-TNCS-O-K9=	NCS 2000 Transport Node Controller w/2x OTDR/OSC	Nos.	6
12.1.2	CON-SNT-NCS2KTNO	SNTC-8X5XNBD NCS 2000 Transport Node Controller w/2x - 3 Years	Nos.	6
12.1.3	SF15454MC-R1090K9	NCS 2K/MSTP - R10.7 SW, TNCE, TSCE, TNCS/O - WSON CP	Nos.	6
12.1.4	NCS2006-SA=	NCS 2006 Shelf Assembly	Nos.	3
12.1.4	CON-SNT-NCS2006A	SNTC-8X5XNBD NCS 2006 Shelf Assembly	Nos.	3
12.1.5	NCS2006-LCD=	NCS 2006 LCD Display with Backup Memory	Nos.	3
12.1.6	15454-BLANK=	Empty slot Filler Panel	Nos.	12
12.1.7	NCS2006-FTA=	NCS 2006 Fan Tray	Nos.	3
12.1.8	NCS2006-AC=	NCS 2006 1,500W AC Power Supply	Nos.	6
12.1.9	NCS2006-ECU=	NCS 2006 External Connections Unit	Nos.	3

12.1.10	15454-LC-LC-2=	Fiber patch cord - LC to LC - 2m	Nos.	6
12.1.11	15454-OPT-EDFA-24=	15454 MSTP - Optical Amplifier - C-band - 24dB Gain	Nos.	6
12.1.12	CON-SNT-15454OPE	SNTC-8X5XNBD 15454 MSTP - Optical Amplifier - C-band - 3 Years	Nos.	6
12.2		Supply, fixing of wall mount 48 port FDMS with required trays and splicing of necessary patch cords	Nos.	3
12.3		EMS Licenses for OLA With 3 Years Support	Set	3

* In case of non-compatibility with Prime Network EMS, bidder shall provide new EMS for management of the devices supplied. Integration with Prime Network EMS is the responsibility of existing SI of AP Fiber.

6. Instructions to the Bidder

6.1 General

1. The Bidders are requested to examine the instructions, terms and conditions and specifications given in the Tender. Failure to furnish all required information in every respect will be at the Bidder's risk and may result in the rejection of bid.
2. It will be imperative for each Bidder(s) to familiarize itself/ themselves with the prevailing legal situations for the execution of contract. APSFL shall not entertain any request for clarification from the Bidder regarding such legal aspects of submission of the Bids.
3. It will be the responsibility of the Bidder that all factors have been investigated and considered while submitting the Bids and no claim whatsoever including those of financial adjustments to the contract awarded under this tender will be entertained by APSFL. Neither any time schedule nor financial adjustments arising thereof shall be permitted on account of failure by the Bidder to appraise themselves.
4. The Bidder shall be deemed to have satisfied itself fully before Bidding as to the correctness and sufficiency of its Bids for the contract and price quoted in the Bid to cover all obligations under this Tender.
5. It must be clearly understood that the Terms and Conditions and specifications are intended to be strictly enforced. No escalation of cost in the Tender by the Bidder will be permitted throughout the period of Agreement or throughout the period of completion of contract whichever is later on account of any reasons whatsoever.
6. The Bidder should be fully and completely responsible to APSFL and State Government for all the deliveries and deliverables.
7. This RFP and its subsequent finalised basic unit prices shall be valid for a period of 5 years from the date of awarding the initial contract by the buyer. During the term of this RFP and subsequent signing of Contract upon submission of PBG by the supplier, if the Purchaser desires to purchase / procure from Supplier, the Purchaser shall issue a Purchase Order in accordance with the contract line items and its

unit price as and when required for any quantity without floating any new RFP and Supplier is obliged to accept the Purchase Order as long as it is in conformance with the contract. In case Supplier wish to discontinue such contracted Product during the validity of the contract, supplier will have to serve 6 months' notice upon Purchaser regarding its intend for such discontinuance of the Product.

6.2 Pre-bid Queries

All enquiries from the Bidders relating to this RFP must be submitted to the Executive Director (Technical), APSFL, Vijayawada. These queries should be e-mailed in MS-Excel format to apsfl@ap.gov.in. The queries should necessarily be submitted in the following Format:

#	RFP Part No.	Section No.	Page no.	Content of the RFP requiring clarification	Clarification Sought

6.3 Language of the Bid

The bids prepared by the Bidder and all subsequent correspondence and documents relating to the bids exchanged by the Bidder and APSFL shall be written in **English** language. Any printed literature furnished by the Bidder, written in another language, shall be accompanied by an accurate English translation, in which case, for purposes of interpretation of the Bid, the English translation shall govern.

6.4 Amendments

Before closing of the Tender, clarifications and amendments if any will be notified in the website mentioned in the Tender Schedule. The Bidders periodically check for the amendments or corrigendum or information in the website till the closing date of this Tender. APSFL will not make any individual communication and will in no way be responsible for any ignorance pleaded by the Bidders.

Before the closing of the Tender, APSFL may amend the Tender document as per requirements or wherever APSFL feels that such amendments are necessary.

Amendments also may be given in response to the queries by the prospective Bidders. Such amendments will be notified in the websites mentioned in the tender schedule. APSFL at its discretion may or may not extend the due date and time for the submission of bids on account of amendments.

APSFL is not responsible for any misinterpretation of the provisions of this tender document on account of the Bidders failure to update the Bid documents on changes announced through the website.

6.5 Clarifications by APSFL

When deemed necessary, APSFL may seek bonafide clarifications on any aspect from the Bidder. However, that would not entitle the Bidder to change or cause any change in the substance of the Bid or price quoted. During the course of Technical Bid evaluation, APSFL may seek additional information or historical documents for verification to facilitate decision making. In case the Bidder failed to comply with the requirements of APSFL as stated above, such Bids may at the discretion of APSFL, shall be rejected as technically non-responsive.

6.6 Suppression of facts and misleading information

During the Bid evaluation, if any suppression or misrepresentation of is brought to the notice of APSFL. APSFL shall have the right to reject the Bid and if after selection, APSFL would terminate the contract, as the case may be, will be without any compensation to the Bidder and the EMD / PBG, as the case may be, shall be forfeited.

Bidders should note that any figures in the proof documents submitted by the Bidders for proving their eligibility is found suppressed or erased, APSFL shall have the right to seek the correct facts and figures or reject such Bids.

It is up to the Bidders to submit the full copies of the proof documents to meet out the criteria. Otherwise, APSFL at its discretion may or may not consider such documents.

Tender calls for full copies of documents to prove Bidder's experience and capacity to undertake the project.

6.7 Contacting Tender Inviting Authority

Bidders shall not make attempts to establish unsolicited and unauthorized contact with APSFL /Tender Committee after the opening of the Tender and prior to the notification of the Award and any attempt by any Bidder to bring to bear extraneous pressures on the Tender Accepting Authority shall be sufficient reason to disqualify the Bidder.

Notwithstanding anything mentioned above, APSFL may seek bonafide clarifications from Bidders relating to the tenders submitted by them during the evaluation of tenders.

6.8 Tender Validity

The offer submitted by the Bidders should be valid for a minimum period of 180 days from the date of opening of the Tender. The Contract will be valid for 5 years from the date of signing of the contract or agreement/date of release of the first Purchase order. However, APSFL reserves the right to extend or short close the Tender/Contract validity period if situation warrants to benefit the Government.

6.9 Hand written documents, Erasures or Alterations

The offers containing erasures or alterations will not be considered. There should be no hand-written material, corrections or alterations in the offer. Filling up of the information using terms such as "OK", "noted", "as given in brochure/manual" is not acceptable and may lead to the disqualification of the Bid.

6.10 Bid Prices

The Bidder shall indicate in the proforma prescribed, the unit rates and total Bid Prices for the equipment / services, it proposes to provide under the Contract. Prices should be shown separately for each item as detailed in this document.

If during the course of execution of the project any minor revisions to the work requirements like technical specifications, equipment sizing, etc. are to be made to meet the goals of the Project; such changes shall be carried out within the proposed price. If any deviation has a major impact on the Project Cost, the Authority shall take appropriate decision and such decisions would be binding on the Bidder.

6.11 Firm Prices

Prices quoted in the Bid must be firm and final and shall not be subject to any modifications, on any account whatsoever. The Bid Prices shall be indicated in Indian Rupees (INR) only.

The Price Bid should clearly indicate the price quoted without any ambiguity / qualifications whatsoever and should include all applicable duties, fees, levies, and other charges as may be applicable in relation to the activities proposed to be carried out. Taxes as applicable shall be paid by APSFL.

Prices in any form or by any reason before opening the Price Bid should not be revealed, failing which the offer shall be liable for rejection. If price change is inevitable due to any factor external to the bidders, the bidders may be given chance to submit revised Bids in a separate sealed cover. Decisions of the Authority shall be final in this regard.

6.12 Letter of Authorization

A letter of Authorization from the Board of Directors / appropriate authority authorizing the Tender submitting authority or a Power of Attorney should be scanned and submitted in the Tender, otherwise the Bids will be summarily rejected.

6.13 Conditional Bids/Offer by the Bidders

The Bidder should abide by all terms and conditions specified in the RFP Document. Conditional bids/offers shall be liable for disqualification.

6.14 Late Tender Bids

Any tender offer received by APSFL after the deadline for submission of tender offer prescribed by the Authority, will be summarily rejected.

6.15 Opening of Bids

Bids received within the prescribed closing date and time will be opened on the e-procurement platform, on the date, time and at the address mentioned in the RFP Documents.

Price Bid of only those Bidders who fulfilled all the eligibility criteria shall be opened.

6.16 Right to Accept or Reject Bids

Authority reserves the right to accept or reject any Bid, and to annul the RFP process and reject all bids at any time prior to award of contract, without thereby incurring any liability to the affected Bidder(s) or any obligation to inform the affected Bidder(s) of the grounds for such action.

6.17 Notification of Award

Authority will notify the Successful Bidder via letter / fax /email of its intent of accepting the bid. Within 7 days of receipt of the Letter of Acceptance (LoA) issued by the Authority, the Successful Bidder shall be required to sign the LoA and return the same to the address specified above as a token of acceptance of the LoA.

6.18 Earnest Money Deposit

An EMD amount as specified in the Tender Schedule should be paid by way of Bank Guarantee drawn in favour of “Andhra Pradesh State FiberNet Limited” payable at Vijayawada.

The EMD of the unsuccessful Bidders will be returned at the expense of the Bidders within a reasonable time consistent with the rules and regulations in this behalf. The EMD amount held by APSFL till it is refunded to the unsuccessful Bidders will not earn any interest thereof.

The EMD amount of the Successful Bidder(s) can be converted as part of Security Deposit (SD) for successful execution of the work and will be returned only after the successful fulfilment of the Contract.

The EMD amount will be forfeited by APSFL, if the Bidder withdraws the bid during the period of its validity specified in the tender or if the Successful Bidder fails to sign the contract or the Successful in bidder fails to remit Security Deposit within the respective due dates.

6.19 Performance Bank Guarantee

As a condition precedent to execution of the Agreement, the Successful Bidder shall ensure submission of the requisite unconditional irrevocable Bank Guarantee, in the prescribed Format within 15 days of receipt of the LOA as a Performance Bank Guarantee (PBG) for **10% of the Contract Value** for the services to be performed under the resultant Agreement. The Performance Bank Guarantee shall be valid for the term of the resultant Agreement + 3 months and shall be renewed and maintained as necessary by the SI for the term of the resultant Agreement, and extensions if any. In case of any delay/ non-submission of PBG, decision of APSFL shall be final & binding on the bidder.

Earnest Money Deposits (EMD) submitted by the bidders along with their bids shall be refunded to all bidders, except the Successful Bidder, within 30 days of issuance of the LOI. EMD of the successful bidder will be considered towards PBG and validity should be extended as per the contract duration.

The Performance Bank Guarantee may be liquidated by the Authority as penalty/liquidated damages resulting from the Successful bidder's failure to complete its obligations under the resultant Agreement. The Performance Bank Guarantee shall be returned by Authority to the Bidder within 120 days of the term/expiration of the resultant Agreement after applicable deductions as per the Agreement, if any.

6.20 Signing of Agreement

Subsequent to Authority notification to the Successful Bidder by way of a LoA, acceptance of the LoA and submission of the Performance Guarantee, the Successful Bidder shall execute the Agreement with the APSFL. Failure of the Successful Bidder to furnish the Performance Guarantee or execute the Agreement within the prescribed time shall cause the EMD of the Successful Bidder to be liquidated. In such event, APSFL shall negotiate with the next eligible bidder. The Successful Bidder will be liable to indemnify APSFL for any additional cost or expense, incurred on account of failure of the Successful Bidder to execute the Agreement.

Notwithstanding anything to the contrary mentioned above, the Authority at its sole discretion shall have the right to extend the timelines for execution of Agreement on the request of the Successful Bidder, provided the same is bonafide.

6.21 Rejection Criteria

Besides other conditions and terms highlighted in the RFP Document, bids may be rejected under following circumstances:

- a) Conditional Bids.
- b) If the information provided by the Bidder is found to be incorrect / misleading / fraudulent at any stage / time during the RFP Evaluation Process.
- c) Any effort on the part of a Bidder to influence the bid evaluation, bid comparison or contract award decisions.
- d) Bids received after the prescribed time & date for receipt of bids.
- e) Bids without signature of person (s) duly authorized on required pages of the bid.
- f) Bids without power of attorney/ board resolution or its certified true copy.
- g) Bids received without submission of the prescribed Bid processing fee/EMD.
- h) Incomplete Price Bid.
- i) Price Bids that do not conform to the RFP's Price Bid Format.
- j) If there is an arithmetic discrepancy in the Price Bid calculations the RFP Evaluation Committee shall rectify the same. If the Bidder does not accept the correction of the errors, its Bid may be rejected.

6.22 Concessions permissible under statutes

Bidder, while quoting against this RFP, must take cognizance of all concessions permissible, if any, under the statutes and ensure the same is passed on to the Authority, failing which it will have to bear extra cost. In case Bidder does not avail concessional rates of levies like customs duty, excise duty, sales tax, etc. APSFL will not take responsibility towards this. However, the Authority may provide necessary assistance, wherever possible, in this regard.

6.23 Bid forms

- a. Wherever a specific form is prescribed in the bid document, the bidder shall use the form to provide relevant information.
- b. For all other cases the bidder shall design a form to hold the required information.

6.24 Delivery Timelines

The Successful Bidder shall deliver the first work order within **six(6)weeks** from the date of entering into contract. If the Successful Bidder fails to commence the assignment, the LOA may be, cancelled /terminated.

However, in case of specific reasons for delay in supply beyond the periods specified herein the bidder should obtain specific written approval from APSFL citing the reasons. The decision of APSFL is final on the issue of extension of the delivery period.

6.25 Delivery & Documents

Delivery of Goods and Services shall be made by the selected vendor strictly in accordance with the specifications of the tender document or in case of deviations, the specifications approved and accepted by APSFL. Corresponding documentation shall be submitted to APSFL along with delivery.

The delivery locations will be informed in the later stage. Delivery to the designated locations is responsibility of the selected bidder.

Successful bidder should maintain adequate spares to support atleast 10% of equipment supplied as part of this RFP.

6.26 Third Party Claims

The selected bidder shall indemnify APSFL against all third-party claims of infringement of patent, trademark or industrial design rights arising from use of the Goods or any part thereof in India.

6.27 Inspection & Test

APSFL and/or its representative reserve the right of inspection and testing of the goods prior to delivery and after delivery at the site, or at any time during the period of the contract.

APSFL reserves the right to inspect, test and, wherever necessary, reject the Goods after the Good's arrival at Project Site. This shall in no way be limited or waived by reason of the Goods having previously been inspected, tested and passed by APSFL or its representative prior to the Goods shipment.

6.28 Execution of Work Order

The Successful Bidder should nominate and intimate APSFL, an Account Manager for Single Point of Contact (SPOC), who should be responsible for effective delivery of work complying with all the terms and conditions. The Successful Bidder should ensure that the Account Manager fully familiarizes with the Tender Conditions, Scope of Work and deliverables.

6.29 Warranty

Equipment:

The selected vendor(s) has to provide comprehensive onsite warranty for all the equipment supplied through this RFP for a period of five(5) years from the date of commissioning as per the terms & conditions in the tender

6.30 Payment Terms

1. 30% of work order value payable against successful delivery of the equipment
2. 60% of the work order value payable against successful commissioning & Acceptance from APSFL.
3. 10% of the total value will be given after completion of the warranty period of 5 years or against PBG which is valid for warranty period.

6.31 Force Majeure

Force Majeure shall not include any events caused due to acts/omissions of such Party or result from a breach/contravention of any of the terms of the Contract, Bid and/or the Tender. It shall also not include any default on the part of a Party due to its negligence or failure to implement the stipulated/proposed precautions, as were required to be taken under the Agreement.

The failure or occurrence of a delay in performance of any of the obligations of either party shall constitute a Force Majeure event only where such failure or delay could not have reasonably been foreseen or where despite the presence of adequate and stipulated safeguards the failure to perform obligations has occurred. In such an event, the affected party shall inform the other party in writing within five days of the occurrence of such event.

APSFL will make the payments due for Services rendered till the occurrence of Force Majeure. However, any failure or lapse on the part of the vendor in performing any obligation as is necessary and proper to negate the damage due to projected force majeure events or to mitigate the damage that may be caused due to the above-mentioned events or the failure to provide adequate disaster management/recovery or any failure in setting up a contingency mechanism would not constitute force majeure, as set out above.

In case of a Force Majeure all Parties will endeavour to agree on an alternate mode of performance in order to ensure the continuity of service and implementation of the obligations of a party under the agreement and to minimize any adverse consequences of Force Majeure.

6.32 Liquidated Damages

Subject to clause for Force Majeure if the bidder fails to complete before the scheduled date or if bidder repudiates the agreement before completion of the Work, APSFL at its discretion may without prejudice to any other right or remedy available to APSFL the Contract recover a maximum of 5% (five percent) of the total value of the work order from the successful bidder as Liquidated Damages (LD).

1% of the late delivered or deemed late delivered/installed deliveries/installations goods for One week or part thereof, 1.5% for Two weeks or part thereof, 2% for Three weeks or part thereof, 2.5% for 4 weeks or part thereof and so on subject to maximum of 5%. If the delay continues beyond 10 weeks, APSFL may terminate the Agreement.

APSFL may without prejudice to its right to effect recovery by any other method deduct the amount of liquidated damages from any money belonging to the bidder in its hands (which includes APSFL's right to claim such amount against successful bidder's Bank Guarantee) or which may become due to the Implementation Agency. Any such recovery or liquidated damages shall not in any way relieve the bidder from any of its obligations to complete the Works or from any other obligations and liabilities under the agreement.

6.33 Termination of Contract

Termination for default

APSFL may without prejudice to any other remedy for breach of contract, by written notice of default with a notice period of 7 days, sent to the Successful Bidder, terminate the contract in whole or part,

- (i) if the Successful Bidder fails to deliver any or all of the goods within the time period(s) specified in the Contract, or fails to supply the items as per the Delivery Schedule or within any extension thereof granted by APSFL; or
- (ii) if the Successful Bidder fails to perform any of the obligation(s) under the contract; or
- (iii) if the Successful Bidder, in the judgement of APSFL, has engaged in fraudulent and corrupt practices in competing for or in executing the Contract.

In the event APSFL terminates the Contract in whole or in part, APSFL may procure, upon terms and in such manner as it deems appropriate, the goods and services similar to those and delivered and the Successful Bidder shall be liable to APSFL for any additional costs for such similar goods. However, the Successful Bidder shall continue the performance of the contract to the extent not terminated.

Termination for Insolvency

APSFL may at any time terminate the Contract by giving written notice with a notice period of 7 days to the Successful Bidder. If the Successful Bidder becomes bankrupt or otherwise insolvent. In this event, termination will be without compensation to the Successful Bidder, provided that such termination will not prejudice or affect any right of action or remedy that has accrued or will accrue thereafter to APSFL.

Termination for Convenience

APSFL may by written notice, with a notice period of seven days sent to the Successful Bidder, may terminate the Contract, in whole or in part, at any time for its convenience. The notice of termination shall specify that termination is for APSFL's convenience, the extent to which performance of work under the Contract is terminated, and the date upon which such termination becomes effective. On termination, the successful Bidder is not entitled to any compensation whatsoever.

6.34 Arbitration and Jurisdiction

In case of any dispute, the matter will be referred to a Sole Arbitrator to be appointed by the Managing Director of APSFL in accordance with the "Arbitration and Conciliation Act 1996". The arbitration shall be held in Vijayawada, India and the language English only.

Subject to the above, the Courts of AP alone only shall have jurisdiction in the matter.

7. Annexures

7.1 Checklist

Sl. No.	Documents	Compliance (Yes/No)
1	Cover Letter as per given format	
2	Bidder Profile as per given format	
3	Financial Information as per given format	
4	Declaration of acceptance of RFP terms and conditions	
5	Declaration of clean track record / No Blacklisting	
6	Price Bid as per given format	
7	In case the Bidder is a Registered Company in India, they should produce the copy of the Certificate of Incorporation.	
8	In case the Bidder is Registered Partnership Company / Firm, they should produce the copy of Registered Partnership Deed.	
9	In case the Bidder is a Sole Proprietary Firm, they should produce the copy of valid Tax Registration Certificate(s)	
10	Registration certificate under equivalent law abroad for foreign company	
11	A notarized or registered agreement between the Consortium members mentioning the details of Lead member and other consortium members and outline the financial strengths, technical strengths and the role and responsibility of each of the members of the consortium.	
12	MSME Certificate	
13	Copy of Purchase Orders/client certificate should be submitted	
15	In the case of authorized distributor/dealer, a Letter of Authorization from the OEM/manufacturer.	
16	In the case of OEM, the documentary proof for manufacturing the products.	
17	Copies of the Audited Balance sheets and Profit and Loss Accounts for the last 2 audited financial years (2015-16 & 2016-17)	
18	Certificate from the Statutory Auditor / Practicing Chartered Accountant for having positive net worth for the last 2 successive audited financial years (2015-16 & 2016-17)	
19	Certified copy of valid GST registration certificates issued by competent authority in India. In case of consortium, this is applicable for all Indian members.	
20	Power of Attorney / Board Resolution authorizing the Tender Signing Authority	
21	The bidder shall submit all the technical leaflets / technical literature / product certifications etc. to confirm the technical compliance.	
22	The OEM should submit the compliance confirmation for each parameter in their letterhead and also MAF	
23	If there is any deviation, the deviation with justification should be spelt out.	
24	Should have at least one service centre in AP or Undertaking to establish the same within the timelines stipulated by APSFL.	
25	Self-certified declaration and address proof of service centres to be submitted.	

7.2 Annexure I –Cover Letter

(To be submitted by Bidder on Original Letterhead)

To [Date]
The Managing Director,
Andhra Pradesh State FiberNet Limited,
3rd Floor, NTR Administrative Block,
Pandit Nehru Bus Station, NH – 65, Vijayawada – 520013

Subject:

Ref. No.

Dear Sir,

With reference to your RFP Document dated I/We, having examined all relevant documents and understood their contents, hereby submit our Proposal.

1. All information provided in the Proposal and in the Appendices, is true and correct and all documents accompanying such Proposal are true copies of their respective originals.
2. I/We shall make available to the Authority any additional information it may deem necessary or require for supplementing or authenticating the Proposal.
3. I/We acknowledge the right of the Authority to reject our Proposal without assigning any reason or otherwise and hereby waive our right to challenge the same on any account whatsoever.
4. I/We to the best of our knowledge certify that in the last three years, we or any of our Associates have neither failed to perform on any contract, as evidenced by imposition of a penalty by an arbitral or judicial authority or a judicial pronouncement or arbitration award against the Bidder, nor been expelled from any project or contract by any public authority nor have had any contract terminated by any public authority for breach on our part.
5. I/We understand that you may cancel the Selection Process at any time and that you are neither bound to accept any Proposal that you may receive nor to select the vendor, without incurring any liability to the Bidders
6. I/We to the best of our knowledge certify that in regard to matters other than security and integrity of the country, we or any of our Associates have not been convicted by a Court of Law or indicted or adverse orders passed by a regulatory authority which would cast a doubt on our ability to undertake the Project or which relates to a grave offence that outrages the moral sense of the community.
7. I/We to the best of our knowledge further certify that in regard to matters relating to security and integrity of the country, we have not been charge-sheeted by any agency of the Government or convicted by a Court of Law for any offence committed by us or by any of our Associates.
8. I/We agree and understand that the Proposal is subject to the provisions of the RFP document. In no case, shall I/We have any claim or right of whatsoever nature if our Proposal is not opened or rejected.

9. I/We agree to keep this offer valid for 180 days from the Proposal Due Date specified in the RFP.
10. I/We agree and undertake to abide by all the terms and conditions of the RFP Document. In witness thereof, I/We submit this Proposal under and in accordance with the terms of the RFP Document.

Yours faithfully,

(Signature, name and designation of the authorized signatory)

(Name and seal of the firm)

7.3 Annexure II - Bidder Profile

(To be submitted by Bidder on original letterhead)

#	Particulars	Details
1.	Name of the Company	
2.	Year of incorporation	
3.	Nature of the Company (Registered Company)	
4.	Registered Office Address	
	Office Telephone Number	
	Fax Number	
5.	Contact Person	
	Name	
	Telephone Number	
	Email Address	
6.	Local presence at Andhra Pradesh	
	Office Address	
	Office Telephone Number	
	Fax Number	
7.	Contact Person(in Andhra Pradesh)	
	Name	
	Telephone Number	
	Email Address	
8.	Registration Details	
	Permanent Account Number (PAN)	
	VAT Registration Number	
	CST Registration Number	
	Service Tax Registration Number	
	GST Number	
9.	Banker's Name, Address and Account Number	

7.4 Annexure III - Financial Information

(To be submitted by Bidder on original letterhead)

Annual Turnover of the Bidder(s)

Criteria	Sub Criteria	FY	Total Financials
Financial Capability	Avg. Annual Turnover (in INR)	FY 2017-18	
		FY 2018-19	
		FY 2019-20	
	Net worth	FY 2017-18	
		FY 2018-19	
		FY 2019-20	

Documentary Proof Required:

- Statutory auditor’s certificate clearly specifying the Turnover & Net worth for the specified years.
- Audited Balance Sheets and Profit & Loss statements for the last 3 financial years.

7.5 Annexure IV- Declaration of Acceptance of RFP Terms & Conditions

(To be submitted by Bidder on original letterhead)

To,
The Managing Director,
Andhra Pradesh State FiberNet Limited,
3rd Floor, NTR Administrative Block,
Pandit Nehru Bus Station, NH – 65, Vijayawada – 520013

[Date]

Subject:

Ref. No.

Sir,

It is to certify that the RFP document – RFP No..... dated..... is carefully read & understood and all the sections and clauses are COMPLIED UNCONDITIONALLY AND UNEQUIVOCALLY. There is no deviation from the terms & conditions of the RFP. We also hereby confirm that the solution proposed by us will meet the project requirements.

Yours faithfully,

(Signature, name and designation of the authorized signatory)

(Name and seal of the firm)

7.6 Annexure V - Declaration of Clean Track Record/ No Blacklisting

(To be submitted by Bidder on original letterhead)

To,
The Managing Director,
Andhra Pradesh State FiberNet Limited,
3rd Floor, NTR Administrative Block,
Pandit Nehru Bus Station, NH – 65, Vijayawada – 520013.

[Date]

Subject:

Ref. No.

I/We hereby declare that my company has not been debarred / black listed as on Bid submission date by any State Government, Central Government, Central & State Govt. Undertakings / Organizations and by any other Quasi Government bodies / Organizations, and any other major Enterprise / Organizations in India for non-satisfactory past performance, corrupt, fraudulent or any other unethical business practices.

Yours faithfully,

(Signature, name and designation of the authorized signatory)
(Name and seal of the firm)

7.7 Annexure VI -EMD Format

(To be executed in Rs.100/- Stamp Paper)

To,
The Managing Director,
Andhra Pradesh State FiberNet Limited,
3rd Floor, NTR Administrative Block,
Pandit Nehru Bus Station,
NH - 65, Vijayawada - 520013

Bank Guarantee No:
Amount of Guarantee:
Guarantee covers from:
Last date for lodgement of claim:

This Guarantee executed by _____ (Banker's Name & Address) having our Head Office at _____ (address) (hereinafter referred to as "Bank") in favour of Andhra Pradesh State FiberNet Limited NTR Administrative Block, 3rd Floor, Pandit Nehru Bus Station, NH -65, Vijayawada - 520013 India (hereinafter referred to as "Beneficiary") for an amount not exceeding Rs. _____/- (Rupees _____ Only) as per the request of M/s. _____ having its office address at _____ (hereinafter referred to as "Bidder") against RFP reference _____ dated ___/___/___ of M/s. Andhra Pradesh State FiberNet Limited (APSFL). This guarantee is issued subject to the condition that the liability of the Bank under this guarantee is limited to a maximum of Rs. _____ /- (Rupees _____ Only) and the guarantee shall remain in full force up to _____ (date) and cannot be invoked otherwise by a written demand or claim by the beneficiary under the Guarantee served on the Bank before _____ (date).

ANDWHEREAS it has been stipulated by you in the said ORDER that the Supplier shall furnish you with a Bank Guarantee by a Scheduled/Nationalized Bank for the sum specified therein as EMD towards bid submission.

ANDWHEREAS we have agreed to give the Bidder a Guarantee.

THEREFORE, we (Bankers address) _____, hereby affirm that we are Guarantors and responsible to you on behalf of the Bidder for Rs. _____/- (Rupees _____ Only) and we undertake to pay you, upon your first written demand without any demur, cavil or argument, any sum or sums within the limit of Rs. _____/- (Rupees _____ Only) as aforesaid, without your needing to prove or show grounds or reasons for your demand or the sum specified therein. We will pay the guaranteed amount notwithstanding any objection or dispute whatsoever raised by the Bidder.

This Guarantee is valid until _____.

Place:

Date:

Signature and seal of Guarantors (Bank)

7.8 Annexure VII – Performance Bank Guarantee Format

(To be submitted by the successful bidder on Rs.100/- stamp paper)

In consideration of APSFL (“Authority”), having agreed to accept from _____ “successful bidder”, a Performance Bank Guarantee as maybe modified from time to time wherever necessary under the terms and conditions of the Agreement entered into by the said successful bidder in respect of work _____, RFP No. _____ under APSFL for the due fulfilment of the terms and conditions of the said Agreement under APSFL, on production of a Bank Guarantee for Rs.____ (Rupees _____ only), we “Bank” _____ branch, hereby undertake the guarantee to pay immediately to APSFL, on demand in writing by APSFL, an amount of Rs. _____ (Rupees _____) without any reservation and recourse against any loss or damage caused to or suffered by APSFL by reason of any breach by the successful bidder of any of the terms and conditions of the said agreement under the said Authority.

We _____ Bank, further agree that the guarantee hereby contained shall remain in full force and effect during the period that will be taken for the performance of the said Agreement under the APSFL and that it shall be in enforcement until all the dues of APSFL under or by virtue of the said Agreement under the APSFL have been fully paid and their claims satisfied or discharged or until the said Authority certifies that the terms and conditions of the said Agreement under the APSFL have been fully and properly carried out by the successful bidder and accordingly discharges the guarantee subject. This bank guarantee is valid till _____ (date) and APSFL shall have no rights under this guarantee after _____ (date).

We _____ Bank, lastly undertake not to revoke this guarantee during its currency except with the previous consent of the APSFL in writing.

Dated _____ day of _____ 2020.

Place:

Date:

Signature and seal of Guarantors (Bank)

7.9 Annexure VIII- Manufacturer's Authorization Form (MAF)

(To be submitted in Manufacturer's letterhead)

To
The Managing Director,
Andhra Pradesh State FiberNet Limited,
3rd Floor, NTR Administrative Block,
Pandit Nehru Bus Station, NH – 65, Vijayawada – 520013

Sir,

We hereby authorize M/s_____to undertake to submit a Bid, and subsequently negotiate & sign the contract with APSFL for the Tender No: _____for product manufactured by us. We hereby extend our full warranty for the goods offered for supply by the above firm against this tender.

We also undertake to provide timely supplies as per terms of tender and as agreed mutually and also to provide a trouble free and continuous support either directly or through our authorized distributors/dealers under our supervision during the said support period. We will provide the necessary support in the event of up gradation of any of the software is necessitated while providing the support will arrange for complete replacement of the item(s) with an equivalent / higher version.

In case of violation of any of the conditions above, I/We understand that I/We are liable to be blacklisted by APSFL for a period of three years.

(Signature of authorized Personnel)

Note: Competent authority of the Manufacturer should issue the letter of authority individually for each bidder separately.

7.10 Annexure IX – Price Bid Form

(To be submitted by Bidder on original letterhead)

To
The Managing Director,
Andhra Pradesh State FiberNet Limited,
3rd Floor, NTR Administrative Block,
Pandit Nehru Bus Station,
NH – 65, Vijayawada – 520013

Date:

Subject: Supply and Installation of Cisco Equipments for AP Fiber Grid Phase 1

S. No	Description	Unity of Measurement	Quantity (A)	Unit Price (B)	Total Price (A*B)
1	Cisco ASR 1000 10x10GE Ethernet Port Adapter with 3 yrs support	Nos.	2		
2	Nexus 9500 NX-OS line card, 48p 10G/25G with 4p (40G/100G) QSFP28	Nos.	2		
3	QSFP-H40G-AOC 15M (40G DAC)	Nos.	6		
4	50G/100G/200G CPAK Multi-Rate Line Card with 3yrs support	Nos.	2		
5	200G - CPAK MR Line Card - C-Band - Licensed with 3yrs Support	Nos.	2		
6	Cisco ISE Virtual Machine Medium with installation	Nos.	2		
6.1	Cisco ISE Base License - to manage 2500 devices for AAA function TECAC+	Nos.	2500		
6.2	Cisco ISE Device Admin Node License	Nos.	2		
7	RAM Upgrade from 128Gb to 256GB, Additional 4TB HDD For Cisco UCS C220 M5 Server	Sets	1		
8	3 Years AMC for Cisco Hyperflex System	Sets	1		
9	Rollover Console Cable for Cisco Router	Nos.	50		
10	Rollover Console Cable for Cisco Router	Nos.	50		
11	12 Port 1G Switch - SG 300	Nos.	1		
12	Supply of Optical Line Cmplifies NCS2006 with installation	Sets	3		
12.1.1	NCS 2000 Transport Node Controller w/2x OTDR/OSC	Nos.	6		
12.1.2	SNTC-8X5XNBD NCS 2000 Transport Node Controller w/2x - 3 Years	Nos.	6		
12.1.3	NCS 2K/MSTP - R10.7 SW, TNCE, TSCE, TNCS/O - WSON CP	Nos.	6		
12.1.4	NCS 2006 Shelf Assembly	Nos.	3		
12.1.4	SNTC-8X5XNBD NCS 2006 Shelf Assembly	Nos.	3		
12.1.5	NCS 2006 LCD Display with Backup Memory	Nos.	3		
12.1.6	Empty slot Filler Panel	Nos.	12		
12.1.7	NCS 2006 Fan Tray	Nos.	3		
12.1.8	NCS 2006 1,500W AC Power Supply	Nos.	6		

12.1.9	NCS 2006 External Connections Unit	Nos.	3		
12.1.10	Fiber patch cord - LC to LC - 2m	Nos.	6		
12.1.11	15454 MSTP - Optical Amplifier - C-band - 24dB Gain	Nos.	6		
12.1.12	SNTC-8X5XNBD 15454 MSTP - Optical Amplifier - C-band - 3 Years	Nos.	6		
12.2	Supply, fixing of wall mount 48 port FDMS with required trays and splicing of necessary patch cords	Nos.	3		
12.3	EMS Licenses for OLA With 3 Years Support	Set	3		
Total Price (Rs.) Exclusive of taxes					

* In case of non-compatibility with Prime Network EMS, bidder shall provide new EMS for management of the devices supplied. Integration with Prime Network EMS is the responsibility of existing SI of AP Fiber.

Note

- Supply to designated locations in AP /central warehouse within AP as informed by APSFL.
- Unit Rate shall include all duties, levies, insurance, transport and other charges excluding Taxes.
- The Bidder offering the **Lowest Grand Total Cost (Exclusive of Taxes)** will be considered for award of contract.
- If there is a discrepancy between words and figures, the amount in words shall prevail.

APSFL reserves the right to

1. Negotiate with the Bidder whose offer is the lowest (L1) for further reduction of prices.
2. Ask other bidders to match the price of L1 to declare them as the shortlisted bidders and issue the order incase L1 defaults in performance of agreed terms and conditions.
3. Modify, reduce or increase the quantity requirements to an extent of the tendered quantity
4. Change the list of areas of work from time to time based upon the requirement of the purchase.
5. If delivery performance of the Bidder is not as per the Schedule, then APSFL reserves the right to take action against them.
6. APSFL reserves its right to withhold any amount for the deficiency in the service aspect of the ordered items supplied.

(Signature, name and designation of the authorized signatory)

(Name and seal of the firm)

7.11 Annexure X – Minimum Tech Specifications

1. Fibre Distribution Management System (FDMS) – 48Fibres

SNo	Description
1	Supply, Assembly and Installation of 48F Rack Mounted FDMS
2	The unit shall have minimum 2U height with minimum 450mm depth & 485mm Width with Rigid Frame and Electro- Phoretic dip coated and then powder coated to Color RAL7035
3	FDMS should include following
4	a. Heavy duty Telescopic Sliding Rails of 2 Sets / Castor Wheels
5	b. Docket Holder on Top of the FDMS Frame “M” Type
6	c. Removable Sliding Tray for easy Maintenance of the Product with preinstalled wire brush/mesh on the rear side.
7	d. Minimum 2 Nos. of Fiber guide ensuring minimum bending dia. of not less than 70mm
8	e. The sliding tray should have Handles Chrome plate / Stainless Steel for easy access to the Cassettes
9	f. Splicing Cassettes with Maximum Capacity of 12 Splices on each Cassettes on Peripheral
10	g. Suitable Cable Clamps for Optical Cable Holding
11	h. Adaptors: 48 Nos. SC/APC from a CACT Approved Source.
12	i. Pigtails: 48 Nos. of SC/APC Pigtails from a CACT Approved Source of min. 1.5m length
13	j. Patch Chord Ports: Minimum of 04 patch chord ports to be supplied with suitable dia of PG Glands and 48 Nos. of SC-APC to SC-APC Patch chords of 10 Mtr Length from CACT Approved Source.
14	k. Splice Protection Sleeves: High Quality Individual Fiber Splice Protection Sleeves from a CACT Approved Source 60 Nos.

2 Product IDs for Optical Line Amplifier NCS2006:

Description	Product ID
NCS 2000 Transport Node Controller w/2x OTDR/OSC	NCS2K-TNCS-O-K9=
SNTC-8X5XNBD NCS 2000 Transport Node Controller w/2x	CON-SNT- NCS2KTNO
NCS 2K/MSTP - R10.7 SW, TNCE, TSCE, TNCS/O - WSON CP	SF-NCS2K-R1070K9
NCS 2006 Shelf Assembly	NCS2006-SA=
SNTC-8X5XNBD NCS 2006 Shelf Assembly	CON-SNT-NCS2006A
NCS 2006 LCD Display with Backup Memory	NCS2006-LCD=
Empty slot Filler Panel	15454-BLANK=
NCS 2006 Fan Tray	NCS2006-FTA=
NCS 2006 1,500W AC Power Supply	NCS2006-AC=
NCS 2006 External Connections Unit	NCS2006-ECU=
Fiber patch cord - LC to LC - 2m	15454-LC-LC-2=
15454 MSTP - Optical Amplifier - C-band - 24dB Gain	15454-OPT-EDFA- 24=
SNTC-8X5XNBD 15454 MSTP - Optical Amplifier - C-band	CON-SNT-15454OPE