

**AFRL-IF-RS-TR-2000-7**  
**Final Technical Report**  
**February 2000**

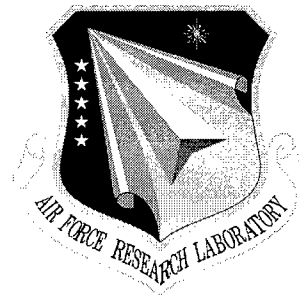

# **ELECTROMAGNETIC EFFECTS ON SYSTEM RELIABILITY**

**Boeing Defense and Space Group**

**Grant Erickson**

*APPROVED FOR PUBLIC RELEASE; DISTRIBUTION UNLIMITED.*

**20000321 112**

**AIR FORCE RESEARCH LABORATORY  
INFORMATION DIRECTORATE  
ROME RESEARCH SITE  
ROME, NEW YORK**

This report has been reviewed by the Air Force Research Laboratory, Information Directorate, Public Affairs Office (IFOIPA) and is releasable to the National Technical Information Service (NTIS). At NTIS it will be releasable to the general public, including foreign nations.

AFRL-IF-RS-TR-2000-7 has been reviewed and is approved for publication.

APPROVED: 

ANTHONY J. PESTA  
Project Engineer

FOR THE DIRECTOR: 

JAMES W. CUSACK, Chief  
Information Systems Division

If your address has changed or if you wish to be removed from the Air Force Research Laboratory Rome Research Site mailing list, or if the addressee is no longer employed by your organization, please notify AFRL/IFSE, 525 Brooks Road, Rome, NY 13441-4505. This will assist us in maintaining a current mailing list.

Do not return copies of this report unless contractual obligations or notices on a specific document require that it be returned.

**REPORT DOCUMENTATION PAGE**

*Form Approved  
OMB No. 0704-0188*

Public reporting burden for this collection of information is estimated to average 1 hour per response, including the time for reviewing instructions, searching existing data sources, gathering and maintaining the data needed, and completing and reviewing the collection of information. Send comments regarding this burden estimate or any other aspect of this collection of information, including suggestions for reducing this burden, to Washington Headquarters Services, Directorate for Information Operations and Reports, 1215 Jefferson Davis Highway, Suite 1204, Arlington, VA 22202-4302, and to the Office of Management and Budget, Paperwork Reduction Project (0704-0188), Washington, DC 20503.

1. AGENCY USE ONLY (Leave blank)		2. REPORT DATE FEBRUARY 2000	3. REPORT TYPE AND DATES COVERED Final Jul 94 - Dec 98	
4. TITLE AND SUBTITLE ELECTROMAGNETIC EFFECTS ON SYSTEM RELIABILITY			5. FUNDING NUMBERS C - F30602-94-C-0121 PE - 62702F PR - 2338 TA - 03 WU - 1M	
6. AUTHOR(S) Grant Erickson				
7. PERFORMING ORGANIZATION NAME(S) AND ADDRESS(ES) Boeing Defense & Space Group Research and Engineering PO Box 3999 Seattle Washington 98124-2499			8. PERFORMING ORGANIZATION REPORT NUMBER  N/A	
9. SPONSORING/MONITORING AGENCY NAME(S) AND ADDRESS(ES) Air Force Research Laboratory/IFSE 525 Brooks Road Rome NY 13441-4505			10. SPONSORING/MONITORING AGENCY REPORT NUMBER  AFRL-IF-RS-TR-2000-7	
11. SUPPLEMENTARY NOTES Air Force Research Laboratory Project Engineer: Anthony J. Pesta/IFSE/(315) 330-2519				
12a. DISTRIBUTION AVAILABILITY STATEMENT APPROVED FOR PUBLIC RELEASE; DISTRIBUTION UNLIMITED			12b. DISTRIBUTION CODE	
13. ABSTRACT (Maximum 200 words) This document contains the final report of the reliability testing of military and commercial analog and digital devices for evaluation of the short and long term effects of electromagnetic (EM) field exposure. This work is to assist the US Air Force in determining electromagnetic effects on electrical device and system reliability and in determining evaluation models to identify, predict and minimize EM effects on the reliability of devices and systems.				
14. SUBJECT TERMS Electromagnetic Effects, Life Time, Reliability			15. NUMBER OF PAGES 482	
			16. PRICE CODE	
17. SECURITY CLASSIFICATION OF REPORT UNCLASSIFIED	18. SECURITY CLASSIFICATION OF THIS PAGE UNCLASSIFIED	19. SECURITY CLASSIFICATION OF ABSTRACT UNCLASSIFIED	20. LIMITATION OF ABSTRACT UL	

## ABSTRACT

This document contains the final report of the reliability testing of military and commercial analog and digital devices for evaluation of the short and long term effects of electromagnetic (EM) field exposure. The report is required by the Electromagnetic Effects on Systems Reliability contract F30602-94-R-0121. The contract is to assist the U S Air Force Laboratory in determining electromagnetic effects on electrical device and systems reliability and in determining evaluation models to identify, predict, and minimize EM effects on the reliability of devices and systems. This work was performed at the Boeing Parts Test Facility in Renton, Washington, and the Boeing Space Center in Kent, Washington.

## KEY WORDS

Acceptance	Mode-Stirred Chamber
Analog Devices	Reliability
Baseline	RF
Digital Devices	Susceptibility
Electromagnetic	Test
Electromagnetic Effects	Thermal
Frequency Sweep	Tuned-Mode Chamber
Life	Wideband

ELECTROMAGNETIC EFFECTS ON SYSTEMS RELIABILITY  
FINAL TEST REPORT  
CLIN 2, CDRL B004

TABLE OF CONTENTS

	<u>Page</u>
ABSTRACT.....	i
KEY WORDS.....	i
TABLE OF CONTENTS .....	i
LIST OF FIGURES .....	v
APPENDICES.....	xi
GLOSSARY .....	xii
1.0 INTRODUCTION .....	1
2.0 TEST APPROACH .....	2
3.0 ANALYSIS OF TEST RESULTS .....	3
3.1 Quick Analysis of Parameter Shift Data .....	3
3.2 Engineering Statistical Analysis .....	14
3.2.1 Engineering Statistical Analysis Approach .....	14
3.2.2 Test Conventions .....	16
3.2.3 Engineering Statistical Analysis Method .....	16
3.2.4 Statistical Analysis - Analog Devices .....	17
3.2.5 Statistical Analysis - Digital Devices.....	21
3.3 Statistical Analysis II .....	25
3.3.1 Analysis of Gain-Bandwidth Parametric Data .....	29
3.3.2 Analysis of Large Signal Voltage Gain Parametric Data ( $R_L=2K$ ) .....	31
3.3.3 Analysis of Large Signal Voltage Gain Parametric Data ( $R_L=10K$ ) .....	37
3.3.4 Analysis of Positive Power Supply Current ( $I_{CC}$ ) Parametric Data .....	37
3.4 Analysis of Reliability Factors .....	44

3.4.1 Objective of Reliability Analysis .....	44
3.4.2 Reliability Analysis Approach .....	44
3.4.3 Reliability Analysis.....	46
3.5 Analysis of Failed Test Parts .....	51
3.6 Summary from Analysis of Test Results .....	54
4.0 SELECTION AND PROCUREMENT OF TEST PARTS .....	55
4.1 Selection of Test Parts .....	55
4.2 Procurement of Test Parts .....	56
5.0 ACCEPTANCE TESTING .....	56
5.1 Acceptance Testing Approach .....	56
5.2 Device Acceptance Tests .....	58
5.3 Reliability Testing Acceptance Test Plan .....	62
5.4 Parts Test Facility .....	62
6.0 PRE-BASELINE CONDUCTED SUSCEPTIBILITY TESTING.....	63
6.1 Conducted Susceptibility Testing Approach and Rationale .....	63
6.2 Digital Device Conducted Susceptibility Testing .....	63
6.3 Analog Device Conducted Susceptibility Testing .....	65
7.0 BASELINE TESTING.....	65
7.1 Baseline RF Radiated Susceptibility Testing Approach .....	70
7.2 Baseline RF Radiated Susceptibility Test Setup .....	70
7.3 Baseline Functionality Test Procedure .....	72
7.4 Baseline RF Radiated Susceptibility Testing .....	72
7.4.1 Baseline Digital Testing .....	75
7.4.2 Baseline Analog Testing .....	89
8.0 RELIABILITY TESTING .....	94
8.1 Reliability Testing Approach .....	94
8.2 Reliability Test Setup .....	100

8.3 Reliability Test Procedure .....	101
8.4 Analog Reliability Testing .....	101
8.5 Digital Reliability Testing .....	105
8.6 Thermal & Life Reliability Testing .....	109
8.7 Wideband Reliability Testing .....	116
8.8 Extended Reliability Testing .....	120
9.0 POST-RELIABILITY ELECTRICAL ACCEPTANCE TEST RESULTS .....	120
9.1 Analog Post-Reliability Electrical Acceptance Test Results .....	123
9.2 Digital Post-Reliability Electrical Acceptance Test Results .....	123
9.3 Thermal and Life Post-Reliability Electrical Acceptance Test Results .....	123
9.4 Wideband Post-Reliability Electrical Acceptance Test Results .....	132
10.0 DESIGN AND FABRICATION OF MODE-STIRRED CHAMBER AND TUNER .....	132
10.1 Test Chamber Shielding and Tuner Effectiveness Testing.....	134
10.2 Long Wire Antenna Installation and EM Field Mapping .....	138
10.3 E-Field vs. Upset Test Data .....	138
11.0 DESIGN AND FABRICATION OF DIGITAL AND ANALOG TEST FIXTURES .....	142
11.1 Digital Test Fixture Design .....	142
11.2 Analog Test Fixture Design .....	146
12.0                   Development OF TEST STIMULUS AND DATA MONITORING	
SYSTEM .....	146
13.0 CONCLUSIONS AND RECOMMENDATIONS .....	152
13.1 Conclusions .....	152
13.2 Recommendations .....	155
14.0 REFERENCES .....	156

## LIST OF FIGURES

	<u>Page</u>
2.0-1 Test Schedule .....	4
3.1-1a Summary of Analog Parametric Test Results .....	6
3.1-1b Summary of Analog Parametric Test Results .....	7
3.1-2a Summary of Digital Parametric Test Results .....	8
3.1-2b Summary of Digital Parametric Test Results .....	9
3.1-2c Summary of Digital Parametric Test Results .....	10
3.1-2d Summary of Digital Parametric Test Results .....	11
3.1-3a Summary of Thermal and Life Parametric Test Results .....	12
3.1-3b Summary of Thermal and Life Parametric Test Results .....	13
3.1-4 Summary of Wideband Parametric Test Results .....	15
3.2.4-1 Average Supply Current, $I_{CC}$ , For Control Lot 8A .....	18
3.2.4-2 Average Supply Current, $I_{CC}$ , For Exposed Lots 3A And 6A .....	18
3.2.4-3 $I_{CC}$ Distribution For Exposed Lot 3A Ceramic Parts, Room Temp .....	20
3.2.4-4 $I_{CC}$ Changes For Individual Components in Exposed Lot 3A Ceramic Parts, Room Temp.....	20
3.2.5-1 Average PR1 Pulse Width with $V_{CC}=5.5V$ , Lot 2D (Control) .....	23
3.2.5-2 Average PR1 Pulse Width with $V_{CC}=5.5V$ , Lots 3D and 6D (Exposed) .....	23
3.2.5-3 Average PR2 Pulse Width with $V_{CC}=5.5V$ , Lot 2D (Control) .....	24
3.2.5-4 Average PR2 Pulse Width with $V_{CC}=5.5V$ , Lots 3D and 6D (Exposed) .....	24
3.2.5-5 Average CLR1 Pulse Width with $V_{CC}=5.5V$ , Lot 2D (Control) .....	26
3.2.5-6 Average CLR1 Pulse Width with $V_{CC}=5.5V$ , Lots 3D and 6D (Exposed) .....	26
3.2.5-7 Average CLR2 Pulse Width with $V_{CC}=5.5V$ , Lot 2D (Control) .....	27



3.2.5-8 Average CLR2 Pulse Width with $V_{CC}=5.5$ , Lots 3D and 6D (Exposed) .....	27
3.2.5-9 Average CLR2 Removal Time with $V_{CC}=5.5V$ , Lot 2D (Control) .....	28
3.2.5-10 Average CLR2 Removal time with $V_{CC}=5.5$ , Lots 3D and 6D (Exposed) .....	28
3.3.1-1 Gain-Bandwidth Data Relative to the 4 MHz Pass Value for Plastic Op-amps .....	30
3.3.1-2 Gain-Bandwidth Data Relative to the 4 MHz Pass Value for Ceramic Op-amps.....	32
3.3.1-3 Gain-Bandwidth Change vs. Measurement Temperature Change for Plastic Op-amps .....	33
3.3.1-4 Gain-Bandwidth Change vs. Measurement Temperature Change for Ceramic Op-amps .....	34
3.3.1-5 t-Test Results and Change in Mean Value for Environmental Conditions for Plastic Operational Amplifiers .....	35
3.3.1-6 t-Test Results and Change in Mean Value for Environmental Conditions for Ceramic Operational Amplifiers .....	35
3.3.2-1 Large Signal Voltage Gain Change and Margin of Pass Summary for Plastic Op-Amps .....	36
3.3.2-2 Large Signal Voltage Gain Change and Margin of Pass Summary for Ceramic Op-Amps .....	38
3.3.2-3 t-Test Results and Change in Mean Value for Environmental Conditions for Plastic Op-Amps .....	38
3.3.2-4 t-Test Results and Change in Mean Value for Environmental Conditions for Ceramic Op-Amps .....	39
3.3.3-1 Large Signal Voltage Gain and Change at $R_L=10K$ for Plastic Op-amps .....	39
3.3.3-2 Large Signal Voltage Gain Change at $R_L=10K$ for Ceramic Op-amps .....	40
3.3.3-3 t-Test Results and Change in Mean Value for Environmental Conditions for Plastic Op-Amps .....	41
3.3.3-4 t-Test Results and Change in Mean Value for Environmental Conditions for Ceramic Op-Amps .....	41
3.3.4-1 $I_{CC}$ Change Vs. Time and Measurement Temperature Changes Data for Plastic Op-amp .....	42
3.3.4-2 $I_{CC}$ Change Vs. Time and Measurement Temperature Changes Data for Ceramic Op-amp .....	43

3.3.4-3 t-Test Results and Change in Mean Value for Environmental Conditions for Plastic	
Op-Amps .....	45
3.3.4-4 t-Test Results and Change in Mean Value for Environmental Conditions for Ceramic	
Op-Amps .....	45
3.4.3-1 Input Offset Current, OP-271 S/N 3299, Cool Temperature Test, Plastic Package .....	49
3.4.3-2 Instantaneous upset rate for analog devices (3 cases) .....	49
3.4.3-3 Two Dimensional Regression Analysis .....	50
3.4.3-4 One Dimensional Polynomial Regression Analysis, Test #4 .....	50
3.5-1 Electrical Test Results From Three Digital Test Parts .....	52
3.5-2 Photograph of Failed Bond Wire on Digital Part #2053 .....	53
3.5-3 Photograph of Digital Part #2053 Showing Physical Damage Near Pin 3 .....	53
3.5-4 Photograph of Digital Part #2053 Showing Physical Damage Near Pin 11 .....	54
5.0-1 Electrical Acceptance Test Flow Diagram .....	57
5.2-1 Analog Test Voltage and Current Parameters .....	59
5.2-2 Digital Test Voltage and Current Parameters .....	59
5.2-3a Digital Test Timing Parameters .....	60
5.2-3b Digital Test Timing Parameters .....	61
6.2-1 Conducted Susceptibility Digital Test Setup .....	64
6.3-1 Conducted Susceptibility Analog Bias Voltage Test Setup .....	66
6.3-2 Voltage Bias Test Results .....	66
6.3-3 Conducted Susceptibility Analog Pulse Generator Test Setup .....	67
6.3-4 Pulse Generator Test Results .....	67
6.3-5 Frequency Dependency Test .....	68
7.2-1 Reverberation Chamber Setup For Radiated Susceptibility Testing .....	71
7.3-1 Analog Device (OP-271) Test Circuit .....	73

7.3-2 Circuit Diagram (1 Of 100) As Implemented On Analog Test Fixture .....	73
7.3-3 Digital Device (54/74ACT74) Test Circuit .....	74
7.3-4 Circuit Diagram (1 Of 100) As Implemented On Digital Test Fixture .....	74
7.4.1-1 Summary of Pulse Width And Period Baseline Tests .....	76
7.4.1-2 Digital Baseline Test - Pulse Width and Period .....	77
7.4.1-3 Digital Baseline Discrete Frequency Test.....	79
7.4.1-4 Frequency Sensitivity Baseline Test Data.....	80
7.4.1-5a Baseline Test - Vary Vd Low .....	81
7.4.1-5b Baseline Test - Vary Vd Low, Continued .....	82
7.4.1-6 Baseline Testing at 500 Watts RF Power .....	83
7.4.1-7 Baseline Testing with Varied RF Power .....	85
7.4.1-8 Summary of Digital Baseline Testing .....	86
7.4.1-9 RF Test Equipment Setup for E-Field Strength Measurement .....	87
7.4.1-10 Summary of E-Field Strength vs. Digital Upset Data .....	88
7.4.2-1 Summary of Analog Baseline Testing - Sort by Vbuff .....	90
7.4.2-2 Summary of Analog Baseline Testing - Sort by RF Power .....	91
7.4.2-3a Comparison Testing of Bare Fixture vs EMI Protected Fixture .....	92
7.4.2-3b Comparison Testing of Bare Fixture vs EMI Protected Fixture .....	93
7.4.2-4 Upsets as a Function of Paddle Position (15 Rotations) .....	95
7.4.2-5 Summary of E-field Strength vs. Analog Upset Data .....	96
8.1-1 Schedule of Radiated Tests .....	97
8.1-2 Test Schedule Showing Test Lot Data .....	98
8.1-3 Lot Number versus Serial Number for Test Parts .....	99
8.3-1 Sample Page From Raw Data File .....	102
8.3-2 Sample Page From "Upset" Data File .....	103

8.3-3 Sample "Totals" Data File .....	104
8.4-1 Test Data Summary for Analog Test #1 .....	106
8.4-2 Test Data Summary for Analog Test #3, Test Period #2 .....	106
8.4-3 Test Data Summary for Analog Test #2, Test Period #3 .....	107
8.4-4 Test Data Summary for Analog Test #4 Test Period #4 .....	107
8.4-5 Analog Test Data Summary .....	108
8.5-1 Test Data Summary for Digital Test #5, .....	110
8.5-2 Test Data Summary for Digital Test #7, Test Period #6 .....	110
8.5-3 Test Data Summary for Digital Test #6, Test Period #7 .....	111
8.5-4 Test Data Summary for Digital Test #8 Test Period #8 .....	111
8.5-5 Digital Test Data Summary .....	112
8.6-1 Block Diagram of Thermal Chamber Setup.....	114
8.6.2 Photograph of Single Test Fixture in Thermal Chamber .....	115
8.6-3 Test Data Summary for Test #10 .....	117
8.6-4 Test Data Summary for Test #11 .....	117
8.6-5 Thermal and Life Test Data Summary .....	118
8.7-1 Wideband Test Schedule .....	119
8.7-2 Test Data Summary for Test Period #11 .....	121
8.8-1 Test Parts Involved in Extended Testing .....	122
9.1-1a Summary of Analog Parametric Test Results .....	124
9.1-1b Summary of Analog Parametric Test Results .....	125
9.2-1a Summary of Digital Parametric Test Results .....	126
9.2-1b Summary of Digital Parametric Test Results .....	127
9.2-1c Summary of Digital Parametric Test Results .....	128
9.2-1d Summary of Digital Parametric Test Results .....	129

9.3-1a Summary of Thermal and Life Parametric Test Results .....	130
9.3-1b Summary of Thermal and Life Parametric Test Results .....	131
9.4-1 Summary of Wideband Parametric Test Results .....	133
10.0-1 Reverberation Chamber Setup for Radiated Susceptibility Testing.....	135
10.0-2 Heating Apparatus for Reverberation Chamber .....	136
10.0-3 RF Signal Generation Equipment for EMESR Testing .....	137
10.2-1 Test Equipment Setup Used to Map Chamber .....	139
10.2-2 Summary of Empty Chamber Mapping Data .....	140
10.2-3 Summary of Loaded Chamber Mapping Data .....	140
10.2-4 Sensor Locations for Loaded Mapping of Reverberation Chamber .....	141
10.3-1 Analog E-Field Strength vs. Upset Summary Data .....	143
10.3.2 Digital E-Field Strength vs. Upset Summary Data .....	143
11.1-1 Digital Device (54/74ACT74) Test Circuit .....	144
11.1-2 Circuit Diagram (1 of 100) as Implemented on Digital Test Fixture .....	144
11.1-3 Top Circuit Layer Of Digital Test Fixture .....	145
11.1-4 Bottom Circuit Layer Of Digital Test Fixture .....	147
11.2-1 Analog Device (OP-271) Test Circuit .....	148
11.2-2 Circuit Diagram (1 of 100) as Implemented on Analog Test Fixture.....	148
11.2-3 Top Circuit Layer Of Analog Test Fixture .....	149
11.2-4 Bottom Circuit Layer Of Digital Test Fixture .....	150
12.0-1 Test Stimulus And Monitoring System ... ..	151
12.0-2 Block Diagram of Monitoring Circuit ... ..	153

## LIST OF APPENDICES

	<u>Page</u>
A	Mathematical Approach to Reliability Prediction..... A1
B	Overview of Reverberation Chamber Operation..... B1
C	Engineering Statistical Analysis Data ..... C1
D	Baseline Digital Test Data - RF Power and Field Intensity versus Upsets ..... D1
E	Baseline Digital Test Data - Upset Data Files ..... E1
F	Baseline Analog Test Data ..... F1
G	Baseline Analog Test Data - RF Power and Field Intensity versus Upsets ..... G1
H	Baseline Analog Test Data - Upset Data Files ..... H1
J	Analog Reliability Test Data - Test #1 ..... J1
K	Analog Reliability Test Data - Test #3 ..... K1
L	Analog Reliability Test Data - Test #2 ..... L1
M	Analog Reliability Test Data - Test #4 ..... M1
N	Digital Reliability Test Data - Test #5 ..... N1
P	Digital Reliability Test Data - Test #7 ..... P1
Q	Digital Reliability Test Data - Test #6 ..... Q1
R	Digital Reliability Test Data - Test #8 ..... R1
S	Analog "LIFE" Reliability Test Data - Test #10 ..... S1
T	Analog "LIFE" Reliability Test Data - Test #11 ..... T1
U	Frequency Sweep Reliability Test Data - Test #12 ..... U1
V	Shielding Effectiveness Report ..... V1

## GLOSSARY

ASIC	Application Specific Integrated Circuit
ATE	Automatic Test Equipment
CLR	Clear (Input On Digital Flip-Flop)
CMOS	Complimentary Metal Oxide Semiconductor
CW	Continuous Wave
DIP	Dual In-Line Package
DVM	Digital Voltmeter
EM	Electromagnetic
EME	Electromagnetic Effects
EMESR	Electromagnetic Effects on System Reliability
EMI	Electromagnetic Interference
ESD	Electrostatic Discharge
GPIB	General Purpose Interface Bus
IC	Integrated Circuit
MTBF	Mean Time Between Failures
NIST	National Institute of Standards and Technology
PC	Personal Computer
PCB	Printed Circuit Board
PR	Preset (Input On Digital Flip-Flop)
RF	Radio Frequency
RFI	Radio Frequency Interference
SOW	Statement of Work
V	Volts
VSWR	Voltage Standing Wave Ratio

## 1.0 INTRODUCTION

The Research and Development Final Report is submitted to the Air Force Laboratory, Rome New York, in accordance with CLIN 0002, CDRL B0004, of contract F30602-93-C-0121, "Electromagnetic Effects on Systems Reliability" (EMESR). The purpose of this report is to describe the activities performed under this contract. These activities include selection and procurement of test parts, acceptance testing, baseline testing and reliability testing in a radiated electromagnetic (EM) environment, statistical analysis of test results, analysis of failed and out-of-specification test parts, evaluation of test results, and formulation of mathematical models. The contract activities also included design and fabrication of a mode stirred reverberation chamber, analog and digital test fixtures, and a test stimulus and data monitoring system.

Through the testing and analysis that was performed under this contract it was discovered that the test devices are affected by electromagnetic energy. They can be made to go into upset at fairly modest levels of RF. The devices also recover quickly and completely from the immediate effects of RF as determined by the measuring tools we had at our disposal. The long-term effects of the radiation are not so easily observed or measured. While we did observe a long term effect on the test devices that were in an EM environment as determined by shifts in their basic device parameters, we also observed that the parameters of the devices that were in a low (ambient) EM environment also shifted. The initial test data appeared to show a definite trend that the parameters of exposed parts shifted more than the control group, but the results of the analyses indicated that the data shifts were somewhat random and showed no definite trend toward exceeding any of the manufacturer's specifications. Two of the test parts failed and the parameters of four parts exceeded the manufacturer's specification, and all had been exposed to an EM environment. Because of these failures we could conclude that the reliability factor of these devices decreased by 2 to 3 orders of magnitude because of exposure to electromagnetic energy. But because the number of test hours was small compared to the intrinsic reliability of the test devices, we don't feel that it would be fair or accurate to quantify the effect yet. With more hours of testing the failure rate might decrease to a rate much closer to that of the devices operated under normal conditions, or it might even increase as more test hours are accumulated. We therefore conclude that the effects of the electromagnetic energy upon these test devices was subtle, and although there appears to be a relationship between the EM exposure and long term device reliability, we feel that more testing and analysis would be required to establish this relationship. However, we do feel that the effect of EM radiation on the reliability of electronic devices is real and should not be discounted.

We also began to develop a mathematical method to express a decrease in mean time between failure (MTBF) due to exposure to electromagnetic radiation. Because the effect of the electromagnetic radiation is more subtle than we initially thought, we were not able to assign a numerical value to the effect of the EM exposure. Nevertheless, the results of our mathematical development are included in appendix A for potential future use.

We feel that additional testing needs to be done in this area. Test devices need to be exposed to electromagnetic radiation over longer periods of time to either firmly establish or totally discount the subtle trends we noticed in this study.



## 2.0 TEST APPROACH

The study of the effects of electromagnetic radiation on the reliability of electronic devices involved a number of different test techniques. Because the contract deals with long-term reliability concerns, it was necessary to obtain data over a large number of test hours, which is done best by concurrent testing of a large number of test devices. It was determined that radiated RF testing would accommodate this requirement more easily than conducted RF testing, although some conducted RF testing was performed in the early stages of testing to determine the effect of RF energy on the devices. To test a large number of devices in a radiated environment where each device experiences approximately the same average EM environment, it was necessary to use mode stirring, which is best accomplished in an RF reverberation chamber. A description of reverberation chamber operation is given in appendix B.

The study employed the use plastic and ceramic integrated circuits currently used in military and commercial service. The electronic parts chosen for the test program were 54ACT74 (ceramic) and 54ACT74 (plastic) digital flip-flops and the OP-271FZ (ceramic) and OP-271GF (plastic) operational amplifiers. See section 4 for a description of how the part selection process.

We wanted to determine the extent to which a population of test devices was being affected by the test conditions, and this was done in two ways. In order to determine if exposure to electromagnetic energy was affecting the basic device parameters, acceptance testing was performed on each test device before doing any EM exposure testing, after the testing was complete, and at monthly intervals between tests. Acceptance testing is discussed in section 5 and the results of the acceptance testing are discussed in section 9. Acceptance testing measures 28 analog device parameters, and they are listed in paragraph 5.2. Acceptance testing measures 127 digital device parameters, and they are shown in Figures 5.2-1 and 5-2-2. In addition to the long-term effects, we felt it was also important to know what was happening to the test devices on a moment by moment basis. Measuring this immediate effect of the EM radiation was accomplished by connecting all the test devices in the chamber to a simple but effective test stimulus and data acquisition system which would detect short term device operation or a fault condition. The test stimulus and data acquisition system is described in section 12 and the radiated testing is discussed in sections 7 and 8.

Baseline RF exposure testing was performed to determine the most appropriate frequencies for the long-term radiated testing, and to determine the approximate RF power level for the test. Test conditions for baseline testing were approximately the same as for formal testing so the baseline test experience could be directly applied to formal testing. Baseline testing is described in section 7.

Reliability testing subjected analog and digital test devices to test conditions of fixed frequency, pulsed, continuous wave (CW) radiation at room temperature, at elevated temperatures with and without exposure to radiation, and at room temperature with exposure to pulsed CW radiation over a wide range of frequencies. Some of the test devices would be under test for only a month, but some would be tested for four months. Reliability testing is described in section 8.

A control group of 100 parts was also tested for 30 days, but in a low (ambient) EM environment with test signal and power supply voltages similar to those of the devices in the chamber.

The parameter shifts of the control group devices would be considered basic to all the devices before the effects of EM energy are considered. A schedule of the tests performed is shown in Figure 2.0-1.

### 3.0 ANALYSIS OF TEST RESULTS

Today's electronic parts are very reliable and we did not expect to have many outright failures during our testing. During the formal test period we did experience one outright failure and three "out of specification" failures in our 2.2 million hours of device testing which utilized 2100 different test devices. Extended reliability testing added 1.6 million device test hours to the experience database and included one more device failure. We also expected that device parameters would change slowly, except in the beginning and end regions of the typical reliability curve. Most electronic devices experience an increased number of failures during burn-in or at the beginning of service, which is followed by a period of very few failures, then the failure rate increases as a population of devices nears the end of useful service. Because we were using new parts, and most of the test devices were only exposed to a month of testing, the "beginning" scenario is very likely for at least some of the parts. During the planning stages of this contract, and in discussions with the program office, everyone expressed the hope that there would be enough evidence to indicate an effect of the EM exposure. It was felt that device parameters of the exposed parts would probably not change very much, but that there might be a few devices that would experience parameter shifts indicative of the EM exposure.

#### 3.1 Quick Analysis of Parameter Shift Data

The results of the parameter testing have been analyzed, and the following observations have been made: There was one part failure in digital test lot 3D: the output of a 74ACT74 digital flip-flop failed to switch between high and low. There were three analog test devices which failed the manufacturers specification during the analog test: OP-271 Operational amplifier part number 3223 (plastic) failed the power supply rejection ratio test at  $-40^{\circ}$  C, and part numbers 4217 and 4224 (ceramic) failed the input offset voltage specification at room temperature. The definitions of these parameter tests are given in Figures 5.2-1 through 5.2-3. There were no outright failures or specification failures in either the analog or the digital control group or in the thermal, life, or wideband test lots. One ceramic operational amplifier was inadvertently reversed in the test socket. It failed (over-temperature) due to a large current draw, but this will not be counted as a failure. One additional digital part failed during extended testing (see section 8.8).

The differences between parametric test results of the analog control group and the analog test lots exposed to RF are not substantial, but there are a number of test parameters which shifted less for several lots of the exposed parts than for the control group. An analysis of the parametric test results shows that typically the test devices exposed to EM radiation had higher parameter shifts and included a higher percentage of test devices whose parameters fell outside of the major trend-lines than did the control group. The results of analog test lot 3A, test 4 are fairly significant because these devices were in test for 4 months. Most of the parameter changes in test lot 3A occurred following the first and

Test Per.	Start Date	Test #	Test Lot Number vs. Test Position						Frequency (MHz)	RF Power
			Reverb.		Ambient		Thermal			
			1	2	1	2	1	2		
0	6/95	Bsl1	1A	2A					Various	Various
0	6/95	Bsl2	1A	1D					Various	Various
1	1/96	1	4A	3A					800	125
2	2/96	3	3A	5A					1400	200
3	3/96	2	6A	3A					800	250
4	5/96	4	3A	7A					1400	375
5	6/96	5	4D	3D					900	200
6	7/96	7	3D	5D					1700	360
6	7/96	Ref			8A	2D			N/A	0
7	8/96	9					9A	10A	N/A	0
7	8/96	6	6D	3D					900	400
8	9/96	9					10A	9A	N/A	0
8	9/96	8	3D	7D					1700	720
9	11/96	9					9A		N/A	0
9	11/96	10	11A	10A					800	125
10	12/96	9					9A		N/A	0
10	12/96	11	10A	12A					800	250
11	1/97	12	13A	8D					8000 to 18000	50
11	1/97	12	13A	8D					4000 to 8000	150
11	2/97	12	13A	8D					2000 to 4000	750
11	2/97	12	13A	8D					1000 to 2000	500
11	2/97	12	13A	8D					700 to 950	250
12	7/97	Post	note 1	note 2					1000	800
12	7/97	Ref			8A	2D			N/A	0

Notes: 1. 50 parts each (25 plastic, 25 ceramic) from test lots 3A and 6A.  
2. 50 parts each (25 plastic, 25 ceramic) from test lots 3D and 6D.

Figure 2.0-1: Test Schedule

second tests, and by the 4th test, not too many additional changes were noticed. In the analog test parts the parameters that seemed to change most were the power supply current and the parameters such as slew rate and gain - bandwidth product that depend on the current. See Figure 3.1-1a and 3.1-1b for the summary of the analog parametric test results.

There were differences between parametric test results of the digital control group and the digital test lots exposed to EM radiation. In most cases the devices exposed to EM changed more than the control group, but in several instances the control group parameter shifts were a little bit larger than those of the EM radiated group. In the timing measurements more of the digital devices that were exposed to EM radiation had large shifts or step increases in timing parameters than the digital control group, and more in the control group had small timing shifts or step decreases than the EM radiated parts. These parameter shifts are not conclusive, but the majority of the evidence shows that EM exposure accelerates reliability mechanisms beyond that of simple aging. The results of test lot 3D are important because these devices were in test for 4 months. Most of the parameter changes to test lot 3D are about what the other EM exposed groups registered, except for the input leakage current (with the input low) on the digital plastic parts. These results show that, in the majority of cases, the parameter shifts occur early in the testing then stabilize. The results of the device upsets measured by the data acquisition system also show that device upsets increase over time, then stabilize. See Figure 3.1-2a to 3.1-2d for the summary of the digital parametric test results.

The results of the thermal (#9) and life (#10, #11) tests indicate that output voltage, common mode rejection ratio and gain changes were about the same for all test lots without regard to EM exposure or length of exposure to the 85 degree C temperature. But the power supply rejection ratio, the plastic device room temperature input bias current test, and the slew rate and power supply currents for the plastic devices all changed more in the reference test lot than in the thermal test and life test lots. This is opposite of what we would have expected, but the parameter shifts remained well within specification, and are all fairly small. For the remainder of the test parameters there was a high degree of correlation between parameter change and exposure to EM radiation and temperature. The net effect we observed was that the test parameters of the thermal and life test devices, lot 10A, appeared to change more than the thermal test devices, lot 9A, which appeared to change more than the short-term EM exposed devices, lots 11A and 12A, which appeared to change more than the control group devices, lot 8A. The changes in these parameters, however, were small, and remained within the manufacturer's specifications. Test lot 9A, which was subjected to an 85 degree C thermal environment, but no EM radiation, appeared to change more than lots 11A and 12A, which were subjected to an EM environment at 85 degrees Celsius. The parts of lot 9A were in test for 4 periods, a total of 120 days while test lots 11A and 12A were only in test for 30 days each, which indicates that length of exposure is also a factor. It also indicates that the thermal and EM environments may have the same long-term effect, and while we don't know the exact influence of each, it appears that they might be of approximately the same order of magnitude. See Figure 3.1-3a and 3.1-3b for the summary of the thermal and life parametric test results.

To determine if temperature might be a major consideration we compared the results of the analog parametric tests with those of the thermal and life parametric tests. A comparison between the

	Plastic, -40C	Test Lot 8A, Analog Control Group	Test Lot 3A, Test 1 (1 Temp Test Only)	Test Lot 3A, Test 4	
1	PSRR	+/- 300 nV/V		+/- 400 nV/V	1
2	ICC/IEE	+3 to +9% (most +4%), 6 parts decreased		+/- 1% typ, 12 parts decr (-2 to -6%)	2
3	VIO	+/- 40 uV typ, 3426 +80uV		+/- 40uV typ; 4 parts +/-50 to +/-90uV	3
4	IIB	some > +/-1nA but drift toward 0A		16 parts +1 to +3nA, 7 parts -1 to -6nA	4
5	IIO	some +/- 1nA, 3423 +10nA		25 parts > +/-1nA most drift to 0A	5
6	Gain	all showed compressive decrease		8 parts incr; rest compressive decr	6
7	Slew rate	+2 to +10% (prop to ICC), 6 parts decreased		+/- 2% typ, 10 parts decr (-2 to -8%)	7
8	CMRR	few with hi initial values decreased		many with hi initial values decreased	8
9	VOP	very little change		very little change	9
10	GBW	+0 to +2% (prop to ICC)		+0 to +1.5%, 11 parts decr	10
Plastic, +25C					
11	PSRR	+/- 300 nV/V	+/- 200 nV/V	+/- 300 nV/V	11
12	ICC/IEE	+1 to +3%	+1 to +2.5%	+1.5 to +3%	12
13	VIO	+/-20uV, tight distribution	+/-30uV typ	+/-30uV typ	13
14	IIB	2prts, +500pA; most -.5 to -1 nA.	most increased, +1.5 nA max	9 parts +/-1 to +/- 2nA	14
15	IIO	+/-400pA max	+/- 2.0 nA max	16 parts > +/-1nA but drift toward 0A	15
16	Gain	13 parts big compr decr; rest normal decr	all showed compressive decrease	3273 unstable, rest compressive decr	16
17	Slew rate	+1 to +4% (prop to ICC)	+1.5 to +3% (prop to ICC)	+1.5 to +4% (prop to ICC)	17
18	CMRR	few with hi initial values decreased	many with hi initial values decreased	many with hi initial values decreased	18
19	VOP	very little change	very little change	very little change	19
20	GBW	very little change	+1 to +2% (prop to ICC)	+0 to +2% (prop to ICC)	20
Plastic, +85C					
21	PSRR	+/- 300 nV/V		+/- 300 nV/V	21
22	ICC/IEE	0 to +2% typ, 6 parts small decrease		+2 to +4%	22
23	VIO	+/- 25uV typ, 3 parts > +50 uV		+/- 40uV typ; 3276 +88uV, 3285 +59uV	23
24	IIB	+/- 500 to 1000 pA max		12 parts +/-1 to +/- 2nA	24
25	IIO	+/-500pA max		18 parts > +/-1nA but drift toward 0A	25
26	Gain	fluctuated a bit		fluctuated a bit	26
27	Slew rate	0 to +3%. Correlated to ICC		+2 to +4%	27
28	CMRR	few with hi initial values decreased		many with hi initial values decreased	28
29	VOP	very little change		very little change	29
30	GBW	0 to +1.5%		+/- 1%	30
Ceramic, -40C					
31	PSRR	+/- 300 nV/V		+/- 400 nV/V, 4264 -811 nV/V	31
32	ICC/IEE	+2 to +4% typ, 5 parts decr or 0		15 parts -2% to -9%, 3 parts incr	32
33	VIO	+/-50uV typ; 3 parts > 100 uV		4251 +160uV, 5 parts +/- 70uV	33
34	IIB	12 parts > +/-1nA but drift toward 0A		10 parts +/- 1 to +/-4 nA	34
35	IIO	13 parts > +/-1nA but drift toward 0A		16 parts +/- 1 to +/-6 nA	35
36	Gain	both + and -, no trend		2 parts incr, rest compr decr	36
37	Slew rate	+3 to +5% (prop to ICC), 5 parts decr		10 parts -10 to -12%, rest < +/- 4%	37
38	CMRR	few with hi initial values decreased		few with hi initial values decreased	38
39	VOP	very little change		couple -0.5 to -1%	39
40	GBW	+1 to 2%		10 parts -5%, rest < +/- 1%	40
Ceramic, +25C					
41	PSRR	+/- 300 nV/V	+/- 500 nV/V	+/- 400 nV/V	41
42	ICC/IEE	+0.5 to +2%, 13 parts no change	+1 to +2.5%, 10 parts decr (-5%)	+1 to 4%; 10 prts decr (-5 to -6%)	42
43	VIO	+/-20uV typ	+/-20uV typ	+/-35uV typ	43
44	IIB	+/-200pA max	17 parts > +/-1nA	+/-300pA typ, 15 parts > +/-1 nA	44
45	IIO	+/-200pA max	17 parts > -1nA drift toward 0A	17 parts > +/-1nA but drift toward 0A	45
46	Gain	both + and - small changes. No compression	all showed compr decrease	4 parts net incr; rest compr decr	46
47	Slew rate	+1 to +3% (prop to ICC), 13 parts no change	+1 to +2%; 10 parts decr (-6%)	+2 to 4%; 10 prts decr (-6 to -8%)	47
48	CMRR	few with hi initial values decreased	17 parts with hi init vals decreased	17 parts with hi init vals decreased	48
49	VOP	very little change	very little change	very little change	49
50	GBW	small incr, correlated to ICC	+1 to +2%, 10 parts decr (-2%)	+0 to 2%; 10 prts decr (-3.5%)	50
Ceramic, +85C					
51	PSRR	+/- 200 nV/V		+/- 500 nV/V	51
52	ICC/IEE	+0.5 to +2%,		+2 to 4%; 10 prts decr (-4 to -6%)	52
53	VIO	+/-20uV typ; 4439 +50 uV		+/- 30uV typ; 5 parts +/-50 to +/-90uV	53
54	IIB	+/-200pA typ, few at +/-500pA		+/- 400 pA typ; 16 parts -1 to -2 nA	54
55	IIO	+/-200pA typ, few at +/-400pA		16 parts > +/-1nA but drift toward 0A	55
56	Gain	fluctuated a bit		Fluctuated a bit	56
57	Slew rate	+1 to +3% (prop to ICC)		+2 to 4%; 10 prts decr (-6 to -8%)	57
58	CMRR	Few with hi initial decreased		17 parts with hi init vals decreased	58
59	VOP	very little change		very little change	59
60	GBW	+1 to 2%		+/- 1%, 10 parts decr (-3 to -4%)	60

Figure 3.1-1a: Summary of Analog Parametric Test Results

	Test Lot 4A, Test 1	Test Lot 5A, Test 3, (Test Period 2)	Test Lot 6A, Test 2, (Test Per 3)	Test Lot 7A, Test Period 4
	Plastic, -40C			
1	+/- 500 nV/V, 3223 failed spec	Several +1 to +3 uV/V (related to IIB)	very little change	+/- 300 nV/V
2	+1 to +4%, 25 parts decr or 0	+2 to +5%, 3350 decr	+1 to +9%, wide distribution	+3 to +5% typ, 4 parts decr
3	+/-60uV typ (many > +/- 50uV)	+/- 40 uV typ; 3339 +60uV	+/- 50uV typ, 2 parts > +50uV	+/- 50uV typ
4	many -1 to -4 nA but drift toward 0A	several shift up to +/- 8.0 nA	few parts shift > +/- 1 nA	+/- 3 nA typ, few up to +/- 7 nA
5	5 parts > +/- 6 nA, rest +/- 2nA	several shift up to +/- 5.0 nA	1 part > +/- 1 nA	+/- 2 nA typ, few up to +/- 8 nA
6	1 part incr; rest compr decr	3 parts incr; rest compr decr	drop, exc 3 prts with sm incr.	3025 incr; rest compr decr
7	+2 to +10%, 25 parts < +2%	+3 to +5%, 3350 decr (-5%)	Proportional to ICC/IEE	+3 to +7%, 6 parts decr
8	few with hi initial values decreased	very little change	3387 big decr, rest no change	Few with hi initial decreased
9	very little change	very little change	very little change	very little change
10	+0 to +3%, tracked ICC	+1 to +2%	+1 to 2%	small increase, 8 parts decr
	Plastic, +25C			
11	+/- 400 nV/V	+/- 300 nV/V	+/- 300 nV/V	+/- 250 nV/V
12	+1.5 to +2.5%, 3250 -2%	+1.5 to +2.5%, 3350 decr	0 to +2% typ, 6 parts decr	+1% typ, 8 parts decr (-2%)
13	+/-25uV typ	+/-25uV typ	+/-30uV typ	+/-15uV typ
14	6 parts > +/-1nA but drift toward 0A	+/-500pA max	-100 to -500 pA	-200 to -1000 pA; 2 parts incr
15	5 parts > +/- 3 nA, rest +/- 2nA	+/-400pA max	+/-200pA max	+/-350pA max
16	2 parts incr; rest compr decr	2 parts incr; rest compr decr	7 parts incr; rest compr decr	few small incr; rest compr decr
17	+7 to +8%, 3250 +3%	+2 to +3%, 3350 decreased	+1 to 3%, 6 parts decr or 0	+1 to +2% typ, 8 parts decr (-2%)
18	very little change	few with hi initial values decreased	very little change	Few with hi initial decreased
19	very little change	very little change	very little change	very little change
20	+3 to +4%, 3250 +1.5%	small increase, 3350 decreased	0 to +1% all parts	-1%, all parts
	Plastic, +85C			
21	+/- 350 nV/V	+/- 300 nV/V	+/- 300 nV/V	+/- 300 nV/V
22	+1 to +2.5%, 3250 -1%, 2 parts 0	+1 to +2%, 3350 decr, 3325 +9%	+1 to +2% typ, 2 parts decr	+1 to +2% typ, 8 parts decr
23	+/- 40 uV typ; 3243 +53uV	+/-25uV typ, 3301 -55 uV	+/-30uV typ, a few > +50 uV	+/-30uV typ
24	some +/-1 to +/-2nA drift toward 0A	+/-600pA typ, 3325 +1.6nA	-100 to -700 pA	-300 to -700 pA
25	all +/-1 to +/-4 nA	+/-500pA max	+/-500pA max	+/-300pA max
26	fluctuated a bit	fluctuated, no trends	fluctuated a bit	fluctuated a bit
27	+1 to +4%, 17 parts +7%, 3250 -0.5%	+2 to +3%, 3350 decr, 3325 +18%	+1.5 to +3% all parts	+2 to +3% typ, 8 parts decr or 0
28	few with hi initial values increased	very little change	few with hi initial values decr	Few with hi initial decreased
29	very little change	very little change	very little change	very little change
30	+0 to +2%, 17 parts +3 to +4%	small gain typ, 2 decr, 3325 +13%	sm incr, all parts	small incr, 8 parts decr
	Ceramic, -40C			
31	+/- 500 nV/V, 2 parts +700 nV/V	+/- 400 nV/V, 2 parts -600 nV/V	+/- 300 nV/V	+/- 600 nV/V
32	18 parts +/-1 to +/-4%, rest < +/- 1%	+1 to 6%; 8 prts decr (-1 to -8%)	+1 to +5% typ, 5 parts decr	+1 to +2%, 12 small decr, 6 big decr
33	+/- 40uV; 4214 +69uV, 4235 +121uV	+/-40uV typ, 7 parts +/- 70uV	5 parts > +/- 50 uV	4001 +139 uV, several +/-50 to 100uV
34	+/-700pA max	+/-300pA typ, 1 part > 1nA	several > +/- 1nA	several > +/- 2nA, 4037 -6nA
35	+/-400pA typ, 2 parts +700 pA	+/-300pA typ, few parts > +/- 1nA	several > +/- 1nA	several > +/- 2nA, 4049 -6nA
36	many small incr; rest compr decr	fluctuated widely, no trends	values unstable	12 parts incr; rest compr decr
37	+/-2%, 8 parts with +/- 5% shifts	+2 to +8%, many < +1%, 6 parts decr	+2 to +10%, 5 parts decr	-10% to +7% prop to ICC
38	few with hi initial values decreased	few with hi initial values decreased	few with hi initial values decr	very little change
39	very little change	very little change	very little change	very little change
40	+1 to +2.5%	+1 to +2%, 8 parts decr	+1%, 5 parts decr	Proportional to ICC
	Ceramic, +25C			
41	+/- 500 nV/V, 4240 +700 nV/V	+/- 500 nV/V	+/- 300 nV/V	+/- 500 nV/V
42	+1.5 to 3.5%; 2 prts decr	+0.5 to 1.5%; 4 prts decr	very little change	+1 to +2.5%, 15 parts decr or 0
43	+/-25uV, 4217&4224 failed spec	+/-10uV typ, very tight distribution	+/-20uV typ, very tight distrib	+/-20uV typ, very tight distribution
44	+/-300pA max	+/-500pA max	+/- 1 nA max	+/-500pA max
45	+/-250pA max	+/-500pA max	+/- 1 nA max	+/-200pA max
46	all showed compr decrease	2 parts incr, rest compr decr	divergent	4022 incr; rest compr decr
47	+2 to 4%; 2 prts decr	+1 to 2%; 4 prts decr (-5%)	very little change	+2%, 15 parts decr (0 to -7%)
48	few with hi initial values decreased	very little change	very little change	very little change
49	very little change	very little change	very little change	very little change
50	+1.5 to 3%; 2 prts decr	small increase, 4 prts small decr	very little change	sm decr; correlated to ICC
	Ceramic, +85C			
51	+/- 500 nV/V	+/- 600 nV/V	+/- 300 nV/V	+/- 500 nV/V
52	+1.5 to 3.5%; 2 prts decr	+1 to 2%; 4 prts decr (-6%)	+0.5 to 2% typ, 3 parts decr	+1 to +2.5%, 11 parts decr or 0
53	+/-40uV typ, 4 parts +/- 50uV	+/-40uV typ, several up to +/- 60uV	6 parts > +/- 50 uV	+/-30uV typ, 2 parts +/- 60uV
54	+/-300pA max	+/-300pA max	+/-400pA max	+/-300pA max
55	+/-350pA, 4228 + 1nA	+/-300pA max	+/-600pA max	+/-300pA max
56	Fluctuated a bit	Fluctuated a lot	Fluctuated a lot	Fluctuated a lot
57	+2 to 4%; 2 prts decr	+1 to 3%; 4 prts decr	+1 to 2%; 3 with low ICC +0.5%	+2%, 11 parts decr (0 to -6%)
58	few with hi initial values incr or decr	2 parts big incr, rest no change	very little change	Few with hi initial decreased
59	very little change	very little change	very little change	very little change
60	+1 to +2%, 2 parts at 0	small increase, 4 parts small decr	small increase	little change, 11 parts small decr

Figure 3.1-1b: Summary of Analog Parametric Test Results

Plastic, -40 C	Test Lot 8D, Control Group	Test Lot 4D	Test Lot 5D
IIL	Few inputs at 1 nA	Several inputs > +/- 10 nA	Few inputs at 1 to 10 nA
IIH	drift toward 0.2 to 0.4 nA, few at +10 nA	drift toward 0.4 nA. Many inputs > +/- 100 nA	drift toward 0.4 nA. Several inputs > +/- 100 nA
VIH(CLK)	moderate shift at 5.5V	moderate shift at 5.5V	med-large drop at 5.5V
VIH(DAT)	Little change	Little change	Little change
VIH(CLR)	large drop related to VCC	large shifts at 5.5V	large drop related to VCC
VIH(PRE)	large drop related to VCC	med-high drop related to VCC	large drop related to VCC
VIL(CLK)	Little change	Little change	Little change
VIL(DAT)	Little change	Little change	Little change
VIL(CLR)	Little change	moderate drop at all VCC	small drop at all VCC
VIL(PRE)	moderate shift at 5.5V	Little change	small drop at all VCC
VOH	Little change	2 parts had larger than normal shift	1 part dropped more than normal
VOL	Little change	2 parts had larger than normal shift	Little change
ICC	drift toward 100 nA	no drift, +/- 1uA with no pattern	drift toward 100 nA
Small Shift	T0, T2, T5, T7, T9, T10, T11, T15	T2, T5, T10, T11, T15, T17	T5
Large Shift	T16	T14, T16	T11, T15
Step Inc	T18	T18, T19, T22, T25	T18, T21, T23, T25
Step Dec	T19, T24, T25	T20	
2 Value		T24	T19, T20, T24
Misc		T21 few step increases	
Plastic, +25 C	Test Lot 8D, Control Group	Test Lot 4D	Test Lot 5D
IIL	All 0A	All 0A	All 0A
IIH	drift toward 0.2 to 0.4 nA	drift toward 0.2 to 0.4 nA	drift toward 0.2 to 0.4 nA
VIH(CLK)	moderate shift 5.5V	moderate shift 5.5V	moderate drop at 5.5V
VIH(DAT)	Little change	Little change	Little change
VIH(CLR)	large shift 5.5V (most increase)	large drop at 5.5V	large drop related to VCC
VIH(PRE)	med-large drop related to VCC	med-large drop related to VCC	large drop related to VCC
VIL(CLK)	Little change	Little change	Little change
VIL(DAT)	Little change	Little change	Little change
VIL(CLR)	Little change	moderate shift at all VCC	Little change
VIL(PRE)	Little change	Little change	Little change
VOH	Little change	Little change (1 higher than norm)	Little change (1 higher than norm)
VOL	Little change (1 higher than norm)	Little change	Little change (1 higher than norm)
ICC	drift toward 100 nA	small increase	No pattern
Small Shift	T0, T2, T9, T10, T11, T14	T2, T11, T14, T16	T0, T2, T5
Large Shift	T15		T11, T14-17
Step Inc	None	T21, T23, T25	T25
Step Dec	T21-25	T18, T20	T18, T22-24
2 Value	T18, T20		T20, T21
Misc	T16 & 17 had 1 part with large drop		
Plastic, +85 C	Test Lot 8D, Control Group	Test Lot 4D	Test Lot 5D
IIL	All at 0A	All at 0A	All at 0A
IIH	drift toward 0.2 to 0.4 nA	drift toward 0.2 to 0.4 nA	drift toward 0.2 to 0.4 nA
VIH(CLK)	Little change	Little change	Little change
VIH(DAT)	Little change	Little change	Little change
VIH(CLR)	large drop related to VCC	large drop related to VCC	large drop related to VCC
VIH(PRE)	Med-large drop at all VCC	medium shift at 5.5V	Med-large drop related to VCC
VIL(CLK)	Little change	Little change	few parts with small drop
VIL(DAT)	Little change	Little change	Little change
VIL(CLR)	Little change	Little change	Little change
VIL(PRE)	Little change	modest drop at 5.5V	Little change
VOH	Little change	Little change	several dropped more than normal
VOL	Little change	Little change	several increased more than norm
ICC	No pattern	No pattern	No pattern
Small Shift	T2, T7, T10, T11, T14, T16	T2, T6, T11, T13, T15, T17	T15
Large Shift	T15	T14, T16	T5, T11, T14
Step Inc		T21, T23, T25	T19, T21, T25
Step Dec	T19, T21-25		T20, T24
2 Value	T18	T18, T19, T22, T24	T18, T22, T23
Misc		T20 few step decreases	T16 & 17 a few large shifts

Figure 3.1-2a: Summary of Digital Parametric Test Results

Plastic, -40 C	Test Lot 6D	Test Lot 7D	Test Lot 3D (Final)
IIL	Several inputs > +/- 10 nA	Few inputs at -500 nA, some at +/- 1nA	Many inputs -1 to -900 nA
IIH	drift toward 0.4 nA. Several inputs > +/- 100 nA	drift toward 0.4 nA. a few inputs > + 20 nA	drift toward 0.4 nA. several inputs at +10 to +60 nA
VIH(CLK)	medium shift at 5V & 5.5V	modest shift at 5V & 5.5V	modest increase at 5V & 5.5V
VIH(DAT)	Little change	Little change	Little change
VIH(CLR)	large drop related to VCC	med-large shift related to VCC	Medium shift at all VCC
VIH(PRE)	small drop or large gain at all VCC	modest drop at all VCC	large gain or medium drop at all VCC
VIL(CLK)	Little change	Little change	small drop at 4.5V
VIL(DAT)	Little change	Little change	Little change
VIL(CLR)	Little change	Little change	small drop at all VCC
VIL(PRE)	modest drop at 5V & 5.5V	small drop related to VCC	small drop at all VCC
VOH	Little change	1 part dropped more than normal	2 parts dropped more than normal
VOL	1 part increased more than norm	1 part increased more than normal	2 parts increased more than normal
ICC	no pattern	Little change	no pattern
Small Shift	T0, T3, T5, T11, T17	T0, T2, T5	T0, T2, T7, T10, T11, T14, T17
Large Shift	T14, T16	T16	T15, T16
Step Inc	T19, T21, T23, T25	T19, T21, T25	T19-23, T25
Step Dec	T22	T22, T24	T24
2 Value	T18, T24	T18, T20	T18
Misc	T15 & T20 couple step decreases	T15 & T23 one part large gain	
Plastic, +25 C	Test Lot 6D	Test Lot 7D	Test Lot 3D (Final)
IIL	All 0A	few non-zero values recorded	intermediate shifts but all end at 0A
IIH	drift toward 0.2 to 0.4 nA	drift toward 0.2 to 0.4 nA	drift toward 0.2 to 0.4 nA
VIH(CLK)	small drop at 5.5V	modest drop at 5.5V	modest shift at 5.5V
VIH(DAT)	Little change	Little change	Little change
VIH(CLR)	large drop related to VCC or med incr at 5.5V	moderate shift 5.5V	medium shifts at 5V, med-large shifts at 5.5V
VIH(PRE)	Little change	small shift or large drop related to VCC	large gain related to VCC or moderate drop at all VCC
VIL(CLK)	Little change	Little change	Little change
VIL(DAT)	Little change	Little change	Little change
VIL(CLR)	moderate increase at all VCC	Little change	small drop at all VCC
VIL(PRE)	Little change	Little change	Little change
VOH	Little change	1 part lower than norm	1 part failed
VOL	1 part higher than normal	1 part higher than norm	1 part failed
ICC	all increased to 1 to 2 uA	Little change	little movement, drift toward 0 A
Small Shift	T0, T2, T11, T14, T15	T2, T5	T0, T2, T5, T7, T8, T17
Large Shift	T5	T0	T16
Step Inc	T19, T21, T25	T20, T23	T18, T25
Step Dec	T22, T24		T21, T22, T24
2 Value	T18, T20	T18, T22, T24, T25	T20
Misc		T9, 14, 16, 17, 21 1 part large shifts	
Plastic, +85 C	Test Lot 6D	Test Lot 7D	Test Lot 3D (Final)
IIL	All at 0A	All at 0A	All at 0A
IIH	drift toward 0.2 to 0.4 nA	drift toward 0.2 to 0.4 nA	drift toward 0.2 to 0.4 nA
VIH(CLK)	Little change	Little change	Little change
VIH(DAT)	Little change	Little change	Little change
VIH(CLR)	med-large drop related to VCC	medium shift at 5.5V	med-large drop related to VCC
VIH(PRE)	modest drop at all	Little change	large increase related to VCC or medium drop related to VCC
VIL(CLK)	Little change	Little change	Little change
VIL(DAT)	Little change	Little change	Little change
VIL(CLR)	Little change	Little change	Little change
VIL(PRE)	Little change	Little change	Little change
VOH	1 part dropped more than normal	Little change	Little change
VOL	1 part increased more than norm	Little change	Little change
ICC	No pattern	Little change	small shifts
Small Shift	T0, T4, T8	T0, T5, T8	T2, T5, T7, T8, T11, T13, T14
Large Shift	T11	T11	T16, T17
Step Inc	T19, T21, T23-25	T25	T23, T25
Step Dec	T22	T22, T24	T22, T24
2 Value	T18	T18, T19, T23	T18, T19
Misc			

Figure 3.1-2b: Summary of Digital Parametric Test Results



Cerdip, -40 C	Test Lot 8D, Control Group	Test Lot 4D	Test Lot 5D
IIL	few inputs at 1nA	few inputs shifted by +/- 10n A or more	few inputs shifted by - 10n A or more
IIH	drift toward 0.2 nA, several +1 to +120 nA	drift toward 0.2 nA, a few > +/- 10 nA	drift toward 0.2 nA, a few +10 to +200 nA
VIH(CLK)	modest increase at 5V & 5.5V	modest increase at 5.5V	moderate drop related to VCC
VIH(DAT)	Little change	Little change	Little change
VIH(CLR)	modest shift at 5V, large shift at 5.5V	med-large drop at all VCC	large drop related to VCC
VIH(PRE)	large drop related to VCC	moderate drop at all VCC	modest shift at all VCC
VIL(CLK)	Little change	Little change	Little change
VIL(DAT)	Little change	Little change	Little change
VIL(CLR)	modest shift 4.5V, large shift 5/5.5V	med-large drop related to VCC	med-large shift at all VCC
VIL(PRE)	modest drop at all	Little change	medium drop at all VCC
VOH	Little change	Little change	Little change
VOL	Little change	Little change	Little change
ICC	drift to 100 nA	all increased, no pattern	most parts drop toward 0 A
Small Shift	T5, T9, T11, T14	T9, T11	T0, T3, T7
Large Shift	T15	T16, T17	T11, T15
Step Inc		T21, T23-25	T21, T23, T25
Step Dec	T18-25		T18, T24
2 Value		T20	T19, T20, T22
Misc		T14, T15, T18, T22 had a few large increases	
Cerdip, +25C	Test Lot 8D, Control Group	Test Lot 4D	Test Lot 5D
IIL	All at 0A	All at 0A	All at 0A
IIH	drift toward 0.2 to 0.4 nA	drift toward 0.2 to 0.4 nA	drift toward 0.2 to 0.4 nA
VIH(CLK)	modest increase at 5V & 5.5V	small increase related to VCC	small drop at 5.5V
VIH(DAT)	Little change	Little change	Little change
VIH(CLR)	modest shift at 4.5/5V, large shift at 5.5V	large drop related to VCC	large drop related to VCC
VIH(PRE)	large drop related to VCC	small increase related to VCC	small increase at 5.5V
VIL(CLK)	Little change	Little change	Little change
VIL(DAT)	Little change	Little change	Little change
VIL(CLR)	modest drop on all	modest drop on all	modest drop on all
VIL(PRE)	modest drop, slight relation to VCC	Little change	modest shift on all
VOH	Little change	Little change	Little change
VOL	Little change	Little change	Little change
ICC	drift to 100 nA	most increased, no pattern	no pattern
Small Shift	T2, T11, T14, T16	T0, T8, T9, T11, T13, T15, T17	T0, T3, T5, T9, T10, T16
Large Shift	T15		T11, T15
Step Inc	T18, T20	T21, T24	T19, T21, T25
Step Dec	T19, T21-25		T20, T22, T24
2 Value		T18, T19, T20, T22, T23	T18, T23
Cerdip, +85C	Test Lot 8D, Control Group	Test Lot 4D	Test Lot 5D
IIL	All at 0A	All at 0A	All at 0A
IIH	drift toward 0.2 to 0.4 nA	drift toward 0.2 to 0.4 nA	drift toward 0.2 to 0.4 nA
VIH(CLK)	modest shift at 5.5V	modest increase at 5.5V	modest drop at 5.5V
VIH(DAT)	Little change	Little change	Little change
VIH(CLR)	large drop related to VCC	large drop related to VCC	large drop related to VCC
VIH(PRE)	large drop related to VCC	med-large drop at 5.5V	medium shift on all
VIL(CLK)	Little change	Little change	Little change
VIL(DAT)	Little change	Little change	Little change
VIL(CLR)	Little change	medium drop at all VCC	small drop at 5.5V
VIL(PRE)	Little change	Little change	small drop at 5V & 5.5V
VOH	Little change	Little change	Little change
VOL	Little change	Little change	Little change
ICC	No pattern	No pattern	No pattern
Small Shift	T5, T8, T11, T14, T16	T7, T8, T9, T11, T13	T0, T3, T4, T7, T16
Large Shift	T15	T16, T17	T11
Step Inc		T21, T22, T25	T19, T21, T23, T25
Step Dec	T18-25		T20, T22, T24
2 Value		T20, T24	T18
Misc			

Figure 3.1-2c: Summary of Digital Parametric Test Results

Cerdip, -40 C	Test Lot 6D	Test Lot 7D	Test Lot 3D (Final)
IIL	several shift by +/- 10 nA	several shift by +/- 1 nA	few shift by +/- 5 nA
IIH	drift toward 0.2 nA, several +10 to +150 nA	drift toward 0.2 nA, several +10 to +180 nA	drift toward 0.2 nA, many +10 to +100 nA
VIH(CLK)	modest shift related to VCC	medium shift at 5V & 5.5V	medium shift at 5V & 5.5V
VIH(DAT)	Little change	Little change	small drop at 5.5V
VIH(CLR)	med-large drop related to VCC	large gain related to VCC	med-large shift at all VCC
VIH(PRE)	small drop or large incr. at all VCC	large drop related to VCC	modest shift at all VCC
VIL(CLK)	Little change	Little change	Little change
VIL(DAT)	Little change	Little change	Little change
VIL(CLR)	large gain at 5.5V for some parts	modest shift at 5.5V	med-large drop at all VCC
VIL(PRE)	med-large drop at all VCC	Little change	Little change
VOH	Little change	Little change	Little change
VOL	Little change	Little change	Little change
ICC	Little change	larger than normal shifts	larger than normal shifts
Small Shift	T0, T3, T5, T9, T17	T1	T0, T7, T11
Large Shift	T11, T14, T16		T15, T16
Step Inc	T22, T24	T19, T22-25	T20-24
Step Dec	T18-21, T23, T25	T20	T25
2 Value		T21	
Misc			
Cerdip, +25C	Test Lot 6D	Test Lot 7D	Test Lot 3D (Final)
IIL	All at 0A	All at 0A	All at 0A
IIH	drift toward 0.2 to 0.4 nA	drift toward 0.2 to 0.4 nA	drift toward 0.2 to 0.4 nA
VIH(CLK)	modest shift at 5V & 5.5V	modest shift at 5.5V	modest increase at 5.5V
VIH(DAT)	Little change	Little change	Little change
VIH(CLR)	large drop related to VCC or med shift all VCC	medium increase related to VCC, or modest shift on all	medium-large drop related to VCC or no change
VIH(PRE)	med drop related to VCC or med shift all VCC	large drop related to VCC, or little change	modest shift at all VCC
VIL(CLK)	Little change	Little change	Little change
VIL(DAT)	Little change	Little change	Little change
VIL(CLR)	modest shift on all	Little change	Medium drop at all VCC
VIL(PRE)	modest drop on all	Little change	med-large drop at all VCC
VOH	Little change	Little change	Little change
VOL	Little change	Little change	Little change
ICC	Little change	drift toward 0 A	drift toward 0 A
Small Shift	T0, T3, T9, T11, T14-17	T2, T17	T0, T2, T14, T15
Large Shift			
Step Inc	T18, T19, T21, T23, T25	T18-25	T25
Step Dec	T22, T24		T19, T21-24
2 Value	T20		T18, T20
Cerdip, +85C	Test Lot 6D	Test Lot 7D	Test Lot 3D (Final)
IIL	All at 0A	All at 0A	All at 0A
IIH	drift toward 0.2 to 0.4 nA	drift toward 0.2 to 0.4 nA	drift toward 0.2 to 0.4 nA
VIH(CLK)	modest shift at 5.5V	small drop at 5.5V	modest shift at 5.5V
VIH(DAT)	Little change	Little change	Little change
VIH(CLR)	large drop related to VCC	large gain related to VCC	large drop related to VCC
VIH(PRE)	modest shift at 5.5V	Large shift related to VCC	modest shift at all VCC
VIL(CLK)	Little change	Little change	Little change
VIL(DAT)	Little change	Little change	Little change
VIL(CLR)	Little change	Little change	small drop at all VCC
VIL(PRE)	small drop at 5V & 5.5V	Little change	small drop at all VCC
VOH	Little change	Little change	Little change
VOL	Little change	Little change	Little change
ICC	No pattern	No pattern	Little change
Small Shift	T0, T3, T11		T0, T6, T7, T8, T11, T14, T16, T17
Large Shift		T20, T23	T15
Step Inc	T19, T21, T23, T25	T19, T22, T24	
Step Dec	T18, T20, T24	T21, T25	T18, T20-25
2 Value	T22		
Misc			

Figure 3.1-2d: Summary of Digital Parametric Test Results

Plastic, -40C		Lot 9A, Plastic, Final Test		Lot 10A, Plastic, Final Test	
PSRR		+/- 300 nV/V, 1 outlyer		+/- 150 nV/V, 1 outlyer	
ICC/IEE		-1 to -2% typ, some to -9%, several 0 to +3%		+1 to +8%, 14 parts at +/- 1%	
VIO		+/- 50 uV typ, 4 outlyers up to +/- 100 uV		+/- 50 uV	
IIB		+/- 2.0 nA		+700 to -1300 pA	
IIO		+/- 3.0 nA, 3 parts up to +/- 10 nA		-300 to -2300 pA	
Gain		Slight compr decr typ, 10 parts small incr.		Most compr decr, several incr with slight expansive trend	
Slew rate		-1 to -3% typ, some to -11%, several 0 to		+1 to +10% typ, 14 parts at +/- 2%	
CMRR		Few with high init val shifted		Few with high init val shifted	
VOP		Few shifted more than normal		Few shifted more than normal	
GBW		+1.5 to +3.5%, several no change		+1 to +3%	

Plastic, +25C		Lot 9A, Plastic, 1st Int. Test		Lot 9A, Plastic, Final Test		Lot 10A, Plastic, 1st Int. Test		Lot 10A, Plastic, Final Test	
PSRR		+/- 200 nV/V, 1 outlyer		+/- 250 nV/V, 1 outlyer		+/- 250 nV/V		+/- 150 nV/V, 1outlyer	
ICC/IEE		+/- 1%, 10 parts +/- 2%		+1 to +2.5%		+/- 1%, 13 parts +0.5 to +2.0%		< +/- 1% typ, 13 parts +1 to +2%	
VIO		+/- 25 uV		+/- 30uV, tight distribution		+/- 30uV, 1 outlyer		-20 to +50 uV, 1 part at +100 uV	
IIB		+/- 500 pA, 1 outlyer		0 to -600 pA		+/- 300 pA, 2 outlyers out to +1 nA		+200 to -500 pA	
IIO		-200 to -1100 pA		-100 to -800 pA		-200 to -1000 pA		-200 to -1500 pA	
Gain		Compressive decrease		Compressive decrease		Compressive decrease		Compressive decrease	
Slew rate		+/- 1%, 10 parts +/- 3%		+1 to +3%		+/- 1%, 13 parts +1.0 to +2.5%		< +/- 1% typ, 13 parts +1 to +2%	
CMRR		Few with higher init vals shifted		Few with higher init vals shifted		One part with high init val shifted		Few with higher init vals shifted	
VOP		Little Change		Little Change		Little Change		Little Change	
GBW		+0 to +2%		+2 to +3.5%		+0 to +2%		+1 to +3%	

Plastic, +85C		Lot 9A, Plastic, Final Test		Lot 10A, Plastic, Final Test	
PSRR		+/- 200 nV/V, 1outlyer		+/- 150 nV/V, 1outlyer	
ICC/IEE		+1 to +4%, few with no change		+/- 1%	
VIO		+/- 40 uV		+/- 40 uV, 3 outlyers up to +80 uV	
IIB		-100 to -1300 pA		+/- 500 pA	
IIO		+300 to -600 pA		-1000 to +500 pA	
Gain		No pattern		No pattern	
Slew rate		+1 to +4%, few with no change		+/- 1%	
CMRR		Few with high init vals shifted		Few with high init vals shifted	
VOP		-VOP shifted more than normal		Little change	
GBW		+1 to +3%		+1 to +4.5%	

Ceramic, -40C		Lot 9A, Ceramic, Final Test		Lot 10A, Ceramic, Final Test	
PSRR		+/- 300 nV/V, 2 outlyer		+/- 200 nV/V, 4 outlyer to +/- 1100 nV/V	
ICC/IEE		+/- 4% (more decreases)		+/- 3%, 3 outlyers	
VIO		+/- 50 uV typ, 2 outlyers		+/- 50 uV typ, 6 outlyers	
IIB		0 to +1.5 nA typ, 5 had large drops to -9nA		+/- 600 pA	
IIO		+1.2 to +1.7nA typ, 6 parts up to +/- 10 nA		+/- 1 nA, some outlyers to +/- 2nA	
Gain		Most compr decr, several incr		Most compr decr, few incr	
Slew rate		+4 to -5%, tracked ICC		+/- 3%, 3 outlyers	
CMRR		Few with high init val shifted		Few with high init val shifted	
VOP		1 part larger than normal drop		Little Change	
GBW		+1.5 to +4.5%		+/- 3%	

Ceramic, +25C		Lot 9A, Ceramic, 1st Int. Test		Lot 9A, Ceramic, Final Test		Lot 10A, Ceramic, 1st Int. Test		Lot 10A, Ceramic, Final Test	
PSRR		+/- 300 nV/V, 2 parts at -500 nV/V		+/- 300 nV/V		+/- 300 nV/V, 4 parts at +/-500 nV/V		+/- 100 nV/V, 4 parts +/- 500 nV/V	
ICC/IEE		+1 to +2% typ, 11 parts +3.5 to		+1 to +3%, 2 parts small drop		+0.5 to +2.5%, 4 parts dropped, 2 no chg		0 to +3% typ, 5 parts -1 to -3%	
VIO		+/- 25 uV		+/- 25uV typ, several +/- 50uV		+/- 35 uV		+/-50 uV, 1 part at +75 uV	
IIB		-1300 to +100 pA		+200 to -800 pA		+/- 400 pA, 23 parts at -1.2 to -2.4 nA		+/- 300 pA or -1.0 to -2.5 nA	
IIO		+/- 350 pA, 14 parts at -700 to -		+/- 200 pA typ, 14 parts -0.7 to -1.7 nA		-300 to +600 pA, 23 parts -2.1 to -4.7 nA		-700 to +400 pA or -2.0 to -4.0 nA	
Gain		Slight compressive decrease		Compr decr typ, 1 part increased		Compressive decrease		Compr decr typ, 4 part increased	
Slew rate		+1.0 to +2.5%, 11 parts +4.0 to		+0.5 to +3.0% typ, 2 parts small drop		+0.5 to +2.5%, 4 parts dropped, 2 no		0 to +2% typ, 4 parts -2 to -5%	
CMRR		Few with higher init vals shifted		Few with higher init vals shifted		Few with higher init vals shifted		Few with higher init vals shifted	
VOP		Little Change		Little Change		Little Change		Little Change	
GBW		0 to +1%, 11 parts +1.5 to +3.0%		+1.5% to +3.5%		+/- 1%, 4 parts at -2 to -3.5%		0 to +2% typ, 4 parts small drop	

Ceramic, +25C		Lot 9A, Ceramic, Final Test		Lot 10A, Ceramic, Final Test	
PSRR		+/- 300 nV/V, 1outlyer		+/- 300 nV/V, 3 outlyers	
ICC/IEE		+1 to +3%		0 to -2% typ, 4 parts -3 to -5%	
VIO		+/- 50 uV, 3 outlyers		+/- 60 uV, 4 outlyers up to +110 uV	
IIB		+/- 350 pA, 1 outlyer		+/- 500 pA	
IIO		+/- 500 pA		-800 to +400 pA	
Gain		No pattern		No pattern	
Slew rate		+1 to +3.5%		0 to -2% typ, 4 parts -3 to -6%	
CMRR		Few with high init vals shifted		Few with high init vals shifted	
VOP		Little change		Little change	
GBW		+1 to +4%		+1 to +3%	

Figure 3.1-3a: Summary of Thermal and Life Parametric Test Results

Plastic, -40C	Test Lot 8A, Analog Control Group	Lot 11A, Plastic	Lot 12A, Plastic
PSRR	+/- 300 nV/V	+/- 250 nV/V	+/- 175 nV/V
ICC/IEE	+3 to +9% (most +4%), 6 parts decr.	+/- 1.5%, grouped by S/N	+1 to +3% typ, several little change, 3
VIO	+/- 40 uV typ. 3426 +80uV	+/- 50 uV typ, 3 outlyers	+/- 50 uV
IIB	some > +/-1nA but drift toward 0A	-1.0 to +1.5 nA	-500 to +600 pA
IIO	some +/- 1nA, 3423 +10nA	-0.5 to +1.0 nA	-1000 to +500 pA
Gain	all showed compressive decrease	Compressive decrease	Compressive decrease
Slew rate	+2 to +10% (prop to ICC), 6 parts decr.	+/- 1%, tracked ICC	+1 to +3% typ, several little change, 3
CMRR	few with hi initial values decreased	Few with high init val shifted	Few with high init val shifted
VOP	very little change	Little Change	Little Change
GBW	+0 to +2% (prop to ICC)	+/- 1%	+0 to +2%

Plastic, +25C	Test Lot 8A, Analog Control Group	Lot 11A, Plastic	Lot 12A, Plastic
PSRR	+/- 300 nV/V	+/- 200 nV/V	+/- 200 nV/V
ICC/IEE	+1 to +3%	0 to +1% (very small)	+/- 1%
VIO	+/-20uV, tight distribution	+/- 30uV, 2 outlyers	+/- 30uV, 1 outlyer
IIB	2ppts, +500pA; most -.5 to -1 nA.	-500 to +700 pA	-500 to +600 pA, 1 outlyer
IIO	+/-400pA max	+/- 300 pA	+/- 500 pA
Gain	13 parts big compr decr; rest norm decr	Compressive decrease	Compressive decrease
Slew rate	+1 to +4% (prop to ICC)	+0.5 to +1.5%	+0.5 to +1.5%
CMRR	few with hi initial values decreased	Few with higher init vals shifted	Little Change
VOP	very little change	Little Change	Little Change
GBW	very little change	+0.5 to +1.5%	+0.5 to +1.5%

Plastic, +85C	Test Lot 8A, Analog Control Group	Lot 11A, Plastic	Lot 12A, Plastic
PSRR	+/- 300 nV/V	+/- 200 nV/V	+/- 250 nV/V
ICC/IEE	0 to +2% typ, 6 parts small decrease	0 to +1.5%	0 to +1.5%
VIO	+/- 25uV typ, 3 parts > +50 uV	+/- 50 uV, 1 outlyer	+/- 50 uV, 2 outlyer
IIB	+/- 500 to 1000 pA max	+/- 600 pA	+/- 500 pA
IIO	+/-500pA max	+/- 350 pA, few outlyers	+/- 300 pA, few outlyers
Gain	fluctuated a bit	No pattern	No pattern
Slew rate	0 to +3%, Correlated to ICC	+0.5 to +2.0%	+0 to +2%
CMRR	few with hi initial values decreased	Few with high init vals shifted	Few with high init vals shifted
VOP	very little change	Little change	Little change
GBW	0 to +1.5%	+/- 1%	+0 to +2%

Ceramic, -40C	Test Lot 8A, Analog Control Group	Lot 11A, Ceramic	Lot 12A, Ceramic
PSRR	+/- 300 nV/V	+/- 200 nV/V	+/- 200 nV/V
ICC/IEE	+2 to +4% typ, 5 parts decr or 0	0 to +3%, few with small drops	+/- 1%
VIO	+/-50uV typ; 3 parts > 100 uV	+/- 50 uV typ, several large drops	+/- 50 uV typ, 5 parts with large shifts
IIB	12 parts > +/-1nA but drift toward 0A	-500 to +800 pA	-100 to +1000 pA
IIO	13 parts > +/-1nA but drift toward 0A	-1000 to +600 pA	-1000 to +300 pA
Gain	both + and -, no trend	Most decr, no pattern	slight compr decr
Slew rate	+3 to +5% (prop to ICC), 5 parts decr	0 to +3% typ, few -1%	+/- 1%
CMRR	few with hi initial values decreased	Few with high init val shifted	Few with high init val shifted
VOP	very little change	Little Change	Little Change
GBW	+1 to 2%	+1 to +2.5%	+0.5% to +1.5%

Ceramic, +25C	Test Lot 8A, Analog Control Group	Lot 11A, Ceramic	Lot 12A, Ceramic
PSRR	+/- 300 nV/V	+/- 200 nV/V	+/- 250 nV/V
ICC/IEE	+0.5 to +2%, 13 parts no change	+1 to +3%	+/- 1%
VIO	+/-20uV typ	+/- 15 uV, tight distribution	+/- 25 uV
IIB	+/-200pA max	+/- 300 pA	-100 to +500 pA
IIO	+/-200pA max	+/- 300 pA, 1 outlyer	-600 to +100 pA
Gain	both + and - small changes. No compr.	Both incr and decr	Slight compressive decrease
Slew rate	+1 to +3% (prop to ICC), 13 no change	+1 to +2.5%	+0 to +2%
CMRR	few with hi initial values decreased	Few with higher init vals shifted	Few with higher init vals shifted
VOP	very little change	Little Change	Little Change
GBW	small incr, correlated to ICC	+1 to +2%	+0 to +2%

Ceramic, +25C	Test Lot 8A, Analog Control Group	Lot 11A, Ceramic	Lot 12A, Ceramic
PSRR	+/- 200 nV/V	+/- 300 nV/V	+/- 250 nV/V
ICC/IEE	+0.5 to +2%,	+1.0 to +2.5%	+0.5 to +1.7%
VIO	+/-20uV typ; 4439 +50 uV	+/- 60 uV, 2 outlyers	+/- 50 uV, 6 outlyers up to +/- 100 uV
IIB	+/-200pA typ, few at +/-500pA	+/- 300 pA, 1 outlyer	+/- 300 pA
IIO	+/-200pA typ, few at +/-400pA	+/- 500 pA	-500 to +200 pA
Gain	fluctuated a bit	No pattern	No pattern
Slew rate	+1 to +3% (prop to ICC)	+1.5 to +2.5%	+1.0 to +2.5%
CMRR	few with hi initial values decreased	Few with high init vals shifted	Few with high init vals shifted
VOP	very little change	Little change	Little change
GBW	+1 to 2%	+0.5 to +1.5%	+0.75 to +1.5%

Figure 3.1-3b: Summary of Thermal and Life Parametric Test Results

thermal and life tests and of the analog tests, especially between lot 10A in Figure 3.1-1 with lot 3A in Figure 3.1-3, shows that the data shifts are of approximately the same magnitude. This would indicate that the effect on device parameters is not thermally related, but related more to the time and intensity of exposure to electromagnetic energy.

An analysis of the parameter test results of devices involved in the wideband tests shows that typically the test lots exposed to EM radiation had higher parameter shifts, and also had more devices whose parameters were outside of the major trend lines, than did the control group. See Figure 3.1-4 for the summary of the wideband parametric test results.

This analysis of the test devices indicates that the failure rate of devices exposed to electromagnetic radiation is higher than those operated in a low (ambient) EM environment. We also found that electromagnetic exposure does cause parameters of these analog devices to shift beyond that which would be expected for normal operation in a low (ambient) EM environment.

### **3.2 Engineering Statistical Analysis**

The study of the effects of electromagnetic radiation on the reliability of electronic devices employed the use of military and commercial integrated circuit part versions for both analog integrated circuit parts and digital integrated circuit parts in both ceramic and plastic packaging. The analog test devices were operational amplifiers, Analog Devices part number OP-271, configured as unity gain buffer amplifiers, and the digital test devices were high speed digital flip-flops, Fairchild part number 54/74ACT74. Before any radiated susceptibility or control lot testing was performed, acceptance testing was performed using automated test equipment to establish the initial parameter values. See Section 5.0 for further information on acceptance testing. Reference lots served as control groups and were used for comparison with the EM irradiated lots in order to allow the use of statistical confidence interval testing in order to assess the statistical significance of the results.

The effects observed during testing included the nominal variation of the integrated circuit test parameters within the manufacturer parameter performance specifications and superimposed variations that are attributed to the effects of EM radiation exposure. The observation and identification of statistically significant effects were performed by employing statistical confidence interval hypothesis testing and techniques that are described and developed in appendix A. In summary, the test parameters used to characterize the performance of the integrated circuits included input and output voltages and currents, leakage currents, timing tests, and operational upset performance measurements.

#### **3.2.1 Engineering Statistical Analysis Approach**

The statistical analysis and testing for the parts reliability study began by selecting the data to be studied and examined. The data obtained during digital component testing and analog component testing were investigated separately, although identical testing methods were used in both cases and the information and data were organized by using the same data base structures and organizations. The statistical analysis and format of the measured statistical data sets that were used to characterize the tested devices were similar for all tests that were analyzed.

The test data used during the initial test assessments consisted of analog component data from

TEST	Test Lot 8A, Plastic Control Group	Test Lot 13A, Plastic
PSRR	+/- 300 nV/V	+/- 300 nV/V
ICC/IEE	+3 to +9% (most +4%), 6 parts decreased	+/- 2% with no pattern
VIO	+/- 40 uV typ. 3426 +80uV	+/- 25 uV typ, some outliers to +/- 50 uV
IIB	some > +/-1nA but drift toward 0A	+/- 1.4 nA
IIO	some +/- 1nA, 3423 +10nA	0 to -2 nA
Gain	all showed compressive decrease	most compressive decrease, few parts increased
Slew rate	+2 to +10% (prop to ICC), 6 parts decreased	+/- 3%, no pattern, related to ICC
CMRR	few with hi initial values decreased	few with hi initial values shifted
VOP	very little change	few parts +/- 20 mV
GBW	+0 to +2% (prop to ICC)	small increase +0.5 to +1.5%
TEST	Test Lot 8A, Ceramic Control Group	Test Lot 13A, Ceramic
PSRR	+/- 300 nV/V	+/- 800 nV/V, 2 parts at -1000 nV/V
ICC/IEE	+2 to +4% typ, 5 parts decr or 0	-4 to -9% typ, #4682 -11%, 5 parts at 0 to -2%
VIO	+/-50uV typ; 3 parts > 100 uV	+/- 60uV typ, 3 parts at +/-50 to +/- 100uV
IIB	12 parts > +/-1nA but drift toward 0A	-200 to +600 pA
IIO	13 parts > +/-1nA but drift toward 0A	-800 to +600 pA
Gain	both + and -, no trend	Both + and -, decreases were compressive
Slew rate	+3 to +5% (prop to ICC), 5 parts decr	-5% to -11% typ, #4682 at -14%, 5 parts at -1 to -3%
CMRR	few with hi initial values decreased	few with hi initial values shifted
VOP	very little change	few parts +/- 30 mV
GBW	+1 to 2%	-1 to -3% typ. #4682 -4%, 5 parts no change
TEST	Test Lot 8A, Plastic Control Group	Test Lot 13A, Plastic
PSRR	+/- 300 nV/V	+/- 300 nV/V
ICC/IEE	+1 to +3%	+1 to +3.5% grouped by S/N
VIO	+/-20uV, tight distribution	+/-25uV, tight distribution
IIB	2prts,+500pA; most -.5 to -1 nA.	+100 to -600 pA, dev #2 up to +2 nA
IIO	+/-400pA max	+100 to -800 pA, dev #2 up to +4 nA
Gain	13 parts big compr decr; rest normal decr	compressive decrease
Slew rate	+1 to +4% (prop to ICC)	+1 to +4% (related to ICC)
CMRR	few with hi initial values decreased	few with hi initial values shifted
VOP	very little change	very little change
GBW	very little change	very little change
TEST	Test Lot 8A, Ceramic Control Group	Test Lot 13A, Ceramic
PSRR	+/- 300 nV/V	+/- 400 nV/V with 2 outliers
ICC/IEE	+0.5 to +2%, 13 parts no change	-2 to -4%, 5 parts increased (+1%)
VIO	+/-20uV typ	+/-30uV, tight distribution
IIB	+/-200pA max	+/-200pA max
IIO	+/-200pA max	+/-200pA max
Gain	both + and - small changes. No compression	Most increased, no pattern
Slew rate	+1 to +3% (prop to ICC), 13 parts no change	-2 to -5%, 5 parts increased (+1.5%)
CMRR	few with hi initial values decreased	very few with hi initial values shifted
VOP	very little change	very little change
GBW	small incr, correlated to ICC	small drop, 5 parts with small increase
TEST	Test Lot 8A, Plastic Control Group	Test Lot 13A, Plastic
PSRR	+/- 300 nV/V	+/- 300 nV/V
ICC/IEE	0 to +2% typ, 6 parts small decrease	+1.5 to +3.0%
VIO	+/- 25uV typ, 3 parts > +50 uV	+/- 30uV typ, 3 parts up to +/-55 uV
IIB	+/- 500 to 1000 pA max	-100 to -800 pA
IIO	+/-500pA max	+200 to -500 pA
Gain	fluctuated a bit	fluctuated a bit
Slew rate	0 to +3%, Correlated to ICC	+1.5 to +3.0%
CMRR	few with hi initial values decreased	few with hi initial values shifted
VOP	very little change	very little change
GBW	0 to +1.5%	0 to +1.5%
TEST	Test Lot 8A, Ceramic Control Group	Test Lot 13A, Ceramic
PSRR	+/- 200 nV/V	+/- 300 nV/V, 2 parts at +/- 500 nV/V
ICC/IEE	+0.5 to +2%,	-1 to -2.5% typ, 5 parts +1 to +2.5%
VIO	+/-20uV typ; 4439 +50 uV	+/-60uV typ; 2 parts +80 uV, 1 part -180 uV
IIB	+/-200pA typ, few at +/-500pA	+/- 300 pA with one outlier
IIO	+/-200pA typ, few at +/-400pA	+/- 350 pA with one outlier
Gain	fluctuated a bit	fluctuated a bit
Slew rate	+1 to +3% (prop to ICC)	-1.5 to -3.0% typ, 5 parts +1.5 to +2.5%
CMRR	Few with hi initial decreased	few with hi initial values shifted
VOP	very little change	very little change
GBW	+1 to 2%	-0.5 to -1.5% typ, 5 parts no change

Figure 3.1-4: Summary of Wideband Parametric Test Results

test lots 3A, 6A and 8A. These test lots were chosen because, before they were exposed to any radiation exposure, their device parameters were centered well within the manufacturer's specifications. The test lots for the digital components consisted of test data lots 3D, 6D, and 2D which were also chosen because the device parameter values were also near the center of the manufacturer's device specifications.

### **3.2.2 Test Conventions**

The data sets analyzed are referred to as 3A, 3D, 6A, 6D, 8A, and 2D. 3A is analog test lot number 3, 3D is digital test lot number 3, etc. These particular lots represent the testing performance base line that is available for comparative studies and statistical analyses. Within these lots there were no parts whose parameters were out of the manufacture specification ranges after testing and no failures occurred. Test lots 8A and 2D are the reference lots that were not exposed to radiation and these lots are the radiation lot control groups for the studies and statistical analyses.

The parameter data obtained during acceptance testing was not organized such that it could be used to perform comparative studies for the different test groups and test conditions. In order to organize the data for review and analysis it was rearranged using a spreadsheet tabular format, such that the parameter data obtained during the tests are each uniquely labeled with the number assigned to each of the respective tests.

There were 28 separate parameter tests performed on the analog parts and 127 separate tests on the digital parts. The test parameter data that was measured and placed into the spread sheet data columns includes the associated environmental test conditions, parameter value test conditions, and calculated data statistics for the measured test parameter data. The calculated statistical information include maximum, minimum, standard deviation, and deltas between successive test period data. Also, the data at the bottom of each of the columns, for all temperatures and test periods, is compiled into test summary data files.

For each test period, a sampled data file was saved for each test temperature. The code name used for each of the tests includes the following encoded information about the tests: Plastic or ceramic components are indicated as 'P' or 'C'; the lot number of the component part being tested; analog or digital components as 'A' or 'D'; and the temperature description of 'cool', 'room', or 'warm', -40° C, +25° C, and +85° C respectively. All of the data files along with the summary information and the graphical data are included on a computer data disk, or disks, that are supporting information for this report.

### **3.2.3 Engineering Statistical Analysis Method**

Quick look maximum and minimum values were measured for the various test parameters during the test operations in order to confirm that the various part parameters were within the manufacturer provided device parameter specification ranges.

The computed parameter average values and standard deviations that were obtained from the data taken at the outset of testing and prior to the parts EM effects irradiation were used in order to observe how centered the measured parameter values were within the manufacturer specifications for

the different part lots. This activity was used in order to select and provide parts for testing by screening out those parts that were initially out-of-specification. The result is that parts were thereby excluded from the testing process that were "outliers", i. e. initially had parameter performance values that were outside of the manufacturer provided parameter specification ranges.

After each of the test periods, statistical analysis was performed in order to monitor the device parameter values, compare them to the average parameter performance observed for the control group lots, and check to see if any observed shifts in the nominal parameter values could be attributed to device radiation exposure. Also, the parameter average values obtained at the different device temperatures were computed and tabulated and are displayed in sequence as bar graphs on the horizontal axes of the figures for the various test periods and for the different test part lots.

### 3.2.4 Statistical Analysis - Analog Devices

The purpose of acceptance testing was to identify shifts in the average parameter values for the devices. Secondary goals included determining whether observed shifts in the device average parameter values appear to be converging to stable values or whether the shifts indicated that the parameter values were diverging and might eventually exceed the manufacturer's parameter specification ranges.

The first device parameter that was analyzed during the testing and subsequent data reduction was the device power supply input current,  $I_{CC}$ .  $I_{CC}$  was chosen as the first parameter to study because of its sensitivity to other device parameter anomalies, degradations, and failed conditions.

The graphs in this analysis plot the averages of the data measurements that were obtained for 25 different parts. The lot numbers for the associated devices, i. e. the component parts, are plotted on the horizontal axes of the graphs. Also, the graphs are arranged such that the abscissa axes, i. e. the horizontal x axes, have the same x axis scales and as a result the same parts are always shown such that the parts have the same x axis locations, i. e. the same x axis values. Therefore, it is possible to compare the performance durability of the devices, as represented by the part parameter value variations, for the individual parts as a function of the part exposure times to radiation and temperature effects. To observe these parameter value variations, notice the change in the parameter values of the individual parts by comparing the ordinate value variations observed between the different charts at specific x axis values, i. e. parameter value variations observed between the different charts for particular x axis coordinate locations.

Figure 3.2.4-1 presents the control group bar graph average data for  $I_{CC}$ , which is the power supply current in units of amperes. This data was measured for parts that were not exposed to EM effects radiation, but were operated during each of the test periods. The legend 1 indicator identifies the measured  $I_{CC}$  performance at the start of the tests, test period number 1, and legend 2 identifies the performance at the end of the test period, which was approximately one month long. There was one set of ceramic parts and one set of plastic parts in the control group parts set which corresponds to parts lot 8.

Figure 3.2.4-2 presents the bar graph average data for  $I_{CC}$ , the power supply current in units of amperes, before the parts were exposed to EM effects radiation and after the parts were exposed to between 1 and 4 periods of EM effects radiation. The legend numbers 1 to 5 in Figure 3.2.4-2 indicate



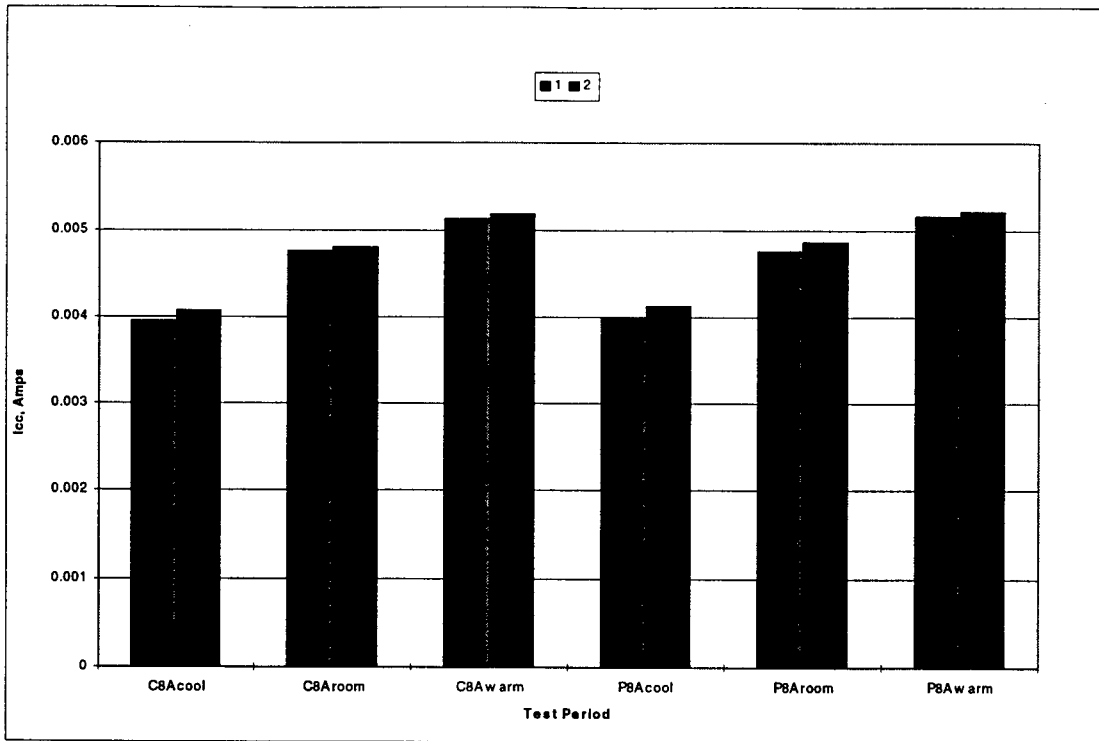

Figure 3.2.4-1: Average Supply Current, I<sub>CC</sub>, for Control Lot 8A

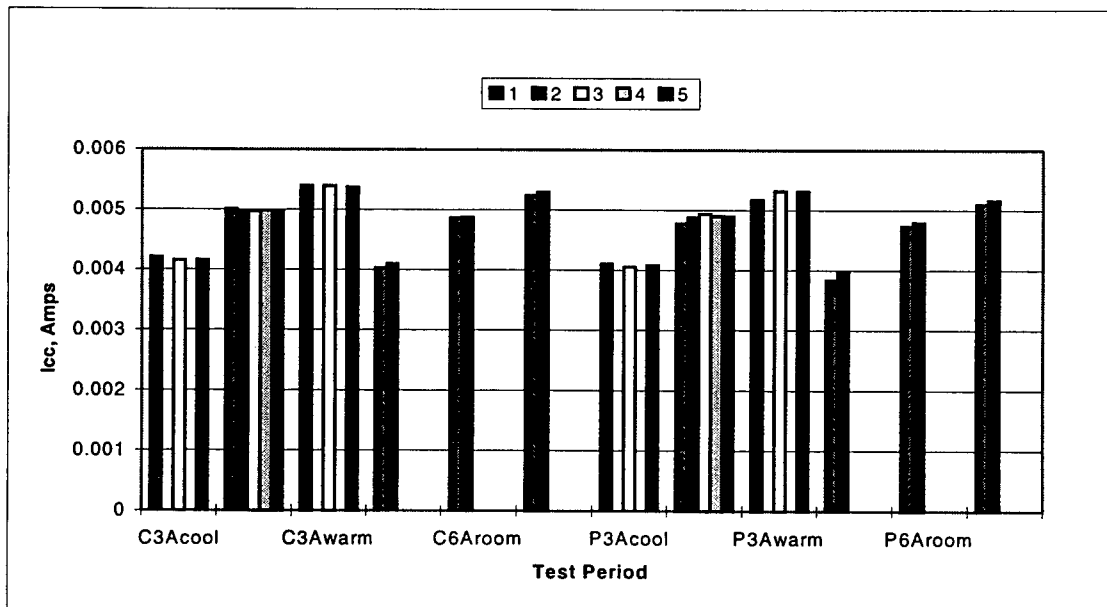

Figure 3.2.4-2: Average Supply Current, I<sub>CC</sub>, for Exposed Lots 3A and 6A

the lengths of the EM effects radiation periods that the parts were exposed to while the parts were being operated and during which the respective  $I_{CC}$  current measurements were made. Legend 1 indicates the current measurements that were made prior to the first radiated test period and legends 2 through 4 indicate the current measurements that were made during each of the four following and successive irradiation periods, i. e. four total and numbered from 2 to 5 respectively. The spaces between the bars in the bar graphs for a particular parts lot and temperature set indicate that no measurement were made at the indicated temperature at the end of the specified test period. There were two sets of ceramic parts and two sets of plastic parts in the EM effects radiation exposed parts set which corresponds to parts lots 3A and 6A.

It is apparent from Figures 3.2.4-1 and 3.2.4-2 that the current averages in the control group, lot 8A, and in the EM effects radiation exposed parts set, lots 3A and 6A, that the parts lots track each other very closely, especially at room temperature (+25° C). Also, the current data averages that are presented in Figures 3.2.4-1 and 3.2.4-2 both consist of data that was measured for 25 device parts. A more detailed look at each of the 25 device parts is shown in Figure 3.2.4-3 where the distribution of the supply current  $I_{CC}$  values is plotted. Each of the line curves represents the  $I_{CC}$  values of a different test period. The curve for legend 1 identifies and corresponds to device parts prior to their exposure to any radiation exposure. Figure 3.2.4-4 presents the changes that were measured for each of the individual 25 parts as a function of the test period times that are illustrated on the graphs by using the independent test period variable that is plotted on the horizontal axis. Additional test results for other device part lots and temperatures ranges are included in appendix C.

By assessing the results obtained from the tests, observe that it is apparent that the ceramic components in Lot 3A did not shift very much except for the eight parts with the highest original  $I_{CC}$  supply current values. None of the observed variations which are a function of time yielded a change that is interpreted as being unusual or yielded current values that are out of the manufacturer parameter specification ranges for any of the results that are presented in Figure 3.2.4-4.

The individual parts for the 25° C temperature testing did not appear to experience effects that are interpreted, in terms of the supply current parameter  $I_{CC}$ , to be adverse. However, although ceramic Lot 6A did have a much wider distribution for the initial values for the supply current  $I_{CC}$ , after testing the observed changes and variations in the supply current for the ceramic parts for Lot 6A appeared to be small. Even though the distribution for the supply current for ceramic Lot 6A is wider than for lot 3A none of the parts have supply currents that are out of manufacturer parameter specification ranges.

In summary, it appears from Figures 3.2.4-3 and 3.2.4-4 that the effect of exposing the device parts to radiation was to stabilize the supply current  $I_{CC}$  and shift it to a new set of mean value ranges. It also reduced the associated standard deviations of  $I_{CC}$  in comparison to the initial supply current values that were measured prior to exposing the parts to radiation as identified by legend 1 in Figures 3.2.4-3 and 3.2.4-4.

Following electromagnetic exposure testing, the parameters of the plastic components in lots 3A and 6A were very similar to those in the control lot. The initial distributions for the supply currents of the different parts in lots 3A and 6A are nearly identical and the differences in their values after testing appear to be insignificant.

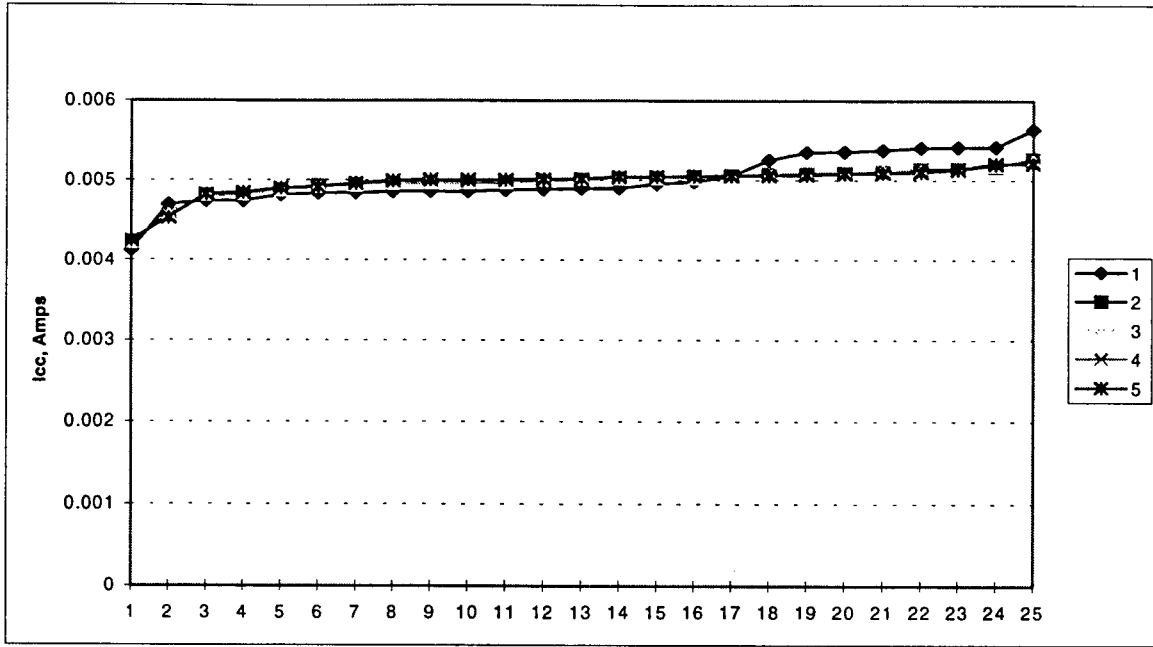

Figure 3.2.4-3: ICC Distribution for Exposed Lot 3A Ceramic Parts, Room Temp

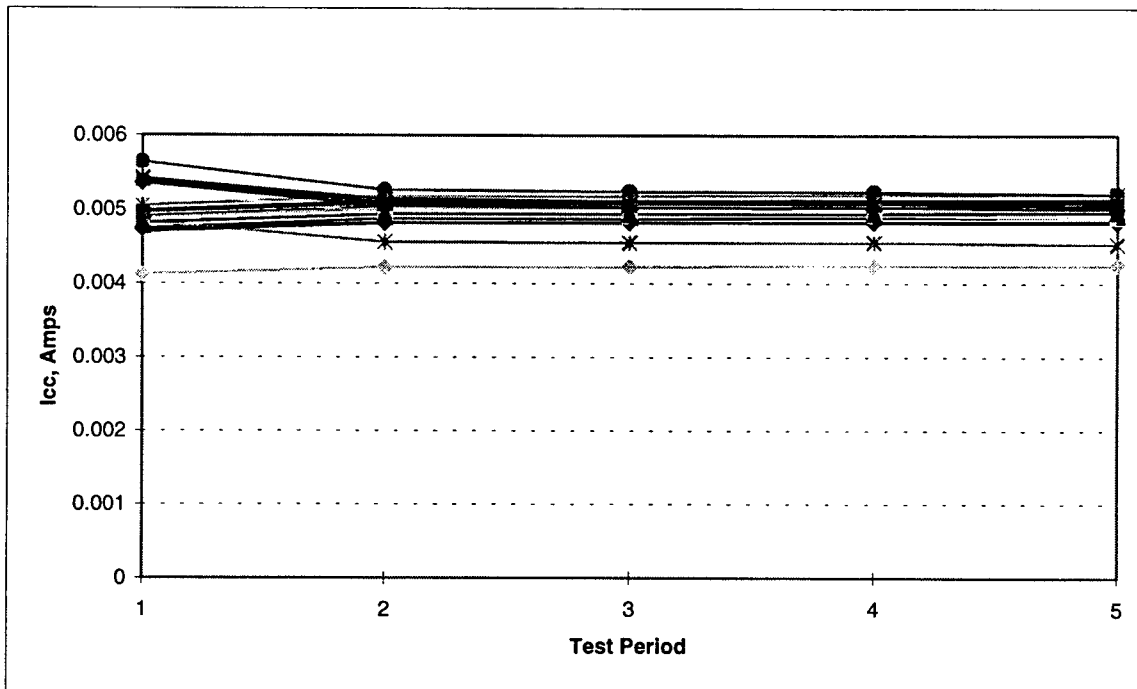

Figure 3.2.4-4: ICC Changes for Individual Components in Exposed lot 3A, Ceramic, Room Temp

The following observations made for the device supply current parameter testing and analysis are representative of those that were made during subsequent testing and analysis for the other device parameters. The main conclusion concerning the effects of the exposure of the analog device parts in lots 3A and 6A to radiation is that there appears to be a minimal shift in the average values of the supply currents with respect to the parts in control lot 8A. Notice that the supply currents for all of these parts remained within the specification range provided by the manufacturer.

For the other parameters, however, it can be said that the data testing and analyses revealed as many questions as they provided answers. For example, there were many shifts in the data parameter averages that are presented in appendix C. Many of these changes appear to be random in nature for the exposed parts lots and do not appear to be correlated with the pattern of shifts in the control lots. Generally it is difficult to draw inferences from this data about the effects of radiation exposure on the analog parts. However, for example, the input bias current went up in Lot 3A and 6A for the plastic components, while for the ceramic parts it did not seem to change. This response of the analog parts to radiation exposure could be related to the observation that the plastic components do not dissipate heat as efficiently as do the ceramic components.

Many of the other device parameters tested exhibited significant changes during one or more of the test periods; and then, during a subsequent test period, the observed deviations from the control lot device parameter values disappeared. As a result, the values of the device parameters were observed to shift or drift back into alignment with the values of the control lot part parameter values. The conclusion drawn is that the parameters of the analog test devices do not appear to be sensitive to the levels of radiation exposure and duration in our tests; and it is, therefore, difficult to make statistical predictions about the adverse effects that radiation exposure has on analog device parts based on the amount of testing that was performed.

Another occurrence observed for a large majority of the devices tested was that following exposure to radiation their parameters values had drifted with respect to the parameter values of the control lot devices that were not exposed to radiation. Although the parameter value drifted, the devices analyzed were still within the manufacturer specification ranges, but the drift in the device parameter values did not converge to stabilized values. Therefore, it is possible that these device parameter values could continue to drift during periods of additional radiation exposure or even after the exposure to radiation ceased, until eventually the device parameter values would move outside of the manufacturer specification parameter value ranges. But many of the exposed parts continued to drift even when the control lot parameter values appeared to level off and stabilize.

In summary, what appears to be certain as a result of analog testing is that device parameter value drift occurs in response to RF radiation exposure. A potential also exists for violating the device manufacture parameter specifications, and the likelihood of violating the device manufacture parameter specifications appears to increase with continuing electromagnetic field radiation exposure.

### **3.2.5 Statistical Analysis - Digital Devices**

Using the same approach as for the analog components, we carried out the testing and statistical analysis for the digital components. The device supply currents and parameter value shifts were

measured and the current maximums, minimums, and standard deviations were computed for each of the test periods. Neither the digital device part lots exposed to radiation, 3D and 6D, nor the digital device control part lot not exposed to radiation, 2D, had any parts with parameter values that were out of the manufacturer parameter value specification ranges.

The changes observed in parameter values for the digital devices are similar to those observed for the analog devices. The measured data and summary graphical results for this work are presented in appendix C.

During testing it was observed that generally the performances of the various device parameters were dependent on and sensitive to the performance of the device supply current parameter value. In order to better describe and understand the performance of the various device parameters and avoid masking their behavior with the behavior of the device supply current, the device supply current parameters were thoroughly tested, analyzed, and characterized.

The initial supply current parameter data for control lot 2 for the plastic components at room temperature is in error due to a fault in the automated test system. As a result, the supply current for these first sets of test data is too low in every instance. This test system problem was corrected for the subsequent test periods and it did not affect the other test results or the overall test results.

The text in this section was copied almost intact from the test log and, as a result, it is somewhat rough, but it still highlights and summarizes the main observations that were made during testing for the digital devices.

As the data in appendix C illustrates, the device input currents varied significantly between the beginning and the ends of the different test periods. The input current for the exposed lots increased in many cases as well as decreased. Some of the lots that were measured between several test periods showed up and down variations with no continuing trend, which was unexpected. The cause of the difference in the behavior of the exposed lots and the control lots is most likely due to the radiation exposure the devices received during the test periods. The rate of change as well as the direction of the change is interpreted to be unpredictable and therefore trends cannot be predicted with any degree of certainty. The result of varying the input current has effects on many of the other parameters that could be a reason for their apparently dependent changes. The results can still be compared to the control lot for use as a reference.

The most significant changes that the digital components experienced were the changes in the pulse widths. The Preset (PR) pulse width decreased much more for the RF exposed parts than for those in the control lot. Figures 3.2.5-1 and 3.2.5-2 show the decrease in PR1 pulse width for the control and the exposed lots respectively. PR2 pulse width averages are shown in Figures 3.2.5-3 and 3.2.5-4, but the results were not clear until further investigation. The individual component values were tracked for the exposed lots in a two graph per page format. The first represents the distribution of the values for each component. The blue lines and diamonds labeled '1' are the values measured before exposure. Each of the other lines shows the values after testing. They are arranged in ascending order to see the extremes easily. The second graph on each of the pages has individual lines for each of the parts showing the change with time at discrete measuring points. Many of the parts had the same original value and changed by the same amount, which means that the lines are overlaid. This indicates

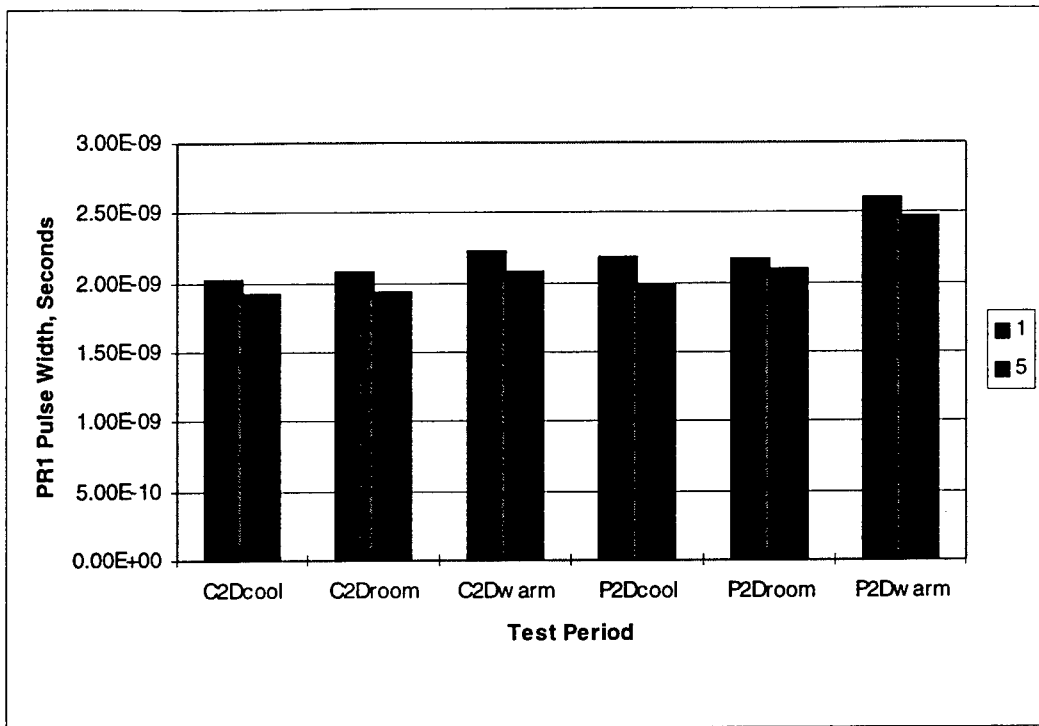

Figure 3.2.5-1: Average PR1 Pulse Width with V<sub>CC</sub>=5.5V, Lot 2D (Control)

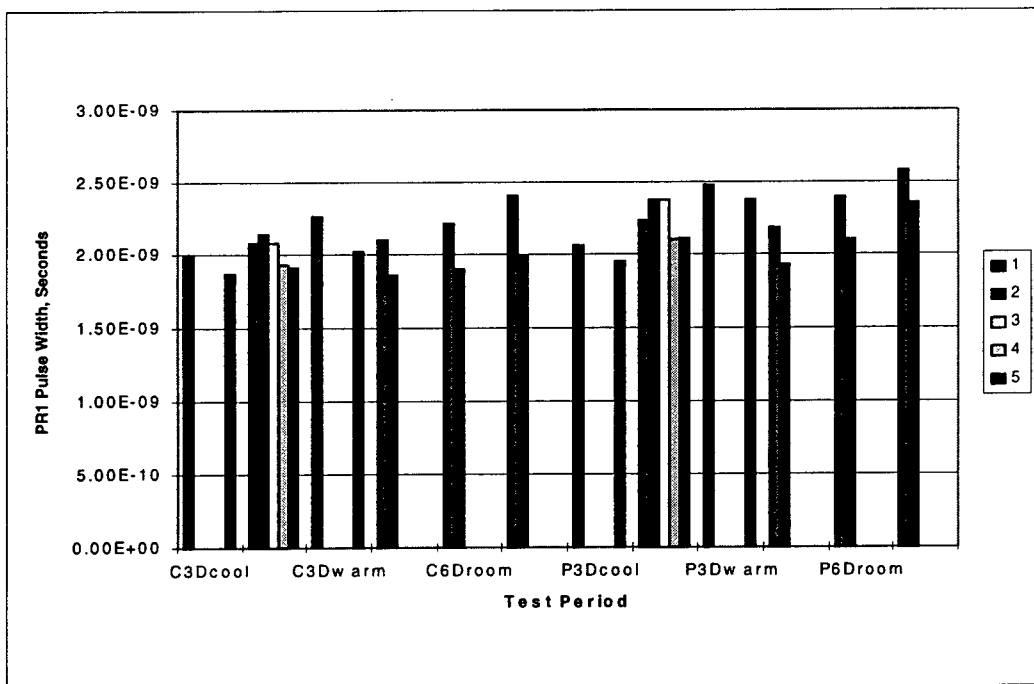

Figure 3.2.5-2: Average PR1 Pulse Width with V<sub>CC</sub>=5.5V, Lots 3D and 6D (Exposed)

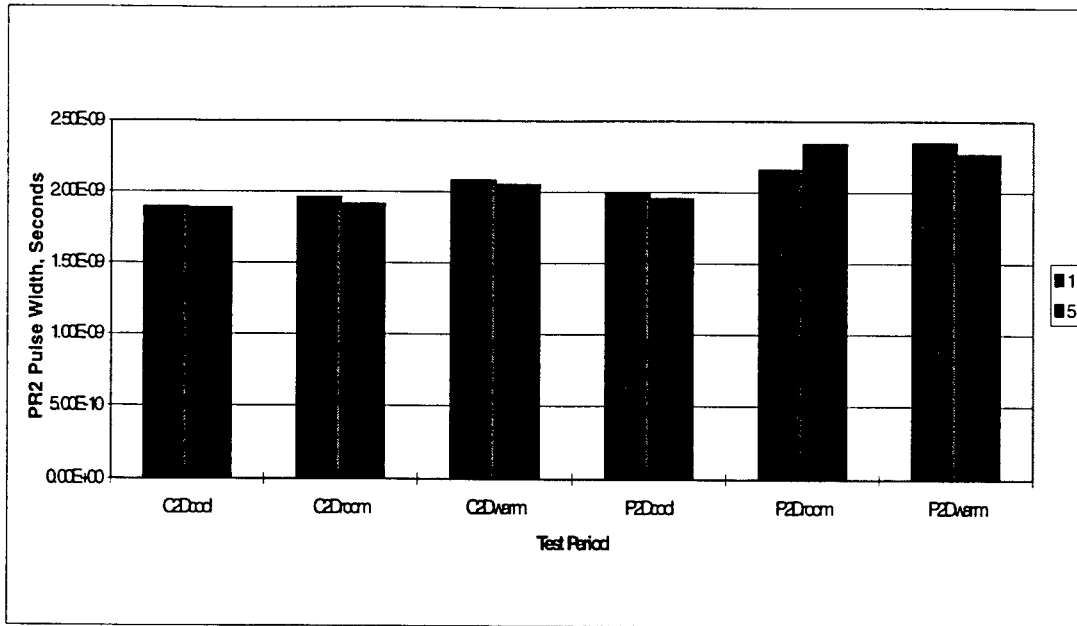

Figure 3.2.5-3: Average PR2 Pulse Width with V<sub>CC</sub>=5.5V, Lot 2D (Control)

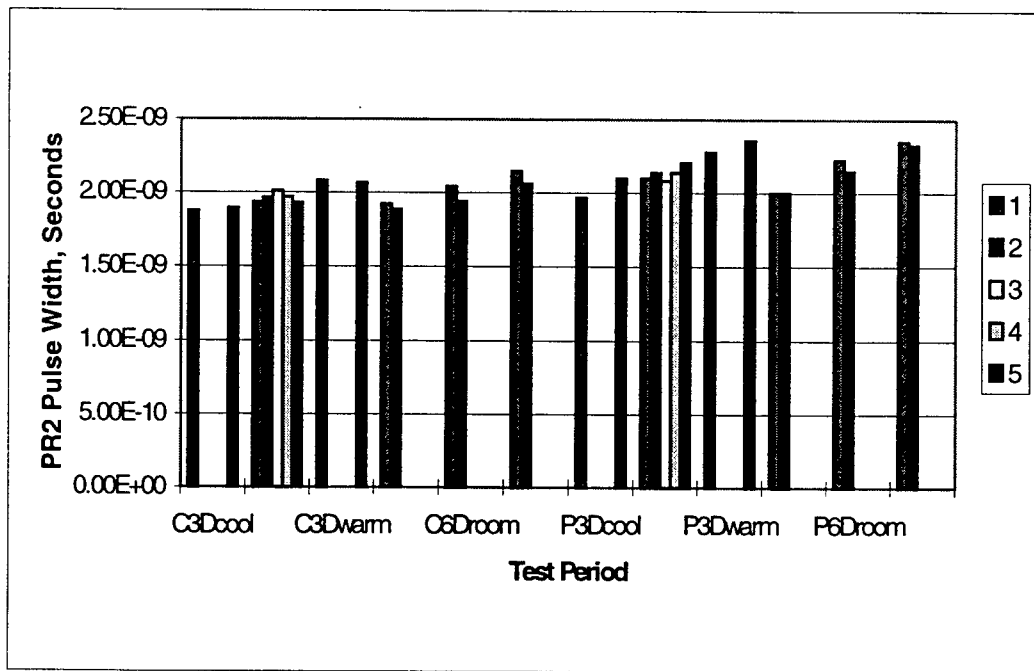

Figure 3.2.5-4: Average PR2 Pulse Width with V<sub>CC</sub>=5.5V, Lots 3D and 6D (Exposed)

the parts are behaving in a somewhat similar fashion, which is positive when it comes to making predictions.

The CLR pulse widths seem to increase in many cases, opposite of the PR pulse width. The control lot however, is not as stable and the baseline provided is not as good for reference (see Figures 3.2.5-5 and 3.2.5-6 for CLR1 and Figures 3.2.5-7 and 3.2.5-8 for CLR2 averages). The graphs for individual components in the exposed lots show clear evidence of an increasing pulse width trend for the CLR pulses. The similarities in the original part values and the changed values can again be seen. It also seems as if there are several discrete value changes, but that has not been verified. The individual part changes for CLR1 and CLR2 can be seen in appendix C.

Clear and preset removal times were also investigated and the variation seen was similar in direction to the control lots, but the change itself was more extreme in most cases. This again has exceptions, but Figures 3.2.5-9 and 3.2.5-10 show the average CLR2 removal times for the control and exposed lots. Additional parameters were analyzed, but the results of those investigations were inconclusive. Many of the parameters were extremely consistent and comparable to the control lots, but others were somewhat erratic and unpredictable. One interesting note is the leakage current tests. The leakage current in nearly all the devices in the control lots and the test lots decreased greatly from the levels at the start of testing to the levels observed at the end of testing, i. e. after operating the parts during the test periods. No attempts were made to interpret the leakage current observations.

### **3.3 Statistical Analysis II**

A statistical analysis was performed on the data collected during the test phase of this contract. The analysis presented in this section was performed by statistics professionals on a larger set of data than the analysis in section 3.2. This analysis is performed on test devices that were subjected to a variety of environmental conditions.

The devices under test were subjected to varying environmental conditions and then specific parameter values were measured at distinct time intervals and at three measurement temperatures. The environmental conditions were thermal exposure, radiated exposure, and combinations of thermal and radiated exposure. The statistical analysis was performed to determine any trends in the parameter values that could be attributed to the environmental conditions, length of exposure, or measurement temperature.

The approach taken in the statistical analysis was to first determine if the parameter values were within manufacturer's specification limits. Also, the margin between the specification limit and the actual value was calculated where applicable. Then the change in the mean values of the parameters between the first and the last test period for a particular environmental setup were compared with other environmental setups. The rationale for this comparison was to show any correlation between mean value changes that could be attributed to the varying environmental conditions. A comparison was not made with the control since data only existed for one time period for the control. Such a comparison between the control and the various environmental conditions would not yield useful data. Percentage change calculations were also performed. The first calculation was the percentage change between test periods for a unique environmental condition to show any parameter



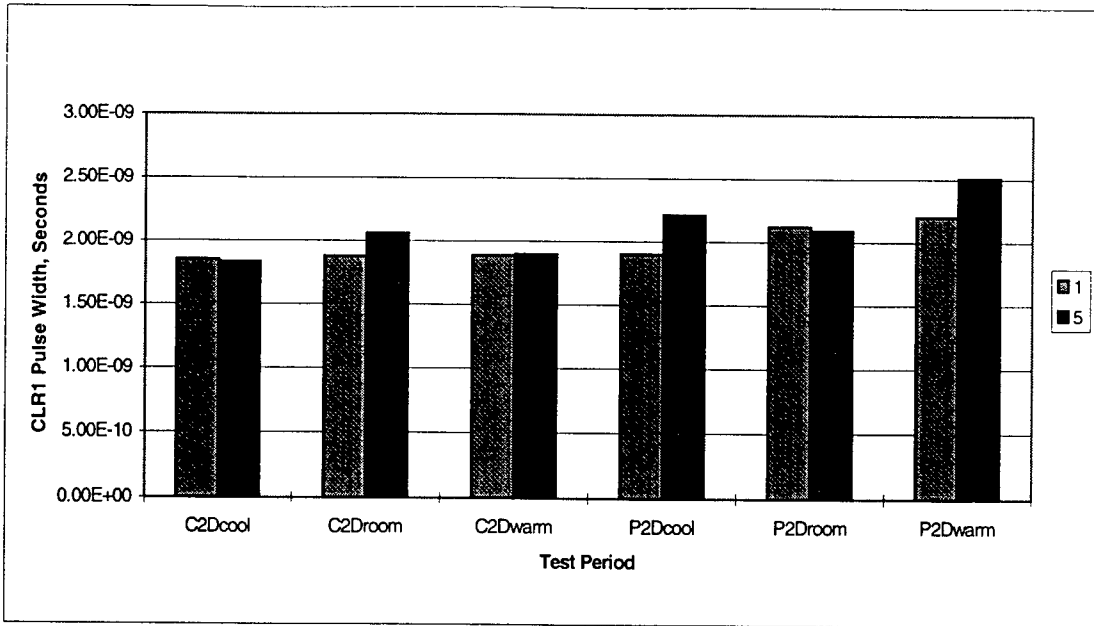

Figure 3.2.5-5: Average CLR1 Pulse Width with V<sub>CC</sub>=5.5V, Lot 2D (Control)

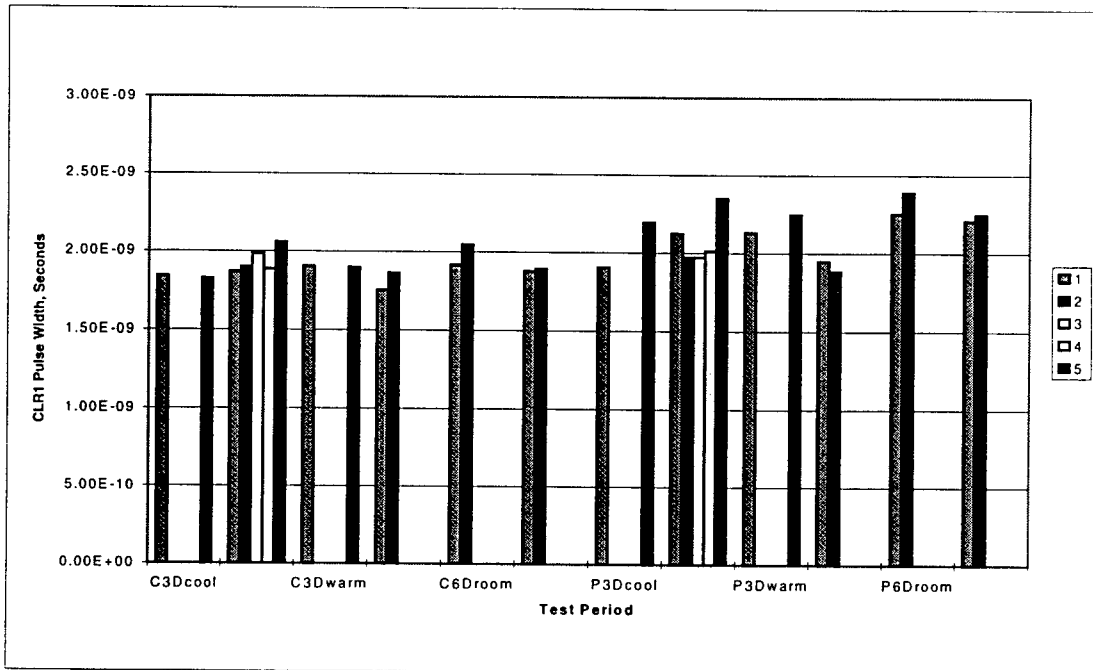

Figure 3.2.5-6: Average CLR1 Pulse Width with V<sub>CC</sub>=5.5V, Lots 3D and 6D (Exposed)

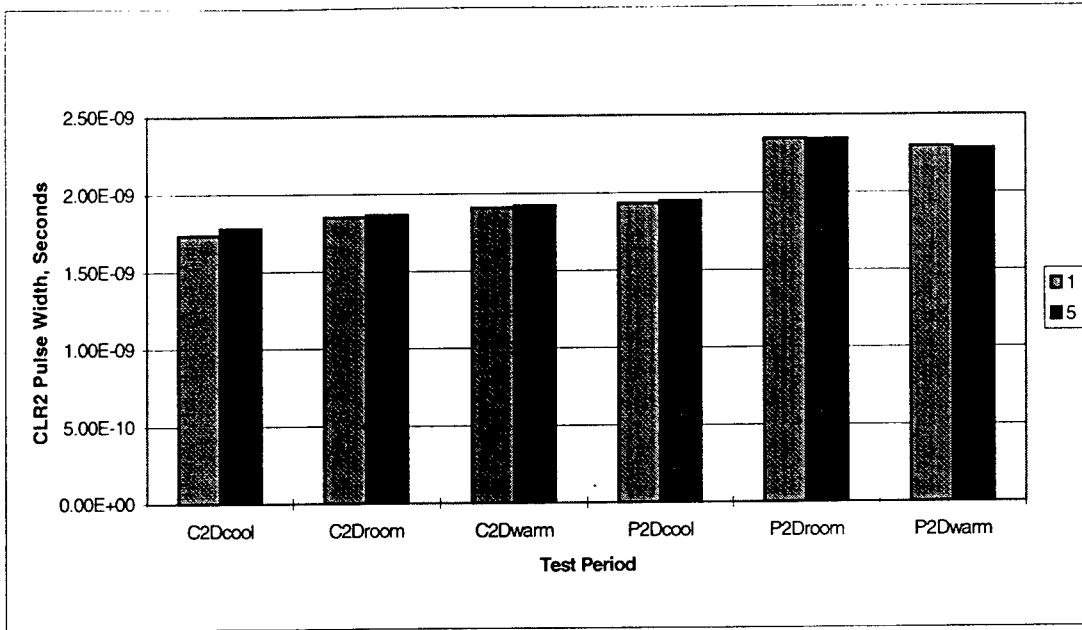

Figure 3.2.5-7: Average CLR2 Pulse Width with V<sub>CC</sub>=5.5V, Lot 2D (Control)

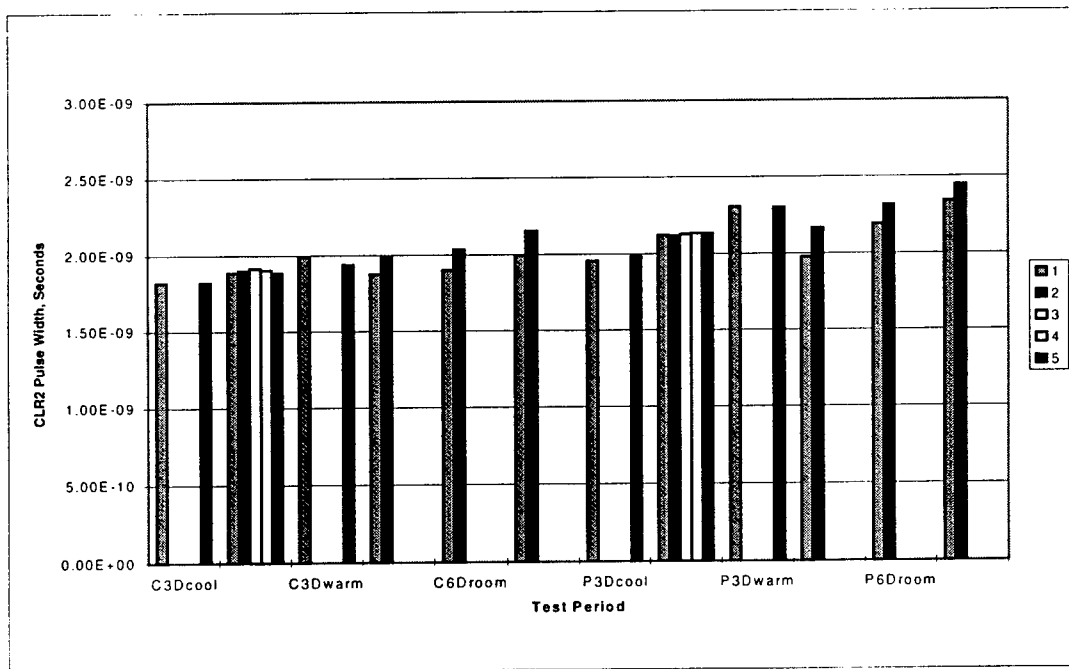

Figure 3.2.5-8: Average CLR2 Pulse Width with V<sub>CC</sub>=5.5, Lots 3D and 6D (Exposed)

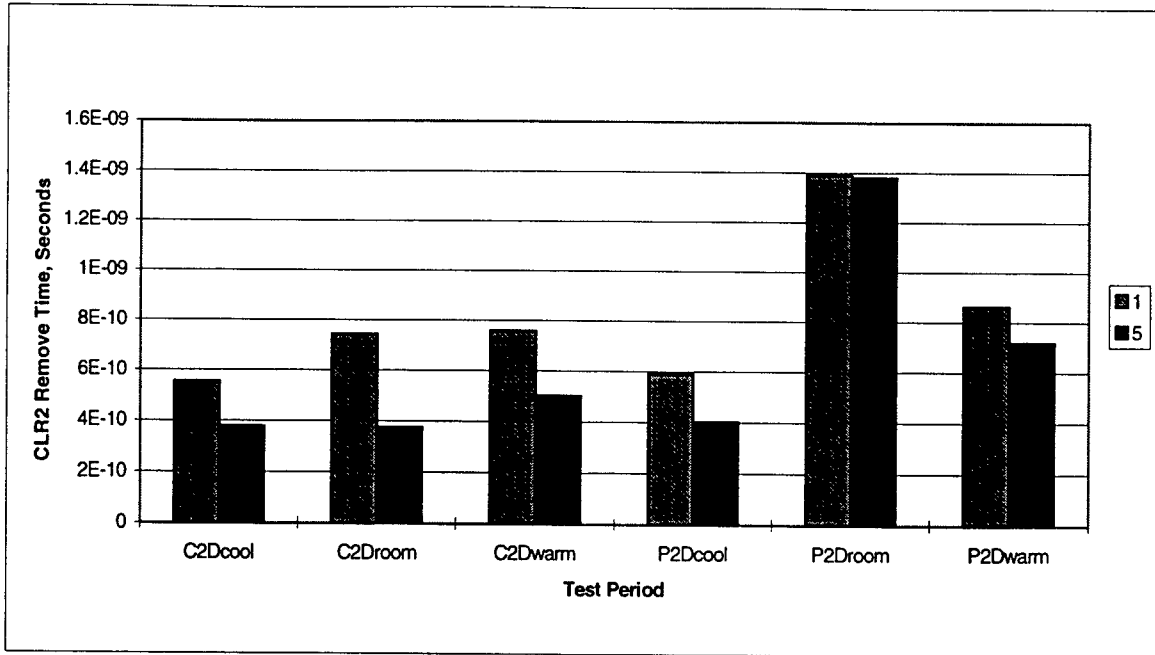

Figure 3.2.5-9: Average CLR2 Removal Time with  $V_{CC}=5.5V$ , Lot 2D (Control)

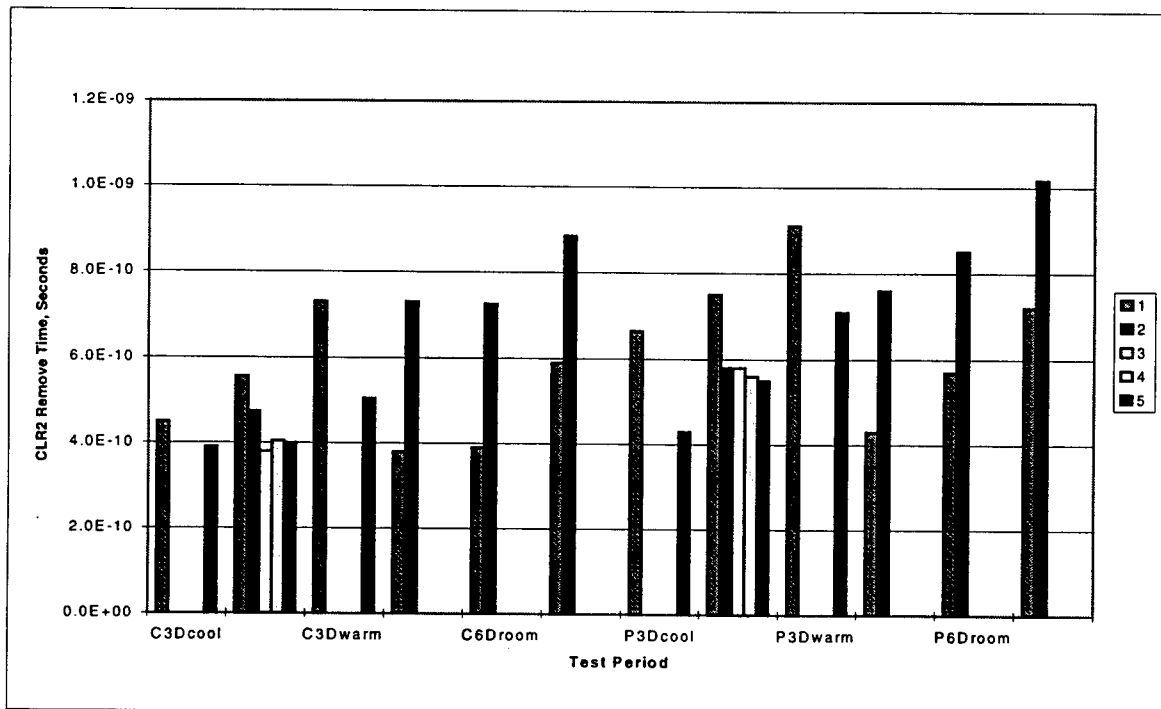

Figure 3.2.5-10: Average CLR2 Removal Time with  $V_{CC}=5.5V$ , Lots 3D and 6D (Exposed)

value changes due to extended exposure to environmental conditions. The second calculation was for one time period between the different measurement temperatures. This was to show how the measurement temperatures affected the parameter values. The data and calculations for the gain bandwidth, large signal voltage gain, and positive supply current for ceramic and plastic components will be listed and discussed below.

The devices under test were exposed to four varying environmental conditions. The first condition was a control scenario where the operational amplifiers tested were not exposed to either thermal or irradiated conditions. Their parameters were initially measured and then measured again after one test period. The next condition considered was a thermal scenario where the devices under test were exposed to 85° C for four test periods. The next test lot of operational amplifiers was exposed to two test periods of thermal exposure followed by two test periods of thermal and irradiated exposure. The final scenario considered was exposure to four test periods of radiation and no thermal exposure.

Based upon the data and analysis below it can be seen that the parameter values tended to increase when the measurement temperature was increased from cool to room temperatures. The  $I_{CC}$  values showed the largest increases (approximately 18-20%) and the gain-bandwidth showed the smallest increases (approximately 0.5-1.5%). Also, it could be observed that the parameter values either decreased or showed significantly lower increases when transitioned from room to warm conditions.

All parameter values easily passed the minimum specification limits. Most were fifty percent or more above the passing values. For  $I_{CC}$ , the specification sheet listed that the passing value should not exceed 15 nA and most values were around 4-5 nA.

Other conclusions could not be determined based upon the analysis performed. Some slight trends were observed, but the changes seen were only a few percent. These slight changes should not be used to extrapolate any expected values due to the limited number of data points and burn-in effects. Data was collected before any of the devices were exposed to environmental conditions and after each month of exposure for four months. This gave a total of five data points for each device's parameter values. Included in these data values are the effects of burn in of the operational amplifier. These effects should not be used to determine a model of system reliability. Therefore, it would be worthwhile to determine the length of time for burn in, and then conduct similar tests again excluding the burn in period. The test should either be performed for a longer period or data should be recorded more frequently so any trends in system performance due to the varying environments could be observed. The basis for this argument is that it can be difficult to observe trends when only five data points are plotted.

### **3.3.1 Analysis of Gain-Bandwidth Parametric Data**

Gain-bandwidth is the product of the frequency and the maximum gain of the operational amplifier at that frequency, and for voltage-feedback op-amps it remains relatively constant over the useable frequency range of the op-amp. The minimum passing value for the OP-271 operational amplifier is 4 MHz while the typical value is 5 MHz. All devices exceeded the minimum gain-bandwidth value and most were significantly higher. It can be seen in Figure 3.3.1-1 that gain-

Control	average value above 4MHz		% above 4MHz	
	TP1	TP2	TP1	TP2
cool	2.51E+06	2.58E+06	62.85	64.53
room	2.60E+06	2.63E+06	65.02	65.86
warm	2.27E+06	2.31E+06	56.70	57.80
4 thermal	average value above 4MHz		% above 4MHz	
	TP1	TP5	TP1	TP5
cool	2.36E+06	2.51E+06	58.95	62.64
room	2.38E+06	2.56E+06	59.61	64.05
warm	2.09E+06	2.19E+06	52.16	54.82
2 radiated, 4 thermal	average value above 4MHz		% above 4MHz	
	TP1	TP5	TP1	TP5
cool	2.41E+06	2.55E+06	60.17	63.81
room	2.44E+06	2.59E+06	61.04	64.71
warm	2.14E+06	2.28E+06	53.42	57.07
4 radiated	average value above 4MHz		% above 4MHz	
	TP1	TP5	TP1	TP5
cool	2.67E+06	2.70E+06	66.80	67.50
room	2.72E+06	2.81E+06	68.09	70.16
warm	2.46E+06	2.46E+06	61.44	61.60

Figure 3.3.1-1: Gain-Bandwidth Data Relative to the 4 MHz Pass Value for Plastic Op-amps

bandwidth for plastic components increased with extended exposure for every environmental condition. This increase was only a few percent in most cases, and was also observed in the control lot so it can not be directly linked to a particular environment. This may be a burn-in characteristic of the amplifier. In ceramic operational amplifiers, the gain-bandwidth increased in small amounts for all cases, except one, with extended exposure to environmental conditions, as shown in Figure 3.3.1-2.

It is also of interest to see how the data varied according to measurement temperature. After the components were exposed to the different conditions their parameter values were measured at three different temperatures. As you can see in Figure 3.3.1-3, the gain-bandwidth value increased slightly when the measurement temperature was changed from cool to room. However, when the temperature was changed from room to warm, the gain-bandwidth decreased by approximately 5%. For ceramic op-amps the gain-bandwidth increased by a percent or two when transitioned from cool to room but decreased by approximately 5% when transitioned from room to warm as shown in Figure 3.3.1-4. The overall change in mean value for the environmental conditions showed a slight increase as seen in Figure 3.3.1-5. A t-Test is a statistical comparison between the means of two groups of data to determine if the variances and the distributions of the two groups are similar. This test informs the user of how the mean and the distribution of the data changed when different environmental conditions are applied. A t-Test can be for two unknown variances that are considered equal or for two unknown variances that are considered unequal with appropriate equations employed for the two different cases. The data above displays the means of the difference between the parameter values before and after exposure. The means of the distributions are expected to change and the shape of the distribution does not necessarily remain constant when exposed to the environmental conditions. Based upon a statistical t-Test of two means, the 4 times thermal and 2 times radiated plus 4 times thermal had similar distributions. So based upon the above description of the t-Test, the two sets of data had similar changes in value as can be seen in the chart above and similar distributions with respect to each other. However, their means and distributions differ from that of the control. So it can be concluded that the two environmental conditions had similar effects on the gain-bandwidth values.

It should be noted that the 4 month radiated data did not consider the warm measurement data because it was very erratic. None of the distributions for the ceramic data were similar as shown in Figure 3.3.1-6. This was again based upon the statistical t-Test of two means for the different possible groups. So every environmental condition affected the parameter values differently and their distributions' shapes were all different as well. The data did show a slight trend towards decreasing gain bandwidth with increasing exposure to radiation.

### **3.3.2 Analysis of Large Signal Voltage Gain Parametric Data ( $R_L=2k$ )**

The next parameter considered was large signal voltage gain with a load resistance of  $2k\Omega$ . These parameter values were measured only at room temperature so no comparison can be made for varying measurement temperatures.

All plastic components easily passed the minimum large signal voltage gain of 90 V/mV, and the summary of this analysis is shown in Figure 3.3.2-1. The data did show a slight decreasing trend in gain value for extended exposure. All ceramic components easily passed the minimum large signal

Control	average value above 4MHz		% above 4MHz	
	TP1	TP2	TP1	TP2
cool	2.31E+06	2.42E+06	57.7879	60.54505
room	2.40E+06	2.53E+06	59.9105	63.1302
warm	2.13E+06	2.22E+06	53.20795	55.58775
4 thermal	average value above 4MHz		% above 4MHz	
	TP1	TP5	TP1	TP5
cool	3.81E+06	4.02E+06	95.1333	100.4026
room	3.85E+06	4.06E+06	96.3294	101.3837
warm	3.40E+06	3.57E+06	84.94935	89.191
2 radiated, 4 thermal	average value above 4MHz		% above 4MHz	
	TP1	TP5	TP1	TP5
cool	2.73E+06	2.78E+06	68.30185	69.6013
room	2.82E+06	2.87E+06	70.5466	71.6369
warm	2.48E+06	2.60E+06	61.9948	64.8834
4 radiated	average value above 4MHz		% above 4MHz	
	TP1	TP5	TP1	TP5
cool	2.92E+06	2.84E+06	73.01645	71.0844
room	2.95E+06	2.96E+06	73.84405	73.92155
warm	2.67E+06	2.62E+06	66.79615	65.4845

Figure 3.3.1-2: Gain-Bandwidth Data Relative to the 4 MHz Pass Value for Ceramic Op-amps

	Actual Gain-Bandwidth Values				
	TP1	TP2	% diff (TP2-TP1)	% Change TP1 (cool to room)	% Change TP2 (cool to room)
cool	6.51E+06	6.58E+06	1.03	1.33	0.81
room	6.60E+06	6.63E+06	0.51	% Change TP1 (room to warm)	% Change TP2 (room to warm)
warm	6.27E+06	6.31E+06	0.70	-5.041638703	-4.861790848
	TP1	TP5	% diff (TP5-TP1)	% Change TP1 (cool to room)	% Change TP5 (cool to room)
cool	6.36E+06	6.51E+06	2.32	0.410781545	0.869759034
room	6.38E+06	6.56E+06	2.79	% Change TP1 (room to warm)	% Change TP5 (room to warm)
warm	6.09E+06	6.19E+06	1.75	-4.663576349	-5.626646015
	TP1	TP5	% diff (TP5-TP1)	% Change TP1 (cool to room)	% Change TP5 (cool to room)
cool	6.41E+06	6.55E+06	2.27	0.542009227	0.549429418
room	6.44E+06	6.59E+06	2.28	% Change TP1 (room to warm)	% Change TP5 (room to warm)
warm	6.14E+06	6.28E+06	2.38	-4.73392751	-4.634157892
	TP1	TP5	% diff (TP5-TP1)	% Change TP1 (cool to room)	% Change TP5 (cool to room)
cool	6.67E+06	6.70E+06	0.42	0.774105128	1.584078737
room	6.72E+06	6.81E+06	1.23	% Change TP1 (room to warm)	% Change TP5 (room to warm)
warm	6.46E+06	6.46E+06	0.10	-3.954482785	-5.027248253

Figure 3.3.1-3: Gain-Bandwidth Change vs. Measurement Temperature Change for Plastic Op-amps



	TP1	TP2		% Change TP1 (cool to room)	% Change TP2 (cool to room)
cool	6.31E+06	6.42E+06	1.75	1.35	1.61
room	6.40E+06	6.53E+06	2.01	% Change TP1 (room to warm)	% Change TP2 (room to warm)
warm	6.13E+06	6.22E+06	1.55	-4.191438336	-4.62357675
	TP1	TP5	% diff (TP5-TP1)	% Change TP1 (cool to room)	% Change TP5 (cool to room)
cool	7.81E+06	8.02E+06	2.70	0.612965598	0.489564507
room	7.85E+06	8.06E+06	2.57	% Change TP1 (room to warm)	% Change TP5 (room to warm)
warm	7.40E+06	7.57E+06	2.29	-5.796406448	-6.054462203
	TP1	TP5	% diff (TP5-TP1)	% Change TP1 (cool to room)	% Change TP5 (cool to room)
cool	6.73E+06	6.78E+06	0.77	1.333764305	1.200226649
room	6.82E+06	6.87E+06	0.64	% Change TP1 (room to warm)	% Change TP5 (room to warm)
warm	6.48E+06	6.60E+06	1.78	-5.014347985	-3.93475995
	TP1	TP5	% diff (TP5-TP1)	% Change TP1 (cool to room)	% Change TP5 (cool to room)
cool	6.92E+06	6.84E+06	-1.12	0.478336019	1.658333548
room	6.95E+06	6.96E+06	0.04	% Change TP1 (room to warm)	% Change TP5 (room to warm)
warm	6.67E+06	6.62E+06	-0.79	-4.054150832	-4.851066472

Figure 3.3.1-4: Gain-Bandwidth Change vs. Measurement Temperature Change for Ceramic Op-amps

	Control	4 thermal	2 radiated, 4 thermal	overall percent change
Control	48261.3			0.746961676
4 thermal	different	143835.3		2.291724933
2 radiated, 4 thermal	different	similar	146076.7	2.308269761
	Ref (minus warm)	4xradiated		
Control	50435.0			
4 radiated	similar	39106.7		0.590934564

Figure 3.3.1-5: t-Test Results and Change in Mean Value for Environmental Conditions for Plastic Operational Amplifiers

	Control	4 thermal	2 radiated, 4 thermal	4 radiated	overall percent change
Control	111422				1.774588514
4 thermal	different	194203			2.526881595
2 radiated, 4 thermal	different	different	70378		1.05389261
4 radiated	different	different	different	-42216	-0.616403973

Figure 3.3.1-6: t-Test Results and Change in Mean Value for Environmental Conditions for Ceramic Operational Amplifiers

The minimum passing value for the large signal voltage gain is 90 V/mV					
Control	Avg. Values			% above passing value	
	TP1	TP2	% Diff.	TP1	TP2
room	155.9527027	149.031081	-4.44	73.28078	65.59009
4 thermal					
	TP1	TP5	% Diff.	TP1	TP5
room	155.9448	153.4172	-1.62	73.272	70.46356
2 radiated, 4 thermal					
	TP1	TP5	% Diff.	TP1	TP5
room	152.1688	150.388	-1.17	69.07644	67.09778
4 radiated					
	TP1	TP5	% Diff.	TP1	TP5
room	156.0744	154.5274	-0.99	73.416	71.69711

Figure 3.3.2-1: Large Signal Voltage Gain Change and Margin of Pass Summary for Plastic Op-Amps

voltage gain of 100 V/mV as shown in Figure 3.3.2-2. This Figure also shows that there was a slight decreasing trend in gain value with extended exposure. However, this trend shows a change of only a few percent between conditions, which does not provide tangible evidence that the change can be attributed to the radiation exposure.

The t-Test data for plastic and ceramic op-amps is shown in Figures 3.3.2-3 and 3.3.2-4 respectively. Based upon the t-Test between two means, the distributions for all conditions were different except the plastic 4 radiated and 2 radiated plus 4 thermal that had similar distributions. Based upon this test the groups exposed to four radiation periods and the group exposed to two radiation periods plus four thermal periods experienced similar shifts in mean value and their distribution shapes were similar.

### **3.3.3 Analysis of Large Signal Voltage Gain Parametric Data ( $R_L=10K$ )**

Figures 3.3.3-1 and 3.3.3-2 show the average values of large signal voltage gain into a high impedance load for plastic and ceramic op-amps respectively. These parameter values were all measured at room temperature. The specification sheet for these components calls for a minimum large signal voltage gain of 150 V/mV when a load resistance of 10 k $\Omega$  is applied. However, much larger gain values were encountered. The gain significantly decreased with extended exposure for all cases in both plastic and ceramic devices.

Figure 3.3.3-3 shows the t-Test results for plastic test parts exposed to various test scenarios. Figure 3.3.3-4 shows the same t-Test for ceramic parts. For both types of parts, the 4-month thermal and 4-month radiated exposure had similar distributions. This is the first case when an observable trend in t-Tests was seen between ceramic and plastic components for the same environment. This shows that for ceramic and plastic components the four month exposure to radiation and four month exposure to thermal conditions produced approximately the same effect on parameter values. Their change in mean values and their distribution shapes were similar.

### **3.3.4 Analysis of Positive Power Supply Current ( $I_{CC}$ ) Parametric Data**

The next parameter analyzed was the positive supply current ( $I_{CC}$ ) of the operational amplifiers. This value should not exceed 15 nA as described on the specification sheet. The extended exposure analysis of  $I_{CC}$  for the plastic op-amps, which is shown in Figure 3.3.4-1, is inconclusive. There were some observed increases in the supply current with extended exposure and some decreases in supply current. The currents were always less than 15 nA and the values were usually around 4-5 nA. There were significantly large increases in supply current when transitioning from cool to room measurement temperatures. There were increases from room to warm measurement temperatures but they were much less than the cool to room transition. For the ceramic parts there were inconclusive trends observed for extended exposure, which is shown in Figure 3.3.4-2. All supply current measurements were within specification and were approximately 5 nA in magnitude. There were large increases from cool to room measurement temperatures and smaller increases from room to warm temperatures.

The t-Test showed that there were similar distributions for the 4 month thermal and 2 month radiated plus 4 month thermal environments for the plastic op-amp as shown above in Figure 3.3.4-3.

The minimum passing value for the large signal voltage gain is 100 V/mV					
Control	Avg Values			% above passing value	
	TP1	TP2	% Diff.	TP1	TP2
room	155.4686	156.2616	0.51	55.4686	56.2616
4 thermal					
	TP1	TP5	% Diff.	TP1	TP5
room	157.999	154.0662	-2.49	57.999	54.0662
2 radiated, 4 thermal					
	TP1	TP5	% Diff.	TP1	TP5
room	156.9	152.1838	-3.01	56.9	52.1838
4 radiated					
	TP1	TP5	% Diff.	TP1	TP5
room	155.1058	152.445	-1.72	55.1058	52.445

Figure 3.3.2-2: Large Signal Voltage Gain Change and Margin of Pass Summary for Ceramic Op-Amps

	Control	4 thermal	2 radiated, 4 thermal	4 radiated
Control	-6.92162162			
4 thermal	different	-2.5276		
2 radiated, 4 thermal	different	different	-1.7808	
4 radiated	different	different	similar	-1.547

Figure 3.3.2-3: t-Test Results and Change in Mean Value for Environmental Conditions for Plastic Op-Amps

	Control	4 thermal	2 radiated, 4 thermal	4 radiated
Control	0.793			
4 thermal	different	-3.9328		
2 radiated, 4 thermal	different	different	-4.7162	
4 radiated	different	different	different	-2.6608

Figure 3.3.2-4: t-Test Results and Change in Mean Value for Environmental Conditions for Ceramic Op-Amps

The minimum passing value large signal voltage gain for $R_L=10k$ and plastic components is 150 V/mV				
Control	Avg Values			
	TP1	TP2	% Diff	
room	7047.92	3350.024	-52.47	
4 thermal				
	TP1	TP5	% Diff	
room	5988.5063	4783.642	-20.12	
2 radiated, 4 thermal				
	TP1	TP5	% Diff	
room	4232.06	3592.34	-15.12	
4 radiated				
	TP1	TP5	% Diff	
room	6531.8042	4710.89	-27.88	

Figure 3.3.3-1: Large Signal Voltage Gain and Change at  $R_L=10K$  for Plastic Op-amps

The minimum passing value large signal voltage gain for $R_L=10k$ and ceramic components is 200 V/mV							
Control	TP1	TP2	% Diff				
room	7256.532	7090.042	-2.29				
4 thermal							
	TP1	TP5	% Diff				
room	6798.012	4981.406	-26.72				
2 radiated, 4 thermal							
	TP1	TP5	% Diff				
room	10293.82	8062.608	-21.68				
4 radiated							
	TP1	TP5	% Diff				
room	6165.271	4391.504082	-28.77				

Figure 3.3.3-2: Large Signal Voltage Gain Change at  $R_L=10K$  for Ceramic Op-amps

	Control	4 thermal	2 radiated, 4 thermal	4 radiated
Control	-3698			
4 thermal	different	-1204		
2 radiated, 4 thermal	different	different	-639.72	
4 radiated	different	similar	different	-1821

Figure 3.3.3-3: t-Test Results and Change in Mean Value for Environmental Conditions for Plastic Op-Amps

	Control	4 thermal	2 radiated, 4 thermal	4 radiated
Control	-169.89			
4 thermal	different	-1816.61		
2 radiated, 4 thermal	different	different	-2231.22	
4 radiated	different	similar	different	-1773.77

Figure 3.3.3-4: t-Test Results and Change in Mean Value for Environmental Conditions for Ceramic Op-Amps



Control	Avg Values		% Diff	% Change TP1 (cool to room)	% Change TP2 (cool to room)
	TP1 ( $\mu\text{A}$ )	TP2 ( $\mu\text{A}$ )			
cool	0.00399394	0.00413248	3.47	19.42492877	17.56330339
room	0.00476976	0.00485828	1.86	% Change TP1 (room to warm)	% Change TP2 (room to warm)
warm	0.0051617	0.005219	1.11	8.217184932	7.424849947
4 thermal					
	TP1 ( $\mu\text{A}$ )	TP5 ( $\mu\text{A}$ )	% Diff (TP1 vs TP5)	% Change TP1 (cool to room)	% Change TP5 (cool to room)
cool	0.00403114	0.00396896	-1.54	17.28096767	20.49705716
room	0.00472776	0.00478248	1.16	% Change TP1 (room to warm)	% Change TP5 (room to warm)
warm	0.0050361	0.00513736	2.01	6.521904665	7.420417859
2 radiated, 4 thermal					
	TP1 ( $\mu\text{A}$ )	TP5 ( $\mu\text{A}$ )	% Diff (TP1 vs TP5)	% Change TP1 (cool to room)	% Change TP5 (cool to room)
cool	0.003997	0.00408728	2.26	18.31223418	16.15450862
room	0.00472894	0.00474756	0.39	% Change TP1 (room to warm)	% Change TP5 (room to warm)
warm	0.00506296	0.0050609	-0.04	7.063316515	6.600021906
4 radiated					
	TP1 ( $\mu\text{A}$ )	TP5 ( $\mu\text{A}$ )	% Diff (TP1 vs TP5)	% Change TP1 (cool to room)	% Change TP5 (cool to room)
cool	0.0040946	0.00406446	-0.74	16.3913447	20.13502409
room	0.00476576	0.00488284	2.46	% Change TP1 (room to warm)	% Change TP5 (room to warm)
warm	0.00515832	0.00530028	2.75	8.237091251	8.549123051

Figure 3.3.4-1:  $I_{CC}$  Change Vs. Time and Measurement Temperature Changes Data for Plastic Op-amp

Control	Avg Values		% Diff (TP1 vs TP2)	% Change TP1 (cool to room)	% Change TP2 (cool to room)
	TP1 ( $\mu$ A)	TP2 ( $\mu$ A)			
cool	0.003946	0.00406686	3.05	20.64647243	18.11963038
room	0.004761	0.00480376	0.90	% Change TP1 (room to warm)	% Change TP2 (room to warm)
warm	0.005133	0.00519442	1.20	7.807406661	8.132379636
4 thermal					
	TP1 ( $\mu$ A)	TP5 ( $\mu$ A)	% Diff (TP1 vs TP5)	% Change TP1 (cool to room)	% Change TP5 (cool to room)
cool	0.004204	0.00417894	-0.59	17.06544235	19.66192384
room	0.004921	0.0050006	1.62	% Change TP1 (room to warm)	% Change TP5 (room to warm)
warm	0.005262	0.0053758	2.15	6.936688694	7.503099628
2 radiated, 4 thermal					
	TP1 ( $\mu$ A)	TP5 ( $\mu$ A)	% Diff (TP1 vs TP5)	% Change TP1 (cool to room)	% Change TP5 (cool to room)
cool	0.004179	0.00420042	0.52	16.11092233	16.15362273
room	0.004852	0.00487894	0.55	% Change TP1 (room to warm)	% Change TP5 (room to warm)
warm	0.005249	0.0051987	-0.95	8.173502995	6.553882606
4 radiated					
	TP1 ( $\mu$ A)	TP5 ( $\mu$ A)	% Diff (TP1 vs TP5)	% Change TP1 (cool to room)	% Change TP5 (cool to room)
cool	0.004229	0.0041328	-2.28	16.41484718	20.09388308
room	0.004923	0.00496324	0.81	% Change TP1 (room to warm)	% Change TP5 (room to warm)
warm	0.005298	0.00534878	0.96	7.602814292	7.767909672

Figure 3.3.4-2:  $I_{CC}$  Change Vs. Time and Measurement Temperature Changes Data for Ceramic Op-amp

This shows that their shift in mean values and the shape of the distributions for both cases were similar for both environments. The distributions were all different for the ceramic op-amp as shown in Figure 3.3.4-4.

### **3.4 Analysis of Reliability Factors**

The EMESR program has measured a substantial body of data on two types of semiconductor devices exposed to electromagnetic radiation in an effort to determine if the long term reliability of these devices were degraded. One device, an op amp, is a representative analog device. The second device, a flip-flop, is a representative digital device. The devices were placed in a mode-stirred chamber and exposed to electromagnetic radiation continuously for a month at a time, for a total of four months. Before and after each test period, the manufacturers specified parameters were measured. Parameter changes were inspected to determine degradation. For this reliability analysis of the data, only the analog components will be addressed.

Based on the data examined, no variation was large enough to be interpreted as degradation. Further exposure to EM radiation may establish a trend, or may cause catastrophic failure of a device. However, the data does not indicate the existence of a trend. There appears to be an increase in the instantaneous upset rate of the devices over time. The increase is most noticeable at the beginning of the test, and tends to level off to a constant level. The cause for this correlation is not known.

Energy coupled to the wiring outside of the device provides the main electrical stress, not the energy coupled directly into the device. Thus, the main electrical stress occurs to junctions connected to external pins.

#### **3.4.1 Objective of Reliability Analysis**

The objective of the reliability analysis was to examine the EMESR program test data and assess degradation of semiconductor devices due to exposure to electromagnetic radiation. A critical aspect is to determine the definition of degradation. Failure is easy to define and measure. A device either meets its manufacturer specifications or it fails. Degradation is inherently more difficult. How much does a device parameter have to vary before it is considered degraded? What should the change in device parameters be compared with? If the device parameters change, can the change be attributed to the electromagnetic exposure, or is it due to normal device performance? Measured variations will have to be separated by changes due to "burn-in" and test measurement errors. The measured parameters may inherently have a wide variation to begin with. The data will be examined to determine if a definition of degradation can be determined.

A second objective will be to assess potential damage mechanisms due to the electrical stress. Potential areas of vulnerability will be identified. The parameters associated with damage to the vulnerable areas will be examined.

#### **3.4.2 Reliability Analysis Approach**

Manufacturer specified parameters were measured before and after each test. This data was examined for changes and related to the specification to determine if the device failed. Then an attempt

	Control	4 thermal	2 radiated 4 thermal	4 radiated	Overall change (%)
Control	9.47867E-05				2.051659452
4 thermal	different	3.12667E-05			0.6800058
2 radiated 4 thermal	different	similar	3.56E-05		0.774876704
4 radiated	different	different	different	7.63E-05	1.632784079

Figure 3.3.4-3: t-Test Results and Change in Mean Value for Environmental Conditions for Plastic Op-Amps

	Control	4 thermal	2 radiated 4 thermal	4 radiated	Overall change (%)
Control	7.49E-05				1.623961269
4 thermal	different	5.60E-05			1.168473728
2 radiated 4 thermal	different	different	-4.47E-07		-0.009383754
4 radiated	different	different	different	-1.87E-06	-0.038751643

Figure 3.3.4-4: t-Test Results and Change in Mean Value for Environmental Conditions for Ceramic Op-Amps

will be made to define degradation. The data will be examined to determine if a trend exists towards exceeding the specification. Such a trend may be extrapolated to predict device failure. Also, a discrete shift in the device parameters may be an indication that a change occurred in the device. Such a change may be determined to be degradation. Secondly, the average upset rate during the test will be examined as a function of time. An increase in the upset rate may indicate the degradation of the device.

Previous electromagnetic pulse (EMP) and electro-static discharge (ESD) studies can offer insight into the damage mechanisms of electromagnetic stress on semiconductor devices. Basically there are two damage mechanisms. The first is electric breakdown due to excessive voltage. An example would be breakdown of the dielectric layer of a JFET gate. The second mechanism is thermal. Most electrical properties of semiconductors have temperature dependence. An example of thermal failure is melting inside a p-n junction. In the case of reversed breakdown of the junction, most of the energy is deposited in the depletion region, which is typically  $1 \mu\text{m}$  long. An electromagnetic transient pulse can deposit energy much faster than thermal diffusion can remove the energy. Therefore, the temperature of the junction can be much higher than the case temperature for a pulse on the order of  $1 \mu\text{s}$ . Electromagnetic energy is deposited in a small junction region and locally heats the region until the material melts. The material will cool and re-crystallize, which shorts the junction. The junction temperature will depend on the energy deposited, the rate at which it is deposited, the electrical and thermal properties of the material. The failure energy levels for a given device inherently have a large spread. It is common to have at least a factor of 10 variation, even when stressed under similar conditions. Therefore in assessing damage due to EMESR, a large scatter to the data should be expected.

### 3.4.3 Reliability Analysis

The primary focus of an Electrostatic Discharge (ESD) failure is the input stages of the device, for two reasons. First, the input stage is usually the most sensitive part of the amplifier. Secondly, the input terminals are connected to the external environment via the leads. In the case of EMESR, the external leads will act as antenna collecting electromagnetic energy and placing that energy across the input stage transistors.

The voltages induced inside the semiconductor by direct electric field illumination are much less than voltages induced by field coupling to the external wiring and conducted inside the chip. A simple calculation will demonstrate this point. The maximum E field strength at 800 MHz at 1000 W input power to the reverberation chamber was measured to be 336 V/m. (Reference 14.3 p.16). The voltage induced by direct illumination across a p-n junction is:

$$V=E \cdot dl.$$

The typical p-n junction is about  $1 \mu\text{m}$ .

The voltage is then:

$$V = 336 \text{ (V/m)} * 1(\mu \text{ m}) = 336 * 10^{-6} \text{ V, or } 336 \mu \text{ V.}$$

If two pins on the chip are 2mm apart, the open circuit voltage between them is:

$$V = 336 * 10^{-6} \text{ (V/m)} * 2(\text{mm}) = 672\text{mV}$$

If these two pins were the input to a transistor, this voltage would be dropped directly across the base-emitter junction. The 672mV induced voltage is hardly a threat. Any significant energy must be coupled to the external wiring and conducted into the chip. A more involved analysis could be performed to calculate the voltage induced on the current traces on the test fixture. This example is only meant to demonstrate that the maximum stress is induced by coupling to the external wiring and then is conducted directly inside the chip. The components inside the chip are too small to couple enough energy to affect the performance. The focus of the analysis will be on areas connected to external pins.

Two parameters that indicate damage to the input stage of an operational amplifier are the input offset current and the input offset voltage. If the input transistors are damaged, they will tend to have an increase in the leakage current.

The initial focus of the study was to look at changes in the input offset voltage and input offset current. None of the parts had significant increases in the offset voltage. Only a few parts had significant increases in the input offset current. S/N 3299 had an increase of over 100%. However, as seen in Figure 3.4.3-1, when this change was compared to the specification, the part was not even close to going out of specification. In fact, the change was closer to the typical value than to any of the extremes. Some parts had increases, then decreases in the values making it impossible to determine a trend. Also, a trend with only three data points does not instill much confidence.

The focus of the study was broadened to include all measured parameters of the test. Using a previous assessment of the parameter changes, focus was on the parameter values noted with the most severe changes. In no case was a parameter out of specification. When all the parameter changes were compared to the allowed specified values, no parameter change was even close to bringing a device out of specification.

Trends to the changes in data are impossible to establish. Many of the parameters increase significantly, then decrease for a small net change. In addition, only three, and in some cases, only five data points exist to establish a trend. For data on these devices, one would expect a large amount of scatter due to the nature of the problem. Failures are easy to detect since it either meets specification or it doesn't. An assessment on degradation is inherently much more difficult. Variations due to degradation are smaller and can conceivably be masked by other factors, such as measurement errors, etc. The amount of scatter and the trend of the data are impossible to predict with a limited number of test periods.

The upset rate data was examined to determine if upsets increased over the course of a test. A clear increase in upset rate may be interpreted as degradation. The upset rate and power were recorded

every two days. Three test periods are shown in Figure 3.4.3-2. Since the power varied over the time period, a two-dimensional regression analysis was performed with input power and time being the independent variables, and upset rate being the dependent variable. The results are shown in Figure 3.4.3-3. Figure 3.4.3-3 (top) indicates that the upset rate varies more with the variation in power, than with time during test period 2. Figure 3.4.3-3 (bottom right) shows when the power variation is not as great, a stronger dependence on the time is seen for test period 3. Finally, in Figure 3.4.3-3 (bottom left), the power variation is only 5.6%, and a clear dependence on upset rate is seen. A one dimensional regression analysis for the data in Figure 3.4.3-3 (bottom left) was performed to investigate the dependence of the upset rate on time alone. Figure 3.4.3-4, shows a simple 3<sup>rd</sup> order polynomial curve fit that shows the dependence of the upset rate on time. The upset rate increases during the first part of the test then tends to level off to a constant value. cursory examination of the instantaneous upset rate for other tests confirm this trend, showing an increase in upset rate in the first few days of testing, and These results establish a correlation between upset rate and exposure time. This does not necessarily imply a direct cause and effect relationship between exposure time and upset rate. The upset rate could have increased due to "burn in", an increase in temperature, or other variable over the course of the test.

The ESD community has identified the existence of latent failures. A latent failure is one where the device is damaged, but still meets its manufacturer's specifications. The device will continue to degrade due to the latent failure into a full failure, either by exceeding the manufacturer's specifications or by a catastrophic failure where the device no longer operates. The full failure can develop due to event dependence, i.e. additional electrical stresses, or time dependence, similar to an accelerated aging process. The event dependent mechanisms have been validated. The time dependent mechanisms have not, although some studies indicate they may exist.

The problems of proving time dependent failures are similar to proving degradation to electromagnetic exposure. Issues dealing with the length of time it takes to develop failure, and the ability to separate this slow degradation due to electrical stress from all other potential causes. Reference 14.3 (chapter 6) has some methods to detect latent failures, both internal inspection failure analysis and electrical parameter tests.

The following is a list of potential damage mechanisms.

1. Mechanical failure to thermal stresses. Electromagnetic transients can cause large thermal gradients to exist in the device, due to the fast nature of the transient relative to the thermal diffusion time constant. Thermal gradients, as well as different coefficients of thermal expansion of different materials can cause mechanical stresses in the device. Over time, constantly stressing the device in this manner may cause a mechanical failure. (Reference 14.4, page 101)
2. Damage to the dielectric of the gate of a MOSFET transistor. Dielectrics degrade over time. Electrical stress and temperature accelerate degradation of wire dielectric. It is conceivable that the FET gate dielectric may potentially degrade over time as well due to the added stress of electromagnetic transients.
3. Latch-up. CMOS circuits are particularly susceptible to latch up. The flip-flop is a CMOS device. Latch up can occur when the input voltages exceed the supply voltage and a parasitic bipolar transistor becomes forward biased and turns on. This effectively shorts the power supply and in the

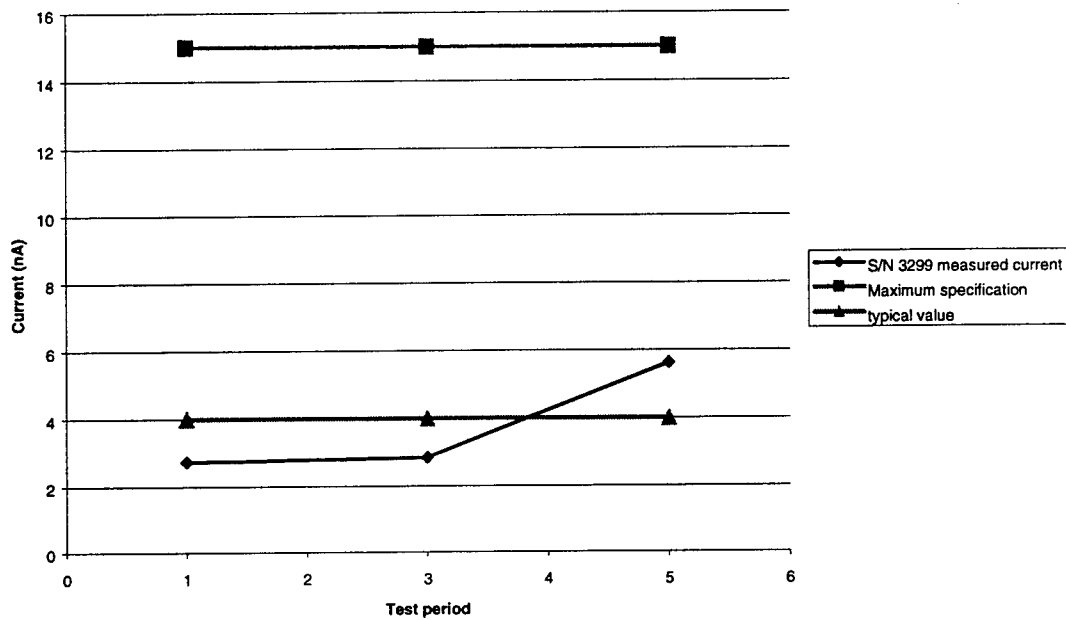

Figure 3.4.3-1: Input Offset Current, OP-271 S/N 3299, Cool Temperature Test, Plastic Package

Test #3, Test period #2			Test #2, Test period #3			Test #4, Test period #4		
time	power	upset rate	time	power	upset rate	time	power	upset rate
1	210	5.9	1	250	77.2	1	350	23.4
2	210	6.6	2	240	74.4	2	340	23.3
3	200	5.1	3	240	71.4	3	350	27.7
4	200	4.7	4	250	73.8	4	340	28.8
5	210	4.8	5	240	77.5	5	340	28.3
6	210	5.3	6	260	81.8	6	350	29.3
7	190	4.9	7	250	77.1	7	360	30
8	230	6.5	8	250	77.2	8	360	30.5
9	220	6.8	9	260	80.9	9	350	31.6
10	220	6.3	10	250	81.6	10	360	31.3
11	225	7	11	250	74.1	11	360	31.4
12	230	6.9	12	260	80.2	12	340	30.8
13	235	7.7	13	270	78.7	13	355	32
14	235	7.8	14	250	77.3	14	345	30.7
15	235	83.9	15	270	83.9	15	340	30.3

Figure 3.4.3-2: Instantaneous upset rate for analog devices (3 cases)



Test period 1  
no data

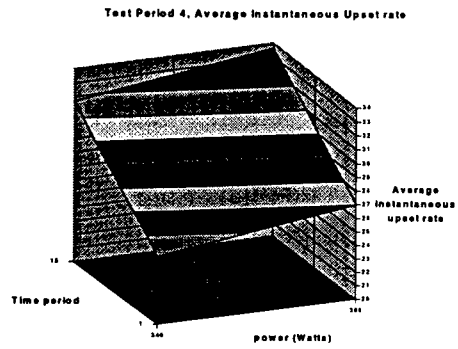
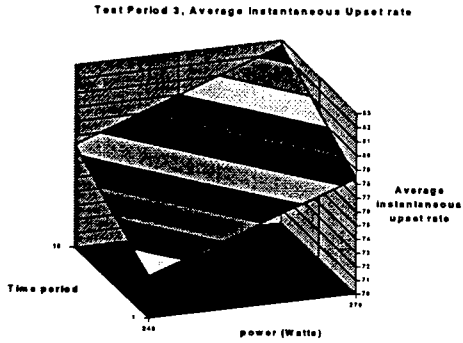
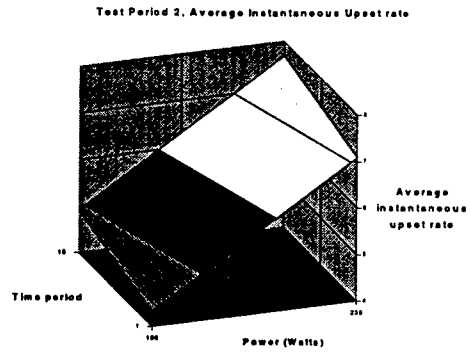

Figure 3.4.3-3: Two-Dimensional Regression Analysis

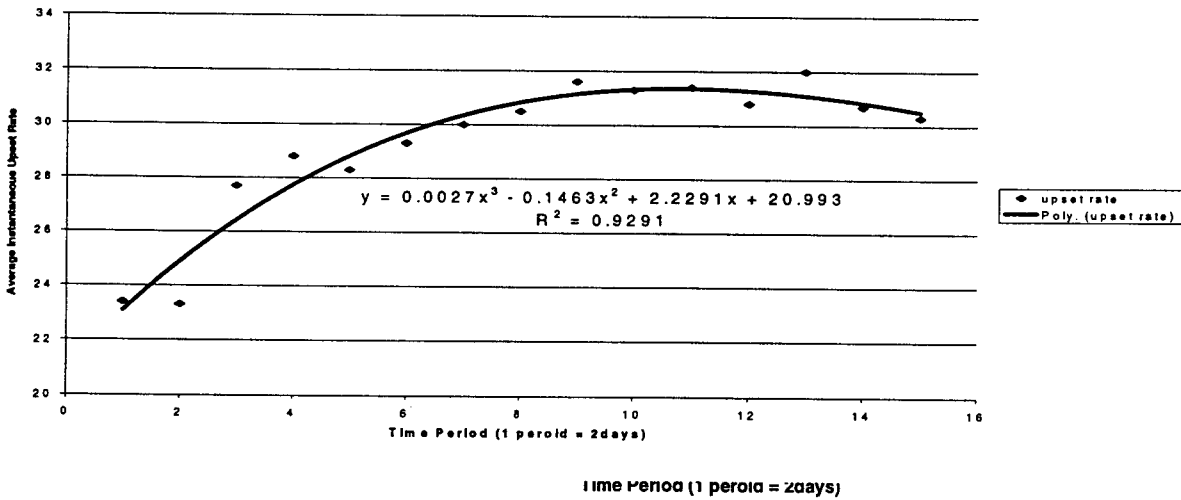

Figure 3.4.3-4: One Dimensional Polynomial Regression Analysis, Test #4

right conditions is self-sustaining, potentially damaging the part. Damage often takes the form of an open circuit due to melting of a circuit trace. One digital device had failed with an open circuit on the voltage input. A potential cause of this failure may be latch up.

### 3.5 Analysis of Failed Test Parts

The reliability lab of the Air Force Laboratory in Rome New York performed electrical testing and failure analysis on a small number of the parts from our testing. It had been hoped that they would be able to find the cause of parametric shift as well as device failure, but they were not able to accomplish this. Five digital parts and seven analog parts were submitted for analysis, and those parts were representative of the parts subjected to the testing performed under this contract. The two digital parts that failed during test and one of the three analog parts that exceeded the manufacturer's specification were also included. Only 3 digital parts were actually subjected to their testing and only one analog part and one digital part were subjected to failure analysis by visual inspection. The following parts were those recommended for failure and parameter shift analysis. Please note that #1xxx and #3xxx are plastic parts, #2xxx and #4xxx are ceramic parts.

- 1 - Digital plastic part that failed in first EM radiated test: #1081
- 2 - Digital parts from reference test: #1162, #2197
- 2 - Digital parts in EM radiated test 7 months: #1057, #2053(failed)
- 1 - Analog ceramic part from EM radiated test - exceeded Vio specification limits: #4217
- 2 - Analog parts from reference test: #3401, #4432
- 2 - Analog parts in EM radiated test 7 months: #3253, #4268
- 2 - Analog parts in thermal test + thermal EM radiated test: #3537, #4514

Digital parts 2197, 1081, and 2053 were given an electrical functional test. Part 2197 passed the test and parts 1081 and 2053 failed the test. The result of the electrical testing of these three devices is shown in Figure 3.5-1.

The ceramic package lid was removed from digital part 2053 and photographs were taken. Figure 3.5-2 shows the melted ends of the (open) bond wire from pin 7 to the die. This is typical of a long direct current overstress. Figure 3.5-3 shows a 200X magnification of an area of part 2053 near pin 3. This is an area of the die that has melted metallization visible to the left of the bond pad, and there is some metal penetration into the contacts in the protective network component to the left. This part has an electrical short between pin 3 and pin 14, which is the positive power supply lead. Figure 3.5-4 shows a 200X magnification of pin 11, which is also shorted to pin 14 and shows physical damage similar to that of pin 3.

The analog part that was subjected to visual analysis was operational amp #4217, which had exceeded Input Offset Voltage (Vio) specification limits. It was visually inspected at 500X. The die looked clean, there were no overstresses, and nothing out of the ordinary was seen that might explain the parameter drift. The cause of the drift is unknown. Some of the possible causes of parameter drift suggested by the Air Force Laboratory were ambient gas containing water vapor, trace contaminants in the oxide, and non-visible damage to the input stage transistors.

+ pin	- pin	2197 (OK)	1081 (Failed)	2053 (Failed)
7	1	0.5v	0.5v	high res. (Fig. 1)
7	2	0.5v	0.5v	high res.
7	3	0.5v	0.5v	high res.
7	4	0.5v	0.5v	high res.
7	5	0.3v	short	high res.
7	6	0.3v	0.25v	high res.
7	8	0.3v	0.25v	high res.
7	9	0.3v	0.25v	high res.
7	10	0.5v	0.5v	high res.
7	11	0.5v	0.5v	high res.
7	12	0.5v	0.5v	high res.
7	13	0.5v	0.5v	high res.
7	14	0.3v	0.3v	high res.
14	1	2.5v	1.5v	0.6v
14	2	2.0v R	1.5v	0.5v
14	3	2.0v R	1.5v	Shorted (Fig. 2)
14	4	2.0v R	1.5v	0.5v
14	5	1.2v	1.1v	0.3v
14	6	2.0v	0.9v	short
14	7	2.0v	0.9v	high res.
14	8	2.0v	0.9v	0.3v
14	9	0.9v	1.1v	R,0.3v,R
14	10	2.0v, R	1.5v	0.5v
14	11	2.0v, R	1.5v	Short (Fig. 3)
14	12	2.0v, R	1.5v	0.5v
14	13	2.0v, R	1.5v	0.5v

Figure 3.5-1: Electrical Test Results From Three Digital Test Parts

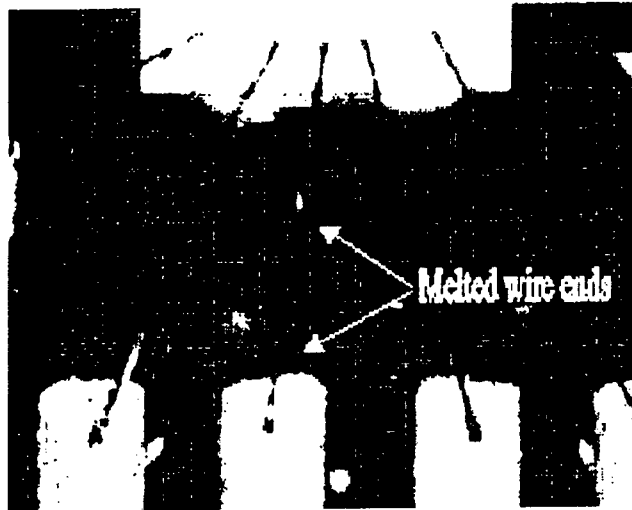

Figure 3.5-2: Photograph of Failed Bond Wire on Digital Part #2053

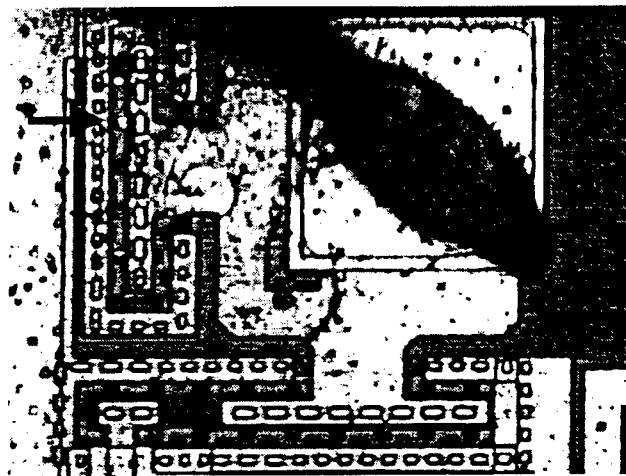

Figure 3.5-3: Photograph of Digital Part #2053 Showing Physical Damage Near Pin 3

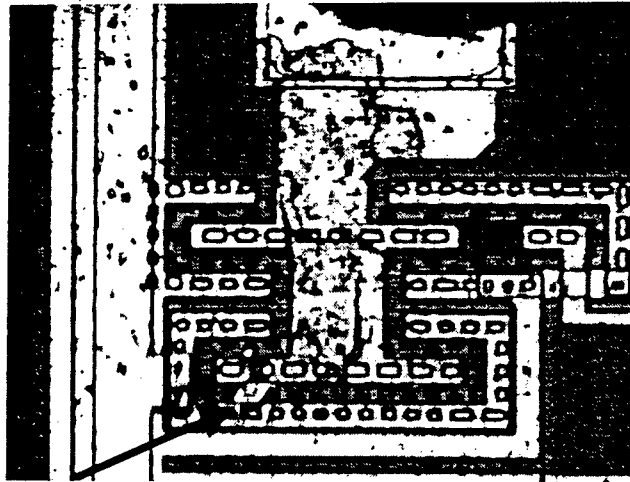

Figure 3.5-4: Photograph of Digital Part #2053 Showing Physical Damage Near Pin 11

### 3.6 Summary From Analysis of Test Results

The analyses performed on the test data indicates that the failure rate of devices exposed to electromagnetic radiation is higher than those operated in a low (ambient) EM environment. We also found that electromagnetic exposure does cause parameters of the analog devices to shift beyond that which would be expected for normal operation in a low (ambient) EM environment. It also appears that RF radiation exposure may cause the drift in the values of analog device parameters to be more erratic than the drift in the parameter values of the control lot analog devices.

The digital devices exposed to EM energy changed more, in most cases, than did the digital control group, but in several instances the digital control group parameter shifts were a little bit larger than those of the EM radiated digital group. In the timing measurements more of the digital devices that were exposed to EM radiation had large shifts or step increases in timing parameters than did the digital control group, and more in the digital control group had small timing shifts or step decreases than the EM radiated digital parts. The test results also show that, in the majority of cases, the parameter shifts occur early in the testing then stabilize.

We feel that additional testing needs to be done in this area in order to observe device failure rates, failure modes, and to monitor the device parameter values to see whether these device parameter values remain within the manufacturer parameter specification ranges. Test devices need to be exposed to electromagnetic radiation over longer periods of time to either firmly establish or totally discount the subtle trends we noticed in these studies. We also believe that not enough data has been accumulated to be able to assign a numerical value to the electromagnetic effects that we have observed on the reliability of the analog and digital test devices. A detailed conclusion is contained in section 13.

## 4.0 SELECTION AND PROCUREMENT OF TEST PARTS

The parts selected for this test program were the 54ACT74 (ceramic) and 54ACT74 (plastic) digital flip-flops and the OP271FZ (ceramic) and OP271GF (plastic) operational amplifiers. A total of 2340 parts were purchased, which supplied the needs of all the tests.

### 4.1 Selection of Test Parts

At the beginning of the contract we determined that it would be good to test both analog and digital devices, because each has its own set of unique characteristics that need to be addressed. Our preliminary survey of candidate devices indicated that basic analog components (such as operational amplifiers and comparators) and digital glue logic (such as buffers and gates) offered more benefits than more highly integrated devices. We wanted the test devices to be representative of the most up to date proven technology, to be in current use in both commercial and military applications, to be cost effective so that a large number of the devices could be procured for the test program, and for the test devices to have a physical interface that would allow easy insertion and removal from the test fixtures. It would have been nice to test several of the highly integrated devices, but the cost and complexity associated with testing digital VLSI, Hybrids, and ASICs were beyond the scope or available resources of this program. During the part selection phase of the contract, we found two device types that met all of our criteria. These are digital flip-flops and analog operational amplifiers.

In our technical proposal we originally favored the octal buffer as a digital test device. Signal line measurement of an octal buffer adds unnecessary complexity to the test fixture and monitoring system. We believe the digital flip-flop is a better test device choice when test fixture design and device signal line monitoring are considered. In addition, we chose dual device packages as opposed to quad packaging to simplify monitoring and test fixture design. We feel that within the limits of what we were able to achieve with our device monitoring design, the dual device package emphasized the separately packaged parts as opposed to multiple parts in each package.

The digital device we recommended is a dual "D" type flop-flop of the 74X74 family of devices. The specific device numbers we chose are the CD54ACT74F3A and the CD74ACT74E manufactured by Harris Semiconductor. These are fabricated in advanced CMOS technology that, at the time it was chosen, was the most advanced version available for standard logic devices. We have chosen CMOS technology due to its popularity in system design and low power dissipation, which is becoming an increasingly important design consideration. An additional factor that favored CMOS over fast TTL or ECL was the fact that complex VLSI and digital ASICs are predominantly manufactured in CMOS technology.

The 54ACT74 is a military part packaged in a ceramic dual-in-line package (DIP). The 74ACT74 is a commercially specified plastic DIP device. The specified performance for both devices are very similar with the major difference being that the CD74ACT74E is rated for operation from  $-40^{\circ}$  C to  $+125^{\circ}$  C and the CD54ACT74F3A is rated from  $-55^{\circ}$  C to  $+125^{\circ}$  C. The flip-flop function performed by these devices is useful and a very common feature found in electronic system design.

The analog test device type we recommended is a high speed, voltage feedback, operational amplifier. We feel this is a good choice since these types of op-amps are very common in avionics design. Boeing's part procurement data for it's commercial airplane electronic systems shows that high speed op-amps are always one of the more frequent candidates for study, and we have chosen an Op-271 for this program. The OP-271 is a dual, high-speed, low noise operational amplifier that has been designed into the 767-AWACS and F-22 airplanes.

This part is also available in both ceramic and plastic DIP packages (OP271FZ and OP271GP respectively). Both of these devices are specified to operate from -40° to 85° degrees C. The ceramic OP271FX device however does have slightly tighter limits and tolerances for some parameters than the plastic OP271GP. The primary manufacturer of these devices is Analog Devices Inc, and test parts were purchased from PMI and Analog Devices.

#### **4.2 Procurement of Test Parts**

Our initial purchase of test parts consisted of 450 each of the 74ACT74 ceramic flip-flop and 74ACT74 plastic flip-flop, and 450 each of the OP271FZ ceramic operational amplifier and OP271GF plastic operational amplifier. The flip-flops were all made by Harris and the operational amplifiers were made by PMI. Following test period 6 it was determined that analog test devices rather than digital test devices would be used in the thermal and life tests. In August 1996, 210 each of the OP271FZ ceramic operational amplifier and OP271GF plastic operational amplifier were ordered. A total of 2340 parts were ordered to supply the test needs of the contract. Analog Devices manufactured the follow-on lots of op-amps because they had acquired the PMI production facilities. It is our understanding that the Analog Devices OP-271 were produced on the same production line as those purchased from PMI.

### **5.0 ACCEPTANCE TESTING**

The electrical acceptance test is performed on each test device before and after each radiated susceptibility test. The purpose of the electrical acceptance test is to record the initial performance data of all test devices, to verify that they meet manufacturer specifications, and to record performance data following each test. Electrical acceptance testing is the first step in the electrical test flow for each device, which is shown in Figure 5.0-1. As this figure illustrates, each device will be evaluated a minimum of twice, but possibly as many as 5 times during the course of the program to measure performance and parameter trends. The automated test system is able to perform all of the electrical tests required for acceptance testing.

#### **5.1 Acceptance Testing Approach**

The electrical acceptance testing will verify device functionality and measure device parameters. We are aware that the cumulative effects of exposure to RF energy may show up as a degradation of performance rather than a catastrophic failure, especially in analog devices. We are also aware that this performance degradation may be small, which makes pass/fail testing unacceptable;

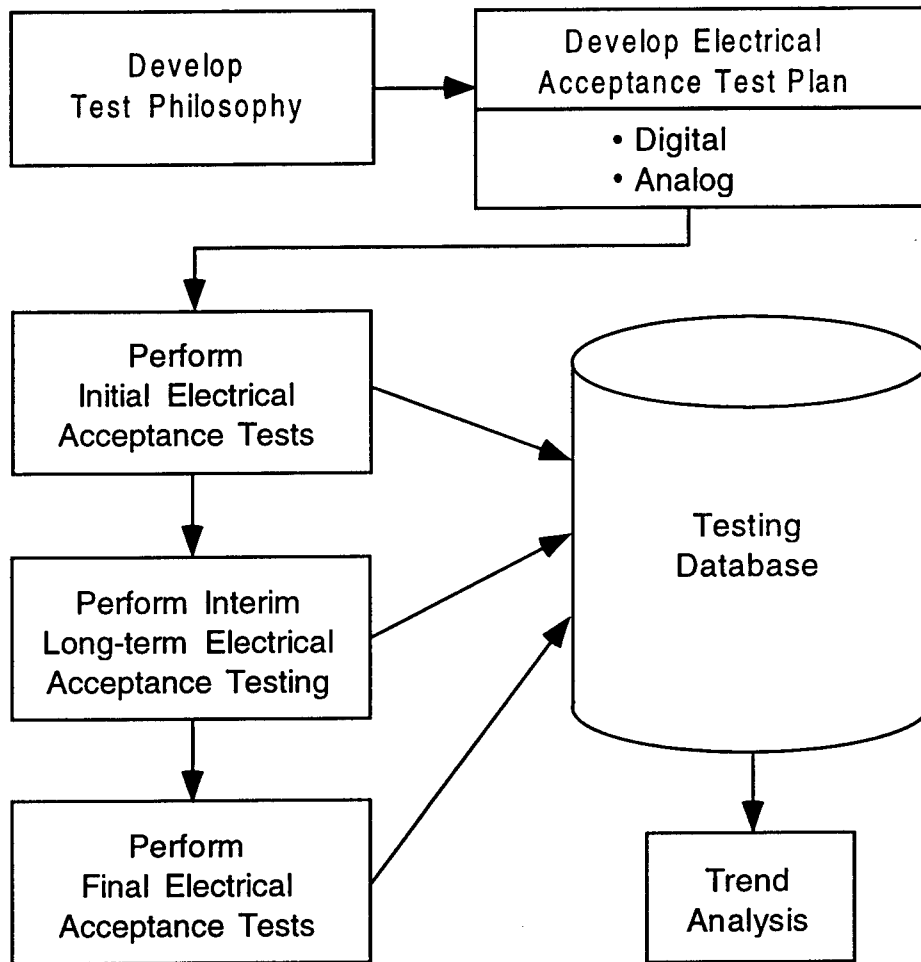

Figure 5.0-1: Electrical Acceptance Test Flow Diagram



hence the emphasis on parametric testing. From these issues the following test philosophy was developed:

- 1) Will read and record all test data: The need to perform trend analysis requires that actual test values be stored.
- 2) Will perform complete parametric test: Since the potential failure modes of RF exposure have not been defined, all parameters of each device type must be examined.
- 3) Tests will cover entire operating temperature range: Both the OP-271GP (plastic op-amp) and OP-271FZ (ceramic op-amp) are specified for operation from  $-40^{\circ}\text{C}$  to  $+85^{\circ}\text{C}$ ., so testing was done at  $-40^{\circ}\text{C}$ ,  $+25^{\circ}\text{C}$ , and  $+85^{\circ}\text{C}$ . For the digital devices, the 74ACT74E (plastic flip-flop) is specified for  $-40^{\circ}\text{C}$  to  $+125^{\circ}\text{C}$  while the military 54ACT74F3A (ceramic flip-flop) has a temperature range of  $-55^{\circ}\text{C}$  to  $+125^{\circ}\text{C}$ . Since there is much interest in having a common temperature baseline with the analog parts as well as comparing plastic vs. ceramic part data, all the digital test devices were tested at  $-40^{\circ}\text{C}$  and  $+85^{\circ}\text{C}$ , the same as the analog parts. However, 25% of the 54ACT74F3A (ceramic) digital test devices were also tested at  $-55^{\circ}\text{C}$  and  $+125^{\circ}\text{C}$  to evaluate trends at the higher operating temperature limits of the digital parts where higher stress levels might be noticed. None of the commercial devices were stressed to these levels.

## **5.2 Device Acceptance Tests**

The acceptance test to evaluate the OP-271 operational amplifiers will accommodate both the OP-271GP plastic devices and the OP-271FZ ceramic devices. The test requirements for the program were developed from the Boeing Defense & Space Group receiving inspection test documents supplemented with the manufacturer specifications.

Section 5.4 describes the automated test system (ATS) and the special application module that is used to test operational amplifiers such as the OP-271. The OP-271 program measures 28 operational parameters. These parameters, which are measured for both devices in the package, are shown in Figure 5.2-1. The conditions used to make these measurements are those defined in the manufacturer's specification. Test setups and measurement procedures also follow procedures defined in the "Analog Testing Handbook" published by Rome Laboratory.

The acceptance test to evaluate the 54/74ACT74 digital flip-flops will accommodate both the 74ACT74E plastic devices and the 54ACT74F ceramic devices. The test requirements for the program were also developed from the Boeing Defense & Space Group receiving inspection test documents supplemented with the manufacturer's specifications.

The automated test system uses a general-purpose application module to test digital flip-flops such as the 54/74ACT74. The 54/74ACT74 program measures the voltage and current parameters that are listed in Figure 5.2-2 and the timing parameters that are listed in Figures 5.2-3a and 5.2-3b; a total of 127 different tests. The conditions used to make these measurements are those defined in the manufacturer's specification. Test setups and measurement procedures follow industry standard methods outlined in MIL-STD-883C.

- V<sub>IO</sub>** - **Input Offset Voltage:** The voltage difference between the inputs when the output voltage is 0 V.
- I<sub>IO</sub>** - **Input Offset Current:** The difference between the currents flowing into the inputs when the output voltage is 0.
- I<sub>IB</sub>** - **Input Bias Current:** Current flowing into the inputs.
- IVR** - **Input Voltage Range:** The maximum range of voltages that may be applied to the inputs.
- A<sub>VO</sub>** - **Small-Signal Voltage Gain:** (Voltage out)/(voltage in) for a small output (usually less than 1V) signal.
- CMRR** - **Common Mode Rejection Ratio:** The ratio, usually expressed in dB, at which the output voltage is affected by a voltage applied to both inputs simultaneously.
- PSRR** - **Power Supply Rejection Ratio:** The ratio, usually expressed in dB, at which the output voltage is affected by a voltage applied to the power supply terminal.
- V<sub>OP</sub>** - **Output Voltage Swing:** Maximum range of voltages the output can achieve.
- I<sub>CC</sub>** - **Positive Supply Current:** Current into the positive pin of the Op-amp.
- I<sub>EE</sub>** - **Negative Supply Current:** Current into the negative pin of the Op-amp.
- SR** - **Slew Rate:** Maximum rate of change of the output voltage in V/us.
- t<sub>s</sub>** - **Settling Time:** Time for the output to settle to .01% from a 10 V Step.
- GBW** - **Gain Bandwidth Product:** Gain multiplied by bandwidth - usually a constant over a fairly wide range of frequencies for voltage-feedback operational amplifiers.

Figure 5.2-1: Analog Test Voltage and Current Parameters

- I<sub>IL</sub>** - **Input leakage current, input low:** The leakage current into an input with the input at 0 volts.
- I<sub>IH</sub>** - **Input leakage current, input high:** The leakage current into an input with the input high.
- V<sub>IL</sub>** - **Voltage Input low threshold:** The highest voltage that the device recognizes as a low input.
- V<sub>IH</sub>** - **Voltage Input high threshold:** The lowest voltage that the device recognizes as a high input.
- V<sub>OH</sub>** - **Voltage output high:** The “logic 1” voltage at the output for a specified load.
- V<sub>OL</sub>** - **Voltage output low:** The “logic 0” voltage at the output for a specified load.
- I<sub>CC</sub>** - **Supply current:** The current drawn by the device under static conditions with open outputs.

Figure 5.2-2: Digital Test Voltage and Current Parameters

- T0 - PR1 Pulse Width:** The minimum pulse width that can be applied to the PRESET 1 input of the device that can still be recognized as a valid signal.
- T1 - PR2 Pulse Width:** The minimum pulse width that can be applied to the PRESET 2 input of the device that can still be recognized as a valid signal.
- T2 - CLR1 Pulse Width:** The minimum pulse width that can be applied to the CLEAR 1 input of the device that can still be recognized as a valid signal.
- T3 - CLR2 Pulse Width:** The minimum pulse width that can be applied to the CLEAR 2 input of the device that can still be recognized as a valid signal.
- T4 - D1 Setup:** The minimum amount of time that valid data must be applied to D1 before the rising edge of CLOCK 1 for the flip-flop to recognize the desired logic level.
- T5 - D2 Setup:** The minimum amount of time that valid data must be applied to D2 before the rising edge of CLOCK 2 for the flip-flop to recognize the desired logic level.
- T6 - D1 Hold:** The minimum amount of time that valid data must remain on D1 after the rising edge of CLOCK 1 for the flip-flop to recognize the desired logic level.
- T7 - D2 Hold:** The minimum amount of time that valid data must remain on D2 after the rising edge of CLOCK 2 for the flip-flop to recognize the desired logic level.
- T8 - PR1 Remove:** The minimum amount of time that a valid signal on PRESET 1 must be removed before the rising edge of CLOCK 1 for the flip-flop to latch data correctly. If this parameter is violated, then the flip-flop will stay in the preset state regardless of what is on the data input.
- T9 - PR2 Remove:** The minimum amount of time that a valid signal on PRESET 2 must be removed before the rising edge of CLOCK 2 for the flip-flop to latch data correctly. If this parameter is violated, then the flip-flop will stay in the preset state regardless of what is on the data input.
- T10 - CLR1 Remove:** The minimum amount of time that a valid signal on CLEAR 1 must be removed before the rising edge of CLOCK 1 for the flip-flop to latch data correctly. If this parameter is violated, then the flip-flop will stay in the clear state regardless of what is on the data input.
- T11 - CLR2 Remove:** The minimum amount of time that a valid signal on CLEAR 2 must be removed before the rising edge of CLOCK 2 for the flip-flop to latch data correctly. If this parameter is violated, then the flip-flop will stay in the clear state regardless of what is on the data input.

Figure 5.2-3a: Digital Test Timing Parameters

**T12 - CLK1 Pulse Width:** The minimum pulse width that can be applied to the CLOCK 1 input of the device that can still be recognized as a valid signal.

**T13 - CLK2 Pulse Width:** The minimum pulse width that can be applied to the CLOCK 2 input of the device that can still be recognized as a valid signal.

**T14 - CLK to Q1 Delay:** The propagation delay from the rising edge of CLOCK 1 to valid data being outputted on Q1.

**T15 - CLK to ~Q1 Delay:** The propagation delay from the rising edge of CLOCK 1 to valid data being outputted on ~Q1.

**T16 - CLK to Q2 Delay:** The propagation delay from the rising edge of CLOCK 2 to valid data being outputted on Q2.

**T17 - CLK to ~Q2 Delay:** The propagation delay from the rising edge of CLOCK 2 to valid data being outputted on ~Q2.

**T18 - CLR1 to Q1 TPHL:** The propagation delay from the falling edge of CLEAR 1 to the Q1 output going to the low (clear) state.

**T19 - CLR2 to Q2 TPHL:** The propagation delay from the falling edge of CLEAR 2 to the Q2 output going to the low (clear) state.

**T20 - CLR1 to ~Q1 TPLH:** The propagation delay from the falling edge of CLEAR 1 to the ~Q1 output going to the high (clear) state.

**T21 - CLR2 to ~Q2 TPLH:** The propagation delay from the falling edge of CLEAR 2 to the ~Q2 output going to the high (clear) state.

**T22 - PR1 to ~Q1 TPHL:** The propagation delay from the falling edge of PRESET 1 to the ~Q1 output going to the low (preset) state.

**T23 - PR2 to ~Q2 TPHL:** The propagation delay from the falling edge of PRESET 2 to the ~Q2 output going to the low (preset) state.

**T24 - PR1 to Q1 TPLH:** The propagation delay from the falling edge of PRESET 1 to the Q1 output going to the high (preset) state.

**T25 - PR2 to Q2 TPLH:** The propagation delay from the falling edge of PRESET 2 to the Q2 output going to the high (preset) state.

Figure 5.2-3b: Digital Test Timing Parameters

Results from each test are stored as data files on the PDP-11 computer that acts as the automated test system's processing unit. This information was transferred to other computers for analysis.

### **5.3 Reliability Testing Acceptance Test Plan**

Acceptance testing was accomplished by subjecting each device used in the test program to the complete electrical test described in section 5.2. Testing that was performed at 3 temperatures across the full temperature range used a Thermostream environmental chamber to quickly provide the correct temperatures for testing the devices.

As previously shown in Figure 5.0-1, test programs will be used to measure and store parametric data. Data recorded for these tests were given a "sequence number" which allows data to be examined in the order it was taken for trend analysis. During these tests, devices that were operational but failed to meet one or more dc parametric or ac timing tests were not removed from the program but proceeded through the testing to see if continued RF stress would cause the device to progress to a catastrophic failure state. Devices that experienced catastrophic failures were removed.

### **5.4 Parts Test Facility**

Electrical acceptance testing was performed using an automated test system (ATS) located at the Boeing Parts Test Laboratory. This facility is equipped with several different automated test systems that can be used to test and evaluate analog and digital microcircuits. Testing of both the analog OP-271 operational amplifiers and the 54/74ACT74 digital flip-flops was performed on a Teradyne A312 linear test system. This automated test system has both analog and digital test capability that allows it to test mixed signal devices as well as purely linear parts. The A312 uses a switching matrix structure to allow the connection of specialized test sources and measurement equipment to the pins on the device under test. This includes a time measurement subsystem, voltage and current meters, power supplies, and other test stimuli. The A312 comes with special application test modules that contain pre-wired test setups that facilitate testing of basic linear and mixed signal devices. The OP-271 is placed in a basic operational amplifier test module that is wired to provide a test setup similar to the recommended military setup described in MIL-STD-883C and the "Analog Testing Handbook" published by Rome Laboratory. The 54/74ACT74 flip-flop is placed in a different general-purpose test module that is wired to provide a test setup similar to the recommended military setup described in MIL-STD-883C. These capabilities enable the A312 to perform a complete electrical test of the OP-271 op-amp and 54/74ACT74 flip-flop. The A312 test system is calibrated and certified on a regular schedule by the Quality Assurance organization at Boeing.

Additional test equipment used to support electrical acceptance testing included a Temptronics Thermostream, for thermal control, and computing resources for storage of the test data. Part of the test procedure calls for electrical testing to be performed at the specified temperature extremes for the test devices, which is  $-40^{\circ}\text{C}$  to  $+85^{\circ}\text{C}$  for both the OP-271 operational amplifiers and 54/74ACT74 flip-flop. This temperature environment was provided by the Temptronics Thermostream system which is used to force heated or cooled air on the test device to maintain the temperature environment called for

during electrical testing. A  $\mu$ VAX workstation that has over 1.2 Gigabytes of disk storage was used to store the large amounts of test data generated by the testing.

## **6.0 PRE-BASELINE CONDUCTED SUSCEPTIBILITY TESTING**

### **6.1 Conducted Susceptibility Testing Approach and Rationale**

The purpose of this test was to ascertain the effects of conducted RF signals on the performance of the selected analog and digital devices. A breadboard was built to test both the analog and digital test circuits. No particular care was taken in the design of the breadboard to assure good signal propagation across the desired frequency range. The breadboard, as such, was only useful in determining whether or not the injected signal caused interference, and not for predicting interfering signal levels.

### **6.2 Digital Device Conducted Susceptibility Testing**

The test for the digital device, an 74ACT74 flip-flop, was set up as shown in Figure 6.2-1. The test used two pulse generators that were synchronized together and connected to the test fixture. Figure 6.2-1 also shows the nominal signal timing diagrams that were used for the test. The clock signal was free running, and the "D" signal was synchronized to the clock. The transition of the output signal occurred at the positive transition of the clock as shown in the diagram. Since the digital device would not produce a faulty output when the "high" level of one of the signal voltages was increased to the maximum allowed by specification, we reduced the "high" level of the input signal below its switching threshold to cause a faulty output. We held the amplitude of the "clock" steady at a nominal 4 volts and reduced the "high" level voltage of the "D" signal. With no RF interference present, the output of the flip-flop was present when the "D" input was 1.35 volts or higher for chip number 1001. If "D" was 1.30 volts, the output of the op-amp was steady with the RF signal generator putting out 750 MHz at +13 dBm, but it produced no output signal with the RF off. With "D" at 1.25 volts the output of the flip-flop was off with or without the RF signal.

The results of the digital test are somewhat inconclusive, except that the presence of RF energy does influence the output signal of the "D" flip-flop. The test voltages are in a region that is out of specification for normal operation of the device, so these effects may not be seen during normal device operation. The output of the RF signal generator is quite small, and because of the impedance mismatches in the circuit even less RF power was actually delivered to the test device. More RF energy might have caused more of an effect. The typical upset mode for the D flip-flops was the generation of a second output pulse resulting from the test device interpreting RF noise on the clock input as a valid rising edge.

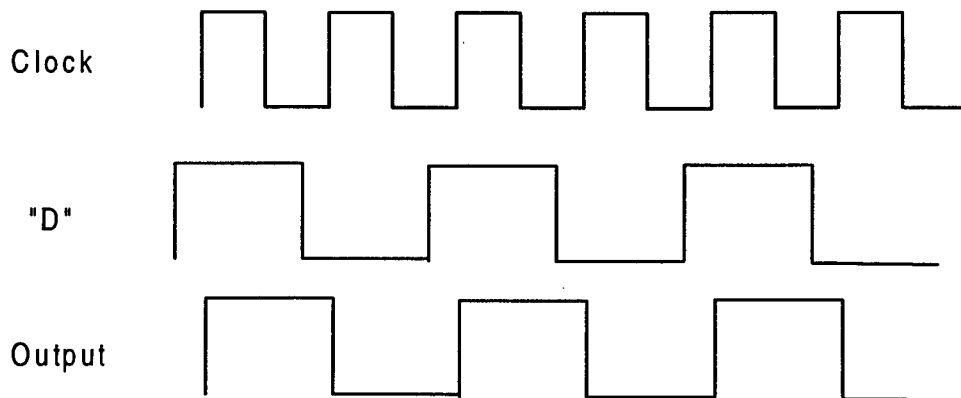
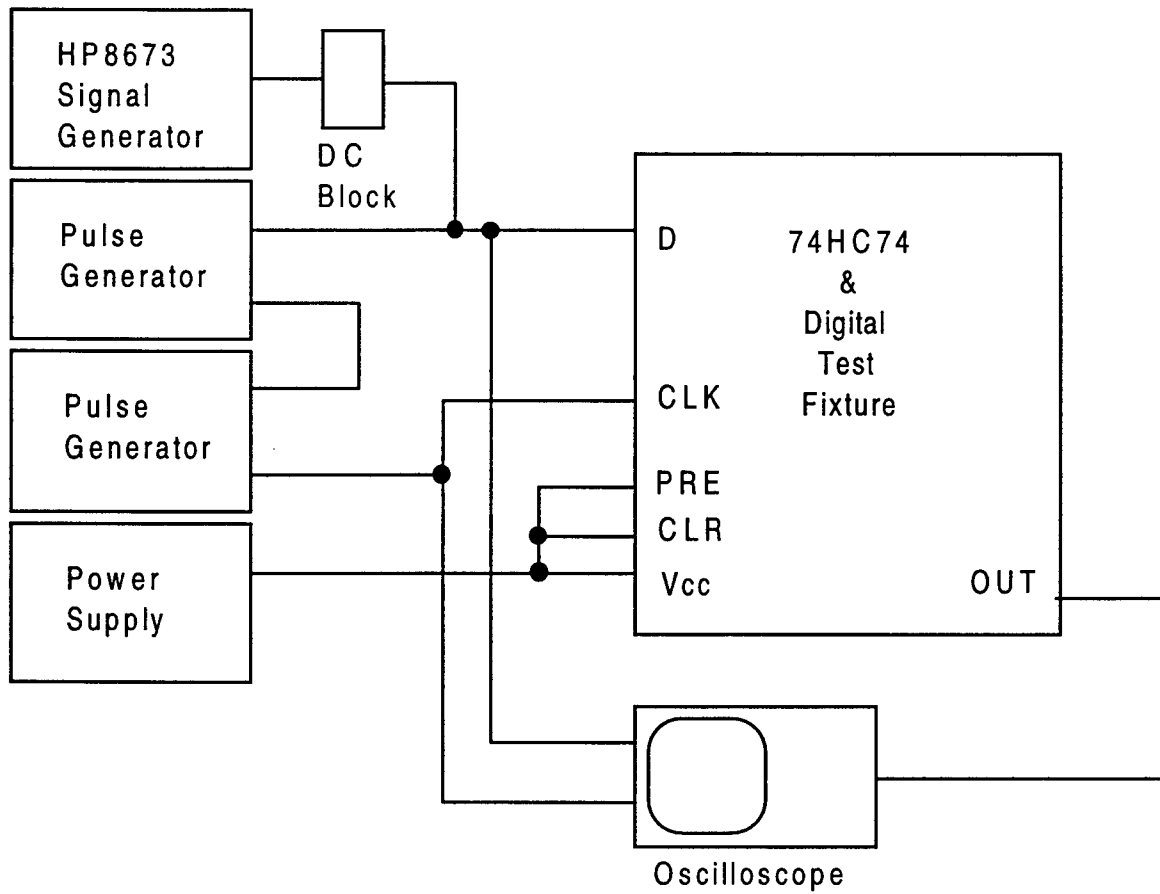

Figure 6.2-1: Conducted Susceptibility Digital Test Setup

### 6.3 Analog Device Conducted Susceptibility Testing

The analog breadboard circuit was set up to test one section of the OP-271 dual operational amplifier. Figure 6.3-1 shows the test setup for the bias voltage test. This test was set up with the output of a precision potentiometer connected to the input of the op-amp and a voltmeter so the voltage could be accurately measured. The input voltage was slowly increased and the output of the OP-271 would go into oscillation as the input voltage approached the positive power supply voltage. The voltage at which the output of the op-amp went into oscillation was noted. The voltage was then reduced and the voltage at which the output of the op amp came out of oscillation was also noted. The RF signal generator was turned on with the frequency at 750 MHz at its maximum output power (+13 dBm) and the measurement was repeated. The frequency was increased to 2 GHz and the measurements were taken again. These measurements were made using 8 plastic and 8 ceramic packaged devices in order to get some idea of the range of values that might be expected for a large population of devices. The results of this test are shown in Figure 6.3-2.

It was found that for a given device, the device would go into oscillation at a lower voltage in the presence of an interfering RF signal than with no interference. It was also shown that the devices were more susceptible to interference at 750 MHz than at 2 GHz.

The test setup was then changed to that shown in Figure 6.3-3. A pulse generator was used as the signal source and the voltage at which the operational amplifier went into oscillation was read from an oscilloscope. Although the readings are not the same as before due to differences in the measuring instruments, the trends are still the same, with the "no RF" voltage being the highest, the 2 GHz RFI next lowest (if any different at all), and the 750 MHz RFI case being the lowest and having the most effect. The results of this test are shown in tabular format in Figure 6.3-4.

The operational amplifiers were then tested, using the same test setup, to see if the input pulse frequency affected the susceptibility. The results of this test are shown in both tabular and graphical form in Figure 6.3-5. There appears to be no conclusive trend to the data that we can use to predict the effect of input pulse frequency on the susceptibility of the devices. The typical upset mode for the operational amplifiers was for the device output to go into oscillation when the  $V_{IH}$  level of the input square wave combined with the RF noise approached the  $+V_{CC}$  power supply level.

## 7.0 BASELINE TESTING

The purpose of baseline testing was to develop a susceptibility profile that could be used to set up the test conditions for the long term radiated device testing, and to learn what we could about the performance of the test devices in the reverberation chamber environment. Baseline testing was performed to determine instantaneous upset level, and if possible, the damage level, for the digital and analog test devices over the frequency range of 0.7 to 18.0 GHz, and also to see if any devices failures could be caused. The upset levels have been measured and are discussed in section 8.1. The recommendations for long term testing are discussed in section 7.3.



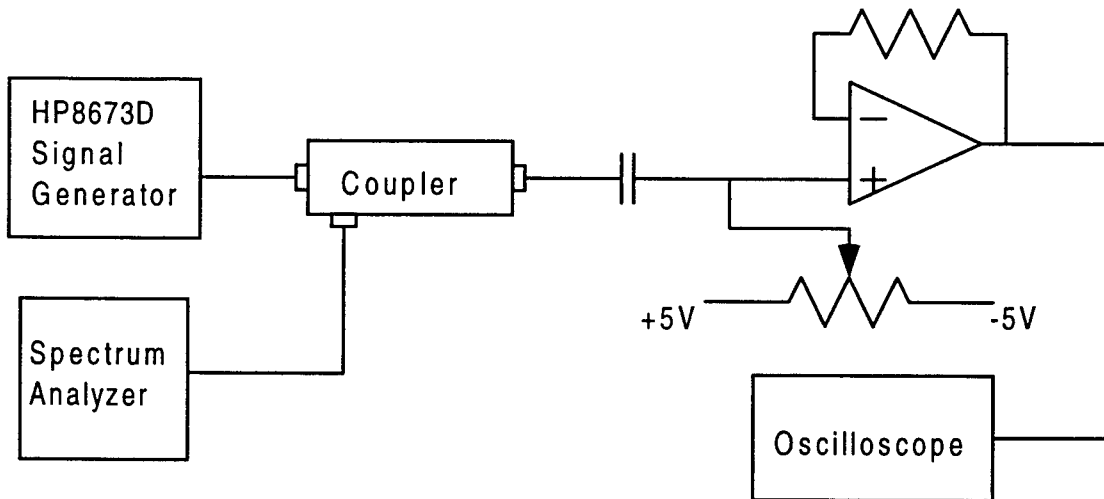

Figure 6.3-1: Conducted Susceptibility Analog Bias Voltage Test Setup

Op Amp Serial Number	NO RF		Interference - 750MHz		Interference - 2GHz	
	V_Osc	V_Osc Dropout	V_Osc	V_Osc Dropout	V_Osc	V_Osc Dropout
4001	3.17	2.60	3.13	2.72	3.15	2.58
4002	3.30	2.78	3.27	2.98	3.30	2.80
4003	3.41	2.85	3.36	2.90	3.39	2.80
4004	3.24	2.76	3.18	2.87	3.22	2.77
4005	3.60	3.39	3.56	3.44	3.56	3.38
4006	3.41	3.16	3.33	3.20	3.38	3.13
4007	3.40	3.17	3.36	3.20	3.38	3.13
4008	3.27	2.68	3.21	2.75	3.22	2.70
3001	3.29	3.06	3.22	3.09	3.29	3.04
3002	3.44	2.90	3.38	2.92	3.42	2.89
3003	3.12	2.55	3.08	2.66	3.11	2.55
3004	3.16	2.88	3.07	2.90	3.14	2.84
3005	3.37	3.16	3.31	3.14	3.32	3.09
3006	3.44	3.20	3.41	3.23	3.42	3.22
3007	3.46	3.07	3.39	3.09	3.42	3.09
3008	3.48	3.30	3.42	3.29	3.46	3.27

Figure 6.3-2: Voltage Bias Test Results

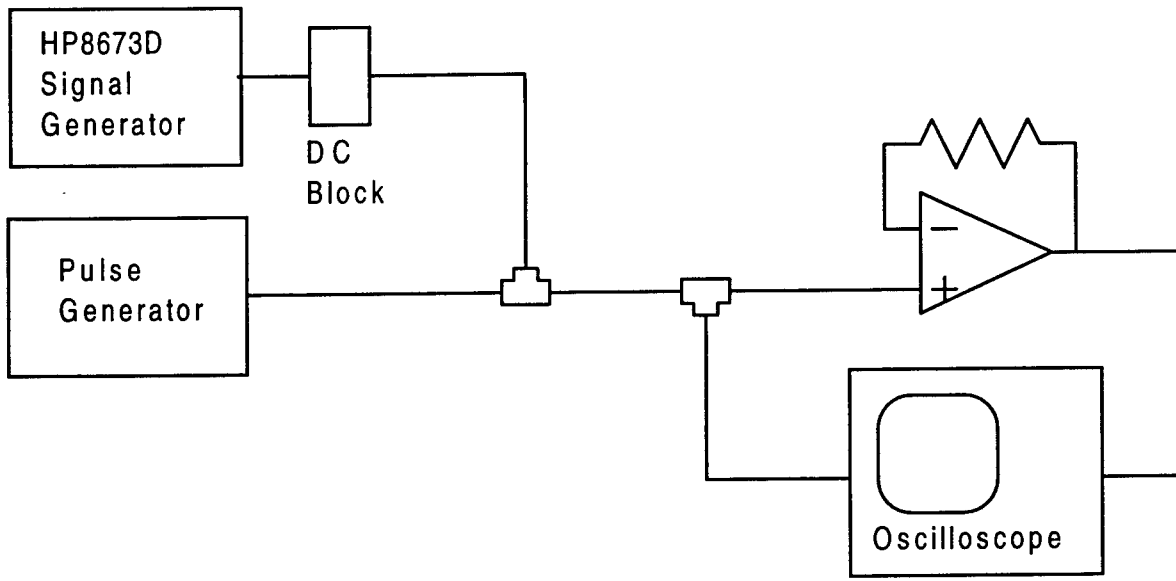

Figure 6.3-3: Conducted Susceptibility Analog Pulse Generator Test Setup

Op Amp			
Serial	No	750MHz	2GHz
Number	RFI	RFI	RFI
4001	3.20	3.18	3.20
4002	3.37	3.32	3.36
4003	3.48	3.40	3.47
4004	3.30	3.28	3.30
4005	3.60	3.58	3.60
4006	3.45	3.40	3.40
4007	3.41	3.39	3.40
4008	3.30	3.27	3.28
3001	3.37	3.30	3.35
3002	3.49	3.41	3.47
3003	3.18	3.10	3.17
3004	3.19	3.12	3.19
3005	3.40	3.35	3.39
3006	3.49	3.45	3.49
3007	3.49	3.42	3.49
3008	3.50	3.45	3.50

Figure 6.3-4: Pulse Generator Test Results

Input Pulse Frequency	10,000	50,000	100,000	250,000	500,000
Op Amp Serial #					
4001 No RF	3.34	3.34	3.36	3.74	4.63
4001 RF On	3.24	3.3	3.31	3.69	4.66
4001	-0.1	-0.04	-0.05	-0.05	0.03
4002 No RF	3.58	3.57	3.63	4.11	5.11
4002 RF On	3.5	3.49	3.54	4.03	5.06
4002	-0.08	-0.08	-0.09	-0.08	-0.05
3001 No RF	3.61	3.58	3.63	4.05	5.12
3001 RF On	3.55	3.55	3.61	4.01	5
3001	-0.06	-0.03	-0.02	-0.04	-0.12
3002 No RF	3.83	3.83	3.89	4.32	5.14
3002 RF On	3.79	3.79	3.85	4.29	5.09
3002	-0.04	-0.04	-0.04	-0.03	-0.05
3003 No RF	3.3	3.26	3.29	3.64	4.29
3003 RF On	3.22	3.2	3.26	3.57	4.25
3003	-0.08	-0.06	-0.03	-0.07	-0.04
3004 No RF	3.3	3.31	3.31	3.71	4.54
3004 RF On	3.24	3.26	3.28	3.64	4.53
3004	-0.06	-0.05	-0.03	-0.07	-0.01

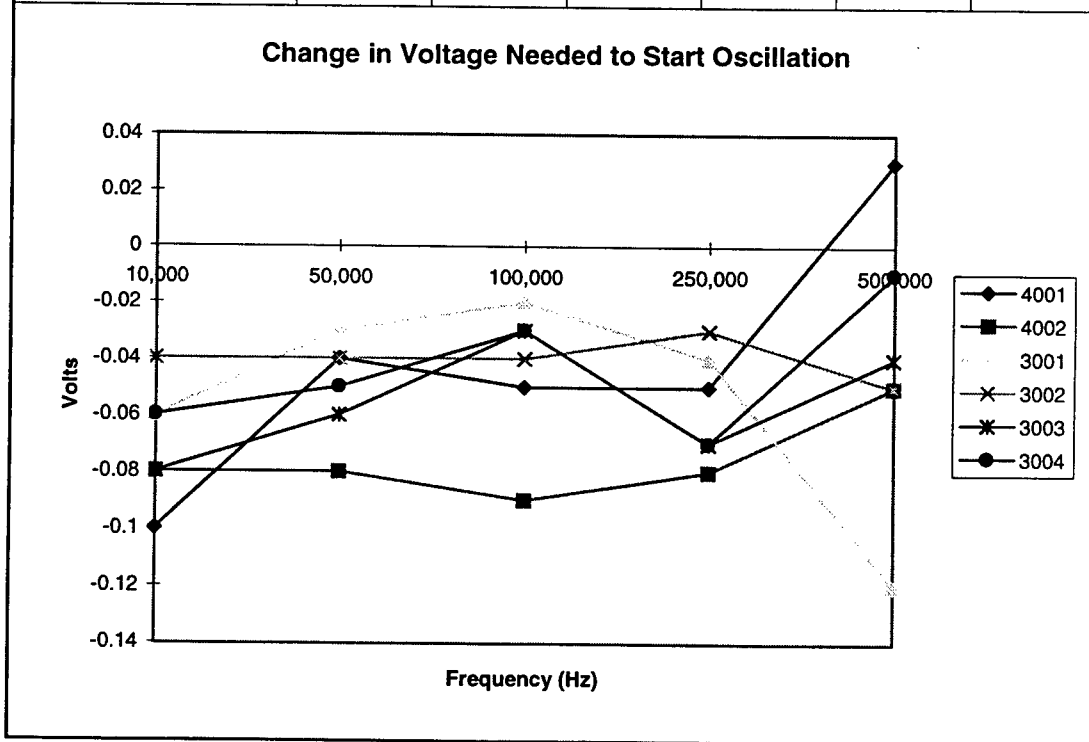

Figure 6.3-5: Frequency Dependency Test

As a part of baseline testing, electrical acceptance test procedures were developed and parts were tested to determine and record their initial electrical performance characteristics. Each part was numbered so that changes in these characteristics could be tracked through all the testing performed as a part of this contract. The parts allocated for baseline testing were then inserted in the test fixtures and baseline testing was performed. Following baseline testing, the acceptance test procedure was performed on each part to determine if exposure to the RF energy during baseline testing had any effect on the basic electrical device parameters. A summary of results of that testing is given in section 7.2. No devices failed during the baseline test and no parts drifted far enough to indicate impending failure. However, a number of parameter drifts were noted that might be significant in the long term.

During baseline testing a number of things were discovered. We found that the width of the RF pulse needed to be at or above some minimum value before there would be enough energy in the chamber to cause any devices to upset. This seems to be much like the relaxation time associated with coaxial cables, and seems to be a function of the volume of the chamber and the RF power level. At a pulse width of 200 nano-seconds we experienced very few upsets because the RF pulse had ended before the electrical field intensity in the chamber had climbed to a value sufficient to cause more than just a few devices to upset. We found that a pulse width of 1.2 microseconds was sufficient for the electrical field intensity to reach a steady-state value and to induce upsets in the population of both the analog and digital test devices.

The test fixture is a multi-layer printed wiring board with test sockets, connectors, and the circuit elements necessary to support the specific test configuration of the test devices. It was designed so that the top side of the circuit board, which contains the signal input and power supply traces, would be exposed to the EM field while the back side of the board, which contains the output signal traces, could be protected through the use of an aluminum shielding panel. With the digital test fixture configured as designed with the input signal and power traces exposed and the output signal traces protected, and we found that the digital test devices, 75/54ACT74 flip-flops, did exhibit susceptibility. We were curious about the effect of the EM energy on the output lines, and we found that by removing the shielding from the back of the digital test fixtures and allowing the device outputs as well as the inputs to be radiated, a larger number of upsets was experienced than with only the front traces exposed. We reasoned that although the input circuits are probably more sensitive than the output drive circuits, most digital devices have diode protection on their inputs but no protection on the outputs, which might explain why the outputs seem to be more susceptible. We also found that digital signals operating between the upper "low" voltage specification of 1.2 volts and the lower "high" specification of 2.0 volts would cause the digital test devices to upset with or without the influence of RF energy, but the devices would not go into upset at their specified operating conditions unless the RF power level was quite high.

The analog test devices appear to be more susceptible to the interfering RF signal because they can be made to upset in the presence of a fairly low intensity RF signal while operating within the voltage specification. However, if operated outside their specification limits, they would upset at a lower RF power level.

With respect to the reverberation chamber, the chamber calculations indicate that a sufficient number of modes exist within the chamber for it to provide an adequate EM test environment at 400 MHz and above. After watching the testing and analyzing the test data, we believe that the chamber does provide an adequate EM test environment over the frequency range covered by our test equipment, which is 700 MHz to 18 GHz. The mode stirring within the chamber coupled with the design of the test fixtures appears to cause the test device upsets to be random without regard to the device number or the location of the device within the test fixture. Thus it appears that adequate mode stirring is occurring in the chamber and that only a statistical correlation of the device upsets within chamber is possible.

### **7.1 Baseline RF Radiated Susceptibility Testing Approach**

Our initial test plan called for the design of baseline test fixtures that would hold a few test devices, whereas the long-term test fixtures were designed to hold 100 test devices each. We realized that the test fixture, test cables, test stands and the powered-up test devices might influence the fields inside the chamber and have an effect on the instantaneous upset level of the test devices. Since this seemed quite likely, we changed our baseline test philosophy and the baseline RF test was performed using the long-term test fixtures configured as they would be during long-term testing. This will ensure that the susceptibility profiles developed in baseline tests will be valid for long-term testing.

The baseline test was performed by subjecting 3 test lots of analog parts and one test lot of digital test devices to an EM environment for one or more 30-day test periods. The test devices were supplied with DC power and test signals during the RF susceptibility testing.

### **7.2 Baseline RF Radiated Susceptibility Test Setup**

Testing was performed in the mode-stirred reverberation chamber using the test fixtures described in section 9. Since two fixtures will be in the chamber during long-term testing, two fixtures, each containing 100 devices, were also used during baseline testing. Either one digital test fixture and one analog test fixture or two analog test fixtures were in the chamber during baseline testing, with both test fixtures powered up but only one being tested at a time. The fixtures were placed on nonconductive stands in the chamber as shown in Figure 7.2-1. The fixtures were in a vertical position and were facing each other at approximately a 35-degree angle from the side chamber wall. The fixtures were positioned so that they were 16 inches from the chamber walls, 8 inches from the long wire antenna, 31 inches from the floor, 16 inches below the stirring paddle, and 12 inches from each other. Each test fixture also has 4 output connectors, 1 power input connector, and 2 coaxial input connectors. Shielded test cables were attached to these connectors and routed to mating connectors on the access panel at the rear of the chamber. The source of the RF energy inside the chamber is a terminated long-wire antenna mounted to the walls of the chamber.

The test stimulus and monitoring system, power supplies, and RF power system are located outside the chamber. The test stimulus and monitoring system is described in section 12 and the RF power system was described in section 10.

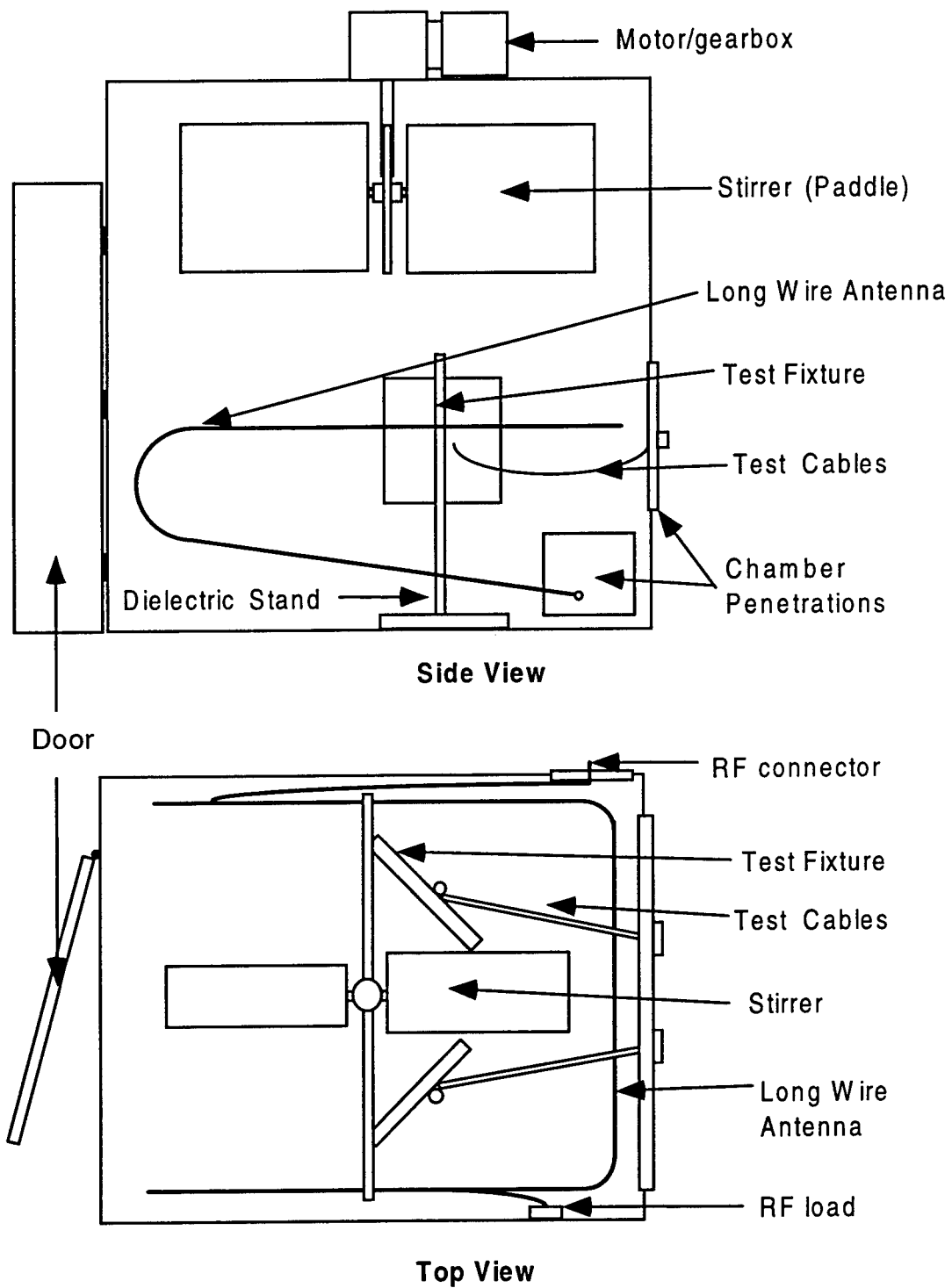

Figure 7.2-1: Reverberation Chamber Setup for Radiated Susceptibility Testing

### **7.3 Baseline Functionality Test Procedure**

Because it is important to know whether the test devices are functional when exposed to RF power the test stimulus and monitoring system was used for baseline testing. Although it would be desirable to have the results of a complete electrical test every second, that is not possible, especially for 200 devices at a time. A complete electrical test would require the use of a sophisticated automated tester, which typically tests only one device at a time. But in order to provide at least a "go/no-go" evaluation of every test device on a real time basis, a basic functional test, which gives the same results for both the analog and digital parts, was created. The long-term analog and digital test fixtures were designed to accommodate this test. The analog test circuit is shown in Figure 7.3-1 and the schematic diagram of the test circuit as implemented on the analog test fixture is shown in Figure 7.3-2. The digital test circuit is shown in Figure 7.3-3 and the schematic diagram of the test circuit as implemented on the digital test fixture is shown in Figure 7.3-4. The 74/54ACT74 flip-flop requires two test signals, a "Clock" signal and a "D" signal. The computer commands the dual pulse generators to send two clock pulses and one "D" signal pulse to the test devices. The "D" signal is synchronized with the clock such that "D" is high on the rising edge of the first clock pulse and low with the rising edge of the second clock. This results in the Q output of the flip-flop toggling once between logic 1 and logic 0 (which produces a positive pulse). The computer also conditions the monitor circuit to look for this pair of transitions in each of the 100 devices on the test board it is monitoring. After each pulse the computer queries the monitor board and the monitor board outputs to the computer the sequence number of the devices that have failed. The parallel port of the computer is wired such that it is connected to both monitor boards and reads the status from both boards after each pulse and then once each second it stores this data in a data file on the PC's hard drive.

In order to test the OP-271 operational amplifier, the analog test board is wired as a unity gain amplifier for each of the 100 test parts, and it requires only a single 0 to 4 volt pulse from the pulse generator in order for each test device to produce an output. The output from the OP-271 is identical to that from the ACT74, except that the op-amp has a much slower slew rate, so the edges of the square wave output are more obvious. However, to the monitor circuit, the signal looks the same, and it will flag and report a faulty op-amp output just like it does for the flip-flop. The entire process is automated which allows the PC to continuously test, check and record the functionality of each test device in the chamber.

The test devices in the chamber were driven with the pulse generators programmed to provide input stimulus at a 2 KHz rate. However the test rate for an entire "test-check-record" cycle is much slower due to the time needed to retrieve data via the parallel port when a device has been flagged as a failure (it seems to average about 10 to 13 cycles per second). This test will allow us to determine whether a device is capable of functioning. The same method was used for both baseline and long-term testing.

### **7.4 Baseline RF Radiated Susceptibility Testing**

It was proposed to carry out RF radiated susceptibility testing in two parts; 1) to determine the instantaneous upset levels of the devices across the 500 MHz to 18.0 GHz range, and 2) to use higher

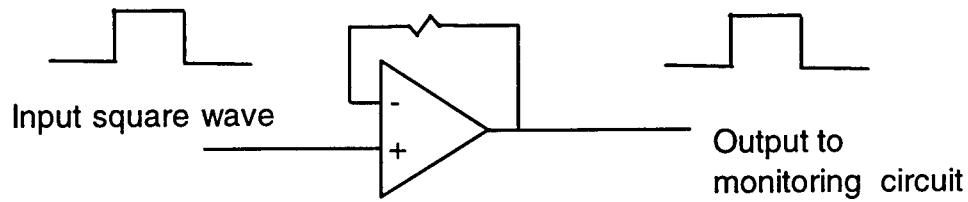

Figure 7.3-1: Analog Device (OP-271) Test Circuit

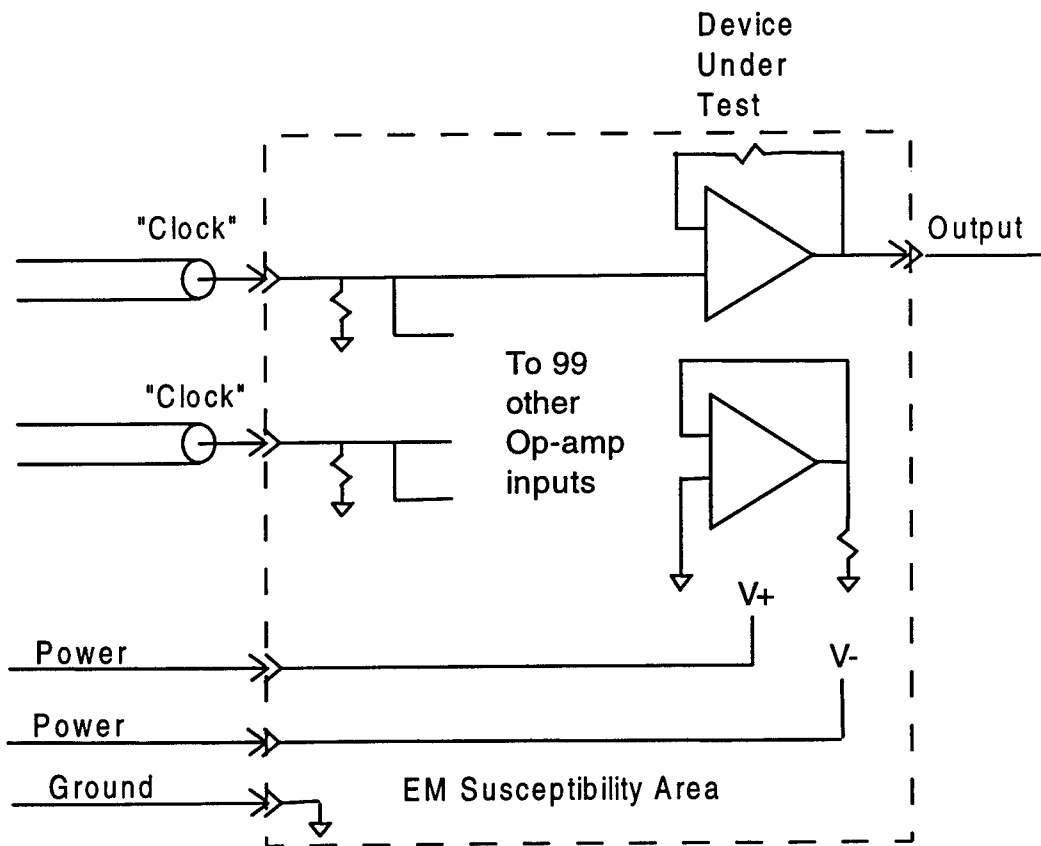

Figure 7.3-2: Circuit Diagram (1 of 100) as Implemented on Analog Test Fixture



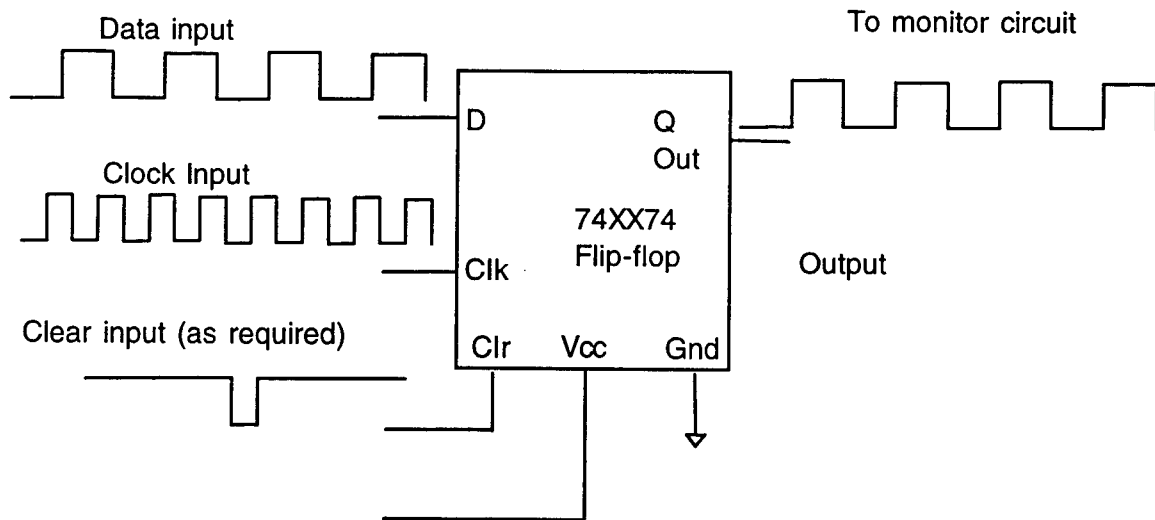

Figure 7.3-3: Digital Device (54/74ACT74) Test Circuit

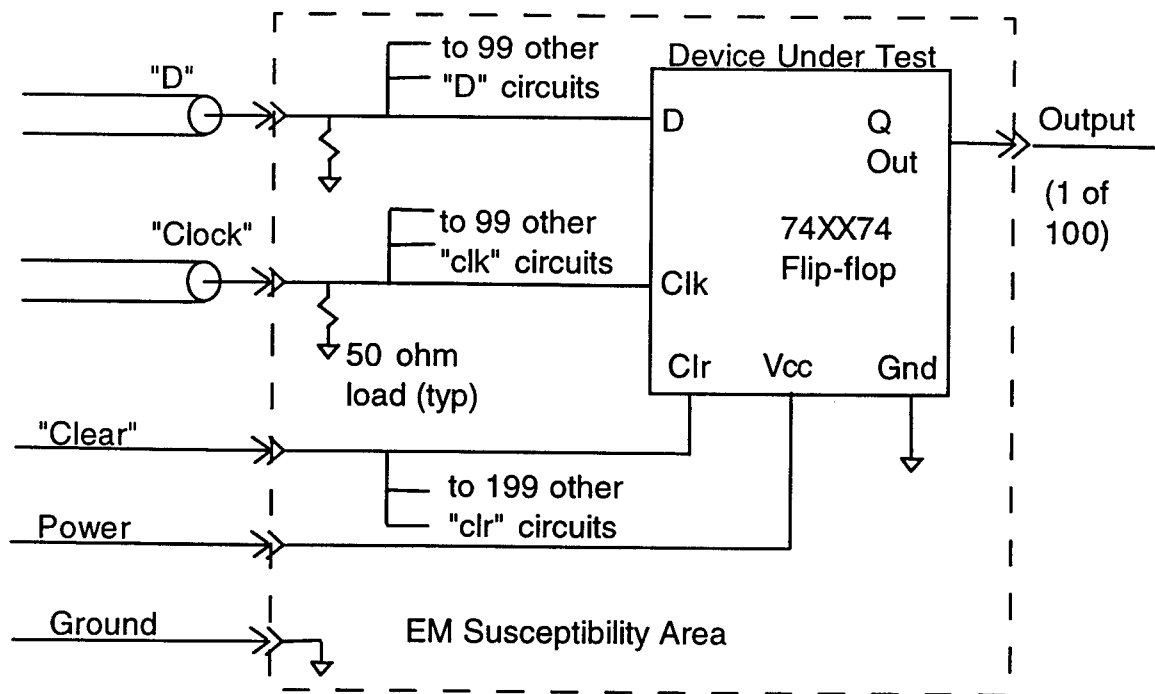

Figure 7.3-4: Circuit Diagram (1 of 100) as Implemented on Digital Test Fixture

RF power levels in an attempt to cause burn-out of devices. While doing some preliminary testing, we discovered that in most cases, the maximum RF power available was just barely enough to force a sufficient population of the test devices into an upset condition. Most test conditions that were used to determine instantaneous upset levels included the use of maximum RF power. It did not appear that we caused any of the devices to burn out during baseline testing, so the second part of the proposed test was not accomplished. The baseline testing proceeded as follows: The mode stirred reverberation chamber was set up as shown in Figure 6.2-1. One digital test fixture populated with 50 CD54ACT74F (ceramic) and 50 CD74ACT74E (plastic) flip-flops, and one analog test fixture populated with 50 OP271FZ (ceramic) and 50 OP271GP (plastic) operational amplifiers, were placed in the stirred mode chamber and connected to the test instrumentation via test cables. These parts had passed functional test before being inserted into the test fixtures. The test conditions were as follows: The paddle was set to turn at 1 RPM and the  $V_{CC}$  supplied to the digital test parts was 5.0 V. While testing digital parts, the analog parts in the chamber were supplied with +5.0 V and -5.0 V, but no input signal. While testing analog parts, the analog power supply voltages were +7.5 V and -7.5 V, and the digital parts in the chamber were supplied with 5.0V but no input signal. The monitor circuit voltage was 4.3 V. The clock pulse was 0 V to 4 V, and the "D" signal pulse was 1.14 V to 4 V. Each test segment was nominally one minute in length which allowed the stirring paddle to make one complete revolution.

#### 7.4.1 Baseline Digital Testing

The digital baseline testing was performed on 100 parts in the digital test fixture. The EMI shielding was removed from the digital test fixtures because the test devices were more sensitive to RF with both the inputs, the power lines, and the outputs exposed to the RF energy in the chamber. The removal of the shielding did not appear to have any adverse effect on the monitoring circuits. The test conditions were as follows:  $V_{CC}$  supplied to the test parts was 5.0 volts and the clock pulse was 0 V to 3 V. The high level of the "D" signal pulse ( $V_D$  high) was 4.0 V and the low level ( $V_D$  low) of the "D" signal was varied from 0 V to approximately 1.2 V during the testing. The stirring paddle in the chamber was turned at 1 rpm and the test stimulus and data acquisition system recorded the test data. Each test was nominally one minute in length, and during that time 60 test samples were collected. The voltage specification for both the "D" and clock signals is 0 to 0.8 V for the "low" and 2.0 V to  $V_{CC}$  for the "high" part of the signal.

The first digital baseline test performed was to vary the pulse width and period and hold the rest of test conditions fixed, with  $V_D$  low just below the upset threshold. First we found the threshold voltage for  $V_D$  low by increasing the voltage on the pulse generator in 0.01 volt steps until the test devices began to upset. We discovered that the threshold is approximately 1.14 V to 1.15 V. We set  $V_D$  low to just below the threshold where device upsets would occur. During this testing we found that the pulse power amplifier could be run at 1000 Watts output power and 0.2% duty factor for short pulses, but when the pulses were lengthened the duty factor had to be reduced 0.1% to ensure stability of the amplifier. At the given test conditions, we did not observe any upsets when no RF was applied to the test chamber. Figure 7.4.1-1 shows the summary test results of a digital test when the pulse width and pulse period are varied. Figure 7.4.1-2 shows the complete data for that test. From the complete test

PW (ns)	Period (ms)	RF Power	Total Upsets	Periods Upset	Upsets/ Period
200	1	1000	137	29	4.72
300	1	1000	288	47	6.13
400	1	1000	559	59	9.47
500	1	1000	701	56	12.52
600	1	1000	750	59	12.71
800	1	1000	1070	60	17.38
1000	1	1000	1173	56	20.95
1200	1.5	1000	1295	55	23.55
1200	1.5	500	880	49	17.96
2000	2.5	1000	614	60	10.23
1200	2.5	1000	438	38	11.53

Figure 7.4.1-1: Summary of Pulse Width and Period Baseline Tests

PW (ns)	200	300	400	500	600	800	1000	1200	1200	2000	1200
Period (ms)	1	1	1	1	1	1	1	1.5	1.5	2.5	2.5
RF Power	1000	1000	1000	1000	1000	1000	1000	1000	500	1000	1000
	3	4	14	39	5	5	55	6	2	11	6
	5	5	5	5	5	5	33	48	3	5	8
	5	6	8	6	35	7	43	70	3	7	6
	5	5	7	22	7	5	6	55	37	6	4
	5	5	4	5	5	43	57	41	2	6	14
	5	6	5	6	5	6	34	16	59	5	4
	5	5	5	5	15	43	6	8	4	3	7
	5	4	5	5	8	70	8	85	5	12	51
	4	5	6	7	5	37	35	5	23	7	5
	5	5	5	5	11	73	50	5	66	5	41
	5	5	5	5	50	32	15	21	3	6	5
	5	5	4	6	52	5	44	5	39	52	7
	4	5	5	5	6	6	6	35	79	5	5
	5	5	5	7	43	50	23	77	4	8	5
	5	30	6	5	17	57	7	5	3	7	7
	5	5	4	5	5	15	38	54	7	6	9
	3	6	7	5	5	15	7	5	84	35	13
	5	5	5	15	10	4	58	6	5	5	25
	5	5	5	37	33	5	48	5	6	3	7
	5	5	5	5	5	5	66	42	6	4	5
	4	3	47	7	5	5	7	24	44	3	6
	5	3	6	5	5	6	52	5	37	16	6
	6	3	8	8	6	6	8	5	7	3	6
	3	5	5	4	6	6	35	2	6	7	7
	5	5	5	30	60	5	5	6	18	8	5
	5	5	5	10	6	50	67	66	18	6	5
	5	5	5	15	38	45	24	6	5	4	12
	5	5	5	11	17	15	6	5	5	83	5
	5	5	5	5	6	5	6	5	5	23	8
		4	65	5	5	6	4	6	3	37	30
		5	45	5	7	6	3	5	6	8	19
		4	5	6	5	5	5	4	14	7	10
		5	5	6	5	31	5	28	4	11	5
		6	5	5	6	26	5	51	47	46	3
		7	5	5	6	7	39	4	14	5	5
		5	5	5	33	7	21	7	45	15	5
		4	5	6	6	6	5	16	3	8	6
		5	5	5	12	5	24	7	13	5	61
		7	6	41	17	14	46	5	36	6	
		4	5	6	13	6	5	14	5	5	
		5	5	5	9	4	4	4	56	6	
		38	5	89	3	6	4	8	3	5	
		5	7	6	7	6	5	100	17	6	
		5	51	5	5	5	4	36	4	5	
		5	5	5	4	5	5	1	5	6	
		4	2	6	5	6	5	6	5	5	
		5	5	51	6	47	5	5	6	6	
			5	5	8	13	7	5	4	5	
			7	41	7	5	5	5	5	6	
			6	8	6	8	37	13		5	
			6	5	5	7	5	50		6	
			5	5	5	40	8	66		5	
			5	3	6	50	6	56		6	
			6	6	5	42	5	32		5	
			5	6	52	15	38	43		6	
			8	65	10	6	19			5	
			5		5	5				6	
			46		6	5				5	
			13		5	38				6	
						7				5	
Total	137	288	559	701	750	1070	1173	1295	880	614	438
Periods	29	47	59	56	59	60	56	55	49	60	38
Ave	4.72	6.13	9.47	12.52	12.71	17.83	20.95	23.55	17.96	10.23	11.53
Maximum	6	38	65	89	60	73	67	100	84	83	61
Minimum	3	3	2	3	3	4	3	1	2	3	3

Figure 7.4.1-2: Digital Baseline Test - Pulse Width and Period

data we extracted the number of periods in which one or more upsets occurred, the total number of upsets recorded during the test, the average number of upsets per period, and the highest number of upsets in any period during the test. This test verifies that short pulses (in the range of 200 ns) would not allow the energy in the chamber to reach a steady-state value high enough to cause any device upsets. As can be seen, the number of upsets increase dramatically as the pulse width is increased from 200 ns to 1200 ns. The combination of period and pulse width that seems to cause the highest number of upsets, and still be within the operational limitations of the pulse amplifier, is a 1.5 ms period with a 1.2  $\mu$ s pulse width. We feel that the test conditions are adequate because each one of the devices on the digital test board was upset at least once during the test period. The fact that the number of upsets ranged between 0 and 100 over one paddle rotation verified that the test fixture, the test stimulus and monitor system, and the reverberation chamber were working as they should. This testing established that a pulse width of 1.2 microseconds and a pulse period of 1.5 milliseconds was the highest pulse width and duty factor that could be produced by the pulse power amplifier at full output power in the 700 MHz to 2 GHz frequency range. The 1.2 microsecond pulse also seemed to be the most effective pulse width in terms of causing a maximum number of upsets. This testing also established that 900 MHz is the most effective frequency in that frequency band for causing digital device upset.

The next testing was performed to determine the frequency sensitivity of the test fixtures and test parts. The test conditions were: RF power was 1000 W,  $V_D$  low was 1.14 V, and all other test conditions were the same. A number of discrete frequencies between 700 MHz and 2 GHz were tested. The complete test results are shown in Figure 7.4.1-3. New plug-ins were inserted into the pulse power amplifier and testing was continued from 2 GHz to 18 GHz. The susceptibility of the test devices and/or the coupling effectiveness of the test fixture fall off rapidly above 2 GHz. The power output of the plug-ins which operate from 2 to 4 GHz and from 8 to 18 GHz is less than 1000 W. This test equipment anomaly did not allow us to look at device susceptibility between 2 and 4 GHz where we might have seen some device upsets. But the sensitivity of the test devices was dropping off significantly around 2 GHz with the 1000 Watts of RF that was produced by the 0.7 GHz to 2 GHz plug-in. No upsets were detected between 4 and 8 GHz at the 1000 Watts RF power level, so the device sensitivity to RF above 2 GHz seems to be rapidly diminishing. Testing was performed on both analog and digital test devices from 2 to 18 GHz, and a summary of all the frequency sensitivity testing is shown in Figure 7.4.1-4. Although frequency sweep testing between 700 MHz and 2 GHz was done only with digital test devices, we feel the analog test devices would react about the same because of their similar performance below 2 GHz. The test conditions for the analog devices are listed in the analog test section.

For the next test the RF power was set to 1000 Watts at 900 MHz with a 1.2  $\mu$ s RF pulse width and  $V_D$  low was varied. We were able to reduce  $V_D$  low to 0 V and still have a significant number of upsets. The complete test data is shown in Figures 7.4.1-5a and 7.4.1-5b.

Next we returned  $V_D$  low back to 1.14 V, reduced the RF power 3 dB to 500 W peak and varied  $V_D$  low. At 1.14 V upsets occurred during 23 out of 60 periods, at 1.13 V upsets occurred during 5 periods. When we reduced  $V_D$  low to 1.12 V there were no upsets. These results are shown in Figure 7.4.1-6.

Frequency	700	700	800	900	900	1000	1100	1200	1300	1400	1500	1600	1700	1800	1900	2000
1	17	1	1	52	1	15	56	16	19	3	0	28	48	43	34	0
2	0	2	0	74	2	57	41	39	53	0	16	0	0	0	0	0
3	0	22	88	56	5	83	0	37	57	0	0	82	0	0	0	0
4	0	32	2	2	6	86	0	48	0	15	0	0	0	0	34	0
5	0	1	3	38	17	21	32	0	3	1	83	0	0	0	0	0
6	9	0	83	51	1	0	0	2	0	2	0	71	0	0	0	0
7	1	16	0	0	39	0	6	51	41	89	0	0	52	0	0	0
8	0	6	31	3	15	65	17	30	57	0	0	0	0	0	0	0
9	9	24	0	44	3	10	56	8	67	0	27	0	70	0	0	59
10	1	0	0	9	45	0	1	1	56	3	2	0	0	0	0	0
11	9	0	3	62	53	25	0	1	16	0	10	71	57	0	0	0
12	0	0	13	87	93	0	12	32	0	3	0	0	0	0	0	59
13	0	0	100	77	90	48	0	2	0	5	0	0	0	0	41	0
14	3	0	6	68	42	20	0	6	0	0	0	0	1	62	1	0
15	11	0	1	56	70	1	38	23	0	1	0	0	6	0	0	0
16	53	5	0	34	53	13	0	0	0	67	0	0	42	0	9	0
17	53	10	15	33	68	39	1	0	47	62	0	0	0	0	0	0
18	1	53	6	4	71	56	0	47	0	14	0	0	0	0	0	0
19	31	8	16	56	74	41	9	0	1	15	19	0	0	0	0	0
20	20	0	6	55	62	53	56	0	0	52	26	72	0	0	0	42
21	9	0	0	56	69	3	41	0	34	28	3	0	0	0	1	0
22	0	54	10	52	85	38	41	0	0	28	0	0	85	0	0	0
23	0	2	38	56	86	47	0	0	57	0	0	0	0	30	35	0
24	0	3	0	9	54	74	11	1	0	1	0	0	0	85	0	0
25	15	0	53	48	87	28	0	35	0	0	0	0	0	0	0	0
26	2	0	0	58	53	10	0	34	0	0	53	0	86	0	0	8
27	0	69	66	24	33	41	3	0	0	10	0	0	0	0	0	54
28	6	9	0	74	42	40	85	38	0	50	0	0	15	0	0	0
29	73	3	34	74	52	0	71	28	1	31	10	0	0	0	0	81
30	0	3	0	38	49	18	28	34	4	0	40	0	0	0	0	0
31	0	0	27	0	64	23	6	43	23	3	0	0	0	0	0	22
32	0	0	0	15	1	29	21	11	10	28	0	0	0	0	0	4
33	1	2	3	49	33	2	0	0	0	19	0	0	0	0	1	0
34	0	75	33	1	39	13	6	2	34	3	5	0	0	1	22	0
35	0	1	88	25	6	6	81	89	0	0	0	0	62	0	0	0
36	3	0	2	35	52	0	0	61	0	0	2	0	0	87	0	85
37	0	23	5	38	1	0	1	7	1	1	3	0	71	0	0	0
38	0	4	20	54	0	34	0	9	0	21	0	0	0	0	0	64
39	0	42	22	63	42	16	0	0	15	30	0	0	76	32	0	0
40	0	16	10	85	79	71	3	0	3	0	28	52	71	0	0	0
41	1	0	0	40	62	0	16	9	0	0	8	0	0	0	0	0
42	0	53	0	62	41	0	34	23	5	0	52	12	0	0	0	0
43	0	19	3	53	51	0	0	3	15	16	0	0	0	0	0	0
44	0	52	0	39	23	6	44	58	2	3	68	0	80	23	0	10
45	0	5	0	57	30	83	62	10	9	16	44	0	0	30	0	0
46	0	17	45	75	0	71	31	15	23	22	4	0	0	0	0	0
47	58	0	0	41	86	6	0	48	0	0	4	0	0	0	0	0
48	37	0	0	43	50	62	0	32	3	0	0	0	1	0	0	0
49	0	9	1	67	33	54	0	0	9	1	0	0	0	0	0	34
50	17	1	0	63	54	29	56	2	0	62	10	0	0	0	0	0
51	34	0	0	56	57	26	7	100	71	2	15	30	0	0	0	0
52	35	2	0	62	88	28	42	1	0	0	19	0	9	0	49	0
53	8	0	0	16	19	20	79	0	1	28	11	0	0	0	0	0
54	57	2	1	59	47	35	10	9	0	32	0	0	0	0	0	0
55	52	1	1	44	53	27	54	11	0	0	0	0	51	0	0	0
56	0	5	0	18	57	1	52	33	10	3	44	0	67	0	0	0
57	0	34	0	51	82	0	10	0	10	9	15	0	0	0	0	0
58	37	4	0	62	87	10	6	62	2	0	71	80	0	22	86	0
59	8	0	39	52	1	28	0	0	30	15	0	0	0	0	0	0
60	0	15	3	45	1	19	0	11	6	2	2	0	0	0	0	0
Total	671	705	878	2720	2659	1631	1226	1162	738	853	694	498	950	415	313	522
Periods	60	60	60	60	60	60	60	60	60	60	60	60	60	60	60	60
Average	11.18	11.75	14.63	45.33	44.32	27.18	20.43	19.37	12.3	14.22	11.57	8.3	15.83	6.917	5.217	8.7
Maximum	73	75	100	87	93	86	85	100	71	89	83	82	86	87	86	85
Minimum	0	0	0	0	0	0	0	0	0	0	0	0	0	0	0	0

Figure 7.4.1-3: Digital Baseline Discrete Frequency Test

Frequency (GHz)	Peak RF Power (Watts)	Type	Number of Upsets		
			Average	Maximum	Minimum
0.70	1000	Digital	11.18	73	0
0.70	1000	Digital	11.75	75	0
0.80	1000	Digital	14.63	100	0
0.90	1000	Digital	45.33	87	0
0.90	1000	Digital	44.32	93	0
1.00	1000	Digital	27.18	86	0
1.10	1000	Digital	20.43	85	0
1.20	1000	Digital	19.37	100	0
1.30	1000	Digital	12.30	71	0
1.40	1000	Digital	14.22	89	0
1.50	1000	Digital	11.57	83	0
1.60	1000	Digital	8.30	82	0
1.70	1000	Digital	15.83	86	0
1.80	1000	Digital	6.92	87	0
1.90	1000	Digital	5.22	86	0
2.00	1000	Digital	8.70	85	0
2.00	350	Analog	0.40	2	0
2.00	350	Digital	0.45	21	0
3.00	325	Analog	0.00	0	0
3.00	325	Digital	0.00	0	0
3.35	290	Analog	0.00	0	0
3.35	290	Digital	0.00	0	0
4.00	1000	Analog	0.00	0	0
4.00	1000	Digital	0.00	0	0
6.00	1000	Analog	0.00	0	0
6.00	1000	Digital	0.00	0	0
8.00	1000	Analog	0.00	0	0
8.00	1000	Digital	0.00	0	0
8.00	150	Analog	0.00	0	0
8.00	150	Digital	0.00	0	0
12.00	260	Analog	0.00	0	0
12.00	260	Digital	0.00	0	0
15.00	120	Analog	0.00	0	0
15.00	120	Digital	0.00	0	0
17.00	40	Digital	0.00	0	0
18.00	20	Analog	0.00	0	0
18.00	20	Digital	0.00	0	0

Figure 7.4.1-4: Frequency Sensitivity Baseline Test Data

Vd low	1.14	1.14	1.13	1.12	1.11	1.1	1.09	1.08	10.7	1.06	1.05	1.04	1.03	1.02	1.01	1	0.98
1	24	71	10	1	0	0	0	1	0	3	0	1	0	0	0	0	0
2	48	3	6	1	1	14	2	0	2	3	0	0	0	0	1	0	1
3	28	57	1	1	2	0	3	1	0	1	0	0	0	0	2	0	1
4	75	52	0	0	0	0	0	0	0	1	0	0	1	0	1	0	1
5	52	50	5	1	1	0	2	0	1	1	2	4	0	1	0	0	1
6	40	23	4	2	0	0	1	2	0	0	0	4	0	1	2	86	0
7	2	52	1	1	0	0	1	2	0	0	1	0	0	0	1	1	0
8	1	10	0	1	0	0	0	2	0	0	1	2	0	1	0	0	1
9	23	42	1	0	0	0	1	0	0	0	0	1	0	1	0	0	5
10	22	23	0	0	1	0	1	0	0	0	0	1	1	0	0	0	0
11	0	0	0	2	3	1	1	0	26	0	94	0	1	0	0	0	0
12	11	0	0	0	3	1	0	0	1	0	1	2	1	0	1	0	0
13	11	8	0	0	0	0	0	0	2	1	0	1	1	1	1	0	1
14	14	54	0	1	2	0	0	0	0	0	2	1	0	1	0	0	1
15	38	36	0	0	2	0	0	0	0	5	0	0	1	2	4	0	0
16	36	48	0	0	1	0	0	3	0	1	0	0	1	2	3	0	0
17	47	49	0	0	1	1	0	4	0	0	1	0	1	0	1	0	1
18	28	59	0	0	0	2	0	3	0	1	1	0	1	0	0	0	5
19	34	29	1	0	0	0	0	0	0	1	0	0	0	2	1	1	1
20	44	1	0	0	1	0	0	2	1	0	0	0	0	0	0	1	0
21	11	86	1	0	2	2	1	1	1	0	0	0	0	0	0	0	2
22	88	1	1	0	0	1	0	1	1	1	0	0	0	0	0	0	2
23	35	54	0	0	2	1	0	2	0	1	1	0	1	0	0	0	1
24	51	70	0	0	4	1	0	0	2	1	0	0	2	0	0	1	0
25	85	82	2	0	1	0	0	1	1	1	1	0	2	0	0	0	2
26	63	39	1	0	0	0	0	0	1	0	100	0	0	0	0	2	1
27	75	2	1	0	0	1	0	0	1	1	2	0	0	0	0	0	0
28	52	22	1	1	0	1	0	0	0	5	1	0	0	0	1	3	0
29	10	44	1	23	0	0	0	0	1	0	0	0	11	0	1	3	0
30	90	6	0	1	0	5	2	0	0	0	1	0	0	0	1	1	0
31	54	3	0	2	0	4	0	0	2	0	0	0	0	0	1	1	0
32	50	0	1	1	0	1	1	0	2	0	0	0	0	0	1	1	0
33	74	28	0	0	0	0	0	0	3	0	1	2	2	0	1	0	0
34	22	43	0	3	0	0	0	0	0	0	0	1	4	0	0	0	0
35	34	64	2	0	0	0	0	0	0	0	0	2	0	1	0	1	0
36	32	65	0	1	0	0	0	0	0	0	0	0	0	0	1	0	0
37	76	48	0	0	1	1	1	0	0	0	1	0	2	1	2	1	0
38	5	44	0	0	1	0	2	0	1	0	0	0	0	1	0	4	0
39	22	13	0	0	1	0	1	0	0	0	0	0	1	1	2	2	6
40	0	44	17	0	1	0	0	0	0	0	1	1	1	0	0	1	0
41	44	70	0	2	1	0	1	0	0	0	0	2	0	3	0	1	0
42	100	35	0	2	0	0	1	0	4	0	1	1	2	3	1	1	0
43	34	52	0	5	0	0	1	0	1	0	1	0	0	2	0	0	0
44	36	51	3	0	1	1	1	0	0	0	0	2	0	1	0	1	6
45	22	36	0	0	2	0	0	0	2	0	0	2	0	0	1	0	2
46	0	73	0	0	1	1	0	1	1	0	0	0	0	1	0	0	0
47	74	31	0	0	0	1	1	1	1	1	1	0	0	0	0	0	1
48	42	81	0	0	0	4	1	0	0	1	1	1	0	2	0	0	1
49	2	34	0	0	0	0	0	0	1	0	1	0	0	1	0	3	0
50	30	10	1	0	0	0	4	0	1	1	2	1	0	2	0	0	0
51	11	23	1	1	0	1	4	0	0	1	0	1	0	0	0	0	0
52	85	6	1	2	0	1	1	1	0	0	0	0	0	0	0	1	0
53	0	24	0	1	1	2	0	3	0	1	2	9	0	0	0	0	1
54	59	32	1	0	1	0	1	0	0	0	0	8	0	2	0	2	2
55	55	7	3	2	0	0	0	1	0	1	0	1	0	1	0	1	1
56	100	9	1	1	0	0	0	1	0	0	0	0	0	0	0	1	0
57	52	32	1	1	0	0	0	1	0	1	0	2	0	0	0	0	3
58	60	0	0	0	0	0	0	1	0	1	0	0	0	0	0	0	1
59	23	0	0	1	0	0	0	1	0	3	0	0	0	4	0	1	1
60	1	0	0	1	0	1	0	0	0	2	0	0	0	1	1	1	1
Total	2337	2031	69	62	38	49	36	36	60	41	221	53	37	39	32	123	53
Periods	60	60	60	60	60	60	60	60	60	60	60	60	60	60	60	60	60
Average	39	33.9	1.15	1.03	0.63	0.82	0.6	0.6	1	0.68	3.68	0.88	0.62	0.65	0.53	2.05	0.88
Maximum	100	86	17	23	4	14	4	4	26	5	100	9	11	4	4	86	6
Minimum	0	0	0	0	0	0	0	0	0	0	0	0	0	0	0	0	0

Figure 7.4.1-5a: Baseline Test - Vary Vd Low



Vd low	0.96	0.94	0.92	0.9	0.86	0.82	0.8	0.75	0.7	0.65	0.6	0.55	0.5	0.4	0.3	0.2	0.1	0
1	1	0	0	0	0	0	13	0	1	0	1	0	0	1	1	1	1	2
2	0	0	0	1	2	1	10	0	0	0	0	0	0	0	0	1	1	0
3	0	1	0	1	0	0	1	0	0	0	1	0	0	0	0	2	1	1
4	1	0	0	1	1	0	0	0	0	0	0	1	1	0	0	0	0	2
5	0	1	0	0	0	1	1	1	3	0	0	2	1	0	0	2	0	0
6	0	7	1	1	0	0	1	1	4	0	0	0	0	0	0	1	0	0
7	0	2	1	0	1	0	62	0	0	0	0	1	0	0	0	1	5	0
8	0	1	0	1	0	0	1	0	1	0	0	0	0	0	0	1	1	0
9	0	1	0	8	2	0	0	0	1	0	0	0	0	0	0	0	0	0
10	0	1	0	0	1	0	0	0	1	0	0	0	1	0	0	0	1	1
11	3	0	0	0	3	0	0	0	0	0	1	0	2	0	0	0	0	0
12	0	0	1	0	0	0	0	2	1	0	0	1	0	1	0	2	0	1
13	0	0	2	0	0	0	0	0	0	1	2	1	0	0	2	1	5	
14	0	0	1	0	0	0	0	0	1	1	1	1	2	0	0	2	0	2
15	0	0	0	0	0	1	1	1	0	1	1	0	1	0	0	0	0	1
16	0	0	2	0	1	0	1	1	0	0	0	3	1	0	0	0	1	1
17	0	0	1	0	0	0	1	0	0	0	0	1	0	1	0	0	1	1
18	1	1	1	0	0	0	1	1	0	2	0	0	0	2	0	1	0	0
19	1	0	0	0	1	0	1	0	0	0	0	0	0	1	0	1	0	0
20	0	1	0	0	3	0	1	0	0	1	1	0	1	5	1	0	0	1
21	1	0	0	0	1	0	0	1	0	0	0	0	0	2	1	0	0	0
22	0	1	1	0	0	0	0	1	0	0	0	1	0	0	1	0	0	0
23	1	1	1	0	2	1	1	1	1	0	1	1	4	1	1	4	0	0
24	1	0	0	0	1	1	0	4	1	10	0	1	3	0	0	1	0	0
25	23	0	4	0	1	2	2	2	0	1	0	2	1	0	0	0	0	0
26	1	0	3	0	0	0	0	1	0	4	1	3	0	0	0	2	0	0
27	0	1	1	1	2	1	0	0	0	2	0	1	1	1	0	1	0	1
28	1	0	0	0	1	1	1	1	0	0	0	0	0	1	1	1	0	0
29	0	2	1	1	0	1	1	0	0	0	0	3	0	0	2	0	0	1
30	0	1	0	0	0	1	0	0	0	0	0	1	0	2	0	2	0	0
31	2	0	0	0	0	0	0	0	0	2	0	4	0	3	1	1	1	0
32	2	0	0	0	0	0	7	0	0	0	0	0	0	1	2	1	0	0
33	2	2	0	0	0	0	0	0	0	0	0	0	0	0	1	0	2	0
34	0	0	0	1	0	1	0	0	0	0	0	0	0	1	0	0	0	1
35	0	0	0	1	0	2	0	0	1	1	0	0	0	0	1	0	1	0
36	0	0	0	2	10	3	0	1	0	3	0	0	0	0	0	0	2	0
37	1	0	0	0	0	0	0	0	8	1	0	1	2	1	0	0	0	0
38	0	0	0	2	0	0	0	1	0	0	0	0	1	0	1	0	1	0
39	0	0	1	2	0	0	0	1	0	2	0	1	1	0	0	0	0	0
40	0	0	1	1	0	0	0	1	1	0	0	1	2	0	1	0	0	2
41	3	0	1	0	0	1	0	1	1	1	0	0	1	0	5	0	0	0
42	4	0	1	0	0	0	0	0	2	0	1	1	0	0	2	1	0	0
43	0	0	0	0	0	0	0	0	0	3	0	0	0	0	1	0	0	0
44	0	0	0	0	0	0	0	0	1	1	1	0	1	1	0	0	2	0
45	3	0	0	1	0	3	1	1	2	0	1	0	1	1	1	0	2	0
46	1	0	2	0	0	4	0	1	1	0	1	1	2	1	0	0	0	0
47	0	0	2	1	0	0	0	2	1	0	0	1	1	1	0	0	0	0
48	1	0	1	10	0	0	2	2	0	0	2	0	0	0	1	0	0	0
49	2	13	2	1	1	2	1	1	0	0	1	2	0	0	0	0	1	0
50	1	0	0	0	1	1	0	0	1	0	1	0	0	0	0	0	0	0
51	0	1	0	1	0	0	1	4	1	26	1	0	0	0	0	0	0	0
52	0	0	4	1	0	3	0	0	0	0	0	1	7	1	0	0	0	0
53	0	1	0	0	0	0	1	0	3	0	0	0	1	0	0	1	2	0
54	0	0	0	0	0	1	0	0	6	0	1	0	0	1	0	0	5	0
55	0	2	1	0	1	0	1	0	1	0	1	7	0	0	1	0	0	0
56	0	0	0	0	2	0	0	0	0	0	0	0	0	0	0	0	0	0
57	0	1	0	0	1	0	0	0	1	0	2	0	0	0	1	0	2	0
58	0	1	0	0	0	0	0	0	0	0	0	0	0	0	0	1	0	1
59	0	0	0	0	3	0	1	0	0	0	0	0	0	0	1	2	1	1
60	0	0	0	0	2	0	2	0	1	0	0	0	0	1	1	1	1	1
Total	57	43	37	39	44	32	117	34	47	62	22	45	40	31	29	36	36	26
Periods	60	60	60	60	60	60	60	60	60	60	60	60	60	60	60	60	60	60
Average	0.95	0.72	0.62	0.65	0.73	0.53	1.95	0.57	0.78	1.03	0.37	0.75	0.67	0.52	0.48	0.6	0.6	0.43
Maximum	23	13	4	10	10	4	62	4	8	26	2	7	7	5	5	4	5	5
Minimum	0	0	0	0	0	0	0	0	0	0	0	0	0	0	0	0	0	0

Figure 7.4.1-5b: Baseline Test - Vary Vd Low, Continued

V <sub>D</sub> low			
	1.14	1.13	1.12
	0	0	0
	20	0	0
	0	0	0
	0	0	0
	56	0	0
	1	0	0
	0	4	0
	1	39	0
	16	91	0
	0	0	0
	0	0	0
	1	0	0
	1	0	0
	0	0	0
	0	0	0
	39	0	0
	0	0	0
	54	0	0
	0	0	0
	45	0	0
	0	0	0
	0	0	0
	0	0	0
	58	0	0
	1	0	0
	0	0	0
	1	0	0
	0	0	0
	0	0	0
	0	0	0
	0	0	0
	1	0	0
	0	0	0
	0	0	0
	0	0	0
	1	0	0
	0	0	0
	0	0	0
	0	0	0
	0	0	0
	0	0	0
	0	0	0
	0	0	0
	53	0	0
	63	0	0
	0	0	0
	0	0	0
	74	0	0
	0	0	0
	0	39	0
	0	45	0
	0	0	0
	71	0	0
	1	0	0
	0	0	0
	0	0	0
	0	0	0
	1	0	0
	1	0	0
	0	0	0
	0	0	0
	28	0	0
Total	588.00	218.00	0.00
Periods	60.00	60.00	60.00
Average	9.80	3.63	0.00
Maximum	74.00	91.00	0.00
Minimum	0.00	0.00	0.00

Figure 7.4.1-6: Baseline Testing at 500 Watts RF Power

The next test varied the RF power and held  $V_D$  low constant at 1.14 V. The results are shown in Figure 7.4.1-7.

Figure 7.4.1-8 is a composite of Figures 7.4.1-5, 7.6.1-6, and 7.4.1-7, and it gives a summary of the variations of RF power and  $V_D$  low, which is essentially a summary of the digital baseline testing at 900 MHz. The results of these digital baseline tests show that the digital parts are susceptible to RF energy even when the devices are operated within their normal specification limits, although it requires maximum RF power to do it. At  $V_D$  low = 0.8 V, the upper specification level for that signal, and 1000 W RF power, over 60% of the devices were upset during one of the test periods. We have found test conditions where a 3 dB decrease in RF power makes the difference between most of the devices being upset at some paddle positions and no upsets. We suspect that there may be an RF effect on the parts even with no upsets, but this supposition was not tested during the long term tests because we were testing at fairly high levels of RF power, and even in those tests the effects of the RF energy were not easy to see.

One final series of tests was performed on the digital test devices to correlate the mean upset level with the mean E-field strength in volts per meter inside the stirred mode chamber for a number of different test conditions. The test chamber was set up with one digital test board containing 100 parts and one analog test board containing 100 parts in the two test fixture locations. The RF test equipment was set up as shown in Figure 7.4.1-9. A log spiral receive antenna was set up on a tripod in the approximate geometric center of the chamber and was connected to a pulsed RF power meter through an attenuator. An EMCO P.N. 3101 antenna was used below 1 GHz and an EMCO P.N. 3102 antenna was used between 1 and 2 GHz. An RF pulsed signal with a 1.2 microsecond pulse width and 1.5 millisecond period was generated by the RF test equipment. The number of upsets was logged automatically by the data acquisition system, but the RF power picked up by the antenna had to be read manually from the peak RF power meter's CRT display. The stirrer in the test chamber was set to rotate at 1/15 rpm, and power readings were taken every 5 seconds for 15 minutes, which gave us 181 data points, or one for every 2 degrees of paddle rotation. The RF power data was added manually to the table of upset data created by the data acquisition system. The maximum, minimum, average, and mean values were found for the number of upsets and the RF power level. The E field strength was calculated from the RF power level from the formula:  $P = E^2/Z$ , where Z is 50 ohms, and P, the power measured by the pulsed power meter, was increased by the gain of the antenna and the amount of in-line attenuation. Testing was done at 900 and 1700 MHz at power levels of 1000, 500, 250, 125, and 63 watts. The digital "clock" and "D" input signals were both set at 0.8 to 2.0 Volts, which is at the limits allowed by the manufacturer's specification. The supply voltage for the test devices was 5.0 volts, and the data acquisition system voltage was 4.3 volts. Following the tests, the data was processed to find the maximum, minimum, average, and mean E-field strength and number of upsets. The total number of devices upset during the complete paddle rotation is also recorded. The summary of the E-field strength versus digital device upset rate is shown in Figure 7.4.1-10. The test data from which these summaries were taken is shown in appendix D and appendix E. appendix D shows the number of upsets and RF power measured at the log spiral antenna and the calculated electric field intensity for all 181 test samples for the indicated test conditions. appendix E contains the data files that are captured by the

RF Power	1000	1000	1000	1000	500	500	250	250	125	125	63	63
	3	70	1	68	26	0	28	0	0	0	0	0
	62	0	0	2	54	0	0	0	0	0	0	2
	12	72	0	16	0	0	0	70	45	0	0	0
	0	0	1	0	0	68	0	0	0	0	0	0
	0	0	57	36	0	0	72	0	0	0	0	0
	0	0	0	12	0	3	60	0	78	0	0	0
	9	0	0	8	38	9	0	0	0	0	0	0
	0	0	1	28	0	0	31	0	6	0	0	0
	0	0	2	2	0	0	0	0	0	0	0	0
	0	10	27	0	3	0	0	0	0	0	0	0
	0	0	21	10	71	0	0	87	0	0	0	0
	0	0	35	47	6	0	0	0	0	0	0	0
	0	2	61	1	0	0	37	0	0	0	0	0
	0	3	0	0	0	0	57	0	0	0	0	0
	0	0	1	1	0	6	0	58	0	0	0	0
	57	0	0	1	0	52	0	0	0	0	0	0
	9	0	0	0	0	0	0	0	0	0	0	0
	26	1	0	1	1	0	0	0	0	0	0	0
	22	17	0	1	0	19	0	0	0	0	0	0
	3	4	0	0	3	15	85	0	0	0	0	0
	0	0	0	0	0	0	0	0	0	0	0	0
	1	7	0	0	0	0	0	0	0	54	0	0
	0	1	1	0	0	0	0	0	0	0	0	0
	1	0	0	0	0	0	10	0	0	0	0	0
	12	39	0	0	0	0	0	0	0	0	0	0
	2	0	0	0	0	0	0	0	0	3	0	0
	0	0	0	87	28	0	20	0	0	29	0	0
	0	10	0	0	0	0	0	0	0	0	0	0
	53	86	0	43	0	0	0	0	0	0	0	0
	0	1	0	12	70	0	0	0	53	0	0	0
	80	71	0	0	1	0	0	0	0	0	0	0
	0	4	0	0	16	0	0	0	0	0	0	0
	0	3	11	0	0	0	0	0	0	0	0	0
	34	0	0	1	0	0	0	0	0	0	0	0
	86	10	0	1	0	0	0	86	0	22	0	0
	0	0	0	64	0	0	0	0	0	0	0	0
	0	0	0	3	0	0	77	0	0	0	0	0
	3	0	28	4	0	0	0	0	0	0	0	0
	62	0	1	1	0	0	0	90	0	0	0	0
	0	14	0	69	0	0	0	0	0	0	0	0
	0	10	0	0	0	0	0	0	0	0	0	0
	0	14	2	0	0	39	0	0	0	4	0	0
	0	1	0	0	1	0	0	0	0	0	0	0
	1	2	1	0	0	0	0	0	0	11	0	0
	0	22	1	64	0	0	0	0	0	0	0	0
	90	19	0	16	0	0	71	0	0	10	0	0
	34	7	0	2	0	9	0	0	44	0	0	0
	36	82	0	1	0	0	0	0	0	0	0	0
	1	17	0	0	7	0	0	0	0	0	0	0
	33	23	1	0	34	3	0	0	52	0	0	0
	26	53	2	28	38	1	2	0	0	0	0	0
	9	28	0	57	0	77	4	0	0	0	0	0
	1	0	0	0	0	0	0	0	0	0	0	0
	19	17	0	0	0	2	0	0	0	89	0	0
	20	5	0	0	85	0	0	0	0	0	0	0
	32	2	1	19	43	0	0	1	0	66	0	0
	13	57	0	12	0	0	0	0	9	0	0	0
	0	10	0	34	73	51	0	0	0	0	0	0
	1	3	37	1	0	0	0	0	0	0	0	0
	11	27	1	1	17	0	0	0	0	0	0	0
Total	864	824	294	754	615	354	554	392	287	288	2	0
Periods	60	60	60	60	60	60	60	60	60	60	60	60
Average	14.4	13.73	4.9	12.57	10.25	5.9	9.233	6.533	4.783	4.8	0.033	0
Maximum	90	86	61	87	85	77	85	90	78	89	2	0
Minimum	0	0	0	0	0	0	0	0	0	0	0	0

Figure 7.4.1-7: Baseline Test with Varied RF Power

Power	Vd low	Upsets		
		Ave	Max	Min
1000	1.14	38.95	100	0
1000	1.14	33.85	86	0
1000	1.14	14.40	90	0
1000	1.14	13.73	86	0
1000	1.14	4.90	61	0
1000	1.14	12.57	87	0
500	1.14	10.25	85	0
500	1.14	5.90	77	0
500	1.14	9.80	74	0
250	1.14	9.23	85	0
250	1.14	6.53	90	0
125	1.14	4.78	78	0
125	1.14	4.80	89	0
63	1.14	0.03	2	0
63	1.14	0.00	0	0
1000	1.13	1.15	17	0
500	1.13	3.63	91	0
1000	1.12	1.03	23	0
500	1.12	0.00	0	0
1000	1.11	0.63	4	0
1000	1.1	0.82	14	0
1000	1.09	0.60	4	0
1000	1.08	0.60	4	0
1000	1.07	1.00	26	0
1000	1.06	0.68	5	0
1000	1.05	3.68	100	0
1000	1.04	0.88	9	0
1000	1.03	0.62	11	0
1000	1.02	0.65	4	0
1000	1.01	0.53	4	0
1000	1	2.05	86	0
1000	0.98	0.88	6	0
1000	0.96	0.95	23	0
1000	0.94	0.72	13	0
1000	0.92	0.62	4	0
1000	0.9	0.65	10	0
1000	0.86	0.73	10	0
1000	0.82	0.53	4	0
1000	0.8	1.95	62	0
1000	0.75	0.57	4	0
1000	0.7	0.78	8	0
1000	0.65	1.03	26	0
1000	0.6	0.37	2	0
1000	0.55	0.75	7	0
1000	0.5	0.67	7	0
1000	0.4	0.52	5	0
1000	0.3	0.48	5	0
1000	0.2	0.60	4	0
1000	0.1	0.60	5	0
1000	0	0.43	5	0

Figure 7.4.1-8: Summary of Digital Baseline Testing

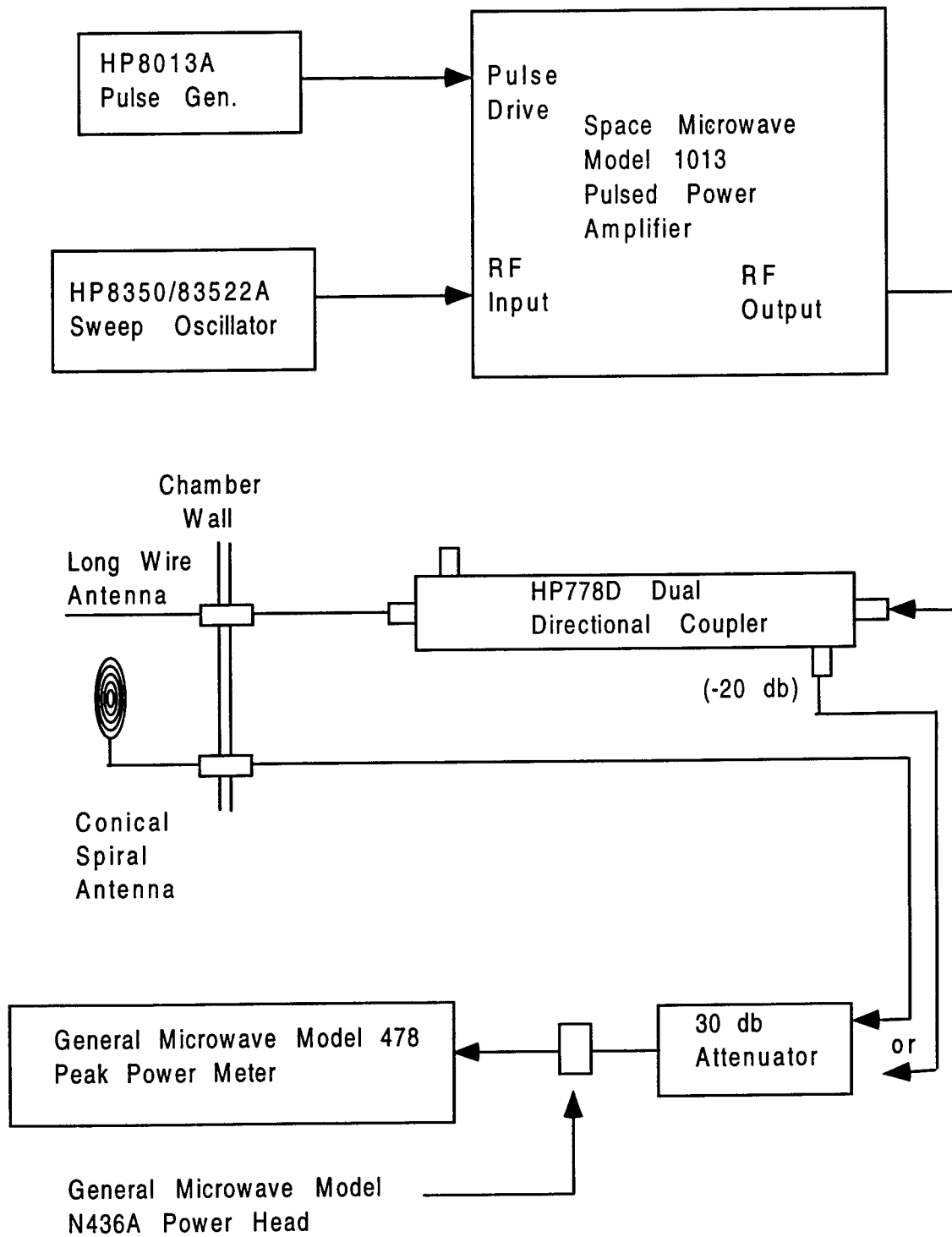

Figure 7.4.1-9: RF Test Equipment Setup for E-Field Strength Measurement

frequency	RF pwr	Upsets					E Field Strength (V/M)			
		ave	max	min	mean	total	ave	max	min	mean
900	1000	39.13	91	1	38	100	147	323	42	132
900	500	24.84	86	0	23	100	95	200	42	93
900	250	13.27	69	2	11	100	66	156	13	59
900	125	8.07	20	1	8	100<A>	49	102	19	46
900	63	2.62	11	0	2	100<B>	29	66	9	26
1700	1000	14.72	31	5	14	100	180	367	63	178
1700	500	4.87	17	0	4	77	132	345	49	126
1700	250	0.49	5	0	0	100<C>	96	199	40	89

Note: Quiescent test conditions - 0 devices upset

Note A: There were 71 devices with 5 or more upsets, 29 devices with 1, 2, or 3 upsets

Note B: There were 22 devices with 14 or more upsets, 78 devices with exactly 2 upsets

Note C: There were 19 devices with 6 or more upsets, 81 devices with 1, 2, or 3 upsets

Figure 7.4.1-10: Summary of E-Field Strength vs. Digital Upset Data

data acquisition program for each test run, which totals the number of times a test device was upset during each particular test.

#### **7.4.2 Baseline Analog Testing**

During our initial analog baseline testing the analog test devices likewise showed very little susceptibility to the RF energy. The op-amp manufacturer recommends that the input signal be at least 2.5 volts below the positive power supply voltage, and we were operating with only 1.0 to 2.0 volts difference in order to induce upsets. We also found that there was an oscillation signal of almost 1 volt peak to peak present at the input to the monitor board, which made it difficult to determine upset levels. The problem was due to feedback from the output signal wires. Placing a 200 ohm load resistor on each of the output signal lines caused the oscillation to disappear. A set of adapters, which load the outputs of the analog test devices, were fabricated. They do not appear to have any negative effect on the devices because the current into these loads is within the manufacturer's specification.

The analog baseline testing was performed on 200 parts in two analog test fixtures in the reverberation chamber. The test conditions were as follows:  $V_{CC}$  was +7.5 V,  $V_{EE}$  was -7.5 V, the monitor board power supply voltage was 4.3 V, and voltage of the buffer, which supplies the signal to the operational amplifiers, was varied from +4.0 V to +7.0 V. The stirring paddle in the chamber was turned at 1 rpm and the data acquisition system recorded the test results. The pulse power amplifier was set at 900 MHz with a pulse width of 1.2 microseconds and a pulse period of 1.5 milliseconds. Each test was nominally one minute in length, and during that time 60 test samples were collected. The summary results of the analog baseline tests are shown in Figures 7.4.2-1 and 7.4.2-2. The same data is presented in both figures, but Figure 7.4.2-1 is sorted by buffer voltage and Figure 7.4.2-2 is sorted by RF power. appendix F contains the complete test data from which the summary data was generated.

Testing was performed using both an EMI protected test fixture and a bare fixture, or one with the EMI protection removed. The results of this testing is shown in Figure 7.4.2-3a and 7.4.2-3b. The bare test fixture is a little more sensitive than the EMI protected fixture, as you would expect. The manufacturer specifies that the input signal to the op-amp should be 2.5 volts less than both the positive and negative power supply voltages, which would be 5 volts maximum. An input voltage (buffer voltage) of 5 volts appears to be a good test condition for the long term test because the number of upsets is pretty linear when the buffer voltage is varied between 4.5 and 6.5 volts and a low RF power will produce the test conditions required for long term testing.

One final analog test was performed to determine if the device upsets we observed during testing were more a result of device sensitivity or test fixture location sensitivity. To test this supposition, we removed the test devices from the "bare board" analog test fixture and moved (rotated) them half way around the test fixture and then re-ran several of the tests. For example, in the "rotated" test, device number 3101 becomes device number 4101, etc. The tests were performed at 800 and 1400 MHz at 1000 watts and 500 watts of RF power. The raw data from these tests was processed to sum the number of device upsets were observed for each one second test cycle. The results of this test are shown in Figures 7.4.2-3a and 7.4.2-3b. Like the digital data, the analog test data revealed no correlation between either device number or test fixture location, which indicates that modes are being



Conditions		Upsets - Bare Board Fixture			Upsets - EMI Protected Fixture		
Power	Vbuff	Ave	Max	Min	Ave	Max	Min
1000	4.00	81.92	95	35	62.25	86	40
1000	4.50				57.73	84	29
500	4.50				30.29	59	6
250	4.50	22.98	47	2	7.76	31	0
125	4.50				1.67	14	0
63	4.50				0.04	1	0
0	4.50				0.00	0	0
1000	5.00	69.27	88	25	53.47	81	18
500	5.00	44.34	75	15	25.48	55	5
125	5.00	8.46	25	1	1.04	11	0
63	5.00				0.00	1	0
63	5.00	1.98	15	1			
31	5.00	1.02	2	1			
0	5.00	1.00	1	1	0.00	0	0
1000	5.20	69.12	84	51			
1000	5.40	69.27	84	49			
1000	5.50	52.72	87	21	54.20	81	20
500	5.50	34.97	66	8	29.27	56	11
250	5.50	15.70	38	2	15.49	36	10
125	5.50	6.07	24	1	10.81	17	10
63	5.50				10.00	10	10
63	5.50	1.62	11	1			
0	5.50	7.32	8	1	10.00	10	10
1000	5.60	70.27	90	56			
1000	5.80	71.12	95	51			
1000	6.00	68.43	100	40	54.50	82	26
500	6.00	41.55	64	17	29.64	55	10
250	6.00	19.75	38	3	15.50	32	9
125	6.00	7.30	21	1	10.90	18	9
63	6.00	1.68	11	1	9.65	11	9
0	6.00	6.15	8	4	9.00	9	9
1000	6.10	67.68	93	42			
1000	6.20	59.18	87	24	53.70	75	30
0	6.20				9.97	10	9
1000	6.25	69.93	98	44			
500	6.25	44.63	67	25			
250	6.25	21.23	49	5			
125	6.25	8.08	23	1			
63	6.25	1.90	11	1			
1000	6.30	64.42	96	41	53.97	75	33
0	6.30	1.00	1	1	11.00	11	11
1000	6.40	67.60	99	38	54.70	76	28
0	6.40	8.00	8	8	11.00	11	11
1000	6.50	71.63	99	40	55.33	81	28
500	6.50	49.50	86	21	28.98	63	11
250	6.50	28.78	75	11	15.38	33	10
125	6.50	15.00	31	8	10.83	17	9
63	6.50				9.99	11	9
63	6.50	8.95	18	8			
0	6.50	7.65	8	7	11.00	11	11
0	6.50	8.00	8	8			
1000	6.60	75.07	100	43	64.52	96	34
0	6.60	8.00	8	8	30.10	36	29
1000	6.70	75.58	100	30	70.77	99	44
0	6.70	8.00	8	8	32.62	36	30
1000	6.80	87.07	100	48	70.55	99	48
0	6.80	44.25	57	33	38.25	40	36
1000	6.82				74.42	100	48
0	6.82				42.62	46	40
1000	6.84				94.67	100	60
0	6.84				98.95	99	98
0	6.90	100.00	100	100	99.00	99	99

Figure 7.4.2-1: Summary of Analog Baseline Testing - Sort by Vbuff

Conditions		Upsets - Bare Board Fixture			Upsets - EMI Protected Fixture		
Power	Vbuff	Ave	Max	Min	Ave	Max	Min
1000	4.00	81.92	95	35	62.25	86	40
1000	4.50				57.73	84	29
1000	5.00	69.27	88	25	53.47	81	18
1000	5.20	69.12	84	51			
1000	5.40	69.27	84	49			
1000	5.50	52.72	87	21	54.20	81	20
1000	5.60	70.27	90	56			
1000	5.80	71.12	95	51			
1000	6.00	68.43	100	40	54.50	82	26
1000	6.10	67.68	93	42			
1000	6.20	59.18	87	24	53.70	75	30
1000	6.25	69.93	98	44			
1000	6.30	64.42	96	41	53.97	75	33
1000	6.40	67.60	99	38	54.70	76	28
1000	6.50	71.63	99	40	55.33	81	28
1000	6.60	75.07	100	43	64.52	96	34
1000	6.70	75.58	100	30	70.77	99	44
1000	6.80	87.07	100	48	70.55	99	48
1000	6.82				74.42	100	48
1000	6.84				94.67	100	60
500	4.50				30.29	59	6
500	5.00	44.34	75	15	25.48	55	5
500	5.50	34.97	66	8	29.27	56	11
500	6.00	41.55	64	17	29.64	55	10
500	6.25	44.63	67	25			
500	6.50	49.50	86	21	28.98	63	11
250	4.50	22.98	47	2	7.76	31	0
250	5.50	15.70	38	2	15.49	36	10
250	6.00	19.75	38	3	15.50	32	9
250	6.25	21.23	49	5			
250	6.50	28.78	75	11	15.38	33	10
125	4.50				1.67	14	0
125	5.00	8.46	25	1	1.04	11	0
125	5.50	6.07	24	1	10.81	17	10
125	6.00	7.30	21	1	10.90	18	9
125	6.25	8.08	23	1			
125	6.50	15.00	31	8	10.83	17	9
63	4.50				0.04	1	0
63	5.00				5.00	1	0
63	5.00	1.98	15	1			
63	5.50				10.00	10	10
63	5.50	1.62	11	1			
63	6.00	1.68	11	1	9.65	11	9
63	6.25	1.90	11	1			
63	6.50				9.99	11	9
63	6.50	8.95	18	8			
31	5.00	1.02	2	1			
0	4.50				0.00	0	0
0	5.00	1.00	1	1	0.00	0	0
0	5.50	7.32	8	1	10.00	10	10
0	6.00	6.15	8	4	9.00	9	9
0	6.20				9.97	10	9
0	6.30	1.00	1	1	11.00	11	11
0	6.40	8.00	8	8	11.00	11	11
0	6.50	7.65	8	7	11.00	11	11
0	6.50	8.00	8	8			
0	6.60	8.00	8	8	30.10	36	29
0	6.70	8.00	8	8	32.62	36	30
0	6.80	44.25	57	33	38.25	40	36
0	6.82				42.62	46	40
0	6.84				98.95	99	98
0	6.90	100.00	100	100	99.00	99	99

Figure 7.4.2-2: Summary of Analog Baseline Testing - Sort by RF Power

Conditions		Upsets - Bare Bd Fixture			Upsets - EMI Fixture		
Power	Vbuff	Ave	Max	Min	Ave	Max	Min
1000	4.00	81.92	95	35	62.25	86	40
1000	4.50				57.73	84	29
1000	5.00	69.27	88	25	53.47	81	18
1000	5.20	69.12	84	51			
1000	5.40	69.27	84	49			
1000	5.50	52.72	87	21	54.20	81	20
1000	5.60	70.27	90	56			
1000	5.80	71.12	95	51			
1000	6.00	68.43	100	40	54.50	82	26
1000	6.10	67.68	93	42			
1000	6.20	59.18	87	24	53.70	75	30
1000	6.25	69.93	98	44			
1000	6.30	64.42	96	41	53.97	75	33
1000	6.40	67.60	99	38	54.70	76	28
1000	6.50	71.63	99	40	55.33	81	28
1000	6.60	75.07	100	43	64.52	96	34
1000	6.70	75.58	100	30	70.77	99	44
1000	6.80	87.07	100	48	70.55	99	48
1000	6.82				74.42	100	48
1000	6.84				94.67	100	60
500	4.50				30.29	59	6
500	5.00	44.34	75	15	25.48	55	5
500	5.50	34.97	66	8	29.27	56	11
500	6.00	41.55	64	17	29.64	55	10
500	6.25	44.63	67	25			
500	6.50	49.50	86	21	28.98	63	11
250	4.50	22.98	47	2	7.76	31	0
250	5.50	15.70	38	2	15.49	36	10
250	6.00	19.75	38	3	15.50	32	9
250	6.25	21.23	49	5			
250	6.50	28.78	75	11	15.38	33	10

Figure 7.4.2-3a: Comparison Testing of Bare Fixture vs EMI Protected Fixture

Conditions		Upsets - Bare Bd Fixture			Upsets - EMI Fixture		
Power	Vbuff	Ave	Max	Min	Ave	Max	Min
125	4.50				1.67	14	0
125	5.00	8.46	25	1	1.04	11	0
125	5.50	6.07	24	1	10.81	17	10
125	6.00	7.30	21	1	10.90	18	9
125	6.25	8.08	23	1			
125	6.50	15.00	31	8	10.83	17	9
63	4.50				0.04	1	0
63	5.00				5.00	1	0
63	5.00	1.98	15	1			
63	5.50				10.00	10	10
63	5.50	1.62	11	1			
63	6.00	1.68	11	1	9.65	11	9
63	6.25	1.90	11	1			
63	6.50				9.99	11	9
63	6.50	8.95	18	8			
31	5.00	1.02	2	1			
0	4.50				0.00	0	0
0	5.00	1.00	1	1	0.00	0	0
0	5.50	7.32	8	1	10.00	10	10
0	6.00	6.15	8	4	9.00	9	9
0	6.20				9.97	10	9
0	6.30	1.00	1	1	11.00	11	11
0	6.40	8.00	8	8	11.00	11	11
0	6.50	7.65	8	7	11.00	11	11
0	6.50	8.00	8	8			
0	6.60	8.00	8	8	30.10	36	29
0	6.70	8.00	8	8	32.62	36	30
0	6.80	44.25	57	33	38.25	40	36
0	6.82				42.62	46	40
0	6.84				98.95	99	98
0	6.90	100.00	100	100	99.00	99	99

Figure 7.4.2-3b: Comparison Testing of Bare Fixture vs EMI Protected Fixture

stirred within the chamber and that only a statistical correlation of the chamber is valid.

A one hour long analog test was also performed to look at conditions in the reverberation chamber. The test conditions were as follows: Paddle speed was 1/4 rpm, power supply voltages were +/- 7.5 V, monitor voltage was 4.3 V, buffer voltage was 5.0 V, and the RF power was 250 Watts at 900 MHz. Upsets were logged at the rate of 1 per second throughout the test, so a lot of data was taken. The data was divided into 15 - 240 second blocks, each of which represented one paddle rotation. All 15 sets of data were plotted on the same graph, which is shown in Figure 7.4.2-4. The data shows that the number of upsets, which is a measure of the RF power intensity at the test fixture, varies quite a bit across a complete paddle rotation, but that it is very consistent from one rotation of the paddle to the next. This data indicates that adequate stirring is taking place in the reverberation chamber.

A series of tests were performed on the analog test devices to correlate the mean upset level with the mean E-field strength in volts per meter inside the stirred mode chamber for a number of different test conditions. The tests were set up like that described at the end of section 7.4-1 for the digital devices. Testing of the analog devices was done at 800 and 1400 MHz at power levels of 1000, 500, 250, 125, and 63 watts. The power supply voltages for the analog test devices were +/- 7.5 volts, the buffer voltage was 5.0 volts, and the monitor board voltage was 4.3 volts. The summary of the E-field strength vs. analog upset data is shown in Figure 7.4.2-5. The test data from which these summaries were taken is shown in appendix G and appendix H. Appendix G shows the number of upsets and RF power measured at the log spiral antenna and the electric field intensity for all 181 test samples for the indicated test conditions. The data files that are captured by the data acquisition program for each test run are shown in appendix H. These data files show the number of times a test device was upset and the total number of devices being upset during each test.

## **8.0 RELIABILITY TESTING**

### **8.1 Reliability Testing Approach**

The purpose of reliability testing was to assess the long term effects of electromagnetic radiation. This was done by subjecting the test devices to an electromagnetic (EM) environment over a frequency range of 700 MHz to 18 GHz, under a variety of test situations through a series of one-month tests, to determine if the effects of long-term exposure to EM energy could be found, isolated, and quantified. Most of the tests utilized a fixed frequency pulsed RF source, but the last test utilized a swept frequency RF source. Several of the tests were performed at 85 degrees C. to determine the parts response to the EM environment at elevated temperature. The test schedule along with test frequency and peak R power is shown in Figure 8.1-1. Another version of the test schedule that shows the location of the test parts on the test fixtures is shown in Figure 8.1-2. A table showing the serial numbers that comprise the test lots is shown in Figure 8.1-3. Baseline testing was performed, as described in section 7.0, prior to the start of reliability testing to determine the frequencies at which the analog devices should be tested, and to determine the approximate response of the test devices to different RF power levels. Based on experience gained during baseline testing a series of short pre-tests would be

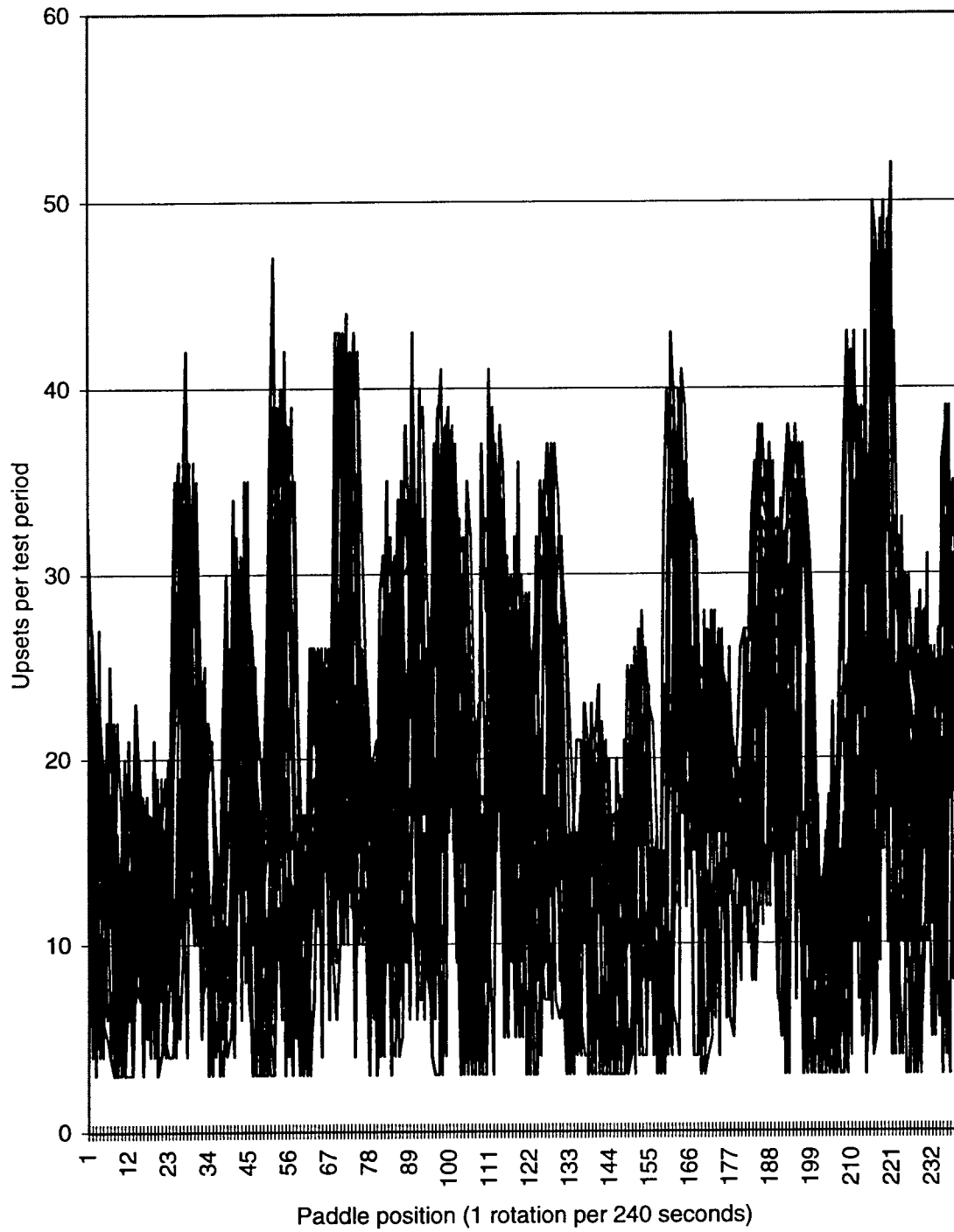

Figure 7.4.2-4: Upsets as a Function of Paddle Position (15 Rotations)

RF	RF	Upsets					E Field Strength (V/M)			
Frequency	Power	ave	max	min	mean	total	ave	max	min	mean
800	1000	44	67	11	44	100	162	336	50	158
800	500	32	60	6	32	88	142	307	35	137
800	250	19	37	2	20	71	88	194	35	87
800	125	9	29	2	7	42	70	162	22	71
800	63	3	11	2	2	29	40	90	11	35
1400	1000	27	62	7	26	97	222	447	71	224
1400	500	8	25	2	7	75	152	354	50	141
1400	250	3	10	2	3	52	120	274	32	112
1400	125	2	2	2	2	3	74	141	32	71
1400	63	2	2	2	2	2	49	100	22	45

Note: Quiescent test conditions - 2 devices upset

Figure 7.4.2-5: Summary of E-field Strength vs. Analog Upset Data

Test Period	Start Date	Test #	Test Position		Frequency (MHz)	RF Power
			1 Test Lot	2 Test Lot		
1	1/23/96	1	4A	3A	800	125
2	2/23/96	3	3A	5A	1400	200
3	3/28/96	2	6A	3A	800	250
4	5/6/96	4	3A	7A	1400	375
5	6/7/96	5	4D	3D	900	200
6	7/9/96	7	3D	5D	1700	360
7	8/20/96	6	6D	3D	900	400
8	9/24/96	8	3D	7D	1700	720
9	11/12/96	10	11A	10A	800	125
10	12/13/96	11	10A	12A	800	250
11	1/17/97	12	13A	8D	8000 to 18000	50
11	1/24/97	12	13A	8D	4000 to 8000	150
11	2/4/97	12	13A	8D	2000 to 4000	750
11	2/12/97	12	13A	8D	1000 to 2000	500
11	2/17/97	12	13A	8D	700 to 950	250

- Notes:
1. 50 parts each (25 plastic, 25 ceramic) from test lots an3 and an6.
  2. 50 parts each (25 plastic, 25 ceramic) from test lots dg3 and dg6.

Figure 8.1-1: Schedule of Radiated Tests



		EM chamber test position 1 (East)				EM chamber test position 2 (West)			
Test	Test			Package Type				Package Type	
Period	Number	Lot #	Board	1 to 50	51 +	Lot #	Board	1 to 50	51 +
	Baseline	1A	A2	Plastic	Ceramic	2A	A4	Plastic	Ceramic
	Baseline	1A	A2	Ceramic	Plastic	1D	D1	Plastic	Ceramic
1	1	4A	A2	Plastic	Ceramic	3A	A4	Ceramic	Plastic
2	3	3A	A2	Plastic	Ceramic	5A	A4	Ceramic	Plastic
3	2	6A	A2	Ceramic	Plastic	3A	A4	Plastic	Ceramic
4	4	3A	A2	Ceramic	Plastic	7A	A4	Plastic	Ceramic
5	5	4D	D2	Ceramic	Plastic	3D	D1	Plastic	Ceramic
6	7	3D	D2	Ceramic	Plastic	5D	D1	Plastic	Ceramic
7	6	6D	D2	Plastic	Ceramic	3D	D1	Ceramic	Plastic
8	8	3D	D2	Plastic	Ceramic	7D	D1	Ceramic	Plastic
9	10	11A	A2	Ceramic	Plastic	10A	A4	Plastic	Ceramic
10	11	10A	A2	Plastic	Ceramic	12A	A4	Ceramic	Plastic
11	12	13A	A2	Ceramic	Plastic	8D	D1	Plastic	Ceramic
12	N/A	note 1	A2	mixed	mixed	note 2	D1	mixed	mixed

		Test bench							
Test	Test			Serial numbers					
Period	Number	Lot #	Board	1 to 50	51 +				
6	D_ref	2D	D3	Plastic	Ceramic				
6	A_ref	8A	A2	Plastic	Ceramic				

		Thermal chamber position 1 (East)				Thermal chamber position 2 (West)			
Test	Test			Package Type				Package Type	
Period	Number	Lot #	Board	1 to 50	51 +	Lot #	Board	1 to 50	51 +
7	9a	9A	A1	Plastic	Ceramic	10A	A3	Ceramic	Plastic
8	9b	10A	A1	Ceramic	Plastic	9A	A3	Plastic	Ceramic
10	9c	9A	A1	Ceramic	Plastic				
11	9d	9A	A1	Plastic	Ceramic				

- Notes: 1. 50 parts each (25 plastic, 25 ceramic) from test lots 3A and 6A.  
2. 50 parts each (25 plastic, 25 ceramic) from test lots 3D and 6D.

Figure 8.1-2: Test Schedule Showing Test Lot Data

Lot #	Serial Numbers					
	Plastic			Ceramic		
1A	3101	to	3150	4101	to	4150
2A	3151	to	3200	4151	to	4200
3A	3251	to	3300	4251	to	4300
4A	3201	to	3250	4201	to	4250
5A	3301	to	3350	4301	to	4350
6A	3351	to	3400	4351	to	4400
7A	3001	to	3050	4001	to	4050
8A	3401	to	3450	4401	to	4450
9A	3451	to	3500	4451	to	4500
10A	3501	to	3550	4501	to	4550
11A	3551	to	3600	4551	to	4600
12A	3601	to	3650	4601	to	4650
13A	3651	to	3700	4651	to	4700
1D	1301	to	1350	2301	to	2350
2D	1151	to	1200	2151	to	2200
3D	1051	to	1100	2051	to	2100
4D	1101	to	1150	2101	to	2150
5D	1201	to	1250	2201	to	2250
6D	1251	to	1300	2251	to	2300
7D	1351	to	1400	2351	to	2400
8D	1001	to	1050	2001	to	2050

Figure 8.1-3: Lot Number versus Serial Number for Test Parts

performed at the start of each test to determine the RF power to be used during that test. This process was somewhat iterative since it calls for finding the power level at which approximately 50% of the population of test devices would be upset at least once during one cycle of the stirring paddle in the reverberation chamber.

Each test part was numbered, so that their performance during the reliability test as well as any changes in their parameters could be tracked. All the test parts were subjected to parametric testing before and after each reliability test to determine the effect of the testing on the device parameters.

The immediate effect of the EM radiation was that the test devices experience soft failures or upsets when exposed to EM radiation, and we found that the upset rate as well as the number of devices experiencing upset increases with increasing EM radiated power. Test data was taken continuously throughout the test to determine which devices were being upset during each 1-hour period. The test data was analyzed to determine the total number of devices being upset during each test period and also the average number of devices being upset at any moment. This data is presented, and it shows that the upset rate is proportional to the power level of the EM radiation, that it is dependent on the frequency of the radiation, and that it is somewhat dependent on the amount of time the devices are exposed to the EM radiation.

Control groups of 100 analog parts and 100 digital parts were also tested for 30 days, but in an environment of low (ambient) EM energy with test signal and power supply voltages similar to those of the devices in the chamber. The parameter shifts of the control group devices would be considered basic to all the devices before the effects of the EM energy are considered.

## **8.2 Reliability Test Setup**

The tests were set up in the reverberation chamber as described in section 7. 100 test devices were installed in the same test fixtures that were used in the baseline testing and were placed in the mode stirred chamber on dielectric stands. The test fixtures were connected to the power supplies and signal generators via test cables. The test fixtures were connected to the test instrumentation via test cables. These parts had passed functional test before being placed on the test fixtures. The fixtures were in a vertical position and were facing each other at an angle of approximately 35 degrees from the chamber sidewall. The fixtures were positioned so that they were 16 inches from the chamber walls, 35 inches above the floor, 16 inches below the stirring paddle, and 12 inches apart. Each test fixture has 1 power connector, 2 coaxial input signal connectors, and 4 output connectors. The test cables, which originate at external power supplies, test signal generators, and the data acquisition boards, are shielded beginning at the point where they pass through the connector bulkhead at the rear of the chamber. The test stimulus and data monitoring system, power supplies, and RF power system are located outside the chamber. The test stimulus and data monitoring system was described in section 12 and the RF power system was described in section 10.

### 8.3 Reliability Test Procedure

Reliability testing was performed in the stirred mode reverberation chamber for the 30 day test periods as indicated in the test schedule. The analog test devices were supplied with +7.5 V and -7.5 V DC power and a 0 to 5 volt square wave pulse which is 500 microseconds wide. The digital test devices were supplied with +5.0 V DC, a 0.8 V to 2.0 V square wave "D" input signal, and a 0.8 V to 2.0 V data clock signal. The "D" and clock signals, which have been properly timed by the pulse generator, cause the "D" flip-flop to produce a square wave output signal which is similar to the square wave output signal produced by the analog test devices. The RF equipment was set at the appropriate frequency up using the amplifier plug-in that covered that frequency, and the mode stirring paddle was set to turn at 1/4 RPM. At the beginning of tests 1, 2, 5, 6, 10, and 12, a short pre-test was run to set up the amplifier and determine the RF power level for the test. Although the susceptibility profiles developed in baseline tests were helpful in determining the frequencies to use during reliability testing and the approximate response to EM energy at those frequencies, this pre-test was needed at the start of the reliability test to determine the appropriate RF power levels for the test. The test stimulus and monitoring system described in section 12 was used to record and store the test data. The test operator would start the test automated test program, then the computer would start a new test every hour. Raw data files are composed of a time and date stamp, the serial numbers of the devices that are being upset, and the number of times the upset occurred, for each 1 second period. A sample page of a raw data file is shown in Figure 8.3-1. This data file shows five - one second periods of no upsets, before the RF power was energized, then two - one second periods with upsets. The upsets are a result of the short term effect of the RF energy upon the devices. The computer creates three other data files besides the hourly raw data files. Two "upset" files are created one for each test board of 100 devices. The "upset" file is an hourly compilation of the number of devices that have been upset and the number of times the upset occurred. A sample page of an "upset" data file is shown in Figure 8.3-2. This file shows the results from two tests of 1-hour duration. The "totals" file is composed of a time and date stamp followed by the number of devices suffering upset during each hour long test period. A sample "totals" file is shown in Figure 8.3-3. The raw data files have been compressed for storage, but the other test data files have been stored just as they were received from the computer. The complete set of compressed data for the wideband test takes about 125 Mbytes of disk space.

The two data items that are used to determine the effect of EM radiation on the test parts are the "totals" files and the size of the raw data files. The size of the raw data files relates directly to the total number of upsets that were suffered during the test period, and from that we can figure the average number of upsets over the period. A test report format has been created which tracks these quantities by test number and date.

### 8.4 Analog Reliability Testing

Two test lots of analog test devices in two analog test fixtures were placed in the test chamber during each analog reliability test period. Each test lot was composed of 50 OP-271GP operational amplifiers (plastic package) and 50 OP-271FZ operational amplifiers (ceramic package). Each test period was a minimum of 30 days long. One of the test lots was in the chamber for all 4 test periods,

Start Time is: Fri Jan 26 15:48:52 1996

Fri Jan 26 15:49:20 1996

Fri Jan 26 15:49:21 1996

Fri Jan 26 15:49:22 1996

Fri Jan 26 15:49:23 1996

Fri Jan 26 15:49:24 1996

#3220: 1,

Fri Jan 26 15:49:25 1996

#3202: 1, #3203: 1, #4253: 6, #3204: 2, #3209: 1, #3210: 1,  
#3213: 2, #3214: 1, #4264: 6, #3215: 1, #3216: 1, #3217: 2, #3219: 2,  
#3220: 12, #3221: 2, #3222: 2, #3223: 2, #3224: 12, #3227: 1, #3228: 1,  
#3232: 1, #4289: 6, #4296: 6, #3269: 4, #4220: 2, #4221: 2, #4224: 2,  
#3279: 1, #4230: 2, #4236: 2, #4240: 1, #4241: 2, #4244: 2, #4245: 1,  
#4246: 2,

Fri Jan 26 15:49:26 1996

#3203: 6, #4253: 11, #3204: 6, #3209: 6, #3210: 6, #3212: 6,  
#3213: 6, #3214: 6, #4264: 11, #3215: 6, #3217: 6, #3219: 6, #3220: 11,  
#3221: 6, #3222: 6, #3223: 6, #3224: 11, #3227: 6, #3228: 6, #3232: 6,  
#4289: 11, #4296: 11, #4220: 6, #4221: 6, #4224: 6, #4230: 6, #4236: 6,  
#4239: 1, #4240: 1, #4241: 6, #4244: 6, #4245: 6, #4246: 6, #4250: 1,

Fri Jan 26 15:49:27 1996

#3204: 2, #3209: 2, #3210: 2, #3212: 2, #3213: 2, #3214: 2, #3215: 2,  
#3219: 2, #3220: 12, #3221: 2, #3222: 2, #3223: 2, #3224: 12, #3227: 2,  
#3232: 2, #4220: 2, #4221: 10, #4224: 1, #4230: 2, #4245: 2,

Fri Jan 26 15:49:28 1996

#4253: 9,

#3204: 6, #3209: 6, #3210: 6, #3212: 6, #3213: 1, #3214: 6, #4264: 4,  
#3215: 6, #3219: 6, #3220: 11, #3221: 6, #3222: 3, #3223: 6, #3224: 6,  
#3227: 6, #3232: 6, #4289: 1, #4220: 6, #4221: 9, #3273: 2, #4230: 6,  
#4245: 3,

Figure 8.3-1: Sample Page From Raw Data File

Start Time is: Tue Jan 30 10:11:33 1996

Tue Jan 30 10:16:16 1996

#3201: 2 F #3202: 42 F #3203: 58 F #3204: 377 F #3205: 121 F #3207: 10 F #3208: 25 F  
#3209: 469 F #3210: 548 F #3212: 382 F #3213: 229 F #3214: 599 F #3215: 638 F #3216: 230  
F #3217: 99 F #3219: 146 F #3220: 1135 F #3221: 64 F #3222: 36 F #3223: 212 F #3224:  
448 F #3225: 12 F #3226: 3 F #3227: 411 F #3228: 124 F #3232: 166 F #3234: 66 F #3235:  
17 F  
#3236: 3 F #3238: 87 F #3239: 220 F #3240: 17 F #3241: 13 F #3242: 70 F #3243: 93 F  
#3245: 3 F #3247: 77 F #3249: 99 F #4202: 20 F #4203: 59 F #4204: 1 F #4205: 46 F  
#4206: 7 F #4208: 17 F #4212: 19 F #4213: 33 F #4214: 49 F #4215: 1 F #4217: 1 F  
#4218: 1 F #4220: 137 F #4221: 400 F #4223: 93 F #4224: 418 F #4225: 134 F #4227: 38 F  
#4228: 67 F #4230: 379 F #4231: 12 F #4232: 232 F #4233: 11 F #4235: 31 F #4236: 261 F  
#4238: 347 F #4239: 58 F #4240: 6 F #4241: 431 F #4242: 450 F #4243: 215 F #4244: 112 F  
#4245: 697 F #4246: 294 F #4248: 6 F #4250: 148 F

END OF TEST

Start Time is: Tue Jan 30 10:16:23 1996

Tue Jan 30 11:16:24 1996

#3201: 22 F #3202: 521 F #3203: 799 F #3204: 5445 F #3205: 1693 F #3207: 118 F #3208:  
349 F #3209: 6986 F #3210: 8342 F #3212: 5572 F #3213: 3209 F #3214: 9171 F #3215: 9619 F  
#3216: 3339 F #3217: 1300 F #3219: 2166 F #3220: 17322 F #3221: 983 F #3222: 481 F #3223:  
3026 F #3224: 6503 F #3225: 164 F #3226: 56 F #3227: 6183 F #3228: 1864 F #3232: 2340 F  
#3234: 912 F #3235: 236 F #3236: 63 F #3238: 1346 F #3239: 3157 F #3240: 273 F #3241:  
243 F #3242: 1045 F #3243: 1403 F #3245: 56 F #3247: 1162 F #3249: 1571 F #4202: 291 F  
#4203: 861 F #4204: 8 F #4205: 721 F #4206: 113 F #4208: 307 F #4212: 354 F #4213: 557  
F #4214: 727 F #4215: 12 F #4217: 6 F #4218: 30 F #4220: 2033 F #4221: 6174 F #4223:  
1342 F #4224: 6405 F #4225: 2053 F #4226: 1 F #4227: 520 F #4228: 1083 F #4230: 5812 F  
#4231: 138 F #4232: 3475 F #4233: 188 F #4235: 478 F #4236: 3936 F #4237: 2 F #4238:  
5068 F #4239: 831 F #4240: 39 F #4241: 6307 F #4242: 6762 F #4243: 3196 F #4244: 1681 F  
#4245: 10436 F #4246: 4245 F #4247: 3 F #4248: 115 F #4250: 2260 F

Figure 8.3-2: Sample Page From "Upset" Data File

Thu Feb 15 15:22:06 1996_	71	76
Thu Feb 15 16:22:06 1996_	73	76
Thu Feb 15 17:22:06 1996_	75	79
Thu Feb 15 18:22:06 1996_	76	78
Thu Feb 15 19:22:06 1996_	74	77
Thu Feb 15 20:22:06 1996_	70	77
Thu Feb 15 21:22:06 1996_	73	77
Thu Feb 15 22:22:06 1996_	71	77
Thu Feb 15 23:22:06 1996_	70	78
Fri Feb 16 00:22:06 1996_	72	75
Fri Feb 16 01:22:06 1996_	72	76
Fri Feb 16 02:22:06 1996_	71	76
Fri Feb 16 03:22:06 1996_	71	76
Fri Feb 16 04:22:06 1996_	72	80
Fri Feb 16 05:22:06 1996_	73	77
Fri Feb 16 06:22:06 1996_	73	76
Fri Feb 16 07:22:06 1996_	74	76
Fri Feb 16 08:22:06 1996_	74	77
Fri Feb 16 09:22:06 1996_	72	75
Fri Feb 16 10:22:06 1996_	75	78
Fri Feb 16 11:22:06 1996_	75	78
Fri Feb 16 12:22:06 1996_	74	74
Fri Feb 16 13:17:40 1996_	76	79

Figure 8.3-3: Sample "Totals" Data File

and four other test lots were in the chamber for one test each. The test schedule, including start dates and test lot locations, is shown in Figure 8.1-1.

The test devices did suffer long term degradation as shown by changes in basic device parameters. No devices suffered outright failures during the analog reliability test, but the parameters of three parts drifted far enough that they were no longer within the manufacturer's specification. A summary of results of the device parameter testing is given in section 9.

The analog reliability tests were performed by subjecting five test lots of analog test devices to EM energy at two different frequencies and 4 different RF power levels. Baseline testing was performed in the same test fixtures and with the same test setup as were the reliability tests. This was done because test fixture design and test setup might influence the fields inside the chamber and affect the test results. Although the susceptibility profiles developed in baseline tests were helpful in determining the frequencies to use during reliability testing and the approximate response to EM energy at those frequencies, testing was needed at the start of each reliability test to determine the appropriate RF power levels for the test. The placement of the test fixtures in the chamber remained the same for all the tests, but the location of the parts in the test fixtures (positions 1 through 50 or 51 through 100) was changed.

The test conditions were as follows: The mode stirring paddle was set to turn at 1/4 RPM, The OP-271 op-amps were supplied with +7.5 volts and -7.5 volts, and the monitor board supply was 5.5 volts.

The complete set of data (compressed raw data plus other test data files) for the analog tests takes about 550 Mbytes of disk space. The complete report for analog test 1 is shown in appendix J. The reports for test periods 2, 3, and 4 for tests 3, 2, and 4 respectively are shown in appendices K, L, and M. A summary of each test has been made which condenses the data for each page to a single line, yet contains enough data to show how trends develop over time. These test data summaries are shown in Figures 8.4-1, 8.4-2, 8.4-3, and 8.4-4. A log of RF power levels was kept after the first test, and this data is also included in the last three summary reports. A report that is based on Figure 8.0-1 and summarizes the data even further is shown in Figure 8.4-5.

### **8.5 Digital Reliability Testing**

Two test lots of digital test devices in two identical test fixtures were placed in the test chamber during each digital reliability test period. Each test lot was composed of 50 CD74ACT74E digital flip-flops (plastic package) and 50 CD54ACT74F3A digital flip-flops (ceramic package). Each test period was a minimum of 30 days long. One of the test lots of digital parts was in the chamber for all 4-test periods, and four other test lots were in the chamber for one 30-day period each.

One digital device suffered an outright failure, the inability of its output to switch at high speed, during the testing. In addition, all the test devices suffered some degree of long term degradation as shown by changes in basic device parameters. A summary of results of device parameter testing is given in section 9.

The 54/74ACT74 digital flip-flops require a single positive power supply voltages, two input signals, and high voltage levels on the "preset" and "clear" signal inputs in order to operate.



Data Page	End Date		Average # being upset	Average file size in Mbytes	Average instantaneous upset rate
	Mo.	Day			
1	1	26	150	0.95	28
2	1	27	150	0.96	29
3	1	31	154	0.99	30
4	2	2	155	1.07	32
5	2	4	157	1.13	34
6	2	6	155	1.15	35
7	2	9	151	1.02	31
8	2	15	148	1.01	30
9	2	17	150	1.01	30
10	2	20	156	1.19	36
11	2	22	148	1.27	39
Averages			152		32

Figure 8.4-1: Test Data Summary for Analog Test #1

Data Page	End Date		Average # being upset	Average file size in Mbytes	Average instantaneous upset rate	RF power
	Month	Day				
1	2	25	137	0.28	5.9	210
2	2	27	133	0.30	6.6	210
3	2	29	115	0.25	5.1	200
4	3	2	109	0.24	4.7	200
5	3	4	111	0.24	4.8	210
6	3	6	120	0.26	5.3	210
7	3	8	114	0.25	4.9	190
8	3	11	132	0.30	6.5	230
9	3	13	137	0.30	6.8	220
10	3	15	134	0.29	6.3	220
11	3	17	138	0.31	7.0	225
12	3	19	138	0.31	6.9	230
13	3	21	141	0.33	7.7	235
14	3	23	143	0.33	7.8	235
15	3	23	145	0.35	8.2	235
Averages			130		6.3	

Figure 8.4-2: Test Data Summary for Analog Test #3, Test Period #2

Data Page	End Date Mo.	End Date Day	Ave # being upset	File size (Mbytes)	Average instantaneous upset rate	RF power
1	3	30	193	2.42	77.2	250
2	4	1	194	2.33	74.4	240
3	4	3	193	2.24	71.4	240
4	4	6	194	2.31	73.8	250
5	4	8	195	2.42	77.5	240
6	4	10	194	2.56	81.8	260
7	4	12	194	2.41	77.1	250
8	4	14	194	2.42	77.2	250
9	4	16	195	2.53	80.9	260
10	4	19	195	2.55	81.6	250
11	4	21	182	2.32	74.1	250
12	4	23	196	2.51	80.2	260
13	4	25	197	2.46	78.7	270
14	4	27	196	2.42	77.3	250
15	4	29	196	2.62	83.9	270
Averages			194		78	

Figure 8.4-3: Test Data Summary for Analog Test #2, Test Period #3

Data Page	End Date Mo.	End Date Day	Ave # being upset	File size (Mbytes)	Average instantaneous upset rate	RF power
1	5	8	189.0	0.80	23.4	350
2	5	10	187.5	0.80	23.3	340
3	5	12	189.6	0.93	27.7	350
4	5	14	189.3	0.97	28.8	340
5	5	16	189.9	0.95	28.3	340
6	5	18	190.1	0.98	29.3	350
7	5	20	190.2	1.00	30.0	360
8	5	23	190.2	1.01	30.5	360
9	5	25	190.4	1.05	31.6	350
10	5	27	190.6	1.04	31.3	360
11	5	28	190.7	1.04	31.4	360
12	5	31	188.9	1.02	30.8	340
13	6	2	190.9	1.06	32.0	355
14	6	4	189.9	1.02	30.7	345
15	6	5	190.1	1.01	30.3	340
Averages			189.8		29.3	

Figure 8.4-4: Test Data Summary for Analog Test #4 Test Period #4

<u>Analog Reliability Tests</u>									
Test Period	Test #	Start Date	Test Lot, Pos 1	Test Lot, Pos 2	Test Lot, Bench	Frequency (MHz)	RF Power	Average Upset Rate	Average Upsets per hour
1	1	1/23/96	4A	3A		800	125	32	152
2	3	2/23/96	3A	5A		1400	200	78	194
3	2	3/28/96	6A	3A		800	250	6.3	130
4	4	5/6/96	3A	7A		1400	375	29	190

<u>Analog Reference Test</u>									
Test Period	Test #	Start Date	Test Lot, Pos 1	Test Lot, Pos 2	Test Lot, Bench	Frequency (MHz)	RF Power	Average Upset Rate	Average Upsets per hour
6	Ref.	7/3/96			8A	N/A	0	0	0

Figure 8.4-5: Analog Test Data Summary

The test conditions for the digital testing were as follows: The mode stirring paddle was set to turn at 1/4 RPM, The 54/74ACT74 flip-flops were supplied with +5.0 volts, and the monitor board supply was +5.0 volts. The input signals were created by a dual pulse generator such that the flip-flop will produce a pulse that is 500 microseconds long from 0 V to +5 V in amplitude. The RF signal had a pulse width of 1.2 microseconds and a period of 1.2 milliseconds.

Because the raw data files are so large, they have been compressed for storage, but the other test data files have been stored as they were received from the computer. The complete set of data (compressed raw data plus other test data files) for the digital tests takes about 350 Mbytes of disk space.

The complete report for digital test 5 is shown in appendix N. The reports for test periods 6, 7, and 8 for tests 7, 6, and 8 respectively are shown in appendices P, Q, and R. A summary of each test has been made which condenses the data for each page to a single line, yet contains enough data to show how trends develop over time. These test data summaries are shown in Figures 8.5-1, -2, -3, and -4. A log of RF power levels was kept, and this data is also included in the summary reports. A report that is based on Figure 8.0-1 and summarizes the data even further is shown in Figure 8.5-5.

## 8.6 Thermal & Life Reliability Testing

The purpose of thermal and life reliability testing was to operate analog test devices in high temperature Electromagnetic (EM) and non-EM environments to determine if the effects observed in prior EM testing are thermally related. Thermal testing refers to 2 or 4 test periods that the test devices were subjected to a high temperature low (ambient) EM environment. "Life" testing refers to the 2 test periods that the test devices were subjected to a high temperature EM environment inside the reverberation chamber. Analog test devices were chosen over digital test devices for the thermal and life testing for the following reasons:

1. Because small parameter shifts seem to degrade operation of analog devices more than digital devices.
2. Because the RF power level that is required to cause 50% of the population of test devices to upset was less for analog devices than it was for the digital devices.
3. We felt that Parameters of analog devices would probably shift more with temperature than would parameters of digital devices.

Two lots of analog test devices were placed in two analog test fixtures in a thermal chamber in a low (ambient) EM environment for two 30-day thermal test periods. The chamber temperature was maintained at 85° C (185° F) throughout the test, and the test devices were supplied with DC power and a test signal. The test devices were given a functional test at the end of each test.

At the end of the second thermal test, one test lot continued in the non-EM thermal chamber for two more 30-day test periods. The second test lot was tested in the presence of EM radiation in the stirred mode reverberation for the third and fourth 30 day tests. Two more test lots, each containing 100 fresh analog parts, were in the mode stirred chamber, one during the third test and one during the fourth, with the second test lot. The reverberation chamber was heated to 85° C for these tests. RF energy was added to the chamber and the stirrer was rotated at 1/4 rpm as in the previous tests.

Data Page	End Date Mo.	Day	Ave. # being upset	File size	Ave. upset rate	RF power
1	6	9	197.8	0.48	9.5	200
2	6	12	197.7	0.55	11.3	200
3	6	14	194.2	0.59	12.2	200
4	6	16	169.2	0.60	12.4	200
5	6	18	162.1	0.60	12.4	200
6	6	20	162.3	0.59	12.4	200
7	6	22	162.7	0.61	12.7	200
8	6	24	163.1	0.61	12.8	200
9	6	26	162.3	0.60	12.6	200
10	6	28	162.2	0.61	12.6	200
11	6	30	163.5	0.60	12.5	200
12	7	3	160.7	0.60	12.5	210
13	7	5	160.2	0.60	12.5	200
14	7	7	160.1	0.61	12.7	200
15	7	8	160.4	0.61	12.7	210
	Average		169.2		12.2	201

Figure 8.5-1: Test Data Summary for Digital Test #5

Data Page	End Date Mo.	Day	Ave. # being upset	File size (Mbytes)	Ave. upset rate	RF Power
1	7	11	173	0.166	1.6	360
2	7	13	172	0.159	1.5	360
3	7	15	173	0.165	1.6	360
4	7	17	175	0.166	1.7	380
5	7	19	172	0.164	1.6	370
6	7	21	170	0.162	1.6	360
7	7	23	155	0.145	1.1	340
8	7	25	153	0.141	1.0	350
9	7	27	140	0.136	0.9	340
10	7	30	142	0.137	0.9	360
11	8	1	154	0.146	1.2	360
12	8	3	148	0.142	1.0	360
13	8	6	149	0.144	1.1	360
14	8	8	157	0.149	1.2	370
15	8	9	166	0.159	1.5	360
	Average		159.9		1.3	359.3

Figure 8.5-2: Test Data Summary for Digital Test #7, Test Period #6

Data Page	End Date Mo.	End Date Day	Ave. # being upset	File size (Mbytes)	Ave. upset rate	RF Power
1	8	22	197.1	1.64	38.5	400
2	8	24	197.0	1.57	36.9	400
3	8	26	197.1	1.58	36.9	400
4	8	28	197.3	1.62	37.9	400
5	9	4	197.3	1.61	37.9	400
6	9	6	197.5	1.66	39.1	420
7	9	8	198.2	1.69	39.8	420
8	9	10	198.0	1.67	39.3	430
9	9	13	198.3	1.63	38.2	380
10	9	15	199.5	2.12	50.4	380
11	9	17	198.5	1.85	43.8	380
12	9	19	197.5	1.54	36.1	400
13	9	21	196.8	1.50	35.0	400
14	9	23	197.2	1.54	36.1	380
Average			197.7		39.0	399.3

Figure 8.5-3: Test Data Summary for Digital Test #6, Test Period #7

Data Page	End Date Mo.	End Date Day	Ave. # being upset	File size (Mbytes)	Ave. upset rate	RF Power
1	9	26	193.2	0.46	9.1	575
2	9	28	194.9	0.52	10.4	720
3	9	30	198.7	0.77	16.7	720
4	10	2	197.5	0.65	13.7	825
5	10	4	194.3	0.49	9.8	720
6	10	6	193.9	0.43	8.2	720
7	10	9	194.9	0.47	9.2	700
8	10	11	197.2	0.54	11.1	650
9	10	13	194.9	0.47	9.1	650
10	10	15	194.8	0.49	9.8	700
11	10	17	196.1	0.48	9.6	675
12	10	19	195.1	0.48	9.6	750
13	10	21	193.3	0.47	9.1	675
14	10	23	193.9	0.46	8.9	675
15	10	24	192.3	0.45	8.7	720
Average			195.0		10.2	698

Figure 8.5-4: Test Data Summary for Digital Test #8, Test Period #8

Digital Reliability Tests									
Test Period	Test #	Start Date	Test Lot, Pos. 1	Test Lot, Pos. 2	Frequency (MHz)	RF Power	Average Upset Rate	Average Upsets per hour	
5	5	6/7/96	4D	3D	900	200	12	169	
6	7	7/8/96	3D	5D	1700	400	36	198	
7	6	8/20/96	6D	3D	900	360	1.3	160	
8	8	9/24/96	3D	7D	1700	700	10	195	

Digital Reference Test									
Test Period	Test #	Start Date	Test Lot, Bench	Frequency (MHz)	RF Power	Average Upset Rate	Average Upsets per hour		
6	Ref.	7/5/96	2D	N/A	0	0	0	0	

Figure 8.5-5: Digital Test Data Summary

All of the test devices suffered long term degradation as shown by changes in basic device parameters, but the parameters of all the test devices stayed within the manufacturer's specification. The single lot of test devices that was in the thermal chamber for four test periods is a thermal "control group" for the devices tested in the EM environment.

The thermal test was set up by placing two analog test fixtures, each populated with 50 OP271FZ (ceramic) and 50 OP271GP (plastic) operational amplifiers, in the thermal chamber, which is simply an oven with reasonably fine thermostatic control. The test fixtures were connected to the power supplies and signal generators via test cables. The electrical connections for this test are shown in Figure 8.6-1. The fixtures were in simple wooden stands to keep them in the middle of the chamber and away from the metal chamber walls. The fixtures were placed in a vertical position and the "chip" sides of the test fixtures were facing away from the cable entrance into the chamber for ease in routing the cables. No data monitoring was performed during the thermal test. Following the end of the second thermal test, one of the test fixtures and its associated cable, was removed from the chamber. A photograph of the single board installation in the thermal chamber is shown in Figure 8.6-2.

The difference between the test setup for the "life" test and that used in the analog reliability tests is that 1" of thermal insulation covered the roof of the reverberation chamber, and 2" of thermal insulation covered the outside walls and floor to minimize heat flow out of the chamber. A sheet of ½" plywood was laid on top of the floor insulation to protect it from damage, and the test fixtures were placed on top of the plywood.

With the thermal chamber set up and the temperature maintained at 85° C, the 200 analog test devices on two test fixtures were supplied with DC power and a square wave signal. At the end of 30 days, the test devices were removed from the test fixtures, subjected to room temperature parametric testing, re-installed in the fixtures, and tested for a second 30 days. At the end of the second 30-day test, the devices were removed and subjected to three temperature parametric testing. One of the test fixtures with its 100 test devices was removed from thermal testing and moved into the life test. The remaining test fixtures and 100 test devices were put back in the chamber for the third test. The test devices were removed and subjected to another room temperature parametric test, and re-installed in the chamber for the fourth 30-day test. At the end of the last test, a three temperature parametric test was performed on the 100 test devices.

Life testing was performed in the high temperature reverberation chamber for two 30-day test periods. The first life test included the test lot that was removed from the thermal test at the end of the second thermal test period and fresh lot of 100 analog test parts. These two lots of test devices were supplied with DC power and a square wave signal. They were subjected to 125 Watts of peak RF power at a 0.1% duty factor at 800 MHz in the reverberation chamber environment. The temperature in the chamber was maintained at 85° C for the test. The devices were removed from the test fixtures and tested at the end of the first life test. A second fresh lot of analog test devices plus the original lot from the thermal chamber were in the chamber for the second life test, which was conducted at 250 Watts of RF power, with all other test conditions remaining the same. These test devices were also subjected to parametric testing at the end of the test. The complete set of compressed data for the thermal and life tests takes about 550 Mbytes of disk space.



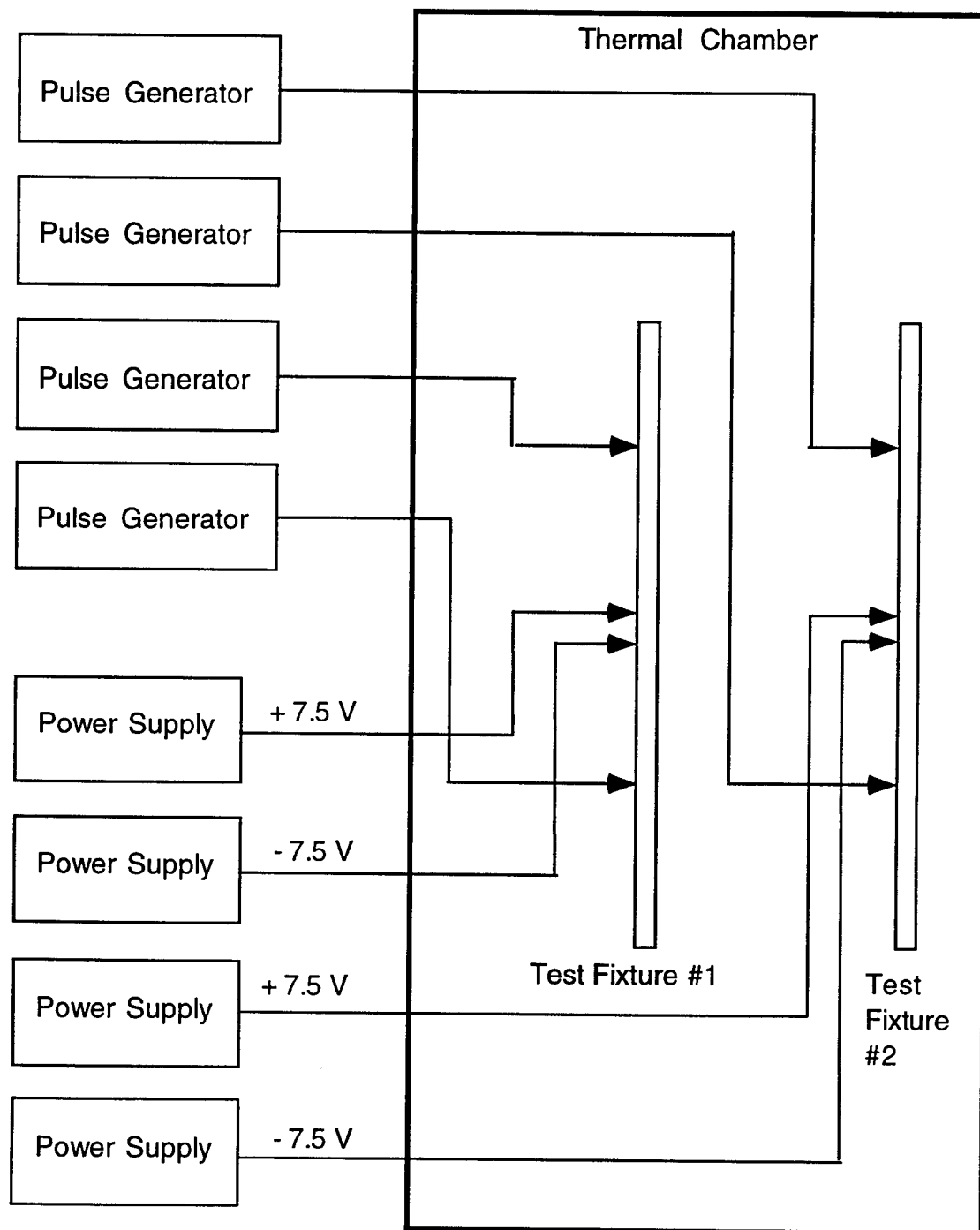

Figure 8.6-1: Block Diagram of Thermal Chamber Test Setup

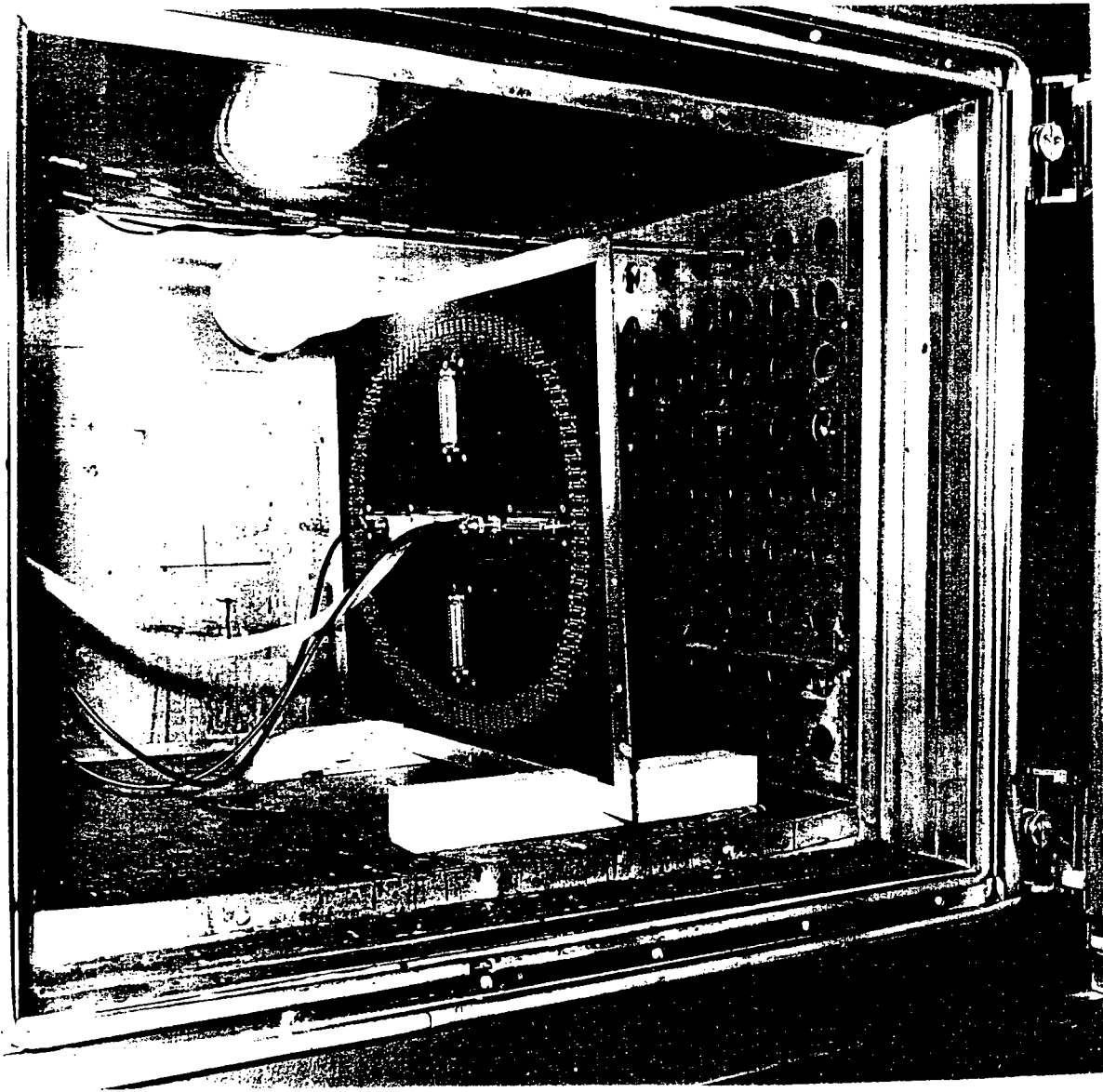

Figure 8-6.2: Photograph of Single Test Fixture in Thermal Chamber

The complete report for the life test period 10 is shown in appendix S, and the report for life test period 11 is shown in appendix T. A summary of each test has been made which condenses the data for each page to a single line, yet contains enough data to show how trends develop over time. These tests are shown in Figures 8.6-3 and -4. A log of RF power levels was kept after the first test and this data is also included in the last three summary reports. A report which is based on Figure 8.0-1 and which summarizes the data from the thermal and life test even further is shown in Figure 8.6-5.

### **8.7 Wideband Reliability Testing**

One test lot of analog test devices in an analog test fixture and one test lot of digital test devices in a digital test fixture were placed in the mode-stirred chamber for one 30-day test period. The chamber temperature was maintained at room temperature (approximately 72° F), and the test devices were supplied with DC power and test signals. The analog test lot was composed of 50 OP-271GP operational amplifiers (plastic package) and 50 OP-271FZ operational amplifiers (ceramic package) and the digital test lot was composed of 50 74ACT74E flip-flops (plastic package) and 50 54ACT74F3A flip-flops (ceramic package).

In the reliability testing performed to date, testing below 2 GHz caused the test devices to experience soft failures or upsets when exposed to EM radiation, and we found that the upset rate as well as the number of devices experiencing upset increased with increasing EM radiated power. In baseline testing performed at a number of discrete frequencies between 2 and 18 GHz we did not detect that any of the test devices had experienced any upsets. In the high frequency part of the wideband testing, we wanted to subject the test devices to high levels of EM radiation and see if the device parameters were affected even though there might be an absence of any upsets. Sweep testing between 8 and 18 GHz validated previous test data, in that no upsets occurred. Sweep testing performed between 4 and 8 GHz yielded a number of upsets, which occurred mainly between 5 and 6 GHz. These upsets occurred at a lower rate than would occur below 2 GHz. There were also upsets in wideband tests performed between 2 and 4 GHz, although this was also at a lower rate than below 2 GHz.

In this as in other tests, the test devices suffered long term degradation as shown by changes in basic device parameters. No devices suffered outright failures during the wideband reliability tests. A summary of results of the device parameter testing is given in section 9.

The purpose of wideband reliability testing was to subject the test devices to an Electromagnetic (EM) environment over a wide frequency range to determine if the effects in addition to those observed in prior EM testing can be found. The test schedule is shown in Figure 8.7-1. Wideband testing was performed in the reverberation chamber for one 30-day test period. The analog test devices were supplied with +7.5 V and -7.5 V DC power and a 0 to 5 volt 1 KHz square wave signal. The digital test devices were supplied with +5.0 V DC, a 0.8 V to 2.0 V square wave "D" input signal, and a 0.8 V to 2.0 V data clock signal. The "D" and clock signals, which have been properly timed by the pulse generator, cause the "D" flip-flop to produce a square wave output signal which is similar to the square wave output signal produced by the analog test devices. The RF equipment was set up to sweep from 8 to 18 GHz using the amplifier plug-in that covered that frequency. A short pre-test was run to set up the amplifier and determine the power level for the test. As noted previously, no test

Data	End Date		Ave #	File	Ave	RF
Page	Mo	Day	being	size	upset	power
			upset	(Mbytes)	rate	
1	11	14	125	0.90	20	125
2	11	21	128	0.84	19	125
3	11	23	140	1.07	24	190
4	11	25	135	0.95	21	190
5	11	28	112	0.74	16	125
6	11	30	120	0.86	19	125
7	12	3	119	0.87	19	125
8	12	5	122	0.90	20	125
9	12	7	121	0.90	20	125
10	12	9	123	0.91	20	125
11	12	11	125	0.90	20	125
12	12	13	124	0.92	21	125
Average			125		20.0	136

Figure 8.6-3: Test Data Summary for Test # 10

Data	End Date		Ave #	File	Ave	RF
Page	Mo	Day	being	size	upset	power
			upset		rate	
1	12	15	190.7	2.67	85.8	250
2	12	17	189.2	2.54	81.3	250
3	12	19	187.4	2.48	79.3	250
4	12	22	187.6	2.43	77.6	250
5	12	24	187.5	2.45	78.3	250
6	12	26	193.6	2.42	77.2	260
7	12	30	195.1	2.53	81.0	250
8	1	1	195.1	2.53	80.9	250
9	1	3	194.6	2.52	80.5	260
10	1	5	194.9	2.36	75.5	260
11	1	7	188.4	2.43	77.8	260
12	1	9	181.4	2.42	77.3	260
13	1	14	180.4	2.37	75.7	250
14	1	16	178.5	2.31	73.7	260
15	1	16	179.9	2.30	73.3	260
Average			188.3		78.3	

Figure 8.6-4: Test Data Summary for Test # 11

Thermal Test								
Test	Test	Start	Test Lot,	Test Lot,	Frequency	RF	Average Upset	Average Upsets
Period	#	Date	Pos. 1	Pos. 2	(MHz)	Power	Rate	per hour
7	9a	9/11/96	9A	10A	N/A	0	0	0
8	9b	10/11/96	10A	9A	N/A	0	0	0
9	9c	11/12/96	9B		N/A	0	0	0
10	9d	12/16/96	9B		N/A	0	0	0
Life Test								
Test	Test	Start	Test Lot,	Test Lot,	Frequency	RF	Average Upset	Average Upsets
Period	#	Date	Pos. 1	Pos. 2	(MHz)	Power	Rate	per hour
9	10	11/12/96	11A	10A	800	136	125	20
10	11	12/13/96	10A	12A	800	255	188	78

Figure 8.6-5: Thermal and Life Test Data Summary

Day #	Date	Day	day	Freq GHz	Sweep Rate	Paddle Speed	RF Power	Notes
359	17-Jan-97	Fri	0	8 to 18	1 S	0.25	140 W	Start test 12
360	18-Jan-97	Sat	1	8 to 18			140 W	
361	19-Jan-97	Sun	2	8 to 18			140 W	
362	20-Jan-97	Mon	3	8 to 18	3 S	0.5	140 W	
363	21-Jan-97	Tue	4	8 to 18			140 W	
364	22-Jan-97	Wed	5	8 to 18	0.1 S	1	140 W	
365	23-Jan-97	Thur	6	8 to 18			140 W	
366	24-Jan-97	Fri	7	4 to 8	10 S	0.25	300 W	
367	25-Jan-97	Sat	8	4 to 8			300 W	RF Power Off
368	26-Jan-97	Sun	9	4 to 8			300 W	RF Power Off
369	27-Jan-97	Mon	10	4 to 8	3 S	0.5	300 W	
370	28-Jan-97	Tue	11	4 to 8			300 W	RF Power Off
371	29-Jan-97	Wed	12	4 to 8	0.1 S	1	300 W	
372	30-Jan-97	Thur	13	4 to 8			300 W	
373	31-Jan-97	Fri	14	4 to 8	10 S	0.25	300 W	
374	1-Feb-97	Sat	15	4 to 8			300 W	RF Power Off
375	2-Feb-97	Sun	16	4 to 8			300 W	RF Power Off
376	3-Feb-97	Mon	17	4 to 8			300 W	
377	4-Feb-97	Tue	18	2 to 4	10S	0.25	1000 W	
378	5-Feb-97	Wed	19	2 to 4	3 S	0.5	1000 W	
379	6-Feb-97	Thur	20	2 to 4			1000 W	
380	7-Feb-97	Fri	21	2 to 4	0.1 S	1	1000 W	
381	8-Feb-97	Sat	22	2 to 4			1000 W	
382	9-Feb-97	Sun	23	2 to 4			1000 W	
383	10-Feb-97	Mon	24	2 to 4	10 S	0.25	1000 W	
384	11-Feb-97	Tue					250 W.	Remove & Test Parts
385	12-Feb-97	Wed	25	1 to 2	10 S	0.25	250 W.	Re-start Test.
386	13-Feb-97	Thur	26	1 to 2	3 S	0.5	500 W.	
387	14-Feb-97	Fri	27	1 to 2	0.1 S	1	500 W.	
388	15-Feb-97	Sat	28	1 to 2			500 W.	
389	16-Feb-97	Sun	29	1 to 2			500 W.	
390	17-Feb-97	Mon	30	0.7 to 1	10 S	0.25	500 W.	
391	18-Feb-97	Tue	31	0.7 to 1	3 S	0.5	500 W.	
392	19-Feb-97	Wed	32	0.7 to 1	0.1 S	1	500 W.	End test 12

Figure 8.7-1: Wideband Test Schedule

devices were upset between 8 and 18 GHz, so the RF power was set at the highest RF power the pulse power amplifier would produce. The devices were tested at three different frequency sweep rates and three different mode stirrer paddle rotation rates. The frequency was changed to 4 to 8 GHz, the amplifier plug-in was changed, and this procedure was repeated until all the frequency bands were covered. After wideband testing was performed from 2 to 18 GHz, the devices were removed from the test fixtures and subjected to room temperature parametric testing. The test devices were re-installed in the test fixtures and wideband testing from 700 MHz to 2 GHz was performed. These test devices were removed again from the test fixtures and subjected to three temperature parametric testing. The raw data files have been compressed for storage, but the other test data files have been stored just as they were received from the computer. The complete set of compressed data for the wideband test takes about 125 Mbytes of disk space. The complete report for the wideband test period 11 is shown in appendix U. A summary of this test, sorted by frequency band, the sweep rate, and stirrer rpm is shown in Figure 8.7-2.

### **8.8 Extended Reliability Testing**

Following the formal reliability tests, time was still available before the end of the contract to perform more reliability testing. Because of our desire to obtain the results of additional testing, we received the approval of the Air Force program office and proceeded with the testing. During the extended testing, not much upset data was taken in order to keep costs to a minimum. However, parametric testing and analysis were done following the extended testing, and the results of the analysis are reported in section 3.2. The testing included radiated electromagnetic testing of analog and digital parts from lots 3A, 6A, 3D, and 6D. The placement of parts for this testing is shown in Figure 8.8-1. It also included control lot testing in a low (ambient) electromagnetic environment of analog test lot 3A and digital test lot 6D. The additional radiated part testing contributed 0.87 million device test hours to the experience database and the control group part testing added another 0.76 million device test hours, or 1.6 additional device test hours. One digital plastic part failed the functional test at the end of the extended reliability test, which makes a total of 2 outright failures and 3 specification failures during the total testing.

## **9.0 POST RELIABILITY ELECTRICAL ACCEPTANCE TEST RESULTS**

The purpose of reliability testing was to operate analog and digital test devices in an Electromagnetic (EM) environment, in a variety of test situations, to determine if there are short and long term effects associated with EM exposure effects over the frequency range of 700 MHz to 18 GHz.

Before and after each test of the reliability tests, the analog and digital test devices were subjected to electrical acceptance (parametric) testing as described in section 8.0, Electrical Acceptance Testing. This included all the test devices subjected to the EM exposure reliability testing, plus the

		Ave #	Ave	Ave					Sweep
End Date		being	File	upset		Frequency	RF	Stirrer	Rate
Mo.	Day	upset	size	rate	Start	Stop	power	rpm	(seconds)
1	20	0	0.10	0	8	18	50 W	0.25	1
1	22	0	0.10	0	8	18	50 W	0.5	3
1	24	0	0.10	0	8	18	50 W	1	0.1
1	27	94	0.25	5	4	8	150 W	0.25	10
1	29	97	0.43	11	4	8	150 W	0.5	3
2	4	88	0.36	9	4	8	150 W	1	0.1
2	5	183	0.95	28	2	4	750 W	0.25	10
2	7	185	1.91	60	2	4	750 W	0.5	3
2	10	176	2.14	68	2	4	750 W	1	0.1
2	11	169	0.89	26	2	4	750 W	0.25	10
2	13	197	1.26	39	1	2	500 W	0.25	10
2	14	198	2.18	69	1	2	500 W	0.5	3
2	17	198	3.39	110	1	2	500 W	1	0.1
2	18	196	1.40	43	0.7	0.95	150 W	0.25	10
2	19	138	1.76	55	0.7	0.95	150 W	0.5	3
2	20	134	4.14	135	0.7	0.95	150 W	1	0.1

Figure 8.7-2: Test Data Summary for Test Period # 11



Stirred mode chamber test position 1 (East)							
Test	Test	Socket	Board	Lot			
Period	#	numbers	Number	Number	Serial numbers		
21	21	1 to 25	A2	3A	4251	to	4275
21	21	26 to 50	A2	6A	4351	to	4375
21	21	51 to 75	A2	3A	3251	to	3275
21	21	76 to 100	A2	6A	3351	to	3375
22	24	1 to 25	A2	3A	3251	to	3275
22	24	26 to 50	A2	6A	3351	to	3375
22	24	51 to 75	A2	3A	4251	to	4275
22	24	76 to 100	A2	6A	4351	to	4375

Stirred mode chamber test position 2 (West)							
Test	Test	Socket	Board	Lot			
Period	#	numbers	Number	Number	Serial numbers		
21	22	1 to 25	D1	3D	2051	to	2075
21	22	26 to 50	D1	6D	2251	to	2275
21	22	51 to 75	D1	3D	1051	to	1075
21	22	76 to 100	D1	6D	1251	to	1275
22	25	1 to 25	D1	3D	1051	to	1075
22	25	26 to 50	D1	6D	1251	to	1275
22	25	51 to 75	D1	3D	2051	to	2075
22	25	76 to 100	D1	6D	2251	to	2275

Reference test							
Test	Test	Socket	Board	Lot			
Period	#	numbers	Number	Number	Serial numbers		
21	23	1 to 50	A3	8A	3401	to	3450
21	23	51 to 100	A3	8A	4401	to	4450
21	23	1 to 50	D3	2D	2151	to	2200
21	23	51 to 100	D3	2D	1151	to	1200
22	26	1 to 50	A3	8A	4401	to	4450
22	26	51 to 100	A3	8A	3401	to	3450
22	26	1 to 50	D3	2D	1151	to	1200
22	26	51 to 100	D3	2D	2151	to	2200

Figure 8.8-1: Test Parts Involved in Extended Testing

devices involved in the analog and digital reference tests. The test engineer reviewed the electrical test data and submitted summary descriptions of the data.

In all tests, including the reference tests, the test devices suffered degradation as shown by changes in basic device parameters. In general, the parameters of devices exposed to an EM environment changed more than did the parameters of the reference parts. However, in many cases the differences are not large, nor is it obvious which parameter shifts are significant and which are not. But what we do know is that device parameters did change in the presence of EM energy. An analysis of the test results was given in section 3.

### **9.1 Analog Post-Reliability Electrical Acceptance Test Results**

The results of the analog tests are presented in tabular form in Figure 9.1-1a and 9.1-1b. The test results of the control group are listed first, then those of the test lots exposed to EM energy, so that differences in test results can be compared with each other. For convenience, the results are sorted by test temperature and device type. Test lot 3A was tested following each of the four tests, but only test 1 and test 4 results are presented, because many of the parameters stabilized somewhat during the intermediate tests, and these two tests seem to contain the most significant data. The lot 3A testing following test period 1 was performed only at room temperature. An analysis of these test results is presented in paragraph 3.1. It should be noted that part 3223 (plastic) failed the power supply rejection ratio test at -40 C, and parts 4217 and 4224 (ceramic) failed the input offset voltage specification at room temperature. There were no specification failures for the analog control group.

### **9.2 Digital Post-Reliability Electrical Acceptance Test Results**

The results of the digital tests are presented in tabular form in Figure 9.2-1a, 9.2-1b, 9.2-1c, and 9.2-1d. The test results of the control group are listed first, then those of the test lots exposed to EM energy. For convenience, the results are sorted by test temperature and device type. Test lot 3D was tested following each of the 4 digital tests, but only the results of the final test are reported. An analysis of these test results is presented in paragraph 3.1. Part number 2053 in test lot 3D failed the  $V_{OH}$  and  $V_{OL}$  tests (output would not transition between high and low).

### **9.3 Thermal and Life Post-Reliability Electrical Acceptance Test Results**

The results of the thermal and life tests are presented in tabular form in Figure 9.3-1a and 9.3-1b. The test results of the thermal test lots are listed first, which is followed by the results from the test lots exposed to EM energy. For convenience, the results are sorted by test temperature and device type. Test lot 9A was subjected to four 30-day tests in the thermal chamber in a low EM environment. Test lot 9A is the "control" group for the other thermal and life test lots. Test lot 10A was subjected to two 30-day tests in the thermal chamber in a low (ambient) EM environment and two 30 day tests in the thermal reverberation chamber while being subjected to EM energy. Test lots 11A and 12A were subjected to one 30-day test period each while being subjected to EM energy in the thermal reverberation chamber.

Plastic, -40C		Test Lot 8A, Analog Control Group	Test Lot 3A, Test 1 (1 Temp Test Only)	Test Lot 3A, Test 4	
1	PSRR	+/- 300 nV/V		+/- 400 nV/V	1
2	ICC/IEE	+3 to +9% (most +4%), 6 parts decreased		+/- 1% typ, 12 parts decr (-2 to -6%)	2
3	VIO	+/- 40 uV typ. 3426 +80uV		+/- 40uV typ; 4 parts +/-50 to +/-90uV	3
4	IIB	some > +/-1nA but drift toward 0A		16 parts +1 to +3nA, 7 parts -1 to -6nA	4
5	IIO	some +/- 1nA, 3423 +10nA		25 parts > +/-1nA most drift to 0A	5
6	Gain	all showed compressive decrease		8 parts incr; rest compressive decr	6
7	Slew rate	+2 to +10% (prop to ICC), 6 parts decreased		+/- 2% typ, 10 parts decr (-2 to -8%)	7
8	CMRR	few with hi initial values decreased		many with hi initial values decreased	8
9	VOP	very little change		very little change	9
10	GBW	+0 to +2% (prop to ICC)		+0 to +1.5%, 11 parts decr	10
Plastic, +25C					
11	PSRR	+/- 300 nV/V	+/- 200 nV/V	+/- 300 nV/V	11
12	ICC/IEE	+1 to +3%	+1 to +2.5%	+1.5 to +3%	12
13	VIO	+/-20uV, tight distribution	+/-30uV typ	+/-30uV typ	13
14	IIB	2prts,+500pA; most -.5 to -.1 nA.	most increased, +1.5 nA max	9 parts +/-1 to +/- 2nA	14
15	IIO	+/-400pA max	+/- 2.0 nA max	16 parts > +/-1nA but drift toward 0A	15
16	Gain	13 parts big compr decr; rest normal decr	all showed compressive decrease	3273 unstable, rest compressive decr	16
17	Slew rate	+1 to +4% (prop to ICC)	+1.5 to +3% (prop to ICC)	+1.5 to +4% (prop to ICC)	17
18	CMRR	few with hi initial values decreased	many with hi initial values decreased	many with hi initial values decreased	18
19	VOP	very little change	very little change	very little change	19
20	GBW	very little change	+1 to +2% (prop to ICC)	+0 to +2% (prop to ICC)	20
Plastic, +85C					
21	PSRR	+/- 300 nV/V		+/- 300 nV/V	21
22	ICC/IEE	0 to +2% typ, 6 parts small decrease		+2 to +4%	22
23	VIO	+/- 25uV typ, 3 parts > +50 uV		+/- 40uV typ; 3276 +88uV, 3285 +59uV	23
24	IIB	+/- 500 to 1000 pA max		12 parts +/-1 to +/- 2nA	24
25	IIO	+/-500pA max		18 parts > +/-1nA but drift toward 0A	25
26	Gain	fluctuated a bit		fluctuated a bit	26
27	Slew rate	0 to +3%, Correlated to ICC		+2 to +4%	27
28	CMRR	few with hi initial values decreased		many with hi initial values decreased	28
29	VOP	very little change		very little change	29
30	GBW	0 to +1.5%		+/- 1%	30
Ceramic, -40C					
31	PSRR	+/- 300 nV/V		+/- 400 nV/V, 4264 -811 nV/V	31
32	ICC/IEE	+2 to +4% typ, 5 parts decr or 0		15 parts -2% to -9%, 3 parts incr	32
33	VIO	+/-50uV typ; 3 parts > 100 uV		4251 +160uV, 5 parts +/- 70uV	33
34	IIB	12 parts > +/-1nA but drift toward 0A		10 parts +/- 1 to +/-4 nA	34
35	IIO	13 parts > +/-1nA but drift toward 0A		16 parts +/- 1 to +/-6 nA	35
36	Gain	both + and -, no trend		2 parts incr, rest compr decr	36
37	Slew rate	+3 to +5% (prop to ICC), 5 parts decr		10 parts -10 to -12%, rest < +/- 4%	37
38	CMRR	few with hi initial values decreased		few with hi initial values decreased	38
39	VOP	very little change		couple -.05 to -.1%	39
40	GBW	+1 to 2%		10 parts -5%, rest < +/- 1%	40
Ceramic, +25C					
41	PSRR	+/- 300 nV/V	+/- 500 nV/V	+/- 400 nV/V	41
42	ICC/IEE	+0.5 to +2%, 13 parts no change	+1 to +2.5%, 10 parts decr (-5%)	+1 to 4%; 10 prts decr (-5 to -6%)	42
43	VIO	+/-20uV typ	+/-20uV typ	+/-35uV typ	43
44	IIB	+/-200pA max	17 parts > +/-1nA	+/-300pA typ, 15 parts > +/-1 nA	44
45	IIO	+/-200pA max	17 parts > -1nA drift toward 0A	17 parts > +/-1nA but drift toward 0A	45
46	Gain	both + and - small changes. No compression	all showed compr decrease	4 parts net incr; rest compr decr	46
47	Slew rate	+1 to +3% (prop to ICC), 13 parts no change	+1 to +2%; 10 parts decr (-6%)	+2 to 4%; 10 prts decr (-6 to -8%)	47
48	CMRR	few with hi initial values decreased	17 parts with hi init vals decreased	17 parts with hi init vals decreased	48
49	VOP	very little change	very little change	very little change	49
50	GBW	small incr, correlated to ICC	+1 to +2%, 10 parts decr (-2%)	+0 to 2%; 10 prts decr (-3.5%)	50
Ceramic, +85C					
51	PSRR	+/- 200 nV/V		+/- 500 nV/V	51
52	ICC/IEE	+0.5 to +2%,		+2 to 4%; 10 prts decr (-4 to -6%)	52
53	VIO	+/-20uV typ; 4439 +50 uV		+/- 30uV typ; 5 parts +/-50 to +/-90uV	53
54	IIB	+/-200pA typ, few at +/-500pA		+/- 400 pA typ; 16 parts -1 to -2 nA	54
55	IIO	+/-200pA typ, few at +/-400pA		16 parts > +/-1nA but drift toward 0A	55
56	Gain	fluctuated a bit		Fluctuated a bit	56
57	Slew rate	+1 to +3% (prop to ICC)		+2 to 4%; 10 prts decr (-6 to -8%)	57
58	CMRR	Few with hi initial decreased		17 parts with hi init vals decreased	58
59	VOP	very little change		very little change	59
60	GBW	+1 to 2%		+/- 1%, 10 parts decr (-3 to -4%)	60

Figure 9.1-1a: Summary of Analog Parametric Test Results

	Test Lot 4A, Test 1	Test Lot 5A, Test 3, (Test Period 2)	Test Lot 6A, Test 2, (Test Per 3)	Test Lot 7A, Test Period 4
	Plastic, -40C			
1	+/- 500 nV/V, 3223 failed spec	Several +1 to +3 uV/V (related to IIB)	very little change	+/- 300 nV/V
2	+1 to +4%, 25 parts decr or 0	+2 to +5%, 3350 decr	+1 to +9%, wide distribution	+3 to +5% typ, 4 parts decr
3	+/-60uV typ (many > +/- 50uV)	+/- 40 uV typ; 3339 +60uV	+/- 50uV typ, 2 parts > +50uV	+/- 50uV typ
4	many -1 to -4 nA but drift toward 0A	several shift up to +/- 8.0 nA	few parts shift > +/- 1 nA	+/- 3 nA typ, few up to +/- 7 nA
5	5 parts > +/- 6 nA, rest +/- 2nA	several shift up to +/- 5.0 nA	1 part > +/- 1 nA	+/- 2 nA typ, few up to +/- 8 nA
6	1 part incr; rest compr decr	3 parts incr; rest compr decr	drop, exc 3 prts with sm incr.	3025 incr; rest compr decr
7	+2 to +10%, 25 parts < +2%	+3 to +5%, 3350 decr (-5%)	Proportional to ICC/IEE	+3 to +7%, 6 parts decr
8	few with hi initial values decreased	very little change	3387 big decr, rest no change	Few with hi initial decreased
9	very little change	very little change	very little change	very little change
10	+0 to +3%, tracked ICC	+1 to +2%	+1 to 2%	small increase, 8 parts decr
	Plastic, +25C			
11	+/- 400 nV/V	+/- 300 nV/V	+/- 300 nV/V	+/- 250 nV/V
12	+1.5 to +2.5%, 3250 -2%	+1.5 to +2.5%, 3350 decr	0 to +2% typ, 6 parts decr	+1% typ, 8 parts decr (-2%)
13	+/-25uV typ	+/-25uV typ	+/-30uV typ	+/-15uV typ
14	6 parts > +/-1nA but drift toward 0A	+/-500pA max	-100 to -500 pA	-200 to -1000 pA; 2 parts incr
15	5 parts > +/- 3 nA, rest +/- 2nA	+/-400pA max	+/-200pA max	+/-350pA max
16	2 parts incr; rest compr decr	2 parts incr; rest compr decr	7 parts incr; rest compr decr	few small incr; rest compr decr
17	+7 to +8%, 3250 +3%	+2 to +3%, 3350 decreased	+1 to 3%, 6 parts decr or 0	+1 to +2% typ, 8 parts decr (-2%)
18	very little change	few with hi initial values decreased	very little change	Few with hi initial decreased
19	very little change	very little change	very little change	very little change
20	+3 to +4%, 3250 +1.5%	small increase, 3350 decreased	0 to +1% all parts	-1%, all parts
	Plastic, +85C			
21	+/- 350 nV/V	+/- 300 nV/V	+/- 300 nV/V	+/- 300 nV/V
22	+1 to +2.5%, 3250 -1%, 2 parts 0	+1 to +2%, 3350 decr, 3325 +9%	+1 to +2% typ, 2 parts decr	+1 to +2% typ, 8 parts decr
23	+/- 40 uV typ; 3243 +53uV	+/-25uV typ, 3301 -55 uV	+/-30uV typ, a few > +50 uV	+/-30uV typ
24	some +/-1 to +/-2nA drift toward 0A	+/-600pA typ, 3325 +1.6nA	-100 to -700 pA	-300 to -700 pA
25	all +/-1 to +/-4 nA	+/-500pA max	+/-500pA max	+/-300pA max
26	fluctuated a bit	fluctuated, no trends	fluctuated a bit	fluctuated a bit
27	+1 to +4%, 17 parts +7%, 3250 -0.5%	+2 to +3%, 3350 decr, 3325 +18%	+1.5 to +3% all parts	+2 to +3% typ, 8 parts decr or 0
28	few with hi initial values increased	very little change	few with hi initial values decr	Few with hi initial decreased
29	very little change	very little change	very little change	very little change
30	+0 to +2%, 17 parts +3 to +4%	small gain typ, 2 decr, 3325 +13%	sm incr, all parts	small incr, 8 parts decr
	Ceramic, -40C			
31	+/- 500 nV/V, 2 parts +700 nV/V	+/- 400 nV/V, 2 parts -600 nV/V	+/- 300 nV/V	+/- 600 nV/V
32	18 parts +/-1 to +/-4%, rest < +/- 1%	+1 to 6%; 8 prts decr (-1 to -8%)	+1 to +5% typ, 5 parts decr	+1 to +2%, 12 small decr, 6 big decr
33	+/- 40uV; 4214 +69uV, 4235 +121uV	+/-40uV typ, 7 parts +/- 70uV	5 parts > +/- 50 uV	4001 +139 uV, several +/-50 to 100uV
34	+/-700pA max	+/-300pA typ, 1 part > 1nA	several > +/- 1nA	several > +/- 2nA, 4037 -6nA
35	+/-400pA typ, 2 parts +700 pA	+/-300pA typ, few parts > +/- 1nA	several > +/- 1nA	several > +/- 2nA, 4049 -6nA
36	many small incr; rest compr decr	fluctuated widely, no trends	values unstable	12 parts incr; rest compr decr
37	+/-2%, 8 parts with +/- 5% shifts	+2 to +8%, many < +1%, 6 parts decr	+2 to +10%, 5 parts decr	-10% to +7% prop to ICC
38	few with hi initial values decreased	few with hi initial values decreased	few with hi initial values decr	very little change
39	very little change	very little change	very little change	very little change
40	+1 to +2.5%	+1 to +2%, 8 parts decr	+1%, 5 parts decr	Proportional to ICC
	Ceramic, +25C			
41	+/- 500 nV/V, 4240 +700 nV/V	+/- 500 nV/V	+/- 300 nV/V	+/- 500 nV/V
42	+1.5 to 3.5%; 2 prts decr	+0.5 to 1.5%; 4 prts decr	very little change	+1 to +2.5%, 15 parts decr or 0
43	+/-25uV, 4217&4224 failed spec	+/-10uV typ, very tight distribution	+/-20uV typ, very tight distrib	+/-20uV typ, very tight distribution
44	+/-300pA max	+/-500pA max	+/- 1 nA max	+/-500pA max
45	+/-250pA max	+/-500pA max	+/- 1 nA max	+/-200pA max
46	all showed compr decrease	2 parts incr, rest compr decr	divergent	4022 incr; rest compr decr
47	+2 to 4%; 2 prts decr	+1 to 2%; 4 prts decr (-5%)	very little change	+2%, 15 parts decr (0 to -7%)
48	few with hi initial values decreased	very little change	very little change	very little change
49	very little change	very little change	very little change	very little change
50	+1.5 to 3%; 2 prts decr	small increase, 4 prts small decr	very little change	sm decr; correlated to ICC
	Ceramic, +85C			
51	+/- 500 nV/V	+/- 600 nV/V	+/- 300 nV/V	+/- 500 nV/V
52	+1.5 to 3.5%; 2 prts decr	+1 to 2%; 4 prts decr (-6%)	+0.5 to 2% typ, 3 parts decr	+1 to +2.5%, 11 parts decr or 0
53	+/-40uV typ, 4 parts +/- 50uV	+/-40uV typ, several up to +/- 60uV	6 parts > +/- 50 uV	+/-30uV typ, 2 parts +/- 60uV
54	+/-300pA max	+/-300pA max	+/-400pA max	+/-300pA max
55	+/-350pA, 4228 + 1nA	+/-300pA max	+/-600pA max	+/-300pA max
56	Fluctuated a bit	Fluctuated a lot	Fluctuated a lot	Fluctuated a lot
57	+2 to 4%; 2 prts decr	+1 to 3%; 4 prts decr	+1 to 2%; 3 with low ICC +0.5%	+2%, 11 parts decr (0 to -6%)
58	few with hi initial values incr or decr	2 parts big incr, rest no change	very little change	Few with hi initial decreased
59	very little change	very little change	very little change	very little change
60	+1 to +2%, 2 parts at 0	small increase, 4 parts small decr	small increase	little change, 11 parts small decr

Figure 9.1-1b: Summary of Analog Parametric Test Results

Plastic, -40 C	Test Lot 8D, Control Group	Test Lot 4D	Test Lot 5D
IIL	Few inputs at 1 nA	Several inputs > +/- 10 nA	Few inputs at 1 to 10 nA
IIH	drift toward 0.2 to 0.4 nA, few at +10 nA	drift toward 0.4 nA. Many inputs > +/- 100 nA	drift toward 0.4 nA. Several inputs > +/- 100 nA
VIH(CLK)	moderate shift at 5.5V	moderate shift at 5.5V	med-large drop at 5.5V
VIH(DAT)	Little change	Little change	Little change
VIH(CLR)	large drop related to VCC	large shifts at 5.5V	large drop related to VCC
VIH(PRE)	large drop related to VCC	med-high drop related to VCC	large drop related to VCC
VIL(CLK)	Little change	Little change	Little change
VIL(DAT)	Little change	Little change	Little change
VIL(CLR)	Little change	moderate drop at all VCC	small drop at all VCC
VIL(PRE)	moderate shift at 5.5V	Little change	small drop at all VCC
VOH	Little change	2 parts had larger than normal shift	1 part dropped more than normal
VOL	Little change	2 parts had larger than normal shift	Little change
ICC	drift toward 100 nA	no drift, +/- 1uA with no pattern	drift toward 100 nA
Small Shift	T0, T2, T5, T7, T9, T10, T11, T15	T2, T5, T10, T11, T15, T17	T5
Large Shift	T16	T14, T16	T11, T15
Step Inc	T18	T18, T19, T22, T25	T18, T21, T23, T25
Step Dec	T19, T24, T25	T20	
2 Value		T24	T19, T20, T24
Misc		T21 few step increases	
Plastic, +25 C	Test Lot 8D, Control Group	Test Lot 4D	Test Lot 5D
IIL	All 0A	All 0A	All 0A
IIH	drift toward 0.2 to 0.4 nA	drift toward 0.2 to 0.4 nA	drift toward 0.2 to 0.4 nA
VIH(CLK)	moderate shift 5.5V	moderate shift 5.5V	moderate drop at 5.5V
VIH(DAT)	Little change	Little change	Little change
VIH(CLR)	large shift 5.5V (most increase)	large drop at 5.5V	large drop related to VCC
VIH(PRE)	med-large drop related to VCC	med-large drop related to VCC	large drop related to VCC
VIL(CLK)	Little change	Little change	Little change
VIL(DAT)	Little change	Little change	Little change
VIL(CLR)	Little change	moderate shift at all VCC	Little change
VIL(PRE)	Little change	Little change	Little change
VOH	Little change	Little change (1 higher than norm)	Little change (1 higher than norm)
VOL	Little change (1 higher than norm)	Little change	Little change (1 higher than norm)
ICC	drift toward 100 nA	small increase	No pattern
Small Shift	T0, T2, T9, T10, T11, T14	T2, T11, T14, T16	T0, T2, T5
Large Shift	T15		T11, T14-17
Step Inc	None	T21, T23, T25	T25
Step Dec	T21-25	T18, T20	T18, T22-24
2 Value	T18, T20		T20, T21
Misc	T16 & 17 had 1 part with large drop		
Plastic, +85 C	Test Lot 8D, Control Group	Test Lot 4D	Test Lot 5D
IIL	All at 0A	All at 0A	All at 0A
IIH	drift toward 0.2 to 0.4 nA	drift toward 0.2 to 0.4 nA	drift toward 0.2 to 0.4 nA
VIH(CLK)	Little change	Little change	Little change
VIH(DAT)	Little change	Little change	Little change
VIH(CLR)	large drop related to VCC	large drop related to VCC	large drop related to VCC
VIH(PRE)	Med-large drop at all VCC	medium shift at 5.5V	Med-large drop related to VCC
VIL(CLK)	Little change	Little change	few parts with small drop
VIL(DAT)	Little change	Little change	Little change
VIL(CLR)	Little change	Little change	Little change
VIL(PRE)	Little change	modest drop at 5.5V	Little change
VOH	Little change	Little change	several dropped more than normal
VOL	Little change	Little change	several increased more than norm
ICC	No pattern	No pattern	No pattern
Small Shift	T2, T7, T10, T11, T14, T16	T2, T6, T11, T13, T15, T17	T15
Large Shift	T15	T14, T16	T5, T11, T14
Step Inc		T21, T23, T25	T19, T21, T25
Step Dec	T19, T21-25		T20, T24
2 Value	T18	T18, T19, T22, T24	T18, T22, T23
Misc		T20 few step decreases	T16 & 17 a few large shifts

Figure 9.2-1a: Summary of Digital Parametric Test Results

Plastic, -40 C	Test Lot 6D	Test Lot 7D	Test Lot 3D (Final)
IIL	Several inputs > +/- 10 nA	Few inputs at -500 nA, some at +/- 1nA	Many inputs -1 to -900 nA
IIH	drift toward 0.4 nA. Several inputs > +/- 100 nA	drift toward 0.4 nA. a few inputs > + 20 nA	drift toward 0.4 nA. several inputs at +10 to +60 nA
VIH(CLK)	medium shift at 5V & 5.5V	modest shift at 5V & 5.5V	modest increase at 5V & 5.5V
VIH(DAT)	Little change	Little change	Little change
VIH(CLR)	large drop related to VCC	med-large shift related to VCC	Medium shift at all VCC
VIH(PRE)	small drop or large gain at all VCC	modest drop at all VCC	large gain or medium drop at all VCC
VIL(CLK)	Little change	Little change	small drop at 4.5V
VIL(DAT)	Little change	Little change	Little change
VIL(CLR)	Little change	Little change	small drop at all VCC
VIL(PRE)	modest drop at 5V & 5.5V	small drop related to VCC	small drop at all VCC
VOH	Little change	1 part dropped more than normal	2 parts dropped more than normal
VOL	1 part increased more than norm	1 part increased more than normal	2 parts increased more than normal
ICC	no pattern	Little change	no pattern
Small Shift	T0, T3, T5, T11, T17	T0, T2, T5	T0,T2, T7, T10, T11, T14, T17
Large Shift	T14, T16	T16	T15, T16
Step Inc	T19, T21, T23, T25	T19, T21, T25	T19-23, T25
Step Dec	T22	T22, T24	T24
2 Value	T18, T24	T18, T20	T18
Misc	T15 & T20 couple step decreases	T15 & T23 one part large gain	
Plastic, +25 C	Test Lot 6D	Test Lot 7D	Test Lot 3D (Final)
IIL	All 0A	few non-zero values recorded	intermediate shifts but all end at 0A
IIH	drift toward 0.2 to 0.4 nA	drift toward 0.2 to 0.4 nA	drift toward 0.2 to 0.4 nA
VIH(CLK)	small drop at 5.5V	modest drop at 5.5V	modest shift at 5.5V
VIH(DAT)	Little change	Little change	Little change
VIH(CLR)	large drop related to VCC or med incr at 5.5V	moderate shift 5.5V	medium shifts at 5V, med-large shifts at 5.5V
VIH(PRE)	Little change	small shift or large drop related to VCC	large gain related to VCC or moderate drop at all VCC
VIL(CLK)	Little change	Little change	Little change
VIL(DAT)	Little change	Little change	Little change
VIL(CLR)	moderate increase at all VCC	Little change	small drop at all VCC
VIL(PRE)	Little change	Little change	Little change
VOH	Little change	1 part lower than norm	1 part failed
VOL	1 part higher than normal	1 part higher than norm	1 part failed
ICC	all increased to 1 to 2 uA	Little change	little movement, drift toward 0 A
Small Shift	T0, T2, T11, T14, T15	T2, T5	T0, T2, T5, T7, T8, T17
Large Shift	T5	T0	T16
Step Inc	T19, T21, T25	T20, T23	T18, T25
Step Dec	T22, T24		T21, T22, T24
2 Value	T18, T20	T18, T22, T24, T25	T20
Misc		T9,14,16,17,21 1 part large shifts	
Plastic, +85 C	Test Lot 6D	Test Lot 7D	Test Lot 3D (Final)
IIL	All at 0A	All at 0A	All at 0A
IIH	drift toward 0.2 to 0.4 nA	drift toward 0.2 to 0.4 nA	drift toward 0.2 to 0.4 nA
VIH(CLK)	Little change	Little change	Little change
VIH(DAT)	Little change	Little change	Little change
VIH(CLR)	med-large drop related to VCC	medium shift at 5.5V	med-large drop related to VCC
VIH(PRE)	modest drop at all	Little change	large increase related to VCC or medium drop related to VCC
VIL(CLK)	Little change	Little change	Little change
VIL(DAT)	Little change	Little change	Little change
VIL(CLR)	Little change	Little change	Little change
VIL(PRE)	Little change	Little change	Little change
VOH	1 part dropped more than normal	Little change	Little change
VOL	1 part increased more than norm	Little change	Little change
ICC	No pattern	Little change	small shifts
Small Shift	T0, T4, T8	T0, T5, T8	T2, T5, T7, T8, T11, T13, T14
Large Shift	T11	T11	T16, T17
Step Inc	T19, T21, T23-25	T25	T23, T25
Step Dec	T22	T22, T24	T22, T24
2 Value	T18	T18, T19, T23	T18, T19
Misc			

Figure 9.2-1b: Summary of Digital Parametric Test Results

Cerdip, -40 C	Test Lot 8D, Control Group	Test Lot 4D	Test Lot 5D
IIL	few inputs at 1nA	few inputs shifted by +/- 10n A or more	few inputs shifted by - 10n A or more
IIH	drift toward 0.2 nA, several +1 to +120 nA	drift toward 0.2 nA, a few > +/- 10 nA	drift toward 0.2 nA, a few +10 to +200 nA
VIH(CLK)	modest increase at 5V & 5.5V	modest increase at 5.5V	moderate drop related to VCC
VIH(DAT)	Little change	Little change	Little change
VIH(CLR)	modest shift at 5V, large shift at 5.5V	med-large drop at all VCC	large drop related to VCC
VIH(PRE)	large drop related to VCC	moderate drop at all VCC	modest shift at all VCC
VIL(CLK)	Little change	Little change	Little change
VIL(DAT)	Little change	Little change	Little change
VIL(CLR)	modest shift 4.5V, large shift 5/5.5V	med-large drop related to VCC	med-large shift at all VCC
VIL(PRE)	modest drop at all	Little change	medium drop at all VCC
VOH	Little change	Little change	Little change
VOL	Little change	Little change	Little change
ICC	drift to 100 nA	all increased, no pattern	most parts drop toward 0 A
Small Shift	T5, T9, T11, T14	T9, T11	T0, T3, T7
Large Shift	T15	T16, T17	T11, T15
Step Inc		T21, T23-25	T21, T23, T25
Step Dec	T18-25		T18, T24
2 Value		T20	T19, T20, T22
Misc		T14, T15, T18, T22 had a few large increases	
Cerdip, +25C	Test Lot 8D, Control Group	Test Lot 4D	Test Lot 5D
IIL	All at 0A	All at 0A	All at 0A
IIH	drift toward 0.2 to 0.4 nA	drift toward 0.2 to 0.4 nA	drift toward 0.2 to 0.4 nA
VIH(CLK)	modest increase at 5V & 5.5V	small increase related to VCC	small drop at 5.5V
VIH(DAT)	Little change	Little change	Little change
VIH(CLR)	modest shift at 4.5/5V, large shift at 5.5V	large drop related to VCC	large drop related to VCC
VIH(PRE)	large drop related to VCC	small increase related to VCC	small increase at 5.5V
VIL(CLK)	Little change	Little change	Little change
VIL(DAT)	Little change	Little change	Little change
VIL(CLR)	modest drop on all	modest drop on all	modest drop on all
VIL(PRE)	modest drop, slight relation to VCC	Little change	modest shift on all
VOH	Little change	Little change	Little change
VOL	Little change	Little change	Little change
ICC	drift to 100 nA	most increased, no pattern	no pattern
Small Shift	T2, T11, T14, T16	T0, T8, T9, T11, T13, T15, T17	T0, T3, T5, T9, T10, T16
Large Shift	T15		T11, T15
Step Inc	T18, T20	T21, T24	T19, T21, T25
Step Dec	T19, T21-25		T20, T22, T24
2 Value		T18, T19, T20, T22, T23	T18, T23
Cerdip, +85C	Test Lot 8D, Control Group	Test Lot 4D	Test Lot 5D
IIL	All at 0A	All at 0A	All at 0A
IIH	drift toward 0.2 to 0.4 nA	drift toward 0.2 to 0.4 nA	drift toward 0.2 to 0.4 nA
VIH(CLK)	modest shift at 5.5V	modest increase at 5.5V	modest drop at 5.5V
VIH(DAT)	Little change	Little change	Little change
VIH(CLR)	large drop related to VCC	large drop related to VCC	large drop related to VCC
VIH(PRE)	large drop related to VCC	med-large drop at 5.5V	medium shift on all
VIL(CLK)	Little change	Little change	Little change
VIL(DAT)	Little change	Little change	Little change
VIL(CLR)	Little change	medium drop at all VCC	small drop at 5.5V
VIL(PRE)	Little change	Little change	small drop at 5V & 5.5V
VOH	Little change	Little change	Little change
VOL	Little change	Little change	Little change
ICC	No pattern	No pattern	No pattern
Small Shift	T5, T8, T11, T14, T16	T7, T8, T9, T11, T13	T0, T3, T4, T7, T16
Large Shift	T15	T16, T17	T11
Step Inc		T21, T22, T25	T19, T21, T23, T25
Step Dec	T18-25		T20, T22, T24
2 Value		T20, T24	T18
Misc			

Figure 9.2-1c: Summary of Digital Parametric Test Results

CerDip, -40 C	Test Lot 6D	Test Lot 7D	Test Lot 3D (Final)
IIL	several shift by +/- 10 nA	several shift by +/- 1 nA	few shift by +/- 5 nA
IIH	drift toward 0.2 nA, several +10 to +150 nA	drift toward 0.2 nA, several +10 to +180 nA	drift toward 0.2 nA, many +10 to +100 nA
VIH(CLK)	modest shift related to VCC	medium shift at 5V & 5.5V	medium shift at 5V & 5.5V
VIH(DAT)	Little change	Little change	small drop at 5.5V
VIH(CLR)	med-large drop related to VCC	large gain related to VCC	med-large shift at all VCC
VIH(PRE)	small drop or large incr. at all VCC	large drop related to VCC	modest shift at all VCC
VIL(CLK)	Little change	Little change	Little change
VIL(DAT)	Little change	Little change	Little change
VIL(CLR)	large gain at 5.5V for some parts	modest shift at 5.5V	med-large drop at all VCC
VIL(PRE)	med-large drop at all VCC	Little change	Little change
VOH	Little change	Little change	Little change
VOL	Little change	Little change	Little change
ICC	Little change	larger than normal shifts	larger than normal shifts
Small Shift	T0, T3, T5, T9, T17	T1	T0, T7, T11
Large Shift	T11, T14, T16		T15, T16
Step Inc	T22, T24	T19, T22-25	T20-24
Step Dec	T18-21, T23, T25	T20	T25
2 Value		T21	
Misc			
CerDip, +25C	Test Lot 6D	Test Lot 7D	Test Lot 3D (Final)
IIL	All at 0A	All at 0A	All at 0A
IIH	drift toward 0.2 to 0.4 nA	drift toward 0.2 to 0.4 nA	drift toward 0.2 to 0.4 nA
VIH(CLK)	modest shift at 5V & 5.5V	modest shift at 5.5V	modest increase at 5.5V
VIH(DAT)	Little change	Little change	Little change
VIH(CLR)	large drop related to VCC or med shift all VCC	medium increase related to VCC, or modest shift on all	medium-large drop related to VCC or no change
VIH(PRE)	med drop related to VCC or med shift all VCC	large drop related to VCC, or little change	modest shift at all VCC
VIL(CLK)	Little change	Little change	Little change
VIL(DAT)	Little change	Little change	Little change
VIL(CLR)	modest shift on all	Little change	Medium drop at all VCC
VIL(PRE)	modest drop on all	Little change	med-large drop at all VCC
VOH	Little change	Little change	Little change
VOL	Little change	Little change	Little change
ICC	Little change	drift toward 0 A	drift toward 0 A
Small Shift	T0, T3, T9, T11, T14-17	T2, T17	T0, T2, T14, T15
Large Shift			
Step Inc	T18, T19, T21, T23, T25	T18-25	T25
Step Dec	T22, T24		T19, T21-24
2 Value	T20		T18, T20
CerDip, +85C	Test Lot 6D	Test Lot 7D	Test Lot 3D (Final)
IIL	All at 0A	All at 0A	All at 0A
IIH	drift toward 0.2 to 0.4 nA	drift toward 0.2 to 0.4 nA	drift toward 0.2 to 0.4 nA
VIH(CLK)	modest shift at 5.5V	small drop at 5.5V	modest shift at 5.5V
VIH(DAT)	Little change	Little change	Little change
VIH(CLR)	large drop related to VCC	large gain related to VCC	large drop related to VCC
VIH(PRE)	modest shift at 5.5V	Large shift related to VCC	modest shift at all VCC
VIL(CLK)	Little change	Little change	Little change
VIL(DAT)	Little change	Little change	Little change
VIL(CLR)	Little change	Little change	small drop at all VCC
VIL(PRE)	small drop at 5V & 5.5V	Little change	small drop at all VCC
VOH	Little change	Little change	Little change
VOL	Little change	Little change	Little change
ICC	No pattern	No pattern	Little change
Small Shift	T0, T3, T11		T0, T6, T7, T8, T11, T14, T16, T17
Large Shift		T20, T23	T15
Step Inc	T19, T21, T23, T25	T19, T22, T24	
Step Dec	T18, T20, T24	T21, T25	T18, T20-25
2 Value	T22		
Misc			

Figure 9.2-1d: Summary of Digital Parametric Test Results



Plastic, -40C		Lot 9A, Plastic, Final Test		Lot 10A, Plastic, Final Test	
PSRR		+/- 300 nV/V, 1 outlyer		+/- 150 nV/V, 1 outlyer	
ICC/IEE		-1 to -2% typ, some to -9%, several 0 to +3%		+1 to +8%, 14 parts at +/- 1%	
VIO		+/- 50 uV typ, 4 outlyers up to +/- 100 uV		+/- 50 uV	
IIB		+/- 2.0 nA		+700 to -1300 pA	
IIO		+/- 3.0 nA, 3 parts up to +/- 10 nA		-300 to -2300 pA	
Gain		Slight compr decr typ, 10 parts small incr.		Most compr decr, several incr with slight expansive trend	
Slew rate		-1 to -3% typ, some to -11%, several 0 to		+1 to +10% typ, 14 parts at +/- 2%	
CMRR		Few with high init val shifted		Few with high init val shifted	
VOP		Few shifted more than normal		Few shifted more than normal	
GBW		+1.5 to +3.5%, several no change		+1 to +3%	

Plastic, +25C		Lot 9A, Plastic, 1st Int. Test		Lot 9A, Plastic, Final Test		Lot 10A, Plastic, 1st Int. Test		Lot 10A, Plastic, Final Test	
PSRR		+/- 200 nV/V, 1 outlyer		+/- 250 nV/V, 1 outlyer		+/- 250 nV/V		+/- 150 nV/V, 1outlyer	
ICC/IEE		+/- 1%, 10 parts +/- 2%		+1 to +2.5%		+/- 1%, 13 parts +0.5 to +2.0%		< +/- 1% typ, 13 parts +1 to +2%	
VIO		+/- 25 uV		+/- 30uV, tight distribution		+/- 30uV, 1 outlyer		-20 to +50 uV, 1 part at +100 uV	
IIB		+/- 500 pA, 1 outlyer		0 to -600 pA		+/- 300 pA, 2 outlyers out to +1 nA		+200 to -500 pA	
IIO		-200 to -1100 pA		-100 to -800 pA		-200 to -1000 pA		-200 to -1500 pA	
Gain		Compressive decrease		Compressive decrease		Compressive decrease		Compressive decrease	
Slew rate		+/- 1%, 10 parts +/- 3%		+1 to +3%		+/- 1%, 13 parts +1.0 to +2.5%		< +/- 1% typ, 13 parts +1 to +2%	
CMRR		Few with higher init vals shifted		Few with higher init vals shifted		One part with high init val shifted		Few with higher init vals shifted	
VOP		Little Change		Little Change		Little Change		Little Change	
GBW		+0 to +2%		+2 to +3.5%		+0 to +2%		+1 to +3%	

Plastic, +85C		Lot 9A, Plastic, Final Test		Lot 10A, Plastic, Final Test	
PSRR		+/- 200 nV/V, 1outlyer		+/- 150 nV/V, 1outlyer	
ICC/IEE		+1 to +4%, few with no change		+/- 1%	
VIO		+/- 40 uV		+/- 40 uV, 3 outlyers up to +80 uV	
IIB		-100 to -1300 pA		+/- 500 pA	
IIO		+300 to -600 pA		-1000 to +500 pA	
Gain		No pattern		No pattern	
Slew rate		+1 to +4%, few with no change		+/- 1%	
CMRR		Few with high init vals shifted		Few with high init vals shifted	
VOP		-VOP shifted more than normal		Little change	
GBW		+1 to +3%		+1 to +4.5%	

Ceramic, -40C		Lot 9A, Ceramic, Final Test		Lot 10A, Ceramic, Final Test	
PSRR		+/- 300 nV/V, 2 outlyer		+/- 200 nV/V, 4 outlyer to +/- 1100 nV/V	
ICC/IEE		+/- 4% (more decreases)		+/- 3%, 3 outlyers	
VIO		+/- 50 uV typ, 2 outlyers		+/- 50 uV typ, 6 outlyers	
IIB		0 to +1.5 nA typ, 5 had large drops to -9nA		+/- 600 pA	
IIO		+1.2 to +1.7nA typ, 6 parts up to +/- 10 nA		+/- 1 nA, some outlyers to +/- 2nA	
Gain		Most compr decr, several incr		Most compr decr, few incr	
Slew rate		+4 to -5%, tracked ICC		+/- 3%, 3 outlyers	
CMRR		Few with high init val shifted		Few with high init val shifted	
VOP		1 part larger than normal drop		Little Change	
GBW		+1.5 to +4.5%		+/- 3%	

Ceramic, +25C		Lot 9A, Ceramic, 1st Int. Test		Lot 9A, Ceramic, Final Test		Lot 10A, Ceramic, 1st Int. Test		Lot 10A, Ceramic, Final Test	
PSRR		+/- 300 nV/V, 2 parts at -500 nV/V		+/- 300 nV/V		+/- 300 nV/V, 4 parts at +/-500 nV/V		+/- 100 nV/V, 4 parts +/- 500 nV/V	
ICC/IEE		+1 to +2% typ, 11 parts +3.5 to		+1 to +3%, 2 parts small drop		+0.5 to +2.5%, 4 parts dropped, 2 no chg		0 to +3% typ, 5 parts -1 to -3%	
VIO		+/- 25 uV		+/- 25uV typ, several +/- 50uV		+/- 35 uV		+/-50 uV, 1 part at +75 uV	
IIB		-1300 to +100 pA		+200 to -800 pA		+/- 400 pA, 23 parts at -1.2 to -2.4 nA		+/- 300 pA or -1.0 to -2.5 nA	
IIO		+/- 350 pA, 14 parts at -700 to -		+/- 200 pA typ, 14 parts -0.7 to -1.7 nA		-300 to +600 pA, 23 parts -2.1 to -4.7 nA		-700 to +400 pA or -2.0 to -4.0 nA	
Gain		Slight compressive decrease		Compr decr typ, 1 part increased		Compressive decrease		Compr decr typ, 4 part increased	
Slew rate		+1.0 to +2.5%, 11 parts +4.0 to		+0.5 to +3.0% typ, 2 parts small drop		+0.5 to +2.5%, 4 parts dropped, 2 no		0 to +2% typ, 4 parts -2 to -5%	
CMRR		Few with higher init vals shifted		Few with higher init vals shifted		Few with higher init vals shifted		Few with higher init vals shifted	
VOP		Little Change		Little Change		Little Change		Little Change	
GBW		0 to +1%, 11 parts +1.5 to +3.0%		+1.5% to +3.5%		+/- 1%, 4 parts at -2 to -3.5%		0 to +2% typ, 4 parts small drop	

Ceramic, +25C		Lot 9A, Ceramic, Final Test		Lot 10A, Ceramic, Final Test	
PSRR		+/- 300 nV/V, 1outlyer		+/- 300 nV/V, 3 outlyers	
ICC/IEE		+1 to +3%		0 to -2% typ, 4 parts -3 to -5%	
VIO		+/- 50 uV, 3 outlyers		+/- 60 uV, 4 outlyers up to +110 uV	
IIB		+/- 350 pA, 1 outlyer		+/- 500 pA	
IIO		+/- 500 pA		-800 to +400 pA	
Gain		No pattern		No pattern	
Slew rate		+1 to +3.5%		0 to -2% typ, 4 parts -3 to -6%	
CMRR		Few with high init vals shifted		Few with high init vals shifted	
VOP		Little change		Little change	
GBW		+1 to +4%		+1 to +3%	

Figure 9.3-1a: Summary of Thermal and Life Parametric Test Results

Plastic, -40C	Test Lot 8A, Analog Control Group	Lot 11A, Plastic	Lot 12A, Plastic
PSRR	+/- 300 nV/V	+/- 250 nV/V	+/- 175 nV/V
ICC/IEE	+3 to +9% (most +4%), 6 parts decr.	+/- 1.5%, grouped by S/N	+1 to +3% typ, several little change, 3
VIO	+/- 40 uV typ, 3426 +80uV	+/- 50 uV typ, 3 outliers	+/- 50 uV
IIB	some > +/-1nA but drift toward 0A	-1.0 to +1.5 nA	-500 to +600 pA
IIO	some +/- 1nA, 3423 +10nA	-0.5 to +1.0 nA	-1000 to +500 pA
Gain	all showed compressive decrease	Compressive decrease	Compressive decrease
Slew rate	+2 to +10% (prop to ICC), 6 parts decr.	+/- 1%, tracked ICC	+1 to +3% typ, several little change, 3
CMRR	few with hi initial values decreased	Few with high init val shifted	Few with high init val shifted
VOP	very little change	Little Change	Little Change
GBW	+0 to +2% (prop to ICC)	+/- 1%	+0 to +2%

Plastic, +25C	Test Lot 8A, Analog Control Group	Lot 11A, Plastic	Lot 12A, Plastic
PSRR	+/- 300 nV/V	+/- 200 nV/V	+/- 200 nV/V
ICC/IEE	+1 to +3%	0 to +1% (very small)	+/- 1%
VIO	+/-20uV, tight distribution	+/- 30uV, 2 outliers	+/- 30uV, 1 outlier
IIB	2prts, +500pA; most -.5 to -1 nA.	-500 to +700 pA	-500 to +600 pA, 1 outlier
IIO	+/-400pA max	+/- 300 pA	+/- 500 pA
Gain	13 parts big compr decr; rest norm decr	Compressive decrease	Compressive decrease
Slew rate	+1 to +4% (prop to ICC)	+0.5 to +1.5%	+0.5 to +1.5%
CMRR	few with hi initial values decreased	Few with higher init vals shifted	Little Change
VOP	very little change	Little Change	Little Change
GBW	very little change	+0.5 to +1.5%	+0.5 to +1.5%

Plastic, +85C	Test Lot 8A, Analog Control Group	Lot 11A, Plastic	Lot 12A, Plastic
PSRR	+/- 300 nV/V	+/- 200 nV/V	+/- 250 nV/V
ICC/IEE	0 to +2% typ, 6 parts small decrease	0 to +1.5%	0 to +1.5%
VIO	+/- 25uV typ, 3 parts > +50 uV	+/- 50 uV, 1 outlier	+/- 50 uV, 2 outlier
IIB	+/- 500 to 1000 pA max	+/- 600 pA	+/- 500 pA
IIO	+/-500pA max	+/- 350 pA, few outliers	+/- 300 pA, few outliers
Gain	fluctuated a bit	No pattern	No pattern
Slew rate	0 to +3%, Correlated to ICC	+0.5 to +2.0%	+0 to +2%
CMRR	few with hi initial values decreased	Few with high init vals shifted	Few with high init vals shifted
VOP	very little change	Little change	Little change
GBW	0 to +1.5%	+/- 1%	+0 to +2%

Ceramic, -40C	Test Lot 8A, Analog Control Group	Lot 11A, Ceramic	Lot 12A, Ceramic
PSRR	+/- 300 nV/V	+/- 200 nV/V	+/- 200 nV/V
ICC/IEE	+2 to +4% typ, 5 parts decr or 0	0 to +3%, few with small drops	+/- 1%
VIO	+/-50uV typ; 3 parts > 100 uV	+/- 50 uV typ, several large drops	+/- 50 uV typ, 5 parts with large shifts
IIB	12 parts > +/-1nA but drift toward 0A	-500 to +800 pA	-100 to +1000 pA
IIO	13 parts > +/-1nA but drift toward 0A	-1000 to +600 pA	-1000 to +300 pA
Gain	both + and - no trend	Most decr, no pattern	slight compr decr
Slew rate	+3 to +5% (prop to ICC), 5 parts decr	0 to +3% typ, few -1%	+/- 1%
CMRR	few with hi initial values decreased	Few with high init val shifted	Few with high init val shifted
VOP	very little change	Little Change	Little Change
GBW	+1 to 2%	+1 to +2.5%	+0.5% to +1.5%

Ceramic, +25C	Test Lot 8A, Analog Control Group	Lot 11A, Ceramic	Lot 12A, Ceramic
PSRR	+/- 300 nV/V	+/- 200 nV/V	+/- 250 nV/V
ICC/IEE	+0.5 to +2%, 13 parts no change	+1 to +3%	+/- 1%
VIO	+/-20uV typ	+/- 15 uV, tight distribution	+/- 25 uV
IIB	+/-200pA max	+/- 300 pA	-100 to +500 pA
IIO	+/-200pA max	+/- 300 pA, 1 outlier	-600 to +100 pA
Gain	both + and - small changes. No compr.	Both incr and decr	Slight compressive decrease
Slew rate	+1 to +3% (prop to ICC), 13 no change	+1 to +2.5%	+0 to +2%
CMRR	few with hi initial values decreased	Few with higher init vals shifted	Few with higher init vals shifted
VOP	very little change	Little Change	Little Change
GBW	small incr, correlated to ICC	+1 to +2%	+0 to +2%

Ceramic, +25C	Test Lot 8A, Analog Control Group	Lot 11A, Ceramic	Lot 12A, Ceramic
PSRR	+/- 200 nV/V	+/- 300 nV/V	+/- 250 nV/V
ICC/IEE	+0.5 to +2%	+1.0 to +2.5%	+0.5 to +1.7%
VIO	+/-20uV typ; 4439 +50 uV	+/- 60 uV, 2 outliers	+/- 50 uV, 6 outliers up to +/- 100 uV
IIB	+/-200pA typ, few at +/-500pA	+/- 300 pA, 1 outlier	+/- 300 pA
IIO	+/-200pA typ, few at +/-400pA	+/- 500 pA	-500 to +200 pA
Gain	fluctuated a bit	No pattern	No pattern
Slew rate	+1 to +3% (prop to ICC)	+1.5 to +2.5%	+1.0 to +2.5%
CMRR	few with hi initial values decreased	Few with high init vals shifted	Few with high init vals shifted
VOP	very little change	Little change	Little change
GBW	+1 to 2%	+0.5 to +1.5%	+0.75 to +1.5%

Figure 9.3-1b: Summary of Thermal and Life Parametric Test Results

A comparison was made between the thermal and life test results and the analog reliability test results. The data summary from the analog test is shown in Figures 9.1-1a and 9.1-1b. The analog reliability test was conducted in generally the same manner as the thermal and life tests, except that all the testing was done at room temperature. A comparison between the thermal and life tests and of the analog tests, especially between lot 10a in Figure 9.3-1a with lot 3a in Figure 9.1-1a, shows that the data shifts are of approximately the same magnitude. This would indicate that the effect on device parameters is not thermally related, but related more to the time and intensity of exposure to electromagnetic energy. An analysis of these test results is presented in paragraph 3.1. No test device failures occurred during the thermal and life testing.

#### **9.4 Wideband Post-Reliability Electrical Acceptance Test Results**

The results of the wideband tests are presented in Figure 9.4-1. The results of the "control" group parametric tests are also shown for comparison. An analysis of these test results is presented in paragraph 3.1. No test device failures occurred during the wideband testing.

### **10.0 DESIGN AND FABRICATION OF MODE-STIRRED CHAMBER AND TUNER**

A mode-stirred reverberation chamber was designed and fabricated for the contract. Mode stirring provides a nearly uniform mean RF field intensity level everywhere in the chamber except in the area  $\frac{1}{2}$  wavelength or less from the chamber walls. This allows the test parts to be subjected to uniform energy distributions at high RF power levels. The chamber is of metal panel and seam construction with a walk-through entry door and a rear connector access panel. The door is a high quality unit with a beryllium copper finger seal that extends completely around the doorframe to keep out any electromagnetic interference. Panel and seam construction was chosen so that the chamber could be taken apart, shipped, and re-assembled if required. NIST Technical Note 1092 describes the design, evaluation, and use of a reverberation chamber for performing electromagnetic susceptibility/vulnerability measurements. The same design analysis, calibration, and measurement procedures given in the NIST Technical Note 1092 were employed for the design of our chamber. The chamber has inside dimensions of approximately 5' by 6' by 7', which is approximately  $\frac{1}{2}$  the largest dimension and  $\frac{1}{6}$ th the volume of the NIST chamber. It is large enough to provide uniform excitation of internal test fixtures with NIST recommended clearance relative to walls and other internal features, and accommodate the RF power feeds, stirring paddle, thermal control hardware, and device-holder test fixtures. Using the calculations in the NIST reference, a chamber of this size will support sufficient mode density to perform as a reverberation chamber at 400 MHz and higher. Appropriate treatment of the panel and door edges has been provided, and the chamber has been tested per MIL-STD-285 at 500 MHz and above to ensure its shielding integrity after construction.

Mode stirring is accomplished by a motor-driven four-blade stirrer or paddle that is located in the center of the chamber near the ceiling. The paddle is driven by a computer controlled stepper motor

TEST	Test Lot 8A, Plastic Control Group	Test Lot 13A, Plastic
PSRR	+/- 300 nV/V	+/- 300 nV/V
ICC/IEE	+3 to +9% (most +4%), 6 parts decreased	+/- 2% with no pattern
VIO	+/- 40 uV typ. 3426 +80uV	+/- 25 uV typ, some outliers to +/- 50 uV
IIB	some > +/-1nA but drift toward 0A	+/- 1.4 nA
IIO	some +/- 1nA, 3423 +10nA	0 to -2 nA
Gain	all showed compressive decrease	most compressive decrease, few parts increased
Slew rate	+2 to +10% (prop to ICC), 6 parts decreased	+/- 3%, no pattern, related to ICC
CMRR	few with hi initial values decreased	few with hi initial values shifted
VOP	very little change	few parts +/- 20 mV
GBW	+0 to +2% (prop to ICC)	small increase +0.5 to +1.5%
TEST	Test Lot 8A, Ceramic Control Group	Test Lot 13A, Ceramic
PSRR	+/- 300 nV/V	+/- 800 nV/V, 2 parts at -1000 nV/V
ICC/IEE	+2 to +4% typ, 5 parts decr or 0	-4 to -9% typ, #4682 -11%, 5 parts at 0 to -2%
VIO	+/-50uV typ; 3 parts > 100 uV	+/- 60uV typ, 3 parts at +/-50 to +/- 100uV
IIB	12 parts > +/-1nA but drift toward 0A	-200 to +600 pA
IIO	13 parts > +/-1nA but drift toward 0A	-800 to +600 pA
Gain	both + and -, no trend	Both + and -, decreases were compressive
Slew rate	+3 to +5% (prop to ICC), 5 parts decr	-5% to -11% typ, #4682 at -14%, 5 parts at -1 to -3%
CMRR	few with hi initial values decreased	few with hi initial values shifted
VOP	very little change	few parts +/- 30 mV
GBW	+1 to 2%	-1 to -3% typ. #4682 -4%, 5 parts no change
TEST	Test Lot 8A, Plastic Control Group	Test Lot 13A, Plastic
PSRR	+/- 300 nV/V	+/- 300 nV/V
ICC/IEE	+1 to +3%	+1 to +3.5% grouped by S/N
VIO	+/-20uV, tight distribution	+/-25uV, tight distribution
IIB	2ppts,+500pA; most -.5 to -1 nA.	+100 to -600 pA, dev #2 up to +2 nA
IIO	+/-400pA max	+100 to -800 pA, dev #2 up to +4 nA
Gain	13 parts big compr decr; rest normal decr	compressive decrease
Slew rate	+1 to +4% (prop to ICC)	+1 to +4% (related to ICC)
CMRR	few with hi initial values decreased	few with hi initial values shifted
VOP	very little change	very little change
GBW	very little change	very little change
TEST	Test Lot 8A, Ceramic Control Group	Test Lot 13A, Ceramic
PSRR	+/- 300 nV/V	+/- 400 nV/V with 2 outliers
ICC/IEE	+0.5 to +2%, 13 parts no change	-2 to -4%, 5 parts increased (+1%)
VIO	+/-20uV typ	+/-30uV, tight distribution
IIB	+/-200pA max	+/-200pA max
IIO	+/-200pA max	+/-200pA max
Gain	both + and - small changes. No compression	Most increased, no pattern
Slew rate	+1 to +3% (prop to ICC), 13 parts no change	-2 to -5%, 5 parts increased (+1.5%)
CMRR	few with hi initial values decreased	very few with hi initial values shifted
VOP	very little change	very little change
GBW	small incr, correlated to ICC	small drop, 5 parts with small increase
TEST	Test Lot 8A, Plastic Control Group	Test Lot 13A, Plastic
PSRR	+/- 300 nV/V	+/- 300 nV/V
ICC/IEE	0 to +2% typ, 6 parts small decrease	+1.5 to +3.0%
VIO	+/- 25uV typ, 3 parts > +50 uV	+/- 30uV typ, 3 parts up to +/-55 uV
IIB	+/- 500 to 1000 pA max	-100 to -800 pA
IIO	+/-500pA max	+200 to -500 pA
Gain	fluctuated a bit	fluctuated a bit
Slew rate	0 to +3%, Correlated to ICC	+1.5 to +3.0%
CMRR	few with hi initial values decreased	few with hi initial values shifted
VOP	very little change	very little change
GBW	0 to +1.5%	0 to +1.5%
TEST	Test Lot 8A, Ceramic Control Group	Test Lot 13A, Ceramic
PSRR	+/- 200 nV/V	+/- 300 nV/V, 2 parts at +/- 500 nV/V
ICC/IEE	+0.5 to +2%,	-1 to -2.5% typ, 5 parts +1 to +2.5%
VIO	+/-20uV typ; 4439 +50 uV	+/-60uV typ; 2 parts +80 uV, 1 part -180 uV
IIB	+/-200pA typ, few at +/-500pA	+/- 300 pA with one outlier
IIO	+/-200pA typ, few at +/-400pA	+/- 350 pA with one outlier
Gain	fluctuated a bit	fluctuated a bit
Slew rate	+1 to +3% (prop to ICC)	-1.5 to -3.0% typ, 5 parts +1.5 to +2.5%
CMRR	Few with hi initial decreased	few with hi initial values shifted
VOP	very little change	very little change
GBW	+1 to 2%	-0.5 to -1.5% typ, 5 parts no change

Figure 9.4-1: Summary of Wideband Parametric Test Results

coupled to a right angle gear reduction drive that allows slow rotation rates from approximately 1/15 rpm to 10 rpm to be accurately programmed. The motor and gearbox sit on top of the chamber and the gearbox output shaft is supported within a tubular housing by a bearing at each end. The shaft and shaft housing protrude through the ceiling of the chamber and a fitting on the end of the shaft holds the paddle blades. The shaft housing has a rotating EMI gasket that prevents EM leakage past the shaft and out of the chamber. The 4 rectangular blades, approximately 24" long by 16" wide were fabricated from surplus honeycomb aircraft floor panels and flame-sprayed with a metallic coating. The blades were set to different angles between vertical and approximately 45 degrees from vertical, to improve mode stirring within the chamber. A two-view layout of the chamber is shown in Figure 10.0-1. The paddle was turned at 1/4 rpm during most of the testing to minimize wear on the rotating EMI shaft seal. The chamber was tested for EM leakage before the start of the tests and following test periods four, eight, and 11, and there was still negligible EM leakage after more than 120,000 rotations of the EM seal after test period eleven. The floor, the outside walls, and the top of the chamber were insulated with rigid polyurethane foam panels, and heating was provided by two thermostatically controlled electric heaters in order to raise the chamber temperature to +85° C (+185° F) for the life tests. The heating apparatus for the reverberation chamber is shown in Figure 10.0-2

RF power for the baseline and reliability tests is provided by a pulsed RF amplifier, which is believed to have certain advantages over a CW amplifier, for our test objectives. The test equipment used to generate the RF power for the testing is shown in Figure 10.0-3. The RF signal enters the chamber via an bulkhead coaxial fitting and is launched onto a long-wire antenna which is constructed of 10 gauge aluminum wire. The antenna is held approximately 8" from the chamber walls by stand-offs and it is terminated in a 50-ohm load. The launch region of the antenna is held in shape by a piece of rigid polyurethane foam. The routing of the long wire antenna is also shown in Figure 10.0-1.

### **10.1 Test Chamber Shielding and Tuner Effectiveness Testing**

The shielding effectiveness of the empty stirred mode reverberation chamber was tested to the requirements of NSA 65-6 and was found to have plane wave shielding effectiveness of greater than 100 dB from 500 MHz to 10 GHz. After drilling holes and installing the filter connectors and shielded cable assemblies into the connector panel assembly and installing the mode stirring motor and shaft assembly, the shielding effectiveness of the stirred mode chamber was measured again. With the filter connectors mounted in the feed-through panel, the shielded cables attached to the connectors, and the EM gasket installed between the shaft and the bushing of the stirrer paddle, the shielding effectiveness was found to be between 45 dB and 60 dB from 400 MHz to 10 GHz. Although the shielding effectiveness of the finished chamber is less than the chamber without the test penetrations, the shielding is adequate to assure that the "Q" factor of the chamber is not below what is required to meet the qualifications for a tuned mode chamber.

The chamber was also tested for shielding effectiveness following the eighth and eleventh reliability tests, and it was found to still meet the shielding effectiveness level measured for the modified chamber. The report of this shielding effectiveness test is shown in appendix V. According to

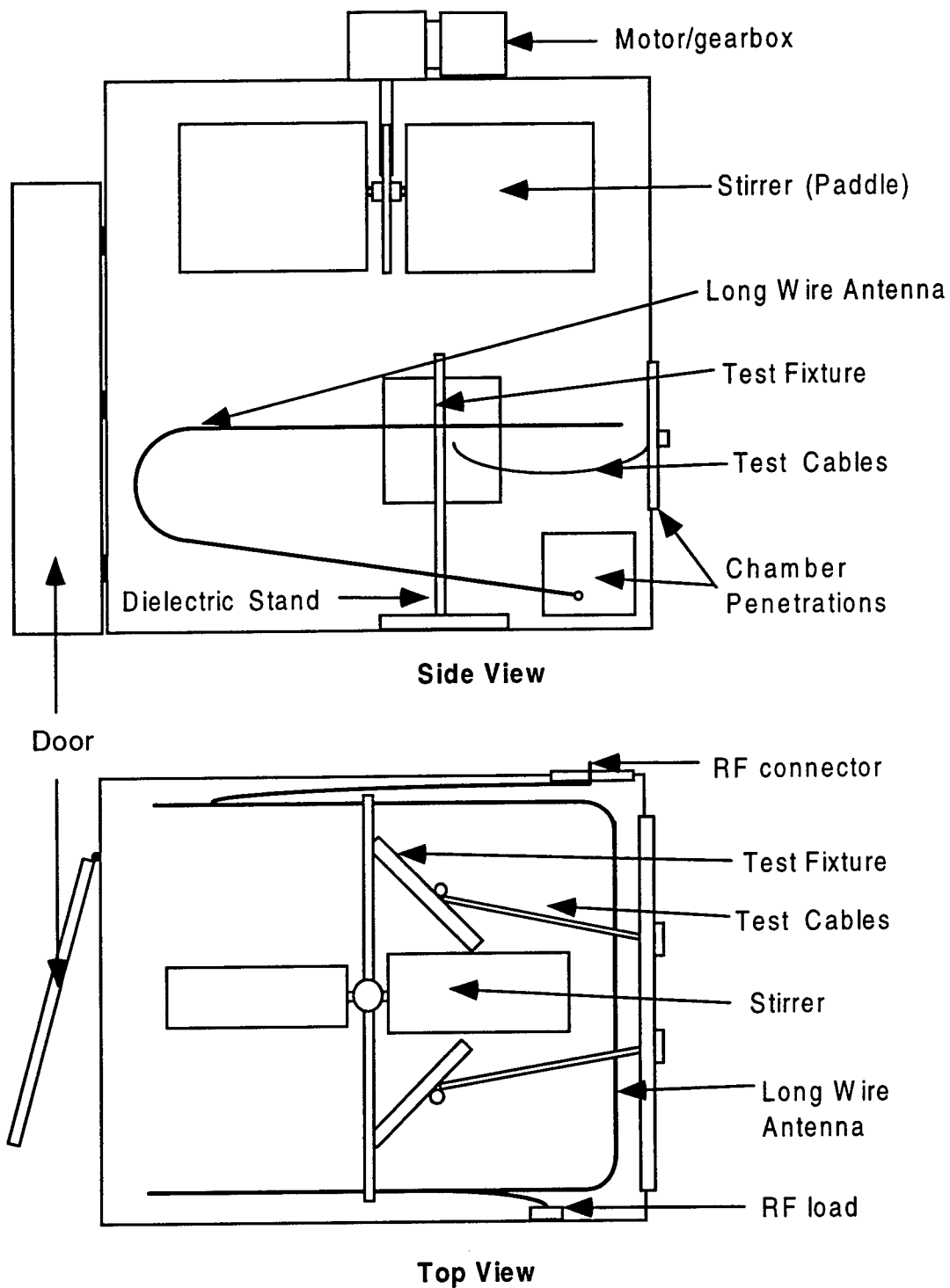

Figure 10.0-1: Reverberation Chamber Setup for Radiated Susceptibility Testing

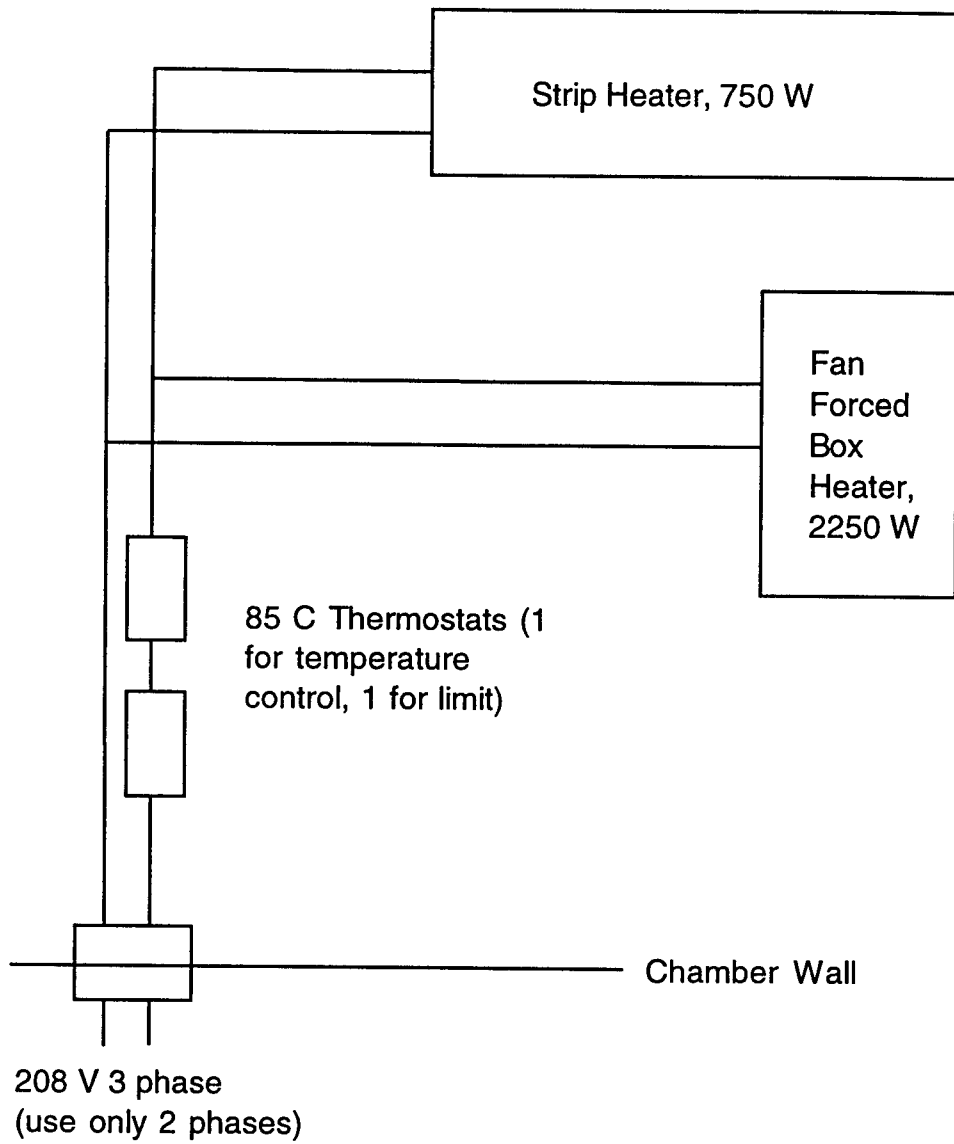

Figure 10.0-2: Heating Apparatus for Reverberation Chamber

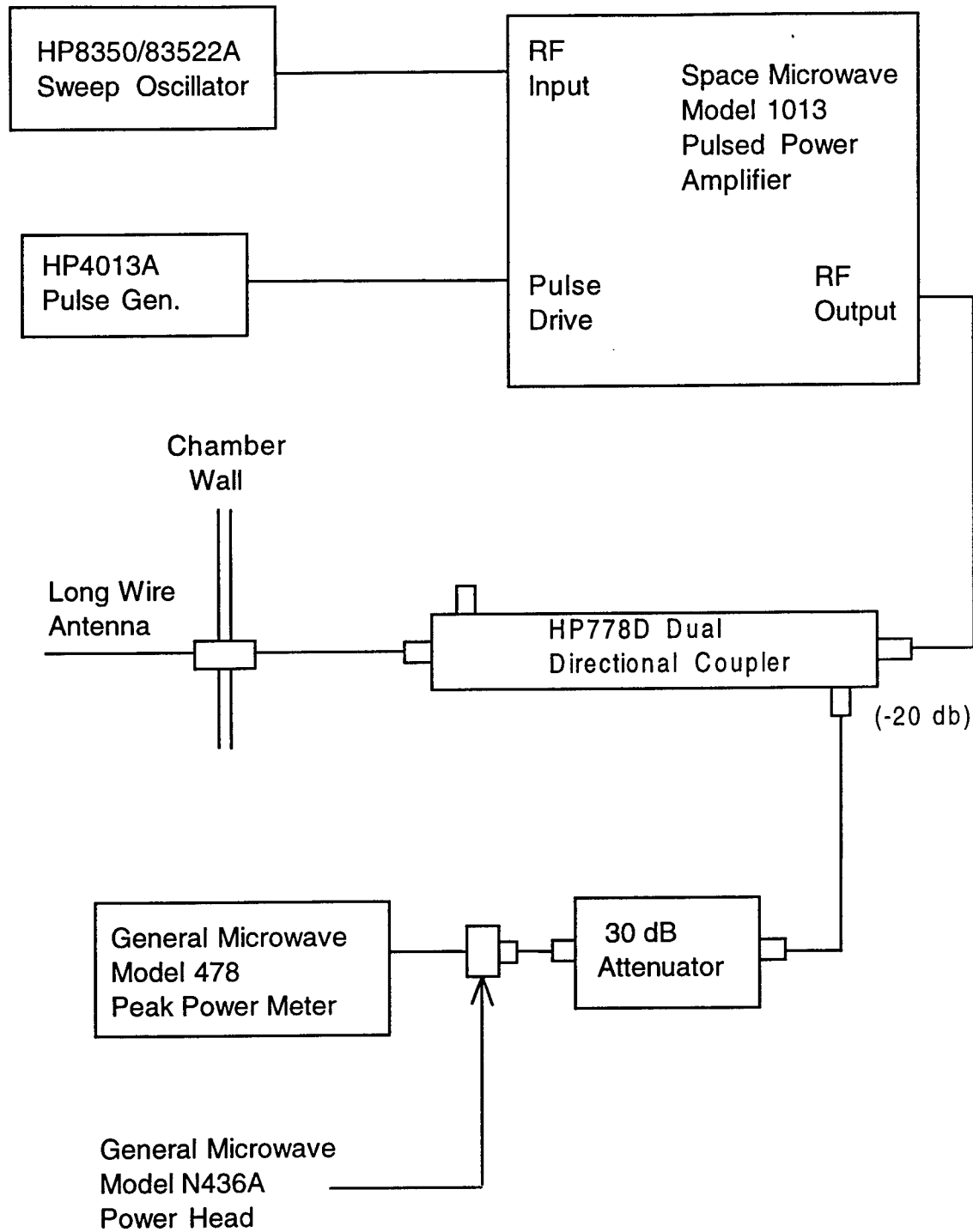

Figure 10.0-3: RF Signal Generation Equipment for EMESR Testing



the National Institute of Standards and Technology (NIST) criteria a good reverberation chamber should have a stirring ratio, which is the difference between maximum and minimum signal strength over a complete paddle rotation, of at least 20 dB. In tests performed on the chamber the 20 dB stirring ratio was met. Upset patterns during RF testing also verify a good stirring ratio for this chamber.

### **10.2 Long Wire Antenna Installation and EM Field Mapping**

Part of setting up the chamber includes installation and final positioning of the long-wire antenna, which provides power to the chamber. For most of its length, the antenna is held away from the wall of the chamber by 8" long wooden spacers, but in the launch area it is taped to a polyurethane foam shape that was cut to the calculated launch geometry. When the wire antenna is accurately formed to the launch shape, the VSWR of the antenna is less than 2.0:1 over most of the frequency band from 600 MHz to 3 GHz.

The test equipment setup used to map the chamber is shown in Figure 10.2-1. The bare chamber was mapped at a total of 18 locations; a 3 by 3 matrix of points where each of the test fixtures were to be located. The chamber was mapped as follows: The sensor was placed at one of the test locations, the door to the chamber was closed, and the EM signal was energized. Then the computer would record the field strengths in the X, Y, and Z directions from the sensor measurements. The computer would then command the stepper motor to move the stirring paddles to the next position, and after waiting several seconds for the blades to stop moving, it would read the data from the sensor monitor again. Data was taken at 201 discrete positions for one complete rotation of the paddle, or 1.8° between each position. The summary of the test data for the bare chamber is shown in Figure 10.2-2. The mean signal strength values shown in the summary indicate that the signal strengths do vary somewhat in the chamber, but the test locations in the center of the test board, which are close to where the signal couples into the test fixtures there is less than a 7% difference between the two boards. The bare chamber also meets the 20 dB stirring ratio criteria as shown by the measured data.

The chamber was also mapped with the two test fixtures in place, loaded with test devices, and with DC power applied. Figure 10.2.3 shows the mean field intensities measured in the loaded chamber. Figure 10.2-4 shows a top view of the test chamber, the location of the test fixtures, and where the measurement sensors were located. These measurement locations are different than those for the bare chamber mapping because the boards occupy the space where the sensors were located for the bare chamber mapping. The energy distribution was quite uniform, which gives added confidence in the results from the reliability tests.

### **10.3 E-field vs. Upset Test Data**

A series of tests were performed as part of baseline testing to correlate the mean upset level with the mean E-field strength, in volts per meter, inside the stirred mode chamber. A calibrated log spiral antenna was placed in the center of the chamber in addition to the test fixtures, and the E-field strength was calculated from the RF power measured at the output of the antenna. The computer data acquisition system logged the upsets experienced by the test devices, and the RF power was read and recorded manually because the power meter could not be read by the GPIB bus. Upset and power

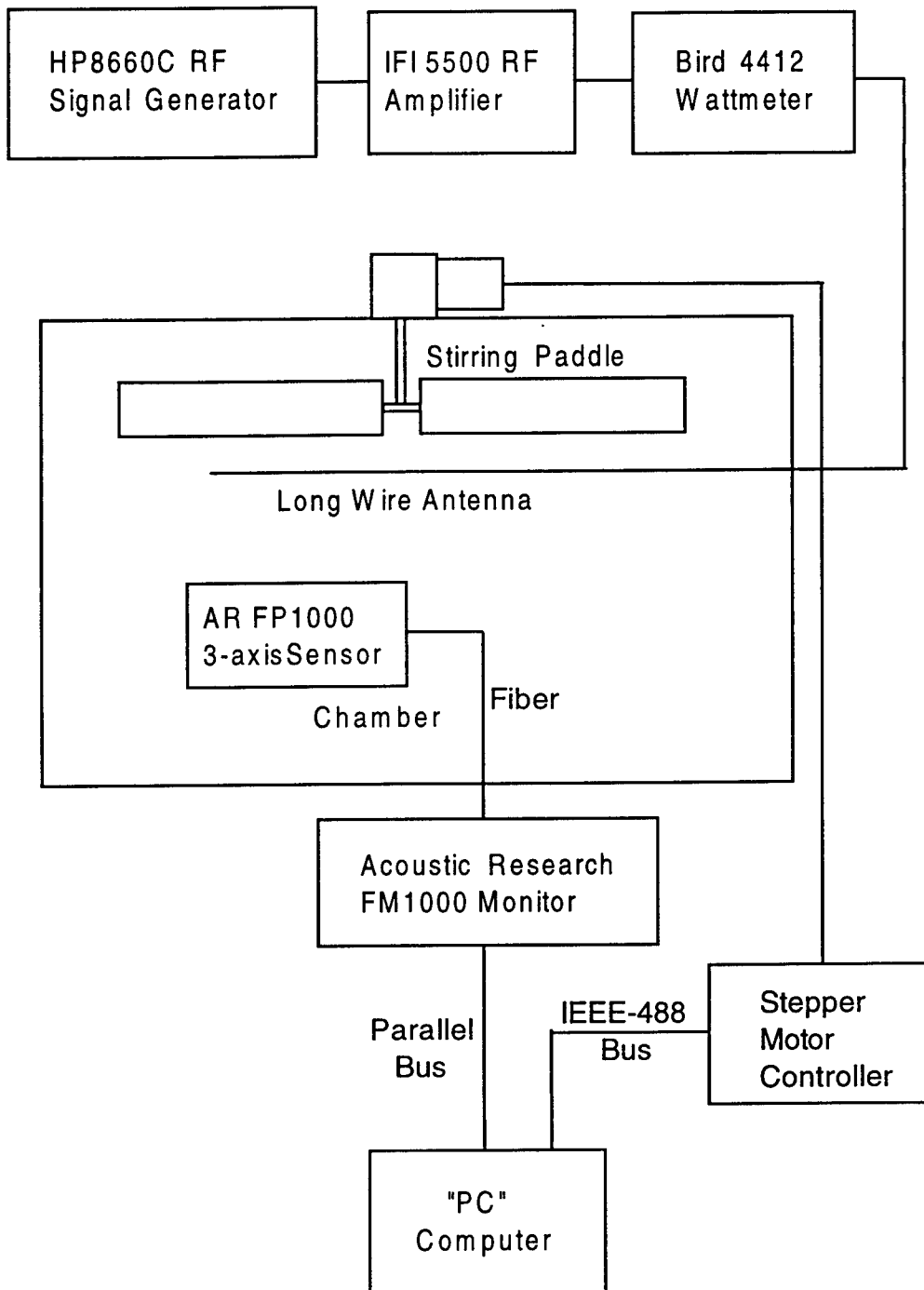

Figure 10.2-1: Test Equipment Setup Used to Map Chamber

Mean Values (E<sub>mean</sub> V/m)

	Left Board			Right Board		
	Left	Center	Right	Left	Center	Right
Top	67.4209	70.1065	75.8985	57.5741	61.406	63.5721
Center	61.4876	67.6398	61.4736	58.6826	63.2418	57.3383
Bottom	72.8955	75.3612	64.6796	60.1532	80.9553	55.005

Stirring Ratios (20\*LOG<sub>10</sub>(E<sub>max</sub>/E<sub>min</sub>))

	Left Board			Right Board		
	Left	Center	Right	Left	Center	Right
Top	18.1503	16.1549	16.9376	17.1705	13.3505	15.2276
Center	13.9201	19.854	20.1848	16.763	17.4899	16.6817
Bottom	21.6584	14.5892	17.5972	15.0666	17.6599	17.4707

Figure 10.2-2: Summary of Empty Chamber Mapping Data

Mean Values (E<sub>mean</sub> V/m)

	Center Plane			Large L-R Plane		
	Front	Center	Back	Left	Center	Right
Top	43.68	43.68	50.69	44.29	43.68	63.57
Center	39.43	38.15	51.99	52.55	38.15	45.91
Bottom	42.29	42.85	41.37	59.94	42.85	43.06

Stirring Ratios (20\*LOG<sub>10</sub>(E<sub>max</sub>/E<sub>min</sub>))

	Center Plane			Large L-R Plane		
	Front	Center	Back	Left	Center	Right
Top	12.94	11.78	12.17	16.02	11.78	12.53
Center	12.96	13.53	11.89	17.31	13.53	14.87
Bottom	10.25	12.59	15.13	15.30	12.59	11.99

Figure 10.2-3: Summary of Loaded Chamber Mapping Data

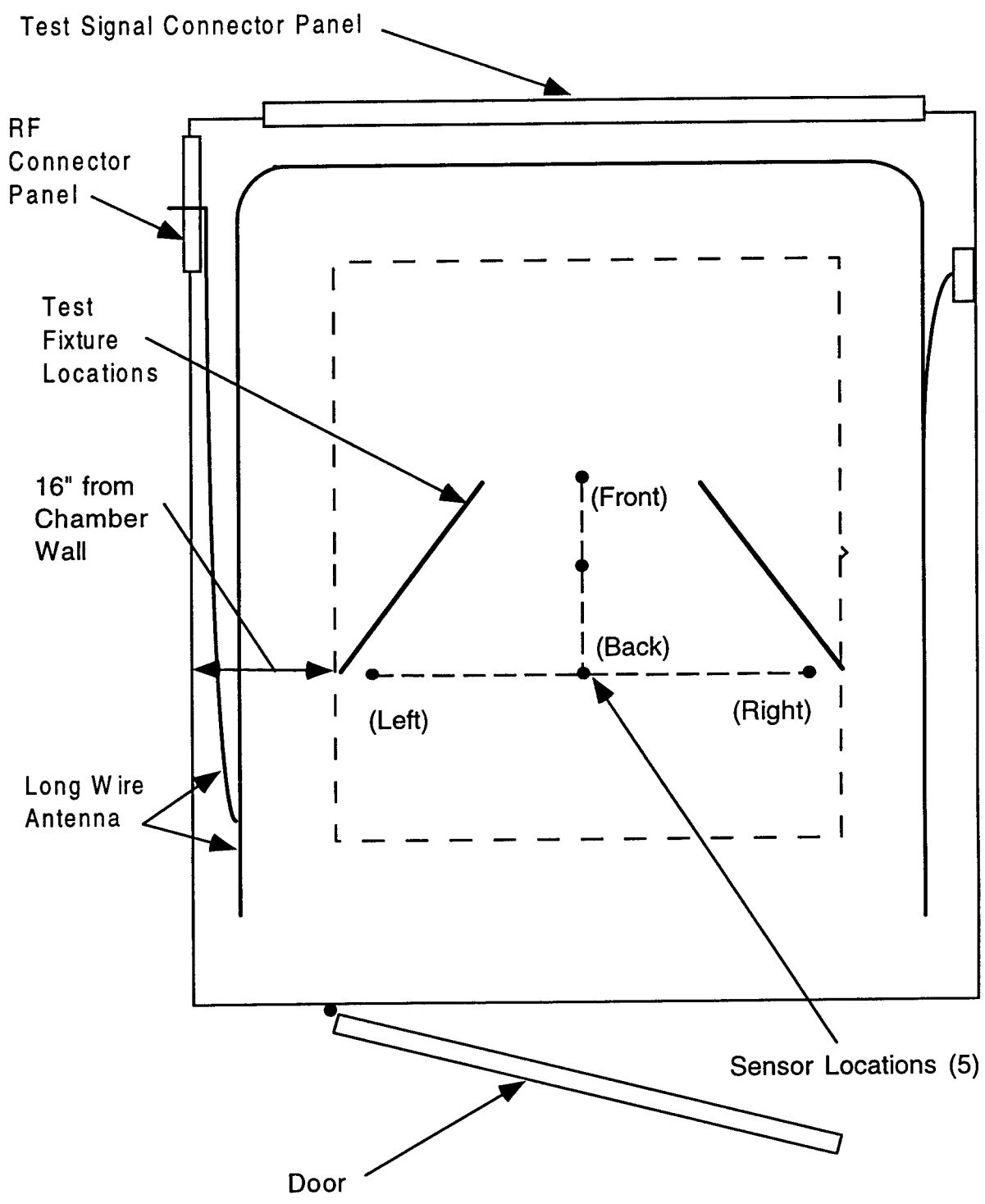

Figure 10.2-4: Sensor Locations for Loaded Mapping of Reverberation Chamber

readings were taken for every 1.8 degrees of paddle rotation. This procedure was performed on analog test devices at power levels of 1000, 500, 250, 125, and 63 watts at 800 MHz and 1400 MHz. This procedure was also performed on digital test devices at power levels of 1000, 500, 250, 125, and 63 watts at 900 MHz and 1700 MHz. The data for each test was put into a spreadsheet where the mean, average, maximum, and minimum values were found for the RF power and device upsets. A summary of the analog E-field strength versus RF power level and frequency data is shown in Figure 10.3-1. A summary of the digital E-field strength versus RF power level and frequency is shown in Figure 10.3-2.

## **11.0 DESIGN AND FABRICATION OF DIGITAL AND ANALOG TEST FIXTURES**

The test fixtures were designed to expose the test samples to the EM environment inside the reverberation chamber over the frequency range of 500 MHz to 18 GHz. Each test fixture is composed of a multi-layer printed circuit board with test sockets, connectors, and other circuit elements. The RF energy couples into the signal and power lines on the surface of the printed circuit board between the central connector and the ring of 100 analog or digital test devices placed around the perimeter of the board. The test devices are mounted in test sockets that allow easy removal and insertion of devices between test runs. The fixtures were designed to allow equivalent RF exposure on all test device input lines, and to place each device in a nearly identical test configuration. Shielded cables and connectors provide signal paths to the external power supplies, test signal generators, and the external test stimulus and data monitoring system. The test fixtures are approximately 17 inches by 19 inches.

### **11.1 Digital Test Fixture Design**

The digital test parts we selected are the CD54ACT74F3E (ceramic) and CD74ACT74E (plastic) flip-flop. The RF exposure testing of these devices consists of applying square waves on the data and clock inputs of the test part as illustrated in Figure 11.1-1. The test stimulus and monitoring system will look for the correct passage of a single output square wave pulse on a continuous basis. An external pulse generator provides data and clock signals. The clear signal will be used to place the test device into a known state at the start of the test. Power and ground are provided using external power supplies. The 54/74ACT74 is composed of two high speed digital flip-flops in a 14 pin DIP (dual-inline package). Each digital test fixture has sockets to hold 100 54/74ACT74 test devices. The signals, which enter each of the two coaxial connectors on the test fixture, are terminated in 50 ohms, then they feed the "D" and "clock" inputs of one flip-flop in each of the 100 test devices. The inputs of the second flip-flop in each package are tied to ground and its outputs are left open. The output of each flip-flop connects to a pin in one of 4 output connectors on the test fixture. The 54/74ACT74 digital circuit requires a single power supply voltage of approximately 5 volts.

The test circuit is implemented for 100 test parts in a geometrically symmetrical configuration on a 16.4" X 18.6" seven layer PCB. A block diagram of the circuit schematic for each flip-flop on the test fixture is shown in Figure 11.1-2. The layout of the top circuit layer, which is signal and power distribution from the central connector to the 100 test devices, is shown in Figure 11.1-3. The bottom

RF Frequency	RF Power	Upsets					E Field Strength (V/M)			
		ave	max	min	mean	total	ave	max	min	mean
800	1000	44	67	11	44	100	162	336	50	158
800	500	32	60	6	32	88	142	307	35	137
800	250	19	37	2	20	71	88	194	35	87
800	125	9	29	2	7	42	70	162	22	71
800	63	3	11	2	2	29	40	90	11	35
1400	1000	27	62	7	26	97	222	447	71	224
1400	500	8	25	2	7	75	152	354	50	141
1400	250	3	10	2	3	52	120	274	32	112
1400	125	2	2	2	2	3	74	141	32	71
1400	63	2	2	2	2	2	49	100	22	45

Figure 10.3-1: Analog E-Field Strength vs. Upset Summary Data

RF Frequency	RF Power	upsets					E Field Strength			
		Ave.	Max.	Min.	Mean	Total	Ave.	Max.	Min.	Mean
900	1000	39.1	91	1	38	100	147.1	322.5	41.6	131.7
900	500	24.8	86	0	23	100	95.0	199.7	41.6	93.1
900	250	13.3	69	2	11	100	66.1	155.8	13.2	58.9
900	125	8.1	20	1	8	100	48.7	102.0	18.6	45.6
900	63	2.6	11	0	2	100	29.3	65.8	9.3	26.3
1700	1000	14.7	31	5	14	100	180.0	367.0	62.9	178.0
1700	500	4.9	17	0	4	77	131.9	344.8	48.8	125.9
1700	250	0.5	5	0	0	100	96.2	199.1	39.8	89.0

Figure 10.3.2: Digital E-Field Strength vs. Upset Summary Data

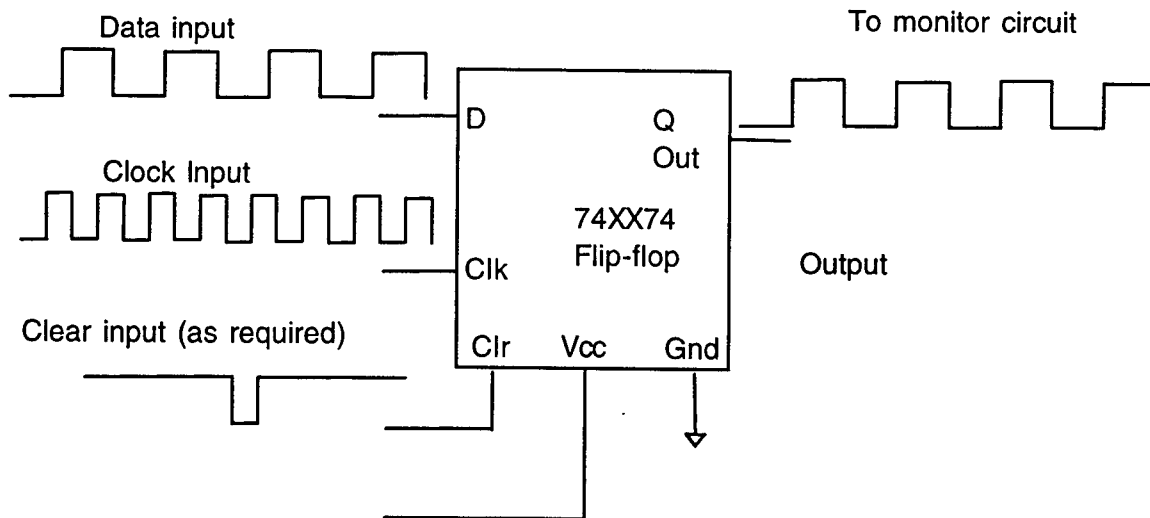

Figure 11.1-1: Digital Device (54/74ACT74) Test Circuit

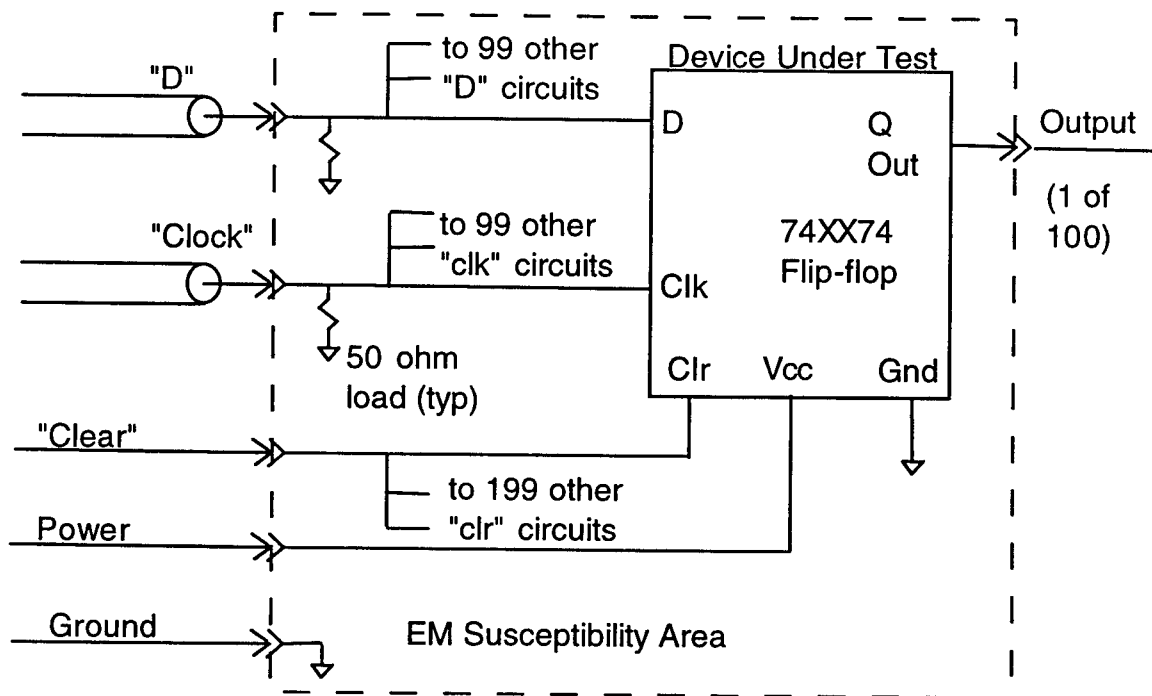

Figure 11.1-2: Circuit Diagram (1 of 100) as Implemented on Digital Test Fixture

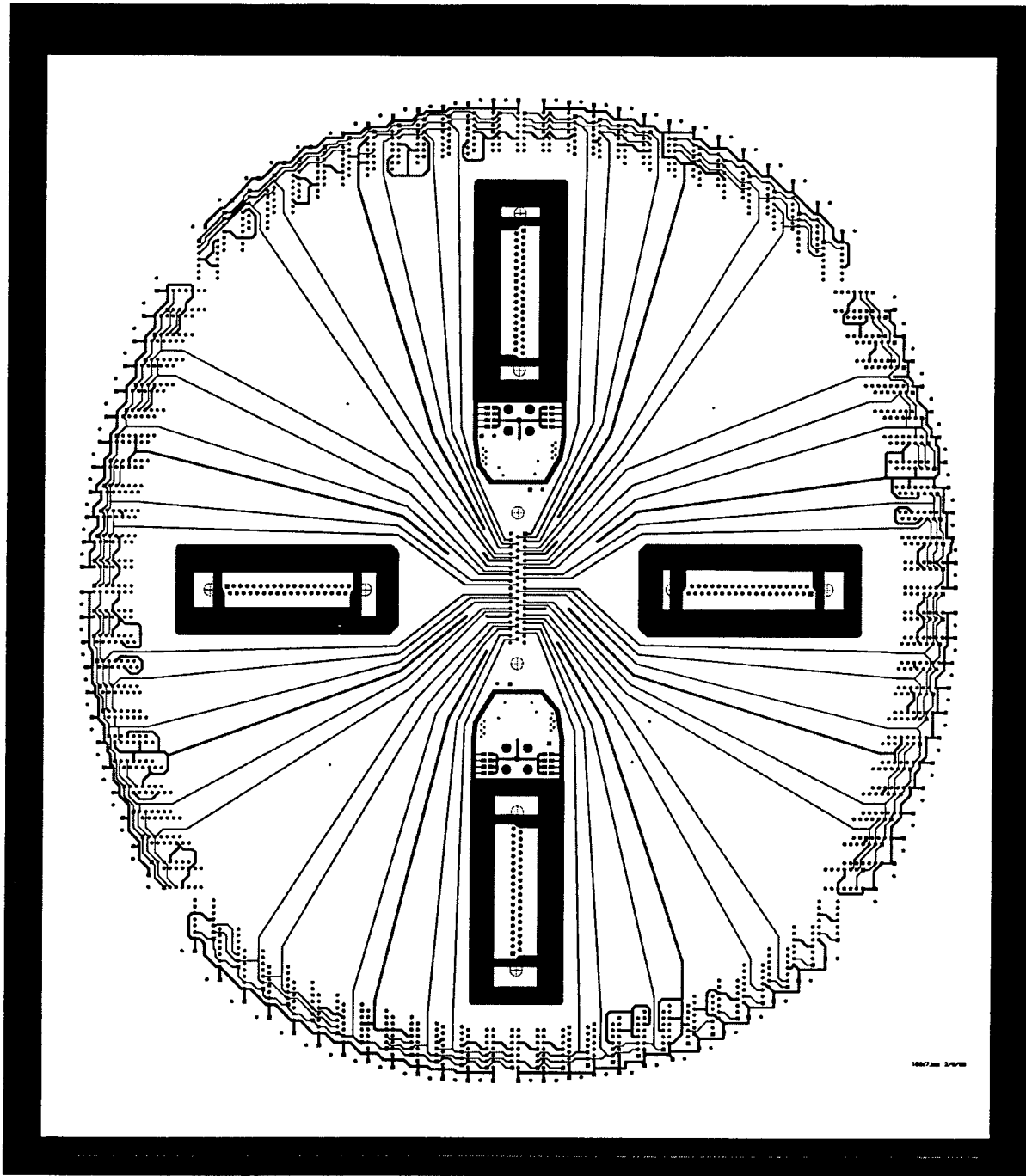

Figure 11.1-3: Top Circuit Layer of Digital Test Fixture.



circuit layer, which is the output signal distribution, is shown in Figure 11.1-4. In addition to the top and bottom circuit layers there is a second layer for signal and power distribution, two ground plane layers, and two layers to distribute the "D" and clock signals to the test devices. The complete set of layouts for the digital test fixture PCB can be found in CLIN 2, CDRL A005, System/Subsystem Design Plan.

### **11.2 Analog Test Fixture Design**

We have selected the OP271 operational amplifier as the analog test device. The test fixture is configured as a unity-gain amplifier as illustrated in Figure 11.2-1. The RF exposure testing of these devices consists of applying a square wave to the input of the test part. The test stimulus and monitoring system will look for the correct passage of a single output square wave pulse on a continuous basis. As long as the test device is functional the output signal will duplicate the signal on the positive input. An upset/failure will be detected if the monitor does not see the passage of a single, valid square wave pulse from the test device.

The analog test circuit is implemented for 100 test parts in a geometrically symmetrical configuration on a 16.4" X 18.6" six layer PCB. A block diagram of the circuit schematic for each op-amp on the test fixture is shown in Figure 11.2-1. The analog test fixture PCB layout is simpler than the digital PCB because there is only one input signal per test device and only one signal distribution layer is required.

A block diagram of the circuit schematic for each operational amplifier on the test fixture is shown in Figure 11.2-2. The layout of the top circuit layer, which is signal and power distribution from the central connector to the 100 test devices, is shown in Figure 11.2-3. The bottom circuit layer, which is the output signal distribution, is shown in Figure 11.2-4. In addition to the top and bottom circuit layers there is a second layer for signal and power distribution, two ground plane layers, and one layer to distribute the input signal to the test devices. The complete set of layouts for the analog test fixture PCB can be found in CLIN 2, CDRL A005, System/Subsystem Design Plan.

## **12.0 DEVELOPMENT OF TEST STIMULUS AND DATA MONITORING SYSTEM**

A test stimulus and monitoring system was developed to provide the test stimulus to the devices under test and record the test data. A block diagram of the system is shown in Figure 12.0-1. It consists of an IBM compatible computer with a general-purpose interface bus (GPIB) card, two HP8160 dual pulse generators, two monitor boards, power supplies, and cables. The stimulus and monitoring system is connected to the test fixtures via test cables. Bench power supplies provide regulated DC power to the analog and digital devices under test and to the monitoring boards. An oscilloscope was also used occasionally to observe device input and output signals to verify circuit upsets or failures.

To apply the stimulus to the test devices the computer first sets up the pulse generators with the correct pulse geometry. It does this through the IEEE-488 interface card under program control. After the test is started, the computer commands the pulse generators to transmit their signals to the test

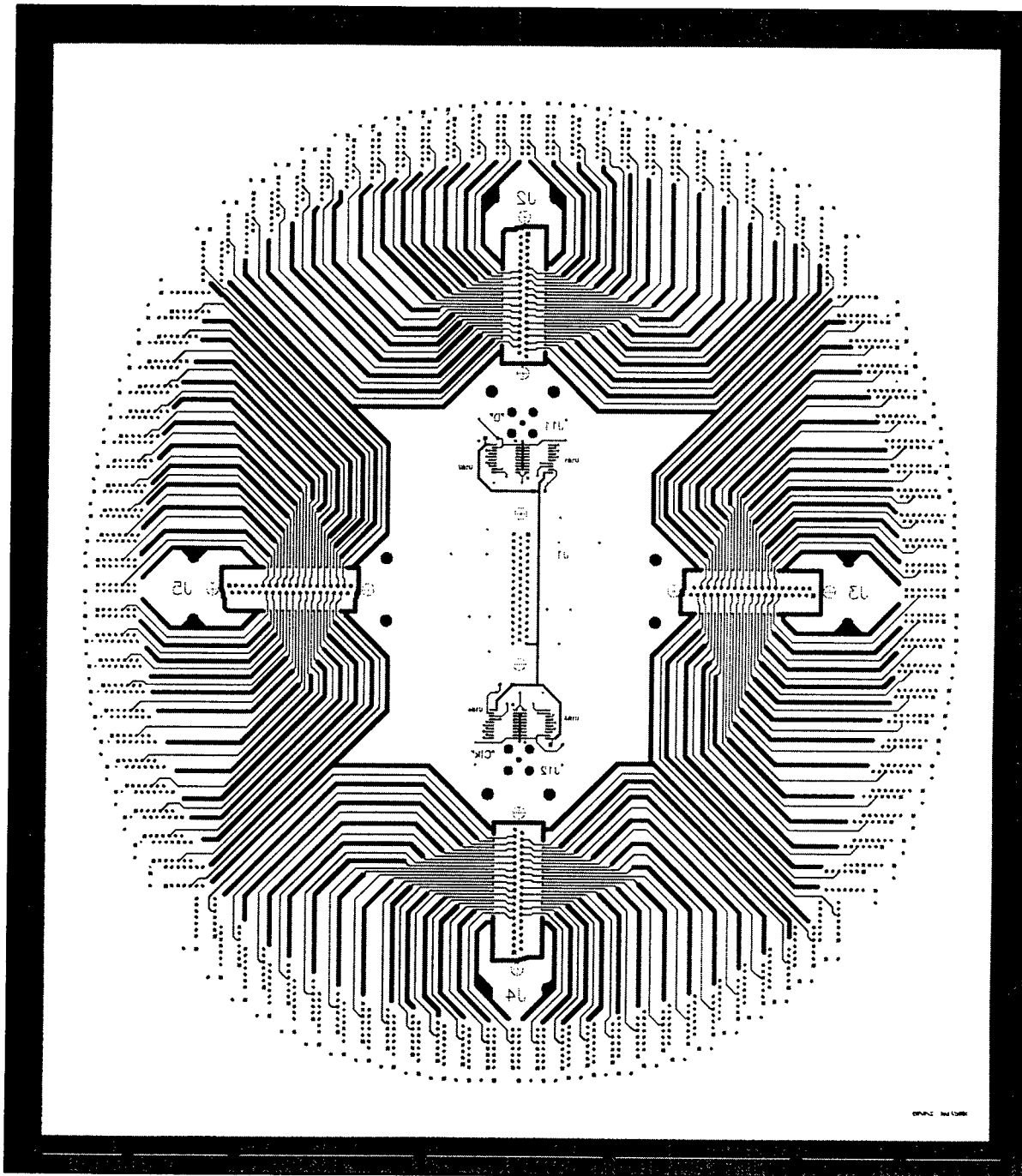

Figure 11.1-4: Bottom Circuit Layer of Digital Test Fixture.

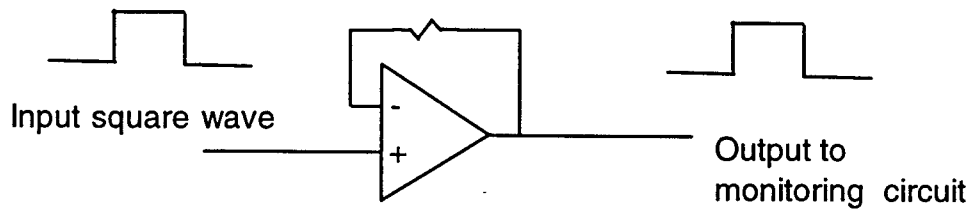

Figure 11.2-1: Analog Device (OP-271) Test Circuit

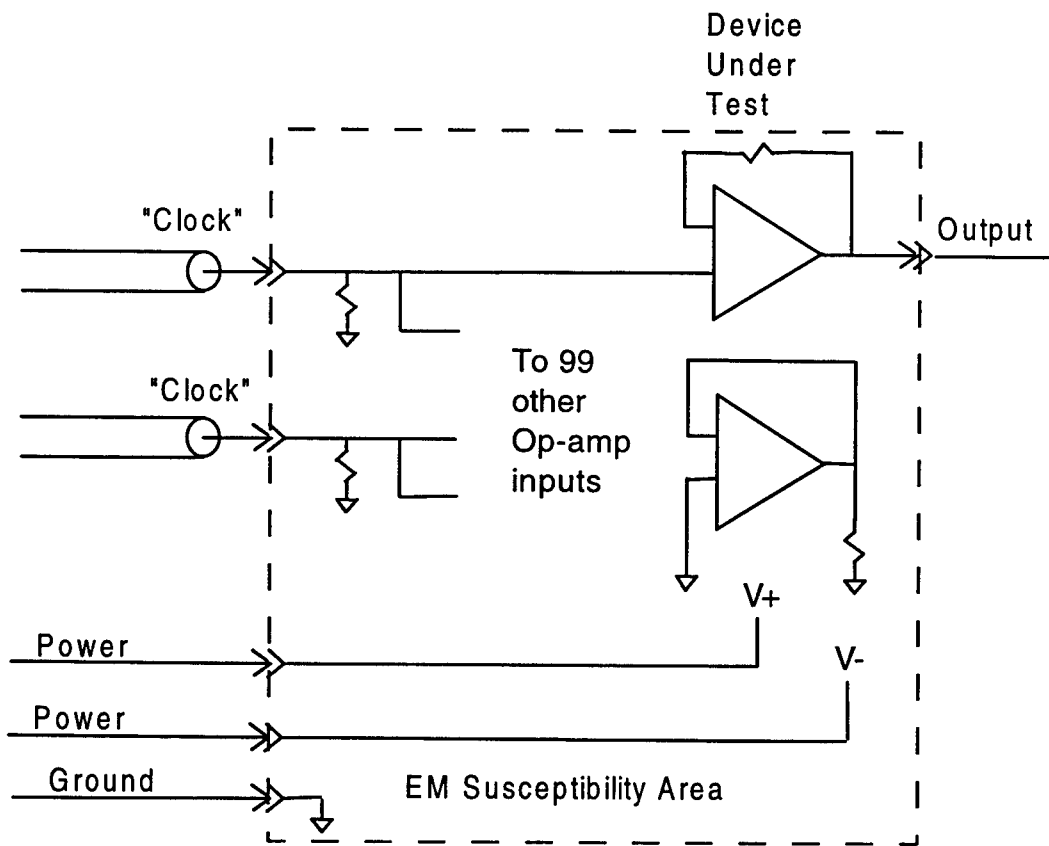

Figure 11.2-2: Circuit Diagram (1 of 100) as Implemented on Analog Test Fixture

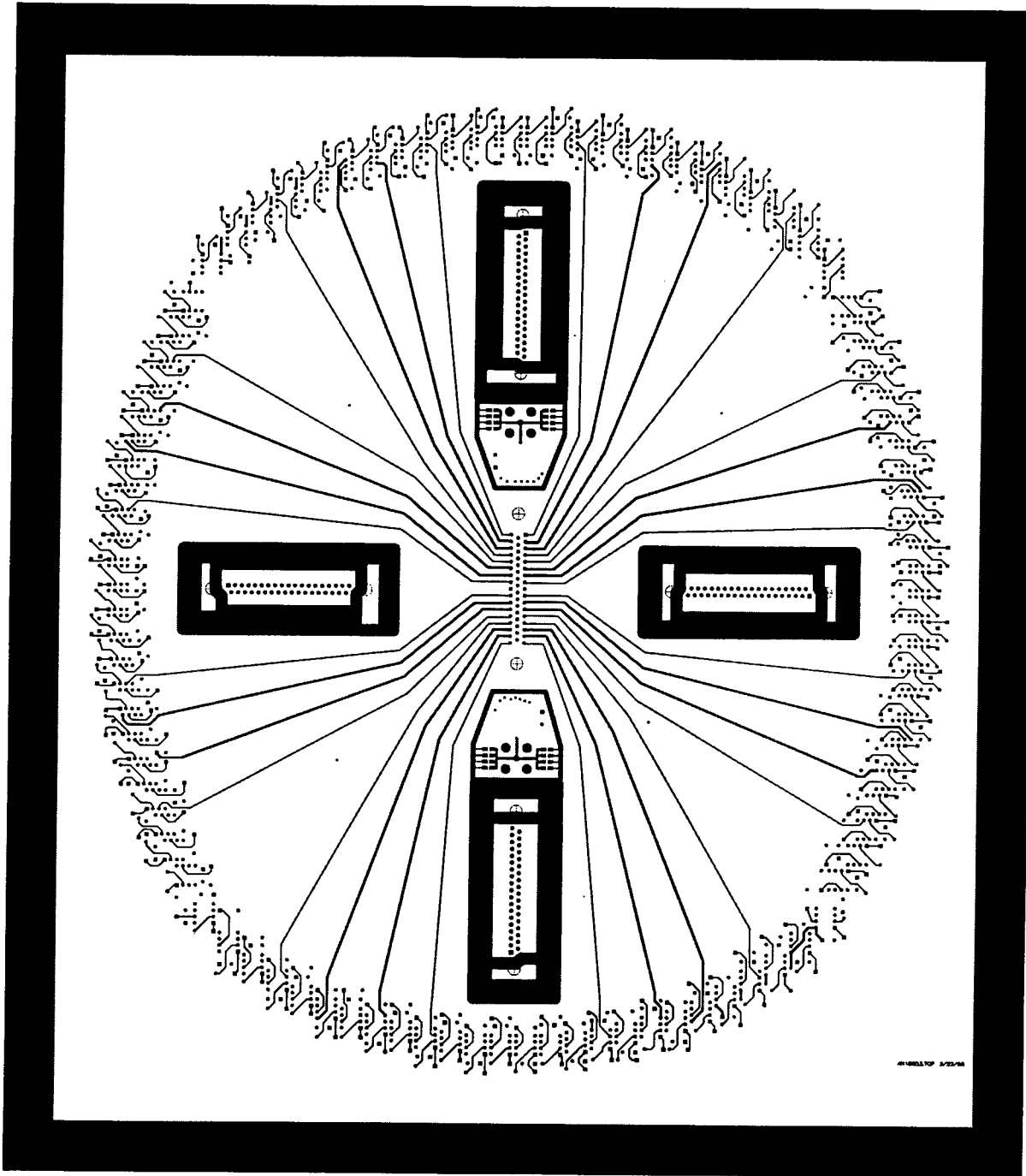

Figure 11.2-3: Top Circuit Layer of Analog Test Fixture

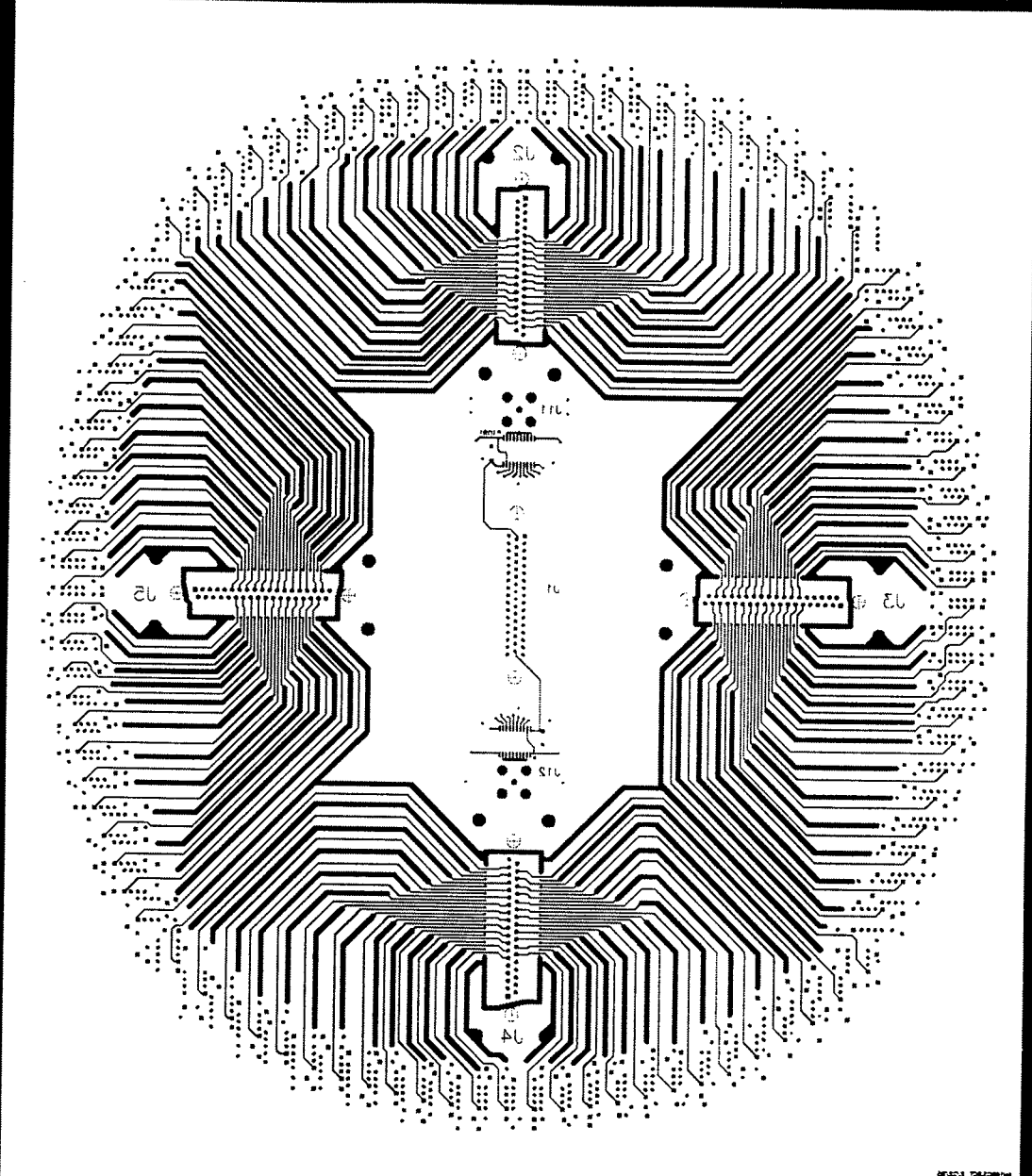

Figure 11.2-4 Bottom Circuit Layer of Analog Test Fixture.

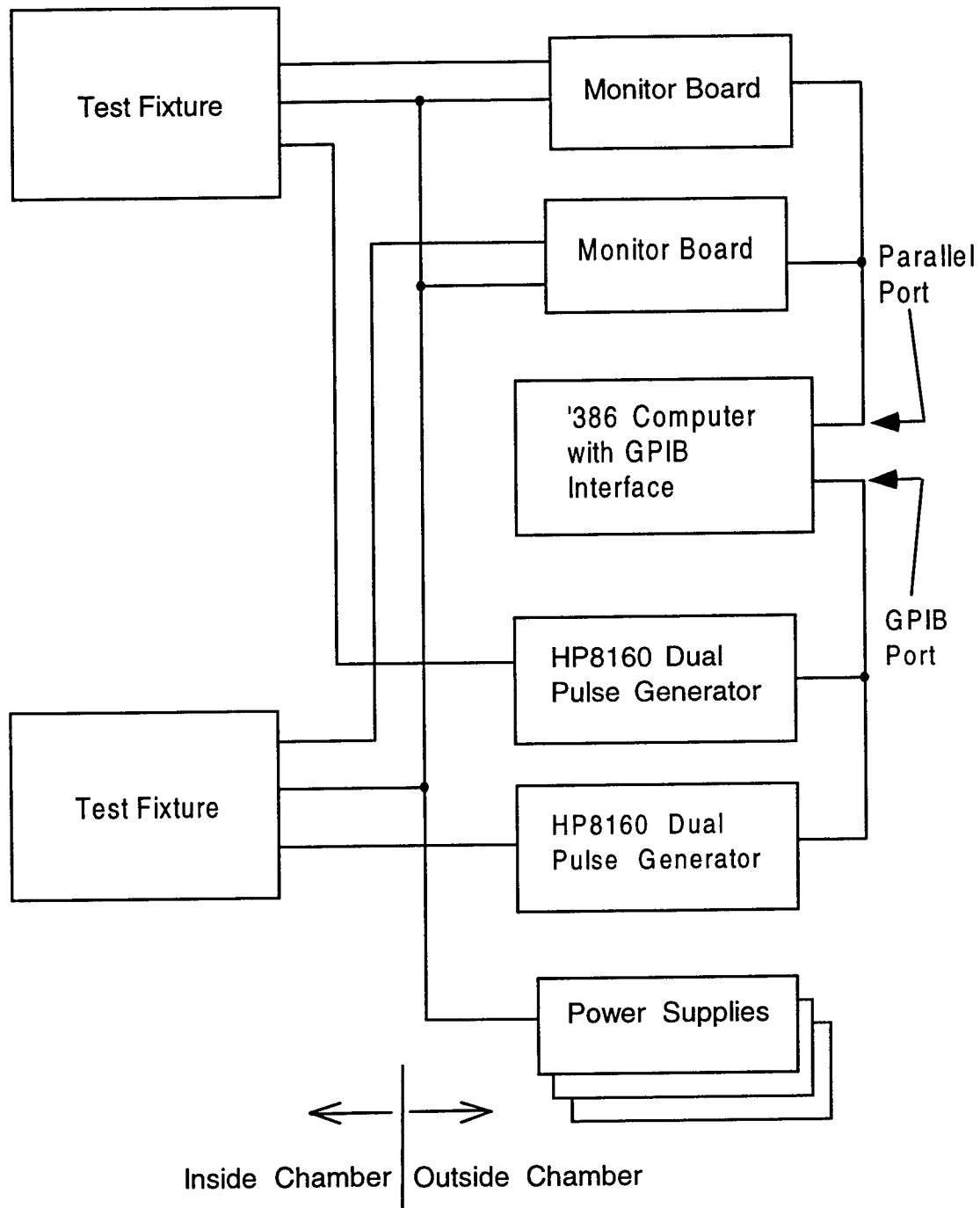

Figure 12.0-1: Test Stimulus and Monitoring System

devices. The monitor circuit then conditions the monitor circuits to look for this pulse in all 200 test devices and determines if the 100 signals it received were correct. The computer then communicates with two monitor circuit boards through the computer's parallel port to determine how many devices were upset. If any devices were upset the computer commands the monitor circuit to dump the contents of its serial register, which contains a record of the devices which suffered an upset. If no devices were upset, the serial register is not copied to the computer. A simplified block diagram of the monitor circuit board is shown in Figure 12.0-2. The computer repeats this process about 10 times a second, then once each second it stores the number of upsets along with the serial numbers of the devices which suffered upsets in a file on the hard drive. The monitor boards were located outside the chamber near its rear connector access panel. The test output signals are carried from the test fixtures to filtered connectors at the chamber wall through shielded cables, and from the outside of the chamber to the monitor boards via a set of unshielded cables. In order to facilitate the tests, computer code was developed to apply the test stimulus and monitor analog devices, and digital devices, and both analog and digital at the same test.

## 13.0 CONCLUSIONS AND RECOMMENDATIONS

### 13.1 Conclusions

The analog and digital test devices that were studied in this contract are affected by electromagnetic radiation. They could be made to upset at fairly modest levels of RF, but they would also recover quickly and completely from the immediate effects of the RF exposure as determined by the measuring tools we had at our disposal. There appeared to be an increase in the instantaneous upset rate of the devices as a function of time. The increase was most noticeable at the beginning of the test, then it tended to level off to a more or less constant rate. The main electrical stress appears to be caused by energy coupled to the printed wiring conductors that are connected to the device, not by the electric field at the device. Thus, the main electrical stress occurs to junctions connected to external pins.

Exposure to electromagnetic energy also affected the measured parameters of the test devices. Parameter shifts were noticed in both the control group and the exposed lots of test devices, and we tried to determine if the parameter shifts experienced by the exposed parts were more significant than those of the control group. There was an increase in the instantaneous upset rate of the exposed devices as a function of time. Initial test data also indicated that the parameter shifts in the exposed parts were greater than in the control group. Over time the change in instantaneous upset rate and in the parameter shifts of the exposed parts slowed somewhat, and we determined that there was not enough test data to predict the device reliability based on shifts in the parameters. The results of the analyses we performed indicated that the data shifts were somewhat random and showed no definite trend toward exceeding any of the manufacturer's specifications but the parameters of the devices exposed to RF radiation did seem to drift more erratically than did the parameter values of the control lot devices. We would therefore conclude that the effects of the electromagnetic energy upon these test devices were very subtle, and no variation was large enough to be interpreted as degradation. We were not able to

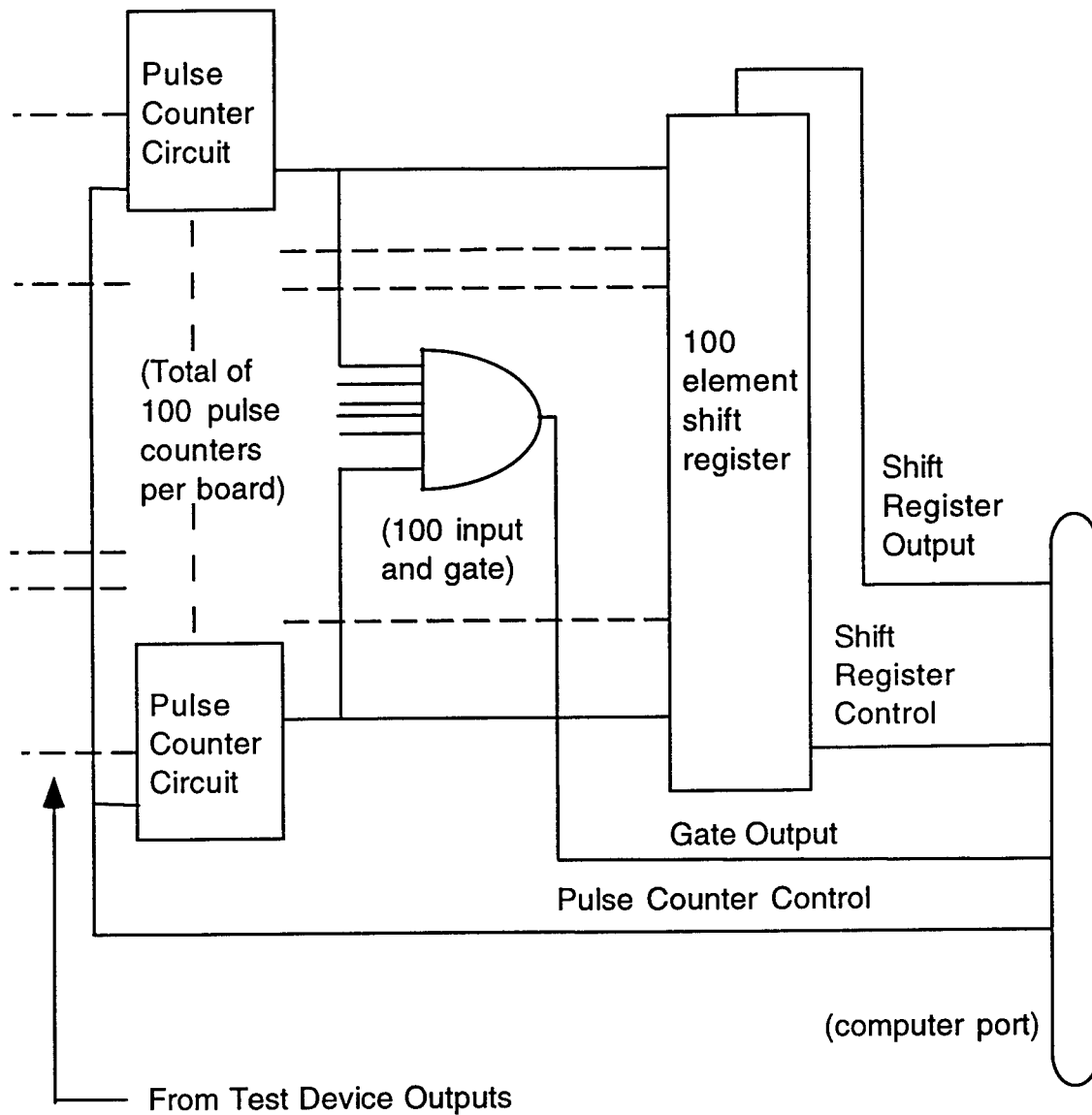

Figure 12.0-2: Block Diagram of Monitoring Circuit



establish a definite relationship between the EM exposure and long term device reliability, although with more testing and analysis, this relationship might be established.

The long-term effect of electromagnetic radiation was the main thrust of this research effort. Formal testing totaled approximately 2.2 million device operating hours, which included 1.58 million hours of radiated electromagnetic testing and 0.58 million hours of thermal and control lot testing. In addition to the formal testing there were over 1.6 million device hours of extended testing, which included 0.87 million hours of radiated electromagnetic testing and 0.76 million hours of control lot testing. There were two device failures, and these occurred in the test groups that were exposed to electromagnetic energy. There were also 4 devices for which the parameters changed enough that they exceeded the manufacturer's specification. We consider these 4 devices to have failed from the standpoint that their operation as part of a system might cause some type of system failure, even though the device might still be operating. Because of the failures it would be reasonable to conclude that electromagnetic exposure has a negative effect on the reliability of these devices. With the number of failures that we experienced during this test, we would like to conclude that the reliability factor of these devices decreased by 2 to 3 orders of magnitude because of exposure to electromagnetic energy. But because the number of test hours was small compared to the intrinsic reliability of the test devices, we don't feel that it would be fair or accurate to quantify the effect. It is possible that these failures would be considered in the "infant mortality" or "beginning of life" region of the device reliability curve and that with more hours of testing the failure rate might decrease to a rate much closer to that of the devices that are operated under normal conditions. We do not believe that enough data has been accumulated to be able to assign a numerical value to the electromagnetic effects on the reliability of the analog and digital test devices. However, we do believe that the effect of electromagnetic radiation on the reliability of electronic devices is real and should not be discounted.

A number of conclusions were drawn from acceptance test results. For the analog testing, test periods 1 through 4, three test devices which were exposed to RF failed the manufacturers specification. Part 3223 (plastic) failed the power supply rejection ratio test at -40 C, and parts 4217 and 4224 (ceramic) failed the input offset voltage specification at room temperature. There were no specification failures for the control group. An analysis of the analog parametric test results showed that typically the test devices exposed to EM radiation had higher parameter shifts and included a higher percentage of test devices whose parameters fell outside of the major trendlines than did the control group. Most of the parameter changes to test lot 3 occurred following the first and second tests, and by the 4th test, not too many additional changes were noticed.

For digital testing, there were no outright failures in the digital control group but there was one part in test lot 3D which failed the  $V_{OH}$  and  $V_{OL}$  tests (output would not transition between high and low). In most cases the devices exposed to EM radiation changed more than the control group, but in several instances the control group parameter shifts were a little bit larger than those of the EM radiated group. In the timing measurements more devices that were exposed to EM radiation had large shifts or step increases in timing parameters than the reference group, and more in the control group had small timing shifts or step decreases than the EM radiated parts.

For thermal and life testing, the parameters of the devices exposed to EM radiation experienced a little more change than did those simply exposed to the increased temperature. The devices exposed to the higher temperature also changed a little more than did those of the analog control group, which was previously tested in a room temperature low EM environment. The output voltage, common mode rejection ratio and gain changes were about the same for all test lots without regard to EM exposure or length of exposure to the 85 degree C temperature. The power supply rejection ratio, the plastic device room temperature input bias current test, and the slew rate and power supply currents for the plastic devices all changed more in the reference test lot than in the thermal test and life test lots. This is opposite of what we would have expected, but the parameter shifts remained well within specification, and are all fairly small. For the remainder of the test parameters there was a high degree of correlation between parameter change and exposure to EM radiation and temperature. The net effect we observed was that the tests parameters of the thermal and life test devices, lot 10, appeared to change more than the thermal test devices, lot 9, which appeared to change more than the short-term EM exposed devices, lots 11 and 12, which appeared to change more than the control group devices, lot 8. The only minor discrepancy is that test lot 9, which was subjected to an 85 degree C thermal environment, but no EM radiation, appeared to change more than lots 11 and 12, which were subjected to an EM environment at 85 degrees C. But the parts of lot 9 were in test for 4 periods, a total of 120 days while test lots 11 and 12 were only in test for 30 days each. This indicates that length of exposure is a factor. A comparison between the thermal and life tests and of the analog tests, especially between lot 10A with lot 3A shows that the data shifts are of approximately the same magnitude. This would indicate that the effect on device parameters is not thermally related, but related more to the time and intensity of exposure to electromagnetic energy.

For wideband testing, the test lots exposed to EM radiation had higher parameter shifts, and also had more devices whose parameters were outside of the major trend lines, than did the control group. The digital devices exposed to wideband EM radiation had more devices with large shifts or step increases than did the control group, but there were several parameters for which the results were not so clear-cut.

The failure analysis (see section 3.5) performed on the failed digital parts did not offer any conclusions other than the fact that several circuits on the die were shorted to the positive power supply terminal and that the ground lead bond wire had melted, apparently due to over current stresses. It was not possible by the visual inspection method to determine any degradation to the parts that had experienced parameter shifts.

### **13.2 Recommendations**

Additional radiated testing is needed to be able to further characterize the behavior of the electronic devices in an electromagnetic radiation environment. The test devices need to be exposed to electromagnetic radiation over longer periods of time to either establish or discount the subtle trends that were noticed in this study. Testing needs to be done with continuous wave (CW) RF signals as well as low duty-factor pulsed CW waveforms to differentiate between stresses that might be thermal in nature and those that are not. If all other test conditions were equal, CW signals would normally induce

more heating in a device than would a pulsed waveform and high power low duty-factor pulsed waveform would impose higher voltage stresses than would the CW waveform. All of our testing was performed using a pulsed CW RF power source.

An analysis to predict the voltages induced in the circuit traces should be performed. This would determine the level of stress on the device. Junction temperatures could be calculated using the thermal properties of the device. Since the excitation is a transient pulse of about  $1 \mu\text{s}$  duration, a transient thermal analysis should be performed. The rate at which energy is deposited into the device is much faster than the rate of thermal diffusion. The junction temperature of p-n junctions inside the device can be expected to have a much higher temperature than the case.

Since the main effect of the radiation is energy coupled to the external wiring connected to the device, direct current injection tests might be beneficial. This would provide good control over the test conditions. The voltage drive would be known and controllable. Some or all of the pins could be driven. The degradation levels could be related to exposure. Analysis would relate the currents on the external wiring to an external field environment.

Since the semi-conductor junctions that are connected to external pins are stressed the most, they are most likely to be degraded. Degradation may be detected by making electrical parameter measurements on those pins to locate suspected damaged areas. Once potential damaged areas are identified, the internal inspection failure analysis may be used to validate the suspected damage, although internal inspection may not be able to identify the suspected damage. The issues associated with detecting latent damage due to electrostatic discharge (ESD) are similar to those on this program. The ESD community has used internal inspection failure analysis to show damage to a device that still meets its manufacturers specification. This same techniques may be applied to parts damaged by electromagnetic exposure. (Reference 14.3).

#### 14.0 REFERENCES

14.1 Erickson, Grant J., Pesta, Anthony, Mode-Stirred Reverberation Chamber Testing for Long Term Exposure Electromagnetic Effects on Discrete Analog and Digital Electronic Devices, Digest of 1997 Reverberation Chamber, Anechoic Chamber, and OATS Users Meeting, Vail, CO, April 28 to May 2, 1997.

14.2 Erickson, Grant J., Pesta, Anthony, Long Term Exposure Electromagnetic Effects on Discrete Analog and Digital Electronic Devices, Government Microelectronics Conference (GOMAC) 1997 Digest of Papers, p 247.

14.3 Research and Development Reliability Test Report (Analog Tests), CLIN 0002, CDRL A008, 22 October 1996. Submitted to Rome Laboratory under contract F30602-94-C-0121

14.4 Hellstom, Sten, "ESD The Scourge of Electronics" Springer-Verlag, 1998

14.5 Ricketts, L. W., Bridges, J. E., and Miletta, J. "EMP Radiation and Protective Techniques" John Wiley & Sons 1976

## Appendix A:

### Mathematical Approach to Reliability Calculation

#### 1.0 Summary

The reliability modeling consisted of studying and analyzing the effects of the EM radiation exposure in terms of the statistical variation of the integrated circuit performance parameters and the conceptual development of electronic device reliability models. Electronic device reliability models employ statistical circuit parameters and EM effects, the integrated circuit parameter means and standard deviations, and associated sensitivity derivatives for the reliability of the electronic devices.

The conclusions of the study, in summary, are that working reliability models can be developed for electronic devices that predict the reliability of individual parts and systems of parts in environments that are exposed to electromagnetic radiation. The nature of a working reliability model is that initially, during its early development, the error sensitivity derivatives for predicted device reliability can be estimated by using whatever data and estimators are available. As more experience is obtained with the particular electronic devices, then the quality of the sensitivity derivative estimates is improved and the associated  $1 - \alpha$  confidence intervals for the predicted reliability of the electronic devices is increased.

For example, the reliability of an electronic device in an electromagnetic effects environment is said to be predicted accurately with a confidence of  $1 - \alpha$ , i. e. is claimed to be within a set of stated limits with a percentage confidence of  $1 - \alpha$ .

#### 1.1 Statistical Significance

The concept of a specified confidence interval and the computed range within which an associated standard deviation  $\sigma$  falls, provides a means with which to define and measure the statistical significance of a result and conclusion. Further, statistical significance as presented in this document is a statistical data quality indicator for sampled statistical data.

#### 1.2 Reliability

A quantitative reliability assessment covers the probability of occurrence and the magnitude of the consequence of failure.<sup>2 p. 45-8</sup> Assessment of failure consequence is probably more the task of design, but it cannot be neglected in a reliability assessment, particularly when assigning reliability targets or allocating reliability to subsystems. Refer to the reference for more insight and details.

#### 1.3 Summary

The conclusions of the study, in summary, are that working reliability models in accordance with the techniques and results defined in this report can be developed for electronic devices that predict the reliability of individual parts and systems of parts in environments that are exposed to electromagnetic radiation.

#### 2.0 System Error Analyses in General

A systems error analysis examines the ability of a system to meet specification requirements for various functions. Generally, specification requirements are dictated by specification documents, analyses reference pertinent specification paragraph numbers, and in conclusion the results of the system error analyses define and confirm the predicted performance of the system. Typically effects that are not accounted for by analyses are listed, and could include items such as, for example, inter-instrumentation cabling, different ground plane potentials, antenna ground plane variations, and environmental specifications that are called out at the subsystem and instrumentation documentation level.

## Appendix A:

The final output of each error analysis is a statistical number to show, i. e. that presents and is equal to, the expected error in performing a particular function. In general, the error presented is that for the standard deviation  $1\sigma$  unless the specification specifically reflects a  $2\sigma$  or  $3\sigma$  confidence level requirement.

The format of each error analysis consists of an introduction with a descriptive narrative, generally accompanied by a block diagram that describes the signal flow and the contributing sources for the error. The error distribution for each contributor is assumed to be Gaussian unless otherwise noted.

The error tolerances used in an error analysis are stated in, implied by, or assumed by the performance requirements for each error contributor; and the error tolerances are obtained from either the specification drawings or specifications, testing, or from an engineering estimate based on experience. Typically, the error budgets used in an error analysis are updated periodically as more information is received during testing and/or manufacturing.

The standard deviations for the individual performance parameters specify the errors associated with the individual error contributors. Typically the standard deviations for the performance parameters are described by using the associated error tolerances and appropriate statistical error probability density distributions, i. e. functions, such as Gaussian or uniform distribution in order to characterize and model the effects of the error contributors. Next, the standard deviations for the individual error contributors are computed by using analyses that are based on the statistical error probability distributions that were chosen to describe each of the performance parameters.

The results of the system level error analyses are obtained by computing the standard deviation of the performance for each complete system. In order to compute a system level performance standard deviation, using a first level approximation, assume it is obtained from the  $1\sigma$  values of the associated individual error parameters by RSS'ing them together, i. e. by taking the square root of the sum of the squares of the individual error parameter  $1\sigma$  values. When necessary, in order to more accurately represent the system level error function in terms of the  $1\sigma$  values of the individual error parameters, use error sensitivity derivatives and the following expression in order to compute the system level error function, i. e. in order to compute  $\sigma_x$  where

$$\sigma_x^2 = \sum_{i=1}^N \left( \left. \frac{\partial X}{\partial Q_i} \right|_0 \right)^2 \sigma_i^2 \quad \text{which is described below in 6.7.}$$

Finally, in conclusion, each system level error analysis is concluded with a listing of the associated error tolerances, error parameter budgets, and a summary description of the error analysis.

### 2.1 Probability Error Distributions

In order to characterize the system error parameters for use in a system level error analysis, select an error distribution for each contributing error parameter. For example, select error distributions from the following probability density functions and then use the associated expressions in order to compute the standard deviation,  $1\sigma$ , values from the parameter error tolerances,  $V_e$  and  $V_m$ .

**2.1.1 Uniform Distribution:**

$$\sigma = \frac{V_m - V_e}{\sqrt{3}}$$

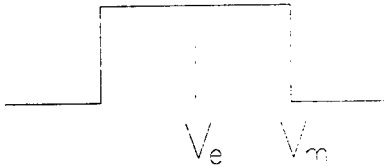
**2.1.2 Triangular Distribution:**

$$\sigma = \frac{V_m - V_e}{\sqrt{6}}$$

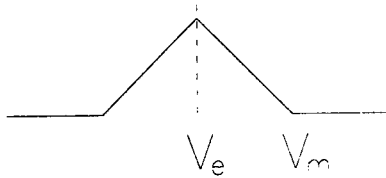
**2.1.3 Gaussian Distribution (using 99.74 % tolerance values):**

$$\sigma = \frac{V_m - V_e}{3}$$

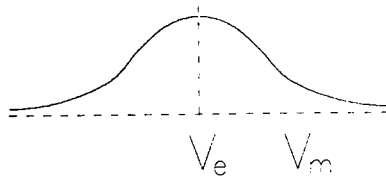
**2.1.4 Digital Quantizing Error (Uniform Distribution):**

$$\sigma = \frac{A}{\sqrt{12}}$$

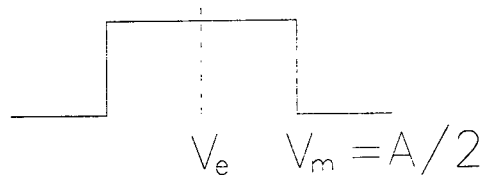

$$\sigma = \frac{V_m - V_e}{\sqrt{3}} = \frac{A}{2\sqrt{12}} \quad \text{where } A \text{ is the quantizing step value.}$$

**3.0 System Error Analysis for a System Level Error Function**

The following derivation presents the developments for a statistical analysis that describes the statistical attributes of a system level error function  $\delta X$  in terms a set of independent and measurable parameters  $Q_j$ .

The function  $X$  is defined as  $X = X_0 + \delta X$ , where  $X_0$  is the zero error value

## Appendix A:

for  $X$  and  $\delta X = \sum_{i=1}^N \left. \frac{\partial X}{\partial Q_i} \right|_0 \delta Q_i$ . For example, the function  $X$  could be defined as the reliability of a system with measurable system parameters  $Q_i$ .

The quantities  $\left. \frac{\partial X}{\partial Q_i} \right|_0$  are the error sensitivity derivatives of  $X$  due to the parameters  $Q_i$  and are estimated and evaluated for the system parameters  $Q_i$  at  $\delta Q_i = 0$ , i. e. when the system parameter value deviations from their mean values,  $\mu_i$  are zero.

The parameter value deviation  $\delta Q_i$  is the  $i$ th error parameter which is described by an appropriate probability distribution such as a normal distribution,  $Normal(\delta Q_i, 0, \sigma_{Q_i}^2)$ , or a uniform distribution,  $Uniform(\delta Q_i, 0, \sigma_{Q_i}^2)$ . For such normal and uniform distributions, as represented by these expressions, the means have values of zero,  $\mu_i = 0$ , and the variances are  $\sigma_{Q_i}^2$ .

The sensitivity derivatives  $\left. \frac{\partial X}{\partial Q_i} \right|_0$  can be evaluated if an analytic expression can be written for  $X$  which includes the parameter value deviations  $\delta Q_i$ , which correspond to the mean values  $\mu_i$  for the parameters  $Q_i$ , in the correct functional relationship to  $X$ .

### 3.1 Empirical Sampled Data Technique

Alternate sampled data techniques can be used that include obtaining an analytic expression for  $X$ , an empirical form for  $X$ , or a combination of empirical data and analytic expressions. Then use a Monte Carlo analysis in order to evaluate  $X_i$  for  $i = 1$  to  $N$  and use the resulting data in order to calculate the sample statistics  $\mu_X$  and  $\sigma_X$  for  $X$ . Therefore, use the following expressions to estimate  $\sigma_X$  for the system function  $X$ :

$$\bar{X} = \frac{1}{N} \sum_{i=1}^N X_i \quad \text{and} \quad \sigma_X = \sqrt{\frac{\sum_{i=1}^N X_i^2 - N * \bar{X}^2}{N - 1}}$$

The Monte Carlo analysis loop is

Monte Carlo Loop  $I = 1$  to  $N$

Evaluate  $X(I)$  by selecting  $\delta Q_i$  using appropriate probability distributions and empirical or analytic data.

End of loop

### 3.2 Analytic Development

Appendix A:

For a function  $X$  the system error analysis development is

$$X = X_0 + \delta X \quad \text{where } X_0 \text{ is the zero error value.}$$

As mentioned above, the sampled data statistics for the mean and standard deviation,  $\mu_X$  and  $\sigma_X$ , can be obtained for  $X$  when empirical data is available for  $X$  by using the following expressions.

$$\bar{X} = \frac{1}{N} \sum_{i=1}^N X_i, \quad \text{and } X_i = X_0 + \delta X_i.$$

When  $X_0 = 0$ ,  $\bar{X} = 0$ , and the measured data is  $|\delta X_i|$ ; then  $X_i = \delta X_i$  and therefore,

$$\sigma_X = \sqrt{\frac{1}{N-1} \sum_{i=1}^N X_i^2} = \sqrt{\frac{1}{N-1} \sum_{i=1}^N |\delta X_i|^2}$$

$$\sigma_X = \sqrt{\frac{1}{N-1} \sum_{i=1}^N |\delta X_i|^2}$$

When  $X$  can be represented by using an analytic form, then use the following analysis in order to obtain the variance of  $X$ , i. e.  $\sigma_X^2$ . Using the definition for the expected value of  $\sigma_X^2$  yields

$$\sigma_X^2 = E[(X - \mu_X)^2] = E[X^2 - 2X\mu_X + \mu_X^2]$$

Since  $X = X_0 + \sum_{i=1}^N \left. \frac{\partial X}{\partial Q_i} \right|_0 \delta Q_i$ , where  $X_0$  is the zero error value for  $X$ .

Therefore,

$$X^2 = X_0^2 + \left[ \sum_{i=1}^N \left. \frac{\partial X}{\partial Q_i} \right|_0 \delta Q_i \right]^2 + 2 \sum_{i=1}^N \left. \frac{\partial X}{\partial Q_i} \right|_0 \delta Q_i$$

$$X^2 = X_0^2 + \sum_{i=1}^N \left[ \left. \frac{\partial X}{\partial Q_i} \right|_0 \delta Q_i \right]^2 + \sum_{i=1}^N \sum_{j=1, j \neq i}^N \left[ \left. \frac{\partial X}{\partial Q_i} \right|_0 \delta Q_i \right] \left[ \left. \frac{\partial X}{\partial Q_j} \right|_0 \delta Q_j \right] + 2 X_0 \sum_{i=1}^N \left. \frac{\partial X}{\partial Q_i} \right|_0 \delta Q_i$$

$$X^2 = X_0^2 + \sum_{i=1}^N \left[ \left. \frac{\partial X}{\partial Q_i} \right|_0 \delta Q_i \right]^2 + 2 \sum_{i=1}^N \sum_{j=1, j < i}^N \left[ \left. \frac{\partial X}{\partial Q_i} \right|_0 \delta Q_i \right] \left[ \left. \frac{\partial X}{\partial Q_j} \right|_0 \delta Q_j \right] + 2 X_0 \sum_{i=1}^N \left. \frac{\partial X}{\partial Q_i} \right|_0 \delta Q_i$$

and where from above,



Appendix A:

$$\sigma^2 = E[X^2] - 2\mu_x^2 + \mu_x^2$$

$$\sigma^2 = E[X^2] - \mu_x^2$$

Then

$$E[X^2] = X_0^2 + E\left[\sum_{i=1}^N \left[\frac{\partial X}{\partial Q_i}\bigg|_0 \delta Q_i\right]^2\right] + 2E\left[\sum_{i=1}^N \sum_{\substack{j=1 \\ i < j}}^N \left[\frac{\partial X}{\partial Q_i}\bigg|_0 \delta Q_i\right] \left[\frac{\partial X}{\partial Q_j}\bigg|_0 \delta Q_j\right]\right] + \dots \\ + 2X_0 E\left[\sum_{i=1}^N \frac{\partial X}{\partial Q_i}\bigg|_0 \delta Q_i\right]$$

$$\mu_x = E[X] = X_0 + E[\delta X] = X_0 + E\left[\sum_{i=1}^N \frac{\partial X}{\partial Q_i}\bigg|_0 \delta Q_i\right] \text{ and for } \delta Q_i \text{ uniformly}$$

distributed about zero or normally distributed about zero then  $E[\delta X] = 0$ .

Then,  $\mu_x = X_0$ . Therefore

$$E[X^2] = X_0^2 + E\left[\sum_{i=1}^N \left[\frac{\partial X}{\partial Q_i}\bigg|_0 \delta Q_i\right]^2\right] + 2E\left[\sum_{i=1}^N \sum_{\substack{j=1 \\ i < j}}^N \left[\frac{\partial X}{\partial Q_i}\bigg|_0 \delta Q_i\right] \left[\frac{\partial X}{\partial Q_j}\bigg|_0 \delta Q_j\right]\right]$$

$$E[X^2] = X_0^2 + \sum_{i=1}^N \left(\frac{\partial X}{\partial Q_i}\bigg|_0\right)^2 E[(\delta Q_i)^2] + 2 \sum_{i=1}^N \sum_{\substack{j=1 \\ i < j}}^N \left(\frac{\partial X}{\partial Q_i}\bigg|_0\right) \left(\frac{\partial X}{\partial Q_j}\bigg|_0\right) E[\delta Q_i \delta Q_j]$$

the covariance of  $\delta Q_i \delta Q_j$ , i. e.  $\text{cov}[\delta Q_i \delta Q_j]$  is given by the expression

$$\text{cov}[\delta Q_i \delta Q_j] = E[\delta Q_i \delta Q_j] - \mu_i \mu_j$$

$\text{cov}[\delta Q_i \delta Q_j] = \rho \sigma_i \sigma_j$  where  $\rho$  is the correlation coefficient for the parameters  $Q_i$  and  $Q_j$ .

When  $\mu_i = \mu_j = 0$  then  $\text{cov}[\delta Q_i \delta Q_j] = E[\delta Q_i \delta Q_j]$  and also,

$$\sigma_i^2 = E[\delta Q_i^2].$$

Therefore,

$$E[X^2] = X_0^2 + \sum_{i=1}^N \left(\frac{\partial X}{\partial Q_i}\bigg|_0\right)^2 \sigma_i^2 + 2 \sum_{i=1}^N \sum_{\substack{j=1 \\ i < j}}^N \left(\frac{\partial X}{\partial Q_i}\bigg|_0\right) \left(\frac{\partial X}{\partial Q_j}\bigg|_0\right) \rho \sigma_i \sigma_j$$

Then since as stated above  $\sigma^2 = E[X^2] - \mu_x^2$  and for  $\delta Q_i$  uniformly or normally

Appendix A:

distributed about zero, as assumed above, then  $\mu_x = 0$  and

$$\sigma_x^2 = \sum_{i=1}^N \left( \frac{\partial X}{\partial Q_i} \Big|_0 \right)^2 \sigma_i^2 + 2 \sum_{\substack{i=1 \\ i < j}}^N \sum_{j=1}^N \left( \frac{\partial X}{\partial Q_i} \Big|_0 \right) \left( \frac{\partial X}{\partial Q_j} \Big|_0 \right) \rho \sigma_i \sigma_j$$

Finally,

for 0% correlation between the errors parameter  $\delta Q_i$ , then  $\rho = 0$ , and

$$\sigma_x^2 = \sum_{i=1}^N \left( \frac{\partial X}{\partial Q_i} \Big|_0 \right)^2 \sigma_i^2$$

for 100% correlation between the errors parameter  $\delta Q_i$ , then  $\rho = 1$ , and

$$\sigma_x^2 = \sum_{i=1}^N \left( \frac{\partial X}{\partial Q_i} \Big|_0 \right)^2 \sigma_i^2 + 2 \sum_{\substack{i=1 \\ i < j}}^N \sum_{j=1}^N \left( \frac{\partial X}{\partial Q_i} \Big|_0 \right) \left( \frac{\partial X}{\partial Q_j} \Big|_0 \right) \sigma_i \sigma_j$$

### 3.3 Example of a System Error Analysis for a Function R

Define the system error function  $\delta R$  in terms of the system parameter value errors

$\delta x$  and  $\delta y$  where

$$R = R_0 + \delta R \quad , \quad x = x_0 + \delta x \quad , \quad y = y_0 + \delta y$$

$$\text{and } R = \sqrt{x^2 + y^2}$$

Therefore the associated system error sensitivity derivatives for  $x$  and  $y$  can be derived using the following approach.

$$R = \sqrt{(x_0 + \delta x)^2 + (y_0 + \delta y)^2}$$

$$\frac{\partial R}{\partial x} \Big|_0 = \frac{1}{2} \cdot 2 \frac{\frac{\partial \delta x}{\partial x}}{\sqrt{(x_0 + \delta x)^2 + (y_0 + \delta y)^2}} = \frac{1}{2} \cdot 2 \frac{\frac{\partial \delta x}{\partial x}}{\sqrt{x^2 + y^2}} = \frac{1}{R} \frac{\partial \delta x}{\partial x} = \frac{1}{R}$$

$$\frac{\partial R}{\partial x} \Big|_0 = \frac{1}{R} \quad \text{and similarly,}$$

$$\frac{\partial R}{\partial y} \Big|_0 = \frac{1}{R}$$

Therefore the system error  $\delta R$  for the function  $R$  can be described in terms of the  $x$  and  $y$  parameter errors value  $\delta x$  and  $\delta y$ , as presented above for  $\rho = 0$  which corresponds to 0% correlation between the errors parameter  $\delta Q_i$ , i. e. between  $\delta x$  and  $\delta y$ .

Appendix A:

$$\delta R = \sum_{i=1}^N \left. \frac{\partial R}{\partial Q_i} \right|_0 \delta Q_i$$

$\delta R = \frac{1}{R} \delta x + \frac{1}{R} \delta y$  where, for example,  $\delta x$  and  $\delta y$  could be assumed to be described by the uniform error probability distributions  $Uniform(\delta x, 0, \sigma_x^2)$  and  $Uniform(\delta y, 0, \sigma_y^2)$  respectively.

Notice for a uniform probability distribution,  $Uniform(\delta Q_i, 0, \sigma_{Q_i}^2)$ , that

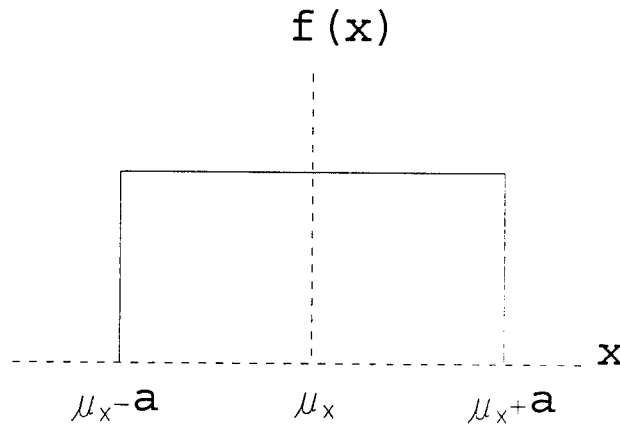

Figure. Uniform Probability Distribution,  $Uniform(x, \mu_x, \sigma_x^2)$

$$f(x) = \begin{cases} \frac{1}{2a} & \mu_x - a \leq x \leq \mu_x + a \\ 0 & x < \mu_x - a, \mu_x + a < x \end{cases}$$

$$\bar{x} = \int_{\mu_x - a}^{\mu_x + a} x f(x) dx = \frac{1}{2a} \left. \frac{x^2}{2} \right|_{\mu_x - a}^{\mu_x + a} = \frac{1}{2a} \left[ \frac{(\mu_x + a)^2}{2} - \frac{(\mu_x - a)^2}{2} \right] = \frac{1}{2a} [2\mu_x a]$$

$$\bar{x} = \mu_x$$

$$\sigma_x^2 = \int_{\mu_x - a}^{\mu_x + a} (x - \mu_x)^2 f(x) dx$$

$$\sigma_x^2 = E[(x - \mu_x)^2] = E[x^2 - 2\mu_x x + \mu_x^2]$$

$$\sigma_x^2 = E[(x)^2] - 2\mu_x^2 + \mu_x^2$$

$$\sigma_x^2 = E[(x)^2] - \mu_x^2$$

Appendix A:

$$\sigma_x^2 = \int_{\mu_x-a}^{\mu_x+a} x^2 f(x) dx - \mu_x^2 = \frac{1}{2a} \int_{\mu_x-a}^{\mu_x+a} x^2 dx - \mu_x^2 = \frac{1}{2a} \frac{x^3}{3} \Big|_{\mu_x-a}^{\mu_x+a} - \mu_x^2$$

$$\sigma_x^2 = \frac{1}{2a} \left[ \frac{(\mu_x+a)^3}{3} - \frac{(\mu_x-a)^3}{3} \right] - \mu_x^2$$

$$\sigma_x^2 = \frac{1}{6a} \left[ (\mu_x^3 + 3\mu_x^2 a + 3\mu_x a^2 + a^3) - (\mu_x^3 - 3\mu_x^2 a + 3\mu_x a^2 - a^3) \right] - \mu_x^2$$

$$\sigma_x^2 = \frac{1}{6a} [6\mu_x^2 a + 2a^3] - \mu_x^2 = \frac{a^2}{3} + \mu_x^2 - \mu_x^2$$

$$\sigma_x = \frac{a}{\sqrt{3}}$$

Finally, from the analyses presented above, the standard deviation  $\sigma_R$  for the error in R,  $\delta R$ , is given by the following expressions in terms of the standard deviations for the errors in  $\delta x$  and  $\delta y$  and the sensitivity derivatives of R to the errors in  $\delta x$  and  $\delta y$  as

$$\sigma_x^2 = \sum_{i=1}^N \left( \frac{\partial X}{\partial Q_i} \Big|_0 \right)^2 \sigma_i^2 \text{ using the expression from 6.7.2 and where, therefore}$$

$$\sigma_R^2 = \left( \frac{1}{R} \right)^2 \sigma_x^2 + \left( \frac{1}{R} \right)^2 \sigma_y^2$$

$$\sigma_R = \sqrt{\frac{1}{R^2} \sigma_x^2 + \frac{1}{R^2} \sigma_y^2}$$

Then, using the developments above for a uniform distribution,  $\sigma_x$  and  $\sigma_y$  are given by the expressions

$$\sigma_x = \frac{a_x}{\sqrt{3}} \quad \text{and} \quad \sigma_y = \frac{a_y}{\sqrt{3}}$$

where  $a_x$  and  $a_y$  are the assigned expected typical maximum observed errors in x and y respectively.

Similarly and alternatively, the normal distributions  $Normal(\delta x, 0, \sigma_x^2)$  and  $Normal(\delta y, 0, \sigma_y^2)$  could be used in order to characterize and describe the errors in x and y. For normal distributions with 3 sigma 99.74 % case parameter tolerance value limits, then use

$$\sigma_x = \frac{a_x}{3} \quad \text{and} \quad \sigma_y = \frac{a_y}{3} .$$

#### 4.0 Confidence Interval, $1 - \alpha$ , for a Sample Size $N$ and Statistical Significance

The analysis below describes and defines how to use the idea of interval estimation, the concept of a confidence interval, in order to compute the sample size  $N$  required in order to estimate a standard deviation  $\sigma$  with a  $1 - \alpha$  confidence interval, i. e. specify that  $\sigma$  is within a computed range with a confidence of  $1 - \alpha$ .<sup>1 p. 234-235 problems 4, 5</sup> Additionally, the concept of statistical significance is introduced, defined, and evaluated.

#### 4.1 Statistical Significance

Statistical significance as presented in this document is a sampled data quantity, a quality indicator for statistical sampled data. This new definition for statistical significance provides a means with which to define and measure the statistical significance of a result and conclusion. Further, this definition is based on the concepts of specifying a confidence interval and then estimating an associated parameter value range within which a standard deviation  $\sigma$  is expected to reside with a confidence that is equal to the specified confidence interval.

Specifically, the statistical significance of a set of statistical sampled parameter data, i. e. the quality of the sampled data, is defined as being equal to the inverse of  $\Delta\%$ . This quantity,  $\Delta\%$ , is the maximum expected percentage plus or minus error, deviation, or range of the statistical data parameter that is being sampled. This is an important representation for statistical data that is defined as

$$\text{Significance} = \frac{1}{\Delta\%} \times 100$$

It is believed that this unique definition for statistical significance is being defined, specified, and used here for the first time in this document. The advantage of this definition and usage of statistical significance is that it presents a meaningful way in which to measure the quality of any statistical data that is being sampled; it is inversely proportional to the expected maximum percentage plus or minus error in the sampled data; and it provides a consistent means for calculating, discussing, and comparing the statistical quality of sampled data.

Also, and conversely, the maximum expected plus or minus percentage error of sampled data,  $\Delta\%$ , is inversely proportional to the statistical significance of the associated sampled data set and is given by the expression

$$\Delta\% = \frac{1}{\text{Significance}} \times 100.$$

In summary, the meaning coined and presented in this document for statistical significance is well defined and provides an intuitive and qualitative statistical concept for describing the goodness of sampled data.

Also, notice that previously statistical significance has been used in association with confidence interval hypothesis testing in order to refer to the probability of making an error, i. e. the probability of rejecting a hypothesis when in fact the hypothesis was true. In such an instance, for example, this probability of rejection was called the significance level of the statistical test. Therefore in some prior works, the significance level of a statistical test has been defined as the probability that a test statistic yields a false conclusion, makes a contradictory measurement, or measures erroneously the weight of the evidence favoring rejection.<sup>3 p. 173</sup> Specifically notice that this definition,

described in this paragraph only for reference purposes, is not being used in this document.

#### 4.2 Analysis for a Confidence Interval of $1 - \alpha$ for a Sample Size of N

The question answered by the following analysis is, what is the sample size N that is required in order to compute a standard deviation  $\sigma$  such that it is known to be within a required range with a confidence of  $1 - \alpha$ , or equivalently, with a percentage confidence of  $(1 - \alpha)100$  %? For example, if the percentage confidence is 95 %, then  $\alpha = 0.05$ . In the analysis below,  $\alpha$  is used in order to compute the required sample size N, the maximum associated percentage error,  $\Delta$ , in the standard deviation  $\sigma$  computed with a sample size N, and the associated interval range for  $\sigma$ , i. e. the span  $\sigma_{Min} < \sigma < \sigma_{Max}$  within which  $\sigma$  resides, or equivalently can be said to reside, with a stated confidence of  $1 - \alpha$ . Also, specifically notice that  $\sigma$  is said to be greater than  $\sigma_{Min}$  and less than  $\sigma_{Max}$ .

#### 4.3 The Analysis

Although the following analysis can be described as thorough, or at least complicated, it has the advantage of being fundamentally rigorous in its approach. Also, and even though the presentation is rigorous, it has the benefit of leading to and reducing to a small set of simple statistical equations. These equations are generally applicable in order to evaluate and ascertain the statistical significance of the results obtained from sampled data analyses.

Paraphrasing, the summary equations below are applicable to most statistical problems where the sample size is in excess of 30; and these equations can be used in order to establish that the results from statistical analyses are significant or, equivalently, have significance, i. e. are significant in accordance with the associated confidence interval statements that are specified.

The following example and question is analyzed and answered in the subsequent sections.

Question: For a confidence of  $1 - \alpha$ , what is the sample size N that is required in order to compute an estimated value for  $\sigma$  that is in error by less than  $\Delta$  percent? Also, specify the statistical significance of the computed value of  $\sigma$ , i. e. the sampled standard deviation s, by computing the large sample  $1 - \alpha$  confidence interval for  $\sigma$ , i. e. the  $1 - \alpha$  confidence interval range values of s.

##### 4.3.1 Chi-Squared Confidence Intervals for Variances

From a fundamental theorem of statistics,

If  $s^2$  is the variance of a random sample of size n from the normal population  $Normal(x, \mu, \sigma^2)$ , then  $(n - 1)s^2/\sigma^2$  has a chi-squared distribution with n-1 degrees of freedom.<sup>1 p. 195</sup>

$$\text{Notice that } (n - 1)s^2/\sigma^2 = \frac{(n - 1)}{\sigma^2} \sum_{i=1}^n \frac{(x_i - \bar{x})^2}{(n - 1)} = \frac{1}{\sigma^2} \sum_{i=1}^n (x_i - \bar{x})^2 = \sum_{i=1}^n \left( \frac{x_i - \bar{x}}{\sigma} \right)^2.$$

Therefore, using the chi-squared distribution, it can be stated using the theorem above that the probability that  $\chi^2_{1-\alpha/2, n-1} < (n - 1)s^2/\sigma^2 < \chi^2_{\alpha/2, n-1}$  is

true, is equal to  $1 - \alpha$ . In this expression  $\chi^2_{\alpha, \nu}$  is the chi-square distribution random variable with  $\nu$  degrees of freedom. Then from the chi-square distribution it can be stated that the probability that  $\chi^2$  is greater than  $\chi^2_{\alpha, \nu}$  is equal to  $\alpha$ , or, equivalently,

$$P(\chi^2_{\alpha, \nu} < \chi^2) = \alpha$$

Also, when  $\nu$  is greater than 30 then the chi-square distribution is usually approximated with a normal distribution. <sup>1 p. 197</sup> Equivalently, then, the theorem above can be stated as

$$P\left[\chi^2_{1-\alpha/2, n-1} < (n-1)s^2/\sigma^2 < \chi^2_{\alpha/2, n-1}\right] = 1 - \alpha$$

Then equivalently, this expression can be restated in terms of the variance  $\sigma^2$  as

$$P\left[\frac{(n-1)s^2}{\chi^2_{\alpha/2, n-1}} < \sigma^2 < \frac{(n-1)s^2}{\chi^2_{1-\alpha/2, n-1}}\right] = 1 - \alpha$$

and where this probability statement is illustrated in the following figure by a chi-square probability distribution.

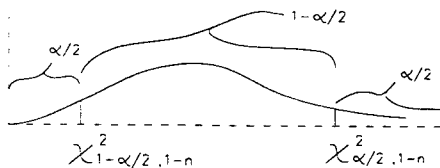

Figure. Chi-Square Distribution for a  $1 - \alpha$  Confidence Interval

#### 4.3.2 Standard Normal Confidence Intervals for Variances

Next, observe that the distribution used to define a  $1 - \alpha$  confidence interval for the standard deviation  $\sigma$  for a system with a variance sampled parameter  $s^2$  and a large sample size, can be approximated, as illustrated below, by a standard normal distribution.

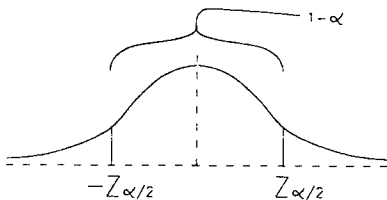

Figure. Standard Normal  $1 - \alpha$  Confidence Interval Distribution

Observe that a fundamental theorem of statistics states that

If  $\bar{x}$  is the mean of a random sample of size  $n$  from the normal population  $Normal(x, \mu, \sigma^2)$ , then the sampling distribution of  $\bar{x}$  is the normal distribution

Appendix A:

$Normal(\bar{x}, \mu, \sigma^2/n)$ .<sup>1 p. 191</sup> This statement can be justified by the Central Limit Theorem when  $n$  is sufficiently large.<sup>1 p. 187</sup>

Similarly assert, with a probability of  $1 - \alpha$ , that the distribution for the sampled standard deviation random variable  $s$  for a  $1 - \alpha$  confidence interval can be approximated by a normal distribution having the mean  $\mu' = \sigma$  and the variance  $\sigma'^2 = \sigma^2/2N$ .<sup>1 p. 234</sup> Also, notice that  $s^2$  is the sampled variance of a random sample of size  $N$  from the normal population  $Normal(x, \mu, \sigma^2)$ .

Then, using the normal distribution  $Normal(Z, \mu', \sigma'^2)$  yields

$$P(s_2 < s < s_1) = 1 - \alpha \quad \text{with the normal distribution} \\ Normal(s, \mu', \sigma'^2)$$

which leads to

$$P\left(\frac{s_2 - \mu'}{\sigma'} < \frac{s - \mu'}{\sigma'} < \frac{s_1 - \mu'}{\sigma'}\right) = 1 - \alpha \quad \text{with the standard normal distribution} \\ Normal\left(\frac{s - \mu'}{\sigma'}, 0, \sigma'^2\right) \rightarrow Normal(Z, 0, \sigma'^2)$$

Then

$$\frac{s_2 - \mu'}{\sigma'} < \frac{s - \mu'}{\sigma'} < \frac{s_1 - \mu'}{\sigma'} \\ -Z_{\alpha/2} < \frac{s - \sigma}{\sigma/\sqrt{2N}} < Z_{\alpha/2} \\ \frac{-Z_{\alpha/2}}{\sqrt{2N}} < \frac{s}{\sigma} - 1 < \frac{Z_{\alpha/2}}{\sqrt{2N}} \\ 1 - \frac{Z_{\alpha/2}}{\sqrt{2N}} < \frac{s}{\sigma} < 1 + \frac{Z_{\alpha/2}}{\sqrt{2N}} \\ \frac{1}{s} \left(1 - \frac{Z_{\alpha/2}}{\sqrt{2N}}\right) < \frac{1}{\sigma} < \frac{1}{s} \left(1 + \frac{Z_{\alpha/2}}{\sqrt{2N}}\right) \quad \text{and therefore}$$



$$\frac{s}{1 + \left( \frac{Z_{\alpha/2}}{\sqrt{2N}} \right)} < \sigma < \frac{s}{1 - \left( \frac{Z_{\alpha/2}}{\sqrt{2N}} \right)}$$

which is the large sample  $1 - \alpha$  confidence interval expression for  $\sigma$ . 1 p. 235

$$\text{Also, } P \left[ \frac{s}{1 + \left( \frac{Z_{\alpha/2}}{\sqrt{2N}} \right)} < \sigma < \frac{s}{1 - \left( \frac{Z_{\alpha/2}}{\sqrt{2N}} \right)} \right] = 1 - \alpha$$

In order to compute the  $1 - \alpha$  confidence interval for a computed standard deviation  $s$ , specify  $1 - \alpha$ , compute  $\alpha/2$  and  $\frac{1 - \alpha}{2}$ , observe that

$P(0 < Z < Z_{\alpha/2}) = \frac{1 - \alpha}{2}$ , and then look up  $Z_{\alpha/2}$  in a table for the Standard Normal Distribution values. Finally, in order to define the statistical significance of the data measured for the standard deviation  $s$ , compute the  $1 - \alpha$  confidence intervals for  $\sigma$  by using the large sample  $1 - \alpha$  confidence interval expression for  $\sigma$  above.

#### 4.3.3.3 Maximum Percentage Error with confidence of $1 - \alpha$

The maximum percentage error,  $\Delta$ , in the standard deviation  $s$  is, with a confidence of  $1 - \alpha$ , given by the following expressions

$$\Delta\% = \frac{\sigma_0 - \sigma_{Min}}{\sigma_0} 100 \quad \text{where } \sigma_0 = \frac{\sigma_{Max} - \sigma_{Min}}{2} + \sigma_{Min}$$

$$\text{and from above } \sigma_{Min} = \frac{s}{1 + \left( \frac{Z_{\alpha/2}}{\sqrt{2N}} \right)} \quad \text{and} \quad \sigma_{Max} = \frac{s}{1 - \left( \frac{Z_{\alpha/2}}{\sqrt{2N}} \right)}$$

Then these expressions when substituted together reduce to

$$\Delta\% = \frac{Z_{\alpha/2}}{\sqrt{2N}} 100.$$

Finally, the sample size required in order to obtain a percentage error in the standard deviation  $s$  of less than  $\Delta$  with a confidence of  $1 - \alpha$  is given by the expression above by solving for  $N$ .

$$\text{Therefore } N = \frac{1}{2} \left( \frac{Z_{\alpha/2}}{\Delta\%} \right)^2 10^4.$$

## Appendix A:

Additionally, as presented and discussed below, statistical significance could be defined as  $Significance = \frac{1}{\Delta} = \frac{\sqrt{2N}}{Z_{\alpha/2}}$ .

Also, the maximum error in the standard deviation  $s$ , with a confidence of  $1 - \alpha$ , can be expressed in decibels, dB, as follows,

$$\pm \text{ Error in dB} = 20 \text{ Log}_{10} \left( \frac{V + \Delta V}{V} \right) = 20 \text{ Log}_{10} \left( 1 + \frac{\Delta V}{V} \right), \text{ and therefore}$$

$$1 + \frac{\Delta V}{V} = 10^{dB/20} \quad \text{and} \quad \Delta\% = \frac{\Delta V}{V} 100 = \left[ 10^{dB/20} - 1 \right] 100$$

Using the expression above for  $\Delta\%$  yields  $\left[ 10^{dB/20} - 1 \right] 100 = \frac{Z_{\alpha/2}}{\sqrt{2N}} 100$ . Then solving for dB yields

$$dB = 20 \text{ Log}_{10} \left[ 1 + \frac{Z_{\alpha/2}}{\sqrt{2N}} \right] \text{ and for } N, \text{ in terms of dB, as}$$

$$N = \frac{1}{2} \left[ \frac{Z_{\alpha/2}}{10^{dB/20} - 1} \right]^2 \text{ where } N \text{ is rounded up to the nearest integer.}$$

### 4.3.4 Summary Equations and Sample Problems

A subset of the important statistical equations developed above in section 6.8 include

$$\frac{s}{1 + \left( \frac{Z_{\alpha/2}}{\sqrt{2N}} \right)} < \sigma < \frac{s}{1 - \left( \frac{Z_{\alpha/2}}{\sqrt{2N}} \right)}$$

which is the large sample  $1 - \alpha$  confidence interval expression for  $\sigma$ ,

$$\Delta\% = \frac{Z_{\alpha/2}}{\sqrt{2N}} 100$$

which is the percentage error in the standard deviation  $s$  associated with a  $1 - \alpha$  confidence interval for a sample size of  $N$ ,

and similarly, the sample size required in order to obtain a percentage error in the standard deviation  $s$  of less than  $\Delta$  with a confidence of  $1 - \alpha$  is given by the expression above by solving for  $N$ .

$$\text{Therefore } N = \frac{1}{2} \left( \frac{Z_{\alpha/2}}{\Delta\%} \right) 10^4.$$

#### 4.3.4.1 Confidence Intervals for Variances<sup>1 p. 235</sup>

Use the developments above in order to illustrate how to characterize the statistical significance of results obtained from the random sampling of electronic device parameter values.

For example, define a measure of the statistical significance of the results of testing as being a function of the  $1 - \alpha$  confidence interval for the variances of the results. The statistical significance of the results could then be interpreted as being inversely proportional to the span of the  $1 - \alpha$  confidence intervals for the sampled standard deviations. Then when the span becomes small the statistical significance becomes large or, equivalently, significant. Acceptable levels of statistical significance could be defined by specifying, or establishing by test experience, required threshold levels for the estimated statistical significance, i. e. for a quantity proportional to

$$\frac{1}{\frac{1}{2} \text{ of the Span of the confidence interval for the standard deviation}}, \text{ for}$$

the random sampling of electronic device parameter values.

Sample Problem: Therefore, for example, a sample problem<sup>1 p. 235</sup> can be stated as

The lifetimes of a random sample of 200 electronic devices selected at random by the manufacturer during shipment have a variance of 132 days. Use a large sample  $1 - \alpha$  confidence interval in order to construct an approximate 0.95 confidence interval for  $\sigma$ , the standard deviation of the lifetimes of all of the manufacturer's standard stock electronic devices from which the sample was obtained.

Then,

1. assume the sample,  $s^2$ , is a random sample from the population  $Normal(x, \mu, \sigma^2)$
2.  $s^2 = 132$ , then  $s = 11.49$
3.  $N = 200$
4.  $\alpha = 1 - \alpha' = 0.95$  for the large sample normal distribution confidence interval approximation for  $s$ , and
5. therefore  $\alpha = 0.95$  and  $\alpha/2 = 0.475$
6.  $Z_{\alpha/2} = Z_{0.475} = 1.96$ , from the area under a standard normal distribution curve obtained from a standard normal distribution table.

$$7. \sigma_{Min} = \frac{s}{1 + \left( \frac{Z_{\alpha/2}}{\sqrt{2N}} \right)} = \frac{11.49}{1 + \frac{1.96}{\sqrt{400}}} = 10.46$$

$$8. \sigma_{Max} = \frac{s}{1 - \left( \frac{Z_{\alpha/2}}{\sqrt{2N}} \right)} = \frac{11.49}{1 - \frac{1.96}{\sqrt{400}}} = 12.74$$

9. then, using the large sample variance confidence interval equation presented above yields,

$$\frac{s}{1 + \left( \frac{Z_{\alpha/2}}{\sqrt{2N}} \right)} < \sigma < \frac{s}{1 - \left( \frac{Z_{\alpha/2}}{\sqrt{2N}} \right)}$$

$$10.46 < \sigma < 12.74$$

9. also, from above  $\Delta\% = \frac{Z_{\alpha/2}}{\sqrt{2N}} 100$ , and therefore

$$\Delta\% = \frac{1.96}{\sqrt{400}} 100 = 9.8\%$$

then, in a manner directly analogous to the prior discussion about measures of statistical significance,

10. this result for the expected maximum percentage plus or minus error for the standard deviation of the lifetimes of the electronic devices could be defined as being the inverse of a measure of the statistical significance of the result. Then as  $\Delta\%$  decreases the statistical significance of the result would increase. For example, the statistical significance, Significance, could be defined as being equal to

$$\text{Significance} = \frac{1}{\Delta} = \frac{\sqrt{2N}}{Z_{\alpha/2}} \text{ which yields}$$

11. *Significance* = 10.20 for this example.

#### 4.3.4.2 Tests Concerning Variances<sup>1 p. 271</sup>

Hypothesis tests concerning variances,  $\sigma^2$ , are often a prerequisite for tests about the statistical significance of results and tests concerning other parameters of populations. In practice, it is often necessary to test the reasonableness of the assumption that the variances of two populations are equal or, similarly, that the variance of a normal population equals a given constant. A test for whether the variance of a normal population equals a given constant is referred to as the null hypothesis,  $H_0$ , and as an alternative hypothesis,  $H_A$ , such as the variance is not equal to the constant.

Therefore the null hypothesis is  $H_0: \sigma^2 = \sigma_0^2$  and the two-sided alternative is  $\sigma^2 < \sigma_0^2$  and  $\sigma_0^2 < \sigma^2$ . Applying a likelihood ratio technique yields a test based on the sample variance  $s^2$ , such that the critical regions, for testing the null hypothesis against the two-sided alternative, are

Appendix A:

$$\chi^2 \leq \chi^2_{1-\alpha/2, n-1} \quad \text{or} \quad \chi^2_{\alpha/2, n-1} \leq \chi^2 \quad \text{where} \quad \chi^2 = (n-1)s^2/\sigma_0^2$$

which can again, as used above previously, be restated as

$$P\left[\chi^2_{1-\alpha/2, n-1} < (n-1)s^2/\sigma^2 < \chi^2_{\alpha/2, n-1}\right] = 1 - \alpha$$

where the total size of the critical regions is  $\alpha$ .

Sample Problem: Then, for example, a sample problem<sup>1 p. 274</sup> can be stated as

The lifetimes of certain electronic devices are suppose to have a variance of 5000 hours. Test the null hypothesis  $\sigma^2 = 5000$  against the two-sided alternative  $\sigma^2 \neq 5000$  with  $\alpha = 0.02$ , if 25 of these electronic devices had a sample variance of  $s^2 = 7200$  hours. Assume that it is reasonable to treat these data as a random sample from a normal population.

Then,

1. assume the sample,  $s^2$ , is a random sample from a population  $Normal(x, \mu, \sigma^2)$
2.  $N = 25$
3. the null hypothesis is  $H_0: \sigma^2 = 5000$
4. the alternative hypothesis is  $H_A: \sigma^2 \neq 5000$
5.  $\chi^2 = (n-1)s^2/\sigma_0^2 = (25-1)7200/5000 = 34.56$  which from the previous develops above was shown to have a chi-squared distribution with  $n-1$  degrees of freedom. Therefore,
6.  $\chi^2_{1-\alpha/2, n-1} = \chi^2_{0.99, 24} = 10.856$  , from a chi-squared  $\chi^2_{\alpha, v}$  table
7.  $\chi^2_{\alpha/2, n-1} = \chi^2_{0.01, 24} = 42.980$  , from a chi-squared  $\chi^2_{\alpha, v}$  table
8. therefore  $\chi^2_{1-\alpha/2, n-1} < \chi^2 < \chi^2_{\alpha/2, n-1}$  and the conclusion from this test is to
9. accept the null hypothesis  $H_0$ .

Observe that the  $1 - \alpha$  confidence interval for the test is 98%, i. e.  $1 - \alpha = 0.98$ .

Using the inverse of half of the span from  $\chi^2_{1-\alpha/2, n-1}$  to  $\chi^2_{\alpha/2, n-1}$  as a measure of the statistical significance yields

$$\text{Significance} = \frac{\sqrt{2 \cdot N}}{\frac{1}{2} \text{ of the Span of the confidence interval for } \chi}$$

$$\text{Significance} = \frac{\sqrt{2 \cdot N}}{\frac{1}{2} \left( \chi^2_{\alpha/2, n-1} - \chi^2_{1-\alpha/2, n-1} \right)}$$

Appendix A:

$$10. \text{Significance} = \frac{2\sqrt{2 \cdot 25}}{(\sqrt{42.980} - \sqrt{10.856})} = 4.34$$

11. If, instead, the expression  $\text{Significance} = \frac{1}{\Delta} = \frac{\sqrt{2N}}{Z_{\alpha/2}}$ , which was specified

above, were used with  $\alpha = 1 - \alpha' = 0.98$  and  $\alpha/2 = 0.49$

$$\text{then } \text{Significance} = \frac{1}{\Delta} = \frac{\sqrt{2N}}{Z_{\alpha/2}} = \frac{\sqrt{2 \cdot 25}}{Z_{0.49}} = \frac{7.07}{2.33} = 3.03$$

where  $Z_{\alpha/2}$  was obtained from a standard normal distribution table. <sup>1 p. 366</sup>

Notice that when, for this problem, the statistical significance was approximated with the large sample standard normal distribution equation that then the computed statistical significance went down from 4.34 to 3.03.

In conclusion, the general use of statistical tests with hypotheses tends to be quite complicated and is beyond the scope of this discussion. The one caveat that should be mentioned is that in order to obtain valid results from statistical testing, it is necessary to have a statistician carefully define the tests, analyze the data, and draw the conclusions. For additional information, refer to statistical books such as reference 1, since the theory for the tests of hypotheses can be useful.

For instance, tests with hypotheses can be useful for making decisions concerning statistical significance, statistical parameters, and for concluding that a chosen probability distribution correctly describes an experimental situation and thereby provides a valid statistical model. Also, for example, it may be desirable to test whether it is reasonable to assume that a statistical parameter is a member of a population from and with a particular probability distribution.

## 5.0 References

1. Freund, John E., *Mathematical Statistics*, Prentice-Hall, Inc. Englewood Cliffs, N.J., LCCN 62-9287, 1962.
2. Jordan, Edward C., *Reference Data for Engineers: Radio, Electronics, Computer, and Communications*, Seventh Edition, 1985, Howard W. Sams & Co., Inc., ISBN 0-672-21563-2, LCCC No. 43-14665.
3. Mendenhall, William, *Introduction to Statistics*, Wadsworth Publishing Company, Inc. Belmont California, 1964, LCCC No. 63-18328.

## OVERVIEW OF REVERBERATION CHAMBER OPERATION

### 1. Introduction

A Reverberation Chamber is a shielded enclosure with the smallest dimension being large with respect to the wavelength at the lowest useable frequency. The chamber is normally equipped with a mechanical tuning/stirring device whose dimensions are a significant fraction of the chamber dimensions and of the wavelength at the lowest useable frequency. When the chamber is excited with RF energy the resulting multi-mode electromagnetic environment can be "stirred" by the mechanical tuner/stirrer. The resulting environment is both isotropic and uniform when averaged over a sufficient number of positions of the mechanical tuner/stirrer.

The lowest useable frequency of a reverberation chamber is determined by its volume. For a rectangular-shaped chamber of dimensions a, b, and d, the first resonant mode occurs at a frequency of:

$$f_{(011)} = c/2 * [(i/a)^2 + (j/b)^2 + (k/d)^2]^{1/2}$$

where a is the smallest dimension (m),  $i = 0$ ,  $j = k = 1$ , and c is the speed of light ( $3 \times 10^8$  m/s)

The chamber mode density and the effectiveness of the mechanical tuner/stirrer determine the lowest useable frequency. The lowest useable frequency is generally accepted to be the frequency at which the number of modes excited within the  $BW_Q$  is greater than or equal to 1,0. This frequency generally occurs at a frequency slightly above  $3 \times f_{(011)}$ . In practice the tuner/stirrer effectiveness and the chamber "Q" determine the lowest useable frequency. For this alternative procedure of IEC 1000-4-3, it is the frequency at which the tuner/stirrer effectively yields a field uniformity of -0 to +6 dB over a 75% majority of an 8-location calibration data set.

The chamber input power ( $P_{input}$ ) is normally taken to be the forward power delivered to the antenna terminals. In some cases it is necessary to take into account the reflected power caused by antenna/excitation induced mismatch. In such cases the input power shall be the net input power which is equal to:

$$P_{Net} = P_{Forward} - P_{Reflected}$$

The amount of power needed to generate a specific field inside a chamber can be determined from the empty chamber calibration outlined in Section 3.2. However the EUT, the required support equipment, or any absorbing material present may load the chamber, reduce the cavity Q, and hence reduce the test fields for the same input power. Therefore the fields in a loaded chamber must be monitored and input power increased, if necessary, to compensate for this loading.

The tuners/stirrers should be adequate to provide the desired field uniformity. In most chambers it will be necessary to use multiple tuners/stirrers to obtain the desired field uniformity at frequencies approaching the chambers lowest useable frequency. Stepping motors with computer control are desirable. Variable speed, continuous motors are acceptable, but the time response of the EUT

## Appendix B

must be fast relative to tuner/stirrer speed for this option to be viable. A method of evaluating tuner/stirrer performance is given in section 3.

### 2. Theory

The modes in a cavity are determined by the boundary conditions. For a rectangular cavity of dimensions L (length), W (width) and H (height), the mode frequencies can be shown to be [1]

$$F_{l,m,n} = 150 \left( (1/L)^2 + (m/W)^2 + (n/H)^2 \right)^{0.5}$$

where l, m and n are the mode indices.

Figure 1 shows a hypothetical mode distribution as a function of frequency. Each mode represents a unique field variation (modal structure) as a function of spatial location throughout the cavity.

The cavity quality factor bandwidth,  $BW_Q$ , is defined as  $F/Q$  at the 3 dB points of a gaussian distribution. A representative  $BW_Q$  is shown at  $F_0$  in Figure 2. In this case, only one mode is excited when the cavity is driven at  $F_0$ . The effective modal structure at  $F_0$  would be that of the  $F_{l,m,n} = F_0$  mode.

Figure 3 shows the effects of an increased  $BW_Q$ . In this case, three additional modes can be excited when the cavity is driven at  $F_0$ . The effective modal structure would be the vector sum of the four modes with different amplitudes. The spatial field variation will be different than that obtained from the single  $F_0$  mode. Thus varying the cavity Q can change the effective modal structure.

Figure 4 shows how the effective modal structure can be impacted by the theoretical mode density which, at a specific frequency, depends on the cavity size. The increased mode density yields additional modes for the same  $BW_Q$  as in Figure 3. In this case the field variation will be based on the vector sum of seven modes when the cavity is driven at  $F_0$ .

The effective modal structure depends on both the theoretical mode density and the quality factor bandwidth at the frequency of interest. The number of modes M excited in a  $BW_Q$  is given as [1]

$$M = 8\pi V f^3 / (c^3 Q)$$

which is independent of the shape of the cavity.

Current theory suggests that an overmoded condition implies the cavity has ten to fifteen or more modes within the  $BW_Q$ . In the overmoded condition the field distribution has been shown to fit a Chi Squared distribution.[2] At lower mode densities (i.e.  $M < 15$ ) the distributions do not fit the Chi Squared distribution. Recent research [3] has resulted in distributions that describe the field distributions for mode densities less than 15. As shown in Figure 5, the distributions approach the Chi Squared distribution as the mode density approaches 15.



## Appendix B

Given the distribution of the fields within a cavity, the number of samples that would have to be taken in order to determine the field level to within a given uncertainty can be determined. Figure 6 shows the number of samples required to obtain a 6 dB field uncertainty at a 95% level of confidence for a given cavity. As Figure 6 shows, at lower mode densities the number of samples required increases rapidly. If the confidence level is lowered, then the number of samples required to obtain the same uncertainty is reduced. As shown in Figure 7, the number of samples is reduced significantly when the confidence level is reduced to 75%.

To date most testing conducted in reverberation chambers has been collected using 200 samples or steps of the mechanical tuner. This resulted in uncertainties in the field that varied as a function of frequency. As shown in Figure 8, the uncertainty for a typical chamber varied considerably as a function of frequency as the number of tuner steps remained constant. The procedure developed for this specification optimizes the number of steps or samples to obtain a fixed uncertainty as a function of frequency.

The fact that the distributions of the fields in the chamber can be described statistically allows the fields within the chamber to be accurately predicted using a measurement at a single location. Figure 9 depicts the layout of a test on a reverberation chamber measuring approximately 14m x 7m x 3m. The chamber was equipped with two tuners/stirrers and the fields were measured using a system of ten (10) isotropic probes and one (1) log-periodic reference antenna. The probes were distributed throughout the chamber volume and were placed in excess of 7 meters apart. Each probe allowed access to each element of the probe. Data collected using this setup are shown in Figures 10, 11 and 12. Figure 10 compares the mean field strength of the electric field squared as measured by a single element of one probe to the peak field of a single axis of all probes. The heavily dark line in Figure 10 is the predicted peak field based on the number of tuner steps (225 in this case) and the mean field measured by the single probe. The data clearly shows that the peak data was accurately predicted, within acceptable uniformity, by theory using only the mean measurement from a single probe. Figure 11, which shows the peak data for all elements of all probes, clearly shows the prediction is accurate for all of the probe readings. Figure 12 compares the mean of all elements of all the probes (30 elements total) to the mean of the field calculated based on the mean power received by the single reference antenna. This clearly shows that the peak fields can be accurately predicted based on the mean received power measured by a reference antenna located within the working volume of a reverberation chamber.

The calibration procedure is based on a comparison of the peak fields measured by E-field probes to the mean received power of a reference antenna. To enhance accuracy the mean antenna data is obtained for eight locations within the working volume.

### 3. Tuner Efficiency

Tuner performance data is obtained by monitoring the received power at evenly spaced intervals over one tuner rotation (Note: the number of points per rotation determines the resolution of the correlation calculation). The tuner performance is evaluated by calculating the correlation coefficient between the data obtained to that of the original data that has been shifted one sample and the last data point moved into the first position as shown below (450 samples assumed).

## Appendix B

D1, D2, D3, D4, D5, D6,.....	D450
D450, D1, D2, D3, D4, D5, D6,.....	D449
D449, D450, D1, D2, D3, D4, D5, D6,.....	D448
D448, D449, D450, D1, D2, D3, D4, D5, D6.....	D447

The correlation coefficient can be calculated using the following formula:

$$r = \frac{\frac{1}{N} \sum_i^N (x_i - u_x)(y_i - u_y)}{\sqrt{\left( \frac{\sum_i^N (x_i - u_x)^2}{N} \right) \left( \frac{\sum_j^N (y_j - u_y)^2}{N} \right)}}$$

$$\underbrace{\sigma_x^2} \quad \underbrace{\sigma_y^2}$$

Note:  $y_i$  are received power values

$y_i$  is the same distribution as  $x_i$  but shifted by M samples ( in this case tuner positions)

$u_i$  is the mean of the original received power vs tuner position

since the y distribution is the same as the x distribution except for the notation of tuner position

$$u_y = u_x \quad \text{and} \quad \sigma_x = \sigma_y$$

The correlation coefficient can be obtained using the correlation function built into most spreadsheets by comparing the original data set to the shifted data sets. The data becomes uncorrelated when the correlation coefficient is less than 0.36.

### 4. Summary

In order to meet the requirements of the current 1000-4-3 specification of maintaining a -0 to 6 dB uniformity over 75% of an 8 location data set, the distributions mentioned above were used to determine the number of samples (i.e. tuner steps) required to collect the necessary data.

## Appendix B

In an effort to keep the calibration for mode stirred chambers similar to that currently used, a volume based calibration scheme was developed.

As stated above, the number of samples required is determined by the mode density of a given cavity. Although a minimum sized chamber was estimated for calculating the mode densities at which the minimum requirements at 80 MHz are met, it is not practical to attempt to define a minimum sized chamber for this specification. A chamber's lowest useable frequency depends on its dimensions and on the Q of the chamber, which is heavily influenced by the construction materials, types of antennas used (antennas contribute significantly to chamber loading at lower frequencies), etc.. The calibration procedure does place a stringent requirement on the chamber being evaluated. The data required places the need for the fields generated within the test volume to be both uniform and isotropic. To ensure this dual requirement is met, three measurements are required at each of the 8 locations using three mutually perpendicular orientations. Each measurement is independent which results in a total of 24 measurements being taken. This results in 6 measurements (i.e. 25%) being discarded to achieve the 75% confidence level. A chamber that passes this calibration procedure will have demonstrated its ability to generate the required field uniformity.

The number of samples are based on a "theoretical" chamber of minimum size and typical Q. The number of samples required were rounded up to account for variations from this "theoretical" chamber in order to ensure a conservative test. It is possible that a larger chamber or one with a lower Q than the "theoretical" chamber could meet this calibration requirement using less than the required number of steps.

As previously stated, it is not practical to define a minimum size test chamber and it is outside the scope of this specification to provide detailed design guidance. The bottom line is that if a chamber passes the calibration procedure then it has demonstrated that it will provide the required environment at the desired level of confidence.

### 5. References

[1] Crawford, M.L. and Koepke, G.H. "Design, Evaluation, and Use of a Reverberation Chamber for Performing Susceptibility/Vulnerability Measurements". NBS Technical Note 1092, April 1986.

[2] Freyer, G.J., Hatfield, M.O., Johnson, D.M. and Slocum, M.B., "Comparison of Measured and Theoretical Statistical Parameters of Complex Cavities", presented at the IEEE Symposium on EMC, Santa Clara, CA, August 1996

[3] Research conducted under NAVSEA SBIR contract N96-076 by SEA, Inc., Albuquerque, NM, Principle investigator T.H. Lehman.

Appendix B

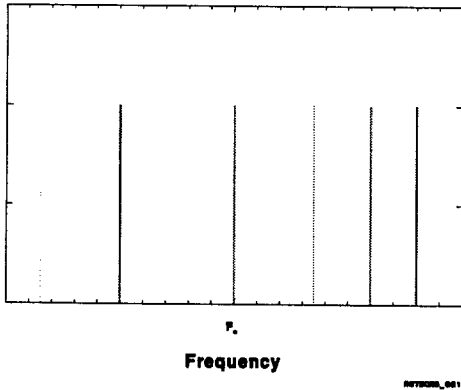

FIGURE 1. HYPOTHETICAL CAVITY MODE STRUCTURE.

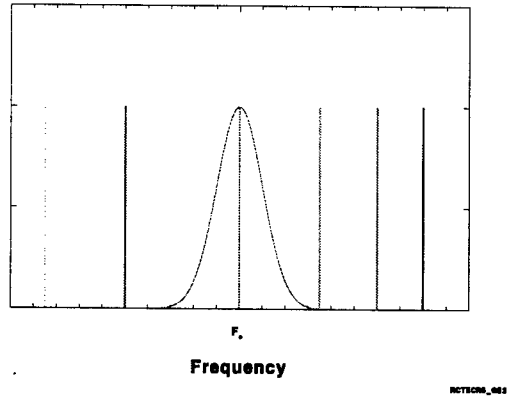

FIGURE 2. HYPOTHETICAL MODE STRUCTURE WITH QUALITY FACTOR BANDWIDTH.

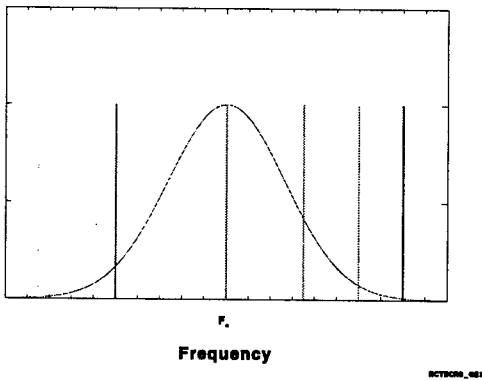

FIGURE 3. HYPOTHETICAL MODE STRUCTURE WITH LARGER QUALITY FACTOR BANDWIDTH.

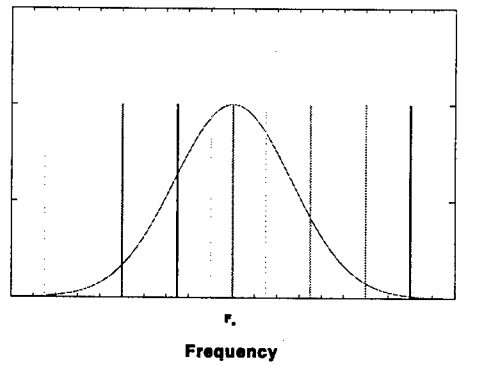

FIGURE 4. HYPOTHETICAL HIGHER MODE DENSITY WITH LARGER QUALITY FACTOR BANDWIDTH.

# Appendix B

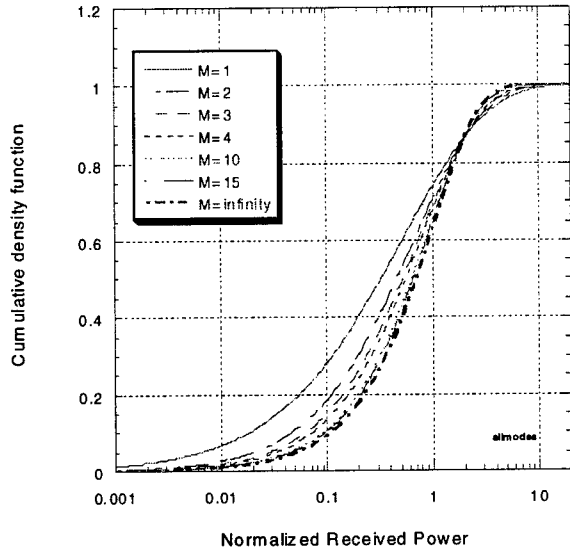

FIGURE 5. CONVERGENCE OF DISTRIBUTION TO CHI-SQUARED.

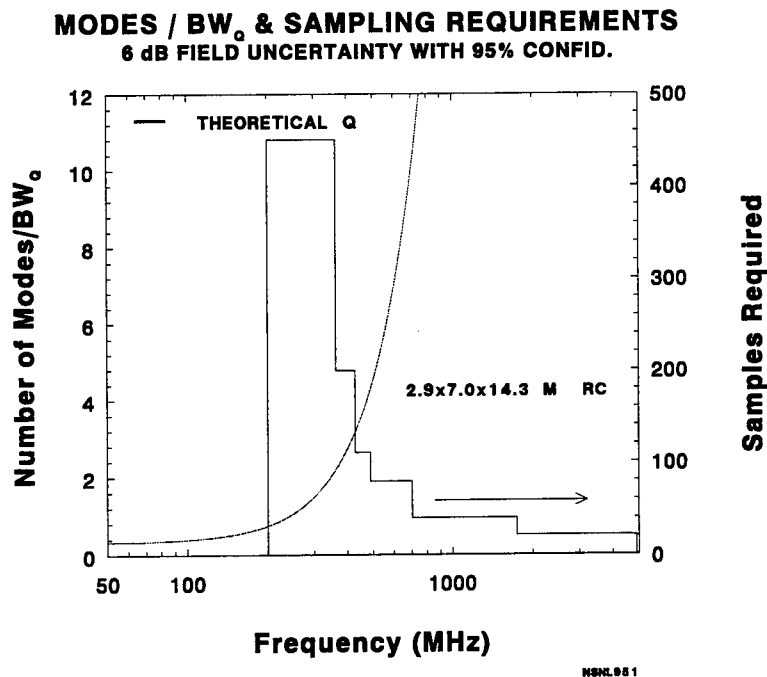
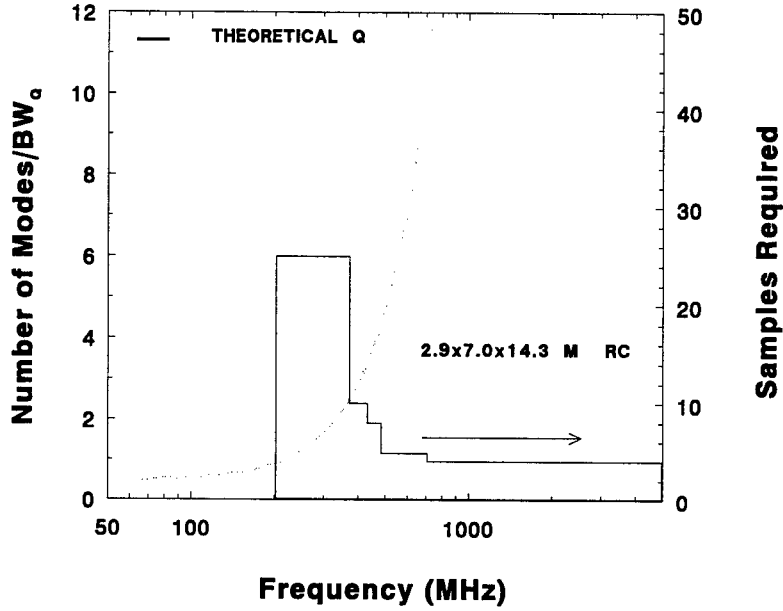

FIGURE 6. SAMPLING REQUIREMENTS FOR 95% CONFIDENCE.

**MODES / BW<sub>0</sub> & SAMPLING REQUIREMENTS**  
**6 dB FIELD UNCERTAINTY WITH 75% CONFID.**



N8NL751

FIGURE 7. SAMPLING REQUIREMENTS FOR 95% CONFIDENCE.

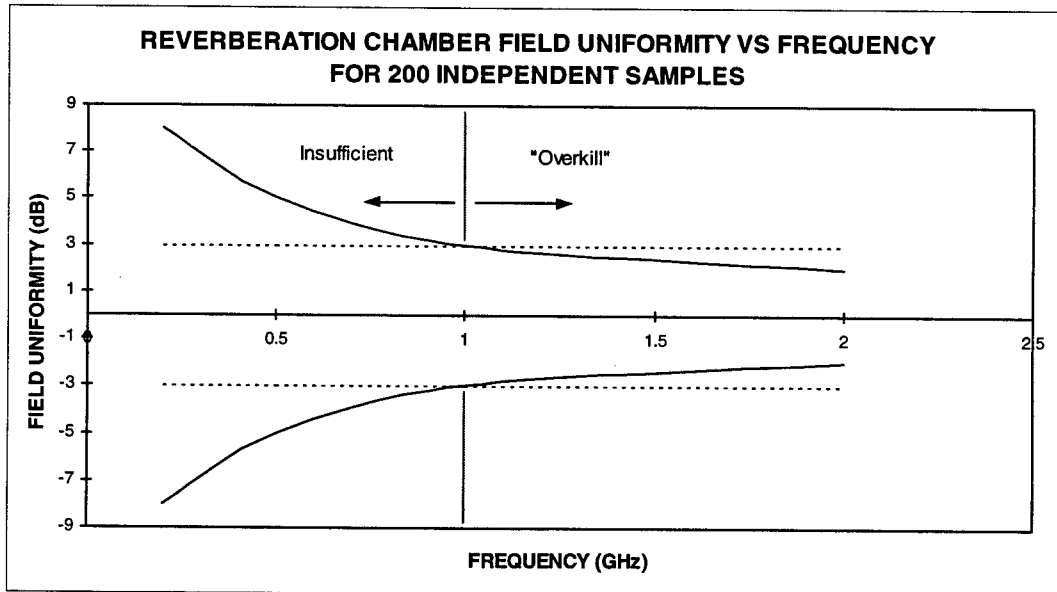

FIGURE 8. TYPICAL FIELD UNIFORMITY FOR 200 TUNER STEPS

## Appendix B

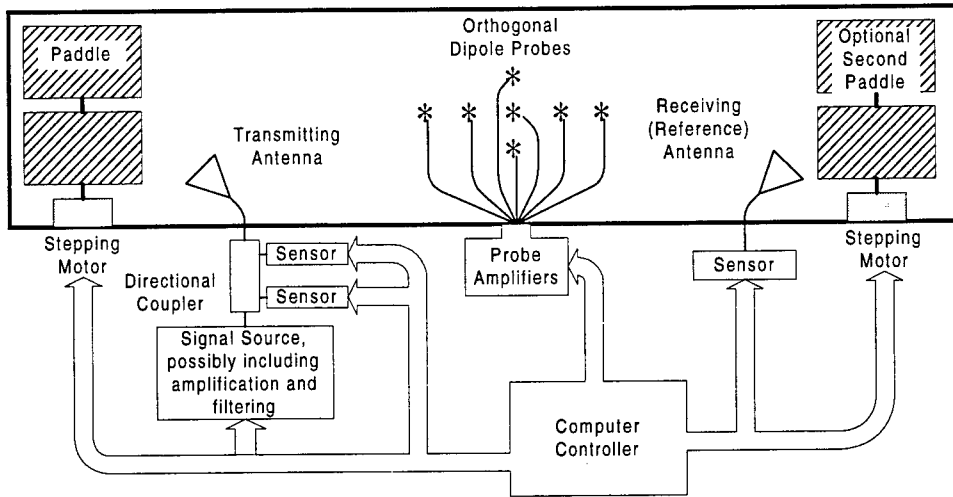

FIGURE 9. MEASUREMENT BLOCK DIAGRAM.

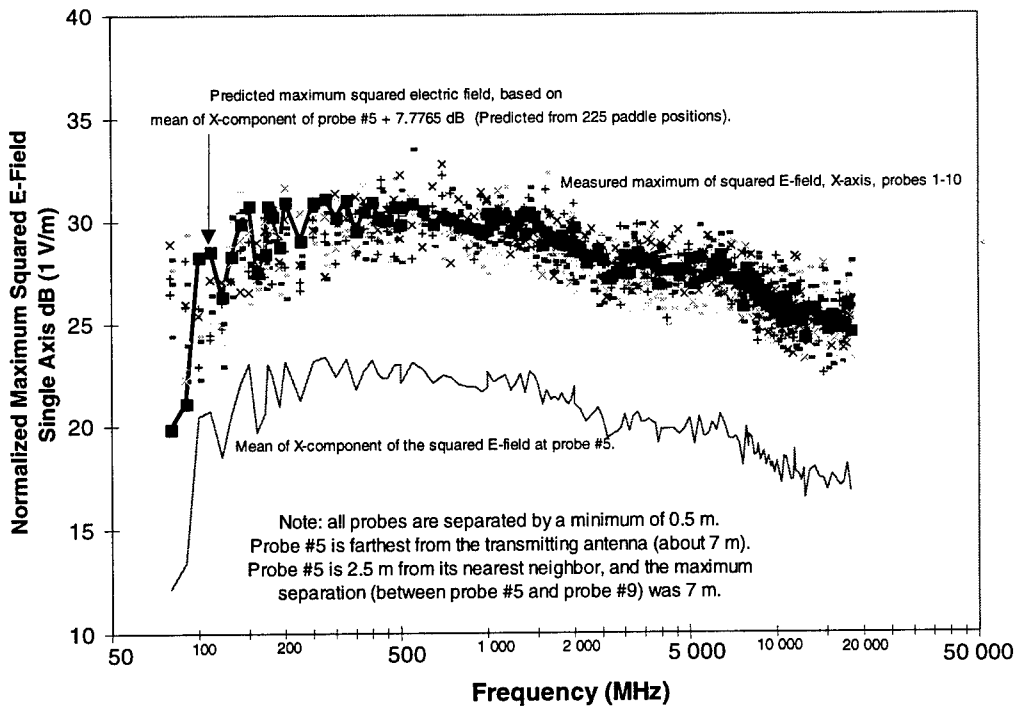

FIGURE 10. PREDICTED MAXIMUM FIELD STRENGTH BASE ON A SINGLE  
AXIS MEAN MEASUREMENT. COMPARISON TO DATA FROM 10 PROBES  
DISTRIBUTED THROUGHOUT A REVERBERATION CHAMBER.

Appendix B

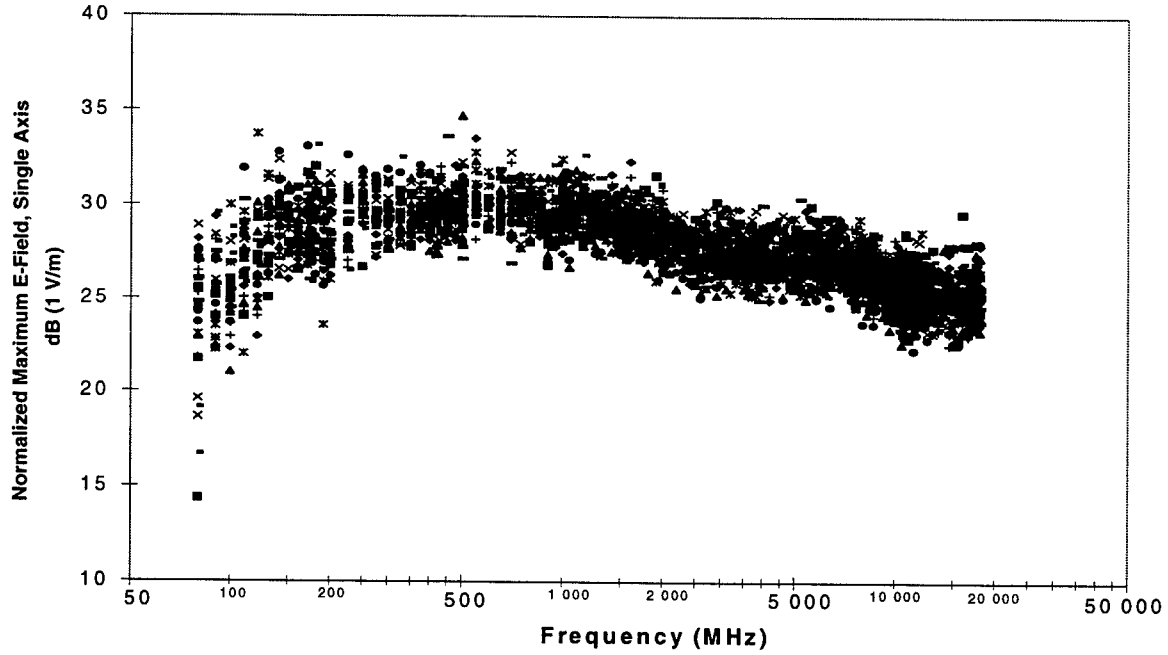

FIGURE 11. MAXIMUM MEASURED ELECTRIC FIELD (SINGLE POLARIZATION) FOR EACH OF 30 SHORT DIPOLES.

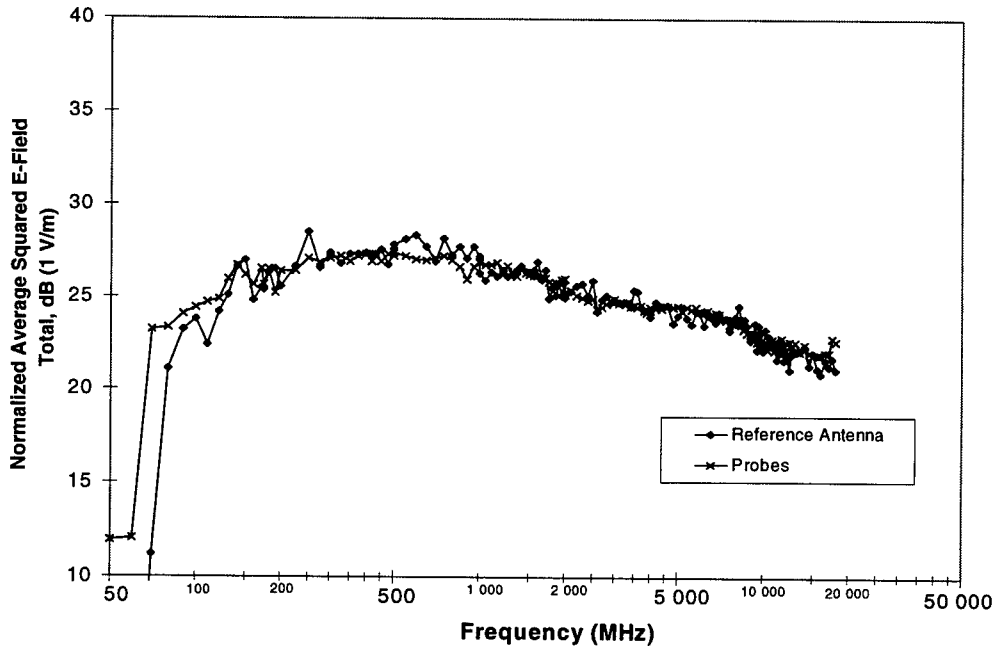
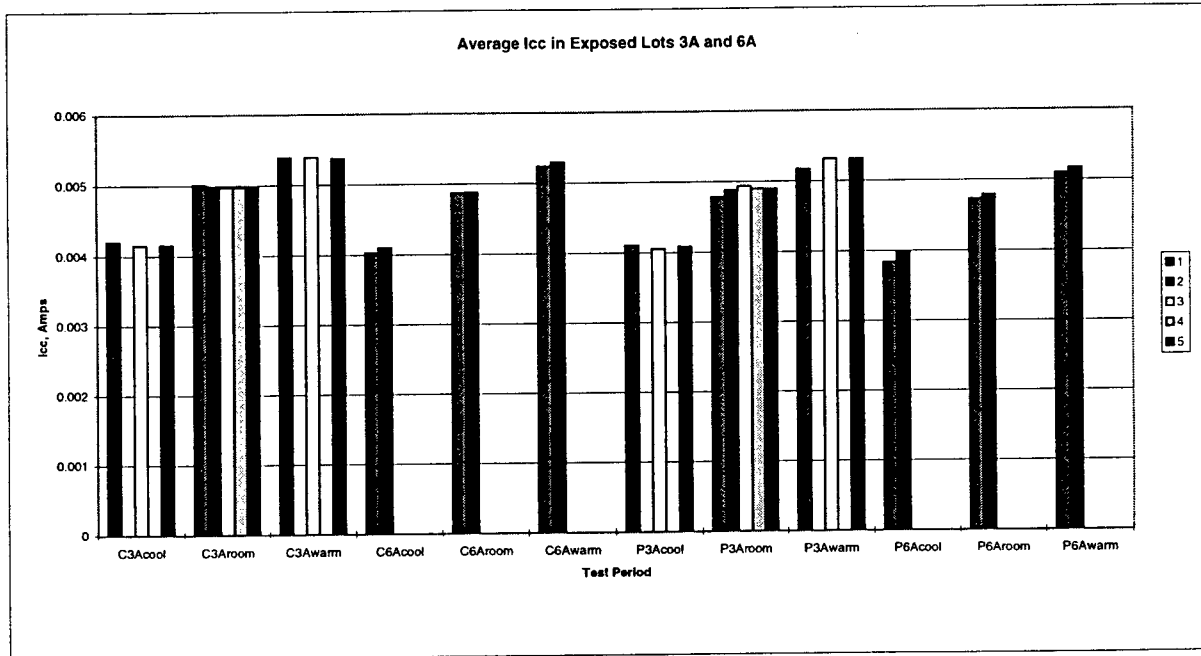
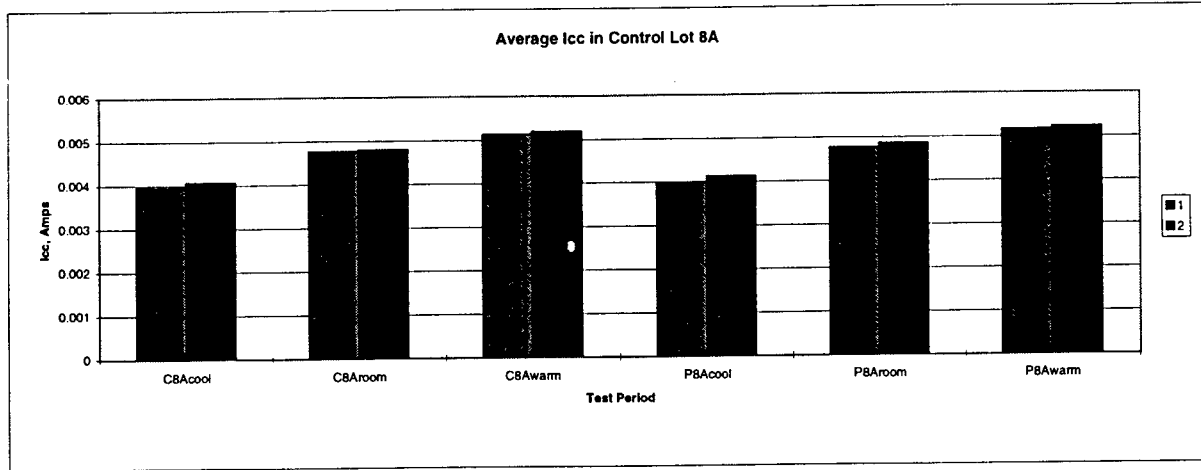

FIGURE 12. MEASUREMENTS OF NORMALIZED AVERAGE SQUARED E-FIELD TOTAL; COMPARISON OF PREDICTED FIELD STRENGTH BASED ON REFERENCE ANTENNA VS PROBE DATA.



## Appendix C: Engineering Statistical Analysis Data



Appendix C: Engineering Statistical Analysis Data

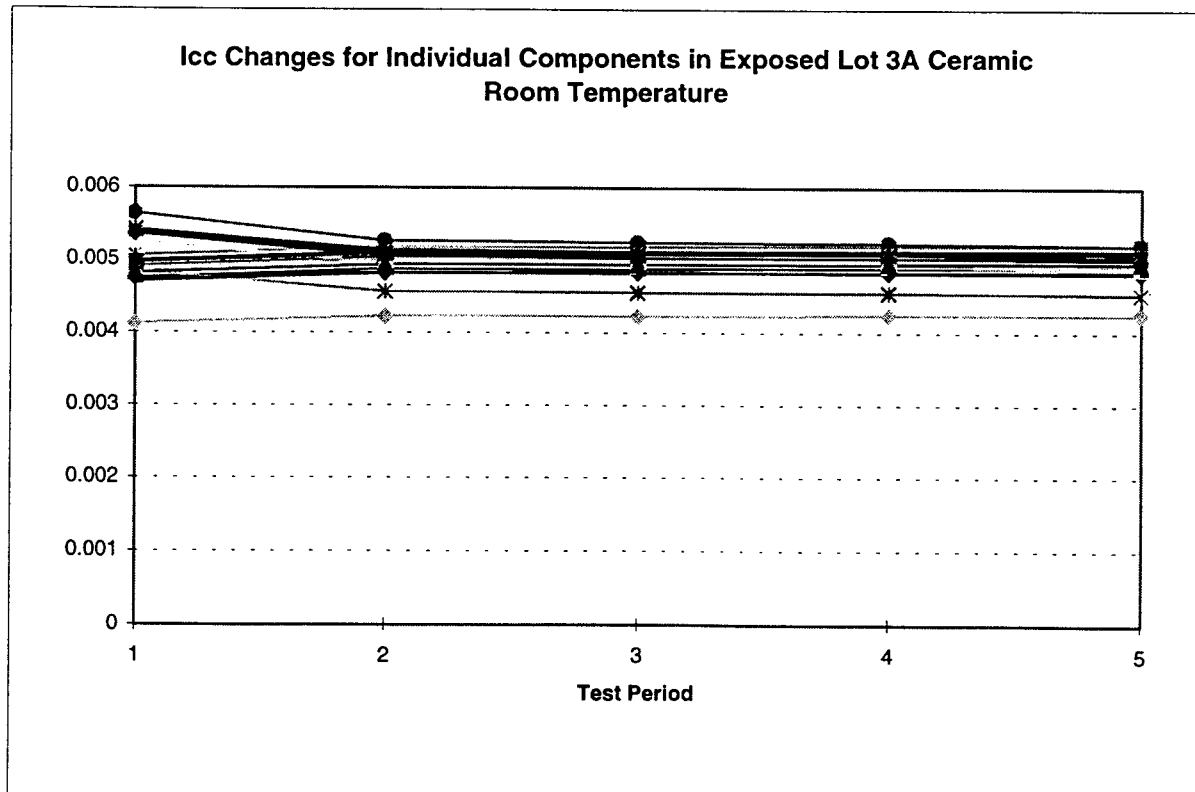
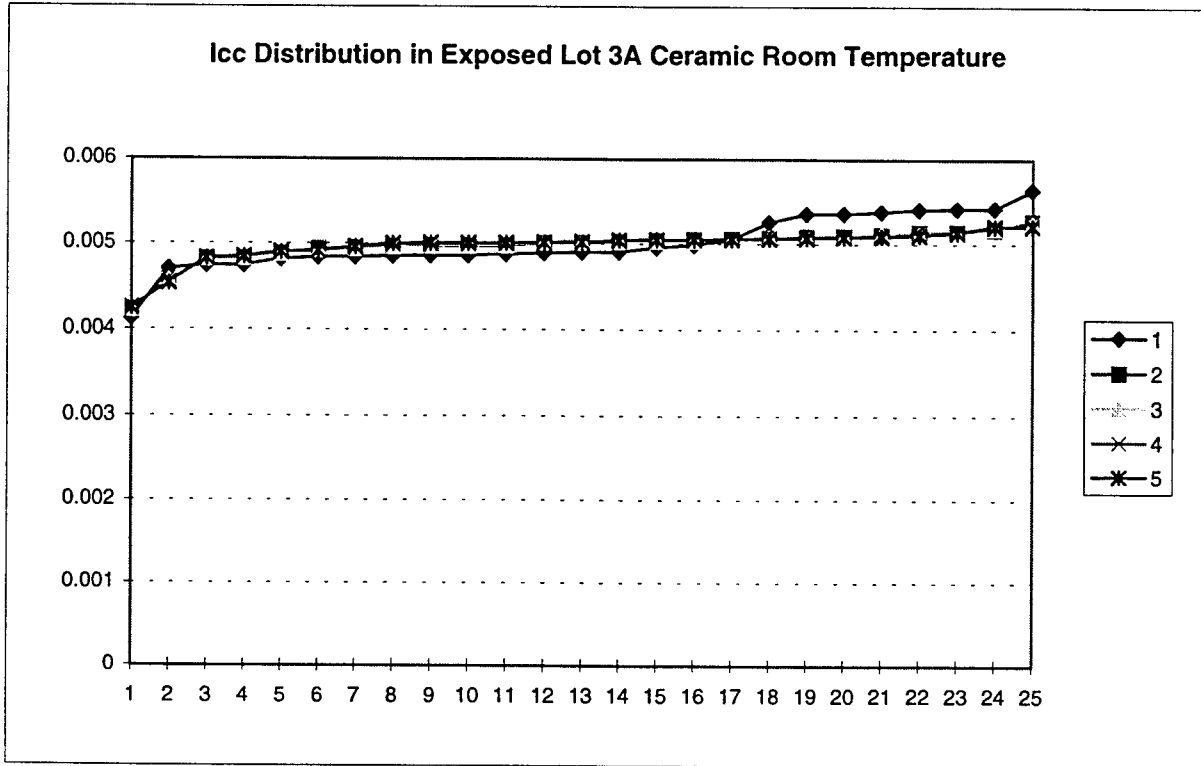

Appendix C: Engineering Statistical Analysis Data

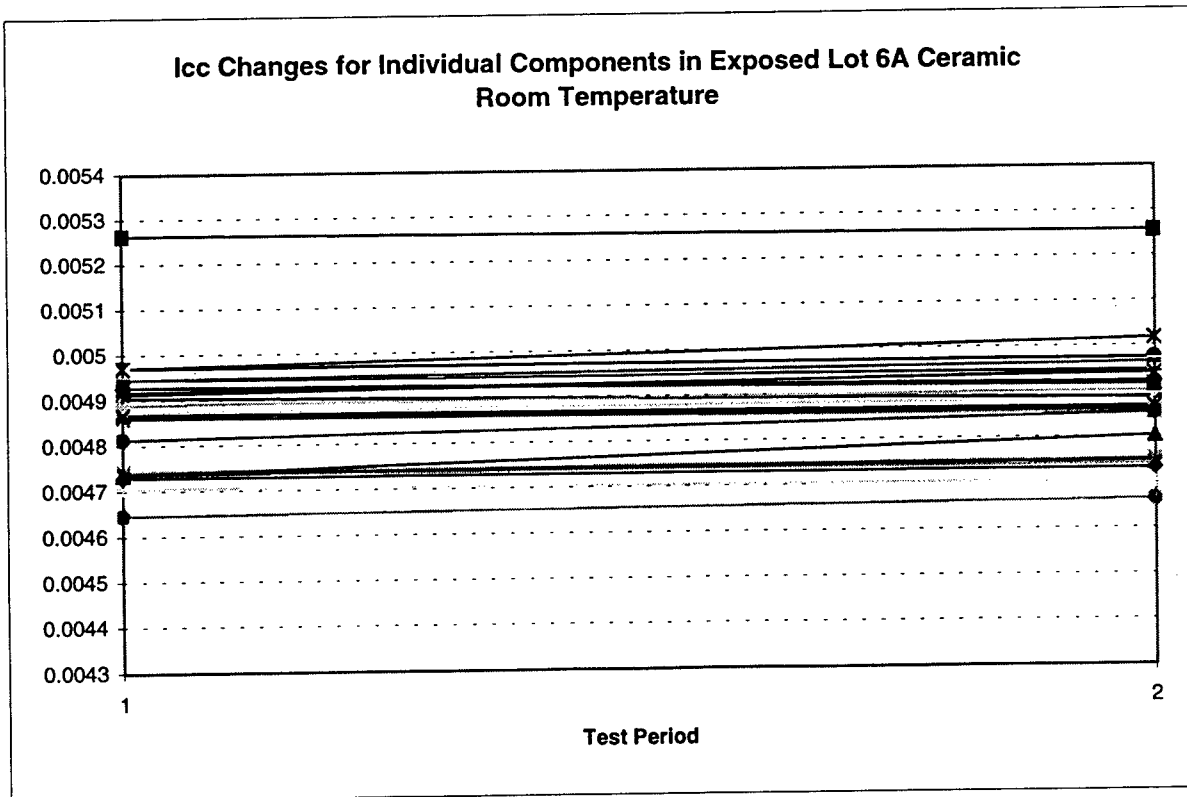
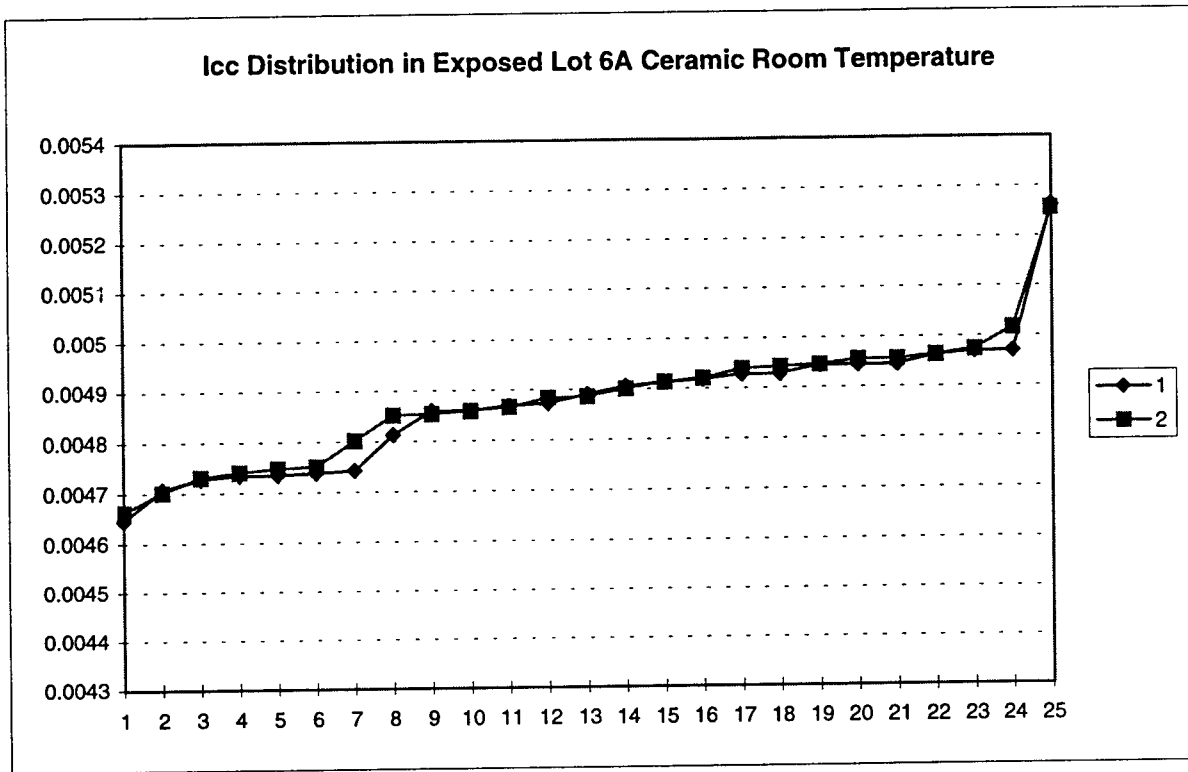

Appendix C: Engineering Statistical Analysis Data

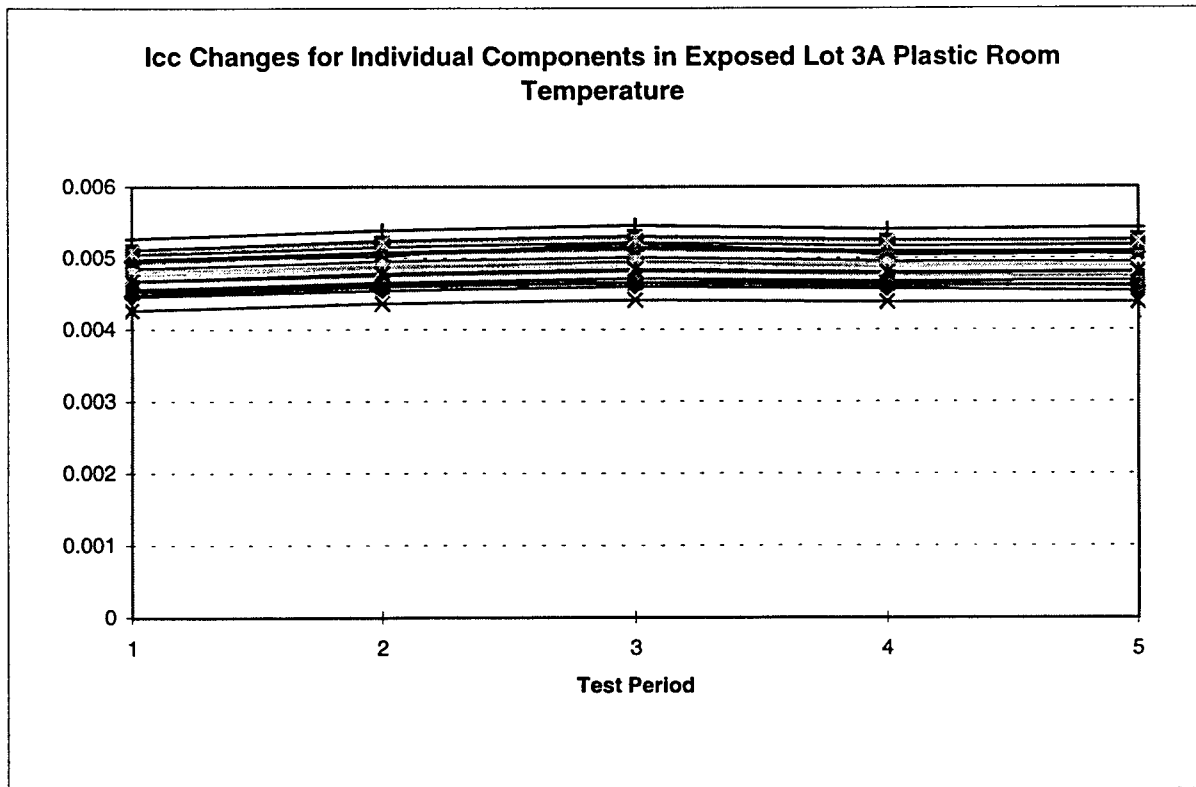
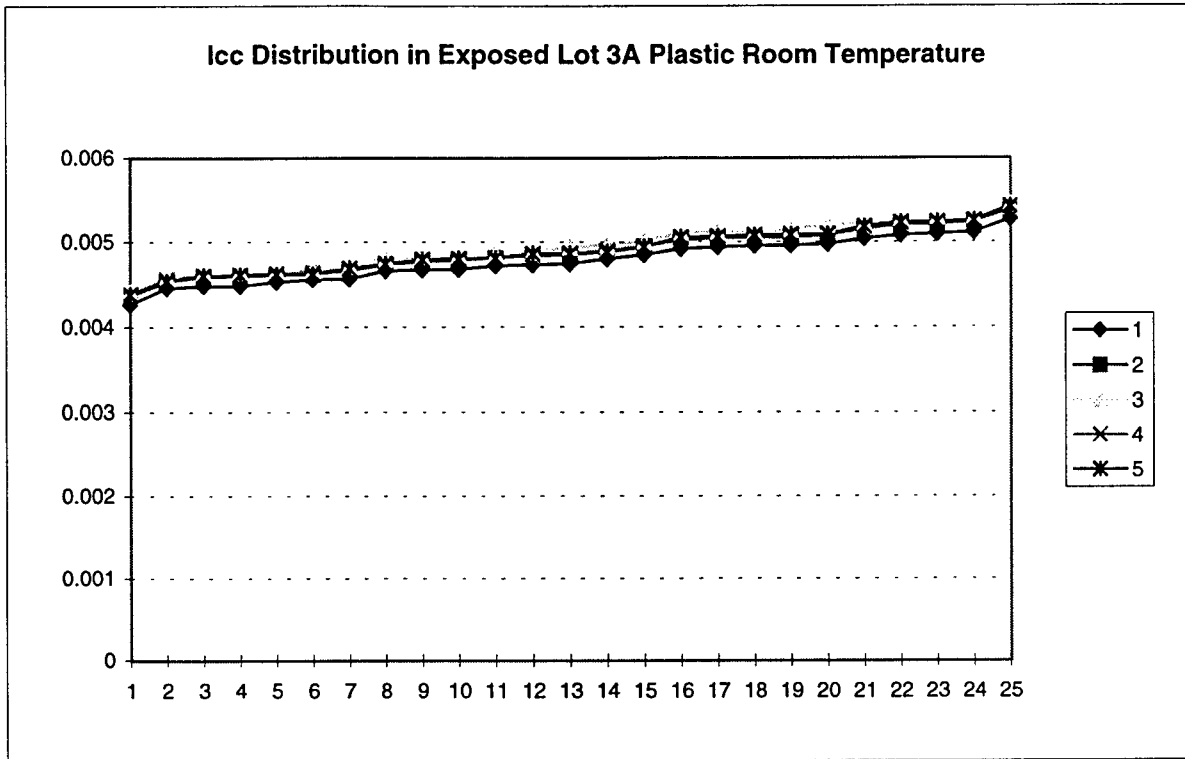

Appendix C: Engineering Statistical Analysis Data

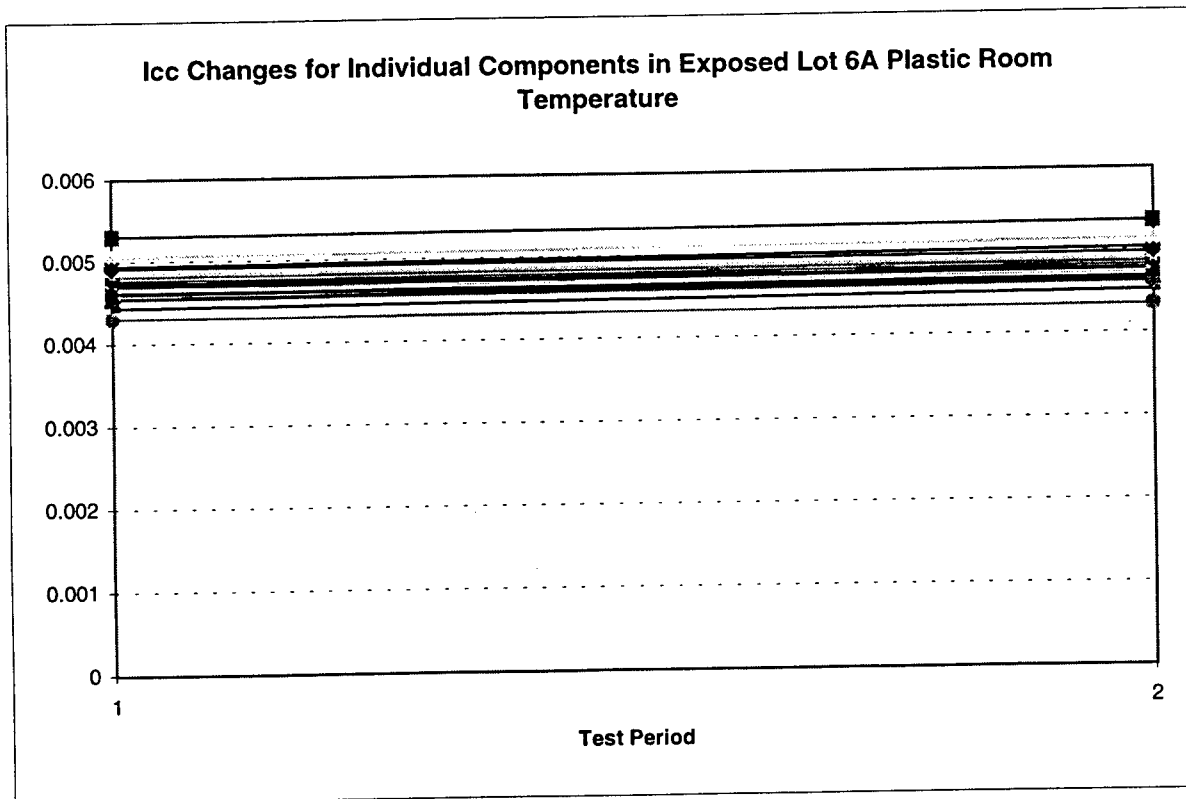
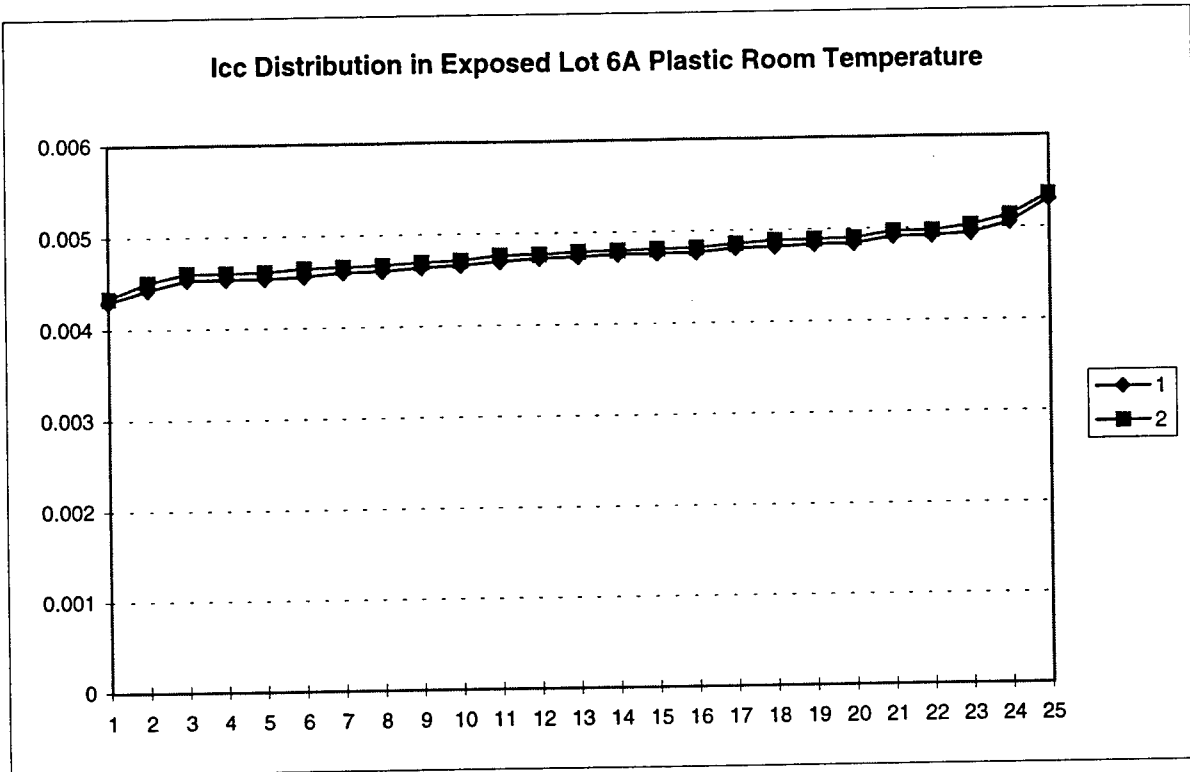

Appendix C: Engineering Statistical Analysis Data

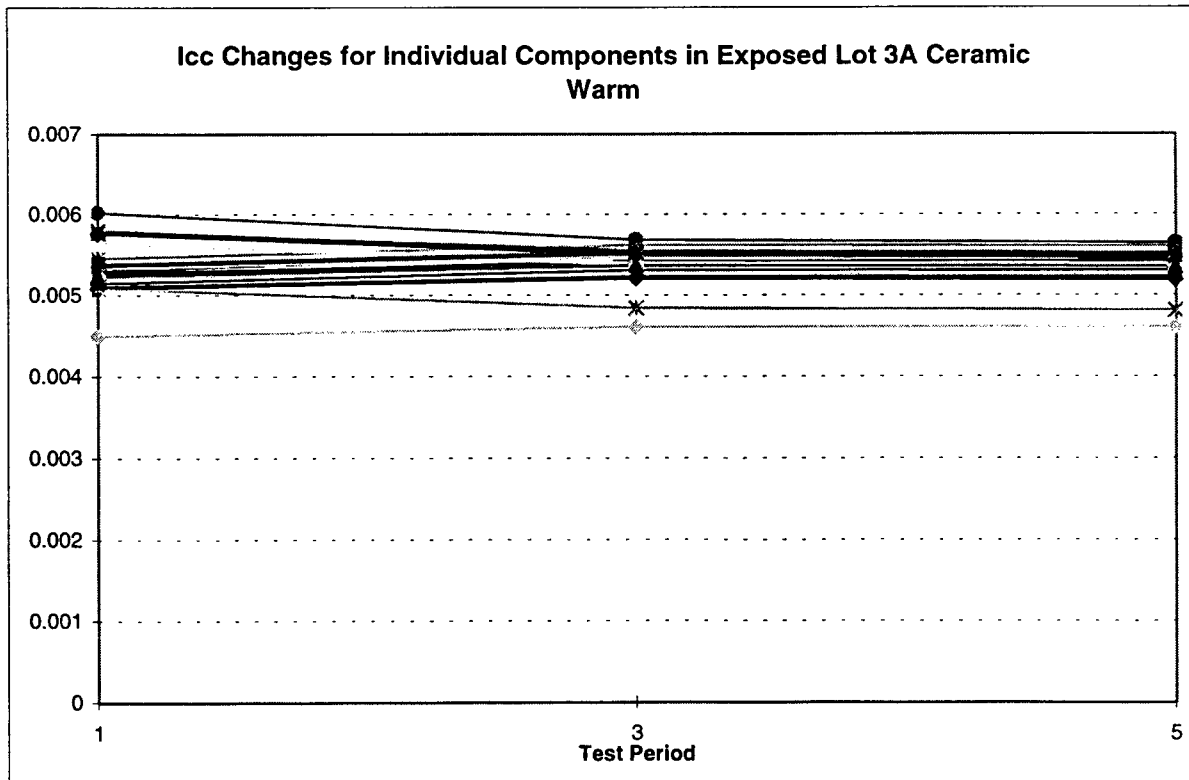
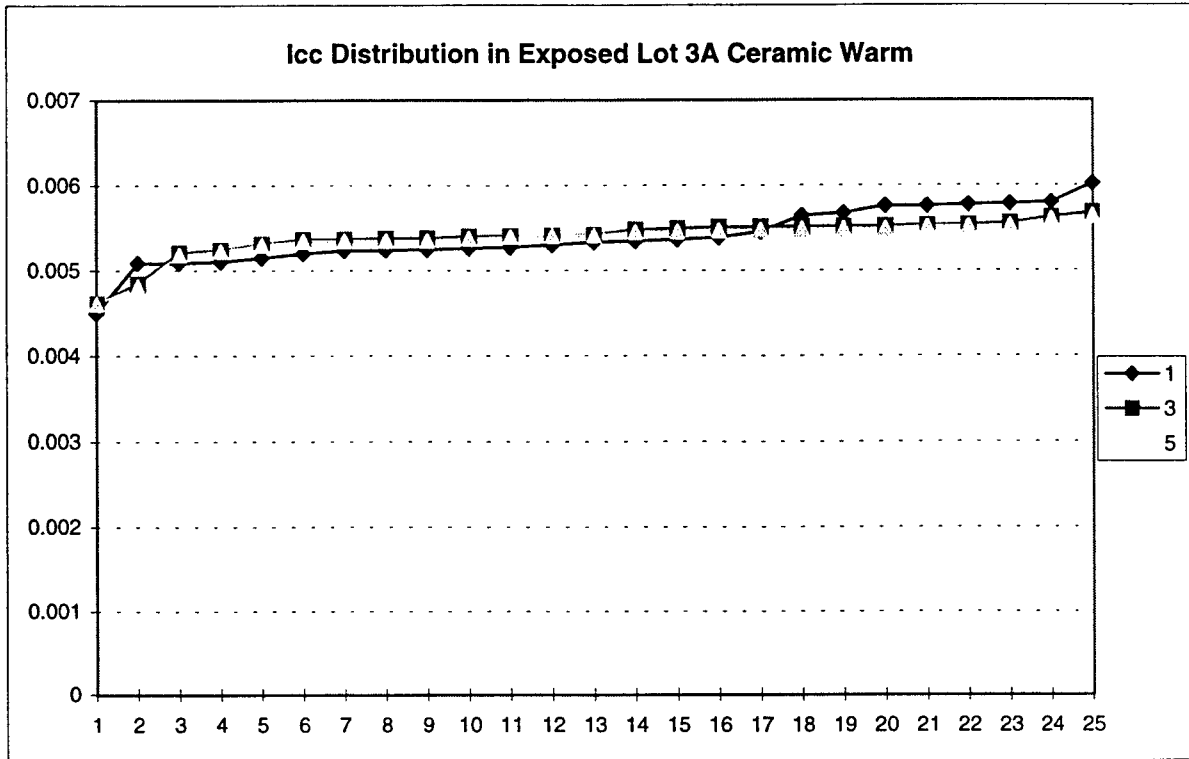

Appendix C: Engineering Statistical Analysis Data

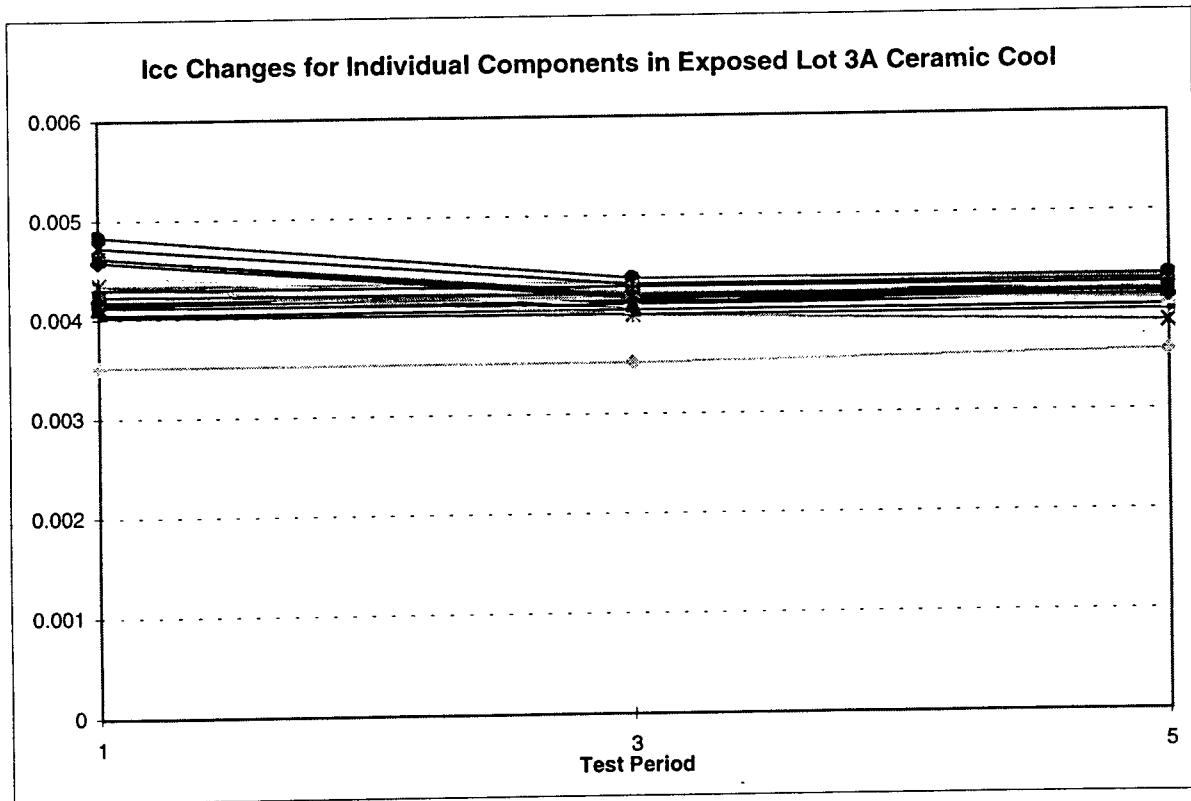
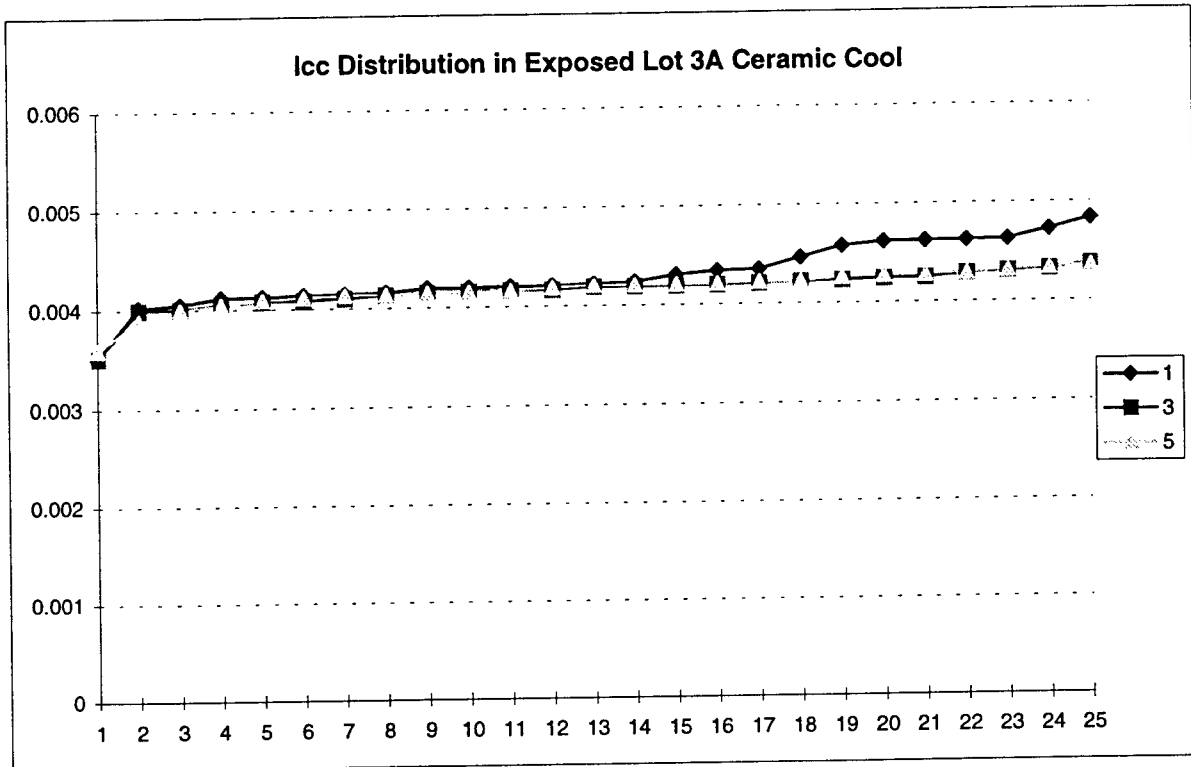





Appendix C: Engineering Statistical Analysis Data

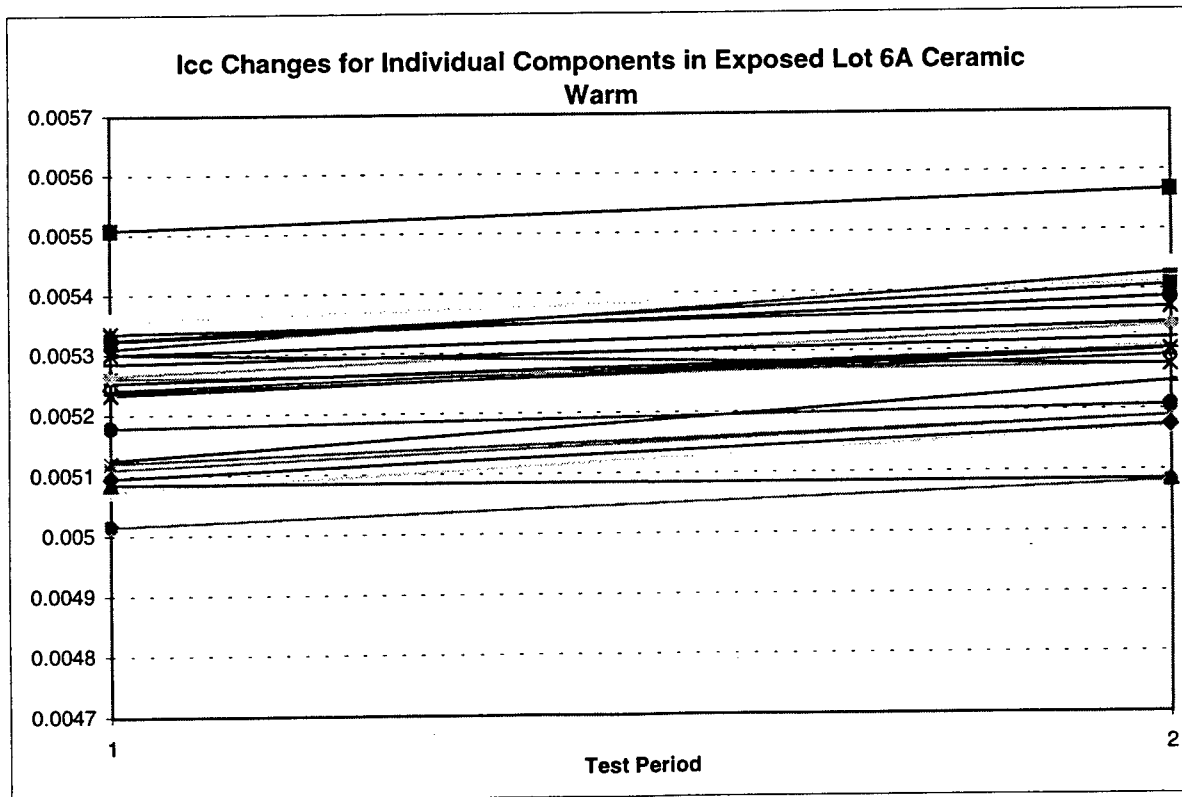
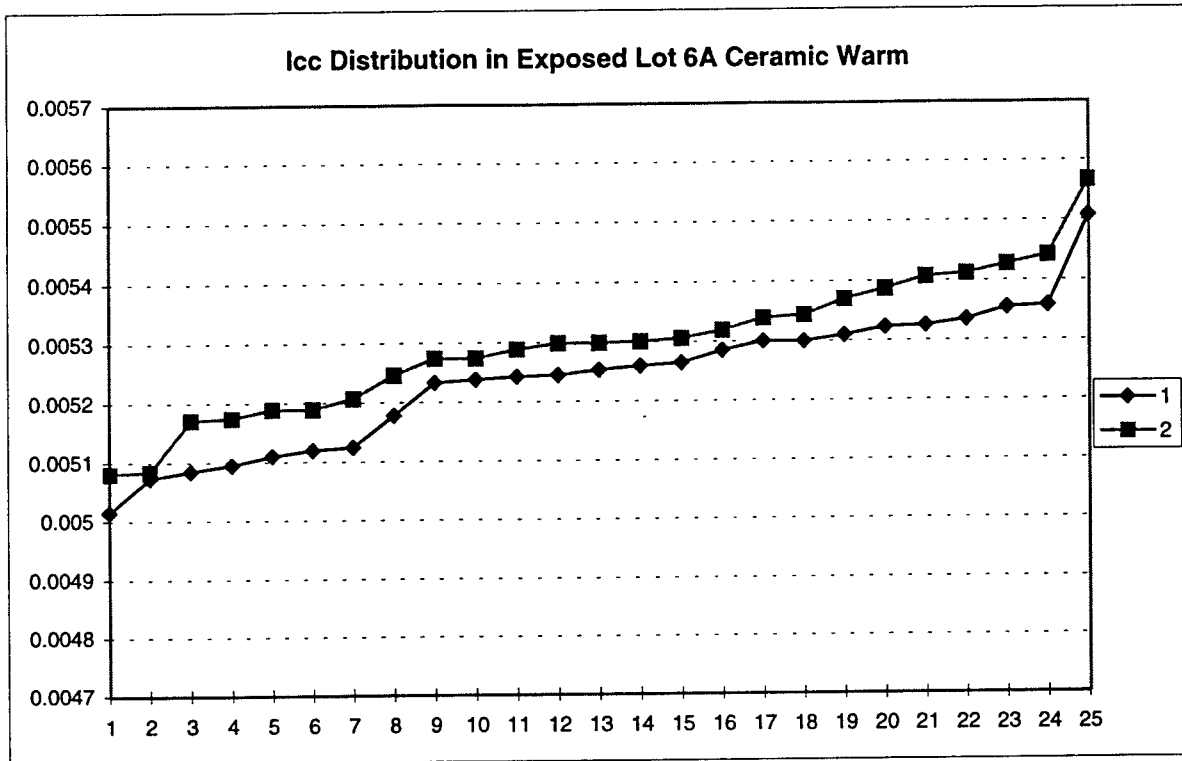

Appendix C: Engineering Statistical Analysis Data

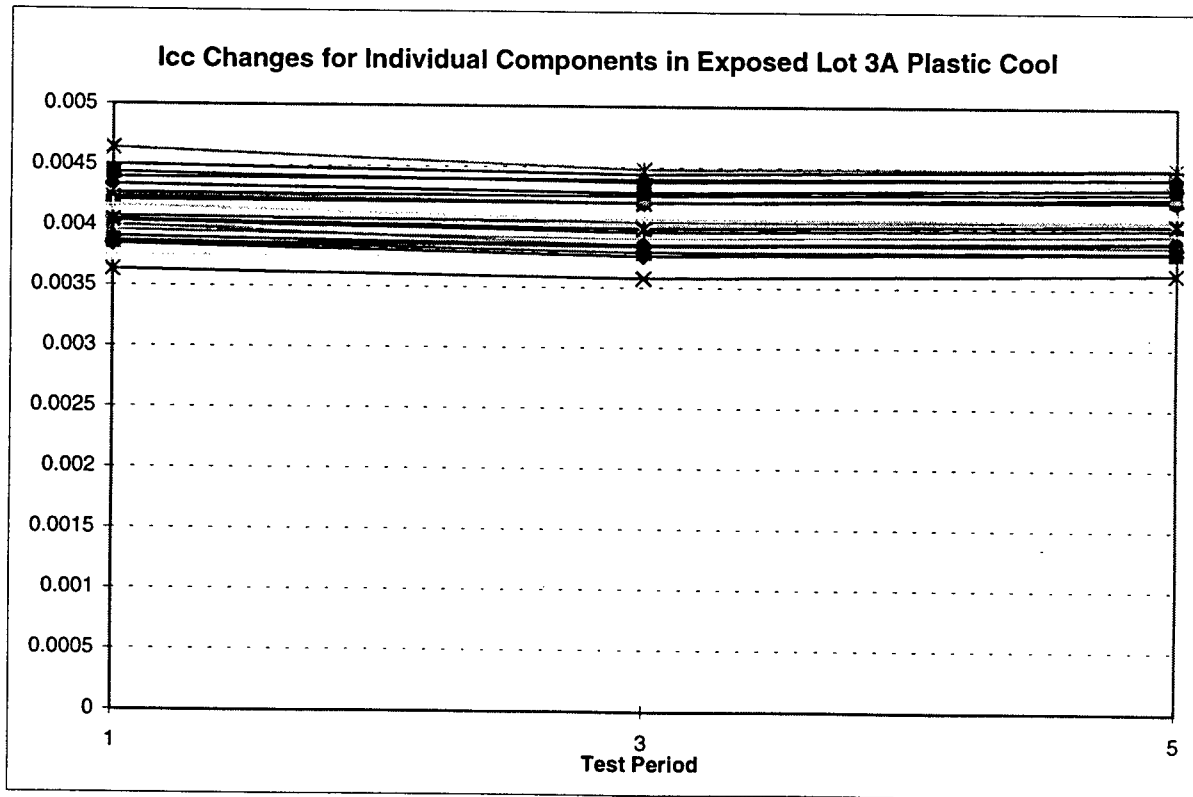
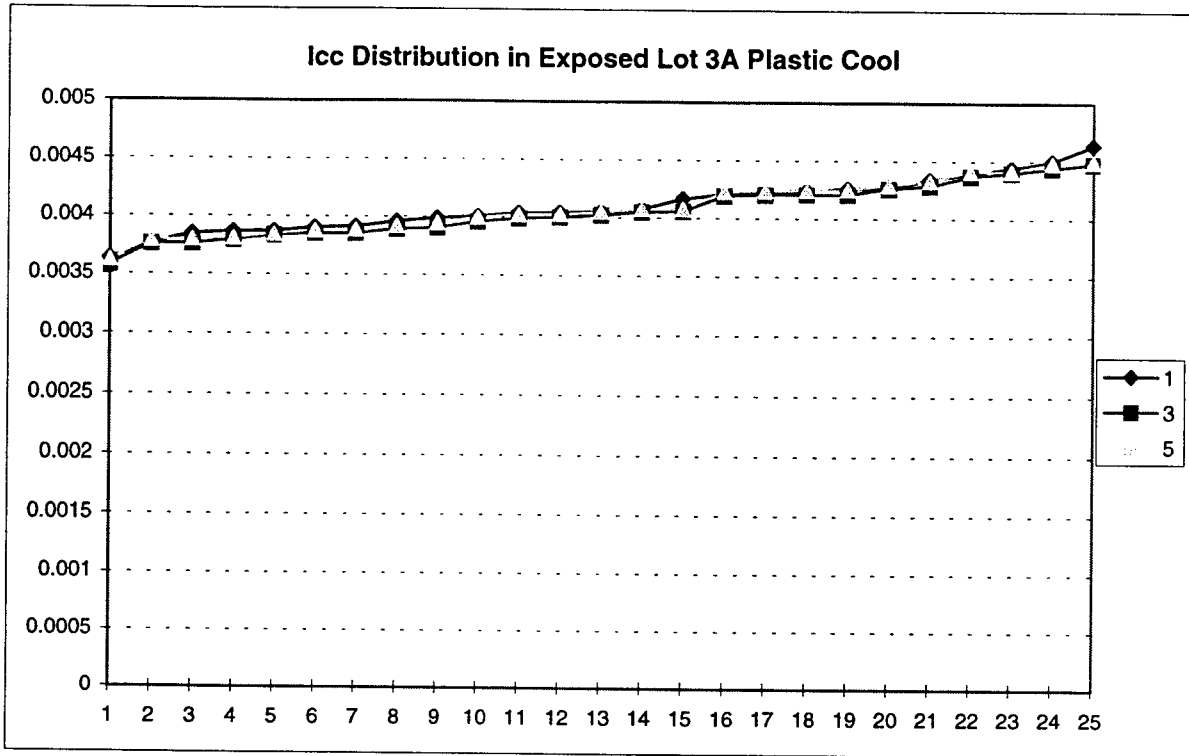

Appendix C: Engineering Statistical Analysis Data

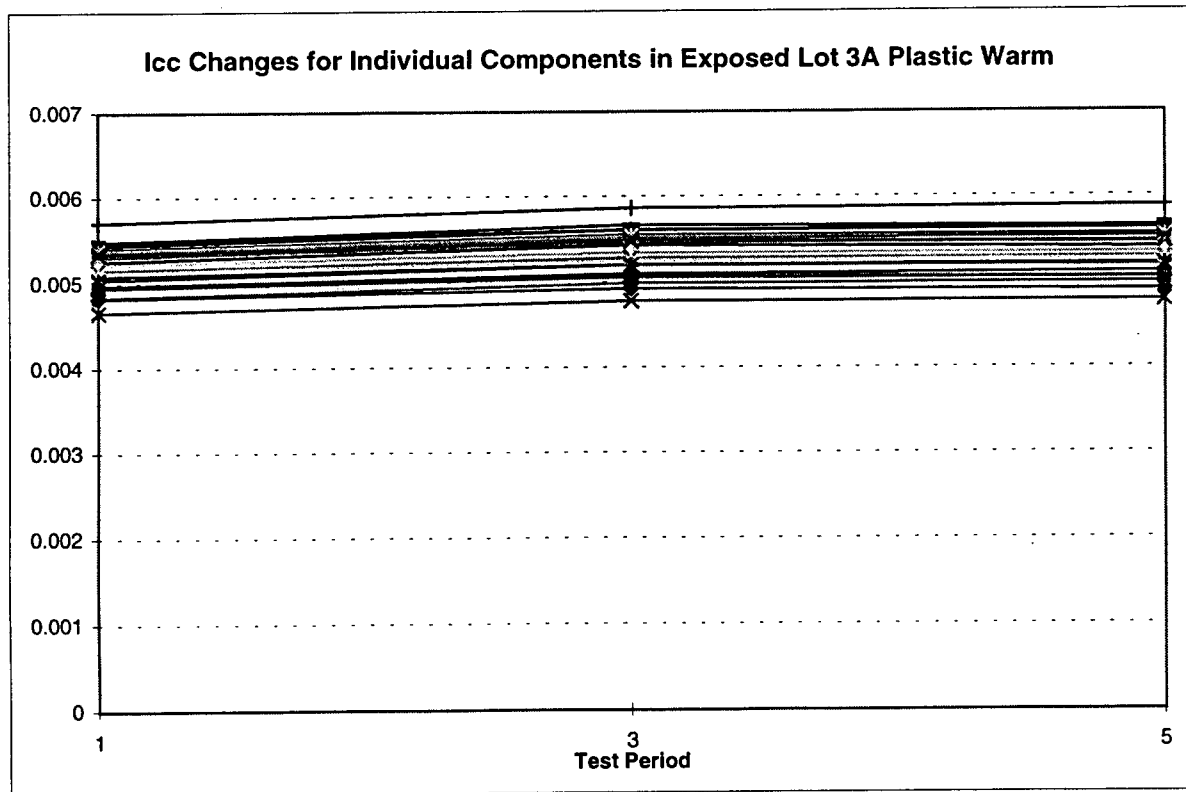
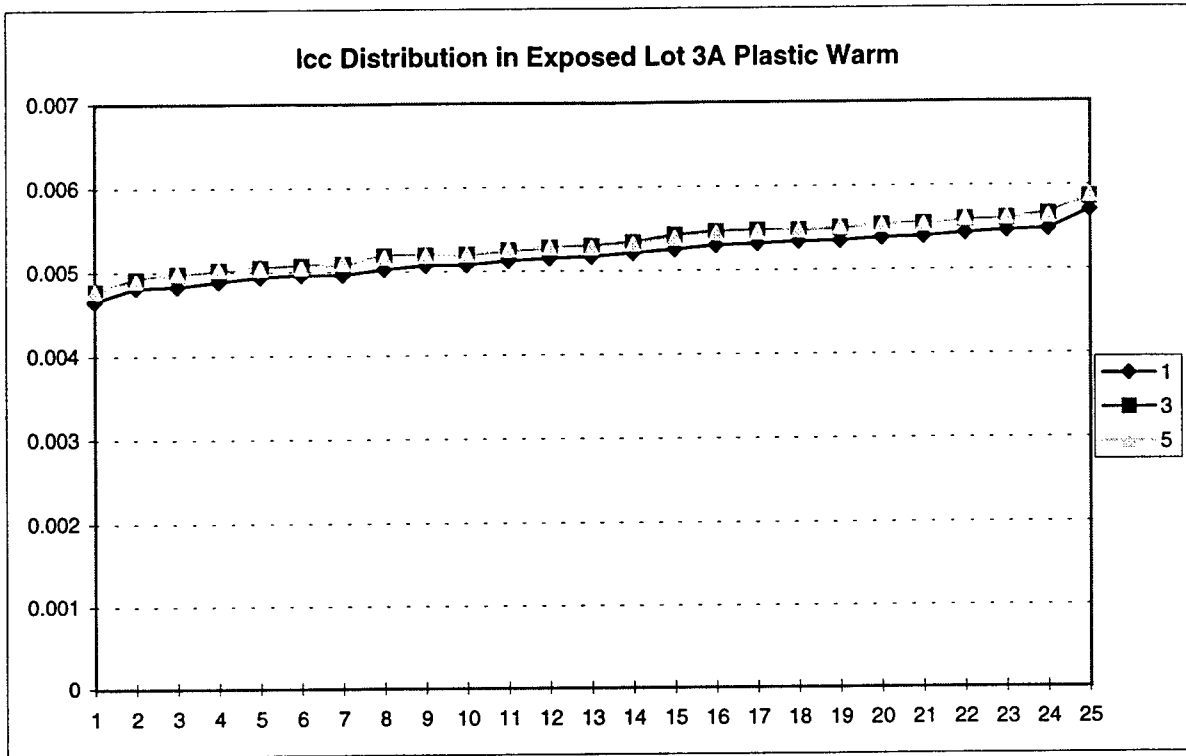

Appendix C: Engineering Statistical Analysis Data

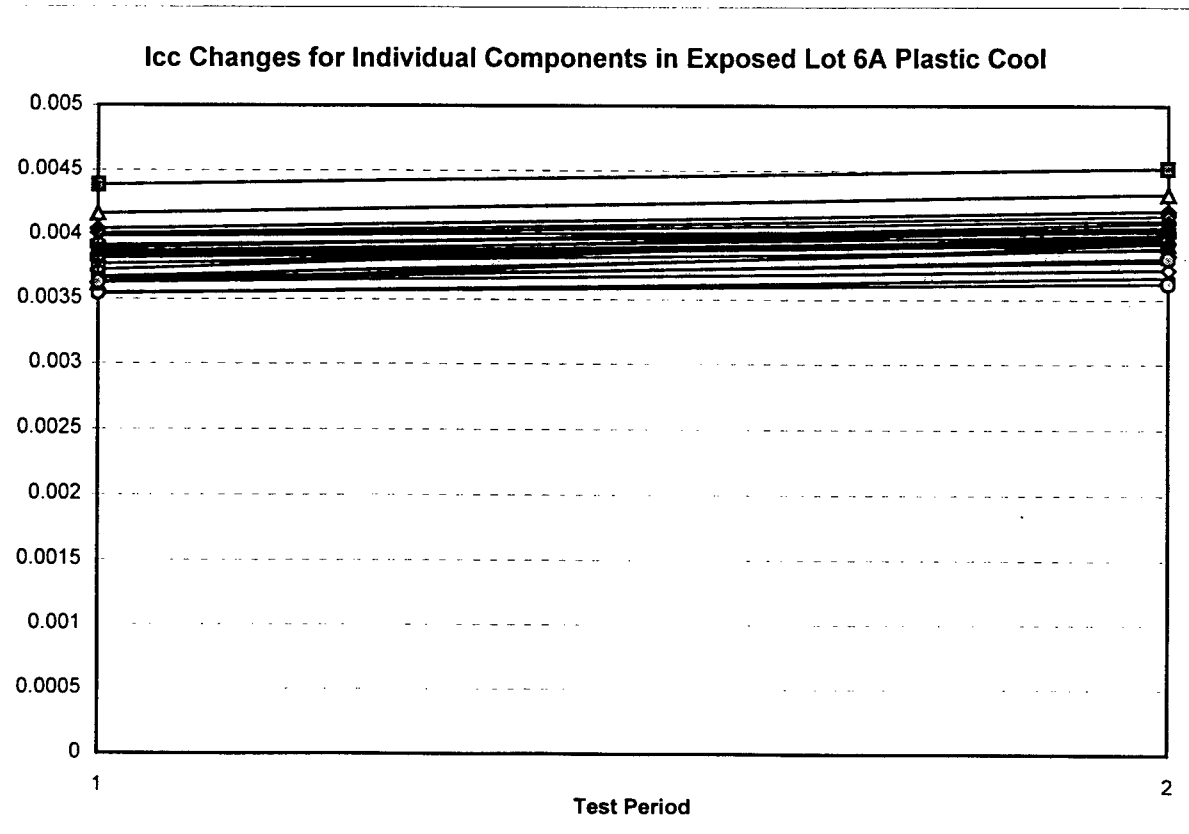
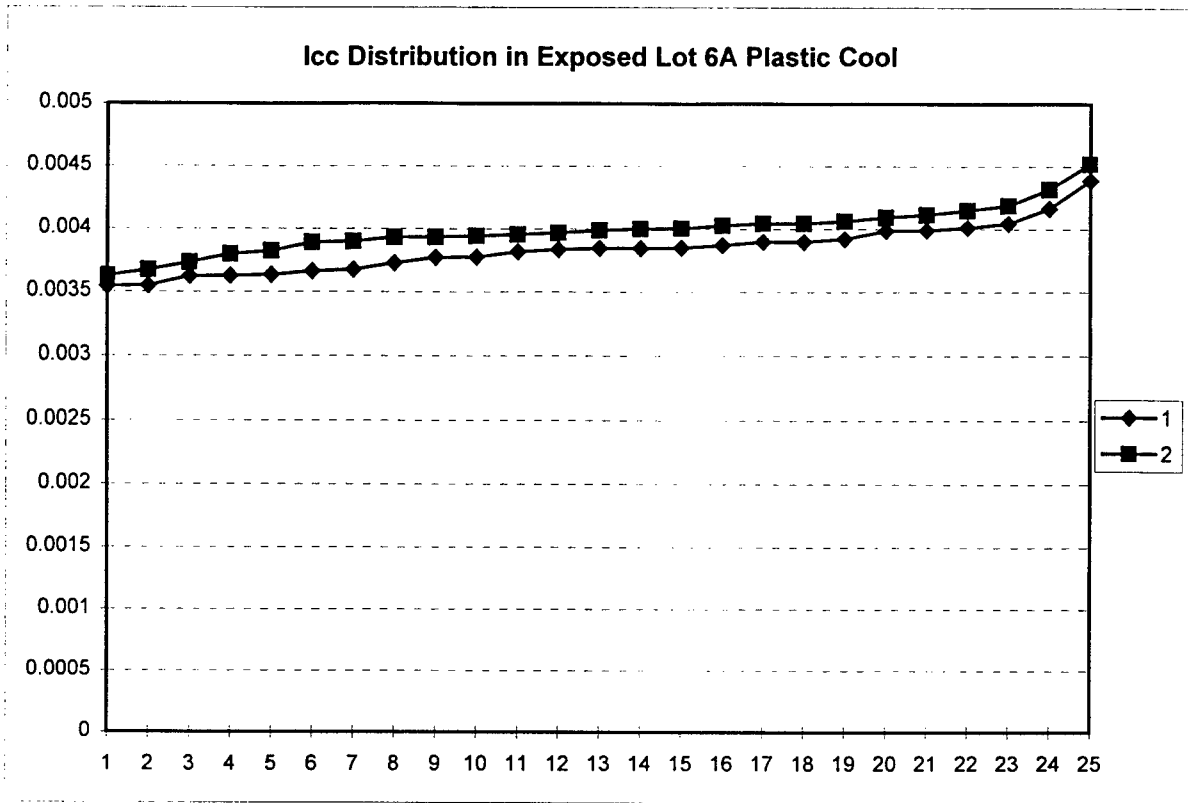

Appendix C: Engineering Statistical Analysis Data

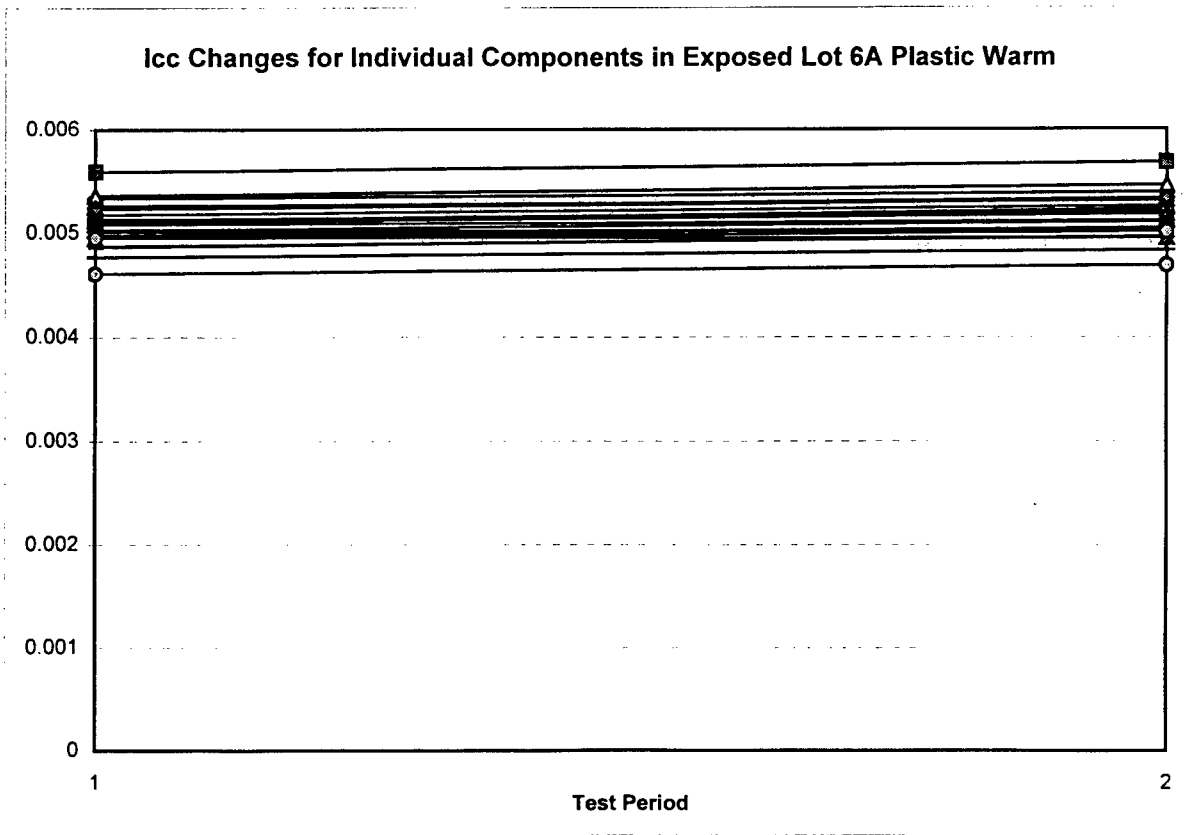
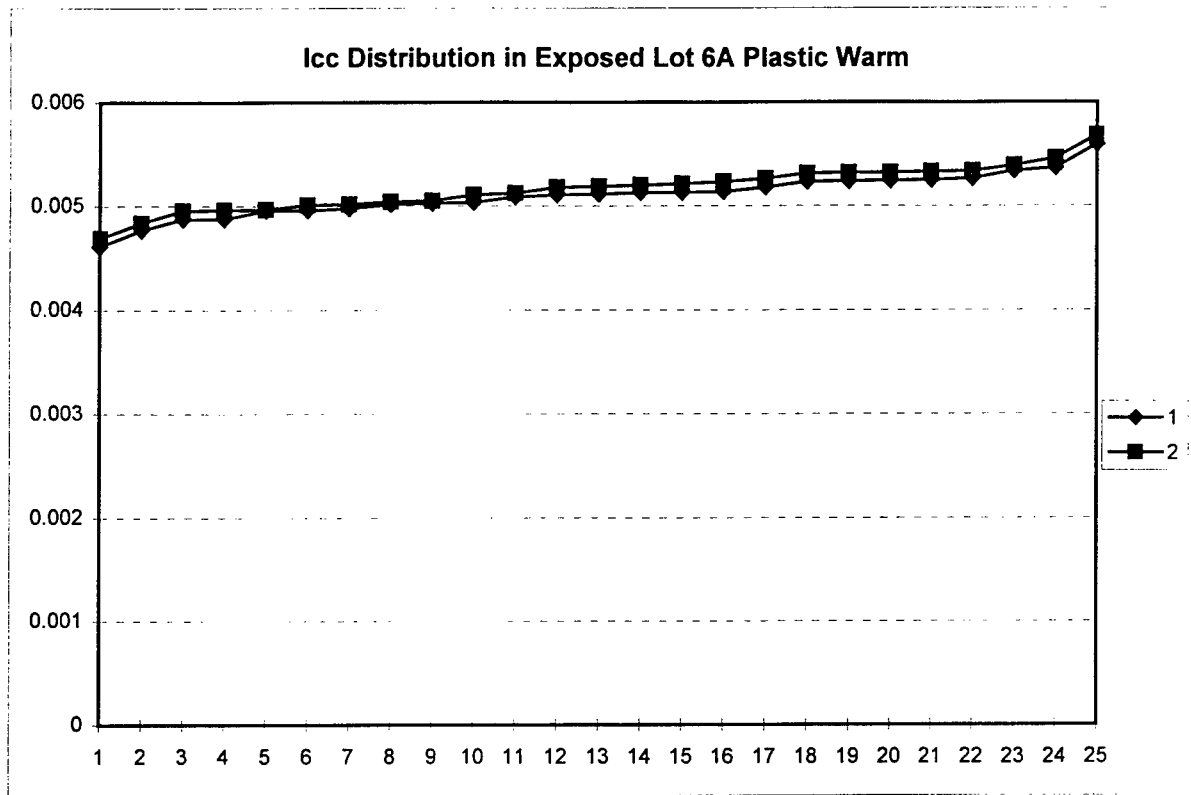

# Appendix C: Engineering Statistical Analysis Data

Average lee in Control Lot 8A

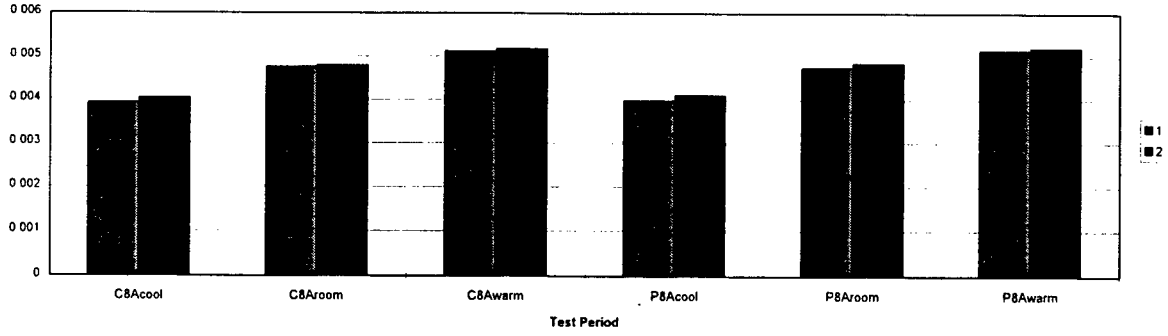

Average lee in Control Lot 8A

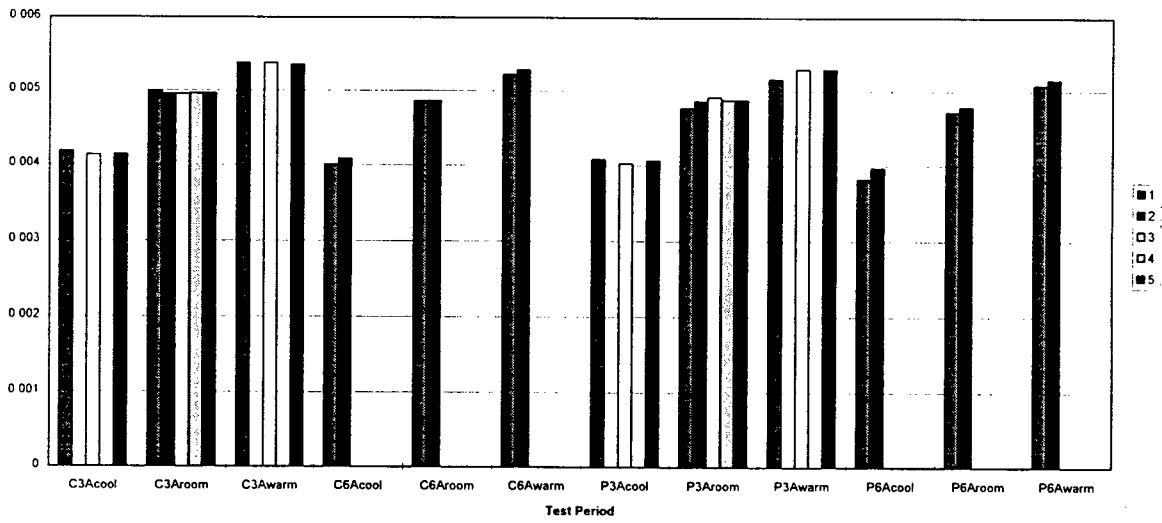

## Appendix C: Engineering Statistical Analysis Data

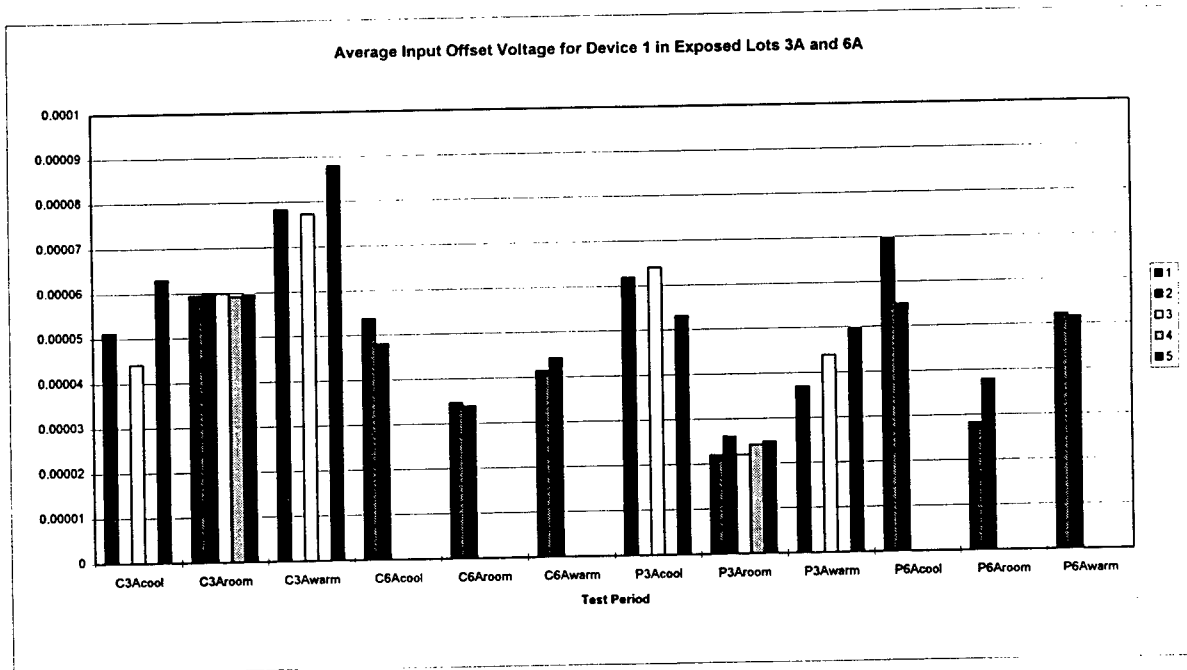
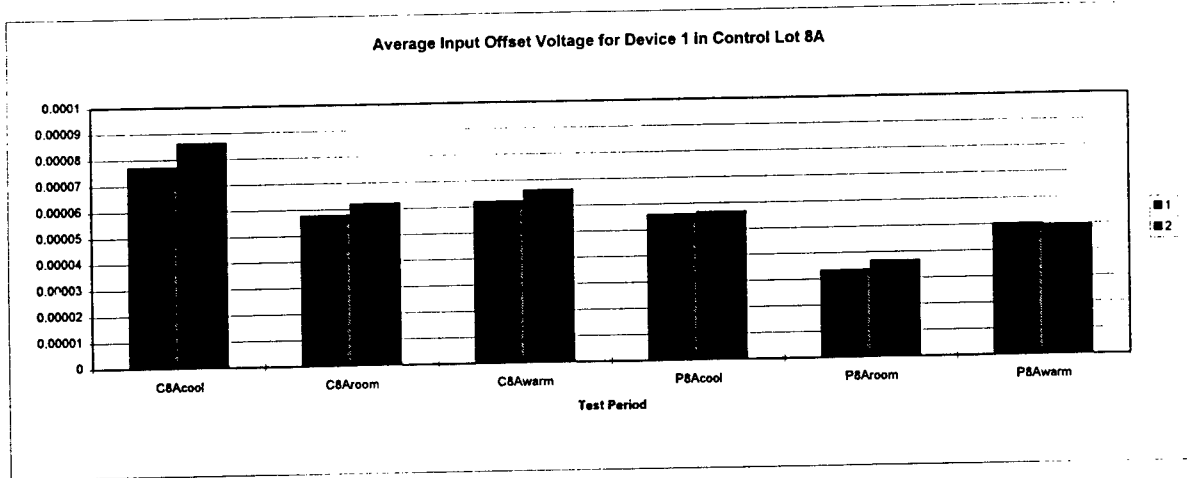

Appendix C: Engineering Statistical Analysis Data

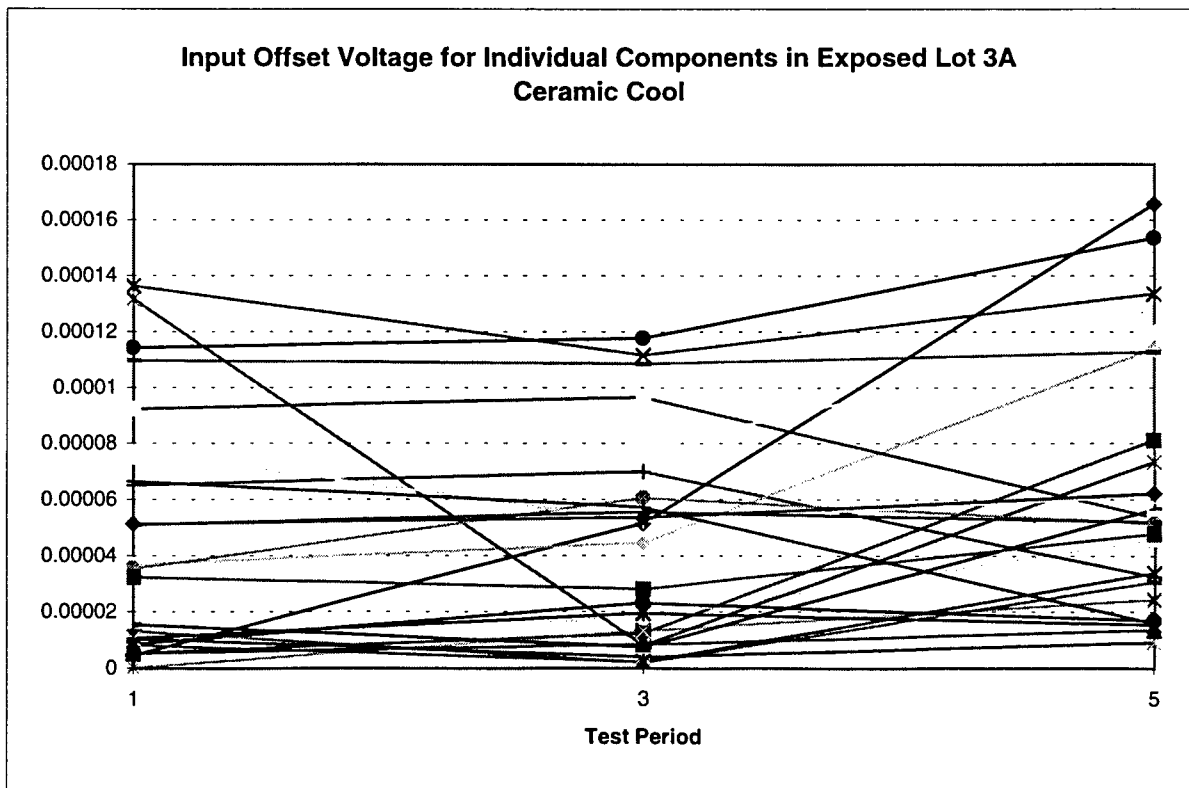
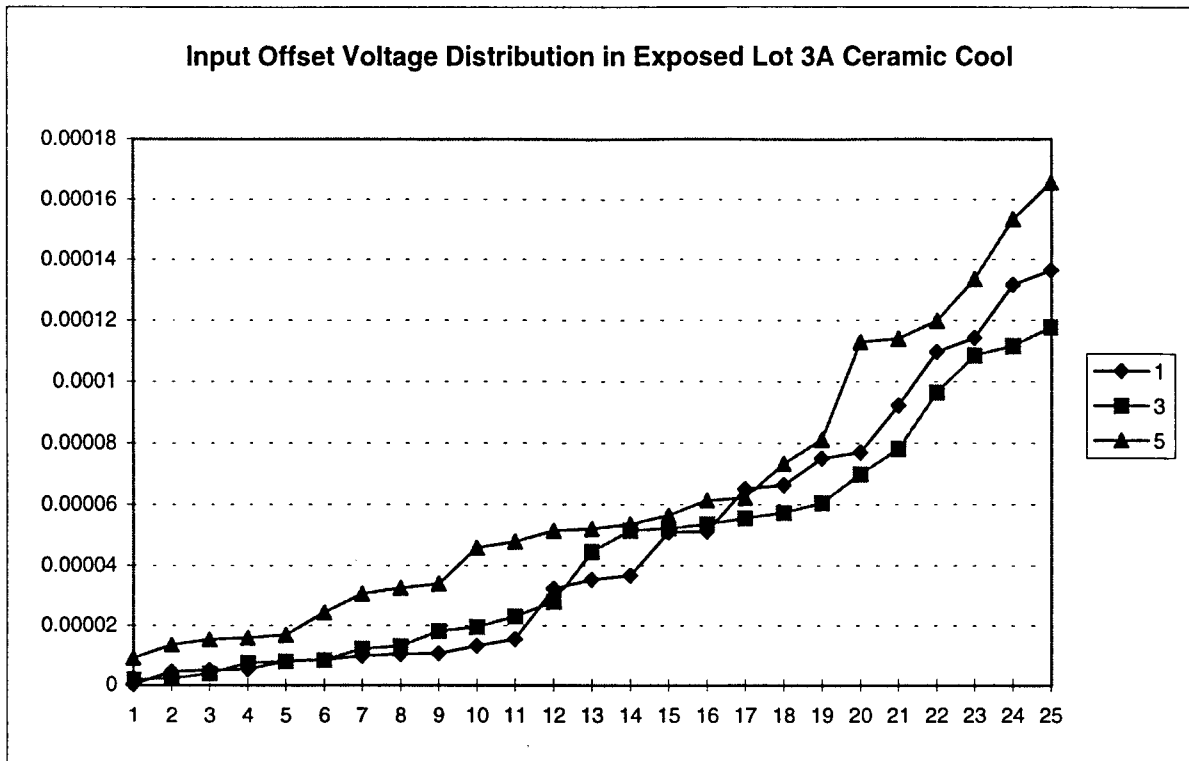



Appendix C: Engineering Statistical Analysis Data

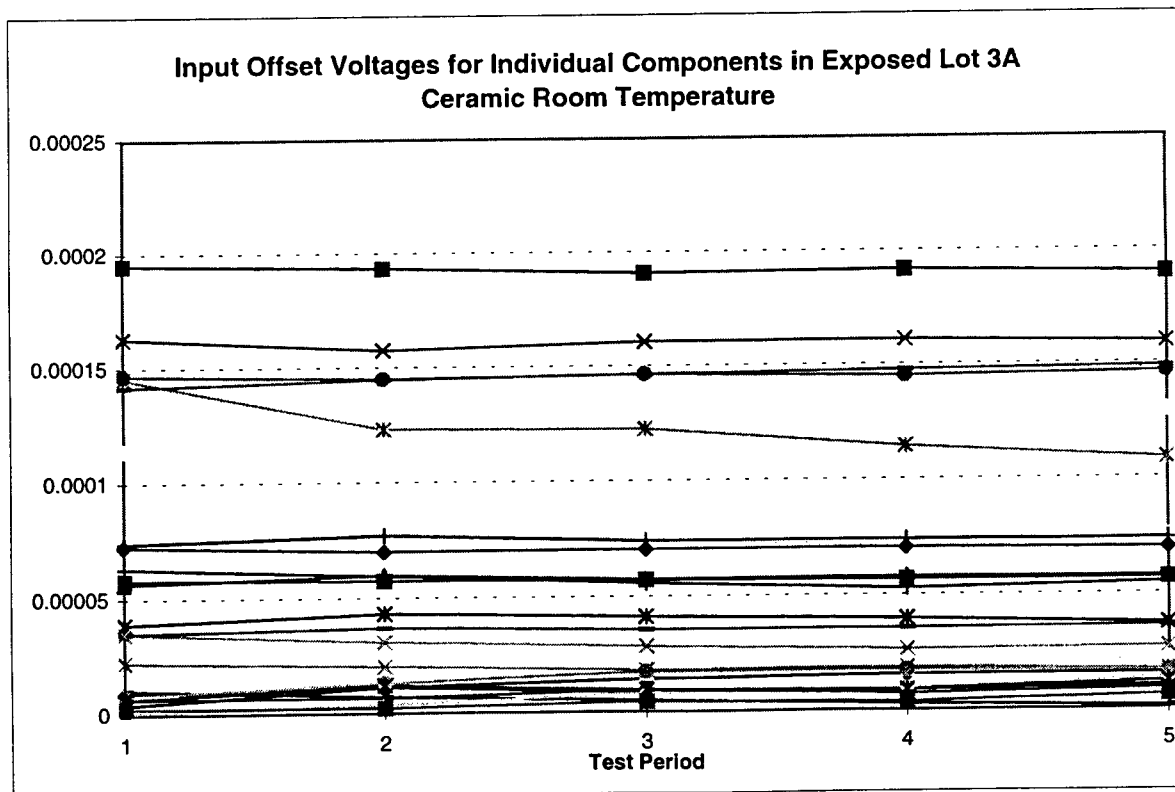
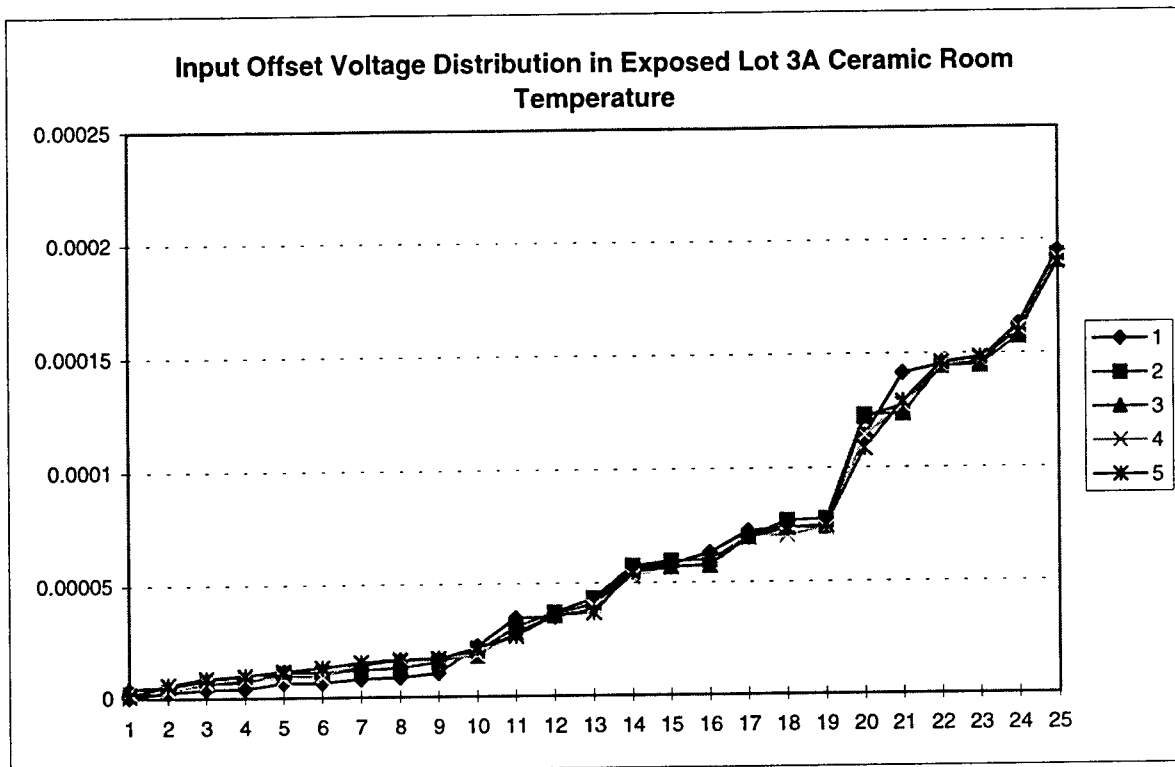

Appendix C: Engineering Statistical Analysis Data

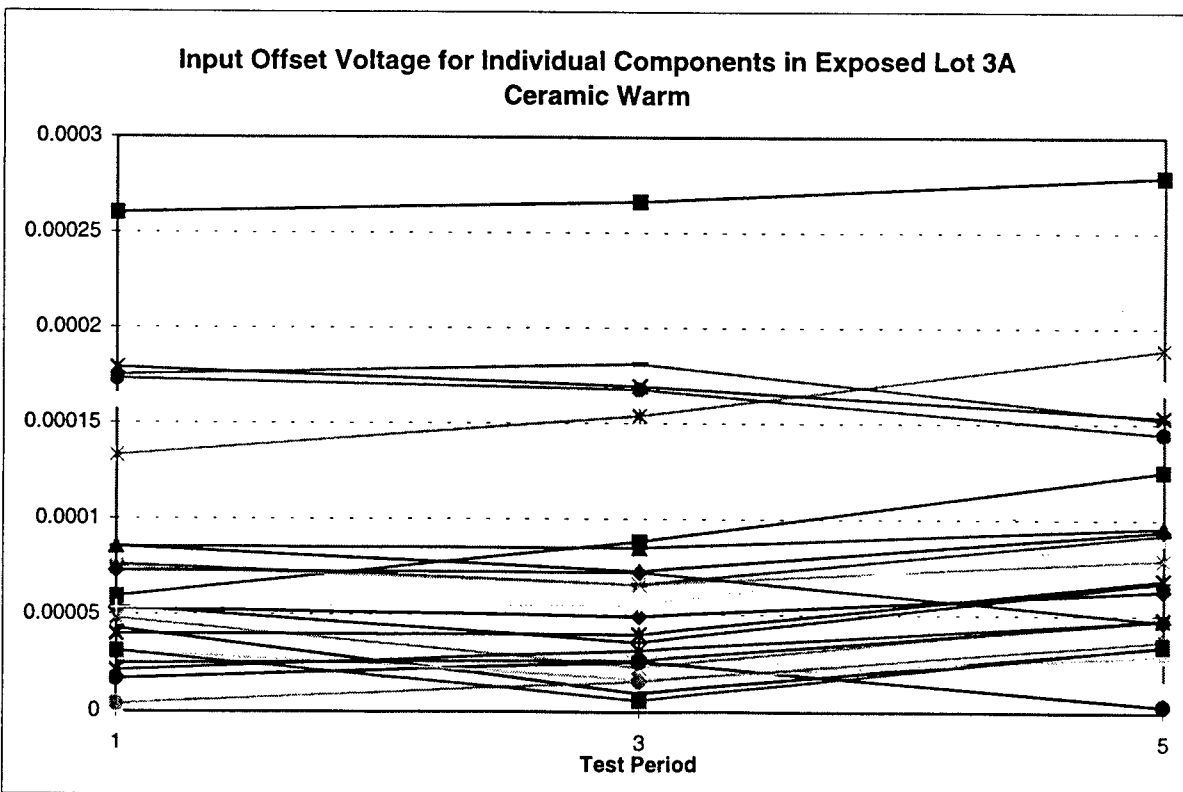
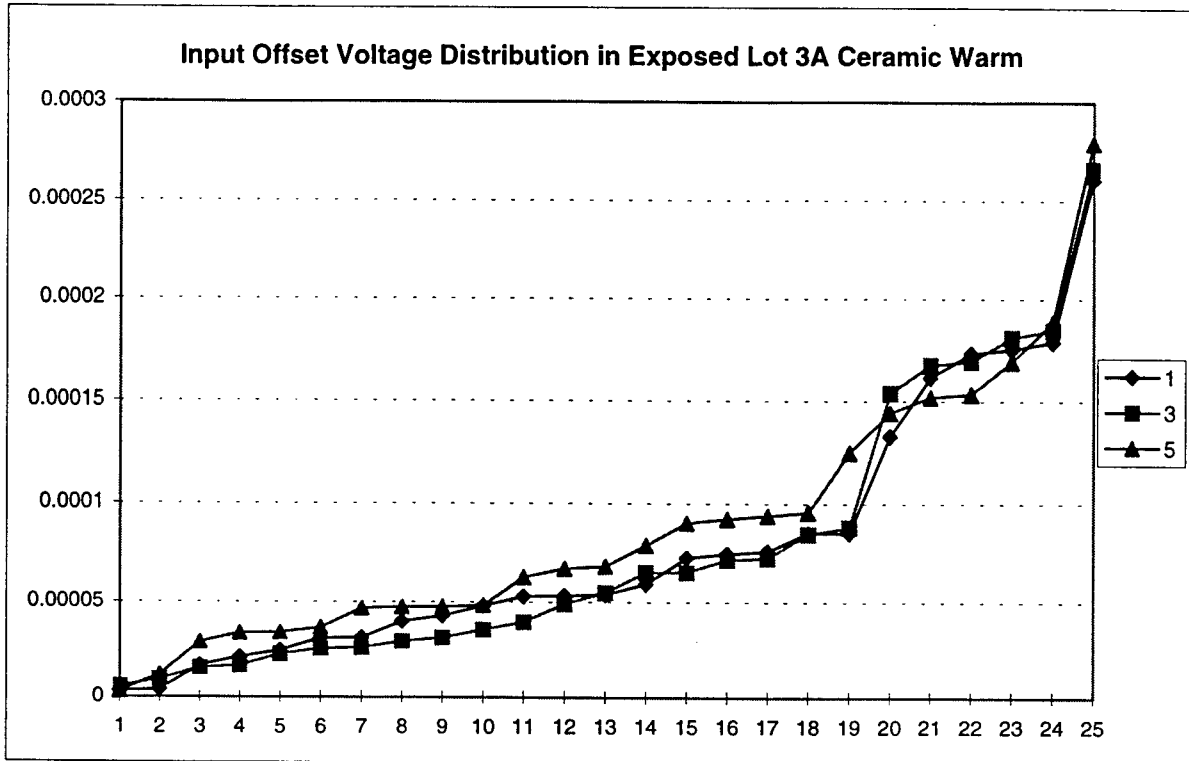

Appendix C: Engineering Statistical Analysis Data

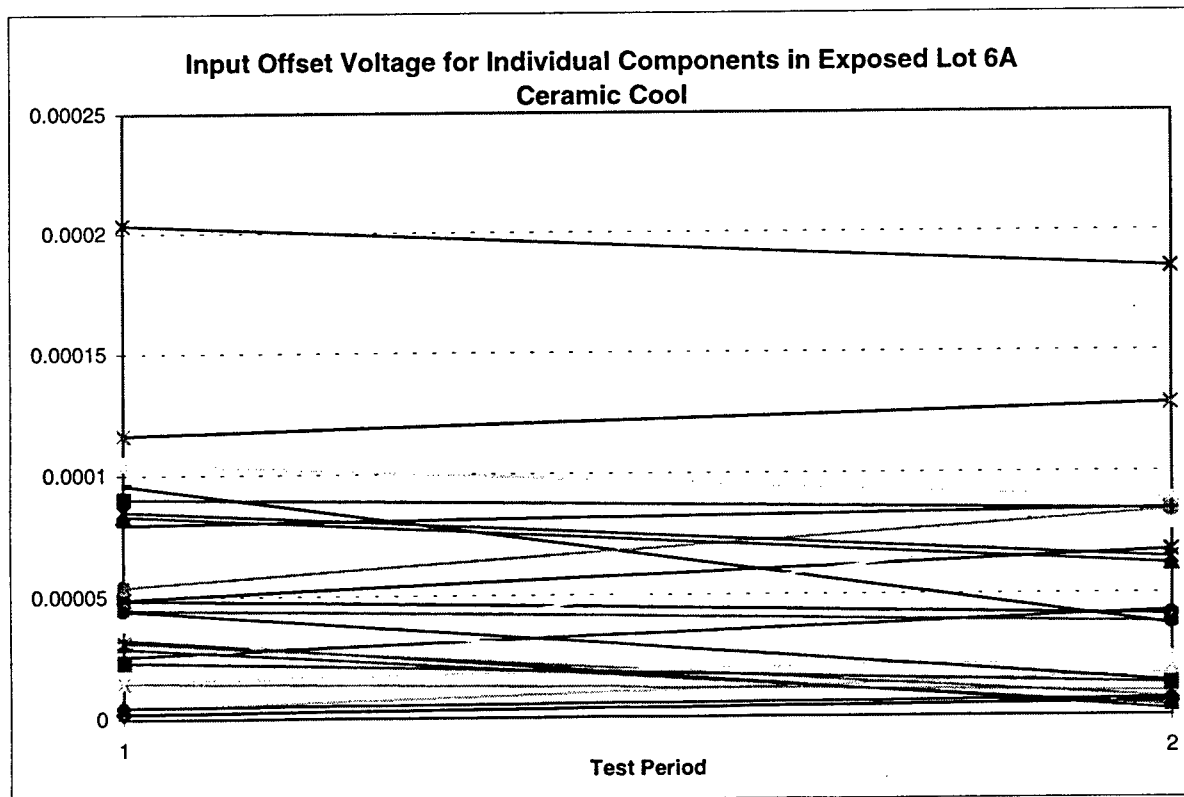
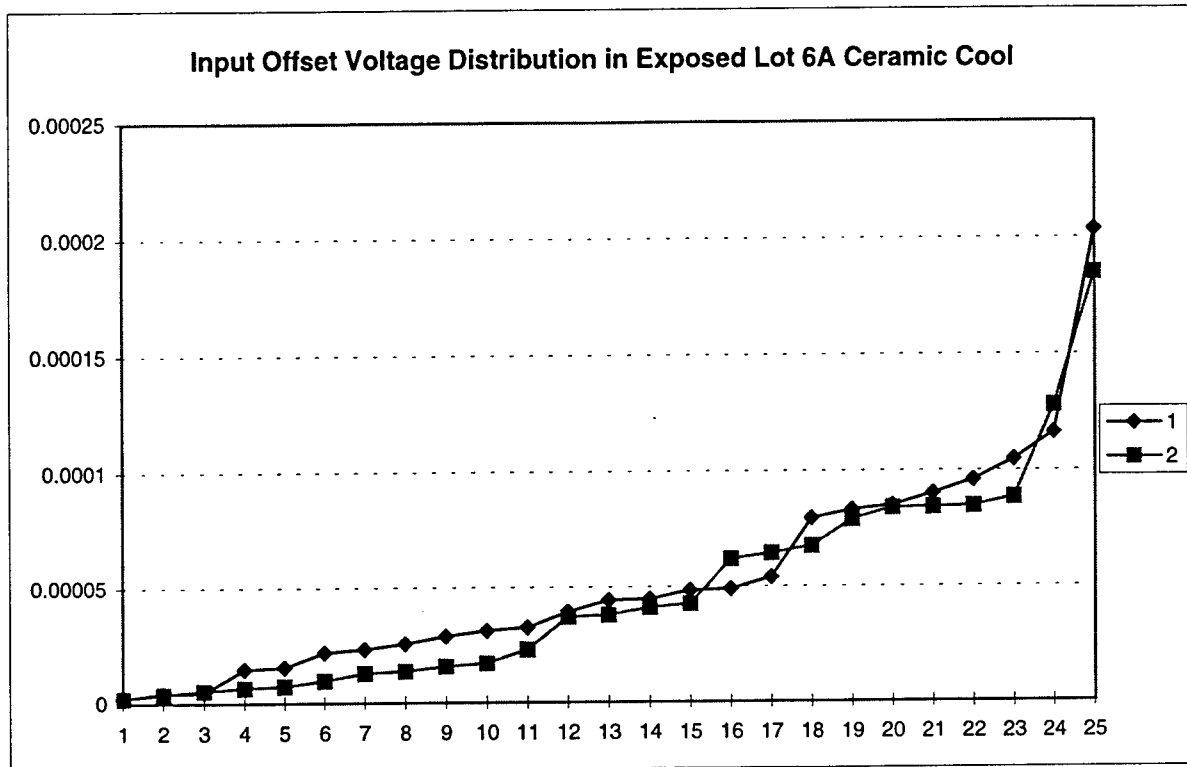

Appendix C: Engineering Statistical Analysis Data

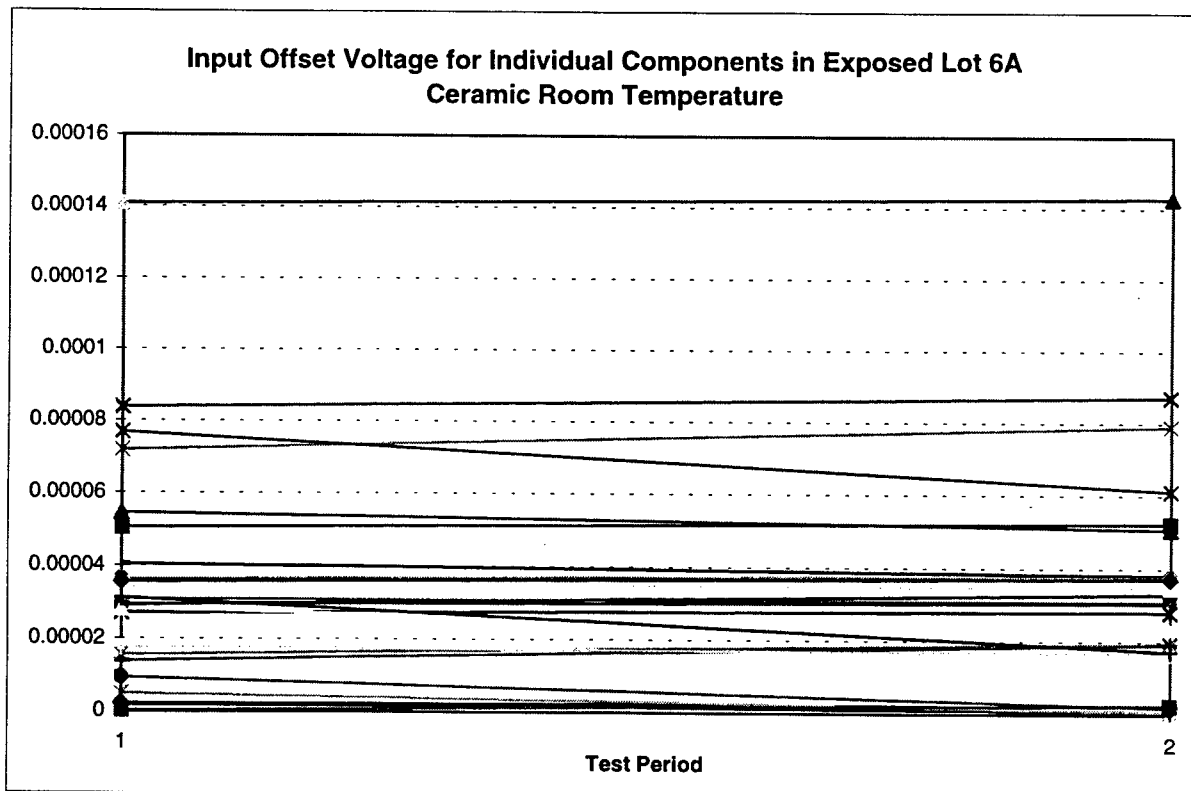
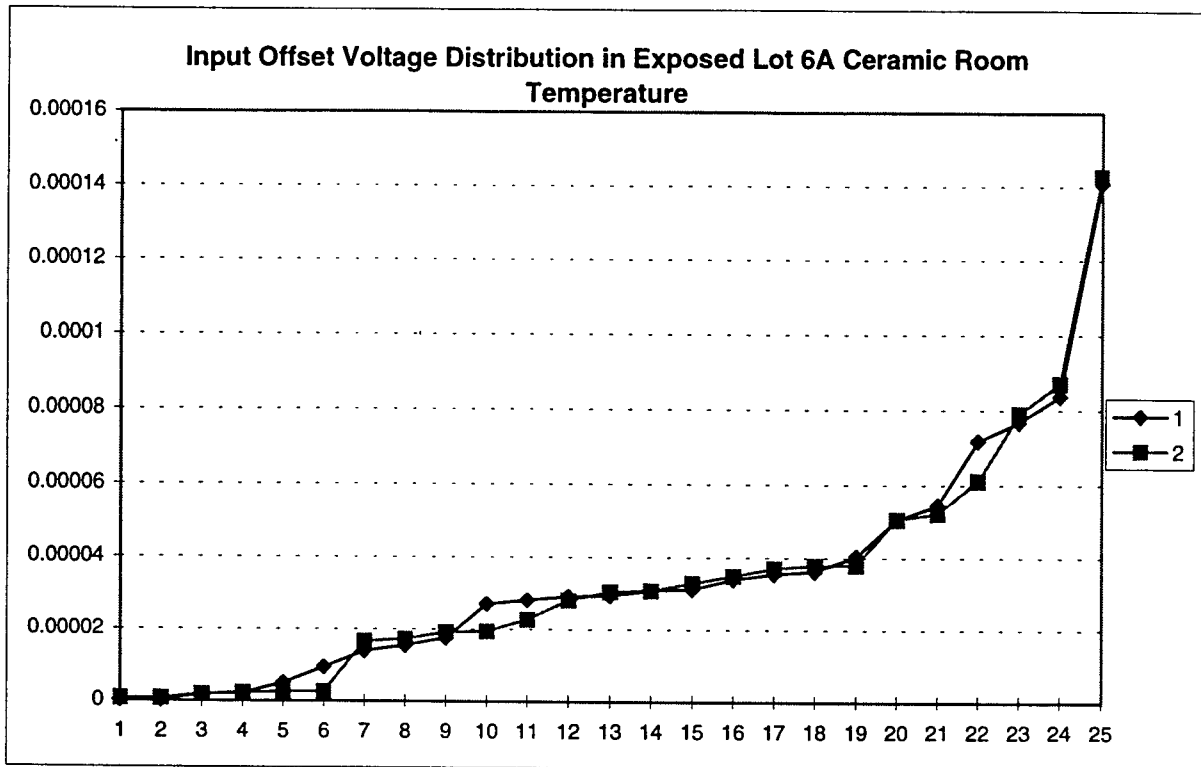

Appendix C: Engineering Statistical Analysis Data

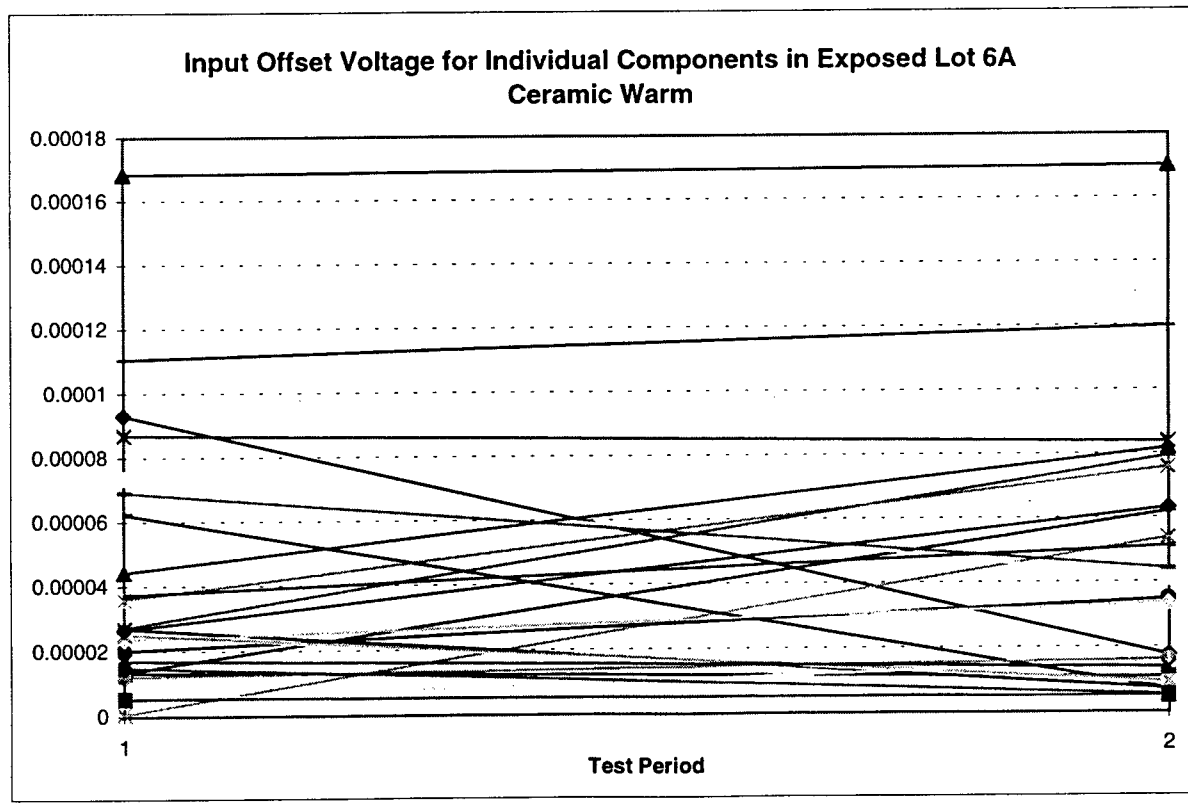
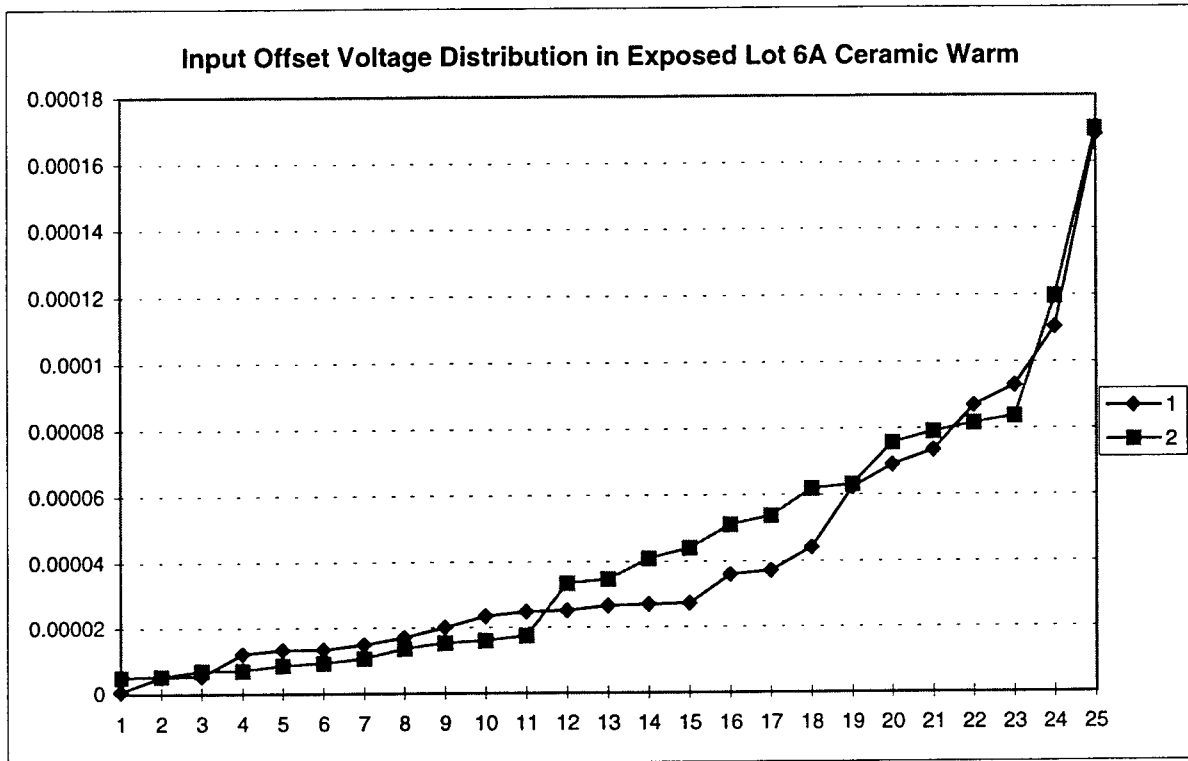

Appendix C: Engineering Statistical Analysis Data

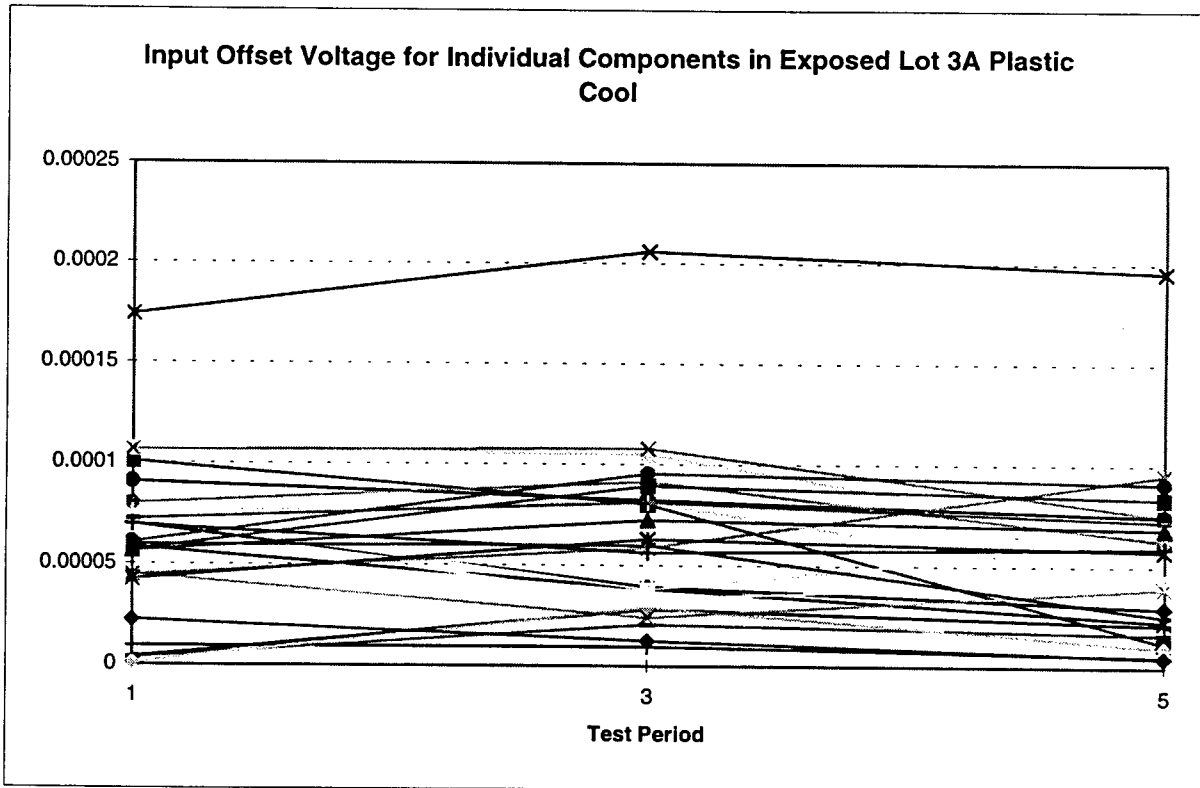
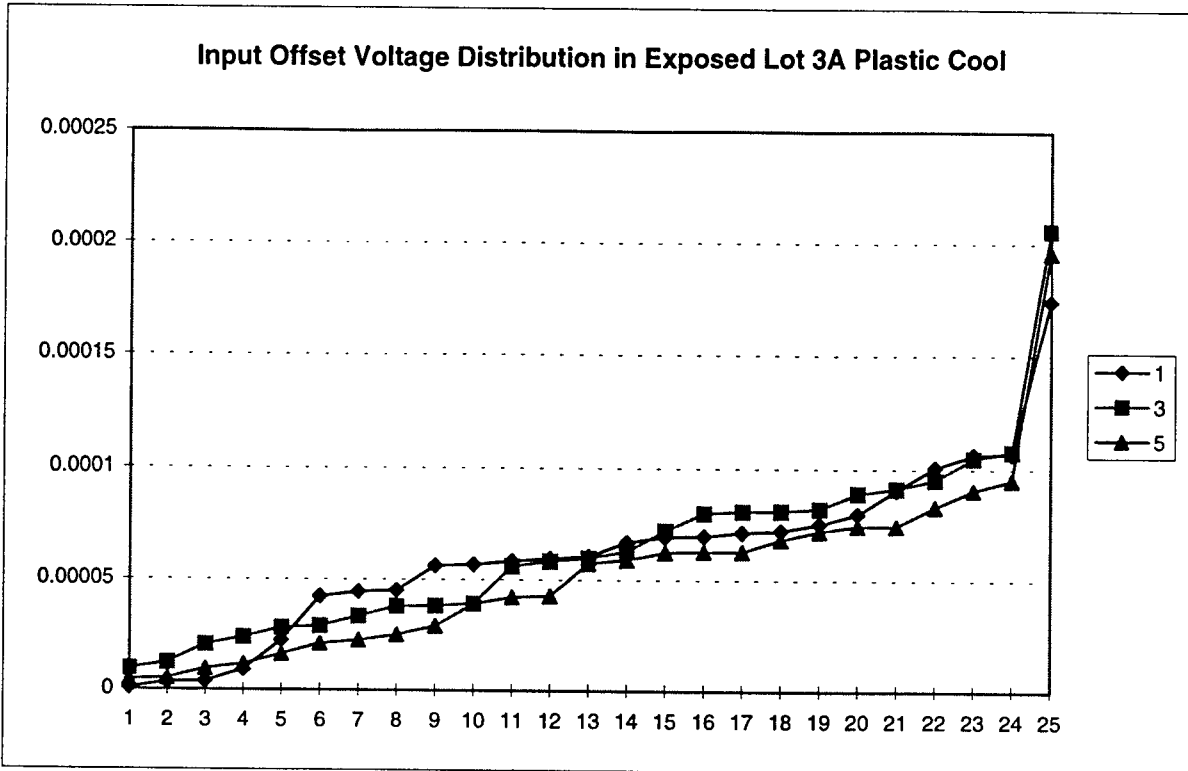

Appendix C: Engineering Statistical Analysis Data

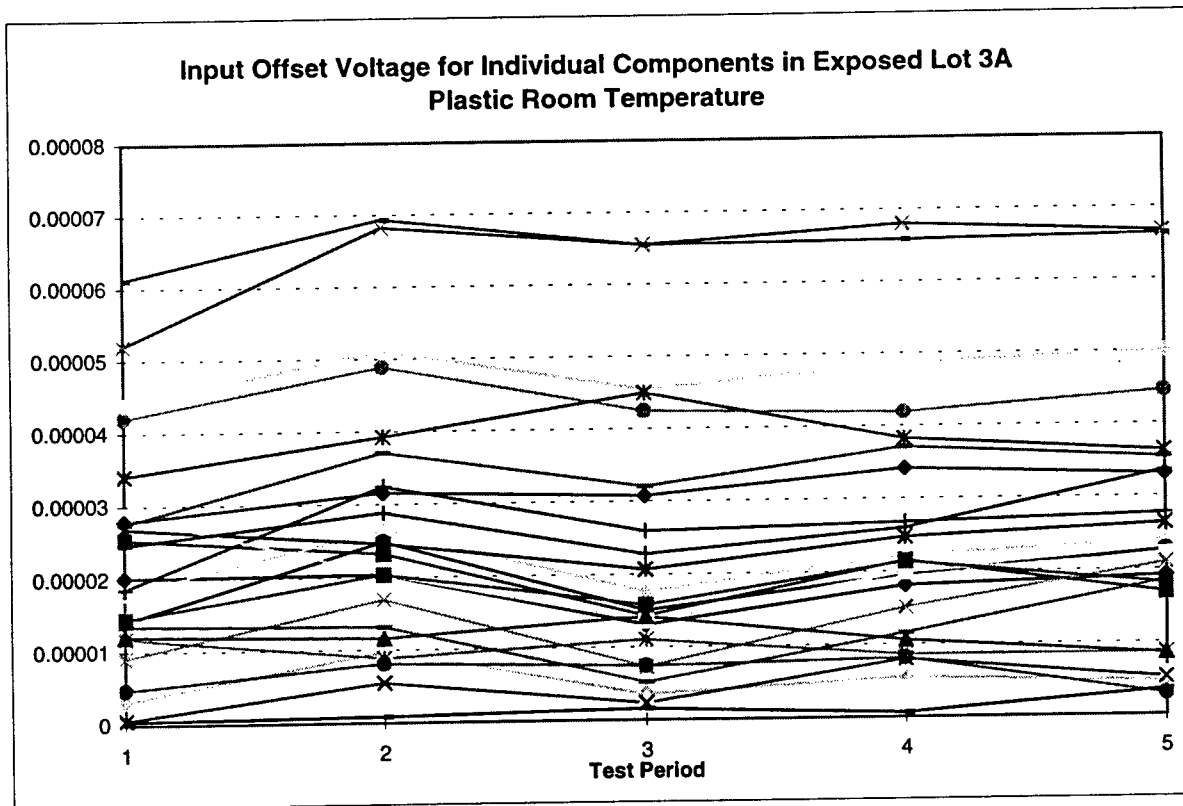
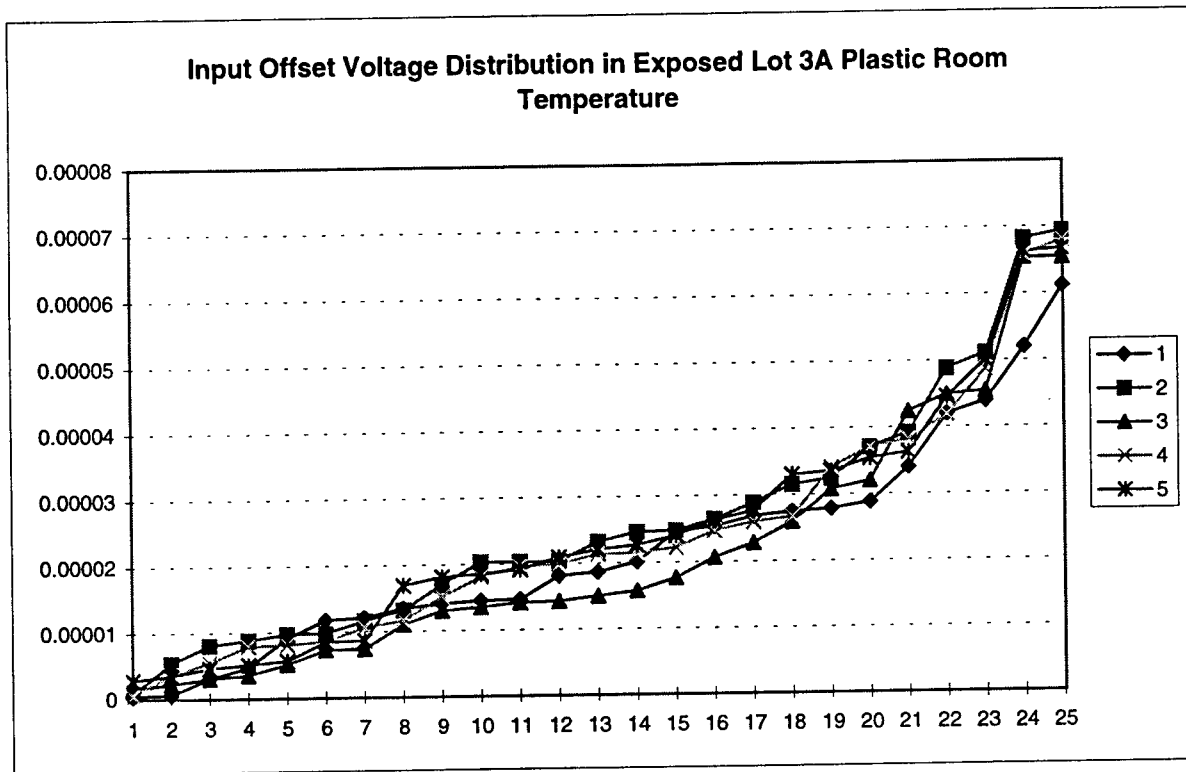

Appendix C: Engineering Statistical Analysis Data

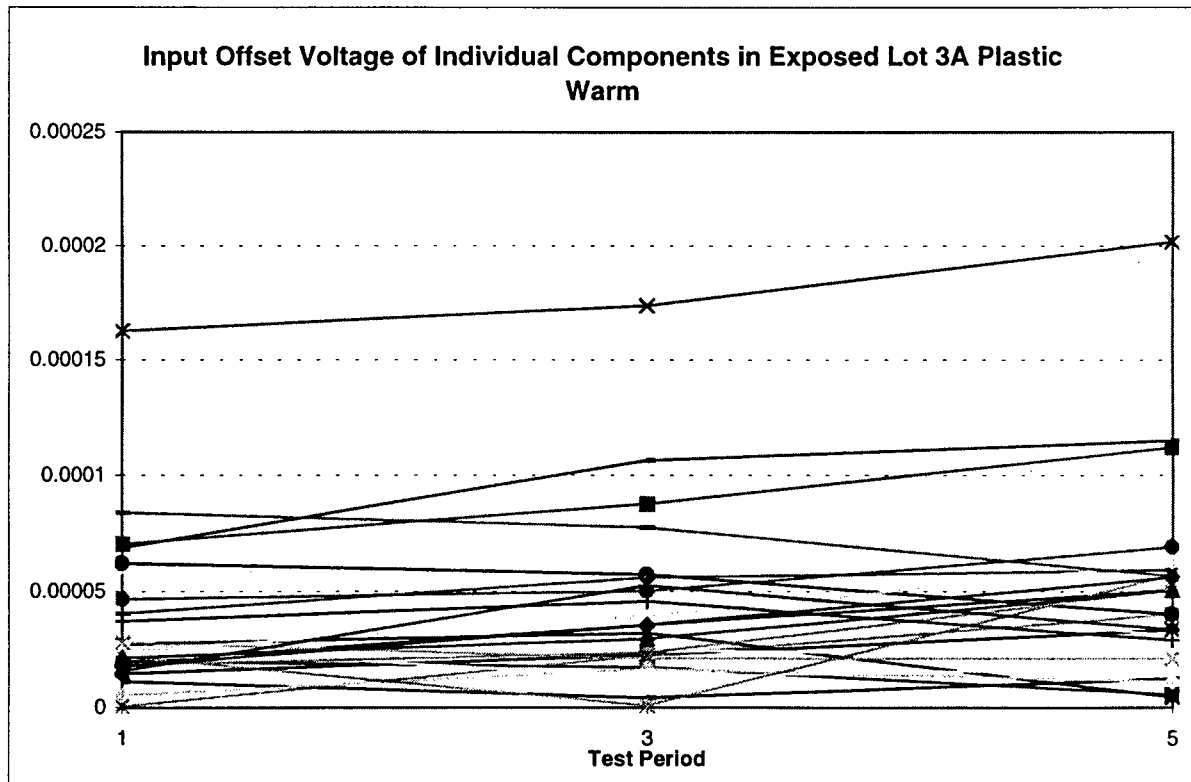
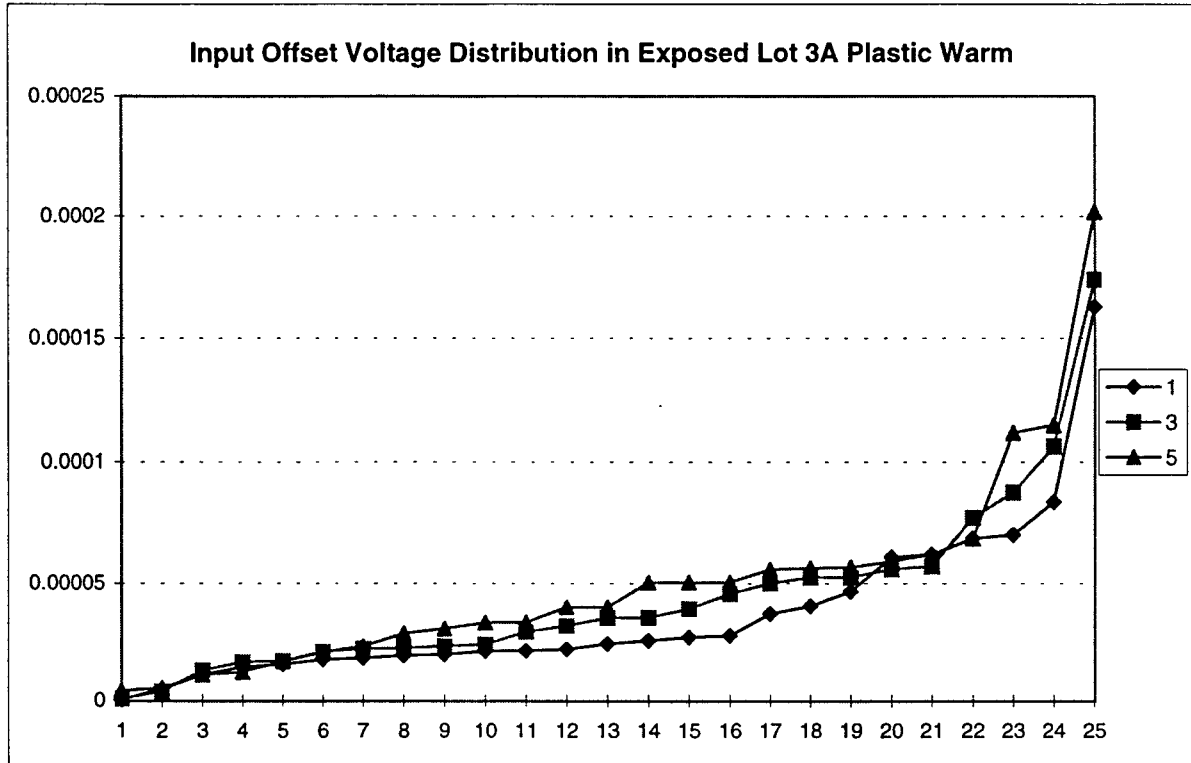



Appendix C: Engineering Statistical Analysis Data

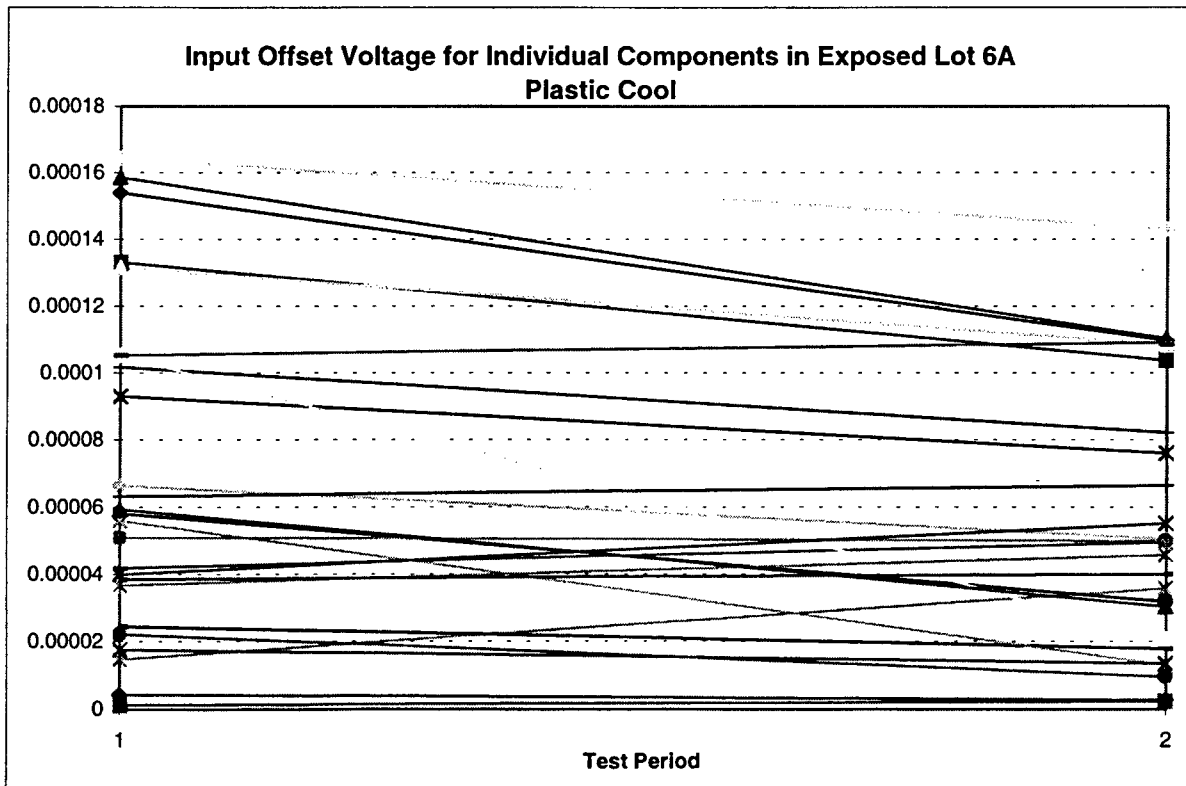
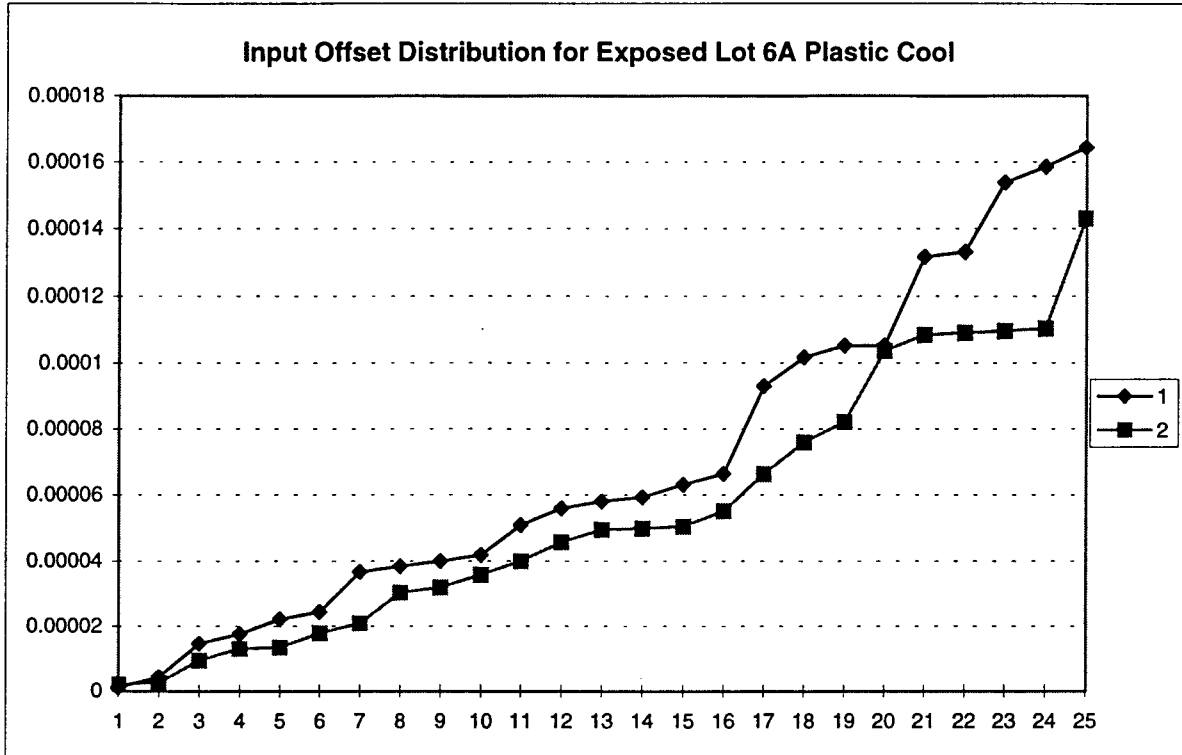

Appendix C: Engineering Statistical Analysis Data

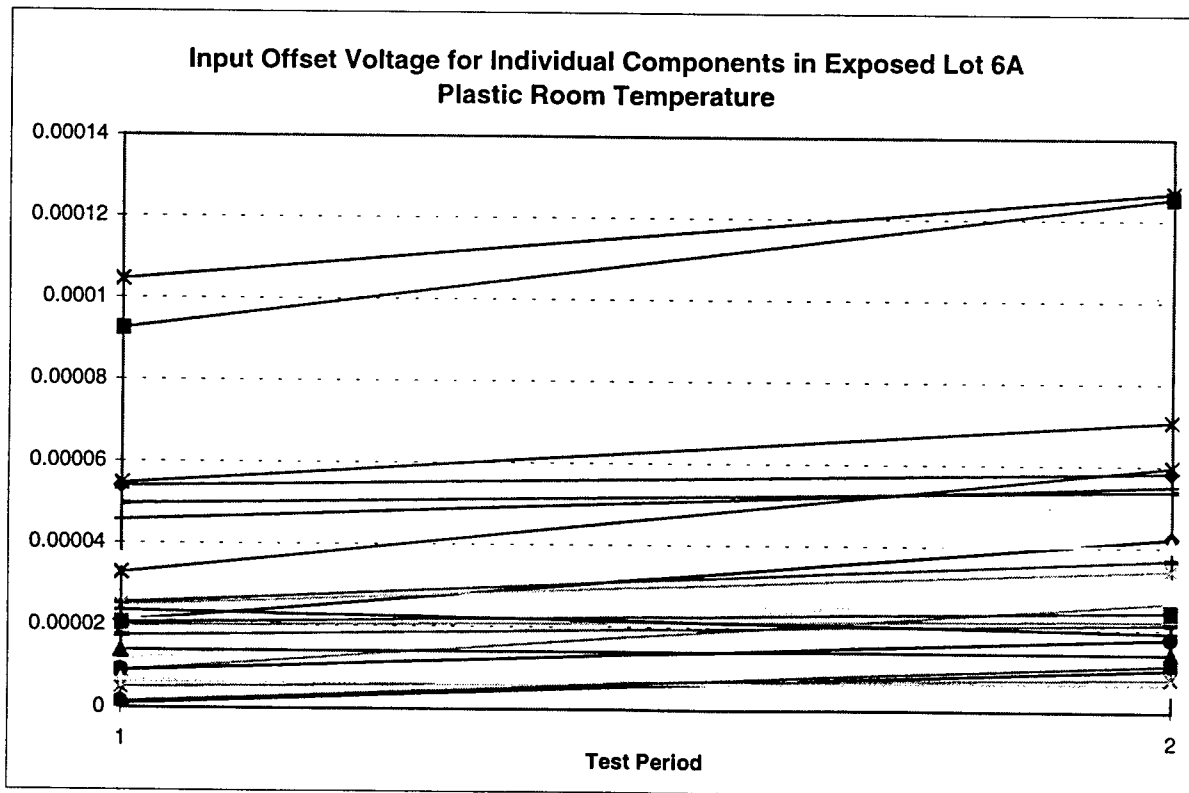
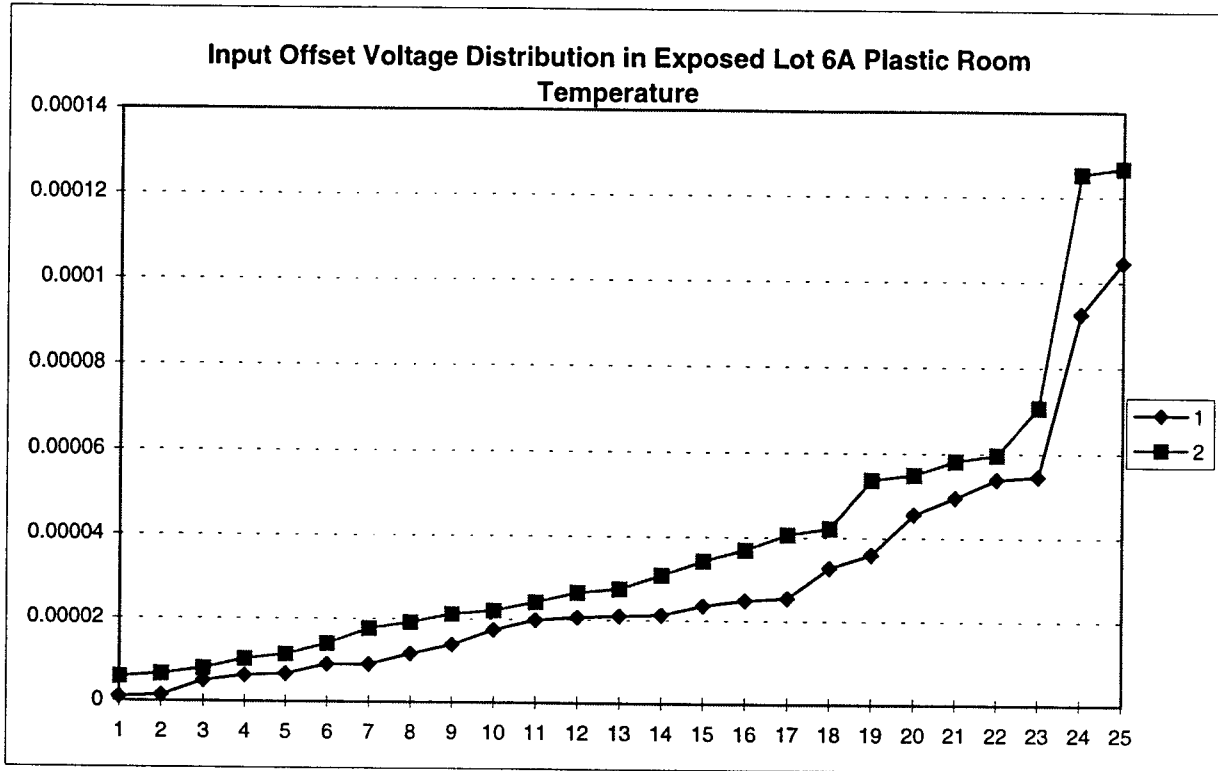

Appendix C: Engineering Statistical Analysis Data

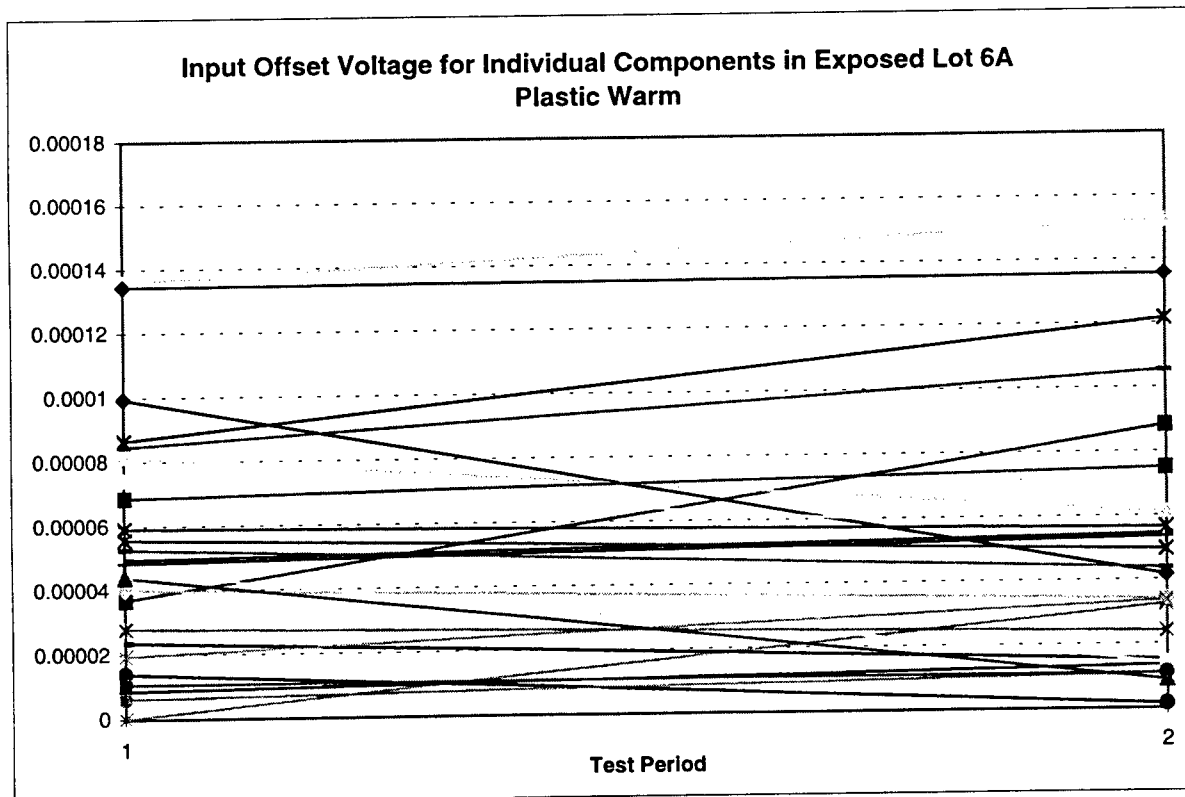
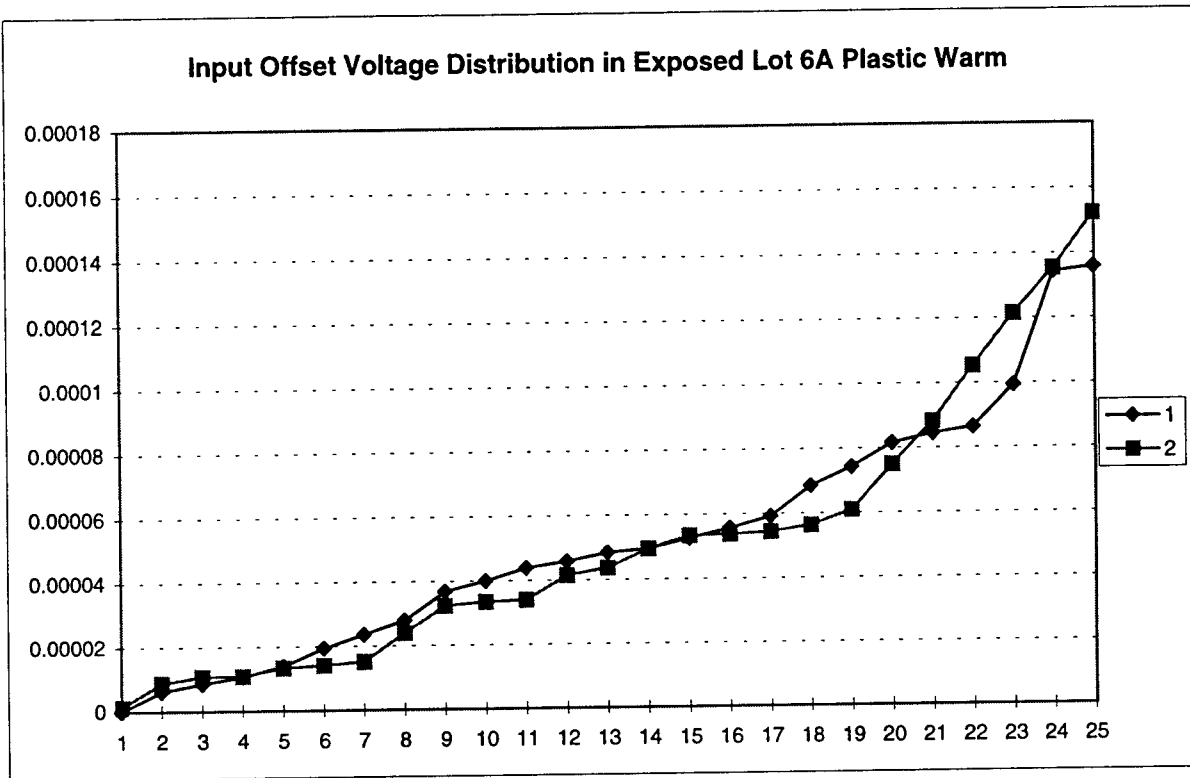

## Appendix C: Engineering Statistical Analysis Data

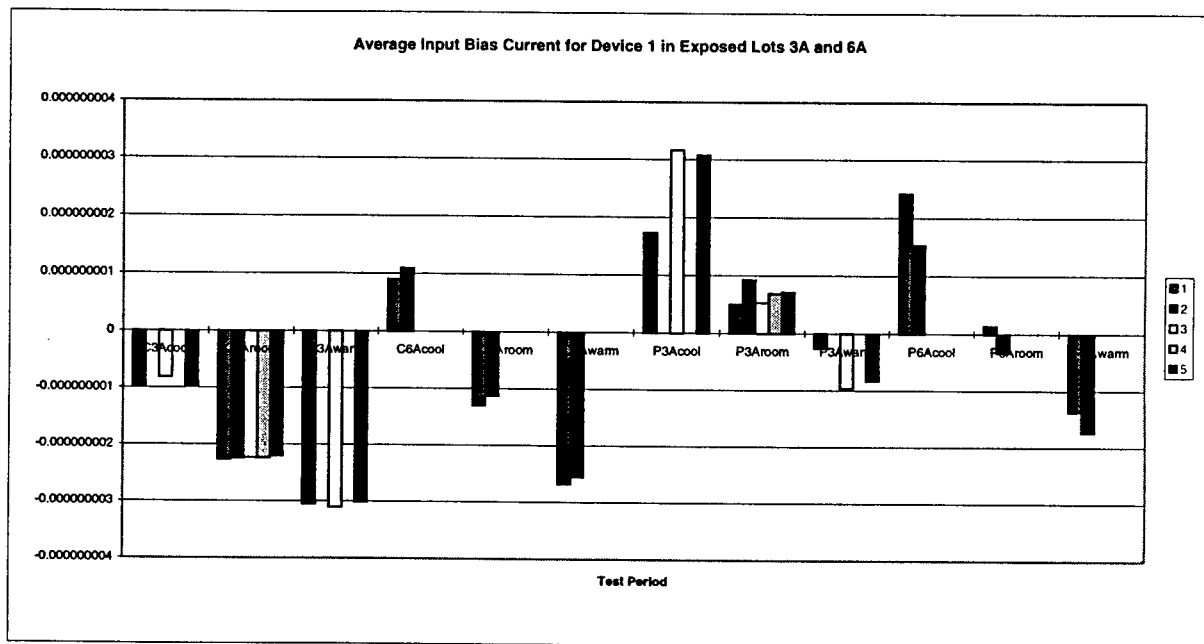
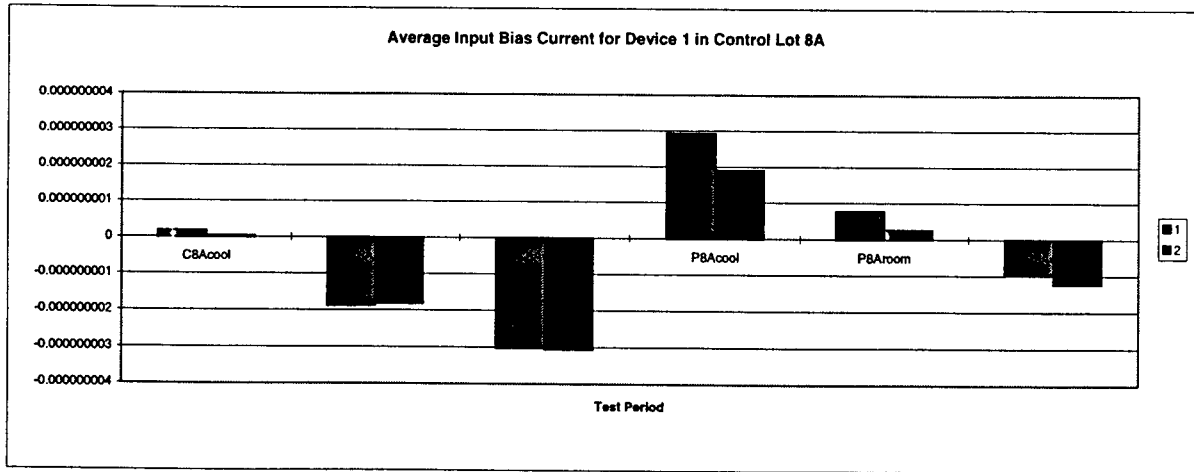

Appendix C: Engineering Statistical Analysis Data

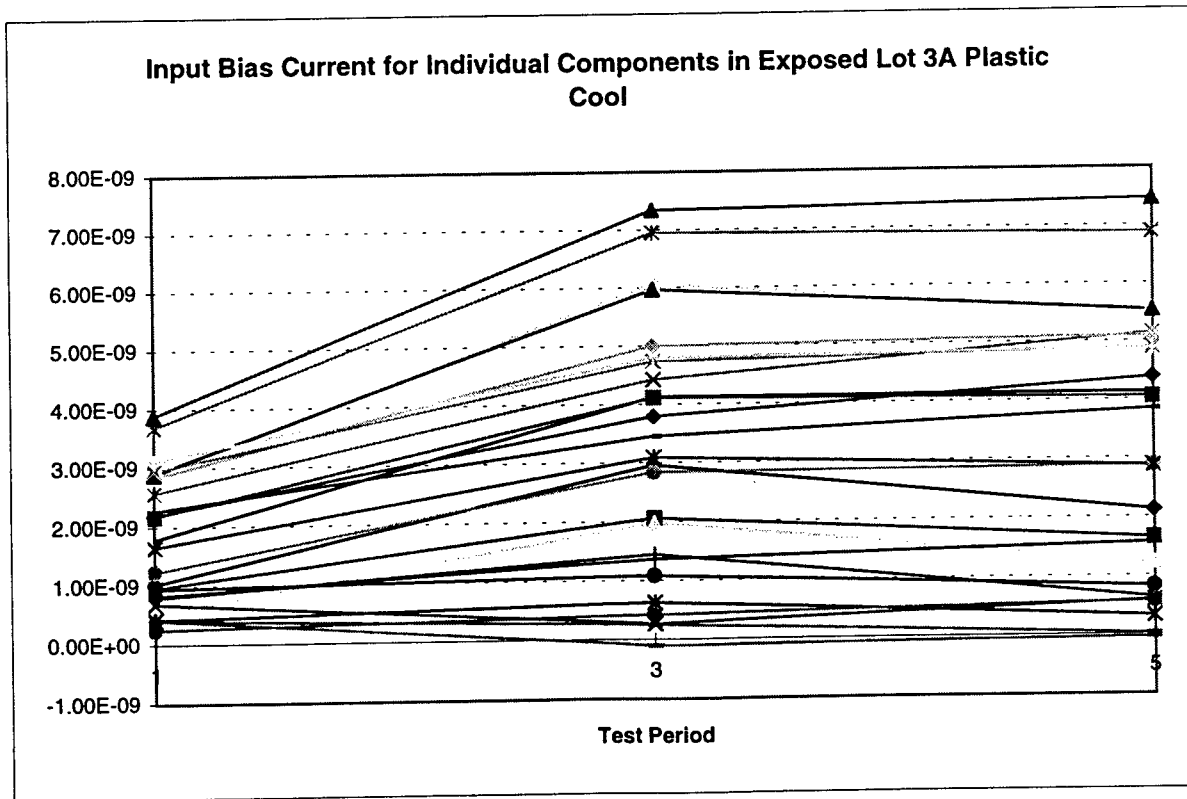
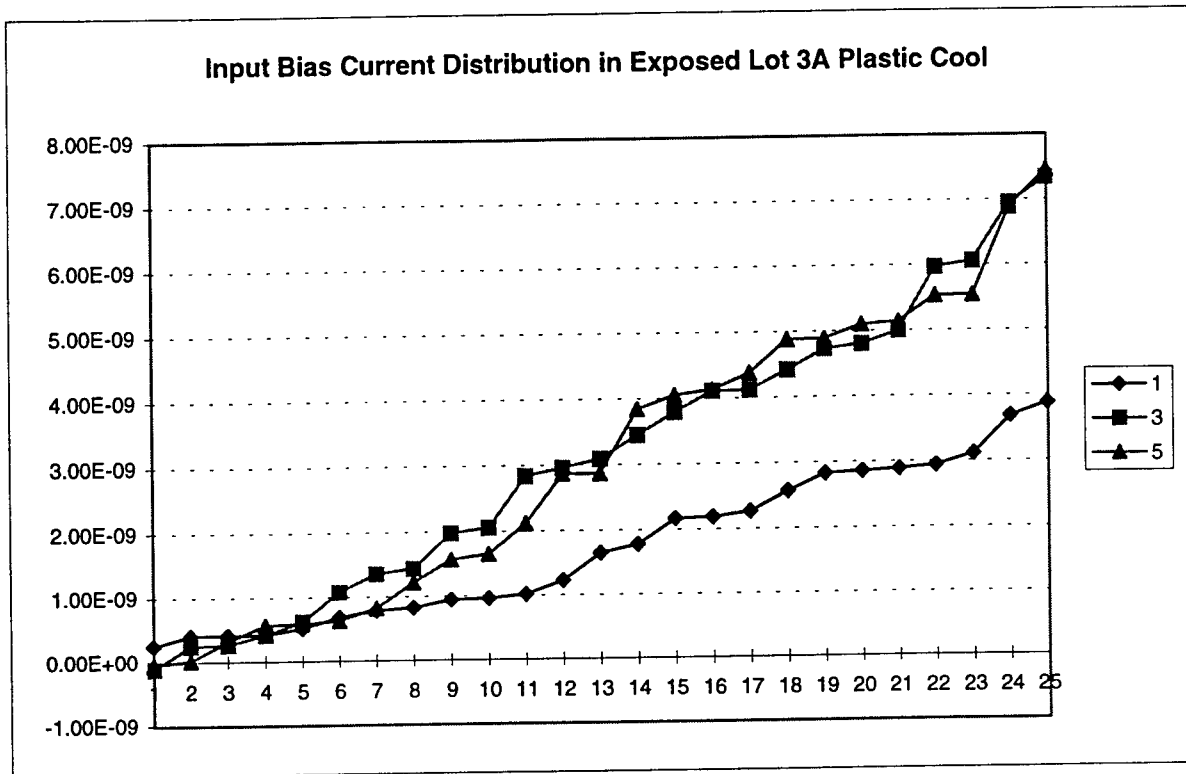

Appendix C: Engineering Statistical Analysis Data

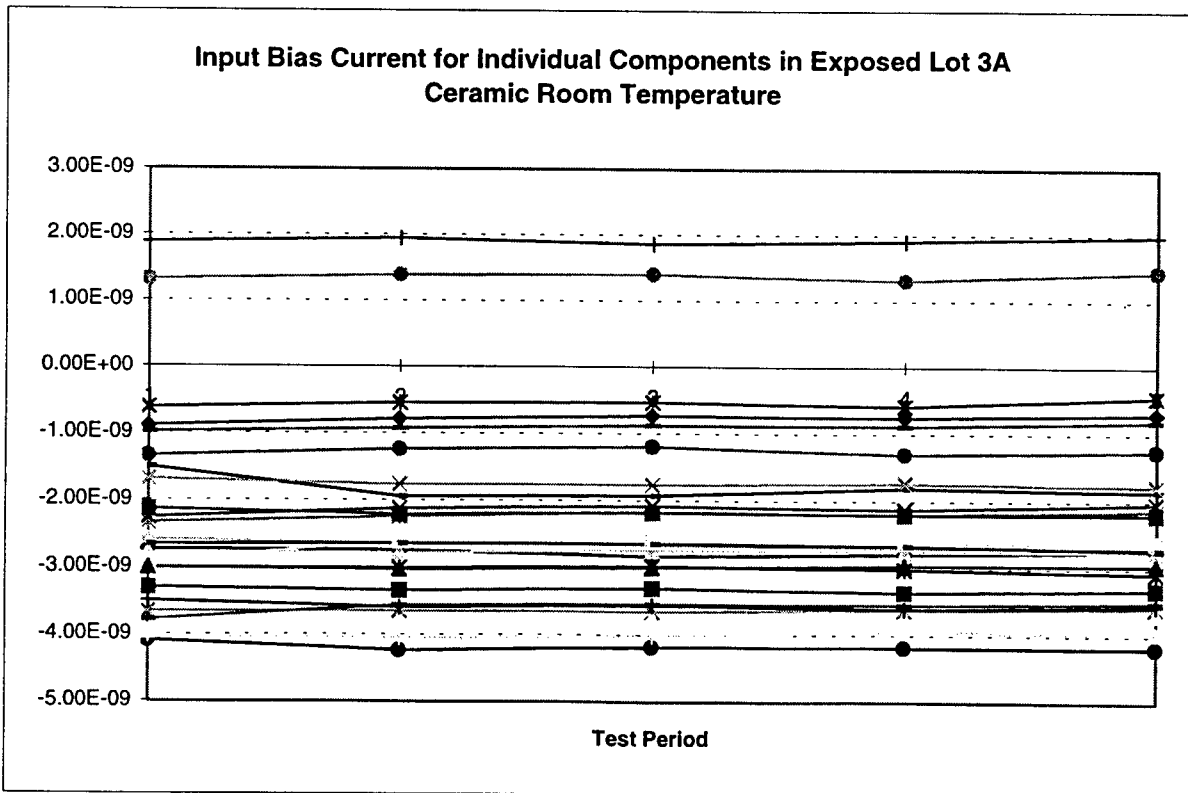
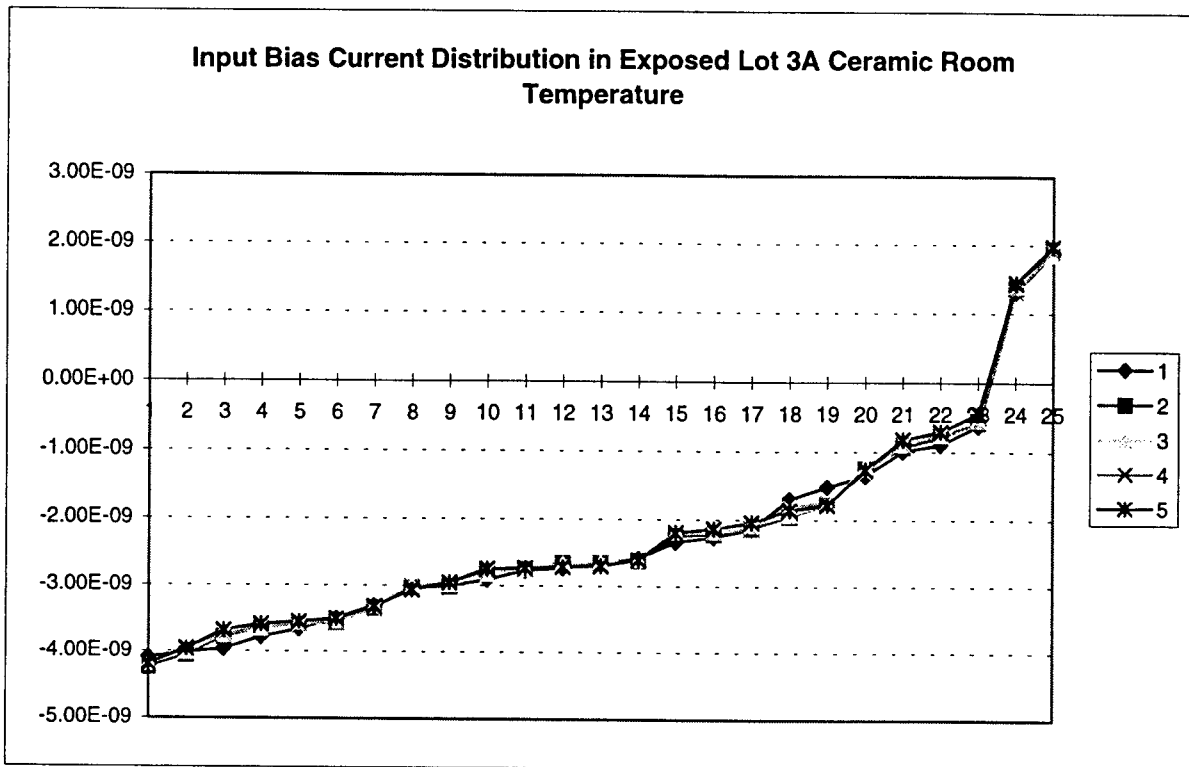

Appendix C: Engineering Statistical Analysis Data

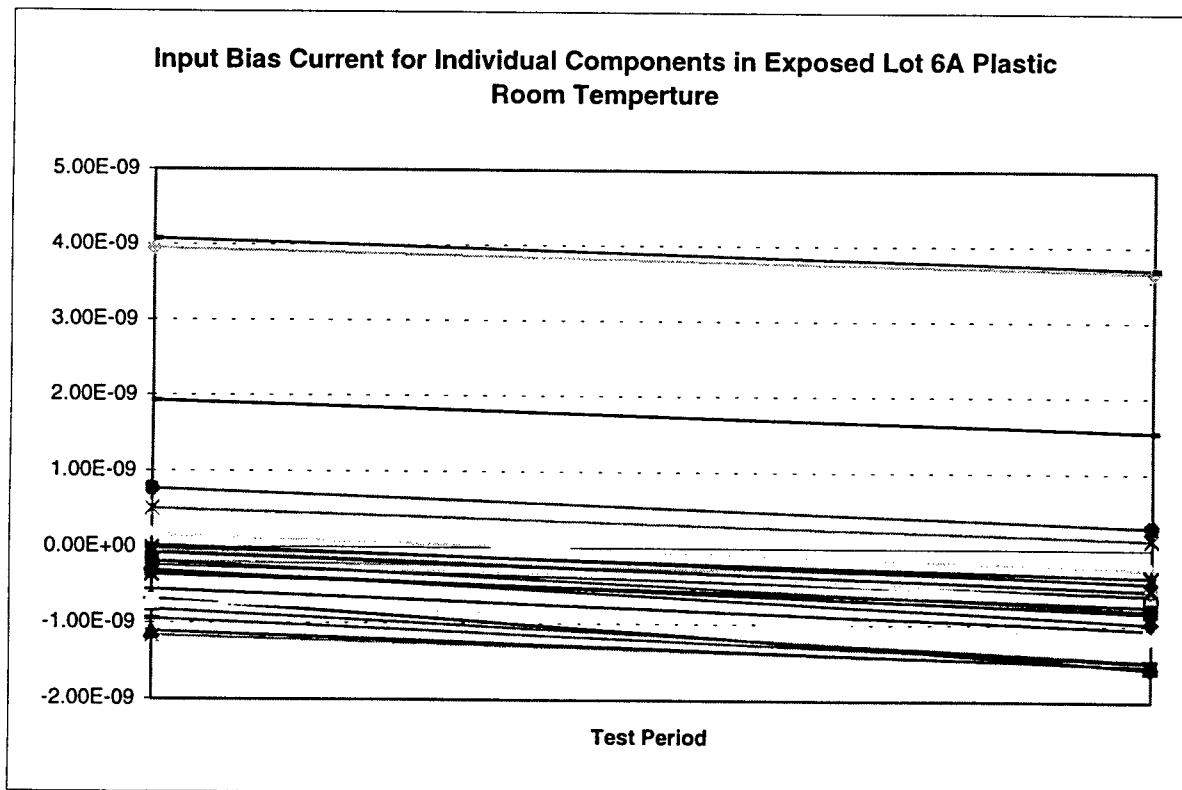
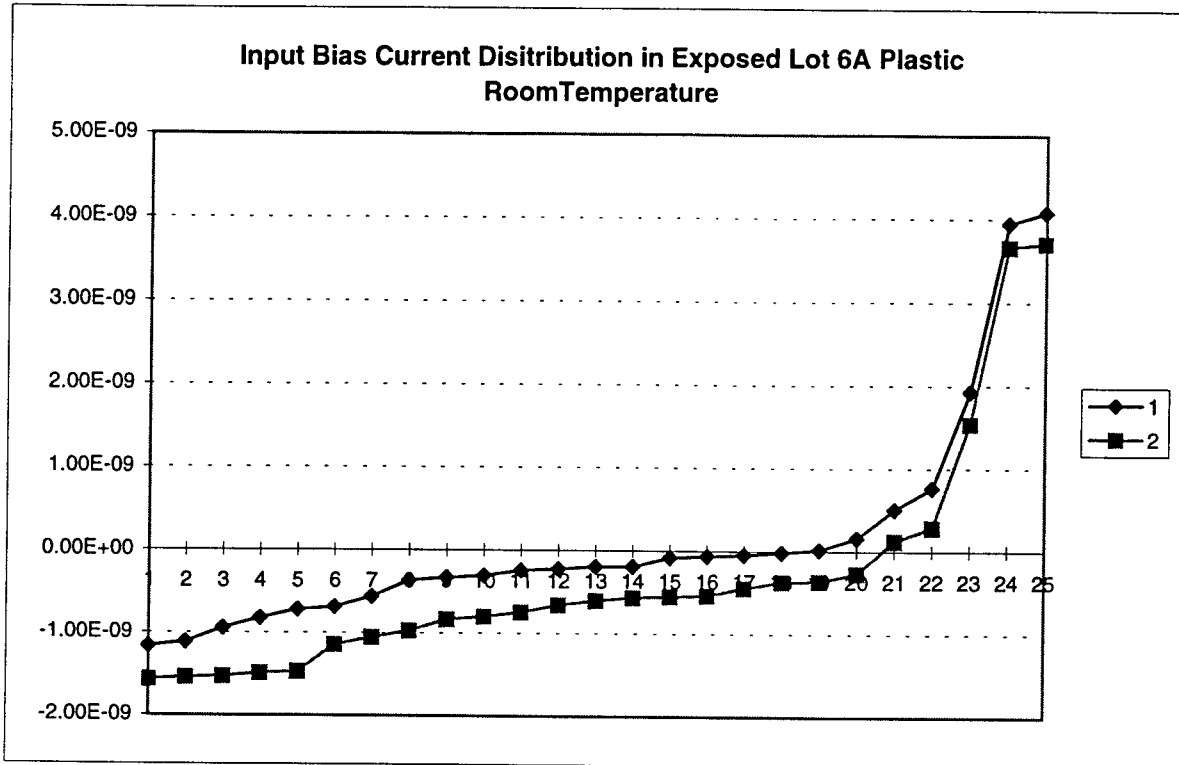

Appendix C: Engineering Statistical Analysis Data

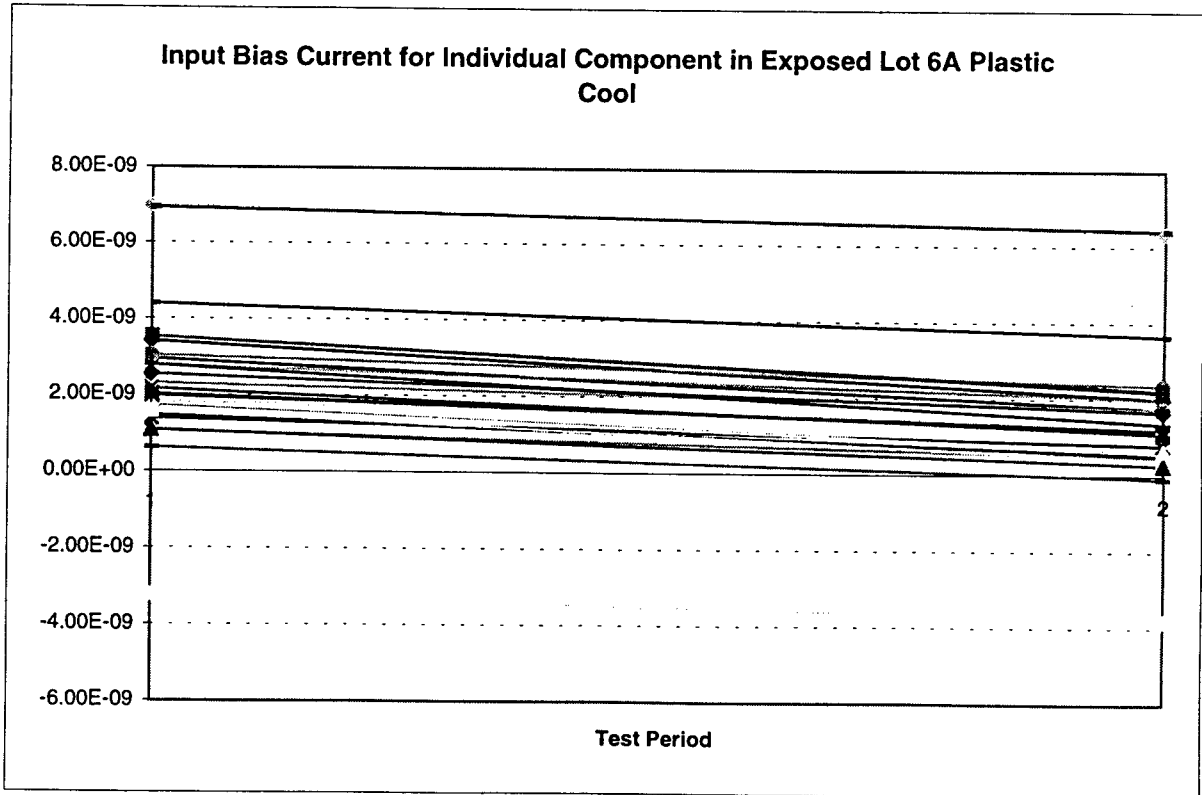
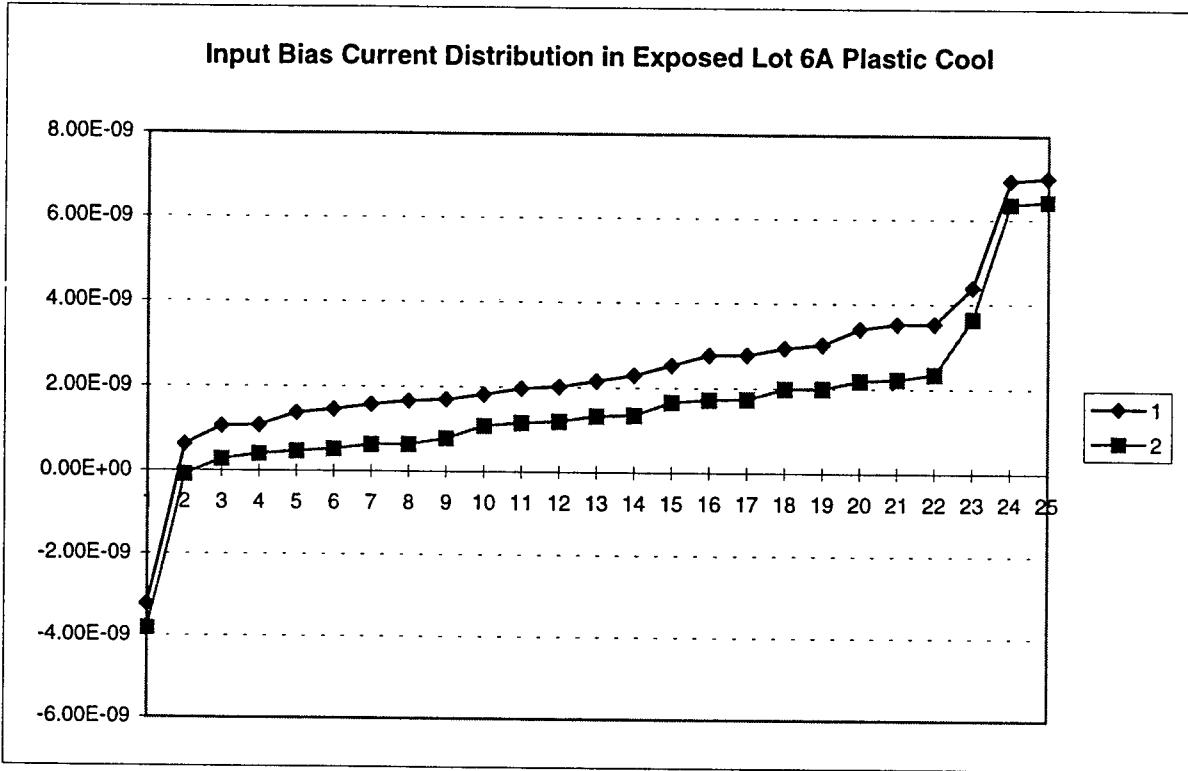



Appendix C: Engineering Statistical Analysis Data

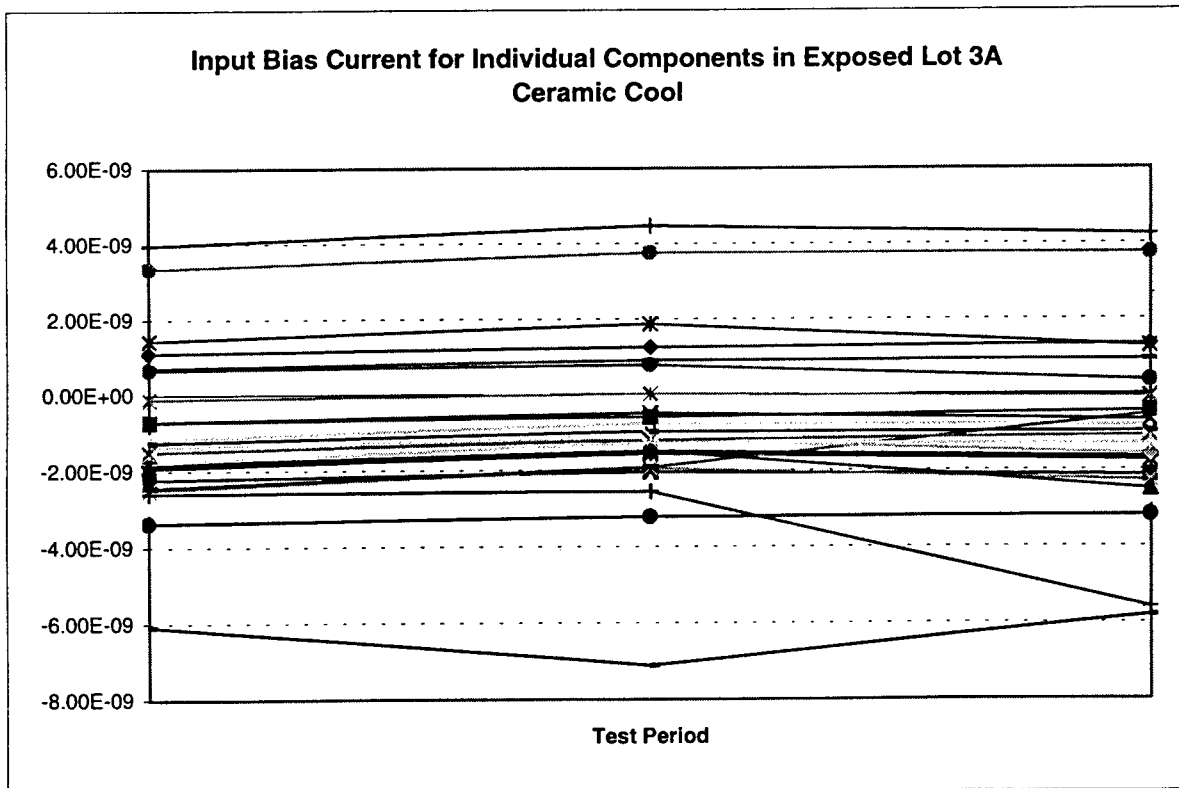
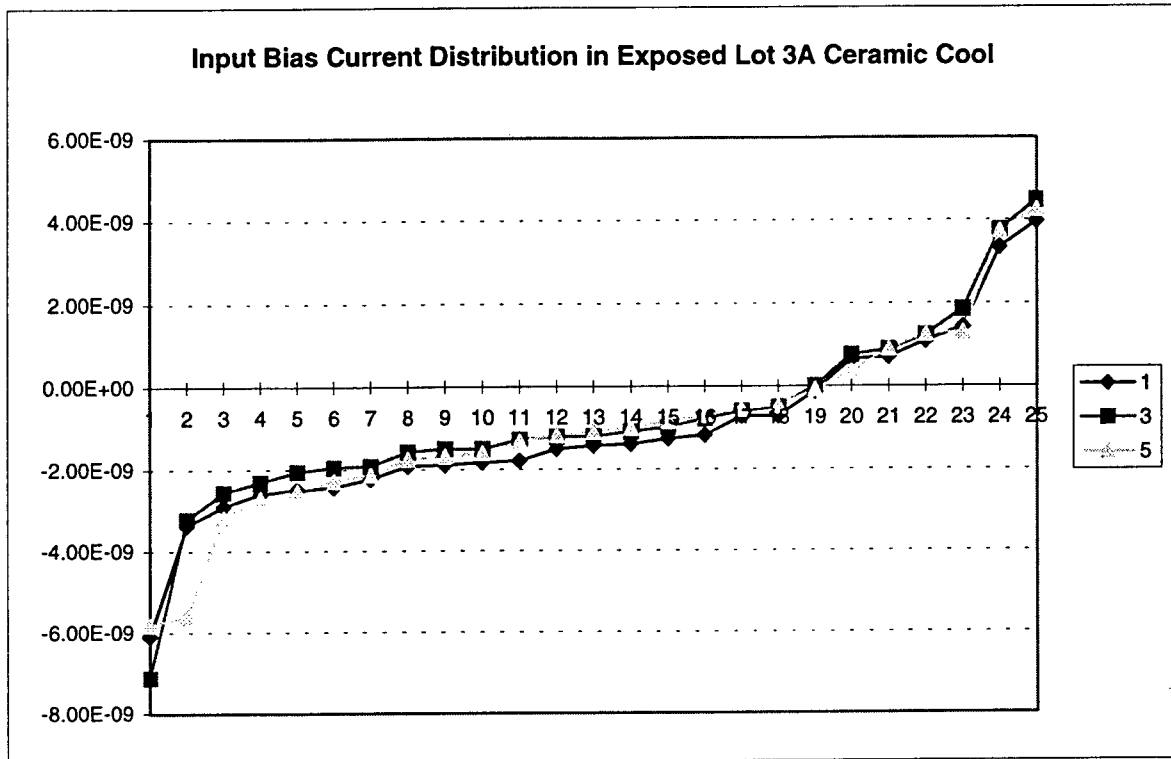

## Appendix C: Engineering Statistical Analysis Data

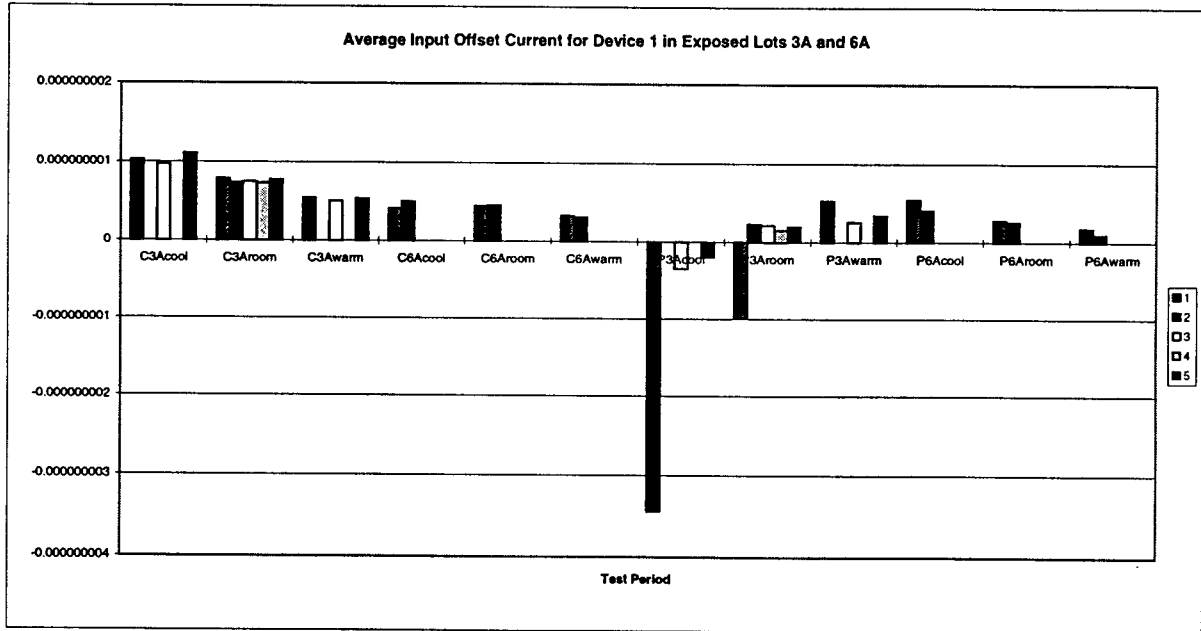
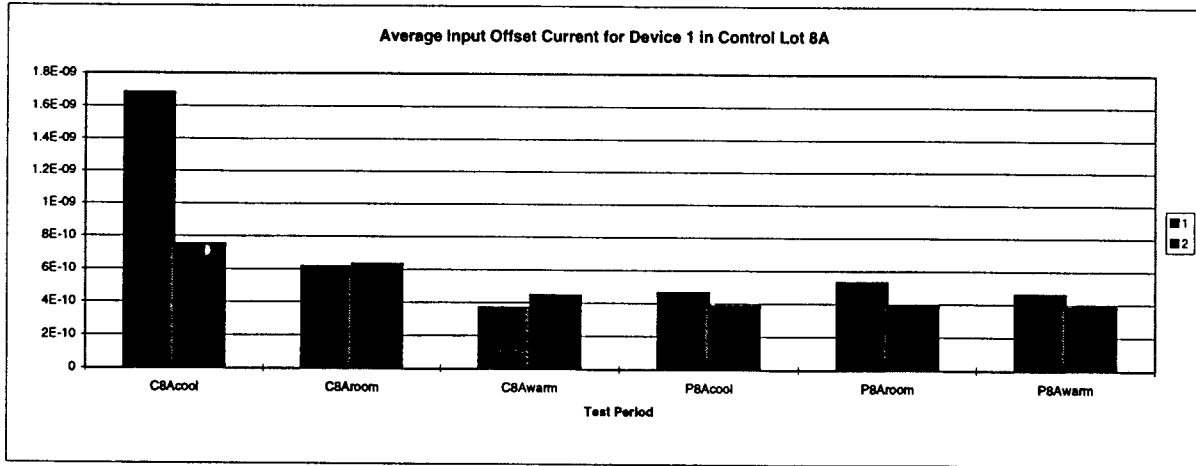

## Appendix C: Engineering Statistical Analysis Data

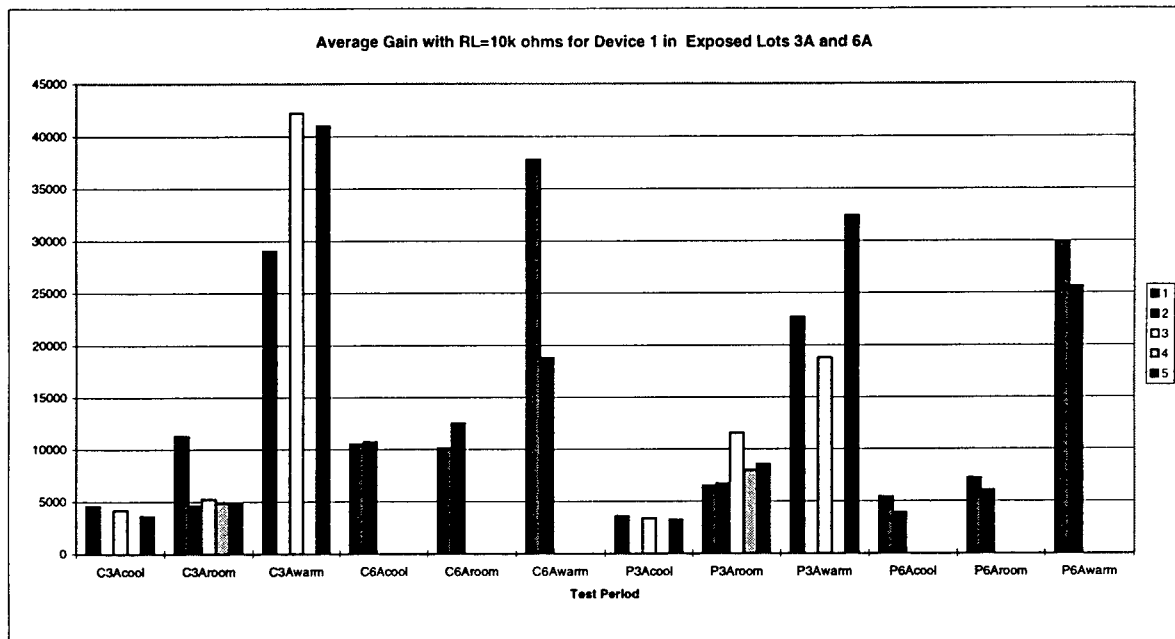
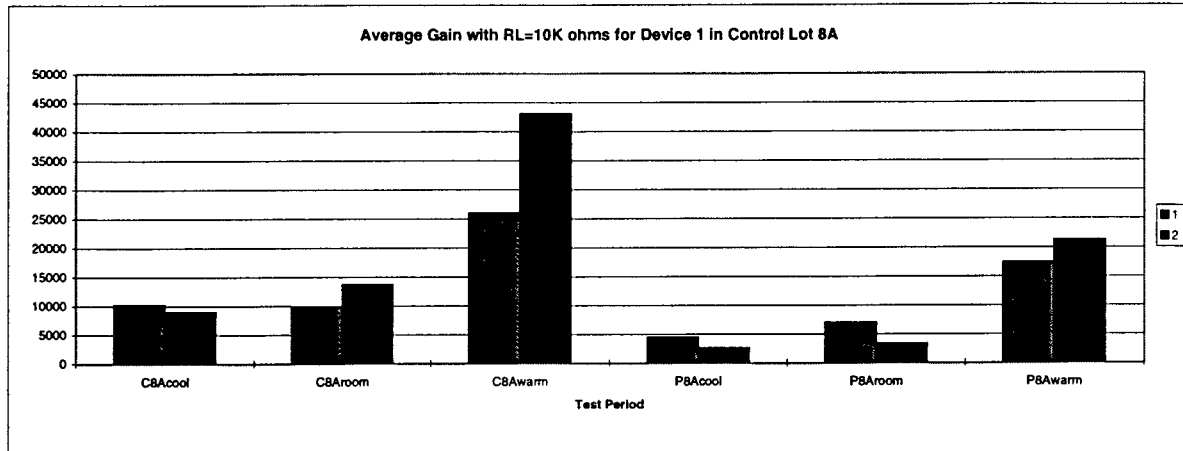

## Appendix C: Engineering Statistical Analysis Data

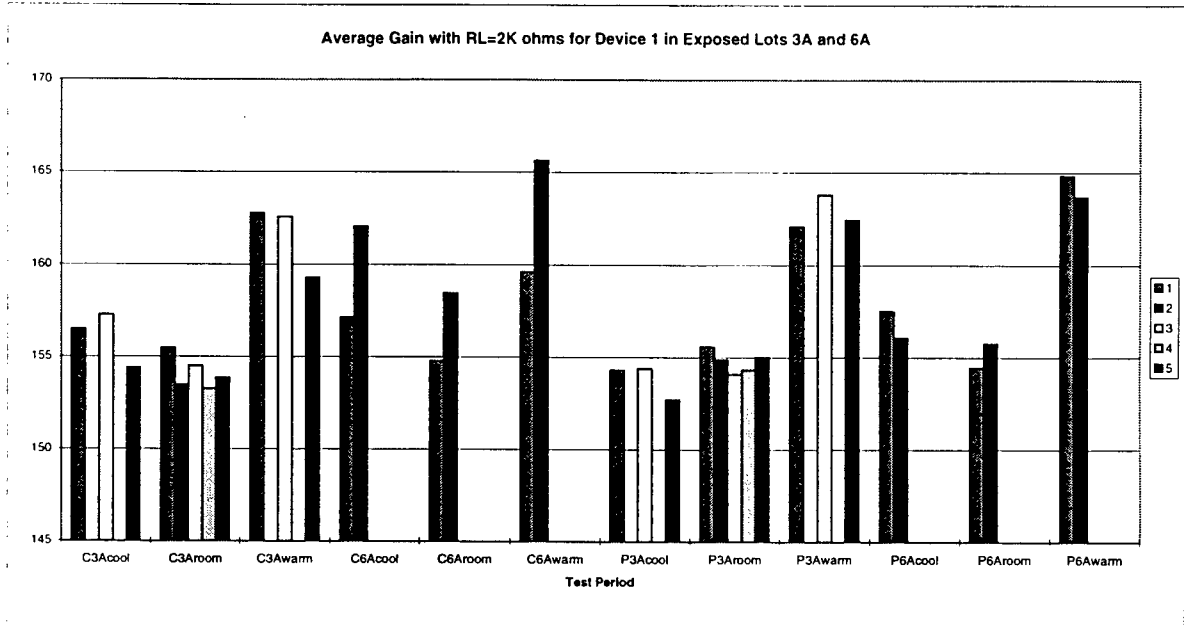
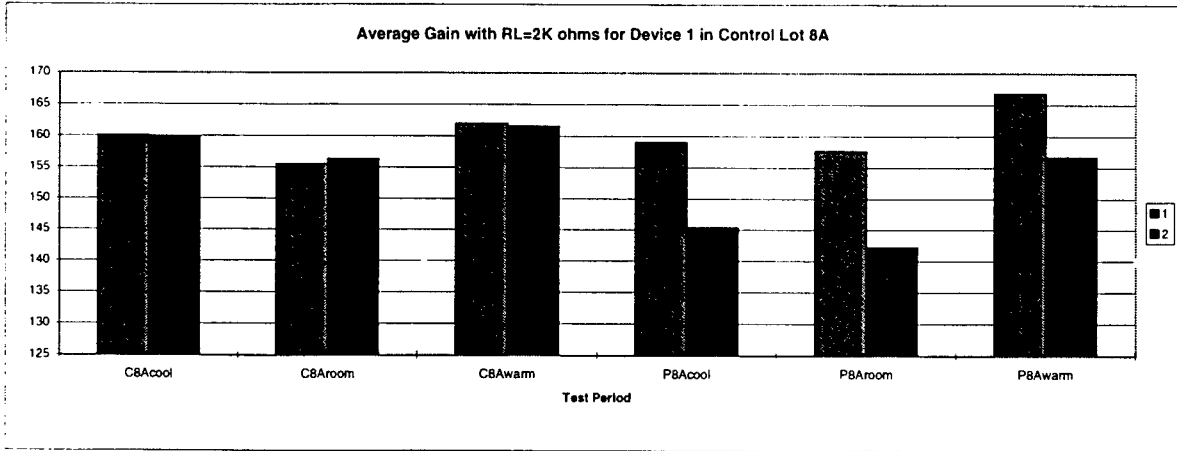

## Appendix C: Engineering Statistical Analysis Data

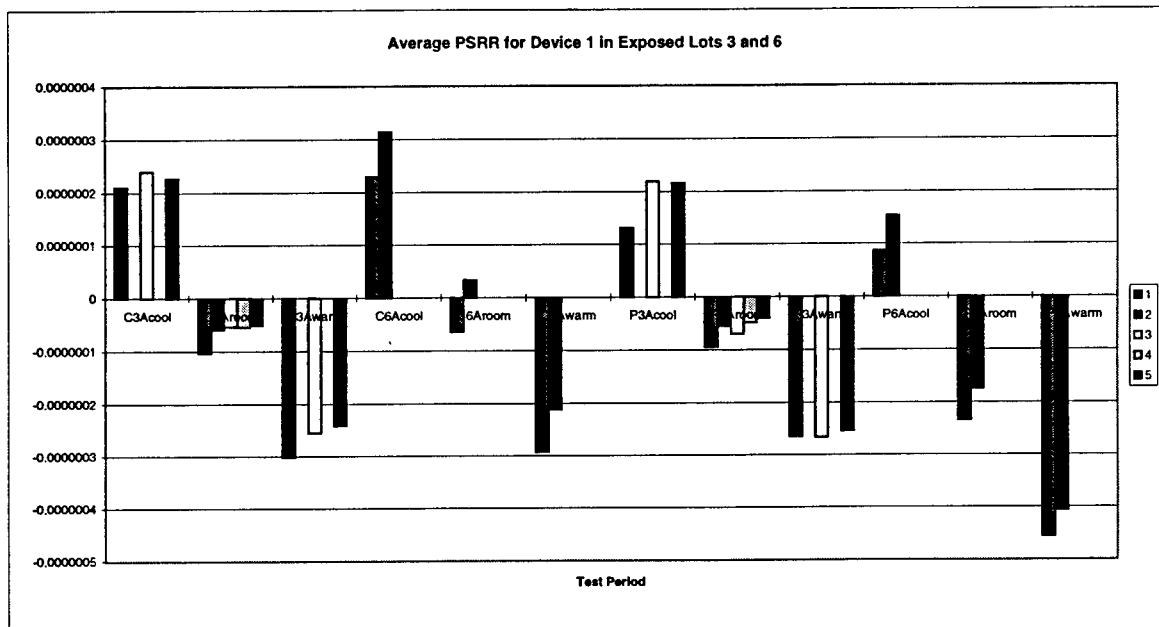
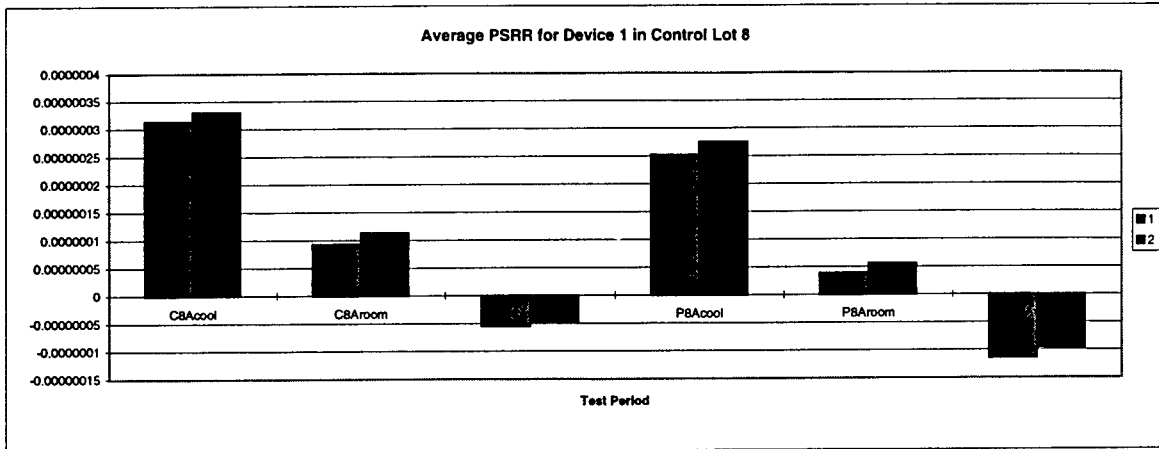

## Appendix C: Engineering Statistical Analysis Data

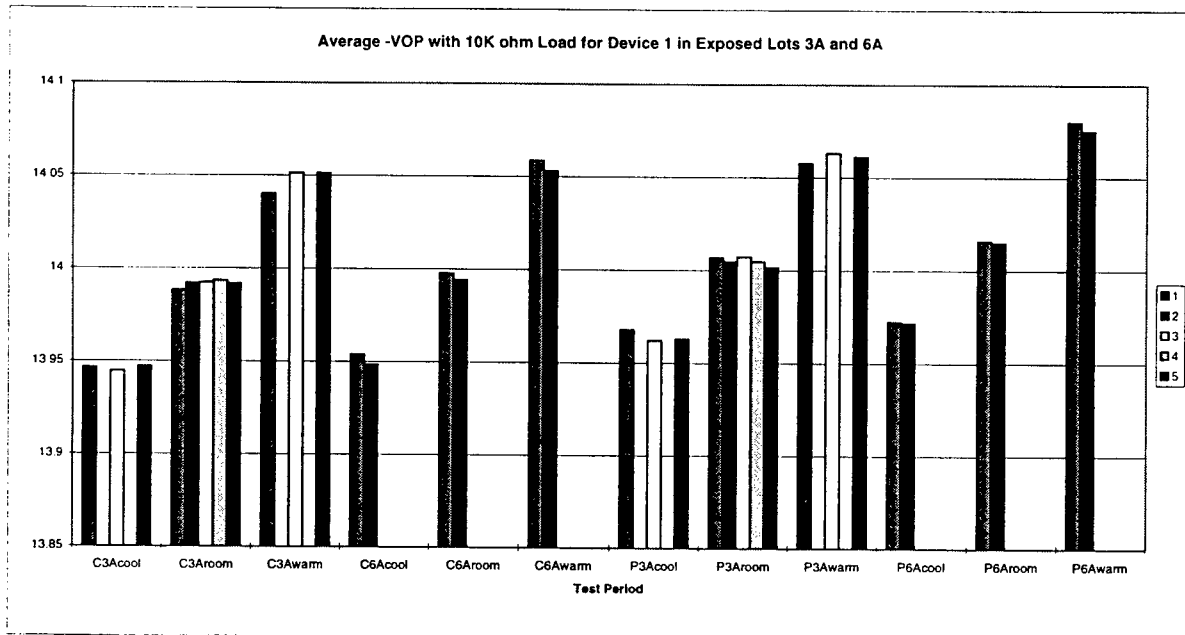
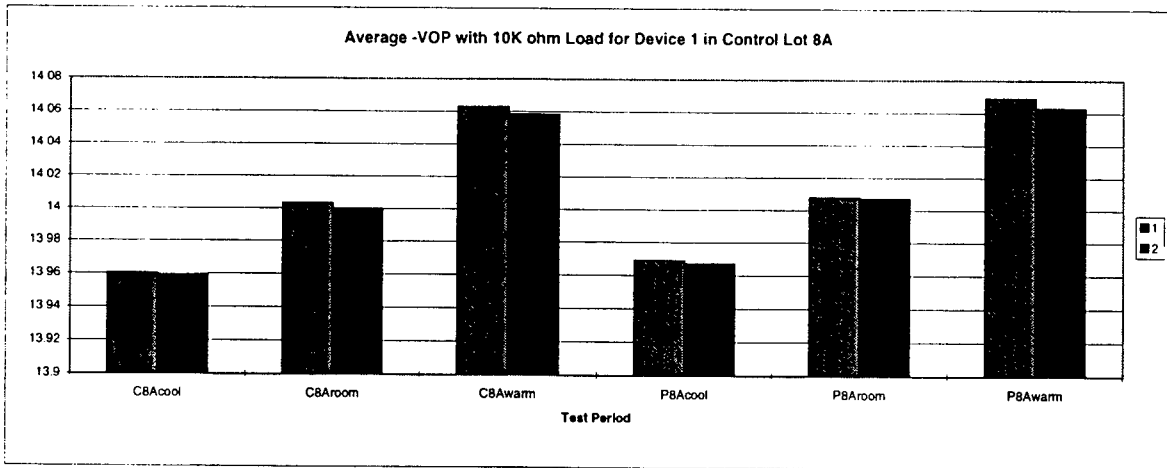

## Appendix C: Engineering Statistical Analysis Data

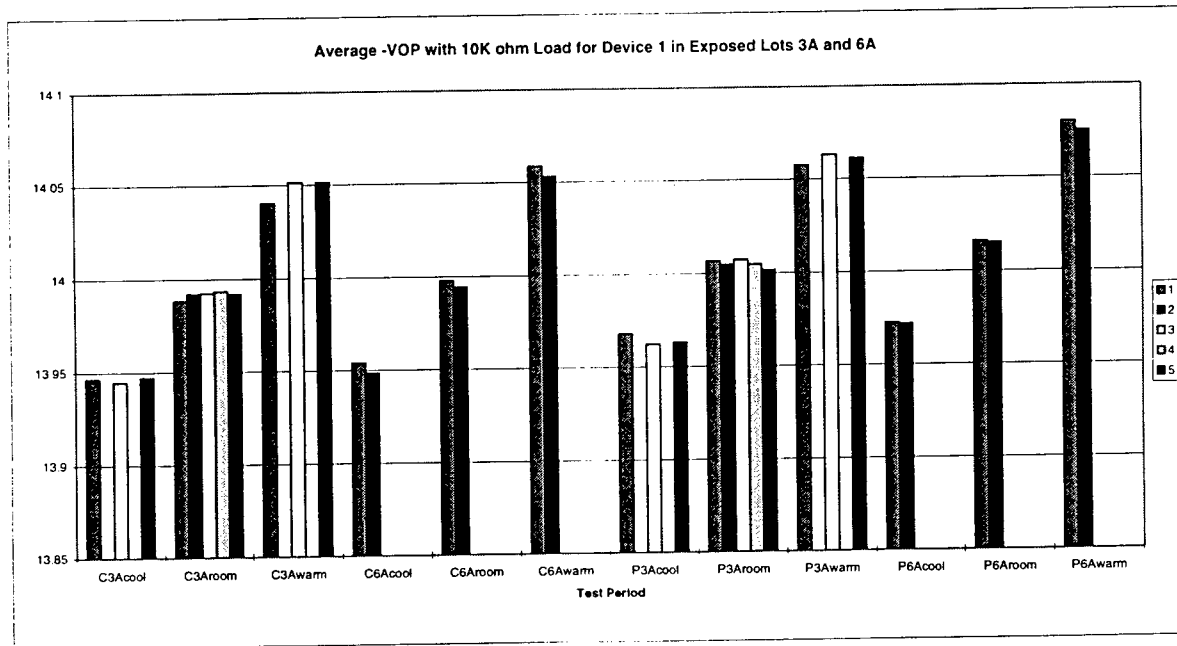
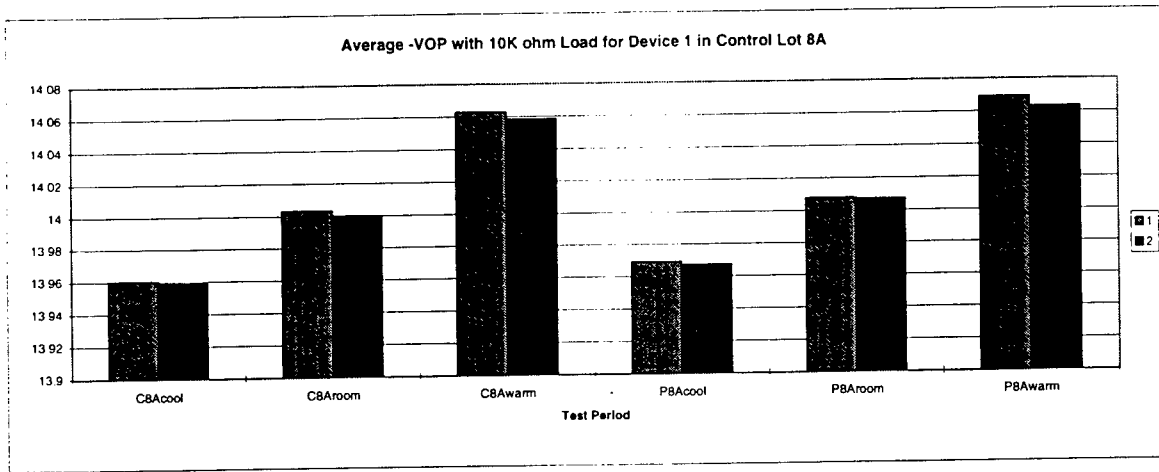

## Appendix C: Engineering Statistical Analysis Data

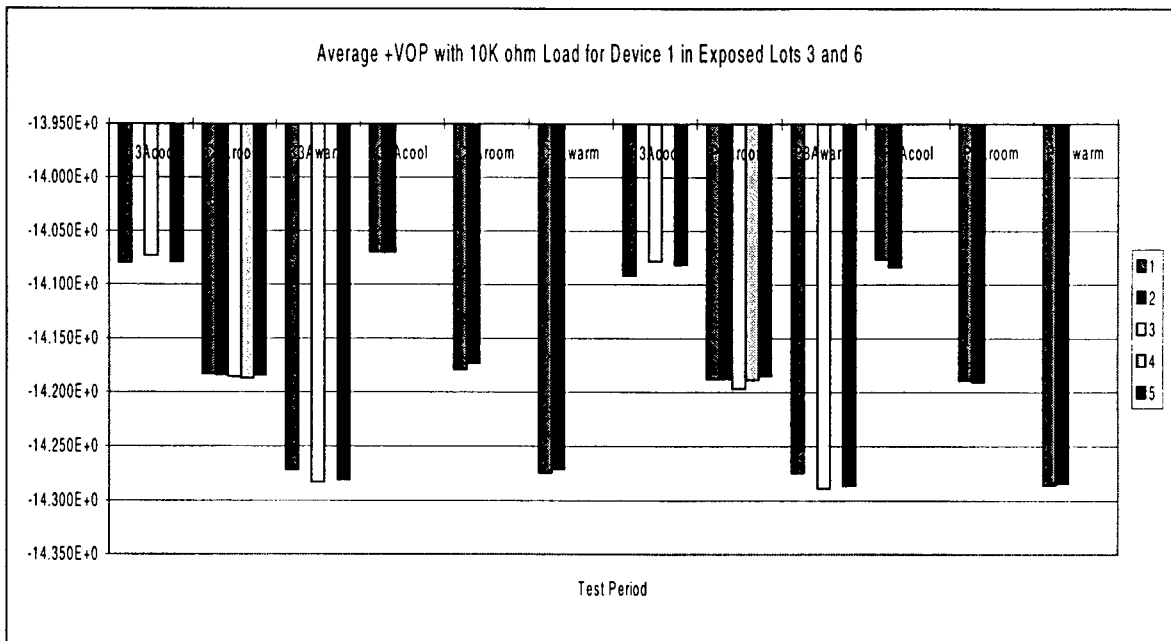
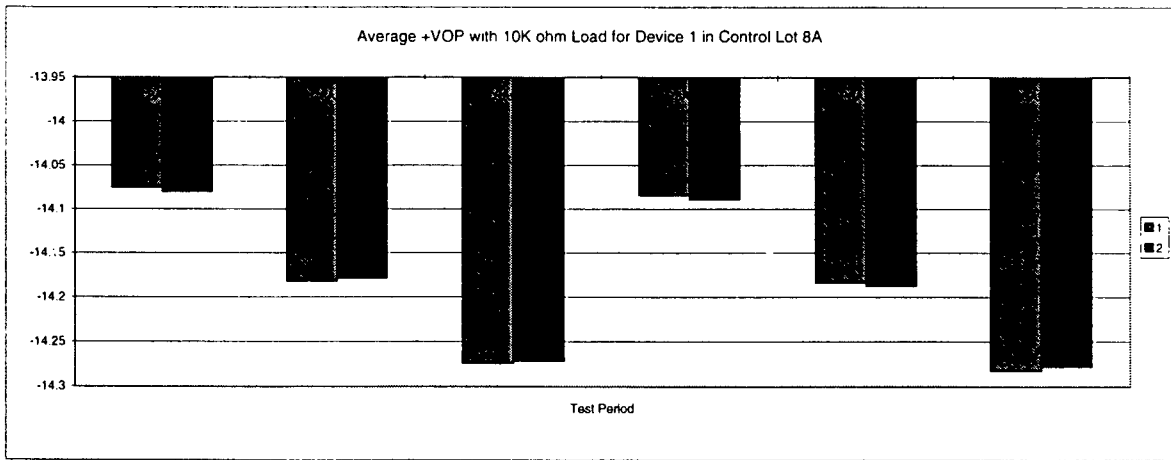



## Appendix C: Engineering Statistical Analysis Data

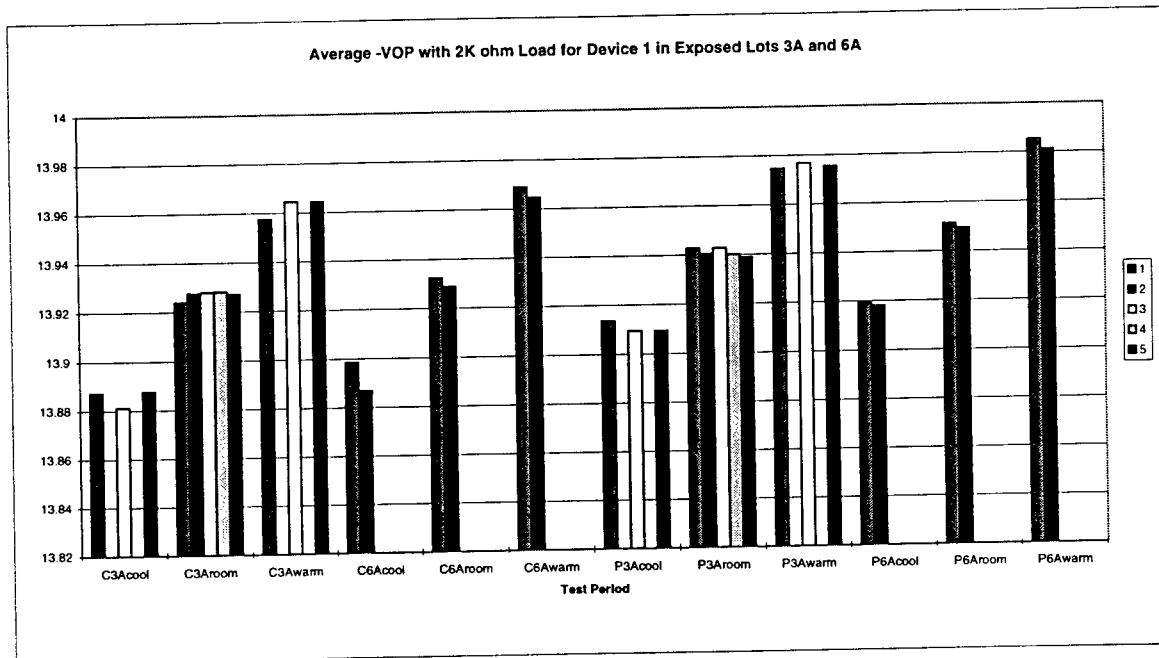
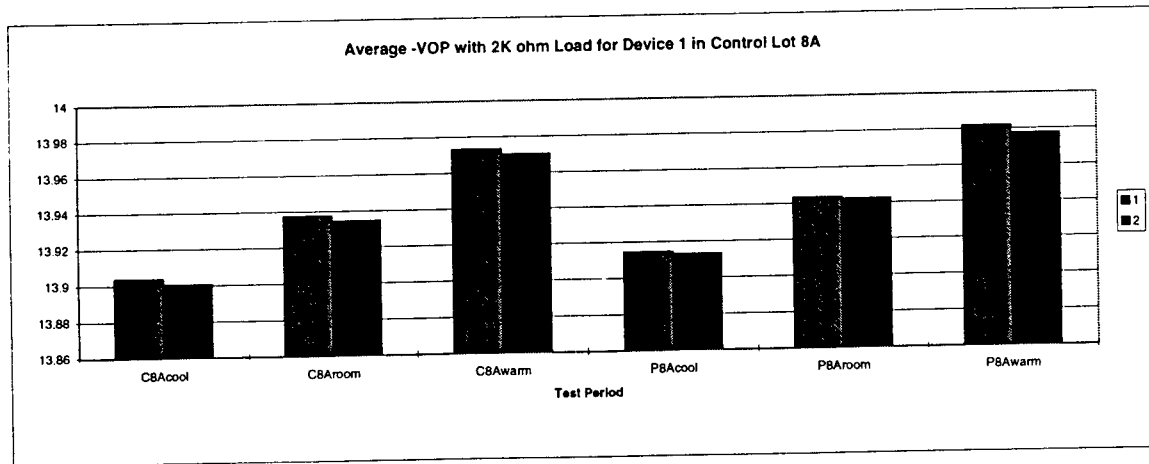

# Appendix C: Engineering Statistical Analysis Data

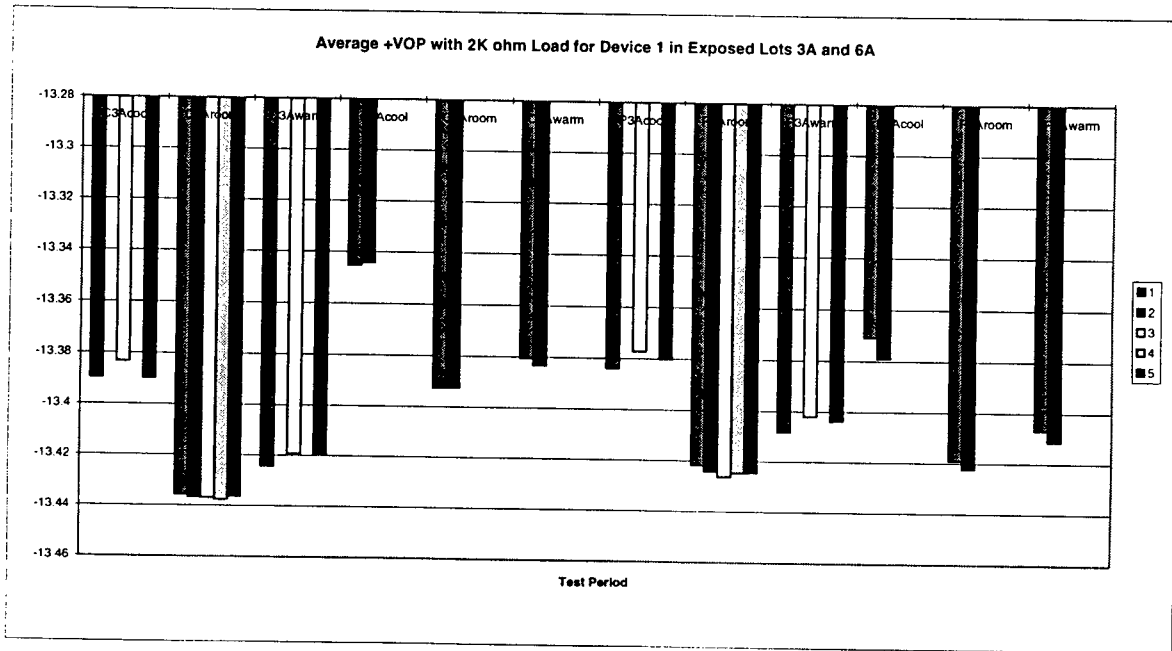
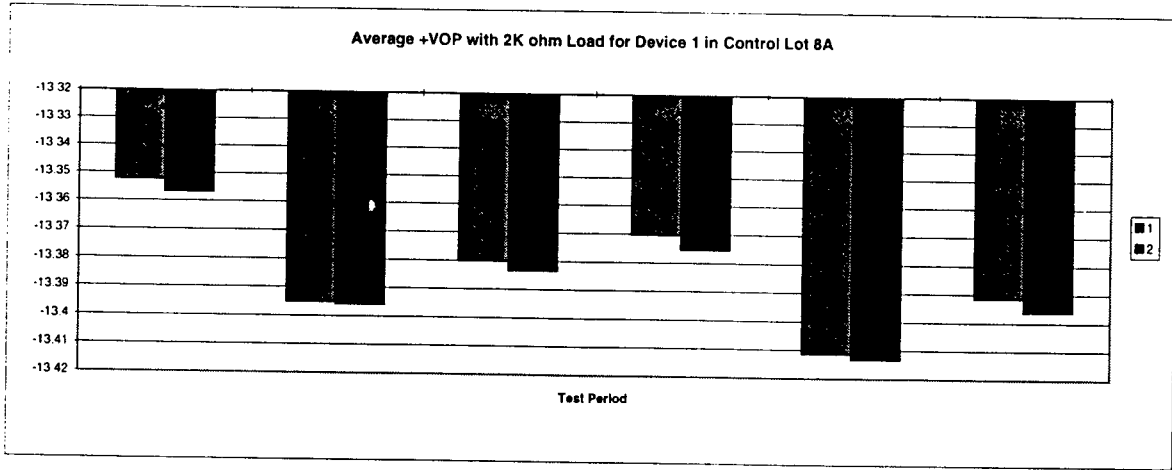

## Appendix C: Engineering Statistical Analysis Data

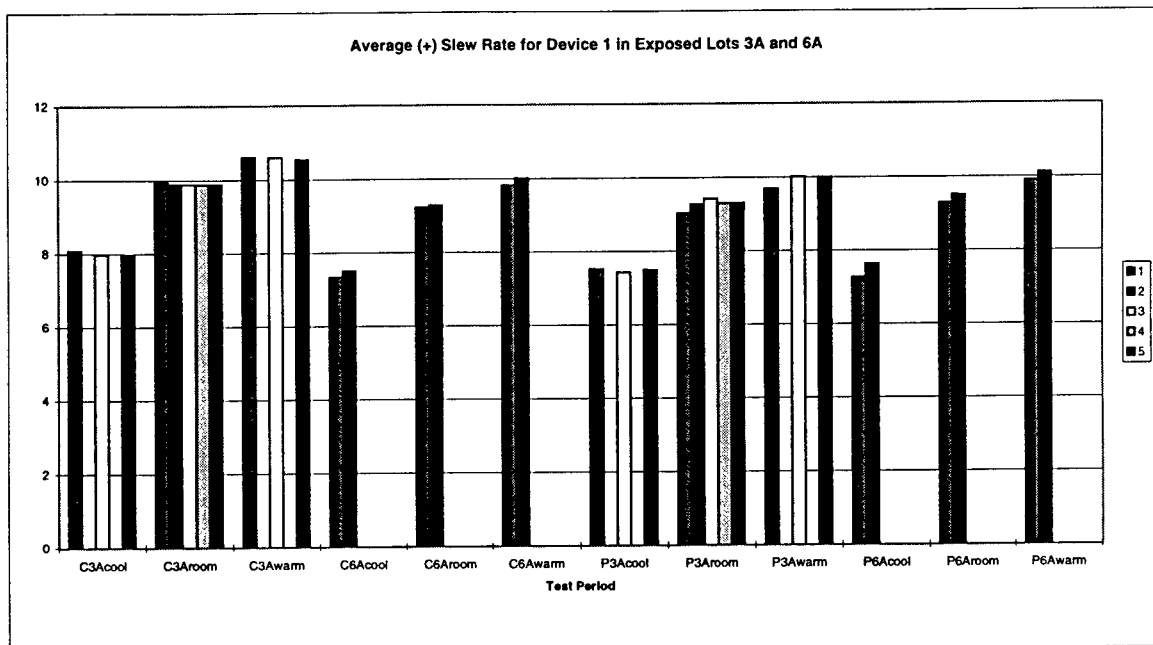
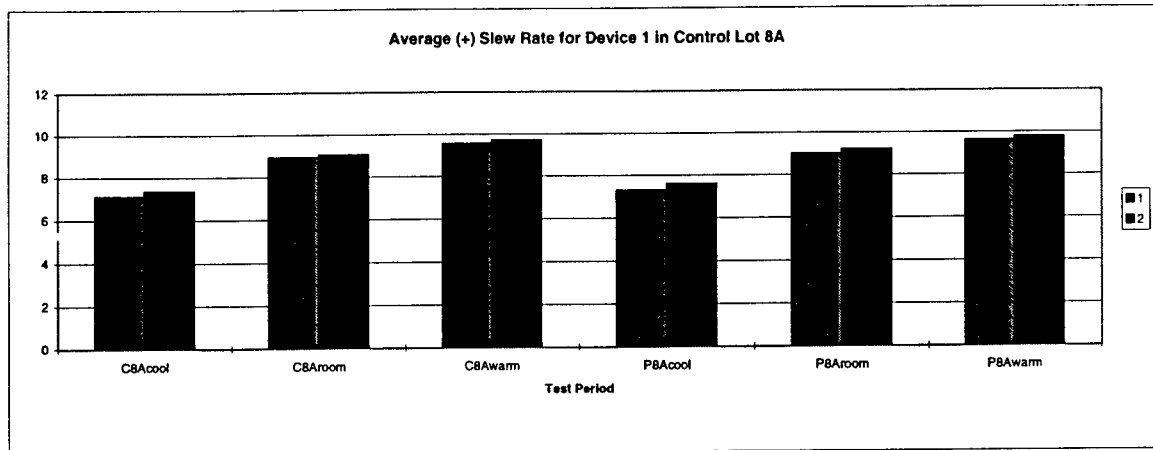

## Appendix C: Engineering Statistical Analysis Data

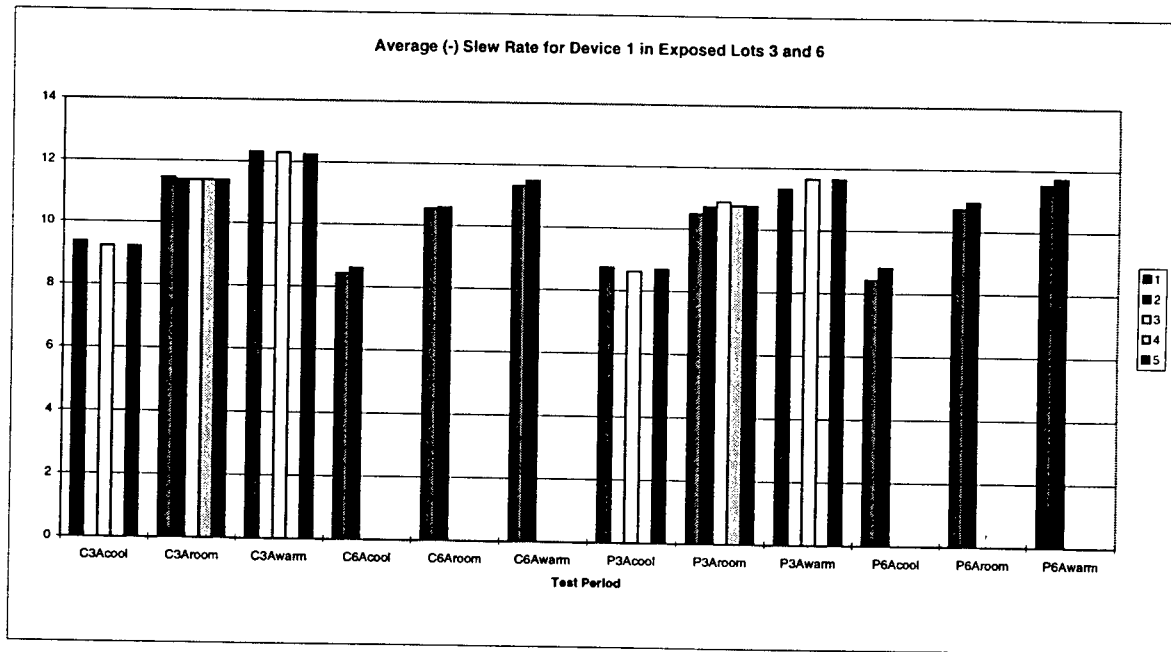
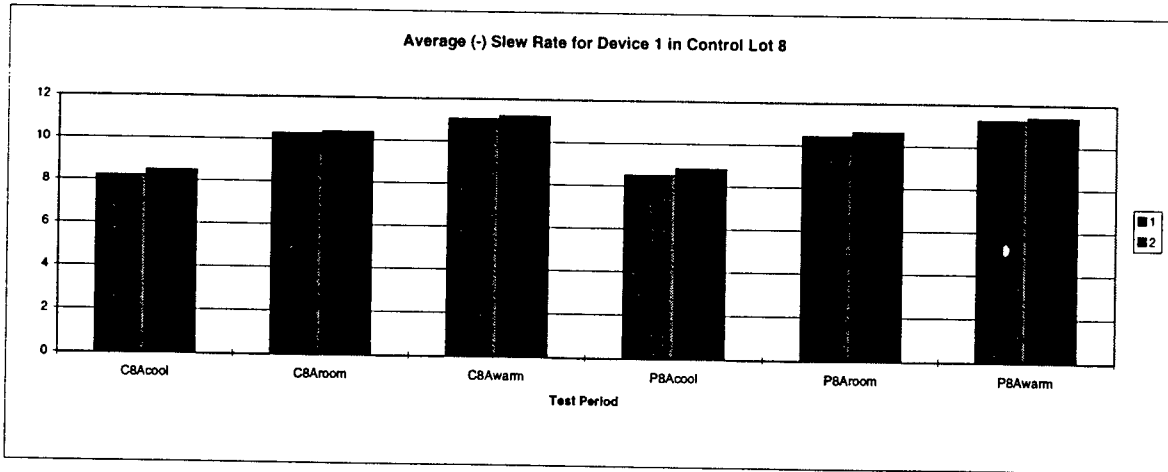

Appendix C: Engineering Statistical Analysis Data

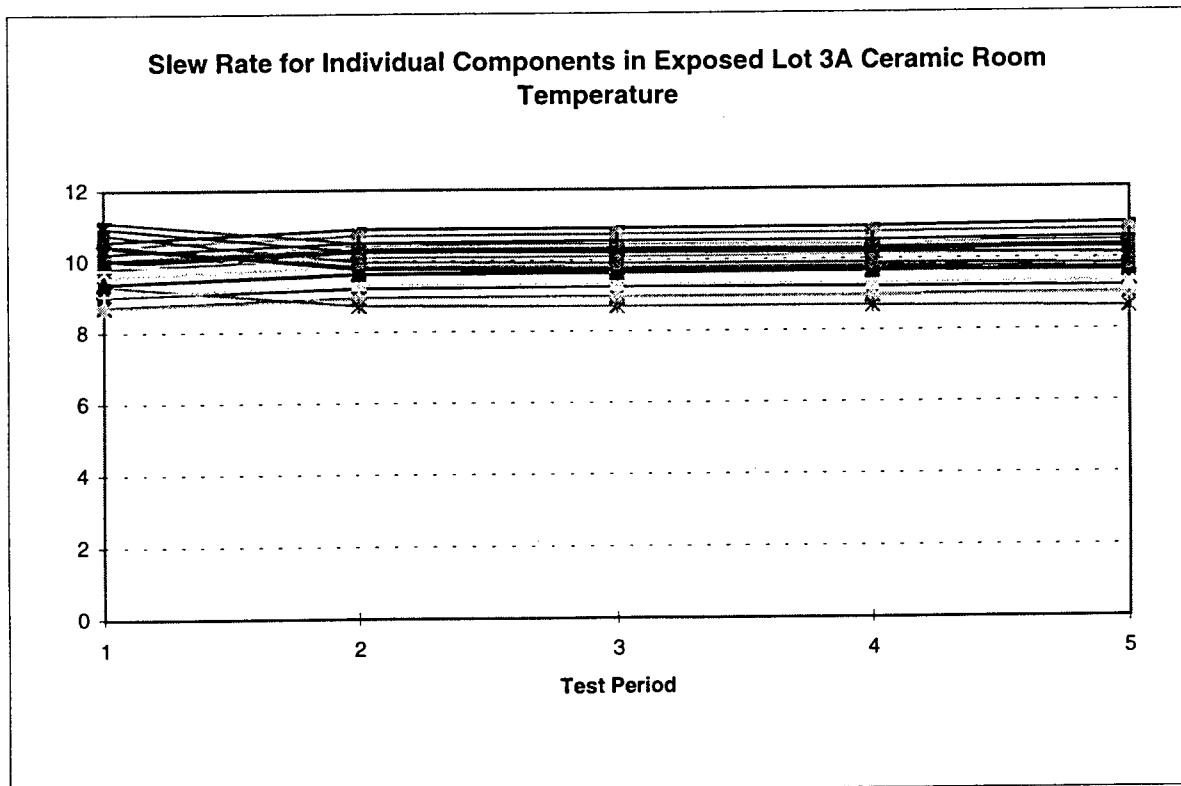
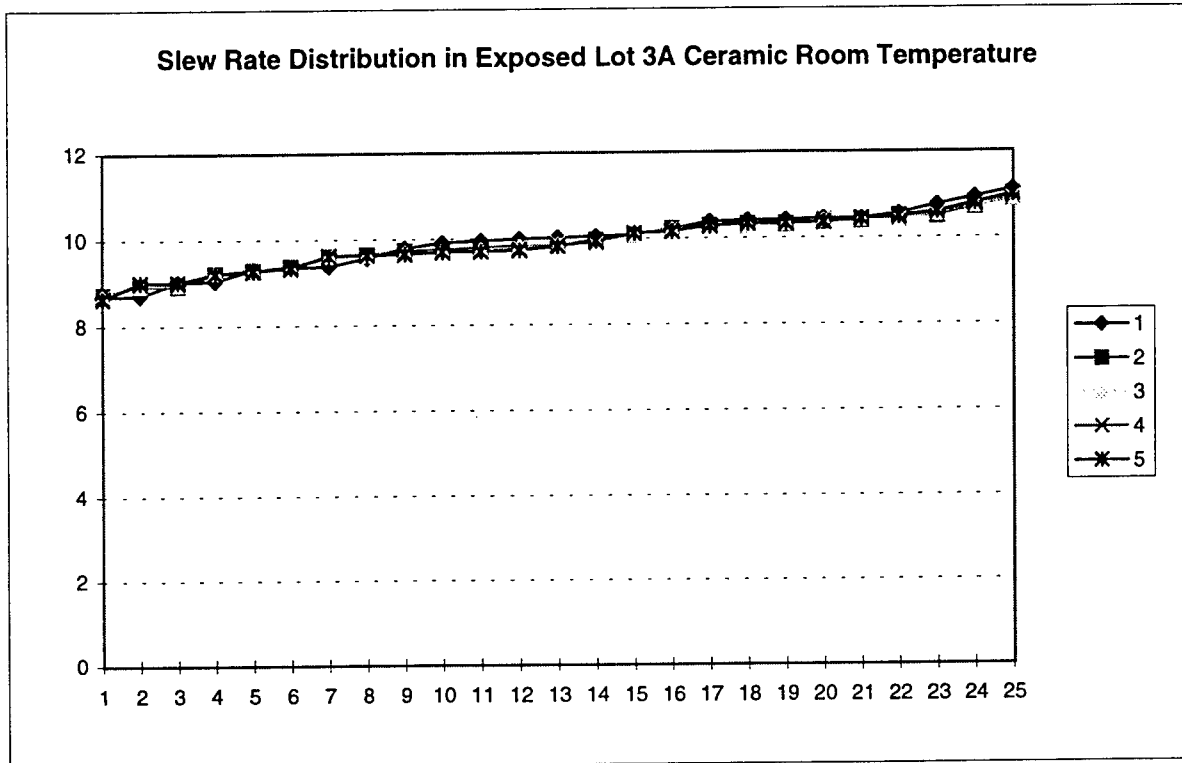

Appendix C: Engineering Statistical Analysis Data

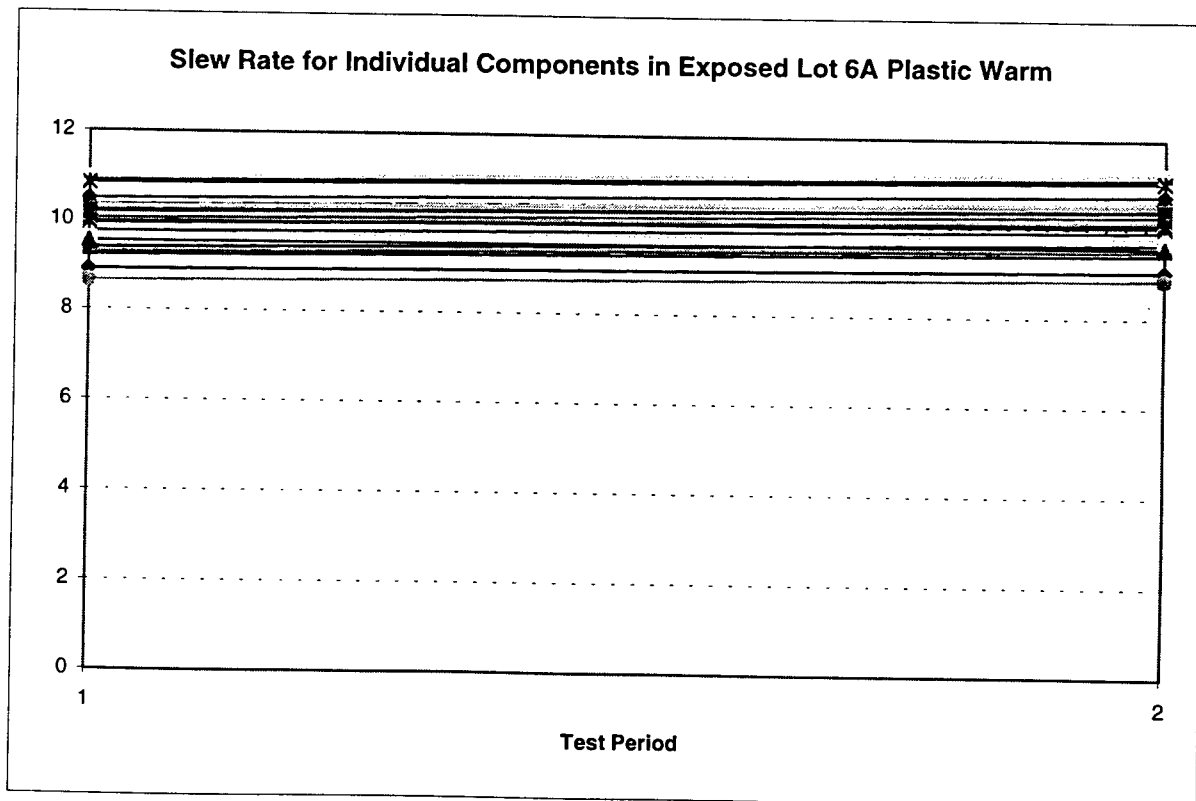
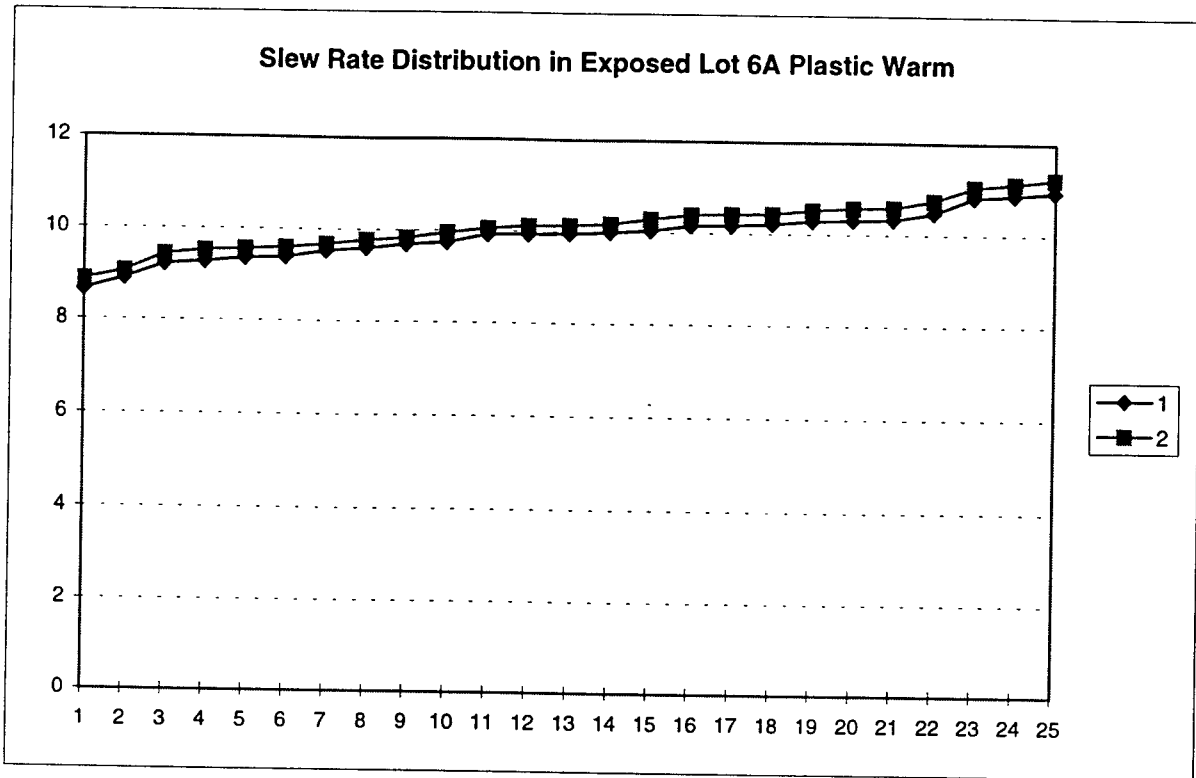

Appendix C: Engineering Statistical Analysis Data

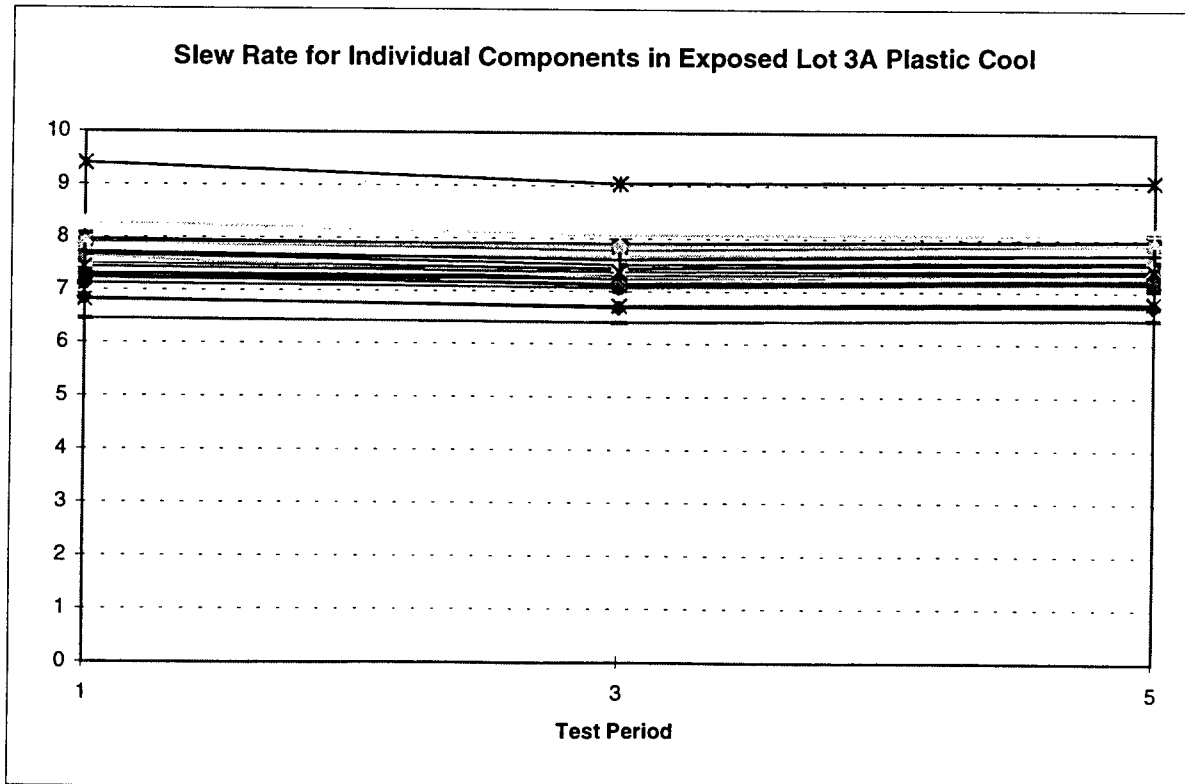
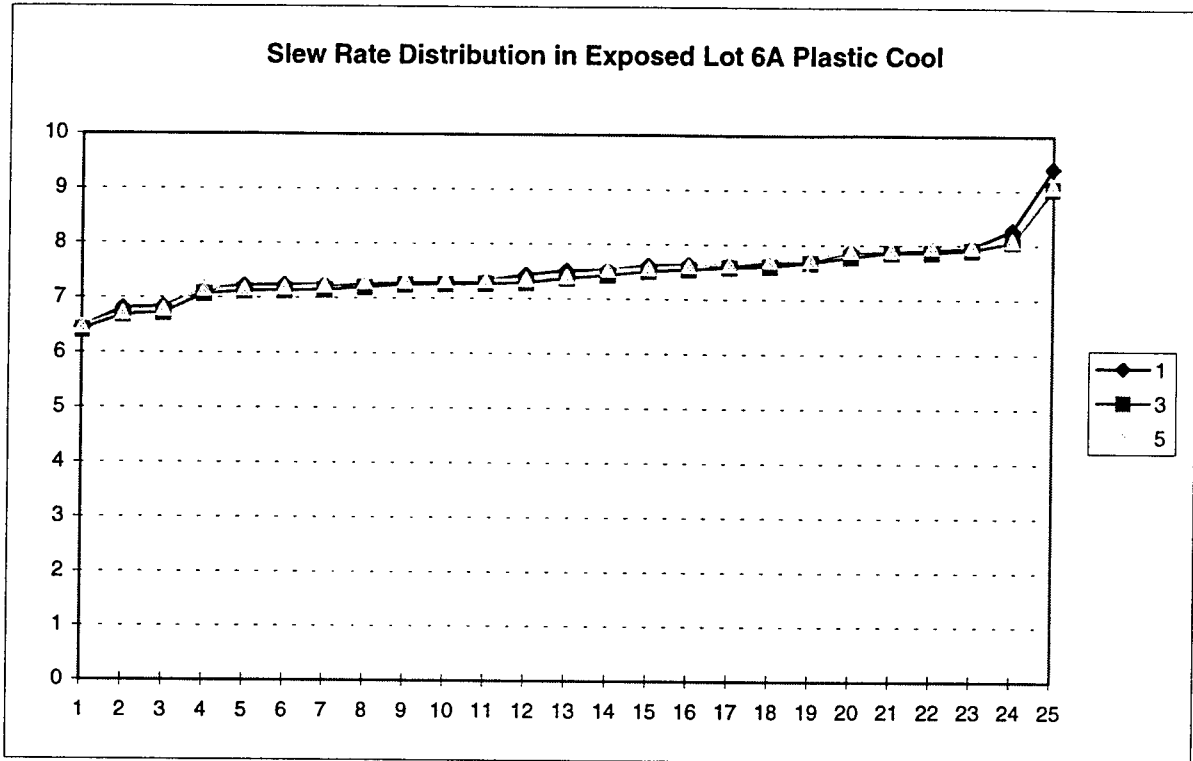

## Appendix C: Engineering Statistical Analysis Data

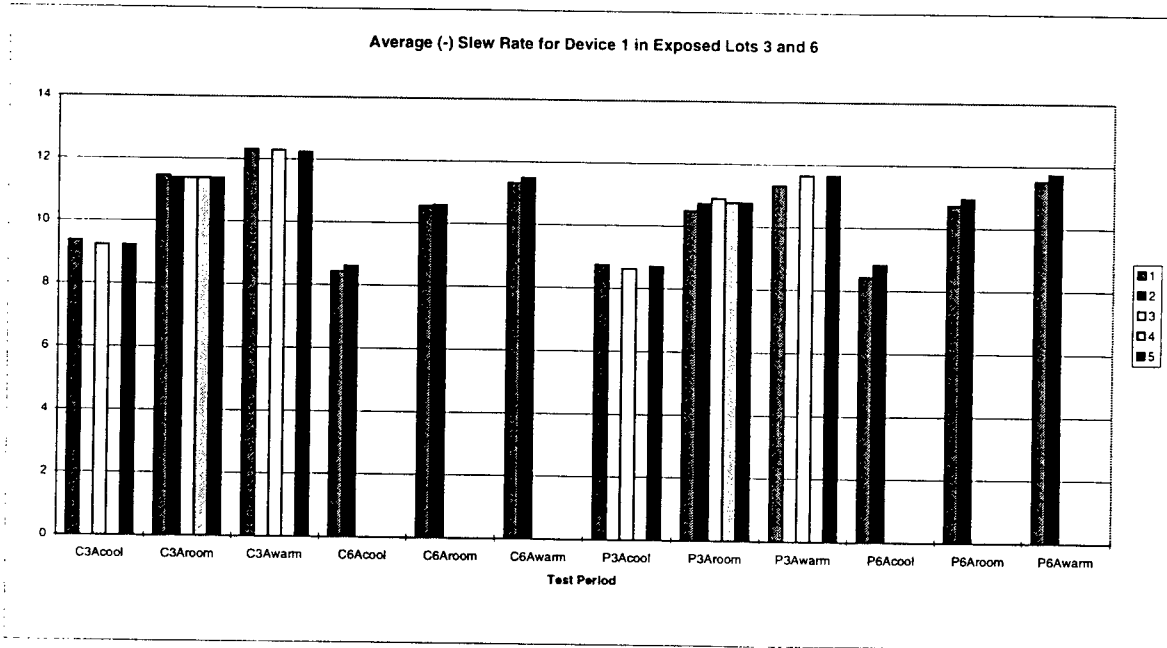
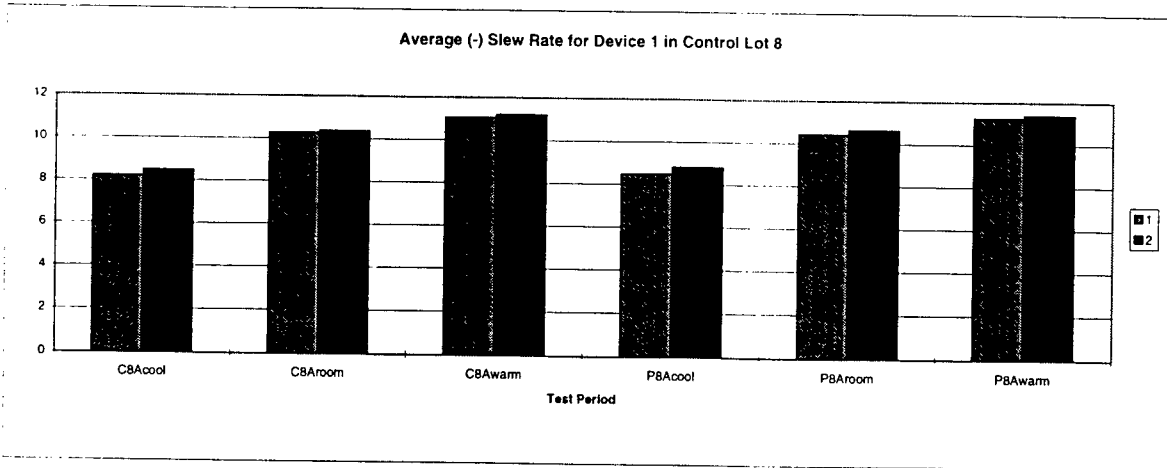



## Appendix C: Engineering Statistical Analysis Data

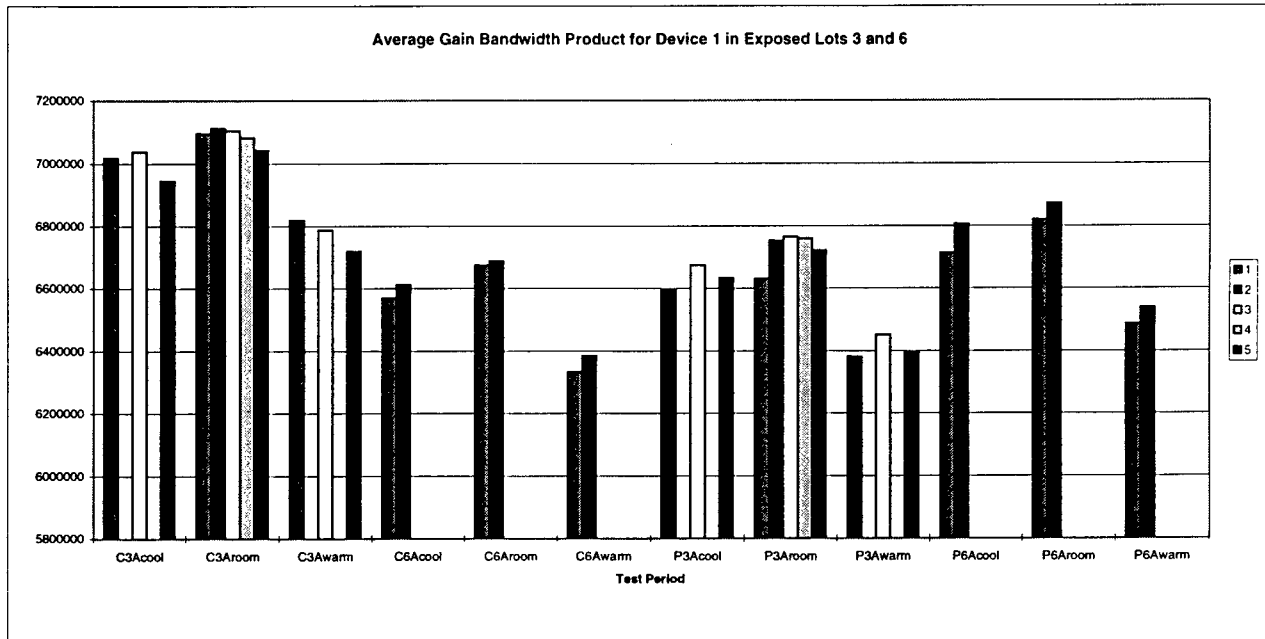
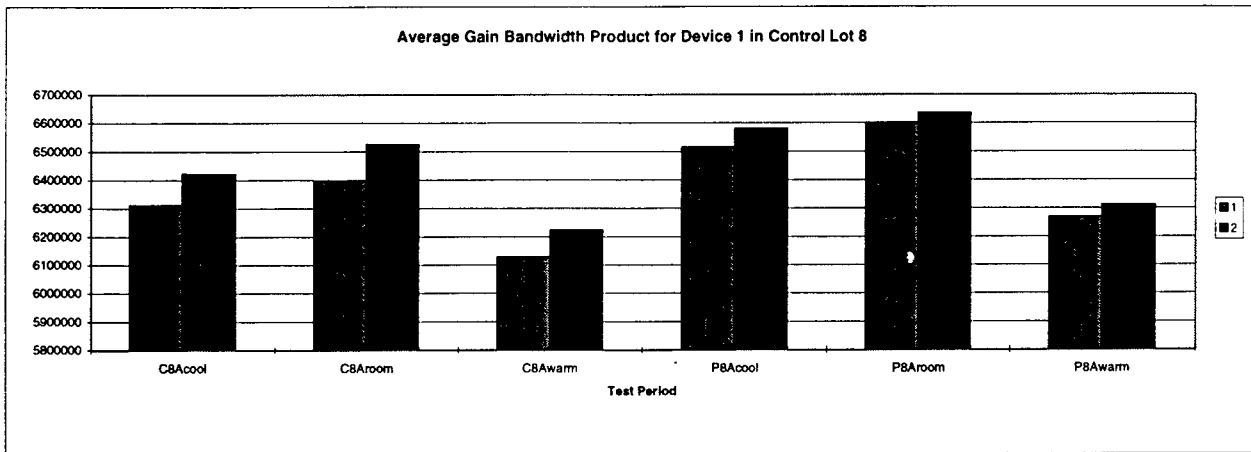

Appendix C: Engineering Statistical Analysis Data

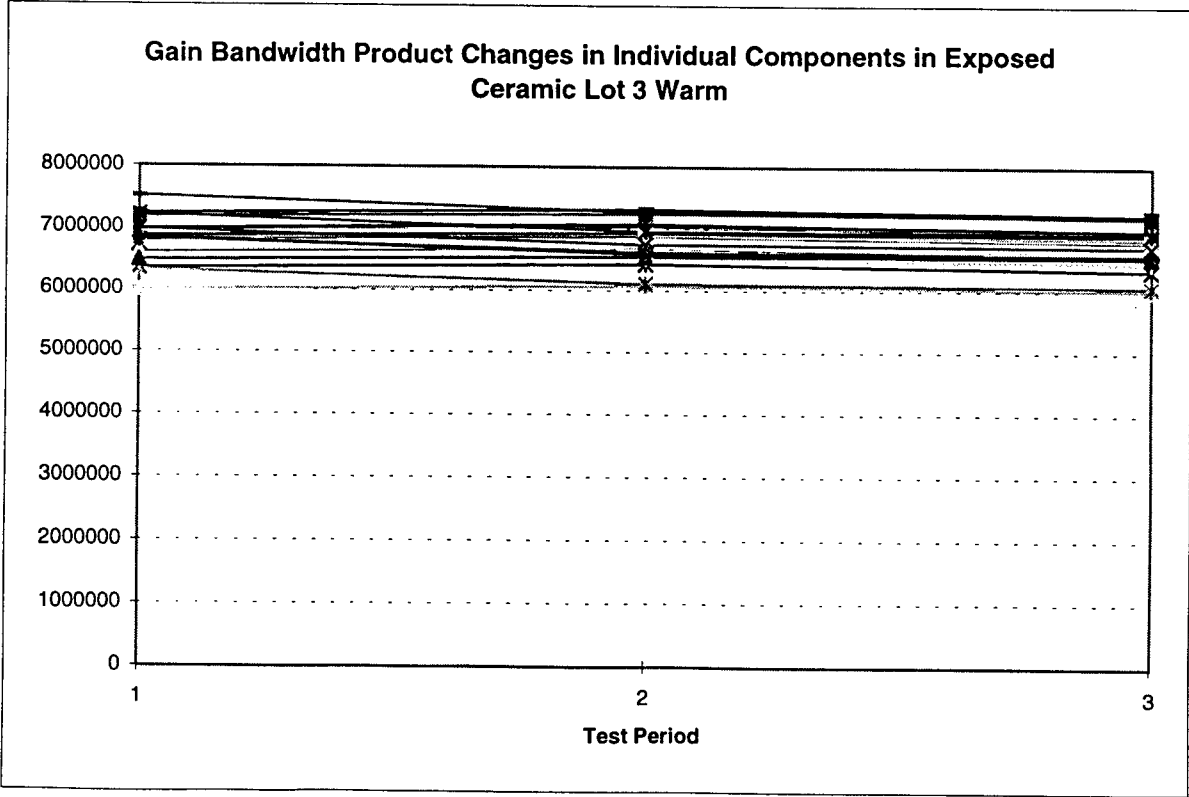
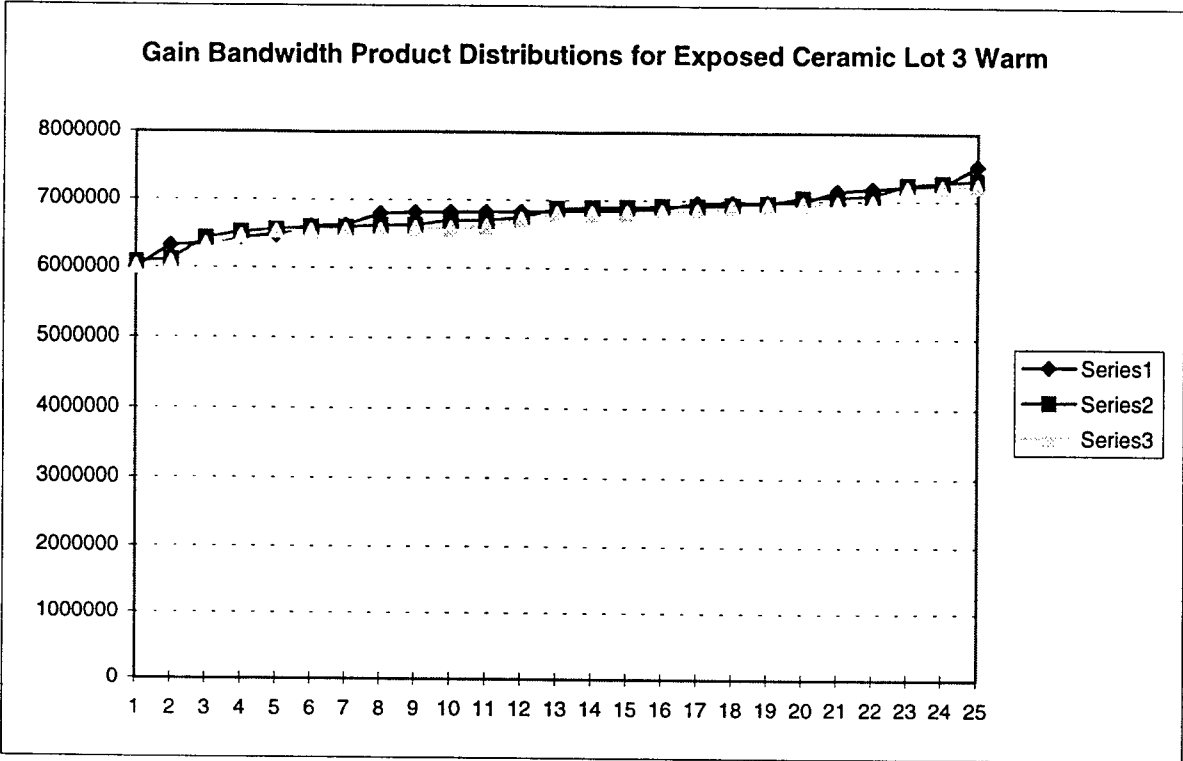

Appendix C: Engineering Statistical Analysis Data

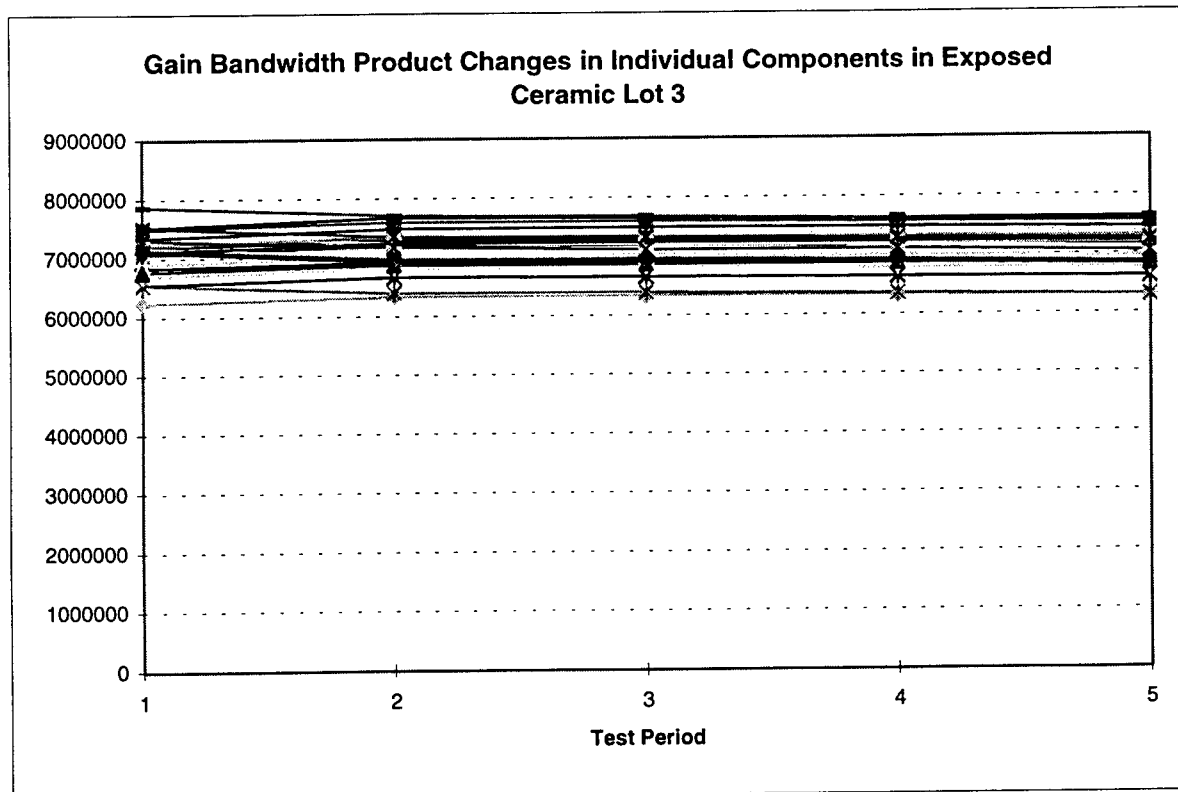
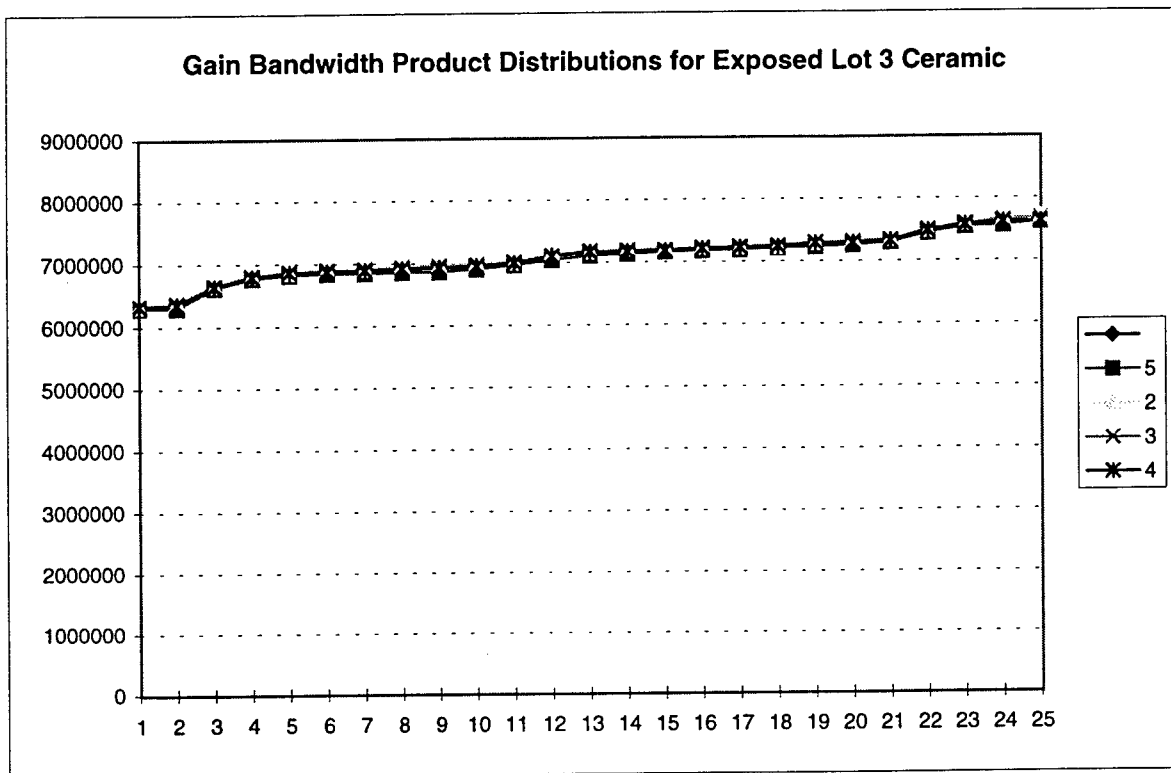

Appendix C: Engineering Statistical Analysis Data

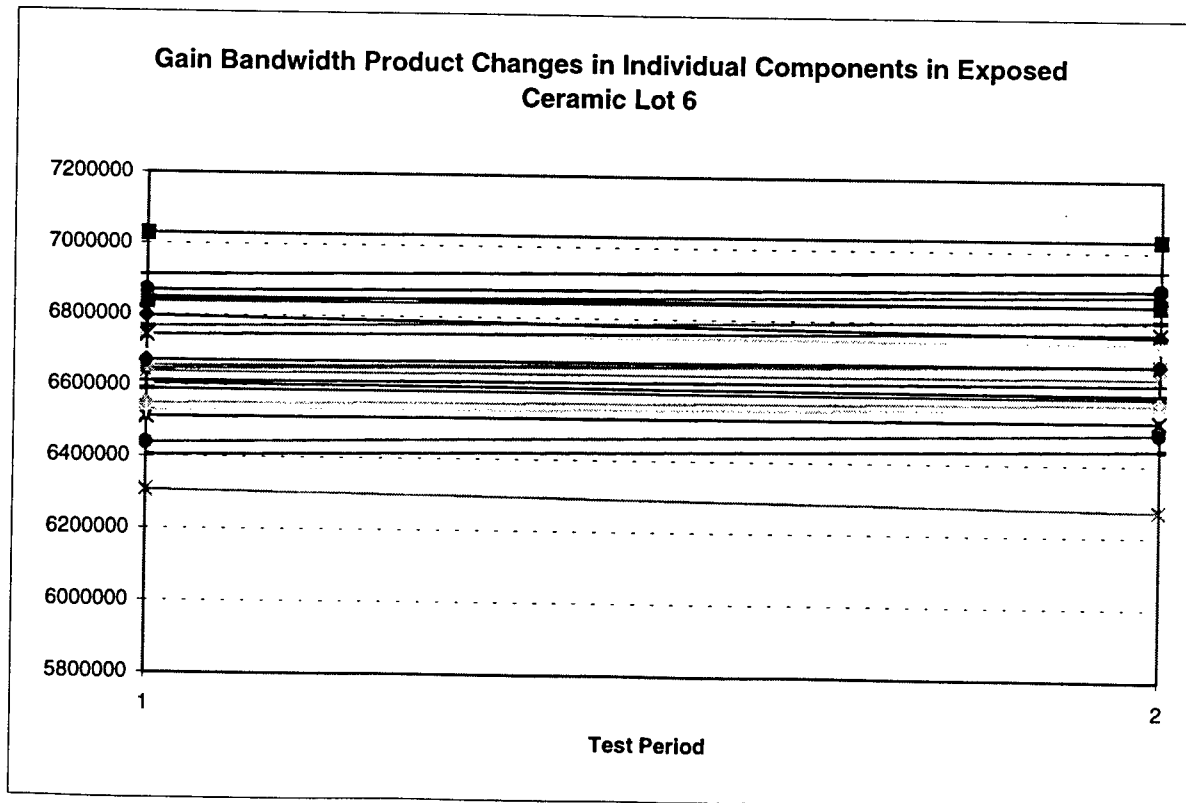
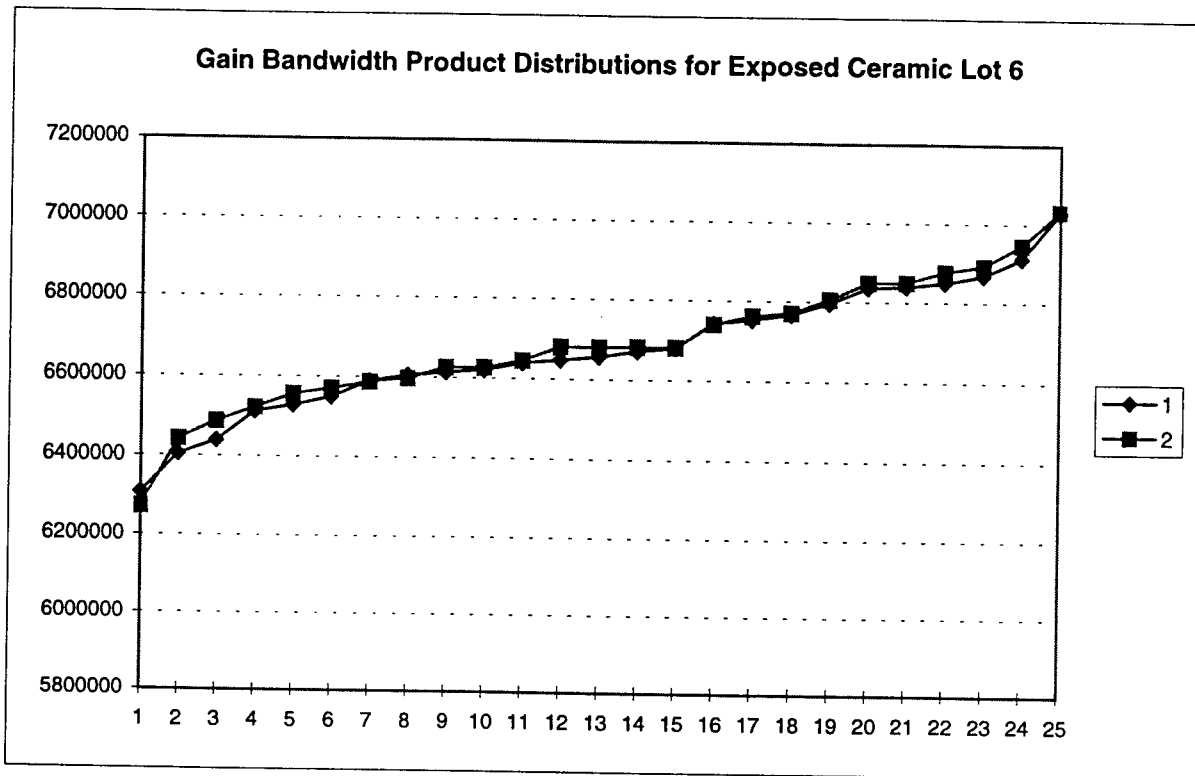

Appendix C: Engineering Statistical Analysis Data

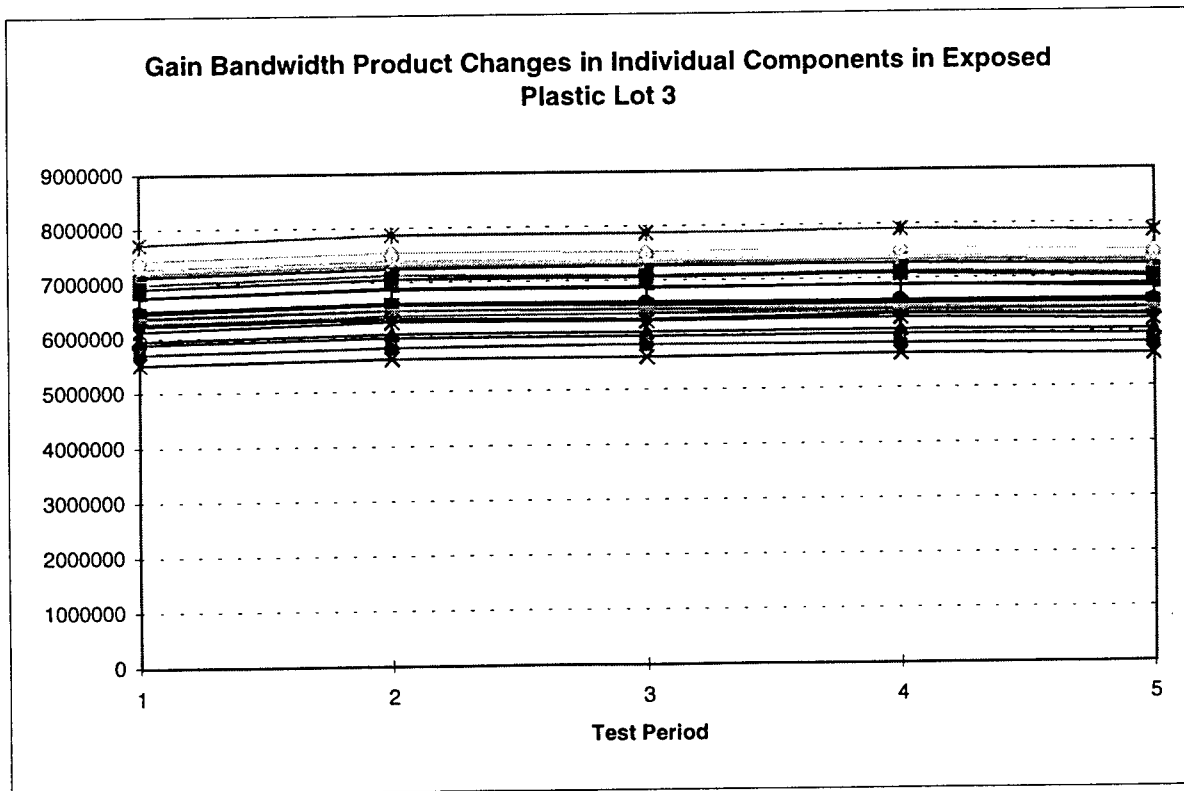
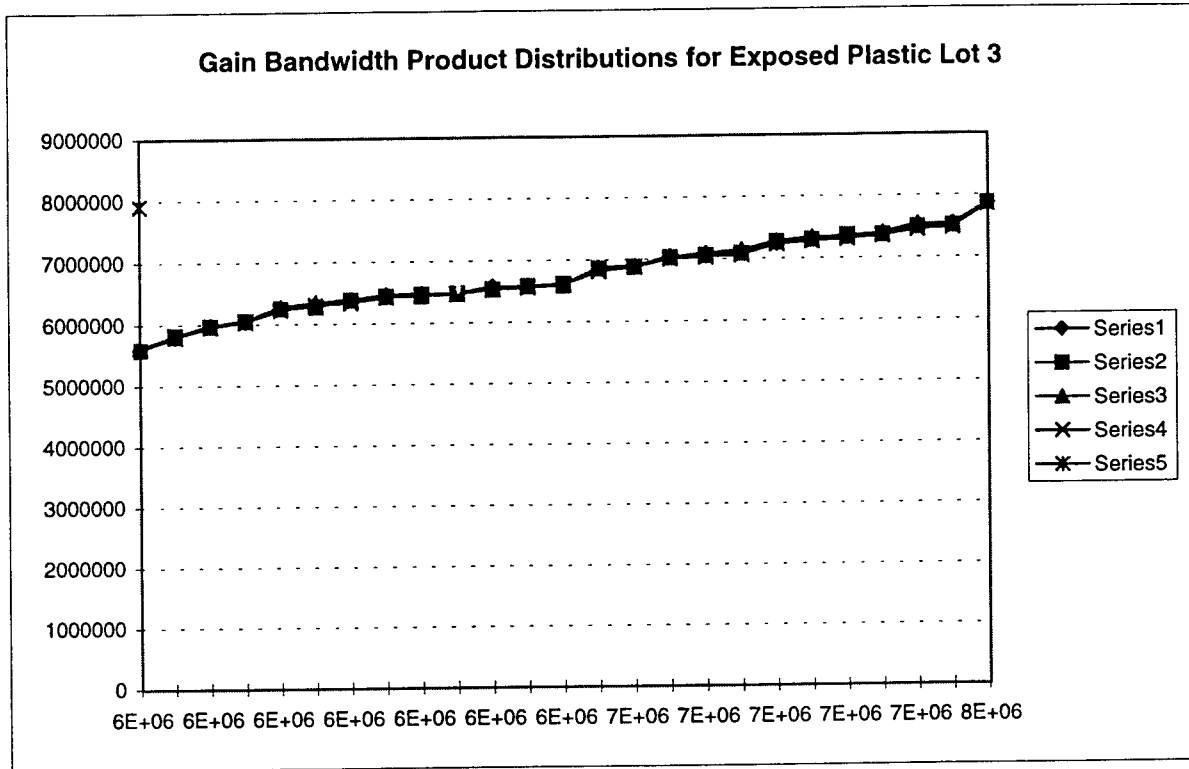

Appendix C: Engineering Statistical Analysis Data

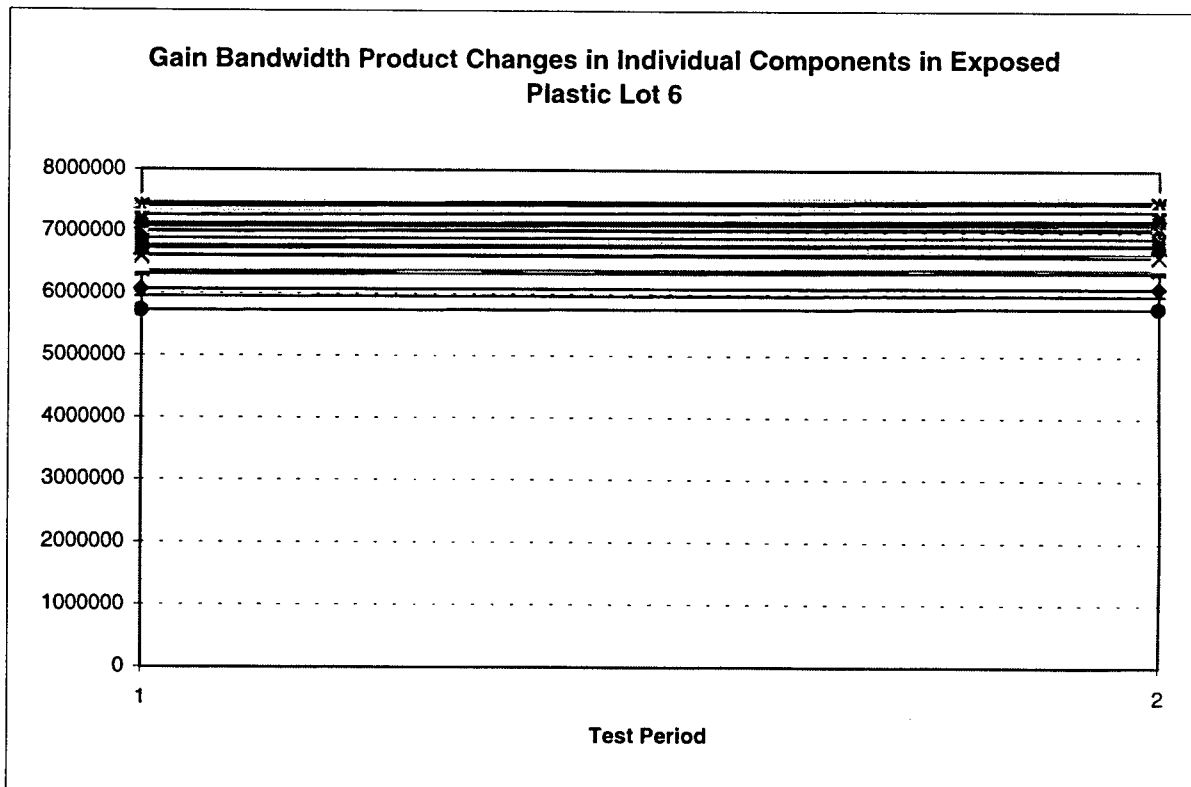
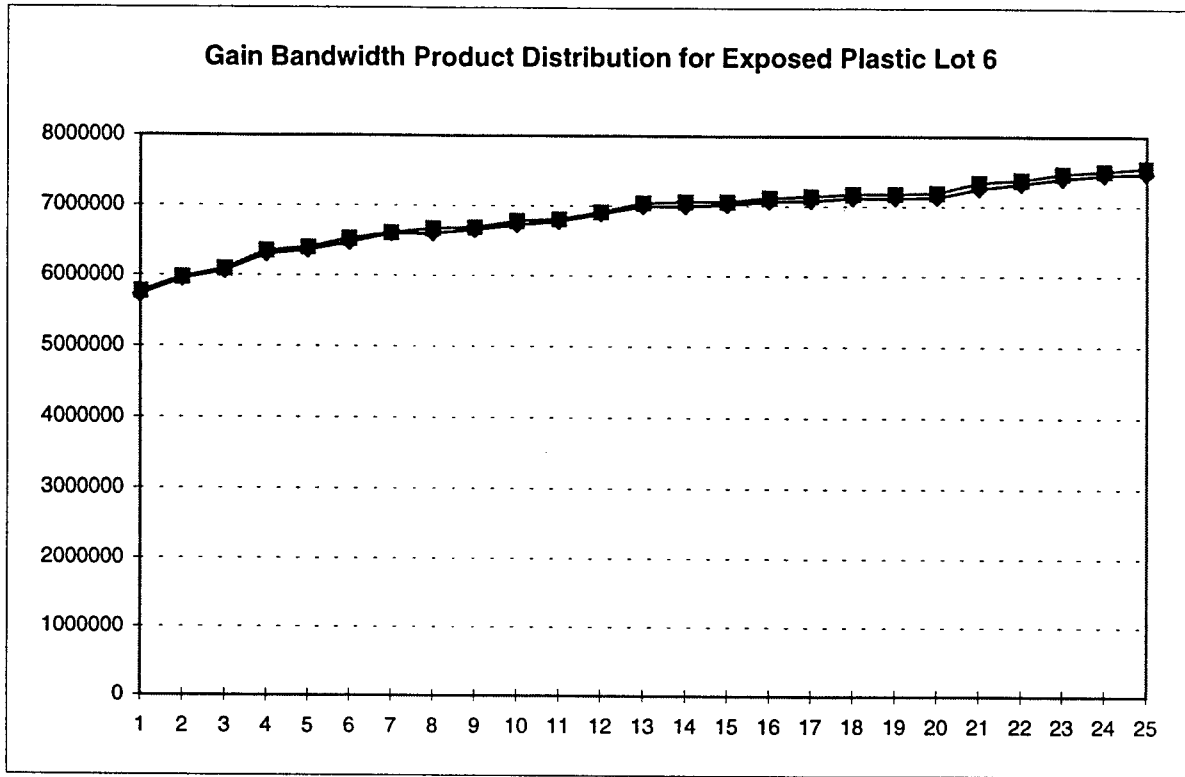

## Appendix C: Engineering Statistical Analysis Data

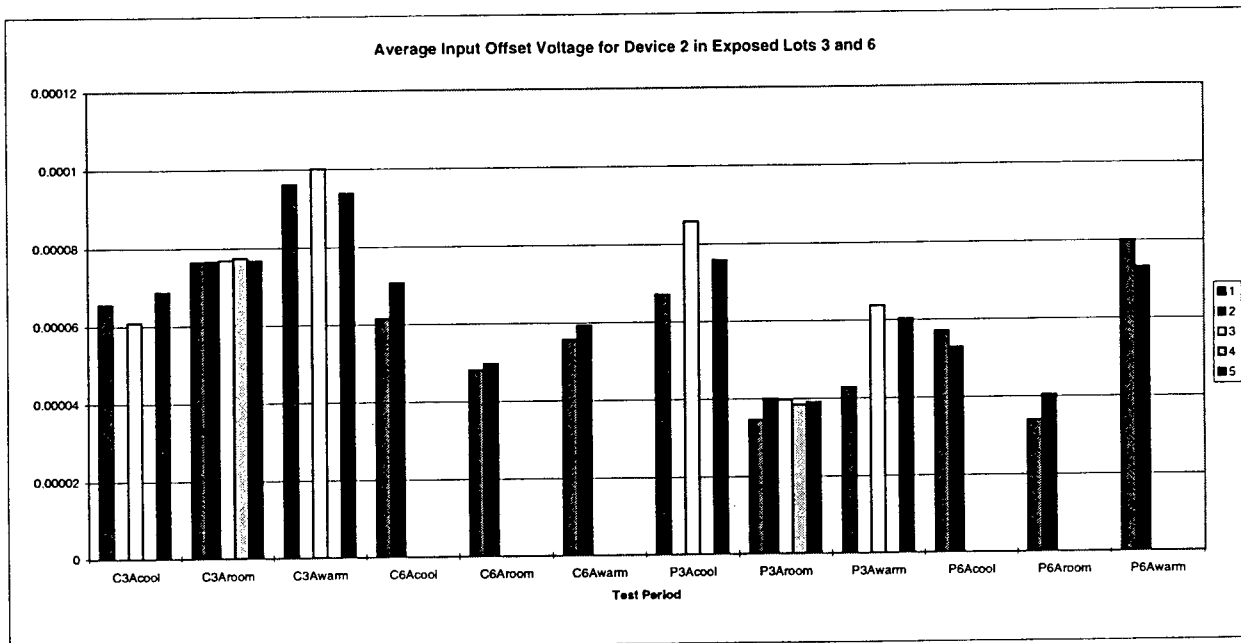
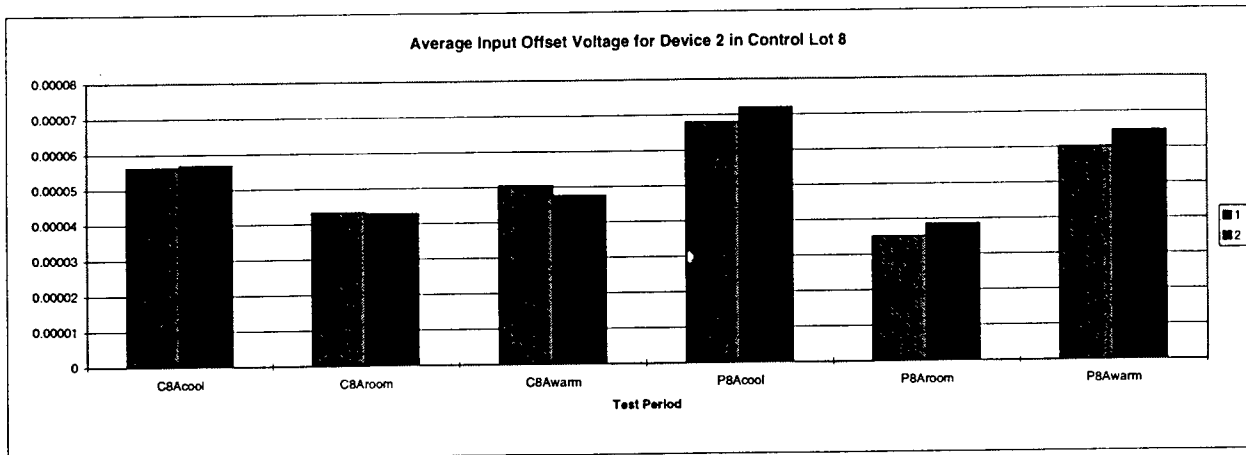

## Appendix C: Engineering Statistical Analysis Data

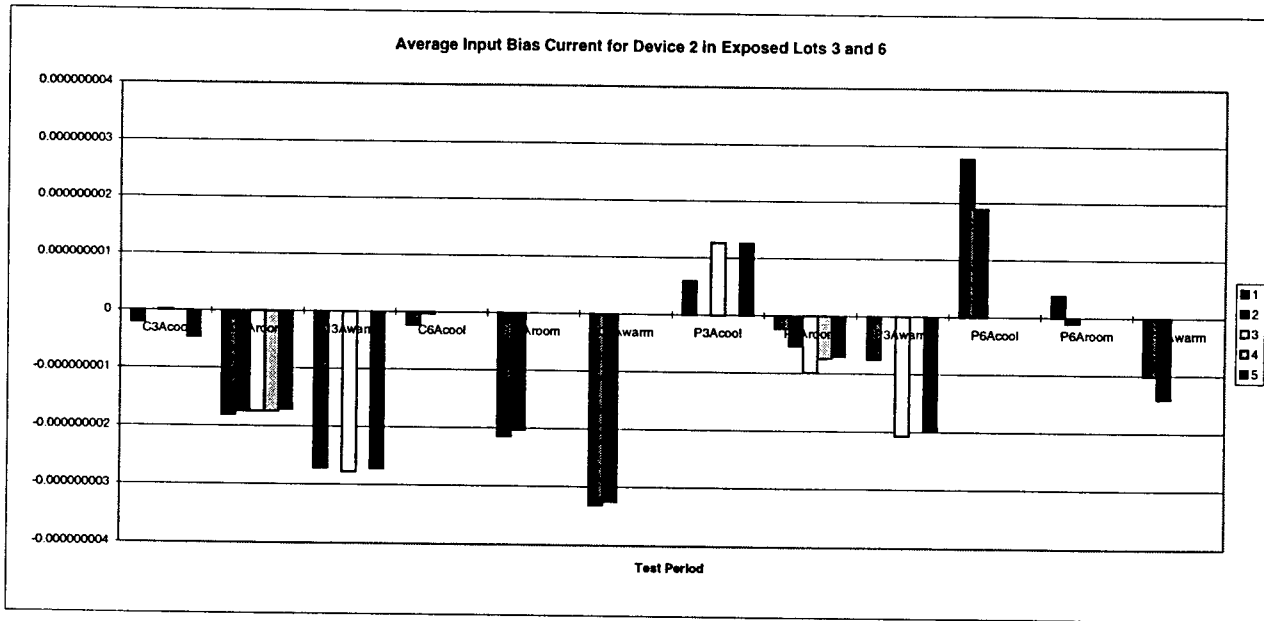
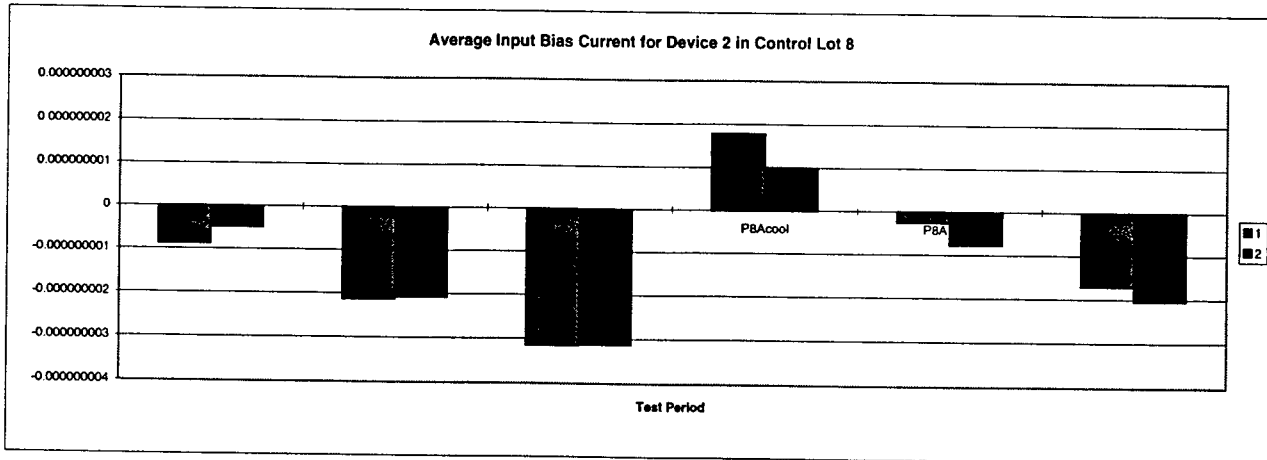



## Appendix C: Engineering Statistical Analysis Data

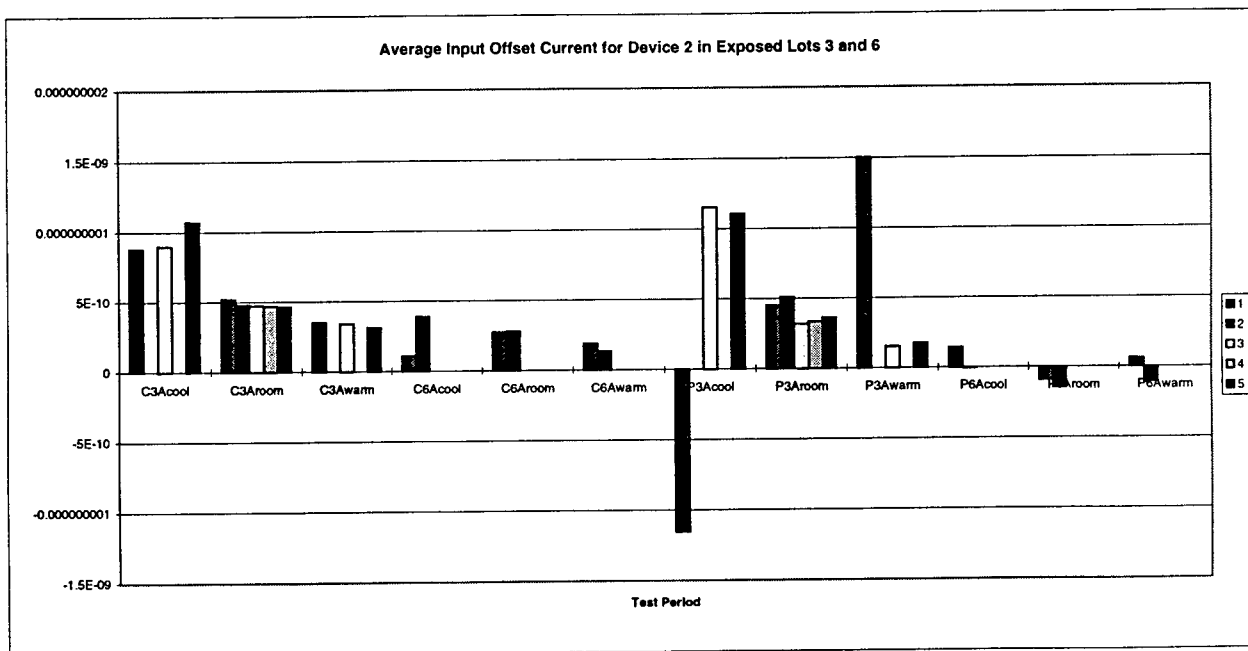
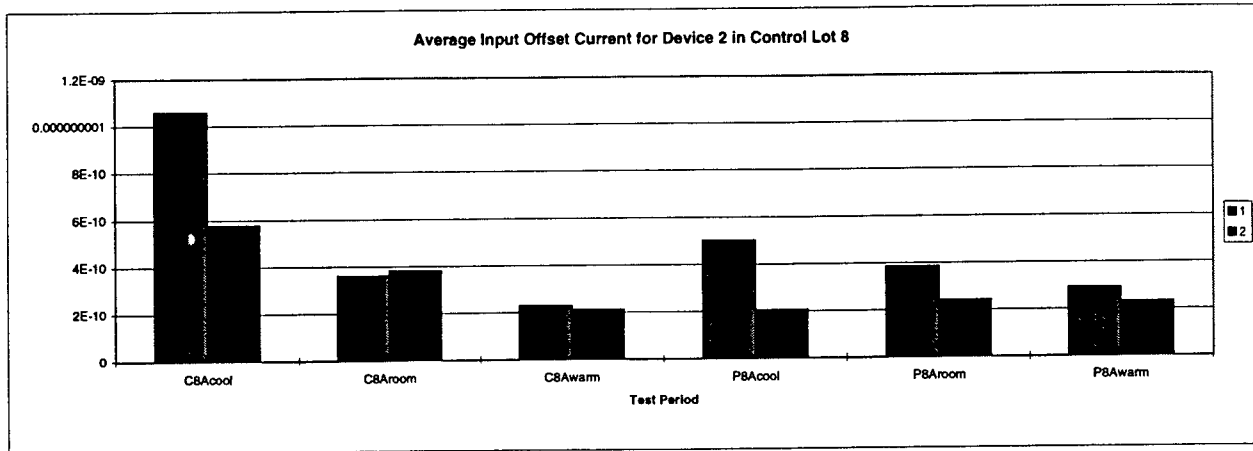

## Appendix C: Engineering Statistical Analysis Data

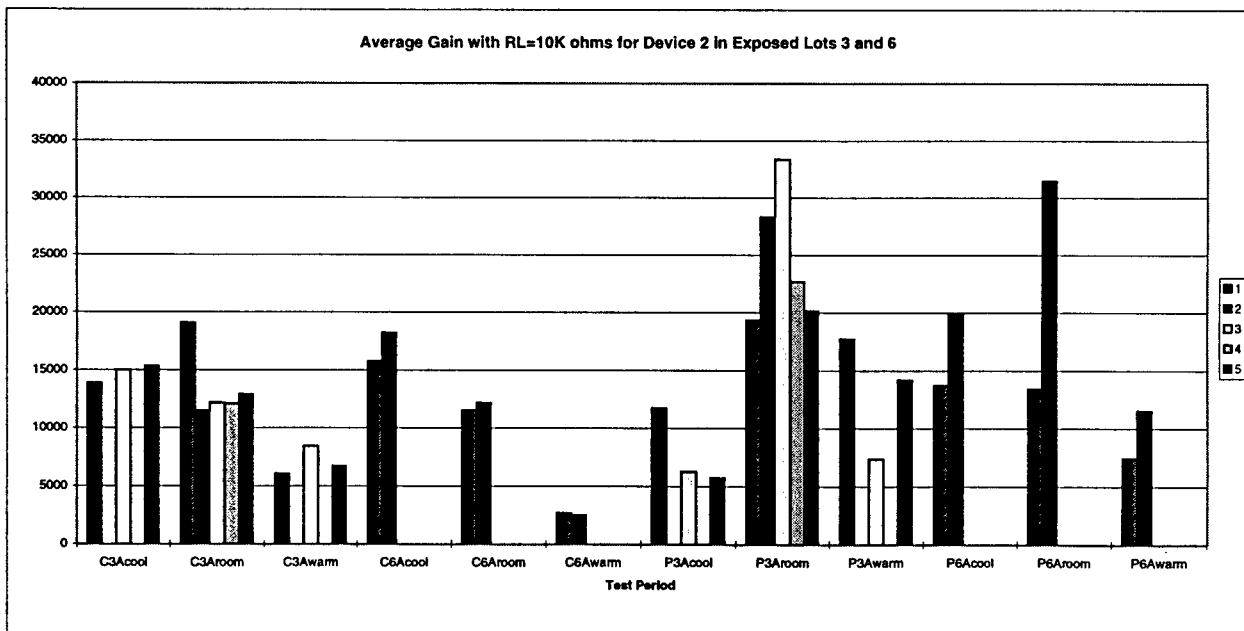
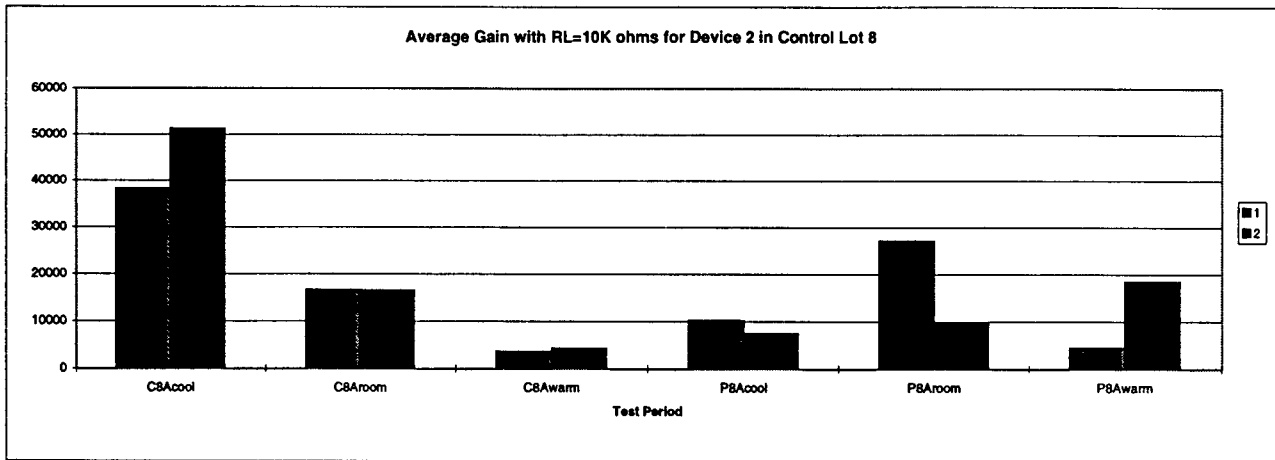

## Appendix C: Engineering Statistical Analysis Data

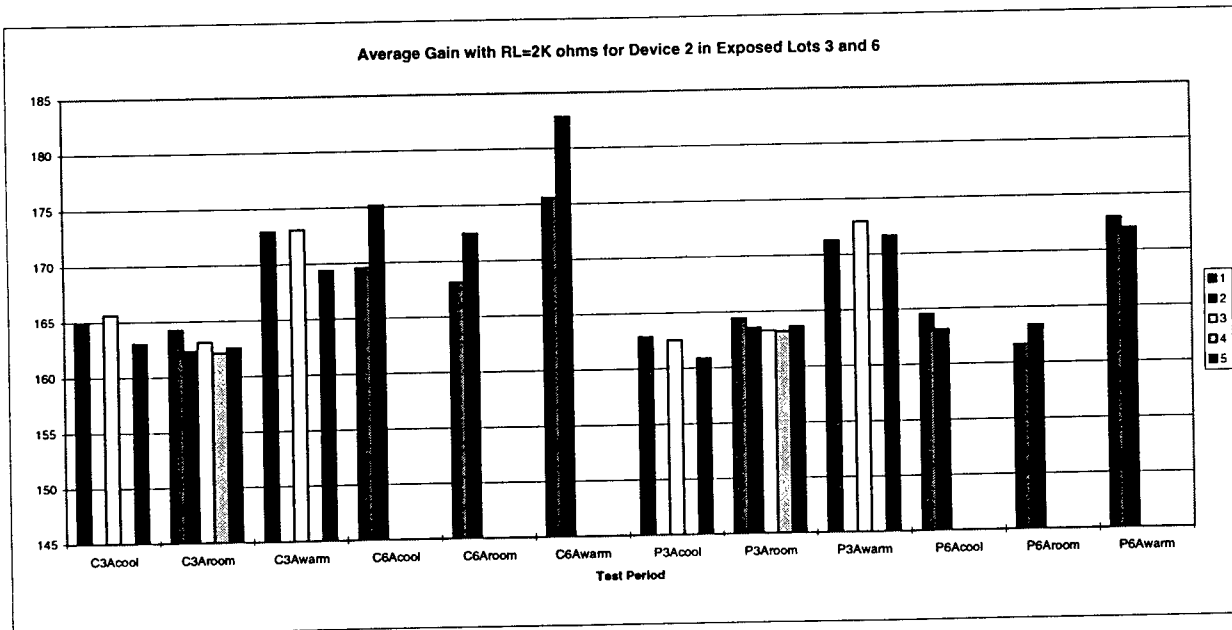
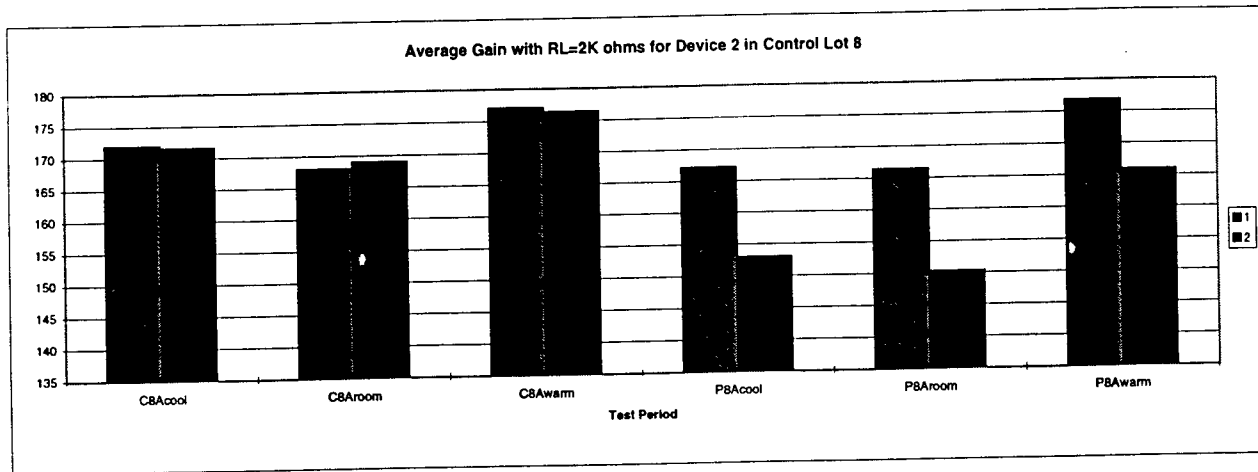

# Appendix C: Engineering Statistical Analysis Data

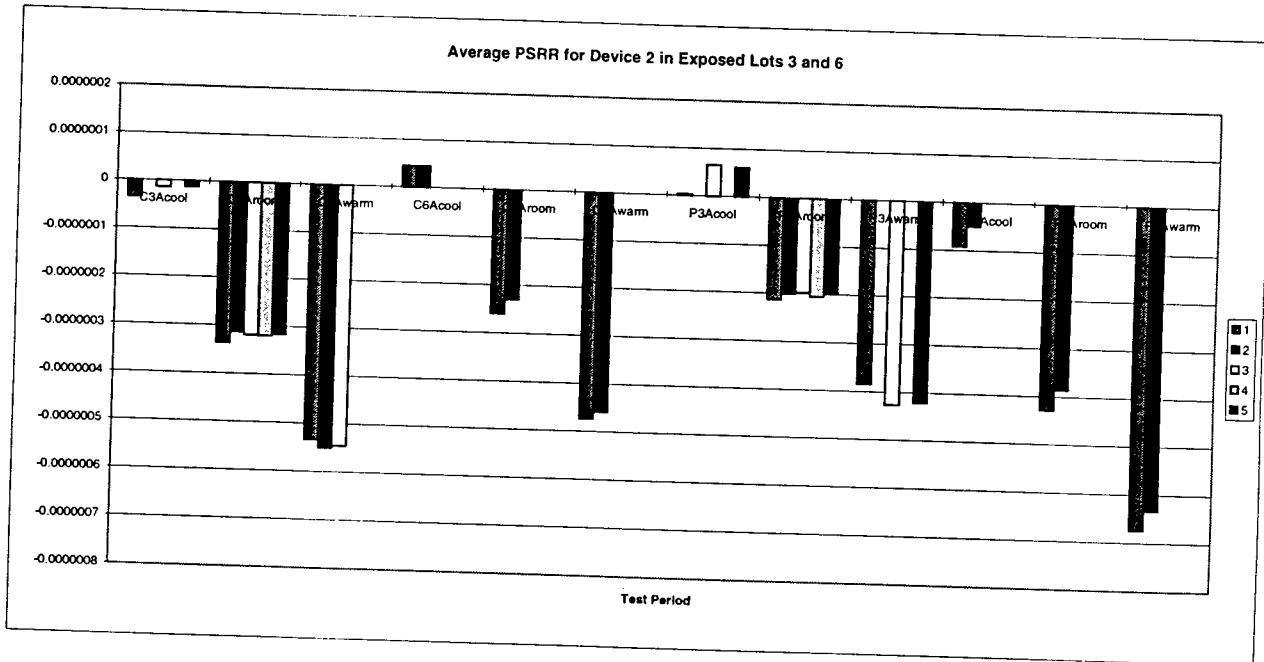
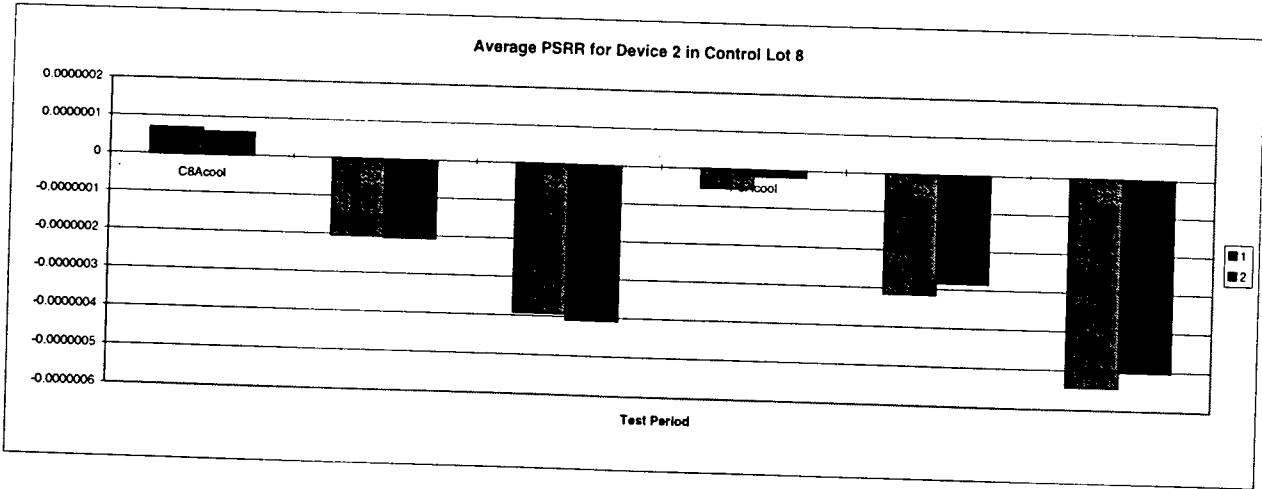

## Appendix C: Engineering Statistical Analysis Data

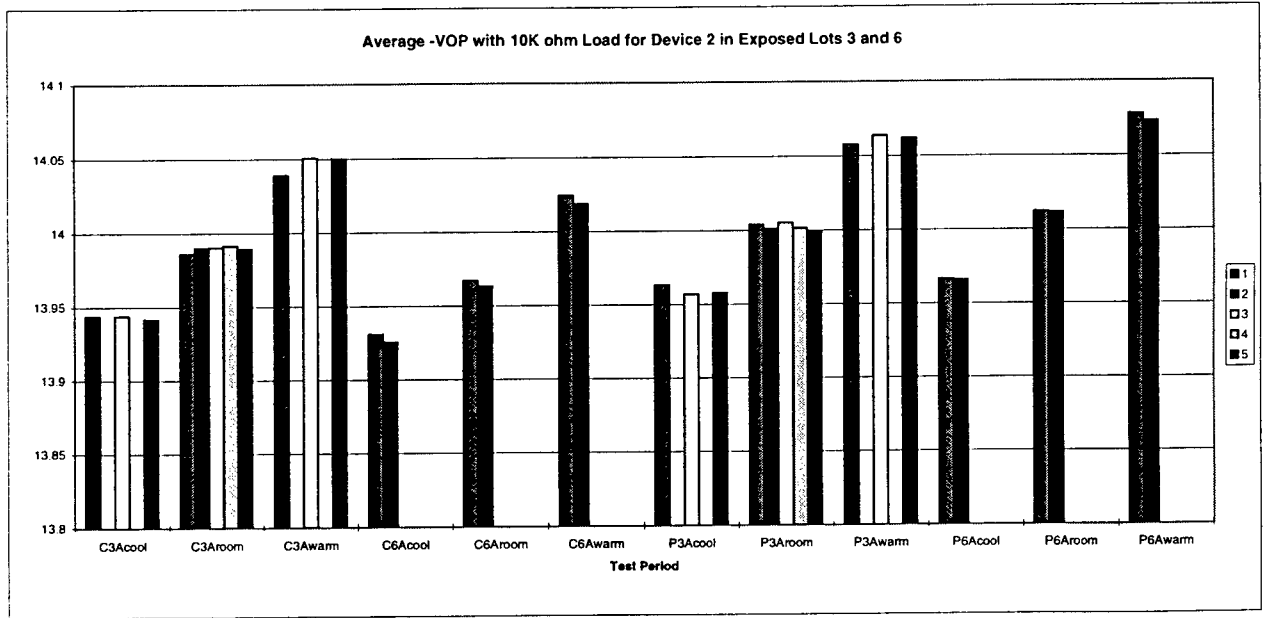
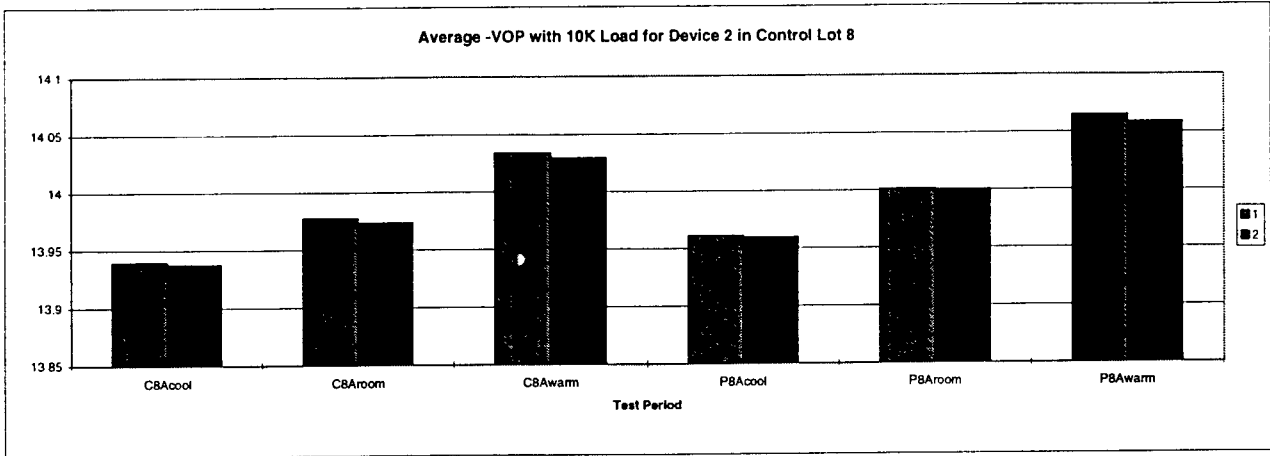

# Appendix C: Engineering Statistical Analysis Data

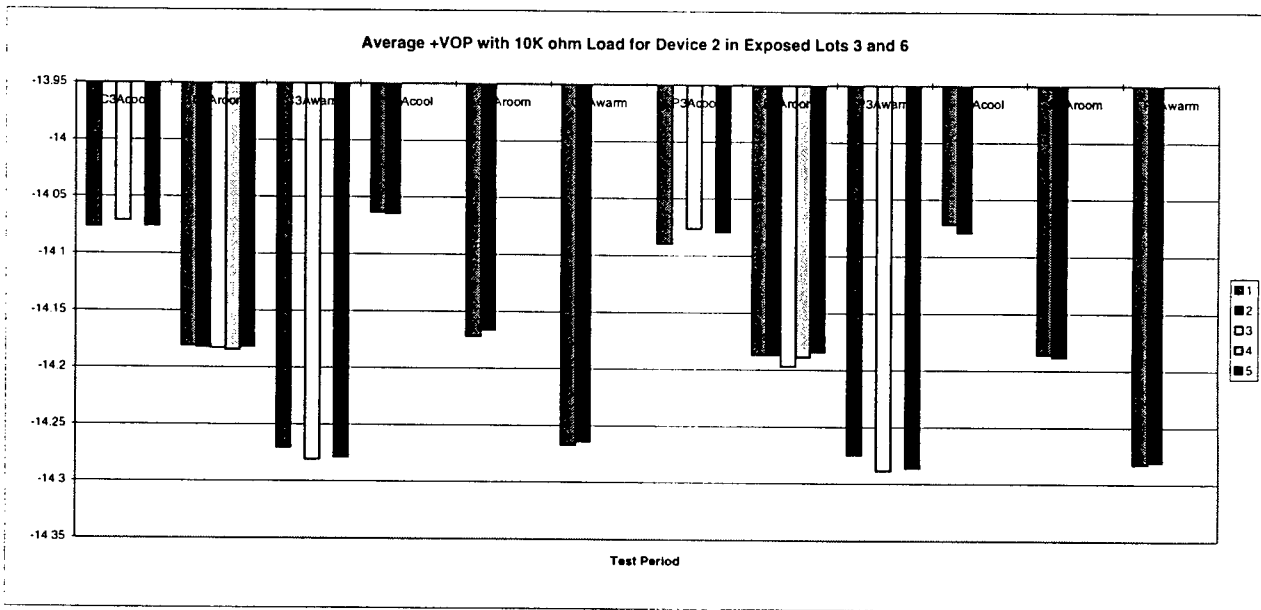
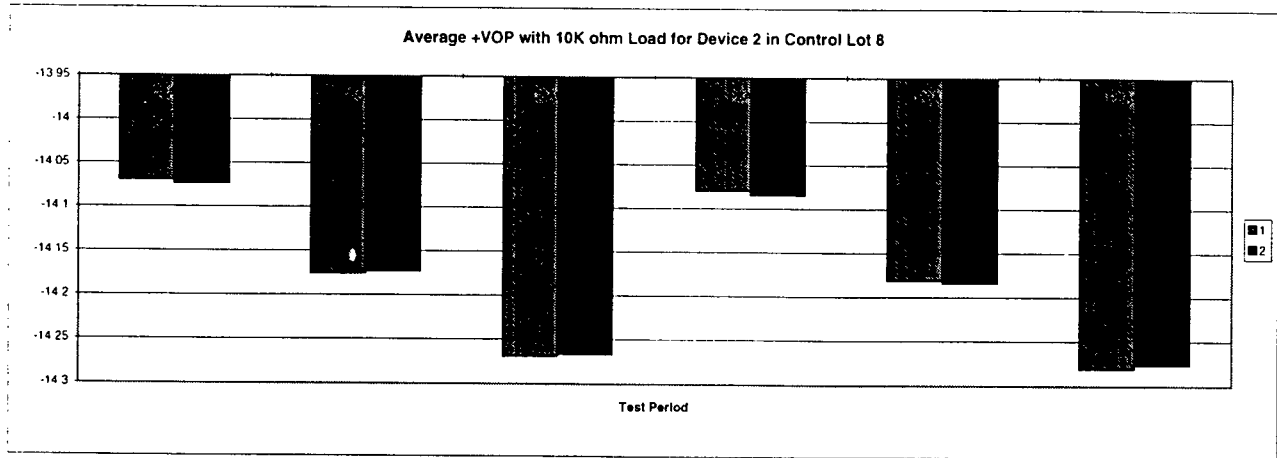

## Appendix C: Engineering Statistical Analysis Data

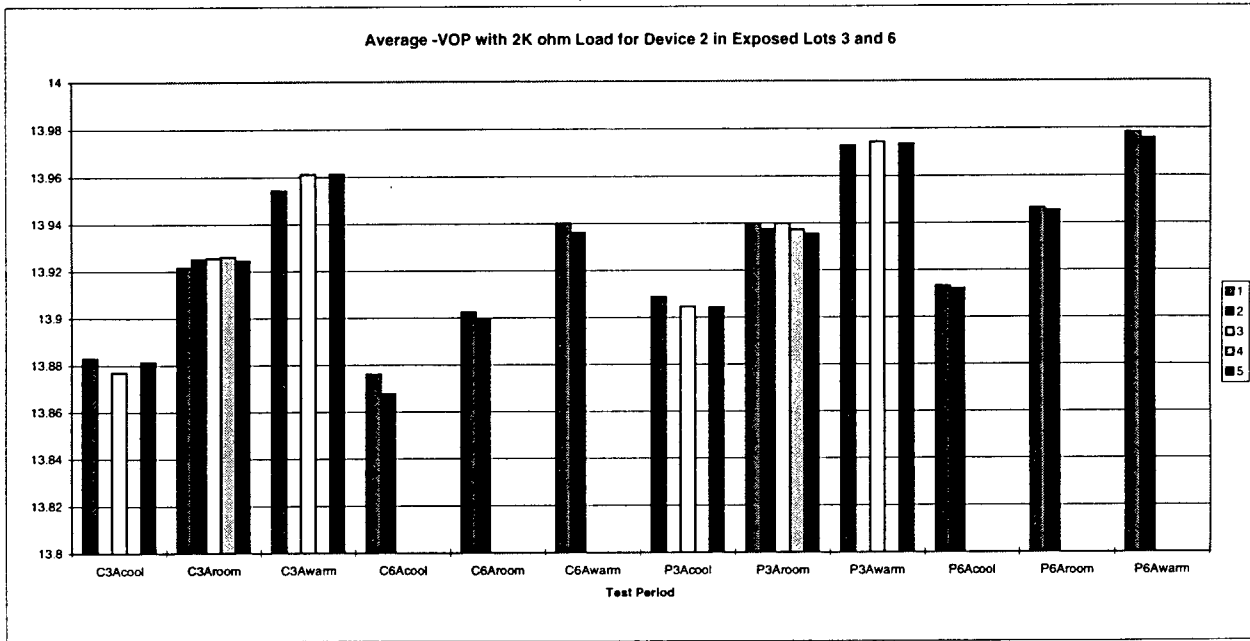
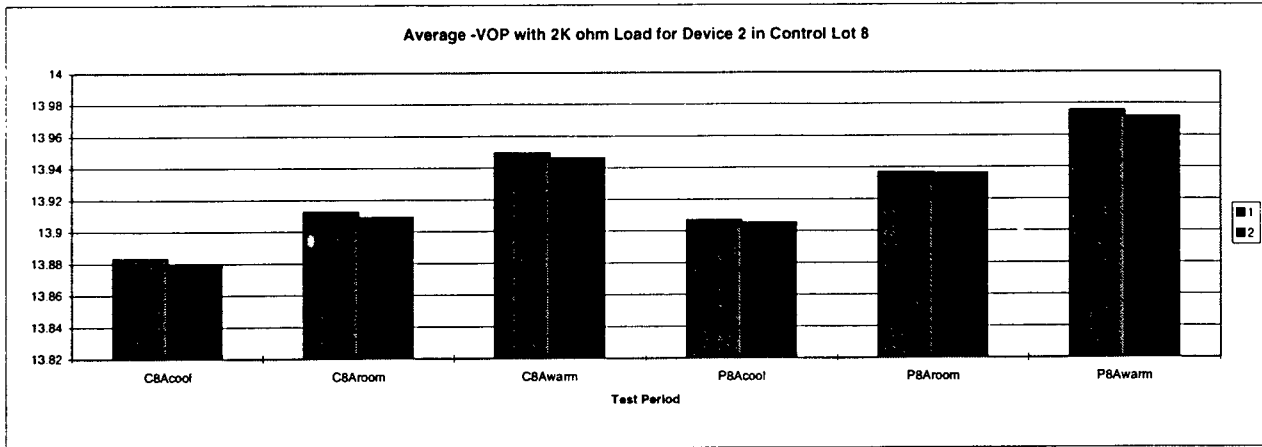

# Appendix C: Engineering Statistical Analysis Data

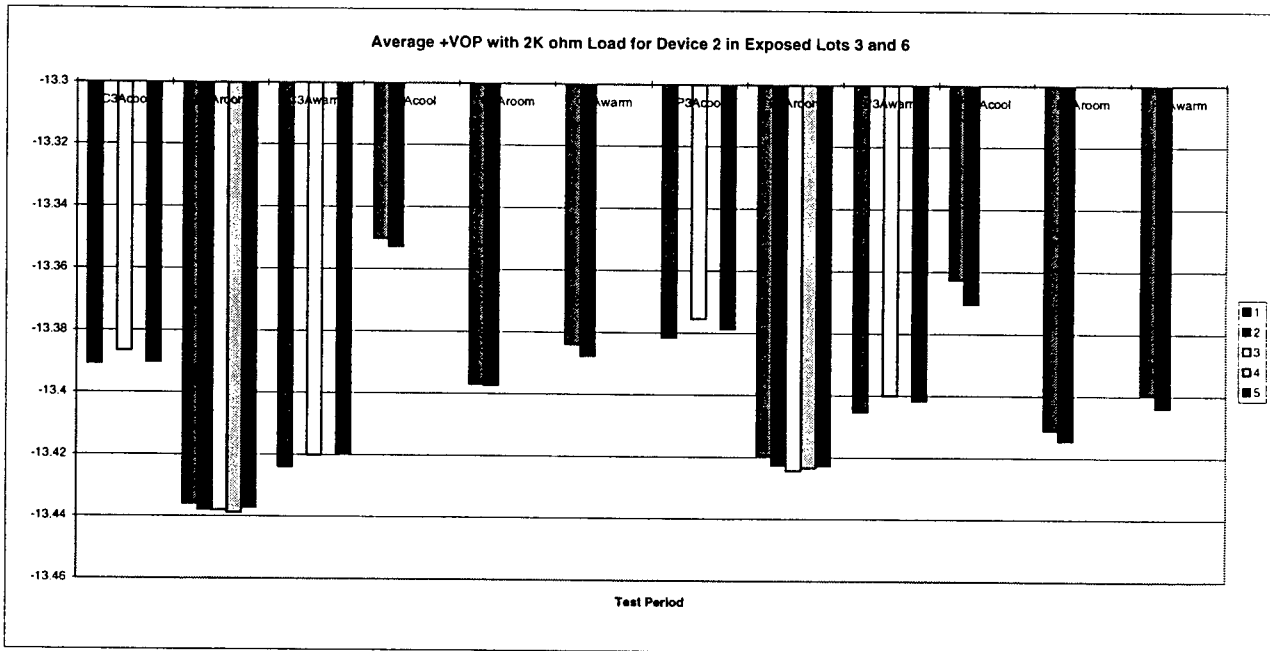
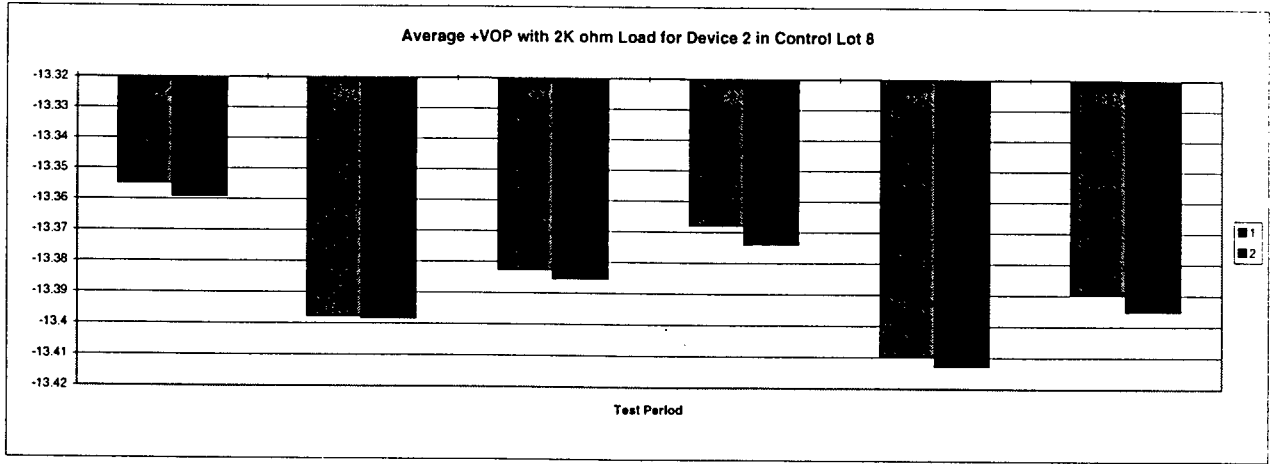



## Appendix C: Engineering Statistical Analysis Data

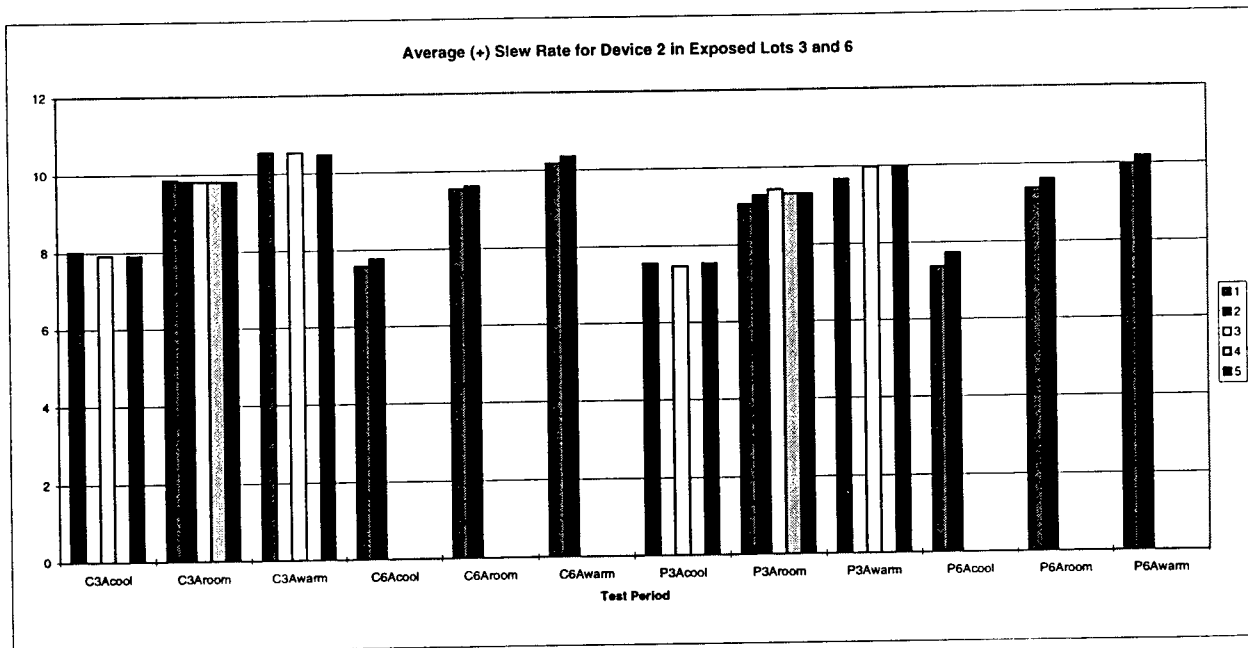
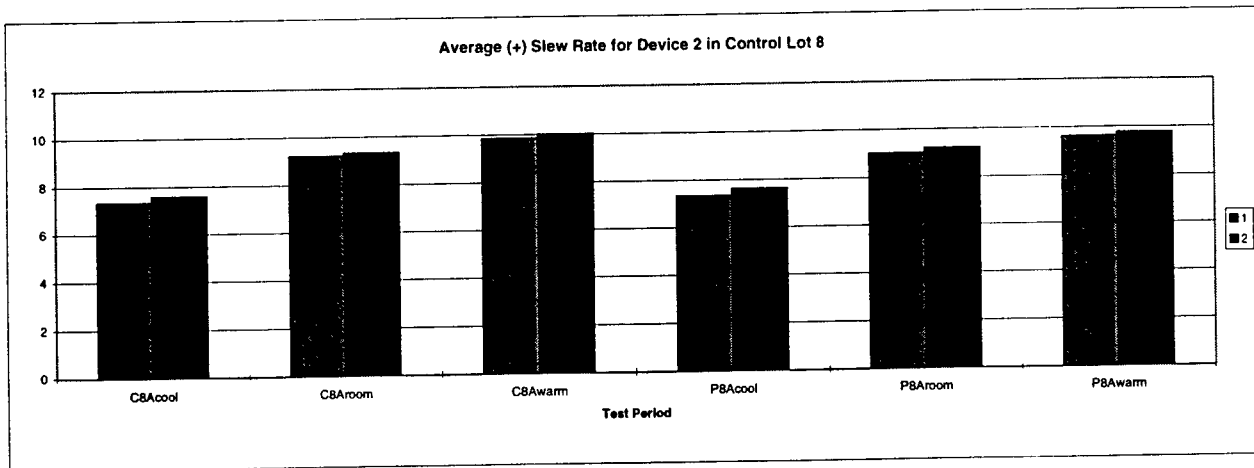

## Appendix C: Engineering Statistical Analysis Data

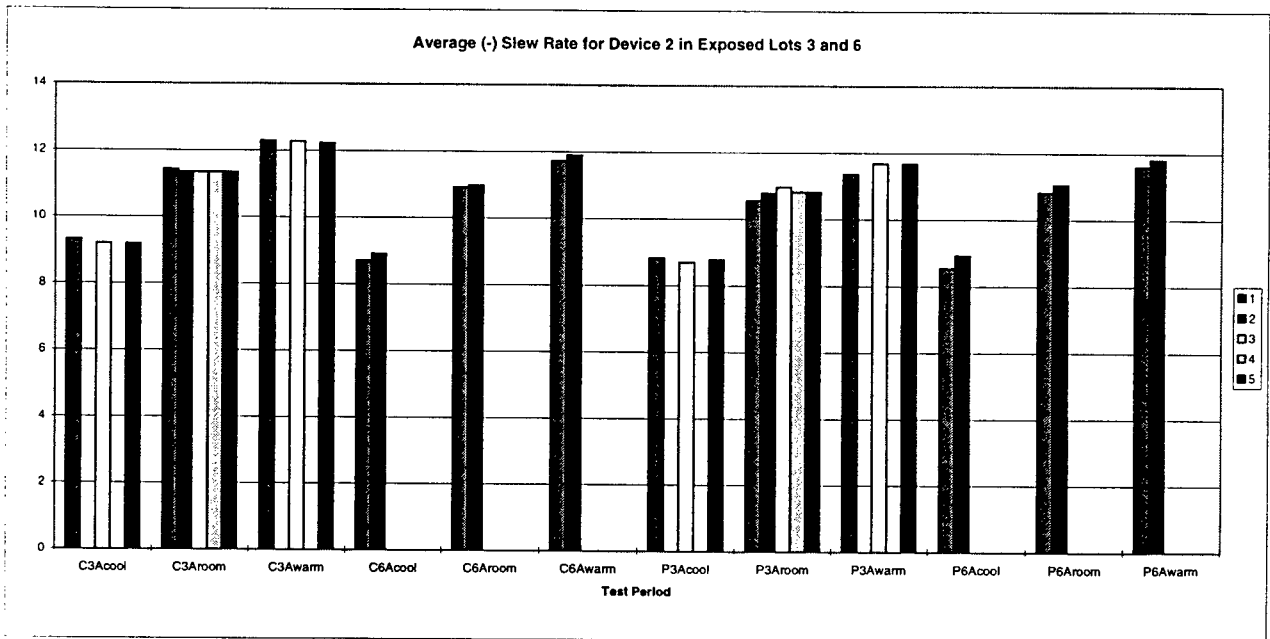
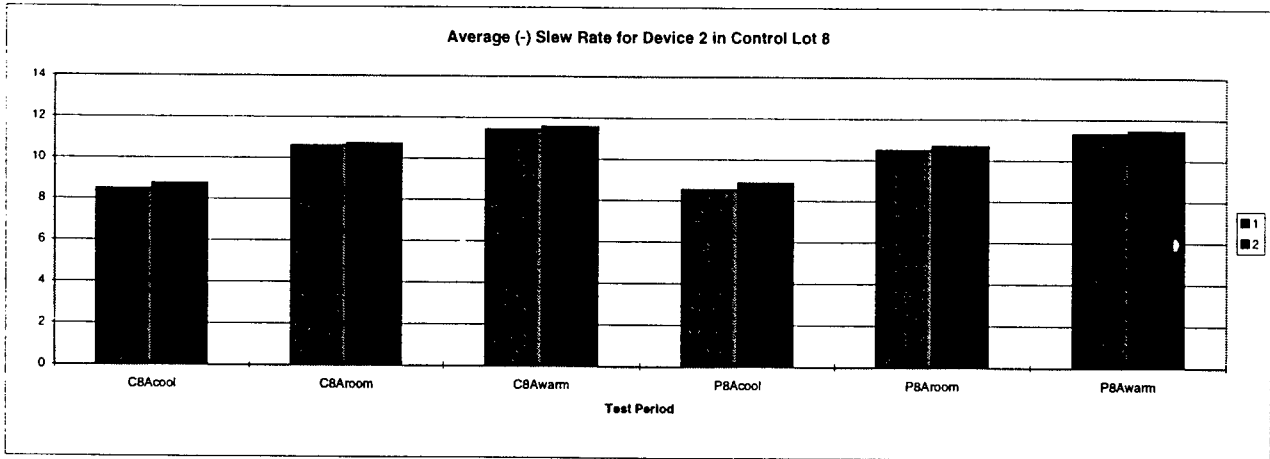

## Appendix C: Engineering Statistical Analysis Data

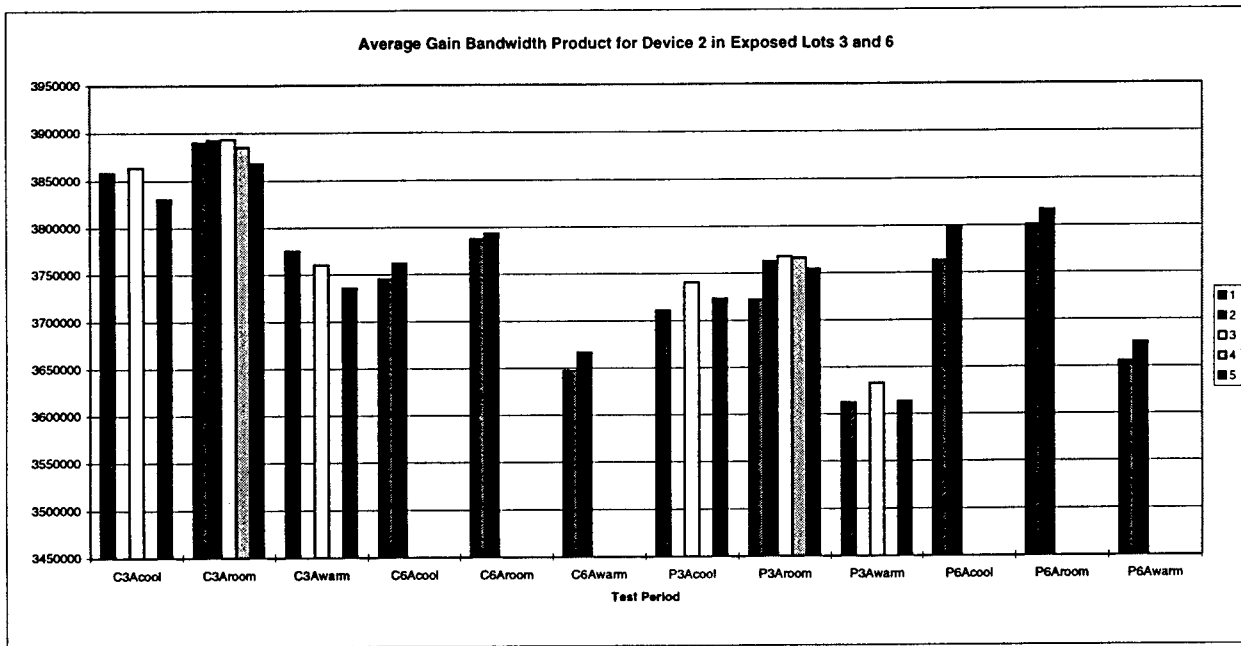
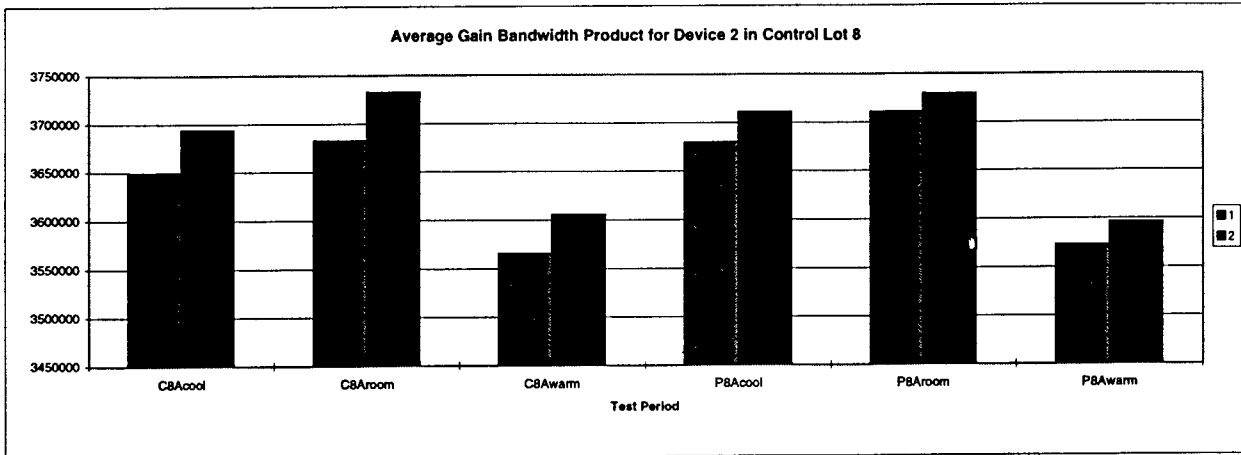

Appendix D: Baseline Digital Test Data - RF Power and Field Intensity vs. Upsets

RF pwr	1000			500			250			125		
frequency	900			900			900			900		
Antenna Gain	25.4			25.4			25.4			25.4		
In-line Attenuation	30			20			20			20		
test	upsets	power	E Field	upsets	power	E Field	upsets	power	E Field	upsets	power	E Field
period		(mw)	Strength		(mw)	Strength		(mw)	Strength		(mw)	Strength
1	21	1	131.67	7	8	117.77	8	2.5	65.83	9	2.5	65.83
2	44	0.5	93.10	1	1	41.64	10	1.5	51.00	10	2	58.88
3	40	0.2	58.88	22	1	41.64	7	0.3	22.81	20	0.3	22.81
4	35	0.3	72.12	22	2	58.88	10	0.3	22.81	15	0.2	18.62
5	18	1	131.67	19	8	117.77	7	2	58.88	9	0.8	37.24
6	13	1.5	161.26	17	12	144.24	13	4	83.28	10	2	58.88
7	39	2	186.21	3	12	144.24	13	5	93.10	12	3	72.12
8	13	3	228.06	3	18	176.65	4	8	117.77	7	4	83.28
9	31	2	186.21	13	8	117.77	9	4	83.28	3	2	58.88
10	35	0.5	93.10	36	5	93.10	3	1.5	51.00	6	1	41.64
11	22	0.7	110.16	17	9	124.91	6	2	58.88	8	2	58.88
12	1	1	131.67	25	7	110.16	7	1	41.64	9	1.5	51.00
13	10	0.4	83.28	28	3	72.12	5	1	41.64	2	1.5	51.00
14	8	0.7	110.16	33	3	72.12	8	1	41.64	9	0.8	37.24
15	11	0.9	124.91	26	3.5	77.90	10	0.8	37.24	11	1	41.64
16	15	0.5	93.10	14	4	83.28	11	0.5	29.44	10	0.5	29.44
17	34	0.4	83.28	11	3	72.12	8	1.5	51.00	10	0.5	29.44
18	72	0.7	110.16	36	4	83.28	21	2.5	65.83	11	1	41.64
19	51	1.4	155.79	23	5	93.10	10	3	72.12	6	1.5	51.00
20	18	1	131.67	15	2	58.88	17	1	41.64	9	1.5	51.00
21	34	1	131.67	21	3	72.12	16	2.5	65.83	6	0.6	32.25
22	14	1.5	161.26	12	5	93.10	12	4	83.28	6	1.2	45.61
23	40	1.5	161.26	5	7	110.16	8	3	72.12	9	1.8	55.86
24	35	1	131.67	38	3	72.12	6	2	58.88	9	1.6	52.67
25	21	0.3	72.12	37	1	41.64	14	0.3	22.81	12	0.5	29.44
26	50	1.5	161.26	23	10	131.67	16	4	83.28	7	0.7	34.84
27	20	1.2	144.24	37	5	93.10	17	2	58.88	11	2.5	65.83
28	58	0.3	72.12	50	3	72.12	5	1.5	51.00	11	0.4	26.33
29	55	1.7	171.68	40	5	93.10	10	3	72.12	5	1	41.64
30	54	1.5	161.26	38	1.5	51.00	10	1	41.64	10	0.8	37.24
31	50	0.1	41.64	38	2.5	65.83	9	0.6	32.25	8	0.3	22.81
32	53	0.3	72.12	36	2	58.88	4	0.5	29.44	9	0.4	26.33
33	33	0.6	101.99	17	10	131.67	7	2	58.88	11	2.5	65.83
34	36	3	228.06	31	12	144.24	3	10	131.67	1	3	72.12
35	51	2	186.21	39	6	101.99	16	5	93.10	8	2.5	65.83
36	35	0.4	83.28	39	2.5	65.83	9	1	41.64	13	1	41.64
37	37	0.4	83.28	38	4	83.28	6	1.2	45.61	10	0.6	32.25
38	49	1.5	161.26	42	9	124.91	17	2	58.88	6	1.2	45.61
39	39	2	186.21	16	12	144.24	12	4	83.28	9	3	72.12
40	38	1.5	161.26	9	8	117.77	2	3	72.12	10	2.5	65.83
41	27	3	228.06	3	14	155.79	15	6	101.99	9	3	72.12
42	27	5	294.42	34	21	190.81	14	14	155.79	4	5.5	97.65
43	26	3	228.06	13	6	101.99	8	4	83.28	3	1.5	51.00
44	32	1.2	144.24	11	5	93.10	8	2	58.88	4	1	41.64
45	27	2.2	195.30	22	5	93.10	5	3	72.12	7	1	41.64
46	33	1	131.67	14	2	58.88	12	2	58.88	4	0.3	22.81
47	31	1.3	150.13	13	4	83.28	13	2	58.88	3	0.6	32.25
48	4	2	186.21	32	6	101.99	15	4	83.28	3	1.5	51.00
49	43	3	228.06	18	5	93.10	3	4.5	88.33	9	1.5	51.00
50	41	2	186.21	4	10	131.67	4	4.5	88.33	11	2	58.88
51	34	2.5	208.19	0	12	144.24	13	4	83.28	14	4	83.28
52	57	1.2	144.24	47	5	93.10	14	1	41.64	9	1	41.64
53	56	1	131.67	34	20	186.21	16	6	101.99	14	2.5	65.83
54	79	6	322.52	45	22	195.30	43	12	144.24	10	6	101.99
55	81	4	263.34	42	8	117.77	36	5	93.10	16	4	83.28
56	85	0.3	72.12	43	1.5	51.00	34	0.5	29.44	17	2	58.88
57	86	1.3	150.13	44	4	83.28	68	2	58.88	13	0.3	22.81
58	57	0.6	101.99	23	3	72.12	67	2	58.88	9	1	41.64
59	46	0.5	93.10	19	3	72.12	27	3	72.12	15	0.5	29.44
60	46	0.5	93.10	13	1	41.64	18	2.5	65.83	12	0.5	29.44
61	29	0.2	58.88	2	2	58.88	14	0.8	37.24	8	0.3	22.81
62	23	1	131.67	14	3	72.12	16	1.5	51.00	7	1.5	51.00
63	28	1.5	161.26	9	3	72.12	14	3	72.12	12	1.5	51.00

Appendix D: Baseline Digital Test Data - RF Power and Field Intensity vs. Upsets

RF pwr	1000				500				250				125			
frequency	900				900				900				900			
Antenna Gain	25.4				25.4				25.4				25.4			
In-line Attenuation	30				20				20				20			
test	upsets	power	E Field	upsets	power	E Field	upsets	power	E Field	upsets	power	E Field	upsets	power	E Field	
period		(mw)	Strength		(mw)	Strength		(mw)	Strength		(mw)	Strength		(mw)	Strength	
64	32	1.4	155.79	21	1.5	51.00	9	2	58.88	8	1	41.64				
65	58	0.3	72.12	28	2	58.88	13	0.5	29.44	11	0.3	22.81				
66	19	0.6	101.99	38	1	41.64	9	1	41.64	13	0.6	32.25				
67	10	0.5	93.10	18	3	72.12	7	2	58.88	5	0.8	37.24				
68	30	1.2	144.24	37	5	93.10	12	3	72.12	8	1.2	45.61				
69	41	1.4	155.79	39	3	72.12	15	3.5	77.90	7	0.5	29.44				
70	63	0.3	72.12	28	2	58.88	16	1.5	51.00	13	1	41.64				
71	41	1.8	176.65	0	4	83.28	21	1	41.64	10	2	58.88				
72	46	1	131.67	4	3	72.12	13	2	58.88	10	0.8	37.24				
73	39	1.2	144.24	18	3.5	77.90	13	2.5	65.83	4	0.8	37.24				
74	35	1.3	150.13	15	3	72.12	10	1	41.64	8	0.7	34.84				
75	36	1.2	144.24	44	5	93.10	15	2	58.88	5	1	41.64				
76	53	3.5	246.33	34	10	131.67	5	6	101.99	4	1.5	51.00				
77	51	4.5	279.31	18	13	150.13	11	7	110.16	5	4	83.28				
78	53	2	186.21	16	4	83.28	10	3	72.12	5	2	58.88				
79	41	0.5	93.10	68	1	41.64	5	1	41.64	7	1	41.64				
80	27	1	131.67	20	8	117.77	9	1	41.64	8	1.5	51.00				
81	54	2	186.21	36	5	93.10	6	1	41.64	9	1.5	51.00				
82	57	1	131.67	53	5	93.10	5	1.8	55.86	2	1	41.64				
83	65	1	131.67	9	6	101.99	6	3	72.12	3	1.5	51.00				
84	50	1	131.67	23	6	101.99	12	2.5	65.83	8	1.5	51.00				
85	54	0.8	117.77	42	5	93.10	15	2.5	65.83	7	1.5	51.00				
86	75	1.5	161.26	43	8	117.77	6	3.5	77.90	7	1.5	51.00				
87	71	2	186.21	51	21	190.81	37	9	124.91	5	3	72.12				
88	80	6	322.52	41	22	195.30	63	12	144.24	5	6	101.99				
89	45	4	263.34	20	9	124.91	13	5	93.10	7	3.5	77.90				
90	28	1.5	161.26	4	4	83.28	6	3	72.12	11	2	58.88				
91	36	1.4	155.79	39	4	83.28	6	3	72.12	12	1	41.64				
92	60	1.4	155.79	35	3.5	77.90	13	3	72.12	6	1	41.64				
93	60	1.2	144.24	32	2	58.88	10	2	58.88	12	0.5	29.44				
94	40	0.5	93.10	56	3	72.12	11	0.8	37.24	11	1.5	51.00				
95	58	0.8	117.77	52	8	117.77	7	2	58.88	5	2	58.88				
96	37	4	263.34	10	20	186.21	12	6	101.99	3	2.5	65.83				
97	12	5	294.42	19	23	199.69	7	9	124.91	7	6	101.99				
98	43	3	228.06	18	10	131.67	22	4	83.28	12	4	83.28				
99	60	3	228.06	24	20	186.21	69	6	101.99	8	3.5	77.90				
100	57	4	263.34	22	13	150.13	8	6	101.99	7	5	93.10				
101	85	2.5	208.19	26	8	117.77	29	3	72.12	11	3	72.12				
102	19	1	131.67	34	1	41.64	19	2	58.88	11	0.8	37.24				
103	7	0.5	93.10	0	1.5	51.00	8	1	41.64	7	0.3	22.81				
104	5	0.4	83.28	13	1.5	51.00	7	0.5	29.44	5	0.3	22.81				
105	40	0.5	93.10	40	2	58.88	8	1.5	51.00	7	0.7	34.84				
106	36	0.8	117.77	0	4	83.28	13	2	58.88	6	1.2	45.61				
107	32	2	186.21	19	8	117.77	16	3	72.12	5	0.5	29.44				
108	7	1.8	176.65	0	5	93.10	17	2	58.88	4	1.5	51.00				
109	37	0.8	117.77	16	5	93.10	14	2	58.88	16	1.5	51.00				
110	26	1.3	150.13	14	4	83.28	11	1	41.64	9	1	41.64				
111	35	3	228.06	11	7	110.16	6	4	83.28	7	2	58.88				
112	58	4	263.34	41	14	155.79	40	8	117.77	14	3	72.12				
113	49	2.5	208.19	42	5	93.10	12	4	83.28	7	2	58.88				
114	39	1	131.67	34	3	72.12	18	2	58.88	5	1	41.64				
115	51	0.8	117.77	39	4	83.28	15	1.5	51.00	6	0.8	37.24				
116	53	0.8	117.77	33	5	93.10	8	0.8	37.24	12	1.5	51.00				
117	51	0.8	117.77	41	6	101.99	10	2	58.88	1	2	58.88				
118	49	3.5	246.33	86	12	144.24	7	6	101.99	7	3.5	77.90				
119	56	2.5	208.19	26	6	101.99	13	5	93.10	11	2	58.88				
120	61	1	131.67	24	5	93.10	5	2	58.88	11	1.5	51.00				
121	60	1	131.67	39	5	93.10	11	1.5	51.00	6	1.5	51.00				
122	60	0.5	93.10	35	3	72.12	41	1	41.64	13	1	41.64				
123	33	0.3	72.12	36	2	58.88	7	1	41.64	10	0.8	37.24				
124	34	0.8	117.77	11	3	72.12	14	1	41.64	7	0.8	37.24				
125	42	1.2	144.24	39	4	83.28	2	1.5	51.00	11	1	41.64				
126	59	0.6	101.99	37	2	58.88	3	2	58.88	3	1	41.64				

Appendix D: Baseline Digital Test Data - RF Power and Field Intensity vs. Upsets

RF pwr	1000			500			250			125		
frequency	900			900			900			900		
Antenna Gain	25.4			25.4			25.4			25.4		
In-line Attenuation	30			20			20			20		
test	upsets	power	E Field	upsets	power	E Field	upsets	power	E Field	upsets	power	E Field
period		(mw)	Strength		(mw)	Strength		(mw)	Strength		(mw)	Strength
127	35	0.4	83.28	22	2	58.88	11	2	58.88	5	0.5	29.44
128	52	0.4	83.28	25	1.5	51.00	8	1.5	51.00	10	0.3	22.81
129	62	1.2	144.24	25	3	72.12	9	2.5	65.83	3	0.2	18.62
130	23	2	186.21	22	7	110.16	5	4	83.28	7	1.5	51.00
131	21	1.5	161.26	13	8	117.77	14	5	93.10	14	2	58.88
132	43	2	186.21	36	10	131.67	6	5	93.10	8	2.5	65.83
133	49	2	186.21	24	10	131.67	7	6	101.99	4	2.5	65.83
134	40	0.2	58.88	40	5	93.10	21	1.5	51.00	4	1.5	51.00
135	54	0.2	58.88	36	3	72.12	13	1.5	51.00	7	1	41.64
136	32	0.2	58.88	23	2	58.88	16	1	41.64	7	0.8	37.24
137	25	0.4	83.28	21	1	41.64	11	0.8	37.24	6	0.5	29.44
138	91	0.3	72.12	62	1	41.64	14	0.8	37.24	7	0.2	18.62
139	39	0.3	72.12	24	1.5	51.00	7	1	41.64	6	0.4	26.33
140	36	0.5	93.10	38	1.5	51.00	6	0.8	37.24	13	0.8	37.24
141	42	0.7	110.16	29	3	72.12	12	2.5	65.83	9	0.6	32.25
142	50	1.5	161.26	39	8	117.77	10	3.5	77.90	11	1.5	51.00
143	31	1	131.67	26	5	93.10	8	2	58.88	9	1	41.64
144	42	0.5	93.10	20	3	72.12	6	1	41.64	8	1	41.64
145	28	2.5	208.19	9	15	161.26	8	8	117.77	4	1.5	51.00
146	41	5	294.42	7	23	199.69	11	12	144.24	8	5	93.10
147	26	5	294.42	21	18	176.65	12	8	117.77	6	5	93.10
148	58	4	263.34	20	20	186.21	48	8	117.77	10	5	93.10
149	59	4	263.34	10	18	176.65	29	9	124.91	13	6	101.99
150	34	2	186.21	1	12	144.24	19	5	93.10	7	4	83.28
151	37	0.5	93.10	8	3	72.12	16	2	58.88	9	1	41.64
152	26	0.4	83.28	2	2	58.88	12	1	41.64	8	0.5	29.44
153	8	1.3	150.13	3	3.5	77.90	8	1.7	54.29	5	0.8	37.24
154	41	0.3	72.12	11	1	41.64	22	0.5	29.44	5	0.5	29.44
155	68	0.4	83.28	33	1.5	51.00	14	0.3	22.81	8	0.3	22.81
156	70	0.5	93.10	28	2	58.88	25	1.5	51.00	10	0.5	29.44
157	41	0.6	101.99	27	2	58.88	10	0.8	37.24	6	0.7	34.84
158	38	0.6	101.99	35	1.5	51.00	7	0.5	29.44	3	0.3	22.81
159	29	0.6	101.99	20	2	58.88	15	0.1	13.17	5	0.4	26.33
160	20	1.5	161.26	34	5	93.10	8	1.5	51.00	7	1	41.64
161	30	1	131.67	31	7	110.16	8	5	93.10	7	1.5	51.00
162	41	1	131.67	39	3	72.12	10	2	58.88	8	1	41.64
163	40	0.5	93.10	5	1	41.64	10	0.5	29.44	1	0.5	29.44
164	40	0.5	93.10	35	2	58.88	7	1	41.64	7	0.5	29.44
165	24	0.7	110.16	0	5	93.10	9	2	58.88	7	1.3	47.47
166	9	1.5	161.26	13	5	93.10	8	2	58.88	9	1.5	51.00
167	31	0.8	117.77	33	3	72.12	10	1	41.64	8	0.3	22.81
168	21	0.8	117.77	21	2	58.88	9	0.8	37.24	6	0.4	26.33
169	6	2.5	208.19	35	8	117.77	11	6	101.99	4	1.8	55.86
170	53	6	322.52	25	17	171.68	10	12	144.24	8	4	83.28
171	31	5	294.42	28	12	144.24	12	6	101.99	7	3	72.12
172	31	1	131.67	24	6	101.99	10	5	93.10	12	1.8	55.86
173	13	1.5	161.26	3	2	58.88	13	3	72.12	11	1	41.64
174	24	0.8	117.77	16	2	58.88	10	0.8	37.24	7	0.5	29.44
175	37	0.7	110.16	16	3	72.12	12	2	58.88	4	1	41.64
176	13	2.5	208.19	0	15	161.26	13	7	110.16	5	2.5	65.83
177	13	2	186.21	11	12	144.24	13	6	101.99	5	4	83.28
178	34	1	131.67	56	5	93.10	7	2	58.88	6	2	58.88
179	25	0.2	58.88	15	2	58.88	12	1	41.64	12	0.2	18.62
180	23	0.5	93.10	4	2	58.88	8	2	58.88	5	0.7	34.84
181	20	1	131.67	5	4	83.28	7	2.5	65.83	9	1.5	51.00
ave	60.12	2.09	147.06	40.31	6.63	94.96	25.97	3.49	66.11	19.39	2.10	48.68
max	1000	30	322.52	900	25.4	199.69	900	25.4	155.79	900	25.4	101.99
min	1	0.1	41.64	0	1	41.64	2	0.1	13.17	1	0.2	18.62
mean	38	1	131.66944	23	5	93.10	11	2	58.88	8	1.2	45.61
RF pwr	1000	1000	1000	500	500	500	250	250	250	125	125	125
frequency	900	900	900	900	900	900	900	900	900	900	900	900
	upsets	power	E Field	upsets	power	E Field	upsets	power	E Field	upsets	power	E Field
		(mw)	Strength		(mw)	Strength		(mw)	Strength		(mw)	Strength

Appendix D: Baseline Digital Test Data - RF Power and Field Intensity vs. Upsets

RF pwr	63				1000				500				250			
frequency	900				1700				1700				1700			
Antenna Gain	25.4				32				32				32			
In-line Attenuation	20				30				20				20			
test	upsets	power	E Field	upsets	power	E Field	upsets	power	E Field	upsets	power	E Field				
period		(mw)	Strength		(mw)	Strength		(mw)	Strength		(mw)	Strength				
1	5	0.7	34.84	11	0.5	199.05	3	2.5	140.75	0	1.2	97.52				
2	2	0.5	29.44	11	1.7	367.04	8	7	235.52	0	4.5	188.84				
3	2	0.2	18.62	15	1.2	308.37	3	6	218.05	0	3	154.19				
4	3	0.1	13.17	16	0.9	267.06	3	7	235.52	0	3	154.19				
5	1	0.3	22.81	17	0.3	154.19	8	3.5	166.54	0	1.5	109.03				
6	0	0.8	37.24	10	0.1	89.02	5	1	89.02	0	0.2	39.81				
7	0	0.9	39.50	12	0.5	199.05	10	3	154.19	0	1.8	119.43				
8	0	1.5	51.00	17	0.2	125.89	1	2	125.89	0	1.5	109.03				
9	0	0.6	32.25	10	0.2	125.89	4	0.7	74.48	0	0.4	56.30				
10	1	0.5	29.44	11	0.2	125.89	4	1.5	109.03	0	1	89.02				
11	0	0.2	18.62	12	0.7	235.52	8	3	154.19	0	2.2	132.04				
12	1	0.7	34.84	17	0.1	89.02	2	1	89.02	0	1.5	109.03				
13	1	0.3	22.81	15	0.4	178.04	3	1.9	122.70	0	1	89.02				
14	1	0.2	18.62	18	0.5	199.05	5	2.5	140.75	0	1.1	93.36				
15	1	0.3	22.81	20	1	281.50	6	4	178.04	0	3.5	166.54				
16	2	0.1	13.17	16	1.5	344.77	2	3	154.19	1	4.5	188.84				
17	4	0.1	13.17	11	0.7	235.52	3	2	125.89	0	2	125.89				
18	7	0.3	22.81	12	0.3	154.19	3	0.5	62.95	0	0.7	74.48				
19	8	0.6	32.25	15	0.3	154.19	3	1.5	109.03	1	0.4	56.30				
20	3	0.4	26.33	21	0.7	235.52	1	3	154.19	0	1.5	109.03				
21	5	0.2	18.62	15	0.5	199.05	1	2	125.89	0	1	89.02				
22	5	0.5	29.44	19	0.3	154.19	5	2	125.89	0	0.5	62.95				
23	4	0.7	34.84	12	0.1	89.02	5	1	89.02	0	0.3	48.76				
24	3	0.5	29.44	19	0.5	199.05	8	0.8	79.62	0	0.8	79.62				
25	4	0.2	18.62	14	0.3	154.19	4	0.5	62.95	0	0.4	56.30				
26	4	1	41.64	7	0.5	199.05	2	0.7	74.48	0	1.3	101.50				
27	2	0.5	29.44	21	0.1	89.02	4	1	89.02	0	0.2	39.81				
28	3	0.4	26.33	11	1	281.50	4	10	281.50	1	0.8	79.62				
29	2	0.7	34.84	6	0.3	154.19	9	8	251.79	0	1	89.02				
30	2	0.2	18.62	12	0.2	125.89	9	3	154.19	1	0.3	48.76				
31	2	0.15	16.13	23	0.5	199.05	10	1.5	109.03	0	0.7	74.48				
32	2	0.1	13.17	15	0.5	199.05	4	5	199.05	1	2	125.89				
33	0	0.5	29.44	13	0.2	125.89	7	3	154.19	0	0.5	62.95				
34	0	1.5	51.00	15	0.1	89.02	2	2	125.89	0	0.2	39.81				
35	3	0.5	29.44	12	0.6	218.05	4	2.5	140.75	0	0.3	48.76				
36	3	0.1	13.17	12	0.5	199.05	0	3	154.19	0	1.8	119.43				
37	2	0.3	22.81	16	0.4	178.04	1	4	178.04	0	1	89.02				
38	2	0.7	34.84	24	0.5	199.05	4	1	89.02	0	1.4	105.33				
39	0	0.9	39.50	18	0.3	154.19	6	0.5	62.95	0	0.8	79.62				
40	1	0.6	32.25	10	0.2	125.89	13	1	89.02	0	0.3	48.76				
41	0	1.2	45.61	31	0.4	178.04	11	2.5	140.75	2	0.6	68.95				
42	0	2.5	65.83	23	0.5	199.05	9	6	218.05	1	0.7	74.48				
43	0	1.2	45.61	14	1.3	320.96	2	4	178.04	1	3	154.19				
44	0	0.3	22.81	13	0.7	235.52	9	3	154.19	0	3	154.19				
45	0	0.7	34.84	24	0.4	178.04	8	2	125.89	3	1	89.02				
46	0	0.5	29.44	16	0.2	125.89	7	1.5	109.03	2	0.4	56.30				
47	0	0.4	26.33	24	0.3	154.19	4	1.5	109.03	0	1.3	101.50				
48	0	0.5	29.44	16	0.2	125.89	0	0.5	62.95	0	0.7	74.48				
49	2	1	41.64	18	0.1	89.02	3	0.5	62.95	0	0.5	62.95				
50	3	1.2	45.61	8	0.2	125.89	7	2	125.89	1	1.3	101.50				
51	0	1.5	51.00	5	0.5	199.05	3	5	199.05	1	1.8	119.43				
52	5	0.2	18.62	25	1	281.50	1	5	199.05	0	2	125.89				
53	7	0.8	37.24	16	0.2	125.89	4	1	89.02	0	2.5	140.75				
54	7	2	58.88	7	0.05	62.95	6	0.3	48.76	4	0.5	62.95				
55	9	1.5	51.00	12	0.05	62.95	4	0.4	56.30	1	0.2	39.81				
56	9	0.5	29.44	15	0.3	154.19	5	0.8	79.62	1	0.7	74.48				
57	6	0.05	9.31	16	0.5	199.05	4	3	154.19	3	0.7	74.48				
58	7	0.3	22.81	24	0.5	199.05	5	3.5	166.54	3	0.6	68.95				
59	7	0.3	22.81	15	0.4	178.04	4	1	89.02	1	0.7	74.48				
60	3	0.3	22.81	19	0.3	154.19	3	2	125.89	1	0.3	48.76				
61	1	0.2	18.62	16	0.1	89.02	2	2	125.89	1	1.2	97.52				
62	1	0.6	32.25	18	0.3	154.19	5	1	89.02	0	1.8	119.43				
63	1	0.6	32.25	20	0.2	125.89	6	1.5	109.03	0	0.2	39.81				

Appendix D: Baseline Digital Test Data - RF Power and Field Intensity vs. Upsets

RF pwr	63			1000			500			250		
frequency	900			1700			1700			1700		
Antenna Gain	25.4			32			32			32		
In-line Attenuation	20			30			20			20		
test	upsets	power	E Field	upsets	power	E Field	upsets	power	E Field	upsets	power	E Field
period		(mw)	Strength		(mw)	Strength		(mw)	Strength		(mw)	Strength
64	4	0.4	26.33	24	0.2	125.89	5	3	154.19	0	0.7	74.48
65	0	0.1	13.17	23	0.2	125.89	7	2	125.89	0	0.3	48.76
66	0	0.2	18.62	15	1	281.50	8	8	251.79	2	1.5	109.03
67	3	0.1	13.17	7	1.2	308.37	3	7	235.52	0	3.5	166.54
68	4	0.2	18.62	15	0.6	218.05	3	2	125.89	2	1.8	119.43
69	3	0.3	22.81	11	0.1	89.02	4	1	89.02	0	0.8	79.62
70	4	0.2	18.62	12	0.3	154.19	5	2	125.89	0	0.8	79.62
71	1	0.6	32.25	14	0.3	154.19	4	3	154.19	4	1.2	97.52
72	1	0.5	29.44	20	0.1	89.02	6	3	154.19	0	0.8	79.62
73	1	0.5	29.44	13	0.05	62.95	3	2	125.89	0	0.7	74.48
74	1	0.4	26.33	12	0.05	62.95	2	1.5	109.03	0	0.5	62.95
75	1	0.5	29.44	14	0.3	154.19	1	0.7	74.48	0	1.2	97.52
76	0	1	41.64	13	0.2	125.89	3	1	89.02	0	1.5	109.03
77	0	1.2	45.61	19	0.3	154.19	4	1	89.02	0	0.3	48.76
78	3	0.5	29.44	9	0.5	199.05	5	3	154.19	0	1.5	109.03
79	2	0.2	18.62	8	0.3	154.19	6	2	125.89	1	1	89.02
80	0	0.4	26.33	9	0.4	178.04	16	5	199.05	1	2	125.89
81	1	0.5	29.44	13	1.7	367.04	0	15	344.77	0	5	199.05
82	4	0.3	22.81	12	0.5	199.05	8	9	267.06	0	4	178.04
83	5	0.4	26.33	15	0.3	154.19	3	4	178.04	0	0.8	79.62
84	6	0.3	22.81	26	0.3	154.19	4	2.5	140.75	0	0.7	74.48
85	8	0.3	22.81	21	0.1	89.02	4	1	89.02	0	0.4	56.30
86	7	0.7	34.84	18	0.3	154.19	1	2	125.89	0	0.7	74.48
87	7	1.5	51.00	9	0.1	89.02	2	2	125.89	0	1.4	105.33
88	7	2.5	65.83	16	0.1	89.02	3	0.5	62.95	0	0.3	48.76
89	6	1.2	45.61	22	0.1	89.02	5	2	125.89	0	0.2	39.81
90	4	0.7	34.84	9	0.3	154.19	11	4	178.04	0	0.8	79.62
91	4	0.6	32.25	9	0.1	89.02	1	3	154.19	0	0.4	56.30
92	6	0.6	32.25	18	0.4	178.04	8	1	89.02	0	1	89.02
93	6	0.5	29.44	13	0.5	199.05	5	0.8	79.62	2	1	89.02
94	3	0.3	22.81	14	1.5	344.77	3	7	235.52	0	2	125.89
95	0	0.7	34.84	10	1.5	344.77	2	3	154.19	0	3.5	166.54
96	0	1.5	51.00	12	1.2	308.37	3	0.4	56.30	0	1.5	109.03
97	1	1.9	57.39	15	0.9	267.06	3	2	125.89	0	3	154.19
98	5	0.7	34.84	23	0.2	125.89	3	1	89.02	0	1.5	109.03
99	6	1	41.64	12	0.2	125.89	1	0.5	62.95	0	0.3	48.76
100	11	1	41.64	22	0.1	89.02	7	0.5	62.95	0	0.3	48.76
101	6	0.8	37.24	12	0.3	154.19	3	4	178.04	3	0.2	39.81
102	5	0.2	18.62	14	0.4	178.04	3	2	125.89	0	1.5	109.03
103	0	0.2	18.62	15	0.5	199.05	6	4	178.04	0	1.5	109.03
104	0	0.15	16.13	20	0.5	199.05	6	5	199.05	0	2.5	140.75
105	1	0.15	16.13	19	0.1	89.02	5	1.5	109.03	3	0.3	48.76
106	0	0.2	18.62	12	0.3	154.19	4	0.5	62.95	0	1	89.02
107	0	0.8	37.24	17	0.3	154.19	4	1	89.02	0	0.8	79.62
108	0	0.6	32.25	13	0.4	178.04	0	1	89.02	0	0.8	79.62
109	0	0.4	26.33	15	0.3	154.19	4	1.5	109.03	0	0.7	74.48
110	2	0.3	22.81	23	0.5	199.05	5	1	89.02	0	1.3	101.50
111	2	0.7	34.84	14	1.2	308.37	3	10	281.50	0	2.5	140.75
112	4	1.5	51.00	7	1.5	344.77	5	6	218.05	2	5	199.05
113	8	0.8	37.24	15	0.7	235.52	3	3.5	166.54	0	2	125.89
114	8	0.4	26.33	20	1	281.50	11	4	178.04	1	2	125.89
115	4	0.3	22.81	21	1.4	333.08	8	5	199.05	2	2.5	140.75
116	3	0.2	18.62	13	0.5	199.05	6	1	89.02	0	0.8	79.62
117	6	0.1	13.17	9	0.1	89.02	3	0.8	79.62	0	1	89.02
118	7	0.6	32.25	11	0.8	251.79	0	4	178.04	0	0.5	62.95
119	5	1.2	45.61	22	0.8	251.79	4	3	154.19	0	0.8	79.62
120	3	0.4	26.33	17	0.4	178.04	10	0.5	62.95	0	0.5	62.95
121	5	0.4	26.33	12	0.1	89.02	4	2	125.89	0	0.6	68.95
122	2	0.3	22.81	20	0.4	178.04	2	1	89.02	0	1.2	97.52
123	2	0.3	22.81	15	0.1	89.02	0	1	89.02	0	0.5	62.95
124	0	0.2	18.62	19	0.1	89.02	1	1	89.02	0	0.2	39.81
125	0	0.3	22.81	12	0.3	154.19	4	2.5	140.75	1	0.7	74.48
126	0	0.3	22.81	19	0.2	125.89	2	1	89.02	0	0.8	79.62



Appendix D: Baseline Digital Test Data - RF Power and Field Intensity vs. Upsets

RF pwr	63			1000			500			250		
frequency	900			1700			1700			1700		
Antenna Gain	25.4			32			32			32		
In-line Attenuation	20			30			20			20		
test period	upsets	power (mw)	E Field Strength	upsets	power (mw)	E Field Strength	upsets	power (mw)	E Field Strength	upsets	power (mw)	E Field Strength
127	0	0.1	13.17	27	0.3	154.19	6	0.5	62.95	0	0.4	56.30
128	0	0.2	18.62	21	0.2	125.89	3	2	125.89	0	0.4	56.30
129	1	0.4	26.33	7	0.2	125.89	5	1.5	109.03	0	0.6	68.95
130	1	0.5	29.44	17	0.3	154.19	5	1.5	109.03	0	1.3	101.50
131	1	0.8	37.24	9	0.6	218.05	7	2	125.89	1	1.8	119.43
132	0	0.9	39.50	13	0.2	125.89	9	1	89.02	1	1.3	101.50
133	1	1	41.64	12	0.05	62.95	7	0.5	62.95	1	0.3	48.76
134	7	0.5	29.44	17	1.5	344.77	9	1.5	109.03	0	2	125.89
135	3	0.1	13.17	16	0.9	267.06	9	2	125.89	1	3.5	166.54
136	0	0.05	9.31	14	0.2	125.89	7	2	125.89	0	2	125.89
137	0	0.15	16.13	11	0.8	251.79	13	3	154.19	5	2.5	140.75
138	3	0.1	13.17	15	0.5	199.05	14	7	235.52	4	2	125.89
139	5	0.1	13.17	14	0.2	125.89	6	1	89.02	0	0.8	79.62
140	1	0.2	18.62	16	0.1	89.02	7	1	89.02	1	0.2	39.81
141	1	0.3	22.81	14	0.2	125.89	8	0.5	62.95	0	1	89.02
142	1	0.7	34.84	11	0.4	178.04	8	1	89.02	0	1	89.02
143	0	0.5	29.44	16	0.2	125.89	9	1.5	109.03	2	0.7	74.48
144	2	0.3	22.81	10	0.3	154.19	2	2	125.89	1	0.8	79.62
145	6	0.6	32.25	12	0.3	154.19	11	3	154.19	2	0.6	68.95
146	5	2.2	61.76	18	0.2	125.89	6	0.5	62.95	0	0.3	48.76
147	5	1.8	55.86	16	0.3	154.19	3	4	178.04	0	0.7	74.48
148	7	2.2	61.76	12	0.5	199.05	1	6	218.05	0	1.5	109.03
149	3	1.6	52.67	15	0.5	199.05	11	4	178.04	0	0.3	48.76
150	1	0.5	29.44	9	0.2	125.89	17	0.5	62.95	3	0.4	56.30
151	2	0.1	13.17	12	0.5	199.05	8	0.8	79.62	0	0.5	62.95
152	1	0.25	20.82	7	0.3	154.19	3	0.8	79.62	0	1	89.02
153	1	0.35	24.63	11	0.6	218.05	2	5	199.05	0	1	89.02
154	6	0.1	13.17	9	0.1	89.02	4	1.5	109.03	0	1.8	119.43
155	8	0.1	13.17	12	0.3	154.19	3	0.8	79.62	0	1	89.02
156	4	0.3	22.81	13	0.7	235.52	6	1.5	109.03	1	1	89.02
157	0	0.3	22.81	16	0.8	251.79	2	6	218.05	0	0.6	68.95
158	0	0.15	16.13	11	1.2	308.37	6	4	178.04	0	2.5	140.75
159	0	0.2	18.62	14	1.6	356.08	1	5	199.05	0	4	178.04
160	0	0.7	34.84	16	0.4	178.04	7	2	125.89	0	1.5	109.03
161	2	0.6	32.25	27	0.05	62.95	5	1	89.02	1	0.8	79.62
162	4	0.6	32.25	11	0.5	199.05	3	4	178.04	0	1.8	119.43
163	4	0.4	26.33	19	0.1	89.02	2	1	89.02	0	2	125.89
164	3	0.3	22.81	9	0.1	89.02	6	6	218.05	0	2	125.89
165	2	0.4	26.33	8	1.4	333.08	5	2	125.89	1	2.5	140.75
166	2	0.4	26.33	16	0.5	199.05	5	1.5	109.03	0	2	125.89
167	1	0.2	18.62	15	0.7	235.52	1	1.5	109.03	0	2	125.89
168	0	0.3	22.81	10	1.7	367.04	2	5	199.05	0	4	178.04
169	0	1.3	47.47	9	1	281.50	11	1.5	109.03	0	5	199.05
170	3	2.2	61.76	17	0.4	178.04	8	1.5	109.03	1	2	125.89
171	0	1.2	45.61	8	0.8	251.79	2	1	89.02	4	2	125.89
172	1	1	41.64	5	0.4	178.04	10	2	125.89	2	1.5	109.03
173	0	1	41.64	10	1	281.50	3	2	125.89	1	2.5	140.75
174	0	0.4	26.33	11	0.5	199.05	4	2	125.89	0	2	125.89
175	0	0.3	22.81	12	0.6	218.05	2	1.5	109.03	0	1.8	119.43
176	0	0.3	22.81	9	0.4	178.04	4	1.5	109.03	0	0.5	62.95
177	0	1.3	47.47	10	0.9	267.06	0	3.5	166.54	0	2.5	140.75
178	1	0.2	18.62	16	1	281.50	5	7	235.52	0	2	125.89
179	6	0.2	18.62	21	0.7	235.52	2	6	218.05	0	4	178.04
180	6	0.3	22.81	19	0.4	178.04	7	2	125.89	0	2	125.89
181	6	0.6	32.25	11	0.5	199.05	2	2	125.89	0	0.8	79.62
ave	13.26	1.08	29.29	44.56	1.16	180.03	29.18	3.15	131.94	22.03	1.93	96.20
max	900	25.4	65.83	1700	32	367.04	1700	32	344.77	1700	32	199.05
min	0	0.05	9.31	5	0.05	62.95	0	0.3	48.76	0	0.2	39.81
mean	2	0.4	26.33	14	0.4	178.04	4	2	125.89	0	1	89.02
RF pwr	63	63	63	1000	1000	1000	500	500	500	250	250	250
frequency	900	900	900	1700	1700	1700	1700	1700	1700	1700	1700	1700
	upsets	power (mw)	E Field Strength	upsets	power (mw)	E Field Strength	upsets	power (mw)	E Field Strength	upsets	power (mw)	E Field Strength

Appendix E: Baseline Digital Test Data - Upset Data Files

UPSET.050  
1.7 GHz, 1000 Watts, Digital

Start Time is: Thu Dec 21 13:51:24 1995  
Thu Dec 21 14:09:42 1995

#1000: 3354 F  
#1001: 2924 F  
#1002: 56 F  
#1003: 990 F  
#1004: 1160 F  
#1005: 849 F  
#1006: 371 F  
#1007: 615 F  
#1008: 82 F  
#1009: 517 F  
#1010: 150 F  
#1011: 211 F  
#1012: 373 F  
#1013: 741 F  
#1014: 1308 F  
#1015: 3661 F  
#1016: 1112 F  
#1017: 2609 F  
#1018: 1020 F  
#1019: 1443 F  
#1020: 215 F  
#1021: 348 F  
#1022: 109 F  
#1023: 107 F  
#1024: 555 F  
#1025: 613 F  
#1026: 389 F  
#1027: 704 F  
#1028: 464 F  
#1029: 892 F  
#1030: 126 F  
#1031: 571 F  
#1032: 60 F  
#1033: 191 F  
#1034: 92 F  
#1035: 591 F  
#1036: 264 F  
#1037: 986 F  
#1038: 390 F  
#1039: 1991 F  
#1040: 209 F  
#1041: 166 F  
#1042: 357 F  
#1043: 190 F  
#1044: 569 F  
#1045: 15 F  
#1046: 104 F  
#1047: 46 F

#1048: 106 F  
#1049: 352 F  
#2000: 293 F  
#2001: 1835 F  
#2002: 194 F  
#2003: 702 F  
#2004: 42 F  
#2005: 91 F  
#2006: 224 F  
#2007: 212 F  
#2008: 183 F  
#2009: 134 F  
#2010: 614 F  
#2011: 512 F  
#2012: 371 F  
#2013: 532 F  
#2014: 517 F  
#2015: 54 F  
#2016: 350 F  
#2017: 395 F  
#2018: 51 F  
#2019: 72 F  
#2020: 94 F  
#2021: 53 F  
#2022: 62 F  
#2023: 819 F  
#2024: 643 F  
#2025: 543 F  
#2026: 123 F  
#2027: 118 F  
#2028: 237 F  
#2029: 494 F  
#2030: 280 F  
#2031: 67 F  
#2032: 654 F  
#2033: 280 F  
#2034: 853 F  
#2035: 476 F  
#2036: 1995 F  
#2037: 370 F  
#2038: 662 F  
#2039: 108 F  
#2040: 795 F  
#2041: 106 F  
#2042: 114 F  
#2043: 38 F  
#2044: 112 F  
#2045: 52 F  
#2046: 1139 F  
#2047: 44 F  
#2048: 119  
#2049: 882 F

100 total devices being upset

Appendix E: Baseline Digital Test Data - Upset Data Files

UPSET.051	#2000: 1 F
1.7 GHz, 250 Watts, Digital	#2001: 82 F
Start Time is: Thu Dec 21 14:10:08 1995	#2002: 1 F
Thu Dec 21 14:29:18 1995	#2003: 1 F
#1000: 885 F	#2004: 18 F
#1001: 426 F	#2005: 1 F
#1002: 1 F	#2006: 1 F
#1003: 7 F	#2007: 1 F
#1004: 1 F	#2008: 1 F
#1005: 24 F	#2009: 1 F
#1006: 1 F	#2010: 1 F
#1007: 1 F	#2011: 1 F
#1008: 1 F	#2012: 17 F
#1009: 1 F	#2013: 21 F
#1010: 1 F	#2014: 1 F
#1011: 1 F	#2015: 1 F
#1012: 1 F	#2016: 1 F
#1013: 1 F	#2017: 1 F
#1014: 104 F	#2018: 1 F
#1015: 690 F	#2019: 1 F
#1016: 38 F	#2020: 1 F
#1017: 354 F	#2021: 1 F
#1018: 1 F	#2022: 1 F
#1019: 1 F	#2023: 1 F
#1020: 1 F	#2024: 1 F
#1021: 1 F	#2025: 1 F
#1022: 1 F	#2026: 1 F
#1023: 1 F	#2027: 1 F
#1024: 1 F	#2028: 1 F
#1025: 3 F	#2029: 1 F
#1026: 8 F	#2030: 1 F
#1027: 2 F	#2031: 1 F
#1028: 1 F	#2032: 1 F
#1029: 116 F	#2033: 1 F
#1030: 1 F	#2034: 1 F
#1031: 6 F	#2035: 1 F
#1032: 1 F	#2036: 41 F
#1033: 1 F	#2037: 1 F
#1034: 1 F	#2038: 1 F
#1035: 3 F	#2039: 1 F
#1036: 1 F	#2040: 1 F
#1037: 27 F	#2041: 1 F
#1038: 1 F	#2042: 1 F
#1039: 123 F	#2043: 1 F
#1040: 1 F	#2044: 1 F
#1041: 1 F	#2045: 1 F
#1042: 1 F	#2046: 38 F
#1043: 1 F	#2047: 1 F
#1044: 3 F	#2048: 1 F
#1045: 1 F	#2049: 1 F
#1046: 1 F	
#1047: 1 F	
#1048: 1 F	
#1049: 1 F	

100 Total devices being upset  
81 with 1 - 3 upsets  
19 with 6 or more upsets

## Appendix E: Baseline Digital Test Data - Upset Data Files

UPSET.052  
900 MHz, 1000 Watts, Digital

Start Time is: Thu Dec 21 14:32:24 1995  
Thu Dec 21 14:53:08 1995

#1000: 2415 F  
#1001: 5573 F  
#1002: 1456 F  
#1003: 1256 F  
#1004: 905 F  
#1005: 744 F  
#1006: 1472 F  
#1007: 866 F  
#1008: 994 F  
#1009: 1234 F  
#1010: 1023 F  
#1011: 4587 F  
#1012: 808 F  
#1013: 450 F  
#1014: 3908 F  
#1015: 1310 F  
#1016: 5758 F  
#1017: 3202 F  
#1018: 4426 F  
#1019: 5393 F  
#1020: 1192 F  
#1021: 1569 F  
#1022: 4917 F  
#1023: 4776 F  
#1024: 1537 F  
#1025: 1242 F  
#1026: 2654 F  
#1027: 2031 F  
#1028: 326 F  
#1029: 138 F  
#1030: 420 F  
#1031: 1866 F  
#1032: 1689 F  
#1033: 348 F  
#1034: 1709 F  
#1035: 1263 F  
#1036: 2209 F  
#1037: 577 F  
#1038: 3383 F  
#1039: 1864 F  
#1040: 247 F  
#1041: 1608 F  
#1042: 2407 F  
#1043: 493 F  
#1044: 1101 F  
#1045: 861 F  
#1046: 1801 F  
#1047: 856 F

#1048: 433 F  
#1049: 174 F  
#2000: 301 F  
#2001: 237 F  
#2002: 176 F  
#2003: 253 F  
#2004: 710 F  
#2005: 893 F  
#2006: 1415 F  
#2007: 1360 F  
#2008: 292 F  
#2009: 1190 F  
#2010: 193 F  
#2011: 120 F  
#2012: 94 F  
#2013: 332 F  
#2014: 1457 F  
#2015: 1734 F  
#2016: 1158 F  
#2017: 1259 F  
#2018: 1555 F  
#2019: 1801 F  
#2020: 1517 F  
#2021: 1269 F  
#2022: 1930  
#2024: 1544 F  
#2025: 1461 F  
#2026: 1458 F  
#2027: 1411 F  
#2028: 1485 F  
#2029: 1660 F  
#2030: 361 F  
#2031: 1421 F  
#2032: 1330 F  
#2033: 2091 F  
#2034: 1669 F  
#2035: 1387 F  
#2036: 1836 F  
#2037: 1987 F  
#2038: 748 F  
#2039: 154 F  
#2040: 999 F  
#2041: 387 F  
#2042: 101 F  
#2043: 866 F  
#2044: 315 F  
#2045: 591 F  
#2046: 271 F  
#2047: 1115 F  
#2048: 286 F  
#2049: 342 F

100 total devices being upset

Appendix E: Baseline Digital Test Data - Upset Data Files

UPSET.053  
900 MHz, 250 Watts, Digital

Start Time is: Thu Dec 21 14:54:48 1995  
Thu Dec 21 15:13:05 1995

#1000: 1039 F  
#1001: 439 F  
#1002: 323 F  
#1003: 148 F  
#1004: 97 F  
#1005: 117 F  
#1006: 217 F  
#1007: 175 F  
#1008: 290 F  
#1009: 149 F  
#1010: 256 F  
#1011: 474 F  
#1012: 99 F  
#1013: 35 F  
#1014: 925 F  
#1015: 499 F  
#1016: 657 F  
#1017: 1051 F  
#1018: 870 F  
#1019: 1194 F  
#1020: 360 F  
#1021: 257 F  
#1022: 455 F  
#1023: 422 F  
#1024: 462 F  
#1025: 291 F  
#1026: 359 F  
#1027: 802 F  
#1028: 263 F  
#1029: 83 F  
#1030: 254 F  
#1031: 153 F  
#1032: 168 F  
#1033: 180 F  
#1034: 164 F  
#1035: 366 F  
#1036: 228 F  
#1037: 363 F  
#1038: 445 F  
#1039: 729 F  
#1040: 228 F  
#1041: 370 F  
#1042: 645 F  
#1043: 178 F  
#1044: 318 F  
#1045: 479 F  
#1046: 199 F  
#1047: 255 F

#1048: 247 F  
#1049: 86 F  
#2000: 1486 F  
#2001: 454 F  
#2002: 204 F  
#2003: 724 F  
#2004: 21 F  
#2005: 445 F  
#2006: 549 F  
#2007: 245 F  
#2008: 237 F  
#2009: 255 F  
#2010: 381 F  
#2011: 860 F  
#2012: 127 F  
#2013: 497 F  
#2014: 370 F  
#2015: 260 F  
#2016: 203 F  
#2017: 463 F  
#2018: 201 F  
#2019: 205 F  
#2020: 215 F  
#2021: 355 F  
#2022: 749 F  
#2023: 196 F  
#2024: 506 F  
#2025: 192 F  
#2026: 214 F  
#2027: 214 F  
#2028: 242 F  
#2029: 1716 F  
#2030: 309 F  
#2031: 182 F  
#2032: 182 F  
#2033: 212 F  
#2034: 472 F  
#2035: 237 F  
#2036: 947 F  
#2037: 185 F  
#2038: 1098 F  
#2039: 370 F  
#2040: 773 F  
#2041: 98 F  
#2042: 61 F  
#2043: 1369 F  
#2044: 377 F  
#2045: 625 F  
#2046: 67 F  
#2047: 531 F  
#2048: 57 F  
#2049: 599 F

100 total devices being upset

Appendix E: Baseline Digital Test Data - Upset Data Files

UPSET.054  
 900 MHz, 63 Watts, Digital  
 Start Time is: Thu Dec 21 15:13:41 1995  
 Thu Dec 21 15:35:55 1995

#1000: 1269 F  
 #1001: 196 F  
 #1002: 39 F  
 #1003: 2 F  
 #1004: 2 F  
 #1005: 2 F  
 #1006: 2 F  
 #1007: 2 F  
 #1008: 41 F  
 #1009: 2 F  
 #1010: 28 F  
 #1011: 423 F  
 #1012: 2 F  
 #1013: 2 F  
 #1014: 3019 F  
 #1015: 520 F  
 #1016: 3169 F  
 #1017: 2744 F  
 #1018: 1477 F  
 #1019: 3092 F  
 #1020: 2 F  
 #1021: 2 F  
 #1022: 82 F  
 #1023: 412 F  
 #1024: 2 F  
 #1025: 2 F  
 #1026: 2 F  
 #1027: 63 F  
 #1028: 2 F  
 #1029: 2 F  
 #1030: 2 F  
 #1031: 2 F  
 #1032: 2 F  
 #1033: 2 F  
 #1034: 2 F  
 #1035: 2 F  
 #1036: 2 F  
 #1037: 2 F  
 #1038: 73 F  
 #1039: 209 F  
 #1040: 2 F  
 #1041: 288 F  
 #1042: 14 F  
 #1043: 2 F  
 #1044: 2 F  
 #1045: 31 F  
 #1046: 2 F  
 #1047: 2 F  
 #1048: 2 F

#1049: 2 F  
 #2000: 15 F  
 #2001: 2 F  
 #2002: 2 F  
 #2003: 2 F  
 #2004: 49 F  
 #2005: 2 F  
 #2006: 2 F  
 #2007: 2 F  
 #2008: 2 F  
 #2009: 2 F  
 #2010: 2 F  
 #2011: 2 F  
 #2012: 2 F  
 #2013: 2 F  
 #2014: 2 F  
 #2015: 2 F  
 #2016: 2 F  
 #2017: 2 F  
 #2018: 2 F  
 #2019: 2 F  
 #2020: 2 F  
 #2021: 2 F  
 #2022: 2 F  
 #2023: 2 F  
 #2024: 2 F  
 #2025: 2 F  
 #2026: 2 F  
 #2027: 2 F  
 #2028: 2 F  
 #2029: 2 F  
 #2030: 2 F  
 #2031: 2 F  
 #2032: 2 F  
 #2033: 2 F  
 #2034: 2 F  
 #2035: 2 F  
 #2036: 2 F  
 #2037: 2 F  
 #2038: 2 F  
 #2039: 2 F  
 #2040: 2 F  
 #2041: 2 F  
 #2042: 2 F  
 #2043: 2 F  
 #2044: 2 F  
 #2045: 2 F  
 #2046: 2 F  
 #2047: 2 F  
 #2048: 2 F  
 #2049: 2 F

100 total devices being upset.  
 22 with 14 or more upsets, 22 with exactly 2

Appendix E: Baseline Digital Test Data - Upset Data Files

Upset.055  
1.7 GHz, 500 Watts, Digital

Start Time is: Mon Jan 08 09:53:09 1996  
Mon Jan 08 10:15:28 1996

#1000: 3438 F  
#1001: 2546 F  
#1002: 9 F  
#1003: 298 F  
#1004: 434 F  
#1005: 479 F  
#1006: 138 F  
#1007: 102 F  
#1009: 74 F  
#1010: 17 F  
#1011: 5 F  
#1012: 135 F  
#1013: 251 F  
#1014: 676 F  
#1015: 3423 F  
#1016: 508 F  
#1017: 1815 F  
#1018: 155 F  
#1019: 284 F  
#1021: 1 F  
#1022: 37 F  
#1024: 313 F  
#1025: 33 F  
#1026: 182 F  
#1027: 310 F  
#1028: 271 F  
#1029: 998 F  
#1030: 17 F  
#1031: 89 F  
#1033: 30 F  
#1034: 12 F  
#1035: 32 F  
#1036: 53 F  
#1037: 1138 F  
#1038: 497 F  
#1039: 2083 F  
#1040: 71 F  
#1041: 12 F  
#1042: 91 F  
#1043: 27 F  
#1044: 36 F  
#1046: 26 F  
#1049: 34 F  
#2000: 4 F  
#2001: 1222 F  
#2002: 10 F  
#2003: 210 F  
#2004: 142 F

#2010: 117 F  
#2011: 16 F  
#2012: 183 F  
#2013: 379 F  
#2014: 121 F  
#2015: 2 F  
#2016: 61 F  
#2017: 38 F  
#2023: 71 F  
#2024: 43 F  
#2025: 76 F  
#2026: 4 F  
#2027: 4 F  
#2028: 12 F  
#2029: 73 F  
#2030: 156 F  
#2032: 96 F  
#2034: 398 F  
#2035: 346 F  
#2036: 1204 F  
#2037: 10 F  
#2038: 30 F  
#2039: 4 F  
#2040: 54 F  
#2042: 12 F  
#2044: 8 F  
#2045: 6 F  
#2046: 316 F  
#2049: 73 F

77 total devices being upset.

## Appendix E: Baseline Digital Test Data - Upset Data Files

Upset.056  
900 MHz, 500 Watts, Digital

Start Time is: Mon Jan 08 10:17:54 1996  
Mon Jan 08 10:36:25 1996

#1000: 268 F  
#1001: 1398 F  
#1002: 502 F  
#1003: 279 F  
#1004: 443 F  
#1005: 367 F  
#1006: 408 F  
#1007: 341 F  
#1008: 289 F  
#1009: 269 F  
#1010: 177 F  
#1011: 978 F  
#1012: 294 F  
#1013: 297 F  
#1014: 1063 F  
#1015: 517 F  
#1016: 2471 F  
#1017: 914 F  
#1018: 988 F  
#1019: 2144 F  
#1020: 86 F  
#1021: 224 F  
#1022: 1516 F  
#1023: 954 F  
#1024: 134 F  
#1025: 1092 F  
#1026: 68 F  
#1027: 254 F  
#1028: 108 F  
#1029: 125 F  
#1030: 172 F  
#1031: 258 F  
#1032: 134 F  
#1033: 97 F  
#1034: 187 F  
#1035: 1106 F  
#1036: 96 F  
#1037: 227 F  
#1038: 160 F  
#1039: 157 F  
#1040: 91 F  
#1041: 163 F  
#1042: 246 F  
#1043: 103 F  
#1044: 874 F  
#1045: 463 F  
#1046: 150 F  
#1047: 153 F

#1048: 164 F  
#1049: 137 F  
#2000: 172 F  
#2001: 181 F  
#2002: 187 F  
#2003: 151 F  
#2004: 157 F  
#2005: 558 F  
#2006: 2077 F  
#2007: 2017 F  
#2008: 144 F  
#2009: 93 F  
#2010: 186 F  
#2011: 187 F  
#2012: 130 F  
#2013: 165 F  
#2014: 1971 F  
#2015: 2161 F  
#2016: 1794 F  
#2017: 1885 F  
#2018: 2096 F  
#2019: 2010 F  
#2020: 2094 F  
#2021: 1935 F  
#2022: 2103 F  
#2023: 2191 F  
#2024: 2178 F  
#2025: 2177 F  
#2026: 2002 F  
#2027: 2062 F  
#2028: 2161 F  
#2029: 2424 F  
#2030: 268 F  
#2031: 2089 F  
#2032: 2070 F  
#2033: 2374  
#2034: 1939 F  
#2035: 2035 F  
#2036: 2281 F  
#2037: 2224 F  
#2038: 484 F  
#2039: 224 F  
#2040: 294 F  
#2041: 262 F  
#2042: 208 F  
#2043: 461 F  
#2044: 260 F  
#2045: 224 F  
#2046: 271 F  
#2047: 230 F  
#2048: 287 F  
#2049: 367 F

100 total devices being upset.



Appendix E: Baseline Digital Test Data - Upset Data Files

Upset.057	#2000: 637 F
900 MHz, 125 Watts, Digital	#2001: 133 F
Start Time is: Mon Jan 08 10:37:58 1996	#2002: 2 F
Mon Jan 08 10:56:20 1996	#2003: 21 F
#1000: 3372 F	#2004: 68 F
#1001: 1172 F	#2005: 394 F
#1002: 704 F	#2006: 52 F
#1003: 70 F	#2007: 1 F
#1004: 42 F	#2008: 2 F
#1005: 62 F	#2009: 2 F
#1006: 95 F	#2010: 7 F
#1007: 27 F	#2011: 33 F
#1008: 327 F	#2012: 2 F
#1009: 1 F	#2013: 3 F
#1010: 212 F	#2014: 65 F
#1011: 1134 F	#2015: 1 F
#1012: 38 F	#2016: 2 F
#1013: 2 F	#2017: 2 F
#1014: 3203 F	#2018: 1 F
#1015: 1187 F	#2019: 1 F
#1016: 2518 F	#2020: 1 F
#1017: 3349 F	#2021: 2 F
#1018: 3320 F	#2022: 2 F
#1019: 3474 F	#2023: 5 F
#1020: 326 F	#2024: 32 F
#1021: 63 F	#2025: 1 F
#1022: 578 F	#2026: 2 F
#1023: 978 F	#2027: 2 F
#1024: 774 F	#2028: 1 F
#1025: 15 F	#2029: 364 F
#1026: 1173 F	#2030: 177 F
#1027: 2191 F	#2031: 1 F
#1028: 26 F	#2032: 2 F
#1029: 1 F	#2033: 7 F
#1030: 138 F	#2034: 184 F
#1031: 7 F	#2035: 6 F
#1032: 37 F	#2036: 32 F
#1033: 70 F	#2037: 1 F
#1034: 18 F	#2038: 114 F
#1035: 15 F	#2039: 30 F
#1036: 190 F	#2040: 117 F
#1037: 222 F	#2041: 2 F
#1038: 1462 F	#2042: 20 F
#1039: 1844 F	#2043: 253 F
#1040: 48 F	#2044: 20 F
#1041: 1547 F	#2045: 53 F
#1042: 1392 F	#2046: 2 F
#1043: 8 F	#2047: 342 F
#1044: 15 F	#2048: 2 F
#1045: 386 F	#2049: 111 F
#1046: 16 F	
#1047: 79 F	
#1048: 2 F	
#1049: 2 F	

100 total devices being upset.  
71 devices with 5 or more upsets, 29 with 1, 2,  
or 3 upsets

Appendix F1: Baseline Analog Test Data

Analog Baseline Testing, test - Test2.o18 (Sorted)																					10/18/95			
Conditions: Vbuff=5.0, Vmon=4.3, Vps=+-7.5, Paddle at 1 rpm																								
Test fixture A3 (bare board) in West location using West monitor board																								
1.2 us pulse, 1.5 ms period										(Raw data from T2018.xls)														
RF Power	0	0	0	0	0	0	0	1000	1000	1000	1000	1000	1000	1000	1000	1000	1000	1000	1000	1000				
Vbuff	6.3	6.4	6.5	6.6	6.7	6.8	6.9	3.5	4	5	5.2	5.4	5.6	5.8	6	6.1	6.2	6.3	6.4	6.5	6.6	6.7	6.8	
	1	8	8	8	8	33	100	92	35	69	69	56	83	73	63	73	54	66	60	71	81	100		
	1	8	8	8	8	44	100	96	85	80	76	73	74	52	72	56	76	55	66	81	60	79	100	
	1	8	8	8	8	54	100	98	86	72	77	59	69	79	60	76	62	46	45	74	67	63	86	
	1	8	8	8	8	44	100	99	83	68	65	84	58	56	57	59	50	70	57	70	75	80	100	
	1	8	8	8	8	37	100	98	70	62	56	71	71	64	75	58	52	56	55	62	98	30	100	
	1	8	8	8	8	40	100	99	81	71	69	68	61	58	76	59	74	71	70	76	87	38	53	
		8	8	8	8	47	100	96	74	75	59	68	73	62	86	66	78	51	57	75	78	32	83	
		8	7	8	8	42	100	99	95	68	84	66	80	81	83	74	70	50	72	81	93	87	54	
		8	7	8	8	41	100	98	86	88	72	72	61	65	57	59	58	63	60	75	94	98	89	
		8	7	8	8	42	100	83	84	69	61	79	95	86	93	75	66	66	69	71	78	59	59	
		8	8	8	8	44	99	91	70	84	78	85	77	100	71	77	82	80	57	65	63	89		
		8	7	8	8	36	97	92	71	74	82	68	76	73	63	70	68	60	78	75	38	100		
		8	7	8	8	45	99	82	75	69	69	70	79	52	70	48	57	71	66	65	58	98		
		7	8	8	8	52	97	90	71	64	79	70	81	73	76	68	47	51	65	91	93	100		
		8	8	8	8	44	92	83	67	68	72	72	75	44	74	49	69	73	61	70	62	100		
		8				41	96	86	65	67	69	56	64	40	62	24	51	74	99	61	100	99		
		8				51	97	72	74	51	66	65	59	78	60	70	61	75	76	88	84	64		
						47	99	80	64	71	63	67	66	55	63	61	62	64	65	64	100			
						57	99	78	62	62	59	73	57	62	42	57	63	57	99	56	98	100		
						44	100	77	71	66	60	77	51	68	45	69	72	65	70	76	100	100		
							97	86	60	76	66	72	77	59	69	54	67	72	70	71	77	100		
							97	83	71	73	74	65	59	68	55	55	96	72	88	83	75	73		
							100	73	76	60	49	75	89	79	88	72	64	72	69	81	91	100		
							98	86	72	75	78	60	70	54	74	53	73	85	71	62	83	86		
							95	94	70	73	72	83	67	82	67	71	68	89	77	89	90	100		
							98	87	76	75	70	64	75	59	83	56	74	86	57	94	70	100		
							98	75	61	53	69	58	88	62	54	66	69	76	58	87	62	100		
							100	80	68	60	77	77	63	77	50	61	65	58	40	71	66	93		
							99	85	68	67	62	76	74	79	67	81	44	65	57	72	49	97		
							97	90	73	78	68	78	65	72	65	72	45	48	69	73	80	90		
							97	89	78	78	64	71	77	60	77	66	41	67	65	77	56	100		
							97	85	66	71	76	70	89	70	79	49	46	53	77	73	87	87		
							99	83	58	62	77	82	63	78	66	70	66	60	56	62	62	49		
							100	85	68	80	67	74	61	73	58	24	54	73	76	73	61	100		
							98	83	62	71	55	71	69	63	65	55	84	57	73	75	62	100		
							95	83	87	65	69	60	67	49	85	60	42	55	68	76	70	52		
							100	82	75	64	62	67	84	60	69	68	65	66	69	75	82	100		
							99	85	72	69	78	73	87	82	66	45	84	77	71	99	95	77		
							100	83	78	74	74	66	63	63	68	59	38	94	72	78	86			
							100	84	74	69	69	90	78	96	67	50	74	74	73	87	70	62		
							96	86	76	82	84	69	89	89	78	84	63	61	69	94	98	98		
							99	85	66	73	75	71	72	71	72	71	72	70	65	96	98	85		
							95	81	67	78	77	72	66	79	53	74	79	80	61	66	90	81		
							98	87	67	74	70	80	71	78	73	49	75	80	67	65	95	100		
							98	84	61	69	68	74	66	73	61	32	57	71	69	67	54	59		
							96	84	72	71	67	70	53	73	65	57	65	70	79	59	95	51		
							99	77	64	67	50	66	70	60	71	49	62	53	82	43	82	100		
							96	81	59	58	69	61	72	63	66	52	72	79	66	57	93	100		
							96	82	73	71	68	62	66	58	75	24	79	61	79	72	68	100		
							99	77	77	63	68	57	78	56	75	51	69	71	78	53	81	95		
							91	74	60	62	76	73	65	71	67	69	66	70	88	100	71	100		
							98	77	75	70	75	58	59	61	65	49	95	70	62	45	92	86		
							100	75	77	54	60	73	81	83	79	87	72	76	69	65	98	72		
							99	88	75	78	75	74	65	51	64	45	76	69	80	87	100	73		
							94	84	61	71	71	66	77	47	73	55	59	99	73	75	97	100		
							100	84	65	64	76	75	53	74	60	75	64	68	71	52	65	100		
							99	80	66	72	59	72	73	58	55	37	48	69	62	90	69	100		
							98	90	79	77	66	63	75	54	81	40	64	75	69	86	71	50		
							96	72	75	59	68	73	92	78	89	69	73	74	82	98	75	100		
							96	77	72	69	83	63	89	56	78	34	62	65	56	76	51	48		
Tot Upsets	6	104	130	120	120	885	900	5857	4915	4227	4147	4156	4216	4267	4097	4061	3551	3865	4056	4263	4504	4535	5224	
#hits/min	6	13	17	15	15	20	9	60	60	60	60	60	60	60	60	60	60	60	60	60	60	60	60	
Average	1	8	7.65	8	8	44.3	100	97.6	81.9	70.5	69.1	69.3	70.3	71.1	68.3	67.7	59.2	64.4	67.6	71.1	75.1	75.6	87.1	
Max	1	8	8	8	8	57	100	100	95	88	84	84	90	95	100	93	87	96	99	99	100	100	100	
Min	1	8	7	8	8	33	100	91	35	58	51	49	56	51	40	42	24	41	38	40	43	30	48	
Vbuff	6.3	6.4	6.5	6.6	6.7	6.8	6.9	3.5	4	5	5.2	5.4	5.6	5.8	6	6.1	6.2	6.3	6.4	6.5	6.6	6.7	6.8	
RF Power	0	0	0	0	0	0	0	1000	1000	1000	1000	1000	1000	1000	1000	1000	1000	1000	1000	1000	1000	1000	1000	

Appendix F: Baseline Analog Test Data

Analog Baseline Testing, Test3.o18				10/18/95		
Conditions: Vbuff=5.0, Vmon=4.3, Vps=+/-7.5, paddle at 1 rpm						
Test fixture A3 (bare board) in West location using West monitor board						
1.2 us pulse, 1.5 ms period				Source data Test3.o18		
RF Power (Watts)	1000	500	250	125	63	31
	73	63	39	18	1	1
	79	55	23	18	1	1
	73	58	29	10	1	1
	74	39	36	10	2	1
	63	54	5	7	3	1
	70	59	27	13	3	1
	50	46	28	25	2	2
	73	45	33	9	1	1
	66	48	43	4	1	1
	65	52	7	9	3	1
	75	61	47	11	15	1
	72	44	28	15	4	1
	66	69	14	4	1	1
	78	44	32	3	1	1
	71	46	26	1	2	1
	74	48	2	13	3	1
	62	42	13	9	1	1
	58	39	28	5	1	1
	68	35	17	16	1	1
	72	43	4	4	1	1
	79	36	24	1	1	1
	76	46	30	11	1	1
	59	31	3	15	5	1
	76	48	5	10	2	1
	76	42	15	13	1	1
	71	45	8	5	2	1
	73	35	43	4	8	1
	65	31	25	11	3	1
	74	60	17	19	2	1
	74	35	13	14	2	1
	72	31	18	12	2	1
	81	29	32	15	3	1
	64	40	35	17	3	1
	80	47	32	5	1	1
	75	54	21	7	1	1
	70	49	25	18	1	1
	65	29	34	18	3	1
	66	50	39	11	1	1
	65	59	22	5	2	1
	57	26	25	21	5	1
	71	21	34	9	10	1
	66	15	33	3	2	1
	58	58	39	10	1	1
	74	50	12	10	3	1
	78	53	16	4	1	1
	58	18	7	5	1	1
	69	35	34	14	1	1
	80	18	26	6	1	1
	70	59	16	9	1	1
	64	44	27	6	1	1
	67	36	27	10	4	1
	72	55	19	3	1	1
	63	55	42	9	2	1
	78	41	29	6	2	1
	72	54	8	4	1	1
	63	57	32	20	1	1
	61	54	19	14	2	1
	81	44	20	3	2	1
	73	37	29	2	1	1
	71	34	40	8	3	1
Total	4189	2651	1456	591	138	61
# hits/min	60	60	60	60	60	60
Ave	69.82	44.18	24.27	9.85	2.30	1.02
Max	81	69	47	25	15	2
Min	50	15	2	1	1	1
RF Power	1000	500	250	125	63	31
Vbuff	5	5	5	5	5	5
Bd	A3	A3	A3	A3	A3	A3
Test	3	3	3	3	3	3

Appendix F: Baseline Analog Test Data

Analog Baseline Testing_Test4.o20		10/20/95																												
Conditions: Vmon=4.3, Vps=+-7.5, paddle at 1 rpm																														
1.2 us pulse, 1.5 ms period																														
Test fixture A3 (bare board) in West location using West monitor board																														
Source data Test4o20.xls																														
Vbuff	5.0 V	5	5	5	5	5.5 V	5.5	5.5	5.5	5.5	6.0 V	6	6	6	6	6.25	6.25	6.25	6.25	6.3	6.5 V	6.5	6.5	6.5	6.5	6.5	6	5.5	5	
RF Pwr	1000	500	250	125	63	1000	500	250	125	63	1000	500	250	125	63	1000	500	250	125	63	1000	500	250	125	63	1000	500	250	125	63
(Watts)																														
25	22	22	3	1	23	46	26	2	3	72	21	15	2	2	83	49	6	13	1	95	21	27	10	8	8	6	8	1		
73	38	18	5	1	40	57	38	6	1	95	29	17	2	2	73	43	16	4	2	69	48	21	20	8	8	8	8	1		
72	35	14	2	2	33	37	20	1	1	59	48	21	6	1	61	34	31	2	2	84	58	36	14	10	8	8	8	1		
60	29	28	6	1	59	16	16	5	1	65	17	20	8	1	79	59	22	6	1	86	67	33	8	8	8	6	8	1		
73	39	22	10	1	52	24	16	4	2	68	39	19	4	1	71	52	17	3	1	72	49	26	19	8	8	8	8	1		
68	40	23	10	3	57	20	12	1	1	88	57	21	3	1	82	42	19	10	2	76	53	28	21	8	8	6	8	1		
50	54	37	7	1	70	46	19	4	1	77	37	18	18	1	65	33	21	10	1	73	70	30	14	9	8	6	8	1		
68	47	20	3	1	76	31	21	20	1	58	28	21	7	2	44	40	25	2	2	63	46	28	17	8	8	6	8	1		
70	40	16	6	1	41	66	18	1	1	66	28	29	9	5	69	25	38	8	1	57	47	43	11	8	8	6	8	1		
70	55	28	17	1	50	40	16	1	2	46	33	7	1	1	89	48	15	11	1	64	48	20	11	9	8	6	8	1		
55	53	28	21	1	37	14	22	8	2	60	47	27	7	1	78	40	12	19	1	67	66	26	17	8	8	6	8	1		
68	45	17	11	1	65	52	9	15	2	62	59	22	19	1	74	25	31	6	1	86	32	34	19	9	8	8	8	1		
56	46	40	10	1	33	45	25	2	1	61	41	32	7	2	68	57	28	10	1	82	42	37	12	8	8	6	8	1		
72	40	35	2	1	65	44	7	15	3	91	34	12	4	2	72	52	32	14	1	69	40	35	13	8	8	6	8	1		
78	53	4	3	1	55	23	3	4	7	94	60	18	6	1	84	25	11	19	5	73	21	20	17	8	8	6	8	1		
77	45	14	9	1	45	39	10	7	11	55	39	27	12	2	63	45	20	2	4	72	44	27	23	9	8	6	8	1		
72	39	32	9	1	21	39	15	1	2	70	56	35	17	2	76	60	8	13	1	74	40	17	14	8	8	6	8	1		
75	35	17	6	3	36	38	23	15	1	65	42	13	21	2	69	44	22	17	1	77	34	29	17	8	8	5	1	1		
77	34	23	6	4	73	29	24	3	1	47	27	29	9	1	79	51	17	3	1	72	51	15	27	10	8	6	8	1		
73	45	10	6	1	29	46	11	2	2	82	22	34	6	1	70	26	17	3	1	64	60	24	28	11	8	6	8	1		
64	57	15	4	1	62	38	15	3	2	58	43	22	4	1	77	46	32	9	2	72	35	38	13	8	8	5	8	1		
71	58	15	11	1	56	26	11	3	1	77	43	10	12	2	97	53	5	8	2	80	47	15	9	8	8	4	8	1		
44	43	13	10	2	25	26	5	2	1	79	28	33	9	3	63	49	13	2	1	82	58	13	29	8	8	6	8	1		
75	41	24	5	2	66	40	18	10	1	56	47	28	4	1	63	29	34	3	3	70	58	39	18	8	8	6	8	1		
71	52	15	1	2	47	45	4	2	1	56	25	10	6	1	75	37	23	8	3	63	51	32	8	10	8	6	8	1		
61	45	26	7	1	40	45	15	2	1	56	43	9	5	2	77	34	20	2	11	68	42	28	14	10	6	8	1			
74	39	21	5	1	30	48	7	3	2	54	43	16	7	3	62	45	21	8	1	79	45	27	16	8	6	8	1			
58	54	19	3	4	37	10	18	16	2	85	48	4	4	1	69	57	19	2	1	58	51	30	9	10	8	1				
73	39	26	2	3	72	47	24	2	1	83	57	23	5	1	69	38	16	2	1	78	51	30	9	10	8	1				
67	31	26	3	8	42	62	15	5	1	64	25	14	16	3	54	36	26	6	2	63	43	32	16	18	8	1				
88	40	23	4	2	40	30	14	14	2	66	50	11	1	1	71	67	18	12	2	71	36	40	10	10	8	1				
67	48	24	2	1	63	38	14	2	1	92	44	7	2	1	67	50	12	2	1	75	45	16	15	8	1					
67	41	20	7	1	59	17	21	5	2	69	51	35	10	1	54	58	22	3	1	77	66	24	9	8	1					
73	32	32	3	2	69	16	14	1	1	73	59	4	14	2	65	34	22	19	1	89	58	35	9	9	1					
72	39	31	2	2	73	41	10	1	2	64	32	14	4	1	84	28	28	13	1	60	55	31	9	10	1					
67	37	22	5	3	52	50	13	2	1	43	42	33	4	1	56	31	19	7	1	73	51	26	18	8	1					
73	54	19	14	1	61	33	27	8	1	54	41	16	5	1	71	40	46	24	3	1	69	65	23	8	8	1				
61	38	19	19	1	37	43	9	6	1	64	64	20	3	1	78	45	29	7	5	80	47	34	9	8	1					
67	54	29	7	1	41	37	24	7	1	60	25	3	7	2	63	33	40	14	1	58	56	56	22	8	1					
56	39	36	5	1	66	50	12	11	1	52	39	14	5	1	81	55	16	11	1	88	36	26	15	8	1					
64	46	33	7	2	84	34	32	19	1	74	50	38	2	1	75	42	34	4	1	67	40	26	11	9	1					
62	53	22	11	2	76	28	4	24	1	74	61	17	6	1	73	37	49	5	2	47	39	47	10	10	1					
68	53	8	5	1	60	30	18	3	1	46	43	17	9	1	71	53	16	11	2	70	46	31	14	8	1					
71	33	25	15	1	39	8	29	1	1	83	64	17	10	1	67	53	14	17	2	87	47	28	22	8	1					
65	37	26	15	1	70	10	3	5	2	79	63	23	8	1	52	59	23	23	2	63	38	39	13	9	1					
68	44	24	4	1	70	51	14	2	1	90	29	25	5	3	60	40	27	9	2	64	66	38	15	12	1					
82	53	25	4	2	68	41	6	10	1	70	42	36	10	2	62	38	16	3	2	90	44	21	11	9	1					
71	57	25	16	1	57	21	15	9	1	69	49	19	17	1	81	40	17	9	1	71	46	11	16	8	1					
68	46	16	4	2	65	9	13	3	3	63	46	19	1	1	80	57	22	15	1	66	55	25	20	9	1					
72	42	19	3	1	34	32	12	5	1	80	51	31	8	1	82	56	7	14	1	77	55	16	31	9	1					
77	51	29	4	1	60	29	11	6	1	79	30	32	17	2	75	42	20	6	3	61	50	25	10	9	1					
76	50	20	2	1	66	50	2	4	2	63	36	29	6	2	98	36	10	5	4	78	45	19	11	8	1					
77	56	15	2	1	36	54	24	14	2	62	24	12	1	2	72	50	11	3	1	66	40	21	15	8	1					
58	75	10	5	1	45	10	30	15	1	64	44	19	11	1	76	64	10	4	2	83	45	15	15	8	1					
58	45	13	11	4	87	22	2	1	1	87	24	8	7	2	64	34	39	4	6	71	56	75	24	8	1					
55	25	22	6	5	60	59	23	1	1	49	40	16	5	3	52	51	7	5	3	73	86	15	11	11	1					
72	44	16	14	1	47	22	16	4	1	71	52	13	3	11	47	51	20	18	1	61	55	24	18	8	1					
73	57	20	6	1	35	48	14	12	1	71	59	18	5	1	65	57	33	1	1	82	41	41	10	8	1					
76	41	13	4	1	65	34	27	2	1	78	28	29	2	1	69	45	19	1	3	58	50	26	11	9	1					
58	47	18	16	1	41	12	6	2	1	77	45	4	10	1	61	52	33	12	1	70	65	34	15	15	1					
Total	4052	2670	1302	425	99	3163	2098	942	364	97	4115	2493	1185	438	101	4196	2678	1274	485	114	4333	2970	1727	90						

Appendix F: Baseline Analog Test Data

Analog Baseline Testing, Test55.o25 (Sorted)																						10/25/95			
Conditions: Vmon=4.3, Vps=+-7.5, paddle at 1 rpm																									
1.2 us pulse, 1.5 ms period																									
Test fixture A2 (emi protected) in East location, using West monitor bd.																									
Source data Test55.o25 and test57.o26																									
Vbuff	4	4.5	5	5.5	6	6.2	6.3	6.4	6.5	6.6	6.7	6.8	6.82	6.84	4.5	5	5.5	6	6.5	4.5	5	5.5	6		
RF Pwr (Watts)	1000	1000	1000	1000	1000	1000	1000	1000	1000	1000	1000	1000	1000	1000	500	500	500	500	500	250	250	250	250		
65	58	79	23	57	33	48	32	36	71	53	68	48	100	34	21	38	23	15	10	1	13	10			
59	76	62	55	54	45	55	67	64	62	58	67	84	95	34	9	37	28	36	2	2	14	11			
73	52	47	59	65	71	53	66	58	70	73	62	59	100	51	17	31	55	41	16	31	16	11			
79	72	60	25	72	74	61	71	64	50	94	63	98	100	15	33	17	35	23	13	17	17	10			
58	84	57	54	51	70	65	43	75	45	54	76	50	88	26	36	38	30	34	14	7	16	18			
50	67	53	66	53	58	54	36	45	46	62	89	79	68	13	29	28	27	29	17	8	20	19			
58	65	57	76	44	46	61	41	59	55	63	99	73	99	33	11	35	13	36	12	0	16	11			
61	48	33	45	60	30	39	51	48	66	44	66	58	100	19	5	25	13	41	11	0	11	10			
44	42	40	39	41	40	43	40	57	64	70	56	66	76	27	10	25	10	20	3	0	13	11			
56	48	45	40	52	51	56	60	41	91	84	58	66	100	58	5	22	30	32	3	8	13	11			
64	46	53	47	34	54	43	66	49	64	60	73	62	100	42	23	26	31	29	2	0	12	13			
71	53	63	37	63	62	56	41	49	84	74	69	96	100	17	34	26	28	21	1	1	13	11			
71	61	57	50	59	51	60	49	71	77	82	80	71	100	24	26	41	42	25	4	3	21	16			
60	63	55	66	54	59	59	74	59	64	62	91	66	91	39	16	31	37	25	4	1	20	15			
81	67	71	51	75	60	70	76	59	62	73	58	77	99	33	31	36	48	36	5	8	19	22			
47	64	47	37	51	61	43	49	58	80	60	91	75	100	15	42	27	24	38	6	1	12	17			
51	67	63	67	41	53	73	51	54	89	99	75	66	69	31	28	36	38	33	13	6	13	23			
46	58	81	74	57	45	75	73	36	61	97	90	77	100	42	21	56	28	35	6	0	11	12			
64	68	66	54	59	61	68	68	54	85	73	80	84	100	28	7	37	39	21	6	6	13	9			
82	71	53	47	76	75	58	46	66	57	72	51	88	100	39	37	33	38	20	17	9	11	20			
54	74	41	60	39	50	46	54	73	94	59	83	67	100	30	27	32	22	18	22	3	19	11			
48	44	32	61	36	52	34	28	39	48	48	64	55	100	30	31	14	36	36	0	1	21	13			
50	49	46	47	38	46	45	44	32	59	54	66	74	100	28	16	13	23	40	20	3	11	12			
63	51	45	54	57	56	50	53	41	49	64	62	81	100	10	18	15	23	33	23	8	11	19			
40	64	56	47	36	39	54	48	46	96	80	66	65	70	29	17	27	26	23	8	6	12	11			
59	36	54	52	46	53	58	61	48	88	73	68	76	60	20	13	29	26	14	2	9	11	11			
64	55	56	54	69	45	55	60	68	58	70	86	78	100	31	26	35	37	19	1	18	15	15			
67	44	59	41	39	70	58	59	70	70	67	57	61	72	52	34	42	37	16	6	11	15	19			
61	69	65	58	44	59	61	67	41	56	88	62	75	100	45	33	43	30	24	1	10	14	20			
60	66	61	62	67	53	59	44	58	59	82	80	81	100	51	36	41	37	29	2	4	16	23			
72	63	55	57	67	72	64	70	67	72	67	88	87	100	28	20	26	20	28	14	1	24	12			
71	79	57	75	52	53	46	73	68	95	65	73	78	100	32	21	32	17	22	17	0	20	11			
57	61	68	50	48	36	64	69	59	74	85	70	68	100	41	55	29	16	37	1	0	23	32			
66	31	66	74	45	57	74	64	60	61	92	58	94	100	40	43	41	26	41	22	8	19	22			
66	56	48	81	67	61	49	43	69	36	69	58	63	95	21	33	34	44	35	23	15	10	17			
58	65	44	66	49	74	53	32	72	51	83	77	68	99	21	24	23	33	26	6	15	19	16			
72	79	46	56	52	42	59	36	47	66	63	55	100	100	19	9	31	23	17	9	2	12	9			
54	50	53	44	49	35	57	48	61	50	68	48	54	99	16	5	25	13	37	19	1	13	10			
48	38	31	37	54	39	41	57	39	68	69	66	79	74	29	10	22	20	28	17	1	11	9			
61	34	50	46	57	48	51	61	48	94	65	65	84	69	24	25	23	16	30	1	1	18	14			
66	59	42	48	51	39	37	56	55	74	57	77	56	100	40	24	23	24	27	1	8	12	10			
73	39	64	56	63	46	71	56	57	64	93	81	87	100	24	23	37	33	27	1	7	11	12			
67	52	55	52	59	68	52	69	67	68	68	84	66	100	6	39	35	27	21	6	4	21	18			
67	64	53	49	56	40	49	43	60	49	68	84	80	100	33	30	34	26	25	4	8	21	17			
76	53	72	75	58	56	73	55	62	59	64	81	86	100	35	43	40	39	29	15	18	19	17			
63	58	58	60	45	65	48	48	67	59	69	56	67	100	8	17	18	43	39	23	16	18	10			
69	67	40	70	55	64	38	61	52	75	62	51	100	100	41	29	22	34	33	25	12	14	12			
86	79	51	55	82	50	56	72	74	68	85	69	94	100	40	15	18	29	33	3	10	12	16			
71	54	55	55	71	52	63	47	73	37	88	70	86	94	30	36	36	16	31	11	0	36	14			
66	62	70	73	57	63	73	58	59	52	86	88	76	100	25	36	40	38	31	21	20	25	16			
57	63	36	73	42	63	41	54	65	40	70	82	57	100	27	22	37	28	63	6	1	17	11			
48	69	33	44	35	53	34	56	56	35	49	64	63	75	29	29	30	26	36	6	8	17	11			
58	50	40	52	44	53	38	42	32	68	59	56	63	100	12	22	13	30	29	15	2	11	12			
44	61	56	56	53	35	46	54	32	34	79	75	82	100	15	17	19	25	31	12	12	11	14			
62	51	29	67	52	42	33	36	49	65	61	89	74	100	51	22	15	23	14	0	0	10	10			
59	46	45	42	58	65	50	74	48	64	88	49	69	100	35	25	30	24	14	8	1	15	15			
66	57	61	48	50	47	66	57	64	83	79	85	77	100	43	33	35	34	11	0	1	10	19			
70	52	39	42	62	69	36	58	64	74	56	52	81	100	52	28	26	44	30	19	10	14	16			
70	61	45	69	67	61	55	65	63	39	71	70	93	88	59	36	22	35	26	8	18	18	18			
66	69	66	68	45	52	61	50	63	77	76	56	77	100	42	33	38	39	28	1	17	18	10			
# Upsets	3735	3504	3185	3288	3234	3222	3238	3282	3370	3871	4246	4233	4465	5680	1864	1496	1790	1759	1721	564	399	938	864		
Period	60	60	60	60	60	60	60	60	60	60	60	60	60	60	60	60	60	60	60	60	60	60	60		
Ave Upsets	62.3	58.4	53.1	54.8	53.9	53.7	54	54.7	56.2	64.5	70.8	70.6	74.4	94.7	31.1	24.9	29.8	29.3	28.7	9.4	6.65	15.6	14.4		

Appendix F: Baseline Analog Test Data

Analog Baseline Testing, Test55.o25 (Sorted) - page 2																									
Vbuff	6.5	4.5	5	5.5	6	6.5	4.5	5	5.5	6	6.5	5	5.5	6	6.2	6.3	6.4	6.5	6.6	6.7	6.8	6.82	6.84	6.9	
RF Pwr (Watts)	250	125	125	125	125	125	63	63	63	63	63	0	0	0	0	0	0	0	0	0	0	0	0	0	
17	7	1	11	9	10	0	0	10	9	10	0	10	9	10	11	11	11	29	32	36	40	99	99		
21	7	1	11	16	11	0	0	10	10	10	0	10	9	10	11	11	11	29	31	38	40	98	99		
18	2	0	11	15	11	0	0	10	9	10	0	10	9	10	11	11	11	31	31	38	43	99	99		
11	5	0	10	10	11	0	0	10	9	10	0	10	9	10	11	11	11	31	31	38	42	99	99		
19	0	1	11	9	12	0	0	10	9	10	0	10	9	10	11	11	11	29	31	38	44	99	99		
12	1	1	11	9	10	0	0	10	9	10	0	10	9	10	11	11	11	30	36	38	45	99	99		
15	0	3	10	9	10	0	0	10	9	10	0	10	9	10	11	11	11	30	32	40	44	99	99		
14	0	0	11	9	10	0	0	10	9	10	0	10	9	10	11	11	11	29	31	38	43	99	99		
19	1	0	10	9	11	0	0	10	9	10	0	10	9	10	11	11	11	30	31	39	41	99	99		
13	1	0	10	9	10	0	0	10	9	10	0	10	9	10	11	11	11	29	36	39	40	99	99		
12	0	0	10	9	10	0	0	10	9	10	0	10	9	10	11	11	11	31	30	39	44	99	99		
18	0	0	10	11	10	0	0	10	9	10	0	10	9	10	11	11	11	31	36	39	44	99	99		
19	0	0	11	10	10	0	0	10	9	10	0	10	9	10	11	11	11	31	36	39	44	99	99		
20	4	0	10	10	13	0	0	10	9	10	0	10	9	10	11	11	11	32	31	38	42	99	99		
22	0	0	11	9	12	0	0	10	9	10	0	10	9	10	11	11	11	32	31	38	42	99	99		
14	13	6	11	10	13	0	0	10	9	10	0	10	9	10	11	11	11	30	35	38	42	99	99		
12	2	9	10	10	13	0	0	10	9	11	0	10	9	10	11	11	11	30	31	38	43	99	99		
33	0	2	17	10	10	0	0	10	9	10	0	10	9	10	11	11	11	31	36	38	42	99	99		
27	8	3	14	9	11	0	0	10	9	10	0	10	9	10	11	11	11	30	36	38	44	99	99		
17	11	0	11	9	11	0	0	10	9	10	0	10	9	10	11	11	11	29	31	38	42	99	99		
19	1	1	10	9	10	0	0	10	9	10	0	10	9	10	11	11	11	30	32	38	42	99	99		
12	2	0	10	9	10	0	0	10	9	10	0	10	9	10	11	11	11	30	36	39	41	99	99		
12	0	0	10	9	10	0	0	10	9	10	0	10	9	10	11	11	11	30	32	38	41	99	99		
11	0	1	10	9	10	0	1	10	9	10	0	10	9	10	11	11	11	30	32	38	41	99	99		
14	0	0	11	9	11	0	0	10	9	10	0	10	9	10	11	11	11	31	31	38	41	99	99		
12	0	0	10	9	10	0	0	10	9	10	0	10	9	10	11	11	11	29	31	39	44	99	99		
13	0	0	10	13	10	0	0	10	9	10	0	10	9	10	11	11	11	29	30	40	44	99	99		
19	0	0	12	10	10	0	0	10	9	10	0	10	9	10	11	11	11	29	31	40	41	99	99		
15	3	1	11	10	12	0	0	10	9	10	0	10	9	10	11	11	11	29	36	38	40	98	99		
18	1	0	11	10	12	0	0	10	9	10	0	10	9	10	11	11	11	30	31	38	41	99	99		
18	1	0	11	10	12	0	0	10	9	10	0	10	9	10	11	11	11	30	33	38	43	99	99		
12	3	3	10	9	11	0	0	10	9	10	0	10	9	10	11	11	11	30	36	38	46	99	99		
12	1	1	11	9	17	0	0	10	9	10	0	10	9	10	11	11	11	30	36	38	46	99	99		
17	1	0	10	9	17	0	0	10	9	10	0	10	9	10	11	11	11	30	31	38	43	99	99		
16	2	0	11	10	11	1	0	10	9	10	0	10	9	10	11	11	11	29	33	39	44	99	99		
20	0	11	11	11	10	0	0	10	9	10	0	10	9	10	11	11	11	30	30	37	41	99	99		
11	4	0	10	9	10	0	1	10	9	10	0	10	9	10	11	11	11	30	31	38	42	99	99		
13	0	0	10	9	10	0	0	10	9	10	0	10	9	10	11	11	11	29	33	38	46	99	99		
16	0	0	11	9	10	0	0	10	9	10	0	10	9	10	11	11	11	31	36	39	42	99	99		
11	1	0	10	9	10	0	0	10	9	10	0	10	9	10	11	11	11	31	32	38	42	99	99		
12	0	0	10	11	10	0	0	10	9	10	0	10	9	10	11	11	11	30	31	38	43	99	99		
18	1	1	10	9	10	0	0	10	9	10	0	10	9	10	11	11	11	29	36	38	43	99	99		
19	1	0	11	9	12	0	0	10	9	10	0	10	9	10	11	11	11	29	31	38	42	99	99		
17	0	0	11	9	11	0	0	10	9	10	0	10	9	10	11	11	11	29	30	38	44	99	99		
18	1	1	11	13	12	0	0	10	9	10	0	10	9	10	11	11	11	30	31	38	44	99	99		
12	1	0	10	14	11	0	0	10	9	10	0	10	9	10	11	11	11	30	31	38	44	99	99		
13	0	0	11	11	12	1	0	10	9	10	0	10	9	10	11	11	11	29	31	38	43	99	99		
13	1	0	11	11	11	1	0	10	9	10	0	10	9	10	11	11	11	29	31	38	44	99	99		
13	0	1	10	9	12	0	0	10	9	10	0	10	9	10	11	11	11	30	31	38	44	99	99		
15	0	0	11	10	13	0	0	10	9	10	0	10	9	10	11	11	11	30	31	40	43	99	99		
20	0	2	11	9	11	0	0	10	10	10	0	10	9	10	11	11	11	36	31	38	42	99	99		
20	2	1	13	9	11	0	0	10	9	10	0	10	9	10	11	11	11	30	36	38	41	99	99		
11	4	0	10	9	11	0	0	10	9	10	0	10	9	10	11	11	11	30	33	38	40	99	99		
12	0	0	10	9	11	0	0	10	9	10	0	10	9	10	11	11	11	30	36	38	41	99	99		
13	0	0	10	9	11	0	0	10	9	10	0	10	9	10	11	11	11	30	36	38	43	99	99		
12	0	0	10	9	11	0	0	10	9	10	0	10	9	10	11	11	11	30	36	39	42	99	99		
16	0	0	10	9	11	0	0	10	9	10	0	10	9	10	11	11	11	30	36	38	43	99	99		
13	0	0	10	9	11	0	0	10	9	10	0	10	9	10	11	11	11	30	34	38	46	99	99		
14	0	1	10	9	11	0	0	10	9	10	0	10	9	10	11	11	11	29	31	38	45	99	99		
16	0	0	10	14	11	0	0	10	9	10	0	10	9	10	11	11	11	30	35	38	42	99	99		
21	0	0	15	10	12	0	0	10	9	10	0	10	9	10	11	11	11	29	31	38	46	99	99		
# Upsets	944	92	52	645	593	666	3	2	600	542	241	0	600	414	359	484	660	539	1806	1957	2295	2557	5937	5940	
Period	60	60	60	60	60	60	60	60	60	60	24	31	60	46	36	44	60	49	60	60	60	60	60	60	
Ave Upsets	15.7	1.53	0.87	10.8	9.88	11.1	0.05	0.03	10	9.03	10	0	10	9	9.97	11	11	11	30.1	32.6	38.3	42.6	99	99	

Appendix F: Baseline Analog Test Data

Analog Baseline Testing, Test56.o25 (Sorted)		10/25/95																																							
Conditions: Vmon=4.3, Vps=+-7.5, paddle at 1 rpm																																									
1.2 us pulse, 1.5 ms period																																									
Test fixture A2 (With EMI protection) in West location, using West monitor bd.																																									
Source data Test56.o25																																									
Vbuff	4.5	4.5	4.5	4.5	4.5	5	5	5	5	5	5.5	5.5	5.5	5.5	5.5	6	6	6	6	6	6.5	6.5	6.5	6.5	6.5	6.5	6.5	6.5	6.5	6.5	6.5	6.5	6.5	6.5	6.5						
RF Pwr (Watts)	1000	500	250	125	63	1000	500	250	125	63	1000	500	250	125	63	1000	500	250	125	63	1000	500	250	125	63	1000	500	250	125	63	1000	500	250	125	63	1000	500	250	125	63	
1	62	23	11	0	0	26	19	8	0	0	76	28	16	10	10	35	11	19	11	9	53	13	11	10	10	10	10	10	10	10	10	10	10	10	10	10	10	10			
2	70	7	3	1	0	60	53	1	2	0	57	37	24	11	10	51	41	15	12	11	58	27	14	10	10	10	10	10	10	10	10	10	10	10	10	10	10	10	10		
3	61	39	14	6	0	62	25	18	0	0	81	21	10	13	10	36	41	15	12	9	81	20	13	10	10	10	10	10	10	10	10	10	10	10	10	10	10	10	10	10	
4	59	38	21	0	1	64	31	7	2	0	40	26	14	11	10	51	36	17	11	10	60	33	10	10	10	10	10	10	10	10	10	10	10	10	10	10	10	10	10	10	
5	65	26	16	0	0	60	35	11	1	0	69	44	16	10	10	59	46	23	13	10	61	35	14	10	10	10	10	10	10	10	10	10	10	10	10	10	10	10	10	10	
6	68	25	9	0	0	43	33	9	1	0	76	42	20	12	10	45	50	28	16	10	55	39	14	11	10	10	10	10	10	10	10	10	10	10	10	10	10	10	10	10	
7	55	18	2	0	0	48	23	11	1	0	52	28	17	14	10	59	30	20	11	9	62	28	18	11	10	10	10	10	10	10	10	10	10	10	10	10	10	10	10	10	
8	68	17	4	0	0	58	17	10	2	0	33	20	14	12	10	69	29	15	11	9	58	28	20	10	10	10	10	10	10	10	10	10	10	10	10	10	10	10	10	10	10
9	49	31	3	1	0	54	16	0	0	0	38	11	10	10	10	68	36	19	12	9	71	27	10	10	10	10	10	10	10	10	10	10	10	10	10	10	10	10	10	10	
10	58	16	4	3	0	40	19	2	0	0	39	13	10	10	10	46	30	17	11	9	56	30	16	10	10	10	10	10	10	10	10	10	10	10	10	10	10	10	10	10	
11	39	27	13	1	0	54	22	2	1	0	36	20	11	10	10	53	32	17	11	10	67	19	14	11	10	10	10	10	10	10	10	10	10	10	10	10	10	10	10	10	
12	50	21	23	0	0	56	37	2	0	0	46	31	12	10	10	26	18	14	11	9	61	21	15	10	10	10	10	10	10	10	10	10	10	10	10	10	10	10	10	10	10
13	35	20	16	1	0	63	37	14	0	0	47	34	20	10	10	41	38	19	12	10	43	22	12	10	10	10	10	10	10	10	10	10	10	10	10	10	10	10	10	10	10
14	55	33	13	4	0	58	24	12	0	0	63	43	23	10	10	44	36	22	14	10	55	31	11	10	10	10	10	10	10	10	10	10	10	10	10	10	10	10	10	10	10
15	54	19	11	2	0	70	18	17	1	0	56	39	16	13	10	66	21	12	11	10	59	37	16	11	10	10	10	10	10	10	10	10	10	10	10	10	10	10	10	10	10
16	29	53	12	0	0	47	18	12	0	0	37	36	14	14	10	62	21	12	11	10	60	22	13	10	10	10	10	10	10	10	10	10	10	10	10	10	10	10	10	10	10
17	71	30	4	5	0	66	33	9	0	0	56	29	16	11	10	68	28	17	11	11	36	61	13	12	10	10	10	10	10	10	10	10	10	10	10	10	10	10	10	10	10
18	63	40	18	14	0	70	12	18	1	0	56	19	18	11	10	55	30	14	11	10	62	31	17	11	10	10	10	10	10	10	10	10	10	10	10	10	10	10	10	10	10
19	65	49	22	1	1	40	30	2	3	0	42	23	22	10	10	73	19	11	11	10	63	28	18	10	10	10	10	10	10	10	10	10	10	10	10	10	10	10	10	10	10
20	64	38	18	1	0	39	39	12	1	0	62	26	27	12	10	69	35	14	11	10	63	35	16	11	10	10	10	10	10	10	10	10	10	10	10	10	10	10	10	10	10
21	50	21	6	0	0	38	37	15	1	0	65	26	16	13	10	62	37	19	12	10	61	23	18	11	10	10	10	10	10	10	10	10	10	10	10	10	10	10	10	10	10
22	51	19	3	0	0	39	22	16	4	0	70	28	11	10	10	81	36	19	13	11	54	25	13	10	10	10	10	10	10	10	10	10	10	10	10	10	10	10	10	10	10
23	63	17	0	0	0	43	16	5	9	0	41	14	15	10	10	65	34	20	16	11	54	15	13	10	10	10	10	10	10	10	10	10	10	10	10	10	10	10	10	10	10
24	56	20	2	0	0	54	5	9	5	0	49	24	12	11	10	53	22	12	11	10	57	28	11	10	10	10	10	10	10	10	10	10	10	10	10	10	10	10	10	10	10
25	46	23	3	2	0	63	6	0	0	0	32	26	18	10	10	50	29	17	12	11	49	25	10	10	10	10	10	10	10	10	10	10	10	10	10	10	10	10	10	10	10
26	65	46	8	3	0	63	14	1	0	0	41	20	15	10	10	63	31	15	11	9	50	19	11	10	10	10	10	10	10	10	10	10	10	10	10	10	10	10	10	10	10
27	62	34	12	1	0	43	26	0	0	0	46	37	16	10	10	57	23	17	12	11	45	40	12	10	10	10	10	10	10	10	10	10	10	10	10	10	10	10	10	10	10
28	74	29	13	2	0	30	33	2	0	0	67	44	23	11	10	69	27	12	11	11	56	31	14	11	10	10	10	10	10	10	10	10	10	10	10	10	10	10	10	10	10
29	68	18	6	1	0	58	34	10	0	0	65	19	11	12	10	57	28	12	11	11	70	25	17	10	10	10	10	10	10	10	10	10	10	10	10	10	10	10	10	10	10
30	82	28	18	0	0	50	28	18	0	0	73	21	12	10	10	64	30	17	11	11	38	21	14	10	10	10	10	10	10	10	10	10	10	10	10	10	10	10	10	10	10
31	54	43	17	9	0	18	41	13	3	0	44	29	16	10	10	70	37	16	13	11	74	22	13	11	10	10	10	10	10	10	10	10	10	10	10	10	10	10	10	10	10
32	69	11	17	9	0	48	43	10	3	0	75	25	12	11	10	42	27	13	12	11	46	33	12	12	10	10	10	10	10	10	10	10	10	10	10	10	10	10	10	10	10
33	76	25	21	1	0	59	24	14	0	0	63	16	10	10	10	53	41	25	13	11	64	26	22	12	9	10	10	10	10	10	10	10	10	10	10	10	10	10	10	10	10
34	62	44	22	1	0	67	41	8	1	0	71	29	16	10	10	53	25	17	12	11	68	36	14	10	10	10	10	10	10	10	10	10	10	10	10	10	10	10	10	10	10
35	43	36	9	3	0	41	46	22	0	0	40	30	14	10	10	59	30	18	12	10	48	43	15	13	10	10	10	10	10	10	10	10	10	10	10	10	10	10	10	10	10
36	38	29	15	0	0	52	31	22	2	0	64	35	16	10	10	39	39	19	12	11	35	49	17	11	10	10	10	10	10	10	10	10	10	10	10	10	10	10	10	10	10
37	50	26	16	1	0	25	23	8	11	0	28	34	17	13	10	41	29	19	13	11	36	23	23	14	10	10	10	10	10	10	10	10	10	10	10	10	10	10	10	10	10
38	49	6	17	0	0	38	34	5	0	0	50	22	12	15	10	64	26	16	11	10	54	26	15	10	10	10	10	10	10	10	10	10	10	10	10	10	10	10	10	10	10
39	57	21	9	3	0	44	34	15	0	0	63	32	14	10	10	64	13	12	11	10	49	11	11	10	10	10	10	10	10	10	10	10	10	10	10	10	10	10	10	10	10
40	67	11	2	4	0	68	27	8	0	0	28	33	13	11	10	63	29	13	11	11																					

Appendix G: Baseline Analog Test Data - Upset Data Files vs. Upsets

RF pwr	1000			500			250			125			63		
frequency	800			800			800			800			800		
Antenna Gain	24			24			24			24			24		
In-line Attenuation	30			30			30			20			20		
test period	upsets	power (mw)	E Field Strength	upsets	power (mw)	E Field Strength	upsets	power (mw)	E Field Strength	upsets	power (mw)	E Field Strength	upsets	power (mw)	E Field Strength
1	39	2	158.49	34	0.7	93.76	7	0.7	93.76	9	2	50.12	2	2	50.12
2	38	2	158.49	42	1.3	127.78	22	1.5	137.26	14	2.2	52.56	3	1.5	43.40
3	36	3.2	200.47	43	1.5	137.26	22	1.5	137.26	22	2	50.12	3	0.7	29.65
4	33	4	224.14	37	2	158.49	21	1	112.07	17	2.2	52.56	6	1	35.44
5	36	8	316.98	24	1.3	127.78	22	0.25	56.03	17	2	50.12	4	1.5	43.40
6	43	2	158.49	26	1.5	137.26	24	0.6	86.81	10	1	35.44	3	0.8	31.70
7	35	3.6	212.64	25	0.7	93.76	14	1.3	127.78	7	2	50.12	2	0.4	22.41
8	31	8	316.98	27	2	158.49	9	2	158.49	2	4	70.88	2	0.4	22.41
9	44	9	336.21	29	1	112.07	29	3	194.11	3	1.5	43.40	2	0.6	27.45
10	57	0.5	79.24	36	0.5	79.24	36	1.5	137.26	10	0.8	31.70	5	0.6	27.45
11	51	2	158.49	35	0.3	61.38	32	0.25	56.03	17	1	35.44	6	0.4	22.41
12	37	1	112.07	34	0.2	50.12	25	0.5	79.24	13	1.5	43.40	2	0.5	25.06
13	38	1.2	122.77	42	0.2	50.12	9	0.7	93.76	11	0.5	25.06	2	1	35.44
14	38	1.2	122.77	54	0.5	79.24	19	0.1	35.44	16	4.5	75.18	2	2	50.12
15	38	1.8	150.36	59	3	194.11	23	0.2	50.12	15	8	100.24	2	4	70.88
16	35	2	158.49	51	4	224.14	28	1	112.07	16	5	79.24	2	4	70.88
17	43	2.2	166.23	46	1.6	141.76	23	0.7	93.76	10	1.5	43.40	2	1.5	43.40
18	49	1.5	137.26	29	0.6	86.81	22	0.4	70.88	3	2	50.12	2	0.2	15.85
19	43	4	224.14	17	0.3	61.38	16	1.3	127.78	2	2	50.12	2	1	35.44
20	53	6	274.51	15	0.3	61.38	20	1.5	137.26	2	3	61.38	2	2	50.12
21	43	5.8	269.90	23	0.3	61.38	21	1.5	137.26	2	2	50.12	2	1	35.44
22	48	4	224.14	18	0.6	86.81	23	1	112.07	2	1.2	38.82	3	1	35.44
23	47	3.5	209.66	18	0.2	50.12	18	1	112.07	3	0.5	25.06	3	0.2	15.85
24	41	2.5	177.20	19	0.9	106.32	15	1.1	117.54	2	2	50.12	2	0.2	15.85
25	42	2	158.49	26	0.4	70.88	16	0.6	86.81	4	1.4	41.93	2	0.3	19.41
26	53	2.5	177.20	47	0.4	70.88	24	0.5	79.24	3	1	35.44	2	0.3	19.41
27	44	4	224.14	42	0.4	70.88	17	1.8	150.36	6	1	35.44	2	0.2	15.85
28	31	9	336.21	32	1.5	137.26	4	2.5	177.20	9	2	50.12	2	0.2	15.85
29	23	7	296.51	36	1.8	150.36	2	2	158.49	7	2.5	56.03	2	0.5	25.06
30	29	4	224.14	33	0.8	100.24	5	1	112.07	6	3	61.38	2	0.4	22.41
31	51	2	158.49	26	1.8	150.36	23	0.6	86.81	7	3.5	66.30	2	0.5	25.06
32	52	0.5	79.24	25	0.8	100.24	26	0.5	79.24	3	1	35.44	2	0.5	25.06
33	45	2.5	177.20	31	0.4	70.88	4	0.8	100.24	5	1	35.44	2	0.3	19.41
34	24	3.5	209.66	33	0.5	79.24	8	0.8	100.24	7	1	35.44	2	0.3	19.41
35	39	2	158.49	31	0.4	70.88	17	0.4	70.88	5	1.5	43.40	2	0.8	31.70
36	48	1	112.07	27	0.4	70.88	21	0.4	70.88	6	1.5	43.40	2	1.3	40.41
37	37	0.5	79.24	30	0.3	61.38	18	0.15	43.40	7	1	35.44	2	1	35.44
38	44	0.5	79.24	33	1.6	141.76	19	0.1	35.44	8	0.8	31.70	4	1.8	47.55
39	57	0.6	86.81	30	3	194.11	35	0.8	100.24	12	6	86.81	6	0.4	22.41
40	61	3.5	209.66	28	1.5	137.26	29	1	112.07	10	4.5	75.18	6	0.2	15.85
41	52	7	296.51	30	0.6	86.81	22	2.5	177.20	7	5	79.24	2	0.2	15.85
42	52	7	296.51	37	2.5	177.20	30	2	158.49	6	2	50.12	2	0.3	19.41
43	47	4	224.14	44	1	112.07	16	1.2	122.77	10	2	50.12	2	1	35.44
44	37	2.5	177.20	40	0.3	61.38	19	0.5	79.24	10	0.9	33.62	2	1	35.44
45	39	2	158.49	36	0.4	70.88	21	0.6	86.81	6	0.8	31.70	2	1	35.44
46	40	2	158.49	35	0.6	86.81	27	1	112.07	8	1.4	41.93	5	1	35.44
47	46	3.5	209.66	23	1	112.07	32	1.3	127.78	9	1	35.44	6	2	50.12
48	52	2.5	177.20	16	1	112.07	26	0.5	79.24	2	2	50.12	2	2	50.12
49	18	1.5	137.26	27	2.8	187.53	26	0.3	61.38	5	5	79.24	2	2	50.12
50	57	1.5	137.26	27	3.8	218.46	25	0.3	61.38	3	8	100.24	4	2.5	56.03
51	18	0.5	79.24	30	3.5	209.66	30	0.3	61.38	4	7	93.76	4	2	50.12
52	67	0.2	50.12	36	2	158.49	33	0.2	50.12	14	5	79.24	2	2	50.12
53	63	0.5	79.24	46	3	194.11	20	0.5	79.24	19	8	100.24	2	1	35.44
54	19	1	112.07	40	4	224.14	16	0.5	79.24	14	12	122.77	2	1	35.44
55	11	1	112.07	34	7	296.51	21	0.5	79.24	8	19	154.48	2	3	61.38
56	48	1.5	137.26	34	7.5	306.91	27	0.2	50.12	4	17	146.12	2	4.5	75.18
57	57	1	112.07	22	7	296.51	19	0.1	35.44	2	13	127.78	2	3.5	66.30
58	43	1	112.07	18	3.6	212.64	15	0.2	50.12	2	8	100.24	2	4	70.88
59	36	1	112.07	26	3.8	218.46	15	0.4	70.88	2	9	106.32	2	3.5	66.30
60	33	1.5	137.26	29	4	224.14	13	1	112.07	2	10	112.07	2	1.5	43.40
61	40	5	250.59	17	4	224.14	21	1	112.07	2	9	106.32	2	1	35.44
62	51	6	274.51	6	4	224.14	27	1.2	122.77	2	9	106.32	2	3	61.38
63	42	2	158.49	20	6	274.51	25	0.4	70.88	2	18	150.36	2	5	79.24



Appendix G: Baseline Analog Test Data - Upset Data Files vs. Upsets

RF pwr	1000			500			250			125			63		
frequency	800			800			800			800			800		
Antenna Gain	24			24			24			24			24		
In-line Attenuation	30			30			30			20			20		
test	upsets	power	E Field	upsets	power	E Field	upsets	power	E Field	upsets	power	E Field	upsets	power	E Field
period		(mw)	Strength		(mw)	Strength		(mw)	Strength		(mw)	Strength		(mw)	Strength
64	35	1	112.07	30	7	296.51	13	0.1	35.44	3	21	162.40	2	4	70.88
65	34	1.5	137.26	38	4	224.14	17	1.3	127.78	2	9	106.32	11	3	61.38
66	39	5	250.59	44	1.8	150.36	23	1.5	137.26	5	6	86.81	11	1.5	43.40
67	43	4	224.14	32	1	112.07	20	0.7	93.76	4	3	61.38	2	0.7	29.65
68	44	2	158.49	39	2	158.49	6	0.5	79.24	9	4	70.88	2	0.3	19.41
69	36	1	112.07	45	3	194.11	20	0.3	61.38	7	6.5	90.35	2	0.8	31.70
70	42	1	112.07	44	2	158.49	24	0.3	61.38	6	2	50.12	2	1.5	43.40
71	40	1.5	137.26	43	4.5	237.73	20	0.5	79.24	12	9	106.32	2	1.5	43.40
72	33	1	112.07	51	2.5	177.20	4	0.3	61.38	20	12	122.77	2	4.5	75.18
73	29	3	194.11	60	1	112.07	4	0.2	50.12	22	0.4	22.41	2	4	70.88
74	33	1	112.07	53	0.3	61.38	2	0.3	61.38	23	1	35.44	4	2	50.12
75	35	2	158.49	55	0.5	79.24	9	0.3	61.38	25	2	50.12	8	1	35.44
76	35	2	158.49	43	1	112.07	17	0.7	93.76	10	5	79.24	7	1.5	43.40
77	44	4	224.14	24	3.5	209.66	26	1.3	127.78	2	7	93.76	5	2	50.12
78	41	2	158.49	26	2.5	177.20	15	0.5	79.24	4	6	86.81	2	1	35.44
79	37	0.5	79.24	26	2	158.49	20	0.2	50.12	5	4	70.88	2	1	35.44
80	56	0.5	79.24	23	2	158.49	26	0.2	50.12	14	6	86.81	2	1	35.44
81	60	1	112.07	28	6	274.51	32	0.4	70.88	4	12	122.77	2	1	35.44
82	54	1	112.07	16	5	250.59	22	0.6	86.81	3	9	106.32	2	1	35.44
83	47	1.5	137.26	20	3	194.11	14	0.6	86.81	5	5	79.24	2	2	50.12
84	36	2	158.49	37	1.5	137.26	7	0.5	79.24	14	5	79.24	4	1	35.44
85	35	3.5	209.66	36	0.6	86.81	11	1.5	137.26	9	4.5	75.18	4	2	50.12
86	36	4	224.14	31	0.1	35.44	11	1.4	132.60	12	0.4	22.41	5	1.5	43.40
87	54	6	274.51	36	3.8	218.46	20	1	112.07	15	9	106.32	5	0.5	25.06
88	53	3	194.11	12	3.5	209.66	31	0.4	70.88	2	8	100.24	3	0.3	19.41
89	56	1.5	137.26	28	3.5	209.66	22	0.2	50.12	11	7	93.76	2	1	35.44
90	47	2	158.49	41	2	158.49	12	0.2	50.12	13	4	70.88	2	2	50.12
91	42	2	158.49	32	2	158.49	14	0.3	61.38	5	7	93.76	2	1	35.44
92	37	2.5	177.20	27	4.2	229.67	16	0.6	86.81	12	10	112.07	2	0.5	25.06
93	36	2	158.49	29	4	224.14	15	0.6	86.81	17	7	93.76	4	0.7	29.65
94	45	1	112.07	23	2.5	177.20	27	0.3	61.38	15	6	86.81	3	1.6	44.83
95	37	1	112.07	31	2.5	177.20	24	0.2	50.12	11	5	79.24	2	2	50.12
96	49	4	224.14	27	3	194.11	17	1.3	127.78	4	6	86.81	2	4	70.88
97	49	3	194.11	12	1.3	127.78	15	1.5	137.26	2	1.6	44.83	2	2	50.12
98	46	2	158.49	27	0.3	61.38	14	1	112.07	5	1	35.44	2	1.5	43.40
99	44	3.5	209.66	43	0.7	93.76	14	0.8	100.24	10	4	70.88	2	1.5	43.40
100	39	1.5	137.26	36	1.5	137.26	18	0.3	61.38	12	6	86.81	2	0.4	22.41
101	51	1	112.07	27	4	224.14	29	0.3	61.38	6	10	112.07	5	0.4	22.41
102	49	1	112.07	15	3.5	209.66	23	0.4	70.88	4	8	100.24	3	0.3	19.41
103	39	1	112.07	36	3	194.11	17	0.4	70.88	11	5	79.24	2	0.5	25.06
104	46	2	158.49	46	2.5	177.20	27	0.6	86.81	23	5	79.24	6	1	35.44
105	49	3	194.11	49	2	158.49	27	0.8	100.24	26	5.5	83.11	3	2.5	56.03
106	52	3.5	209.66	45	2	158.49	25	1	112.07	29	4.5	75.18	2	2	50.12
107	63	3	194.11	42	2	158.49	28	0.7	93.76	22	6	86.81	2	0.3	19.41
108	65	4	224.14	36	2	158.49	28	1.4	132.60	9	5	79.24	2	0.8	31.70
109	52	7	296.51	23	1	112.07	22	2.5	177.20	7	3	61.38	2	0.5	25.06
110	51	8	316.98	26	0.3	61.38	16	2	158.49	8	1	35.44	2	0.7	29.65
111	48	6	274.51	19	0.2	50.12	19	1	112.07	2	2	50.12	3	1	35.44
112	51	2	158.49	24	0.1	35.44	18	0.5	79.24	2	2	50.12	3	1	35.44
113	48	1	112.07	35	0.2	50.12	17	0.3	61.38	3	1	35.44	2	1	35.44
114	48	0.5	79.24	37	1.3	127.78	14	0.1	35.44	3	4	70.88	2	1.5	43.40
115	51	0.5	79.24	32	1.8	150.36	18	0.2	50.12	3	2	50.12	3	2	50.12
116	47	2	158.49	26	2	158.49	22	0.7	93.76	4	3	61.38	3	1.5	43.40
117	48	4	224.14	39	1.8	150.36	20	0.7	93.76	13	2	50.12	3	0.6	27.45
118	43	6	274.51	33	1.5	137.26	13	1.2	122.77	12	6	86.81	2	1	35.44
119	43	8	316.98	25	3	194.11	6	2	158.49	10	8	100.24	5	1	35.44
120	39	6	274.51	33	3	194.11	9	1.5	137.26	7	6.5	90.35	3	3	61.38
121	38	2	158.49	37	1.5	137.26	9	0.2	50.12	6	1.5	43.40	2	3	61.38
122	46	2	158.49	32	0.5	79.24	11	0.7	93.76	3	0.5	25.06	2	2	50.12
123	44	5	250.59	31	0.8	100.24	9	1.5	137.26	3	4	70.88	2	0.5	25.06
124	36	6	274.51	36	4	224.14	14	1.5	137.26	2	8	100.24	2	0.5	25.06
125	48	4	224.14	34	2.4	173.62	23	1	112.07	3	5	79.24	2	0.7	29.65
126	51	4	224.14	44	1.2	122.77	23	1.1	117.54	12	2.5	56.03	3	0.8	31.70

Appendix G: Baseline Analog Test Data - Upset Data Files vs. Upsets

RF pwr	1000			500			250			125			63		
frequency	800			800			800			800			800		
Antenna Gain	24			24			24			24			24		
In-line Attenuation	30			30			30			20			20		
test	upsets	power	E Field	upsets	power	E Field	upsets	power	E Field	upsets	power	E Field	upsets	power	E Field
period		(mw)	Strength		(mw)	Strength		(mw)	Strength		(mw)	Strength		(mw)	Strength
127	58	3	194.11	34	1.5	137.26	26	0.6	86.81	13	3	61.38	5	1.5	43.40
128	64	2	158.49	39	2	158.49	23	0.2	50.12	15	5	79.24	9	0.8	31.70
129	58	1	112.07	43	1.2	122.77	30	0.5	79.24	23	3.5	66.30	11	0.8	31.70
130	60	1.5	137.26	44	2	158.49	31	0.5	79.24	16	5	79.24	5	0.3	19.41
131	51	2	158.49	39	1.5	137.26	30	0.7	93.76	10	3	61.38	3	0.5	25.06
132	52	3	194.11	32	0.4	70.88	27	0.9	106.32	2	1.5	43.40	5	0.7	29.65
133	52	2	158.49	16	0.5	79.24	14	0.6	86.81	2	2	50.12	2	0.7	29.65
134	30	2	158.49	40	1.5	137.26	8	0.6	86.81	2	5	79.24	4	1	35.44
135	47	2	158.49	40	2	158.49	19	0.4	70.88	5	6	86.81	4	2	50.12
136	55	2	158.49	35	2.8	187.53	28	0.7	93.76	3	6	86.81	2	2	50.12
137	51	1.5	137.26	25	3	194.11	21	0.7	93.76	2	7	93.76	2	1.5	43.40
138	45	2	158.49	22	1.8	150.36	11	0.7	93.76	2	5	79.24	2	2	50.12
139	44	1.5	137.26	20	1.5	137.26	7	0.4	70.88	2	5	79.24	2	2.5	56.03
140	35	0.5	79.24	26	1.5	137.26	6	0.1	35.44	3	5	79.24	3	4	70.88
141	38	0.3	61.38	25	0.6	86.81	18	0.1	35.44	2	4	70.88	2	5	79.24
142	53	0.4	70.88	19	1	112.07	32	0.1	35.44	2	5	79.24	2	3.5	66.30
143	55	2	158.49	20	2	158.49	22	0.3	61.38	4	6	86.81	2	0.3	19.41
144	45	1	112.07	20	2.5	177.20	30	0.6	86.81	7	6	86.81	2	0.5	25.06
145	43	1	112.07	31	2.8	187.53	23	0.7	93.76	15	7	93.76	2	0.2	15.85
146	43	2	158.49	36	2.2	166.23	23	0.5	79.24	22	6	86.81	2	0.3	19.41
147	42	1	112.07	41	1.2	122.77	30	0.3	61.38	22	2.5	56.03	2	1	35.44
148	40	1	112.07	37	0.9	106.32	27	0.2	50.12	12	1.8	47.55	2	2	50.12
149	44	0.4	70.88	27	0.8	100.24	20	0.1	35.44	2	2	50.12	2	1.5	43.40
150	40	0.4	70.88	31	0.2	50.12	12	0.2	50.12	6	1.5	43.40	2	0.3	19.41
151	39	0.6	86.81	29	1	112.07	19	0.3	61.38	8	1.8	47.55	2	1	35.44
152	44	0.5	79.24	32	0.7	93.76	22	0.1	35.44	8	3	61.38	2	4	70.88
153	50	0.5	79.24	36	1.2	122.77	19	0.1	35.44	7	2.5	56.03	2	6	86.81
154	40	0.3	61.38	38	2	158.49	17	0.1	35.44	8	6	86.81	2	6.5	90.35
155	54	0.5	79.24	35	3.5	209.66	21	0.2	50.12	14	13	127.78	3	5	79.24
156	53	0.5	79.24	35	6	274.51	14	0.3	61.38	19	13	127.78	3	2	50.12
157	44	0.8	100.24	34	2.5	177.20	11	0.3	61.38	19	7	93.76	2	1	35.44
158	43	0.5	79.24	30	1.2	122.77	18	0.1	35.44	5	1	35.44	2	1	35.44
159	44	0.5	79.24	18	0.4	70.88	23	0.2	50.12	6	1	35.44	2	2	50.12
160	35	0.4	70.88	31	0.2	50.12	22	0.6	86.81	7	1.5	43.40	2	2	50.12
161	28	2	158.49	40	0.3	61.38	6	1.5	137.26	17	0.8	31.70	2	2.5	56.03
162	45	5	250.59	38	0.2	50.12	11	1	112.07	13	0.7	29.65	2	3	61.38
163	38	2	158.49	30	0.2	50.12	12	0.7	93.76	2	1	35.44	2	3	61.38
164	43	1	112.07	20	0.4	70.88	24	0.3	61.38	2	1	35.44	2	0.5	25.06
165	48	3	194.11	19	1	112.07	29	0.5	79.24	2	3	61.38	4	1	35.44
166	44	5	250.59	26	0.7	93.76	16	1.3	127.78	3	1.5	43.40	4	2.5	56.03
167	33	4	224.14	29	0.2	50.12	3	1.2	122.77	13	0.5	25.06	4	0.5	25.06
168	19	2	158.49	29	0.2	50.12	2	1	112.07	16	1	35.44	3	0.5	25.06
169	36	2	158.49	43	0.4	70.88	10	0.5	79.24	17	3.5	66.30	2	0.1	11.21
170	47	0.5	79.24	36	2.5	177.20	31	0.2	50.12	15	6	86.81	2	0.1	11.21
171	66	0.5	79.24	30	4	224.14	37	0.1	35.44	12	10	112.07	7	0.1	11.21
172	59	1	112.07	38	5	250.59	33	0.2	50.12	9	14	132.60	10	1.5	43.40
173	56	0.5	79.24	25	5	250.59	34	0.1	35.44	13	12	122.77	3	6.5	90.35
174	44	1	112.07	28	5	250.59	16	0.4	70.88	7	13	127.78	2	4	70.88
175	44	1	112.07	27	4.5	237.73	24	0.3	61.38	5	12	122.77	2	2	50.12
176	48	1.5	137.26	28	3.5	209.66	27	0.5	79.24	4	8	100.24	2	1	35.44
177	33	2.5	177.20	25	3	194.11	21	0.6	86.81	4	3	61.38	2	0.7	29.65
178	49	2.5	177.20	36	0.4	70.88	28	0.6	86.81	11	0.6	27.45	2	1.5	43.40
179	47	1.5	137.26	41	0.2	50.12	23	0.2	50.12	7	0.8	31.70	2	2.4	54.90
180	36	1.5	137.26	36	0.4	70.88	16	0.5	79.24	5	1	35.44	2	2.6	57.14
181	36	2.5	177.20	39	0.7	93.76	7	1.5	137.26	8	2	50.12	2	2	50.12
ave	63.75	3.02	161.92	46.40	2.52	141.75	31.03	1.31	87.77	18.73	5.13	70.17	12.42	2.02	40.38
max	1000	30	336.21	800.0	30.00	306.91	800	30	194.11	800.0	24.00	162.40	800.0	24.00	90.35
min	11	0.2	50.12	6.00	0.10	35.44	2	0.1	35.44	2.00	0.40	22.41	2.00	0.10	11.21
mean	44	2	158.49	32	1.5	137.26	20	0.6	86.81	7	4	70.87858	2	1	35.44
RF pwr	1000	1000	1000	500	500	500	250	250	250	125	125	125	63	63	63
frequency	800	800	800	800	800	800	800	800	800	800	800	800	800	800	800
	upsets	power	E Field	upsets	power	E Field	upsets	power	E Field	upsets	power	E Field	upsets	power	E Field
		(mw)	Strength		(mw)	Strength		(mw)	Strength		(mw)	Strength		(mw)	Strength

Appendix G: Baseline Analog Test Data - Upset Data Files vs. Upsets

RF pwr	1000				500				250				125				63			
frequenc	1400				1400				1400				1400				1400			
Antenna Gain	30				30				30				30				30			
In-line Atten.	30				20				20				20				20			
test	upsets	power	E Field	upsets	power	E Field	upsets	power	E Field	upsets	power	E Field	upsets	power	E Field					
period	(mw)	Strength		(mw)	Strength		(mw)	Strength		(mw)	Strength		(mw)	Strength						
1	18	1	223.61	3	10	223.61	2	4.5	150.00	2	1.4	83.67	2	0.2	31.62					
2	34	1	223.61	3	7	187.08	3	4	141.42	2	0.7	59.16	2	0.3	38.73					
3	36	1	223.61	4	5	158.11	2	3	122.47	2	0.5	50.00	2	0.8	63.25					
4	36	0.8	200.00	9	9	212.13	3	2	100.00	2	1.3	80.62	2	1.4	83.67					
5	27	0.6	173.21	4	3	122.47	4	2	100.00	2	1.2	77.46	2	1	70.71					
6	27	0.4	141.42	10	7	187.08	3	1	70.71	2	0.6	54.77	2	0.2	31.62					
7	22	0.8	200.00	3	8	200.00	3	1	70.71	2	0.5	50.00	2	0.4	44.72					
8	32	0.8	200.00	15	5	158.11	2	3	122.47	2	1.5	86.60	2	0.7	59.16					
9	26	1.5	273.86	10	3	122.47	2	8	200.00	2	3	122.47	2	0.2	31.62					
10	13	4	447.21	6	7	187.08	2	14	264.58	2	2	100.00	2	0.2	31.62					
11	29	3.5	418.33	3	17	291.55	3	10	223.61	2	0.5	50.00	2	0.4	44.72					
12	34	2	316.23	5	6	173.21	2	6	173.21	2	0.4	44.72	2	0.6	54.77					
13	28	2	316.23	3	3	122.47	2	5	158.11	2	1	70.71	2	0.3	38.73					
14	15	1	223.61	4	0.8	63.25	2	2	-100.00	2	2.5	111.80	2	0.3	38.73					
15	16	1	223.61	6	0.8	63.25	2	4	141.42	2	1	70.71	2	0.3	38.73					
16	13	0.6	173.21	7	1.5	86.60	4	1	70.71	2	1.8	94.87	2	0.3	38.73					
17	29	4	447.21	14	2.5	111.80	5	11	234.52	2	0.9	67.08	2	0.5	50.00					
18	25	3.5	418.33	19	5	158.11	6	10	223.61	2	0.8	63.25	2	0.1	22.36					
19	23	2	316.23	19	12	244.95	5	5	158.11	2	0.5	50.00	2	0.5	50.00					
20	22	2	316.23	7	18	300.00	3	5	158.11	2	0.3	38.73	2	2	100.00					
21	13	1.5	273.86	7	22	331.66	2	3	122.47	2	0.2	31.62	2	2	100.00					
22	15	1	223.61	6	10	223.61	2	5	158.11	2	0.5	50.00	2	0.3	38.73					
23	19	0.8	200.00	10	10	223.61	5	3	122.47	2	1.2	77.46	2	0.1	22.36					
24	21	0.5	158.11	5	7	187.08	2	1.5	86.60	2	0.8	63.25	2	0.2	31.62					
25	31	0.8	200.00	8	6	173.21	4	1.5	86.60	2	0.3	38.73	2	0.5	50.00					
26	27	0.3	122.47	8	20	316.23	5	2	100.00	2	0.3	38.73	2	0.3	38.73					
27	14	0.2	100.00	12	7	187.08	2	0.5	50.00	2	0.2	31.62	2	0.2	31.62					
28	19	0.2	100.00	11	10	223.61	2	0.5	50.00	2	0.4	44.72	2	0.3	38.73					
29	22	1	223.61	6	11	234.52	2	1.5	86.60	2	1.6	89.44	2	0.4	44.72					
30	31	1	223.61	10	6	173.21	3	3	122.47	2	0.8	63.25	2	0.2	31.62					
31	24	1	223.61	6	2	100.00	2	2	100.00	2	2	100.00	2	0.5	50.00					
32	20	1.5	273.86	5	3	122.47	2	5	158.11	2	1.2	77.46	2	0.1	22.36					
33	27	1.5	273.86	8	1	70.71	2	5	158.11	2	0.4	44.72	2	0.3	38.73					
34	24	1	223.61	17	0.8	63.25	6	2.5	111.80	2	2	100.00	2	0.2	31.62					
35	25	1	223.61	5	2	100.00	5	2	100.00	2	1.6	89.44	2	0.3	38.73					
36	11	4	447.21	7	1.2	77.46	2	8	200.00	2	0.6	54.77	2	0.6	54.77					
37	15	4	447.21	5	4	141.42	5	0.5	50.00	2	0.2	31.62	2	0.3	38.73					
38	22	0.5	158.11	6	1.5	86.60	2	1	70.71	2	0.5	50.00	2	0.5	50.00					
39	40	1.5	273.86	2	2	100.00	7	1.5	86.60	2	4	141.42	2	0.7	59.16					
40	38	0.3	122.47	3	5	158.11	5	1	70.71	2	3.5	132.29	2	1	70.71					
41	31	0.6	173.21	6	7	187.08	4	2	100.00	2	0.9	67.08	2	1	70.71					
42	35	1.5	273.86	10	2.5	111.80	3	4	141.42	2	1.8	94.87	2	1.2	77.46					
43	16	2	316.23	8	3	122.47	2	6	173.21	2	1	70.71	2	0.2	31.62					
44	24	1	223.61	11	12	244.95	3	4	141.42	2	0.4	44.72	2	0.6	54.77					
45	33	1	223.61	8	6	173.21	5	2.5	111.80	2	2	100.00	2	0.5	50.00					
46	40	1.4	264.58	10	5	158.11	8	3	122.47	2	2.5	111.80	2	0.7	59.16					
47	62	0.5	158.11	4	10	223.61	7	1.5	86.60	2	4	141.42	2	1	70.71					
48	29	0.2	100.00	10	8	200.00	2	1.5	86.60	2	3.5	132.29	2	0.7	59.16					
49	16	1.5	273.86	4	2	100.00	2	0.3	38.73	2	2.4	109.54	2	0.8	63.25					
50	18	0.5	158.11	6	1	70.71	2	0.2	31.62											
51	16	0.2	100.00	6	3.5	132.29	2	6	173.21											
52	23	0.3	122.47	14	2.5	111.80	3	5	158.11											
53	22	0.5	158.11	12	3	122.47	2	0.8	63.25											
54	28	1.5	273.86	10	2	100.00	7	4	141.42											
55	44	0.5	158.11	6	4	141.42	4	1	70.71											
56	29	0.4	141.42	21	7	187.08	3	0.5	50.00											
57	32	0.8	200.00	24	1.5	86.60	2	2	100.00											
58	43	0.6	173.21	15	3	122.47	4	2	100.00											
59	33	0.1	70.71	5	3	122.47	2	0.4	44.72											
60	30	0.2	100.00	5	9	212.13	3	0.3	38.73											
61	27	0.3	122.47	7	5	158.11	3	0.7	59.16											
62	28	0.5	158.11	13	1	70.71	3	2	100.00											
63	24	1	223.61	9	2	100.00	2	2	100.00											

Appendix G: Baseline Analog Test Data - Upset Data Files vs. Upsets

RF pwr	1000			500			250			125			63		
frequenc	1400			1400			1400			1400			1400		
Antenna Gain	30			30			30			30			30		
In-line Atten.	30			20			20			20			20		
test period	upsets	power	E Field	upsets	power	E Field	upsets	power	E Field	upsets	power	E Field	upsets	power	E Field
		(mw)	Strength		(mw)	Strength		(mw)	Strength		(mw)	Strength		(mw)	Strength
64	28	2.5	353.55	4	6	173.21	2	3	122.47						
65	25	2	316.23	3	2	100.00	3	6	173.21						
66	19	0.5	158.11	4	3	122.47	5	1	70.71						
67	23	0.4	141.42	5	4	141.42	2	1.5	86.60						
68	14	0.4	141.42	4	2	100.00	2	0.5	50.00						
69	26	0.2	100.00	2	6	173.21	2	1	70.71						
70	25	1.2	244.95	4	3	122.47	2	6	173.21						
71	22	3.2	400.00	8	5	158.11	3	5	158.11						
72	24	0.6	173.21	9	3	122.47	4	3	122.47						
73	32	0.6	173.21	18	5	158.11	4	2	100.00						
74	31	0.2	100.00	7	3	122.47	3	2.5	111.80						
75	31	0.2	100.00	8	2	100.00	2	0.5	50.00						
76	25	0.7	187.08	15	1	70.71	2	2	100.00						
77	19	0.4	141.42	11	7	187.08	2	4	141.42						
78	22	1	223.61	3	18	300.00	3	5	158.11						
79	16	3	387.30	5	23	339.12	2	8	200.00						
80	21	0.5	158.11	7	15	273.86	2	1.5	86.60						
81	32	1	223.61	3	25	353.55	2	3	122.47						
82	28	2	316.23	2	18	300.00	2	7	187.08						
83	30	2.5	353.55	10	2	100.00	2	4	141.42						
84	37	1.5	273.86	19	4	141.42	4	4	141.42						
85	35	1	223.61	21	4	141.42	2	3	122.47						
86	7	0.5	158.11	25	0.9	67.08	2	3	122.47						
87	11	0.8	200.00	19	7	187.08	2	2	100.00						
88	22	1	223.61	12	6	173.21	4	3	122.47						
89	36	1.8	300.00	10	3	122.47	3	4	141.42						
90	40	1	223.61	12	4	141.42	3	5	158.11						
91	24	1.5	273.86	8	13	254.95	2	5	158.11						
92	38	1	223.61	11	10	223.61	4	1.5	86.60						
93	39	1	223.61	3	8	200.00	6	4	141.42						
94	31	2.5	353.55	9	5	158.11	3	6	173.21						
95	40	1	223.61	9	1	70.71	2	3	122.47						
96	33	1.5	273.86	2	2	100.00	5	4	141.42						
97	17	1.5	273.86	7	0.5	50.00	2	1.5	86.60						
98	18	0.8	200.00	11	1	70.71	2	2	100.00						
99	19	0.4	141.42	9	7	187.08	2	2	100.00						
100	31	2	316.23	6	18	300.00	2	4	141.42						
101	20	1.3	254.95	6	7	187.08	2	3	122.47						
102	20	0.5	158.11	5	4	141.42	2	1.5	86.60						
103	16	1.5	273.86	3	5	158.11	2	5	158.11						
104	23	1.5	273.86	6	8	200.00	2	4	141.42						
105	30	1.5	273.86	4	10	223.61	2	3	122.47						
106	28	0.5	158.11	4	6	173.21	2	1	70.71						
107	29	0.5	158.11	9	4	141.42	3	1	70.71						
108	16	1	223.61	11	3	122.47	2	3	122.47						
109	22	1.5	273.86	5	3	122.47	2	4	141.42						
110	28	3	387.30	15	1	70.71	4	9	212.13						
111	23	1.5	273.86	10	1.5	86.60	4	4	141.42						
112	31	0.6	173.21	5	2.5	111.80	5	2	100.00						
113	24	1.5	273.86	8	3	122.47	5	5	158.11						
114	25	1.5	273.86	9	6	173.21	3	1.5	86.60						
115	16	0.2	100.00	11	5	158.11	2	1	70.71						
116	15	1	223.61	12	1.5	86.60	3	2	100.00						
117	23	0.1	70.71	7	3	122.47	2	2	100.00						
118	13	0.7	187.08	3	5	158.11	2	1	70.71						
119	25	0.3	122.47	7	3	122.47	2	0.5	50.00						
120	29	0.5	158.11	11	2.5	111.80	6	1.5	86.60						
121	21	0.2	100.00	11	2.5	111.80	5	2	100.00						
122	24	0.4	141.42	5	3	122.47	3	1	70.71						
123	24	0.8	200.00	5	5	158.11	3	2	100.00						
124	25	1	223.61	4	0.8	63.25	3	8	200.00						
125	31	3.5	418.33	3	0.5	50.00	6	6	173.21						
126	34	1	223.61	4	1.8	94.87	3	5	158.11						

Appendix G: Baseline Analog Test Data - Upset Data Files vs. Upsets

RF pwr	1000			500			250			125			63		
frequenc	1400			1400			1400			1400			1400		
Antenna Gain	30			30			30			30			30		
In-line Atten.	30			20			20			20			20		
test period	upsets	power (mw)	E Field Strength	upsets	power (mw)	E Field Strength	upsets	power (mw)	E Field Strength	upsets	power (mw)	E Field Strength	upsets	power (mw)	E Field Strength
127	40	1.5	273.86	8	2.5	111.80	6	2	100.00						
128	34	0.5	158.11	5	2	100.00	5	2	100.00						
129	35	0.4	141.42	9	1.9	97.47	6	2	100.00						
130	26	1.3	254.95	6	1	70.71	4	4	141.42						
131	25	1	223.61	2	0.7	59.16	2	2	100.00						
132	32	0.5	158.11	2	5	158.11	4	2	100.00						
133	31	0.4	141.42	2	6	173.21	2	1.5	86.60						
134	40	0.5	158.11	4	1.5	86.60	10	5	158.11						
135	37	2	316.23	7	1.5	86.60	4	8	200.00						
136	28	4	447.21	7	4.5	150.00	5	10	223.61						
137	28	0.5	158.11	9	5	158.11	2	3	122.47						
138	37	0.4	141.42	10	3	122.47	2	1	70.71						
139	28	1	223.61	12	2	100.00	2	3	122.47						
140	26	2	316.23	7	6	173.21	2	6	173.21						
141	34	0.3	122.47	2	9	212.13	5	2.5	111.80						
142	22	0.4	141.42	4	12	244.95	5	1.5	86.60						
143	15	0.5	158.11	8	4	141.42	3	2	100.00						
144	20	1	223.61	6	3	122.47	2	2	100.00						
145	26	1.5	273.86	12	5	158.11	2	4	141.42						
146	42	0.5	158.11	12	10	223.61	5	2	100.00						
147	46	0.6	173.21	10	4	141.42	5	4	141.42						
148	42	0.8	200.00	9	6	173.21	6	4	141.42						
149	40	1	223.61	7	4	141.42	7	3	122.47						
150	33	0.2	100.00	5	2.5	111.80	9	1	70.71						
151	26	1	223.61	4	2	100.00	4	4	141.42						
152	24	4	447.21	5	1	70.71	8	15	273.86						
153	23	4	447.21	7	2	100.00	2	15	273.86						
154	26	0.5	158.11	8	2	100.00	3	0.5	50.00						
155	17	0.4	141.42	5	6	173.21	2	1	70.71						
156	19	0.4	141.42	4	5	158.11	2	2	100.00						
157	34	1	223.61	12	0.8	63.25	3	3	122.47						
158	45	0.3	122.47	14	1	70.71	4	1.5	86.60						
159	35	0.4	141.42	11	2	100.00	3	1	70.71						
160	40	0.7	187.08	13	4.5	150.00	4	2	100.00						
161	30	1	223.61	3	4	141.42	2	3	122.47						
162	23	0.4	141.42	9	4	141.42	2	1	70.71						
163	30	0.8	200.00	10	8	200.00	5	0.3	38.73						
164	32	0.1	70.71	10	5	158.11	3	1.5	86.60						
165	25	0.4	141.42	3	3	122.47	3	0.5	50.00						
166	43	0.5	158.11	6	3	122.47	4	1.5	86.60						
167	35	0.5	158.11	11	7	187.08	2	1.5	86.60						
168	23	1	223.61	4	2	100.00	2	3.5	132.29						
169	20	0.5	158.11	7	6	173.21	3	1.5	86.60						
170	23	0.8	200.00	2	2	100.00	2	2.5	111.80						
171	29	1	223.61	4	2	100.00	2	4	141.42						
172	26	1.9	308.22	6	5	158.11	2	7	187.08						
173	32	2.1	324.04	8	18	300.00	4	7	187.08						
174	27	2.1	324.04	9	7	187.08	5	6	173.21						
175	34	1	223.61	14	6	173.21	3	2	100.00						
176	22	1.2	244.95	5	4	141.42	3	4	141.42						
177	23	1	223.61	8	4	141.42	3	3	122.47						
178	36	2	316.23	3	12	244.95	3	4.5	150.00						
179	29	2.2	331.66	5	15	273.86	2	5	158.11						
180	26	1.2	244.95	2	14	264.58	2	4	141.42						
181	19	1.8	300.00	2	10	223.61	3	5	158.11						
ave	53.45	1.79	221.52	28.80	5.96	151.86	21.47	3.85	119.59	64.24	3.33	74.48	61.71	2.58	48.64
max	1400	30.0	447.21	#####	30.00	353.55	1400.0	30.00	273.86	1400	30.00	141.42	1400	30.00	100.00
min	7.00	0.10	70.71	2.00	0.50	50.00	2.00	0.20	31.62	2.00	0.20	31.62	2.00	0.10	22.36
mean	26	1	223.61	7	4	141.42	3	2.5	111.80	2	1	70.71	2	0.4	44.72
RF pwr	1000	1000	1000	500	500	500	250	250	250	125	125	125	63	63	63
frequenc	1400	1400	1400	1400	1400	1400	1400	1400	1400	1400	1400	1400	1400	1400	1400
	upsets	power (mw)	E Field Strength	upsets	power (mw)	E Field Strength	upsets	power (mw)	E Field Strength	upsets	power (mw)	E Field Strength	upsets	power (mw)	E Field Strength

## Appendix H: Baseline Analog Test Data - Upset Data Files

UPSET.030

800 MHz, 1000 Watts, Analog

Start Time is: Tue Dec 19 02:23:49 1995

Tue Dec 19 02:44:21 1995

#3151: 67 F #3152: 66 F #3153: 67 F #3154: 67 F #3155: 67 F #3156: 67 F #3157: 67 F  
#3158: 67 F #3159: 67 F #3160: 67 F #3161: 67 F #3162: 67 F #3163: 67 F #3164: 67 F  
#3165: 67 F #3166: 67 F #3167: 67 F #3168: 67 F #3169: 67 F #3170: 66 F #3171: 66 F  
#3172: 66 F #3173: 66 F #3174: 66 F #3175: 67 F #3176: 67 F #3177: 67 F #3178: 67 F  
#3179: 67 F #3180: 67 F #3181: 67 F #3182: 67 F #3183: 67 F #3184: 67 F #3185: 67 F  
#3186: 67 F #3187: 67 F #3188: 67 F #3189: 67 F #3190: 67 F #3191: 67 F #3192: 67 F  
#3193: 67 F #3194: 67 F #3195: 67 F #3196: 67 F #3197: 67 F #3198: 67 F #3199: 67 F  
#3200: 67 F #4151: 67 F #4152: 67 F #4153: 67 F #4154: 67 F #4155: 66 F #4156: 67 F  
#4157: 67 F #4158: 67 F #4159: 67 F #4160: 67 F #4161: 67 F #4162: 67 F #4163: 67 F  
#4164: 67 F #4165: 67 F #4166: 67 F #4167: 67 F #4168: 67 F #4169: 67 F #4170: 67 F  
#4171: 67 F #4172: 67 F #4173: 67 F #4174: 67 F #4175: 67 F #4176: 67 F #4177: 67 F  
#4178: 67 F #4179: 67 F #4180: 67 F #4181: 67 F #4182: 67 F #4183: 67 F #4184: 67 F  
#4185: 67 F #4186: 67 F #4187: 67 F #4188: 67 F #4189: 67 F #4190: 67 F #4191: 67 F  
#4192: 67 F #4193: 67 F #4194: 67 F #4195: 67 F #4196: 67 F #4197: 67 F #4198: 67 F  
#4199: 67 F #4200: 67 F

100 total devices being upset

Appendix H: Baseline Analog Test Data - Upset Data Files

UPSET.031  
800 MHz, 250 Watts, Analog

Start Time is: Tue Dec 19 02:49:00 1995  
Tue Dec 19 03:10:19 1995

#3101: 855 F  
#3102: 5100 F  
#3103: 112 F  
#3104: 32 F  
#3105: 3661 F  
#3106: 10 F  
#3107: 22 F  
#3108: 327 F  
#3109: 1725 F  
#3110: 234 F  
#3111: 2746 F  
#3112: 1922 F  
#3114: 2808 F  
#3115: 2367 F  
#3116: 18 F  
#3117: 1 F  
#3118: 309 F  
#3119: 1851 F  
#3120: 5238 F  
#3121: 1465 F  
#3122: 1817 F  
#3123: 350 F  
#3124: 1465 F  
#3125: 48 F  
#3126: 27 F  
#3127: 150 F  
#3128: 5 F  
#3129: 11 F  
#3131: 348 F  
#3132: 12466 F  
#3137: 24 F  
#3138: 7 F  
#3139: 8 F  
#3140: 9 F  
#3142: 2 F  
#3144: 64 F  
#3145: 7 F  
#3146: 166 F  
#3147: 28 F  
#3148: 8 F  
#3150: 2 F  
#4102: 12466 F  
#4103: 1 F  
#4107: 21 F  
#4110: 4 F  
#4113: 1 F  
#4115: 32 F  
#4120: 246 F

#4123: 117 F  
#4124: 5286 F  
#4125: 41 F  
#4126: 9 F  
#4127: 2684 F  
#4131: 1257 F  
#4132: 3697 F  
#4133: 5260 F  
#4134: 94 F  
#4135: 1653 F  
#4136: 355 F  
#4137: 3260 F  
#4138: 2999 F  
#4139: 1938 F  
#4141: 2767 F  
#4142: 3245 F  
#4143: 5306 F  
#4144: 2802 F  
#4145: 6643 F  
#4146: 2628 F  
#4147: 2965 F  
#4148: 1 F  
#4150: 25 F

71 total devices being upset

## Appendix H: Baseline Analog Test Data - Upset Data Files

UPSET.032  
800 MHz, 63 Watts, Analog

Start Time is: Wed Dec 20 13:41:17 1995  
Wed Dec 20 14:02:58 1995

#3102: 552 F  
#3104: 1 F  
#3105: 157 F  
#3109: 50 F  
#3111: 9 F  
#3112: 23 F  
#3114: 75 F  
#3115: 115 F  
#3119: 8 F  
#3120: 531 F  
#3122: 8 F  
#3132: 11274 F  
#4102: 11274 F  
#4124: 287 F  
#4127: 15 F  
#4132: 100 F  
#4133: 59 F  
#4135: 1 F  
#4137: 24 F  
#4138: 20 F  
#4139: 5 F  
#4141: 34 F  
#4142: 125 F  
#4143: 147 F  
#4144: 15 F  
#4145: 521 F  
#4146: 4 F  
#4147: 4 F  
#4150: 2 F

29 total devices being upset



Appendix H: Baseline Analog Test Data - Upset Data Files

UPSET.033  
1.4 GHz, 1000 Watts, Analog

Start Time is: Wed Dec 20 14:07:42 1995  
Wed Dec 20 14:24:23 1995

#3101: 897 F  
#3102: 409 F  
#3103: 734 F  
#3104: 1389 F  
#3105: 2364 F  
#3106: 201 F  
#3107: 297 F  
#3108: 1636 F  
#3109: 851 F  
#3110: 2332 F  
#3111: 921 F  
#3112: 1062 F  
#3113: 382 F  
#3114: 1387 F  
#3115: 994 F  
#3116: 293 F  
#3118: 2588 F  
#3119: 1272 F  
#3120: 1866 F  
#3121: 2024 F  
#3122: 1267 F  
#3123: 1013 F  
#3124: 1244 F  
#3125: 234 F  
#3126: 385 F  
#3127: 166 F  
#3128: 492 F  
#3129: 1257 F  
#3130: 622 F  
#3131: 114 F  
#3132: 10833 F  
#3133: 2355 F  
#3134: 593 F  
#3135: 833 F  
#3136: 1216 F  
#3137: 1071 F  
#3138: 1255 F  
#3139: 704 F  
#3140: 546 F  
#3141: 498 F  
#3142: 642 F  
#3143: 1436 F  
#3144: 2283 F  
#3145: 2707 F  
#3146: 2904 F  
#3147: 1646 F  
#3148: 259 F  
#3149: 116 F

#3150: 334 F  
#4101: 377 F  
#4102: 10833 F  
#4103: 107 F  
#4104: 315 F  
#4105: 991 F  
#4106: 622 F  
#4107: 343 F  
#4108: 135 F  
#4109: 308 F  
#4110: 520 F  
#4111: 963 F  
#4112: 989 F  
#4113: 1036 F  
#4114: 421 F  
#4115: 1023 F  
#4116: 364 F  
#4117: 120 F  
#4118: 977 F  
#4119: 992 F  
#4120: 1811 F  
#4121: 569 F  
#4122: 1181 F  
#4123: 1042 F  
#4124: 1135 F  
#4125: 895 F  
#4126: 582 F  
#4127: 905 F  
#4128: 336 F  
#4129: 590 F  
#4130: 902 F  
#4131: 1025 F  
#4132: 1490 F  
#4133: 304 F  
#4134: 2079 F  
#4135: 818 F  
#4136: 501 F  
#4137: 975 F  
#4138: 1326 F  
#4139: 2013 F  
#4141: 3336 F  
#4142: 1300 F  
#4143: 2531  
#4144: 819 F  
#4145: 2343 F  
#4146: 1961 F  
#4147: 1124 F  
#4148: 1813 F  
#4150: 1456 F

97 total devices being upset

## Appendix H: Baseline Analog Test Data - Upset Data Files

UPSET.034  
1.4 GHz, 250 Watts, Analog

Start Time is: Wed Dec 20 14:26:14 1995  
Wed Dec 20 14:43:09 1995

#4145: 313 F  
#4146: 137 F  
#4148: 32 F  
#4150: 48 F

52 total devices being upset.

#3104: 43 F  
#3105: 216 F  
#3108: 68 F  
#3109: 3 F  
#3110: 258 F  
#3111: 11 F  
#3112: 20 F  
#3114: 52 F  
#3115: 16 F  
#3118: 350 F  
#3119: 24 F  
#3120: 217 F  
#3121: 304 F  
#3122: 114 F  
#3123: 17 F  
#3124: 19 F  
#3126: 3 F  
#3129: 32 F  
#3132: 11192 F  
#3133: 73 F  
#3135: 14 F  
#3136: 13 F  
#3137: 4 F  
#3138: 47 F  
#3141: 12 F  
#3142: 17 F  
#3143: 8 F  
#3144: 65 F  
#3145: 160 F  
#3146: 97 F  
#4102: 11192 F  
#4103: 1 F  
#4105: 4 F  
#4106: 24 F  
#4111: 12 F  
#4112: 1 F  
#4113: 4 F  
#4119: 3 F  
#4120: 37 F  
#4122: 38 F  
#4132: 75 F  
#4134: 182 F  
#4135: 9 F  
#4138: 13 F  
#4139: 117 F  
#4141: 222 F  
#4142: 4 F  
#4143: 158 F

Appendix H: Baseline Analog Test Data - Upset Data Files

Appendix F: Total Analog Device Upset Test Data

UPSET.035  
1.4 GHz, 63 Watts, Analog

Start Time is: Wed Dec 20 14:45:40 1995  
Wed Dec 20 14:51:13 1995

#3132: 3184 F  
#4102: 3184 F

2 total devices being upset  
(2 is the quiescent upset level)

Appendix H: Baseline Analog Test Data - Upset Data Files

UPSET.036  
800 MHz, 500 Watts, Analog

Start Time is: Fri Dec 22 13:53:13 1995  
Fri Dec 22 14:16:01 1995

#3101: 2846 F  
#3102: 6543 F  
#3103: 1008 F  
#3104: 548 F  
#3105: 4059 F  
#3106: 654 F  
#3107: 434 F  
#3108: 2586 F  
#3109: 3084 F  
#3110: 1579 F  
#3111: 5547 F  
#3112: 5204 F  
#3113: 12 F  
#3114: 4375 F  
#3115: 3205 F  
#3116: 248 F  
#3118: 1968 F  
#3119: 3822 F  
#3120: 7264 F  
#3121: 3345 F  
#3122: 3567 F  
#3123: 1589 F  
#3124: 3980 F  
#3125: 665 F  
#3126: 244 F  
#3127: 1064 F  
#3128: 93 F  
#3129: 141 F  
#3130: 226 F  
#3131: 1054 F  
#3132: 11265 F  
#3133: 47 F  
#3134: 117 F  
#3135: 54 F  
#3136: 312 F  
#3137: 351 F  
#3138: 191  
#3139: 609 F  
#3140: 229 F  
#3141: 64 F  
#3142: 211 F  
#3143: 323 F  
#3144: 603 F  
#3145: 301 F  
#3146: 406 F  
#3147: 670 F  
#3148: 312 F  
#3150: 1679 F

#4101: 492 F  
#4102: 11265 F  
#4103: 360 F  
#4106: 287 F  
#4107: 136 F  
#4110: 5 F  
#4111: 600 F  
#4112: 283 F  
#4113: 1228 F  
#4114: 40 F  
#4115: 1226 F  
#4116: 665 F  
#4118: 117 F  
#4119: 68 F  
#4120: 2920 F  
#4121: 751 F  
#4123: 763 F  
#4124: 5139 F  
#4125: 674 F  
#4126: 542 F  
#4127: 3218 F  
#4129: 628 F  
#4131: 2917 F  
#4132: 4427 F  
#4133: 5312 F  
#4134: 537 F  
#4135: 2342 F  
#4136: 1115 F  
#4137: 3096 F  
#4138: 4604 F  
#4139: 2335 F  
#4141: 3443 F  
#4142: 4514 F  
#4143: 6196 F  
#4144: 3773 F  
#4145: 5991 F  
#4146: 4124 F  
#4147: 4512 F  
#4148: 87 F  
#4150: 307 F

88 total devices being upset

Appendix H: Baseline Analog Test Data - Upset Data Files

UPSET.037

800 MHz, 125 Watts, Analog

Start Time is: Fri Dec 22 14:18:44 1995

Fri Dec 22 14:35:56 1995

#3101: 236 F  
#3102: 2960 F  
#3103: 2 F  
#3104: 3 F  
#3105: 1592 F  
#3108: 58 F  
#3109: 688 F  
#3110: 26 F  
#3111: 866 F  
#3112: 590 F  
#3114: 1088 F  
#3115: 1271 F  
#3116: 3 F  
#3118: 41 F  
#3119: 672 F  
#3120: 2799 F  
#3121: 435 F  
#3122: 449 F  
#3123: 19 F  
#3124: 393 F  
#3126: 1 F  
#3132: 11157 F  
#3150: 1 F  
#4102: 11157 F  
#4110: 1 F  
#4113: 18 F  
#4124: 1915 F  
#4127: 538 F  
#4131: 254 F  
#4132: 1229 F  
#4133: 1133 F  
#4135: 362 F  
#4137: 617 F  
#4138: 498 F  
#4139: 126 F  
#4141: 565 F  
#4142: 1331 F  
#4143: 1468 F  
#4144: 778 F  
#4145: 2690 F  
#4146: 452 F  
#4147: 433 F

42 total devices being upset

Appendix H: Baseline Analog Test Data - Upset Data Files

UPSET.038  
1.4 GHz, 500 Watts, Analog

Start Time is: Fri Dec 22 14:37:29 1995  
Fri Dec 22 14:54:29 1995

#3101: 103 F  
#3102: 19 F  
#3103: 70 F  
#3104: 223 F  
#3105: 1078 F  
#3106: 51 F  
#3107: 33 F  
#3108: 405 F  
#3109: 156 F  
#3110: 1272 F  
#3111: 174 F  
#3112: 188 F  
#3113: 33 F  
#3114: 280 F  
#3115: 198 F  
#3116: 1 F  
#3118: 999 F  
#3119: 235 F  
#3120: 497 F  
#3121: 631 F  
#3122: 259 F  
#3123: 61 F  
#3124: 193 F  
#3125: 5 F  
#3126: 39 F  
#3127: 21 F  
#3128: 5 F  
#3129: 356 F  
#3130: 21 F  
#3132: 11130 F  
#3133: 578 F  
#3134: 88 F  
#3135: 1 F  
#3136: 110 F  
#3137: 454 F  
#3138: 120 F  
#3139: 106 F  
#3140: 49 F  
#3141: 31 F  
#3142: 157 F  
#3143: 35 F  
#3144: 227 F  
#3145: 209 F  
#3146: 186 F  
#3147: 149 F  
#3148: 8 F  
#4101: 18 F  
#4102: 11130 F

#4105: 23 F  
#4106: 54 F  
#4107: 7 F  
#4110: 57 F  
#4111: 130 F  
#4112: 70 F  
#4113: 124 F  
#4114: 15 F  
#4115: 286 F  
#4116: 41 F  
#4118: 77 F  
#4119: 196 F  
#4120: 261 F  
#4121: 45 F  
#4122: 83 F  
#4123: 191 F  
#4138: 359 F  
#4139: 441 F  
#4141: 767 F  
#4142: 163 F  
#4143: 880 F  
#4144: 53 F  
#4145: 1196 F  
#4146: 444 F  
#4147: 41 F  
#4148: 233 F  
#4150: 242 F

75 total devices being upset

Appendix H: Baseline Analog Test Data - Upset Data Files

UPSET.039  
1.4 GHz, 125 Watts, Analog

Start Time is: Fri Dec 22 14:55:44 1995  
Fri Dec 22 15:01:10 1995

#3132: 3185 F  
#4102: 3185 F  
#4139: 1 F

3 total devices being upset  
(2 upsets is the uiescent level)

Appendix J: Analog Reliability Test Data - Test #1

Stored in:	Test #	Devices Upset				Ave	Date(1996)		Time		File size (Mb)			Notes
		Bd #1	Bd #2	Total					full	ave	part			
DAT0123	201	74	84	158		1	23	15	43	0.88				
DAT0123	202	72	79	151		1	23	16	43	0.90				
DAT0123	203	71	80	151		1	23	17	43	0.93				
DAT0123	204	73	75	148		1	23	18	43	0.91				
DAT0123	205	73	77	150		1	23	19	43	0.92				
DAT0123	206	72	76	148		1	23	20	43	0.95				
DAT0123	207	72	79	151		1	23	21	43	0.94				
DAT0123	208	72	75	147		1	23	22	43	0.95				
DAT0123	209	73	75	148		1	23	23	43	0.95				
DAT0123	211	73	75	148	150	1	24	8	49	0.92	0.93			
DAT0123	212	72	79	151		1	24	9	49	0.93				
DAT0123	213	73	76	149		1	24	10	49	0.95				
DAT0123	214	72	78	150		1	24	11	49	0.93				
DAT0123	215	73	76	149		1	24	12	49	0.95				
DAT0123	216	75	78	153		1	24	13	49	0.96				
DAT0123	217	73	80	153		1	24	14	49	0.95				
DAT0123	218	72	78	150		1	24	15	49			0.74		
DAT0125	219	68	68	136		1	24	16	3			0.07	4 Min	
DAT0125	220	72	76	148		1	24	17	6	0.96				
DAT0125	221	74	76	150	149	1	24	18	6	0.95	0.95			
DAT0125	222	74	78	152		1	24	19	6	0.96				
DAT0125	223	72	81	153		1	24	20	6	0.94				
DAT0125	224	74	77	151		1	24	21	6	0.93				
DAT0125	225	72	75	147		1	24	22	6	0.92				
DAT0125	226	72	80	152		1	24	23	6	0.89				
DAT0125	227	75	75	150		1	25	12	6	0.98				
DAT0125	228	73	74	147		1	25	1	6	0.95				
DAT0125	229	72	74	146		1	25	2	6	0.92				
DAT0125	230	72	77	149		1	25	3	6	0.91				
DAT0125	231	75	77	152	150	1	25	4	6	0.94	0.93			
DAT0125	232	72	78	150		1	25	5	6	0.94				
DAT0125	233	74	78	152		1	25	6	6	0.95				
DAT0125	234	73	77	150		1	25	7	6	0.97				
DAT0125	235	72	78	150		1	25	8	6	0.99				
DAT0125	236	73	76	149		1	25	9	6	0.98				
DAT0125	237	74	78	152		1	25	10	6	0.98				
DAT0125	238	73	75	148		1	25	11	6	0.96				
DAT0125	239	72	78	150		1	25	12	6	0.97				
DAT0125	240	74	77	151		1	25	13	6	0.96				
DAT0125	241	75	78	153	151	1	25	13	50		0.97	0.71		
DAT0126	242	68	70	138		1	25	15	25			0.07		
DAT0126	243	74	77	151		1	25	16	25	1.01				
DAT0126	244	73	76	149		1	25	17	25	1.02				
DAT0126	245	74	76	150		1	25	18	25	0.76				
DAT0126	246	73	76	149		1	25	19	25	1.00				
DAT0126	247	72	77	149		1	25	20	25	1.00				
DAT0126	248	72	78	150		1	25	21	25	1.00				
DAT0126	249	74	75	149		1	25	22	25	1.00				
DAT0126	250	72	74	146		1	25	23	25	1.00				
DAT0126	251	73	79	152	148	1	26	0	25	1.00	0.98			



Appendix J: Analog Reliability Test Data - Test #1

SubDir	Test #	Devices Upset				Ave	Date(1996)		Time		File size (Mb)			Notes
		Bd #1	Bd #2	Total					full	ave	part			
DAT0126	252	74	77	151		1	26	1	25	1.00				
DAT0126	253	72	79	151		1	26	2	25	1.00				
DAT0126	254	72	80	152		1	26	3	25	0.99				
DAT0126	255	74	73	147		1	26	4	25	0.99				
DAT0126	256	70	80	150		1	26	5	25	0.99				
DAT0126	257	71	75	146		1	26	6	25	1.00				
DAT0126	258	72	78	150		1	26	7	25	1.00				
DAT0126	259	72	78	150		1	26	8	25	0.99				
DAT0126	260	73	78	151		1	26	9	25	0.94				
DAT0126	261	71	79	150	150	1	26	10	26	0.97	0.99			
DAT0126	262	68	75	143		1	26	10	39			0.22		
DAT0126	263	72	77	149		1	26	12	14	0.95				
DAT0126	264	74	78	152		1	26	13	14	1.00				
DAT0126	265	73	78	151		1	26	14	14	1.02				
DAT0126	266	73	78	151		1	26	15	14	1.02				
DAT0126	267	70	66	136		1	26	15	19			0.09		
DAT0126	268	71	66	137		1	26	15	25			0.07	4 Min	
DAT0129	269	70	72	142		1	26	15	53			0.07	4 Min	
DAT0129	270	74	78	152		1	26	16	54	0.98				
DAT0129	271	75	74	149	146	1	26	17	54	1.00	1			
DAT0129	272	74	76	150		1	26	18	54	0.99				
DAT0129	273	75	76	151		1	26	19	54	0.96				
DAT0129	274	75	79	154		1	26	20	54	0.98				
DAT0129	275	72	74	146		1	26	21	54	1.01				
DAT0129	276	73	75	148		1	26	22	54	0.96				
DAT0129	277	74	74	148		1	26	23	54	0.97				
DAT0129	278	72	78	150		1	27	0	54	0.96				
DAT0129	279	73	76	149		1	27	1	54	1.00				
DAT0129	280	73	75	148		1	27	2	54	0.97				
DAT0129	281	74	79	153	150	1	27	3	54	0.98	0.98			
DAT0129	282	75	77	152		1	27	4	54	1.01				
DAT0129	283	74	79	153		1	27	5	54	1.03				
DAT0129	284	73	74	147		1	27	6	54	1.03				
DAT0129	285	74	77	151		1	27	7	54	1.06				
DAT0129	286	75	76	151		1	27	8	54	1.02				
DAT0129	287	76	75	151		1	27	9	54	1.00				
DAT0129	288	75	76	151		1	27	10	54	1.00				
DAT0129	289	76	78	154		1	27	11	54	1.00				
DAT0129	290	75	78	153		1	27	12	54	0.93				
DAT0129	291	74	78	152	152	1	27	13	54	0.95	1			
DAT0129	292	73	76	149		1	27	14	54	1.04				
DAT0129	293	75	77	152		1	27	15	54	1.03				
DAT0129	294	74	76	150		1	27	16	54	1.00				
DAT0129	295	74	78	152		1	27	17	54	1.05				
DAT0129	296	75	76	151		1	27	18	54	0.76				
DAT0129	297	73	80	153		1	27	19	54	0.63				
DAT0129	298	74	77	151		1	27	20	54	0.62				
DAT0129	299	76	79	155		1	27	21	54	0.73				
DAT0129	300	74	75	149		1	27	22	54	0.85				
DAT0129	301	77	75	152	151	1	27	23	54	0.90	0.86			

Appendix J: Analog Reliability Test Data - Test #1

SubDir	Test #	Devices Upset				Date(1996)	Time		File size (Mb)			Notes
		Bd #1	Bd #2	Total	Ave		full	ave	part			
DAT0129	302	74	78	152		1	28	0	54	0.89		
DAT0129	303	78	78	156		1	28	1	54	0.93		
DAT0129	304	74	77	151		1	28	2	54	1.03		
DAT0129	305	75	77	152		1	28	3	54	0.71		
DAT0129	306	75	75	150		1	28	4	55	0.69		
DAT0129	307	75	79	154		1	28	5	55	0.78		
DAT0129	308	76	81	157		1	28	6	55	0.71		
DAT0129	309	75	79	154		1	28	7	55	0.76		
DAT0129	310	74	78	152		1	28	8	55	0.70		
DAT0129	311	75	77	152	153	1	28	9	55	0.88	0.81	
DAT0130	312	73	70	143		1	29	11	50			0.09 4 Min
DAT0130	313	75	79	154		1	29	12	51	1.08		
DAT0130	314	78	76	154		1	29	13	51	0.99		
DAT0130	315	76	79	155		1	29	14	51	0.90		
DAT0130	316	76	76	152		1	29	15	51	0.71		
DAT0130	317	75	81	156		1	29	16	51	0.77		
DAT0130	318	78	78	156		1	29	17	51	0.90		
DAT0130	319	76	80	156		1	29	18	51	0.96		
DAT0130	320	76	79	155		1	29	19	51	1.00		
DAT0130	321	76	76	152	153	1	29	20	51	1.06	0.93	
DAT0130	322	75	78	153		1	29	21	51	1.05		
DAT0130	323	76	84	160		1	29	22	51	1.11		
DAT0130	324	78	80	158		1	29	23	51	1.09		
DAT0130	325	76	78	154		1	30	0	51	1.10		
DAT0130	326	76	80	156		1	30	1	51	1.12		
DAT0130	327	79	78	157		1	30	2	51	1.11		
DAT0130	328	76	81	157		1	30	3	51	1.12		
DAT0130	329	76	80	156		1	30	4	51	1.12		
DAT0130	330	76	79	155		1	30	5	51	1.13		
DAT0130	331	76	79	155	156	1	30	6	51	1.11	1.11	
DAT0130	332	76	81	157		1	30	7	51	1.13		
DAT0130	333	76	79	155		1	30	8	51	1.14		
DAT0130	334	76	81	157		1	30	9	51	1.13		
DAT0130	335	75	71	146		1	30	10	1		0.12	
DAT0131	336	74	69	143		1	30	10	16		0.08	4 Min
DAT0131	337	77	79	156		1	30	11	16	1.11		
DAT0131	338	77	79	156		1	30	12	16	1.10		
DAT0131	339	75	79	154		1	30	13	16	1.08		
DAT0131	340	76	80	156		1	30	14	16	1.02		
DAT0131	341	76	79	155	154	1	30	15	16	0.96	1.08	
DAT0131	342	76	81	157		1	30	16	16	0.95		
DAT0131	343	76	79	155		1	30	17	16	0.94		
DAT0131	344	77	82	159		1	30	18	16	0.95		
DAT0131	345	76	83	159		1	30	19	16	0.99		
DAT0131	346	76	81	157		1	30	20	16	1.04		
DAT0131	347	75	82	157		1	30	21	16	1.09		
DAT0131	348	76	79	155		1	30	22	16	1.10		
DAT0131	349	77	80	157		1	30	23	16	1.10		
DAT0131	350	75	78	153		1	31	0	16	1.10		
DAT0131	351	76	80	156	157	1	31	1	16	1.10	1.04	

Appendix J: Analog Reliability Test Data - Test #1

SubDir	Test #	Devices Upset				Date(1996)	Time	File size (Mb)			Notes
		Bd #1	Bd #2	Total	Ave			full	ave	part	
DAT0131	352	75	82	157		1 31	2 16	1.11			
DAT0131	353	76	82	158		1 31	3 16	1.09			
DAT0131	354	76	81	157		1 31	4 16	1.09			
DAT0131	355	75	81	156		1 31	5 16	1.11			
DAT0131	356	75	82	157		1 31	6 16	1.10			
DAT0131	357	75	79	154		1 31	7 16	1.09			
DAT0131	358	78	77	155		1 31	8 16	1.11			
DAT0131	359	74	77	151		1 31	9 3			0.82	
DAT0201	360	71	69	140		1 31	9 27			0.08	4 Min
DAT0201	361	75	79	154	154	1 31	10 27	1.16	1.11		
DAT0201	362	75	82	157		1 31	11 27	1.14			
DAT0201	363	74	81	155		1 31	12 27	1.09			
DAT0201	364	74	81	155		1 31	13 27	0.99			
DAT0201	365	74	79	153		1 31	14 27	0.95			
DAT0201	366	76	80	156		1 31	15 27	0.89			
DAT0201	367	76	80	156		1 31	16 27	0.87			
DAT0201	368	75	82	157		1 31	17 27	0.88			
DAT0201	369	71	79	150		1 31	18 27	0.92			
DAT0201	370	77	82	159		1 31	19 27	0.94			
DAT0201	371	74	81	155	155	1 31	20 27	1.00	0.97		
DAT0201	372	75	79	154		1 31	21 27	1.06			
DAT0201	373	75	78	153		1 31	22 27	1.07			
DAT0201	374	76	83	159		1 31	23 27	1.08			
DAT0201	375	76	78	154		2 1	0 27	1.09			
DAT0201	376	75	81	156		2 1	1 27	1.10			
DAT0201	377	75	79	154		2 1	2 27	1.09			
DAT0201	378	76	81	157		2 1	3 27	1.10			
DAT0201	379	75	80	155		2 1	4 27	1.10			
DAT0201	380	74	80	154		2 1	5 27	1.12			
DAT0201	381	74	78	152	155	2 1	6 27	1.13	1.09		
DAT0201	382	74	82	156		2 1	7 27	1.15			
DAT0201	383	75	82	157		2 1	8 27	1.13			
DAT0201	384	76	82	158		2 1	9 27	1.13			
DAT0201	385	75	76	151		2 1	10 1			0.52	
DAT0202	386	72	70	142		2 1	11 5			0.08	4 Min
DAT0202	387	75	79	154		2 2	12 6	1.12			
DAT0202	388	76	80	156		2 2	13 6	1.10			
DAT0202	389	77	81	158		2 2	14 6	1.06			
DAT0202	390	76	79	155		2 2	15 6	1.00			
DAT0202	391	76	78	154	154	2 2	16 6	1.03	1.09		
DAT0202	392	76	77	153		2 2	17 6	1.05			
DAT0202	393	76	78	154		2 2	18 6	0.98			
DAT0202	394	72	77	149		2 2	19 6	1.02			
DAT0202	395	75	80	155		2 2	20 6	1.06			
DAT0202	396	77	80	157		2 2	21 6	1.07			
DAT0202	397	75	78	153		2 2	22 6	1.08			
DAT0205	398	75	72	147		2 2	14 28			0.08	4 Min
DAT0205	399	77	82	159		2 2	15 29	1.15			
DAT0205	400	77	82	159		2 2	16 28	1.14			
DAT0205	401	78	83	161	155	2 2	17 33	1.17	1.08		

Appendix J: Analog Reliability Test Data - Test #1

SubDir	Test #	Devices Upset				Date(1996)	Time		File size (Mb)			Notes
		Bd #1	Bd #2	Total	Ave		full	ave	part			
DAT0205	402	76	83	159		2	2	18	33	1.07		
DAT0205	403	78	79	157		2	2	19	33	1.14		
DAT0205	404	76	82	158		2	2	20	33	1.18		
DAT0205	405	77	84	161		2	2	21	33	1.19		
DAT0205	406	76	84	160		2	2	22	33	1.19		
DAT0205	407	76	85	161		2	2	23	33	1.17		
DAT0205	408	77	83	160		2	3	0	33	1.18		
DAT0205	409	77	85	162		2	3	1	33	1.15		
DAT0205	410	77	81	158		2	3	2	33	1.15		
DAT0205	411	76	84	160	160	2	3	3	33	1.17	1.16	
DAT0205	412	76	84	160		2	3	4	33	1.17		
DAT0205	413	75	80	155		2	3	5	33	1.17		
DAT0205	414	76	82	158		2	3	6	33	1.20		
DAT0205	415	77	85	162		2	3	7	33	1.22		
DAT0205	416	77	83	160		2	3	8	33	1.21		
DAT0205	417	76	82	158		2	3	9	33	1.19		
DAT0205	418	77	83	160		2	3	10	33	1.19		
DAT0205	419	76	83	159		2	3	11	33	1.17		
DAT0205	420	76	81	157		2	3	12	33	1.16		
DAT0205	421	77	84	161	159	2	3	13	33	1.17	1.19	
DAT0205	422	79	81	160		2	3	14	33	1.15		
DAT0205	423	77	82	159		2	3	15	33	1.16		
DAT0205	424	76	81	157		2	3	16	33	1.16		
DAT0205	425	77	80	157		2	3	17	33	1.15		
DAT0205	426	76	82	158		2	3	18	33	1.15		
DAT0205	427	77	82	159		2	3	19	33	1.14		
DAT0205	428	76	84	160		2	3	20	33	1.06		
DAT0205	429	76	83	159		2	3	21	33	1.02		
DAT0205	430	77	80	157		2	3	22	33	1.02		
DAT0205	431	73	77	150	158	2	3	23	33	1.16	1.12	
DAT0205	432	76	80	156		2	4	0	33	1.14		
DAT0205	433	74	83	157		2	4	1	33	1.15		
DAT0205	434	77	79	156		2	4	2	33	0.86		
DAT0205	435	75	83	158		2	4	3	33	0.87		
DAT0205	436	74	80	154		2	4	4	33	1.03		
DAT0205	437	76	79	155		2	4	5	33	1.08		
DAT0205	438	73	81	154		2	4	6	33	1.05		
DAT0205	439	75	82	157		2	4	7	33	1.05		
DAT0205	440	76	82	158		2	4	8	33	1.12		
DAT0205	441	76	78	154	156	2	4	9	33	1.13	1.05	
DAT0205	442	75	81	156		2	4	10	33	1.14		
DAT0205	443	75	83	158		2	4	11	34	1.14		
DAT0205	444	75	79	154		2	4	12	34	1.14		
DAT0205	445	74	81	155		2	4	13	34	1.15		
DAT0205	446	73	80	153		2	4	14	34	1.15		
DAT0205	447	74	81	155		2	4	15	34	1.13		
DAT0205	448	73	80	153		2	4	16	34	1.14		
DAT0205	449	72	81	153		2	4	17	34	1.14		
DAT0205	450	73	80	153		2	4	18	34	1.14		
DAT0205	451	74	79	153	154	2	4	19	34	1.15	1.14	

Appendix J: Analog Reliability Test Data - Test #1

SubDir	Test #	Devices Upset				Date(1996)	Time		File size (Mb)			Notes
		Bd #1	Bd #2	Total	Ave		full	ave	part			
DAT0205	452	74	82	156		2	4	20	34	1.15		
DAT0205	453	74	79	153		2	4	21	34	1.15		
DAT0205	454	73	81	154		2	4	22	34	1.15		
DAT0205	455	74	77	151		2	4	23	34	1.15		
DAT0205	456	72	84	156		2	4	0	34	1.15		
DAT0205	457	74	81	155		2	5	1	34	1.16		
DAT0205	458	73	80	153		2	5	2	34	1.14		
DAT0205	459	73	82	155		2	5	3	34	1.13		
DAT0205	460	74	81	155		2	5	4	34	1.11		
DAT0205	461	73	75	148	154	2	5	5	34	1.11	1.14	
DAT0205	462	72	80	152		2	5	6	34	1.11		
DAT0205	463	73	82	155		2	5	7	34	1.11		
DAT0205	464	73	83	156		2	5	8	34	1.10		
DAT0205	465	72	78	150		2	5	9	17		0.69	
DAT0206	466	69	69	138		2	5	9	49		0.08	4 Min
DAT0206	467	75	84	159		2	5	10	49	1.16		
DAT0206	468	75	83	158		2	5	11	49	1.16		
DAT0206	469	75	86	161		2	5	12	49	1.15		
DAT0206	470	77	82	159		2	5	13	49	1.15		
DAT0206	471	75	80	155	154	2	5	14	49	1.18	1.14	
DAT0206	472	75	81	156		2	5	15	49	1.19		
DAT0206	473	75	78	153		2	5	16	49	1.18		
DAT0206	474	75	82	157		2	5	17	49	1.20		
DAT0206	475	79	81	160		2	5	18	49	1.21		
DAT0206	476	76	83	159		2	5	19	49	1.20		
DAT0206	477	76	81	157		2	5	20	49	1.20		
DAT0206	478	75	82	157		2	5	21	49	1.11		
DAT0206	479	76	81	157		2	5	22	49	1.08		
DAT0206	480	77	81	158		2	5	23	49	1.06		
DAT0206	481	75	84	159	157	2	6	0	49	1.17	1.16	
DAT0206	482	76	82	158		2	6	1	49	1.20		
DAT0206	483	75	77	152		2	6	2	49	1.21		
DAT0206	484	77	81	158		2	6	3	49	1.22		
DAT0206	485	74	83	157		2	6	4	49	1.22		
DAT0206	486	77	82	159		2	6	5	49	1.22		
DAT0206	487	77	81	158		2	6	6	49	1.22		
DAT0206	488	76	79	155		2	6	7	49	1.23		
DAT0206	489	76	85	161		2	6	8	33		0.87	
DAT0207	490	73	73	146		2	6	9	25		0.08	4 Min
DAT0207	491	76	79	155	156	2	6	10	26	1.2	1.22	
DAT0207	492	78	81	159		2	6	11	26	1.21		
DAT0207	493	77	82	159		2	6	12	26	1.18		
DAT0207	494	76	81	157		2	6	13	26	1.1		
DAT0207	495	74	73	147		2	6	14	26	1.09		
DAT0207	496	76	75	151		2	6	15	26	1.09		
DAT0207	497	76	77	153		2	6	16	26	1.09		
DAT0207	498	77	74	151		2	6	17	26	1.1		
DAT0207	499	77	77	154		2	6	18	26	1.11		
DAT0207	500	78	78	156		2	6	19	26	1.1		
DAT0207	501	77	74	151	154	2	6	20	26	1.1	1.12	

Appendix J: Analog Reliability Test Data - Test #1

SubDir	Test #	Devices Upset				Date(1996)	Time		File size (Mb)			Notes
		Bd #1	Bd #2	Total	Ave		full	ave	part			
DAT0207	502	76	76	152		2	6	21	26	1.09		
DAT0207	503	78	75	153		2	6	22	26	1.09		
DAT0207	504	76	76	152		2	6	23	26	1.08		
DAT0208	505	72	68	140		2	7	9	45		0.08	4 Min
DAT0208	506	76	77	153		2	7	10	45	1.09		
DAT0208	507	77	75	152		2	7	11	45	1.09		
DAT0208	508	77	78	155		2	7	12	45	1.08		
DAT0208	509	75	76	151		2	7	13	45	1.08		
DAT0208	510	76	77	153		2	7	14	45	1.09		
DAT0208	511	76	77	153	151	2	7	15	45	1.09	1.09	
DAT0208	512	76	78	154		2	7	16	45	1.08		
DAT0208	513	76	76	152		2	7	17	45	1.06		
DAT0208	514	73	76	149		2	7	18	45	1.02		
DAT0208	515	72	76	148		2	7	19	45	1		
DAT0208	516	75	76	151		2	7	20	45	0.98		
DAT0208	517	72	78	150		2	7	21	45	0.96		
DAT0208	518	74	77	151		2	7	22	45	0.96		
DAT0208	519	75	80	155		2	7	23	45	0.97		
DAT0208	520	74	77	151		2	8	0	45	0.96		
DAT0208	521	74	77	151	151	2	8	1	45	0.99	1	
DAT0208	522	77	77	154		2	8	2	45	0.94		
DAT0208	523	77	75	152		2	8	3	45	0.99		
DAT0208	524	77	74	151		2	8	4	45	1.03		
DAT0208	525	75	80	155		2	8	5	45	1.04		
DAT0208	526	77	78	155		2	8	6	45	1.08		
DAT0208	527	77	78	155		2	8	7	45	1.09		
DAT0208	528	76	80	156		2	8	8	45	1.1		
DAT0208	529	76	78	154		2	8	9	45	1.1		
DAT0208	530	77	74	151		2	8	10	45	1.12		
DAT0208	531	77	78	155	154	2	8	11	45	1.12	1.06	
DAT0208	532	73	77	150		2	8	12	45	1.11		
DAT0208	533	2	4	6		2	8	12	46		0.004	no RF
DAT0209	534	70	70	140		2	8	13	16		0.08	4-min
DAT0209	535	77	77	154		2	8	14	16	1.08		
DAT0209	536	73	76	149		2	8	15	17	1.09		
DAT0209	537	77	78	155		2	8	16	17	1.09		
DAT0209	538	76	80	156		2	8	17	17	1.08		
DAT0209	539	74	78	152		2	8	18	17	1.08		
DAT0209	540	73	77	150		2	8	19	17	1.06		
DAT0209	541	73	78	151	151	2	8	20	17	0.88	1.06	
DAT0209	542	72	80	152		2	8	21	17	0.77		
DAT0209	543	73	77	150		2	8	22	17	0.88		
DAT0209	544	73	76	149		2	8	23	17	1		
DAT0209	545	74	78	152		2	9	0	17	0.68		
DAT0209	546	73	79	152		2	9	1	17	0.66		
DAT0209	547	73	76	149		2	9	2	17	0.96		
DAT0209	548	72	74	146		2	9	3	17	0.96		
DAT0209	549	69	77	146		2	9	4	17	0.96		
DAT0209	550	71	76	147		2	9	5	17	0.98		
DAT0209	551	72	76	148	149	2	9	6	17	0.98	0.88	

Appendix J: Analog Reliability Test Data - Test #1

SubDir	Test #	Devices Upset				Date(1996)	Time		File size (Mb)			Notes	
		Bd #1	Bd #2	Total	Ave		full	ave	part				
DAT0209	552	70	76	146		2	9	7	17	0.98			
DAT0209	553	72	75	147		2	9	8	17	0.96			
DAT0209	554	70	76	146		2	9	9	17	0.95			
DAT0209	555	72	77	149		2	9	10	17	0.96			
DAT0209	556	72	80	152		2	9	11	17	0.89			
DAT0209	557	72	78	150		2	9	12	17	0.91			
DAT0209	558	74	81	155		2	9	13	17	0.9			
DAT0209	559	74	79	153		2	9	14	17	0.87			
DAT0209	560	74	79	153		2	9	15	17	0.96			
DAT0209	561	70	66	136	149	2	9	15	25		0.93	0.09	
DAT0212	562	69	71	140		2	9	16	3			0.08	4Min
DAT0212	563	74	72	146		2	9	17	3	1.06			
DAT0212	564	73	76	149		2	9	18	3	1			
DAT0212	565	74	77	151		2	9	19	3	0.99			
DAT0212	566	72	77	149		2	9	20	3	1			
DAT0212	567	73	78	151		2	9	21	3	1			
DAT0212	568	72	75	147		2	9	22	3	1.01			
DAT0212	569	73	77	150		2	9	23	3	1.01			
DAT0214	570	71	67	138		2	12	8	16			0.08	4Min
DAT0214	571	71	73	144	147	2	12	12	11	0.99	1.01		
DAT0214	572	73	80	153		2	12	13	11	0.97			
DAT0214	573	72	80	152		2	12	14	11	0.75			
DAT0214	574	67	67	134		2	13	8	15			0.07	4 Min
DAT0214	575	75	74	149		2	13	9	15	1.01			
DAT0214	576	74	74	148		2	13	10	15	1.01			
DAT0214	577	73	77	150		2	13	11	16	1.02			
DAT0214	578	74	73	147		2	13	12	16	0.98			
DAT0214	579	73	77	150		2	13	13	16	1.01			
DAT0214	580	73	77	150		2	13	14	16	0.96			
DAT0214	581	74	74	148	148	2	13	15	16	1.01	0.97		
DAT0214	582	73	78	151		2	13	16	16	1.02			
DAT0214	583	73	73	146		2	13	17	16	0.98			
DAT0214	584	74	75	149		2	13	18	16	1.04			
DAT0214	585	75	72	147		2	13	19	16	1.01			
DAT0215	586	69	65	134		2	14	8	51			0.08	4 Min
DAT0215	587	72	77	149		2	14	9	51	1.11			
DAT0215	588	73	75	148		2	14	10	51	1.1			
DAT0215	589	72	78	150		2	14	11	51	1.08			
DAT0215	590	74	80	154		2	14	12	51	1.08			
DAT0215	591	73	78	151	148	2	14	13	51	1.1	1.06		
DAT0215	592	75	74	149		2	14	14	51	1.1			
DAT0215	593	74	74	148		2	14	15	51	1.09			
DAT0215	594	73	75	148		2	14	16	51	1.09			
DAT0215	595	74	73	147		2	14	17	51	1.06			
DAT0215	596	73	75	148		2	14	18	51	1.09			
DAT0215	597	70	69	139		2	15	7	7			0.08	4 Min
DAT0215	598	73	73	146		2	15	8	8	1.1			
DAT0215	599	72	72	144		2	15	9	8	1.1			
DAT0215	600	74	76	150		2	15	10	8	1.13			
DAT0215	601	74	74	148	147	2	15	11	8	1.1	1.1		

Appendix J: Analog Reliability Test Data - Test #1

SubDir	Test #	Devices Upset				Date(1996)	Time		File size (Mb)			Notes
		Bd #1	Bd #2	Total	Ave		full	ave	part			
DAT0215	602	73	76	149		2	15	12	8	1		
DAT0215	603	73	75	148		2	15	13	8	1.05		
DAT0215	604	72	73	145		2	15	14	8	1.12		
DAT0215	605	71	70	141		2	15	14	17		0.16	
DAT0216	606	72	75	147		2	15	15	22	0.95		
DAT0216	607	74	75	149		2	15	16	22	1		
DAT0216	608	76	78	154		2	15	17	22	1		
DAT0216	609	77	77	154		2	15	18	22	1.02		
DAT0216	610	75	76	151		2	15	19	22	0.91		
DAT0216	611	71	76	147	149	2	15	20	22	1.03	1.01	
DAT0216	612	74	76	150		2	15	21	22	1.03		
DAT0216	613	72	76	148		2	15	22	22	1.01		
DAT0216	614	71	77	148		2	15	23	22	0.98		
DAT0216	615	73	74	147		2	16	0	22	1.02		
DAT0216	616	73	75	148		2	16	1	22	1.02		
DAT0216	617	72	75	147		2	16	2	22	0.94		
DAT0216	618	72	75	147		2	16	3	22	0.82		
DAT0216	619	73	79	152		2	16	4	22	0.86		
DAT0216	620	74	76	150		2	16	5	22	0.97		
DAT0216	621	74	75	149	149	2	16	6	22	1.03	0.97	
DAT0216	622	75	75	150		2	16	7	22	1.03		
DAT0216	623	75	76	151		2	16	8	22	1.04		
DAT0216	624	73	74	147		2	16	9	22	1.04		
DAT0216	625	76	77	153		2	16	10	22	1.05		
DAT0216	626	76	77	153		2	16	11	22	1.04		
DAT0216	627	75	73	148		2	16	12	22	1.02		
DAT0216	628	77	78	155		2	16	13	22	0.94		
DAT0219	629	73	75	148		2	16	14	26	1.02		
DAT0219	630	76	74	150		2	16	15	26	1.02		
DAT0219	631	78	77	155	151	2	16	16	26	1.04	1.02	
DAT0219	632	76	79	155		2	16	17	26	1.04		
DAT0219	633	77	77	154		2	16	18	26	1.04		
DAT0219	634	76	77	153		2	16	19	26	1.06		
DAT0219	635	77	76	153		2	16	20	26	1.02		
DAT0219	636	75	74	149		2	16	21	26	1.05		
DAT0219	637	76	77	153		2	16	22	26	1		
DAT0219	638	74	78	152		2	16	23	26	1		
DAT0219	639	73	75	148		2	17	0	26	1.02		
DAT0219	640	75	76	151		2	17	1	27	1.01		
DAT0219	641	75	71	146	151	2	17	2	27	0.94	1.02	
DAT0219	642	74	80	154		2	17	3	27	0.99		
DAT0219	643	73	77	150		2	17	4	27	1.06		
DAT0219	644	75	76	151		2	17	5	27	1.04		
DAT0219	645	75	77	152		2	17	6	27	1.02		
DAT0219	646	76	76	152		2	17	7	27	1.01		
DAT0219	647	76	73	149		2	17	8	27	1.01		
DAT0219	648	74	75	149		2	17	9	27	1.01		
DAT0219	649	73	75	148		2	17	10	27	1.04		
DAT0219	650	76	74	150		2	17	11	27	1.02		
DAT0219	651	76	74	150	151	2	17	12	27	1.04	1.02	



Appendix J: Analog Reliability Test Data - Test #1

SubDir	Test #	Devices Upset				Date(1996)	Time		File size (Mb)			Notes
		Bd #1	Bd #2	Total	Ave		full	ave	part			
DAT0219	652	77	76	153		2	17	13	27	1.05		
DAT0219	653	76	78	154		2	17	14	27	1.05		
DAT0219	654	77	79	156		2	17	15	27	1.03		
DAT0219	655	76	77	153		2	17	16	27	1.03		
DAT0219	656	75	77	152		2	17	17	27	1.05		
DAT0219	657	75	74	149		2	17	18	27	1.02		
DAT0219	658	74	77	151		2	17	19	27	1.01		
DAT0219	659	74	77	151		2	17	20	27	1.03		
DAT0219	660	75	79	154		2	17	21	27	1.02		
DAT0219	661	74	79	153	153	2	17	22	27	0.78	1.01	
DAT0219	662	78	79	157		2	17	23	27	0.93		
DAT0219	663	77	76	153		2	18	0	27	0.86		
DAT0219	664	74	76	150		2	18	1	27	0.99		
DAT0219	665	74	76	150		2	18	2	27	1		
DAT0219	666	75	77	152		2	18	3	27	1.01		
DAT0219	667	75	77	152		2	18	4	27	1.02		
DAT0219	668	74	76	150		2	18	5	27	1.02		
DAT0219	669	76	78	154		2	18	6	27	1.02		
DAT0220	670	72	72	144		2	19	10	10		0.09	4 Min
DAT0220	671	75	80	155	152	2	19	11	11	1.2	1.01	
DAT0220	672	75	80	155		2	19	12	11	1.2		
DAT0220	673	76	87	163		2	19	13	11	1.22		
DAT0220	674	76	84	160		2	19	14	11	1.13		
DAT0220	675	78	82	160		2	19	15	11	1.21		
DAT0220	676	78	86	164		2	19	16	11	1.22		
DAT0220	677	77	86	163		2	19	17	11	1.27		
DAT0220	678	77	85	162		2	19	18	11	1.27		
DAT0220	679	76	85	161		2	19	19	11	1.17		
DAT0220	680	75	84	159		2	19	20	11	1.23		
DAT0220	681	77	85	162	161	2	19	21	11	1.27	1.22	
DAT0220	682	75	83	158		2	19	22	11	1.27		
DAT0220	683	76	92	168		2	19	23	11	1.26		
DAT0220	684	74	85	159		2	20	0	11	1.25		
DAT0220	685	75	81	156		2	20	1	11	1.24		
DAT0220	686	75	81	156		2	20	2	11	1.23		
DAT0220	687	76	81	157		2	20	3	11	1.26		
DAT0220	688	74	82	156		2	20	4	11	1.26		
DAT0220	689	75	83	158		2	20	5	11	1.25		
DAT0220	690	76	84	160		2	20	6	11	1.25		
DAT0220	691	75	86	161	159	2	20	7	11	1.25	1.25	
DAT0220	692	77	84	161		2	20	8	11	1.27		
DAT0220	693	74	83	157		2	20	8	53		0.86	
DAT0221	694	74	75	149		2	20	9	17		0.11	4 Min
DAT0221	695	77	79	156		2	20	10	17	1.48		
DAT0221	696	76	83	159		2	20	11	17	1.42		
DAT0221	697	75	86	161		2	20	12	17	1.44		
DAT0221	698	79	82	161		2	20	13	17	1.5		
DAT0221	699	77	79	156		2	20	14	17	1.53		
DAT0221	700	76	84	160		2	20	15	17	1.54		
DAT0221	701	77	82	159	158	2	20	16	17	1.56	1.47	

Appendix J: Analog Reliability Test Data - Test #1

SubDir	Test #	Devices Upset				Ave	Date(1996)		Time		File size (Mb)			Notes
		Bd #1	Bd #2	Total					full	ave	part			
DAT0221	702	77	82	159		2	20	17	17	1.52				
DAT0221	703	77	82	159		2	20	18	17	1.49				
DAT0221	704	75	80	155		2	20	19	17	1.52				
DAT0221	705	73	84	157		2	20	20	17	1.53				
DAT0221	706	74	82	156		2	20	21	17	1.54				
DAT0221	707	75	81	156		2	20	22	17	1.52				
DAT0221	708	73	81	154		2	20	23	17	1.51				
DAT0221	709	73	80	153		2	21	0	17	1.43				
DAT0221	710	73	81	154		2	21	1	17	1.47				
DAT0221	711	74	81	155	156	2	21	2	17	1.48	1.5			
DAT0221	712	73	80	153		2	21	3	17	1.54				
DAT0221	713	74	80	154		2	21	4	17	1.56				
DAT0221	714	73	80	153		2	21	5	17	1.57				
DAT0221	715	75	80	155		2	21	6	17	1.57				
DAT0221	716	75	82	157		2	21	7	17	1.46				
DAT0221	717	77	82	159		2	21	8	17	1.4				
DAT0221	718	77	81	158		2	21	9	17	1.5				
DAT0221	719	73	81	154		2	21	9	52			0.8		
DAT0222	720	63	69	132		2	21	11	57			0.09	4 Min	
DAT0222	721	69	85	154	153	2	21	12	57	1.23	1.48			
DAT0222	722	69	80	149		2	21	13	57	1.18				
DAT0222	723	68	79	147		2	21	14	57	1.14				
DAT0222	724	71	79	150		2	21	15	57	1.25				
DAT0222	725	66	75	141		2	21	16	57			0.33		
DAT0222	726	69	78	147		2	21	17	48	1.31				
DAT0222	727	69	79	148		2	21	18	48	1.32				
DAT0222	728	66	79	145		2	21	19	48	1.32				
DAT0222	729	65	76	141		2	21	20	48	1.21				
DAT0222	730	66	78	144		2	21	21	48	1.21				
DAT0222	731	67	81	148	146	2	21	22	48	1.02	1.22			
DAT0222	732	66	77	143		2	21	23	48	1.12				
DAT0222	733	69	78	147		2	22	0	48	1.08				
DAT0222	734	67	75	142		2	22	1	48	1.06				
DAT0222	735	65	78	143		2	22	2	48	1				
DAT0222	736	66	78	144		2	22	3	48	0.94				
DAT0222	737	65	78	143		2	22	4	48	1				
DAT0222	738	66	78	144		2	22	5	48	1.03				
DAT0222	739	65	77	142		2	22	6	48	1.05				
DAT0222	740	68	77	145		2	22	7	48	1.15				
DAT0222	741	70	78	148	144	2	22	8	48	1.19	1.06			
DAT0222	742	66	76	142		2	22	9	48	1.21				
DAT0222	743	65	76	141		2	22	10	48	1.1				
DAT0222	744	67	80	147		2	22	11	48	0.95				
DAT0222	745	66	77	143		2	22	12	48	1.01				
DAT0222	746	67	78	145	144	2	22	13	26		1.07	0.64		

Appendix K: Analog Reliability Test Data - Test #3 (Test Period #2)

SubDir	Test #	Devices Upset				Date(1996)	Time		File size (Mb)			Notes	
		Bd #1	Bd #2	Total	Ave				full	ave	part		
DAT0226	801	60	55	115		2	23	16	45			0.02	4 Min
DAT0226	802	67	65	132		2	23	17	45	0.22			
DAT0226	803	68	70	138		2	23	18	45	0.23			
DAT0226	804	67	71	138		2	23	19	45	0.26			
DAT0226	805	66	68	134		2	23	20	45	0.24			
DAT0226	806	70	72	142		2	23	21	45	0.26			
DAT0226	807	76	79	155		2	23	22	45	0.27			
DAT0226	808	80	81	161		2	23	23	45	0.27			
DAT0226	809	75	80	155		2	24	0	45	0.26			
DAT0226	810	75	79	154	142.4	2	24	1	45	0.24	0.25		
DAT0226	811	67	68	135		2	24	2	45	0.26			
DAT0226	812	69	70	139		2	24	3	45	0.30			
DAT0226	813	66	67	133		2	24	4	45	0.28			
DAT0226	814	66	67	133		2	24	5	45	0.28			
DAT0226	815	69	71	140		2	24	6	45	0.31			
DAT0226	816	69	69	138		2	24	7	45	0.31			
DAT0226	817	69	67	136		2	24	8	45	0.31			
DAT0226	818	66	66	132		2	24	9	45	0.29			
DAT0226	819	66	71	137		2	24	10	45	0.28			
DAT0226	820	66	68	134	135.7	2	24	11	45	0.30	0.292		
DAT0226	821	68	67	135		2	24	12	45	0.25			
DAT0226	822	65	69	134		2	24	13	45	0.29			
DAT0226	823	67	67	134		2	24	14	45	0.24			
DAT0226	824	67	65	132		2	24	15	45	0.23			
DAT0226	825	69	65	134		2	24	16	45	0.23			
DAT0226	826	66	68	134		2	24	17	45	0.26			
DAT0226	827	65	67	132		2	24	18	45	0.31			
DAT0226	828	68	71	139		2	24	19	45	0.31			
DAT0226	829	69	70	139		2	24	20	45	0.32			
DAT0226	830	69	73	142	135.5	2	24	21	45	0.31	0.275		
DAT0226	831	65	70	135		2	24	22	45	0.31			
DAT0226	832	68	68	136		2	24	23	45	0.22			
DAT0226	833	69	70	139		2	25	0	45	0.24			
DAT0226	834	68	68	136		2	25	1	45	0.24			
DAT0226	835	68	69	137		2	25	2	45	0.26			
DAT0226	836	66	70	136		2	25	3	45	0.24			
DAT0226	837	65	69	134		2	25	4	45	0.24			
DAT0226	838	63	71	134		2	25	5	45	0.25			
DAT0226	839	65	66	131		2	25	6	45	0.28			
DAT0226	840	60	70	130	134.8	2	25	7	45	0.29	0.257		
DAT0226	841	65	72	137		2	25	8	45	0.29			
DAT0226	842	64	72	136		2	25	9	45	0.31			
DAT0226	843	66	75	141		2	25	10	45	0.32			
DAT0226	844	66	74	140		2	25	11	45	0.31			
DAT0226	845	66	69	135		2	25	12	45	0.30			
DAT0226	846	64	73	137		2	25	13	45	0.31			
DAT0226	847	63	72	135		2	25	14	45	0.31			
DAT0226	848	62	73	135		2	25	15	45	0.31			
DAT0226	849	66	71	137		2	25	16	45	0.30			
DAT0226	850	63	71	134	136.7	2	25	17	45	0.31	0.307	137	0.28

Appendix K: Analog Reliability Test Data - Test #3 (Test Period #2)

SubDir	Test #	Devices Upset				Date(1996)	Time		File size (Mb)			Notes
		Bd #1	Bd #2	Total	Ave		full	ave	part			
DAT0226	851	64	74	138		2	25	18	45	0.32		
DAT0226	852	66	72	138		2	25	19	45	0.30		
DAT0226	853	64	71	135		2	25	20	45	0.27		
DAT0226	854	68	72	140		2	25	21	45	0.29		
DAT0226	855	65	73	138		2	25	22	45	0.28		
DAT0226	856	67	74	141		2	25	23	45	0.30		
DAT0226	857	66	72	138		2	26	0	45	0.30		
DAT0226	858	68	71	139		2	26	1	45	0.31		
DAT0226	859	65	70	135		2	26	2	45	0.31		
DAT0226	860	71	74	145	138.7	2	26	3	45	0.32	0.3	
DAT0226	861	61	71	132		2	26	4	45	0.30		
DAT0226	862	61	71	132		2	26	5	45	0.29		
DAT0226	863	68	72	140		2	26	6	45	0.25		
DAT0226	864	63	73	136		2	26	7	45	0.29		
DAT0226	865	63	73	136		2	26	8	45	0.29		
DAT0226	866	68	72	140		2	26	9	45	0.30		
DAT0226	867	64	73	137		2	26	10	45	0.30		
DAT0226	868	59	67	126		2	26	11	4		0.08	
DAT0227	869	55	54	109		2	26	11	58		0.02	4 Min
DAT0227	870	57	68	125	131.3	2	26	12	58	0.30	0.29	
DAT0227	871	56	66	122		2	26	13	58	0.29		
DAT0227	872	60	68	128		2	26	14	58	0.29		
DAT0227	873	58	68	126		2	26	16	5	0.29		
DAT0227	874	60	64	124		2	26	17	5	0.29		
DAT0227	875	64	71	135		2	26	18	5	0.29		
DAT0227	876	66	73	139		2	26	19	5	0.29		
DAT0227	877	60	65	125		2	26	20	5	0.28		
DAT0227	878	59	63	122		2	26	21	5	0.28		
DAT0227	879	65	69	134		2	26	22	5	0.30		
DAT0227	880	64	63	127	128.2	2	26	23	5	0.29	0.289	
DAT0227	881	61	65	126		2	26	0	5	0.29		
DAT0227	882	64	68	132		2	27	1	5	0.29		
DAT0227	883	66	71	137		2	27	2	5	0.30		
DAT0227	884	70	73	143		2	27	3	5	0.32		
DAT0227	885	71	76	147		2	27	4	5	0.34		
DAT0227	886	74	74	148		2	27	5	5	0.35		
DAT0227	887	73	74	147		2	27	6	5	0.34		
DAT0227	888	76	71	147		2	27	7	5	0.36		
DAT0227	889	75	73	148		2	27	8	5	0.36		
DAT0227	890	75	73	148	142.3	2	27	9	5	0.36	0.331	
DAT0227	891	72	74	146		2	27	10	4	0.34		
DAT0228	892	71	73	144		2	27	11	29	0.33		
DAT0228	893	67	72	139		2	27	12	29	0.29		
DAT0228	894	58	63	121		2	27	13	29	0.26		
DAT0228	895	57	65	122		2	27	14	29	0.26		
DAT0228	896	60	62	122		2	27	15	29	0.27		
DAT0228	897	58	61	119		2	27	16	29	0.27		
DAT0228	898	59	66	125		2	27	17	29	0.27		
DAT0228	899	51	60	111		2	27	18	29	0.25		
DAT0228	900	53	61	114	126.3	2	27	19	29	0.25	0.279	

Appendix K: Analog Reliability Test Data - Test #3 (Test Period #2)

SubDir	Test #	Devices Upset				Ave	Date(1996)	Time		File size (Mb)			Notes
		Bd #1	Bd #2	Total				full	ave	part			
DAT0228	901	52	64	116		2	27	20	29	0.25			
DAT0228	902	52	58	110		2	27	21	29	0.23			
DAT0228	903	53	58	111		2	27	22	29	0.24			
DAT0228	904	57	62	119		2	27	23	29	0.26			
DAT0228	905	52	62	114		2	28	0	29	0.25			
DAT0228	906	55	60	115		2	28	1	29	0.26			
DAT0228	907	53	61	114		2	28	2	29	0.25			
DAT0228	908	54	60	114		2	28	3	29	0.26			
DAT0228	909	53	61	114		2	28	4	29	0.25			
DAT0228	910	49	63	112	113.9	2	28	5	29	0.25	0.25		
DAT0228	911	51	60	111		2	28	6	29	0.25			
DAT0228	912	55	61	116		2	28	7	29	0.24			
DAT0228	913	53	62	115		2	28	8	29	0.24			
DAT0228	914	51	64	115		2	28	9	29	0.25			
DAT0228	915	58	61	119		2	28	10	23			0.23	
DAT0229	916	55	55	110		2	28	10	47			0.02	4 Min
DAT0229	917	59	66	125		2	28	11	47	0.28			
DAT0229	918	58	63	121		2	28	12	47	0.28			
DAT0229	919	58	64	122		2	28	13	47	0.28			
DAT0229	920	61	65	126	118	2	28	14	47	0.28	0.263		
DAT0229	921	60	65	125		2	28	15	47	0.26			
DAT0229	922	54	62	116		2	28	16	47	0.25			
DAT0229	923	55	62	117		2	28	17	47	0.24			
DAT0229	924	59	59	118		2	28	18	47	0.24			
DAT0229	925	51	57	108		2	28	19	47	0.23			
DAT0229	926	61	67	128		2	28	20	47	0.27			
DAT0229	927	64	64	128		2	28	21	47	0.28			
DAT0229	928	63	65	128		2	28	22	47	0.29			
DAT0229	929	58	64	122		2	28	23	47	0.28			
DAT0229	930	58	59	117	120.7	2	29	0	47	0.28	0.262		
DAT0229	931	56	62	118		2	29	1	47	0.26			
DAT0229	932	55	61	116		2	29	2	47	0.26			
DAT0229	933	55	59	114		2	29	3	47	0.26			
DAT0229	934	56	61	117		2	29	4	47	0.26			
DAT0229	935	53	59	112		2	29	5	47	0.26			
DAT0229	936	56	62	118		2	29	6	47	0.25			
DAT0229	937	60	63	123		2	29	7	47	0.26			
DAT0229	938	55	62	117		2	29	8	47	0.26			
DAT0229	939	54	60	114		2	29	9	47	0.26			
DAT0229	940	48	57	105	115.4	2	29	10	47	0.24	0.257		
DAT0229	941	45	53	98		2	29	10	59			0.05	
DAT0301	942	41	49	90		2	29	11	24			0.02	4 Min
DAT0301	943	46	64	110		2	29	12	24	0.24			
DAT0301	944	48	58	106		2	29	13	24	0.24			
DAT0301	945	50	62	112		2	29	14	24	0.24			
DAT0301	946	53	61	114		2	29	15	24	0.23			
DAT0301	947	55	57	112		2	29	16	24	0.23			
DAT0301	948	50	57	107		2	29	17	24	0.22			
DAT0301	949	50	60	110		2	29	18	24	0.22			
DAT0301	950	53	62	115	107.4	2	29	19	24	0.24	0.233		

Appendix K: Analog Reliability Test Data - Test #3 (Test Period #2)

SubDir	Test #	Devices Upset				Date(1996)	Time		File size (Mb)			Notes
		Bd #1	Bd #2	Total	Ave				full	ave	part	
DAT0301	951	57	58	115		2	29	20	24	0.25		
DAT0301	952	56	59	115		2	29	21	24	0.25		
DAT0301	953	57	63	120		2	29	22	24	0.25		
DAT0301	954	54	59	113		3	29	23	24	0.25		
DAT0301	955	53	61	114		3	1	0	24	0.25		
DAT0301	956	52	57	109		3	1	1	24	0.26		
DAT0301	957	52	60	112		3	1	2	24	0.26		
DAT0301	958	51	59	110		3	1	3	24	0.25		
DAT0301	959	53	63	116		3	1	4	24	0.25		
DAT0301	960	48	58	106	113	3	1	5	24	0.25	0.252	
DAT0301	961	48	62	110		3	1	6	24	0.25		
DAT0301	962	48	63	111		3	1	7	24	0.25		
DAT0301	963	48	60	108		3	1	8	24	0.24		
DAT0301	964	50	60	110		3	1	9	24	0.24		
DAT0301	965	48	60	108		3	1	10	24	0.24		
DAT0301	966	45	56	101		3	1	11	24	0.24		
DAT0301	967	45	57	102		3	1	12	24	0.24		
DAT0301	968	46	59	105		3	1	13	24	0.24		
DAT0301	969	52	59	111		3	1	14	24	0.24		
DAT0301	970	42	47	89	105.5	3	1	14	30		0.242	0.02
DAT0304	971	37	48	85		3	1	15	3			0.01 4 Min
DAT0304	972	50	59	109		3	1	16	3	0.22		
DAT0304	973	44	61	105		3	1	17	3	0.22		
DAT0304	974	47	59	106		3	1	18	3	0.21		
DAT0304	975	50	61	111		3	1	19	3	0.24		
DAT0304	976	46	58	104		3	1	20	3	0.24		
DAT0304	977	55	61	116		3	1	21	3	0.25		
DAT0304	978	55	62	117		3	1	22	3	0.27		
DAT0304	979	54	60	114		3	1	23	3	0.25		
DAT0304	980	49	57	106	107.3	3	1	0	3	0.23	0.237	
DAT0304	981	48	56	104		3	2	1	3	0.23		
DAT0304	982	55	55	110		3	2	2	3	0.23		
DAT0304	983	54	57	111		3	2	3	3	0.25		
DAT0304	984	46	60	106		3	2	4	3	0.23		
DAT0304	985	49	54	103		3	2	5	3	0.23		
DAT0304	986	46	55	101		3	2	6	3	0.23		
DAT0304	987	43	50	93		3	2	7	3	0.22		
DAT0304	988	44	54	98		3	2	8	3	0.22		
DAT0304	989	48	58	106		3	2	9	3	0.23		
DAT0304	990	55	64	119	105.1	3	2	10	3	0.24	0.231	
DAT0304	991	53	59	112		3	2	11	3	0.24		
DAT0304	992	53	63	116		3	2	12	3	0.25		
DAT0304	993	55	64	119		3	2	13	3	0.26		
DAT0304	994	57	63	120		3	2	14	3	0.26		
DAT0304	995	56	64	120		3	2	15	3	0.26		
DAT0304	996	56	66	122		3	2	16	3	0.25		
DAT0304	997	49	62	111		3	2	17	3	0.24		
DAT0304	998	50	60	110		3	2	18	3	0.24		
DAT0304	999	48	60	108		3	2	19	3	0.24		
DAT0304	1000	49	59	108	114.6	3	2	20	3	0.25	0.249	

Appendix K: Analog Reliability Test Data - Test #3 (Test Period #2)

SubDir	Test #	Devices Upset				Ave	Date(1996)	Time		File size (Mb)			Notes
		Bd #1	Bd #2	Total				full	ave	part			
DAT0304	1001	51	65	116		3	2	21	3	0.24			
DAT0304	1002	48	57	105		3	2	22	3	0.23			
DAT0304	1003	51	57	108		3	2	23	3	0.23			
DAT0304	1004	47	54	101		3	3	0	3	0.23			
DAT0304	1005	58	63	121		3	3	1	3	0.23			
DAT0304	1006	59	67	126		3	3	2	3	0.25			
DAT0304	1007	52	53	105		3	3	3	3	0.23			
DAT0304	1008	47	57	104		3	3	4	3	0.23			
DAT0304	1009	51	58	109		3	3	5	3	0.24			
DAT0304	1010	52	60	112	110.7	3	3	6	3	0.24	0.235		
DAT0304	1011	52	62	114		3	3	7	3	0.25			
DAT0304	1012	49	62	111		3	3	8	3	0.24			
DAT0304	1013	52	60	112		3	3	9	3	0.24			
DAT0304	1014	60	63	123		3	3	10	3	0.27			
DAT0304	1015	57	65	122		3	3	11	3	0.27			
DAT0304	1016	56	60	116		3	3	12	3	0.26			
DAT0304	1017	57	63	120		3	3	13	3	0.26			
DAT0304	1018	48	64	112		3	3	14	3	0.24			
DAT0304	1019	46	61	107		3	3	15	3	0.24			
DAT0304	1020	47	59	106	114.3	3	3	16	3	0.24	0.251		
DAT0304	1021	44	60	104		3	3	17	3	0.23			
DAT0304	1022	43	57	100		3	3	18	3	0.23			
DAT0304	1023	52	59	111		3	3	19	3	0.24			
DAT0304	1024	50	60	110		3	3	20	3	0.24			
DAT0304	1025	50	58	108		3	3	21	3	0.23			
DAT0304	1026	50	61	111		3	3	22	3	0.25			
DAT0304	1027	45	56	101		3	3	23	3	0.23			
DAT0304	1028	41	58	99		3	4	0	3	0.23			
DAT0304	1029	45	56	101		3	4	1	3	0.23			
DAT0304	1030	44	58	102	104.7	3	4	2	3	0.23	0.234		
DAT0304	1031	50	60	110		3	4	3	3	0.23			
DAT0304	1032	49	59	108		3	4	4	3	0.24			
DAT0304	1033	53	60	113		3	4	5	3	0.26			
DAT0304	1034	52	64	116		3	4	6	3	0.26			
DAT0304	1035	56	63	119		3	4	7	3	0.26			
DAT0304	1036	56	64	120		3	4	8	3	0.27			
DAT0304	1037	56	64	120		3	4	9	3	0.27			
DAT0304	1038	51	61	112		3	4	10	3	0.26			
DAT0304	1039	53	60	113		3	4	10	54			0.22	
DAT0305	1040	45	59	104	113.5	3	4	11	12		0.256	0.03	4 Min
DAT0305	1041	49	65	114		3	4	12	12	0.25			
DAT0305	1042	48	65	113		3	4	13	12	0.24			
DAT0305	1043	52	62	114		3	4	14	12	0.25			
DAT0305	1044	48	62	110		3	4	15	12	0.25			
DAT0305	1045	49	61	110		3	4	16	12	0.25			
DAT0305	1046	49	59	108		3	4	17	12	0.25			
DAT0305	1047	47	61	108		3	4	18	12	0.25			
DAT0305	1048	51	58	109		3	4	19	12	0.24			
DAT0305	1049	47	57	104		3	4	20	12	0.23			
DAT0305	1050	46	58	104	109.4	3	4	21	12	0.23	0.244		

Appendix K: Analog Reliability Test Data - Test #3 (Test Period #2)

SubDir	Test #	Devices Upset				Ave	Date(1996)		Time		File size (Mb)			Notes
		Bd #1	Bd #2	Total					full	ave	part			
DAT0305	1051	45	57	102		3	4	22	12	0.23				
DAT0305	1052	54	63	117		3	4	23	12	0.22				
DAT0305	1053	64	66	130		3	5	0	12	0.26				
DAT0305	1054	58	65	123		3	5	1	12	0.26				
DAT0305	1055	56	65	121		3	5	2	12	0.26				
DAT0305	1056	62	65	127		3	5	3	12	0.25				
DAT0305	1057	60	66	126		3	5	4	12	0.26				
DAT0305	1058	64	65	129		3	5	5	12	0.27				
DAT0305	1059	53	62	115		3	5	6	12	0.24				
DAT0305	1060	50	64	114	120.4	3	5	7	12	0.24	0.249			
DAT0305	1061	50	62	112		3	5	8	12	0.24				
DAT0305	1062	57	63	120		3	5	9	12	0.24				
DAT0305	1063	56	63	119		3	5	10	12	0.26				
DAT0305	1064	60	67	127		3	5	11	12	0.26				
DAT0305	1065	56	67	123		3	5	12	12	0.26				
DAT0305	1066	56	60	116		3	5	12	37			0.11		
DAT0306	1067	46	56	102		3	5	12	59			0.02	4 Min	
DAT0306	1068	59	66	125		3	5	14	0	0.27				
DAT0306	1069	52	62	114		3	5	15	0	0.26				
DAT0306	1070	53	62	115	117.3	3	5	16	0	0.23	0.253			
DAT0306	1071	47	63	110		3	5	17	0	0.23				
DAT0306	1072	56	64	120		3	5	18	0	0.26				
DAT0306	1073	57	71	128		3	5	19	0	0.28				
DAT0306	1074	59	67	126		3	5	20	0	0.28				
DAT0306	1075	53	65	118		3	5	21	0	0.26				
DAT0306	1076	57	65	122		3	5	22	0	0.27				
DAT0306	1077	50	64	114		3	5	23	0	0.26				
DAT0306	1078	53	62	115		3	6	0	0	0.25				
DAT0306	1079	49	65	114		3	6	1	0	0.24				
DAT0306	1080	63	71	134	120.1	3	6	2	0	0.30	0.263			
DAT0306	1081	59	72	131		3	6	3	0	0.28				
DAT0306	1082	58	72	130		3	6	4	0	0.29				
DAT0306	1083	52	58	110		3	6	5	0	0.26				
DAT0306	1084	50	60	110		3	6	6	0	0.25				
DAT0306	1085	47	59	106		3	6	7	0	0.23				
DAT0306	1086	58	71	129		3	6	8	0	0.27				
DAT0306	1087	59	67	126		3	6	9	0	0.27				
DAT0306	1088	59	71	130		3	6	10	0	0.28				
DAT0306	1089	58	71	129		3	6	11	0	0.29				
DAT0306	1090	57	67	124	122.5	3	6	12	0	0.28	0.27			
DAT0306	1091	65	69	134		3	6	13	0	0.29				
DAT0306	1092	61	71	132		3	6	13	52			0.26		
DAT0307	1093	50	58	108		3	6	14	18			0.02	4 Min	
DAT0307	1094	55	67	122		3	6	15	18	0.28				
DAT0307	1095	55	66	121		3	6	16	18	0.27				
DAT0307	1096	56	64	120		3	6	17	18	0.27				
DAT0307	1097	58	64	122		3	6	18	18	0.26				
DAT0307	1098	57	63	120		3	6	19	18	0.25				
DAT0307	1099	56	65	121		3	6	20	18	0.26				
DAT0307	1100	56	64	120	122	3	6	21	18	0.26	0.268			



Appendix K: Analog Reliability Test Data - Test #3 (Test Period #2)

SubDir	Test #	Devices Upset				Ave	Date(1996)		Time		File size (Mb)			Notes
		Bd #1	Bd #2	Total					full	ave	part			
DAT0307	1101	55	62	117		3	6	22	18	0.25				
DAT0307	1102	53	63	116		3	6	23	18	0.25				
DAT0307	1103	56	60	116		3	7	0	18	0.24				
DAT0307	1104	57	62	119		3	7	1	18	0.26				
DAT0307	1105	51	60	111		3	7	2	18	0.24				
DAT0307	1106	52	60	112		3	7	3	18	0.24				
DAT0307	1107	49	60	109		3	7	4	18	0.24				
DAT0307	1108	52	61	113		3	7	5	18	0.25				
DAT0307	1109	58	63	121		3	7	6	18	0.28				
DAT0307	1110	55	61	116	115	3	7	7	18	0.28	0.253			
DAT0307	1111	58	64	122		3	7	8	18	0.23				
DAT0307	1112	51	62	113		3	7	9	18	0.21				
DAT0307	1113	56	64	120		3	7	10	18	0.23				
DAT0307	1114	54	63	117		3	7	11	18	0.23				
DAT0307	1115	54	65	119		3	7	12	18	0.23				
DAT0307	1116	56	64	120		3	7	13	18	0.23				
DAT0308	1117	45	57	102		3	7	14	5			0.02	4 Min	
DAT0308	1118	61	66	127		3	7	15	5	0.26				
DAT0308	1119	59	65	124		3	7	16	5	0.26				
DAT0308	1120	59	68	127	119.1	3	7	17	5	0.26	0.238			
DAT0308	1121	55	61	116		3	7	18	5	0.25				
DAT0308	1122	59	63	122		3	7	19	5	0.25				
DAT0308	1123	54	62	116		3	7	20	5	0.25				
DAT0308	1124	54	61	115		3	7	21	5	0.24				
DAT0308	1125	53	63	116		3	7	22	5	0.24				
DAT0308	1126	49	63	112		3	7	23	5	0.24				
DAT0308	1127	51	58	109		3	8	0	5	0.24				
DAT0308	1128	47	58	105		3	8	1	5	0.24				
DAT0308	1129	52	56	108		3	8	2	5	0.23				
DAT0308	1130	46	55	101	112	3	8	3	5	0.23	0.241			
DAT0308	1131	45	58	103		3	8	4	5	0.23				
DAT0308	1132	55	62	117		3	8	5	5	0.27				
DAT0308	1133	51	62	113		3	8	6	5	0.25				
DAT0308	1134	57	65	122		3	8	7	5	0.26				
DAT0308	1135	51	62	113		3	8	8	5	0.24				
DAT0308	1136	48	61	109		3	8	9	5	0.24				
DAT0308	1137	52	61	113		3	8	10	5	0.24				
DAT0308	1138	52	60	112		3	8	11	5	0.26				
DAT0308	1139	53	61	114		3	8	12	5	0.26				
DAT0308	1140	52	63	115	113.1	3	8	13	5	0.24	0.249			
DAT0311	1141	36	49	85		3	8	13	40			0.02	4 Min	
DAT0311	1142	47	61	108		3	8	14	40	0.23				
DAT0311	1143	46	63	109		3	8	15	40	0.24				
DAT0311	1144	53	60	113		3	8	16	40	0.24				
DAT0311	1145	53	61	114		3	8	17	40	0.25				
DAT0311	1146	54	62	116		3	8	18	40	0.26				
DAT0311	1147	54	62	116		3	8	19	40	0.26				
DAT0311	1148	51	66	117		3	8	20	40	0.26				
DAT0311	1149	53	65	118		3	8	21	40	0.26				
DAT0311	1150	61	70	131	112.7	3	8	22	40	0.29	0.254			

Appendix K: Analog Reliability Test Data - Test #3 (Test Period #2)

SubDir	Test #	Devices Upset				Date(1996)	Time		File size (Mb)			Notes
		Bd #1	Bd #2	Total	Ave				full	ave	part	
DAT0311	1151	60	70	130		3	8	23	40	0.30		
DAT0311	1152	60	69	129		3	9	0	40	0.29		
DAT0311	1153	62	68	130		3	9	1	40	0.30		
DAT0311	1154	62	67	129		3	9	2	40	0.30		
DAT0311	1155	58	67	125		3	9	3	40	0.29		
DAT0311	1156	60	66	126		3	9	4	40	0.29		
DAT0311	1157	59	67	126		3	9	5	40	0.28		
DAT0311	1158	57	66	123		3	9	6	40	0.27		
DAT0311	1159	62	67	129		3	9	7	40	0.28		
DAT0311	1160	57	66	123	127	3	9	8	40	0.28	0.288	
DAT0311	1161	60	66	126		3	9	9	40	0.29		
DAT0311	1162	65	73	138		3	9	10	40	0.30		
DAT0311	1163	62	68	130		3	9	11	40	0.29		
DAT0311	1164	60	69	129		3	9	12	40	0.28		
DAT0311	1165	61	72	133		3	9	13	40	0.28		
DAT0311	1166	62	73	135		3	9	14	40	0.28		
DAT0311	1167	61	71	132		3	9	15	40	0.29		
DAT0311	1168	61	76	137		3	9	16	40	0.31		
DAT0311	1169	61	72	133		3	9	17	40	0.30		
DAT0311	1170	62	70	132	132.5	3	9	18	40	0.31	0.293	
DAT0311	1171	66	74	140		3	9	19	40	0.31		
DAT0311	1172	65	71	136		3	9	20	40	0.31		
DAT0311	1173	64	73	137		3	9	21	40	0.30		
DAT0311	1174	62	71	133		3	9	22	40	0.32		
DAT0311	1175	62	70	132		3	9	23	40	0.31		
DAT0311	1176	61	72	133		3	10	0	40	0.31		
DAT0311	1177	61	70	131		3	10	1	40	0.30		
DAT0311	1178	65	70	135		3	10	2	40	0.29		
DAT0311	1179	62	68	130		3	10	3	40	0.30		
DAT0311	1180	63	69	132	133.9	3	10	4	40	0.30	0.305	
DAT0311	1181	62	67	129		3	10	5	40	0.30		
DAT0311	1182	63	70	133		3	10	6	40	0.30		
DAT0311	1183	62	67	129		3	10	7	40	0.30		
DAT0311	1184	63	71	134		3	10	8	40	0.30		
DAT0311	1185	58	70	128		3	10	9	40	0.30		
DAT0311	1186	61	68	129		3	10	10	40	0.30		
DAT0311	1187	62	70	132		3	10	11	40	0.29		
DAT0311	1188	62	70	132		3	10	12	40	0.29		
DAT0311	1189	64	70	134		3	10	13	40	0.27		
DAT0311	1190	62	69	131	131.1	3	10	14	40	0.27	0.292	
DAT0311	1191	61	71	132		3	10	15	40	0.28		
DAT0311	1192	60	70	130		3	10	16	40	0.27		
DAT0311	1193	64	72	136		3	10	17	40	0.30		
DAT0311	1194	62	67	129		3	10	18	40	0.29		
DAT0311	1195	61	72	133		3	10	19	40	0.31		
DAT0311	1196	60	72	132		3	10	20	40	0.31		
DAT0311	1197	64	70	134		3	10	21	40	0.31		
DAT0311	1198	63	71	134		3	10	22	40	0.31		
DAT0311	1199	64	71	135		3	10	23	40	0.31		
DAT0311	1200	67	70	137	133.2	3	11	0	40	0.31	0.3	

Appendix K: Analog Reliability Test Data - Test #3 (Test Period #2)

SubDir	Test #	Devices Upset				Ave	Date(1996)		Time		File size (Mb)			Notes
		Bd #1	Bd #2	Total					full	ave	part			
DAT0311	1201	66	72	138		3	11	1	40	0.30				
DAT0311	1202	68	72	140		3	11	2	40	0.30				
DAT0311	1203	62	70	132		3	11	3	40	0.30				
DAT0311	1204	65	70	135		3	11	4	40	0.30				
DAT0311	1205	65	69	134		3	11	5	40	0.31				
DAT0311	1206	62	71	133		3	11	6	40	0.31				
DAT0311	1207	66	70	136		3	11	7	40	0.31				
DAT0311	1208	66	71	137		3	11	8	40	0.31				
DAT0311	1209	63	69	132		3	11	9	18			0.2		
DAT0313	1210	52	57	109	132.6	3	11	9	53		0.305	0.2	4 Min	
DAT0313	1211	62	74	136		3	11	10	53	0.27				
DAT0313	1212	65	70	135		3	11	11	53	0.27				
DAT0313	1213	69	70	139		3	11	12	53	0.27				
DAT0313	1214	65	71	136		3	11	13	53	0.27				
DAT0313	1215	65	72	137		3	11	14	53	0.27				
DAT0313	1216	68	74	142		3	11	15	53	0.29				
DAT0313	1217	61	69	130		3	11	16	53	0.30				
DAT0313	1218	60	70	130		3	11	17	53	0.28				
DAT0313	1219	64	70	134		3	11	18	53	0.30				
DAT0313	1220	63	68	131	135	3	11	19	53	0.31	0.283			
DAT0313	1221	62	69	131		3	11	20	53	0.31				
DAT0313	1222	64	70	134		3	11	21	53	0.31				
DAT0313	1223	65	75	140		3	11	22	53	0.32				
DAT0313	1224	62	71	133		3	11	23	53	0.32				
DAT0313	1225	63	73	136		3	12	0	53	0.32				
DAT0313	1226	63	73	136		3	12	1	53	0.31				
DAT0313	1227	63	72	135		3	12	2	53	0.31				
DAT0313	1228	66	73	139		3	12	3	53	0.31				
DAT0313	1229	66	72	138		3	12	4	53	0.32				
DAT0313	1230	65	77	142	136.4	3	12	5	53	0.32	0.315			
DAT0313	1231	70	74	144		3	12	6	53	0.32				
DAT0313	1232	64	76	140		3	12	7	53	0.32				
DAT0313	1233	65	78	143		3	12	8	53	0.32				
DAT0313	1234	65	76	141		3	12	9	53	0.32				
DAT0313	1235	68	75	143		3	12	10	53	0.32				
DAT0313	1236	64	75	139		3	12	11	53	0.32				
DAT0313	1237	65	75	140		3	12	12	53	0.32				
DAT0313	1238	63	75	138		3	12	13	53	0.32				
DAT0313	1239	65	74	139		3	12	14	53	0.29				
DAT0313	1240	65	74	139	140.6	3	12	15	53	0.27	0.312			
DAT0313	1241	65	75	140		3	12	16	53	0.27				
DAT0313	1242	65	74	139		3	12	17	53	0.30				
DAT0313	1243	64	76	140		3	12	18	53	0.32				
DAT0313	1244	66	75	141		3	12	19	53	0.32				
DAT0313	1245	63	75	138		3	12	20	53	0.31				
DAT0313	1246	66	77	143		3	12	21	53	0.31				
DAT0313	1247	65	75	140		3	12	22	53	0.31				
DAT0313	1248	64	73	137		3	12	23	53	0.31				
DAT0313	1249	62	75	137		3	13	0	53	0.30				
DAT0313	1250	62	71	133	138.8	3	13	1	53	0.30	0.305			

Appendix K: Analog Reliability Test Data - Test #3 (Test Period #2)

SubDir	Test #	Devices Upset				Date(1996)	Time		File size (Mb)			Notes
		Bd #1	Bd #2	Total	Ave				full	ave	part	
DAT0313	1251	65	73	138		3	13	2	53	0.30		
DAT0313	1252	63	76	139		3	13	3	53	0.30		
DAT0313	1253	63	72	135		3	13	4	53	0.30		
DAT0313	1254	66	73	139		3	13	5	53	0.30		
DAT0313	1255	62	72	134		3	13	6	53	0.29		
DAT0313	1256	64	73	137		3	13	7	53	0.29		
DAT0313	1257	61	72	133		3	13	8	53	0.29		
DAT0313	1258	62	72	134		3	13	9	53	0.30		
DAT0313	1259	62	71	133		3	13	10	53	0.29		
DAT0313	1260	59	69	128	135	3	13	11	53	0.26	0.292	
DAT0313	1261	58	72	130		3	13	12	53	0.26		
DAT0313	1262	59	67	126		3	13	13	31			0.15
DAT0315	1263	48	62	110		3	13	14	5			0.02 4 Min
DAT0315	1264	60	67	127		3	13	15	6	0.25		
DAT0315	1265	62	66	128		3	13	16	6	0.25		
DAT0315	1266	58	66	124		3	13	17	6	0.25		
DAT0315	1267	61	68	129		3	13	18	6	0.25		
DAT0315	1268	59	70	129		3	13	19	6	0.27		
DAT0315	1269	62	67	129		3	13	20	6	0.29		
DAT0315	1270	63	71	134	126.6	3	13	21	6	0.30	0.265	
DAT0315	1271	63	74	137		3	13	22	6	0.30		
DAT0315	1272	60	71	131		3	13	23	6	0.30		
DAT0315	1273	63	70	133		3	14	0	6	0.30		
DAT0315	1274	63	69	132		3	14	1	6	0.31		
DAT0315	1275	62	74	136		3	14	2	6	0.31		
DAT0315	1276	66	73	139		3	14	3	6	0.31		
DAT0315	1277	64	71	135		3	14	4	6	0.31		
DAT0315	1278	64	72	136		3	14	5	6	0.31		
DAT0315	1279	62	72	134		3	14	6	6	0.31		
DAT0315	1280	64	73	137	135	3	14	7	6	0.32	0.308	
DAT0315	1281	62	73	135		3	14	8	6	0.32		
DAT0315	1282	66	73	139		3	14	9	6	0.32		
DAT0315	1283	61	75	136		3	14	10	6	0.32		
DAT0315	1284	64	72	136		3	14	11	6	0.31		
DAT0315	1285	66	74	140		3	14	12	6	0.32		
DAT0315	1286	64	72	136		3	14	13	6	0.27		
DAT0315	1287	67	69	136		3	14	14	6	0.26		
DAT0315	1288	66	68	134		3	14	15	6	0.28		
DAT0315	1289	65	69	134		3	14	16	6	0.28		
DAT0315	1290	68	74	142	136.8	3	14	17	6	0.29	0.297	
DAT0315	1291	67	73	140		3	14	18	6	0.29		
DAT0315	1292	67	71	138		3	14	19	6	0.27		
DAT0315	1293	69	73	142		3	14	20	6	0.27		
DAT0315	1294	63	73	136		3	14	21	6	0.27		
DAT0315	1295	66	73	139		3	14	22	6	0.29		
DAT0315	1296	69	76	145		3	14	23	6	0.28		
DAT0315	1297	64	73	137		3	15	0	6	0.27		
DAT0315	1298	63	74	137		3	15	1	6	0.30		
DAT0315	1299	65	73	138		3	15	2	6	0.30		
DAT0315	1300	65	73	138	139	3	15	3	6	0.31	0.285	

Appendix K: Analog Reliability Test Data - Test #3 (Test Period #2)

SubDir	Test #	Devices Upset				Date(1996)	Time		File size (Mb)			Notes
		Bd #1	Bd #2	Total	Ave				full	ave	part	
DAT0315	1301	67	72	139		3	15	4	6	0.31		
DAT0315	1302	65	74	139		3	15	5	6	0.31		
DAT0315	1303	64	72	136		3	15	6	6	0.31		
DAT0315	1304	67	74	141		3	15	7	6	0.31		
DAT0315	1305	66	74	140		3	15	8	6	0.31		
DAT0315	1306	64	73	137		3	15	9	6	0.31		
DAT0315	1307	65	75	140		3	15	10	6	0.31		
DAT0315	1308	64	73	137		3	15	11	6	0.31		
DAT0315	1309	64	73	137		3	15	12	6	0.29		
DAT0315	1310	64	70	134	138	3	15	13	6	0.28	0.305	
DAT0315	1311	66	73	139		3	15	14	6	0.26		
DAT0315	1312	64	70	134		3	15	15	6	0.26		
DAT0315	1313	63	69	132		3	15	16	6	0.26		
DAT0315	1314	64	67	131		3	15	16	39		0.15	
DAT0318	1315	56	66	122		3	15	16	58		0.02	4 Min
DAT0318	1316	64	72	136		3	15	17	59	0.26		
DAT0318	1317	64	72	136		3	15	18	59	0.29		
DAT0318	1318	64	71	135		3	15	19	59	0.30		
DAT0318	1319	62	71	133		3	15	20	59	0.31		
DAT0318	1320	66	73	139	133.7	3	15	21	59	0.31	0.281	
DAT0318	1321	64	73	137		3	15	22	59	0.31		
DAT0318	1322	60	74	134		3	15	23	59	0.31		
DAT0318	1323	65	73	138		3	16	0	59	0.31		
DAT0318	1324	65	72	137		3	16	1	59	0.31		
DAT0318	1325	62	74	136		3	16	2	59	0.31		
DAT0318	1326	67	76	143		3	16	3	59	0.34		
DAT0318	1327	67	76	143		3	16	4	59	0.33		
DAT0318	1328	67	76	143		3	16	5	59	0.34		
DAT0318	1329	68	79	147		3	16	6	59	0.33		
DAT0318	1330	69	76	145	140.3	3	16	7	59	0.35	0.324	
DAT0318	1331	66	74	140		3	16	8	59	0.34		
DAT0318	1332	66	76	142		3	16	9	59	0.33		
DAT0318	1333	65	75	140		3	16	10	59	0.33		
DAT0318	1334	64	74	138		3	16	11	59	0.33		
DAT0318	1335	66	76	142		3	16	12	59	0.31		
DAT0318	1336	68	76	144		3	16	13	59	0.33		
DAT0318	1337	65	74	139		3	16	14	59	0.28		
DAT0318	1338	66	75	141		3	16	15	59	0.33		
DAT0318	1339	67	75	142		3	16	16	59	0.30		
DAT0318	1340	68	74	142	141	3	16	17	59	0.34	0.322	
DAT0318	1341	64	76	140		3	16	18	59	0.33		
DAT0318	1342	61	74	135		3	16	19	59	0.33		
DAT0318	1343	63	73	136		3	16	20	59	0.32		
DAT0318	1344	64	72	136		3	16	21	59	0.32		
DAT0318	1345	65	74	139		3	16	22	59	0.32		
DAT0318	1346	64	75	139		3	16	23	59	0.32		
DAT0318	1347	63	75	138		3	17	0	59	0.32		
DAT0318	1348	65	74	139		3	17	1	59	0.32		
DAT0318	1349	61	72	133		3	17	2	59	0.31		
DAT0318	1350	62	73	135	137	3	17	3	59	0.31	0.32	

Appendix K: Analog Reliability Test Data - Test #3 (Test Period #2)

SubDir	Test #	Devices Upset				Date(1996)	Time		File size (Mb)			Notes
		Bd #1	Bd #2	Total	Ave				full	ave	part	
DAT0318	1351	61	77	138		3	17	4	59	0.33		
DAT0318	1352	65	74	139		3	17	5	59	0.32		
DAT0318	1353	62	74	136		3	17	6	59	0.31		
DAT0318	1354	61	71	132		3	17	7	59	0.31		
DAT0318	1355	63	72	135		3	17	8	59	0.31		
DAT0318	1356	63	73	136		3	17	9	59	0.31		
DAT0318	1357	60	70	130		3	17	10	59	0.30		
DAT0318	1358	60	72	132		3	17	11	59	0.28		
DAT0318	1359	64	67	131		3	17	12	59	0.26		
DAT0318	1360	66	72	138	134.7	3	17	13	59	0.26	0.299	
DAT0318	1361	61	71	132		3	17	14	59	0.26		
DAT0318	1362	66	71	137		3	17	15	59	0.26		
DAT0318	1363	63	70	133		3	17	16	59	0.27		
DAT0318	1364	64	70	134		3	17	17	59	0.27		
DAT0318	1365	62	71	133		3	17	18	59	0.27		
DAT0318	1366	59	74	133		3	17	19	59	0.28		
DAT0318	1367	62	77	139		3	17	20	59	0.29		
DAT0318	1368	63	75	138		3	17	21	59	0.29		
DAT0318	1369	62	73	135		3	17	22	59	0.29		
DAT0318	1370	65	76	141	135.5	3	17	23	59	0.30	0.278	
DAT0318	1371	63	74	137		3	18	0	59	0.31		
DAT0318	1372	64	73	137		3	18	1	59	0.31		
DAT0318	1373	61	73	134		3	18	2	59	0.31		
DAT0318	1374	67	75	142		3	18	3	59	0.32		
DAT0318	1375	63	75	138		3	18	4	59	0.32		
DAT0318	1376	63	73	136		3	18	5	59	0.32		
DAT0318	1377	63	76	139		3	18	6	59	0.32		
DAT0318	1378	64	74	138		3	18	7	59	0.32		
DAT0318	1379	66	74	140		3	18	8	58	0.32		
DAT0320	1380	59	66	125	136.6	3	18	9	49		0.317	0.02 4 Min
DAT0320	1381	63	75	138		3	18	10	49	0.33		
DAT0320	1382	63	77	140		3	18	11	49	0.33		
DAT0320	1383	65	74	139		3	18	12	49	0.29		
DAT0320	1384	69	74	143		3	18	13	49	0.27		
DAT0320	1385	61	70	131		3	18	14	49	0.27		
DAT0320	1386	66	70	136		3	18	15	49	0.29		
DAT0320	1387	66	72	138		3	18	16	49	0.29		
DAT0320	1388	67	70	137		3	18	17	49	0.29		
DAT0320	1389	65	71	136		3	18	18	49	0.28		
DAT0320	1390	69	72	141	137.9	3	18	19	49	0.30	0.294	
DAT0320	1391	68	78	146		3	18	20	49	0.31		
DAT0320	1392	70	76	146		3	18	21	49	0.33		
DAT0320	1393	70	76	146		3	18	22	49	0.35		
DAT0320	1394	68	76	144		3	18	23	49	0.35		
DAT0320	1395	68	74	142		3	18	0	49	0.35		
DAT0320	1396	71	75	146		3	19	1	49	0.35		
DAT0320	1397	70	74	144		3	19	2	49	0.36		
DAT0320	1398	70	73	143		3	19	3	49	0.35		
DAT0320	1399	72	73	145		3	19	4	49	0.35		
DAT0320	1400	69	73	142	144.4	3	19	5	49	0.35	0.345	

Appendix K: Analog Reliability Test Data - Test #3 (Test Period #2)

SubDir	Test #	Devices Upset				Date(1996)	Time	File size (Mb)			Notes
		Bd #1	Bd #2	Total	Ave			full	ave	part	
DAT0320	1401	68	72	140		3 19	6 49	0.35			
DAT0320	1402	66	76	142		3 19	7 49	0.35			
DAT0320	1403	67	75	142		3 19	8 49	0.35			
DAT0320	1404	70	75	145		3 19	9 49	0.34			
DAT0320	1405	68	75	143		3 19	10 49	0.34			
DAT0320	1406	68	74	142		3 19	11 49	0.34			
DAT0320	1407	68	75	143		3 19	12 49	0.34			
DAT0320	1408	70	72	142		3 19	13 49	0.34			
DAT0320	1409	69	74	143		3 19	14 49	0.32			
DAT0320	1410	69	74	143	142.5	3 19	15 49	0.33	0.34		
DAT0320	1411	69	74	143		3 19	16 49	0.32			
DAT0320	1412	69	75	144		3 19	17 49	0.31			
DAT0320	1413	69	74	143		3 19	18 49	0.34			
DAT0320	1414	70	74	144		3 19	19 49	0.34			
DAT0320	1415	67	73	140		3 19	20 49	0.34			
DAT0320	1416	66	72	138		3 19	21 49	0.34			
DAT0320	1417	66	75	141		3 19	22 49	0.35			
DAT0320	1418	66	76	142		3 19	23 49	0.35			
DAT0320	1419	65	72	137		3 20	0 49	0.35			
DAT0320	1420	66	73	139	141.1	3 20	1 49	0.34	0.338		
DAT0320	1421	65	73	138		3 20	2 49	0.34			
DAT0320	1422	67	76	143		3 20	3 49	0.34			
DAT0320	1423	67	74	141		3 20	4 49	0.34			
DAT0320	1424	68	72	140		3 20	5 49	0.35			
DAT0320	1425	68	77	145		3 20	6 49	0.35			
DAT0320	1426	65	74	139		3 20	7 49	0.35			
DAT0320	1427	69	77	146		3 20	8 49	0.35			
DAT0320	1428	68	75	143		3 20	9 49	0.35			
DAT0320	1429	65	76	141		3 20	10 49	0.35			
DAT0320	1430	73	75	148	142.4	3 20	11 49	0.34	0.346		
DAT0322	1431	64	69	133		3 20	12 22			0.03	4 Min
DAT0322	1432	69	77	146		3 20	13 22	0.32			
DAT0322	1433	71	73	144		3 20	14 22	0.28			
DAT0322	1434	68	74	142		3 20	15 22	0.29			
DAT0322	1435	69	71	140		3 20	16 22	0.30			
DAT0322	1436	71	75	146		3 20	17 22	0.31			
DAT0322	1437	71	72	143		3 20	18 22	0.30			
DAT0322	1438	67	74	141		3 20	19 22	0.29			
DAT0322	1439	66	75	141		3 20	20 22	0.31			
DAT0322	1440	64	74	138	141.4	3 20	21 22	0.31	0.301		
DAT0322	1441	65	73	138		3 20	22 22	0.32			
DAT0322	1442	67	76	143		3 20	23 22	0.33			
DAT0322	1443	66	72	138		3 21	0 22	0.33			
DAT0322	1444	65	75	140		3 21	1 22	0.33			
DAT0322	1445	67	74	141		3 21	2 22	0.33			
DAT0322	1446	67	74	141		3 21	3 22	0.33			
DAT0322	1447	65	75	140		3 21	4 22	0.33			
DAT0322	1448	63	75	138		3 21	5 22	0.33			
DAT0322	1449	66	72	138		3 21	6 22	0.33			
DAT0322	1450	68	72	140	139.7	3 21	7 22	0.34	0.33		

Appendix K: Analog Reliability Test Data - Test #3 (Test Period #2)

SubDir	Test #	Devices Upset				Date(1996)	Time		File size (Mb)			Notes
		Bd #1	Bd #2	Total	Ave		full	ave	part			
DAT0322	1451	65	73	138		3	21	8	22	0.34		
DAT0322	1452	68	73	141		3	21	9	22	0.34		
DAT0322	1453	66	74	140		3	21	10	22	0.34		
DAT0322	1454	67	75	142		3	21	11	22	0.34		
DAT0322	1455	69	75	144		3	21	12	22	0.33		
DAT0322	1456	69	73	142		3	21	13	22	0.30		
DAT0322	1457	67	73	140		3	21	14	22	0.30		
DAT0322	1458	71	74	145		3	21	15	22	0.31		
DAT0322	1459	70	77	147		3	21	16	22	0.31		
DAT0322	1460	68	72	140	141.9	3	21	17	22	0.31	0.322	
DAT0322	1461	69	73	142		3	21	18	22	0.31		
DAT0322	1462	68	75	143		3	21	19	22	0.32		
DAT0322	1463	70	75	145		3	21	20	22	0.30		
DAT0322	1464	68	75	143		3	21	21	22	0.32		
DAT0322	1465	67	75	142		3	21	22	22	0.32		
DAT0322	1466	69	74	143		3	21	23	22	0.33		
DAT0322	1467	70	76	146		3	22	0	22	0.33		
DAT0322	1468	67	76	143		3	22	1	22	0.33		
DAT0322	1469	68	73	141		3	22	2	22	0.33		
DAT0322	1470	68	76	144	143.2	3	22	3	22	0.33	0.322	
DAT0322	1471	70	72	142		3	22	4	22	0.33		
DAT0322	1472	68	76	144		3	22	5	22	0.32		
DAT0322	1473	69	75	144		3	22	6	22	0.32		
DAT0322	1474	69	74	143		3	22	7	22	0.33		
DAT0322	1475	70	73	143		3	22	8	22	0.33		
DAT0322	1476	70	73	143		3	22	9	22	0.32		
DAT0322	1477	67	74	141		3	22	10	22	0.33		
DAT0322	1478	68	75	143		3	22	11	22	0.33		
DAT0322	1479	67	74	141		3	22	12	22	0.33		
DAT0322	1480	68	74	142	142.6	3	22	13	22	0.33	0.327	
DAT0322	1481	66	73	139		3	22	14	22	0.33		
DAT0322	1482	66	69	135		3	22	14	38			0.08 end
DAT0325	1483	63	68	131		3	22	15	23			0.03 4 Min
DAT0325	1484	68	73	141		3	22	16	23	0.35		
DAT0325	1485	68	74	142		3	22	17	23	0.35		
DAT0325	1486	69	75	144		3	22	18	23	0.35		
DAT0325	1487	67	77	144		3	22	19	23	0.35		
DAT0325	1488	69	76	145		3	22	20	23	0.35		
DAT0325	1489	68	78	146		3	22	21	23	0.35		
DAT0325	1490	68	76	144	141.1	3	22	22	23	0.35	0.348	
DAT0325	1491	69	77	146		3	22	23	23	0.36		
DAT0325	1492	68	74	142		3	23	0	23	0.36		
DAT0325	1493	70	75	145		3	23	1	23	0.36		
DAT0325	1494	68	75	143		3	23	2	23	0.36		
DAT0325	1495	69	78	147		3	23	3	23	0.35		
DAT0325	1496	69	76	145		3	23	4	23	0.35		
DAT0325	1497	69	74	143		3	23	5	23	0.35		
DAT0325	1498	69	77	146		3	23	6	23	0.36		
DAT0325	1499	69	75	144		3	23	7	23	0.35		
DAT0325	1500	70	77	147	144.8	3	23	8	23	0.35	0.355	



Appendix K: Analog Reliability Test Data - Test #3 (Test Period #2)

SubDir	Test #	Devices Upset				Date(1996)	Time		File size (Mb)			Notes
		Bd #1	Bd #2	Total	Ave		full	ave	part			
DAT0325	1501	69	75	144		3	23	9	23	0.36		
DAT0325	1502	69	75	144		3	23	10	23	0.35		
DAT0325	1503	68	75	143		3	23	11	23	0.35		
DAT0325	1504	70	78	148		3	23	12	23	0.35		
DAT0325	1505	68	77	145		3	23	13	23	0.34		
DAT0325	1506	69	74	143		3	23	14	23	0.31		
DAT0325	1507	73	73	146		3	23	15	23	0.30		
DAT0325	1508	70	72	142		3	23	16	23	0.30		
DAT0325	1509	69	73	142		3	23	17	23	0.31		
DAT0325	1510	68	75	143	144	3	23	18	23	0.34	0.331	
DAT0325	1511	67	76	143		3	23	19	23	0.34		
DAT0325	1512	69	74	143		3	23	20	23	0.35		
DAT0325	1513	72	76	148		3	23	21	23	0.35		
DAT0325	1514	71	74	145		3	23	22	23	0.36		
DAT0325	1515	67	74	141		3	23	23	23	0.36		
DAT0325	1516	67	76	143		3	24	0	23	0.35		
DAT0325	1517	68	75	143		3	24	1	23	0.35		
DAT0325	1518	71	73	144		3	24	2	23	0.35		
DAT0325	1519	66	74	140		3	24	3	23	0.35		
DAT0325	1520	68	76	144	143.4	3	24	4	23	0.35	0.351	
DAT0325	1521	66	76	142		3	24	5	23	0.35		
DAT0325	1522	69	75	144		3	24	6	23	0.35		
DAT0325	1523	66	77	143		3	24	7	23	0.35		
DAT0325	1524	68	77	145		3	24	8	23	0.35		
DAT0325	1525	71	75	146		3	24	9	23	0.35		
DAT0325	1526	72	74	146		3	24	10	23	0.35		
DAT0325	1527	72	73	145		3	24	11	23	0.35		
DAT0325	1528	72	77	149		3	24	12	23	0.35		
DAT0325	1529	71	76	147		3	24	13	23	0.35		
DAT0325	1530	70	75	145	145.2	3	24	14	23	0.35	0.35	
DAT0325	1531	72	75	147		3	24	15	23	0.30		
DAT0325	1532	70	74	144		3	24	16	23	0.31		
DAT0325	1533	70	75	145		3	24	17	23	0.32		
DAT0325	1534	70	75	145		3	24	18	23	0.34		
DAT0325	1535	69	73	142		3	24	19	23	0.34		
DAT0325	1536	67	74	141		3	24	20	23	0.34		
DAT0325	1537	71	73	144		3	24	21	23	0.34		
DAT0325	1538	70	75	145		3	24	22	23	0.34		
DAT0325	1539	73	74	147		3	24	23	23	0.35		
DAT0325	1540	70	76	146	144.6	3	25	0	23	0.35	0.333	
DAT0325	1541	72	75	147		3	25	1	23	0.36		
DAT0325	1542	72	74	146		3	25	2	23	0.36		
DAT0325	1543	71	77	148		3	25	3	23	0.36		
DAT0325	1544	73	73	146		3	25	4	23	0.36		
DAT0325	1545	71	75	146		3	25	5	23	0.36		
DAT0325	1546	72	77	149		3	25	6	23	0.36		
DAT0325	1547	73	76	149		3	25	7	23	0.36		
DAT0325	1548	72	75	147		3	25	8	23	0.36		
DAT0325	1549	73	73	146	147.1	3	25	9	23	0.36	0.36	End

### Appendix L: Analog Reliability Test Data - Test #2 (Test Period #3)

Stored in:	Test #	Devices Upset				Ave	Date(1996)		Time		File size (Mb)			Notes
		Bd #1	Bd #2	Total					full	ave	part			
DAT0329	1601	86	94	180		3	28	11	30			0.16	4 Min	
DAT0329	1602	94	100	194		3	28	12	31	2.4				
DAT0329	1603	94	100	194		3	28	13	31	2.4				
DAT0329	1604	94	100	194		3	28	14	31	2.4				
DAT0329	1605	94	100	194		3	28	15	31	2.4				
DAT0329	1606	94	100	194		3	28	16	31	2.5				
DAT0329	1607	94	100	194		3	28	17	31	2.5				
DAT0329	1608	93	100	193		3	28	18	31	2.5				
DAT0329	1609	94	98	192		3	28	19	31	2.5				
DAT0329	1610	93	100	193	192	3	28	20	31	2.4	2.44			
DAT0329	1611	93	100	193		3	28	21	31	2.4				
DAT0329	1612	93	100	193		3	28	22	31	2.5				
DAT0329	1613	92	100	192		3	28	23	31	2.5				
DAT0329	1614	93	100	193		3	29	0	31	2.4				
DAT0329	1615	94	99	193		3	29	1	31	2.5				
DAT0329	1616	93	100	193		3	29	2	31	2.5				
DAT0329	1617	93	100	193		3	29	3	31	2.5				
DAT0329	1618	93	100	193		3	29	4	31	2.5				
DAT0329	1619	93	100	193		3	29	5	31	2.5				
DAT0329	1620	94	100	194	193	3	29	6	31	2.5	2.48			
DAT0329	1621	94	98	192		3	29	7	31	2.5				
DAT0329	1622	94	100	194		3	29	8	31	2.5				
DAT0329	1623	93	98	191		3	29	9	31	2.4				
DAT0329	1624	92	100	192		3	29	10	31	2.5				
DAT0329	1625	94	100	194		3	29	11	31	2.5				
DAT0329	1626	93	100	193		3	29	12	31	2.5				
DAT0329	1627	92	100	192		3	29	13	31	2.4				
DAT0329	1628	93	99	192		3	29	14	31	2.4				
DAT0329	1629	93	100	193		3	29	15	31	2.4				
DAT0401	1630	90	94	184	192	3	29	16	30		2.46	0.16		
DAT0401	1631	93	100	193		3	29	17	30	2.4				
DAT0401	1632	94	100	194		3	29	18	30	2.4				
DAT0401	1633	93	100	193		3	29	19	30	2.4				
DAT0401	1634	92	100	192		3	29	20	30	2.4				
DAT0401	1635	95	100	195		3	29	21	30	2.4				
DAT0401	1636	93	100	193		3	29	22	30	2.4				
DAT0401	1637	92	100	192		3	29	23	30	2.4				
DAT0401	1638	94	100	194		3	30	0	30	2.3				
DAT0401	1639	92	100	192		3	30	1	30	2.4				
DAT0401	1640	93	100	193	193	3	30	2	30	2.4	2.39			
DAT0401	1641	93	100	193		3	30	3	30	2.3				
DAT0401	1642	94	99	193		3	30	4	30	2.3				
DAT0401	1643	93	100	193		3	30	5	30	2.3				
DAT0401	1644	94	100	194		3	30	6	30	2.3				
DAT0401	1645	94	100	194		3	30	7	30	2.3				
DAT0401	1646	95	100	195		3	30	8	30	2.3				
DAT0401	1647	94	100	194		3	30	9	30	2.3				
DAT0401	1648	93	100	193		3	30	10	30	2.4				
DAT0401	1649	97	100	197		3	30	11	30	2.3				
DAT0401	1650	96	100	196	194	3	30	12	30	2.3	2.31			

Appendix L: Analog Reliability Test Data - Test #2 (Test Period #3)

Stored in:	Test #	Devices Upset				Ave	Date(1996)		Time		File size (Mb)			Notes
		Bd #1	Bd #2	Total					full	ave	part			
DAT0401	1651	93	100	193		3	30	13	30	2.4				
DAT0401	1652	92	100	192		3	30	14	30	2.4				
DAT0401	1653	94	99	193		3	30	15	30	2.4				
DAT0401	1654	94	100	194		3	30	16	30	2.4				
DAT0401	1655	99	100	199		3	30	17	30	2.4				
DAT0401	1656	93	100	193		3	30	18	30	2.3				
DAT0401	1657	98	99	197		3	30	19	30	2.1				
DAT0401	1658	94	100	194		3	30	20	30	2.0				
DAT0401	1659	92	100	192		3	30	21	30	2.1				
DAT0401	1660	95	99	194	194	3	30	22	30	2.1	2.26			
DAT0401	1661	93	100	193		3	30	23	30	2.1				
DAT0401	1662	94	100	194		3	31	0	30	2.2				
DAT0401	1663	93	100	193		3	31	1	30	2.3				
DAT0401	1664	98	100	198		3	31	2	30	2.3				
DAT0401	1665	93	100	193		3	31	3	30	2.4				
DAT0401	1666	93	100	193		3	31	4	30	2.3				
DAT0401	1667	94	100	194		3	31	5	30	2.3				
DAT0401	1668	93	100	193		3	31	6	30	2.3				
DAT0401	1669	93	100	193		3	31	7	30	2.4				
DAT0401	1670	93	100	193	194	3	31	8	30	2.4	2.3			
DAT0401	1671	93	100	193		3	31	9	30	2.4				
DAT0401	1672	97	100	197		3	31	10	30	2.3				
DAT0401	1673	95	100	195		3	31	11	30	2.3				
DAT0401	1674	95	99	194		3	31	12	30	2.1				
DAT0401	1675	93	99	192		3	31	13	30	2.3				
DAT0401	1676	94	100	194		3	31	14	30	2.4				
DAT0401	1677	94	100	194		3	31	15	30	2.4				
DAT0401	1678	94	100	194		3	31	16	30	2.4				
DAT0401	1679	94	100	194		3	31	17	30	2.4				
DAT0401	1680	94	100	194	194	3	31	18	30	2.4	2.34			
DAT0401	1681	94	100	194		3	31	19	30	2.4				
DAT0401	1682	93	100	193		3	31	20	30	2.4				
DAT0401	1683	93	100	193		3	31	21	30	2.4				
DAT0401	1684	94	100	194		3	31	22	30	2.4				
DAT0401	1685	94	100	194		3	31	23	30	2.3				
DAT0401	1686	92	100	192		4	1	0	30	2.3				
DAT0401	1687	94	100	194		4	1	1	30	2.2				
DAT0401	1688	94	100	194		4	1	2	30	2.2				
DAT0401	1689	93	99	192		4	1	3	30	2.3				
DAT0401	1690	94	100	194	193	4	1	4	30	2.3	2.32			
DAT0401	1691	93	100	193		4	1	5	30	2.3				
DAT0401	1692	95	100	195		4	1	6	30	2.4				
DAT0401	1693	93	100	193		4	1	7	30	2.4				
DAT0401	1694	93	100	193		4	1	8	30	2.4				
DAT0402	1695	92	98	190		4	1	10	47			0.14	4 Min	
DAT0402	1696	94	100	194		4	1	11	47	2.5				
DAT0402	1697	96	100	196		4	1	12	47	2.5				
DAT0402	1698	94	100	194		4	1	13	47	2.5				
DAT0402	1699	93	100	193		4	1	14	47	2.5				
DAT0402	1700	96	100	196	194	4	1	15	47	2.5	2.44			

Appendix L: Analog Reliability Test Data - Test #2 (Test Period #3)

Stored in:	Test #	Devices Upset				Ave	Date(1996)		Time		File size (Mb)			Notes
		Bd #1	Bd #2	Total					full	ave	part			
DAT0402	1701	96	100	196		4	1	16	47	2.5				
DAT0402	1702	93	100	193		4	1	17	47	2.5				
DAT0402	1703	93	100	193		4	1	18	47	2.5				
DAT0402	1704	93	99	192		4	1	19	47	2.5				
DAT0402	1705	95	100	195		4	1	20	47	2.4				
DAT0402	1706	93	100	193		4	1	21	47	2.5				
DAT0402	1707	93	100	193		4	1	22	47	2.5				
DAT0402	1708	94	100	194		4	1	23	47	2.5				
DAT0402	1709	93	100	193		4	2	0	47	2.5				
DAT0402	1710	93	100	193	194	4	2	1	47	2.5	2.49			
DAT0402	1711	96	100	196		4	2	2	47	2.4				
DAT0402	1712	92	100	192		4	2	3	47	2.4				
DAT0402	1713	92	100	192		4	2	4	47	2.4				
DAT0402	1714	93	100	193		4	2	5	47	2.4				
DAT0402	1715	94	100	194		4	2	6	47	2.4				
DAT0402	1716	96	100	196		4	2	7	47	2.4				
DAT0403	1717	90	95	185		4	2	13	52			0.17	4Min	
DAT0403	1718	93	100	193		4	2	14	52	2.4				
DAT0403	1719	93	99	192		4	2	15	52	2.5				
DAT0403	1720	93	100	193	193	4	2	16	52	2.5	2.42			
DAT0403	1721	97	100	197		4	2	17	52	2.1				
DAT0403	1722	94	100	194		4	2	18	52	2.0				
DAT0403	1723	94	99	193		4	2	19	52	2.0				
DAT0403	1724	94	100	194		4	2	20	52	2.0				
DAT0403	1725	94	100	194		4	2	21	52	2.0				
DAT0403	1726	94	100	194		4	2	22	52	2.0				
DAT0403	1727	95	100	195		4	2	23	52	2.0				
DAT0403	1728	94	100	194		4	3	0	52	2.0				
DAT0403	1729	93	100	193		4	3	1	52	2.0				
DAT0403	1730	93	100	193	194	4	3	2	52	1.9	2			
DAT0403	1731	93	100	193		4	3	3	52	1.9				
DAT0403	1732	94	100	194		4	3	4	52	2.0				
DAT0403	1733	93	100	193		4	3	5	52	2.0				
DAT0403	1734	96	100	196		4	3	6	52	2.0				
DAT0403	1735	93	100	193		4	3	7	52	2.0				
DAT0403	1736	93	100	193		4	3	8	52	2.0				
DAT0403	1737	94	100	194		4	3	9	52	2.0				
DAT0403	1738	94	100	194		4	3	10	52	2.0				
DAT0403	1739	95	100	195		4	3	11	52	2.2				
DAT0403	1740	94	100	194	194	4	3	12	52	2.3	2.04			
DAT0404	1741	89	98	187		4	3	14	17			0.17	4 Min	
DAT0404	1742	94	100	194		4	3	15	18	2.4				
DAT0404	1743	93	100	193		4	3	16	18	2.4				
DAT0404	1744	94	100	194		4	3	17	18	2.4				
DAT0404	1745	93	100	193		4	3	18	18	2.4				
DAT0404	1746	93	100	193		4	3	19	18	2.0				
DAT0404	1747	94	100	194		4	3	20	18	2.1				
DAT0404	1748	95	100	195		4	3	21	18	2.1				
DAT0404	1749	94	100	194		4	3	22	18	2.2				
DAT0404	1750	94	100	194	193	4	3	23	18	2.3	2.26			

Appendix L: Analog Reliability Test Data - Test #2 (Test Period #3)

Stored in:	Test #	Devices Upset				Ave	Date(1996)		File size (Mb)			Notes
		Bd #1	Bd #2	Total			Time	full	ave	part		
DAT0404	1751	95	100	195		4	4	0	18	2.3		
DAT0404	1752	93	100	193		4	4	1	18	2.3		
DAT0404	1753	92	100	192		4	4	2	18	2.3		
DAT0404	1754	96	100	196		4	4	3	18	2.2		
DAT0404	1755	96	100	196		4	4	4	18	2.2		
DAT0404	1756	95	99	194		4	4	5	18	2.2		
DAT0404	1757	94	100	194		4	4	6	18	2.2		
DAT0404	1758	92	100	192		4	4	7	18	2.2		
DAT0404	1759	93	100	193		4	4	8	18	2.2		
DAT0404	1760	92	100	192	194	4	4	9	18	2.3	2.24	
DAT0404	1761	93	100	193		4	4	10	18	2.3		
DAT0404	1762	93	100	193		4	4	11	18	2.2		
DAT0404	1763	94	100	194		4	4	12	18	2.4		
DAT0404	1764	94	99	193		4	4	13	18	2.5		
DAT0404	1765	93	100	193		4	4	14	18	2.5		
DAT0405	1766	92	98	190		4	4	16	15		0.18	4 Min
DAT0405	1767	93	100	193		4	4	17	15	2.5		
DAT0405	1768	95	100	195		4	4	18	15	2.6		
DAT0405	1769	96	100	196		4	4	19	15	2.5		
DAT0405	1770	95	100	195	194	4	4	20	15	2.4	2.43	
DAT0405	1771	96	100	196		4	4	21	15	2.2		
DAT0405	1772	97	100	197		4	4	22	15	2.0		
DAT0405	1773	93	100	193		4	4	23	15	2.2		
DAT0405	1774	92	100	192		4	5	0	15	2.1		
DAT0405	1775	92	100	192		4	5	1	15	2.3		
DAT0405	1776	93	100	193		4	5	2	15	2.3		
DAT0405	1777	93	100	193		4	5	3	15	2.3		
DAT0405	1778	92	100	192		4	5	4	15	2.3		
DAT0405	1779	92	100	192		4	5	5	15	2.3		
DAT0405	1780	92	100	192	193	4	5	6	15	2.3	2.23	
DAT0405	1781	94	100	194		4	5	7	15	2.4		
DAT0405	1782	92	100	192		4	5	8	15	2.3		
DAT0405	1783	93	100	193		4	5	9	15	2.4		
DAT0405	1784	92	100	192		4	5	10	15	2.2		
DAT0405	1785	92	100	192		4	5	11	15	2.1		
DAT0405	1786	95	100	195		4	5	12	15	2.3		
DAT0405	1787	93	100	193		4	5	13	15	2.4		
DAT0405	1788	93	99	192		4	5	13	24		0.34	end
DAT0408	1789	94	100	194		4	5	16	11	2.5		
DAT0408	1790	94	100	194	193	4	5	17	11	2.6	2.36	
DAT0408	1791	96	100	196		4	5	18	11	2.5		
DAT0408	1792	94	100	194		4	5	19	11	2.5		
DAT0408	1793	94	100	194		4	5	20	11	2.4		
DAT0408	1794	98	100	198		4	5	21	11	2.3		
DAT0408	1795	96	100	196		4	5	22	11	2.1		
DAT0408	1796	94	100	194		4	5	23	11	2.1		
DAT0408	1797	92	100	192		4	6	0	11	2.2		
DAT0408	1798	93	100	193		4	6	1	11	2.2		
DAT0408	1799	97	100	197		4	6	2	11	2.4		
DAT0408	1800	93	100	193	195	4	6	3	11	2.4	2.31	

Appendix L: Analog Reliability Test Data - Test #2 (Test Period #3)

Stored in:	Test #	Devices Upset				Ave	Date(1996)		File size (Mb)			Notes
		Bd #1	Bd #2	Total			Time	full	ave	part		
DAT0408	1801	94	99	193		4	6	4	11	2.4		
DAT0408	1802	95	100	195		4	6	5	11	2.4		
DAT0408	1803	97	100	197		4	6	6	11	2.5		
DAT0408	1804	96	100	196		4	6	7	11	2.4		
DAT0408	1805	96	100	196		4	6	8	11	2.3		
DAT0408	1806	95	100	195		4	6	9	11	2.3		
DAT0408	1807	99	100	199		4	6	10	11	2.3		
DAT0408	1808	96	100	196		4	6	11	11	2.3		
DAT0408	1809	93	100	193		4	6	12	11	2.4		
DAT0408	1810	95	100	195	196	4	6	13	11	2.3	2.36	
DAT0408	1811	95	100	195		4	6	14	11	2.3		
DAT0408	1812	94	100	194		4	6	15	11	2.3		
DAT0408	1813	95	100	195		4	6	16	11	2.2		
DAT0408	1814	94	100	194		4	6	17	11	2.3		
DAT0408	1815	95	100	195		4	6	18	11	2.3		
DAT0408	1816	95	100	195		4	6	19	11	2.3		
DAT0408	1817	95	100	195		4	6	20	11	2.3		
DAT0408	1818	95	100	195		4	6	21	11	2.3		
DAT0408	1819	98	100	198		4	6	22	11	2.3		
DAT0408	1820	94	100	194	195	4	6	23	11	2.2	2.28	
DAT0408	1821	95	100	195		4	7	0	11	2.2		
DAT0408	1822	97	100	197		4	7	1	11	2.3		
DAT0408	1823	95	100	195		4	7	3	11	4.5		
DAT0408	1824	94	100	194		4	7	4	11	2.5		
DAT0408	1825	96	100	196		4	7	5	11	2.4		
DAT0408	1826	93	100	193		4	7	6	11	2.4		
DAT0408	1827	95	99	194		4	7	7	11	2.5		
DAT0408	1828	96	100	196		4	7	8	11	2.3		
DAT0408	1829	99	100	199		4	7	9	11	2.4		
DAT0408	1830	94	100	194	195	4	7	10	11	2.2	2.57	
DAT0408	1831	93	100	193		4	7	11	11	2.2		
DAT0408	1832	96	100	196		4	7	12	11	2.3		
DAT0408	1833	95	100	195		4	7	13	11	2.6		
DAT0408	1834	93	100	193		4	7	14	11	2.6		
DAT0408	1835	93	100	193		4	7	15	11	2.6		
DAT0408	1836	93	100	193		4	7	16	11	2.6		
DAT0408	1837	93	100	193		4	7	17	11	2.6		
DAT0408	1838	95	100	195		4	7	18	11	2.6		
DAT0408	1839	94	100	194		4	7	19	11	2.6		
DAT0408	1840	94	100	194	194	4	7	20	11	2.6	2.53	
DAT0408	1841	96	100	196		4	7	21	11	2.6		
DAT0408	1842	95	100	195		4	7	22	11	2.5		
DAT0408	1843	97	100	197		4	7	23	11	2.5		
DAT0408	1844	95	100	195		4	8	0	11	2.2		
DAT0408	1845	94	100	194		4	8	1	11	2.2		
DAT0408	1846	95	100	195		4	8	2	11	2.4		
DAT0408	1847	98	100	198		4	8	3	11	2.3		
DAT0408	1848	96	100	196		4	8	4	11	2.4		
DAT0408	1849	95	100	195		4	8	5	11	2.4		
DAT0408	1850	96	100	196	196	4	8	6	11	2.3	2.38	

Appendix L: Analog Reliability Test Data - Test #2 (Test Period #3)

Stored in:	Test #	Devices Upset				Ave	Date(1996)		File size (Mb)			Notes
		Bd #1	Bd #2	Total			Time	full	ave	part		
DAT0408	1851	94	100	194		4	8	7	11	2.3		
DAT0408	1852	95	100	195		4	8	8	11	2.2		
DAT0408	1853	95	100	195		4	8	9	11	2.2		
DAT0408	1854	97	100	197		4	8	10	11	2.4		
DAT0408	1855	96	100	196		4	8	11	11	2.5		
DAT0408	1856	93	100	193		4	8	11	29		0.07	
DAT0410	1857	90	97	187		4	8	12	46		0.02	4 Min
DAT0410	1858	95	100	195		4	8	13	49	2.5		
DAT0410	1859	97	99	196		4	8	14	49	2.6		
DAT0410	1860	93	100	193	194	4	8	15	49	2.7	2.43	
DAT0410	1861	93	100	193		4	8	16	49	2.7		
DAT0410	1862	95	100	195		4	8	17	49	2.7		
DAT0410	1863	93	100	193		4	8	18	49	2.7		
DAT0410	1864	97	100	197		4	8	19	49	2.7		
DAT0410	1865	96	100	196		4	8	20	49	2.7		
DAT0410	1866	95	100	195		4	8	21	49	2.7		
DAT0410	1867	94	100	194		4	8	22	49	2.7		
DAT0410	1868	96	100	196		4	8	23	49	2.7		
DAT0410	1869	96	100	196		4	9	0	49	2.7		
DAT0410	1870	93	100	193	195	4	9	1	49	2.7	2.7	
DAT0410	1871	93	100	193		4	9	2	49	2.6		
DAT0410	1872	95	100	195		4	9	3	49	2.6		
DAT0410	1873	95	100	195		4	9	4	49	2.6		
DAT0410	1874	96	100	196		4	9	5	49	2.6		
DAT0410	1875	93	100	193		4	9	6	49	2.6		
DAT0410	1876	93	100	193		4	9	7	49	2.6		
DAT0410	1877	93	100	193		4	9	8	49	2.6		
DAT0410	1878	93	100	193		4	9	9	49	2.6		
DAT0410	1879	93	100	193		4	9	10	49	2.6		
DAT0410	1880	93	100	193	194	4	9	11	49	2.7	2.61	
DAT0410	1881	93	100	193		4	9	12	49	2.7		
DAT0410	1882	95	100	195		4	9	13	49	2.7		
DAT0410	1883	95	100	195		4	9	14	49	2.7		
DAT0410	1884	93	100	193		4	9	15	49	2.7		
DAT0410	1885	94	100	194		4	9	16	49	2.7		
DAT0410	1886	95	100	195		4	9	17	49	2.7		
DAT0410	1887	95	100	195		4	9	18	49	2.6		
DAT0410	1888	94	100	194		4	9	19	49	2.6		
DAT0410	1889	96	100	196		4	9	20	49	2.6		
DAT0410	1890	93	100	193	194	4	9	21	49	2.6	2.66	
DAT0410	1891	93	100	193		4	9	22	49	2.5		
DAT0410	1892	94	100	194		4	9	23	49	2.6		
DAT0410	1893	94	100	194		4	10	0	49	2.5		
DAT0410	1894	93	100	193		4	10	1	49	2.4		
DAT0410	1895	94	100	194		4	10	2	49	2.2		
DAT0410	1896	93	100	193		4	10	3	49	2.1		
DAT0410	1897	95	100	195		4	10	4	49	2.2		
DAT0410	1898	97	100	197		4	10	5	49	2.5		
DAT0410	1899	94	100	194		4	10	6	49	2.4		
DAT0410	1900	96	100	196	194	4	10	7	49	2.4	2.38	

### Appendix L: Analog Reliability Test Data - Test #2 (Test Period #3)

Stored in:	Test #	Devices Upset				Ave	Date(1996)		File size (Mb)			Notes
		Bd #1	Bd #2	Total			Time	full	ave	part		
DAT0410	1901	97	100	197		4	10	8	49	2.4		
DAT0410	1902	96	100	196		4	10	9	49	2.2		
DAT0410	1903	95	100	195		4	10	10	49	2.3		
DAT0410	1904	94	100	194		4	10	11	49	2.5		
DAT0410	1905	94	100	194		4	10	12	49	2.6		
DAT0410	1906	93	99	192		4	10	13	14		0.11	
DAT0412	1907	92	97	189		4	10	16	17		0.15	4 Min
DAT0412	1908	95	100	195		4	10	17	17	2.5		
DAT0412	1909	94	100	194		4	10	18	17	2.4		
DAT0412	1910	93	100	193	194	4	10	19	17	2.3	2.4	
DAT0412	1911	93	100	193		4	10	20	17	2.2		
DAT0412	1912	94	100	194		4	10	21	17	2.5		
DAT0412	1913	94	100	194		4	10	22	17	2.5		
DAT0412	1914	95	100	195		4	10	23	17	2.6		
DAT0412	1915	96	100	196		4	11	0	17	2.6		
DAT0412	1916	93	100	193		4	11	1	17	2.6		
DAT0412	1917	95	100	195		4	11	2	17	2.6		
DAT0412	1918	94	100	194		4	11	3	17	2.6		
DAT0412	1919	95	100	195		4	11	4	17	2.6		
DAT0412	1920	94	100	194	194	4	11	5	17	2.6	2.54	
DAT0412	1921	93	100	193		4	11	6	17	2.6		
DAT0412	1922	94	100	194		4	11	7	17	2.6		
DAT0412	1923	99	100	199		4	11	8	17	2.6		
DAT0412	1924	94	100	194		4	11	9	17	2.6		
DAT0412	1925	95	100	195		4	11	10	17	2.3		
DAT0412	1926	93	100	193		4	11	11	17	2.3		
DAT0412	1927	95	100	195		4	11	12	17	2.3		
DAT0412	1928	99	100	199		4	11	13	17	2.4		
DAT0412	1929	98	100	198		4	11	14	17	2.3		
DAT0412	1930	94	100	194	195	4	11	15	17	2.3	2.43	
DAT0412	1931	94	100	194		4	11	16	17	2.5		
DAT0412	1932	95	100	195		4	11	17	17	2.6		
DAT0412	1933	94	100	194		4	11	18	17	2.6		
DAT0412	1934	94	100	194		4	11	19	17	2.3		
DAT0412	1935	93	100	193		4	11	20	17	2.5		
DAT0412	1936	94	100	194		4	11	21	17	2.6		
DAT0412	1937	93	100	193		4	11	22	17	2.6		
DAT0412	1938	93	100	193		4	11	23	17	2.5		
DAT0412	1939	95	100	195		4	12	0	17	2.4		
DAT0412	1940	93	100	193	194	4	12	1	17	2.3	2.49	
DAT0412	1941	94	100	194		4	12	2	17	2.2		
DAT0412	1942	94	100	194		4	12	3	17	2.2		
DAT0412	1943	94	100	194		4	12	4	17	2.2		
DAT0412	1944	93	100	193		4	12	5	17	2.2		
DAT0412	1945	95	100	195		4	12	6	17	2.1		
DAT0412	1946	95	100	195		4	12	7	17	2.1		
DAT0412	1947	94	100	194		4	12	8	17	2.2		
DAT0412	1948	93	99	192		4	12	9	17	2.3		
DAT0412	1949	94	100	194		4	12	10	17	2.2		
DAT0412	1950	95	100	195	194	4	12	11	17	2.3	2.2	



Appendix L: Analog Reliability Test Data - Test #2 (Test Period #3)

Stored in:	Test #	Devices Upset				Date(1996)		File size (Mb)			part	Notes
		Bd #1	Bd #2	Total	Ave	Time	full	ave				
DAT0412	1951	93	100	193		4	12	12	17	2.5		
DAT0412	1952	94	100	194		4	12	13	17	2.5		
DAT0412	1953	93	100	193		4	12	14	17	2.5		
DAT0412	1954	93	100	193		4	12	15	5			2
DAT0415	1955	90	95	185		4	12	17	5		0.14	4 Min
DAT0415	1956	95	100	195		4	12	18	5	2.2		
DAT0415	1957	93	100	193		4	12	19	5	2.4		
DAT0415	1958	94	100	194		4	12	20	5	2.4		
DAT0415	1959	94	100	194		4	12	21	5	2.3		
DAT0415	1960	95	100	195	193	4	12	22	5	2.2	2.38	
DAT0415	1961	93	100	193		4	12	23	5	2.3		
DAT0415	1962	94	100	194		4	13	0	5	2.4		
DAT0415	1963	94	100	194		4	13	1	5	2.4		
DAT0415	1964	93	100	193		4	13	2	5	2.4		
DAT0415	1965	93	100	193		4	13	3	5	2.5		
DAT0415	1966	93	100	193		4	13	4	5	2.5		
DAT0415	1967	94	100	194		4	13	5	5	2.6		
DAT0415	1968	94	100	194		4	13	6	5	2.6		
DAT0415	1969	97	100	197		4	13	7	5	2.6		
DAT0415	1970	93	100	193	194	4	13	8	5	2.6	2.49	
DAT0415	1971	94	100	194		4	13	9	5	2.6		
DAT0415	1972	95	100	195		4	13	10	5	2.4		
DAT0415	1973	94	100	194		4	13	11	5	2.2		
DAT0415	1974	96	100	196		4	13	12	5	2.4		
DAT0415	1975	96	100	196		4	13	13	5	2.6		
DAT0415	1976	94	100	194		4	13	14	5	2.6		
DAT0415	1977	96	100	196		4	13	15	5	2.7		
DAT0415	1978	94	100	194		4	13	16	5	2.6		
DAT0415	1979	94	100	194		4	13	17	5	2.6		
DAT0415	1980	94	100	194	195	4	13	18	5	2.6	2.53	
DAT0415	1981	94	100	194		4	13	19	5	2.7		
DAT0415	1982	95	100	195		4	13	20	5	2.7		
DAT0415	1983	95	100	195		4	13	21	5	2.6		
DAT0415	1984	96	100	196		4	13	22	5	2.4		
DAT0415	1985	95	100	195		4	13	23	5	2.2		
DAT0415	1986	94	100	194		4	14	0	5	2.1		
DAT0415	1987	93	100	193		4	14	1	5	2.1		
DAT0415	1988	93	100	193		4	14	2	5	2.0		
DAT0415	1989	96	100	196		4	14	3	5	2.1		
DAT0415	1990	93	100	193	194	4	14	4	5	2.1	2.3	
DAT0415	1991	94	100	194		4	14	5	5	2.0		
DAT0415	1992	95	100	195		4	14	6	5	2.2		
DAT0415	1993	93	100	193		4	14	7	5	2.3		
DAT0415	1994	93	100	193		4	14	8	5	2.4		
DAT0415	1995	94	100	194		4	14	9	5	2.4		
DAT0415	1996	95	100	195		4	14	10	5	2.2		
DAT0415	1997	94	100	194		4	14	11	5	2.4		
DAT0415	1998	93	100	193		4	14	12	5	2.6		
DAT0415	1999	93	100	193		4	14	13	5	2.7		
DAT0415	2000	93	100	193	194	4	14	14	5	2.6	2.38	

Appendix L: Analog Reliability Test Data - Test #2 (Test Period #3)

Stored in:	Test #	Devices Upset				Ave	Date(1996)		File size (Mb)			Notes
		Bd #1	Bd #2	Total			Time	full	ave	part		
DAT0415	2001	94	100	194		4	14	15	5	2.6		
DAT0415	2002	93	100	193		4	14	16	5	2.6		
DAT0415	2003	92	99	191		4	14	17	5	2.6		
DAT0415	2004	94	100	194		4	14	18	5	2.7		
DAT0415	2005	95	99	194		4	14	19	5	2.7		
DAT0415	2006	94	100	194		4	14	20	5	2.7		
DAT0415	2007	96	100	196		4	14	21	5	2.7		
DAT0415	2008	94	100	194		4	14	22	5	2.7		
DAT0415	2009	98	100	198		4	14	23	5	2.7		
DAT0415	2010	93	100	193	194	4	15	0	5	2.7	2.67	
DAT0415	2011	94	100	194		4	15	1	5	2.7		
DAT0415	2012	95	100	195		4	15	2	5	2.6		
DAT0415	2013	97	100	197		4	15	3	5	2.4		
DAT0415	2014	94	100	194		4	15	4	5	2.5		
DAT0415	2015	93	100	193		4	15	5	5	2.2		
DAT0415	2016	95	100	195		4	15	6	5	2.6		
DAT0415	2017	94	100	194		4	15	7	5	2.1		
DAT0415	2018	94	100	194		4	15	8	5	2.6		
DAT0415	2019	94	100	194		4	15	9	5	2.2		
DAT0415	2020	94	100	194	194	4	15	9	40		2.43	1.2
DAT0417	2021	93	98	191		4	15	14	49			0.19 4 Min
DAT0417	2022	94	100	194		4	15	15	50	2.7		
DAT0417	2023	95	100	195		4	15	16	50	2.7		
DAT0417	2024	96	100	196		4	15	17	50	2.7		
DAT0417	2025	93	100	193		4	15	18	50	2.8		
DAT0417	2026	96	100	196		4	15	19	50	2.8		
DAT0417	2027	95	100	195		4	15	20	50	2.5		
DAT0417	2028	95	100	195		4	15	21	50	2.4		
DAT0417	2029	94	100	194		4	15	22	50	2.3		
DAT0417	2030	94	100	194	194	4	15	23	50	2.4	2.59	
DAT0417	2031	98	100	198		4	16	0	50	2.5		
DAT0417	2032	95	100	195		4	16	1	50	2.5		
DAT0417	2033	98	100	198		4	16	2	50	2.6		
DAT0417	2034	94	100	194		4	16	3	50	2.6		
DAT0417	2035	94	100	194		4	16	4	50	2.6		
DAT0417	2036	94	100	194		4	16	5	50	2.6		
DAT0417	2037	98	100	198		4	16	6	50	2.6		
DAT0417	2038	94	100	194		4	16	7	50	2.6		
DAT0417	2039	96	100	196		4	16	8	50	2.6		
DAT0417	2040	96	100	196	196	4	16	9	50	2.3	2.55	
DAT0417	2041	95	100	195		4	16	10	50	2.4		
DAT0417	2042	97	100	197		4	16	11	50	2.4		
DAT0417	2043	95	100	195		4	16	12	50	2.3		
DAT0417	2044	95	100	195		4	16	13	50	2.3		
DAT0417	2045	94	100	194		4	16	14	50	2.5		
DAT0417	2046	95	100	195		4	16	15	50	2.4		
DAT0417	2047	94	100	194		4	16	16	50	2.6		
DAT0417	2048	95	100	195		4	16	17	50	2.4		
DAT0417	2049	95	100	195		4	16	18	50	2.4		
DAT0417	2050	96	100	196	195	4	16	19	50	2.3	2.4	

Appendix L: Analog Reliability Test Data - Test #2 (Test Period #3)

Stored in:	Test #	Devices Upset				Ave	Date(1996)		File size (Mb)			part	Notes
		Bd #1	Bd #2	Total			Time	full	ave				
DAT0417	2051	94	100	194		4	16	20	50	2.5			
DAT0417	2052	94	100	194		4	16	21	50	2.6			
DAT0417	2053	95	100	195		4	16	22	50	2.6			
DAT0417	2054	94	100	194		4	16	23	50	2.6			
DAT0417	2055	94	100	194		4	17	0	50	2.6			
DAT0417	2056	94	100	194		4	17	1	50	2.6			
DAT0417	2057	93	100	193		4	17	2	50	2.6			
DAT0417	2058	93	100	193		4	17	3	50	2.6			
DAT0417	2059	95	100	195		4	17	4	50	2.6			
DAT0417	2060	95	100	195	194	4	17	5	50	2.6	2.59		
DAT0417	2061	98	100	198		4	17	6	50	2.6			
DAT0417	2062	96	100	196		4	17	7	50	2.6			
DAT0417	2063	94	100	194		4	17	8	35			1.9	
DAT0418	2064	93	95	188		4	17	11	17			18	4 Min
DAT0418	2065	93	95	188		4	17	12	17	2.5			
DAT0418	2066	95	100	195		4	17	13	17	2.7			
DAT0418	2067	93	100	193		4	17	14	17	2.7			
DAT0418	2068	94	100	194		4	17	15	17	2.7			
DAT0418	2069	94	100	194		4	17	16	17	2.6			
DAT0418	2070	98	100	198	194	4	17	17	17	2.7	2.64		
DAT0418	2071	94	100	194		4	17	18	17	2.7			
DAT0418	2072	94	100	194		4	17	19	17	2.7			
DAT0418	2073	96	100	196		4	17	20	17	2.6			
DAT0418	2074	94	99	193		4	17	21	17	2.6			
DAT0418	2075	99	100	199		4	17	22	17	2.6			
DAT0418	2076	95	100	195		4	17	23	17	2.6			
DAT0418	2077	94	100	194		4	18	0	17	2.6			
DAT0418	2078	96	100	196		4	18	1	17	2.6			
DAT0418	2079	94	100	194		4	18	2	17	2.6			
DAT0418	2080	97	100	197	195	4	18	3	17	2.6	2.62		
DAT0418	2081	98	100	198		4	18	4	17	2.7			
DAT0418	2082	97	100	197		4	18	5	17	2.7			
DAT0418	2083	94	99	193		4	18	6	17	2.7			
DAT0418	2084	97	100	197		4	18	7	17	2.7			
DAT0418	2085	98	99	197		4	18	8	17	2.7			
DAT0418	2086	96	100	196		4	18	9	17	2.7			
DAT0418	2087	97	100	197		4	18	10	17	2.8			
DAT0419	2088	97	100	197		4	18	13	4			15	4 Min
DAT0419	2089	92	95	187		4	18	14	4	2.3			
DAT0419	2090	96	100	196	196	4	18	15	4	2.6	2.66		
DAT0419	2091	94	100	194		4	18	16	4	2.6			
DAT0419	2092	96	100	196		4	18	17	27	2.5			
DAT0419	2093	97	100	197		4	18	18	27	2.4			
DAT0419	2094	94	100	194		4	18	19	27	2.1			
DAT0419	2095	95	100	195		4	18	20	27	2.1			
DAT0419	2096	98	100	198		4	18	21	27	2.1			
DAT0419	2097	95	100	195		4	18	22	27	2.1			
DAT0419	2098	96	100	196		4	18	23	27	2.1			
DAT0419	2099	95	100	195		4	19	0	27	2.2			
DAT0419	2100	95	100	195	196	4	19	1	27	2.2	2.24		

Appendix L: Analog Reliability Test Data - Test #2 (Test Period #3)

Stored in:	Test #	95		100		Total		Ave		Date(1996)		File size (Mb)			Notes
		Bd #1	Bd #2					Time	full	ave	part				
DAT0419	2101	96	100	196		4	19	2	27	2.3					
DAT0419	2102	96	100	196		4	19	3	27	2.4					
DAT0419	2103	94	100	194		4	19	4	27	2.5					
DAT0419	2104	93	100	193		4	19	5	27	2.6					
DAT0419	2105	39	90	129		4	19	9	39	2.3					
DAT0419	2106	41	92	133		4	19	10	39	2.2					
DAT0419	2107	38	91	129		4	19	11	39	2.2					
DAT0419	2108	39	90	129		4	19	12	39	2.1					
DAT0419	2109	41	92	133		4	19	13	39	1.8					
DAT0419	2110	40	90	130	156	4	19	14	39	1.8	2.22				
DAT0419	2111	40	93	133		4	19	15	39	1.9					
DAT0419	2112	41	89	130		4	19	16	39	1.9					
DAT0419	2113	40	92	132		4	19	17	39	2.0					
DAT0419	2114	93	99	192		4	19	18	8				1		
DAT0422	2115	92	92	184		4	19	19	7			0.17	4 Min		
DAT0422	2116	98	100	198		4	19	20	7	2.4					
DAT0422	2117	96	100	196		4	19	21	7	2.2					
DAT0422	2118	95	100	195		4	19	22	7	2.1					
DAT0422	2119	95	100	195		4	19	23	7	2.0					
DAT0422	2120	94	100	194	175	4	20	0	7	2.1	2.08				
DAT0422	2121	95	100	195		4	20	1	7	2.3					
DAT0422	2122	94	100	194		4	20	2	7	2.4					
DAT0422	2123	92	100	192		4	20	3	7	2.4					
DAT0422	2124	92	99	191		4	20	4	7	2.4					
DAT0422	2125	93	100	193		4	20	5	7	2.5					
DAT0422	2126	91	100	191		4	20	6	7	2.5					
DAT0422	2127	91	100	191		4	20	7	7	2.5					
DAT0422	2128	91	100	191		4	20	8	7	2.5					
DAT0422	2129	92	100	192		4	20	9	7	2.5					
DAT0422	2130	91	100	191	192	4	20	10	7	2.5	2.45				
DAT0422	2131	90	100	190		4	20	11	7	2.5					
DAT0422	2132	92	100	192		4	20	12	7	2.5					
DAT0422	2133	92	100	192		4	20	13	7	2.5					
DAT0422	2134	95	100	195		4	20	14	7	2.5					
DAT0422	2135	93	100	193		4	20	15	7	2.5					
DAT0422	2136	93	100	193		4	20	16	7	2.5					
DAT0422	2137	93	100	193		4	20	17	7	2.5					
DAT0422	2138	96	100	196		4	20	18	7	2.5					
DAT0422	2139	96	100	196		4	20	19	7	2.5					
DAT0422	2140	96	100	196	194	4	20	20	7	2.4	2.49				
DAT0422	2141	97	100	197		4	20	21	7	2.5					
DAT0422	2142	97	100	197		4	20	22	7	2.2					
DAT0422	2143	98	100	198		4	20	23	7	2.2					
DAT0422	2144	96	100	196		4	21	0	7	2.2					
DAT0422	2145	97	100	197		4	21	1	7	2.3					
DAT0422	2146	94	100	194		4	21	2	7	2.4					
DAT0422	2147	93	100	193		4	21	3	7	2.5					
DAT0422	2148	91	100	191		4	21	4	7	2.5					
DAT0422	2149	92	100	192		4	21	5	7	2.5					
DAT0422	2150	93	100	193	195	4	21	6	7	2.5	2.38				

Appendix L: Analog Reliability Test Data - Test #2 (Test Period #3)

Stored in:	Devices Upset					File size (Mb)							
	Test #	Bd #1	Bd #2	Total	Ave	Date(1996)		Time		full	ave	part	Notes
DAT0422	2151	96	100	196		4	21	7	7	2.5			
DAT0422	2152	92	100	192		4	21	8	7	2.5			
DAT0422	2153	95	100	195		4	21	9	7	2.5			
DAT0422	2154	93	100	193		4	21	10	7	2.6			
DAT0422	2155	92	99	191		4	21	11	7	2.6			
DAT0422	2156	94	100	194		4	21	12	7	2.5			
DAT0422	2157	93	100	193		4	21	13	7	2.4			
DAT0422	2158	94	100	194		4	21	14	7	2.5			
DAT0422	2159	92	100	192		4	21	15	7	2.6			
DAT0422	2160	93	100	193	193	4	21	16	7	2.5	2.52		
DAT0422	2161	92	100	192		4	21	17	7	2.5			
DAT0422	2162	92	100	192		4	21	18	7	2.5			
DAT0422	2163	94	100	194		4	21	19	7	2.6			
DAT0422	2164	93	100	193		4	21	20	7	2.6			
DAT0422	2165	94	100	194		4	21	21	7	2.6			
DAT0422	2166	95	100	195		4	21	22	7	2.4			
DAT0422	2167	94	100	194		4	21	23	7	2.1			
DAT0422	2168	94	100	194		4	22	0	7	2.2			
DAT0422	2169	98	100	198		4	22	1	7	2.3			
DAT0422	2170	98	100	198	194	4	22	2	7	2.4	2.42		
DAT0422	2171	94	100	194		4	22	3	7	2.4			
DAT0422	2172	97	100	197		4	22	4	7	2.5			
DAT0422	2173	97	100	197		4	22	5	7	2.5			
DAT0422	2174	96	100	196		4	22	6	7	2.5			
DAT0422	2175	97	100	197		4	22	7	7	2.4			
DAT0422	2176	96	100	196		4	22	8	7	2.3			
DAT0422	2177	97	100	197		4	22	9	7	2.4			
DAT0422	2178	94	98	192		4	22	9	21			0.52	
DAT0424	2179	93	96	189		4	22	12	17			0.16	4 Min
DAT0424	2180	97	100	197	195	4	22	13	17	2.6	2.45		
DAT0424	2181	98	100	198		4	22	14	17	2.7			
DAT0424	2182	99	100	199		4	22	15	17	2.7			
DAT0424	2183	98	100	198		4	22	16	17	2.5			
DAT0424	2184	97	100	197		4	22	17	17	2.6			
DAT0424	2185	98	100	198		4	22	18	17	2.3			
DAT0424	2186	98	100	198		4	22	19	17	2.5			
DAT0424	2187	98	100	198		4	22	20	17	2.3			
DAT0424	2188	98	100	198		4	22	21	17	2.4			
DAT0424	2189	99	100	199		4	22	22	17	2.5			
DAT0424	2190	96	100	196	198	4	22	23	17	2.6	2.51		
DAT0424	2191	98	100	198		4	23	0	17	2.7			
DAT0424	2192	98	100	198		4	23	1	17	2.7			
DAT0424	2193	99	100	199		4	23	2	17	2.7			
DAT0424	2194	98	100	198		4	23	3	17	2.8			
DAT0424	2195	97	100	197		4	23	4	17	2.7			
DAT0424	2196	98	100	198		4	23	5	17	2.7			
DAT0424	2197	99	100	199		4	23	6	17	2.7			
DAT0424	2198	98	100	198		4	23	7	17	2.3			
DAT0424	2199	98	100	198		4	23	8	17	2.5			
DAT0424	2200	97	100	197	198	4	23	9	17	2.5	2.63		

Appendix L: Analog Reliability Test Data - Test #2 (Test Period #3)

Stored in:	Devices Upset				Ave	Date(1996)	File size (Mb)			Notes		
	Test #	Bd #1	Bd #2	Total			Time	full	ave		part	
DAT0424	2201	99	100	199		4	23	10	17	2.4		
DAT0424	2202	99	100	199		4	23	11	17	2.5		
DAT0424	2203	98	100	198		4	23	12	17	2.4		
DAT0424	2204	97	100	197		4	23	13	17	2.4		
DAT0424	2205	99	100	199		4	23	14	17	2.6		
DAT0424	2206	100	100	200		4	23	15	17	2.4		
DAT0424	2207	98	100	198		4	23	16	17	2.5		
DAT0424	2208	98	100	198		4	23	17	17	2.5		
DAT0424	2209	97	100	197		4	23	18	17	2.6		
DAT0424	2210	98	100	198	198	4	23	19	17	2.6	2.49	
DAT0424	2211	99	100	199		4	23	20	17	2.4		
DAT0424	2212	99	100	199		4	23	21	17	2.4		
DAT0424	2213	98	100	198		4	23	22	17	2.3		
DAT0424	2214	99	100	199		4	23	23	17	2.3		
DAT0424	2215	99	100	199		4	24	0	17	2.3		
DAT0424	2216	99	100	199		4	24	1	17	2.2		
DAT0424	2217	99	100	199		4	24	2	17	2.2		
DAT0424	2218	96	100	196		4	24	3	17	2.3		
DAT0424	2219	98	100	198		4	24	4	17	2.4		
DAT0424	2220	98	100	198	198	4	24	5	17	2.4	2.32	
DAT0424	2221	98	100	198		4	24	6	17	2.5		
DAT0424	2222	97	100	197		4	24	7	17	2.6		
DAT0424	2223	95	100	195		4	24	8	17	2.6		
DAT0424	2224	97	100	197		4	24	9	17	2.6		
DAT0424	2225	97	100	197		4	24	10	17	2.6		
DAT0424	2226	97	100	197		4	24	11	17	2.6		
DAT0424	2227	96	100	196		4	24	12	17	2.5		
DAT0424	2228	99	100	199		4	24	13	17	2.3		
DAT0424	2229	96	100	196		4	24	13	29		0.48	
DAT0426	2230	93	96	189	196	4	24	15	53		2.54	0.16
DAT0426	2231	96	100	196		4	24	16	54	2.6		
DAT0426	2232	98	100	198		4	24	17	54	2.7		
DAT0426	2233	98	100	198		4	24	18	54	2.7		
DAT0426	2234	96	100	196		4	24	19	54	2.6		
DAT0426	2235	97	100	197		4	24	20	54	2.3		
DAT0426	2236	98	100	198		4	24	21	54	2.5		
DAT0426	2237	96	100	196		4	24	22	54	2.5		
DAT0426	2238	96	100	196		4	24	23	54	2.5		
DAT0426	2239	96	100	196		4	25	0	54	2.5		
DAT0426	2240	96	100	196	197	4	25	1	54	2.4	2.53	
DAT0426	2241	96	100	196		4	25	2	54	2.4		
DAT0426	2242	95	100	195		4	25	3	54	2.4		
DAT0426	2243	95	100	195		4	25	4	54	2.3		
DAT0426	2244	96	100	196		4	25	5	54	2.4		
DAT0426	2245	96	100	196		4	25	6	54	2.4		
DAT0426	2246	97	100	197		4	25	7	54	2.4		
DAT0426	2247	95	100	195		4	25	8	54	2.4		
DAT0426	2248	96	100	196		4	25	9	54	2.5		
DAT0426	2249	97	100	197		4	25	10	54	2.5		
DAT0426	2250	97	100	197	196	4	25	11	54	2.5	2.42	

Appendix L: Analog Reliability Test Data - Test #2 (Test Period #3)

Stored in:	Devices Upset					File size (Mb)							
	Test #	Bd #1	Bd #2	Total	Ave	Date(1996)		Time		full	ave	part	Notes
DAT0426	2251	98	100	198		4	25	12	54	2.6			
DAT0426	2252	98	100	198		4	25	13	54	2.7			
DAT0426	2253	97	100	197		4	25	14	54	2.7			
DAT0426	2254	97	100	197		4	25	15	54	2.7			
DAT0426	2255	97	100	197		4	25	16	54	2.8			
DAT0426	2256	98	100	198		4	25	17	54	2.7			
DAT0426	2257	97	100	197		4	25	18	54	2.6			
DAT0426	2258	96	100	196		4	25	19	54	2.5			
DAT0426	2259	97	100	197		4	25	20	54	2.7			
DAT0426	2260	96	100	196	197	4	25	21	54	2.7	2.67		
DAT0426	2261	96	100	196		4	25	22	54	2.6			
DAT0426	2262	98	100	198		4	25	23	54	2.5			
DAT0426	2263	96	100	196		4	26	0	54	2.5			
DAT0426	2264	97	100	197		4	26	1	54	2.4			
DAT0426	2265	98	100	198		4	26	2	54	2.3			
DAT0426	2266	96	100	196		4	26	3	54	2.2			
DAT0426	2267	96	100	196		4	26	4	54	2.1			
DAT0426	2268	95	100	195		4	26	5	54	2.1			
DAT0426	2269	94	100	194		4	26	6	54	2.2			
DAT0426	2270	97	100	197	196	4	26	7	54	2.2	2.31		
DAT0426	2271	95	100	195		4	26	8	54	2.1			
DAT0426	2272	96	100	196		4	26	9	54	2.1			
DAT0426	2273	98	100	198		4	26	10	54	2.2			
DAT0426	2274	97	100	197		4	26	11	54	2.3			
DAT0426	2275	97	100	197		4	26	12	54	2.4			
DAT0426	2276	97	100	197		4	26	13	54	2.5			
DAT0426	2277	96	99	195		4	26	14	20			1.1	
DAT0429	2278	95	98	193		4	26	15	58			17	
DAT0429	2279	97	100	197		4	26	17	4	2.6			
DAT0429	2280	92	100	192	196	4	26	18	4	2.4	2.33		
DAT0429	2281	95	100	195		4	26	19	4	2.7			
DAT0429	2282	96	100	196		4	26	20	4	2.4			
DAT0429	2283	97	100	197		4	26	21	4	2.3			
DAT0429	2284	97	100	197		4	26	22	4	2.4			
DAT0429	2285	97	100	197		4	26	23	4	2.3			
DAT0429	2286	96	100	196		4	27	0	4	2.3			
DAT0429	2287	97	100	197		4	27	1	4	2.2			
DAT0429	2288	96	100	196		4	27	2	4	2.2			
DAT0429	2289	95	100	195		4	27	3	4	2.2			
DAT0429	2290	98	100	198	196	4	27	4	4	2.4	2.34		
DAT0429	2291	96	100	196		4	27	5	4	2.5			
DAT0429	2292	94	100	194		4	27	6	4	2.6			
DAT0429	2293	94	100	194		4	27	7	4	2.5			
DAT0429	2294	93	100	193		4	27	8	4	2.5			
DAT0429	2295	93	100	193		4	27	9	4	2.5			
DAT0429	2296	96	100	196		4	27	10	4	2.5			
DAT0429	2297	96	100	196		4	27	11	4	2.1			
DAT0429	2298	99	100	199		4	27	12	4	2.2			
DAT0429	2299	96	100	196		4	27	13	4	2.5			
DAT0429	2300	96	100	196	195	4	27	14	4	2.6	2.45		

Appendix L: Analog Reliability Test Data - Test #2 (Test Period #3)

Stored in:	Devices Upset				Ave	Date(1996)	File size (Mb)			part	Notes	
	Test #	Bd #1	Bd #2	Total			Time	full	ave			
DAT0429	2301	97	100	197		4	27	15	4	2.7		
DAT0429	2302	96	100	196		4	27	16	4	2.7		
DAT0429	2303	94	100	194		4	27	17	4	2.6		
DAT0429	2304	94	100	194		4	27	18	4	2.6		
DAT0429	2305	94	100	194		4	27	19	4	2.6		
DAT0429	2306	93	100	193		4	27	20	4	2.6		
DAT0429	2307	92	100	192		4	27	21	4	2.6		
DAT0429	2308	93	100	193		4	27	22	4	2.5		
DAT0429	2309	96	100	196		4	27	23	4	2.4		
DAT0429	2310	97	100	197	195	4	28	0	4	2.4	2.57	
DAT0429	2311	96	100	196		4	28	1	4	2.4		
DAT0429	2312	95	100	195		4	28	2	4	2.5		
DAT0429	2313	97	100	197		4	28	3	4	2.6		
DAT0429	2314	95	100	195		4	28	4	4	2.6		
DAT0429	2315	94	100	194		4	28	5	4	2.6		
DAT0429	2316	97	100	197		4	28	6	4	2.7		
DAT0429	2317	93	100	193		4	28	7	4	2.6		
DAT0429	2318	94	100	194		4	28	8	4	2.6		
DAT0429	2319	93	100	193		4	28	9	4	2.6		
DAT0429	2320	95	100	195	195	4	28	10	4	2.6	2.58	
DAT0429	2321	95	100	195		4	28	11	4	2.6		
DAT0429	2322	94	100	194		4	28	12	4	2.5		
DAT0429	2323	96	100	196		4	28	13	4	2.5		
DAT0429	2324	96	100	196		4	28	14	4	2.5		
DAT0429	2325	96	100	196		4	28	15	4	2.6		
DAT0429	2326	96	100	196		4	28	16	4	2.7		
DAT0429	2327	96	100	196		4	28	17	4	2.6		
DAT0429	2328	96	100	196		4	28	18	4	2.6		
DAT0429	2329	96	100	196		4	28	19	4	2.5		
DAT0429	2330	98	100	198	196	4	28	20	4	2.4	2.55	
DAT0429	2331	96	100	196		4	28	21	4	2.3		
DAT0429	2332	98	100	198		4	28	22	4	2.4		
DAT0429	2333	97	100	197		4	28	23	4	2.4		
DAT0429	2334	97	100	197		4	29	0	4	2.4		
DAT0429	2335	99	100	199		4	29	1	4	2.6		
DAT0429	2336	97	100	197		4	29	2	4	2.7		
DAT0429	2337	96	99	195		4	29	3	4	2.7		
DAT0429	2338	98	100	198		4	29	4	4	2.8		
DAT0429	2339	97	100	197		4	29	5	4	2.8		
DAT0429	2340	97	99	196	197	4	29	6	4	2.8	2.59	
DAT0429	2341	97	100	197		4	29	7	4	2.8		
DAT0429	2342	97	100	197		4	29	8	4	2.8		
DAT0429	2343	99	100	199		4	29	9	4	2.8		
DAT0429	2344	99	97	196		4	29	10	0			0.35
						4						
						4						
						4						
						4						
						4						
					197	4					2.8	



Appendix M: Analog Reliability Test Data - Test #4

Stored in:	Test #	Devices Upset				Date(96)	Time		File size (Mb)			Notes
		Bd #1	Bd #2	Total	Ave				full	ave	part	
DAT0508	2351	89	90	179		5 6	10 29			0.05	4 Min	
DAT0508	2352	95	94	189		5 6	11 29	0.76				
DAT0508	2353	94	94	188		5 6	12 29	0.77				
DAT0508	2354	94	94	188		5 6	13 29	0.80				
DAT0508	2355	94	95	189		5 6	14 29	0.74				
DAT0508	2356	93	95	188		5 6	15 26	0.77				
DAT0508	2357	94	95	189		5 6	16 26	0.74				
DAT0508	2358	93	95	188		5 6	17 26	0.74				
DAT0508	2359	95	94	189		5 6	18 26	0.77				
DAT0508	2360	94	95	189	188	5 6	19 26	0.83	0.77			
DAT0508	2361	97	95	192		5 6	20 26	0.82				
DAT0508	2362	97	94	191		5 6	21 26	0.81				
DAT0508	2363	95	95	190		5 6	22 26	0.80				
DAT0508	2364	94	94	188		5 6	23 26	0.80				
DAT0508	2365	95	93	188		5 7	0 26	0.79				
DAT0508	2366	94	96	190		5 7	1 26	0.80				
DAT0508	2367	95	95	190		5 7	2 26	0.80				
DAT0508	2368	95	94	189		5 7	3 26	0.81				
DAT0508	2369	96	95	191		5 7	4 26	0.82				
DAT0508	2370	92	95	187	190	5 7	5 26	0.82	0.81			
DAT0508	2371	93	94	187		5 7	6 26	0.82				
DAT0508	2372	93	93	186		5 7	7 26	0.82				
DAT0508	2373	93	96	189		5 7	8 26			0.63	Unplugged	
DAT0508	2374	95	94	189		5 7	9 26	0.78				
DAT0508	2375	94	94	188		5 7	10 26	0.80				
DAT0508	2376	94	95	189		5 7	11 26	0.80				
DAT0508	2377	95	96	191		5 7	12 26	0.80				
DAT0508	2378	94	96	190		5 7	13 26	0.81				
DAT0508	2379	93	91	184		5 7	13 35			0.12	Opened	
DAT0508	2380	94	94	188	188	5 7	14 39	0.81	0.81			
DAT0508	2381	93	96	189		5 7	15 39	0.83				
DAT0508	2382	96	96	192		5 7	16 39	0.82				
DAT0508	2383	95	95	190		5 7	17 39	0.82				
DAT0508	2384	94	94	188		5 7	18 39	0.81				
DAT0508	2385	96	96	192		5 7	19 39	0.80				
DAT0508	2386	94	95	189		5 7	20 39	0.79				
DAT0508	2387	94	95	189		5 7	21 39	0.80				
DAT0508	2388	94	96	190		5 7	22 39	0.79				
DAT0508	2389	94	94	188		5 7	23 39	0.80				
DAT0508	2390	94	94	188	190	5 8	0 39	0.80	0.81			
DAT0508	2391	93	95	188		5 8	1 39	0.81				
DAT0508	2392	94	95	189		5 8	2 39	0.81				
DAT0508	2393	95	98	193		5 8	3 39	0.82				
DAT0508	2394	95	96	191		5 8	4 39	0.82				
DAT0508	2395	94	95	189		5 8	5 39	0.82				
DAT0508	2396	95	94	189		5 8	6 39	0.82				
DAT0508	2397	96	96	192		5 8	7 39	0.82				
DAT0508	2398	93	96	189		5 8	8 39	0.83				
DAT0508	2399	94	96	190		5 8	9 39	0.82				
DAT0508	2400	94	97	191	190	5 8	10 39	0.83	0.82			

Appendix M: Analog Reliability Test Data - Test #4

Stored in:	Test #	Devices Upset				Ave	Date(96)		Time		File size (Mb)			Notes
		Bd #1	Bd #2	Total					full	ave	part			
DAT0508	2401	94	96	190		5	8	11	39	0.83				
DAT0508	2402	94	95	189		5	8	12	39	0.82				
DAT0508	2403	94	93	187		5	8	13	7			0.37		
DAT0510	2404	86	91	177		5	8	15	31			0.05	4 Min	
DAT0510	2405	92	94	186		5	8	16	31	0.65				
DAT0510	2406	93	95	188		5	8	17	31	0.77				
DAT0510	2407	96	93	189		5	8	18	31	0.82				
DAT0510	2408	95	94	189		5	8	19	31	0.81				
DAT0510	2409	94	93	187		5	8	20	31	0.80				
DAT0510	2410	94	95	189	187	5	8	21	31	0.81	0.79			
DAT0510	2411	94	93	187		5	8	22	31	0.81				
DAT0510	2412	94	93	187		5	8	23	31	0.80				
DAT0510	2413	93	96	189		5	9	0	31	0.80				
DAT0510	2414	93	93	186		5	9	1	31	0.80				
DAT0510	2415	94	95	189		5	9	2	31	0.79				
DAT0510	2416	94	95	189		5	9	3	31	0.90				
DAT0510	2417	93	95	188		5	9	4	31	0.79				
DAT0510	2418	94	95	189		5	9	5	31	0.79				
DAT0510	2419	93	94	187		5	9	6	31	0.79				
DAT0510	2420	95	92	187	188	5	9	7	31	0.79	0.81			
DAT0510	2421	94	94	188		5	9	8	31	0.79				
DAT0510	2422	94	95	189		5	9	9	31	0.79				
DAT0510	2423	94	94	188		5	9	10	31	0.80				
DAT0510	2424	94	94	188		5	9	11	31	0.80				
DAT0510	2425	94	93	187		5	9	12	31	0.80				
DAT0510	2426	93	94	187		5	9	13	31	0.82				
DAT0510	2427	94	95	189		5	9	14	31	0.79				
DAT0510	2428	94	95	189		5	9	15	31	0.74				
DAT0510	2429	93	95	188		5	9	16	31	0.68				
DAT0510	2430	92	92	184	188	5	9	17	31	0.67	0.77			
DAT0510	2431	93	96	189		5	9	18	31	0.79				
DAT0510	2432	94	93	187		5	9	19	31	0.83				
DAT0510	2433	95	92	187		5	9	20	31	0.84				
DAT0510	2434	94	94	188		5	9	21	31	0.82				
DAT0510	2435	94	93	187		5	9	22	31	0.81				
DAT0510	2436	94	95	189		5	9	23	31	0.81				
DAT0510	2437	93	94	187		5	10	0	31	0.81				
DAT0510	2438	94	93	187		5	10	1	31	0.81				
DAT0510	2439	93	94	187		5	10	2	31	0.81				
DAT0510	2440	95	91	186	187	5	10	3	31	0.80	0.81			
DAT0510	2441	93	96	189		5	10	4	31	0.81				
DAT0510	2442	92	93	185		5	10	5	31	0.81				
DAT0510	2443	93	94	187		5	10	6	31	0.81				
DAT0510	2444	95	94	189		5	10	7	31	0.82				
DAT0510	2445	94	96	190		5	10	8	31	0.83				
DAT0510	2446	96	92	188		5	10	9	31	0.82				
DAT0510	2447	94	93	187		5	10	10	31	0.82				
DAT0510	2448	94	96	190		5	10	11	31	0.84				
DAT0510	2449	92	95	187		5	10	11	44			0.17		
DAT0513	2450	95	90	185	188	5	10	13	0		0.82		4 Min	

Appendix M: Analog Reliability Test Data - Test #4

Stored in:	Devices Upset					Date(96)		Time		File size (Mb)			Notes
	Test #	Bd #1	Bd #2	Total	Ave					full	ave	part	
DAT0513	2451	97	94	191		5	10	14	0	1.07			
DAT0513	2452	96	95	191		5	10	15	0	1.06			
DAT0513	2453	96	96	192		5	10	16	0	1.06			
DAT0513	2454	97	94	191		5	10	17	0	1.00			
DAT0513	2455	96	93	189		5	10	18	0	1.01			
DAT0513	2456	95	92	187		5	10	19	0	0.97			
DAT0513	2457	95	94	189		5	10	20	0	0.88			
DAT0513	2458	95	96	191		5	10	21	0	0.68			
DAT0513	2459	96	92	188		5	10	22	0	0.76			
DAT0513	2460	96	94	190	190	5	10	23	0	0.83	0.9		
DAT0513	2461	96	93	189		5	11	0	0	0.85			
DAT0513	2462	96	93	189		5	11	1	0	0.86			
DAT0513	2463	97	93	190		5	11	2	0	0.86			
DAT0513	2464	95	96	191		5	11	3	0	0.86			
DAT0513	2465	95	93	188		5	11	4	0	0.87			
DAT0513	2466	95	95	190		5	11	5	0	0.87			
DAT0513	2467	97	94	191		5	11	6	0	0.92			
DAT0513	2468	97	93	190		5	11	7	0	0.99			
DAT0513	2469	97	94	191		5	11	8	0	0.99			
DAT0513	2470	97	93	190	190	5	11	9	0	0.90	0.9		
DAT0513	2471	97	94	191		5	11	10	0	0.85			
DAT0513	2472	96	91	187		5	11	11	0	0.96			
DAT0513	2473	97	93	190		5	11	12	0	0.90			
DAT0513	2474	97	93	190		5	11	13	0	0.91			
DAT0513	2475	97	92	189		5	11	14	0	1.00			
DAT0513	2476	98	90	188		5	11	15	0	1.02			
DAT0513	2477	97	93	190		5	11	16	0	0.94			
DAT0513	2478	97	93	190		5	11	17	0	0.93			
DAT0513	2479	96	96	192		5	11	18	0	0.88			
DAT0513	2480	97	93	190	190	5	11	19	0	0.94	0.9		
DAT0513	2481	97	91	188		5	11	20	0	0.96			
DAT0513	2482	97	91	188		5	11	21	0	0.84			
DAT0513	2483	98	94	192		5	11	22	0	0.91			
DAT0513	2484	98	94	192		5	11	23	0	0.89			
DAT0513	2485	96	93	189		5	12	0	0	0.96			
DAT0513	2486	96	92	188		5	12	1	0	0.82			
DAT0513	2487	96	92	188		5	12	2	0	0.94			
DAT0513	2488	96	94	190		5	12	3	0	0.85			
DAT0513	2489	97	92	189		5	12	4	0	0.95			
DAT0513	2490	97	95	192	190	5	12	5	0	0.83	0.9		
DAT0513	2491	96	94	190		5	12	6	0	0.94			
DAT0513	2492	96	92	188		5	12	7	0	0.93			
DAT0513	2493	97	96	193		5	12	8	0	0.94			
DAT0513	2494	96	92	188		5	12	9	0	0.91			
DAT0513	2495	95	92	187		5	12	10	0	1.02			
DAT0513	2496	97	90	187		5	12	11	0	1.04			
DAT0513	2497	97	94	191		5	12	12	0	1.05			
DAT0513	2498	96	92	188		5	12	13	0	1.05			
DAT0513	2499	97	92	189		5	12	14	0	1.03			
DAT0513	2500	97	93	190	189	5	12	15	0	1.01	1.0		

Appendix M: Analog Reliability Test Data - Test #4

Stored in:	Test #	Devices Upset				Date(96)	Time		File size (Mb)			Notes
		Bd #1	Bd #2	Total	Ave		full	ave	part			
DAT0513	2501	97	93	190		5	12	16	0	1.00		
DAT0513	2502	97	92	189		5	12	17	0	1.03		
DAT0513	2503	97	91	188		5	12	18	0	1.00		
DAT0513	2504	98	93	191		5	12	19	0	0.97		
DAT0513	2505	97	91	188		5	12	20	0	1.00		
DAT0513	2506	97	92	189		5	12	21	0	1.00		
DAT0513	2507	96	92	188		5	12	22	0	0.99		
DAT0513	2508	95	95	190		5	12	23	0	0.98		
DAT0513	2509	97	94	191		5	13	0	0	1.02		
DAT0513	2510	96	94	190	189	5	13	1	0	0.98	1.0	
DAT0513	2511	96	93	189		5	13	2	0	0.91		
DAT0513	2512	96	91	187		5	13	3	0	0.94		
DAT0513	2513	96	93	189		5	13	4	0	0.95		
DAT0513	2514	95	92	187		5	13	5	0	0.89		
DAT0513	2515	96	94	190		5	13	6	0	0.88		
DAT0513	2516	96	91	187		5	13	7	0	0.96		
DAT0513	2517	97	93	190		5	13	8	0	0.93		
DAT0513	2518	95	90	185		5	13	8	30		0.46	
DAT0513	2519	95	90	185		5	13	10	44		0.07	
DAT0513	2520	97	92	189	188	5	13	11	44	0.95	0.9	
DAT0513	2521	97	92	189		5	13	12	44	1.06		
DAT0513	2522	97	97	194		5	13	13	44	1.06		
DAT0513	2523	97	92	189		5	13	14	44	1.03		
DAT0513	2524	97	92	189		5	13	15	44	1.07		
DAT0513	2525	97	92	189		5	13	16	44	1.03		
DAT0513	2526	97	91	188		5	13	17	44	0.97		
DAT0513	2527	97	93	190		5	13	18	44	0.94		
DAT0513	2528	96	93	189		5	13	19	44	0.95		
DAT0513	2529	97	92	189		5	13	20	44	0.91		
DAT0513	2530	97	93	190	190	5	13	21	44	0.88	1.0	
DAT0513	2531	97	94	191		5	13	22	44	0.90		
DAT0513	2532	97	91	188		5	13	23	44	0.93		
DAT0513	2533	96	96	192		5	14	0	44	0.90		
DAT0513	2534	96	96	192		5	14	1	44	0.88		
DAT0513	2535	97	94	191		5	14	2	44	0.88		
DAT0513	2536	96	92	188		5	14	3	44	0.95		
DAT0513	2537	97	94	191		5	14	4	44	0.90		
DAT0513	2538	97	92	189		5	14	5	44	0.93		
DAT0513	2539	95	92	187		5	14	6	44	0.98		
DAT0513	2540	97	93	190	190	5	14	7	44	0.89	0.9	
DAT0513	2541	96	95	191		5	14	8	44	0.92		
DAT0513	2542	97	94	191		5	14	9	44	0.95		
DAT0513	2543	97	93	190		5	14	10	44	0.91		
DAT0513	2544	97	94	191		5	14	11	44	0.91		
DAT0513	2545	97	95	192		5	14	12	44	1.01		
DAT0513	2546	97	92	189		5	14	13	44	1.01		
DAT0513	2547	96	93	189		5	14	14	44	1.03		
DAT0513	2548	97	90	187		5	14	15	44	1.03		
DAT0513	2549	96	91	187		5	14	16	44	1.06		
DAT0513	2550	96	93	189	190	5	14	17	44	1.07	1.0	

Appendix M: Analog Reliability Test Data - Test #4

Stored in:	Test #	Devices Upset				Ave	Date(96)		Time		File size (Mb)			Notes
		Bd #1	Bd #2	Total					full	ave	part			
DAT0515	2551	97	94	191		5	14	18	44	1.05				
DAT0515	2552	97	91	188		5	14	19	44	0.98				
DAT0515	2553	97	91	188		5	14	20	44	0.73				
DAT0515	2554	96	93	189		5	14	21	44	0.72				
DAT0515	2555	97	91	188		5	14	22	44	0.76				
DAT0515	2556	97	91	188		5	14	23	44	0.78				
DAT0515	2557	97	91	188		5	15	0	44	0.80				
DAT0515	2558	96	92	188		5	15	1	44	0.81				
DAT0515	2559	97	92	189		5	15	2	44	0.82				
DAT0515	2560	96	93	189	189	5	15	3	44	0.83	0.8			
DAT0515	2561	97	91	188		5	15	4	44	0.84				
DAT0515	2562	96	93	189		5	15	5	44	0.87				
DAT0515	2563	98	94	192		5	15	6	44	0.88				
DAT0515	2564	98	93	191		5	15	7	44	0.91				
DAT0515	2565	99	91	190		5	15	8	44	0.93				
DAT0515	2566	98	95	193		5	15	9	44	0.88				
DAT0515	2567	98	94	192		5	15	10	44	0.96				
DAT0515	2568	98	95	193		5	15	11	44	0.98				
DAT0515	2569	98	94	192		5	15	12	44	1.00				
DAT0515	2570	98	93	191	191	5	15	13	44	1.01	0.9			
DAT0515	2571	97	91	188		5	15	14	4			0.33		
DAT0517	2572	97	90	187		5	15	14	42			0.07	4 Min	
DAT0517	2573	98	93	191		5	15	15	42	0.84				
DAT0517	2574	98	92	190		5	15	16	42	1.03				
DAT0517	2575	98	91	189		5	15	17	42	1.05				
DAT0517	2576	98	93	191		5	15	18	42	1.06				
DAT0517	2577	98	95	193		5	15	19	42	1.02				
DAT0517	2578	98	93	191		5	15	20	42	0.93				
DAT0517	2579	98	94	192		5	15	21	42	0.84				
DAT0517	2580	97	93	190	190	5	15	22	42	0.97	1.0			
DAT0517	2581	97	93	190		5	15	23	42	0.99				
DAT0517	2582	96	92	188		5	16	0	42	1.00				
DAT0517	2583	96	93	189		5	16	1	42	1.00				
DAT0517	2584	95	93	188		5	16	2	42	1.00				
DAT0517	2585	96	90	186		5	16	3	42	1.00				
DAT0517	2586	96	96	192		5	16	4	42	1.00				
DAT0517	2587	97	93	190		5	16	5	42	1.00				
DAT0517	2588	97	93	190		5	16	6	42	1.00				
DAT0517	2589	96	92	188		5	16	7	42	1.00				
DAT0517	2590	95	92	187	189	5	16	8	42	1.01	1.0			
DAT0517	2591	97	94	191		5	16	9	42	0.94				
DAT0517	2592	97	93	190		5	16	10	42	0.91				
DAT0517	2593	98	93	191		5	16	11	42	0.93				
DAT0517	2594	98	94	192		5	16	12	42	0.94				
DAT0517	2595	98	93	191		5	16	13	42	1.04				
DAT0517	2596	98	92	190		5	16	14	42	1.07				
DAT0517	2597	98	92	190		5	16	15	42	1.09				
DAT0517	2598	98	93	191		5	16	16	42	1.10				
DAT0517	2599	98	93	191		5	16	17	42	1.09				
DAT0517	2600	98	92	190	191	5	16	18	42	1.09	1.0			

Appendix M: Analog Reliability Test Data - Test #4

Stored in:	Test #	Devices Upset				Date(96)	Time		File size (Mb)			Notes
		Bd #1	Bd #2	Total	Ave		full	ave	part			
DAT0517	2601	97	94	191		5	16	19	42	1.08		
DAT0517	2602	98	92	190		5	16	20	42	1.04		
DAT0517	2603	98	96	194		5	16	21	42	0.88		
DAT0517	2604	98	93	191		5	16	22	42	0.97		
DAT0517	2605	97	93	190		5	16	23	42	0.91		
DAT0517	2606	98	93	191		5	17	0	42	0.89		
DAT0517	2607	98	92	190		5	17	1	42	0.98		
DAT0517	2608	98	93	191		5	17	2	42	1.00		
DAT0517	2609	98	93	191		5	17	3	42	1.00		
DAT0517	2610	98	94	192	191	5	17	4	42	1.00	0.98	
DAT0517	2611	96	95	191		5	17	5	42	0.99		
DAT0517	2612	97	92	189		5	17	6	42	1.00		
DAT0517	2613	97	95	192		5	17	7	42	1.00		
DAT0517	2614	96	96	192		5	17	8	42	0.94		
DAT0517	2615	98	93	191		5	17	9	42	0.89		
DAT0517	2616	98	91	189		5	17	10	24			0.62
DAT0520	2617	96	92	188		5	17	11	47			0.85 4 Min
DAT0520	2618	98	94	192		5	17	12	47	1.00		
DAT0520	2619	97	91	188		5	17	13	47	0.95		
DAT0520	2620	98	91	189	190	5	17	14	47	0.93	0.96	
DAT0520	2621	98	91	189		5	17	15	47	1.00		
DAT0520	2622	98	96	194		5	17	16	47	1.05		
DAT0520	2623	97	93	190		5	17	17	47	0.93		
DAT0520	2624	98	93	191		5	17	18	47	0.96		
DAT0520	2625	97	92	189		5	17	19	47	0.95		
DAT0520	2626	98	92	190		5	17	20	47	1.02		
DAT0520	2627	97	92	189		5	17	21	47	1.02		
DAT0520	2628	98	93	191		5	17	22	47	1.02		
DAT0520	2629	96	90	186		5	17	23	47	1.02		
DAT0520	2630	96	92	188	190	5	18	0	47	1.02	1	
DAT0520	2631	98	92	190		5	18	1	47	1.02		
DAT0520	2632	98	93	191		5	18	2	47	1.01		
DAT0520	2633	98	92	190		5	18	3	47	1.01		
DAT0520	2634	98	92	190		5	18	4	47	1.00		
DAT0520	2635	97	92	189		5	18	5	47	1.01		
DAT0520	2636	98	93	191		5	18	6	47	1.01		
DAT0520	2637	98	96	194		5	18	7	47	1.01		
DAT0520	2638	97	93	190		5	18	8	47	1.02		
DAT0520	2639	98	91	189		5	18	9	47	0.94		
DAT0520	2640	98	92	190	190	5	18	10	47	0.96	1	
DAT0520	2641	95	93	188		5	18	11	47	0.90		
DAT0520	2642	96	95	191		5	18	12	47	0.89		
DAT0520	2643	96	92	188		5	18	13	47	0.97		
DAT0520	2644	96	95	191		5	18	14	47	0.96		
DAT0520	2645	96	93	189		5	18	15	47	0.91		
DAT0520	2646	97	91	188		5	18	16	47	0.98		
DAT0520	2647	97	93	190		5	18	17	47	0.91		
DAT0520	2648	97	93	190		5	18	18	47	0.98		
DAT0520	2649	95	92	187		5	18	19	47	1.00		
DAT0520	2650	97	93	190	189	5	18	20	47	1.00	0.95	

Appendix M: Analog Reliability Test Data - Test #4

Stored in:	Test #	Devices Upset				Date(96)	Time		File size (Mb)			Notes
		Bd #1	Bd #2	Total	Ave				full	ave	part	
DAT0520	2651	96	93	189		5	18	21	47	0.99		
DAT0520	2652	96	92	188		5	18	22	47	1.00		
DAT0520	2653	96	91	187		5	18	23	47	1.00		
DAT0520	2654	96	93	189		5	19	0	47	0.99		
DAT0520	2655	95	93	188		5	19	1	47	1.00		
DAT0520	2656	97	95	192		5	19	2	47	0.99		
DAT0520	2657	98	93	191		5	19	3	47	1.00		
DAT0520	2658	97	92	189		5	19	4	47	1.00		
DAT0520	2659	98	93	191		5	19	5	47	1.00		
DAT0520	2660	97	94	191	190	5	19	6	47	1.00	1	
DAT0520	2661	98	92	190		5	19	7	47	1.00		
DAT0520	2662	97	93	190		5	19	8	47	1.00		
DAT0520	2663	97	92	189		5	19	9	47	1.00		
DAT0520	2664	98	92	190		5	19	10	47	0.92		
DAT0520	2665	98	92	190		5	19	11	47	1.00		
DAT0520	2666	98	95	193		5	19	12	47	0.92		
DAT0520	2667	98	93	191		5	19	13	47	0.94		
DAT0520	2668	98	93	191		5	19	14	47	1.04		
DAT0520	2669	97	93	190		5	19	15	47	1.00		
DAT0520	2670	98	93	191	191	5	19	16	47	1.01	0.98	
DAT0520	2671	98	93	191		5	19	17	47	1.06		
DAT0520	2672	98	94	192		5	19	18	47	1.01		
DAT0520	2673	98	92	190		5	19	19	47	0.92		
DAT0520	2674	98	92	190		5	19	20	47	1.00		
DAT0520	2675	97	93	190		5	19	21	47	0.99		
DAT0520	2676	98	91	189		5	19	22	47	0.98		
DAT0520	2677	98	94	192		5	19	23	47	0.99		
DAT0520	2678	98	92	190		5	20	0	47	0.98		
DAT0520	2679	98	91	189		5	20	1	47	0.99		
DAT0520	2680	98	93	191	190	5	20	2	47	0.99	0.99	
DAT0520	2681	98	92	190		5	20	3	47	0.99		
DAT0520	2682	97	93	190		5	20	4	47	0.99		
DAT0520	2683	97	91	188		5	20	5	47	1.00		
DAT0520	2684	97	93	190		5	20	6	47	0.99		
DAT0520	2685	98	91	189		5	20	7	47	1.00		
DAT0520	2686	98	94	192		5	20	8	28		0.68	
DAT0524	2687	94	90	184		5	20	10	49		0.07	4 Min
DAT0524	2688	98	93	191		5	20	11	49	0.96		
DAT0524	2689	98	93	191		5	20	12	49	0.99		
DAT0524	2690	98	95	193	190	5	20	13	49	0.99	0.99	
DAT0524	2691	98	92	190		5	20	14	49	1.07		
DAT0524	2692	98	94	192		5	20	15	49	1.08		
DAT0524	2693	98	92	190		5	20	16	49	1.09		
DAT0524	2694	98	92	190		5	20	17	49	1.08		
DAT0524	2695	98	94	192		5	20	18	49	1.08		
DAT0524	2696	98	92	190		5	20	19	49	0.97		
DAT0524	2697	98	92	190		5	20	20	49	0.96		
DAT0524	2698	98	93	191		5	20	21	49	1.00		
DAT0524	2699	98	93	191		5	20	22	49	1.00		
DAT0524	2700	98	92	190	191	5	20	23	49	1.00	1.03	

Appendix M: Analog Reliability Test Data - Test #4

Stored in:	Test #	Devices Upset				Ave	Date(96)		Time		File size (Mb)			Notes
		Bd #1	Bd #2	Total					full	ave	part			
DAT0524	2701	97	92	189		5	21	0	49	1.01				
DAT0524	2702	97	93	190		5	21	1	49	1.00				
DAT0524	2703	97	92	189		5	21	2	49	1.01				
DAT0524	2704	96	94	190		5	21	3	49	1.01				
DAT0524	2705	98	93	191		5	21	4	49	1.01				
DAT0524	2706	98	94	192		5	21	5	49	1.01				
DAT0524	2707	97	93	190		5	21	6	49	1.01				
DAT0524	2708	96	92	188		5	21	7	49	1.00				
DAT0524	2709	98	95	193		5	21	8	49	1.01				
DAT0524	2710	98	94	192	190	5	21	9	49	1.02	1.01			
DAT0524	2711	98	94	192		5	21	10	49	1.03				
DAT0524	2712	98	93	191		5	21	11	49	1.03				
DAT0524	2713	98	92	190		5	21	12	49	1.03				
DAT0524	2714	97	93	190		5	21	13	49	1.02				
DAT0524	2715	98	93	191		5	21	14	49	1.01				
DAT0524	2716	97	92	189		5	21	15	49	1.02				
DAT0524	2717	97	92	189		5	21	16	49	1.01				
DAT0524	2718	98	91	189		5	21	17	49	1.02				
DAT0524	2719	98	93	191		5	21	18	49	1.02				
DAT0524	2720	98	92	190	190	5	21	19	49	1.02	1.02			
DAT0524	2721	98	90	188		5	21	20	49	1.02				
DAT0524	2722	98	93	191		5	21	21	49	1.02				
DAT0524	2723	98	93	191		5	21	22	49	1.02				
DAT0524	2724	97	93	190		5	21	23	49	1.01				
DAT0524	2725	98	94	192		5	22	0	49	1.01				
DAT0524	2726	98	92	190		5	22	1	49	1.02				
DAT0524	2727	98	95	193		5	22	2	49	1.02				
DAT0524	2728	97	92	189		5	22	3	49	1.02				
DAT0524	2729	98	93	191		5	22	4	49	1.02				
DAT0524	2730	98	92	190	191	5	22	5	49	1.02	1.02			
DAT0524	2731	98	93	191		5	22	6	49	1.01				
DAT0524	2732	98	92	190		5	22	7	49	1.01				
DAT0524	2733	98	92	190		5	22	8	49	1.02				
DAT0524	2734	98	93	191		5	22	9	49	1.02				
DAT0524	2735	98	91	189		5	22	10	49	1.03				
DAT0524	2736	98	91	189		5	22	11	49	1.00				
DAT0524	2737	98	93	191		5	22	12	49	0.98				
DAT0524	2738	98	94	192		5	22	13	49	0.97				
DAT0524	2739	97	93	190		5	22	14	49	1.06				
DAT0524	2740	98	92	190	190	5	22	15	49	1.09	1.02			
DAT0524	2741	98	92	190		5	22	16	49	1.10				
DAT0524	2742	98	90	188		5	22	17	49	1.04				
DAT0524	2743	98	93	191		5	22	18	49	0.92				
DAT0524	2744	98	92	190		5	22	19	49	1.02				
DAT0524	2745	98	93	191		5	22	20	49	0.91				
DAT0524	2746	98	92	190		5	22	21	49	0.99				
DAT0524	2747	97	94	191		5	22	22	49	0.99				
DAT0524	2748	96	92	188		5	22	23	49	1.01				
DAT0524	2749	97	92	189		5	23	0	49	1.02				
DAT0524	2750	96	93	189	190	5	23	1	49	1.03	1			



Appendix M: Analog Reliability Test Data - Test #4

Stored in:	Devices Upset					Date(96)	Time		File size (Mb)			Notes
	Test #	Bd #1	Bd #2	Total	Ave		full	ave	part			
DAT0524	2751	96	92	188		5 23	2 49	1.03				
DAT0524	2752	97	93	190		5 23	3 49	1.02				
DAT0524	2753	97	91	188		5 23	4 49	1.03				
DAT0524	2754	96	92	188		5 23	5 49	1.03				
DAT0524	2755	97	94	191		5 23	6 49	1.03				
DAT0524	2756	98	94	192		5 23	7 49	1.03				
DAT0524	2757	98	92	190		5 23	8 49	1.01				
DAT0524	2758	98	92	190		5 23	9 49	1.02				
DAT0524	2759	98	93	191		5 23	10 49	1.04				
DAT0524	2760	98	92	190	190	5 23	11 49	1.03	1.03			
DAT0524	2761	98	95	193		5 23	12 49	0.97				
DAT0524	2762	98	95	193		5 23	13 49	0.98				
DAT0524	2763	98	92	190		5 23	14 49	1.05				
DAT0524	2764	98	96	194		5 23	15 49	1.12				
DAT0524	2765	98	92	190		5 23	16 49	1.13				
DAT0524	2766	98	93	191		5 23	17 49	1.14				
DAT0524	2767	98	96	194		5 23	18 49	1.15				
DAT0524	2768	98	94	192		5 23	19 49	1.12				
DAT0524	2769	98	92	190		5 23	20 49	0.96				
DAT0524	2770	98	91	189	192	5 23	21 49	1.00	1.06			
DAT0524	2771	98	93	191		5 23	22 49	1.04				
DAT0524	2772	97	92	189		5 23	23 49	1.04				
DAT0524	2773	98	93	191		5 24	0 49	1.04				
DAT0524	2774	97	91	188		5 24	1 49	1.04				
DAT0524	2775	97	92	189		5 24	2 49	1.03				
DAT0524	2776	97	91	188		5 24	3 49	1.03				
DAT0524	2777	98	92	190		5 24	4 49	1.03				
DAT0524	2778	98	92	190		5 24	5 49	1.03				
DAT0524	2779	98	93	191		5 24	6 49	1.03				
DAT0524	2780	98	91	189	190	5 24	7 12		1.03	0.4		
DAT0528	2781	96	89	185		5 24	10 12			0.07	4 Min	
DAT0528	2782	98	93	191		5 24	11 23	1.03				
DAT0528	2783	98	92	190		5 24	12 23	0.99				
DAT0528	2784	98	93	191		5 24	13 23	1.09				
DAT0528	2785	98	93	191		5 24	14 23	1.12				
DAT0528	2786	98	95	193		5 24	15 23	1.14				
DAT0528	2787	98	93	191		5 24	16 23	1.13				
DAT0528	2788	98	93	191		5 24	17 23	1.14				
DAT0528	2789	98	94	192		5 24	18 23	1.13				
DAT0528	2790	98	94	192	191	5 24	19 23	1.13	1.1			
DAT0528	2791	98	94	192		5 24	20 23	1.13				
DAT0528	2792	98	95	193		5 24	21 23	1.07				
DAT0528	2793	98	92	190		5 24	22 23	1.03				
DAT0528	2794	98	91	189		5 24	23 23	0.93				
DAT0528	2795	98	94	192		5 25	0 23	0.95				
DAT0528	2796	98	92	190		5 25	1 23	1.02				
DAT0528	2797	98	91	189		5 25	2 23	1.04				
DAT0528	2798	97	91	188		5 25	3 23	1.04				
DAT0528	2799	98	93	191		5 25	4 23	1.03				
DAT0528	2800	98	92	190	190	5 25	5 23	1.03	1.03			

Appendix M: Analog Reliability Test Data - Test #4

Stored in:	Test #	Devices Upset				Ave	Date(96)		Time		File size (Mb)			Notes
		Bd #1	Bd #2	Total					full	ave	part			
DAT0528	2801	96	95	191		5	25	6	23	1.03				
DAT0528	2802	96	95	191		5	25	7	23	1.03				
DAT0528	2803	98	92	190		5	25	8	23	0.97				
DAT0528	2804	97	91	188		5	25	9	23	0.98				
DAT0528	2805	98	93	191		5	25	10	23	0.94				
DAT0528	2806	98	93	191		5	25	11	23	0.98				
DAT0528	2807	98	93	191		5	25	12	23	1.05				
DAT0528	2808	98	93	191		5	25	13	23	1.08				
DAT0528	2809	98	93	191		5	25	14	23	1.10				
DAT0528	2810	98	93	191	191	5	25	15	23	1.10	1.03			
DAT0528	2811	98	95	193		5	25	16	23	1.10				
DAT0528	2812	98	94	192		5	25	17	23	1.11				
DAT0528	2813	98	93	191		5	25	18	23	1.11				
DAT0528	2814	98	94	192		5	25	19	23	1.11				
DAT0528	2815	98	94	192		5	25	20	23	1.09				
DAT0528	2816	98	93	191		5	25	21	23	1.05				
DAT0528	2817	97	93	190		5	25	22	23	0.92				
DAT0528	2818	97	95	192		5	25	23	23	0.99				
DAT0528	2819	98	93	191		5	26	0	23	0.92				
DAT0528	2820	98	92	190	191	5	26	1	23	1.02	1.04			
DAT0528	2821	98	92	190		5	26	2	23	1.02				
DAT0528	2822	97	93	190		5	26	3	23	1.01				
DAT0528	2823	96	93	189		5	26	4	23	1.01				
DAT0528	2824	97	93	190		5	26	5	23	1.02				
DAT0528	2825	98	93	191		5	26	6	23	1.01				
DAT0528	2826	97	94	191		5	26	7	23	1.01				
DAT0528	2827	97	91	188		5	26	8	23	0.94				
DAT0528	2828	98	92	190		5	26	9	23	1.00				
DAT0528	2829	97	93	190		5	26	10	23	0.93				
DAT0528	2830	98	92	190	190	5	26	11	23	0.98	0.99			
DAT0528	2831	98	92	190		5	26	12	23	1.02				
DAT0528	2832	98	94	192		5	26	13	23	1.08				
DAT0528	2833	98	93	191		5	26	14	23	1.11				
DAT0528	2834	98	93	191		5	26	15	23	1.13				
DAT0528	2835	98	93	191		5	26	16	23	1.13				
DAT0528	2836	98	92	190		5	26	17	23	1.13				
DAT0528	2837	98	92	190		5	26	18	23	1.13				
DAT0528	2838	98	91	189		5	26	19	23	1.13				
DAT0528	2839	98	93	191		5	26	20	23	1.12				
DAT0528	2840	98	93	191	191	5	26	21	23	1.02	1.1			
DAT0528	2841	98	93	191		5	26	22	23	1.04				
DAT0528	2842	98	93	191		5	26	23	23	0.94				
DAT0528	2843	98	91	189		5	27	0	23	1.04				
DAT0528	2844	98	92	190		5	27	1	23	1.05				
DAT0528	2845	98	91	189		5	27	2	23	1.04				
DAT0528	2846	97	93	190		5	27	3	23	1.04				
DAT0528	2847	98	93	191		5	27	4	23	1.05				
DAT0528	2848	98	94	192		5	27	5	23	1.05				
DAT0528	2849	98	92	190		5	27	6	23	1.05				
DAT0528	2850	98	92	190	190	5	27	7	23	1.05	1.04			

Appendix M: Analog Reliability Test Data - Test #4

Stored in:	Devices Upset						Date(96)		Time		File size (Mb)			Notes
	Test #	Bd #1	Bd #2	Total	Ave	full					ave	part		
DAT0528	2851	98	91	189		5	27	8	23	1.04				
DAT0528	2852	98	93	191		5	27	9	23	0.98				
DAT0528	2853	98	91	189		5	27	10	23	1.04				
DAT0528	2854	98	91	189		5	27	11	23	0.97				
DAT0528	2855	98	93	191		5	27	12	23	1.02				
DAT0528	2856	98	93	191		5	27	13	23	0.98				
DAT0528	2857	98	92	190		5	27	14	23	1.05				
DAT0528	2858	98	92	190		5	27	15	23	1.10				
DAT0528	2859	98	92	190		5	27	16	23	1.13				
DAT0528	2860	98	96	194	190	5	27	17	23	1.14	1.05			
DAT0528	2861	98	92	190		5	27	18	23	1.13				
DAT0528	2862	98	90	188		5	27	19	23	1.08				
DAT0528	2863	98	92	190		5	27	20	23	0.98				
DAT0528	2864	97	93	190		5	27	21	23	0.94				
DAT0528	2865	98	92	190		5	27	22	23	1.04				
DAT0528	2866	98	92	190		5	27	23	23	1.05				
DAT0528	2867	98	92	190		5	28	0	23	1.06				
DAT0528	2868	98	93	191		5	28	1	23	1.06				
DAT0528	2869	98	94	192		5	28	2	23	1.06				
DAT0528	2870	98	94	192	190	5	28	3	23	1.06	1.05			
DAT0528	2871	98	91	189		5	28	4	23	1.06				
DAT0528	2872	97	92	189		5	28	5	23	1.07				
DAT0528	2873	98	93	191		5	28	6	23	1.07				
DAT0528	2874	97	94	191		5	28	7	23	1.07				
DAT0528	2875	98	92	190		5	28	8	23	1.05				
DAT0529	2876	95	89	184		5	28	10	48			0.08	4 Min	
DAT0529	2877	98	92	190		5	28	11	48	0.83				
DAT0529	2878	0	1	1		5	28	12	48			0.10	Amp off	
DAT0529	2879	0	0	0		5	28	13	48			0.10	Amp off	
DAT0529	2880	0	0	0	133	5	28	14	48		1.03	0.10	Amp off	
DAT0529	2881	0	0	0		5	28	15	48			0.10	Amp off	
DAT0529	2882	0	0	0		5	28	16	48			0.10	Amp off	
DAT0529	2883	0	0	0		5	28	17	48			0.10	Amp off	
DAT0529	2884	0	0	0		5	28	18	48			0.10	Amp off	
DAT0529	2885	0	0	0		5	28	19	48			0.10	Amp off	
DAT0529	2886	0	0	0		5	28	20	48			0.10	Amp off	
DAT0529	2887	0	0	0		5	28	21	48			0.10	Amp off	
DAT0529	2888	0	0	0		5	28	22	48			0.10	Amp off	
DAT0529	2889	0	0	0		5	28	23	48			0.10	Amp off	
DAT0529	2890	0	1	1	0.1	5	28	24	48		0	0.10	Amp off	
DAT0529	2891	0	1	1		5	28	25	48			0.10	Amp off	
DAT0529	2892	0	2	2		5	28	26	48			0.11	Amp off	
DAT0529	2893	0	2	2		5	28	27	48			0.10	Amp off	
DAT0529	2894	0	1	1		5	28	28	48			0.11	Amp off	
DAT0529	2895	0	1	1		5	28	29	48			0.13	Amp off	
DAT0529	2896	0	2	2		5	28	30	48			0.11	Amp off	
DAT0529	2897	0	2	2		5	28	31	48			0.11	Amp off	
DAT0529	2898	0	2	2		5	28	32	48			0.11	Amp off	
DAT0529	2899	0	2	2		5	28	33	48			0.10	Amp off	
DAT0529	2900	0	1	1	1.6	5	28	34	48		0	0.10	Amp off	

Appendix M: Analog Reliability Test Data - Test #4

Stored in:	Test #	Devices Upset				Date(96)	Time		File size (Mb)			Notes	
		Bd #1	Bd #2	Total	Ave		full	ave	part				
DAT0529	2901	72	53	125		5	29	11	46			0.10	end
DAT0603	2902	95	89	184		5	29	12	5			0.09	4 Min
DAT0603	2903	98	93	191		5	29	13	7	0.96			
DAT0603	2904	97	93	190		5	29	14	7	0.95			
DAT0603	2905	98	94	192		5	29	15	7	1.06			
DAT0603	2906	98	93	191		5	29	16	7	1.08			
DAT0603	2907	98	93	191		5	29	17	7	1.07			
DAT0603	2908	98	92	190		5	29	18	7	1.07			
DAT0603	2909	98	97	195		5	29	19	7	1.08			
DAT0603	2910	98	92	190	184	5	29	20	7	1.06	1.04		
DAT0603	2911	97	95	192		5	29	21	7	0.93			
DAT0603	2912	97	94	191		5	29	22	7	1.01			
DAT0603	2913	98	94	192		5	29	23	7	1.01			
DAT0603	2914	98	93	191		5	30	0	7	1.02			
DAT0603	2915	97	95	192		5	30	1	7	1.02			
DAT0603	2916	97	94	191		5	30	2	7	1.02			
DAT0603	2917	97	92	189		5	30	3	7	1.02			
DAT0603	2918	97	92	189		5	30	4	7	1.02			
DAT0603	2919	96	93	189		5	30	5	7	1.02			
DAT0603	2920	98	92	190	191	5	30	6	7	1.02	1.01		
DAT0603	2921	97	92	189		5	30	7	7	1.03			
DAT0603	2922	96	93	189		5	30	8	7	1.03			
DAT0603	2923	97	91	188		5	30	9	7	1.03			
DAT0603	2924	97	93	190		5	30	10	7	0.99			
DAT0603	2925	97	92	189		5	30	11	7	0.99			
DAT0603	2926	97	91	188		5	30	12	7	0.96			
DAT0603	2927	98	94	192		5	30	13	7	0.99			
DAT0603	2928	98	94	192		5	30	14	7	1.08			
DAT0603	2929	98	93	191		5	30	15	7	1.09			
DAT0603	2930	98	94	192	190	5	30	16	7	1.10	1.03		
DAT0603	2931	97	91	188		5	30	17	7	1.07			
DAT0603	2932	98	92	190		5	30	18	7	1.08			
DAT0603	2933	98	91	189		5	30	19	7	1.07			
DAT0603	2934	98	93	191		5	30	20	7	1.03			
DAT0603	2935	97	94	191		5	30	21	7	0.94			
DAT0603	2936	98	93	191		5	30	22	7	0.96			
DAT0603	2937	98	90	188		5	30	23	7	1.02			
DAT0603	2938	98	95	193		5	31	0	7	1.04			
DAT0603	2939	98	92	190		5	31	1	7	1.03			
DAT0603	2940	97	95	192	190	5	31	2	7	1.00	1.02		
DAT0603	2941	96	94	190		5	31	3	7	0.97			
DAT0603	2942	98	91	189		5	31	4	7	1.02			
DAT0603	2943	97	93	190		5	31	5	7	1.03			
DAT0603	2944	98	93	191		5	31	6	7	1.04			
DAT0603	2945	97	93	190		5	31	7	7	1.05			
DAT0603	2946	97	93	190		5	31	8	7	1.05			
DAT0603	2947	97	91	188		5	31	9	7	1.05			
DAT0603	2948	98	94	192		5	31	10	7	1.02			
DAT0603	2949	97	93	190		5	31	11	7	0.96			
DAT0603	2950	98	90	188	190	5	31	12	7	0.95	1.01		

Appendix M: Analog Reliability Test Data - Test #4

Stored in:	Test #	Devices Upset				Date(96)	Time		File size (Mb)			Notes
		Bd #1	Bd #2	Total	Ave				full	ave	part	
DAT0603	2951	98	92	190		5	31	13	7	1.04		
DAT0603	2952	98	97	195		5	31	14	7	1.10		
DAT0603	2953	98	93	191		5	31	15	7	1.11		
DAT0603	2954	98	92	190		5	31	16	7	1.12		
DAT0603	2955	98	94	192		5	31	17	7	1.14		
DAT0603	2956	98	96	194		5	31	18	7	1.14		
DAT0603	2957	98	94	192		5	31	19	7	1.13		
DAT0603	2958	98	93	191		5	31	20	7	1.14		
DAT0603	2959	98	94	192		5	31	21	7	1.12		
DAT0603	2960	98	92	190	192	5	31	22	7	1.08	1.11	
DAT0603	2961	98	91	189		5	31	23	7	1.03		
DAT0603	2962	98	93	191		6	1	0	7	1.01		
DAT0603	2963	98	93	191		6	1	1	7	1.02		
DAT0603	2964	98	93	191		6	1	2	7	0.97		
DAT0603	2965	98	94	192		6	1	3	7	0.99		
DAT0603	2966	98	95	193		6	1	4	7	1.03		
DAT0603	2967	98	95	193		6	1	5	7	1.06		
DAT0603	2968	98	93	191		6	1	6	7	1.06		
DAT0603	2969	97	92	189		6	1	7	7	0.98		
DAT0603	2970	97	94	191	191	6	1	8	7	1.04	1.02	
DAT0603	2971	98	92	190		6	1	9	7	0.99		
DAT0603	2972	98	93	191		6	1	10	7	1.00		
DAT0603	2973	98	91	189		6	1	11	7	1.08		
DAT0603	2974	98	94	192		6	1	12	7	1.11		
DAT0603	2975	98	93	191		6	1	13	7	1.12		
DAT0603	2976	98	92	190		6	1	14	7	1.13		
DAT0603	2977	98	92	190		6	1	15	7	1.13		
DAT0603	2978	98	93	191		6	1	16	7	1.14		
DAT0603	2979	98	92	190		6	1	17	7	1.13		
DAT0603	2980	98	93	191	191	6	1	18	7	1.14	1.1	
DAT0603	2981	98	96	194		6	1	19	7	1.14		
DAT0603	2982	98	93	191		6	1	20	7	1.14		
DAT0603	2983	97	97	194		6	1	21	7	1.13		
DAT0603	2984	97	92	189		6	1	22	7	1.12		
DAT0603	2985	96	95	191		6	1	23	7	1.10		
DAT0603	2986	97	95	192		6	2	0	7	1.07		
DAT0603	2987	97	93	190		6	2	1	7	1.03		
DAT0603	2988	97	91	188		6	2	2	7	0.97		
DAT0603	2989	97	93	190		6	2	3	7	0.93		
DAT0603	2990	97	93	190	191	6	2	4	7	0.94	1.06	
DAT0603	2991	98	93	191		6	2	5	7	1.00		
DAT0603	2992	97	92	189		6	2	6	7	0.94		
DAT0603	2993	98	93	191		6	2	7	7	0.95		
DAT0603	2994	97	93	190		6	2	8	7	0.94		
DAT0603	2995	97	93	190		6	2	9	7	0.97		
DAT0603	2996	98	95	193		6	2	10	7	0.97		
DAT0603	2997	97	91	188		6	2	11	7	1.05		
DAT0603	2998	97	93	190		6	2	12	7	1.08		
DAT0603	2999	98	93	191		6	2	13	7	1.09		
DAT0603	3000	98	92	190	190	6	2	14	7	1.11	1.01	

Appendix M: Analog Reliability Test Data - Test #4

Stored in:	Devices Upset					Date(96)		Time		File size (Mb)			Notes
	Test #	Bd #1	Bd #2	Total	Ave					full	ave	part	
DAT0603	3001	99	92	191		6	2	15	7	1.10			
DAT0603	3002	97	94	191		6	2	16	7	1.12			
DAT0603	3003	98	93	191		6	2	17	7	1.12			
DAT0603	3004	97	92	189		6	2	18	7	1.12			
DAT0603	3005	97	94	191		6	2	19	7	1.12			
DAT0603	3006	97	93	190		6	2	20	7	1.12			
DAT0603	3007	97	92	189		6	2	21	7	1.12			
DAT0603	3008	97	93	190		6	2	22	7	1.09			
DAT0603	3009	97	92	189		6	2	23	7	1.04			
DAT0603	3010	97	91	188	190	6	3	0	7	1.00	1.1		
DAT0603	3011	96	91	187		6	3	1	7	0.99			
DAT0603	3012	97	93	190		6	3	2	7	0.97			
DAT0603	3013	97	92	189		6	3	3	7	0.96			
DAT0603	3014	97	95	192		6	3	4	7	0.93			
DAT0603	3015	97	92	189		6	3	5	7	0.91			
DAT0603	3016	97	94	191		6	3	6	7	0.94			
DAT0603	3017	97	93	190		6	3	7	7	0.93			
DAT0603	3018	96	94	190		6	3	8	7	0.95			
DAT0603	3019	94	91	185		6	3	8	26			0.31	
DAT0605	3020	96	90	186	189	6	3	11	30		0.95	0.07	4 Min
DAT0605	3021	97	93	190		6	3	12	30	1.00			
DAT0605	3022	97	92	189		6	3	13	30	1.06			
DAT0605	3023	96	92	188		6	3	14	30	1.07			
DAT0605	3024	97	92	189		6	3	15	30	1.08			
DAT0605	3025	97	95	192		6	3	16	30	1.09			
DAT0605	3026	97	91	188		6	3	17	30	1.10			
DAT0605	3027	97	91	188		6	3	18	30	1.10			
DAT0605	3028	97	92	189		6	3	19	30	1.08			
DAT0605	3029	98	93	191		6	3	20	30	1.03			
DAT0605	3030	98	94	192	190	6	3	21	30	0.98	1.06		
DAT0605	3031	97	92	189		6	3	22	30	0.96			
DAT0605	3032	97	94	191		6	3	23	30	0.98			
DAT0605	3033	97	94	191		6	4	0	30	0.95			
DAT0605	3034	97	92	189		6	4	1	30	0.96			
DAT0605	3035	96	93	189		6	4	2	30	0.96			
DAT0605	3036	96	91	187		6	4	3	30	0.99			
DAT0605	3037	97	93	190		6	4	4	30	0.96			
DAT0605	3038	97	95	192		6	4	5	30	0.99			
DAT0605	3039	97	94	191		6	4	6	30	0.97			
DAT0605	3040	98	95	193	190	6	4	7	30	0.95	0.97		
DAT0605	3041	97	91	188		6	4	8	30	0.97			
DAT0605	3042	97	93	190		6	4	9	30	0.97			
DAT0605	3043	97	92	189		6	4	10	30	0.95			
DAT0605	3044	98	92	190		6	4	11	30	0.95			
DAT0605	3045	98	94	192		6	4	12	30	0.94			
DAT0605	3046	97	92	189		6	4	13	30	1.02			
DAT0605	3047	98	95	193		6	4	14	30	1.08			
DAT0605	3048	98	93	191		6	4	15	30	1.10			
DAT0605	3049	98	95	193		6	4	16	30	1.12			
DAT0605	3050	98	94	192	191	6	4	17	30	1.12	1.02		



Appendix N: Digital Reliability Test Data - Test # 5

Stored in:	Test #	Devices Upset				Ave	Date(96)		Time		File size (Mb)			Notes
		Bd #1	Bd #2	Total					full	ave	part			
DAT0610	3101	59	52	111		6	7	15	33			0.04	4 Min	
DAT0610	3102	100	100	200		6	7	16	33	0.49				
DAT0610	3103	96	100	196		6	7	17	33	0.49				
DAT0610	3104	100	100	200		6	7	18	33	0.48				
DAT0610	3105	100	100	200		6	7	19	33	0.49				
DAT0610	3106	100	100	200		6	7	20	33	0.48				
DAT0610	3107	100	100	200		6	7	21	33	0.48				
DAT0610	3108	100	100	200		6	7	22	33	0.47				
DAT0610	3109	100	100	200		6	7	23	33	0.47				
DAT0610	3110	100	100	200	191	6	8	0	33	0.47	0.48			
DAT0610	3111	100	100	200		6	8	1	33	0.46				
DAT0610	3112	100	100	200		6	8	2	33	0.46				
DAT0610	3113	100	100	200		6	8	3	33	0.47				
DAT0610	3114	100	100	200		6	8	4	33	0.47				
DAT0610	3115	100	100	200		6	8	5	33	0.46				
DAT0610	3116	100	100	200		6	8	6	33	0.47				
DAT0610	3117	100	100	200		6	8	7	33	0.48				
DAT0610	3118	100	100	200		6	8	8	33	0.47				
DAT0610	3119	100	100	200		6	8	9	33	0.47				
DAT0610	3120	100	100	200	200	6	8	10	33	0.48	0.47			
DAT0610	3121	100	100	200		6	8	11	33	0.48				
DAT0610	3122	100	100	200		6	8	12	33	0.48				
DAT0610	3123	100	100	200		6	8	13	33	0.48				
DAT0610	3124	100	100	200		6	8	14	33	0.47				
DAT0610	3125	100	100	200		6	8	15	33	0.48				
DAT0610	3126	100	100	200		6	8	16	33	0.49				
DAT0610	3127	100	100	200		6	8	17	33	0.49				
DAT0610	3128	100	100	200		6	8	18	33	0.49				
DAT0610	3129	100	100	200		6	8	19	33	0.49				
DAT0610	3130	100	100	200	200	6	8	20	33	0.49	0.48			
DAT0610	3131	100	100	200		6	8	21	33	0.48				
DAT0610	3132	100	100	200		6	8	22	33	0.49				
DAT0610	3133	100	100	200		6	8	23	33	0.51				
DAT0610	3134	100	100	200		6	9	0	33	0.49				
DAT0610	3135	100	100	200		6	9	1	33	0.49				
DAT0610	3136	99	100	199		6	9	2	33	0.48				
DAT0610	3137	100	100	200		6	9	3	33	0.47				
DAT0610	3138	92	100	192		6	9	4	33	0.46				
DAT0610	3139	100	100	200		6	9	5	33	0.47				
DAT0610	3140	93	100	193	198	6	9	6	33	0.46	0.48			
DAT0610	3141	100	100	200		6	9	7	33	0.47				
DAT0610	3142	100	100	200		6	9	8	33	0.47				
DAT0610	3143	100	100	200		6	9	9	33	0.48				
DAT0610	3144	100	100	200		6	9	10	33	0.48				
DAT0610	3145	100	100	200		6	9	11	33	0.47				
DAT0610	3146	100	100	200		6	9	12	33	0.48				
DAT0610	3147	100	100	200		6	9	13	33	0.48				
DAT0610	3148	100	100	200		6	9	14	33	0.48				
DAT0610	3149	100	100	200		6	9	15	33	0.50				
DAT0610	3150	100	100	200	200	6	9	16	33	0.49	0.48			



Appendix N: Digital Reliability Test Data - Test # 5

Stored in:	Test #	Devices Upset				Ave	Date(96)		Time		File size (Mb)			Notes
		Bd #1	Bd #2	Total					full	ave	part			
DAT0610	3151	100	100	200		6	9	17	33	0.50				
DAT0610	3152	100	100	200		6	9	18	33	0.51				
DAT0610	3153	100	100	200		6	9	19	33	0.51				
DAT0610	3154	100	100	200		6	9	20	33	0.49				
DAT0610	3155	100	100	200		6	9	21	33	0.50				
DAT0610	3156	100	100	200		6	9	22	33	0.50				
DAT0610	3157	100	100	200		6	9	23	33	0.48				
DAT0610	3158	97	100	197		6	10	0	33	0.48				
DAT0610	3159	100	100	200		6	10	1	33	0.49				
DAT0610	3160	100	100	200	200	6	10	2	33	0.48	0.49			
DAT0610	3161	100	100	200		6	10	3	33	0.47				
DAT0610	3162	100	100	200		6	10	4	33	0.48				
DAT0610	3163	100	100	200		6	10	5	33	0.47				
DAT0610	3164	100	100	200		6	10	6	33	0.49				
DAT0610	3165	100	100	200		6	10	7	33	0.48				
DAT0610	3166	100	100	200		6	10	8	33	0.48				
DAT0610	3167	100	100	200		6	10	9	33			0.23		
DAT0611	3168	61	96	157		6	10	10	51			0.39	4 Min	
DAT0611	3169	100	100	200		6	10	11	51	0.58				
DAT0611	3170	100	100	200	196	6	10	12	51	0.58	0.5			
DAT0611	3171	83	87	170		6	10	13	57	0.60				
DAT0611	3172	100	100	200		6	10	15	41	0.60				
DAT0611	3173	100	100	200		6	10	16	41	0.59				
DAT0611	3174	100	100	200		6	10	17	41	0.58				
DAT0611	3175	100	100	200		6	10	18	41	0.59				
DAT0611	3176	100	100	200		6	10	19	41	0.59				
DAT0611	3177	100	100	200		6	10	20	41	0.59				
DAT0611	3178	100	100	200		6	10	21	41	0.57				
DAT0611	3179	100	100	200		6	10	22	41	0.60				
DAT0611	3180	100	100	200	197	6	10	23	41	0.58	0.59			
DAT0611	3181	100	100	200		6	11	0	41	0.56				
DAT0611	3182	100	100	200		6	11	1	41	0.56				
DAT0611	3183	100	100	200		6	11	2	41	0.56				
DAT0611	3184	100	100	200		6	11	3	41	0.56				
DAT0611	3185	92	100	192		6	11	4	41	0.55				
DAT0611	3186	100	100	200		6	11	5	41	0.55				
DAT0611	3187	100	100	200		6	11	6	41	0.56				
DAT0611	3188	98	100	198		6	11	7	41	0.55				
DAT0611	3189	94	100	194		6	11	8	41	0.56				
DAT0611	3190	100	100	200	198	6	11	9	19		0.56	0.36		
DAT0612	3191	83	93	176		6	11	16	32	0.64				
DAT0612	3192	100	100	200		6	11	18	24	0.63				
DAT0612	3193	100	100	200		6	11	19	24	0.63				
DAT0612	3194	100	100	200		6	11	20	24	0.62				
DAT0612	3195	100	100	200		6	11	21	24	0.62				
DAT0612	3196	100	100	200		6	11	22	24	0.60				
DAT0612	3197	100	100	200		6	11	23	24	0.61				
DAT0612	3198	100	100	200		6	12	0	24	0.59				
DAT0612	3199	100	100	200		6	12	1	24	0.59				
DAT0612	3200	100	100	200	198	6	12	2	24	0.60	0.61			

Appendix N: Digital Reliability Test Data - Test # 5

Stored in:	Test #	Devices Upset				Ave	Date(96)		Time		File size (Mb)			Notes
		Bd #1	Bd #2	Total					full	ave	part			
DAT0612	3201	97	100	197		6	12	3	24	0.59				
DAT0612	3202	100	100	200		6	12	4	24	0.59				
DAT0612	3203	100	100	200		6	12	5	24	0.59				
DAT0612	3204	100	100	200		6	12	6	24	0.58				
DAT0612	3205	100	100	200		6	12	7	24	0.59				
DAT0612	3206	100	100	200		6	12	8	24	0.59				
DAT0612	3207	100	100	200		6	12	9	24	0.59				
DAT0612	3208	100	100	200		6	12	10	24	0.60				
DAT0612	3209	92	100	192		6	12	10	35			0.11		
DAT0613	3210	89	82	171	196	6	12	11	57	0.59	0.59			
DAT0613	3211	67	70	137		6	12	12	4			0.06		
DAT0613	3212	70	52	122		6	12	12	28			0.04	4 Min	
DAT0613	3213	84	85	169		6	12	13	29	0.62				
DAT0613	3214	85	81	166		6	12	16	33	0.64				
DAT0613	3215	100	100	200		6	12	18	27	0.62				
DAT0613	3216	100	100	200		6	12	19	27	0.61				
DAT0613	3217	100	100	200		6	12	20	27	0.60				
DAT0613	3218	100	100	200		6	12	21	27	0.60				
DAT0613	3219	100	100	200		6	12	22	27	0.60				
DAT0613	3220	100	100	200	179	6	12	23	27	0.58	0.61			
DAT0613	3221	100	100	200		6	13	0	27	0.58				
DAT0613	3222	100	100	200		6	13	1	27	0.56				
DAT0613	3223	100	100	200		6	13	2	27	0.56				
DAT0613	3224	100	100	200		6	13	3	27	0.55				
DAT0613	3225	100	100	200		6	13	4	27	0.56				
DAT0613	3226	100	100	200		6	13	5	27	0.55				
DAT0613	3227	100	100	200		6	13	6	27	0.55				
DAT0613	3228	100	100	200		6	13	7	27	0.55				
DAT0613	3229	100	100	200		6	13	8	27	0.57				
DAT0613	3230	100	100	200	200	6	13	9	27	0.57	0.56			
DAT0613	3231	100	100	200		6	13	10	27	0.57				
DAT0613	3232	100	100	200		6	13	11	27	0.56				
DAT0613	3233	100	100	200		6	13	12	27	0.58				
DAT0613	3234	100	100	200		6	13	13	27	0.58				
DAT0613	3235	100	100	200		6	13	14	27	0.58				
DAT0613	3236	96	100	196		6	13	14	45			0.17		
DAT0614	3237	65	100	165		6	13	15	20			0.04	4 Min	
DAT0614	3238	100	100	200		6	13	16	20	0.59				
DAT0614	3239	100	100	200		6	13	17	20	0.60				
DAT0614	3240	100	100	200	196	6	13	18	20	0.59	0.58			
DAT0614	3241	100	100	200		6	13	19	20	0.61				
DAT0614	3242	100	100	200		6	13	20	20	0.61				
DAT0614	3243	100	100	200		6	13	21	20	0.61				
DAT0614	3244	95	100	195		6	13	22	20	0.61				
DAT0614	3245	100	100	200		6	13	23	20	0.60				
DAT0614	3246	100	100	200		6	14	0	20	0.58				
DAT0614	3247	100	100	200		6	14	1	20	0.59				
DAT0614	3248	100	100	200		6	14	2	20	0.57				
DAT0614	3249	100	100	200		6	14	3	20	0.56				
DAT0614	3250	100	100	200	200	6	14	4	20	0.58	0.59			

Appendix N: Digital Reliability Test Data - Test # 5

Stored in:	Test #	Devices Upset				Ave	Date(96)		Time		File size (Mb)			Notes
		Bd #1	Bd #2	Total					full	ave	part			
DAT0614	3251	100	100	200		6	14	5	20	0.59				
DAT0614	3252	100	100	200		6	14	6	20	0.58				
DAT0614	3253	100	100	200		6	14	7	20	0.58				
DAT0614	3254	100	100	200		6	14	8	20	0.58				
DAT0614	3255	98	100	198		6	14	9	20	0.57				
DAT0614	3256	98	100	198		6	14	10	20	0.57				
DAT0614	3257	100	100	200		6	14	11	20	0.58				
DAT0614	3258	99	100	199		6	14	12	20	0.58				
DAT0614	3259	100	100	200		6	14	13	20	0.59				
DAT0614	3260	100	100	200	200	6	14	14	20	0.58	0.58			
DAT0614	3261	70	100	170		6	14	14	29			0.07		
DAT0617	3262	60	50	110		6	14	15	2			0.04	4 Min	
DAT0617	3263	83	84	167		6	14	16	3	0.61				
DAT0617	3264	86	76	162		6	14	17	3	0.62				
DAT0617	3265	88	85	173		6	14	18	3	0.62				
DAT0617	3266	87	90	177		6	14	19	3	0.63				
DAT0617	3267	79	85	164		6	14	20	3	0.61				
DAT0617	3268	81	84	165		6	14	21	3	0.61				
DAT0617	3269	82	84	166		6	14	22	3	0.61				
DAT0617	3270	84	81	165	162	6	14	23	3	0.61	0.62			
DAT0617	3271	83	84	167		6	15	0	3	0.61				
DAT0617	3272	83	87	170		6	15	1	3	0.60				
DAT0617	3273	81	79	160		6	15	2	3	0.59				
DAT0617	3274	86	71	157		6	15	3	3	0.59				
DAT0617	3275	80	85	165		6	15	4	3	0.58				
DAT0617	3276	83	86	169		6	15	5	3	0.58				
DAT0617	3277	84	71	155		6	15	6	3	0.58				
DAT0617	3278	68	83	151		6	15	7	3	0.58				
DAT0617	3279	75	75	150		6	15	8	3	0.58				
DAT0617	3280	84	76	160	160	6	15	9	3	0.58	0.59			
DAT0617	3281	85	80	165		6	15	10	3	0.58				
DAT0617	3282	80	79	159		6	15	11	3	0.59				
DAT0617	3283	85	80	165		6	15	12	3	0.59				
DAT0617	3284	79	83	162		6	15	13	3	0.60				
DAT0617	3285	83	75	158		6	15	14	3	0.59				
DAT0617	3286	83	83	166		6	15	15	3	0.59				
DAT0617	3287	83	73	156		6	15	16	3	0.60				
DAT0617	3288	86	77	163		6	15	17	3	0.60				
DAT0617	3289	86	77	163		6	15	18	3	0.61				
DAT0617	3290	82	78	160	162	6	15	19	3	0.61	0.6			
DAT0617	3291	85	84	169		6	15	20	3	0.61				
DAT0617	3292	86	83	169		6	15	21	3	0.61				
DAT0617	3293	87	81	168		6	15	22	3	0.61				
DAT0617	3294	79	82	161		6	15	23	3	0.60				
DAT0617	3295	84	80	164		6	16	0	3	0.60				
DAT0617	3296	79	82	161		6	16	1	3	0.60				
DAT0617	3297	81	82	163		6	16	2	3	0.59				
DAT0617	3298	78	71	149		6	16	3	3	0.59				
DAT0617	3299	78	88	166		6	16	4	3	0.59				
DAT0617	3300	83	74	157	163	6	16	5	3	0.58	0.6			

Appendix N: Digital Reliability Test Data - Test # 5

Stored in:	Test #	Devices Upset				Date(96)	Time		File size (Mb)			Notes	
		Bd #1	Bd #2	Total	Ave		full	ave	part				
DAT0617	3301	78	77	155		6	16	6	3	0.59			
DAT0617	3302	74	79	153		6	16	7	3	0.59			
DAT0617	3303	82	79	161		6	16	8	3	0.59			
DAT0617	3304	92	88	180		6	16	9	3	0.59			
DAT0617	3305	90	82	172		6	16	10	3	0.59			
DAT0617	3306	78	79	157		6	16	11	3	0.59			
DAT0617	3307	80	84	164		6	16	12	3	0.59			
DAT0617	3308	83	84	167		6	16	13	3	0.60			
DAT0617	3309	80	80	160		6	16	14	3	0.60			
DAT0617	3310	80	86	166	164	6	16	15	3	0.60	0.59		
DAT0617	3311	83	84	167		6	16	16	3	0.60			
DAT0617	3312	84	81	165		6	16	17	3	0.60			
DAT0617	3313	82	87	169		6	16	18	3	0.60			
DAT0617	3314	81	70	151		6	16	19	3	0.59			
DAT0617	3315	86	79	165		6	16	20	3	0.60			
DAT0617	3316	83	81	164		6	16	21	3	0.60			
DAT0617	3317	85	81	166		6	16	22	3	0.61			
DAT0617	3318	83	79	162		6	16	23	3	0.60			
DAT0617	3319	83	80	163		6	17	0	3	0.59			
DAT0617	3320	90	84	174	165	6	17	1	3	0.61	0.6		
DAT0617	3321	78	75	153		6	17	2	3	0.60			
DAT0617	3322	81	80	161		6	17	3	3	0.60			
DAT0617	3323	84	85	169		6	17	4	3	0.59			
DAT0617	3324	81	92	173		6	17	5	3	0.58			
DAT0617	3325	81	88	169		6	17	6	3	0.59			
DAT0617	3326	78	76	154		6	17	7	3	0.59			
DAT0617	3327	88	84	172		6	17	8	3	0.59			
DAT0617	3328	75	80	155		6	17	9	3	0.59			
DAT0617	3329	84	82	166		6	17	10	3	0.59			
DAT0617	3330	80	82	162	163	6	17	11	1		0.59	0.57	
DAT0621	3331	61	58	119		6	17	13	13			0.04	4 Min
DAT0621	3332	83	81	164		6	17	14	13	0.60			
DAT0621	3333	80	74	154		6	17	15	13	0.59			
DAT0621	3334	81	82	163		6	17	16	13	0.59			
DAT0621	3335	80	81	161		6	17	17	13	0.60			
DAT0621	3336	83	83	166		6	17	18	13	0.60			
DAT0621	3337	80	84	164		6	17	19	13	0.61			
DAT0621	3338	82	79	161		6	17	20	13	0.61			
DAT0621	3339	88	78	166		6	17	21	13	0.60			
DAT0621	3340	80	79	159	158	6	17	22	13	0.59	0.6		
DAT0621	3341	80	86	166		6	17	23	13	0.59			
DAT0621	3342	84	75	159		6	18	0	13	0.59			
DAT0621	3343	85	80	165		6	18	1	13	0.59			
DAT0621	3344	85	83	168		6	18	2	13	0.60			
DAT0621	3345	81	81	162		6	18	3	13	0.60			
DAT0621	3346	77	81	158		6	18	4	13	0.60			
DAT0621	3347	82	83	165		6	18	5	13	0.60			
DAT0621	3348	81	72	153		6	18	6	13	0.60			
DAT0621	3349	81	75	156		6	18	7	13	0.60			
DAT0621	3350	84	77	161	161	6	18	8	13	0.60	0.6		

Appendix N: Digital Reliability Test Data - Test # 5

Stored in:	Test #	Devices Upset				Ave	Date(96)		Time		File size (Mb)			Notes
		Bd #1	Bd #2	Total					full	ave	part			
DAT0621	3351	75	77	152		6	18	9	13	0.60				
DAT0621	3352	85	77	162		6	18	10	13	0.60				
DAT0621	3353	83	82	165		6	18	11	13	0.61				
DAT0621	3354	88	81	169		6	18	12	13	0.60				
DAT0621	3355	80	85	165		6	18	13	13	0.59				
DAT0621	3356	87	80	167		6	18	14	13	0.59				
DAT0621	3357	79	83	162		6	18	15	13	0.59				
DAT0621	3358	82	80	162		6	18	16	13	0.59				
DAT0621	3359	84	83	167		6	18	17	13	0.60				
DAT0621	3360	82	74	156	163	6	18	18	13	0.60	0.6			
DAT0621	3361	85	82	167		6	18	19	13	0.60				
DAT0621	3362	84	82	166		6	18	20	13	0.60				
DAT0621	3363	82	83	165		6	18	21	13	0.60				
DAT0621	3364	85	79	164		6	18	22	13	0.60				
DAT0621	3365	85	87	172		6	18	23	13	0.60				
DAT0621	3366	80	83	163		6	19	0	13	0.60				
DAT0621	3367	80	83	163		6	19	1	13	0.59				
DAT0621	3368	80	81	161		6	19	2	13	0.59				
DAT0621	3369	85	83	168		6	19	3	13	0.59				
DAT0621	3370	82	81	163	165	6	19	4	13	0.59	0.6			
DAT0621	3371	82	83	165		6	19	5	13	0.59				
DAT0621	3372	75	80	155		6	19	6	13	0.59				
DAT0621	3373	83	82	165		6	19	7	13	0.59				
DAT0621	3374	86	79	165		6	19	8	13	0.59				
DAT0621	3375	81	85	166		6	19	9	13	0.60				
DAT0621	3376	83	86	169		6	19	10	13	0.59				
DAT0621	3377	80	79	159		6	19	11	13	0.60				
DAT0621	3378	87	73	160		6	19	12	13	0.59				
DAT0621	3379	82	79	161		6	19	13	13	0.59				
DAT0621	3380	84	79	163	163	6	19	14	13	0.60	0.59			
DAT0621	3381	78	74	152		6	19	15	13	0.59				
DAT0621	3382	82	84	166		6	19	16	13	0.59				
DAT0621	3383	79	72	151		6	19	17	13	0.59				
DAT0621	3384	82	81	163		6	19	18	13	0.60				
DAT0621	3385	78	76	154		6	19	19	13	0.60				
DAT0621	3386	78	84	162		6	19	20	13	0.60				
DAT0621	3387	80	79	159		6	19	21	13	0.59				
DAT0621	3388	84	83	167		6	19	22	13	0.60				
DAT0621	3389	83	85	168		6	19	23	13	0.60				
DAT0621	3390	84	77	161	160	6	20	0	13	0.59	0.6			
DAT0621	3391	80	84	164		6	20	1	13	0.59				
DAT0621	3392	81	75	156		6	20	2	13	0.59				
DAT0621	3393	80	88	168		6	20	3	13	0.59				
DAT0621	3394	84	77	161		6	20	4	13	0.58				
DAT0621	3395	88	78	166		6	20	5	13	0.59				
DAT0621	3396	77	78	155		6	20	6	13	0.59				
DAT0621	3397	80	78	158		6	20	7	13	0.59				
DAT0621	3398	82	78	160		6	20	8	13	0.59				
DAT0621	3399	81	74	155		6	20	9	13	0.60				
DAT0621	3400	79	82	161	160	6	20	10	13	0.59	0.59			

Appendix N: Digital Reliability Test Data - Test # 5

Stored in:	Test #	Devices Upset				Ave	Date(96)	Time		File size (Mb)			Notes
		Bd #1	Bd #2	Total						full	ave	part	
DAT0621	3401	82	91	173		6 20	11	13	0.59				
DAT0621	3402	83	78	161		6 20	12	13	0.60				
DAT0621	3403	82	82	164		6 20	13	13	0.60				
DAT0621	3404	85	72	157		6 20	14	13	0.59				
DAT0621	3405	83	80	163		6 20	15	13	0.60				
DAT0621	3406	82	76	158		6 20	16	13	0.60				
DAT0621	3407	84	80	164		6 20	17	13	0.61				
DAT0621	3408	87	84	171		6 20	18	13	0.61				
DAT0621	3409	84	81	165		6 20	19	13	0.61				
DAT0621	3410	91	86	177	165	6 20	20	13	0.62	0.6			
DAT0621	3411	85	81	166		6 20	21	13	0.61				
DAT0621	3412	84	86	170		6 20	22	13	0.61				
DAT0621	3413	77	79	156		6 20	23	13	0.62				
DAT0621	3414	86	82	168		6 21	0	13	0.62				
DAT0621	3415	85	75	160		6 21	1	13	0.61				
DAT0621	3416	83	84	167		6 21	2	13	0.62				
DAT0621	3417	85	78	163		6 21	3	13	0.61				
DAT0621	3418	78	77	155		6 21	4	13	0.60				
DAT0621	3419	85	88	173		6 21	5	13	0.60				
DAT0621	3420	82	78	160	164	6 21	6	13	0.60	0.61			
DAT0621	3421	78	89	167		6 21	7	13	0.59				
DAT0621	3422	78	79	157		6 21	8	13	0.60				
DAT0621	3423	81	87	168		6 21	9	13	0.60				
DAT0621	3424	79	77	156		6 21	10	13	0.61				
DAT0621	3425	83	83	166		6 21	11	13	0.61				
DAT0621	3426	79	76	155		6 21	11	57			0.45		
DAT0623	3427	61	48	109		6 21	14	31			0.04	4 Min	
DAT0623	3428	85	79	164		6 21	15	32	0.62				
DAT0623	3429	80	76	156		6 21	16	32	0.61				
DAT0623	3430	82	77	159	156	6 21	17	32	0.62	0.61			
DAT0623	3431	82	86	168		6 21	18	32	0.63				
DAT0623	3432	88	79	167		6 21	19	32	0.63				
DAT0623	3433	82	81	163		6 21	20	32	0.62				
DAT0623	3434	81	80	161		6 21	21	32	0.62				
DAT0623	3435	81	82	163		6 21	22	32	0.63				
DAT0623	3436	81	84	165		6 21	23	32	0.62				
DAT0623	3437	80	81	161		6 22	0	32	0.61				
DAT0623	3438	79	79	158		6 22	1	32	0.60				
DAT0623	3439	81	84	165		6 22	2	32	0.60				
DAT0623	3440	84	85	169	164	6 22	3	32	0.60	0.62			
DAT0623	3441	78	85	163		6 22	4	32	0.59				
DAT0623	3442	79	83	162		6 22	5	32	0.60				
DAT0623	3443	84	79	163		6 22	6	32	0.60				
DAT0623	3444	79	91	170		6 22	7	32	0.60				
DAT0623	3445	81	81	162		6 22	8	32	0.60				
DAT0623	3446	80	81	161		6 22	9	32	0.61				
DAT0623	3447	85	88	173		6 22	10	32	0.61				
DAT0623	3448	79	80	159		6 22	11	32	0.61				
DAT0623	3449	83	83	166		6 22	12	32	0.61				
DAT0623	3450	85	81	166	165	6 22	13	32	0.62	0.61			

Appendix N: Digital Reliability Test Data - Test # 5

Stored in:	Test #	Devices Upset				Ave	Date(96)		Time		File size (Mb)			Notes
		Bd #1	Bd #2	Total					full	ave	part			
DAT0623	3451	87	81	168		6	22	14	32	0.62				
DAT0623	3452	86	78	164		6	22	15	32	0.61				
DAT0623	3453	86	76	162		6	22	16	32	0.62				
DAT0623	3454	81	86	167		6	22	17	32	0.62				
DAT0623	3455	84	84	168		6	22	18	32	0.62				
DAT0623	3456	88	84	172		6	22	19	32	0.62				
DAT0623	3457	78	83	161		6	22	20	32	0.62				
DAT0623	3458	79	83	162		6	22	21	32	0.62				
DAT0623	3459	76	84	160		6	22	22	32	0.62				
DAT0623	3460	85	74	159	164	6	22	23	32	0.62	0.62			
DAT0623	3461	87	85	172		6	23	0	32	0.62				
DAT0623	3462	84	84	168		6	23	1	32	0.61				
DAT0623	3463	85	80	165		6	23	2	32	0.61				
DAT0623	3464	83	82	165		6	23	3	32	0.61				
DAT0623	3465	78	78	156		6	23	4	32	0.61				
DAT0623	3466	81	81	162		6	23	5	32	0.61				
DAT0623	3467	85	83	168		6	23	6	32	0.60				
DAT0623	3468	79	75	154		6	23	7	32	0.60				
DAT0623	3469	80	82	162		6	23	8	32	0.60				
DAT0623	3470	81	84	165	164	6	23	9	32	0.60	0.61			
DAT0623	3471	80	88	168		6	23	10	32	0.61				
DAT0623	3472	83	84	167		6	23	11	32	0.61				
DAT0623	3473	81	78	159		6	23	12	32	0.61				
DAT0623	3474	83	84	167		6	23	13	32	0.62				
DAT0623	3475	81	82	163		6	23	14	32	0.62				
DAT0623	3476	83	86	169		6	23	15	32	0.62				
DAT0623	3477	79	86	165		6	23	16	32	0.62				
DAT0623	3478	85	84	169		6	23	17	32	0.62				
DAT0623	3479	84	87	171		6	23	18	32	0.62				
DAT0623	3480	86	77	163	166	6	23	19	32	0.62	0.62			
DAT0623	3481	87	80	167		6	23	20	27			0.56		
DAT0628	3482	70	52	122		6	23	20	43			0.04	4 Min	
DAT0628	3483	87	83	170		6	23	21	43	0.61				
DAT0628	3484	85	86	171		6	23	22	43	0.62				
DAT0628	3485	82	78	160		6	23	23	43	0.61				
DAT0628	3486	80	80	160		6	24	0	43	0.61				
DAT0628	3487	80	84	164		6	24	1	43	0.61				
DAT0628	3488	84	80	164		6	24	2	43	0.61				
DAT0628	3489	82	77	159		6	24	3	43	0.60				
DAT0628	3490	81	81	162	160	6	24	4	43	0.60	0.61			
DAT0628	3491	82	78	160		6	24	5	43	0.60				
DAT0628	3492	79	86	165		6	24	6	43	0.60				
DAT0628	3493	82	74	156		6	24	7	43	0.60				
DAT0628	3494	78	78	156		6	24	8	43	0.60				
DAT0628	3495	83	80	163		6	24	9	43	0.61				
DAT0628	3496	81	82	163		6	24	10	43	0.61				
DAT0628	3497	85	76	161		6	24	11	43	0.62				
DAT0628	3498	83	80	163		6	24	12	43	0.62				
DAT0628	3499	79	80	159		6	24	13	43	0.62				
DAT0628	3500	81	86	167	161	6	24	14	43	0.62	0.61			

Appendix N: Digital Reliability Test Data - Test # 5

Stored in:	Test #	Devices Upset				Ave	Date(96)		Time		File size (Mb)			Notes
		Bd #1	Bd #2	Total					full	ave	part			
DAT0628	3501	85	81	166		6	24	15	43	0.61				
DAT0628	3502	83	78	161		6	24	16	43	0.61				
DAT0628	3503	83	75	158		6	24	17	43	0.60				
DAT0628	3504	82	82	164		6	24	18	43	0.60				
DAT0628	3505	81	80	161		6	24	19	43	0.61				
DAT0628	3506	80	80	160		6	24	20	43	0.61				
DAT0628	3507	80	76	156		6	24	21	43	0.61				
DAT0628	3508	83	75	158		6	24	22	43	0.62				
DAT0628	3509	85	68	153		6	24	23	43	0.61				
DAT0628	3510	82	81	163	160	6	25	0	43	0.60	0.61			
DAT0628	3511	83	81	164		6	25	1	43	0.60				
DAT0628	3512	79	85	164		6	25	2	43	0.60				
DAT0628	3513	76	81	157		6	25	3	43	0.59				
DAT0628	3514	87	82	169		6	25	4	43	0.60				
DAT0628	3515	81	77	158		6	25	5	43	0.60				
DAT0628	3516	85	77	162		6	25	6	43	0.60				
DAT0628	3517	82	83	165		6	25	7	43	0.60				
DAT0628	3518	79	81	160		6	25	8	43	0.61				
DAT0628	3519	83	84	167		6	25	9	43	0.60				
DAT0628	3520	80	80	160	163	6	25	10	43	0.61	0.6			
DAT0628	3521	78	89	167		6	25	11	43	0.61				
DAT0628	3522	87	76	163		6	25	12	43	0.61				
DAT0628	3523	84	85	169		6	25	13	43	0.61				
DAT0628	3524	81	84	165		6	25	14	43	0.60				
DAT0628	3525	81	80	161		6	25	15	43	0.61				
DAT0628	3526	78	78	156		6	25	16	43	0.61				
DAT0628	3527	82	85	167		6	25	17	43	0.61				
DAT0628	3528	77	80	157		6	25	18	43	0.61				
DAT0628	3529	81	84	165		6	25	19	43	0.61				
DAT0628	3530	82	81	163	163	6	25	20	43	0.61	0.61			
DAT0628	3531	79	78	157		6	25	21	43	0.61				
DAT0628	3532	84	83	167		6	25	22	43	0.61				
DAT0628	3533	77	86	163		6	25	23	43	0.61				
DAT0628	3534	83	80	163		6	26	0	43	0.61				
DAT0628	3535	79	79	158		6	26	1	43	0.60				
DAT0628	3536	84	84	168		6	26	2	43	0.60				
DAT0628	3537	80	78	158		6	26	3	43	0.60				
DAT0628	3538	80	77	157		6	26	4	43	0.59				
DAT0628	3539	83	85	168		6	26	5	43	0.59				
DAT0628	3540	77	77	154	161	6	26	6	43	0.59	0.6			
DAT0628	3541	82	77	159		6	26	7	43	0.59				
DAT0628	3542	81	82	163		6	26	8	43	0.59				
DAT0628	3543	82	88	170		6	26	9	43	0.59				
DAT0628	3544	83	83	166		6	26	10	43	0.60				
DAT0628	3545	82	77	159		6	26	11	43	0.60				
DAT0628	3546	85	80	165		6	26	12	43	0.60				
DAT0628	3547	83	79	162		6	26	13	43	0.60				
DAT0628	3548	83	80	163		6	26	14	43	0.60				
DAT0628	3549	84	84	168		6	26	15	43	0.61				
DAT0628	3550	87	80	167	164	6	26	16	43	0.61	0.6			



Appendix N: Digital Reliability Test Data - Test # 5

Stored in:	Test #	Devices Upset				Ave	Date(96)		Time		File size (Mb)			Notes
		Bd #1	Bd #2	Total					full	ave	part			
DAT0628	3551	81	83	164		6	26	17	43	0.62				
DAT0628	3552	82	81	163		6	26	18	43	0.62				
DAT0628	3553	82	83	165		6	26	19	43	0.61				
DAT0628	3554	83	80	163		6	26	20	43	0.62				
DAT0628	3555	84	88	172		6	26	21	43	0.61				
DAT0628	3556	77	79	156		6	26	22	43	0.61				
DAT0628	3557	80	84	164		6	26	23	43	0.61				
DAT0628	3558	80	84	164		6	27	0	43	0.61				
DAT0628	3559	81	83	164		6	27	1	43	0.61				
DAT0628	3560	80	84	164	164	6	27	2	43	0.60	0.61			
DAT0628	3561	81	75	156		6	27	3	43	0.60				
DAT0628	3562	83	84	167		6	27	4	43	0.60				
DAT0628	3563	80	89	169		6	27	5	43	0.59				
DAT0628	3564	83	82	165		6	27	6	43	0.60				
DAT0628	3565	81	86	167		6	27	7	43	0.60				
DAT0628	3566	86	85	171		6	27	8	43	0.60				
DAT0628	3567	84	75	159		6	27	9	43	0.60				
DAT0628	3568	83	88	171		6	27	10	43	0.60				
DAT0628	3569	79	82	161		6	27	11	43	0.60				
DAT0628	3570	84	81	165	165	6	27	12	43	0.61	0.6			
DAT0628	3571	86	81	167		6	27	13	43	0.61				
DAT0628	3572	79	84	163		6	27	14	43	0.61				
DAT0628	3573	81	80	161		6	27	15	43	0.61				
DAT0628	3574	82	84	166		6	27	16	43	0.61				
DAT0628	3575	82	78	160		6	27	17	43	0.61				
DAT0628	3576	83	80	163		6	27	18	43	0.61				
DAT0628	3577	79	85	164		6	27	19	43	0.61				
DAT0628	3578	83	81	164		6	27	20	43	0.61				
DAT0628	3579	82	83	165		6	27	21	43	0.61				
DAT0628	3580	79	86	165	164	6	27	22	43	0.61	0.61			
DAT0628	3581	84	80	164		6	27	23	43	0.61				
DAT0628	3582	84	72	156		6	28	0	43	0.60				
DAT0628	3583	80	81	161		6	28	1	43	0.60				
DAT0628	3584	82	82	164		6	28	2	43	0.60				
DAT0628	3585	81	82	163		6	28	3	43	0.60				
DAT0628	3586	81	81	162		6	28	4	43	0.60				
DAT0628	3587	81	85	166		6	28	5	43	0.60				
DAT0628	3588	80	79	159		6	28	6	43	0.59				
DAT0628	3589	84	78	162		6	28	7	43	0.59				
DAT0628	3590	82	81	163	162	6	28	8	43	0.60	0.6			
DAT0628	3591	82	81	163		6	28	9	43	0.60				
DAT0628	3592	81	80	161		6	28	10	43	0.59				
DAT0701	3593	60	56	116		6	28	13	54			0.04	4 Min	
DAT0701	3594	76	78	154		6	28	14	55	0.61				
DAT0701	3595	79	73	152		6	28	15	55	0.61				
DAT0701	3596	78	79	157		6	28	16	55	0.61				
DAT0701	3597	76	79	155		6	28	17	55	0.62				
DAT0701	3598	80	90	170		6	28	18	55	0.62				
DAT0701	3599	81	85	166		6	28	19	55	0.61				
DAT0701	3600	81	85	166	156	6	28	20	55	0.61	0.61			

Appendix N: Digital Reliability Test Data - Test # 5

Stored in:	Test #	Devices Upset				Ave	Date(96)		Time		File size (Mb)			Notes
		Bd #1	Bd #2	Total					full	ave	part			
DAT0701	3601	83	87	170		6	28	21	55	0.62				
DAT0701	3602	79	85	164		6	28	22	55	0.61				
DAT0701	3603	84	82	166		6	28	23	55	0.61				
DAT0701	3604	85	86	171		6	29	0	55	0.60				
DAT0701	3605	83	81	164		6	29	1	55	0.59				
DAT0701	3606	78	88	166		6	29	2	55	0.58				
DAT0701	3607	83	73	156		6	29	3	55	0.58				
DAT0701	3608	80	86	166		6	29	4	55	0.58				
DAT0701	3609	82	89	171		6	29	5	55	0.58				
DAT0701	3610	79	79	158	165	6	29	6	55	0.58	0.59			
DAT0701	3611	80	78	158		6	29	7	55	0.58				
DAT0701	3612	82	87	169		6	29	8	55	0.58				
DAT0701	3613	81	79	160		6	29	9	55	0.58				
DAT0701	3614	88	80	168		6	29	10	55	0.60				
DAT0701	3615	85	79	164		6	29	11	55	0.60				
DAT0701	3616	81	81	162		6	29	12	55	0.61				
DAT0701	3617	81	76	157		6	29	13	55	0.61				
DAT0701	3618	83	79	162		6	29	14	55	0.61				
DAT0701	3619	86	84	170		6	29	15	55	0.61				
DAT0701	3620	78	77	155	163	6	29	16	55	0.61	0.6			
DAT0701	3621	82	85	167		6	29	17	55	0.61				
DAT0701	3622	82	83	165		6	29	18	55	0.61				
DAT0701	3623	86	82	168		6	29	19	55	0.61				
DAT0701	3624	83	83	166		6	29	20	55	0.61				
DAT0701	3625	75	82	157		6	29	21	55	0.61				
DAT0701	3626	78	90	168		6	29	22	55	0.61				
DAT0701	3627	75	74	149		6	29	23	55	0.60				
DAT0701	3628	80	78	158		6	30	0	55	0.60				
DAT0701	3629	84	82	166		6	30	1	55	0.59				
DAT0701	3630	81	80	161	163	6	30	2	55	0.58	0.6			
DAT0701	3631	81	83	164		6	30	3	55	0.59				
DAT0701	3632	82	81	163		6	30	4	55	0.59				
DAT0701	3633	86	79	165		6	30	5	55	0.57				
DAT0701	3634	83	78	161		6	30	6	55	0.58				
DAT0701	3635	84	80	164		6	30	7	55	0.58				
DAT0701	3636	87	78	165		6	30	8	55	0.58				
DAT0701	3637	87	77	164		6	30	9	55	0.59				
DAT0701	3638	82	75	157		6	30	10	55	0.59				
DAT0701	3639	78	85	163		6	30	11	55	0.60				
DAT0701	3640	85	85	170	164	6	30	12	55	0.61	0.59			
DAT0701	3641	82	79	161		6	30	13	55	0.61				
DAT0701	3642	81	83	164		6	30	14	55	0.61				
DAT0701	3643	81	79	160		6	30	15	55	0.61				
DAT0701	3644	80	79	159		6	30	16	55	0.61				
DAT0701	3645	78	88	166		6	30	17	55	0.62				
DAT0701	3646	83	79	162		6	30	18	55	0.62				
DAT0701	3647	84	79	163		6	30	19	55	0.62				
DAT0701	3648	91	83	174		6	30	20	55	0.61				
DAT0701	3649	82	83	165		6	30	21	55	0.61				
DAT0701	3650	80	84	164	164	6	30	22	55	0.61	0.61			

Appendix N: Digital Reliability Test Data - Test # 5

Stored in:	Devices Upset						Date(96)			Time			File size (Mb)			Notes
	Test #	Bd #1	Bd #2	Total	Ave							full	ave	part		
DAT0701	3651	77	77	154		6	30	23	55	0.60						
DAT0701	3652	83	88	171		7	1	0	55	0.60						
DAT0701	3653	83	76	159		7	1	1	55	0.60						
DAT0701	3654	79	75	154		7	1	2	55	0.59						
DAT0701	3655	83	73	156		7	1	3	55	0.58						
DAT0701	3656	83	80	163		7	1	4	55	0.59						
DAT0701	3657	80	70	150		7	1	5	55	0.58						
DAT0701	3658	75	73	148		7	1	6	55	0.57						
DAT0701	3659	82	79	161		7	1	7	55	0.58						
DAT0701	3660	84	76	160	158	7	1	8	48		0.59	0.52				
DAT0705	3661	60	55	115		7	1	10	53			0.04		4 Min		
DAT0705	3662	85	76	161		7	1	11	53	0.61						
DAT0705	3663	83	80	163		7	1	12	53	0.61						
DAT0705	3664	86	80	166		7	1	13	53	0.61						
DAT0705	3665	79	78	157		7	1	14	53	0.61						
DAT0705	3666	86	81	167		7	1	15	53	0.61						
DAT0705	3667	89	81	170		7	1	16	53	0.62						
DAT0705	3668	85	78	163		7	1	17	53	0.62						
DAT0705	3669	82	75	157		7	1	18	53	0.62						
DAT0705	3670	87	84	171	159	7	1	19	53	0.62	0.61					
DAT0705	3671	82	77	159		7	1	20	53	0.60						
DAT0705	3672	85	82	167		7	1	21	53	0.60						
DAT0705	3673	88	86	174		7	1	22	53	0.60						
DAT0705	3674	83	80	163		7	1	23	53	0.60						
DAT0705	3675	85	87	172		7	2	0	53	0.60						
DAT0705	3676	79	75	154		7	2	1	53	0.60						
DAT0705	3677	79	77	156		7	2	2	53	0.59						
DAT0705	3678	86	84	170		7	2	3	53	0.60						
DAT0705	3679	83	73	156		7	2	4	53	0.60						
DAT0705	3680	81	84	165	164	7	2	5	53	0.59	0.6					
DAT0705	3681	82	75	157		7	2	6	53	0.59						
DAT0705	3682	84	80	164		7	2	7	53	0.59						
DAT0705	3683	82	79	161		7	2	8	53	0.60						
DAT0705	3684	82	84	166		7	2	9	53	0.60						
DAT0705	3685	80	79	159		7	2	10	53	0.60						
DAT0705	3686	81	83	164		7	2	11	53	0.61						
DAT0705	3687	84	76	160		7	2	12	53	0.60						
DAT0705	3688	78	76	154		7	2	13	53	0.61						
DAT0705	3689	83	78	161		7	2	14	53	0.61						
DAT0705	3690	81	75	156	160	7	2	15	53	0.60	0.6					
DAT0705	3691	86	85	171		7	2	16	53	0.61						
DAT0705	3692	80	76	156		7	2	17	53	0.60						
DAT0705	3693	84	85	169		7	2	18	53	0.61						
DAT0705	3694	81	83	164		7	2	19	53	0.60						
DAT0705	3695	84	80	164		7	2	20	53	0.60						
DAT0705	3696	83	80	163		7	2	21	53	0.60						
DAT0705	3697	83	77	160		7	2	22	53	0.61						
DAT0705	3698	84	80	164		7	2	23	53	0.60						
DAT0705	3699	83	82	165		7	3	0	53	0.60						
DAT0705	3700	82	75	157	163	7	3	1	53	0.60	0.6					

Appendix N: Digital Reliability Test Data - Test # 5

Stored in:	Test #	Devices Upset				Date(96)	Time		File size (Mb)			Notes
		Bd #1	Bd #2	Total	Ave		full	ave	part			
DAT0705	3701	82	73	155		7	3	2	53	0.60		
DAT0705	3702	77	79	156		7	3	3	53	0.60		
DAT0705	3703	85	75	160		7	3	4	53	0.60		
DAT0705	3704	84	75	159		7	3	5	53	0.60		
DAT0705	3705	82	81	163		7	3	6	53	0.60		
DAT0705	3706	82	83	165		7	3	7	53	0.61		
DAT0705	3707	80	82	162		7	3	8	53	0.61		
DAT0705	3708	80	77	157		7	3	9	53	0.61		
DAT0705	3709	81	83	164		7	3	10	53	0.61		
DAT0705	3710	78	82	160	160	7	3	11	53	0.61	0.67	
DAT0705	3711	84	82	166		7	3	12	53	0.61		
DAT0705	3712	85	84	169		7	3	13	53	0.61		
DAT0705	3713	84	80	164		7	3	14	53	0.61		
DAT0705	3714	72	61	133		7	3	15	14			0.21 Interrupted
DAT0705	3715	82	85	167		7	3	18	54	0.61		
DAT0705	3716	87	79	166		7	3	19	54	0.60		
DAT0705	3717	74	74	148		7	3	20	54	0.61		
DAT0705	3718	79	77	156		7	3	21	54	0.60		
DAT0705	3719	78	80	158		7	3	22	54	0.60		
DAT0705	3720	84	77	161	159	7	3	23	54	0.59	0.54	
DAT0705	3721	82	77	159		7	4	0	54	0.59		
DAT0705	3722	79	81	160		7	4	1	54	0.58		
DAT0705	3723	77	77	154		7	4	2	54	0.59		
DAT0705	3724	84	80	164		7	4	3	54	0.58		
DAT0705	3725	84	78	162		7	4	4	54	0.59		
DAT0705	3726	84	80	164		7	4	5	54	0.58		
DAT0705	3727	83	86	169		7	4	6	54	0.58		
DAT0705	3728	76	79	155		7	4	7	54	0.58		
DAT0705	3729	81	78	159		7	4	8	54	0.58		
DAT0705	3730	79	81	160	161	7	4	9	54	0.59	0.58	
DAT0705	3731	77	82	159		7	4	10	54	0.60		
DAT0705	3732	82	77	159		7	4	11	54	0.60		
DAT0705	3733	80	78	158		7	4	12	54	0.61		
DAT0705	3734	80	85	165		7	4	13	54	0.61		
DAT0705	3735	80	79	159		7	4	14	54	0.60		
DAT0705	3736	89	82	171		7	4	15	54	0.61		
DAT0705	3737	83	77	160		7	4	16	54	0.61		
DAT0705	3738	80	84	164		7	4	17	54	0.61		
DAT0705	3739	83	84	167		7	4	18	54	0.60		
DAT0705	3740	82	81	163	163	7	4	19	54	0.60	0.61	
DAT0705	3741	85	80	165		7	4	20	54	0.60		
DAT0705	3742	82	77	159		7	4	21	54	0.61		
DAT0705	3743	82	77	159		7	4	22	54	0.60		
DAT0705	3744	80	76	156		7	4	23	54	0.60		
DAT0705	3745	78	75	153		7	5	0	54	0.59		
DAT0705	3746	76	80	156		7	5	1	54	0.59		
DAT0705	3747	84	80	164		7	5	2	54	0.58		
DAT0705	3748	78	79	157		7	5	3	54	0.58		
DAT0705	3749	78	80	158		7	5	4	54	0.58		
DAT0705	3750	84	79	163	159	7	5	5	54	0.59	0.59	

Appendix N: Digital Reliability Test Data - Test # 5

Stored in:	Test #	Devices Upset				Ave	Date(96)		Time		File size (Mb)			Notes
		Bd #1	Bd #2	Total					full	ave	part			
DAT0705	3751	82	86	168		7	5	6	54	0.60				
DAT0705	3752	86	82	168		7	5	7	54	0.59				
DAT0705	3753	82	82	164		7	5	8	53	0.59				
DAT0708	3754	61	55	116		7	5	14	36			0.04	4 Min	
DAT0708	3755	82	82	164		7	5	15	36	0.61				
DAT0708	3756	86	73	159		7	5	16	36	0.61				
DAT0708	3757	78	82	160		7	5	17	36	0.61				
DAT0708	3758	82	78	160		7	5	18	36	0.61				
DAT0708	3759	82	81	163		7	5	19	36	0.61				
DAT0708	3760	79	74	153	158	7	5	20	36	0.61	0.6			
DAT0708	3761	80	81	161		7	5	21	36	0.61				
DAT0708	3762	83	72	155		7	5	22	36	0.61				
DAT0708	3763	88	74	162		7	5	23	36	0.61				
DAT0708	3764	78	77	155		7	6	0	36	0.61				
DAT0708	3765	79	82	161		7	6	1	36	0.60				
DAT0708	3766	81	68	149		7	6	2	36	0.60				
DAT0708	3767	74	74	148		7	6	3	36	0.60				
DAT0708	3768	79	78	157		7	6	4	36	0.60				
DAT0708	3769	81	80	161		7	6	5	36	0.60				
DAT0708	3770	85	80	165	157	7	6	6	36	0.59	0.6			
DAT0708	3771	82	77	159		7	6	7	36	0.58				
DAT0708	3772	83	73	156		7	6	8	36	0.59				
DAT0708	3773	83	80	163		7	6	9	36	0.60				
DAT0708	3774	85	79	164		7	6	10	36	0.60				
DAT0708	3775	82	78	160		7	6	11	36	0.60				
DAT0708	3776	81	82	163		7	6	12	36	0.61				
DAT0708	3777	79	77	156		7	6	13	36	0.61				
DAT0708	3778	83	70	153		7	6	14	36	0.61				
DAT0708	3779	81	84	165		7	6	15	36	0.61				
DAT0708	3780	87	82	169	161	7	6	16	36	0.61	0.6			
DAT0708	3781	83	71	154		7	6	17	36	0.61				
DAT0708	3782	80	81	161		7	6	18	36	0.61				
DAT0708	3783	77	79	156		7	6	19	36	0.61				
DAT0708	3784	84	79	163		7	6	20	36	0.61				
DAT0708	3785	82	81	163		7	6	21	36	0.61				
DAT0708	3786	84	75	159		7	6	22	36	0.61				
DAT0708	3787	82	84	166		7	6	23	36	0.62				
DAT0708	3788	82	83	165		7	7	0	36	0.62				
DAT0708	3789	83	74	157		7	7	1	36	0.62				
DAT0708	3790	80	75	155	160	7	7	2	36	0.61	0.61			
DAT0708	3791	83	75	158		7	7	3	36	0.61				
DAT0708	3792	89	88	177		7	7	4	36	0.61				
DAT0708	3793	90	74	164		7	7	5	36	0.60				
DAT0708	3794	85	87	172		7	7	6	36	0.60				
DAT0708	3795	82	77	159		7	7	7	36	0.60				
DAT0708	3796	82	83	165		7	7	8	36	0.61				
DAT0708	3797	81	85	166		7	7	9	36	0.61				
DAT0708	3798	82	78	160		7	7	10	36	0.62				
DAT0708	3799	83	82	165		7	7	11	36	0.62				
DAT0708	3800	88	77	165	165	7	7	12	36	0.62	0.61			



Appendix P: Digital Reliability Test Data - Test # 7 (Test Period # 6)

Stored in:	Test #	Devices Upset				Date(96)	Time		File size (Mb)			Notes	
		Bd #1	Bd #2	Total	Ave		full	ave	part				
DAT0710	3851	56	18	74		7	9	11	32			0.01	4 Min
DAT0710	3852	90	90	180		7	9	12	32	0.17			
DAT0710	3853	89	75	164		7	9	13	32	0.17			
DAT0710	3854	95	84	179		7	9	14	32	0.17			
DAT0710	3855	92	72	164		7	9	15	32	0.16			
DAT0710	3856	73	56	129		7	9	15	41			0.02	
DAT0710	3857	41	22	63		7	9	16	43	0.10			Vlo=.6 volt
DAT0710	3858	94	93	187		7	9	17	44	0.17			
DAT0710	3859	93	75	168		7	9	18	44	0.17			
DAT0710	3860	97	82	179	149	7	9	19	44	0.17	0.16		
DAT0710	3861	93	80	173		7	9	20	44	0.17			
DAT0710	3862	95	87	182		7	9	21	44	0.17			
DAT0710	3863	96	87	183		7	9	22	44	0.18			
DAT0710	3864	93	79	172		7	9	23	44	0.17			
DAT0710	3865	94	75	169		7	10	0	44	0.17			
DAT0710	3866	91	85	176		7	10	1	44	0.17			
DAT0710	3867	96	86	182		7	10	2	44	0.17			
DAT0710	3868	93	71	164		7	10	3	44	0.16			
DAT0710	3869	95	87	182		7	10	4	44	0.17			
DAT0710	3870	96	75	171	175	7	10	5	44	0.16	0.17		
DAT0710	3871	97	82	179		7	10	6	44	0.16			
DAT0710	3872	95	83	178		7	10	7	44	0.17			
DAT0710	3873	97	78	175		7	10	8	44	0.16			
DAT0710	3874	81	74	155		7	10	8	59			0.04	
DAT0712	3875	52	42	94		7	10	9	15			0.01	4 Min
DAT0712	3876	97	77	174		7	10	10	16	0.17			
DAT0712	3877	90	86	176		7	10	11	16	0.16			
DAT0712	3878	91	82	173		7	10	12	16	0.17			
DAT0712	3879	93	91	184		7	10	13	16	0.17			
DAT0712	3880	90	81	171	166	7	10	14	16	0.16	0.17		
DAT0712	3881	93	89	182		7	10	15	17	0.17			
DAT0712	3882	91	87	178		7	10	16	17	0.17			
DAT0712	3883	93	90	183		7	10	17	17	0.17			
DAT0712	3884	95	93	188		7	10	18	17	0.18			
DAT0712	3885	94	75	169		7	10	19	17	0.17			
DAT0712	3886	93	89	182		7	10	20	17	0.17			
DAT0712	3887	92	83	175		7	10	21	17	0.17			
DAT0712	3888	92	85	177		7	10	22	17	0.17			
DAT0712	3889	92	86	178		7	10	23	17	0.17			
DAT0712	3890	96	84	180	179	7	11	0	17	0.17	0.17		
DAT0712	3891	97	81	178		7	11	1	17	0.17			
DAT0712	3892	94	86	180		7	11	2	17	0.17			
DAT0712	3893	94	89	183		7	11	3	17	0.16			
DAT0712	3894	89	83	172		7	11	4	17	0.16			
DAT0712	3895	94	81	175		7	11	5	17	0.16			
DAT0712	3896	94	81	175		7	11	6	17	0.16			
DAT0712	3897	85	88	173		7	11	7	17	0.16			
DAT0712	3898	96	83	179		7	11	8	17	0.16			
DAT0712	3899	97	90	187		7	11	9	17	0.17			
DAT0712	3900	91	85	176	178	7	11	10	17	0.16	0.16		

Appendix P: Digital Reliability Test Data - Test # 7 (Test Period # 6)

Stored in:	Test #	Devices Upset				Ave	Date(96)		Time		File size (Mb)			Notes
		Bd #1	Bd #2	Total					full	ave	part			
DAT0712	3901	91	75	166		7	11	11	17	0.16				
DAT0712	3902	94	81	175		7	11	12	17	0.16				
DAT0712	3903	88	87	175		7	11	13	17	0.16				
DAT0712	3904	91	77	168		7	11	14	17	0.17				
DAT0712	3905	94	88	182		7	11	15	17	0.17				
DAT0712	3906	89	89	178		7	11	16	17	0.17				
DAT0712	3907	95	80	175		7	11	17	17	0.17				
DAT0712	3908	91	88	179		7	11	18	17	0.17				
DAT0712	3909	95	82	177		7	11	19	17	0.17				
DAT0712	3910	97	79	176	175	7	11	20	17	0.17	0.17			
DAT0712	3911	94	86	180		7	11	21	17	0.17				
DAT0712	3912	96	89	185		7	11	22	17	0.17				
DAT0712	3913	91	92	183		7	11	23	17	0.17				
DAT0712	3914	92	86	178		7	12	0	17	0.17				
DAT0712	3915	98	76	174		7	12	1	17	0.17				
DAT0712	3916	95	76	171		7	12	2	17	0.16				
DAT0712	3917	93	82	175		7	12	3	17	0.17				
DAT0712	3918	91	68	159		7	12	4	17	0.16				
DAT0712	3919	92	84	176		7	12	5	17	0.16				
DAT0712	3920	93	88	181	176	7	12	6	17	0.16	0.16			
DAT0712	3921	91	81	172		7	12	7	17	0.16				
DAT0712	3922	92	73	165		7	12	8	17	0.16				
DAT0712	3923	95	77	172		7	12	9	17	0.16				
DAT0712	3924	96	90	186		7	12	10	17	0.17				
DAT0712	3925	93	85	178		7	12	11	17	0.17				
DAT0712	3926	87	90	177		7	12	12	17	0.16				
DAT0712	3927	85	60	145		7	12	12	35			0.05		
DAT0715	3928	54	35	89		7	12	13	3			0.01	4 Min	
DAT0715	3929	90	84	174		7	12	14	4	0.17				
DAT0715	3930	93	81	174	163	7	12	15	4	0.17	0.17			
DAT0715	3931	92	79	171		7	12	16	4	0.17				
DAT0715	3932	94	85	179		7	12	17	4	0.17				
DAT0715	3933	94	82	176		7	12	18	4	0.17				
DAT0715	3934	95	92	187		7	12	19	4	0.17				
DAT0715	3935	94	90	184		7	12	20	4	0.17				
DAT0715	3936	90	78	168		7	12	21	4	0.17				
DAT0715	3937	95	97	192		7	12	22	4	0.17				
DAT0715	3938	93	80	173		7	12	23	4	0.17				
DAT0715	3939	90	82	172		7	13	0	4	0.17				
DAT0715	3940	91	86	177	178	7	13	1	4	0.16	0.17			
DAT0715	3941	93	77	170		7	13	2	4	0.16				
DAT0715	3942	93	85	178		7	13	3	4	0.16				
DAT0715	3943	90	74	164		7	13	4	4	0.16				
DAT0715	3944	90	73	163		7	13	5	4	0.16				
DAT0715	3945	95	66	161		7	13	6	4	0.16				
DAT0715	3946	86	81	167		7	13	7	4	0.16				
DAT0715	3947	98	75	173		7	13	8	4	0.16				
DAT0715	3948	88	78	166		7	13	9	4	0.16				
DAT0715	3949	90	74	164		7	13	10	4	0.16				
DAT0715	3950	93	74	167	167	7	13	11	4	0.16	0.13			



Appendix P: Digital Reliability Test Data - Test # 7 (Test Period # 6)

Stored in:	Test #	Devices Upset				Ave	Date(96)		Time		File size (Mb)			Notes
		Bd #1	Bd #2	Total					full	ave	part			
DAT0715	3951	94	82	176		7	13	12	4	0.16				
DAT0715	3952	92	87	179		7	13	13	4	0.17				
DAT0715	3953	92	80	172		7	13	14	4	0.16				
DAT0715	3954	97	82	179		7	13	15	4	0.17				
DAT0715	3955	88	79	167		7	13	16	4	0.16				
DAT0715	3956	92	87	179		7	13	17	4	0.17				
DAT0715	3957	91	84	175		7	13	18	4	0.17				
DAT0715	3958	96	87	183		7	13	19	4	0.17				
DAT0715	3959	97	85	182		7	13	20	4	0.17				
DAT0715	3960	94	83	177	177	7	13	21	4	0.17	0.17			
DAT0715	3961	90	82	172		7	13	22	4	0.17				
DAT0715	3962	96	83	179		7	13	23	4	0.17				
DAT0715	3963	93	86	179		7	14	0	4	0.17				
DAT0715	3964	90	85	175		7	14	1	4	0.17				
DAT0715	3965	96	86	182		7	14	2	4	0.16				
DAT0715	3966	97	86	183		7	14	3	4	0.17				
DAT0715	3967	85	76	161		7	14	4	4	0.16				
DAT0715	3968	95	92	187		7	14	5	4	0.16				
DAT0715	3969	92	86	178		7	14	6	4	0.16				
DAT0715	3970	93	82	175	177	7	14	7	4	0.16	0.17			
DAT0715	3971	92	84	176		7	14	8	4	0.16				
DAT0715	3972	93	89	182		7	14	9	4	0.16				
DAT0715	3973	93	81	174		7	14	10	4	0.16				
DAT0715	3974	93	83	176		7	14	11	4	0.16				
DAT0715	3975	93	82	175		7	14	12	4	0.17				
DAT0715	3976	92	85	177		7	14	13	4	0.17				
DAT0715	3977	90	78	168		7	14	14	4	0.16				
DAT0715	3978	99	87	186		7	14	15	4	0.17				
DAT0715	3979	97	85	182		7	14	16	4	0.17				
DAT0715	3980	92	88	180	178	7	14	17	4	0.17	0.17			
DAT0715	3981	95	88	183		7	14	18	4	0.18				
DAT0715	3982	95	94	189		7	14	19	4	0.17				
DAT0715	3983	91	89	180		7	14	20	4	0.17				
DAT0715	3984	92	86	178		7	14	21	4	0.17				
DAT0715	3985	98	77	175		7	14	22	4	0.17				
DAT0715	3986	97	84	181		7	14	23	4	0.17				
DAT0715	3987	92	85	177		7	15	0	4	0.17				
DAT0715	3988	95	72	167		7	15	1	4	0.16				
DAT0715	3989	95	82	177		7	15	2	4	0.17				
DAT0715	3990	93	86	179	179	7	15	3	4	0.16	0.17			
DAT0715	3991	89	91	180		7	15	4	4	0.16				
DAT0715	3992	95	76	171		7	15	5	4	0.16				
DAT0715	3993	94	79	173		7	15	6	4	0.16				
DAT0715	3994	95	87	182		7	15	7	4	0.16				
DAT0715	3995	90	73	163		7	15	8	4	0.16				
DAT0715	3996	92	76	168		7	15	9	4	0.16				
DAT0715	3997	56	41	97		7	15	9	16			0.03		
DAT0719	3998	49	20	69		7	15	9	42			0.01	4 Min	
DAT0719	3999	93	79	172		7	15	10	42	0.16				
DAT0719	4000	95	74	169	154	7	15	11	30		0.16	0.13	Interrupt	

Appendix P: Digital Reliability Test Data - Test # 7 (Test Period # 6)

Stored in:	Test #	Devices Upset				Date(96)	Time		File size (Mb)			Notes
		Bd #1	Bd #2	Total	Ave		full	ave	part			
DAT0719	4001	94	75	169		7	15	12	47	0.16		
DAT0719	4002	89	94	183		7	15	13	47	0.17		
DAT0719	4003	95	88	183		7	15	14	47	0.17		
DAT0719	4004	91	86	177		7	15	15	47	0.17		
DAT0719	4005	89	87	176		7	15	16	47	0.17		
DAT0719	4006	88	84	172		7	15	17	47	0.17		
DAT0719	4007	93	78	171		7	15	18	47	0.17		
DAT0719	4008	91	87	178		7	15	19	47	0.17		
DAT0719	4009	91	81	172		7	15	20	47	0.17		
DAT0719	4010	92	82	174	176	7	15	21	47	0.17	0.17	
DAT0719	4011	95	85	180		7	15	22	47	0.17		
DAT0719	4012	91	98	189		7	15	23	47	0.17		
DAT0719	4013	91	87	178		7	16	0	47	0.16		
DAT0719	4014	96	64	160		7	16	1	47	0.16		
DAT0719	4015	94	83	177		7	16	2	47	0.16		
DAT0719	4016	94	79	173		7	16	3	47	0.16		
DAT0719	4017	91	81	172		7	16	4	47	0.16		
DAT0719	4018	91	73	164		7	16	5	47	0.16		
DAT0719	4019	94	84	178		7	16	6	47	0.17		
DAT0719	4020	93	84	177	175	7	16	7	47	0.16	0.16	
DAT0719	4021	96	89	185		7	16	8	47	0.17		
DAT0719	4022	91	83	174		7	16	9	47	0.16		
DAT0719	4023	93	88	181		7	16	10	47	0.16		
DAT0719	4024	92	80	172		7	16	11	47	0.17		
DAT0719	4025	90	87	177		7	16	12	47	0.17		
DAT0719	4026	95	89	184		7	16	13	47	0.17		
DAT0719	4027	91	78	169		7	16	14	47	0.17		
DAT0719	4028	89	82	171		7	16	15	47	0.17		
DAT0719	4029	95	91	186		7	16	16	47	0.17		
DAT0719	4030	94	88	182	178	7	16	17	47	0.17	0.17	
DAT0719	4031	97	81	178		7	16	18	47	0.17		
DAT0719	4032	97	86	183		7	16	19	47	0.18		
DAT0719	4033	92	82	174		7	16	20	47	0.17		
DAT0719	4034	92	90	182		7	16	21	47	0.17		
DAT0719	4035	95	83	178		7	16	22	47	0.17		
DAT0719	4036	94	83	177		7	16	23	47	0.17		
DAT0719	4037	96	88	184		7	17	0	47	0.17		
DAT0719	4038	93	85	178		7	17	1	47	0.16		
DAT0719	4039	89	76	165		7	17	2	47	0.16		
DAT0719	4040	87	84	171	177	7	17	3	47	0.17	0.17	
DAT0719	4041	86	85	171		7	17	4	47	0.16		
DAT0719	4042	94	68	162		7	17	5	47	0.16		
DAT0719	4043	88	82	170		7	17	6	47	0.16		
DAT0719	4044	94	63	157		7	17	7	47	0.16		
DAT0719	4045	92	81	173		7	17	8	47	0.17		
DAT0719	4046	94	71	165		7	17	9	47	0.16		
DAT0719	4047	95	85	180		7	17	10	47	0.17		
DAT0719	4048	91	73	164		7	17	11	47	0.16		
DAT0719	4049	93	79	172		7	17	12	47	0.16		
DAT0719	4050	94	81	175	169	7	17	13	47	0.16	0.16	

Appendix P: Digital Reliability Test Data - Test # 7 (Test Period # 6)

Stored in:	Test #	Devices Upset				Ave	Date(96)		Time		File size (Mb)			Notes
		Bd #1	Bd #2	Total					full	ave	part			
DAT0719	4051	94	84	178		7	17	14	47	0.16				
DAT0719	4052	93	77	170		7	17	15	47	0.17				
DAT0719	4053	93	77	170		7	17	16	47	0.17				
DAT0719	4054	94	83	177		7	17	17	47	0.17				
DAT0719	4055	93	83	176		7	17	18	47	0.17				
DAT0719	4056	95	75	170		7	17	19	47	0.17				
DAT0719	4057	95	80	175		7	17	20	47	0.17				
DAT0719	4058	95	86	181		7	17	21	47	0.16				
DAT0719	4059	97	79	176		7	17	22	47	0.17				
DAT0719	4060	90	80	170	174	7	17	23	47	0.16	0.17			
DAT0719	4061	91	79	170		7	18	0	47	0.16				
DAT0719	4062	94	73	167		7	18	1	47	0.16				
DAT0719	4063	94	76	170		7	18	2	47	0.16				
DAT0719	4064	95	80	175		7	18	3	47	0.16				
DAT0719	4065	91	85	176		7	18	4	47	0.16				
DAT0719	4066	96	80	176		7	18	5	47	0.16				
DAT0719	4067	97	74	171		7	18	6	47	0.17				
DAT0719	4068	93	77	170		7	18	7	47	0.16				
DAT0719	4069	90	74	164		7	18	8	47	0.16				
DAT0719	4070	90	91	181	172	7	18	9	47	0.16	0.16			
DAT0719	4071	95	83	178		7	18	10	47	0.16				
DAT0719	4072	97	80	177		7	18	11	47	0.16				
DAT0719	4073	97	85	182		7	18	12	47	0.17				
DAT0719	4074	93	79	172		7	18	13	47	0.17				
DAT0719	4075	86	85	171		7	18	14	47	0.16				
DAT0719	4076	95	81	176		7	18	15	47	0.17				
DAT0719	4077	94	83	177		7	18	16	47	0.17				
DAT0719	4078	95	67	162		7	18	17	47	0.16				
DAT0719	4079	90	87	177		7	18	18	47	0.16				
DAT0719	4080	93	77	170	174	7	18	19	47	0.16	0.16			
DAT0719	4081	93	81	174		7	18	20	47	0.16				
DAT0719	4082	95	82	177		7	18	21	47	0.17				
DAT0719	4083	95	74	169		7	18	22	47	0.16				
DAT0719	4084	94	75	169		7	18	23	47	0.16				
DAT0719	4085	92	86	178		7	19	0	47	0.16				
DAT0719	4086	92	80	172		7	19	1	47	0.16				
DAT0719	4087	92	89	181		7	19	2	47	0.16				
DAT0719	4088	95	86	181		7	19	3	47	0.16				
DAT0719	4089	95	89	184		7	19	4	47	0.17				
DAT0719	4090	95	80	175	176	7	19	5	47	0.17	0.16			
DAT0719	4091	94	79	173		7	19	6	47	0.16				
DAT0719	4092	91	75	166		7	19	7	47	0.16				
DAT0719	4093	93	77	170		7	19	8	47	0.16				
DAT0722	4094	38	33	71		7	19	9	14			0.01	4 Min	
DAT0722	4095	91	82	173		7	19	10	14	0.17				
DAT0722	4096	94	81	175		7	19	11	14	0.17				
DAT0722	4097	92	84	176		7	19	12	14	0.17				
DAT0722	4098	93	81	174		7	19	13	14	0.17				
DAT0722	4099	93	87	180		7	19	14	14	0.17				
DAT0722	4100	94	87	181	164	7	19	15	14	0.17	0.17			

Appendix P: Digital Reliability Test Data - Test # 7 (Test Period # 6)

Stored in:	Test #	Devices Upset				Ave	Date(96)		Time		File size (Mb)			Notes
		Bd #1	Bd #2	Total					full	ave	part			
DAT0722	4101	94	93	187		7	19	16	14	0.17				
DAT0722	4102	93	83	176		7	19	17	14	0.17				
DAT0722	4103	98	85	183		7	19	18	14	0.17				
DAT0722	4104	99	87	186		7	19	19	14	0.17				
DAT0722	4105	94	85	179		7	19	20	14	0.17				
DAT0722	4106	90	88	178		7	19	21	14	0.16				
DAT0722	4107	93	79	172		7	19	22	14	0.16				
DAT0722	4108	97	87	184		7	19	23	14	0.16				
DAT0722	4109	96	83	179		7	20	0	14	0.16				
DAT0722	4110	94	75	169	179	7	20	1	14	0.16	0.17			
DAT0722	4111	91	88	179		7	20	2	14	0.17				
DAT0722	4112	96	92	188		7	20	3	14	0.17				
DAT0722	4113	92	77	169		7	20	4	14	0.16				
DAT0722	4114	95	74	169		7	20	5	14	0.17				
DAT0722	4115	98	90	188		7	20	6	14	0.17				
DAT0722	4116	92	81	173		7	20	7	14	0.17				
DAT0722	4117	95	83	178		7	20	8	14	0.16				
DAT0722	4118	90	76	166		7	20	9	14	0.16				
DAT0722	4119	94	78	172		7	20	10	14	0.17				
DAT0722	4120	95	83	178	176	7	20	11	14	0.17	0.17			
DAT0722	4121	98	87	185		7	20	12	14	0.17				
DAT0722	4122	92	82	174		7	20	13	14	0.17				
DAT0722	4123	93	69	162		7	20	14	14	0.16				
DAT0722	4124	96	89	185		7	20	15	14	0.17				
DAT0722	4125	91	91	182		7	20	16	14	0.17				
DAT0722	4126	92	84	176		7	20	17	14	0.17				
DAT0722	4127	97	73	170		7	20	18	14	0.17				
DAT0722	4128	97	82	179		7	20	19	14	0.17				
DAT0722	4129	90	68	158		7	20	20	14	0.17				
DAT0722	4130	96	74	170	174	7	20	21	14	0.17	0.17			
DAT0722	4131	96	76	172		7	20	22	14	0.17				
DAT0722	4132	94	85	179		7	20	23	14	0.17				
DAT0722	4133	94	88	182		7	21	0	14	0.17				
DAT0722	4134	93	81	174		7	21	1	14	0.16				
DAT0722	4135	89	79	168		7	21	2	14	0.16				
DAT0722	4136	86	75	161		7	21	3	14	0.16				
DAT0722	4137	90	77	167		7	21	4	14	0.16				
DAT0722	4138	87	61	148		7	21	5	14	0.16				
DAT0722	4139	88	58	146		7	21	6	14	0.15				
DAT0722	4140	92	77	169	167	7	21	7	14	0.15	0.16			
DAT0722	4141	88	67	155		7	21	8	14	0.15				
DAT0722	4142	87	74	161		7	21	9	14	0.15				
DAT0722	4143	90	66	156		7	21	10	14	0.14				
DAT0722	4144	84	60	144		7	21	11	14	0.14				
DAT0722	4145	86	64	150		7	21	12	14	0.15				
DAT0722	4146	91	62	153		7	21	13	14	0.15				
DAT0722	4147	90	63	153		7	21	14	14	0.15				
DAT0722	4148	88	64	152		7	21	15	14	0.15				
DAT0722	4149	93	78	171		7	21	16	14	0.15				
DAT0722	4150	88	65	153	155	7	21	17	14	0.15	0.15			

Appendix P: Digital Reliability Test Data - Test # 7 (Test Period # 6)

Stored in:	Test #	Devices Upset				Date(96)	Time		File size (Mb)			Notes
		Bd #1	Bd #2	Total	Ave				full	ave	part	
DAT0722	4151	88	77	165		7	21	18	14	0.15		
DAT0722	4152	90	70	160		7	21	19	14	0.15		
DAT0722	4153	81	69	150		7	21	20	14	0.14		
DAT0722	4154	94	68	162		7	21	21	14	0.15		
DAT0722	4155	92	60	152		7	21	22	14	0.15		
DAT0722	4156	93	76	169		7	21	23	14	0.15		
DAT0722	4157	88	71	159		7	22	0	14	0.15		
DAT0722	4158	77	72	149		7	22	1	14	0.14		
DAT0722	4159	90	60	150		7	22	2	14	0.14		
DAT0722	4160	83	58	141	156	7	22	3	14	0.14	0.15	
DAT0722	4161	86	81	167		7	22	4	14	0.14		
DAT0722	4162	91	75	166		7	22	5	14	0.14		
DAT0722	4163	89	63	152		7	22	6	14	0.15		
DAT0722	4164	89	68	157		7	22	7	14	0.15		
DAT0722	4165	90	69	159		7	22	8	14	0.14		
DAT0722	4166	90	57	147		7	22	9	14	0.15		
DAT0722	4167	83	70	153		7	22	9	47		0.08	
DAT0726	4168	34	25	59		7	22	9	57		0.01	4 Min
DAT0726	4169	86	70	156		7	22	10	57	0.14		
DAT0726	4170	93	74	167	148	7	22	11	57	0.15	0.15	
DAT0726	4171	92	84	176		7	22	12	57	0.15		
DAT0726	4172	90	75	165		7	22	13	57	0.15		
DAT0726	4173	93	78	171		7	22	14	57	0.15		
DAT0726	4174	87	75	162		7	22	15	57	0.15		
DAT0726	4175	90	65	155		7	22	16	57	0.15		
DAT0726	4176	88	71	159		7	22	17	57	0.15		
DAT0726	4177	87	79	166		7	22	18	57	0.15		
DAT0726	4178	92	67	159		7	22	19	57	0.15		
DAT0726	4179	93	77	170		7	22	20	57	0.16		
DAT0726	4180	91	73	164	165	7	22	21	57	0.16	0.15	
DAT0726	4181	96	71	167		7	22	22	57	0.15		
DAT0726	4182	88	81	169		7	22	23	57	0.15		
DAT0726	4183	86	71	157		7	23	0	57	0.14		
DAT0726	4184	89	69	158		7	23	1	57	0.14		
DAT0726	4185	82	52	134		7	23	2	57	0.14		
DAT0726	4186	85	73	158		7	23	3	57	0.14		
DAT0726	4187	86	56	142		7	23	4	57	0.14		
DAT0726	4188	77	57	134		7	23	5	57	0.13		
DAT0726	4189	84	69	153		7	23	6	57	0.14		
DAT0726	4190	86	66	152	152	7	23	7	57	0.14	0.14	
DAT0726	4191	86	62	148		7	23	8	57	0.14		
DAT0726	4192	79	63	142		7	23	9	57	0.14		
DAT0726	4193	81	75	156		7	23	10	57	0.14		
DAT0726	4194	86	69	155		7	23	11	57	0.14		
DAT0726	4195	89	63	152		7	23	12	57	0.14		
DAT0726	4196	84	70	154		7	23	13	57	0.14		
DAT0726	4197	85	67	152		7	23	14	57	0.14		
DAT0726	4198	92	66	158		7	23	15	57	0.14		
DAT0726	4199	83	64	147		7	23	16	57	0.14		
DAT0726	4200	89	79	168	153	7	23	17	57	0.14	0.14	

Appendix P: Digital Reliability Test Data - Test # 7 (Test Period # 6)

Stored in:	Test #	Devices Upset				Date(96)	Time		File size (Mb)			Notes
		Bd #1	Bd #2	Total	Ave		full	ave	part			
DAT0726	4201	90	83	173		7	23	18	57	0.15		
DAT0726	4202	87	66	153		7	23	19	57	0.15		
DAT0726	4203	89	80	169		7	23	20	57	0.15		
DAT0726	4204	88	75	163		7	23	21	57	0.14		
DAT0726	4205	88	64	152		7	23	22	57	0.15		
DAT0726	4206	92	82	174		7	23	23	57	0.14		
DAT0726	4207	88	67	155		7	24	0	57	0.14		
DAT0726	4208	98	67	165		7	24	1	57	0.15		
DAT0726	4209	92	62	154		7	24	2	57	0.14		
DAT0726	4210	95	74	169	163	7	24	3	57	0.14	0.15	
DAT0726	4211	92	64	156		7	24	4	57	0.14		
DAT0726	4212	85	58	143		7	24	5	57	0.14		
DAT0726	4213	91	61	152		7	24	6	57	0.14		
DAT0726	4214	94	58	152		7	24	7	57	0.14		
DAT0726	4215	91	61	152		7	24	8	57	0.14		
DAT0726	4216	91	71	162		7	24	9	57	0.14		
DAT0726	4217	92	76	168		7	24	10	57	0.15		
DAT0726	4218	91	72	163		7	24	11	57	0.15		
DAT0726	4219	80	63	143		7	24	12	57	0.14		
DAT0726	4220	88	66	154	155	7	24	13	57	0.15	0.14	
DAT0726	4221	86	59	145		7	24	14	57	0.14		
DAT0726	4222	92	78	170		7	24	15	57	0.14		
DAT0726	4223	85	60	145		7	24	16	57	0.14		
DAT0726	4224	88	77	165		7	24	17	57	0.14		
DAT0726	4225	87	66	153		7	24	18	57	0.14		
DAT0726	4226	91	75	166		7	24	19	57	0.14		
DAT0726	4227	89	52	141		7	24	20	57	0.14		
DAT0726	4228	87	63	150		7	24	21	57	0.14		
DAT0726	4229	93	72	165		7	24	22	57	0.14		
DAT0726	4230	87	68	155	156	7	24	23	57	0.14	0.14	
DAT0726	4231	82	63	145		7	25	0	57	0.14		
DAT0726	4232	84	76	160		7	25	1	57	0.14		
DAT0726	4233	80	61	141		7	25	2	57	0.14		
DAT0726	4234	85	48	133		7	25	3	57	0.14		
DAT0726	4235	87	58	145		7	25	4	57	0.14		
DAT0726	4236	83	61	144		7	25	5	57	0.14		
DAT0726	4237	84	48	132		7	25	6	57	0.13		
DAT0726	4238	87	76	163		7	25	7	57	0.14		
DAT0726	4239	88	79	167		7	25	8	57	0.14		
DAT0726	4240	87	57	144	147	7	25	9	57	0.14	0.14	
DAT0726	4241	91	71	162		7	25	10	57	0.14		
DAT0726	4242	81	58	139		7	25	11	57	0.14		
DAT0726	4243	85	56	141		7	25	12	57	0.14		
DAT0726	4244	81	54	135		7	25	13	57	0.14		
DAT0726	4245	92	55	147		7	25	14	57	0.14		
DAT0726	4246	74	54	128		7	25	15	57	0.14		
DAT0726	4247	86	65	151		7	25	16	57	0.14		
DAT0726	4248	88	73	161		7	25	17	57	0.14		
DAT0726	4249	82	58	140		7	25	18	57	0.14		
DAT0726	4250	90	58	148	145	7	25	19	57	0.14	0.14	

Appendix P: Digital Reliability Test Data - Test # 7 (Test Period # 6)

Stored in:	Test #	Devices Upset				Ave	Date(96)		Time		File size (Mb)			Notes
		Bd #1	Bd #2	Total					full	ave	part			
DAT0726	4251	90	67	157		7	25	20	57	0.14				
DAT0726	4252	85	63	148		7	25	21	57	0.14				
DAT0726	4253	82	57	139		7	25	22	57	0.14				
DAT0726	4254	82	56	138		7	25	23	57	0.14				
DAT0726	4255	85	63	148		7	26	0	57	0.14				
DAT0726	4256	90	64	154		7	26	1	57	0.14				
DAT0726	4257	91	52	143		7	26	2	57	0.14				
DAT0726	4258	87	53	140		7	26	3	57	0.13				
DAT0726	4259	81	52	133		7	26	4	57	0.13				
DAT0726	4260	85	50	135	144	7	26	5	57	0.13	0.14			
DAT0726	4261	86	58	144		7	26	6	57	0.13				
DAT0726	4262	85	63	148		7	26	7	57	0.13				
DAT0726	4263	86	59	145		7	26	8	57	0.13				
DAT0726	4264	79	67	146		7	26	9	57	0.14				
DAT0726	4265	60	29	89		7	26	10	12			0.03		
DAT0729	4266	37	23	60		7	26	10	40			0.01	4 Min	
DAT0729	4267	86	67	153		7	26	11	40	0.14				
DAT0729	4268	82	64	146		7	26	12	40	0.14				
DAT0729	4269	79	61	140		7	26	13	40	0.14				
DAT0729	4270	84	48	132	130	7	26	14	40	0.14	0.14			
DAT0729	4271	77	59	136		7	26	15	40	0.14				
DAT0729	4272	79	47	126		7	26	16	40	0.14				
DAT0729	4273	81	56	137		7	26	17	40	0.14				
DAT0729	4274	76	60	136		7	26	18	40	0.14				
DAT0729	4275	87	64	151		7	26	19	40	0.14				
DAT0729	4276	86	55	141		7	26	20	40	0.14				
DAT0729	4277	81	64	145		7	26	21	40	0.14				
DAT0729	4278	87	60	147		7	26	22	40	0.14				
DAT0729	4279	84	68	152		7	26	23	40	0.14				
DAT0729	4280	84	66	150	142	7	27	0	40	0.14	0.14			
DAT0729	4281	68	61	129		7	27	1	40	0.13				
DAT0729	4282	84	56	140		7	27	2	40	0.14				
DAT0729	4283	88	54	142		7	27	3	40	0.14				
DAT0729	4284	91	62	153		7	27	4	40	0.14				
DAT0729	4285	89	52	141		7	27	5	40	0.13				
DAT0729	4286	90	52	142		7	27	6	40	0.13				
DAT0729	4287	83	53	136		7	27	7	40	0.14				
DAT0729	4288	81	59	140		7	27	8	40	0.13				
DAT0729	4289	79	55	134		7	27	9	40	0.13				
DAT0729	4290	83	62	145	140	7	27	10	40	0.13	0.13			
DAT0729	4291	85	55	140		7	27	11	40	0.13				
DAT0729	4292	84	56	140		7	27	12	40	0.13				
DAT0729	4293	83	64	147		7	27	13	40	0.13				
DAT0729	4294	87	45	132		7	27	14	40	0.14				
DAT0729	4295	81	58	139		7	27	15	40	0.14				
DAT0729	4296	87	61	148		7	27	16	40	0.14				
DAT0729	4297	79	57	136		7	27	17	40	0.13				
DAT0729	4298	84	61	145		7	27	18	40	0.14				
DAT0729	4299	80	71	151		7	27	19	40	0.13				
DAT0729	4300	90	60	150	143	7	27	20	40	0.14	0.14			

Appendix P: Digital Reliability Test Data - Test # 7 (Test Period # 6)

Stored in:	Test #	Devices Upset				Ave	Date(96)		Time		File size (Mb)			Notes
		Bd #1	Bd #2	Total					full	ave	part			
DAT0729	4301	84	62	146		7	27	21	40	0.13				
DAT0729	4302	95	74	169		7	27	22	40	0.14				
DAT0729	4303	78	51	129		7	27	23	40	0.13				
DAT0729	4304	89	54	143		7	28	0	40	0.14				
DAT0729	4305	83	51	134		7	28	1	40	0.13				
DAT0729	4306	80	68	148		7	28	2	40	0.13				
DAT0729	4307	81	58	139		7	28	3	40	0.13				
DAT0729	4308	91	54	145		7	28	4	40	0.14				
DAT0729	4309	72	56	128		7	28	5	40	0.13				
DAT0729	4310	87	56	143	142	7	28	6	40	0.13	0.13			
DAT0729	4311	77	54	131		7	28	7	40	0.13				
DAT0729	4312	87	48	135		7	28	8	40	0.13				
DAT0729	4313	82	59	141		7	28	9	40	0.13				
DAT0729	4314	87	55	142		7	28	10	40	0.14				
DAT0729	4315	88	48	136		7	28	11	40	0.13				
DAT0729	4316	75	48	123		7	28	12	40	0.13				
DAT0729	4317	91	57	148		7	28	13	40	0.14				
DAT0729	4318	82	54	136		7	28	14	40	0.13				
DAT0729	4319	85	57	142		7	28	15	40	0.13				
DAT0729	4320	86	58	144	138	7	28	16	40	0.14	0.13			
DAT0729	4321	89	52	141		7	28	17	40	0.14				
DAT0729	4322	83	64	147		7	28	18	40	0.14				
DAT0729	4323	81	52	133		7	28	19	40	0.13				
DAT0729	4324	81	66	147		7	28	20	40	0.14				
DAT0729	4325	84	60	144		7	28	21	40	0.14				
DAT0729	4326	81	53	134		7	28	22	40	0.13				
DAT0729	4327	73	61	134		7	28	23	40	0.13				
DAT0729	4328	85	58	143		7	29	0	40	0.13				
DAT0729	4329	86	55	141		7	29	1	40	0.14				
DAT0729	4330	81	55	136	140	7	29	2	40	0.14	0.14			
DAT0729	4331	90	56	146		7	29	3	40	0.14				
DAT0729	4332	89	56	145		7	29	4	40	0.13				
DAT0729	4333	80	57	137		7	29	5	40	0.13				
DAT0729	4334	80	72	152		7	29	6	40	0.13				
DAT0729	4335	72	67	139		7	29	7	40	0.13				
DAT0729	4336	86	59	145		7	29	8	40	0.13				
DAT0729	4337	74	58	132		7	29	9	40	0.13				
DAT0729	4338	58	30	88		7	29	9	56			0.04		
DAT0802	4339	32	15	47		7	29	10	47			0.01	4 Min	
DAT0802	4340	89	68	157	129	7	29	11	47	0.15	0.13			
DAT0802	4341	84	71	155		7	29	12	46	0.14				
DAT0802	4342	92	77	169		7	30	11	44	0.15			Interrupt	
DAT0802	4343	83	69	152		7	30	12	44	0.15				
DAT0802	4344	85	64	149		7	30	13	44	0.15				
DAT0802	4345	87	75	162		7	30	14	44	0.15				
DAT0802	4346	89	67	156		7	30	15	44	0.15				
DAT0802	4347	90	66	156		7	30	16	44	0.15				
DAT0802	4348	91	67	158		7	30	17	44	0.15				
DAT0802	4349	87	72	159		7	30	18	44	0.15				
DAT0802	4350	91	79	170	159	7	30	19	44	0.15	0.15			



Appendix P: Digital Reliability Test Data - Test # 7 (Test Period # 6)

Stored in:	Test #	Devices Upset				Ave	Date(96)		Time		File size (Mb)			Notes
		Bd #1	Bd #2	Total					full	ave	part			
DAT0802	4351	87	67	154		7	30	20	44	0.15				
DAT0802	4352	88	57	145		7	30	21	44	0.15				
DAT0802	4353	93	70	163		7	30	22	44	0.15				
DAT0802	4354	90	67	157		7	30	23	44	0.15				
DAT0802	4355	90	82	172		7	31	0	44	0.15				
DAT0802	4356	85	73	158		7	31	1	44	0.14				
DAT0802	4357	84	58	142		7	31	2	44	0.15				
DAT0802	4358	80	63	143		7	31	3	44	0.14				
DAT0802	4359	93	65	158		7	31	4	44	0.15				
DAT0802	4360	91	81	172	156	7	31	5	44	0.15	0.15			
DAT0802	4361	82	65	147		7	31	6	44	0.14				
DAT0802	4362	90	69	159		7	31	7	44	0.14				
DAT0802	4363	79	67	146		7	31	8	44	0.14				
DAT0802	4364	87	62	149		7	31	9	44	0.15				
DAT0802	4365	92	64	156		7	31	10	44	0.15				
DAT0802	4366	95	69	164		7	31	11	44	0.15				
DAT0802	4367	89	61	150		7	31	12	44	0.15				
DAT0802	4368	87	71	158		7	31	13	44	0.15				
DAT0802	4369	90	72	162		7	31	14	44	0.15				
DAT0802	4370	90	66	156	155	7	31	15	44	0.15	0.15			
DAT0802	4371	89	68	157		7	31	16	44	0.15				
DAT0802	4372	95	59	154		7	31	17	44	0.15				
DAT0802	4373	90	65	155		7	31	18	44	0.15				
DAT0802	4374	87	66	153		7	31	19	44	0.15				
DAT0802	4375	87	56	143		7	31	20	44	0.14				
DAT0802	4376	90	62	152		7	31	21	44	0.15				
DAT0802	4377	92	73	165		7	31	22	44	0.15				
DAT0802	4378	88	57	145		7	31	23	44	0.14				
DAT0802	4379	91	57	148		8	1	0	44	0.14				
DAT0802	4380	88	63	151	152	8	1	1	44	0.14	0.15			
DAT0802	4381	88	63	151		8	1	2	44	0.14				
DAT0802	4382	93	64	157		8	1	3	44	0.14				
DAT0802	4383	83	54	137		8	1	4	44	0.14				
DAT0802	4384	85	68	153		8	1	5	44	0.14				
DAT0802	4385	90	63	153		8	1	6	44	0.14				
DAT0802	4386	96	53	149		8	1	7	44	0.14				
DAT0802	4387	93	66	159		8	1	8	44	0.15				
DAT0802	4388	93	56	149		8	1	9	44	0.15				
DAT0802	4389	87	73	160		8	1	10	44	0.15				
DAT0802	4390	93	57	150	152	8	1	11	44	0.15	0.14			
DAT0802	4391	86	56	142		8	1	12	44	0.14				
DAT0802	4392	89	65	154		8	1	13	44	0.15				
DAT0802	4393	85	56	141		8	1	14	44	0.14				
DAT0802	4394	87	55	142		8	1	15	44	0.14				
DAT0802	4395	83	67	150		8	1	16	44	0.14				
DAT0802	4396	96	65	161		8	1	17	44	0.15				
DAT0802	4397	90	80	170		8	1	18	44	0.15				
DAT0802	4398	88	71	159		8	1	19	44	0.15				
DAT0802	4399	94	82	176		8	1	20	44	0.15				
DAT0802	4400	85	69	154	155	8	1	21	44	0.15	0.15			

Appendix P: Digital Reliability Test Data - Test # 7 (Test Period # 6)

Stored in:	Test #	Devices Upset				Ave	Date(96)		Time		File size (Mb)			Notes
		Bd #1	Bd #2	Total					full	ave	part			
DAT0802	4401	90	67	157		8	1	22	44	0.15				
DAT0802	4402	81	60	141		8	1	23	44	0.14				
DAT0802	4403	89	61	150		8	2	0	44	0.14				
DAT0802	4404	89	69	158		8	2	1	44	0.15				
DAT0802	4405	85	72	157		8	2	2	44	0.15				
DAT0802	4406	92	60	152		8	2	3	44	0.15				
DAT0802	4407	89	59	148		8	2	4	44	0.14				
DAT0802	4408	90	61	151		8	2	5	44	0.14				
DAT0802	4409	88	56	144		8	2	6	44	0.14				
DAT0802	4410	85	60	145	150	8	2	7	44	0.14	0.14			
DAT0802	4411	90	51	141		8	2	8	34			0.12		
DAT0805	4412	36	28	64		8	2	9	3			0.01	4 Min	
DAT0805	4413	89	64	153		8	2	10	3	0.15				
DAT0805	4414	79	53	132		8	2	11	3	0.14				
DAT0805	4415	76	62	138		8	2	12	3	0.14				
DAT0805	4416	86	64	150		8	2	13	3	0.14				
DAT0805	4417	92	66	158		8	2	14	3	0.14				
DAT0805	4418	92	49	141		8	2	15	3	0.14				
DAT0805	4419	70	39	109		8	2	15	16			0.03	Interrupt	
DAT0805	4420	88	54	142	133	8	2	16	42	0.14	0.14			
DAT0805	4421	84	58	142		8	2	17	42	0.14				
DAT0805	4422	90	69	159		8	2	18	42	0.15				
DAT0805	4423	91	69	160		8	2	19	42	0.15				
DAT0805	4424	86	68	154		8	2	20	42	0.14				
DAT0805	4425	90	73	163		8	2	21	42	0.14				
DAT0805	4426	91	88	179		8	2	22	42	0.15				
DAT0805	4427	90	60	150		8	2	23	42	0.14				
DAT0805	4428	82	56	138		8	3	0	42	0.14				
DAT0805	4429	91	55	146		8	3	1	42	0.14				
DAT0805	4430	92	53	145	154	8	3	2	42	0.14	0.14			
DAT0805	4431	84	74	158		8	3	3	42	0.14				
DAT0805	4432	84	64	148		8	3	4	42	0.14				
DAT0805	4433	90	66	156		8	3	5	42	0.14				
DAT0805	4434	77	60	137		8	3	6	42	0.14				
DAT0805	4435	91	61	152		8	3	7	42	0.14				
DAT0805	4436	94	62	156		8	3	8	42	0.14				
DAT0805	4437	89	67	156		8	3	9	42	0.14				
DAT0805	4438	92	65	157		8	3	10	42	0.14				
DAT0805	4439	89	62	151		8	3	11	42	0.14				
DAT0805	4440	83	58	141	151	8	3	12	42	0.14	0.14			
DAT0805	4441	88	56	144		8	3	13	42	0.14				
DAT0805	4442	80	63	143		8	3	14	42	0.14				
DAT0805	4443	83	58	141		8	3	15	42	0.14				
DAT0805	4444	87	75	162		8	3	16	42	0.14				
DAT0805	4445	91	66	157		8	3	17	42	0.14				
DAT0805	4446	87	65	152		8	3	18	42	0.14				
DAT0805	4447	81	64	145		8	3	19	42	0.14				
DAT0805	4448	81	59	140		8	3	20	42	0.14				
DAT0805	4449	95	57	152		8	3	21	42	0.14				
DAT0805	4450	93	70	163	150	8	3	22	42	0.15	0.14			

Appendix P: Digital Reliability Test Data - Test # 7 (Test Period # 6)

Stored in:	Test #	Devices Upset				Date(96)	Time		File size (Mb)			Notes
		Bd #1	Bd #2	Total	Ave		full	ave	part			
DAT0805	4451	93	51	144		8	3	23	42	0.14		
DAT0805	4452	91	63	154		8	4	0	42	0.14		
DAT0805	4453	82	70	152		8	4	1	42	0.14		
DAT0805	4454	89	72	161		8	4	2	42	0.14		
DAT0805	4455	82	56	138		8	4	3	42	0.14		
DAT0805	4456	88	63	151		8	4	4	42	0.14		
DAT0805	4457	82	60	142		8	4	5	42	0.14		
DAT0805	4458	86	70	156		8	4	6	42	0.14		
DAT0805	4459	96	63	159		8	4	7	42	0.15		
DAT0805	4460	91	70	161	152	8	4	8	42	0.15	0.14	
DAT0805	4461	78	75	153		8	4	9	42	0.14		
DAT0805	4462	84	61	145		8	4	10	42	0.14		
DAT0805	4463	90	61	151		8	4	11	42	0.14		
DAT0805	4464	86	63	149		8	4	12	42	0.14		
DAT0805	4465	89	55	144		8	4	13	42	0.14		
DAT0805	4466	91	76	167		8	4	14	42	0.14		
DAT0805	4467	96	65	161		8	4	15	42	0.15		
DAT0805	4468	95	63	158		8	4	16	42	0.14		
DAT0805	4469	87	58	145		8	4	17	42	0.14		
DAT0805	4470	83	67	150	152	8	4	18	42	0.14	0.14	
DAT0805	4471	86	83	169		8	4	19	42	0.15		
DAT0805	4472	93	57	150		8	4	20	42	0.14		
DAT0805	4473	83	55	138		8	4	21	42	0.14		
DAT0805	4474	87	60	147		8	4	22	42	0.14		
DAT0805	4475	88	48	136		8	4	23	42	0.14		
DAT0805	4476	87	70	157		8	5	0	42	0.14		
DAT0805	4477	90	62	152		8	5	1	42	0.14		
DAT0805	4478	85	51	136		8	5	2	42	0.14		
DAT0805	4479	85	60	145		8	5	3	42	0.14		
DAT0805	4480	91	65	156	149	8	5	4	42	0.14	0.14	
DAT0805	4481	85	62	147		8	5	5	42	0.14		
DAT0805	4482	80	72	152		8	5	6	42	0.14		
DAT0805	4483	81	41	122		8	5	7	42	0.14		
DAT0805	4484	93	64	157		8	5	8	42	0.14		
DAT0805	4485	86	63	149		8	5	9	22		0.1	
DAT0809	4486	33	23	56		8	5	10	29		0.01	4 Min
DAT0809	4487	89	66	155		8	5	11	29	0.15		
DAT0809	4488	88	57	145		8	5	12	29	0.15		
DAT0809	4489	90	65	155		8	5	13	29	0.15		
DAT0809	4490	85	73	158	140	8	5	14	29	0.15	0.15	
DAT0809	4491	82	67	149		8	5	15	29	0.15		
DAT0809	4492	94	67	161		8	5	16	29	0.15		
DAT0809	4493	93	72	165		8	5	17	29	0.15		
DAT0809	4494	93	68	161		8	5	18	29	0.15		
DAT0809	4495	82	67	149		8	5	19	29	0.15		
DAT0809	4496	82	72	154		8	5	20	29	0.15		
DAT0809	4497	85	69	154		8	5	21	29	0.15		
DAT0809	4498	92	64	156		8	5	22	29	0.15		
DAT0809	4499	88	56	144		8	5	23	29	0.15		
DAT0809	4500	84	69	153	155	8	6	0	29	0.15	0.15	

Appendix P: Digital Reliability Test Data - Test # 7 (Test Period # 6)

Stored in:	Test #	Devices Upset				Ave	Date(96)		Time		File size (Mb)			Notes
		Bd #1	Bd #2	Total					full	ave	part			
DAT0809	4501	86	68	154		8	6	1	29	0.15				
DAT0809	4502	90	63	153		8	6	2	29	0.15				
DAT0809	4503	84	69	153		8	6	3	29	0.15				
DAT0809	4504	96	54	150		8	6	4	29	0.15				
DAT0809	4505	89	67	156		8	6	5	29	0.15				
DAT0809	4506	94	72	166		8	6	6	29	0.15				
DAT0809	4507	93	70	163		8	6	7	29	0.15				
DAT0809	4508	86	58	144		8	6	8	29	0.15				
DAT0809	4509	85	78	163		8	6	9	29	0.15				
DAT0809	4510	89	65	154	156	8	6	10	29	0.15	0.15			
DAT0809	4511	92	71	163		8	6	11	29	0.15				
DAT0809	4512	92	72	164		8	6	12	29	0.15				
DAT0809	4513	84	73	157		8	6	13	29	0.14				
DAT0809	4514	90	81	171		8	6	14	29	0.15				
DAT0809	4515	77	62	139		8	6	15	29	0.15				
DAT0809	4516	84	79	163		8	6	16	29	0.15				
DAT0809	4517	88	70	158		8	6	17	29	0.15				
DAT0809	4518	96	81	177		8	6	18	29	0.15				
DAT0809	4519	94	65	159		8	6	19	29	0.15				
DAT0809	4520	91	66	157	161	8	6	20	29	0.15	0.15			
DAT0809	4521	90	62	152		8	6	21	29	0.15				
DAT0809	4522	90	62	152		8	6	22	29	0.15				
DAT0809	4523	91	61	152		8	6	23	29	0.15				
DAT0809	4524	89	67	156		8	7	0	29	0.15				
DAT0809	4525	92	73	165		8	7	1	29	0.15				
DAT0809	4526	89	83	172		8	7	2	29	0.15				
DAT0809	4527	88	51	139		8	7	3	29	0.14				
DAT0809	4528	84	56	140		8	7	4	29	0.14				
DAT0809	4529	96	73	169		8	7	5	29	0.15				
DAT0809	4530	76	59	135	153	8	7	6	29	0.15	0.15			
DAT0809	4531	98	68	166		8	7	7	29	0.15				
DAT0809	4532	85	69	154		8	7	8	29	0.14				
DAT0809	4533	84	65	149		8	7	9	29	0.15				
DAT0809	4534	85	64	149		8	7	10	29	0.15				
DAT0809	4535	85	73	158		8	7	11	29	0.15				
DAT0809	4536	94	71	165		8	7	12	29	0.15				
DAT0809	4537	84	63	147		8	7	13	29	0.15				
DAT0809	4538	86	65	151		8	7	14	29	0.15				
DAT0809	4539	80	63	143		8	7	15	29	0.15				
DAT0809	4540	90	76	166	155	8	7	16	29	0.15	0.15			
DAT0809	4541	85	76	161		8	7	17	29	0.15				
DAT0809	4542	87	83	170		8	7	18	29	0.15				
DAT0809	4543	96	79	175		8	7	19	29	0.15				
DAT0809	4544	88	80	168		8	7	20	29	0.15				
DAT0809	4545	94	74	168		8	7	21	29	0.15				
DAT0809	4546	88	74	162		8	7	22	29	0.15				
DAT0809	4547	91	64	155		8	7	23	29	0.15				
DAT0809	4548	91	62	153		8	8	0	29	0.15				
DAT0809	4549	88	72	160		8	8	1	29	0.15				
DAT0809	4550	87	68	155	163	8	8	2	29	0.15	0.15			



Appendix Q: Digital Reliability Test Data - Test #6 (Test Period # 7)

Stored in:	Test #	Devices Upset				Ave	Date(96)		Time		File size (Mb)			Notes
		Bd #1	Bd #2	Total					full	ave	part			
DAT0822	4601	95	97	192		8	20	15	18			0.11	4 Min	
DAT0822	4602	100	100	200		8	20	16	19	1.54				
DAT0822	4603	99	98	197		8	20	17	19	1.55				
DAT0822	4604	96	99	195		8	20	18	19	1.56				
DAT0822	4605	98	99	197		8	20	19	19	1.59				
DAT0822	4606	97	99	196		8	20	20	19	1.59				
DAT0822	4607	98	98	196		8	20	21	19	1.58				
DAT0822	4608	97	99	196		8	20	22	19	1.58				
DAT0822	4609	97	99	196		8	20	23	19	1.58				
DAT0822	4610	99	100	199	196	8	21	0	19	1.60	1.57			
DAT0822	4611	98	99	197		8	21	1	19	1.60				
DAT0822	4612	98	99	197		8	21	2	19	1.59				
DAT0822	4613	98	99	197		8	21	3	19	1.59				
DAT0822	4614	97	99	196		8	21	4	19	1.57				
DAT0822	4615	99	99	198		8	21	5	19	1.56				
DAT0822	4616	97	99	196		8	21	6	19	1.55				
DAT0822	4617	99	99	198		8	21	7	19	1.55				
DAT0822	4618	99	99	198		8	21	8	19	1.55				
DAT0822	4619	99	99	198		8	21	9	19	1.57				
DAT0822	4620	100	99	199	197	8	21	10	19	1.58	1.57			
DAT0822	4621	99	99	198		8	21	11	19	1.59				
DAT0822	4622	98	99	197		8	21	12	19	1.59				
DAT0822	4623	100	99	199		8	21	13	19	1.60				
DAT0822	4624	98	99	197		8	21	14	19	1.60				
DAT0822	4625	99	99	198		8	21	15	19	1.60				
DAT0822	4626	99	99	198		8	21	16	19	1.61				
DAT0822	4627	98	99	197		8	21	17	19	1.61				
DAT0822	4628	99	99	198		8	21	18	19	1.61				
DAT0822	4629	97	99	196		8	21	19	19	1.60				
DAT0822	4630	96	99	195	197	8	21	20	19	1.59	1.6			
DAT0822	4631	99	99	198		8	21	21	19	1.60				
DAT0822	4632	99	99	198		8	21	22	19	1.59				
DAT0822	4633	98	99	197		8	21	23	19	1.58				
DAT0822	4634	98	99	197		8	22	0	19	1.58				
DAT0822	4635	99	99	198		8	22	1	19	1.57				
DAT0822	4636	97	99	196		8	22	2	19	1.57				
DAT0822	4637	98	99	197		8	22	3	19	1.57				
DAT0822	4638	97	99	196		8	22	4	19	1.56				
DAT0822	4639	99	99	198		8	22	5	19	1.55				
DAT0822	4640	98	99	197	197	8	22	6	19	1.54	1.57			
DAT0822	4641	99	99	198		8	22	7	19	1.54				
DAT0822	4642	98	99	197		8	22	8	19	1.54				
DAT0822	4643	97	99	196		8	22	9	19	1.54				
DAT0822	4644	99	99	198		8	22	10	19	1.54				
DAT0824	4645	95	96	191		8	22	11	28		0.11	4 Min		
DAT0824	4646	98	99	197		8	22	12	28	1.57				
DAT0824	4647	100	99	199		8	22	13	28	1.58				
DAT0824	4648	100	99	199		8	22	14	28	4.47				
DAT0824	4649	99	99	198		8	22	15	28	1.58				
DAT0824	4650	99	99	198	197	8	22	16	28	1.57	1.88			

Appendix Q: Digital Reliability Test Data - Test #6 (Test Period # 7)

Stored in:	Test #	Devices Upset				Date(96)	Time	File size (Mb)			Notes
		Bd #1	Bd #2	Total	Ave			full	ave	part	
DAT0824	4651	97	98	195		8 22	17 28	1.57			
DAT0824	4652	98	99	197		8 22	18 28	1.57			
DAT0824	4653	97	99	196		8 22	19 28	1.57			
DAT0824	4654	96	99	195		8 22	20 28	1.55			
DAT0824	4655	99	99	198		8 22	21 28	1.55			
DAT0824	4656	98	99	197		8 22	22 28	1.55			
DAT0824	4657	97	99	196		8 22	23 28	1.57			
DAT0824	4658	98	99	197		8 23	0 28	1.58			
DAT0824	4659	97	99	196		8 23	1 28	1.59			
DAT0824	4660	98	99	197	196	8 23	2 28	1.58	1.57		
DAT0824	4661	100	100	200		8 23	3 28	1.58			
DAT0824	4662	96	99	195		8 23	4 28	1.57			
DAT0824	4663	97	99	196		8 23	5 28	1.56			
DAT0824	4664	98	99	197		8 23	6 28	1.56			
DAT0824	4665	97	99	196		8 23	7 28	1.55			
DAT0824	4666	98	99	197		8 23	8 28	1.54			
DAT0824	4667	99	99	198		8 23	9 28	1.56			
DAT0824	4668	98	99	197		8 23	10 28	1.56			
DAT0824	4669	98	99	197		8 23	11 28	1.56			
DAT0824	4670	99	99	198	197	8 23	12 28	1.57	1.56		
DAT0824	4671	98	99	197		8 23	13 28	1.59			
DAT0824	4672	96	99	195		8 23	14 28	1.59			
DAT0824	4673	99	99	198		8 23	15 28	1.60			
DAT0824	4674	100	99	199		8 23	16 28	1.60			
DAT0824	4675	98	100	198		8 23	17 28	1.59			
DAT0824	4676	97	99	196		8 23	18 28	1.60			
DAT0824	4677	99	99	198		8 23	19 28	1.60			
DAT0824	4678	99	99	198		8 23	20 28	1.60			
DAT0824	4679	99	99	198		8 23	21 28	1.59			
DAT0824	4680	99	100	199	198	8 23	22 28	1.59	1.6		
DAT0824	4681	98	99	197		8 23	23 28	1.61			
DAT0824	4682	98	99	197		8 24	0 28	1.60			
DAT0824	4683	98	99	197		8 24	1 28	1.59			
DAT0824	4684	98	99	197		8 24	2 28	1.58			
DAT0824	4685	98	99	197		8 24	3 28	1.57			
DAT0824	4686	100	99	199		8 24	4 28	1.56			
DAT0824	4687	97	99	196		8 24	5 28	1.55			
DAT0824	4688	99	99	198		8 24	6 28	1.55			
DAT0824	4689	98	99	197		8 24	7 28	1.55			
DAT0824	4690	99	99	198	197	8 24	8 28	1.56	1.57		
DAT0824	4691	98	100	198		8 24	9 28	1.56			
DAT0824	4692	99	99	198		8 24	10 28	1.56			
DAT0824	4693	98	99	197		8 24	11 28	1.56			
DAT0824	4694	97	99	196		8 24	12 28	1.57			
DAT0824	4695	98	99	197		8 24	13 28	1.58			
DAT0824	4696	96	99	195		8 24	14 28	1.59			
DAT0824	4697	97	99	196		8 24	15 28	1.60			
DAT0824	4698	99	99	198		8 24	16 28	1.58			
DAT0824	4699	98	99	197		8 24	17 28	1.59			
DAT0824	4700	97	99	196	197	8 24	18 28	1.59	1.58		

Appendix Q: Digital Reliability Test Data - Test #6 (Test Period # 7)

Stored in:	Test #	Devices Upset				Date(96)	Time		File size (Mb)			Notes
		Bd #1	Bd #2	Total	Ave		full	ave	part			
DAT0824	4701	99	99	198		8	24	19	28	1.59		
DAT0824	4702	97	99	196		8	24	20	28	1.59		
DAT0824	4703	97	99	196		8	24	21	28	1.59		
DAT0824	4704	98	100	198		8	24	22	28	1.58		
DAT0824	4705	98	99	197		8	24	23	28	1.56		
DAT0827	4706	99	99	198		8	25	0	28	1.55		
DAT0827	4707	99	99	198		8	25	1	28	1.55		
DAT0827	4708	97	99	196		8	25	2	28	1.55		
DAT0827	4709	99	99	198		8	25	3	28	1.55		
DAT0827	4710	98	99	197	197	8	25	4	28	1.55	1.57	
DAT0827	4711	99	99	198		8	25	5	28	1.54		
DAT0827	4712	97	99	196		8	25	6	28	1.54		
DAT0827	4713	99	99	198		8	25	7	28	1.57		
DAT0827	4714	99	99	198		8	25	8	28	1.58		
DAT0827	4715	97	99	196		8	25	9	28	1.58		
DAT0827	4716	97	99	196		8	25	10	28	1.59		
DAT0827	4717	100	99	199		8	25	11	28	1.59		
DAT0827	4718	98	99	197		8	25	12	28	1.59		
DAT0827	4719	98	100	198		8	25	13	28	1.60		
DAT0827	4720	98	99	197	197	8	25	14	28	1.60	1.58	
DAT0827	4721	98	99	197		8	25	15	28	1.61		
DAT0827	4722	99	99	198		8	25	16	28	1.61		
DAT0827	4723	98	99	197		8	25	17	28	1.57		
DAT0827	4724	98	99	197		8	25	18	28	1.56		
DAT0827	4725	95	99	194		8	25	19	28	1.57		
DAT0827	4726	96	99	195		8	25	20	28	1.58		
DAT0827	4727	97	99	196		8	25	21	28	1.56		
DAT0827	4728	98	100	198		8	25	22	28	1.56		
DAT0827	4729	96	99	195		8	25	23	28	1.57		
DAT0827	4730	100	99	199	197	8	26	0	28	1.58	1.58	
DAT0827	4731	99	99	198		8	26	1	28	1.57		
DAT0827	4732	100	99	199		8	26	2	28	1.57		
DAT0827	4733	98	99	197		8	26	3	28	1.56		
DAT0827	4734	98	99	197		8	26	4	28	1.56		
DAT0827	4735	99	99	198		8	26	5	28	1.56		
DAT0827	4736	99	99	198		8	26	6	28	1.55		
DAT0827	4737	98	99	197		8	26	7	28	1.55		
DAT0827	4738	97	99	196		8	26	8	28	1.55		
DAT0827	4739	97	99	196		8	26	9	28	1.58		
DAT0827	4740	97	99	196	197	8	26	10	28	1.58	1.56	
DAT0827	4741	97	99	196		8	26	11	28	1.59		
DAT0827	4742	99	99	198		8	26	12	28	1.58		
DAT0827	4743	98	100	198		8	26	13	28	1.60		
DAT0827	4744	98	99	197		8	26	14	28	1.60		
DAT0827	4745	99	99	198		8	26	15	28	1.59		
DAT0827	4746	98	99	197		8	26	16	28	1.59		
DAT0827	4747	97	99	196		8	26	17	28	1.60		
DAT0827	4748	98	99	197		8	26	18	28	1.61		
DAT0827	4749	98	100	198		8	26	19	28	1.60		
DAT0827	4750	96	100	196	197	8	26	20	28	1.60	1.6	



Appendix Q: Digital Reliability Test Data - Test #6 (Test Period # 7)

Stored in:	Test #	Devices Upset				Ave	Date(96)		Time		File size (Mb)			Notes
		Bd #1	Bd #2	Total					full	ave	part			
DAT0827	4751	98	99	197		8	26	21	28	1.59				
DAT0827	4752	100	100	200		8	26	22	28	1.58				
DAT0827	4753	97	100	197		8	26	23	28	1.57				
DAT0827	4754	97	99	196		8	27	0	28	1.56				
DAT0827	4755	99	99	198		8	27	1	28	1.56				
DAT0827	4756	98	100	198		8	27	2	28	1.58				
DAT0827	4757	97	99	196		8	27	3	28	1.58				
DAT0827	4758	98	99	197		8	27	4	28	1.58				
DAT0827	4759	98	100	198		8	27	5	28	1.58				
DAT0827	4760	99	100	199	198	8	27	6	28	1.58	1.58			
DAT0827	4761	99	99	198		8	27	7	28	1.58				
DAT0827	4762	98	99	197		8	27	8	28	1.57				
DAT0827	4763	98	99	197		8	27	9	28	1.63				
DAT0827	4764	100	99	199		8	27	10	28	1.59				
DAT0827	4765	97	99	196		8	27	10	45			0.42		
DAT0903	4766	95	98	193		8	27	13	46			0.11	4 Min	
DAT0903	4767	99	99	198		8	27	14	46	1.62				
DAT0903	4768	97	99	196		8	27	15	46	1.62				
DAT0903	4769	98	99	197		8	27	16	46	1.62				
DAT0903	4770	98	99	197	197	8	27	17	46	1.62	1.61			
DAT0903	4771	96	99	195		8	27	18	46	1.62				
DAT0903	4772	98	99	197		8	27	19	46	1.62				
DAT0903	4773	99	100	199		8	27	20	46	1.62				
DAT0903	4774	100	99	199		8	27	21	46	1.62				
DAT0903	4775	99	99	198		8	27	22	46	1.62				
DAT0903	4776	99	99	198		8	27	23	46	1.63				
DAT0903	4777	98	100	198		8	28	0	46	1.62				
DAT0903	4778	97	99	196		8	28	1	46	1.62				
DAT0903	4779	100	99	199		8	28	2	46	1.62				
DAT0903	4780	100	99	199	198	8	28	3	46	1.62	1.62			
DAT0903	4781	97	99	196		8	28	4	46	1.63				
DAT0903	4782	97	99	196		8	28	5	46	1.62				
DAT0903	4783	98	99	197		8	28	6	46	1.60				
DAT0903	4784	96	100	196		8	28	7	46	1.60				
DAT0903	4785	98	99	197		8	28	8	46	1.60				
DAT0903	4786	99	99	198		8	28	9	46	1.60				
DAT0903	4787	98	99	197		8	28	10	46	1.57				
DAT0903	4788	99	99	198		8	28	11	46	1.61				
DAT0903	4789	96	99	195		8	28	12	46	1.64				
DAT0903	4790	99	99	198	197	8	28	13	46	1.65	1.61			
DAT0903	4791	99	99	198		8	28	14	46	1.63				
DAT0903	4792	97	100	197		8	28	15	46	1.63				
DAT0903	4793	99	99	198		8	28	16	46	1.61				
DAT0903	4794	100	99	199		8	28	17	46	1.61				
DAT0903	4795	97	99	196		8	28	18	46	1.63				
DAT0903	4796	98	99	197		8	28	19	46	1.75				
DAT0903	4797	99	99	198		8	28	20	46	1.74				
DAT0903	4798	99	99	198		8	28	21	46	1.73				
DAT0903	4799	97	99	196		8	28	22	46	1.67				
DAT0903	4800	97	99	196	197	8	28	23	46	1.62	1.66			

Appendix Q: Digital Reliability Test Data - Test #6 (Test Period # 7)

Stored in:	Test #	Devices Upset				Date(96)	Time		File size (Mb)			Notes
		Bd #1	Bd #2	Total	Ave		full	ave	part			
DAT0903	4801	97	99	196		8	29	0	46	1.62		
DAT0903	4802	98	99	197		8	29	1	46	1.61		
DAT0903	4803	99	99	198		8	29	2	46	1.61		
DAT0903	4804	97	99	196		8	29	3	46	1.61		
DAT0903	4805	96	99	195		8	29	4	46	1.61		
DAT0903	4806	98	99	197		8	29	5	46	1.60		
DAT0903	4807	99	99	198		8	29	6	46	1.60		
DAT0903	4808	99	99	198		8	29	7	46	1.59		
DAT0903	4809	97	99	196		8	29	8	46	1.60		
DAT0903	4810	98	99	197	197	8	29	9	46	1.60	1.61	
DAT0903	4811	99	99	198		8	29	10	46	1.61		
DAT0903	4812	100	99	199		8	29	11	46	1.62		
DAT0903	4813	98	100	198		8	29	12	46	1.64		
DAT0903	4814	98	99	197		8	29	13	46	1.63		
DAT0903	4815	97	99	196		8	29	14	46	1.62		
DAT0903	4816	98	99	197		8	29	15	46	1.63		
DAT0903	4817	100	100	200		8	29	16	46	1.64		
DAT0903	4818	98	99	197		8	29	17	46	1.62		
DAT0903	4819	98	99	197		8	29	18	46	1.62		
DAT0903	4820	99	99	198	198	8	29	19	46	1.63	1.63	
DAT0903	4821	98	100	198		8	29	20	46	1.62		
DAT0903	4822	97	99	196		8	29	21	46	1.60		
DAT0903	4823	100	99	199		8	29	22	46	1.63		
DAT0903	4824	100	100	200		8	29	23	46	1.62		
DAT0903	4825	98	99	197		8	30	0	46	1.61		
DAT0903	4826	97	99	196		8	30	1	46	1.61		
DAT0903	4827	100	99	199		8	30	2	46	1.60		
DAT0903	4828	98	100	198		8	30	3	46	1.60		
DAT0903	4829	98	99	197		8	30	4	46	1.60		
DAT0903	4830	98	100	198	198	8	30	5	46	1.59	1.61	
DAT0903	4831	98	99	197		8	30	6	46	1.60		
DAT0903	4832	97	98	195		8	30	7	46	1.60		
DAT0903	4833	98	99	197		8	30	8	46	1.59		
DAT0903	4834	99	99	198		8	30	9	46	1.59		
DAT0903	4835	98	99	197		8	30	10	46	1.60		
DAT0903	4836	99	99	198		8	30	11	46	1.61		
DAT0903	4837	98	99	197		8	30	12	46	1.62		
DAT0903	4838	99	99	198		8	30	13	46	1.62		
DAT0903	4839	99	99	198		8	30	14	46	1.61		
DAT0903	4840	98	99	197	197	8	30	15	46	1.59	1.6	
DAT0906	4841	100	100	200		9	3	11	43	1.97		
DAT0906	4842	96	100	196		9	3	12	43	1.39		
DAT0906	4843	98	100	198		9	3	13	43	1.59		
DAT0906	4844	96	99	195		9	4	10	11		0.12	4 Min
DAT0906	4845	98	99	197		9	4	11	11	1.64		
DAT0906	4846	98	99	197		9	4	12	11	1.65		
DAT0906	4847	99	99	198		9	4	13	11	1.69		
DAT0906	4848	98	99	197		9	4	14	11	1.68		
DAT0906	4849	98	99	197		9	4	15	11	1.60		
DAT0906	4850	98	99	197	197	9	4	16	11	1.46	1.63	

Appendix Q: Digital Reliability Test Data - Test #6 (Test Period # 7)

Stored in:	Test #	Devices Upset				Date(96)	Time		File size (Mb)			Notes
		Bd #1	Bd #2	Total	Ave		full	ave	part			
DAT0906	4851	96	99	195		9	4	17	11	1.53		
DAT0906	4852	98	99	197		9	4	18	11	1.65		
DAT0906	4853	98	99	197		9	4	19	11	1.65		
DAT0906	4854	98	100	198		9	4	20	11	1.64		
DAT0906	4855	99	99	198		9	4	21	11	1.63		
DAT0906	4856	98	99	197		9	4	22	11	1.63		
DAT0906	4857	96	99	195		9	4	23	11	1.63		
DAT0906	4858	99	99	198		9	5	0	11	1.61		
DAT0906	4859	97	99	196		9	5	1	11	1.66		
DAT0906	4860	100	99	199	197	9	5	2	11	1.67	1.63	
DAT0906	4861	98	100	198		9	5	3	11	1.65		
DAT0906	4862	99	99	198		9	5	4	11	1.66		
DAT0906	4863	98	99	197		9	5	5	11	1.63		
DAT0906	4864	96	99	195		9	5	6	11	1.66		
DAT0906	4865	99	99	198		9	5	7	11	1.68		
DAT0906	4866	96	99	195		9	5	8	11	1.68		
DAT0906	4867	97	99	196		9	5	9	11	1.68		
DAT0906	4868	99	99	198		9	5	10	11	1.67		
DAT0906	4869	99	99	198		9	5	11	11	1.69		
DAT0906	4870	97	99	196	197	9	5	12	11	1.70	1.67	
DAT0906	4871	98	99	197		9	5	13	11	1.69		
DAT0906	4872	99	100	199		9	5	14	11	1.71		
DAT0906	4873	99	99	198		9	5	15	11	1.67		
DAT0906	4874	98	99	197		9	5	16	11	1.71		
DAT0906	4875	99	99	198		9	5	17	11	1.71		
DAT0906	4876	99	99	198		9	5	18	11	1.70		
DAT0906	4877	97	100	197		9	5	19	11	1.71		
DAT0906	4878	99	99	198		9	5	20	11	1.70		
DAT0906	4879	100	100	200		9	5	21	11	1.70		
DAT0906	4880	98	100	198	198	9	5	22	11	1.71	1.7	
DAT0906	4881	99	100	199		9	5	23	11	1.69		
DAT0906	4882	99	100	199		9	6	0	11	1.68		
DAT0906	4883	99	99	198		9	6	1	11	1.69		
DAT0906	4884	97	99	196		9	6	2	11	1.69		
DAT0906	4885	99	99	198		9	6	3	11	1.70		
DAT0906	4886	99	99	198		9	6	4	11	1.70		
DAT0906	4887	98	99	197		9	6	5	11	1.69		
DAT0906	4888	99	99	198		9	6	6	11	1.70		
DAT0906	4889	96	99	195		9	6	7	11	1.69		
DAT0906	4890	99	99	198	198	9	6	8	11	1.68	1.69	
DAT0906	4891	99	99	198		9	6	9	11	1.69		
DAT0906	4892	98	99	197		9	6	10	11	1.70		
DAT0906	4893	98	99	197		9	6	11	11	1.70		
DAT0909	4894	96	98	194		9	6	12	59		0.11	4 Min
DAT0909	4895	100	100	200		9	6	13	59	1.62		
DAT0909	4896	99	100	199		9	6	14	59	1.58		
DAT0909	4897	100	99	199		9	6	15	59	1.58		
DAT0909	4898	98	99	197		9	6	16	59	1.59		
DAT0909	4899	100	99	199		9	6	17	59	1.59		
DAT0909	4900	100	99	199	198	9	6	18	59	1.59	1.63	

Appendix Q: Digital Reliability Test Data - Test #6 (Test Period # 7)

Stored in:	Test #	Devices Upset				Ave	Date(96)		Time		File size (Mb)			Notes
		Bd #1	Bd #2	Total					full	ave	part			
DAT0909	4901	97	99	196		9	6	19	59	1.57				
DAT0909	4902	99	99	198		9	6	20	59	1.56				
DAT0909	4903	99	99	198		9	6	21	59	1.58				
DAT0909	4904	100	99	199		9	6	22	59	1.62				
DAT0909	4905	99	99	198		9	6	23	59	1.66				
DAT0909	4906	100	99	199		9	7	0	59	1.68				
DAT0909	4907	98	99	197		9	7	1	59	1.68				
DAT0909	4908	100	99	199		9	7	2	59	1.67				
DAT0909	4909	100	99	199		9	7	3	59	1.67				
DAT0909	4910	98	99	197	198	9	7	4	59	1.66	1.64			
DAT0909	4911	98	99	197		9	7	5	59	1.67				
DAT0909	4912	99	99	198		9	7	6	59	1.69				
DAT0909	4913	100	100	200		9	7	7	59	1.66				
DAT0909	4914	100	99	199		9	7	8	59	1.66				
DAT0909	4915	100	99	199		9	7	9	59	1.61				
DAT0909	4916	100	99	199		9	7	10	59	1.62				
DAT0909	4917	99	99	198		9	7	11	59	1.62				
DAT0909	4918	99	99	198		9	7	12	59	1.71				
DAT0909	4919	100	99	199		9	7	13	59	1.72				
DAT0909	4920	97	100	197	198	9	7	14	59	1.72	1.67			
DAT0909	4921	99	100	199		9	7	15	59	1.72				
DAT0909	4922	99	100	199		9	7	16	59	1.72				
DAT0909	4923	100	100	200		9	7	17	59	1.72				
DAT0909	4924	100	100	200		9	7	18	59	1.72				
DAT0909	4925	98	100	198		9	7	19	59	1.70				
DAT0909	4926	98	99	197		9	7	20	59	1.72				
DAT0909	4927	99	99	198		9	7	21	59	1.71				
DAT0909	4928	98	99	197		9	7	22	59	1.71				
DAT0909	4929	100	99	199		9	7	23	59	1.71				
DAT0909	4930	98	99	197	198	9	8	0	59	1.71	1.71			
DAT0909	4931	100	99	199		9	8	1	59	1.70				
DAT0909	4932	98	99	197		9	8	2	59	1.70				
DAT0909	4933	99	99	198		9	8	3	59	1.70				
DAT0909	4934	99	99	198		9	8	4	59	1.70				
DAT0909	4935	99	99	198		9	8	5	59	1.69				
DAT0909	4936	100	99	199		9	8	6	59	1.64				
DAT0909	4937	99	99	198		9	8	7	59	1.60				
DAT0909	4938	99	99	198		9	8	8	59	1.73				
DAT0909	4939	99	100	199		9	8	9	59	1.73				
DAT0909	4940	99	99	198	198	9	8	10	59	1.73	1.69			
DAT0909	4941	98	99	197		9	8	11	59	1.74				
DAT0909	4942	100	99	199		9	8	12	59	1.73				
DAT0909	4943	98	99	197		9	8	13	59	1.74				
DAT0909	4944	99	100	199		9	8	14	59	1.75				
DAT0909	4945	100	99	199		9	8	15	59	1.74				
DAT0909	4946	100	99	199		9	8	16	59	1.74				
DAT0909	4947	98	99	197		9	8	17	59	1.74				
DAT0909	4948	97	100	197		9	8	18	59	1.76				
DAT0909	4949	98	99	197		9	8	19	59	1.76				
DAT0909	4950	99	100	199	198	9	8	20	59	1.76	1.75			

Appendix Q: Digital Reliability Test Data - Test #6 (Test Period # 7)

Stored in:	Test #	Devices Upset				Ave	Date(96)		Time		File size (Mb)			Notes
		Bd #1	Bd #2	Total					full	ave	part			
DAT0909	4951	99	99	198		9	8	21	59	1.76				
DAT0909	4952	99	99	198		9	8	22	59	1.74				
DAT0909	4953	100	99	199		9	8	23	59	1.74				
DAT0909	4954	100	99	199		9	9	0	59	1.74				
DAT0909	4955	98	99	197		9	9	1	59	1.74				
DAT0909	4956	98	99	197		9	9	2	59	1.74				
DAT0909	4957	100	99	199		9	9	3	59	1.74				
DAT0909	4958	100	99	199		9	9	4	59	1.73				
DAT0909	4959	99	100	199		9	9	5	59	1.73				
DAT0909	4960	99	99	198	198	9	9	6	59	1.75	1.74			
DAT0909	4961	100	99	199		9	9	7	59	1.75				
DAT0909	4962	99	99	198		9	9	8	59	1.76				
DAT0909	4963	100	99	199		9	9	9	59	1.76				
DAT0909	4964	99	99	198		9	9	10	59	1.76				
DAT0909	4965	97	99	196		9	9	11	22			0.62		
DAT0913	4966	98	98	196		9	9	12	47			0.12	4 Min	
DAT0913	4967	99	99	198		9	9	13	47	1.81				
DAT0913	4968	100	99	199		9	9	14	47	1.68				
DAT0913	4969	100	99	199		9	9	15	47	1.67				
DAT0913	4970	100	99	199	198	9	9	16	47	1.66	1.73			
DAT0913	4971	99	99	198		9	9	17	47	1.63				
DAT0913	4972	100	100	200		9	9	18	47	1.63				
DAT0913	4973	100	99	199		9	9	19	47	1.64				
DAT0913	4974	99	99	198		9	9	20	47	1.66				
DAT0913	4975	99	100	199		9	9	21	47	1.65				
DAT0913	4976	100	99	199		9	9	22	47	1.66				
DAT0913	4977	99	99	198		9	9	23	47	1.65				
DAT0913	4978	97	99	196		9	10	0	47	1.64				
DAT0913	4979	100	99	199		9	10	1	47	1.64				
DAT0913	4980	98	99	197	198	9	10	2	47	1.63	1.64			
DAT0913	4981	98	99	197		9	10	3	47	1.60				
DAT0913	4982	97	99	196		9	10	4	47	1.60				
DAT0913	4983	97	99	196		9	10	5	47	1.64				
DAT0913	4984	97	99	196		9	10	6	47	1.61				
DAT0913	4985	99	99	198		9	10	7	47	1.61				
DAT0913	4986	99	99	198		9	10	8	47	1.61				
DAT0913	4987	98	99	197		9	10	9	47	1.62				
DAT0913	4988	99	99	198		9	10	10	47	1.64				
DAT0913	4989	100	99	199		9	10	11	47	1.63				
DAT0913	4990	99	99	198	197	9	10	13	40	1.65	1.62			
DAT0913	4991	97	99	196		9	10	14	40	1.63				
DAT0913	4992	99	99	198		9	10	15	40	1.62				
DAT0913	4993	99	99	198		9	10	16	40	1.61				
DAT0913	4994	99	99	198		9	10	17	40	1.61				
DAT0913	4995	99	99	198		9	10	18	40	1.60				
DAT0913	4996	98	99	197		9	10	19	40	1.60				
DAT0913	4997	100	99	199		9	10	20	40	1.61				
DAT0913	4998	99	99	198		9	10	21	40	1.62				
DAT0913	4999	98	100	198		9	10	22	40	1.64				
DAT0913	5000	100	99	199	198	9	10	23	40	1.63	1.62			

Appendix Q: Digital Reliability Test Data - Test #6 (Test Period # 7)

Stored in:	Test #	Devices Upset				Ave	Date(96)		Time		File size (Mb)			Notes
		Bd #1	Bd #2	Total					full	ave	part			
DAT0913	5001	99	99	198		9	11	0	40	1.63				
DAT0913	5002	98	100	198		9	11	1	40	1.62				
DAT0913	5003	98	99	197		9	11	2	40	1.61				
DAT0913	5004	100	99	199		9	11	3	40	1.61				
DAT0913	5005	99	99	198		9	11	4	40	1.61				
DAT0913	5006	99	99	198		9	11	5	40	1.62				
DAT0913	5007	99	99	198		9	11	6	40	1.61				
DAT0913	5008	100	99	199		9	11	7	40	1.63				
DAT0913	5009	98	100	198		9	11	8	40	1.63				
DAT0913	5010	100	99	199	198	9	11	9	40	1.63	1.62			
DAT0913	5011	100	99	199		9	11	10	40	1.63				
DAT0913	5012	99	99	198		9	11	11	40	1.63				
DAT0913	5013	100	99	199		9	11	12	40	1.63				
DAT0913	5014	100	99	199		9	11	13	40	1.63				
DAT0913	5015	100	99	199		9	11	14	40	1.62				
DAT0913	5016	98	99	197		9	11	15	40	1.61				
DAT0913	5017	100	99	199		9	11	16	40	1.62				
DAT0913	5018	100	100	200		9	11	17	40	1.63				
DAT0913	5019	99	99	198		9	11	18	40	1.63				
DAT0913	5020	98	99	197	199	9	11	19	40	1.63	1.63			
DAT0913	5021	99	99	198		9	11	20	40	1.64				
DAT0913	5022	100	99	199		9	11	21	40	1.64				
DAT0913	5023	99	100	199		9	11	22	40	1.64				
DAT0913	5024	97	99	196		9	11	23	40	1.64				
DAT0913	5025	99	99	198		9	12	0	40	1.63				
DAT0913	5026	98	99	197		9	12	1	40	1.64				
DAT0913	5027	99	99	198		9	12	2	40	1.63				
DAT0913	5028	98	99	197		9	12	3	40	1.63				
DAT0913	5029	100	99	199		9	12	4	40	1.63				
DAT0913	5030	100	100	200	198	9	12	5	40	1.62	1.63			
DAT0913	5031	99	99	198		9	12	6	40	1.62				
DAT0913	5032	99	99	198		9	12	7	40	1.62				
DAT0913	5033	99	99	198		9	12	8	40	1.63				
DAT0913	5034	99	99	198		9	12	9	40	1.64				
DAT0913	5035	99	99	198		9	12	10	40	1.63				
DAT0913	5036	96	100	196		9	12	11	40	1.63				
DAT0913	5037	99	99	198		9	12	12	40	1.62				
DAT0913	5038	100	99	199		9	12	13	40	1.63				
DAT0913	5039	98	99	197		9	12	14	40	1.62				
DAT0913	5040	99	99	198	198	9	12	15	40	1.64	1.63			
DAT0913	5041	99	100	199		9	12	16	40	1.63				
DAT0913	5042	100	99	199		9	12	17	40	1.63				
DAT0913	5043	100	100	200		9	12	18	40	1.63				
DAT0913	5044	99	99	198		9	12	19	40	1.63				
DAT0913	5045	98	100	198		9	12	20	40	1.63				
DAT0913	5046	100	99	199		9	12	21	40	1.62				
DAT0913	5047	100	100	200		9	12	22	40	1.63				
DAT0913	5048	98	99	197		9	12	23	40	1.62				
DAT0913	5049	100	99	199		9	13	0	40	1.62				
DAT0913	5050	99	99	198	199	9	13	1	40	1.63	1.63			

Appendix Q: Digital Reliability Test Data - Test #6 (Test Period # 7)

Stored in:	Test #	Devices Upset				Ave	Date(96)		Time		File size (Mb)			Notes
		Bd #1	Bd #2	Total					full	ave	part			
DAT0913	5051	99	99	198		9	13	2	40	1.62				
DAT0913	5052	99	99	198		9	13	3	40	1.62				
DAT0913	5053	100	99	199		9	13	4	40	1.62				
DAT0913	5054	98	99	197		9	13	5	40	1.62				
DAT0913	5055	99	99	198		9	13	6	40	1.62				
DAT0913	5056	99	99	198		9	13	7	40	1.63				
DAT0913	5057	98	100	198		9	13	8	40	1.62				
DAT0913	5058	99	99	198		9	13	9	40	1.62				
DAT0913	5059	98	99	197		9	13	10	40	1.63				
DAT0913	5060	96	99	195	198	9	13	11	1		1.62	0.57		
DAT0916	5061	100	100	200		9	13	14	42			0.16	4 Min	
DAT0916	5062	100	100	200		9	13	15	43	2.30			changed Vlo	
DAT0916	5063	100	100	200		9	13	16	43	2.30				
DAT0916	5064	100	100	200		9	13	17	43	2.31				
DAT0916	5065	100	100	200		9	13	18	43	2.29				
DAT0916	5066	100	100	200		9	13	19	43	2.28				
DAT0916	5067	100	100	200		9	13	20	43	2.30				
DAT0916	5068	100	100	200		9	13	21	43	2.28				
DAT0916	5069	100	100	200		9	13	22	43	2.29				
DAT0916	5070	100	100	200	200	9	13	23	43	2.29	2.29			
DAT0916	5071	100	100	200		9	14	0	43	2.27				
DAT0916	5072	100	100	200		9	14	1	43	2.29				
DAT0916	5073	100	100	200		9	14	2	43	2.27				
DAT0916	5074	100	100	200		9	14	3	43	2.27				
DAT0916	5075	100	100	200		9	14	4	43	2.27				
DAT0916	5076	100	100	200		9	14	5	43	2.26				
DAT0916	5077	100	100	200		9	14	6	43	2.27				
DAT0916	5078	100	100	200		9	14	7	43	2.26				
DAT0916	5079	100	100	200		9	14	8	43	2.27				
DAT0916	5080	100	100	200	200	9	14	9	43	2.27	2.5			
DAT0916	5081	100	100	200		9	14	10	43	2.28				
DAT0916	5082	100	100	200		9	14	11	43	2.27				
DAT0916	5083	100	100	200		9	14	12	43	2.27				
DAT0916	5084	100	100	200		9	14	13	43	2.28				
DAT0916	5085	100	100	200		9	14	14	43	2.27				
DAT0916	5086	100	100	200		9	14	15	43	2.25				
DAT0916	5087	100	100	200		9	14	16	43	2.22				
DAT0916	5088	100	100	200		9	14	17	43	2.18				
DAT0916	5089	100	100	200		9	14	18	43	2.19				
DAT0916	5090	100	100	200	200	9	14	19	43	2.18	2.01			
DAT0916	5091	100	100	200		9	14	20	43	2.19				
DAT0916	5092	100	100	200		9	14	21	43	2.18				
DAT0916	5093	100	100	200		9	14	22	43	2.15				
DAT0916	5094	100	100	200		9	14	23	43	2.17				
DAT0916	5095	100	99	199		9	15	0	43	2.12				
DAT0916	5096	100	99	199		9	15	1	43	2.12				
DAT0916	5097	100	100	200		9	15	2	43	2.12				
DAT0916	5098	100	99	199		9	15	3	43	2.16				
DAT0916	5099	100	100	200		9	15	4	43	2.17				
DAT0916	5100	100	100	200	200	9	15	5	43	2.19	2.16			

Appendix Q: Digital Reliability Test Data - Test #6 (Test Period # 7)

Stored in:	Test #	Devices Upset				Date(96)	Time		File size (Mb)			Notes
		Bd #1	Bd #2	Total	Ave		full	ave	part			
DAT0916	5101	100	100	200		9 15	6 43	2.19				
DAT0916	5102	100	100	200		9 15	7 43	2.18				
DAT0916	5103	100	99	199		9 15	8 43	2.09				
DAT0916	5104	100	100	200		9 15	9 43	2.15				
DAT0916	5105	100	100	200		9 15	10 43	2.22				
DAT0916	5106	100	100	200		9 15	11 43	2.22				
DAT0916	5107	100	100	200		9 15	12 43	2.24				
DAT0916	5108	100	100	200		9 15	13 43	2.24				
DAT0916	5109	100	100	200		9 15	14 43	2.24				
DAT0916	5110	100	100	200	200	9 15	15 43	2.24	2.2			
DAT0916	5111	100	100	200		9 15	16 43	2.24				
DAT0916	5112	100	100	200		9 15	17 43	2.20				
DAT0916	5113	100	100	200		9 15	18 43	2.17				
DAT0916	5114	100	100	200		9 15	19 43	2.18				
DAT0916	5115	100	100	200		9 15	20 43	2.19				
DAT0916	5116	100	100	200		9 15	21 43	2.12				
DAT0916	5117	100	100	200		9 15	22 43	2.10				
DAT0916	5118	100	99	199		9 15	23 43	2.03				
DAT0916	5119	100	100	200		9 16	0 43	2.00				
DAT0916	5120	100	99	199	200	9 16	1 43	2.00	2.12			
DAT0916	5121	100	100	200		9 16	2 43	2.00				
DAT0916	5122	100	100	200		9 16	3 43	2.02				
DAT0916	5123	100	100	200		9 16	4 43	2.06				
DAT0916	5124	100	100	200		9 16	5 43	2.04				
DAT0916	5125	100	100	200		9 16	6 43	2.05				
DAT0916	5126	100	100	200		9 16	7 43	2.11				
DAT0916	5127	100	100	200		9 16	8 43	2.16				
DAT0916	5128	100	100	200		9 16	9 16			1.12		
DAT0920	5129	95	96	191		9 16	11 20			0.10	4 Min	
DAT0920	5130	97	99	196	199	9 16	12 20	1.50	1.99			
DAT0920	5131	98	99	197		9 16	13 20	1.50				
DAT0920	5132	99	99	198		9 16	14 20	1.49				
DAT0920	5133	98	99	197		9 16	15 20	1.46				
DAT0920	5134	98	98	196		9 16	16 20	1.32				
DAT0920	5135	100	98	198		9 16	17 20	1.36				
DAT0920	5136	99	98	197		9 16	18 20	1.46				
DAT0920	5137	98	99	197		9 16	19 20	1.49				
DAT0920	5138	97	99	196		9 16	20 20	1.47				
DAT0920	5139	99	99	198		9 16	21 20	1.48				
DAT0920	5140	100	99	199	197	9 16	22 20	1.48	1.45			
DAT0920	5141	98	99	197		9 16	23 20	1.48				
DAT0920	5142	98	99	197		9 17	0 20	1.48				
DAT0920	5143	98	99	197		9 17	1 20	1.48				
DAT0920	5144	96	99	195		9 17	2 20	1.50				
DAT0920	5145	99	99	198		9 17	3 20	1.50				
DAT0920	5146	98	99	197		9 17	4 20	1.50				
DAT0920	5147	98	100	198		9 17	5 20	1.49				
DAT0920	5148	99	98	197		9 17	6 20	1.49				
DAT0920	5149	100	99	199		9 17	7 20	1.50				
DAT0920	5150	97	98	195	197	9 17	8 20	1.49	1.49			



Appendix Q: Digital Reliability Test Data - Test #6 (Test Period # 7)

Stored in:	Test #	Devices Upset				Ave	Date(96)		Time		File size (Mb)			Notes
		Bd #1	Bd #2	Total					full	ave	part			
DAT0920	5151	97	98	195		9	17	9	20	1.47				
DAT0920	5152	98	99	197		9	17	10	20	1.45				
DAT0920	5153	98	99	197		9	17	11	20	1.47				
DAT0920	5154	100	99	199		9	17	12	20	1.46				
DAT0920	5155	98	100	198		9	17	13	20	1.48				
DAT0920	5156	99	98	197		9	17	14	20	1.51				
DAT0920	5157	97	99	196		9	17	15	20	1.48				
DAT0920	5158	100	99	199		9	17	16	20	1.54				
DAT0920	5159	100	99	199		9	17	17	20	1.56				
DAT0920	5160	100	99	199	198	9	17	18	20	1.54	1.5			
DAT0920	5161	98	99	197		9	17	19	20	1.57				
DAT0920	5162	100	100	200		9	17	20	20	1.57				
DAT0920	5163	100	100	200		9	17	21	20	1.56				
DAT0920	5164	98	99	197		9	17	22	20	1.57				
DAT0920	5165	96	99	195		9	17	23	20	1.58				
DAT0920	5166	100	98	198		9	18	0	20	1.57				
DAT0920	5167	99	99	198		9	18	1	20	1.55				
DAT0920	5168	98	99	197		9	18	2	20	1.56				
DAT0920	5169	99	99	198		9	18	3	20	1.56				
DAT0920	5170	97	99	196	198	9	18	4	20	1.55	1.56			
DAT0920	5171	100	99	199		9	18	5	20	1.57				
DAT0920	5172	98	99	197		9	18	6	20	1.58				
DAT0920	5173	100	99	199		9	18	7	20	1.58				
DAT0920	5174	98	99	197		9	18	8	20	1.58				
DAT0920	5175	98	99	197		9	18	9	20	1.58				
DAT0920	5176	99	99	198		9	18	10	20	1.58				
DAT0920	5177	96	99	195		9	18	11	20	1.58				
DAT0920	5178	99	99	198		9	18	12	20	1.57				
DAT0920	5179	98	99	197		9	18	13	20	1.59				
DAT0920	5180	100	98	198	198	9	18	14	20	1.58	1.58			
DAT0920	5181	97	99	196		9	18	15	20	1.55				
DAT0920	5182	99	99	198		9	18	16	20	1.50				
DAT0920	5183	99	99	198		9	18	17	20	1.54				
DAT0920	5184	99	98	197		9	18	18	20	1.53				
DAT0920	5185	98	99	197		9	18	19	20	1.55				
DAT0920	5186	98	99	197		9	18	20	20	1.52				
DAT0920	5187	99	99	198		9	18	21	20	1.54				
DAT0920	5188	100	98	198		9	18	22	20	1.54				
DAT0920	5189	98	99	197		9	18	23	20	1.52				
DAT0920	5190	99	99	198	197	9	19	0	20	1.52	1.53			
DAT0920	5191	99	99	198		9	19	1	20	1.53				
DAT0920	5192	99	99	198		9	19	2	20	1.52				
DAT0920	5193	99	99	198		9	19	3	20	1.51				
DAT0920	5194	97	99	196		9	19	4	20	1.57				
DAT0920	5195	99	99	198		9	19	5	20	1.57				
DAT0920	5196	99	99	198		9	19	6	20	1.57				
DAT0920	5197	98	99	197		9	19	7	20	1.57				
DAT0920	5198	99	98	197		9	19	8	20	1.56				
DAT0920	5199	99	99	198		9	19	9	20	1.56				
DAT0920	5200	99	99	198	198	9	19	10	20	1.58	1.55			

Appendix Q: Digital Reliability Test Data - Test #6 (Test Period # 7)

Stored in:	Test #	Devices Upset				Date(96)	Time		File size (Mb)			Notes	
		Bd #1	Bd #2	Total	Ave				full	ave	part		
DAT0920	5201	98	99	197		9	19	11	20	1.57			
DAT0920	5202	97	99	196		9	19	12	20	1.56			
DAT0920	5203	100	99	199		9	19	13	20	1.53			
DAT0920	5204	99	99	198		9	19	14	20	1.55			
DAT0920	5205	98	98	196		9	19	15	20	1.51			
DAT0920	5206	98	100	198		9	19	16	20	1.47			
DAT0920	5207	98	98	196		9	19	17	20	1.52			
DAT0920	5208	99	99	198		9	19	18	20	1.49			
DAT0920	5209	100	98	198		9	19	19	20	1.49			
DAT0920	5210	96	99	195	197	9	19	20	20	1.53	1.52		
DAT0920	5211	100	99	199		9	19	21	20	1.52			
DAT0920	5212	98	100	198		9	19	22	20	1.51			
DAT0920	5213	99	98	197		9	19	23	20	1.48			
DAT0920	5214	96	98	194		9	20	0	20	1.47			
DAT0920	5215	100	99	199		9	20	1	20	1.46			
DAT0920	5216	100	99	199		9	20	2	20	1.44			
DAT0920	5217	98	100	198		9	20	3	20	1.45			
DAT0920	5218	99	99	198		9	20	4	20	1.47			
DAT0920	5219	97	99	196		9	20	5	20	1.48			
DAT0920	5220	98	100	198	198	9	20	6	20	1.48	1.48		
DAT0920	5221	97	99	196		9	20	7	20	1.50			
DAT0920	5222	98	98	196		9	20	8	20	1.49			
DAT0920	5223	96	98	194		9	20	9	20	1.49			
DAT0920	5224	98	98	196		9	20	10	20	1.48			
DAT0920	5225	98	98	196		9	20	11	20	1.48			
DAT0920	5226	96	98	194		9	20	11	37			0.38	
DAT0923	5227	94	94	188		9	20	15	23			0.10	4 Min
DAT0923	5228	97	99	196		9	20	16	23	1.47			
DAT0923	5229	99	99	198		9	20	17	23	1.49			
DAT0923	5230	100	98	198	195	9	20	18	23	1.48	1.49		
DAT0923	5231	99	99	198		9	20	19	23	1.47			
DAT0923	5232	99	99	198		9	20	20	23	1.50			
DAT0923	5233	97	99	196		9	20	21	23	1.46			
DAT0923	5234	98	99	197		9	20	22	23	1.48			
DAT0923	5235	97	98	195		9	20	23	23	1.50			
DAT0923	5236	97	99	196		9	21	0	23	1.48			
DAT0923	5237	99	99	198		9	21	1	23	1.47			
DAT0923	5238	99	98	197		9	21	2	23	1.46			
DAT0923	5239	98	99	197		9	21	3	23	1.44			
DAT0923	5240	99	99	198	197	9	21	4	23	1.46	1.47		
DAT0923	5241	96	99	195		9	21	5	23	1.48			
DAT0923	5242	99	99	198		9	21	6	23	1.54			
DAT0923	5243	99	99	198		9	21	7	23	1.55			
DAT0923	5244	97	98	195		9	21	8	23	1.54			
DAT0923	5245	98	99	197		9	21	9	23	1.56			
DAT0923	5246	98	99	197		9	21	10	23	1.56			
DAT0923	5247	100	98	198		9	21	11	23	1.56			
DAT0923	5248	99	98	197		9	21	12	23	1.56			
DAT0923	5249	99	99	198		9	21	13	23	1.57			
DAT0923	5250	98	99	197	197	9	21	14	23	1.57	1.55		

Appendix Q: Digital Reliability Test Data - Test #6 (Test Period # 7)

Stored in:	Test #	Devices Upset				Date(96)	Time		File size (Mb)			Notes	
		Bd #1	Bd #2	Total	Ave				full	ave	part		
DAT0923	5251	96	99	195		9	21	15	23	1.57			
DAT0923	5252	98	99	197		9	21	16	23	1.57			
DAT0923	5253	98	99	197		9	21	17	23	1.58			
DAT0923	5254	99	99	198		9	21	18	23	1.58			
DAT0923	5255	97	99	196		9	21	19	23	1.59			
DAT0923	5256	98	99	197		9	21	20	23	1.58			
DAT0923	5257	98	99	197		9	21	21	23	1.58			
DAT0923	5258	99	99	198		9	21	22	23	1.58			
DAT0923	5259	97	100	197		9	21	23	23	1.58			
DAT0923	5260	98	99	197	197	9	22	0	23	1.57	1.58		
DAT0923	5261	100	99	199		9	22	1	23	1.57			
DAT0923	5262	95	99	194		9	22	2	23	1.57			
DAT0923	5263	98	99	197		9	22	3	23	1.58			
DAT0923	5264	97	99	196		9	22	4	23	1.58			
DAT0923	5265	100	98	198		9	22	5	23	1.58			
DAT0923	5266	99	99	198		9	22	6	23	1.58			
DAT0923	5267	98	99	197		9	22	7	23	1.57			
DAT0923	5268	97	99	196		9	22	8	23	1.52			
DAT0923	5269	98	99	197		9	22	9	23	1.51			
DAT0923	5270	98	99	197	197	9	22	10	23	1.50	1.56		
DAT0923	5271	98	98	196		9	22	11	23	1.50			
DAT0923	5272	98	99	197		9	22	12	23	1.55			
DAT0923	5273	100	99	199		9	22	13	23	1.49			
DAT0923	5274	100	98	198		9	22	14	23	1.50			
DAT0923	5275	100	99	199		9	22	15	23	1.49			
DAT0923	5276	98	99	197		9	22	16	23	1.51			
DAT0923	5277	97	100	197		9	22	17	23	1.49			
DAT0923	5278	99	99	198		9	22	18	23	1.52			
DAT0923	5279	99	99	198		9	22	19	23	1.58			
DAT0923	5280	98	100	198	198	9	22	20	23	1.58	1.52		
DAT0923	5281	99	99	198		9	22	21	23	1.55			
DAT0923	5282	96	99	195		9	22	22	23	1.57			
DAT0923	5283	99	99	198		9	22	23	23	1.57			
DAT0923	5284	98	99	197		9	23	0	23	1.52			
DAT0923	5285	99	100	199		9	23	1	23	1.50			
DAT0923	5286	99	99	198		9	23	2	23	1.51			
DAT0923	5287	97	98	195		9	23	3	23	1.50			
DAT0923	5288	99	99	198		9	23	4	23	1.51			
DAT0923	5289	98	98	196		9	23	5	23	1.51			
DAT0923	5290	97	99	196	197	9	23	6	23	1.53	1.53		
DAT0923	5291	100	99	199		9	23	7	23	1.54			
DAT0923	5292	99	99	198		9	23	8	23	1.51			
DAT0923	5293	100	99	199		9	23	9	23	1.52			
DAT0923	5294	98	99	197		9	23	9	46			0.54	End of test
	5295			0		9							
	5296			0		9							
	5297			0		9							
	5298			0		9							
	5299			0		9							
	5300			0	79	9					1.52		

Appendix R: Digital Reliability Test Data - Test #8

Stored in:	Test #	Devices Upset				Date(96)	Time		File size (Mb)			Notes	
		Bd #1	Bd #2	Total	Ave		full	ave	part				
DAT0924	5301	81	78	159		9	24	13	46			0.04	4 Min
DAT0924	5302	98	100	198		9	24	14	47	0.57			
DAT0924	5303	96	100	196		9	24	15	47	0.49			
DAT0924	5304	99	100	199		9	24	16	47	0.61			
DAT0924	5305	99	100	199		9	24	17	47	0.61			
DAT0924	5306	98	100	198		9	24	18	47	0.61			
DAT0924	5307	100	100	200		9	24	19	47	0.59			
DAT0924	5308	98	100	198		9	24	20	47	0.49			
DAT0924	5309	96	97	193		9	24	21	47	0.43			
DAT0924	5310	97	98	195	194	9	24	22	47	0.44	0.54		
DAT0924	5311	95	100	195		9	24	23	47	0.44			
DAT0924	5312	95	99	194		9	25	0	47	0.48			
DAT0924	5313	95	98	193		9	25	1	47	0.46			
DAT0924	5314	98	98	196		9	25	2	47	0.53			
DAT0924	5315	95	100	195		9	25	3	47	0.48			
DAT0924	5316	96	100	196		9	25	4	47	0.46			
DAT0924	5317	95	99	194		9	25	5	47	0.47			
DAT0924	5318	94	99	193		9	25	6	47	0.46			
DAT0924	5319	97	99	196		9	25	7	47	0.47			
DAT0924	5320	94	99	193	195	9	25	8	47	0.46	0.47		
DAT0924	5321	96	100	196		9	25	9	47	0.48			
DAT0924	5322	99	99	198		9	25	10	47	0.50			
DAT0924	5323	96	100	196		9	25	11	47	0.46			
DAT0924	5324	98	99	197		9	25	12	47	0.41			
DAT0924	5325	86	83	169		9	25	13	12			0.14	
DAT0927	5326	85	82	167		9	25	13	43			0.03	4 Min
DAT0927	5327	97	100	197		9	25	14	44	0.48			
DAT0927	5328	99	100	199		9	25	15	44	0.52			
DAT0927	5329	95	98	193		9	25	16	44	0.42			
DAT0927	5330	96	98	194	191	9	25	17	44	0.42	0.46		
DAT0927	5331	96	100	196		9	25	18	44	0.42			
DAT0927	5332	92	100	192		9	25	19	44	0.35			
DAT0927	5333	93	98	191		9	25	20	44	0.36			
DAT0927	5334	92	88	180		9	25	21	44	0.33			
DAT0927	5335	96	100	196		9	25	22	44	0.39			
DAT0927	5336	95	98	193		9	25	23	44	0.39			
DAT0927	5337	97	96	193		9	26	0	44	0.32			
DAT0927	5338	95	92	187		9	26	1	44	0.30			
DAT0927	5339	97	99	196		9	26	2	44	0.37			
DAT0927	5340	93	98	191	192	9	26	3	44	0.31	0.35		
DAT0927	5341	93	98	191		9	26	4	44	0.31			
DAT0927	5342	97	99	196		9	26	5	44	0.35			
DAT0927	5343	97	99	196		9	26	6	44	0.44			
DAT0927	5344	97	97	194		9	26	7	44	0.40			
DAT0927	5345	96	98	194		9	26	8	44	0.46			
DAT0927	5346	97	100	197		9	26	9	44	0.62			
DAT0927	5347	99	100	199		9	26	10	44	0.63			
DAT0927	5348	100	100	200		9	26	11	44	0.60			
DAT0927	5349	95	100	195		9	26	12	44	0.55			
DAT0927	5350	97	100	197	196	9	26	13	44	0.52	0.49		

Appendix R: Digital Reliability Test Data - Test #8

Stored in:	Test #	Devices Upset				Date(96)	Time		File size (Mb)			Notes
		Bd #1	Bd #2	Total	Ave		full	ave	part			
DAT0927	5351	93	100	193		9	26	14	44	0.42		
DAT0927	5352	98	98	196		9	26	15	44	0.39		
DAT0927	5353	96	99	195		9	26	16	44	0.41		
DAT0927	5354	97	100	197		9	26	17	44	0.43		
DAT0927	5355	97	99	196		9	26	18	44	0.37		
DAT0927	5356	98	97	195		9	26	19	44	0.38		
DAT0927	5357	95	100	195		9	26	20	44	0.40		
DAT0927	5358	96	100	196		9	26	21	44	0.40		
DAT0927	5359	95	100	195		9	26	22	44	0.45		
DAT0927	5360	96	100	196	195	9	26	23	44	0.47	0.41	
DAT0927	5361	99	100	199		9	27	0	44	0.48		
DAT0927	5362	100	99	199		9	27	1	44	0.48		
DAT0927	5363	97	99	196		9	27	2	44	0.50		
DAT0927	5364	98	98	196		9	27	3	44	0.51		
DAT0927	5365	96	99	195		9	27	4	44	0.51		
DAT0927	5366	97	98	195		9	27	5	44	0.49		
DAT0927	5367	98	100	198		9	27	6	44	0.50		
DAT0927	5368	98	99	197		9	27	7	44	0.50		
DAT0927	5369	95	100	195		9	27	8	44	0.45		
DAT0927	5370	98	99	197	197	9	27	9	44	0.37	0.48	
DAT0927	5371	95	97	192		9	27	10	44	0.32		
DAT0927	5372	97	95	192		9	27	11	44	0.32		
DAT0927	5373	95	89	184		9	27	12	44	0.33		
DAT0927	5374	92	89	181		9	27	13	17		0.18	
DAT1002	5375	75	55	130		9	27	13	52		0.02	4 min
DAT1002	5376	95	93	188		9	27	14	52	0.32		
DAT1002	5377	98	100	198		9	27	15	52	0.40		
DAT1002	5378	98	99	197		9	27	16	52	0.55		
DAT1002	5379	100	98	198		9	27	17	52	0.57		
DAT1002	5380	99	100	199	186	9	27	18	52	0.57	0.42	
DAT1002	5381	99	100	199		9	27	19	52	0.57		
DAT1002	5382	99	100	199		9	27	20	52	0.64		
DAT1002	5383	99	100	199		9	27	21	52	0.78		
DAT1002	5384	100	100	200		9	27	22	52	0.76		
DAT1002	5385	96	100	196		9	27	23	52	0.64		
DAT1002	5386	99	100	199		9	28	0	52	0.63		
DAT1002	5387	98	100	198		9	28	1	52	0.60		
DAT1002	5388	96	98	194		9	28	2	52	0.57		
DAT1002	5389	97	99	196		9	28	3	52	0.55		
DAT1002	5390	99	98	197	198	9	28	4	52	0.50	0.62	
DAT1002	5391	96	100	196		9	28	5	52	0.50		
DAT1002	5392	100	99	199		9	28	6	52	0.52		
DAT1002	5393	99	100	199		9	28	7	52	0.51		
DAT1002	5394	100	99	199		9	28	8	52	0.61		
DAT1002	5395	98	100	198		9	28	9	52	0.66		
DAT1002	5396	98	100	198		9	28	10	52	0.69		
DAT1002	5397	99	100	199		9	28	11	52	0.70		
DAT1002	5398	100	100	200		9	28	12	52	0.75		
DAT1002	5399	100	100	200		9	28	13	52	0.78		
DAT1002	5400	98	100	198	199	9	28	14	52	0.77	0.65	

Appendix R: Digital Reliability Test Data - Test #8

Stored in:	Test #	Devices Upset				Date(96)	Time		File size (Mb)			Notes
		Bd #1	Bd #2	Total	Ave		full	ave	part			
DAT1002	5401	99	100	199		9	28	15	52	0.79		
DAT1002	5402	100	100	200		9	28	16	52	0.81		
DAT1002	5403	98	100	198		9	28	17	52	0.80		
DAT1002	5404	98	100	198		9	28	18	52	0.79		
DAT1002	5405	98	100	198		9	28	19	52	0.80		
DAT1002	5406	98	100	198		9	28	20	52	0.77		
DAT1002	5407	99	100	199		9	28	21	52	0.79		
DAT1002	5408	98	100	198		9	28	22	52	0.78		
DAT1002	5409	99	100	199		9	28	23	52	0.76		
DAT1002	5410	99	100	199	199	9	29	0	52	0.77	0.79	
DAT1002	5411	98	100	198		9	29	1	52	0.76		
DAT1002	5412	99	100	199		9	29	2	52	0.74		
DAT1002	5413	100	100	200		9	29	3	52	0.74		
DAT1002	5414	100	100	200		9	29	4	52	0.76		
DAT1002	5415	100	100	200		9	29	5	52	0.76		
DAT1002	5416	99	100	199		9	29	6	52	0.77		
DAT1002	5417	99	99	198		9	29	7	52	0.77		
DAT1002	5418	98	100	198		9	29	8	52	0.76		
DAT1002	5419	99	100	199		9	29	9	52	0.78		
DAT1002	5420	100	100	200	199	9	29	10	52	0.77	0.76	
DAT1002	5421	97	100	197		9	29	11	52	0.77		
DAT1002	5422	100	100	200		9	29	12	52	0.77		
DAT1002	5423	99	100	199		9	29	13	52	0.78		
DAT1002	5424	100	100	200		9	29	14	52	0.79		
DAT1002	5425	97	100	197		9	29	15	52	0.80		
DAT1002	5426	100	100	200		9	29	16	52	0.77		
DAT1002	5427	97	100	197		9	29	17	52	0.79		
DAT1002	5428	98	100	198		9	29	18	52	0.80		
DAT1002	5429	99	100	199		9	29	19	52	0.76		
DAT1002	5430	98	100	198	199	9	29	20	52	0.76	0.78	
DAT1002	5431	100	100	200		9	29	21	52	0.75		
DAT1002	5432	99	100	199		9	29	22	52	0.76		
DAT1002	5433	98	100	198		9	29	23	52	0.76		
DAT1002	5434	99	100	199		9	30	0	52	0.76		
DAT1002	5435	100	100	200		9	30	1	52	0.75		
DAT1002	5436	99	100	199		9	30	2	52	0.75		
DAT1002	5437	98	99	197		9	30	3	52	0.75		
DAT1002	5438	100	100	200		9	30	4	52	0.75		
DAT1002	5439	98	100	198		9	30	5	52	0.70		
DAT1002	5440	98	100	198	199	9	30	6	52	0.78	0.75	
DAT1002	5441	98	100	198		9	30	7	52	0.76		
DAT1002	5442	99	100	199		9	30	8	52	0.78		
DAT1002	5443	100	99	199		9	30	9	52	0.78		
DAT1002	5444	98	100	198		9	30	10	52	0.77		
DAT1002	5445	99	100	199		9	30	11	52	0.76		
DAT1002	5446	98	100	198		9	30	12	52	0.74		
DAT1002	5447	99	100	199		9	30	13	52	0.79		
DAT1002	5448	98	100	198		9	30	14	52	0.76		
DAT1002	5449	99	100	199		9	30	15	52	0.74		
DAT1002	5450	97	100	197	198	9	30	16	52	0.77	0.77	

Appendix R: Digital Reliability Test Data - Test #8

Stored in:	Test #	Devices Upset				Ave	Date(96)		Time		File size (Mb)			Notes
		Bd #1	Bd #2	Total					full	ave	part			
DAT1002	5451	98	100	198		9	30	17	52	0.81				
DAT1002	5452	98	100	198		9	30	18	52	0.83				
DAT1002	5453	98	100	198		9	30	19	52	0.81				
DAT1002	5454	100	100	200		9	30	20	52	0.78				
DAT1002	5455	99	100	199		9	30	21	52	0.78				
DAT1002	5456	99	100	199		9	30	22	52	0.79				
DAT1002	5457	98	100	198		9	30	23	52	0.73				
DAT1002	5458	98	100	198		10	1	0	52	0.74				
DAT1002	5459	98	100	198		10	1	1	52	0.69				
DAT1002	5460	100	100	200	199	10	1	2	52	0.67	0.76			
DAT1002	5461	100	100	200		10	1	3	52	0.71				
DAT1002	5462	100	100	200		10	1	4	52	0.72				
DAT1002	5463	99	99	198		10	1	5	52	0.67				
DAT1002	5464	98	100	198		10	1	6	52	0.66				
DAT1002	5465	100	100	200		10	1	7	52	0.70				
DAT1002	5466	99	100	199		10	1	8	52	0.75				
DAT1002	5467	100	100	200		10	1	9	52	0.74				
DAT1002	5468	100	100	200		10	1	10	52	0.73				
DAT1002	5469	96	100	196		10	1	11	52	0.70				
DAT1002	5470	97	100	197	199	10	1	12	52	0.69	0.78			
DAT1002	5471	99	100	199		10	1	13	52	0.71				
DAT1002	5472	95	100	195		10	1	14	52	0.69				
DAT1002	5473	99	100	199		10	1	15	52	0.69				
DAT1002	5474	98	100	198		10	1	16	52	0.66				
DAT1002	5475	98	100	198		10	1	17	52	0.68				
DAT1002	5476	99	100	199		10	1	18	52	0.66				
DAT1002	5477	100	100	200		10	1	19	52	0.65				
DAT1002	5478	98	100	198		10	1	20	52	0.64				
DAT1002	5479	100	100	200		10	1	21	52	0.65				
DAT1002	5480	97	100	197	198	10	1	22	52	0.63	0.65			
DAT1002	5481	99	100	199		10	1	23	52	0.59				
DAT1002	5482	99	100	199		10	2	0	52	0.58				
DAT1002	5483	98	100	198		10	2	1	52	0.59				
DAT1002	5484	97	100	197		10	2	2	52	0.58				
DAT1002	5485	97	100	197		10	2	3	52	0.58				
DAT1002	5486	93	98	191		10	2	4	52	0.58				
DAT1002	5487	97	100	197		10	2	5	52	0.61				
DAT1002	5488	96	100	196		10	2	6	52	0.62				
DAT1002	5489	99	100	199		10	2	7	52	0.65				
DAT1002	5490	100	100	200	197	10	2	8	52	0.65	0.62			
DAT1002	5491	100	100	200		10	2	9	52	0.73				
DAT1002	5492	92	97	189		10	2	10	11			0.22		
DAT1007	5493	80	96	176		10	2	12	36			0.05	4 Min	
DAT1007	5494	99	100	199		10	2	13	37	0.55				
DAT1007	5495	94	100	194		10	2	14	37	0.51				
DAT1007	5496	98	100	198		10	2	15	37	0.51				
DAT1007	5497	97	100	197		10	2	16	37	0.52				
DAT1007	5498	97	97	194		10	2	17	37	0.49				
DAT1007	5499	100	100	200		10	2	18	38	0.43				
DAT1007	5500	96	100	196	194	10	2	19	38	0.47	0.44			

Appendix R: Digital Reliability Test Data - Test #8

Stored in:	Test #	Devices Upset				Date(96)	Time		File size (Mb)			Notes
		Bd #1	Bd #2	Total	Ave		full	ave	part			
DAT1007	5501	95	99	194		10	2	20	38	0.49		
DAT1007	5502	96	100	196		10	2	21	38	0.46		
DAT1007	5503	96	97	193		10	2	22	38	0.46		
DAT1007	5504	99	99	198		10	2	23	38	0.54		
DAT1007	5505	99	100	199		10	3	0	38	0.63		
DAT1007	5506	96	100	196		10	3	1	38	0.59		
DAT1007	5507	97	98	195		10	3	2	38	0.58		
DAT1007	5508	99	100	199		10	3	3	38	0.62		
DAT1007	5509	95	100	195		10	3	4	38	0.62		
DAT1007	5510	99	99	198	196	10	3	5	38	0.63	0.56	
DAT1007	5511	98	100	198		10	3	6	38	0.63		
DAT1007	5512	100	100	200		10	3	7	38	0.64		
DAT1007	5513	94	100	194		10	3	8	38	0.62		
DAT1007	5514	97	100	197		10	3	9	38	0.62		
DAT1007	5515	99	100	199		10	3	10	38	0.83		
DAT1007	5516	98	100	198		10	3	11	38	0.61		
DAT1007	5517	95	99	194		10	3	12	38	0.54		
DAT1007	5518	97	98	195		10	3	13	38	0.46		
DAT1007	5519	97	98	195		10	3	14	38	0.46		
DAT1007	5520	94	97	191	196	10	3	15	38	0.43	0.58	
DAT1007	5521	95	100	195		10	3	16	38	0.41		
DAT1007	5522	94	100	194		10	3	17	38	0.40		
DAT1007	5523	99	98	197		10	3	18	38	0.50		
DAT1007	5524	96	100	196		10	3	19	38	0.67		
DAT1007	5525	100	100	200		10	3	20	38	0.68		
DAT1007	5526	99	100	199		10	3	21	38	0.67		
DAT1007	5527	97	100	197		10	3	22	38	0.66		
DAT1007	5528	99	100	199		10	3	23	38	0.67		
DAT1007	5529	98	98	196		10	4	0	38	0.64		
DAT1007	5530	97	98	195	197	10	4	1	38	0.48	0.58	
DAT1007	5531	98	99	197		10	4	2	38	0.42		
DAT1007	5532	92	100	192		10	4	3	38	0.41		
DAT1007	5533	96	100	196		10	4	4	38	0.41		
DAT1007	5534	97	99	196		10	4	5	38	0.43		
DAT1007	5535	98	98	196		10	4	6	38	0.41		
DAT1007	5536	95	98	193		10	4	7	38	0.39		
DAT1007	5537	96	97	193		10	4	8	38	0.38		
DAT1007	5538	94	97	191		10	4	9	38	0.37		
DAT1007	5539	97	96	193		10	4	10	38	0.37		
DAT1007	5540	94	91	185	193	10	4	11	38	0.36	0.4	
DAT1007	5541	96	99	195		10	4	12	38	0.35		
DAT1007	5542	92	100	192		10	4	13	38	0.34		
DAT1007	5543	96	94	190		10	4	14	38	0.33		
DAT1007	5544	96	94	190		10	4	15	38	0.34		
DAT1007	5545	94	89	183		10	4	16	38	0.31		
DAT1007	5546	93	99	192		10	4	17	38	0.35		
DAT1007	5547	95	91	186		10	4	18	38	0.34		
DAT1007	5548	97	94	191		10	4	19	38	0.32		
DAT1007	5549	96	95	191		10	4	20	38	0.32		
DAT1007	5550	91	91	182	189	10	4	21	38	0.31	0.33	



Appendix R: Digital Reliability Test Data - Test #8

Stored in:	Test #	Devices Upset				Ave	Date(96)		Time		File size (Mb)			Notes
		Bd #1	Bd #2	Total					full	ave	part			
DAT1007	5551	97	96	193		10	4	22	38	0.30				
DAT1007	5552	93	97	190		10	4	23	38	0.31				
DAT1007	5553	97	94	191		10	5	0	38	0.30				
DAT1007	5554	91	94	185		10	5	1	38	0.32				
DAT1007	5555	95	95	190		10	5	2	38	0.34				
DAT1007	5556	96	88	184		10	5	3	38	0.33				
DAT1007	5557	94	95	189		10	5	4	38	0.36				
DAT1007	5558	97	95	192		10	5	5	38	0.35				
DAT1007	5559	97	91	188		10	5	6	38	0.36				
DAT1007	5560	96	94	190	189	10	5	7	38	0.37	0.33			
DAT1007	5561	94	99	193		10	5	8	38	0.37				
DAT1007	5562	98	100	198		10	5	9	38	0.39				
DAT1007	5563	97	97	194		10	5	10	38	0.39				
DAT1007	5564	93	96	189		10	5	11	38	0.38				
DAT1007	5565	96	94	190		10	5	12	38	0.40				
DAT1007	5566	99	95	194		10	5	13	38	0.40				
DAT1007	5567	92	97	189		10	5	14	38	0.39				
DAT1007	5568	100	98	198		10	5	15	38	0.40				
DAT1007	5569	96	96	192		10	5	16	38	0.38				
DAT1007	5570	95	97	192	193	10	5	17	38	0.39	0.39			
DAT1007	5571	95	99	194		10	5	18	38	0.40				
DAT1007	5572	93	100	193		10	5	19	38	0.41				
DAT1007	5573	96	96	192		10	5	20	38	0.40				
DAT1007	5574	95	99	194		10	5	21	38	0.58				
DAT1007	5575	98	98	196		10	5	22	38	0.60				
DAT1007	5576	96	100	196		10	5	23	38	0.59				
DAT1007	5577	100	100	200		10	6	0	38	0.61				
DAT1007	5578	97	97	194		10	6	1	38	0.59				
DAT1007	5579	98	98	196		10	6	2	38	0.49				
DAT1007	5580	95	97	192	195	10	6	3	38	0.47	0.51			
DAT1007	5581	98	98	196		10	6	4	38	0.45				
DAT1007	5582	97	98	195		10	6	5	38	0.45				
DAT1007	5583	98	99	197		10	6	6	38	0.47				
DAT1007	5584	100	99	199		10	6	7	38	0.46				
DAT1007	5585	97	100	197		10	6	8	38	0.46				
DAT1007	5586	97	100	197		10	6	9	38	0.44				
DAT1007	5587	96	97	193		10	6	10	38	0.43				
DAT1007	5588	95	96	191		10	6	11	38	0.42				
DAT1007	5589	98	97	195		10	6	12	38	0.43				
DAT1007	5590	97	99	196	196	10	6	13	38	0.45	0.45			
DAT1007	5591	97	100	197		10	6	14	38	0.45				
DAT1007	5592	97	99	196		10	6	15	38	0.44				
DAT1007	5593	99	96	195		10	6	16	38	0.44				
DAT1007	5594	100	100	200		10	6	17	38	0.52				
DAT1007	5595	99	100	199		10	6	18	38	0.47				
DAT1007	5596	98	98	196		10	6	19	38	0.48				
DAT1007	5597	97	100	197		10	6	20	38	0.46				
DAT1007	5598	99	99	198		10	6	21	38	0.47				
DAT1007	5599	96	98	194		10	6	22	38	0.45				
DAT1007	5600	97	100	197	197	10	6	23	38	0.45	0.46			

Appendix R: Digital Reliability Test Data - Test #8

Stored in:	Test #	Devices Upset				Date(96)	Time	File size (Mb)			Notes
		Bd #1	Bd #2	Total	Ave			full	ave	part	
DAT1007	5601	99	96	195		10 7	0 38	0.46			
DAT1007	5602	97	100	197		10 7	1 38	0.45			
DAT1007	5603	94	97	191		10 7	2 38	0.43			
DAT1007	5604	97	100	197		10 7	3 38	0.42			
DAT1007	5605	99	96	195		10 7	4 38	0.41			
DAT1007	5606	94	100	194		10 7	5 38	0.43			
DAT1007	5607	97	99	196		10 7	6 38	0.40			
DAT1007	5608	96	100	196		10 7	7 38	0.41			
DAT1007	5609	95	100	195		10 7	8 38	0.38			
DAT1007	5610	97	100	197	195	10 7	9 38	0.37	0.42		
DAT1007	5611	96	96	192		10 7	10 38	0.37			
DAT1007	5612	97	95	192		10 7	11 38	0.35			
DAT1007	5613	96	100	196		10 7	12 15			0.24	
DAT1011	5614	88	79	167		10 7	14 24			0.04	4 Min
DAT1011	5615	96	100	196		10 7	15 25	0.49			
DAT1011	5616	99	100	199		10 7	16 25	0.49			
DAT1011	5617	95	96	191		10 7	17 25	0.49			
DAT1011	5618	98	98	196		10 7	18 25	0.49			
DAT1011	5619	96	99	195		10 7	19 25	0.49			
DAT1011	5620	98	98	196	192	10 7	20 25	0.49	0.46		
DAT1011	5621	96	98	194		10 7	21 25	0.47			
DAT1011	5622	97	100	197		10 7	22 25	0.46			
DAT1011	5623	100	100	200		10 7	23 25	0.45			
DAT1011	5624	95	100	195		10 8	0 25	0.46			
DAT1011	5625	97	98	195		10 8	1 25	0.45			
DAT1011	5626	99	98	197		10 8	2 25	0.43			
DAT1011	5627	98	99	197		10 8	3 25	0.43			
DAT1011	5628	97	100	197		10 8	4 25	0.44			
DAT1011	5629	94	98	192		10 8	5 25	0.44			
DAT1011	5630	97	97	194	196	10 8	6 25	0.43	0.45		
DAT1011	5631	100	98	198		10 8	7 25	0.45			
DAT1011	5632	98	99	197		10 8	8 25	0.60			
DAT1011	5633	96	100	196		10 8	9 25	0.52			
DAT1011	5634	96	98	194		10 8	10 25	0.45			
DAT1011	5635	93	96	189		10 8	11 25	0.44			
DAT1011	5636	98	100	198		10 8	12 25	0.52			
DAT1011	5637	98	100	198		10 8	13 25	0.62			
DAT1011	5638	97	99	196		10 8	14 25	0.64			
DAT1011	5639	95	99	194		10 8	15 25	0.56			
DAT1011	5640	96	100	196	196	10 8	16 25	0.54	0.53		
DAT1011	5641	98	99	197		10 8	17 25	0.54			
DAT1011	5642	99	100	199		10 8	18 25	0.48			
DAT1011	5643	97	98	195		10 8	19 25	0.50			
DAT1011	5644	99	100	199		10 8	20 25	0.53			
DAT1011	5645	98	99	197		10 8	21 25	0.48			
DAT1011	5646	95	100	195		10 8	22 25	0.47			
DAT1011	5647	95	93	188		10 8	23 25	0.45			
DAT1011	5648	98	99	197		10 9	0 25	0.45			
DAT1011	5649	96	100	196		10 9	1 25	0.45			
DAT1011	5650	97	99	196	196	10 9	2 25	0.45	0.48		

Appendix R: Digital Reliability Test Data - Test #8

Stored in:	Test #	Devices Upset				Ave	Date(96)		Time		File size (Mb)			Notes
		Bd #1	Bd #2	Total					full	ave	part			
DAT1011	5651	97	98	195		10	9	3	25	0.44				
DAT1011	5652	94	100	194		10	9	4	25	0.46				
DAT1011	5653	99	98	197		10	9	5	25	0.44				
DAT1011	5654	99	96	195		10	9	6	25	0.45				
DAT1011	5655	98	100	198		10	9	7	25	0.47				
DAT1011	5656	96	97	193		10	9	8	25	0.45				
DAT1011	5657	98	98	196		10	9	9	25	0.44				
DAT1011	5658	96	100	196		10	9	10	25	0.45				
DAT1011	5659	97	99	196		10	9	11	25	0.59				
DAT1011	5660	99	100	199	196	10	9	12	25	0.65	0.48			
DAT1011	5661	99	99	198		10	9	13	25	0.66				
DAT1011	5662	98	100	198		10	9	14	25	0.66				
DAT1011	5663	98	100	198		10	9	15	25	0.56				
DAT1011	5664	96	100	196		10	9	16	25	0.64				
DAT1011	5665	97	100	197		10	9	17	25	0.63				
DAT1011	5666	99	100	199		10	9	18	25	0.59				
DAT1011	5667	99	100	199		10	9	19	25	0.62				
DAT1011	5668	100	100	200		10	9	20	25	0.62				
DAT1011	5669	100	100	200		10	9	21	25	0.63				
DAT1011	5670	99	100	199	198	10	9	22	25	0.61	0.62			
DAT1011	5671	98	100	198		10	9	23	25	0.61				
DAT1011	5672	99	99	198		10	10	0	25	0.59				
DAT1011	5673	98	100	198		10	10	1	25	0.61				
DAT1011	5674	100	99	199		10	10	2	25	0.62				
DAT1011	5675	99	98	197		10	10	3	25	0.61				
DAT1011	5676	98	100	198		10	10	4	25	0.58				
DAT1011	5677	98	100	198		10	10	5	25	0.62				
DAT1011	5678	97	100	197		10	10	6	25	0.56				
DAT1011	5679	96	100	196		10	10	7	25	0.62				
DAT1011	5680	98	100	198	198	10	10	8	25	0.56	0.6			
DAT1011	5681	98	99	197		10	10	9	25	0.55				
DAT1011	5682	95	99	194		10	10	10	25	0.54				
DAT1011	5683	99	100	199		10	10	11	25	0.54				
DAT1011	5684	98	99	197		10	10	12	25	0.51				
DAT1011	5685	99	100	199		10	10	13	25	0.53				
DAT1011	5686	100	100	200		10	10	14	25	0.50				
DAT1011	5687	96	100	196		10	10	15	25	0.50				
DAT1011	5688	98	99	197		10	10	16	25	0.51				
DAT1011	5689	98	100	198		10	10	17	25	0.50				
DAT1011	5690	98	99	197	197	10	10	18	25	0.50	0.52			
DAT1011	5691	95	97	192		10	10	19	25	0.49				
DAT1011	5692	98	99	197		10	10	20	25	0.49				
DAT1011	5693	96	99	195		10	10	21	25	0.55				
DAT1011	5694	95	100	195		10	10	22	25	0.51				
DAT1011	5695	99	100	199		10	10	23	25	0.52				
DAT1011	5696	99	100	199		10	11	0	25	0.49				
DAT1011	5697	98	99	197		10	11	1	25	0.48				
DAT1011	5698	96	98	194		10	11	2	25	0.46				
DAT1011	5699	98	99	197		10	11	3	25	0.46				
DAT1011	5700	99	100	199	196	10	11	4	25	0.47	0.49			

Appendix R: Digital Reliability Test Data - Test #8

Stored in:	Test #	Devices Upset				Ave	Date(96)		Time		File size (Mb)			Notes
		Bd #1	Bd #2	Total					full	ave	part			
DAT1011	5701	95	100	195		10	11	5	25	0.46				
DAT1011	5702	96	100	196		10	11	6	25	0.45				
DAT1011	5703	97	99	196		10	11	7	25	0.46				
DAT1011	5704	98	96	194		10	11	8	25	0.48				
DAT1011	5705	97	99	196		10	11	9	25	0.47				
DAT1011	5706	97	98	195		10	11	10	25	0.47				
DAT1011	5707	97	99	196		10	11	11	25	0.47				
DAT1011	5708	98	99	197		10	11	12	25	0.47				
DAT1011	5709	96	98	194		10	11	13	25	0.47				
DAT1011	5710	100	100	200	196	10	11	14	25	0.48	0.47			
DAT1015	5711	78	59	137		10	11	16	20			0.03	4 Min	
DAT1015	5712	95	98	193		10	11	17	20	0.46				
DAT1015	5713	99	99	198		10	11	18	20	0.48				
DAT1015	5714	99	99	198		10	11	19	20	0.50				
DAT1015	5715	98	99	197		10	11	20	20	0.46				
DAT1015	5716	96	98	194		10	11	21	20	0.45				
DAT1015	5717	95	100	195		10	11	22	20	0.54				
DAT1015	5718	98	100	198		10	11	23	20	0.53				
DAT1015	5719	99	100	199		10	12	0	20	0.50				
DAT1015	5720	97	100	197	191	10	12	1	20	0.48	0.49			
DAT1015	5721	99	100	199		10	12	2	20	0.46				
DAT1015	5722	97	100	197		10	12	3	20	0.45				
DAT1015	5723	95	100	195		10	12	4	20	0.45				
DAT1015	5724	100	97	197		10	12	5	20	0.46				
DAT1015	5725	97	99	196		10	12	6	20	0.48				
DAT1015	5726	97	100	197		10	12	7	20	0.47				
DAT1015	5727	95	99	194		10	12	8	20	0.47				
DAT1015	5728	97	98	195		10	12	9	20	0.46				
DAT1015	5729	95	97	192		10	12	10	20	0.46				
DAT1015	5730	99	99	198	196	10	12	11	20	0.47	0.46			
DAT1015	5731	98	98	196		10	12	12	20	0.46				
DAT1015	5732	95	99	194		10	12	13	20	0.46				
DAT1015	5733	97	99	196		10	12	14	20	0.47				
DAT1015	5734	97	100	197		10	12	15	20	0.45				
DAT1015	5735	96	97	193		10	12	16	20	0.46				
DAT1015	5736	97	100	197		10	12	17	20	0.45				
DAT1015	5737	98	99	197		10	12	18	20	0.48				
DAT1015	5738	99	98	197		10	12	19	20	0.46				
DAT1015	5739	97	99	196		10	12	20	20	0.45				
DAT1015	5740	98	97	195	196	10	12	21	20	0.44	0.46			
DAT1015	5741	96	98	194		10	12	22	20	0.43				
DAT1015	5742	98	100	198		10	12	23	20	0.45				
DAT1015	5743	99	100	199		10	13	0	20	0.46				
DAT1015	5744	96	98	194		10	13	1	20	0.43				
DAT1015	5745	95	100	195		10	13	2	20	0.44				
DAT1015	5746	98	99	197		10	13	3	20	0.43				
DAT1015	5747	95	98	193		10	13	4	20	0.42				
DAT1015	5748	97	100	197		10	13	5	20	0.47				
DAT1015	5749	99	97	196		10	13	6	20	0.49				
DAT1015	5750	98	99	197	196	10	13	7	20	0.46	0.45			

Appendix R: Digital Reliability Test Data - Test #8

Stored in:	Test #	Devices Upset				Date(96)	Time		File size (Mb)			Notes	
		Bd #1	Bd #2	Total	Ave		full	ave	part				
DAT1015	5751	98	100	198		10	13	8	20	0.46			
DAT1015	5752	95	99	194		10	13	9	20	0.48			
DAT1015	5753	97	100	197		10	13	10	20	0.47			
DAT1015	5754	97	99	196		10	13	11	20	0.46			
DAT1015	5755	97	100	197		10	13	12	20	0.47			
DAT1015	5756	96	96	192		10	13	13	20	0.45			
DAT1015	5757	97	99	196		10	13	14	20	0.43			
DAT1015	5758	100	99	199		10	13	15	20	0.54			
DAT1015	5759	98	97	195		10	13	16	20	0.55			
DAT1015	5760	97	100	197	196	10	13	17	20	0.52	0.48		
DAT1015	5761	97	100	197		10	13	18	20	0.52			
DAT1015	5762	97	99	196		10	13	19	20	0.50			
DAT1015	5763	99	100	199		10	13	20	20	0.74			
DAT1015	5764	99	100	199		10	13	21	20	0.58			
DAT1015	5765	97	100	197		10	13	22	20	0.51			
DAT1015	5766	99	100	199		10	13	23	20	0.49			
DAT1015	5767	95	98	193		10	14	0	20	0.46			
DAT1015	5768	99	98	197		10	14	1	20	0.51			
DAT1015	5769	97	100	197		10	14	2	20	0.50			
DAT1015	5770	97	100	197	197	10	14	3	20	0.47	0.53		
DAT1015	5771	100	99	199		10	14	4	20	0.48			
DAT1015	5772	97	100	197		10	14	5	20	0.48			
DAT1015	5773	98	97	195		10	14	6	20	0.48			
DAT1015	5774	100	100	200		10	14	7	20	0.48			
DAT1015	5775	94	100	194		10	14	8	20	0.49			
DAT1015	5776	99	100	199		10	14	9	20	0.50			
DAT1015	5777	86	69	155		10	14	9	28			0.06	
DAT1018	5778	73	87	160		10	14	11	42			0.03	4 Min
DAT1018	5779	98	100	198		10	14	12	42	0.51			
DAT1018	5780	98	99	197	189	10	14	13	42	0.51	0.49		
DAT1018	5781	99	98	197		10	14	14	42	0.48			
DAT1018	5782	98	99	197		10	14	15	42	0.47			
DAT1018	5783	98	100	198		10	14	16	42	0.47			
DAT1018	5784	100	98	198		10	14	17	42	0.48			
DAT1018	5785	98	99	197		10	14	18	42	0.48			
DAT1018	5786	97	99	196		10	14	19	42	0.48			
DAT1018	5787	96	99	195		10	14	20	42	0.48			
DAT1018	5788	98	97	195		10	14	21	42	0.48			
DAT1018	5789	98	98	196		10	14	22	42	0.48			
DAT1018	5790	97	96	193	196	10	14	23	42	0.47	0.48		
DAT1018	5791	94	99	193		10	15	0	42	0.45			
DAT1018	5792	95	92	187		10	15	1	42	0.46			
DAT1018	5793	96	100	196		10	15	2	42	0.47			
DAT1018	5794	96	99	195		10	15	3	42	0.46			
DAT1018	5795	98	100	198		10	15	4	42	0.48			
DAT1018	5796	97	98	195		10	15	5	42	0.48			
DAT1018	5797	98	100	198		10	15	6	42	0.48			
DAT1018	5798	96	99	195		10	15	7	42	0.50			
DAT1018	5799	99	98	197		10	15	8	42	0.49			
DAT1018	5800	99	100	199	195	10	15	9	42	0.48	0.48		

Appendix R: Digital Reliability Test Data - Test #8

Stored in:	Test #	Devices Upset				Date(96)	Time		File size (Mb)			Notes	
		Bd #1	Bd #2	Total	Ave		full	ave	part				
DAT1018	5801	98	98	196		10	15	10	42	0.48			
DAT1018	5802	97	99	196		10	15	11	42	0.49			
DAT1018	5803	98	100	198		10	15	12	42	0.48			
DAT1018	5804	97	97	194		10	15	13	42	0.48			
DAT1018	5805	97	98	195		10	15	14	42	0.48			
DAT1018	5806	97	99	196		10	15	15	42	0.48			
DAT1018	5807	97	100	197		10	15	16	42	0.48			
DAT1018	5808	98	100	198		10	15	17	42	0.50			
DAT1018	5809	99	100	199		10	15	18	42	0.48			
DAT1018	5810	97	99	196	197	10	15	19	42	0.48	0.48		
DAT1018	5811	96	99	195		10	15	20	42	0.47			
DAT1018	5812	96	98	194		10	15	21	42	0.53			
DAT1018	5813	95	99	194		10	15	22	42	0.49			
DAT1018	5814	98	98	196		10	15	23	42	0.47			
DAT1018	5815	99	99	198		10	16	0	42	0.49			
DAT1018	5816	99	100	199		10	16	1	42	0.45			
DAT1018	5817	97	99	196		10	16	2	42	0.45			
DAT1018	5818	99	98	197		10	16	3	42	0.45			
DAT1018	5819	96	98	194		10	16	4	42	0.48			
DAT1018	5820	98	98	196	196	10	16	5	42	0.47	0.48		
DAT1018	5821	97	100	197		10	16	6	42	0.50			
DAT1018	5822	94	97	191		10	16	7	42	0.50			
DAT1018	5823	97	98	195		10	16	8	42	0.48			
DAT1018	5824	98	100	198		10	16	9	42	0.49			
DAT1018	5825	98	99	197		10	16	10	42	0.48			
DAT1018	5826	96	97	193		10	16	11	42	0.50			
DAT1018	5827	94	99	193		10	16	12	42	0.48			
DAT1018	5828	98	100	198		10	16	13	42	0.50			
DAT1018	5829	94	100	194		10	16	14	42	0.49			
DAT1018	5830	98	100	198	195	10	16	15	42	0.48	0.49		
DAT1018	5831	98	99	197		10	16	16	42	0.50			
DAT1018	5832	99	100	199		10	16	17	42	0.50			
DAT1018	5833	94	100	194		10	16	18	42	0.50			
DAT1018	5834	98	100	198		10	16	19	42	0.52			
DAT1018	5835	96	100	196		10	16	20	42	0.50			
DAT1018	5836	98	100	198		10	16	21	42	0.50			
DAT1018	5837	97	98	195		10	16	22	42	0.50			
DAT1018	5838	99	99	198		10	16	23	42	0.47			
DAT1018	5839	96	95	191		10	17	0	42	0.47			
DAT1018	5840	98	99	197	196	10	17	1	42	0.46	0.49		
DAT1018	5841	98	100	198		10	17	2	42	0.48			
DAT1018	5842	99	99	198		10	17	3	42	0.48			
DAT1018	5843	95	100	195		10	17	4	42	0.47			
DAT1018	5844	99	97	196		10	17	5	42	0.48			
DAT1018	5845	98	100	198		10	17	6	42	0.48			
DAT1018	5846	95	97	192		10	17	7	42	0.48			
DAT1018	5847	96	100	196		10	17	8	42	0.51			
DAT1018	5848	99	100	199		10	17	9	42	0.49			
DAT1018	5849	96	100	196		10	17	10	42	0.48			
DAT1018	5850	98	100	198	197	10	17	11	42	0.49	0.48		

Appendix R: Digital Reliability Test Data - Test #8

Stored in:	Test #	Devices Upset				Ave	Date(96)		Time		File size (Mb)			Notes
		Bd #1	Bd #2	Total					full	ave	part			
DAT1018	5851	97	99	196		10	17	12	42	0.49				
DAT1018	5852	98	100	198		10	17	13	42	0.53				
DAT1018	5853	97	100	197		10	17	14	42	0.50				
DAT1018	5854	99	100	199		10	17	15	42	0.49				
DAT1018	5855	96	97	193		10	17	16	42	0.49				
DAT1018	5856	98	98	196		10	17	17	42	0.50				
DAT1018	5857	98	100	198		10	17	18	42	0.48				
DAT1018	5858	98	99	197		10	17	19	42	0.47				
DAT1018	5859	97	98	195		10	17	20	42	0.47				
DAT1018	5860	99	100	199	197	10	17	21	42	0.49	0.49			
DAT1018	5861	95	99	194		10	17	22	42	0.48				
DAT1018	5862	97	97	194		10	17	23	42	0.49				
DAT1018	5863	96	99	195		10	18	0	42	0.46				
DAT1018	5864	99	99	198		10	18	1	42	0.46				
DAT1018	5865	94	100	194		10	18	2	42	0.45				
DAT1018	5866	97	100	197		10	18	3	42	0.47				
DAT1018	5867	99	100	199		10	18	4	42	0.49				
DAT1018	5868	99	99	198		10	18	5	42	0.49				
DAT1018	5869	98	99	197		10	18	6	42	0.50				
DAT1018	5870	99	100	199	197	10	18	7	42	0.51	0.48			
DAT1018	5871	94	98	192		10	18	8	42	0.55				
DAT1018	5872	92	91	183		10	18	8	54			0.11		
DAT1021	5873	82	80	162		10	18	11	6			0.03	4 Min	
DAT1021	5874	97	100	197		10	18	12	6	0.51				
DAT1021	5875	97	98	195		10	18	13	6	0.50				
DAT1021	5876	97	100	197		10	18	14	6	0.49				
DAT1021	5877	97	100	197		10	18	15	6	0.49				
DAT1021	5878	97	98	195		10	18	16	6	0.49				
DAT1021	5879	97	100	197		10	18	17	6	0.48				
DAT1021	5880	95	98	193	191	10	18	18	6	0.48	0.5			
DAT1021	5881	99	99	198		10	18	19	6	0.47				
DAT1021	5882	98	100	198		10	18	20	6	0.48				
DAT1021	5883	96	100	196		10	18	21	6	0.51				
DAT1021	5884	94	99	193		10	18	22	6	0.49				
DAT1021	5885	97	100	197		10	18	23	6	0.49				
DAT1021	5886	96	100	196		10	19	0	6	0.47				
DAT1021	5887	93	100	193		10	19	1	6	0.47				
DAT1021	5888	97	99	196		10	19	2	6	0.49				
DAT1021	5889	100	97	197		10	19	3	6	0.48				
DAT1021	5890	97	95	192	196	10	19	4	6	0.48	0.48			
DAT1021	5891	97	98	195		10	19	5	6	0.45				
DAT1021	5892	98	97	195		10	19	6	6	0.47				
DAT1021	5893	97	99	196		10	19	7	6	0.47				
DAT1021	5894	97	97	194		10	19	8	6	0.46				
DAT1021	5895	99	99	198		10	19	9	6	0.49				
DAT1021	5896	98	99	197		10	19	10	6	0.48				
DAT1021	5897	97	98	195		10	19	11	6	0.50				
DAT1021	5898	97	98	195		10	19	12	6	0.46				
DAT1021	5899	96	99	195		10	19	13	6	0.48				
DAT1021	5900	100	98	198	196	10	19	14	6	0.46	0.47			

Appendix R: Digital Reliability Test Data - Test #8

Stored in:	Test #	Devices Upset				Date(96)	Time		File size (Mb)			Notes	
		Bd #1	Bd #2	Total	Ave		full	ave	part				
DAT1021	5901	97	100	197		10	19	15	6	0.49			
DAT1021	5902	99	100	199		10	19	16	6	0.46			
DAT1021	5903	96	97	193		10	19	17	6	0.45			
DAT1021	5904	98	97	195		10	19	18	6	0.52			
DAT1021	5905	97	99	196		10	19	19	6	0.47			
DAT1021	5906	98	100	198		10	19	20	6	0.49			
DAT1021	5907	99	100	199		10	19	21	6	0.47			
DAT1021	5908	95	97	192		10	19	22	6	0.48			
DAT1021	5909	96	99	195		10	19	23	6	0.46			
DAT1021	5910	96	98	194	196	10	20	0	6	0.44	0.47		
DAT1021	5911	95	98	193		10	20	1	6	0.48			
DAT1021	5912	97	100	197		10	20	2	6	0.45			
DAT1021	5913	98	99	197		10	20	3	6	0.45			
DAT1021	5914	96	98	194		10	20	4	6	0.47			
DAT1021	5915	98	99	197		10	20	5	6	0.44			
DAT1021	5916	100	97	197		10	20	6	6	0.44			
DAT1021	5917	97	98	195		10	20	7	6	0.49			
DAT1021	5918	97	96	193		10	20	8	6	0.49			
DAT1021	5919	98	98	196		10	20	9	6	0.48			
DAT1021	5920	98	99	197	196	10	20	10	6	0.48	0.47		
DAT1021	5921	96	100	196		10	20	11	6	0.45			
DAT1021	5922	97	99	196		10	20	12	6	0.45			
DAT1021	5923	94	97	191		10	20	13	6	0.43			
DAT1021	5924	98	100	198		10	20	14	6	0.43			
DAT1021	5925	96	100	196		10	20	15	6	0.43			
DAT1021	5926	94	98	192		10	20	16	6	0.48			
DAT1021	5927	97	100	197		10	20	17	6	0.49			
DAT1021	5928	99	99	198		10	20	18	6	0.52			
DAT1021	5929	95	100	195		10	20	19	6	0.46			
DAT1021	5930	95	98	193	195	10	20	20	6	0.47	0.46		
DAT1021	5931	99	98	197		10	20	21	6	0.49			
DAT1021	5932	95	99	194		10	20	22	6	0.47			
DAT1021	5933	96	99	195		10	20	23	6	0.49			
DAT1021	5934	97	95	192		10	21	0	6	0.47			
DAT1021	5935	97	98	195		10	21	1	6	0.45			
DAT1021	5936	98	99	197		10	21	2	6	0.44			
DAT1021	5937	94	98	192		10	21	3	6	0.44			
DAT1021	5938	97	98	195		10	21	4	6	0.44			
DAT1021	5939	95	97	192		10	21	5	6	0.45			
DAT1021	5940	94	97	191	194	10	21	6	6	0.45	0.46		
DAT1021	5941	98	99	197		10	21	7	6	0.46			
DAT1021	5942	98	99	197		10	21	8	6	0.46			
DAT1021	5943	98	100	198		10	21	9	6	0.47			
DAT1021	5944	97	97	194		10	21	10	6	0.47			
DAT1021	5945	96	100	196		10	21	11	6	0.46			
DAT1021	5946	95	99	194		10	21	12	6	0.47			
DAT1021	5947	98	100	198		10	21	13	6	0.47			
DAT1021	5948	94	96	190		10	21	14	6	0.46			
DAT1021	5949	86	95	181		10	21	14	32		0.19		
DAT1024	5950	62	53	115	186	10	21	15	27		0.47	0.03	4 Min



Appendix R: Digital Reliability Test Data - Test #8

Stored in:	Test #	Devices Upset				Ave	Date(96)		Time		File size (Mb)			Notes
		Bd #1	Bd #2	Total					full	ave	part			
DAT1024	5951	96	96	192		10	21	16	28	0.44				
DAT1024	5952	98	96	194		10	21	17	28	0.46				
DAT1024	5953	96	100	196		10	21	18	28	0.46				
DAT1024	5954	95	99	194		10	21	19	28	0.48				
DAT1024	5955	93	99	192		10	21	20	28	0.46				
DAT1024	5956	96	99	195		10	21	21	28	0.48				
DAT1024	5957	95	97	192		10	21	22	28	0.48				
DAT1024	5958	100	100	200		10	21	23	28	0.50				
DAT1024	5959	95	97	192		10	22	0	28	0.44				
DAT1024	5960	94	100	194	194	10	22	1	28	0.46	0.47			
DAT1024	5961	95	100	195		10	22	2	28	0.45				
DAT1024	5962	96	99	195		10	22	3	28	0.42				
DAT1024	5963	95	100	195		10	22	4	28	0.42				
DAT1024	5964	98	99	197		10	22	5	28	0.44				
DAT1024	5965	94	99	193		10	22	6	28	0.45				
DAT1024	5966	97	98	195		10	22	7	28	0.46				
DAT1024	5967	99	97	196		10	22	8	28	0.46				
DAT1024	5968	95	98	193		10	22	9	28	0.48				
DAT1024	5969	94	95	189		10	22	10	28	0.46				
DAT1024	5970	95	96	191	194	10	22	11	28	0.44	0.45			
DAT1024	5971	97	92	189		10	22	12	28	0.47				
DAT1024	5972	94	95	189		10	22	13	28	0.47				
DAT1024	5973	95	99	194		10	22	14	28	0.45				
DAT1024	5974	97	99	196		10	22	15	28	0.47				
DAT1024	5975	95	100	195		10	22	16	28	0.47				
DAT1024	5976	97	100	197		10	22	17	28	0.47				
DAT1024	5977	96	100	196		10	22	18	28	0.47				
DAT1024	5978	96	99	195		10	22	19	28	0.48				
DAT1024	5979	95	97	192		10	22	20	28	0.49				
DAT1024	5980	97	99	196	194	10	22	21	28	0.54	0.48			
DAT1024	5981	94	97	191		10	22	22	28	0.47				
DAT1024	5982	94	99	193		10	22	23	28	0.44				
DAT1024	5983	92	100	192		10	23	0	28	0.43				
DAT1024	5984	94	99	193		10	23	1	28	0.43				
DAT1024	5985	94	96	190		10	23	2	28	0.42				
DAT1024	5986	93	97	190		10	23	3	28	0.41				
DAT1024	5987	96	99	195		10	23	4	28	0.59				
DAT1024	5988	94	94	188		10	23	5	28	0.47				
DAT1024	5989	100	100	200		10	23	6	28	0.53				
DAT1024	5990	96	98	194	193	10	23	7	28	0.50	0.47			
DAT1024	5991	100	99	199		10	23	8	28	0.50				
DAT1024	5992	95	100	195		10	23	9	28	0.46				
DAT1024	5993	97	100	197		10	23	10	28	0.47				
DAT1024	5994	98	98	196		10	23	11	28	0.46				
DAT1024	5995	98	100	198		10	23	12	28	0.48				
DAT1024	5996	94	99	193		10	23	13	28	0.46				
DAT1024	5997	99	99	198		10	23	14	28	0.46				
DAT1024	5998	97	95	192		10	23	15	28	0.48				
DAT1024	5999	95	98	193		10	23	16	28	0.45				
DAT1024	6000	93	98	191	195	10	23	17	28	0.45	0.42			

Appendix R: Digital Reliability Test Data - Test #8

Stored in:	Test #	Devices Upset				Date(96)	Time		File size (Mb)			Notes
		Bd #1	Bd #2	Total	Ave				full	ave	part	
DAT1024	6001	93	99	192		10	23	18	28	0.45		
DAT1024	6002	98	98	196		10	23	19	28	0.45		
DAT1024	6003	93	98	191		10	23	20	28	0.45		
DAT1024	6004	95	96	191		10	23	21	28	0.44		
DAT1024	6005	97	100	197		10	23	22	28	0.44		
DAT1024	6006	94	97	191		10	23	23	28	0.43		
DAT1024	6007	93	99	192		10	24	0	28	0.43		
DAT1024	6008	97	95	192		10	24	1	28	0.44		
DAT1024	6009	91	96	187		10	24	2	28	0.40		
DAT1024	6010	97	100	197	193	10	24	3	28	0.41	0.43	
DAT1024	6011	96	93	189		10	24	4	28	0.42		
DAT1024	6012	91	97	188		10	24	5	28	0.41		
DAT1024	6013	95	100	195		10	24	6	28	0.42		
DAT1024	6014	95	96	191		10	24	7	28	0.44		
DAT1024	6015	99	100	199		10	24	8	28	0.71		
DAT1024	6016	97	93	190		10	24	9	28	0.44		
DAT1024	6017	95	96	191		10	24	10	28	0.43		
DAT1024	6018	95	99	194		10	24	11	28	0.44		
DAT1024	6019	98	93	191		10	24	12	28	0.43		
DAT1024	6020	93	100	193	192	10	24	13	28	0.46	0.46	
DAT1024	6021	94	97	191		10	24	14	28	0.47		
	6022			0		10						
	6023			0		10						
	6024			0		10						
	6025			0		10						
	6026			0		10						
	6027			0		10						
	6028			0		10						
	6029			0		10						
	6030			0	19	10				0.47		
	6031			0		10						
	6032			0		10						
	6033			0		10						
	6034			0		10						
	6035			0		10						
	6036			0		10						
	6037			0		10						
	6038			0		10						
	6039			0		10						
	6040			0	0	10				0		
	6041			0		10						
	6042			0		10						
	6043			0		10						
	6044			0		10						
	6045			0		10						
	6046			0		10						
	6047			0		10						
	6048			0		10						
	6049			0		10						
	6050			0	0	10				0		

Appendix S: Thermal and Life Test #10 (Test Period # 9)

Stored in:	Test #	Devices Upset				Date(96)	Time	File size (Mb)			Notes
		Bd #1	Bd #2	Total	Ave			full	ave	part	
DAT1113	6051	70	40	110		11 12	17 59			0.05	4 Min
DAT1113	6052	73	44	117		11 12	18 59	0.74			
DAT1113	6053	73	43	116		11 12	19 59	0.76			
DAT1113	6054	72	45	117		11 12	20 59	0.80			
DAT1113	6055	73	50	123		11 12	21 59	0.82			
DAT1113	6056	71	48	119		11 12	22 59	0.82			
DAT1113	6057	71	48	119		11 12	23 59	0.84			
DAT1113	6058	72	47	119		11 13	0 59	0.85			
DAT1113	6059	72	44	116		11 13	1 59	0.84			
DAT1113	6060	72	44	116	117	11 13	2 59	0.86	0.81		
DAT1113	6061	74	44	118		11 13	3 59	0.85			
DAT1113	6062	76	44	120		11 13	4 59	0.85			
DAT1113	6063	75	44	119		11 13	5 59	0.85			
DAT1113	6064	75	43	118		11 13	6 59	0.87			
DAT1113	6065	73	45	118		11 13	7 59	0.88			
DAT1113	6066	75	44	119		11 13	8 59	0.83			
DAT1113	6067	78	45	123		11 13	9 59	0.86			
DAT1113	6068	76	46	122		11 13	10 59	0.91			
DAT1113	6069	76	74	150		11 13	11 59	0.83			
DAT1114	6070	70	41	111	122	11 13	12 33		0.86	0.06	4 Min
DAT1114	6071	77	50	127		11 13	13 33	0.90			
DAT1114	6072	75	52	127		11 13	14 54	0.93			
DAT1114	6073	77	52	129		11 13	15 54	0.92		0.63	
DAT1114	6074	79	48	127		11 13	16 54	0.92			
DAT1114	6075	78	52	130		11 13	17 54	0.92			
DAT1114	6076	76	48	124		11 13	18 54	0.91			
DAT1114	6077	76	50	126		11 13	19 54	0.92			
DAT1114	6078	78	46	124		11 13	20 54	0.92			
DAT1114	6079	77	51	128		11 13	21 54	0.92		0.12	
DAT1114	6080	77	50	127	127	11 13	22 54	0.93	0.92		
DAT1114	6081	80	50	130		11 13	23 54	0.92			
DAT1114	6082	77	52	129		11 14	0 54	0.93			
DAT1114	6083	76	48	124		11 14	1 54	0.93			
DAT1114	6084	78	50	128		11 14	2 54	0.93			
DAT1114	6085	77	51	128		11 14	3 54	0.93			
DAT1114	6086	78	50	128		11 14	4 54	0.93			
DAT1114	6087	77	50	127		11 14	5 54	0.94			
DAT1114	6088	78	50	128		11 14	6 54	0.94			
DAT1114	6089	77	53	130		11 14	7 54	0.93			
DAT1114	6090	77	50	127	128	11 14	8 54	0.95	0.93		
DAT1114	6091	77	53	130		11 14	9 54	0.95			
DAT1114	6092	79	52	131		11 14	10 54	0.96			
DAT1114	6093	78	54	132		11 14	11 54	0.95			
DAT1114	6094	80	52	132		11 14	12 54	0.95			
DAT1114	6095	78	55	133		11 14	13 54	0.96			
DAT1114	6096	80	52	132		11 14	14 54	0.97			
DAT1114	6097	82	54	136		11 14	15 54	0.98			
DAT1114	6098	77	55	132		11 14	16 54	0.96			
DAT1114	6099	80	53	133		11 14	17 36			0.66	
DAT1115	6100	74	46	120	131	11 14	18 19		0.96	0.06	4 Min

Appendix S: Thermal and Life Test #10 (Test Period # 9)

Stored in:	Test #	Devices Upset				Ave	Date(96)		Time		File size (Mb)			Notes
		Bd #1	Bd #2	Total					full	ave	part			
DAT1115	6101	79	48	127		11	14	19	19	0.9				
DAT1115	6102	79	48	127		11	14	20	19	0.94				
DAT1115	6103	79	48	127		11	14	21	19	0.92				
DAT1115	6104	79	46	125		11	14	22	19	0.90				
DAT1115	6105	79	45	124		11	14	23	19	0.90				
DAT1115	6106	82	48	130		11	15	0	19	0.91				
DAT1115	6107	79	48	127		11	15	1	19	0.90				
DAT1115	6108	80	47	127		11	15	2	19	0.90				
DAT1115	6109	79	47	126		11	15	3	19	0.89				
DAT1115	6110	79	48	127	127	11	15	4	19	0.89	0.91			
DAT1115	6111	81	45	126		11	15	5	19	0.88				
DAT1115	6112	80	46	126		11	15	6	19	0.87				
DAT1115	6113	79	48	127		11	15	7	19	0.87				
DAT1115	6114	80	47	127		11	15	8	19	0.89				
DAT1115	6115	79	45	124		11	15	9	19	0.90				
DAT1115	6116	80	47	127		11	15	10	19	0.90				
DAT1115	6117	75	44	119		11	15	11	19	0.71				
DAT1115	6118	68	36	104		11	15	12	19	0.58				
DAT1115	6119	73	42	115		11	15	13	19	0.71				
DAT1115	6120	71	42	113	121	11	15	14	19	0.69	0.8			
DAT1115	6121	69	36	105		11	15	15	19	0.60				
DAT1115	6122	72	42	114		11	15	16	19	0.63				
DAT1122	6123	73	37	110		11	20	13	13			0.05	4min	
DAT1122	6124	87	58	145		11	20	14	13	0.88				
DAT1122	6125	88	62	150		11	20	15	13	0.93				
DAT1122	6126	89	55	144		11	20	16	13	0.84				
DAT1122	6127	83	48	131		11	20	17	13	0.81				
DAT1122	6128	78	43	121		11	20	18	13	0.79				
DAT1122	6129	86	55	141		11	20	19	13	0.86				
DAT1122	6130	82	49	131	129	11	20	20	13	0.88	0.8			
DAT1122	6131	85	52	137		11	20	21	13	1.02				
DAT1122	6132	84	50	134		11	20	22	13	0.99				
DAT1122	6133	85	50	135		11	20	23	13	0.95				
DAT1122	6134	86	52	138		11	21	0	13	1.01				
DAT1122	6135	83	48	131		11	21	1	13	0.90				
DAT1122	6136	84	49	133		11	21	2	13	0.86				
DAT1122	6137	80	44	124		11	21	3	13	0.85				
DAT1122	6138	81	44	125		11	21	4	13	0.82				
DAT1122	6139	78	43	121		11	21	5	13	0.81				
DAT1122	6140	80	45	125	130	11	21	6	13	0.78	0.9			
DAT1122	6141	81	42	123		11	21	7	13	0.79				
DAT1122	6142	81	52	133		11	21	8	13	0.81				
DAT1122	6143	79	41	120		11	21	9	13	0.79				
DAT1122	6144	81	42	123		11	21	10	13	0.79				
DAT1122	6145	79	41	120		11	21	11	13	0.78				
DAT1122	6146	86	64	150		11	21	12	13	0.90				
DAT1122	6147	88	66	154		11	21	13	13	1.11				
DAT1122	6148	90	65	155		11	21	14	13	1.23				
DAT1122	6149	79	41	120		11	21	15	13	0.77				
DAT1122	6150	78	39	117	132	11	21	16	13	0.77	0.8			

Appendix S: Thermal and Life Test #10 (Test Period # 9)

Stored in:	Test #	Devices Upset				Date(96)	Time		File size (Mb)			Notes
		Bd #1	Bd #2	Total	Ave		full	ave	part			
DAT1122	6151	82	42	124		11	21	17	13	0.8		
DAT1122	6152	82	43	125		11	21	18	13	0.78		
DAT1122	6153	76	46	122		11	21	19	13	0.77		
DAT1122	6154	82	53	135		11	21	20	13	0.80		
DAT1122	6155	88	52	140		11	21	21	13	0.82		
DAT1122	6156	81	43	124		11	21	22	13	0.78		
DAT1122	6157	83	51	134		11	21	23	13	0.86		
DAT1122	6158	89	60	149		11	22	0	13	4.44		
DAT1122	6159	79	50	129		11	22	1	13	0.79		
DAT1122	6160	90	63	153	134	11	22	2	13	1.02	1.18	
DAT1122	6161	87	56	143		11	22	3	13	0.86		
DAT1122	6162	87	57	144		11	22	4	13	1.00		
DAT1122	6163	88	62	150		11	22	5	13	1.16		
DAT1122	6164	93	66	159		11	22	6	13	1.40		
DAT1122	6165	93	64	157		11	22	7	13	1.41		
DAT1122	6166	91	63	154		11	22	8	13	1.38		
DAT1122	6167	92	65	157		11	22	9	13	1.44		
DAT1122	6168	89	61	150		11	22	10	13	1.19		
DAT1122	6169	87	56	143		11	22	11	13	1.05		
DAT1122	6170	91	63	154	151	11	22	12	13	1.36	1.23	
DAT1122	6171	91	64	155		11	22	13	13	1.39		
DAT1122	6172	92	67	159		11	22	14	13	1.39		
DAT1122	6173	91	65	156		11	22	15	13	1.35		
DAT1122	6174	94	63	157		11	22	16	13	1.37		
DAT1122	6175	93	64	157		11	22	17	13	1.36		
DAT1122	6176	90	61	151		11	22	18	13	1.06		
DAT1122	6177	87	53	140		11	22	19	14	0.85		
DAT1125	6178	82	49	131		11	22	20	15	0.82		
DAT1125	6179	88	58	146		11	22	21	15	0.88		
DAT1125	6180	84	54	138	149	11	22	22	15	0.99	1.15	
DAT1125	6181	81	51	132		11	22	23	15	0.91		
DAT1125	6182	81	47	128		11	23	0	15	0.87		
DAT1125	6183	84	51	135		11	23	1	15	0.95		
DAT1125	6184	87	53	140		11	23	2	15	0.99		
DAT1125	6185	85	50	135		11	23	3	15	0.92		
DAT1125	6186	83	47	130		11	23	4	15	0.93		
DAT1125	6187	84	49	133		11	23	5	15	0.94		
DAT1125	6188	84	53	137		11	23	6	15	0.96		
DAT1125	6189	86	50	136		11	23	7	15	0.96		
DAT1125	6190	89	53	142	135	11	23	8	15	1.05	0.95	
DAT1125	6191	84	52	136		11	23	9	15	0.98		
DAT1125	6192	82	49	131		11	23	10	15	0.91		
DAT1125	6193	84	50	134		11	23	11	15	0.88		
DAT1125	6194	87	54	141		11	23	12	15	0.90		
DAT1125	6195	82	50	132		11	23	13	15	0.81		
DAT1125	6196	79	41	120		11	23	14	15	0.75		
DAT1125	6197	89	60	149		11	23	15	15	1.01		
DAT1125	6198	77	42	119		11	23	16	15	0.75		
DAT1125	6199	86	51	137		11	23	17	15	0.85		
DAT1125	6200	81	49	130	133	11	23	18	15	0.86	0.87	

Appendix S: Thermal and Life Test #10 (Test Period # 9)

Stored in:	Test #	Devices Upset				Ave	Date(96)		Time		File size (Mb)			Notes
		Bd #1	Bd #2	Total					full	ave	part			
DAT1125	6201	80	45	125		11	23	19	15	0.8				
DAT1125	6202	81	42	123		11	23	20	15	0.80				
DAT1125	6203	78	44	122		11	23	21	15	0.80				
DAT1125	6204	77	45	122		11	23	22	15	0.80				
DAT1125	6205	77	44	121		11	23	23	15	0.79				
DAT1125	6206	89	60	149		11	24	0	15	0.83				
DAT1125	6207	79	41	120		11	24	1	15	0.78				
DAT1125	6208	77	40	117		11	24	2	15	0.77				
DAT1125	6209	76	40	116		11	24	3	15	0.77				
DAT1125	6210	76	40	116	123	11	24	4	15	0.77	0.79			
DAT1125	6211	78	39	117		11	24	5	15	0.78				
DAT1125	6212	78	40	118		11	24	6	15	0.78				
DAT1125	6213	88	57	145		11	24	7	15	0.85				
DAT1125	6214	76	41	117		11	24	8	15	0.77				
DAT1125	6215	76	40	116		11	24	9	15	0.77				
DAT1125	6216	85	53	138		11	24	10	15	0.80				
DAT1125	6217	85	49	134		11	24	11	15	0.89				
DAT1125	6218	79	51	130		11	24	12	15	0.80				
DAT1125	6219	81	48	129		11	24	13	15	0.78				
DAT1125	6220	78	43	121	127	11	24	14	15	0.77	0.8			
DAT1125	6221	79	45	124		11	24	15	15	0.77				
DAT1125	6222	79	41	120		11	24	16	15	0.73				
DAT1125	6223	79	46	125		11	24	17	15	0.79				
DAT1125	6224	89	59	148		11	24	18	15	0.84				
DAT1125	6225	90	62	152		11	24	19	15	0.97				
DAT1125	6226	87	59	146		11	24	20	15	0.81				
DAT1125	6227	75	47	122		11	24	21	15	0.76				
DAT1125	6228	88	58	146		11	24	22	15	0.81				
DAT1125	6229	83	49	132		11	24	23	15	0.78				
DAT1125	6230	87	59	146	136	11	25	0	15	0.89	0.82			
DAT1125	6231	88	61	149		11	25	1	15	0.87				
DAT1125	6232	91	67	158		11	25	2	15	1.40				
DAT1125	6233	93	66	159		11	25	3	15	1.46				
DAT1125	6234	93	64	157		11	25	4	15	1.46				
DAT1125	6235	92	68	160		11	25	5	15	1.46				
DAT1125	6236	93	67	160		11	25	6	15	1.46				
DAT1125	6237	95	66	161		11	25	7	15	1.46				
DAT1125	6238	95	68	163		11	25	8	15	1.50				
DAT1125	6239	94	68	162		11	25	9	15	1.47				
DAT1125	6240	95	67	162	159	11	25	10	15	1.48	1.4			
DAT1125	6241	95	71	166		11	25	11	15	1.48				
DAT1125	6242	95	69	164		11	25	12	15	1.49				
DAT1125	6243	87	64	151		11	25	12	26		0.25			
DAT1126	6244	87	62	149		11	25	13	45		0.1	4 Min		
DAT1126	6245	91	66	157		11	25	14	46	1.46				
DAT1126	6246	90	67	157		11	25	15	46	1.04				
DAT1126	6247	73	44	117		11	25	16	46	0.74				
DAT1126	6248	73	39	112		11	25	17	46	0.68				
DAT1126	6249	55	20	75		11	25	18	46	0.37				
DAT1126	6250	55	18	73	132	11	25	19	46	0.36	0.95			

Appendix S: Thermal and Life Test #10 (Test Period # 9)

Stored in:	Test #	Devices Upset				Date(96)	Time		File size (Mb)			Notes
		Bd #1	Bd #2	Total	Ave		full	ave	part			
DAT1126	6251	55	18	73		11	25	20	46	0.4		
DAT1126	6252	67	28	95		11	25	21	46	0.40		
DAT1126	6253	69	34	103		11	25	22	46	0.42		
DAT1126	6254	56	18	74		11	25	23	46	0.37		
DAT1126	6255	56	18	74		11	26	0	46	0.37		
DAT1126	6256	57	18	75		11	26	1	46	0.37		
DAT1126	6257	58	19	77		11	26	2	46	0.38		
DAT1126	6258	64	26	90		11	26	3	46	0.39		
DAT1126	6259	60	23	83		11	26	4	46	0.39		
DAT1126	6260	58	18	76	82	11	26	5	46	0.38	0.38	
DAT1126	6261	60	19	79		11	26	6	46	0.37		
DAT1126	6262	60	23	83		11	26	7	46	0.41		
DAT1126	6263	77	41	118		11	26	8	46	0.76		
DAT1126	6264	72	38	110		11	26	9	46	0.74		
DAT1126	6265	72	41	113		11	26	10	46	0.72		
DAT1126	6266	69	45	114		11	26	11	46	0.72		
DAT1202	6267	73	48	121		11	27	12	49		0.07	4 Min
DAT1202	6268	77	50	127		11	27	13	50	0.95		
DAT1202	6269	78	50	128		11	27	14	50	0.96		
DAT1202	6270	77	48	125	112	11	27	15	50	0.92	0.73	
DAT1202	6271	75	49	124		11	27	16	50	0.90		
DAT1202	6272	73	50	123		11	27	17	50	0.90		
DAT1202	6273	76	48	124		11	27	18	50	0.90		
DAT1202	6274	75	48	123		11	27	19	50	0.89		
DAT1202	6275	74	47	121		11	27	20	50	0.88		
DAT1202	6276	73	49	122		11	27	21	50	0.88		
DAT1202	6277	74	50	124		11	27	22	50	0.88		
DAT1202	6278	74	47	121		11	27	23	50	0.86		
DAT1202	6279	73	45	118		11	28	0	50	0.86		
DAT1202	6280	74	48	122	122	11	28	1	50	0.86	0.88	
DAT1202	6281	74	46	120		11	28	2	50	0.86		
DAT1202	6282	75	47	122		11	28	3	50	0.86		
DAT1202	6283	76	47	123		11	28	4	50	0.86		
DAT1202	6284	75	47	122		11	28	5	50	0.86		
DAT1202	6285	74	48	122		11	28	6	50	0.86		
DAT1202	6286	73	47	120		11	28	7	50	0.86		
DAT1202	6287	74	49	123		11	28	8	50	0.86		
DAT1202	6288	74	47	121		11	28	9	50	0.86		
DAT1202	6289	74	46	120		11	28	10	50	0.86		
DAT1202	6290	73	46	119	121	11	28	11	50	0.86	0.86	
DAT1202	6291	79	45	124		11	28	12	50	0.86		
DAT1202	6292	76	46	122		11	28	13	50	0.86		
DAT1202	6293	76	47	123		11	28	14	50	0.86		
DAT1202	6294	75	45	120		11	28	15	50	0.86		
DAT1202	6295	75	45	120		11	28	16	50	0.85		
DAT1202	6296	76	49	125		11	28	17	50	0.87		
DAT1202	6297	75	45	120		11	28	18	50	0.87		
DAT1202	6298	74	46	120		11	28	19	50	0.86		
DAT1202	6299	76	42	118		11	28	20	50	0.86		
DAT1202	6300	76	45	121	121	11	28	21	50	0.87	0.86	

Appendix S: Thermal and Life Test #10 (Test Period # 9)

Stored in:	Test #	Devices Upset				Ave	Date(96)		Time		File size (Mb)			Notes
		Bd #1	Bd #2	Total					full	ave	part			
DAT1202	6301	75	44	119		11	28	22	50	0.9				
DAT1202	6302	78	45	123		11	28	23	50	0.86				
DAT1202	6303	75	46	121		11	29	0	50	0.84				
DAT1202	6304	76	45	121		11	29	1	50	0.85				
DAT1202	6305	76	44	120		11	29	2	50	0.86				
DAT1202	6306	75	42	117		11	29	3	50	0.84				
DAT1202	6307	77	45	122		11	29	4	50	0.86				
DAT1202	6308	75	44	119		11	29	5	50	0.85				
DAT1202	6309	77	44	121		11	29	6	50	0.83				
DAT1202	6310	78	43	121	120	11	29	7	50	0.84	0.85			
DAT1202	6311	74	44	118		11	29	8	50	0.86				
DAT1202	6312	77	41	118		11	29	9	50	0.86				
DAT1202	6313	76	45	121		11	29	10	50	0.85				
DAT1202	6314	76	43	119		11	29	11	50	0.86				
DAT1202	6315	77	43	120		11	29	12	50	0.86				
DAT1202	6316	76	46	122		11	29	13	50	0.87				
DAT1202	6317	75	44	119		11	29	14	50	0.85				
DAT1202	6318	73	45	118		11	29	15	50	0.86				
DAT1202	6319	74	43	117		11	29	16	50	0.85				
DAT1202	6320	76	45	121	119	11	29	17	50	0.85	0.86			
DAT1202	6321	77	42	119		11	29	18	50	0.85				
DAT1202	6322	77	46	123		11	29	19	50	0.85				
DAT1202	6323	75	43	118		11	29	20	50	0.84				
DAT1202	6324	77	41	118		11	29	21	50	0.86				
DAT1202	6325	76	42	118		11	29	22	50	0.85				
DAT1202	6326	74	44	118		11	29	23	50	0.86				
DAT1202	6327	75	42	117		11	30	0	50	0.86				
DAT1202	6328	75	45	120		11	30	1	50	0.87				
DAT1202	6329	77	44	121		11	30	2	50	0.85				
DAT1202	6330	77	42	119	119	11	30	3	50	0.87	0.86			
DAT1202	6331	75	43	118		11	30	4	50	0.86				
DAT1202	6332	75	44	119		11	30	5	50	0.87				
DAT1202	6333	78	45	123		11	30	6	50	0.87				
DAT1202	6334	76	45	121		11	30	7	50	0.88				
DAT1202	6335	77	45	122		11	30	8	50	0.86				
DAT1202	6336	76	42	118		11	30	9	50	0.86				
DAT1202	6337	76	45	121		11	30	10	50	0.87				
DAT1202	6338	75	44	119		11	30	11	50	0.89				
DAT1202	6339	76	42	118		11	30	12	50	0.87				
DAT1202	6340	78	42	120	120	11	30	13	50	0.88	0.87			
DAT1202	6341	77	43	120		11	30	14	50	0.87				
DAT1202	6342	74	45	119		11	30	15	50	0.87				
DAT1202	6343	78	43	121		11	30	16	50	0.88				
DAT1202	6344	75	43	118		11	30	17	50	0.88				
DAT1202	6345	75	45	120		11	30	18	50	0.89				
DAT1202	6346	79	45	124		11	30	19	50	0.88				
DAT1202	6347	75	42	117		11	30	20	50	0.88				
DAT1202	6348	76	45	121		11	30	21	50	0.87				
DAT1202	6349	78	44	122		11	30	22	50	0.87				
DAT1202	6350	76	42	118	120	11	30	23	50	0.87	0.88			



Appendix S: Thermal and Life Test #10 (Test Period # 9)

Stored in:	Test #	Devices Upset				Date(96)	Time	File size (Mb)			Notes	
		Bd #1	Bd #2	Total	Ave			full	ave	part		
DAT1202	6351	76	44	120		12	1	0	50	0.87		
DAT1202	6352	77	42	119		12	1	1	50	0.85		
DAT1202	6353	79	41	120		12	1	2	50	0.85		
DAT1202	6354	77	43	120		12	1	3	50	0.86		
DAT1202	6355	76	43	119		12	1	4	50	0.86		
DAT1202	6356	76	43	119		12	1	5	50	0.84		
DAT1202	6357	76	42	118		12	1	6	50	0.86		
DAT1202	6358	75	42	117		12	1	7	50	0.86		
DAT1202	6359	78	43	121		12	1	8	50	0.86		
DAT1202	6360	77	41	118	119	12	1	9	50	0.87	0.86	
DAT1202	6361	76	41	117		12	1	10	50	0.87		
DAT1202	6362	76	43	119		12	1	11	50	0.87		
DAT1202	6363	77	42	119		12	1	12	50	0.86		
DAT1202	6364	75	45	120		12	1	13	50	0.88		
DAT1202	6365	78	44	122		12	1	14	50	0.88		
DAT1202	6366	77	41	118		12	1	15	50	0.88		
DAT1202	6367	78	44	122		12	1	16	50	0.85		
DAT1202	6368	75	42	117		12	1	17	50	0.85		
DAT1202	6369	76	43	119		12	1	18	50	0.85		
DAT1202	6370	76	40	116	119	12	1	19	50	0.85	0.86	
DAT1202	6371	75	42	117		12	1	20	50	0.86		
DAT1202	6372	77	42	119		12	1	21	50	0.86		
DAT1202	6373	76	42	118		12	1	22	50	0.87		
DAT1202	6374	76	42	118		12	1	23	50	0.87		
DAT1202	6375	75	41	116		12	2	0	50	0.87		
DAT1202	6376	78	41	119		12	2	1	50	0.87		
DAT1202	6377	75	41	116		12	2	2	50	0.87		
DAT1202	6378	76	43	119		12	2	3	50	0.87		
DAT1202	6379	77	44	121		12	2	4	50	0.88		
DAT1202	6380	79	43	122	119	12	2	5	50	0.88	0.87	
DAT1202	6381	77	42	119		12	2	6	50	0.88		
DAT1202	6382	77	44	121		12	2	7	50	0.88		
DAT1202	6383	77	45	122		12	2	8	50	0.88		
DAT1202	6384	76	41	117		12	2	9	50	0.88		
DAT1202	6385	77	40	117		12	2	10	50	0.87		
DAT1202	6386	74	40	114		12	2	11	16			0.38
DAT1206	6387	75	42	117		12	2	12	56			0.06
DAT1206	6388	75	44	119		12	2	13	57	0.87		4 Min
DAT1206	6389	75	45	120		12	2	14	57	0.87		
DAT1206	6390	74	42	116	118	12	2	15	57	0.87	0.88	
DAT1206	6391	75	41	116		12	2	16	57			0.52
DAT1206	6392	0	0	0		12	2	17	57			0.1
DAT1206	6393	0	0	0		12	2	18	57			0.1
DAT1206	6394	0	0	0		12	2	19	57			0.1
DAT1206	6395	0	0	0		12	2	20	57			0.1
DAT1206	6396	0	0	0		12	2	21	57			0.1
DAT1206	6397	0	0	0		12	2	22	57			0.1
DAT1206	6398	0	0	0		12	2	23	57			0.1
DAT1206	6399	0	0	0		12	3	0	57			0.1
DAT1206	6400	0	0	0	12	12	3	1	57		0	0.1

Appendix S: Thermal and Life Test #10 (Test Period # 9)

Stored in:	Test #	Devices Upset				Date(96)	Time		File size (Mb)			Notes	
		Bd #1	Bd #2	Total	Ave		full	ave	part				
DAT1206	6401	0	0	0		12	3	2	57			0.1	PwrAmp Off
DAT1206	6402	0	0	0		12	3	3	57			0.1	PwrAmp Off
DAT1206	6403	0	0	0		12	3	4	57			0.1	PwrAmp Off
DAT1206	6404	0	0	0		12	3	5	57			0.1	PwrAmp Off
DAT1206	6405	0	0	0		12	3	6	57			0.1	PwrAmp Off
DAT1206	6406	0	0	0		12	3	7	57			0.1	PwrAmp Off
DAT1206	6407	0	0	0		12	3	8	57			0.1	PwrAmp Off
DAT1206	6408	0	0	0		12	3	9	57			0.1	PwrAmp Off
DAT1206	6409	0	0	0		12	3	10	57			0.1	PwrAmp Off
DAT1206	6410	0	0	0	0	12	3	11	57		0	0.1	PwrAmp Off
DAT1206	6411	0	0	0		12	3	12	57			0.1	PwrAmp Off
DAT1206	6412	0	0	0		12	3	13	57			0.1	PwrAmp Off
DAT1206	6413	0	0	0		12	3	14	57			0.1	PwrAmp Off
DAT1206	6414	0	0	0		12	3	15	57			0.1	PwrAmp Off
DAT1206	6415	0	0	0		12	3	16	57			0.1	PwrAmp Off
DAT1206	6416	0	0	0		12	3	17	57			0.1	PwrAmp Off
DAT1206	6417	0	0	0		12	3	18	57			0.1	PwrAmp Off
DAT1206	6418	0	0	0		12	3	19	57			0.1	PwrAmp Off
DAT1206	6419	0	0	0		12	3	20	57			0.1	PwrAmp Off
DAT1206	6420	0	0	0	0	12	3	21	57		0	0.1	PwrAmp Off
DAT1206	6421	0	0	0		12	3	22	57			0.1	PwrAmp Off
DAT1206	6422	0	0	0		12	3	23	57			0.1	PwrAmp Off
DAT1206	6423	0	0	0		12	4	0	57			0.1	PwrAmp Off
DAT1206	6424	0	0	0		12	4	1	57			0.1	PwrAmp Off
DAT1206	6425	0	0	0		12	4	2	57			0.1	PwrAmp Off
DAT1206	6426	0	0	0		12	4	3	57			0.1	PwrAmp Off
DAT1206	6427	0	0	0		12	4	4	57			0.1	PwrAmp Off
DAT1206	6428	0	0	0		12	4	5	57			0.1	PwrAmp Off
DAT1206	6429	0	0	0		12	4	6	57			0.1	PwrAmp Off
DAT1206	6430	0	0	0	0	12	4	7	57		0	0.1	PwrAmp Off
DAT1206	6431	0	0	0		12	4	8	57			0.1	PwrAmp Off
DAT1206	6432	78	44	122		12	4	9	57			0.1	PwrAmp Off
DAT1206	6433	76	48	124		12	4	10	57	0.91			
DAT1206	6434	77	46	123		12	4	11	57	0.90			
DAT1206	6435	78	48	126		12	4	12	57	0.89			
DAT1206	6436	75	48	123		12	4	13	57	0.89			
DAT1206	6437	75	44	119		12	4	14	57	0.90			
DAT1206	6438	75	48	123		12	4	15	57	0.91			
DAT1206	6439	77	47	124		12	4	16	57	0.92			
DAT1206	6440	78	47	125	111	12	4	17	57	0.92	0.91		
DAT1206	6441	79	48	127		12	4	18	57	0.91			
DAT1206	6442	77	45	122		12	4	19	57	0.91			
DAT1206	6443	77	47	124		12	4	20	57	0.92			
DAT1206	6444	76	45	121		12	4	21	57	0.90			
DAT1206	6445	75	46	121		12	4	22	57	0.91			
DAT1206	6446	75	43	118		12	4	23	57	0.91			
DAT1206	6447	79	43	122		12	5	0	57	0.90			
DAT1206	6448	79	41	120		12	5	1	57	0.89			
DAT1206	6449	77	42	119		12	5	2	57	0.89			
DAT1206	6450	75	43	118	121	12	5	3	57	0.90	0.9		

Appendix S: Thermal and Life Test #10 (Test Period # 9)

Stored in:	Devices Upset						File size (Mb)			Notes	
	Test #	Bd #1	Bd #2	Total	Ave	Date(96)	Time	full	ave		part
DAT1206	6451	76	44	120		12 5	4 57	0.90			
DAT1206	6452	79	44	123		12 5	5 57	0.90			
DAT1206	6453	78	44	122		12 5	6 57	0.90			
DAT1206	6454	76	45	121		12 5	7 57	0.90			
DAT1206	6455	75	44	119		12 5	8 57	0.89			
DAT1206	6456	77	46	123		12 5	9 57	0.90			
DAT1206	6457	75	46	121		12 5	10 57	0.90			
DAT1206	6458	75	43	118		12 5	11 57	0.90			
DAT1206	6459	77	44	121		12 5	12 57	0.90			
DAT1206	6460	76	46	122	121	12 5	13 57	0.91	0.9		
DAT1206	6461	77	44	121		12 5	14 57	0.90			
DAT1206	6462	76	42	118		12 5	15 57	0.90			
DAT1206	6463	78	43	121		12 5	16 57	0.91			
DAT1206	6464	78	45	123		12 5	17 57	0.91			
DAT1206	6465	78	45	123		12 5	18 57	0.91			
DAT1206	6466	78	42	120		12 5	19 57	0.91			
DAT1206	6467	75	43	118		12 5	20 57	0.91			
DAT1206	6468	78	43	121		12 5	21 57	0.91			
DAT1206	6469	77	46	123		12 5	22 57	0.91			
DAT1206	6470	75	43	118	121	12 5	23 57	0.90	0.91		
DAT1206	6471	77	43	120		12 6	0 57	0.90			
DAT1206	6472	79	44	123		12 6	1 57	0.90			
DAT1206	6473	75	45	120		12 6	2 57	0.90			
DAT1206	6474	76	44	120		12 6	3 57	0.89			
DAT1206	6475	75	42	117		12 6	4 57	0.90			
DAT1206	6476	75	49	124		12 6	5 57	0.90			
DAT1206	6477	75	45	120		12 6	6 57	0.90			
DAT1206	6478	75	44	119		12 6	7 57	0.90			
DAT1206	6479	79	44	123		12 6	8 57	0.91			
DAT1206	6480	73	44	117	120	12 6	9 57		0.9	0.47	
DAT1209	6481	73	41	114		12 6	11 6			0.06	4 Min
DAT1209	6482	77	47	124		12 6	12 6	0.91			
DAT1209	6483	77	47	124		12 6	13 6	0.91			
DAT1209	6484	80	47	127		12 6	14 6	0.90			
DAT1209	6485	74	44	118		12 6	15 6	0.90			
DAT1209	6486	74	46	120		12 6	16 6	0.92			
DAT1209	6487	77	47	124		12 6	17 6	0.92			
DAT1209	6488	77	43	120		12 6	18 6	0.91			
DAT1209	6489	76	46	122		12 6	19 6	0.90			
DAT1209	6490	77	43	120	121	12 6	20 6	0.89	0.91		
DAT1209	6491	75	47	122		12 6	21 6	0.90			
DAT1209	6492	78	44	122		12 6	22 6	0.90			
DAT1209	6493	75	47	122		12 6	23 6	0.90			
DAT1209	6494	77	42	119		12 7	0 6	0.89			
DAT1209	6495	77	44	121		12 7	1 6	0.88			
DAT1209	6496	78	43	121		12 7	2 6	0.90			
DAT1209	6497	76	44	120		12 7	3 6	0.90			
DAT1209	6498	80	42	122		12 7	4 6	0.88			
DAT1209	6499	77	44	121		12 7	5 6	0.88			
DAT1209	6500	79	44	123	121	12 7	6 6	0.89	0.89		

Appendix S: Thermal and Life Test #10 (Test Period # 9)

Stored in:	Test #	Devices Upset				Date(96)	Time		File size (Mb)			Notes
		Bd #1	Bd #2	Total	Ave		full	ave	part			
DAT1209	6501	75	44	119		12	7	7	6	0.90		
DAT1209	6502	78	44	122		12	7	8	6	0.91		
DAT1209	6503	78	44	122		12	7	9	6	0.91		
DAT1209	6504	74	46	120		12	7	10	6	0.91		
DAT1209	6505	75	47	122		12	7	11	6	0.91		
DAT1209	6506	75	44	119		12	7	12	6	0.91		
DAT1209	6507	77	43	120		12	7	13	6	0.91		
DAT1209	6508	75	46	121		12	7	14	6	0.91		
DAT1209	6509	79	42	121		12	7	15	6	0.90		
DAT1209	6510	76	44	120	121	12	7	16	6	0.91	0.91	
DAT1209	6511	77	47	124		12	7	17	6	0.92		
DAT1209	6512	78	45	123		12	7	18	6	0.90		
DAT1209	6513	77	47	124		12	7	19	6	0.91		
DAT1209	6514	76	48	124		12	7	20	6	0.90		
DAT1209	6515	76	49	125		12	7	21	6	0.90		
DAT1209	6516	75	45	120		12	7	22	6	0.90		
DAT1209	6517	79	48	127		12	7	23	6	0.91		
DAT1209	6518	78	48	126		12	8	0	6	0.91		
DAT1209	6519	79	45	124		12	8	1	6	0.91		
DAT1209	6520	79	49	128	125	12	8	2	6	0.91	0.91	
DAT1209	6521	79	45	124		12	8	3	6	0.90		
DAT1209	6522	79	48	127		12	8	4	6	0.91		
DAT1209	6523	77	45	122		12	8	5	6	0.89		
DAT1209	6524	78	44	122		12	8	6	6	0.91		
DAT1209	6525	76	47	123		12	8	7	6	0.91		
DAT1209	6526	74	46	120		12	8	8	6	0.90		
DAT1209	6527	74	46	120		12	8	9	6	0.91		
DAT1209	6528	77	46	123		12	8	10	6	0.91		
DAT1209	6529	76	47	123		12	8	11	6	0.91		
DAT1209	6530	77	48	125	123	12	8	12	6	0.91	0.91	
DAT1209	6531	76	42	118		12	8	13	6	0.90		
DAT1209	6532	80	48	128		12	8	14	6	0.91		
DAT1209	6533	77	48	125		12	8	15	6	0.91		
DAT1209	6534	76	46	122		12	8	16	6	0.90		
DAT1209	6535	77	48	125		12	8	17	6	0.92		
DAT1209	6536	78	49	127		12	8	18	6	0.92		
DAT1209	6537	76	49	125		12	8	19	6	0.92		
DAT1209	6538	79	48	127		12	8	20	6	0.93		
DAT1209	6539	78	45	123		12	8	21	6	0.91		
DAT1209	6540	77	49	126	125	12	8	22	6	0.93	0.92	
DAT1209	6541	78	47	125		12	8	23	6	0.93		
DAT1209	6542	77	49	126		12	9	0	6	0.93		
DAT1209	6543	76	44	120		12	9	1	6	0.92		
DAT1209	6544	79	47	126		12	9	2	6	0.92		
DAT1209	6545	78	45	123		12	9	3	6	0.93		
DAT1209	6546	76	46	122		12	9	4	6	0.93		
DAT1209	6547	77	48	125		12	9	5	6	0.93		
DAT1209	6548	76	48	124		12	9	6	6	0.93		
DAT1209	6549	77	44	121		12	9	7	6	0.93		
DAT1209	6550	76	48	124	124	12	9	8	6	0.93	0.93	

Appendix S: Thermal and Life Test #10 (Test Period # 9)

Stored in:	Test #	Devices Upset				Date(96)	Time		File size (Mb)			Notes
		Bd #1	Bd #2	Total	Ave				full	ave	part	
DAT1209	6551	78	46	124		12	9	9	6	0.92		
DAT1209	6552	75	47	122		12	9	10	6	0.91		
DAT1213	6553	75	40	115		12	9	13	34		0.06	4 Min
DAT1213	6554	82	51	133		12	9	14	39	0.94		
DAT1213	6555	78	50	128		12	9	15	39	0.94		
DAT1213	6556	78	50	128		12	9	16	39	0.94		
DAT1213	6557	79	49	128		12	9	17	39	0.93		
DAT1213	6558	79	49	128		12	9	18	39	0.92		
DAT1213	6559	76	46	122		12	9	19	39	0.92		
DAT1213	6560	78	49	127	126	12	9	20	39	0.92	0.83	
DAT1213	6561	78	49	127		12	9	21	39	0.92		
DAT1213	6562	76	47	123		12	9	22	39	0.93		
DAT1213	6563	79	47	126		12	9	23	39	0.92		
DAT1213	6564	77	48	125		12	10	0	39	0.92		
DAT1213	6565	78	48	126		12	10	1	39	0.93		
DAT1213	6566	78	49	127		12	10	2	39	0.93		
DAT1213	6567	77	48	125		12	10	3	39	0.93		
DAT1213	6568	84	50	134		12	10	4	39	0.94		
DAT1213	6569	77	49	126		12	10	5	39	0.93		
DAT1213	6570	78	48	126	127	12	10	6	39	0.93	0.93	
DAT1213	6571	80	52	132		12	10	7	39	0.93		
DAT1213	6572	78	48	126		12	10	8	39	0.94		
DAT1213	6573	77	49	126		12	10	9	39	0.94		
DAT1213	6574	79	49	128		12	10	10	39	0.93		
DAT1213	6575	77	50	127		12	10	11	39	0.93		
DAT1213	6576	78	49	127		12	10	12	39	0.93		
DAT1213	6577	78	50	128		12	10	13	39	0.94		
DAT1213	6578	76	51	127		12	10	14	39	0.94		
DAT1213	6579	77	49	126		12	10	15	39	0.93		
DAT1213	6580	77	49	126	127	12	10	16	39	0.92	0.93	
DAT1213	6581	76	49	125		12	10	17	39	0.92		
DAT1213	6582	77	48	125		12	10	18	39	0.91		
DAT1213	6583	80	49	129		12	10	19	39	0.92		
DAT1213	6584	76	48	124		12	10	20	39	0.92		
DAT1213	6585	77	45	122		12	10	21	39	0.92		
DAT1213	6586	76	45	121		12	10	22	39	0.91		
DAT1213	6587	77	45	122		12	10	23	39	0.90		
DAT1213	6588	76	46	122		12	11	0	39	0.90		
DAT1213	6589	76	44	120		12	11	1	39	0.90		
DAT1213	6590	77	46	123	123	12	11	2	39	0.90	0.91	
DAT1213	6591	76	43	119		12	11	3	39	0.90		
DAT1213	6592	77	43	120		12	11	4	39	0.91		
DAT1213	6593	76	47	123		12	11	5	39	0.92		
DAT1213	6594	79	47	126		12	11	6	39	0.92		
DAT1213	6595	76	46	122		12	11	7	39	0.91		
DAT1213	6596	82	51	133		12	11	8	39	0.92		
DAT1213	6597	77	49	126		12	11	9	39	0.92		
DAT1213	6598	76	49	125		12	11	10	39	0.91		
DAT1213	6599	76	50	126		12	11	11	39	0.92		
DAT1213	6600	77	49	126	125	12	11	12	39	0.93	0.92	

Appendix S: Thermal and Life Test #10 (Test Period # 9)

Stored in:	Devices Upset					Date(96)			Time			File size (Mb)			Notes
	Test #	Bd #1	Bd #2	Total	Ave						full	ave	part		
DAT1213	6601	78	49	127		12	11	13	39	0.93					
DAT1213	6602	82	50	132		12	11	14	39	0.94					
DAT1213	6603	79	48	127		12	11	15	39	0.93					
DAT1213	6604	77	50	127		12	11	16	39	0.93					
DAT1213	6605	77	45	122		12	11	17	39	0.92					
DAT1213	6606	79	49	128		12	11	18	39	0.93					
DAT1213	6607	75	46	121		12	11	19	39	0.92					
DAT1213	6608	75	49	124		12	11	20	39	0.93					
DAT1213	6609	79	46	125		12	11	21	39	0.92					
DAT1213	6610	78	45	123	126	12	11	22	39	0.92	0.93				
DAT1213	6611	78	47	125		12	11	23	39	0.92					
DAT1213	6612	79	47	126		12	12	0	39	0.92					
DAT1213	6613	77	47	124		12	12	1	39	0.92					
DAT1213	6614	78	45	123		12	12	2	39	0.91					
DAT1213	6615	76	46	122		12	12	3	39	0.91					
DAT1213	6616	76	48	124		12	12	4	39	0.91					
DAT1213	6617	77	47	124		12	12	5	39	0.92					
DAT1213	6618	76	45	121		12	12	6	39	0.92					
DAT1213	6619	76	49	125		12	12	7	39	0.92					
DAT1213	6620	77	49	126	124	12	12	8	39	0.93	0.92				
DAT1213	6621	79	50	129		12	12	9	39	0.92					
DAT1213	6622	79	49	128		12	12	10	39	0.92					
DAT1213	6623	77	48	125		12	12	11	39	0.93					
DAT1213	6624	75	50	125		12	12	12	39	0.93					
DAT1213	6625	79	49	128		12	12	13	39	0.93					
DAT1213	6626	77	48	125		12	12	14	39	0.93					
DAT1213	6627	76	51	127		12	12	15	39	0.92					
DAT1213	6628	77	48	125		12	12	16	39	0.92					
DAT1213	6629	78	45	123		12	12	17	39	0.92					
DAT1213	6630	75	51	126	126	12	12	18	39	0.92	0.92				
DAT1213	6631	79	47	126		12	12	19	39	0.92					
DAT1213	6632	77	48	125		12	12	20	39	0.92					
DAT1213	6633	77	49	126		12	12	21	39	0.93					
DAT1213	6634	76	47	123		12	12	22	39	0.92					
DAT1213	6635	75	47	122		12	12	23	39	0.92					
DAT1213	6636	80	3	83		12	13	0	39	0.91					
DAT1213	6637	78	45	123		12	13	1	39	0.91					
DAT1213	6638	79	48	127		12	13	2	39	0.92					
DAT1213	6639	77	45	122		12	13	3	39	0.92					
DAT1213	6640	76	44	120	120	12	13	4	39	0.91	0.92				
DAT1213	6641	80	42	122		12	13	5	39	0.91					
DAT1213	6642	77	50	127		12	13	6	39	0.91					
DAT1213	6643	77	48	125		12	13	7	39	0.92					
DAT1213	6644	79	47	126		12	13	8	39	0.92					
DAT1213	6645	77	47	124		12	13	9	39	0.92					
DAT1213	6646	78	46	124		12	13	10	19			0.61			
			0												
			0												
			0												
			0	75							0.76				

Appendix T: "Life" Reliability Test Data, Test #11 (Test Period #10)

Stored in:	Test #	Devices Upset				Date(96)	Time		File size (Mb)			Notes	
		Bd #1	Bd #2	Total	Ave		16	26	full	ave	part		
DAT1216	6701	91	89	180		12	13	16	28			0.18	4 Min
DAT1216	6702	97	93	190		12	13	17	28	2.5			
DAT1216	6703	97	94	191		12	13	18	28	2.5			
DAT1216	6704	97	96	193		12	13	19	28	2.8			
DAT1216	6705	97	95	192		12	13	20	28	2.7			
DAT1216	6706	94	94	188		12	13	21	28	2.6			
DAT1216	6707	94	95	189		12	13	22	28	2.7			
DAT1216	6708	95	95	190		12	13	23	28	2.7			
DAT1216	6709	96	94	190		12	14	0	28	2.7			
DAT1216	6710	96	95	191	189	12	14	1	28	2.7	2.66		
DAT1216	6711	98	97	195		12	14	2	28	2.7			
DAT1216	6712	96	96	192		12	14	3	28	2.6			
DAT1216	6713	95	95	190		12	14	4	28	2.7			
DAT1216	6714	95	95	190		12	14	5	28	2.7			
DAT1216	6715	96	95	191		12	14	6	28	2.7			
DAT1216	6716	96	97	193		12	14	7	28	2.7			
DAT1216	6717	97	95	192		12	14	8	28	2.6			
DAT1216	6718	95	94	189		12	14	9	28	2.6			
DAT1216	6719	97	95	192		12	14	10	28	2.6			
DAT1216	6720	97	96	193	192	12	14	11	28	2.7	2.66		
DAT1216	6721	95	96	191		12	14	12	28	2.7			
DAT1216	6722	97	94	191		12	14	13	28	2.7			
DAT1216	6723	95	95	190		12	14	14	28	2.6			
DAT1216	6724	96	96	192		12	14	15	28	2.7			
DAT1216	6725	95	96	191		12	14	16	28	2.7			
DAT1216	6726	96	96	192		12	14	17	28	2.7			
DAT1216	6727	97	96	193		12	14	18	28	2.7			
DAT1216	6728	95	94	189		12	14	19	28	2.7			
DAT1216	6729	96	96	192		12	14	20	28	2.7			
DAT1216	6730	94	94	188	191	12	14	21	28	2.7	2.69		
DAT1216	6731	95	97	192		12	14	22	28	2.7			
DAT1216	6732	94	95	189		12	14	23	28	2.7			
DAT1216	6733	97	95	192		12	15	0	28	2.7			
DAT1216	6734	95	95	190		12	15	1	28	2.7			
DAT1216	6735	96	95	191		12	15	2	28	2.6			
DAT1216	6736	95	95	190		12	15	3	28	2.6			
DAT1216	6737	96	95	191		12	15	4	28	2.6			
DAT1216	6738	95	95	190		12	15	5	28	2.7			
DAT1216	6739	94	95	189		12	15	6	28	2.7			
DAT1216	6740	95	95	190	190	12	15	7	28	2.7	2.67		
DAT1216	6741	96	96	192		12	15	8	28	2.7			
DAT1216	6742	95	94	189		12	15	9	28	2.6			
DAT1216	6743	97	96	193		12	15	10	28	2.7			
DAT1216	6744	96	96	192		12	15	11	28	2.7			
DAT1216	6745	95	97	192		12	15	12	28	2.7			
DAT1216	6746	95	95	190		12	15	13	28	2.7			
DAT1216	6747	96	96	192		12	15	14	28	2.7			
DAT1216	6748	94	94	188		12	15	15	28	2.7			
DAT1216	6749	95	96	191		12	15	16	28	2.7			
DAT1216	6750	95	96	191	191	12	15	17	28	2.7	2.69		

Appendix T: "Life" Reliability Test Data, Test #11 (Test Period #10)

Stored in:	Test #	Devices Upset				Date(96)	Time		File size (Mb)			Notes
		Bd #1	Bd #2	Total	Ave		full	ave	part			
DAT1216	6751	95	97	192		12	15	18	28	2.6		
DAT1216	6752	97	96	193		12	15	19	28	2.6		
DAT1216	6753	94	96	190		12	15	20	28	2.6		
DAT1216	6754	94	96	190		12	15	21	28	2.6		
DAT1216	6755	94	97	191		12	15	22	28	2.6		
DAT1216	6756	96	96	192		12	15	23	28	2.7		
DAT1216	6757	95	96	191		12	16	0	28	2.6		
DAT1216	6758	93	97	190		12	16	1	28	2.6		
DAT1216	6759	94	96	190		12	16	2	28	2.6		
DAT1216	6760	94	95	189	191	12	16	3	28	2.6	2.61	
DAT1216	6761	94	96	190		12	16	4	28	2.6		
DAT1216	6762	96	96	192		12	16	5	28	2.6		
DAT1216	6763	96	95	191		12	16	6	28	2.6		
DAT1216	6764	94	96	190		12	16	7	28	2.6		
DAT1216	6765	94	95	189		12	16	8	28	2.6		
DAT1216	6766	95	95	190		12	16	9	28	2.6		
DAT1216	6767	94	95	189		12	16	10	28	2.6		
DAT1216	6768	95	96	191		12	16	11	28	2.6		
DAT1216	6769	94	95	189		12	16	12	28	2.6		
DAT1216	6770	93	96	189	190	12	16	13	28	2.6	2.6	
DAT1216	6771	92	94	186		12	16	14	7			0.16
DAT1218	6772	89	92	181		12	16	16	17			0.18
DAT1218	6773	93	96	189		12	16	17	18	2.5		4 Min
DAT1218	6774	95	95	190		12	16	18	18	2.5		
DAT1218	6775	93	95	188		12	16	19	18	2.5		
DAT1218	6776	93	96	189		12	16	20	18	2.5		
DAT1218	6777	93	96	189		12	16	21	18	2.5		
DAT1218	6778	93	95	188		12	16	22	18	2.5		
DAT1218	6779	94	95	189		12	16	23	18	2.5		
DAT1218	6780	93	95	188	188	12	17	0	18	2.4	2.49	
DAT1218	6781	94	95	189		12	17	1	18	2.4		
DAT1218	6782	95	95	190		12	17	2	18	2.4		
DAT1218	6783	95	95	190		12	17	3	18	2.6		
DAT1218	6784	94	96	190		12	17	4	18	2.6		
DAT1218	6785	94	95	189		12	17	5	18	2.5		
DAT1218	6786	93	96	189		12	17	6	18	2.6		
DAT1218	6787	93	95	188		12	17	7	18	2.5		
DAT1218	6788	94	95	189		12	17	8	18	2.6		
DAT1218	6789	92	96	188		12	17	9	18	2.5		
DAT1218	6790	94	96	190	189	12	17	10	18	2.5	2.52	
DAT1218	6791	94	96	190		12	17	11	18	2.5		
DAT1218	6792	93	95	188		12	17	12	18	2.5		
DAT1218	6793	94	95	189		12	17	13	18	2.5		
DAT1218	6794	94	95	189		12	17	14	18	2.4		
DAT1218	6795	93	95	188		12	17	15	18	2.4		
DAT1218	6796	92	96	188		12	17	16	18	2.4		
DAT1218	6797	93	95	188		12	17	17	18	2.5		
DAT1218	6798	94	96	190		12	17	18	18	2.5		
DAT1218	6799	92	96	188		12	17	19	18	2.5		
DAT1218	6800	92	95	187	189	12	17	20	18	2.4	2.46	



Appendix T: "Life" Reliability Test Data, Test #11 (Test Period #10)

Stored in:	Test #	Devices Upset				Date(96)	Time		File size (Mb)			Notes
		Bd #1	Bd #2	Total	Ave		full	ave	part			
DAT1218	6801	92	96	188		12	17	21	18	2.4		
DAT1218	6802	92	95	187		12	17	22	18	2.4		
DAT1218	6803	93	94	187		12	17	23	18	2.4		
DAT1218	6804	92	96	188		12	18	0	18	2.4		
DAT1218	6805	92	94	186		12	18	1	18	2.4		
DAT1218	6806	91	94	185		12	18	2	18	2.5		
DAT1218	6807	93	94	187		12	18	3	18	2.5		
DAT1218	6808	92	97	189		12	18	4	18	2.4		
DAT1218	6809	92	96	188		12	18	5	18	2.5		
DAT1218	6810	94	95	189	187	12	18	6	18	2.5	2.44	
DAT1218	6811	93	97	190		12	18	7	18	2.5		
DAT1218	6812	93	95	188		12	18	8	18	2.5		
DAT1218	6813	93	95	188		12	18	9	18	2.5		
DAT1218	6814	95	95	190		12	18	9	55		1.5	
DAT1220	6815	87	89	176		12	18	11	51		0.17	4 Min
DAT1220	6816	95	94	189		12	18	12	51	2.5		
DAT1220	6817	94	95	189		12	18	13	51	2.5		
DAT1220	6818	94	96	190		12	18	14	51	2.5		
DAT1220	6819	91	95	186		12	18	15	51	2.5		
DAT1220	6820	93	95	188	187	12	18	16	51	2.5	2.5	
DAT1220	6821	93	95	188		12	18	17	51	2.5		
DAT1220	6822	93	95	188		12	18	18	51	2.5		
DAT1220	6823	93	96	189		12	18	19	51	2.5		
DAT1220	6824	92	95	187		12	18	20	51	2.5		
DAT1220	6825	92	94	186		12	18	21	51	2.5		
DAT1220	6826	91	97	188		12	18	22	51	2.5		
DAT1220	6827	93	94	187		12	18	23	51	2.5		
DAT1220	6828	91	95	186		12	19	0	51	2.4		
DAT1220	6829	93	94	187		12	19	1	51	2.5		
DAT1220	6830	91	95	186	187	12	19	2	51	2.4	2.48	
DAT1220	6831	91	94	185		12	19	3	51	2.4		
DAT1220	6832	91	95	186		12	19	4	51	2.4		
DAT1220	6833	91	95	186		12	19	5	51	2.5		
DAT1220	6834	93	95	188		12	19	6	51	2.5		
DAT1220	6835	93	95	188		12	19	7	51	2.5		
DAT1220	6836	93	95	188		12	19	8	51	2.5		
DAT1220	6837	94	95	189		12	19	9	51	2.5		
DAT1220	6838	93	95	188		12	19	10	51	2.5		
DAT1220	6839	93	95	188		12	19	11	51	2.5		
DAT1220	6840	93	95	188	187	12	19	12	51	2.5	2.48	
DAT1220	6841	93	96	189		12	19	13	51	2.5		
DAT1220	6842	94	96	190		12	19	14	51	2.5		
DAT1220	6843	93	95	188		12	19	15	51	2.5		
DAT1220	6844	93	94	187		12	19	16	51	2.5		
DAT1220	6845	91	94	185		12	19	17	51	2.5		
DAT1220	6846	91	95	186		12	19	18	51	2.5		
DAT1220	6847	93	95	188		12	19	19	51	2.5		
DAT1220	6848	92	95	187		12	19	20	51	2.5		
DAT1220	6849	95	95	190		12	19	21	51	2.5		
DAT1220	6850	92	95	187	188	12	19	22	51	2.5	2.5	

Appendix T: "Life" Reliability Test Data, Test #11 (Test Period #10)

Stored in:	Test #	Devices Upset				Ave	Date(96)		Time		File size (Mb)			Notes
		Bd #1	Bd #2	Total					full	ave	part			
DAT1220	6851	93	96	189		12	19	23	51	2.5				
DAT1220	6852	92	95	187		12	20	0	51	2.5				
DAT1220	6853	92	95	187		12	20	1	51	2.4				
DAT1220	6854	93	95	188		12	20	2	51	2.4				
DAT1220	6855	94	95	189		12	20	3	51	2.4				
DAT1220	6856	92	94	186		12	20	4	51	2.4				
DAT1220	6857	93	95	188		12	20	5	51	2.5				
DAT1220	6858	96	95	191		12	20	6	51	2.4				
DAT1220	6859	93	95	188		12	20	7	51	2.5				
DAT1220	6860	94	95	189	188	12	20	8	51	2.5	2.45			
DAT1220	6861	93	95	188		12	20	9	51	2.4				
DAT1220	6862	93	95	188		12	20	10	51	2.5				
DAT1220	6863	92	94	186		12	20	11	51	2.5				
DAT1220	6864	93	96	189		12	20	12	51			2.1		
DAT1224	6865	89	90	179		12	20	15	28			0.17	4 Min	
DAT1224	6866	94	95	189		12	20	16	28	2.4				
DAT1224	6867	94	95	189		12	20	17	28	2.4				
DAT1224	6868	95	94	189		12	20	18	28	2.4				
DAT1224	6869	93	95	188		12	20	19	28	2.4				
DAT1224	6870	93	94	187	187	12	20	20	28	2.5	2.44			
DAT1224	6871	93	96	189		12	20	21	28	2.4				
DAT1224	6872	94	95	189		12	20	22	28	2.5				
DAT1224	6873	91	95	186		12	20	23	28	2.4				
DAT1224	6874	93	95	188		12	21	0	28	2.4				
DAT1224	6875	92	94	186		12	21	1	28	2.4				
DAT1224	6876	94	95	189		12	21	2	28	2.4				
DAT1224	6877	92	95	187		12	21	3	28	2.4				
DAT1224	6878	93	95	188		12	21	4	28	2.4				
DAT1224	6879	93	95	188		12	21	5	28	2.4				
DAT1224	6880	93	95	188	188	12	21	6	28	2.4	2.66			
DAT1224	6881	94	95	189		12	21	7	28	2.4				
DAT1224	6882	92	94	186		12	21	8	28	2.4				
DAT1224	6883	94	94	188		12	21	9	28	2.4				
DAT1224	6884	93	95	188		12	21	10	28	2.4				
DAT1224	6885	92	95	187		12	21	11	28	2.4				
DAT1224	6886	91	95	186		12	21	12	28	2.4				
DAT1224	6887	93	95	188		12	21	13	28	2.5				
DAT1224	6888	93	94	187		12	21	14	28	2.4				
DAT1224	6889	93	96	189		12	21	15	28	2.4				
DAT1224	6890	93	95	188	188	12	21	16	28	2.4	2.41			
DAT1224	6891	93	95	188		12	21	17	28	2.4				
DAT1224	6892	92	94	186		12	21	18	28	2.4				
DAT1224	6893	93	95	188		12	21	19	28	2.5				
DAT1224	6894	92	95	187		12	21	20	28	2.5				
DAT1224	6895	93	94	187		12	21	21	28	2.4				
DAT1224	6896	92	95	187		12	21	22	28	2.4				
DAT1224	6897	93	96	189		12	21	23	28	2.4				
DAT1224	6898	94	96	190		12	22	0	28	2.4				
DAT1224	6899	91	95	186		12	22	1	28	2.5				
DAT1224	6900	91	95	186	187	12	22	2	28	2.4	2.43			

Appendix T: "Life" Reliability Test Data, Test #11 (Test Period #10)

Stored in:	Test #	Devices Upset				Date(96)	Time		File size (Mb)			Notes
		Bd #1	Bd #2	Total	Ave				full	ave	part	
DAT1224	6901	93	95	188		12	22	3	28	2.5		
DAT1224	6902	94	95	189		12	22	4	28	2.5		
DAT1224	6903	92	95	187		12	22	5	28	2.5		
DAT1224	6904	93	95	188		12	22	6	28	2.5		
DAT1224	6905	91	95	186		12	22	7	28	2.5		
DAT1224	6906	94	94	188		12	22	8	28	2.5		
DAT1224	6907	92	95	187		12	22	9	28	2.5		
DAT1224	6908	94	96	190		12	22	10	28	2.5		
DAT1224	6909	92	96	188		12	22	11	28	2.4		
DAT1224	6910	93	94	187	188	12	22	12	28	2.4	2.48	
DAT1224	6911	92	95	187		12	22	13	28	2.5		
DAT1224	6912	92	94	186		12	22	14	28	2.4		
DAT1224	6913	93	94	187		12	22	15	28	2.4		
DAT1224	6914	92	95	187		12	22	16	28	2.5		
DAT1224	6915	93	96	189		12	22	17	28	2.5		
DAT1224	6916	93	95	188		12	22	18	28	2.5		
DAT1224	6917	91	95	186		12	22	19	28	2.5		
DAT1224	6918	93	95	188		12	22	20	28	2.5		
DAT1224	6919	93	94	187		12	22	21	28	2.5		
DAT1224	6920	93	94	187	187	12	22	22	28	2.5	2.48	
DAT1224	6921	92	95	187		12	22	23	28	2.5		
DAT1224	6922	93	94	187		12	23	0	28	2.5		
DAT1224	6923	92	94	186		12	23	1	28	2.4		
DAT1224	6924	93	95	188		12	23	2	28	2.4		
DAT1224	6925	94	94	188		12	23	3	28	2.4		
DAT1224	6926	91	95	186		12	23	4	28	2.4		
DAT1224	6927	92	95	187		12	23	5	28	2.4		
DAT1224	6928	92	95	187		12	23	6	28	2.4		
DAT1224	6929	95	95	190		12	23	7	28	2.5		
DAT1224	6930	93	95	188	187	12	23	8	28	2.5	2.44	
DAT1224	6931	92	95	187		12	23	9	28	2.5		
DAT1224	6932	93	94	187		12	23	10	28	2.5		
DAT1224	6933	93	94	187		12	23	11	28	2.4		
DAT1224	6934	94	95	189		12	23	12	28	2.4		
DAT1224	6935	93	95	188		12	23	13	28	2.5		
DAT1224	6936	93	95	188		12	23	14	28	2.4		
DAT1224	6937	92	95	187		12	23	15	28	2.4		
DAT1224	6938	92	95	187		12	23	16	28	2.5		
DAT1224	6939	94	96	190		12	23	17	28	2.4		
DAT1224	6940	93	95	188	188	12	23	18	28	2.4	2.44	
DAT1224	6941	94	94	188		12	23	19	28	2.4		
DAT1224	6942	94	95	189		12	23	20	28	2.4		
DAT1224	6943	93	96	189		12	23	21	28	2.4		
DAT1224	6944	92	95	187		12	23	22	28	2.4		
DAT1224	6945	94	94	188		12	23	23	28	2.4		
DAT1224	6946	92	95	187		12	24	0	28	2.4		
DAT1224	6947	92	95	187		12	24	1	28	2.4		
DAT1224	6948	92	94	186		12	24	2	28	2.4		
DAT1224	6949	91	93	184		12	24	3	28	2.4		
DAT1224	6950	93	95	188	187	12	24	4	28	2.4	2.4	

Appendix T: "Life" Reliability Test Data, Test #11 (Test Period #10)

Stored in:	Test #	Devices Upset				Ave	Date(96)		Time		File size (Mb)			Notes
		Bd #1	Bd #2	Total					full	ave	part			
DAT1224	6951	94	95	189		12	24	5	28	2.4				
DAT1224	6952	93	94	187		12	24	6	28	2.4				
DAT1224	6953	91	96	187		12	24	7	28	2.4				
DAT1224	6954	93	95	188		12	24	8	28	2.4				
DAT1224	6955	91	94	185		12	24	9	28	2.4				
DAT1224	6956	94	95	189		12	24	10	28	2.4				
DAT1224	6957	91	94	185		12	24	11	15			1.8		
DAT1227	6958	92	92	184		12	24	13	22			0.16	4 Min	
DAT1227	6959	99	96	195		12	24	14	22	2.4			Vmon=5.4	
DAT1227	6960	99	96	195	188	12	24	15	22	2.4	2.4			
DAT1227	6961	98	96	194		12	24	16	22	2.4				
DAT1227	6962	98	95	193		12	24	17	22	2.3				
DAT1227	6963	98	96	194		12	24	18	22	2.3				
DAT1227	6964	98	96	194		12	24	19	22	2.4				
DAT1227	6965	99	97	196		12	24	20	22	2.4				
DAT1227	6966	96	96	192		12	24	21	22	2.4				
DAT1227	6967	99	97	196		12	24	22	22	2.4				
DAT1227	6968	99	96	195		12	24	23	22	2.4				
DAT1227	6969	98	96	194		12	25	0	22	2.4				
DAT1227	6970	98	96	194	194	12	25	1	22	2.4	2.38			
DAT1227	6971	99	97	196		12	25	2	22	2.4				
DAT1227	6972	99	96	195		12	25	3	22	2.4				
DAT1227	6973	99	97	196		12	25	4	22	2.4				
DAT1227	6974	99	96	195		12	25	5	22	2.4				
DAT1227	6975	98	96	194		12	25	6	22	2.4				
DAT1227	6976	98	96	194		12	25	7	22	2.4				
DAT1227	6977	98	95	193		12	25	8	22	2.4				
DAT1227	6978	99	97	196		12	25	9	22	2.4				
DAT1227	6979	98	97	195		12	25	10	22	2.5				
DAT1227	6980	99	97	196	195	12	25	11	22	2.5	2.42			
DAT1227	6981	99	95	194		12	25	12	22	2.5				
DAT1227	6982	98	97	195		12	25	13	22	2.5				
DAT1227	6983	99	97	196		12	25	14	22	2.5				
DAT1227	6984	99	96	195		12	25	15	22	2.5				
DAT1227	6985	99	97	196		12	25	16	22	2.5				
DAT1227	6986	99	96	195		12	25	17	22	2.5				
DAT1227	6987	99	96	195		12	25	18	22	2.5				
DAT1227	6988	99	97	196		12	25	19	22	2.5				
DAT1227	6989	99	98	197		12	25	20	22	2.4				
DAT1227	6990	97	96	193	195	12	25	21	22	2.4	2.48			
DAT1227	6991	98	98	196		12	25	22	22	2.4				
DAT1227	6992	99	96	195		12	25	23	22	2.4				
DAT1227	6993	99	97	196		12	26	0	22	2.4				
DAT1227	6994	99	96	195		12	26	1	22	2.4				
DAT1227	6995	99	96	195		12	26	2	22	2.4				
DAT1227	6996	99	96	195		12	26	3	22	2.4				
DAT1227	6997	99	96	195		12	26	4	22	2.4				
DAT1227	6998	98	97	195		12	26	5	22	2.4				
DAT1227	6999	99	96	195		12	26	6	22	2.4				
DAT1227	7000	99	97	196	195	12	26	7	22	2.4	2.4			

Appendix T: "Life" Reliability Test Data, Test #11 (Test Period #10)

Stored in:	Test #	Devices Upset				Date(96)	Time		File size (Mb)			Notes
		Bd #1	Bd #2	Total	Ave		full	ave	part			
DAT1227	7001	99	96	195		12	26	8	22	2.4		
DAT1227	7002	98	97	195		12	26	9	22	2.4		
DAT1227	7003	98	97	195		12	26	10	22	2.4		
DAT1227	7004	99	96	195		12	26	11	22	2.4		
DAT1227	7005	100	96	196		12	26	12	22	2.4		
DAT1227	7006	99	98	197		12	26	13	22	2.4		
DAT1227	7007	96	97	193		12	26	14	22	2.4		
DAT1227	7008	99	97	196		12	26	15	22	2.4		
DAT1227	7009	98	97	195		12	26	16	22	2.4		
DAT1227	7010	99	97	196	195	12	26	17	22	2.4	2.4	
DAT1227	7011	98	96	194		12	26	18	22	2.4		
DAT1227	7012	99	96	195		12	26	19	22	2.4		
DAT1227	7013	98	96	194		12	26	20	22	2.3		
DAT1227	7014	99	97	196		12	26	21	22	2.4		
DAT1227	7015	99	96	195		12	26	22	22	2.3		
DAT1227	7016	100	97	197		12	26	23	22	2.4		
DAT1227	7017	98	97	195		12	27	0	22	2.4		
DAT1227	7018	100	100	200		12	27	1	22	4.9		
DAT1230	7019	92	93	185		12	28	22	24		0.16	4 Min
DAT1230	7020	98	96	194	195	12	28	23	24	2.5	2.67	
DAT1230	7021	99	98	197		12	29	0	24	2.5		
DAT1230	7022	99	97	196		12	29	1	24	2.5		
DAT1230	7023	99	98	197		12	29	2	24	2.6		
DAT1230	7024	99	97	196		12	29	3	24	2.5		
DAT1230	7025	99	97	196		12	29	4	24	2.6		
DAT1230	7026	99	97	196		12	29	5	24	2.6		
DAT1230	7027	98	98	196		12	29	6	24	2.5		
DAT1230	7028	97	95	192		12	29	7	24	2.6		
DAT1230	7029	97	96	193		12	29	8	24	2.5		
DAT1230	7030	99	97	196	196	12	29	9	24	2.6	2.55	
DAT1230	7031	98	97	195		12	29	10	24	2.5		
DAT1230	7032	99	97	196		12	29	11	24	2.5		
DAT1230	7033	99	97	196		12	29	12	24	2.5		
DAT1230	7034	98	97	195		12	29	13	24	2.6		
DAT1230	7035	99	97	196		12	29	14	24	2.5		
DAT1230	7036	98	98	196		12	29	15	24	2.6		
DAT1230	7037	97	96	193		12	29	16	24	2.5		
DAT1230	7038	98	96	194		12	29	17	24	2.6		
DAT1230	7039	99	98	197		12	29	18	24	2.5		
DAT1230	7040	99	95	194	195	12	29	19	24	2.4	2.52	
DAT1230	7041	99	97	196		12	29	20	24	2.5		
DAT1230	7042	98	96	194		12	29	21	24	2.5		
DAT1230	7043	97	97	194		12	29	22	24	2.6		
DAT1230	7044	99	97	196		12	29	23	24	2.5		
DAT1230	7045	99	97	196		12	30	0	24	2.5		
DAT1230	7046	98	96	194		12	30	1	24	2.5		
DAT1230	7047	99	96	195		12	30	2	24	2.5		
DAT1230	7048	98	96	194		12	30	3	24	2.6		
DAT1230	7049	98	96	194		12	30	4	24	2.6		
DAT1230	7050	98	97	195	195	12	30	5	24	2.5	2.53	

Appendix T: "Life" Reliability Test Data, Test #11 (Test Period #10)

Stored in:	Test #	Devices Upset				Ave	Date(96)		Time		File size (Mb)			Notes
		Bd #1	Bd #2	Total					full	ave	part			
DAT1230	7051	99	96	195		12	30	6	24	2.6				
DAT1230	7052	99	97	196		12	30	7	24	2.6				
DAT1230	7053	99	97	196		12	30	8	24	2.6				
DAT1230	7054	98	96	194		12	30	9	24	2.6				
DAT1230	7055	98	96	194		12	30	10	24	2.5				
DAT1230	7056	99	96	195		12	30	11	24	2.5				
DAT1230	7057	97	98	195		12	30	12	24	2.6				
DAT1230	7058	99	96	195		12	30	13	24	2.5				
DAT1230	7059	99	97	196		12	30	14	24	2.5				
DAT1230	7060	98	95	193	195	12	30	15	24	2.5	2.55			
DAT1230	7061	99	98	197		12	30	16	24	2.5				
DAT1230	7062	99	97	196		12	30	17	24	2.6				
DAT1230	7063	99	97	196		12	30	18	24	2.6				
DAT1230	7064	99	98	197		12	30	19	24	2.6				
DAT1230	7065	100	97	197		12	30	20	24	2.6				
DAT1230	7066	98	97	195		12	30	21	24	2.6				
DAT0101	7067	99	96	195		12	30	22	24	2.5				
DAT0101	7068	99	98	197		12	30	23	24	2.6				
DAT0101	7069	98	97	195		12	31	0	24	2.6				
DAT0101	7070	97	95	192	196	12	31	1	24	2.6	2.58			
DAT0101	7071	99	95	194		12	31	2	24	2.5				
DAT0101	7072	96	96	192		12	31	3	24	2.5				
DAT0101	7073	98	96	194		12	31	4	24	2.5				
DAT0101	7074	98	97	195		12	31	5	24	2.5				
DAT0101	7075	99	97	196		12	31	6	24	2.5				
DAT0101	7076	98	96	194		12	31	7	24	2.5				
DAT0101	7077	98	98	196		12	31	8	24	2.5				
DAT0101	7078	99	96	195		12	31	9	24	2.5				
DAT0101	7079	99	97	196		12	31	10	24	2.5				
DAT0101	7080	99	96	195	195	12	31	11	24	2.5	2.5			
DAT0101	7081	99	97	196		12	31	12	24	2.5				
DAT0101	7082	98	96	194		12	31	13	24	2.5				
DAT0101	7083	99	97	196		12	31	14	24	2.5				
DAT0101	7084	97	97	194		12	31	15	24	2.6				
DAT0101	7085	99	97	196		12	31	16	24	2.5				
DAT0101	7086	98	97	195		12	31	17	24	2.5				
DAT0101	7087	99	97	196		12	31	18	24	2.5				
DAT0101	7088	99	96	195		12	31	19	24	2.5				
DAT0101	7089	98	97	195		12	31	20	24	2.5				
DAT0101	7090	99	97	196	195	12	31	21	24	2.5	2.51			
DAT0101	7091	99	97	196		12	31	22	24	2.5				
DAT0101	7092	98	96	194		12	31	23	24	2.5				
DAT0101	7093	99	96	195		1	1	0	24	2.5				
DAT0101	7094	97	96	193		1	1	1	24	2.5				
DAT0101	7095	98	97	195		1	1	2	24	2.5				
DAT0101	7096	98	96	194		1	1	3	24	2.4				
DAT0101	7097	99	97	196		1	1	4	24	2.5				
DAT0101	7098	98	96	194		1	1	5	24	2.5				
DAT0101	7099	99	97	196		1	1	6	24	2.5				
DAT0101	7100	98	96	194	195	1	1	7	24	2.5	2.49			

Appendix T: "Life" Reliability Test Data, Test #11 (Test Period #10)

Stored in:	Test #	Devices Upset				Ave	Date(96)		Time		File size (Mb)			Notes
		Bd #1	Bd #2	Total					full	ave	part			
DAT0101	7101	98	98	196		1	1	8	24	2.4				
DAT0101	7102	98	96	194		1	1	9	24	2.5				
DAT0101	7103	98	97	195		1	1	10	24	2.5				
DAT0101	7104	99	96	195		1	1	11	24	2.5				
DAT0101	7105	98	96	194		1	1	12	24	2.5				
DAT0101	7106	98	97	195		1	1	13	24	2.5				
DAT0101	7107	99	95	194		1	1	14	24	2.5				
DAT0101	7108	99	97	196		1	1	15	24	2.5				
DAT0101	7109	98	97	195		1	1	16	24	2.5				
DAT0101	7110	98	96	194	195	1	1	17	24	2.5	2.49			
DAT0101	7111	99	97	196		1	1	18	24	2.5				
DAT0101	7112	97	97	194		1	1	19	24	2.5				
DAT0101	7113	99	98	197		1	1	20	24	2.5				
DAT0101	7114	99	97	196		1	1	21	24	2.5				
DAT0103	7115	89	92	181		1	1	22	56			0.17	4 Min	
DAT0103	7116	99	96	195		1	1	23	56	2.5				
DAT0103	7117	98	97	195		1	2	0	56	2.5				
DAT0103	7118	99	97	196		1	2	1	56	2.5				
DAT0103	7119	99	96	195		1	2	2	56	2.5				
DAT0103	7120	95	99	194	194	1	2	3	56	2.6	2.51			
DAT0103	7121	99	96	195		1	2	4	56	2.5				
DAT0103	7122	99	96	195		1	2	5	56	2.6				
DAT0103	7123	99	96	195		1	2	6	56	2.5				
DAT0103	7124	98	95	193		1	2	7	56	2.6				
DAT0103	7125	98	96	194		1	2	8	56	2.5				
DAT0103	7126	98	97	195		1	2	9	56	2.5				
DAT0103	7127	99	96	195		1	2	10	56	2.5				
DAT0103	7128	99	98	197		1	2	11	56	2.5				
DAT0103	7129	99	96	195		1	2	12	56	2.5				
DAT0103	7130	99	96	195	195	1	2	13	56	2.5	2.52			
DAT0103	7131	99	94	193		1	2	14	56	2.5				
DAT0103	7132	99	97	196		1	2	15	56	2.5				
DAT0103	7133	99	95	194		1	2	16	56	2.5				
DAT0103	7134	99	97	196		1	2	17	56	2.5				
DAT0103	7135	98	96	194		1	2	18	56	2.6				
DAT0103	7136	99	97	196		1	2	19	56	2.5				
DAT0103	7137	99	97	196		1	2	20	56	2.6				
DAT0103	7138	99	97	196		1	2	21	56	2.6				
DAT0103	7139	99	96	195		1	2	22	56	2.6				
DAT0103	7140	100	96	196	195	1	2	23	56	2.6	2.55			
DAT0103	7141	99	96	195		1	3	0	56	2.6				
DAT0103	7142	99	97	196		1	3	1	56	2.5				
DAT0103	7143	96	96	192		1	3	2	56	2.5				
DAT0103	7144	98	97	195		1	3	3	56	2.5				
DAT0103	7145	98	96	194		1	3	4	56	2.5				
DAT0103	7146	99	96	195		1	3	5	56	2.5				
DAT0103	7147	99	96	195		1	3	6	56	2.5				
DAT0103	7148	99	96	195		1	3	7	56	2.5				
DAT0103	7149	97	95	192		1	3	8	56	2.5				
DAT0103	7150	99	96	195	194	1	3	9	56	2.5	2.51			

Appendix T: "Life" Reliability Test Data, Test #11 (Test Period #10)

Stored in:	Test #	Devices Upset				Ave	Date(96)		Time		File size (Mb)			Notes
		Bd #1	Bd #2	Total					full	ave	part			
DAT0103	7151	98	97	195		1	3	10	56	2.5				
DAT0103	7152	97	95	192		1	3	11	56	2.5				
DAT0103	7153	99	97	196		1	3	12	56	2.5				
DAT0103	7154	99	98	197		1	3	13	56	2.5				
DAT0103	7155	99	95	194		1	3	14	56	2.5				
DAT0103	7156	99	98	197		1	3	15	56	2.5				
DAT0103	7157	98	97	195		1	3	16	56	2.5				
DAT0103	7158	99	96	195		1	3	17	56	2.5				
DAT0103	7159	99	90	195		1	3	18	56	2.5				
DAT0103	7160	99	96	195	195	1	3	19	56	2.5	2.5			
DAT0103	7161	99	96	195		1	3	20	56	2.5				
DAT0103	7162	99	95	194		1	3	21	45			1.9		
DAT0106	7163	93	92	185		1	3	23	19			0.17	4 Min	
DAT0106	7164	99	96	195		1	4	0	19	2.4				
DAT0106	7165	98	96	194		1	4	1	19	2.5				
DAT0106	7166	100	96	196		1	4	2	19	2.5				
DAT0106	7167	98	97	195		1	4	3	19	2.4				
DAT0106	7168	99	97	196		1	4	4	19	2.5				
DAT0106	7169	99	95	194		1	4	5	19	2.5				
DAT0106	7170	99	97	196	194	1	4	6	19	2.4	2.46			
DAT0106	7171	99	97	196		1	4	7	19	2.5				
DAT0106	7172	100	97	197		1	4	8	19	2.5				
DAT0106	7173	99	96	195		1	4	9	19	2.5				
DAT0106	7174	99	95	194		1	4	10	19	2.4				
DAT0106	7175	98	95	193		1	4	11	19	2.5				
DAT0106	7176	99	96	195		1	4	12	19	2.5				
DAT0106	7177	98	98	196		1	4	13	19	2.5				
DAT0106	7178	98	95	193		1	4	14	19	2.5				
DAT0106	7179	99	97	196		1	4	15	19	2.5				
DAT0106	7180	99	96	195	195	1	4	16	19	2.5	2.49			
DAT0106	7181	96	96	192		1	4	17	19	2.5				
DAT0106	7182	99	97	196		1	4	18	19	2.5				
DAT0106	7183	99	96	195		1	4	19	19	2.5				
DAT0106	7184	99	97	196		1	4	20	19	2.5				
DAT0106	7185	99	96	195		1	4	21	19	2.4				
DAT0106	7186	98	95	193		1	4	22	19	2.5				
DAT0106	7187	99	98	197		1	4	23	19	2.4				
DAT0106	7188	98	97	195		1	5	0	19	2.4				
DAT0106	7189	99	98	197		1	5	1	19	2.4				
DAT0106	7190	99	97	196	195	1	5	2	19	2.4	2.45			
DAT0106	7191	99	97	196		1	5	3	19	2.4				
DAT0106	7192	99	97	196		1	5	4	19	2.4				
DAT0106	7193	99	95	194		1	5	5	19	2.4				
DAT0106	7194	98	96	194		1	5	6	19	2.4				
DAT0106	7195	99	96	195		1	5	7	19	2.4				
DAT0106	7196	99	97	196		1	5	8	19	2.4				
DAT0106	7197	99	95	194		1	5	9	19	2.4				
DAT0106	7198	98	97	195		1	5	10	19	2.4				
DAT0106	7199	99	96	195		1	5	11	19	2.4				
DAT0106	7200	99	98	197	195	1	5	12	19	2.5	2.41			



Appendix T: "Life" Reliability Test Data, Test #11 (Test Period #10)

Stored in:	Test #	Devices Upset				Ave	Date(96)		Time		File size (Mb)			Notes
		Bd #1	Bd #2	Total					full	ave	part			
DAT0106	7201	98	98	196		1	5	13	19	2.5				
DAT0106	7202	99	97	196		1	5	14	19	2.6				
DAT0106	7203	99	97	196		1	5	15	19	2.5				
DAT0106	7204	99	97	196		1	5	16	19	2.4				
DAT0106	7205	98	97	195		1	5	17	19	2.5				
DAT0106	7206	99	96	195		1	5	18	19	2.5				
DAT0106	7207	99	97	196		1	5	19	19	2.4				
DAT0106	7208	99	98	197		1	5	20	19	2.4				
DAT0106	7209	99	98	197		1	5	21	19	2.4				
DAT0106	7210	99	96	195	196	1	5	22	19	2.4	2.46			
DAT0106	7211	99	97	196		1	5	23	19	2.4				
DAT0106	7212	99	98	197		1	6	0	19	2.4				
DAT0106	7213	99	95	194		1	6	1	19	2.4				
DAT0106	7214	99	97	196		1	6	2	19	2.4				
DAT0106	7215	99	96	195		1	6	3	19	2.4				
DAT0106	7216	99	98	197		1	6	4	19	2.4				
DAT0106	7217	99	96	195		1	6	5	19	2.4				
DAT0106	7218	99	96	195		1	6	6	19	2.4				
DAT0106	7219	99	98	197		1	6	7	19	2.5				
DAT0106	7220	99	97	196	196	1	6	8	19	2.5	2.42			
DAT0106	7221	99	97	196		1	6	9	19	2.5				
DAT0106	7222	99	98	197		1	6	10	19	2.5				
DAT0106	7223	94	97	191		1	6	10	31	2.5				
DAT0108	7224	88	90	178		1	6	16	36			0.17	4 Min	
DAT0108	7225	91	93	184		1	6	17	36	2.5				
DAT0108	7226	90	93	183		1	6	18	36	2.4				
DAT0108	7227	91	92	183		1	6	19	36	2.5				
DAT0108	7228	91	92	183		1	6	20	36	2.5				
DAT0108	7229	91	93	184		1	6	21	36	2.5				
DAT0108	7230	90	92	182	186	1	6	22	36	2.4	2.48			
DAT0108	7231	90	92	182		1	6	23	36	2.5				
DAT0108	7232	90	94	184		1	7	0	36	2.4				
DAT0108	7233	91	91	182		1	7	1	36	2.4				
DAT0108	7234	89	91	180		1	7	2	36	2.4				
DAT0108	7235	89	94	183		1	7	3	36	2.4				
DAT0108	7236	90	93	183		1	7	4	36	2.4				
DAT0108	7237	89	92	181		1	7	5	36	2.4				
DAT0108	7238	91	92	183		1	7	6	36	2.4				
DAT0108	7239	90	93	183		1	7	7	36	2.4				
DAT0108	7240	90	92	182	182	1	7	8	36	2.5	2.42			
DAT0108	7241	90	94	184		1	7	9	36	2.4				
DAT0108	7242	89	92	181		1	7	10	36	2.4				
DAT0108	7243	90	93	183		1	7	11	36	2.4				
DAT0108	7244	89	91	180		1	7	12	36	2.4				
DAT0108	7245	91	93	184		1	7	13	36	2.4				
DAT0108	7246	91	92	183		1	7	14	36	2.4				
DAT0108	7247	90	93	183		1	7	15	36	2.4				
DAT0108	7248	89	92	181		1	7	16	36	2.4				
DAT0108	7249	89	93	182		1	7	17	36	2.4				
DAT0108	7250	89	91	180	182	1	7	18	36	2.4	2.4			

Appendix T: "Life" Reliability Test Data, Test #11 (Test Period #10)

Stored in:	Test #	Devices Upset				Ave	Date(96)		Time		File size (Mb)			Notes
		Bd #1	Bd #2	Total					full	ave	part			
DAT0108	7251	90	92	182		1	7	19	36	2.4				
DAT0108	7252	89	93	182		1	7	20	36	2.4				
DAT0108	7253	90	91	181		1	7	21	36	2.4				
DAT0108	7254	90	92	182		1	7	22	36	2.4				
DAT0108	7255	90	93	183		1	7	23	36	2.4				
DAT0108	7256	89	93	182		1	8	0	36	2.4				
DAT0108	7257	91	91	182		1	8	1	36	2.4				
DAT0108	7258	91	92	183		1	8	2	36	2.4				
DAT0108	7259	90	90	180		1	8	3	36	2.4				
DAT0108	7260	91	91	182	182	1	8	4	36	2.4	2.4			
DAT0108	7261	90	90	180		1	8	5	36	2.4				
DAT0108	7262	91	91	182		1	8	6	36	2.5				
DAT0108	7263	90	90	180		1	8	7	36	2.4				
DAT0108	7264	91	92	183		1	8	8	36	2.5				
DAT0108	7265	91	89	180		1	8	9	36	2.5				
DAT0108	7266	90	89	179		1	8	10	10			1.3		
DAT0110	7267	87	85	172		1	8	14	11	2.4		0.16	4 Min	
DAT0110	7268	90	92	182		1	8	15	11	2.4				
DAT0110	7269	90	92	182		1	8	16	11	2.4				
DAT0110	7270	89	92	181	180	1	8	17	11	2.4	2.43			
DAT0110	7271	89	92	181		1	8	18	11	2.4				
DAT0110	7272	90	91	181		1	8	19	11	2.4				
DAT0110	7273	89	92	181		1	8	20	11	2.4				
DAT0110	7274	90	90	180		1	8	21	11	2.4				
DAT0110	7275	90	92	182		1	8	22	11	2.5				
DAT0110	7276	90	93	183		1	8	23	11	2.4				
DAT0110	7277	89	93	182		1	9	0	11	2.5				
DAT0110	7278	90	93	183		1	9	1	11	2.5				
DAT0110	7279	90	91	181		1	9	2	11	2.4				
DAT0110	7280	90	92	182	182	1	9	3	11	2.5	2.44			
DAT0110	7281	89	90	179		1	9	4	11	2.4				
DAT0110	7282	90	90	180		1	9	5	11	2.5				
DAT0110	7283	89	94	183		1	9	6	11	2.5				
DAT0110	7284	89	93	182		1	9	7	11	2.4				
DAT0110	7285	89	91	180		1	9	8	11	2.4				
DAT0110	7286	89	92	181		1	9	9	11	2.4				
DAT0110	7287	90	93	183		1	9	10	11	2.4				
DAT0110	7288	89	93	182		1	9	11	11	2.4				
DAT0110	7289	91	92	183		1	9	12	11	2.4				
DAT0110	7290	91	91	182	182	1	9	13	11	2.4	2.42			
DAT0110	7291	89	92	181		1	9	14	11	2.4				
DAT0110	7292	90	92	182		1	9	15	11	2.4				
DAT0110	7293	92	93	185		1	9	16	11	2.4				
DAT0110	7294	89	93	182		1	9	17	11	2.4				
DAT0110	7295	92	91	183		1	9	18	11	2.4				
DAT0110	7296	90	92	182		1	9	19	11	2.4				
DAT0110	7297	89	93	182		1	9	20	11	2.4				
DAT0110	7298	90	92	182		1	9	21	11	2.4				
DAT0110	7299	89	91	180		1	9	22	11	2.4				
DAT0110	7300	89	92	181	182	1	9	23	11	2.4	2.4			

Appendix T: "Life" Reliability Test Data, Test #11 (Test Period #10)

Stored in:	Test #	Devices Upset				Date(96)	Time		File size (Mb)			Notes
		Bd #1	Bd #2	Total	Ave				full	ave	part	
DAT0110	7301	90	92	182		1	10	0	11	2.4		
DAT0110	7302	90	91	181		1	10	1	11	2.4		
DAT0110	7303	89	90	179		1	10	2	11	2.4		
DAT0110	7304	91	91	182		1	10	3	11	2.4		
DAT0110	7305	90	91	181		1	10	4	11	2.4		
DAT0110	7306	91	92	183		1	10	5	11	2.4		
DAT0110	7307	90	90	180		1	10	6	11	2.4		
DAT0110	7308	90	93	183		1	10	7	11	2.4		
DAT0110	7309	90	91	181		1	10	8	11	2.4		
DAT0110	7310	91	93	184	182	1	10	9	11	2.4	2.4	
DAT0110	7311	92	91	183		1	10	10	11	2.4		
DAT0110	7312	89	90	179		1	10	11	11	2.4		
DAT0110	7313	90	91	181		1	10	12	11	2.4		
DAT0110	7314	90	91	181		1	10	13	11	2.4		
DAT0110	7315	92	92	184		1	10	14	11	2.4		
DAT0110	7316	90	90	180		1	10	14	35		0.94	
DAT0111	7317	87	84	171		1	10	15	39		0.16	4 Min
DAT0111	7318	89	91	180		1	10	16	39	2.4		
DAT0111	7319	90	91	181		1	10	17	39	2.4		
DAT0111	7320	90	90	180	180	1	10	18	39	2.4	2.4	
DAT0111	7321	89	92	181		1	10	19	39	2.4		
DAT0111	7322	89	91	180		1	10	20	39	2.4		
DAT0111	7323	89	91	180		1	10	21	39	2.3		
DAT0111	7324	89	92	181		1	10	22	39	2.4		
DAT0111	7325	89	93	182		1	10	23	39	2.4		
DAT0111	7326	89	91	180		1	11	0	39	2.3		
DAT0111	7327	89	92	181		1	11	1	39	2.3		
DAT0111	7328	89	92	181		1	11	2	39	2.4		
DAT0111	7329	89	92	181		1	11	3	39	2.4		
DAT0111	7330	89	89	178	181	1	11	4	39	2.4	2.37	
DAT0111	7331	91	92	183		1	11	5	39	2.4		
DAT0111	7332	89	92	181		1	11	6	39	2.4		
DAT0115	7333	87	85	172		1	13	10	58		0.16	4 Min
DAT0115	7334	89	91	180		1	13	11	58	2.3		
DAT0115	7335	88	92	180		1	13	12	58	2.4		
DAT0115	7336	88	93	181		1	13	13	58	2.4		
DAT0115	7337	88	92	180		1	13	14	58	2.4		
DAT0115	7338	89	90	179		1	13	15	58	2.4		
DAT0115	7339	89	92	181		1	13	16	58	2.3		
DAT0115	7340	88	91	179	180	1	13	17	58	2.4	2.38	
DAT0115	7341	88	89	177		1	13	18	58	2.4		
DAT0115	7342	89	91	180		1	13	19	58	2.4		
DAT0115	7343	89	90	179		1	13	20	58	2.3		
DAT0115	7344	88	92	180		1	13	21	58	2.3		
DAT0115	7345	89	91	180		1	13	22	58	2.3		
DAT0115	7346	90	91	181		1	13	23	58	2.3		
DAT0115	7347	90	91	181		1	14	0	58	2.3		
DAT0115	7348	89	90	179		1	14	1	58	2.3		
DAT0115	7349	92	93	185		1	14	2	58	2.3		
DAT0115	7350	90	92	182	180	1	14	3	58	2.3	2.32	

Appendix T: "Life" Reliability Test Data, Test #11 (Test Period #10)

Stored in:	Test #	Devices Upset				Ave	Date(96)		Time		File size (Mb)			Notes
		Bd #1	Bd #2	Total					full	ave	part			
DAT0115	7351	90	92	182		1	14	4	58	2.3				
DAT0115	7352	88	88	176		1	14	5	58	2.3				
DAT0115	7353	90	91	181		1	14	6	58	2.3				
DAT0115	7354	89	90	179		1	14	7	58	2.3				
DAT0115	7355	89	90	179		1	14	8	58	2.3				
DAT0115	7356	89	90	179		1	14	9	58	2.3				
DAT0115	7357	90	91	181		1	14	10	58	2.3				
DAT0115	7358	91	92	183		1	14	11	58	2.3				
DAT0115	7359	88	89	177		1	14	12	58	2.3				
DAT0115	7360	90	89	179	180	1	14	13	58	2.3	2.3			
DAT0115	7361	90	90	180		1	14	14	58	2.4				
DAT0115	7362	89	88	177		1	14	15	58	2.4				
DAT0115	7363	89	89	178		1	14	16	58	2.3				
DAT0115	7364	88	87	175		1	14	17	58	2.3				
DAT0115	7365	89	88	177		1	14	18	58	2.3				
DAT0115	7366	89	88	177		1	14	19	58	2.3				
DAT0115	7367	89	90	179		1	14	20	58	2.3				
DAT0115	7368	88	87	175		1	14	21	58	2.3				
DAT0115	7369	89	89	178		1	14	22	58	2.3				
DAT0115	7370	90	89	179	178	1	14	23	58	2.3	2.32			
DAT0115	7371	90	87	177		1	15	0	58	2.3				
DAT0115	7372	89	90	179		1	15	1	58	2.3				
DAT0115	7373	89	89	178		1	15	2	58	2.3				
DAT0115	7374	89	89	178		1	15	3	58	2.3				
DAT0115	7375	88	88	176		1	15	4	58	2.3				
DAT0115	7376	88	90	178		1	15	5	58	2.3				
DAT0115	7377	89	89	178		1	15	6	58	2.3				
DAT0115	7378	88	91	179		1	15	7	58	2.3				
DAT0115	7379	88	90	178		1	15	8	58	2.3				
DAT0115	7380	88	90	178	178	1	15	9	58	2.3	2.3			
DAT0115	7381	91	90	181		1	15	10	58	2.3				
DAT0115	7382	89	89	178		1	15	11	58	2.3				
DAT0116	7383	87	85	172		1	15	14	6			0.17	4 Min	
DAT0116	7384	91	87	178		1	15	15	6	2.4				
DAT0116	7385	90	88	178		1	15	16	6	2.4				
DAT0116	7386	88	93	181		1	15	17	6	2.4				
DAT0116	7387	89	90	179		1	15	18	6	2.4				
DAT0116	7388	88	93	181		1	15	19	6	2.3				
DAT0116	7389	89	92	181		1	15	20	6	2.3				
DAT0116	7390	90	91	181	179	1	15	21	6	2.3	2.34			
DAT0116	7391	89	89	178		1	15	22	6	2.3				
DAT0116	7392	90	90	180		1	15	23	6	2.3				
DAT0116	7393	89	92	181		1	16	0	6	2.3				
DAT0116	7394	89	89	178		1	16	1	6	2.3				
DAT0116	7395	88	90	178		1	16	2	6	2.3				
DAT0116	7396	90	88	178		1	16	3	6	2.3				
DAT0116	7397	90	88	178		1	16	4	6	2.3				
DAT0116	7398	88	88	176		1	16	5	6	2.3				
DAT0116	7399	88	89	177		1	16	6	6	2.3				
DAT0116	7400	89	90	179	178	1	16	7	6	2.3	2.3			



APPENDIX U: Sweep Reliability Test Data, Test # 12, (Test Period 11)

Stored in:	Test #	Devices Upset				Date(97)	Time	File size (Mb)			Notes
		Bd #1	Bd #2	Total	Ave			full	ave	part	
DAT0120	7451	0	0	0		1 17	17 11	0.10			.7 to 2 GHz
DAT0120	7452	0	0	0		1 17	18 11	0.10			0.25 rpm
DAT0120	7453	0	0	0		1 17	19 11	0.10			1 sec sweep
DAT0120	7454	0	0	0		1 17	20 11	0.10			140 W @ 8 GHz
DAT0120	7455	0	0	0		1 17	21 11	0.10			30 W @ 18 GHz
DAT0120	7456	0	0	0		1 17	22 11	0.10			50 W ave
DAT0120	7457	0	0	0		1 17	23 11	0.10			
DAT0120	7458	0	0	0		1 18	0 11	0.10			
DAT0120	7459	0	0	0		1 18	1 11	0.10			
DAT0120	7460	0	0	0	0	1 18	2 11	0.10	0.1		
DAT0120	7461	0	0	0		1 18	3 11	0.10			
DAT0120	7462	0	0	0		1 18	4 11	0.10			
DAT0120	7463	0	0	0		1 18	5 11	0.10			
DAT0120	7464	0	0	0		1 18	6 11	0.10			
DAT0120	7465	0	0	0		1 18	7 11	0.10			
DAT0120	7466	0	0	0		1 18	8 11	0.10			
DAT0120	7467	0	0	0		1 18	9 11	0.10			
DAT0120	7468	0	0	0		1 18	10 11	0.10			
DAT0120	7469	0	0	0		1 18	11 11	0.10			
DAT0120	7470	0	0	0	0	1 18	12 11	0.10	0.1		
DAT0120	7471	0	0	0		1 18	13 11	0.10			
DAT0120	7472	0	0	0		1 18	14 11	0.10			
DAT0120	7473	0	0	0		1 18	15 11	0.10			
DAT0120	7474	0	0	0		1 18	16 11	0.10			
DAT0120	7475	0	0	0		1 18	17 11	0.10			
DAT0120	7476	0	0	0		1 18	18 11	0.10			
DAT0120	7477	0	0	0		1 18	19 11	0.10			
DAT0120	7478	0	0	0		1 18	20 11	0.10			
DAT0120	7479	0	0	0		1 18	21 11	0.10			
DAT0120	7480	0	0	0	0	1 18	22 11	0.10	0.1		
DAT0120	7481	0	0	0		1 18	23 11	0.10			
DAT0120	7482	0	0	0		1 19	0 11	0.10			
DAT0120	7483	0	0	0		1 19	1 11	0.10			
DAT0120	7484	0	0	0		1 19	2 11	0.10			
DAT0120	7485	0	0	0		1 19	3 11	0.10			
DAT0120	7486	0	0	0		1 19	4 11	0.10			
DAT0120	7487	0	0	0		1 19	5 11	0.10			
DAT0120	7488	0	0	0		1 19	6 11	0.10			
DAT0120	7489	0	0	0		1 19	7 11	0.10			
DAT0120	7490	0	0	0	0	1 19	8 11	0.10	0.1		
DAT0120	7491	0	0	0		1 19	9 11	0.10			
DAT0120	7492	0	0	0		1 19	10 11	0.10			
DAT0120	7493	0	0	0		1 19	11 11	0.10			
DAT0120	7494	0	0	0		1 19	12 11	0.10			
DAT0120	7495	0	0	0		1 19	13 11	0.10			
DAT0120	7496	0	0	0		1 19	14 11	0.10			
DAT0120	7497	0	0	0		1 19	15 11	0.10			
DAT0120	7498	0	0	0		1 19	16 11	0.10			
DAT0120	7499	0	0	0		1 19	17 11	0.10			
DAT0120	7500	0	0	0	0	1 19	18 11	0.10	0.1		

APPENDIX U: Sweep Reliability Test Data, Test # 12, (Test Period 11)

Stored in:	Test #	Devices Upset				Date(97)	Time	File size (Mb)			Notes
		Bd #1	Bd #2	Total	Ave			full	ave	part	
DAT0120	7501	0	0	0		1 19	19 11	0.10			
DAT0120	7502	0	0	0		1 19	20 11	0.10			
DAT0120	7503	0	0	0		1 19	21 11	0.10			
DAT0120	7504	0	0	0		1 19	22 11	0.10			
DAT0120	7505	0	0	0		1 19	23 11	0.10			
DAT0120	7506	0	0	0		1 20	0 11	0.10			
DAT0120	7507	0	0	0		1 20	1 11	0.10			
DAT0120	7508	0	0	0		1 20	2 11	0.10			
DAT0120	7509	0	0	0		1 20	3 11	0.10			
DAT0120	7510	0	0	0	0	1 20	4 11	0.10	0.1		
DAT0120	7511	0	0	0		1 20	5 11	0.10			
DAT0120	7512	0	0	0		1 20	6 11	0.10			
DAT0120	7513	0	0	0		1 20	7 11	0.10			
DAT0120	7514	0	0	0		1 20	8 11	0.10			
DAT0120	7515	0	0	0		1 20	9 11	0.10			
DAT0120	7516	0	0	0		1 20	9 41			0.5	
DAT0122	7517	0	0	0		1 20	10 55	0.10			0.5 rpm
DAT0122	7518	0	0	0		1 20	11 55	0.10			3 sec sweep
DAT0122	7519	0	0	0		1 20	12 55	0.10			
DAT0122	7520	0	0	0	0	1 20	13 55	0.10	0.1		
DAT0122	7521	0	0	0		1 20	14 55	0.10			
DAT0122	7522	0	0	0		1 20	15 55	0.10			
DAT0122	7523	0	0	0		1 20	16 55	0.10			
DAT0122	7524	0	0	0		1 20	17 55	0.10			
DAT0122	7525	0	0	0		1 20	18 55	0.10			
DAT0122	7526	0	0	0		1 20	19 55	0.10			
DAT0122	7527	0	0	0		1 20	20 55	0.10			
DAT0122	7528	0	0	0		1 20	21 55	0.10			
DAT0122	7529	0	0	0		1 20	22 55	0.10			
DAT0122	7530	0	0	0	0	1 20	23 55	0.10	0.1		
DAT0122	7531	0	0	0		1 21	0 55	0.10			
DAT0122	7532	0	0	0		1 21	1 55	0.10			
DAT0122	7533	0	0	0		1 21	2 55	0.10			
DAT0122	7534	0	0	0		1 21	3 55	0.10			
DAT0122	7535	0	0	0		1 21	4 55	0.10			
DAT0122	7536	0	0	0		1 21	5 55	0.10			
DAT0122	7537	0	0	0		1 21	6 55	0.10			
DAT0122	7538	0	0	0		1 21	7 55	0.10			
DAT0122	7539	0	0	0		1 21	8 55	0.10			
DAT0122	7540	0	0	0	0	1 21	9 55	0.10	0.1		
DAT0122	7541	0	0	0		1 21	10 55	0.10			
DAT0122	7542	0	0	0		1 21	11 55	0.10			
DAT0122	7543	0	0	0		1 21	12 55	0.10			
DAT0122	7544	0	0	0		1 21	13 55	0.10			
DAT0122	7545	0	0	0		1 21	14 55	0.10			
DAT0122	7546	0	0	0		1 21	15 55	0.10			
DAT0122	7547	0	0	0		1 21	16 55	0.10			
DAT0122	7548	0	0	0		1 21	17 55	0.10			
DAT0122	7549	0	0	0		1 21	18 55	0.10			
DAT0122	7550	0	0	0	0	1 21	19 55	0.10	0.1		

APPENDIX U: Sweep Reliability Test Data, Test # 12, (Test Period 11)

Stored in:	Test #	Devices Upset				Date(97)	Time	File size (Mb)			Notes
		Bd #1	Bd #2	Total	Ave			full	ave	part	
DAT0122	7551	0	0	0		1 21	20 55	0.1			
DAT0122	7552	0	0	0		1 21	21 55	0.10			
DAT0122	7553	0	0	0		1 21	22 55	0.10			
DAT0122	7554	0	0	0		1 21	23 55	0.10			
DAT0122	7555	0	0	0		1 22	0 55	0.10			
DAT0122	7556	0	0	0		1 22	1 55	0.10			
DAT0122	7557	0	0	0		1 22	2 55	0.10			
DAT0122	7558	0	0	0		1 22	3 55	0.10			
DAT0122	7559	0	0	0		1 22	4 55	0.10			
DAT0122	7560	0	0	0	0	1 22	5 55	0.10	0.1		
DAT0122	7561	0	0	0		1 22	6 55	0.10			
DAT0122	7562	0	0	0		1 22	7 55	0.10			
DAT0122	7563	0	0	0		1 22	8 55	0.10			
DAT0122	7564	0	0	0		1 22	9 55	0.10			
DAT0122	7565	0	0	0		1 22	10 55	0.10			
DAT0122	7566	0	0	0		1 22	10 58			0.04	
DAT0124	7567	0	0	0		1 22	12 15	0.10			1 rpm
DAT0124	7568	0	0	0		1 22	13 15	0.10			0.1 sec sweep
DAT0124	7569	0	0	0		1 22	14 15	0.10			
DAT0124	7570	0	0	0	0	1 22	15 15	0.10	0.1		
DAT0124	7571	0	0	0		1 22	16 15	0.10			
DAT0124	7572	0	0	0		1 22	17 15	0.10			
DAT0124	7573	0	0	0		1 22	18 15	0.10			
DAT0124	7574	0	0	0		1 22	19 15	0.10			
DAT0124	7575	0	0	0		1 22	20 15	0.10			
DAT0124	7576	0	0	0		1 22	21 15	0.10			
DAT0124	7577	0	0	0		1 22	22 15	0.10			
DAT0124	7578	0	0	0		1 22	23 15	0.10			
DAT0124	7579	0	0	0		1 23	0 15	0.10			
DAT0124	7580	0	0	0	0	1 23	1 15	0.10	0.1		
DAT0124	7581	0	0	0		1 23	2 15	0.10			
DAT0124	7582	0	0	0		1 23	3 15	0.10			
DAT0124	7583	0	0	0		1 23	4 15	0.10			
DAT0124	7584	0	0	0		1 23	5 15	0.10			
DAT0124	7585	0	0	0		1 23	6 15	0.10			
DAT0124	7586	0	0	0		1 23	7 15	0.10			
DAT0124	7587	0	0	0		1 23	8 15	0.10			
DAT0124	7588	0	0	0		1 23	9 15	0.10			
DAT0124	7589	0	0	0		1 23	10 15	0.10			
DAT0124	7590	0	0	0	0	1 23	11 15	0.10	0.1		
DAT0124	7591	0	0	0		1 23	12 15	0.10			
DAT0124	7592	0	0	0		1 23	13 15	0.10			
DAT0124	7593	0	0	0		1 23	14 15	0.10			
DAT0124	7594	0	0	0		1 23	15 15	0.10			
DAT0124	7595	0	0	0		1 23	16 15	0.10			
DAT0124	7596	0	0	0		1 23	17 15	0.10			
DAT0124	7597	0	0	0		1 23	18 15	0.10			
DAT0124	7598	0	0	0		1 23	19 15	0.10			
DAT0124	7599	0	0	0		1 23	20 15	0.10			
DAT0124	7600	0	0	0	0	1 23	21 15	0.10	0.1		



APPENDIX U: Sweep Reliability Test Data, Test # 12, (Test Period 11)

Stored in:	Test #	Devices Upset				Date(97)	Time	File size (Mb)			Notes
		Bd #1	Bd #2	Total	Ave			full	ave	part	
DAT0124	7601	0	0	0		1 23	22 15	0.10			
DAT0124	7602	0	0	0		1 23	23 15	0.10			
DAT0124	7603	0	0	0		1 24	0 15	0.10			
DAT0124	7604	0	0	0		1 24	1 15	0.10			
DAT0124	7605	0	0	0		1 24	2 15	0.10			
DAT0124	7606	0	0	0		1 24	3 15	0.10			
DAT0124	7607	0	0	0		1 24	4 15	0.10			
DAT0124	7608	0	0	0		1 24	5 15	0.10			
DAT0124	7609	0	0	0		1 24	6 15	0.10			
DAT0124	7610	0	0	0	0	1 24	7 15	0.10	0.1		
DAT0124	7611	0	0	0		1 24	8 15	0.10			
DAT0124	7612	0	0	0		1 24	9 15	0.10			
DAT0124	7613	0	0	0		1 24	10 15	0.10			
DAT0124	7614	0	0	0		1 24	11 15	0.10			
DAT0124	7615	0	0	0		1 24	12 15	0.10			
DAT0124	7616	0	0	0		1 24	13 15	0.10			
DAT0124	7617	0	0	0		1 24	14 15	0.10			
DAT0124	7618	0	0	0		1 24	15 11			0.9	
DAT0127	7619	59	35	94		1 24	17 1	0.26			4 to 8 GHz
DAT0127	7620	59	39	98	19	1 24	18 1	0.26	0.14		1/4 rpm
DAT0127	7621	58	34	92		1 24	19 1	0.26			10 sec sweep
DAT0127	7622	58	36	94		1 24	20 1	0.26			300W @ 4 GHz
DAT0127	7623	57	36	93		1 24	21 1	0.25			50 W @ 8 GHz
DAT0127	7624	61	39	100		1 24	22 1	0.25			150 W average
DAT0127	7625	60	38	98		1 24	23 1	0.25			
DAT0127	7626	54	32	86		1 25	0 1	0.21			
DAT0127	7627	0	0	0		1 25	1 1	0.10			RF pwr amp off
DAT0127	7628	0	0	0		1 25	2 1	0.10			"
DAT0127	7629	0	0	0		1 25	3 1	0.10			"
DAT0127	7630	0	0	0	56	1 25	4 1	0.10	0.19		"
DAT0127	7631	0	0	0		1 25	5 1	0.10			"
DAT0127	7632	0	0	0		1 25	6 1	0.10			"
DAT0127	7633	0	0	0		1 25	7 1	0.10			"
DAT0127	7634	0	0	0		1 25	8 1	0.10			"
DAT0127	7635	0	0	0		1 25	9 1	0.10			"
DAT0127	7636	0	0	0		1 25	10 1	0.10			"
DAT0127	7637	0	0	0		1 25	11 1	0.10			"
DAT0127	7638	0	0	0		1 25	12 1	0.10			"
DAT0127	7639	0	0	0		1 25	13 1	0.10			"
DAT0127	7640	0	0	0	0	1 25	14 1	0.10	0.1		"
DAT0127	7641	0	0	0		1 25	15 1	0.10			"
DAT0127	7642	0	0	0		1 25	16 1	0.10			"
DAT0127	7643	0	0	0		1 25	17 1	0.10			"
DAT0127	7644	0	0	0		1 25	18 1	0.10			"
DAT0127	7645	0	0	0		1 25	19 1	0.10			"
DAT0127	7646	0	0	0		1 25	20 1	0.10			"
DAT0127	7647	0	0	0		1 25	21 1	0.10			"
DAT0127	7648	0	0	0		1 25	22 1	0.10			"
DAT0127	7649	0	0	0		1 25	23 1	0.10			"
DAT0127	7650	0	0	0	0	1 26	0 1	0.10	0.1		"

APPENDIX U: Sweep Reliability Test Data, Test # 12, (Test Period 11)

Stored in:	Test #	Devices Upset				Date(97)	Time		File size (Mb)			Notes
		Bd #1	Bd #2	Total	Ave		full	ave	part			
DAT0127	7651	0	0	0		1	26	1	1	0.10		RF pwr amp off
DAT0127	7652	0	0	0		1	26	2	1	0.10		.
DAT0127	7653	0	0	0		1	26	3	1	0.10		.
DAT0127	7654	0	0	0		1	26	4	1	0.10		.
DAT0127	7655	0	0	0		1	26	5	1	0.10		.
DAT0127	7656	0	0	0		1	26	6	1	0.10		.
DAT0127	7657	0	0	0		1	26	7	1	0.10		.
DAT0127	7658	0	0	0		1	26	8	1	0.10		.
DAT0127	7659	0	0	0		1	26	9	1	0.10		.
DAT0127	7660	0	0	0	0	1	26	10	1	0.10	0.1	.
DAT0127	7661	0	0	0		1	26	11	1	0.10		.
DAT0127	7662	0	0	0		1	26	12	1	0.10		.
DAT0127	7663	0	0	0		1	26	13	1	0.10		.
DAT0127	7664	0	0	0		1	26	14	1	0.10		.
DAT0127	7665	0	0	0		1	26	15	1	0.10		.
DAT0127	7666	0	0	0		1	26	16	1	0.10		.
DAT0127	7667	0	0	0		1	26	17	1	0.10		.
DAT0127	7668	0	0	0		1	26	18	1	0.10		.
DAT0127	7669	0	0	0		1	26	19	1	0.10		.
DAT0127	7670	0	0	0	0	1	26	20	1	0.10	0.1	.
DAT0127	7671	0	0	0		1	26	21	1	0.10		.
DAT0127	7672	0	0	0		1	26	22	1	0.10		.
DAT0127	7673	0	0	0		1	26	23	1	0.10		.
DAT0127	7674	0	0	0		1	27	0	1	0.10		.
DAT0127	7675	0	0	0		1	27	1	1	0.10		.
DAT0127	7676	0	0	0		1	27	2	1	0.10		.
DAT0127	7677	0	0	0		1	27	3	1	0.10		.
DAT0127	7678	0	0	0		1	27	4	1	0.10		.
DAT0127	7679	0	0	0		1	27	5	1	0.10		.
DAT0127	7680	0	0	0	0	1	27	6	1	0.10	0.1	.
DAT0127	7681	0	0	0		1	27	7	1	0.10		.
DAT0127	7682	0	0	0		1	27	8	1	0.10		.
DAT0127	7683	0	0	0		1	27	9	1	0.10		.
DAT0127	7684	0	0	0		1	27	10	1	0.10		.
DAT0127	7685	55	100	155		1	27	11	1	0.19		
DAT0129	7686	61	39	100		1	27	12	14	0.48		1/2 rpm
DAT0129	7687	61	38	99		1	27	13	14	0.48		3 sec sweep
DAT0129	7688	60	41	101		1	27	14	14	0.48		
DAT0129	7689	61	39	100		1	27	15	14	0.47		
DAT0129	7690	60	40	100	66	1	27	16	14	0.47	0.3	
DAT0129	7691	59	41	100		1	27	17	14	0.47		
DAT0129	7692	61	35	96		1	27	18	14	0.47		
DAT0129	7693	60	40	100		1	27	19	14	0.46		
DAT0129	7694	59	40	99		1	27	20	14	0.46		
DAT0129	7695	59	39	98		1	27	21	14	0.46		
DAT0129	7696	59	39	98		1	27	22	14	0.45		
DAT0129	7697	59	38	97		1	27	23	14	0.45		
DAT0129	7698	59	38	97		1	28	0	14	0.45		
DAT0129	7699	59	39	98		1	28	1	14	0.45		
DAT0129	7700	58	39	97	98	1	28	2	14	0.45	0.46	

APPENDIX U: Sweep Reliability Test Data, Test # 12, (Test Period 11)

Stored in:	Test #	Devices Upset				Date(97)	Time	File size (Mb)			Notes
		Bd #1	Bd #2	Total	Ave			full	ave	part	
DAT0129	7701	59	37	96		1 28	3 14	0.44			
DAT0129	7702	58	36	94		1 28	4 14	0.44			
DAT0129	7703	61	38	99		1 28	5 14	0.44			
DAT0129	7704	59	38	97		1 28	6 14	0.44			
DAT0129	7705	60	39	99		1 28	7 14	0.44			
DAT0129	7706	59	37	96		1 28	8 14	0.44			
DAT0129	7707	60	37	97		1 28	9 14	0.44			
DAT0129	7708	57	36	93		1 28	10 14	0.43			
DAT0129	7709	58	36	94		1 28	11 14	0.43			
DAT0129	7710	57	35	92	96	1 28	12 14	0.43	0.44		
DAT0129	7711	59	38	97		1 28	13 14	0.43			
DAT0129	7712	59	37	96		1 28	14 14	0.12			
DAT0129	7713	48	27	75		1 28	15 14	0.10			
DAT0129	7714	0	0	0		1 28	16 14	0.10			RF pwr amp off
DAT0129	7715	0	0	0		1 28	17 14	0.10			"
DAT0129	7716	0	0	0		1 28	18 14	0.10			"
DAT0129	7717	0	0	0		1 28	19 14	0.10			"
DAT0129	7718	0	0	0		1 28	20 14	0.10			"
DAT0129	7719	0	0	0		1 28	21 14	0.10			"
DAT0129	7720	0	0	0	27	1 28	22 14	0.10	0.14		"
DAT0129	7721	0	0	0		1 28	23 14	0.10			"
DAT0129	7722	0	0	0		1 29	0 14	0.10			"
DAT0129	7723	0	0	0		1 29	1 14	0.10			"
DAT0129	7724	0	0	0		1 29	2 14	0.10			"
DAT0129	7725	0	0	0		1 29	3 14	0.10			"
DAT0129	7726	0	0	0		1 29	4 14	0.10			"
DAT0129	7727	0	0	0		1 29	5 14	0.10			"
DAT0129	7728	0	0	0		1 29	6 14	0.10			"
DAT0129	7729	0	0	0		1 29	7 14	0.10			"
DAT0129	7730	0	0	0	0	1 29	8 14	0.10	0.1		"
DAT0129	7731	0	0	0		1 29	9 13	0.10			"
DAT0131	7732	55	33	88		1 29	10 34	0.52			1 rpm
DAT0131	7733	55	33	88		1 29	11 34	0.51			0.1 sec sweep
DAT0131	7734	55	36	91		1 29	12 34	0.51			
DAT0131	7735	52	37	89		1 29	13 34	0.51			
DAT0131	7736	55	35	90		1 29	14 34	0.51			
DAT0131	7737	53	36	89		1 29	15 34	0.51			
DAT0131	7738	56	35	91		1 29	16 34	0.51			
DAT0131	7739	55	33	88		1 29	17 34	0.51			
DAT0131	7740	55	36	91	81	1 29	18 34	0.51	0.47		
DAT0131	7741	53	38	91		1 29	19 34	0.50			
DAT0131	7742	54	36	90		1 29	20 34	0.51			
DAT0131	7743	57	34	91		1 29	21 34	0.50			
DAT0131	7744	53	33	86		1 29	22 34	0.50			
DAT0131	7745	58	36	94		1 29	23 34	0.50			
DAT0131	7746	54	37	91		1 30	0 34	0.50			
DAT0131	7747	55	34	89		1 30	1 34	0.50			
DAT0131	7748	57	35	92		1 30	2 34	0.49			
DAT0131	7749	56	34	90		1 30	3 34	0.50			
DAT0131	7750	55	36	91	91	1 30	4 34	0.49	0.5		

APPENDIX U: Sweep Reliability Test Data, Test # 12, (Test Period 11)

Stored in:	Test #	Devices Upset				Date(97)	Time	File size (Mb)			Notes
		Bd #1	Bd #2	Total	Ave			full	ave	part	
DAT0131	7751	54	32	86		1 30	5 34	0.49			
DAT0131	7752	56	34	90		1 30	6 34	0.49			
DAT0131	7753	55	33	88		1 30	7 34	0.48			
DAT0131	7754	53	34	87		1 30	8 34	0.49			
DAT0131	7755	57	36	93		1 30	9 34	0.48			
DAT0131	7756	58	34	92		1 30	10 34	0.48			
DAT0131	7757	57	32	89		1 30	11 34	0.48			
DAT0131	7758	52	33	85		1 30	12 34	0.48			
DAT0131	7759	55	34	89		1 30	13 34	0.48			
DAT0131	7760	55	35	90	89	1 30	14 34	0.48	0.48		
DAT0131	7761	55	35	90		1 30	15 34	0.48			
DAT0131	7762	54	33	87		1 30	16 34	0.48			
DAT0131	7763	57	36	93		1 30	17 34	0.48			
DAT0131	7764	54	34	88		1 30	18 34	0.48			
DAT0131	7765	53	34	87		1 30	19 34	0.48			
DAT0131	7766	54	35	89		1 30	20 34	0.48			
DAT0131	7767	55	32	87		1 30	21 34	0.48			
DAT0131	7768	55	34	89		1 30	22 34	0.48			
DAT0131	7769	58	32	90		1 30	23 34	0.48			
DAT0131	7770	53	34	87	89	1 31	0 34	0.48	0.48		
DAT0131	7771	52	34	86		1 31	1 34	0.48			
DAT0131	7772	55	33	88		1 31	2 34	0.48			
DAT0131	7773	53	34	87		1 31	3 34	0.48			
DAT0131	7774	55	34	89		1 31	4 34	0.48			
DAT0131	7775	52	34	86		1 31	5 34	0.48			
DAT0131	7776	55	36	91		1 31	6 34	0.48			
DAT0131	7777	55	36	91		1 31	7 34	0.48			
DAT0131	7778	54	35	89		1 31	8 34	0.48			
DAT0131	7779	53	35	88		1 31	9 34	0.48			
DAT0131	7780	53	33	86	88	1 31	10 34	0.48	0.48		
DAT0131	7781	52	33	85		1 31	11 34	0.48			
DAT0131	7782	39	28	67		1 31	11 41			0.06	
DAT0203	7783	51	34	85		1 31	13 0	0.22			
DAT0203	7784	52	35	87		1 31	14 0	0.22			
DAT0203	7785	56	33	89		1 31	15 0	0.22			
DAT0203	7786	54	33	87		1 31	16 0	0.22			
DAT0203	7787	55	33	88		1 31	17 0	0.22			
DAT0203	7788	53	35	88		1 31	18 0	0.22			
DAT0203	7789	56	34	90		1 31	19 0	0.22			
DAT0203	7790	55	34	89	86	1 31	20 0	0.22	0.25		
DAT0203	7791	56	33	89		1 31	21 0	0.22			
DAT0203	7792	53	34	87		1 31	22 0	0.22			
DAT0203	7793	55	33	88		1 31	23 0	0.22			
DAT0203	7794	55	32	87		2 1	0 0	0.22			
DAT0203	7795	54	32	86		2 1	1 0	0.22			
DAT0203	7796	53	30	83		2 1	2 0	0.20			
DAT0203	7797	0	0	0		2 1	3 0	0.10			RF pwr amp off
DAT0203	7798	0	0	0		2 1	4 0	0.10			"
DAT0203	7799	0	0	0		2 1	5 0	0.10			"
DAT0203	7800	0	0	0	52	2 1	6 0	0.10	0.17		"

APPENDIX U: Sweep Reliability Test Data, Test # 12, (Test Period 11)

Stored in:	Test #	Devices Upset				Date(97)	Time	File size (Mb)			Notes
		Bd #1	Bd #2	Total	Ave			full	ave	part	
DAT0203	7801	0	0	0		2 1	7 0	0.10			RF pwr amp off
DAT0203	7802	0	0	0		2 1	8 0	0.10			"
DAT0203	7803	0	0	0		2 1	9 0	0.10			"
DAT0203	7804	0	0	0		2 1	10 0	0.10			"
DAT0203	7805	0	0	0		2 1	11 0	0.10			"
DAT0203	7806	0	0	0		2 1	12 0	0.10			"
DAT0203	7807	0	0	0		2 1	13 0	0.10			"
DAT0203	7808	0	0	0		2 1	14 0	0.10			"
DAT0203	7809	0	0	0		2 1	15 0	0.10			"
DAT0203	7810	0	0	0	0	2 1	16 0	0.10	0.1		"
DAT0203	7811	0	0	0		2 1	17 0	0.10			"
DAT0203	7812	0	0	0		2 1	18 0	0.10			"
DAT0203	7813	0	0	0		2 1	19 0	0.10			"
DAT0203	7814	0	0	0		2 1	20 0	0.10			"
DAT0203	7815	0	0	0		2 1	21 0	0.10			"
DAT0203	7816	0	0	0		2 1	22 0	0.10			"
DAT0203	7817	0	0	0		2 1	23 0	0.10			"
DAT0203	7818	0	0	0		2 2	0 0	0.10			"
DAT0203	7819	0	0	0		2 2	1 0	0.10			"
DAT0203	7820	0	0	0	0	2 2	2 0	0.10	0.1		"
DAT0203	7821	0	0	0		2 2	3 0	0.10			"
DAT0203	7822	0	0	0		2 2	4 0	0.10			"
DAT0203	7823	0	0	0		2 2	5 0	0.10			"
DAT0203	7824	0	0	0		2 2	6 0	0.10			"
DAT0203	7825	0	0	0		2 2	7 0	0.10			"
DAT0203	7826	0	0	0		2 2	8 0	0.10			"
DAT0203	7827	0	0	0		2 2	9 0	0.10			"
DAT0203	7828	0	0	0		2 2	10 0	0.10			"
DAT0203	7829	0	0	0		2 2	11 0	0.10			"
DAT0203	7830	0	0	0	0	2 2	12 0	0.10	0.1		"
DAT0203	7831	0	0	0		2 2	13 0	0.10			"
DAT0203	7832	0	0	0		2 2	14 0	0.10			"
DAT0203	7833	0	0	0		2 2	15 0	0.10			"
DAT0203	7834	0	0	0		2 2	16 0	0.10			"
DAT0203	7835	0	0	0		2 2	17 0	0.10			"
DAT0203	7836	0	0	0		2 2	18 0	0.10			"
DAT0203	7837	0	0	0		2 2	19 0	0.10			"
DAT0203	7838	0	0	0		2 2	20 0	0.10			"
DAT0203	7839	0	0	0		2 2	21 0	0.10			"
DAT0203	7840	0	0	0	0	2 2	22 0	0.10	0.1		"
DAT0203	7841	0	0	0		2 2	23 0	0.10			"
DAT0203	7842	0	0	0		2 3	0 0	0.10			"
DAT0203	7843	0	0	0		2 3	1 0	0.10			"
DAT0203	7844	0	0	0		2 3	2 0	0.10			"
DAT0203	7845	0	0	0		2 3	3 0	0.10			"
DAT0203	7846	0	0	0		2 3	4 0	0.10			"
DAT0203	7847	0	0	0		2 3	5 0	0.10			"
DAT0203	7848	0	0	0		2 3	6 0	0.10			"
DAT0203	7849	0	0	0		2 3	7 0	0.10			"
DAT0203	7850	0	0	0	0	2 3	8 0	0.10	0.1		"

APPENDIX U: Sweep Reliability Test Data, Test # 12, (Test Period 11)

Stored in:	Test #	Devices Upset				Ave	Date(97)		Time		File size (Mb)			Notes
		Bd #1	Bd #2	Total					full	ave	part			
DAT0203	7851	0	0	0		2	3	9	0	0.10			RF pwr amp off	
DAT0203	7852	18	13	31		2	3	9	54			0.09		
DAT0204	7853	55	35	90		2	3	11	7	0.22				
DAT0204	7854	54	33	87		2	3	12	7	0.22				
DAT0204	7855	55	34	89		2	3	13	7	0.22				
DAT0204	7856	54	34	88		2	3	14	7	0.22				
DAT0204	7857	53	33	86		2	3	15	7	0.22				
DAT0204	7858	59	34	93		2	3	16	7	0.22				
DAT0204	7859	58	32	90		2	3	17	7	0.22				
DAT0204	7860	54	35	89	74	2	3	18	7	0.22	0.21			
DAT0204	7861	55	37	92		2	3	19	7	0.22				
DAT0204	7862	54	35	89		2	3	20	7	0.22				
DAT0204	7863	55	37	92		2	3	21	7	0.22				
DAT0204	7864	55	34	89		2	3	22	7	0.22				
DAT0204	7865	54	35	89		2	3	23	7	0.22				
DAT0204	7866	53	34	87		2	4	0	7	0.22				
DAT0204	7867	55	33	88		2	4	1	7	0.22				
DAT0204	7868	54	35	89		2	4	2	7	0.22				
DAT0204	7869	54	34	88		2	4	3	7	0.22				
DAT0204	7870	55	34	89	89	2	4	4	7	0.22	0.22			
DAT0204	7871	56	33	89		2	4	5	7	0.22				
DAT0204	7872	55	36	91		2	4	6	7	0.22				
DAT0204	7873	53	32	85		2	4	7	7	0.22				
DAT0204	7874	55	34	89		2	4	8	7	0.22				
DAT0204	7875	51	35	86		2	4	9	7	0.22				
DAT0204	7876	49	30	79		2	4	9	33			0.1		
DAT0205	7877	87	100	187		2	4	12	6	0.96			2 to 4 GHz	
DAT0205	7878	85	100	185		2	4	13	6	0.95			0.25 rpm	
DAT0205	7879	83	99	182		2	4	14	6	0.95			10 sec sweep	
DAT0205	7880	82	100	182	126	2	4	15	6	0.95	0.55		1000 W @2 GHz	
DAT0205	7881	86	100	186		2	4	16	6	0.95			1500 W @2.5 GHz	
DAT0205	7882	82	100	182		2	4	17	6	0.95			750 W ave	
DAT0205	7883	82	99	181		2	4	18	6	0.95				
DAT0205	7884	80	100	180		2	4	19	6	0.95				
DAT0205	7885	81	99	180		2	4	20	6	0.96				
DAT0205	7886	82	100	182		2	4	21	6	0.95				
DAT0205	7887	82	100	182		2	4	22	6	0.96				
DAT0205	7888	83	100	183		2	4	23	6	0.95				
DAT0205	7889	82	100	182		2	5	0	6	0.95				
DAT0205	7890	82	99	181	182	2	5	1	6	0.95	0.95			
DAT0205	7891	84	100	184		2	5	2	6	0.95				
DAT0205	7892	82	100	182		2	5	3	6	0.96				
DAT0205	7893	86	100	186		2	5	4	6	0.96				
DAT0205	7894	83	100	183		2	5	5	6	0.96				
DAT0205	7895	82	100	182		2	5	6	6	0.96				
DAT0205	7896	86	100	186		2	5	7	6	0.96				
DAT0205	7897	82	99	181		2	5	8	6	0.96				
DAT0205	7898	81	100	181		2	5	9	6	0.96				
DAT0205	7899	79	100	179		2	5	9	45			0.63		
DAT0207	7900	86	100	186	183	2	5	11	18	2.0	1.07			

APPENDIX U: Sweep Reliability Test Data, Test # 12, (Test Period 11)

Stored in:	Devices Upset						File size (Mb)			Notes	
	Test #	Bd #1	Bd #2	Total	Ave	Date(97)	Time	full	ave		part
DAT0207	7901	85	100	185		2 5	12 18	2.0			2 to 4 GHz
DAT0207	7902	86	100	186		2 5	13 18	2.0			0.5 rpm
DAT0207	7903	86	100	186		2 5	14 18	1.9			3 sec sweep
DAT0207	7904	87	100	187		2 5	15 18	1.9			1000 W @2 GHz
DAT0207	7905	83	100	183		2 5	16 18	1.9			1500 W @2.5 GHz
DAT0207	7906	84	100	184		2 5	17 18	1.9			750 W ave
DAT0207	7907	84	100	184		2 5	18 18	1.9			
DAT0207	7908	85	100	185		2 5	19 18	1.9			
DAT0207	7909	86	100	186		2 5	20 18	1.9			
DAT0207	7910	84	100	184	185	2 5	21 18	1.9	1.92		
DAT0207	7911	81	100	181		2 5	22 18	1.9			
DAT0207	7912	86	100	186		2 5	23 18	1.9			
DAT0207	7913	86	100	186		2 6	0 18	1.9			
DAT0207	7914	84	100	184		2 6	1 18	1.9			
DAT0207	7915	87	100	187		2 6	2 18	1.9			
DAT0207	7916	87	100	187		2 6	3 18	1.9			
DAT0207	7917	88	100	188		2 6	4 18	1.9			
DAT0207	7918	85	100	185		2 6	5 18	1.9			
DAT0207	7919	87	100	187		2 6	6 18	1.9			
DAT0207	7920	87	100	187	186	2 6	7 18	1.9	1.9		
DAT0207	7921	86	100	186		2 6	8 18	1.9			
DAT0207	7922	87	100	187		2 6	9 18	1.9			
DAT0207	7923	86	100	186		2 6	10 18	1.9			
DAT0207	7924	86	100	186		2 6	11 18	1.9			
DAT0207	7925	86	100	186		2 6	12 18	1.9			
DAT0207	7926	86	100	186		2 6	13 18	1.9			
DAT0207	7927	84	100	184		2 6	14 18	1.9			
DAT0207	7928	86	100	186		2 6	15 18	1.9			
DAT0207	7929	87	100	187		2 6	16 18	1.9			
DAT0207	7930	86	100	186	186	2 6	17 18	1.9	1.9		
DAT0207	7931	85	100	185		2 6	18 18	1.9			
DAT0207	7932	88	100	188		2 6	19 18	1.9			
DAT0207	7933	85	100	185		2 6	20 18	1.9			
DAT0207	7934	84	100	184		2 6	21 18	1.9			
DAT0207	7935	86	100	186		2 6	22 18	1.9			
DAT0207	7936	85	100	185		2 6	23 18	1.9			
DAT0207	7937	86	100	186		2 7	0 18	1.9			
DAT0207	7938	84	100	184		2 7	1 18	1.9			
DAT0207	7939	87	100	187		2 7	2 18	1.9			
DAT0207	7940	84	100	184	185	2 7	3 18	1.9	1.9		
DAT0207	7941	85	100	185		2 7	4 18	1.9			
DAT0207	7942	85	100	185		2 7	5 18	1.9			
DAT0207	7943	84	100	184		2 7	6 18	1.9			
DAT0207	7944	81	100	181		2 7	7 18	1.9			
DAT0207	7945	84	100	184		2 7	8 18	1.9			
DAT0207	7946	84	100	184		2 7	9 18	1.9			
DAT0207	7947	82	100	182		2 7	10 18	1.9			
DAT0207	7948	84	100	184		2 7	11 18	1.9			
DAT0207	7949	86	100	186		2 7	12 18	1.9			
DAT0207	7950	86	100	186	184	2 7	13 18	1.9	1.9		

APPENDIX U: Sweep Reliability Test Data, Test # 12, (Test Period 11)

Stored in:	Test #	Devices Upset				Date(97)	Time	File size (Mb)			Notes
		Bd #1	Bd #2	Total	Ave			full	ave	part	
DAT0207	7951	86	100	186		2 7	14 18	1.9			
DAT0207	7952	85	100	185		2 7	15 18	1.9			
DAT0210	7953	77	100	177		2 7	17 9	2.2			2 to 4 GHz
DAT0210	7954	79	100	179		2 7	18 9	2.2			1 rpm
DAT0210	7955	72	100	172		2 7	19 9	2.2			0.1 sec sweep
DAT0210	7956	76	100	176		2 7	20 9	2.2			1000 W @2 GHz
DAT0210	7957	75	100	175		2 7	21 9	2.2			1500 W @2.5 GHz
DAT0210	7958	80	100	180		2 7	22 9	2.2			750 W ave
DAT0210	7959	79	100	179		2 7	23 9	2.2			
DAT0210	7960	79	100	179	179	2 8	0 9	2.2	2.14		
DAT0210	7961	77	100	177		2 8	1 9	2.2			
DAT0210	7962	78	100	178		2 8	2 9	2.2			
DAT0210	7963	77	100	177		2 8	3 9	2.2			
DAT0210	7964	79	100	179		2 8	4 9	2.2			
DAT0210	7965	77	100	177		2 8	5 9	2.2			
DAT0210	7966	76	100	176		2 8	6 9	2.2			
DAT0210	7967	74	100	174		2 8	7 9	2.2			
DAT0210	7968	77	100	177		2 8	8 9	2.2			
DAT0210	7969	76	100	176		2 8	9 9	2.2			
DAT0210	7970	75	100	175	177	2 8	10 9	2.2	2.2		
DAT0210	7971	77	100	177		2 8	11 9	2.2			
DAT0210	7972	76	100	176		2 8	12 9	2.2			
DAT0210	7973	80	100	180		2 8	13 9	2.2			
DAT0210	7974	73	100	173		2 8	14 9	2.2			
DAT0210	7975	77	100	177		2 8	15 9	2.1			
DAT0210	7976	75	100	175		2 8	16 9	2.2			
DAT0210	7977	80	100	180		2 8	17 9	2.2			
DAT0210	7978	76	100	176		2 8	18 9	2.1			
DAT0210	7979	75	100	175		2 8	19 9	2.2			
DAT0210	7980	80	100	180	177	2 8	20 9	2.2	2.18		
DAT0210	7981	75	100	175		2 8	21 9	2.1			
DAT0210	7982	76	100	176		2 8	22 9	2.1			
DAT0210	7983	78	100	178		2 8	23 9	2.1			
DAT0210	7984	76	100	176		2 9	0 9	2.1			
DAT0210	7985	77	100	177		2 9	1 9	2.1			
DAT0210	7986	76	100	176		2 9	2 9	2.1			
DAT0210	7987	77	100	177		2 9	3 9	2.1			
DAT0210	7988	73	100	173		2 9	4 9	2.1			
DAT0210	7989	75	100	175		2 9	5 9	2.1			
DAT0210	7990	73	100	173	176	2 9	6 9	2.1	2.1		
DAT0210	7991	76	100	176		2 9	7 9	2.1			
DAT0210	7992	77	100	177		2 9	8 9	2.1			
DAT0210	7993	74	100	174		2 9	9 9	2.1			
DAT0210	7994	75	100	175		2 9	10 9	2.1			
DAT0210	7995	76	100	176		2 9	11 9	2.1			
DAT0210	7996	72	99	171		2 9	12 9	2.1			
DAT0210	7997	74	100	174		2 9	13 9	2.1			
DAT0210	7998	79	100	179		2 9	14 9	2.1			
DAT0210	7999	77	99	176		2 9	15 9	2.1			
DAT0210	8000	74	100	174	175	2 9	16 9	2.1	2.1		



APPENDIX U: Sweep Reliability Test Data, Test # 12, (Test Period 11)

Stored in:	Test #	Devices Upset				Ave	Date(97)	Time	File size (Mb)			Notes
		Bd #1	Bd #2	Total					full	ave	part	
DAT0210	8001	77	100	177		2 9	17 9	2.1				
DAT0210	8002	75	100	175		2 9	18 9	2.1				
DAT0210	8003	76	100	176		2 9	19 9	2.1				
DAT0210	8004	72	100	172		2 9	20 9	2.1				
DAT0210	8005	73	99	172		2 9	21 9	2.1				
DAT0210	8006	75	100	175		2 9	22 9	2.1				
DAT0210	8007	79	100	179		2 9	23 9	2.1				
DAT0210	8008	76	100	176		2 10	0 9	2.1				
DAT0210	3009	74	99	173		2 10	1 9	2.1				
DAT0210	8010	76	100	176	175	2 10	2 9	2.1	2.1			
DAT0210	8011	76	100	176		2 10	3 9	2.1				
DAT0210	8012	75	100	175		2 10	4 9	2.1				
DAT0210	8013	73	100	173		2 10	5 9	2.1				
DAT0210	8014	81	100	181		2 10	6 9	2.1				
DAT0210	8015	74	100	174		2 10	7 9	2.1				
DAT0210	8016	77	100	177		2 10	8 9	2.1				
DAT0210	8017	74	100	174		2 10	9 9	2.1				
DAT0210	8018	77	100	177		2 10	10 9	2.1				
DAT0210	8019	66	99	165		2 10	10 30			0.7		
DAT0211	8020	72	98	170	174	2 10	13 25	0.89	1.97		2 to 4 GHz	
DAT0211	8021	71	95	166		2 10	14 25	0.89			1/4 rpm	
DAT0211	8022	73	96	169		2 10	15 25	0.88			10 sec sweep	
DAT0211	8023	69	97	166		2 10	16 25	0.89			1000 W @2 GHz	
DAT0211	8024	70	100	170		2 10	17 25	0.89			1500 W @2.5 GHz	
DAT0211	8025	67	97	164		2 10	18 25	0.89			750 W ave	
DAT0211	8026	77	98	175		2 10	19 25	0.89				
DAT0211	8027	75	98	173		2 10	20 25	0.89				
DAT0211	8028	76	100	176		2 10	21 25	0.89				
DAT0211	8029	77	99	176		2 10	22 25	0.89				
DAT0211	8030	67	99	166	170	2 10	23 25	0.88	0.89			
DAT0211	8031	74	99	173		2 11	0 25	0.89				
DAT0211	8032	68	98	166		2 11	1 25	0.89				
DAT0211	8033	67	97	164		2 11	2 25	0.89				
DAT0211	8034	68	97	165		2 11	3 25	0.89				
DAT0211	8035	72	99	171		2 11	4 25	0.89				
DAT0211	8036	70	98	168		2 11	5 25	0.89				
DAT0211	8037	69	100	169		2 11	6 25	0.89				
DAT0211	8038	68	95	163		2 11	7 25	0.89				
DAT0211	8039	70	100	170		2 11	8 25	0.89				
DAT0211	8040	72	97	169	168	2 11	9 25	0.89	0.89			
DAT0211	8041	74	96	170		2 11	9 59			0.50		
DAT0213	8042	97	88	185		2 12	12 53	0.5			1 to 2 GHz	
DAT0213	8043	96	90	186		2 12	13 53	0.5			1/4 RPM	
DAT0213	8044	97	93	190		2 12	14 53	0.5			10 sec sweep	
DAT0213	8045	96	91	187		2 12	15 54	0.4			500 W ave	
DAT0213	8046	100	99	199		2 12	16 54	1.3				
DAT0213	8047	100	99	199		2 12	17 54	1.3				
DAT0213	8048	100	99	199		2 12	18 54	1.4				
DAT0213	8049	100	100	200		2 12	19 54	1.4				
DAT0213	8050	100	99	199	191	2 12	20 54	1.4	0.95			

APPENDIX U: Sweep Reliability Test Data, Test # 12, (Test Period 11)

Stored in:	Test #	Devices Upset				Date(97)	Time	File size (Mb)			Notes
		Bd #1	Bd #2	Total	Ave			full	ave	part	
DAT0213	8051	100	99	199		2 12	21 54	1.4			1 to 2 GHz
DAT0213	8052	100	99	199		2 12	22 54	1.4			1/4 RPM
DAT0213	8053	100	99	199		2 12	23 54	1.4			10 sec sweep
DAT0213	8054	100	99	199		2 13	0 54	1.4			500 W ave
DAT0213	8055	100	99	199		2 13	1 54	1.4			
DAT0213	8056	100	99	199		2 13	2 54	1.4			
DAT0213	8057	100	99	199		2 13	3 54	1.4			
DAT0213	8058	100	99	199		2 13	4 54	1.4			
DAT0213	8059	100	100	200		2 13	5 54	1.4			
DAT0213	8060	100	99	199	199	2 13	6 54	1.4	1.4		
DAT0213	8061	100	99	199		2 13	7 54	1.4			
DAT0213	8062	100	99	199		2 13	8 54	1.4			
DAT0213	8063	100	100	200		2 13	9 54	1.4			
DAT0213	8064	100	99	199		2 13	10 54	1.4			
DAT0213	8065	100	100	200		2 13	11 54	1.4			
DAT0213	8066	100	99	199		2 13	12 54	1.4			
DAT0213	8067	100	99	199		2 13	13 54	1.4			
DAT0213	8068	100	99	199		2 13	14 54	1.4			
DAT0213	8069	100	99	199		2 13	15 54	1.4			
DAT0213	8070	99	99	198	199	2 13	16 22		1.4	0.62	
DAT0217	8071	100	97	197		2 13	17 48	2.2			1 to 2 GHz
DAT0217	8072	100	97	197		2 13	18 48	2.2			1/2 RPM
DAT0217	8073	99	97	196		2 13	19 48	2.2			3 sec sweep
DAT0217	8074	100	97	197		2 13	20 48	2.2			500 W ave
DAT0217	8075	100	98	198		2 13	21 48	2.2			
DAT0217	8076	100	98	198		2 13	22 48	2.2			
DAT0217	8077	99	98	197		2 13	23 48	2.1			
DAT0217	8078	100	99	199		2 14	0 48	2.1			
DAT0217	8079	100	97	197		2 14	1 48	2.2			
DAT0217	8080	100	97	197	197	2 14	2 48	2.2	2.18		
DAT0217	8081	100	99	199		2 14	3 48	2.2			
DAT0217	8082	100	99	199		2 14	4 48	2.2			
DAT0217	8083	100	97	197		2 14	5 48	2.2			
DAT0217	8084	99	98	197		2 14	6 48	2.2			
DAT0217	8085	100	97	197		2 14	7 48	2.2			
DAT0217	8086	100	98	198		2 14	8 48	2.2			
DAT0217	8087	99	98	197		2 14	9 48	2.2			
DAT0217	8088	100	98	198		2 14	10 48	2.2			
DAT0217	8089	99	97	196		2 14	11 48	2.2			
DAT0217	8090	100	98	198	198	2 14	12 48	2.1	2.19		
DAT0217	8091	100	99	199		2 14	13 48	2.1			
DAT0217	8092	100	98	198		2 14	14 48	3.4			
DAT0217	8093	100	98	198		2 14	15 48	3.4			
DAT0217	8094	100	99	199		2 14	16 48	3.4			
DAT0217	8095	99	98	197		2 14	17 48	3.4			
DAT0217	8096	99	98	197		2 14	18 48	3.4			
DAT0217	8097	99	98	197		2 14	19 48	3.4			
DAT0217	8098	99	99	198		2 14	20 48	3.4			
DAT0217	8099	99	99	198		2 14	21 48	3.4			
DAT0217	8100	99	99	198	198	2 14	22 48	3.4	3.27		

APPENDIX U: Sweep Reliability Test Data, Test # 12, (Test Period 11)

Stored in:	Test #	Devices Upset				Date(97)	Time	File size (Mb)			Notes
		Bd #1	Bd #2	Total	Ave			full	ave	part	
DAT0217	8101	99	99	198		2 14	23 48	3.4			
DAT0217	8102	99	98	197		2 15	0 48	3.4			
DAT0217	8103	99	99	198		2 15	1 48	3.4			
DAT0217	8104	99	99	198		2 15	2 48	3.3			
DAT0217	8105	98	98	196		2 15	3 48	3.4			
DAT0217	8106	99	98	197		2 15	4 48	3.4			
DAT0217	8107	99	99	198		2 15	5 48	3.4			
DAT0217	8108	100	100	200		2 15	6 48	3.4			
DAT0217	8109	98	99	197		2 15	7 48	3.4			
DAT0217	8110	99	99	198	198	2 15	8 48	3.4	3.39		
DAT0217	8111	99	98	197		2 15	9 48	3.4			
DAT0217	8112	98	99	197		2 15	10 48	3.4			
DAT0217	8113	99	98	197		2 15	11 48	3.3			
DAT0217	8114	99	100	199		2 15	12 48	3.3			
DAT0217	8115	99	98	197		2 15	13 48	3.3			
DAT0217	8116	99	99	198		2 15	14 48	3.3			
DAT0217	8117	99	97	196		2 15	15 48	3.3			
DAT0217	8118	100	99	199		2 15	16 48	3.2			
DAT0217	8119	99	99	198		2 15	17 48	3.2			
DAT0217	8120	98	99	197	198	2 15	18 48	3.3	3.3		
DAT0217	8121	98	99	197		2 15	19 48	3.3			
DAT0217	8122	100	99	199		2 15	20 48	3.3			
DAT0217	8123	99	99	198		2 15	21 48	3.3			
DAT0217	8124	99	99	198		2 15	22 48	3.4			
DAT0217	8125	100	98	198		2 15	23 48	3.4			
DAT0217	8126	99	98	197		2 16	0 48	3.4			
DAT0217	8127	99	99	198		2 16	1 48	3.4			
DAT0217	8128	98	98	196		2 16	2 48	3.4			
DAT0217	8129	100	98	198		2 16	3 48	3.4			
DAT0217	8130	98	98	196	198	2 16	4 48	3.4	3.37		
DAT0217	8131	99	99	198		2 16	5 48	3.4			
DAT0217	8132	99	99	198		2 16	6 48	3.4			
DAT0217	8133	99	100	199		2 16	7 48	3.4			
DAT0217	8134	99	99	198		2 16	8 48	3.4			
DAT0217	8135	98	99	197		2 16	9 48	3.4			
DAT0217	8136	99	99	198		2 16	10 48	3.4			
DAT0217	8137	98	99	197		2 16	11 48	3.4			
DAT0217	8138	99	99	198		2 16	12 48	3.4			
DAT0217	8139	99	99	198		2 16	13 48	3.4			
DAT0217	8140	99	100	199	198	2 16	14 48	3.4	3.4		
DAT0217	8141	98	100	198		2 16	15 48	3.4			
DAT0217	8142	99	99	198		2 16	16 48	3.4			
DAT0217	8143	99	98	197		2 16	17 48	3.4			
DAT0217	8144	99	99	198		2 16	18 48	3.4			
DAT0217	8145	99	98	197		2 16	19 48	3.4			
DAT0217	8146	99	99	198		2 16	20 48	3.5			
DAT0217	8147	99	99	198		2 16	21 48	3.4			
DAT0217	8148	100	99	199		2 16	22 48	3.4			
DAT0217	8149	99	100	199		2 16	23 48	3.4			
DAT0217	8150	99	100	199	198	2 17	0 48	3.4	3.41		

APPENDIX U: Sweep Reliability Test Data, Test # 12, (Test Period 11)

Stored in:	Test #	Devices Upset				Date(97)	Time		File size (Mb)			Notes
		Bd #1	Bd #2	Total	Ave		full	ave	part			
DAT0217	8151	99	99	198		2	17	1	48	3.4		
DAT0217	8152	98	98	196		2	17	2	48	3.5		
DAT0217	8153	100	98	198		2	17	3	48	3.5		
DAT0217	8154	100	99	199		2	17	4	48	3.5		
DAT0217	8155	98	99	197		2	17	5	48	3.5		
DAT0217	8156	98	99	197		2	17	6	48			1.5
DAT0218	8157	96	100	196		2	17	13	33	1.4		700 to 950 MHz
DAT0218	8158	95	100	195		2	17	14	33	1.4		1/4 RPM
DAT0218	8159	97	100	197		2	17	15	33	1.4		10 sec sweep
DAT0218	8160	95	100	195	197	2	17	16	33	1.4	2.56	250 W, 900 MHz
DAT0218	8161	96	100	196		2	17	17	33	1.4		150 W ave.
DAT0218	8162	95	100	195		2	17	18	33	1.4		
DAT0218	8163	95	100	195		2	17	19	33	1.4		
DAT0218	8164	98	100	198		2	17	20	33	1.4		
DAT0218	8165	96	100	196		2	17	21	33	1.4		
DAT0218	8166	97	100	197		2	17	22	33	1.4		
DAT0218	8167	96	100	196		2	17	23	33	1.4		
DAT0218	8168	97	100	197		2	18	0	33	1.4		
DAT0218	8169	97	100	197		2	18	1	33	1.4		
DAT0218	8170	95	100	195	196	2	18	2	33	1.4	1.4	
DAT0218	8171	95	100	195		2	18	3	33	1.4		
DAT0218	8172	97	100	197		2	18	4	33	1.4		
DAT0218	8173	96	100	196		2	18	5	33	1.4		
DAT0218	8174	96	100	196		2	18	6	33	1.4		
DAT0218	8175	98	100	198		2	18	7	33	1.4		
DAT0218	8176	96	100	196		2	18	8	33	1.4		
DAT0218	8177	97	100	197		2	18	9	33	1.4		
DAT0219	8178	97	100	197		2	18	10	53	2.5		700 to 950 MHz
DAT0219	8179	97	100	197		2	18	11	53	2.5		1/2 RPM
DAT0219	8180	96	100	196	197	2	18	12	53	2.5	1.73	3 sec sweep
DAT0219	8181	97	100	197		2	18	13	53	2.5		250 W, 900 MHz
DAT0219	8182	95	100	195		2	18	14	53	2.5		150 W ave.
DAT0219	8183	96	100	196		2	18	15	53	2.5		
DAT0219	8184	95	100	195		2	18	16	53	2.5		
DAT0219	8185	97	100	197		2	18	17	53	2.5		
DAT0219	8186	96	100	196		2	18	18	53	2.5		
DAT0219	8187	96	100	196		2	18	19	53	2.4		
DAT0219	8188	96	100	196		2	18	20	53	2.5		
DAT0219	8189	96	100	196		2	18	21	53	2.5		
DAT0219	8190	96	100	196	196	2	18	22	53	2.5	2.49	
DAT0219	8191	96	100	196		2	18	23	53	2.5		
DAT0219	8192	96	100	196		2	19	0	53	2.5		
DAT0219	8193	96	100	196		2	19	1	53	2.4		
DAT0219	8194	96	100	196		2	19	2	53	2.5		
DAT0219	8195	96	100	196		2	19	3	53	2.4		
DAT0219	8196	97	100	197		2	19	4	53	2.5		
DAT0219	8197	95	100	195		2	19	5	53	2.5		
DAT0219	8198	94	100	194		2	19	6	53	2.5		
DAT0219	8199	96	100	196		2	19	7	53	2.5		
DAT0219	8200	95	100	195	196	2	19	8	53	2.5	2.48	



Appendix V: Shielding Effectiveness Report

RF SHIELDING EFFECTIVENESS  
TEST REPORT OF

18-41 BARGE ANNEX BUILDING  
SPECIAL PROJECTS  
MODE STIRRED FACILITY

JUNE 06, 1997

Prepared For:

BOEING DEFENSE & SPACE GROUP

Prepared By:

ISS ELECTROMAGNETICS  
P.O. BOX 3707  
Seattle, Washington 98124-2207

Document Number: 326-97001-RPT-3

Project File Number: SEC-4-97001-97001

Prepared By:

  
V. DiPinto

Approved By:

  
J. H. Rogneby

## Appendix V: Shielding Effectiveness Report

### BSS ELECTROMAGNETICS

---

#### 1.0 INTRODUCTION

This report presents the results of shielding effectiveness reverification tests performed on the RF shielded enclosure in the 18-41 Barge Annex facility, Special Projects, Mode Stirred Test Chamber, Boeing Defense and Space Group, Kent, Washington. The testing was performed to certify the shielding integrity of the enclosure. The RF shielding effectiveness testing began on 19 June 1997 and was completed on 20 June 1997.

#### 2.0 DESCRIPTION OF FACILITY

The Special Projects Mode Stirred facility is a self-supporting shielded enclosure that is approximately 6' 2 5/8" long, 5' 2 5/8" wide, and 7' 8 5/8" high. The enclosure is electrically isolated from the parent building and is constructed of galvanized steel panels provided by Universal Shielding Corporation (USC). The enclosure is grounded at one point, and has a swinging mechanically sealed 3' X 7' single knife edge shielded entry/exit door.

#### 3.0 SHIELDING REQUIREMENTS

The shielding effectiveness testing was performed to evaluate the room with respect to the modified requirements of Specification NSA No. 65-6, National Security Agency Specification for RF Shielded Enclosures for Communications Equipment: General Specification. The test frequencies evaluated and respective attenuation requirements are shown below:

<u>NOMINAL FREQUENCY</u>	<u>FIELD</u>	<u>REQUIRED ATTENUATION</u>
1 kHz	E	70 dB
10 kHz	E	100 dB
100 kHz	E	100 dB
1 MHz	E	100 dB
10 MHz	E	100 dB
100 MHz	P	100 dB
400 MHz	P	100 dB
1 GHz	P	100 dB
10 GHz	P	100 dB

E = Electric

P = Plane Wave

## Appendix V: Shielding Effectiveness Report

### BSS ELECTROMAGNETICS

---

#### 4.0 TEST CONDUCT

The RF shielding effectiveness testing began on 19 June, 1997 and was completed on 20 June, 1997. The testing was performed using the procedures of NSA 65-6 as a guide. The tests were conducted by Lance Benjamin and Mark Sanders under the supervision of Vince DiPinto, Certification Analyst, ISS Electromagnetics. Figure 4-1 contains sketches of the shielded enclosure and shows the approximate location of the points tested. A short description of each test point is included on the test summary sheet in Table I. Appendix A contains the Raw Data Sheets. A total of 153 measurements were made while evaluating the shielded test chamber. A tabulation of the test equipment utilized during test conduct is contained in Table II. All equipment requiring calibration was in current calibration traceable to the National Institute of Standards and Technology (NIST) at the time of test conduct.

#### 5.0 TEST RESULTS AND DISCUSSION

##### Plane Wave Testing

Testing was initially performed at 10 GHz with deficiencies noted at test points #2 and #3 (RF personnel door), 8-13 dB out of specification. Corrective action consisted of the following:

- o Test points #2 and #3 deficiencies were isolated to the vertical seams adjacent to the test points. Required the re-tightening of the closure strip. Re-test of the area met specification.

The remaining test points met the required shielding effectiveness specification at 10 GHz.

Testing was then performed at 1 GHz plane wave with deficiencies noted at test points #1- #6 door area 15-20 dB out of specification. Deficiencies were isolated to the face plate screws around the door handle. Corrective action consisted of the following:

- o Removed the inner door cover, removed the locking nuts to the face plate and latch cover assembly, cleaned the center latch cover plate then re-assembled and re-tightened all hardware. The shielding effectiveness re-test met the required specification.

The remaining test points did not require any corrective action and met the required shielding effectiveness specification at 1 GHz. Testing was then performed at 400 MHz and 100 MHz with no deficiencies noted.

##### Electric Field Testing

Electric field testing was performed at all frequencies with no deficiencies noted.

#### 6.0 CONCLUSIONS

Full compliance was achieved for all electric field and plane wave shielding effectiveness requirements.



Appendix V: Shielding Effectiveness Report

**BSS**  
**ELECTROMAGNETICS**

---

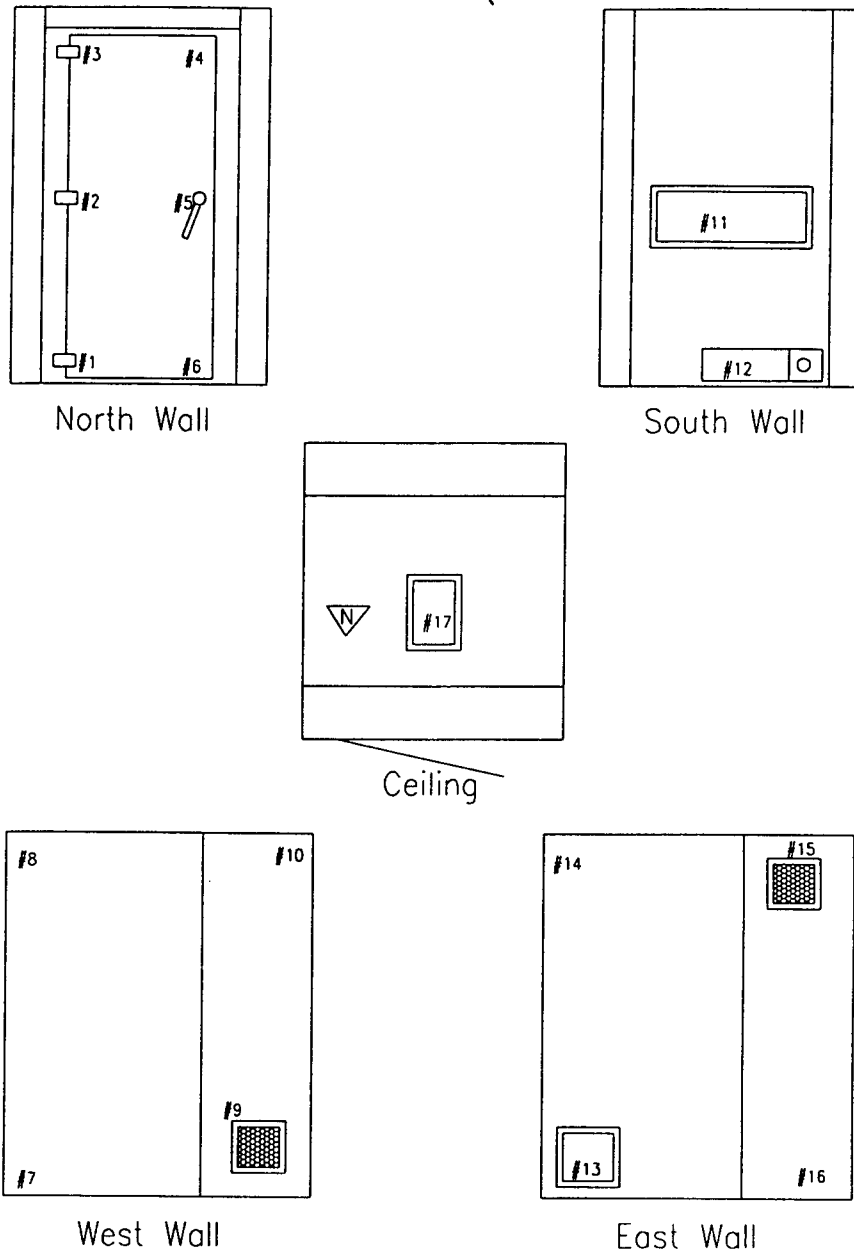

All Views From Outside In

Figure 4-1 Chamber Test Points

Appendix V: Shielding Effectiveness Report

TEST POINT		SHIELDING EFFECTIVENESS (dB)														
NO.	DESCRIPTION	H-FIELD			E-FIELD			PLANE WAVE								
		1 kHz N/A	10 kHz N/A	100 kHz N/A	1 MHz N/A	10 kHz 70dB	100 kHz 100dB	1 MHz 100dB	10 MHz 100dB	100 MHz 100dB	400 MHz 100dB	1 GHz 100dB	10 GHz 100dB			
1	DOOR TEST POINT					>80	>110	>110	>110	>110	>110	>110	>110	>110	104	108
2	DOOR TEST POINT					>80	>110	>110	>110	>110	>110	>110	>110	>110	105	>110
3	DOOR TEST POINT					>80	>110	>110	>110	>110	>110	>110	>110	>110	109	108
4	DOOR TEST POINT					>80	>110	>110	>110	>110	>110	>110	>110	>110	103	106
5	DOOR TEST POINT					>80	>110	>110	>110	>110	>110	>110	>110	>110	103	>110
6	DOOR TEST POINT					>80	>110	>110	>110	>110	>110	>110	>110	>110	108	108
7	STD SEAM					>80	>110	>110	>110	>110	>110	>110	>110	>110	104	>110
8	STD SEAM					>80	>110	>110	>110	>110	>110	>110	>110	>110	>110	>110
9	RF AIR VENT					>80	>110	>110	>110	>110	>110	>110	>110	>110	>110	>110
10	STD SEAM					>80	>110	>110	>110	>110	>110	>110	>110	>110	>110	>110
11	CONNECTOR PANEL					>80	>110	>110	>110	>110	>110	>110	>110	>110	106	>110
12	RF FILTER					>80	>110	>110	>110	>110	>110	>110	>110	>110	103	107
13	CONNECTOR PANEL					>80	>110	>110	>110	>110	>110	>110	>110	>110	>110	106
14	STD SEAM					>80	>110	>110	>110	>110	>110	>110	>110	>110	105	104
15	RF AIR VENT					>80	>110	>110	>110	>110	>110	>110	>110	>110	103	107
16	STD SEAM					>80	>110	>110	>110	>110	>110	>110	>110	>110	106	>110
17	MOTOR PANEL					>80	>110	>110	>110	>110	>110	>110	>110	>110	109	105

Data Summary Sheet

Appendix V: Shielding Effectiveness Report

**BSS**  
**ELECTROMAGNETICS**

---

TABLE II  
TEST EQUIPMENT LOG

<u>MANUFACTURER</u>	<u>MODEL NUMBER</u>	<u>NOMENCLATURE</u>	<u>SERIAL NUMBER</u>	<u>CAL DUE DATE:</u>
HP	3561A	Spectrum Analyzer	30271036	01/16/98
TEKTRONIX	494P	Spectrum Analyzer	30272419	10/02/97
HP	3324A	Signal Generator	30272290	Ind Only
HP	83620A	Synthesized Sweeper	30272798	Ind Only
ELECTRO METRIC	BPA1000	Amplifier	30142689	Ind Only
HP	8349B	Amplifier	30272343	Ind Only
KROHN-HITE	7500	Amplifier	30272263	Ind Only
ENI	2100L	Amplifier	10242375	Ind Only
ENI	603L	Amplifier	30272352	Ind Only
HUGHES	X-BAND 1277H	TWTA	31076122	Ind Only
EMCO	3303	41" Rod Antennas	30271250	Ind Only
			30271251	Ind Only
A-H SYSTEMS	TDS-200/535	Dipole Antenna Set	30272329	Ind Only
			30272453	Ind Only
SCIENTIFIC	18-12.4	Standard Gain Horns	02009865	Ind Only
ATLANTA			00234834	Ind Only
SCIENTIFIC	12-8.2	Standard Gain Horns	02009866	Ind Only
ATLANTA			02009825	Ind Only
MISC.		Cables, Adapters, fittings and Tripods		



