

AD-A219 641

④

Technical Report 1317
December 1989

Water Entry Structural Technique (WEST):

An Analytical Technique to
Determine Frangible Nosecap
Behavior During Water Entry

P. A. Jung
R. C. Shaw

SDTIC
ELECTE
MAR 20 1990
S E D

This document contains color
plates. The color reproduction
will be in black and
white.

Approved for public release; distribution is unlimited.

90 03 20 197

NAVAL OCEAN SYSTEMS CENTER
San Diego, California 92152-5000

J. D. FONTANA, CAPT, USN
Commander

R. M. HILLYER
Technical Director

ADMINISTRATIVE INFORMATION

This work was performed for the Office of the Chief of Naval Research, Independent Exploratory Development Programs (IED), Arlington, VA 22217, under program element 060293. The work described was performed by members of NOSC Code 931.

Released by
P. A. Jung, Head
Structural Mechanics,
Analysis, and Design Branch

Under authority of
C. L. Ward, Jr., Head
Design and Development
Division

SUMMARY

OBJECTIVE

Develop an efficient and accurate computational method for rational design of frangible nosecones for air- and surface-launched undersea weapons.

RESULTS

The powerful geometry and finite element model (FEM) pre- and post-processor PATRAN¹, a potential-flow computer code that can calculate dynamic pressure-time histories of an arbitrary entry body called ENTRY, and the nonlinear finite element analysis (FEA) code ABAQUS have been effectively linked. This linkage allows rapid and accurate assessment of the state of stress and deformation of missile nosecones intended to break up at water entry. This technique has been dubbed the Water Entry Structural Technique (WEST).

Two sample nosecone analyses are included in this report. One, a 90-degree cone, is an example of a known shape, previously experimentally characterized for water entry behavior. This shape serves as the control shape for results evaluation. The other is an engineering example of a nosecone that can be used on missiles like the vertical launch ASROC (VLA).

Since no single computer at the Naval Ocean Systems Center (NOSC) has the correct combination of processing power and graphics capability to host the various parts of WEST, portions of the codes are hosted on various computers at different locations within NOSC. The PATRAN pre- and post-processor is hosted on the NOSC Code 936-owned VAX 11/785 computer, named FLIPPER, as is the water entry portion of this code called ENTRY. The nonlinear FEA code ABAQUS is hosted on both FLIPPER and the General Purpose Computer Center (GPCC)-owned Convex mini-supercomputer STINGRAY. A small computer code called YADAP, used for plotting results of pressure-time histories, is hosted on a personal computer (PC).

An abbreviated operating manual for WEST has been written and is included as appendix G.

CONCLUSIONS

The objective of this in-house Independent Exploratory Development (IED) effort has been met. The code linkage has been validated through comparison with experimental work. WEST is a valuable analytical tool that reduces the design cycle time for frangible nosecones used for water entry.

¹PATRAN is a registered trademark of PDA Engineering, Inc.

RECOMMENDATIONS

The code linkage process described in this report is suitable for a scientific engineering application within a Naval laboratory such as NOSC. It should not be considered a "production" code suitable for commercial application, as there are several "rough edges" within the execution of WEST. In particular, the limitations of the water entry portion of the code must be recognized during the development of the initial geometry and finite element model (FEM) within the pre-processor portion of WEST. While arbitrary shapes can be accommodated in the water entry process, there are limitations pertaining to mesh density, spacing, and numbering that preclude executing any old FEM that happens to describe a particular geometry of a nose cap.

The user must have a background in the PATRAN pre- and post-processor. This IED project does not attempt to reduce or foreshorten the complex task of translating nose cap drawings into "PATRANese". A FEA background is essential to create viable FEMs that will not only execute throughout WEST, but will truly produce "right" answers at the conclusion of the process. As with any FEA technique, it is often as much art as science, and not something that can be learned overnight by reading this report.

Accession For	
NTIS / CASI	<input checked="" type="checkbox"/>
DEIC / DDC	<input type="checkbox"/>
Unannounced	<input type="checkbox"/>
JPL Distribution	
By	
Distribution/	
Availability Code	
avail and/or	
Dist	Special
A-1	



... color
... reproduction
... in black and

INTRODUCTION

Improvements to the analytical procedure described for the VLA nose cap can be made in the following areas:

- (a) **ABAPAT translator revision.** The PDA Engineering Release 3.0 ABAPAT translator has numerous "bugs" in it. In particular, while the outer fiber normal stresses are computed by ABAQUS and are contained in the FILENAME.FIL postprocessing file, ABAPAT cannot translate all of them into the FILENAME.STPiIj.NOD files needed for complete investigation of the results. According to PDA Engineering, Inc. this deficiency will be corrected in Version 4.0, which will soon be released.
- (b) **Non-linear material model.** ABAQUS is equipped to accommodate nonlinear stress-strain curves. As the plastic materials typically used in nose caps are nonmetallic, increased accuracy would result by taking advantage of this feature. For the work accomplished for this IED project, linear-elastic materials properties were used.
- (c) **Nonlinear geometry model.** In addition to material nonlinearities, ABAQUS can accommodate geometric nonlinearities. These should be used in the area of the fin-shell interface of the VLA nose cap, to improve the accuracy of the relative deformations of the structural elements.

BACKGROUND

Early investigations into the phenomena of water entry were concerned with the behavior of seaplane hulls upon landing. At the heart of these investigations was the determination of the surface pressures, forces, and moments on the entering object. Because of the mathematical difficulty of the problem, these investigations relied on many assumptions. Rather than attempt to rewrite a compilation of approaches found in the literature, an excerpt from Wardlaw, Morrison, and Baldwin (1977) follows.

(NOTE: Superscripted numbers in the following quoted passage refer to the original authors' work. For complete citations see Wardlaw et al. (1977), and the bibliography at the end of this report.)

Attempts to analyze the water-entry problem originate (circa 1929) with the work of Von Karman.¹ Comprehensive surveys of this field are provided by May,² Thingpen,³ Szebehely,⁴ and Moran.⁵ The main thrust of early work follows the formulation developed by Von Karman and Wagner.⁶ In this approach, a potential flow model is used and forces are calculated by the added mass concept. The submerged portion of the body is often fitted or replaced by another with the same surface cross-sectional area for which a closed form solution is available. A linearized version of the free-surface boundary conditions is applied to determine the surface shape. Most of the theories are

restricted to vertical entry of simple geometries. In recent years, computational efforts have been made to obtain a solution using the nonlinear boundary conditions. An early example of such work is that of Chu and Falconer.⁷ A relaxation method was used to solve the potential problem for arbitrary bodies. This project was abandoned due to problems with excessive computational time and surface contact discontinuities. The same formulation for the vertical entry of cones has been treated by Weber⁸ using a distribution of source dipoles. More recently, Shere and Vander Vorst⁹ and Vander Vorst and Rogers¹⁰ have used the marker and cell method to develop a detailed viscous model of vertical cone entry.

Although the description of the pressures, forces, and moments on entry bodies is of major importance to designers of water-entry bodies, the ability to characterize these loads is only part of the solution to the general engineering design problem of frangible nosecones. Once the water-entry loads are known, the structural performance of the entry body must be obtained, and the optimization of the body made to accommodate these loads.

The application of traditional analytical tools to this type of engineering design has been supplemented in the last 15 years by the FEA approach. FEA codes are currently available, such as MSC/PAL-II,² CASA/GIFTS,³ and NISA II-PC⁴ which run on PCs on a design engineer's desktop. More powerful versions of these codes, such as MSC/NASTRAN⁵ execute on higher power workstations, mainframe, and supercomputer platforms.

These codes, however, (especially those hosted on PC platforms) are normally used for linear analyses, which are necessarily limited to small displacements and a constant relationship between stress and strain in the material. Unfortunately, structures designed to fail (frange) upon water impact, such as torpedo nosecones used in weapon systems for air- or surface-launched antisubmarine warfare, cannot be analyzed by the linear-elastic method. Due to the nature of the design, these structures undergo relatively large strains during the entry phenomena, well beyond the application of linear stress analysis. In addition, these structures are necessarily fabricated from some sort of engineering plastic, which typically has an extremely nonlinear stress-strain curve. Also, resolution of stresses within complicated nosecone geometries can result in large problem sizes. Lastly, these structures usually possess some form of nonlinear contact boundary condition, which cannot be handled by linear-elastic theory. These limitations become insurmountable when dealing with linear FEA codes.

In the early 1980s, NOSC was tasked to design a frangible nosecone for the VLA. Because of the highly streamlined profile of the nosecone required for Mach 2 flight, the subsequent pressure profile generated over the nosecone surface upon water entry was significantly smaller than on the antisubmarine rocket (ASROC) nosecone,

²MSC/PAL-II is a registered trademark of the MacNeal-Schwendler Corporation.

³CASA/GIFTS is a registered trademark of Computer-Aided Structural Analysis, Inc.

⁴NISA II-PC is a registered trademark of Engineering Mechanics Research Corporation.

⁵MSC/NASTRAN is a registered trademark of the MacNeal-Schwendler Corporation.

upon which the initial design was based (Jung, 1984). The VLA nose cap showed a marked propensity to remain intact upon water entry, rendering the torpedo payload useless.

A new design concept was subsequently developed by NOSC, in collaboration with Loral Systems Group, the prime contractor for VLA. In this design, an ogival-shaped plastic shell is filled with segmented rigid foam. The tip of the shell is cut off at approximately the 5-inch-diameter station to form a "hollow point" nose cap shell. A multipound, lead-filled, aluminum nosetip is attached to the front of the shell. The nosetip is designed to remain in place from launch through airframe separation, to provide an aerodynamic profile. At parachute deployment, the nosetip is to fall away, revealing a high-drag, hollow-nose cap shell designed to break apart at water entry. Although complicated by a difficult and restrictive design envelope, a workable design was developed.

In 1988, an effort to find alternative designs was initiated by Jung and Plapp (1988). Two designs were investigated: an ogival shell stiffened with tapered foam columnar supports, and an ogival shell with blade stiffening. Wardlaw's, et al. (1977) computer code ENTRY was used to determine the entry body pressure profile. The linear analysis capabilities of MSC/NASTRAN were used to generate the subsequent stress and displacement time histories of the nose caps. The analysis revealed two shortcomings: First, the manual coding of ENTRY to produce a suitable pressure-time distribution on the VLA profile for FEA was extremely laborious and error-prone. Second, the linear capabilities of MSC/NASTRAN did not accurately predict the structural response of the nose caps to the dynamic water entry load. Significant concerns were voiced by Jung and Plapp (1988) to the effect that potentially viable alternatives to the "hollow point" VLA nose cap were being discarded due to the lack of suitable analytical tools to properly develop the design of these alternatives.

This in-house IED project was developed to assuage that concern, and significantly improve NOSC's capabilities to design frangible nose caps for water entry.

APPROACH

As extensively documented in the literature, the mathematical approach to the determination of the water-entry loads on a nose cap is extremely complex computationally. Therefore, some type of computer code is necessary to solve the frangible nose cap design problem. A literature search revealed only a few codes, such as PHOENICS⁶ and PISCES-3DE,⁷ that can solve fast transient compressible flow phenomena to characterize the pressure-time history during water entry. Unfortunately, these are not public-domain softwares, and are consequently extremely expensive to own or lease. As a goal of this project was to obtain an inexpensive solution to the water entry structural problem, these codes were not pursued.

In the late 1970s, an engineering code was developed by the Naval Surface Weapons Center/White Oak Laboratory (NSWC/WOL) for calculating pressures and

⁶PHOENICS is a registered trademark of CHAM of North America, Inc.

⁷PISCES-3DE is a registered trademark of Physics International Company, a California company.

loads at high speed water entries. Rather than attempt to rewrite in original form the authors' intent, an excerpt from Wardlaw et al. (1977) is included:

...The present approach differs from such efforts (Von Karman, May, Moran, et al.) in several important aspects. Application of Hess and Smith's numerical solution method allows arbitrary bodies to be treated and makes it possible to calculate pressures on the surface of the body. These pressures are themselves of interest and can be integrated to provide both force and moment information... "

The flow field about the entry body is described by Laplace's equation. The boundary condition

$$-\nabla\phi \cdot e_n = V_E \cdot e_n \quad (1)$$

is applied on the entry body and $\phi = 0$ to the effective planar surface. This surface is assumed to rise at the rate $(C_w - 1) V_E \sin(\theta)$. Pressures are calculated from successive solutions at differing depths using the unsteady Bernoulli's equation, which is cast in a reference frame moving with the model

$$C_p = \left[2 \frac{\partial\phi}{\partial t} - 2ZV_E \cdot \nabla\phi - (\nabla\phi)^2 \right] / V_E^2 \quad (2)$$

The preceding equation produces pressure and force coefficients that are independent of model scale and entry velocity. The value of these two parameters must be simulated through an appropriate choice of the rate of surface rise (i.e., picking the correct C_w value).

To implement the potential flow solution, the nose of the entry body is approximated with a series of planar, quadrilateral elements. Each of these elements is defined by four points or nodes lying on the body surface. The computation proceeds by inserting the model into the water in a series of steps, each at a depth, Δh , greater than the previous one. At every step, the group of elements comprising the submerged portion of the model is redefined and arranged into a form amenable to the potential flow calculative procedure. The nodes defining a particular element are checked to determine whether they are above or below the water line. Elements with all four nodes above the water surface are discarded, whereas those elements with all four nodes below it are included without change. Elements which are intersected by the water surface are redefined with an upper edge coincident with it. A constant source strength is assumed distributed over the surface of each element, and the value of this strength is determined by satisfying eq. 1 at the centroid of each element. The boundary condition, $\phi = 0$, is satisfied by locating an image of each element of opposite source strength above the water surface.

At each depth, the pressure coefficient, C_p , is evaluated at element centroids using eq. 2, which is a body-fixed frame of reference. The quantity $\nabla\phi$ appearing in this equation is determined directly at each depth, but must be calculated using the value of ϕ at the same body location in adjacent steps. In most cases, this requirement does not pose a problem, since ϕ is calculated at the element centroids that are

at fixed locations on the entry body. Defining ϕ_{c_n} to be the value of ϕ at a specific element centroid at step n and using the central differences,

$$\frac{\partial \phi}{\partial t} = \frac{\partial h}{\partial t} \frac{\partial \phi}{\partial h} = V_E \sin \theta C_w \left[\phi \frac{C_{n+1} - \phi}{2\Delta h} C_{n-1} \right]. \quad (3)$$

The foregoing procedure cannot be applied directly to elements that are intersected by the water surface. Under these conditions, the element centroid location on the entry body changes slightly from step to step and certain approximates must be introduced.

The computational method has been applied to the oblique entry of disk cylinders, spheres, and to the vertical entry of cones and spheres. In each case C_w is assigned a value consistent with existing experimental data. The computed pressure coefficients are in good agreement with measurements on the wide variety of bodies studied. The calculated pressures reflect not only basic body geometry, but also position on the model surface. The peak pressures tend to be somewhat larger than the measured ones. Fortunately, these act over very small areas and thus do not affect the calculated loads significantly....

This computational method is described in detail by Wardlaw et al. (1977), in which the computer code ENTRY is described, written in FORTRAN for a Control Data Corporation (CDC) computer. As this is public domain software, and thus available at no cost to NOSC, it was obtained from NSWC/WOL and installed by Wardlaw and Youngs from NSWC/WOL on the NOSC computer FLIPPER.

Describing the geometry of the entry body in a form that ENTRY can read can be a time-consuming and error-prone task. No graphics pre-processor exists for ENTRY. There is no post-processor to enable graphical display of the resulting pressure-time slices on the geometry either. As it was the intent of this IED task to develop a general purpose computational capability, it was decided to alter ENTRY to enable it to interface with the commercial pre- and post-processor PATRAN. Unfortunately, PATRAN is not available as public domain software. This compromise was accepted upon receipt of assurances from the GPCC for long-term support for PATRAN at NOSC.

There are a number of large, nonlinear FEA codes on the open market such as DYCAST/GC,⁸ and MARC.⁹ Unfortunately, most of them are extremely expensive to obtain, either on a purchase or a lease basis. Some, such as DYNA-3D, are available as public domain software, but are so user "unfriendly" as to make them virtually useless to the less-than-dedicated user.

ABAQUS,¹⁰ a general purpose FEA program, has special emphasis on nonlinear structural engineering applications. It has extensive material, element, and procedure libraries. Material models include plasticity for metals as well as rubber

⁸DYCAST/GC is a registered trademark of the Grumman Corporate Research Center.

⁹MARC is a registered trademark of MARC Analysis Research Corporation.

¹⁰ABAQUS is a registered trademark of Hibbitt, Karlson, & Sorenson, Inc.

elasticity. It features both user-specified and automatic control of step size and a simple, compact problem-definition language. In addition, the David Taylor Research Center (DTRC) makes this code available to all Naval laboratories through the Naval Engineering Software Support (NESS) Office, for a nominal annual fee. This code was chosen for implementation in this IED program.

Figure 1 describes the linkages and program flow to interconnect PATRAN with ENTRY and ABAQUS. Figure 1 also describes the various translators that were written to facilitate this linkage. The ability to execute this data flow is the final product of this IED project.

Figure 1 illustrates the flow of information, from the geometry and FEM pre-processor PATRAN (black figures) through the water entry code ENTRY (red figures), and into the FEA code ABAQUS for stress and displacement analysis (green figures), then back again to PATRAN to view the resultant stress and displacement.

FRANGIBLE NOSECAP ANALYSIS

To illustrate this process, a step-by-step example for a 90-degree (included angle) cone-shaped nosecap is presented (at times referred to by bullet numbers).

The analysis process begins with the construction of the geometry of the nosecap via the PATRAN Phase I modeling technique on FLIPPER. This geometry model is then meshed with nodes, and four-noded quadrilateral shell elements to produce the Phase II FEM within PATRAN (bullet 1). Figure 2 is a hardcopy image of the cone, modeled as a half-symmetric nosecap, created within PATRAN. This image shows 100 nodes, and 84 four-noded quadrilateral elements which form the Phase II finite element PATRAN model. Figure 3 is a side view of the nosecap, showing the 90-degree included angle. Figure 4 is an expanded view of the tip of the nosecap, showing the four quadrilateral elements used to mesh the flat tip of the nosecap, and node 100 at the center of the truncated tip.

Note that one of the peculiarities of the ENTRY code is that it will not execute a pressure-time history on a pointed (zero radius) entry body. Thus, it is necessary to create a very small flat tip on any pointed geometry to accommodate this quirk.

Upon completion of this Phase II FEM, a request for neutral file generation is made within PATRAN. This neutral file contains only the Phase II FEM, and is named PATRAN.OUT (bullet 2). This completes the mesh definition portion of the problem, and PATRAN is exited. Exiting of PATRAN results in the generation of the default PATRAN data file PATRAN.DAT (bullet 3), which must be manually renamed to FILENAME.PAT (bullet 4). ("FILENAME" is a user-optional identifier for the particular nosecap.) This completes the initial PATRAN pre-processing portion of the analysis task. All files generated to this point now reside in the user's space on FLIPPER.

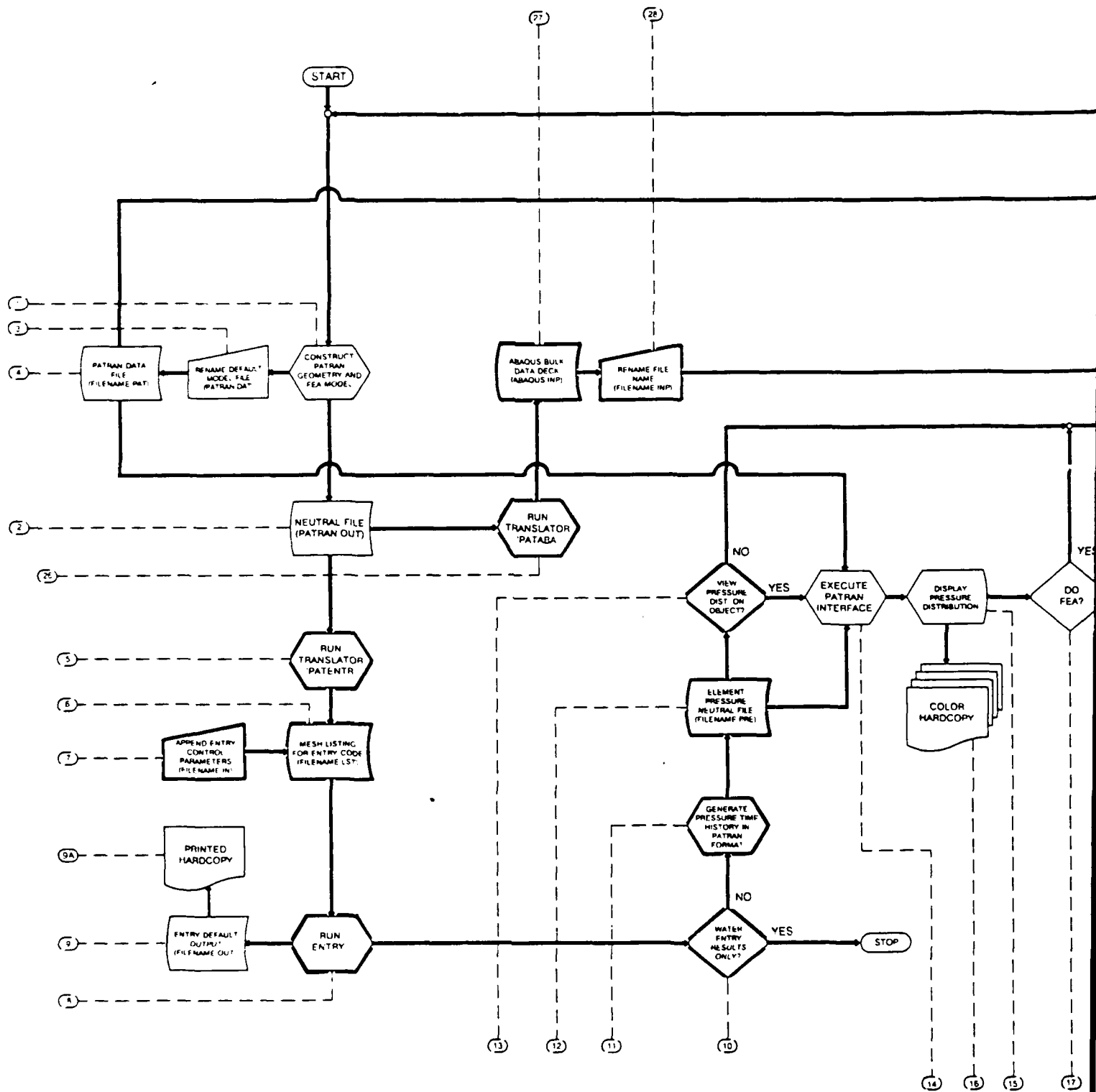
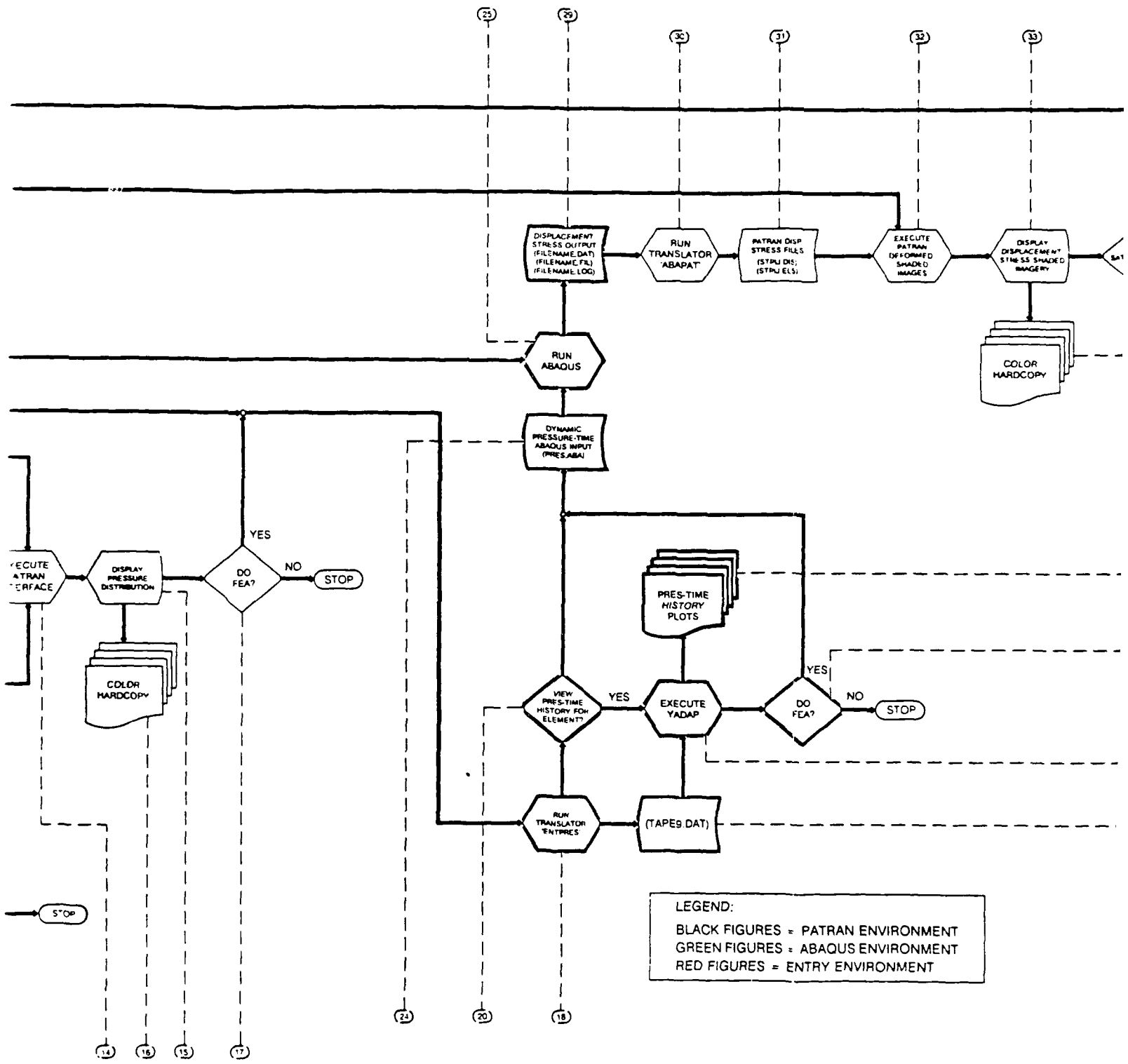

Figure 1. Flow chart of frangible nose

173



Flow chart of frangible nose cap analysis at water entry.

293

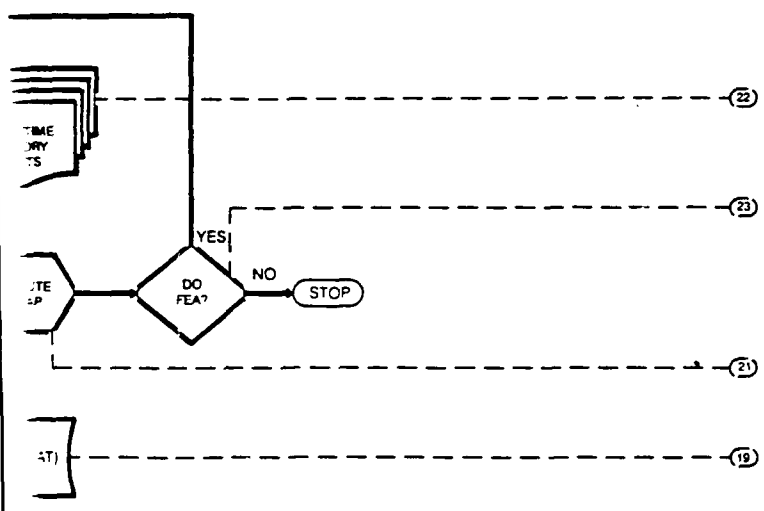
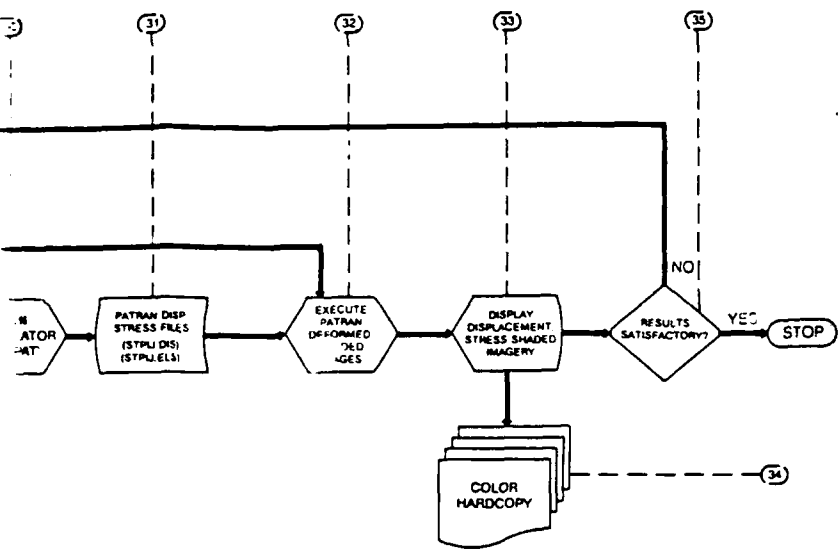

END:
 BLACK FIGURES = PATRAN ENVIRONMENT
 GREEN FIGURES = ABAQUS ENVIRONMENT
 RED FIGURES = ENTRY ENVIRONMENT

3063

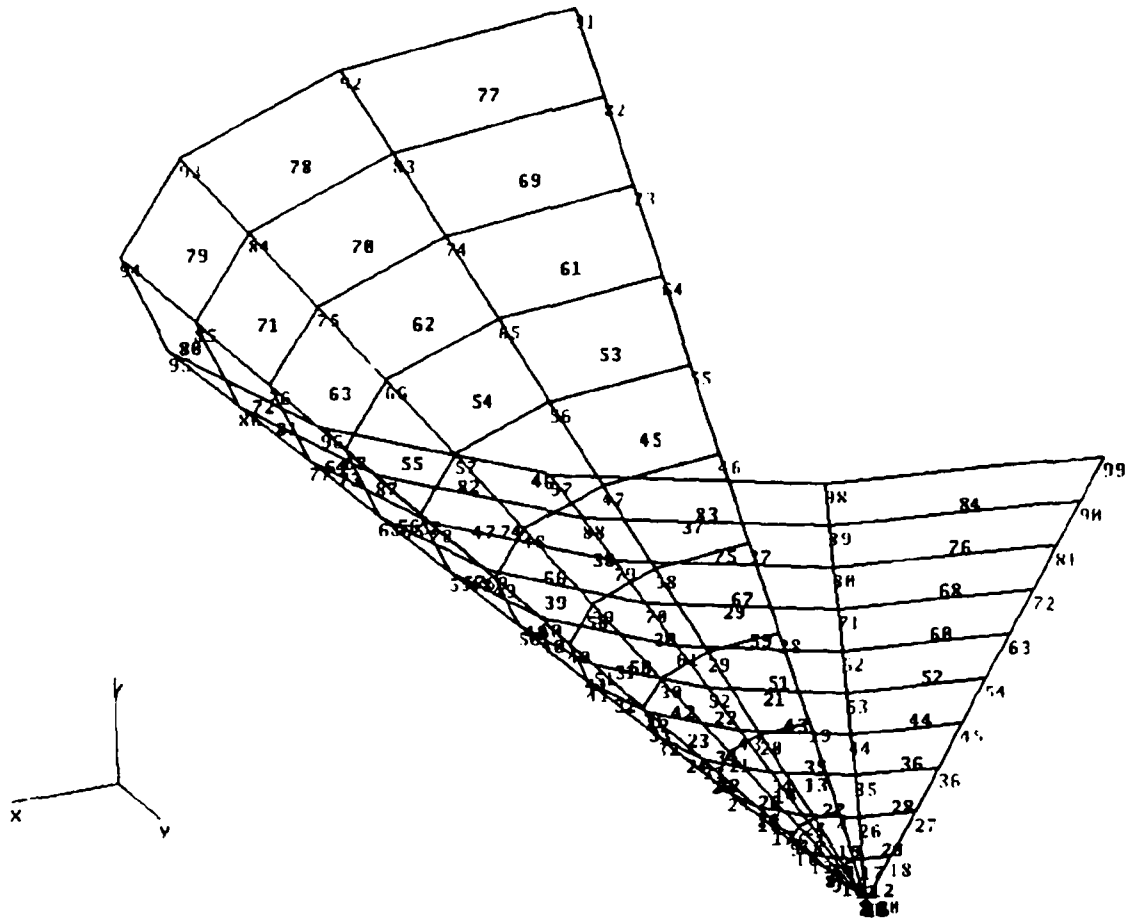

Figure 2. Half-symmetric water-entry and FEA model of a 90-degree cone.

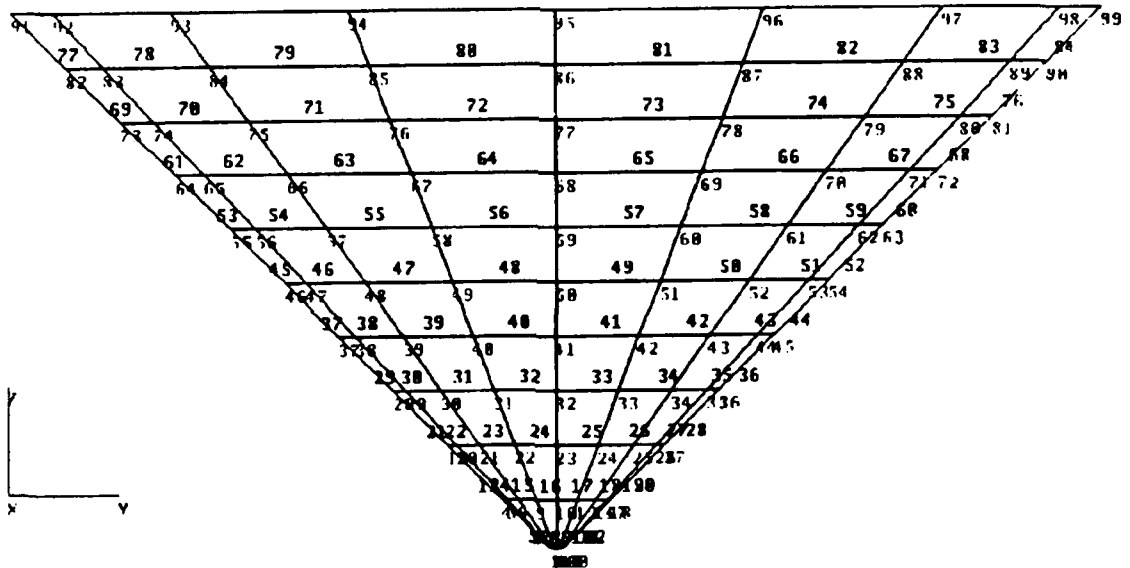

Figure 3. Side view of 90-degree blunted cone model.

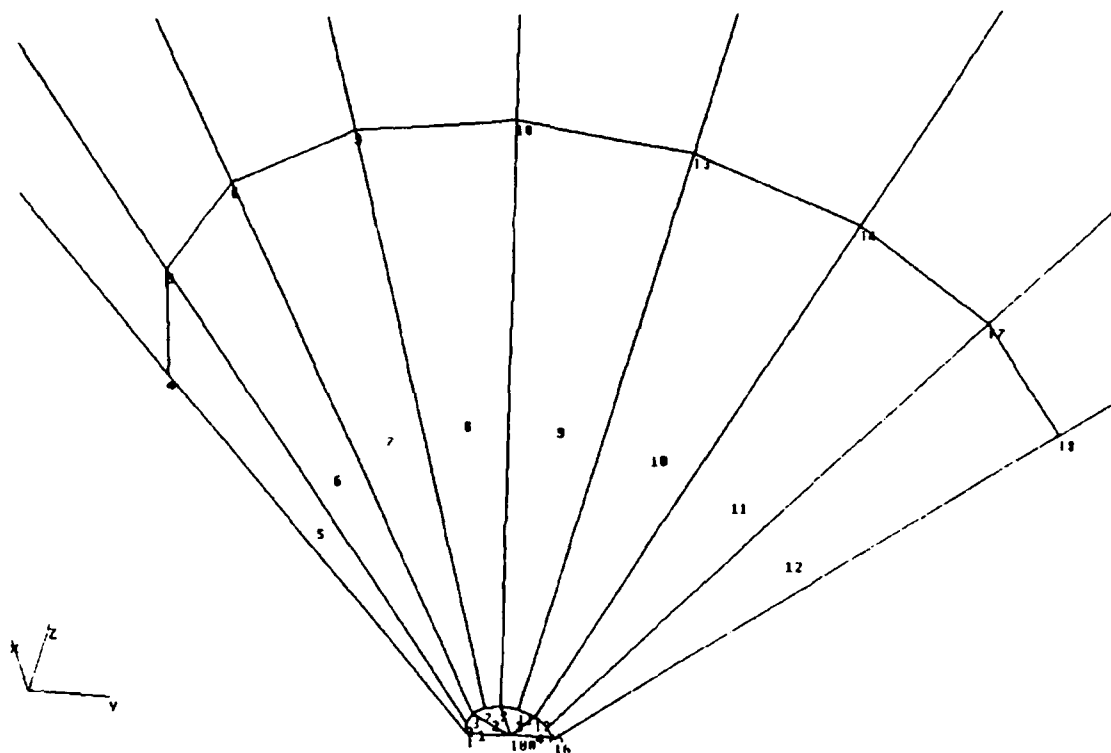

Figure 4. Enlarged view of the tip area of the 90-degree blunted cone.

Bullet 5 is a translator program written for this project called PATENTR. PATENTR resides on, and is executed from the operating system of FLIPPER to translate the nodal definition and connectivity generated within PATRAN in neutral file format (PATRAN.OUT, bullet 2) into a nodal definition and connectivity format readable by the ENTRY code. The output of PATENTR is a file called FILENAME.LST (bullet 6). Using the FLIPPER text editor, a file containing ENTRY control parameters (entry velocity, angle, wetting factor, etc.) is then appended to FILENAME.LST and renamed to FILENAME.IN (bullet 7). The sample ENTRY input file CONE90.IN is included in appendix A for reference. At this point, ENTRY is ready for execution.

ENTRY is executed from the FLIPPER operating system (bullet 8), using FILENAME.IN for the ENTRY input file. This process automatically produces the ENTRY default output file FILENAME.OUT (bullet 9), and the file FILENAME.PRE (bullet 12), which are saved to the user's space on FLIPPER. The output file FILENAME.OUT may be edited by the FLIPPER text editor or printed at the user's discretion. It contains a complete listing of the water entry parameters, the nodal definition and connectivity of the geometry, pressure-time history of each element, integrated forces, and moments over the entire nose cap. The file CONE90.OUT is included in appendix B as an example of a typical ENTRY output file.

Within ENTRY is an option to produce only the file FILENAME.OUT, and exit the entry process (bullet 10). This option would be chosen early in the analysis process, for error checking, steady-state drag coefficient calculations, or use of ENTRY for some other purpose. If this option is not exercised, then ENTRY uses a

portion of the ENTRY code (bullet 11) to produce the file FILENAME.PRE (bullet 12). This option discards all extraneous information printed in FILENAME.OUT, and rearranges the pressure-time history on each element into a format that can be read by PATRAN. FILENAME.PRE is created in the user's space on FLIPPER.

At bullet 13, a decision is made whether or not to view the pressure distribution displayed at the centroids of the elements of the nose cap as a function of time during the entry event. If desired, PATRAN is reentered at bullet 14. This execution of PATRAN calls upon the PATRAN data file FILENAME.PAT (bullet 4), and the formatted results file FILENAME.PRE (bullet 12) to produce color displays of the pressure distribution overlaid on the FEM. These graphics images, one per time-step, are displayed on a suitable color graphics terminal (bullet 15). These images may be captured on hardcopy (bullet 16) if desired.

Figures 5 through 15 are typical hardcopy images which illustrate this step. These figures show the pressure distribution on the 90-degree nose cap during the water entry event. Figure 5, at 0.16 ms after vertical entry, shows elements 1 through 4 fully wetted. The pressure, displayed at the centroid of the quadrilateral elements 1 through 4, is 24.1 psi. Figure 6, at 0.80 ms after entry, shows the pressure on the flat tip rising to 129.0 psi, and the pressure on the ring of elements 5 through 12 wetted with a pressure of 131.0 psi at their centroids. Figure 7, 1.61 ms after entry, shows the nose cap wetted to the upper edges of elements 13 through 20. The tip pressure has decayed to 106.0 psi, while the pressure on elements 5 through 12 has decayed to 95.7 psi, and the pressure on elements 13 through 20 has risen to 135.0 psi. By following figures 5 through 15, the progression of the nose cap entry into the water, as well as the progression of the pressure distribution up the nose cap, can be seen. At figure 15, full submergence has occurred after 8.06 ms. The pressure has decayed from a high of 129.0 psi at the tip, to a value of 79.2 psi around the ring of elements 53 through 60, and has not yet decayed to steady state along the upper ring of elements 77 through 84, which have just been wetted. The pressure peak has passed up the nose cap, while the earlier-wetted elements have reached their steady state drag phase pressure profiles.

Referring back to figure 1, bullet 17 is a decision whether or not to proceed with the FEA portion of this analysis task. If the color hardcopies of the pressure distribution, such as figures 5 through 15, are satisfactory to complete the task at hand, and no FEA work is intended on the nose cap FEM, then PATRAN may be exited at bullet 17 and the task completed. However, if the pressure distributions are acceptable to the analyst, and additional FEA work is required, then PATRAN is exited at bullet 17 and the WEST process rejoined.

The translator ENTPRES (bullet 18), another special-purpose translator written for this project, resides on FLIPPER. Execution of ENTPRES from the operating system of FLIPPER produces a file called TAPE9.DAT (bullet 19), and the file PRES.ABA (bullet 24), both stored in the user's space on FLIPPER.

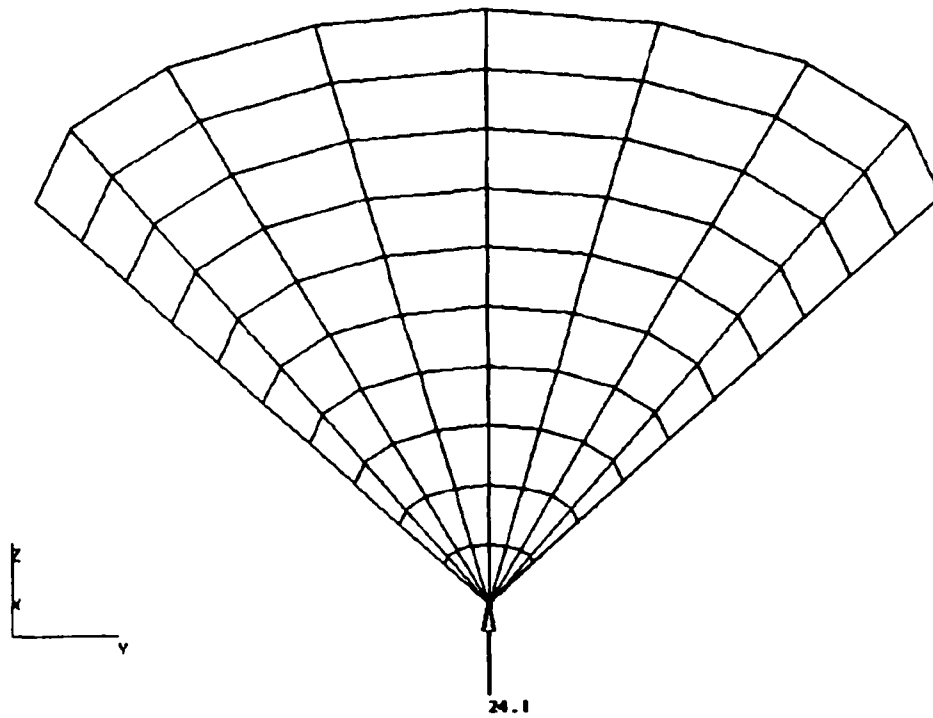

Figure 5. Ninety-degree blunted cone impacting water at 100 ft/s, pressure distribution at $t = 0.1612$ ms (step 1, initial wetting).

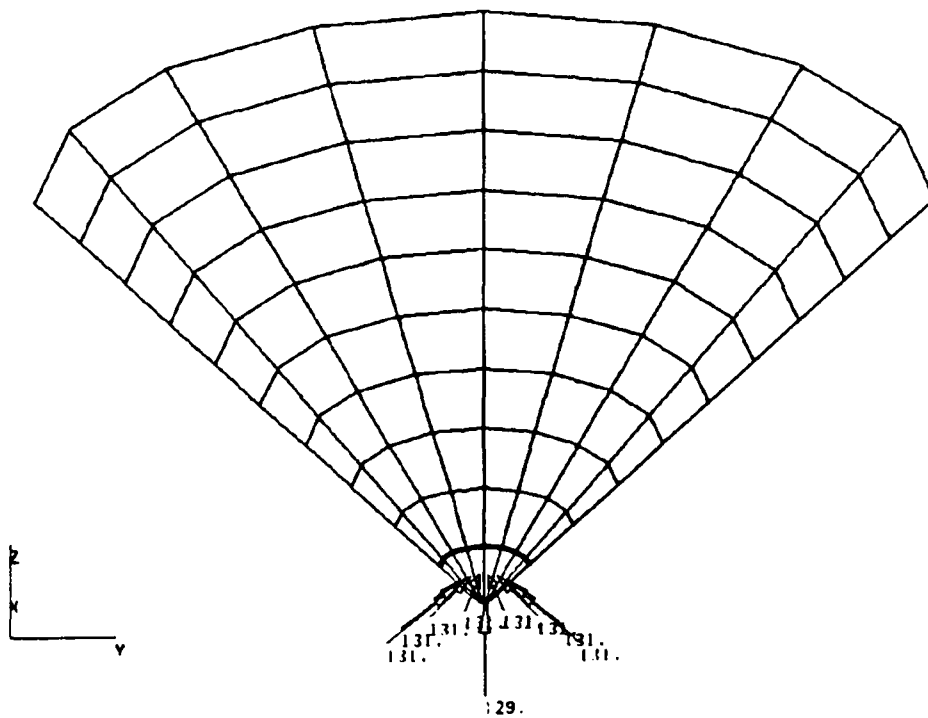

Figure 6. Pressure distribution on 90-degree blunted cone at $t = 0.8068$ ms (step 2).

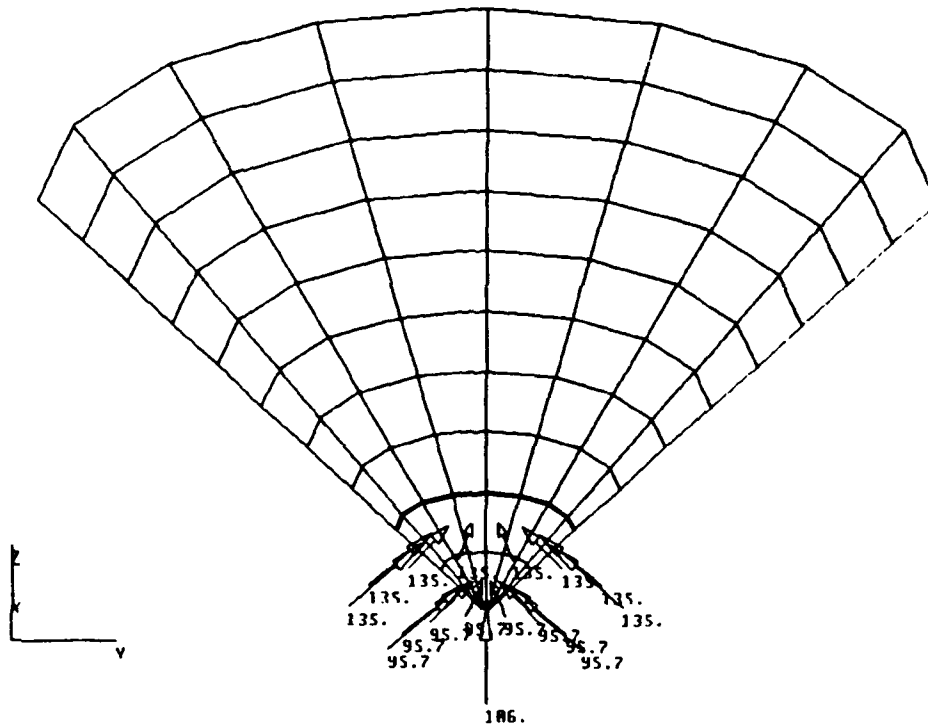

Figure 7. Pressure distribution on 90-degree blunted cone at $t = 1.6119$ ms (step 3).

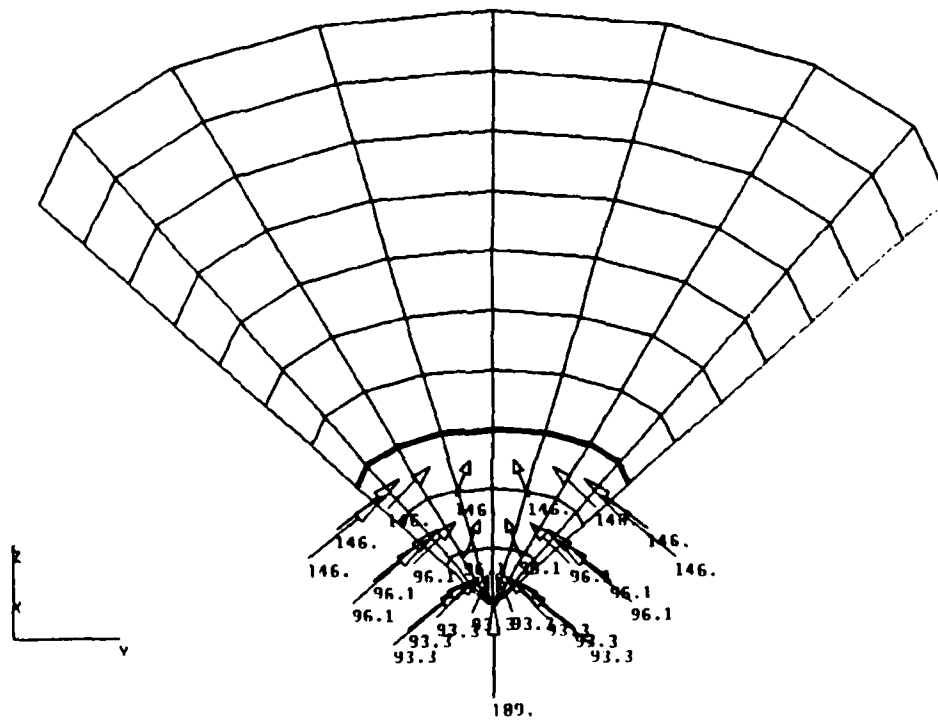

Figure 8. Pressure distribution on 90-degree blunted cone at $t = 2.4179$ ms (step 4).

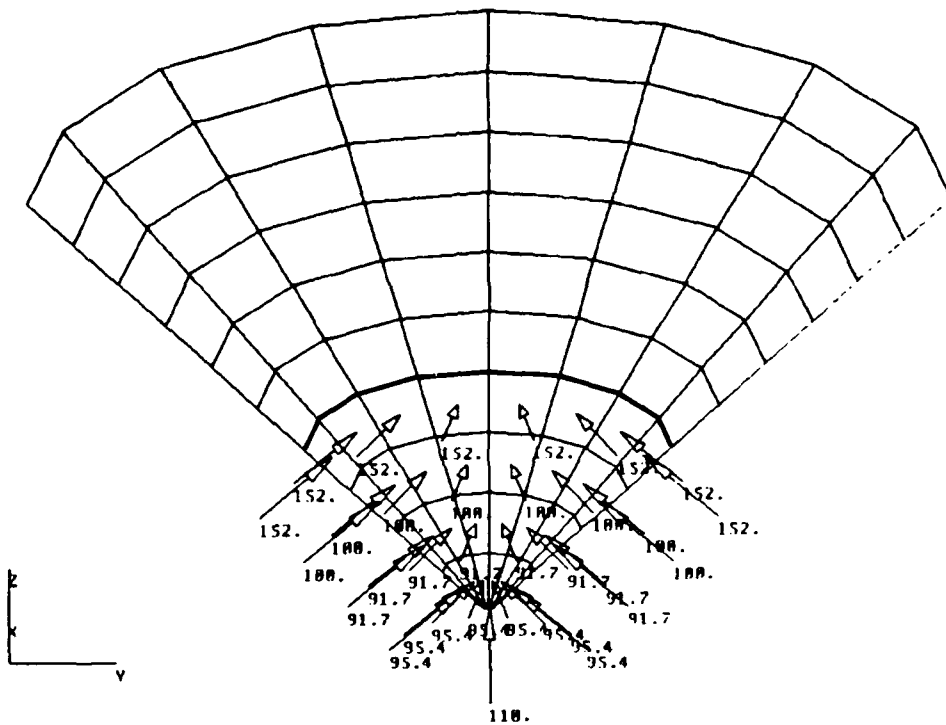

Figure 9. Pressure distribution on 90-degree blunted cone at $t = 3.2238$ ms (step 5).

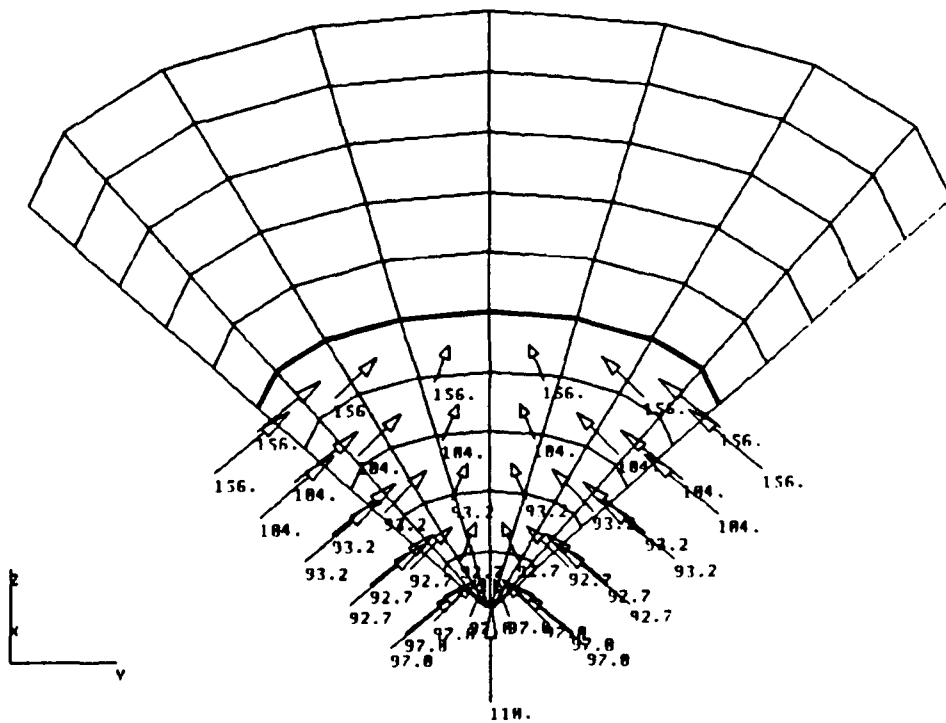

Figure 10. Pressure distribution on 90-degree blunted cone at $t = 4.0298$ ms (step 6).

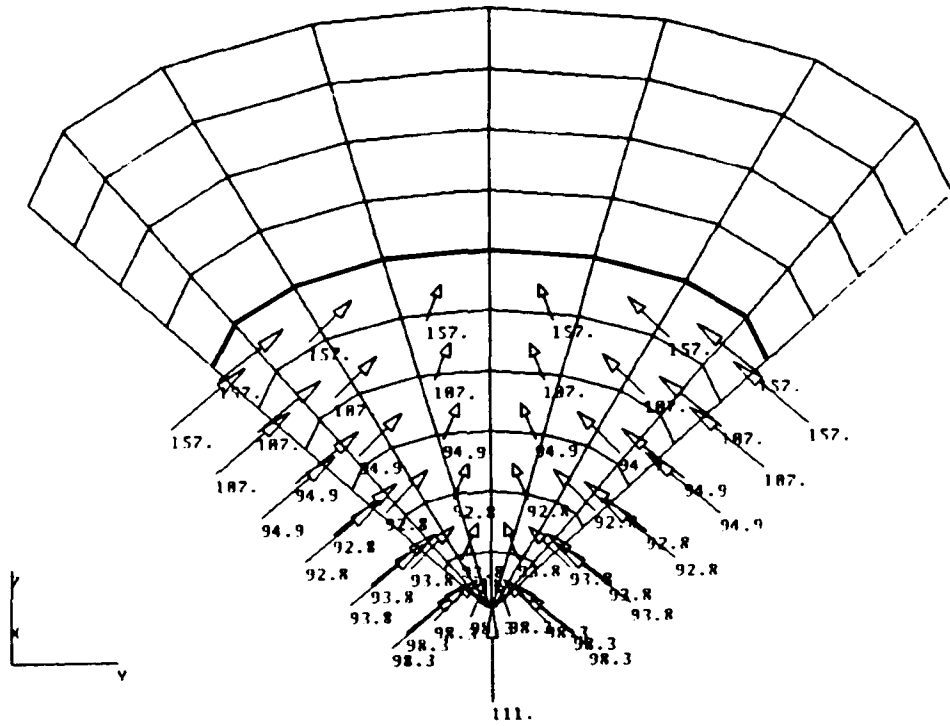

Figure 11. Pressure distribution on 90-degree blunted cone at $t = 4.8357$ ms (step 7).

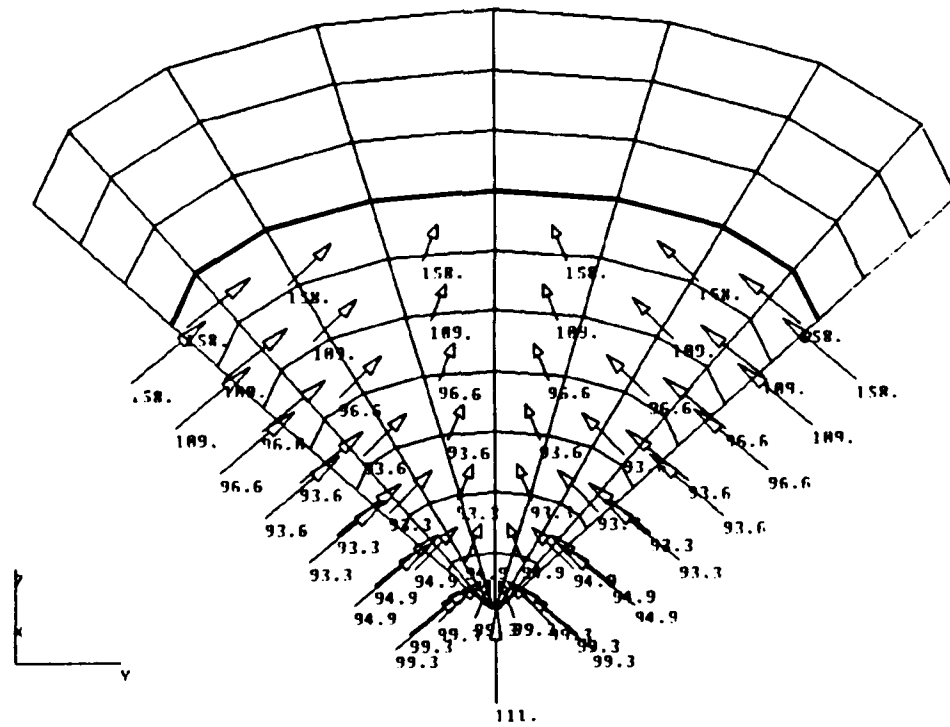

Figure 12. Pressure distribution on 90-degree blunted cone at $t = 5.6417$ ms (step 8).

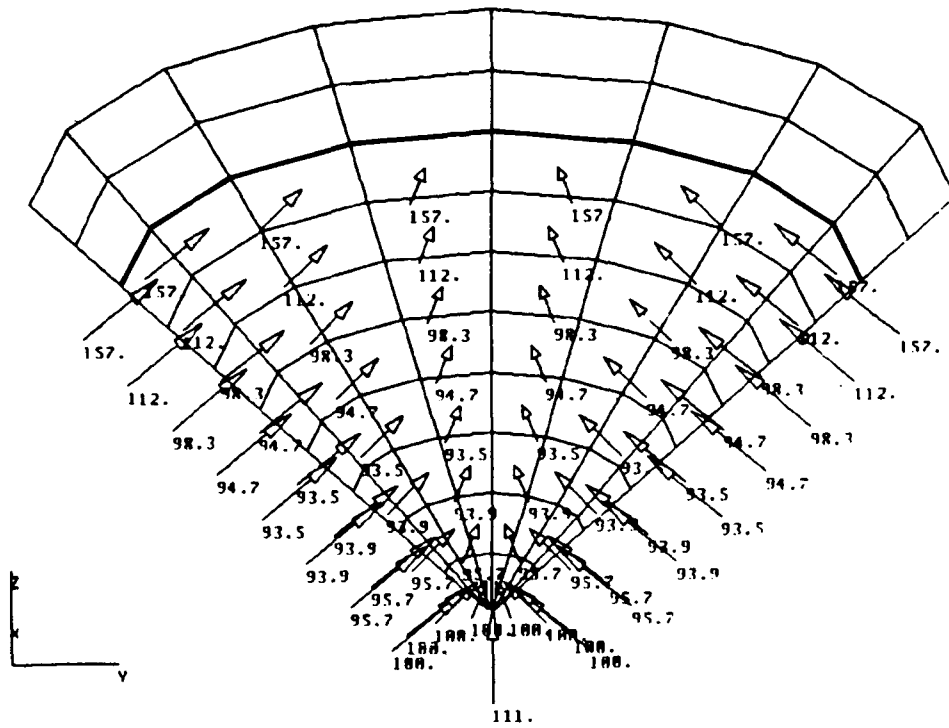

Figure 13. Pressure distribution on 90-degree blunted cone at $t = 6.4476$ ms (step 9).

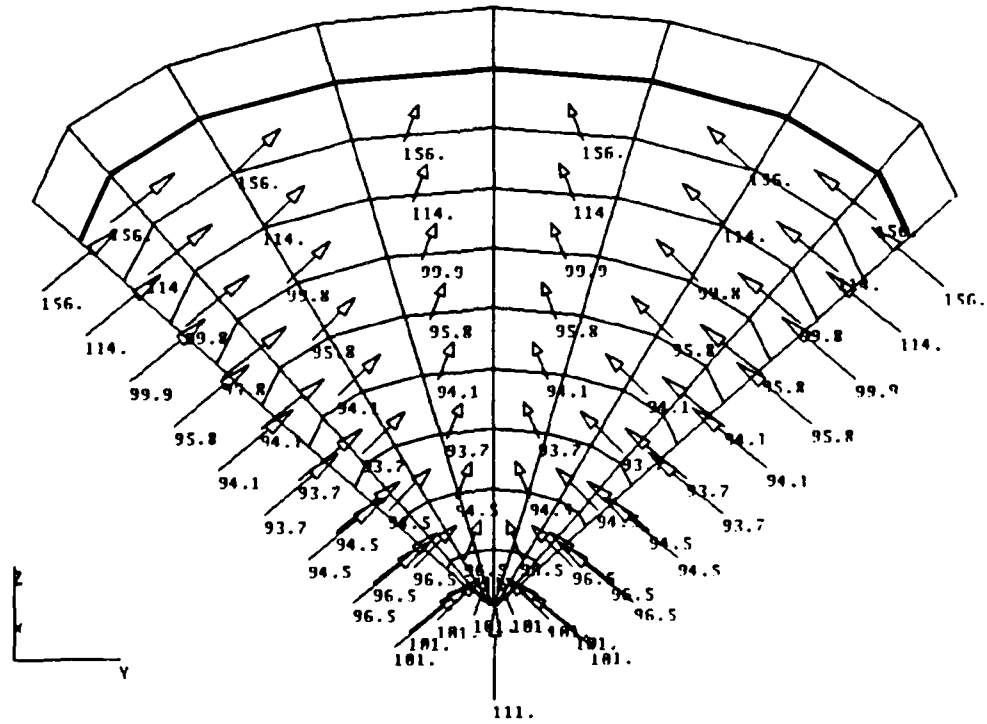

Figure 14. Pressure distribution on 90-degree blunted cone at $t = 7.2536$ ms (step 10).

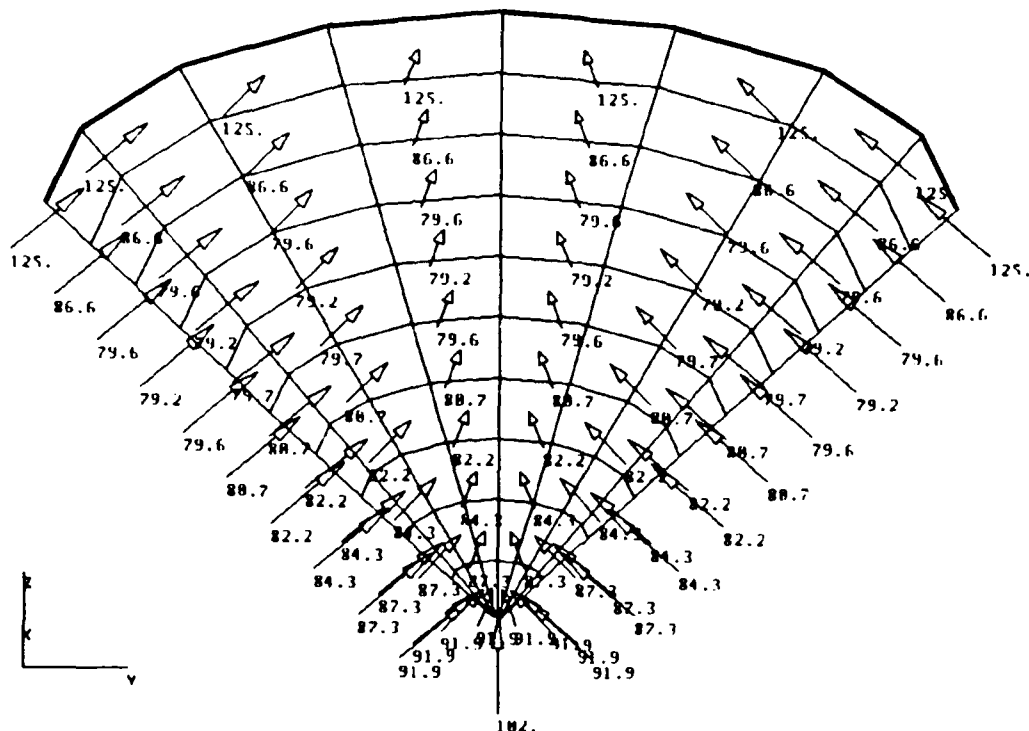

Figure 15. Pressure distribution on 90-degree blunted cone at $t = 8.0595$ ms (step 11, fully submerged).

At bullet 20, a decision is made whether or not to view the pressure-time history on an elemental basis. If the decision is made to do so, then the user must log off FLIPPER and go to the personal computer that hosts YADAP (bullet 21). YADAP is an interactive plotting package that plots the pressure on each element as a function of time. Through the General Communications Backbone (GCB), a remote login to FLIPPER must be made. The file TAPE9.DAT (bullet 9) must then be transmitted via the MCP communications protocol from the user's space on FLIPPER to the user's hard disk on his PC. After executing YADAP, the elemental time-history plots can be captured as hardcopy images on a suitable graphics printer or plotter (bullet 22).

Figure 16 illustrates this portion of the analytical process, showing pressure-time histories for "rings" or "groups" of elements. Element group 1 consists of elements 1 through 4 on the flat face, element group 2 is the ring of elements 5 through 12, and so forth. These YADAP plots show, on an elemental basis, how the pressure peaks at a later time the farther up the nose cap the element is located, as well as the reduction in peak pressure the farther from the nose cap tip the element is located.

Another decision point is reached at bullet 23. Here, if the analyst decides that there is enough information about the problem, he/she can exit the process. However, if the analyst is satisfied with the pressure distribution time-histories to date, (figure 16) but wishes to do the FEA on the nose cap, he/she returns to the main program flow in the program stream.

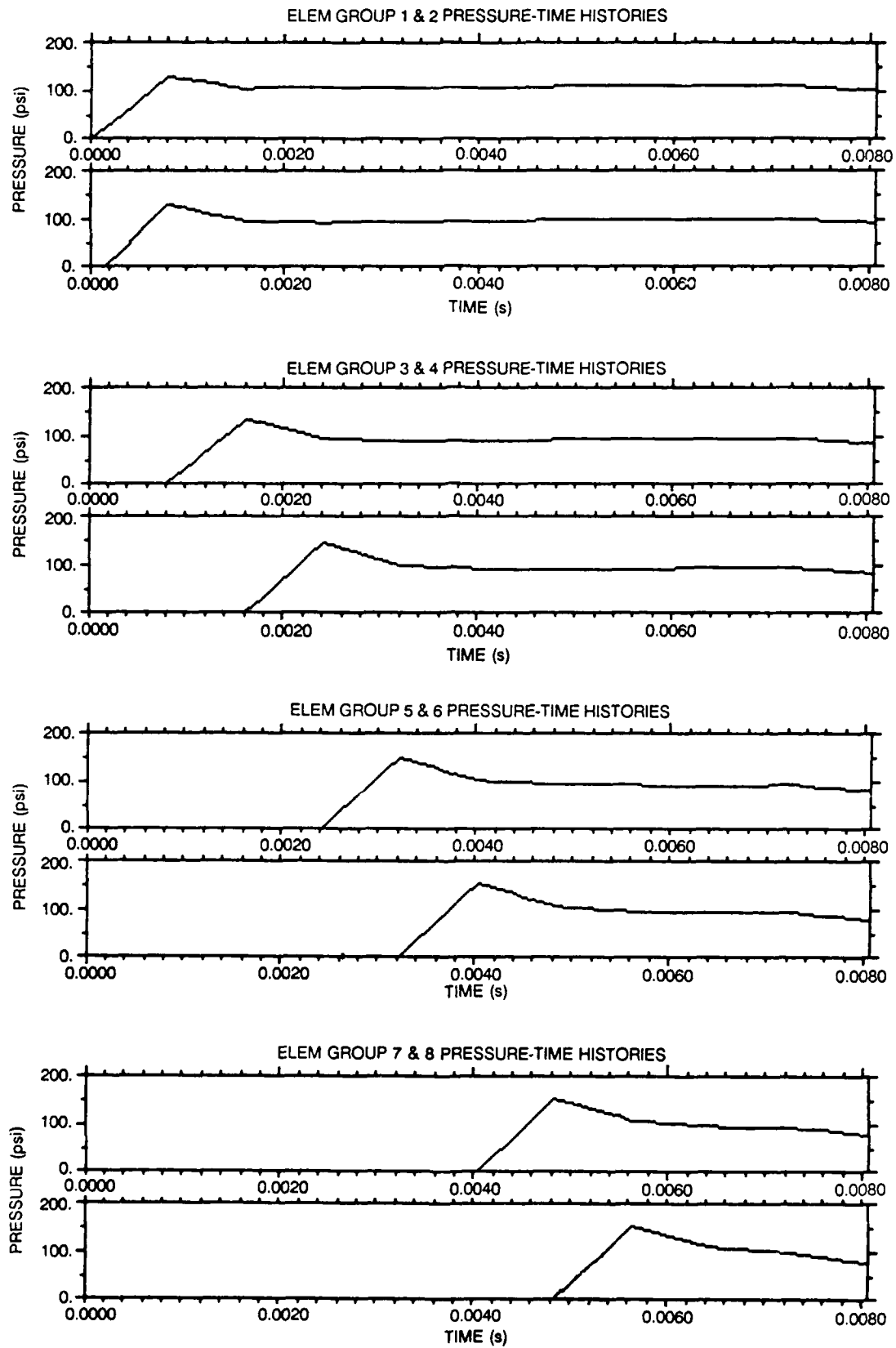

Figure 16. Pressure-time histories (0.000–0.008 s).

Earlier in the process, the translator ENTPRES (bullet 18) produced a file called PRES.ABA (bullet 24), which was stored in the user's space on FLIPPER. This file is a portion of the "history" input file needed by ABAQUS (bullet 25) for the FEA of the nose cap. To execute ABAQUS and produce the FEA of the nose cap, it is necessary to execute the translator PATABA (a PDA Engineering translator, part of the PATRAN software) from FLIPPER (bullet 26). This translator operates on the PATRAN neutral file PATRAN.OUT (bullet 2) previously created and stored on FLIPPER, and produces the ABAQUS model input file called ABAQUS.INP (bullet 27). This file must then be manually renamed to FILENAME.INP (bullet 28). After appending it to the file PRES.ABA (bullet 24), it is possible to complete the FEA portion of this process by executing ABAQUS in bullet 25.

ABAQUS is executed from the operating system of FLIPPER, using FILENAME.INP as the input file. Successful execution of ABAQUS in bullet 25 on FLIPPER produces several permanent files of the analyst's choice (bullet 29), and a myriad of temporary files which are erased at program halt. These files are stored in the user's space on FLIPPER. Typically, the following are the files which are retained at this point:

FILENAME.INP	input file
FILENAME.DAT	output file
FILENAME.FIL	post-processing output file
FILENAME.LOG	accounting file

The sample ABAQUS input file for the 90-degree cone (CONE90.INP) is shown in appendix C.

Upon completion of ABAQUS, the translator ABAPAT (another PDA Engineering translator, bullet 30) is called upon to operate on the post-processing output file FILENAME.FIL (bullet 29). ABAPAT produces the PATRAN displacement, elemental stress, and average nodal stress files (bullet 31) called STPiIj.DIS, STPiIj.ELS, and STPiIj.NOD respectively. In these files, *i* is the step number, and *j* is the increment number within each step. Obviously, a complex nonlinear dynamics problem can have many steps, and numerous increments within each step. Thus, this portion of the code tends to produce massive amounts of data, that the analyst is well advised to prescreen for need.

Once the displacement and stress files are complete in bullet 31, the post-processing of the results can begin. In bullet 32, after executing ABAPAT, the PATRAN environment is re-entered. Here, after calling up the PATRAN model file FILENAME.PAT (bullet 4), displaced geometry and stress contours for each time increment during the entry process can be created. These images can be viewed on the appropriate graphics terminal (bullet 33) or output as color hardcopy in bullet 34.

For example, figure 17 is a hardcopy image of the displacement of the 90-degree nose cap 0.15 ms after entry. As the tip is just wetted, no appreciable deformation of the nose cap structure has occurred. Figure 18, at 0.80 ms after entry, shows the beginnings of deformation of the nose cap under the pressure distribution previously illustrated at this same time-step in figure 6. By following the progression from figures 17 through 23, the deformation of the nose cap in response to the pressure-time history can be clearly seen. This deformation is greatly enlarged for clarity.

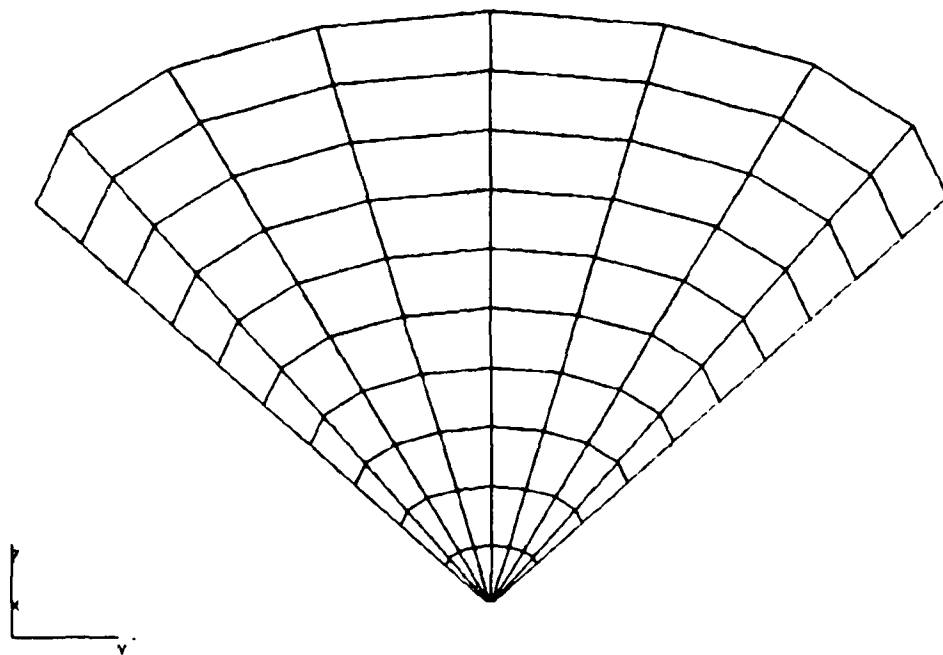

Figure 17. Deformed shape of 90-degree blunted cone at $t = 0.1612$ ms (step 1, initial wetting).

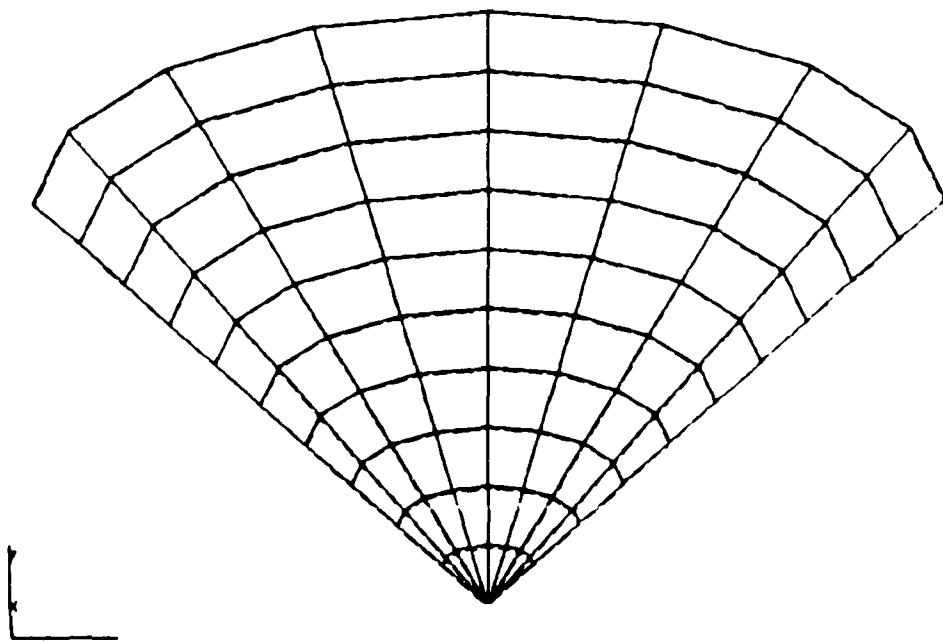

Figure 18. Deformed shape of 90-degree blunted cone at $t = 0.8060$ ms (step 2).

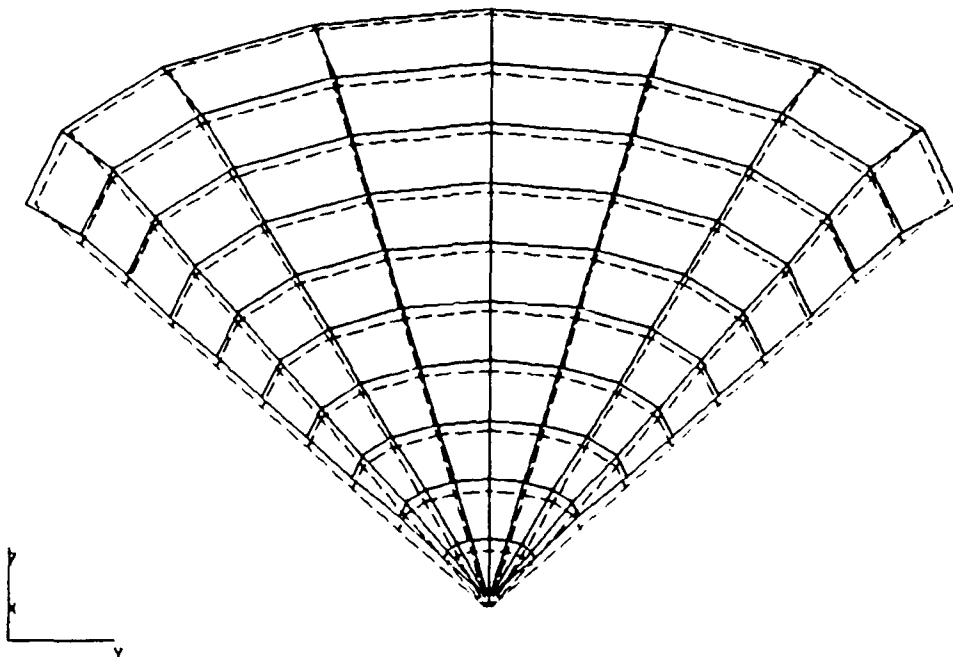

Figure 19. Deformed shape of 90-degree blunted cone at $t = 1.6119$ ms (step 3).

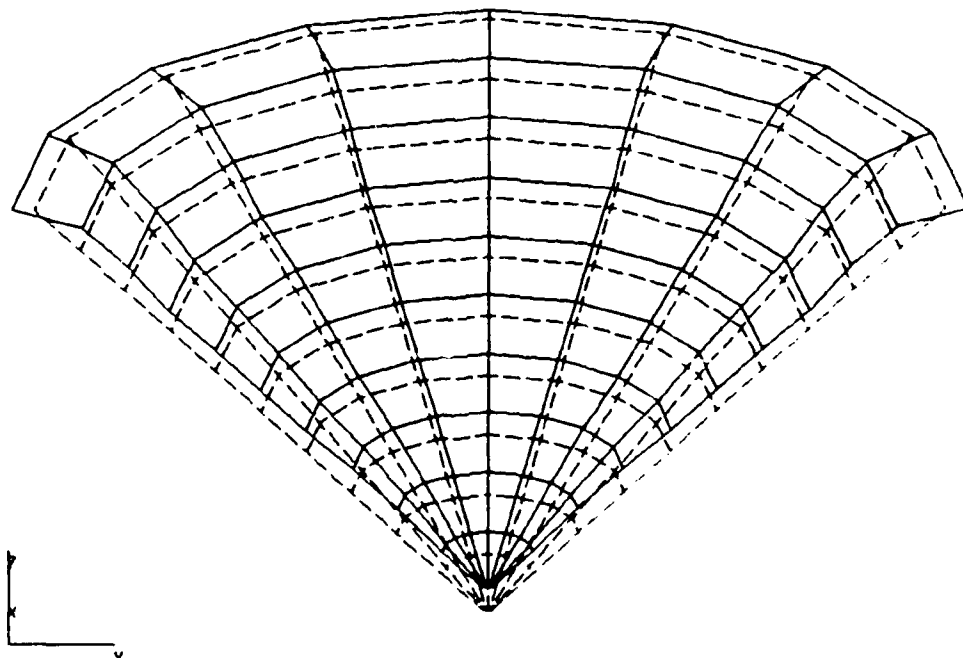

Figure 20. Deformed shape of 90-degree blunted cone at $t = 2.4179$ ms (step 4).

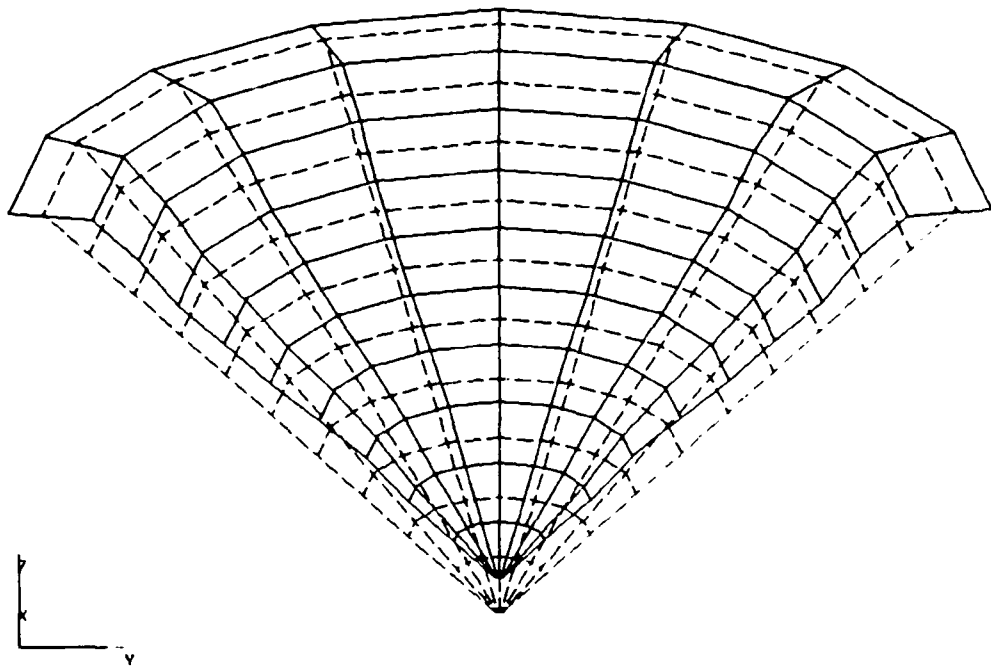

Figure 21. Deformed shape of 90-degree blunted cone at $t = 3.2238$ ms (step 5).

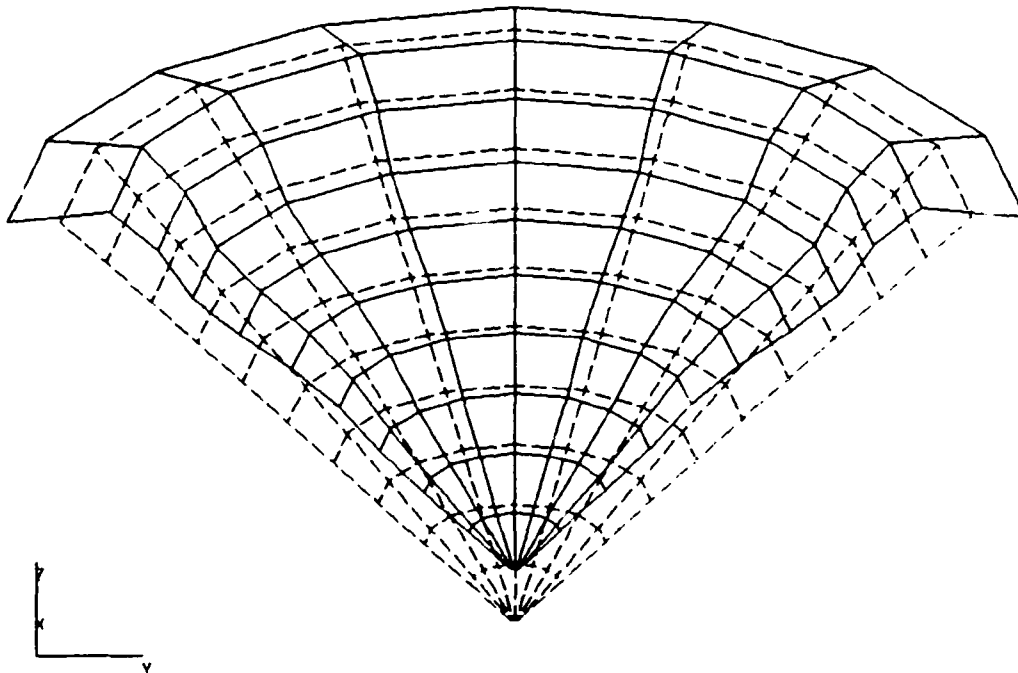

Figure 22. Deformed shape of 90-degree blunted cone at $t = 4.0298$ ms (step 6).

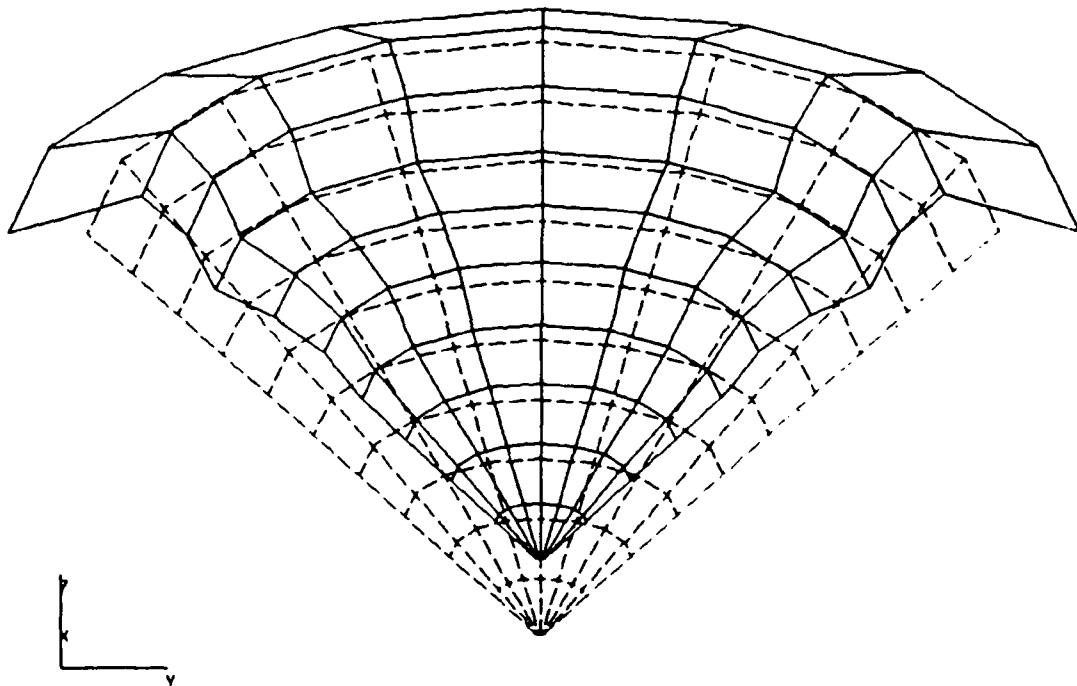

Figure 23. Deformed shape of 90-degree blunted cone at $t = 4.8357$ ms (step 7).

Deformations of elastic bodies result in associated stresses. Figure 24, a maximum distortion energy theory (Von Mises) stress plot, shows the state of stress of the nosecap at time-step 2, 0.80 ms after water entry. As only the tip of the nosecap has been wetted, the Von Mises stresses have only built to a low value on the nosecap. Note that, since no effort was made to accurately model the upper supported edge of this nosecap mode, the actual stress values reported in the stress spectrum along the right edge of the figure are meaningless. They serve only as relative values during the event.

Figures 25 and 26, time-step 3 at 1.61 ms after entry, indicate that the stress levels in the blunted tip have risen to a level exceeding 2.72×10^4 psi.

Figures 27 through 30 are a progression of the Von Mises stresses through the nosecap during the water-entry process, at the same time-steps as the previously displayed deformation histories (figures 17-23). The stress levels along the edge can be seen to fall during the entry process, and then rise again as the stress wave approaches this boundary. As the stress wave follows the pressure pulse up the shell, the boundary condition imposes an inordinate amount of bending into the shell at the upper edge. This bending skews the stress contouring to the point where the analysis is considered unrealistic beyond the point where the nosecap is fully wetted.

As this nosecap has been included only to illustrate the flow of information through this analytical process, the final few figures indicate some of the details of this discipline that require extreme attention by the analyst. Blind faith in computer-generated numbers easily leads to unrealistic expectations from the FEA approach and dangerously incorrect answers.

Assuming the analyst is satisfied with the progress to date, production of these displacement and stress contours completes the program flow at bullet 33. The propensity of the noscap to break up at some point in the entry sequence can be determined at this time and a decision made on optimization of the noscap structure. Obviously, if the results are not satisfactory, the program can be started over (bullet 35), or exited at this point.

RESULTS

Jung and Plapp's (1988) technical report (TR 1221) dealt with a frangible noscap design for the VLA program. In that document, it was reported that a frangible one-piece noscap was not suitable for the current VLA, due to the difficult, restrictive design envelope.

The approach used to develop this conclusion was a manual design optimization of the noscap shell. The water entry pressure profile was generated using ENTRY, and the resultant stress analysis completed using the linear-elastic capabilities of the MacNeal/Schwendler version of MSC/NASTRAN.

To further illustrate the engineering application of the WEST developed in the current IED project, it was decided to review the water entry portion of the VLA noscap analysis.

Figure 31 is the nodal pattern of a half-symmetric 1.25-caliber Von Karman ogival noscap water entry FEM, suitable for use on the VLA missile. This noscap consists of 262 nodes on the exterior of the shell. Figure 32 is a plot of the 228 four-noded quadrilateral elements which form the elemental connectivity for the water entry model, while figure 33 shows an enlarged view of the tip of the noscap FEM. These figures were produced within the PATRAN portion of WEST (bullet 1, figure 1).

Appendix D is the resultant ENTRY input, entitled CAP90.IN;6. This is the result of bullet 7 in figure 1 and is used in the execution of the ENTRY portion of WEST in bullet 8.

Appendix E is the hardcopy output from ENTRY (bullet 9a). Figures 34 through 40 show the plotted resultant pressure distribution as a function of time for the ogival noscap undergoing vertical entry at a velocity of 130.0 ft/s during the time period 0.0 to 3.92 ms. Note that only even time-steps after step 2 are shown for brevity.

These pressure-time histories are shown as element groups (elements grouped as rings in the axial direction) in figure 41. This figure shows how the pressure peak decays in time during water entry.

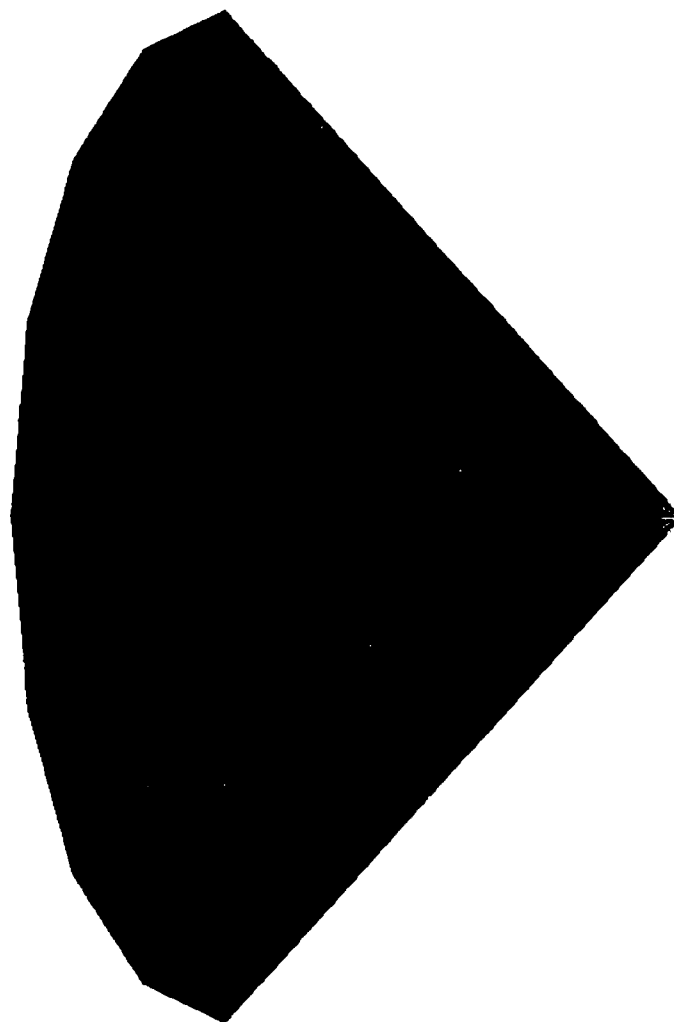
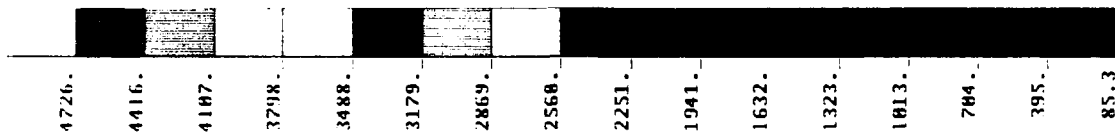

Figure 24. Stress plot showing inside surface Von Mises stresses at $t = 0.8060$ ms (step 2).

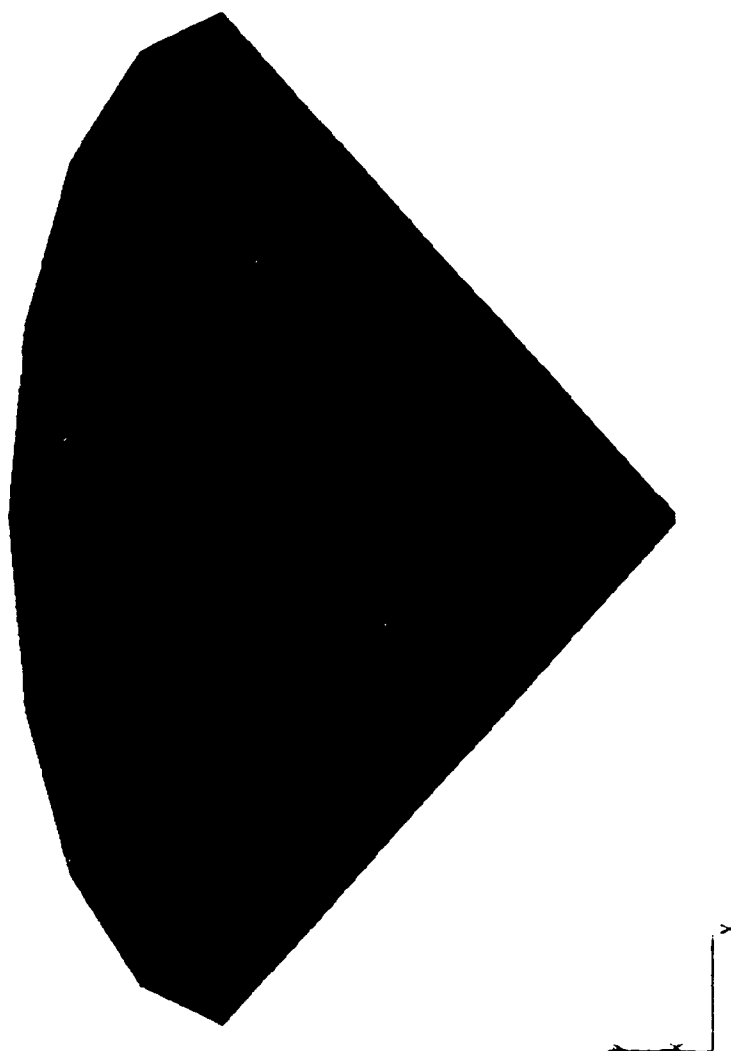
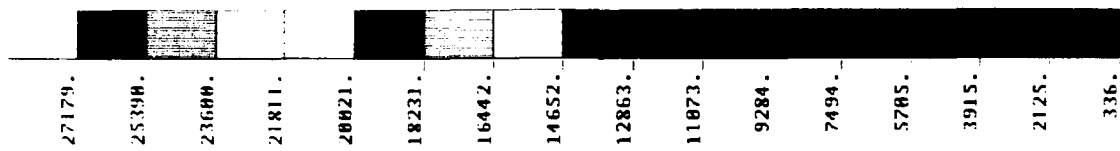

Figure 25. Stress plot showing inside surface Von Mises stresses at $t = 1.6119$ ms (step 3).

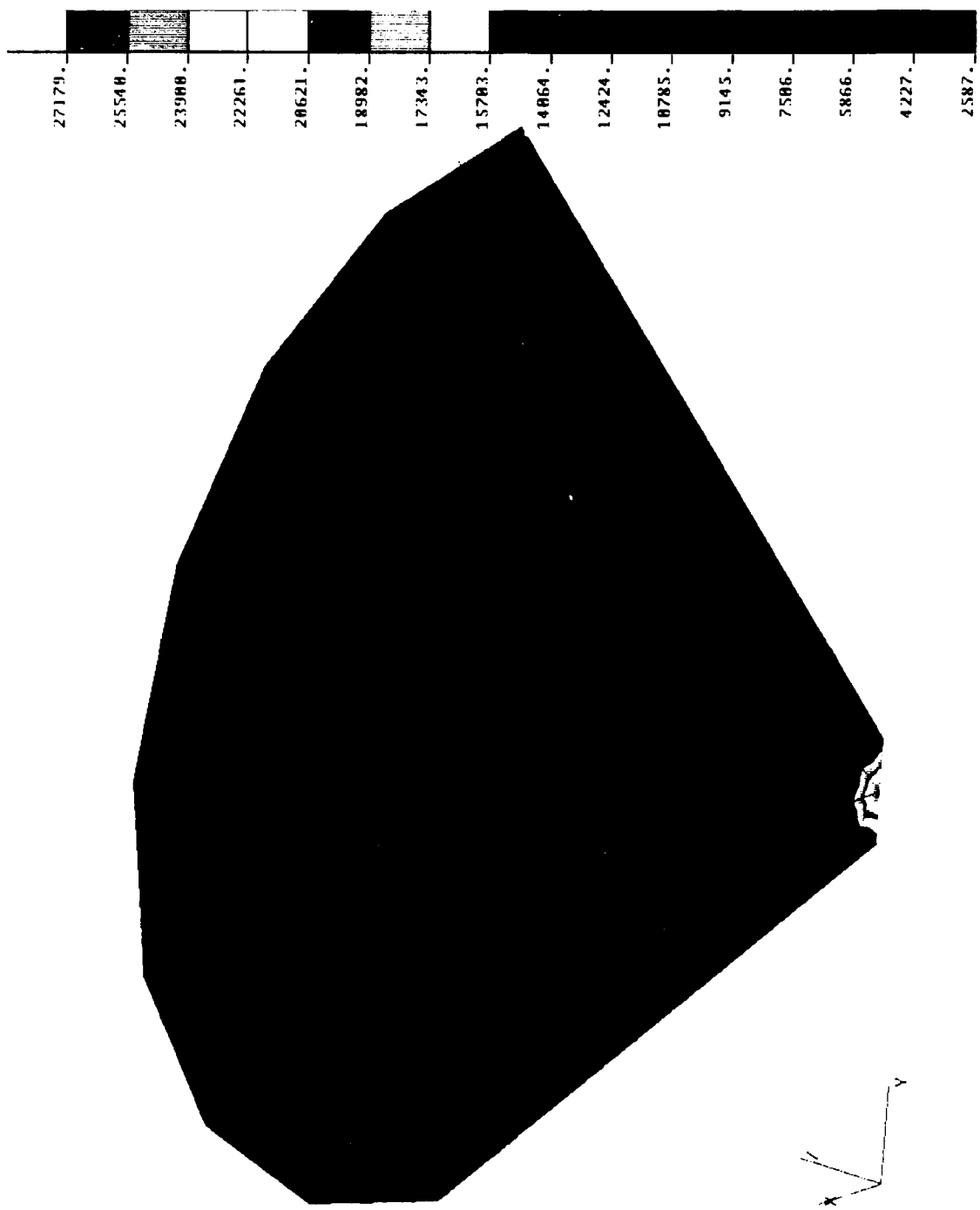

Figure 26. Stress plot showing inside surface Von Mises stresses of tip area at $t = 1.6119$ ms (step 3).

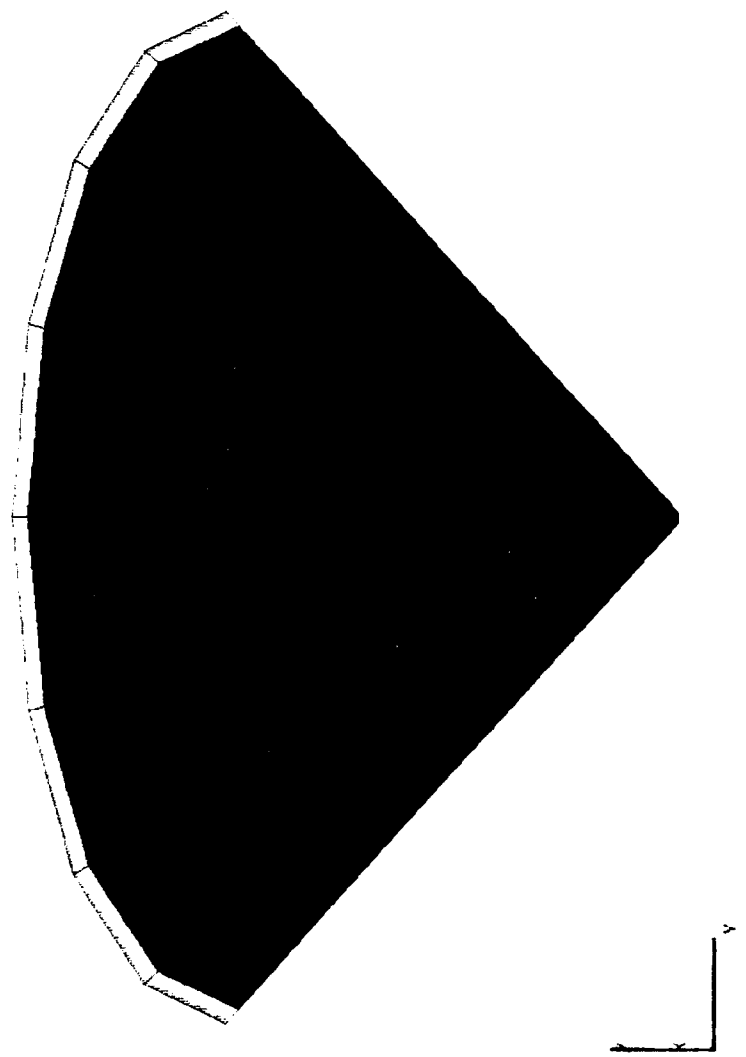
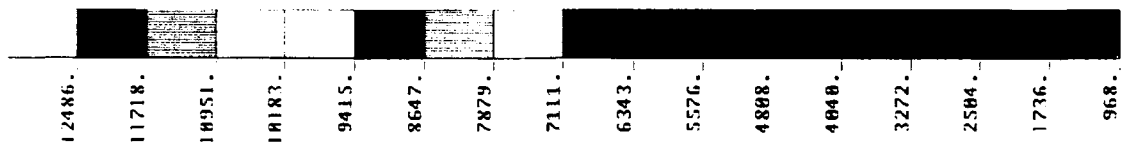

Figure 27. Stress plot showing inside surface Von Mises stresses at $t = 2.4179$ ms (step 4).

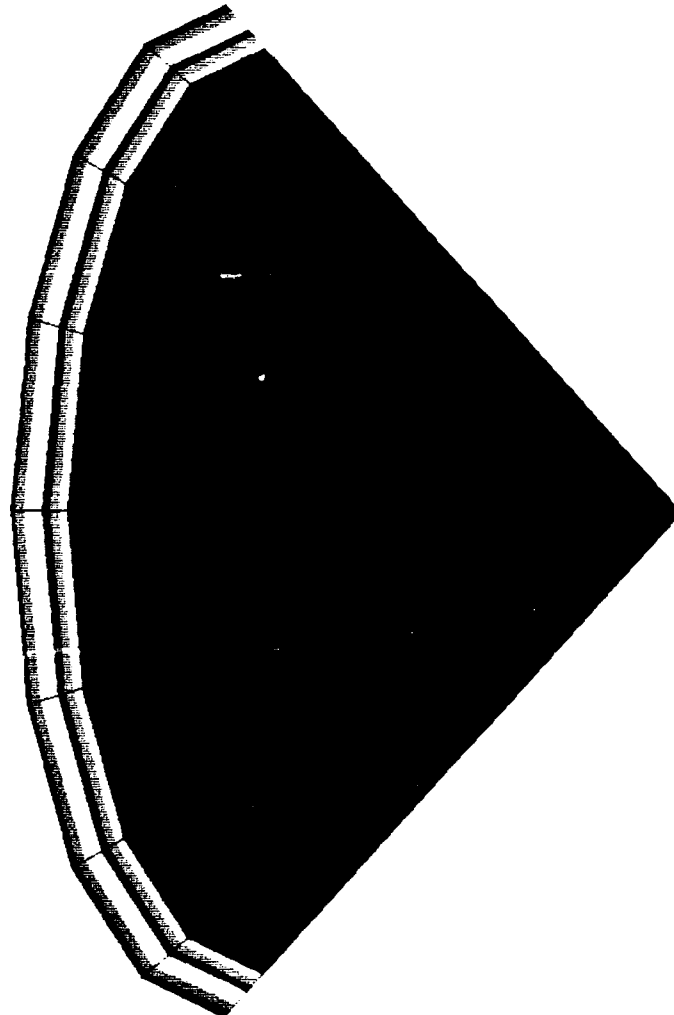
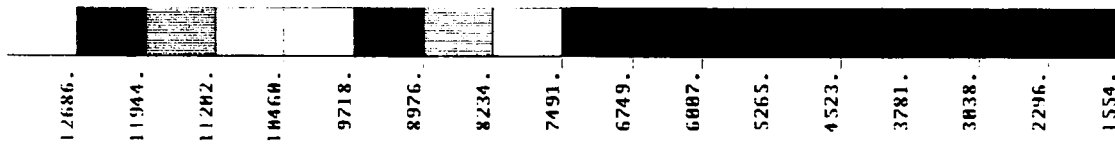

Figure 28. Stress plot showing inside surface Von Mises stresses at $t = 3.2238$ ms (step 5).

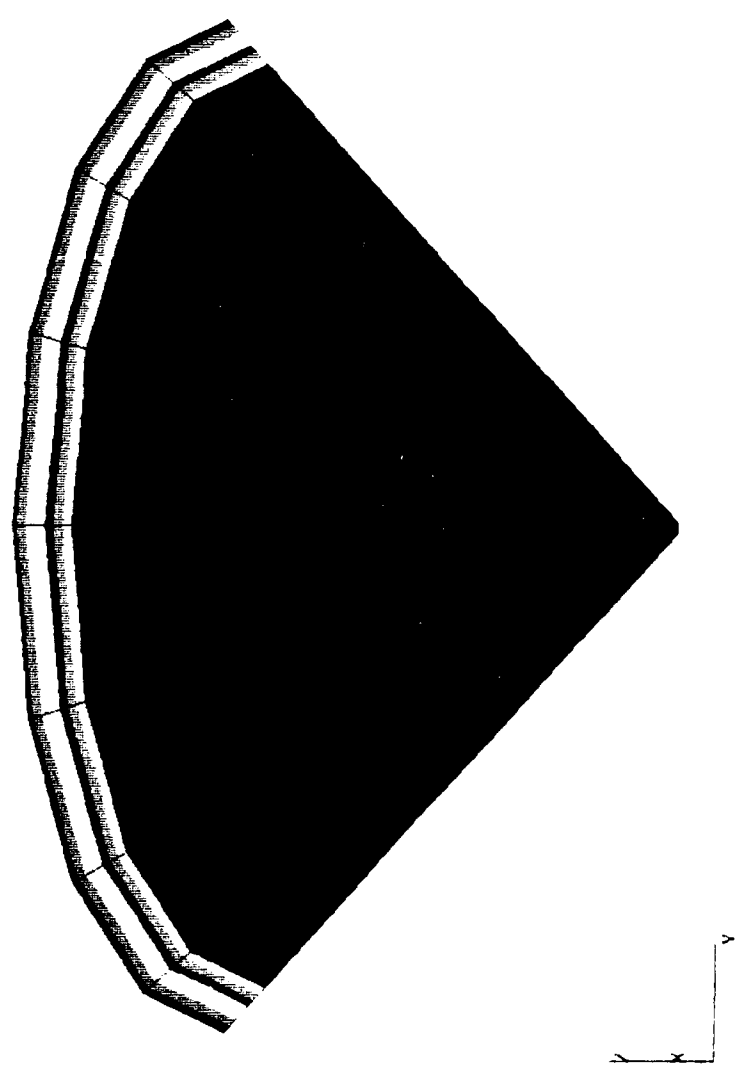
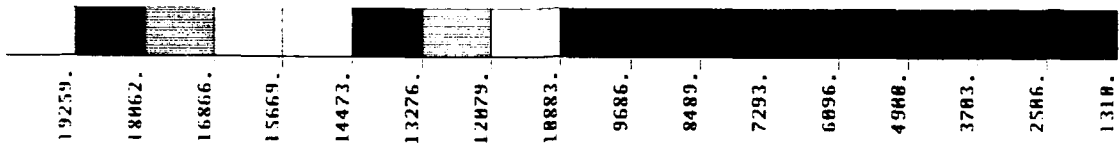

Figure 29. Stress plot showing inside surface Von Mises stresses at $t = 4.0298$ ms (step 6).

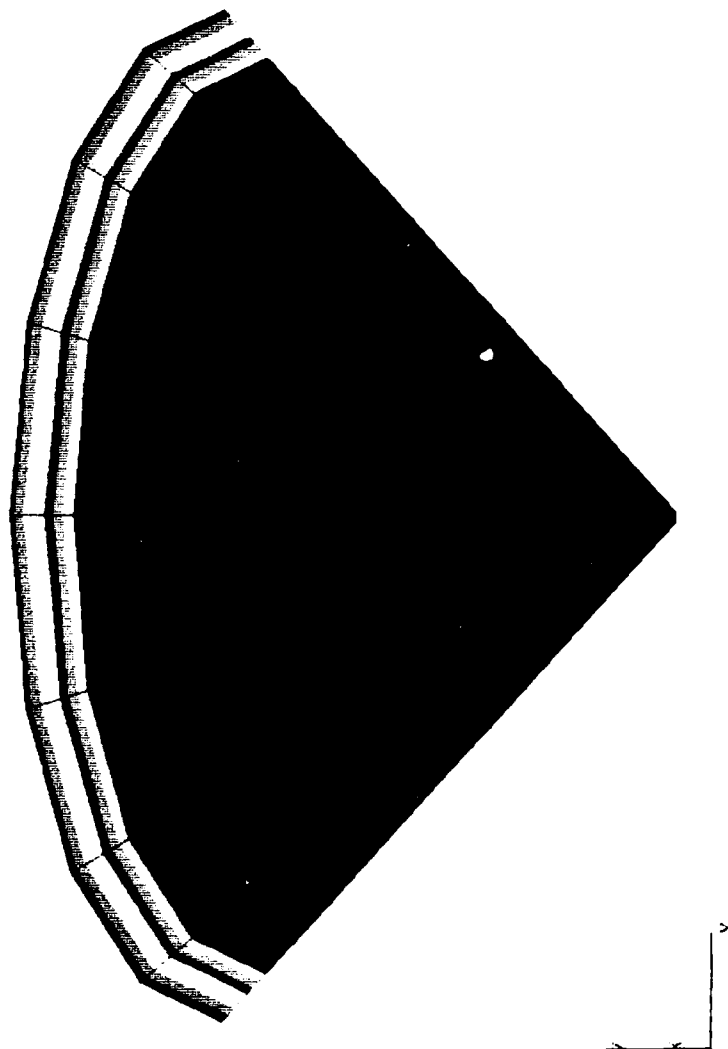
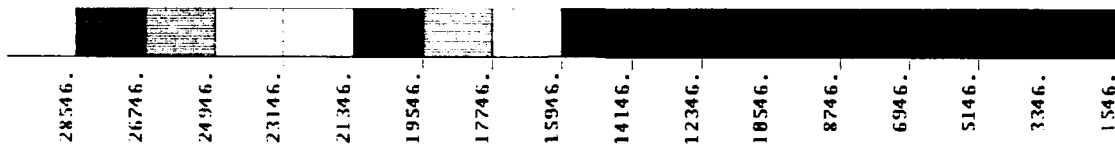

Figure 30. Stress plot showing inside surface Von Mises stresses at $t = 4.8357$ ms (step 7).

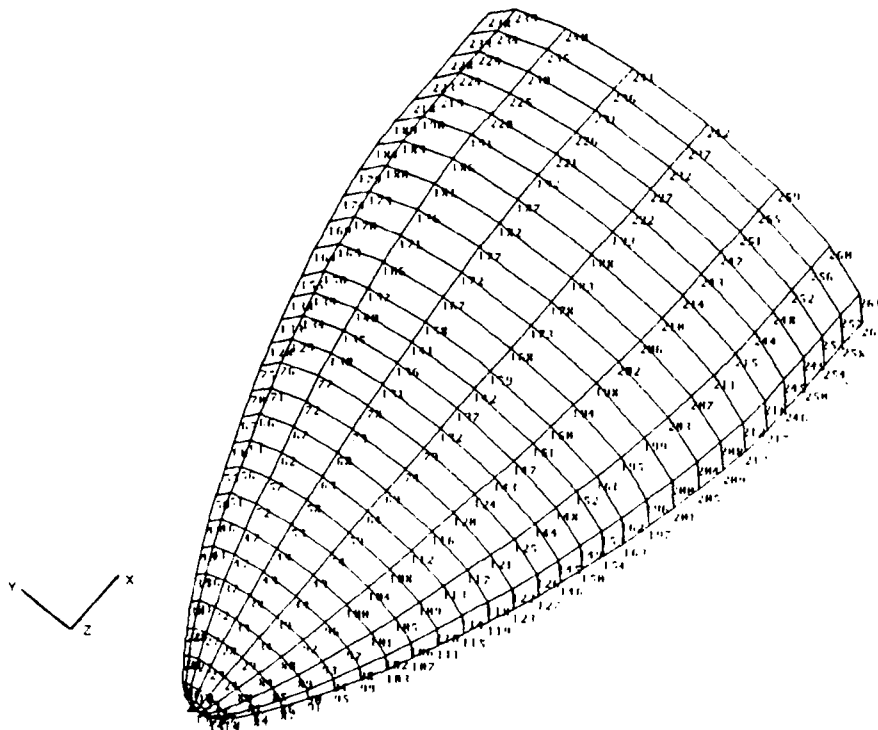

Figure 31. Nodal point pattern of half-symmetric 1.25-cal. Von Karman ogival nose cap water-entry model.

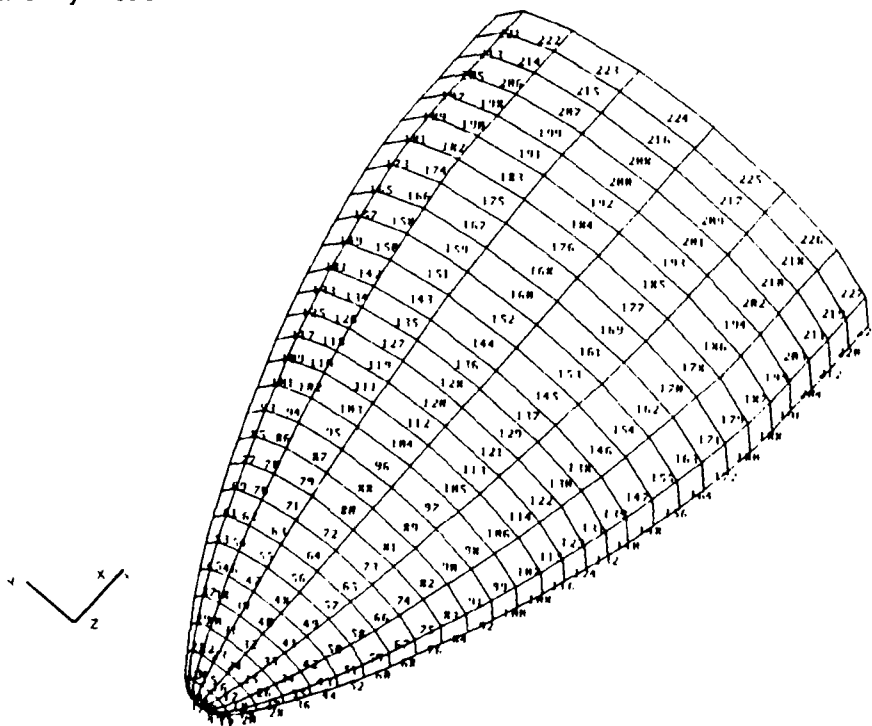

Figure 32. Element-numbering pattern of half-symmetric 1.25-cal. Von Karman ogival nose cap water-entry model.

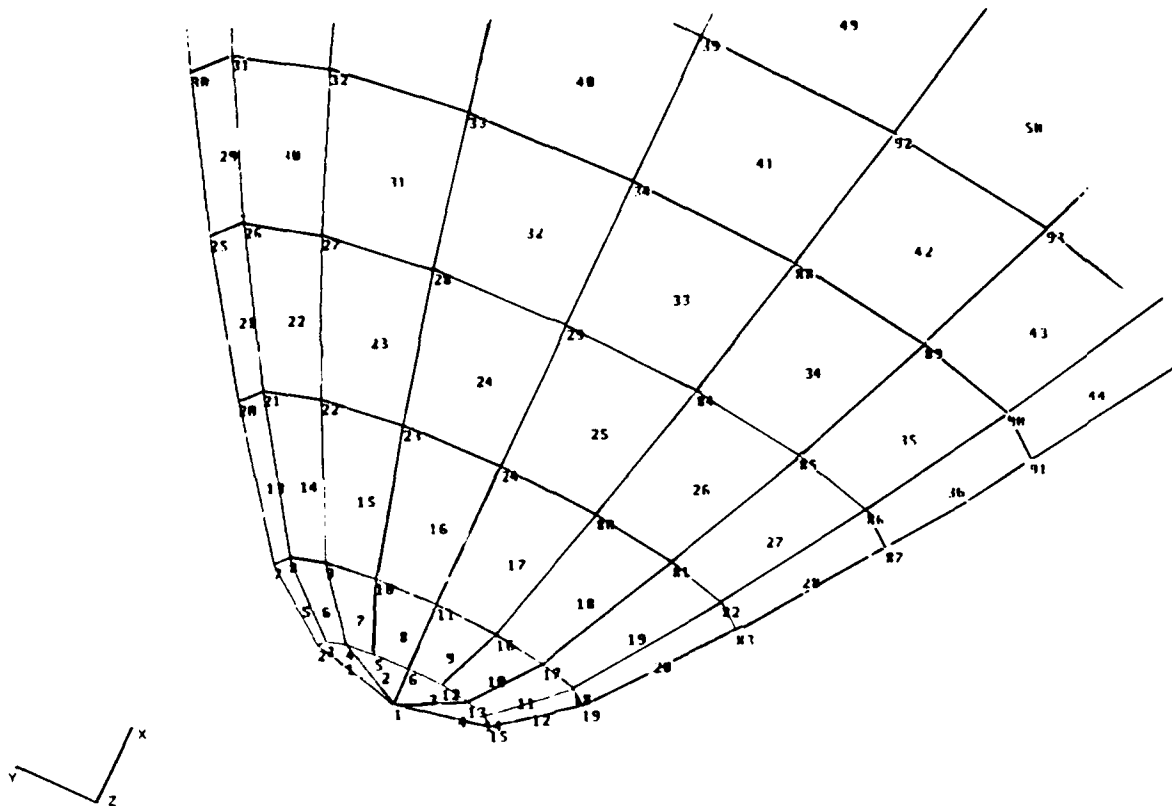

Figure 33. Enlarged view of the tip area of ogive model.

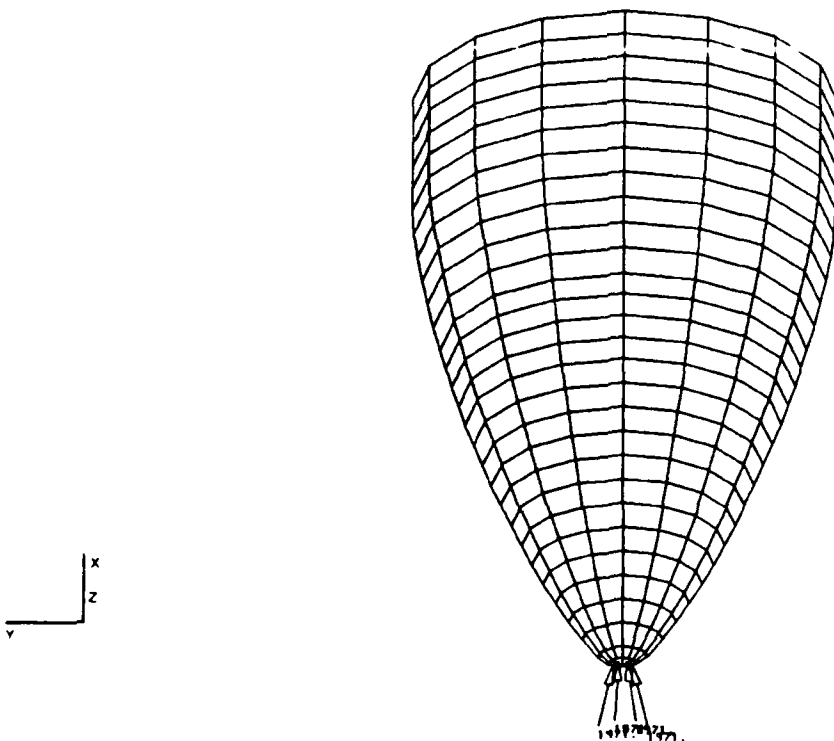

Figure 34. Vertical water-entry nose cap impacting water at 130 ft/s, pressure distribution at $t = 0.0445$ ms (step 1, initial wetting).

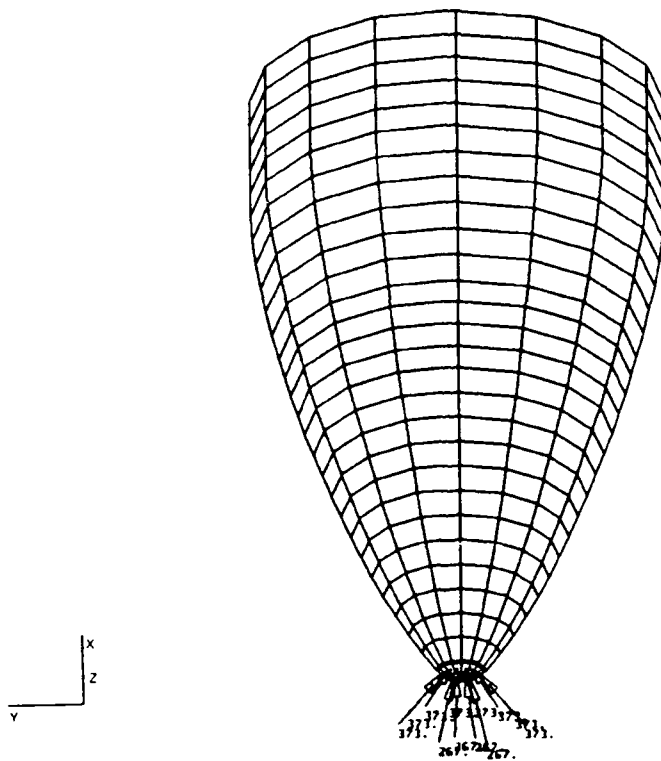

Figure 35. Pressure distribution on vertical water-entry nosecap at $t = 0.1770$ ms (step 2).

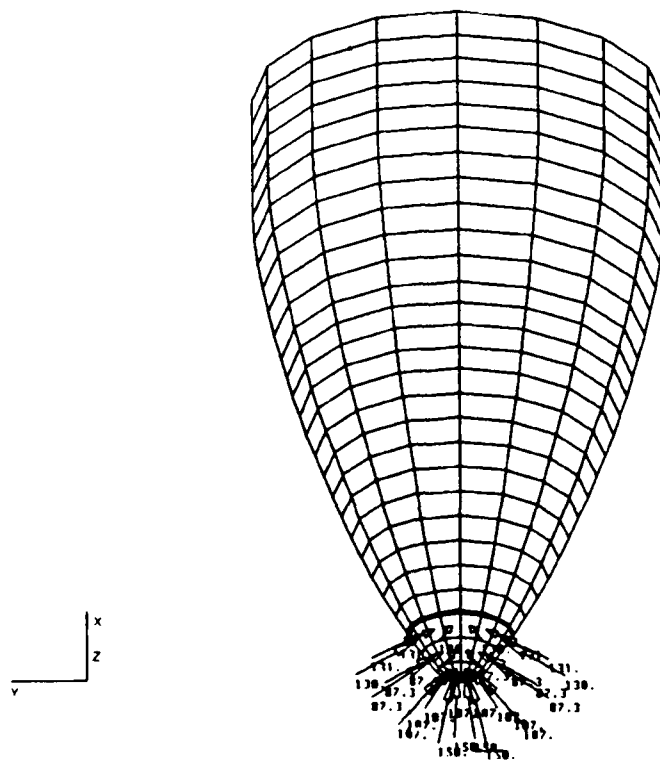

Figure 36. Pressure distribution on vertical water-entry nosecap at $t = 0.8440$ ms (step 4).

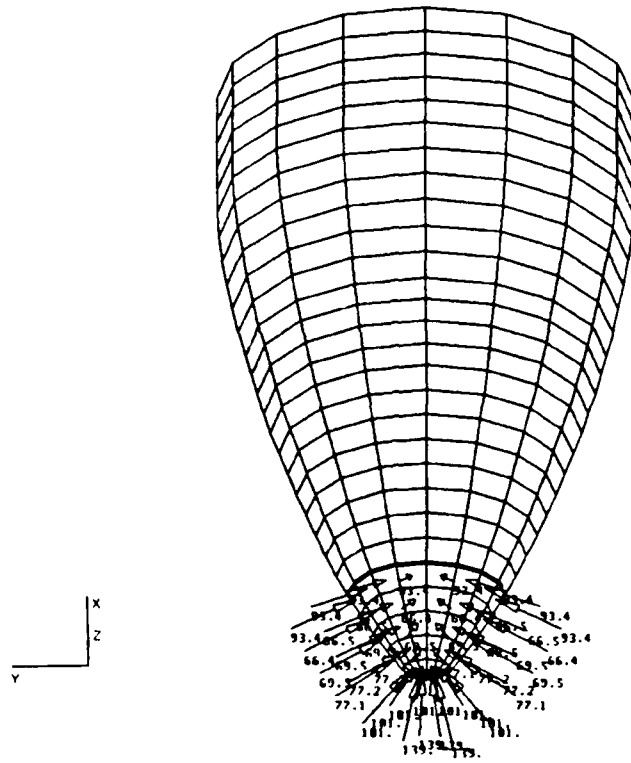

Figure 37. Pressure distribution on vertical water-entry nosecap at $t = 1.5624$ ms (step 6).

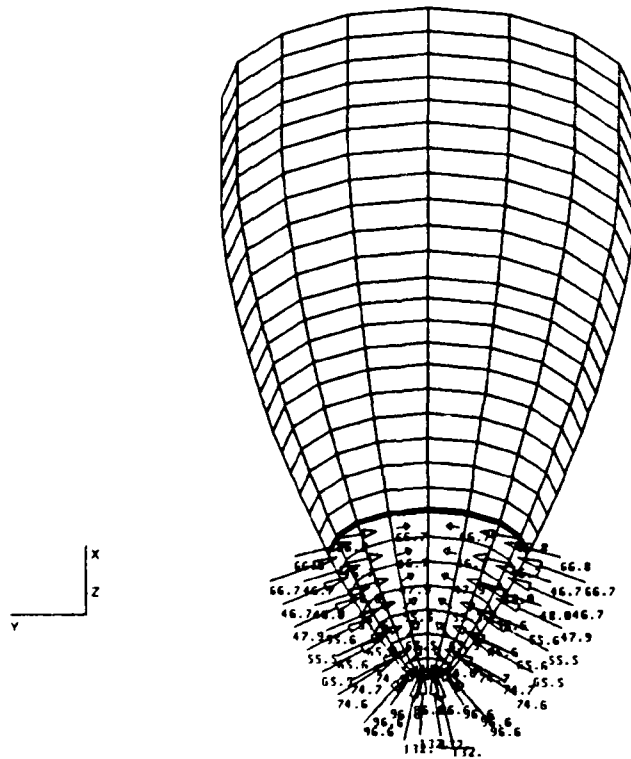

Figure 38. Pressure distribution on vertical water-entry nosecap at $t = 2.3226$ ms (step 8).

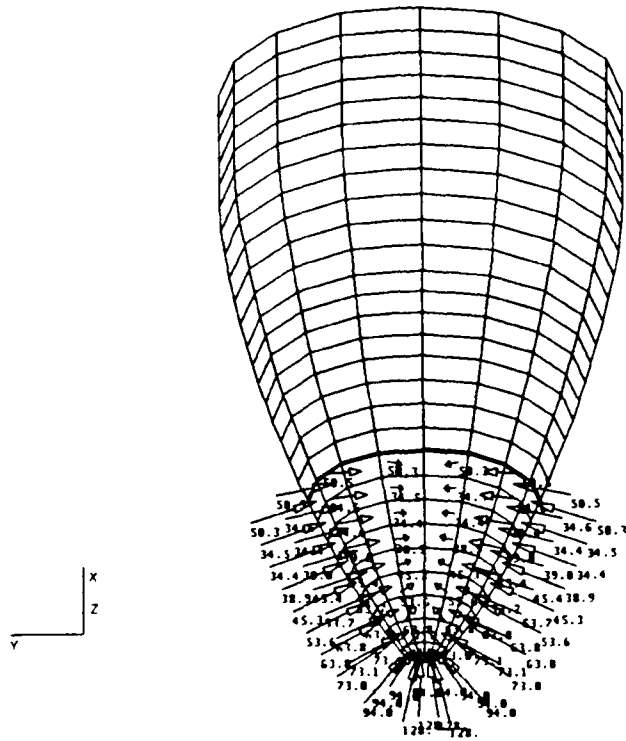

Figure 39. Pressure distribution on vertical water-entry nosecap at $t = 3.1128$ ms (step 10).

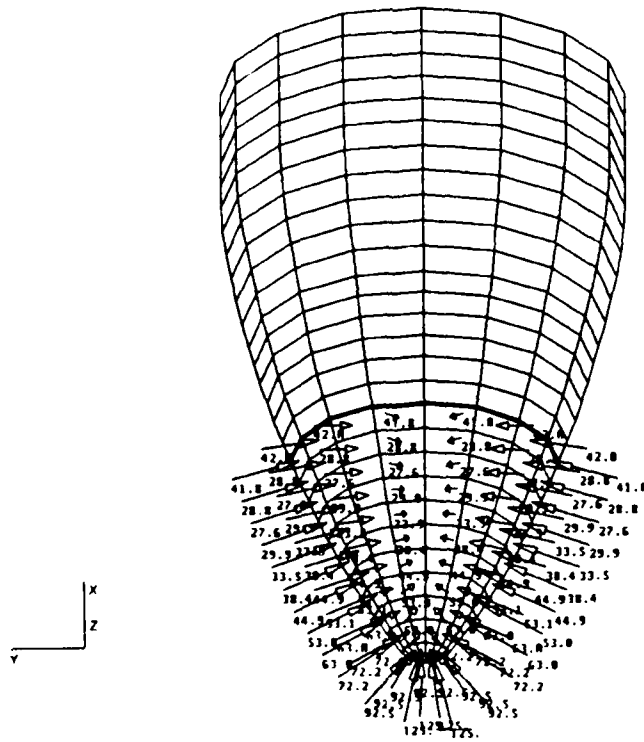

Figure 40. Pressure distribution on vertical water-entry nosecap at $t = 3.9200$ ms (step 12).

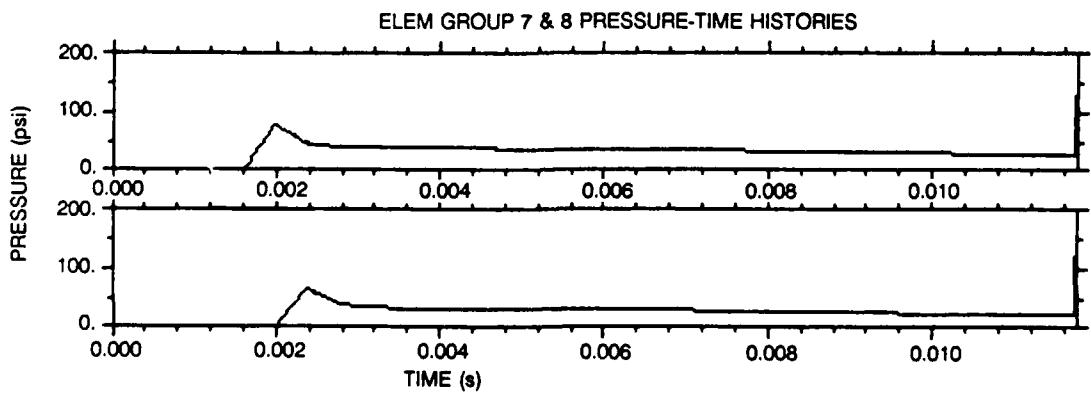
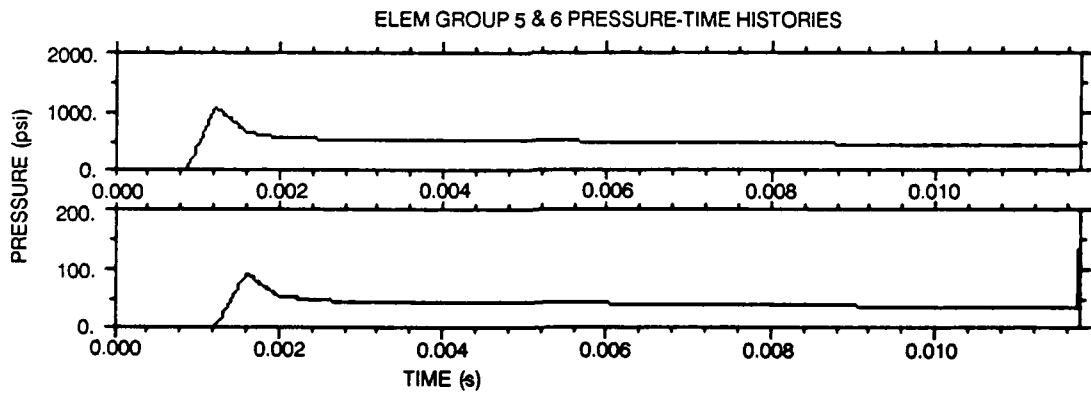
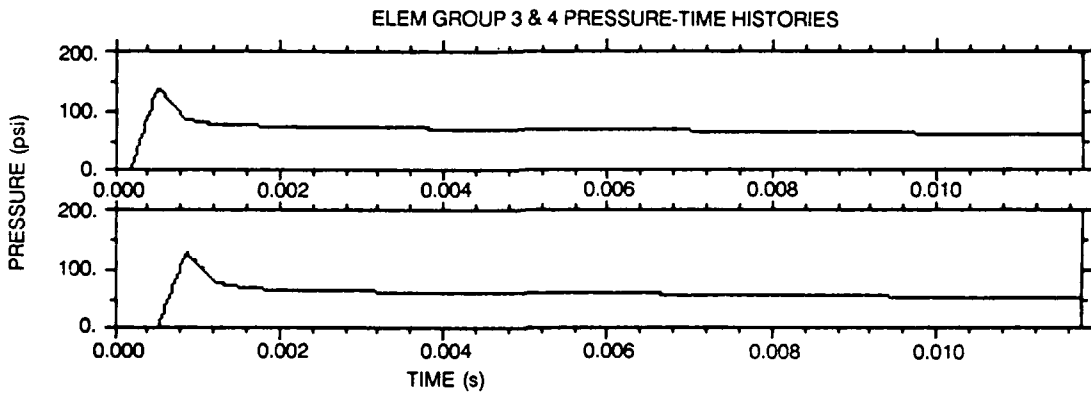
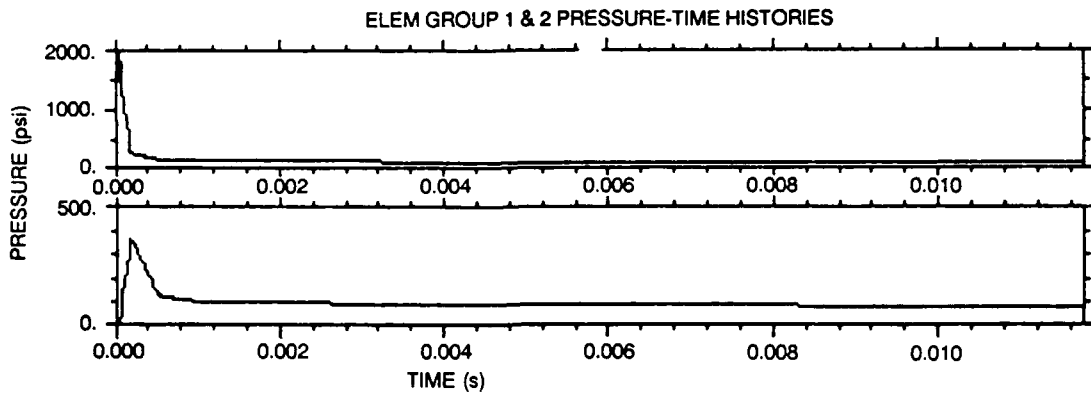

Figure 41. Pressure-time histories (0.000-0.010 s).

To increase computational efficiency, it is possible to take advantage of symmetry in the FEM generated in bullet 1. Figure 42 is a nodal plot of a quarter-symmetric FEM of the nose cap. Notice that this FEM includes two "blade stiffeners" inside the nose cap, which are also composed of four-noded quadrilateral and three-noded shell elements, none of which are wetted during the water entry process. By re-entering PATRAN, it is possible to modify the figures 31 and 32 FEMs to reduce the nodal and elemental count, and add the internal stiffeners, all without compromising the pressure distribution information generated to date. As this is a non-generic detail of the FEM process, it is not specifically shown in figure 1, but can be accommodated by the experienced user in the WEST process. In addition, the elemental resolution in the circumferential direction has been increased from four to eight elements per 90-degree segment. As reversed bending is expected in the unsupported regions in the center of the nose cap, this increased resolution will improve the computational accuracy of the FEA.

The figure 42 FEM, after being transferred to neutral file format in bullet 2, translated into ABAQUS input format in bullet 26, and after being appended with the pressure-distribution information generated in bullet 24, was used to produce the ABAQUS input file CAP90.INP;10. This input deck is included as appendix F of this report.

Execution of ABAQUS in bullet 25 produces the output files CAP90.DAT, CAP90.FIL, CAP90.LIS, etc. The post-processing file CAP90.FIL is operated on by the results translator, ABAPAT, in bullet 30 to produce the hardcopy deformation plots shown in figures 43 through 52, from 0.04 ms to 6.26 ms after water entry.

Obviously, after the initial wetting shown in figure 43, negligible deformation has taken place, despite the extreme pressure on the tip of the nose cap (see figure 34).

The progression of deformation in the nose cap shell with respect to time during water entry is shown in figures 43 through 52. Notice that a "hump" develops just upstream from the two blade stiffeners, which is first visible in figure 46 at 1.56 ms after water entry. In addition, a concavity in the shell forms between the stiffeners, first visible in figure 47 at 2.32 ms after entry. These deformations become progressively more severe the further the nose cap is immersed.

As previously illustrated with the 90-degree cone example, deformation of a structure body is accompanied by associated stress levels within the structure. In this stress analysis process of the nose cap, the nose cap shell is predicted to fail as the stress in the shell material reaches some measure of a failure criterion. In the case of nonmetallic brittle materials in a nonuniform geometrical arrangement such as a nose cap, it is appropriate to use the maximum principal stress theory for a failure criterion. This theory asserts that failure or fracture of a material occurs when the maximum principal stress at any point in the structure reaches a critical value regardless of the other stresses. The critical value of stress is usually determined in a tensile experiment, where the failure of a specimen is defined to be either excessively large elongation or fracture. Failure is characterized by the separation, or the cleavage, fracture. This mechanism of failure differs drastically from a ductile fracture typical of metallic materials, which is accompanied by large deformations due to slips along the planes of maximum shearing stress.

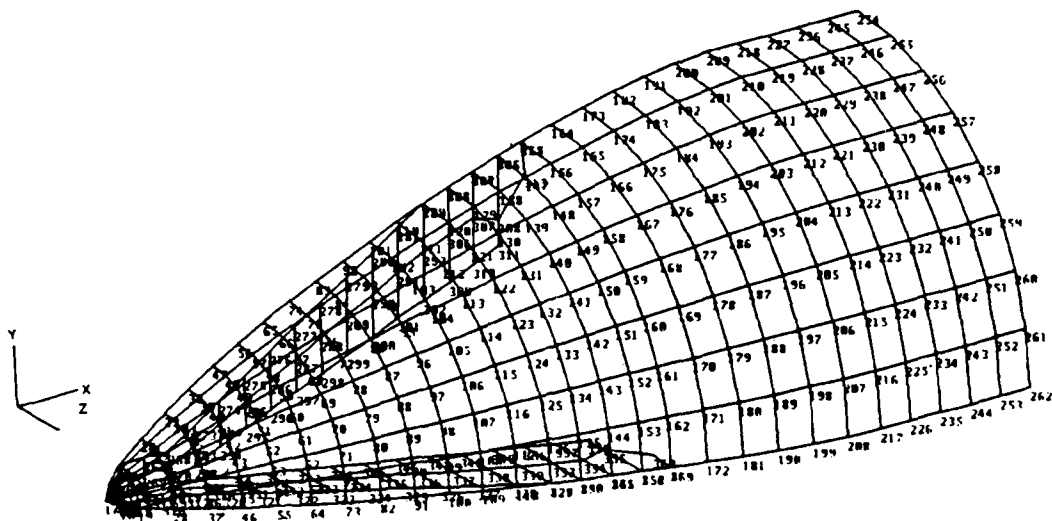

Figure 42. Nodal point pattern of a nosecap quarter-symmetric model with internal blade supports.

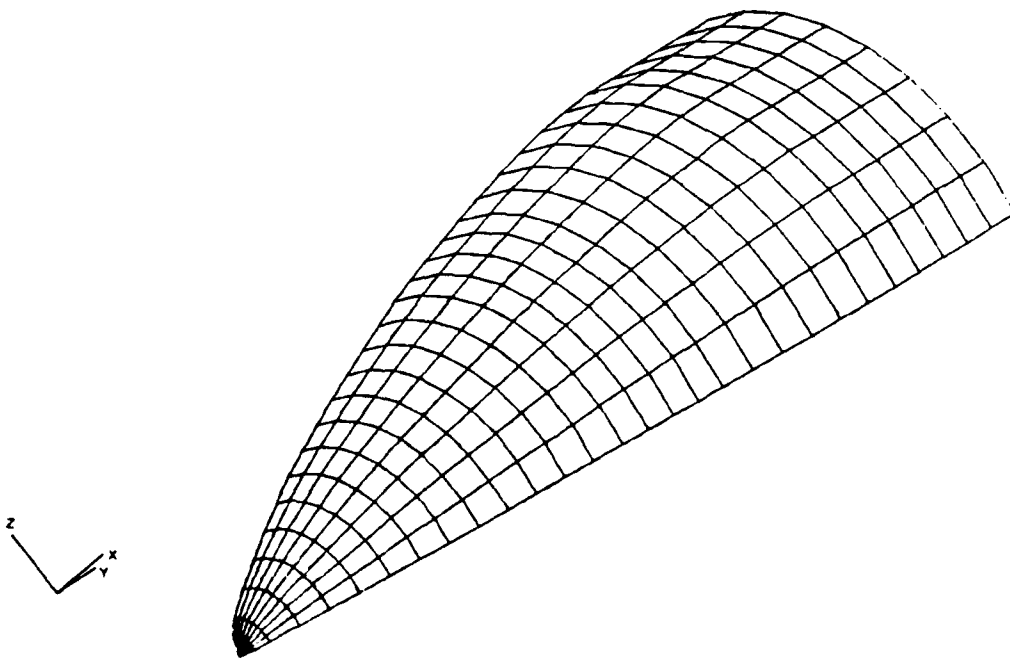

Figure 43. Progression of deformation of the nosecap shell, at $t = 0.0445$ ms (step 1, initial wetting).

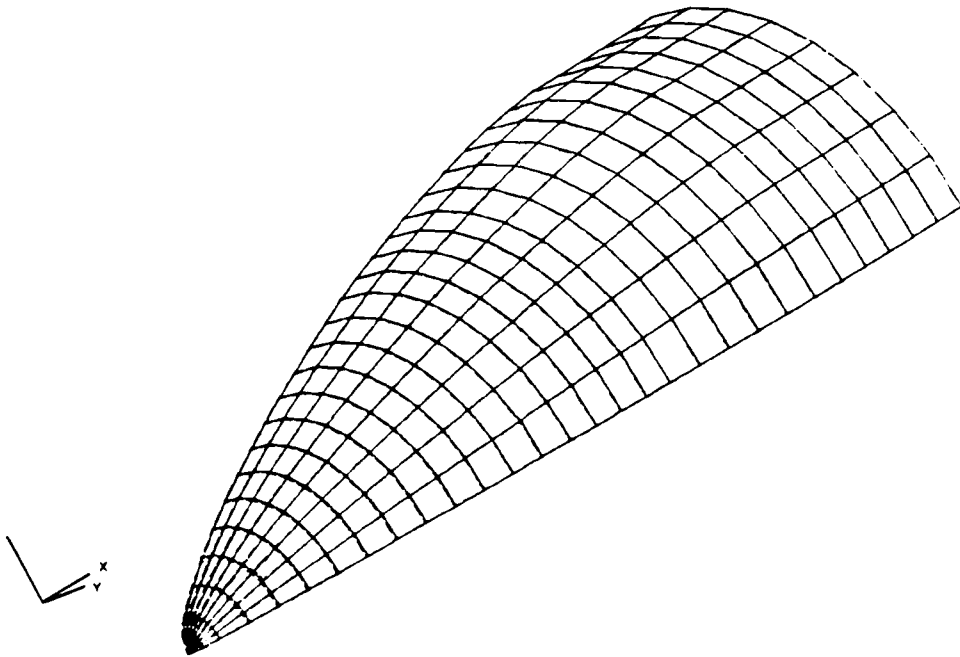

Figure 44. Deformed shape of shell at $t = 0.1770$ ms (step 2).

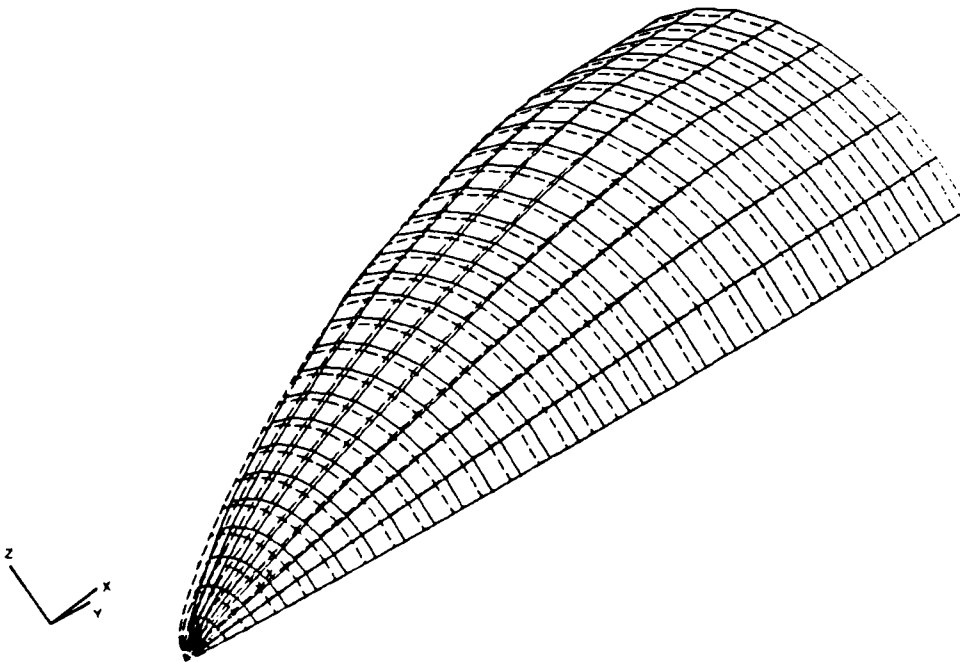

Figure 45. Deformed shape of shell at $t = 0.8440$ ms (step 4).

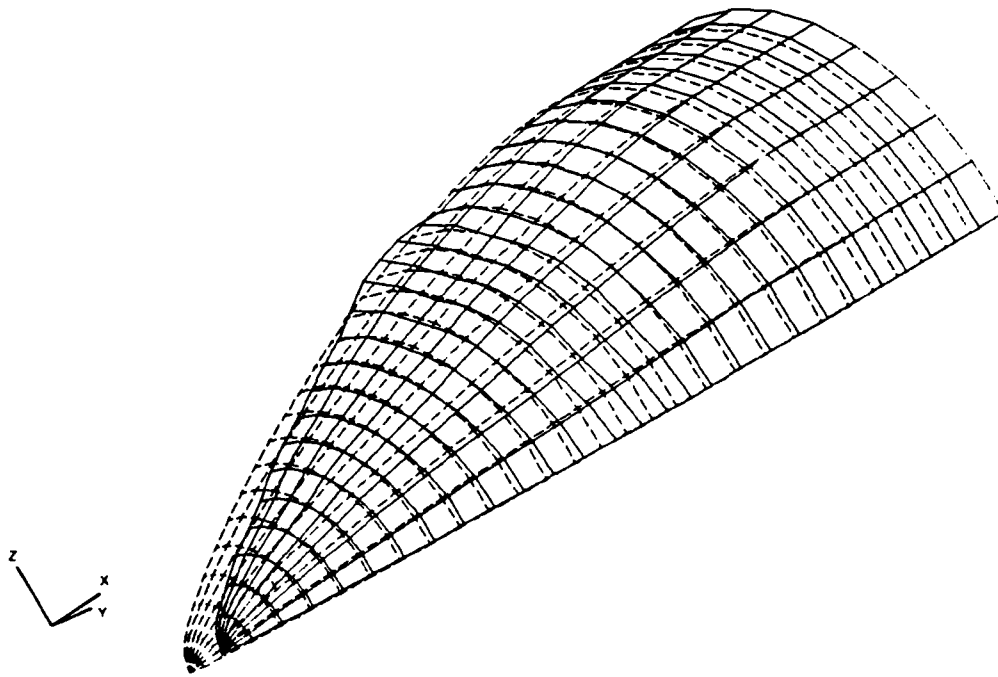

Figure 46. Deformed shape of shell at $t = 1.5624$ ms (step 6).

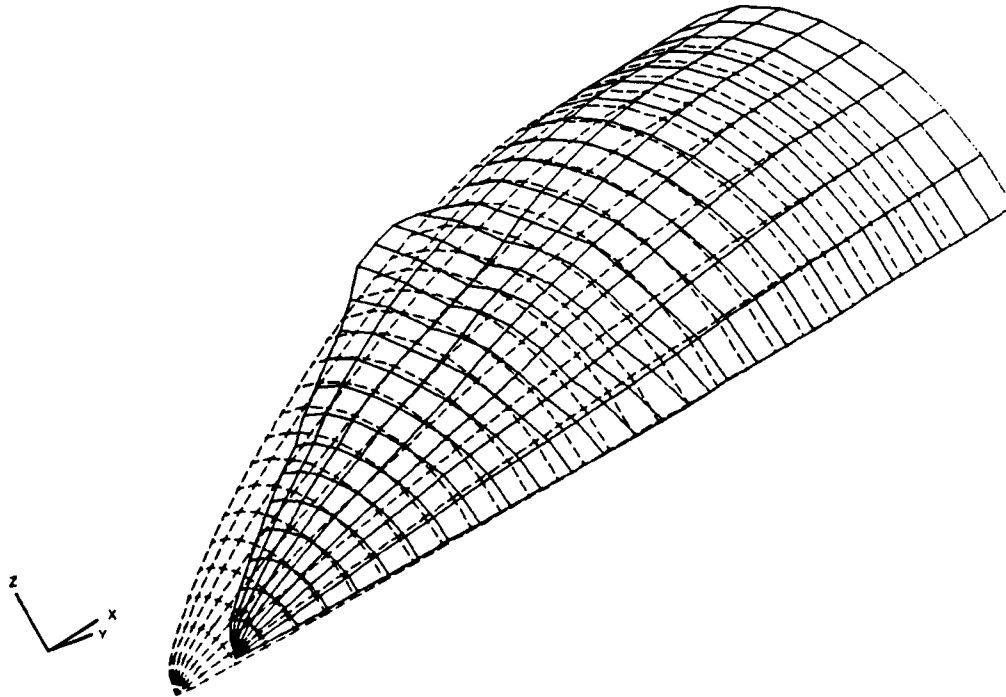

Figure 47. Deformed shape of shell at $t = 2.3226$ ms (step 8).

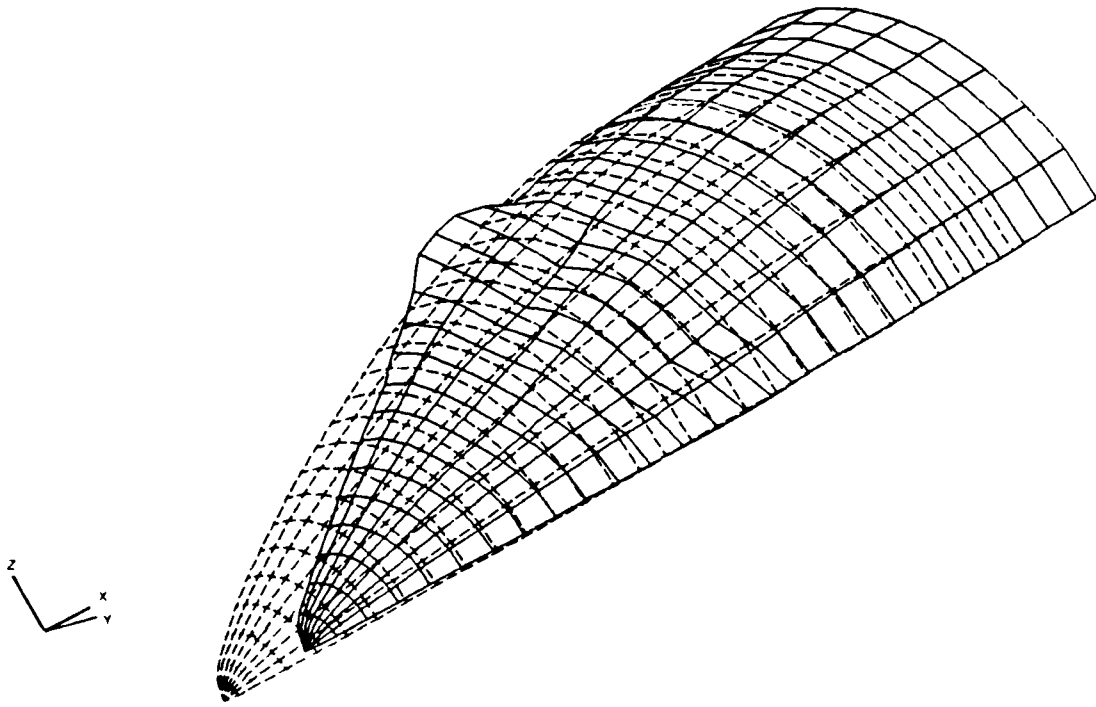

Figure 48. Deformed shape of shell at $t = 3.1128$ ms (step 10).

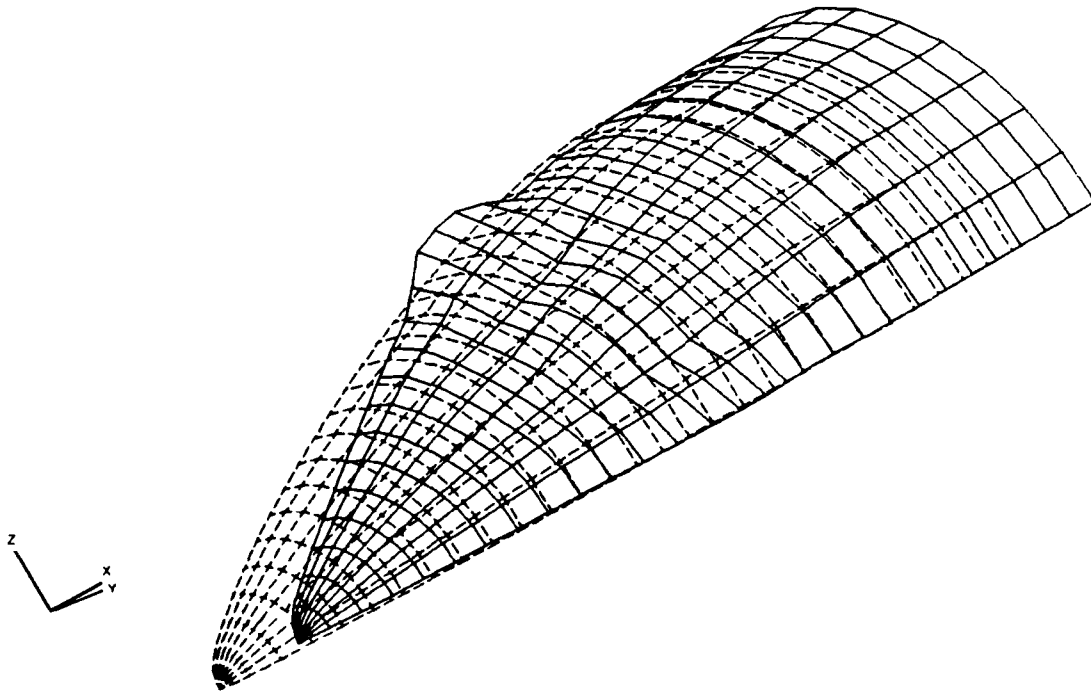

Figure 49. Deformed shape of shell at $t = 3.9200$ ms (step 12).

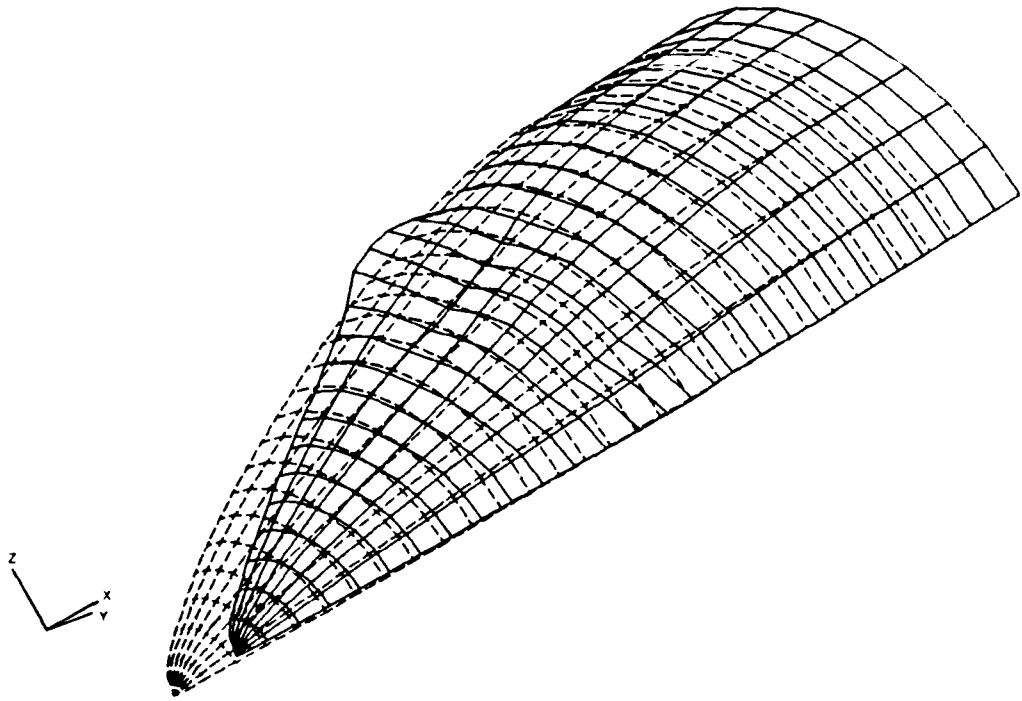

Figure 50. Deformed shape of shell at $t = 4.7335$ ms (step 14).

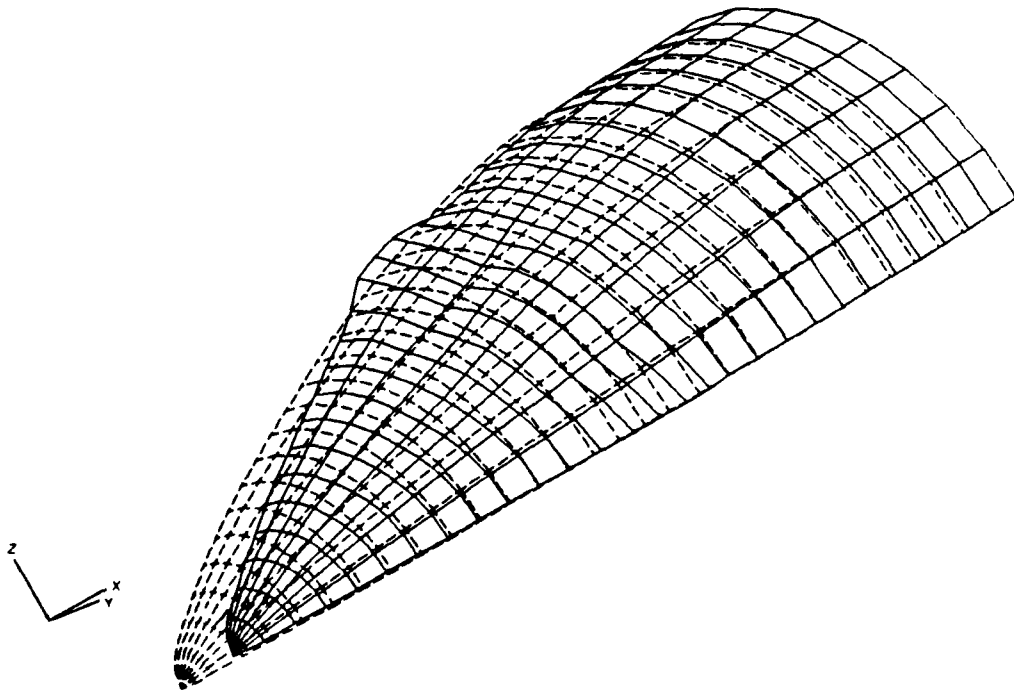

Figure 51. Deformed shape of shell at $t = 5.5041$ ms (step 16).

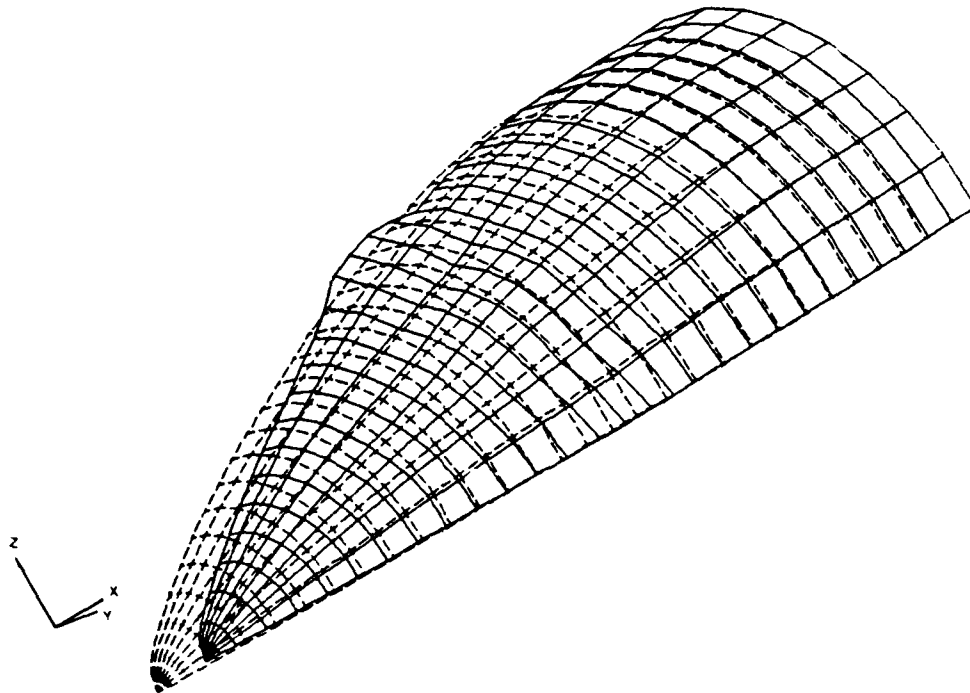

Figure 52. Deformed shape of shell at $t = 6.2642$ ms (step 18).

The ultimate tensile strength (UTS) of the fiber-reinforced PHENOLIC material for the VLA nose cap has an average UTS in the transverse (hoop) direction of the nose cap of 5.68×10^3 psi (5.68 KSI) and a UTS of 7.57 KSI in the longitudinal (axial) direction of the nose cap. Therefore, failure of the nose cap can be predicted any time the value of any of the three principal stresses exceed these values. Note that, as this is a thin shell, the through-the-thickness stress gradient is virtually zero, and will not be reported.

Figures 53 through 62 are stress contour plots of the inner fiber first principal stress of the nose cap, from initial entry to 6.26 ms after entry. Nodal values are shown in the color bar to the right of the plots, which are averaged by PATRAN throughout the elements to produce the color contours shown. To reduce repetition, only five time-steps are reported.

Figure 53, at 0.04 ms after entry, shows the maximum first principal stress occurring in the second and third rings of elements from the tip. As the nose cap is barely wetted at this time-step (see figure 35), the deformation has not had a chance to propagate to any great extent, and the stress level has only risen to -4303 psi.

Figure 54 indicates that the maximum stress has risen to -4565 psi in several areas along the midspan between the tip and the stiffener interface. The concavity in the shell along the center meridian has started to develop significant stresses of its own.

Figure 55, at 3.11 ms after entry, indicates that the stress level in the midspan area along the edges of the FEM have reached a stress level of -11,648 psi, while the center meridional stress level has increased to approximately -5400 psi.

In figure 56, at 4.73 ms after entry, the stress in the midspan along the edges has fallen to -11,327 psi, with a corresponding decrease to -5286 psi along the center meridian. The point of maximum stress has moved up the nosecap in the approximate location of the water surface.

Figure 57, at 6.26 ms after entry, indicates that the midspan stress has continued to fall, along with the meridional stress. As previously shown in figure 41, the magnitude of the pressure distribution decreases with time as the nosecap enters the water. As the shell diameter increases with distance from the tip, the stress level would be expected to increase with time, had the pressure distribution been constant with time. However, this is obviously not the case, and the stress level in the shell has been shown to peak at some time after entry, but before the shell is fully wetted.

To reduce redundancy, the second principal stress distribution is not reported.

Figures 58 through 62 are stress contour plots of the third principal stresses, from 0.18 to 6.26 ms after water entry. In general, these follow the same trends as reported in figures 53 through 57. However, the third principal stresses are all tensile (positive in magnitude) stresses, and are greatly influenced by the reverse bending that occurs in the equatorial direction around the shell.

A cross-sectional view of the nosecap along the axial meridians reveals some bending behavior occurring near the "hump" in the shell. However, the predominant deformation is compressive, yielding predominantly compressive normal stresses in the axial direction. A cross-sectional view of the nosecap along the hoop direction equators reveals considerable reverse bending response in the hoop direction. It is this bending response that dominates the stress field used to compute the third principal stresses.

As the direction cosines of the normal stresses are not reported by ABAQUS, it is extremely difficult to describe the directions of the principal stresses. Although care was taken in this analysis to insure that the elemental numbering scheme used resulted in a uniformly "outboard normal" for each element, ABAQUS sorts the resultant principal stresses by magnitude. Therefore, it is not possible to state that the first principal stresses are aligned in predominantly axial direction, or that the third principal stresses are predominantly aligned in the hoop direction. In addition, the deformation in response to the pressure-time history is extremely complex, both due to the changing loads, and the presence of the blade stiffeners. The principal stresses are simply compared to UTS in the maximum principal stress theory. If a failure is indicated in one of the three principal directions, it is not important to know in what direction that stress lies.

Figures 53 through 62 show that a dynamic state of stress exists within the nosecap during water entry. To attempt to simplify the large amount of data collected, figures 63 through 66 were condensed from the data. These are plots of the state of stress as a function of time for four points on the nosecap shell, aligned with the 90-degree meridian and the blade stiffener. Node 28 is located near the tip of the shell, node 73 in the midspan between the tip and the blade-shell interface, node 118 near the lower edge of the blade stiffener, and node 136 near the middle of the blade-shell interface (see figure 42).

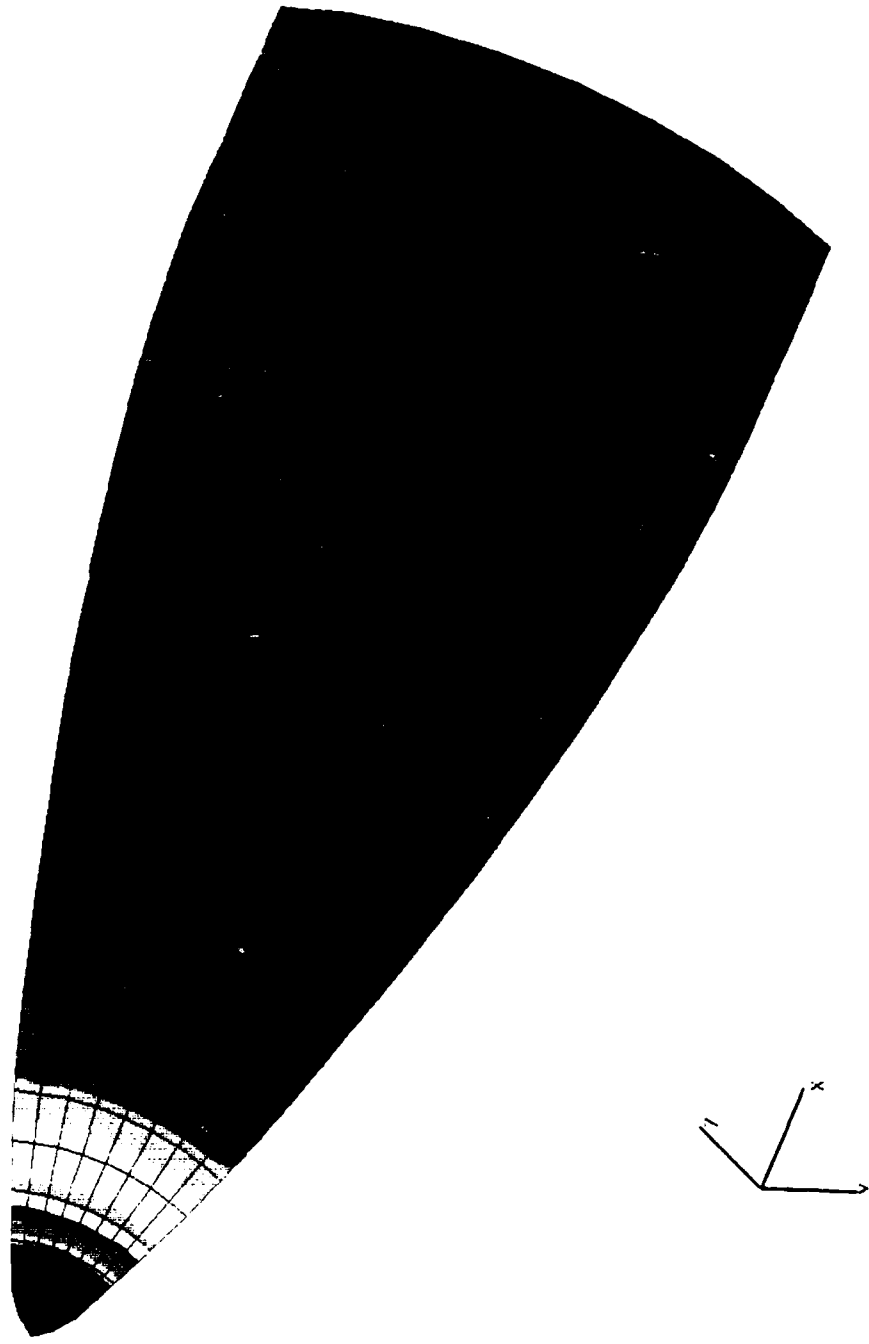
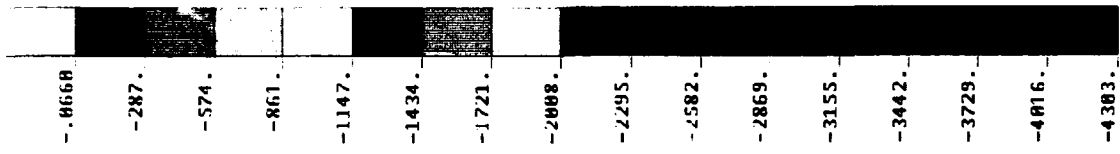

Figure 53. Stress contour plot of the inside shell surface first principal stresses at $t = 0.0445$ ms (step 1).

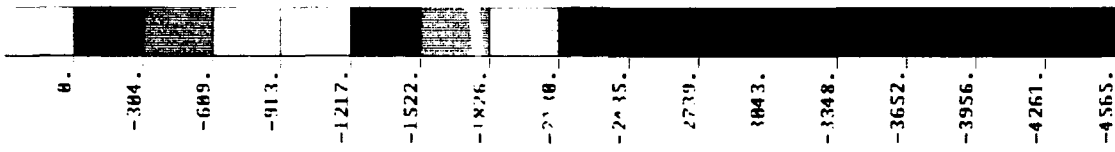

Figure 54. Inside shell surface first principal stresses at $t = 1.5624$ ms (step 6).

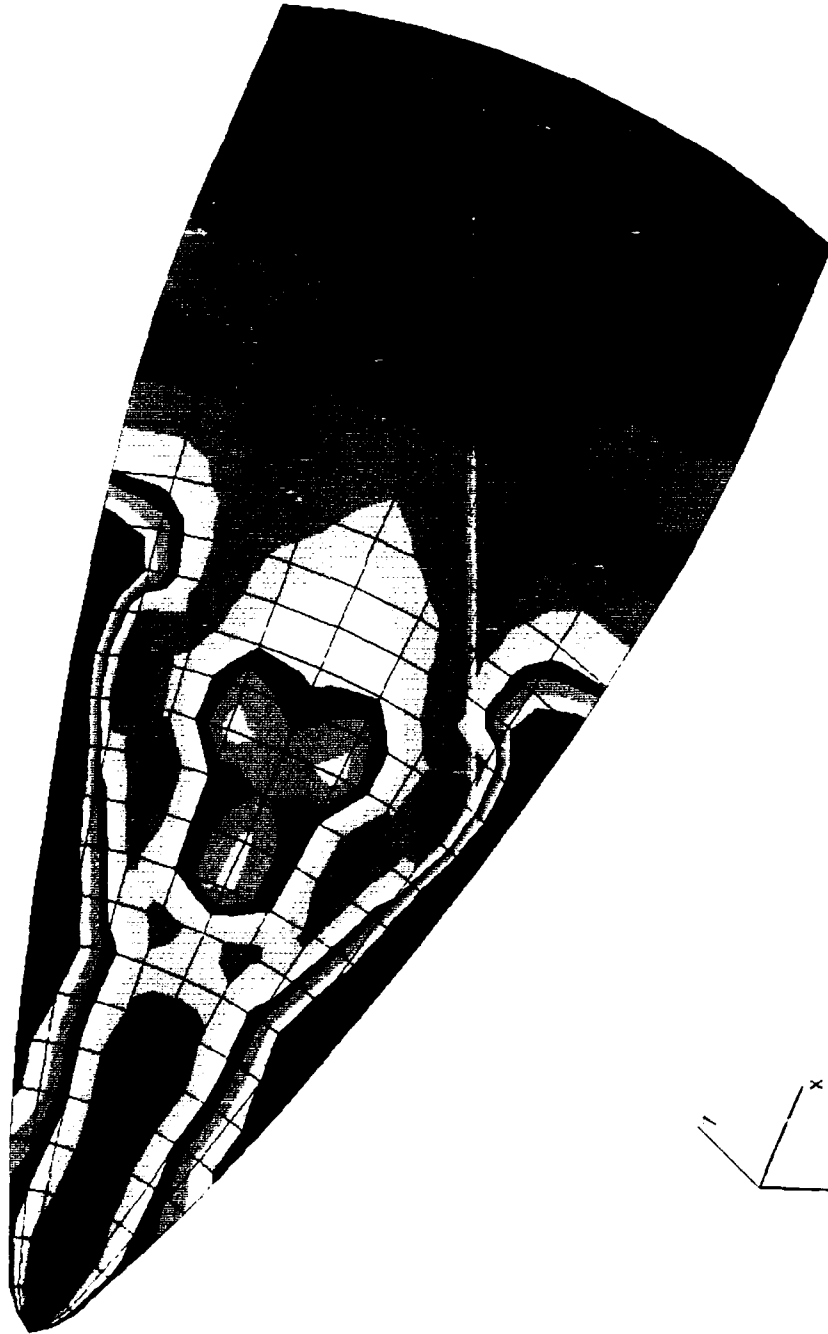
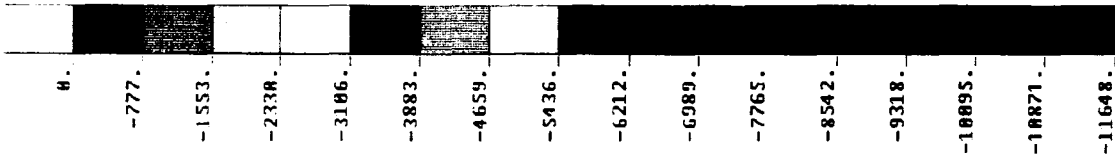

Figure 55. Inside shell surface first principal stresses at $t = 3.1128$ ms (step 10).

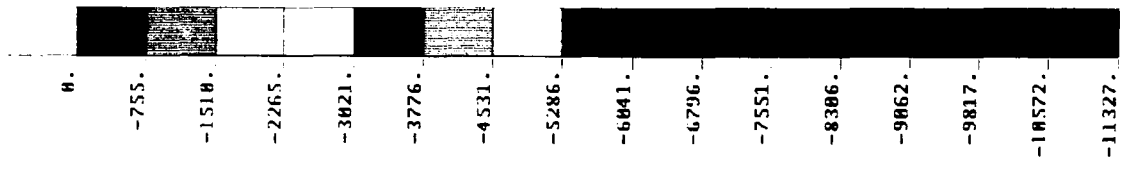

Figure 56. Inside shell surface first principal stresses at $t = 4.7335$ ms (step 14).

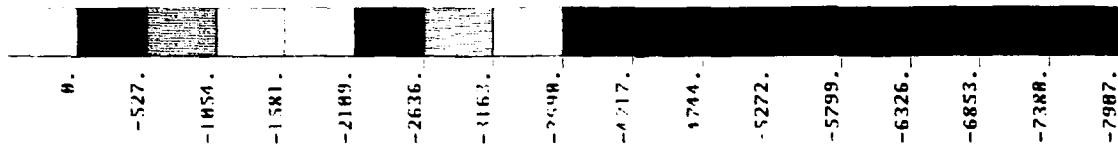

Figure 57. Inside shell surface first principal stresses at $t = 6.2642$ ms (step 18).

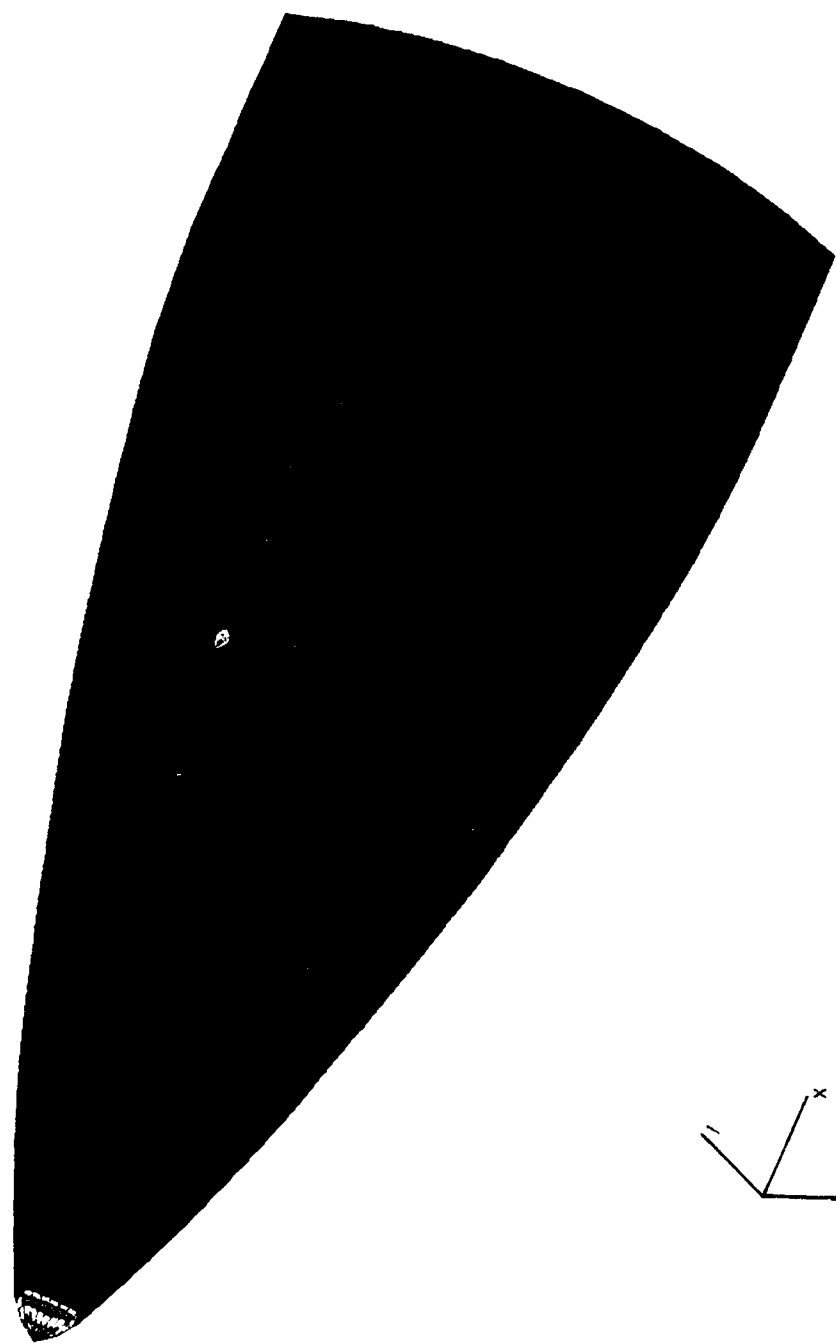
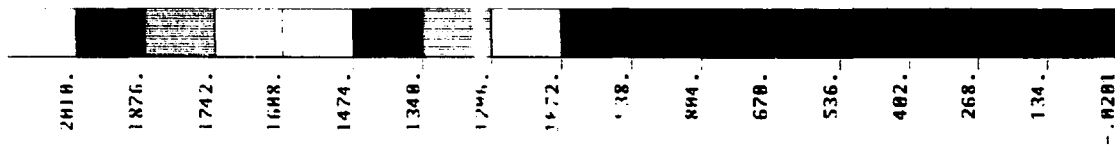

Figure 58. Inside shell surface third principal stresses at $t = 0.1770$ ms (step 2).

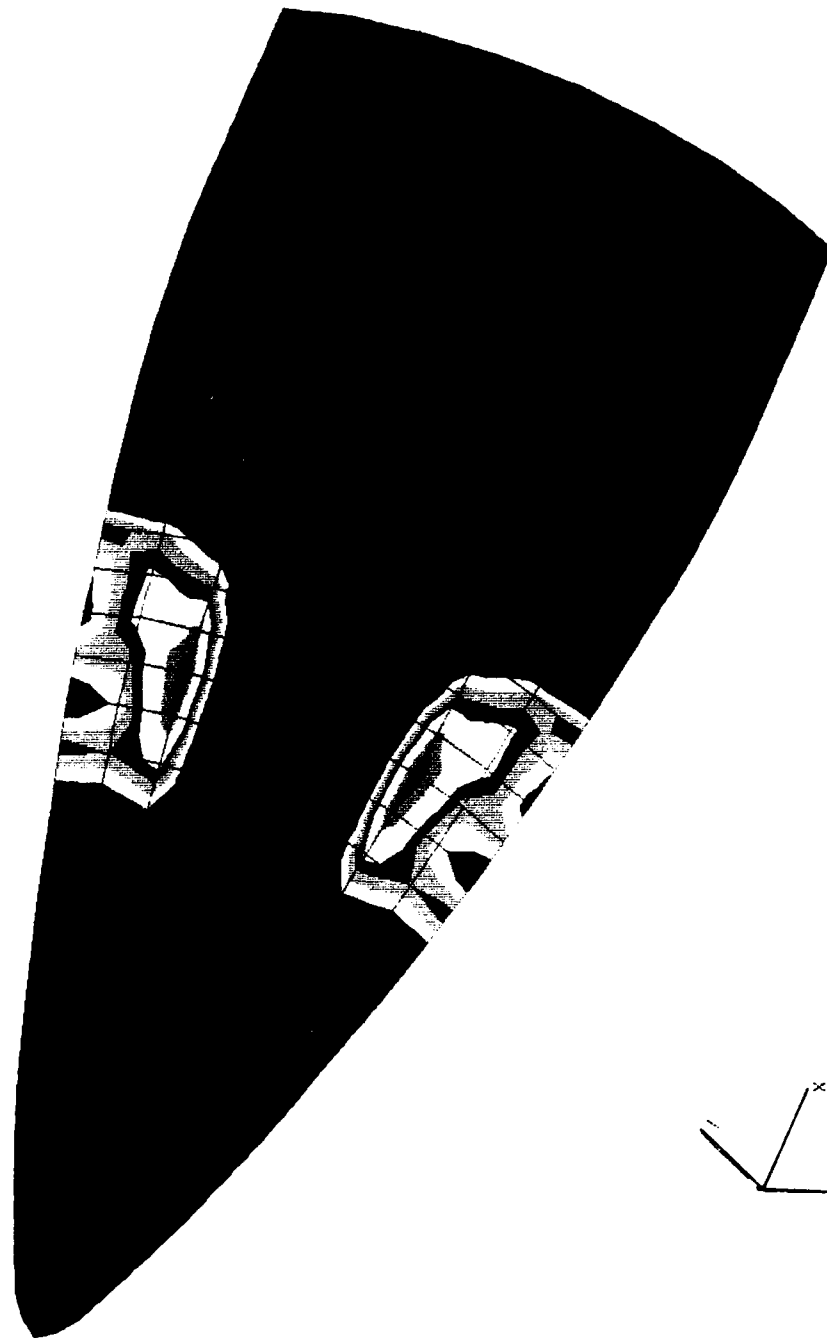
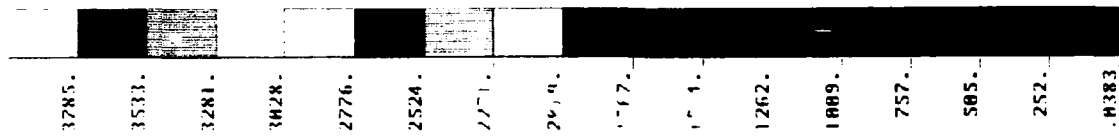

Figure 59. Inside shell surface third principal stresses at $t = 1.5624$ ms (step 6).

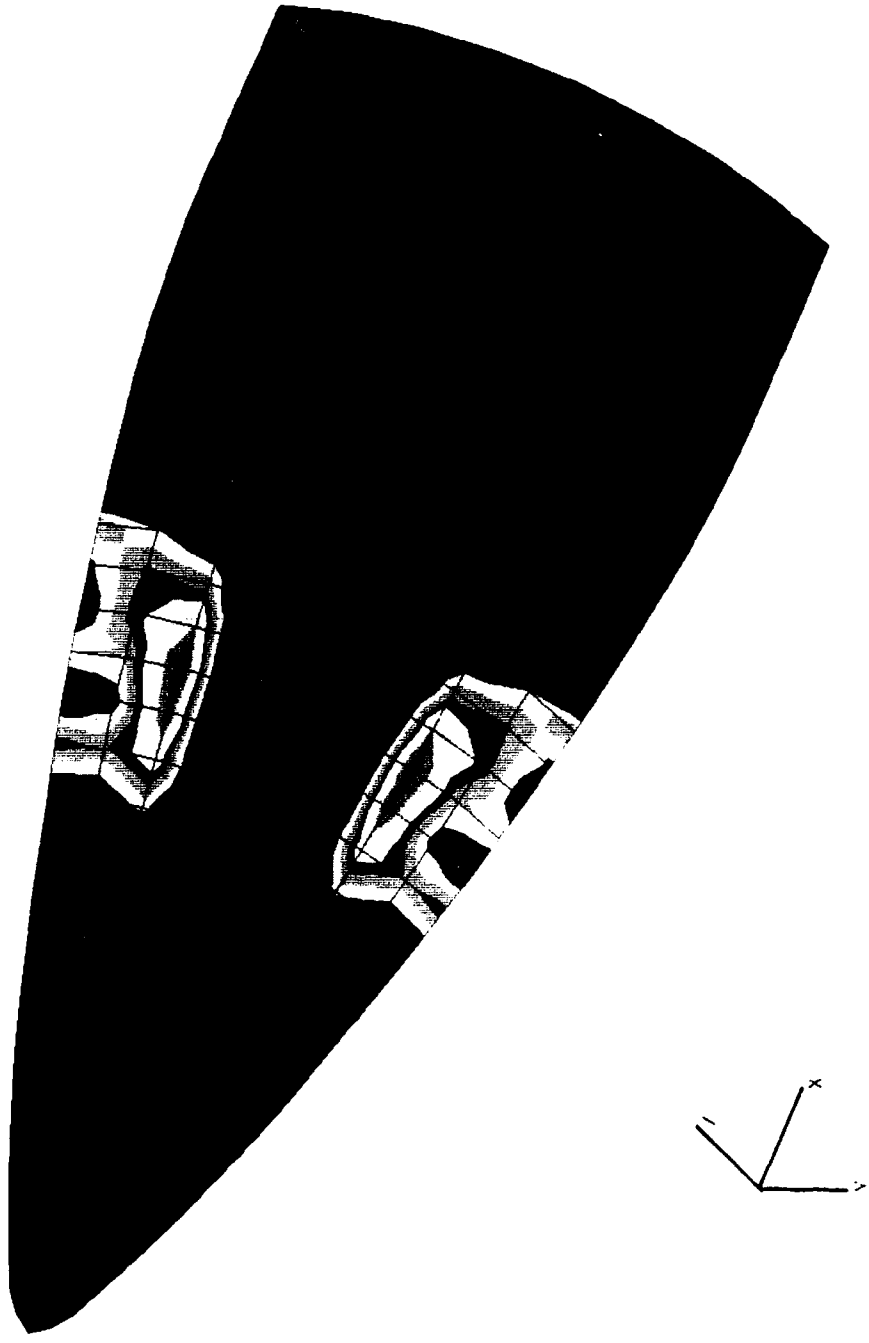
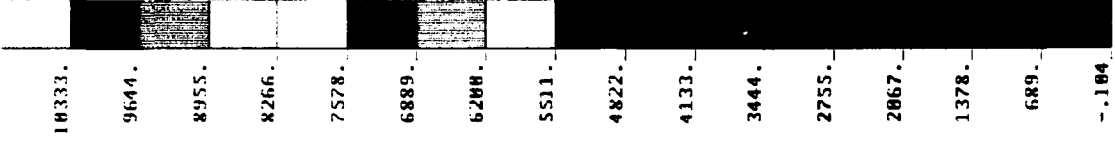

Figure 60. Inside shell surface third principal stresses at $t = 3.1128$ ms (step 10).

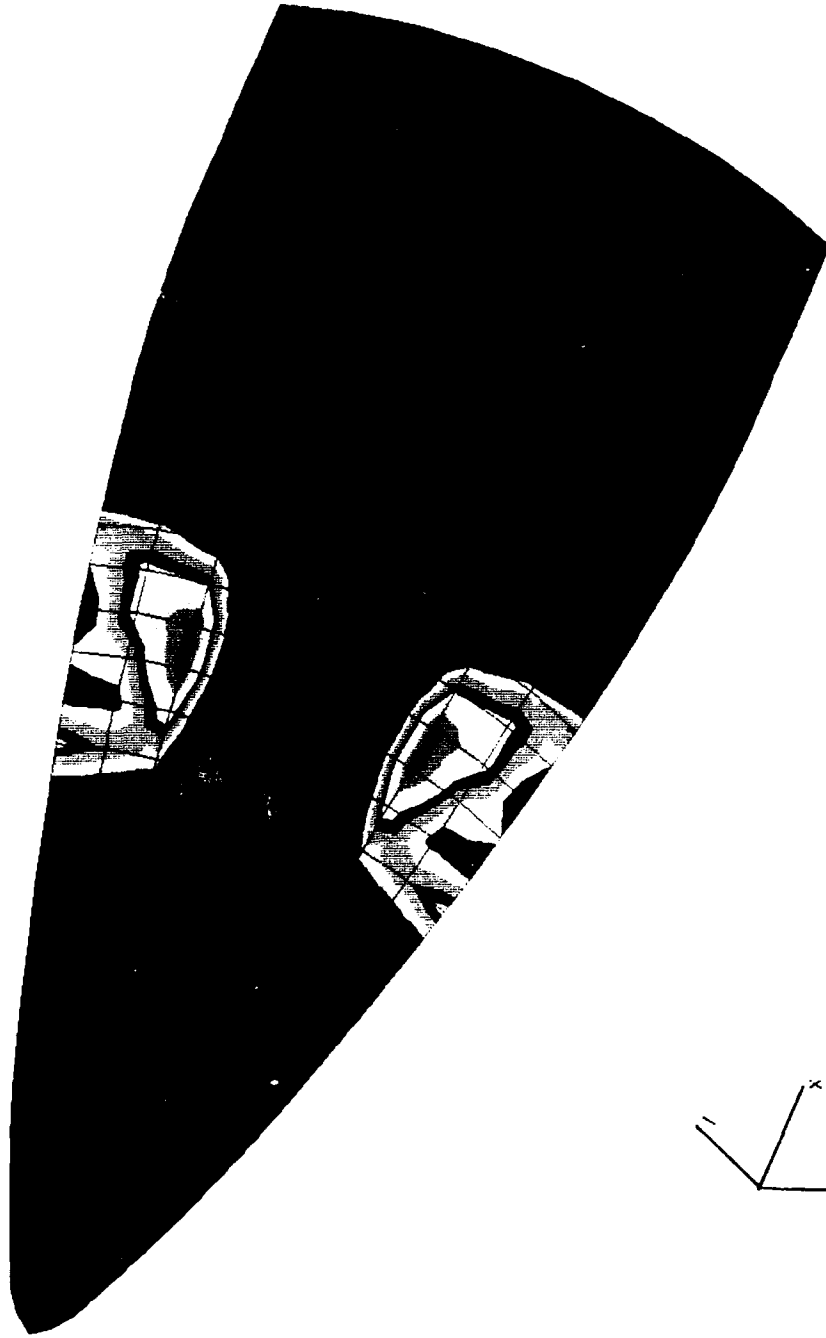
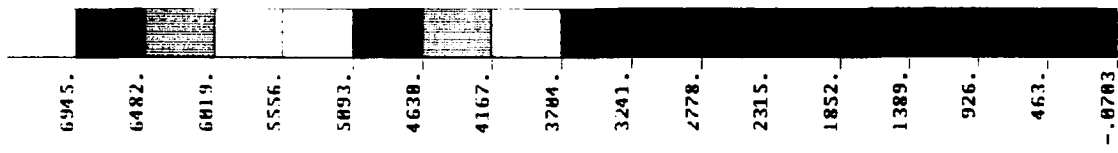

Figure 61. Inside shell surface third principal stresses at $t = 4.7335$ ms (step 14).

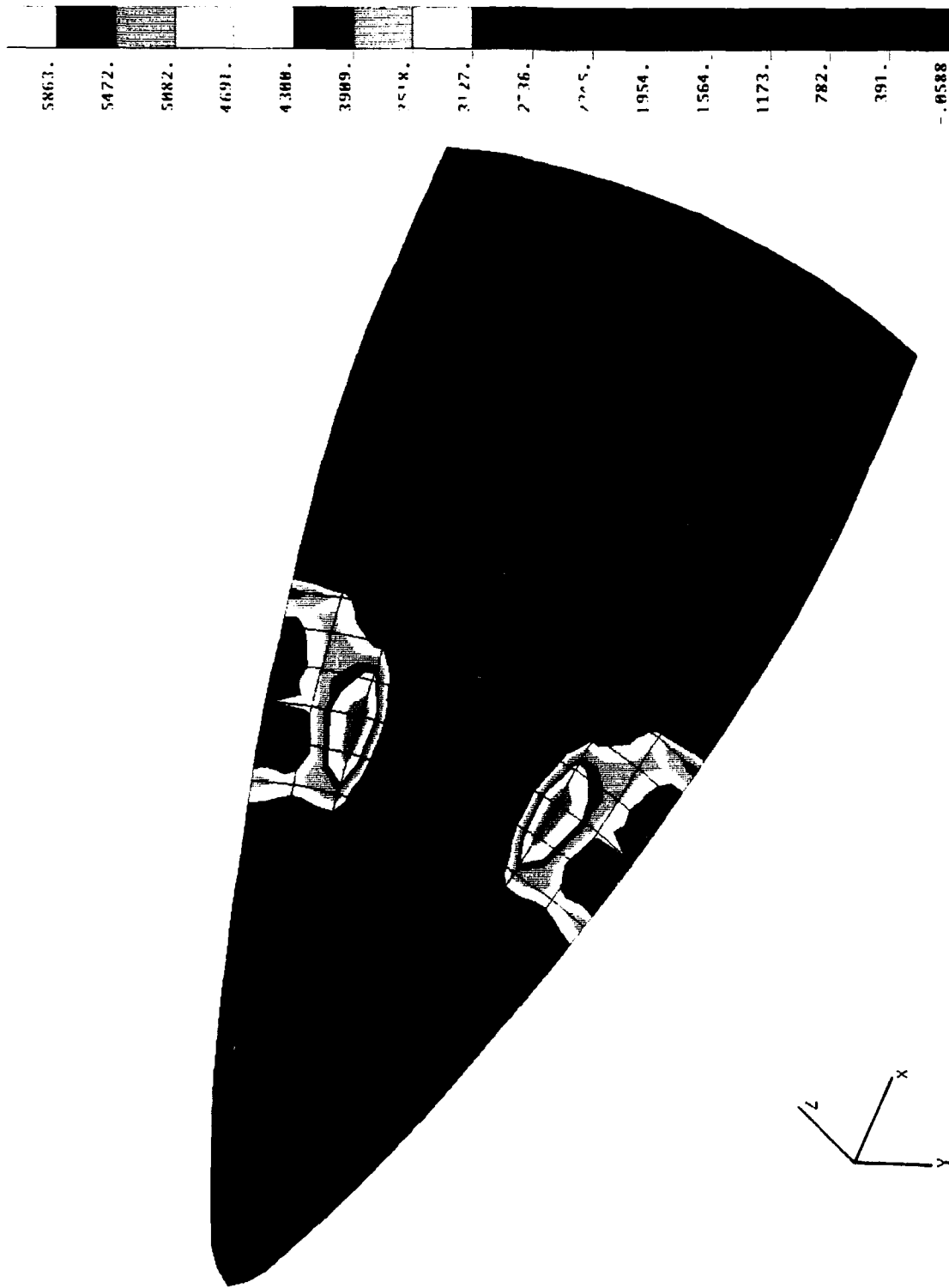

Figure 62. Inside shell surface third principal stresses at $t = 6.2642$ ms (step 18).

These stress-time histories indicate an obvious periodicity of the data. This could be indicative of the period of the moving stress wave within the shell, or the lowest order response of the shell. It is also likely that there are considerable higher frequency stress waves propagating through the structure that either the nodal spacing in the FEM was unable to resolve, or the time steps used in the dynamic analysis were too large. In any case, there is no need to lend any large degree of engineering significance to this periodicity.

Figures 63 and 64 are the plots of the first principal stresses at nodes 28, 73, 118, and 136 on the inner and outer fibers respectively. Note that the inner fiber stress reaches a maximum value of -12,560 psi at 4.32 ms after water entry, while the outer fiber first principal stress for the same node has a value of 0 psi at the same time. This apparent anomaly is due to the method that ABAQUS uses to sort principal stresses. Although not shown, it is suspected that the second principal stress at this time period and nodal location has a nonzero stress value of some negative value, which has a great deal more engineering significance than the zero value shown at node 118 at this time-step.

Figures 65 and 66 show the third principal stresses for the same nodes on the inner and outer surfaces respectively. In figure 65, it is seen that the third principal stress at both nodes 118 and 136 exceed the value of UTS shortly after 3.0 ms after water entry, reaching a peak value of 7312 psi.

At the same time, the third principal stress on the outer surface in figure 66 reaches a maximum value of 21,240 psi at node 136, while the value at node 118 rises to 12,650 psi. Each of these values greatly exceed the UTS of 5680 psi, shown as a horizontal line in figures 65 and 66.

Figure 67 is a maximum envelope of the stress-time history of the entire nose cap. This indicates the maximum value of the second principal stress (17,856 psi), and the maximum value of the third principal stress (21,129 psi) occur simultaneously at 3.11 ms after water entry. The corresponding minimum values are shown in figure 68.

The UTS of the material is 5.68 KSI (Dimelfi, July 1988), while the ultimate compressive strength (UCS) is 30.16 KSI (Fogg, October 1989). Therefore, the minimum margin of safety of the nose cap during water entry occurs in tension at 3.11 ms after entry, and has a value of:

$$\begin{aligned} \text{MS} &= (\text{UTS}/\text{Max Principal Stress})-1 \\ &= (5680/21,129)-1 \\ &= -0.73 \end{aligned}$$

A dynamic stress analysis of this nose cap structure is a very complicated proposition. Not only are the stress levels affected by the blade-shell interface, but the presence of a dynamic load, with associated moving stress waves and the possibility of high-frequency shell responses, makes interpretation of these stress contours very difficult indeed. As this nose cap example was included to illustrate the WEST process, little attempt was made to exactly model the nose cap structure. Thus, while these results are considerably more accurate than those reported by Jung and Plapp (1988), they should only be used as an indicator of the ability of the WEST to aid the analytical process used to design this type of frangible nose cap.

CONCLUSIONS

The objective of this IED effort has been met. The WEST has been validated through two separate examples of nose caps, a 90-degree cone and an engineering example of a typical VLA nose cap. While both these examples described undergoing vertical entry, the WEST is equally facile at oblique entry. Note that the use of symmetrical FEM must be adjusted accordingly, as an oblique entry results in nonsymmetrical loading. In addition, a greatly increased amount of data results from the analysis, as each element has a unique pressure-time history throughout the water entry process.

Development of the WEST has led to a many-fold reduction in the time required to execute a meaningful design iteration of a frangible nose cap. In addition, due to the ability to use both geometric and material nonlinearities, the potential accuracy of the solution has greatly improved as well. Note that the analytical techniques described in this report did not take advantage of these features.

While investigation of an alternate frangible nose cap for the VLA project is certainly not complete, the results from the water entry portion of that task indicate that breakup at water entry appears likely.

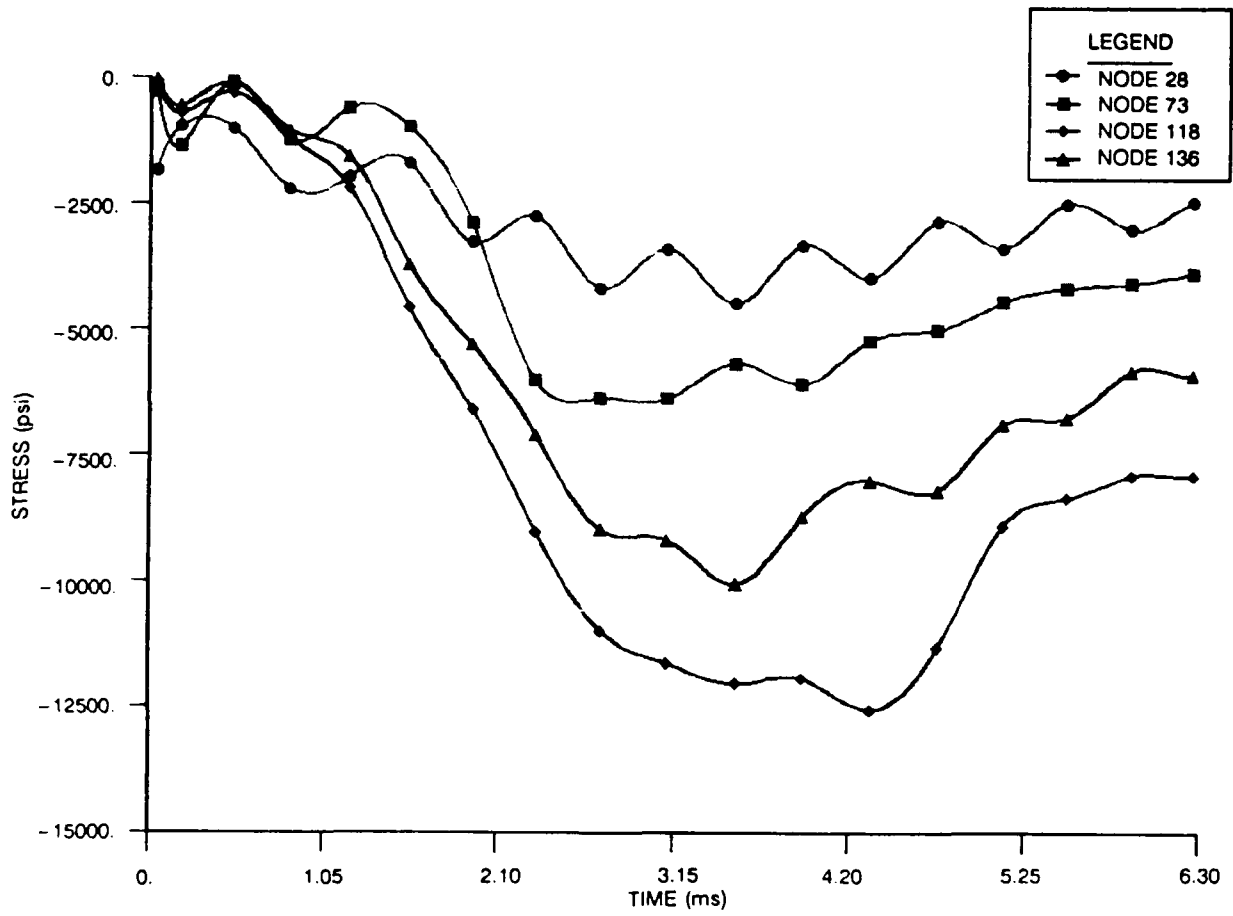

Figure 63. VLA nose cap first principal stresses of the inner surface.

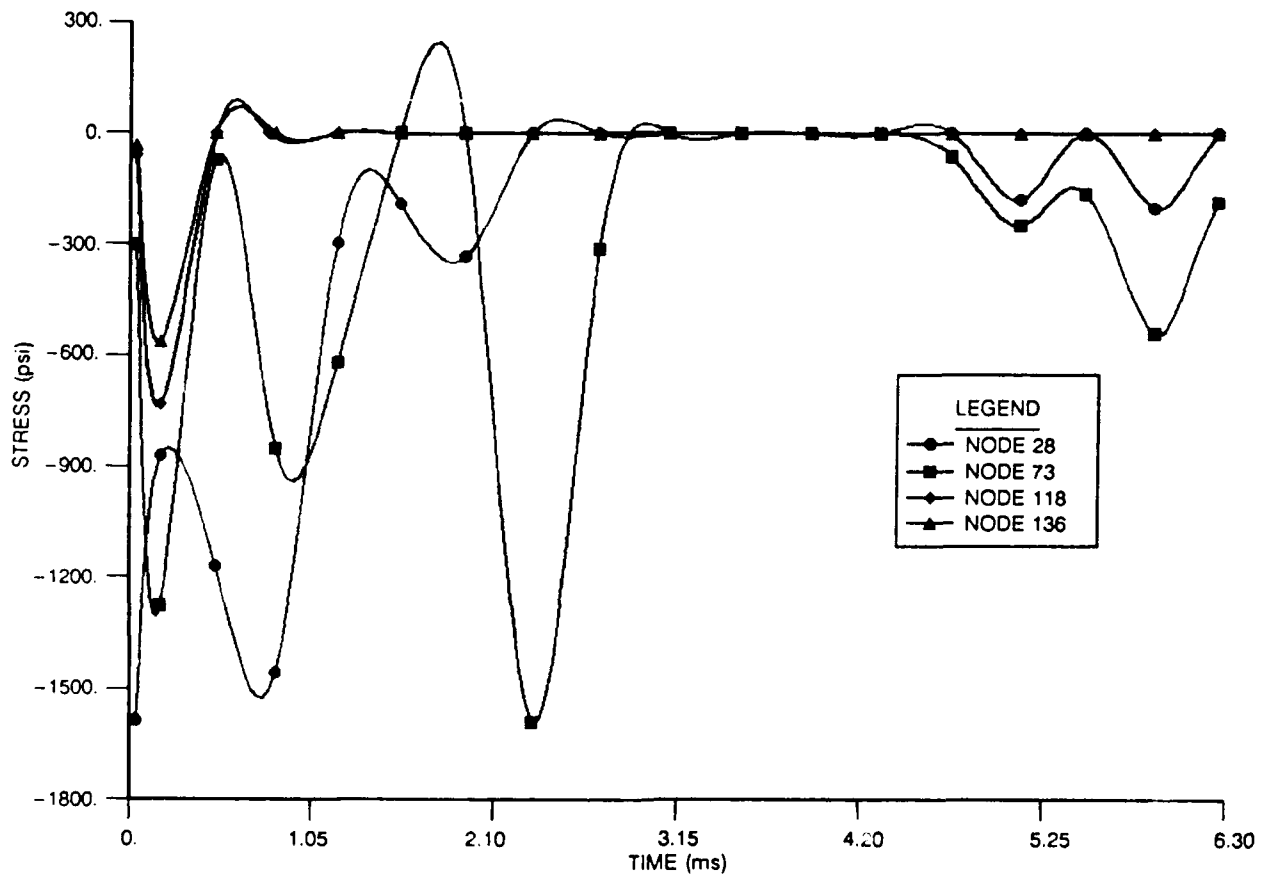

Figure 64. VLA nosecap first principal stresses of the outer surface.

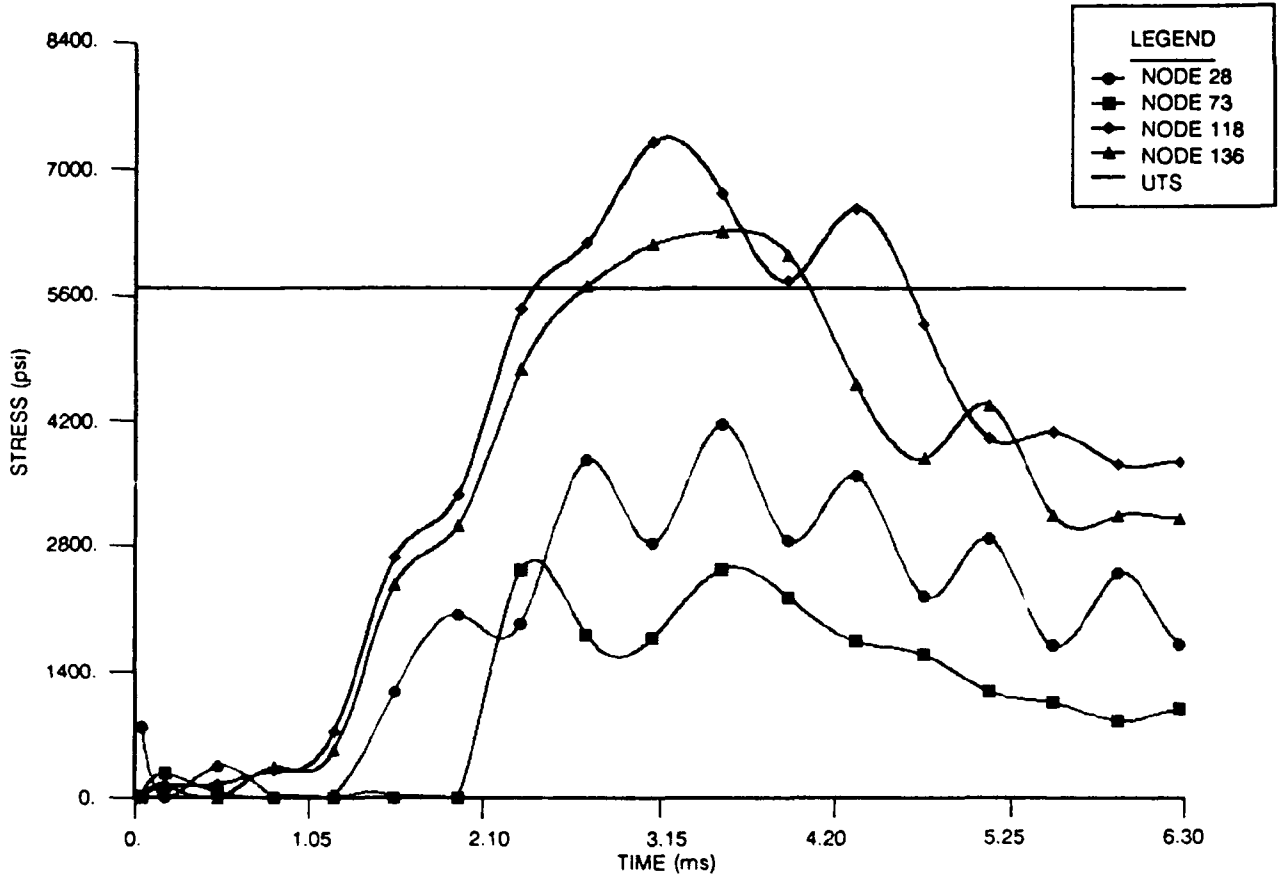

Figure 65. VLA nose cap third principal stresses of the inner surface.

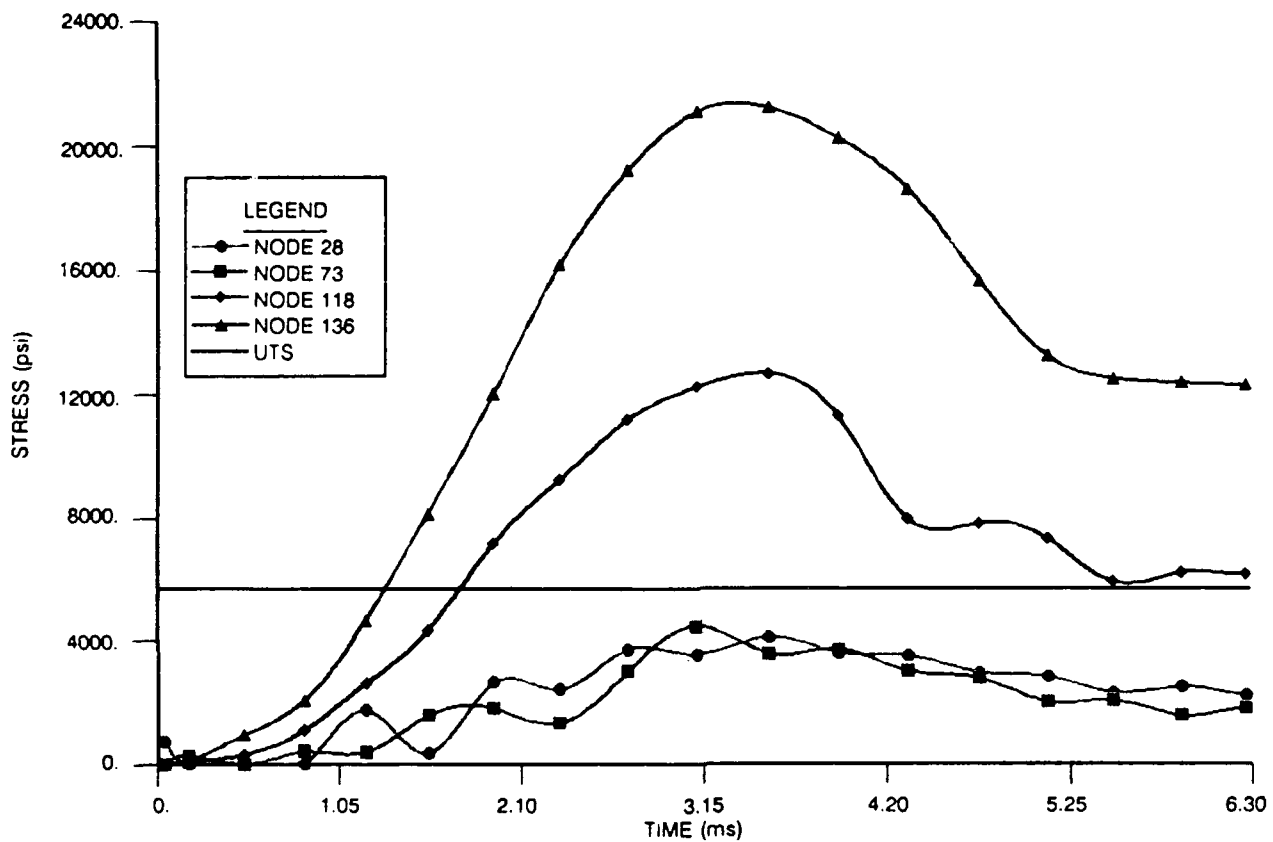

Figure 66. VLA nose cap third principal stresses of the outer surface.

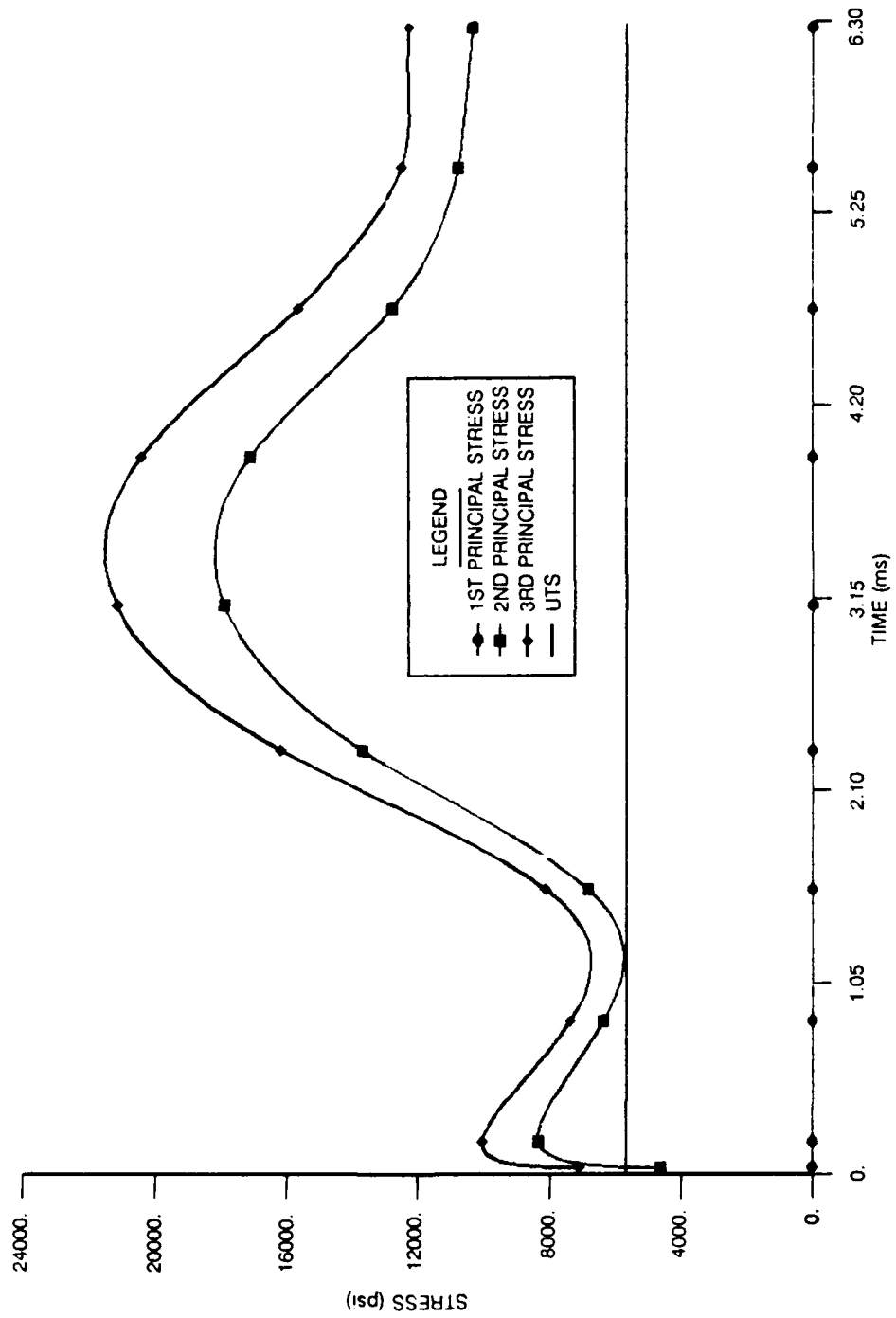

Figure 67. VLA nosecap maximum principal stresses.

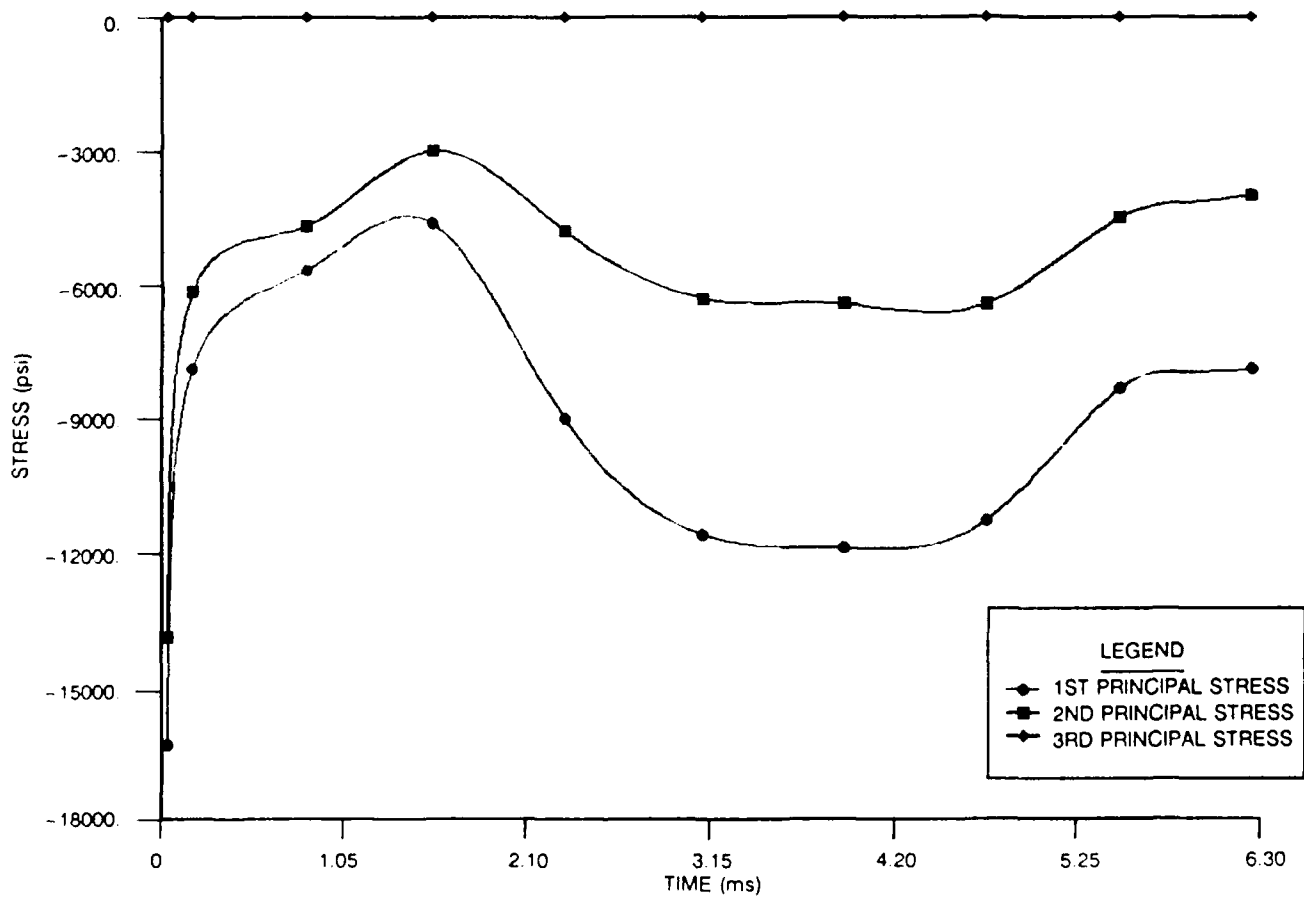

Figure 68. VLA nose cap minimum principal stresses.

RECOMMENDATIONS

The code linkage process described in this report is only suitable for a scientific engineering application within a Naval laboratory such as NOSC. It should not be considered a "production" code suitable for commercial application, as there are several "rough edges" within the execution of WEST. In particular, care must be taken during the development of the initial geometry and FEM within the pre-processor portion of WEST, to acknowledge the limitations of the water entry portion of the code. While arbitrary shapes can be accommodated in the water entry process, there are limitations pertaining to mesh density, spacing, and numbering that preclude executing any old FEM that happens to describe a particular geometry of a nosecap.

In addition, it is assumed that the user has a background in using the PATRAN pre- and post-processor. This IED project does not attempt to reduce or foreshorten the complex task of translating nosecap drawings into "PATRANese". A FEA background is essential to create viable FEMs that not only will execute throughout WEST, but will truly produce "right" answers at the conclusion of the process. As with any FEA technique, it is often as much art as science, and not something that can be learned overnight by reading this report.

Improvements to the analytical procedure described for the VLA nosecap can be made in the following areas:

- (a) **ABAPAT translator revision.** The PDA Engineering Release 3.0 ABAPAT translator has numerous "bugs" in it. In particular, while the outer fiber normal stresses are computed by ABAQUS and are contained in the FILENAME.FIL post-processing file, ABAPAT cannot translate all of them into the FILENAME.STPiJ.NOD files needed for complete investigation of the results. Therefore, they are not included in this report. According to PDA Engineering, this will be fixed in Release 4.0, which is due for release within 90 days.
- (b) **Nonlinear material model.** ABAQUS is equipped to accommodate nonlinear materials models. As the plastic materials typically used in nosecaps exhibit considerably nonlinear stress-strain behavior, increased accuracy would result by taking advantage of this feature. For the work accomplished for this IED project, linear-elastic materials properties were used.
- (c) **Nonlinear geometry model.** In addition to material nonlinearities, ABAQUS can accommodate geometric non-linearities. These should be used in the area of the fin-shell interface of the VLA nosecap, to improve the accuracy of the relative deformations of the structural elements.
- (d) **Mesh rezoning.** As the nosecap deforms, the geometry presented to the water surface during water entry changes. Yet, in the present form of the WEST process, the pressure-time histories are considered to be developed by a constant, invariant geometry. With significant deformation, this can introduce significant error in the process. A worthwhile improvement would be to halt the deformation process at some point in the analysis

loop, remesh the deformed geometry, use this new meshed geometry as input to the ENTRY code, re-apply the revised pressure-time histories to the deformed geometry, and re-start the analysis. This iteration could be performed several times if necessary, until the analyst was satisfied that accuracy had been achieved.

Investigation of the VLA nose cap shape during the development of this WEST revealed several areas for improvement in the analytical process used to examine the nose cap structure. Because of the negative margin of safety at water entry, additional investigation into the design optimization of this nose cap should be pursued, followed by fabrication and test of sample one-piece nose caps. The potential for success is there, and the rewards for major simplifications to the nose cap design are many.

REFERENCES

- Dimelfi, R. J., 20 July 1988. Memorandum Ser 932/114-88 on Nosecap Materials Studies.
- Fogg, R. K., 3 October 1989. Memorandum Ser 932/85-89 on Nosecap Materials Compression Tests.
- Jung, P. A., December 1984. *Some Design Considerations for Vertical Launch ASROC Nosecap*, NOSC Technical Report 1024.
- Jung, P. A. and M. J. Plapp. May 1988. *Frangible Nosecap for the Vertical Launch ASROC — A Design Evaluation*, NOSC Technical Report 1221.
- Wardlaw, A. B., Jr., A. M. Morrison, and J. L. Baldwin. January 1977. *Prediction of Impact Pressure Forces and Moments During Vertical and Oblique Water Entry*, Naval Surface Weapons Center, White Oak Laboratory Technical Report 77-16.
- Wardlaw, A. B., Jr. and P. M. Aronson. July 1977. "Prediction of Surface Pressures During Water Impact," *Journal of Hydronautics*, pp. 65-66.

BIBLIOGRAPHY

- Chu, W. H. and D. R. Falconer. 1963. *Further Development of a More Accurate Method for Calculating Body-Water Impact Pressures*, Southwest Research Institute Technical Report 5.
- Hess, J. L. and H. M. O. Smith. 1967. "Calculation of Potential Flow About Arbitrary Bodies," *Progress in Aeronautical Sciences*, Edited by D. Kuchemann, vol. 8, pp. 1-138, Pergamon Press, New York.
- May, A. December 1972. *Forces at Water Impact*, Alden Research Laboratories, ARL 119-72/SP.
- Moran, J. P. March 1965. *On the Hydrodynamic Theory of Water Exit and Entry*, Therm Advanced Research Technical Report TAR-TR 6501.
- Shere, K. D. and M. M. Vander Vorst. 1973. *Vertical Water Entry of Finite Cones — A Numerical Calculation*, Naval Surface Weapons Center, White Oak Laboratory, NOLTR 73-22.
- Szebehely, V. G. 1959. "Hydrodynamic Impact," *Applicable Mechanical Review*, vol. 12, pp. 297-300.
- Thigpen, A. June 1971. *Water-Entry Technology — A Review*, Sandia Corporation Technical Report SC-Dr 71 0196.
- Vander Vorst, M. J. and J. C. W. Rogers. 1976. "Calculation of Vertical Water Entry by the Partial Cell Marker and Cell Method," *Proceedings of the 1976 Heat Transfer and Fluid Mechanics Institute*, McKillop, Vaugh, and Dwyer, Stanford University Press.
- Von Karman, T. October 1929. *The Impact on Seaplane Floats During Landing*, NACA TN 321.
- Wagner, H. 1932. "Über Stoss-und Gleitvorgänge an der Oberfläche von Flüssigkeiten," *ZAMM* vol. 12, no. 4, pp. 193-215.
- Weber, C. F. January 1963. *The Vertical Water Entry of a Cone*, NOLTR 69-26.

GLOSSARY

ABAQUS	An FEA computer code that is a registered trademark of Hibbitt, Karlson, & Sorenson, Inc.
ASROC	Antisubmarine rocket
ABAPAT	A PDA Engineering translator
CASA/GIFTS	An FEA computer code that is a trademark of Computer-Aided Structural Analysis, Inc.
CDC	Control Data Corporation
C_p	Pressure coefficient
$\nabla\phi$	The gradient operator
C_w	Wetting factor
Δh	Increment in effective depth between successive steps
DTRC	David Taylor Research Center
DYCAST/GC	An FEA computer code that is a registered trademark of the Grumman Corporate Research Center
DYNA-3D	An FEA computer code
ENTPRES	A NOSC-developed translator
ENTRY	A computer code for the prediction of impact loads of an arbitrary body during water entry
ϕ_{cn}	The value of ϕ at a specific element centroid at step n
FEA	Finite element analysis
FEM	Finite element model
FLIPPER	A NOSC Code 936-owned VAX 11/785 computer
FORTRAN	A computer language
GCB	General Communications Backbone
GPCC	General Purpose Computer Center
IED	Independent Exploratory Development (Program)
KSI	1000 pounds per square inch
ϕ	A velocity potential function
MARC	An FEA computer code that is a trademark of MARC Analysis Research Corporation

ms	Millisecond
MSC/NASTRAN	An FEA computer code that is a registered trademark of the MacNeal/Schwendler Corporation
MSC/PAL-II	An FEA code that is a registered trademark of MacNeal/Schwendler Corporation
MCP	A VAX command to download a VAX file to PC, or vice versa.
MS	Margin of safety
NESS	Naval Engineering Software Support (Office)
NISAI-PC	An FEA computer code that is a registered trademark of Engineering Mechanics Research Corporation
NOSC	Naval Ocean Systems Center
NSWC/WOL	Naval Surface Weapons Center, White Oak Laboratory
PC	Personal computer
PATRAN	A registered trademark of PDA Engineering, Inc.
PHOENICS	An FEA computer code that is a registered trademark of CHAM of North America, Inc.
PISCES-3DE	An FEA computer code that is a trademark of Physics International Company
PATABA	Another PDA Engineering translator
PATENTR	A NOSC-developed translator
psi	Pounds per square inch
STINGRAY	A GPCC-owned convex mini-supercomputer
UCS	Ultimate compressive strength
UTS	Ultimate tensile strength
VLA	Vertical launch ASROC
WEST	Water Entry Structure Technique
YADAP	A PC computer code for display and plotting of time-histories

APPENDIX A
ENTRY INPUT FILE
CONE90.IN

VARIABLE	COUNT	PRINT	SYMMETRIC			
0.	11	24.0	1200.	90.	250.	0.
0.	3	0.67	0.	0		
0.		0.	-1200.	0.	1.24078	0.24
0.		0.	-1200.	0.	1.24078	0.96001
0.		0.	-1200.	0.	1.24078	1.20001
LIST						
100	84					
0.0000		-0.1200	0.1200			
0.0459		-0.1109	0.1200			
0.0849		-0.0849	0.1200			
0.0000		-1.2000	1.2000			
0.4592		-1.1087	1.2000			
0.8485		-0.8485	1.2000			
0.1109		-0.0459	0.1200			
0.1200		0.0000	0.1200			
1.1087		-0.4592	1.2000			
1.2000		0.0000	1.2000			
0.1109		0.0459	0.1200			
0.0849		0.0849	0.1200			
1.1087		0.4592	1.2000			
0.8485		0.8485	1.2000			
0.0459		0.1109	0.1200			
0.0000		0.1200	0.1200			
0.4592		1.1087	1.2000			
0.0000		1.2000	1.2000			
0.0000		-2.4000	2.4000			
0.9184		-2.2173	2.4000			
1.6971		-1.6971	2.4000			
2.2173		-0.9184	2.4000			
2.4000		0.0000	2.4000			
2.2173		0.9184	2.4000			
1.6971		1.6971	2.4000			
0.9184		2.2173	2.4000			
0.0000		2.4000	2.4000			
0.0000		-3.6000	3.6000			
1.3777		-3.3260	3.6000			
2.5456		-2.5456	3.6000			
3.3260		-1.3777	3.6000			
3.6000		0.0000	3.6000			
3.3260		1.3777	3.6000			
2.5456		2.5456	3.6000			
1.3777		3.3260	3.6000			
0.0000		3.6000	3.6000			
0.0000		-4.8000	4.8000			
1.8369		-4.4346	4.8000			
3.3941		-3.3941	4.8000			
4.4346		-1.8369	4.8000			
4.8000		0.0000	4.8000			
4.4346		1.8369	4.8000			
3.3941		3.3941	4.8000			
1.8369		4.4346	4.8000			
0.0000		4.8000	4.8000			
0.0000		-6.0000	6.0000			
2.2961		-5.5433	6.0000			
4.2426		-4.2426	6.0000			
5.5433		-2.2961	6.0000			
6.0000		0.0000	6.0000			
5.5433		2.2961	6.0000			
4.2426		4.2426	6.0000			
2.2961		5.5433	6.0000			
0.0000		6.0000	6.0000			

0.0000	-7.2000	7.2000
2.7553	-6.6519	7.2000
5.0912	-5.0912	7.2000
6.6519	-2.7553	7.2000
7.2000	0.0000	7.2000
6.6519	2.7553	7.2000
5.0912	5.0912	7.2000
2.7553	6.6519	7.2000
0.0000	7.2000	7.2000
0.0000	-8.4000	8.4000
3.2145	-7.7606	8.4000
5.9397	-5.9397	8.4000
7.7606	-3.2145	8.4000
8.4000	0.0000	8.4000
7.7606	3.2145	8.4000
5.9397	5.9397	8.4000
3.2145	7.7606	8.4000
0.0000	8.4000	8.4000
0.0000	-9.6000	9.6000
3.6738	-8.8692	9.6000
6.7882	-6.7882	9.6000
8.8692	-3.6738	9.6000
9.6000	0.0000	9.6000
8.8692	3.6738	9.6000
6.7882	6.7882	9.6000
3.6738	8.8692	9.6000
0.0000	9.6000	9.6000
0.0000	-10.8000	10.8000
4.1330	-9.9779	10.8000
7.6368	-7.6368	10.8000
9.9779	-4.1330	10.8000
10.8000	0.0000	10.8000
9.9779	4.1330	10.8000
7.6368	7.6368	10.8000
4.1330	9.9779	10.8000
0.0000	10.8000	10.8000
0.0000	-12.0000	12.0000
4.5922	-11.0866	12.0000
8.4853	-8.4853	12.0000
11.0866	-4.5922	12.0000
12.0000	0.0000	12.0000
11.0866	4.5922	12.0000
8.4853	8.4853	12.0000
4.5922	11.0866	12.0000
0.0000	12.0000	12.0000
0.0000	0.0000	0.1200
3	2	100
8	7	100
12	11	100
16	15	100
4	5	1
5	6	2
6	9	3
9	10	7
10	13	8
13	14	11
14	17	12
17	18	15
19	20	16
20	21	5
21	22	6
22	23	10
23	24	9
24	25	13
25	26	14
26	27	17

28	29	20	19
29	30	21	20
30	31	22	21
31	32	23	22
32	33	24	23
33	34	25	24
34	35	26	25
35	36	27	26
37	38	29	28
38	39	30	29
39	40	31	30
40	41	32	31
41	42	33	32
42	43	34	33
43	44	35	34
44	45	36	35
46	47	38	37
47	48	39	38
48	49	40	39
49	50	41	40
50	51	42	41
51	52	43	42
52	53	44	43
53	54	45	44
55	56	47	46
56	57	48	47
57	58	49	48
58	59	50	49
59	60	51	50
60	61	52	51
61	62	53	52
62	63	54	53
64	65	56	55
65	66	57	56
66	67	58	57
67	68	59	58
68	69	60	59
69	70	61	60
70	71	62	61
71	72	63	62
73	74	65	64
74	75	66	65
75	76	67	66
76	77	68	67
77	78	69	68
78	79	70	69
79	80	71	70
80	81	72	71
82	83	74	73
83	84	75	74
84	85	76	75
85	86	77	76
86	87	78	77
87	88	79	78
88	89	80	79
89	90	81	80
91	92	83	82
92	93	84	83
93	94	85	84
94	95	86	85
95	96	87	86
96	97	88	87
97	98	89	88
98	99	90	89

APPENDIX B
ENTRY INPUT FILE
CONE90.OUT

*****PROGRAM OPTIONS*****
 VARIABLE BODY ORIENTATION
 DON'T PRINT
 SYMMETRIC CONFIGURATION

*****PROBLEM PARAMETERS*****
 DIAMETER 24.00000 IN
 ENTRY VELOCITY 1200.000 (IN/SEC)
 BODY ORIENTATION ANGLE 90.00 DEGREES
 INITIAL DEPTH 0.00000 IN TERMINATION STEP 11
 INITIAL PRESSURE CORRECTION FACTOR = 0.6700
 CENROIDE COORDINATES 0.00000 C.00000

NO	VX	VY	VZ	WX	CWT	H
1	0.0000	0.0000-1200.0000	0.0000	0.0	1.240780	0.240000
2	0.0000	0.0000-1200.0000	0.0000	0.0	1.240780	0.960010
3	0.0000	0.0000-1200.0000	0.0000	0.0	1.240780	1.200010

*****GRID OPTIONS*****
 LIST

NODE	X	Y	Z	XP	YP	ZP
1	0.0000	-0.1200	0.1200	0.0000	-0.1200	0.1200
2	0.0459	-0.1109	0.1200	0.0459	-0.1109	0.1200
3	0.0849	-0.0849	0.1200	0.0849	-0.0849	0.1200
4	0.0000	-1.2000	1.2000	0.0000	-1.2000	1.2000
5	0.4592	-1.1087	1.2000	0.4592	-1.1087	1.2000
6	0.8485	-0.8485	1.2000	0.8485	-0.8485	1.2000
7	0.1109	-0.0459	0.1200	0.1109	-0.0459	0.1200
8	0.1200	0.0000	0.1200	0.1200	0.0000	0.1200
9	1.1087	-0.4592	1.2000	1.1087	-0.4592	1.2000
10	1.2000	0.0000	1.2000	1.2000	0.0000	1.2000
11	0.1109	0.0459	0.1200	0.1109	0.0459	0.1200
12	0.0849	0.0849	0.1200	0.0849	0.0849	0.1200
13	1.1087	0.4592	1.2000	1.1087	0.4592	1.2000
14	0.8485	0.8485	1.2000	0.8485	0.8485	1.2000
15	0.0459	0.1109	0.1200	0.0459	0.1109	0.1200
16	0.0000	0.1200	0.1200	0.0000	0.1200	0.1200
17	0.4592	1.1087	1.2000	0.4592	1.1087	1.2000
18	0.0000	1.2000	1.2000	0.0000	1.2000	1.2000
19	0.0000	2.4000	2.4000	0.0000	2.4000	2.4000
20	0.9184	-2.2173	2.4000	0.9184	-2.2173	2.4000
21	1.6971	-1.6971	2.4000	1.6971	-1.6971	2.4000
22	2.2173	-0.9184	2.4000	2.2173	-0.9184	2.4000
23	2.4000	0.0000	2.4000	2.4000	0.0000	2.4000
24	2.2173	0.9184	2.4000	2.2173	0.9184	2.4000
25	1.6971	1.6971	2.4000	1.6971	1.6971	2.4000
26	0.9184	2.2173	2.4000	0.9184	2.2173	2.4000
27	0.0000	2.4000	2.4000	0.0000	2.4000	2.4000
28	1.0000	-3.6000	3.6000	1.0000	-3.6000	3.6000
29	1.3777	-3.3260	3.6000	1.3777	-3.3260	3.6000
30	2.5456	-2.5456	3.6000	2.5456	-2.5456	3.6000
31	3.3260	-1.3777	3.6000	3.3260	-1.3777	3.6000
32	3.6000	0.0000	3.6000	3.6000	0.0000	3.6000
33	3.3260	1.3777	3.6000	3.3260	1.3777	3.6000
34	2.5456	2.5456	3.6000	2.5456	2.5456	3.6000
35	1.3777	3.3260	3.6000	1.3777	3.3260	3.6000
36	0.0000	3.6000	3.6000	0.0000	3.6000	3.6000
37	0.0000	4.8000	4.8000	0.0000	4.8000	4.8000
38	1.8369	-4.4346	4.8000	1.8369	-4.4346	4.8000
39	3.3941	-3.3941	4.8000	3.3941	-3.3941	4.8000
40	4.4346	-1.8369	4.8000	4.4346	-1.8369	4.8000
41	4.8000	0.0000	4.8000	4.8000	0.0000	4.8000
42	4.4346	1.8369	4.8000	4.4346	1.8369	4.8000
43	3.3941	3.3941	4.8000	3.3941	3.3941	4.8000
44	1.8369	4.4346	4.8000	1.8369	4.4346	4.8000

74	87	79	88	87	81	82	83	84	85	86	87	88	89	90	78	8.2276	5.5644	10.2118	10.0156	56.250	0.6690E+01
75	88	80	89	89	81	82	83	84	85	86	87	88	89	90	79	5.5644	8.3276	10.2118	10.0156	33.750	0.6690E+01
76	89	81	90	90	82	83	84	85	86	87	88	89	90	91	80	1.9540	9.8231	10.2118	10.0156	33.750	0.6690E+01
77	91	82	92	92	83	84	85	86	87	88	89	90	91	92	81	2.1833	-10.9762	11.4105	11.1913	168.750	0.7477E+01
78	92	83	93	93	84	85	86	87	88	89	90	91	92	93	82	6.2176	-9.3052	11.4105	11.1913	146.250	0.7477E+01
79	93	84	94	94	85	86	87	88	89	90	91	92	93	94	83	9.7052	-6.2176	11.4105	11.1913	123.750	0.7477E+01
80	94	85	95	95	86	87	88	89	90	91	92	93	94	95	84	10.9763	-2.1833	11.4105	11.1913	101.250	0.7477E+01
81	95	86	96	96	87	88	89	90	91	92	93	94	95	96	85	10.9762	2.1833	11.4105	11.1913	78.750	0.7477E+01
82	96	87	97	97	88	89	90	91	92	93	94	95	96	97	86	9.3052	6.2176	11.4105	11.1913	56.250	0.7477E+01
83	97	88	98	98	89	90	91	92	93	94	95	96	97	98	87	6.2176	9.3052	11.4105	11.1913	33.750	0.7477E+01
84	98	89	99	99	90	91	92	93	94	95	96	97	98	99	88	6.2176	10.9763	11.4105	11.1913	11.250	0.7477E+01

STEP	1	COMPLETE.CP TIME FOR STEP IS	0.00000
STEP	2	COMPLETE.CP TIME FOR STEP IS	0.00000
STEP	3	COMPLETE.CP TIME FOR STEP IS	0.00000
STEP	4	COMPLETE.CP TIME FOR STEP IS	0.00000
STEP	5	COMPLETE.CP TIME FOR STEP IS	0.00000
STEP	6	COMPLETE.CP TIME FOR STEP IS	0.00000
STEP	7	COMPLETE.CP TIME FOR STEP IS	0.00000
STEP	8	COMPLETE.CP TIME FOR STEP IS	0.00000
STEP	9	COMPLETE.CP TIME FOR STEP IS	0.00000
STEP	10	COMPLETE.CP TIME FOR STEP IS	0.00000
STEP	11	COMPLETE.CP TIME FOR STEP IS	0.00000
STEP	12	COMPLETE.CP TIME FOR STEP IS	0.00000

STEP 1 DEPTH = 0.1200000 TIME = 0.0001612 DIMENSIONLESS TIME 0.0080594 WETTING FACTORS = 1.2407800 1.2407800
 AVERAGE VELOCITY 0.000 -1200.000 WX 0.000 ORIENTATION 90.000

NO.	1	MOD	0	AREA	0.5513E-02	X	0.0295	Y	-0.0711	Z	0.1200	T*	0.00403	CP	0.3576	P	0.2409E+02	FORCE	0.1328E+00
	2	0	0	0.5513E-02	0.0711	0.0711	-0.0295	-0.0295	0.0711	0.1200	0.00403	0.00403	0.3576	0.3576	0.2409E+02	0.2409E+02	0.1328E+00	0.1328E+00	
	3	0	0	0.5513E-02	0.0711	0.0711	0.0295	0.0295	0.0711	0.1200	0.00403	0.00403	0.3576	0.3576	0.2409E+02	0.2409E+02	0.1328E+00	0.1328E+00	
	4	0	0	0.5513E-02	0.0357	0.0357	0.0295	0.0295	0.0357	0.1867	0.00179	0.00179	1.6303	1.6303	0.1098E+03	0.1098E+03	0.1296E+01	0.1296E+01	
	5	1	1	0.1180E-01	0.1017	0.1017	-0.1523	-0.1523	-0.1017	0.1867	0.00179	0.00179	1.6303	1.6303	0.1098E+03	0.1098E+03	0.1296E+01	0.1296E+01	
	6	1	1	0.1180E-01	0.1796	0.1796	-0.0357	-0.0357	-0.1017	0.1867	0.00179	0.00179	1.6303	1.6303	0.1098E+03	0.1098E+03	0.1296E+01	0.1296E+01	
	7	1	1	0.1180E-01	0.1796	0.1796	0.0357	0.0357	0.1017	0.1867	0.00179	0.00179	1.6303	1.6303	0.1098E+03	0.1098E+03	0.1296E+01	0.1296E+01	
	8	1	1	0.1180E-01	0.1017	0.1017	0.1523	0.1523	0.1017	0.1867	0.00179	0.00179	1.6303	1.6303	0.1098E+03	0.1098E+03	0.1296E+01	0.1296E+01	
	9	1	1	0.1180E-01	0.0357	0.0357	0.1523	0.1523	0.1017	0.1867	0.00179	0.00179	1.6303	1.6303	0.1098E+03	0.1098E+03	0.1296E+01	0.1296E+01	
	10	1	1	0.1180E-01	0.0357	0.0357	0.1796	0.1796	0.1017	0.1867	0.00179	0.00179	1.6303	1.6303	0.1098E+03	0.1098E+03	0.1296E+01	0.1296E+01	
	11	1	1	0.1180E-01	0.1017	0.1017	0.1523	0.1523	0.1017	0.1867	0.00179	0.00179	1.6303	1.6303	0.1098E+03	0.1098E+03	0.1296E+01	0.1296E+01	
	12	1	1	0.1180E-01	0.0357	0.0357	0.1796	0.1796	0.1017	0.1867	0.00179	0.00179	1.6303	1.6303	0.1098E+03	0.1098E+03	0.1296E+01	0.1296E+01	

FX= 0.000000E+00 FD= 0.1346298E+02 FN= 0.2294517E-04 SMX= 0.8032766E-05 SMY= 0.000000E+00 SMZ= 0.000000E+00
 CX= 0.00000000 CD= 0.0004418 CN= 0.00000000 MX= 0.00000000 MY= 0.00000000 MZ= 0.00000000

STEP 2 DEPTH = 1.0800100 TIME = 0.0008060 DIMENSIONLESS TIME 0.0402976 WETTING FACTORS = 1.2407800 1.2407800
 AVERAGE VELOCITY 0.000 -1200.000 WX 0.000 ORIENTATION 90.000

NO.	1	MOD	0	AREA	0.5513E-02	X	0.0295	Y	-0.0711	Z	0.1200	T*	0.03627	CP	1.9133	P	0.1289E+03	FORCE	0.7105E+00
	2	0	0	0.5513E-02	0.0711	0.0711	-0.0295	-0.0295	0.0711	0.1200	0.03627	0.03627	1.9133	1.9133	0.1289E+03	0.1289E+03	0.7105E+00	0.7105E+00	

3	0	0.5513E-02	0.0711	0.0295	0.1200	0.03627	1.9132	0.1289E+03	0.7105E+00
4	0	0.5513E-02	0.0711	0.0295	0.1200	0.03627	1.9132	0.1289E+03	0.7105E+00
5	0	0.3895E+00	0.1545	-0.7766	0.8072	0.01319	1.9504	0.1314E+03	0.5118E+02
6	0	0.3895E+00	0.4399	-0.6583	0.8072	0.01319	1.9504	0.1314E+03	0.5118E+02
7	0	0.3895E+00	0.6583	-0.4398	0.8072	0.01319	1.9504	0.1314E+03	0.5118E+02
8	0	0.3895E+00	0.7766	-0.1545	0.8072	0.01319	1.9504	0.1314E+03	0.5118E+02
9	0	0.3895E+00	0.7766	-0.1545	0.8072	0.01319	1.9504	0.1314E+03	0.5118E+02
10	0	0.3895E+00	0.6583	-0.4398	0.8072	0.01319	1.9504	0.1314E+03	0.5118E+02
11	0	0.3895E+00	0.4399	-0.6583	0.8072	0.01319	1.9504	0.1314E+03	0.5118E+02
12	0	0.3895E+00	0.1545	-0.7766	0.8072	0.01319	1.9504	0.1314E+03	0.5118E+02

EX= 0.0000000E+00 FD= 0.5676921E+03 FN= 0.3451768E-03 SMX= 0.5464889E-03 SMY= 0.0000000E+00 SMZ= 0.0000000E+00
 CX= 0.0000000 CD= 0.0186291 CN= 0.0000000 MX= 0.0000000 MY= 0.0000000 MZ= 0.0000000

STEP 3 DEPTH = 2.2800200 TIME = 0.0016119 DIMENSIONLESS TIME 0.0905951 WETTING FACTORS = 1.2407800 1.2407800
 AVERAGE VELOCITY 0.000 WX -1200.000 WY 0.000ORIENTATION 90.000

NO	REF.NO.	MOD	AREA	X	Y	Z	T*	CP	P	FORCE
1	1	0	0.5513E-02	0.0295	-0.0711	0.1200	0.07657	1.5727	0.1059E+03	0.5841E+00
2	2	0	0.5513E-02	0.0711	-0.0295	0.1200	0.07657	1.5727	0.1059E+03	0.5841E+00
3	3	0	0.5513E-02	0.0295	0.0711	0.1200	0.07657	1.5727	0.1059E+03	0.5841E+00
4	4	0	0.3895E+00	0.1545	-0.7766	0.8072	0.05349	1.4201	0.9566E+02	0.3727E+02
5	5	0	0.3895E+00	0.4398	-0.6583	0.8072	0.05349	1.4201	0.9566E+02	0.3727E+02
6	6	0	0.3895E+00	0.6583	-0.4398	0.8072	0.05349	1.4201	0.9566E+02	0.3727E+02
7	7	0	0.3895E+00	0.7766	-0.1545	0.8072	0.05349	1.4201	0.9566E+02	0.3727E+02
8	8	0	0.3895E+00	0.7766	-0.1545	0.8072	0.05349	1.4201	0.9566E+02	0.3727E+02
9	9	0	0.3895E+00	0.6583	-0.4398	0.8072	0.05349	1.4201	0.9566E+02	0.3727E+02
10	10	0	0.3895E+00	0.4398	-0.6583	0.8072	0.05349	1.4201	0.9566E+02	0.3727E+02
11	11	0	0.3895E+00	0.1545	-0.7766	0.8072	0.05349	1.4201	0.9566E+02	0.3727E+02
12	12	0	0.1180E+01	0.3572	-1.7956	1.8667	0.01791	2.0114	0.1355E+03	0.1599E+03
13	13	0	0.1180E+01	1.0171	-1.5223	1.8667	0.01791	2.0114	0.1355E+03	0.1599E+03
14	14	0	0.1180E+01	1.0171	-1.5223	1.8667	0.01791	2.0114	0.1355E+03	0.1599E+03
15	15	0	0.1180E+01	1.7956	-0.3572	1.8667	0.01791	2.0114	0.1355E+03	0.1599E+03
16	16	0	0.1180E+01	1.7956	-0.3572	1.8667	0.01791	2.0114	0.1355E+03	0.1599E+03
17	17	0	0.1180E+01	1.5223	-1.0171	1.8667	0.01791	2.0114	0.1355E+03	0.1599E+03
18	18	0	0.1180E+01	1.5223	-1.0171	1.8667	0.01791	2.0114	0.1355E+03	0.1599E+03
19	19	0	0.1180E+01	1.0171	-1.5223	1.8667	0.01791	2.0114	0.1355E+03	0.1599E+03
20	20	0	0.1180E+01	0.3572	-1.7956	1.8667	0.01791	2.0114	0.1355E+03	0.1599E+03

EX= 0.0000000E+00 FD= 0.2204765E+04 FN= 0.1640546E-03 SMX= 0.5168516E-03 SMY= 0.0000000E+00 SMZ= 0.0000000E+00
 CX= 0.0000000 CD= 0.0723503 CN= 0.0000000 MX= 0.0000000 MY= 0.0000000 MZ= 0.0000000

STEP 4 DEPTH = 3.4800300 TIME = 0.0024179 DIMENSIONLESS TIME 0.1208927 WETTING FACTORS = 1.2407800 1.2407800
 AVERAGE VELOCITY 0.000 WX -1200.000 WY 0.000ORIENTATION 90.000

NO	REF.NO.	MOD	AREA	X	Y	Z	T*	CP	P	FORCE
1	1	0	0.5513E-02	0.0295	-0.0711	0.1200	0.11686	1.6171	0.1089E+03	0.6006E+00
2	2	0	0.5513E-02	0.0711	-0.0295	0.1200	0.11686	1.6171	0.1089E+03	0.6006E+00
3	3	0	0.5513E-02	0.0295	0.0711	0.1200	0.11686	1.6171	0.1089E+03	0.6006E+00
4	4	0	0.3895E+00	0.1545	-0.7766	0.8072	0.09378	1.3853	0.9332E+02	0.3636E+02
5	5	0	0.3895E+00	0.4398	-0.6583	0.8072	0.09378	1.3853	0.9332E+02	0.3636E+02
6	6	0	0.3895E+00	0.6583	-0.4398	0.8072	0.09378	1.3853	0.9332E+02	0.3636E+02
7	7	0	0.3895E+00	0.7766	-0.1545	0.8072	0.09378	1.3853	0.9332E+02	0.3636E+02
8	8	0	0.3895E+00	0.7766	-0.1545	0.8072	0.09378	1.3853	0.9332E+02	0.3636E+02
9	9	0	0.3895E+00	0.6583	-0.4398	0.8072	0.09378	1.3853	0.9332E+02	0.3636E+02
10	10	0	0.3895E+00	0.4398	-0.6583	0.8072	0.09378	1.3853	0.9332E+02	0.3636E+02
11	11	0	0.3895E+00	0.1545	-0.7766	0.8072	0.09378	1.3853	0.9332E+02	0.3636E+02
12	12	0	0.1180E+01	0.3572	-1.7956	1.8667	0.05821	1.4269	0.9612E+02	0.1135E+03
13	13	0	0.1180E+01	1.0171	-1.5223	1.8667	0.05821	1.4269	0.9612E+02	0.1135E+03
14	14	0	0.1180E+01	1.0171	-1.5223	1.8667	0.05821	1.4269	0.9612E+02	0.1135E+03
15	15	0	0.1180E+01	1.7956	-0.3572	1.8667	0.05821	1.4269	0.9612E+02	0.1135E+03
16	16	0	0.1180E+01	1.7956	-0.3572	1.8667	0.05821	1.4269	0.9612E+02	0.1135E+03

17	1780E+01	1.7956	0.3572	1.8667	0.5821	1.4269	0.9612E+02	0.1135E+03
18	0.1181E+01	1.5223	1.0171	1.8667	0.5821	1.4269	0.9612E+02	0.1135E+03
19	0.1181E+01	1.5223	1.0171	1.8667	0.5821	1.4269	0.9612E+02	0.1135E+03
20	0.1180E+01	0.3572	1.7956	1.8667	0.5821	1.4269	0.9612E+02	0.1135E+03
21	0.1968E+01	0.5817	-2.9243	3.0400	0.01881	2.1660	0.1459E+03	0.2871E+03
22	0.1968E+01	1.6565	-2.4791	3.0400	0.01881	2.1660	0.1459E+03	0.2871E+03
23	0.1968E+01	2.4791	-0.5817	3.0400	0.01881	2.1660	0.1459E+03	0.2871E+03
24	0.1968E+01	2.9243	1.6565	3.0400	0.01881	2.1660	0.1459E+03	0.2871E+03
25	0.1968E+01	2.4791	1.6565	3.0400	0.01881	2.1660	0.1459E+03	0.2871E+03
26	0.1968E+01	1.6565	2.4791	3.0400	0.01881	2.1660	0.1459E+03	0.2871E+03
27	0.1968E+01	0.5817	2.9243	3.0400	0.01881	2.1660	0.1459E+03	0.2871E+03
28	0.1968E+01	0.5817	2.9243	3.0400	0.01881	2.1660	0.1459E+03	0.2871E+03

FX= 0.000000E+00 FD= 0.4889904E+04 FN= -0.5540183E-03 SMX= -0.2826666E-02 SMV= 0.000000E+00 SMZ= 0.0000000E+00
 CX= 0.00000000 CD= 0.1604644 CN= 0.00000000 MX= -1200.0000 WX= 0.00000000 MY= 0.00000000 MZ= 0.00000000

STEP 5 DEPTH = 4.6800400 TIME = 0.0032238 DIMENSIONLESS TIME 0.1611903 WEAVING FACTORS = 1.2407800 1.2407800
 AVERAGE VELOCITY 0.000 MOD

NO	AREA	X	Y	Z	TM	CP	P	FORCE
1	0.5513E-02	0.0295	-0.0711	0.1200	0.15716	1.6313	0.1099E+03	0.6058E+00
2	0.5513E-02	0.0711	-0.0295	0.1200	0.15716	1.6313	0.1099E+03	0.6058E+00
3	0.5513E-02	0.0295	0.0711	0.1200	0.15716	1.6313	0.1099E+03	0.6058E+00
4	0.3896E+00	0.1545	-0.7766	0.8072	0.13408	1.4165	0.9542E+02	0.3718E+02
5	0.3896E+00	0.4399	-0.6583	0.8072	0.13408	1.4165	0.9542E+02	0.3718E+02
6	0.3896E+00	0.6583	-0.4399	0.8072	0.13408	1.4165	0.9542E+02	0.3718E+02
7	0.3896E+00	0.7766	-0.1545	0.8072	0.13408	1.4165	0.9542E+02	0.3718E+02
8	0.3896E+00	0.6583	0.4399	0.8072	0.13408	1.4165	0.9542E+02	0.3718E+02
9	0.3896E+00	0.4399	0.6583	0.8072	0.13408	1.4165	0.9542E+02	0.3718E+02
10	0.3896E+00	0.1545	0.7766	0.8072	0.13408	1.4165	0.9542E+02	0.3718E+02
11	0.1180E+01	0.3572	-1.7956	1.8667	0.09851	1.3611	0.9169E+02	0.1082E+03
12	0.1180E+01	0.7956	-1.0171	1.8667	0.09851	1.3611	0.9169E+02	0.1082E+03
13	0.1180E+01	1.0171	-0.3572	1.8667	0.09851	1.3611	0.9169E+02	0.1082E+03
14	0.1180E+01	1.7956	-0.0711	1.8667	0.09851	1.3611	0.9169E+02	0.1082E+03
15	0.1180E+01	1.0171	0.0711	1.8667	0.09851	1.3611	0.9169E+02	0.1082E+03
16	0.1180E+01	0.3572	0.3572	1.8667	0.09851	1.3611	0.9169E+02	0.1082E+03
17	0.1180E+01	1.7956	1.0171	1.8667	0.09851	1.3611	0.9169E+02	0.1082E+03
18	0.1180E+01	1.0171	1.5223	1.8667	0.09851	1.3611	0.9169E+02	0.1082E+03
19	0.1180E+01	0.3572	1.7956	1.8667	0.09851	1.3611	0.9169E+02	0.1082E+03
20	0.1968E+01	1.6565	-2.4791	3.0400	0.05910	1.4887	0.1003E+03	0.1973E+03
21	0.1968E+01	2.4791	-1.6565	3.0400	0.05910	1.4887	0.1003E+03	0.1973E+03
22	0.1968E+01	1.6565	2.4791	3.0400	0.05910	1.4887	0.1003E+03	0.1973E+03
23	0.1968E+01	2.4791	1.6565	3.0400	0.05910	1.4887	0.1003E+03	0.1973E+03
24	0.2754E+01	0.8091	-4.0676	4.2286	0.01919	2.2577	0.1521E+03	0.4189E+03
25	0.2754E+01	2.4041	-3.4484	4.2286	0.01919	2.2577	0.1521E+03	0.4189E+03
26	0.2754E+01	3.4484	-2.4041	4.2286	0.01919	2.2577	0.1521E+03	0.4189E+03
27	0.2754E+01	4.0676	-0.8091	4.2286	0.01919	2.2577	0.1521E+03	0.4189E+03
28	0.2754E+01	3.4484	0.8091	4.2286	0.01919	2.2577	0.1521E+03	0.4189E+03
29	0.2754E+01	2.4041	3.4484	4.2286	0.01919	2.2577	0.1521E+03	0.4189E+03
30	0.2754E+01	0.8091	4.0676	4.2286	0.01919	2.2577	0.1521E+03	0.4189E+03
31	0.2754E+01	0.8091	4.0676	4.2286	0.01919	2.2577	0.1521E+03	0.4189E+03
32	0.2754E+01	0.8091	4.0676	4.2286	0.01919	2.2577	0.1521E+03	0.4189E+03
33	0.2754E+01	0.8091	4.0676	4.2286	0.01919	2.2577	0.1521E+03	0.4189E+03
34	0.2754E+01	0.8091	4.0676	4.2286	0.01919	2.2577	0.1521E+03	0.4189E+03
35	0.2754E+01	0.8091	4.0676	4.2286	0.01919	2.2577	0.1521E+03	0.4189E+03
36	0.2754E+01	0.8091	4.0676	4.2286	0.01919	2.2577	0.1521E+03	0.4189E+03

FX= 0.000000E+00 FD= 0.8527767E+04 FN= 0.1780290E-02 SMX= 0.1549412E-01 SMV= 0.000000E+00 SMZ= 0.0000000E+00
 CX= 0.00000000 CD= 0.2798424 CN= 0.00000001 MX= -1200.0000 WX= 0.00000000 MY= 0.00000000 MZ= 0.00000000

STEP 6 DEPTH = 5.8800500 TIME = 0.0040298 DIMENSIONLESS TIME 0.2014878 WEAVING FACTORS = 1.2407800 1.2407800
 AVERAGE VELOCITY 0.000 MOD

NO. 1	REF. NO. 0	MOD 0	AREA 0.5513E-02	X 0.0295	Y -0.0711	Z 0.1200	T* 0.19746	CP 1.0388	P 0.1104E+03	FORCE 0.6086E+00
2	0	0	0.5513E-02	0.0711	-0.0295	0.1200	0.19746	1.0388	0.1104E+03	0.6086E+00
3	0	0	0.5513E-02	0.0295	0.0711	0.1200	0.19746	1.0388	0.1104E+03	0.6086E+00
4	0	0	0.5513E-02	0.1545	-0.7766	0.8072	0.17438	1.4406	0.9704E+02	0.3780E+02
5	0	0	0.3895E+00	0.4399	-0.6583	0.8072	0.17438	1.4406	0.9704E+02	0.3780E+02
6	0	0	0.3895E+00	0.6583	-0.4399	0.8072	0.17438	1.4406	0.9704E+02	0.3780E+02
7	0	0	0.3895E+00	0.7766	-0.1545	0.8072	0.17438	1.4406	0.9704E+02	0.3780E+02
8	0	0	0.3895E+00	0.6583	0.4399	0.8072	0.17438	1.4406	0.9704E+02	0.3780E+02
9	0	0	0.3895E+00	0.4399	0.6583	0.8072	0.17438	1.4406	0.9704E+02	0.3780E+02
10	0	0	0.3895E+00	0.1545	0.7766	0.8072	0.17438	1.4406	0.9704E+02	0.3780E+02
11	0	0	0.1180E+01	0.3572	-1.7956	1.8667	0.33880	1.3757	0.9267E+02	0.1094E+03
12	0	0	0.1180E+01	1.0171	-1.5223	1.8667	0.33880	1.3757	0.9267E+02	0.1094E+03
13	0	0	0.1180E+01	1.5223	-1.0171	1.8667	0.33880	1.3757	0.9267E+02	0.1094E+03
14	0	0	0.1180E+01	1.0171	1.5223	1.8667	0.33880	1.3757	0.9267E+02	0.1094E+03
15	0	0	0.1180E+01	1.5223	1.0171	1.8667	0.33880	1.3757	0.9267E+02	0.1094E+03
16	0	0	0.1180E+01	1.7956	-0.3572	1.8667	0.33880	1.3757	0.9267E+02	0.1094E+03
17	0	0	0.1180E+01	1.5223	1.0171	1.8667	0.33880	1.3757	0.9267E+02	0.1094E+03
18	0	0	0.1180E+01	1.0171	1.5223	1.8667	0.33880	1.3757	0.9267E+02	0.1094E+03
19	0	0	0.1180E+01	1.0171	1.5223	1.8667	0.33880	1.3757	0.9267E+02	0.1094E+03
20	0	0	0.1180E+01	0.3572	-1.7956	1.8667	0.33880	1.3757	0.9267E+02	0.1094E+03
21	0	0	0.1968E+01	0.5817	-2.9243	3.0400	0.09940	1.3829	0.9315E+02	0.1833E+03
22	0	0	0.1968E+01	1.6565	-2.4791	3.0400	0.09940	1.3829	0.9315E+02	0.1833E+03
23	0	0	0.1968E+01	2.4791	-1.6565	3.0400	0.09940	1.3829	0.9315E+02	0.1833E+03
24	0	0	0.1968E+01	2.9243	-0.5817	3.0400	0.09940	1.3829	0.9315E+02	0.1833E+03
25	0	0	0.1968E+01	2.4791	2.9243	3.0400	0.09940	1.3829	0.9315E+02	0.1833E+03
26	0	0	0.1968E+01	1.6565	2.4791	3.0400	0.09940	1.3829	0.9315E+02	0.1833E+03
27	0	0	0.1968E+01	0.5817	2.9243	3.0400	0.09940	1.3829	0.9315E+02	0.1833E+03
28	0	0	0.2754E+01	0.8091	-4.0676	4.2286	0.05949	1.5413	0.1038E+03	0.2860E+03
29	0	0	0.2754E+01	3.041	-3.4484	4.2286	0.05949	1.5413	0.1038E+03	0.2860E+03
30	0	0	0.2754E+01	3.4484	-2.3041	4.2286	0.05949	1.5413	0.1038E+03	0.2860E+03
31	0	0	0.2754E+01	4.0676	-0.8091	4.2286	0.05949	1.5413	0.1038E+03	0.2860E+03
32	0	0	0.2754E+01	4.0676	3.041	4.2286	0.05949	1.5413	0.1038E+03	0.2860E+03
33	0	0	0.2754E+01	3.4484	3.4484	4.2286	0.05949	1.5413	0.1038E+03	0.2860E+03
34	0	0	0.2754E+01	2.3041	4.0676	4.2286	0.05949	1.5413	0.1038E+03	0.2860E+03
35	0	0	0.2754E+01	2.3041	4.0676	4.2286	0.05949	1.5413	0.1038E+03	0.2860E+03
36	0	0	0.3541E+01	0.8091	-5.2158	5.4222	0.01940	2.3097	0.1556E+03	0.5510E+03
37	0	0	0.3541E+01	1.0375	-2.9545	5.4222	0.01940	2.3097	0.1556E+03	0.5510E+03
38	0	0	0.3541E+01	2.9545	-4.4218	5.4222	0.01940	2.3097	0.1556E+03	0.5510E+03
39	0	0	0.3541E+01	4.4218	-2.9545	5.4222	0.01940	2.3097	0.1556E+03	0.5510E+03
40	0	0	0.3541E+01	5.2158	-1.0375	5.4222	0.01940	2.3097	0.1556E+03	0.5510E+03
41	0	0	0.3541E+01	4.4218	4.4218	5.4222	0.01940	2.3097	0.1556E+03	0.5510E+03
42	0	0	0.3541E+01	2.9545	4.4218	5.4222	0.01940	2.3097	0.1556E+03	0.5510E+03
43	0	0	0.3541E+01	2.9545	4.4218	5.4222	0.01940	2.3097	0.1556E+03	0.5510E+03
44	0	0	0.3541E+01	1.0375	5.2159	5.4222	0.01940	2.3097	0.1556E+03	0.5510E+03

FX= 0.000000E+00 FD= 0.1307436E+05 FI= -0.3279485E-03 SMY= -0.7242138E-02 SMZ= 0.000000E+00
 CX= 0.00000000 CD= 0.4290410 CF= 0.00000000 CM= 0.00000000 CW= 0.00000000 CZ= 0.00000000
 SMX= 0.00000000 SMY= 0.00000000 SMZ= 0.00000000
 WETTING FACTORS = 1.2407800 1.2407800 1.2407800
 90.000

STEP 7 DEPTH = 7.0800600 TIME = 0.0048357 DIMENSIONLESS TIME 0.2417854 WETTING FACTORS = 1.2407800 1.2407800
 AVERAGE VELOCITY 0.000

NO. 1	REF. NO. 0	MOD 0	AREA 0.5513E-02	X 0.0295	Y -0.0711	Z 0.1200	T* 0.23776	CP 1.6431	P 0.1107E+03	FORCE 0.6102E+00
2	0	0	0.5513E-02	0.0711	-0.0295	0.1200	0.23776	1.6431	0.1107E+03	0.6102E+00
3	0	0	0.5513E-02	0.0295	0.0711	0.1200	0.23776	1.6431	0.1107E+03	0.6102E+00
4	0	0	0.5513E-02	0.1545	-0.7766	0.8072	0.23776	1.6431	0.1107E+03	0.6102E+00
5	0	0	0.3895E+00	0.4399	-0.6583	0.8072	0.23776	1.6431	0.1107E+03	0.6102E+00
6	0	0	0.3895E+00	0.6583	-0.4399	0.8072	0.23776	1.6431	0.1107E+03	0.6102E+00
7	0	0	0.3895E+00	0.7766	-0.1545	0.8072	0.23776	1.6431	0.1107E+03	0.6102E+00
8	0	0	0.3895E+00	0.6583	0.4399	0.8072	0.23776	1.6431	0.1107E+03	0.6102E+00
9	0	0	0.3895E+00	0.4399	0.6583	0.8072	0.23776	1.6431	0.1107E+03	0.6102E+00
10	0	0	0.3895E+00	0.1545	0.7766	0.8072	0.23776	1.6431	0.1107E+03	0.6102E+00

EX=	0.000000E+00	FD=	0.1850813E+05	FN=	-0.2967498E-03	SMX=	-0.1340228E-02	SMY=	0.000000E+00	SMZ=	0.000000E+00
CA=	0.00000000	CD=	0.6073525	CN=	0.00000000	MX=	0.00000000	MY=	0.00000000	MZ=	0.00000000

STEP	8	DEPTH =	8.2800700	TIME =	0.0056417	DIMENSIONLESS	TIME	0.2820830	WEIGHTING FACTORS =	1.2407800	1.2407800
AVERAGE VELOCITY	0.000				0.000	-1200.000	WX	0.00ORIENTATION	90.0000		

NO.	1	2	3	4	5	6	7	8	9	10	11	12	13	14
REF.NO.	0	0	0	0	0	0	0	0	0	0	0	0	0	0
MOD	AREA	AREA	AREA	AREA	AREA	AREA	AREA	AREA	AREA	AREA	AREA	AREA	AREA	AREA
	0.3895E+00	0.3895E+00	0.1180E+01	0.1180E+01	0.1180E+01	0.1180E+01	0.1180E+01	0.1180E+01	0.1180E+01	0.1180E+01	0.1180E+01	0.1180E+01	0.1180E+01	0.1180E+01
	0.00000000	0.00000000	0.00000000	0.00000000	0.00000000	0.00000000	0.00000000	0.00000000	0.00000000	0.00000000	0.00000000	0.00000000	0.00000000	0.00000000
	0.4398	0.1545	0.3572	1.0171	1.5223	1.7956	1.5223	1.0171	0.4398	0.1545	0.3572	1.0171	1.5223	1.7956
	0.6583	0.7766	-1.7956	-1.5223	-1.0171	0.4398	0.1545	0.3572	0.6583	0.7766	-1.7956	-1.5223	-1.0171	0.4398
	0.8072	1.8667	1.8667	1.8667	1.8667	1.8667	1.8667	1.8667	0.8072	1.8667	1.8667	1.8667	1.8667	1.8667
	0.21468	0.21468	0.17910	0.17910	0.17910	0.17910	0.17910	0.17910	0.21468	0.21468	0.17910	0.17910	0.17910	0.17910
	1.4590	1.4590	1.3929	1.3929	1.3929	1.3929	1.3929	1.3929	1.4590	1.4590	1.3929	1.3929	1.3929	1.3929
	0.5828E+02	0.5828E+02	0.9383E+02	0.9383E+02	0.9383E+02	0.9383E+02	0.9383E+02	0.9383E+02	0.5828E+02	0.5828E+02	0.9383E+02	0.9383E+02	0.9383E+02	0.9383E+02
	0.3829E+02	0.3828E+02	0.1108E+03	0.1108E+03	0.1108E+03	0.1108E+03	0.1108E+03	0.1108E+03	0.3829E+02	0.3828E+02	0.1108E+03	0.1108E+03	0.1108E+03	0.1108E+03

NO.	1	2	3	4	5	6	7	8	9	10	11	12	13	14
REF.NO.	0	0	0	0	0	0	0	0	0	0	0	0	0	0
MOD	AREA	AREA	AREA	AREA	AREA	AREA	AREA	AREA	AREA	AREA	AREA	AREA	AREA	AREA
	0.5513E-02	0.5513E-02	0.5513E-02	0.5513E-02	0.5513E-02	0.5513E-02	0.5513E-02	0.5513E-02	0.5513E-02	0.5513E-02	0.5513E-02	0.5513E-02	0.5513E-02	0.5513E-02
	0.00000000	0.00000000	0.00000000	0.00000000	0.00000000	0.00000000	0.00000000	0.00000000	0.00000000	0.00000000	0.00000000	0.00000000	0.00000000	0.00000000
	1.6459	1.6459	1.6459	1.6459	1.6459	1.6459	1.6459	1.6459	1.6459	1.6459	1.6459	1.6459	1.6459	1.6459
	0.1109E+03	0.1109E+03	0.1109E+03	0.1109E+03	0.1109E+03	0.1109E+03	0.1109E+03	0.1109E+03	0.1109E+03	0.1109E+03	0.1109E+03	0.1109E+03	0.1109E+03	0.1109E+03
	0.6113E+00	0.6113E+00	0.6113E+00	0.6113E+00	0.6113E+00	0.6113E+00	0.6113E+00	0.6113E+00	0.6113E+00	0.6113E+00	0.6113E+00	0.6113E+00	0.6113E+00	0.6113E+00

15	0.1181E+01	1.5233	-1.0171	1.8567	0.21940	1.4083	0.9486E+02	0.1120E+03
16	0.1180E+01	1.7956	-0.3572	1.1667	0.21940	1.4083	0.9486E+02	0.1120E+03
17	0.1181E+01	1.5233	1.0171	1.8667	0.21940	1.4083	0.9486E+02	0.1120E+03
18	0.1181E+01	1.0171	1.5233	1.8667	0.21940	1.4083	0.9486E+02	0.1120E+03
19	0.1181E+01	0.5233	1.0171	1.8667	0.21940	1.4083	0.9486E+02	0.1120E+03
20	0.1180E+01	0.21940	0.5233	3.0400	0.18000	1.3846	0.9327E+02	0.1835E+03
21	0.1968E+01	0.5817	-2.9243	3.0400	0.18000	1.3846	0.9327E+02	0.1835E+03
22	0.1968E+01	1.2491	-2.4791	3.0400	0.18000	1.3846	0.9327E+02	0.1835E+03
23	0.1968E+01	2.4791	-1.6565	3.0400	0.18000	1.3846	0.9327E+02	0.1835E+03
24	0.1968E+01	2.9243	0.5817	3.0400	0.18000	1.3846	0.9327E+02	0.1835E+03
25	0.1968E+01	2.4791	0.5817	3.0400	0.18000	1.3846	0.9327E+02	0.1835E+03
26	0.1968E+01	2.4791	1.6565	3.0400	0.18000	1.3846	0.9327E+02	0.1835E+03
27	0.1968E+01	0.5817	2.9243	3.0400	0.18000	1.3846	0.9327E+02	0.1835E+03
28	0.1968E+01	0.5817	2.9243	3.0400	0.18000	1.3846	0.9327E+02	0.1835E+03
29	0.2754E+01	0.8091	4.2286	4.2286	0.14008	1.3902	0.9364E+02	0.2579E+03
30	0.2754E+01	2.3414	4.0676	4.2286	0.14008	1.3902	0.9364E+02	0.2579E+03
31	0.2754E+01	3.4844	2.3041	4.2286	0.14008	1.3902	0.9364E+02	0.2579E+03
32	0.2754E+01	4.0676	0.8091	4.2286	0.14008	1.3902	0.9364E+02	0.2579E+03
33	0.2754E+01	4.0676	0.8091	4.2286	0.14008	1.3902	0.9364E+02	0.2579E+03
34	0.2754E+01	3.4844	2.3041	4.2286	0.14008	1.3902	0.9364E+02	0.2579E+03
35	0.2754E+01	2.3041	3.4844	4.2286	0.14008	1.3902	0.9364E+02	0.2579E+03
36	0.2754E+01	0.8091	4.0676	4.2286	0.14008	1.3902	0.9364E+02	0.2579E+03
37	0.3422E+01	1.0375	-5.2128	5.4222	0.10000	1.4346	0.9664E+02	0.3422E+03
38	0.3422E+01	2.9545	-4.2218	5.4222	0.10000	1.4346	0.9664E+02	0.3422E+03
39	0.3422E+01	4.4218	-2.9545	5.4222	0.10000	1.4346	0.9664E+02	0.3422E+03
40	0.3422E+01	5.2159	-1.0375	5.4222	0.10000	1.4346	0.9664E+02	0.3422E+03
41	0.3422E+01	5.2159	1.0375	5.4222	0.10000	1.4346	0.9664E+02	0.3422E+03
42	0.3422E+01	4.4218	2.9545	5.4222	0.10000	1.4346	0.9664E+02	0.3422E+03
43	0.3422E+01	2.9545	4.4218	5.4222	0.10000	1.4346	0.9664E+02	0.3422E+03
44	0.3422E+01	1.0375	5.2159	5.4222	0.10000	1.4346	0.9664E+02	0.3422E+03
45	0.4328E+01	1.2663	-6.3663	6.6182	0.05984	1.6244	0.1094E+03	0.4736E+03
46	0.4328E+01	3.3971	-5.3971	6.6182	0.05984	1.6244	0.1094E+03	0.4736E+03
47	0.4328E+01	5.3971	-3.3971	6.6182	0.05984	1.6244	0.1094E+03	0.4736E+03
48	0.4328E+01	6.3663	-1.2663	6.6182	0.05984	1.6244	0.1094E+03	0.4736E+03
49	0.4328E+01	6.3663	1.2663	6.6182	0.05984	1.6244	0.1094E+03	0.4736E+03
50	0.4328E+01	5.3971	3.6062	6.6182	0.05984	1.6244	0.1094E+03	0.4736E+03
51	0.4328E+01	3.6062	5.3971	6.6182	0.05984	1.6244	0.1094E+03	0.4736E+03
52	0.4328E+01	1.2663	6.3663	6.6182	0.05984	1.6244	0.1094E+03	0.4736E+03
53	0.5115E+01	1.4954	-7.8154	7.8154	0.01963	2.3414	0.1577E+03	0.8068E+03
54	0.5115E+01	4.2586	-6.3734	7.8154	0.01963	2.3414	0.1577E+03	0.8068E+03
55	0.5115E+01	6.3734	-4.2586	7.8154	0.01963	2.3414	0.1577E+03	0.8068E+03
56	0.5115E+01	7.5179	-1.4954	7.8154	0.01963	2.3414	0.1577E+03	0.8068E+03
57	0.5115E+01	7.5179	1.4954	7.8154	0.01963	2.3414	0.1577E+03	0.8068E+03
58	0.5115E+01	6.3734	4.2586	7.8154	0.01963	2.3414	0.1577E+03	0.8068E+03
59	0.5115E+01	4.2586	6.3734	7.8154	0.01963	2.3414	0.1577E+03	0.8068E+03
60	0.5115E+01	1.4954	7.5179	7.8154	0.01963	2.3414	0.1577E+03	0.8068E+03

FX= 0.000000E+00 FD= 0.248038E+05 FN= -0.267769E-02 SMX= -0.357591E-01 SMY= 0.000000E+00 SMZ= 0.000000E+00
 CX= 0.000000E+00 CD= 0.8140978 CN= -0.000000E+00 MX= 0.000000E+00 MY= 0.000000E+00 MZ= 0.000000E+00

STEP 9 DEPTH = 9.4800800 TIME = 0.0064476 DIMENSIONLESS TIME 0.3223805 WEITING FACTORS = 1.2407800 1.2407800
 AVERAGE VELOCITY 0.0000000 0.0000000 -1200.0000 WX 0.0000000 WY 0.0000000 WZ 90.0000

NO.	1	2	3	4	5	6	7	8	9	10
REF.NO.	0	0	0	0	0	0	0	0	0	0
MOD	0	0	0	0	0	0	0	0	0	0
AREA	0.5513E-02	0.0711	0.0295	0.0711	0.0295	0.0711	0.0295	0.0711	0.0295	0.0711
CP	1.6480	1.6480	1.6480	1.6480	1.6480	1.6480	1.6480	1.6480	1.6480	1.6480
CP	1.6480	1.6480	1.6480	1.6480	1.6480	1.6480	1.6480	1.6480	1.6480	1.6480
T*	0.31835	0.31835	0.31835	0.31835	0.31835	0.31835	0.31835	0.31835	0.31835	0.31835
Z	0.1200	0.1200	0.1200	0.1200	0.1200	0.1200	0.1200	0.1200	0.1200	0.1200
Y	-0.0711	-0.0295	0.0711	0.0295	-0.0711	-0.0295	0.0711	0.0295	-0.0711	-0.0295
X	0.0295	0.0711	0.0295	0.0711	0.0295	0.0711	0.0295	0.0711	0.0295	0.0711
AREA	0.5513E-02	0.0711	0.0295	0.0711	0.0295	0.0711	0.0295	0.0711	0.0295	0.0711
CP	1.6480	1.6480	1.6480	1.6480	1.6480	1.6480	1.6480	1.6480	1.6480	1.6480
CP	1.6480	1.6480	1.6480	1.6480	1.6480	1.6480	1.6480	1.6480	1.6480	1.6480
T*	0.31835	0.31835	0.31835	0.31835	0.31835	0.31835	0.31835	0.31835	0.31835	0.31835
Z	0.1200	0.1200	0.1200	0.1200	0.1200	0.1200	0.1200	0.1200	0.1200	0.1200
Y	-0.0711	-0.0295	0.0711	0.0295	-0.0711	-0.0295	0.0711	0.0295	-0.0711	-0.0295
X	0.0295	0.0711	0.0295	0.0711	0.0295	0.0711	0.0295	0.0711	0.0295	0.0711
AREA	0.5513E-02	0.0711	0.0295	0.0711	0.0295	0.0711	0.0295	0.0711	0.0295	0.0711
CP	1.6480	1.6480	1.6480	1.6480	1.6480	1.6480	1.6480	1.6480	1.6480	1.6480
CP	1.6480	1.6480	1.6480	1.6480	1.6480	1.6480	1.6480	1.6480	1.6480	1.6480
T*	0.31835	0.31835	0.31835	0.31835	0.31835	0.31835	0.31835	0.31835	0.31835	0.31835
Z	0.1200	0.1200	0.1200	0.1200	0.1200	0.1200	0.1200	0.1200	0.1200	0.1200
Y	-0.0711	-0.0295	0.0711	0.0295	-0.0711	-0.0295	0.0711	0.0295	-0.0711	-0.0295
X	0.0295	0.0711	0.0295	0.0711	0.0295	0.0711	0.0295	0.0711	0.0295	0.0711

11	0.000000E+00	0.3896E+00	0.4398	0.6583	0.8072	0.29527	1.4852	0.1000E+03	3896E+02
12	0.000000E+00	0.3895E+00	0.1545	0.7766	0.8073	0.29527	1.4852	0.1000E+03	3897E+02
13	0.000000E+00	0.3572	0.3572	-1.5223	1.8667	0.25970	1.4212	0.9574E+02	1130E+03
14	0.000000E+00	0.10171	0.10171	-1.5223	1.8667	0.25970	1.4212	0.9574E+02	1130E+03
15	0.000000E+00	0.1181E+01	0.1181E+01	-0.3572	1.8667	0.25970	1.4212	0.9574E+02	1130E+03
16	0.000000E+00	0.1180E+01	0.1180E+01	0.3572	1.8667	0.25970	1.4212	0.9574E+02	1130E+03
17	0.000000E+00	0.1180E+01	0.1180E+01	0.3572	1.8667	0.25970	1.4212	0.9574E+02	1130E+03
18	0.000000E+00	0.1181E+01	0.1181E+01	0.10171	1.8667	0.25970	1.4212	0.9574E+02	1130E+03
19	0.000000E+00	0.1181E+01	0.1181E+01	1.5223	1.8667	0.25970	1.4212	0.9574E+02	1130E+03
20	0.000000E+00	0.1180E+01	0.1180E+01	1.5223	1.8667	0.25970	1.4212	0.9574E+02	1130E+03
21	0.000000E+00	0.1968E+01	0.1968E+01	-2.4791	3.0400	0.22029	1.3934	0.9366E+02	1847E+03
22	0.000000E+00	0.1968E+01	0.1968E+01	-2.4791	3.0400	0.22029	1.3934	0.9366E+02	1847E+03
23	0.000000E+00	0.1968E+01	0.1968E+01	2.4791	3.0400	0.22029	1.3934	0.9366E+02	1847E+03
24	0.000000E+00	0.1968E+01	0.1968E+01	2.4791	3.0400	0.22029	1.3934	0.9366E+02	1847E+03
25	0.000000E+00	0.1968E+01	0.1968E+01	2.4791	3.0400	0.22029	1.3934	0.9366E+02	1847E+03
26	0.000000E+00	0.1968E+01	0.1968E+01	2.4791	3.0400	0.22029	1.3934	0.9366E+02	1847E+03
27	0.000000E+00	0.1968E+01	0.1968E+01	2.4791	3.0400	0.22029	1.3934	0.9366E+02	1847E+03
28	0.000000E+00	0.1968E+01	0.1968E+01	2.4791	3.0400	0.22029	1.3934	0.9366E+02	1847E+03
29	0.000000E+00	0.2754E+01	0.2754E+01	-4.0676	4.2286	0.18038	1.3878	0.9399E+02	2575E+03
30	0.000000E+00	0.2754E+01	0.2754E+01	-4.0676	4.2286	0.18038	1.3878	0.9399E+02	2575E+03
31	0.000000E+00	0.2754E+01	0.2754E+01	-4.0676	4.2286	0.18038	1.3878	0.9399E+02	2575E+03
32	0.000000E+00	0.2754E+01	0.2754E+01	-4.0676	4.2286	0.18038	1.3878	0.9399E+02	2575E+03
33	0.000000E+00	0.2754E+01	0.2754E+01	-4.0676	4.2286	0.18038	1.3878	0.9399E+02	2575E+03
34	0.000000E+00	0.2754E+01	0.2754E+01	-4.0676	4.2286	0.18038	1.3878	0.9399E+02	2575E+03
35	0.000000E+00	0.2754E+01	0.2754E+01	-4.0676	4.2286	0.18038	1.3878	0.9399E+02	2575E+03
36	0.000000E+00	0.2754E+01	0.2754E+01	-4.0676	4.2286	0.18038	1.3878	0.9399E+02	2575E+03
37	0.000000E+00	0.3542E+01	0.3542E+01	-5.4218	5.4222	0.14030	1.4054	0.9467E+02	3353E+03
38	0.000000E+00	0.3542E+01	0.3542E+01	-5.4218	5.4222	0.14030	1.4054	0.9467E+02	3353E+03
39	0.000000E+00	0.3542E+01	0.3542E+01	-5.4218	5.4222	0.14030	1.4054	0.9467E+02	3353E+03
40	0.000000E+00	0.3542E+01	0.3542E+01	-5.4218	5.4222	0.14030	1.4054	0.9467E+02	3353E+03
41	0.000000E+00	0.3542E+01	0.3542E+01	-5.4218	5.4222	0.14030	1.4054	0.9467E+02	3353E+03
42	0.000000E+00	0.3542E+01	0.3542E+01	-5.4218	5.4222	0.14030	1.4054	0.9467E+02	3353E+03
43	0.000000E+00	0.3542E+01	0.3542E+01	-5.4218	5.4222	0.14030	1.4054	0.9467E+02	3353E+03
44	0.000000E+00	0.4328E+01	0.4328E+01	-6.3663	6.3663	0.10013	1.4596	0.9832E+02	4256E+03
45	0.000000E+00	0.4328E+01	0.4328E+01	-6.3663	6.3663	0.10013	1.4596	0.9832E+02	4256E+03
46	0.000000E+00	0.4328E+01	0.4328E+01	-6.3663	6.3663	0.10013	1.4596	0.9832E+02	4256E+03
47	0.000000E+00	0.4328E+01	0.4328E+01	-6.3663	6.3663	0.10013	1.4596	0.9832E+02	4256E+03
48	0.000000E+00	0.4328E+01	0.4328E+01	-6.3663	6.3663	0.10013	1.4596	0.9832E+02	4256E+03
49	0.000000E+00	0.4328E+01	0.4328E+01	-6.3663	6.3663	0.10013	1.4596	0.9832E+02	4256E+03
50	0.000000E+00	0.4328E+01	0.4328E+01	-6.3663	6.3663	0.10013	1.4596	0.9832E+02	4256E+03
51	0.000000E+00	0.4328E+01	0.4328E+01	-6.3663	6.3663	0.10013	1.4596	0.9832E+02	4256E+03
52	0.000000E+00	0.5115E+01	0.5115E+01	-7.5179	7.5179	0.10014	1.4596	0.9832E+02	4256E+03
53	0.000000E+00	0.5115E+01	0.5115E+01	-7.5179	7.5179	0.10014	1.4596	0.9832E+02	4256E+03
54	0.000000E+00	0.5115E+01	0.5115E+01	-7.5179	7.5179	0.10014	1.4596	0.9832E+02	4256E+03
55	0.000000E+00	0.5115E+01	0.5115E+01	-7.5179	7.5179	0.10014	1.4596	0.9832E+02	4256E+03
56	0.000000E+00	0.5115E+01	0.5115E+01	-7.5179	7.5179	0.10014	1.4596	0.9832E+02	4256E+03
57	0.000000E+00	0.5115E+01	0.5115E+01	-7.5179	7.5179	0.10014	1.4596	0.9832E+02	4256E+03
58	0.000000E+00	0.5115E+01	0.5115E+01	-7.5179	7.5179	0.10014	1.4596	0.9832E+02	4256E+03
59	0.000000E+00	0.5115E+01	0.5115E+01	-7.5179	7.5179	0.10014	1.4596	0.9832E+02	4256E+03
60	0.000000E+00	0.5902E+01	0.5902E+01	-8.7246	8.7246	0.01970	2.3330	0.1572E+03	5276E+03
61	0.000000E+00	0.5902E+01	0.5902E+01	-8.7246	8.7246	0.01970	2.3330	0.1572E+03	5276E+03
62	0.000000E+00	0.5902E+01	0.5902E+01	-8.7246	8.7246	0.01970	2.3330	0.1572E+03	5276E+03
63	0.000000E+00	0.5902E+01	0.5902E+01	-8.7246	8.7246	0.01970	2.3330	0.1572E+03	5276E+03
64	0.000000E+00	0.5902E+01	0.5902E+01	-8.7246	8.7246	0.01970	2.3330	0.1572E+03	5276E+03
65	0.000000E+00	0.5902E+01	0.5902E+01	-8.7246	8.7246	0.01970	2.3330	0.1572E+03	5276E+03
66	0.000000E+00	0.5902E+01	0.5902E+01	-8.7246	8.7246	0.01970	2.3330	0.1572E+03	5276E+03
67	0.000000E+00	0.5902E+01	0.5902E+01	-8.7246	8.7246	0.01970	2.3330	0.1572E+03	5276E+03
68	0.000000E+00	0.5902E+01	0.5902E+01	-8.7246	8.7246	0.01970	2.3330	0.1572E+03	5276E+03

FX= 0.000000E+00 FD= 0.3196502E+05 FN= 0.4791352E-02 SMV= 0.8532471E-01 SMZ= 0.0000000E+00
 CX= 0.00000000 CD= 1.0489461 CN= 0.00000002 MX= 0.00000001 MZ= 0.00000000
 STEP 10 DEPTH = 10.6800900 TIME = 0.0072536 DIMENSIONLESS TIME 0.3626781 WEITING FACTORS = 1.2407800 1.2407800
 AVERAGE VELOCITY 0.000 -1200.000 WX 0.00ORIENTATION 90.000

NO.	REF. NO.	MOD	AREA	X	Y	Z	T*	CP	P	FORCE
1	1	0	5513E-02	0.0295	-0.0711	0.1200	0.35865	1.6496	0.1111E+03	0.6126E+00
2	2	0	5513E-02	0.0711	-0.0295	0.1200	0.35865	1.6496	0.1111E+03	0.6126E+00
3	3	0	5513E-02	0.0295	0.0711	0.1200	0.35865	1.6496	0.1111E+03	0.6126E+00
4	4	0	3895E+00	0.1545	-0.7166	0.8072	0.33557	1.4950	0.1007E+03	0.3924E+02
5	5	0	3896E+00	0.4399	-0.4398	0.8072	0.33557	1.4950	0.1007E+03	0.3924E+02
6	6	0	3896E+00	0.7766	-0.1545	0.8072	0.33557	1.4950	0.1007E+03	0.3924E+02
7	7	0	3895E+00	0.7766	0.1545	0.8072	0.33557	1.4950	0.1007E+03	0.3924E+02
8	8	0	3896E+00	0.6583	0.4399	0.8072	0.33557	1.4950	0.1007E+03	0.3924E+02
9	9	0	3896E+00	0.1545	0.7166	0.8072	0.33557	1.4950	0.1007E+03	0.3924E+02
10	10	0	1180E+01	0.1572	-1.7956	1.8667	0.29999	1.4329	0.9652E+02	0.1139E+03
11	11	0	1180E+01	0.0171	-1.5223	1.8667	0.29999	1.4329	0.9652E+02	0.1139E+03
12	12	0	1180E+01	0.0171	-1.0171	1.8667	0.29999	1.4329	0.9652E+02	0.1139E+03
13	13	0	1180E+01	0.0171	-0.3572	1.8667	0.29999	1.4329	0.9652E+02	0.1139E+03
14	14	0	1180E+01	0.0171	0.3572	1.8667	0.29999	1.4329	0.9652E+02	0.1139E+03
15	15	0	1180E+01	0.0171	1.0171	1.8667	0.29999	1.4329	0.9652E+02	0.1139E+03
16	16	0	1180E+01	0.0171	1.5223	1.8667	0.29999	1.4329	0.9652E+02	0.1139E+03
17	17	0	1180E+01	0.0171	1.7956	1.8667	0.29999	1.4329	0.9652E+02	0.1139E+03
18	18	0	1180E+01	0.0171	1.9565	1.8667	0.29999	1.4329	0.9652E+02	0.1139E+03
19	19	0	1180E+01	0.0171	2.0171	1.8667	0.29999	1.4329	0.9652E+02	0.1139E+03
20	20	0	1180E+01	0.0171	2.0171	1.8667	0.29999	1.4329	0.9652E+02	0.1139E+03
21	21	0	1968E+01	0.2572	-2.9243	3.0400	0.26059	1.4023	0.9446E+02	0.1859E+03
22	22	0	1968E+01	0.4791	-2.4791	3.0400	0.26059	1.4023	0.9446E+02	0.1859E+03
23	23	0	1968E+01	0.6565	-2.4791	3.0400	0.26059	1.4023	0.9446E+02	0.1859E+03
24	24	0	1968E+01	0.9243	-1.5817	3.0400	0.26059	1.4023	0.9446E+02	0.1859E+03
25	25	0	1968E+01	0.9243	0.5817	3.0400	0.26059	1.4023	0.9446E+02	0.1859E+03
26	26	0	1968E+01	0.4791	1.5817	3.0400	0.26059	1.4023	0.9446E+02	0.1859E+03
27	27	0	1968E+01	0.2572	2.9243	3.0400	0.26059	1.4023	0.9446E+02	0.1859E+03
28	28	0	1968E+01	0.0676	4.0676	3.0400	0.26059	1.4023	0.9446E+02	0.1859E+03
29	29	0	2754E+01	0.8091	-2.9243	4.2224	0.22068	1.3906	0.9367E+02	0.2800E+03
30	30	0	2754E+01	0.3041	-4.484	4.2224	0.22068	1.3906	0.9367E+02	0.2800E+03
31	31	0	2754E+01	0.484	-4.2224	4.2224	0.22068	1.3906	0.9367E+02	0.2800E+03
32	32	0	2754E+01	0.676	-2.9243	4.2224	0.22068	1.3906	0.9367E+02	0.2800E+03
33	33	0	2754E+01	0.676	0.8091	4.2224	0.22068	1.3906	0.9367E+02	0.2800E+03
34	34	0	2754E+01	0.484	2.9243	4.2224	0.22068	1.3906	0.9367E+02	0.2800E+03
35	35	0	2754E+01	0.3041	4.484	4.2224	0.22068	1.3906	0.9367E+02	0.2800E+03
36	36	0	2754E+01	0.484	4.2224	4.2224	0.22068	1.3906	0.9367E+02	0.2800E+03
37	37	0	2754E+01	0.676	2.9243	4.2224	0.22068	1.3906	0.9367E+02	0.2800E+03
38	38	0	2754E+01	0.676	0.8091	4.2224	0.22068	1.3906	0.9367E+02	0.2800E+03
39	39	0	3542E+01	0.4218	-2.0375	5.4222	0.18059	1.3962	0.9405E+02	0.3331E+03
40	40	0	3542E+01	0.2159	-1.0375	5.4222	0.18059	1.3962	0.9405E+02	0.3331E+03
41	41	0	3542E+01	0.2159	0.0375	5.4222	0.18059	1.3962	0.9405E+02	0.3331E+03
42	42	0	3542E+01	0.4218	1.0375	5.4222	0.18059	1.3962	0.9405E+02	0.3331E+03
43	43	0	3542E+01	0.6545	2.0375	5.4222	0.18059	1.3962	0.9405E+02	0.3331E+03
44	44	0	3542E+01	0.6545	0.375	5.4222	0.18059	1.3962	0.9405E+02	0.3331E+03
45	45	0	3542E+01	0.4218	1.0375	5.4222	0.18059	1.3962	0.9405E+02	0.3331E+03
46	46	0	4329E+01	0.2662	-3.3971	6.6182	0.14043	1.4224	0.9581E+02	0.4147E+03
47	47	0	4329E+01	0.0662	-3.6062	6.6182	0.14043	1.4224	0.9581E+02	0.4147E+03
48	48	0	4329E+01	0.3971	-2.663	6.6182	0.14043	1.4224	0.9581E+02	0.4147E+03
49	49	0	4329E+01	0.5663	-1.2663	6.6182	0.14043	1.4224	0.9581E+02	0.4147E+03
50	50	0	4329E+01	0.5663	0.662	6.6182	0.14043	1.4224	0.9581E+02	0.4147E+03
51	51	0	4329E+01	0.3971	2.663	6.6182	0.14043	1.4224	0.9581E+02	0.4147E+03
52	52	0	4329E+01	0.2662	3.6062	6.6182	0.14043	1.4224	0.9581E+02	0.4147E+03
53	53	0	5115E+01	1.4954	-6.5179	7.8154	0.10023	1.4823	0.9985E+02	0.5108E+03
54	54	0	5115E+01	0.5586	-7.5174	7.8154	0.10023	1.4823	0.9985E+02	0.5108E+03
55	55	0	5115E+01	0.5586	-4.5174	7.8154	0.10023	1.4823	0.9985E+02	0.5108E+03
56	56	0	5115E+01	0.3179	-1.5179	7.8154	0.10023	1.4823	0.9985E+02	0.5108E+03
57	57	0	5115E+01	0.3179	0.586	7.8154	0.10023	1.4823	0.9985E+02	0.5108E+03
58	58	0	5115E+01	0.5179	1.5179	7.8154	0.10023	1.4823	0.9985E+02	0.5108E+03
59	59	0	5115E+01	0.3179	2.5174	7.8154	0.10023	1.4823	0.9985E+02	0.5108E+03
60	60	0	5902E+01	0.4954	-7.5174	9.0133	0.06000	1.6852	0.1135E+03	0.6700E+03
61	61	0	5902E+01	0.2416	-8.5174	9.0133	0.06000	1.6852	0.1135E+03	0.6700E+03
62	62	0	5902E+01	0.2416	-7.5174	9.0133	0.06000	1.6852	0.1135E+03	0.6700E+03
63	63	0	5902E+01	0.4954	-4.5174	9.0133	0.06000	1.6852	0.1135E+03	0.6700E+03
64	64	0	5902E+01	0.4954	-1.7246	9.0133	0.06000	1.6852	0.1135E+03	0.6700E+03

65	0.000000E+00	FD=	0.3997372E+05	FN=	0.2332501E-03	SNX=	-0.2365194E-01	SMY=	0.0000000E+00	SMZ=	0.0000000E+00
66	0.00000000	CD=	1.3117551	CN=	0.00000000	MX=	0.00000000	MY=	0.00000000	MZ=	0.00000000
67	8.6703				9.0133				0.05000		0.1135E+03
68	7.3503				9.0133				0.06000		0.1135E+03
69	4.9113				9.0133				0.06000		0.1135E+03
70	1.7246				10.2118				0.01976		0.1559E+03
71	5.5644				10.2118				0.01976		0.1559E+03
72	8.3276				10.2118				0.01976		0.1559E+03
73	9.8231				10.2118				0.01976		0.1559E+03
74	8.3276				10.2118				0.01976		0.1559E+03
75	5.5644				10.2118				0.01976		0.1559E+03
76	1.9540				10.2118				0.01976		0.1559E+03

STEP 11 DEPTH = 11.8801000 TIME = 0.0080595 DIMENSIONLESS TIME 0.4029757 WEITING FACTORS = 1.2407800 1.2407800
 AVERAGE VELOCITY 0.000 MOD

NO.	REF.NO.	MOD	AREA	X	Y	Z	T*	CP	P	FORCE
1	1	0	0.5513E-02	0.0295	-0.0711	0.1200	0.39895	1.5156	0.1021E+03	0.5628E+00
2	2	0	0.5513E-02	0.0711	-0.0295	0.1200	0.39895	1.5156	0.1021E+03	0.5628E+00
3	3	0	0.5513E-02	0.0295	0.0711	0.1200	0.39895	1.5156	0.1021E+03	0.5628E+00
4	4	0	0.3895E+00	0.1545	-0.7766	0.8072	0.37587	1.3645	0.9191E+02	0.3580E+02
5	5	0	0.3895E+00	0.4399	-0.6583	0.8072	0.37587	1.3645	0.9191E+02	0.3580E+02
6	6	0	0.3895E+00	0.6583	-0.4399	0.8072	0.37587	1.3645	0.9191E+02	0.3580E+02
7	7	0	0.3895E+00	0.7766	-0.1545	0.8072	0.37587	1.3645	0.9191E+02	0.3580E+02
8	8	0	0.3895E+00	0.7766	0.1545	0.8072	0.37587	1.3645	0.9191E+02	0.3580E+02
9	9	0	0.3895E+00	0.6583	0.4399	0.8072	0.37587	1.3645	0.9191E+02	0.3580E+02
10	10	0	0.3895E+00	0.4399	0.6583	0.8072	0.37587	1.3645	0.9191E+02	0.3580E+02
11	11	0	0.3895E+00	0.1545	0.7766	0.8072	0.37587	1.3645	0.9191E+02	0.3580E+02
12	12	0	0.1180E+01	0.1545	-1.7956	0.8072	0.34029	1.2959	0.8229E+02	0.1030E+03
13	13	0	0.1180E+01	0.3572	-1.5223	1.8667	0.34029	1.2959	0.8229E+02	0.1030E+03
14	14	0	0.1180E+01	0.1711	-1.5223	1.8667	0.34029	1.2959	0.8229E+02	0.1030E+03
15	15	0	0.1180E+01	1.5223	-1.0171	1.8667	0.34029	1.2959	0.8229E+02	0.1030E+03
16	16	0	0.1180E+01	1.7956	-0.3572	1.8667	0.34029	1.2959	0.8229E+02	0.1030E+03
17	17	0	0.1180E+01	1.5223	0.10171	1.8667	0.34029	1.2959	0.8229E+02	0.1030E+03
18	18	0	0.1180E+01	1.0171	1.5223	1.8667	0.34029	1.2959	0.8229E+02	0.1030E+03
19	19	0	0.1180E+01	0.1711	1.7956	1.8667	0.34029	1.2959	0.8229E+02	0.1030E+03
20	20	0	0.1968E+01	0.3572	-2.9243	3.0400	0.30089	1.2315	0.8430E+02	0.1659E+03
21	21	0	0.1968E+01	0.5817	-2.4791	3.0400	0.30089	1.2315	0.8430E+02	0.1659E+03
22	22	0	0.1968E+01	1.6565	-1.6565	3.0400	0.30089	1.2315	0.8430E+02	0.1659E+03
23	23	0	0.1968E+01	2.4791	-0.5817	3.0400	0.30089	1.2315	0.8430E+02	0.1659E+03
24	24	0	0.1968E+01	2.9243	0.5817	3.0400	0.30089	1.2315	0.8430E+02	0.1659E+03
25	25	0	0.1968E+01	2.4791	1.6565	3.0400	0.30089	1.2315	0.8430E+02	0.1659E+03
26	26	0	0.1968E+01	1.6565	2.4791	3.0400	0.30089	1.2315	0.8430E+02	0.1659E+03
27	27	0	0.1968E+01	0.5817	2.9243	3.0400	0.30089	1.2315	0.8430E+02	0.1659E+03
28	28	0	0.2754E+01	0.8091	-4.0676	4.2286	0.26098	1.1977	0.8219E+02	0.2264E+03
29	29	0	0.2754E+01	3.041	-3.4484	4.2286	0.26098	1.1977	0.8219E+02	0.2264E+03
30	30	0	0.2754E+01	2.3041	-2.3041	4.2286	0.26098	1.1977	0.8219E+02	0.2264E+03
31	31	0	0.2754E+01	4.0676	-0.8091	4.2286	0.26098	1.1977	0.8219E+02	0.2264E+03
32	32	0	0.2754E+01	4.0676	0.8091	4.2286	0.26098	1.1977	0.8219E+02	0.2264E+03
33	33	0	0.2754E+01	3.4484	2.3041	4.2286	0.26098	1.1977	0.8219E+02	0.2264E+03
34	34	0	0.2754E+01	2.3041	3.4484	4.2286	0.26098	1.1977	0.8219E+02	0.2264E+03
35	35	0	0.2754E+01	0.8091	4.0676	4.2286	0.26098	1.1977	0.8219E+02	0.2264E+03
36	36	0	0.3541E+01	0.8091	-5.2158	5.4222	0.22089	1.1977	0.8068E+02	0.2857E+03
37	37	0	0.3541E+01	2.9545	-4.4218	5.4222	0.22089	1.1977	0.8068E+02	0.2857E+03
38	38	0	0.3541E+01	4.4218	-2.9545	5.4222	0.22089	1.1977	0.8068E+02	0.2857E+03
39	39	0	0.3541E+01	5.2158	-1.0375	5.4222	0.22089	1.1977	0.8068E+02	0.2857E+03
40	40	0	0.3541E+01	5.2158	1.0375	5.4222	0.22089	1.1977	0.8068E+02	0.2857E+03
41	41	0	0.3541E+01	4.4218	2.9545	5.4222	0.22089	1.1977	0.8068E+02	0.2857E+03
42	42	0	0.3541E+01	2.9545	4.4218	5.4222	0.22089	1.1977	0.8068E+02	0.2857E+03
43	43	0	0.3541E+01	1.0375	5.2158	5.4222	0.22089	1.1977	0.8068E+02	0.2857E+03
44	44	0	0.3541E+01	1.0375	4.4218	5.4222	0.22089	1.1977	0.8068E+02	0.2857E+03

45	0.000000E+00	FD=	0.3974394E+05	FN=	-0.5387968E-02	SMX=	-0.9018519E-01	SMW=	0.0000000E+00	SMZ=	0.0000000E+00
46	0.000000E+00	CD=	1.3042148	CF=	-0.0000002	MX=	-0.0000001	MY=	0.0000000	MZ=	0.0000000
47	0.000000E+00										
48	0.000000E+00										
49	0.000000E+00										
50	0.000000E+00										
51	0.000000E+00										
52	0.000000E+00										
53	0.000000E+00										
54	0.000000E+00										
55	0.000000E+00										
56	0.000000E+00										
57	0.000000E+00										
58	0.000000E+00										
59	0.000000E+00										
60	0.000000E+00										
61	0.000000E+00										
62	0.000000E+00										
63	0.000000E+00										
64	0.000000E+00										
65	0.000000E+00										
66	0.000000E+00										
67	0.000000E+00										
68	0.000000E+00										
69	0.000000E+00										
70	0.000000E+00										
71	0.000000E+00										
72	0.000000E+00										
73	0.000000E+00										
74	0.000000E+00										
75	0.000000E+00										
76	0.000000E+00										
77	0.000000E+00										
78	0.000000E+00										
79	0.000000E+00										
80	0.000000E+00										
81	0.000000E+00										
82	0.000000E+00										
83	0.000000E+00										
84	0.000000E+00										

APPENDIX C
SAMPLE ABAQUS INPUT FILE
CON90.IN

*HEADING
 C0-D BLUNTED FIBERITE CONE (12-IN LONG, 0.1-IN THICK)
 ** NEUTRAL FILE GENERATED ON: 24-AUG-89 17:20:26 PATABA VERSION: 3.0

**
 ** NODE DEFINITIONS
 **

*NODE

1,	0.00000000E+00,	-0.119999997E+00,	0.119999997E+00
2,	0.459220074E-01,	-0.110865541E+00,	0.119999997E+00
3,	0.848527998E-01,	-0.848528072E-01,	0.119999997E+00
4,	0.00000000E+00,	-0.120000017E+01,	0.120000017E+01
5,	0.459220171E+00,	-0.110865557E+01,	0.120000005E+01
6,	0.848528504E+00,	-0.848528266E+00,	0.120000017E+01
7,	0.110865526E+00,	-0.459220074E-01,	0.120000012E+00
8,	0.119999990E+00,	0.000000000E+00,	0.120000005E+00
9,	0.110865569E+01,	-0.459220231E+00,	0.120000005E+01
10,	0.120000017E+01,	0.000000000E+00,	0.120000017E+01
11,	0.110865541E+00,	0.459220111E-01,	0.120000005E+00
12,	0.848527998E-01,	0.848528147E-01,	0.119999997E+00
13,	0.110865557E+01,	0.459220141E+00,	0.120000005E+01
14,	0.848528028E+00,	0.848528326E+00,	0.120000017E+01
15,	0.459220074E-01,	0.110865548E+00,	0.119999997E+00
16,	0.000000000E+00,	0.119999997E+00,	0.119999997E+00
17,	0.459220141E+00,	0.110865569E+01,	0.120000005E+01
18,	0.000000000E+00,	0.120000017E+01,	0.120000017E+01
19,	0.000000000E+00,	-0.240000010E+01,	0.240000010E+01
20,	0.918440223E+00,	-0.221731091E+01,	0.239999986E+01
21,	0.169705665E+01,	-0.169705629E+01,	0.240000010E+01
22,	0.221731114E+01,	-0.918440163E+00,	0.239999986E+01
23,	0.240000033E+01,	0.000000000E+00,	0.240000010E+01
24,	0.221731091E+01,	0.918440104E+00,	0.239999986E+01
25,	0.169705617E+01,	0.169705629E+01,	0.240000010E+01
26,	0.918439984E+00,	0.221731091E+01,	0.239999986E+01
27,	0.000000000E+00,	0.240000010E+01,	0.240000010E+01
28,	0.000000000E+00,	-0.360000014E+01,	0.360000014E+01
29,	0.137766027E+01,	-0.332596660E+01,	0.360000014E+01
30,	0.254558420E+01,	-0.254558444E+01,	0.360000014E+01
31,	0.332596636E+01,	-0.137766027E+01,	0.360000062E+01
32,	0.360000014E+01,	0.000000000E+00,	0.360000038E+01
33,	0.332596636E+01,	0.137766063E+01,	0.360000038E+01
34,	0.254558444E+01,	0.254558444E+01,	0.360000014E+01
35,	0.137766016E+01,	0.332596660E+01,	0.360000014E+01
36,	0.000000000E+00,	0.360000014E+01,	0.360000014E+01
37,	0.000000000E+00,	-0.480000019E+01,	0.480000019E+01
38,	0.183688033E+01,	-0.443462181E+01,	0.479999971E+01
39,	0.339411306E+01,	-0.339411259E+01,	0.480000019E+01
40,	0.443462229E+01,	-0.183688056E+01,	0.479999971E+01
41,	0.480000067E+01,	0.000000000E+00,	0.480000019E+01
42,	0.443462181E+01,	0.183688021E+01,	0.479999971E+01
43,	0.339411211E+01,	0.339411235E+01,	0.480000019E+01
44,	0.183688009E+01,	0.443462181E+01,	0.479999971E+01
45,	0.000000000E+00,	0.480000019E+01,	0.480000019E+01
46,	0.000000000E+00,	-0.600000048E+01,	0.600000048E+01
47,	0.229610062E+01,	-0.554327726E+01,	0.600000048E+01
48,	0.424264002E+01,	-0.424264097E+01,	0.600000048E+01
49,	0.554327726E+01,	-0.229610062E+01,	0.600000095E+01
50,	0.600000000E+01,	0.000000000E+00,	0.600000095E+01
51,	0.554327726E+01,	0.229610062E+01,	0.600000048E+01
52,	0.424264050E+01,	0.424264097E+01,	0.600000048E+01
53,	0.229610014E+01,	0.554327774E+01,	0.600000048E+01
54,	0.000000000E+00,	0.600000048E+01,	0.600000048E+01
55,	0.000000000E+00,	-0.720000076E+01,	0.720000076E+01
56,	0.275532103E+01,	-0.665193319E+01,	0.719999981E+01
57,	0.509116983E+01,	-0.509116936E+01,	0.720000076E+01
58,	0.665193272E+01,	-0.275532055E+01,	0.720000124E+01
59,	0.720000029E+01,	0.000000000E+00,	0.720000124E+01

60,	0.665193272E+01,	0.275532103E+01,	0.720000124E+01
61,	0.509116888E+01,	0.509116936E+01,	0.720000076E+01
62,	0.275532031E+01,	0.665193319E+01,	0.719999981E+01
63,	0.000000000E+00,	0.720000076E+01,	0.720000076E+01
64,	0.000000000E+00,	-0.840000057E+01,	0.840000057E+01
65,	0.321454024E+01,	-0.776058865E+01,	0.840000057E+01
66,	0.593969679E+01,	-0.593969727E+01,	0.840000057E+01
67,	0.776058865E+01,	-0.321454072E+01,	0.840000057E+01
68,	0.840000153E+01,	0.000000000E+00,	0.840000057E+01
69,	0.776058817E+01,	0.321454096E+01,	0.840000057E+01
70,	0.593969679E+01,	0.593969774E+01,	0.840000057E+01
71,	0.321454048E+01,	0.776058865E+01,	0.840000057E+01
72,	0.000000000E+00,	0.840000057E+01,	0.840000057E+01
73,	0.000000000E+00,	-0.960000038E+01,	0.960000038E+01
74,	0.367376065E+01,	-0.886924362E+01,	0.959999943E+01
75,	0.678822517E+01,	-0.678822517E+01,	0.960000038E+01
76,	0.886924458E+01,	-0.367376113E+01,	0.959999943E+01
77,	0.960000134E+01,	0.000000000E+00,	0.960000038E+01
78,	0.886924362E+01,	0.367376065E+01,	0.959999943E+01
79,	0.678822422E+01,	0.678822565E+01,	0.960000038E+01
80,	0.367375994E+01,	0.886924362E+01,	0.959999943E+01
81,	0.000000000E+00,	0.960000038E+01,	0.960000038E+01
82,	0.000000000E+00,	-0.108000002E+02,	0.108000002E+02
83,	0.413298035E+01,	-0.997789955E+01,	0.108000002E+02
84,	0.763675261E+01,	-0.763675308E+01,	0.108000002E+02
85,	0.997789860E+01,	-0.413298082E+01,	0.108000002E+02
86,	0.10800011E+02,	0.000000000E+00,	0.108000002E+02
87,	0.997789955E+01,	0.413298082E+01,	0.108000002E+02
88,	0.763675213E+01,	0.763675356E+01,	0.108000002E+02
89,	0.413298035E+01,	0.997789955E+01,	0.108000002E+02
90,	0.000000000E+00,	0.108000002E+02,	0.108000002E+02
91,	0.000000000E+00,	-0.120000000E+02,	0.120000000E+02
92,	0.459220076E+01,	-0.110865545E+02,	0.120000000E+02
93,	0.848528194E+01,	-0.848528099E+01,	0.120000000E+02
94,	0.110865536E+02,	-0.459220123E+01,	0.120000000E+02
95,	0.119999990E+02,	0.000000000E+00,	0.120000010E+02
96,	0.110865536E+02,	0.459220171E+01,	0.120000010E+02
97,	0.848528004E+01,	0.848528099E+01,	0.120000000E+02
98,	0.459220028E+01,	0.110865545E+02,	0.120000000E+02
99,	0.000000000E+00,	0.120000000E+02,	0.120000000E+02
100,	0.000000000E+00,	0.000000000E+00,	0.119999997E+00

*NSET, NSET=SYMLT, GENERATE

19, 91, 9

*NSET, NSET=SYMRT, GENERATE

18, 99, 3

*NSET, NSET=SYMALL

1, 4, 16, 100, SYMLT, SYMRT

*NSET, NSET=BASE, GENERATE

91, 99, 1

*BOUNDARY

SYMALL, XSYMM

BASE, 3

**

** ELEMENT DEFINITIONS

**

*ELEMENT, TYPE=S4R5, ELSET=ALL

1,	100,	3,	2,	1
2,	100,	8,	7,	3
3,	100,	12,	11,	8
4,	100,	16,	15,	12
5,	1,	2,	5,	4
6,	2,	3,	6,	5
7,	3,	7,	9,	6
8,	7,	8,	10,	9
9,	8,	11,	13,	10
10,	11,	12,	14,	13

11,	13,	15,	17,	14,
12,	14,	16,	18,	15,
13,	15,	17,	19,	16,
14,	16,	18,	20,	17,
15,	17,	19,	21,	18,
16,	18,	20,	22,	19,
17,	19,	21,	23,	20,
18,	20,	22,	24,	21,
19,	21,	23,	25,	22,
20,	22,	24,	26,	23,
21,	23,	25,	27,	24,
22,	24,	26,	28,	25,
23,	25,	27,	29,	26,
24,	26,	28,	30,	27,
25,	27,	29,	31,	28,
26,	28,	30,	32,	29,
27,	29,	31,	33,	30,
28,	30,	32,	34,	31,
29,	31,	33,	35,	32,
30,	32,	34,	36,	33,
31,	33,	35,	37,	34,
32,	34,	36,	38,	35,
33,	35,	37,	39,	36,
34,	36,	38,	40,	37,
35,	37,	39,	41,	38,
36,	38,	40,	42,	39,
37,	39,	41,	43,	40,
38,	40,	42,	44,	41,
39,	41,	43,	45,	42,
40,	42,	44,	46,	43,
41,	43,	45,	47,	44,
42,	44,	46,	48,	45,
43,	45,	47,	49,	46,
44,	46,	48,	50,	47,
45,	47,	49,	51,	48,
46,	48,	50,	52,	49,
47,	49,	51,	53,	50,
48,	50,	52,	54,	51,
49,	51,	53,	55,	52,
50,	52,	54,	56,	53,
51,	53,	55,	57,	54,
52,	54,	56,	58,	55,
53,	55,	57,	59,	56,
54,	56,	58,	60,	57,
55,	57,	59,	61,	58,
56,	58,	60,	62,	59,
57,	59,	61,	63,	60,
58,	60,	62,	64,	61,
59,	61,	63,	65,	62,
60,	62,	64,	66,	63,
61,	63,	65,	67,	64,
62,	64,	66,	68,	65,
63,	65,	67,	69,	66,
64,	66,	68,	70,	67,
65,	67,	69,	71,	68,
66,	68,	70,	72,	69,
67,	69,	71,	73,	70,
68,	70,	72,	74,	71,
69,	71,	73,	75,	72,
70,	72,	74,	76,	73,
71,	73,	75,	77,	74,
72,	74,	76,	78,	75,
73,	75,	77,	79,	76,
74,	76,	78,	80,	77,
75,	77,	79,	81,	78,
76,	78,	80,		79,
	79,	81,		80,
	80,			81,
	81,			82,
				83,
				84,
				85,
				86,
				87,
				88,
				89,
				90,

77,	82,	83,	92,	91
78,	83,	84,	93,	92
79,	84,	85,	94,	93
80,	85,	86,	95,	94
81,	86,	87,	96,	95
82,	87,	88,	97,	96
83,	88,	89,	98,	97
84,	89,	90,	99,	98

*ELSET, ELSET=ELG1, GENERATE
1, 4
*ELSET, ELSET=ELG2, GENERATE
5, 12
*ELSET, ELSET=ELG3, GENERATE
13, 20
*ELSET, ELSET=ELG4, GENERATE
21, 28
*ELSET, ELSET=ELG5, GENERATE
29, 36
*ELSET, ELSET=ELG6, GENERATE
37, 44
*ELSET, ELSET=ELG7, GENERATE
45, 52
*ELSET, ELSET=ELG8, GENERATE
53, 60
*ELSET, ELSET=ELG9, GENERATE
61, 68
*ELSET, ELSET=ELG10, GENERATE
69, 76
*ELSET, ELSET=ELG11, GENERATE
77, 84
*SHELL SECTION, ELSET=ALL, MATERIAL=FIBERITE
0, 1, 3
*MATERIAL, NAME=FIBERITE
*ELASTIC
1.9E+06, 0.28, 72.
*DENSITY
1.682E-4
**
** TIME-VARYING PRESSURE LOADS ON Q-SHELL ELEMENTS
**
*AMPLITUDE, NAME=ELG1, TIME=D, VALUE=A
1.612E-04-2.409E+01 8.060E-04-1.289E+02 1.612E-03-1.059E+02 2.418E-03-1.089E+02
3.224E-03-1.099E+02 4.030E-03-1.104E+02 4.836E-03-1.107E+02 5.642E-03-1.109E+02
6.448E-03-1.110E+02 7.254E-03-1.111E+02 8.059E-03-1.021E+02
*AMPLITUDE, NAME=ELG2, TIME=D, VALUE=A
1.612E-04 0.000E+00 8.060E-04-1.314E+02 1.612E-03-9.566E+01 2.418E-03-9.332E+01
3.224E-03-9.542E+01 4.030E-03-9.704E+01 4.836E-03-9.828E+01 5.642E-03-9.925E+01
6.448E-03-1.000E+02 7.254E-03-1.007E+02 8.059E-03-9.191E+01
*AMPLITUDE, NAME=ELG3, TIME=D, VALUE=A
1.612E-04 0.000E+00 8.060E-04 0.000E+00 1.612E-03-1.355E+02 2.418E-03-9.612E+01
3.224E-03-9.169E+01 4.030E-03-9.267E+01 4.836E-03-9.383E+01 5.642E-03-9.486E+01
6.448E-03-9.574E+01 7.254E-03-9.652E+01 8.059E-03-8.729E+01
*AMPLITUDE, NAME=ELG4, TIME=D, VALUE=A
1.612E-04 0.000E+00 8.060E-04 0.000E+00 1.612E-03 0.000E+00 2.418E-03-1.459E+02
3.224E-03-1.003E+02 4.030E-03-9.315E+01 4.836E-03-9.284E+01 5.642E-03-9.327E+01
6.448E-03-9.386E+01 7.254E-03-9.446E+01 8.059E-03-8.430E+01
*AMPLITUDE, NAME=ELG5, TIME=D, VALUE=A
1.612E-04 0.000E+00 8.060E-04 0.000E+00 1.612E-03 0.000E+00 2.418E-03 0.000E+00
3.224E-03-1.521E+02 4.030E-03-1.038E+02 4.836E-03-9.489E+01 5.642E-03-9.364E+01
6.448E-03-9.349E+01 7.254E-03-9.367E+01 8.059E-03-8.219E+01
*AMPLITUDE, NAME=ELG6, TIME=D, VALUE=A
1.612E-04 0.000E+00 8.060E-04 0.000E+00 1.612E-03 0.000E+00 2.418E-03 0.000E+00
3.224E-02 0.000E+00 4.030E-03-1.556E+02 4.836E-03-1.068E+02 5.642E-03-9.664E+01
6.448E-03-9.467E+01 7.254E-03-9.405E+01 8.059E-03-8.068E+01
*AMPLITUDE, NAME=ELG7, TIME=D, VALUE=A
1.612E-04 0.000E+00 8.060E-04 0.000E+00 1.612E-03 0.000E+00 2.418E-03 0.000E+00

```

3.224E-03 0.000E+00 4.030E-03 0.000E+00 4.836E-03-1.573E+02 5.642E-03-1.094E+02
6.448E-03-9.832E+01 7.254E-03-9.581E+01 8.059E-03-7.965E+01
*AMPLITUDE, NAME=ELG8, TIME=D, VALUE=A
1.612E-04 0.000E+00 8.060E-04 0.000E+00 1.612E-03 0.000E+00 2.418E-03 0.000E+00
3.224E-03 0.000E+00 4.030E-03 0.000E+00 4.836E-03 0.000E+00 5.642E-03-1.577E+02
6.448E-03-1.116E+02 7.254E-03-9.985E+01 8.059E-03-7.923E+01
*AMPLITUDE, NAME=ELG9, TIME=D, VALUE=A
1.612E-04 0.000E+00 8.060E-04 0.000E+00 1.612E-03 0.000E+00 2.418E-03 0.000E+00
3.224E-03 0.000E+00 4.030E-03 0.000E+00 4.836E-03 0.000E+00 5.642E-03 0.000E+00
6.448E-03-1.572E+02 7.254E-03-1.135E+02 8.059E-03-7.959E+01
*AMPLITUDE, NAME=ELG10, TIME=D, VALUE=A
1.612E-04 0.000E+00 8.060E-04 0.000E+00 1.612E-03 0.000E+00 2.418E-03 0.000E+00
3.224E-03 0.000E+00 4.030E-03 0.000E+00 4.836E-03 0.000E+00 5.642E-03 0.000E+00
6.448E-03 0.000E+00 7.254E-03-1.559E+02 8.059E-03-8.655E+01
*AMPLITUDE, NAME=ELG11, TIME=D, VALUE=A
1.612E-04 0.000E+00 8.060E-04 0.000E+00 1.612E-03 0.000E+00 2.418E-03 0.000E+00
3.224E-03 0.000E+00 4.030E-03 0.000E+00 4.836E-03 0.000E+00 5.642E-03 0.000E+00
6.448E-03 0.000E+00 7.254E-03 0.000E+00 8.059E-03-1.247E+02
*STEP, AMPLITUDE=RAMP, LINEAR, INC= 1, CYCLE=1
TRANSIENT RESPONSE TO FIRST STEP OF 100 FT/SEC VERTICAL WATER-ENTRY PRESSURE
*DYNAMIC
1.6120E-04, 1.6120E-04
*DLOAD, AMPLITUDE=ELG1
ELG1, P, 1.
*EL FILE, POSITION=AVERAGED AT NODES
S
SINV
*EL PRINT, POSITION=AVERAGED AT NODES
S
SINV
*NODE FILE, GLOBAL=YES
U
*NODE PRINT, GLOBAL=YES
U
*FILE FORMAT, ASCII
*END STEP
*STEP, AMPLITUDE=RAMP, LINEAR, INC= 1, CYCLE= 1
TRANSIENT RESPONSE TO 2ND STEP OF WATER-ENTRY PRESSURE
*DYNAMIC
6.4480E-04, 6.4480E-04
*DLOAD, AMPLITUDE=ELG1
ELG1, P, 1.
*DLOAD, AMPLITUDE=ELG2
ELG2, P, 1.
*EL FILE, POSITION=AVERAGED AT NODES
S
SINV
*EL PRINT, POSITION=AVERAGED AT NODES
S
SINV
*NODE FILE, GLOBAL=YES
U
*NODE PRINT, GLOBAL=YES
U
*FILE FORMAT, ASCII
*END STEP
*STEP, AMPLITUDE=RAMP, LINEAR, INC= 5, CYCLE= 1
TRANSIENT RESPONSE TO 5 SUBSEQUENT STEPS OF WATER-ENTRY PRESSURES
*DYNAMIC
8.0600E-04, 4.0300E-03
*DLOAD, AMPLITUDE=ELG1
ELG1, P, 1.
*DLOAD, AMPLITUDE=ELG2
ELG2, P, 1.
*DLOAD, AMPLITUDE=ELG3
ELG3, P, 1.

```

```
*DLOAD, AMPLITUDE=ELG4
ELG4, P, 1.
*DLOAD, AMPLITUDE=ELG5
ELG5, P, 1.
*DLOAD, AMPLITUDE=ELG6
ELG6, P, 1.
*DLOAD, AMPLITUDE=ELG7
ELG7, P, 1.
*EL FILE, POSITION=AVERAGED AT NODES
S
SINV
*EL PRINT, POSITION=AVERAGED AT NODES
S
SINV
*NODE FILE, GLOBAL=YES
U
*NODE PRINT, GLOBAL=YES
U
*FILE FORMAT, ASCII
*END STEP
```

APPENDIX D
ENTRY INPUT FILE
CAP90.IN;6

VARIABLE
 CAN'T PRINT
 SYMMETRIC

0.	29	13.1	1560.	90.	300.	0.
0.	25	0.67	0.	0		
0.0.	0.0.	0.0.	-1560.	0.0.	1.3710	0.09521
0.0.	0.0.	0.0.	-1560.	0.0.	1.2415	0.2566
0.0.	0.0.	0.0.	-1560.	0.0.	1.1990	0.6116
0.0.	0.0.	0.0.	-1560.	0.0.	1.1871	0.6297
0.0.	0.0.	0.0.	-1560.	0.0.	1.1757	0.6479
0.0.	0.0.	0.0.	-1560.	0.0.	1.1655	0.6639
0.0.	0.0.	0.0.	-1560.	0.0.	1.1564	0.6775
0.0.	0.0.	0.0.	-1560.	0.0.	1.1485	0.6891
0.0.	0.0.	0.0.	-1560.	0.0.	1.1417	0.6985
0.0.	0.0.	0.0.	-1560.	0.0.	1.1362	0.7055
0.0.	0.0.	0.0.	-1560.	0.0.	1.1320	0.7104
0.0.	0.0.	0.0.	-1560.	0.0.	1.1290	0.7131
0.0.	0.0.	0.0.	-1560.	0.0.	1.1274	0.7136
0.0.	0.0.	0.0.	-1560.	0.0.	1.1192	0.7119
0.0.	0.0.	0.0.	-1560.	0.0.	1.1083	0.6620
0.0.	0.0.	0.0.	-1560.	0.0.	1.1021	0.6667
0.0.	0.0.	0.0.	-1560.	0.0.	1.0993	0.6706
0.0.	0.0.	0.0.	-1560.	0.0.	1.0948	0.6302
0.0.	0.0.	0.0.	-1560.	0.0.	1.0870	0.8083
0.0.	0.0.	0.0.	-1560.	0.0.	1.0797	0.8127
0.0.	0.0.	0.0.	-1560.	0.0.	1.0695	0.8173
0.0.	0.0.	0.0.	-1560.	0.0.	1.0562	0.8221
0.0.	0.0.	0.0.	-1560.	0.0.	1.0396	0.8271
0.0.	0.0.	0.0.	-1560.	0.0.	1.0152	0.8325
0.0.	0.0.	0.0.	-1560.	0.0.	1.0000	0.7880

LIST 1

262	228	0.0000	0.0000
0.0000	-0.4263	0.0952	
0.1659	-0.3928	0.0952	
0.3015	-0.3015	0.0952	
0.3928	-0.1659	0.0952	
0.4263	0.0000	0.0952	
0.0000	-0.7615	0.3518	
0.2964	-0.7017	0.3518	
0.5385	-0.5385	0.3518	
0.7017	-0.2964	0.3518	
0.7615	0.0000	0.3518	
0.3928	0.1659	0.0952	
0.3015	0.3015	0.0952	
0.1659	0.3928	0.0952	
0.0000	0.4263	0.0952	
0.7017	0.2964	0.3518	
0.5385	0.5385	0.3518	
0.2964	0.7017	0.3518	
0.0000	0.7615	0.3518	
0.0000	-1.2262	0.9634	
0.4773	-1.1298	0.9634	
0.8670	-0.8670	0.9634	
1.1298	-0.4773	0.9634	
1.2262	0.0000	0.9634	
0.0000	-1.6605	1.5931	
0.6464	-1.5300	1.5931	
1.1742	-1.1742	1.5931	
1.5300	-0.6464	1.5931	
1.6605	0.0000	1.5931	
0.0000	-2.0659	2.2410	
0.8041	-1.9035	2.2410	
1.4608	-1.4608	2.2410	

1.9035	-0.8041	2.2410
2.0659	0.0000	2.2410
0.0000	-2.4451	2.9049
0.9517	-2.2530	2.9049
1.7289	-1.7289	2.9049
2.2530	-0.9517	2.9049
2.4451	0.0000	2.9049
0.0000	-2.8010	3.5824
1.0903	-2.5809	3.5824
1.9806	-1.9806	3.5824
2.5809	-1.0903	3.5824
2.8010	0.0000	3.5824
0.0000	-3.1366	4.2715
1.2209	-2.8901	4.2715
2.2179	-2.2179	4.2715
2.8901	-1.2209	4.2715
3.1366	0.0000	4.2715
0.0000	-3.4546	4.9700
1.3447	-3.1831	4.9700
2.4427	-2.4427	4.9700
3.1831	-1.3447	4.9700
3.4546	0.0000	4.9700
0.0000	-3.7578	5.6755
1.4627	-3.4625	5.6755
2.6572	-2.6572	5.6755
3.4625	-1.4627	5.6755
3.7578	0.0000	5.6755
0.0000	-4.0493	6.3859
1.5762	-3.7310	6.3859
2.8633	-2.8633	6.3859
3.7310	-1.5762	6.3859
4.0493	0.0000	6.3859
0.0000	-4.3317	7.0990
1.6861	-3.9913	7.0990
3.0630	-3.0630	7.0990
3.9913	-1.6861	7.0990
4.3317	0.0000	7.0990
0.0000	-4.6080	7.8126
1.7936	-4.2459	7.8126
3.2584	-3.2584	7.8126
4.2459	-1.7936	7.8126
4.6080	0.0000	7.8126
0.0000	-4.8811	8.5245
1.8999	-4.4975	8.5245
3.4514	-3.4514	8.5245
4.4975	-1.8999	8.5245
4.8811	0.0000	8.5245
1.1298	0.4773	0.9634
0.8670	0.8670	0.9634
0.4773	1.1298	0.9634
0.0000	1.2262	0.9634
1.5300	0.6464	1.5931
1.1742	1.1742	1.5931
0.6464	1.5300	1.5931
0.0000	1.6605	1.5931
1.9035	0.8041	2.2410
1.4608	1.4608	2.2410
0.8041	1.9035	2.2410
0.0000	2.0659	2.2410
2.2530	0.9517	2.9049
1.7289	1.7289	2.9049
0.9517	2.2530	2.9049
0.0000	2.4451	2.9049
2.5809	1.0903	3.5824
1.9806	1.9806	3.5824
1.0903	2.5809	3.5824

0.0000	2.8010	3.5824
2.8901	1.2209	4.2715
2.2179	2.2179	4.2715
1.2209	2.8901	4.2715
0.0000	3.1366	4.2715
3.1831	1.3447	4.9700
2.4427	2.4427	4.9700
1.3447	3.1831	4.9700
0.0000	3.4546	4.9700
3.4625	1.4627	5.6755
2.6572	2.6572	5.6755
1.4627	3.4625	5.6755
0.0000	3.7578	5.6755
3.7310	1.5762	6.3859
2.8633	2.8633	6.3859
1.5762	3.7310	6.3859
0.0000	4.0493	6.3859
3.9913	1.6861	7.0990
3.0630	3.0630	7.0990
1.6861	3.9913	7.0990
0.0000	4.3317	7.0990
4.2459	1.7936	7.8126
3.2584	3.2584	7.8126
1.7936	4.2459	7.8126
0.0000	4.6080	7.8126
4.4975	1.8999	8.5245
3.4514	3.4514	8.5245
1.8999	4.4975	8.5245
0.0000	4.8811	8.5245
0.0000	-5.0972	9.1865
1.9841	-4.6967	9.1865
3.6043	-3.6043	9.1865
4.6967	-1.9841	9.1865
5.0972	0.0000	9.1865
0.0000	-5.3003	9.8532
2.0631	-4.8838	9.8532
3.7479	-3.7479	9.8532
4.8838	-2.0631	9.8532
5.3003	0.0000	9.8532
0.0000	-5.4902	10.5238
2.1370	-5.0588	10.5238
3.8822	-3.8822	10.5238
5.0588	-2.1370	10.5238
5.4902	0.0000	10.5238
4.6967	1.9841	9.1865
3.6043	3.6043	9.1865
1.9841	4.6967	9.1865
0.0000	5.0972	9.1865
4.8838	2.0631	9.8532
3.7479	3.7479	9.8532
2.0631	4.8838	9.8532
0.0000	5.3003	9.8532
5.0588	2.1370	10.5238
3.8822	3.8822	10.5238
2.1370	5.0588	10.5238
0.0000	5.4902	10.5238
0.0000	-5.6700	11.1540
2.2070	-5.2244	11.1540
4.0093	-4.0093	11.1540
5.2244	-2.2070	11.1540
5.6700	0.0000	11.1540
5.2244	2.2070	11.1540
4.0093	4.0093	11.1540
2.2070	5.2244	11.1540
0.0000	5.6700	11.1540
0.0000	-5.8751	11.9623

2.2869	-5.4134	11.9623
4.1543	-4.1543	11.9623
5.4134	-2.2869	11.9623
5.8751	0.0000	11.9623
0.0000	-6.0658	12.7750
2.3611	-5.5891	12.7750
4.2892	-4.2892	12.7750
5.5891	-2.3611	12.7750
6.0658	0.0000	12.7750
0.0000	-6.2353	13.5923
2.4271	-5.7453	13.5923
4.4090	-4.4090	13.5923
5.7453	-2.4271	13.5923
6.2353	0.0000	13.5923
0.0000	-6.3770	14.4144
2.4822	-5.8759	14.4144
4.5092	-4.5092	14.4144
5.8759	-2.4822	14.4144
6.3770	0.0000	14.4144
0.0000	-6.4842	15.2415
2.5239	-5.9746	15.2415
4.5850	-4.5850	15.2415
5.9746	-2.5239	15.2415
6.4842	0.0000	15.2415
0.0000	-6.5500	16.0740
2.5496	-6.0353	16.0740
4.6315	-4.6315	16.0740
6.0353	-2.5496	16.0740
6.5500	0.0000	16.0740
5.4134	2.2869	11.9623
4.1543	4.1543	11.9623
2.2869	5.4134	11.9623
0.0000	5.8751	11.9623
5.5891	2.3611	12.7750
4.2892	4.2892	12.7750
2.3611	5.5891	12.7750
0.0000	6.0658	12.7750
5.7453	2.4271	13.5923
4.4090	4.4090	13.5923
2.4271	5.7453	13.5923
0.0000	6.2353	13.5923
5.8759	2.4822	14.4144
4.5092	4.5092	14.4144
2.4822	5.8759	14.4144
0.0000	6.3770	14.4144
5.9746	2.5239	15.2415
4.5850	4.5850	15.2415
2.5239	5.9746	15.2415
0.0000	6.4842	15.2415
6.0353	2.5496	16.0740
4.6315	4.6316	16.0740
2.5496	6.0353	16.0740
0.0000	6.5500	16.0740
0.0000	-6.5500	16.8620
2.5496	-6.0353	16.8620
4.6315	-4.6315	16.8620
6.0353	-2.5496	16.8620
6.5500	0.0000	16.8620
0.0000	-6.5500	17.6500
2.5496	-6.0353	17.6500
4.6315	-4.6315	17.6500
6.0353	-2.5496	17.6500
6.5500	0.0000	17.6500
0.0000	-6.5500	18.4380
2.5496	-6.0353	18.4380
4.6315	-4.6315	18.4380

6.0353	-2.5496	18.4380
6.5500	0.0000	18.4380
0.0000	-6.5500	19.2260
2.5496	-6.0353	19.2260
4.6315	-4.6315	19.2260
6.0353	-2.5496	19.2260
6.5500	0.0000	19.2260
0.0000	-6.5500	20.0140
2.5496	-6.0353	20.0140
4.6315	-4.6315	20.0140
6.0353	-2.5496	20.0140
6.5500	0.0000	20.0140
6.0353	2.5496	16.8620
4.6315	4.6316	16.8620
2.5496	6.0353	16.8620
0.0000	6.5500	16.8620
6.0353	2.5496	17.6500
4.6315	4.6316	17.6500
2.5496	6.0353	17.6500
0.0000	6.5500	17.6500
6.0353	2.5496	18.4380
4.6315	4.6316	18.4380
2.5496	6.0353	18.4380
0.0000	6.5500	18.4380
6.0353	2.5496	19.2260
4.6315	4.6316	19.2260
2.5496	6.0353	19.2260
0.0000	6.5500	19.2260
6.0353	2.5496	20.0140
4.6315	4.6316	20.0140
2.5496	6.0353	20.0140
0.0000	6.5500	20.0140
22	3	4
24	5	6
46	12	13
137	14	15
88	8	3
99	9	4
10	10	5
11	11	6
16	16	12
17	17	13
18	18	14
18	19	15
20	21	8
21	22	9
22	23	10
22	24	11
24	80	16
80	81	17
81	82	18
82	83	19
82	26	21
26	27	22
27	28	23
28	29	24
84	80	24
84	81	80
85	82	81
85	83	82
86	26	25
86	27	26
30	28	27
31	29	28
32	84	29
33	85	84
34		
88		
89		

89	90	86	85
90	91	87	86
35	36	31	30
36	37	32	31
37	38	33	32
38	39	34	33
39	92	88	34
92	93	89	88
93	94	90	89
94	95	91	90
40	41	36	35
41	42	37	36
42	43	38	37
43	44	39	38
44	96	92	39
96	97	93	92
97	98	94	93
98	99	95	94
45	46	41	40
46	47	42	41
47	48	43	42
48	49	44	43
49	100	96	44
100	101	97	96
101	102	98	97
102	103	99	98
50	51	46	45
51	52	47	46
52	53	48	47
53	54	49	48
54	104	100	49
104	105	101	100
105	106	102	101
106	107	103	102
55	56	51	50
56	57	52	51
57	58	53	52
58	59	54	53
59	108	104	54
108	109	105	104
109	110	106	105
110	111	107	106
60	61	56	55
61	62	57	56
62	63	58	57
63	64	59	58
64	112	108	59
112	113	109	108
113	114	110	109
114	115	111	110
65	66	61	60
66	67	62	61
67	68	63	62
68	69	64	63
69	116	112	64
116	117	113	112
117	118	114	113
118	119	115	114
70	71	66	65
71	72	67	66
72	73	68	67
73	74	69	68
74	120	116	69
120	121	117	116
121	122	118	117
122	123	119	118

75	76	71	70
76	77	72	71
77	78	73	72
78	79	74	73
79	124	120	74
124	125	121	120
125	126	122	121
126	127	123	122
128	129	76	75
129	130	77	76
130	131	78	77
131	132	79	78
132	143	124	79
143	144	125	124
144	145	126	125
145	146	127	126
133	134	129	128
134	135	130	129
135	136	131	130
136	137	132	131
137	147	143	132
147	148	144	143
148	149	145	144
149	50	146	145
138	139	134	133
139	140	135	134
140	141	136	135
141	142	137	136
142	151	147	137
151	152	148	147
152	153	149	148
153	154	150	149
155	156	139	138
156	157	140	139
157	158	141	140
158	159	142	141
159	160	151	142
160	161	152	151
161	162	153	152
162	163	154	153
164	165	156	155
165	166	157	156
166	167	158	157
167	168	159	158
168	194	160	159
194	195	161	160
195	196	162	161
196	197	163	162
169	170	165	164
170	171	166	165
171	172	167	166
172	173	168	167
173	198	194	168
198	199	195	194
199	200	196	195
200	201	197	196
174	175	170	169
175	176	171	170
176	177	172	171
177	178	173	172
178	202	198	173
202	203	199	198
203	204	200	199
204	205	201	200
179	180	175	174
180	181	176	175

181	182	177	176
182	183	178	177
183	206	202	178
206	207	203	202
207	208	204	203
208	209	205	204
184	185	180	179
185	186	181	180
186	187	182	181
187	188	183	182
188	210	206	183
210	211	207	206
211	212	208	207
212	213	209	208
189	190	185	184
190	191	186	185
191	192	187	186
192	193	188	187
193	214	210	188
214	215	211	210
215	216	212	211
216	217	213	212
218	219	190	189
219	220	191	190
220	221	192	191
221	222	193	192
222	243	214	193
243	244	215	214
244	245	216	215
245	246	217	216
223	224	219	218
224	225	220	219
225	226	221	220
226	227	222	221
227	247	243	222
247	248	244	243
248	249	245	244
249	250	246	245
228	229	224	223
229	230	225	224
230	231	226	225
231	232	227	226
232	251	247	227
251	252	248	247
252	253	249	248
253	254	250	249
233	234	229	228
234	235	230	229
235	236	231	230
236	237	232	231
237	255	251	232
255	256	252	251
256	257	253	252
257	258	254	253
238	239	234	233
239	240	235	234
240	241	236	235
241	242	237	236
242	259	255	237
259	260	256	255
260	261	257	256
261	262	258	257

APPENDIX E
HARDCOPY OUTPUT FROM ENTRY

*****PROGRAM OPTIONS*****
 VARIABLE BODY ORIENTATION
 DON'T PRINT
 SYMMETRIC CONFIGURATION

*****PROBLEM PARAMETERS*****
 DIAMETER 13.10000 IN
 ENTRY VELOCITY 1560.000 (IN/SEC)
 BODY ORIENTATION ANGL; 90.00 DEGREES
 INITIAL DEPTH 0.00000 IN TERMINATION STEP 29
 INITIAL PRESSURE CORRECTION FACTOR = 0.6700
 CENTROIDE COORDINATES 0.00000 0.00000 0.00000

NO	VX	VY	VZ	WX	CWT	H
1	0.0000	0.0000-1560.0000	0.0000	0.0	1.371000	0.095210
2	0.0000	0.0000-1560.0000	0.0000	0.0	1.241500	0.256600
3	0.0000	0.0000-1560.0000	0.0000	0.0	1.199000	0.611600
4	0.0000	0.0000-1560.0000	0.0000	0.0	1.187100	0.629700
5	0.0000	0.0000-1560.0000	0.0000	0.0	1.175700	0.647900
6	0.0000	0.0000-1560.0000	0.0000	0.0	1.165500	0.663900
7	0.0000	0.0000-1560.0000	0.0000	0.0	1.156400	0.677500
8	0.0000	0.0000-1560.0000	0.0000	0.0	1.148500	0.689100
9	0.0000	0.0000-1560.0000	0.0000	0.0	1.141700	0.698500
10	0.0000	0.0000-1560.0000	0.0000	0.0	1.136200	0.705500
11	0.0000	0.0000-1560.0000	0.0000	0.0	1.132000	0.710400
12	0.0000	0.0000-1560.0000	0.0000	0.0	1.129000	0.713100
13	0.0000	0.0000-1560.0000	0.0000	0.0	1.127400	0.713600
14	0.0000	0.0000-1560.0000	0.0000	0.0	1.124000	0.713600
15	0.0000	0.0000-1560.0000	0.0000	0.0	1.119200	0.711900
16	0.0000	0.0000-1560.0000	0.0000	0.0	1.108300	0.662000
17	0.0000	0.0000-1560.0000	0.0000	0.0	1.102100	0.666700
18	0.0000	0.0000-1560.0000	0.0000	0.0	1.099300	0.670600
19	0.0000	0.0000-1560.0000	0.0000	0.0	1.094800	0.630200
20	0.0000	0.0000-1560.0000	0.0000	0.0	1.087000	0.808300
21	0.0000	0.0000-1560.0000	0.0000	0.0	1.079700	0.812700
22	0.0000	0.0000-1560.0000	0.0000	0.0	1.069500	0.817300
23	0.0000	0.0000-1560.0000	0.0000	0.0	1.056200	0.822100
24	0.0000	0.0000-1560.0000	0.0000	0.0	1.039600	0.827100
25	0.0000	0.0000-1560.0000	0.0000	0.0	1.015200	0.832500
					1.000000	0.788000

*****GRID OPTIONS*****
 LIST

NODE	X	Y	Z	XP	YP	ZP
1	0.0000	0.0000	0.0000	0.0000	0.0000	0.0000
2	0.0000	-0.4263	0.0952	0.0000	-0.4263	0.0952
3	0.1659	-0.3928	0.0952	0.1659	-0.3928	0.0952
4	0.3015	-0.3015	0.0952	0.3015	-0.3015	0.0952
5	0.3928	-0.1659	0.0952	0.3928	-0.1659	0.0952
6	0.4263	0.0000	0.0952	0.4263	0.0000	0.0952
7	0.0000	0.7615	0.3518	0.0000	0.7615	0.3518
8	0.2964	-0.7017	0.3518	0.2964	-0.7017	0.3518
9	0.5385	-0.2964	0.3518	0.5385	-0.2964	0.3518
10	0.7615	0.0000	0.3518	0.7615	0.0000	0.3518
11	0.3928	0.1659	0.0952	0.3928	0.1659	0.0952
12	0.3015	0.3015	0.0952	0.3015	0.3015	0.0952
13	0.1659	0.3928	0.0952	0.1659	0.3928	0.0952
14	0.0000	0.4263	0.0952	0.0000	0.4263	0.0952
15	0.0000	0.2964	0.3518	0.0000	0.2964	0.3518
16	0.7017	0.2964	0.3518	0.7017	0.2964	0.3518
17	0.5385	0.5385	0.3518	0.5385	0.5385	0.3518
18	0.2964	0.7017	0.3518	0.2964	0.7017	0.3518
19	0.0000	0.7615	0.3518	0.0000	0.7615	0.3518
20	0.0000	-1.2262	0.9634	-1.2262	0.9634	0.9634
21	0.4773	-1.1298	0.9634	-1.1298	0.9634	0.9634
22	0.8670	-0.8670	0.9634	-0.8670	0.9634	0.9634

22	1.1298	1.1298	0.4773	9634
23	1.2262	1.2262	0.0000	0.6634
24	0.0000	0.0000	-1.6605	0.5931
25	0.6464	0.6464	-1.5300	1.5931
26	1.1742	1.1742	-0.6464	1.5931
27	0.0000	1.5300	0.0000	1.5931
28	0.0000	1.6605	0.0000	2.2410
29	0.8041	0.8041	-2.0659	2.2410
30	1.9035	1.9035	-1.4608	2.2410
31	0.0000	1.4608	-0.8041	2.2410
32	0.0000	1.9035	-0.0000	2.2410
33	0.9517	0.9517	-2.4451	2.9049
34	1.7289	1.7289	-2.2530	2.9049
35	0.0000	2.2530	-1.7289	2.9049
36	1.2298	1.2298	-0.9517	2.9049
37	2.4451	2.4451	-0.0000	3.5824
38	0.0000	0.0000	-2.8010	3.5824
39	1.9806	1.9806	-1.5809	3.5824
40	0.0000	1.9806	-1.0903	3.5824
41	0.0000	2.5809	-0.0000	3.5824
42	0.8010	0.8010	-3.1366	4.2715
43	2.2209	2.2209	-2.8901	4.2715
44	0.0000	1.2179	-2.2209	4.2715
45	1.2179	1.2179	-1.8901	4.2715
46	2.8901	2.8901	-0.0000	4.2715
47	0.0000	3.1366	-3.4546	4.9700
48	0.0000	3.4427	-3.1831	4.9700
49	1.3447	1.3447	-2.4427	4.9700
50	1.8311	1.8311	-1.3447	4.9700
51	0.0000	4.546	-0.0000	5.6755
52	0.0000	4.627	-3.7578	5.6755
53	1.4627	1.4627	-3.4625	5.6755
54	2.6572	2.6572	-2.6572	5.6755
55	3.4625	3.4625	-1.4627	5.6755
56	0.0000	0.0000	0.0000	6.3859
57	0.0000	0.0000	-4.7310	6.3859
58	0.0000	0.0000	-3.3117	6.3859
59	0.0000	0.0000	-2.8633	6.3859
60	0.0000	0.0000	-1.5762	6.3859
61	0.0000	0.0000	-0.0000	7.0990
62	0.0000	0.0000	-4.3317	7.0990
63	0.0000	0.0000	-3.9913	7.0990
64	0.0000	0.0000	-3.0630	7.0990
65	0.0000	0.0000	-1.6861	7.0990
66	0.0000	0.0000	-0.0000	7.8126
67	0.0000	0.0000	-4.6080	7.8126
68	0.0000	0.0000	-4.2459	7.8126
69	0.0000	0.0000	-3.2584	7.8126
70	0.0000	0.0000	-1.7936	7.8126
71	0.0000	0.0000	-0.0000	8.5245
72	0.0000	0.0000	-4.8811	8.5245
73	0.0000	0.0000	-4.4975	8.5245
74	0.0000	0.0000	-3.4514	8.5245
75	0.0000	0.0000	-1.8999	8.5245
76	0.0000	0.0000	-0.0000	8.5245
77	0.0000	0.0000	-4.4975	8.5245
78	0.0000	0.0000	-4.8811	8.5245
79	0.0000	0.0000	-0.0000	0.9634
80	1.298	1.298	0.4773	0.9634
81	2.262	2.262	0.8670	0.9634
82	0.0000	0.0000	1.1298	0.9634
83	0.0000	0.0000	1.2262	0.9634
84	0.0000	0.0000	0.6464	1.5931
85	0.0000	0.0000	1.1742	1.5931
86	0.0000	0.0000	1.5300	1.5931
87	0.0000	0.0000	1.6605	1.5931
88	0.8041	0.8041	0.0000	2.2410

ELEMENT	1	2	3	4	XC	YC	ZC	RC	TC	AREA
211	6.0353	-2.5496	16.8620	6.0353	-2.5496	16.8620	0.0658	0.2731	157.482	0.7142E-01
212	6.0000	-0.0000	17.6500	6.0000	0.0000	17.6500	0.0658	0.2731	112.518	0.7142E-01
223	6.0353	-0.0353	17.6500	6.0353	0.0353	17.6500	0.0658	0.2731	62.518	0.7142E-01
224	6.0353	-2.5496	17.6500	6.0353	-2.5496	17.6500	0.2356	0.5985	168.052	0.9502E-01
225	6.0000	-0.0000	18.4380	6.0000	0.0000	18.4380	0.2356	0.5985	146.052	0.9502E-01
227	6.0000	-0.0353	18.4380	6.0000	0.0353	18.4380	0.2356	0.5985	101.451	0.9831E-01
228	6.0353	-2.5496	18.4380	6.0353	-2.5496	18.4380	0.2356	0.5985	78.948	0.9502E-01
230	6.0353	-0.0353	18.4380	6.0353	0.0353	18.4380	0.2356	0.5985	33.451	0.9831E-01
231	6.0000	-0.0000	18.4380	6.0000	0.0000	18.4380	0.6814	0.5976	11.451	0.3010E+00
232	6.0000	-0.0000	18.4380	6.0000	0.0000	18.4380	0.6814	0.5976	168.051	0.2907E+00
233	6.0000	-0.0353	19.2260	6.0000	0.0353	19.2260	0.6814	0.5976	146.051	0.2907E+00
234	6.0353	-2.5496	19.2260	6.0353	-2.5496	19.2260	0.6814	0.5976	123.949	0.3010E+00
235	6.0353	-0.0353	19.2260	6.0353	0.0353	19.2260	0.6814	0.5976	101.452	0.3010E+00
236	6.0000	-0.0000	19.2260	6.0000	0.0000	19.2260	0.6814	0.5976	78.948	0.2907E+00
237	6.0000	-0.0000	19.2260	6.0000	0.0000	19.2260	0.6814	0.5976	56.051	0.2907E+00
238	6.0000	-0.0353	20.0140	6.0000	0.0353	20.0140	0.6814	0.5976	33.949	0.2907E+00
239	6.0353	-2.5496	20.0140	6.0353	-2.5496	20.0140	0.6814	0.5976	11.452	0.3010E+00
240	6.0353	-0.0353	20.0140	6.0353	0.0353	20.0140	0.6814	0.5976	168.051	0.2907E+00
241	6.0000	-0.0000	20.0140	6.0000	0.0000	20.0140	0.6814	0.5976	146.051	0.2907E+00
242	6.0000	-0.0000	20.0140	6.0000	0.0000	20.0140	0.6814	0.5976	123.949	0.3010E+00
243	6.0353	-2.5496	16.8620	6.0353	-2.5496	16.8620	0.6814	0.5976	78.948	0.2907E+00
244	6.0353	-0.0353	16.8620	6.0353	0.0353	16.8620	0.6814	0.5976	56.051	0.2907E+00
245	6.0000	-0.0000	16.8620	6.0000	0.0000	16.8620	0.6814	0.5976	33.949	0.2907E+00
246	6.0000	-0.0000	16.8620	6.0000	0.0000	16.8620	0.6814	0.5976	11.452	0.3010E+00
247	6.0353	-2.5496	17.6500	6.0353	-2.5496	17.6500	0.6814	0.5976	168.051	0.2907E+00
248	6.0353	-0.0353	17.6500	6.0353	0.0353	17.6500	0.6814	0.5976	146.051	0.2907E+00
249	6.0000	-0.0000	17.6500	6.0000	0.0000	17.6500	0.6814	0.5976	123.949	0.3010E+00
250	6.0000	-0.0000	17.6500	6.0000	0.0000	17.6500	0.6814	0.5976	78.948	0.2907E+00
251	6.0353	-2.5496	18.4380	6.0353	-2.5496	18.4380	0.6814	0.5976	56.051	0.2907E+00
252	6.0353	-0.0353	18.4380	6.0353	0.0353	18.4380	0.6814	0.5976	33.949	0.2907E+00
253	6.0000	-0.0000	18.4380	6.0000	0.0000	18.4380	0.6814	0.5976	11.452	0.3010E+00
254	6.0000	-0.0000	18.4380	6.0000	0.0000	18.4380	0.6814	0.5976	168.051	0.2907E+00
255	6.0353	-2.5496	18.4380	6.0353	-2.5496	18.4380	0.6814	0.5976	146.051	0.2907E+00
256	6.0353	-0.0353	19.2260	6.0353	0.0353	19.2260	0.6814	0.5976	123.949	0.3010E+00
257	6.0000	-0.0000	19.2260	6.0000	0.0000	19.2260	0.6814	0.5976	78.948	0.2907E+00
258	6.0000	-0.0000	19.2260	6.0000	0.0000	19.2260	0.6814	0.5976	56.051	0.2907E+00
259	6.0353	-2.5496	20.0140	6.0353	-2.5496	20.0140	0.6814	0.5976	33.949	0.2907E+00
260	6.0353	-0.0353	20.0140	6.0353	0.0353	20.0140	0.6814	0.5976	11.452	0.3010E+00
261	6.0000	-0.0000	20.0140	6.0000	0.0000	20.0140	0.6814	0.5976	168.051	0.2907E+00
262	6.0000	-0.0000	20.0140	6.0000	0.0000	20.0140	0.6814	0.5976	146.051	0.2907E+00

154	199	195	194	4.8619	3.2732	12.3708	5.8610	56.051	0.1909E+01
155	200	196	195	3.2732	5.7363	12.3708	5.8619	33.949	0.1909E+01
156	174	170	196	1.1971	5.9092	13.1855	6.0293	146.051	0.2037E+01
157	175	171	197	3.0085	5.9092	13.1855	6.0293	168.051	0.2037E+01
158	176	172	198	5.9092	1.1971	13.1855	6.0293	101.452	0.2037E+01
159	177	173	199	3.0085	3.0085	13.1855	6.0293	78.051	0.2037E+01
160	178	174	200	5.9092	5.0085	13.1855	6.0293	56.051	0.1967E+01
161	202	198	199	1.1971	3.0085	13.1855	6.0293	33.949	0.2037E+01
162	203	199	200	3.0085	5.0085	13.1855	6.0293	168.051	0.2037E+01
163	204	200	201	5.9092	1.1971	13.1855	6.0293	101.452	0.2037E+01
164	205	201	202	3.0085	3.0085	13.1855	6.0293	78.051	0.2037E+01
165	206	202	203	5.9092	5.0085	13.1855	6.0293	56.051	0.2037E+01
166	180	175	204	1.1971	1.1971	14.0049	6.1817	168.051	0.2088E+01
167	181	176	205	3.2274	3.2274	14.0049	6.1817	146.051	0.2088E+01
168	182	177	206	5.0586	5.0586	14.0049	6.1817	123.949	0.2088E+01
169	183	178	207	1.2570	1.2570	14.0049	6.1817	101.452	0.2088E+01
170	184	179	208	3.2274	3.2274	14.0049	6.1817	78.051	0.2088E+01
171	185	180	209	5.0586	5.0586	14.0049	6.1817	56.051	0.2088E+01
172	186	181	210	1.1971	1.1971	14.8291	6.3036	33.949	0.2129E+01
173	187	182	211	3.2274	3.2274	14.8291	6.3036	168.051	0.2129E+01
174	188	183	212	5.0586	5.0586	14.8291	6.3036	146.051	0.2129E+01
175	189	184	213	1.2570	1.2570	14.8291	6.3036	123.949	0.2129E+01
176	190	185	214	3.2274	3.2274	14.8291	6.3036	101.452	0.2129E+01
177	191	186	215	5.0586	5.0586	14.8291	6.3036	78.051	0.2129E+01
178	192	187	216	1.1971	1.1971	15.6584	6.3972	33.949	0.2161E+01
179	193	188	217	3.2274	3.2274	15.6584	6.3972	168.051	0.2161E+01
180	194	189	218	5.0586	5.0586	15.6584	6.3972	146.051	0.2161E+01
181	195	190	219	1.2570	1.2570	15.6584	6.3972	123.949	0.2161E+01
182	196	191	220	3.2274	3.2274	15.6584	6.3972	101.452	0.2161E+01
183	197	192	221	5.0586	5.0586	15.6584	6.3972	78.051	0.2161E+01
184	198	193	222	1.1971	1.1971	16.4680	6.4294	33.949	0.2199E+01
185	199	194	223	3.2274	3.2274	16.4680	6.4294	168.051	0.2199E+01
186	200	195	224	5.0586	5.0586	16.4680	6.4294	146.051	0.2199E+01
187	201	196	225	1.2570	1.2570	16.4680	6.4294	123.949	0.2199E+01
188	202	197	226	3.2274	3.2274	16.4680	6.4294	101.452	0.2199E+01
189	203	198	227	5.0586	5.0586	16.4680	6.4294	78.051	0.2199E+01
190	204	199	228	1.1971	1.1971	17.2560	6.4294	33.949	0.2199E+01
191	205	200	229	3.2274	3.2274	17.2560	6.4294	168.051	0.2199E+01
192	206	201	230	5.0586	5.0586	17.2560	6.4294	146.051	0.2199E+01
193	207	202	231	1.2570	1.2570	17.2560	6.4294	123.949	0.2199E+01
194	208	203	232	3.2274	3.2274	17.2560	6.4294	101.452	0.2199E+01
195	209	204	233	5.0586	5.0586	17.2560	6.4294	78.051	0.2199E+01
196	210	205	234	1.1971	1.1971	18.0440	6.4294	33.949	0.2199E+01
197	211	206	235	3.2274	3.2274	18.0440	6.4294	168.051	0.2199E+01
198	212	207	236	5.0586	5.0586	18.0440	6.4294	146.051	0.2199E+01
199	213	208	237	1.2570	1.2570	18.0440	6.4294	123.949	0.2199E+01
200	214	209	238	3.2274	3.2274	18.0440	6.4294	101.452	0.2199E+01
201	215	210	239	5.0586	5.0586	18.0440	6.4294	78.051	0.2199E+01
202	216	211	240	1.1971	1.1971	18.8320	6.4294	33.949	0.2199E+01
203	217	212	241	3.2274	3.2274	18.8320	6.4294	168.051	0.2199E+01
204	218	213	242	5.0586	5.0586	18.8320	6.4294	146.051	0.2199E+01
205	219	214	243	1.2570	1.2570	18.8320	6.4294	123.949	0.2199E+01
206	220	215	244	3.2274	3.2274	18.8320	6.4294	101.452	0.2199E+01
207	221	216	245	5.0586	5.0586	18.8320	6.4294	78.051	0.2199E+01
208	222	217	246	1.1971	1.1971	18.8320	6.4294	33.949	0.2199E+01
209	223	218	247	3.2274	3.2274	18.8320	6.4294	168.051	0.2199E+01
210	224	219	248	5.0586	5.0586	18.8320	6.4294	146.051	0.2199E+01
211	225	220	249	1.2570	1.2570	18.8320	6.4294	123.949	0.2199E+01
212	226	221	250	3.2274	3.2274	18.8320	6.4294	101.452	0.2199E+01
213	227	222	251	5.0586	5.0586	18.8320	6.4294	78.051	0.2199E+01
214	228	223	252	1.1971	1.1971	18.8320	6.4294	33.949	0.2199E+01
215	229	224	253	3.2274	3.2274	18.8320	6.4294	168.051	0.2199E+01
216	230	225	254	5.0586	5.0586	18.8320	6.4294	146.051	0.2199E+01
217	231	226	255	1.2570	1.2570	18.8320	6.4294	123.949	0.2199E+01
218	232	227	256	3.2274	3.2274	18.8320	6.4294	101.452	0.2199E+01
219	233	228	257	5.0586	5.0586	18.8320	6.4294	78.051	0.2199E+01

220	257	254	253	1.2748	6.2927	18.8320	6.4205	11.452	0.2050E+01
221	238	234	233	1.2748	6.2927	19.6200	6.4205	168.548	0.2050E+01
222	239	240	234	3.5906	-9.3334	19.6200	6.4294	148.051	0.1979E+01
223	240	241	235	5.3334	-3.5906	19.6200	6.4294	123.949	0.1979E+01
224	241	242	235	6.2927	-1.2748	19.6200	6.4205	101.452	0.2050E+01
225	242	243	236	6.2927	1.2748	19.6200	6.4205	78.548	0.2050E+01
226	259	255	237	5.3334	3.5906	19.6200	6.4294	56.050	0.1979E+01
227	260	256	255	3.5906	5.3334	19.6200	6.4294	33.949	0.1979E+01
228	261	257	256	1.2748	6.2927	19.6200	6.4205	11.452	0.2050E+01
229	262	258	257	1.2748	6.2927	19.6200	6.4205	11.452	0.2050E+01
STEP 1	COMPLETE.CP TIME FOR STEP IS	0.00000	0.00000						
STEP 2	COMPLETE.CP TIME FOR STEP IS	0.00000	0.00000						
STEP 3	COMPLETE.CP TIME FOR STEP IS	0.00000	0.00000						
STEP 4	COMPLETE.CP TIME FOR STEP IS	0.00000	0.00000						
STEP 5	COMPLETE.CP TIME FOR STEP IS	0.00000	0.00000						
STEP 6	COMPLETE.CP TIME FOR STEP IS	0.00000	0.00000						
STEP 7	COMPLETE.CP TIME FOR STEP IS	0.00000	0.00000						
STEP 8	COMPLETE.CP TIME FOR STEP IS	0.00000	0.00000						
STEP 9	COMPLETE.CP TIME FOR STEP IS	0.00000	0.00000						
STEP 10	COMPLETE.CP TIME FOR STEP IS	0.00000	0.00000						
STEP 11	COMPLETE.CP TIME FOR STEP IS	0.00000	0.00000						
STEP 12	COMPLETE.CP TIME FOR STEP IS	0.00000	0.00000						
STEP 13	COMPLETE.CP TIME FOR STEP IS	0.00000	0.00000						
STEP 14	COMPLETE.CP TIME FOR STEP IS	0.00000	0.00000						
STEP 15	COMPLETE.CP TIME FOR STEP IS	0.00000	0.00000						
STEP 16	COMPLETE.CP TIME FOR STEP IS	0.00000	0.00000						
STEP 17	COMPLETE.CP TIME FOR STEP IS	0.00000	0.00000						
STEP 18	COMPLETE.CP TIME FOR STEP IS	0.00000	0.00000						
STEP 19	COMPLETE.CP TIME FOR STEP IS	0.00000	0.00000						
STEP 20	COMPLETE.CP TIME FOR STEP IS	0.00000	0.00000						
STEP 21	COMPLETE.CP TIME FOR STEP IS	0.00000	0.00000						
STEP 22	COMPLETE.CP TIME FOR STEP IS	0.00000	0.00000						
STEP 23	COMPLETE.CP TIME FOR STEP IS	0.00000	0.00000						
STEP 24	COMPLETE.CP TIME FOR STEP IS	0.00000	0.00000						
STEP 25	COMPLETE.CP TIME FOR STEP IS	0.00000	0.00000						
STEP 26	COMPLETE.CP TIME FOR STEP IS	0.00000	0.00000						
STEP 27	COMPLETE.CP TIME FOR STEP IS	0.00000	0.00000						
STEP 28	COMPLETE.CP TIME FOR STEP IS	0.00000	0.00000						

STEP 29 COMPLETE.CP TIME FOR STEP IS 0.00000
 STEP 30 COMPLETE.CP TIME FOR STEP IS 0.00000

STEP 1 DEPTH = 0.0952100 TIME = 0.0000445 DIMENSIONLESS TIME 0.0053012 WEITTING FACTORS = 1.3710000 1.2415000
 AVERAGE VELOCITY 0.0000 WX -1560.000 ORIENTATION 90.000

NO.	REF.NO.	MOD	AREA	X	Y	Z	TM*	CP	P	FORCE
1	1	0	0.7142E-01	0.1046	-0.2523	0.0658	0.00164	17.3140	0.1971E+04	0.1408E+03
2	2	0	0.7142E-01	0.2523	-0.1046	0.0658	0.00164	17.3140	0.1971E+04	0.1408E+03
3	3	0	0.7142E-01	0.2523	0.1046	0.0658	0.00164	17.3140	0.1971E+04	0.1408E+03
4	4	0	0.7142E-01	0.1046	0.2523	0.0658	0.00164	17.3140	0.1971E+04	0.1408E+03

FX= 0.0000000E+00 FD= 0.1099060E+04 FN= -0.4909268E-07 SMX= -0.6357989E-07 SMY= 0.0000000E+00 SMZ= 0.0000000E+00
 CX= 0.0000000 CD= 0.0716297 CN= 0.0000000 MX= 0.0000000 MY= 0.0000000 MZ= 0.0000000

STEP 2 DEPTH = 0.3518100 TIME = 0.0001770 DIMENSIONLESS TIME 0.0210787 WEITTING FACTORS = 1.2415000 1.1990000
 AVERAGE VELOCITY 0.0000 WX -1560.000 ORIENTATION 90.000

NO.	REF.NO.	MOD	AREA	X	Y	Z	TM*	CP	P	FORCE
1	1	0	0.7142E-01	0.1046	-0.2523	0.0658	0.01741	2.3474	0.2672E+03	0.1908E+02
2	2	0	0.7142E-01	0.2523	-0.1046	0.0658	0.01741	2.3474	0.2672E+03	0.1908E+02
3	3	0	0.7142E-01	0.2523	0.1046	0.0658	0.01741	2.3474	0.2672E+03	0.1908E+02
4	4	0	0.7142E-01	0.1046	0.2523	0.0658	0.01741	2.3474	0.2672E+03	0.1908E+02
5	5	0	0.9831E-01	0.1186	-0.5857	0.2356	0.00715	3.2751	0.3728E+03	0.3665E+02
6	6	0	0.9502E-01	0.3342	-0.4965	0.2356	0.00715	3.2733	0.3728E+03	0.3541E+02
7	7	0	0.9502E-01	0.4965	-0.3342	0.2356	0.00715	3.2750	0.3728E+03	0.3665E+02
8	8	0	0.9831E-01	0.5857	-0.1186	0.2356	0.00715	3.2751	0.3728E+03	0.3665E+02
9	9	0	0.9502E-01	0.4965	0.3342	0.2356	0.00715	3.2733	0.3728E+03	0.3541E+02
10	10	0	0.9502E-01	0.3342	0.4965	0.2356	0.00715	3.2735	0.3728E+03	0.3541E+02
11	11	0	0.9502E-01	0.4965	0.3342	0.2356	0.00715	3.2735	0.3728E+03	0.3541E+02
12	12	0	0.9831E-01	0.1186	0.5857	0.2356	0.00715	3.2750	0.3728E+03	0.3665E+02

FX= 0.0000000E+00 FD= 0.6034956E+03 FN= 0.3205215E-04 SMX= 0.3741649E-04 SMY= 0.0000000E+00 SMZ= 0.0000000E+00
 CX= 0.0000000 CD= 0.0393320 CN= 0.0000000 MX= 0.0000000 MY= 0.0000000 MZ= 0.0000000

STEP 3 DEPTH = 0.9634100 TIME = 0.0005040 DIMENSIONLESS TIME 0.0600170 WEITTING FACTORS = 1.1990000 1.1871000
 AVERAGE VELOCITY 0.0000 WX -1560.000 ORIENTATION 90.000

NO.	REF.NO.	MOD	AREA	X	Y	Z	TM*	CP	P	FORCE
1	1	0	0.7142E-01	0.1046	-0.2523	0.0658	0.05635	1.4377	0.1637E+03	0.1169E+02
2	2	0	0.7142E-01	0.2523	-0.1046	0.0658	0.05635	1.4377	0.1637E+03	0.1169E+02
3	3	0	0.7142E-01	0.2523	0.1046	0.0658	0.05635	1.4377	0.1637E+03	0.1169E+02
4	4	0	0.7142E-01	0.1046	0.2523	0.0658	0.05635	1.4377	0.1637E+03	0.1169E+02
5	5	0	0.9831E-01	0.1186	-0.5857	0.2356	0.04609	1.1368	0.1294E+03	0.1272E+02
6	6	0	0.9502E-01	0.3342	-0.4965	0.2356	0.04609	1.1373	0.1295E+03	0.1230E+02
7	7	0	0.9502E-01	0.4965	-0.3342	0.2356	0.04609	1.1373	0.1295E+03	0.1230E+02
8	8	0	0.9831E-01	0.5857	-0.1186	0.2356	0.04609	1.1368	0.1294E+03	0.1272E+02
9	9	0	0.9502E-01	0.4965	0.3342	0.2356	0.04609	1.1368	0.1294E+03	0.1272E+02
10	10	0	0.9502E-01	0.3342	0.4965	0.2356	0.04609	1.1373	0.1295E+03	0.1230E+02
11	11	0	0.9502E-01	0.4965	0.3342	0.2356	0.04609	1.1373	0.1295E+03	0.1230E+02
12	12	0	0.9831E-01	0.1186	0.5857	0.2356	0.04609	1.1368	0.1294E+03	0.1272E+02
13	13	0	0.3010E+00	0.1969	-0.9722	0.6814	0.01795	1.2513	0.1425E+03	0.4287E+02
14	14	0	0.2907E+00	0.5547	-0.8240	0.6814	0.01795	1.2510	0.1424E+03	0.4140E+02
15	15	0	0.2907E+00	0.8240	-0.5547	0.6814	0.01795	1.2514	0.1425E+03	0.4140E+02
16	16	0	0.3010E+00	0.9722	-0.1969	0.6814	0.01795	1.2513	0.1425E+03	0.4287E+02
17	17	0	0.3010E+00	0.9722	0.1969	0.6814	0.01795	1.2513	0.1425E+03	0.4287E+02
18	18	0	0.2907E+00	0.8240	0.5547	0.6814	0.01795	1.2510	0.1424E+03	0.4140E+02
19	19	0	0.2907E+00	0.5547	0.8240	0.6814	0.01795	1.2510	0.1424E+03	0.4140E+02
20	20	0	0.3010E+00	0.1969	0.9722	0.6814	0.01795	1.2513	0.1425E+03	0.4287E+02

EX= 0.0000000E+00 FD= 0.6519165E+03 FN= 0.9899530E-03 SMX= 0.1360385E-02 SMY= 0.0000000E+00 SMZ= 0.0000000E+00
 CX= 0.0000000 CD= 0.0424877 CN= 0.0000001 MX= 0.0000000 MY= 0.0000000 MZ= 0.0000000

STEP 4 DEPTH = 1.5931100 TIME = 0.0008440 DIMENSIONLESS TIME 0.1005096 WEITTING FACTORS = 1.1871000 1.1757000
 AVERAGE VELOCITY 0.000 -1560.000 WX 0.000 ORIENTATION 90.000

NO.	REF.NO.	MOD	AREA	X	Y	Z	TX*	CP	P	FORCE
1	1	0	0.7142E-01	0.1046	-0.2523	0.0658	0.09684	1.3144	0.1456E+03	0.1069E+02
2	2	0	0.7142E-01	0.2523	-0.1046	0.0658	0.09684	1.3144	0.1456E+03	0.1069E+02
3	3	0	0.7142E-01	0.1046	0.1046	0.0658	0.09684	1.3144	0.1456E+03	0.1069E+02
4	4	0	0.7142E-01	0.1046	0.2523	0.0658	0.09684	1.3144	0.1456E+03	0.1069E+02
5	5	0	0.9831E-01	0.1186	-0.5857	0.2356	0.08658	0.9408	0.1071E+03	0.1053E+02
6	6	0	0.9502E-01	0.3342	-0.4965	0.2356	0.08658	0.9408	0.1071E+03	0.1018E+02
7	7	0	0.9502E-01	0.4965	-0.3342	0.2356	0.08658	0.9408	0.1071E+03	0.1053E+02
8	8	0	0.9831E-01	0.5857	-0.1186	0.2356	0.08658	0.9404	0.1071E+03	0.1053E+02
9	9	0	0.9831E-01	0.5857	0.1186	0.2356	0.08658	0.9404	0.1071E+03	0.1053E+02
10	10	0	0.9502E-01	0.4965	0.3342	0.2356	0.08658	0.9408	0.1071E+03	0.1018E+02
11	11	0	0.9502E-01	0.3342	0.4965	0.2356	0.08658	0.9408	0.1071E+03	0.1053E+02
12	12	0	0.9831E-01	0.1186	0.5857	0.2356	0.08658	0.9404	0.1071E+03	0.1053E+02
13	13	0	0.9831E-01	0.1186	0.5857	0.2356	0.08658	0.9404	0.1071E+03	0.1053E+02
14	14	0	0.9502E-01	0.5547	-0.8240	0.6814	0.05845	0.7671	0.8733E+02	0.2538E+02
15	15	0	0.2907E+00	0.8240	-0.5547	0.6814	0.05845	0.7671	0.8733E+02	0.2538E+02
16	16	0	0.3010E+00	0.9722	-0.1969	0.6814	0.05845	0.7665	0.8726E+02	0.2626E+02
17	17	0	0.3010E+00	0.9722	0.1969	0.6814	0.05845	0.7665	0.8726E+02	0.2626E+02
18	18	0	0.2907E+00	0.8240	0.5547	0.6814	0.05845	0.7671	0.8733E+02	0.2538E+02
19	19	0	0.2907E+00	0.5547	0.8240	0.6814	0.05845	0.7671	0.8733E+02	0.2538E+02
20	20	0	0.3010E+00	0.369	0.9722	0.6814	0.05844	0.7665	0.8726E+02	0.2626E+02
21	21	0	0.3575E+00	0.830	-1.3371	1.2940	0.01923	1.1460	0.1305E+03	0.5684E+02
22	22	0	0.4208E+00	0.972	-1.1841	1.2940	0.01923	1.1464	0.1305E+03	0.5491E+02
23	23	0	0.4208E+00	1.1841	-0.7972	1.2940	0.01923	1.1464	0.1305E+03	0.5491E+02
24	24	0	0.4357E+00	1.3971	-0.2830	1.2940	0.01923	1.1460	0.1305E+03	0.5684E+02
25	25	0	0.4357E+00	1.3971	0.2830	1.2940	0.01923	1.1460	0.1305E+03	0.5684E+02
26	26	0	0.4208E+00	1.1841	0.7972	1.2940	0.01923	1.1464	0.1305E+03	0.5491E+02
27	27	0	0.4208E+00	0.7972	1.1841	1.2940	0.01923	1.1464	0.1305E+03	0.5491E+02
28	28	0	0.4357E+00	0.2830	1.3971	1.2940	0.01923	1.1460	0.1305E+03	0.5684E+02

EX= 0.0000000E+00 FD= 0.9618618E+03 FN= -0.1098441E-02 SMX= -0.2630384E-02 SMY= 0.0000000E+00 SMZ= 0.0000000E+00
 CX= 0.0000000 CD= 0.0626880 CN= -0.0000001 MX= 0.0000000 MY= 0.0000000 MZ= 0.0000000

STEP 5 DEPTH = 2.2410100 TIME = 0.0011973 DIMENSIONLESS TIME 0.1425764 WEITTING FACTORS = 1.1757000 1.1655000
 AVERAGE VELOCITY 0.000 -1560.000 WX 0.000 ORIENTATION 90.000

NO.	REF.NO.	MOD	AREA	X	Y	Z	TX*	CP	P	FORCE
1	1	0	0.7142E-01	0.1046	-0.2523	0.0658	0.13891	1.2582	0.1432E+03	0.1023E+02
2	2	0	0.7142E-01	0.2523	-0.1046	0.0658	0.13891	1.2582	0.1432E+03	0.1023E+02
3	3	0	0.7142E-01	0.1046	0.1046	0.0658	0.13891	1.2582	0.1432E+03	0.1023E+02
4	4	0	0.7142E-01	0.1046	0.2523	0.0658	0.13891	1.2582	0.1432E+03	0.1023E+02
5	5	0	0.9831E-01	0.1186	-0.5857	0.2356	0.12864	0.9078	0.1034E+03	0.1016E+02
6	6	0	0.9502E-01	0.3342	-0.4965	0.2356	0.12864	0.9081	0.1034E+03	0.9823E+01
7	7	0	0.9502E-01	0.4965	-0.3342	0.2356	0.12864	0.9078	0.1034E+03	0.9823E+01
8	8	0	0.9831E-01	0.5857	-0.1186	0.2356	0.12864	0.9078	0.1034E+03	0.9823E+01
9	9	0	0.9831E-01	0.5857	0.1186	0.2356	0.12864	0.9078	0.1034E+03	0.9823E+01
10	10	0	0.9502E-01	0.4965	0.3342	0.2356	0.12864	0.9081	0.1034E+03	0.9823E+01
11	11	0	0.9502E-01	0.3342	0.4965	0.2356	0.12864	0.9078	0.1034E+03	0.9823E+01
12	12	0	0.9831E-01	0.1186	0.5857	0.2356	0.12864	0.9078	0.1034E+03	0.9823E+01
13	13	0	0.9831E-01	0.1186	0.5857	0.2356	0.12864	0.9078	0.1034E+03	0.9823E+01
14	14	0	0.3010E+00	0.1969	-0.9722	0.6814	0.10051	0.6944	0.7899E+02	0.2377E+02
15	15	0	0.2907E+00	0.5547	-0.8240	0.6814	0.10051	0.6944	0.7899E+02	0.2298E+02
16	16	0	0.2907E+00	0.8240	-0.5547	0.6814	0.10051	0.6944	0.7899E+02	0.2298E+02
17	17	0	0.3010E+00	0.9722	-0.1969	0.6814	0.10051	0.6944	0.7899E+02	0.2377E+02
18	18	0	0.2907E+00	0.8240	0.5547	0.6814	0.10051	0.6944	0.7899E+02	0.2298E+02

19	0.2907E+00	0.8240	0.6814	0.10051	0.6944	0.7905E+02	0.2298E+02
20	0.3010E+00	0.9722	0.6814	0.10051	0.6939	0.7899E+02	0.2377E+02
21	0.4357E+00	-1.3971	1.2940	0.06130	0.6940	0.7900E+02	0.3442E+02
22	0.4208E+00	-1.1841	1.2940	0.06130	0.6945	0.7906E+02	0.3327E+02
23	0.4208E+00	-0.7972	1.2940	0.06130	0.6940	0.7900E+02	0.3442E+02
24	0.4357E+00	-0.2830	1.2940	0.06130	0.6940	0.7900E+02	0.3442E+02
25	0.4357E+00	0.2830	1.2940	0.06130	0.6945	0.7906E+02	0.3327E+02
26	0.4208E+00	0.7972	1.2940	0.06130	0.6945	0.7906E+02	0.3442E+02
27	0.4208E+00	1.1841	1.2940	0.06130	0.6940	0.7900E+02	0.3442E+02
28	0.4357E+00	1.3971	1.2940	0.06130	0.6940	0.7900E+02	0.3442E+02
29	0.5623E+00	-1.5231	1.9288	0.02027	0.9750	0.1110E+03	0.6029E+02
30	0.5430E+00	-1.0254	1.9288	0.02027	0.9753	0.1110E+03	0.6029E+02
31	0.5430E+00	1.5231	1.9288	0.02027	0.9750	0.1110E+03	0.6242E+02
32	0.5623E+00	-0.3641	1.9288	0.02027	0.9750	0.1110E+03	0.6242E+02
33	0.5623E+00	1.7970	1.9288	0.02027	0.9753	0.1110E+03	0.6029E+02
34	0.5430E+00	1.5231	1.9288	0.02027	0.9753	0.1110E+03	0.6029E+02
35	0.5430E+00	1.0254	1.9288	0.02027	0.9750	0.1110E+03	0.6242E+02
36	0.5623E+00	0.3641	1.9288	0.02027	0.9750	0.1110E+03	0.6242E+02

FX= 0.000000E+00 FD= 0.1246260E+04 FN= 0.4656304E-03 SMX= 0.2336365E-02 SMY= 0.0000000E+00 SMZ= 0.0000000E+00
 CX= 0.00000000 CD= 0.081232 CN= 0.00000000 MX= -1560.0000 WX= 0.00000000 MY= 0.00000000 MZ= 0.00000000

STEP 6 DEPTH = 2.9049100 TIME = 0.0015624 DIMENSIONLESS TIME 0.1860594 WEITING FACTORS = 1.1655000 1.1564000
 AVERAGE VELOCITY 0.000 -1560.0000 WX 0.00000000

NO.	REF.NO.	MOD	AREA	X	Y	Z	T*	CP	P	FORCE
1	1	0	0.7142E-01	0.046	0.2523	0.0658	0.18239	1.2170	0.1385E+03	0.9894E+01
2	2	0	0.7142E-01	0.2523	-0.1046	0.0658	0.18239	1.2170	0.1385E+03	0.9894E+01
3	3	0	0.7142E-01	0.2523	0.1046	0.0658	0.18239	1.2170	0.1385E+03	0.9894E+01
4	4	0	0.9831E-01	0.1186	-0.5857	0.2356	0.17213	0.8838	0.1006E+03	0.9562E+01
5	5	0	0.9831E-01	0.4965	-0.1342	0.2356	0.17213	0.8840	0.1006E+03	0.9562E+01
6	6	0	0.9831E-01	0.5857	0.1186	0.2356	0.17213	0.8838	0.1006E+03	0.9562E+01
7	7	0	0.9831E-01	0.5857	-0.1186	0.2356	0.17213	0.8838	0.1006E+03	0.9562E+01
8	8	0	0.9831E-01	0.3342	0.3342	0.2356	0.17213	0.8840	0.1006E+03	0.9562E+01
9	9	0	0.9502E-01	0.3342	0.4965	0.2356	0.17213	0.8840	0.1006E+03	0.9562E+01
10	10	0	0.9502E-01	0.1186	0.5857	0.2356	0.17213	0.8838	0.1006E+03	0.9562E+01
11	11	0	0.9831E-01	0.1969	-0.9722	0.6814	0.14399	0.6778	0.7716E+02	0.2242E+02
12	12	0	0.3010E+00	0.5547	-0.8240	0.6814	0.14399	0.6778	0.7716E+02	0.2242E+02
13	13	0	0.2907E+00	0.8240	-0.5547	0.6814	0.14399	0.6778	0.7716E+02	0.2242E+02
14	14	0	0.2907E+00	0.8240	0.5547	0.6814	0.14399	0.6778	0.7716E+02	0.2242E+02
15	15	0	0.3010E+00	0.9722	-0.1969	0.6814	0.14399	0.6778	0.7716E+02	0.2242E+02
16	16	0	0.3010E+00	0.9722	0.1969	0.6814	0.14399	0.6778	0.7716E+02	0.2242E+02
17	17	0	0.2907E+00	0.8240	0.5547	0.6814	0.14399	0.6778	0.7716E+02	0.2242E+02
18	18	0	0.2907E+00	0.5547	-0.8240	0.6814	0.14399	0.6778	0.7716E+02	0.2242E+02
19	19	0	0.3010E+00	0.9722	-0.1969	0.6814	0.14399	0.6778	0.7716E+02	0.2242E+02
20	20	0	0.3010E+00	0.9722	0.1969	0.6814	0.14399	0.6778	0.7716E+02	0.2242E+02
21	21	0	0.4357E+00	0.2830	-1.3971	1.2940	0.10478	0.6104	0.6949E+02	0.3028E+02
22	22	0	0.4208E+00	0.7972	-1.1841	1.2940	0.10478	0.6109	0.6954E+02	0.2926E+02
23	23	0	0.4208E+00	0.7972	1.1841	1.2940	0.10478	0.6109	0.6954E+02	0.2926E+02
24	24	0	0.4357E+00	1.3971	-0.2830	1.2940	0.10478	0.6104	0.6949E+02	0.3028E+02
25	25	0	0.4208E+00	1.3971	0.2830	1.2940	0.10478	0.6104	0.6949E+02	0.3028E+02
26	26	0	0.4208E+00	1.1841	-0.7972	1.2940	0.10478	0.6109	0.6954E+02	0.2926E+02
27	27	0	0.4208E+00	1.1841	0.7972	1.2940	0.10478	0.6109	0.6954E+02	0.2926E+02
28	28	0	0.4357E+00	0.2830	-1.3971	1.2940	0.10478	0.6104	0.6949E+02	0.3028E+02
29	29	0	0.4208E+00	0.7972	-1.1841	1.2940	0.10478	0.6104	0.6949E+02	0.3028E+02
30	30	0	0.4208E+00	0.7972	1.1841	1.2940	0.10478	0.6104	0.6949E+02	0.3028E+02
31	31	0	0.5623E+00	0.3641	-1.5231	1.9288	0.06375	0.5837	0.6645E+02	0.3609E+02
32	32	0	0.5430E+00	1.5231	-1.0254	1.9288	0.06375	0.5838	0.6645E+02	0.3609E+02
33	33	0	0.5430E+00	1.5231	1.0254	1.9288	0.06375	0.5838	0.6645E+02	0.3609E+02
34	34	0	0.5623E+00	1.7970	-0.3641	1.9288	0.06375	0.5837	0.6645E+02	0.3609E+02
35	35	0	0.5430E+00	1.7970	0.3641	1.9288	0.06375	0.5838	0.6645E+02	0.3609E+02
36	36	0	0.5623E+00	0.3641	-1.5231	1.9288	0.06375	0.5837	0.6645E+02	0.3609E+02
37	37	0	0.6581E+00	0.4400	-2.1720	2.5822	0.02113	0.8201	0.9336E+02	0.6150E+02
38	38	0	0.6581E+00	1.2393	-1.8409	2.5822	0.02113	0.8201	0.9336E+02	0.6150E+02

39 0 0.6581E+00 1.8409 -1.2393 2.5823 0.02113 0.8209 0.9345E+02 0.6150E+02
 40 0 0.6815E+00 2.1720 0.4400 2.5823 0.02113 0.8201 0.9336E+02 0.6362E+02
 41 0 0.6815E+00 2.1720 0.4400 2.5823 0.02113 0.8201 0.9336E+02 0.6362E+02
 42 0 0.6581E+00 1.8409 1.2393 2.5823 0.02113 0.8208 0.9345E+02 0.6150E+02
 43 0 0.6581E+00 1.2393 1.8409 2.5823 0.02113 0.8209 0.9345E+02 0.6150E+02
 44 0 0.6815E+00 0.4400 2.1720 2.5823 0.02113 0.8201 0.9336E+02 0.6362E+02

EX= 0.000000E+00 FD= 0.1481563E+04 FN= -0.4404552E-03 FMX= -0.2218339E-02 SMW= 0.0000000E+00 SMZ= 0.0000000E+00
 CX= 0.0000000 CD= 0.0965587 CN= 0.0000000 MX= 0.0000000 MY= 0.0000000 MZ= 0.0000000

STEP 7 DEPTH = 3.5824100 TIME = 0.0019380 DIMENSIONLESS TIME 0.2307823 WEIHING FACTORS = 1.1564000 1.1485000
 AVERAGE VELOCITY 0.000 -1560.000 WX 0.000 ORIENTATION 90.000

NO.	REF. NO.	MOD	AREA	X	Y	Z	T*	CP	P	FORCE
1	1	0	0.7142E-01	0.1046	-0.2523	0.0658	0.22712	1.1850	0.1349E+03	0.8634E+01
2	2	0	0.7142E-01	0.2523	-0.1046	0.0658	0.22712	1.1850	0.1349E+03	0.9634E+01
3	3	0	0.7142E-01	0.2523	0.1046	0.0658	0.22712	1.1850	0.1349E+03	0.9634E+01
4	4	0	0.7142E-01	0.1046	-0.2523	0.0658	0.22712	1.1850	0.1349E+03	0.8634E+01
5	5	0	0.9831E-01	0.1186	-0.5857	0.2356	0.21685	0.8645	0.9844E+02	0.9675E+01
6	6	0	0.9502E-01	0.3342	-0.4965	0.2356	0.21685	0.8648	0.9844E+02	0.9354E+01
7	7	0	0.9502E-01	0.4965	-0.3342	0.2356	0.21685	0.8648	0.9844E+02	0.9354E+01
8	8	0	0.9831E-01	0.5857	-0.1186	0.2356	0.21685	0.8645	0.9844E+02	0.9675E+01
9	9	0	0.9831E-01	0.4965	0.1186	0.2356	0.21685	0.8645	0.9844E+02	0.9675E+01
10	10	0	0.9502E-01	0.3342	0.4965	0.2356	0.21685	0.8648	0.9844E+02	0.9354E+01
11	11	0	0.9502E-01	0.1186	0.5857	0.2356	0.21685	0.8645	0.9844E+02	0.9675E+01
12	12	0	0.9831E-01	0.186	-0.5857	0.2356	0.21685	0.8645	0.9844E+02	0.9675E+01
13	13	0	0.9831E-01	0.5857	-0.186	0.2356	0.21685	0.8645	0.9844E+02	0.9675E+01
14	14	0	0.907E+00	0.8240	-0.8240	0.6814	0.18872	0.6658	0.7580E+02	0.2203E+02
15	15	0	0.907E+00	0.8240	-0.547	0.6814	0.18872	0.6658	0.7580E+02	0.2203E+02
16	16	0	0.3010E+00	0.9722	-0.1969	0.6814	0.18872	0.6655	0.7576E+02	0.2280E+02
17	17	0	0.3010E+00	0.9722	0.1969	0.6814	0.18872	0.6655	0.7576E+02	0.2280E+02
18	18	0	0.2907E+00	0.8240	0.547	0.6814	0.18872	0.6658	0.7580E+02	0.2203E+02
19	19	0	0.2907E+00	0.8240	0.8240	0.6814	0.18872	0.6658	0.7580E+02	0.2203E+02
20	20	0	0.3010E+00	0.1969	-0.9722	0.6814	0.18872	0.6655	0.7576E+02	0.2280E+02
21	21	0	0.4357E+00	0.2830	-1.3971	1.2940	0.14950	0.5886	0.6701E+02	0.2919E+02
22	22	0	0.4357E+00	0.2830	-1.1841	1.2940	0.14950	0.5886	0.6701E+02	0.2919E+02
23	23	0	0.4357E+00	0.7972	-1.1841	1.2940	0.14950	0.5886	0.6701E+02	0.2919E+02
24	24	0	0.4357E+00	0.7972	-0.2830	1.2940	0.14950	0.5886	0.6701E+02	0.2919E+02
25	25	0	0.4357E+00	0.3971	-0.2830	1.2940	0.14950	0.5886	0.6701E+02	0.2919E+02
26	26	0	0.4208E+00	1.1841	0.7972	1.2940	0.14950	0.5886	0.6701E+02	0.2919E+02
27	27	0	0.4208E+00	0.7972	1.1841	1.2940	0.14950	0.5886	0.6701E+02	0.2919E+02
28	28	0	0.4357E+00	0.2830	-1.3971	1.2940	0.14950	0.5886	0.6701E+02	0.2919E+02
29	29	0	0.4357E+00	0.2830	-1.1841	1.2940	0.14950	0.5886	0.6701E+02	0.2919E+02
30	30	0	0.530E+00	0.3641	-1.054	1.9288	0.10848	0.5075	0.5777E+02	0.3246E+02
31	31	0	0.530E+00	0.3641	-1.5231	1.9288	0.10848	0.5075	0.5777E+02	0.3246E+02
32	32	0	0.530E+00	0.7970	-1.054	1.9288	0.10848	0.5075	0.5777E+02	0.3246E+02
33	33	0	0.530E+00	0.7970	-1.5231	1.9288	0.10848	0.5075	0.5777E+02	0.3246E+02
34	34	0	0.5623E+00	1.1841	0.3641	1.9288	0.10848	0.5075	0.5777E+02	0.3246E+02
35	35	0	0.5623E+00	1.1841	0.254	1.9288	0.10848	0.5075	0.5777E+02	0.3246E+02
36	36	0	0.5623E+00	0.3641	-1.054	1.9288	0.10848	0.5075	0.5777E+02	0.3246E+02
37	37	0	0.5623E+00	0.3641	-1.5231	1.9288	0.10848	0.5075	0.5777E+02	0.3246E+02
38	38	0	0.6581E+00	0.4400	-2.18409	2.5823	0.05586	0.4878	0.5553E+02	0.3658E+02
39	39	0	0.6581E+00	0.4400	-1.8409	2.5823	0.05586	0.4878	0.5553E+02	0.3658E+02
40	40	0	0.6581E+00	1.1841	-2.18409	2.5823	0.05586	0.4878	0.5553E+02	0.3658E+02
41	41	0	0.6581E+00	1.1841	-1.8409	2.5823	0.05586	0.4878	0.5553E+02	0.3658E+02
42	42	0	0.6581E+00	0.4400	-2.18409	2.5823	0.05586	0.4878	0.5553E+02	0.3658E+02
43	43	0	0.6581E+00	0.4400	-1.8409	2.5823	0.05586	0.4878	0.5553E+02	0.3658E+02
44	44	0	0.6815E+00	1.2393	-2.1720	2.5823	0.02186	0.6906	0.7861E+02	0.6240E+02
45	45	0	0.6815E+00	1.2393	-1.4101	2.5823	0.02186	0.6906	0.7861E+02	0.6240E+02
46	46	0	0.665E+00	1.4101	-2.1720	2.5823	0.02186	0.6906	0.7861E+02	0.6240E+02
47	47	0	0.665E+00	1.4101	-1.4101	2.5823	0.02186	0.6906	0.7861E+02	0.6240E+02
48	48	0	0.7937E+00	2.2339	-0.5113	3.2513	0.02186	0.6906	0.7861E+02	0.6240E+02
49	49	0	0.7937E+00	2.2339	-0.5113	3.2513	0.02186	0.6906	0.7861E+02	0.6240E+02
50	50	0	0.7665E+00	2.1391	-1.4440	3.2513	0.02186	0.6920	0.7878E+02	0.6039E+02
50	50	0	0.7665E+00	2.1391	-1.4440	3.2513	0.02186	0.6920	0.7878E+02	0.6039E+02

51 51 0 0.7665E+00 1.4401 2.1391 3.2513 0.02186 0.6920 0.7878E+02 0.6039E+02
 52 52 0 0.7937E+00 0.5113 2.5239 3.2513 0.02186 0.6906 0.7862E+02 0.6240E+02
 FX= 0.000000E+00 FD= 0.1675008E+04 FN= -0.6438222E-03 SMX= -0.1439198E-02 SMY= 0.0000000E+00 SMZ= 0.0000000E+00
 CX= 0.0000000E+00 CD= 0.1091662 CN= 0.0000000E+00 MX= 0.0000000E+00 MY= 0.0000000E+00 MZ= 0.0000000E+00

STEP 8 DEPTH = 4.2715100 TIME = 0.0023226 DIMENSIONLESS TIME 0.2765838 MELTING FACTORS = 1.1485000 1.1417000
 AVERAGE VELOCITY 0.000 -1560.000 WX 0.000 KRENAVATION 90.000

NO.	REF.NO.	MOD	AREA	X	Y	Z	TM	CP	P	FORCE
1	1	0	0.7142E-01	0.1046	0.2523	0.0658	0.27292	1.1591	0.1320E+03	0.9424E+01
2	2	0	0.7142E-01	0.2523	-0.1046	0.0658	0.27292	1.1591	0.1320E+03	0.9424E+01
3	3	0	0.7142E-01	0.2523	0.1046	0.0658	0.27292	1.1591	0.1320E+03	0.9424E+01
4	4	0	0.9831E-01	0.1186	-0.5857	0.2356	0.26265	0.8488	0.9662E+02	0.9499E+01
5	5	0	0.9502E-01	0.3342	-0.4965	0.2356	0.26265	0.8488	0.9664E+02	0.9183E+01
6	6	0	0.9831E-01	0.4965	-0.3342	0.2356	0.26265	0.8488	0.9662E+02	0.9499E+01
7	7	0	0.9502E-01	0.5857	-0.1186	0.2356	0.26265	0.8488	0.9664E+02	0.9183E+01
8	8	0	0.9831E-01	0.5857	0.1186	0.2356	0.26265	0.8488	0.9662E+02	0.9499E+01
9	9	0	0.9502E-01	0.4965	0.3342	0.2356	0.26265	0.8488	0.9664E+02	0.9183E+01
10	10	0	0.9831E-01	0.3342	0.5857	0.2356	0.26265	0.8488	0.9662E+02	0.9499E+01
11	11	0	0.9502E-01	0.1186	0.4965	0.2356	0.26265	0.8488	0.9664E+02	0.9183E+01
12	12	0	0.9831E-01	0.1186	0.5857	0.2356	0.26265	0.8488	0.9662E+02	0.9499E+01
13	13	0	0.9502E-01	0.1969	-0.9722	0.6814	0.23452	0.6560	0.7465E+02	0.2247E+02
14	14	0	0.2907E+00	0.5547	-0.8240	0.6814	0.23452	0.6560	0.7468E+02	0.2171E+02
15	15	0	0.2907E+00	0.8240	-0.5547	0.6814	0.23452	0.6560	0.7465E+02	0.2247E+02
16	16	0	0.3010E+00	0.9722	-0.1969	0.6814	0.23452	0.6560	0.7468E+02	0.2171E+02
17	17	0	0.3010E+00	0.8240	0.1969	0.6814	0.23452	0.6560	0.7465E+02	0.2247E+02
18	18	0	0.2907E+00	0.8240	0.5547	0.6814	0.23452	0.6560	0.7468E+02	0.2171E+02
19	19	0	0.3010E+00	0.5547	0.8240	0.6814	0.23452	0.6560	0.7465E+02	0.2247E+02
20	20	0	0.3010E+00	0.1969	0.9722	0.6814	0.23452	0.6560	0.7468E+02	0.2171E+02
21	21	0	0.4352E+00	0.2830	-1.3971	1.2940	0.19531	0.5757	0.6559E+02	0.2856E+02
22	22	0	0.4208E+00	0.7972	-1.1841	1.2940	0.19531	0.5762	0.6559E+02	0.2760E+02
23	23	0	0.4208E+00	1.1841	-0.7972	1.2940	0.19531	0.5762	0.6559E+02	0.2856E+02
24	24	0	0.4352E+00	1.841	-0.2830	1.2940	0.19531	0.5757	0.6554E+02	0.2856E+02
25	25	0	0.4352E+00	1.3971	0.2830	1.2940	0.19531	0.5757	0.6554E+02	0.2760E+02
26	26	0	0.4208E+00	1.1841	0.7972	1.2940	0.19531	0.5762	0.6559E+02	0.2856E+02
27	27	0	0.4208E+00	0.7972	1.1841	1.2940	0.19531	0.5757	0.6554E+02	0.2760E+02
28	28	0	0.4352E+00	0.2830	-1.3971	1.2940	0.19531	0.5757	0.6554E+02	0.2856E+02
29	29	0	0.3623E+00	0.3641	-1.3971	1.9288	0.15428	0.4877	0.5552E+02	0.3122E+02
30	30	0	0.5430E+00	1.0254	-1.5231	1.9288	0.15428	0.4881	0.5552E+02	0.3017E+02
31	31	0	0.5430E+00	1.5231	-1.0254	1.9288	0.15428	0.4881	0.5552E+02	0.3122E+02
32	32	0	0.5623E+00	1.7970	-0.3641	1.9288	0.15428	0.4877	0.5552E+02	0.3122E+02
33	33	0	0.5623E+00	1.7970	0.3641	1.9288	0.15428	0.4877	0.5552E+02	0.3017E+02
34	34	0	0.5430E+00	1.5231	1.0254	1.9288	0.15428	0.4881	0.5552E+02	0.3122E+02
35	35	0	0.5430E+00	1.0254	-1.5231	1.9288	0.15428	0.4881	0.5552E+02	0.3017E+02
36	36	0	0.5623E+00	0.3641	-1.7970	2.5822	0.11166	0.4212	0.4795E+02	0.3267E+02
37	37	0	0.6815E+00	0.4400	-2.1720	2.5822	0.11166	0.4217	0.4800E+02	0.3159E+02
38	38	0	0.6581E+00	1.2393	-1.8409	2.5822	0.11166	0.4217	0.4800E+02	0.3267E+02
39	39	0	0.6581E+00	1.8409	-1.2393	2.5822	0.11166	0.4212	0.4795E+02	0.3159E+02
40	40	0	0.6815E+00	1.8409	1.2393	2.5822	0.11166	0.4212	0.4795E+02	0.3267E+02
41	41	0	0.6815E+00	1.2393	-1.8409	2.5822	0.11166	0.4212	0.4795E+02	0.3159E+02
42	42	0	0.6581E+00	1.8409	1.2393	2.5822	0.11166	0.4217	0.4800E+02	0.3267E+02
43	43	0	0.6581E+00	1.2393	-1.8409	2.5822	0.11166	0.4217	0.4800E+02	0.3159E+02
44	44	0	0.6815E+00	0.4400	-2.1720	2.5822	0.11166	0.4212	0.4795E+02	0.3267E+02
45	45	0	0.7932E+00	0.5113	-2.5239	2.5822	0.06766	0.4098	0.4666E+02	0.3703E+02
46	46	0	0.7665E+00	1.4401	-2.1391	3.2513	0.06766	0.4104	0.4672E+02	0.3581E+02
47	47	0	0.7665E+00	2.1391	-1.4401	3.2513	0.06766	0.4104	0.4672E+02	0.3703E+02
48	48	0	0.7932E+00	2.5239	-0.5113	3.2513	0.06766	0.4098	0.4666E+02	0.3703E+02
49	49	0	0.7932E+00	2.5239	0.5113	3.2513	0.06766	0.4098	0.4666E+02	0.3581E+02
50	50	0	0.7665E+00	1.4401	-2.1391	3.2513	0.06766	0.4104	0.4672E+02	0.3581E+02
51	51	0	0.7665E+00	2.1391	-1.4401	3.2513	0.06766	0.4104	0.4672E+02	0.3703E+02
52	52	0	0.7932E+00	2.5239	-0.5113	3.2513	0.06766	0.4098	0.4666E+02	0.3703E+02
53	53	0	0.7932E+00	2.5239	0.5113	3.2513	0.06766	0.4098	0.4666E+02	0.3581E+02
54	54	0	0.8693E+00	1.6292	-2.4199	3.9334	0.02247	0.5871	0.6683E+02	0.5809E+02

55 0.8693E+00 2.4200 -1.6292 3.9334 0.02247 0.5871 0.6683E+02 0.5809E+02
 56 0.9002E+00 2.8552 -0.5784 3.9334 0.02247 0.5861 0.6672E+02 0.6006E+02
 57 0.9002E+00 2.8552 0.5784 3.9334 0.02247 0.5861 0.6672E+02 0.6006E+02
 58 0.8693E+00 2.4200 1.6292 3.9334 0.02247 0.5871 0.6683E+02 0.5809E+02
 59 0.8693E+00 2.4200 2.4520 3.9334 0.02247 0.5861 0.6672E+02 0.6006E+02
 60 0.9002E+00 1.6292 2.8552 3.9334 0.02247 0.5871 0.6683E+02 0.5809E+02

FX= 0.000000E+00 FD= 0.1836884E+04 FN= 0.5126317E-04 SMX= 0.1123169E-02 SMY= 0.0000000E+00 SMZ= 0.0000000E+00
 CF= 0.0000000 CD= 0.1197163 CF= 0.0000000 MX= 0.0000000 MY= 0.0000000 MZ= 0.0000000

STEP 9 DEPTH = 4.9700100 TIME = 0.0027148 DIMENSIONLESS TIME 0.3222866 WERTING FACTORS = 1.1417000 1.1362000
 AVERAGE VELOCITY 0.000 VELOCITY 0.000 0.000 -1560.000 WX 0.000 ORIENTATION 90.000

NO.	REL. NO.	MOD	AREA	X	Y	Z	TM*	CP	P	FORCE
1	1	0	0.7142E-01	0.1046	-0.2523	0.0658	0.31962	1.1387	0.1296E+03	0.9257E+01
2	2	0	0.7142E-01	0.2523	-0.1046	0.0658	0.31962	1.1387	0.1296E+03	0.9257E+01
3	3	0	0.7142E-01	0.2523	0.1046	0.0658	0.31962	1.1387	0.1296E+03	0.9257E+01
4	4	0	0.7142E-01	0.1046	0.2523	0.0658	0.31962	1.1387	0.1296E+03	0.9257E+01
5	5	0	0.9311E-01	0.186	-0.587	0.2356	0.30936	0.8359	0.9516E+02	0.9356E+01
6	6	0	0.9311E-01	0.342	-0.342	0.2356	0.30936	0.8359	0.9516E+02	0.9356E+01
7	7	0	0.9311E-01	0.342	0.342	0.2356	0.30936	0.8359	0.9516E+02	0.9356E+01
8	8	0	0.9311E-01	0.186	0.587	0.2356	0.30936	0.8359	0.9516E+02	0.9356E+01
9	9	0	0.9831E-01	0.5857	0.3342	0.2356	0.30936	0.8359	0.9516E+02	0.9356E+01
10	10	0	0.9831E-01	0.3342	0.5857	0.2356	0.30936	0.8359	0.9516E+02	0.9356E+01
11	11	0	0.9831E-01	0.3342	0.5857	0.2356	0.30936	0.8359	0.9516E+02	0.9356E+01
12	12	0	0.9831E-01	0.186	-0.922	0.6814	0.28122	0.6478	0.7378E+02	0.2219E+02
13	13	0	0.3010E+00	0.547	-0.8240	0.6814	0.28122	0.6478	0.7378E+02	0.2219E+02
14	14	0	0.2907E+00	0.547	0.8240	0.6814	0.28122	0.6478	0.7378E+02	0.2219E+02
15	15	0	0.2907E+00	0.722	-0.922	0.6814	0.28122	0.6478	0.7378E+02	0.2219E+02
16	16	0	0.3010E+00	0.722	0.922	0.6814	0.28122	0.6478	0.7378E+02	0.2219E+02
17	17	0	0.2907E+00	0.547	-0.8240	0.6814	0.28122	0.6478	0.7378E+02	0.2219E+02
18	18	0	0.2907E+00	0.547	0.8240	0.6814	0.28122	0.6478	0.7378E+02	0.2219E+02
19	19	0	0.3010E+00	0.722	-0.922	0.6814	0.28122	0.6478	0.7378E+02	0.2219E+02
20	20	0	0.3010E+00	0.722	0.922	0.6814	0.28122	0.6478	0.7378E+02	0.2219E+02
21	21	0	0.4357E+00	0.2830	-1.1841	1.2940	0.24201	0.5671	0.6456E+02	0.2716E+02
22	22	0	0.4357E+00	0.2830	1.1841	1.2940	0.24201	0.5671	0.6456E+02	0.2716E+02
23	23	0	0.408E+00	1.1841	-0.7972	1.2940	0.24201	0.5671	0.6456E+02	0.2716E+02
24	24	0	0.4357E+00	1.1841	0.7972	1.2940	0.24201	0.5671	0.6456E+02	0.2716E+02
25	25	0	0.4357E+00	1.3971	-0.2830	1.2940	0.24201	0.5671	0.6456E+02	0.2716E+02
26	26	0	0.4357E+00	1.3971	0.2830	1.2940	0.24201	0.5671	0.6456E+02	0.2716E+02
27	27	0	0.4208E+00	1.1841	-0.7972	1.2940	0.24201	0.5671	0.6456E+02	0.2716E+02
28	28	0	0.4208E+00	1.1841	0.7972	1.2940	0.24201	0.5671	0.6456E+02	0.2716E+02
29	29	0	0.523E+00	0.3641	-1.5231	1.9288	0.20098	0.4777	0.5438E+02	0.2953E+02
30	30	0	0.523E+00	0.3641	1.5231	1.9288	0.20098	0.4777	0.5438E+02	0.2953E+02
31	31	0	0.530E+00	1.0254	-1.0254	1.9288	0.20098	0.4777	0.5438E+02	0.2953E+02
32	32	0	0.5623E+00	1.7970	-0.3641	1.9288	0.20098	0.4777	0.5438E+02	0.2953E+02
33	33	0	0.5623E+00	1.7970	0.3641	1.9288	0.20098	0.4777	0.5438E+02	0.2953E+02
34	34	0	0.530E+00	1.5231	-1.5231	1.9288	0.20098	0.4777	0.5438E+02	0.2953E+02
35	35	0	0.530E+00	1.5231	1.5231	1.9288	0.20098	0.4777	0.5438E+02	0.2953E+02
36	36	0	0.523E+00	0.3641	-1.0254	1.9288	0.20098	0.4777	0.5438E+02	0.2953E+02
37	37	0	0.6815E+00	0.400	-2.18409	2.5822	0.15836	0.4060	0.4622E+02	0.3042E+02
38	38	0	0.6815E+00	0.400	2.18409	2.5822	0.15836	0.4060	0.4622E+02	0.3042E+02
39	39	0	0.6815E+00	1.2393	-1.8409	2.5822	0.15836	0.4060	0.4622E+02	0.3042E+02
40	40	0	0.6815E+00	1.2393	1.8409	2.5822	0.15836	0.4060	0.4622E+02	0.3042E+02
41	41	0	0.6815E+00	1.720	-0.4400	2.5822	0.15836	0.4060	0.4622E+02	0.3042E+02
42	42	0	0.6815E+00	1.720	0.4400	2.5822	0.15836	0.4060	0.4622E+02	0.3042E+02
43	43	0	0.6815E+00	1.8409	-1.8409	2.5822	0.15836	0.4060	0.4622E+02	0.3042E+02
44	44	0	0.6815E+00	1.8409	1.8409	2.5822	0.15836	0.4060	0.4622E+02	0.3042E+02
45	45	0	0.7937E+00	0.5113	-2.5239	3.3513	0.11436	0.3532	0.4027E+02	0.3087E+02
46	46	0	0.7665E+00	1.4401	-1.4401	3.3513	0.11436	0.3532	0.4027E+02	0.3087E+02
47	47	0	0.7665E+00	1.4401	1.4401	3.3513	0.11436	0.3532	0.4027E+02	0.3087E+02
48	48	0	0.7937E+00	2.239	-0.5113	3.3513	0.11436	0.3532	0.4027E+02	0.3087E+02
49	49	0	0.7937E+00	2.239	0.5113	3.3513	0.11436	0.3532	0.4027E+02	0.3087E+02
50	50	0	0.7665E+00	2.1391	-1.4401	3.3513	0.11436	0.3532	0.4027E+02	0.3087E+02

51	0.000000E+00	FX=	0.000000E+00	FN=	0.1272262E-02	SMX=	0.7134259E-02	SMY=	0.0000000E+00	SMZ=	0.0000000E+00
52	0.00000000	CX=	0.00000000	CN=	0.00000001	MX=	0.00000000	MY=	0.00000000	MZ=	0.00000000
53	1.4401		2.1391		3.2513		0.11436		0.3538		0.4027E+02
54	0.5113		2.5239		3.2513		0.11436		0.3532		0.4021E+02
55	0.5784		-2.8552		3.9334		0.06917		0.3488		0.3971E+02
56	1.6292		-2.4199		3.9334		0.06917		0.3494		0.3977E+02
57	2.4200		-0.5292		3.9334		0.06917		0.3488		0.3977E+02
58	2.8552		-0.5784		3.9334		0.06917		0.3488		0.3977E+02
59	2.8552		0.5784		3.9334		0.06917		0.3494		0.3977E+02
60	1.6292		2.4200		3.9334		0.06917		0.3488		0.3977E+02
61	0.5784		2.8552		3.9334		0.06917		0.3488		0.3977E+02
62	0.5113		-2.1391		4.6264		0.02298		0.5047		0.5746E+02
63	0.8693E+00		-2.5239		4.6264		0.02298		0.5037		0.5734E+02
64	0.9002E+00		-2.4199		4.6264		0.02298		0.5037		0.5734E+02
65	0.9666E+00		-0.5292		4.6264		0.02298		0.5047		0.5746E+02
66	0.1001E+01		-0.5784		4.6264		0.02298		0.5037		0.5734E+02
67	0.9666E+00		2.1391		4.6264		0.02298		0.5047		0.5746E+02
68	0.1001E+01		2.5239		4.6264		0.02298		0.5037		0.5734E+02

STEP 10 DEPTH = 5.6755100 TIME = 0.0031128 DIMENSIONLESS TIME 0.3706858 WEITING FACTORS = 1.1362000 1.1320000
AVERAGE VELOCITY 0.000

NO.	1	2	3	4	5	6	7	8	9	10	11	12	13	14	15	16	17	18	19	20	21	22	23	24	25	26	27	28	29	30	31	32	33	34	35	36	37	38
REF.NO.	0	0	0	0	0	0	0	0	0	0	0	0	0	0	0	0	0	0	0	0	0	0	0	0	0	0	0	0	0	0	0	0	0	0	0	0	0	0
AREA	0.7142E-01	0.7142E-01	0.7142E-01	0.7142E-01	0.9831E-01	0.9502E-01	0.9502E-01	0.9831E-01	0.9831E-01	0.9502E-01	0.9502E-01	0.9831E-01	0.9831E-01	0.9502E-01	0.9502E-01	0.9831E-01	0.9831E-01	0.9502E-01	0.9502E-01	0.9831E-01	0.9831E-01	0.9502E-01	0.9502E-01	0.9831E-01	0.9831E-01	0.9502E-01	0.9502E-01	0.9831E-01	0.9831E-01	0.9502E-01	0.9502E-01	0.9831E-01	0.9831E-01	0.9502E-01	0.9502E-01	0.9831E-01	0.9831E-01	
X	0.1046	0.2523	0.1046	0.1046	0.1186	0.3342	0.3342	0.1186	0.1186	0.3342	0.3342	0.1186	0.1186	0.3342	0.3342	0.1186	0.1186	0.3342	0.3342	0.1186	0.1186	0.3342	0.3342	0.1186	0.1186	0.3342	0.3342	0.1186	0.1186	0.3342	0.3342	0.1186	0.1186	0.3342	0.3342	0.1186	0.1186	
Y	-0.2523	-0.1046	0.1046	0.2523	-0.4965	0.5857	0.5857	-0.4965	-0.4965	0.5857	0.5857	-0.4965	-0.4965	0.5857	0.5857	-0.4965	-0.4965	0.5857	0.5857	-0.4965	-0.4965	0.5857	0.5857	-0.4965	-0.4965	0.5857	0.5857	-0.4965	-0.4965	0.5857	0.5857	-0.4965	-0.4965	0.5857	0.5857	-0.4965	-0.4965	
Z	0.0658	0.0658	0.0658	0.0658	0.2356	0.2356	0.2356	0.2356	0.2356	0.2356	0.2356	0.2356	0.2356	0.2356	0.2356	0.2356	0.2356	0.2356	0.2356	0.2356	0.2356	0.2356	0.2356	0.2356	0.2356	0.2356	0.2356	0.2356	0.2356	0.2356	0.2356	0.2356	0.2356	0.2356	0.2356	0.2356	0.2356	0.2356
T*	0.36702	0.36702	0.36702	0.36702	0.35675	0.35675	0.35675	0.35675	0.35675	0.35675	0.35675	0.35675	0.35675	0.35675	0.35675	0.35675	0.35675	0.35675	0.35675	0.35675	0.35675	0.35675	0.35675	0.35675	0.35675	0.35675	0.35675	0.35675	0.35675	0.35675	0.35675	0.35675	0.35675	0.35675	0.35675	0.35675	0.35675	
CP	1.1227	1.1227	1.1227	1.1227	0.8260	0.8260	0.8260	0.8260	0.8260	0.8260	0.8260	0.8260	0.8260	0.8260	0.8260	0.8260	0.8260	0.8260	0.8260	0.8260	0.8260	0.8260	0.8260	0.8260	0.8260	0.8260	0.8260	0.8260	0.8260	0.8260	0.8260	0.8260	0.8260	0.8260	0.8260	0.8260	0.8260	0.8260
P	0.1278E+03	0.1278E+03	0.1278E+03	0.1278E+03	0.9404E+02	0.9404E+02	0.9404E+02	0.9404E+02	0.9404E+02	0.9404E+02	0.9404E+02	0.9404E+02	0.9404E+02	0.9404E+02	0.9404E+02	0.9404E+02	0.9404E+02	0.9404E+02	0.9404E+02	0.9404E+02	0.9404E+02	0.9404E+02	0.9404E+02	0.9404E+02	0.9404E+02	0.9404E+02	0.9404E+02	0.9404E+02	0.9404E+02	0.9404E+02	0.9404E+02	0.9404E+02	0.9404E+02	0.9404E+02	0.9404E+02	0.9404E+02	0.9404E+02	0.9404E+02
FORCE	0.9127E+01	0.9127E+01	0.9127E+01	0.9127E+01	0.8935E+01	0.8935E+01	0.8935E+01	0.8935E+01	0.8935E+01	0.8935E+01	0.8935E+01	0.8935E+01	0.8935E+01	0.8935E+01	0.8935E+01	0.8935E+01	0.8935E+01	0.8935E+01	0.8935E+01	0.8935E+01	0.8935E+01	0.8935E+01	0.8935E+01	0.8935E+01	0.8935E+01	0.8935E+01	0.8935E+01	0.8935E+01	0.8935E+01	0.8935E+01	0.8935E+01	0.8935E+01	0.8935E+01	0.8935E+01	0.8935E+01	0.8935E+01	0.8935E+01	

39	0.6581E+00	1.8409	-1.2933	2.5823	0.20576	0.3987	0.4539E+02	0.2987E+02
40	0.6815E+00	2.1720	-0.4400	2.5823	0.20576	0.3983	0.4535E+02	0.3090E+02
41	0.6815E+00	2.1720	0.4400	2.5823	0.20576	0.3983	0.4535E+02	0.3090E+02
42	0.6815E+00	1.8409	1.2393	2.5823	0.20576	0.3987	0.4539E+02	0.2987E+02
43	0.6815E+00	1.2393	1.8409	2.5823	0.20576	0.3983	0.4535E+02	0.3090E+02
44	0.6815E+00	0.4400	2.1720	2.5823	0.20576	0.3983	0.4535E+02	0.3090E+02
45	0.7655E+00	0.5113	-2.1401	3.2513	0.16176	0.3422	0.3896E+02	0.2986E+02
46	0.7655E+00	1.4401	-1.4401	3.2513	0.16176	0.3422	0.3896E+02	0.2986E+02
47	0.7655E+00	2.3391	0.5113	3.2513	0.16176	0.3416	0.3889E+02	0.3087E+02
48	0.7937E+00	2.5239	-0.5113	3.2513	0.16176	0.3416	0.3889E+02	0.3087E+02
49	0.7937E+00	2.1491	1.4401	3.2513	0.16176	0.3422	0.3896E+02	0.2986E+02
50	0.7937E+00	1.4401	2.1491	3.2513	0.16176	0.3422	0.3896E+02	0.2986E+02
51	0.7937E+00	0.5113	-2.1491	3.2513	0.16176	0.3417	0.3889E+02	0.3087E+02
52	0.8693E+00	0.5113	-2.5239	3.9334	0.11657	0.3020	0.3437E+02	0.2994E+02
53	0.8693E+00	0.5784	-2.8552	3.9334	0.11657	0.3020	0.3437E+02	0.2994E+02
54	0.8693E+00	1.2393	-2.4199	3.9334	0.11657	0.3024	0.3443E+02	0.2993E+02
55	0.8693E+00	2.4200	-1.6292	3.9334	0.11657	0.3025	0.3443E+02	0.2993E+02
56	0.9022E+00	2.8552	0.5784	3.9334	0.11657	0.3020	0.3437E+02	0.2994E+02
57	0.9022E+00	2.8552	0.5784	3.9334	0.11657	0.3020	0.3437E+02	0.2994E+02
58	0.9022E+00	2.4999	1.6292	3.9334	0.11657	0.3024	0.3443E+02	0.2993E+02
59	0.9022E+00	1.6292	2.4999	3.9334	0.11657	0.3025	0.3443E+02	0.2993E+02
60	0.9022E+00	0.5784	-2.8552	3.9334	0.11657	0.3020	0.3437E+02	0.2994E+02
61	0.9022E+00	0.6419	-2.8552	3.9334	0.11657	0.3024	0.3443E+02	0.2993E+02
62	0.9666E+00	1.8080	-2.1686	4.6264	0.07038	0.3032	0.3422E+02	0.3455E+02
63	0.9666E+00	2.6855	-1.8080	4.6264	0.07038	0.3032	0.3422E+02	0.3455E+02
64	0.9666E+00	3.1086	-0.6419	4.6264	0.07038	0.3032	0.3422E+02	0.3455E+02
65	0.9666E+00	3.1086	0.6419	4.6264	0.07038	0.3032	0.3422E+02	0.3455E+02
66	0.9666E+00	2.6855	1.8080	4.6264	0.07038	0.3032	0.3422E+02	0.3455E+02
67	0.9666E+00	1.8079	2.6855	4.6264	0.07038	0.3032	0.3422E+02	0.3455E+02
68	0.9666E+00	0.6419	3.1086	4.6264	0.07038	0.3032	0.3422E+02	0.3455E+02
69	0.9666E+00	0.7023	3.1086	4.6264	0.07038	0.3032	0.3422E+02	0.3455E+02
70	0.9666E+00	1.9780	-2.4965	5.3277	0.02337	0.4419	0.5047E+02	0.5515E+02
71	0.9666E+00	2.5381	-2.9381	5.3277	0.02337	0.4419	0.5047E+02	0.5515E+02
72	0.9666E+00	3.4665	-1.9780	5.3277	0.02337	0.4433	0.5047E+02	0.5515E+02
73	0.9666E+00	3.4665	0.7023	5.3277	0.02337	0.4419	0.5047E+02	0.5515E+02
74	0.9666E+00	2.9381	1.9780	5.3277	0.02337	0.4433	0.5047E+02	0.5515E+02
75	0.9666E+00	1.9780	2.9381	5.3277	0.02337	0.4433	0.5047E+02	0.5515E+02
76	0.9666E+00	0.7023	3.4665	5.3277	0.02337	0.4419	0.5047E+02	0.5515E+02

FX= 0.000000E+00 FD= 0.2115000E+04 FN= -0.1233918E-02 SMX= -0.9274557E-02 SMV= 0.0000000E+00 SMZ= 0.0000000E+00
 CY= 0.0000000 CD= 0.1378421 CN= -0.0000001 MX= 0.0000000 MY= 0.0000000 MZ= 0.0000000

STEP 11 DEPTH = 6.3859100 TIME = 0.0035151 DIMENSIONLESS TIME 0.4185913 WEITING FACTORS = 1.1320000 1.1290000
 AVERAGE VELOCITY 0.000 -1560.000 WX 0.000 ORIENTATION 90.000

NO	1	2	3	4	5	6	7	8	9	10	11	12	13	14	15	16	17	18
REF.NO.	1	2	3	4	5	6	7	8	9	10	11	12	13	14	15	16	17	18
MOD	0	0	0	0	0	0	0	0	0	0	0	0	0	0	0	0	0	0
AREA	0.7142E-01	0.7142E-01	0.7142E-01	0.7142E-01	0.9831E-01	0.9502E-01	0.9502E-01	0.9831E-01	0.9831E-01	0.9502E-01	0.9502E-01	0.9831E-01	0.9831E-01	0.9502E-01	0.9502E-01	0.9831E-01	0.9831E-01	0.9502E-01
X	0.1046	0.2523	0.2523	0.1046	0.1186	0.3342	0.4965	0.5857	0.5857	0.4965	0.3342	0.1186	0.1046	0.1046	0.2523	0.2523	0.1046	0.1046
Y	-0.2523	-0.1046	0.2523	0.1046	-0.5857	-0.4965	-0.3342	-0.1186	-0.1186	-0.3342	-0.4965	-0.5857	-0.1046	-0.1046	-0.2523	-0.2523	-0.1046	-0.1046
Z	0.0658	0.0658	0.0658	0.0658	0.2356	0.2356	0.2356	0.2356	0.2356	0.2356	0.2356	0.2356	0.2356	0.2356	0.2356	0.2356	0.2356	0.2356
TM*	0.41493	0.41493	0.41493	0.41493	0.40466	0.40466	0.40466	0.40466	0.40466	0.40466	0.40466	0.40466	0.40466	0.40466	0.40466	0.40466	0.40466	0.40466
CP	1.1096	1.1096	1.1096	1.1096	0.8183	0.8183	0.8183	0.8183	0.8183	0.8183	0.8183	0.8183	0.8183	0.8183	0.8183	0.8183	0.8183	0.8183
P	0.1263E+03	0.1263E+03	0.1263E+03	0.1263E+03	0.9318E+02	0.9318E+02	0.9318E+02	0.9318E+02	0.9318E+02	0.9318E+02	0.9318E+02	0.9318E+02	0.9318E+02	0.9318E+02	0.9318E+02	0.9318E+02	0.9318E+02	0.9318E+02
FORCE	0.9021E+01	0.9021E+01	0.9021E+01	0.9021E+01	0.9158E+01	0.8854E+01	0.8854E+01	0.8854E+01	0.8854E+01	0.8854E+01	0.8854E+01	0.8854E+01	0.8854E+01	0.8854E+01	0.8854E+01	0.8854E+01	0.8854E+01	0.8854E+01

FX= 0.000000E+00 FD= 0.2256365E+04 FN= 0.4866028E-03 SFK= 0.6570108E-02 SMV= 0.000000E+00 SMZ= 0.000000E+00
 CX= 0.00000000 CD= 0.1470553 CN= 0.00000000 MX= -1560.0000 WX 0.00000000 MY= 0.00000000 MZ= 0.00000000

STEP 12 DEPTH = 7.0990100 TIME = 0.0039200 DIMENSIONLESS TIME 0.4668066 WEITING FACTORS = 1.12:0000 1.1274000
 AVERAGE VELOCITY 0.000 -1560.000 WX 0.000 ORIENTATION 90.000

NO.	REF. NO.	MOD	AREA	X	Y	Z	TM*	CP	P	FORCE
1	1	0	0.7142E-01	0.1046	-0.2523	0.0658	0.46314	1.0990	0.1251E+03	0.8935E+01
2	2	0	0.7142E-01	0.2523	-0.1046	0.0658	0.46314	1.0990	0.1251E+03	0.8935E+01
3	3	0	0.7142E-01	0.1046	0.2523	0.0658	0.46314	1.0990	0.1251E+03	0.8935E+01
4	4	0	0.9831E-01	0.1186	-0.5857	0.2356	0.45288	0.8124	0.9248E+02	0.9092E+01
5	5	0	0.9831E-01	0.3342	-0.4965	0.2356	0.45288	0.8124	0.9248E+02	0.8790E+01
6	6	0	0.9502E-01	0.4965	-0.3342	0.2356	0.45288	0.8124	0.9248E+02	0.8790E+01
7	7	0	0.9831E-01	0.5857	-0.1186	0.2356	0.45288	0.8124	0.9248E+02	0.9092E+01
8	8	0	0.9502E-01	0.4965	0.3342	0.2356	0.45288	0.8124	0.9248E+02	0.8790E+01
9	9	0	0.9831E-01	0.1186	0.5857	0.2356	0.45288	0.8124	0.9248E+02	0.8790E+01
10	10	0	0.9502E-01	0.3342	0.4965	0.2356	0.45288	0.8124	0.9248E+02	0.8790E+01
11	11	0	0.9831E-01	0.1186	0.5857	0.2356	0.45288	0.8124	0.9248E+02	0.8790E+01
12	12	0	0.9502E-01	0.3342	0.4965	0.2356	0.45288	0.8124	0.9248E+02	0.8790E+01
13	13	0	0.3010E+00	0.1969	-0.8722	0.6814	0.42474	0.6342	0.7222E+02	0.2173E+02
14	14	0	0.2907E+00	0.5547	-0.8240	0.6814	0.42474	0.6342	0.7222E+02	0.2099E+02
15	15	0	0.2907E+00	0.8240	-0.5547	0.6814	0.42474	0.6342	0.7222E+02	0.2099E+02
16	16	0	0.3010E+00	0.9722	-0.1969	0.6814	0.42474	0.6342	0.7222E+02	0.2173E+02
17	17	0	0.2907E+00	0.9722	0.1969	0.6814	0.42474	0.6342	0.7222E+02	0.2099E+02
18	18	0	0.2907E+00	0.8240	0.5547	0.6814	0.42474	0.6342	0.7222E+02	0.2099E+02
19	19	0	0.2907E+00	0.5547	0.8240	0.6814	0.42474	0.6342	0.7222E+02	0.2099E+02
20	20	0	0.3010E+00	0.1969	0.9722	0.6814	0.42474	0.6342	0.7222E+02	0.2173E+02
21	21	0	0.4357E+00	0.2830	-1.3971	1.2940	0.38553	0.5333	0.6299E+02	0.2744E+02
22	22	0	0.4208E+00	0.7972	-1.1841	1.2940	0.38553	0.5333	0.6299E+02	0.2653E+02
23	23	0	0.4208E+00	1.1841	-0.7972	1.2940	0.38553	0.5333	0.6299E+02	0.2653E+02
24	24	0	0.4357E+00	1.3971	-0.2830	1.2940	0.38553	0.5333	0.6299E+02	0.2744E+02
25	25	0	0.4357E+00	1.3971	0.2830	1.2940	0.38553	0.5333	0.6299E+02	0.2744E+02
26	26	0	0.4208E+00	1.1841	0.7972	1.2940	0.38553	0.5333	0.6299E+02	0.2653E+02
27	27	0	0.4208E+00	0.7972	1.1841	1.2940	0.38553	0.5333	0.6299E+02	0.2653E+02
28	28	0	0.4357E+00	0.2830	-1.3971	1.2940	0.38553	0.5333	0.6299E+02	0.2744E+02
29	29	0	0.5623E+00	0.3641	-1.7970	1.9288	0.34450	0.4658	0.5303E+02	0.2982E+02
30	30	0	0.5430E+00	1.0254	-1.5231	1.9288	0.34450	0.4658	0.5303E+02	0.2881E+02
31	31	0	0.5430E+00	1.5231	-1.0254	1.9288	0.34450	0.4658	0.5303E+02	0.2881E+02
32	32	0	0.5623E+00	1.7970	-0.3641	1.9288	0.34450	0.4658	0.5303E+02	0.2982E+02
33	33	0	0.5623E+00	1.7970	0.3641	1.9288	0.34450	0.4658	0.5303E+02	0.2982E+02
34	34	0	0.5430E+00	1.0254	-1.5231	1.9288	0.34450	0.4658	0.5303E+02	0.2881E+02
35	35	0	0.5430E+00	1.5231	-1.0254	1.9288	0.34450	0.4658	0.5303E+02	0.2881E+02
36	36	0	0.5623E+00	1.7970	-0.3641	1.9288	0.34450	0.4658	0.5303E+02	0.2982E+02
37	37	0	0.5623E+00	1.7970	0.3641	1.9288	0.34450	0.4658	0.5303E+02	0.2982E+02
38	38	0	0.6815E+00	0.4400	-2.1720	2.5822	0.30188	0.3940	0.4489E+02	0.3057E+02
39	39	0	0.6815E+00	1.2393	-1.8409	2.5822	0.30188	0.3940	0.4489E+02	0.2955E+02
40	40	0	0.6815E+00	1.8409	-1.2393	2.5822	0.30188	0.3940	0.4489E+02	0.3057E+02
41	41	0	0.6815E+00	2.1720	-0.4400	2.5822	0.30188	0.3940	0.4489E+02	0.3057E+02
42	42	0	0.6815E+00	2.1720	0.4400	2.5822	0.30188	0.3940	0.4489E+02	0.2955E+02
43	43	0	0.6815E+00	1.8409	1.2393	2.5822	0.30188	0.3940	0.4489E+02	0.2955E+02
44	44	0	0.6815E+00	1.2393	1.8409	2.5822	0.30188	0.3940	0.4489E+02	0.3057E+02
45	45	0	0.7937E+00	0.5113	-2.5239	3.2513	0.25788	0.3373	0.3844E+02	0.2946E+02
46	46	0	0.7665E+00	1.4401	-2.1391	3.2513	0.25788	0.3373	0.3844E+02	0.2946E+02
47	47	0	0.7665E+00	2.1391	-1.4401	3.2513	0.25788	0.3373	0.3844E+02	0.2946E+02
48	48	0	0.7937E+00	2.5239	-0.5113	3.2513	0.25788	0.3373	0.3844E+02	0.3048E+02
49	49	0	0.7937E+00	2.5239	0.5113	3.2513	0.25788	0.3373	0.3844E+02	0.2946E+02
50	50	0	0.9002E+00	1.3911	-1.4401	3.2513	0.25788	0.3373	0.3844E+02	0.2946E+02
51	51	0	0.9002E+00	1.4401	-1.3911	3.2513	0.25788	0.3373	0.3844E+02	0.2946E+02
52	52	0	0.9002E+00	1.3911	1.4401	3.2513	0.25788	0.3373	0.3844E+02	0.3048E+02
53	53	0	0.7937E+00	0.5113	-2.5239	3.2513	0.25788	0.3373	0.3844E+02	0.2946E+02
54	54	0	0.8693E+00	1.5784	-2.8552	3.9334	0.21269	0.2944	0.3351E+02	0.2913E+02
55	55	0	0.8693E+00	1.5784	2.8552	3.9334	0.21269	0.2944	0.3351E+02	0.2913E+02
56	56	0	0.9002E+00	2.8552	-1.5784	3.9334	0.21269	0.2944	0.3351E+02	0.3014E+02
57	57	0	0.9002E+00	2.8552	1.5784	3.9334	0.21269	0.2944	0.3351E+02	0.3014E+02

57	0.9002E+00	0.5784	3.9334	0.21269	0.2941	0.3348E+02	0.3014E+02
58	0.8693E+00	1.6292	3.9334	0.21269	0.2944	0.3351E+02	0.2913E+02
59	0.8693E+00	1.6292	3.9334	0.21269	0.2944	0.3351E+02	0.2913E+02
60	0.9002E+00	2.8552	3.9334	0.21269	0.2941	0.3348E+02	0.3014E+02
61	0.9002E+00	2.8552	3.9334	0.21269	0.2941	0.3348E+02	0.3014E+02
62	0.9666E+00	1.8080	4.6264	0.16650	0.2629	0.2993E+02	0.2893E+02
63	0.9666E+00	1.8080	4.6264	0.16650	0.2629	0.2993E+02	0.2893E+02
64	0.1001E+01	0.6419	4.6264	0.16650	0.2625	0.2989E+02	0.2993E+02
65	0.1001E+01	0.6419	4.6264	0.16650	0.2625	0.2989E+02	0.2993E+02
66	0.9666E+00	3.6855	4.6264	0.16650	0.2629	0.2993E+02	0.2893E+02
67	0.9666E+00	3.6855	4.6264	0.16650	0.2629	0.2993E+02	0.2893E+02
68	0.1096E+01	0.7023	5.3277	0.11949	0.2424	0.2760E+02	0.3025E+02
69	0.1096E+01	0.7023	5.3277	0.11949	0.2424	0.2760E+02	0.3025E+02
70	0.1059E+01	1.9780	5.3277	0.11949	0.2429	0.2765E+02	0.2927E+02
71	0.1059E+01	1.9780	5.3277	0.11949	0.2429	0.2765E+02	0.2927E+02
72	0.1096E+01	3.4665	5.3277	0.11949	0.2424	0.2760E+02	0.3025E+02
73	0.1096E+01	3.4665	5.3277	0.11949	0.2424	0.2760E+02	0.3025E+02
74	0.1059E+01	2.9381	5.3277	0.11949	0.2429	0.2765E+02	0.2927E+02
75	0.1059E+01	2.9381	5.3277	0.11949	0.2429	0.2765E+02	0.2927E+02
76	0.1096E+01	0.7023	6.0351	0.07187	0.2526	0.2760E+02	0.3025E+02
77	0.1096E+01	0.7023	6.0351	0.07187	0.2526	0.2760E+02	0.3025E+02
78	0.1146E+01	2.1408	6.0351	0.07187	0.2530	0.2880E+02	0.3301E+02
79	0.1146E+01	2.1408	6.0351	0.07187	0.2530	0.2880E+02	0.3301E+02
80	0.1187E+01	3.7519	6.0351	0.07187	0.2526	0.2876E+02	0.3413E+02
81	0.1187E+01	3.7519	6.0351	0.07187	0.2526	0.2876E+02	0.3413E+02
82	0.1146E+01	0.7023	6.7465	0.02384	0.2674	0.2876E+02	0.3413E+02
83	0.1146E+01	0.7023	6.7465	0.02384	0.2674	0.2876E+02	0.3413E+02
84	0.1187E+01	0.8159	6.7465	0.02384	0.2685	0.4852E+02	0.5157E+02
85	0.1187E+01	0.8159	6.7465	0.02384	0.2685	0.4852E+02	0.5157E+02
86	0.1229E+01	2.2980	6.7465	0.02384	0.2685	0.4852E+02	0.5157E+02
87	0.1229E+01	2.2980	6.7465	0.02384	0.2685	0.4852E+02	0.5157E+02
88	0.1273E+01	4.0274	6.7465	0.02384	0.2685	0.4852E+02	0.5157E+02
89	0.1273E+01	4.0274	6.7465	0.02384	0.2685	0.4852E+02	0.5157E+02
90	0.1229E+01	2.2980	6.7465	0.02384	0.2685	0.4852E+02	0.5157E+02
91	0.1229E+01	2.2980	6.7465	0.02384	0.2685	0.4852E+02	0.5157E+02
92	0.1273E+01	4.0274	6.7465	0.02384	0.2674	0.4822E+02	0.5323E+02

FX= 0.000000E+00 FD= 0.2414261E+04 FN= 0.8590710E-03 SMX= 0.3067418E-02 SMY= 0.0000000E+00 SMZ= 0.0000000E+00
 CX= 0.00000000 CD= 0.1573460 CN= 0.00000000 CMX= -1560.0000 CWX= 0.00000000 CMY= 0.00000000 CMZ= 0.00000000

STEP 13 DEPTH = 7.8126100 TIME = 0.0043257 DIMENSIONLESS TIME 0.5151243 METTING FACTORS = 1.1274000 1.1192000
 AVERAGE VELOCITY 0.000

NO.	1	2	3	4	5	6	7	8	9	10	11	12	13	14	15	16	17	18	19	20
REF.NO.	0	0	0	0	0	0	0	0	0	0	0	0	0	0	0	0	0	0	0	0
MOD	0	0	0	0	0	0	0	0	0	0	0	0	0	0	0	0	0	0	0	0
AREA	0.7142E-01	0.7142E-01	0.7142E-01	0.7142E-01	0.9831E-01	0.9502E-01	0.9502E-01	0.9831E-01	0.9831E-01	0.9502E-01	0.9502E-01	0.9831E-01	0.9831E-01	0.9502E-01	0.9502E-01	0.9831E-01	0.9831E-01	0.9502E-01	0.9502E-01	0.9831E-01
X	0.1046	0.2523	0.2523	0.1046	0.1186	0.3342	0.4965	0.3342	0.1186	0.5857	0.4965	0.3342	0.1186	0.5547	0.8240	0.9722	0.3010E+00	0.2907E+00	0.8240	0.5547
Y	-0.2523	-0.1046	0.2523	0.1046	-0.5857	-0.4965	-0.3342	0.4965	-0.1186	0.3342	0.4965	-0.3342	0.1186	-0.5547	-0.8240	-0.9722	0.3010E+00	0.2907E+00	-0.8240	-0.5547
Z	0.0658	0.0658	0.0658	0.0658	0.2356	0.2356	0.2356	0.2356	0.2356	0.2356	0.2356	0.2356	0.2356	0.6814	0.6814	0.6814	0.6814	0.6814	0.6814	0.6814
TX	0.51146	0.51146	0.51146	0.51146	0.50119	0.50119	0.50119	0.50119	0.50119	0.50119	0.50119	0.50119	0.50119	0.47306	0.47306	0.47306	0.47306	0.47306	0.47306	0.47306
TY	0.51146	0.51146	0.51146	0.51146	0.50119	0.50119	0.50119	0.50119	0.50119	0.50119	0.50119	0.50119	0.50119	0.47306	0.47306	0.47306	0.47306	0.47306	0.47306	0.47306
CP	1.0904	1.0904	1.0904	1.0904	0.8076	0.8076	0.8076	0.8076	0.8076	0.8076	0.8076	0.8076	0.8076	0.6322	0.6322	0.6322	0.6322	0.6322	0.6322	0.6322
FORCE	0.1241E+03	0.1241E+03	0.1241E+03	0.1241E+03	0.9194E+02	0.9194E+02	0.9194E+02	0.9194E+02	0.9194E+02	0.9194E+02	0.9194E+02	0.9194E+02	0.9194E+02	0.2166E+02	0.2166E+02	0.2166E+02	0.2166E+02	0.2166E+02	0.2166E+02	0.2166E+02

87 0.000000E+00 FD= 0.2594219E+04 EN= -0.2903725E-02 SMX= -0.2161438E-01 SMV= 0.0000000E+00 SMZ= 0.0000000E+00
 CX= 0.000000000 CD= 0.1690745 CN= -0.00000002 MX= -0.00000001 MY= 0.00000000 MZ= 0.00000000

STEP 14 DEPTH = 8.5245100 TIME = 0.0047335 DIMENSIONLESS TIME 0.5636799 WEITING FACTORS = 1.1192000 1.1083000
 AVERAGE VELOCITY 0.000 MOD

NO.	REF.NO.	MOD	AREA	X	Y	Z	T*	CP	P	FORCE
1	1	0	0.1046	0.1046	-0.2523	0.0658	0.56002	1.0806	0.1230E+03	0.8785E+01
2	2	0	0.2523	-0.1046	0.2523	0.0658	0.56002	1.0806	0.1230E+03	0.8785E+01
3	3	0	0.2523	0.1046	0.2523	0.0658	0.56002	1.0806	0.1230E+03	0.8785E+01
4	4	0	0.1046	0.2523	-0.1046	0.0658	0.56002	1.0806	0.1230E+03	0.8785E+01
5	5	0	0.186	0.5857	-0.5857	0.2356	0.54975	0.8012	0.9122E+02	0.8668E+01
6	6	0	0.3342	-0.5857	0.5857	0.2356	0.54975	0.8012	0.9122E+02	0.8668E+01
7	7	0	0.4965	0.3342	-0.3342	0.2356	0.54975	0.8012	0.9122E+02	0.8668E+01
8	8	0	0.5857	0.5857	0.5857	0.2356	0.54975	0.8012	0.9122E+02	0.8668E+01
9	9	0	0.4965	-0.3342	-0.3342	0.2356	0.54975	0.8012	0.9122E+02	0.8668E+01
10	10	0	0.186	0.5857	0.5857	0.2356	0.54975	0.8012	0.9122E+02	0.8668E+01
11	11	0	0.3342	-0.5857	-0.5857	0.2356	0.54975	0.8012	0.9122E+02	0.8668E+01
12	12	0	0.4965	0.3342	0.3342	0.2356	0.54975	0.8012	0.9122E+02	0.8668E+01
13	13	0	0.5857	0.5857	0.5857	0.2356	0.54975	0.8012	0.9122E+02	0.8668E+01
14	14	0	0.186	0.5857	-0.5857	0.2356	0.54975	0.8012	0.9122E+02	0.8668E+01
15	15	0	0.3342	-0.5857	0.5857	0.2356	0.54975	0.8012	0.9122E+02	0.8668E+01
16	16	0	0.4965	0.3342	-0.3342	0.2356	0.54975	0.8012	0.9122E+02	0.8668E+01
17	17	0	0.5857	0.5857	0.5857	0.2356	0.54975	0.8012	0.9122E+02	0.8668E+01
18	18	0	0.186	0.5857	-0.5857	0.2356	0.54975	0.8012	0.9122E+02	0.8668E+01
19	19	0	0.3342	-0.5857	0.5857	0.2356	0.54975	0.8012	0.9122E+02	0.8668E+01
20	20	0	0.4965	0.3342	-0.3342	0.2356	0.54975	0.8012	0.9122E+02	0.8668E+01
21	21	0	0.5857	0.5857	0.5857	0.2356	0.54975	0.8012	0.9122E+02	0.8668E+01
22	22	0	0.186	0.5857	-0.5857	0.2356	0.54975	0.8012	0.9122E+02	0.8668E+01
23	23	0	0.3342	-0.5857	0.5857	0.2356	0.54975	0.8012	0.9122E+02	0.8668E+01
24	24	0	0.4965	0.3342	-0.3342	0.2356	0.54975	0.8012	0.9122E+02	0.8668E+01
25	25	0	0.5857	0.5857	0.5857	0.2356	0.54975	0.8012	0.9122E+02	0.8668E+01
26	26	0	0.186	0.5857	-0.5857	0.2356	0.54975	0.8012	0.9122E+02	0.8668E+01
27	27	0	0.3342	-0.5857	0.5857	0.2356	0.54975	0.8012	0.9122E+02	0.8668E+01
28	28	0	0.4965	0.3342	-0.3342	0.2356	0.54975	0.8012	0.9122E+02	0.8668E+01
29	29	0	0.5857	0.5857	0.5857	0.2356	0.54975	0.8012	0.9122E+02	0.8668E+01
30	30	0	0.186	0.5857	-0.5857	0.2356	0.54975	0.8012	0.9122E+02	0.8668E+01
31	31	0	0.3342	-0.5857	0.5857	0.2356	0.54975	0.8012	0.9122E+02	0.8668E+01
32	32	0	0.4965	0.3342	-0.3342	0.2356	0.54975	0.8012	0.9122E+02	0.8668E+01
33	33	0	0.5857	0.5857	0.5857	0.2356	0.54975	0.8012	0.9122E+02	0.8668E+01
34	34	0	0.186	0.5857	-0.5857	0.2356	0.54975	0.8012	0.9122E+02	0.8668E+01
35	35	0	0.3342	-0.5857	0.5857	0.2356	0.54975	0.8012	0.9122E+02	0.8668E+01
36	36	0	0.4965	0.3342	-0.3342	0.2356	0.54975	0.8012	0.9122E+02	0.8668E+01
37	37	0	0.5857	0.5857	0.5857	0.2356	0.54975	0.8012	0.9122E+02	0.8668E+01
38	38	0	0.186	0.5857	-0.5857	0.2356	0.54975	0.8012	0.9122E+02	0.8668E+01
39	39	0	0.3342	-0.5857	0.5857	0.2356	0.54975	0.8012	0.9122E+02	0.8668E+01
40	40	0	0.4965	0.3342	-0.3342	0.2356	0.54975	0.8012	0.9122E+02	0.8668E+01
41	41	0	0.5857	0.5857	0.5857	0.2356	0.54975	0.8012	0.9122E+02	0.8668E+01
42	42	0	0.186	0.5857	-0.5857	0.2356	0.54975	0.8012	0.9122E+02	0.8668E+01

43	0.658	1240	1.8409	5822	3.9875	3915	0.4456	0.2933
44	0.681	1440	1.1720	5822	3.9875	3915	0.4452	0.3034
45	0.793	1440	2.5239	3.2513	0.3547	0.3356	0.4817	0.2929
46	0.766	1391	-2.1391	3.2513	0.3547	0.3356	0.3821	0.3030
47	0.766	1440	-1.4401	3.2513	0.3547	0.3356	0.3818	0.2929
48	0.793	1440	0.5113	3.2513	0.3547	0.3356	0.3817	0.3030
49	0.766	1440	0.4401	3.2513	0.3547	0.3356	0.3821	0.2929
50	0.793	1440	2.5239	3.2513	0.3547	0.3356	0.3818	0.3030
51	0.766	1391	-2.1391	3.2513	0.3547	0.3356	0.3821	0.2929
52	0.766	1440	-1.4401	3.2513	0.3547	0.3356	0.3817	0.3030
53	0.793	1440	0.5113	3.2513	0.3547	0.3356	0.3818	0.2929
54	0.766	1440	0.4401	3.2513	0.3547	0.3356	0.3821	0.3030
55	0.900	1440	2.8552	3.9334	0.3095	0.2926	0.3311	0.2900
56	0.869	1440	-2.4193	3.9334	0.3095	0.2926	0.3311	0.2900
57	0.900	1440	2.8552	3.9334	0.3095	0.2926	0.3311	0.2900
58	0.869	1440	-2.4193	3.9334	0.3095	0.2926	0.3311	0.2900
59	0.900	1440	2.8552	3.9334	0.3095	0.2926	0.3311	0.2900
60	0.900	1440	2.8552	3.9334	0.3095	0.2926	0.3311	0.2900
61	0.966	1440	4.6264	4.6264	0.2633	0.2612	0.2732	0.2874
62	0.966	1440	4.6264	4.6264	0.2633	0.2612	0.2732	0.2874
63	1.001	1440	-2.6419	4.6264	0.2633	0.2612	0.2732	0.2874
64	1.001	1440	-2.6419	4.6264	0.2633	0.2612	0.2732	0.2874
65	0.966	1440	4.6264	4.6264	0.2633	0.2612	0.2732	0.2874
66	0.966	1440	4.6264	4.6264	0.2633	0.2612	0.2732	0.2874
67	1.001	1440	-2.6419	4.6264	0.2633	0.2612	0.2732	0.2874
68	1.001	1440	-2.6419	4.6264	0.2633	0.2612	0.2732	0.2874
69	1.059	1440	3.9381	5.3277	0.2163	0.2385	0.2715	0.2874
70	1.059	1440	3.9381	5.3277	0.2163	0.2385	0.2715	0.2874
71	1.059	1440	3.9381	5.3277	0.2163	0.2385	0.2715	0.2874
72	1.059	1440	3.9381	5.3277	0.2163	0.2385	0.2715	0.2874
73	1.096	1440	0.7023	5.3277	0.2163	0.2385	0.2715	0.2874
74	1.096	1440	0.7023	5.3277	0.2163	0.2385	0.2715	0.2874
75	1.096	1440	0.7023	5.3277	0.2163	0.2385	0.2715	0.2874
76	1.118	1440	3.4665	5.3277	0.2163	0.2385	0.2715	0.2874
77	1.118	1440	3.4665	5.3277	0.2163	0.2385	0.2715	0.2874
78	1.146	1440	3.1800	6.0351	0.1687	0.2225	0.2533	0.2900
79	1.146	1440	3.1800	6.0351	0.1687	0.2225	0.2533	0.2900
80	1.187	1440	-2.7601	6.0351	0.1687	0.2225	0.2533	0.3003
81	1.187	1440	-2.7601	6.0351	0.1687	0.2225	0.2533	0.3003
82	1.146	1440	3.1800	6.0351	0.1687	0.2225	0.2533	0.2900
83	1.146	1440	3.1800	6.0351	0.1687	0.2225	0.2533	0.2900
84	1.187	1440	3.7579	6.0351	0.1687	0.2225	0.2533	0.3003
85	1.187	1440	3.7579	6.0351	0.1687	0.2225	0.2533	0.3003
86	1.239	1440	4.0273	6.7465	0.1207	0.2115	0.2408	0.2959
87	1.239	1440	4.0273	6.7465	0.1207	0.2115	0.2408	0.2959
88	1.239	1440	4.0273	6.7465	0.1207	0.2115	0.2408	0.3060
89	1.239	1440	4.0273	6.7465	0.1207	0.2115	0.2408	0.3060
90	1.273	1440	0.8159	6.7465	0.1207	0.2115	0.2408	0.2959
91	1.273	1440	0.8159	6.7465	0.1207	0.2115	0.2408	0.2959
92	1.295	1440	3.4134	6.7465	0.1207	0.2115	0.2408	0.3060
93	1.295	1440	3.4134	6.7465	0.1207	0.2115	0.2408	0.3060
94	1.355	1440	4.0274	7.4595	0.0724	0.2178	0.2474	0.3352
95	1.355	1440	4.0274	7.4595	0.0724	0.2178	0.2474	0.3352
96	1.398	1440	3.6408	7.4595	0.0724	0.2178	0.2474	0.3243
97	1.398	1440	3.6408	7.4595	0.0724	0.2178	0.2474	0.3243
98	1.355	1440	4.0274	7.4595	0.0724	0.2178	0.2474	0.3352
99	1.355	1440	4.0274	7.4595	0.0724	0.2178	0.2474	0.3352
100	1.398	1440	3.6408	8.1720	0.0240	0.2998	0.3413	0.4722
101	1.398	1440	3.6408	8.1720	0.0240	0.2998	0.3413	0.4722
102	1.398	1440	3.6408	8.1720	0.0240	0.2998	0.3413	0.4874
103	1.398	1440	3.6408	8.1720	0.0240	0.2998	0.3413	0.4874
104	1.434	1440	-2.6015	8.1720	0.0240	0.2998	0.3413	0.4722
105	1.434	1440	-2.6015	8.1720	0.0240	0.2998	0.3413	0.4722
106	1.434	1440	3.8644	8.1720	0.0240	0.2998	0.3413	0.4874
107	1.434	1440	3.8644	8.1720	0.0240	0.2998	0.3413	0.4874
108	1.434	1440	3.8644	8.1720	0.0240	0.2998	0.3402	0.4874

EX= 0.000000E+00 FD= 0.2700456E+04 FN= 0.1743856E-02 SMX= 0.1980766E-01 SMY= 0.0000000E+00 SMZ= 0.0000000E+00
 CX= 0.0000000 CD= 0.1759983 CF= 0.0000001 CX= 0.0000001 MY= 0.0000000 MZ= 0.0000000

STEP 15 DEPTH = 9.1865100 TIME = 0.0051164 DIMENSIONLESS TIME 0.6092762 WEITTING FACTORS = 1.1083000 1.1021000
 AVERAGE VELOCITY 0.000 MOD -1560.000 WX 0.000 ORIENTATION 90.000

NO.	REF.NO.	MOD	AREA	X	Y	Z	TM*	CP	P	FORCE
1	1	0	0.7142E-01	0.1046	-0.2523	0.0658	0.60561	1.0698	0.1218E+03	0.8698E+01
2	2	0	0.7142E-01	0.2523	-0.1046	0.0658	0.60561	1.0698	0.1218E+03	0.8698E+01
3	3	0	0.7142E-01	0.1046	0.2523	0.0658	0.60561	1.0698	0.1218E+03	0.8698E+01
4	4	0	0.9831E-01	0.1186	-0.5857	0.2356	0.59534	0.7930	0.9027E+02	0.8875E+01
5	5	0	0.9502E-01	0.3342	-0.4965	0.2356	0.59534	0.7931	0.9029E+02	0.8579E+01
6	6	0	0.9502E-01	0.4965	-0.3342	0.2356	0.59534	0.7931	0.9027E+02	0.8579E+01
7	7	0	0.9831E-01	0.1186	0.4965	0.2356	0.59534	0.7930	0.9029E+02	0.8875E+01
8	8	0	0.9502E-01	0.3342	-0.1186	0.2356	0.59534	0.7931	0.9027E+02	0.8579E+01
9	9	0	0.9502E-01	0.4965	0.1186	0.2356	0.59534	0.7931	0.9029E+02	0.8579E+01
10	10	0	0.9831E-01	0.1186	0.3342	0.2356	0.59534	0.7930	0.9027E+02	0.8875E+01
11	11	0	0.9502E-01	0.3342	-0.4965	0.2356	0.59534	0.7931	0.9029E+02	0.8579E+01
12	12	0	0.9502E-01	0.4965	-0.3342	0.2356	0.59534	0.7931	0.9027E+02	0.8579E+01
13	13	0	0.9831E-01	0.1186	0.4965	0.2356	0.59534	0.7930	0.9029E+02	0.8875E+01
14	14	0	0.9502E-01	0.3342	-0.1186	0.2356	0.59534	0.7931	0.9027E+02	0.8579E+01
15	15	0	0.9502E-01	0.4965	0.1186	0.2356	0.59534	0.7931	0.9029E+02	0.8579E+01
16	16	0	0.9831E-01	0.1186	0.3342	0.2356	0.59534	0.7930	0.9027E+02	0.8875E+01
17	17	0	0.9502E-01	0.3342	-0.4965	0.2356	0.59534	0.7931	0.9029E+02	0.8579E+01
18	18	0	0.9502E-01	0.4965	-0.3342	0.2356	0.59534	0.7931	0.9027E+02	0.8579E+01
19	19	0	0.9831E-01	0.1186	0.4965	0.2356	0.59534	0.7930	0.9029E+02	0.8875E+01
20	20	0	0.9502E-01	0.3342	-0.1186	0.2356	0.59534	0.7931	0.9027E+02	0.8579E+01
21	21	0	0.9502E-01	0.4965	0.1186	0.2356	0.59534	0.7931	0.9029E+02	0.8579E+01
22	22	0	0.9831E-01	0.1186	0.3342	0.2356	0.59534	0.7930	0.9027E+02	0.8875E+01
23	23	0	0.9502E-01	0.3342	-0.4965	0.2356	0.59534	0.7931	0.9029E+02	0.8579E+01
24	24	0	0.9502E-01	0.4965	-0.3342	0.2356	0.59534	0.7931	0.9027E+02	0.8579E+01
25	25	0	0.9831E-01	0.1186	0.4965	0.2356	0.59534	0.7930	0.9029E+02	0.8875E+01
26	26	0	0.9502E-01	0.3342	-0.1186	0.2356	0.59534	0.7931	0.9027E+02	0.8579E+01
27	27	0	0.9502E-01	0.4965	0.1186	0.2356	0.59534	0.7931	0.9029E+02	0.8579E+01
28	28	0	0.9831E-01	0.1186	0.3342	0.2356	0.59534	0.7930	0.9027E+02	0.8875E+01
29	29	0	0.9502E-01	0.3342	-0.4965	0.2356	0.59534	0.7931	0.9029E+02	0.8579E+01
30	30	0	0.9502E-01	0.4965	-0.3342	0.2356	0.59534	0.7931	0.9027E+02	0.8579E+01
31	31	0	0.9831E-01	0.1186	0.4965	0.2356	0.59534	0.7930	0.9029E+02	0.8875E+01
32	32	0	0.9502E-01	0.3342	-0.1186	0.2356	0.59534	0.7931	0.9027E+02	0.8579E+01
33	33	0	0.9502E-01	0.4965	0.1186	0.2356	0.59534	0.7931	0.9029E+02	0.8579E+01
34	34	0	0.9831E-01	0.1186	0.3342	0.2356	0.59534	0.7930	0.9027E+02	0.8875E+01
35	35	0	0.9502E-01	0.3342	-0.4965	0.2356	0.59534	0.7931	0.9029E+02	0.8579E+01
36	36	0	0.9502E-01	0.4965	-0.3342	0.2356	0.59534	0.7931	0.9027E+02	0.8579E+01
37	37	0	0.9831E-01	0.1186	0.4965	0.2356	0.59534	0.7930	0.9029E+02	0.8875E+01
38	38	0	0.9502E-01	0.3342	-0.1186	0.2356	0.59534	0.7931	0.9027E+02	0.8579E+01
39	39	0	0.9502E-01	0.4965	0.1186	0.2356	0.59534	0.7931	0.9029E+02	0.8579E+01
40	40	0	0.9831E-01	0.1186	0.3342	0.2356	0.59534	0.7930	0.9027E+02	0.8875E+01
41	41	0	0.9502E-01	0.3342	-0.4965	0.2356	0.59534	0.7931	0.9029E+02	0.8579E+01
42	42	0	0.9502E-01	0.4965	-0.3342	0.2356	0.59534	0.7931	0.9027E+02	0.8579E+01
43	43	0	0.9831E-01	0.1186	0.4965	0.2356	0.59534	0.7930	0.9029E+02	0.8875E+01
44	44	0	0.9502E-01	0.3342	-0.1186	0.2356	0.59534	0.7931	0.9027E+02	0.8579E+01
45	45	0	0.9502E-01	0.4965	0.1186	0.2356	0.59534	0.7931	0.9029E+02	0.8579E+01
46	46	0	0.9831E-01	0.1186	0.3342	0.2356	0.59534	0.7930	0.9027E+02	0.8875E+01
47	47	0	0.9502E-01	0.3342	-0.4965	0.2356	0.59534	0.7931	0.9029E+02	0.8579E+01
48	48	0	0.9502E-01	0.4965	-0.3342	0.2356	0.59534	0.7931	0.9027E+02	0.8579E+01
49	49	0	0.9831E-01	0.1186	0.4965	0.2356	0.59534	0.7930	0.9029E+02	0.8875E+01
50	50	0	0.9502E-01	0.3342	-0.1186	0.2356	0.59534	0.7931	0.9027E+02	0.8579E+01
51	51	0	0.9502E-01	0.4965	0.1186	0.2356	0.59534	0.7931	0.9029E+02	0.8579E+01
52	52	0	0.9831E-01	0.1186	0.3342	0.2356	0.59534	0.7930	0.9027E+02	0.8875E+01
53	53	0	0.9502E-01	0.3342	-0.4965	0.2356	0.59534	0.7931	0.9029E+02	0.8579E+01
54	54	0	0.9502E-01	0.4965	-0.3342	0.2356	0.59534	0.7931	0.9027E+02	0.8579E+01
55	55	0	0.9831E-01	0.1186	0.4965	0.2356	0.59534	0.7930	0.9029E+02	0.8875E+01
56	56	0	0.9502E-01	0.3342	-0.1186	0.2356	0.59534	0.7931	0.9027E+02	0.8579E+01

57	0.000000E+00	FD=	0.2544336E+04	FN=	0.4320802E-04	SMX=	-0.3177558E-02	SMY=	0.0000000E+00	SMZ=	0.0000000E+00
58	0.00000000	CD=	0.1658234	CF=	0.00000000	MX=	0.00000000	MY=	0.00000000	NZ=	0.00000000
59	0.000000E+00										
60	0.000000E+00										
61	0.000000E+00										
62	0.000000E+00										
63	0.000000E+00										
64	0.000000E+00										
65	0.000000E+00										
66	0.000000E+00										
67	0.000000E+00										
68	0.000000E+00										
69	0.000000E+00										
70	0.000000E+00										
71	0.000000E+00										
72	0.000000E+00										
73	0.000000E+00										
74	0.000000E+00										
75	0.000000E+00										
76	0.000000E+00										
77	0.000000E+00										
78	0.000000E+00										
79	0.000000E+00										
80	0.000000E+00										
81	0.000000E+00										
82	0.000000E+00										
83	0.000000E+00										
84	0.000000E+00										
85	0.000000E+00										
86	0.000000E+00										
87	0.000000E+00										
88	0.000000E+00										
89	0.000000E+00										
90	0.000000E+00										
91	0.000000E+00										
92	0.000000E+00										
93	0.000000E+00										
94	0.000000E+00										
95	0.000000E+00										
96	0.000000E+00										
97	0.000000E+00										
98	0.000000E+00										
99	0.000000E+00										
100	0.000000E+00										
101	0.000000E+00										
102	0.000000E+00										
103	0.000000E+00										
104	0.000000E+00										
105	0.000000E+00										
106	0.000000E+00										
107	0.000000E+00										
108	0.000000E+00										
109	0.000000E+00										
110	0.000000E+00										
111	0.000000E+00										
112	0.000000E+00										
113	0.000000E+00										
114	0.000000E+00										
115	0.000000E+00										
116	0.000000E+00										

STEP 16 DEPTH = 9.8532100 TIME = 0.0055041 DIMENSIONLESS TIME 0.6554545 WETTING FACTORS = 1.1021000 1.0993000
 AVERAGE VELOCITY 0.000 TIME = 0.000 -1560.000 WX 0.00ORIENTATION 90.000

NO.	REF. NO.	MOD	AREA	X	Y	Z	T*	CP	P	FORCE
1	1	0	0.7142E-01	0.1046	-0.2523	0.0658	0.65179	1.0599	0.1207E+03	0.8617E+01
2	2	0	0.7142E-01	0.2523	0.1046	0.0658	0.65179	1.0599	0.1207E+03	0.8617E+01
3	3	0	0.7142E-01	0.2523	-0.2523	0.0658	0.65179	1.0599	0.1207E+03	0.8617E+01
4	4	0	0.7142E-01	0.1046	0.2523	0.0658	0.65179	1.0599	0.1207E+03	0.8617E+01
5	5	0	0.9502E-01	0.4965	-0.3342	0.2356	0.64152	0.7855	0.8940E+02	0.8789E+01
6	6	0	0.9502E-01	0.4965	0.3342	0.2356	0.64152	0.7855	0.8940E+02	0.8789E+01
7	7	0	0.9502E-01	0.4965	-0.3342	0.2356	0.64152	0.7855	0.8940E+02	0.8789E+01
8	8	0	0.9502E-01	0.4965	0.3342	0.2356	0.64152	0.7855	0.8940E+02	0.8789E+01
9	9	0	0.9502E-01	0.4965	-0.3342	0.2356	0.64152	0.7855	0.8940E+02	0.8789E+01
10	10	0	0.9502E-01	0.4965	0.3342	0.2356	0.64152	0.7855	0.8940E+02	0.8789E+01
11	11	0	0.9831E-01	0.1186	0.5857	0.2356	0.64152	0.7855	0.8940E+02	0.8789E+01
12	12	0	0.9831E-01	0.1186	-0.5857	0.2356	0.64152	0.7855	0.8940E+02	0.8789E+01
13	13	0	0.3010E+00	0.1969	0.8240	0.6814	0.61339	0.6147	0.6995E+02	0.2105E+02
14	14	0	0.2907E+00	0.5547	-0.8240	0.6814	0.61339	0.6147	0.6995E+02	0.2105E+02
15	15	0	0.2907E+00	0.5547	0.8240	0.6814	0.61339	0.6147	0.6995E+02	0.2105E+02
16	16	0	0.3010E+00	0.9722	-0.8240	0.6814	0.61339	0.6147	0.6995E+02	0.2105E+02
17	17	0	0.2907E+00	0.8240	0.9722	0.6814	0.61339	0.6147	0.6995E+02	0.2105E+02
18	18	0	0.2907E+00	0.8240	-0.9722	0.6814	0.61339	0.6147	0.6995E+02	0.2105E+02
19	19	0	0.3010E+00	0.5547	0.8240	0.6814	0.61339	0.6147	0.6995E+02	0.2105E+02
20	20	0	0.3010E+00	0.5547	-0.8240	0.6814	0.61339	0.6147	0.6995E+02	0.2105E+02
21	21	0	0.4357E+00	0.2830	0.1841	0.2940	0.57418	0.5353	0.6091E+02	0.2564E+02
22	22	0	0.4208E+00	0.7972	-0.1841	0.2940	0.57418	0.5353	0.6091E+02	0.2564E+02
23	23	0	0.4208E+00	0.7972	0.1841	0.2940	0.57418	0.5353	0.6091E+02	0.2564E+02
24	24	0	0.4357E+00	0.1841	-0.7972	0.2940	0.57418	0.5353	0.6091E+02	0.2564E+02
25	25	0	0.4357E+00	0.1841	0.7972	0.2940	0.57418	0.5353	0.6091E+02	0.2564E+02
26	26	0	0.4208E+00	0.7972	-0.1841	0.2940	0.57418	0.5353	0.6091E+02	0.2564E+02
27	27	0	0.4208E+00	0.7972	0.1841	0.2940	0.57418	0.5353	0.6091E+02	0.2564E+02
28	28	0	0.4357E+00	0.3641	-0.7972	0.2830	0.53315	0.4494	0.5113E+02	0.2778E+02
29	29	0	0.5430E+00	0.2324	0.5231	0.9288	0.53315	0.4494	0.5113E+02	0.2778E+02
30	30	0	0.5430E+00	0.2324	-0.5231	0.9288	0.53315	0.4494	0.5113E+02	0.2778E+02
31	31	0	0.5430E+00	0.2324	0.5231	0.9288	0.53315	0.4494	0.5113E+02	0.2778E+02
32	32	0	0.5430E+00	0.2324	-0.5231	0.9288	0.53315	0.4494	0.5113E+02	0.2778E+02
33	33	0	0.5430E+00	0.2324	0.5231	0.9288	0.53315	0.4494	0.5113E+02	0.2778E+02
34	34	0	0.5430E+00	0.2324	-0.5231	0.9288	0.53315	0.4494	0.5113E+02	0.2778E+02
35	35	0	0.5430E+00	0.2324	0.5231	0.9288	0.53315	0.4494	0.5113E+02	0.2778E+02
36	36	0	0.5623E+00	0.3641	-0.7972	0.9288	0.53315	0.4494	0.5113E+02	0.2778E+02
37	37	0	0.6815E+00	0.4409	0.2393	2.5823	0.49053	0.3785	0.4309E+02	0.2836E+02
38	38	0	0.6511E+00	0.2393	-0.4409	2.5823	0.49053	0.3785	0.4309E+02	0.2836E+02
39	39	0	0.6511E+00	0.2393	0.4409	2.5823	0.49053	0.3785	0.4309E+02	0.2836E+02
40	40	0	0.6815E+00	0.4409	-0.2393	2.5823	0.49053	0.3785	0.4309E+02	0.2836E+02
41	41	0	0.6815E+00	0.4409	0.2393	2.5823	0.49053	0.3785	0.4309E+02	0.2836E+02
42	42	0	0.6511E+00	0.2393	-0.4409	2.5823	0.49053	0.3785	0.4309E+02	0.2836E+02
43	43	0	0.6511E+00	0.2393	0.4409	2.5823	0.49053	0.3785	0.4309E+02	0.2836E+02
44	44	0	0.6815E+00	0.4409	-0.2393	2.5823	0.49053	0.3785	0.4309E+02	0.2836E+02
45	45	0	0.7937E+00	0.5113	-0.4409	2.5823	0.44653	0.3222	0.3668E+02	0.2935E+02
46	46	0	0.7655E+00	0.4409	0.4409	2.5823	0.44653	0.3222	0.3668E+02	0.2935E+02
47	47	0	0.7937E+00	0.5113	-0.4409	2.5823	0.44653	0.3222	0.3668E+02	0.2935E+02
48	48	0	0.7937E+00	0.5113	0.4409	2.5823	0.44653	0.3222	0.3668E+02	0.2935E+02
49	49	0	0.7655E+00	0.4409	-0.4409	2.5823	0.44653	0.3222	0.3668E+02	0.2935E+02
50	50	0	0.7655E+00	0.4409	0.4409	2.5823	0.44653	0.3222	0.3668E+02	0.2935E+02
51	51	0	0.9022E+00	0.5784	-0.5239	3.9334	0.40134	0.2778	0.3165E+02	0.2846E+02
52	52	0	0.9022E+00	0.5784	0.5239	3.9334	0.40134	0.2778	0.3165E+02	0.2846E+02
53	53	0	0.8633E+00	0.2922	-0.8522	3.9334	0.40134	0.2778	0.3165E+02	0.2846E+02
54	54	0	0.8633E+00	0.2922	0.8522	3.9334	0.40134	0.2778	0.3165E+02	0.2846E+02
55	55	0	0.9022E+00	0.5784	-0.5239	3.9334	0.40134	0.2778	0.3165E+02	0.2846E+02
56	56	0	0.9022E+00	0.5784	0.5239	3.9334	0.40134	0.2778	0.3165E+02	0.2846E+02
57	57	0	0.9022E+00	0.5784	-0.5239	3.9334	0.40134	0.2778	0.3165E+02	0.2846E+02
58	58	0	0.8633E+00	0.2922	0.8522	3.9334	0.40134	0.2778	0.3165E+02	0.2846E+02
59	59	0	0.9022E+00	0.5784	-0.5239	3.9334	0.40134	0.2778	0.3165E+02	0.2846E+02
60	60	0	0.9022E+00	0.5784	0.5239	3.9334	0.40134	0.2778	0.3165E+02	0.2846E+02
61	61	0	0.1001E+01	0.6419	-0.2164	4.6264	0.35514	0.2437	0.2779E+02	0.2686E+02
62	62	0	0.9666E+00	0.8680	0.6865	4.6264	0.35514	0.2441	0.2779E+02	0.2686E+02

STEP 17 DEPTH = 10.5238100 TIME = 0.0058952 DIMENSIONLESS TIME 0.7020213 WEAVING FACTORS = 1.0993000 1.0948000
 AVERAGE VELOCITY 0.000 -1560.000 WX

NO.	REF. NO.	MOD	AREA	X	Y	Z	TH*	CP	P	FORCE
1	1	0	0.7142E-01	0.1046	-0.2523	0.0658	0.69836	1.0517	0.1197E+03	0.8551E+01
2	2	0	0.7142E-01	0.2523	0.1046	0.0658	0.69836	1.0517	0.1197E+03	0.8551E+01
3	3	0	0.7142E-01	0.1046	0.2523	0.0658	0.69836	1.0517	0.1197E+03	0.8551E+01
4	4	0	0.9831E-01	0.1186	-0.5857	0.2356	0.68809	0.7792	0.8870E+02	0.8720E+01
5	5	0	0.9502E-01	0.3342	-0.4965	0.2356	0.68809	0.7793	0.8872E+02	0.8430E+01
6	6	0	0.9831E-01	0.5857	-0.1186	0.2356	0.68809	0.7792	0.8870E+02	0.8720E+01
7	7	0	0.9502E-01	0.4965	0.1186	0.2356	0.68809	0.7793	0.8872E+02	0.8430E+01
8	8	0	0.9831E-01	0.1186	0.5857	0.2356	0.68809	0.7792	0.8870E+02	0.8720E+01
9	9	0	0.9502E-01	0.3342	0.4965	0.2356	0.68809	0.7793	0.8872E+02	0.8430E+01
10	10	0	0.9831E-01	0.5857	-0.1186	0.2356	0.68809	0.7792	0.8870E+02	0.8720E+01
11	11	0	0.9502E-01	0.4965	0.1186	0.2356	0.68809	0.7793	0.8872E+02	0.8430E+01
12	12	0	0.9831E-01	0.1186	0.5857	0.2356	0.68809	0.7792	0.8870E+02	0.8720E+01
13	13	0	0.3010E+00	0.1969	-0.8240	0.6814	0.65996	0.6094	0.6937E+02	0.2088E+02
14	14	0	0.2907E+00	0.5547	-0.8240	0.6814	0.65996	0.6096	0.6940E+02	0.2017E+02
15	15	0	0.2907E+00	0.8240	-0.5547	0.6814	0.65996	0.6096	0.6940E+02	0.2017E+02
16	16	0	0.3010E+00	0.9722	-0.1969	0.6814	0.65996	0.6094	0.6937E+02	0.2088E+02
17	17	0	0.4208E+00	0.9722	0.1969	0.6814	0.65996	0.6094	0.6937E+02	0.2088E+02
18	18	0	0.3010E+00	0.8240	0.5547	0.6814	0.65996	0.6096	0.6940E+02	0.2017E+02
19	19	0	0.2907E+00	0.5547	0.8240	0.6814	0.65996	0.6096	0.6940E+02	0.2017E+02
20	20	0	0.3010E+00	0.1969	-0.9722	0.6814	0.65996	0.6094	0.6937E+02	0.2088E+02
21	21	0	0.4357E+00	0.7830	-0.9722	0.6814	0.65996	0.6094	0.6937E+02	0.2088E+02
22	22	0	0.4208E+00	0.7972	-1.1841	0.2940	0.62074	0.5300	0.6037E+02	0.2540E+02
23	23	0	0.4208E+00	0.7972	-1.1841	0.2940	0.62074	0.5300	0.6037E+02	0.2540E+02
24	24	0	0.4357E+00	1.1841	-0.7972	0.2940	0.62074	0.5300	0.6037E+02	0.2540E+02
25	25	0	0.4208E+00	1.3971	-0.2830	0.2940	0.62074	0.5300	0.6034E+02	0.2629E+02
26	26	0	0.4357E+00	1.3971	0.2830	0.2940	0.62074	0.5300	0.6034E+02	0.2629E+02
27	27	0	0.4208E+00	0.7972	0.1841	0.2940	0.62074	0.5300	0.6037E+02	0.2540E+02
28	28	0	0.4357E+00	0.2830	-0.7972	0.2940	0.62074	0.5300	0.6037E+02	0.2540E+02
29	29	0	0.5622E+00	0.3641	-1.5231	1.9288	0.57972	0.4446	0.5061E+02	0.2846E+02
30	30	0	0.5430E+00	1.0254	-1.5231	1.9288	0.57972	0.4448	0.5064E+02	0.2750E+02
31	31	0	0.5622E+00	1.5231	-1.0254	1.9288	0.57972	0.4448	0.5064E+02	0.2750E+02
32	32	0	0.5430E+00	1.7970	-0.3641	1.9288	0.57972	0.4446	0.5061E+02	0.2846E+02
33	33	0	0.5622E+00	1.7970	0.3641	1.9288	0.57972	0.4448	0.5061E+02	0.2846E+02
34	34	0	0.5430E+00	1.5231	-1.0254	1.9288	0.57972	0.4448	0.5064E+02	0.2750E+02
35	35	0	0.5622E+00	1.0254	-1.5231	1.9288	0.57972	0.4446	0.5061E+02	0.2846E+02
36	36	0	0.5430E+00	1.7970	-0.3641	1.9288	0.57972	0.4448	0.5064E+02	0.2750E+02
37	37	0	0.6815E+00	0.4400	-2.1720	2.5822	0.53709	0.3739	0.4256E+02	0.2900E+02
38	38	0	0.6581E+00	1.2393	-1.8409	2.5822	0.53709	0.3741	0.4259E+02	0.2803E+02
39	39	0	0.6815E+00	1.8409	-1.2393	2.5822	0.53709	0.3741	0.4259E+02	0.2803E+02
40	40	0	0.6815E+00	1.720	0.4400	2.5822	0.53709	0.3739	0.4256E+02	0.2900E+02
41	41	0	0.6815E+00	1.8409	1.2393	2.5822	0.53709	0.3741	0.4259E+02	0.2803E+02
42	42	0	0.6581E+00	1.2393	1.8409	2.5822	0.53709	0.3741	0.4259E+02	0.2803E+02
43	43	0	0.6815E+00	0.4400	-2.1720	2.5822	0.53709	0.3739	0.4256E+02	0.2900E+02
44	44	0	0.6815E+00	1.2393	-1.8409	2.5822	0.53709	0.3741	0.4259E+02	0.2803E+02
45	45	0	0.7937E+00	0.5113	-2.5239	3.2513	0.49310	0.3172	0.3615E+02	0.2866E+02
46	46	0	0.7665E+00	1.4401	-2.1391	3.2513	0.49310	0.3176	0.3615E+02	0.2866E+02
47	47	0	0.7937E+00	2.1391	-1.4401	3.2513	0.49310	0.3172	0.3615E+02	0.2866E+02
48	48	0	0.7665E+00	2.5239	1.4401	3.2513	0.49310	0.3176	0.3615E+02	0.2866E+02
49	49	0	0.7937E+00	2.1391	1.4401	3.2513	0.49310	0.3172	0.3615E+02	0.2866E+02
50	50	0	0.7665E+00	1.4401	-2.1391	3.2513	0.49310	0.3176	0.3615E+02	0.2866E+02
51	51	0	0.7937E+00	2.1391	-1.4401	3.2513	0.49310	0.3172	0.3615E+02	0.2866E+02
52	52	0	0.9002E+00	0.5113	-2.5239	3.9334	0.44791	0.2729	0.3107E+02	0.2704E+02
53	53	0	0.8693E+00	1.5784	-2.8552	3.9334	0.44791	0.2733	0.3111E+02	0.2704E+02
54	54	0	0.8693E+00	1.6292	-2.4199	3.9334	0.44791	0.2733	0.3111E+02	0.2704E+02
55	55	0	0.9002E+00	2.400	-1.6292	3.9334	0.44791	0.2729	0.3107E+02	0.2704E+02
56	56	0	0.8693E+00	2.8552	1.5784	3.9334	0.44791	0.2733	0.3111E+02	0.2704E+02
57	57	0	0.9002E+00	2.4199	-1.6292	3.9334	0.44791	0.2729	0.3107E+02	0.2704E+02
58	58	0	0.8693E+00	2.4199	1.6292	3.9334	0.44791	0.2733	0.3111E+02	0.2704E+02
59	59	0	0.9002E+00	1.6292	-2.4199	3.9334	0.44791	0.2733	0.3111E+02	0.2704E+02
60	60	0	0.9002E+00	1.5784	-2.8552	3.9334	0.44791	0.2729	0.3107E+02	0.2704E+02

61	0.6419	-3.1686	4.6264	0.40171	0.2385	0.2715E+02	0.2717E+02
62	1.8080	-2.8079	4.6264	0.40171	0.2389	0.2628E+02	0.2628E+02
63	2.6855	-0.6419	4.6264	0.40171	0.2385	0.2717E+02	0.2717E+02
64	3.1686	0.6419	4.6264	0.40171	0.2389	0.2628E+02	0.2628E+02
65	3.6855	1.8080	4.6264	0.40171	0.2385	0.2719E+02	0.2719E+02
66	4.8079	3.1686	4.6264	0.40171	0.2389	0.2628E+02	0.2628E+02
67	6.419	4.6264	5.3277	0.35470	0.2117	0.2554E+02	0.2554E+02
68	9.381	-3.4665	5.3277	0.35470	0.2120	0.2554E+02	0.2554E+02
69	1.9780	-0.9780	5.3277	0.35470	0.2117	0.2554E+02	0.2554E+02
70	3.9381	0.9780	5.3277	0.35470	0.2120	0.2554E+02	0.2554E+02
71	5.4665	-0.7023	5.3277	0.35470	0.2117	0.2554E+02	0.2554E+02
72	7.4665	0.7023	5.3277	0.35470	0.2120	0.2554E+02	0.2554E+02
73	9.9381	1.9780	5.3277	0.35470	0.2117	0.2554E+02	0.2554E+02
74	1.9780	2.9381	5.3277	0.35470	0.2120	0.2554E+02	0.2554E+02
75	3.9381	4.6665	6.0351	0.30709	0.1893	0.2413E+02	0.2413E+02
76	5.4665	-3.7519	6.0351	0.30709	0.1896	0.2413E+02	0.2413E+02
77	7.4665	-1.800	6.0351	0.30709	0.1896	0.2413E+02	0.2413E+02
78	9.9381	1.800	6.0351	0.30709	0.1896	0.2413E+02	0.2413E+02
79	1.800	-2.1408	6.0351	0.30709	0.1896	0.2413E+02	0.2413E+02
80	3.7519	0.7601	6.0351	0.30709	0.1896	0.2413E+02	0.2413E+02
81	5.7023	2.1408	6.0351	0.30709	0.1896	0.2413E+02	0.2413E+02
82	7.6665	3.7519	6.0351	0.30709	0.1896	0.2413E+02	0.2413E+02
83	9.6665	5.4665	6.0351	0.30709	0.1896	0.2413E+02	0.2413E+02
84	1.800	-3.1800	6.0351	0.30709	0.1896	0.2413E+02	0.2413E+02
85	3.7519	-1.408	6.0351	0.30709	0.1896	0.2413E+02	0.2413E+02
86	5.7023	1.408	6.0351	0.30709	0.1896	0.2413E+02	0.2413E+02
87	7.6665	3.1800	6.0351	0.30709	0.1896	0.2413E+02	0.2413E+02
88	9.6665	5.4665	6.0351	0.30709	0.1896	0.2413E+02	0.2413E+02
89	1.800	-2.1408	6.0351	0.30709	0.1896	0.2413E+02	0.2413E+02
90	3.7519	0.7601	6.0351	0.30709	0.1896	0.2413E+02	0.2413E+02
91	5.7023	2.1408	6.0351	0.30709	0.1896	0.2413E+02	0.2413E+02
92	7.6665	3.7519	6.0351	0.30709	0.1896	0.2413E+02	0.2413E+02
93	9.6665	5.4665	6.0351	0.30709	0.1896	0.2413E+02	0.2413E+02
94	1.800	-3.1800	6.0351	0.30709	0.1896	0.2413E+02	0.2413E+02
95	3.7519	-1.408	6.0351	0.30709	0.1896	0.2413E+02	0.2413E+02
96	5.7023	1.408	6.0351	0.30709	0.1896	0.2413E+02	0.2413E+02
97	7.6665	3.1800	6.0351	0.30709	0.1896	0.2413E+02	0.2413E+02
98	9.6665	5.4665	6.0351	0.30709	0.1896	0.2413E+02	0.2413E+02
99	1.800	-2.1408	6.0351	0.30709	0.1896	0.2413E+02	0.2413E+02
100	3.7519	0.7601	6.0351	0.30709	0.1896	0.2413E+02	0.2413E+02
101	5.7023	2.1408	6.0351	0.30709	0.1896	0.2413E+02	0.2413E+02
102	7.6665	3.7519	6.0351	0.30709	0.1896	0.2413E+02	0.2413E+02
103	9.6665	5.4665	6.0351	0.30709	0.1896	0.2413E+02	0.2413E+02
104	1.800	-3.1800	6.0351	0.30709	0.1896	0.2413E+02	0.2413E+02
105	3.7519	-1.408	6.0351	0.30709	0.1896	0.2413E+02	0.2413E+02
106	5.7023	1.408	6.0351	0.30709	0.1896	0.2413E+02	0.2413E+02
107	7.6665	3.1800	6.0351	0.30709	0.1896	0.2413E+02	0.2413E+02
108	9.6665	5.4665	6.0351	0.30709	0.1896	0.2413E+02	0.2413E+02
109	1.800	-2.1408	6.0351	0.30709	0.1896	0.2413E+02	0.2413E+02
110	3.7519	0.7601	6.0351	0.30709	0.1896	0.2413E+02	0.2413E+02
111	5.7023	2.1408	6.0351	0.30709	0.1896	0.2413E+02	0.2413E+02
112	7.6665	3.7519	6.0351	0.30709	0.1896	0.2413E+02	0.2413E+02
113	9.6665	5.4665	6.0351	0.30709	0.1896	0.2413E+02	0.2413E+02
114	1.800	-3.1800	6.0351	0.30709	0.1896	0.2413E+02	0.2413E+02
115	3.7519	-1.408	6.0351	0.30709	0.1896	0.2413E+02	0.2413E+02
116	5.7023	1.408	6.0351	0.30709	0.1896	0.2413E+02	0.2413E+02
117	7.6665	3.1800	6.0351	0.30709	0.1896	0.2413E+02	0.2413E+02
118	9.6665	5.4665	6.0351	0.30709	0.1896	0.2413E+02	0.2413E+02
119	1.800	-2.1408	6.0351	0.30709	0.1896	0.2413E+02	0.2413E+02
120	3.7519	0.7601	6.0351	0.30709	0.1896	0.2413E+02	0.2413E+02
121	5.7023	2.1408	6.0351	0.30709	0.1896	0.2413E+02	0.2413E+02
122	7.6665	3.7519	6.0351	0.30709	0.1896	0.2413E+02	0.2413E+02
123	9.6665	5.4665	6.0351	0.30709	0.1896	0.2413E+02	0.2413E+02
124	1.800	-3.1800	6.0351	0.30709	0.1896	0.2413E+02	0.2413E+02
125	3.7519	-1.408	6.0351	0.30709	0.1896	0.2413E+02	0.2413E+02
126	5.7023	1.408	6.0351	0.30709	0.1896	0.2413E+02	0.2413E+02

127 0.000000E+00 FD= 0.2396179E+04 HN= -0.7991858E-03 SMX- -0.7061948E-02 SMY- 0.0000000E+00 SMZ= 0.00000000E+00
 128 0.00000000 CD= 0.1561675 CN= -0.00000001 MX- 0.00000000 MY- 0.00000000 MZ= 0.00000000
 129 4.3936 -2.9579 10.1905 0.02315 0.1072 0.1220E+02 0.1756E+02
 130 5.1838 -1.0501 10.1905 0.02315 0.1060 0.1207E+02 0.1800E+02
 131 4.3936 2.9579 10.1905 0.02315 0.1060 0.1207E+02 0.1800E+02
 132 2.9579 5.1838 10.1905 0.02315 0.1072 0.1220E+02 0.1756E+02
 133 1.0501 0.0000 10.1905 0.02315 0.1060 0.1207E+02 0.1800E+02

STEP 18 DEPTH = 11.1540100 TIME = 0.0062642 DIMENSIONLESS TIME 0.7459625 WAITING FACTORS = 1.0948000 1.0870000
 AVERAGE VELOCITY 0.000 WX -1560.000 WY 0.000 ORIENTATION 90.000

NO.	REF. NO.	MOD	AREA	X	Y	Z	T*	CP	P	FORCE
1	1	0	0.7142E-01	0.1046	-0.2523	0.0658	0.74230	1.0450	0.1190E+03	0.8496E+01
2	2	0	0.7142E-01	0.2523	-0.1046	0.0658	0.74230	1.0450	0.1190E+03	0.8496E+01
3	3	0	0.7142E-01	0.2523	0.1046	0.0658	0.74230	1.0450	0.1190E+03	0.8496E+01
4	4	0	0.9831E-01	0.1046	-0.2523	0.2356	0.73203	1.0450	0.1190E+03	0.8496E+01
5	5	0	0.9831E-01	0.2523	-0.1046	0.2356	0.73203	1.0450	0.1190E+03	0.8496E+01
6	6	0	0.9502E-01	0.3342	-0.4965	0.2356	0.73203	0.7742	0.8813E+02	0.8663E+01
7	7	0	0.9502E-01	0.4965	-0.3342	0.2356	0.73203	0.7742	0.8813E+02	0.8663E+01
8	8	0	0.9831E-01	0.5857	-0.1186	0.2356	0.73203	0.7742	0.8812E+02	0.8663E+01
9	9	0	0.9831E-01	0.5857	0.1186	0.2356	0.73203	0.7742	0.8812E+02	0.8663E+01
10	10	0	0.9502E-01	0.4965	0.3342	0.2356	0.73203	0.7742	0.8813E+02	0.8663E+01
11	11	0	0.9831E-01	0.3342	0.4965	0.2356	0.73203	0.7742	0.8812E+02	0.8663E+01
12	12	0	0.9831E-01	0.1186	0.5857	0.2356	0.73203	0.7742	0.8813E+02	0.8663E+01
13	13	0	0.2907E+00	0.1969	-0.9722	0.6814	0.70390	0.6052	0.6892E+02	0.2003E+02
14	14	0	0.2907E+00	0.5547	-0.8240	0.6814	0.70390	0.6052	0.6892E+02	0.2003E+02
15	15	0	0.2907E+00	0.8240	-0.5547	0.6814	0.70390	0.6052	0.6892E+02	0.2003E+02
16	16	0	0.3010E+00	0.9722	-0.1969	0.6814	0.70390	0.6052	0.6889E+02	0.2073E+02
17	17	0	0.3010E+00	0.9722	0.1969	0.6814	0.70390	0.6052	0.6889E+02	0.2073E+02
18	18	0	0.2907E+00	0.8240	0.5547	0.6814	0.70390	0.6052	0.6892E+02	0.2003E+02
19	19	0	0.2907E+00	0.5547	0.8240	0.6814	0.70390	0.6052	0.6892E+02	0.2003E+02
20	20	0	0.3010E+00	0.1969	0.9722	0.6814	0.70390	0.6052	0.6889E+02	0.2073E+02
21	21	0	0.4357E+00	0.2830	-1.3971	1.2940	0.66468	0.5260	0.5988E+02	0.2609E+02
22	22	0	0.4208E+00	0.7972	-1.1841	1.2940	0.66468	0.5262	0.5991E+02	0.2521E+02
23	23	0	0.4208E+00	0.7972	1.1841	1.2940	0.66468	0.5262	0.5988E+02	0.2609E+02
24	24	0	0.4357E+00	1.3971	-0.2830	1.2940	0.66468	0.5262	0.5991E+02	0.2521E+02
25	25	0	0.4357E+00	1.3971	0.2830	1.2940	0.66468	0.5262	0.5988E+02	0.2609E+02
26	26	0	0.4208E+00	1.1841	-0.7972	1.2940	0.66468	0.5262	0.5991E+02	0.2521E+02
27	27	0	0.4208E+00	0.7972	-1.1841	1.2940	0.66468	0.5262	0.5988E+02	0.2609E+02
28	28	0	0.4357E+00	0.2830	-1.3971	1.2940	0.66468	0.5260	0.5988E+02	0.2609E+02
29	29	0	0.5622E+00	0.3641	-1.3971	1.2940	0.62366	0.4408	0.5018E+02	0.2822E+02
30	30	0	0.5430E+00	1.0254	-1.0254	1.9288	0.62366	0.4410	0.5020E+02	0.2726E+02
31	31	0	0.5430E+00	1.5231	-1.5231	1.9288	0.62366	0.4410	0.5020E+02	0.2726E+02
32	32	0	0.5622E+00	1.7970	-0.3641	1.9288	0.62366	0.4408	0.5018E+02	0.2822E+02
33	33	0	0.5622E+00	1.7970	0.3641	1.9288	0.62366	0.4408	0.5018E+02	0.2822E+02
34	34	0	0.5430E+00	1.5231	1.0254	1.9288	0.62366	0.4410	0.5020E+02	0.2726E+02
35	35	0	0.5430E+00	1.0254	1.5231	1.9288	0.62366	0.4410	0.5020E+02	0.2726E+02
36	36	0	0.6815E+00	0.3641	-1.7970	2.5822	0.58104	0.3703	0.4219E+02	0.2873E+02
37	37	0	0.6815E+00	0.4400	-1.8409	2.5822	0.58104	0.3706	0.4219E+02	0.2873E+02
38	38	0	0.6581E+00	1.2393	-1.2393	2.5822	0.58104	0.3706	0.4219E+02	0.2873E+02
39	39	0	0.6581E+00	1.8409	-1.8409	2.5822	0.58104	0.3706	0.4219E+02	0.2873E+02
40	40	0	0.6815E+00	2.1720	-0.4400	2.5822	0.58104	0.3703	0.4215E+02	0.2873E+02
41	41	0	0.6815E+00	2.1720	0.4400	2.5822	0.58104	0.3703	0.4215E+02	0.2873E+02
42	42	0	0.6581E+00	1.8409	1.2393	2.5822	0.58104	0.3706	0.4219E+02	0.2873E+02
43	43	0	0.6581E+00	1.2393	1.8409	2.5822	0.58104	0.3706	0.4219E+02	0.2873E+02
44	44	0	0.6815E+00	0.4400	-1.7970	2.5822	0.58104	0.3703	0.4215E+02	0.2873E+02
45	45	0	0.7937E+00	1.4401	-2.5239	3.2513	0.53704	0.3137	0.3572E+02	0.2835E+02
46	46	0	0.7937E+00	2.1391	-2.1391	3.2513	0.53704	0.3137	0.3572E+02	0.2835E+02
47	47	0	0.7665E+00	2.1391	2.1391	3.2513	0.53704	0.3137	0.3572E+02	0.2835E+02
48	48	0	0.7937E+00	2.5239	-0.5113	3.2513	0.53704	0.3137	0.3572E+02	0.2835E+02
49	49	0	0.7937E+00	2.5239	0.5113	3.2513	0.53704	0.3137	0.3572E+02	0.2835E+02
50	50	0	0.7665E+00	2.1391	1.4401	3.2513	0.53704	0.3137	0.3572E+02	0.2835E+02

51	14401	2	1391	3	2513	0	53704	0	3141	0	3576E+02	0	2741E+02
52	0	2	5239	3	2513	0	53701	0	2137	0	3572E+02	0	2831E+02
53	0	2	8552	3	3334	0	49185	0	2694	0	3067E+02	0	2763E+02
54	1	2	4199	3	9334	0	49185	0	2697	0	3070E+02	0	2669E+02
55	2	2	4200	3	9334	0	49185	0	2694	0	3070E+02	0	2761E+02
56	2	2	8552	3	9334	0	49185	0	2697	0	3067E+02	0	2761E+02
57	2	2	5784	3	9334	0	49185	0	2694	0	3070E+02	0	2669E+02
58	2	2	5784	3	9334	0	49185	0	2697	0	3070E+02	0	2669E+02
59	2	2	6292	3	9334	0	49185	0	2697	0	3070E+02	0	2669E+02
60	0	2	4200	3	9334	0	49185	0	2694	0	3067E+02	0	2669E+02
61	0	3	8552	4	6264	0	44565	0	2347	0	2672E+02	0	2674E+02
62	1	3	1686	4	6264	0	44565	0	2351	0	2676E+02	0	2587E+02
63	2	3	8079	4	6264	0	44565	0	2351	0	2676E+02	0	2587E+02
64	3	3	8079	4	6264	0	44565	0	2347	0	2672E+02	0	2674E+02
65	3	3	6419	4	6264	0	44565	0	2347	0	2672E+02	0	2674E+02
66	3	3	8080	4	6264	0	44565	0	2351	0	2676E+02	0	2587E+02
67	3	3	6855	4	6264	0	44565	0	2351	0	2676E+02	0	2587E+02
68	1	3	1686	4	6264	0	44565	0	2347	0	2672E+02	0	2674E+02
69	0	3	8079	4	6264	0	44565	0	2351	0	2676E+02	0	2587E+02
70	0	3	4665	5	3277	0	39864	0	2075	0	2362E+02	0	2590E+02
71	1	3	9381	5	3277	0	39864	0	2078	0	2366E+02	0	2503E+02
72	1	3	7023	5	3277	0	39864	0	2075	0	2362E+02	0	2590E+02
73	3	3	4665	5	3277	0	39864	0	2075	0	2362E+02	0	2590E+02
74	2	3	9381	5	3277	0	39864	0	2078	0	2366E+02	0	2503E+02
75	1	3	9381	5	3277	0	39864	0	2075	0	2362E+02	0	2590E+02
76	0	3	4665	5	3277	0	39864	0	2075	0	2362E+02	0	2590E+02
77	0	3	7519	6	0351	0	35103	0	1848	0	2104E+02	0	2497E+02
78	2	3	1800	6	0351	0	35103	0	1851	0	2107E+02	0	2414E+02
79	3	3	1800	6	0351	0	35103	0	1851	0	2107E+02	0	2414E+02
80	0	2	7601	6	0351	0	35103	0	1848	0	2104E+02	0	2497E+02
81	3	3	7519	6	0351	0	35103	0	1848	0	2104E+02	0	2497E+02
82	3	3	1800	6	0351	0	35103	0	1851	0	2107E+02	0	2414E+02
83	3	3	1800	6	0351	0	35103	0	1851	0	2107E+02	0	2414E+02
84	0	3	7519	6	0351	0	35103	0	1848	0	2104E+02	0	2497E+02
85	0	4	0273	6	7465	0	30299	0	1629	0	1851E+02	0	2299E+02
86	3	2	2980	6	7465	0	30299	0	1629	0	1854E+02	0	2279E+02
87	3	4	4134	6	7465	0	30299	0	1626	0	1851E+02	0	2299E+02
88	4	0	8155	6	7465	0	30299	0	1626	0	1851E+02	0	2299E+02
89	4	0	2733	6	7465	0	30299	0	1626	0	1851E+02	0	2299E+02
90	3	4	4134	6	7465	0	30299	0	1629	0	1854E+02	0	2279E+02
91	2	2	2980	6	7465	0	30299	0	1629	0	1851E+02	0	2299E+02
92	0	4	0273	6	7465	0	30299	0	1629	0	1854E+02	0	2279E+02
93	0	4	2956	7	4595	0	25475	0	1341	0	1530E+02	0	2002E+02
94	3	4	6408	7	4595	0	25475	0	1344	0	1530E+02	0	2002E+02
95	3	4	6408	7	4595	0	25475	0	1344	0	1530E+02	0	2002E+02
96	4	2	2956	7	4595	0	25475	0	1341	0	1530E+02	0	2002E+02
97	4	2	8702	7	4595	0	25475	0	1341	0	1527E+02	0	2002E+02
98	3	4	6408	7	4595	0	25475	0	1344	0	1530E+02	0	2002E+02
99	0	4	2956	7	4595	0	25475	0	1341	0	1527E+02	0	2002E+02
100	0	4	2956	7	4595	0	25475	0	1341	0	1527E+02	0	2002E+02
101	0	4	5994	8	1720	0	20633	0	0787	0	8964E+01	0	1284E+02
102	0	4	8644	8	1720	0	20633	0	0791	0	9008E+01	0	1284E+02
103	0	4	6015	8	1720	0	20633	0	0791	0	9008E+01	0	1284E+02
104	0	4	8644	8	1720	0	20633	0	0791	0	9008E+01	0	1284E+02
105	4	3	5594	8	1720	0	20633	0	0787	0	8964E+01	0	1284E+02
106	4	3	5594	8	1720	0	20633	0	0787	0	8964E+01	0	1284E+02
107	3	3	6015	8	1720	0	20633	0	0791	0	9008E+01	0	1284E+02
108	2	3	8644	8	1720	0	20633	0	0787	0	8963E+01	0	1284E+02
109	0	4	5594	8	1720	0	20633	0	0787	0	8963E+01	0	1284E+02
110	4	4	7939	8	8579	0	15932	0	0200	0	2283E+01	0	3143E+01
111	4	4	0631	8	8579	0	15932	0	0206	0	2347E+01	0	3143E+01
112	2	4	0631	8	8579	0	15932	0	0200	0	2283E+01	0	3143E+01
113	0	4	9712	8	8579	0	15932	0	0200	0	2283E+01	0	3143E+01
114	0	4	9712	8	8579	0	15932	0	0206	0	2347E+01	0	3143E+01
115	4	4	0631	8	8579	0	15932	0	0206	0	2347E+01	0	3143E+01
116	4	4	7939	8	8579	0	15932	0	0200	0	2283E+01	0	3143E+01

EX=	0.000000E+00	FD=	0.2425720E+04	FN=	-0.6471470E-03	SMX=	-0.2131731E-02	SMY=	0.0000000E+00	SMZ=	0.0000000E+00
CX=	0.00000000	CD=	0.1580928	CN=	0.00000000	MX=	0.00000000	MY=	0.00000000	MZ=	0.00000000

117	1.0119	-4.9951	9.5220	0.11345	0.0280	0.3184E+01	0.4573E+01
118	2.8502	-2.2337	9.5220	0.11345	0.0284	0.3231E+01	0.4481E+01
119	4.2337	-2.8502	9.5220	0.11345	0.0284	0.3184E+01	0.4573E+01
120	4.9951	-1.0119	9.5220	0.11345	0.0280	0.3184E+01	0.4481E+01
121	4.2337	2.8502	9.5220	0.11345	0.0284	0.3231E+01	0.4481E+01
122	4.9951	4.2337	9.5220	0.11345	0.0284	0.3184E+01	0.4573E+01
123	1.0119	-5.1838	10.1905	0.06709	0.0527	0.6004E+01	0.8953E+01
124	2.8502	-4.3936	10.1905	0.06709	0.0533	0.6064E+01	0.8729E+01
125	4.2337	-4.9951	10.1905	0.06709	0.0527	0.6004E+01	0.8953E+01
126	4.9951	-1.0501	10.1905	0.06709	0.0527	0.6004E+01	0.8729E+01
127	5.1838	1.0501	10.1905	0.06709	0.0533	0.6064E+01	0.8729E+01
128	5.1838	2.9579	10.1905	0.06709	0.0533	0.6064E+01	0.8953E+01
129	4.3936	4.3936	10.1905	0.06709	0.0527	0.6004E+01	0.8729E+01
130	2.9579	5.1838	10.1905	0.06709	0.0527	0.6004E+01	0.8953E+01
131	1.0501	-5.1838	10.1905	0.06709	0.0533	0.6064E+01	0.8729E+01
132	1.0861	-4.5441	10.8406	0.02185	0.1580	0.1798E+02	0.2608E+02
133	3.0591	-4.5441	10.8406	0.02185	0.1590	0.1810E+02	0.2534E+02
134	4.5441	-3.0591	10.8406	0.02185	0.1580	0.1798E+02	0.2608E+02
135	5.3613	-1.0861	10.8406	0.02185	0.1590	0.1810E+02	0.2534E+02
136	5.3613	1.0861	10.8406	0.02185	0.1580	0.1798E+02	0.2608E+02
137	4.5441	3.0591	10.8406	0.02185	0.1590	0.1810E+02	0.2534E+02
138	3.0591	4.5441	10.8406	0.02185	0.1580	0.1798E+02	0.2608E+02
139	1.0861	5.3613	10.8406	0.02185	0.1580	0.1798E+02	0.2608E+02
140	1.0861	5.3613	10.8406	0.02185	0.1580	0.1798E+02	0.2608E+02

STEP 19 DEPTH = 11.9623100 TIME = 0.0067408 DIMENSIONLESS TIME 0.8027264 WETTING FACTORS = 1.0870000 1.0797000
 AVERAGE VELOCITY 0.0000 WX -1560.0000 WY 0.00000000 WZ 90.0000

NO.	1	2	3	4	5	6	7	8	9	10	11	12	13	14	15	16	17	18	19	20	21	22	23	24	25	26	27	28	29	30	31	32
REF.NO.	0	0	0	0	0	0	0	0	0	0	0	0	0	0	0	0	0	0	0	0	0	0	0	0	0	0	0	0	0	0	0	
MOD	0	0	0	0	0	0	0	0	0	0	0	0	0	0	0	0	0	0	0	0	0	0	0	0	0	0	0	0	0	0	0	
AREA	0.7142E-01	0.7142E-01	0.7142E-01	0.9831E-01	0.9502E-01	0.9502E-01	0.9502E-01	0.9831E-01	0.9502E-01	0.9502E-01	0.9502E-01	0.9502E-01	0.9502E-01	0.9502E-01	0.9502E-01	0.9502E-01	0.9502E-01	0.9502E-01	0.9502E-01	0.9502E-01	0.9502E-01	0.9502E-01	0.9502E-01	0.9502E-01	0.9502E-01	0.9502E-01	0.9502E-01	0.9502E-01	0.9502E-01	0.9502E-01	0.9502E-01	
X	0.1046	0.2523	0.1046	0.1186	0.3342	0.4965	0.5857	0.3342	0.4965	0.5857	0.3342	0.4965	0.5857	0.3342	0.4965	0.5857	0.3342	0.4965	0.5857	0.3342	0.4965	0.5857	0.3342	0.4965	0.5857	0.3342	0.4965	0.5857	0.3342	0.4965	0.5857	
Y	-0.2523	-0.1046	0.2523	0.1186	-0.3342	-0.4965	-0.5857	-0.3342	-0.4965	-0.5857	-0.3342	-0.4965	-0.5857	-0.3342	-0.4965	-0.5857	-0.3342	-0.4965	-0.5857	-0.3342	-0.4965	-0.5857	-0.3342	-0.4965	-0.5857	-0.3342	-0.4965	-0.5857	-0.3342	-0.4965	-0.5857	
Z	0.0658	0.0658	0.0658	0.2356	0.2356	0.2356	0.2356	0.2356	0.2356	0.2356	0.2356	0.2356	0.2356	0.2356	0.2356	0.2356	0.2356	0.2356	0.2356	0.2356	0.2356	0.2356	0.2356	0.2356	0.2356	0.2356	0.2356	0.2356	0.2356	0.2356	0.2356	
T*	0.79906	0.79906	0.79906	0.78879	0.78879	0.78879	0.78879	0.78879	0.78879	0.78879	0.78879	0.78879	0.78879	0.78879	0.78879	0.78879	0.78879	0.78879	0.78879	0.78879	0.78879	0.78879	0.78879	0.78879	0.78879	0.78879	0.78879	0.78879	0.78879	0.78879	0.78879	
CP	1.0364	1.0364	1.0364	0.7673	0.7673	0.7673	0.7673	0.7673	0.7673	0.7673	0.7673	0.7673	0.7673	0.7673	0.7673	0.7673	0.7673	0.7673	0.7673	0.7673	0.7673	0.7673	0.7673	0.7673	0.7673	0.7673	0.7673	0.7673	0.7673	0.7673	0.7673	
P	0.1180E+03	0.1180E+03	0.1180E+03	0.8735E+02	0.8735E+02	0.8735E+02	0.8735E+02	0.8735E+02	0.8735E+02	0.8735E+02	0.8735E+02	0.8735E+02	0.8735E+02	0.8735E+02	0.8735E+02	0.8735E+02	0.8735E+02	0.8735E+02	0.8735E+02	0.8735E+02	0.8735E+02	0.8735E+02	0.8735E+02	0.8735E+02	0.8735E+02	0.8735E+02	0.8735E+02	0.8735E+02	0.8735E+02	0.8735E+02	0.8735E+02	
FORCE	0.8426E+01	0.8426E+01	0.8426E+01	0.8426E+01	0.8426E+01	0.8426E+01	0.8426E+01	0.8426E+01	0.8426E+01	0.8426E+01	0.8426E+01	0.8426E+01	0.8426E+01	0.8426E+01	0.8426E+01	0.8426E+01	0.8426E+01	0.8426E+01	0.8426E+01	0.8426E+01	0.8426E+01	0.8426E+01	0.8426E+01	0.8426E+01	0.8426E+01	0.8426E+01	0.8426E+01	0.8426E+01	0.8426E+01	0.8426E+01	0.8426E+01	

33	0.5633E+00	0.3641	1.9288	0.6804	0.4354	0.4957E+02	0.2788E+02
34	0.5402E+00	1.0254	1.9288	0.6804	0.4356	0.4959E+02	0.2693E+02
35	0.5402E+00	1.5231	1.9288	0.6804	0.4354	0.4957E+02	0.2788E+02
36	0.6815E+00	1.7970	2.5822	0.63780	0.3655	0.4157E+02	0.2833E+02
37	0.6518E+00	1.8409	2.5822	0.63780	0.3655	0.4161E+02	0.2738E+02
38	0.6518E+00	2.393	2.5822	0.63780	0.3652	0.4157E+02	0.2833E+02
39	0.6815E+00	0.4400	2.5822	0.63780	0.3652	0.4157E+02	0.2833E+02
40	0.6815E+00	1.2720	2.5822	0.63780	0.3655	0.4161E+02	0.2738E+02
41	0.6518E+00	1.8409	2.5822	0.63780	0.3655	0.4157E+02	0.2833E+02
42	0.6518E+00	1.8409	2.5822	0.63780	0.3652	0.4157E+02	0.2833E+02
43	0.6518E+00	2.393	2.5822	0.63780	0.3652	0.4157E+02	0.2833E+02
44	0.6518E+00	2.393	2.5822	0.63780	0.3652	0.4157E+02	0.2833E+02
45	0.7937E+00	0.5113	2.5113	0.59380	0.3087	0.3517E+02	0.2696E+02
46	0.7937E+00	1.4401	2.5113	0.59380	0.3089	0.3517E+02	0.2696E+02
47	0.7665E+00	0.5113	2.5113	0.59380	0.3089	0.3517E+02	0.2696E+02
48	0.7937E+00	1.4401	2.5113	0.59380	0.3087	0.3517E+02	0.2696E+02
49	0.7937E+00	1.4401	2.5113	0.59380	0.3089	0.3517E+02	0.2696E+02
50	0.7665E+00	0.5113	2.5113	0.59380	0.3089	0.3517E+02	0.2696E+02
51	0.9022E+00	0.5784	2.5113	0.59380	0.3087	0.3517E+02	0.2696E+02
52	0.9022E+00	1.5239	2.5113	0.59380	0.3087	0.3517E+02	0.2696E+02
53	0.9022E+00	2.4199	2.5113	0.59380	0.3087	0.3517E+02	0.2696E+02
54	0.8693E+00	0.6292	2.5113	0.59380	0.2644	0.3010E+02	0.2616E+02
55	0.8693E+00	1.6292	2.5113	0.59380	0.2644	0.3010E+02	0.2616E+02
56	0.8693E+00	2.4199	2.5113	0.59380	0.2644	0.3010E+02	0.2616E+02
57	0.9022E+00	0.5784	2.5113	0.59380	0.2644	0.3010E+02	0.2616E+02
58	0.9022E+00	1.5239	2.5113	0.59380	0.2644	0.3010E+02	0.2616E+02
59	0.9022E+00	2.4199	2.5113	0.59380	0.2644	0.3010E+02	0.2616E+02
60	0.9022E+00	0.6292	2.5113	0.59380	0.2292	0.2609E+02	0.2611E+02
61	0.9022E+00	1.6292	2.5113	0.59380	0.2292	0.2609E+02	0.2611E+02
62	0.9022E+00	2.4199	2.5113	0.59380	0.2292	0.2609E+02	0.2611E+02
63	0.9666E+00	0.8079	4.6264	0.50242	0.2295	0.2613E+02	0.2525E+02
64	0.9666E+00	1.8079	4.6264	0.50242	0.2292	0.2613E+02	0.2525E+02
65	0.9666E+00	2.6419	4.6264	0.50242	0.2292	0.2613E+02	0.2525E+02
66	0.9666E+00	0.6419	4.6264	0.50242	0.2019	0.2293E+02	0.2514E+02
67	0.9666E+00	1.6419	4.6264	0.50242	0.2019	0.2293E+02	0.2514E+02
68	0.9666E+00	2.4865	4.6264	0.50242	0.2019	0.2293E+02	0.2514E+02
69	0.1096E+01	0.7023	5.3277	0.45541	0.2014	0.2293E+02	0.2433E+02
70	0.1096E+01	1.9381	5.3277	0.45541	0.2014	0.2293E+02	0.2433E+02
71	0.1096E+01	3.4665	5.3277	0.45541	0.2014	0.2293E+02	0.2433E+02
72	0.1096E+01	0.7023	5.3277	0.45541	0.1782	0.2029E+02	0.2408E+02
73	0.1096E+01	1.9381	5.3277	0.45541	0.1782	0.2029E+02	0.2408E+02
74	0.1096E+01	3.4665	5.3277	0.45541	0.1782	0.2029E+02	0.2408E+02
75	0.1096E+01	0.7023	5.3277	0.45541	0.1782	0.2029E+02	0.2408E+02
76	0.1096E+01	1.9381	5.3277	0.45541	0.1782	0.2029E+02	0.2408E+02
77	0.1096E+01	3.4665	5.3277	0.45541	0.1782	0.2029E+02	0.2408E+02
78	0.1146E+01	0.7023	6.0351	0.40779	0.1784	0.2030E+02	0.2327E+02
79	0.1146E+01	1.408	6.0351	0.40779	0.1784	0.2030E+02	0.2327E+02
80	0.1146E+01	2.7601	6.0351	0.40779	0.1782	0.2029E+02	0.2327E+02
81	0.1146E+01	0.7023	6.0351	0.40779	0.1782	0.2029E+02	0.2327E+02
82	0.1146E+01	1.408	6.0351	0.40779	0.1784	0.2030E+02	0.2327E+02
83	0.1146E+01	2.7601	6.0351	0.40779	0.1784	0.2030E+02	0.2327E+02
84	0.1146E+01	0.7023	6.0351	0.40779	0.1782	0.2029E+02	0.2327E+02
85	0.1239E+01	4.0273	6.7465	0.35976	0.1553	0.1770E+02	0.2176E+02
86	0.1239E+01	3.4134	6.7465	0.35976	0.1553	0.1770E+02	0.2176E+02
87	0.1239E+01	2.2980	6.7465	0.35976	0.1553	0.1770E+02	0.2176E+02
88	0.1239E+01	0.8159	6.7465	0.35976	0.1553	0.1770E+02	0.2176E+02
89	0.1239E+01	4.0273	6.7465	0.35976	0.1553	0.1770E+02	0.2176E+02
90	0.1239E+01	3.4134	6.7465	0.35976	0.1553	0.1770E+02	0.2176E+02
91	0.1239E+01	2.2980	6.7465	0.35976	0.1553	0.1770E+02	0.2176E+02
92	0.1335E+01	4.2956	7.4595	0.31151	0.1262	0.1436E+02	0.1884E+02
93	0.1335E+01	3.6408	7.4595	0.31151	0.1262	0.1436E+02	0.1884E+02
94	0.1335E+01	2.4511	7.4595	0.31151	0.1262	0.1436E+02	0.1884E+02
95	0.1335E+01	0.8702	7.4595	0.31151	0.1262	0.1436E+02	0.1884E+02
96	0.1335E+01	4.2956	7.4595	0.31151	0.1262	0.1436E+02	0.1884E+02
97	0.1335E+01	3.6408	7.4595	0.31151	0.1262	0.1436E+02	0.1884E+02
98	0.1335E+01	2.4511	7.4595	0.31151	0.1262	0.1436E+02	0.1884E+02

99	0.1308E+01	2.4511	3.6408	7.4595	0.31151	0.1255	0.140E+02	0.1884E+02
100	0.1355E+01	0.8720	4.2956	7.4595	0.31151	0.0715	0.8144E+01	0.1946E+02
101	0.1433E+01	0.9236	4.1594	8.1720	0.26309	0.0719	0.8144E+01	0.1167E+02
102	0.1384E+01	2.6015	8.644	8.1720	0.26309	0.0715	0.8144E+01	0.1167E+02
103	0.1384E+01	3.8644	2.9015	8.1720	0.26309	0.0715	0.8144E+01	0.1167E+02
104	0.1433E+01	4.5594	0.5236	8.1720	0.26309	0.0715	0.8144E+01	0.1167E+02
105	0.1384E+01	4.5594	2.8644	8.1720	0.26309	0.0715	0.8144E+01	0.1167E+02
106	0.1433E+01	0.6015	3.8644	8.1720	0.26309	0.0715	0.8144E+01	0.1167E+02
107	0.1384E+01	2.6015	4.5594	8.1720	0.26309	0.0715	0.8144E+01	0.1167E+02
108	0.1433E+01	0.9236	4.5594	8.1720	0.26309	0.0715	0.8144E+01	0.1167E+02
109	0.1377E+01	0.5712	4.7939	8.8579	0.21608	0.0150	0.1703E+01	0.2345E+01
110	0.1330E+01	2.7354	4.0631	8.8579	0.21608	0.0154	0.1703E+01	0.2345E+01
111	0.1330E+01	4.0631	2.7354	8.8579	0.21608	0.0150	0.1703E+01	0.2345E+01
112	0.1377E+01	4.7939	0.9712	8.8579	0.21608	0.0155	0.1703E+01	0.2345E+01
113	0.1377E+01	4.7939	2.7354	8.8579	0.21608	0.0154	0.1703E+01	0.2345E+01
114	0.1330E+01	4.0631	4.7939	8.8579	0.21608	0.0213	0.2419E+01	0.3475E+01
115	0.1330E+01	2.7354	4.0631	8.8579	0.21608	0.0213	0.2419E+01	0.3475E+01
116	0.1377E+01	0.9712	4.7939	8.8579	0.21608	0.0217	0.2419E+01	0.3475E+01
117	0.1436E+01	1.0119	4.9951	9.5220	0.17021	0.0300	0.3418E+01	0.5098E+01
118	0.1387E+01	2.8502	4.2337	9.5220	0.17021	0.0300	0.3418E+01	0.5098E+01
119	0.1387E+01	4.2337	2.8502	9.5220	0.17021	0.0304	0.3418E+01	0.5098E+01
120	0.1436E+01	4.9951	1.0119	9.5220	0.17021	0.0304	0.3418E+01	0.5098E+01
121	0.1436E+01	4.9951	4.2337	9.5220	0.17021	0.0300	0.3418E+01	0.5098E+01
122	0.1387E+01	2.8502	4.2337	9.5220	0.17021	0.0300	0.3418E+01	0.5098E+01
123	0.1387E+01	4.2337	2.8502	9.5220	0.17021	0.0300	0.3418E+01	0.5098E+01
124	0.1436E+01	1.0119	4.9951	10.1905	0.12385	0.0300	0.3418E+01	0.5098E+01
125	0.1436E+01	4.9951	1.0119	10.1905	0.12385	0.0304	0.3418E+01	0.5098E+01
126	0.1440E+01	2.9579	4.3936	10.1905	0.12385	0.0300	0.3418E+01	0.5098E+01
127	0.1440E+01	4.3936	2.9579	10.1905	0.12385	0.0304	0.3418E+01	0.5098E+01
128	0.1491E+01	5.1838	1.0501	10.1905	0.12385	0.0300	0.3418E+01	0.5098E+01
129	0.1491E+01	4.3936	5.1838	10.1905	0.12385	0.0300	0.3418E+01	0.5098E+01
130	0.1440E+01	2.9579	4.3936	10.1905	0.12385	0.0300	0.3418E+01	0.5098E+01
131	0.1440E+01	4.3936	2.9579	10.1905	0.12385	0.0300	0.3418E+01	0.5098E+01
132	0.1491E+01	5.1838	1.0501	10.1905	0.12385	0.0300	0.3418E+01	0.5098E+01
133	0.1491E+01	4.3936	5.1838	10.1905	0.12385	0.0300	0.3418E+01	0.5098E+01
134	0.1400E+01	3.0591	4.5441	10.8406	0.07862	0.0495	0.5633E+01	0.7887E+01
135	0.1400E+01	4.5441	3.0591	10.8406	0.07862	0.0495	0.5633E+01	0.7887E+01
136	0.1450E+01	3.6113	4.5441	10.8406	0.07862	0.0490	0.5633E+01	0.8096E+01
137	0.1450E+01	5.5463	3.6113	10.8406	0.07862	0.0490	0.5633E+01	0.8096E+01
138	0.1400E+01	4.5441	5.5463	10.8406	0.07862	0.0495	0.5633E+01	0.7887E+01
139	0.1400E+01	3.0591	4.5441	10.8406	0.07862	0.0495	0.5633E+01	0.7887E+01
140	0.1450E+01	1.1236	5.5463	10.8406	0.07862	0.0490	0.5633E+01	0.8096E+01
141	0.1909E+01	3.1647	3.1647	11.5605	0.02821	0.0904	0.1029E+02	0.1948E+02
142	0.1843E+01	4.7009	3.1647	11.5605	0.02821	0.0896	0.1029E+02	0.1897E+02
143	0.1843E+01	3.1647	4.7009	11.5605	0.02821	0.0896	0.1029E+02	0.1897E+02
144	0.1909E+01	5.5463	3.1647	11.5605	0.02821	0.0904	0.1029E+02	0.1948E+02
145	0.1909E+01	3.1647	5.5463	11.5605	0.02821	0.0904	0.1029E+02	0.1948E+02
146	0.1843E+01	4.7009	3.1647	11.5605	0.02821	0.0904	0.1029E+02	0.1897E+02
147	0.1843E+01	3.1647	4.7009	11.5605	0.02821	0.0896	0.1029E+02	0.1897E+02
148	0.1909E+01	1.1236	5.5463	11.5605	0.02821	0.0896	0.1029E+02	0.1948E+02

FX= 0.0000000E+00 FD= 0.2346662E+04 FY= 0.1642791E-02 SWX= 0.1931980E-01 SMY= 0.0000000E+00 SMZ= 0.0000000E+00
CX= 0.0000000 CD= 0.1529403 CQ= 0.0000001 NX= -1560.000 WAX= 0.0000000 MY= 0.0000000 MZ= 0.0000000

STEP 20 DEPTH = 12.7750100 TIME = 0.0072233 DIMENSIONLESS TIME 0.8601851 WEIGHTING FACTORS = 1.0797000 1.0695000
AVERAGE VELOCITY 0.000

NO.	REF.NO.	MOD	AREA	X	Y	Z	IT*	CP	P	FORCE
1	1	0	0.7142E-01	0.1046	-0.2523	0.0658	0.85652	1.0280	0.1170E+03	0.8358E+01
2	2	0	0.7142E-01	0.2523	-0.1046	0.0658	0.85652	1.0280	0.1170E+03	0.8358E+01
3	3	0	0.7142E-01	0.2523	0.1046	0.0658	0.85652	1.0280	0.1170E+03	0.8358E+01
4	4	0	0.7142E-01	0.1046	0.2523	0.0658	0.85652	1.0280	0.1170E+03	0.8358E+01
5	5	0	0.9831E-01	1.186	-0.5857	0.2356	0.84625	0.7606	0.1029E+02	0.8513E+01
6	6	0	0.9502E-01	0.3342	-0.4965	0.2356	0.84625	0.7606	0.8661E+02	0.8229E+01

73	0.1096E+01	0.7023	5.3277	0.51287	0.1948	0.2431E+02
74	0.1059E+01	1.9780	5.3277	0.51287	0.1952	0.2352E+02
75	0.1096E+01	2.34665	5.3277	0.51287	0.1948	0.2431E+02
76	0.1187E+01	0.7601	6.0351	0.46525	0.1708	0.2232E+02
77	0.1146E+01	3.1800	6.0351	0.46525	0.1711	0.2232E+02
78	0.1146E+01	2.1408	6.0351	0.46525	0.1711	0.2232E+02
79	0.1146E+01	0.7601	6.0351	0.46525	0.1708	0.2232E+02
80	0.1187E+01	3.1800	6.0351	0.46525	0.1708	0.2232E+02
81	0.1187E+01	2.1408	6.0351	0.46525	0.1711	0.2232E+02
82	0.1146E+01	0.7601	6.0351	0.46525	0.1708	0.2232E+02
83	0.1146E+01	3.1800	6.0351	0.46525	0.1708	0.2232E+02
84	0.1187E+01	2.1408	6.0351	0.46525	0.1711	0.2232E+02
85	0.1273E+01	4.0273	6.7465	0.41722	0.1472	0.2133E+02
86	0.1229E+01	3.4134	6.7465	0.41722	0.1474	0.2063E+02
87	0.1229E+01	2.2980	6.7465	0.41722	0.1474	0.2063E+02
88	0.1273E+01	4.0273	6.7465	0.41722	0.1472	0.2133E+02
89	0.1229E+01	3.4134	6.7465	0.41722	0.1474	0.2063E+02
90	0.1229E+01	2.2980	6.7465	0.41722	0.1474	0.2063E+02
91	0.1273E+01	4.0273	6.7465	0.41722	0.1472	0.2133E+02
92	0.1355E+01	0.8702	7.4595	0.36897	0.1174	0.1810E+02
93	0.1308E+01	3.6408	7.4595	0.36897	0.1176	0.1752E+02
94	0.1308E+01	2.4511	7.4595	0.36897	0.1174	0.1810E+02
95	0.1355E+01	0.8702	7.4595	0.36897	0.1176	0.1752E+02
96	0.1355E+01	4.2956	7.4595	0.36897	0.1174	0.1810E+02
97	0.1308E+01	3.6408	7.4595	0.36897	0.1176	0.1752E+02
98	0.1308E+01	2.4511	7.4595	0.36897	0.1174	0.1810E+02
99	0.1355E+01	0.8702	7.4595	0.36897	0.1176	0.1752E+02
100	0.1433E+01	0.9236	8.1720	0.32055	0.1174	0.1810E+02
101	0.1384E+01	4.5594	8.1720	0.32055	0.1174	0.1810E+02
102	0.1384E+01	3.8644	8.1720	0.32055	0.1174	0.1810E+02
103	0.1433E+01	0.9236	8.1720	0.32055	0.1174	0.1810E+02
104	0.1384E+01	4.5594	8.1720	0.32055	0.1174	0.1810E+02
105	0.1384E+01	3.8644	8.1720	0.32055	0.1174	0.1810E+02
106	0.1433E+01	0.9236	8.1720	0.32055	0.1174	0.1810E+02
107	0.1384E+01	4.5594	8.1720	0.32055	0.1174	0.1810E+02
108	0.1384E+01	3.8644	8.1720	0.32055	0.1174	0.1810E+02
109	0.1377E+01	0.9712	8.8579	0.27354	0.0666	0.9621E+00
110	0.1330E+01	4.0631	8.8579	0.27354	0.0066	0.1002E+01
111	0.1330E+01	2.7354	8.8579	0.27354	0.0066	0.1002E+01
112	0.1377E+01	0.9712	8.8579	0.27354	0.0066	0.9621E+00
113	0.1377E+01	4.7939	8.8579	0.27354	0.0066	0.9621E+00
114	0.1330E+01	2.7354	8.8579	0.27354	0.0066	0.1002E+01
115	0.1377E+01	0.9712	8.8579	0.27354	0.0066	0.9621E+00
116	0.1377E+01	4.7939	8.8579	0.27354	0.0066	0.9621E+00
117	0.1436E+01	0.9712	9.5220	0.22767	0.0097	0.1585E+01
118	0.1387E+01	4.9951	9.5220	0.22767	0.0100	0.1585E+01
119	0.1387E+01	2.337	9.5220	0.22767	0.0097	0.1585E+01
120	0.1436E+01	0.9712	9.5220	0.22767	0.0097	0.1585E+01
121	0.1387E+01	4.9951	9.5220	0.22767	0.0100	0.1585E+01
122	0.1387E+01	2.337	9.5220	0.22767	0.0097	0.1585E+01
123	0.1387E+01	4.9951	9.5220	0.22767	0.0100	0.1585E+01
124	0.1436E+01	0.9712	9.5220	0.22767	0.0097	0.1585E+01
125	0.1436E+01	4.9951	9.5220	0.22767	0.0100	0.1585E+01
126	0.1440E+01	2.9579	10.1905	0.18131	0.0131	0.220E+01
127	0.1491E+01	3.9336	10.1905	0.18131	0.0135	0.220E+01
128	0.1491E+01	1.0501	10.1905	0.18131	0.0131	0.220E+01
129	0.1440E+01	4.9336	10.1905	0.18131	0.0135	0.220E+01
130	0.1440E+01	2.9579	10.1905	0.18131	0.0131	0.220E+01
131	0.1491E+01	3.9336	10.1905	0.18131	0.0135	0.220E+01
132	0.1491E+01	1.0501	10.1905	0.18131	0.0131	0.220E+01
133	0.1450E+01	4.8613	10.8406	0.13608	0.0080	0.1334E+01
134	0.1400E+01	3.0591	10.8406	0.13608	0.0083	0.1334E+01
135	0.1450E+01	1.0861	10.8406	0.13608	0.0080	0.1334E+01
136	0.1450E+01	5.3613	10.8406	0.13608	0.0080	0.1334E+01
137	0.1450E+01	3.3613	10.8406	0.13608	0.0080	0.1334E+01
138	0.1400E+01	4.5441	10.8406	0.13608	0.0083	0.1334E+01

139	0.000000E+00	FD=	0.221588E+04	FN=	0.1003588E-02	SMX=	0.1291944E-01	SMY=	0.000000E+00	SMZ=	0.000000E+00
140	0.000000E+00	CD=	0.1443978	CN=	0.0000001	MX=	0.0000001	MW=	0.0000000	NZ=	0.0000000
141	0										
142	0										
143	0										
144	0										
145	0										
146	0										
147	0										
148	0										
149	0										
150	0										
151	0										
152	0										
153	0										
154	0										
155	0										
156	0										

STEP 21 DEPTH = 13.5923100 TIME = 0.0077132 DIMENSIONLESS TIME 0.9185201 WETTING FACTORS = 1.0695000 1.0562000
 AVERAGE VELOCITY 0.000 WZ -1560.000 WX 0.000

NO.	REF. NO.	MDD	AREA	X	Y	Z	T*	CP	P	FORCE
1	0	0	0.7142E-01	0.1046	-0.2522	0.0658	0.91486	1.0197	0.1161E+03	0.8290E+01
2	0	0	0.7142E-01	0.2523	-0.1046	0.0658	0.91486	1.0197	0.1161E+03	0.8290E+01
3	0	0	0.7142E-01	0.2523	0.1046	0.0658	0.91486	1.0197	0.1161E+03	0.8290E+01
4	0	0	0.7142E-01	0.1046	0.2523	0.0658	0.91486	1.0197	0.1161E+03	0.8290E+01
5	0	0	0.9031E-01	0.1186	-0.5857	0.2356	0.90459	0.7537	0.8580E+02	0.8435E+01
6	0	0	0.9029E-01	0.3342	-0.4965	0.2356	0.90459	0.7537	0.8580E+02	0.8435E+01
7	0	0	0.9029E-01	0.4965	-0.3342	0.2356	0.90459	0.7537	0.8580E+02	0.8435E+01
8	0	0	0.9031E-01	0.5857	-0.1186	0.2356	0.90459	0.7537	0.8580E+02	0.8435E+01
9	0	0	0.9029E-01	0.3342	0.1186	0.2356	0.90459	0.7537	0.8580E+02	0.8435E+01
10	0	0	0.9029E-01	0.4965	0.3342	0.2356	0.90459	0.7537	0.8580E+02	0.8435E+01
11	0	0	0.9031E-01	0.5857	0.1186	0.2356	0.90459	0.7537	0.8580E+02	0.8435E+01
12	0	0	0.9029E-01	0.3342	0.5857	0.2356	0.90459	0.7537	0.8580E+02	0.8435E+01
13	0	0	0.3010E+00	0.1969	-0.8740	0.6814	0.87646	0.5874	0.6689E+02	0.1944E+02
14	0	0	0.2907E+00	0.5547	-0.8740	0.6814	0.87646	0.5874	0.6689E+02	0.1944E+02
15	0	0	0.2907E+00	0.8240	-0.5547	0.6814	0.87646	0.5874	0.6689E+02	0.1944E+02
16	0	0	0.3010E+00	0.9722	-0.1969	0.6814	0.87646	0.5874	0.6689E+02	0.1944E+02
17	0	0	0.3010E+00	0.9722	0.1969	0.6814	0.87646	0.5874	0.6689E+02	0.1944E+02
18	0	0	0.3007E+00	0.5547	0.8740	0.6814	0.87646	0.5874	0.6689E+02	0.1944E+02
19	0	0	0.3007E+00	0.8240	0.5547	0.6814	0.87646	0.5874	0.6689E+02	0.1944E+02
20	0	0	0.3010E+00	0.9722	-0.9722	0.6814	0.87646	0.5874	0.6689E+02	0.1944E+02
21	0	0	0.4357E+00	0.2830	-1.3971	1.2940	0.83724	0.5084	0.5788E+02	0.2437E+02
22	0	0	0.4208E+00	0.9722	-1.1841	1.2940	0.83724	0.5087	0.5791E+02	0.2437E+02
23	0	0	0.4208E+00	1.1841	-0.9722	1.2940	0.83724	0.5084	0.5788E+02	0.2437E+02
24	0	0	0.4357E+00	1.3971	-0.2830	1.2940	0.83724	0.5087	0.5791E+02	0.2437E+02
25	0	0	0.4208E+00	1.1841	0.9722	1.2940	0.83724	0.5087	0.5791E+02	0.2437E+02
26	0	0	0.4357E+00	1.3971	-0.9722	1.2940	0.83724	0.5084	0.5788E+02	0.2437E+02
27	0	0	0.4208E+00	0.9722	1.1841	1.2940	0.83724	0.5087	0.5791E+02	0.2437E+02
28	0	0	0.4357E+00	1.3971	-1.1841	1.2940	0.83724	0.5084	0.5788E+02	0.2437E+02
29	0	0	0.5623E+00	0.3641	-1.5231	1.9288	0.79622	0.4239	0.4825E+02	0.2620E+02
30	0	0	0.5430E+00	1.0254	-1.5231	1.9288	0.79622	0.4239	0.4825E+02	0.2620E+02
31	0	0	0.5430E+00	1.5231	-1.0254	1.9288	0.79622	0.4239	0.4825E+02	0.2620E+02
32	0	0	0.5623E+00	1.7970	-0.3641	1.9288	0.79622	0.4237	0.4823E+02	0.2620E+02
33	0	0	0.5223E+00	1.7970	0.3641	1.9288	0.79622	0.4237	0.4823E+02	0.2620E+02
34	0	0	0.5430E+00	1.5231	-1.0254	1.9288	0.79622	0.4239	0.4825E+02	0.2620E+02
35	0	0	0.5430E+00	1.5231	1.0254	1.9288	0.79622	0.4239	0.4825E+02	0.2620E+02
36	0	0	0.5623E+00	1.7970	-0.3641	1.9288	0.79622	0.4237	0.4823E+02	0.2620E+02
37	0	0	0.5223E+00	1.7970	0.3641	1.9288	0.79622	0.4237	0.4823E+02	0.2620E+02
38	0	0	0.5681E+00	1.2393	-1.8409	2.5822	0.75359	0.3538	0.4027E+02	0.2650E+02

105	0.000000E+00	FD=	0.209133E+04	FN=	-0.155653E-03	SMX=	0.1092329E-02	SMW=	0.000000E+00	SMZ=	0.000000E+00
106	0.000000E+00	CD=	0.1362998	CF=	0.0000000	MX=	0.0000000	MW=	0.0000000	MZ=	0.0000000
107	0.000000E+00										
108	0.000000E+00										
109	0.000000E+00										
110	0.000000E+00										
111	0.000000E+00										
112	0.000000E+00										
113	0.000000E+00										
114	0.000000E+00										
115	0.000000E+00										
116	0.000000E+00										
117	0.000000E+00										
118	0.000000E+00										
119	0.000000E+00										
120	0.000000E+00										
121	0.000000E+00										
122	0.000000E+00										
123	0.000000E+00										
124	0.000000E+00										
125	0.000000E+00										
126	0.000000E+00										
127	0.000000E+00										
128	0.000000E+00										
129	0.000000E+00										
130	0.000000E+00										
131	0.000000E+00										
132	0.000000E+00										
133	0.000000E+00										
134	0.000000E+00										
135	0.000000E+00										
136	0.000000E+00										
137	0.000000E+00										
138	0.000000E+00										
139	0.000000E+00										
140	0.000000E+00										
141	0.000000E+00										
142	0.000000E+00										
143	0.000000E+00										
144	0.000000E+00										
145	0.000000E+00										
146	0.000000E+00										
147	0.000000E+00										
148	0.000000E+00										
149	0.000000E+00										
150	0.000000E+00										
151	0.000000E+00										
152	0.000000E+00										
153	0.000000E+00										
154	0.000000E+00										
155	0.000000E+00										
156	0.000000E+00										
157	0.000000E+00										
158	0.000000E+00										
159	0.000000E+00										
160	0.000000E+00										
161	0.000000E+00										
162	0.000000E+00										
163	0.000000E+00										
164	0.000000E+00										

DEPTH = 14.414100 TIME = 0.0082122 DIMENSIONLESS TIME 0.9779366 WEITING FACTORS = 1.0562000 1.0396000
 AVERAGE VELOCITY 0.000 0.000 -1560.000 WX 0.00ORIENTATION 90.000

STEP	REF. NO.	MOD	AREA	X	Y	Z	IT*	CP	P	FORCE
1	1	0	0.7142E-01	0.1046	-0.2523	0.0658	0.97427	1.0110	0.1151E+03	0.8219E+01
2	2	0	0.7142E-01	0.2523	-0.1046	0.0658	0.97427	1.0110	0.1151E+03	0.8219E+01
3	3	0	0.7142E-01	0.2523	0.1046	0.0658	0.97427	1.0110	0.1151E+03	0.8219E+01
4	4	0	0.9831E-01	0.1186	-0.5857	0.2356	0.96400	0.7462	0.8494E+02	0.8073E+01
5	5	0	0.9502E-01	0.4965	-0.3342	0.2356	0.96401	0.7462	0.8494E+02	0.8073E+01
6	6	0	0.9502E-01	0.5857	-0.1186	0.2356	0.96401	0.7462	0.8494E+02	0.8073E+01
7	7	0	0.9831E-01	0.5857	0.1186	0.2356	0.96401	0.7462	0.8494E+02	0.8073E+01
8	8	0	0.9502E-01	0.4965	0.3342	0.2356	0.96401	0.7462	0.8494E+02	0.8073E+01
9	9	0	0.9502E-01	0.5857	0.5857	0.2356	0.96401	0.7462	0.8494E+02	0.8073E+01
10	10	0	0.9831E-01	0.5857	-0.5857	0.6814	0.93587	0.5805	0.6608E+02	0.1989E+02
11	11	0	0.9502E-01	0.4965	-0.8240	0.6814	0.93587	0.5805	0.6608E+02	0.1989E+02
12	12	0	0.9502E-01	0.5857	-0.5547	0.6814	0.93587	0.5805	0.6608E+02	0.1989E+02
13	13	0	0.3010E+00	0.1969	-0.1969	0.6814	0.93587	0.5805	0.6608E+02	0.1989E+02
14	14	0	0.2907E+00	0.5547	-0.5547	0.6814	0.93587	0.5805	0.6608E+02	0.1989E+02
15	15	0	0.2907E+00	0.9722	-0.9722	0.6814	0.93587	0.5805	0.6608E+02	0.1989E+02
16	16	0	0.3010E+00	0.9722	-0.5547	0.6814	0.93587	0.5805	0.6608E+02	0.1989E+02
17	17	0	0.2907E+00	0.9722	0.5547	0.6814	0.93587	0.5805	0.6608E+02	0.1989E+02
18	18	0	0.2907E+00	0.5547	0.8240	0.6814	0.93587	0.5805	0.6608E+02	0.1989E+02
19	19	0	0.3010E+00	0.5547	0.8240	0.6814	0.93587	0.5805	0.6608E+02	0.1989E+02
20	20	0	0.3010E+00	0.1969	0.9722	0.6814	0.93587	0.5805	0.6608E+02	0.1989E+02
21	21	0	0.4357E+00	0.2830	-1.3971	1.2940	0.89666	0.5015	0.5709E+02	0.2487E+02
22	22	0	0.4208E+00	0.7972	-1.1841	1.2940	0.89666	0.5015	0.5709E+02	0.2487E+02
23	23	0	0.4208E+00	1.1841	-0.7972	1.2940	0.89666	0.5015	0.5709E+02	0.2487E+02
24	24	0	0.4357E+00	1.3971	-0.2830	1.2940	0.89666	0.5015	0.5709E+02	0.2487E+02
25	25	0	0.4357E+00	1.3971	0.2830	1.2940	0.89666	0.5015	0.5709E+02	0.2487E+02
26	26	0	0.4208E+00	1.1841	0.7972	1.2940	0.89666	0.5015	0.5709E+02	0.2487E+02
27	27	0	0.4208E+00	0.7972	1.1841	1.2940	0.89666	0.5015	0.5709E+02	0.2487E+02
28	28	0	0.4357E+00	0.2830	1.3971	1.2940	0.89666	0.5015	0.5709E+02	0.2487E+02
29	29	0	0.5623E+00	0.3641	-1.5231	1.9288	0.85563	0.4169	0.4746E+02	0.2577E+02
30	30	0	0.5430E+00	0.254	-1.5231	1.9288	0.85563	0.4169	0.4746E+02	0.2577E+02
31	31	0	0.5430E+00	1.5231	-1.0254	1.9288	0.85563	0.4169	0.4746E+02	0.2577E+02
32	32	0	0.5623E+00	1.7970	-0.3641	1.9288	0.85563	0.4169	0.4746E+02	0.2577E+02
33	33	0	0.5130E+00	1.7970	0.3641	1.9288	0.85563	0.4169	0.4746E+02	0.2577E+02
34	34	0	0.5130E+00	1.0254	1.5231	1.9288	0.85563	0.4169	0.4746E+02	0.2577E+02
35	35	0	0.5130E+00	1.5231	1.0254	1.9288	0.85563	0.4169	0.4746E+02	0.2577E+02
36	36	0	0.5623E+00	0.3641	1.7970	1.9288	0.85563	0.4169	0.4746E+02	0.2577E+02
37	37	0	0.6835E+00	0.4400	-2.1720	2.5823	0.81301	0.3464	0.3947E+02	0.2688E+02
38	38	0	0.6581E+00	1.2393	-1.8409	2.5823	0.81301	0.3464	0.3947E+02	0.2688E+02
39	39	0	0.6581E+00	1.8409	-1.2393	2.5823	0.81301	0.3464	0.3947E+02	0.2688E+02
40	40	0	0.6835E+00	2.1720	-0.4400	2.5823	0.81301	0.3464	0.3947E+02	0.2688E+02
41	41	0	0.6581E+00	2.1720	0.4400	2.5823	0.81301	0.3464	0.3947E+02	0.2688E+02
42	42	0	0.6581E+00	1.8409	1.2393	2.5823	0.81301	0.3464	0.3947E+02	0.2688E+02
43	43	0	0.6835E+00	1.2393	1.8409	2.5823	0.81301	0.3464	0.3947E+02	0.2688E+02
44	44	0	0.6581E+00	0.4400	2.1720	2.5823	0.81301	0.3464	0.3947E+02	0.2688E+02
45	45	0	0.7937E+00	0.5113	-2.5239	3.2513	0.76901	0.2900	0.3301E+02	0.2530E+02
46	46	0	0.7655E+00	1.4401	-2.1391	3.2513	0.76901	0.2900	0.3301E+02	0.2530E+02
47	47	0	0.7655E+00	2.1391	-1.4401	3.2513	0.76901	0.2900	0.3301E+02	0.2530E+02
48	48	0	0.7937E+00	2.5239	-0.5113	3.2513	0.76901	0.2900	0.3301E+02	0.2530E+02
49	49	0	0.7937E+00	2.5239	0.5113	3.2513	0.76901	0.2900	0.3301E+02	0.2530E+02
50	50	0	0.7655E+00	1.4401	2.1391	3.2513	0.76901	0.2900	0.3301E+02	0.2530E+02
51	51	0	0.7655E+00	2.1391	1.4401	3.2513	0.76901	0.2900	0.3301E+02	0.2530E+02
52	52	0	0.9023E+00	0.5113	2.5239	3.2513	0.76901	0.2900	0.3301E+02	0.2530E+02
53	53	0	0.8693E+00	0.5784	2.8552	3.2513	0.76901	0.2900	0.3301E+02	0.2530E+02
54	54	0	0.9023E+00	0.5784	-2.8552	3.2513	0.76901	0.2900	0.3301E+02	0.2530E+02
55	55	0	0.8693E+00	2.8552	-0.5784	3.2513	0.76901	0.2900	0.3301E+02	0.2530E+02
56	56	0	0.9023E+00	2.8552	0.5784	3.2513	0.76901	0.2900	0.3301E+02	0.2530E+02
57	57	0	0.8693E+00	2.4200	1.6292	3.2513	0.76901	0.2900	0.3301E+02	0.2530E+02
58	58	0	0.8693E+00	1.6292	2.4200	3.2513	0.76901	0.2900	0.3301E+02	0.2530E+02
59	59	0	0.9023E+00	0.5784	2.8552	3.2513	0.76901	0.2900	0.3301E+02	0.2530E+02
60	60	0	0.9023E+00	0.5784	-2.8552	3.2513	0.76901	0.2900	0.3301E+02	0.2530E+02
61	61	0	0.9666E+00	0.5419	-2.1685	4.6264	0.67763	0.2087	0.2376E+02	0.2296E+02
62	62	0	0.9666E+00	1.8080	-2.6264	4.6264	0.67763	0.2087	0.2376E+02	0.2296E+02

79	3.1800	-2.1408	6.0351	0.64373	0.1433	0.1634E+02	0.1872E+02
80	3.7519	-0.7601	6.0351	0.64373	0.1433	0.1632E+02	0.1936E+02
81	3.7519	0.7601	6.0351	0.64373	0.1433	0.1634E+02	0.1872E+02
82	3.1800	2.1408	6.0351	0.64373	0.1433	0.1634E+02	0.1872E+02
83	0.7601	3.1800	6.0351	0.64373	0.1433	0.1632E+02	0.1936E+02
84	0.7601	3.7519	6.0351	0.64373	0.1433	0.1634E+02	0.1872E+02
85	0.2980	-4.0273	6.7465	0.59570	0.1171	0.1332E+02	0.1642E+02
86	3.4134	-3.4134	6.7465	0.59570	0.1171	0.1336E+02	0.1642E+02
87	3.4134	-2.2980	6.7465	0.59570	0.1171	0.1333E+02	0.1697E+02
88	4.0273	-0.8159	6.7465	0.59570	0.1171	0.1333E+02	0.1697E+02
89	4.0273	0.8159	6.7465	0.59570	0.1171	0.1333E+02	0.1642E+02
90	3.4134	2.2980	6.7465	0.59570	0.1171	0.1336E+02	0.1642E+02
91	3.4134	3.4134	6.7465	0.59570	0.1171	0.1333E+02	0.1697E+02
92	0.8159	4.0274	6.7465	0.59570	0.1171	0.1333E+02	0.1697E+02
93	0.8702	-4.2956	7.4595	0.54746	0.0848	0.9651E+01	0.1308E+02
94	2.4511	-3.6408	7.4595	0.54746	0.0850	0.9679E+01	0.1266E+02
95	3.6408	-2.4511	7.4595	0.54746	0.0850	0.9679E+01	0.1266E+02
96	4.2956	-0.8702	7.4595	0.54746	0.0848	0.9651E+01	0.1308E+02
97	4.2956	0.8702	7.4595	0.54746	0.0848	0.9679E+01	0.1266E+02
98	2.4511	3.6408	7.4595	0.54746	0.0850	0.9679E+01	0.1266E+02
99	2.4511	4.2956	7.4595	0.54746	0.0848	0.9651E+01	0.1308E+02
100	0.8702	4.2956	7.4595	0.54746	0.0850	0.9679E+01	0.1266E+02
101	0.9236	-4.5594	8.1720	0.49903	0.0280	0.3191E+01	0.4572E+01
102	2.6015	-3.8644	8.1720	0.49903	0.0283	0.3225E+01	0.4462E+01
103	3.8644	-2.6015	8.1720	0.49903	0.0283	0.3225E+01	0.4462E+01
104	3.8644	2.6015	8.1720	0.49903	0.0280	0.3190E+01	0.4572E+01
105	4.5594	-0.9236	8.1720	0.49903	0.0280	0.3225E+01	0.4462E+01
106	3.8644	0.9236	8.1720	0.49903	0.0283	0.3225E+01	0.4462E+01
107	2.6015	3.8644	8.1720	0.49903	0.0283	0.3225E+01	0.4462E+01
108	0.9236	4.5594	8.1720	0.49903	0.0280	0.3190E+01	0.4572E+01
109	0.9712	-4.7939	8.8579	0.45203	0.0000	0.0000E+00	0.0000E+00
110	2.7354	-4.0631	8.8579	0.45203	0.0000	0.0000E+00	0.0000E+00
111	4.0631	-2.7354	8.8579	0.45203	0.0000	0.0000E+00	0.0000E+00
112	4.0631	2.7354	8.8579	0.45203	0.0000	0.0000E+00	0.0000E+00
113	4.7939	-0.9712	8.8579	0.45203	0.0000	0.0000E+00	0.0000E+00
114	4.7939	0.9712	8.8579	0.45203	0.0000	0.0000E+00	0.0000E+00
115	4.0631	4.0631	8.8579	0.45203	0.0000	0.0000E+00	0.0000E+00
116	0.9712	4.7939	8.8579	0.45203	0.0000	0.0000E+00	0.0000E+00
117	0.9712	4.0631	8.8579	0.40615	0.0000	0.0000E+00	0.0000E+00
118	1.0119	-4.9951	9.5220	0.40615	0.0000	0.0000E+00	0.0000E+00
119	2.8502	-4.2337	9.5220	0.40615	0.0000	0.0000E+00	0.0000E+00
120	4.2337	-2.8502	9.5220	0.40615	0.0000	0.0000E+00	0.0000E+00
121	4.2337	2.8502	9.5220	0.40615	0.0000	0.0000E+00	0.0000E+00
122	4.9951	-1.0119	9.5220	0.40615	0.0000	0.0000E+00	0.0000E+00
123	4.9951	1.0119	9.5220	0.40615	0.0000	0.0000E+00	0.0000E+00
124	4.2337	4.2337	9.5220	0.40615	0.0000	0.0000E+00	0.0000E+00
125	1.0119	4.9951	9.5220	0.40615	0.0000	0.0000E+00	0.0000E+00
126	2.9579	-5.1838	10.1905	0.35980	0.0000	0.0000E+00	0.0000E+00
127	4.3936	-4.3936	10.1905	0.35980	0.0000	0.0000E+00	0.0000E+00
128	5.1838	-2.9579	10.1905	0.35980	0.0000	0.0000E+00	0.0000E+00
129	5.1838	2.9579	10.1905	0.35980	0.0000	0.0000E+00	0.0000E+00
130	4.3936	4.3936	10.1905	0.35980	0.0000	0.0000E+00	0.0000E+00
131	2.9579	5.1838	10.1905	0.35980	0.0000	0.0000E+00	0.0000E+00
132	1.0501	4.1838	10.8406	0.31456	0.0000	0.0000E+00	0.0000E+00
133	1.0501	5.1838	10.8406	0.31456	0.0000	0.0000E+00	0.0000E+00
134	3.0591	-3.5441	10.8406	0.31456	0.0000	0.0000E+00	0.0000E+00
135	3.0591	3.5441	10.8406	0.31456	0.0000	0.0000E+00	0.0000E+00
136	5.3613	-1.0861	10.8406	0.31456	0.0000	0.0000E+00	0.0000E+00
137	5.3613	1.0861	10.8406	0.31456	0.0000	0.0000E+00	0.0000E+00
138	4.5441	3.0591	10.8406	0.31456	0.0000	0.0000E+00	0.0000E+00
139	3.0591	4.5441	10.8406	0.31456	0.0000	0.0000E+00	0.0000E+00
140	1.0861	5.3613	11.5605	0.26416	0.0000	0.0000E+00	0.0000E+00
141	1.0861	5.3613	11.5605	0.26416	0.0000	0.0000E+00	0.0000E+00
142	3.1647	-4.7009	11.5605	0.26416	0.0000	0.0000E+00	0.0000E+00
143	4.7009	-3.1647	11.5605	0.26416	0.0000	0.0000E+00	0.0000E+00
144	5.5463	-1.1236	11.5605	0.26416	0.0000	0.0000E+00	0.0000E+00

145	0.1909E+01	5.5463	1.1236	11.5605	0.26416	0.0000	0.0000E+00	0.0000E+00
146	0.1843E+01	4.7009	3.1647	11.5605	0.26416	0.0000	0.0000E+00	0.0000E+00
147	0.1843E+01	3.1647	4.7008	11.5605	0.26416	0.0000	0.0000E+00	0.0000E+00
148	0.1909E+01	1.1236	5.5463	11.5605	0.26416	0.0000	0.0000E+00	0.0000E+00
149	0.1909E+01	1.1236	5.5463	11.5605	0.26416	0.0000	0.0000E+00	0.0000E+00
150	0.1909E+01	3.2732	-4.8619	12.3708	0.20706	0.0000	0.0000E+00	0.0000E+00
151	0.1909E+01	4.8619	-3.2732	12.3708	0.20706	0.0000	0.0000E+00	0.0000E+00
152	0.1909E+01	5.7363	-1.1621	12.3708	0.20706	0.0000	0.0000E+00	0.0000E+00
153	0.1909E+01	4.8619	3.2732	12.3708	0.20706	0.0000	0.0000E+00	0.0000E+00
154	0.1909E+01	3.2732	4.8619	12.3708	0.20706	0.0000	0.0000E+00	0.0000E+00
155	0.1977E+01	1.1621	5.7363	12.3708	0.20706	0.0000	0.0000E+00	0.0000E+00
156	0.1977E+01	1.1621	5.7363	12.3708	0.20706	0.0000	0.0000E+00	0.0000E+00
157	0.1977E+01	1.1971	-5.9085	13.1855	0.14918	0.0000	0.0000E+00	0.0000E+00
158	0.1967E+01	3.3718	-3.3718	13.1855	0.14918	0.0000	0.0000E+00	0.0000E+00
159	0.1967E+01	5.0085	-3.3718	13.1855	0.14918	0.0000	0.0000E+00	0.0000E+00
160	0.2037E+01	5.9093	-1.1971	13.1855	0.14918	0.0000	0.0000E+00	0.0000E+00
161	0.2037E+01	5.9092	1.1971	13.1855	0.14918	0.0000	0.0000E+00	0.0000E+00
162	0.1967E+01	3.3718	3.3718	13.1855	0.14918	0.0000	0.0000E+00	0.0000E+00
163	0.1967E+01	3.3718	3.3718	13.1855	0.14918	0.0000	0.0000E+00	0.0000E+00
164	0.2037E+01	1.2274	-6.0586	14.0049	0.09033	0.0000	0.0000E+00	0.0000E+00
165	0.2088E+01	3.4570	-5.1351	14.0049	0.09033	0.0000	0.0000E+00	0.0000E+00
166	0.2016E+01	5.1351	-3.4570	14.0049	0.09033	0.0000	0.0000E+00	0.0000E+00
167	0.2016E+01	6.0586	-1.2274	14.0049	0.09033	0.0000	0.0000E+00	0.0000E+00
168	0.2088E+01	6.0586	1.2274	14.0049	0.09033	0.0000	0.0000E+00	0.0000E+00
169	0.2016E+01	5.1351	3.4570	14.0049	0.09033	0.0000	0.0000E+00	0.0000E+00
170	0.2016E+01	3.4570	5.1351	14.0049	0.09033	0.0000	0.0000E+00	0.0000E+00
171	0.2088E+01	1.2274	6.0586	14.0049	0.09033	0.0000	0.0000E+00	0.0000E+00
172	0.2129E+01	1.2516	-6.1781	14.8291	0.03028	0.0000	0.0000E+00	0.0000E+00
173	0.2129E+01	3.5252	-3.5252	14.8291	0.03028	0.0000	0.0000E+00	0.0000E+00
174	0.2055E+01	5.2363	-1.2516	14.8291	0.03028	0.0000	0.0000E+00	0.0000E+00
175	0.2055E+01	6.1781	1.2516	14.8291	0.03028	0.0000	0.0000E+00	0.0000E+00
176	0.2129E+01	3.5252	3.5252	14.8291	0.03028	0.0000	0.0000E+00	0.0000E+00
177	0.2055E+01	5.2363	5.2363	14.8291	0.03028	0.0000	0.0000E+00	0.0000E+00
178	0.2055E+01	3.5252	6.1781	14.8291	0.03028	0.0000	0.0000E+00	0.0000E+00
179	0.2055E+01	1.2516	6.1781	14.8291	0.03028	0.0000	0.0000E+00	0.0000E+00
180	0.2129E+01	1.2516	6.1781	14.8291	0.03028	0.0000	0.0000E+00	0.0000E+00

FX= 0.000000E+00 FD= 0.1914795E+04 FN= 0.8446868E-03 SMX= 0.6705068E-02 SMY= 0.0000000E+00 SMZ= 0.0000000E+00
CX= 0.00000000 CD= 0.1247940 CN= 0.00000001 MX= -1560.000 WX= 0.00000000 MY= 0.00000000 MZ= 0.00000000

STEP 24 DEPTH = 16.0740100 TIME = 0.0092478 DIMENSIONLESS TIME 1.1012672 WEITING FACTORS = 1.0152000 1.0000000
AVERAGE VELOCITY 0.000

NO.	1	2	3	4	5	6	7	8	9	10	11	12	13	14	15	16	17	18	19	20
REF.NO.	0	0	0	0	0	0	0	0	0	0	0	0	0	0	0	0	0	0	0	0
MOD	0	0	0	0	0	0	0	0	0	0	0	0	0	0	0	0	0	0	0	0
AREA	0.7142E-01	0.7142E-01	0.7142E-01	0.7142E-01	0.9831E-01	0.9502E-01	0.9831E-01	0.9831E-01	0.9831E-01	0.9502E-01	0.9502E-01	0.9831E-01	0.3010E+00	0.2907E+00	0.2907E+00	0.3010E+00	0.3010E+00	0.2907E+00	0.2907E+00	0.3010E+00
X	0.1046	0.2523	0.2523	0.1046	0.186	0.3342	0.4965	-0.1186	0.5857	0.5857	0.4965	0.3342	0.1969	0.5547	0.8240	0.8240	0.5722	0.8240	0.5547	0.1969
Y	-0.2523	0.1046	0.1046	-0.2523	0.3357	-0.4965	0.1186	-0.5857	-0.5857	-0.4965	-0.3342	-0.1969	-0.5547	-0.8240	-0.8240	-0.5722	-0.8240	-0.5547	-0.1969	-0.5547
Z	0.0658	0.0658	0.0658	0.0658	0.2356	0.2356	0.2356	0.2356	0.2356	0.2356	0.2356	0.2356	0.6814	0.6814	0.6814	0.6814	0.6814	0.6814	0.6814	0.6814
T*	1.09760	1.09760	1.09760	1.09760	1.08734	1.08734	1.08734	1.08734	1.08734	1.08734	1.08734	1.08734	1.05920	1.05920	1.05920	1.05920	1.05920	1.05920	1.05920	1.05920
CP	0.9925	0.9925	0.9925	0.9925	0.7297	0.7297	0.7297	0.7297	0.7297	0.7297	0.7297	0.7297	0.5646	0.5646	0.5646	0.5646	0.5646	0.5646	0.5646	0.5646
P	0.1130E+03	0.1130E+03	0.1130E+03	0.1130E+03	0.8305E+02	0.8307E+02	0.8307E+02	0.8307E+02	0.8305E+02	0.8305E+02	0.8307E+02	0.8305E+02	0.6430E+02	0.6430E+02	0.6430E+02	0.6430E+02	0.6430E+02	0.6430E+02	0.6430E+02	0.6430E+02
FORCE	0.8069E+01	0.8069E+01	0.8069E+01	0.8069E+01	0.8165E+01	0.7893E+01	0.7893E+01	0.7893E+01	0.8165E+01	0.8165E+01	0.7893E+01	0.7893E+01	0.1934E+02	0.1869E+02	0.1869E+02	0.1934E+02	0.1934E+02	0.1869E+02	0.1869E+02	0.1934E+02

87	0.1229E+01	3.4134	-2.2980	6.7465	0.64830	0.1042	0.1197E+02	0.1472E+02
88	0.1273E+01	4.0273	-0.8159	6.7465	0.65830	0.1049	0.1195E+02	0.1521E+02
89	0.1273E+01	3.4134	0.2980	6.7465	0.65830	0.1052	0.1197E+02	0.1472E+02
90	0.1273E+01	2.2980	3.4134	6.7465	0.65830	0.1049	0.1195E+02	0.1472E+02
91	0.1355E+01	0.8159	4.0274	6.7465	0.65830	0.1049	0.1195E+02	0.1472E+02
92	0.1355E+01	0.8159	4.0274	6.7465	0.65830	0.1049	0.1195E+02	0.1472E+02
93	0.1355E+01	0.8159	4.0274	6.7465	0.65830	0.1049	0.1195E+02	0.1472E+02
94	0.1355E+01	0.8159	4.0274	6.7465	0.65830	0.1049	0.1195E+02	0.1472E+02
95	0.1355E+01	0.8159	4.0274	6.7465	0.65830	0.1049	0.1195E+02	0.1472E+02
96	0.1355E+01	0.8159	4.0274	6.7465	0.65830	0.1049	0.1195E+02	0.1472E+02
97	0.1355E+01	0.8159	4.0274	6.7465	0.65830	0.1049	0.1195E+02	0.1472E+02
98	0.1355E+01	0.8159	4.0274	6.7465	0.65830	0.1049	0.1195E+02	0.1472E+02
99	0.1355E+01	0.8159	4.0274	6.7465	0.65830	0.1049	0.1195E+02	0.1472E+02
100	0.1355E+01	0.8159	4.0274	6.7465	0.65830	0.1049	0.1195E+02	0.1472E+02
101	0.1384E+01	0.26015	-3.8644	8.1120	0.56163	0.0132	0.1584E+01	0.2237E+01
102	0.1384E+01	2.6015	-3.8644	8.1120	0.56163	0.0132	0.1584E+01	0.2237E+01
103	0.1384E+01	3.8644	-0.9236	8.1120	0.56163	0.0132	0.1584E+01	0.2237E+01
104	0.1433E+01	4.5994	-0.9236	8.1120	0.56163	0.0132	0.1584E+01	0.2237E+01
105	0.1433E+01	4.5994	-0.9236	8.1120	0.56163	0.0132	0.1584E+01	0.2237E+01
106	0.1433E+01	4.5994	-0.9236	8.1120	0.56163	0.0132	0.1584E+01	0.2237E+01
107	0.1433E+01	4.5994	-0.9236	8.1120	0.56163	0.0132	0.1584E+01	0.2237E+01
108	0.1433E+01	4.5994	-0.9236	8.1120	0.56163	0.0132	0.1584E+01	0.2237E+01
109	0.1433E+01	4.5994	-0.9236	8.1120	0.56163	0.0132	0.1584E+01	0.2237E+01
110	0.1330E+01	0.9712	-4.7939	8.8579	0.51463	0.0000	0.1617E+01	0.2269E+01
111	0.1330E+01	2.7354	-4.0631	8.8579	0.51463	0.0000	0.1617E+01	0.2269E+01
112	0.1330E+01	4.0631	-2.7354	8.8579	0.51463	0.0000	0.1617E+01	0.2269E+01
113	0.1330E+01	4.7939	-0.9712	8.8579	0.51463	0.0000	0.1617E+01	0.2269E+01
114	0.1330E+01	4.0631	0.9712	8.8579	0.51463	0.0000	0.1617E+01	0.2269E+01
115	0.1330E+01	2.7354	4.0631	8.8579	0.51463	0.0000	0.1617E+01	0.2269E+01
116	0.1377E+01	0.9712	-4.7939	9.5220	0.46875	0.0000	0.1584E+01	0.2238E+01
117	0.1377E+01	2.8402	-4.0951	9.5220	0.46875	0.0000	0.1584E+01	0.2238E+01
118	0.1377E+01	4.0951	-2.8402	9.5220	0.46875	0.0000	0.1584E+01	0.2238E+01
119	0.1377E+01	4.7939	-0.9712	9.5220	0.46875	0.0000	0.1584E+01	0.2238E+01
120	0.1436E+01	4.9351	-1.0119	9.5220	0.46875	0.0000	0.1584E+01	0.2238E+01
121	0.1436E+01	4.9351	-1.0119	9.5220	0.46875	0.0000	0.1584E+01	0.2238E+01
122	0.1387E+01	4.2337	-2.8502	9.5220	0.46875	0.0000	0.1584E+01	0.2238E+01
123	0.1387E+01	2.8502	-4.2337	9.5220	0.46875	0.0000	0.1584E+01	0.2238E+01
124	0.1436E+01	1.0119	-4.9351	9.5220	0.46875	0.0000	0.1584E+01	0.2238E+01
125	0.1436E+01	1.0119	-4.9351	9.5220	0.46875	0.0000	0.1584E+01	0.2238E+01
126	0.1436E+01	1.0119	-4.9351	9.5220	0.46875	0.0000	0.1584E+01	0.2238E+01
127	0.1436E+01	1.0119	-4.9351	9.5220	0.46875	0.0000	0.1584E+01	0.2238E+01
128	0.1491E+01	4.3936	-2.9579	10.1905	0.42239	0.0000	0.1584E+01	0.2238E+01
129	0.1491E+01	5.1838	-1.0501	10.1905	0.42239	0.0000	0.1584E+01	0.2238E+01
130	0.1491E+01	4.3936	1.0501	10.1905	0.42239	0.0000	0.1584E+01	0.2238E+01
131	0.1491E+01	2.9579	-4.3936	10.1905	0.42239	0.0000	0.1584E+01	0.2238E+01
132	0.1491E+01	2.9579	-4.3936	10.1905	0.42239	0.0000	0.1584E+01	0.2238E+01
133	0.1491E+01	2.9579	-4.3936	10.1905	0.42239	0.0000	0.1584E+01	0.2238E+01
134	0.1400E+01	1.0861	-5.3613	10.8406	0.37716	0.0000	0.1584E+01	0.2238E+01
135	0.1400E+01	3.0591	-4.5441	10.8406	0.37716	0.0000	0.1584E+01	0.2238E+01
136	0.1400E+01	4.5441	-3.0591	10.8406	0.37716	0.0000	0.1584E+01	0.2238E+01
137	0.1400E+01	5.3613	-1.0861	10.8406	0.37716	0.0000	0.1584E+01	0.2238E+01
138	0.1400E+01	3.0591	1.0861	10.8406	0.37716	0.0000	0.1584E+01	0.2238E+01
139	0.1400E+01	4.5441	-3.0591	10.8406	0.37716	0.0000	0.1584E+01	0.2238E+01
140	0.1400E+01	1.0861	-5.3613	10.8406	0.37716	0.0000	0.1584E+01	0.2238E+01
141	0.1400E+01	3.0591	-4.5441	10.8406	0.37716	0.0000	0.1584E+01	0.2238E+01
142	0.1400E+01	4.5441	-3.0591	10.8406	0.37716	0.0000	0.1584E+01	0.2238E+01
143	0.1400E+01	5.3613	-1.0861	10.8406	0.37716	0.0000	0.1584E+01	0.2238E+01
144	0.1400E+01	3.0591	1.0861	10.8406	0.37716	0.0000	0.1584E+01	0.2238E+01
145	0.1400E+01	4.5441	-3.0591	10.8406	0.37716	0.0000	0.1584E+01	0.2238E+01
146	0.1400E+01	1.0861	-5.3613	10.8406	0.37716	0.0000	0.1584E+01	0.2238E+01
147	0.1400E+01	3.0591	-4.5441	10.8406	0.37716	0.0000	0.1584E+01	0.2238E+01
148	0.1400E+01	4.5441	-3.0591	10.8406	0.37716	0.0000	0.1584E+01	0.2238E+01
149	0.1400E+01	5.3613	-1.0861	10.8406	0.37716	0.0000	0.1584E+01	0.2238E+01
150	0.1400E+01	3.0591	1.0861	10.8406	0.37716	0.0000	0.1584E+01	0.2238E+01
151	0.1400E+01	4.5441	-3.0591	10.8406	0.37716	0.0000	0.1584E+01	0.2238E+01
152	0.1400E+01	1.0861	-5.3613	10.8406	0.37716	0.0000	0.1584E+01	0.2238E+01

153	0.1977E+01	5.7363	1.1621	12.3708	0.26966	0.0000	0.0000E+00
154	0.1909E+01	4.8619	3.2732	12.3708	0.26966	0.0000	0.0000E+00
155	0.1909E+01	3.2732	4.8619	12.3708	0.26966	0.0000	0.0000E+00
156	0.2037E+01	1.1621	5.7363	15.1855	0.21178	0.0000	0.0000E+00
157	0.1967E+01	1.1621	5.9092	13.1855	0.21178	0.0000	0.0000E+00
158	0.1967E+01	3.3718	5.0085	13.1855	0.21178	0.0000	0.0000E+00
159	0.1967E+01	5.0085	3.3718	13.1855	0.21178	0.0000	0.0000E+00
160	0.2037E+01	5.9092	1.1621	13.1855	0.21178	0.0000	0.0000E+00
161	0.2037E+01	5.9092	1.1621	13.1855	0.21178	0.0000	0.0000E+00
162	0.1967E+01	3.3718	5.0085	13.1855	0.21178	0.0000	0.0000E+00
163	0.1967E+01	3.3718	5.0085	13.1855	0.21178	0.0000	0.0000E+00
164	0.2037E+01	1.1621	5.7363	14.0049	0.15293	0.0000	0.0000E+00
165	0.2088E+01	1.2274	5.9093	14.0049	0.15293	0.0000	0.0000E+00
166	0.2016E+01	1.2274	5.9093	14.0049	0.15293	0.0000	0.0000E+00
167	0.2016E+01	3.4570	5.1351	14.0049	0.15293	0.0000	0.0000E+00
168	0.2088E+01	3.4570	5.1351	14.0049	0.15293	0.0000	0.0000E+00
169	0.2088E+01	6.0586	1.2274	14.0049	0.15293	0.0000	0.0000E+00
170	0.2016E+01	6.0586	1.2274	14.0049	0.15293	0.0000	0.0000E+00
171	0.2016E+01	5.1351	3.4570	14.0049	0.15293	0.0000	0.0000E+00
172	0.2088E+01	1.2274	5.9093	14.0049	0.15293	0.0000	0.0000E+00
173	0.2129E+01	1.2516	5.2523	14.8291	0.09288	0.0000	0.0000E+00
174	0.2055E+01	1.2516	5.2523	14.8291	0.09288	0.0000	0.0000E+00
175	0.2055E+01	5.2523	1.2516	14.8291	0.09288	0.0000	0.0000E+00
176	0.2129E+01	5.2523	1.2516	14.8291	0.09288	0.0000	0.0000E+00
177	0.2129E+01	6.1781	1.2516	14.8291	0.09288	0.0000	0.0000E+00
178	0.2055E+01	6.1781	1.2516	14.8291	0.09288	0.0000	0.0000E+00
179	0.2055E+01	3.5252	3.2363	14.8291	0.09288	0.0000	0.0000E+00
180	0.2129E+01	1.2516	5.2523	14.8291	0.09288	0.0000	0.0000E+00
181	0.2161E+01	1.2516	5.2523	14.8291	0.09288	0.0000	0.0000E+00
182	0.2086E+01	1.2584	5.3067	15.6585	0.03125	0.0000	0.0000E+00
183	0.2086E+01	3.5725	3.067	15.6585	0.03125	0.0000	0.0000E+00
184	0.2161E+01	3.5725	3.067	15.6585	0.03125	0.0000	0.0000E+00
185	0.2161E+01	6.2611	1.2684	15.6585	0.03125	0.0000	0.0000E+00
186	0.2086E+01	6.2611	1.2684	15.6585	0.03125	0.0000	0.0000E+00
187	0.2086E+01	3.5725	3.067	15.6585	0.03125	0.0000	0.0000E+00
188	0.2161E+01	1.2684	6.2611	15.6585	0.03125	0.0000	0.0000E+00

FX= 0.000000E+00 FD= 0.1826187E+04 FN= 0.3180263E-02 FMX= 0.2529441E-01 SMY= 0.000000E+00 SMZ= 0.0000000E+00
 CX= 0.00000000 CJ= 0.1190191 CN= 0.00000002 MX= 0.00000001 MY= 0.00000000 MZ= 0.00000000

STEP 25 DEPTH = 16.8620100 TIME = 0.0097529 DIMENSIONLESS TIME 1.1614198 WETTING FACTORS = 1.0000000 1.0000000
 AVERAGE VELOCITY 0.000 -1560.000 WK 0.00ORIENTATION 90.000

NO.	1	2	3	4	5	6	7	8	9	10	11	12	13	14	15	16	17	18	19	20
REF.NO.	0	0	0	0	0	0	0	0	0	0	0	0	0	0	0	0	0	0	0	0
MOD	0	0	0	0	0	0	0	0	0	0	0	0	0	0	0	0	0	0	0	0
AREA	0.7142E-01	0.7142E-01	0.7142E-01	0.9831E-01	0.9502E-01	0.9502E-01	0.9831E-01	0.9831E-01	0.9831E-01	0.9502E-01	0.9502E-01	0.9831E-01	0.3010E+00	0.2907E+00	0.3010E+00	0.3010E+00	0.2907E+00	0.2907E+00	0.3010E+00	0.3010E+00
X	0.1046	0.2523	0.1046	0.1186	0.3342	0.4965	0.5857	0.1186	0.3342	0.4965	0.5857	0.1186	0.8240	0.5547	0.8240	0.9722	0.8240	0.5547	0.8240	0.9722
Y	-0.2523	-0.1046	0.2523	-0.5857	-0.4965	-0.3342	-0.1186	0.2523	0.1046	-0.5857	-0.4965	-0.3342	-0.8240	-0.5547	-0.8240	-0.1969	-0.5547	-0.8240	-0.5547	-0.8240
Z	0.0658	0.0658	0.0658	0.2356	0.2356	0.2356	0.2356	0.0658	0.0658	0.2356	0.2356	0.2356	0.6814	0.6814	0.6814	0.6814	0.6814	0.6814	0.6814	0.6814
T*	1.15775	1.15775	1.15775	1.14749	1.14749	1.14749	1.14749	1.15775	1.15775	1.14749	1.14749	1.14749	1.11936	1.11936	1.11936	1.11936	1.11936	1.11936	1.11936	1.11936
CP	0.9847	0.9847	0.9847	0.7223	0.7223	0.7223	0.7223	0.9847	0.9847	0.7223	0.7223	0.7223	0.5576	0.5576	0.5576	0.5576	0.5576	0.5576	0.5576	0.5576
P	0.1121E+03	0.1121E+03	0.1121E+03	0.8224E+02	0.8224E+02	0.8224E+02	0.8224E+02	0.1121E+03	0.1121E+03	0.8224E+02	0.8224E+02	0.8224E+02	0.6348E+02	0.6350E+02	0.6348E+02	0.6348E+02	0.6350E+02	0.6348E+02	0.6350E+02	0.6348E+02
FORCE	0.8005E+01	0.8005E+01	0.8005E+01	0.8084E+01	0.8084E+01	0.8084E+01	0.8084E+01	0.8005E+01	0.8005E+01	0.8084E+01	0.8084E+01	0.8084E+01	0.1846E+02	0.1846E+02	0.1846E+02	0.1846E+02	0.1846E+02	0.1846E+02	0.1846E+02	0.1846E+02

87	0.1229E+01	3.4134	-2.2980	6.7465	0.71845	0.0948	0.1079E+02	0.1327E+02
88	0.1273E+01	4.0273	-0.8159	6.7465	0.71845	0.0946	0.1077E+02	0.1371E+02
89	0.1229E+01	3.2980	0.2980	6.7465	0.71845	0.0948	0.1079E+02	0.1327E+02
90	0.1229E+01	3.4134	3.4134	6.7465	0.71845	0.0946	0.1079E+02	0.1371E+02
91	0.1273E+01	4.0274	4.0274	6.7465	0.71845	0.0604	0.1077E+02	0.1371E+02
92	0.1355E+01	0.8702	-1.2956	7.4595	0.67021	0.0607	0.6881E+01	0.9322E+01
93	0.1308E+01	2.4511	-3.6408	7.4595	0.67021	0.0607	0.6909E+01	0.9038E+01
94	0.1308E+01	3.6408	-2.4511	7.4595	0.67021	0.0607	0.6881E+01	0.9322E+01
95	0.1355E+01	4.2956	0.8702	7.4595	0.67021	0.0604	0.6881E+01	0.9322E+01
96	0.1308E+01	4.2956	2.4511	7.4595	0.67021	0.0607	0.6909E+01	0.9038E+01
97	0.1308E+01	3.6408	3.6408	7.4595	0.67021	0.0607	0.6881E+01	0.9322E+01
98	0.1308E+01	2.4511	4.2956	7.4595	0.67021	0.0604	0.6881E+01	0.9322E+01
99	0.1355E+01	0.8702	4.2956	7.4595	0.67021	0.0607	0.6909E+01	0.9038E+01
100	0.1355E+01	0.8702	-4.2956	8.1720	0.62179	0.0020	0.2249E+00	0.3222E+00
101	0.1433E+01	0.8702	-3.8644	8.1720	0.62179	0.0023	0.2585E+00	0.3577E+00
102	0.1384E+01	2.6015	-2.6015	8.1720	0.62179	0.0023	0.2585E+00	0.3577E+00
103	0.1384E+01	3.8644	3.8644	8.1720	0.62179	0.0020	0.2249E+00	0.3222E+00
104	0.1433E+01	4.5594	4.5594	8.1720	0.62179	0.0020	0.2249E+00	0.3222E+00
105	0.1433E+01	4.5594	-0.9236	8.1720	0.62179	0.0023	0.2585E+00	0.3577E+00
106	0.1384E+01	3.8644	2.6015	8.1720	0.62179	0.0023	0.2585E+00	0.3577E+00
107	0.1384E+01	2.6015	3.8644	8.1720	0.62179	0.0020	0.2249E+00	0.3222E+00
108	0.1433E+01	0.9236	4.5594	8.1720	0.62179	0.0020	0.2249E+00	0.3222E+00
109	0.1377E+01	2.7354	-4.7939	8.8579	0.57478	0.0000	0.0000E+00	0.0000E+00
110	0.1330E+01	4.0631	-4.0631	8.8579	0.57478	0.0000	0.0000E+00	0.0000E+00
111	0.1330E+01	4.0631	-2.7354	8.8579	0.57478	0.0000	0.0000E+00	0.0000E+00
112	0.1377E+01	4.7939	0.9712	8.8579	0.57478	0.0000	0.0000E+00	0.0000E+00
113	0.1330E+01	4.0631	0.9712	8.8579	0.57478	0.0000	0.0000E+00	0.0000E+00
114	0.1330E+01	4.0631	2.7354	8.8579	0.57478	0.0000	0.0000E+00	0.0000E+00
115	0.1377E+01	0.9712	4.7939	8.8579	0.57478	0.0000	0.0000E+00	0.0000E+00
116	0.1377E+01	0.9712	4.7939	8.8579	0.57478	0.0000	0.0000E+00	0.0000E+00
117	0.1436E+01	1.0119	-4.9951	9.5220	0.52890	0.0000	0.0000E+00	0.0000E+00
118	0.1387E+01	2.8502	-4.2337	9.5220	0.52890	0.0000	0.0000E+00	0.0000E+00
119	0.1387E+01	4.2337	-2.8502	9.5220	0.52890	0.0000	0.0000E+00	0.0000E+00
120	0.1436E+01	4.9951	1.0119	9.5220	0.52890	0.0000	0.0000E+00	0.0000E+00
121	0.1436E+01	4.9951	-1.0119	9.5220	0.52890	0.0000	0.0000E+00	0.0000E+00
122	0.1387E+01	2.8502	2.8502	9.5220	0.52890	0.0000	0.0000E+00	0.0000E+00
123	0.1387E+01	2.8502	4.2337	9.5220	0.52890	0.0000	0.0000E+00	0.0000E+00
124	0.1436E+01	1.0119	4.9951	9.5220	0.52890	0.0000	0.0000E+00	0.0000E+00
125	0.1440E+01	2.9579	-5.1838	10.1905	0.48255	0.0000	0.0000E+00	0.0000E+00
126	0.1440E+01	4.3936	-4.3936	10.1905	0.48255	0.0000	0.0000E+00	0.0000E+00
127	0.1491E+01	5.1838	-2.9579	10.1905	0.48255	0.0000	0.0000E+00	0.0000E+00
128	0.1491E+01	5.1838	1.0501	10.1905	0.48255	0.0000	0.0000E+00	0.0000E+00
129	0.1491E+01	5.1838	-1.0501	10.1905	0.48255	0.0000	0.0000E+00	0.0000E+00
130	0.1440E+01	4.3936	2.9579	10.1905	0.48255	0.0000	0.0000E+00	0.0000E+00
131	0.1440E+01	2.9579	4.3936	10.1905	0.48255	0.0000	0.0000E+00	0.0000E+00
132	0.1491E+01	1.0501	5.1838	10.1905	0.48255	0.0000	0.0000E+00	0.0000E+00
133	0.1450E+01	1.0861	-5.3613	10.8406	0.43731	0.0000	0.0000E+00	0.0000E+00
134	0.1450E+01	3.0591	-4.5441	10.8406	0.43731	0.0000	0.0000E+00	0.0000E+00
135	0.1400E+01	3.0591	3.0591	10.8406	0.43731	0.0000	0.0000E+00	0.0000E+00
136	0.1450E+01	4.5441	-3.0591	10.8406	0.43731	0.0000	0.0000E+00	0.0000E+00
137	0.1450E+01	5.3613	1.0861	10.8406	0.43731	0.0000	0.0000E+00	0.0000E+00
138	0.1400E+01	3.0591	3.0591	10.8406	0.43731	0.0000	0.0000E+00	0.0000E+00
139	0.1450E+01	3.0591	4.5441	10.8406	0.43731	0.0000	0.0000E+00	0.0000E+00
140	0.1450E+01	1.0861	5.3613	10.8406	0.43731	0.0000	0.0000E+00	0.0000E+00
141	0.1909E+01	3.1647	-5.5463	11.5605	0.38691	0.0000	0.0000E+00	0.0000E+00
142	0.1843E+01	3.1647	4.7009	11.5605	0.38691	0.0000	0.0000E+00	0.0000E+00
143	0.1843E+01	4.7009	-3.1647	11.5605	0.38691	0.0000	0.0000E+00	0.0000E+00
144	0.1909E+01	5.5463	1.1236	11.5605	0.38691	0.0000	0.0000E+00	0.0000E+00
145	0.1909E+01	5.5463	3.1647	11.5605	0.38691	0.0000	0.0000E+00	0.0000E+00
146	0.1843E+01	4.7009	4.7009	11.5605	0.38691	0.0000	0.0000E+00	0.0000E+00
147	0.1909E+01	3.1647	5.5463	11.5605	0.38691	0.0000	0.0000E+00	0.0000E+00
148	0.1909E+01	1.1621	-5.7363	12.3708	0.32981	0.0000	0.0000E+00	0.0000E+00
149	0.1977E+01	1.1621	4.8619	12.3708	0.32981	0.0000	0.0000E+00	0.0000E+00
150	0.1909E+01	3.2732	-3.2732	12.3708	0.32981	0.0000	0.0000E+00	0.0000E+00
151	0.1909E+01	4.8619	3.2732	12.3708	0.32981	0.0000	0.0000E+00	0.0000E+00
152	0.1977E+01	5.7363	-1.1621	12.3708	0.32981	0.0000	0.0000E+00	0.0000E+00

153	0.1977E+01	5.7363	1.1621	12.3708	0.32981	0.0000E+00
154	0.1909E+01	4.8619	3.2732	12.3708	0.32981	0.0000E+00
155	0.1977E+01	4.8619	5.7363	12.3708	0.32981	0.0000E+00
157	0.2037E+01	1.1971	5.9085	13.1855	0.27193	0.0000E+00
158	0.1967E+01	3.3718	3.3718	13.1855	0.27193	0.0000E+00
159	0.2037E+01	5.9093	-1.1971	13.1855	0.27193	0.0000E+00
160	0.2037E+01	5.9092	3.3718	13.1855	0.27193	0.0000E+00
161	0.2037E+01	5.9085	5.9085	13.1855	0.27193	0.0000E+00
162	0.1967E+01	3.3718	5.9085	13.1855	0.27193	0.0000E+00
163	0.2037E+01	1.1971	5.9093	13.1855	0.27193	0.0000E+00
164	0.2037E+01	1.2274	6.0586	14.0049	0.21308	0.0000E+00
165	0.2088E+01	1.2274	6.0586	14.0049	0.21308	0.0000E+00
166	0.2016E+01	3.4570	5.1351	14.0049	0.21308	0.0000E+00
167	0.2016E+01	5.1351	3.4570	14.0049	0.21308	0.0000E+00
168	0.2088E+01	6.0586	1.2274	14.0049	0.21308	0.0000E+00
169	0.2088E+01	6.0586	1.2274	14.0049	0.21308	0.0000E+00
170	0.2016E+01	3.4570	3.4570	14.0049	0.21308	0.0000E+00
171	0.2016E+01	3.4570	5.1351	14.0049	0.21308	0.0000E+00
172	0.2088E+01	3.2274	6.0586	14.0049	0.21308	0.0000E+00
173	0.2129E+01	1.2516	6.1781	14.8291	0.15303	0.0000E+00
174	0.2055E+01	3.5252	6.1781	14.8291	0.15303	0.0000E+00
175	0.2055E+01	3.5252	6.1781	14.8291	0.15303	0.0000E+00
176	0.2129E+01	6.1781	1.2516	14.8291	0.15303	0.0000E+00
177	0.2129E+01	6.1781	3.5252	14.8291	0.15303	0.0000E+00
178	0.2055E+01	3.5252	3.5252	14.8291	0.15303	0.0000E+00
179	0.2055E+01	3.5252	6.1781	14.8291	0.15303	0.0000E+00
180	0.2129E+01	1.2516	6.1781	14.8291	0.15303	0.0000E+00
181	0.2129E+01	1.2516	6.1781	14.8291	0.15303	0.0000E+00
182	0.2089E+01	3.5725	5.3067	15.6585	0.09140	0.0000E+00
183	0.2089E+01	3.5725	5.3067	15.6585	0.09140	0.0000E+00
184	0.2161E+01	6.2611	1.2684	15.6585	0.09140	0.0000E+00
185	0.2161E+01	6.2611	1.2684	15.6585	0.09140	0.0000E+00
186	0.2089E+01	5.3067	3.5725	15.6585	0.09140	0.0000E+00
187	0.2089E+01	5.3067	3.5725	15.6585	0.09140	0.0000E+00
188	0.2161E+01	1.2684	6.2611	15.6585	0.09140	0.0000E+00
189	0.2161E+01	1.2684	6.2611	15.6585	0.09140	0.0000E+00
190	0.1979E+01	3.5905	9.2926	16.4680	0.03008	0.0000E+00
191	0.1979E+01	3.5905	9.2926	16.4680	0.03008	0.0000E+00
192	0.2050E+01	6.2927	1.2748	16.4680	0.03008	0.0000E+00
193	0.2050E+01	6.2927	1.2748	16.4680	0.03008	0.0000E+00
194	0.1979E+01	3.5905	3.5905	16.4680	0.03008	0.0000E+00
195	0.1979E+01	3.5905	6.2927	16.4680	0.03008	0.0000E+00
196	0.2050E+01	1.2748	6.2927	16.4680	0.03008	0.0000E+00

FX= 0.0000000E+00 CD= 0.171728E+04 FN= 0.3442835E-02 SMAX= 0.2725761E-01 SMV= 0.0000000E+00 CMZ= 0.0000000E+00
 CX= 0.0000000 CD= 0.1141012 CN= 0.0000002 MX= 0.0000001 MY= 0.0000000 MZ= 0.0000000

STEP 26 DEPTH = 17.6500100 TIME = 0.0102581 DIMENSION/IPS TIME 1.2215725 WETTING FACTORS = 1.0000000 1.0000000
 AVERAGE VELOCITY 0.000 -0.000 -1560.000 WX 0.0000000 WY 0.0000000 WZ 90.000

NO.	1	2	3	4	5	6	7	8	9	10	11	12
REF. NO.	0	0	0	0	0	0	0	0	0	0	0	0
MOD	0	0	0	0	0	0	0	0	0	0	0	0
AREA	0.7142E-01	0.7142E-01	0.7142E-01	0.7142E-01	0.9831E-01	0.9502E-01	0.9502E-01	0.9831E-01	0.9831E-01	0.9502E-01	0.9502E-01	0.9831E-01
X	0.1046	0.2523	0.1046	0.2523	0.1186	0.4965	0.4965	0.1186	0.5857	0.3342	0.3342	0.1186
Y	-0.2523	-0.1046	0.2523	0.1046	0.2356	0.2356	0.2356	0.2356	0.2356	0.2356	0.2356	0.2356
Z	0.0658	0.0658	0.0658	0.0658	0.2356	0.2356	0.2356	0.2356	0.2356	0.2356	0.2356	0.2356
T*	1.21791	1.21791	1.21791	1.21791	1.20764	1.20764	1.20764	1.20764	1.20764	1.20764	1.20764	1.20764
CP	0.9785	0.9785	0.9785	0.9785	0.7166	0.7166	0.7166	0.7166	0.7166	0.7166	0.7166	0.7166
P	0.1114E+03	0.1114E+03	0.1114E+03	0.1114E+03	0.8158E+02	0.8158E+02	0.8158E+02	0.8158E+02	0.8158E+02	0.8158E+02	0.8158E+02	0.8158E+02
FORCE	0.7955E+01	0.7955E+01	0.7955E+01	0.7955E+01	0.8021E+01	0.7754E+01	0.7754E+01	0.8021E+01	0.8021E+01	0.7754E+01	0.7754E+01	0.8021E+01

13	0.3010E+00	0.9722	0.6814	1.17951	0.5521	0.6286E+02	0.1892E+02
14	0.2907E+00	-0.8240	0.6814	1.17951	0.5524	0.6288E+02	0.1892E+02
15	0.3010E+00	-0.5547	0.6814	1.17951	0.5521	0.6286E+02	0.1892E+02
16	0.3010E+00	0.1969	0.6814	1.17951	0.5521	0.6286E+02	0.1892E+02
17	0.2907E+00	0.5547	0.6814	1.17951	0.5524	0.6288E+02	0.1892E+02
18	0.2907E+00	0.8240	0.6814	1.17951	0.5524	0.6286E+02	0.1892E+02
19	0.3010E+00	0.9722	0.6814	1.17951	0.5521	0.6286E+02	0.1892E+02
20	0.4352E+00	-1.3971	1.2940	1.14029	0.4730	0.5385E+02	0.2345E+02
21	0.4208E+00	-1.1841	1.2940	1.14029	0.4728	0.5382E+02	0.2266E+02
22	0.4352E+00	-0.7972	1.2940	1.14029	0.4730	0.5385E+02	0.2345E+02
23	0.4208E+00	0.2830	1.2940	1.14029	0.4728	0.5382E+02	0.2266E+02
24	0.4352E+00	0.8240	1.2940	1.14029	0.4730	0.5385E+02	0.2345E+02
25	0.4208E+00	0.2830	1.2940	1.14029	0.4728	0.5382E+02	0.2266E+02
26	0.4208E+00	0.7972	1.2940	1.14029	0.4730	0.5385E+02	0.2345E+02
27	0.4208E+00	1.1841	1.2940	1.14029	0.4728	0.5382E+02	0.2266E+02
28	0.5622E+00	1.3971	1.9288	1.10927	0.4728	0.4413E+02	0.2397E+02
29	0.5433E+00	1.7970	1.9288	1.09927	0.3878	0.4415E+02	0.2482E+02
30	0.5622E+00	1.5231	1.9288	1.09927	0.3878	0.4415E+02	0.2482E+02
31	0.5622E+00	1.0254	1.9288	1.09927	0.3878	0.4415E+02	0.2482E+02
32	0.5622E+00	-0.3641	1.9288	1.09927	0.3878	0.4415E+02	0.2482E+02
33	0.5622E+00	1.7970	1.9288	1.09927	0.3878	0.4415E+02	0.2482E+02
34	0.5433E+00	1.5231	1.9288	1.09927	0.3878	0.4415E+02	0.2482E+02
35	0.5622E+00	1.0254	1.9288	1.09927	0.3878	0.4415E+02	0.2482E+02
36	0.5622E+00	-0.3641	1.9288	1.09927	0.3878	0.4415E+02	0.2482E+02
37	0.6818E+00	2.1720	2.5822	1.05665	0.3166	0.3607E+02	0.2374E+02
38	0.6581E+00	1.8409	2.5822	1.05665	0.3169	0.3607E+02	0.2374E+02
39	0.6818E+00	1.2393	2.5822	1.05665	0.3166	0.3607E+02	0.2374E+02
40	0.6818E+00	-0.4400	2.5822	1.05665	0.3166	0.3607E+02	0.2374E+02
41	0.6818E+00	0.4400	2.5822	1.05665	0.3166	0.3607E+02	0.2374E+02
42	0.6581E+00	1.8409	2.5822	1.05665	0.3169	0.3607E+02	0.2374E+02
43	0.6818E+00	1.2393	2.5822	1.05665	0.3166	0.3607E+02	0.2374E+02
44	0.6818E+00	-0.4400	2.5822	1.05665	0.3166	0.3607E+02	0.2374E+02
45	0.7937E+00	2.5239	3.2513	1.01265	0.2591	0.2946E+02	0.2261E+02
46	0.7665E+00	2.1391	3.2513	1.01265	0.2588	0.2946E+02	0.2261E+02
47	0.7937E+00	1.4401	3.2513	1.01265	0.2590	0.2946E+02	0.2261E+02
48	0.7937E+00	-0.5113	3.2513	1.01265	0.2588	0.2946E+02	0.2261E+02
49	0.7937E+00	0.5113	3.2513	1.01265	0.2590	0.2946E+02	0.2261E+02
50	0.7665E+00	2.1391	3.2513	1.01265	0.2588	0.2946E+02	0.2261E+02
51	0.7937E+00	1.4401	3.2513	1.01265	0.2590	0.2946E+02	0.2261E+02
52	0.7665E+00	-0.5113	3.2513	1.01265	0.2588	0.2946E+02	0.2261E+02
53	0.9003E+00	2.8552	3.9334	0.96746	0.2122	0.2418E+02	0.2102E+02
54	0.8693E+00	2.4199	3.9334	0.96746	0.2124	0.2418E+02	0.2102E+02
55	0.9003E+00	1.6292	3.9334	0.96746	0.2122	0.2418E+02	0.2102E+02
56	0.9003E+00	-0.5784	3.9334	0.96746	0.2124	0.2418E+02	0.2102E+02
57	0.8693E+00	2.4199	3.9334	0.96746	0.2122	0.2418E+02	0.2102E+02
58	0.8693E+00	1.6292	3.9334	0.96746	0.2124	0.2418E+02	0.2102E+02
59	0.9003E+00	-0.5784	3.9334	0.96746	0.2122	0.2418E+02	0.2102E+02
60	0.8693E+00	2.4199	3.9334	0.96746	0.2124	0.2418E+02	0.2102E+02
61	0.9003E+00	1.6292	3.9334	0.96746	0.2122	0.2418E+02	0.2102E+02
62	0.9666E+00	-1.8079	4.6264	0.92126	0.1746	0.1988E+02	0.1921E+02
63	0.9666E+00	1.8079	4.6264	0.92126	0.1746	0.1988E+02	0.1921E+02
64	0.1001E+01	3.1686	4.6264	0.92126	0.1743	0.1988E+02	0.1986E+02
65	0.1001E+01	3.1686	4.6264	0.92126	0.1743	0.1988E+02	0.1986E+02
66	0.9666E+00	-2.6855	4.6264	0.92126	0.1746	0.1988E+02	0.1986E+02
67	0.9666E+00	2.6855	4.6264	0.92126	0.1746	0.1988E+02	0.1986E+02
68	0.1001E+01	0.6419	4.6264	0.92126	0.1429	0.1630E+02	0.1783E+02
69	0.1001E+01	0.6419	4.6264	0.92126	0.1429	0.1630E+02	0.1783E+02
70	0.1059E+01	-2.9381	5.3277	0.87425	0.1432	0.1630E+02	0.1783E+02
71	0.1059E+01	2.9381	5.3277	0.87425	0.1429	0.1630E+02	0.1783E+02
72	0.1059E+01	-0.9780	5.3277	0.87425	0.1429	0.1630E+02	0.1783E+02
73	0.1059E+01	0.9780	5.3277	0.87425	0.1432	0.1630E+02	0.1783E+02
74	0.1059E+01	-2.9381	5.3277	0.87425	0.1429	0.1630E+02	0.1783E+02
75	0.1059E+01	2.9381	5.3277	0.87425	0.1429	0.1630E+02	0.1783E+02
76	0.1099E+01	-0.7023	6.0351	0.82664	0.1150	0.1309E+02	0.1503E+02
77	0.1184E+01	3.7509	6.0351	0.82664	0.1152	0.1312E+02	0.1503E+02
78	0.1146E+01	-3.1800	6.0351	0.82664	0.1152	0.1312E+02	0.1503E+02

145	0.000000E+00	FD=	0.169984E+04	FX=	0.2845786E-02	SMX=	0.000000E-02	SMY=	0.000000E-01	SMZ=	0.000000E+00
146	0.000000E+00	CD=	0.1107744	CF=	0.000000E-02	MX=	0.000000E-01	MY=	0.000000E-01	MZ=	0.000000E+00
147	0.000000E+00										
148	0.000000E+00										
149	0.000000E+00										
150	0.000000E+00										
151	0.000000E+00										
152	0.000000E+00										
153	0.000000E+00										
154	0.000000E+00										
155	0.000000E+00										
156	0.000000E+00										
157	0.000000E+00										
158	0.000000E+00										
159	0.000000E+00										
160	0.000000E+00										
161	0.000000E+00										
162	0.000000E+00										
163	0.000000E+00										
164	0.000000E+00										
165	0.000000E+00										
166	0.000000E+00										
167	0.000000E+00										
168	0.000000E+00										
169	0.000000E+00										
170	0.000000E+00										
171	0.000000E+00										
172	0.000000E+00										
173	0.000000E+00										
174	0.000000E+00										
175	0.000000E+00										
176	0.000000E+00										
177	0.000000E+00										
178	0.000000E+00										
179	0.000000E+00										
180	0.000000E+00										
181	0.000000E+00										
182	0.000000E+00										
183	0.000000E+00										
184	0.000000E+00										
185	0.000000E+00										
186	0.000000E+00										
187	0.000000E+00										
188	0.000000E+00										
189	0.000000E+00										
190	0.000000E+00										
191	0.000000E+00										
192	0.000000E+00										
193	0.000000E+00										
194	0.000000E+00										
195	0.000000E+00										
196	0.000000E+00										
197	0.000000E+00										
198	0.000000E+00										
199	0.000000E+00										
200	0.000000E+00										
201	0.000000E+00										
202	0.000000E+00										
203	0.000000E+00										
204	0.000000E+00										

STEP 27 DEPTH = 18.4380100 TIME = 0.010/6.32 DIMENSIONLESS TIME 1.2817252 METERS FACTORS = 1.0000000 1.0000000
 AVERAGE VELOCITY 0.000 -0.000 -1560.000 WX 0.000 ORIENTATION 90.000

NO.	REF. NO.	MOD	AREA	X	Y	Z	T*	CP	P	FORCE
1	1	0	0.7142E-01	0.1046	-0.2523	0.0658	1.27806	0.9736	0.1108E+03	0.7915E+01
2	2	0	0.7142E-01	0.2523	-0.1046	0.0658	1.27806	0.9736	0.1108E+03	0.7915E+01
3	3	0	0.7142E-01	0.2523	0.1046	0.0658	1.27806	0.9736	0.1108E+03	0.7915E+01
4	4	0	0.9831E-01	0.1186	-0.5827	0.2326	1.26779	0.7122	0.8109E+02	0.7971E+01
5	5	0	0.9502E-01	0.3342	-0.4965	0.2326	1.26779	0.7122	0.8109E+02	0.7971E+01
6	6	0	0.9502E-01	0.4965	-0.3342	0.2326	1.26779	0.7122	0.8109E+02	0.7971E+01
7	7	0	0.9502E-01	0.3342	0.4965	0.2326	1.26779	0.7122	0.8109E+02	0.7971E+01
8	8	0	0.9831E-01	0.5827	-0.1186	0.2326	1.26779	0.7122	0.8109E+02	0.7971E+01
9	9	0	0.9831E-01	0.1186	0.5827	0.2326	1.26779	0.7122	0.8109E+02	0.7971E+01
10	10	0	0.9502E-01	0.4965	-0.3342	0.2326	1.26779	0.7122	0.8109E+02	0.7971E+01
11	11	0	0.9502E-01	0.3342	0.4965	0.2326	1.26779	0.7122	0.8109E+02	0.7971E+01
12	12	0	0.9831E-01	0.1186	-0.5827	0.2326	1.26779	0.7122	0.8109E+02	0.7971E+01
13	13	0	0.3010E+00	0.1969	-0.9722	0.6814	1.23966	0.5479	0.6240E+02	0.1877E+02
14	14	0	0.2907E+00	0.5547	-0.8240	0.6814	1.23966	0.5479	0.6240E+02	0.1877E+02
15	15	0	0.2907E+00	0.8240	-0.5547	0.6814	1.23966	0.5479	0.6240E+02	0.1877E+02
16	16	0	0.3010E+00	0.9722	-0.1969	0.6814	1.23966	0.5479	0.6240E+02	0.1877E+02
17	17	0	0.3010E+00	0.9722	0.1969	0.6814	1.23966	0.5479	0.6240E+02	0.1877E+02
18	18	0	0.2907E+00	0.8240	-0.5547	0.6814	1.23966	0.5479	0.6240E+02	0.1877E+02
19	19	0	0.2907E+00	0.5547	0.8240	0.6814	1.23966	0.5479	0.6240E+02	0.1877E+02
20	20	0	0.3010E+00	0.1969	-0.9722	0.6814	1.23966	0.5479	0.6240E+02	0.1877E+02
21	21	0	0.4357E+00	0.2830	-1.3971	1.2940	1.20045	0.4685	0.5333E+02	0.2324E+02
22	22	0	0.4208E+00	0.7972	-1.1841	1.2940	1.20045	0.4687	0.5333E+02	0.2245E+02
23	23	0	0.4208E+00	0.7972	1.1841	1.2940	1.20045	0.4687	0.5333E+02	0.2245E+02
24	24	0	0.4357E+00	1.1841	-0.7972	1.2940	1.20045	0.4685	0.5333E+02	0.2324E+02
25	25	0	0.4208E+00	1.3971	-0.2830	1.2940	1.20045	0.4685	0.5333E+02	0.2245E+02
26	26	0	0.4208E+00	1.1841	0.7972	1.2940	1.20045	0.4687	0.5333E+02	0.2245E+02
27	27	0	0.4208E+00	0.7972	-1.1841	1.2940	1.20045	0.4687	0.5333E+02	0.2245E+02
28	28	0	0.4357E+00	0.2830	-1.3971	1.2940	1.20045	0.4685	0.5333E+02	0.2324E+02
29	29	0	0.5623E+00	0.3641	-1.5942	1.9288	1.15942	0.3833	0.4366E+02	0.2454E+02
30	30	0	0.5430E+00	1.0254	-1.5231	1.9288	1.15942	0.3835	0.4366E+02	0.2371E+02
31	31	0	0.5430E+00	1.0254	1.5231	1.9288	1.15942	0.3835	0.4366E+02	0.2371E+02
32	32	0	0.5623E+00	1.7970	-0.3641	1.9288	1.15942	0.3833	0.4366E+02	0.2454E+02
33	33	0	0.5623E+00	1.7970	0.3641	1.9288	1.15942	0.3833	0.4366E+02	0.2454E+02
34	34	0	0.5430E+00	1.5231	-1.0254	1.9288	1.15942	0.3835	0.4366E+02	0.2371E+02
35	35	0	0.5430E+00	1.5231	1.0254	1.9288	1.15942	0.3835	0.4366E+02	0.2371E+02
36	36	0	0.5623E+00	1.3971	-0.7972	1.9288	1.15942	0.3833	0.4366E+02	0.2454E+02
37	37	0	0.6815E+00	0.4400	-2.1720	2.5823	1.1680	0.3122	0.3555E+02	0.2422E+02
38	38	0	0.6815E+00	1.2393	-1.8409	2.5823	1.1680	0.3125	0.3555E+02	0.2341E+02
39	39	0	0.6815E+00	1.8409	-1.2393	2.5823	1.1680	0.3125	0.3555E+02	0.2341E+02
40	40	0	0.6815E+00	1.2393	1.8409	2.5823	1.1680	0.3122	0.3555E+02	0.2422E+02
41	41	0	0.6815E+00	1.720	-0.4400	2.5823	1.1680	0.3122	0.3555E+02	0.2341E+02
42	42	0	0.6815E+00	1.720	0.4400	2.5823	1.1680	0.3125	0.3555E+02	0.2341E+02
43	43	0	0.6815E+00	1.8409	-1.2393	2.5823	1.1680	0.3122	0.3555E+02	0.2422E+02
44	44	0	0.6815E+00	1.2393	1.8409	2.5823	1.1680	0.3125	0.3555E+02	0.2341E+02
45	45	0	0.7937E+00	0.4400	-2.1720	3.2513	1.07280	0.2542	0.2898E+02	0.2221E+02
46	46	0	0.7665E+00	1.4401	-2.5239	3.2513	1.07280	0.2545	0.2898E+02	0.2221E+02
47	47	0	0.7665E+00	1.4401	2.5239	3.2513	1.07280	0.2545	0.2898E+02	0.2221E+02
48	48	0	0.7937E+00	1.391	-1.4401	3.2513	1.07280	0.2542	0.2898E+02	0.2221E+02
49	49	0	0.7937E+00	1.391	1.4401	3.2513	1.07280	0.2542	0.2898E+02	0.2221E+02
50	50	0	0.7665E+00	2.5239	-0.5113	3.2513	1.07280	0.2545	0.2898E+02	0.2221E+02
51	51	0	0.7665E+00	2.5239	0.5113	3.2513	1.07280	0.2545	0.2898E+02	0.2221E+02
52	52	0	0.7937E+00	1.4401	-2.5239	3.2513	1.07280	0.2542	0.2898E+02	0.2221E+02
53	53	0	0.7937E+00	1.4401	2.5239	3.2513	1.07280	0.2542	0.2898E+02	0.2221E+02
54	54	0	0.8693E+00	0.5284	-2.8552	3.9334	1.02761	0.2077	0.2365E+02	0.2056E+02
55	55	0	0.8693E+00	1.6292	-2.1699	3.9334	1.02761	0.2077	0.2365E+02	0.2056E+02
56	56	0	0.9002E+00	2.4200	-1.6292	3.9334	1.02761	0.2075	0.2365E+02	0.2126E+02
57	57	0	0.9002E+00	2.8552	-0.5784	3.9334	1.02761	0.2075	0.2365E+02	0.2126E+02
58	58	0	0.8693E+00	2.4199	1.6292	3.9334	1.02761	0.2077	0.2365E+02	0.2056E+02
59	59	0	0.8693E+00	1.6292	1.6292	3.9334	1.02761	0.2075	0.2365E+02	0.2126E+02
60	60	0	0.9002E+00	0.5784	-2.8552	4.6264	0.98142	0.1694	0.1932E+02	0.1867E+02
61	61	0	0.9002E+00	1.6292	-2.1699	4.6264	0.98142	0.1697	0.1932E+02	0.1867E+02
62	62	0	0.9666E+00	1.8080	-3.2685	4.6264	0.98142	0.1697	0.1932E+02	0.1867E+02

63	0.9666E+00	-1.8079	4.6264	0.98142	0.1697	0.1932E+02	0.1867E+02
64	0.1001E+01	-0.6419	4.6264	0.98142	0.1694	0.1929E+02	0.1931E+02
65	0.1001E+01	0.6419	4.6264	0.98142	0.1694	0.1929E+02	0.1867E+02
66	0.9666E+00	3.6855	4.6264	0.98142	0.1697	0.1932E+02	0.1931E+02
67	0.9666E+00	1.8079	4.6264	0.98142	0.1694	0.1929E+02	0.1719E+02
68	0.1096E+01	-0.7023	5.3277	0.93441	0.1378	0.1568E+02	0.1664E+02
69	0.1096E+01	0.7023	5.3277	0.93441	0.1381	0.1572E+02	0.1664E+02
70	0.1059E+01	-2.9381	5.3277	0.93441	0.1378	0.1568E+02	0.1719E+02
71	0.1059E+01	2.9381	5.3277	0.93441	0.1381	0.1572E+02	0.1664E+02
72	0.1096E+01	-0.7023	5.3277	0.93441	0.1378	0.1568E+02	0.1719E+02
73	0.1096E+01	0.7023	5.3277	0.93441	0.1381	0.1572E+02	0.1664E+02
74	0.1096E+01	-1.9780	5.3277	0.93441	0.1378	0.1568E+02	0.1720E+02
75	0.1096E+01	1.9780	5.3277	0.93441	0.1381	0.1572E+02	0.1720E+02
76	0.1096E+01	-3.4665	5.3277	0.93441	0.1378	0.1568E+02	0.1481E+02
77	0.1096E+01	3.4665	5.3277	0.93441	0.1381	0.1572E+02	0.1481E+02
78	0.1149E+01	-2.1408	6.0351	0.88679	0.1098	0.1250E+02	0.1432E+02
79	0.1149E+01	2.1408	6.0351	0.88679	0.1098	0.1248E+02	0.1432E+02
80	0.1187E+01	-0.7601	6.0351	0.88679	0.1096	0.1248E+02	0.1481E+02
81	0.1187E+01	0.7601	6.0351	0.88679	0.1096	0.1248E+02	0.1481E+02
82	0.1187E+01	-2.1408	6.0351	0.88679	0.1098	0.1250E+02	0.1432E+02
83	0.1187E+01	2.1408	6.0351	0.88679	0.1098	0.1248E+02	0.1432E+02
84	0.1273E+01	-4.0273	6.7465	0.83876	0.0811	0.9230E+01	0.1175E+02
85	0.1273E+01	4.0273	6.7465	0.83876	0.0813	0.9256E+01	0.1175E+02
86	0.1299E+01	-2.2980	6.7465	0.83876	0.0813	0.9256E+01	0.1138E+02
87	0.1299E+01	2.2980	6.7465	0.83876	0.0813	0.9256E+01	0.1138E+02
88	0.1273E+01	-0.8159	6.7465	0.83876	0.0811	0.9230E+01	0.1175E+02
89	0.1273E+01	0.8159	6.7465	0.83876	0.0811	0.9230E+01	0.1175E+02
90	0.1299E+01	-3.4134	6.7465	0.83876	0.0813	0.9256E+01	0.1138E+02
91	0.1299E+01	3.4134	6.7465	0.83876	0.0813	0.9256E+01	0.1138E+02
92	0.1273E+01	-0.8159	6.7465	0.83876	0.0811	0.9230E+01	0.1175E+02
93	0.1355E+01	-4.2956	7.4595	0.79051	0.0461	0.5248E+01	0.6901E+01
94	0.1355E+01	4.2956	7.4595	0.79051	0.0461	0.5248E+01	0.6901E+01
95	0.1308E+01	-2.4511	7.4595	0.79051	0.0463	0.5276E+01	0.6901E+01
96	0.1308E+01	2.4511	7.4595	0.79051	0.0463	0.5276E+01	0.6901E+01
97	0.1355E+01	-0.8702	7.4595	0.79051	0.0461	0.5248E+01	0.7110E+01
98	0.1355E+01	0.8702	7.4595	0.79051	0.0461	0.5248E+01	0.7110E+01
99	0.1308E+01	-2.4511	7.4595	0.79051	0.0463	0.5276E+01	0.6901E+01
100	0.1308E+01	2.4511	7.4595	0.79051	0.0463	0.5276E+01	0.6901E+01
101	0.1355E+01	-0.8702	8.1720	0.74209	0.0000	0.0000E+00	0.0000E+00
102	0.1355E+01	0.8702	8.1720	0.74209	0.0000	0.0000E+00	0.0000E+00
103	0.1384E+01	-3.8644	8.1720	0.74209	0.0000	0.0000E+00	0.0000E+00
104	0.1384E+01	3.8644	8.1720	0.74209	0.0000	0.0000E+00	0.0000E+00
105	0.1433E+01	-0.9236	8.1720	0.74209	0.0000	0.0000E+00	0.0000E+00
106	0.1433E+01	0.9236	8.1720	0.74209	0.0000	0.0000E+00	0.0000E+00
107	0.1384E+01	-3.8644	8.1720	0.74209	0.0000	0.0000E+00	0.0000E+00
108	0.1384E+01	3.8644	8.1720	0.74209	0.0000	0.0000E+00	0.0000E+00
109	0.1472E+01	-0.9712	8.8579	0.69508	0.0000	0.0000E+00	0.0000E+00
110	0.1472E+01	0.9712	8.8579	0.69508	0.0000	0.0000E+00	0.0000E+00
111	0.1330E+01	-4.0631	8.8579	0.69508	0.0000	0.0000E+00	0.0000E+00
112	0.1330E+01	4.0631	8.8579	0.69508	0.0000	0.0000E+00	0.0000E+00
113	0.1377E+01	-0.7939	8.8579	0.69508	0.0000	0.0000E+00	0.0000E+00
114	0.1377E+01	0.7939	8.8579	0.69508	0.0000	0.0000E+00	0.0000E+00
115	0.1300E+01	-4.0631	8.8579	0.69508	0.0000	0.0000E+00	0.0000E+00
116	0.1300E+01	4.0631	8.8579	0.69508	0.0000	0.0000E+00	0.0000E+00
117	0.1436E+01	-2.7354	9.5220	0.64921	0.0000	0.0000E+00	0.0000E+00
118	0.1436E+01	2.7354	9.5220	0.64921	0.0000	0.0000E+00	0.0000E+00
119	0.1387E+01	-4.2337	9.5220	0.64921	0.0000	0.0000E+00	0.0000E+00
120	0.1387E+01	4.2337	9.5220	0.64921	0.0000	0.0000E+00	0.0000E+00
121	0.1456E+01	-1.0119	9.5220	0.64921	0.0000	0.0000E+00	0.0000E+00
122	0.1456E+01	1.0119	9.5220	0.64921	0.0000	0.0000E+00	0.0000E+00
123	0.1387E+01	-2.8502	9.5220	0.64921	0.0000	0.0000E+00	0.0000E+00
124	0.1387E+01	2.8502	9.5220	0.64921	0.0000	0.0000E+00	0.0000E+00
125	0.1436E+01	-1.0501	10.1905	0.60285	0.0000	0.0000E+00	0.0000E+00
126	0.1436E+01	1.0501	10.1905	0.60285	0.0000	0.0000E+00	0.0000E+00
127	0.1400E+01	-4.3936	10.1905	0.60285	0.0000	0.0000E+00	0.0000E+00
128	0.1491E+01	4.3936	10.1905	0.60285	0.0000	0.0000E+00	0.0000E+00

129	0.1491E+01	0.0000E+00	0.60285	10.1905	1.0501	5.1838	0.0000E+00	0.0000E+00	0.0000E+00	0.0000E+00
130	0.1440E+01	0.0000E+00	0.60285	10.1905	2.9579	4.3936	0.0000E+00	0.0000E+00	0.0000E+00	0.0000E+00
131	0.1440E+01	0.0000E+00	0.60285	10.1905	4.3936	2.9579	0.0000E+00	0.0000E+00	0.0000E+00	0.0000E+00
132	0.1491E+01	0.0000E+00	0.60285	10.1905	5.1838	1.0501	0.0000E+00	0.0000E+00	0.0000E+00	0.0000E+00
133	0.1450E+01	0.0000E+00	0.55762	10.8406	-5.1613	1.0861	0.0000E+00	0.0000E+00	0.0000E+00	0.0000E+00
134	0.1400E+01	0.0000E+00	0.55762	10.8406	-4.5441	3.0591	0.0000E+00	0.0000E+00	0.0000E+00	0.0000E+00
135	0.1400E+01	0.0000E+00	0.55762	10.8406	3.0591	-4.5441	0.0000E+00	0.0000E+00	0.0000E+00	0.0000E+00
136	0.1450E+01	0.0000E+00	0.55762	10.8406	-1.0861	5.3613	0.0000E+00	0.0000E+00	0.0000E+00	0.0000E+00
137	0.1450E+01	0.0000E+00	0.55762	10.8406	1.0861	-5.3613	0.0000E+00	0.0000E+00	0.0000E+00	0.0000E+00
138	0.1400E+01	0.0000E+00	0.55762	10.8406	3.0591	4.5441	0.0000E+00	0.0000E+00	0.0000E+00	0.0000E+00
139	0.1400E+01	0.0000E+00	0.55762	10.8406	-3.0591	3.0591	0.0000E+00	0.0000E+00	0.0000E+00	0.0000E+00
140	0.1450E+01	0.0000E+00	0.55762	10.8406	-5.3613	1.0861	0.0000E+00	0.0000E+00	0.0000E+00	0.0000E+00
141	0.1450E+01	0.0000E+00	0.55762	10.8406	5.3613	-1.0861	0.0000E+00	0.0000E+00	0.0000E+00	0.0000E+00
142	0.1843E+01	0.0000E+00	0.50721	11.5605	-3.1647	3.1647	0.0000E+00	0.0000E+00	0.0000E+00	0.0000E+00
143	0.1843E+01	0.0000E+00	0.50721	11.5605	3.1647	-3.1647	0.0000E+00	0.0000E+00	0.0000E+00	0.0000E+00
144	0.1909E+01	0.0000E+00	0.50721	11.5605	-1.1236	5.5463	0.0000E+00	0.0000E+00	0.0000E+00	0.0000E+00
145	0.1909E+01	0.0000E+00	0.50721	11.5605	1.1236	-5.5463	0.0000E+00	0.0000E+00	0.0000E+00	0.0000E+00
146	0.1843E+01	0.0000E+00	0.50721	11.5605	-3.1647	4.7009	0.0000E+00	0.0000E+00	0.0000E+00	0.0000E+00
147	0.1843E+01	0.0000E+00	0.50721	11.5605	3.1647	-4.7009	0.0000E+00	0.0000E+00	0.0000E+00	0.0000E+00
148	0.1909E+01	0.0000E+00	0.50721	11.5605	-1.1236	3.1647	0.0000E+00	0.0000E+00	0.0000E+00	0.0000E+00
149	0.1909E+01	0.0000E+00	0.50721	11.5605	1.1236	-3.1647	0.0000E+00	0.0000E+00	0.0000E+00	0.0000E+00
150	0.1909E+01	0.0000E+00	0.50721	11.5605	-3.1647	3.1647	0.0000E+00	0.0000E+00	0.0000E+00	0.0000E+00
151	0.1909E+01	0.0000E+00	0.50721	11.5605	3.1647	-3.1647	0.0000E+00	0.0000E+00	0.0000E+00	0.0000E+00
152	0.2037E+01	0.0000E+00	0.45012	12.3708	-1.1621	5.7363	0.0000E+00	0.0000E+00	0.0000E+00	0.0000E+00
153	0.2037E+01	0.0000E+00	0.45012	12.3708	1.1621	-5.7363	0.0000E+00	0.0000E+00	0.0000E+00	0.0000E+00
154	0.1977E+01	0.0000E+00	0.45012	12.3708	-4.8619	4.8619	0.0000E+00	0.0000E+00	0.0000E+00	0.0000E+00
155	0.1977E+01	0.0000E+00	0.45012	12.3708	4.8619	-4.8619	0.0000E+00	0.0000E+00	0.0000E+00	0.0000E+00
156	0.1909E+01	0.0000E+00	0.45012	12.3708	-1.1621	3.2732	0.0000E+00	0.0000E+00	0.0000E+00	0.0000E+00
157	0.2037E+01	0.0000E+00	0.39224	13.1855	-5.9092	1.1971	0.0000E+00	0.0000E+00	0.0000E+00	0.0000E+00
158	0.1967E+01	0.0000E+00	0.39224	13.1855	5.9092	-1.1971	0.0000E+00	0.0000E+00	0.0000E+00	0.0000E+00
159	0.1967E+01	0.0000E+00	0.39224	13.1855	-3.3718	3.3718	0.0000E+00	0.0000E+00	0.0000E+00	0.0000E+00
160	0.2037E+01	0.0000E+00	0.39224	13.1855	3.3718	-3.3718	0.0000E+00	0.0000E+00	0.0000E+00	0.0000E+00
161	0.1977E+01	0.0000E+00	0.39224	13.1855	-1.1971	5.9092	0.0000E+00	0.0000E+00	0.0000E+00	0.0000E+00
162	0.1977E+01	0.0000E+00	0.39224	13.1855	1.1971	-5.9092	0.0000E+00	0.0000E+00	0.0000E+00	0.0000E+00
163	0.1967E+01	0.0000E+00	0.39224	13.1855	-3.3718	3.3718	0.0000E+00	0.0000E+00	0.0000E+00	0.0000E+00
164	0.2037E+01	0.0000E+00	0.39224	13.1855	3.3718	-3.3718	0.0000E+00	0.0000E+00	0.0000E+00	0.0000E+00
165	0.2088E+01	0.0000E+00	0.33339	14.0049	-6.0586	1.2274	0.0000E+00	0.0000E+00	0.0000E+00	0.0000E+00
166	0.2088E+01	0.0000E+00	0.33339	14.0049	6.0586	-1.2274	0.0000E+00	0.0000E+00	0.0000E+00	0.0000E+00
167	0.2161E+01	0.0000E+00	0.33339	14.0049	-1.2274	3.4570	0.0000E+00	0.0000E+00	0.0000E+00	0.0000E+00
168	0.2161E+01	0.0000E+00	0.33339	14.0049	1.2274	-3.4570	0.0000E+00	0.0000E+00	0.0000E+00	0.0000E+00
169	0.2088E+01	0.0000E+00	0.33339	14.0049	-1.2274	6.0586	0.0000E+00	0.0000E+00	0.0000E+00	0.0000E+00
170	0.2088E+01	0.0000E+00	0.33339	14.0049	1.2274	-6.0586	0.0000E+00	0.0000E+00	0.0000E+00	0.0000E+00
171	0.2016E+01	0.0000E+00	0.33339	14.0049	-3.4570	3.4570	0.0000E+00	0.0000E+00	0.0000E+00	0.0000E+00
172	0.2016E+01	0.0000E+00	0.33339	14.0049	3.4570	-3.4570	0.0000E+00	0.0000E+00	0.0000E+00	0.0000E+00
173	0.2129E+01	0.0000E+00	0.27334	14.8291	-6.1781	1.2516	0.0000E+00	0.0000E+00	0.0000E+00	0.0000E+00
174	0.2129E+01	0.0000E+00	0.27334	14.8291	6.1781	-1.2516	0.0000E+00	0.0000E+00	0.0000E+00	0.0000E+00
175	0.2055E+01	0.0000E+00	0.27334	14.8291	-1.2516	3.5252	0.0000E+00	0.0000E+00	0.0000E+00	0.0000E+00
176	0.2055E+01	0.0000E+00	0.27334	14.8291	1.2516	-3.5252	0.0000E+00	0.0000E+00	0.0000E+00	0.0000E+00
177	0.2129E+01	0.0000E+00	0.27334	14.8291	-3.5252	6.1781	0.0000E+00	0.0000E+00	0.0000E+00	0.0000E+00
178	0.2129E+01	0.0000E+00	0.27334	14.8291	3.5252	-6.1781	0.0000E+00	0.0000E+00	0.0000E+00	0.0000E+00
179	0.2055E+01	0.0000E+00	0.27334	14.8291	-1.2516	3.5252	0.0000E+00	0.0000E+00	0.0000E+00	0.0000E+00
180	0.2129E+01	0.0000E+00	0.27334	14.8291	1.2516	-3.5252	0.0000E+00	0.0000E+00	0.0000E+00	0.0000E+00
181	0.2161E+01	0.0000E+00	0.21171	15.6585	-6.2611	1.2684	0.0000E+00	0.0000E+00	0.0000E+00	0.0000E+00
182	0.2161E+01	0.0000E+00	0.21171	15.6585	6.2611	-1.2684	0.0000E+00	0.0000E+00	0.0000E+00	0.0000E+00
183	0.2086E+01	0.0000E+00	0.21171	15.6585	-3.5725	3.5725	0.0000E+00	0.0000E+00	0.0000E+00	0.0000E+00
184	0.2161E+01	0.0000E+00	0.21171	15.6585	3.5725	-3.5725	0.0000E+00	0.0000E+00	0.0000E+00	0.0000E+00
185	0.2161E+01	0.0000E+00	0.21171	15.6585	-1.2684	6.2611	0.0000E+00	0.0000E+00	0.0000E+00	0.0000E+00
186	0.2086E+01	0.0000E+00	0.21171	15.6585	1.2684	-6.2611	0.0000E+00	0.0000E+00	0.0000E+00	0.0000E+00
187	0.2086E+01	0.0000E+00	0.21171	15.6585	-3.5725	3.5725	0.0000E+00	0.0000E+00	0.0000E+00	0.0000E+00
188	0.2161E+01	0.0000E+00	0.21171	15.6585	3.5725	-3.5725	0.0000E+00	0.0000E+00	0.0000E+00	0.0000E+00
189	0.2050E+01	0.0000E+00	0.21171	15.6585	-6.2611	1.2748	0.0000E+00	0.0000E+00	0.0000E+00	0.0000E+00
190	0.2050E+01	0.0000E+00	0.21171	15.6585	6.2611	-1.2748	0.0000E+00	0.0000E+00	0.0000E+00	0.0000E+00
191	0.1979E+01	0.0000E+00	0.15038	16.4680	-5.3334	3.5905	0.0000E+00	0.0000E+00	0.0000E+00	0.0000E+00
192	0.1979E+01	0.0000E+00	0.15038	16.4680	5.3334	-3.5905	0.0000E+00	0.0000E+00	0.0000E+00	0.0000E+00
193	0.2050E+01	0.0000E+00	0.15038	16.4680	-1.2748	3.5905	0.0000E+00	0.0000E+00	0.0000E+00	0.0000E+00
194	0.2050E+01	0.0000E+00	0.15038	16.4680	1.2748	-3.5905	0.0000E+00	0.0000E+00	0.0000E+00	0.0000E+00

195	0.1979E+01	3.5906	5.3335	16.4680	0.15038	0.0000	0.0000E+00	0.0000E+00
196	0.2050E+01	1.2748	6.2927	16.4680	0.15038	0.0000	0.0000E+00	0.0000E+00
197	0.2050E+01	1.2748	9.2926	17.2560	0.09023	0.0000	0.0000E+00	0.0000E+00
198	0.1979E+01	3.5906	-5.3334	17.2560	0.09023	0.0000	0.0000E+00	0.0000E+00
199	0.1979E+01	3.5906	-3.5905	17.2560	0.09023	0.0000	0.0000E+00	0.0000E+00
200	0.2050E+01	6.2927	1.2748	17.2560	0.09023	0.0000	0.0000E+00	0.0000E+00
201	0.2050E+01	6.2927	1.2748	17.2560	0.09023	0.0000	0.0000E+00	0.0000E+00
202	0.1979E+01	3.5906	3.5906	17.2560	0.09023	0.0000	0.0000E+00	0.0000E+00
203	0.1979E+01	3.5906	3.3335	17.2560	0.09023	0.0000	0.0000E+00	0.0000E+00
204	0.2050E+01	1.2748	6.2927	17.2560	0.09023	0.0000	0.0000E+00	0.0000E+00
205	0.2050E+01	1.2748	6.2927	18.0440	0.03008	0.0000	0.0000E+00	0.0000E+00
206	0.1979E+01	3.5906	-5.3334	18.0440	0.03008	0.0000	0.0000E+00	0.0000E+00
207	0.1979E+01	3.5906	-3.5905	18.0440	0.03008	0.0000	0.0000E+00	0.0000E+00
208	0.2050E+01	6.2927	1.2748	18.0440	0.03008	0.0000	0.0000E+00	0.0000E+00
209	0.2050E+01	6.2927	1.2748	18.0440	0.03008	0.0000	0.0000E+00	0.0000E+00
210	0.1979E+01	3.5906	5.3335	18.0440	0.03008	0.0000	0.0000E+00	0.0000E+00
211	0.1979E+01	3.5906	5.3335	18.0440	0.03008	0.0000	0.0000E+00	0.0000E+00
212	0.2050E+01	1.2748	6.2927	18.0440	0.03008	0.0000	0.0000E+00	0.0000E+00

FX= 0.000000E+00 FD= 0.1662695E+04 FN= 0.2646530E-02 SMX= 0.207877E-01 SMY= 0.0000000E+00 SMZ= 0.0000000E+00
 CX= 0.00000000 CD= 0.1083637 CN= 0.1083637 CM= 0.00000002 MX= 0.00000001 MY= 0.00000000 MZ= 0.00000000

STEP 28 DEPTH = 19.2260100 TIME = 0.0112683 DIMENSIONLESS TIME 1.3418778 WEIHING FACTORS = 1.0000000 1.0000000
 AVERAGE VELOCITY 0.000 AREA 0.000

NO.	1	2	3	4	5	6	7	8	9	10	11	12	13	14	15	16	17	18	19	20	21	22	23	24	25	26	27	28	29	30	31	32	33	34	35	36	37	38		
REF. NO.	0	0	0	0	0	0	0	0	0	0	0	0	0	0	0	0	0	0	0	0	0	0	0	0	0	0	0	0	0	0	0	0	0	0	0	0	0	0		
X	0.1046	0.2533	0.1046	0.2533	0.1046	0.2533	0.1046	0.2533	0.1046	0.2533	0.1046	0.2533	0.1046	0.2533	0.1046	0.2533	0.1046	0.2533	0.1046	0.2533	0.1046	0.2533	0.1046	0.2533	0.1046	0.2533	0.1046	0.2533	0.1046	0.2533	0.1046	0.2533	0.1046	0.2533	0.1046	0.2533	0.1046	0.2533	0.1046	0.2533
Y	-0.2523	-0.1046	0.1046	0.2523	-0.2523	-0.1046	0.1046	0.2523	-0.2523	-0.1046	0.1046	0.2523	-0.2523	-0.1046	0.1046	0.2523	-0.2523	-0.1046	0.1046	0.2523	-0.2523	-0.1046	0.1046	0.2523	-0.2523	-0.1046	0.1046	0.2523	-0.2523	-0.1046	0.1046	0.2523	-0.2523	-0.1046	0.1046	0.2523	-0.2523	-0.1046	0.1046	0.2523
Z	0.0658	0.0658	0.0658	0.0658	0.0658	0.0658	0.0658	0.0658	0.0658	0.0658	0.0658	0.0658	0.0658	0.0658	0.0658	0.0658	0.0658	0.0658	0.0658	0.0658	0.0658	0.0658	0.0658	0.0658	0.0658	0.0658	0.0658	0.0658	0.0658	0.0658	0.0658	0.0658	0.0658	0.0658	0.0658	0.0658	0.0658	0.0658	0.0658	0.0658
T*	1.33821	1.33821	1.33821	1.33821	1.33821	1.33821	1.33821	1.33821	1.33821	1.33821	1.33821	1.33821	1.33821	1.33821	1.33821	1.33821	1.33821	1.33821	1.33821	1.33821	1.33821	1.33821	1.33821	1.33821	1.33821	1.33821	1.33821	1.33821	1.33821	1.33821	1.33821	1.33821	1.33821	1.33821	1.33821	1.33821	1.33821	1.33821	1.33821	1.33821
CP	0.9695	0.9695	0.9695	0.9695	0.9695	0.9695	0.9695	0.9695	0.9695	0.9695	0.9695	0.9695	0.9695	0.9695	0.9695	0.9695	0.9695	0.9695	0.9695	0.9695	0.9695	0.9695	0.9695	0.9695	0.9695	0.9695	0.9695	0.9695	0.9695	0.9695	0.9695	0.9695	0.9695	0.9695	0.9695	0.9695	0.9695	0.9695	0.9695	0.9695
P	0.1104E+03	0.1104E+03	0.1104E+03	0.1104E+03	0.1104E+03	0.1104E+03	0.1104E+03	0.1104E+03	0.1104E+03	0.1104E+03	0.1104E+03	0.1104E+03	0.1104E+03	0.1104E+03	0.1104E+03	0.1104E+03	0.1104E+03	0.1104E+03	0.1104E+03	0.1104E+03	0.1104E+03	0.1104E+03	0.1104E+03	0.1104E+03	0.1104E+03	0.1104E+03	0.1104E+03	0.1104E+03	0.1104E+03	0.1104E+03	0.1104E+03	0.1104E+03	0.1104E+03	0.1104E+03	0.1104E+03	0.1104E+03	0.1104E+03	0.1104E+03	0.1104E+03	0.1104E+03
FORCE	0.7882E+01	0.7882E+01	0.7882E+01	0.7882E+01	0.7882E+01	0.7882E+01	0.7882E+01	0.7882E+01	0.7882E+01	0.7882E+01	0.7882E+01	0.7882E+01	0.7882E+01	0.7882E+01	0.7882E+01	0.7882E+01	0.7882E+01	0.7882E+01	0.7882E+01	0.7882E+01	0.7882E+01	0.7882E+01	0.7882E+01	0.7882E+01	0.7882E+01	0.7882E+01	0.7882E+01	0.7882E+01	0.7882E+01	0.7882E+01	0.7882E+01	0.7882E+01	0.7882E+01	0.7882E+01	0.7882E+01	0.7882E+01	0.7882E+01	0.7882E+01	0.7882E+01	0.7882E+01

105	0	1433E+01	0	9236	1720	0	80224	0	0000E+00
106	0	1384E+01	0	6015	1720	0	80224	0	0000E+00
107	0	1433E+01	0	5594	1720	0	80224	0	0000E+00
108	0	1377E+01	0	5594	8579	0	5524	0	0000E+00
109	0	1330E+01	0	621	8579	0	5524	0	0000E+00
110	0	1330E+01	0	621	8579	0	5524	0	0000E+00
111	0	1377E+01	0	9712	8579	0	5524	0	0000E+00
112	0	1377E+01	0	9712	8579	0	5524	0	0000E+00
113	0	1330E+01	0	0631	8579	0	5524	0	0000E+00
114	0	1330E+01	0	0631	8579	0	5524	0	0000E+00
115	0	1330E+01	0	0631	8579	0	5524	0	0000E+00
116	0	1330E+01	0	0631	8579	0	5524	0	0000E+00
117	0	1330E+01	0	0631	8579	0	5524	0	0000E+00
118	0	1387E+01	0	2337	8579	0	5524	0	0000E+00
119	0	1387E+01	0	2337	8579	0	5524	0	0000E+00
120	0	1436E+01	0	8502	8579	0	5524	0	0000E+00
121	0	1436E+01	0	8502	8579	0	5524	0	0000E+00
122	0	1387E+01	0	2337	8579	0	5524	0	0000E+00
123	0	1387E+01	0	2337	8579	0	5524	0	0000E+00
124	0	1491E+01	0	9579	8579	0	5524	0	0000E+00
125	0	1491E+01	0	9579	8579	0	5524	0	0000E+00
126	0	1440E+01	0	1838	8579	0	5524	0	0000E+00
127	0	1440E+01	0	1838	8579	0	5524	0	0000E+00
128	0	1491E+01	0	9579	8579	0	5524	0	0000E+00
129	0	1491E+01	0	9579	8579	0	5524	0	0000E+00
130	0	1440E+01	0	1838	8579	0	5524	0	0000E+00
131	0	1440E+01	0	1838	8579	0	5524	0	0000E+00
132	0	1450E+01	0	0861	8579	0	5524	0	0000E+00
133	0	1450E+01	0	0861	8579	0	5524	0	0000E+00
134	0	1400E+01	0	5441	8579	0	5524	0	0000E+00
135	0	1400E+01	0	5441	8579	0	5524	0	0000E+00
136	0	1450E+01	0	0861	8579	0	5524	0	0000E+00
137	0	1450E+01	0	0861	8579	0	5524	0	0000E+00
138	0	1400E+01	0	5441	8579	0	5524	0	0000E+00
139	0	1400E+01	0	5441	8579	0	5524	0	0000E+00
140	0	1450E+01	0	0861	8579	0	5524	0	0000E+00
141	0	1450E+01	0	0861	8579	0	5524	0	0000E+00
142	0	1909E+01	0	3613	8579	0	5524	0	0000E+00
143	0	1843E+01	0	1647	8579	0	5524	0	0000E+00
144	0	1909E+01	0	3613	8579	0	5524	0	0000E+00
145	0	1909E+01	0	3613	8579	0	5524	0	0000E+00
146	0	1843E+01	0	1647	8579	0	5524	0	0000E+00
147	0	1843E+01	0	1647	8579	0	5524	0	0000E+00
148	0	1909E+01	0	3613	8579	0	5524	0	0000E+00
149	0	1977E+01	0	7008	8579	0	5524	0	0000E+00
150	0	1909E+01	0	3613	8579	0	5524	0	0000E+00
151	0	1909E+01	0	3613	8579	0	5524	0	0000E+00
152	0	1977E+01	0	7008	8579	0	5524	0	0000E+00
153	0	1977E+01	0	7008	8579	0	5524	0	0000E+00
154	0	1909E+01	0	3613	8579	0	5524	0	0000E+00
155	0	1977E+01	0	7008	8579	0	5524	0	0000E+00
156	0	1977E+01	0	7008	8579	0	5524	0	0000E+00
157	0	1967E+01	0	0085	8579	0	5524	0	0000E+00
158	0	1967E+01	0	0085	8579	0	5524	0	0000E+00
159	0	1967E+01	0	0085	8579	0	5524	0	0000E+00
160	0	2037E+01	0	3718	8579	0	5524	0	0000E+00
161	0	2037E+01	0	3718	8579	0	5524	0	0000E+00
162	0	1967E+01	0	0085	8579	0	5524	0	0000E+00
163	0	1967E+01	0	0085	8579	0	5524	0	0000E+00
164	0	2088E+01	0	9093	8579	0	5524	0	0000E+00
165	0	2088E+01	0	9093	8579	0	5524	0	0000E+00
166	0	2016E+01	0	1351	8579	0	5524	0	0000E+00
167	0	2016E+01	0	1351	8579	0	5524	0	0000E+00
168	0	2088E+01	0	9093	8579	0	5524	0	0000E+00
169	0	2088E+01	0	9093	8579	0	5524	0	0000E+00
170	0	2016E+01	0	1351	8579	0	5524	0	0000E+00

171	0.000000E+00	0.2016E+01	3.4570	5.1351	14.0049	0.39354	0.0000	0.0000E+00
172	0.2088E+01	0.2327E+01	1.2274	6.10586	14.0049	0.39354	0.0000	0.0000E+00
173	0.2055E+01	0.2327E+01	1.2274	6.10586	14.0049	0.39354	0.0000	0.0000E+00
174	0.2055E+01	0.2327E+01	1.2274	6.10586	14.0049	0.39354	0.0000	0.0000E+00
175	0.2055E+01	0.2327E+01	1.2274	6.10586	14.0049	0.39354	0.0000	0.0000E+00
176	0.2055E+01	0.2327E+01	1.2274	6.10586	14.0049	0.39354	0.0000	0.0000E+00
177	0.2055E+01	0.2327E+01	1.2274	6.10586	14.0049	0.39354	0.0000	0.0000E+00
178	0.2055E+01	0.2327E+01	1.2274	6.10586	14.0049	0.39354	0.0000	0.0000E+00
179	0.2055E+01	0.2327E+01	1.2274	6.10586	14.0049	0.39354	0.0000	0.0000E+00
180	0.2055E+01	0.2327E+01	1.2274	6.10586	14.0049	0.39354	0.0000	0.0000E+00
181	0.2055E+01	0.2327E+01	1.2274	6.10586	14.0049	0.39354	0.0000	0.0000E+00
182	0.2055E+01	0.2327E+01	1.2274	6.10586	14.0049	0.39354	0.0000	0.0000E+00
183	0.2055E+01	0.2327E+01	1.2274	6.10586	14.0049	0.39354	0.0000	0.0000E+00
184	0.2055E+01	0.2327E+01	1.2274	6.10586	14.0049	0.39354	0.0000	0.0000E+00
185	0.2055E+01	0.2327E+01	1.2274	6.10586	14.0049	0.39354	0.0000	0.0000E+00
186	0.2055E+01	0.2327E+01	1.2274	6.10586	14.0049	0.39354	0.0000	0.0000E+00
187	0.2055E+01	0.2327E+01	1.2274	6.10586	14.0049	0.39354	0.0000	0.0000E+00
188	0.2055E+01	0.2327E+01	1.2274	6.10586	14.0049	0.39354	0.0000	0.0000E+00
189	0.2055E+01	0.2327E+01	1.2274	6.10586	14.0049	0.39354	0.0000	0.0000E+00
190	0.2055E+01	0.2327E+01	1.2274	6.10586	14.0049	0.39354	0.0000	0.0000E+00
191	0.2055E+01	0.2327E+01	1.2274	6.10586	14.0049	0.39354	0.0000	0.0000E+00
192	0.2055E+01	0.2327E+01	1.2274	6.10586	14.0049	0.39354	0.0000	0.0000E+00
193	0.2055E+01	0.2327E+01	1.2274	6.10586	14.0049	0.39354	0.0000	0.0000E+00
194	0.2055E+01	0.2327E+01	1.2274	6.10586	14.0049	0.39354	0.0000	0.0000E+00
195	0.2055E+01	0.2327E+01	1.2274	6.10586	14.0049	0.39354	0.0000	0.0000E+00
196	0.2055E+01	0.2327E+01	1.2274	6.10586	14.0049	0.39354	0.0000	0.0000E+00
197	0.2055E+01	0.2327E+01	1.2274	6.10586	14.0049	0.39354	0.0000	0.0000E+00
198	0.2055E+01	0.2327E+01	1.2274	6.10586	14.0049	0.39354	0.0000	0.0000E+00
199	0.2055E+01	0.2327E+01	1.2274	6.10586	14.0049	0.39354	0.0000	0.0000E+00
200	0.2055E+01	0.2327E+01	1.2274	6.10586	14.0049	0.39354	0.0000	0.0000E+00
201	0.2055E+01	0.2327E+01	1.2274	6.10586	14.0049	0.39354	0.0000	0.0000E+00
202	0.2055E+01	0.2327E+01	1.2274	6.10586	14.0049	0.39354	0.0000	0.0000E+00
203	0.2055E+01	0.2327E+01	1.2274	6.10586	14.0049	0.39354	0.0000	0.0000E+00
204	0.2055E+01	0.2327E+01	1.2274	6.10586	14.0049	0.39354	0.0000	0.0000E+00
205	0.2055E+01	0.2327E+01	1.2274	6.10586	14.0049	0.39354	0.0000	0.0000E+00
206	0.2055E+01	0.2327E+01	1.2274	6.10586	14.0049	0.39354	0.0000	0.0000E+00
207	0.2055E+01	0.2327E+01	1.2274	6.10586	14.0049	0.39354	0.0000	0.0000E+00
208	0.2055E+01	0.2327E+01	1.2274	6.10586	14.0049	0.39354	0.0000	0.0000E+00
209	0.2055E+01	0.2327E+01	1.2274	6.10586	14.0049	0.39354	0.0000	0.0000E+00
210	0.2055E+01	0.2327E+01	1.2274	6.10586	14.0049	0.39354	0.0000	0.0000E+00
211	0.2055E+01	0.2327E+01	1.2274	6.10586	14.0049	0.39354	0.0000	0.0000E+00
212	0.2055E+01	0.2327E+01	1.2274	6.10586	14.0049	0.39354	0.0000	0.0000E+00
213	0.2055E+01	0.2327E+01	1.2274	6.10586	14.0049	0.39354	0.0000	0.0000E+00
214	0.2055E+01	0.2327E+01	1.2274	6.10586	14.0049	0.39354	0.0000	0.0000E+00
215	0.2055E+01	0.2327E+01	1.2274	6.10586	14.0049	0.39354	0.0000	0.0000E+00
216	0.2055E+01	0.2327E+01	1.2274	6.10586	14.0049	0.39354	0.0000	0.0000E+00
217	0.2055E+01	0.2327E+01	1.2274	6.10586	14.0049	0.39354	0.0000	0.0000E+00
218	0.2055E+01	0.2327E+01	1.2274	6.10586	14.0049	0.39354	0.0000	0.0000E+00
219	0.2055E+01	0.2327E+01	1.2274	6.10586	14.0049	0.39354	0.0000	0.0000E+00
220	0.2055E+01	0.2327E+01	1.2274	6.10586	14.0049	0.39354	0.0000	0.0000E+00

FX= 0.000000E+00 FD= 0.1633415E+04 FN= 0.2531025E-02 SMX= 0.1989389E-01 SMY= 0.0000000E+00 SMZ= 0.0000000E+00
 CX= 0.00000000 CD= 0.1064555 CN= 0.00000002 MX= -1560.000 WX= 0.00000001 MY= 0.00000000 MZ= 0.00000000

STEP 29 DEPTH = 20.0140100 TIME = 0.0117735 DIMENSIONLESS TIME 1.4020305 WEITING FACTORS = 1.0000000 1.0000000
 AVERAGE VELOCITY 0.000 0.000 -1560.000 WX 0.00ORIENTATION 90.000

NO.	REF.NO.	MOD	AREA	X	Y	Z	T*	CP	P	FORCE
1	0	0	0.7142E-01	0.1046	-0.2523	0.0658	1.39837	0.9661	0.1100E+03	0.7855E+01
2	0	0	0.7142E-01	0.2523	-0.1046	0.0658	1.39837	0.9661	0.1100E+03	0.7855E+01
3	0	0	0.7142E-01	0.1046	0.2523	0.0658	1.39837	0.9661	0.1100E+03	0.7855E+01
4	0	0	0.7142E-01	0.1046	-0.2523	0.0658	1.39837	0.9661	0.1100E+03	0.7855E+01
5	0	0	0.9502E-01	0.1186	-0.5857	0.2356	1.38810	0.7056	0.8033E+02	0.7896E+01
6	0	0	0.9502E-01	0.3342	-0.4965	0.2356	1.38810	0.7056	0.8033E+02	0.7633E+01

73	0.1096E+01	0.7023	5.3277	1.05471	0.1305	0.1485E+02	0.1628E+02
74	0.1059E+01	1.9780	5.3277	1.05471	0.1308	0.1489E+02	0.1576E+02
75	0.1096E+01	2.9780	5.3277	1.05471	0.1305	0.1485E+02	0.1628E+02
76	0.1187E+01	3.4665	5.3277	1.00709	0.1020	0.1161E+02	0.1378E+02
77	0.1146E+01	3.4665	6.0351	1.00709	0.1021	0.1163E+02	0.1333E+02
78	0.1146E+01	3.1800	6.0351	1.00709	0.1021	0.1163E+02	0.1333E+02
79	0.1187E+01	2.7601	6.0351	1.00709	0.1020	0.1161E+02	0.1378E+02
80	0.1187E+01	3.7519	6.0351	1.00709	0.1020	0.1161E+02	0.1378E+02
81	0.1187E+01	3.1800	6.0351	1.00709	0.1021	0.1163E+02	0.1333E+02
82	0.1146E+01	2.1408	6.0351	1.00709	0.1021	0.1163E+02	0.1333E+02
83	0.1146E+01	3.1800	6.0351	1.00709	0.1020	0.1161E+02	0.1378E+02
84	0.1187E+01	2.7601	6.0351	1.00709	0.1020	0.1161E+02	0.1378E+02
85	0.1273E+01	0.8159	6.7465	0.95906	0.0730	0.8316E+01	0.1059E+02
86	0.1229E+01	3.4134	6.7465	0.95906	0.0733	0.8342E+01	0.1025E+02
87	0.1229E+01	2.2980	6.7465	0.95906	0.0733	0.8342E+01	0.1025E+02
88	0.1273E+01	4.0274	6.7465	0.95906	0.0730	0.8316E+01	0.1059E+02
89	0.1273E+01	4.0274	6.7465	0.95906	0.0733	0.8342E+01	0.1025E+02
90	0.1229E+01	3.4134	6.7465	0.95906	0.0733	0.8342E+01	0.1025E+02
91	0.1229E+01	2.2980	6.7465	0.95906	0.0730	0.8316E+01	0.1059E+02
92	0.1273E+01	4.0274	6.7465	0.95906	0.0377	0.4290E+01	0.5813E+01
93	0.1308E+01	0.8702	7.4595	0.91082	0.0379	0.4318E+01	0.5649E+01
94	0.1308E+01	2.4511	7.4595	0.91082	0.0379	0.4318E+01	0.5649E+01
95	0.1308E+01	3.6408	7.4595	0.91082	0.0377	0.4290E+01	0.5813E+01
96	0.1355E+01	4.2956	7.4595	0.91082	0.0377	0.4290E+01	0.5813E+01
97	0.1355E+01	0.9272	7.4595	0.91082	0.0377	0.4290E+01	0.5813E+01
98	0.1308E+01	3.6408	7.4595	0.91082	0.0379	0.4318E+01	0.5649E+01
99	0.1355E+01	2.4511	7.4595	0.91082	0.0377	0.4290E+01	0.5813E+01
100	0.1433E+01	0.9272	8.1720	0.86240	0.0000	0.0000E+00	0.0000E+00
101	0.1433E+01	0.9272	8.1720	0.86240	0.0000	0.0000E+00	0.0000E+00
102	0.1384E+01	2.8644	8.1720	0.86240	0.0000	0.0000E+00	0.0000E+00
103	0.1384E+01	3.8644	8.1720	0.86240	0.0000	0.0000E+00	0.0000E+00
104	0.1433E+01	4.5594	8.1720	0.86240	0.0000	0.0000E+00	0.0000E+00
105	0.1433E+01	4.5594	8.1720	0.86240	0.0000	0.0000E+00	0.0000E+00
106	0.1384E+01	3.8644	8.1720	0.86240	0.0000	0.0000E+00	0.0000E+00
107	0.1384E+01	2.8644	8.1720	0.86240	0.0000	0.0000E+00	0.0000E+00
108	0.1433E+01	4.5594	8.1720	0.86240	0.0000	0.0000E+00	0.0000E+00
109	0.1377E+01	0.9272	8.8579	0.81539	0.0000	0.0000E+00	0.0000E+00
110	0.1330E+01	0.9712	8.8579	0.81539	0.0000	0.0000E+00	0.0000E+00
111	0.1330E+01	2.7354	8.8579	0.81539	0.0000	0.0000E+00	0.0000E+00
112	0.1377E+01	4.7939	8.8579	0.81539	0.0000	0.0000E+00	0.0000E+00
113	0.1377E+01	4.7939	8.8579	0.81539	0.0000	0.0000E+00	0.0000E+00
114	0.1330E+01	4.0631	8.8579	0.81539	0.0000	0.0000E+00	0.0000E+00
115	0.1330E+01	2.7354	8.8579	0.81539	0.0000	0.0000E+00	0.0000E+00
116	0.1377E+01	4.7939	8.8579	0.81539	0.0000	0.0000E+00	0.0000E+00
117	0.1330E+01	4.0631	9.5220	0.76952	0.0000	0.0000E+00	0.0000E+00
118	0.1387E+01	1.0119	9.5220	0.76952	0.0000	0.0000E+00	0.0000E+00
119	0.1387E+01	2.8502	9.5220	0.76952	0.0000	0.0000E+00	0.0000E+00
120	0.1433E+01	4.2337	9.5220	0.76952	0.0000	0.0000E+00	0.0000E+00
121	0.1433E+01	4.9951	9.5220	0.76952	0.0000	0.0000E+00	0.0000E+00
122	0.1377E+01	4.2337	9.5220	0.76952	0.0000	0.0000E+00	0.0000E+00
123	0.1387E+01	2.8502	9.5220	0.76952	0.0000	0.0000E+00	0.0000E+00
124	0.1433E+01	1.0501	9.5220	0.76952	0.0000	0.0000E+00	0.0000E+00
125	0.1491E+01	4.9951	10.1905	0.72316	0.0000	0.0000E+00	0.0000E+00
126	0.1491E+01	2.9579	10.1905	0.72316	0.0000	0.0000E+00	0.0000E+00
127	0.1440E+01	4.3936	10.1905	0.72316	0.0000	0.0000E+00	0.0000E+00
128	0.1491E+01	5.1838	10.1905	0.72316	0.0000	0.0000E+00	0.0000E+00
129	0.1491E+01	5.1838	10.1905	0.72316	0.0000	0.0000E+00	0.0000E+00
130	0.1440E+01	4.3936	10.1905	0.72316	0.0000	0.0000E+00	0.0000E+00
131	0.1491E+01	2.9579	10.1905	0.72316	0.0000	0.0000E+00	0.0000E+00
132	0.1491E+01	1.0501	10.1905	0.72316	0.0000	0.0000E+00	0.0000E+00
133	0.1450E+01	3.1633	10.8406	0.67792	0.0000	0.0000E+00	0.0000E+00
134	0.1400E+01	3.0591	10.8406	0.67792	0.0000	0.0000E+00	0.0000E+00
135	0.1440E+01	4.5441	10.8406	0.67792	0.0000	0.0000E+00	0.0000E+00
136	0.1450E+01	5.3613	10.8406	0.67792	0.0000	0.0000E+00	0.0000E+00
137	0.1400E+01	3.1633	10.8406	0.67792	0.0000	0.0000E+00	0.0000E+00
138	0.1400E+01	4.5441	10.8406	0.67792	0.0000	0.0000E+00	0.0000E+00

139	0.1400E+01	3.0591	4.5441	10.8406	0.67792	0.0000	0.0000E+00	0.0000E+00
140	0.1450E+01	1.0861	3.7133	10.8406	0.67792	0.0000	0.0000E+00	0.0000E+00
141	0.1509E+01	1.2336	5.4633	11.5605	0.62752	0.0000	0.0000E+00	0.0000E+00
142	0.1843E+01	4.7009	4.7009	11.5605	0.62752	0.0000	0.0000E+00	0.0000E+00
143	0.1909E+01	4.7008	1.1236	11.5605	0.62752	0.0000	0.0000E+00	0.0000E+00
144	0.1909E+01	5.4633	1.1236	11.5605	0.62752	0.0000	0.0000E+00	0.0000E+00
145	0.1909E+01	1.5463	1.5463	11.5605	0.62752	0.0000	0.0000E+00	0.0000E+00
146	0.1843E+01	1.5463	1.5463	11.5605	0.62752	0.0000	0.0000E+00	0.0000E+00
147	0.1909E+01	1.2336	4.7008	11.5605	0.62752	0.0000	0.0000E+00	0.0000E+00
148	0.1909E+01	1.2336	5.4633	11.5605	0.62752	0.0000	0.0000E+00	0.0000E+00
149	0.1977E+01	4.8619	5.4633	12.3708	0.57042	0.0000	0.0000E+00	0.0000E+00
150	0.1909E+01	4.8619	4.8619	12.3708	0.57042	0.0000	0.0000E+00	0.0000E+00
151	0.1909E+01	1.2336	1.2336	12.3708	0.57042	0.0000	0.0000E+00	0.0000E+00
152	0.1977E+01	1.2336	1.2336	12.3708	0.57042	0.0000	0.0000E+00	0.0000E+00
153	0.1977E+01	5.7363	1.2336	12.3708	0.57042	0.0000	0.0000E+00	0.0000E+00
154	0.1909E+01	4.8619	2.2732	12.3708	0.57042	0.0000	0.0000E+00	0.0000E+00
155	0.1909E+01	3.2732	4.8619	12.3708	0.57042	0.0000	0.0000E+00	0.0000E+00
156	0.1977E+01	1.6211	5.992	13.1855	0.51254	0.0000	0.0000E+00	0.0000E+00
157	0.1977E+01	1.9718	5.992	13.1855	0.51254	0.0000	0.0000E+00	0.0000E+00
158	0.1967E+01	1.9718	5.992	13.1855	0.51254	0.0000	0.0000E+00	0.0000E+00
159	0.1967E+01	5.085	3.718	13.1855	0.51254	0.0000	0.0000E+00	0.0000E+00
160	0.2037E+01	5.093	1.971	13.1855	0.51254	0.0000	0.0000E+00	0.0000E+00
161	0.2037E+01	5.092	1.971	13.1855	0.51254	0.0000	0.0000E+00	0.0000E+00
162	0.1967E+01	3.718	0.085	13.1855	0.51254	0.0000	0.0000E+00	0.0000E+00
163	0.2037E+01	1.971	0.085	13.1855	0.51254	0.0000	0.0000E+00	0.0000E+00
164	0.2037E+01	1.971	0.085	13.1855	0.51254	0.0000	0.0000E+00	0.0000E+00
165	0.2088E+01	3.2274	0.086	14.0049	0.45369	0.0000	0.0000E+00	0.0000E+00
166	0.2016E+01	3.2274	1.351	14.0049	0.45369	0.0000	0.0000E+00	0.0000E+00
167	0.2016E+01	1.351	4.570	14.0049	0.45369	0.0000	0.0000E+00	0.0000E+00
168	0.2088E+01	0.586	2.274	14.0049	0.45369	0.0000	0.0000E+00	0.0000E+00
169	0.2088E+01	0.586	2.274	14.0049	0.45369	0.0000	0.0000E+00	0.0000E+00
170	0.2016E+01	1.351	2.274	14.0049	0.45369	0.0000	0.0000E+00	0.0000E+00
171	0.2016E+01	4.570	1.351	14.0049	0.45369	0.0000	0.0000E+00	0.0000E+00
172	0.2088E+01	3.2274	0.586	14.0049	0.45369	0.0000	0.0000E+00	0.0000E+00
173	0.2129E+01	2.2516	6.1781	14.8291	0.33364	0.0000	0.0000E+00	0.0000E+00
174	0.2055E+01	2.2516	2.2516	14.8291	0.33364	0.0000	0.0000E+00	0.0000E+00
175	0.2055E+01	2.2516	2.2516	14.8291	0.33364	0.0000	0.0000E+00	0.0000E+00
176	0.2129E+01	1.781	5.252	14.8291	0.33364	0.0000	0.0000E+00	0.0000E+00
177	0.2129E+01	1.781	5.252	14.8291	0.33364	0.0000	0.0000E+00	0.0000E+00
178	0.2055E+01	2.2516	3.2252	14.8291	0.33364	0.0000	0.0000E+00	0.0000E+00
179	0.2055E+01	2.252	5.252	14.8291	0.33364	0.0000	0.0000E+00	0.0000E+00
180	0.2161E+01	2.684	1.781	15.6585	0.33201	0.0000	0.0000E+00	0.0000E+00
181	0.2161E+01	2.684	2.611	15.6585	0.33201	0.0000	0.0000E+00	0.0000E+00
182	0.2086E+01	1.725	3.067	15.6585	0.33201	0.0000	0.0000E+00	0.0000E+00
183	0.2086E+01	1.725	3.067	15.6585	0.33201	0.0000	0.0000E+00	0.0000E+00
184	0.2161E+01	2.611	5.225	15.6585	0.33201	0.0000	0.0000E+00	0.0000E+00
185	0.2161E+01	2.611	5.225	15.6585	0.33201	0.0000	0.0000E+00	0.0000E+00
186	0.2086E+01	3.067	3.067	15.6585	0.33201	0.0000	0.0000E+00	0.0000E+00
187	0.2086E+01	3.067	3.067	15.6585	0.33201	0.0000	0.0000E+00	0.0000E+00
188	0.2161E+01	2.684	5.225	16.4680	0.27069	0.0000	0.0000E+00	0.0000E+00
189	0.2050E+01	2.748	5.225	16.4680	0.27069	0.0000	0.0000E+00	0.0000E+00
190	0.1979E+01	3.334	3.334	16.4680	0.27069	0.0000	0.0000E+00	0.0000E+00
191	0.1979E+01	3.334	5.905	16.4680	0.27069	0.0000	0.0000E+00	0.0000E+00
192	0.2050E+01	2.927	2.748	16.4680	0.27069	0.0000	0.0000E+00	0.0000E+00
193	0.2050E+01	2.927	2.748	16.4680	0.27069	0.0000	0.0000E+00	0.0000E+00
194	0.1979E+01	3.334	5.906	16.4680	0.27069	0.0000	0.0000E+00	0.0000E+00
195	0.1979E+01	3.335	3.335	16.4680	0.27069	0.0000	0.0000E+00	0.0000E+00
196	0.2050E+01	2.748	6.2927	17.2560	0.21054	0.0000	0.0000E+00	0.0000E+00
197	0.2050E+01	2.748	6.2927	17.2560	0.21054	0.0000	0.0000E+00	0.0000E+00
198	0.1979E+01	3.334	3.334	17.2560	0.21054	0.0000	0.0000E+00	0.0000E+00
199	0.1979E+01	3.334	5.905	17.2560	0.21054	0.0000	0.0000E+00	0.0000E+00
200	0.2050E+01	2.927	2.748	17.2560	0.21054	0.0000	0.0000E+00	0.0000E+00
201	0.2050E+01	2.927	2.748	17.2560	0.21054	0.0000	0.0000E+00	0.0000E+00
202	0.1979E+01	3.334	3.334	17.2560	0.21054	0.0000	0.0000E+00	0.0000E+00
203	0.1979E+01	3.335	5.2927	17.2560	0.21054	0.0000	0.0000E+00	0.0000E+00
204	0.2050E+01	1.2748	6.2927	17.2560	0.21054	0.0000	0.0000E+00	0.0000E+00

205	0.2050E+01	1.2748	-6.2927	18.0440	0.15038	0.0000	0.0000E+00				
206	0.1979E+01	3.3334	-5.3334	18.0440	0.15038	0.0000	0.0000E+00				
207	0.2050E+01	6.2927	-1.2748	18.0440	0.15038	0.0000	0.0000E+00				
208	0.2050E+01	6.2927	1.2748	18.0440	0.15038	0.0000	0.0000E+00				
209	0.1979E+01	5.3334	3.3335	18.0440	0.15038	0.0000	0.0000E+00				
210	0.1979E+01	3.5906	5.2927	18.0440	0.15038	0.0000	0.0000E+00				
211	0.2050E+01	1.2748	6.2927	18.8320	0.09023	0.0000	0.0000E+00				
212	0.2050E+01	1.2748	-5.3334	18.8320	0.09023	0.0000	0.0000E+00				
213	0.1979E+01	3.5906	-3.3334	18.8320	0.09023	0.0000	0.0000E+00				
214	0.1979E+01	5.3334	-3.5905	18.8320	0.09023	0.0000	0.0000E+00				
215	0.2050E+01	6.2927	-1.2748	18.8320	0.09023	0.0000	0.0000E+00				
216	0.2050E+01	6.2927	1.2748	18.8320	0.09023	0.0000	0.0000E+00				
217	0.1979E+01	5.3334	3.5906	18.8320	0.09023	0.0000	0.0000E+00				
218	0.1979E+01	3.5906	5.2927	18.8320	0.09023	0.0000	0.0000E+00				
219	0.2050E+01	1.2748	6.2927	18.8320	0.09023	0.0000	0.0000E+00				
220	0.2050E+01	1.2748	-5.3334	19.6200	0.03008	0.0000	0.0000E+00				
221	0.1979E+01	3.5906	-3.3334	19.6200	0.03008	0.0000	0.0000E+00				
222	0.1979E+01	5.3334	-3.5905	19.6200	0.03008	0.0000	0.0000E+00				
223	0.2050E+01	6.2927	-1.2748	19.6200	0.03008	0.0000	0.0000E+00				
224	0.2050E+01	6.2927	1.2748	19.6200	0.03008	0.0000	0.0000E+00				
225	0.1979E+01	5.3334	3.5906	19.6200	0.03008	0.0000	0.0000E+00				
226	0.1979E+01	3.5906	5.2927	19.6200	0.03008	0.0000	0.0000E+00				
227	0.2050E+01	1.2748	6.2927	19.6200	0.03008	0.0000	0.0000E+00				
228	0.2050E+01	1.2748	6.2927	19.6200	0.03008	0.0000	0.0000E+00				
EX=	0.0000000E+00	FD=	0.1609684E+04	FX=	0.2457762E-02	SMX=	0.1932133E-01	SMY=	0.0000000E+00	SMZ=	0.0000000E+00
CA=	0.0000000	CD=	0.1049088	CN=	0.0000002	MX=	0.0000001	MY=	0.0000000	MZ=	0.0000000

EEEEEEEEE
EEEEEEEEE
EEEEEEEEE

iiiiiiiiiiiiiiiiiiii Digital Equipment Corporation - VAX/VMS Version V4.5
iiiiiiiiiiiiiiiiiiii
iiiiiiiiiiiiiiiiiiii

EEEEEEEEE
EEEEEEEEE
EEEEEEEEE

```

RRRR CCCC SSSS H H H A A W W
R R C S S H H H A A W W W
R R C S S S H H H H A A W W W
R R C S S S H H H H A A W W W
R R C SSS H H H A A W W W

CCCCC AAAAA PPPPPP 999999 000000
CCCCC AAAAA PPPPPP 999999 000000
CC AA AA AA AA PP 99 00
CC AA AA AA AA PP 99 00 0000
CC AA AA AA AA PP 99 00 0000
CC AA AA AA AA PP 99999999 00 00
CC AA AA AA AA PP 99999999 00 00
CC AAAAAA AA PP 99 0000 00
CC AAAAAA AA PP 99 00 00
CC AA AA AA PP 999999 000000
CC AA AA AA PP 999999 000000

```

File DUB3:[RCSHAW]CAP 90.F;6 (206,63,0) last revised on 27-SEP-1989 10:28, is a 6 block sequential file owned by UIC [WMS,RCSHAW]. The records are variable length with implied (CR) carriage control. The longest record is 84 bytes.
Job CAP 90 (1176) queued to TXAL on 27-SEP-1989 10:38 by user RCSHAW, UIC [WMS,RCSHAW], under account WMS at priority 100, started on printer TXAL on 27-SEP-1989 10:46 from queue TXAL.

EEEEEEEEE
EEEEEEEEE
EEEEEEEEE

TIME HISTORIES OF TOTAL FORCES AND MOMENTS ABOUT C.G.
VW/DIA DRAG FORCE CD NORMAL FORCE X-MOMENT CMX

0.51012E-02	0.71530E-01	0.49100E-07	0.37000E-11	0.61580E-07	0.31612E-12
0.10991E+04	0.39332E-01	0.3252E-04	0.20890E-08	0.37416E-04	0.18655E-09
0.60350E+03	0.42488E-01	0.9895E-03	0.64519E-07	0.13604E-02	0.67680E-08
0.63192E+03	0.62688E-01	0.10984E-02	0.71589E-07	0.26304E-02	0.13086E-07
0.10051E+00	0.81222E-01	0.46563E-03	0.30347E-07	0.23364E-02	0.11624E-07
0.14258E+00	0.96559E-01	0.44046E-03	0.28706E-07	0.22183E-02	0.11036E-07
0.18606E+00	0.10917E+00	0.64382E-03	0.41960E-07	0.14392E-02	0.71601E-08
0.23078E+00	0.11972E+00	0.51263E-04	0.33410E-08	0.11232E-02	0.55879E-08
0.27558E+00	0.12896E+00	0.12723E-02	0.82918E-07	0.71343E-02	0.35494E-07
0.32299E+00	0.13784E+00	0.12339E-02	0.80419E-07	0.92746E-02	0.46142E-07
0.37069E+00	0.14706E+00	0.48660E-03	0.31714E-07	0.65701E-02	0.32687E-07
0.41859E+00	0.15735E+00	0.85907E-03	0.55989E-07	0.30674E-02	0.15261E-07
0.46681E+00	0.16907E+00	0.29017E-02	0.18925E-06	0.21614E-01	0.10753E-06
0.51512E+00	0.17600E+00	0.17439E-02	0.11365E-06	0.19808E-01	0.98545E-07
0.56368E+00	0.16822E+00	0.43208E-04	0.28160E-08	0.1776E-02	0.15809E-07
0.60228E+00	0.16019E+00	0.15891E-02	0.10357E-06	0.11584E-01	0.57632E-07
0.65545E+00	0.15617E+00	0.79919E-03	0.52086E-07	0.70619E-02	0.35134E-07
0.70202E+00	0.15809E+00	0.64715E-03	0.47177E-07	0.21317E-02	0.10606E-07
0.74596E+00	0.15294E+00	0.16428E-02	0.10707E-06	0.19320E-01	0.96118E-07
0.80373E+00	0.14402E+00	0.19036E-02	0.65407E-07	0.12912E-01	0.64275E-07
0.86019E+00	0.13630E+00	0.15265E-03	0.10145E-07	0.10922E-02	0.54344E-08
0.91852E+00	0.13013E+00	0.50695E-03	0.33040E-07	0.41166E-02	0.20481E-07
0.97794E+00	0.12479E+00	0.84469E-03	0.55051E-07	0.67051E-02	0.33584E-07
0.10387E+01	0.11902E+00	0.31803E-02	0.20727E-06	0.25294E-01	0.12584E-06
0.11014E+01	0.11410E+00	0.34288E-02	0.22438E-06	0.27258E-01	0.13566E-06
0.11614E+01	0.11072E+00	0.28458E-02	0.18547E-06	0.22312E-01	0.11102E-06
0.12316E+01	0.10836E+00	0.28465E-02	0.17248E-06	0.20786E-01	0.10342E-06
0.12817E+01	0.10646E+00	0.25210E-02	0.16494E-06	0.19894E-01	0.98974E-07
0.13419E+01	0.10491E+00	0.24578E-02	0.16018E-06	0.19321E-01	0.96123E-07
0.14020E+01	0.16097E+04				

APPENDIX F
ABAQUS INPUT FILE
CAP90.INP; 10

*HEADING
 1.25-CAL OGIVAL NOSECAP QUATER-SYMMETRIC MODEL W/ INTERNAL BLADES
 ** NEUTRAL FILE GENERATED ON: 11-OCT-89 14:47:04 PATABA VERSION: 3.0

**
 ** NODE DEFINITIONS
 **

*NODE

1,	0.305999994E+00,	0.000000000E+00,	0.000000000E+00
2,	0.401172698E+00,	0.426332355E+00,	0.000000000E+00
3,	0.401172698E+00,	0.417670786E+00,	0.859208629E-01
4,	0.401172668E+00,	0.392829031E+00,	0.165947810E+00
5,	0.401172668E+00,	0.353521496E+00,	0.238366514E+00
6,	0.401172668E+00,	0.301462501E+00,	0.301462531E+00
7,	0.401172668E+00,	0.238366485E+00,	0.353521526E+00
8,	0.401172668E+00,	0.165947825E+00,	0.392829090E+00
9,	0.401172698E+00,	0.859208107E-01,	0.417670816E+00
10,	0.401172698E+00,	0.000000000E+00,	0.426332384E+00
11,	0.657798767E+00,	0.761494935E+00,	0.000000000E+00
12,	0.657798767E+00,	0.746024072E+00,	0.153467819E+00
13,	0.657798767E+00,	0.701652884E+00,	0.296408236E+00
14,	0.657798767E+00,	0.631443560E+00,	0.425759137E+00
15,	0.657798767E+00,	0.538458228E+00,	0.538458288E+00
16,	0.657798767E+00,	0.425758988E+00,	0.631443620E+00
17,	0.657798767E+00,	0.296408117E+00,	0.701653004E+00
18,	0.657798767E+00,	0.153467715E+00,	0.746024132E+00
19,	0.657798767E+00,	0.000000000E+00,	0.761495054E+00
20,	0.126937640E+01,	0.122618616E+01,	0.000000000E+00
21,	0.126937628E+01,	0.120127428E+01,	0.247119397E+00
22,	0.126937616E+01,	0.112982631E+01,	0.477287143E+00
23,	0.126937616E+01,	0.101677275E+01,	0.685572505E+00
24,	0.126937616E+01,	0.867044628E+00,	0.867044628E+00
25,	0.126937616E+01,	0.685572386E+00,	0.101677287E+01
26,	0.126937616E+01,	0.477287173E+00,	0.112982643E+01
27,	0.126937628E+01,	0.247119486E+00,	0.120127439E+01
28,	0.126937640E+01,	0.000000000E+00,	0.122618628E+01
29,	0.189911699E+01,	0.166052639E+01,	0.000000000E+00
30,	0.189911687E+01,	0.162679029E+01,	0.334654152E+00
31,	0.189911664E+01,	0.153003383E+01,	0.646352053E+00
32,	0.189911664E+01,	0.137693453E+01,	0.928416312E+00
33,	0.189911652E+01,	0.117416954E+01,	0.117416966E+01
34,	0.189911664E+01,	0.928416193E+00,	0.137693465E+01
35,	0.189911664E+01,	0.646352053E+00,	0.153003407E+01
36,	0.189911675E+01,	0.334654093E+00,	0.162679052E+01
37,	0.189911699E+01,	0.000000000E+00,	0.166052651E+01
38,	0.254701257E+01,	0.206587839E+01,	0.000000000E+00
39,	0.254701233E+01,	0.202390695E+01,	0.416346669E+00
40,	0.254701233E+01,	0.190353131E+01,	0.804133236E+00
41,	0.254701209E+01,	0.171305883E+01,	0.115505230E+01
42,	0.254701209E+01,	0.146079671E+01,	0.146079659E+01
43,	0.254701209E+01,	0.115505260E+01,	0.171305847E+01
44,	0.254701209E+01,	0.804133415E+00,	0.190353107E+01
45,	0.254701233E+01,	0.416347027E+00,	0.202390671E+01
46,	0.254701257E+01,	0.000000000E+00,	0.206587815E+01
47,	0.321085429E+01,	0.244509935E+01,	0.000000000E+00
48,	0.321085405E+01,	0.239542341E+01,	0.492772996E+00
49,	0.321085405E+01,	0.225295115E+01,	0.951743305E+00
50,	0.321085382E+01,	0.202751470E+01,	0.136707854E+01
51,	0.321085382E+01,	0.172894645E+01,	0.172894657E+01
52,	0.321085382E+01,	0.136707854E+01,	0.202751517E+01
53,	0.321085405E+01,	0.951743245E+00,	0.225295162E+01
54,	0.321085405E+01,	0.492773056E+00,	0.239542413E+01
55,	0.321085429E+01,	0.000000000E+00,	0.244509983E+01
56,	0.388843179E+01,	0.280104733E+01,	0.000000000E+00
57,	0.388843155E+01,	0.274413991E+01,	0.564508855E+00
58,	0.388843155E+01,	0.258092713E+01,	0.109029424E+01
59,	0.388843155E+01,	0.232267261E+01,	0.156609237E+01

60,	0.388843131E+01,	0.198063982E+01,	0.198063982E+01
61,	0.388843155E+01,	0.156609249E+01,	0.232267261E+01
62,	0.388843155E+01,	0.109029460E+01,	0.258092737E+01
63,	0.388843155E+01,	0.564509392E+00,	0.274414039E+01
64,	0.388843179E+01,	0.000000000E+00,	0.280104756E+01
65,	0.457753706E+01,	0.313657951E+01,	0.000000000E+00
66,	0.457753706E+01,	0.307285523E+01,	0.632130146E+00
67,	0.457753706E+01,	0.289009166E+01,	0.122089827E+01
68,	0.457753658E+01,	0.260090113E+01,	0.175369155E+01
69,	0.457753658E+01,	0.221789694E+01,	0.221789670E+01
70,	0.457753658E+01,	0.175369179E+01,	0.260090089E+01
71,	0.457753706E+01,	0.122089863E+01,	0.289009166E+01
72,	0.457753706E+01,	0.632130623E+00,	0.307285523E+01
73,	0.457753706E+01,	0.000000000E+00,	0.313657904E+01
74,	0.527595997E+01,	0.345455360E+01,	0.000000000E+00
75,	0.527595997E+01,	0.338436937E+01,	0.696213007E+00
76,	0.527595997E+01,	0.318307781E+01,	0.134466815E+01
77,	0.527595997E+01,	0.286457038E+01,	0.193147385E+01
78,	0.527595997E+01,	0.244273853E+01,	0.244273853E+01
79,	0.527595997E+01,	0.193147409E+01,	0.286457038E+01
80,	0.527595997E+01,	0.134466863E+01,	0.318307781E+01
81,	0.527595997E+01,	0.696213722E+00,	0.338436961E+01
82,	0.527595997E+01,	0.000000000E+00,	0.345455337E+01
83,	0.598149252E+01,	0.375782681E+01,	0.000000000E+00
84,	0.598149252E+01,	0.368148112E+01,	0.757333159E+00
85,	0.598149252E+01,	0.346251822E+01,	0.146271586E+01
86,	0.598149252E+01,	0.311604905E+01,	0.210103679E+01
87,	0.598149252E+01,	0.265718484E+01,	0.265718508E+01
88,	0.598149252E+01,	0.210103679E+01,	0.311604953E+01
89,	0.598149252E+01,	0.146271586E+01,	0.346251845E+01
90,	0.598149252E+01,	0.757333279E+00,	0.368148160E+01
91,	0.598149252E+01,	0.000000000E+00,	0.375782681E+01
92,	0.669192410E+01,	0.404925776E+01,	0.000000000E+00
93,	0.669192410E+01,	0.396699142E+01,	0.816066504E+00
94,	0.669192410E+01,	0.373104715E+01,	0.157615364E+01
95,	0.669192410E+01,	0.335770845E+01,	0.226397824E+01
96,	0.669192410E+01,	0.286325788E+01,	0.286325741E+01
97,	0.669192410E+01,	0.226397896E+01,	0.335770822E+01
98,	0.669192410E+01,	0.157615423E+01,	0.373104668E+01
99,	0.669192410E+01,	0.816067457E+00,	0.396699095E+01
100,	0.669192410E+01,	0.000000000E+00,	0.404925680E+01
101,	0.740504503E+01,	0.433170223E+01,	0.000000000E+00
102,	0.740504503E+01,	0.424369764E+01,	0.872989058E+00
103,	0.740504503E+01,	0.399129581E+01,	0.168609405E+01
104,	0.740504503E+01,	0.359191585E+01,	0.242189598E+01
105,	0.740504503E+01,	0.306297636E+01,	0.306297612E+01
106,	0.740504503E+01,	0.242189646E+01,	0.359191585E+01
107,	0.740504503E+01,	0.168609452E+01,	0.399129581E+01
108,	0.740504503E+01,	0.872989655E+00,	0.424369764E+01
109,	0.740504503E+01,	0.000000000E+00,	0.433170176E+01
110,	0.811864853E+01,	0.460801935E+01,	0.000000000E+00
111,	0.811864853E+01,	0.451440096E+01,	0.928676605E+00
112,	0.811864853E+01,	0.424589872E+01,	0.179364908E+01
113,	0.811864853E+01,	0.382104230E+01,	0.257638741E+01
114,	0.811864853E+01,	0.325836205E+01,	0.325836158E+01
115,	0.811864853E+01,	0.257638764E+01,	0.382104158E+01
116,	0.811864853E+01,	0.179364944E+01,	0.424589825E+01
117,	0.811864853E+01,	0.928677082E+00,	0.451440001E+01
118,	0.811864853E+01,	0.000000000E+00,	0.460801840E+01
119,	0.883052254E+01,	0.488106537E+01,	0.000000000E+00
120,	0.883052254E+01,	0.478189945E+01,	0.98370504E+00
121,	0.883052254E+01,	0.449748707E+01,	0.189993107E+01
122,	0.883052254E+01,	0.404745626E+01,	0.272905016E+01
123,	0.883052254E+01,	0.345143461E+01,	0.345143437E+01
124,	0.883052254E+01,	0.272905040E+01,	0.404745579E+01
125,	0.883052254E+01,	0.189993119E+01,	0.449748659E+01

126,	0.883052254E+01,	0.983705521E+00,	0.478189898E+01
127,	0.883052254E+01,	0.000000000E+00,	0.488106441E+01
128,	0.949249554E+01,	0.509723139E+01,	0.000000000E+00
129,	0.949249554E+01,	0.499367380E+01,	0.102727008E+01
130,	0.949249554E+01,	0.469666576E+01,	0.198407269E+01
131,	0.949249554E+01,	0.422670412E+01,	0.284991097E+01
132,	0.949249554E+01,	0.360428667E+01,	0.360428739E+01
133,	0.949249554E+01,	0.284991002E+01,	0.422670460E+01
134,	0.949249554E+01,	0.198407197E+01,	0.469666672E+01
135,	0.949249554E+01,	0.102726936E+01,	0.499367476E+01
136,	0.949249554E+01,	0.000000000E+00,	0.509723234E+01
137,	0.101592350E+02,	0.530031967E+01,	0.000000000E+00
138,	0.101592350E+02,	0.519263601E+01,	0.106819940E+01
139,	0.101592350E+02,	0.488379431E+01,	0.206312394E+01
140,	0.101592340E+02,	0.439510822E+01,	0.296345949E+01
141,	0.101592340E+02,	0.374789166E+01,	0.374789238E+01
142,	0.101592340E+02,	0.296345878E+01,	0.439510918E+01
143,	0.101592340E+02,	0.206312251E+01,	0.488379478E+01
144,	0.101592350E+02,	0.106819773E+01,	0.519263697E+01
145,	0.101592350E+02,	0.000000000E+00,	0.530032063E+01
146,	0.108298464E+02,	0.549020243E+01,	0.000000000E+00
147,	0.108298464E+02,	0.537866068E+01,	0.110646760E+01
148,	0.108298464E+02,	0.505875444E+01,	0.213703489E+01
149,	0.108298464E+02,	0.455256128E+01,	0.306962490E+01
150,	0.108298464E+02,	0.388215876E+01,	0.388215971E+01
151,	0.108298464E+02,	0.306962347E+01,	0.455256271E+01
152,	0.108298464E+02,	0.213703394E+01,	0.505875587E+01
153,	0.108298464E+02,	0.110646629E+01,	0.537866163E+01
154,	0.108298464E+02,	0.000000000E+00,	0.549020386E+01
155,	0.114600000E+02,	0.567000008E+01,	0.000000000E+00
156,	0.114600000E+02,	0.555480576E+01,	0.114270294E+01
157,	0.114600000E+02,	0.522442293E+01,	0.220702004E+01
158,	0.114600000E+02,	0.470165253E+01,	0.317015100E+01
159,	0.114600000E+02,	0.400929499E+01,	0.400929546E+01
160,	0.114600000E+02,	0.317015004E+01,	0.470165348E+01
161,	0.114600000E+02,	0.220701909E+01,	0.522442341E+01
162,	0.114600000E+02,	0.114270163E+01,	0.555480576E+01
163,	0.114600000E+02,	0.000000000E+00,	0.567000008E+01
164,	0.122683268E+02,	0.587510014E+01,	0.000000000E+00
165,	0.122683268E+02,	0.575573874E+01,	0.118403780E+01
166,	0.122683268E+02,	0.541340494E+01,	0.228685427E+01
167,	0.122683268E+02,	0.487172461E+01,	0.328482461E+01
168,	0.122683268E+02,	0.415432262E+01,	0.415432310E+01
169,	0.122683268E+02,	0.328482342E+01,	0.487172508E+01
170,	0.122683268E+02,	0.228685308E+01,	0.541340590E+01
171,	0.122683268E+02,	0.118403625E+01,	0.575573921E+01
172,	0.122683268E+02,	0.000000000E+00,	0.587510061E+01
173,	0.130810089E+02,	0.606578159E+01,	0.000000000E+00
174,	0.130810089E+02,	0.594254637E+01,	0.122246671E+01
175,	0.130810089E+02,	0.558910227E+01,	0.236107612E+01
176,	0.130810089E+02,	0.502984095E+01,	0.339143634E+01
177,	0.130810089E+02,	0.428915501E+01,	0.428915501E+01
178,	0.130810089E+02,	0.339143586E+01,	0.502984095E+01
179,	0.130810089E+02,	0.236107540E+01,	0.558910179E+01
180,	0.130810089E+02,	0.122246599E+01,	0.594254589E+01
181,	0.130810089E+02,	0.000000000E+00,	0.606578112E+01
182,	0.138982830E+02,	0.623532820E+01,	0.000000000E+00
183,	0.138982830E+02,	0.610864830E+01,	0.125663638E+01
184,	0.138982830E+02,	0.574532509E+01,	0.242707133E+01
185,	0.138982830E+02,	0.517043209E+01,	0.348623157E+01
186,	0.138982830E+02,	0.440904284E+01,	0.440904284E+01
187,	0.138982830E+02,	0.348623109E+01,	0.517043161E+01
188,	0.138982830E+02,	0.242707062E+01,	0.574532509E+01
189,	0.138982830E+02,	0.125663567E+01,	0.610864782E+01
190,	0.138982830E+02,	0.000000000E+00,	0.623532772E+01
191,	0.147203827E+02,	0.637702417E+01,	0.000000000E+00

192	0.147203827E+02	0.624746609E+01	0.128519309E+01
193	0.147203827E+02	0.587588644E+01	0.248222613E+01
194	0.147203827E+02	0.528792858E+01	0.356545544E+01
195	0.147203827E+02	0.450923729E+01	0.450923729E+01
196	0.147203827E+02	0.356545472E+01	0.528792906E+01
197	0.147203827E+02	0.248222518E+01	0.587588644E+01
198	0.147203827E+02	0.128519249E+01	0.624746561E+01
199	0.147203827E+02	0.000000000E+00	0.637702417E+01
200	0.155475445E+02	0.648415327E+01	0.000000000E+00
201	0.155475445E+02	0.635241842E+01	0.130678332E+01
202	0.155475445E+02	0.597459650E+01	0.252292554E+01
203	0.155475445E+02	0.537676191E+01	0.262525262E+01
204	0.155475445E+02	0.458498907E+01	0.458498955E+01
205	0.155475445E+02	0.362535143E+01	0.537676239E+01
206	0.155475445E+02	0.252392459E+01	0.597459745E+01
207	0.155475445E+02	0.130678225E+01	0.635241842E+01
208	0.155475445E+02	0.000000000E+00	0.648415327E+01
209	0.163800011E+02	0.655000067E+01	0.000000000E+00
210	0.163800011E+02	0.641692781E+01	0.132005358E+01
211	0.163800011E+02	0.603526926E+01	0.254955578E+01
212	0.163800030E+02	0.543136311E+01	0.366216779E+01
213	0.163800030E+02	0.463154984E+01	0.463154984E+01
214	0.163800030E+02	0.366216731E+01	0.543136358E+01
215	0.163800030E+02	0.254955530E+01	0.603526926E+01
216	0.163800011E+02	0.132005262E+01	0.641692781E+01
217	0.163800011E+02	0.000000000E+00	0.655000019E+01
218	0.171679993E+02	0.655000019E+01	0.000000000E+00
219	0.171679993E+02	0.641692734E+01	0.132005370E+01
220	0.171679993E+02	0.603526878E+01	0.254955602E+01
221	0.171679993E+02	0.543136311E+01	0.366216755E+01
222	0.171679993E+02	0.463154984E+01	0.463154984E+01
223	0.171679993E+02	0.366216803E+01	0.543136358E+01
224	0.171679993E+02	0.254955626E+01	0.603526926E+01
225	0.171679993E+02	0.132005453E+01	0.641692877E+01
226	0.171679993E+02	0.000000000E+00	0.655000114E+01
227	0.179559975E+02	0.655000019E+01	0.000000000E+00
228	0.179559975E+02	0.641692734E+01	0.132005370E+01
229	0.179559975E+02	0.603526878E+01	0.254955602E+01
230	0.179559975E+02	0.543136311E+01	0.366216755E+01
231	0.179559975E+02	0.463154984E+01	0.463154984E+01
232	0.179559975E+02	0.366216779E+01	0.543136358E+01
233	0.179559975E+02	0.254955626E+01	0.603526926E+01
234	0.179559975E+02	0.132005453E+01	0.641692877E+01
235	0.179559975E+02	0.000000000E+00	0.655000114E+01
236	0.187439976E+02	0.655000019E+01	0.000000000E+00
237	0.187439976E+02	0.641692734E+01	0.132005370E+01
238	0.187439976E+02	0.603526878E+01	0.254955602E+01
239	0.187439976E+02	0.543136311E+01	0.366216755E+01
240	0.187439976E+02	0.463154936E+01	0.463154984E+01
241	0.187439976E+02	0.366216731E+01	0.543136358E+01
242	0.187439976E+02	0.254955578E+01	0.603526926E+01
243	0.187439976E+02	0.132005358E+01	0.641692877E+01
244	0.187439976E+02	0.000000000E+00	0.655000114E+01
245	0.195319977E+02	0.655000019E+01	0.000000000E+00
246	0.195319977E+02	0.641692734E+01	0.132005370E+01
247	0.195319977E+02	0.603526878E+01	0.254955602E+01
248	0.195319977E+02	0.543136311E+01	0.366216755E+01
249	0.195319977E+02	0.463154936E+01	0.463154984E+01
250	0.195319977E+02	0.366216731E+01	0.543136358E+01
251	0.195319977E+02	0.254955578E+01	0.603526926E+01
252	0.195319977E+02	0.132005358E+01	0.641692877E+01
253	0.195319977E+02	0.000000000E+00	0.655000114E+01
254	0.203199997E+02	0.655000019E+01	0.000000000E+00
255	0.203199997E+02	0.641692734E+01	0.132005370E+01
256	0.203199997E+02	0.603526878E+01	0.254955602E+01
257	0.203199997E+02	0.543136311E+01	0.366216755E+01

255,	0.203199997E+02,	0.463154936E+01,	0.463154984E+01
259,	0.203199997E+02,	0.366216731E+01,	0.543136358E+01
260,	0.203199997E+02,	0.254955530E+01,	0.603526926E+01
261,	0.203199997E+02,	0.132005310E+01,	0.641692877E+01
262,	0.203199997E+02,	0.000000000E+00,	0.655000114E+01
263,	0.442086369E+00,	0.213166147E+00,	0.000000000E+00
264,	0.658899486E+00,	0.380747467E+00,	0.000000000E+00
265,	0.483000040E+00,	0.000000000E+00,	0.000000000E+00
266,	0.660000086E+00,	0.000000000E+00,	0.000000000E+00
267,	0.131812525E+01,	0.759999990E+00,	0.000000000E+00
268,	0.197625053E+01,	0.759999990E+00,	0.000000000E+00
269,	0.132406271E+01,	0.379999995E+00,	0.000000000E+00
270,	0.198812544E+01,	0.379999995E+00,	0.000000000E+00
271,	0.133000016E+01,	0.000000000E+00,	0.000000000E+00
272,	0.200000024E+01,	0.000000000E+00,	0.000000000E+00
273,	0.266167736E+01,	0.117210639E+01,	0.000000000E+00
274,	0.334710455E+01,	0.158421278E+01,	0.000000000E+00
275,	0.403253174E+01,	0.199631929E+01,	0.000000000E+00
276,	0.471795893E+01,	0.240842557E+01,	0.000000000E+00
277,	0.540338612E+01,	0.282053208E+01,	0.000000000E+00
278,	0.608881378E+01,	0.323263860E+01,	0.000000000E+00
279,	0.677424049E+01,	0.364474511E+01,	0.000000000E+00
280,	0.745966768E+01,	0.405685186E+01,	0.000000000E+00
281,	0.814509583E+01,	0.446895790E+01,	0.000000000E+00
282,	0.883052254E+01,	0.488106489E+01,	0.000000000E+00
283,	0.267233896E+01,	0.716581345E+00,	0.000000000E+00
284,	0.335655308E+01,	0.105316269E+01,	0.000000000E+00
285,	0.404076719E+01,	0.138974404E+01,	0.000000000E+00
286,	0.472498083E+01,	0.172632551E+01,	0.000000000E+00
287,	0.540919495E+01,	0.206290698E+01,	0.000000000E+00
288,	0.609340954E+01,	0.239948845E+01,	0.000000000E+00
289,	0.677762318E+01,	0.273606968E+01,	0.000000000E+00
290,	0.746183729E+01,	0.307265115E+01,	0.000000000E+00
291,	0.814605141E+01,	0.340923262E+01,	0.000000000E+00
292,	0.883026600E+01,	0.374581409E+01,	0.000000000E+00
293,	0.268300080E+01,	0.261056334E+00,	0.000000000E+00
294,	0.336600137E+01,	0.522112668E+00,	0.000000000E+00
295,	0.404900217E+01,	0.783169031E+00,	0.000000000E+00
296,	0.473200274E+01,	0.104422534E+01,	0.000000000E+00
297,	0.541500330E+01,	0.130528164E+01,	0.000000000E+00
298,	0.609800434E+01,	0.156633806E+01,	0.000000000E+00
299,	0.678100491E+01,	0.182739425E+01,	0.000000000E+00
300,	0.746400642E+01,	0.208845067E+01,	0.000000000E+00
301,	0.814700699E+01,	0.234950686E+01,	0.000000000E+00
302,	0.883000851E+01,	0.261056328E+01,	0.000000000E+00
303,	0.949249649E+01,	0.509723091E+01,	0.000000000E+00
304,	0.101592360E+02,	0.530032015E+01,	0.000000000E+00
305,	0.108298464E+02,	0.549020243E+01,	0.000000000E+00
306,	0.949458408E+01,	0.398130345E+01,	0.000000000E+00
307,	0.101612854E+02,	0.421025372E+01,	0.000000000E+00
308,	0.108299999E+02,	0.400000000E+01,	0.000000000E+00
309,	0.949667168E+01,	0.286537552E+01,	0.000000000E+00
310,	0.101633358E+02,	0.312018776E+01,	0.000000000E+00
311,	0.108299999E+02,	0.337500000E+01,	0.000000000E+00
312,	0.114600000E+02,	0.567000008E+01,	0.000000000E+00
313,	0.115368347E+02,	0.489210892E+01,	0.000000000E+00
314,	0.442086399E+00,	0.000000000E+00,	0.213166162E+00
315,	0.658899486E+00,	0.000000000E+00,	0.380747467E+00
316,	0.131812525E+01,	0.000000000E+00,	0.760000110E+00
317,	0.197625041E+01,	0.000000000E+00,	0.759999990E+00
318,	0.132406259E+01,	0.000000000E+00,	0.379999995E+00
319,	0.198812544E+01,	0.000000000E+00,	0.379999995E+00
320,	0.266167760E+01,	0.000000000E+00,	0.117210650E+01
321,	0.334710503E+01,	0.000000000E+00,	0.158421290E+01
322,	0.403253222E+01,	0.000000000E+00,	0.199631917E+01
323,	0.471795940E+01,	0.000000000E+00,	0.240842557E+01

324,	0.540338612E+01,	0.000000000E+00,	0.282053185E+01
325,	0.608881330E+01,	0.000000000E+00,	0.323263812E+01
326,	0.677424002E+01,	0.000000000E+00,	0.364474440E+01
327,	0.745966768E+01,	0.000000000E+00,	0.405685091E+01
328,	0.814509487E+01,	0.000000000E+00,	0.446895742E+01
329,	0.883052254E+01,	0.000000000E+00,	0.488106441E+01
330,	0.267233920E+01,	0.000000000E+00,	0.716581464E+00
331,	0.335655332E+01,	0.000000000E+00,	0.105316281E+01
332,	0.404076719E+01,	0.000000000E+00,	0.138974416E+01
333,	0.472498083E+01,	0.000000000E+00,	0.172632539E+01
334,	0.540919495E+01,	0.000000000E+00,	0.206290674E+01
335,	0.609340906E+01,	0.000000000E+00,	0.239948821E+01
336,	0.677762222E+01,	0.000000000E+00,	0.273606944E+01
337,	0.746183681E+01,	0.000000000E+00,	0.307265067E+01
338,	0.814605045E+01,	0.000000000E+00,	0.340923214E+01
339,	0.883026505E+01,	0.000000000E+00,	0.374581385E+01
340,	0.268300080E+01,	0.000000000E+00,	0.261056393E+00
341,	0.336600137E+01,	0.000000000E+00,	0.522112727E+00
342,	0.404900217E+01,	0.000000000E+00,	0.783169150E+00
343,	0.473200274E+01,	0.000000000E+00,	0.104422534E+01
344,	0.541500330E+01,	0.000000000E+00,	0.130528164E+01
345,	0.609800434E+01,	0.000000000E+00,	0.156633806E+01
346,	0.678100443E+01,	0.000000000E+00,	0.182739425E+01
347,	0.746400595E+01,	0.000000000E+00,	0.208845043E+01
348,	0.814700603E+01,	0.000000000E+00,	0.234950686E+01
349,	0.883000755E+01,	0.000000000E+00,	0.261056328E+01
350,	0.949249554E+01,	0.000000000E+00,	0.509723139E+01
351,	0.101592350E+02,	0.000000000E+00,	0.530031967E+01
352,	0.108298464E+02,	0.000000000E+00,	0.549020243E+01
353,	0.949458313E+01,	0.000000000E+00,	0.398130369E+01
354,	0.101612844E+02,	0.000000000E+00,	0.421025372E+01
355,	0.108299999E+02,	0.000000000E+00,	0.400000000E+01
356,	0.949667072E+01,	0.000000000E+00,	0.286537576E+01
357,	0.101633348E+02,	0.000000000E+00,	0.312018776E+01
358,	0.108299999E+02,	0.000000000E+00,	0.337500000E+01
359,	0.114600000E+02,	0.000000000E+00,	0.567000008E+01
360,	0.115368347E+02,	0.000000000E+00,	0.489210892E+01
361,	0.442086369E+00,	0.209070000E+00,	0.415900000E-01
362,	0.442086369E+00,	0.196940000E+00,	0.815800000E-01
363,	0.442086369E+00,	0.177240000E+00,	0.118430000E+00
364,	0.442086369E+00,	0.150730000E+00,	0.150730000E+00
365,	0.442086369E+00,	0.118430000E+00,	0.177240000E+00
366,	0.442086369E+00,	0.815800000E-01,	0.196940000E+00
367,	0.442086369E+00,	0.415900000E-01,	0.209070000E+00

*NSET,NSET=MERID11,GENERATE
 3,255,9
 *NSET,NSET=MERID22,GENERATE
 4,256,9
 *NSET,NSET=MERID34,GENERATE
 5,257,9
 *NSET,NSET=MERID45,GENERATE
 6,258,9
 *NSET,NSET=MERID56,GENERATE
 7,259,9
 *NSET,NSET=MERID67,GENERATE
 8,260,9
 *NSET,NSET=MERID79,GENERATE
 9,261,9
 *NSET,NSET=MERID
 MERID11,MERID22,MERID34,MERID45,MERID56,MERID67,MERID79
 *NSET,NSET=STRIP11,GENERATE
 210,255,9
 *NSET,NSET=STRIP22,GENERATE
 211,256,9
 *NSET,NSET=STRIP34,GENERATE
 212,257,9

```

*NSET,NSET=STRIP45,GENERATE
213,258,9
*NSET,NSET=STRIP56,GENERATE
214,259,9
*NSET,NSET=STRIP67,GENERATE
215,260,9
*NSET,NSET=STRIP79,GENERATE
216,261,9
*NSET,NSET=STRIP
STRIP11,STRIP22,STRIP34,STRIP45,STRIP56,STRIP67,STRIP79
*NSET,NSET=TORPEDO
308,311,313,355,358,360
*NSET,NSET=SHLZO,GENERATE
2,254,9
*NSET,NSET=BLADZO,GENERATE
263,313,1
*NSET,NSET=ZO
SHLZO,BLADZO
*NSET,NSET=SHLYO,GENERATE
10,262,9
*NSET,NSET=BLADYO,GENERATE
314,360,1
*NSET,NSET=YO
SHLYO,BLADYO
*NSET,NSET=CORE
265,266,271,272
*NSET,NSET=NHAF
1,ZO,MERID11,MERID22,MERID34,MERID45
*TRANSFORM,NSET=MERID,TYPE=C
0.,0.,0.,20.32,0.,0.
*BOUNDARY
STRIP,1
TORPEDO,1
313,2
360,3
ZO,ZSYMM
YO,YSYMM
CORE,2
CORE,6
1,2,6
**
** ELEMENT DEFINITIONS
**
*ELEMENT, TYPE=STR135, ELSET=SHLP15
1, 3, 2, 1
2, 4, 3, 1
3, 5, 4, 1
4, 6, 5, 1
5, 7, 6, 1
6, 8, 7, 1
7, 9, 8, 1
8, 10, 9, 1
*ELEMENT, TYPE=C3D4, ELSET=BLADSLD
303, 1, 265, 263, 361
304, 1, 265, 361, 362
305, 1, 265, 362, 363
306, 1, 265, 363, 364
307, 1, 265, 364, 365
308, 1, 265, 365, 366
309, 1, 265, 366, 367
310, 1, 265, 367, 314
311, 1, 361, 263, 3
312, 1, 263, 2, 3
313, 1, 362, 361, 4
314, 1, 361, 3, 4
315, 1, 363, 362, 5

```

316,	1,	362,	4,	5
317,	1,	363,	5,	6
318,	1,	364,	6,	7
319,	1,	365,	7,	8
320,	1,	366,	8,	9
321,	1,	367,	9,	10
322,	1,	314,	9,	10
323,	1,	314,	9,	10
324,	1,	314,	9,	10
325,	1,	314,	9,	10
326,	1,	314,	9,	10
*ELEMENT, TYPE=STR135, ELSET=BLADTIP				
233,	263,	1,	2	
235,	265,	1,	263	
268,	314,	1,	10	
270,	265,	1,	314	
*ELEMENT, TYPE=S4R5, ELSET=SHLP15				
9,	2,	3,	12,	11
10,	3,	4,	13,	12
11,	4,	5,	14,	13
12,	5,	6,	15,	14
13,	6,	7,	16,	15
14,	7,	8,	17,	16
15,	8,	9,	18,	17
16,	9,	10,	19,	18
*ELEMENT, TYPE=S4R5, ELSET=SHLP10				
17,	11,	12,	21,	20
18,	12,	13,	22,	21
19,	13,	14,	23,	22
20,	14,	15,	24,	23
21,	15,	16,	25,	24
22,	16,	17,	26,	25
23,	17,	18,	27,	26
24,	18,	19,	28,	27
25,	20,	21,	30,	29
26,	21,	22,	31,	30
27,	22,	23,	32,	31
28,	23,	24,	33,	32
29,	24,	25,	34,	33
30,	25,	26,	35,	34
31,	26,	27,	36,	35
32,	27,	28,	37,	36
*ELEMENT, TYPE=S4R5, ELSET=SHLP05				
33,	29,	30,	39,	38
34,	30,	31,	40,	39
35,	31,	32,	41,	40
36,	32,	33,	42,	41
37,	33,	34,	43,	42
38,	34,	35,	44,	43
39,	35,	36,	45,	44
40,	36,	37,	46,	45
41,	38,	39,	48,	47
42,	39,	40,	49,	48
43,	40,	41,	50,	49
44,	41,	42,	51,	50
45,	42,	43,	52,	51
46,	43,	44,	53,	52
47,	44,	45,	54,	53
48,	45,	46,	55,	54
49,	47,	48,	57,	56
50,	48,	49,	58,	57
51,	49,	50,	59,	58
52,	50,	51,	60,	59
53,	51,	52,	61,	60
54,	52,	53,	62,	61
55,	53,	54,	63,	62

56,	54,	55,	64,	63
57,	56,	57,	66,	65
58,	57,	58,	67,	66
59,	58,	59,	68,	67
60,	59,	60,	69,	68
61,	60,	61,	70,	69
62,	61,	62,	71,	70
63,	62,	63,	72,	71
64,	63,	64,	73,	72
65,	65,	66,	75,	74
66,	66,	67,	76,	75
67,	68,	68,	77,	76
68,	69,	69,	78,	77
69,	70,	70,	79,	78
70,	71,	71,	80,	79
71,	72,	72,	81,	80
72,	74,	73,	82,	81
73,	75,	75,	84,	83
74,	76,	76,	85,	84
75,	77,	78,	86,	85
76,	78,	79,	87,	86
77,	79,	80,	88,	87
78,	80,	81,	89,	88
79,	81,	82,	90,	89
80,	83,	84,	91,	90
81,	84,	85,	93,	92
82,	86,	87,	94,	93
83,	87,	88,	95,	94
84,	88,	89,	96,	95
85,	89,	90,	97,	96
86,	90,	91,	98,	97
87,	92,	93,	99,	98
88,	94,	95,	100,	99
89,	96,	97,	102,	101
90,	98,	99,	103,	102
91,	101,	102,	104,	103
92,	103,	104,	105,	104
93,	105,	106,	106,	105
94,	107,	108,	107,	106
95,	108,	109,	108,	107
96,	110,	111,	109,	108
97,	112,	113,	111,	110
98,	114,	115,	112,	111
99,	116,	117,	113,	112
100,	118,	119,	114,	113
101,	120,	121,	115,	114
102,	122,	123,	116,	115
103,	124,	125,	117,	116
104,	126,	127,	118,	117
105,	128,	129,	120,	119
106,	130,	131,	121,	120
107,	132,	133,	122,	121
108,	134,	135,	123,	122
109,	136,	137,	124,	123
110,	138,		125,	124
111,			126,	125
112,			127,	126
113,			129,	128
114,			130,	129
115,			131,	130
116,			132,	131
117,			133,	132
118,			134,	133
119,			135,	134
120,			136,	135
121,			138,	137

122,	129,	130,	139,	138
123,	130,	131,	140,	139
124,	131,	132,	141,	140
125,	132,	133,	142,	141
126,	133,	134,	143,	142
127,	134,	135,	144,	143
128,	135,	136,	145,	144
129,	137,	138,	147,	146
130,	138,	139,	148,	147
131,	139,	140,	149,	148
132,	140,	141,	150,	149
133,	141,	142,	151,	150
134,	142,	143,	152,	151
135,	143,	144,	153,	152
136,	144,	145,	154,	153
137,	146,	147,	156,	155
138,	147,	148,	157,	156
139,	148,	149,	158,	157
140,	149,	150,	159,	158
141,	150,	151,	160,	159
142,	151,	152,	161,	160
143,	152,	153,	162,	161
144,	153,	154,	163,	162
145,	155,	156,	165,	164
146,	156,	157,	166,	165
147,	157,	158,	167,	166
148,	158,	159,	168,	167
149,	159,	160,	169,	168
150,	160,	161,	170,	169
151,	161,	162,	171,	170
152,	162,	163,	172,	171
153,	164,	165,	174,	173
154,	165,	166,	175,	174
155,	166,	167,	176,	175
156,	167,	168,	177,	176
157,	168,	169,	178,	177
158,	169,	170,	179,	178
159,	170,	171,	180,	179
160,	171,	172,	181,	180
161,	173,	174,	183,	182
162,	174,	175,	184,	183
163,	175,	176,	185,	184
164,	176,	177,	186,	185
165,	177,	178,	187,	186
166,	178,	179,	188,	187
167,	179,	180,	189,	188
168,	180,	181,	190,	189
169,	182,	183,	192,	191
170,	183,	184,	193,	192
171,	184,	185,	194,	193
172,	185,	186,	195,	194
173,	186,	187,	196,	195
174,	187,	188,	197,	196
175,	188,	189,	198,	197
176,	189,	190,	199,	198
177,	191,	192,	201,	200
178,	192,	193,	202,	201
179,	193,	194,	203,	202
180,	194,	195,	204,	203
181,	195,	196,	205,	204
182,	196,	197,	206,	205
183,	197,	198,	207,	206
184,	198,	199,	208,	207
185,	200,	201,	210,	209
186,	201,	202,	211,	210
187,	202,	203,	212,	211

188,	203,	204,	213,	212
189,	204,	205,	214,	213
190,	205,	206,	215,	214
191,	206,	207,	216,	215
192,	207,	208,	217,	216
193,	209,	210,	219,	218
194,	210,	211,	220,	219
195,	211,	212,	221,	220
196,	212,	213,	222,	221
197,	213,	214,	223,	222
198,	214,	215,	224,	223
199,	215,	216,	225,	224
200,	216,	217,	226,	225
201,	218,	219,	228,	227
202,	219,	220,	229,	228
203,	220,	221,	230,	229
204,	221,	222,	231,	230
205,	222,	223,	232,	231
206,	223,	224,	233,	232
207,	224,	225,	234,	233
208,	225,	226,	235,	234
209,	227,	228,	237,	236
210,	228,	229,	238,	237
211,	229,	230,	239,	238
212,	230,	231,	240,	239
213,	231,	232,	241,	240
214,	232,	233,	242,	241
215,	233,	234,	243,	242
216,	234,	235,	244,	243
217,	236,	237,	246,	245
218,	237,	238,	247,	246
219,	238,	239,	248,	247
220,	239,	240,	249,	248
221,	240,	241,	250,	249
222,	241,	242,	251,	250
223,	242,	243,	252,	251
224,	243,	244,	253,	252
225,	245,	246,	255,	254
226,	246,	247,	256,	255
227,	247,	248,	257,	256
228,	248,	249,	258,	257
229,	249,	250,	259,	258
230,	250,	251,	260,	259
231,	251,	252,	261,	260
232,	252,	253,	262,	261
*ELEMENT,	TYPE=S4R5		ELSET=BLADEDY	
234,	2,	11,	264,	263
236,	263,	264,	266,	265
237,	11,	267,	269,	264
238,	267,	268,	270,	269
239,	264,	269,	271,	266
240,	269,	270,	272,	271
241,	268,	273,	283,	270
242,	273,	274,	284,	283
243,	274,	275,	285,	284
244,	275,	276,	286,	285
245,	276,	277,	287,	286
246,	277,	278,	288,	287
247,	278,	279,	289,	288
248,	279,	280,	290,	289
249,	280,	281,	291,	290
250,	281,	282,	292,	291
251,	270,	283,	293,	272
252,	283,	284,	294,	293
253,	284,	285,	295,	294
254,	285,	286,	296,	295

255,	286,	287,	297,	296
256,	287,	288,	298,	297
257,	288,	289,	299,	298
258,	289,	290,	300,	299
259,	290,	291,	301,	300
260,	291,	292,	302,	301
261,	282,	303,	306,	292
262,	303,	304,	307,	306
263,	304,	305,	308,	307
264,	292,	306,	309,	302
265,	306,	307,	310,	309
266,	307,	308,	311,	310
267,	305,	312,	313,	308
269,	10,	19,	315,	314
271,	314,	315,	266,	265
272,	19,	316,	318,	315
273,	316,	317,	319,	318
274,	315,	318,	271,	266
275,	318,	319,	272,	271
276,	317,	320,	330,	319
277,	320,	321,	331,	330
278,	321,	322,	332,	331
279,	322,	323,	333,	332
280,	323,	324,	334,	333
281,	324,	325,	335,	334
282,	325,	326,	336,	335
283,	326,	327,	337,	336
284,	327,	328,	338,	337
285,	328,	329,	339,	338
286,	319,	330,	340,	272
287,	330,	331,	341,	340
288,	331,	332,	342,	341
289,	332,	333,	343,	342
290,	333,	334,	344,	343
291,	334,	335,	345,	344
292,	335,	336,	346,	345
293,	336,	337,	347,	346
294,	337,	338,	348,	347
295,	338,	339,	349,	348
296,	329,	350,	353,	339
297,	350,	351,	354,	353
298,	351,	352,	355,	354
299,	339,	353,	356,	349
300,	353,	354,	357,	356
301,	354,	355,	358,	357
302,	352,	359,	360,	355

*ELEMENT, TYPE=SPRING2, ELSET=YSFRG

327,	282,	119
328,	303,	128
329,	304,	137
330,	305,	146
331,	312,	155

*ELEMENT, TYPE=SPRING2, ELSET=ZSPRG

332,	329,	127
333,	350,	136
334,	351,	145
335,	352,	154
336,	359,	163

*ELEMENT, TYPE=SPRING2, ELSET=XSPRG

337,	282,	119
338,	303,	128
339,	304,	137
340,	305,	146
341,	312,	155
342,	329,	127
343,	350,	136

```

344, 351, 145
345, 352, 154
346, 359, 163
*ELSET, ELSET=BLADE
BLADTIP, BLADBDY
*ELSET, ELSET=ELG1, GENERATE
1, 8
*ELSET, ELSET=ELG2, GENERATE
9, 16
*ELSET, ELSET=ELG3, GENERATE
17, 24
*ELSET, ELSET=ELG4, GENERATE
25, 32
*ELSET, ELSET=ELG5, GENERATE
33, 40
*ELSET, ELSET=ELG6, GENERATE
41, 48
*ELSET, ELSET=ELG7, GENERATE
49, 56
*ELSET, ELSET=ELG8, GENERATE
57, 64
*ELSET, ELSET=ELG9, GENERATE
65, 72
*ELSET, ELSET=ELG10, GENERATE
73, 80
*ELSET, ELSET=ELG11, GENERATE
81, 88
*ELSET, ELSET=ELG12, GENERATE
89, 96
*ELSET, ELSET=ELG13, GENERATE
97, 104
*ELSET, ELSET=ELG14, GENERATE
105, 112
*ELSET, ELSET=ELG15, GENERATE
113, 120
*ELSET, ELSET=ELG16, GENERATE
121, 128
*ELSET, ELSET=ELG17, GENERATE
129, 136
*ELSET, ELSET=ELG18, GENERATE
137, 144
*ELSET, ELSET=ELG19, GENERATE
145, 152
*ELSET, ELSET=ELG20, GENERATE
153, 160
*ELSET, ELSET=SHL1S, GENERATE
1, 225, 8
*ELSET, ELSET=SHL2S, GENERATE
2, 226, 8
*ELSET, ELSET=SHL3S, GENERATE
3, 227, 8
*ELSET, ELSET=SHL4S, GENERATE
4, 228, 8
*ELSET, ELSET=BLDHALF, GENERATE
233, 267, 1
*ELSET, ELSET=ELHALF
SHL1S, SHL2S, SHL3S, SHL4S, BLDHALF
*SHELL SECTION, ELSET=SHLP15, MATERIAL=FIBERITE
0.15, 3
*SHELL SECTION, ELSET=SHLP10, MATERIAL=FIBERITE
0.10, 3
*SHELL SECTION, ELSET=SHLP05, MATERIAL=FIBERITE
0.05, 3
*SHELL SECTION, ELSET=BLADE, MATERIAL=H250
0.25, 3
*SOLID SECTION, ELSET=BLADSLD, MATERIAL=H250

```

```

*SPRING, ELSET=YSFRG
2,2
1.E06
*SPRING, ELSET=ZSFRG
3,3
1.E06
*SPRING, ELSET=XSFRG
1,1
1.E02
*MATERIAL, NAME=FIBERITE
*ELASTIC
2.4E+06, 0.28, 72.
*DENSITY
1.682E-4
*MATERIAL, NAME=H250
*ELASTIC
5.51E+04, 0.1, 72.
*DENSITY
2.34E-05
*AMPLITUDE, NAME=ELG1, TIME=D, VALUE=A
4.450E-05 -1.971E+03 1.770E-04 -2.672E+02 5.040E-04 -1.637E+02 8.440E-04 -1.496E+02
1.197E-03 -1.432E+02 1.562E-03 -1.385E+02 1.938E-03 -1.349E+02 2.323E-03 -1.320E+02
2.715E-03 -1.296E+02 3.113E-03 -1.278E+02 3.515E-03 -1.263E+02 3.920E-03 -1.251E+02
4.326E-03 -1.241E+02 4.734E-03 -1.230E+02 5.116E-03 -1.218E+02 5.504E-03 -1.207E+02
5.895E-03 -1.197E+02 6.264E-03 -1.190E+02 6.741E-03 -1.180E+02 7.223E-03 -1.170E+02
7.713E-03 -1.161E+02 8.212E-03 -1.151E+02 8.722E-03 -1.141E+02 9.248E-03 -1.130E+02
9.753E-03 -1.121E+02 1.026E-02 -1.114E+02 1.076E-02 -1.108E+02 1.127E-02 -1.104E+02
1.177E-02 -1.100E+02
*AMPLITUDE, NAME=ELG2, TIME=D, VALUE=A
4.450E-05 0.000E+00 1.770E-04 -3.728E+02 5.040E-04 -1.294E+02 8.440E-04 -1.071E+02
1.197E-03 -1.033E+02 1.562E-03 -1.006E+02 1.938E-03 -9.841E+01 2.323E-03 -9.662E+01
2.715E-03 -9.516E+01 3.113E-03 -9.402E+01 3.515E-03 -9.315E+01 3.920E-03 -9.248E+01
4.326E-03 -9.194E+01 4.734E-03 -9.121E+01 5.116E-03 -9.027E+01 5.504E-03 -8.940E+01
5.895E-03 -8.870E+01 6.264E-03 -8.812E+01 6.741E-03 -8.735E+01 7.223E-03 -8.659E+01
7.713E-03 -8.580E+01 8.212E-03 -8.494E+01 8.722E-03 -8.402E+01 9.248E-03 -8.305E+01
9.753E-03 -8.223E+01 1.026E-02 -8.158E+01 1.076E-02 -8.108E+01 1.127E-02 -8.066E+01
1.177E-02 -8.031E+01
*AMPLITUDE, NAME=ELG3, TIME=D, VALUE=A
4.450E-05 0.000E+00 1.770E-04 0.000E+00 5.040E-04 -1.425E+02 8.440E-04 -8.726E+01
1.197E-03 -7.899E+01 1.562E-03 -7.711E+01 1.938E-03 -7.576E+01 2.323E-03 -7.465E+01
2.715E-03 -7.375E+01 3.113E-03 -7.304E+01 3.515E-03 -7.251E+01 3.920E-03 -7.220E+01
4.326E-03 -7.197E+01 4.734E-03 -7.146E+01 5.116E-03 -7.069E+01 5.504E-03 -6.995E+01
5.895E-03 -6.937E+01 6.264E-03 -6.889E+01 6.741E-03 -6.825E+01 7.223E-03 -6.758E+01
7.713E-03 -6.687E+01 8.212E-03 -6.608E+01 8.722E-03 -6.520E+01 9.248E-03 -6.427E+01
9.753E-03 -6.348E+01 1.026E-02 -6.286E+01 1.076E-02 -6.237E+01 1.127E-02 -6.198E+01
1.177E-02 -6.165E+01
*AMPLITUDE, NAME=ELG4, TIME=D, VALUE=A
4.450E-05 0.000E+00 1.770E-04 0.000E+00 5.040E-04 0.000E+00 8.440E-04 -1.305E+02
1.197E-03 -7.900E+01 1.562E-03 -6.949E+01 1.938E-03 -6.701E+01 2.323E-03 -6.554E+01
2.715E-03 -6.451E+01 3.113E-03 -6.380E+01 3.515E-03 -6.330E+01 3.920E-03 -6.299E+01
4.326E-03 -6.281E+01 4.734E-03 -6.238E+01 5.116E-03 -6.164E+01 5.504E-03 -6.091E+01
5.895E-03 -6.034E+01 6.264E-03 -5.988E+01 6.741E-03 -5.925E+01 7.223E-03 -5.859E+01
7.713E-03 -5.788E+01 8.212E-03 -5.709E+01 8.722E-03 -5.621E+01 9.248E-03 -5.526E+01
9.753E-03 -5.445E+01 1.026E-02 -5.382E+01 1.076E-02 -5.333E+01 1.127E-02 -5.294E+01
1.177E-02 -5.261E+01
*AMPLITUDE, NAME=ELG5, TIME=D, VALUE=A
4.450E-05 0.000E+00 1.770E-04 0.000E+00 5.040E-04 0.000E+00 8.440E-04 0.000E+00
1.197E-03 -1.110E+02 1.562E-03 -6.642E+01 1.938E-03 -5.773E+01 2.323E-03 -5.552E+01
2.715E-03 -5.434E+01 3.113E-03 -5.364E+01 3.515E-03 -5.323E+01 3.920E-03 -5.303E+01
4.326E-03 -5.295E+01 4.734E-03 -5.256E+01 5.116E-03 -5.182E+01 5.504E-03 -5.113E+01
5.895E-03 -5.061E+01 6.264E-03 -5.018E+01 6.741E-03 -4.957E+01 7.223E-03 -4.893E+01
7.713E-03 -4.823E+01 8.212E-03 -4.744E+01 8.722E-03 -4.655E+01 9.248E-03 -4.559E+01
9.753E-03 -4.476E+01 1.026E-02 -4.413E+01 1.076E-02 -4.364E+01 1.127E-02 -4.324E+01
1.177E-02 -4.291E+01
*AMPLITUDE, NAME=ELG6, TIME=D, VALUE=A
4.450E-05 0.000E+00 1.770E-04 0.000E+00 5.040E-04 0.000E+00 8.440E-04 0.000E+00

```

1.197E-03	0.000E+00	1.562E-03	-9.336E+01	1.938E-03	-5.553E+01	2.323E-03	-4.795E+01
2.715E-03	-4.615E+01	3.113E-03	-4.535E+01	3.515E-03	-4.497E+01	3.920E-03	-4.486E+01
4.326E-03	-4.487E+01	4.734E-03	-4.452E+01	5.116E-03	-4.377E+01	5.504E-03	-4.306E+01
5.895E-03	-4.256E+01	6.264E-03	-4.215E+01	6.741E-03	-4.157E+01	7.223E-03	-4.094E+01
7.713E-03	-4.024E+01	8.212E-03	-3.944E+01	8.722E-03	-3.853E+01	9.248E-03	-3.754E+01
9.753E-03	-3.669E+01	1.026E-02	-3.604E+01	1.076E-02	-3.554E+01	1.127E-02	-3.514E+01
1.177E-02	-3.481E+01						
*AMPLITUDE, NAME=ELG7, TIME=D, VALUE=A							
4.450E-05	0.000E+00	1.770E-04	0.000E+00	5.040E-04	0.000E+00	8.440E-04	0.000E+00
1.197E-03	0.000E+00	1.562E-03	0.000E+00	1.938E-03	-7.861E+01	2.323E-03	-4.666E+01
2.715E-03	-4.021E+01	3.113E-03	-3.889E+01	3.515E-03	-3.846E+01	3.920E-03	-3.840E+01
4.326E-03	-3.849E+01	4.734E-03	-3.817E+01	5.116E-03	-3.737E+01	5.504E-03	-3.663E+01
5.895E-03	-3.611E+01	6.264E-03	-3.572E+01	6.741E-03	-3.514E+01	7.223E-03	-3.451E+01
7.713E-03	-3.380E+01	8.212E-03	-3.298E+01	8.722E-03	-3.203E+01	9.248E-03	-3.101E+01
9.753E-03	-3.013E+01	1.026E-02	-2.946E+01	1.076E-02	-2.894E+01	1.127E-02	-2.853E+01
1.177E-02	-2.820E+01						
*AMPLITUDE, NAME=ELG8, TIME=D, VALUE=A							
4.450E-05	0.000E+00	1.770E-04	0.000E+00	5.040E-04	0.000E+00	8.440E-04	0.000E+00
1.197E-03	0.000E+00	1.562E-03	0.000E+00	1.938E-03	0.000E+00	2.323E-03	-6.672E+01
2.715E-03	-3.971E+01	3.113E-03	-3.437E+01	3.515E-03	-3.355E+01	3.920E-03	-3.348E+01
4.326E-03	-3.364E+01	4.734E-03	-3.331E+01	5.116E-03	-3.247E+01	5.504E-03	-3.162E+01
5.895E-03	-3.107E+01	6.264E-03	-3.067E+01	6.741E-03	-3.007E+01	7.223E-03	-2.941E+01
7.713E-03	-2.869E+01	8.212E-03	-2.784E+01	8.722E-03	-2.685E+01	9.248E-03	-2.577E+01
9.753E-03	-2.485E+01	1.026E-02	-2.415E+01	1.076E-02	-2.362E+01	1.127E-02	-2.320E+01
1.177E-02	-2.285E+01						
*AMPLITUDE, NAME=ELG9, TIME=D, VALUE=A							
4.450E-05	0.000E+00	1.770E-04	0.000E+00	5.040E-04	0.000E+00	8.440E-04	0.000E+00
1.197E-03	0.000E+00	1.562E-03	0.000E+00	1.938E-03	0.000E+00	2.323E-03	0.000E+00
2.715E-03	-5.734E+01	3.113E-03	-3.452E+01	3.515E-03	-3.023E+01	3.920E-03	-2.989E+01
4.326E-03	-3.007E+01	4.734E-03	-2.969E+01	5.116E-03	-2.865E+01	5.504E-03	-2.775E+01
5.895E-03	-2.715E+01	6.264E-03	-2.672E+01	6.741E-03	-2.609E+01	7.223E-03	-2.539E+01
7.713E-03	-2.462E+01	8.212E-03	-2.372E+01	8.722E-03	-2.269E+01	9.248E-03	-2.155E+01
9.753E-03	-2.058E+01	1.026E-02	-1.984E+01	1.076E-02	-1.929E+01	1.127E-02	-1.885E+01
1.177E-02	-1.849E+01						
*AMPLITUDE, NAME=ELG10, TIME=D, VALUE=A							
4.450E-05	0.000E+00	1.770E-04	0.000E+00	5.040E-04	0.000E+00	8.440E-04	0.000E+00
1.197E-03	0.000E+00	1.562E-03	0.000E+00	1.938E-03	0.000E+00	2.323E-03	0.000E+00
2.715E-03	0.000E+00	3.113E-03	-5.031E+01	3.515E-03	-3.094E+01	3.920E-03	-2.760E+01
4.326E-03	-2.760E+01	4.734E-03	-2.710E+01	5.116E-03	-2.583E+01	5.504E-03	-2.477E+01
5.895E-03	-2.410E+01	6.264E-03	-2.362E+01	6.741E-03	-2.293E+01	7.223E-03	-2.218E+01
7.713E-03	-2.135E+01	8.212E-03	-2.039E+01	8.722E-03	-1.929E+01	9.248E-03	-1.808E+01
9.753E-03	-1.705E+01	1.026E-02	-1.627E+01	1.076E-02	-1.568E+01	1.127E-02	-1.522E+01
1.177E-02	-1.485E+01						
*AMPLITUDE, NAME=ELG11, TIME=D, VALUE=A							
4.450E-05	0.000E+00	1.770E-04	0.000E+00	5.040E-04	0.000E+00	8.440E-04	0.000E+00
1.197E-03	0.000E+00	1.562E-03	0.000E+00	1.938E-03	0.000E+00	2.323E-03	0.000E+00
2.715E-03	0.000E+00	3.113E-03	0.000E+00	3.515E-03	-4.526E+01	3.920E-03	-2.876E+01
4.326E-03	-2.614E+01	4.734E-03	-2.530E+01	5.116E-03	-2.365E+01	5.504E-03	-2.234E+01
5.895E-03	-2.155E+01	6.264E-03	-2.104E+01	6.741E-03	-2.029E+01	7.223E-03	-1.945E+01
7.713E-03	-1.854E+01	8.212E-03	-1.750E+01	8.722E-03	-1.632E+01	9.248E-03	-1.503E+01
9.753E-03	-1.393E+01	1.026E-02	-1.309E+01	1.076E-02	-1.248E+01	1.127E-02	-1.200E+01
1.177E-02	-1.161E+01						
*AMPLITUDE, NAME=ELG12, TIME=D, VALUE=A							
4.450E-05	0.000E+00	1.770E-04	0.000E+00	5.040E-04	0.000E+00	8.440E-04	0.000E+00
1.197E-03	0.000E+00	1.562E-03	0.000E+00	1.938E-03	0.000E+00	2.323E-03	0.000E+00
2.715E-03	0.000E+00	3.113E-03	0.000E+00	3.515E-03	0.000E+00	3.920E-03	-4.182E+01
4.326E-03	-2.761E+01	4.734E-03	-2.404E+01	5.116E-03	-2.165E+01	5.504E-03	-2.001E+01
5.895E-03	-1.908E+01	6.264E-03	-1.851E+01	6.741E-03	-1.767E+01	7.223E-03	-1.675E+01
7.713E-03	-1.576E+01	8.212E-03	-1.462E+01	8.722E-03	-1.333E+01	9.248E-03	-1.195E+01
9.753E-03	-1.077E+01	1.026E-02	-9.883E+00	1.076E-02	-9.230E+00	1.127E-02	-8.727E+00
1.177E-02	-8.316E+00						
*AMPLITUDE, NAME=ELG13, TIME=D, VALUE=A							
4.450E-05	0.000E+00	1.770E-04	0.000E+00	5.040E-04	0.000E+00	8.440E-04	0.000E+00
1.197E-03	0.000E+00	1.562E-03	0.000E+00	1.938E-03	0.000E+00	2.323E-03	0.000E+00
2.715E-03	0.000E+00	3.113E-03	0.000E+00	3.515E-03	0.000E+00	3.920E-03	0.000E+00
4.326E-03	-3.981E+01	4.734E-03	-2.474E+01	5.116E-03	-1.907E+01	5.504E-03	-1.694E+01

5.895E-03	-1.586E+01	6.264E-03	-1.526E+01	6.741E-03	-1.436E+01	7.223E-03	-1.336E+01
7.713E-03	-1.228E+01	8.212E-03	-1.104E+01	8.722E-03	-9.651E+00	9.248E-03	-8.148E+00
9.753E-03	-6.881E+00	1.026E-02	-5.938E+00	1.076E-02	-5.248E+00	1.127E-02	-4.714E+00
1.177E-02	-4.290E+00						
*AMPLITUDE, NAME=ELG14, TIME=D, VALUE=A							
4.450E-05	0.000E+00	1.770E-04	0.000E+00	5.040E-04	0.000E+00	8.440E-04	0.000E+00
1.197E-03	0.000E+00	1.562E-03	0.000E+00	1.938E-03	0.000E+00	2.323E-03	0.000E+00
2.715E-03	0.000E+00	3.113E-03	0.000E+00	3.515E-03	0.000E+00	3.920E-03	0.000E+00
4.326E-03	0.000E+00	4.734E-03	-3.402E+01	5.116E-03	-1.449E+01	5.504E-03	-1.040E+01
5.895E-03	-9.370E+00	6.264E-03	-8.964E+00	6.741E-03	-8.144E+00	7.223E-03	-7.108E+00
7.713E-03	-5.989E+00	8.212E-03	-4.679E+00	8.722E-03	-3.191E+00	9.248E-03	-1.584E+00
9.753E-03	-2.249E-01	1.026E-02	0.000E+00	1.076E-02	0.000E+00	1.127E-02	0.000E+00
1.177E-02	0.000E+00						
*AMPLITUDE, NAME=ELG15, TIME=D, VALUE=A							
4.450E-05	0.000E+00	1.770E-04	0.000E+00	5.040E-04	0.000E+00	8.440E-04	0.000E+00
1.197E-03	0.000E+00	1.562E-03	0.000E+00	1.938E-03	0.000E+00	2.323E-03	0.000E+00
2.715E-03	0.000E+00	3.113E-03	0.000E+00	3.515E-03	0.000E+00	3.920E-03	0.000E+00
4.326E-03	0.000E+00	4.734E-03	0.000E+00	5.116E-03	-1.658E+01	5.504E-03	-4.784E+00
5.895E-03	-2.315E+00	6.264E-03	-2.282E+00	6.741E-03	-1.703E+00	7.223E-03	-6.985E-01
7.713E-03	0.000E+00	8.212E-03	0.000E+00	8.722E-03	0.000E+00	9.248E-03	0.000E+00
9.753E-03	0.000E+00	1.026E-02	0.000E+00	1.076E-02	0.000E+00	1.127E-02	0.000E+00
1.177E-02	0.000E+00						
*AMPLITUDE, NAME=ELG16, TIME=D, VALUE=A							
4.450E-05	0.000E+00	1.770E-04	0.000E+00	5.040E-04	0.000E+00	8.440E-04	0.000E+00
1.197E-03	0.000E+00	1.562E-03	0.000E+00	1.938E-03	0.000E+00	2.323E-03	0.000E+00
2.715E-03	0.000E+00	3.113E-03	0.000E+00	3.515E-03	0.000E+00	3.920E-03	0.000E+00
4.326E-03	0.000E+00	4.734E-03	0.000E+00	5.116E-03	0.000E+00	5.504E-03	-1.493E+01
5.895E-03	-4.452E+00	6.264E-03	-3.184E+00	6.741E-03	-2.419E+00	7.223E-03	-1.102E+00
7.713E-03	0.000E+00	8.212E-03	0.000E+00	8.722E-03	0.000E+00	9.248E-03	0.000E+00
9.753E-03	0.000E+00	1.026E-02	0.000E+00	1.076E-02	0.000E+00	1.127E-02	0.000E+00
1.177E-02	0.000E+00						
*AMPLITUDE, NAME=ELG17, TIME=D, VALUE=A							
4.450E-05	0.000E+00	1.770E-04	0.000E+00	5.040E-04	0.000E+00	8.440E-04	0.000E+00
1.197E-03	0.000E+00	1.562E-03	0.000E+00	1.938E-03	0.000E+00	2.323E-03	0.000E+00
2.715E-03	0.000E+00	3.113E-03	0.000E+00	3.515E-03	0.000E+00	3.920E-03	0.000E+00
4.326E-03	0.000E+00	4.734E-03	0.000E+00	5.116E-03	0.000E+00	5.504E-03	0.000E+00
5.895E-03	-1.207E+01	6.264E-03	-6.004E+00	6.741E-03	-3.419E+00	7.223E-03	-1.489E+00
7.713E-03	0.000E+00	8.212E-03	0.000E+00	8.722E-03	0.000E+00	9.248E-03	0.000E+00
9.753E-03	0.000E+00	1.026E-02	0.000E+00	1.076E-02	0.000E+00	1.127E-02	0.000E+00
1.177E-02	0.000E+00						
*AMPLITUDE, NAME=ELG18, TIME=D, VALUE=A							
4.450E-05	0.000E+00	1.770E-04	0.000E+00	5.040E-04	0.000E+00	8.440E-04	0.000E+00
1.197E-03	0.000E+00	1.562E-03	0.000E+00	1.938E-03	0.000E+00	2.323E-03	0.000E+00
2.715E-03	0.000E+00	3.113E-03	0.000E+00	3.515E-03	0.000E+00	3.920E-03	0.000E+00
4.326E-03	0.000E+00	4.734E-03	0.000E+00	5.116E-03	0.000E+00	5.504E-03	0.000E+00
5.895E-03	0.000E+00	6.264E-03	-1.798E+01	6.741E-03	-5.583E+00	7.223E-03	-9.063E-01
7.713E-03	0.000E+00	8.212E-03	0.000E+00	8.722E-03	0.000E+00	9.248E-03	0.000E+00
9.753E-03	0.000E+00	1.026E-02	0.000E+00	1.076E-02	0.000E+00	1.127E-02	0.000E+00
1.177E-02	0.000E+00						
*AMPLITUDE, NAME=ELG19, TIME=D, VALUE=A							
4.450E-05	0.000E+00	1.770E-04	0.000E+00	5.040E-04	0.000E+00	8.440E-04	0.000E+00
1.197E-03	0.000E+00	1.562E-03	0.000E+00	1.938E-03	0.000E+00	2.323E-03	0.000E+00
2.715E-03	0.000E+00	3.113E-03	0.000E+00	3.515E-03	0.000E+00	3.920E-03	0.000E+00
4.326E-03	0.000E+00	4.734E-03	0.000E+00	5.116E-03	0.000E+00	5.504E-03	0.000E+00
5.895E-03	0.000E+00	6.264E-03	0.000E+00	6.741E-03	-1.021E+01	7.223E-03	0.000E+00
7.713E-03	0.000E+00	8.212E-03	0.000E+00	8.722E-03	0.000E+00	9.248E-03	0.000E+00
9.753E-03	0.000E+00	1.026E-02	0.000E+00	1.076E-02	0.000E+00	1.127E-02	0.000E+00
1.177E-02	0.000E+00						
*AMPLITUDE, NAME=ELG20, TIME=D, VALUE=A							
4.450E-05	0.000E+00	1.770E-04	0.000E+00	5.040E-04	0.000E+00	8.440E-04	0.000E+00
1.197E-03	0.000E+00	1.562E-03	0.000E+00	1.938E-03	0.000E+00	2.323E-03	0.000E+00
2.715E-03	0.000E+00	3.113E-03	0.000E+00	3.515E-03	0.000E+00	3.920E-03	0.000E+00
4.326E-03	0.000E+00	4.734E-03	0.000E+00	5.116E-03	0.000E+00	5.504E-03	0.000E+00
5.895E-03	0.000E+00	6.264E-03	0.000E+00	6.741E-03	0.000E+00	7.223E-03	-8.116E+00
7.713E-03	0.000E+00	8.212E-03	0.000E+00	8.722E-03	0.000E+00	9.248E-03	0.000E+00
9.753E-03	0.000E+00	1.026E-02	0.000E+00	1.076E-02	0.000E+00	1.127E-02	0.000E+00

```

1.177E-02 0.000E+00
*STEP, AMPLITUDE=RAMP, LINEAR, INC= 1, CYCLE= 1
TRANSIENT RESPONSE OF NOSECAP TO 1ST WATER-ENTRY STEP PRESSURE
*DYNAMIC
4.45E-05,4.45E-05
*DLOAD, AMPLITUDE=ELG1
ELG1,P,1.
*EL FILE, POSITION=AVERAGED AT NODES
S
SINV
*EL PRINT, POSITION=AVERAGED AT NODES, ELSET=ELHALF
S
SINV
*NODE FILE
U
*NODE PRINT, NSET=NHALF
U
*FILE FORMAT, ASCII
*END STEP
*STEP, AMPLITUDE=RAMP, LINEAR, INC= 1, CYCLE= 1
TRANSIENT RESPONSE OF NOSECAP TO 2ND WATER-ENTRY STEP PRESSURE
*DYNAMIC
1.325E-04,1.325E-04
*DLOAD, AMPLITUDE=ELG1
ELG1,P,1.
*DLOAD, AMPLITUDE=ELG2
ELG2,P,1.
*END STEP
*STEP, AMPLITUDE=RAMP, LINEAR, INC= 1, CYCLE= 1
TRANSIENT RESPONSE OF NOSECAP TO 3RD WATER-ENTRY STEP PRESSURE
*DYNAMIC
3.270E-04,3.270E-04
*DLOAD, AMPLITUDE=ELG1
ELG1,P,1.
*DLOAD, AMPLITUDE=ELG2
ELG2,P,1.
*DLOAD, AMPLITUDE=ELG3
ELG3,P,1.
*END STEP
*STEP, AMPLITUDE=RAMP, LINEAR, INC= 1, CYCLE= 1
TRANSIENT RESPONSE OF NOSECAP TO 4TH WATER-ENTRY STEP PRESSURE
*DYNAMIC
3.400E-04,3.400E-04
*DLOAD, AMPLITUDE=ELG1
ELG1,P,1.
*DLOAD, AMPLITUDE=ELG2
ELG2,P,1.
*DLOAD, AMPLITUDE=ELG3
ELG3,P,1.
*DLOAD, AMPLITUDE=ELG4
ELG4,P,1.
*END STEP
*STEP, AMPLITUDE=RAMP, LINEAR, INC= 1, CYCLE= 1
TRANSIENT RESPONSE OF NOSECAP TO 5TH WATER-ENTRY STEP PRESSURE
*DYNAMIC
3.533E-04,3.533E-04
*DLOAD, AMPLITUDE=ELG1
ELG1,P,1.
*DLOAD, AMPLITUDE=ELG2
ELG2,P,1.
*DLOAD, AMPLITUDE=ELG3
ELG3,P,1.
*DLOAD, AMPLITUDE=ELG4
ELG4,P,1.
*DLOAD, AMPLITUDE=ELG5
ELG5,P,1.

```

```

*END STEP
*STEP, AMPLITUDE=RAMP, LINEAR, INC= 1, CYCLE= 1
TRANSIENT RESPONSE OF NOSECAP TO 6TH WATER-ENTRY STEP PRESSURE
*DYNAMIC
3.651E-04, 3.651E-04
*DLOAD, AMPLITUDE=ELG1
ELG1, P, 1.
*DLOAD, AMPLITUDE=ELG2
ELG2, P, 1.
*DLOAD, AMPLITUDE=ELG3
ELG3, P, 1.
*DLOAD, AMPLITUDE=ELG4
ELG4, P, 1.
*DLOAD, AMPLITUDE=ELG5
ELG5, P, 1.
*DLOAD, AMPLITUDE=ELG6
ELG6, P, 1.
*END STEP
*STEP, AMPLITUDE=RAMP, LINEAR, INC= 1, CYCLE= 1
TRANSIENT RESPONSE OF NOSECAP TO 7TH WATER-ENTRY STEP PRESSURE
*DYNAMIC
3.756E-04, 3.756E-04
*DLOAD, AMPLITUDE=ELG1
ELG1, P, 1.
*DLOAD, AMPLITUDE=ELG2
ELG2, P, 1.
*DLOAD, AMPLITUDE=ELG3
ELG3, P, 1.
*DLOAD, AMPLITUDE=ELG4
ELG4, P, 1.
*DLOAD, AMPLITUDE=ELG5
ELG5, P, 1.
*DLOAD, AMPLITUDE=ELG6
ELG6, P, 1.
*DLOAD, AMPLITUDE=ELG7
ELG7, P, 1.
*END STEP
*STEP, AMPLITUDE=RAMP, LINEAR, INC= 1, CYCLE= 1
TRANSIENT RESPONSE OF NOSECAP TO 8TH WATER-ENTRY STEP PRESSURE
*DYNAMIC
3.846E-04, 3.846E-04
*DLOAD, AMPLITUDE=ELG1
ELG1, P, 1.
*DLOAD, AMPLITUDE=ELG2
ELG2, P, 1.
*DLOAD, AMPLITUDE=ELG3
ELG3, P, 1.
*DLOAD, AMPLITUDE=ELG4
ELG4, P, 1.
*DLOAD, AMPLITUDE=ELG5
ELG5, P, 1.
*DLOAD, AMPLITUDE=ELG6
ELG6, P, 1.
*DLOAD, AMPLITUDE=ELG7
ELG7, P, 1.
*DLOAD, AMPLITUDE=ELG8
ELG8, P, 1.
*END STEP
*STEP, AMPLITUDE=RAMP, LINEAR, INC= 1, CYCLE= 1
TRANSIENT RESPONSE OF NOSECAP TO 9TH WATER-ENTRY STEP PRESSURE
*DYNAMIC
3.922E-04, 3.922E-04
*DLOAD, AMPLITUDE=ELG1
ELG1, P, 1.
*DLOAD, AMPLITUDE=ELG2
ELG2, P, 1.

```

```

*DLOAD, AMPLITUDE=ELG3
ELG3, P, 1.
*DLOAD, AMPLITUDE=ELG4
ELG4, P, 1.
*DLOAD, AMPLITUDE=ELG5
ELG5, P, 1.
*DLOAD, AMPLITUDE=ELG6
ELG6, P, 1.
*DLOAD, AMPLITUDE=ELG7
ELG7, P, 1.
*DLOAD, AMPLITUDE=ELG8
ELG8, P, 1.
*DLOAD, AMPLITUDE=ELG9
ELG9, P, 1.
*END STEP
*STEP, AMPLITUDE=RAMP, LINEAR, INC= 1, CYCLE= 1
TRANSIENT RESPONSE OF NOSECAP TO 10TH WATER-ENTRY STEP PRESSURE
*DYNAMIC
3.980E-04, 3.980E-04
*DLOAD, AMPLITUDE=ELG1
ELG1, P, 1.
*DLOAD, AMPLITUDE=ELG2
ELG2, P, 1.
*DLOAD, AMPLITUDE=ELG3
ELG3, P, 1.
*DLOAD, AMPLITUDE=ELG4
ELG4, P, 1.
*DLOAD, AMPLITUDE=ELG5
ELG5, P, 1.
*DLOAD, AMPLITUDE=ELG6
ELG6, P, 1.
*DLOAD, AMPLITUDE=ELG7
ELG7, P, 1.
*DLOAD, AMPLITUDE=ELG8
ELG8, P, 1.
*DLOAD, AMPLITUDE=ELG9
ELG9, P, 1.
*DLOAD, AMPLITUDE=ELG10
ELG10, P, 1.
*END STEP
*STEP, AMPLITUDE=RAMP, LINEAR, INC= 1, CYCLE= 1
TRANSIENT RESPONSE OF NOSECAP TO 11TH WATER-ENTRY STEP PRESSURE
*DYNAMIC
4.023E-04, 4.023E-04
*DLOAD, AMPLITUDE=ELG1
ELG1, P, 1.
*DLOAD, AMPLITUDE=ELG2
ELG2, P, 1.
*DLOAD, AMPLITUDE=ELG3
ELG3, P, 1.
*DLOAD, AMPLITUDE=ELG4
ELG4, P, 1.
*DLOAD, AMPLITUDE=ELG5
ELG5, P, 1.
*DLOAD, AMPLITUDE=ELG6
ELG6, P, 1.
*DLOAD, AMPLITUDE=ELG7
ELG7, P, 1.
*DLOAD, AMPLITUDE=ELG8
ELG8, P, 1.
*DLOAD, AMPLITUDE=ELG9
ELG9, P, 1.
*DLOAD, AMPLITUDE=ELG10
ELG10, P, 1.
*DLOAD, AMPLITUDE=ELG11
ELG11, P, 1.

```

```

*END STEP
*STEP, AMPLITUDE=RAMP, LINEAR, INC= 1, CYCLE= 1
TRANSIENT RESPONSE OF NOSECAP TO 12TH WATER-ENTRY STEP PRESSURE
*DYNAMIC
4.049E-04, 4.049E-04
*DLOAD, AMPLITUDE=ELG1
ELG1, P, 1.
*DLOAD, AMPLITUDE=ELG2
ELG2, P, 1.
*DLOAD, AMPLITUDE=ELG3
ELG3, P, 1.
*DLOAD, AMPLITUDE=ELG4
ELG4, P, 1.
*DLOAD, AMPLITUDE=ELG5
ELG5, P, 1.
*DLOAD, AMPLITUDE=ELG6
ELG6, P, 1.
*DLOAD, AMPLITUDE=ELG7
ELG7, P, 1.
*DLOAD, AMPLITUDE=ELG8
ELG8, P, 1.
*DLOAD, AMPLITUDE=ELG9
ELG9, P, 1.
*DLOAD, AMPLITUDE=ELG10
ELG10, P, 1.
*DLOAD, AMPLITUDE=ELG11
ELG11, P, 1.
*DLOAD, AMPLITUDE=ELG12
ELG12, P, 1.
*END STEP
*STEP, AMPLITUDE=RAMP, LINEAR, INC= 1, CYCLE= 1
TRANSIENT RESPONSE OF NOSECAP TO 13TH WATER-ENTRY STEP PRESSURE
*DYNAMIC
4.057E-04, 4.057E-04
*DLOAD, AMPLITUDE=ELG1
ELG1, P, 1.
*DLOAD, AMPLITUDE=ELG2
ELG2, P, 1.
*DLOAD, AMPLITUDE=ELG3
ELG3, P, 1.
*DLOAD, AMPLITUDE=ELG4
ELG4, P, 1.
*DLOAD, AMPLITUDE=ELG5
ELG5, P, 1.
*DLOAD, AMPLITUDE=ELG6
ELG6, P, 1.
*DLOAD, AMPLITUDE=ELG7
ELG7, P, 1.
*DLOAD, AMPLITUDE=ELG8
ELG8, P, 1.
*DLOAD, AMPLITUDE=ELG9
ELG9, P, 1.
*DLOAD, AMPLITUDE=ELG10
ELG10, P, 1.
*DLOAD, AMPLITUDE=ELG11
ELG11, P, 1.
*DLOAD, AMPLITUDE=ELG12
ELG12, P, 1.
*DLOAD, AMPLITUDE=ELG13
ELG13, P, 1.
*END STEP
*STEP, AMPLITUDE=RAMP, LINEAR, INC= 1, CYCLE= 1
TRANSIENT RESPONSE OF NOSECAP TO 14TH WATER-ENTRY STEP PRESSURE
*DYNAMIC
4.078E-04, 4.078E-04
*DLOAD, AMPLITUDE=ELG1

```

```

ELG1 P,1.
*DLOAD,AMPLITUDE=ELG2
ELG2 P,1.
*DLOAD,AMPLITUDE=ELG3
ELG3 P,1.
*DLOAD,AMPLITUDE=ELG4
ELG4 P,1.
*DLOAD,AMPLITUDE=ELG5
ELG5 P,1.
*DLOAD,AMPLITUDE=ELG6
ELG6 P,1.
*DLOAD,AMPLITUDE=ELG7
ELG7 P,1.
*DLOAD,AMPLITUDE=ELG8
ELG8 P,1.
*DLOAD,AMPLITUDE=ELG9
ELG9 P,1.
*DLOAD,AMPLITUDE=ELG10
ELG10 P,1.
*DLOAD,AMPLITUDE=ELG11
ELG11 P,1.
*DLOAD,AMPLITUDE=ELG12
ELG12 P,1.
*DLOAD,AMPLITUDE=ELG13
ELG13 P,1.
*DLOAD,AMPLITUDE=ELG14
ELG14 P,1.
*END STEP
*STEP,AMPLITUDE=RAMP,LINEAR,INC= 1,CYCLE= 1
TRANSIENT RESPONSE OF NOSECAP TO 15TH WATER-ENTRY STEP PRESSURE
*DYNAMIC
3.829E-04,3.829E-04
*DLOAD,AMPLITUDE=ELG1
ELG1 P,1.
*DLOAD,AMPLITUDE=ELG2
ELG2 P,1.
*DLOAD,AMPLITUDE=ELG3
ELG3 P,1.
*DLOAD,AMPLITUDE=ELG4
ELG4 P,1.
*DLOAD,AMPLITUDE=ELG5
ELG5 P,1.
*DLOAD,AMPLITUDE=ELG6
ELG6 P,1.
*DLOAD,AMPLITUDE=ELG7
ELG7 P,1.
*DLOAD,AMPLITUDE=ELG8
ELG8 P,1.
*DLOAD,AMPLITUDE=ELG9
ELG9 P,1.
*DLOAD,AMPLITUDE=ELG10
ELG10 P,1.
*DLOAD,AMPLITUDE=ELG11
ELG11 P,1.
*DLOAD,AMPLITUDE=ELG12
ELG12 P,1.
*DLOAD,AMPLITUDE=ELG13
ELG13 P,1.
*DLOAD,AMPLITUDE=ELG14
ELG14 P,1.
*DLOAD,AMPLITUDE=ELG15
ELG15 P,1.
*END STEP
*STEP,AMPLITUDE=RAMP,LINEAR,INC= 1,CYCLE= 1
TRANSIENT RESPONSE OF NOSECAP TO 16TH WATER-ENTRY STEP PRESSURE
*DYNAMIC

```

```

3.877E-04,3.877E-04
*DLOAD,AMPLITUDE=ELG1
ELG1,P,1.
*DLOAD,AMPLITUDE=ELG2
ELG2,P,1.
*DLOAD,AMPLITUDE=ELG3
ELG3,P,1.
*DLOAD,AMPLITUDE=ELG4
ELG4,P,1.
*DLOAD,AMPLITUDE=ELG5
ELG5,P,1.
*DLOAD,AMPLITUDE=ELG6
ELG6,P,1.
*DLOAD,AMPLITUDE=ELG7
ELG7,P,1.
*DLOAD,AMPLITUDE=ELG8
ELG8,P,1.
*DLOAD,AMPLITUDE=ELG9
ELG9,P,1.
*DLOAD,AMPLITUDE=ELG10
ELG10,P,1.
*DLOAD,AMPLITUDE=ELG11
ELG11,P,1.
*DLOAD,AMPLITUDE=ELG12
ELG12,P,1.
*DLOAD,AMPLITUDE=ELG13
ELG13,P,1.
*DLOAD,AMPLITUDE=ELG14
ELG14,P,1.
*DLOAD,AMPLITUDE=ELG15
ELG15,P,1.
*DLOAD,AMPLITUDE=ELG16
ELG16,P,1.
*END STEP
*STEP,AMPLITUDE=RAMP,LINEAR,INC= 1,CYCLE= 1
TRANSIENT RESPONSE OF NOSECAP TO 17TH WATER-ENTRY STEP PRESSURE
*DYNAMIC
3.911E-04,3.911E-04
*DLOAD,AMPLITUDE=ELG1
ELG1,P,1.
*DLOAD,AMPLITUDE=ELG2
ELG2,P,1.
*DLOAD,AMPLITUDE=ELG3
ELG3,P,1.
*DLOAD,AMPLITUDE=ELG4
ELG4,P,1.
*DLOAD,AMPLITUDE=ELG5
ELG5,P,1.
*DLOAD,AMPLITUDE=ELG6
ELG6,P,1.
*DLOAD,AMPLITUDE=ELG7
ELG7,P,1.
*DLOAD,AMPLITUDE=ELG8
ELG8,P,1.
*DLOAD,AMPLITUDE=ELG9
ELG9,P,1.
*DLOAD,AMPLITUDE=ELG10
ELG10,P,1.
*DLOAD,AMPLITUDE=ELG11
ELG11,P,1.
*DLOAD,AMPLITUDE=ELG12
ELG12,P,1.
*DLOAD,AMPLITUDE=ELG13
ELG13,P,1.
*DLOAD,AMPLITUDE=ELG14
ELG14,P,1.

```

```

*DLOAD, AMPLITUDE=ELG15
ELG15, P, 1.
*DLOAD, AMPLITUDE=ELG16
ELG16, P, 1.
*DLOAD, AMPLITUDE=ELG17
ELG17, P, 1.
*END STEP
*STEP, AMPLITUDE=RAMP, LINEAR, INC= 1, CYCLE= 1
TRANSIENT RESPONSE OF NOSECAP TO 18TH WATER-ENTRY STEP PRESSURE
*DYNAMIC
3.690E-04, 3.690E-04
*DLOAD, AMPLITUDE=ELG1
ELG1, P, 1.
*DLOAD, AMPLITUDE=ELG2
ELG2, P, 1.
*DLOAD, AMPLITUDE=ELG3
ELG3, P, 1.
*DLOAD, AMPLITUDE=ELG4
ELG4, P, 1.
*DLOAD, AMPLITUDE=ELG5
ELG5, P, 1.
*DLOAD, AMPLITUDE=ELG6
ELG6, P, 1.
*DLOAD, AMPLITUDE=ELG7
ELG7, P, 1.
*DLOAD, AMPLITUDE=ELG8
ELG8, P, 1.
*DLOAD, AMPLITUDE=ELG9
ELG9, P, 1.
*DLOAD, AMPLITUDE=ELG10
ELG10, P, 1.
*DLOAD, AMPLITUDE=ELG11
ELG11, P, 1.
*DLOAD, AMPLITUDE=ELG12
ELG12, P, 1.
*DLOAD, AMPLITUDE=ELG13
ELG13, P, 1.
*DLOAD, AMPLITUDE=ELG14
ELG14, P, 1.
*DLOAD, AMPLITUDE=ELG15
ELG15, P, 1.
*DLOAD, AMPLITUDE=ELG16
ELG16, P, 1.
*DLOAD, AMPLITUDE=ELG17
ELG17, P, 1.
*DLOAD, AMPLITUDE=ELG18
ELG18, P, 1.
*END STEP

```

APPENDIX G
USER INSTRUCTIONS—WATER
ENTRY STRUCTURAL TECHNIQUE

APPENDIX G

USER INSTRUCTIONS-WATER ENTRY STRUCTURAL TECHNIQUE

These user instructions for WEST are written assuming that the user is familiar with both PATRAN and ABAQUS. Therefore, no effort is expended on their use in these instructions. The user instructions for WEST are divided into three parts:

Part 1 provides the instructions for the generic use of the ENTRY code, without any pre- or post-processing nor finite element analysis of the structure. These instructions are extracted from the original users manual for ENTRY, which is contained in reference 19.

Part 2 lists the special instructions a user will need to generate a finite element mesh that can accommodate or bypass the restrictions imposed by the ENTRY code.

Part 3 provides instructions on how to run the translators PATENTR and ENTPRES, and how to activate the added output options for element pressure- and load-time history files in an ENTRY run.

PART 1

INSTRUCTIONS FOR THE GENERIC USE OF THE ENTRY CODE

The current version of the ENTRY code can be applied to arbitrary bodies. The grid describing the entry body may contain up to 750 nodes and 500 elements. However, execution will terminate when more than 300 of these elements become submerged. These instructions describe the available program options, necessary input cards and output format.

Program Options and Required Input

Program input can be divided into three parts. In the first, the basic program options are specified:

Card No.	Variable	Format
1	CONSTANT or VARIABLE body orientation	2A4
2	PRINT or DON'T PRINT	3A4
3	ASYMMETRIC or SYMMETRIC mode	3A4

Under the CONSTANT body orientation option the entry model is assumed to retain its initial orientation and velocity throughout the entry process. The natural problem variable in this case is depth rather than time. With little increase in computational time, pressures and forces can be evaluated for a number of different wetting factors, C_w . The VARIABLE body orientation option allows the velocity, orientation, wetting factor and time increments between steps to be varied. The only restriction is that the angular velocity of the body must be small enough to insure that the depth of the body increases monotonically in time. The maximum number of steps is limited to 49.

The PRINT option is used to obtain flow field and element information at each step of the calculation. It is applied only for diagnostic purposes. The second option, DON'T PRINT, is recommended and produces only grid information and the final pressures and forces on the model.

If the SYMMETRIC mode option is used, the entry model is assumed to possess planar symmetry about the y-z plane. The ASYMMETRIC option does not assume any symmetry and hence can be applied to arbitrary bodies. This mode is also used on symmetric bodies where V_x is non-zero.

The second set of input cards describes the entry conditions. The required information differs depending on whether the CONSTANT or VARIABLE body orientation option is used. For the CONSTANT option the following data cards are required:

Card No.	Variable	Format
4	IMAX, D, VENTRY, ANG, SUMT, HMIN, DH, ALPHA	I5,5X,7F10.0
5	CGL, FCF, ANGB, NNLD	3F10.0, I5
6	NCW, CW(1), CW(2)....(CW(NCW))	I5,5X,7F10.0/ (8F10.0)
7	omit	

These variables are defined as follows:

- IMAX Number of steps at which pressures and loads are calculated. The present calculative procedure inserts the model into the water in a series of steps, each at a greater depth than the preceding one. When the step count becomes greater than IMAX, execution is terminated.
- D Diameter (in inches). This quantity is only used for calculating force coefficients.
- VENTRY Entry velocity in (in./sec.).
- ANG Orientation of the model (in degrees) relative to the water surface (see Figure G-1).
- SUMT Program time limit. This variable is not used in the VAX implementation of this code. Set equal to zero.
- HMIN Initial body depth (i.e., measured from the lowest point on the body). This parameter is zero if the loads are calculated from the time of initial wetting. Note that if this variable is not zero pressures and forces are first calculated at HMIN+2DH. This parameter allows pressures and forces at a particular depth to be determined without calculating the entire force-time history from initial wetting.
- DH Increment in depth (in inches) between successive steps. It is necessary to coordinate this variable with the specified model grid which is defined on the last set of data cards. The following apply to determining DH:
- a. OBLIQUE ENTRY WITH STANDARD GRID OPTION. DH should be picked so that the average element is submerged in two steps. On models of complex shape this criteria can only be satisfied in the mean and primary consideration should be given to the portion of the body which experiences the greatest load. Generally this will be on elements whose plane is perpendicular to the direction of motion.
 - b. VERTICAL ENTRY WITH STANDARD GRID OPTION OR OBLIQUE ENTRY WITH THE OGIVE OPTION. For vertical entry or if the OGIVE grid option is used, elements will have a pair of sides parallel to the water surface. In this case it is important to choose the step size very precisely so that each element

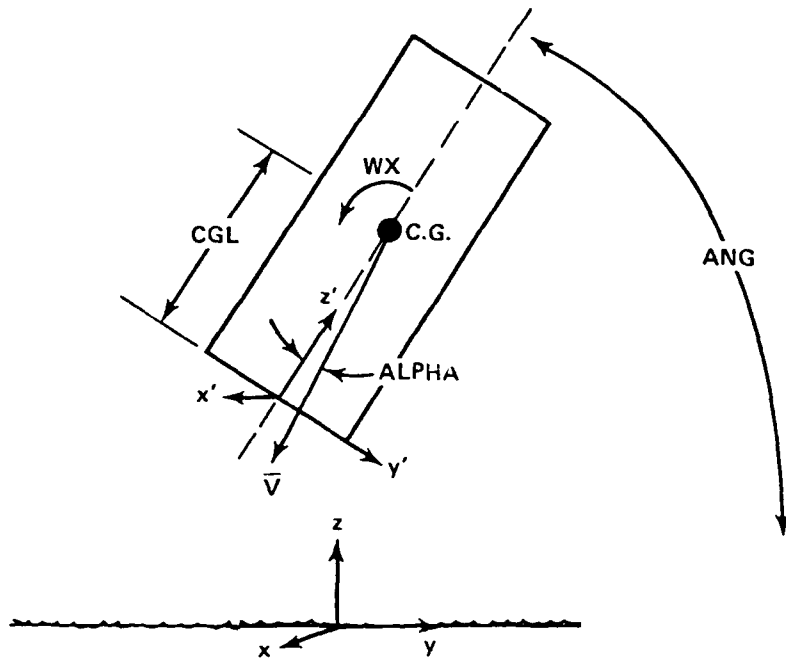

FIG. G-1 TERMS DEFINED

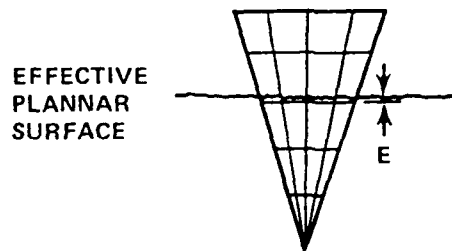

FIG. G-2 PROFILE OF CONE GRID

will be submerged in exactly two steps. To insure that the top row of elements is included in an unmodified state in the code and that the next row of elements is excluded, the actual water surface should fall a small distance ϵ above the upper edge of the top row of elements to be included as shown in Figure G-2. Here $0 < \epsilon < \Delta h$ where Δh is defined by

$$\Delta h = \sqrt{\frac{\text{average element area}}{1000}}$$

- ALPHA Angle of attack (in degrees). See Figure G-1.
- CGL z' coordinate of the center of gravity. See Figure G-1.
- FCF Pressure correction factor on elements with a modification code of 1. For the oblique entry of blunt bodies (nose length/diameter < 1) set to unity. For other cases use a value of 0.67.
- ANGB Yaw angle (in degrees). Velocity components in the x, y, z directions are $V_I \sin(\text{ANGB})$, $-V_I \cos(\text{ANG}) \cos(\text{ANG} + \text{ALPHA})$ and $-V_I \cos(\text{ANG}) \sin(\text{ANG} + \text{ALPHA})$.
- NNLD Number of no-load elements.
- NCW Number of wetting factors to be used. Since the most appropriate value may not be clear, for little extra computational cost, pressure and loads may be calculated for several different wetting factor values.
- CW Wetting Factor. This parameter describes the rate of surface rise and is equal to the ratio of h/h' defined in Figure G-3. For best results, the test cases reported on in Reference 19 should be used as a guide. An approximate rule for determining this parameter is as follows:

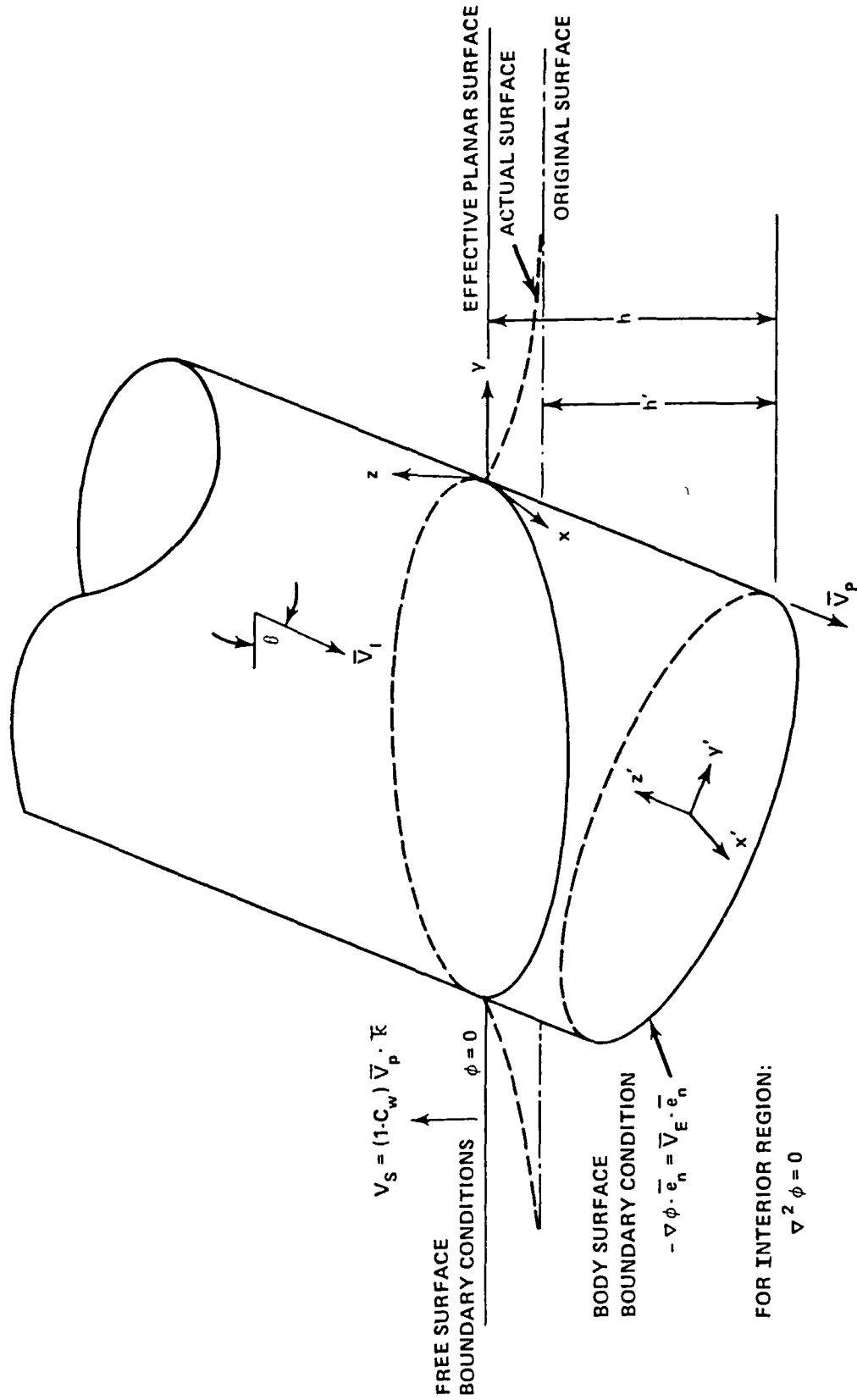

FIG. G-3 PROBLEM FORMULATION

(1) POINTED BODIES (ALSO INCLUDES SLIGHTLY BLUNTED ONES). Determine the angle, θ_c , between the tangent to the body surface and the body axis at both the nosetip and base of the nose. At the nose neglect any effect due to body blunting. Insert the two resulting values of θ_c in radians into:

$$C_w = \frac{1}{(1 - .396 \theta_c + .187 \theta_c^2 - .124 \theta_c^3)} \quad (1)$$

Average the two calculated values of C_w to obtain the final one to be used in the code. If ALPHA is non-zero increment θ_c by ALPHA.

(2) FLAT PLATES. Use a value of 1.45 for ANG>45 degrees and 1.55 for ANG<45 degrees.

(3) SPHERICAL BODIES. Use a value of 1.55 for near vertical entry and 1.35 for oblique entry.

The classification of an arbitrary body into one of the above categories is a matter of experience. On complex shapes classification should be based on the portion of the body sustaining the majority of the impact loading.

If the VARIABLE body orientation option is used the following data cards are required:

Card No.	Variables	Format
4	IMAX, D, VENTRY, ANG, SUMT, HMIN	I5, 5X, 7F10.0
5	CG., FCF, NNLD	2F10.0, 10X, I5
6	NVP	I5
7.1	VX(1), VY(1), VZ(1), WX(1), CW(1), DH(1)	6F10.0
.	.	.
7.NVP	VX(NVP), VY(NVP), VZ(NVP), WX(NVP), CW(NVP), DH(NVP)	6F10.0

The variables on cards 4 and 5 are defined above. In this case, VENTRY is only used in determining the force and pressure coefficients and ANG is the initial body orientation. The body velocity, wetting factor, and increment in depth for each step is defined in cards 7.

NVP Number of different steps at which entry conditions are specified.

VX(I), Velocity components in the x, y, z directions of the center
 VY(I), of gravity (in in./sec.) applied between steps I-1 and I.
 VZ(I)

WX(I) Angular velocity (in degrees/sec.) in the pitch (y-z) plane
 applied between steps I-1 and I.

CW(I) Wetting factor applied between the I-1 and I step. If the value of this parameter remains constant from step to step use the instruction for determining this variable given in the CONSTANT orientation section. For the vertical entry (VX=VY=0) of pointed bodies an estimate of this parameter for each step can be obtained by:

a. Determining the depth of the entry body, H, below the original surface at the start of the step.

b. Calculating the angle, θ_c between a tangent to the body surface and the body axis, $z'=H$.

c. Substituting into equation (1) to determine C_w where

$$\theta_c = \theta_c' + 90 - \text{ANG}$$

d. For blunt bodies, (nose length/diameter < .75), increase this angle by 7% on ogives and decrease it by the same amount on cusps.

DH(I) Increase in depth (in inches) of the center of gravity between steps I-1 and I. See instructions in the CONSTANT orientation entry section.

The entry velocity at step I is taken to be the average of that at steps I-1 and I. It is only necessary to specify data cards for the first few steps in which the above parameters change. For steps larger than NVP the parameter values at step NVP are used.

The final set of data cards is used to define the grid on the surface of the entry body. The three available options for constructing a grid on the body surface are STANDARD, OGIVE, AND LIST. These can be used singularly, in combination with one another and can be called in arbitrary sequence. The only restriction is that the lowest point on the body should occur on that part of the grid constructed by the first option called. To indicate the desired options, the following input cards are required:

Card No.	Variable	Format
8	N	I5
9.1	option 1	3A4
.		
9.N	option N	3A4

Here N is the number of options to be used. The recommended options are STANDARD and LIST. Description of the OGIVE option will not be given in these instructions. For information on this option, refer to Reference 19.

The grid representing the surface of the entry body should cover only the nose of the model and not the afterbody. In all cases the pressures on the afterbody are small. Furthermore, on bodies with sharp shoulders such as a disk cylinder, the flow separates at the edge of the model face. If the afterbody is gridded, the flow is required not to separate since the invicid boundary conditions are enforced at the centroid of each element. This is physically unrealistic and hence neglecting the afterbody is appropriate.

A description of the three available options follows. Under no circumstances should right angles be modeled directly. If the body under consideration has such a surface discontinuity, it should be modeled with a 89.9 or 90.1 degree angle.

STANDARD

This option is applicable to axisymmetric bodies or axisymmetric portions of arbitrary bodies. The user specifies rings along which nodes are located. Adjacent nodes are combined to form elements. A typical grid for a flat, circular plate is shown in Figure G-4. The required input is:

Card No.	Variables	Format
10	NROWS, IANG, ISUP	3I5
11.1	R(1), Z(1)	2F10.0, I5
.	.	.
11.NROWS	R(NROWS), Z(NROWS), IW(NROWS)	2F10.0, I5

- NROWS Number of grid rings.
- IANG If IANG=0, only half of the face is gridded as shown.
If IANG=1, the complete face is gridded.
- ISUP If ISUP=1, the stagnation element (element number 1) is removed. This option is used for running pointed objects. For such bodies, R(1) should be very small (i.e., D/1000) but must be finite.
If ISUP=0 this element is included.
- R(I) Radius of ring I in body fixed coordinates (x',y',z', in inches).
- Z(I) z' coordinate of ring (in inches).
- IW(I) Number of elements in the area between rings I and I-1. Delete this variable on card 1. If IW=0, elements are automatically selected so that they are approximately square.

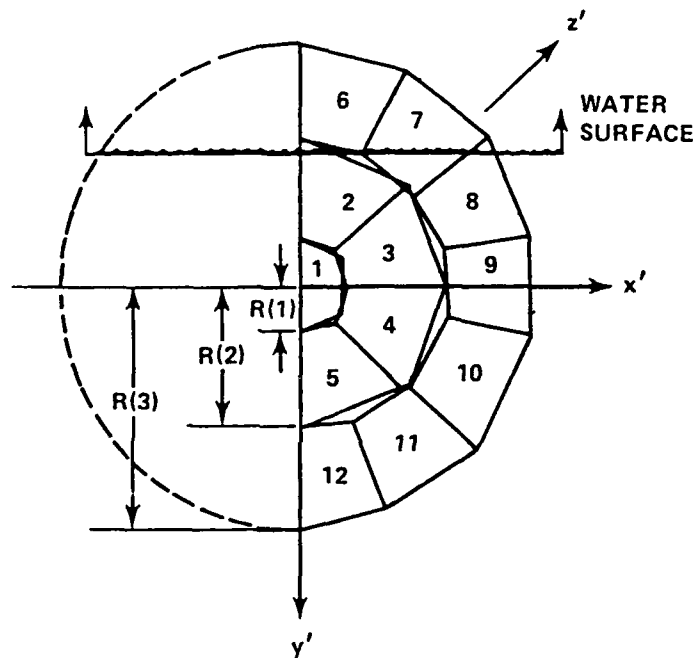

FIG. 6-4 GRID OF A CIRCULAR PLATE

LIST

This option requires that the user input the list of nodes and elements to be used in the run and hence is applicable to arbitrary bodies. The nodes can be read in any order, however, they are numbered sequentially for internal use in the code. Each element is constructed using nodes from the input list. The identification numbers of nodes defining the four corners of each element must be read in a clockwise order with respect to an observer on the outer surface of the element. The required input cards are:

Card No.	Variable	Format
10	NP, NE	2I5
11.1	$x'(1), y'(1), z'(1)$	3F10.0
.		
11.NP	$x'(NP), y'(NP), z'(NP)$	3F10.0
12.1	$IN(1,1), IN(2,1), IN(3,1), IN(4,1)$	4I5
.		
12.NE	$IN(1,NE), IN(2,NE), IN(3,NE), IN(4,NE)$	4I5
NP	Number of node points to be read in.	
NE	Number of elements to be read.	
$x'(I),$ $y'(I)$ $z'(I)$	Location of the Ith node in body fixed coordinates (x', y', z' , in inches).	
$IN(1,I),$ $IN(2,I),$ $IN(3,I),$ $IN(4,I)$	Identification number of the nodes defining the four corners of the element.	

PART 2

SPECIAL INSTRUCTIONS BEFORE GENERATING FEM

ENTRY includes three options to define the grid on the surface of the entry body: STANDARD, OGIVE, AND LIST. The first two options are associated with the automatic grid generation scheme built into the ENTRY code and are not suitable for WEST application. The LIST option requires the user to input the list of nodes and elements to be used in the runstream, and hence is applicable to arbitrary bodies and linkage with the PATRAN pre-processor. The translator PATENTR was developed to translate the PATRAN neutral file (a PATRAN output ASCII file) defining the finite element mesh of the entry body into the water entry model, with the same mesh but in LIST option format suitable for use in ENTRY. ENTPRES is programmed to convert the ENTRY-calculated element pressures and their arrival times into time-varying load specifications in ABAQUS format for dynamic analysis and in YADAP format for time-history plots on a personal computer. In order to make both translations successful, however, several restrictions imposed by ENTRY need to be followed:

(1) In dividing the surface of an entry body into rings and subdividing rings into elements, the node and element identification numbers (ID's) must be numbered sequentially, from tip to tail and from left to right. If neither begins with the number one (1), a number offset must be input for both node and element ID at PATENTR run time. The user will be prompted for them at that time.

(2) Only four-noded quadrilateral (QUAD) elements are permitted in ENTRY. The element connectivities which are generally defined in counter-clockwise convention in FEA, will be reversed by PATENTR for ENTRY. The element pressures calculated by ENTRY are always positive, and are treated as positive only when applied in the outward normal direction. This direction is determined by the element connectivity defined in PATRAN following the right-hand rule. Based on this knowledge, the user must decide whether positive or negative pressures are to apply to the shell elements in the ABAQUS analysis. The user will be prompted for the sign of pressures to be output in an ENTRY run when the element pressure-time history output option is activated.

(3) Define the axis of the entry body as the z-axis. If a FEM is already built with x- or y-axis defined as the body-axis, PATENTR can convert it into a z-axis model for ENTRY. This is done simply by inputting an 'x' or a 'y' when prompted for the body-axis coordinate in the FEM at PATENTR run time. Note that this conversion is necessary only when running ENTRY. Since pressures are independent of the coordinate system chosen, a user can still keep his own body-axis when running ABAQUS downstream.

(4) Although it is not necessary to define the tip of the entry body as the origin of the body-axis, it is recommended to do so. This action will permit determination of the pressure arrival time for each ring of elements to be timed from the tip. This will subsequently facilitate the choosing of time-steps in the ABAQUS FEA. Move the origin to the tip by inputting a z-axis shift (positive if the tip of the ENTRY model is above the origin of the PATRAN FEM) when prompted at PATENTR run time.

(5) It is recommended in the generic use of ENTRY that the increment of depth for water entry be chosen such that the average element is submerged in two steps. To couple with ABAQUS, however, it is necessary to choose the step size precisely so that each ring of elements of the entry body will be submerged in exactly one step. This is because a pressure cannot be applied to only half an element. Since efficient FEM often results in non-uniform mesh density, this situation leads to choosing variable step sizes in ENTRY to properly submerge each ring of elements in a single step. The times required to submerge the variable step-sized rings are computed in ENTRY for given body orientation and entry conditions and can be used to synchronize with the pressure-arrival time for each ring of elements in an ABAQUS analysis.

(6) The only symmetric condition the ENTRY code can take advantage of is half-symmetric, with the y-z plane chosen as the plane of symmetry, for either vertical or oblique entry. However, an experienced user can take better advantage of symmetry conditions in a subsequent ABAQUS analysis by using a quarter- or eighth-symmetric FEM. This becomes automatic with the element grouping technique implemented in ENTPRES for the case of axi-symmetric bodies entering the water vertically.

(7) In the case of vertical entry with a zero angle of attack for an axi-symmetric body surface, the resulting axi-symmetric pressure distribution varies only in the axial direction as the body is submerged. Elements in each ring at any given depth will experience the same pressure. To facilitate the element pressure-time history input for ABAQUS, an element grouping technique is implemented in ENTPRES. The user is prompted for the number of elements in a ring that have the same pressure at ENTPRES run time. Therefore, it is recommended to form a FEM with the same number of elements in each ring of the entry body. This grouping limitation excludes the stagnation elements at the tip of the ENTRY model. The user will also be prompted for the number of such elements included in the model. This exclusion increases the flexibility in FEM by allowing the user to use triangular (TRI) shell elements at the tip of the body while using QUAD elements formed by two TRI shell elements for ENTRY calculation. The near-triangle shaped QUAD elements used in ENTRY must therefore be divided into two TRI elements for ABAQUS. The grouping technique implemented in ENTPRES allows this mixed use of QUAD and TRI elements in ENTRY and ABACUS, respectively.

PART 3

COMPUTER RUN STREAM EXAMPLE

PATENTR, ENTPRES, and options in ENTRY are prompted at run time. Options to output pressure-time history files in PATRAN neutral file format, options for ENTPRES' conversion to ABAQUS load format for analysis, and options to produce YADAP format for time-history plots are programmed in an interactive manner. Input/output filenames and control parameters are also prompted at run time. Table G-1 is a sample listing of a VAX 11/785 computer run stream that begins after a PATRAN session to generate a FEM of a blunt, 90-degree cone impacting water vertically at 100 ft./sec.. Some questions that are annotated require explanations:

(1) CONE90.IN is the file that contains two sets of control parameters for water entry. The first set specifies the basic program options for ENTRY, such as constant or variable body entry orientation, option to print step by step flow field and element information, and the entry body's symmetry condition. The second set specifies the water entry conditions such as entry velocity, angle of attack, increment of depth, and wetting factor. This file is then appended by the PATENTR-converted LIST grid file of the cone (CONE.LST) to form the complete input data to run ENTRY. The complete listing of input data for ENTRY is given in Appendix A.

(2) There are two options to input the LIST grid file for ENTRY. The first option is appending the LIST grid file to the ENTRY run control data file to form a single file for the ENTRY run, as described in note (1) above. The second option is to treat the LIST grid file as a separate external file during the ENTRY run. Since the first option was chosen for this example, the answer to the prompted question is no. If the second option is taken, the answer is yes, and the user will be prompted for the name of the LIST grid file.

(3) As shown in Figure 3 of the main text, the inclined surface of the cone is divided equally into 10 rings, with 8 QUAD elements each. The flat tip is modeled with four near triangle-shaped QUAD elements, as shown in Figure 4.

(4) CONE90.INP is an ASCII file output from running the PATABA interface. This file contains all but the loading data required for an ABAQUS analysis. It includes the FEM definition of the cone, analysis type selection, material and section property cards for elements and boundary condition specifications. This file is appended by ENTPRES converted time-varying loads (PRES.ABA) for dynamic analysis with ABAQUS. A complete listing of input data for an ABAQUS execution is given in Appendix C.

Table G-1. List of VAX 11/785 sample computer run stream.

```
$ RUN PATENTR
ENTER INPUT FILENAME--PATRAN NEUTRAL FILE W/ EXTENSION
CONE90.NEU
ENTER OUTPUT FILENAME--ENTRY "LIST" GRID OPTION FILE
CONE90.LST
IS NODE OR ELEM NUMBER SHIFT REQUIRED FOR ENTRY? Y/N
IF YES, ENTER NODSFT AND NELSFT IN 2I5 FORMAT.
NOTE: NODE & ELEM ID MUST BEGIN WITH 1 & IN SEQUENCE
N
ENTER BODY-AXIS CHOSEN IN FINITE ELEM MODEL, X,Y OR Z
NOTE: NON-Z SYSTEM WILL BE CONVERTED TO Z-X-Y SYSTEM
WITH Z AS BODY-AXIS & Y-Z AS PLANE OF SYMMETRY
Z
IS AXIAL OFFSET REQUIRED FOR ENTRY MODEL? Y/N. IF YES,
ENTER SHIFT (POSITIVE IF TIP IS ABOVE ORIGIN OF FEM)
NOTE: THIS ALLOWS WETTING TO BE TIMED FROM THE TIP.
N
END OF INPUT FILE ENCOUNTERED--NORMAL TERMINATION
FORTRAN STOP
$
$ APPEND CONE90.LST CONE90.IN (1)
$ RUN ENTRY
ENTER INPUT FILENAME INCLUDING EXTENSION
CONE90.IN
ENTER OUTPUT FILENAME INCLUDING EXTENSION
CONE90.OUT
ENTER OUTPUT FILENAME FOR ELEMENT PRESSURE-TIME
HISTORIES IF WANTED, TYPE NO IF NOT WANTED
CONE90.PRE
ENTER FILENAME FOR TOTAL FORCE-TIME HISTORIES, DRAG &
NORMAL FORCES & MOMENTS @ CG IF WANTED, TYPE NO IF NOT
CONE90.F
IS LIST INPUT DEFINING GRID FROM AN EXTERNAL FILE? Y/N
N (2)
FOLLOWING ENTRIES COMFORM TO PATRAN NEUTRAL FILE FORMAT
FOR DISTRIBUTED LOADS:
(1) TITLE CARD (DATA PACKET TYPE 25)
(2) SUMMARY DATA (DATA PACKET TYPE 26)
(3) DISTRIBUTED LOADS (DATA PACKET TYPE 6)
ENTER TITLE OF PRESSURE-FILE (LIMIT 80 CHARS)
PRESSURE-TIME HISTORIES OF 100 FPS VERTICAL ENTRY BLUNT 90-D CONE
ENTER 6 LOAD COMPONENT FLAGS (ICOMP=0/1) AT 6I1 FORMAT
EX: FOR PRESSURE LOADING ON QUAD ELEM, ENTER 001000
001000
ENTER 8 ELEM NODE FLAGS (NODE=0 OR 1) AT 8I1 FORMAT.
1 MEANS THAT NODE IS ON THE LOADED EDGE OR SURFACE.
EX: FOR A PRESSURE-LOADED QUAD ELEM, ENTER 11110000
11110000
ENTER 1ST LOAD SET ID (IV=1) & ELEM FACE NO. (NFE=1-6)
AT 2I5 FORMAT. NFE=0 FOR A PRESSURE-LOADED QUAD ELEM
1 0
ARE PRESSURES APPLIED TO PATRAN MODEL +(P) OR -(N)? P/N
NOTE: PRESSURE IS + IN POSITIVE NORMAL FOR QUAD ELEMS
N
FORTRAN STOP
```

Table G-1. (continued)

```

$ RUN ENTPRES
  ENTER INPUT FILE OF ELEM PRESSURE HISTORY, EX: CONE.PRE
CONE90.PRE
  ENTER OUTPUT FILE FOR ABAQUS FE ANALYSIS, EX: PRES.ABA
PRES.ABA
  DO YOU WANT TAPE9.DAT TIME-HISTORY PLOT FILE? Y/N
    NOTE: TAPE9.DAT FORMAT IS 12E11.4, WITH ELAPSED TIMES
          IN FIRST COLUMN AND UP TO 11 GROUP PRESSURES
          THEREAFTER. IF MORE THAN 11 GROUPS OF OF DATA
          ARE ENCOUNTERED, THEY WILL BE SPREADED OVER TO
          FOR010, FOR011, FOR012.DAT...IN THE SAME FORMAT
Y
  ENTER TITLE FOR TAPE9.DAT PLOT FILE (80 CHARS MAX)
PRESSURE-TIME HISTORIES OF 100 FPS VERTICAL ENTRY BLUNT 90-D CONE
  ENTER NOS. OF STEPS (NSTP,I5) AND NOS. OF ELEMS IN A
  GROUP (NEL,I5) WITH THE SAME PRESSURE IN INPUT FILE
  NOTE: IF ALL ELEMS HAVE DISTINCT PRESSURES, SET NEL=1
      11      8
ARE STAGNATION ELEMS INCLUDED IN WATER-ENTRY MODEL? Y/N
Y
4
  IF YES, ENTER NUMBER OF STAGNATION ELEMS (NSTG,I2)
  NOTE: STAGNATION ELEMS ARE TREATED AS GROUP NO. 1
SUMMARY OF PROCESS:
MAX NUMBER OF PRESSURIZED ELEMS WITHIN STEPS      = 84
NUMBER OF ELEM GROUPS (WITH EQUAL ELEM PRESSURE)= 11
NUMBER OF ELEMS PER GROUP (EXCL STGN ELEM GROUP)= 8
NUMBER OF ELEMS IN STGN ELEM GROUP (GROUP NO. 1)= 4
NUMBER OF TIME-HISTORY PLOT FILES GENERATED      = 1
FORTRAN STOP
$
$ SET DEF [RCSHAW]
$ APPEND [.ENTPRES]PRES.ABA CONE90.INP
$ @ABAQUS
IDENTIFIER : CONE
INPUT FILE NAME (W/O .INP) : CONE90
RESTART READ FILE ? :
OLD 'FILE OUTPUT FILE' FILE ? :
BATCH QUEUE YOU WANT (SYS=<CR> SLOW=S) ? :
GIVE THE AMOUNT OF TIME YOU WANT TO HOLD THE JOB FOR
THE FORMAT IS HH:MM: ( <RET> TO IGNORE) :
Job CONE (queue SYS$BATCH, entry 350) started on SYS$BATCH
$
Job CONE (queue SYS$BATCH, entry 350) completed
$ DIR CONE

Directory USER2:[RCSHAW]

CONE.COM;1          CONE.DAT;1          CONE.FIL;1          CONE.LOG;1
CONE.STA;1

Total of 5 files.
$

```

REPORT DOCUMENTATION PAGE

Form Approved
OMB No. 0704-0188

Public reporting burden for this collection of information is estimated to average 1 hour per response, including the time for reviewing instructions, searching existing data sources, gathering and maintaining the data needed, and completing and reviewing the collection of information. Send comments regarding this burden estimate or any other aspect of this collection of information, including suggestions for reducing this burden, to Washington Headquarters Services, Directorate for Information Operations and Reports, 1215 Jefferson Davis Highway, Suite 1204, Arlington, VA 22202-4302, and to the Office of Management and Budget, Paperwork Reduction Project (0704-0188), Washington, DC 20503.

1 AGENCY USE ONLY (Leave blank)		2 REPORT DATE December 1989		3 REPORT TYPE AND DATES COVERED Final: Mar 1989 - Oct 1989	
4 TITLE AND SUBTITLE WATER ENTRY STRUCTURAL TECHNIQUE (WEST): An Analytical Technique to Determine Frangible Nosecap Behavior During Water Entry			5 FUNDING NUMBERS PE: 060293, RV36I21, 931-ZE84, DN309 053		
6 AUTHOR(S) P. A. Jung and R. C. Shaw			8 PERFORMING ORGANIZATION REPORT NUMBER NOSC TR 1317		
7 PERFORMING ORGANIZATION NAME(S) AND ADDRESS(ES) Structural Mechanics, Analysis and Design Branch Design and Development Division Naval Ocean Systems Center San Diego, CA 92152-5000			10 SPONSORING/MONITORING AGENCY REPORT NUMBER OCNR-20T		
9 SPONSORING/MONITORING AGENCY NAME(S) AND ADDRESS(ES) Office of the Chief of Naval Research Independent Exploratory Development Programs (IED) Arlington, VA 22217			11 SUPPLEMENTARY NOTES		
12a DISTRIBUTION/AVAILABILITY STATEMENT Approved for public release; distribution is unlimited.			12b DISTRIBUTION CODE		
13 ABSTRACT (Maximum 200 words) Described here is a computational method to design frangible nose caps for air- and surface-launched undersea weapons (such as for ASROC, VLA, and Mk-50 torpedoes). WEST is a technique that can rapidly and accurately assess the state of stress and deformation of missile nose caps intended to break up at water entry. WEST links the powerful geometry and FEM pre- and post-processor PATRAN ¹ , a potential-flow computer code that can calculate dynamic pressure-time histories of an arbitrary entry body, and the nonlinear FEA code ABAQUS. This code linkage has been validated through comparison with experimental work. WEST is a valuable analytical tool that reduces the design cycle time for frangible nose caps.					
14 SUBJECT TERMS water entry, nonlinear structural analysis, frangible nosecap, finite element analysis (FEA), finite element model (FEM), antisubmarine rocket (ASROC), vertical-launched ASROC (VLA), deformation				15 NUMBER OF PAGES 217	
17 SECURITY CLASSIFICATION OF REPORT UNCLASSIFIED				16 PRICE CODE	
18 SECURITY CLASSIFICATION OF THIS PAGE UNCLASSIFIED		19 SECURITY CLASSIFICATION OF ABSTRACT UNCLASSIFIED		20 LIMITATION OF ABSTRACT	

¹PATRAN is a trademark of PDA Engineering, Inc.