

AD-A163 327

OCEAN FACILITIES PROGRAM OCEAN CONSTRUCTION EQUIPMENT
INVENTORY (OCEI) EQUIPMENT CATALOG(U) NAVAL FACILITIES
ENGINEERING COMMAND WASHINGTON DC CHESAPEAKE DIV 1976
CHES/NAVFAC-FPO-7510 F/G 13/3

1/3

UNCLASSIFIED

NL

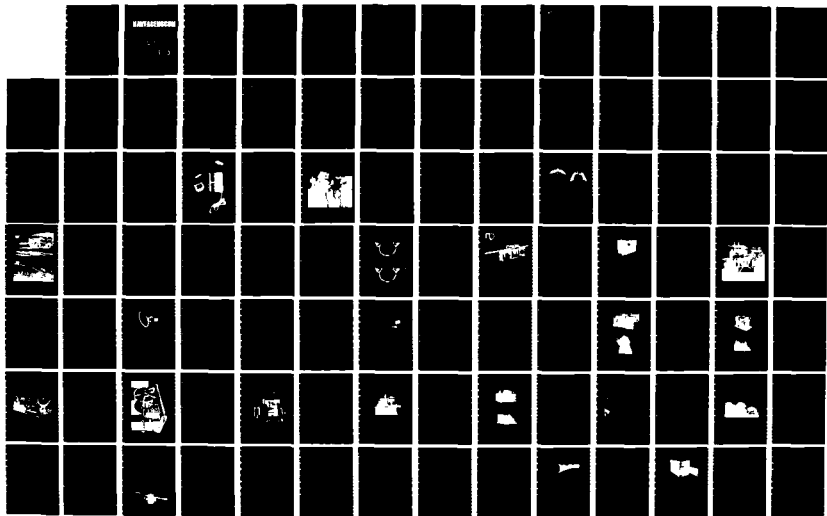

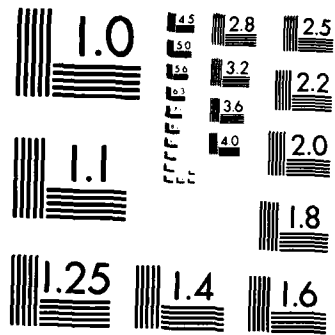

MICROCOPY RESOLUTION TEST CHART
NATIONAL BUREAU OF STANDARDS-1963-A

7510

AD-A163 327

ENCLOSURE (5)

CHESNAVFACENGCOMNST 4860.1A

7

NAVFACENGCOM

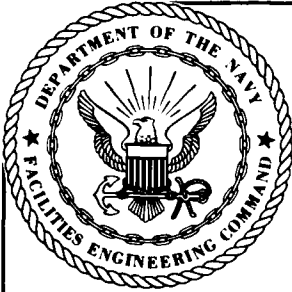

OCEAN FACILITIES PROGRAM

OCEAN CONSTRUCTION EQUIPMENT INVENTORY (OCEI)

EQUIPMENT CATALOG

DTIC FILE COPY

DTIC
ELECTE
JAN 24 1986
S D

DISTRIBUTION STATEMENT A
Approved for public release
Distribution Unlimited

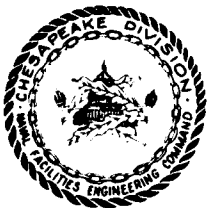

OCEAN ENGINEERING AND CONSTRUCTION PROJECT OFFICE

CHESNAVFACENGCOM

WASHINGTON, D.C. 20374

86 1 23 097

Unclassified

SECURITY CLASSIFICATION OF THIS PAGE

REPORT DOCUMENTATION PAGE

1a. REPORT SECURITY CLASSIFICATION
Unclassified

1b. RESTRICTIVE MARKINGS

2a. SECURITY CLASSIFICATION AUTHORITY

3. DISTRIBUTION AVAILABILITY OF REPORT
Approved for public release;
distribution is unlimited

2b. DECLASSIFICATION/DOWNGRADING SCHEDULE

4. PERFORMING ORGANIZATION REPORT NUMBER
Enclosure (5)CHESNAVFACENGCOMINST 4860.1A

5. MONITORING ORGANIZATION REPORT NUMBER
FPO-7510

6a. NAME OF PERFORM. ORG.
Ocean Engineering
& Construction
Project Office
CHESNAVFACENGCOM

7a. NAME OF MONITORING ORGANIZATION

6c. ADDRESS (City, State, and Zip Code)
BLDG. 212, Washington Navy Yard
Washington, D.C. 20374-2121

7b. ADDRESS (City, State, and Zip Code)

8a. NAME OF FUNDING ORG.

8b. OFFICE SYMBOL

9. PROCUREMENT INSTRUMENT IDENTIFICATION NUMBER

8c. ADDRESS (City, State & Zip)

10. SOURCE OF FUNDING NUMBERS

PROGRAM ELEMENT #	PROJECT #	TASK #	WORK UNIT ACCESS #
-------------------	-----------	--------	--------------------

11. TITLE (Including Security Classification)
Ocean Facilities Program Ocean Construction Equipment Inventory (OCEI)
Equipment Catalog

12. PERSONAL AUTHOR(S)

13a. TYPE OF REPORT

13b. TIME COVERED
FROM TO

14. DATE OF REPORT (YYMMDD) 15. PAGES
1976 257

16. SUPPLEMENTARY NOTATION

17. COSATI CODES
FIELD GROUP SUB-GROUP

18. SUBJECT TERMS (Continue on reverse if necessary)
Ocean construction equipment, Equipment catalogs

19. ABSTRACT (Continue on reverse if necessary & identify by block number)
NAVFAC established the Ocean Facilities Engineering & Construction Program
equipment inventory in December 1974. NAVFACINST 11261.5 promulgates the
policy for management of the inventory and assigns the Chesapeake (Con't)

20. DISTRIBUTION/AVAILABILITY OF ABSTRACT
UNCLASS/UNLIMITED * SAME AS RPT. DTIC

21. ABSTRACT SECURITY CLASSIFICATION

22a. NAME OF RESPONSIBLE INDIVIDUAL
Jac. line B. Riley
DD FORM 1473, 84MAR

22b. TELEPHONE 22c. OFFICE SYMBOL
202-433-3881

SECURITY CLASSIFICATION OF THIS PAGE

BLOCK 19 (con't)

Division of NAVFAC (CHESDIV) responsibility for equipment procurement, storage, maintenance, repair, refurbishment, modification, disposition, and operator and maintenance training. It further establishes that the equipment is to be stored at three sites in the Continental United States: Norfolk, Virginia; Washington, D.C.; and Port Hueneme, CA.

TABLE OF CONTENTS

TAB TITLE/EQUIPMENT CATEGORY	TAB
TABLE OF CONTENTS	1
INTRODUCTION	2
INSTRUCTIONS	3
NAVFACINST 11261.5	
CHESNAVFACENGCOMINST 4860.1	
CABLE SPLICING AND MOLDING EQUIPMENT	4
Hotsplicer, Cable	
Molding Machine, Cable (SB Type)	
CABLE, WIRE ROPE, AND WEIGHT HANDLING EQUIPMENT	5
Bag, Lift (5-Ton Fixed Displacement)	
Bags, Lift (Minor and Professional Range)	
Balloon, Flotation	
Crane, Rough Terrain (35 and 45 Ton)	
Depthometer	
Dynamometer, End-of-Line	
Dynamometer, In-Line	
Dynamometer, Running Line	
Power Unit, Hydraulic (Diesel Driven)	
Pull Machine, Wire Rope	
Reel, Cable Storage	
Scale, Line/Crane	
Stand, Cable Reel	
Tension Machine DOHB	
Winch, Air Powered (4K)	
Winch, Air Powered (7K)	
Winch, Hydraulic, Utility	
Winch, Puller-Tensioner	
Winch, Puller-Tensioner, Single Drum	
Winch, Single Drum (18K)	
Winch, Mooring (20K)	
Winch, Single Drum (30K)	
Winch, Three Drum (140K)	
Winch, Two Drum (146K)	
FACILITIES COMPONENTS	
Air Compressor (250 CFM)	
Anchor, Embedment (20 KIP)	
Anchor, Embedment (100 KIP)	
Cable Protection Assembly (Split Pipe)	
Cable Single Armor (Three Conductor)	
Generator, 60 KW (Diesel Driven)	
NAVIGATION AND BOAT POSITIONING EQUIPMENT	
Mooring System, Modular	
Platform, Auxiliary Propulsion System	
Navigation System, Acoustic Transponder (ATNAV #1)	
Tracking System, Mini-Ranger	

Accession For	
NTIS CRA&I	<input checked="" type="checkbox"/>
DTIC TAB	<input type="checkbox"/>
Unannounced	<input type="checkbox"/>
Justification	
By	
Distribution/	
Availability Codes	
Dist	Avail and/or Special
A-1	

6

7



TAB TITLE/EQUIPMENT CATEGORY

TAB

OCEAN CONSTRUCTION PLATFORM (SEACON)

8

Generator, Thermoelectric
Mini Ranger III System
Vessel, Ocean Construction (SEACON)

SITE SURVEY EQUIPMENT

9

Current Meter, Water, Electromagnetic
Recorder, Depth (4034A)
Recorder, Depth (DE-719B)
Theodolite

TEST EQUIPMENT

10

Amplifier (465A)
Attenuator (4436A)
Attenuator, VHF
Attenuator (3750A)
Attenuator, Conduction Type
Capacitor, Decade
Counter, Digital (1980A)
Counter, Digital Multifunction
Detector, Leak
Deviation Meter, Standard
Fault Locator, Cable (4901A)
Fault Locator, Cable (4910F)
Filter, Hi/Lo, Dual
Filter, Variable
Flaw Detector, Ultrasonic
Function Generator (3310B)
Function Generator (3312A)
Impedance Bridge
Kelvin Bridge
Line Corrector, AC, Dynamic
Measuring System, 5300
Megohmmeter
Multimeter/Counter, Digital (5100)
Multimeter, Digital (3435A)
Multimeter, Digital (3469B)
Multimeter, Digital (6000)
Oscillator (1310-B)
Oscilloscope (211)
Oscilloscope (317)
Oscilloscope (326)
Oscilloscope (485)
Oscilloscope, Storage
Pulse Generator (8011A)
Pulse Generator (214A)
Random Noise Generator
Reflectometer, Time Domain (TDR)
Resistor, Decade
Seismic Sound Processor and Transceiver System
Signal Generator (618C)
Signal Generator (8654B)

TAB TITLE/EQUIPMENT CATEGORY

TAB

TEST EQUIPMENT (Continued)

10

Spectrum Analyzer System
Tester, High Potential (422)
Tester, High Potential (5471)
Tone Burst Generator
Voltmeter, AC
Voltmeter (427A)
Voltmeter, RMS
Voltmeter, Underwater
Wattmeter, Directional, RF
Wheatstone Bridge

VIDEO-AUDIO AND PHOTO EQUIPMENT

11

Camera, Television, Underwater 70MM
Handie-Talkie (220 and MT 500 Series)
Handie-Talkie (PT-400 Series)
Recorder, Audio (Cassette)
Television System, Underwater

MISCELLANEOUS

12

Boat, Inflatable
Buoy System, Spar
Flasher, Submersible
Locker, Bosun
Van, Construction Support

INTRODUCTION

NAVFAC initiated an annual program in fiscal year 1973 for the procurement of ocean construction equipment in an effort to enhance the Navy's capability to perform ocean construction responsively, efficiently, and safely. Equipment needs are identified through an analysis of the assigned NAVFAC missions, Navy requirements, and current and future project workload. These equipment requirements are further defined through a more detailed requirements analysis resulting in an identification of the performance requirements for the individual piece of equipment. A preliminary market search determines the availability of the desired equipment and/or the requirement to develop it. Budgetary cost estimates are then prepared based upon this market search, and the equipment items are programmed for procurement in the desired fiscal year, prioritized based upon need.

NAVFAC established the Ocean Facilities Engineering and Construction Program equipment inventory in December 1974. NAVFACINST 11261.5 promulgates the policy for management of the inventory and assigns the Chesapeake Division of NAVFAC responsibility for equipment procurement, storage, maintenance, repair, refurbishment, modification, disposition, and operator and maintenance training. It further establishes that the equipment is to be stored at the OCEI Support Facility, St. Julians Creek Annex, Portsmouth, Virginia 23702.

In fulfillment of its responsibilities, CHESDIV established guidelines for the use of equipment from the inventory, and promulgated the utilization policy by CHESNAVFACENGCINST 4860.1 of 11 July 1975. This instruction delineates the procedures to be followed by an activity requesting the use of equipment from the inventory and defines the using activity's responsibilities when equipment from the inventory is under their cognizance. These responsibilities primarily entail operating the equipment in accordance with the manufacturer's technical manual or utilizing operators supplied with the equipment, and performing periodic maintenance and corrective field maintenance when required. The user activity is required to support all costs for preparation of the equipment for transportation, costs for transporting the equipment from the inventory site and return to that site, and maintenance costs while the equipment is in the custody of the user. This includes reimbursement for spare parts used, operator expenses incurred by user activity, refurbishment of the equipment prior to returning it to the inventory, operation and maintenance training, and replacement of the equipment if lost or damaged beyond economical repair.

A user activity requiring use of equipment from the inventory will be requested to execute a loan agreement. The loan agreement is a formal document to delineate user activity responsibilities and to temporarily transfer custody of the equipment item to the requestor.

In that the equipment inventory was established to support ocean construction projects assigned to the Naval Construction Force (NCF) or NAVFAC, first choice for use of the equipment will be in support of construction under NAVFAC cognizance being accomplished by NCF or Government contractors. Second priority will be utilization by the NCF on other Fleet projects followed by other Navy activities and DOD agencies.

All inquiries as to available equipment types and capabilities or requests for further information regarding equipment loans should be directed to:

CHESNAVFACENGC
OCEI Support Facility
St. Julians Creek Annex
Portsmouth, VA 23702

Phone: AUTOVON 961-7653
COMMERCIAL (804) 393-7653



DEPARTMENT OF THE NAVY
NAVAL FACILITIES ENGINEERING COMMAND
200 STOVALL STREET
ALEXANDRIA, VA 22332

IN REPLY REFER TO

NAVFACINST 11261.5A
FAC PC-2

16 April 1979

NAVFAC INSTRUCTION 11261.5A

From: Commander, Naval Facilities Engineering Command

Subj: Management Policy for the Ocean Construction Equipment Inventory (OCEI); promulgation of

Ref: (a) NAVFACINST 5450.73B
(b) OPNAVINST 5450.198

Encl: (1) Management Policy for the NAVFAC Ocean Construction Equipment Inventory

1. Purpose. This instruction assigns the responsibilities for and promulgates the policies to be followed in the management of the Ocean Construction Equipment Inventory (OCEI).
2. Cancellation. NAVFACINST 11261.5 of 2 December 1974 is cancelled.
3. Background. In accordance with reference (a), the Ocean Facilities Engineering and Construction Project Office (FPO-1), was established at the Chesapeake Division (CHESNAVFACENGCOM), Naval Facilities Engineering Command to perform the project level functions of planning, design, construction, repair and maintenance for fixed surface and subsurface ocean facilities in support of Navy missions. Included in these major functions is the acquisition of ocean environmental and bathymetric data needed for design and construction of ocean facilities. Reference (b) tasked the Naval Facilities Engineering Command to provide an inventory of specialized ocean construction equipment and facilities components in support of the Naval Construction Force (NCF). In order to fulfill the CHESNAVFACENGCOM and NCF requirements, an inventory of specialized ocean facilities handling, installation, testing, site survey and preparation equipment has been obtained. The equipments are located in storage sites at Portsmouth, Virginia and Port Hueneme, California.
4. Action. The Commanding Officer, Chesapeake Division, Naval Facilities Engineering Command is designated as the manager of the OCEI. As manager, CO, CHESNAVFACENGCOM is tasked to carry out the necessary planning, programming, and acquisition functions required for equipment procurement, storage, utilization and maintenance to assure compliance with reference (b). Further, CO, CHESNAVFACENGCOM shall execute equipment use agreements, provide operators for equipment utilization or conduct operator and maintenance training for equipment users and provide for the release, transportation, refurbishment, repair, modification and disposition of equipments. The OCEI shall be managed in accordance with the policies set forth in enclosure (1).

NAVFACINST 11261.5A

16 April 1979

5. Equipment Utilization. The OCEI is available for use in support of all Navy and government projects. CO, CHESNAVFACENGCOM will annually publish or update a listing of those equipments available for loan from the OCEI. In addition, criteria for executing loan agreements, loan fee schedules, and loan procedures will be established and made available to potential users of the equipment. Organizations who desire to utilize equipments shall submit requests directly to Commanding Officer, Chesapeake Division, Naval Facilities Engineering Command.

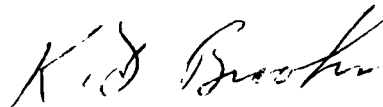

K. D. BROOKS
Deputy Commander for
Facilities Acquisition

Distribution: (2 copies except as otherwise indicated)

SNDL A3	CNO (OPS-21,22,23)
A4A	CNM
21A	Fleet Commanders in Chief (3 copies each)
24	Type Commanders (3 copies each)
26D	UDT's
26F	Operational Test and Evaluation Force Commands and Detachments
26I	Navigation Aids Support Unit
26U	Amphibious Maintenance Support Unit
26WW	Deep Submergence Rescue Vehicle and Deep Submergence Vehicle
28K1	COMSUBDEVGRUONE, COMSUBDEVGRUTWO
39B	Construction Battalions
39C	Construction Regiments
39D	Mobile Construction Battalions
39E	Amphibious Construction Battalions
39G	Underwater Construction Teams
C4K	(Project Managers DSSPO-PM1, TRIDENT Sys Project PM-2, MASWSP PM-4 only)
C4L	DNL
E3A	NRL only (4 copies each)
E3C	NORDA
FA10	SUBASELANT
FA18	AMPHIBASELANT

NAVFACINST 11261.5A
16 April 1979

FA22	COMOCEANSYSLANT
FA25	Public Works Center LANT
FA30	LANTFLTWPNRAN
FA32	CBU
FB13	SUBASEPAC
FB15	NAVSUBSUPFAC
FB21	AMPHIBASEPAC
FB38	COMOCEANSYSPAC
FB41	CBU
FKA1	Systems Command Headquarters (10 copies each)
FKA1B	COMNAVELECSYSCOM (PME-124)
FKA1G	COMNAVSEASYSYSCOM (OOC, PMS-395)
FKA6A	R&D Centers
FKM8	Supply Annex, Cheatham
FKM9	Supply Centers
FKM13	Ships Part Control Center
FKN1	NAVFACENCOMDIV (6 copies each)
FKN2	CBC
FKN5	Public Works Center, NAVFACENCOM
FKP1C	POMFPAC, POMFLANT
FKP1E	NAVTORPSTA
FKP1F	NAVMINENGRFAC
FKP1G	NAVSHIPSPNSYSENGSTA
FKR4A	PACMISLAN
FKR4B	PACMISLANFAC
FKR8C	ENVPREDRSCHFAC

Stocked:

Commanding Officer
Naval Publications and Forms Center
5901 Tabor Avenue
Philadelphia, PA 19120

16 April 1979

MANAGEMENT POLICY FOR THE OCEAN CONSTRUCTION EQUIPMENT INVENTORY

1. Equipment Inventory Management

A. Responsibility. The Ocean Construction Equipment Inventory (OCEI) is under overall management and technical control of the Commanding Officer, Chesapeake Division, Naval Facilities Engineering Command (CO, CHESNAVFACENGCOM). As manager, CO, CHESNAVFACENGCOM has the responsibility for the following:

(1) Define the requirements for all types of ocean construction equipment (including facilities handling and installation equipment, construction platform positioning and control equipment, facilities testing equipment, site survey and preparation equipment, and facility components) which are essential to providing NAVFAC and the Naval Construction Force (NCF) with a low risk, cost effective ocean construction capability.

(2) Develop the performance requirements for the OCEI and prepare the purchase descriptions and specifications necessary for cost effective procurement.

(3) Prepare for approval by higher authority the annual OPN budget requests for the purchase of equipments.

(4) Allocate approved funds to the appropriate Contracting Officers for procurement of equipment.

(5) Monitor the procurement and acceptance testing of the OCEI to assure conformity to design and performance requirements as specified in the purchase descriptions.

(6) Insure a sufficient quantity of repair parts is available to support the equipment on extended deployments.

(7) Establish equipment storage sites within CONUS. (See 1B below) When establishing storage sites, execute as required, appropriate Intraservice Support Agreements to establish, operate and maintain the storage sites.

(8) Establish the requirements for, execute, and monitor an effective maintenance program for the OCEI to insure the equipment remains in a high state of operational readiness as required to meet the NAVFAC/NCF mission. Promulgate equipment operation and maintenance

NAVFACINST 11261.5A

16 April 1979

procedures to be followed by storage site maintenance personnel and equipment users while the equipment is in their possession. Establish procedures for and execute post deployment equipment refurbishment, overhaul and checkout to insure the equipment is restored to an acceptable condition of readiness for future operations.

(9) Prepare annual budget requests for O&MN (Operations and Maintenance, Navy) funds to support the operation and management of the equipment storage sites and for the maintenance and overhaul of OCEI equipments. Establish the requirements for, allocate, and monitor the funds transferred to the support commands who provide storage, management and maintenance services for equipment.

(10) Annually publish or update a list of the OCEI.

(11) Establish and promulgate loan procedures and policies for equipment in accordance with NAVSUPSYSCOM and NAVCOMPT policies for Class III Plant Account Materials.

(12) Process requests for the use of OCEI.

(13) Execute Loan Agreements to delineate the user's financial responsibilities and liabilities for equipment transportation, personnel training, maintenance and repair parts and other funding that may be required for using the equipment. Further, the Loan Agreements shall delineate the duration of the loan period, conditions upon which the equipment will be returned and any limitations on the use of the equipment.

(14) Establish and maintain an operational, maintenance, and financial history for all equipment. This data shall be used to determine equipment lift cycle costs, overhaul requirements, equipment reliability, the effectiveness of the maintenance program and the need for changing the equipment inventory.

(15) Maintain records on each item of equipment concerning its location, material condition, current and future operational commitments, required maintenance schedules and requests for use.

(16) Conduct an operations, maintenance and safety training program for the users of the OCEI as required.

(17) When requested, provide technical assistance to users on specific problems relating to the operation and maintenance of the equipment. Determine the requirements for and provide the services of factory technical representatives to assist with field repairs or the solution of operational problems.

16 April 1979

(18) Dispose of equipment in accordance with existing NAVFAC and DOD policies when equipment no longer meets operational requirements and/or cannot be maintained cost effectively.

(19) Provide operators of the equipment when the CO, CHESNAVFACENCOM determines it is too complex for the user to operate or when requested by the customer.

B. Equipment Maintenance and Storage Site Requirements

OCEI storage and maintenance sites have been established at two locations. These are at the St. Julians Creek Annex, Portsmouth, Virginia and the Construction Battalion Center, Port Hueneme, California. The support services to be provided at the equipment maintenance and storage sites shall be defined in agreements between CO, CHESNAVFACENCOM and the command at which the storage sites are located. These services include the following:

(1) Adequate, secure, covered and open storage space to house the equipments shall be provided. Operating machinery, specialized site survey equipment and all electronic equipment shall be stored indoors in proper environmental controlled storage areas. Facilities components such as anchors, chains, cables, etc., may be stored in the open.

(2) An individual shall be designated to act as the on-site manager and to serve as the point of contact for the base support components (e.g. the Supply Department, Fiscal Department, Public Works Department, Port Services Department, and Equipment Maintenance Departments).

(3) Receive, inspect and inventory all OCEI items arriving at the storage site from the manufacturer, from deployment or from a maintenance facility.

(4) Provide for offloading and placement of all equipment in storage in the designated areas notifying CO, CHESNAVFACENCOM of the receipt and the condition of all equipment coming into the equipment storage site.

(5) Permit no withdrawal or use of the equipment unless prior authorization has been received from CO, CHESNAVFACENCOM.

(6) When notified by CO, CHESNAVFACENCOM that the use of an item of equipment has been authorized, remove the equipment, repair parts and supporting components from storage and prepare them for shipment. Information as to the destination, mode of shipment, consignee,

16 April 1979

approximate date of shipment and fund citation will be supplied. Execute with the base Supply Department the necessary shipping documents notifying CO, CHESNAVFACENGCOM when the equipment has been shipped.

(7) Permit access to the equipment by authorized personnel for the purpose of inspection, maintenance, or training. Provide for any equipment movement or handling required for these efforts.

(8) Manage funds provided by CO, CHESNAVFACENGCOM for the operation of the equipment storage site and for the services provided by the site support activities. Provide a monthly accounting of all operating fund expenditures, in accordance with existing CHESNAVFACENGCOM policy.

2. Funding

A. General. The OCEI equipment will be initially procured and replaced using OPN funding from NAVFACENGCOM. In addition, OPN funds will be used to procure initial stocks of repair parts. The cost of equipment maintenance and storage site operations and equipment maintenance will be funded out of O&MN funds. O&MN funding is authorized for the following:

(1) Personnel and other ancillary cost associated with storage, maintenance, and operation of OCEI equipments.

(2) Providing storage facilities for the OCEI.

(3) Charges for maintenance, personnel and replacement of repair parts and consumables associated with equipment overhaul and repair. The O&MN funds provided for equipment overhaul and repair will be used to supplement those received from equipment users for equipment refurbishment (see paragraph B(2) below). Expenditure of O&MN funds is authorized to insure that the equipments are properly maintained to extend their operating life cycle for the maximum obtainable period.

B. Equipment Use/Loan Fees

NAVFACENGCOM is not required to fund the cost of all maintenance for plant account. NAVSUP Manual, Volume II, paragraph 25848 delineates the loan agreement requirements and financial responsibilities for users of plant equipment. As a result, the following financial responsibilities will be placed on all borrowers or users of OCEI equipment:

(1) All costs incident to preparation of equipment for shipment; transportation, when not otherwise provided by NAVFACENGCOM second destination transportation funds or by lift of opportunity; and all costs incident to the return of the equipment including all cost necessary to prepare the equipment for storage.

16 April 1979

(2) While the equipment is in the custody of the user, all costs required to maintain, protect, preserve and repair the equipment, including necessary replacement of parts.

(3) All costs required to return the equipment to storage in as good as condition as when received; normal wear and tear excepted.

(4) Users shall replace the equipment in the event of loss or damage beyond repair or, at the option of CO, CHESNAVFACENGCOM provide reimbursement for the value of the equipment.

When the equipment is being used by CHESNAVFACENGCOM or the NCF on a cost reimbursable construction project, the costs delineated in subparagraphs (1), (2), and (3) above shall be funded by the customer from project funds. Subparagraph (4) replacement responsibility will be waived.

C. Other Equipment Use Charges

Users shall be required to pay the following charges, if required, incident to the use of OCEI equipments:

(1) Cost of all operator and maintenance training provided.

(2) Cost of support provided by CHESNAVFACENGCOM personnel or factory technical representatives for operating the equipment in the field and/or performing field maintenance and training. These costs include travel, per diem, and salary.

D. Government Furnished Equipment

When OCEI items are loaned to government contractors as Government Furnished Equipment (GFE), the contractor shall pay the Equipment Loan Fee and any additional User Charges associated with the equipment loan.

3. Records and Support Documentation

A. Plant Account

Plant account records for equipment shall be kept under the name, user code and unit identification code of CHESNAVFACENGCOM as required by NAVCOMPT Manual, Volume 3.

B. Inventory List

For each item of equipment, a complete inventory list of the equipment, supporting components, repair parts, special tools,

NAVFACINST 11261.5A
16 April 1979

instruction manuals, diagrams and other nonexpendable items shall be prepared by CHESNAVFACENCOM. A copy of this inventory will accompany the equipment when it is delivered to a user.

C. Instruction Books and Manuals

A complete set of instruction books and manuals for operating and maintaining each item of equipment shall be issued to users of the equipment inventory. These instructions will normally consist of the manufacturer's Operations and Maintenance Manuals, diagrams, drawings, and charts which are provided at the time the equipment is purchased. In addition, supplemental operating and maintenance procedures and safety instructions developed by CHESNAVFACENCOM shall be included as a separate volume. These supplemental procedures are to be used in conjunction with the manufacturer's documents. In the event of a conflict of information, the supplemental procedures shall take precedence.

D. Operation and Maintenance Records

CO, CHESNAVFACENCOM will provide all users of the OCEI with log sheets for recording equipment operating history, maintenance history and the general condition of the equipment. These log sheets will be maintained by the equipment user and returned to CO, CHESNAVFACENCOM upon completion of the loan or usage period.

E. Program Support and Provisioning Technical Documentation (PTD)

Every effort will be made consistent with Ocean Facilities Program objectives and available funding to make maximum use of the Defense Supply System and to provide initial repair parts support for OCEI equipments. Consequently, Allowance Parts Lists (APLs) and/or other suitable support technical documentation shall be provided for each end item piece of equipment with appropriate instruction books/manuals. These support documents will list equipment components, assemblies, and sub-assemblies, manufacturers nomenclature, repair part numbers, and/or National Stock Numbers (NSNs). CO, CHESNAVFACENCOM will determine at the time of equipment procurement the type and kind of PTD to be purchased. When it is determined to be cost effective, PTD required to provide initial repair parts support will be purchased as part of the initial procurement.



DEPARTMENT OF THE NAVY
CHESAPEAKE DIVISION
NAVAL FACILITIES ENGINEERING COMMAND

BUILDING 57, WASHINGTON NAVY YARD
WASHINGTON, D.C. 20374

IN REPLY REFER TO:

CHESNAVFACENGCOMINST 4860.1
FPO-1

JUL 11 1975

CHESNAVFACENGCOM INSTRUCTION 4860.1

From: Commanding Officer, Chesapeake Division,
Naval Facilities Engineering Command

SubJ: Utilization Policy for the Ocean Facilities Program (OFP)
Equipment Inventory; promulgation of

Ref: (a) NAVFACINST 5450.73A
(b) NAVFACINST 11261.5
(c) NAVSUP Manual Volume 2
(d) NAVCOMPT Manual paragraph 035881

Encl: (1) Utilization Procedures
(2) Loan Agreement
(3) Operating Record
(4) Maintenance Record

1. Purpose. This instruction establishes the policy, procedures and requirements for utilization of ocean construction equipment from the Ocean Facilities Program Equipment Inventory.

2. Background. In accordance with reference (a), the Ocean Facilities Engineering and Construction Project Office (FPO-1) was established at the Chesapeake Division, Naval Facilities Engineering Command (CHESDIV) to perform the project level functions of planning, design, construction, repair and maintenance for fixed surface and subsurface ocean facilities in support of Navy missions. To provide CHESDIV and its supporting organizations with the capability to perform these functions reliably and economically, reference (b) directed CHESDIV to obtain an inventory of specialized ocean facilities handling installation, testing, site survey and site preparation equipment. Reference (b) assigned to the Commanding Officer, Chesapeake Division, Naval Facilities Engineering Command, the responsibility of identification, acquisition, storage, utilization and maintenance of all equipment in the OFP Equipment Inventory.

CHESNAVFACENGCOMINST 4860.1

JUL 11 1975

3. Utilization Policy. The OFP Equipment Inventory is available primarily for use in support of NAVFAC projects. When the Naval Construction Force is assigned by the Chief of Naval Operations to support NAVFAC and Fleet projects, these equipments will be available for their use. Navy Laboratories and other Navy and government organizations engaged in ocean projects may use these equipments during periods of low utilization and when conditions are such that the equipment can be returned on short notice for higher priority operations. The equipment may be used by government contractors in their performance of ocean construction work when such utilization is in the best interests of the government. In all cases the Commanding Officer, Chesapeake Division, shall determine the priority for equipment usage.

4. Action. Organizations who desire to utilize equipment from the NAVFAC OFP Equipment Inventory shall submit requests in accordance with and shall comply with the provisions of enclosure (1).

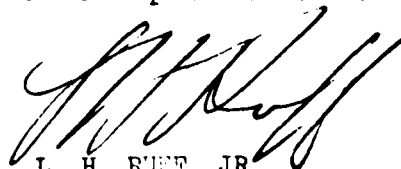

L. H. RUFF, JR.
By Direction

Distribution: (2 copies except as otherwise indicated)

SNDL	A3	CNO (OP's-21,22,23)
	A4A	CNM
	21A	Fleet Commanders in Chief (3 copies each)
	24	Type Commanders (3 copies each)
	26D	UDTs
	26F	Operational Test and Evaluation Force Commands and Detachments
	26I	Navigation Aids Support Team
	26U	Amphibious Maintenance Support Unit
	26WW	Deep Submergence Rescue Vehicle and Deep Submergence Vehicle
	28K1	COMSUBDEVGRUONE, COMSUBDEVGRUTWO
	39B	Construction Battalions
	39C	Construction Regiments
	39D	Mobile Construction Battalions
	39E	Amphibious Construction Battalions
	39G	Underwater Construction Teams

JUL 11 1978

C4K (Project Managers DSSPO-PM1, TRIDENT
Sys Project PM-2, MASWSP PM-4 only)
C4L DNL
E3A NRL only (4 copies each)
FA10 SUBASELANT
FA18 AMPHIBASELANT
FA22 COMOCEANSYSLANT
FA25 Public Works Center LANT
FA30 LANTFLTWPNRAN
FA32 CBU
FB13 SUBASEPAC
FB15 NAVSUBSUPFAC
FB21 AMPHIBASEPAC
FB38 COMOCEANSYSPAC
FB41 CBU
FD1 OCEANAV
FD2 NAVOCEANO
FKA1 Systems Command Headquarters (10 copies each)
FKA1B COMNAVELECSYSCOM (PME-124)
FKA1G COMNAVSEASYSYSCOM (OOC, PMS-395)
FKA6A R&D Centers
FKM8 Supply Annex, Cheatham
FKM9 Supply Centers
FKM13 Ships Part Control Center
FKN1 NAVFACENGCOMDIV (6 copies each)
FKN2 CBC
FKN5 Public Works Centers, NAVFACENGCOM
FKP1E NAVTORPSTA
FKP1F NAVMINENGRFAC
FKP1G NAVSHIPWPNSYSENGSTA
FKR4A PACMISLAN
FKR4B PACMISLANFAC
FKR8C ENVPREDRSCHFAC
FKAIC NAVFACENGCOMHQ

JUL 1964

Utilization Procedures for the Ocean Facilities
Program (OFP) Equipment Inventory

1. Utilization Instructions

a. Requesting Procedures. All requests for the use of OFP Equipment shall be made by letter or message to the Ocean Engineering and Construction Project Office, CHESDIV. All requests for equipment will be expeditiously evaluated as to equipment availability and prior commitments. All requests should contain the following information:

- (1) Requesting Activity
- (2) Type of equipment requested
- (3) Type of project or mission for which the equipment will be used.
- (4) Required delivery date and approximate length of time equipment will be required.
- (5) Exact shipping data (address) for using activity and the requestor's Transportation Account Code (TAC) if applicable.
- (6) Any other relevant information such as prior experience with similar equipment, special transportation requirements, need for modification of the equipment, etc.

All letters of request shall be addressed to:

Commanding Officer
CHESNAVFACENGCOM (FPO-1)
Washington Navy Yard
Washington, DC 20374

All message requests shall be addressed to:

CHESNAVFACENGCOM WASHINGTON DC

Emergency requests for use of the equipment and informal inquiries as to equipment types and availability can be made by calling area code 202-433-3881 or Autovon 288-3881.

Enclosure (1)

b. Approval For Use. When approval for use of the equipment is granted by CHESDIV, an approval letter will be forwarded to the requestor. The letter will contain the following information:

- (1) Type of equipment for which use authority is being granted.
- (2) Current location of the equipment and the projected shipping date.
- (3) Time period that the equipment may be used.
- (4) The requirement for any operations or maintenance training for the user's personnel prior to or after equipment deployment and the requirement in certain cases for the equipment to be accompanied and operated by CHESDIV personnel.
- (5) Any limitations on the use of the equipment and any special maintenance requirements.
- (6) Location to which the equipment is to be returned.

In addition, the approval letter shall contain a Loan Agreement, enclosure (2), which shall be signed by the requesting activity and returned to CHESDIV.

c. Equipment Issue. Upon receipt of a signed Loan Agreement, CHESDIV will make all arrangements to transport the equipment to the user's facility. Included with the basic equipment will be spare parts and accessories, operating and maintenance manuals, operating and maintenance record forms, enclosures (3) and (4), and an inventory list of all equipment and material supplied. Normally, shipment will be made from the storage site utilizing best available government or commercial transportation. The requestor's TAC number and transportation priority code will be cited on the transportation documents where applicable. In the event of an emergency need for the equipment, the equipment will be shipped immediately upon approval of the request and the Loan Agreement will be executed at a later date.

d. Loan Termination. When the loan period is terminated, the user shall be responsible for shipping all equipment and accessories to the place designated by CHESDIV. The completed operation and maintenance records shall be returned to CHESDIV to the address specified in paragraph 1a. The point of return

JUL 11 1975

may differ from the point of the initial shipment depending upon the need for equipment maintenance or other usage requirements, however, the user will not be required to fund transportation costs to a further destination than that from which the equipment was originally shipped. The user shall be responsible for the equipment until it is received at the final destination. Upon receipt, the equipment will be inspected and test operated by CHESDIV representatives to determine the need for repairs and maintenance.

e. User Responsibilities. Any organization using an item of OFP Equipment shall comply with the following conditions of use:

(1) Provide personnel for equipment operations or maintenance training as required by CHESDIV.

(2) Report to CHESDIV any damage to the equipment or loss of items occurring as a result of the shipment.

(3) Install, set-up, assemble and test the equipment in accordance with the manufacturer's technical documents and supplemental CHESNAVFACENGCOM procedures.

(4) Operate the equipment for the purpose for which it was designed and in the manner prescribed by the manufacturer's technical documents and supplemental CHESNAVFACENGCOM instructions.

(5) Perform all periodic preventive maintenance required by the manufacturer's technical documents and supplemental CHESNAVFACENGCOM schedules and procedures. In the event of a conflict of information, the CHESNAVFACENGCOM supplemental procedures shall take precedence.

(6) Perform corrective field maintenance required to correct equipment malfunction or breakdown to restore the equipment to proper operation. The performance of this type of maintenance shall be limited to that which is within the normal capability of the technicians deployed with the equipment.

(7) Report to CHESDIV any equipment breakdown or failure which is beyond the capability of on-site personnel to repair and requires additional technical assistance to restore the equipment to proper operation.

CHESNAVFACENGCOMINST 4860.1

JUL 11 1975

(8) Maintain the equipment Operations and Maintenance Records, enclosures (3) and (4).

(9) Make no modifications to OFP Equipment without prior approval of CHESDIV.

(10) Permit access to the equipment by CHESDIV personnel or authorized representatives for the purpose of inspection and repair.

(11) Reimburse CHESDIV for the items listed in paragraph f.

f. Equipment User Financial Responsibility. Paragraph 25848 of reference (c) delineates the financial responsibilities for users of borrowed plant equipment. The following financial responsibilities are to be borne by users of OFP Equipment:

(1) All costs incident to preparation of equipment for shipment and transportation and, upon expiration or termination of the loan period, all costs incident to the return of the equipment including all costs necessary to prepare the equipment for storage.

(2) While the equipment is in the custody of the user, all costs required to maintain, protect, preserve and effect on-site repairs to the equipment including necessary replacement of parts.

(3) All maintenance costs required to return the equipment to storage in as good a condition as when received, normal wear and tear excepted. This includes the cost of maintenance at a government or commercial facility including replacement of parts and components as required and replacement of all spare parts used during the equipment loan period.

(4) Cost of all operator and maintenance training provided to the user.

(5) Cost of support provided by CHESDIV personnel or factory technical representatives for operating the equipment in the field or performing field maintenance and training. These costs include travel, per diem and salary.

(6) Cost of replacing the equipment in the event of loss or damage, at the option of the Commanding Officer, Chesapeake Division, provide reimbursement for the value of the equipment.

Enclosure (1)

JUL 1977

In some cases CHESDIV will initially fund one or more of the above items and in turn be reimbursed by the user. In other cases the user will be billed directly from the maintenance facility or spare parts source. When the equipment is used by private parties or contractors they will be subject to the payment of rental rates in advance as defined in reference (d).

g. Long Term Assignment of Equipment. In special cases when it is considered to be in the best interest of the Ocean Facilities Program certain items of OFP Equipment will be assigned on an extended loan basis to organizations other than CHESDIV. In such cases the agency involved will be responsible for the day to day operation and maintenance of the equipment. Any operational or maintenance problems of a serious nature shall be referred to CHESDIV for resolution. The equipment will remain under the plant account of CHESDIV and will be subject to recall for use by other organizations should the need arise. All organizations who retain OFP Equipment on an extended loan basis shall be required to sign and return to CHESDIV a custody receipt for the equipment.

2. Ocean Construction Equipment

a. Equipment Types. The OFP Equipment Program Inventory contains, but is not limited to:

(1) Wire rope and cable handling equipment - cable traction winches, linear cable machines, reciprocating wire rope pullers, air tuggers, cable splicing equipment, cable conductor test equipment.

(2) Bottom sampling devices - vibratory corer, boomerang corers, piston gravity corer, grab sampler, rock dredge.

(3) Boat positioning and navigation - Acoustic Transponder Navigation System, Satellite Navigation System, Automatic Boat Positioning System.

(4) Site survey equipment - underwater television recording systems, diver propulsion vehicles, current meters, seismic sound processor, precision depth recorder.

CHESDIV periodically publishes an information brochure listing all of the equipment currently in the inventory as to equipment types and capabilities. A copy of this brochure or information

CHESNAVFACENGCOMINST 4860.1

JUL 11 1975

concerning the availability of the equipment can be obtained by contacting CHESDIV (see paragraph 1.a.(6)).

b. Equipment Location. *OFP Equipment is currently located at three storage sites in CONUS to make it readily available for deployment to ocean construction sites. These storage sites are at the Naval Supply Center, Cheatham Annex, Williamsburg, Virginia; the Naval Construction Battalion Center, Port Hueneme, California; and the Washington Navy Yard, Washington, DC.*

JUL 11 1975

Loan Agreement
Ocean Engineering and Construction Equipment

In consideration for the loan of the below-listed equipment from the NAVFACENGCOM Ocean Facilities Program Equipment Inventory the using agency agrees to the following terms and conditions:

Equipment: _____

1. Assume all costs incident to preparation of the equipment for shipment, all transportation costs to and from the operation site and all costs necessary to prepare the equipment for storage.
2. While the equipment is in the custody of the user assume all costs required to maintain, protect, preserve and repair the equipment including necessary replacement of parts.
3. Assume all maintenance costs required for post operational refurbishment to return the equipment to as good a condition as when received, normal wear and tear excepted, including the cost of replacing any spare parts provided with the equipment.
4. Assume the cost of all required operator and maintenance training.
5. Assume the cost of any necessary support provided by CHESNAVFACENGCOM personnel or factory technical representatives for operating the equipment in the field or performing field maintenance.
6. Maintain the equipment in accordance with the manufacturer's technical documents and CHESNAVFACENGCOM supplementary instructions.
7. In the event of loss or damage beyond repair assume the cost of replacing the equipment in kind or, at the option of the Commanding Officer, Chesapeake Division, provide reimbursement for the value of the equipment.
8. Terminate the loan and immediately return the equipment if requested by CHESNAVFACENGCOM.

Enclosure (2)

CHESNAVFACENGCOMINST 4860.1

JUL 11 1975

This agreement is executed under provisions of NAVFACINST 11261.5
and CHESNAVFACENGCOMINST 4860.1

Signed _____

Title _____

Agency _____

Date _____

OCEAN ENGINEERING AND CONSTRUCTION EQUIPMENT
CHESNAVFACENGCOM

OPERATING RECORD

Type of Equipment: _____ Serial No: _____
 Date Received: _____ Date Returned: _____
 Project: _____
 Location: _____
 Assigned To (person): _____
 Condition of Equipment When Received: _____

 Condition of Equipment When Returned: _____

 Remarks (operating problems, repairs needed, etc.): _____

 Expendable Parts Consumed: _____

DATE	HRS. OPERATED	DATE	HRS. OPERATED	DATE	HRS. OPERATED

Usa additional sheets if necessary

Enclosure (3)

OCEAN ENGINEERING AND CONSTRUCTION EQUIPMENT
 CHESNAVFACENGCOM

MAINTENANCE RECORD

Use this sheet to record all field maintenance performed on Ocean Engineering and Construction Equipment. Include the performance of all equipment preventive maintenance, inspection, adjustment, calibration and corrective repairs.

Type of Equipment: _____ Serial No: _____
 Location: _____

DATE	WORK DESCRIPTION	MAT'L/PARTS USED	MAN HRS	SIGNATURE

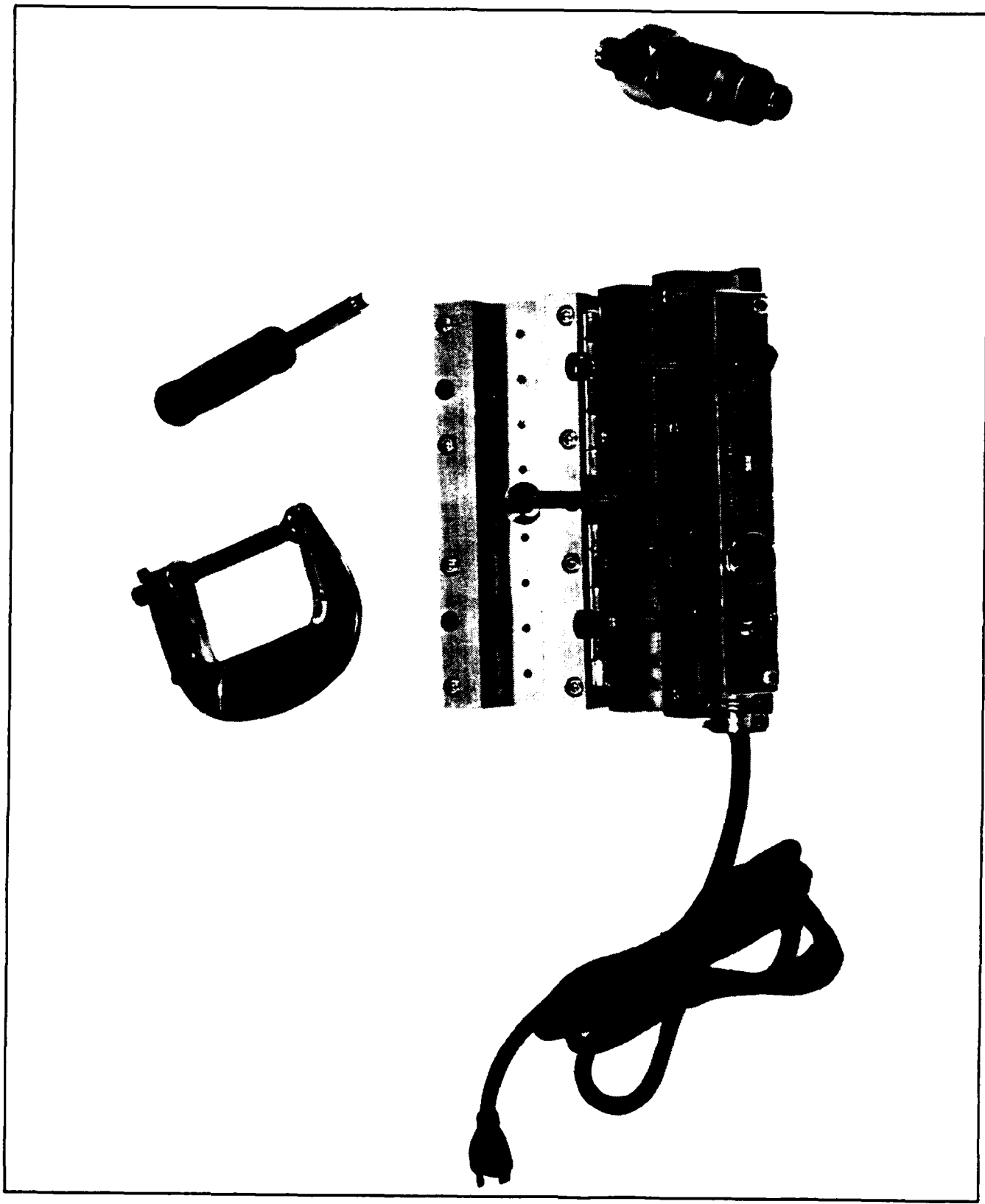

Hotsplicer, Cable

Item

HOTSPLICER, CABLE

Manufacturer

Hotsplicer Corporation, San Diego, CA 92109

Model

301

General Description

The hotsplicer is a portable, heated-platen molding press requiring 115 volts ac, 1200 watts for operation. The unit is designed for splicing and re-jacketing electrical cables and wires having conductor insulation and outer jacket of neoprene, PVC, polyurethane, or cross-linked polyethylene. The hotsplicer consists of two hinged, aluminum alloy, half sections designed to accept a variety of sectionalized (top and bottom) molds for splicing and re-jacketing cables up to 1-1/4 inches in diameter with a maximum molding area of 10 inches. The operating controls are located in front on the bottom section of the hotsplicer and consist of an ON-OFF switch, adjustable temperature control (150-320° F), and a temperature indicator light. The mold can be preheated for use in approximately 10 minutes.

Performance

The hotsplicer is capable of making waterproof, pressureproof, vulcanized splices in cables up to 1-1/4 inches in diameter. Molds are available for .625-, .750-, and .875-inch diameters. The unit splices neoprene, rubber, ethylene propylene rubber, polyvinylchloride, polyurethane, cross-linked polyethylene, and silicone jacketed cables. It splices airhoses and gaskets, re-jackets damaged electrical cables, makes molded rubber parts, and rubber-encapsulates

electrical components. The unit can also be used for transfer molding, which eliminates the requirements for extensive molding skills.

Physical Description

Length	9.0 in.
Width	3.5 in.
Height	3.5 in.
Weight	12.0 lb.

Auxiliary Power or Support Equipment Requirements

An external power source of 115 volts ac is required for operation. A selection of mold cavities is required for a specific use.

Operator/Crew Requirements

One person is required for operating the hotsplicer.

Training Requirements

One day's training in the field or at the manufacturer's facility is required to familiarize operator(s) with the operation and preventive maintenance of the equipment.

Field Maintenance Requirements

Field maintenance will be performed per OCEI instructions and manufacturer's manual. Operating logs and equipment history cards must be maintained.

Spare Parts

Spare parts are available.

Mobilization Time: One day

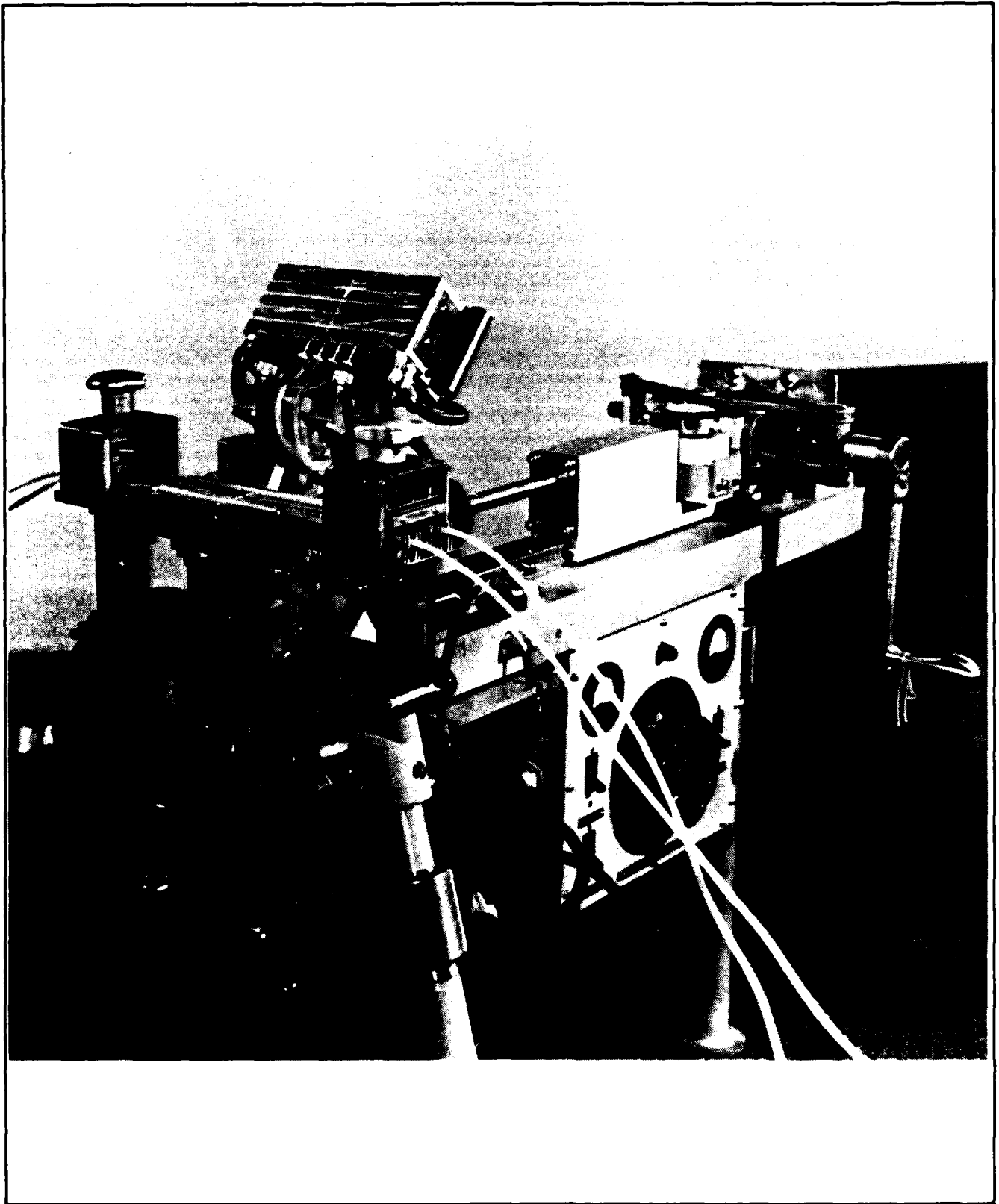

Molding Machine, Cable (SB Type)

Item

MOLDING MACHINE, CABLE, SB TYPE

Manufacturer

Simplex Wire and Cable Co., Newington, NH

Model

NE-307

General Description

The cable molding machine is a portable, self-contained unit for shipboard or field repair of submarine cables of the "SB TYPE." The machine is designed for operation from a 110-volt, 60 Hz ac power supply and consists of mold, injection gun, water pump, electrical supply panel, and mounting frame. The molds are in various sizes and consist of two symmetrical half sections with electrical heaters located in the central portion of each half section. Controlled cooling of the molds is accomplished by circulating cool water through the ends of the molds.

Performance

The cable molding machine is capable of performing molding operations in the field or on shipboard in the repair of polyethylene insulated submarine cables of the "SB Type" 0.620-diameter cable core. Also, with the additional molds available the machine is capable of being used for field repairs of 0.460-, 0.420-, and 0.180-inch core diameters.

Physical Description

Height 36 in.
Length 46 in.

Width 23 in.
Weight 175 lb.

Auxiliary Power or Support Equipment Requirements

An external power source of 110-volt, 60 Hz ac is required for operation of the cable molding machine. A source of water (e.g., from a bucket or barrel) is required for mold cooling.

Operator/Crew Requirements

A minimum of two persons is required to load the cable molding machine, operate the machine, and prepare cable to be repaired.

Training Requirements

Two days' training in the field or at the manufacturer's facility is required to familiarize operator(s) with the operation and preventive maintenance of the equipment.

Field Maintenance Requirements

Field maintenance will be performed per OCEI instructions and manufacturer's manual. Operating logs and equipment history cards must be maintained.

Spare Parts

Spare parts are available.

Mobilization Time: Two days

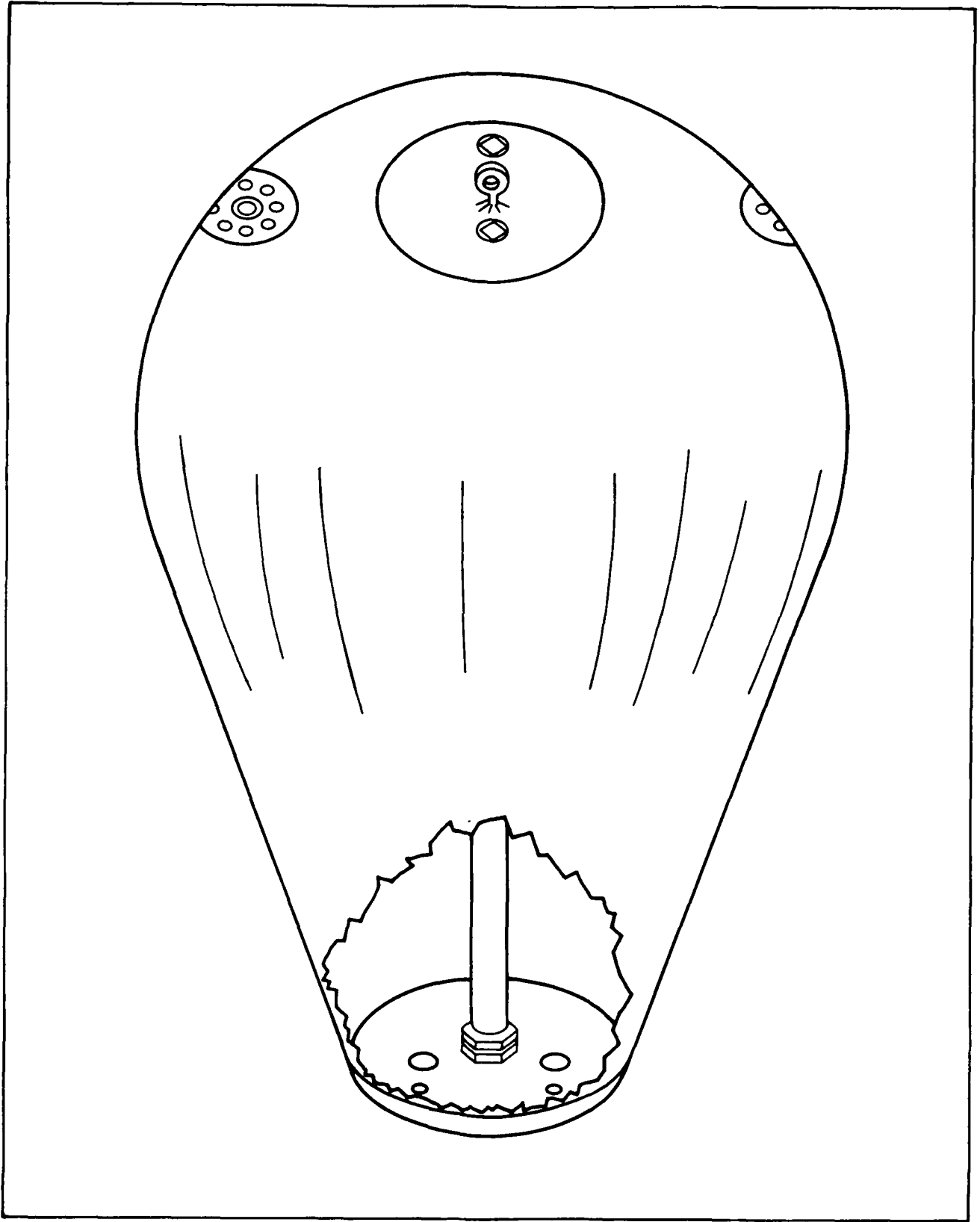

Bag Lift (5-Ton Fixed Displacement)

Item

BAG, LIFT (5-Ton Fixed Displacement)

Manufacturer

Sub-Salve Industries, Inc., Providence, RI

Model

1019

General Description

The lift bag is a lightweight collapsible pontoon designed for lifting objects from the sea floor under controlled conditions. The lift bag is constructed of single-ply, neoprene-coated KEVLAR, with seams stitched and vulcanized for strength.

Performance

Three manifolded ball valves are provided for buoyancy control of the bag. The bag is collapsed and lowered to the object to be lifted. It is then attached and a small amount of air injected to make the bag rise above the object. After checking the rigging, the bag is filled with water. When the bag has assumed its full, unwrinkled form, it is ready for deballasting. Valves are then opened to deballast the bag. The relief valves open at 8.2 psig and flow a total of 1,000 cfm of air. The net buoyancy of the lift bag is 5 long tons in sea water. Maximum through load is 5 long tons.

Overpressurization of the lift bag is not a critical problem since relief valves open at 8.2 psig with a 1,000 cfm air flow.

Physical Description

Diameter (inflated) 84 in.
Height (inflated) 102 in.
Container 50 gal. drum
Weight 175 lb.

Control system (hoses) 308 lb.
Control system (manifold) 15 lb.
Hose dimensions (packaged) . . . 4 ft. X 4 ft. X 1 ft.
Manifold 12 in. X 14 in. X 16 in.

Auxiliary Power or Support Equipment Requirements

Compressed air and water pumping capabilities are required for lift bag control. Weights are required to counteract buoyancy effect of the air hose.

Operator/Crew Requirements

Air bags are designed for use by an underwater construction team possessing familiarity with lift bag use. The crew must be capable of providing the support necessary for safe underwater operation and manning of the shipboard support compressor.

Training Requirements

Training requirements for lift bag operation are incorporated in underwater construction team training programs. Divers and operators would require a brief familiarization and operation period based on the CEL documentation.

Field Maintenance Requirements

Field maintenance will be performed per OCEI instructions and manufacturer's manual. Operating logs and equipment history cards must be maintained.

Spare Parts

Spare parts are not available.

Mobilization Time: Two days



Minor Range



Professional Range

Bags Lift (Minor and Professional Range)

Item

BAGS, LIFT (Minor and Professional Range)

Manufacturer

J. W. Automarine Co., Mt. Kisco, NY 10549

Model

M2, M5, M10, Pr1, Pr1V, Pr2

General Description

These lift bags are buoyancy devices applicable to a wide range of underwater lifting tasks. The bags are available in many sizes to suit various marine salvage operations.

Performance

The lift bags are capable of providing flotation assistance for both concrete and steel platform jackets during load-out, support during pipe and cable laying operations, and general lifting duties for BOP stacks, subsea valves, and hydrocouple removal.

Minor range bags are suitable for a variety of tasks, including recovery of small items and as buoyancy aids for tools and equipment employed underwater. Construction, combined with lightness in weight, of minor range bags makes them ideal to be carried as part of a diver's normal equipment.

Characteristics:

Model M2, M5, and M10

Material: Lightweight fabric with high tenacity polyester coated with PVC

Tensile strength: 412 kg per 5 cm warp and weft

Tear strength: 78 kg warp and weft

Webbing straps: Nylon, 50 mm, with 5,000 kg tensile strength

Valving: Via a diver-controlled dump valve with lanyard and pushbutton operation

Design: Open hemmed to allow excess air to vent off during ascent.

Model Pr1, Pr1V, and Pr2

Material: Heavyweight fabric with high tenacity polyester coated with PVC

Tensile strength: 760 kg per 5 cm strip warp and weft

Tear strength: 120 kg warp and weft

Webbing straps: Nylon, 50 mm wide, with 5,000 kg tensile strength and steel shackle anchor points of up to 5-ton work loads

Valving: Via diver-controlled dump valve with lanyard and pushbutton operation. An air inlet connection hose with quick release coupling is welded within the bag for inflation.

Design: Open hemmed to allow excess air to spill away during ascent. Professional range bags have been designed to enable the commercial user to perform a variety of tasks from vessel and aircraft salvage to providing buoyancy for towing operations.

Physical Description

Model	Lift Strength (lb.)	Overall Width (m)	Overall Length (m)	Shipping Weight (kg) (lb)	
M2	220 (100 kg)	0.45	1.05	4.0	9
M5	551 (250 kg)	0.60	1.3	4.5	10
M10	1,002 (500 kg)	0.75	1.6	7.0	16
Pr1	2,204 (1,000 kg)	1.0	2.5	14.0	31
Pr1V	3,306 (1,500 kg)	1.2	2.7	20.0	44
Pr2	4,409 (2,000 kg)	1.35	2.7	26.0	57

Auxiliary Power or Support Equipment Requirements

Water pumping and adequate air compressor capabilities are required as well as weights to counteract buoyancy effects of the air pumping hose.

Operator/Crew Requirements

An underwater construction team capable of providing the support necessary for safe underwater operation and manning of the shipboard support compressor is required.

Training Requirements

Divers and operators require a brief familiarization and operation period based on the manufacturer's documentation and mission requirements.

Field Maintenance Requirements

Field maintenance will be performed per OCEI instructions and manufacturer's manual. Operating logs and equipment history cards must be maintained.

Spare Parts

Spare parts are not available.

Mobilization Time: Two days

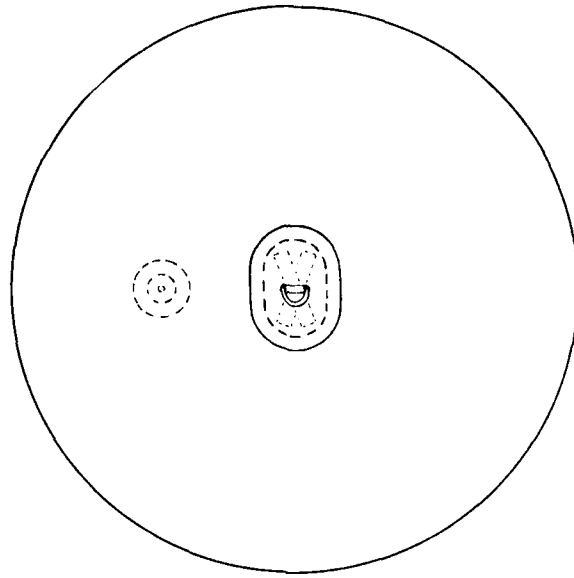

TOP VIEW

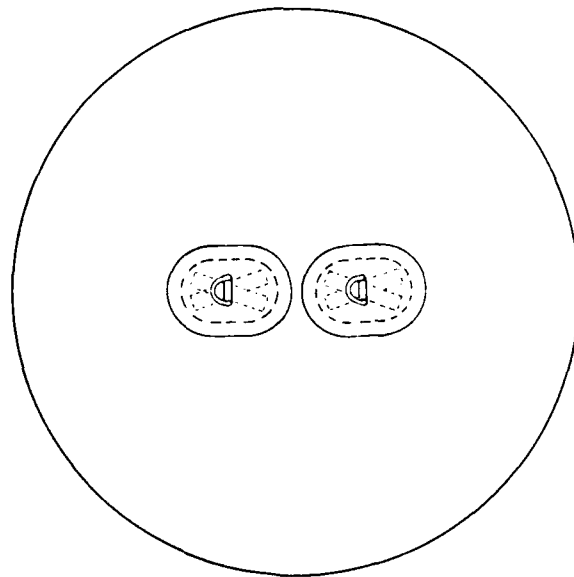

BOTTOM VIEW

Balloon, Flotation

Item

BALLOON, FLOTATION

Manufacturer

Reference NSN 2050-00-574-7963

Model

300-pound float balloon

General Description

The float balloon is a compact flotation device capable of a 300-pound lift via air inflation. A bright orange outer nylon cloth provides visibility during field operations.

Performance

The lightweight balloon is provided with D-ring attachment points capable of withstanding a pull of 300 lb, exerted perpendicular to the base of the patch holding the ring. All nonmetal parts on the float balloon are made of neoprene. Each balloon is tested to 2 lb. psi as measured by a mercury manometer.

The balloon is a minor range float suitable for supporting underwater construction tools, retrieving objects, and performing other underwater tasks requiring compact buoyancy devices.

Physical Description

Diameter 27 in.
Weight 1.75 lb.
Volume 4.5 cu.ft.

Auxiliary Power or Support Equipment Requirements

An air compressor of sufficient capacity is required to fill the balloon through a standard commercial valve adapter.

Operator/Crew Requirements

One person is required to inflate and mount the lift bags.

Training Requirements

One day's training is required to familiarize personnel with the use of the flotation balloon.

Field Maintenance Requirements

Field maintenance will be performed per OCEI instructions and manufacturer's manual. Operating logs and equipment history cards must be maintained.

Spare Parts

Spare parts are not available.

Mobilization Time: Two days

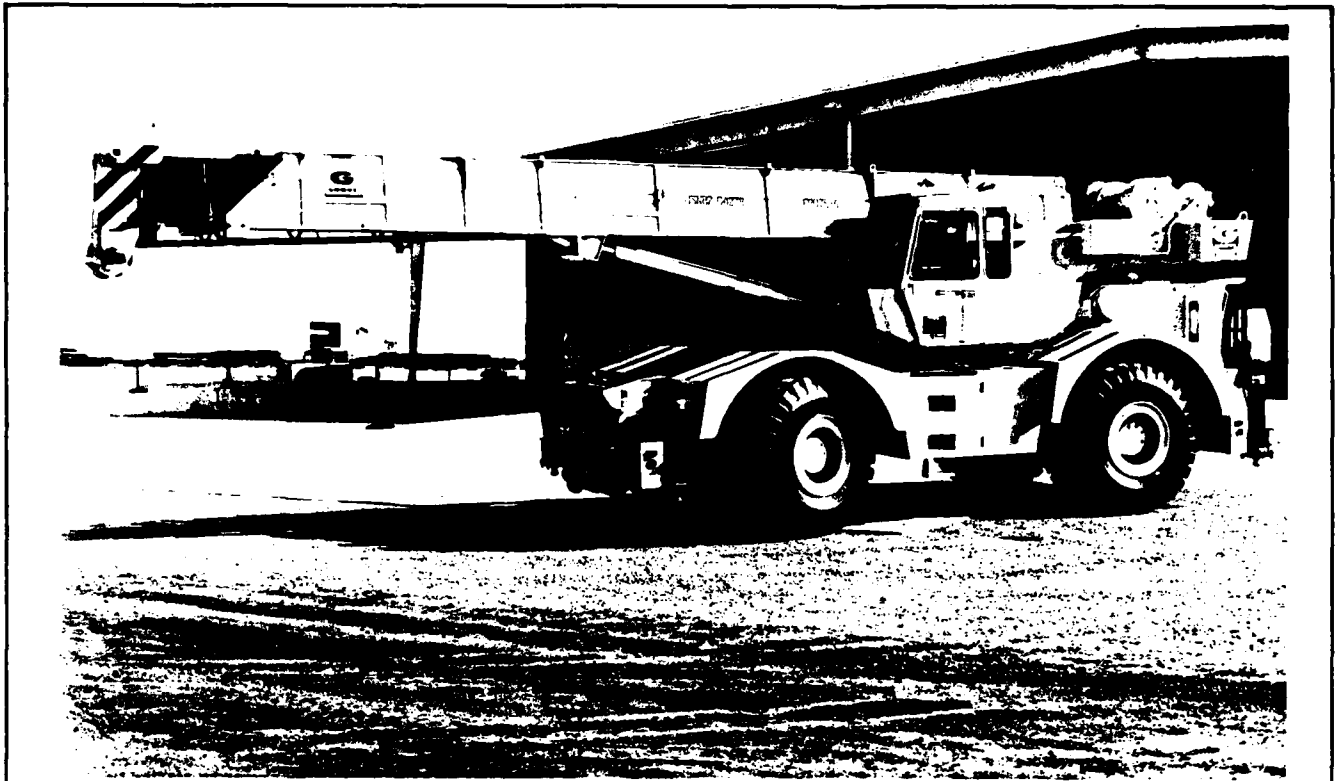

RT 65 S



RT 75 S

Crane, Rough Terrain (35 and 45 Ton)

Item

CRANE, ROUGH TERRAIN

Manufacturer

Grove Manufacturing Co., Shady Grove, PA 17256

Model

RT65S and RT75S

General Description

The Grove rough terrain cranes are self-contained, diesel-driven, hydraulically operated, pneumatic-mounted units. The units feature a two-speed hoist, a four-wheel drive, and four outriggers for leveling and stabilization.

Performance

The RT65S and RT75S units are capable of lifting a maximum load of 35 tons and 45 tons, respectively. The diesel engine power units provide electric power as needed for applicable controls, accessories, lighting system, and indirect drive power for the hydraulic pumps.

Characteristics:

	RT65S	RT75S
Boom sections	3	3
Length retracted	33 ft.	34 ft.
Length extended	80 ft.	84 ft.
Length of extension	32 ft.	32 ft.
Boom max. length w/ext.	112 ft.	116 ft.
Nose sheaves	3 ea.	3 ea.
Sheave thread dia.	15 in.	15 in.
Elevation	4° to 76°	4° to 76°
Swing radius	360°	360°
Swing brake	Mechanical	Auto

Hoist:

	RT65S	RT75S
Lifting capacity (max.)	35 tons	45 tons
Single-line pull		
High (max bare drum)	7,560 lb.	7,560 lb.
Low (max bare drum)	15,120 lb.	15,120 lb.
Single-line speed		
High (max bare drum)		564 fpm.
Low (max bare drum)		282 fpm.
Cable diameter	3/4-in.	3/4-in.

Hoist Limits:

	R65S		R75S	
	cap. (lb.)	Radius (ft.)	cap. (lb.)	Radius (ft.)
Manufacturer	27,200	86	31,000	90
	29,500	110	20,000	115
	9,600	142	17,500	121
	6,000	165	9,600	147
Model			6,000	170

Physical Description

	R65S	R75S
Height	11 ft. 10 in.	12 ft. 8 in.
Length	41 ft. 2 in.	43 ft. 2-1/4 in.
Width	10 ft. 3 in.	10 ft. 11 in.
Weight	68,523 lb.	73,689 lb.
Tail swing	14 ft.	14 ft.
Turning radius	23 ft. 4 in.	20 ft. 8 in.
Max. gradeability	72.8%	74.8%
Engine (diesel)	Cummins	GM
	V555-C200	6-V-53

Auxiliary Power or Support Equipment Requirements

Lifting slings, spreader bars, or other rigging is necessary based upon mission requirements.

Operator/Crew Requirements

One operator and rigger(s) is required for crane operation(s).

Training Requirements

Operators should be licensed and trained in Grove crane operation and have experience with the use of the units obtained either through a factory training period or prior operator experience sufficient to cover standard and ship-board use.

Field Maintenance Requirements

Field maintenance will be performed per OCEI instructions and manufacturer's manual. Operating logs and equipment history cards must be maintained.

Spare Parts

Repair and spare parts are available.

Mobilization Time: Two days

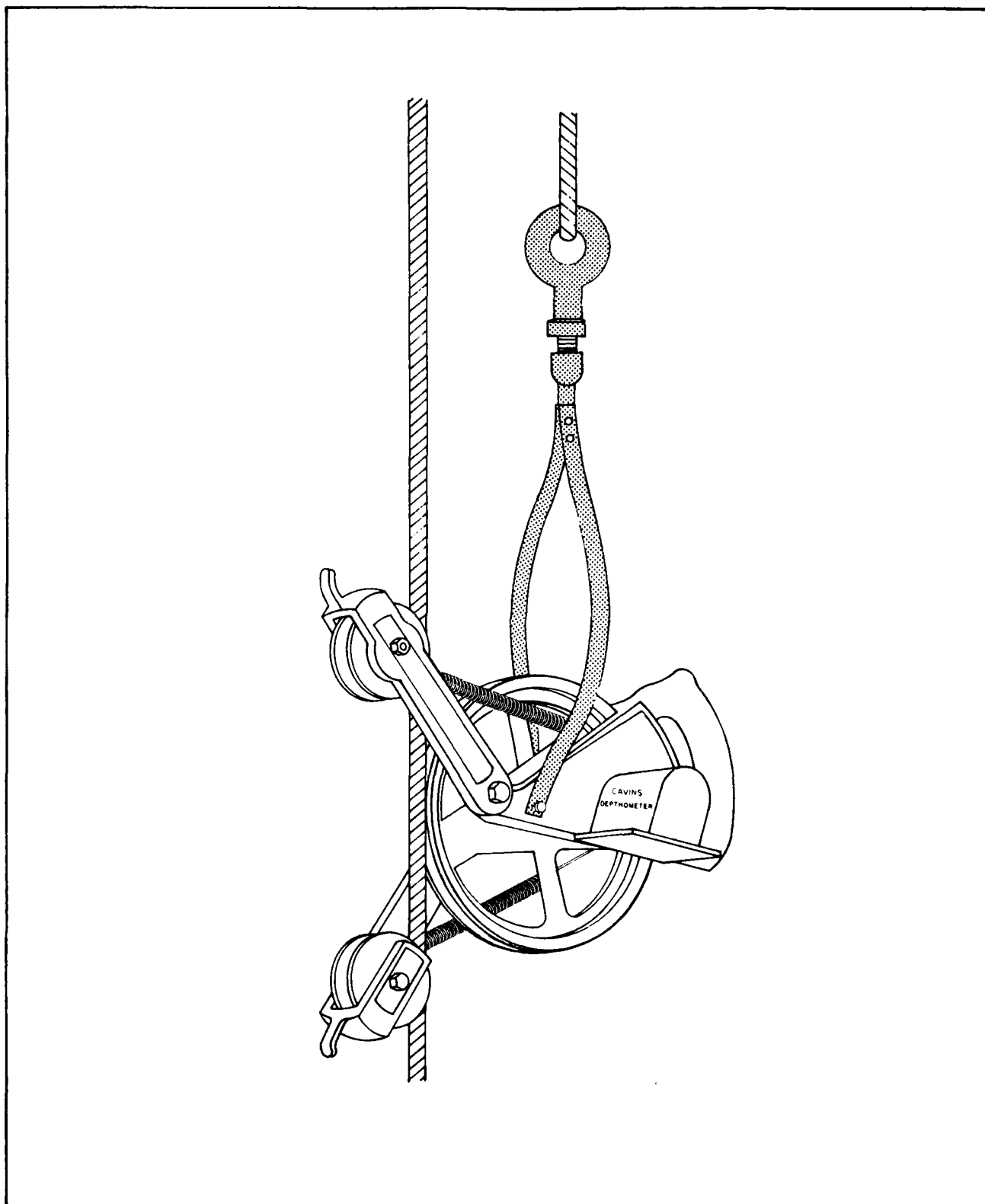

Depthometer

Item

DEPTHOMETER

Manufacturer

The Cavins Company, Long Beach, CA

Model

MC-500-1 "C"

General Description

The Cavins depthometer is a tool used for wire line measurements of oil, gas, and water wells, particularly in perforating, bailing, cleaning out, swabbing, single-shot, or similar operations.

Depths of items are indicated on the counter, which adds or subtracts footage in relationship to direction of travel. The Cavins depthometer is supplied with carrying case and may be assembled for use in a matter of minutes.

Performance

The standard depthometer is designed to measure 7/16-in. – 5/8-in. sand lines in feet. The maximum reading is 99,999 feet.

Proper results depend upon maintaining good traction between the main wheel and line and should be given attention.

Physical Description

Height 21 in.
Width 11 in.
Depth 16 in.
Volume 2.1 cu.ft.
Weight (instrument only) 10 lb. (4.54 kg)

Auxiliary Power or Support Equipment Requirements

N/A

Operator/Crew Requirements

Two days' training in the field or at the manufacturer's facility is required.

Training Requirements

One person is required to operate the depthometer.

Field Maintenance Requirements

Field maintenance will be performed per OCEI instructions and manufacturer's manual. Operating logs and equipment history cards must be maintained.

Spare Parts

Spare parts are not available.

Mobilization Time: Two days

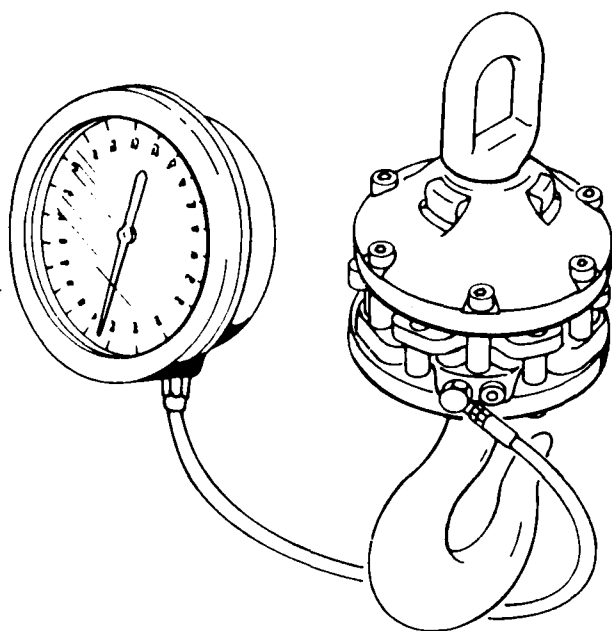

TYPICAL SD SERIES TENSION LOAD CELL SYSTEM

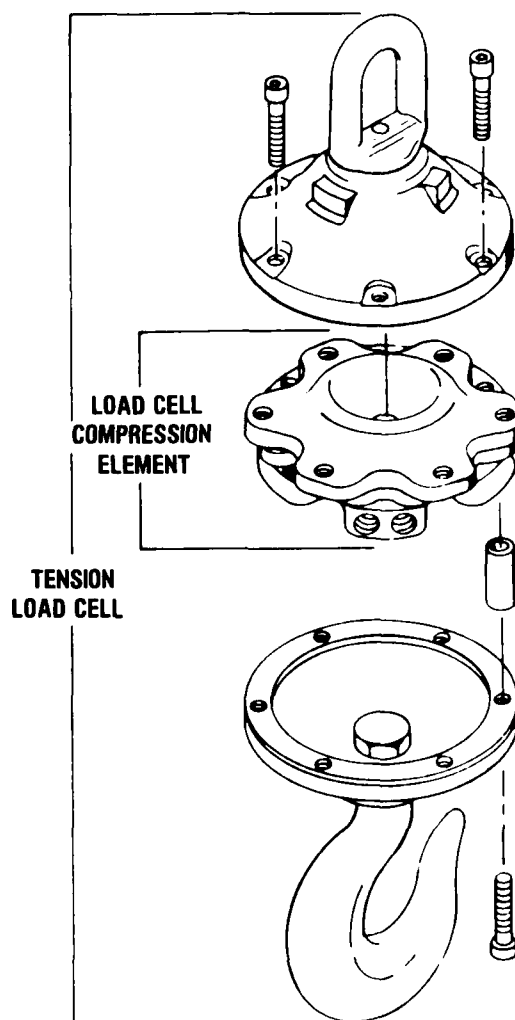

Dynamometer, End-of-Line

Item

DYNAMOMETER, END-OF-LINE

Manufacturer

Martin-Decker Company, Santa Ana, CA 92705

Model

SD18-0200-16

General Description

The end-of-line dynamometer is a self-contained tension-load cell system which is hydraulically operated. The unit consists of an 18-inch gage assembly, a load cell, and a 50-foot hose assembly.

Performance

The end-of-line dynamometer is capable of measuring tension up to 20,000 pounds and is designed to operate in an ambient temperature range of -45° to +65°C (-50° to 150°F). The accuracy of the system is ±0.2% of full-scale capacity.

Physical Description

Load cell	25 in. X 12 in.
Gage	20 in. X 6 in.
Hydraulic hose	50 ft.
Weight of load cell	50 lb.
Weight of gage	20 lb.

Auxiliary Power or Support Equipment Requirements

No auxiliary power or support equipment is required.

Operator/Crew Requirements

A technician-level operator is required to handle the end-of-line dynamometer.

Training Requirements

Use of the dynamometer requires an understanding of the support documentation and a familiarity with use of dynamometers.

Field Maintenance Requirements

Field maintenance will be performed per OCEI instructions and manufacturer's manual. Operating logs and equipment history cards must be maintained.

Spare Parts

Repair parts are not available.

Mobilization Time: Two days

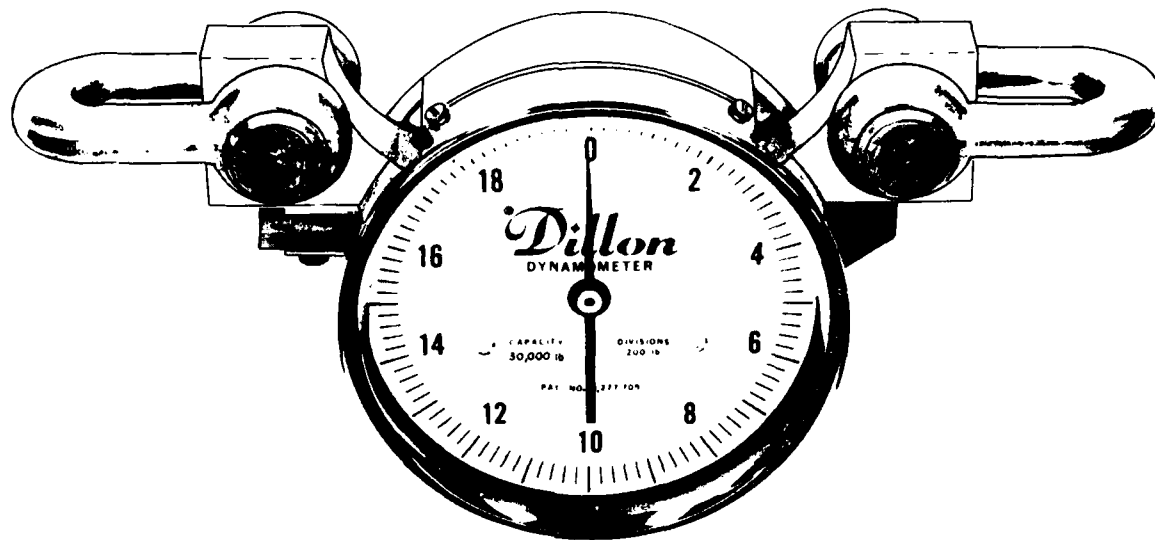

CAPACITY 30,000 LB

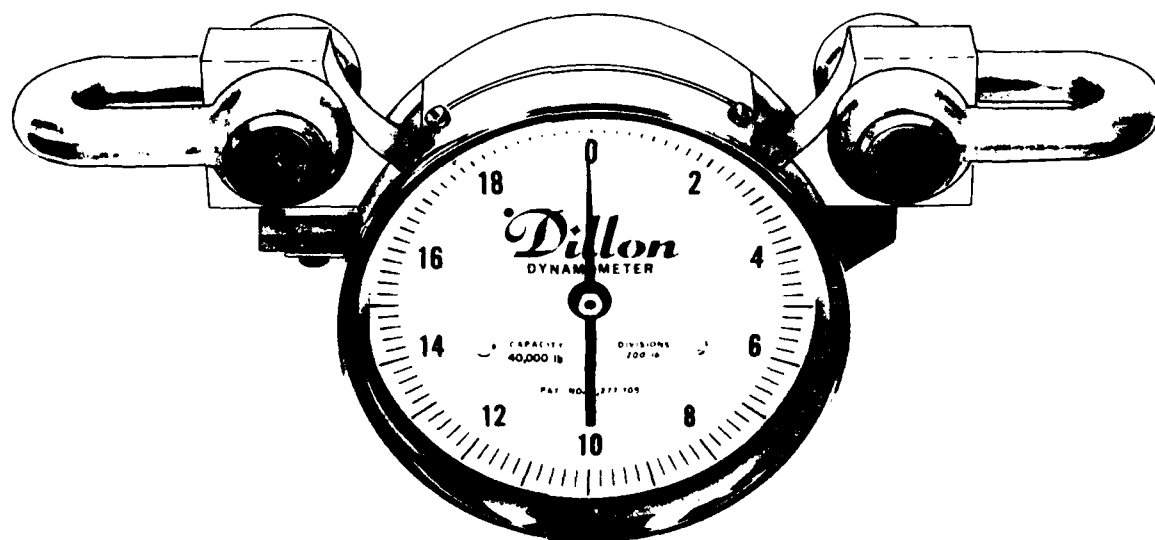

CAPACITY 40,000 LB

Dynamometer, In-Line

Item

DYNAMOMETER, IN-LINE

Manufacturer

W.C. Dillon Co., Van Nuys, CA 91407

Model

N/A

General Description

The dynamometer is a self-contained in-line load measurement device utilizing the deflection of a specially-designed alloy steel beam. The dynamometer can be operated in any position without affecting accuracy. The 6-inch diameter unit is permanently sealed against dust and dirt.

Performance

The in-line dial indicator is capable of providing a reading of 0 to maximum capacity with an accuracy of $\pm 1/2$ %. The unit can be used for a variety of in-line applications for determining weight or tension.

Physical Description

Length	≈ 16 in.
Width	≈ 3 in.
Weight	≈ 20 lb.

Auxiliary Power or Support Equipment Requirements

The dynamometer requires no additional power or support equipment.

Operator/Crew Requirements

N/A

Training Requirements

The technical support literature for this item should be studied prior to using.

Field Maintenance Requirements

Field maintenance will be performed per OCEI instructions and manufacturer's manual. Operating logs and equipment history cards must be maintained.

Spare Parts

Repair parts are not available.

Mobilization Time: Two days

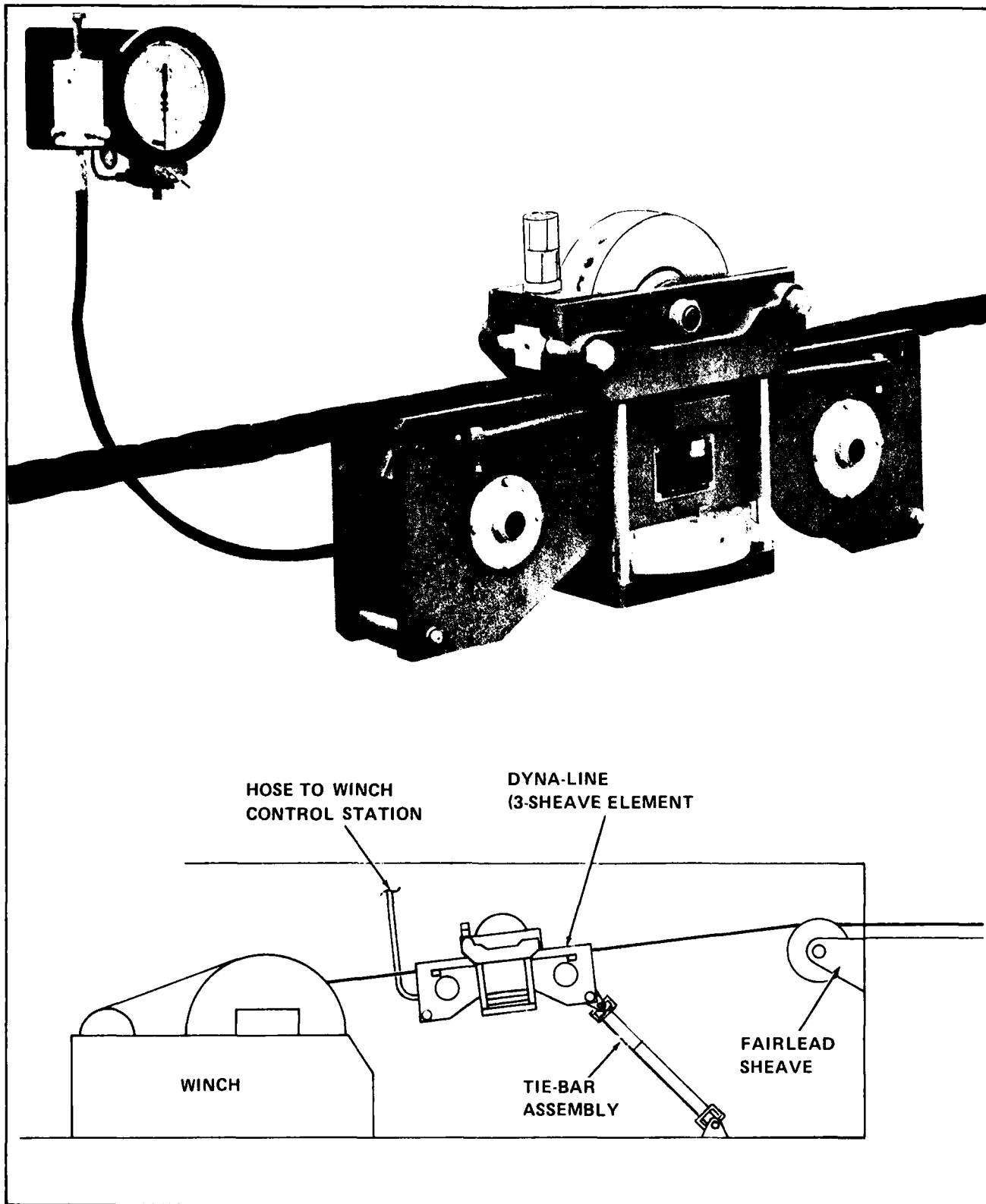

Dynamometer, Running Line

Item

DYNAMOMETER, RUNNING-LINE

Manufacturer

Martin-Decker Company, Santa Ana, CA 92705

Model

D-610-82-502 – Dyna-Line

General Description

The dyna-line tension meter is a self-contained monitoring system designed to transmit a visual indication of tension applied to a wire rope. The dyna-line unit consists of a readout indicator, a hydraulic hose, and a three-sheave element containing a hydraulic compression load cell.

Performance

The tension meter may be used for various applications where a continuous readout of static or moving line tension is required. The 9-inch dial indicator is calibrated in pounds of tension and will provide a reading of 1,000 to 30,000 pounds.

Physical Description

Height 11 in.
Width 6 in.
Length 18 in.
Weight 75 lb.

Auxiliary Power or Support Equipment Requirements

No auxiliary power or support equipment is required.

Operator/Crew Requirements

One qualified technician is required for installing the wire line tension meter.

Training Requirements

One day's training is required, with emphasis on wire line applications.

Field Maintenance Requirements

Field maintenance will be performed per OCEI instructions and manufacturer's manual. Operating logs and equipment history cards must be maintained.

Spare Parts

Spare parts are not available.

Mobilization Time: Two days

Inventory No.: FPO-77-24

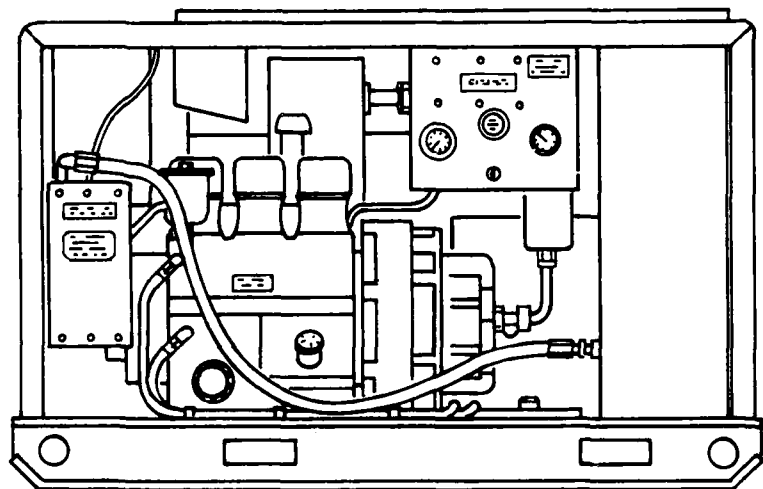
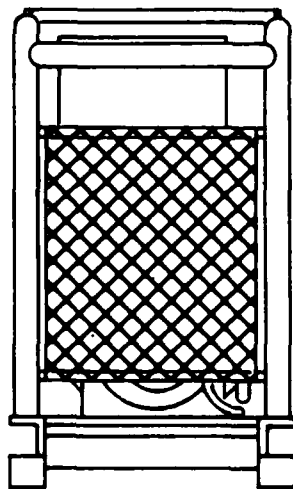
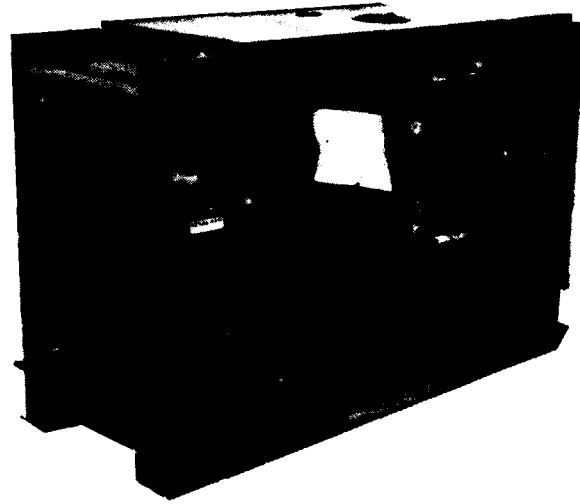

Power Unit, Hydraulic (Diesel Driven)

Item

POWER UNIT, HYDRAULIC (DIESEL DRIVEN)

Manufacturer

Bessemer, Incorporated, York, PA 17405

Model

NORDIV-PD-3950-63-1

General Description

The hydraulic power unit is a diesel-engine-driven, variable volume, in-line, piston-type hydraulic pump mounted on a steel frame and on skids. The diesel engine is an air-cooled, four-cycle, vertical, in-line type with an electric hourmeter, a starter, a battery, and a charging system. Electric controls consist of a glow plug switch, a fuel solenoid switch, and a start switch. Hydraulic instruments include an oil pressure gauge, an oil temperature gauge, and an oil flow meter. The hydraulic pressure is adjustable by hand knob from 150 to 2000 psi. The power unit has a 30-gallon hydraulic fluid reservoir, a fluid level indicator, a hydraulic fluid pump suction filter with a 33-micron-type disposable element, a 14-gallon diesel fuel tank, a steel top plate, and a watertight fabric cover. Two 50-foot sections of 3/4-inch hydraulic fluid hose with quick-disconnect fittings are provided.

Performance

The hydraulic power unit has a rated capacity of 15 gpm at 2000 psi/1800 rpm. The hydraulic fluid cooler maintains the oil temperature below 120° F for a flow of 15 gpm at 2000 psi, and at an ambient temperature of 105° F.

Physical Description

Length 68 in.
Width 23 in.
Height 44 in.
Weight 1000 lb.

Auxiliary Power or Support Equipment Requirements

The hydraulic power unit is self contained and requires no additional power. Sufficient lifting and positioning capability is required.

Operator/Crew Requirements

One person can operate the unit.

Training Requirements

Study of the technical support documents and a brief familiarization period with the hydraulic power unit are required.

Field Maintenance Requirements

Field maintenance will be performed per OCEI instructions and manufacturer's manual. Operating logs and equipment history cards must be maintained.

Spare Parts

Limited spare parts are available.

Mobilization Time: Two days

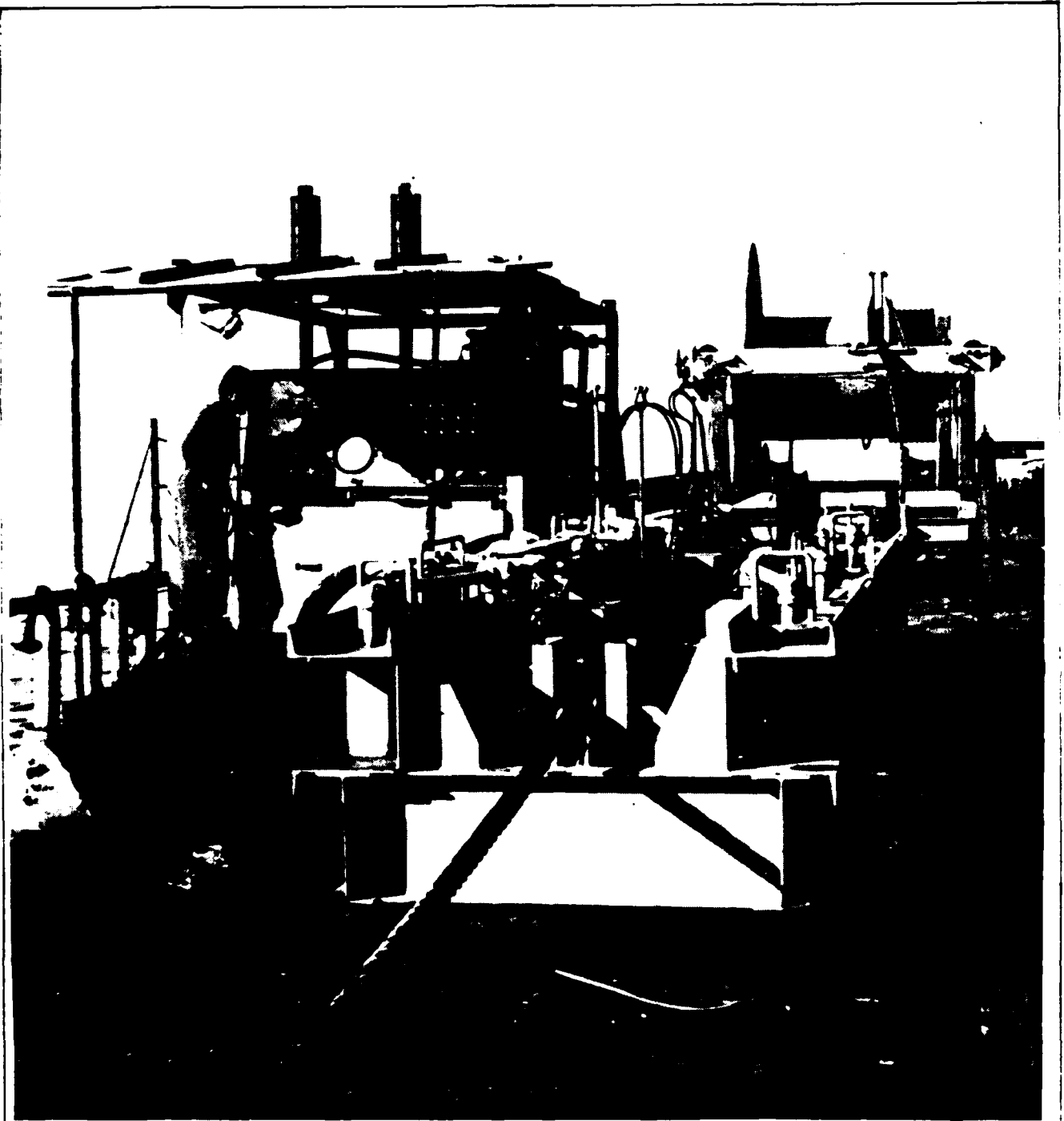

Pull Machine, Wire Rope

Item

PULL MACHINE, WIRE ROPE

Manufacturer

Lucker Manufacturing Co., King of Prussia, PA 19406

Model

74-4A Power Unit
74-4B Puller Unit

General Description

The wire rope pull machine consists of two separate units, a power unit and a pull unit. Each unit may be installed at a convenient location and connected for operation by high pressure hydraulic hose, color coded and equipped with quick disconnect fittings at both ends. The hydraulic power unit is driven by a GMC V-8 diesel engine, developing 275 hp at 2,100 rpm. The pull machine is capable of providing a continuous cable pull of 75,000 pounds and is equipped with cable grips which are adjustable by inserting an appropriately marked liner for 1-inch, 1-1/2-inch, 2-inch, or 3-inch wire rope. The unit may be operated manually or automatically from the control console mounted on the power unit.

Performance

The wire rope pull machine may be used for various applications where a continuous pull is required. The unit may be operated manually or automatically at preset pull pressures. The cable grip is a hinged unit allowing cable to be layed into the grip jaws when in the open position or threaded into the jaws from the end when in the closed position.

Physical Description

Pulling Unit:

Height ≈ 3 ft. 5 in.
Length ≈ 29 ft. 6 in.
Width ≈ 11 ft. 9 in.
Weight N/A

Power Unit:

Height 6 ft. 5 in.
Length 11 ft. 2 in.
Width 7 ft. 7 in.
Weight N/A

Auxiliary Power or Support Equipment Requirements

The wire rope puller requires no auxiliary power. Special provisions are necessary for lifting and positioning the unit aboard ship.

Field Maintenance Requirements

Field maintenance will be performed per OCEI instructions and manufacturer's manual. Operating logs and equipment history cards must be maintained.

CAUTION

Never grease or oil the bevel block at the side of the grip where the lid contacts the grip body.

Operator/Crew Requirements

A minimum number of two technicians is required to prepare the Lucker Puller for operation. One experienced person is required to operate the unit.

Training Requirements

Two days' training in the field or at the manufacturer's facility is required for operation and preventive maintenance of the equipment.

Spare Parts

Spare parts are not available.

Mobilization Time: Two weeks

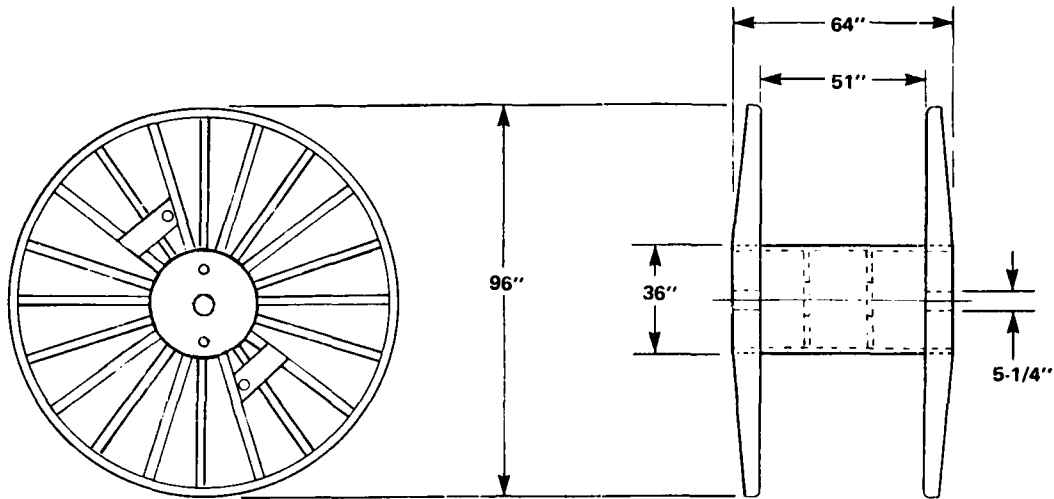

CABLE REEL, 96" DIAMETER

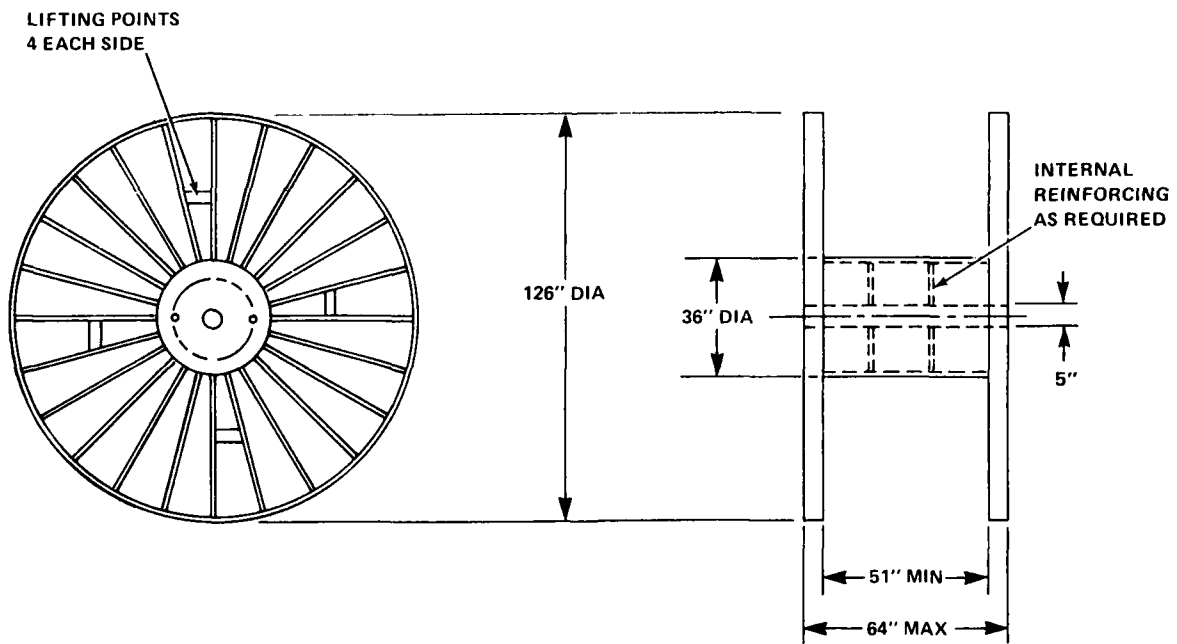

CABLE REEL, 126" DIAMETER

Cable Storage Reel (96-in. and 126-in.)

Item

REEL, CABLE STORAGE

Manufacturer

Pengo Division, Gearhart-Owen Industries Inc.,
Fort Worth, TX 76101

Model

96 in. and 126 in.

General Description

The cable reels are designed for storing cable of various sizes and lengths for use with the Pengo Series 600 puller-tension machines, Model 200 or Model SKVBWPT-20-72-RW and Morgan reel stand, Model L-H 168.

Performance

The cable storage reels are interchangeable with those of the same size and capacity furnished with the original equipment.

Physical Description

Reel, 96-Inch Diameter:	
Width	64 in.
Distance between flanges	51 in.
Core diameter	36 in.
Spindle diameter	5-1/4 in.
Empty weight (approx.)	1,785 lb.
Wire rope storage capacity:	
3/4 in.	56,000 ft.
1 in.	31,000 ft.
1-1/2 in.	13,500 ft.
2 in.	7,500 ft.

Reel, 126-Inch Diameter:

Width	64 in.
Distance between flanges	51 in.
Core diameter	36 in.
Spindle diameter	5 in.
Empty weight (approx.)	2,000 lb.
Wire rope storage capacity:	
3/4 in.	74,149 ft.
1 in.	41,406 ft.
1-1/2 in.	18,537 ft.
2 in.	10,342 ft.

Auxiliary Power or Support Equipment Requirements

A lifting device of sufficient capacity is required for loading and offloading the cable reel(s). The 96-inch and 126-inch cable reels are designed for use with the series 600 Pengo marine winch.

Operator/Crew Requirements

Two persons are required to assist in loading and offloading the cable reels.

Training Requirements

One day's training in the field or at the manufacturer's facility is required for handling the cable reels to prevent damage during loading and offloading.

Field Maintenance Requirements

Field maintenance will be performed per OCEI instructions and manufacturer's manual. Operating logs and equipment history cards must be maintained.

Spare Parts

Spare parts are not available.

Mobilization Time: Two days

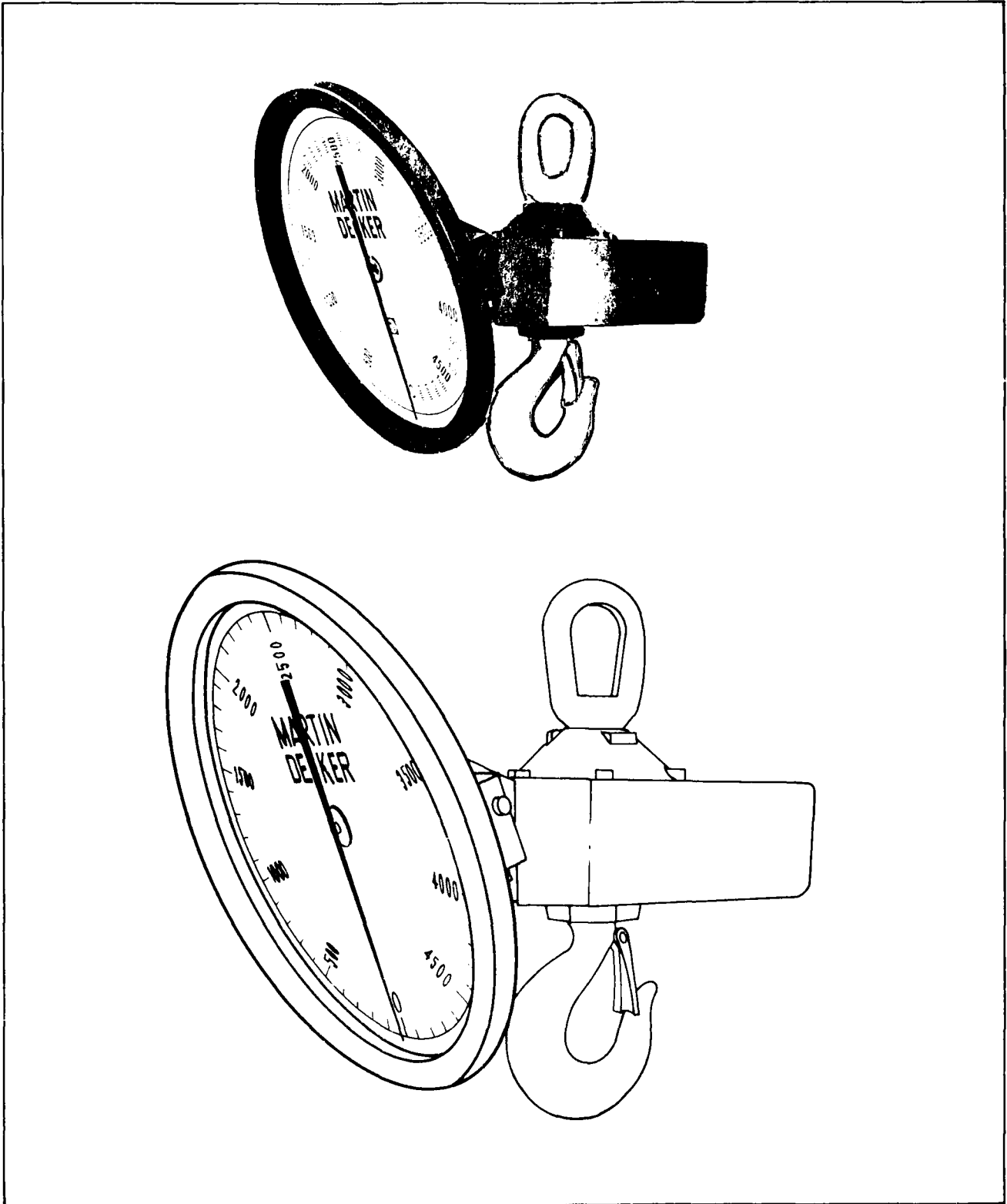

Scale, Line/Crane

Item

SCALE, LINE/CRANE

Manufacturer

Martin-Decker Co., Santa Ana, CA 92705

Model

SU-18 and SU-24 Series

General Description

The line/crane scale is a self-contained unit capable of weighing loads handled by crane or hoisting units up to 300,000 lb.

Performance

The scale is a light-weight portable unit which may be installed between hoist line and load to obtain an accurate weight reading.

Characteristics:

	<u>SU-18</u>	<u>SU-24</u>
Minimum (cap)	0 to 1,000 lb.	0 to 5,000 lb.
Maximum (cap)	300,000 lb.	25,000 lb.

Physical Description

	<u>SU-18</u>	<u>SU-24</u>
Dial dia. (in.)	18	18

Auxiliary Power or Support Equipment Requirements

Auxiliary power or support equipment is not required.

Operator/Crew Requirements

One person is required to install the line/crane scale and obtain weights.

Training Requirements

One day's training is required.

Field Maintenance Requirements

Field maintenance will be performed per OCEI instructions and manufacturer's manual. Operating logs and equipment history cards must be maintained.

Spare Parts

Spare parts are not available.

Mobilization Time: Two days

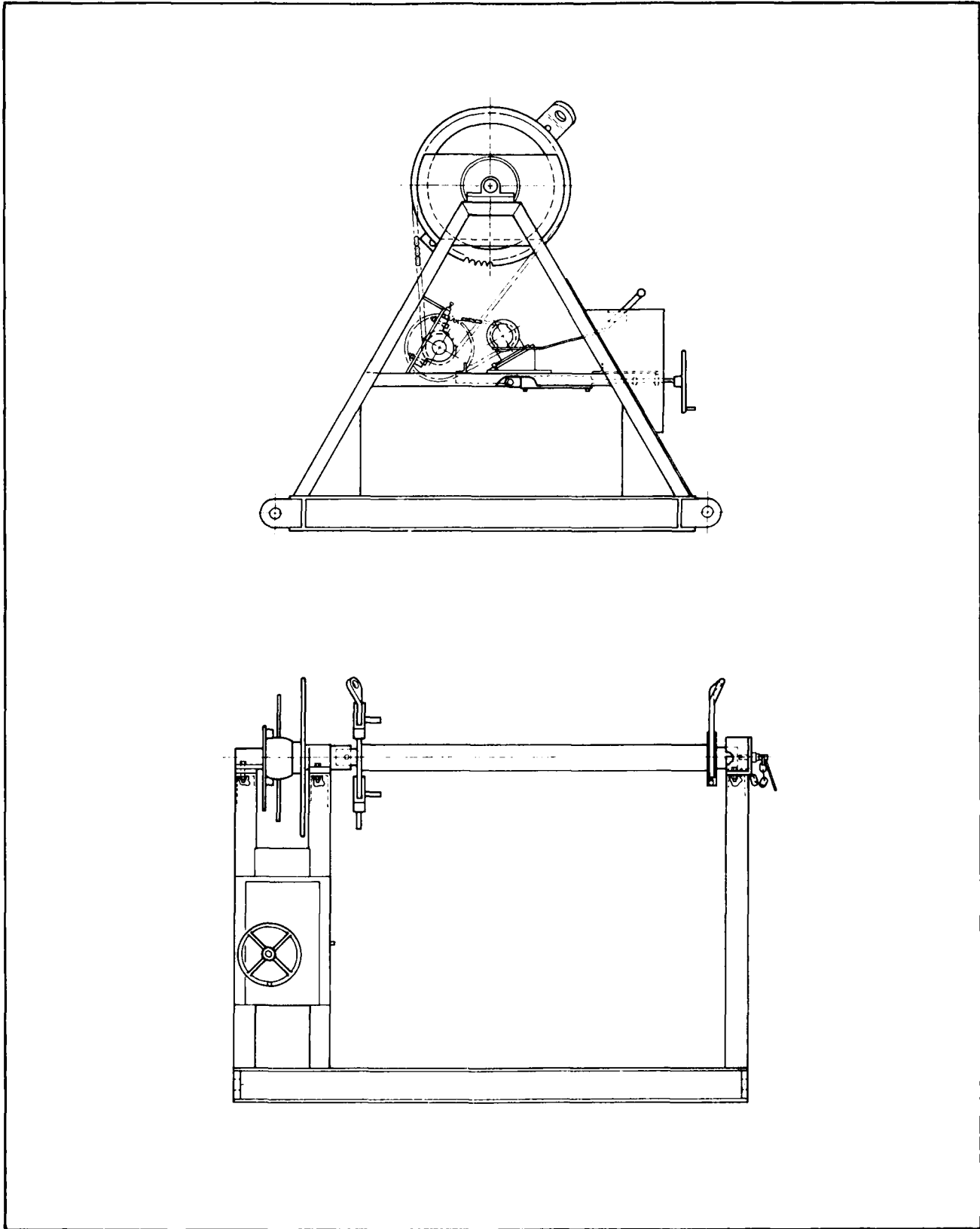

Stand, Cable Reel

Item

STAND, CABLE REEL

Manufacturer

Morgan Apparatus Corp., Seattle, WA

Model

LH-168

General Description

The cable reel stand is a general purpose unit designed for use with heavy-duty, Pengo-type steel cable reels with diameters of 96/126 inches. The stand is skid mounted and power rotated in both directions by an auxiliary hydraulic power source and will support a cable reel weighing approximately 25,000 pounds. The reel stand can be used for light winching, lifting, or cable transfer operations.

Performance

Operating capabilities of the cable reel stand are as follows:

- Designed for use with 96-inch and 126-inch Pengo-type cable reels.
- Provides no-load power at 7 rpm in both directions.
- Has maximum cable pull-off speed of 25 rpm.
- Can provide a 2,800-pound lift at 63 fpm.
- Has a braking resistance of 4,000 pounds without slippage.
- Will support a cable reel weight of approximately 25,000 pounds.

Physical Description

Height 8 ft.
Length 8 ft.
Width 8 ft.
Weight 4,000 lb.

Auxiliary Power or Support Equipment Requirements

The cable reel stand requires an auxiliary hydraulic power supply of approximately 10 gpm at 2,000 psi.

Operator/Crew Requirements

One experienced person is required for operating the cable reel stand. Additional personnel are required based upon application of unit.

Training Requirements

One day's training in the field or at the manufacturer's facility is required to familiarize operator(s) with the operation and preventive maintenance of the equipment.

Field Maintenance Requirements

Field maintenance will be performed per OCEI instructions and manufacturer's manual. Operating logs and equipment history cards must be maintained.

Spare Parts

Spare parts are not available.

Mobilization Time: Two days

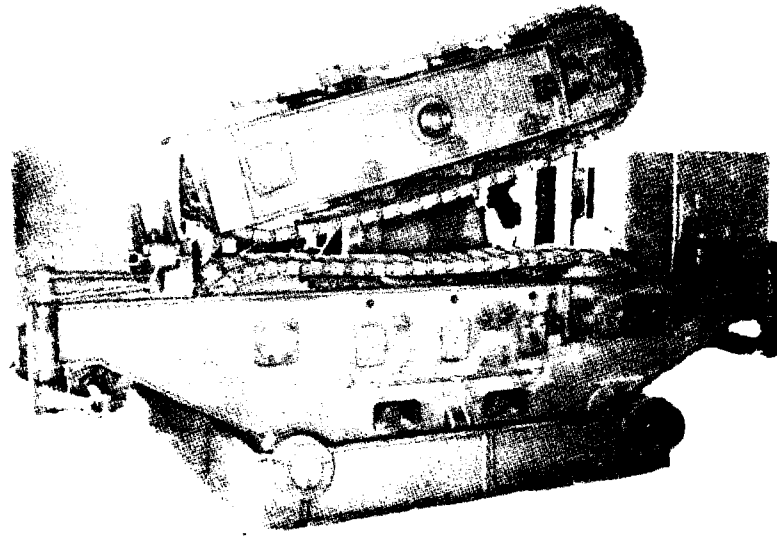

DIMENSIONS IN INCHES

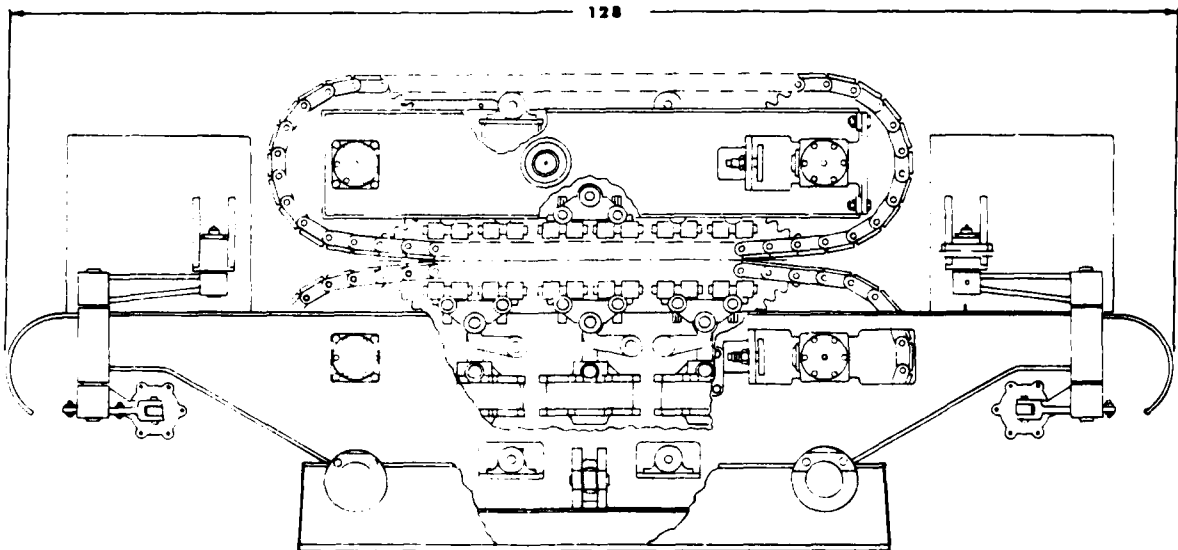

Tension Machine DOHB

Item

TENSION MACHINE, DOHB

Manufacturer

Western Gear Corp., Everett, WA 98201

Model

Draw Off Hold Back Machine (DOHB)

General Description

The draw off hold back machine is a linear cable hauler designed for laying or retrieving long lengths of cables, especially coaxial cables with inline repeaters (T-joints) 6.5 inches in diameter or less. The machine is hydraulically powered, pneumatically operated, with a capability of applying 2,250 pounds of tension at a cable speed of 150 feet per minute (fpm). Power to drive the machine is provided by an electrohydraulic power unit. Air for operation of the pneumatic controls is supplied through the control console from a ship's or an auxiliary air supply. For high speed operation (300 fpm), tension is reduced to 1,125 pounds. The machine consists of two pressure-hydraulic motors, two gear reduction units, two articulated endless belts, air-operated cylinders for track tread slack takeup, and air-operated cylinders to apply squeeze pressure to the cable. A control console unit includes controls and indications for all functions of the main cable engine and the DOHB machine.

Performance

The machine is capable of controlling cable tension to the cable winding drum as it is payed out or hauled in. Controlled tension is achieved through a Vickers PVB-45 variable displacement inline piston pump operating at 1,800 rpm and delivering 45 gpm hydraulic flow to power the two DOHB machine drive motors. The maximum size repeaters which the equipment can pass is limited to 6.5 inches, which is the width of the cable dynamometer assembly. The unit will pull cable at a tension of 0-2,000 pounds at a line speed of 0-3 knots.

Physical Description**DOHB Tension Machine:**

Height (w/track up)	64.8 in.
Height (w/track down)	52.4 in.
Length	127.8 in.
Width	75.4 in.
Weight (approx.)	8,500 lb.
Low gear	2,250 lb @ 150 fpm
High gear	1,125 lbs @ 300 fpm

DOHB Power Unit:

Height	48.0 in.
Length	59.4 in.
Width	44.8 in.

Electric Motors:

Horsepower	30 hp
Electrical input	440 Vac, 3-phase, 60 Hz
Full load speed	1,800 rpm
Enclosure	Watertight

Motor Controllers:

Type	Ac magnetic
Electrical inputs	440 Vac, 3-phase, 60 Hz 115 Vac, 1-phase, 60 Hz

Enclosure Watertight, NEMA IV

Hydraulic Tank:

Capacity	120 US gallons
Immersion heater rating	2,500 watts, 120 Vac, 60 Hz
Thermostatic control	ON at 50° F (10° C) OFF at 80° F (27° C)

Relief Valve Settings:

High pressure relief valve	2,100 psi
Replenishment relief valve	300 psi

Auxiliary Power or Support Equipment Requirements

The DOHB power unit requires 440 volts, 3-phase, 60 Hz electrical power and 100 psi compressed air. Sufficient hoisting facilities are required for lifting and positioning the unit. One box of interconnecting cables and hoses is provided with the unit.

Operator/Crew Requirements

One experienced person is required for operating the DOHB tension machine. Additional personnel are required based upon application of unit.

Training Requirements

Two days' training in the field or at the manufacturer's facility is required to familiarize operator(s) with the operation and preventive maintenance of the equipment.

Field Maintenance Requirements

Field maintenance will be performed per OCEI instructions and manufacturer's manual. Operating logs and equipment history cards must be maintained.

Spare Parts

Spare parts are available.

Mobilization Time: One week

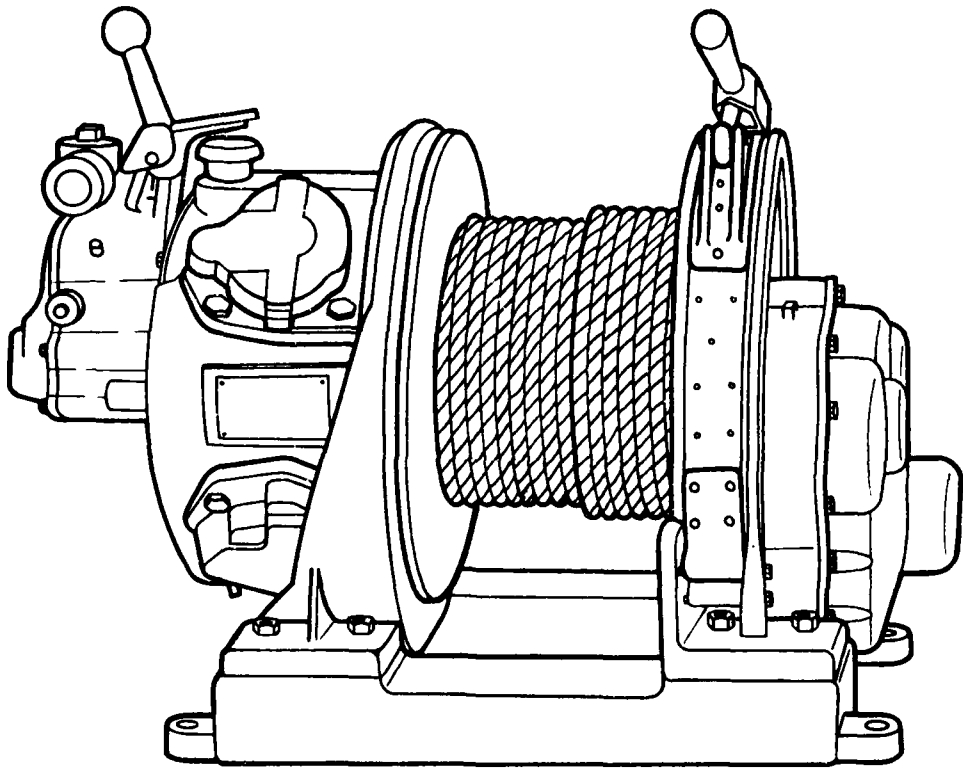

Winch, Air Powered (4K)

Item

WINCH, AIR POWERED (4K)

Manufacturer

Ingersoll Rand, Virginia Beach, VA 23455

Models

K4U and HU 40

General Description

The air winch consists of a radial, piston-type air operated reversible motor and cable drum assembly designed to operate at 90 psi. The winch is controlled by a self closing throttle and band type brake. Power and speed are dependent upon the amount of air pressure applied. The winch is portable and lends itself to a variety of hoisting, pulling/tugging operations.

Performance

The winch is capable of controlled line tension as follows:

<u>Winch</u>	<u>K4U</u>	<u>HU 40</u>
Line pull	4000 lb.	4000 lb.
Line speed	125 fpm.	70 fpm.
Rope size	7/16 in.	3/8 in.

Physical Description

<u>Winch</u>	<u>K4U</u>	<u>HU 40</u>
Weight	850 lb.	525 lb.
Length	39 in.	32-5/8 in.
Width	20-1/4 in.	18-1/4 in.
Height	28-1/2 in.	23-1/2 in.

**Wire Rope
Drum**

	<u>K4U</u>	<u>HU 40</u>
Width	10 in.	7-1/8 in.
Flange Dia.	19 in.	16 in.
Core Dia.	8 in.	7 in.

Capacity, Wire Rope (Full Drum):

<u>Wire Rope Dia.</u>	<u>K4U</u>	<u>HU 40</u>
1/2 in.	687 ft.	391 ft.
5/8-in.	441 ft.	240 ft.

Auxiliary Power or Support Equipment Requirements

An air compressor capable of supplying 90 psi at a minimum of 300 cfm for Model K4U and 179 cfm for Model HU 40 is required to operate the winch drum. A lifting device of sufficient capacity is required for on-off loading.

Operator/Crew Requirements

A minimum of two persons is required to load the cable reel, thread the cable, and monitor the operation of the winch drum. One trained operator familiar with the operation of air-operated winch drums is required.

Training Requirements

One day's training in the field or at the manufacturer's facility is required to familiarize operator(s) with the operation and preventive maintenance of the equipment.

Field Maintenance Requirements

Field maintenance will be performed per OCEI instructions and manufacturer's manual. Operating logs and equipment history cards must be maintained.

Spare Parts

Spare parts are not available.

Mobilization Time: Two days

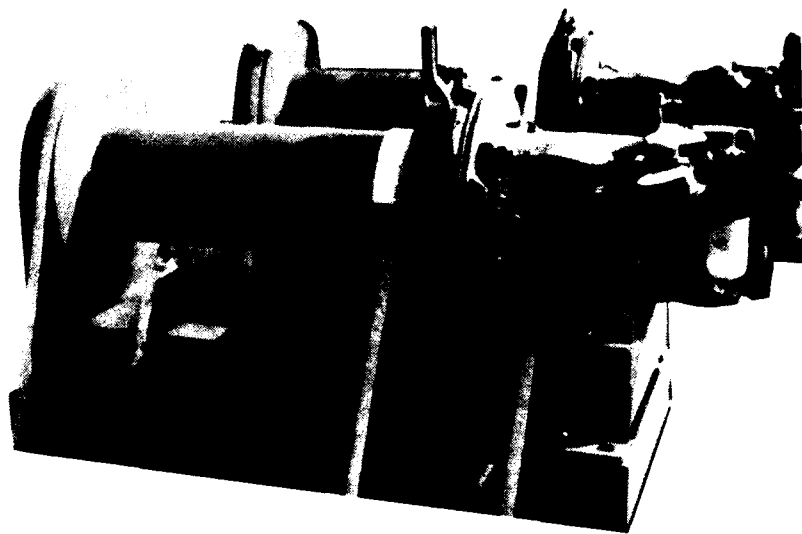

Winch, Air Powered (7K)

Item

WINCH, AIR-POWERED (7K)

Manufacturer

Beebe Brothers, Inc., Seattle, WA 98134

Models

7000-P-80-36 and 3100-P-115-12 AB

General Description

Each winch consists of a radial, piston-type, air-operated motor and cable drum assembly designed to operate at 90 psi. The winch is controlled by an air valve and may be stopped, started, and reversed at any time without removing the load. Power and speed are dependent upon the amount of air pressure applied. The winch is portable and lends itself to a variety of hoisting and pulling/tugging operations.

Performance

The winch drum is capable of controlled line tension at maximum line pull.

Physical Description

	<u>7000-P-80-36</u>	<u>3100-P-115-12AB</u>
Winch Drum:		
Shipping	2200 lb.	1,800 lb.
Length	63 in.	63 in.
Width	31-3/4 in.	32 in.
Height	35-1/2 in.	36 in.
Cable Drum:		
Width	24 in.	36 in.
Flange diameter	25 in.	25 in.
Core diameter	12-3/4 in.	12-3/4 in.

Cable Drum Capacity:

<u>Dia.</u>	<u>Length</u>	<u>Dia.</u>	<u>Length</u>
5/8 in.	1,500 ft.	5/8 in.	1,500 ft.
3/4 in.	1,150 ft.	3/4 in.	1,100 ft.
7/8 in.	850 ft.	7/8 in.	850 ft.

Auxiliary Power or Support Equipment Requirements

An air compressor capable of supplying 90 psi at a minimum of 700 cfm for Model 7000 and 500 cfm for Model 3100 is required to operate the winch drum. A lifting device of sufficient capacity is required for on-off loading.

Operator/Crew Requirements

A minimum of two persons is required to load the cable reel, thread the cable, and monitor the operation of the winch drum. One trained operator familiar with the operation of air-operated winch drums is required.

Training Requirements

One day's training in the field or at the manufacturer's facility is required to familiarize operator(s) with the operation and preventive maintenance of the equipment.

Field Maintenance Requirements

Field maintenance will be performed per OCEI instructions and manufacturer's manual. Operating logs and equipment history cards must be maintained.

Spare Parts

Spare parts are not available.

Mobilization Time: Two days

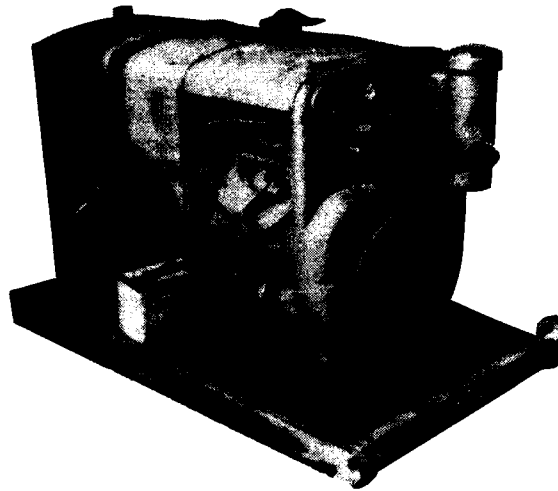

HYDRAULIC POWER PACK

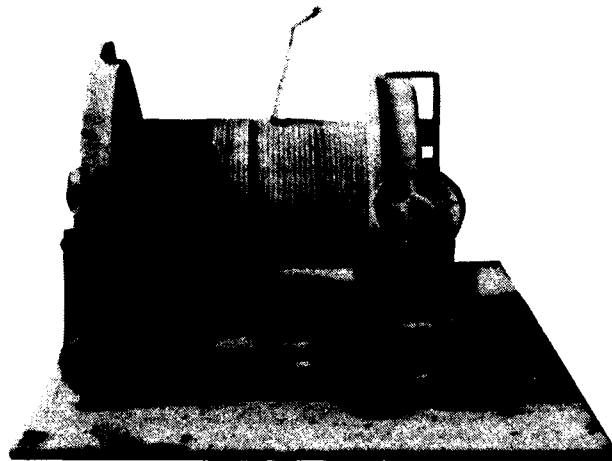

WINCH UNIT

Winch, Hydraulic, Utility

Item

WINCH, HYDRAULIC, UTILITY

Manufacturer

N/A

Model

N/A

General Description

The utility winch is a single-drum, hydraulically driven unit powered by a detached power pack, driven by a Wisconsin V-4, air-cooled gasoline engine.

Performance

The hydraulic-driven winch can be used in a variety of tugging/hoisting applications.

Physical Description

Winch unit:

Length	53 in.
Width	55 in.
Height	45 in.
Weight	700 lb.

Hydraulic Power Pack:

Length	63 in.
Width	34 in.
Height	42 in.
Weight	700 lb.
Engine	Wisconsin, air-cooled, V-4 gasoline

Auxiliary Power or Support Equipment Requirements

No additional power or support equipment is required. High-pressure hose connections are furnished with the equipment.

Operator/Crew Requirements

One person is required to operate the winch.

Training Requirements

Two days' training is required to familiarize personnel with the operation and maintenance of the equipment.

Field Maintenance Requirements

Field maintenance will be performed per OCEI instructions and manufacturer's manuals. Operating logs and equipment history cards must be maintained.

Spare Parts

Spare parts are not available.

Mobilization Time: One week

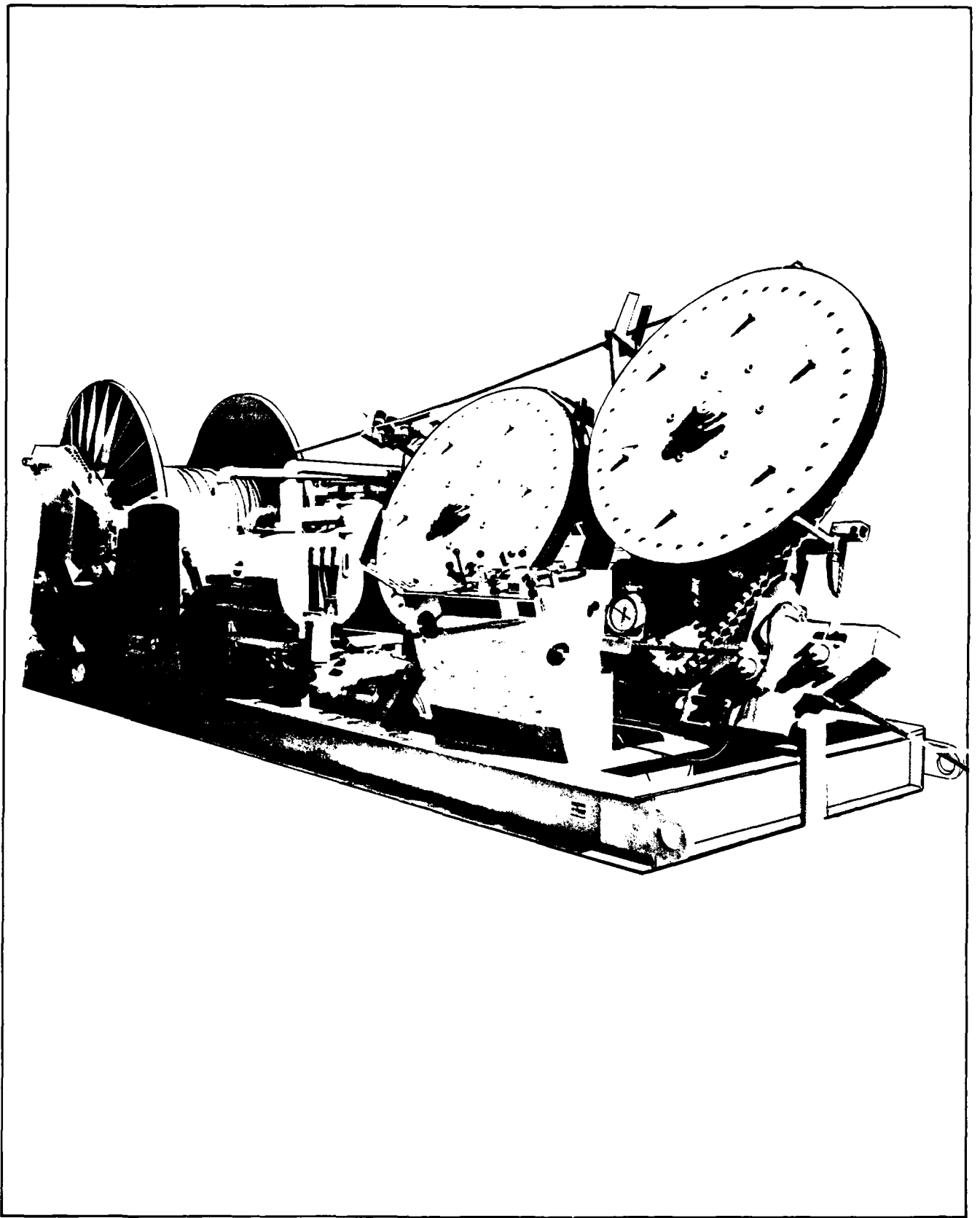

Winch, Puller-Tensioner

Item

WINCH, PULLER-TENSIONER

Manufacturer

Pengo Hydra-Pull Corporation, Gearhart-Owen Industries, Inc., Fort Worth, TX 76101

Model

Model 200, Series 600, and SKVBWPT-20-72-RW

General Description

The winch is a self-contained, skid-mounted, high-tension traction machine which utilizes two in-line V-groove bullwheels to provide high cable tension for raising and lowering. The bullwheels are rubber lined and their configuration permits a 270° cable contact on each wheel. The winch has an integral self-loading cable reel which operates at low tension to provide cable back tension to the bullwheels. The winch is hydraulically powered by a Detroit Allison V6-71 diesel engine developing 238 hp at 2,100 rpm. Controls for the entire system are located on a console mounted at the forward end of the winch. The bullwheel high tension and the cable reel low tension may be preset by the operator to any level up to the equipment rating. A hydraulically operated level wind system is incorporated which tilts the bullwheel frame to keep the wheels in line with the cable entrance/exit point on the reel. Both 96-inch and 126-inch cable reels are available in the OCEI.

Performance

The winch is capable of providing controlled line tension up to 20,000 lb. at 150 fpm. It will handle electro-mechanical cable or synthetic rope 1/2 inch to 2-1/4 inches in diameter.

Physical Description

	Model 200	Model SKVBWPT-20-72-RW
Winch Unit:		
Length w/reel	322 in.	354 in.
Width	96 in.	99 in.
Height w/reel	122 in.	136 in.
Cable reel	96 in.	96 or 126 in.
Bullwheel O.D.	73 in.	73 in.
Weight (approx.)	33,000 lb.	40,000 lb.

Model 200 and SKVBWPT-20-72-RW

Cable reel:

Specifications	Optional Reel	Standard Reel
Size	126-in. od X 64 in.	96-in. od X 64 in.
Distance between flanges	51 in.	51 in.
Core diameter	36 in.	36 in.

Capacity of wire rope (w/2-in. free flange):

Specifications	Optional Reel	Standard Reel
3/4-in. od	80,700 ft.	42,600 ft.
1-in. od	45,400 ft.	24,000 ft.
1-1/2-in. od	20,100 ft.	10,600 ft.
2-in. od	11,400 ft.	6,600 ft.

Auxiliary Power or Support Equipment Requirements

No auxiliary power is required to operate the winch. A crane of sufficient capacity will be necessary for on-off loading of the winch and cable reels. Sufficient space at the back end of the winch must be available to permit operation of the self-loading cable reel mechanism (6 to 8 ft.). Self-loading mechanisms may require the assistance of a crane to position the cable reel if the combined reel/cable weight is excessive.

Operator/Crew Requirements

One experienced person is required to operate and monitor the operation of the winch. Additional personnel requirements are based upon the application of the unit.

Training Requirements

Two days' training in the field or at the manufacturer's facility is required to familiarize operator(s) with the operation and field maintenance of the equipment.

Field Maintenance Requirements

Field maintenance will be performed per OCEI instructions and manufacturer's manual. Operating logs and equipment history cards must be maintained.

Spare Parts

Spare parts are available.

Mobilization Time: One week

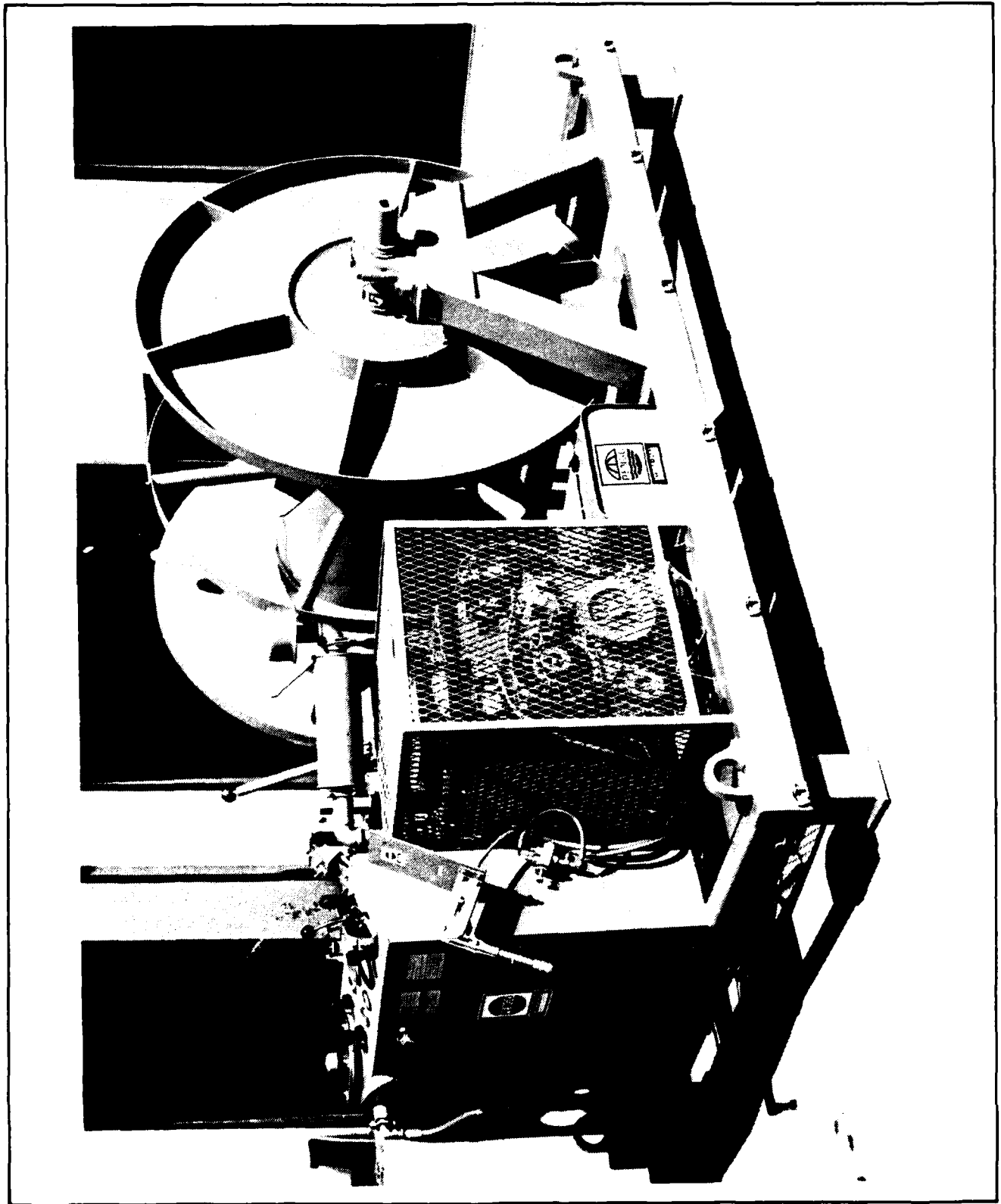

Winch, Puller-Tensioner, Single Drum

Item

WINCH, PULLER-TENSIONER, SINGLE DRUM

MANUFACTURER

Pengo Division, Gearhart-Owen Industries, Inc., Fort Worth, TX 76101

MODEL

SKCP-20

General Description

The winch is a self-contained, base-mounted, variable speed puller-tensioner powered by a Lister, Model HR-3, air-cooled, 49 hp diesel engine. The unit is capable of pulling a line tension of 0-2,000 pounds at 4 mph with a line speed range of 0-4 mph at 2,000 pounds. The unit may be operated at a higher speed but at a reduced line pull.

Performance

The winch is a puller-tensioner having a wide range of speed and tension. The hydrostatic reel drive system is pressure compensated, which enables the operator to pre-set a maximum line pull when used as a puller or to maintain any degree of sag when used as a tensioner. A level-wind is powered by a hydraulic cylinder and is controlled at the operator's station.

Physical Description

Height	78 in.
Width	82 in.
Length	136 in.
Weight	4,280 lb.

Physical Description (continued)

Maximum reel diameter	60 in.
Maximum reel width	44 in.
Maximum hydraulic pressure	4,000 psi
Engine, air-cooled diesel	49 hp
Electrical system	12-volt

Auxiliary Power or Support Equipment Requirements

Auxiliary power or support equipment is not required. Sufficient hoisting facilities are required for loading and off-loading the unit.

Operator/Crew Requirements

One experienced person is required for operating the winch, puller-tensioner. Additional personnel requirements are based upon application of unit.

Training Requirements

Two days' training in the field or at the manufacturer's facility is required to familiarize operator(s) with the operation and field maintenance of the equipment.

Field Maintenance Requirements

Field Maintenance will be performed per OCEI instructions and manufacturer's manual. Operating logs and equipment history cards must be maintained.

Spare Parts

Spare parts are not available.

Mobilization time: Two days

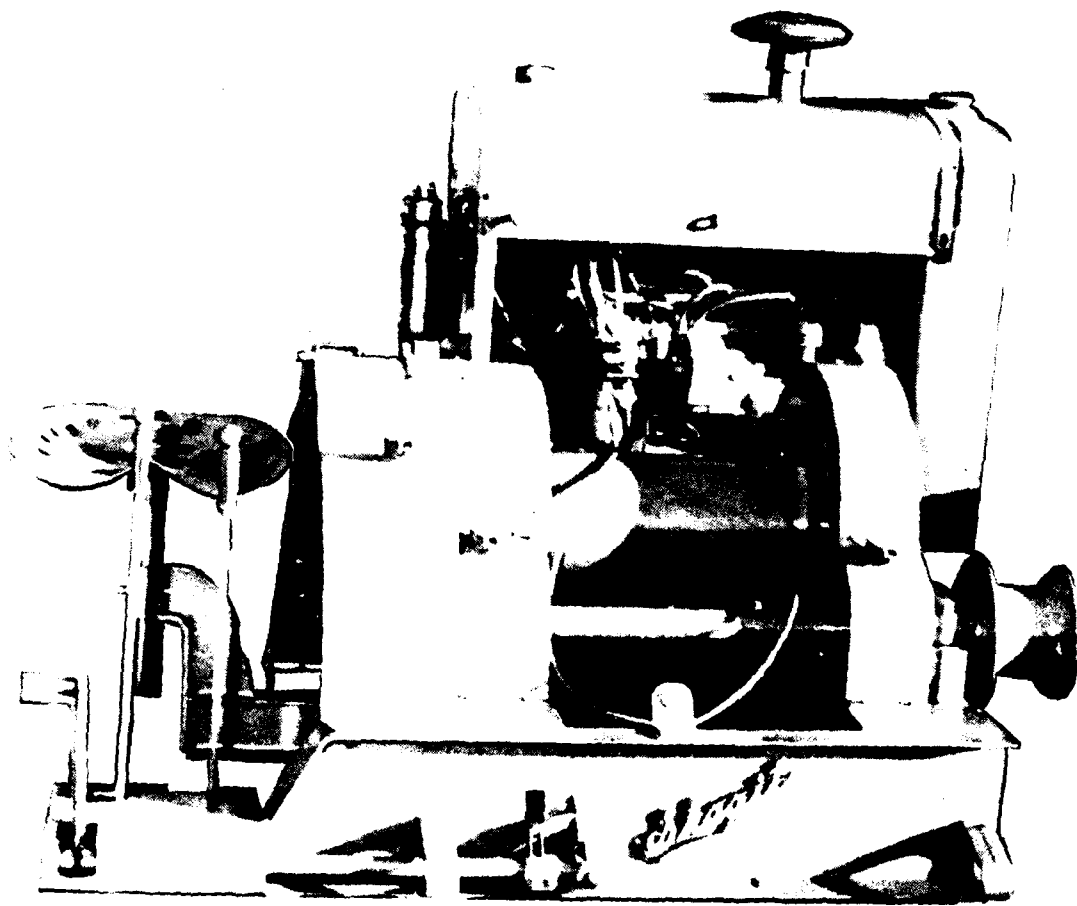

Winch, Single Drum (18K)

Item

WINCH, SINGLE DRUM (18 K)

Manufacturer

Skagit Corp., Sedro-Wooley, WA 98284

Model

GU-8-YD

General Description

The single-drum winch is a self-contained two-speed unit powered by a Waukesha, Model 190 GLU, 57 hp gasoline engine at 2,000 rpm. The unit can be used for a variety of winching, hoisting, and mooring operations.

Performance

The cable winch is capable of performing in two-speed ranges in accordance with the following data:

	<u>Drum</u>	<u>Speed</u>	<u>Pull</u>
High Range:	Full	370 fpm	4,580 lb.
	Average	275 fpm	8,170 lb.
	Bare	189 fpm	18,400 lb.
Low Range:	Full	181 fpm	9,380 lb.
	Average	134 fpm	12,600 lb.
	Bare	92 fpm	18,400 lb.

Physical Description

Winch Unit

Height	52-1/2 in.
Length	67-5/8 in.
Width	81-5/8 in.
Weight	N/A

Cable Drum

Flange	18-1/2 in.
Core (dia.)	9 in.
Length	18 in.

Cable Drum Capacity

Cable	Drum Capacity
3/8 in.	2,180 ft.
1/2 in.	1,230 ft.
5/8 in.	790 ft.

Auxiliary Power or Support Equipment Requirements

Sufficient hoisting facilities are required for loading and off-loading the winch unit.

Operator/Crew Requirements

One experienced person is required for operating the winch unit. Additional personnel are required based upon application of unit.

Training Requirements

Two days' training in the field or at the manufacturer's facility is required to familiarize operator(s) with the operation and preventive maintenance of the equipment.

Field Maintenance Requirements

Field maintenance will be performed per OCEI instructions and manufacturer's manual. Operating logs and equipment history cards must be maintained.

Spare Parts

Spare parts are not available.

Mobilization Time: Two days

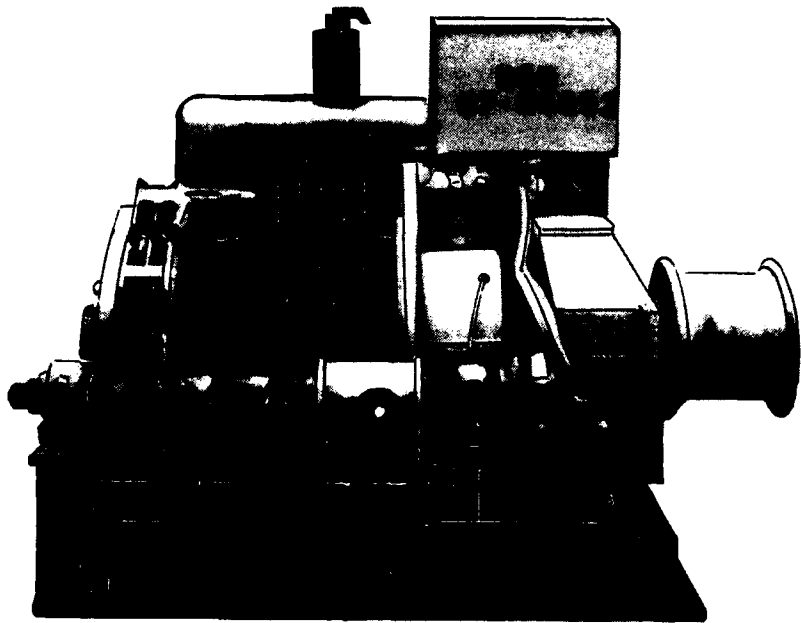

Winch, Mooring (20K)

Item

WINCH, MOORING (20K)

Manufacturer

Dey Manufacturing Co.

Model

PSD-Type 20 M

General Description

The mooring winch is a single-drum self-contained skid-mounted unit with a gypsy head mounted outboard. The winch unit is powered by a General Motors Detroit diesel 4-53, liquid-cooled engine. Power is transmitted to the winch by a soundstrand fluid transmission. A control console mounted on the winch unit contains controls for all operations.

Performance

The mooring winch is capable of providing infinite speed control from zero to a maximum line speed of 150 feet per minute on a mean drum in both directions.

Physical Description

Winch Unit:

- Height 5 ft. 9 in.
- Length 10 ft. 3/4 in.
- Width (w/gypsy head) 7 ft. 9 in.
- Width (w/o gypsy head) 6 ft. 7 in.
- Weight (w/o hoses) 10,444 lb.
- Gross weight (approx.) 11,000 lb.

Physical Description (continued)

Cable Drum:

- Core 20 in.
- Flange dia. 6 in.
- Flange face-to-face 27 in.
- Circumference 32 in.
- Shaft dia. 5 in.
- Wire rope capacity 700 ft.
- Wire rope dia. 1 in.

Auxiliary Power or Support Equipment Requirements

Auxiliary power or support equipment is not required. Sufficient hoisting facilities are required for loading and off-loading the winch unit.

Operator/Crew Requirements

One experienced person is required for operating the winch unit. Additional personnel are required based upon application of unit.

Training Requirements

Two days' training in the field or at the manufacturer's facility is required to familiarize operator(s) with the operation and field maintenance of the equipment.

Field Maintenance Requirements

Field maintenance will be performed per OCEI instructions and manufacturer's manual. Operating logs and equipment history cards must be maintained.

Spare Parts

Limited spare parts are available.

Mobilization Time: One week

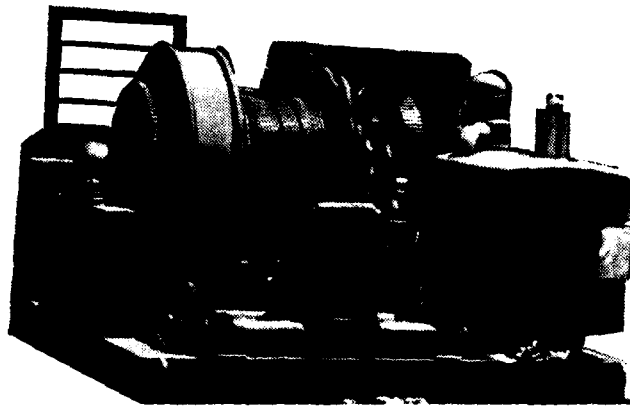

Cable Drum Right Side

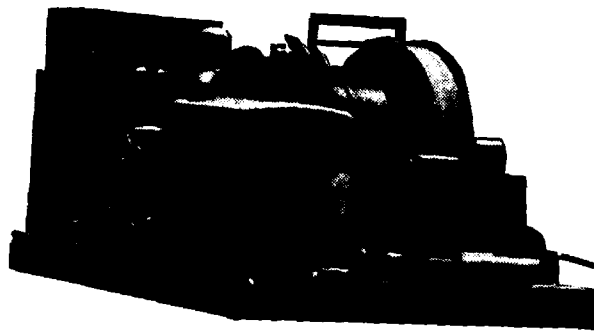

Cable Drum Left Side

Winch, Single Drum (30K)

Item

WINCH, SINGLE DRUM (30 K)

ManufacturerCable Handling and Stringing Equipment, Inc.
Arlington, TX 76013**Model**

SD-304

General Description

The single-drum winch is a self-contained skid-mounted unit powered by a Detroit diesel 3-53 engine. The unit is equipped with a pressure-compensated hydrostatic transmission which provides stepless speed control and automatic stalling torque control. The winch is equipped with a gypsy head, mounted on the outboard side of the main shaft, which is capable of being operated independently of the main cable drum.

Performance

The winch is capable of providing a 30,000-pound line pull at stall and a 150 fpm average line speed. The cable drum is designed to handle 2,000 feet of 1-inch diameter cable and is equipped with an independent level wind with a variable ratio gear box to accommodate other cable diameters. The level wind can be adjusted for automatic or manual operation. A central control console allows the operator to carry out all winch functions from one location.

Physical Description**Winch unit:**

Height	72 in.
Length	120 in.
Width	127 in.
Net weight	17,200 lb.

Cable Drum:

Flange dia.	43 in.
Core dia.	16 in.
Traverse	24 in.
Cable dia.	1 in.
Cable capacity	2,000 ft.

Auxiliary Power or Support Equipment Requirements

Auxiliary power or support equipment is not required. Sufficient hoisting facilities are required for loading and off-loading the winch unit.

Operator/Crew Requirements

One experienced person is required for operating the winch unit. Additional personnel are required based upon application of unit.

Training Requirements

Two days' training in the field or at the manufacturer's facility is required to familiarize operator(s) with the operation and field maintenance of the equipment.

Field Maintenance Requirements

Field maintenance will be performed per OCEI instructions and manufacturer's manual. Operating logs and equipment history cards must be maintained.

Spare Parts

Limited spare parts are available.

Mobilization Time: One week

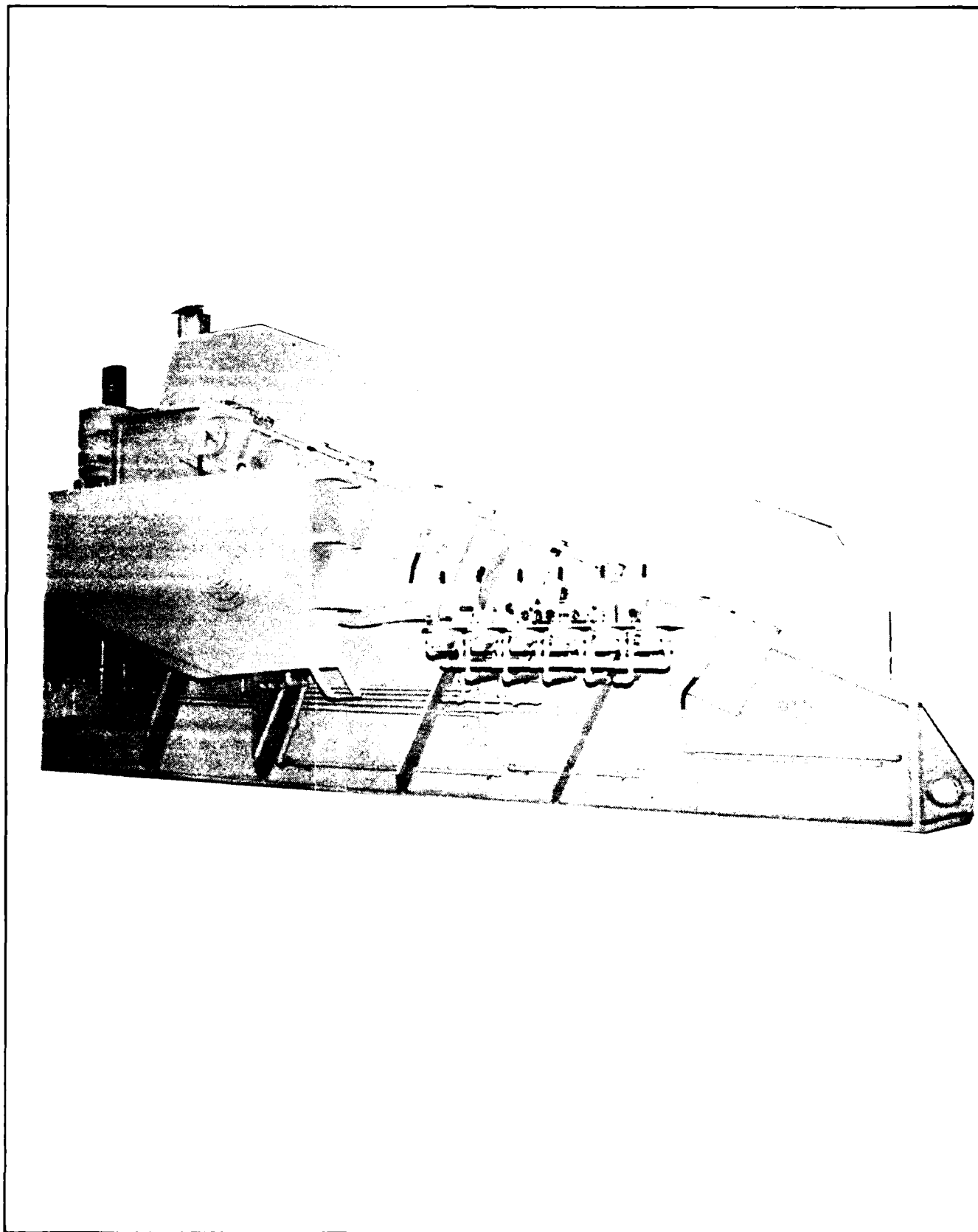

Winch, Three Drum (140K)

Item

WINCH, THREE DRUM (140 K)

Manufacturer

Verne Engineering Corp., Frazier, MI 48026

Model

3-DDD-140

General Description

The three-drum winch is used where heavy duty winching, lifting, or mooring is required. The winch is a self-contained, base-mounted, variable speed unit with air-actuated controls and is powered by a series 71 GMC diesel engine.

Performance

The winch is capable of applying a line pull of 140,000 pounds at a minimum speed of 0-30 fpm or a line pull of 12,000 pounds at a maximum speed of 0-310 fpm.

NOTE: Winch does not payout under power.

Physical Description

Winch:

Height	9 ft.
Length	21 ft. 6 in.
Width	9 ft. 2 in.
Weight (approx.)	55,000 lb.

Winch Drum:

Flange dia.	50 in.
Barrel dia.	19 in.
Barrel length	42 in.

Drum Cable Capacity:

Cable	Length
3/4 in.	9,600 ft.
1-in.	5,300 ft.
1-1/4 in.	3,700 ft.
1-1/2 in. (max)	2,600 ft.

Auxiliary Power or Support Equipment Requirements

A lifting device of sufficient capacity is required for on-off loading.

Operator/Crew Requirements

One experienced person is required for operating the unit. Additional personnel are required based upon application of unit.

Training Requirements

One day's training in the field or at the manufacturer's facility is required to familiarize operator(s) with the operation and preventive maintenance of the equipment.

Field Maintenance Requirements

Field maintenance will be performed per OCEI instructions and manufacturer's manual. Operating logs and equipment history cards must be maintained.

Spare Parts

Spare parts are available.

Mobilization Time: One week

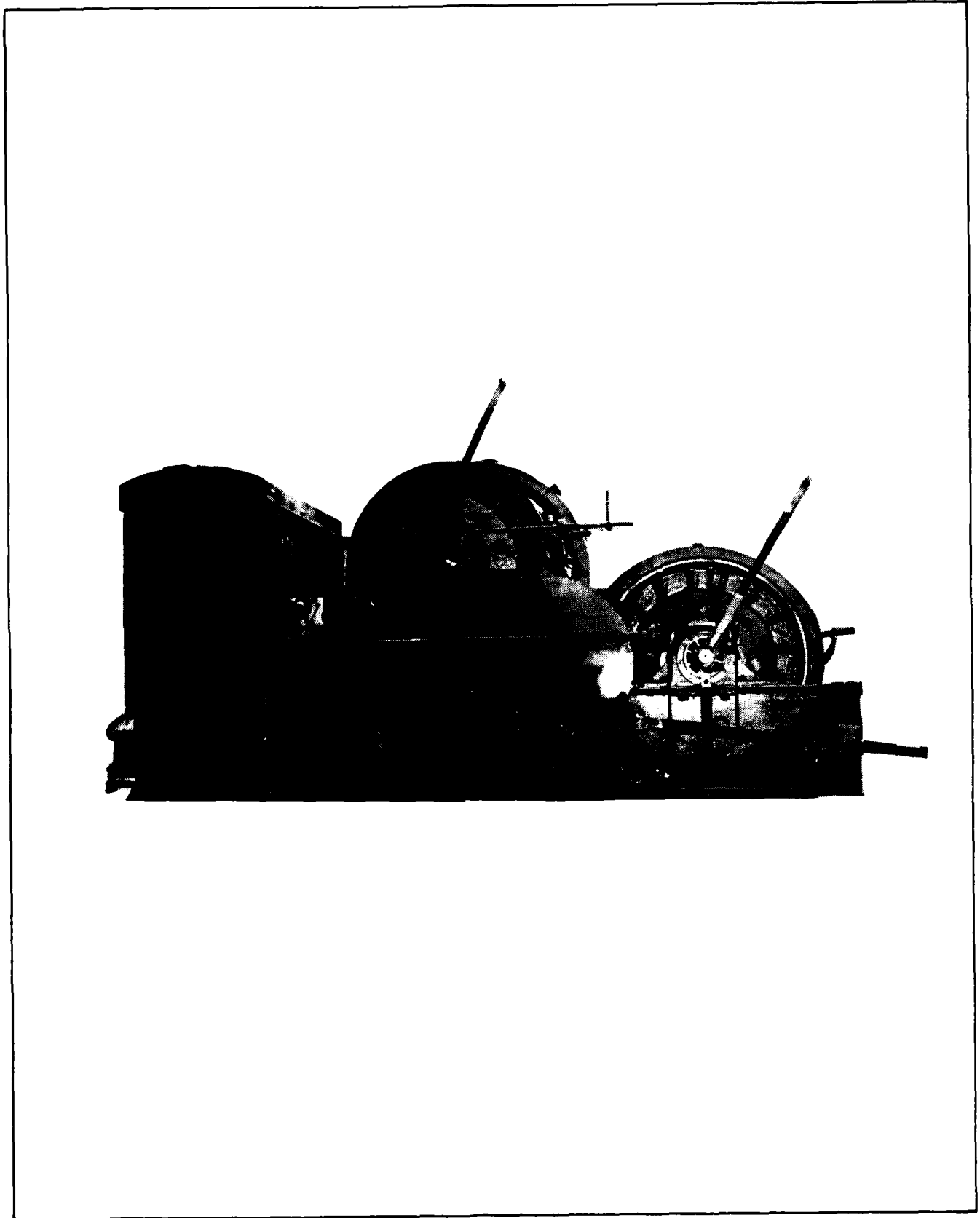

Winch, Two Drum (146K)

Item

WINCH, TWO DRUM (146 K)

Manufacturer

Skagit Corp., Sedro-Wooley, WA 98284

Model

BU-140-YD

General Description

The dual drum winch is a self-contained four-speed unit powered by a Detroit diesel engine, 165 hp at 1,800 rpm. The unit can be used for a variety of winching, hoisting, and mooring operations.

Performance

The cable winch is capable of performing in four speed ranges in accordance with the following data:

Speed	Bare Drum
High	55,000 lb. @ 55 fpm
3rd	87,000 lb. @ 35 fpm
2nd	139,000 lb. @ 22 fpm
Low	222,000 lb. @ 14 fpm

Speed	Full Drum
High	25,000 lb. @ 123 fpm
3rd	39,000 lb. @ 78 fpm
2nd	63,000 lb. @ 49 fpm
Low	100,000 lb. @ 31 fpm

Note: Winch does not payout under power.

Physical Description

Winch Unit:
Height 84 in.

Length 177 in.
Width 113 in.
Weight 28,000 lb.

Cable Drum:

Flange 47 in.
Core (dia.) 20 in.
Length 24 in.

Cable Capacity:

1 in. 2,900 ft.
1-1/8 in. 2,300 ft.
1-1/4 in. 1,850 ft.
1-3/8 in. 1,530 ft.

Auxiliary Power or Support Equipment Requirements

Auxiliary power or support equipment is not required. Sufficient hoisting facilities are required for loading and off-loading the winch unit.

Operator/Crew Requirements

One experienced person is required for operating the winch unit.

Training Requirements

Two days' training in the field or at the manufacturer's facility is required to familiarize operator(s) with the operation and preventive maintenance of the equipment.

Field Maintenance Requirements

Field maintenance will be performed per OCEI instructions and manufacturer's manual. Operating logs and equipment history cards must be maintained.

Spare Parts

Limited spare parts are available.

Mobilization Time: One Week

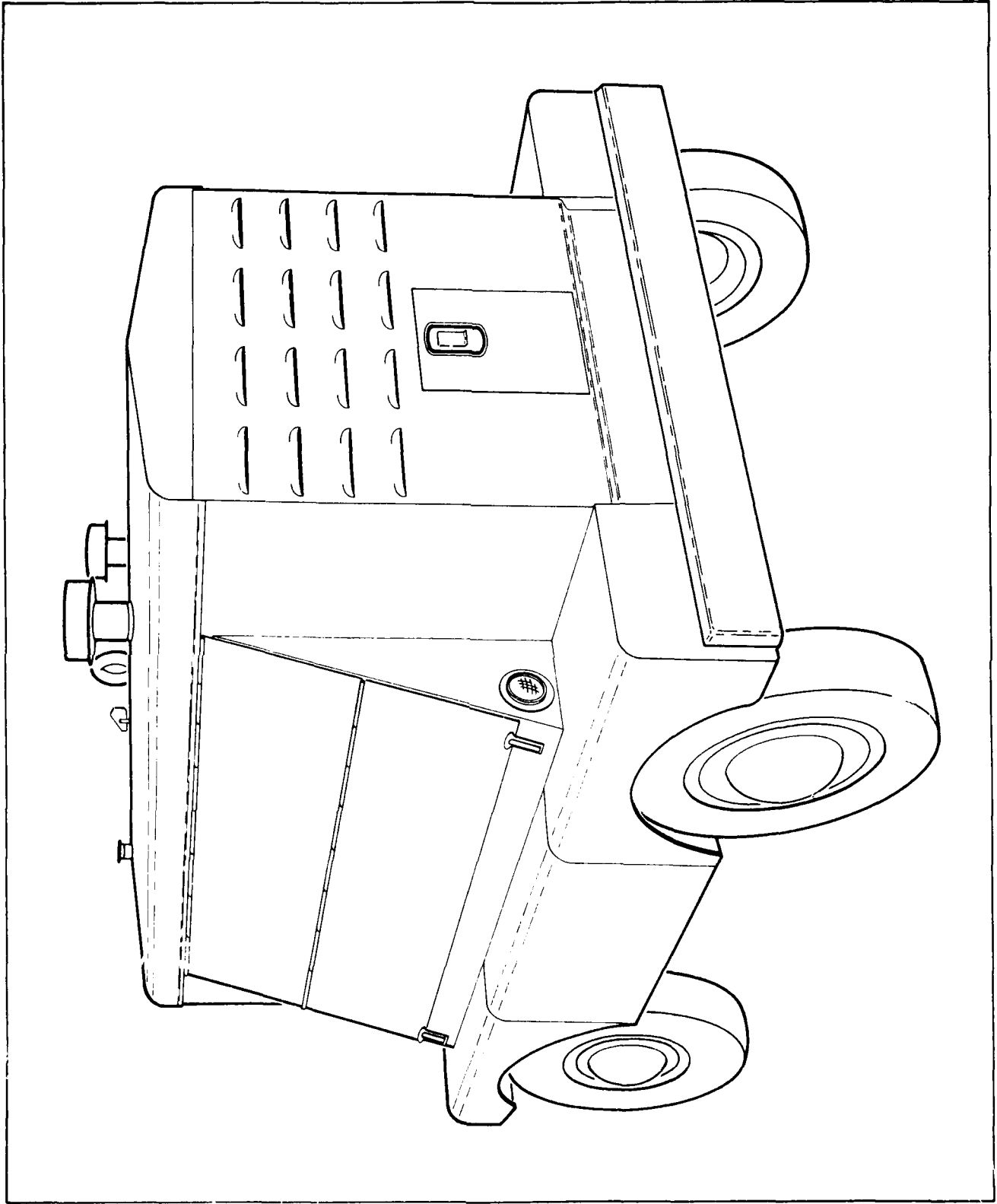

Air Compressor, (250 CFM)

Item

AIR COMPRESSOR (250 CFM)

Manufacturer

Worthington – CEI, Inc., Holyoke, MA 01040

Model

250D

General Description

The air compressor is powered by a GMC 4-53 diesel engine that develops 93 horsepower at 1,800 rpm. The unit is transportable and mounted on a four-wheel pneumatic-tired trailer. Engine controls are located on a control console on the left side of the engine. The console is protected by the compressor housing.

Performance

The air compressor is rated at 250 CFM at 100 psi. Modulation is controlled by air pressure.

Physical Description

Length	105-3/4 in.
Width	66-5/8 in.
Height	75-1/2 in.
Weight	4,300 lb.

Auxiliary Power or Support Equipment Requirements

The air compressor, a self-contained unit, requires no auxiliary power. A vehicle is required for moving and positioning the unit.

Operator/Crew Requirements

One person can operate and maintain the air compressor.

Training Requirements

One day's training in the field or at the manufacturer's facility is required.

Field Maintenance Requirements

Field maintenance will be performed per OCEI instructions and manufacturer's manual. Operating logs and equipment history cards must be maintained.

Spare Parts

Spare parts are not available.

Mobilization Time: Two days

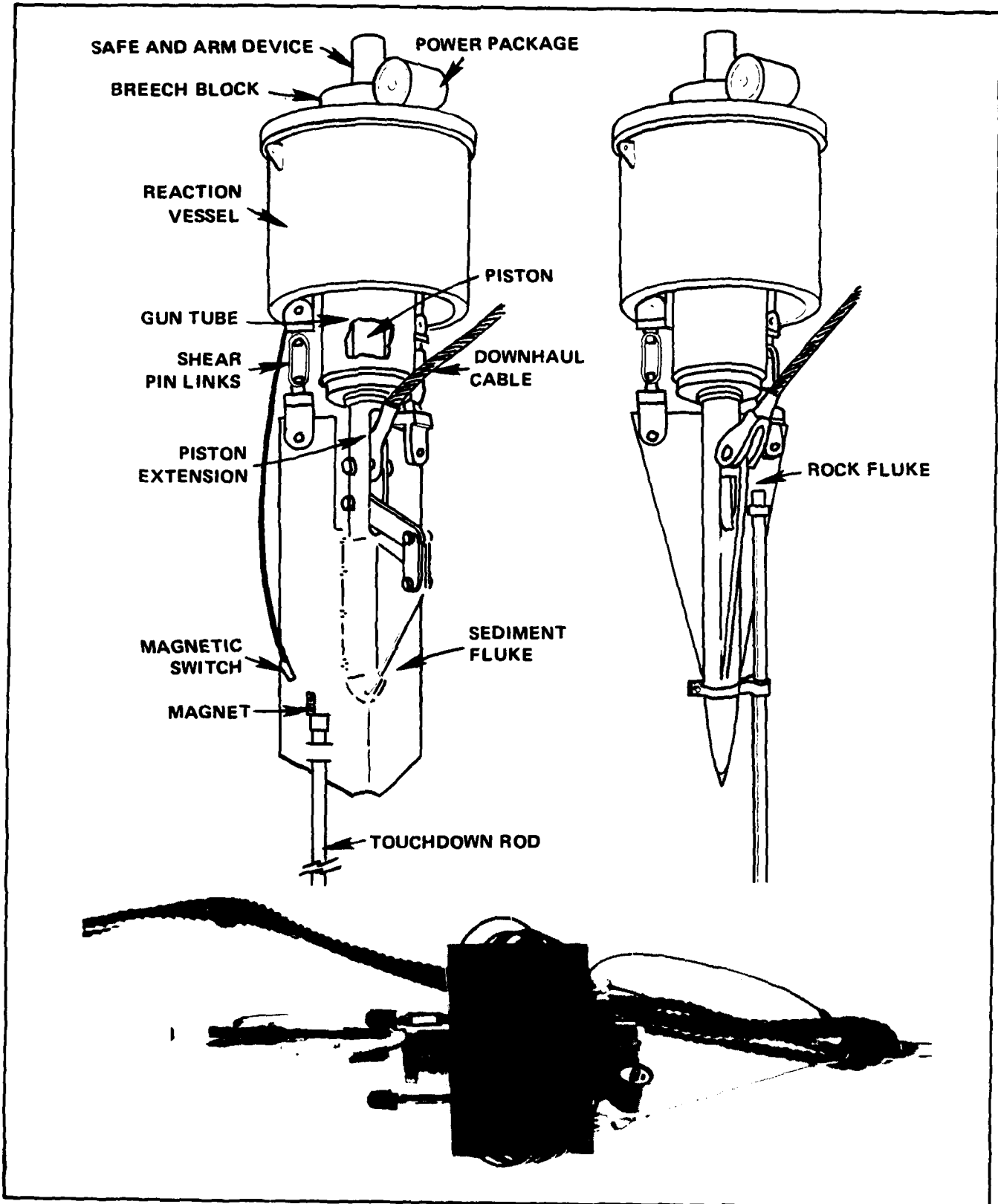

Anchor, Embedment (20 KIP)

Item

ANCHOR, EMBEDMENT (20 KIP)

Manufacturer

N/A

Model

Propellant-Actuated Deep Water Anchor, 20 KIP

General Description

The propellant actuated deep water anchor (embedment anchor) is designed as an expendable hardware item to provide a reliable and efficient anchor for use in mooring surface or subsurface structures in the deep ocean. The anchor consists of two major parts: a launch vehicle and a projectile, which includes piston and fluke. Three different

flukes are available for use in anticipated types of seafloor. The 3-foot-long sand fluke and the 5-foot-long clay fluke are similarly configured, plate-like projectiles.

Performance

The embedment anchor has a holding capacity of 20,000 pounds in seafloors made up of sand, clay, or rock and is designed to be control-lowered to the seafloor in water depths from 75 to 20,000 feet. Above 75 feet, safety switches prevent activation. When a rod protruding 26 inches below the fluke tip contacts the seafloor, the firing sequence is initiated.

The projectile, which is connected to the main lowering line through the downhaul cable, is propelled into the seafloor at velocities up to 400 feet per second. After about 1 week, the launch vehicle, which is attached to the main cable by a corrosive link, falls free, thereby eliminating a potential source of abrasion to the cable.

Physical Description

	Type Anchor		
	<u>Sand</u>	<u>Clay</u>	<u>Rock</u>
Nominal weight:			
Launch vehicle	1,500 lb.	1,500 lb.	1,500 lb.
Anchor projectile	300 lb.	500 lb.	300 lb.
Total weight:	1,800 lb.	2,000 lb.	1,800 lb.
Anchor:			
Length	7 ft.	9 ft.	7 ft.
Diameter	2 ft.	2.5 ft.	2 ft.
Downhaul cable:			
Length	75 ft.	100 ft.	50 ft.
Type	6 X 19 IWRC	6 X 19 IWRC	6 X 19 fibercore
Diameter	3/4 in.	3/4 in.	1 in.
Breaking strength	59,000 lb.	59,000 lb.	89,000 lb.

Auxiliary Power or Support Equipment Requirements

A floating vessel with a lifting device capable of lifting a minimum of 2,000 pounds is required to load/unload the embedment anchor. Adequate cable is required for controlled lowering of the anchor to the seafloor. An ohmmeter with a 100,000-ohm, or higher, scale, and a voltmeter or volt ohmmeter, scaled to read at least 40 Vdc, are required for checking the battery pack.

Operator/Crew Requirements

A minimum number of five persons is required to assemble and deploy the anchor. Qualified ordnance personnel are required for assembling and deploying the anchor. EOD diving personnel are required for underwater disarming in the event of a misfire or other malfunction.

Training Requirements

Three days' training in the field or at the Civil Engineering Laboratory is required to familiarize operator/crew with the operation and preventive maintenance of the equipment.

Field Maintenance Requirements

Field maintenance will be performed per OCEI instructions and manufacturer's manual. Operating logs and equipment history cards must be maintained.

Spare Parts

Spare parts are available.

Mobilization Time: Five days

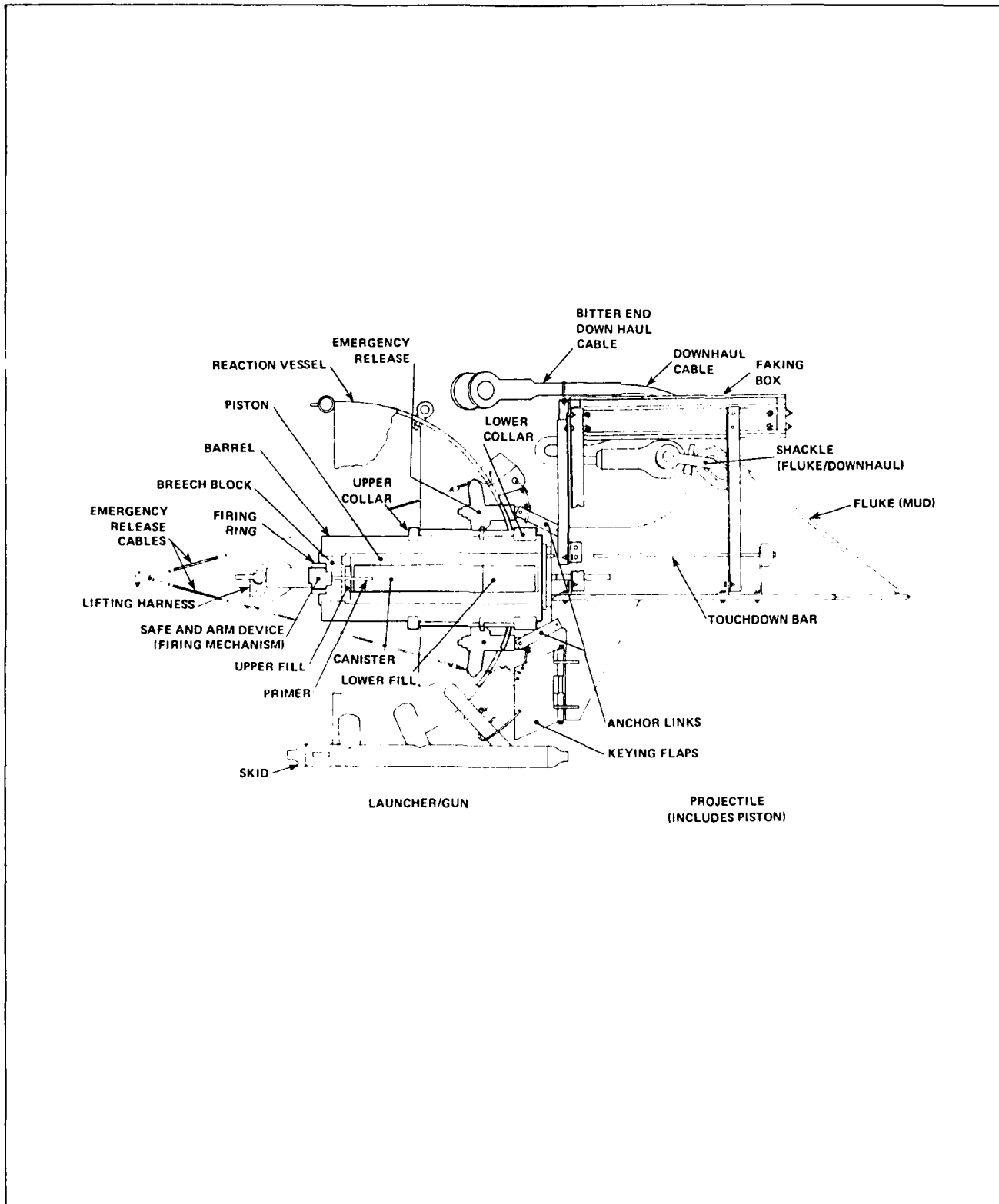

Anchor, Embedment (100 KIP)

Item

ANCHOR, EMBEDMENT (100 KIP)

Manufacturer

N/A

Model

Propellant Actuated Deep Water Anchor, 100 KIP

General Description

The propellant actuated deep water anchor (embedment anchor) is designed as an expendable hardware item to provide a reliable and efficient anchor for use in mooring surface or subsurface structures in the deep ocean.

Performance

The embedment anchor has a holding capacity of 100,000 pounds in seafloors consisting of sand or clay. The anchor can be control-lowered to the seafloor in water depths to 20,000 feet. A Safety and Arming (S&A) device prevents activation of the projectile until the anchor reaches a depth of 35 feet. At 25 feet a hydrostatic lock in the S&A is released allowing the S&A device free travel. When the touchdown bar (which is adjustable to extend below the fluke tip) contacts the seafloor, the firing sequence is initiated. The projectile, which is connected to the main lowering line through the downhaul cable, is propelled into the seafloor.

Physical Description

Anchor:

	<u>Sand</u>	<u>Clay</u>
Length	10 ft.	11 ft.
Diameter	6 ft.	6 ft.
Nominal weight	4,500 lb.	4,500 lb.
Overall weight	6,550 lb.	7,187 lb.

Flukes:

	<u>Sand</u>	<u>Clay</u>
Length	5 ft.	6 ft.
Width	3.5 ft.	5 ft.
Thickness	1.0 in.	1.0 in.
Piston weight	845 lb.	1,482 lb.

Downhaul Cable:

Length	50 ft.
Type	6N37 (GEIPS)
Diameter	2 in.
Breaking Strength	342,000 lb.

Auxiliary Power or Support Equipment Requirements

A floating vessel with a lifting device capable of lifting a minimum of 8,000 pounds is required to load/unload the anchor. Adequate cable is required for controlled lowering of the anchor to the sea floor.

Operator/Crew Requirements

A minimum number of five persons is required, including qualified ordnance personnel for assembling and deploying the anchor. EOD diving personnel are required for disarming in the event of a malfunction.

Training Requirements

Three days' training in the field or at the Civil Engineering Laboratory is required to familiarize operator/crew with operation and maintenance of the equipment.

Field Maintenance Requirements

Field maintenance will be performed per OCEI instructions and manufacturer's manual. Operating logs and equipment history cards must be maintained.

Spare Parts

Sufficient spare parts are available.

Mobilization Time: Five days

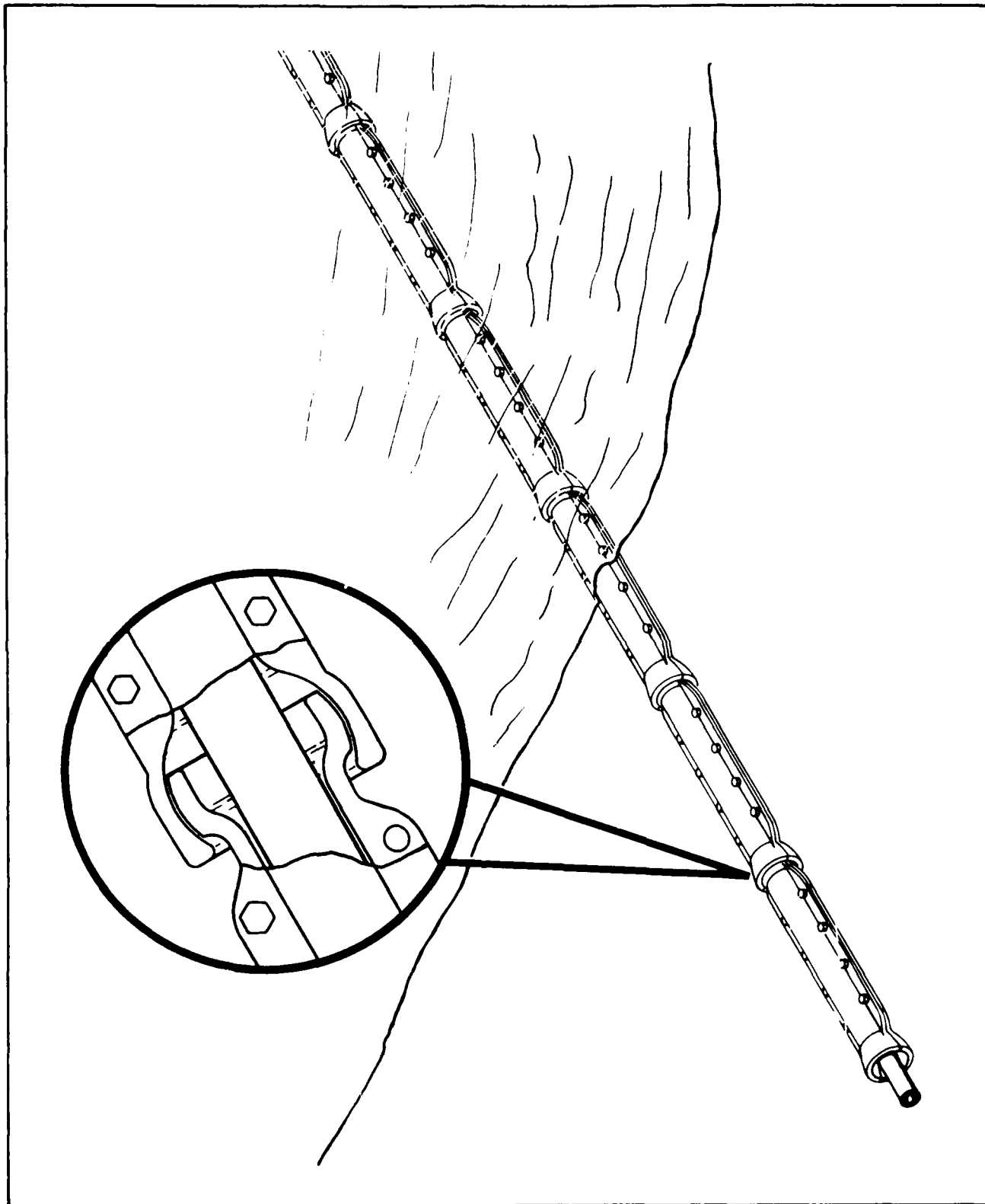

Cable Protection Assembly (Split Pipe)

Item

CABLE PROTECTION ASSEMBLY (SPLIT PIPE)

Manufacturer

Lynchburg Foundry, Lynchburg, VA

Model

Western Electric Co., Inc., Drawings T-250-036 and T-250056

General Description

The cable protection assembly is designed to provide armor protection for submarine cable. The cable protector consists of nodular iron (Grade 60-45 per ASTM A536) cast into two interchangeable half sections. The half sections are bolted together with 5/8-16 X 1-1/2 in. heavy hex bolts to form a pipelike longitudinal configuration with spherical, belled ends which permit articulation from the horizontal of attached assembled pairs.

Performance

The cable protection assembly provides a safeguard against cable motion and possible fatigue failure in hard rock seafloor locations that prevent cables from being buried beneath protective sediment. The cast-iron split pipe sections are obtainable in 3.5-inch and 5-inch inside diameter sizes (enclosed section) approximately 39 inches long. When joined together longitudinally, the effective length (end of spherical bell to end of spherical bell) is 36 inches.

Physical Description

Type 3-1/2 inch I.D.:

Weight (half section):

In air 45 lb.

In water 30 lb.
Overall length 39 in.
Inside diameter 3.5 in.
Overall O.D. 8.0 in.
Bolts, assembly, hex head 5/8-16 X 1.5 in.

Type 5-inch I.D.:

Weight (half section):

In air 73 lb.
Overall length 37-1/2 in.
Inside diameter 5 in.
Overall O.D. 9-1/2 in.
Bolts, assembly, hex head 5/8-16 X 1.5 in.

Auxiliary Power or Support Equipment Requirements

The cable protection assemblies are designed for underwater use and can be most effectively assembled using air tools.

Operator/Crew Requirements

The assemblies can be placed by underwater construction crews and can be accomplished by one person.

Training Requirements

One day's training in the field is required to familiarize operator(s) with the assembly operation.

Field Maintenance Requirements

N/A

Spare Parts

No spare parts are available.

Mobilization Time: One day

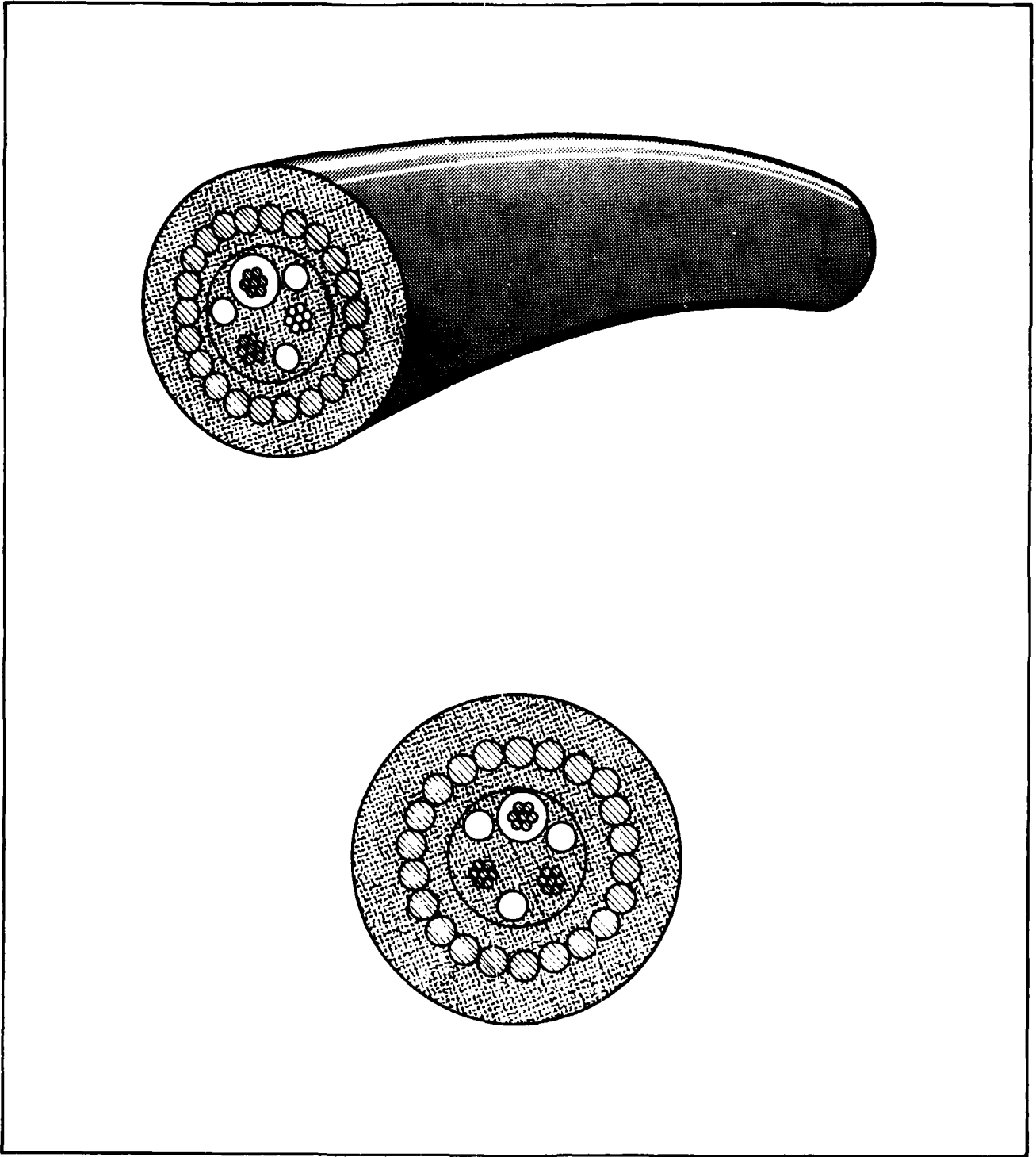

Cable, Single Armor (Three Conductor)

Item

CABLE, SINGLE ARMOR, 3-CONDUCTOR

Manufacturer

Ansonia Wire and Cable Company, Ashton, RI

Model

NSN 6145-00-678-0429

General Description

The three-conductor 10 AWG stranded copper power cable has various applications where transmission of high voltage electrical power is required. Each conductor is insulated by a plastic cover and color coded (red, white, and black). The three conductors are encased in a plastic jacket surrounded by steel reinforcing wire running parallel to the conductors. The three insulated conductors and reinforcing wire are sealed by an outside plastic jacket wrapped with cotton tape. The cable was originally designed for underwater use.

Performance

Each 10 AWG conductor is capable of carrying 2,500 volts of electrical power.

Physical Description

Cable dia.	1-5/8 in.
Weight, cable (per foot)	2-1/2 lb.
Length, cable (per reel)	5,000 ft.
Weight, reel	12,240 lb.

Auxiliary Power or Support Equipment Requirements

Auxiliary power or support equipment is not required. Sufficient hoisting facilities are required for loading and off-loading the cable reel.

Operator/Crew Requirements

Two persons are required to assist in loading and off-loading the cable reel.

Training Requirements

N/A

Field Maintenance Requirements

Field maintenance will be performed per OCEI instructions and manufacturer's manual. Operating logs and equipment history cards must be maintained.

Spare Parts

N/A

Mobilization Time: One Week

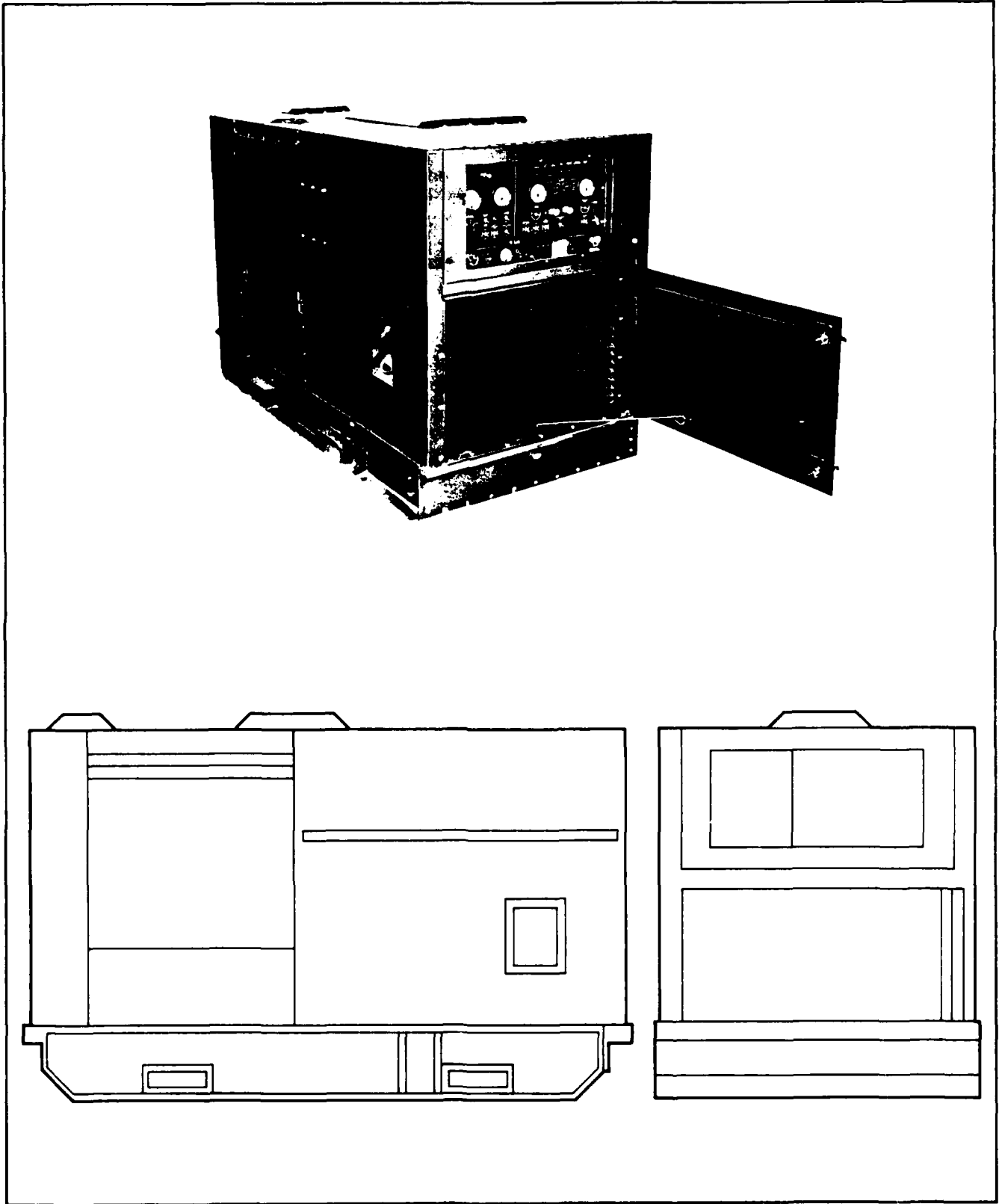

Generator, 60 KW (Diesel Driven)

Item

GENERATOR, 60 KW (DIESEL DRIVEN)

Manufacturer

Consolidated Diesel Electric Company, Old Greenwich, CT 06870

Model

4275

General Description

The generator is a self-contained, diesel-driven, skid-mounted unit. The unit is weather resistant and designed to operate in a wide variety of climates and regions. Major assemblies are modular in design and are readily accessible for operation and servicing with standard tools.

Engine features are an 8-hour fuel tank and oil bath air cleaner. Safety controls include engine overspeed, high coolant temperature, low oil pressure, low fuel, over and under voltage, short circuit, and reverse power.

Performance

The generator provides 60 kW of 60-cycle power with paralleling circuitry for multiunit operation. A removable control panel is provided for remote operation at distances up to 75 feet. The generator speed is controlled by a frequency and load sensing, electronically-controlled, hydraulic-actuated governor providing isochronous frequency regulation from no-load to full load.

The unit provides 3-phase, 4-wire service at 120/208 volts and 240/416 volts, and a duplex 125 Vac convenience receptacle.

The generator is powered by a GMC 4-71 water-cooled engine with a 24 Vdc starting system.

Physical Description

Height	52 in.
Length	90 in.
Width	40 in.
Weight	4,000 lb.

Auxiliary Power or Support Equipment Requirements

Auxiliary power or support is not required. Sufficient lifting and positioning capability must be available to transport and position the generator.

Operator/Crew Requirements

One person can operate the unit.

Training Requirements

One day's training in the field or at the manufacturer's facility is required.

Field Maintenance Requirements

Field maintenance will be performed per OCEI instructions and manufacturer's manual. Operating logs and equipment history cards must be maintained.

Spare Parts

Spare parts are not available.

Mobilization Time: Two days

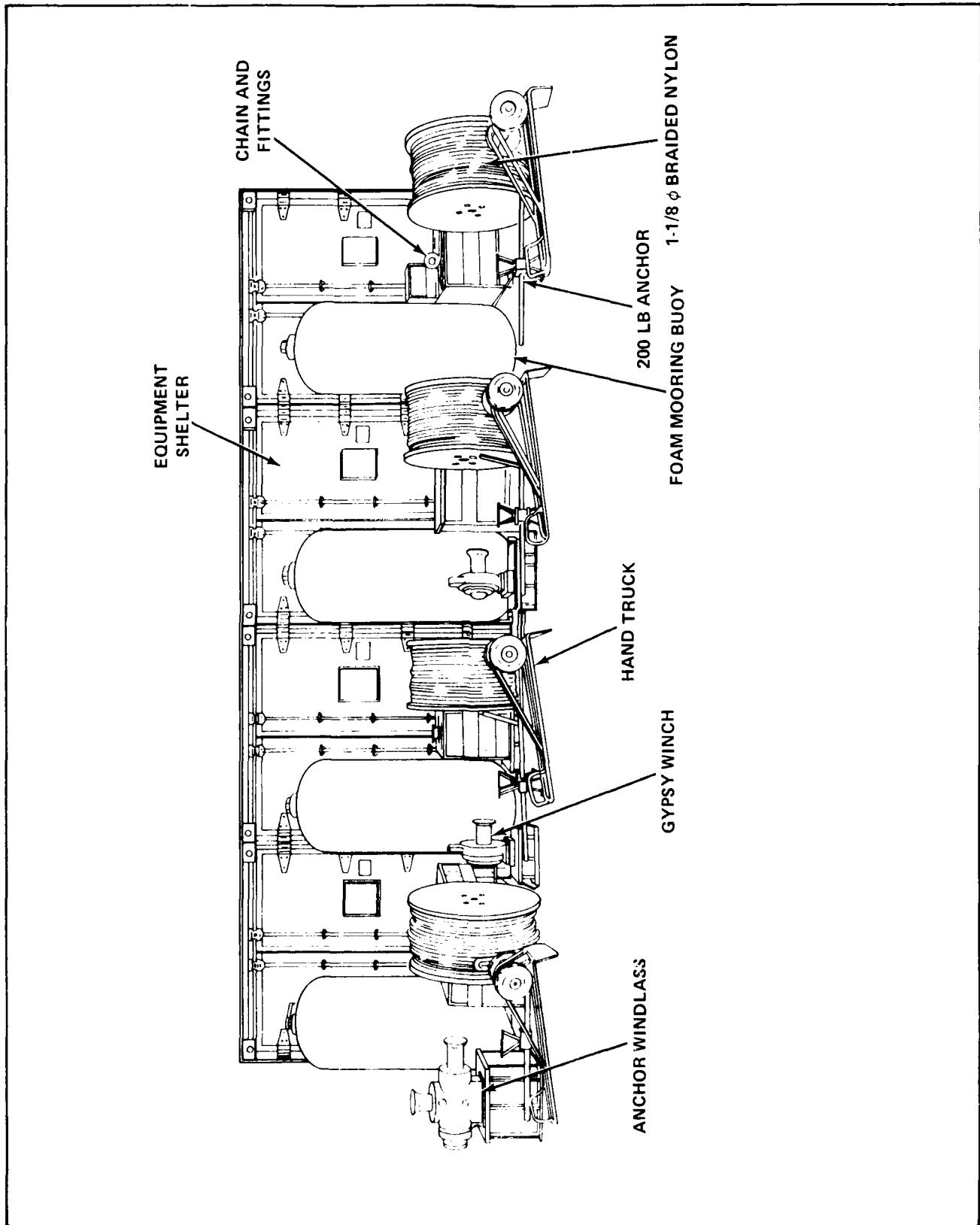

Mooring System, Modular

AD-A163 327

OCEAN FACILITIES PROGRAM OCEAN CONSTRUCTION EQUIPMENT
INVENTORY (OCEI) EQUIPMENT CATALOG(U) NAVAL FACILITIES
ENGINEERING COMMAND WASHINGTON DC CHESAPEAKE DIV 1976

2/3

UNCLASSIFIED

CHES/NAVFAC-FPO-7510

F/G 13/3

NL

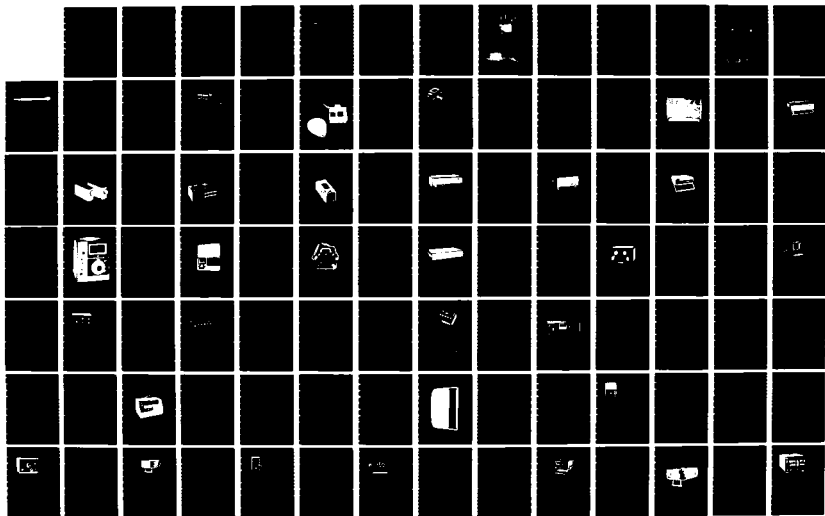

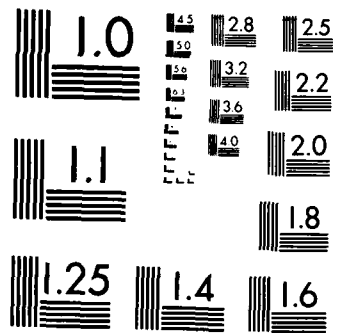

MICROCOPY RESOLUTION TEST CHART
NATIONAL BUREAU OF STANDARDS-1963-A

Item

MOORING SYSTEM, MODULAR

ManufacturerCivil Engineering Laboratory, Port Hueneme,
CA 93043**Model**

MMS-1

General Description

The modular mooring system is a reusable, multileg mooring system for vessels of opportunity. The system will restrain vessels of the LCU-1610 size in sea state 4 with 1.0-knot surface currents in water depths to 200 ft. Components may be assembled with up to four mooring legs, using either all-synthetic or combination chain-buoy-pendant legs. Two hydraulically-powered gypsy winches and a combination chain wildcat and gypsy winch are provided.

Performance

The system configuration is dependent on its intended use and is related to the following:

Single point: Minimal positioning capability and large excursion; exerts minimum force on the anchor and is best for heavy weather or transient mooring.

Two Point: Minimal positioning capability; suitable for transient mooring with limited sea room.

Three point: This system meets needs for situations not requiring optimum position control.

Four point: Best for situations where wind or current direction shift and precise positioning must be maintained.

The design environmental condition for the mooring system is sea state 4 with a 1.0-knot surface current. When wave forces are included, line tensions may reach 10,000 lb. for any vessel in the LCM and LCU classes.

Physical Description

The entire mooring system is contained in four multi-purpose equipment shelters. Gross weight and volume for the complete system are 24,220 lb. and 1,664 cu. ft., respectively.

Shelter length	8 ft.
Shelter width	6.5 ft.
Shelter height	8 ft.
Windlass weight with base	1,150 lb.
Winch with base	680 lb.
Weight of heaviest container	6,750 lb.

Auxiliary Power or Support Equipment Requirements

The modular mooring system is a complex system having specific support requirements. Details are furnished in the CEL technical note No. H-1520. Hydraulic power is necessary to power the windlass and winches 6 to 18 cfs at 2,000 psi.

Operator/Crew Requirements

Approximately six persons trained for assigned mission are required.

Training Requirements

Each team member must have training in all assigned roles for the intended mission.

Field Maintenance Requirements

Field maintenance will be performed per OCEI instructions and manufacturer's manual. Operating logs and equipment history cards must be maintained.

Spare Parts

Spare parts are available.

Mobilization Time: Two days

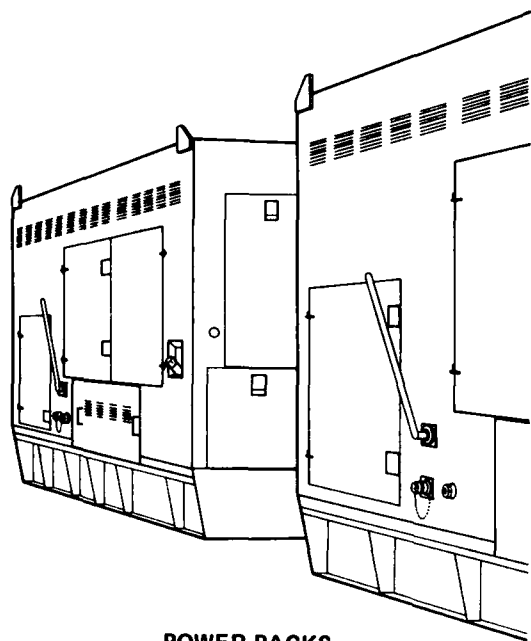

POWER PACKS

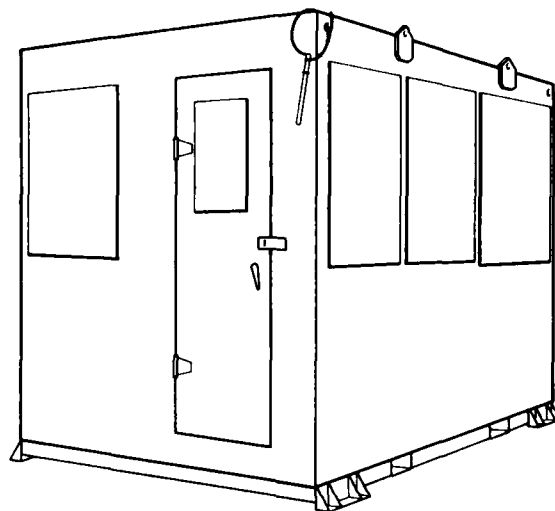

WHEEL HOUSE

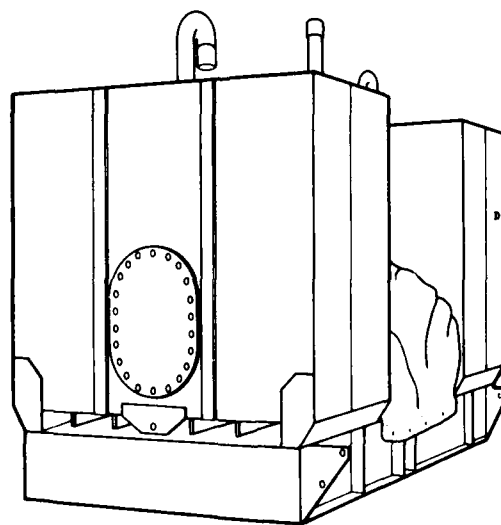

FUEL STORAGE MODULE

Auxiliary Platform Propulsion Sub-systems

Item

PLATFORM, AUXILIARY PROPULSION SYSTEM

ManufacturerMaritime Industries Ltd., British Columbia, Canada
V5B 3B3**Model**

200 R.A.D.

General Description

The auxiliary platform propulsion system is a self-contained portable system consisting of five major subsystems. These include two hydraulically driven, rotatable, deck-mounted thrusters complete with mounting frames; two hydraulic power packs; one fuel storage module; one wheelhouse with central control station; and coupling systems.

Performance

Each thruster will produce 6,000 pounds of thrust in the forward bollard condition and 4,000 pounds of thrust at an advance of 5 knots. Thruster units are steerable 360 degrees cw and ccw at a slewing rate of six revolutions per minute.

The power packs are each driven by a GMC 12V-71 diesel engine powering two hydraulic propulsion pumps. Two pumps are used so that two units can be controlled from the other in the event of a failure of one power pack. The hydraulic reservoir and diesel oil tank are built into the power pack base. Fuel storage is within a self-contained unit powered by 24 Vdc with a total capacity of 850 gallons of diesel fuel.

The wheelhouse contains the central control console for the positioning system, providing propeller speed control and thrust direction control. The main console has monitoring instruments for propeller speeds, thrust direction, and emergency alarms.

Physical Description**Power Pack:**

Height	114 in.
Length	112 in.
Width	67 in.
Weight (dry)	12,000 lb.
Weight (wet)	14,700 lb.

Thrusters:

Height	235 in.
Length	66 in.
Width	48 in.
Weight	17,200 lb.

Fuel Storage Module:

Height	69 in.
Length	107 in.
Width	64 in.
Weight (dry)	4,400 lb.
Weight (wet)	10,400 lb.

Wheelhouse:

Height	96 in.
Length	125 in.
Width	83 in.
Weight	3,500 lb.

Auxiliary Power or Support Equipment Requirements

No auxiliary power is needed. Sufficient hoisting and positioning facilities must be available to deploy the system at the job site.

Operator/Crew Requirements

One person is required to operate the system.

Training Requirements

One week's training in the field or at the manufacturer's facility is required.

Field Maintenance Requirements

Field maintenance will be performed per OCEI instructions and manufacturer's manual. Operating logs and equipment history cards must be maintained.

Spare Parts

Spare parts are not available.

Mobilization Time: One week

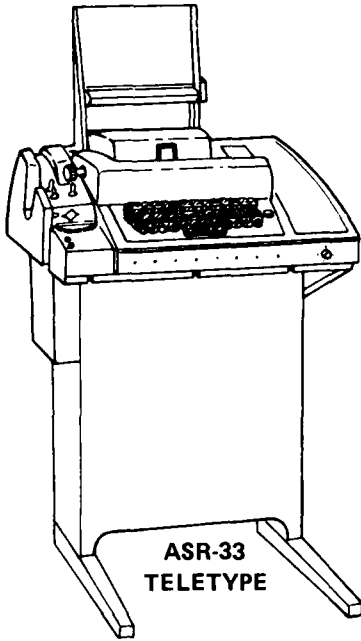

ASR-33
TELETYPE

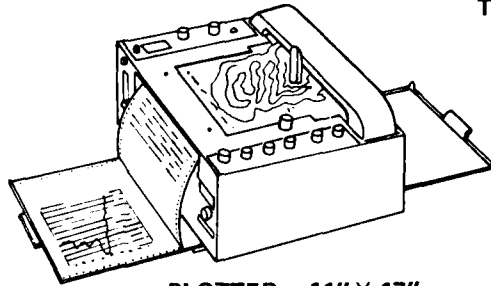

PLOTTER - 11" X 17"

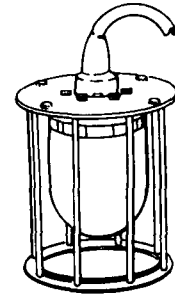

TRANSDUCER
MODEL 200

RANGING RECEIVER
MODEL 205 (FOUR CHANNELS)

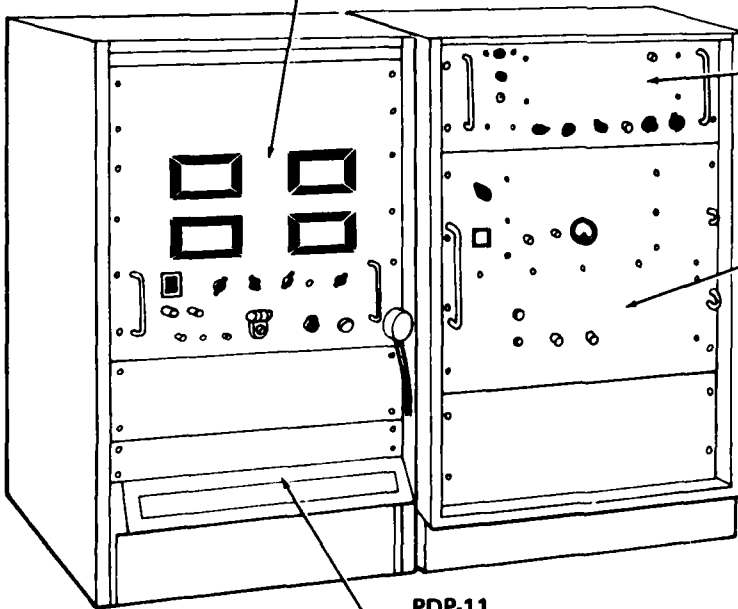

PDP-11
MINI-COMPUTER

CODER
MODEL 200

AMPLIFIER
MODEL 200

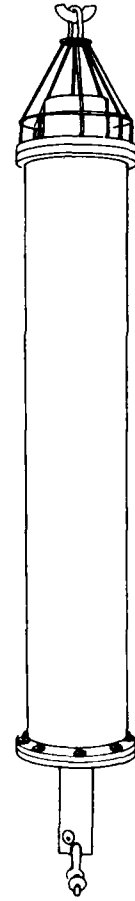

RECOVERABLE
ACOUSTIC
TRANSPONDER
MODEL 324

Acoustic Transponder Navigation System (ATNAV I)

Item

NAVIGATION SYSTEM, ACOUSTIC TRANSPONDER (ATNAV I)

Manufacturer

EG&G Sea Link Systems, Herndon, VA

Model

ATNAV I

General Description

The Acoustic Transponder Navigation System (ATNAV I) provides a real-time continuous X-Y plot and printout of the position of a surface ship and submerged or towed object relative to bottom-moored transponders in an area as great as 50 square miles. The ATNAV I system consists of four underwater transponders (three moored on the bottom and one on the subsurface equipment) and shipboard equipment consisting of a Command/Interrogator and Range Receiver, a PDP-II minicomputer, a teletype, an X-Y plotter, and interface electronics. The ATNAV I software permits both the surveying of the bottom transponder array and the navigation of a ship and subsurface equipment. Once the bottom transponders are deployed and rough estimates of their positions put into the computer, the surface ship has only to move through the area, interrogating the transponders at 10 to 15 random locations. Then the computer has the capability to determine the relative positions of the transponders to within approximately 2 feet. After the transponder array is surveyed, the system, in performing its navigation function, computes, prints, and plots the positions of the surface vessel and subsurface equipment relative to the transponders and to each other with approximately 3-foot accuracy, depending on the accuracy of sound speed data available to the computer.

Performance

The navigation operation begins with interrogation of the bottom transponders from the ship. Each replies individually to the shipboard equipment, which determines their slant range from the ship. Immediately afterwards, another interrogation is sent to the transponder on the subsurface equipment. The reply from this transponder does two things. First, it permits determination of the slant range from the subsurface equipment to the ship. Second, the same reply interrogates the bottom transponders so that the total range from the ship to the subsurface equipment to each of the transponders and back to the ship can be ascertained. The computer uses this range data to determine

the positions of both the ship and the subsurface equipment relative to the previously surveyed positions of the individual bottom transponders. The resulting track information is displayed on the plotter and printed out by the teletype for a permanent record. The model 322 transponders use squibs for actuation of the release function. These squibs are a class C explosive device.

Physical Description

<u>Item</u>	<u>Height</u>	<u>Width</u>	<u>Depth</u>	<u>Weight</u>
Range Receiver (MOD 205)	14 in.	19 in.	19.5 in.	
Mini-Computer (PDP-11)				
Coder (MOD 200)	7 in.	19 in.	6 in.	
Power Amplifier (MOD 206A)	15.75 in.	19 in.	8.5 in.	
X-Y Plotter (MOD 6650)				
Teletype (ASR 33)				

<u>Item</u>	<u>Length</u>	<u>Diameter</u>	<u>Weight in water</u>	<u>Weight in air</u>
Transducer (MOD 200)	8.75 in.	4.75 in.		
Transponder (MOD 282)	59.4 in.	6.8 in.	50 lb.	130 lb.
(MOD 322)	63.3 in.	7.8 in.	70 lb.	145 lb.

Auxiliary Power or Support Equipment Requirements

floating vessel, with sufficient space for equipment installation and for performing survey operations and transponder implant, is required. An enclosed space, approximately 6 by 6 feet, is required for equipment setup and operation. Two equipment racks are supplied containing most of the shipboard equipment. An external power source of 115 volts, 60 Hz ac is required for operation of all units contained in the ATNAV I system.

The type 282 and 322 transponders will normally be supplied with one set of batteries. These batteries, under normal usage, last several months. Additional batteries are available only from the equipment manufacturer.

The type 322 transponder requires squibbs to actuate its release functions. These squibbs are Class C explosive devices.

Operator/Crew Requirements

One trained operator is required for system operation.

Training Requirements

One week's training in the field or at the manufacturer's facility is required to familiarize operator(s) with the operation and preventive maintenance of the equipment.

Field Maintenance Requirements

Field maintenance will be performed per OCEI instructions and manufacturer's manual. Operating logs and equipment history cards must be maintained.

Spare Parts

Spare parts are available.

Mobilization Time: One week

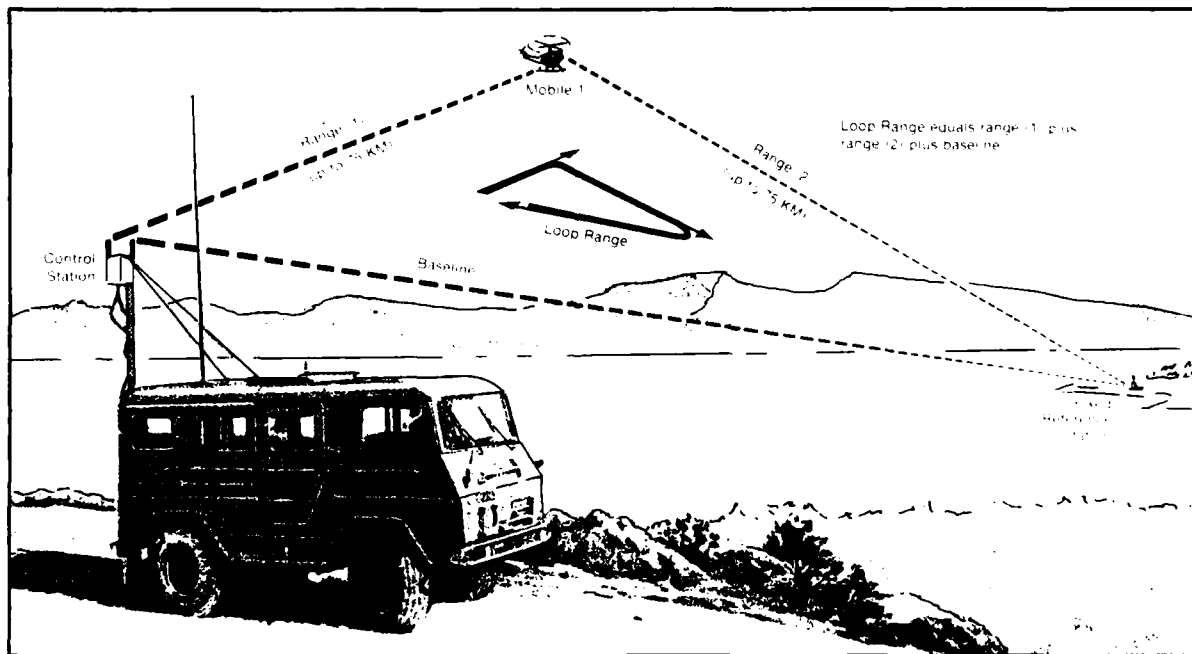
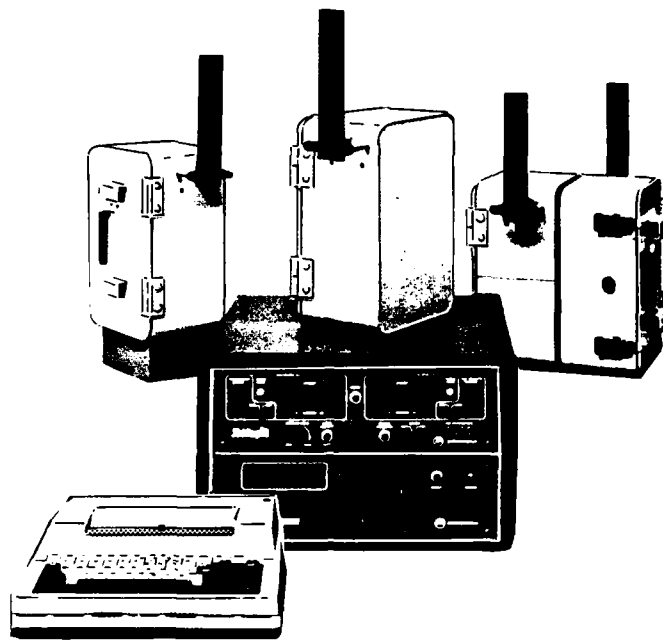

Tracking System, Mini-Ranger

Item

TRACKING SYSTEM, MINI-RANGER

Manufacturer

Motorola, Inc., Tempe, AZ 85282

Model

MRTS

General Description

The Mini-Ranger Tracking System consists of a range console, receiver transmitter (RT 1 and 2), data processor, data terminal, and three reference stations. The system provides a means of locating a mobile station by trilateration. By knowing the location of stationary or fixed reference stations, the position of a moving station may be determined or tracked relative to the position of the control station. The position of a mobile station can be determined using trilateration techniques from range and loop range measurements made by the control station.

Performance

The system operates at line-of-sight ranges up to 45 nautical miles (75 km). Typical applications include: range instrumentation, armored vehicle testing and tracking, buoy tracking, ship trials, airborne horizontal survey control, offshore mining, and ice pack movement studies.

Characteristics

System General:

- Operating frequency 5400 to 5650 MHz
- Accuracy ±2 meters probable range error on direct range
- Number of base lines 1 standard, 3 optional (fixed reference stations)
- Number of codes 4 standard up to 64
- Mobile stations optional
- Operating range Depends on antennas used at each location

Antenna Ranges:

Combination	Range
6 dB omni/6 dB omni (std.)	19 km (10 nmi)
6 dB omni/13 dB sector	37 km (20 nmi)
6 dB omni/19 dB sector	75 km (40 nmi)

Area of Coverage:

Antenna	Angle of Coverage
6 dB omni	360° azimuth, 25° elevation
13 dB sector	80° azimuth, 15° elevation
19 dB sector	80° azimuth, 5° elevation

Control Station Range Console:

- Power 77 watts at 115/230 Vac
50 to 400 Hz or 57 watts at 12 to 32 Vdc
- Dimensions 43 X 46 X 14 cm
(17 X 18 X 5.5 in.)
- Weight 14.5 Kg (32 lb.)

Control Station Receiver/Transmitter:

- Power supplied by range console
- Dimensions 15 X 20 X 30 cm
(6 X 8 X 12 in.)
- Weight 4.3 Kg (9.5 lb.)

Mobile and Fixed Reference Stations:

- Power 13 watts (nominal)
at 22 to 32 Vdc
- Weight 4.3 Kg (9.5 lb.)
- Dimensions 15 X 20 X 30 cm
(6 X 8 X 12 in.)

Data Terminal T1 743 KSR:

- Input power 75 VA Max
- Operating voltage 115 Vac, +10%-15%
47-63 Hz

Auxiliary Power or Support Equipment Requirements

An external power source of 12 to 32 Vdc is required for mobile and fixed reference stations.

Operator/Crew Requirements

One experienced person is required to monitor the system.

Training Requirements

Two days training in the field or at the manufacturer's facility is required to familiarize operator(s) with the operation and preventive maintenance of the equipment.

Field Maintenance Requirements

Field maintenance will be performed per OCEI instructions and manufacturer's manual. Operating logs and equipment history cards must be maintained.

Spare Parts

Limited spare parts are available.

Mobilization Time: Two days

ILLUSTRATION NOT AVAILABLE

Item

GENERATOR, THERMOELECTRIC

Manufacturer

Teledyne Energy Systems, Timonium, MD 21093

Model

2T2P24CL and 2T4PE24XL

General Description

The thermoelectric generator is designed to convert heat from a flameless combustion of propane gas directly into electric energy without risk or hazard. The generator units are weatherproof and intended for outdoor use without additional housing. As there are no moving parts, the mounting platform may be designed for static loads only.

Performance

The generator unit is capable of operating in subzero arctic temperatures to a maximum of 150°F.

<u>Model</u>	<u>2T2P24CL</u>	<u>2T4PE24XL</u>
Nominal output voltage	24	24
Watts	17	36
Gas consumption (Pound per week)	23	45

Physical Description

<u>Model</u>	<u>2T2P24CL</u>	<u>2T4PE24XL</u>
Weight	53 lb.	93 lb.
Height	17 in.	17 in.
Width	25 in.	25 in.
Depth	14.5 in.	22 in.

Auxiliary Power or Support Equipment Requirements

Propane gas is required for generator operation.

Operator/Crew Requirements

The generator unit may be installed and operated by unskilled personnel.

Field Maintenance Requirements

Field maintenance will be performed per OCEI instructions and manufacturer's manual. Operating logs and equipment history cards must be maintained.

Spare Parts

Spare parts are not available.

Mobilization Time: Two days.

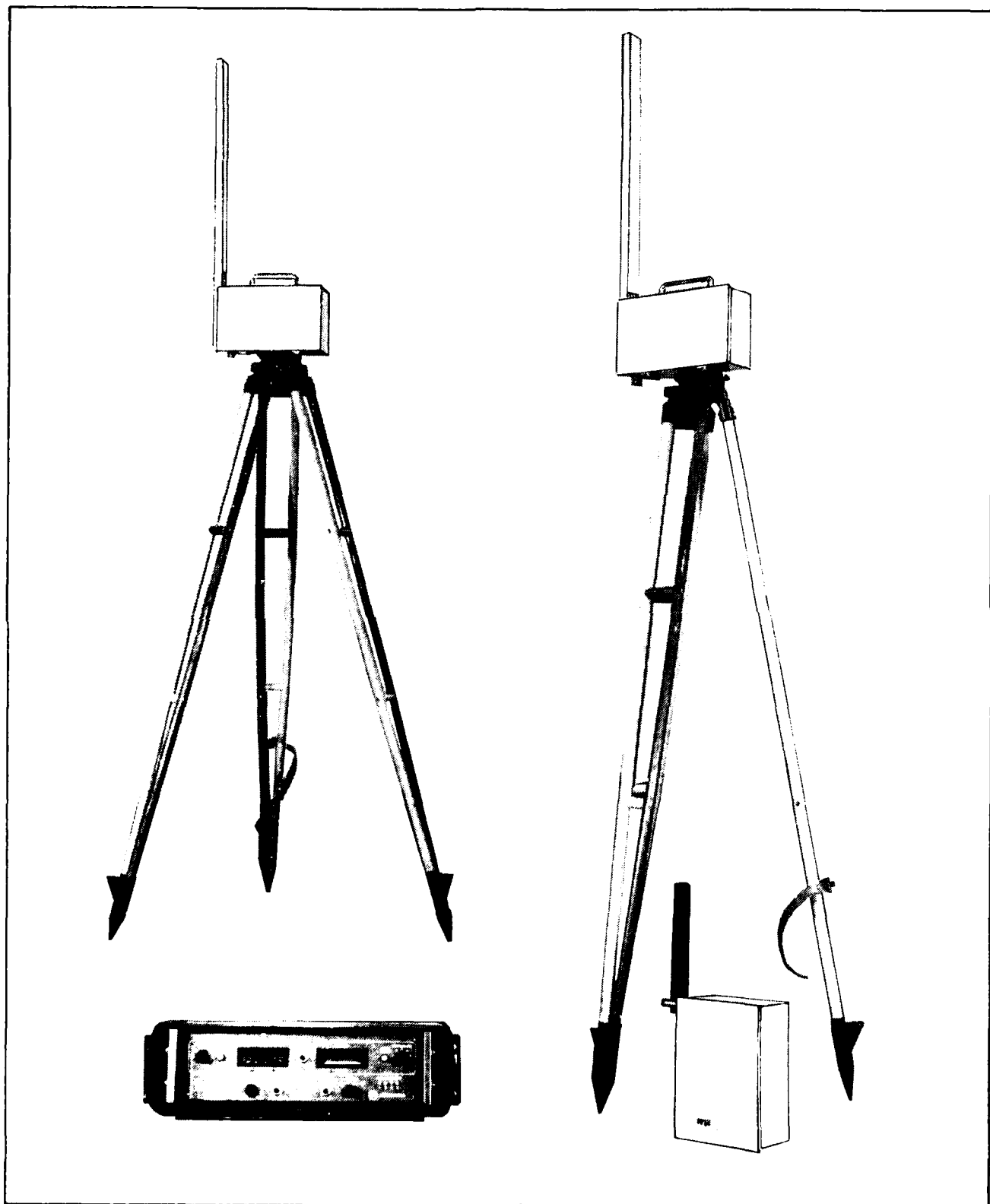

Mini Ranger III System

Item	Dimensions (in.)				Weight (lb.)
	Equipment	Width	Height	Length	
MINI-RANGER III SYSTEM					
Manufacturer	Receiver-Transmitter omnidirectional antenna	1.5	0.75	9.0	3.0
	Motorola, Inc., Tempe, AZ 85282				
Model	Range console cabinet	18.0	5.5	17.0	30.0
	Tripods	—	60.0	—	15.0
	*Printer	8.5	7.25	14.5	10.0
	*Remote range indicator	4.5	5.25	6.5	1.0

General Description

The Mini-Ranger III system consists of a receiver transmitter assembly with an antenna, a range console, and two radar transponders with antennas. This system provides a means of accurately determining the position of a moving unit, such as a vessel, aircraft, or land vehicle, with respect to two radar transponders located at fixed reference points. The MRS III operates on the basic principle of pulse radar. The receiver-transmitter assembly, which is mounted on the moving unit, is used to interrogate the two transponders. The lapsed time between the transmitted interrogation signal and each of the two reply signals is used to determine the range of each transponder. This range information is displayed on the range console and shows range in meters to each of the transponders.

Performance

The system operates at line-of-sight ranges up to 45 nautical miles (with proper transponder elevation). With appropriate calibration, the probable range measurement accuracy is better than 3 meters (10 feet). A coding system is employed in the system to minimize false range readings caused by radar interference and to provide selective transponder interrogation. The system is also capable of interrogating the transponders with a single pulse if desired.

Physical Description

Equipment	Dimensions (in.)			Weight (lb.)
	Width	Height	Length	
Reference station (with mounting bracket)	5.5	6.5	10.5	5.0
Transponder antenna	1.5	1.5	9.5	3.0
Receiver Transmitter (with mounting bracket)	6.25	6.5	9.25	5.0

*Indicates optional accessories.

Auxiliary Power or Support Equipment Requirements

An external power source of 24 Vdc is required for operation of the MRS III console and for each transponder. Two 12 V heavy duty batteries will provide 20 hours of operation for each transponder and 12 hours of range console operation.

Operator/Crew Requirements

One experienced person is required for monitoring the MRS III system.

Training Requirements

Two days' training in the field or at the manufacturer's facility is required to familiarize operator(s) with the operation and preventive maintenance of the equipment.

Field Maintenance Requirements

Field maintenance will be performed per OCEI instructions and manufacturer's manual. Operating logs and equipment history cards must be maintained.

Spare Parts

Spare parts are available (batteries not furnished).

Mobilization Time: Two days

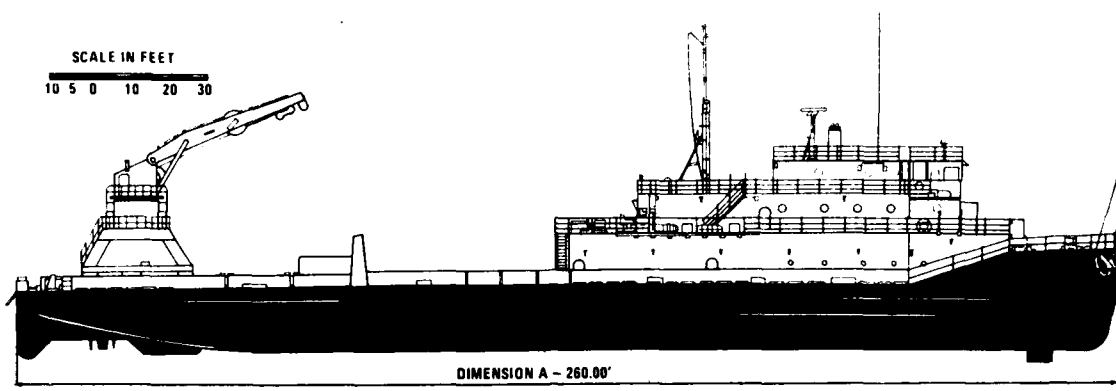

OUTBOARD PROFILE

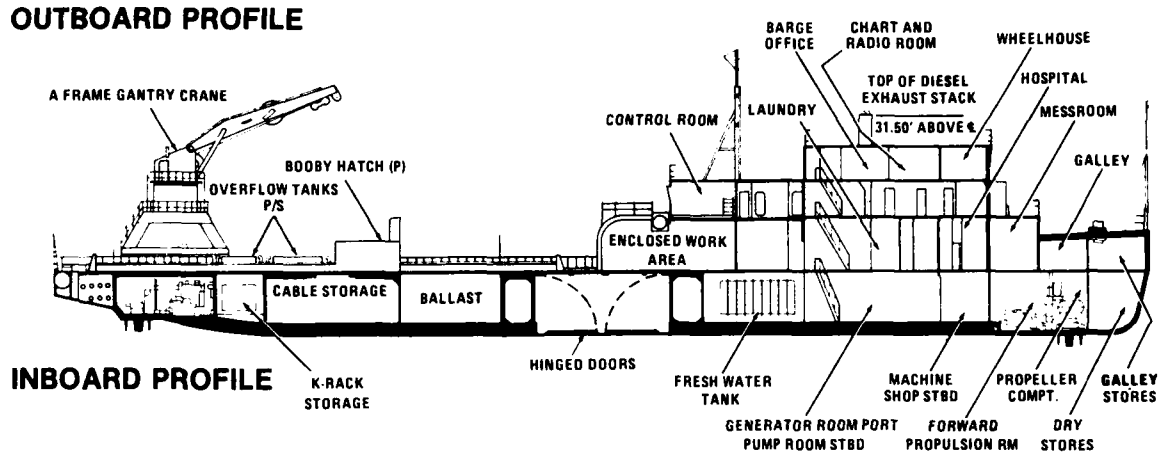

INBOARD PROFILE

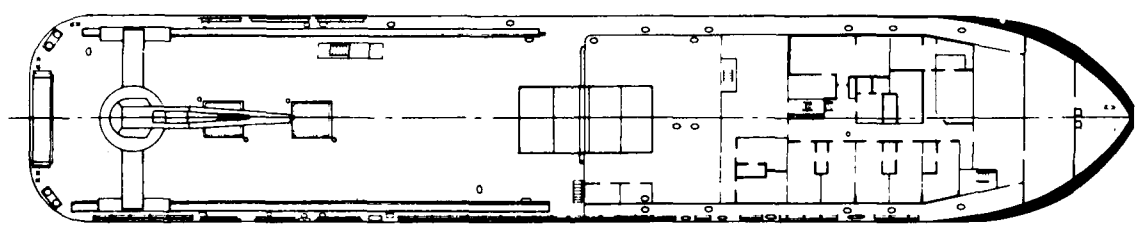

MAIN DECK ARRANGEMENT

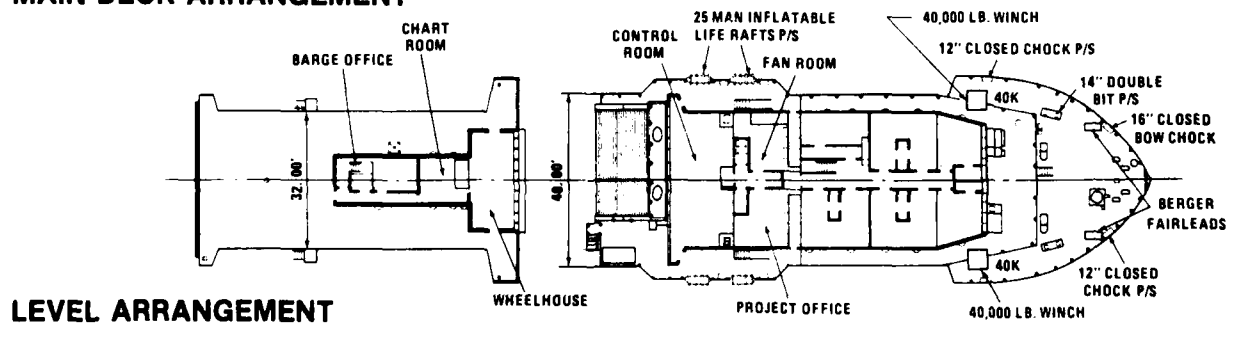

LEVEL ARRANGEMENT

Vessel, Ocean Construction (SEACON)

Item

VESSEL, OCEAN CONSTRUCTION (SEACON)

Manufacturer

Missouri Valley Bridge and Iron (Reconfigured by the Norfolk Shipbuilding and Drydock Company (1976))

Model

Yards Freight Non-Self-Propelled Barge (YFNB) Hull, Modified

General Description

The NAVFACENGCOM ocean construction vessel is a 260-foot YFNB hull which has been reconfigured and outfitted to perform ocean construction operations. The vessel contains the following equipment and features:

Three Voith-Schneider cycloidal propellers, two aft and one forward, for maneuvering, station keeping, and harbor transit.

Centerwell to provide a protected area for electronics, equipment launching, and diver access.

Dynamic positioning capability with suitable navigation system.

Operations control room overlooking deck working area with vessel control, communications, navigation, cable readouts, and underwater television.

Track-mounted traveling gantry crane which can provide up to 10-ton lift at 360°.

Diesel electric generators providing 500 kW of electrical power.

Air conditioned berthing accommodations for up to 50 persons.

World-wide communications system.

Performance

The ocean construction vessel is a surface-towed unit capable of self-maneuvering in shallow and deep ocean waters. The unit has facilities for employing various position-holding methods to meet specific site conditions.

The SEACON is a resource of NAVFACENGCOM with multiple capabilities in highly specialized underwater and

offshore construction tasks involving the handling of heavy loads, cable and pipe laying, diver support, and underwater repair. The SEACON is capable of 4-point mooring in water depths as deep as 600 feet. The ship can hold station to within several feet of the desired location. The SEACON has installed 24 hydrophone structures in water depths of 2,000 to 4,000 feet within a tolerance of 1 to 8 meters of the desired location.

Physical Description

Length	260 ft.
Beam	48 ft.
Displacement/Draft	
Normal	1,700 tons/4.5 ft.
Full load	2,300 tons/7.9 ft.
Open deck space	130 ft. X 48 ft.
Covered deck space	30 ft. X 40 ft.
Center well	16 ft. X 32 ft.
Towing speed	12 knots
Maneuvering speed	6 knots
Water storage	30,000 gal.
Fuel endurance	30 days
Distilling plant	1,900 gpd

Auxiliary Power or Support Equipment Requirements

The SEACON is equipped with a variety of power and support equipment generally suited to a specific function. The SEACON is equipped with a travelling gantry crane of 10-ton capacity and 360° swing. In addition, power winches, compressors, generators, and other power and support items can be added from the OCEI inventory, depending on the ship mission.

Operator/Crew Requirements

When the vessel is deployed to a site for operation, it is normally manned by an integrated team comprised of contractor and civilian personnel from CHESNAV-FACENGCOM. These personnel have received special training in the operation and maintenance of the vessel to enable them to fill SEACON billets during deployment. In addition to the vessel operating personnel, a construction crew is assigned to perform the actual construction operations utilizing the vessel's assets. The vessel is also available for use by contractors performing ocean construction operations under Government contract.

Training Requirements

Accompanying key personnel have received special training in the operation and maintenance of the SEACON.

Field Maintenance Requirements

Field maintenance will be performed per OCEI instructions and manufacturer's manual. Operating logs and equipment history cards must be maintained.

Spare Parts

Sufficient spare parts are available to permit performance of the specific mission and routine maintenance.

Mobilization Time: *Three weeks*

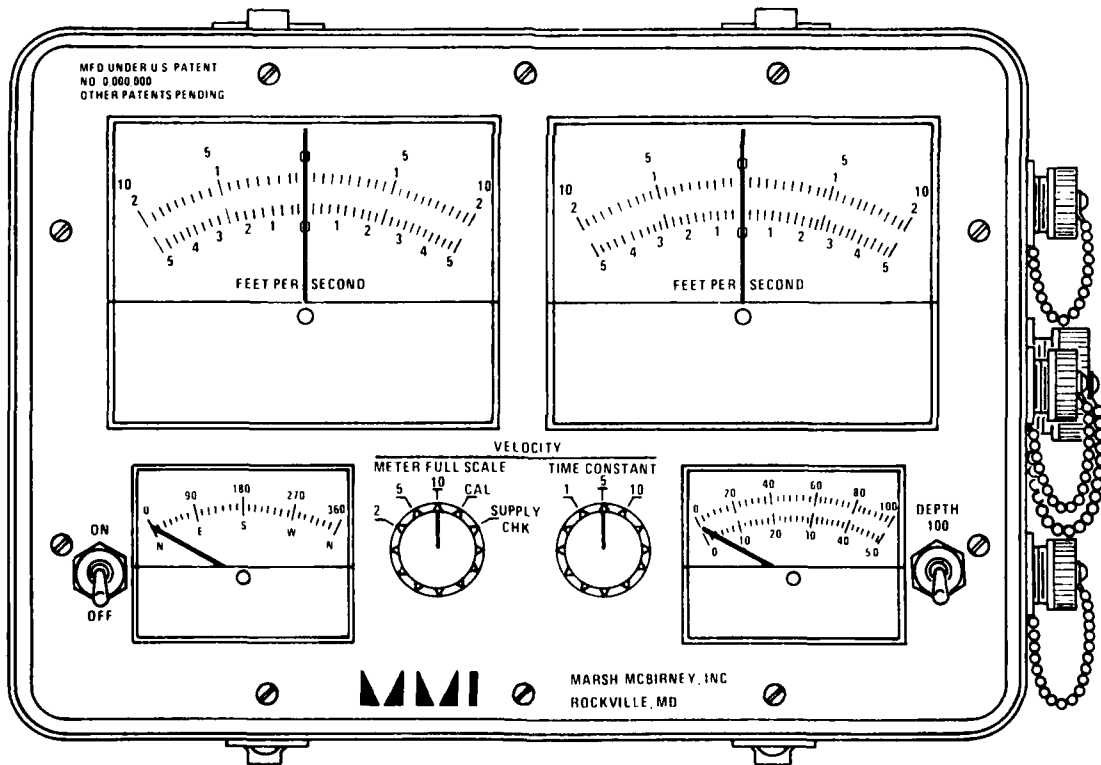
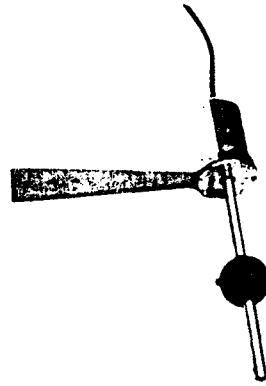
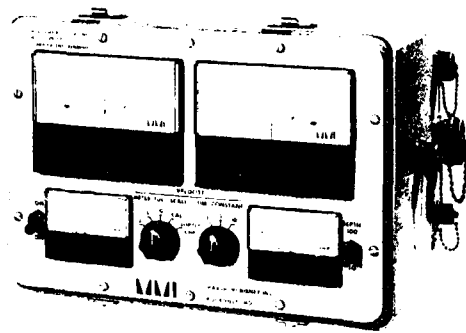

Electromagnetic Water Current Meter

Item

CURRENT METER, WATER, ELECTROMAGNETIC

Manufacturer

Marsh-McBirney, Gaithersburg, MD 20760

Model

527

General Description

The current meter is a device used for measuring water velocity, with a zero stability as good as ± 0.02 ft. per second.

The sensor for the current meter consists of a sphere containing an electromagnet and two pairs of external electrodes in contact with the water. Flow around the probe intersects magnetic flux lines causing voltages to be generated. These voltages are detected by the electrodes and the signals are processed by the signal conditioner and presented as analog voltage, linearly proportional to the X and Y components of the velocity vector.

Components of the system are a sensor, a cable, and an electronic processor. Operation of the sensor with or without the removable wave permits the use of two operating modes.

Performance

In low or turbulent currents the unit is used without the vane, providing visual readout for both X and Y velocity components and compass heading. These readouts allow calculation of water current with respect to magnetic North.

In higher currents, the vane can be attached, converting the unit to direct angle/ magnitude readout. The cross axis channel can be used to verify vane alignment with water flow.

Characteristics:

Measurement: X and Y components of water velocity perpendicular to flow probe

Range: Switch selectable, 0 to ± 2 ft./sec., 0 to ± 5 ft./sec.

Accuracy: The largest of ± 0.07 ft./sec. or $\pm 2\%$ of reading along each axis

Linearity: $\pm 2\%$

Resolution: $0.03 \text{ ft./sec.}/T$ where T is the output time constant

Output Signal: Portable signal processor has a $\pm 1 \text{ V} \pm 10 \text{ ft./sec.}$ output and the rack-mounted processor has a $\pm 5 \text{ V} \pm 10 \text{ ft./sec.}$ signal output.

Depth capability: 500 feet

Compass accuracy: $\pm 10^\circ$ (up to 25° tilt angle)

Physical Description

Processor

Length	14 in.
Height	12 in.
Width	10 in.
Weight	$\approx 20 \text{ lb.}$

Sensor

Height	26 in.
Diameter	5 in.
Cable length	150 ft.

Auxiliary Power or Support Equipment Requirements

The standard signal processor is powered by two rechargeable 6-volt Globe Union, Gel-Cell batteries contained within the portable case. Batteries are charged by a charger mounted in the case.

Operator/Crew Requirements

One person is required for operation of the water current meter.

Training Requirements

One day's training in the field or at the manufacturer's facility is required to operate the system.

Field Maintenance Requirements

Field maintenance will be performed per OCEI instructions and manufacturer's manual. Operating logs and equipment history cards must be maintained.

Spare Parts

Spare parts are not available.

Mobilization Time: Two days

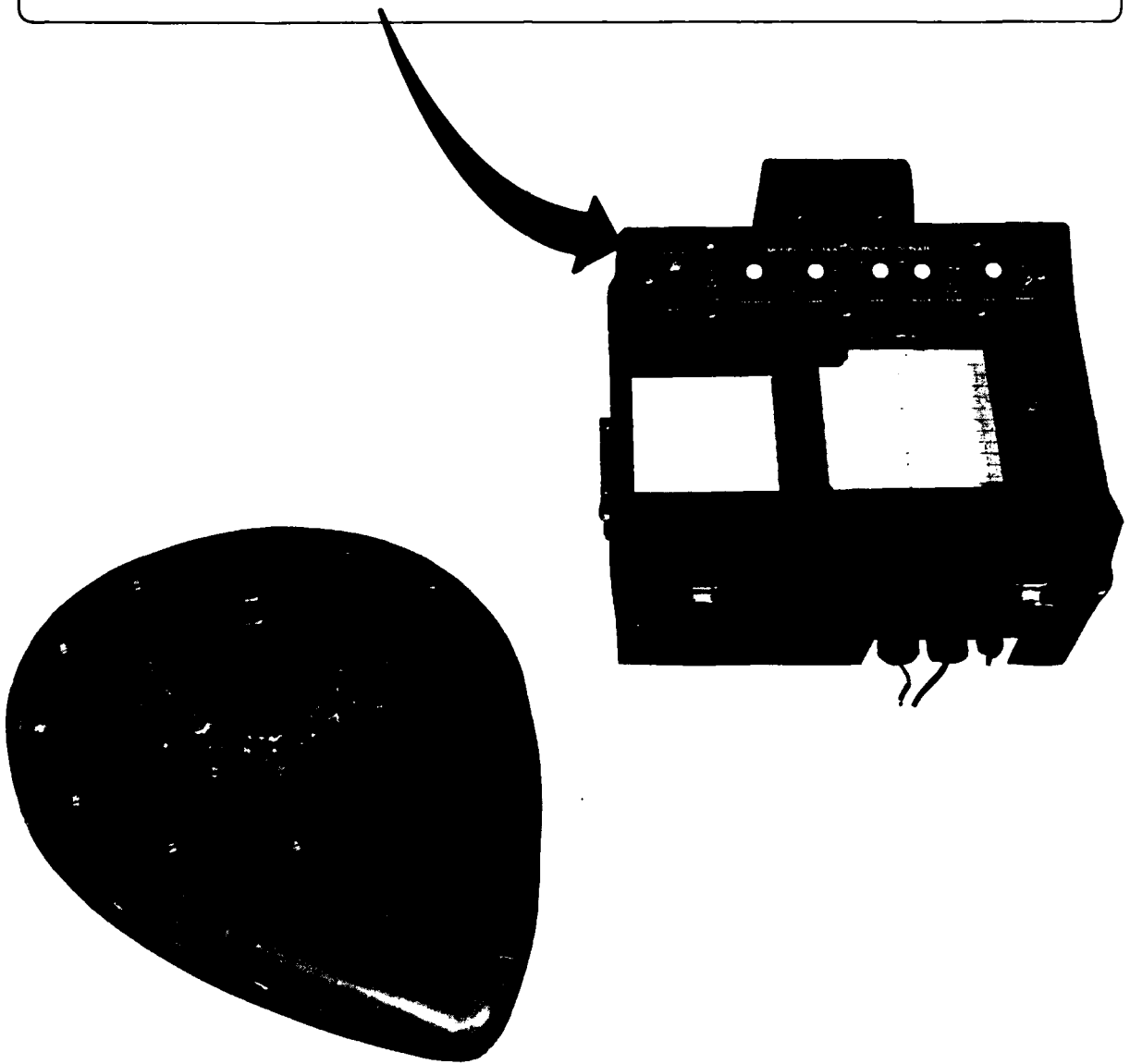
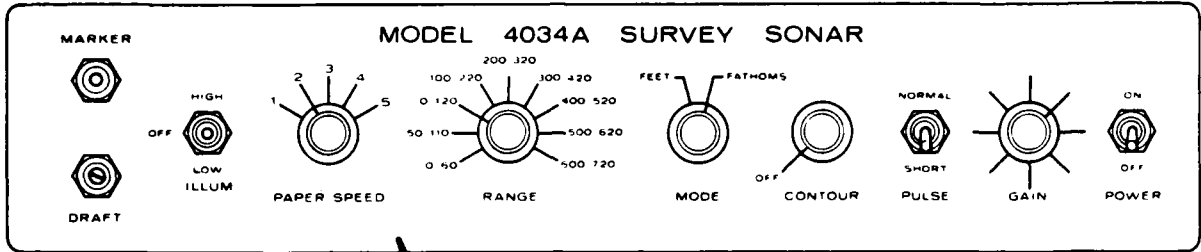

Recorder, Depth (4034A)

Item

RECORDER, DEPTH (4034A)

Manufacturer

Edo Western Corp., Salt Lake City, UT

Model

4034A

General Description

The depth recorder consists of a transmitter-receiver-recorder unit, a transducer, and interconnecting cables. The depth recorder provides a means of measuring and permanently recording water depths beneath a moving ship. The information is presented as a graphic plot of depth versus time on a calibrated paper chart. The transmitter-receiver-recorder unit is housed in a metal cabinet with a hinged front cover containing a rectangular glass window to permit observation/access to the recorder chart surface. The operating controls are located directly above the glass window. External electrical connections (power and transducer cables) are made through connectors located on the front panel. To facilitate bulkhead mounting of the cabinet, there are four raised pads (tapped to bolt-hole size) on the cabinet.

Performance

The depth recorder is capable of measuring and permanently recording water depth beneath a moving ship within the range of 2 feet to 720 fathoms. Continued repetition of the transmit, receive, record cycle, and uniform movement of the chart in a direction parallel to its length produces a linear plot of water depth versus time. A digital readout is also provided which will read depth in feet, fathoms, or meters.

Characteristics:

Transducer

Resonant frequency 24 kHz
Impedance @ 24 kHz 60 ohms
Max. power input 1000 watt
Beamwidth 13°

Physical Description

Depth Recorder

Height 10.12 in.
Width 18.50 in.
Depth 14.75 in.
Weight 40 lb.

Transducer

Diameter 9.00 in.
Height 8.62 in.
Weight 90 lb.

Auxiliary Power or Support Equipment Requirements

An external power source of 115 Vac, or 26 Vdc, is required for operation of the depth recorder unit.

Operator/Crew Requirements

One experienced person is required for monitoring the depth recorder.

Training Requirements

Two days' training in the field or at the manufacturer's facility is required to familiarize operator(s) with the operation and preventive maintenance of the equipment.

Field Maintenance Requirements

Field maintenance will be performed per OCEI instructions and manufacturer's manual. Operating logs and equipment history cards must be maintained.

Spare Parts

Spare parts are available.

Mobilization Time: Two days

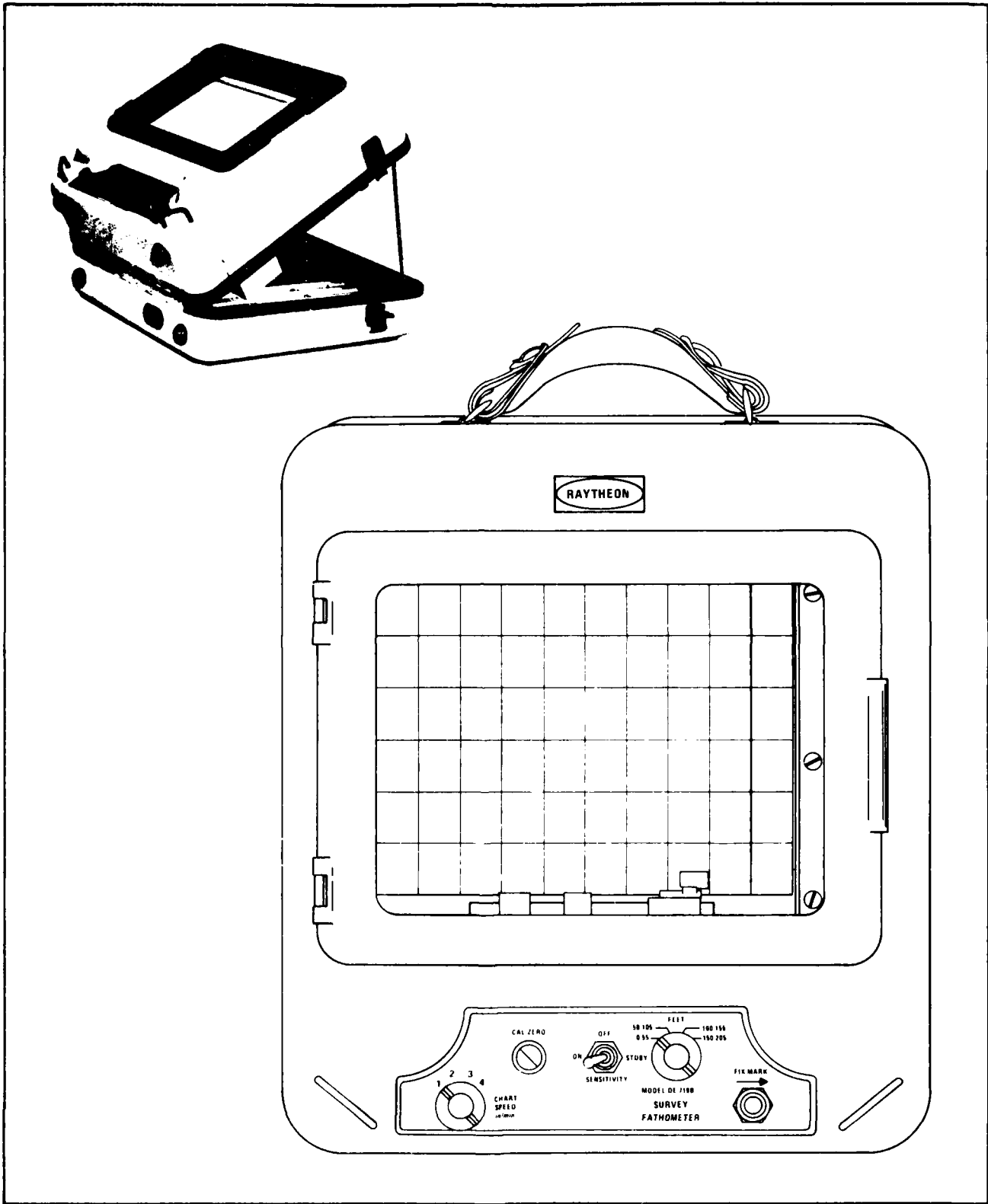

Recorder, Depth (DE-719B)

Item

RECORDER, DEPTH (DE-719B)

Manufacturer

Raytheon Marine Company, Manchester, NH

Model

DE-719B

General Description

This unit is a portable, survey-type depth recorder designed to provide a detailed permanent recording of underwater topography in water depths between 2 and 410 feet.

The fathometer provides high resolution recordings based on narrow transducer beam width, high sounding rate, and high signal frequency. Four selectable chart speeds are provided. Versatility is further enhanced by a TIDE and DRAFT control, a SPEED OF SOUND control, and a RANGE doubling control. Any changes in the settings of the preceding controls are permanently recorded on the chart paper for future reference. Fix marks are inscribed on the chart by a FIX MARK switch. (A remote switch may be connected.)

Performance

The transducer is designed for precision survey work and other applications where a very narrow beam pattern is required. Such requirements result when extreme accuracy is needed in underwater laying of pipe or cable. The narrow beam pattern is also useful for more accurately outlining a submerged object, such as a sunken vessel. The transducer is also useful for measuring wave heights, where the narrow beam can differentiate between wave peaks and troughs.

Characteristics:

Depth range: 0-55, 50-105, 100-155, and 150-205 feet (0-16.5, 15-31.5, 30-41.5, and 45-61.5 meters)

Sounding rate: 534 soundings per minute

Voltage input: 12 Vdc

Current input: 2.5 amperes

Accuracy: $\pm 0.5\% \pm 1$ inch of indicated depth

Operating frequency: 208 kHz

Transducer: Barium titanate — Model 200T5HAD (optional model 7245A)

Transducer beamwidth: 8° at the half-power points

Chart paper speed: 1, 2, 3, and 4 inches per minute

Chart paper: 7 inches X 60 feet

Physical Description

Height	18 in.
Width	15-3/8 in.
Depth	9-1/16 in.
Net weight w/transducer	47 lb.
Recorder weight	38 lb.

Auxiliary Power or Support Equipment Requirements

The fathometer equipment is designed to operate from a 12 Vdc source.

Operator/Crew Requirements

One person can operate the recorder.

Training Requirements

Two days' training in the field or at the manufacturer's facility is required.

Field Maintenance Requirements

Field maintenance will be performed per OCEI instructions and manufacturer's manual. Operating logs and equipment history cards must be maintained.

Spare Parts

A parts kit (P/N 7430-5031G1), furnished with each system, contains replacement fuses, stylus, brushes, and chart paper.

Mobilization Time: Two days

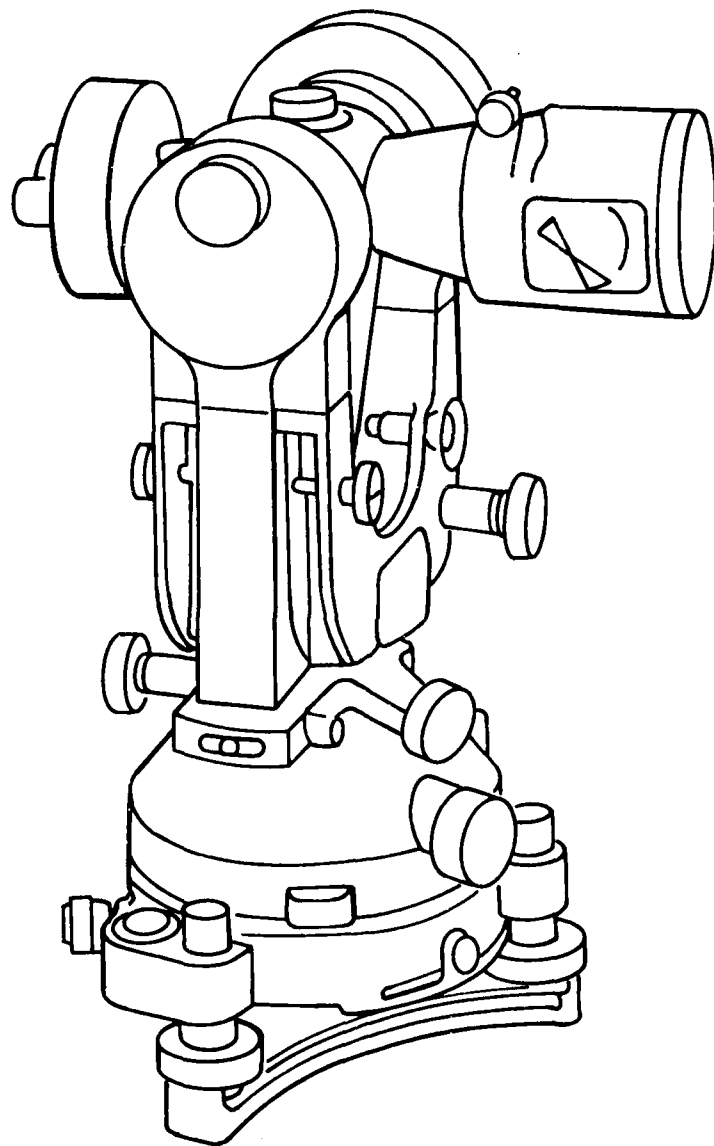

Theodolite

Item

THEODOLITE

Manufacturer

Wild Heerbrugg AG., Heerbrugg, Switzerland

Model

T2

General Description

The theodolite is a surveying instrument used for making measurements and taking astronomical observations. Specific applications are: triangulation; distance measurement; traversing; and surveying observations.

Performance

The primary performance areas of the theodolite are: triangulation (permitting measurement of triangles with lateral lengths up to 10 miles or 2nd-order triangulation), traversing, and distance measurement. This instrument is also available in mills 0 to 640 at 1.2 intervals.

Characteristics:

Limb: 3-1/2-in.-diameter glass circle with 20-to-20 minute graduations and 360 degree numbered divisions.

Alidade: Graduations with 20-minute intervals, marked on a 2-3/4-in.-diameter circle, and numbered from 0 to 359 degrees, respectively.

Telescope: 5-3/4 in. long; can be transited at both the objective and the eyepiece end. The free objective aperture measures 1-5/8 in.; magnification is 28 times.

Physical Description

Overall diameter 6 in.
Height 12 in.
Weight of theodolite and tribrach 12-3/8 lb.
Tripod (111a or 111b) weight 12-3/8 – 12-1/8 lb.
Packing case (baseplate and hood) weight 4-5/8 lb.

Auxiliary Power or Support Equipment Requirements

A tripod is furnished with each unit.

Operator/Crew Requirements

One technician-level operator familiar with surveying instruments is required.

Training Requirements

Two days' training in the field is required.

Field Maintenance Requirements

Field maintenance will be performed per OCEI instructions and manufacturer's manual. Operating logs and equipment history cards must be maintained.

Spare Parts

Spare parts are not available.

Mobilization Time: Two days

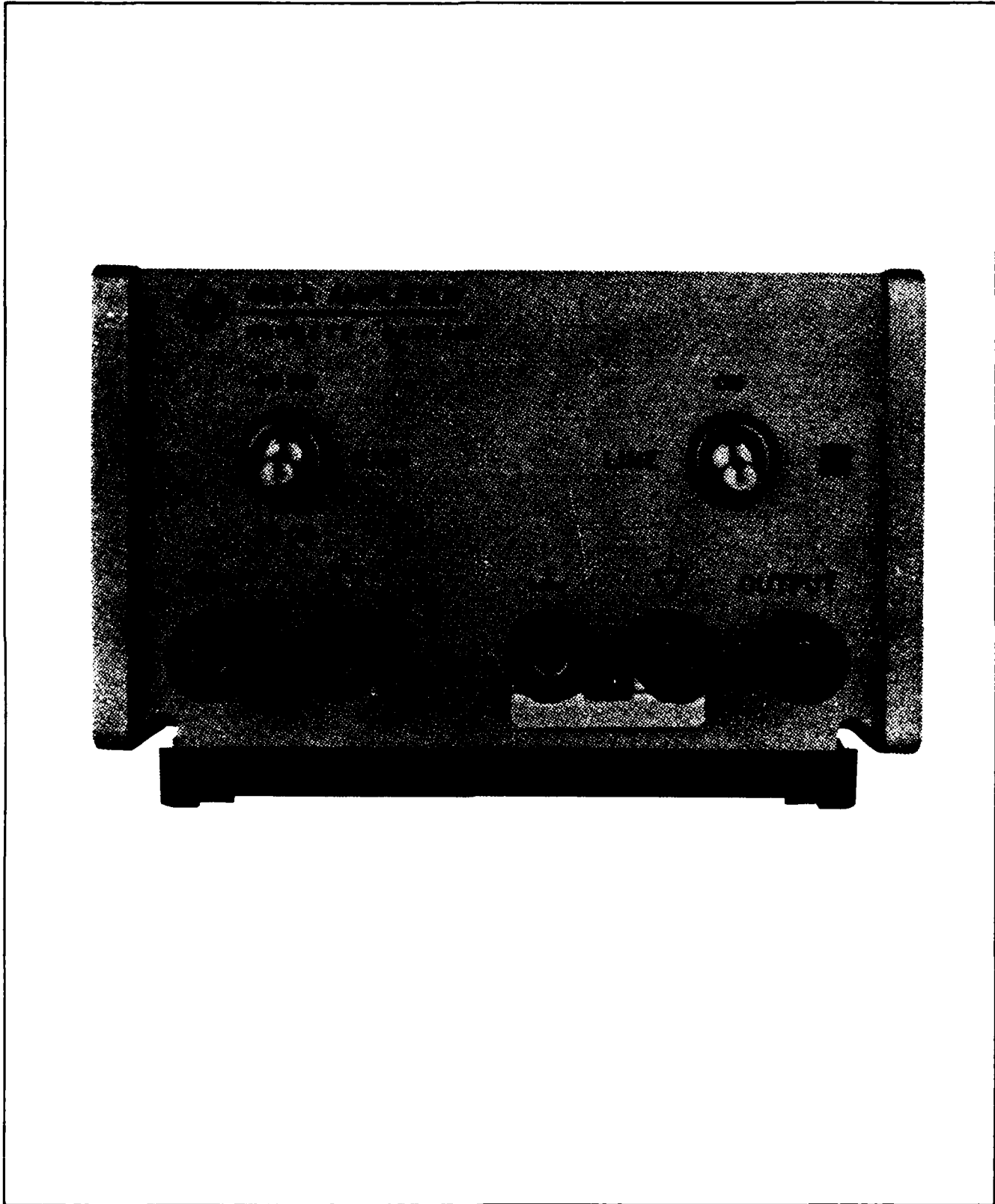

Amplifier (465A)

Item

AMPLIFIER (465A)

Manufacturer

Hewlett-Packard, Palo Alto, CA 94303

Model

465A

General Description

The 465A submodular unit is a general purpose amplifier and impedance converter. The 465A has a selectable gain, stable over a continuous frequency range. The solid state, low noise design allows operation over a wide voltage range for application as both a preamplifier and amplifier.

Performance

Characteristics:

Voltage gain: 20 dB (X10) or 40 dB (X100), open circuit.

Frequency response: ± 1 dB at 100 Hz to 50 KHz; < 2 dB down at 5 Hz and 1 MHz.

Output: > 10 volts rms open circuit; > 5 volts rms into 50 ohms (1/2 W).

Input impedance: 10 M Ω shunted by < 20 pF.

Output impedance: 50 ohms.

Physical Description

Net weight 4 lb.
Shipping weight 6 lb.
Width 5-1/8 in.
Height 3-14/32 in.
Depth 11 in.

Auxiliary Power or Support Equipment Requirements

Power requirements are 115 or 230 V $\pm 10\%$, 50 to 400 Hz, 10 W at full load.

Operator/Crew Requirements

One person familiar with electronic test equipment is required to operate the amplifier.

Training Requirements

Familiarization with the equipment and the accompanying technical manual is required.

Field Maintenance Requirements

Field maintenance will be performed per OCEI instructions and manufacturer's manual. Operating logs and equipment history cards must be maintained.

Spare Parts

Spare parts are not available.

Mobilization Time: Two days

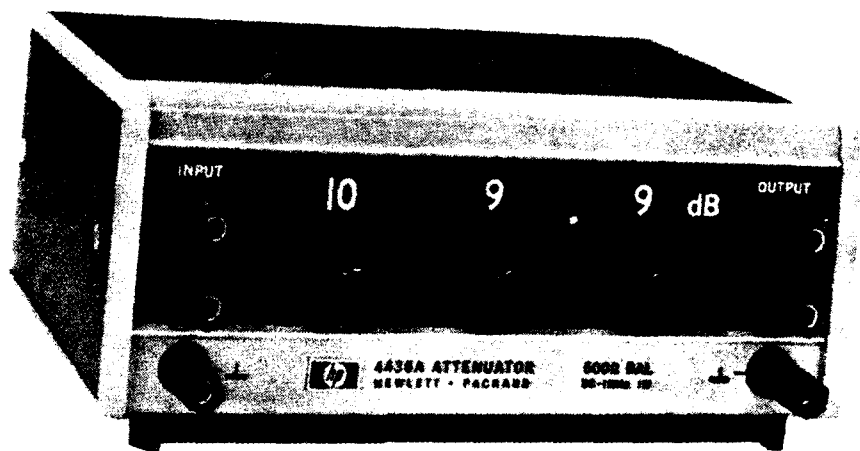

Attenuator (4436A)

Item

ATTENUATOR (4436A)

Manufacturer

Hewlett-Packard, Palo Alto, CA 94303

Model

4436A

General Description

The 4436A Submodular unit is an in-line reading variable attenuator. This attenuator provides accurate steps of attenuation with excellent resolution for power-level measurements, transmission efficiency tests, and gain or loss measurements on filters, amplifiers, and similar equipment.

Performance**Characteristics:**

Frequency range: Dc to 1 MHz.

Maximum attenuation: 119.9 dB

Attenuation increments: 0.1 dB

Input/Output impedance: 600 Ω , balanced.Input/Output impedance accuracy (at 100 kHz): 600 Ω
 $\pm 10 \Omega$.

Unbalanced capacitance: <10 pF.

Maximum input power: 1 W (24.5 V max.)

Physical Description

Net weight	3 lb. 13 oz.
Shipping weight	6 lb.
Width	7-25/32 in.
Height	3-7/16 in.
Depth	6-25/32 in.

Auxiliary Power or Support Equipment Requirements

No auxiliary power is required.

Operator/Crew Requirements

One person familiar with electronic test equipment is required to operate the attenuator.

Training Requirements

Familiarization with the equipment and the accompanying technical manual is required.

Field Maintenance Requirements

Field maintenance will be performed per OCEI instructions and manufacturer's manual. Operating logs and equipment history cards must be maintained.

Spare Parts

Spare parts are not available.

Mobilization Time: Two days

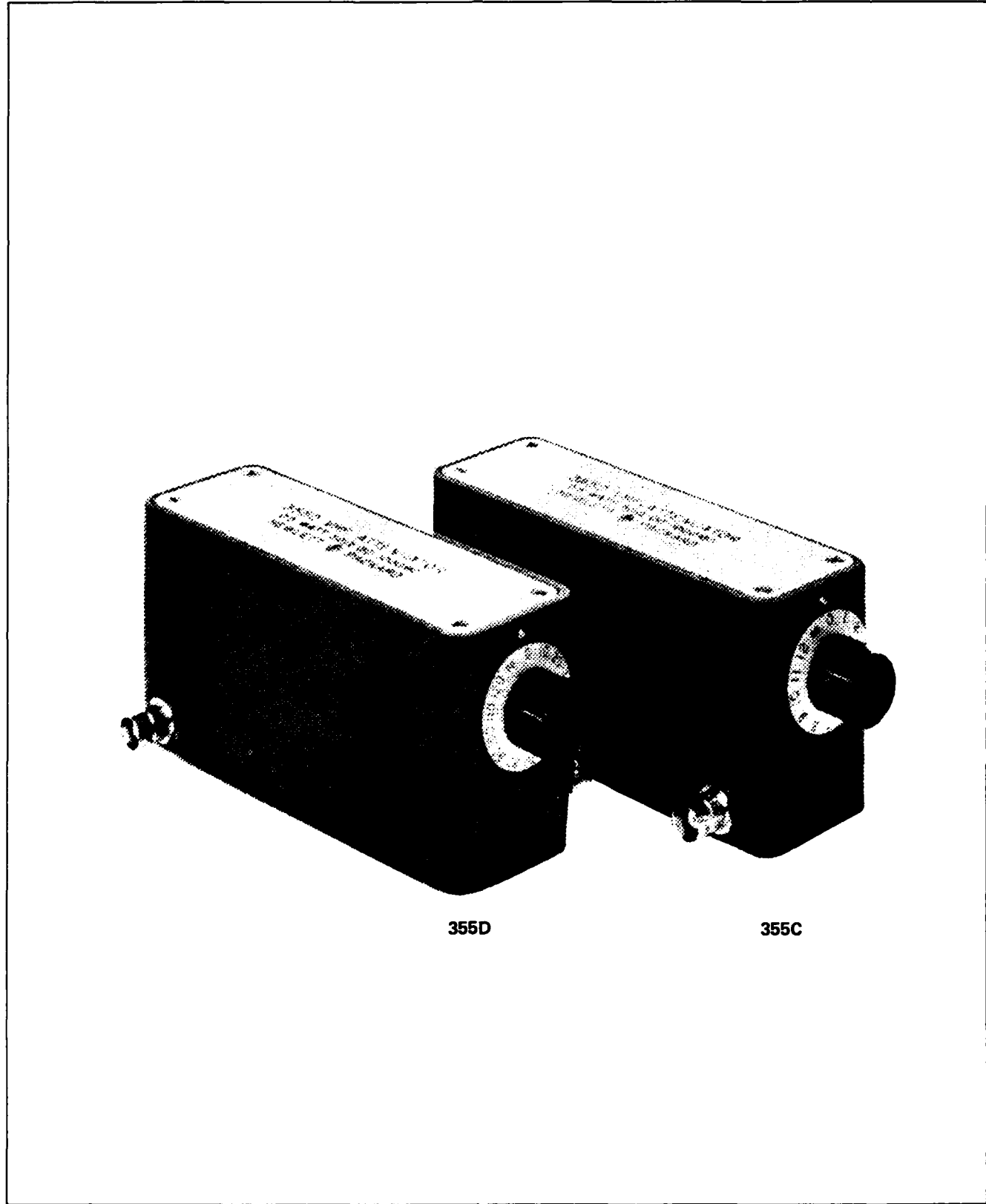

355D

355C

Attenuators, VHF (355C and 355D)

Item

ATTENUATOR, VHF

Manufacturer

Hewlett-Packard, Palo Alto, CA 94303

Model

355C and 355D

General Description

The 355C and 355D are coaxial step attenuators. The attenuator sections consist of resistor pi networks which are switched in or bypassed by microswitches. These microswitches are cam-actuated.

Performance

Characteristics:

Model 355C

Attenuation range: 0 to 12 dB.
Attenuation steps: 1 dB.
Overall accuracy: 0.1 dB at 1 kHz; 0.25 dB, dc to 500 MHz; 0.35 dB, dc to 1000 MHz.

Model 355D

Attenuation range: 0 to 120 dB.
Attenuation steps: 10 dB.
Overall accuracy: At 1 kHz, 0 to 120 dB ± 0.3 dB; below 1000 MHz, 0 to 90 dB ± 1.5 dB; 90 to 120 dB ± 3 dB.

Both Models

Frequency range: Dc to 1000 MHz.
Impedance: 50 ohms (nominal).

Maximum SWR (input and output): 1:2 below 250 MHz; 1:3 below 500 MHz; 1:5 below 1000 MHz.

Maximum residual attenuation: Less than 0.25 dB to 100 MHz; less than 0.75 dB to 500 MHz; less than 1.5 dB to 1000 MHz.

Maximum power dissipation: 0.5 W, average.
Maximum pulse voltage: 350 Vpk.

Physical Description

Both Models

Weight 1.5 lb.
Length 6 in.
Width 2-13/16 in.
Height 2-11/16 in.

Auxiliary Power or Support Equipment Requirements

A solid shield 50 ohm cable, 15 inches long with male BNC connectors (P/N 803A-16E) and an RG-55/U cable, 2 feet long with male type N connector on one end, BNC connector on the other end (P/N 803A-16D) are available for use with the VHF attenuators.

Operator/Crew Requirements

One person familiar with electronic test equipment is required to operate the VHF attenuators.

Training Requirements

Familiarization with the equipment and the accompanying technical manual is required.

Field Maintenance Requirements

Field maintenance will be performed per OCEI instructions and manufacturer's manual. Operating logs and equipment history cards must be maintained.

Spare Parts

Spare parts are not available.

Mobilization Time: Two days



Attenuator (3750A)

Item

ATTENUATOR (3750A)

Manufacturer

Hewlett-Packard, Palo Alto, CA 94303

Model

3750A

General Description

The 3750A is a general purpose attenuator. Attenuation is provided in steps by the operation of pushbutton switches. Although the 3750A is a general purpose attenuator, it is particularly suitable for large value attenuation of RF signals. The 3750A has symmetrical attenuation properties so that it can be used with either terminal as input and the other as output.

Performance

Characteristics:

Frequency range: Dc to 100 MHz.

Attenuation range: 0 to 99 dB in 1 dB steps.

Accuracy: Dc to 100 MHz, ± 0.1 dB to ± 2 dB; 100 to 200 MHz, ± 0.2 dB to ± 2 dB; 200 to 400 MHz, ± 0.2 dB to ± 2 dB.

Characteristic impedance: 75Ω .

Return loss: 28 dB minimum.

Power rating: 250 mW (+24 dBm).

Physical Description

Weight	3 lb.
Width	8 in.
Height	2-1/2 in.
Depth	4 in.

Auxiliary Power or Support Equipment Requirements

N/A

Operator/Crew Requirements

One person familiar with electronic test equipment is required to operate the attenuator.

Training Requirements

Familiarization with the equipment and the accompanying technical manual is required.

Field Maintenance Requirements

Field maintenance will be performed per OCEI instructions and manufacturer's manual. Operating logs and equipment history cards must be maintained.

Spare Parts

Spare parts are not available.

Mobilization Time: Two days

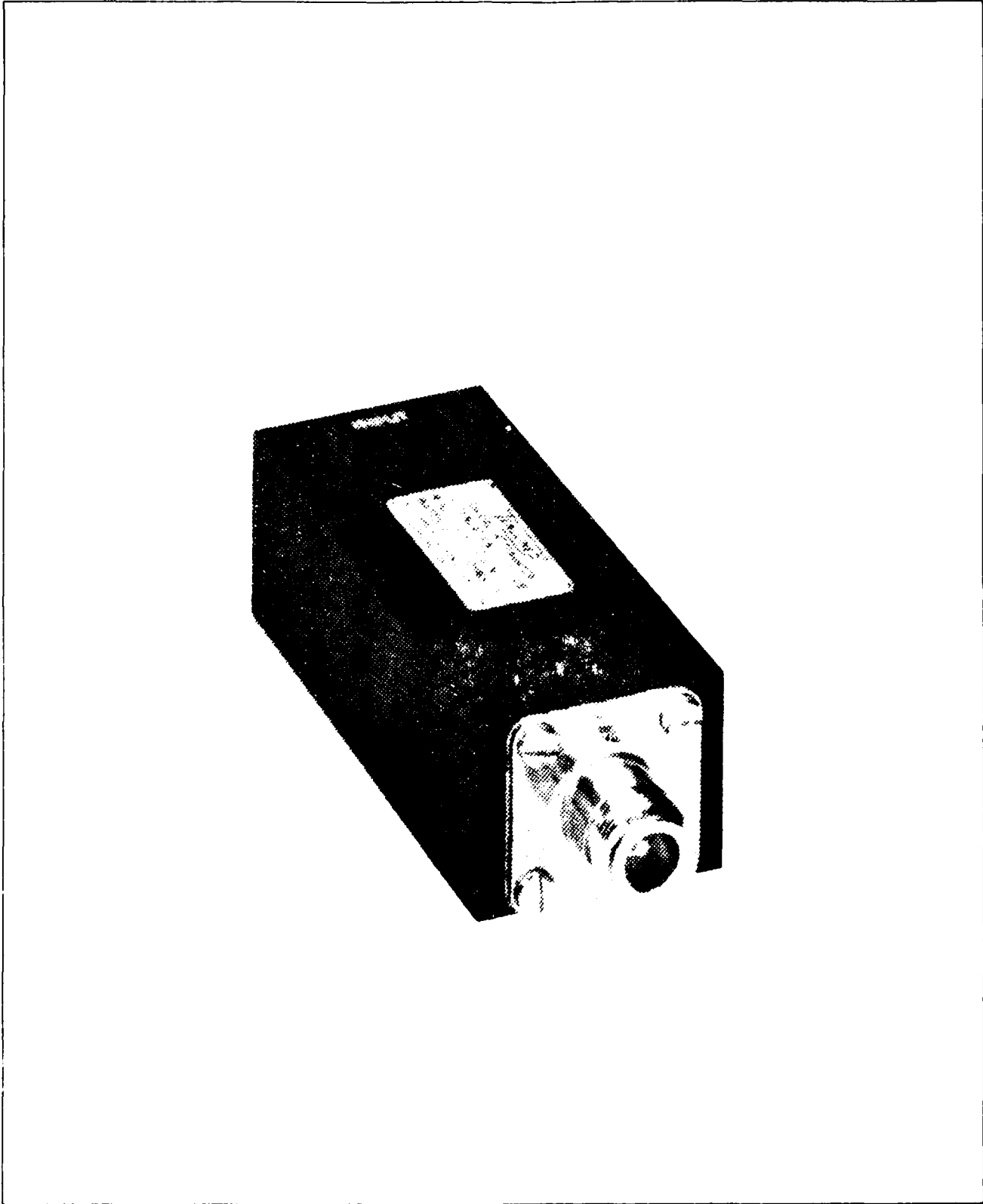

Attenuator, Conduction Type

Item

ATTENUATOR, CONDUCTION TYPE

Manufacturer

Bird Electronic Corp., Cleveland (Solon), OH 44139

Model

8341-060

General Description

The 8341-060 is a low-reflection resistance network for application in the measurement of medium power in controlled and known amounts. It is designed to match commonly-used coaxial transmission lines. The unit may be used for isolation of power sources and for low-level monitoring.

The 8341-060 is intended for fixed attachment to a heat sink to provide full-power capacity.

Performance

Characteristics:

Frequency range: Dc to 1000 MHz.

Attenuation: 6 dB (nominal).

Impedance: 50 Ω (nominal).

Maximum deviation with frequency: ±1/2 dB dc to 500 MHz; ±3/4 dB 500 to 1000 MHz.

Power rating: 40 W.

Input VSWR: 1:10 maximum dc to 500 MHz; 1:15 maximum 500 to 1000 MHz.

Output VSWR: 1:15 maximum dc to 1000 MHz.

Physical Description

Weight	13-1/2 oz.
Width	5-3/16 in.
Height	1-5/8 in.
Depth	1-1/4 in.

Auxiliary Power or Support Equipment Requirements

N/A

Operator/Crew Requirements

One person familiar with electronic test equipment is required to operate the attenuator.

Training Requirements

Familiarization with the equipment and the accompanying technical manual is required.

Field Maintenance Requirements

Field maintenance will be performed per OCEI instructions and manufacturer's manual. Operating logs and equipment history cards must be maintained.

Spare Parts

Spare parts are not available.

Mobilization Time: Two days

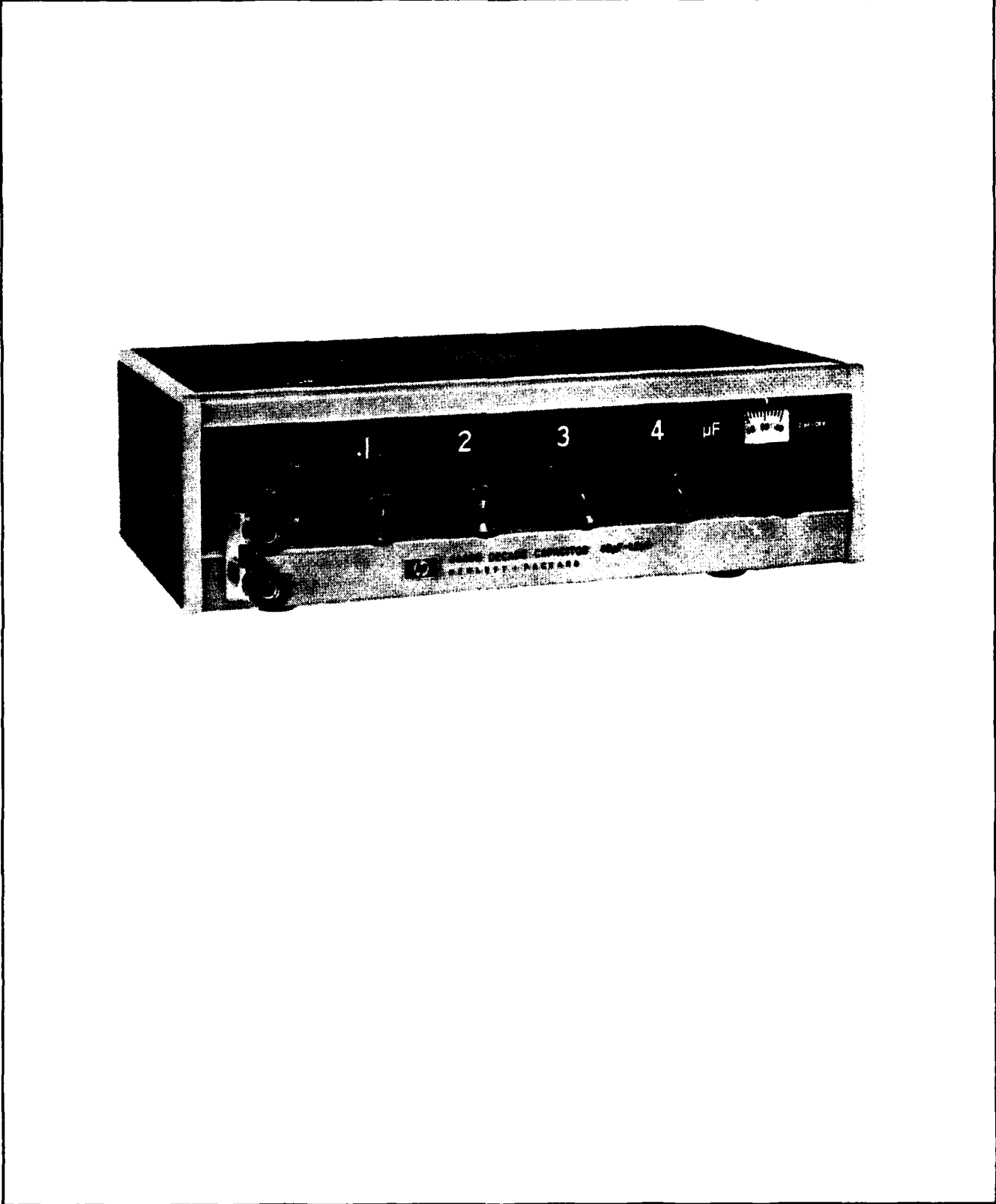

Capacitor, Decade

Item

CAPACITOR, DECADE

Manufacturer

Hewlett-Packard, Palo Alto, CA 94303

Model

4440B

General Description

The 4440B is a high-accuracy decade capacitor providing usable capacitances which aid in circuit design, ac bridge measurements, and any application where accuracy is critical, such as a working standard. The 4440B is also ideally suited for production line testing.

The 4440B offers simplicity of operation combining four easy-to-read decade ranges in a lightweight, compact package designed for operator convenience and speed. An air capacitor vernier provides additional capacitance between the 100 pF steps of the smallest decade.

Performance

Characteristics:

Capacitance range: 40 pF to 1.2 μF in steps of 100 pF with a 40 pF to 140 pF variable air capacitor providing continuous adjustment to better than 2 pF between steps.

Resonant frequency: Typical values of the resonant frequency are 450 kHz at 1 μF, 4 MHz at 0.01 μF, and 40 MHz at 100 pF.

Insulation resistance: 5×10^9 ohms minimum, after 5 minutes at 500 Vdc.

Maximum voltage: 500 V peak.

Physical Description

Weight	5.5 lb (apprx.)
Width	10.4 in.
Height	3.3 in.
Depth	6.9 in.

Auxiliary Power or Support Equipment Requirements

N/A

Operator/Crew Requirements

One person familiar with electronic test equipment is required to operate the decade capacitor.

Training Requirements

Familiarization with the equipment and the accompanying technical manual is required.

Field Maintenance Requirements

Field maintenance will be performed per OCEI instructions and manufacturer's manual. Operating logs and equipment history cards must be maintained.

Spare Parts

Spare parts are not available.

Mobilization Time: Two days

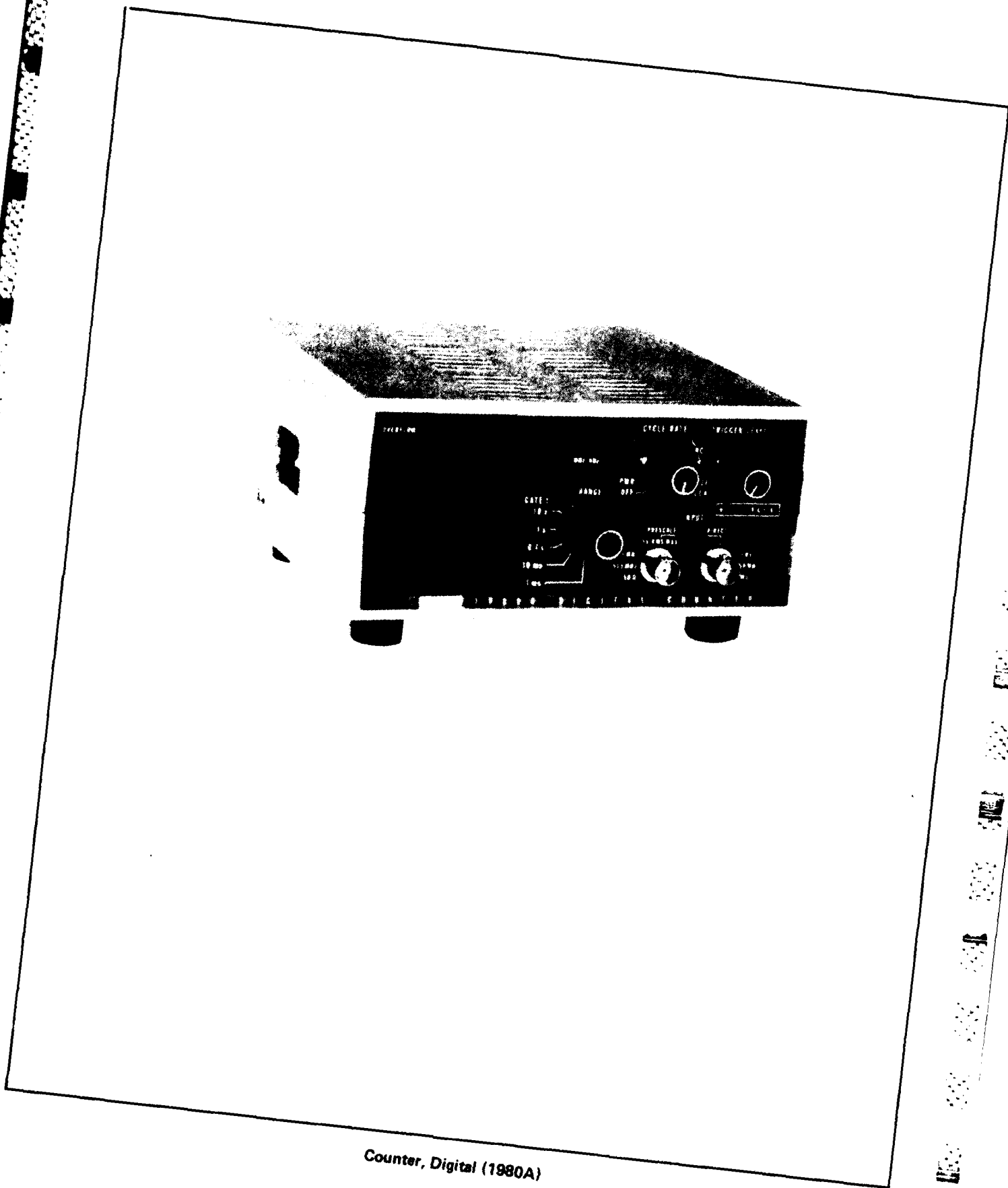

Counter, Digital (1980A)

Item

COUNTER, DIGITAL (1980A)

Manufacturer

John Fluke Mfg. Co., Inc., Seattle, WA 98133

Model

1980A

General Description

The 1980A is a compact, highly portable, lightweight telecommunications frequency counter. The 1980A has a full six-digit LED display, cycle rate and trigger level controls, trigger level status indication, gate time selection, and an overflow indicator that warns when the count has exceeded the last decade of the display.

The 1980A has two selectable inputs. A self-check position on the trigger level control provides a 1 MHz signal from the internal reference oscillator for checking the display and logic circuitry. An optional time base oscillator allows the instrument to be tailored to the stability requirements of the user. A snap-on battery pack is also available, making the 1980A suitable for field applications.

Performance**Characteristics:**

Frequency range: 5 Hz to 515 MHz (2 selectable inputs).

Input sensitivity: 50 m Vrms over entire frequency range or 5 Hz to 50 MHz (DIRECT INPUT); 50 m Vrms from 25 MHz to 515 MHz (PRESCALE INPUT).

Input impedance: 1 M shunted with 30 pF (DIRECT INPUT); 50 ohms (PRESCALE INPUT).

Overload capability: 150 Vrms up to 1 kHz decreasing to 5 Vrms at 50 MHz (DIRECT INPUT); dc + peak Vac must not exceed 250 V, 5 Vrms (PRESCALE INPUT).

Gate times: 1 ms to 10 s in 5 decade steps.

Cycle rate: Variable between 0.2 and 2.0 seconds.

Readout: Six-digit LED display. Measurement units and decimal point automatically indicated, incorporates leading zero suppression.

Physical Description

Weight	4.75 lb.
Width	6.51 in.
Height	3.54 in.
Depth	7.85 in.

Auxiliary Power or Support Equipment Requirements

Power requirements are 115 or 230 V \pm 10%, 50 to 60 Hz, or 400 Hz (11.5 Vdc to 14 Vdc with cable). The counter battery provides up to 4.8 hours of portable counter operation. The battery is a 12 V rechargeable type.

Operator/Crew Requirements

One person familiar with electronic test equipment is required to operate the counter.

Training Requirements

Familiarization with the equipment and the accompanying technical manual is required.

Field Maintenance Requirements

Field maintenance will be performed per OCEI instructions and manufacturer's manual. Operating logs and equipment history cards must be maintained.

Spare Parts

Spare parts are not available.

Mobilization Time: Two days

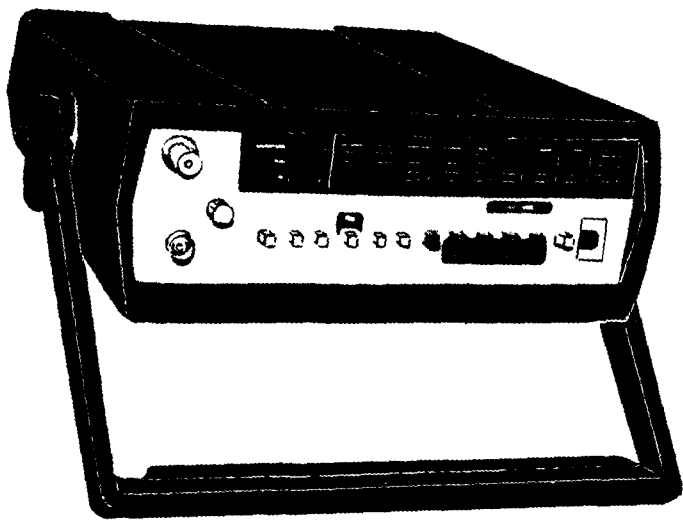

Counter, Digital Multifunction

100 101 102 103 104 105 106 107 108 109 110 111 112 113 114 115 116 117 118 119 120 121 122 123 124 125 126 127 128 129 130 131 132 133 134 135 136 137 138 139 140 141 142 143 144 145 146 147 148 149 150 151 152 153 154 155 156 157 158 159 160 161 162 163 164 165 166 167 168 169 170 171 172 173 174 175 176 177 178 179 180 181 182 183 184 185 186 187 188 189 190 191 192 193 194 195 196 197 198 199 200

Item

COUNTER, DIGITAL, MULTIFUNCTION

Manufacturer

John Fluke Mfg. Co., Inc., Seattle, WA 98133

Model

1912A

General Description

The 1912A is a rugged, portable multifunction counter offering precise, rapid determination of frequency, period, period average, and totalization. The 1912A has a full seven-digit LED display, full auto ranging supplemented by selectable four-range manual operation, a unique hysteresis capability to eliminate up-and-down ranging for between-range signals, an autoreset feature that is activated each time a new range or function is selected, and an "Automatic Clean Dropout" circuit which automatically monitors the Channel B input and gives an instant warning in the form of zero readout whenever the input signal falls below the sensitivity threshold of the trigger circuit. Trigger level and attenuator controls operate over the dynamic range of the input to permit accurate reading in the presence of noise.

The 1912A has two selectable inputs. An optional timebase oscillator allows the instrument to be tailored to the stability requirements of the user. A convenient rear panel external timebase input jack and switch provide for operation with a 10 MHz frequency standard. A rechargeable battery pack is available for field portability.

Performance

Characteristics:

Frequency range: 5 Hz to 520 MHz (2 selectable inputs).

Input sensitivity: 15 m Vrms from 5 Hz to 100 MHz;
25 m Vrms from 100 MHz to 125 MHz (A input);
25 m Vrms from 50 MHz to 520 MHz (B input).

Input impedance: 1 MΩ/30 pF, ac coupled (A input);
50Ω, VSWR <2.5:1 (B input).

Overload capability: 250 Vrms from 5 Hz to 1 kHz; 10 Vrms above 1 kHz; dc + peak Vac must not exceed 360 V (A input), 5 Vrms (fuse protected); dc + peak Vac must not exceed 100 V (B input).

Period: 500 ns to 0.2s (5 Hz – 2 MHz) for A input.

Prescale factor: 4 (B input).

Readout: Seven-digit LED, leading zeroes suppressed.

Physical Description

Weight	3.2 lb.
Width	8.55 in.
Height	2.52 in.
Depth	10.65 in.

Auxiliary Power or Support Equipment Requirements

Power requirements are 100, 115 or 230 V ±10%, 48 to 440 Hz, 8 W maximum.

Operator/Crew Requirements

One person familiar with electronic test equipment is required to operate the counter.

Training Requirements

Familiarization with the equipment and the accompanying technical manual is required.

Field Maintenance Requirements

Field maintenance will be performed per OCEI instructions and manufacturer's manual. Operating logs and equipment history cards must be maintained.

Spare Parts

Spare parts are not available.

Mobilization Time: Two days

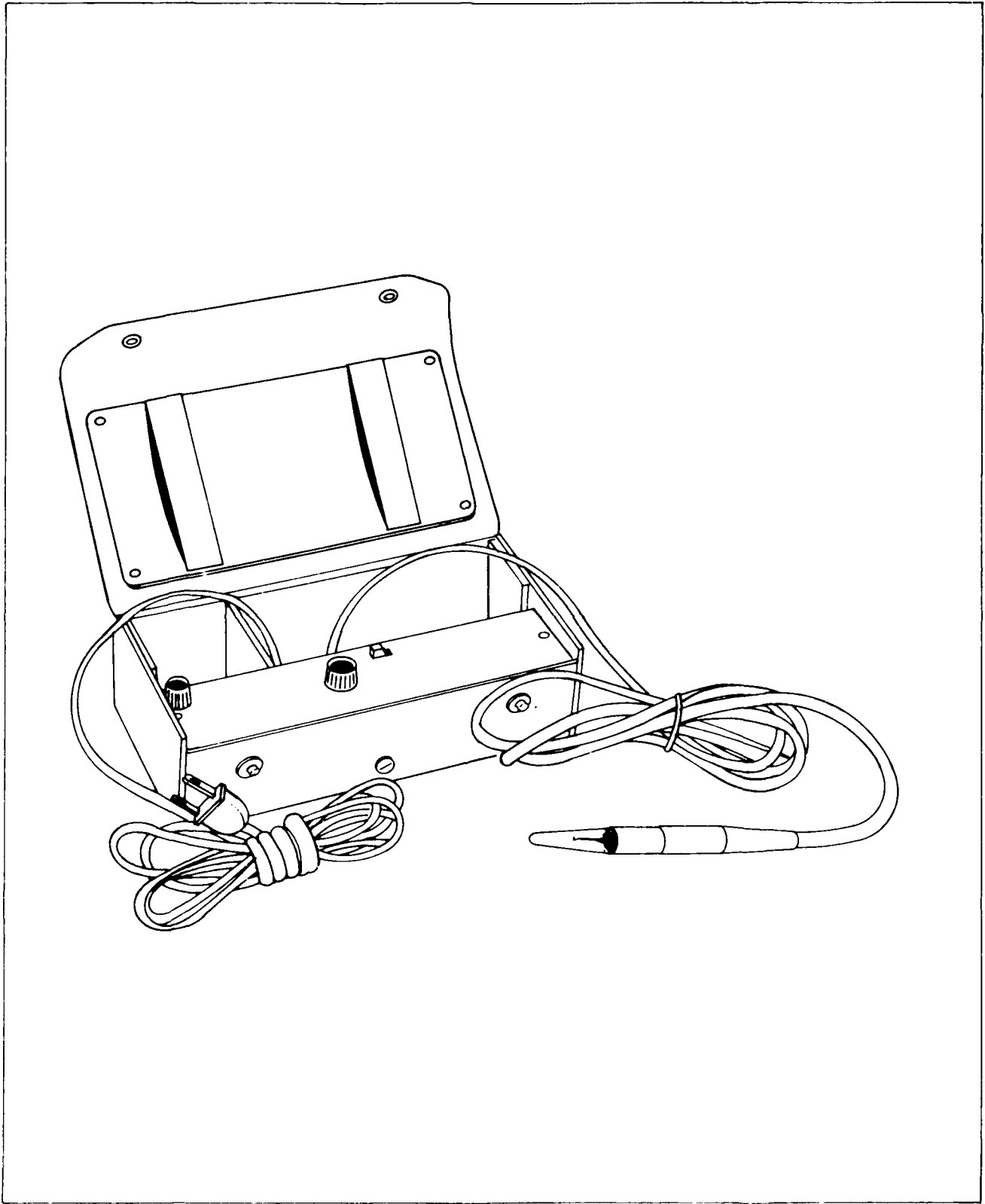

Detector, Leak

Item

DETECTOR, LEAK

Manufacturer

G.E., Instrument Products Operation, Lynn, MA 01910

Model

Type H-10

General Description

The Type H-10 LEAK DETECTOR consists of a control unit, probe, 6-foot hose, and a 6-foot power cord housed in a shock-resistant vinyl case.

Although it can be used for production-line leak checking, the instrument is designed primarily for use as a servicing tool. It is normally used for refrigerant gas leak checking in air conditioning or refrigeration equipment.

A maintenance kit consisting of filters and airflow balls is provided with the instrument.

Performance

Characteristics:

Sensitivity: 0.5 oz./yr. R-12 (gas) on HIGH; 1.0 oz./yr. R-12 on LOW.

Response time: Approximately 1 s.

Reference leak: R-11 (refillable) approximately 1 yr. life.

Warm-up time: Approximately 1 min.

Physical Description

Weight	2.2 lb.
Width	8.5 in.
Height	4.5 in.
Depth	2.6 in.

Auxiliary Power or Support Equipment Requirements

Power requirements are 110-127 V, 60 Hz, 12 W.

Operator/Crew Requirements

One person familiar with air conditioning/refrigeration equipment is required to operate the leak detector.

Training Requirements

Familiarization with the equipment and the accompanying technical manual is required.

Field Maintenance Requirements

Field maintenance will be performed per OCEI instructions and manufacturer's manual. Operating logs and equipment history cards must be maintained.

Spare Parts

Spare parts are not available.

Mobilization Time: Two days

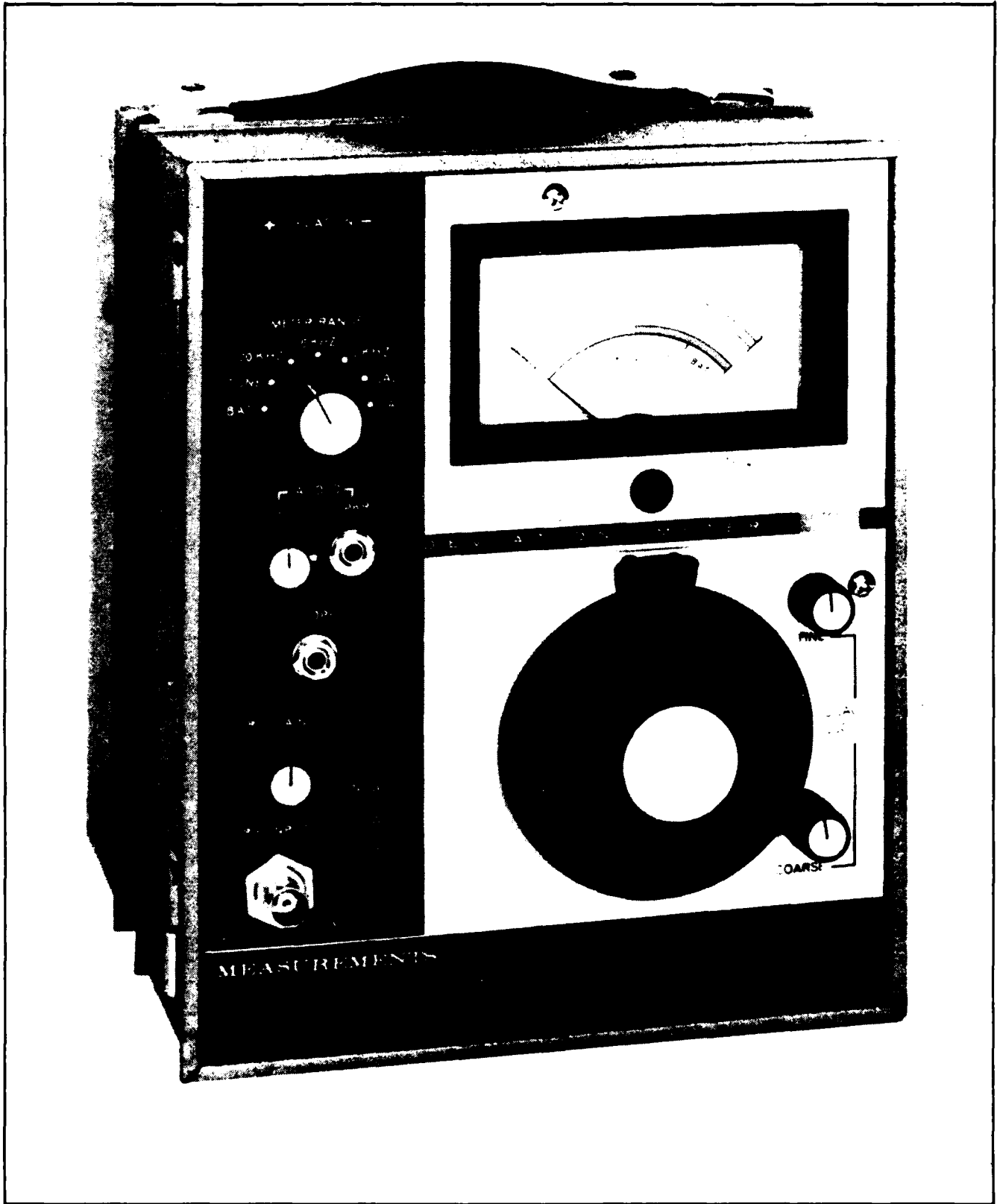

Deviation Meter, Standard

Item

DEVIATION METER, STANDARD

Manufacturer

Edison Electronics Div., McGraw-Edison Co., Manchester, NH 03103

Model

920

General Description

The 920 is a self-contained, portable, solid state instrument designed to accurately measure the peak frequency deviation of frequency modulated communication transmitters. The measurements are easily read from a reliable peak reading voltmeter with three deviation ranges.

A highly stable conversion oscillator allows measurement of frequencies with low inherent frequency modulation and maximum freedom from drift. To extend the useful range of the instrument for low frequencies, an external oscillator may be used to heterodyne transmitter frequencies.

An output from the accurate, linear, counter-type discriminator is available from two front-panel jacks labeled SCOPE and SPKR. The output from the SPKR jack includes a de-emphasis network which allows the 920 to be used as a standard receiver meeting the requirements of EIA Standard RS-152-A. The SCOPE output jack provides a linear output which can be used for noise and distortion measurements. The output of both the SPKR jack and the SCOPE jack may be viewed on an oscilloscope.

Performance

Characteristics:

Carrier frequency range: 25-1000 MHz (25-50 MHz local oscillator provides useful harmonics to 1000 MHz).

Sensitivity: 25 mV at frequencies to 500 MHz; 50 mV to frequencies of 1000 MHz.

Residual frequency modulation: Less than 100 Hz at 500 MHz.

Input impedance: 50Ω, nominal.

Deviation ranges: 0 to 2 kHz, 0 to 6 kHz, 0 to 20 kHz.

Deviation accuracy: ±3% of full scale.

Modulation frequency response: Flat from 100 Hz to 8 kHz.

Input gain control: Linear taper potentiometer provides 26 dB of attenuation.

Maximum power input: 200 mW.

SPKR output jack: Provides a 750 μs de-emphasis network. This jack may be used to drive the 8 ohm speaker provided in the front cover. (The level of de-emphasized audio output may be adjusted with the AUDIO LEVEL control.)

SCOPE output jack: Provides a linear output from an emitter follower.

Physical Description

Net weight (less batteries)	10 lb.
Domestic shipping weight (less batteries)	13 lb.
Width	7 in.
Height	9 in.
Depth	8-1/2 in.

Auxiliary Power or Support Equipment Requirements

Power requirements are 115 V, 50 to 60 Hz, 3 W or three Eveready rechargeable batteries #563 or their equivalent may be used. Nine "D" size cells may also be used. An overnight charge is recommended for the rechargeable batteries.

Operator/Crew Requirements

One person familiar with electronic test equipment is required to operate the deviation meter.

Training Requirements

Familiarization with the equipment and the accompanying technical manual is required.

Field Maintenance Requirements

Field maintenance will be performed per OCEI instructions and manufacturer's manual. Operating logs and equipment history cards must be maintained.

Spare Parts

Spare parts are not available. Batteries are available.

Mobilization Time: Two days

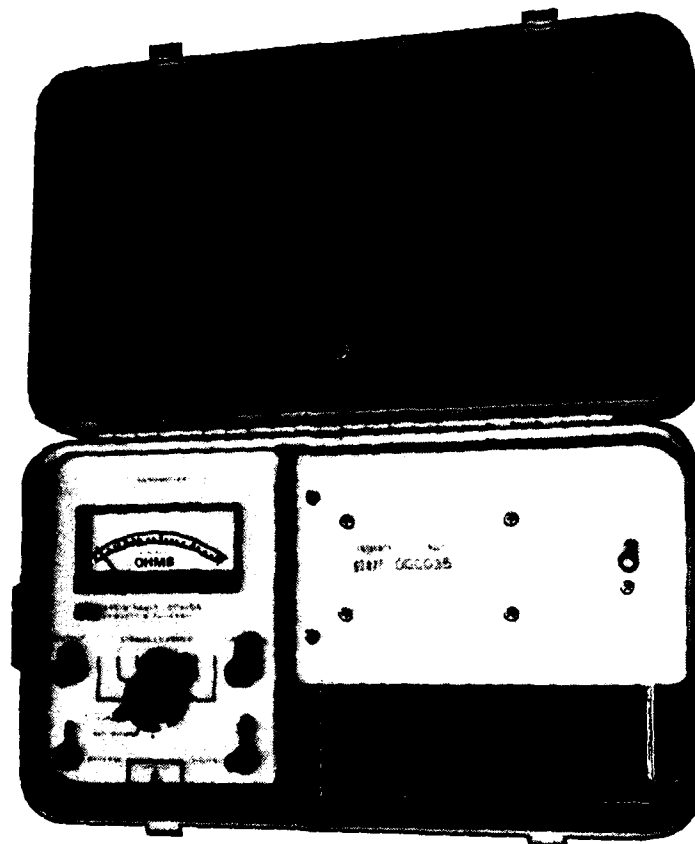

Fault Locator , Cable Model 4901A

Item

FAULT LOCATOR, CABLE (4901A)

Manufacturer

Hewlett-Packard, Rockville, MD 20850

Model

4901A

General Description

The cable fault locator is a pulsed time system for locating shorts, crosses, and grounds in underground and underwater cables. The unit also accurately locates the path and determines the depth of cables. Operating on the principle of electromagnetic induction and voltage gradients, the fault locator functions as a troubleshooting tool.

Performance

The cable fault locator is capable of detecting and locating most major kinds of cable faults and certain cable structures.

Characteristics:Transmitter

Output signal: 900 Hz \pm 10 Hz pulsed at 7 pps; 50% duty cycle

Output power: Adjustable to 2.2 W with a 6 Vdc supply

Output impedance: Variable, 5 to 4,000 ohms through a seven-position switch

Ohmmeter resistance range: Two ranges, 0-1 k (25-ohm midscale) and 0-1 Meg (25 k midscale)

Ohmmeter accuracy: \pm 30% of midscale readings (0° to 50° C)

Receiver

Center frequency: 900 Hz \pm 20 Hz

Bandwidth: 3 dB 70 Hz

Sensitivity: A 1.25 μ V 600-ohm source producing a 10 dB reading on the receiver meter

Meter scales: 0-100 linear logging scale, 0-30 dB scale

Search Wand

Type: Inductive pickup probe

Sensitivity: 2.0 μ gauss for 10 dB reading on meter

Physical Description

Height 9-1/2 in.
 Length 15 in.
 Width 9 in.
 System weight 25 lb.

Auxiliary Power or Support Equipment Requirements

Two 6 V lantern batteries and three 1.35 V batteries are required for test system operation.

Operator/Crew Requirements

One technician familiar with electronic testing equipment is required for operation of the unit.

Training Requirements

Two days' training in the field or at the manufacturer's facility is required to familiarize personnel with the use of the cable fault locator.

Field Maintenance Requirements

Field maintenance will be performed per OCEI instructions and manufacturer's manual. Operating logs and equipment history cards must be maintained.

Spare Parts

Spare parts are not available.

Mobilization Time: Two days

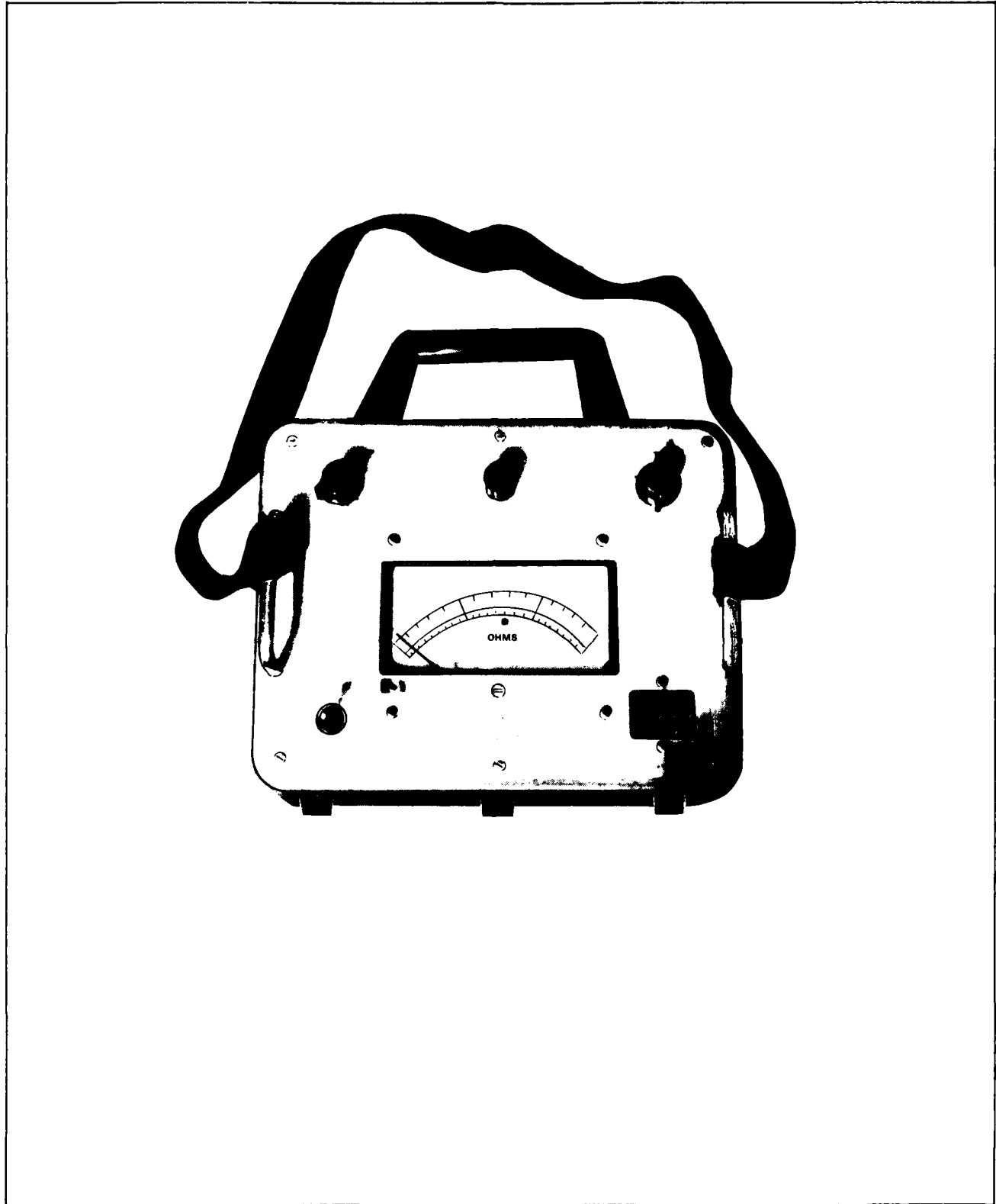

Fault Locator, Cable Model 4910F

Item

FAULT LOCATOR, CABLE (4910F)

Manufacturer

Hewlett-Packard, Palo Alto, CA 94304

Model

4910F

General Description

The cable fault locator is capable of pinpointing an open conductor fault, and provides a direct readout of distance to the fault in feet or meters. The unit is portable and weather resistant, with applications which include testing on service wire, twisted pair, video pair, and coaxial cable in underground or underwater locations.

Performance

Fault location in a conductor is possible with this unit in the presence of cross battery voltage and leakage resistance. A fault-distance averaging system automatically averages several samples of fault readings on a pair to compensate for noise causing errors.

Characteristics:

Range: 0 to 100,000 feet. This distance is displayed on the meter instrument face.

Instrument accuracy (at 20° C): 1%

Leakage resistance: Opens can be located with 10% or better accuracy for shunt resistances as low as 5kΩ on long cables or 75kΩ on short sections.

Cross battery: Opens can be located in the presence of central office battery. Accuracy declines as resistance between battery and instrument decreases.

Foreign voltage: Rejects 60 Hz signals by a factor of 38 dB (factor of 79).

Voltage protection: Instrument circuitry is protected against external voltages to ±200 Vdc or 140 Vrms.

Estimated battery life: 2,000 fault location readings

Self check: An artificial line is built into the test set for verifying open location procedures.

Physical Description

Height	7 in.
Length	10 in.
Width	8 in.
Weight	8 lb.

Auxiliary Power or Support Equipment Requirements

Eight 9-volt alkaline batteries are required. Recommended is Mallory MN 1604 or equivalent.

Operator/Crew Requirements

One technician familiar with electronic testing equipment is required for operation of the unit.

Training Requirements

Two days' training in the field or at the manufacturer's facility is required to familiarize personnel with the use of the cable fault locator.

Field Maintenance Requirements

Field maintenance will be performed per OCEI instructions and manufacturer's manual. Operating logs and equipment history cards must be maintained.

Spare Parts

Spare parts are not available.

Mobilization Time: Two days

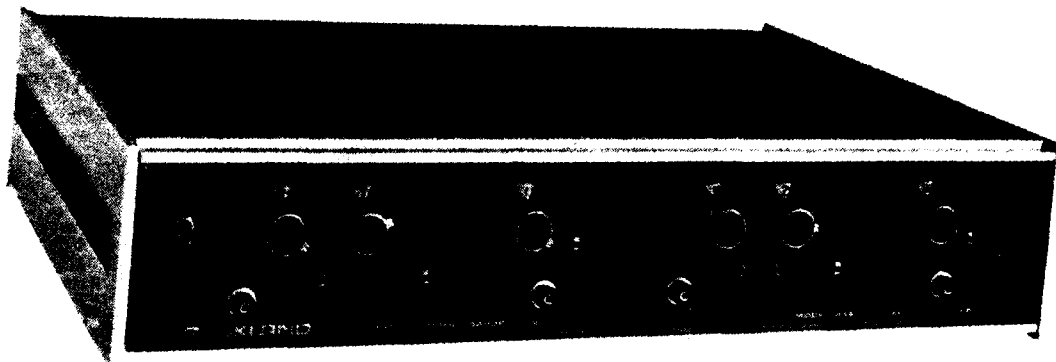

Filter, Hi/Lo, Dual (442)

Item

FILTER, HI/LO, DUAL

Manufacturer

Rockland Systems Corporation, West Nyack, NY 10994

Model

442

General Description

The 442 is a versatile dual-channel filter consisting of two identical channels in a common cabinet. Each filter channel has separate input/output terminals, offers high pass and low pass functions, two different gains (selectable), switch-selectable Butterworth and Linear Phase responses, and 2-digit resolution for cutoff frequency selection.

Individual channels may be readily interconnected for series or parallel operation, resulting in bandpass (or doubled rolloff) and band reject functions respectively.

The Butterworth filter has maximally-flat amplitude response suitable for frequency-domain applications. Its cutoff frequency (f_c) is defined as the frequency at which the amplitude response is down 3 dB.

The Linear Phase filter approximates a constant time delay for frequencies below its cutoff frequency. This filter is suitable for time-domain applications because of its inherent ability to pass transient waveforms with a very small amount of distortion and overshoot.

Frequency-determining passive elements of the filters consist of single precision metal film resistors and close tolerance capacitors. The active elements are IC operational amplifiers which provide highly stable gain, and very low noise and distortion. This combination of active and passive elements produces a filter having high cutoff frequency accuracy and resettability, and excellent temperature and long-term stability.

Performance

Functions:

Each Channel

Low pass with 24 dB/octave roll off (dc coupled).
High pass with 24 dB/octave roll off.

Two Channels Connected in Series

Identical cutoff frequencies: low pass with 48 dB/octave rolloff; high pass with 48 dB/octave rolloff.

One channel high pass, one channel low pass: Band pass with 24 dB/octave rolloffs.

Two Channels Connected in Parallel

Band reject with 24 dB/octave rolloff or sharp notch response.

Cutoff Frequency Range and Resolution:

Frequency settings: Two 11-position switches (0, 1, 2, 3, 4, 5, 6, 7, 8, 9, 10) and associated 4-position (X10, X100, X1K, X10K) multiplier switches.

Frequency range:

<u>Multiplier</u>	<u>Frequency (Hz)</u>	<u>Resolution (Hz)</u>
X10	10 – 1.1K	10
X100	100 – 11K	100
X1K	1K – 110K	1 K
X10K	10K – 1.1M	10 K

Flat Amplitude (Butterworth) Response:

Passband gain (Input $f \leq 0.1 f_c$ in low pass, $\geq 10 f_c$ in high pass): 0 dB/20 dB ± 0.5 dB (± 1 dB in X 10K multiplier position) for low pass; 0 dB/ 20 dB ± 0.5 dB (± 1 dB in 10K multiplier position) for high pass.

Bandpass: Depends on separation of cutoff frequencies. If separation is more than two octaves, the low pass and high pass specifications apply. If low pass and high pass cutoffs are identical, an insertion loss of approximately 6 dB is produced. The 3 dB bandwidth extends from 0.8 f_c to 1.25 f_c and is equal to 0.45 f_c .

Band reject and sharp notch: An insertion loss of approximately 6 dB is produced.

Attenuation at cutoff: 3 dB.

Stopband attenuation rate (rolloff): 24 dB/octave, nominal.

Maximum stopband attenuation: 80 dB (input $f \leq 1$ MHz).

Flat Delay (Linear Phase) Response:

Low pass delay (typical): $\frac{1}{2f_c}$ seconds.

Attenuation at cutoff: Approximately 9 dB.

Input Characteristics:

Circuit: Single-ended, diode-protected.

Impedance: 100 k Ω in parallel with 50 pF.

Full-scale signal at 0 dB gain: ± 7 V (5 Vrms) dc to 1 MHz, decreasing at higher frequencies (divide by 10 at 20 dB gain).

Absolute maximum input: ± 100 V.

Maximum dc component: ± 100 V, 0 dB gain; ± 10 V, 20 dB gain (high pass).

Output Characteristics:

Circuit: Single-ended, short-circuit protected, may be dc isolated from power ground by rear panel switch.

Impedance: 50 Ω , nominal.

Full-scale signal: ± 7 V (5 Vrms) dc to 1 MHz, decreasing at higher frequencies ($R_L \geq 5k$), ± 15 mA maximum current.

Broadband noise at either gain setting: 500 μ V rms maximum for 1 MHz detector bandwidth.

Physical Description

Net weight	10 lb.
Shipping weight	14 lb.
Width	17 in.
Height	3-1/2 in.
Depth	13 in.

Auxiliary Power or Support Equipment Requirements

Power requirements are 115 or 230 V $\pm 10\%$, 50 to 500 Hz, and 5 W.

Operator/Crew Requirements

One person familiar with electronic test equipment is required to operate the filter.

Training Requirements

Familiarization with the equipment and the accompanying technical manual is required.

Field Maintenance Requirements

Field maintenance will be performed per OCEI instructions and manufacturer's manual. Operating logs and equipment history cards must be maintained.

Spare Parts

Spare parts are not available.

Mobilization Time: Two days

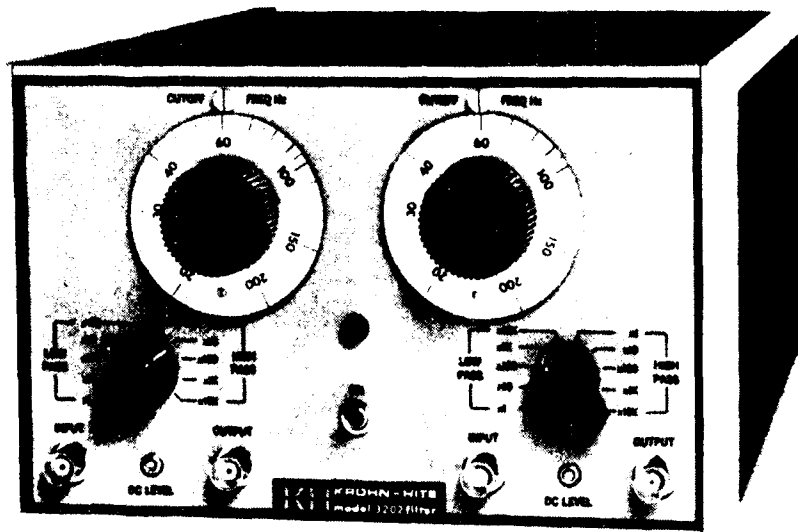

Filter, Variable (3202)

Item

FILTER, VARIABLE

Manufacturer

Krohn-Hite Corporation, Avon, MA 02322

Model

3202

General Description

The 3202 is a solid-state, electronic filter consisting of two variable filters mounted in a single cabinet, isolated from each other with independent power supplies. Each filter channel has separate input/output terminals, offers high pass and low pass functions, and switch selectable Butterworth and RC responses.

Individual channels may be readily interconnected for series or parallel operation, resulting in bandpass (or doubled rolloff) and band reject functions respectively.

The Butterworth filter has maximally-flat fourth-order amplitude response for optimum performance in frequency-domain applications.

The RC filter has fourth-order RC response for transient-free time-domain performance.

Performance

Functions:

Each Channel

Low pass with 24 dB/octave rolloff (dc coupled).

High pass with 24 dB/octave rolloff.

Two Channels Connected in Series

Identical cutoff frequencies: low pass with 48 dB/octave rolloff; high pass with 48 dB/octave rolloff.

One channel high pass, one channel low pass: Bandpass with 24 dB/octave rolloffs.

Two Channels Connected in Parallel

Band rejector sharp notch response.

Cutoff Frequency Range:

Frequency settings: Two single-decade frequency dials (calibrated from 19 to 210) and associated high pass/low pass band switches providing five multiplier ranges for each mode.

Frequency range: High pass and low pass cutoff frequencies continuously adjustable from 20 Hz to 2 MHz in five bands.

<u>Band</u>	<u>Multiplier</u>	<u>Frequency (Hz)</u>
1	X1	20 – 200
2	X10	200 – 2 k
3	X100	2k – 20 k
4	X1K	20k – 200 k
5	X10K	200k – 2M

Cutoff Frequency Calibration Accuracy:

MAX FLAT (Butterworth) position: $\pm 5\%$ bands one to four; $\pm 10\%$ band five (less accurate in RC position).

Relative to mid-band level, the filter output is down 3 dB at cutoff in MAX FLAT position (approximately 13 dB in RC position).

Bandwidth:

Low pass mode: Dc to cutoff frequency set within range from 20 Hz to 2 MHz.

High pass mode: Continuously adjustable between 20 Hz and 2 MHz with upper 3 dB point at approximately 10 MHz.

Bandpass operation: Continuously variable within the cutoff frequency limits of 20 Hz to 2 MHz. For minimum bandwidth the high pass and low pass cutoff frequencies are set equal. This produces an insertion loss of 6 dB, with the 3 dB points at 0.8 and 1.25 times the mid-band frequency.

Band reject and sharp notch: Continuously variable within the cutoff frequency limits of 20 Hz and 2 MHz or sharp notch at any frequency between 40 Hz and 800 kHz. The low pass band extends to dc. The high pass band has its upper 3 dB point at approximately 10 MHz.

Input Characteristics:

Maximum input amplitude: 3 Vrms up to 2 MHz, decreasing to 1 Vrms at 10 MHz.

Maximum dc component: Combined ac plus dc should not exceed 4.2 V peak (low pass); 200 V (high pass).

Impedance: 100 k Ω in parallel with 50 pF.

Output Characteristics:

Maximum voltage: 3 Vrms to 2 MHz (1.5 Vrms in band reject operation).

Maximum current: 10 mA (less in band reject operation).

Internal impedance: 50 Ω , approximately (higher in band reject operation).

General Characteristics:

Maximum attenuation: > 80 dB.

Passband gain: Unity (0 dB).

Insertion loss: Zero \pm 1/2 dB to 2 MHz; 3 dB at approximately 10 MHz; 6 dB in band reject operation.

Hum and noise: <100 μ Vrms for a detector bandwidth of 2 MHz, rising to 150 μ V for a detector bandwidth of 10 MHz.

Floating (ungrounded) operation: Switch selectable.

Physical Description

Net weight 14 lb.
Shipping weight 22 lb.

Width 8-5/8 in.
Height 5-1/4 in.
Depth 15-1/4 in.

Auxiliary Power or Support Equipment Requirements

Power requirements are 105-125 or 210-250 V, 50 to 400 Hz, single-phase, and 15 W.

Operator/Crew Requirements

One person familiar with electronic test equipment is required to operate the filter.

Training Requirements

Familiarization with the equipment and the accompanying technical manual is required.

Field Maintenance Requirements

Field maintenance will be performed per OCEI instructions and manufacturer's manual. Operating logs and equipment history cards must be maintained.

Spare Parts

Spare parts are not available.

Mobilization Time: Two days

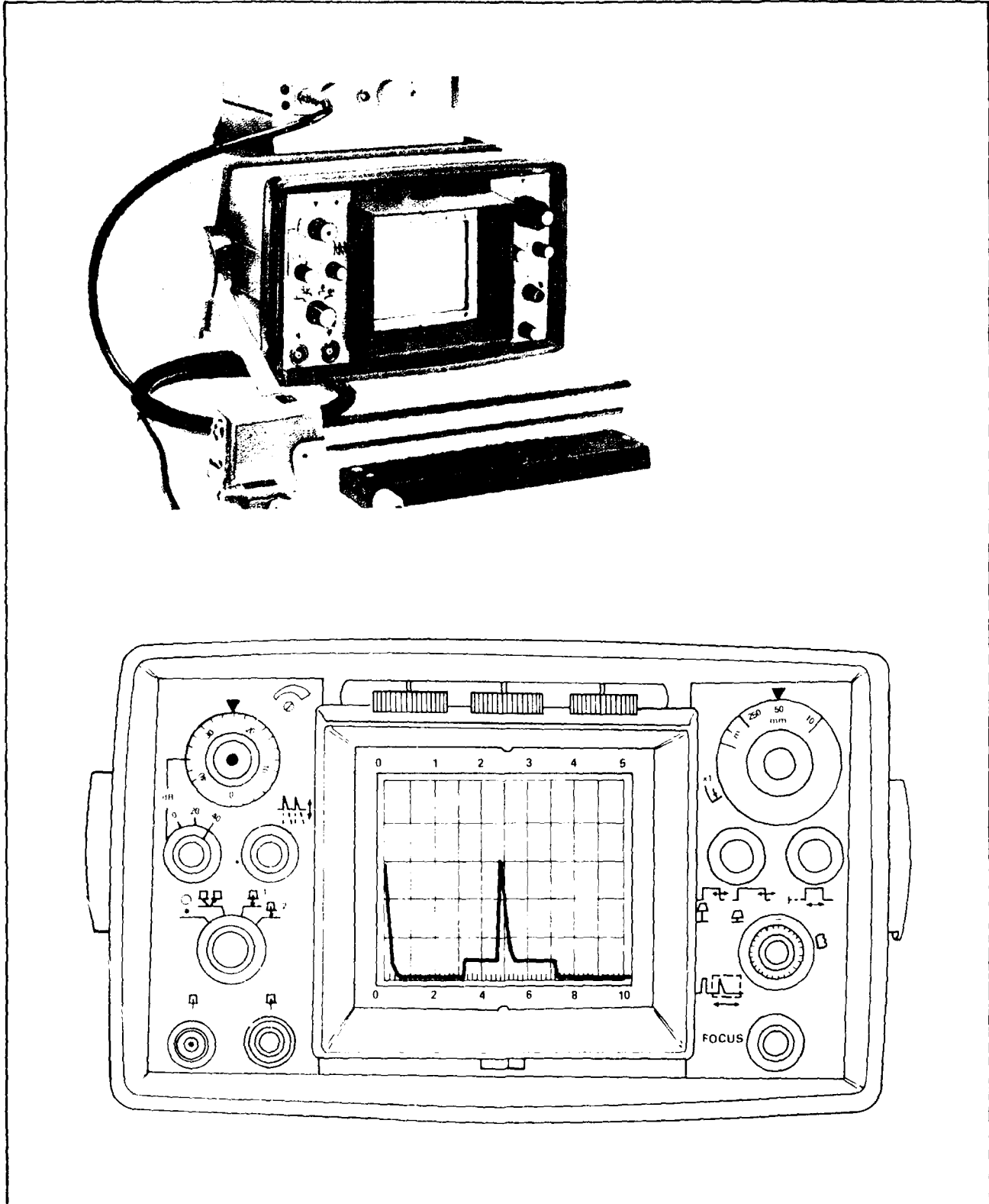

Flaw Detector, Ultrasonic

112 222 422 522 622 722 822 922 1022 1122 1222 1322 1422 1522 1622 1722 1822 1922 2022 2122 2222 2322 2422 2522 2622 2722 2822 2922 3022 3122 3222 3322 3422 3522 3622 3722 3822 3922 4022 4122 4222 4322 4422 4522 4622 4722 4822 4922 5022 5122 5222 5322 5422 5522 5622 5722 5822 5922 6022 6122 6222 6322 6422 6522 6622 6722 6822 6922 7022 7122 7222 7322 7422 7522 7622 7722 7822 7922 8022 8122 8222 8322 8422 8522 8622 8722 8822 8922 9022 9122 9222 9322 9422 9522 9622 9722 9822 9922

Item

FLAW DETECTOR, ULTRASONIC

Manufacturer

Juh Krautkramer, Koln, West Germany, and Krautkramer-Branson, Inc., 250 Long Beach Boulevard, Stratford, CT 06497

Model

USM 2MT

General Description

The ultrasonic flaw detector is a universal testing unit. Due to its weight, and its power supply either through a rechargeable battery pack or a main power pack, it is equally suited for stationary operation, workshop operation, or on construction sites.

Performance

The USM 2MT flaw detector operates by the pulse echo method in the 0.5 to 12 MHz frequency range. It may be used in conjunction with a normal range of probes. Either single-probe, double-probe, or SE operation is possible.

The screen can be calibrated for up to 5 m (16.4 ft.) steel - longitudinal waves. More important, a very short range, namely 10 mm (0.4 in.) steel (for longitudinal waves) can occupy the entire scale. Wall thickness measurement with a tolerance of ±0.1 mm (0.004 in.), and under favorable conditions 0.05 mm (0.002 in.), is possible in this 10 mm (0.4 in.) range.

Characteristics:

Frequency range: 0.5 to 12 MHz by wideband amplifier

Test range: Continuously variable from 10 mm (0.4 in.) to 5 m (16.4 feet) (steel)

Variable scale expansion: Optional cutout range from 10 mm (0.4 in.) up to maximum 500 mm (20 in.) spread across the entire scale

Gain: Variable by 2 dB, graduated stepped switch from 0 to 80 dB (40 dB adjustable to 0 to 40, 20 to 60, or 40 to 80 dB)

Unit sensitivity: Maximum 140 ±3 dB

Monitor response accuracy: ±0.5 dB

Time base sweep drift: <0.7 mm (.028 in.) scale length per 10° C (18° F)

Physical Description

Height 5 in.
Length 10-1/8 in.
Width 13-3/4 in.
Weight 12.8 lb.

Auxiliary Power or Support Equipment Requirements

Power to this system can be provided through main power pack NTM 2, 110 - 240 V, 45 - 60 cps, 20 VA, or through dry cell plug-in battery pack USMB 2, providing 8 hours uninterrupted operation.

Operator/Crew Requirements

One person is required to operate the equipment.

Training Requirements

Two days' training in the field or at the manufacturer's facility is required to familiarize personnel with the use of the flaw detector.

Field Maintenance Requirements

Field maintenance will be performed per OCEI instructions and manufacturer's manual. Operating logs and equipment history cards must be maintained.

Spare Parts

Spares are not available.

Mobilization Time: Two days

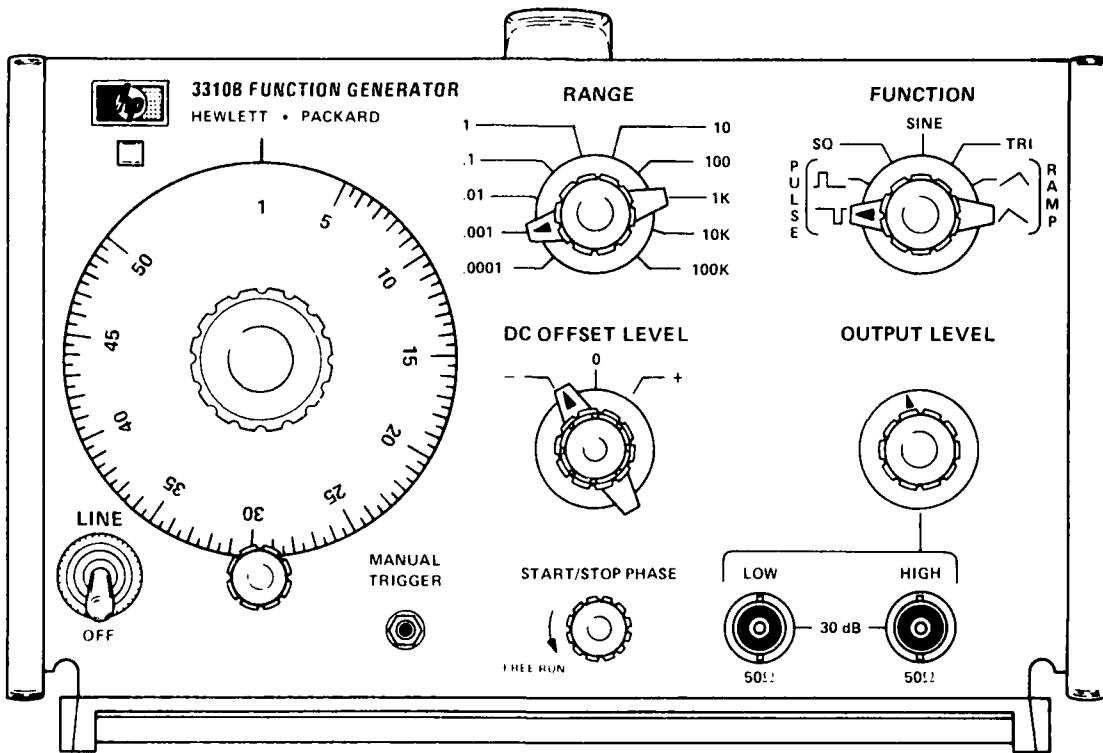
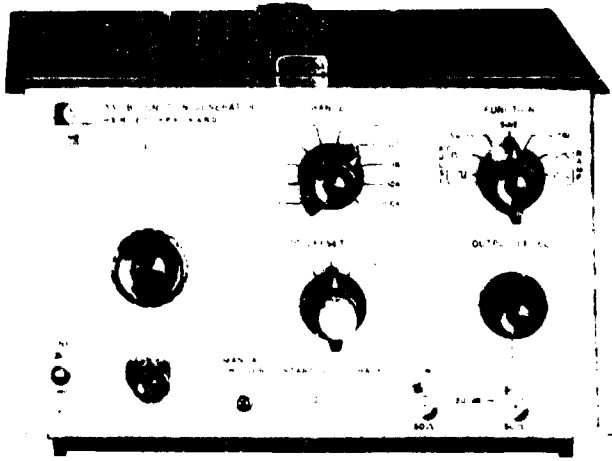

Function Generator (3310B)

Item

FUNCTION GENERATOR (3310B)

Manufacturer

Hewlett-Packard, Palo Alto, CA 94303

Model

3310B

General Description

The function generator has sine, triangle, and square wave outputs, as well as positive- and negative-going pulses and positive- and negative-going ramps. All functions have a maximum output amplitude of 30 V p-p. Functions may be internally dc-offset up to ±10 V. A LOW output connector provides a signal level 30 dB below the HIGH output. With the 30 dB variable attenuator a total attenuation of greater than 60 dB is available. The function generator provides these effects when the START/STOP PHASE control is set to "FREE RUN." If the START/STOP PHASE control is set to any other position, tone bursts of almost any length, adjustable in phase from +90° to -90°, are obtainable.

Performance

Characteristics:

Frequency range: 0005 Hz to 50 kHz (3310B only)

Low output: 30 dB below HIGH output for any amplitude setting, when LOW and HIGH are equally terminated

External Frequency Control:

Range: 50:1 on any range

Input requirement: With dial set to low end mark, 0 to +10 V ±1 V will linearly increase 50:1. With dial set at 50, 0 to -10 V ±1 V will linearly decrease frequency 50:1. An ac voltage will FM the frequency about a dial setting within the limits $(1 > f < 50) \times$ range setting.

Dc Offset:

Amplitude: ±10 V open circuit, ±5 V into 50 ohms, continuously adjustable

Waveforms: Sine, square, triangle, positive pulse, negative pulse, positive ramp, and negative ramp. Pulses and ramps have 50% or 85% duty cycle; SYNC waveform is a square for symmetrical functions, pulse for pulse and ramp functions.

Physical Description

Height 4-1/2 in. (114 mm)
w/o removable feet
Width 7-3/4 in. (197 mm)
Depth 8 in. (203 mm)
Weight 2.7 kg (6 lb.) net;
4.5 kg (10 lb.)
shipping

Auxiliary Power or Support Equipment Requirements

An external power source of 115 V or 230 V ±10%, 48 to 440 Hz, less than 20 VA, is required.

Operator/Crew Requirements

One experienced person is required to operate the function generator.

Training Requirements

Two days' training in the field or at the manufacturer's facility is required.

Field Maintenance Requirements

Field maintenance will be performed per OCEI instructions and manufacturer's manual. Operating logs and equipment history cards must be maintained.

Spare Parts

Spare parts are not available.

Mobilization Time: Two days

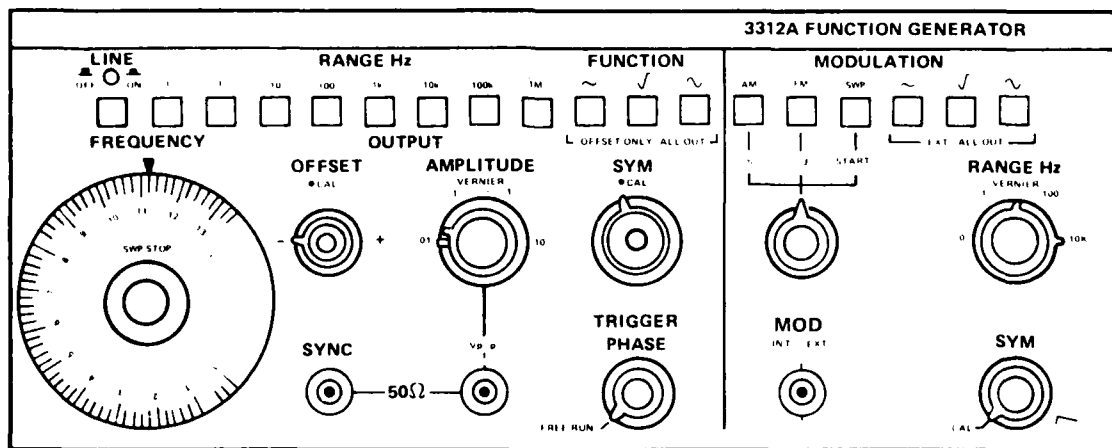
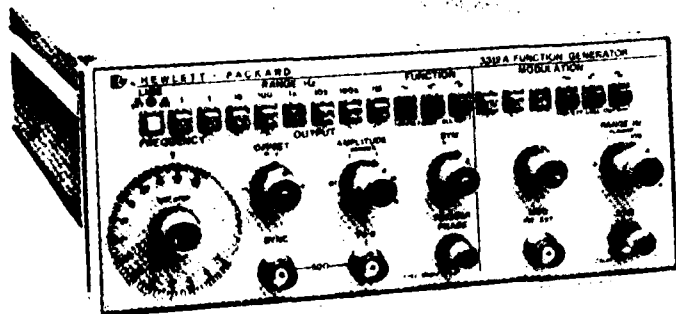

Function Generator (3312A)

Item

FUNCTION GENERATOR (3312A)

Manufacturer

Hewlett-Packard, Palo Alto, CA 94303

Model

3312A

General Description

The function generator is a compact, wide-range, dual-function unit consisting of a main generator and a modulation generator. The main generator provides sine, square, or triangle wave outputs over the frequency range of 0.1 Hz to 13 MHz. The modulation generator produces sine, square, and triangle waveforms with a frequency range of 0.01 Hz to 10 kHz. The modulation generator can be used to Amplitude Modulate (AM) or Frequency Modulate (FM) the output signal of the main generator. The AM envelope can be adjusted from 0% to 100%; FM can change the carrier frequency up to ±5%.

Performance

Main Generator Characteristics:

General: Sine, square, triangle, ramp, and pulse

Variable symmetry range: 80:20 to 20:80

Frequency range: 0.1 Hz to 13 MHz in 8 decade ranges

Attenuator output: 1:1, 10:1, 100:1, 1000:1, and >10:1 continuous control

Modulation Characteristics:

Types: Internal AM, FM, sweep, trigger, gate, or burst; external AM, FM, sweep, trigger, gate, or burst

Amplitude: Depth – 0 to 100%; modulation frequency – 0.01 Hz to 10 kHz (internal); dc to >MHz (external)

Frequency: 0.01 Hz to 10 kHz (internal); dc to >50 kHz (external)

Sweep: Width < range: 100:1 on any range. Rate: 90:10 ramp (0 Hz provides manual setting of "Sweep Start" without modulation generator oscillating). Mode: repetitive linear sweep between start and stop frequency settings. Retrace time can be increased with symmetry control.

Physical Description

Height 4 in. (102 mm)
Width 8-1/2 in. (213 mm)
Depth 14-4/5 in. (377 mm)
Weight 3.8 kg (8 lb., 6 oz.) net;
5.9 kg (15 lb.) shipping

Auxiliary Power or Support Equipment Requirements

A line voltage of 100, 120, 220, or 240 volts ac +5% – 10% of 48 to 440 Hz frequency is required. The instrument can be easily adapted to the available line voltage by changing the position of the slide switches on the rear panel.

Operator/Crew Requirements

One experienced person is required to operate the function generator.

Training Requirements

Two days' training in the field or at the manufacturer's facility is required.

Field Maintenance Requirements

Field maintenance will be performed per OCEI instructions and manufacturer's manual. Operating logs and equipment history cards must be maintained.

Spare Parts

Spare parts are not available.

Mobilization Time: Two days

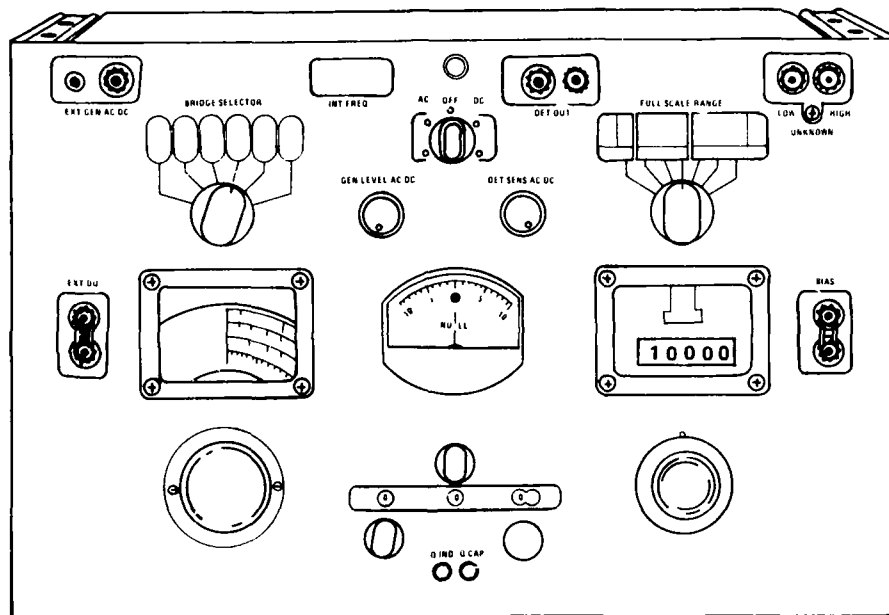

Impedance Bridge

Item

IMPEDANCE BRIDGE

Width 19.00 in.
Height 20-25 in.
Depth 11.00 in.

Manufacturer

General Radio Company, West Concord, MA 01781

Auxiliary Power or Support Equipment Requirements

Power requirements are 115 or 230 V, 50 to 60 Hz.

Model

Type 1608-A

Operator/Crew Requirements

One person familiar with electronic test equipment is required to operate the impedance bridge.

General Description

The Type 1608-A is a self-contained impedance-measuring system, which includes six bridges for the measurement of capacitance, conductance, resistance, and inductance, as well as the generators and detectors necessary for dc and 1 kHz ac measurements.

Training Requirements

Familiarization with the equipment and the accompanying technical manual is required.

Performance

The performance characteristics of the Type 1608-A depend upon its application. Before using the Type 1608-A, read the introduction and operating procedures contained in the manufacturer's manual.

Field Maintenance Requirements

Field maintenance will be performed per OCEI instructions and manufacturer's manual. Operating logs and equipment history cards must be maintained.

Physical Description

Net weight 30 lb.
Shipping weight 40 lb.

Spare Parts

Spare parts are not available.

Mobilization Time: Two days

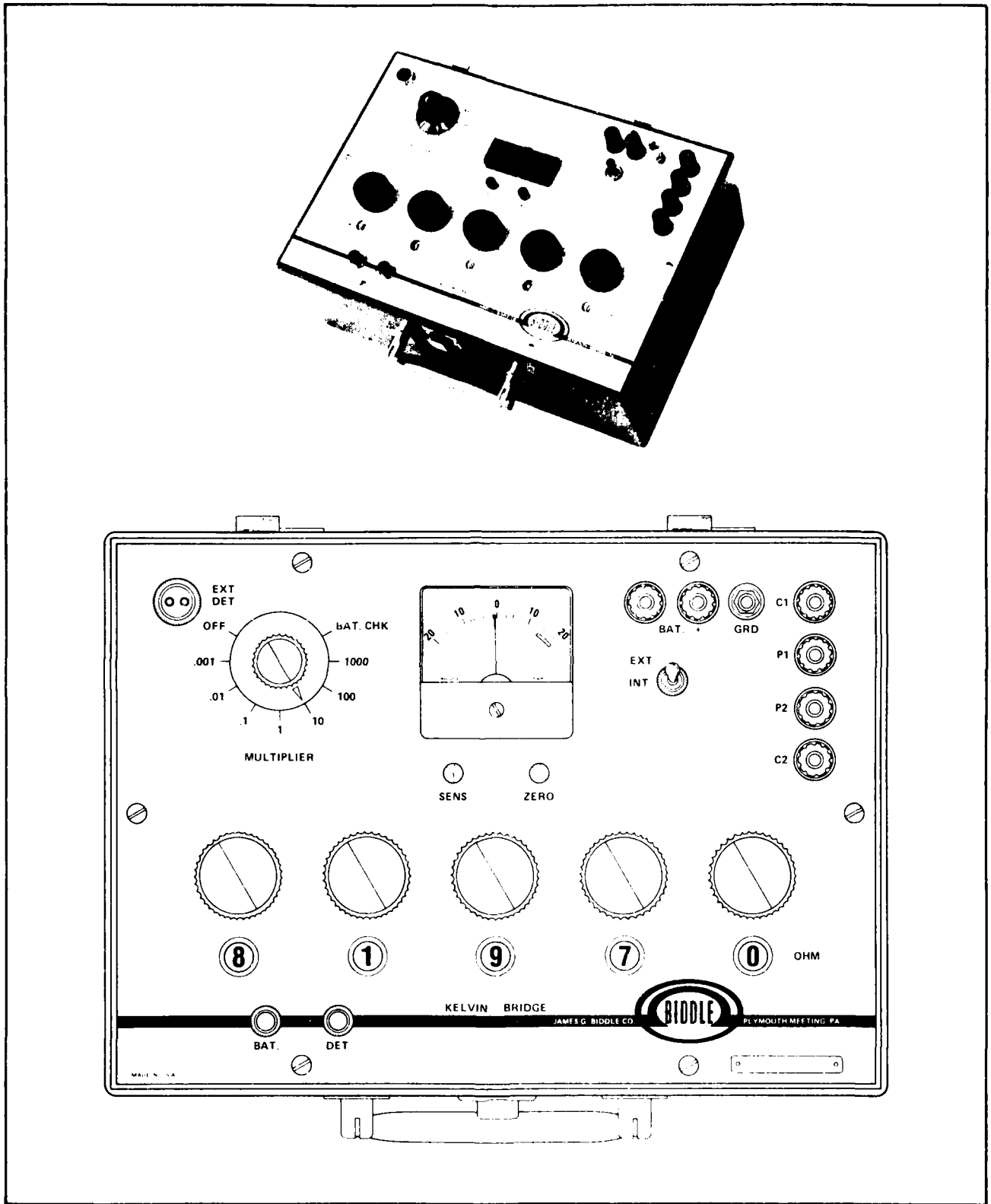

Kelvin Bridge

Item

KELVIN BRIDGE

Manufacturer

James G. Biddle Co., Plymouth Meeting, PA 19462

Model

72-439

General Description

The Kelvin bridge high potential tester is a direct reading, 5-dial unit designed for wide range, low resistance measurements in the field.

The tester is fully self-contained and is equipped with its own batteries and a solid-state null detector. It includes individual battery and detector push keys for control of circuit closure sequence and has four binding posts for connection of the unknown resistance, an auxiliary pair of binding posts for connection of an external battery, and a receptacle for connection of an external null detector.

Applications include measuring electrical conductivity and temperature coefficients of wires and rods; checking the quality of welds in copper or aluminum bus bars; and checking and calibrating low-value resistance standards, current carrying shunts, and power-type resistors.

Performance

The range of the Kelvin bridge is 0.01 microhm to 1111.1 ohms in seven ranges, with a limit error of $\pm 0.03\%$ of the reading. Two fixed arms and two adjustable arms are mechanically linked so that they are adjusted simultaneously. The measuring dial consists of five decades, giving resistance steps equivalent to 10 ohms, for a total range of 1111.1 ohms in steps of 10 microhms.

Physical Description

Height 7 in.
 Width 13 in.
 Weight 15 lb.

Auxiliary Power or Support Equipment Requirements

Measuring circuit: Two 1-1/2-volt No. 6 dry cells (NEDA 906) connected in parallel. Normal battery life for resistance measurements above 0.01 ohm is in excess of 200 hours (10 weeks at 20 hours per week). For resistance measurements below 0.01 ohm, battery life decreases.

Null detector: Two 2.8- or 2.7-volt batteries (Mallory TR 132, TR 132H, TR 132R, or NEDA 200). Four 1.4- or 1.35-volt mercury batteries (Mallory RM1, RM1R, or NEDA 1100) may be used for replacement if more readily available. Battery life is in excess of 1000 hours (approximately 1 year at 20 hours per week).

Operator/Crew Requirements

One person is required for the operation of the Kelvin bridge.

Training Requirements

One day's training in the field or at the manufacturer's facility is required.

Field Maintenance Requirements

Field maintenance will be performed per OCEI instructions and manufacturer's manual. Operating logs and equipment history cards must be maintained.

Spare Parts

Spare parts are not available.

Mobilization Time: Two days

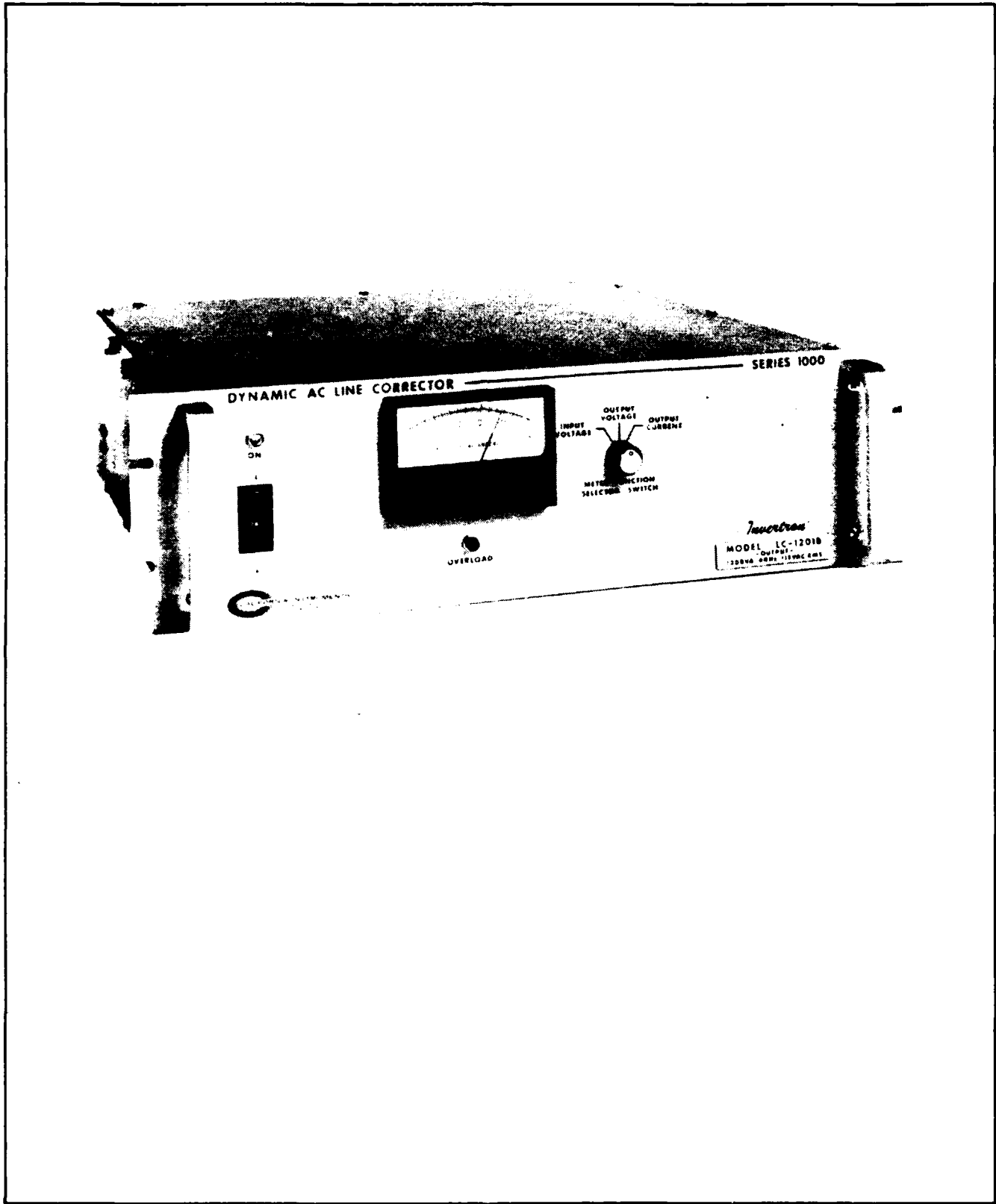

Line Corrector, AC, Dynamic

Item

LINE CORRECTOR, AC, DYNAMIC

Manufacturer

California Instruments, San Diego, CA 92111

Model

LC-1201B

General Description

The LC-1201B is a highly-reliable, solid-state power supply designed to produce precisely-regulated, transient-free ac power.

The LC-1201B is completely designed with silicon semi-conductors using conservative derating techniques to provide years of dependable service. The instrument is protected by a single 20A circuit breaker located on the front panel. A switch selectable front-panel meter monitors either the input voltage, output voltage, or output current of the line corrector. An OVERLOAD indicator, when lit, indicates that unregulated power is being delivered from the line corrector.

Performance**Characteristics:****Input**

Harmonic distortion: 10% maximum.

Isolation: 100 dB common mode isolation. Low side of output line normally strapped to chassis, but may be floated to 300 Vrms.

OutputVoltage: 115 Vrms $\pm 0.15\%$.Voltage setability: $\pm 0.01\%$.

Voltage instability: $\pm 0.05\%$ for 24 hours under constant line, load, and ambient temperature conditions.

Power: 1200 VA from unity to ± 0.7 power factor, 6000 VA maximum instantaneous peak power.

Crest factor: 3.5 to 1 maximum at rated power output.

Harmonic distortion: 0.2% maximum.

Line regulation: 0.025% for a 10-volt incoming line change.

Load regulation: 0.025% for a zero to full resistive load change; 0.05% for a zero to full load change at ± 0.7 power factor.

Cycle-to-cycle peak amplitude stability: $\pm 0.01\%$ for input line cycle-to-cycle phase stability of $\pm 0.18^\circ$ (typical power line).

Load capacitance: 5 μ F at zero power factor; 100 μ F maximum at ≥ 0.1 power factor.

Transient

Line (with 10% step change): Output transient will not exceed 0.5% peak amplitude and will fall to 0.05% in less than 0.5 s.

Load (zero to full load change): Output transient will not exceed 0.5% peak amplitude and will fall 0.05% in less than 0.5 s.

Input line transient attenuation: Reduces 500 V p-p 10 μ s line transients to less than 0.5 V p-p.

Impulse settling time (due to 1A, 1 ms load pulse): $\leq 50 \mu$ s to 0.1% of output voltage.

Overload recovery time: $<$ one cycle when overload is removed (automatic).

Overload protection: 20 A circuit breaker.

Physical Description

Net weight	75 lb.
Shipping weight	80 lb.
Width	19 in.
Height	5.25 in.
Depth	20.50 in.

Auxiliary Power or Support Equipment Requirements

Power requirements are 90-110, 103.5-126.5, or 117-143 Vrms, 57-63 Hz, 2000 W maximum (switch selectable).

Operator/Crew Requirements

One person familiar with electronic test equipment is required to operate the line corrector.

Training Requirements

Familiarization with the equipment and the accompanying technical manual is required.

Field Maintenance Requirements

Field maintenance will be performed per OCEI instructions and manufacturer's manual. Operating logs and equipment history cards must be maintained.

Spare Parts

Spare parts are not available.

Mobilization Time: Two days

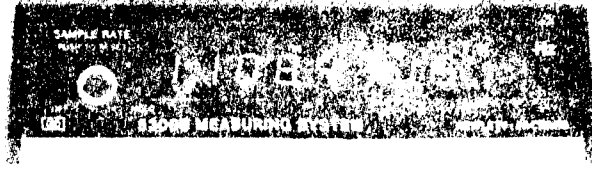

5300B

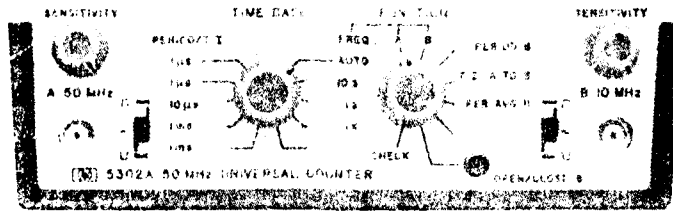

5302A

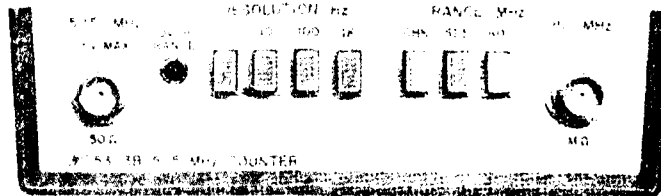

5303B

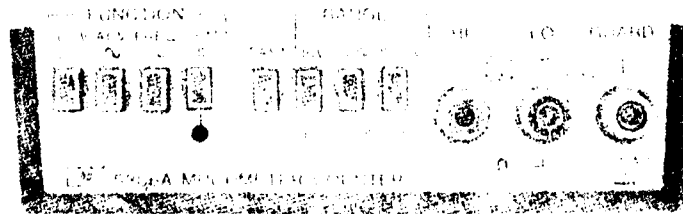

5306A

Item

MEASURING SYSTEM, 5300

Manufacturer

Hewlett-Packard, Palo Alto, CA 94303

Model

5300B – Mainframe, Measurement System
5302A – Counter Module, Universal, 50 MHz
5303B – Counter Module, Frequency, 500 MHz
5306A – Multimeter/Counter

General Description

The 5300 system is a uniquely capable counter. Modular construction makes the 5300 system versatile and current. Snap-on modules are selected and attached to the mainframe to satisfy user requirements. Capability can be expanded with the addition of modules.

Digital output is available in the ASCII format via an interface bus to provide interfacing with digital printers or with other peripheral equipment. Analog output for long-term monitoring with strip chart recorders is provided by a digital-to-analog converter.

The mainframe unit provides the system with power, reference frequency, display, counting logic, and timing control. The 5300B has an 8-digit 7-segment display, standard time base or optional TCXO time base, external time base input, and no digital output from the mainframe.

Performance

Characteristics:

5300B

Standard crystal frequency: 10 MHz.

Oscillator output: 10 MHz, approximately 1 Vrms at rear panel BNC, 100 Ω source impedance.

External input: 1 MHz to 10 MHz, 1 Vrms into 500 Ω .

Overflow: LED light indicates when display range is exceeded.

5302A

Input Channel: A and B:

Range: Channel A 10 Hz to 50 MHz; Channel B 10 Hz to 10 MHz.

Sensitivity (minimum): 25 m Vrms sine wave 50 Hz to 1 MHz; 50 m Vrms sine wave 10 Hz to 10 MHz; 100 m Vrms sine wave at 50 MHz. 150 mV p-p pulse at minimum pulse width, 50 ns.

Trigger level: Selectable position, negative or zero volts.

Marker outputs: Rear BNC, TTL low level while gate is open.

Frequency:

Range: Channel A 10 Hz to 50 MHz, prescaled by 10; Channel B 10 Hz to 10 MHz.

Gate times: Manually selected 0.1, 1, or 10 seconds. AUTO position selects gate time of 1 second for maximum resolution.

Time Interval A to B:

Range: 50 ns to 1000 s.

Resolution: 100 ns to 1 ms in decade steps.

Period B:

Range: 10 Hz to 1 MHz.

Resolution: 100 ns to 1 ms in decade steps.

Period Average B:

Range: 10 Hz to 1 MHz.

Periods averaged: 1 to 10^3 automatically selected.

Frequency counted: 10 MHz.

Ratio:

Display: F_A/F_B times multiplier (N), $N = 10$ to 10^7 .

Range: Channel A 10 Hz to 1 MHz; Channel B 10 Hz to 10 MHz.

Open/Close (Totalizing):

Range: 10 MHz maximum.

5303B

Input Channel A (CW or Burst):

Range: DC to 525 MHz, prescaled by 8.

Sensitivity (fixed): 100 m Vrms sine wave, dc to 500 MHz; 125 m Vrms sine wave, 500 MHz to 525 MHz. Signal must pass through zero.

Input Channel B (CW or Burst):

Range: 50 Hz to 80 MHz, direct.

Sensitivity (automatic): 25 m Vrms sine wave, 100 Hz to 50 MHz; 50 m Vrms sine wave, 50 Hz to 100 Hz and 50 MHz to 80 MHz.

Frequency Measurement:

Resolution (selectable): 1, 10, 100, or 1000 Hz.

5306A

DC Voltage:

Range: $\pm 10V$ to $\pm 1000V$ (3 ranges).

Sensitivity: 100 μV for 10 V range; 1 mV for 100 V range; 10 mV for 1000 V range.

Sample times: Normal 0.5 s; fast 0.05 s.

Input terminals: Floating pair.

Input resistance: 10 M Ω , all ranges.

Maximum input: High to low is 1100 Vdc all ranges; low to guard is ± 200 Vdc or peak ac; guard to ground is ± 500 Vdc or 240 Vrms at 50 or 60 Hz.

AC Voltage:

Range: 10 V to 1000 V (3 ranges).

Frequency: 40 Hz to 100 kHz for 10 V range; 40 Hz to 500 Hz for 100 V range; 40 Hz to 500 Hz for 1000 V range.

Input impedance: 10 M Ω shunted by <75 pF maximum.

Coupling: Ac; maximum dc blocking of ± 1000 V.

Maximum input voltage: High to low is 1000 V except on 10 V range (on 10 V range 5×10^5 VHz (product of voltage and frequency) limit with minimum protection of 50 V, maximum 1000 V); low to guard is ± 200 Vdc or peak ac; guard to ground is ± 500 Vdc or 230 V at 60 Hz.

Ohmmeter:

Range: 10 k Ω to 10 M Ω (3 ranges).

Sensitivity: 0.1 Ω for 10 k Ω range; 1 Ω for 100 k Ω range; 100 Ω for 10 M Ω range.

Input terminals: Floating pair.

Current through unknown: 1 mA on 10 k Ω range; 100 μA on 100 k Ω range; 1 μA on 10 M Ω range.

Overload protection: 240 Vrms for 1 min. 140 Vrms continuously (front-panel warning lamp indicates overvoltage condition) on 10 k Ω range; 240 Vrms continuous on 100 k Ω and 10 M Ω ranges.

Frequency:

Range: 40 Hz to 10 MHz, direct count.

Sensitivity (minimum): 50 m Vrms to 1 MHz; 125 m Vrms to 10 MHz.

Trigger level: Automatically adjust to 40% of peak level of input.

Gate times: Normal 1 s, fast 0.1 s.

Physical Description

Mainframe with any snap-on module

Width	6-1/4 in.
Height	3-1/2 in.
Depth	9-3/4 in.

Auxiliary Power or Support Equipment Requirements

Power requirements are 115 V +13, -17%, 48-440 Hz or 230 V +13, -17%, 48-60 Hz, 25 VA maximum (depends on snap-on module).

Digital output for the 5300B mainframe is provided by a 5312A HP-IB Interface module.

Operator/Crew Requirements

One person familiar with electronic test equipment is required to operate the measuring system.

Training Requirements

Familiarization with the equipment and the accompanying technical manuals is required.

Field Maintenance Requirements

Field maintenance will be performed per OCEI instructions and manufacturer's manuals. Operating logs and equipment history cards must be maintained.

Spare Parts

Spare parts are not available.

Mobilization Time: Two days

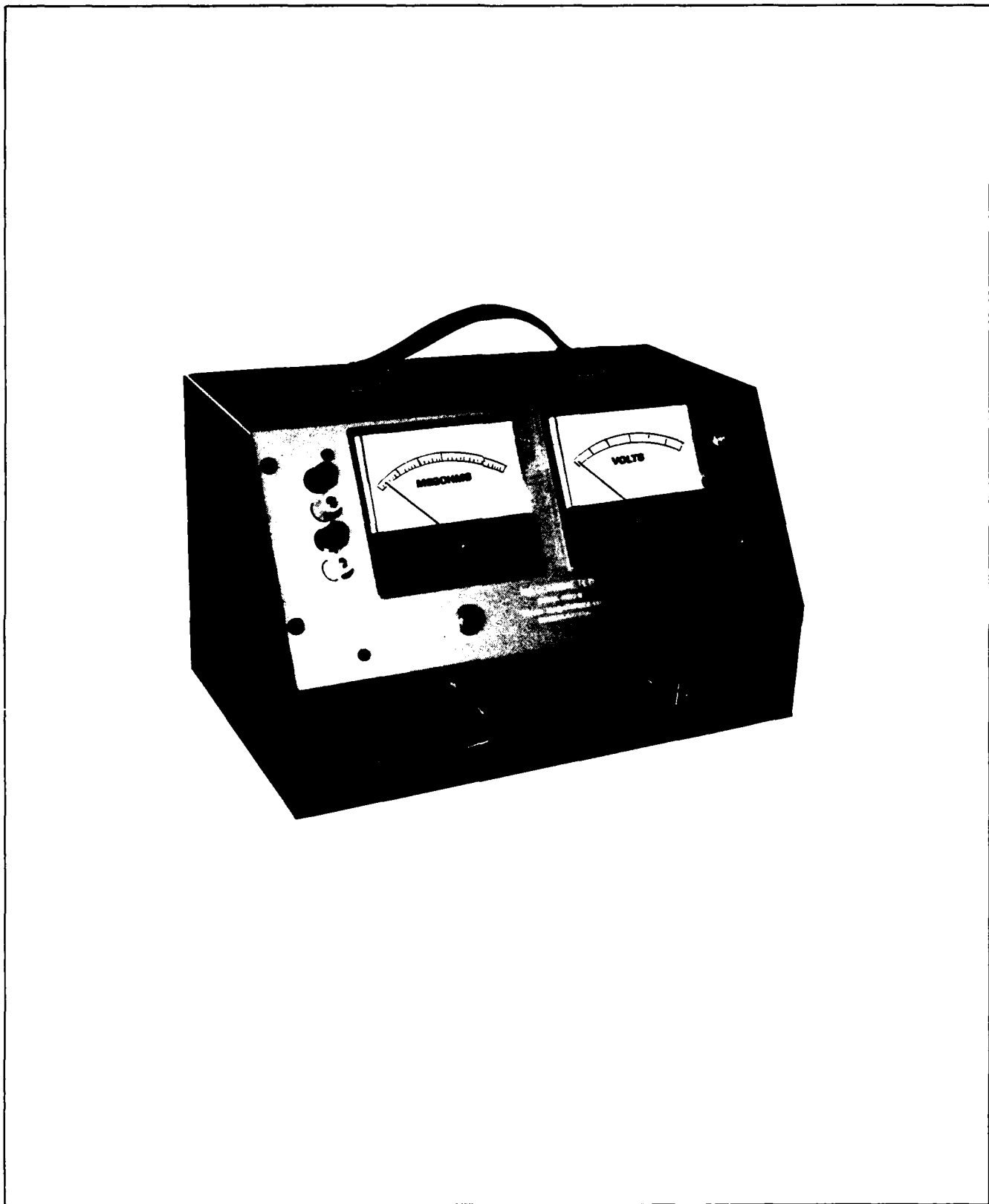

Megohmeter

110 200 300 400 500 600 700 800 900 1000 1100 1200 1300 1400 1500 1600 1700 1800 1900 2000 2100 2200 2300 2400 2500 2600 2700 2800 2900 3000 3100 3200 3300 3400 3500 3600 3700 3800 3900 4000 4100 4200 4300 4400 4500 4600 4700 4800 4900 5000 5100 5200 5300 5400 5500 5600 5700 5800 5900 6000 6100 6200 6300 6400 6500 6600 6700 6800 6900 7000 7100 7200 7300 7400 7500 7600 7700 7800 7900 8000 8100 8200 8300 8400 8500 8600 8700 8800 8900 9000 9100 9200 9300 9400 9500 9600 9700 9800 9900 10000

Item

MEGOHMMETER

Manufacturer

Freed Transformer Co., Inc., Brooklyn, NY

Model

1620B

General Description

The 1620B is a direct-reading, precision electronic ohmmeter with a variable dc supply included as a part of the unit. Insulation resistance is measured in six overlapping ranges and is indicated by an overload-protected meter.

Performance**Characteristics:**

Range: 1 to 200,000 megohms at 250 V; 10 to 2,000,000 megohms at 2500 V. (Instrument is direct-reading at 2500 V, for other test voltages the megohm reading is multiplied by factor indicated on the test voltage meter. The multiplication factor is from 0.1 to 1, which extends the resistance measuring from 1 megohm at 250 V to 2,000,000 megohms at 2500 V.)

Test voltage: Continuously variable from 250 to 2500 V, indicated on taut band meter.

Accuracy: $\pm 5\%$ on all ranges.

Physical Description

Net weight	20.0 lb.
Shipping weight	25.0 lb.
Width	15.0 lb.
Height	10.0 lb.
Depth	10.5 lb.

Auxiliary Power or Support Equipment Requirements

Power requirements are 105 to 125 V, 50 to 60 Hz, 15 W.

Operator/Crew Requirements

One person familiar with electronic test equipment is required to operate the megohmmeter.

Training Requirements

Familiarization with the equipment and the accompanying technical manual is required.

Field Maintenance Requirements

Field maintenance will be performed per OCEI instructions and manufacturer's manual. Operating logs and equipment history cards must be maintained.

Spare Parts

Spare parts are not available.

Mobilization Time: Two days

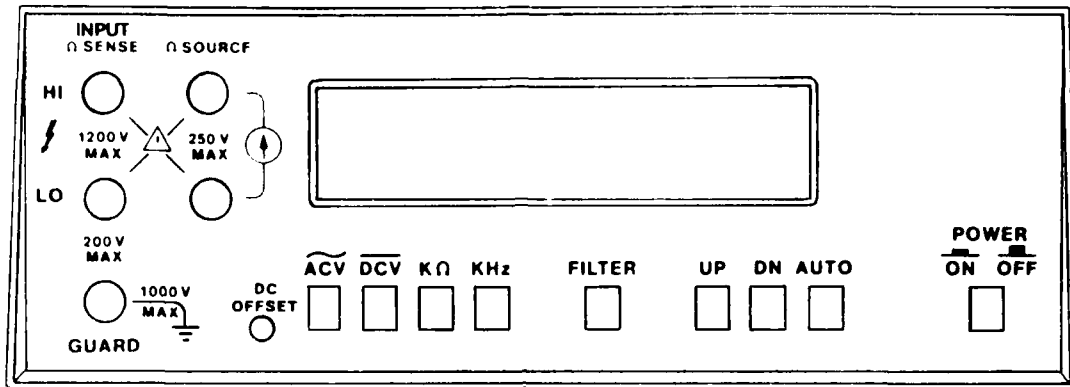

Multimeter/Counter, Digital (5100)

Item

MULTIMETER/COUNTER, DIGITAL (5100)

Manufacturer

Racal-Dana Instruments Inc., Irvine, CA 92715

Model

5100

General Description

The 5100 is a five-digit "Delayed Dual Slope" digital multimeter/counter with a sixth decade for a full-scale reading of 199999. The basic instrument is equipped for dc voltage measurements, ac voltage measurements, and resistance measurements. The basic instrument is also capable of measuring frequency. With the use of various options, the instrument can measure complex waveforms, measure current, provide remote control of the measurement and display cycle at the measurement probe, and provide serial or parallel BCD output data at the rear panel for connection to other instruments. There is also an option used to eliminate ac measurement capability completely. Range can be selected manually or automatically (autorange). Polarity selection is also automatic and displayed on the front panel when in autorange.

Performance

Characteristics:

DC Voltmeter

Voltage range: ± 0 200000 V to ± 1000.00 V (5 ranges).

Input impedance: 0.2 V to 200 V ranges 100,000 M Ω ; 1200 V range 10 M Ω .

Maximum input voltage: 1200 V peak.

Selectable filter: 3-pole active filter.

AC Voltmeter

Voltage range: 2.00000 Vrms to 1000.00 Vrms (4 ranges).

Input impedance: 2 M Ω parallel with 100 pF.

Maximum input voltage: 1000 Vrms, 1500 V peak, decreasing to 20 Vrms at 1 MHz. (2×10^7 VHz product maximum on any range)

Filter: The selectable active filter is automatically engaged whenever the ACV function is selected.

Ohmmeter

Resistance range: .200000 k Ω to 20000.0 k Ω (6 ranges).

Maximum input voltage: 250 Vrms continuous (± 350 V peak) on all ranges.

Maximum open circuit voltage: 5 V.

Current through unknown:

<u>Range</u>	<u>Current</u>
0.2 k Ω	1 mA
2 k Ω	1 mA
20 k Ω	100 μ A
200 k Ω	10 μ A
2000 k Ω	1 μ A
20,000 k Ω	100 μ A

Frequency

Ranges: 2 MHz and 20 MHz full scale.

Input impedance: 510 k Ω parallel with 100 pF.

Maximum input voltage: 350 Vrms (± 500 V peak).

Measurement time: 0.1 s (2 MHz range) and 0.1 s with divide by 10 prescaler (20 MHz range).

General

Maximum counts: 20,000.

Read rate: 2.5 readings per second (fixed) on DCV, ACV, and K Ω .

Overrange indication: "20000" flashing on display.

Warmup time: 30 minutes to full accuracy.

Physical Description

Weight	6.6 lb.
Width	7.87 in.
Height	2.87 in.
Depth	9.84 in.

Auxiliary Power or Support Equipment Requirements

Power requirements are 100, 120, 220, or 240 V $\pm 10\%$, 50 to 400 Hz, 22 W (nominal).

Operator/Crew Requirements

One person familiar with electronic test equipment is required to operate the multimeter/counter.

Training Requirements

Familiarization with the equipment and the accompanying technical manual is required.

Field Maintenance Requirements

Field maintenance will be performed per OCEI instructions and manufacturer's manual. Operating logs and equipment history cards must be maintained.

Spare Parts

Spare parts are not available.

Mobilization Time: Two days

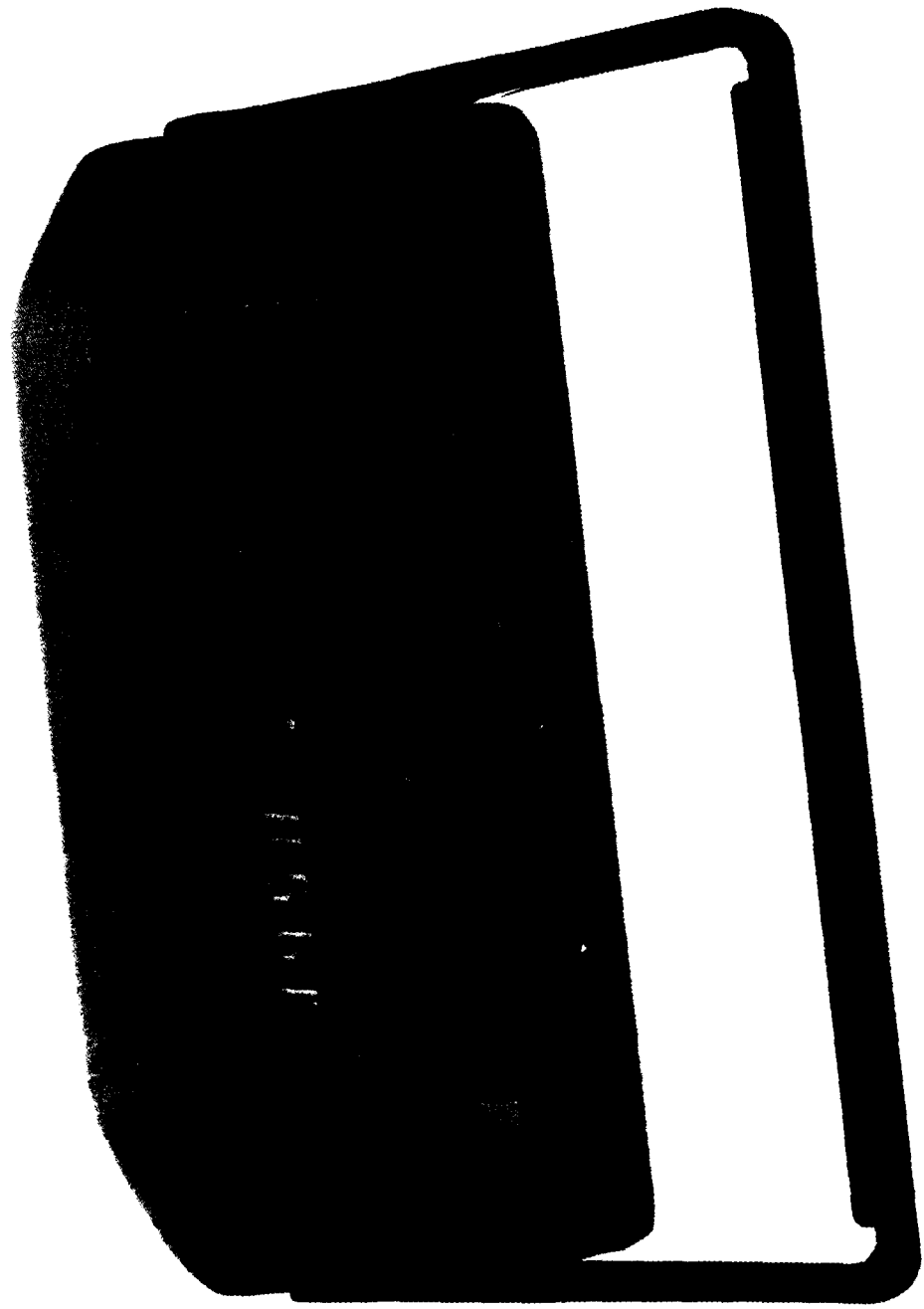

Multimeter, Digital (3435A)

Item

MULTIMETER, DIGITAL

Manufacturer

Hewlett-Packard, Palo Alto, CA 94303

Model

3435A

General Description

The 3435A is a 3-1/2-digit, high-accuracy multimeter providing five functions of ACV, DCV, ACI, DCI, and Ω . It is powered with rechargeable batteries or ac line power. The 3435A case is rugged with a detent position carrying handle which is used also as a tilt stand.

Performance

Characteristics:

DC Voltmeter

Voltage range: 200 mV to 1200 V (5 ranges).

Input resistance: 10 M Ω \pm 1%.

Input type: Floating, 500 V maximum common to ground.

Maximum input: 1200 V (dc + peak ac).

Ranging: Automatic or manual.

Sensitivity: 100 μ V on 200 mV range.

Polarity: Automatically sensed and displayed.

DC Current

Current range: 200 μ A to 2000 mA (5 ranges).

Maximum input: Current 2 amperes (fuse protected); voltage 250 V.

Ranging: Manual only.

Sensitivity: 100 nA on 200 μ A range.

Polarity: Automatically sensed and displayed.

AC Voltmeter

Voltage range: 200 mV to 1200 V (5 ranges).

Input impedance: Resistance 5 M Ω Shunt capacitance <50 pF.

Input type: Floating, 500 V maximum common to ground.

Maximum input: 1700 V (dc + peak ac), 10⁷ volt-Hz maximum.

Ranging: Automatic or manual.

Sensitivity: 100 μ V on 200 mV range.

AC Current

Current range: 200 μ A to 2000 mA (5 ranges).

Maximum input: Current 2 amperes (fuse protected); voltage 250 V.

Ranging: Manual only.

Sensitivity: 100 nA on 200 μ A range.

Ohmmeter

Resistance range: 20 Ω to 20 M Ω (7 ranges).

Input protection: 250 Vrms.

Ranging: Automatic or manual.

Sensitivity: 10 m Ω on 20 Ω range.

Open circuit voltage: < 5 V.

Current through unknown:

<u>Range</u>	<u>Current</u>
20 Ω	5 mA
200 Ω	5 mA
2 k Ω	500 μ A
20 k Ω	50 μ A
200 k Ω	5 μ A
2000 k Ω	500nA
20 M Ω	50nA

Physical Description

Weight 5 lb. 5 oz.
Width 9-3/8 in.
Height 3-7/8 in.
Length 10-7/8 in.

Auxiliary Power or Support Equipment Requirements

The multimeter can be operated continuously for at least 10 hours using fully-charged lead acid batteries. Full recharge time required is 16 hours operating and 12 hours nonoperating. Line power requirements are 86-250 V, 48-440 Hz, 8 W minimum.

Operator/Crew Requirements

One person familiar with electronic test equipment is required to operate the multimeter.

Training Requirements

Familiarization with the equipment and the accompanying technical manual is required.

Field Maintenance Requirements

Field maintenance will be performed per OCEI instructions and manufacturer's manual. Operating logs and equipment history cards must be maintained.

Spare Parts

Spare parts are not available. Batteries are available.

Mobilization Time: Two days

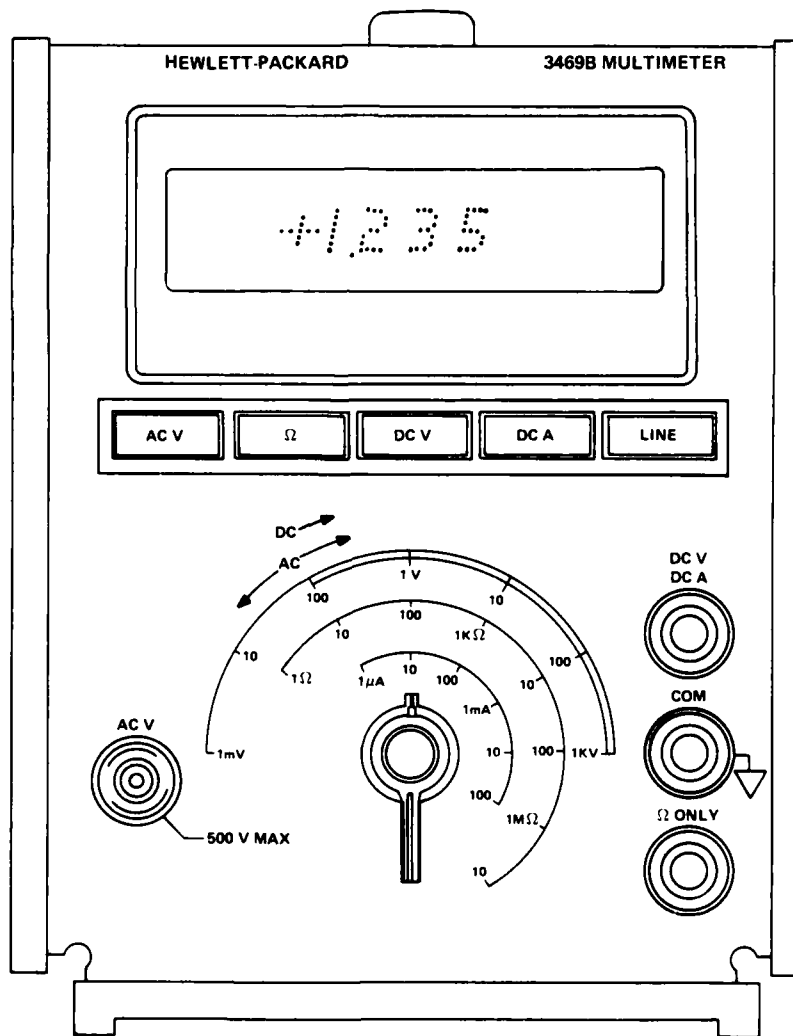
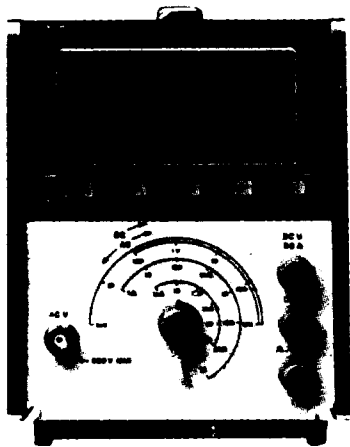

Multimeter, Digital (3469B)

Item

MULTIMETER, DIGITAL (3469B)

Manufacturer

Hewlett-Packard, Palo Alto, CA 94303

Model

3469B

General Description

The multimeter is a fully transistorized unit capable of making ac voltage, dc voltage, dc current, and resistance measurements to three significant digits, with up to 100% average capability and an average (four digit) display. Polarity selection and display are automatic for dc voltage and current measurements. Sample rate is fixed at 7.5 per second.

Performance

Function of the multimeter is controlled by pushbuttons located below the digital display, and range is controlled by a rotary switch. Range markings are color coded to the pushbutton labels.

Characteristics:

Sample rate: 8/s

Overage: 100%

Out of range and illegal range detection: 3 least significant digits blank

Polarity: Automatic

Operating temperature range: 0° to 55° C

Warmup: 10 minutes

Ac voltmeter range: 1 mV, 10 mV, 100 mV, 1 V, 10 V, 100 V, and 1000 V (500 V maximum input)

Dc voltmeter range: 100 mV, 1 V, 10 V, 100 V, and 1000 V

Ohmmeter range: 1 ohm, 100 ohm, 1 k ohm, 10 k ohm, 100 k ohm, 1 M ohm, 10 M ohm

Dc ammeter range: 1 micro A, 10 micro A, 100 micro A, 1 mA, 10 mA, and 100 mA

Physical Description

Length 11 in.
 Width 5-1/8 in.
 Height 7 in.
 Weight 7 lb.
 Shipping weight 9 lb.

Auxiliary Power or Support Equipment Requirements

The multimeter requires 115 V or 230 V $\pm 10\%$, 48 to 440 Hz, 15 VA power.

Operator/Crew Requirements

One person trained in multimeter use is required to operate the unit.

Training Requirements

Two days' training in the field or at the manufacturer's facility is required.

Field Maintenance Requirements

Field maintenance will be performed per OCEI instructions and manufacturer's manual. Operating logs and equipment history cards must be maintained.

Spare Parts

Spare parts are not available.

Mobilization Time: Two days

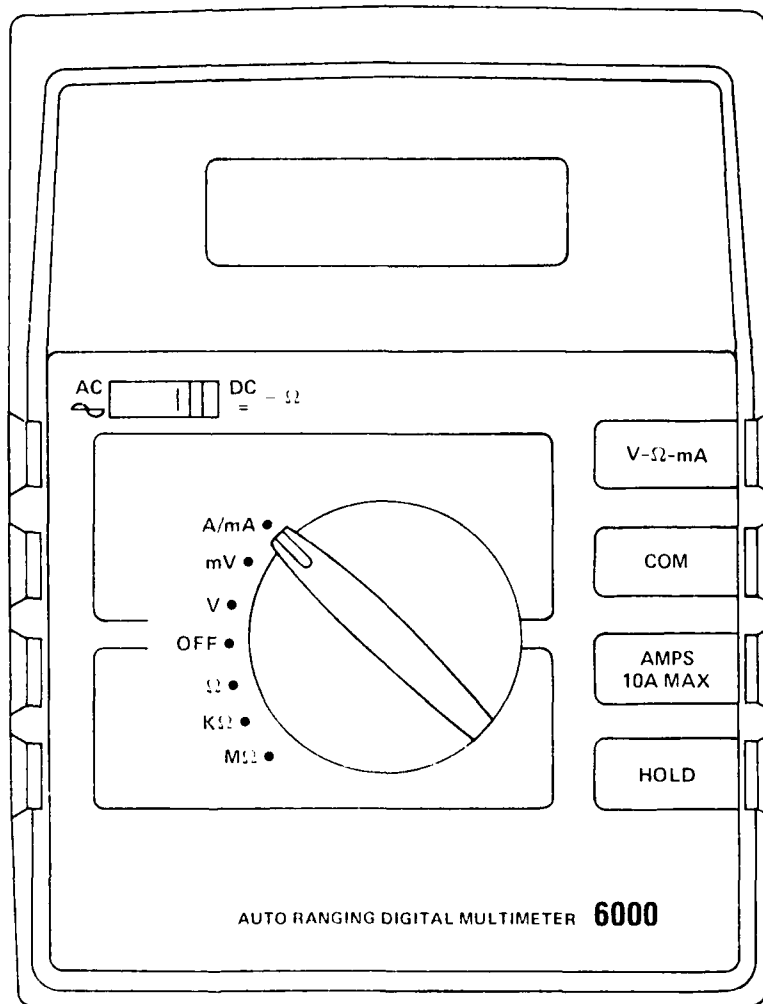
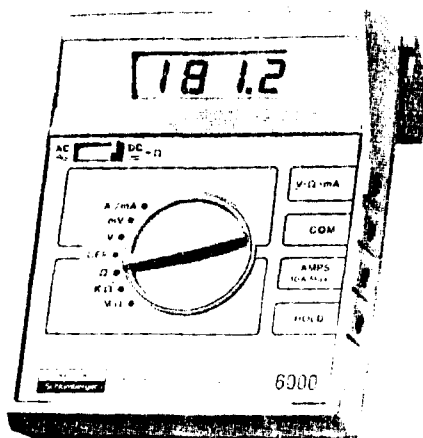

Multimeter, Digital (6000)

Item

MULTIMETER, DIGITAL (6000)

Manufacturer

Weston Instruments, Newark, NJ 07114

Model

6000

General Description

The multimeter is a bi-polar, portable, self-contained digital unit designed for laboratory and field use.

Five ac and dc voltage ranges, five ac and dc current ranges, and six resistance ranges are available. Twenty-six ranges are possible by use of autorange on volts, milli-ampere, ampere, kilohm, and megohm functions. One hundred mV and 200.0-ohm ranges are selected by separate positions on the function switch. Ac and dc measurements are selected with a slide switch.

The multimeter uses a reflective, field effect, liquid crystal display, providing readability over a wide range of ambient light levels. The display numeral height is 0.5 inch.

Performance

The multimeter is capable of measuring ac and dc voltage to 1000 V, current to 10 amperes, and resistance to 20 megohms. Operations must be conducted at an ambient temperature of $23^{\circ}\text{C} \pm 3^{\circ}\text{C}$.

A single pair of banana jacks handles all input functions except amperes. Ampere ranges are provided through a separate jack.

A remote-hold input jack permits storing the result of a measurement as long as the remote-hold input is connected to common.

Physical Description

Length	7 in. (178 mm)
Width	5-3/4 in. (146 mm)
Height	2-1/4 in. (58 mm)
Weight	22 oz (625 g) incl. batteries

Auxiliary Power or Support Equipment Requirements

Two batteries, 9-volt, NEDA 1604 (No. 216, PP3 or RR3, or equivalent) are required.

Operator/Crew Requirements

One person is required to operate the equipment.

Training Requirements

Two days' training in the field or at the manufacturer's facility is required.

Field Maintenance Requirements

Field maintenance will be performed per OCEI instructions and manufacturer's manual. Operating logs and equipment history cards must be maintained.

Spare Parts

Spare parts are not available.

Mobilization Time: Two days

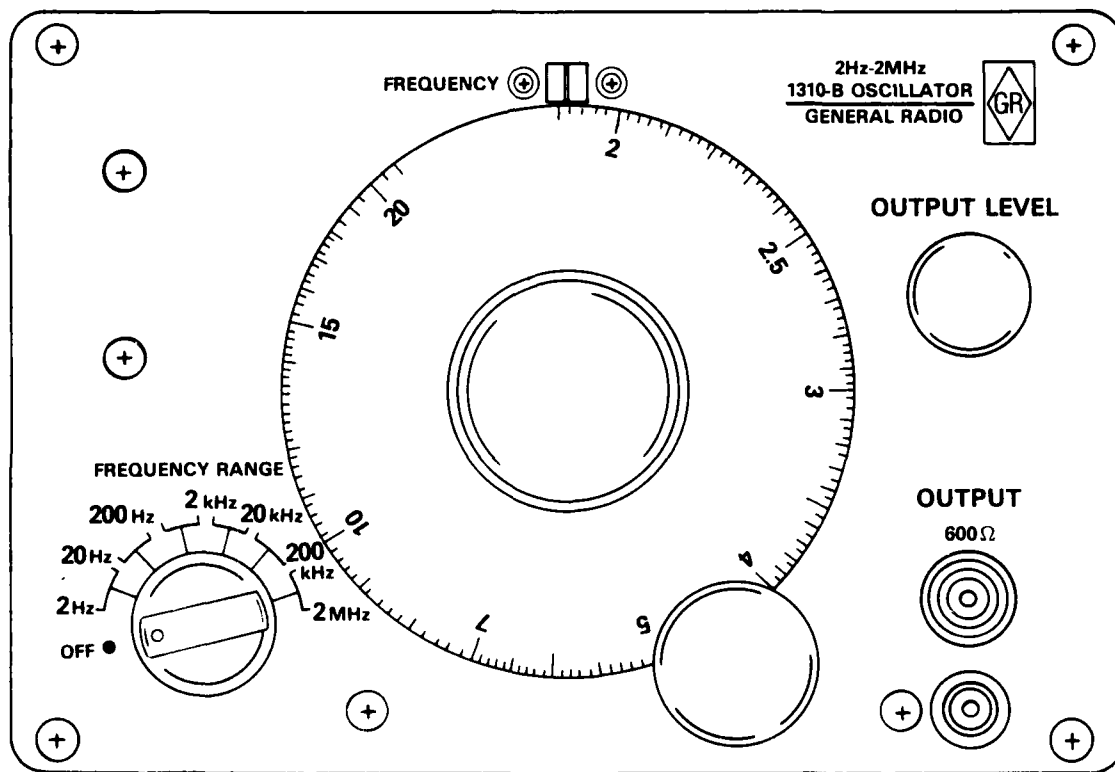

Oscillator (1310-B)

Item

OSCILLATOR (1310-B)

Manufacturer

General Radio Co., Concord, MA 01742

Model

1310-B

General Description

This oscillator provides constant output over a wide frequency range. The high resolution dial, amplitude, and frequency stability of the unit allow filter and narrow band device measurement. Controls are continuously adjustable and cover decade range in 305° and vernier in four turns.

Performance

A jack is provided for introduction of a synchronizing signal for phase locking or to furnish a signal independent of the output attenuator setting. This jack also allows the operation of a counter or the synchronization of an oscilloscope or another oscillator.

Characteristics:

Frequency range: 2 Hz to 2 MHz in six decade ranges. Overlap between ranges is 5%.

Accuracy: ±3% of the setting

Stability (typical at 1 kHz): Warmup drift is 0.1%. After warmup it is 0.003% short term (10 min.) and 0.03% long-term (12 hr.).

Synchronization: Frequency can be locked to an external signal. Lock range is ±3% per volt rms input up to 10 V. Frequency dial functions as phase adjustment.

Output voltage: Twenty $\sqrt{}$ open circuit, nominal

Power: \geq 160 mW in to 600 Ω

Output impedance: 600 Ω , one terminal grounded

Attenuation: continuously adjustable attenuator with $>$ 46 dB range

Distortion: $<$ 0.25%, 50 Hz to 50 kHz with any linear load. Oscillator will drive a short circuit without clipping.

Hum: $<$ 0.02% independent of attenuator setting

Amplitude vs. frequency: \pm 2%, 20 Hz to 200 kHz, into open circuit or 600 Ω load

Physical Description

Height 6 in.
 Width 8 in.
 Depth 8.13 in.
 Net weight 7.75 lb.
 Shipping weight 10 lb.

Auxiliary Power or Support Equipment Requirements

A line voltage of 105 to 125, 195 to 235, or 210 to 250 V, 50 to 400 Hz, 12 W is required.

Operator/Crew Requirements

One person familiar with electronic test equipment is required.

Training Requirements

Two days' training in the field or at the manufacturer's facility is required.

Field Maintenance Requirements

Field maintenance will be performed per OCEI instructions and manufacturer's manual. Operating logs and equipment history cards must be maintained.

Spare Parts

No spare parts are available.

Mobilization Time: Two days

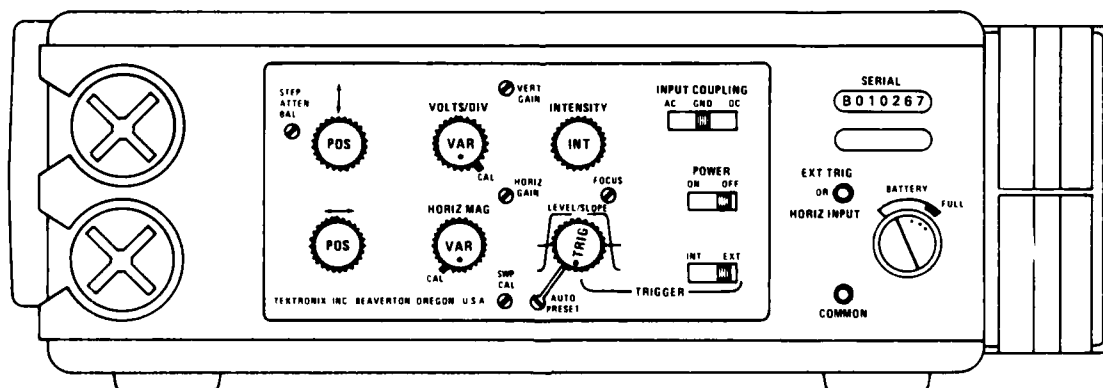
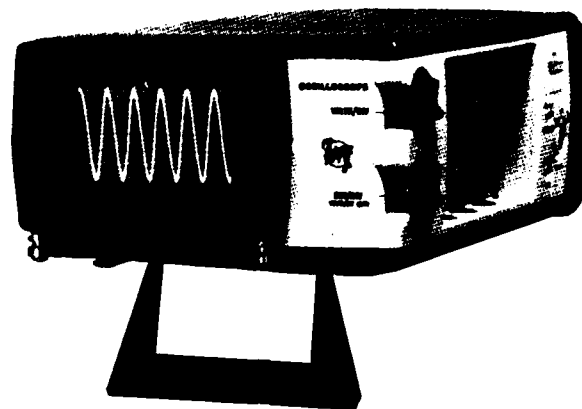

Oscilloscope (211)

Item

OSCILLOSCOPE (211)

Manufacturer

Tektronix, Inc., Beaverton, OR 97005

Model

211

General Description

The oscilloscope is a portable, compact, laboratory quality unit in the 500 kHz range. The oscilloscope comes with an integral flip stand for adjusting viewing angle.

Performance

The oscilloscope may be used for a wide range of applications, including industrial controls, mobile electronic facilities, audio communications, logic probing, marine electronics, and others. The unit provides deflection factors from 1 millivolt to 5 volts/divisions, and sweep rates from 5 microseconds to 200 milliseconds/divisions, and are read out directly from the front panel where they relate easily to the CRT display.

Characteristics:Vertical Deflection

Deflection factor: 1 mV/div to 50 V/div in 15 calibrated steps (1-2-5 sequence); accuracy within 5%

Bandwidth: Dc to at least 500 kHz from 10 mV/div to 50 V/div, reducing to at least 100 kHz at 1 mV/div

Insulation voltage: 500 Vrms or 700 V (dc + peak ac) when operated from internal batteries

Maximum input voltage: 60 V (dc + peak ac), 600 V p-p ac, (5 MHz or less) from 50 V/div to 0.1 V/div

Horizontal Deflection

Time base: 5 μ s/div to 200 ms/div in 15 calibrated steps

Variable magnifier: Increases each sweep rate by at least 5 times

External horizontal input: 1 and 10 V/div within 10%; dc to 75 kHz. Maximum input voltage, 200 V (dc + peak ac), 200 V p-p ac, referenced to probe common.

Trigger

Internal: Triggers on signals of at least 0.2 division from 2 Hz to 500 kHz. Maximum usable external input voltage, 20 volts (dc + peak ac), 20 V p-p ac, referenced to probe common.

CRT:

Display area: 6 X 10 div with each div approximately 0.2 inches. Graticule is internal, black non-illuminated internal type.

Physical Description

Height	3 in.
Width	5.3 in.
Depth	8.9 in.
Net weight	3.0 lb.
Shipping weight	7.5 lb.

Auxiliary Power or Support Equipment Requirements

Internal dc source contains 10 size "AA" HiCel cells providing 5 hours of operation. Full recharge time required is 16 hours.

Operator/Crew Requirements

One person is required for operating the oscilloscope.

Training Requirements

A brief familiarization period is required, supported by the technical manual material.

Field Maintenance Requirements

Field maintenance will be performed per OCEI instructions and manufacturer's manual. Operating logs and equipment history cards must be maintained.

Spare Parts

Spare parts are not available.

Mobilization Time: Two days

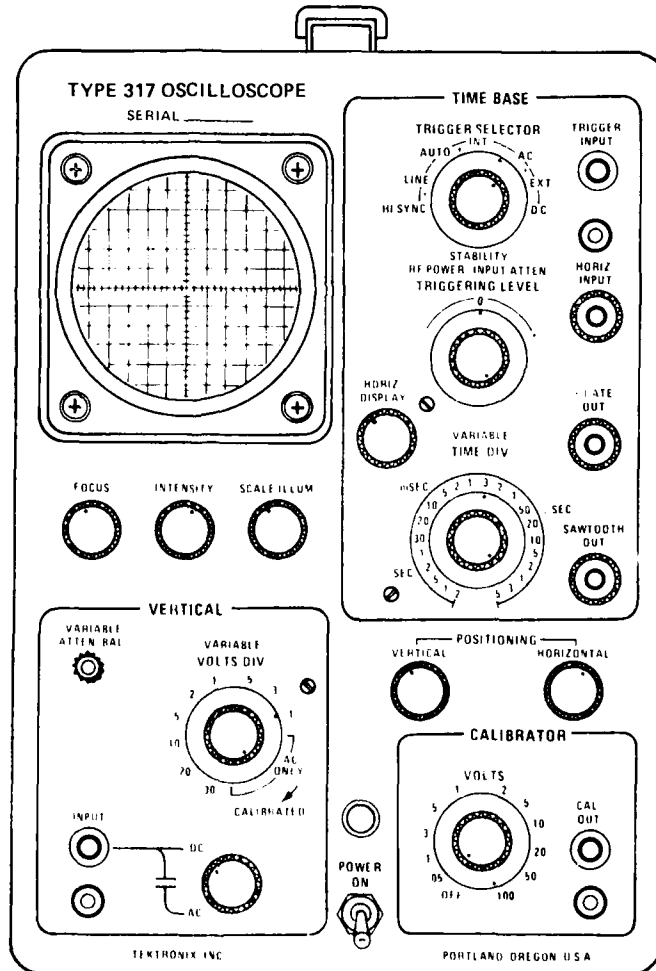
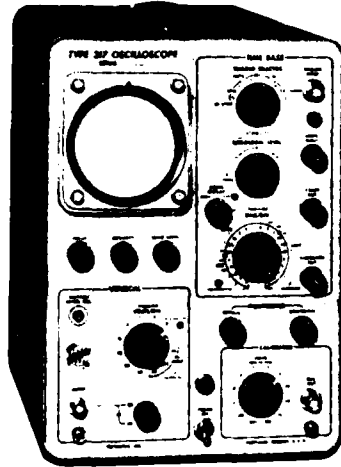

Oscilloscope (317)

Item

OSCILLOSCOPE (317)

Manufacturer

Tektronix, Inc., Beaverton, OR 97005

Model

317

General Description

The oscilloscope is a daylight condition oscilloscope useful for field and test applications in which there is a great deal of ambient light. Its brilliant bright trace, provided by a 9 kV accelerating potential on a Tektronix 3-inch CRT, is easily readable, even at low sweep-repetition rates.

Performance**Characteristics:**Vertical Deflection

Deflection factor: 10 mV/div to 50 V/div in 12 calibrated steps; ac coupled at 10 mV/div to 50 mV/div

Bandwidth: Dc to 10 MHz at 3 dB down to 10 mV/div; low-frequency 3 dB point, ac coupled, 2 Hz direct, 0.2 Hz with the 10X probe

Horizontal Deflection

Time base: 0.2 μ s/div to 2 s/div in 22 calibrated steps (1-2-5 sequence), accurate within 3%

Magnifier: X5 operating over the full time base; magnified time base accurate within 5%

External input: 1.4 V/div, adjustable; dc to 500 kHz at 3 dB; input reliability approximately 100 km

Triggering: Manual or automatic triggering, high frequency sync.

CRT

8 X 10 div display, each div 1/4 inch; 3-inch tube provides bright trace with 9 kV accelerating potential. Z-axis input for external modulation of CRT; approximately 10 V will modulate CRT at normal intensity.

Physical Description

Height	12-3/8 in.
Width	8-1/2 in.
Depth	18-11/16 in.
Net weight	33 lb.
Shipping weight	46 lb.

Auxiliary Power or Support Equipment Requirements

The oscilloscope is wired for 105 to 125 Vac (117 V nominal). Transformer taps permit operation at nominal voltages of 110, 117, 124, 220, 234, and 248 Vac, 50 to 60 Hz. Power consumption is 300 W maximum.

Operator/Crew Requirements

One person is required for operating the oscilloscope.

Training Requirements

Two days' training in the field or at the manufacturer's facility is required.

Field Maintenance Requirements

Field maintenance will be performed per OCEI instructions and manufacturer's manual. Operating logs and equipment history cards must be maintained.

Spare Parts

Spare parts are not available.

Mobilization Time: Two days

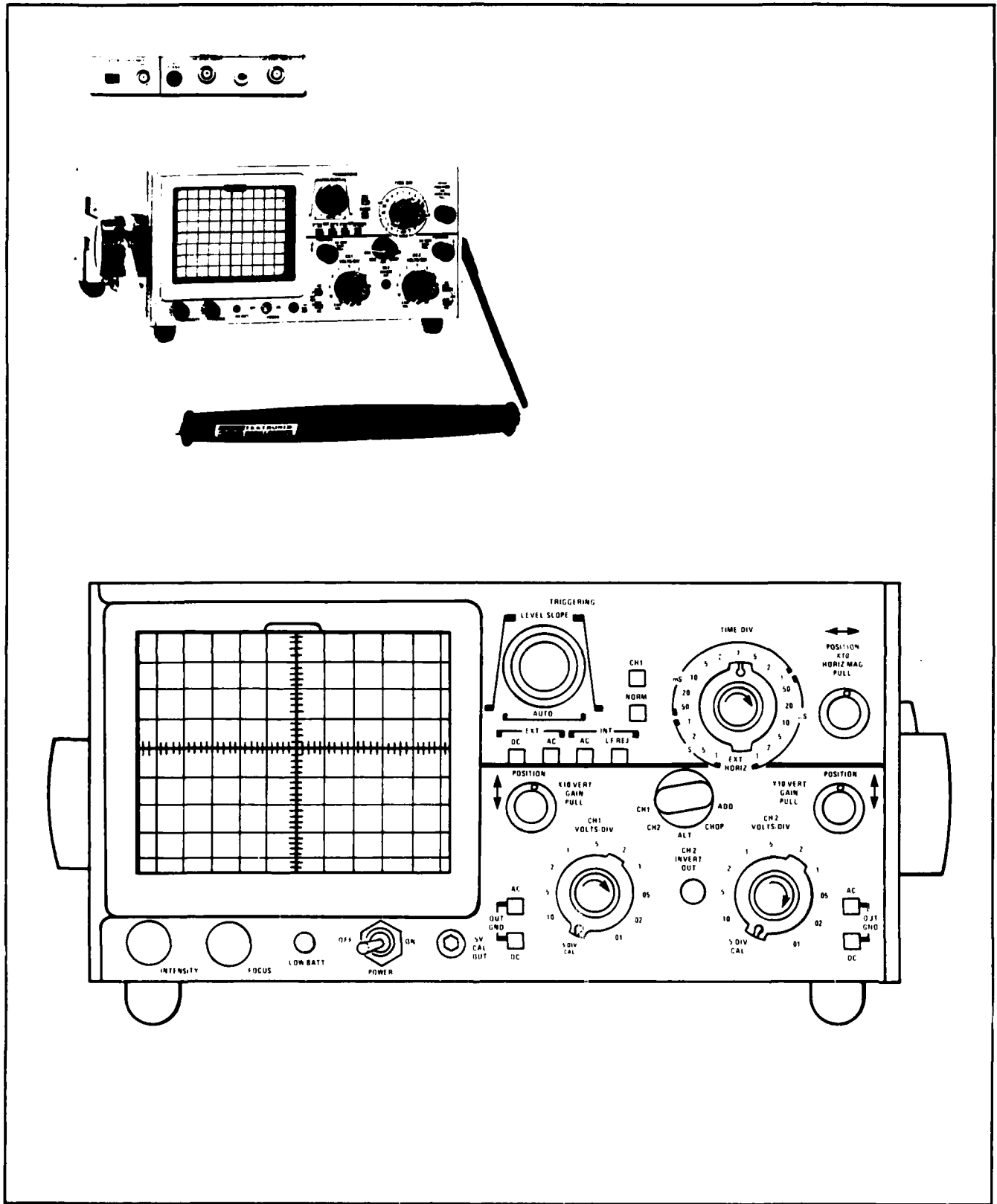

Oscilloscope (326)

Item

OSCILLOSCOPE (326)

Manufacturer

Tektronix, Inc., Beaverton, OR 97005

Model

326

General Description

The oscilloscope is a solid-state portable instrument that combines small size and light weight with the ability to make precision waveform measurements.

A dual-trace dc to 10 MHz vertical system provides calibrated deflection factors from 0.01 Volt/Div to 10 Volts/Div (0.001 Volt/Div minimum with reduced frequency response).

The trigger circuit provides stable triggering over the full vertical bandwidth. A 300 ns delay line in the vertical system allows the operator to view the portion of the waveform on which triggering occurs.

The horizontal deflection system provides calibrated sweep rates from 1 μ s/Div to 1 s/Div. A 10X magnifier extends the sweep rate to 0.1 μ s/Div.

Performance

Characteristics:

Ranges: 10 mV/Div to 10 V/Div in X1 gain and 1 mV/Div to 1 V/Div in X10 gain, 10 steps in a 1-2-5 sequence, accuracy within 3% over the calibrated range

Bandwidth (variable Volts/Div at CAL, 4-division reference) direct coupled: 1X gain, dc to at least 10 MHz (upper - 3 dB point) with the P6049A probe; capacitively coupled, 4-division reference: from 10 Hz or less (lower - 3 dB point) at all deflection factors; one Hz or less with the P6049A probe

Physical Description

Height	4.0 in. (10.2 cm)
Width with handle	8.7 in. (22.2 cm)
Depth, handle extended:	
With charger	18.2 in. (46.2 cm)
Without charger	15.8 in. (40.1 cm)
Net weight without accessories	
With charger	13 lb. (5.9 kg)
Without charger	10 lb. (4.5 kg)
Domestic shipping weight	21 lb. (9.5 kg)
Export-packed weight	29 lb. (13.1 kg)

Auxiliary Power or Support Equipment Requirements

Power line: Voltage ranges (battery charger) - 90 V to 136 V and 180 V to 272 V

External dc: Voltage ranges - +9 V to +32 V

Internal battery: Full charge after 16 hours, resulting in 1.5 to 4.0 hours operation time.

Operator/Crew Requirements

One person is required for operation of this instrument.

Training Requirements

Proper operation of the instrument requires comprehension of the Tektronix instruction manual and operator familiarity with electronic equipment.

Field Maintenance Requirements

Field maintenance will be performed per OCEI instructions and manufacturer's manual. Operating logs and equipment history cards must be maintained.

Spare Parts

Spare parts are not available.

Mobilization Time: Two days

Item

OSCILLOSCOPE (326)

Manufacturer

Tektronix, Inc., Beaverton, OR 97005

Model

326

General Description

The oscilloscope is a solid-state portable instrument that combines small size and light weight with the ability to make precision waveform measurements.

A dual-trace dc to 10 MHz vertical system provides calibrated deflection factors from 0.01 Volt/Div to 10 Volts/Div (0.001 Volt/Div minimum with reduced frequency response).

The trigger circuit provides stable triggering over the full vertical bandwidth. A 300 ns delay line in the vertical system allows the operator to view the portion of the waveform on which triggering occurs.

The horizontal deflection system provides calibrated sweep rates from 1 μ s/Div to 1 s/Div. A 10X magnifier extends the sweep rate to 0.1 μ s/Div.

Performance**Characteristics:**

Ranges: 10 mV/Div to 10 V/Div in X1 gain and 1 mV/Div to 1 V/Div in X10 gain, 10 steps in a 1-2-5 sequence, accuracy within 3% over the calibrated range

Bandwidth (variable Volts/Div at CAL, 4-division reference) direct coupled: 1X gain, dc to at least 10 MHz (upper - 3 dB point) with the P6049A probe; capacitively coupled, 4-division reference: from 10 Hz or less (lower - 3 dB point) at all deflection factors; one Hz or less with the P6049A probe

Physical Description

Height	4.0 in. (10.2 cm)
Width with handle	8.7 in. (22.2 cm)
Depth, handle extended:	
With charger	18.2 in. (46.2 cm)
Without charger	15.8 in. (40.1 cm)
Net weight without accessories	
With charger	13 lb. (5.9 kg)
Without charger	10 lb. (4.5 kg)
Domestic shipping weight	21 lb. (9.5 kg)
Export-packed weight	29 lb. (13.1 kg)

Auxiliary Power or Support Equipment Requirements

Power line: Voltage ranges (battery charger) - 90 V to 136 V and 180 V to 272 V

External dc: Voltage ranges - +9 V to +32 V

Internal battery: Full charge after 16 hours, resulting in 1.5 to 4.0 hours operation time.

Operator/Crew Requirements

One person is required for operation of this instrument.

Training Requirements

Proper operation of the instrument requires comprehension of the Tektronix instruction manual and operator familiarity with electronic equipment.

Field Maintenance Requirements

Field maintenance will be performed per OCEI instructions and manufacturer's manual. Operating logs and equipment history cards must be maintained.

Spare Parts

Spare parts are not available.

Mobilization Time: Two days

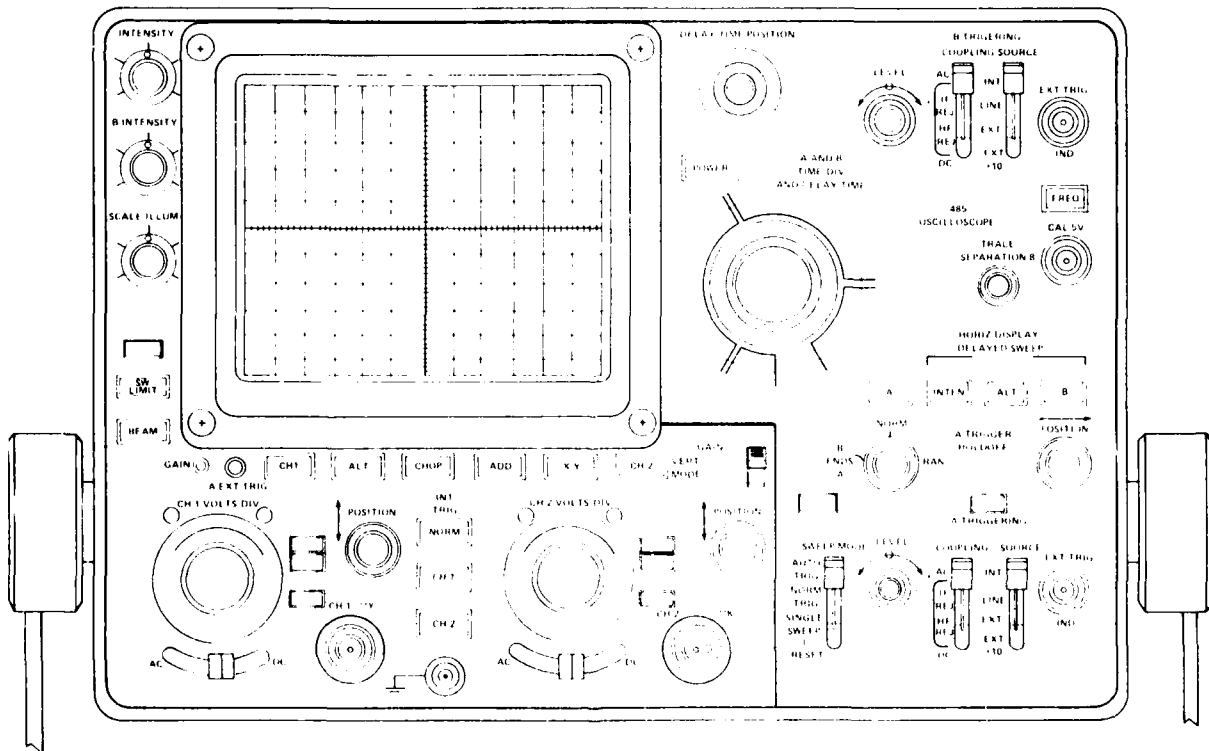
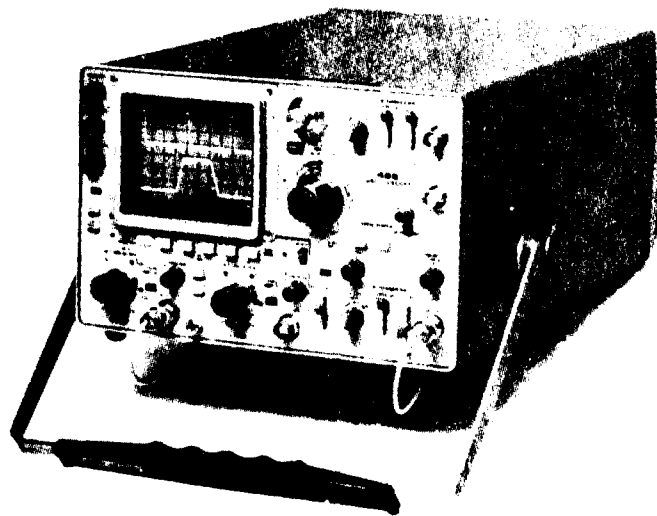

Oscilloscope (485)

Item

OSCILLOSCOPE (485)

Manufacturer

Tektronix, Inc., Beaverton, OR 97005

Model

485

General Description

The oscilloscope is a general-purpose, environmentalized, high performance, portable, wideband unit which has a dual channel vertical amplifier with selectable input impedance.

Performance

Selectable input impedance is dc to 350 MHz bandwidth with 50 Ω input impedance; dc to 250 MHz bandwidth with 1 MΩ input impedance. The 485 has a 1 ns sweep rate, stable triggering to bandwidth limits, and calibrated X-Y capabilities. Delayed sweep has calibrated delay time, can be triggered after delay, and can be displayed with the intensified main sweep in an alternate sweep switching display.

Additional features are X10, X100 probe scale factor readout, 8 div X10 div graticule area, small spot size, and high writing rate. A 20 MHz bandwidth limiter, a 1 MHz and 1 kHz fast-rise calibrator, and an autofocus are also included. The 50 Ω input is automatically disconnected from excessive voltages. An external trigger view feature is also provided.

Physical Description

Height 6-9/16 in.
Width (with handle) 12 in.

Depth (including panel cover) 18-1/2 in.
Depth (handle extended) 20-5/8 in.
Net weight (without accessory case
and panel cover) 21 lb.
Net weight (with panel cover, accessory case
and accessories) 24 lb.
Domestic shipping weight 31 lb.
Export-packed weight 42 lb.

Auxiliary Power or Support Equipment Requirements

The oscilloscope can be operated from either a 115 V or 230 V nominal line voltage source or a 220 V external battery pack. A line voltage selector switch on the rear panel converts this instrument from one operating voltage to the other.

Operator/Crew Requirements

One person is required for the operation of this unit.

Training Requirements

Operation of the oscilloscope requires familiarity with the Tektronix instruction manual and operator familiarity with electronic equipment.

Field Maintenance Requirements

Field maintenance will be performed per OCEI instructions and manufacturer's manual. Operating logs and equipment history cards must be maintained.

Spare Parts

Spare parts are not available.

Mobilization Time: Two days



Oscilloscope, Storage (214)

Item

OSCILLOSCOPE, STORAGE

Manufacturer

Tektronix, Inc., Beaverton, OR 97005

Model

214

General Description

The 214 is a solid-state, portable, dual-trace storage oscilloscope designed for general-purpose applications where display storage is desired, along with conventional operation. This small, lightweight instrument is mechanically constructed to withstand the rough handling associated with portability.

Performance

Characteristics:

Vertical Deflection

Deflection factors: 1 mV/div to 50 V/div in calibrated steps (1-2-5 sequence); Uncalibrated, continuously variable between steps to at least 125 V/div.

Bandwidth: Dc to at least 500 kHz from 10 mV/div to 50 V/div, reducing at least 100 kHz at 1 mV/div.

Insulation voltage: 500 Vrms or 700 V (dc + peak ac) when operated from internal batteries, with the line cord and plug stored. When operated from ac, line voltage plus floating voltage not to exceed 250 Vrms or 1.4X line + peak ac not to exceed 350 V.

Maximum input voltage (1X probe only): 1 mV/div to 50 mV/div ranges 600 V (dc + peak ac); ac not over 2 kHz; 0.1 V/div to 50 V/div ranges 600 V (dc + peak ac) or 600 V p-p ac, 5 MHz or less.

Horizontal Deflection

Time base: 5 μ s/div to 500 ms/div.

Variable magnifier: Increases each sweep rate X5 with a maximum sweep speed of 1 μ s/div.

External horizontal input: 1 mV/div to 50 V/div \pm 10%; dc to 100 kHz.

Maximum external horizontal input voltage: 50 V (dc + peak ac; 100 V (p-p).

Trigger

Trigger modes: Automatic or normal.

Single sweep: Sweep generator produces one sweep when trigger is received.

Display

CRT: Bistable storage, 6 X 10 div (0.52 cm/div).

Storage viewing time: Approximately one hour.

Physical Description

Net weight (without accessories)	3.5 lb.
Shipping weight	7.0 lb.
Width	5.3 in.
Height	3.0 in.
Depth	9.5 in.

Auxiliary Power or Support Equipment Requirements

Internal nickel-cadmium batteries provide approximately five hours of operation. Full recharge time required is 16 hours. External ac source power requirements are 110 to 126, 58 to 62 Hz, 3 W.

Operator/Crew Requirements

One person familiar with electronic test equipment is required to operate the oscilloscope.

Training Requirements

Familiarization with the equipment and the accompanying technical manual is required.

Field Maintenance Requirements

Field maintenance will be performed per OCEI instructions and manufacturer's manual. Operating logs and equipment history cards must be maintained.

Spare Parts

Spare parts are not available. Batteries are available.

Mobilization Time: Two days

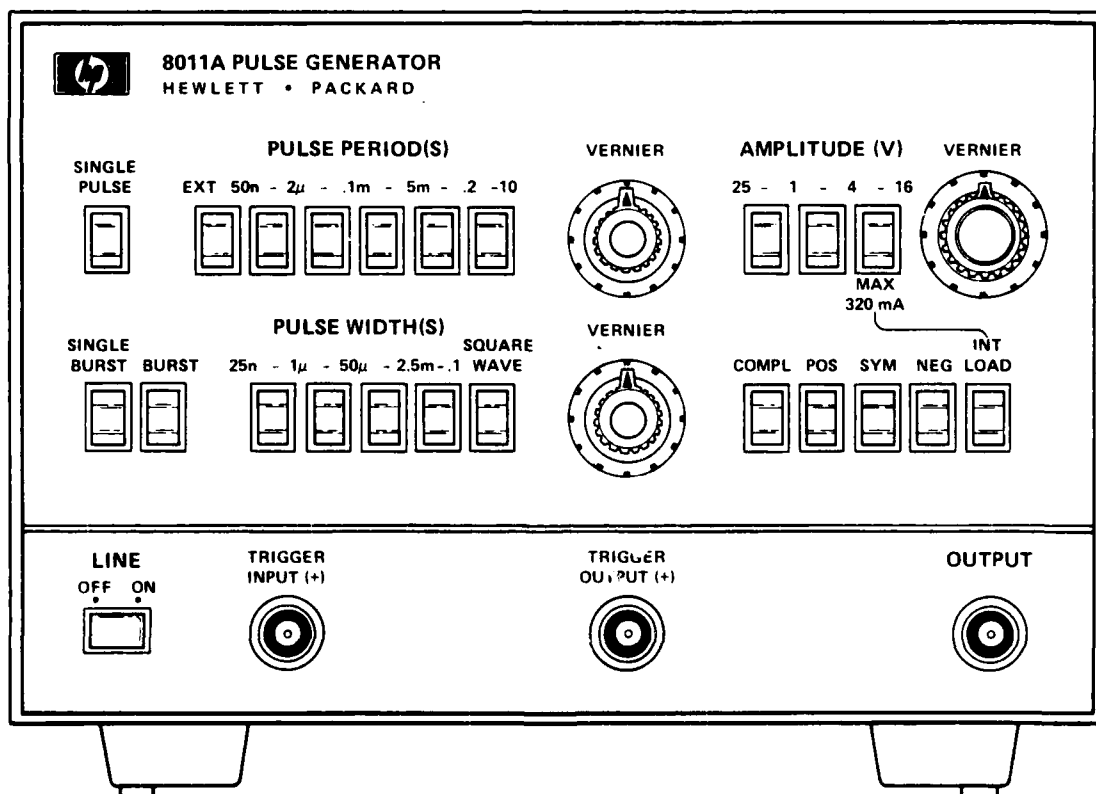
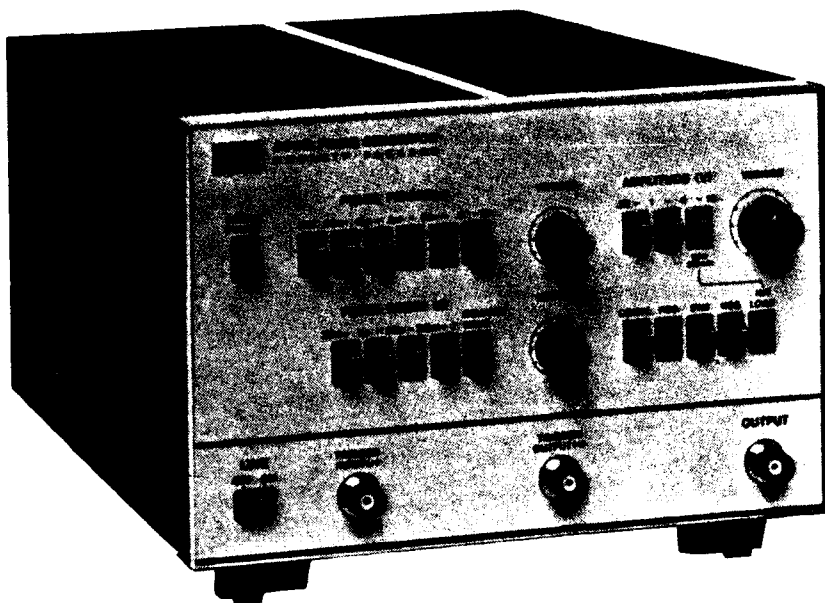

Pulse Generator (8011A)

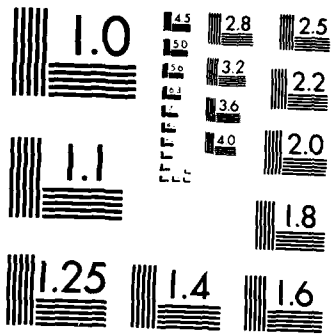

MICROCOPY RESOLUTION TEST CHART
NATIONAL BUREAU OF STANDARDS-1963-A

Item

PULSE GENERATOR (8011A)

Manufacturer

Hewlett-Packard, Palo Alto, CA

Model

8011A

General Description

The pulse generator is a 20 MHz pulse source that can be triggered externally and manually.

Pulse amplitudes up to 16 V and a selectable output format ensure compatibility with most logic families powered from either positive or negative supplies and using either positive or negative logic conventions.

Performance

Pulse width of the pulse generator is continuously variable from 25 ns to 100 ms or can be 50% of pulse period by selecting square wave mode.

Variable pulse width or square wave operation, with up to 16 V amplitude, and the ability to produce positive, negative, or symmetrical pulses in positive or negative logic make the instrument suitable for driving TTL, DTL, RTL, HTL, and CMOS as well as discrete logic and linear circuits.

Characteristics:

Maximum duty cycle: > 50% (100% using pulse complement)

Maximum output: 16 V with internal 50 ohms and external high impedance load, or with internal high impedance and external 50 Ω ; 8 V and 50 Ω source and load impedances

Attenuator: Ranges 0.25 V – 1 V – 4 V – 16 V; vernier provides continuous adjustment within each range

Source impedance: 0.25 V – 1 V – 4 V ranges, 50 ohms \pm 10% shunted by 30 pF; 4 V – 16 V range, 50 ohms \pm 10% or high impedance switch selectable

Physical Description

Net weight	4 kg (9 lb.)
Shipping weight	6.5 kg (14.6 lb.)
Width	200 mm (7.9 in.)
Height	142 mm (5.6 in.)
Depth	300 mm (11.8 in.)

Auxiliary Power or Support Equipment Requirements

Power requirements are: 100 V, 120 V, 220 V, or 240 V, +5%, -10%; 48 to 440 Hz, 70 VA max

Operator/Crew Requirements

One technician-level operator is required.

Training Requirements

Training requirements are determined by comprehension of the technical manual under standard operating conditions.

Field Maintenance Requirements

Field maintenance will be performed per OCEI instructions and manufacturer's manual. Operating logs and equipment history cards must be maintained.

Spare Parts

Spare parts are not available.

Mobilization Time: Two days

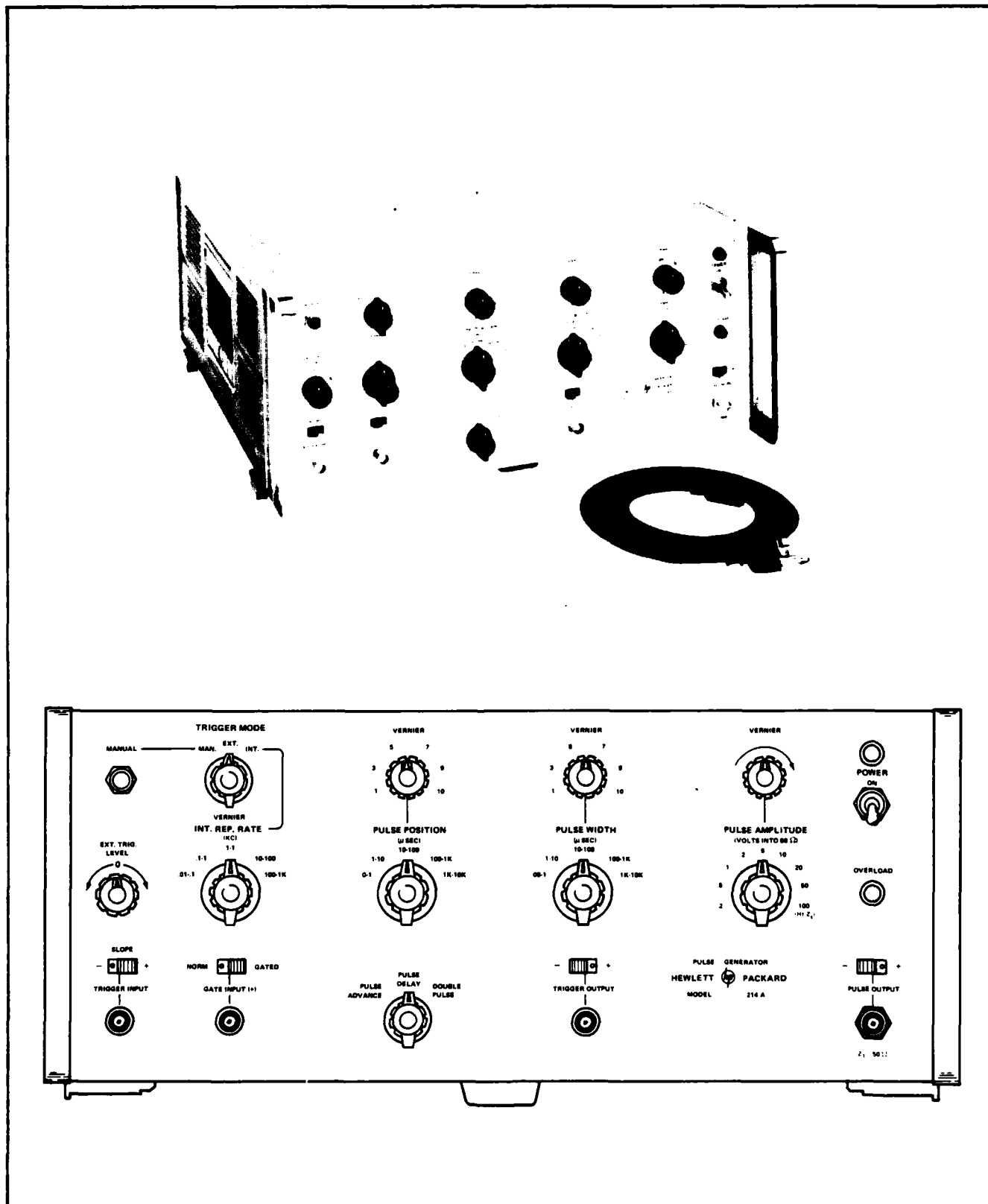

Pulse Generator (214A)

Item

PULSE GENERATOR (214A)

Manufacturer

Hewlett-Packard, Palo Alto, CA 94303

Model

214A

General Description

The pulse generator, with its variable pulse characteristics, is a general purpose laboratory or production line test instrument. The high peak current output available (2 amps) is useful for testing current-driven devices, such as magnetic memory cores, high-power modulators, and power amplifiers. Fast rise and fall time, combined with high-power output pulses, facilitate checking switching time of high-power semiconductors. The positive or negative pulse output, with identical characteristics, provides an easy technique for checking either npn- or pnp-type transistors. By gating the output, a burst of pulses may be obtained for making computer logic measurements. The double pulse feature may also be used for pulse resolution tests of amplifiers and memory cores.

Performance**Characteristics:**

Source impedance: 50 ohms on the 50-volt and lower range; approximately 1500 ohms on the 100-volt range

Pulse shape rise and fall time: < 13 nsec on 20-volt and lower ranges and the -50-volt range, < 15 nsec on the +50-volt range; typically < 10 nsec with vernier set for maximum attenuation; 100 V range is typically 15 nsec

Pulse amplitude: 100 volts into 50 ohms. An attenuator provides 0.2 to 100 volts in a 1, 2, 5, 10 sequence (9 ranges). Vernier reduces output of 0.2 V setting to 80 mV and provides continuous adjustment between ranges.

Pulse width: 50 nsec to 10 ms in 5 decade ranges; continuously adjustable vernier

Internal repetition rate: 10 cps to 1 Mc (5 ranges); continuously adjustable vernier

External repetition rate: Dc to 1 Mc

Physical Description

Net weight 35 lb. (15.8 kg)
 Shipping weight 41 lb. (18.5 kg)
 Width 16-3/4 in. (426 mm)
 Height 7 in. (178 mm)
 Depth 18-3/8 in. (467 mm)

Auxiliary Power or Support Equipment Requirements

Power requirements are 115 or 230 V $\pm 10\%$, 50 to 60 Hz, and approximately 325 VA.

Operator/Crew Requirements

One person familiar with electronic test equipment is required to operate the pulse generator.

Training Requirements

Familiarization with the equipment and the accompanying technical manual is required.

Field Maintenance Requirements

Field maintenance will be performed per OCEI instructions and manufacturer's manual. Operating logs and equipment history cards must be maintained.

Spare Parts

Spare parts are not available.

Mobilization Time: Two days

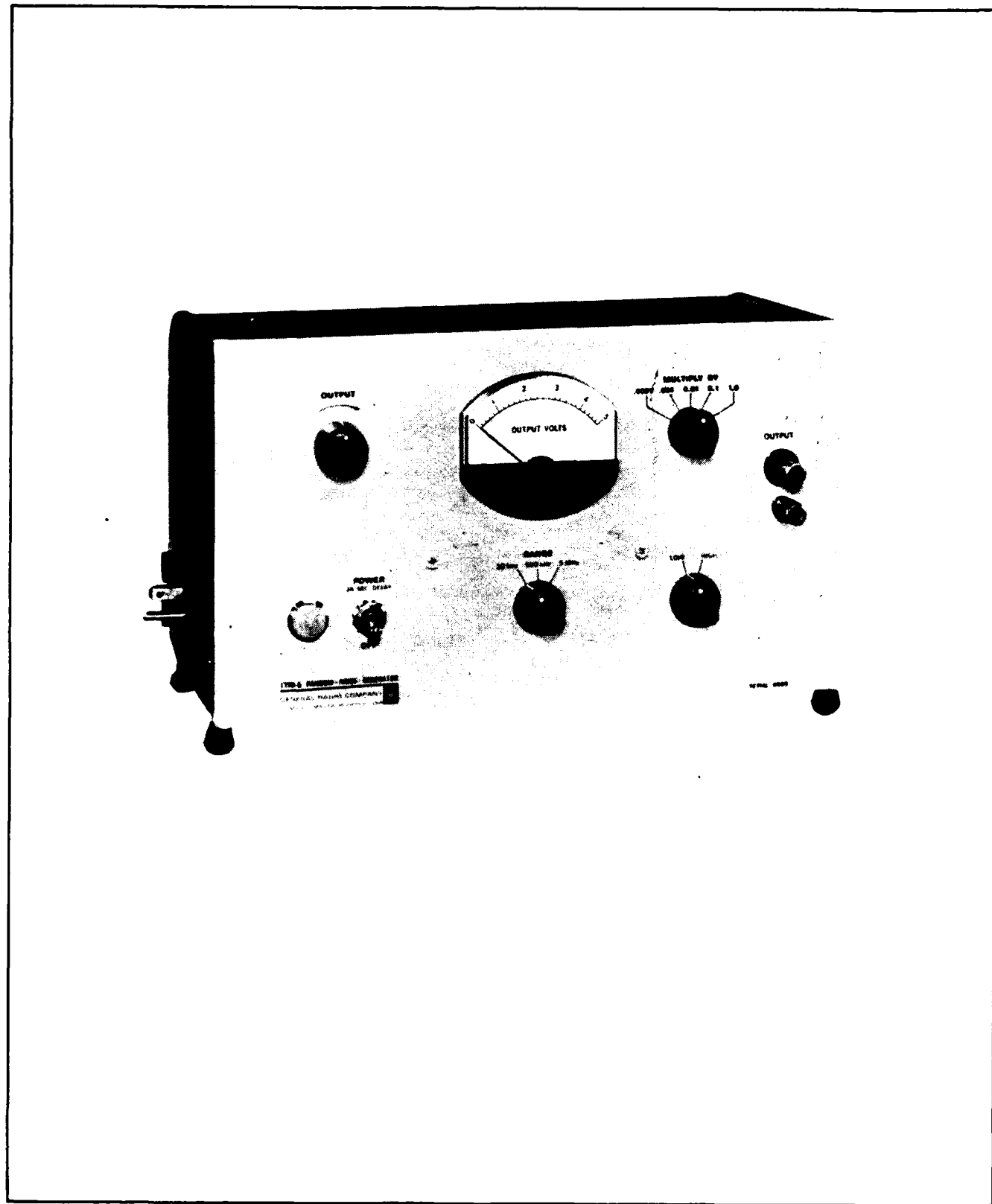

Random Noise Generator

Item

RANDOM-NOISE GENERATOR

Manufacturer

General Radio Co., Concord, MA 01742

Model

GR 1390-B

General Description

The GR 1390-B provides a high level of electrical noise for use in various tests and measurements. An internal voltmeter measures the rms value of its output noise and an internal attenuator multiplies the output with a choice of five factors.

Performance**Characteristics:**

Frequency range: 5 Hz to 5 MHz.

Output voltage: Maximum open circuit output is ≥ 3 V for 20 kHz range; 2 V for 500 kHz range; 1 V for 5 MHz range.

Output impedance: Source impedance for maximum output is approximately 900Ω ; source impedance for attenuated output is 200Ω .

Physical Description

Net weight	12 lb.
Shipping weight	16 lb.
Width	12.75 in.
Height	7.5 in.
Depth	9.75 in.

Auxiliary Power or Support Equipment Requirements

Power requirements are 105 to 125 or 210 to 250 V, 50 to 400 Hz, 50 W.

A pink-noise filter (P/N 1390-9602) is available for use with the random-noise generator.

Operator/Crew Requirements

One person familiar with electronic test equipment is required to operate the random-noise generator.

Training Requirements

Familiarization with the equipment and the accompanying technical manual is required.

Field Maintenance Requirements

Field maintenance will be performed per OCEI instructions and manufacturer's manual. Operating logs and equipment history cards must be maintained.

Spare Parts

Spare parts are not available.

Mobilization Time: Two days

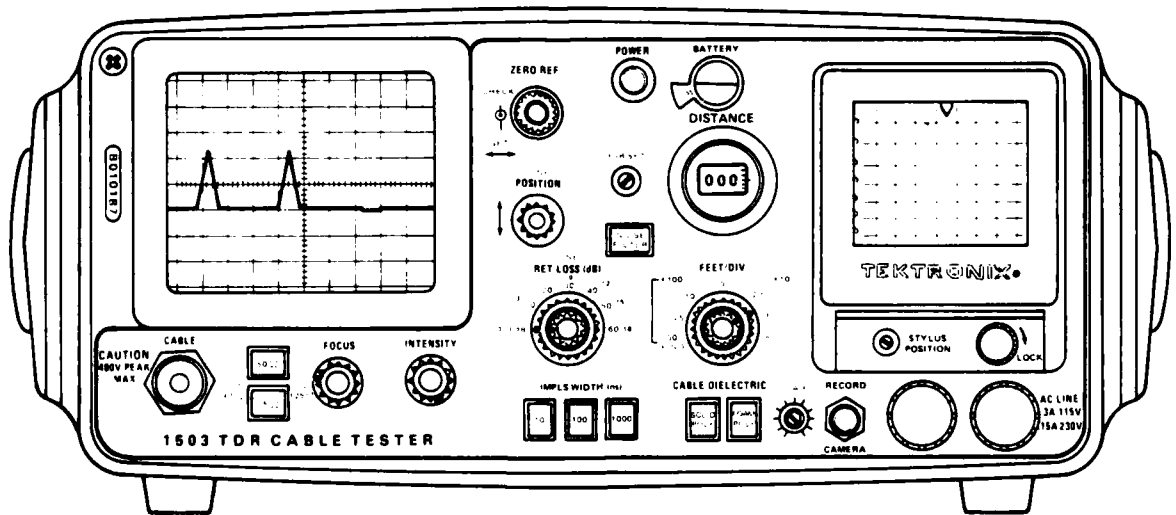
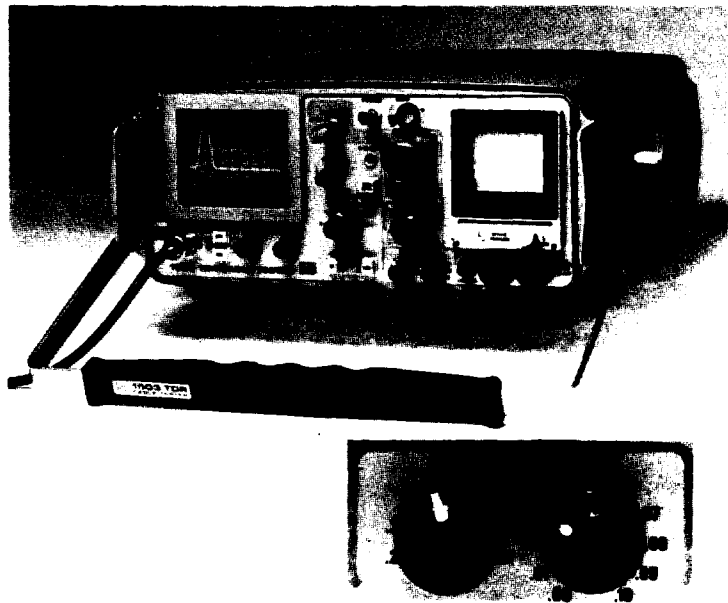

Reflectometer, Time Domain (TDR)

Item

REFLECTOMETER, TIME DOMAIN (TDR)

Manufacturer

Tektronix, Inc., Beaverton, OR 97005

Model

1503

General Description

The Tektronix 1503 TDR cable tester consists of a high energy pulse generator and a CRT display. A small light-weight carrying case is provided.

Performance

The 1503 TDR sends high-energy, 1/2-sine-shaped pulses through cables up to 50,000 feet in length. The pulses reflected back are displayed. The shape of the display identifies the type of fault. The displayed interval from test pulse to fault pulse indicates the fault distance. Resolution capability resolves faults to within 3 feet on short cables. Impedance levels of 50, 75, 93, and 125 ohms are selectable. The 1503 will operate at least 5 hours on internal rechargeable batteries.

Characteristics:

Test Signal

Duration: 10 ns, 100 ns, 1000 ns $\pm 20\%$ at half amplitude

Amplitude: 10 V $\pm 20\%$ unterminated; 5 V $\pm 20\%$ terminated

Shape: 1/2 sine $\pm 20\%$

Termination: 50 Ω , 75 Ω , and 93 Ω , with 1%; 125 Ω within 3%

Jitter: 0.2 div max

Test connector: BNC, ac coupling; max input ± 400 V (dc + peak ac at max frequency of 440 Hz)

Vertical System

Display: Range +6 to -18 dB from reference, accuracy $\pm 3\%$

Display reference: Range 0 to 60 dB, 7 steps, 10 dB per step; accuracy ± 0.1 dB; variable 0 to 18 dB additive to steps

Displayed noise: Aberrations -30 dB p-p; random -80 dB rms

Low-noise operation: 86 dB rms, random

Horizontal System

Distance controls:

Distance dial range: 0 to 2,500 ft. at X10 (0 to 500 m at X1); 0 to 25,000 ft. at X100 (0 to 15,000 m at X10); accuracy 2% of reading + 1 digit on dial

FEET/DIV control range: 5 to 500 ft/div at X10 (1 to 100 m/div at X1); 50 to 5000 ft/div at X100 (10 to 1000 m/div at X10); accuracy 2% of reading + 1 digit on dial

CABLE DIELECTRIC scales (Vp/Vair): SOLID POLY, 0.66; FOAM POLY, 0.81; VAR, 0.31-1.0; VAR is calibrated for air when turned fully cw.

DISTANCE CAL scales, Option 01 only (Vp/Vair): Selectable from 0.2 to 1.0 in .01 increments

Sweep repetition: 35 ± 5 Hz with NOISE FILTER switch "out"; 20 s/sweep nominal in chart recorder mode (dependent upon chart recorder)

Physical Description

Height	5.0 in.
Width	12.4 in.
Depth	16.5 in.
Weight	24 lb.

Auxiliary Power or Support Equipment Requirements

The unit will operate with input power of 115 Vac or 230 Vac. The unit can also be powered by self-contained nickel-cadmium batteries.

Operator/Crew Requirements

One person can operate the Tektronix 1503.

Training Requirements

Review of the associated technical manual and familiarity with the equipment, or other similar electronic equipment, is required.

Field Maintenance Requirements

Field maintenance will be performed per OCEI instructions and manufacturer's manual. Operating logs and equipment history cards must be maintained.

Spare Parts

Spare parts are not available.

Mobilization Time: Two days

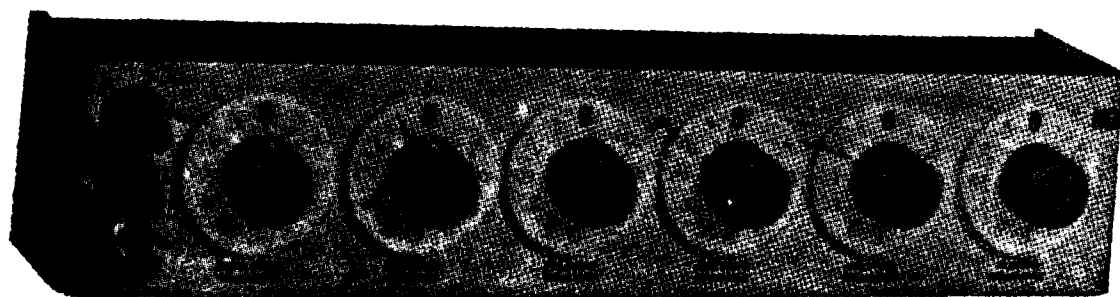

Resistor, Decade

001 002 003 004 005 006 007 008 009 010 011 012 013 014 015 016 017 018 019 020 021 022 023 024 025 026 027 028 029 030 031 032 033 034 035 036 037 038 039 040 041 042 043 044 045 046 047 048 049 050 051 052 053 054 055 056 057 058 059 060 061 062 063 064 065 066 067 068 069 070 071 072 073 074 075 076 077 078 079 080 081 082 083 084 085 086 087 088 089 090 091 092 093 094 095 096 097 098 099 100

Item

RESISTOR, DECADE

Manufacturer

GenRad Inc., Concord, MA 01742

Model

1434-M

General Description

The 1434-M is a laboratory-quality decade box that can be used in measurement, testing, and development work. Small size and clear readout make the 1434-M particularly useful in setups using small, modern components. Five step-decades of resistance are contained within the unit. The resistances are combined by switching.

Performance**Characteristics:**

Overall: The differences between the resistances at any setting and at the zero setting are equal to the indicated value $\pm 0.02\% + 5 \text{ m}\Omega$.

Zero resistance: Approximately $3 \text{ m}\Omega$ per dial at low frequencies.

Total resistance: 111,110 ohms.

Resistance per step: 1.0 ohm.

Maximum current: These values appear on the panel of the decade box.

Physical Description

Net weight 3 lb.
Shipping weight 4 lb.
Width 11-3/4 in.
Height 2-3/4 in.
Depth 4-1/4 in.

Auxiliary Power or Support Equipment Requirements

N/A

Operator/Crew Requirements

One person familiar with electronic test equipment is required to operate the decade resistor.

Training Requirements

Familiarization with the equipment and the accompanying technical manual is required.

Field Maintenance Requirements

Field maintenance will be performed per OCEI instructions and manufacturer's manual. Operating logs and equipment history cards must be maintained.

Spare Parts

Spare parts are not available.

Mobilization Time: Two days

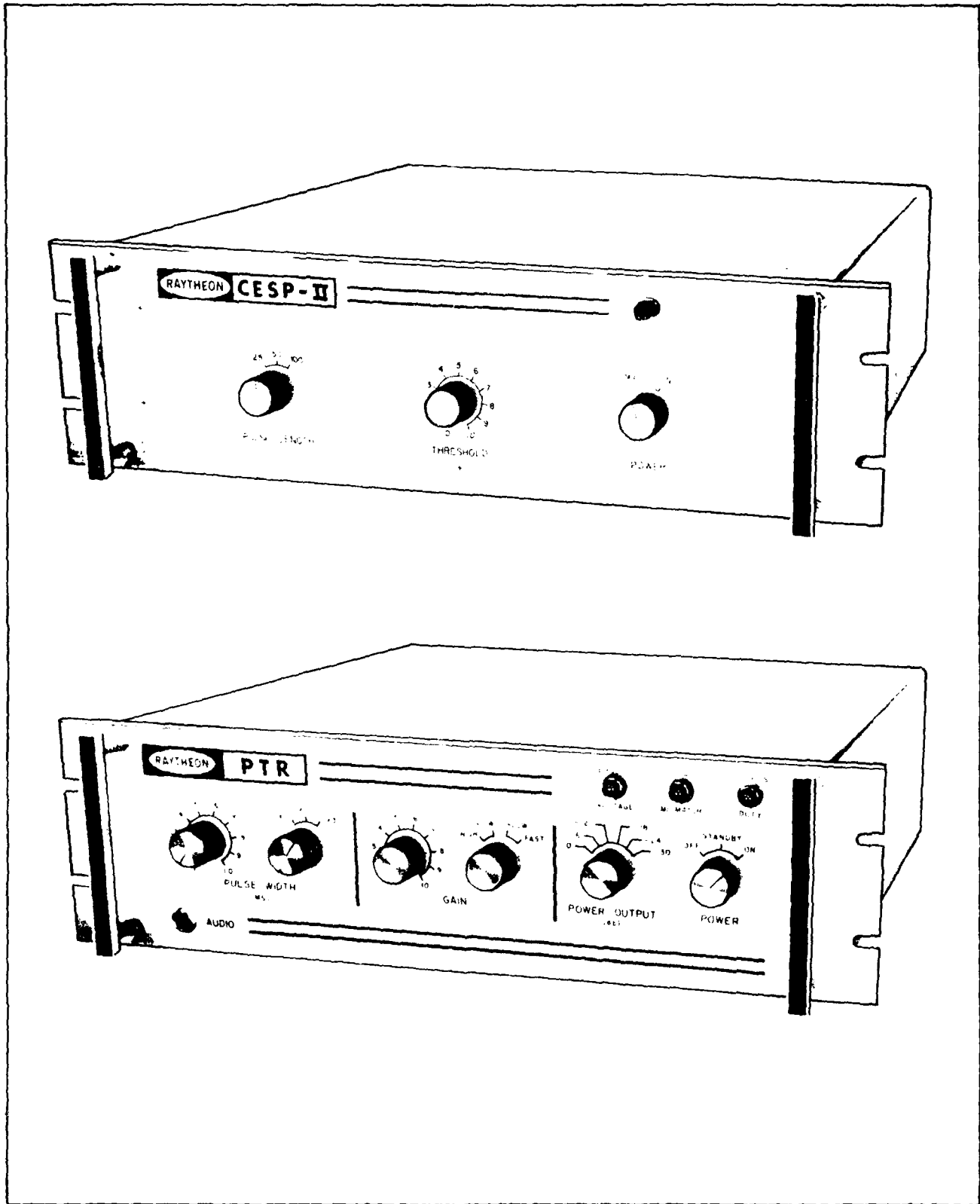

Seismic Sound Processor and Transceiver System

Item

SEISMIC SOUND PROCESSOR AND TRANSCEIVER SYSTEM

Manufacturer

Ocean Systems Center, Portsmouth, RI 02871

Model

CESP II with PTR 105A

General Description

The CESP II is a replica correlator used to improve performance in a depth sounding system. It consists of a transmitter (including a signal generator, receiver, timing, and sync) and a correlator (including output conditioning) and has a power generation and distribution capability. The CESP II operates with the Raytheon PFR or UGR series, or other similar oceanographic recorders, and a Raytheon PTR-105A transceiver, or most other bathymetric transceivers or power amplifiers.

Performance

The CESP II can process internally or externally generated signals to attain 20 dB of processing gain and provide increased noise immunity. It permits the user to obtain bathymetric records of high clarity and resolution in the presence of man-made and environmental noise using modest power levels. It can provide increased penetration with high resolution in near sub-bottom profiling.

Physical Description

Height	5.5 in.
Depth (without connectors)	15.0 in.
Depth (with connector bend)	19.0 in.
Relay rack (standard)	19.0 in.
Weight	25.0 lb.

Auxiliary Power or Support Equipment Requirements

The CESP II requires an external power source of 115 ±10 Vac, 47 to 440 Hz, single-phase. The unit can be mounted in any standard 19-inch wide equipment rack, with allowance for a front panel of 5-1/4 inches in height. The required depth behind the front panel is approximately 19 inches. This allows adequate room for mating connections and for proper cable routing. The unit is designed to operate in conjunction with most oceanographic recorders and transceivers or linear power amplifiers.

Operator/Crew Requirements

One person familiar with obtaining bathymetric records and trained for operation of the CESP II equipment is required. Generally, the CESP II is designed for hands-off operation requiring only adjustment procedures.

Training Requirements

Two days' training in the field or at the manufacturer's facility is required to familiarize operator(s) with the operation and preventive maintenance of the equipment.

Field Maintenance Requirements

Field maintenance will be performed per OCEI instructions and manufacturer's manual. Operating logs and equipment history cards must be maintained.

Spare Parts

Spare parts are not available.

Mobilization Time: Two days

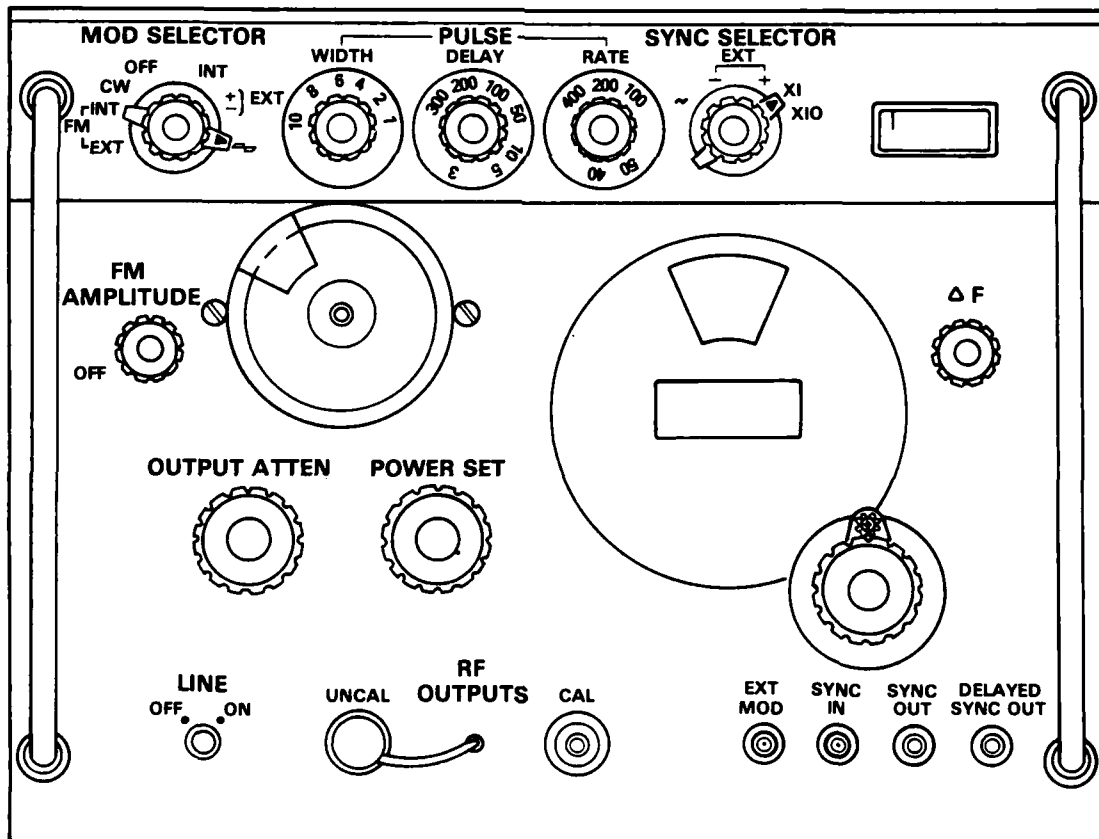
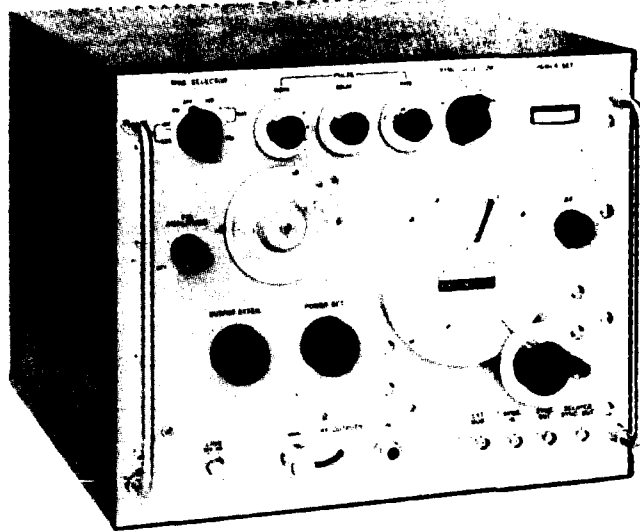

Signal Generator (618C)

Item

SIGNAL GENERATOR (618C)

Manufacturer

Hewlett-Packard, Palo Alto, CA

Model

618C

General Description

The signal generator provides RF signal output in the frequency ranges of 3800 to 7600 MHz and 7000 to 11,000 MHz, respectively. At least 1 mW power output is available over the entire frequency range. The output frequency is indicated on a direct-reading dial. The RF output power is adjustable by an attenuator that is calibrated in μV and dB.

Performance

Five types of modulation are available: internal pulse, external pulse, internal frequency, external frequency, and internal square-wave.

The internal pulse modulation has a variable repetition rate of 40 to 4,000 Hz. Pulse width is variable from 0.5 to 10 μs as measured at the pulse 50% amplitude points. Internal square wave modulation is variable from 40 to 4,000 Hz.

The signal generator can be modulated by external pulses of positive or negative polarity. The amplitude of the modulating pulses may be 20 to 70 V and the pulse width between 0.5 and 2500 μs .

Internal frequency modulation comprises a sawtooth sweep rate of 40 to 4000 Hz. Frequency deviation is variable from 0 to 5 MHz over most of the band. External frequency modulation from an external sine wave is provided. Frequency deviation is approximately 5 MHz.

Synchronization outputs of the signal generator comprise two types: delayed and undelayed. The delayed synchronization output is a positive pulse that occurs

simultaneously with the RF pulse. The pulse has an amplitude of 25 V minimum and a rise time less than 1 μs when terminated in a load of 1000 ohms or more. The undelayed synchronization pulse has the same characteristics as the delayed pulse, except the pulse occurs between 3 to 300 μs (as adjusted by front-panel control) before the RF pulse.

Physical Description

Height	13-7/8 in. (353 mm)
Width	17-1/2 in. (445 mm)
Depth	20-3/8 in. (518 mm)
Net weight	69 lb. (31.1 kg)
Shipping weight	74 lb. (33.5 kg)

Auxiliary Power or Support Equipment Requirements

Required power is 115 or 230 volts $\pm 10\%$, 50 to 60 Hz, 230 W. One Hewlett-Packard cable assembly 11500A is furnished with the signal generator. This cable is 6 ft. of RG-214 A/U 50-ohm coax terminated on each end by Type N connectors.

Operator/Crew Requirements

One technician-level operator is required.

Training Requirements

Review of the associated technical manual and familiarity with the equipment, or with other similar electronic equipment, is required.

Field Maintenance Requirements

Field maintenance will be performed per OCEI instructions and manufacturer's manual. Operating logs and equipment history cards must be maintained.

Spare Parts

Spare parts are not provided with the item.

Mobilization Time: Two days

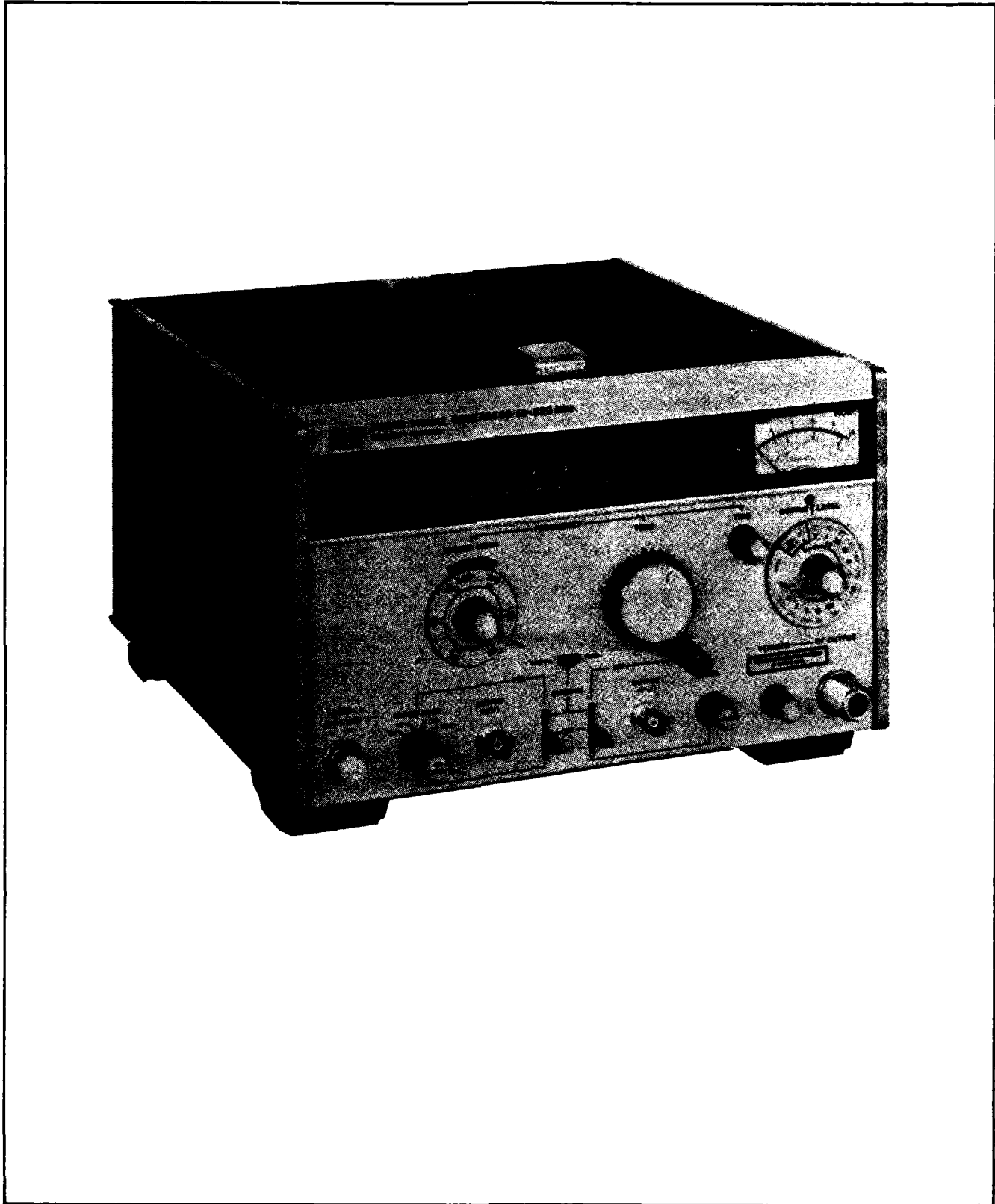

Signal Generator (8654B)

Item

SIGNAL GENERATOR (8654B)

Manufacturer

Hewlett-Packard, Palo Alto, CA 94303

Model

8654B

General Description

The 8654B is a portable, solid-state RF source providing calibrated and leveled signals. An internal oscillator provides calibrated amplitude and frequency modulation. Calibrated modulation from an external source is also possible. A front-panel meter indicates output level, percent AM, or FM peak frequency deviation.

Performance**Characteristics:**

Frequency range: 10 to 520 MHz.

Output range: 10 dB steps and a 13 dB vernier provide power settings from +10 dBm to -130 dBm (0.7 V to 0.07 μ V) into 50 Ω .

Output impedance: 50 Ω ac coupled.

Auxiliary RF output: -7 dBm (100 mV) into 50 Ω .

Reverse power damage level: 75 Vdc maximum. Output range 1 V and 0.3 V, 250 mW (+24 dBm). All other output ranges, 500 mW (+27 dBm).

AM modulation rate: Internal, 400 and 1000 Hz \pm 10%; external 3 dB bandwidth, dc-coupled to >20 kHz.

FM modulation rate: Internal, 400 to 1000 Hz \pm 10%; external 3 dB bandwidth, dc-coupled to > 25 kHz.

Physical Description

Net weight 17 lb. 6 oz.
Width 10-1/2 in.
Height 7 in.
Depth 12 in.

Auxiliary Power or Support Equipment Requirements

Power requirements are 100, 120, 220, or 240 volts +5%, -10%, 48 to 440 Hz, 25 VA maximum. A power cable furnished with main plugs to match destination requirements is supplied.

Operator/Crew Requirements

One person familiar with electronic test equipment is required to operate the signal generator.

Training Requirements

Familiarization with the equipment and the accompanying technical manual is required.

Field Maintenance Requirements

Field maintenance will be performed per OCEI instructions and manufacturer's manual. Operating logs and equipment history cards must be maintained.

Spare Parts

Spare parts are not available.

Mobilization Time: Two days

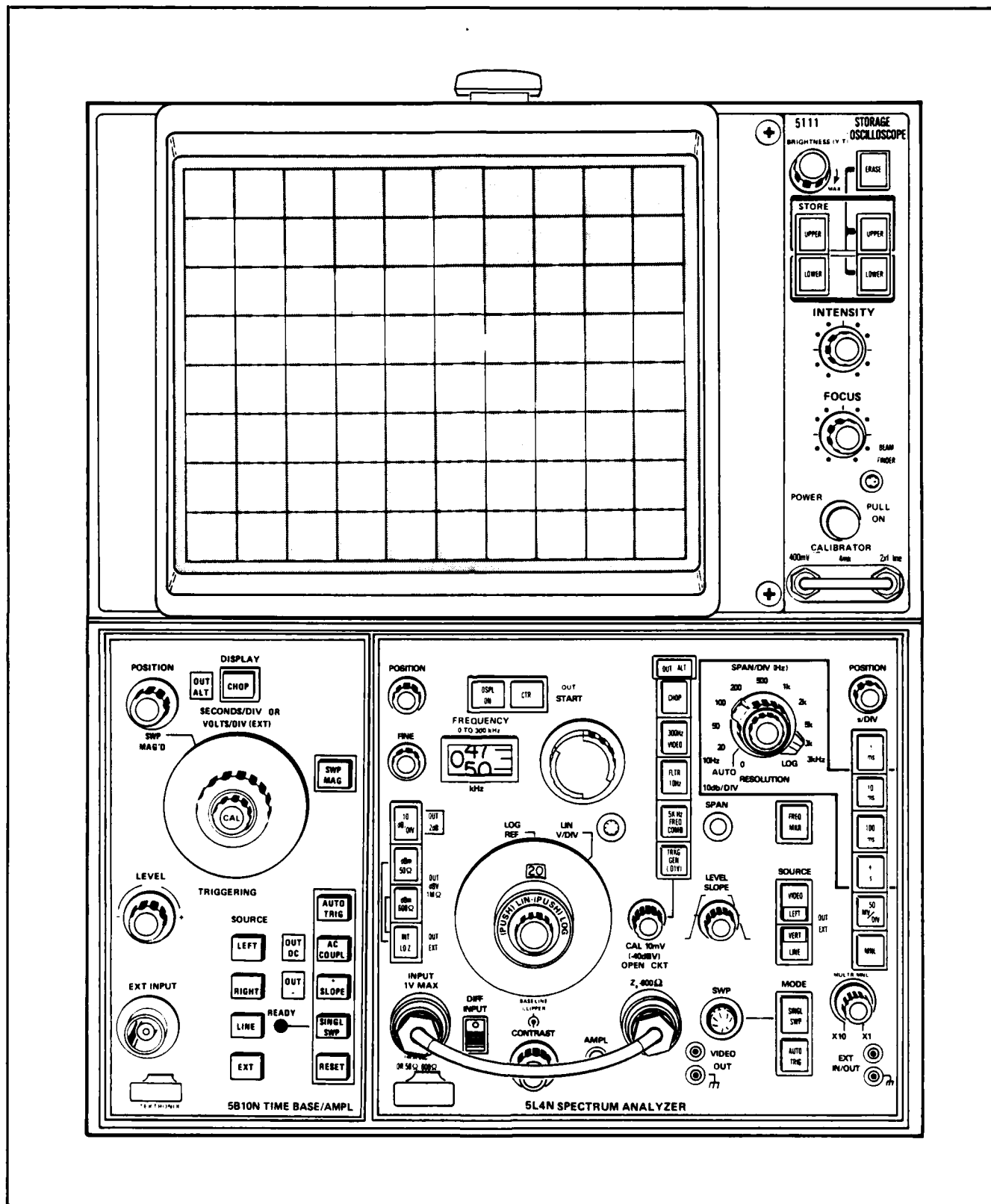

Spectrum Analyzer System

Item

SPECTRUM ANALYZER SYSTEM

Manufacturer

Tektronix, Inc., Beaverton, OR 97005

Model

5111 Storage Oscilloscope
54LN Spectrum Analyzer
5B10N Time Base/Amplifier

General Description

Oscilloscope:

The oscilloscope is a solid-state, light-weight instrument designed for general-purpose measuring applications. It is capable of extending measurements into areas requiring storage of displays for long-term examination and photography. This instrument has three plug-in compartments that accept plug-in units to form a complete measurement system.

Spectrum Analyzer:

This high-performance, low-frequency spectrum analyzer plugs into and operates with the 5000-series mainframe oscilloscope. It is a swept front-end analyzer that displays absolute amplitude information of signals within the frequency span of 0 Hz to 100 kHz. The analyzer features selectable input impedances, 80 dB of dynamic range, and a built-in tracking generator. This instrument occupies two of the three plug-in compartments of the oscilloscope mainframe.

Time Base/Amplifier:

This time base/amplifier unit plugs into and generates a sweep in the 5000 series mainframe oscilloscope. An external input allows use of the unit as a voltage amplifier with calibrated deflection factors of 50 mV/div and 500 mV/div. Multiple triggering modes may be pushbutton selected on this unit.

Performance

Oscilloscope:

This instrument features a large screen, 8 X 10 division display. Each division equals 0.5 inch (1.27 centimeters). Regulated dc power supplies ensure that performance is not affected by variations in line voltage and frequency or by changes in the load due to the varying power requirements of the plug-in units.

Spectrum Analyzer:

Maximum sensitivity: -134 dBm (50Ω), -145 dBm (600Ω), -147 dBV (high Z) and 45 nV (linear mode)

Intermodulation products: Down more than 70 dB

Selection: Differential (balanced) or single-ended input

Selectable input impedance: 50Ω, 600Ω, or 1 MΩ shunted by 50 pF (high Z)

Vertical display range: Fully calibrated 80 dB appropriate to input impedance selected

Reference level selections: From -10 dBm/dBV to -130 dBm/dBV

Deflection factor selections: From 50 mV/Div to 20 nV/Div

Incidental FM'ing: Less than 2 Hz

Resolution bandwidth: From 3 kHz to less than 10 Hz or automatic resolution for selected sweep spans and rates

Signal source: Tracking generator

Noise averaging: Two video filters

Sweep: Internal, external, or automatically triggered

Time Base/Amplifier:

Sweep rate: 1μs/div to 5 s/div in 21 calibrated steps) (X10 magnifier extends displayed sweep time/div to 100 ns. Uncalibrated, continuously variable between steps and 12.5 s/div)

Sweep triggering: Internal, external, or automatic.

Physical Description

Oscilloscope:

Height	12.0 in (30.5 cm)
Length	20.4 in. (51.8 cm)
Width	8.4 in. (21.4 cm)
Net weight	22.5 lb. (10.3 kg)
Shipping weight	30.0 lb. (13.6 kg)

Spectrum Analyzer:

Height 5.0 in. (12.7 cm)
Width 5.2 in. (13.2 cm)
Length 12.0 in. (30.5 cm)
Shipping weight 10.8 lb. (4.9 kg)

Time Base/Amplifier:

Height
Width
Length
Shipping weight

Auxiliary Power or Support Equipment Requirements

The spectrum analyzer system can be operated from either a 120-volt or 240-volt nominal line-voltage source, 48 to 440 Hz. In addition, three regulating ranges are provided for each nominal line-voltage source.

Operator/Crew Requirements

One person is necessary for operation of this instrument.

Training Requirements

Familiarity with electronic test equipment and comprehension of the instruction manual is required.

Field Maintenance Requirements

Field maintenance will be performed per OCEI instructions and manufacturer's manual. Operating logs and equipment history cards must be maintained.

Spare Parts

Spare parts are not available.

Mobilization Time: Two days

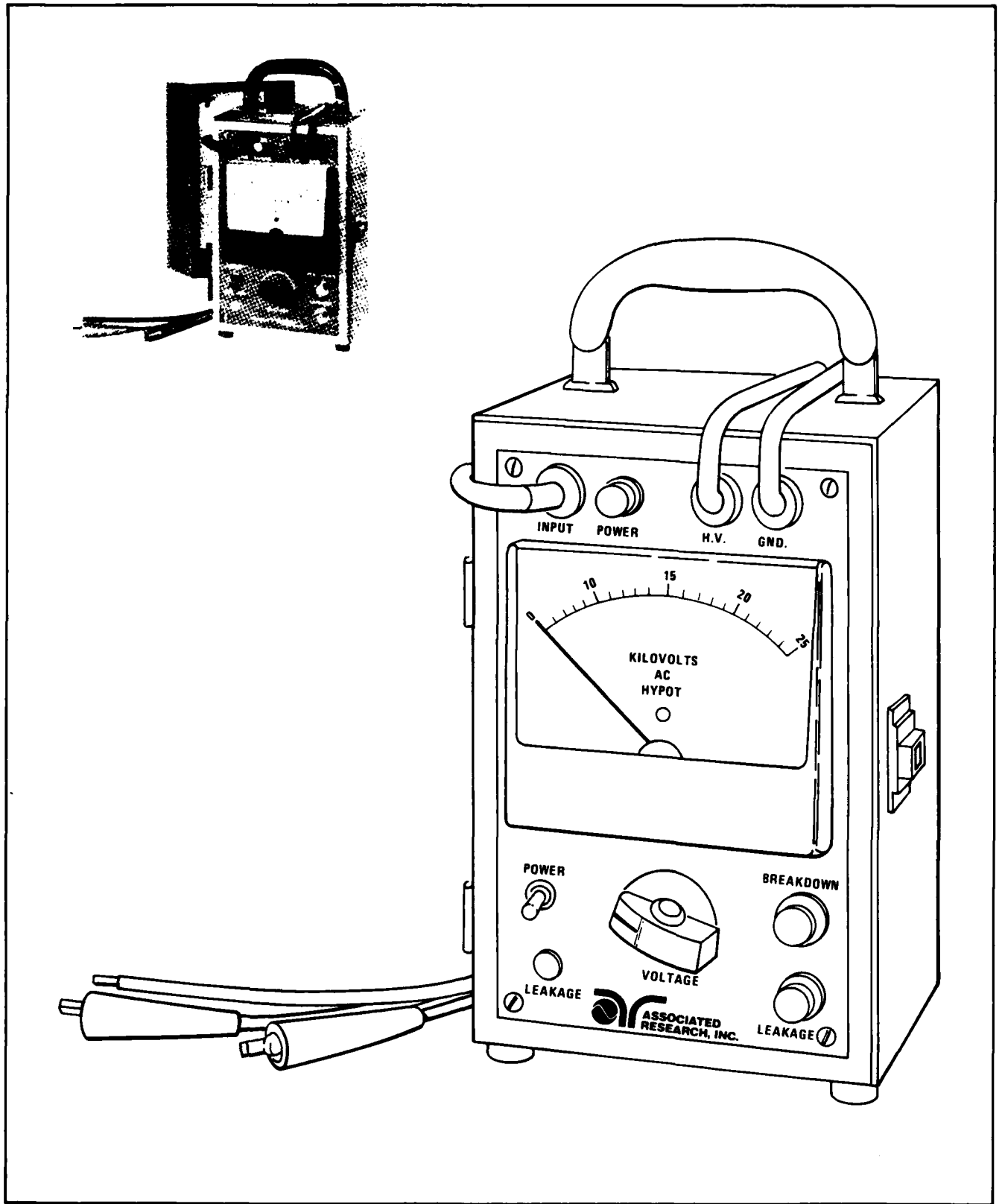

Tester, High Potential (422)

Item

TESTER, HIGH POTENTIAL (422)

Manufacturer

Associated Research, Inc., Skokie, IL 60076

Model

422

General Description

The tester is a portable instrument used for high voltage testing of electrical equipment and components. The unit is used to test equipment adequacy, to detect defects in workmanship, and to determine an item's ability to meet minimum standards. Use is extended to service and maintenance testing also.

Performance

The tester uses a high reaction type transformer, designed so that the output voltage will collapse should the current exceed a given value. The kilo-voltmeter is a diode-rectified meter connected directly across the high voltage output (accuracy is $\pm 3\%$ of full scale). The meter scale reads to 10 kilovolts.

The tester has a "breakdown" indicator, which is a neon lamp connected across an RF choke in the ground return lead. When sufficient RF energy is available, the voltage drop across the choke fires the lamp. "Breakdown" is indicated since arcing failure of the equipment under test is necessary to generate sufficient RF energy to cause the lamp to fire. A "leakage" light is also present to indicate when the current flowing in the test exceeds a certain value.

Physical Description

Length	12-1/2 in.
Width	9-3/4 in.
Height	9-1/2 in.
Weight	33 lb.

Auxiliary Power or Support Equipment Requirements

The tester requires 115 Vac for operation. Effective grounding must be sustained.

Operator/Crew Requirements

One technician familiar with high potential testing equipment is required.

Training Requirements

Familiarity with the tester should be obtained using the manufacturer's support documentation. Safety precautions must be observed in view of the high voltages encountered.

Field Maintenance Requirements

Field maintenance will be performed per OCEI instructions and manufacturer's manual. Operating logs and equipment history cards must be maintained.

Spare Parts

Spare parts are not available.

Mobilization Time: Two days

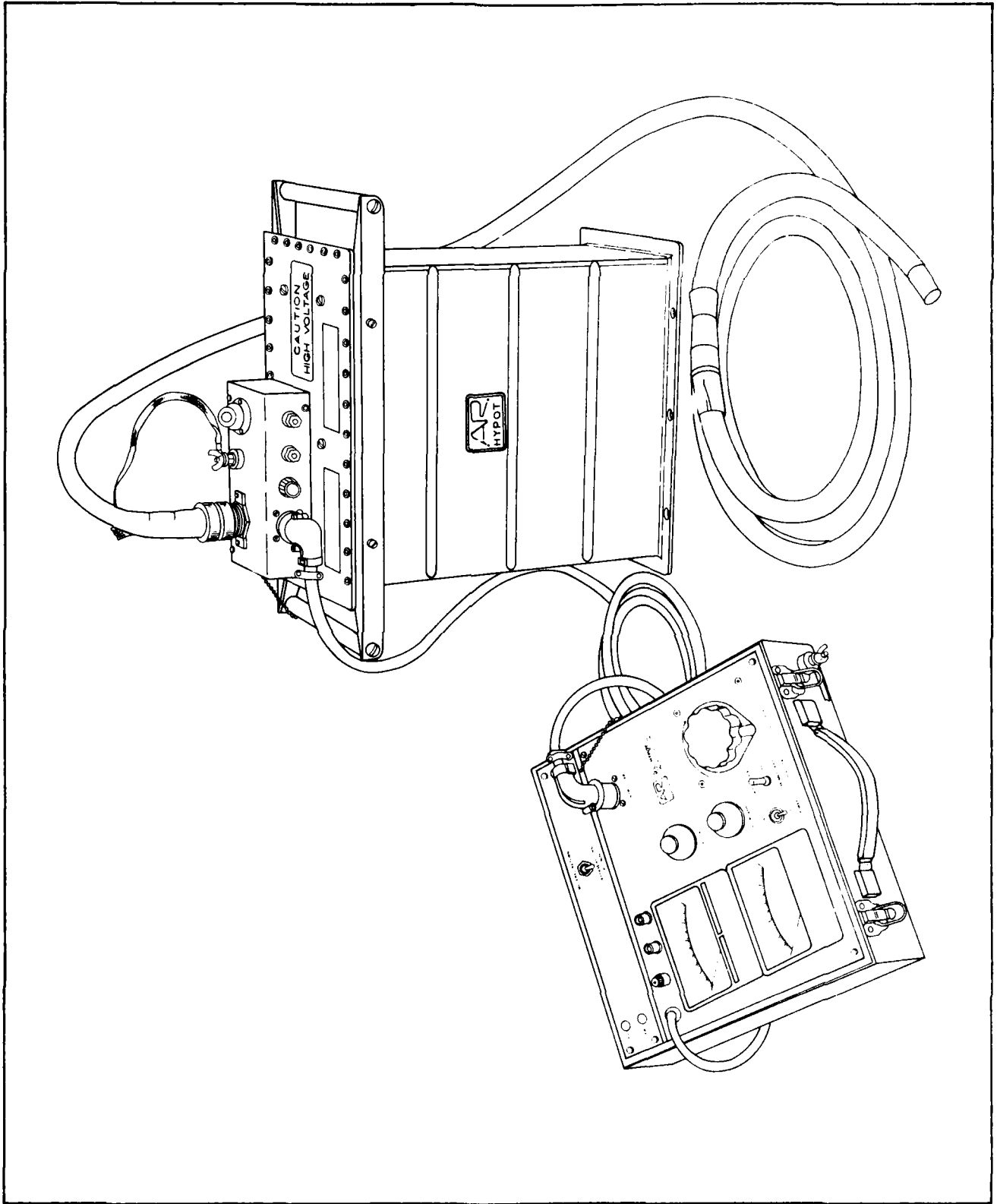

Tester, High Potential (5471)

Item

TESTER, HIGH POTENTIAL (5471)

Manufacturer

Associated Research, Inc., Skokie, IL 60076

Model

5471

General Description

The high potential tester is a portable device used to determine equipment performance levels. The tester allows application of a voltage higher than the rated voltage for a specified time to assess maintenance requirements on older equipment or to proof test new apparatus.

Performance**Characteristics:**

Input: 115 volts, 60 Hz, single-phase, 4 amperes, through a 5-foot, three-conductor line cord with standard three-prong grounding plug

Output: 0 to 50 kV dc continuously adjustable from zero

Output shorting: Accomplished by a gravity-operated device which automatically shorts the output when H.V. is off.

Electronic circuit breaker: Continuously adjustable for high voltage shutoff in two ranges, LO 10 to 1,000 micro-amperes, HI 1,000 to 5,000 micro-amperes

Electronic current meter ranges: 0-5/50/500/5,000 micro-amperes dc

Physical Description

Height	23 in.
Weight	23 in.
Depth	24 in.
Gross weight	180 lb.
Net weight	138 lb.

Auxiliary Power or Support Equipment Requirements

Power requirements are 115 Vac, 60 Hz, single phase at 5 amperes for operation.

Operator/Crew Requirements

Due to inherent dangers in high voltage work, trained personnel are required including safety personnel. The operator and crew must determine procedures prior to test initiation.

Training Requirements

The operator must be familiar with high potential testing and the unique characteristics of the tester. The supporting documentation must be studied, with special consideration given to safety aspects and equipment grounding instructions of the instrument due to the high currents encountered in use. Careful advance planning is essential to a proper and safe test. Proper test equipment, ground leads, high voltage cables, hot stick, rubber gloves, and any other special tools should be assembled at the test site.

Field Maintenance Requirements

Field maintenance will be performed per OCEI instructions and manufacturer's manual. Operating logs and equipment history cards must be maintained.

Spare Parts

Spare parts are not available.

Mobilization Time: Two days

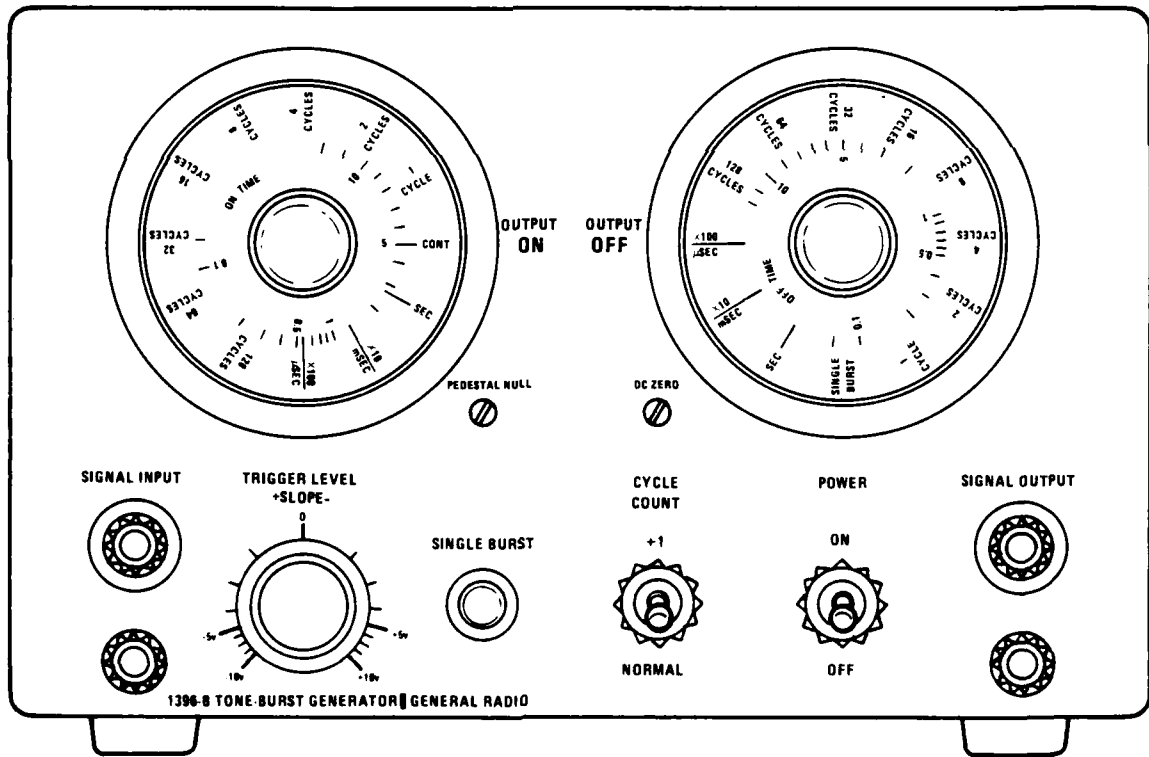
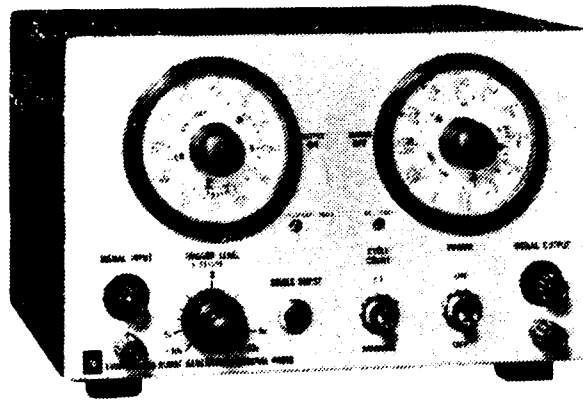

Tone Burst Generator

Item

TONE BURST GENERATOR

Manufacturer

General Radio Co., Concord, MA 01742

Model

1396-B

General Description

The tone burst generator is suited for test and calibration of sonar transducers and amplifiers, measurement of distortion and transient response of amplifiers and loudspeakers, and routine testing of filters and ac meters. Other uses are measurement of room acoustics and automatic-gain-control circuits, and synthesis of time ticks on standard-time radio transmissions.

Performance

The timing and counting circuits of the tone burst generator will produce a count when the input signal or external timing signal passes through the triggering level with the proper slope.

Characteristics:

Signal input: Amplitude ± 1 to ± 10 V p-p (7V rms with 0-Vdc component) for proper operation. Frequency range is dc to 2 MHz and input impedance is approximately 50 k Ω .

Timing input: The timing input has the same specifications as the signal input with the exception of the input impedance which is 20 k Ω .

Signal output: With output on, replica of signal input at approximately the same voltage level; dc coupled; down 3 dB at > 1 MHz. Output current limits at > 25

mA ph, decreasing to > 15 mA at 2 MHz. Total distortion contribution $< 0.3\%$ at 1 kHz and 10 kHz. With output off, input-to-output transfer (feedthrough), < 10 mV (< -60 dB full output), dc to 1 MHz, increasing above 1 MHz.

Physical Description

Height 5-7/32 in.
 Width 8-1/2 in.
 Depth 7-5/16 in.
 Weight 10 lb.

Auxiliary Power or Support Equipment Requirements

A line voltage of either 100 to 125 V or 200 to 250 V, 50 to 400 Hz, 16 W, depending on the setting of the two-position line-voltage switch on the rear panel, is required.

Operator/Crew Requirements

One person is required for the operation of the unit.

Training Requirements

Two days' training in the field or at the manufacturer's facility is required.

Field Maintenance Requirements

Field maintenance will be performed per OCEI instructions and manufacturer's manual. Operating logs and equipment history cards must be maintained.

Spare Parts

Spare parts are not available.

Mobilization Time: Two days

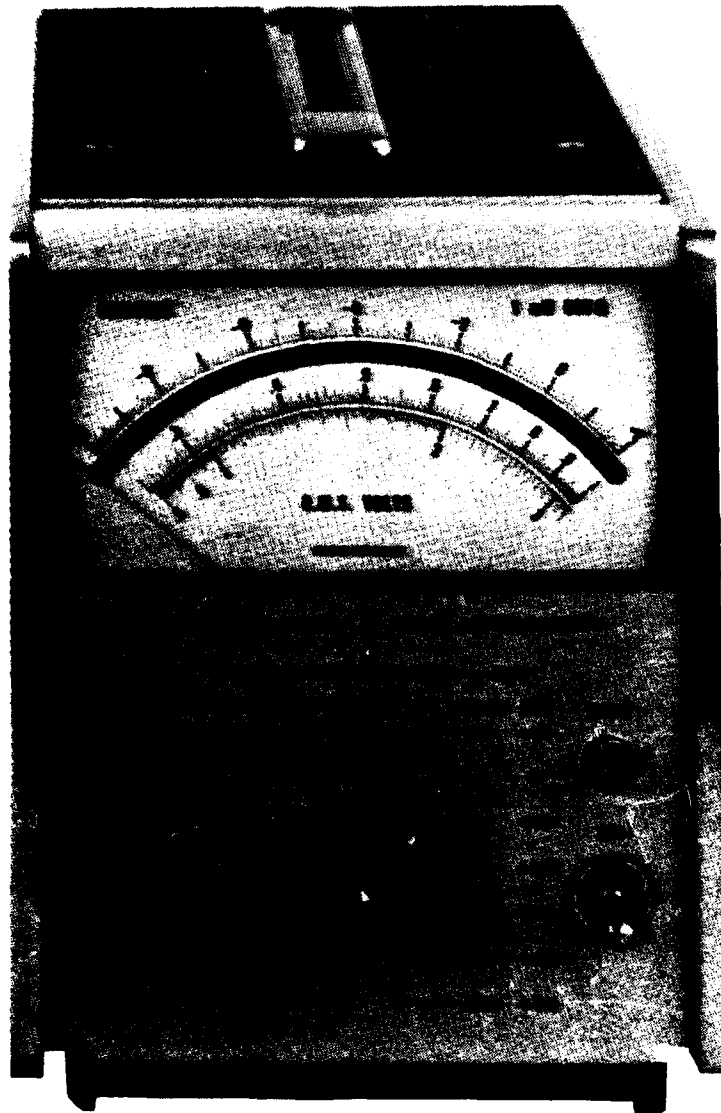

Voltmeter, AC

Item

VOLTMETER, AC

Manufacturer

Hewlett-Packard, Palo Alto, CA 94303

Model

400FL

General Description

Although the 400FL is primarily intended for use as a dB meter, it can also be used for voltage measurements. The 400FL has a linear dB scale with a logarithmic ac scale underneath.

Performance

Characteristics:

Voltage range: 100 μ V to 300 V full scale (14 ranges).

Frequency range: 20 Hz to 4 MHz.

Input impedance: 10 M Ω shunted by \leq 30 pF on the 100 μ V – 300 mV ranges and 10 M Ω shunted by \leq 15 pF on the 1 V – 300 V ranges.

Amplifier AC output: 1 V_{rms}, open circuit, for full scale indication; output impedance 600 Ω .

Frequency response: 20 Hz to 4 MHz on 1 mV to 300 V ranges; 30 Hz to 100 kHz on 100 μ V and 300 μ V range (100 kHz filter set to IN on the 100 μ V and 300 μ V range).

Physical Description

Net weight	6 lb.
Shipping weight	9 lb.
Width	5-1/8 in.
Height	6-1/2 in.
Depth	11 in.

Auxiliary Power or Support Equipment Requirements

Power requirements are 115 or 230 V \pm 10%, 48 to 440 Hz, 5 W.

Operator/Crew Requirements

One person familiar with electronic test equipment is required to operate the ac voltmeter.

Training Requirements

Familiarization with the equipment and the accompanying technical manual is required.

Field Maintenance Requirements

Field maintenance will be performed per OCEI instructions and manufacturer's manual. Operating logs and equipment history cards must be maintained.

Spare Parts

Spare parts are not available.

Mobilization Time: Two days

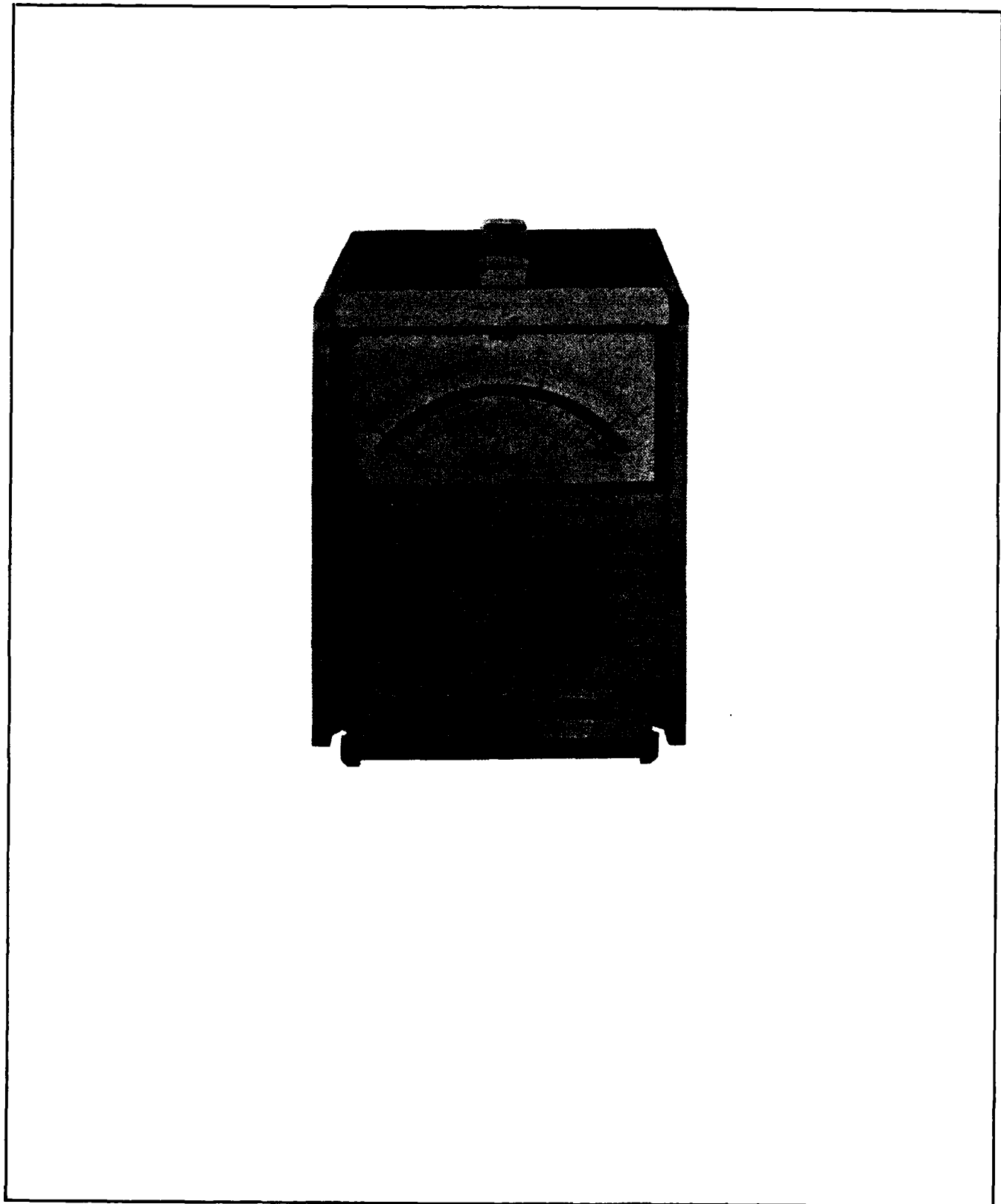

Voltmeter (427A)

Item

VOLTMETER (427A)

Manufacturer

Hewlett-Packard, Palo Alto, CA 94303

Model

427A

General Description

The 427A is a versatile, compact, self-contained voltmeter. It is capable of making dc voltage measurements, ac voltage measurements, and resistance measurements. The 427A uses an internal dry cell battery for its primary power source. However, if Option 01 is included, it can be operated from an ac line source.

Performance

Characteristics:

DC Voltmeter

Voltage range: ± 100 mV to ± 1000 V full scale (9 ranges).

Input Resistance: 10 megohms on all ranges.

Overload: 1200 Vdc on any range.

AC Voltmeter

Voltage range: 10 mV to 300 Vrms full scale (10 ranges).

Frequency range: 10 Hz to 1 MHz.

Input Impedance: 10 megohms shunted by 40 pF on 10 mV to 1 V range; 20 pF on 3 V to 300 V ranges.

Overload: 300 Vrms momentarily, 1 V range and below; 425 Vrms maximum above 1 V range.

Ohmmeter

Resistance range: 10 ohms center scale to 10 megohms center scale (7 ranges).

Polarity: Common terminal negative.

Source current:

<u>Range</u>	<u>Open Circuit voltage</u>	<u>Short Circuit voltage</u>
X10	0.1V	10 mA
X100	0.1V	1 mA
X1K	1V	1 mA
X10K	1V	100 μ A
X100K	1V	10 μ A
X1M	1V	1 μ A
X10M	1V	0.1 μ A

General

Floating input: May be operated up to 500 Vdc above ground. (Ohms input open in any function except ohms; volts input open when instrument is in OFF position.)

Physical Description

Net weight	2.00 lb
Shipping weight	5.00 lb
Width	5.12 in
Height	7.00 in
Depth	9.00 in

Auxiliary Power or Support Equipment Requirements

The battery used in the 427A is 22-1/2 volts (Eveready No. 763 or RCA VS102). Typical battery life is more than 300 hours continuous operation or 700 hours intermittent operation.

Operator/Crew Requirements

One person familiar with electronic test equipment is required to operate the pulse generator.

Training Requirements

Familiarization with the equipment and the accompanying technical manual is required.

Field Maintenance Requirements

Field maintenance will be performed per OCEI instructions and manufacturer's manual. Operating logs and equipment history cards must be maintained.

Spare Parts

Spare parts are not available. Batteries are available.

Mobilization Time: Two days

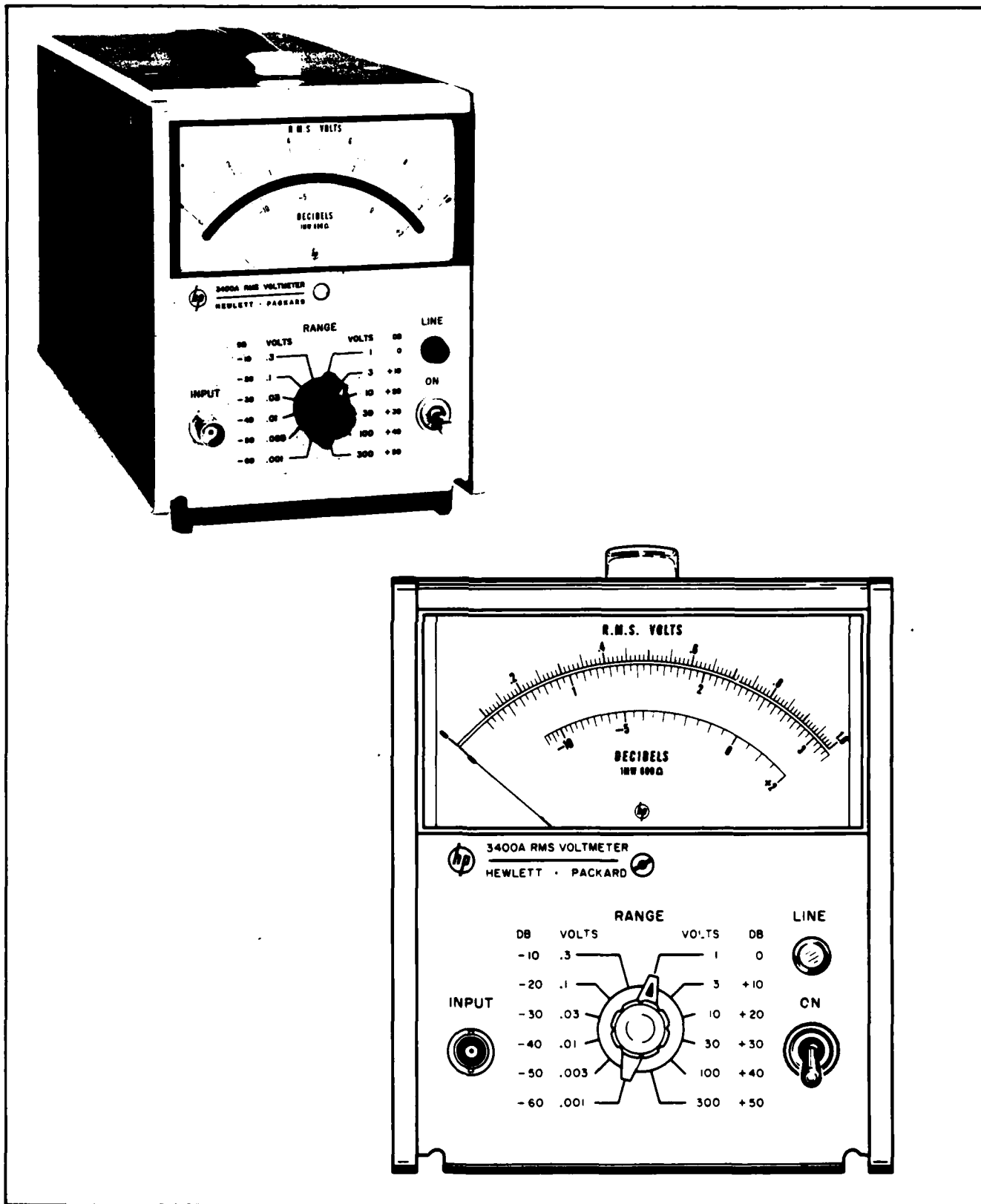

Voltmeter, RMS

Item

VOLTMETER, RMS

Manufacturer

Hewlett-Packard, Palo Alto, CA

Model

3400A

General Description

The root-mean-square voltmeter is a submodular unit suitable for bench top use, and can be used in conjunction with other test instruments to measure the rms value of ac signal with a dc component, measure rms current, and act as an rms ac to dc converter.

Performance

The voltmeter is capable of measuring the actual rms value of ac voltage between 100 microvolts and 300 volts. Frequency range is from 10 Hz to 10 MHz. Full scale measurements of nonsinusoidal waveforms with crest factors (ratio of peak voltage rms voltage) of 10 can be made.

Characteristics:

Voltage range: 1 mV to 300 V full scale, 12 ranges

dB range: -72 to +52 dBm (0 dBm = 1 mW in 600Ω)

Frequency range: 10 Hz to 10 MHz

Response: Responds to rms value (heating value) of input signal

Meter accuracy: % of full scale (20° to 30° C):

- 10 to 50 Hz ± 5%
- 50 to 1 MHz ± 0.75%
- 1 to 2 MHz ± 2%
- 2 to 3 MHz ± 3%
- 3 to 10 MHz ± 5%

Ac-to-dc converter accuracy: % of full scale (20° to 30° C):

- 10 to 50 Hz ± 5%
- 50 to 1 MHz ± 0.75%
- 1 to 2 MHz ± 2%
- 2 to 3 MHz ± 3%
- 3 to 10 MHz ± 5%

Output: Negative 1 Vdc into open circuit for full-scale deflection, proportional to meter deflection; 1 mA maximum; nominal source impedance 1000 Ω

Output noise: <1 mV rms

Crest factor: (ratio of peak-to-rms amplitude of input signal): 10:1 at full scale (except where limited by maximum input), inversely proportional to meter deflection (e.g., 20:1 at half-scale, 100:1 at tenth-scale)

Input impedance: 0.001 to 0.3 V range; 10 MΩ shunted by < 50 pF; 1.0 to 300 V range; 10 MΩ shunted by < 20 pF; ac-coupled input

Ac overload: 30 dB above full scale or 800 V peak, whichever is less, on each range

Maximum dc input: 600 V on any range

Response time: For a step function, < 5 seconds to respond to final value

Physical Description

- Height 6-1/4 in. (159 mm)
- Width 5-1/8 in. (130 mm)
- Depth 11 in. (279 mm)
- Shipping weight 10 lb. (4.5 kg)

Auxiliary Power or Support Equipment Requirements

A line voltage of either 115 V or 230 V ±10%, 48 to 440 Hz, with approximately 7 watts is required.

Operator/Crew Requirements

One person is required for operation of the voltmeter.

Training Requirements

Two days' training in the field or at the manufacturer's facility is required.

Field Maintenance Requirements

Field maintenance will be performed per OCEI instructions and manufacturer's manual. Operating logs and equipment history cards must be maintained.

Spare Parts

Spare parts are not available.

Mobilization Time: Two days

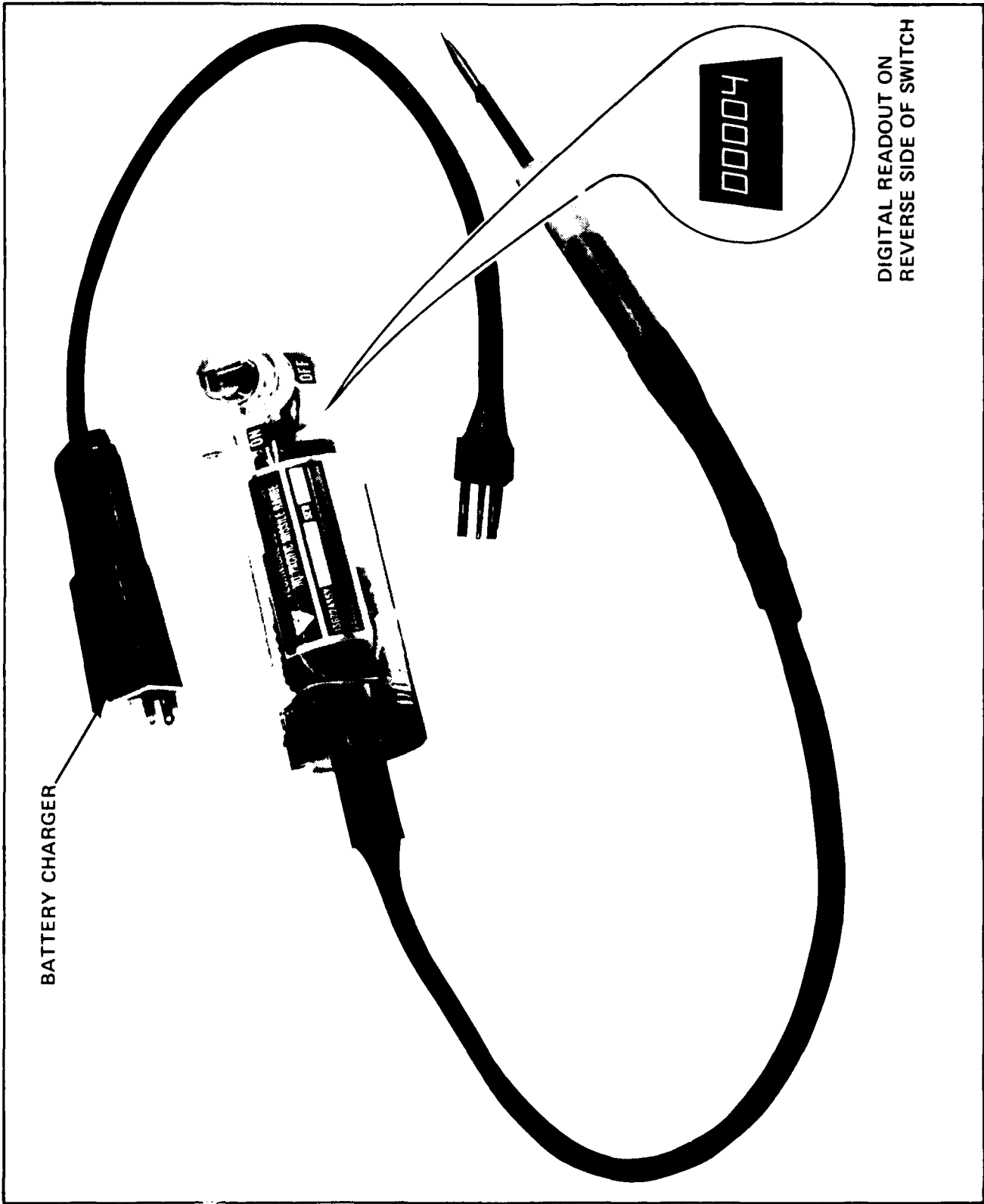

BATTERY CHARGER

00004

DIGITAL READOUT ON
REVERSE SIDE OF SWITCH

Voltmeter, Underwater

112 202 201 200 199 198 197 196 195 194 193 192 191 190 189 188 187 186 185 184 183 182 181 180 179 178 177 176 175 174 173 172 171 170 169 168 167 166 165 164 163 162 161 160 159 158 157 156 155 154 153 152 151 150 149 148 147 146 145 144 143 142 141 140 139 138 137 136 135 134 133 132 131 130 129 128 127 126 125 124 123 122 121 120 119 118 117 116 115 114 113 112 111 110 109 108 107 106 105 104 103 102 101 100 99 98 97 96 95 94 93 92 91 90 89 88 87 86 85 84 83 82 81 80 79 78 77 76 75 74 73 72 71 70 69 68 67 66 65 64 63 62 61 60 59 58 57 56 55 54 53 52 51 50 49 48 47 46 45 44 43 42 41 40 39 38 37 36 35 34 33 32 31 30 29 28 27 26 25 24 23 22 21 20 19 18 17 16 15 14 13 12 11 10 9 8 7 6 5 4 3 2 1

Item

VOLTMETER, UNDERWATER

Manufacturer

Pacific Missile Test Center, Point Mugu, CA

Model

TS-D-74D 300

General Description

The underwater voltmeter is a self-contained unit, modified for underwater use by encapsulating the electrical components in a clear plastic waterproof case. The voltmeter is used to measure the potential difference between dissimilar metals in seawater to determine if galvanic corrosion is occurring and/or to evaluate the extent of cathodic protection that may be required. The voltage readings are indicated by a digital display contained in the head of the voltmeter. The voltmeter is battery operated and contains a titanium probe with a silver/silver chloride reference electrode near the base of the probe in the probe holder. The rechargeable battery pack provides 2 to 3 hours of continuous operation.

Performance

The voltmeter is capable of continuous underwater operation for a period up to 3 hours with fully charged batteries. The voltmeter can provide the necessary voltage measurement between a variety of dissimilar metals which can be used for comparison with known potential ranges to determine if galvanic corrosion is present in an underwater structure. Also, when a structure is being protected by either galvanic anodes (e.g., zinc) or impressed current, the voltage measurements obtained can be used to determine if this protection is adequate. The underwater voltmeter can measure voltages from 10 microvolts to 500 Vdc.

Physical Description

Length 10 in.
Diameter 4.5 in.
Net weight 1 lb. 7 oz.
Shipping weight 4 lb.

Auxiliary Power or Support Equipment Requirements

A power source of 90-130 volts is required to operate the battery charger furnished with the voltmeter.

Operator/Crew Requirements

One person trained in the operation of the equipment is required.

Training Requirements

One hour's training in the field is required to familiarize operator(s) with the operation of the equipment.

Field Maintenance Requirements

Field maintenance will be performed per OCEI instructions and manufacturer's manual. Operating logs and equipment history cards must be maintained.

Spare Parts

Spare parts are not available.

Mobilization Time: Two days

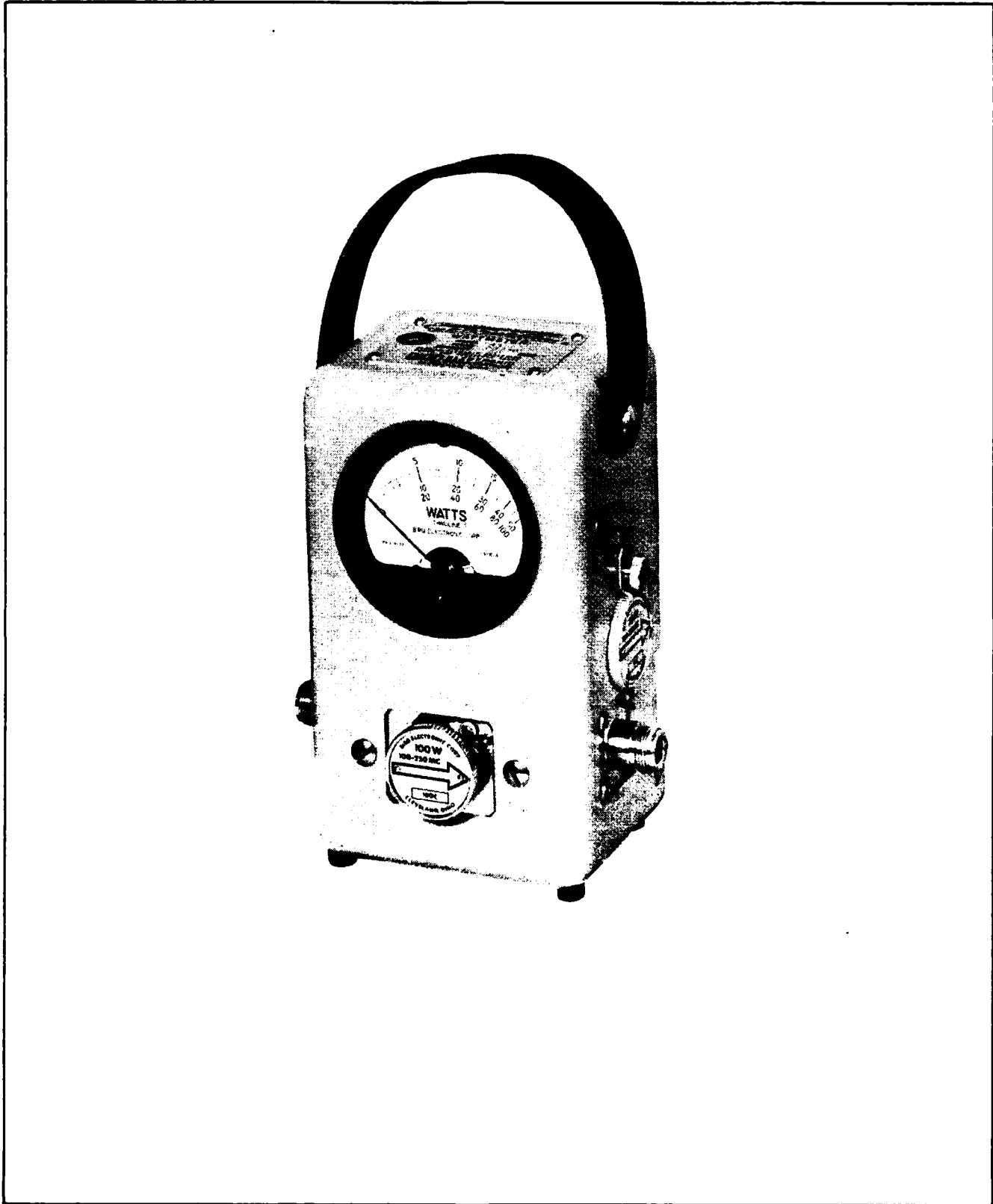

Wattmeter, Directional, RF

Item

WATTMETER, DIRECTIONAL, RF

Manufacturer

Bird Electronic Corp., Cleveland (Solon), OH 44139

Model

43

General Description

The 43 is a portable insertion type RF wattmeter, designed to measure power flow and load match in 50-ohm coaxial transmission lines. It is intended for use on CW, AM, FM, and TV modulation envelopes, but not pulsed modes. The meter is direct reading in watts, expanded down scale for easy reading. The power ranges are determined by the plug-in elements.

Performance**Characteristics:**

Frequency range: 2 to 1000 MHz in six standard element types (range can be expanded by use of special elements).

Circuit impedance: 50 Ω

Insertion VSWR: Less than 1.05 VSWR up to 1000 MHz.

Measurement range: 5 W to 5000 W.

Physical Description

Weight	4 lb.
Width	4 in.
Height	3 in.
Length	7 in.

Auxiliary Power or Support Equipment Requirements

Six standard plug-in elements (types A, B, C, D, E, and H) are required for use. Special plug-in elements are available.

Operator/Crew Requirements

One person familiar with electronic test equipment is required to operate the wattmeter.

Training Requirements

Familiarization with the equipment and the accompanying technical manual is required.

Field Maintenance Requirements

Field maintenance will be performed per OCEI instructions and manufacturer's manual. Operating logs and equipment history cards must be maintained.

Spare Parts

Spare parts are not available.

Mobilization Time: Two days

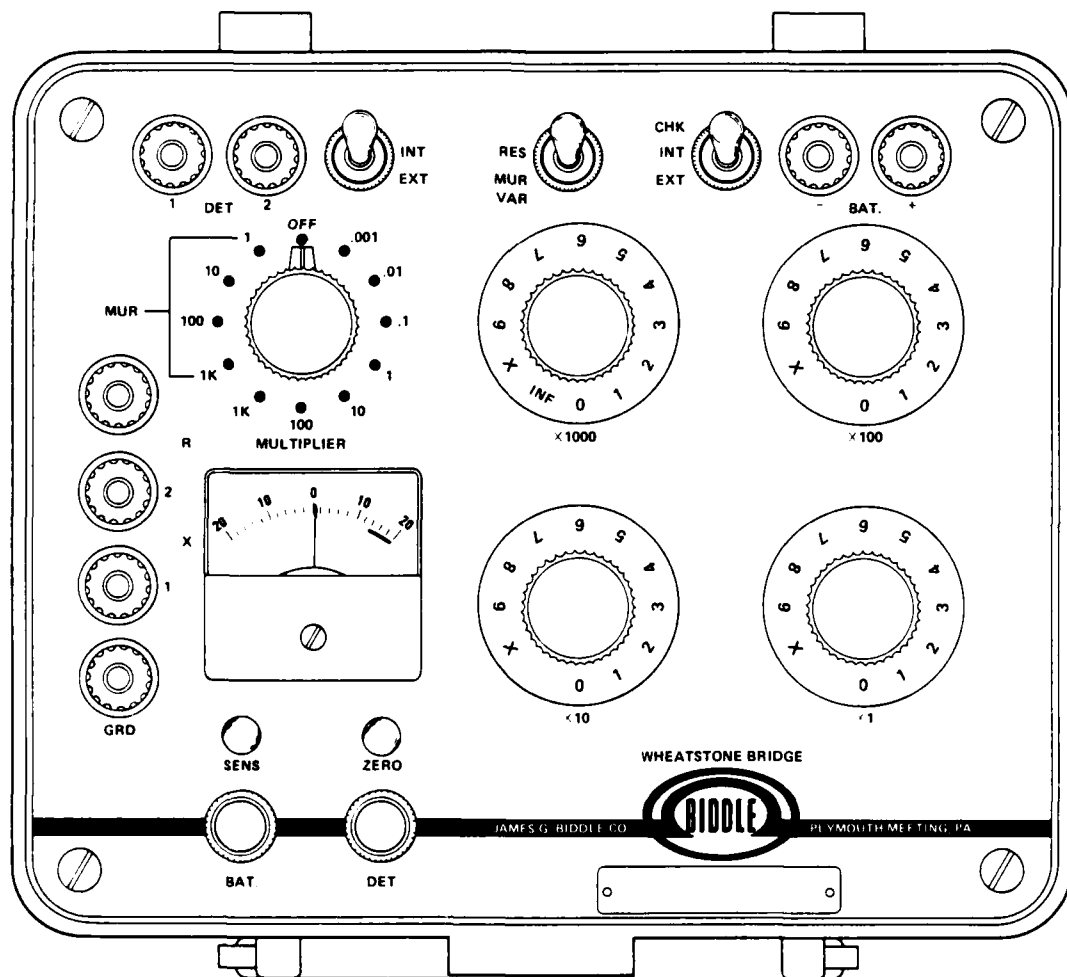
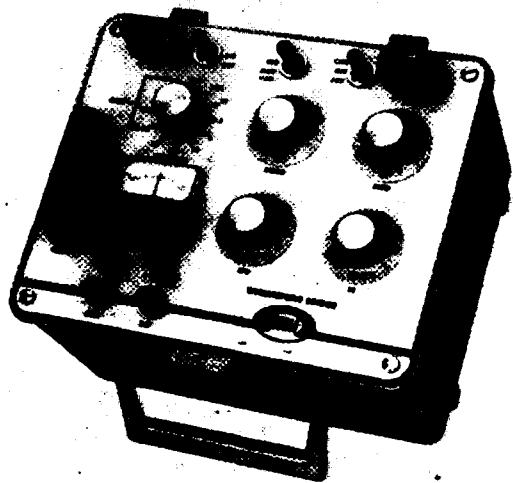

Wheatstone Bridge

Item

WHEATSTONE BRIDGE

Manufacturer

James G. Biddle Co., Plymouth Meeting, PA 19462

Model

72-432

General Description

The Wheatstone bridge is designed for wide range resistance measurements in the field. The unit is portable and relatively rugged for shipboard use. Additional features are the provision of Murray and Varley loop circuitry for the location of grounds, crosses, and opens in multiconductor communications and power cables.

The Wheatstone bridge is fully self-contained and is equipped with batteries and a solid-state null detector. The bridge rheostat arm may be used independently as a 4-dial resistance box.

Performance**Characteristics:**

As a bridge: 0.1 ohm to 11.1 megohms

As a resistance box: 0 to 11,110 ohms

Bridge error: $\pm(0.1\%$ of reading + 0.01 ohm)Resistance box error: $\pm(0.05\%$ of reading + 0.02 ohm)

Measuring dials: Four-decade rheostat arms in steps of 10 (1000 + 100 + 10 + 1) ohms

Null detector sensitivity: 4 microvolts continuously adjustable from FULL to 40:1 reduction

Physical Description

Height	7-1/2 in.
Width	9 in.
Depth	7-1/2 in.
Weight	5-1/2 lb.

Auxiliary Power or Support Equipment Requirements

Battery requirements for field operation are as follows: the measuring circuit requires three 1-1/2 V "D" cells in series and the null detector requires two 9 V Burgess 2U6 or Eveready 216 (NEDA 1604).

Operator/Crew Requirements

One technician is required for operation of the Wheatstone bridge.

Training Requirements

The operator should be familiar with electronic testing equipment and with the supporting documentation for the instrument.

Field Maintenance Requirements

Field maintenance will be performed per OCEI instructions and manufacturer's manual. Operating logs and equipment history cards must be maintained.

Spare Parts

Spare parts are not available.

Mobilization Time: Two days

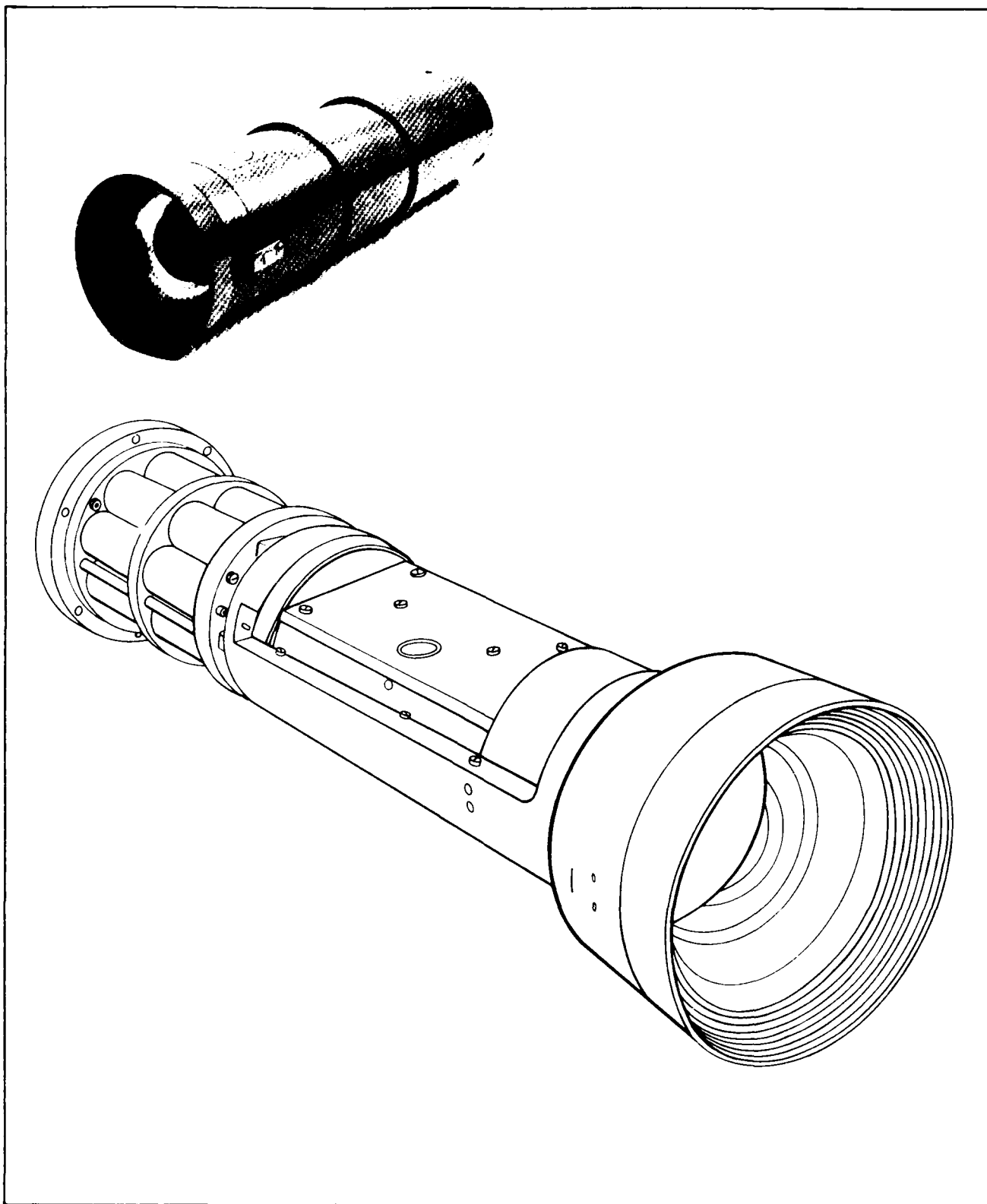

Camera, Television, Underwater, 70MM

Item

CAMERA, TELEVISION, UNDERWATER, 70MM

Manufacturer

Hydro Products, San Diego, CA 92112

Model

PC-785-BP

General Description

The underwater camera is a 70-millimeter high resolution camera designed for use on manned submersibles or remote vehicles at depths to 6,100 meters (20,000 feet). The camera is standard, with preset focus, shutter speed, and aperture setting. Remote actuation of the shutter is a standard feature.

The camera may be used for a wide variety of underwater photographic applications, including stereo photogrammetry or in combination with other underwater camera equipment.

Performance

The camera utilizes a Leitz 43.7 mm, f/2.8 water contact, fully corrected lens system. Designed specifically for underwater use, this lens system eliminates all distortions due to refractions, or spherical and chromatic aberrations. The front element for the Leitz system utilizes acrylic optics designed to withstand operating pressures of 9,030 psi (6,100 meters - 20,000 feet) and test pressures to 13,500 psi (9,144 meters - 30,000 feet).

The camera features cartridge loading, which allows rapid change of film between dives. Additional cartridges may be loaded with various types of film and interchanged as the necessity arises.

The film cartridge is designed to accept #10 reels with up to 45.7 meters (150 feet) of perforated or unperforated film. The film cartridge allows complete interchangeability of film types without exposing the unused portion of film. Film advance is automatic after shutter actuation, with a maximum cycle time of 8 seconds. The shutter is a Prontor with full "X" synchronization.

Physical Description

Length (maximum)	30 in.
Diameter	7 in.
Weight in air maximum	70 lb.
Weight in water maximum	29 lb.
Temperature	-2° to +50° C (+28° to +120° F)

Auxiliary Power or Support Equipment Requirements

The camera is supplied with a 24 Vdc internal battery pack permanently mounted to the housing. The battery pack contains rechargeable nickel-cadmium batteries which, when fully charged, will operate the camera and strobe for one 100-foot roll of film. Each camera is supplied with a battery charger and cable which fully charge the batteries in 14 hours. Options available with the camera are an underwater strobe and an automatic film processor.

Operator/Crew Requirements

The camera is designed to be used by one camera operator in an underwater environment.

Training Requirements

The camera operator should be a trained diver familiar with the use of the camera through the technical support documentation and through a short familiarization course.

Field Maintenance Requirements

Field maintenance will be performed per OCEI instructions and manufacturer's manual. Operating logs and equipment history cards must be maintained.

Spare Parts

Spare parts are not available.

Mobilization Time: Two days

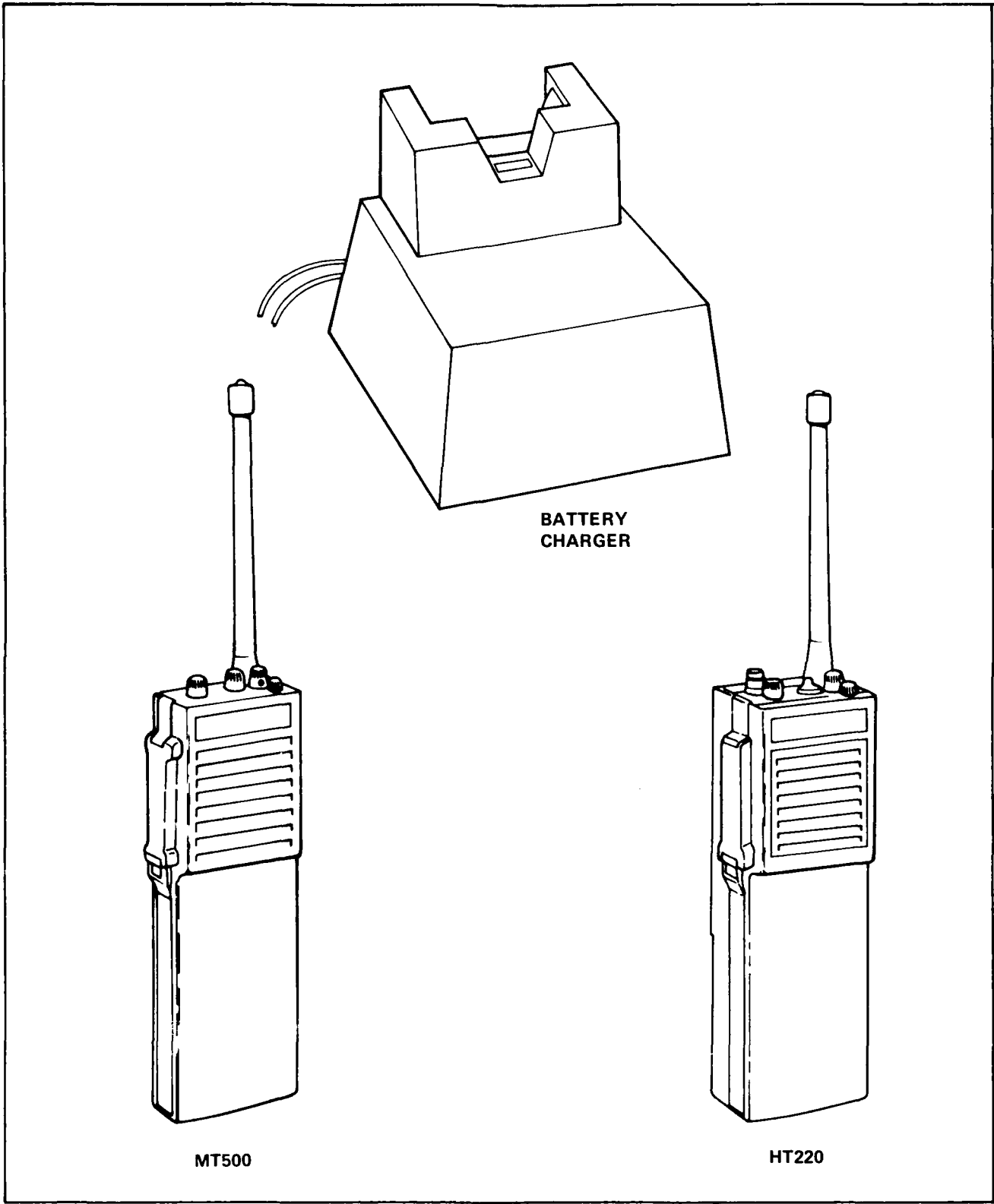

BATTERY
CHARGER

MT500

HT220

Handie-Talkie (HT 220 and MT500 Series)

Item

HANDIE-TALKIE

Manufacturer

Motorola Inc., Schaumburg, IL 60196

Model

HT 220 and MT 500 Series

General Description

Each handie-talkie is a portable, two-way, FM radio communications instrument.

Performance

These handie-talkies provide 5 watts of RF transmitter power for voice communications up to 5 miles between two units. They are normally supplied with the following operating frequencies:

Channel 1	139.480 MHz
Channel 2	139.550 MHz
Channel 3	140.050 MHz
Channel 4	140.350 MHz

These frequencies have been allocated to CHESNAVFAC-ENGCOM on a time-shared basis with other government users. It has been noted that minimal interference is caused by these other users; however, these frequencies are not private.

Two channels can be used to communicate with the higher powered PT400 units described in this catalog.

Physical Description

HT 220

Height (excluding antenna and knobs)	7 in.
Width	2.77 in.
Depth	1.83 in.
Weight	27 oz.

MT 500

Height (excluding antenna and knobs)	7.62 in.
Width	2.73 in.
Depth	1.85 in.
Weight	25.9 oz.

Auxiliary Power or Support Equipment Requirements

The handie-talkie is supplied with a rechargeable nickel-cadmium battery. The supplied battery charger provides standard or rapid rate charging cycles from a 117 Vac power source. The radios may be left in a monitoring mode during the charge cycle.

Operator/Crew Requirements

One person can operate each handie-talkie after a brief familiarization period.

Training Requirements

An operator should be familiar with proper operating procedures.

Field Maintenance Requirements

Field maintenance will be performed per OCEI instructions and manufacturer's manual. Operating logs and equipment history cards must be maintained.

Spare Parts

Spare parts are not available. (batteries will be furnished)

Mobilization Time: Two days

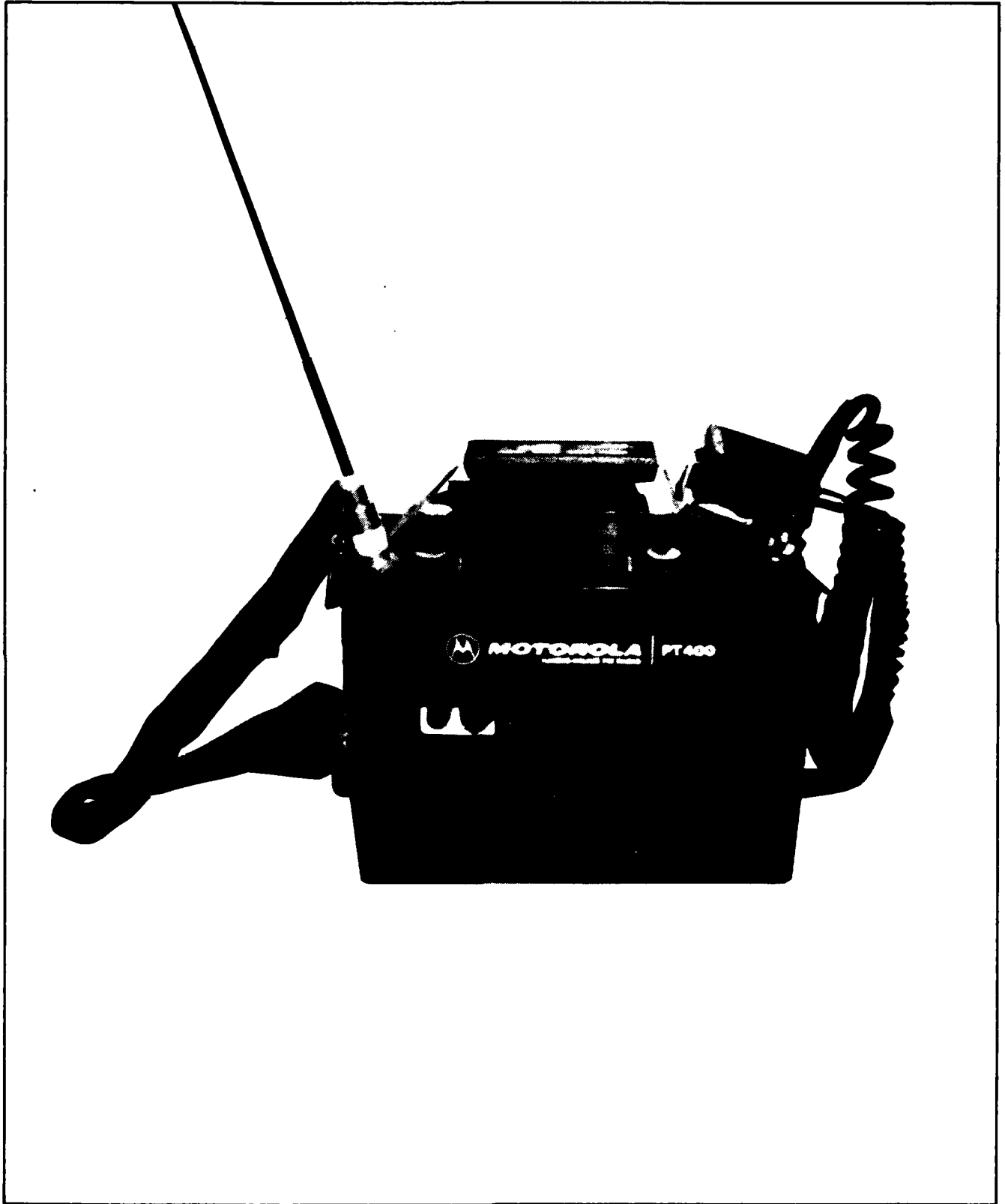

Handie-Talkie (PT400 Series)

Item

HANDIE-TALKIE (PT 400 Series)

Manufacturer

Motorola Inc., Schaumburg, IL 60196

Model

P 43DEN

General Description

The handie-talkie is a high-power, portable, two-way FM radio communications instrument.

Performance

The handie-talkie provides 10 watts of RF transmitter power for voice communications up to 7 miles between two units. The operating frequency range is from 132 to 174 MHz. The unit is normally supplied with operating frequencies of 140.050 and 140.350 MHz for communications with the lower powered HT 220/MT 500 units described in this catalog.

Physical Description

Overall (excluding antenna and battery charger):

Height	7-1/2 in.
Width	10 in.
Depth	3-3/4 in.
Weight	10 lb. 10 oz.

Auxiliary Power or Support Equipment Requirements

Power supply is supplied from a battery pack containing a rechargeable nickel-cadmium battery. A battery charger and cord are supplied with each unit.

Operator/Crew Requirements

One person can operate each handie-talkie after only a brief familiarization period.

Training Requirements

An operator should be familiar with proper operating procedures.

Field Maintenance Requirements

Field maintenance will be performed per OCEI instructions and manufacturer's manual. Operating logs and equipment history cards must be maintained.

Spare Parts

Spare parts are not available. (batteries are supplied)

Mobilization Time: Two days

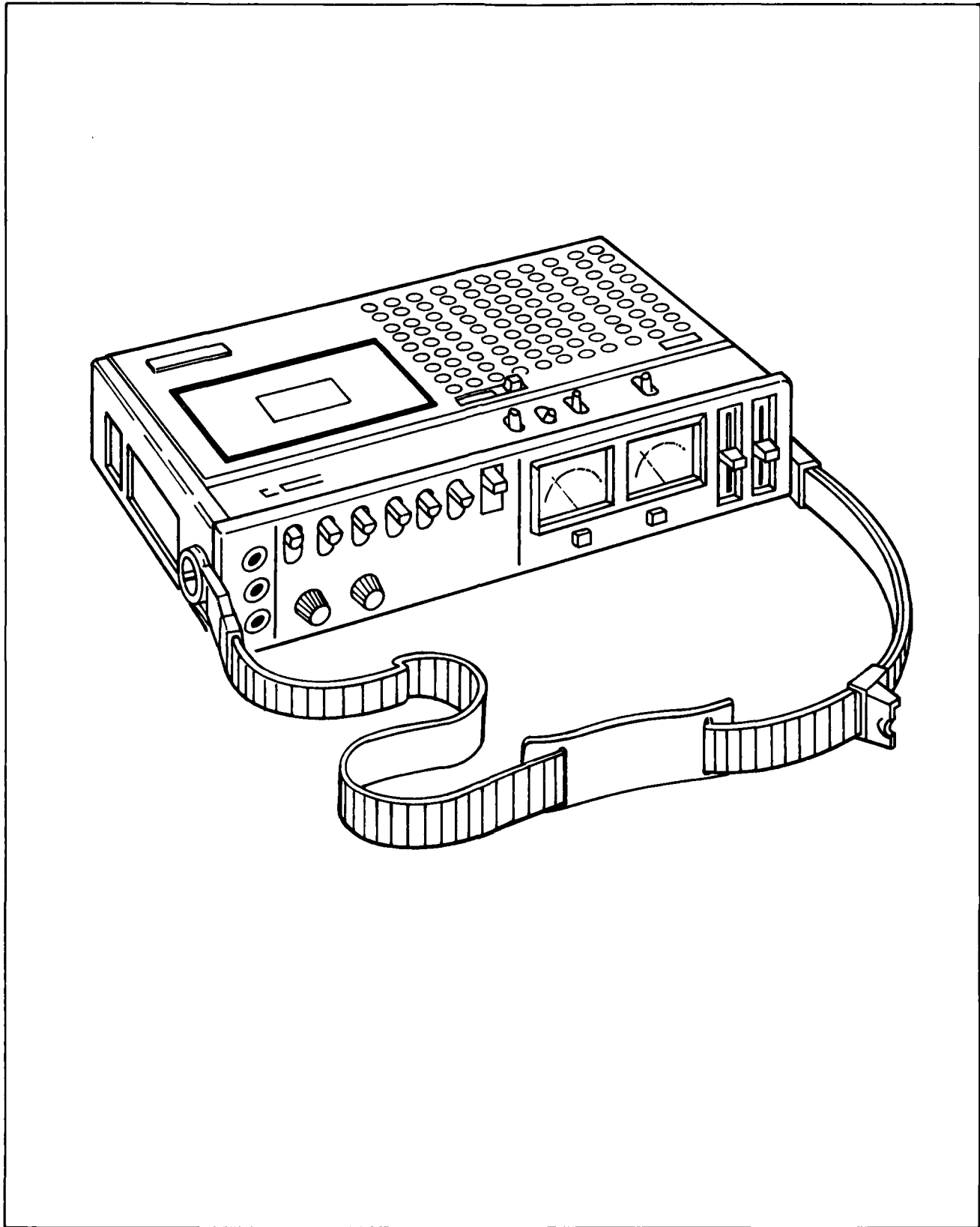

Recorder, Audio (Cassette)

11 12 13 14 15 16 17 18 19 20 21 22 23 24 25 26 27 28 29 30 31 32 33 34 35 36 37 38 39 40 41 42 43 44 45 46 47 48 49 50 51 52 53 54 55 56 57 58 59 60 61 62 63 64 65 66 67 68 69 70 71 72 73 74 75 76 77 78 79 80 81 82 83 84 85 86 87 88 89 90 91 92 93 94 95 96 97 98 99 100

Item

RECORDER, AUDIO (CASSETTE)

Manufacturer

Sony/Superscope, Inc., Sun Valley, CA 91352

Model

TC-152SD

General Description

The recorder is a portable unit incorporating the Dolby noise reduction system, ac/dc format, and a four-track stereo or two-track monaural recording capability.

Performance**Characteristics:**

Power consumption: 12 W

Tape speed: 1-7/8 ips

Fast forward and rewind time: 90 sec. with C-60

Recording system: 4-track stereo, 2-track monaural

Speaker: 4-in. diameter

Output power: 1.5 W (ac); 0.8 W (dc)

Motor: Dc servo control motor

Recording bias frequency: 105 kHz

Signal-to-noise ratio: Dolby NR OFF; 48 dB Dolby NR ON; improved 5 dB at 1 kHz, improved 10 dB above 5 kHz

THD (Total Harmonic Distortion): 2% (with standard cassette)

Frequency response: 30-15,000 Hz with chromium dioxide cassette; 30-13,000 Hz with standard cassette

Wow and flutter: 0.15% (Vrms)

Microphone inputs: 2 inputs with 0.2 mV (-72 dB) sensitivity

Line inputs: 2 inputs with .06 V (-22 dB) sensitivity

Physical Description

Height 4-1/8 in.
Width 14-7/8 in.
Depth 9-3/8 in.
Weight 11 lb. 15 oz
Speaker 4-in. diameter

Auxiliary Power or Support Equipment Requirements

Power requirement: 120 Vac, 60 Hz, 6 Vdc from four batteries UM-1, Rechargeable Battery Pack Sony BP-8, and 12 V car/boat battery with Car Battery Cord Sony DCC-128.

Accessories:

A Sony ECM-33P microphone and a Marantz SD-5 headphone are provided with the recorder.

Operator/Crew Requirements

One person is required to operate unit.

Training Requirements

No specific training requirements are indicated.

Field Maintenance Requirements

Field maintenance will be performed per OCEI instructions and manufacturer's manual. Operating logs and equipment history cards must be maintained.

Spare Parts

Spares are not available.

Mobilization Time: Two days

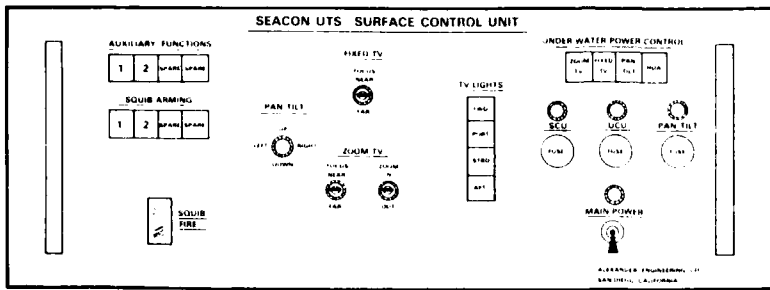

SURFACE CONTROL UNIT

UNDERWATER CONTROL UNIT

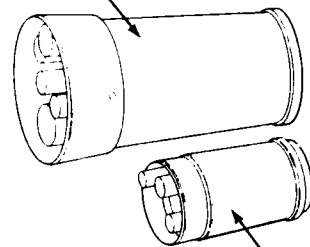

BATTERY PACK FOR SQUIBS

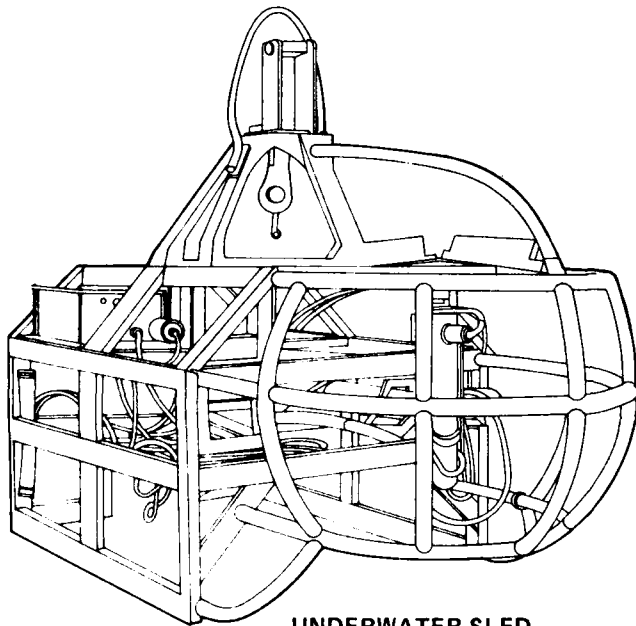

UNDERWATER SLED

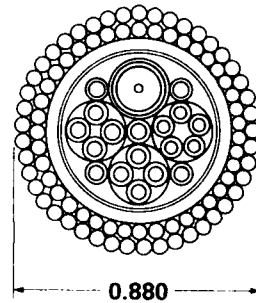

CABLE, UNDERWATER

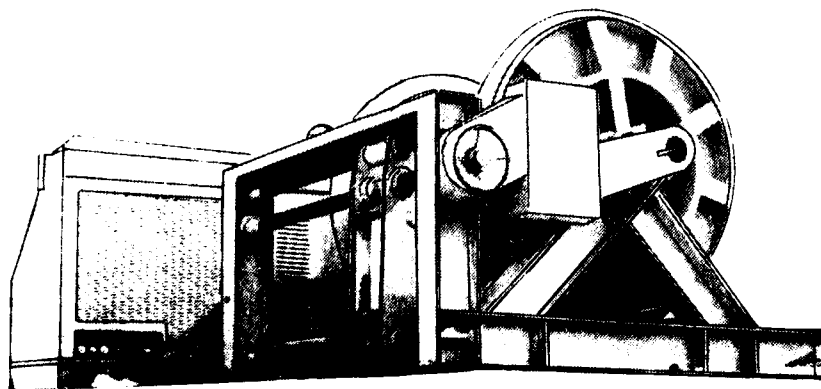

WINCH, UNDERWATER TELEVISION SYSTEM

Underwater Television System

Item

TELEVISION SYSTEM, UNDERWATER

Manufacturer

Alexander Engineering Co., San Diego, CA 92122

Model

UTS-6000 Series

General Description

The underwater television system is mounted in the main central console of the SEACON vessel. The system is divided into three major elements; a surface control unit, an underwater control unit, and a battery pack.

The surface control unit is a standard rack-mounted electronic cabinet serving as the operator's control panel and containing the electronics to encode and transmit control data.

The underwater control unit (UCU) serves as the central underwater interface between the main cable and all other underwater equipment mounted on the underwater sled. The UCU is contained in an underwater pressure housing mounted on the underwater sled. Commands for reception, decoding, distribution, and power control are all governed by this link.

The system is capable of carrying out underwater television monitoring functions and deployment/recovery of structures weighing up to seven tons. Release is via AMF acoustic release or hand-wired explosive squibs.

The UTS cable is a specialized double-armored cable designed for use with the underwater television system. The cable has all necessary coaxial and other conductors required for power, operation, and control of the UTS vehicle.

A cable winch is provided for deployment and recovery of the underwater sled and cable. The winch is a self-contained two-speed unit driven by a Cummins diesel engine which is capable of developing 170 hp at 1,800 rpm. The engine is coupled to a hydrostatic pump that supplies fluid flow and pressure to the winch. Direction and speed control of the winch are accomplished through an electrical command signal from a manually-operated controller to the pump. An electrical generator capable of providing 75 kw, 440 volts, 60 Hz, 3-phase current is an integral component of the winch unit. It has no function in the present power system but may be used as an auxiliary power source when required.

Performance

The maximum operating depth of the system is 10,000 feet, but is presently limited by an existing cable length of 5,500 feet. A 10,000-foot cable and portable control console is planned to enhance the system versatility.

The underwater sled is propelled by two stern-mounted thrusters which provide forward, aft, right, and left maneuverability. Instrumentation and components on the sled are monitored from the SEACON via four TV monitors, a video tape recorder, UTS surface control unit, and a video character generator.

The UTS cable has a 35,600 lb. breaking strength, with a recommended minimum bend diameter of 17 inches for storage, 35 inches at 25% breaking strength.

The winch is hydraulically powered and has a two-speed capability. In low speed the maximum line pull on the brake drum is 39,500 pounds at a haul in rate of 70 fpm. In high speed the winch line pull is 19,500 pounds at a haul in rate of 140 fpm. A level wind system allows proper winding of cable on the drum. The gear ratio of the level wind can be changed to accommodate additional cable sizes 7/8 in. to 2 in. All controls and instrumentation necessary to operate the system are located on the control console.

Physical Description

Surface Control Unit:

Length 20.75 in.
Width 19.00 in.
Height 7.00 in.
Weight (approximate) 100 lb.

Underwater Control Unit:

Length 19.38 in.
Overall diameter 9.00 in.

Battery Pack for Squibs:

Length 10.00 in.
Overall diameter 5.00 in.

Underwater sled/frame:

Length 12 ft.
Width 5 ft.
Height 8 ft. 7 in.
Dry weight 2,600 lb.
Wet weight 1,900 lb.

Underwater cable:

Overall diameter 0.880 in.
Weight in air 996 lb. per 1000 ft.
Weight in water 772 lb. per 1000 ft.

Cable Winch:

Height 8 ft.
Length 10 ft. 9 in.

Physical Description (continued)

Depth	10 ft. 8-1/2 in.
Weight (w/o cable)	21,000 lb.
Drum, barrel diameter	48 in.
Drum, flange diameter	84 in.
Drum, width	72-3/4 in.
Power Supply Unit:	
Height (w/o muffler)	8 ft.
Length	13 ft. 9 in.
Depth	3 ft. 6 in.
Weight	9,000 lb.
Fuel capacity	60 gal.

Auxiliary Power or Support Equipment Requirements

The power source is provided by SEACON.

Operator/Crew Requirements

One person is required to operate and monitor the TV control subsystem and one person is required to operate the winch. Need for additional personnel is based upon mission requirements.

Training Requirements

One week's training in the field or at the manufacturer's facility is required.

Field Maintenance Requirements

Field maintenance will be performed per OCEI instructions and manufacturer's manual. Operating logs and equipment history cards must be maintained.

Spare Parts

Spare parts are available.

Mobilization Time: Two days

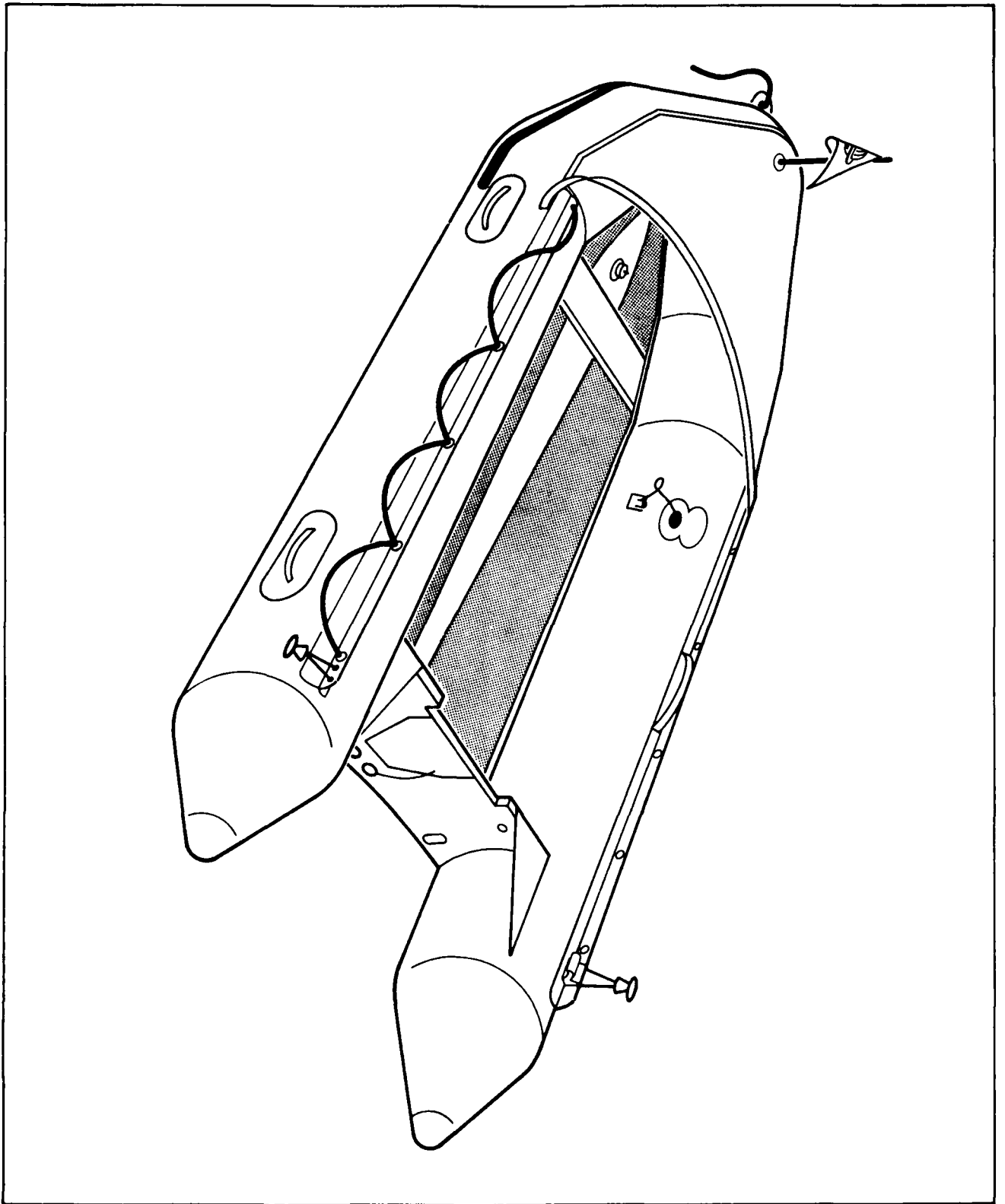

Zodiac Inflatable Boat

Item

BOAT, INFLATABLE

Manufacturer

Zodiac of North America, Annapolis, MD 21401

Model

Mark V Heavy Duty

General Description

The Zodiac Mark V is a small inflatable general purpose boat. The buoyancy chamber is U shaped with five interconnected chambers. A keel chamber is inflated to provide a V bottom. Wooden floorboards and transom are fixed to the hull. The hull has a front hood with spray cuff and a lifeline and rowlock supports on each side.

Performance

The inflated boat is easily maneuvered under normal operating conditions.

Physical Description

Weight capacity 4400 lb.
Personnel capacity 15
Shipping weight 529 lb.

Auxiliary Power or Support Equipment Requirements

A minimum of two 25 hp motors is required.

Operator/Crew Requirements

One person can operate this boat.

Training Requirements

One day's training in the field is required.

Field Maintenance Requirements

Field maintenance will be performed per OCEI instructions and manufacturer's manual. Operating logs and equipment history cards must be maintained.

Spare Parts

Spare parts are not available.

Mobilization Time: Two days

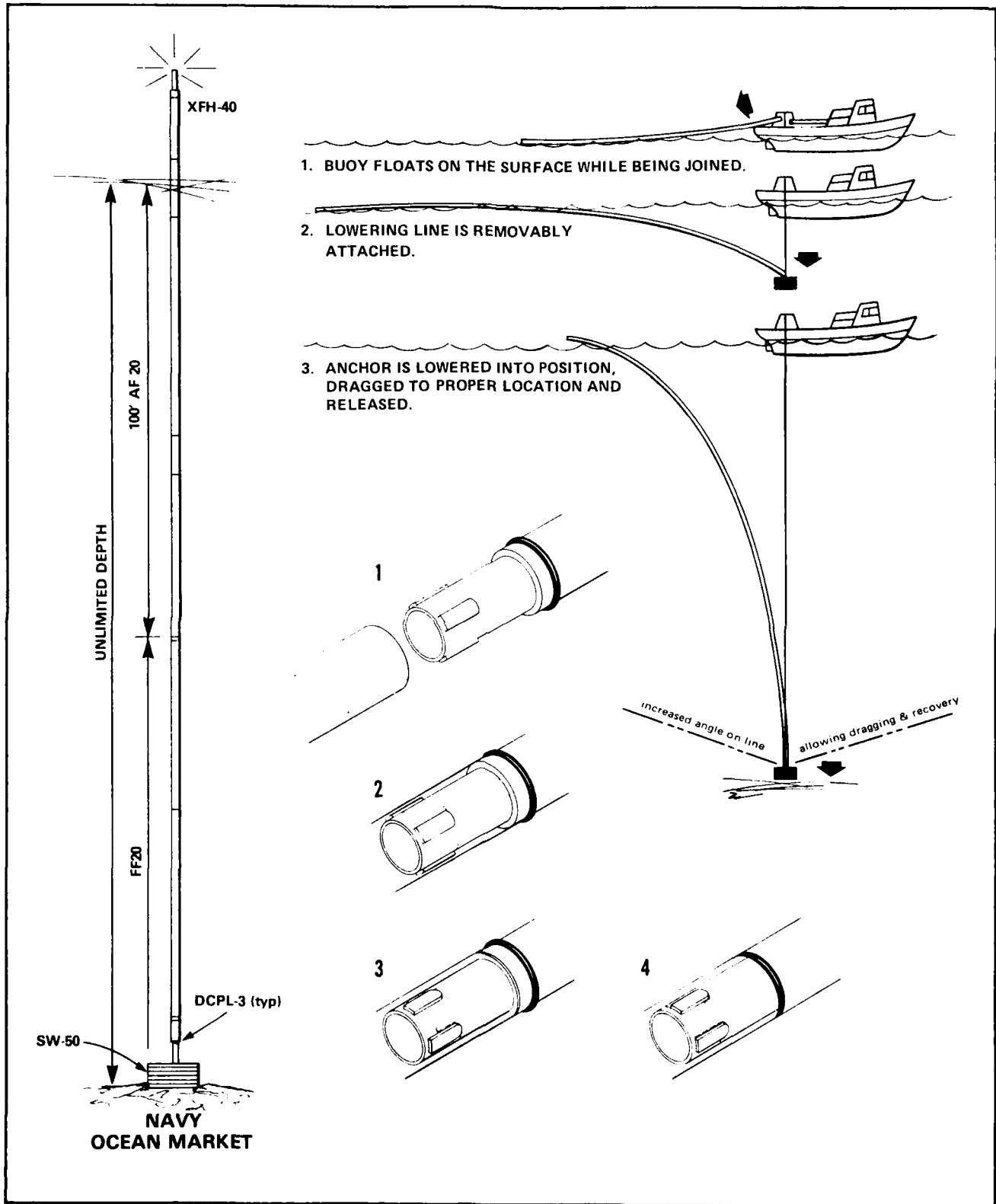

Buoy System, Spar

Item

BUOY SYSTEM, SPAR

Manufacturer

Deep Ocean Work Systems, San Pedro, CA 90731

Model

Shelton

General Description

The spar buoy is a mechanically-connected, segmented, slender, buoyant member intended as a building block from which a variety of underwater devices may be attached. Each segment of the system is hydraulically isolated from the adjacent member, but mechanically connected to produce a structural continuity. There are two types of buoy described below.

AF Type: The AF type is equipped with an automotive-type air valve within the female connector, and is designed to be pressurized prior to installation. The AF type may be used only to depths where the ambient pressure does not exceed the internal pressure.

FF Type: The free-flooded or fluid-filled type is equipped with an internal piston that is moveably sealed to the inside of the pipe with an O-ring. A 3/4-inch pipe plug is in the center of the piston, allowing the pipe to be fluid-filled and sealed.

Performance

The spar buoys have been used for supporting batteries, hydrophones, and other instrumentation in the sea, and for xenon flashers, transmitters, and antennae above the sea. The bottom-attached members have been used for water-quality surveys, video search for sunken objects, markers for fishing reefs, markers for dredging operations, markers for pipeline location, and markers for anchor location.

The air-filled buoy is designed to work as a tension member, generally standing vertically in the ocean. Working load is up to 1,500 lb. (5,000 lb. yield); bend radius is 30 ft. Normal pressurization is 25 to 50 psig (300 lb. test) and is generally used in the top 100 feet of the ocean.

The free-flooding or fluid-filled buoy is designed to work as a tension member. Working load is up to 1,500 lb. (5,000 lb. yield); bend radius is 30 ft.

Physical Description

<u>Component</u>	<u>Length(ft.)</u>	<u>Diameter(in.)</u>	<u>Weight(lb.)</u>
PVC buoy (air-filled)	20	2-1/2	16.5
PVC buoy (air-filled)	10	2-1/2	—
PVC buoy (piston-type)	20	2-1/2	—
Top cap	—	2-1/2	—
Male termination	—	2-1/2	—
Modular wt.	—	—	50

Auxiliary Power or Support Equipment Requirements

A small boat capable of deploying the spar buoy is required.

Operator/Crew Requirements

Two men capable of deploying the spar buoy for simple ocean marking purposes are required.

Training Requirements

Two days' training in the field or at the manufacturer's facility is required.

Field Maintenance Requirements

Field maintenance will be performed per OCEI instructions and manufacturer's manual. Operating logs and equipment history cards must be maintained.

Spare Parts

Spare parts are not available.

Mobilization Time: Two days

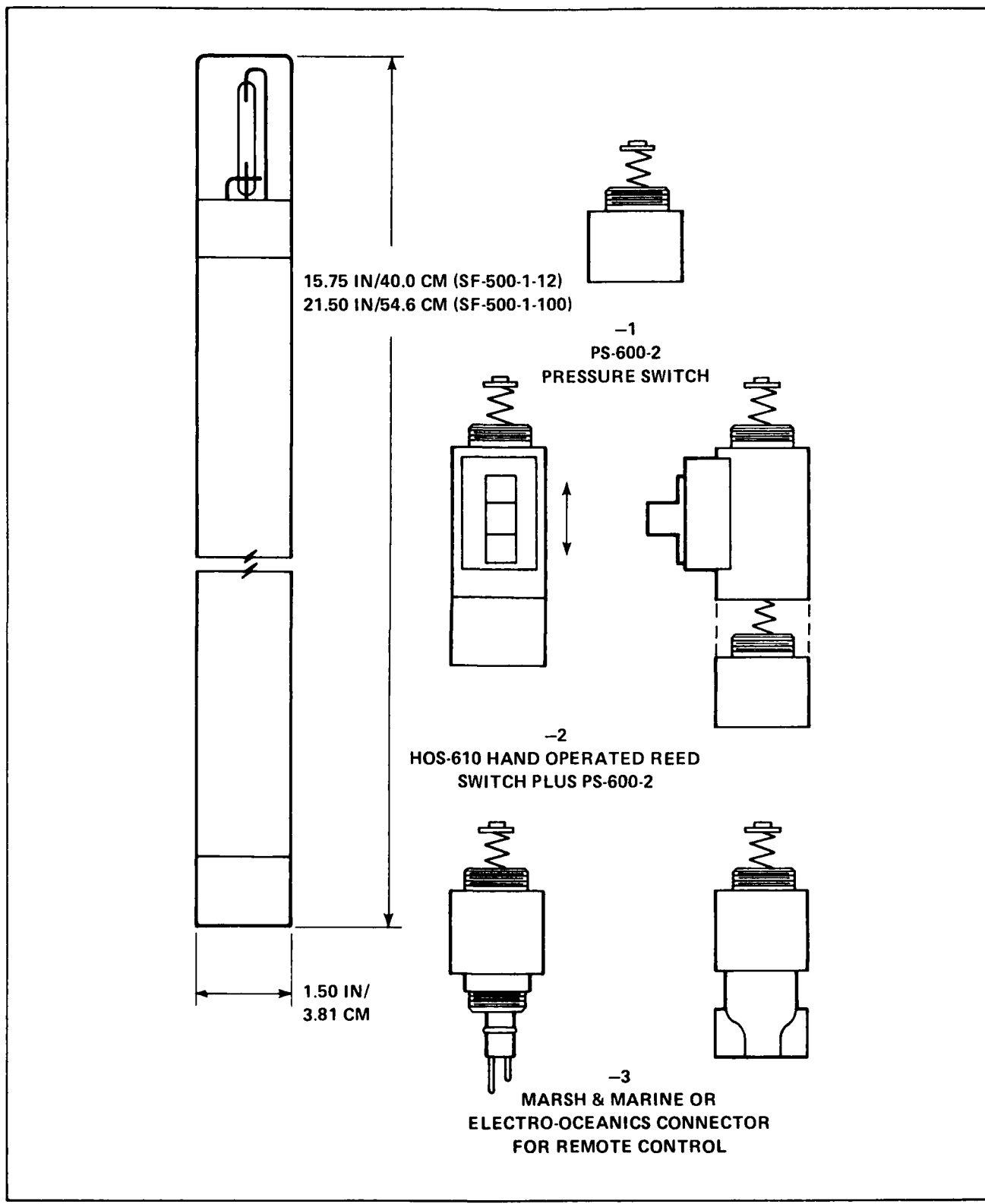

Flasher, Submersible

Item

FLASHER, SUBMERSIBLE

ManufacturerOcean Applied Research Corporation, San Diego, CA
92121**Model**

SF-500

General Description

The submersible flasher is a compact, high-intensity xenon beacon designed for use as a visual aid to locate untethered instrument packages and other submersibles. The flasher is also used as an underwater marker for divers, work sites, navigation hazards, and geographic positions.

The standard flasher is a self-contained unit available with a 12 or 100-hour battery life at 1 flash per 2 seconds duty cycle setting. Flasher electronics and dry cell batteries are contained in an aluminum pressure housing rated for 10,000 psi (23,000 feet/7,000 meters).

Performance

A 01 watt-second xenon gas-discharge lamp, permanently encapsulated inside a clear, solid plastic lens, is attached to the top of the electronics case. Surface-to-surface visibility range varies from about 1/2 to 10 miles, depending on wave conditions, flasher/observer height above sea level, atmospheric conditions, and background light level. Underwater sighting distance varies from a few feet to about 300 feet, depending on water turbidity.

A pressure-sensing switch contained in the battery-access cap on the base of the flasher housing is normally used to turn the lamp off when the flasher is submerged below 25- to 50 foot (7.6 to 15.2 meters) water depth. Lamp turns on when the flasher surfaces. Switching options include a photocell daylight shutoff circuit and a pressure actuation during standby/storage/transport periods.

Physical Description

Length	15.75 in.
Circumference	1.50 in.
Weight in air	2.80 lb.
Weight in sea water	22.2 oz.

Auxiliary Power or Support Equipment Requirements

One 9-volt battery, transistor type No. 226, or equivalent, is required for 12 hours of operation. Four "C" type alkaline batteries are required for 100 hours of operation.

Operator/Crew Requirements

One technician-level operator is required for deployment of the submersible flasher.

Training Requirements

The instruction manual for the SF-500 submersible flasher must be read, with special attention given to the cautions and warnings therein.

Field Maintenance Requirements

Field maintenance will be performed per OCEI instructions and manufacturer's manual. Operating logs and equipment history cards must be maintained.

WARNING

Flasher housings may be under pressure, especially after submersion. Use caution when opening flasher for any reason.

Spare Parts

Spare parts are not available.

Mobilization Time: Two days

ILLUSTRATION NOT AVAILABLE

Item

LOCKER, BOSUNS

Manufacturer

OCEI Facility, St. Julians Creek Annex

Model

Bosuns Locker

General Description

The Bosuns locker contains an aggregate of items useful for ocean construction activities. Equipment includes deck hardware, tools, rigging, and tackle. The equipment augments the available items on barges, small craft, or other vessels of opportunity.

The equipment is contained in a lockable SEABEE equipment shelter (TRICOM) outfitted with shelving and hooks for the various items included.

The Bosuns locker contents include the following items:

Splicing tool kits for Samson double braid

D-rings, drop forged

Shackles, drop forged, screw back

Rings, welded carbon steel

Steel rings, weldless drop forged

Oblong Links, weldless steel

Pear links, weldless steel

Hooks, HD drop forged, steel eye and grab

Chains, log

Chains, alloy steel trail

Swivels, drop forged, free turn

Thimbles, HD, wire rope

Clips, safety, wire rope

Marlinspikes, wire rope

Cutter, hydraulic, wire rope

Blade sets, wire rope cutter

Hoist, 1,500 lb. all purpose lever

Hoist, 3-ton, come-along spur geared

Hooks, pelican

Chain, 12-ft length, anchor

Hoist, 1-1/2-ton, high speed aluminum chain

Blocks, wire rope snatch

Blocks, nylon, for fibrous rope

Jacks, 5-ton, screw-type, reel

Cable grips, preformed, for .66 to 1.25 cable

Cable grips, Chinese fingers, for .66 to 1.25 cable

Wire pendants w/eye, 6 ft./12 ft./18 ft. lengths

Shipping/storage container

Weather-proofed inventory list of Bosuns locker contents.

Performance

N/A

Physical Description

Length	8 ft.
Width	6.5 ft.
Height	8 ft.

Auxiliary Power or Support Equipment Requirements

The Bosuns storage locker is a self-contained unit and requires no auxiliary power. Hoisting and positioning capability is required.

Operator/Crew Requirements

One person can apply the items.

Training Requirements

Familiarity with items and their application is required.

Field Maintenance Requirements

Field maintenance will be performed per OCEI instructions and manufacturer's manual. Operating logs and equipment history cards must be maintained.

Spare Parts

Spare parts are not available.

Mobilization Time: Two days

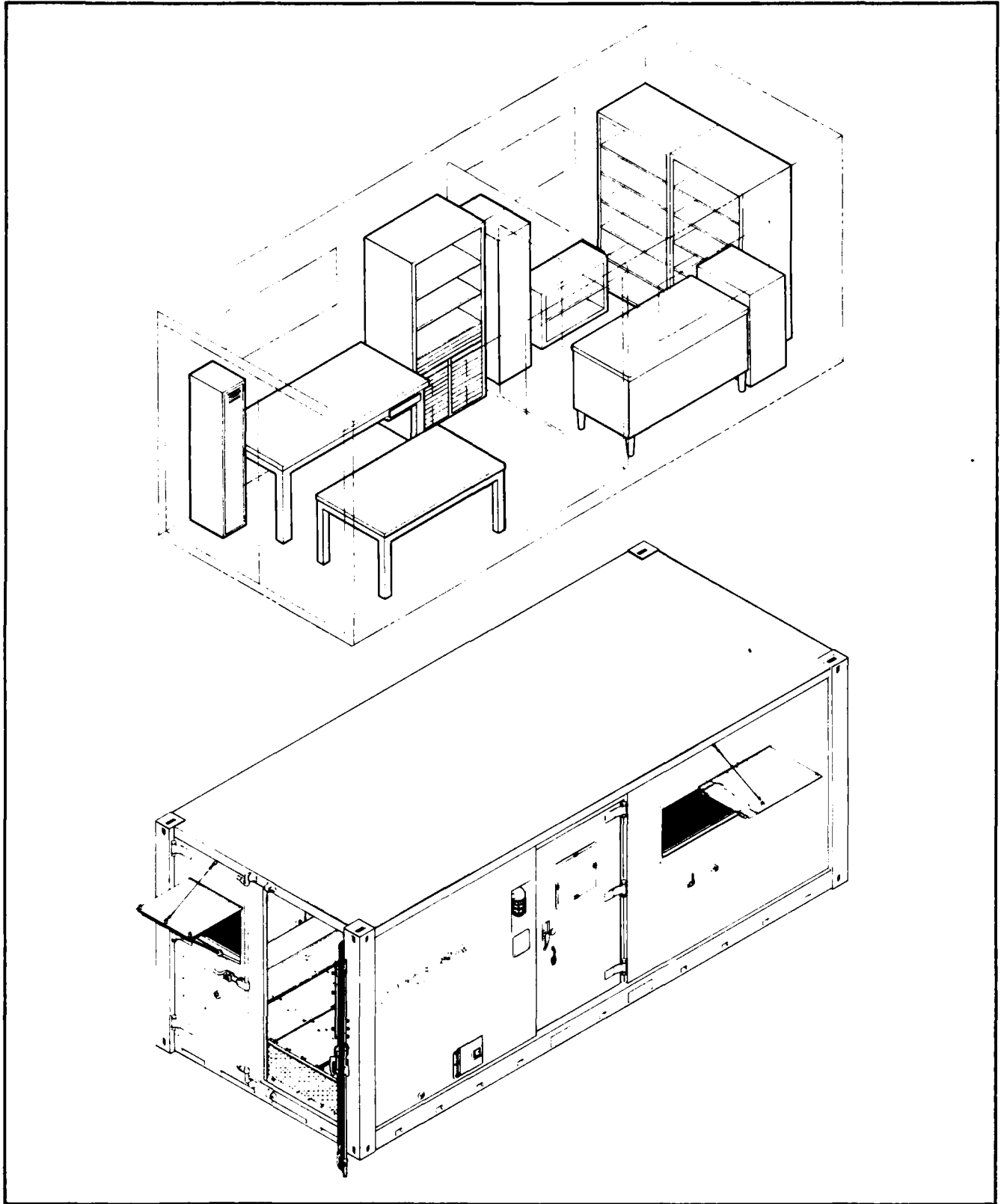

Van, Construction Support

Item

VAN, CONSTRUCTION SUPPORT

Manufacturer

Line Fast Corporation, Container and Trailer Securing Systems, Alabama and New York

Model

20' Navy Support Van

General Description

The construction support van is a multipurpose, transportable unit designed for a variety of field uses. The van is constructed largely of aluminum and has facilities for using a forklift to position the unit. Two separate work areas are provided within the trailer, a shop section and an office section separated by a partition.

Performance

The construction support van can be used in the field as as a small shop or office, or a combination of the two. The container is land, sea, or air transportable and can be mounted on a container-type chassis for tractor-trailer towing.

Characteristics:

Lighting: Interior fluorescent

Power: Three-phase, 240 Vac, available at receptacles throughout the interior of the van

Drainage: Water drainage provided

Furnishings: Office and shop furniture, bookshelves, dishes, workbenches, lockers, and work tables

Temperature control: Windows and air conditioning

Physical Description

Height	8 ft.
Width	8 ft.
Length	20 ft.
Weight	5,000 lb.

Auxiliary Power or Support Equipment Requirements

A power source of 240 Vac, three-phase current is required.

Operator/Crew Requirements

Number of personnel required is based upon mission assignment.

Training Requirements

Training requirements are based upon mission assignment.

Field Maintenance Requirements

Field maintenance will be performed per OCEI instructions and manufacturer's manual. Operating logs and equipment history cards must be maintained.

Spare Parts

Spare parts are not available.

Mobilization Time: One week

END

FILMED

2-86

DTIC