

AD-A058 520

ARINC RESEARCH CORP ANNAPOLIS MD
SHIP SYSTEMS STAGING DIAGRAMS FOR DDG-2 CLASS SHIPS.(U)
JUN 78

F/G 13/10

N00140-76-D-0813

UNCLASSIFIED

1806-01-4-1742

NL

2 of 3
AD
A058520

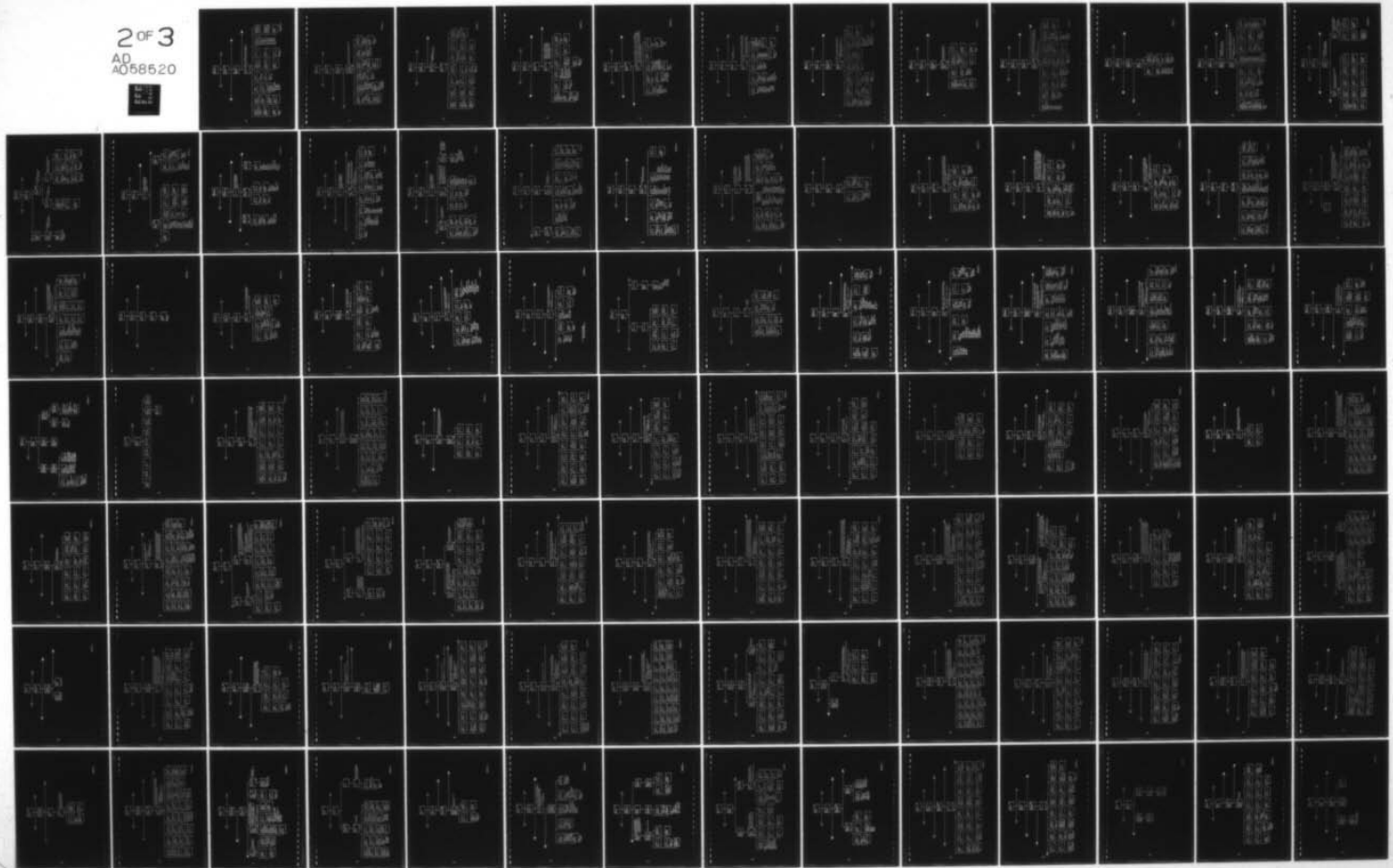

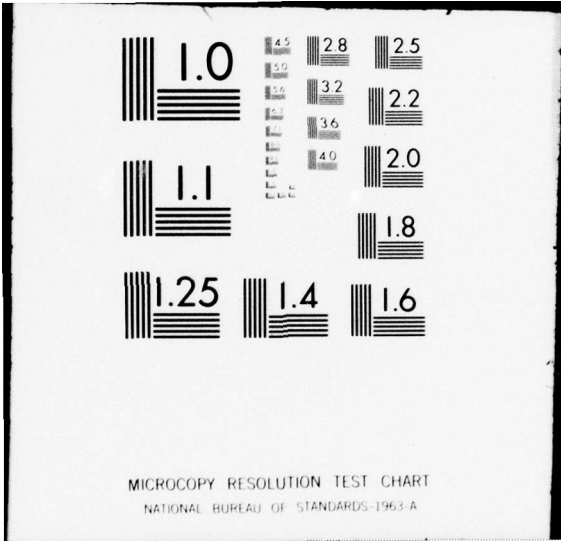

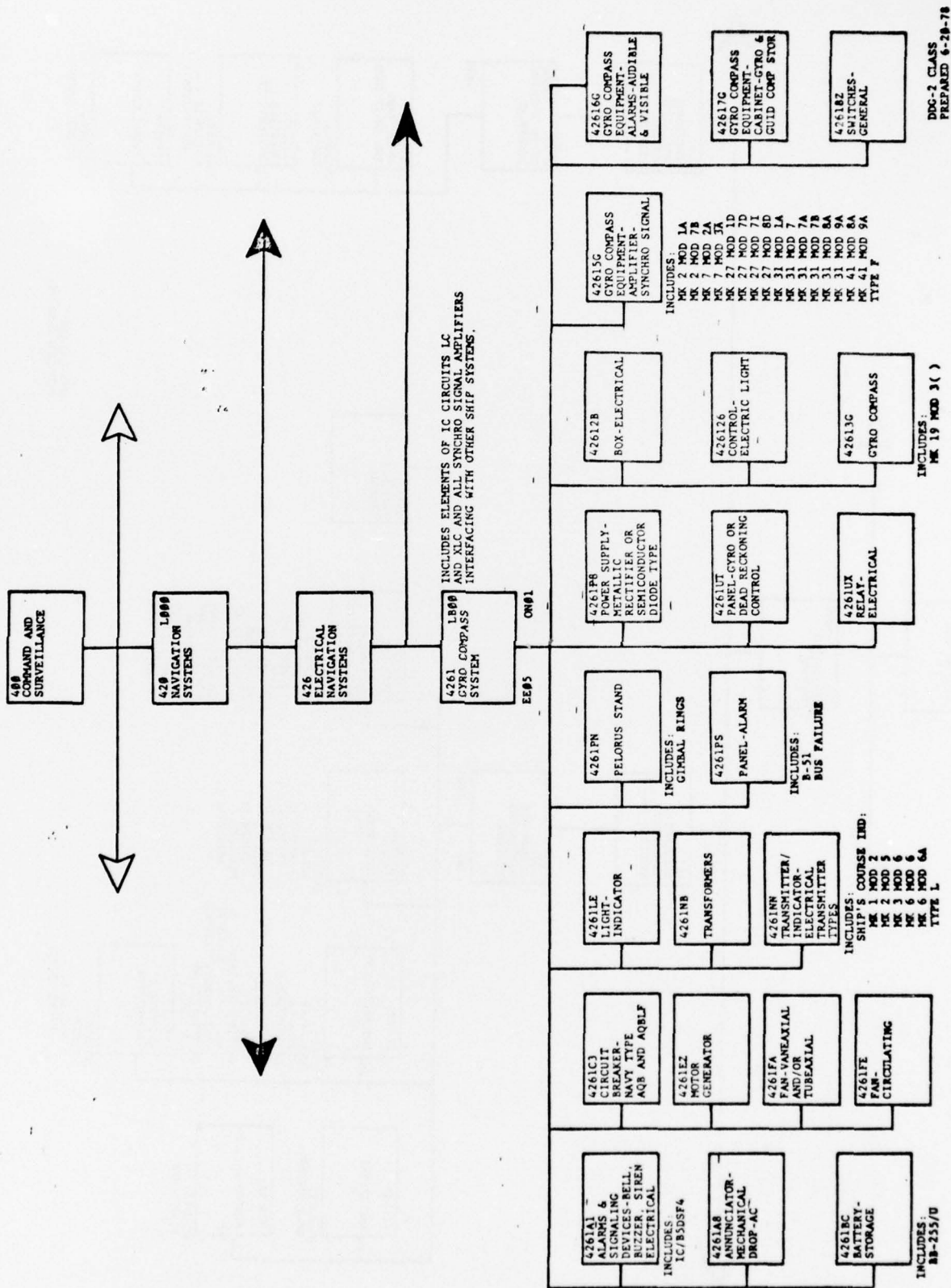

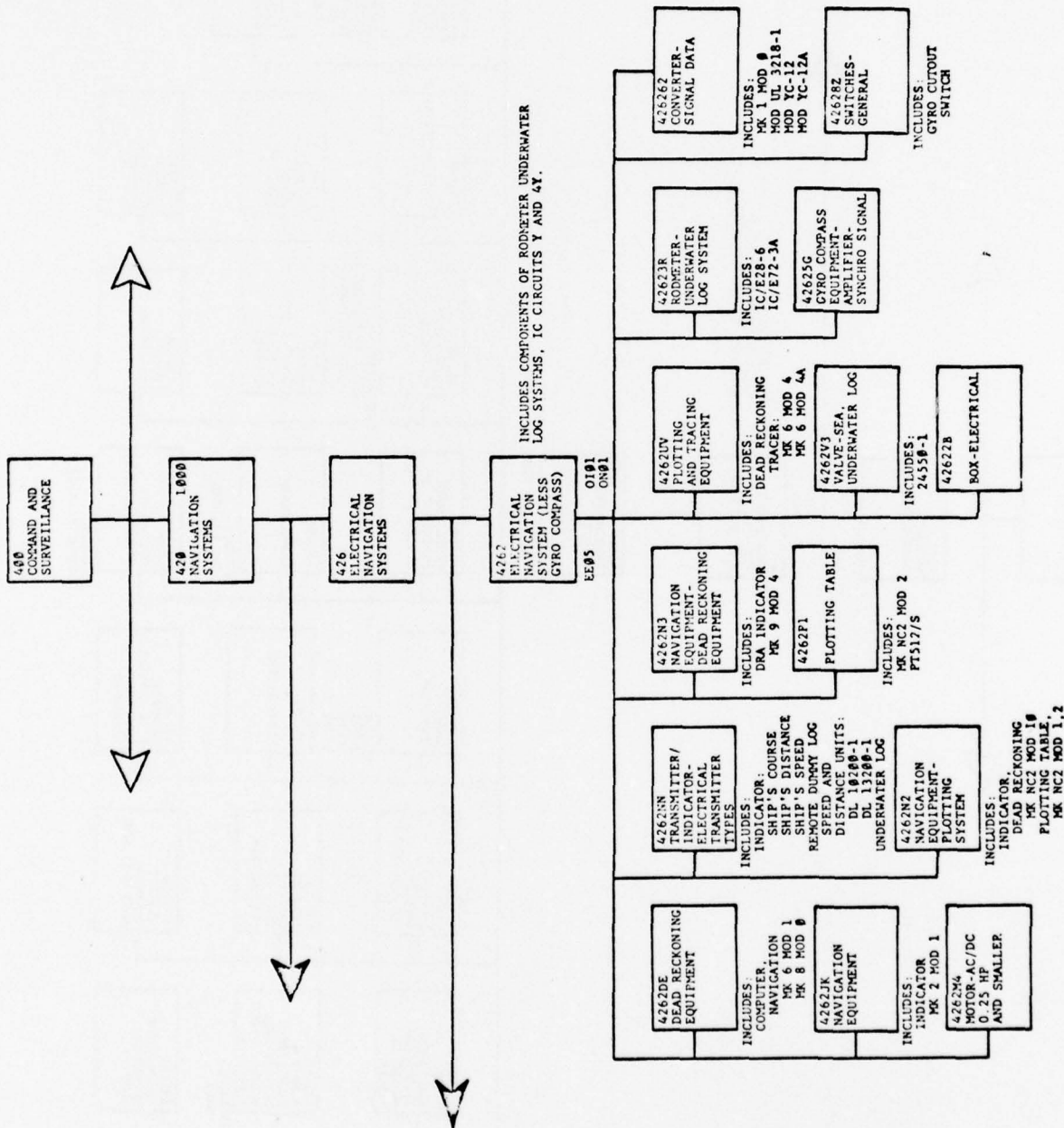

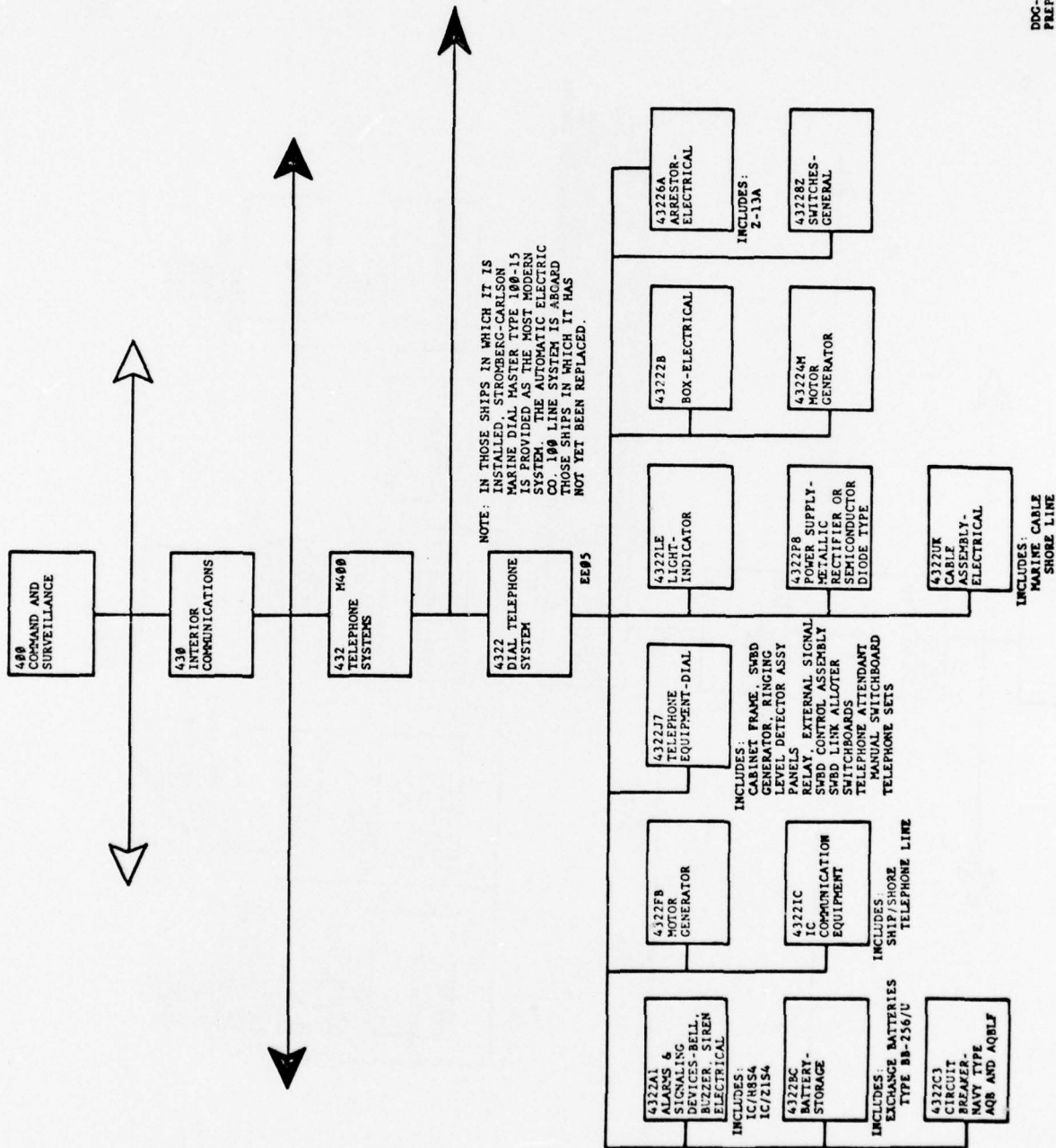

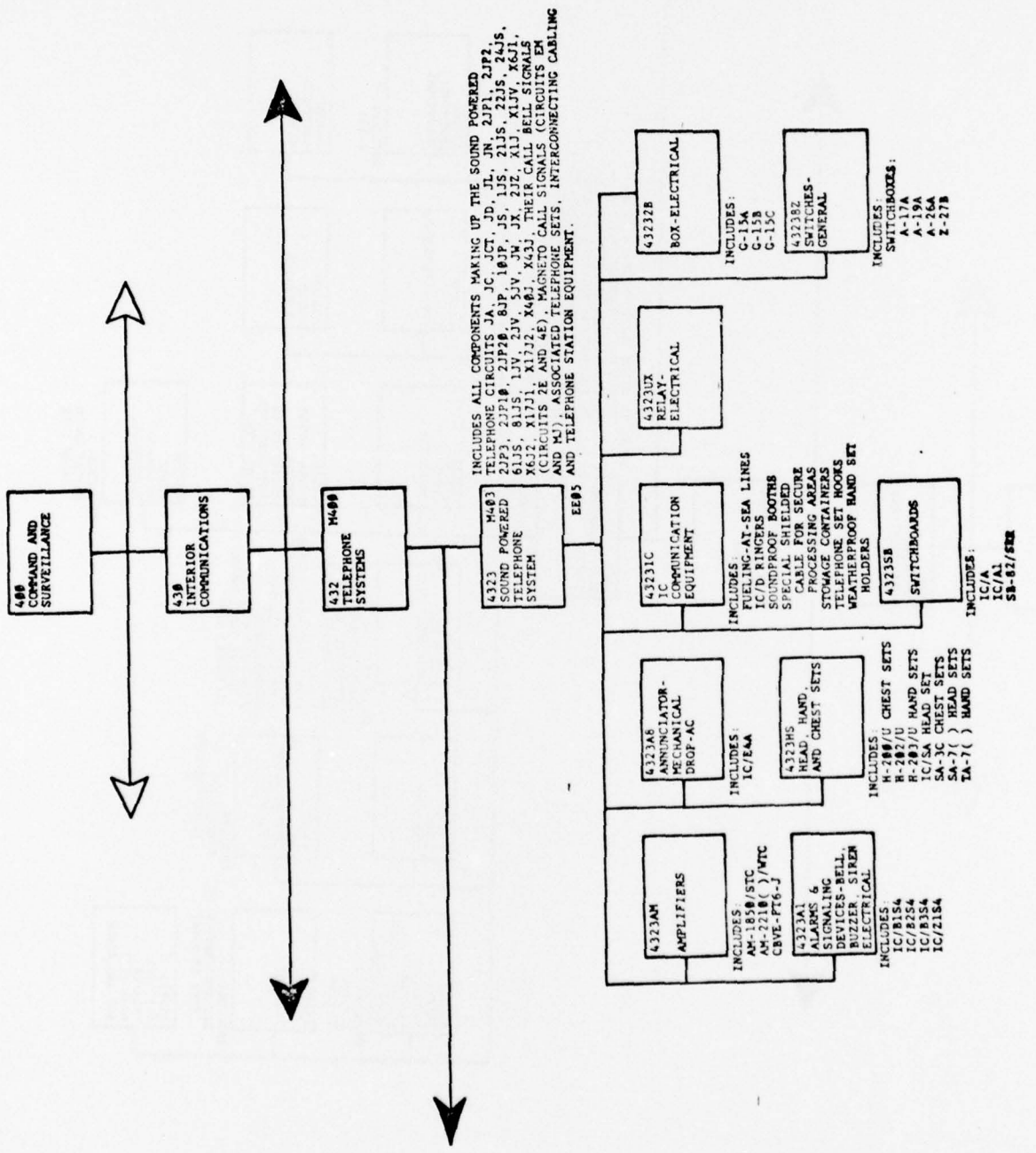

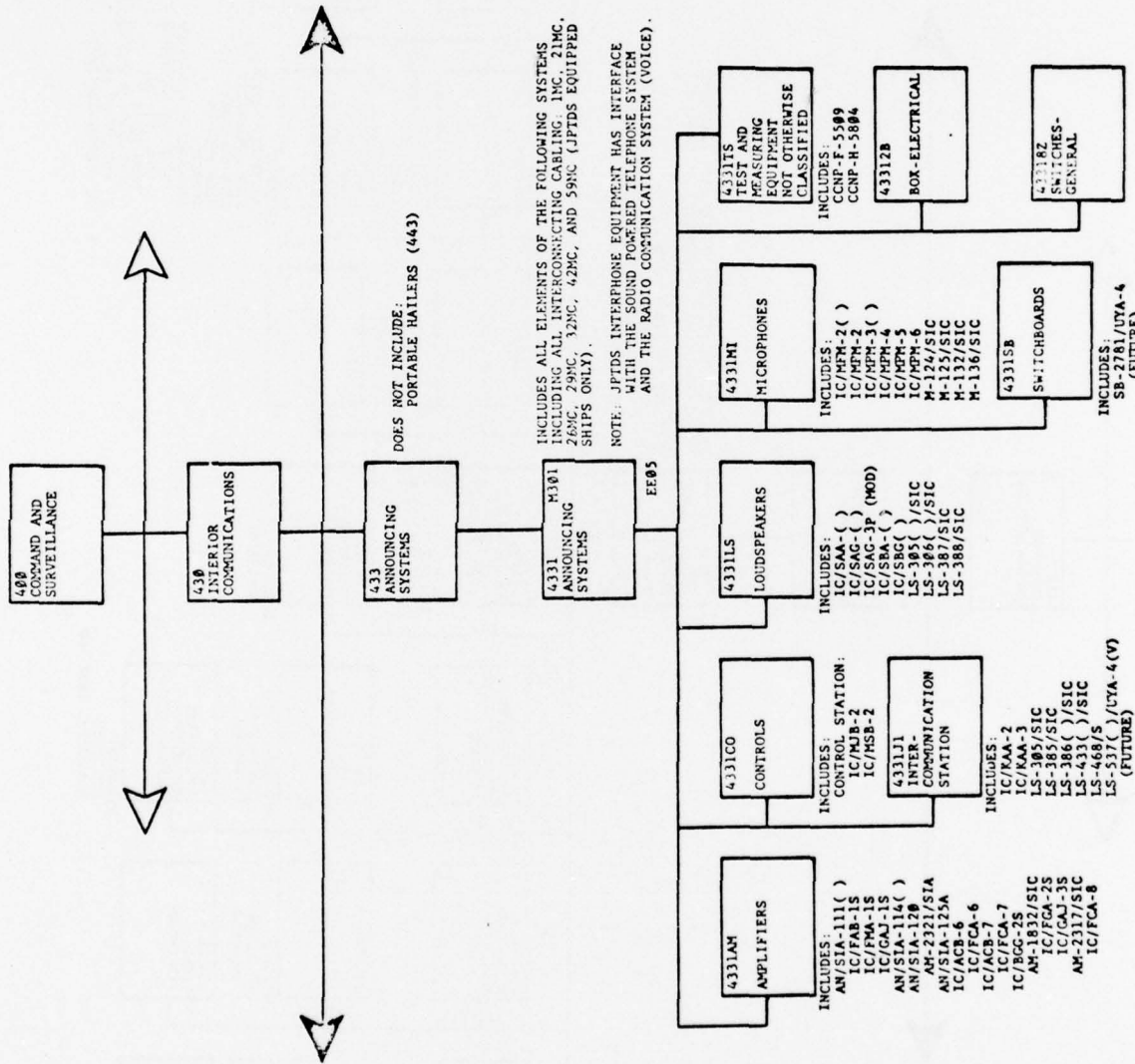

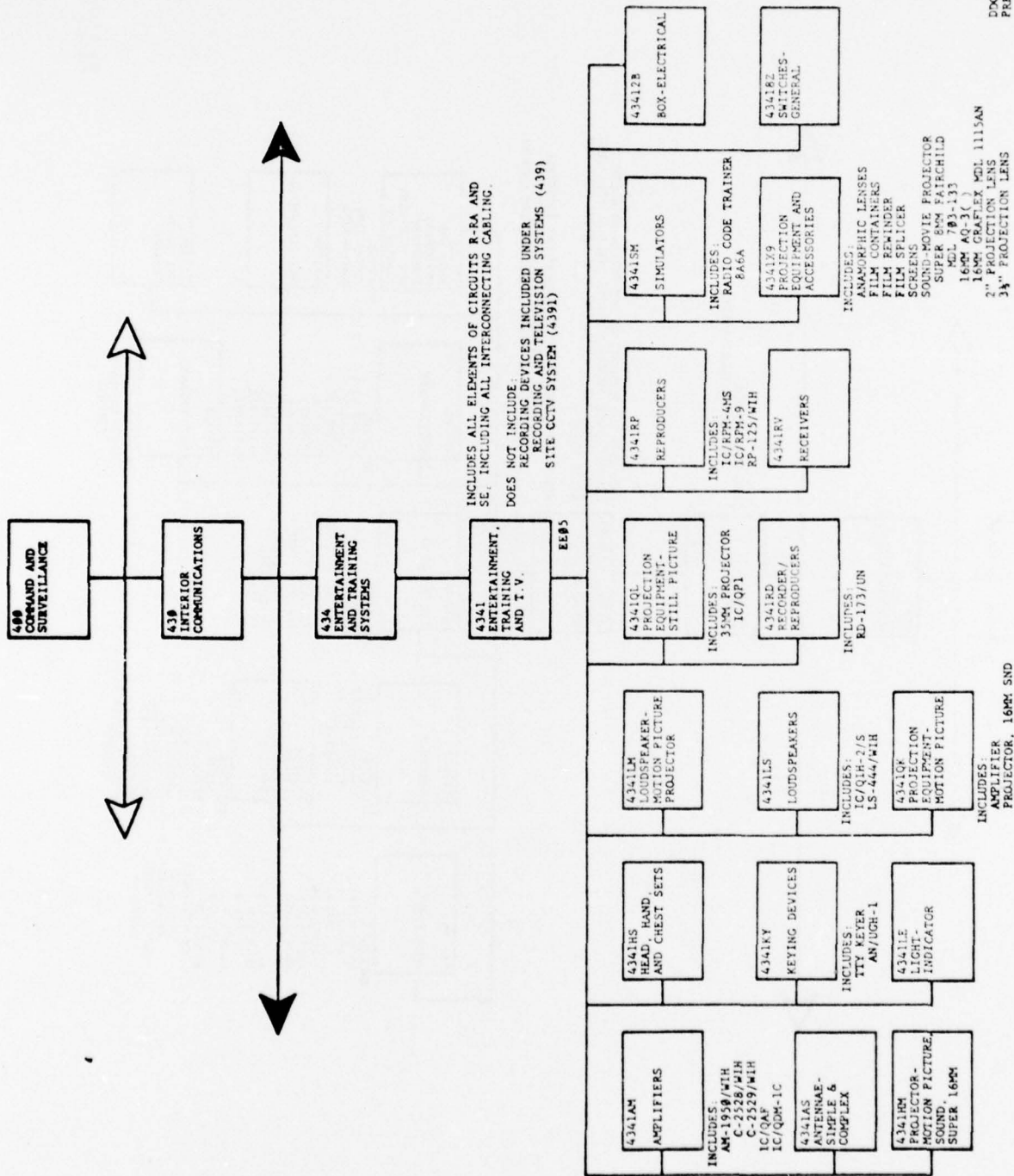

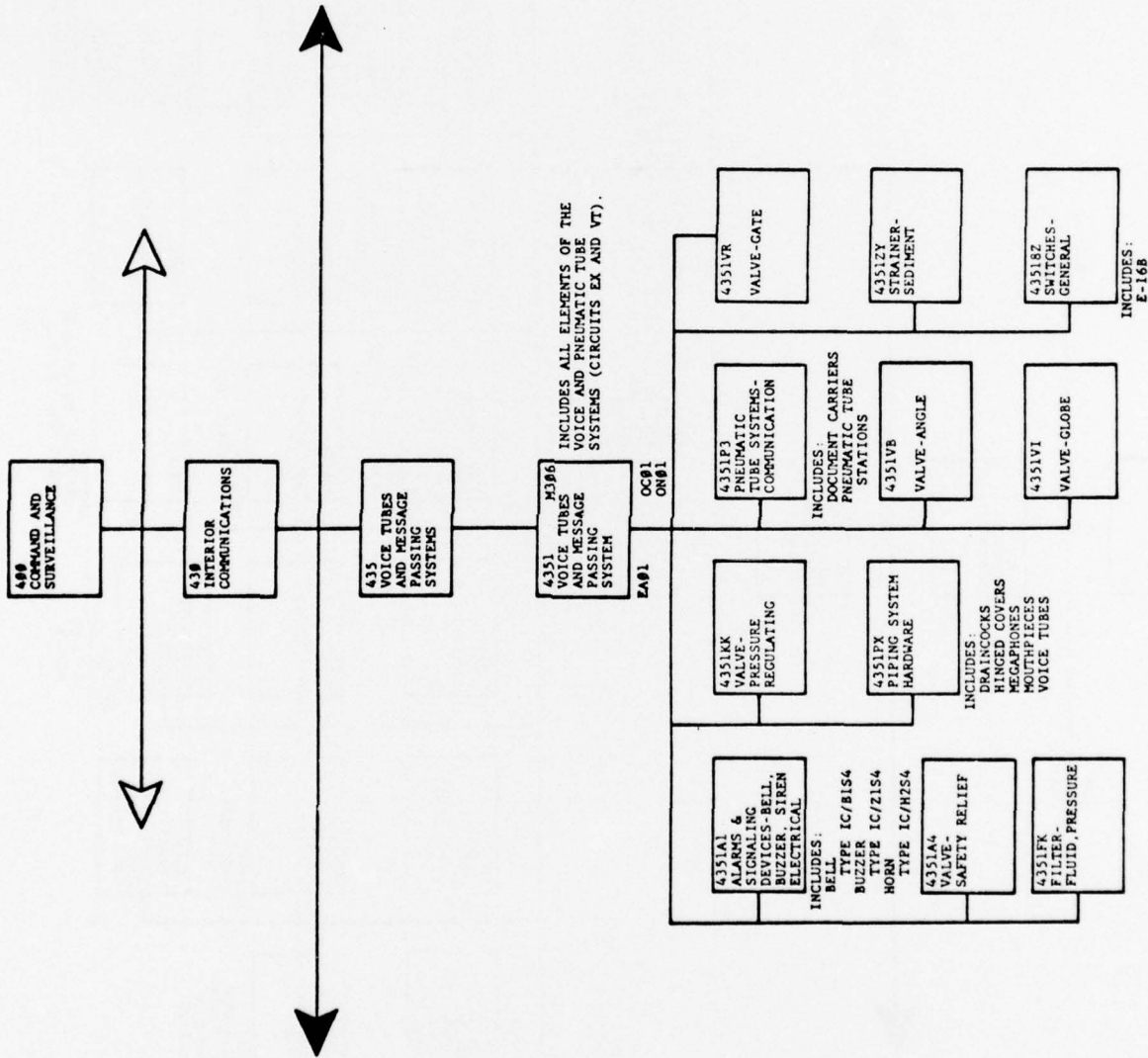

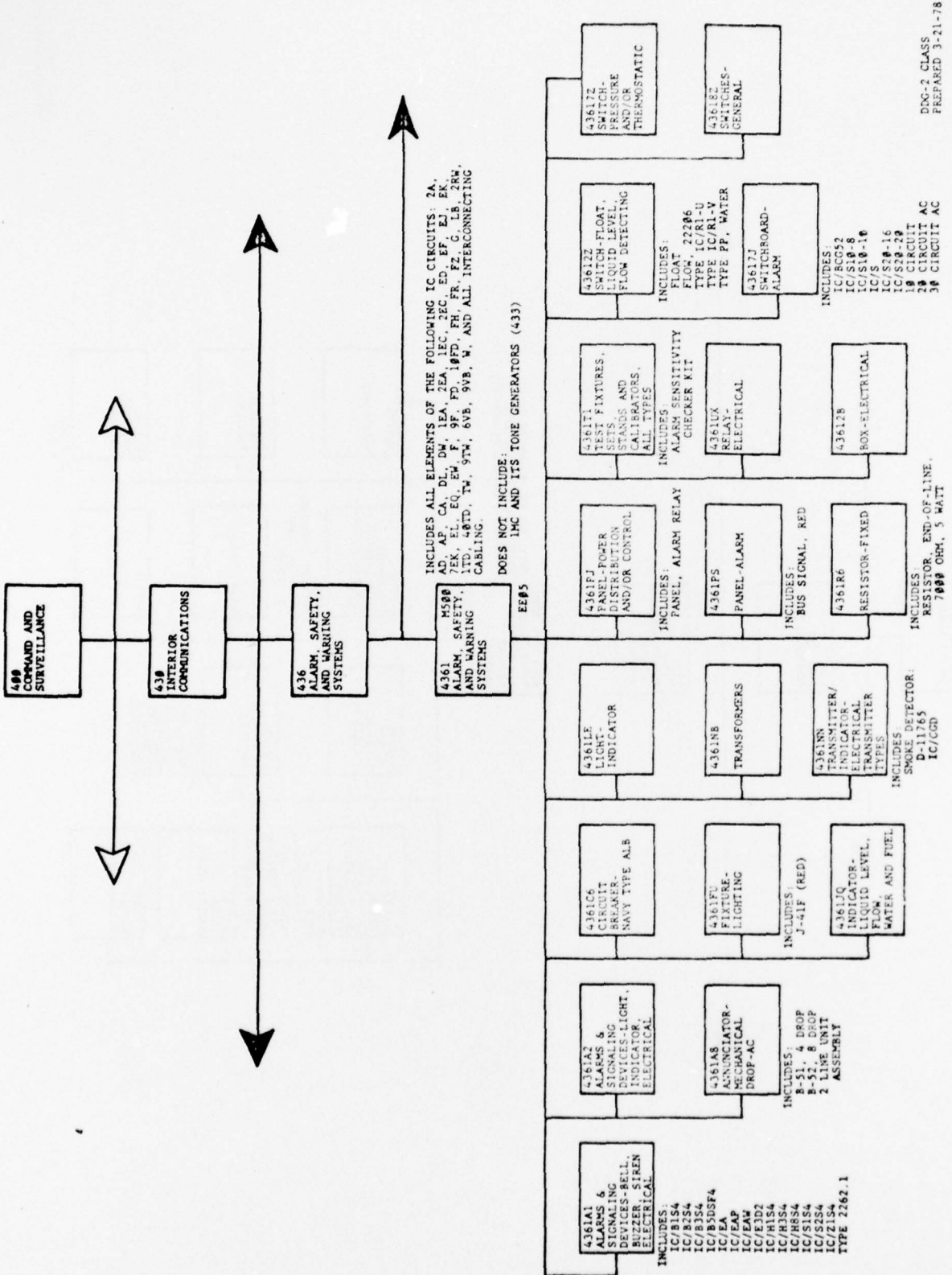

INCLUDES ALL ELEMENTS OF THE FOLLOWING IC CIRCUITS: 2A, 15, AP, CA, CD, DE, EA, 2EA, EC, ED, EE, EF, EG, EH, 2EH, EK, EL, EO, EP, F, FA, FB, FC, FD, FE, FF, FG, FH, FI, FJ, FK, FL, FM, FN, FO, FP, FQ, FR, FS, FT, FU, FV, FW, FX, FY, FZ, GA, GB, GC, GD, GE, GF, GG, GH, GI, GJ, GK, GL, GM, GN, GO, GP, GQ, GR, GS, GT, GU, GV, GW, GX, GY, GZ, HA, HB, HC, HD, HE, HF, HG, HH, HI, HJ, HK, HL, HM, HN, HO, HP, HQ, HR, HS, HT, HU, HV, HW, HX, HY, HZ, IA, IB, IC, ID, IE, IF, IG, IH, II, IJ, IK, IL, IM, IN, IO, IP, IQ, IR, IS, IT, IU, IV, IW, IX, IY, IZ, JA, JB, JC, JD, JE, JF, JG, JH, JI, JJ, JK, JL, JM, JN, JO, JP, JQ, JR, JS, JT, JU, JV, JW, JX, JY, JZ, KA, KB, KC, KD, KE, KF, KG, KH, KI, KJ, KK, KL, KM, KN, KO, KP, KQ, KR, KS, KT, KU, KV, KW, KX, KY, KZ, LA, LB, LC, LD, LE, LF, LG, LH, LI, LJ, LK, LL, LM, LN, LO, LP, LQ, LR, LS, LT, LU, LV, LW, LX, LY, LZ, MA, MB, MC, MD, ME, MF, MG, MH, MI, MJ, MK, ML, MM, MN, MO, MP, MQ, MR, MS, MT, MU, MV, MW, MX, MY, MZ, NA, NB, NC, ND, NE, NF, NG, NH, NI, NJ, NK, NL, NM, NN, NO, NP, NQ, NR, NS, NT, NU, NV, NW, NX, NY, NZ, OA, OB, OC, OD, OE, OF, OG, OH, OI, OJ, OK, OL, OM, ON, OO, OP, OQ, OR, OS, OT, OU, OV, OW, OX, OY, OZ, PA, PB, PC, PD, PE, PF, PG, PH, PI, PJ, PK, PL, PM, PN, PO, PP, PQ, PR, PS, PT, PU, PV, PW, PX, PY, PZ, QA, QB, QC, QD, QE, QF, QG, QH, QI, QJ, QK, QL, QM, QN, QO, QP, QQ, QR, QS, QT, QU, QV, QW, QX, QY, QZ, RA, RB, RC, RD, RE, RF, RG, RH, RI, RJ, RK, RL, RM, RN, RO, RP, RQ, RR, RS, RT, RU, RV, RW, RX, RY, RZ, SA, SB, SC, SD, SE, SF, SG, SH, SI, SJ, SK, SL, SM, SN, SO, SP, SQ, SR, SS, ST, SU, SV, SW, SX, SY, SZ, TA, TB, TC, TD, TE, TF, TG, TH, TI, TJ, TK, TL, TM, TN, TO, TP, TQ, TR, TS, TT, TU, TV, TW, TX, TY, TZ, UA, UB, UC, UD, UE, UF, UG, UH, UI, UJ, UK, UL, UM, UN, UO, UP, UQ, UR, US, UT, UY, UZ, VA, VB, VC, VD, VE, VF, VG, VH, VI, VJ, VK, VL, VM, VN, VO, VP, VQ, VR, VS, VT, VU, VV, VW, VX, VY, VZ, WA, WB, WC, WD, WE, WF, WG, WH, WI, WJ, WK, WL, WM, WN, WO, WP, WQ, WR, WS, WT, WU, WV, WW, WX, WY, WZ, XA, XB, XC, XD, XE, XF, XG, XH, XI, XJ, XK, XL, XM, XN, XO, XP, XQ, XR, XS, XT, XU, XV, XW, XX, XY, XZ, YA, YB, YC, YD, YE, YF, YG, YH, YI, YJ, YK, YL, YM, YN, YO, YP, YQ, YR, YS, YT, YU, YV, YW, YX, YY, YZ, ZA, ZB, ZC, ZD, ZE, ZF, ZG, ZH, ZI, ZJ, ZK, ZL, ZM, ZN, ZO, ZP, ZQ, ZR, ZS, ZT, ZU, ZV, ZW, ZX, ZY, ZZ.

DOES NOT INCLUDE:

1MC AND ITS TONE GENERATORS (433)

EE#5

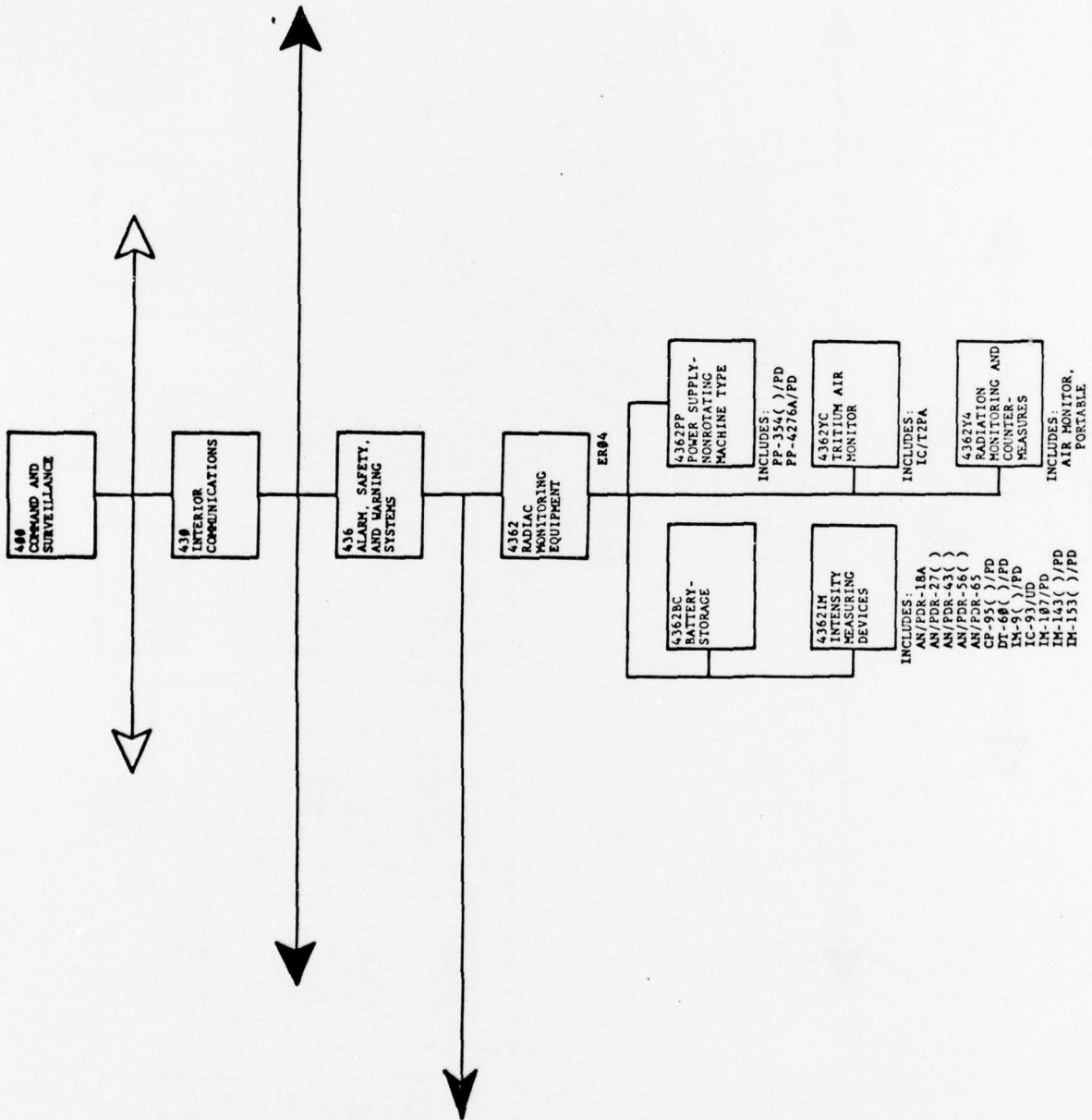

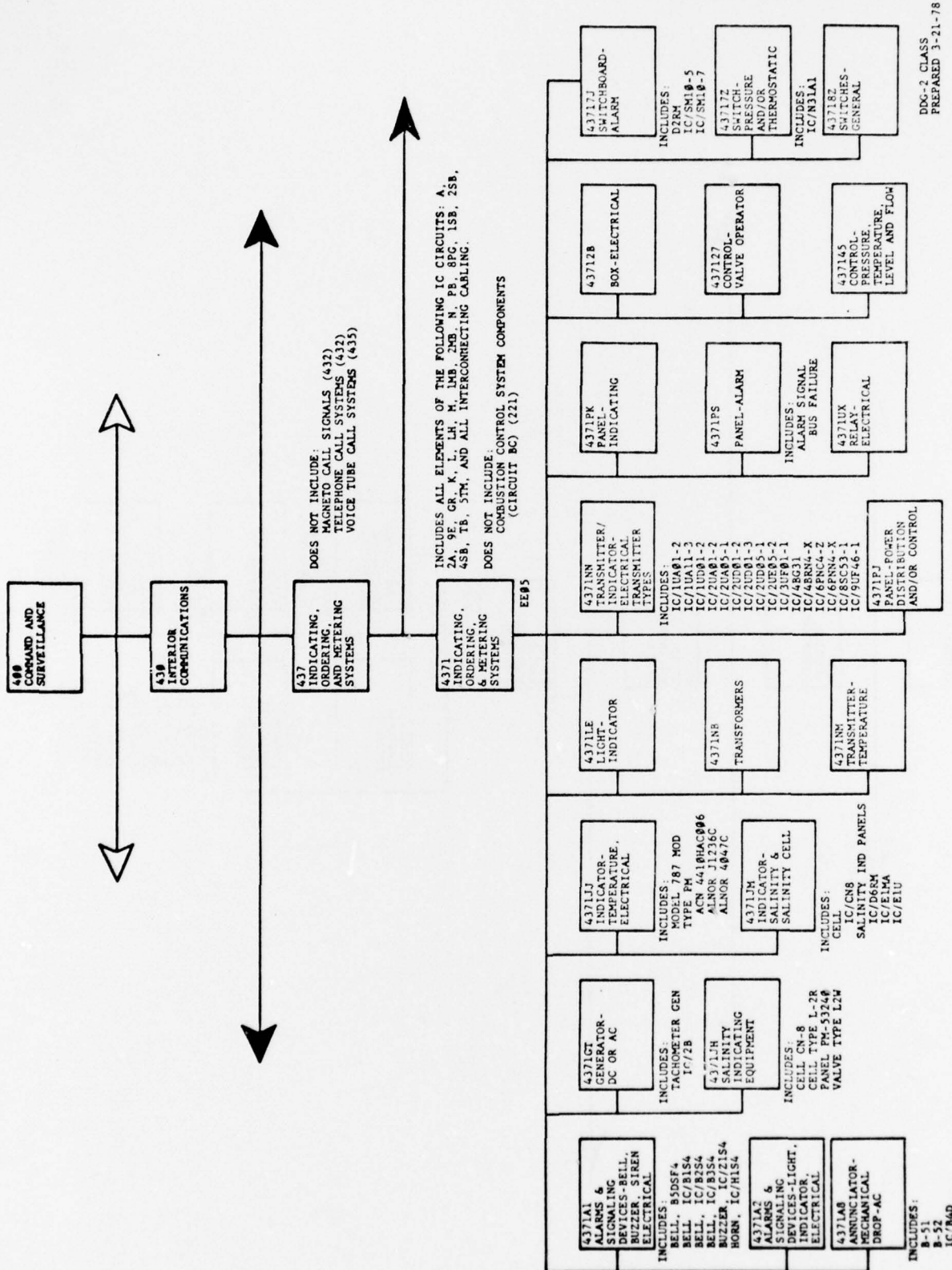

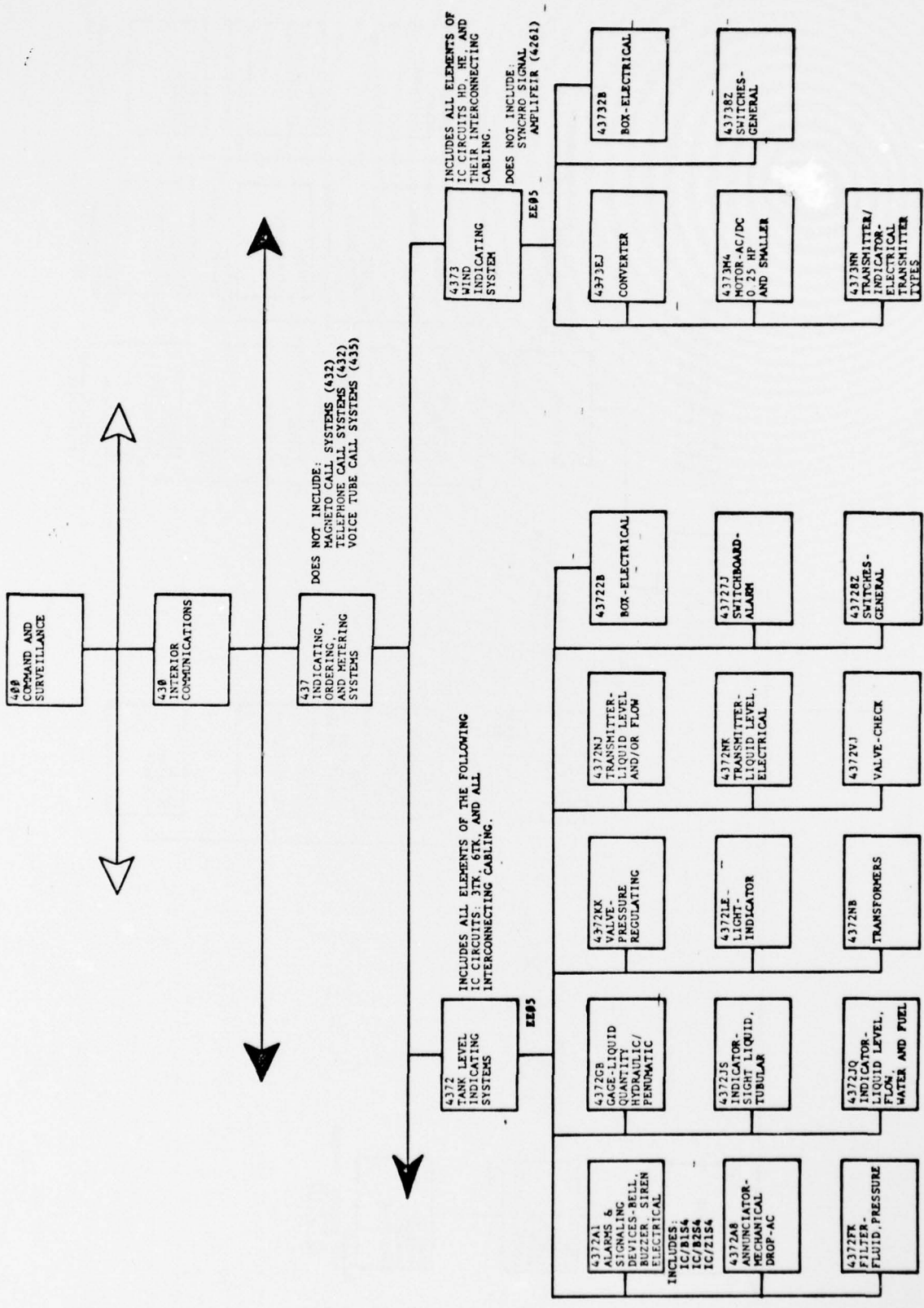

DDG-2 CLASS
PREPARED 6-28-78

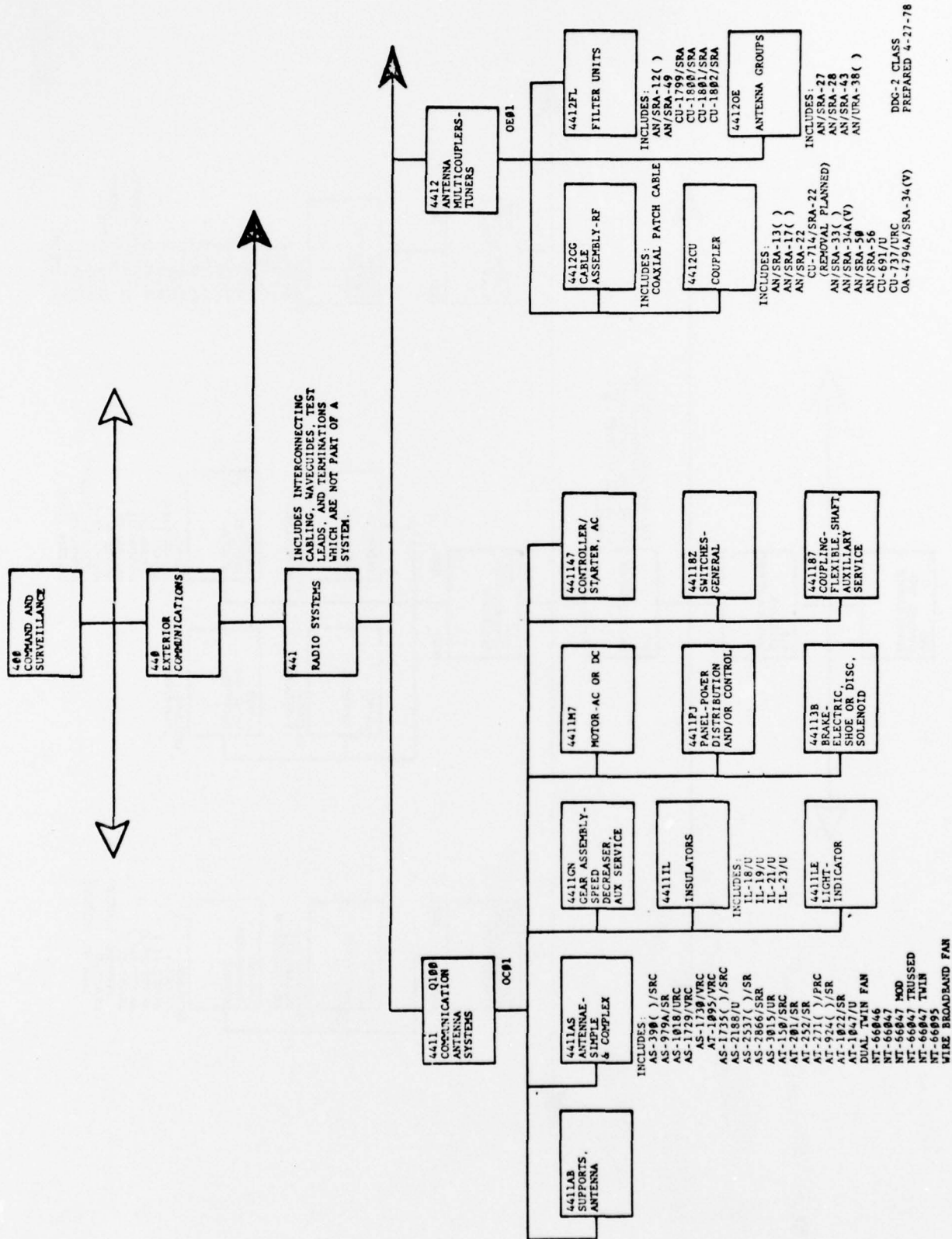

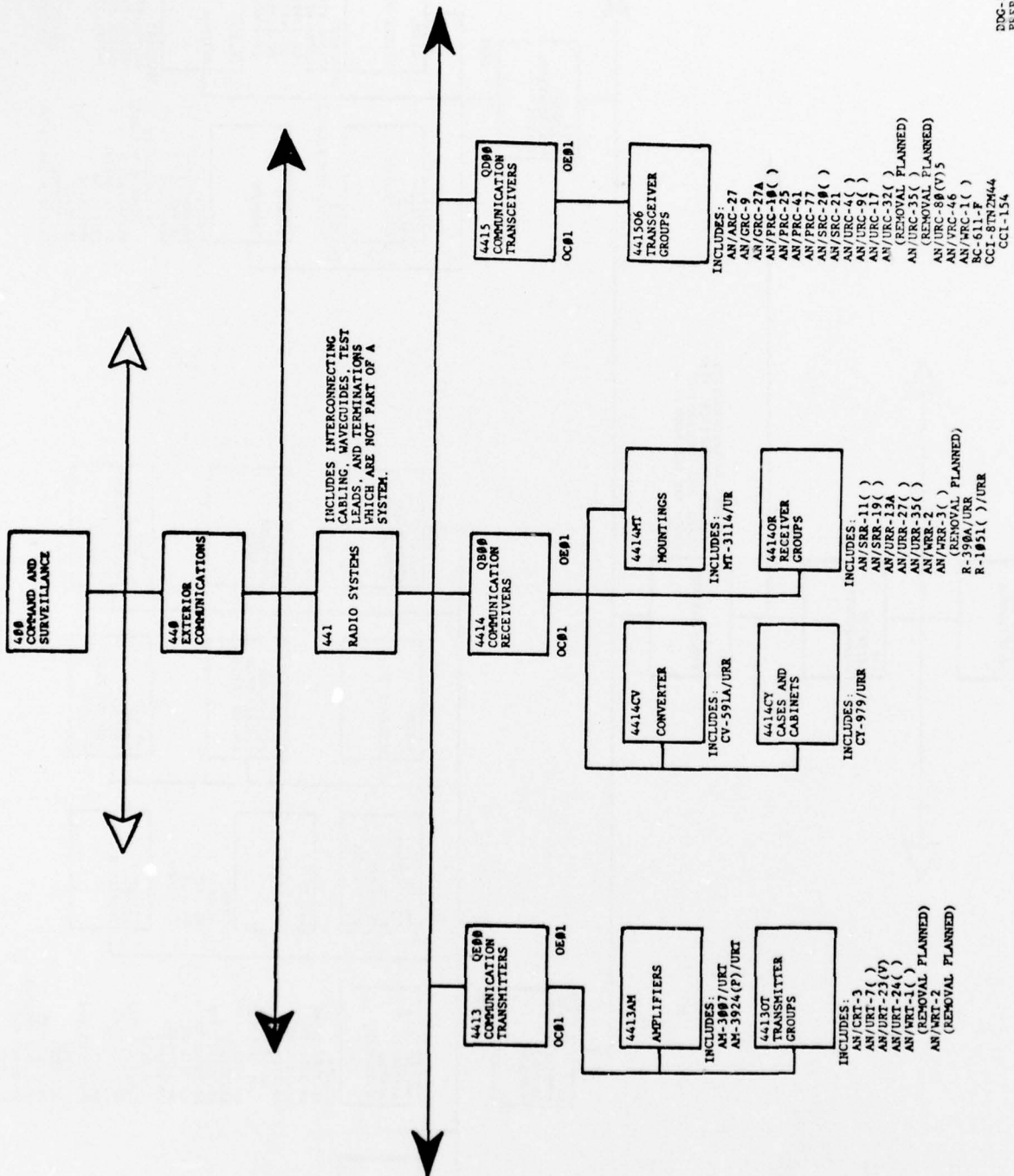

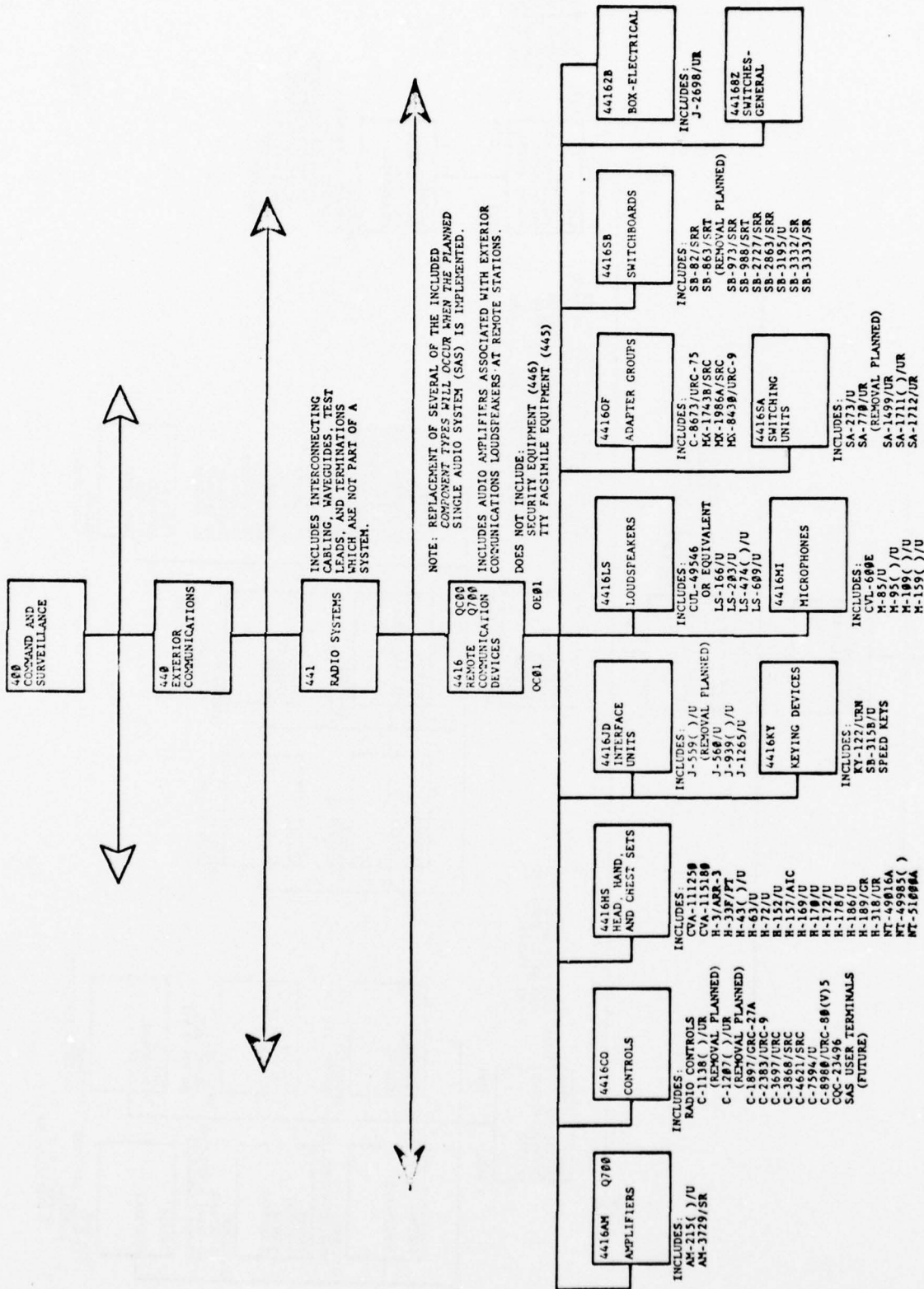

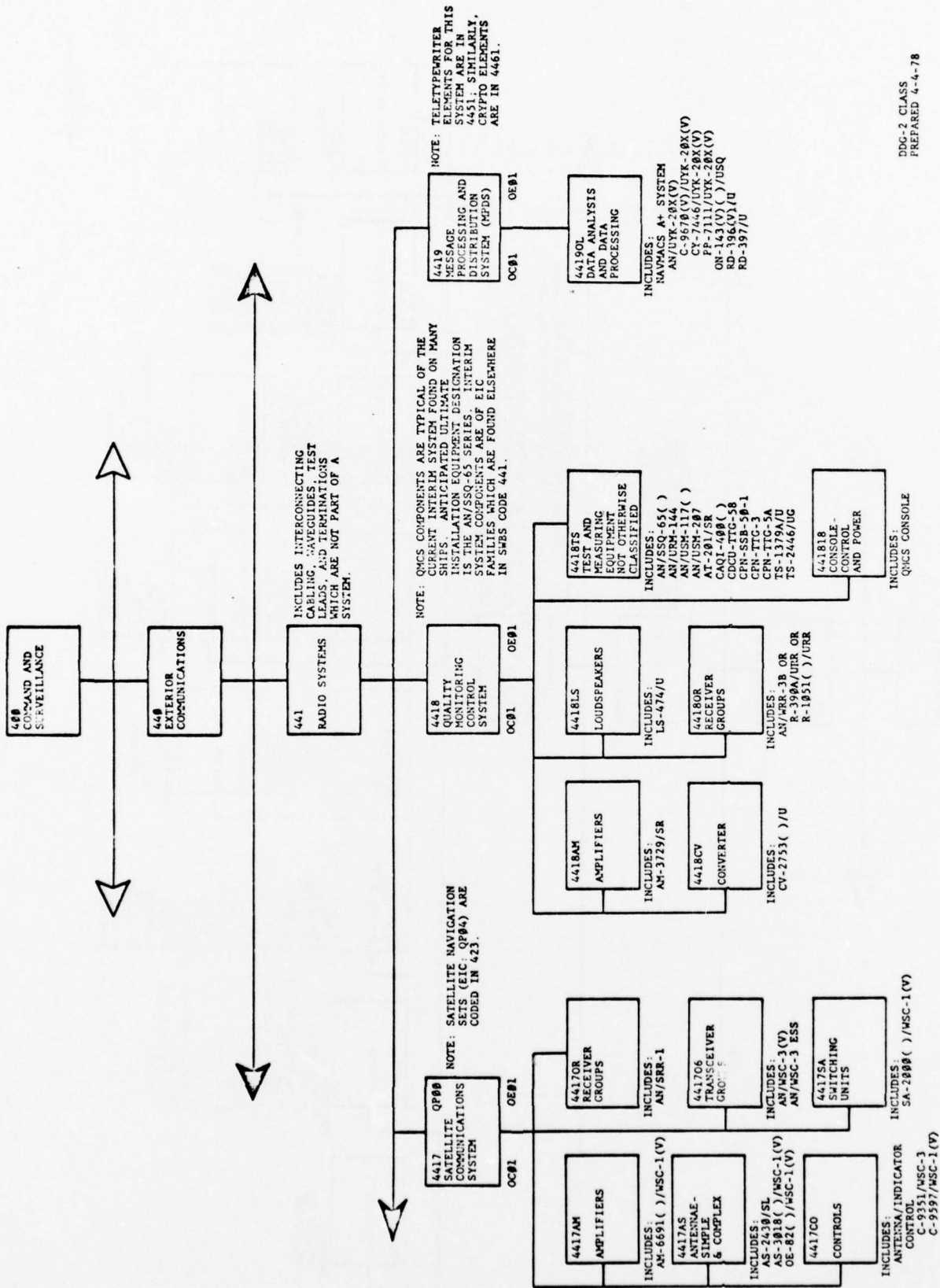

DDC-2 CLASS
PREPARED 4-4-78

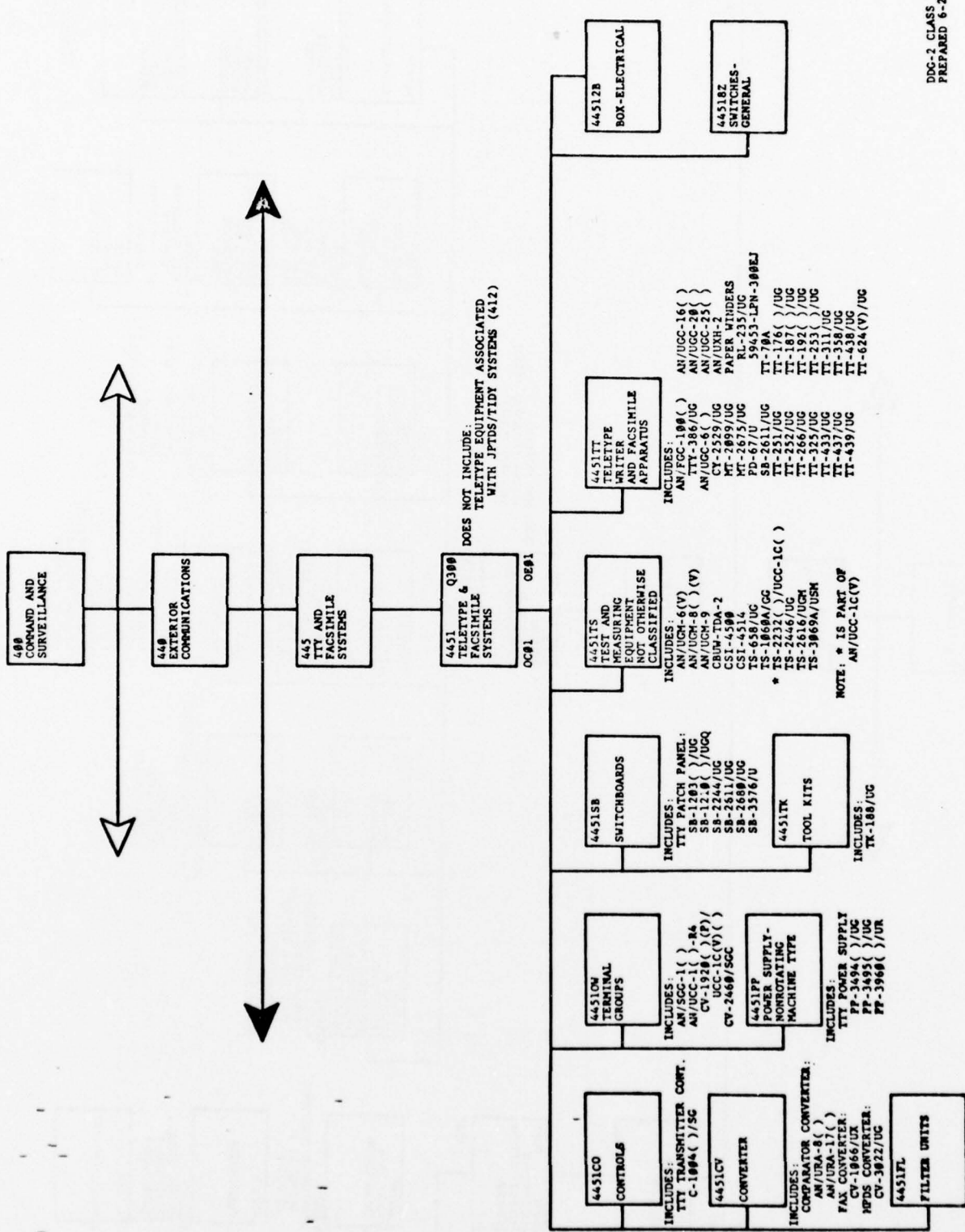

DGC-2 CLASS
PREPARED 6-20-78

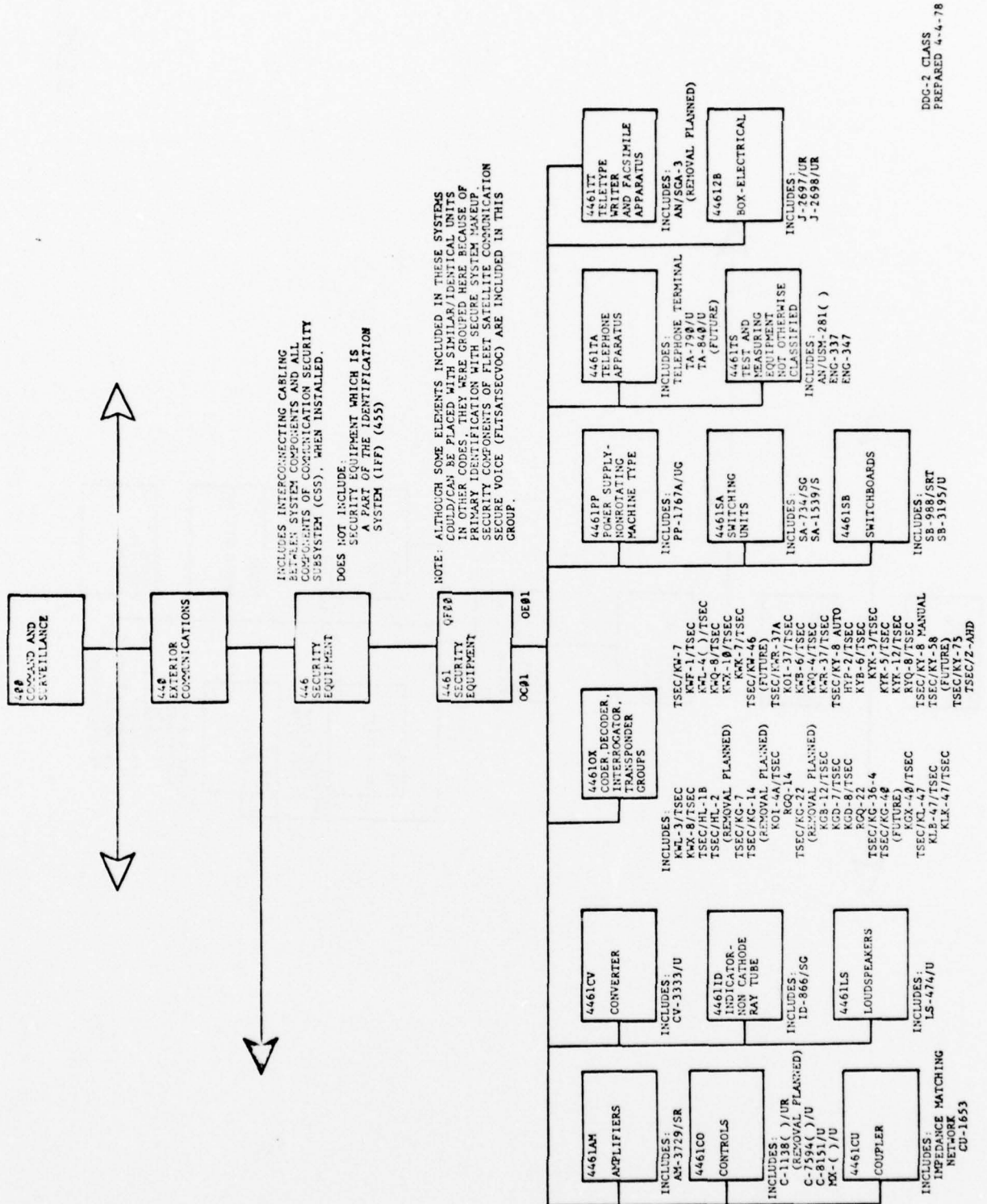

DDG-2 CLASS
PREPARED 4-4-78

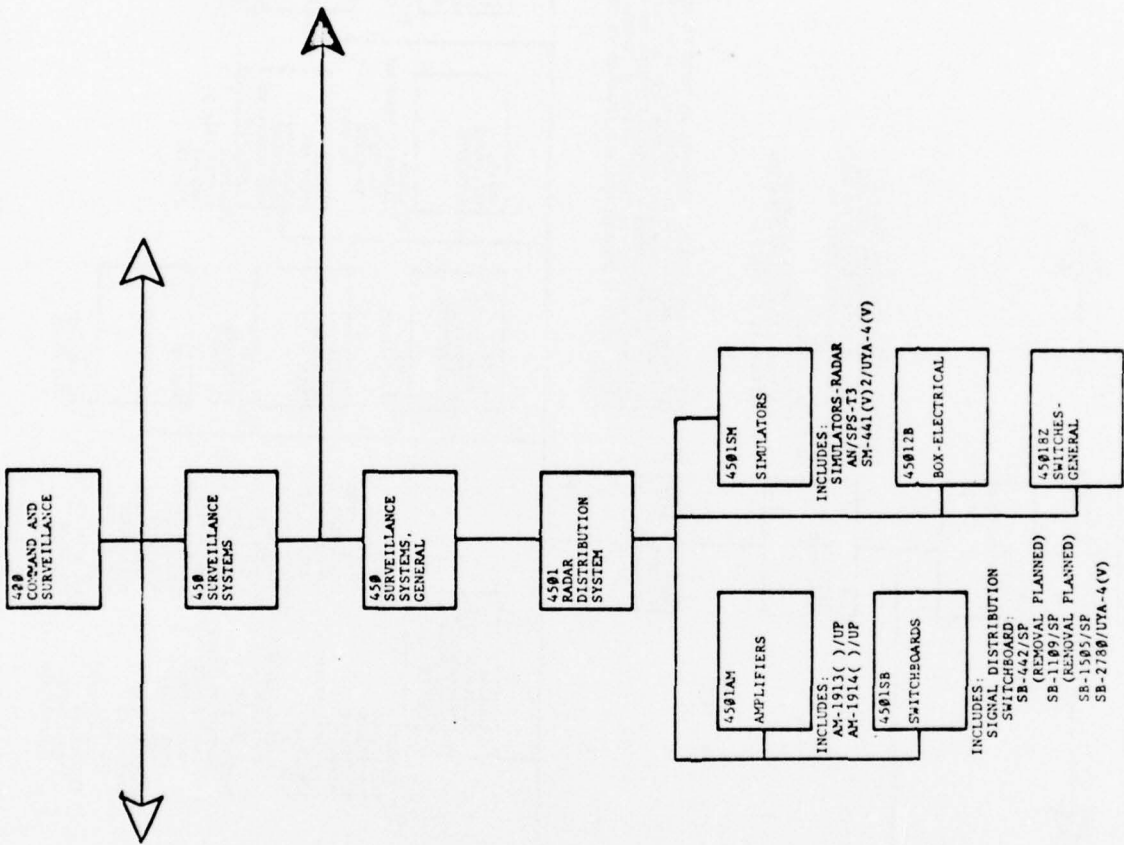

DDG-2 CLASS
PREPARED 4-4-78

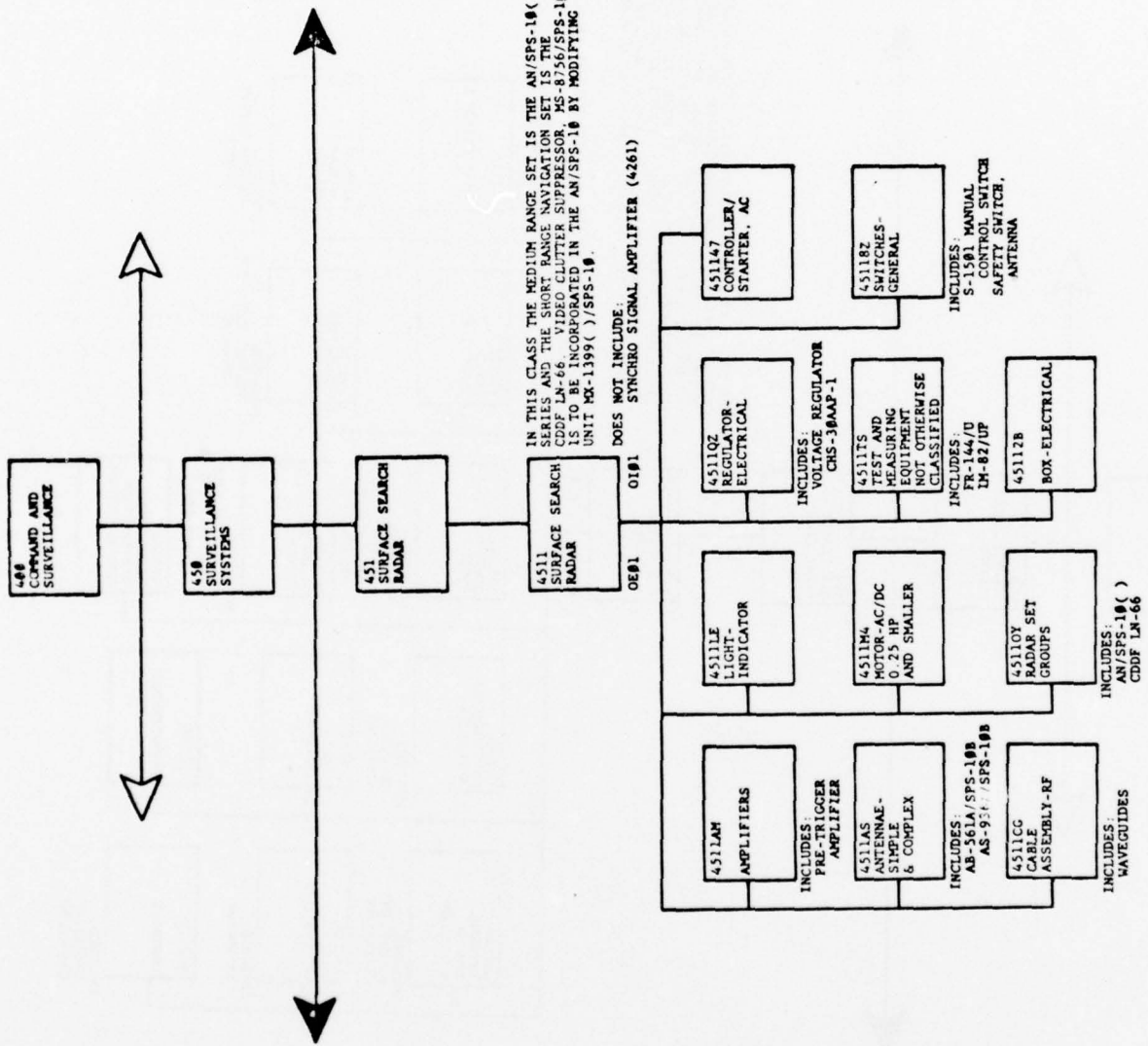

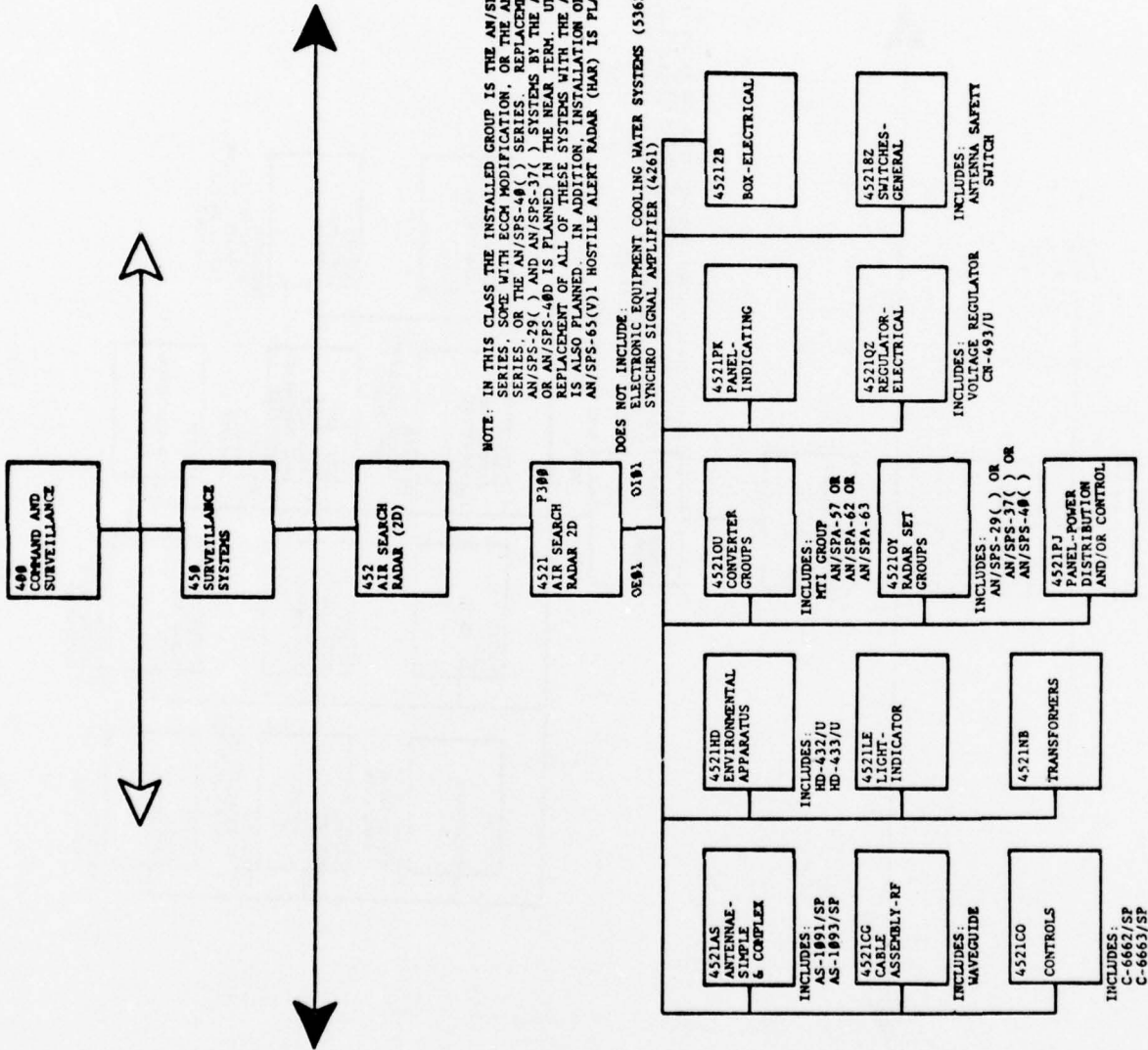

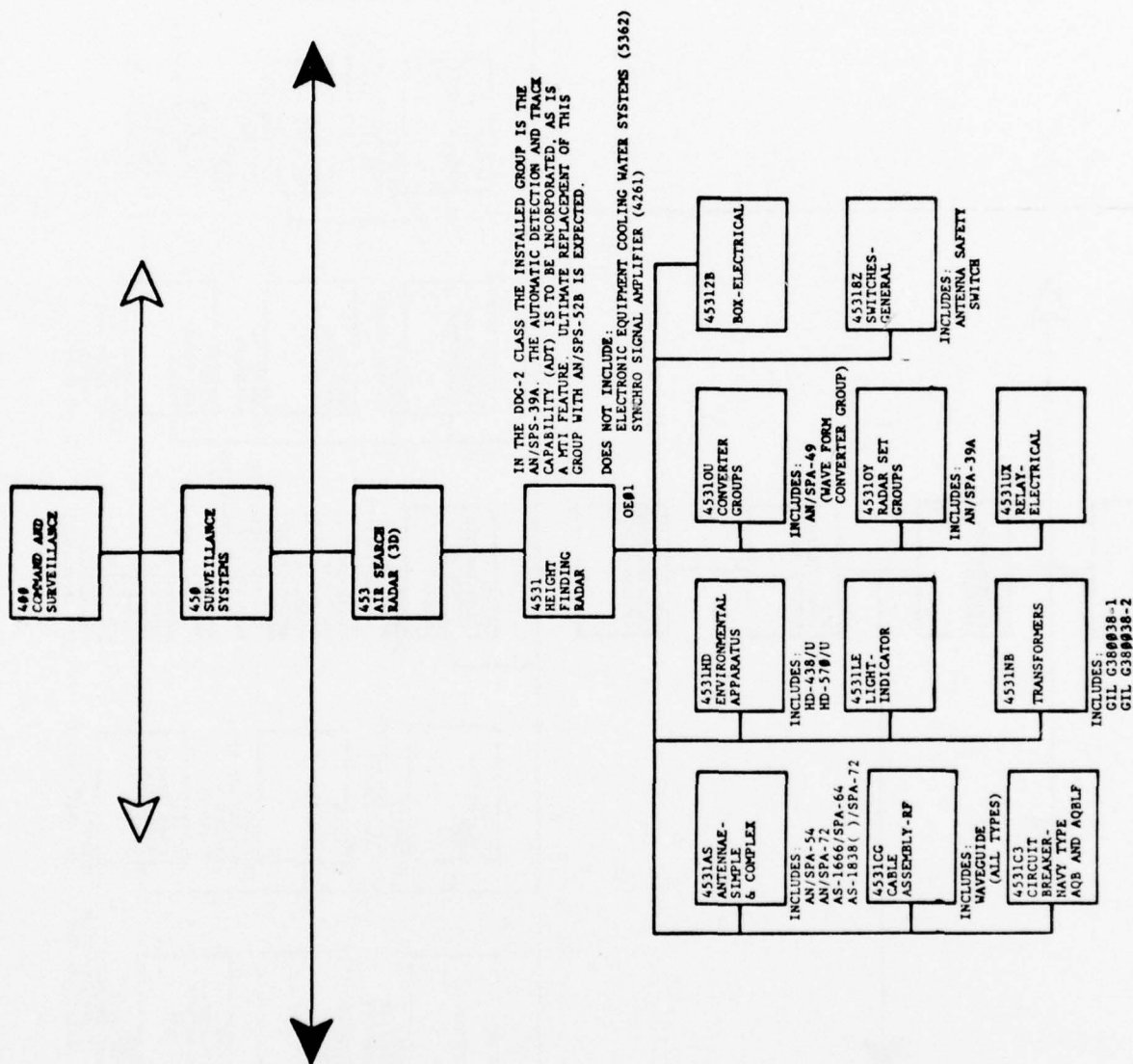

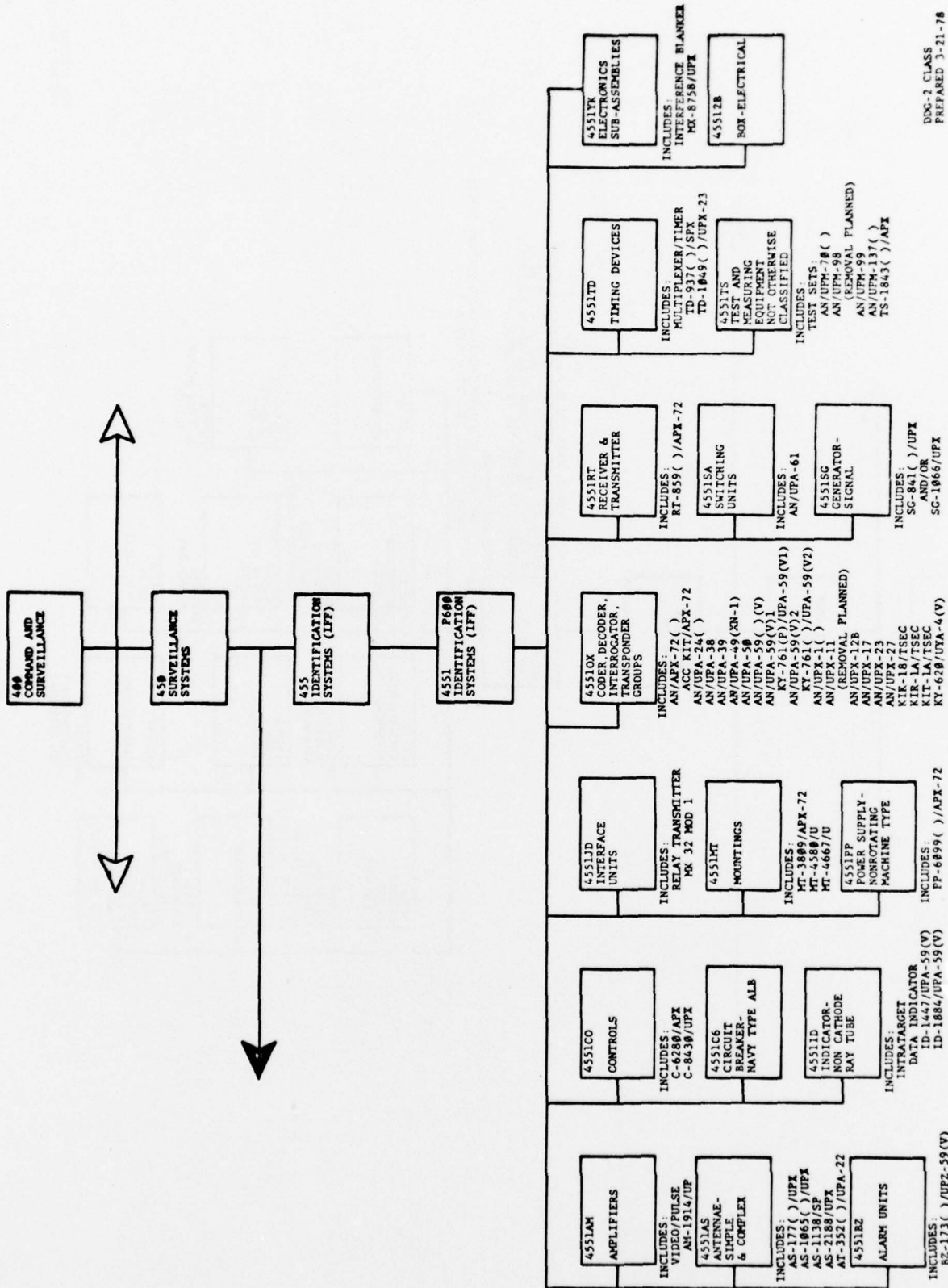

DOC-2 CLASS
PREPARED 3-21-78

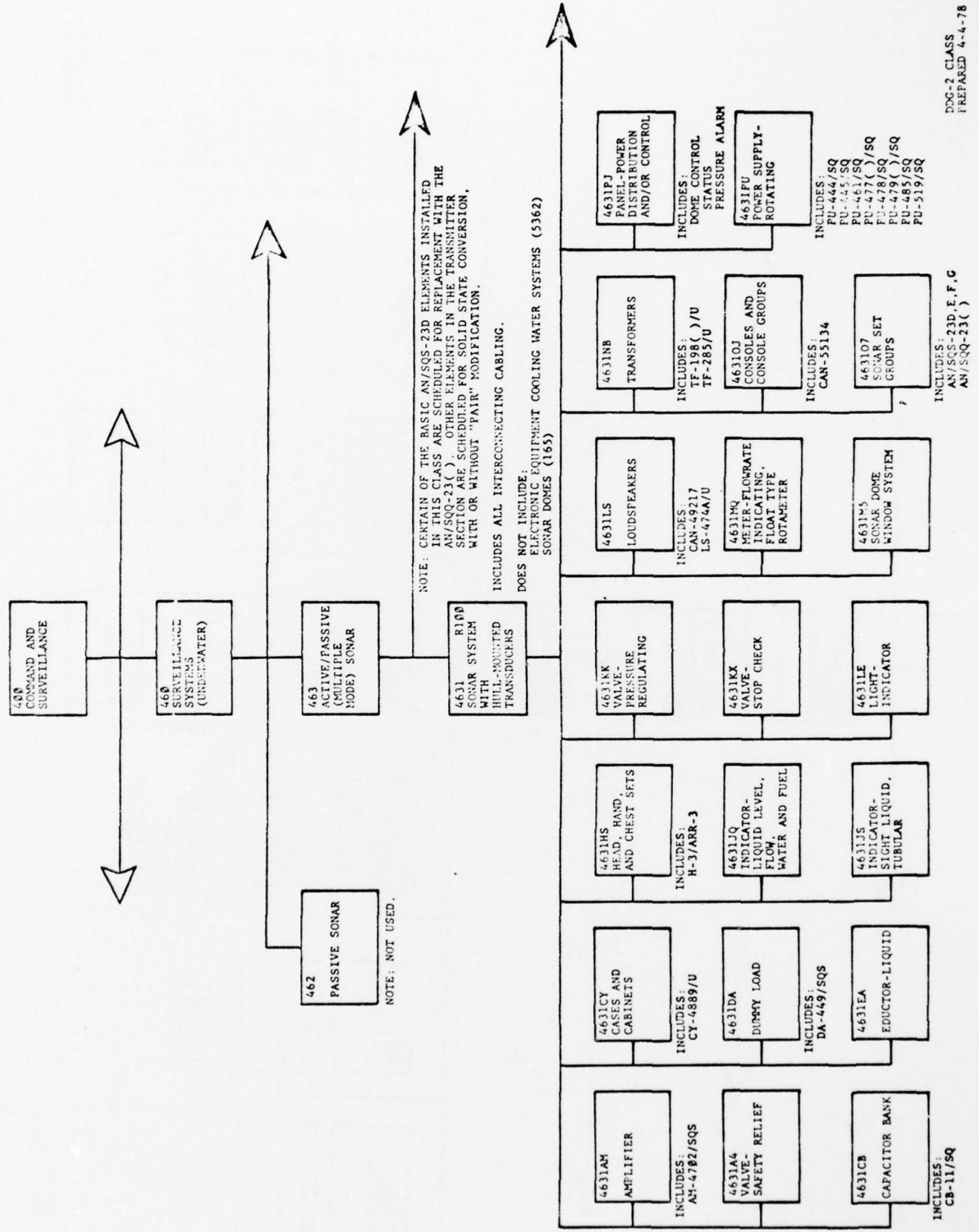

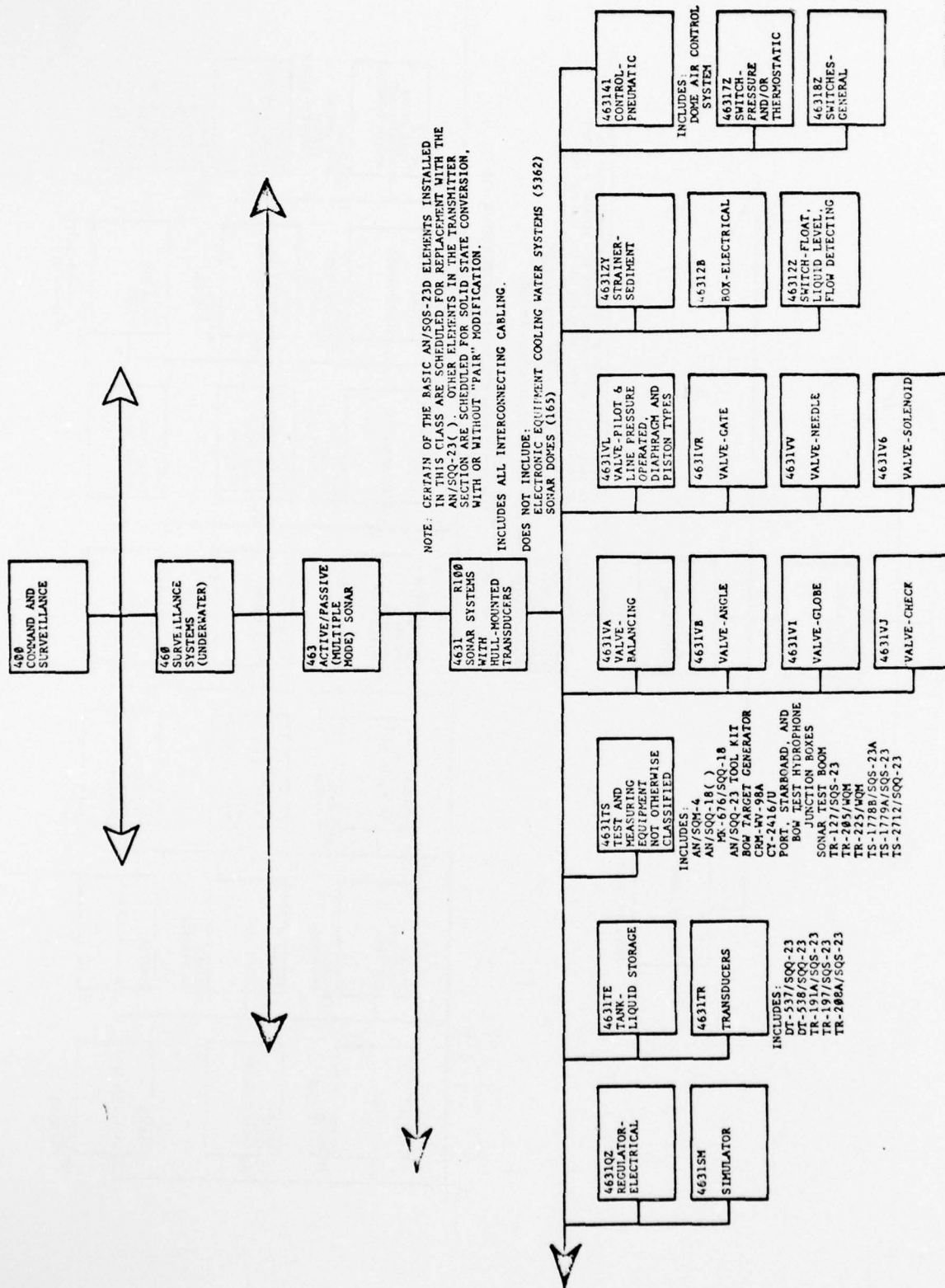

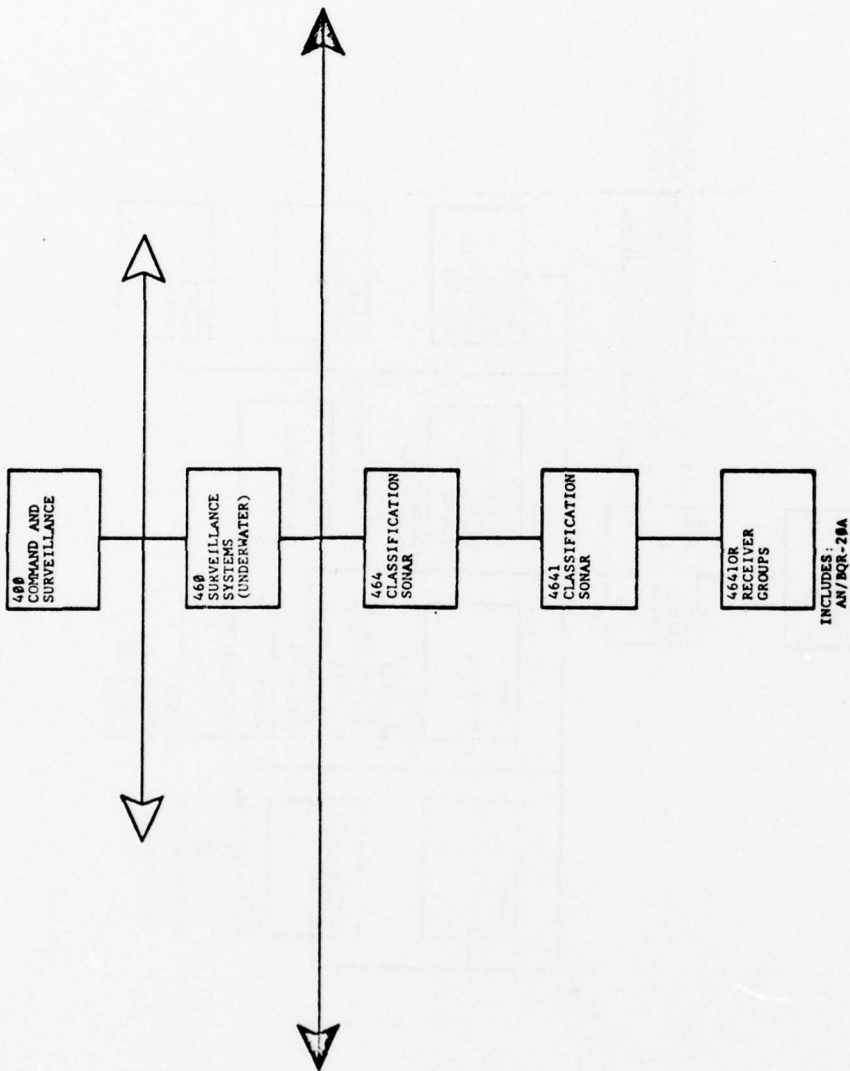

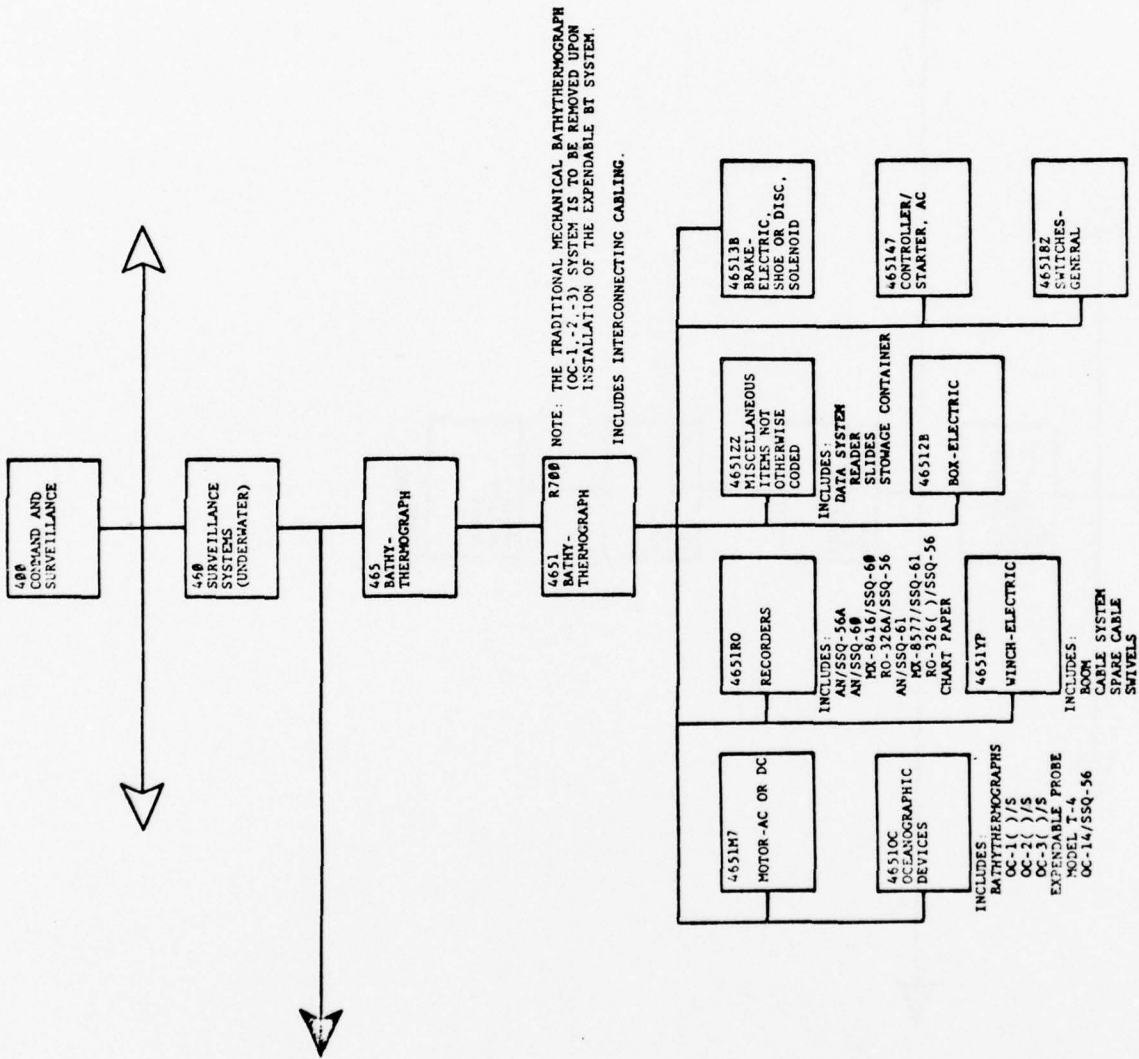

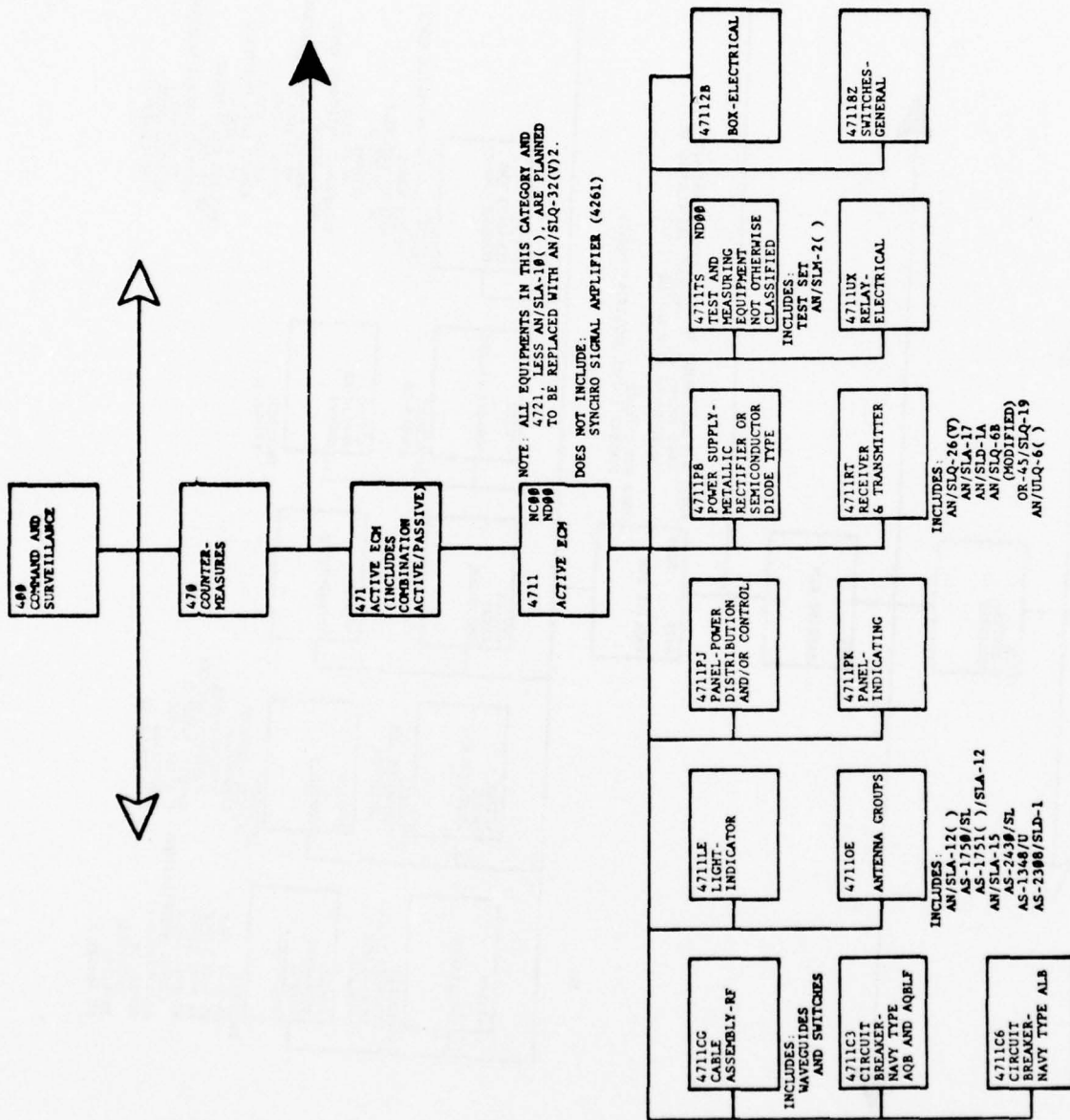

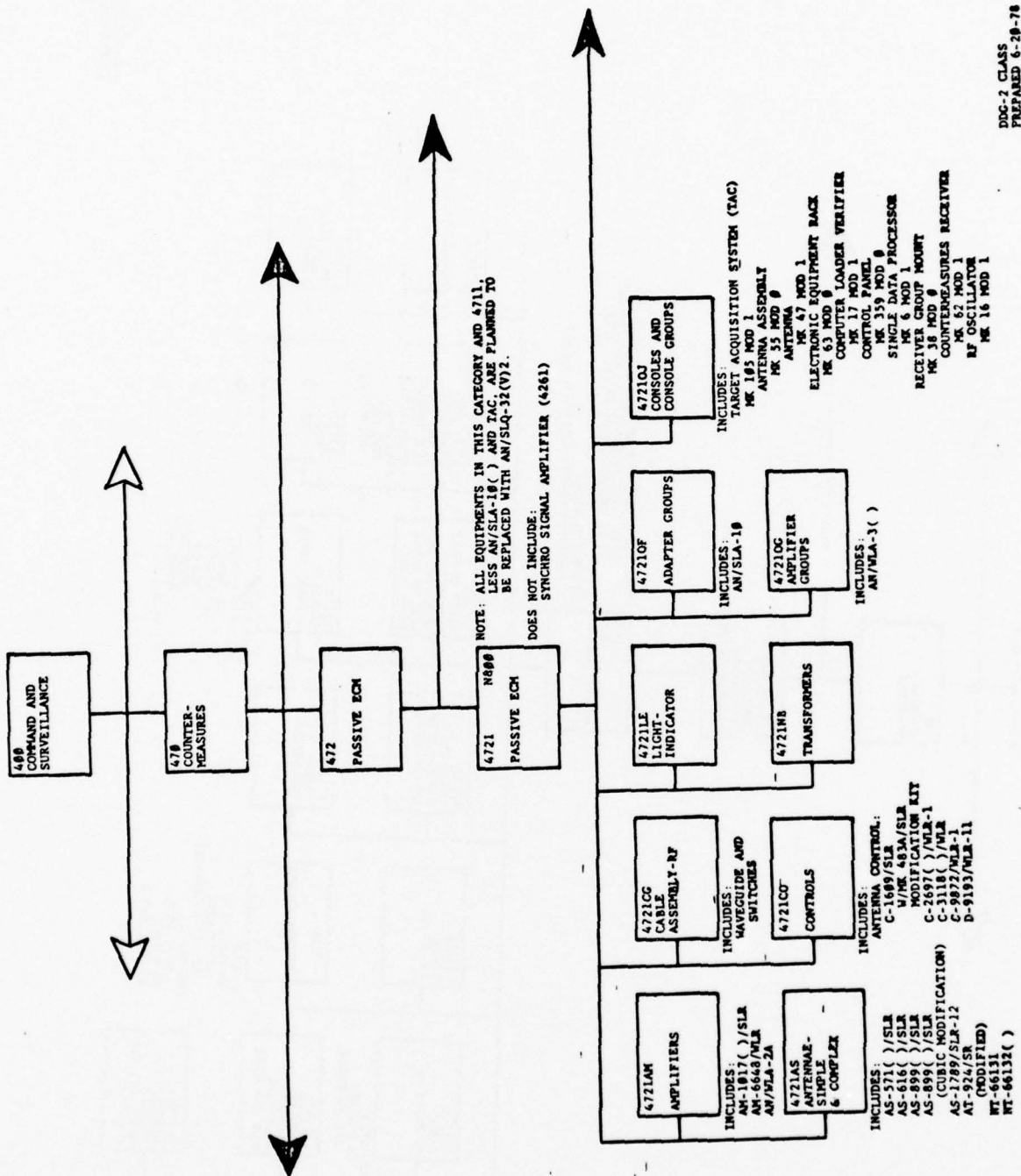

DOC-2 CLASS
PREPARED 6-29-78

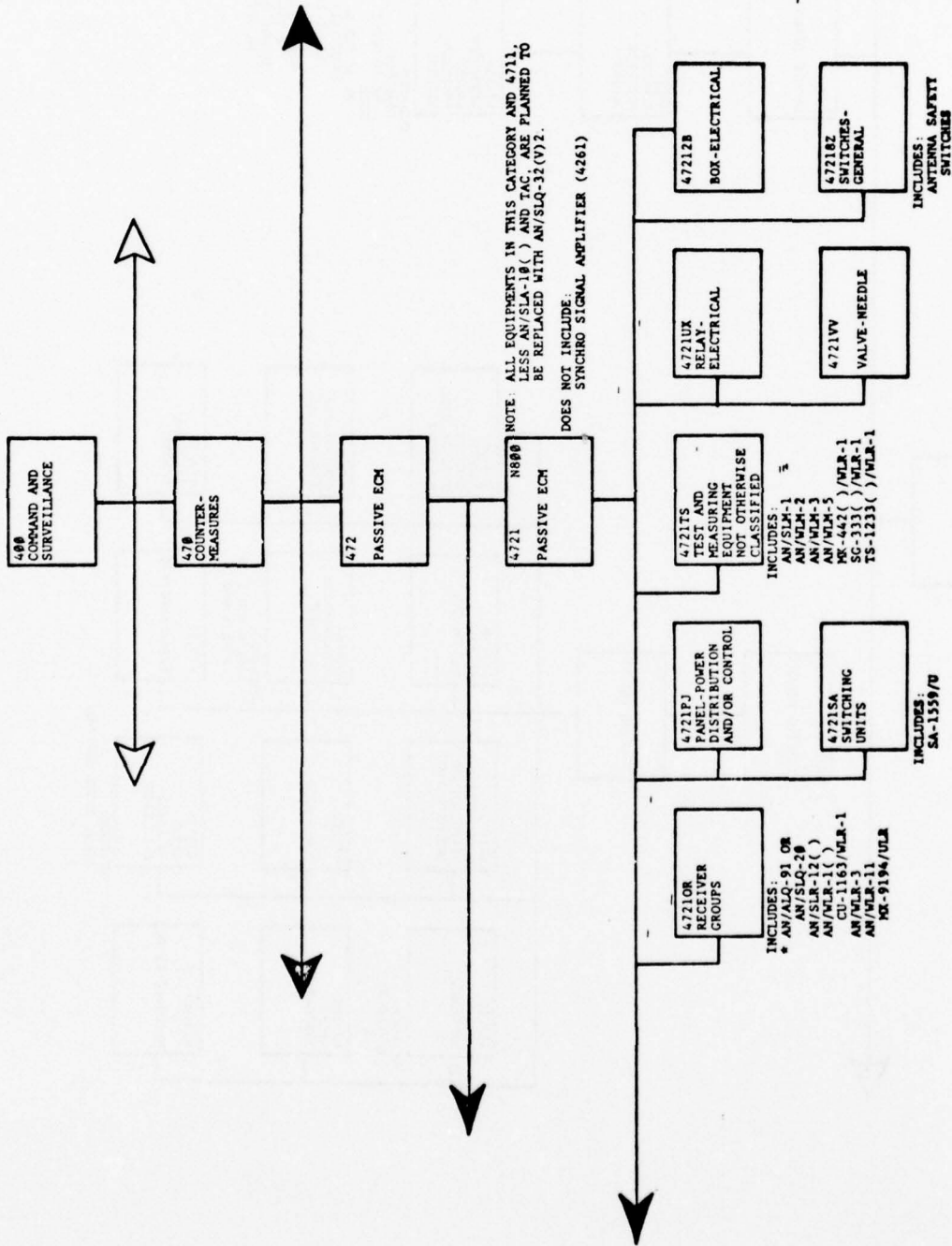

NOTE: ALL EQUIPMENTS IN THIS CATEGORY AND 4711, LESS AN/SLA-18() AND TAC, ARE PLANNED TO BE REPLACED WITH AN/SLQ-32(V)2. DOES NOT INCLUDE: SYNCHRO SIGNAL AMPLIFIER (4261)

* NOTE: SOME SHIPS MAY HAVE ONLY CABLING AND FOUNDATIONS PROVIDED FOR THIS INSTALLATION.

DDC-2 CLASS PREPARED 6-20-78

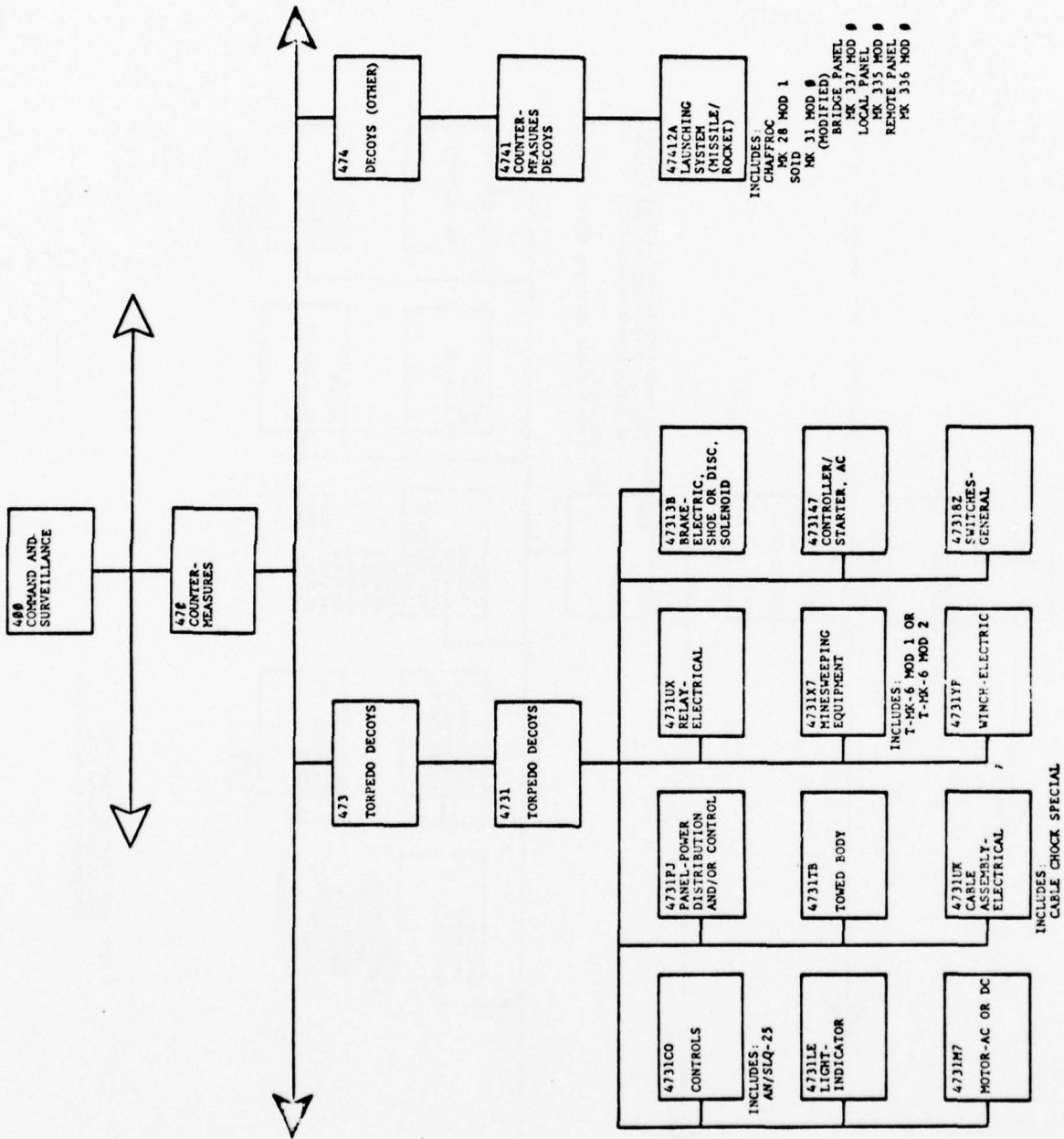

DDC-2 CLASS
PREPARED 4-4-78

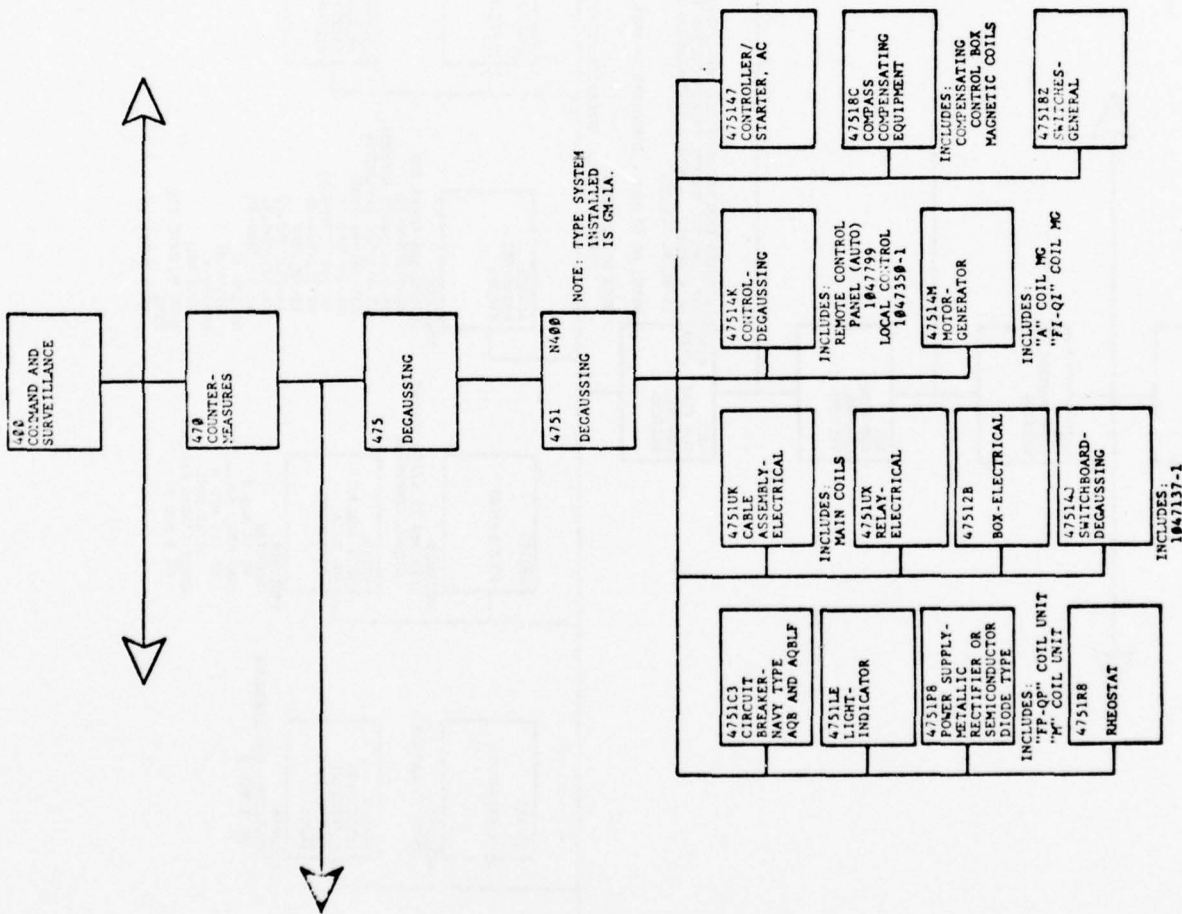

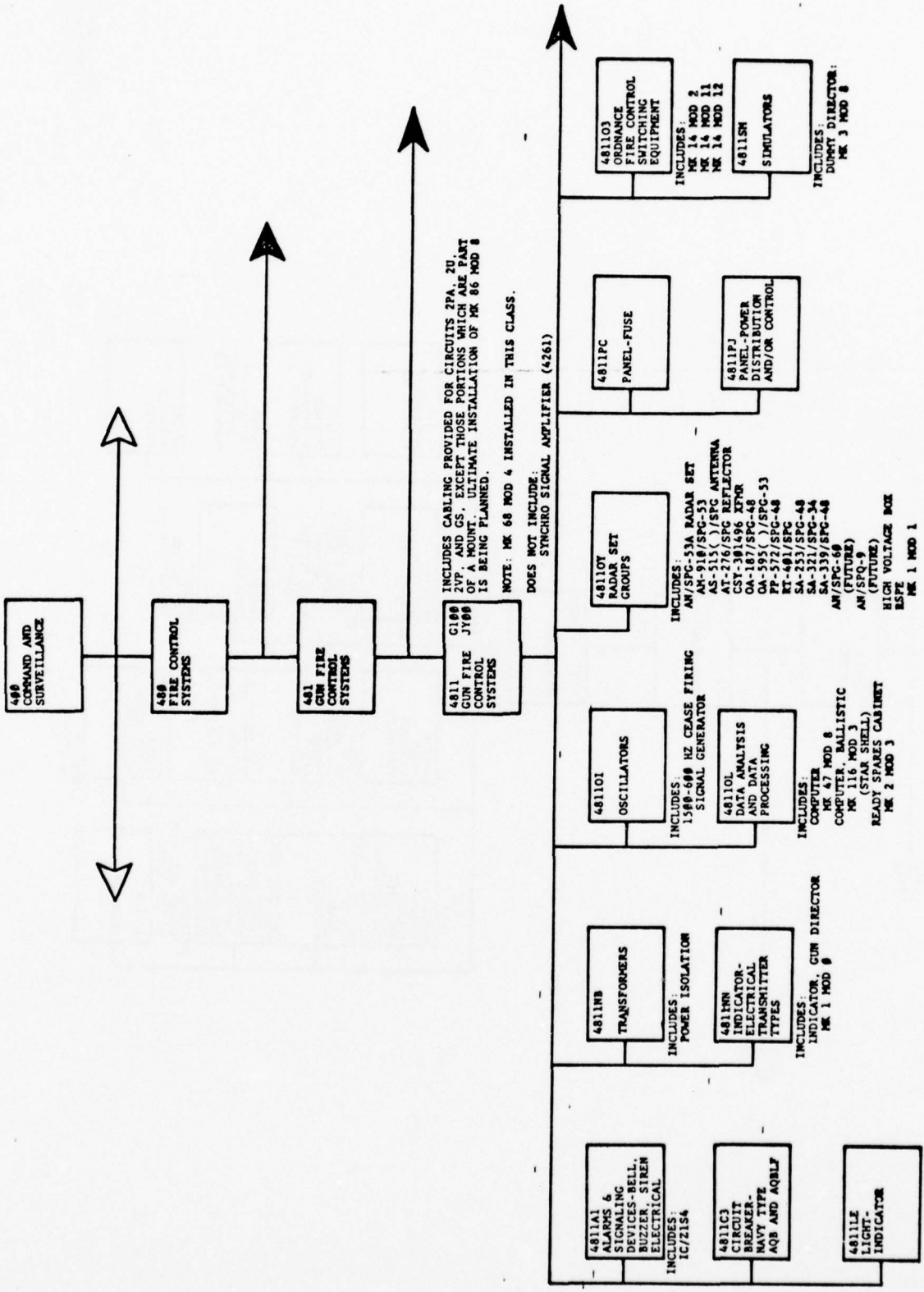

INCLUDES CABLING PROVIDED FOR CIRCUITS 2PA, 2H, 2VP, AND GS, EXCEPT THOSE PORTIONS WHICH ARE PART OF A MOUNT. ULTIMATE INSTALLATION OF MK 86 MOD 8 IS BEING PLANNED.

NOTE: MK 68 MOD 4 INSTALLED IN THIS CLASS.

DOES NOT INCLUDE: SYNCHRO SIGNAL AMPLIFIER (4261)

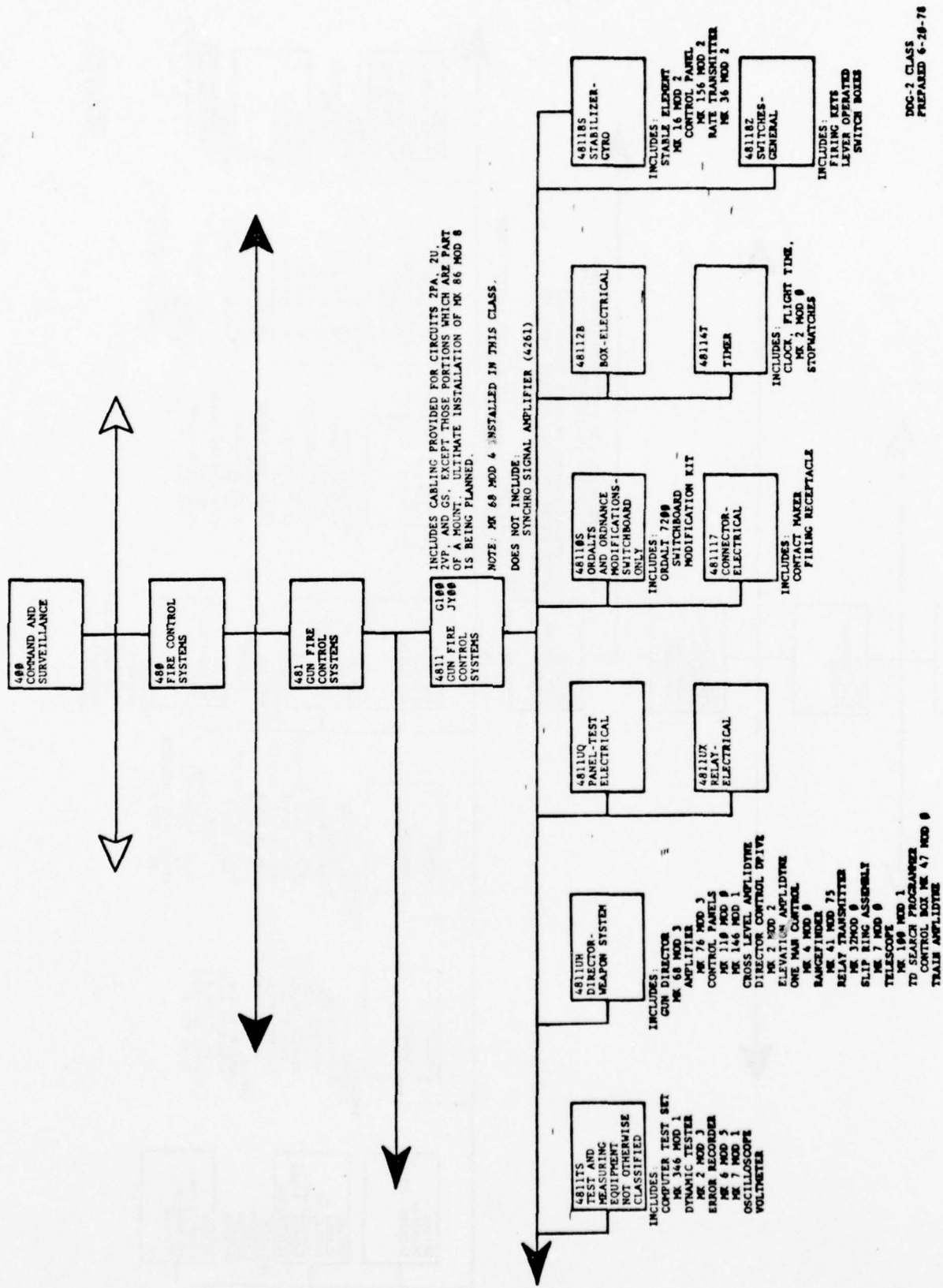

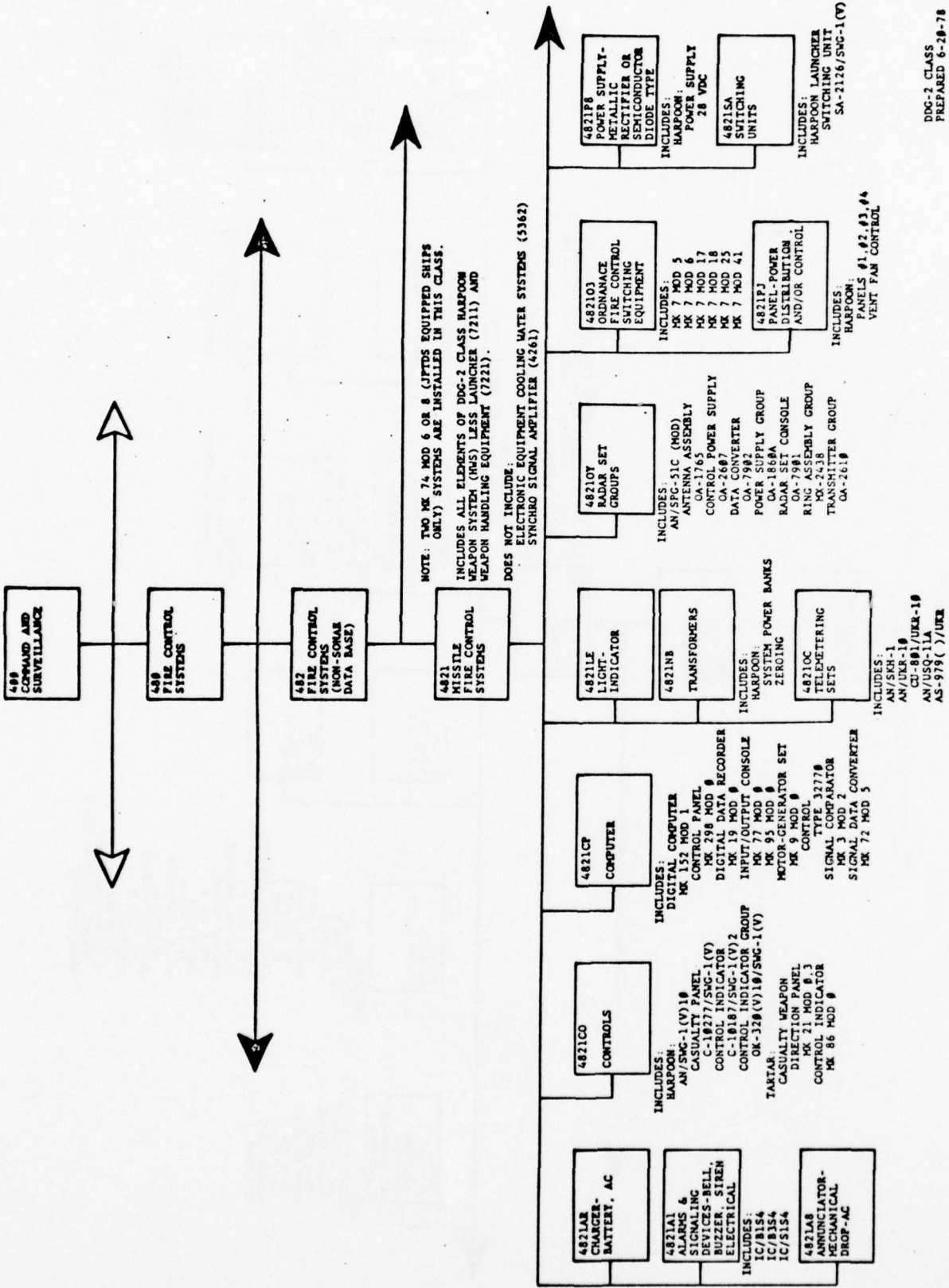

DDG-2 CLASS
PREPARED 6-28-78

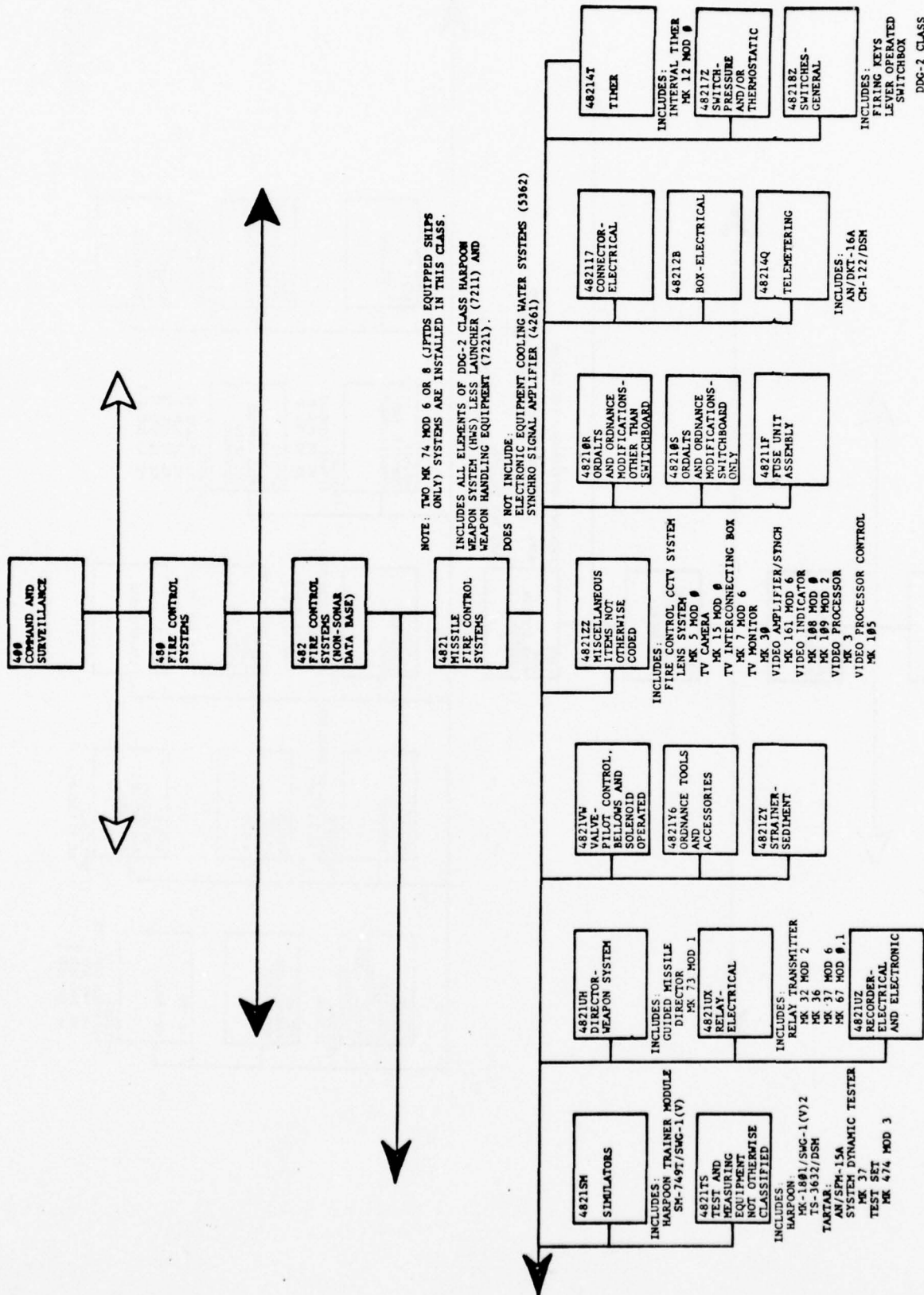

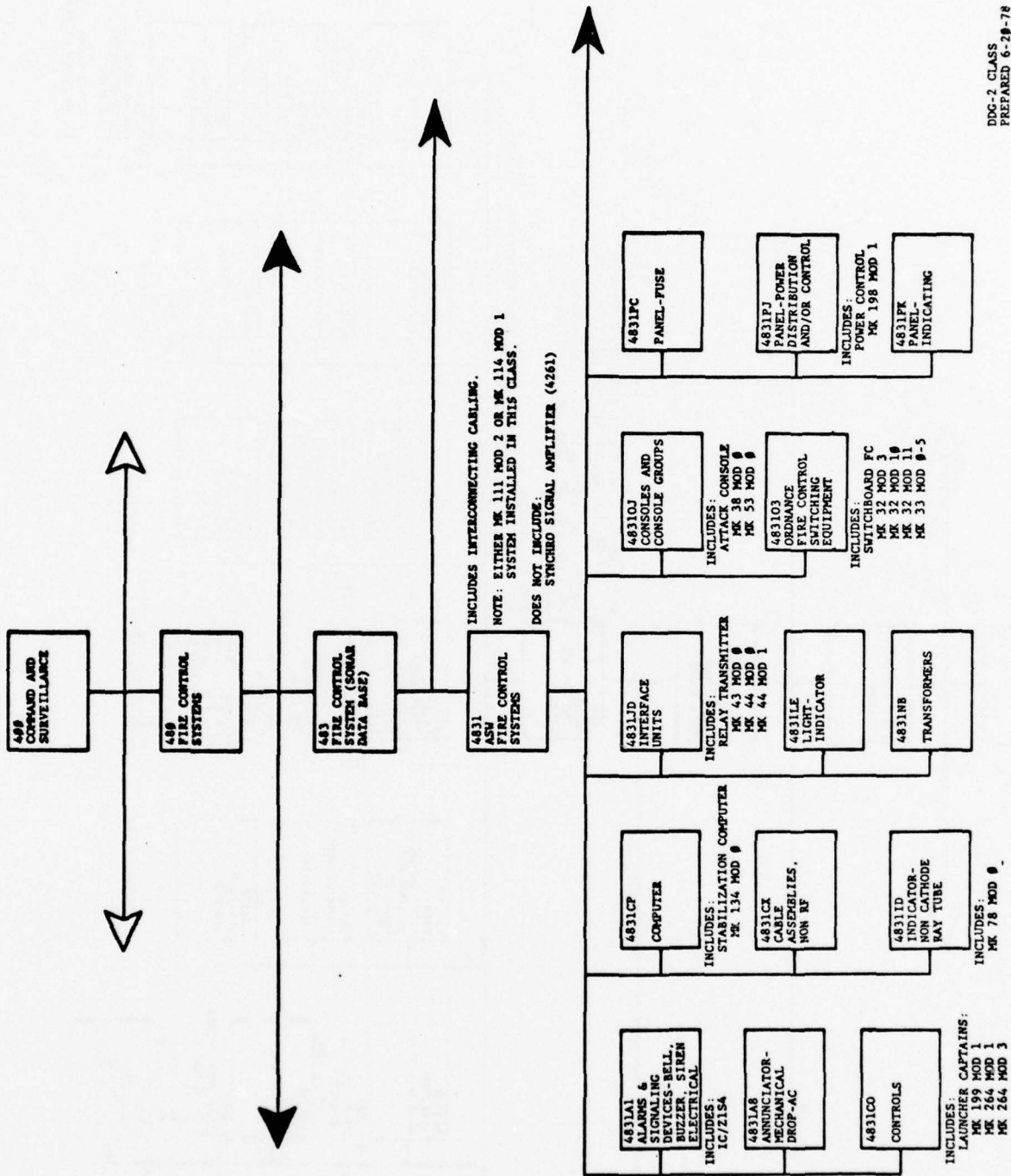

DDG-2 CLASS
PREPARED 6-20-78

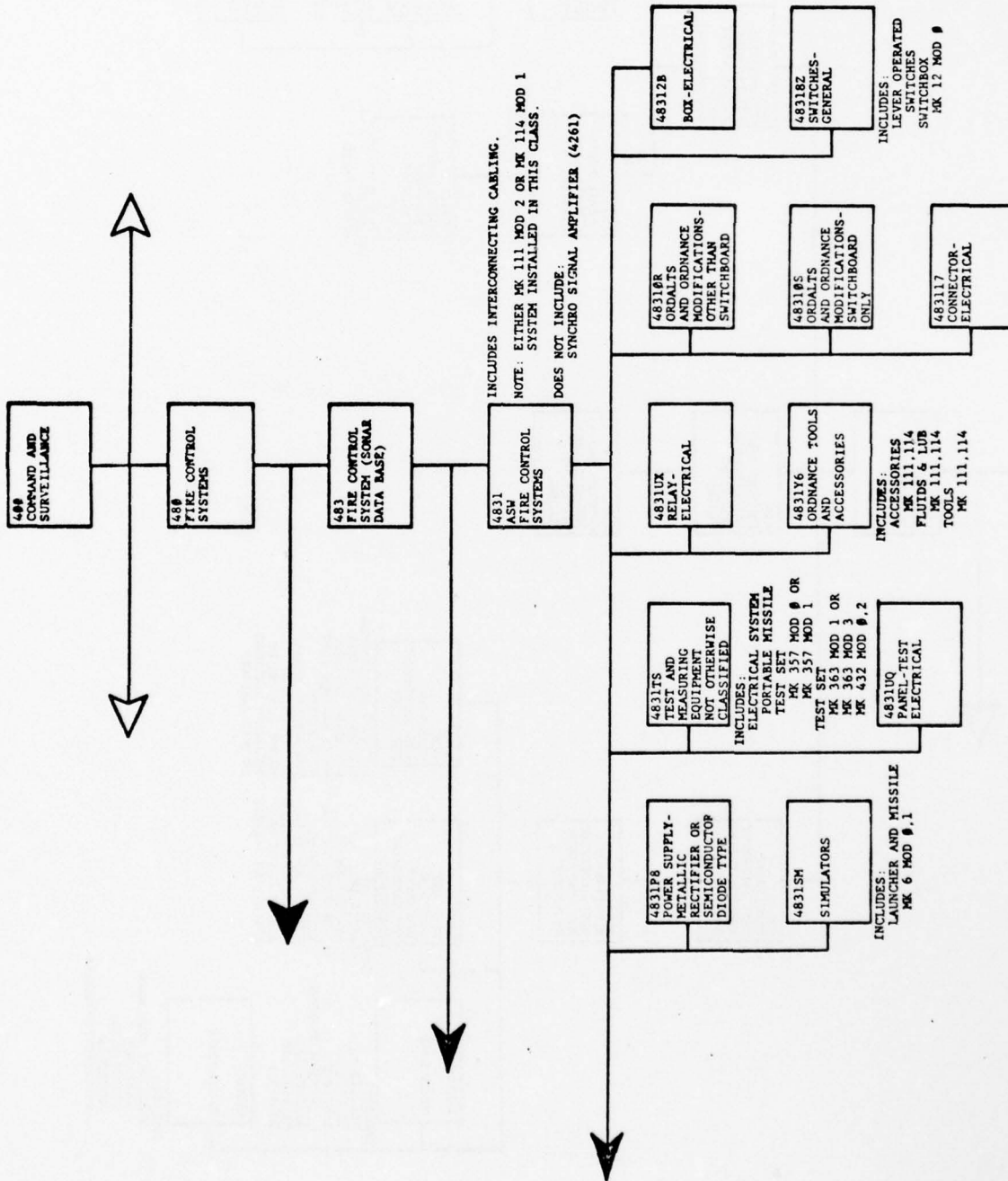

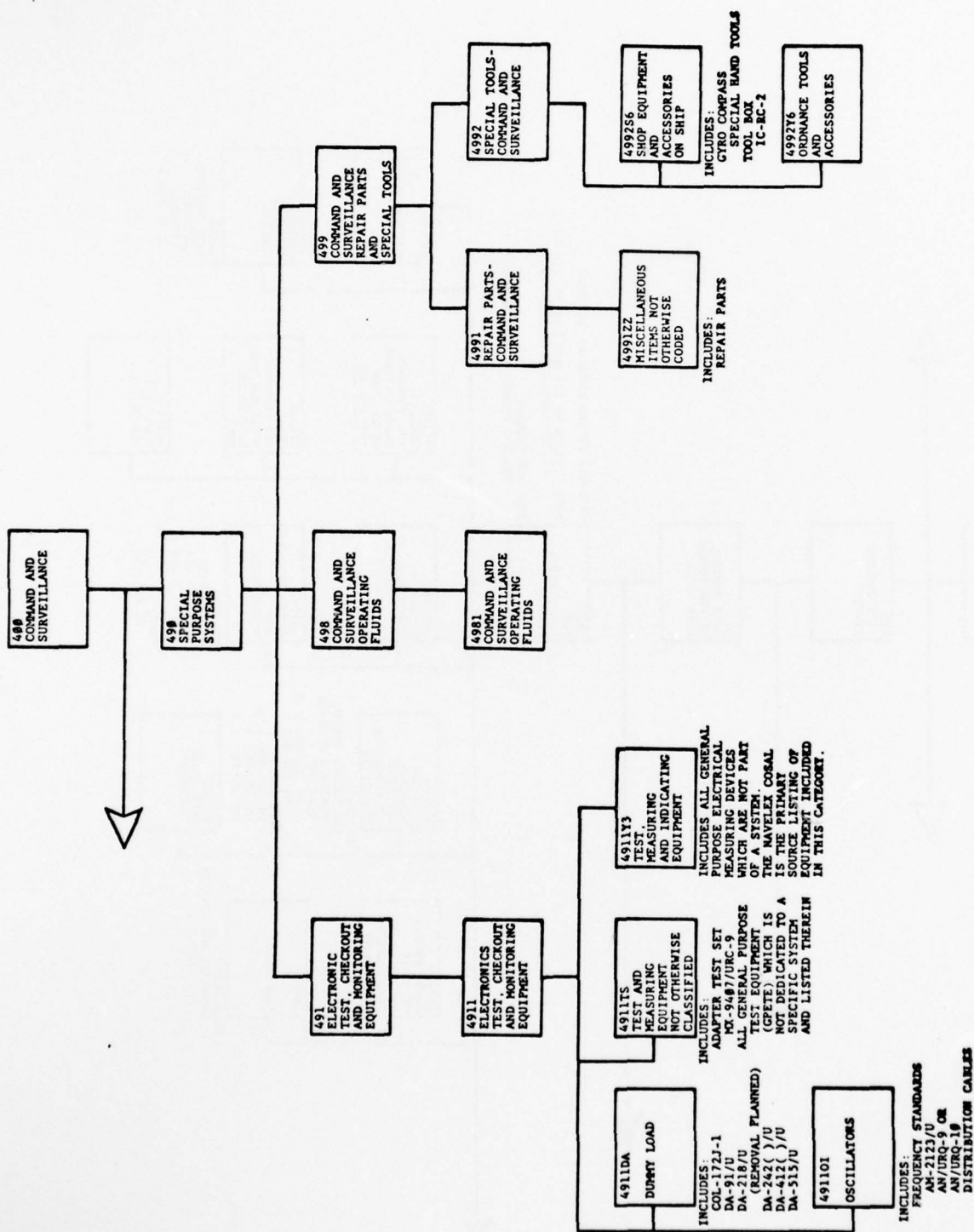

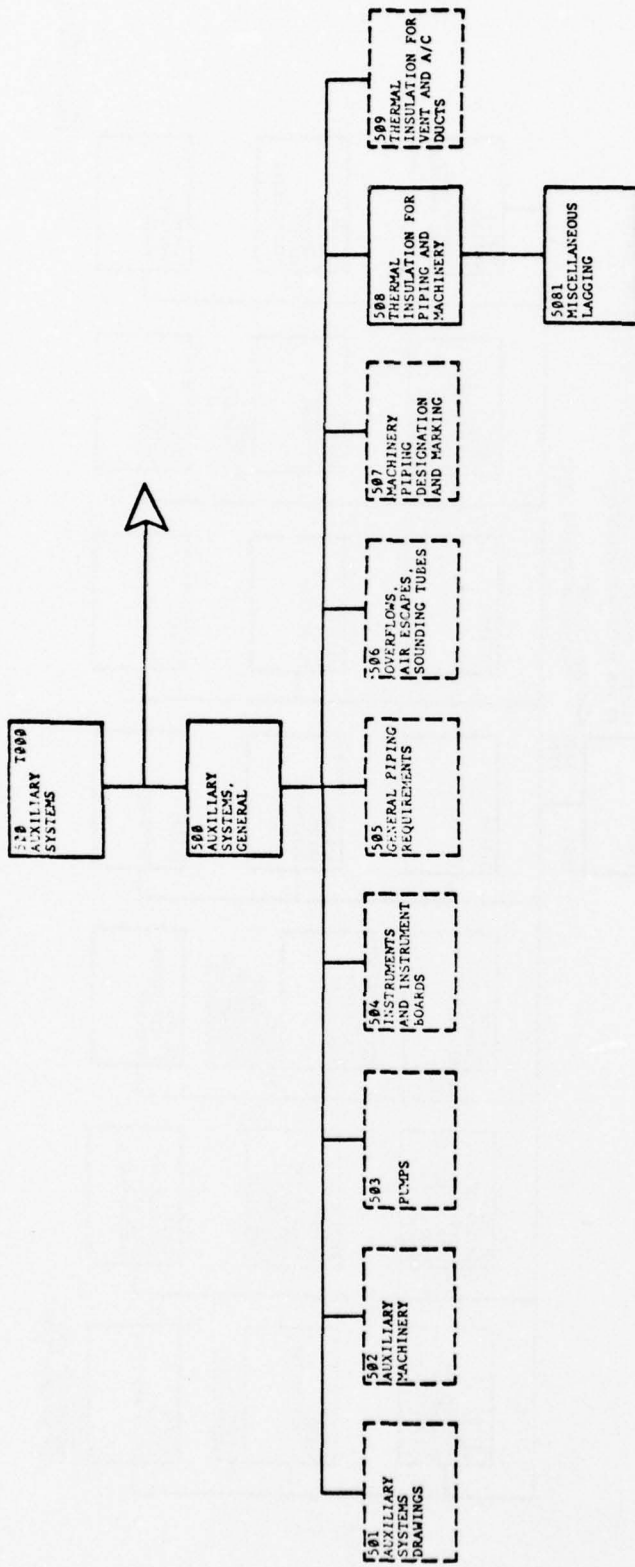

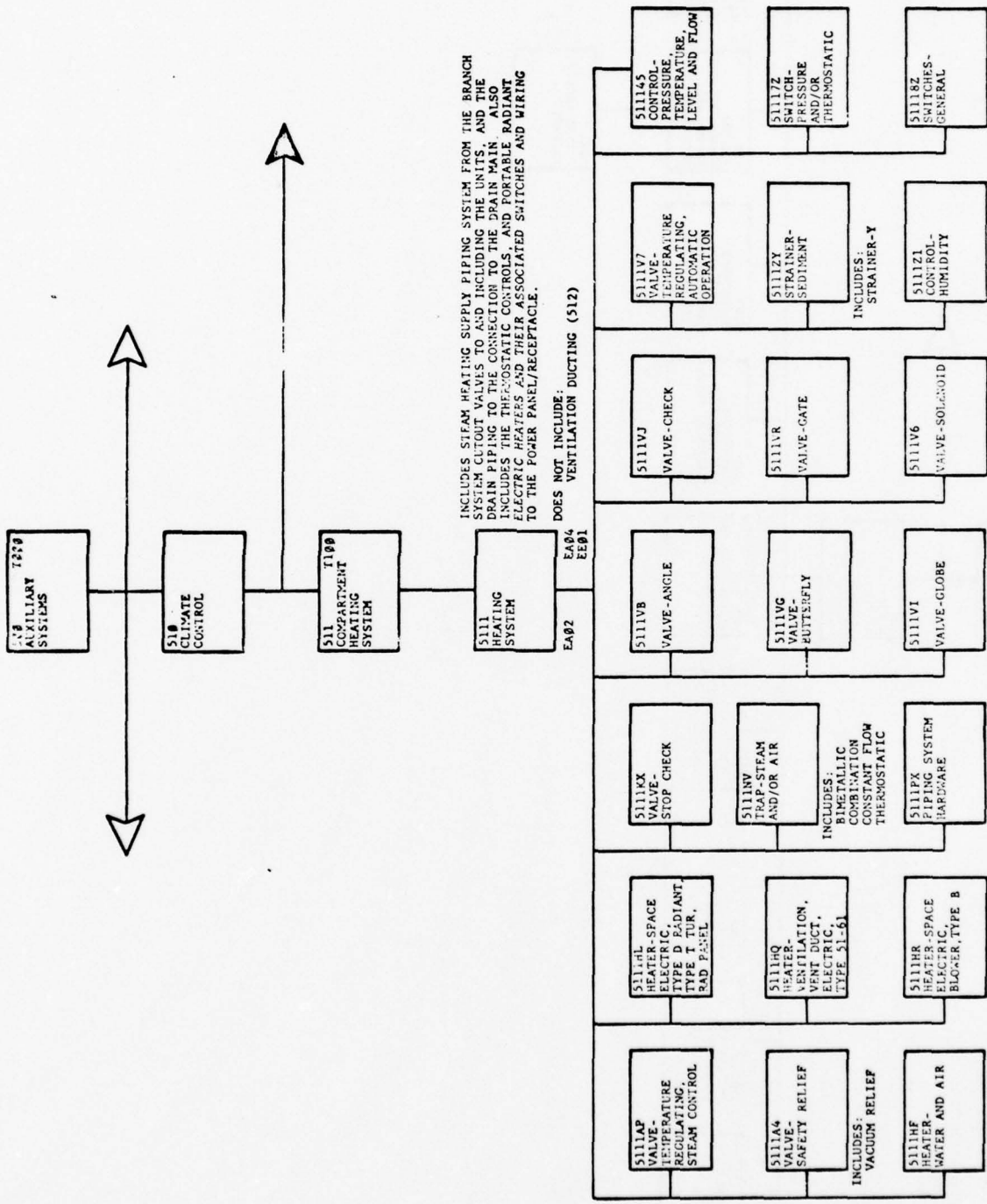

INCLUDES STEAM HEATING SUPPLY PIPING SYSTEM FROM THE BRANCH SYSTEM CUTOFF VALVES TO AND INCLUDING THE UNITS, AND THE DRAIN PIPING TO THE CONNECTION TO THE DRAIN MAIN. ALSO INCLUDES THE THERMOSTATIC CONTROLS, AND PORTABLE RADIANT ELECTRIC HEATERS AND THEIR ASSOCIATED SWITCHES AND WIRING TO THE POWER PANEL/RECEPTACLE.

DOES NOT INCLUDE:
VENTILATION DUCTING (512)

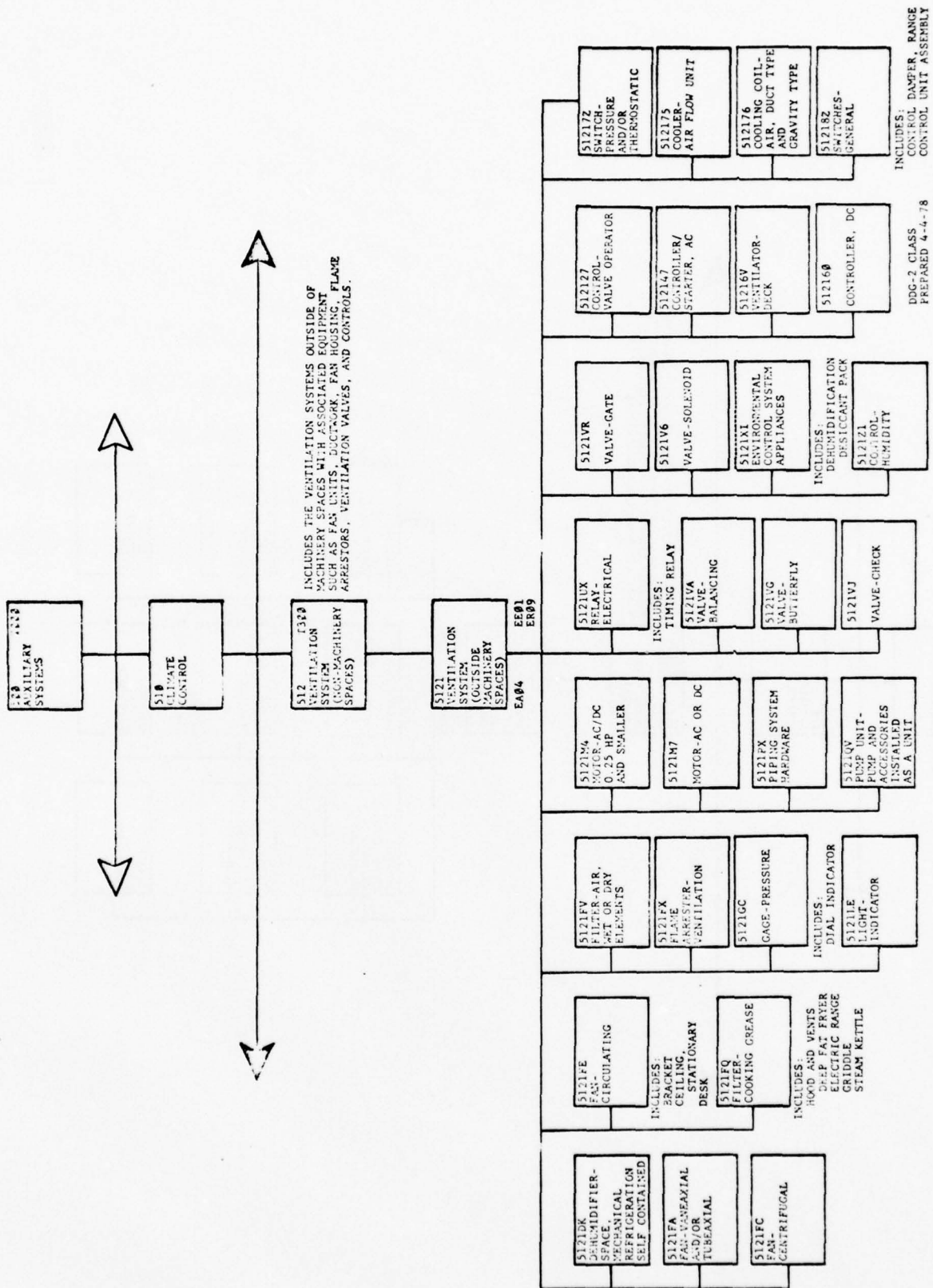

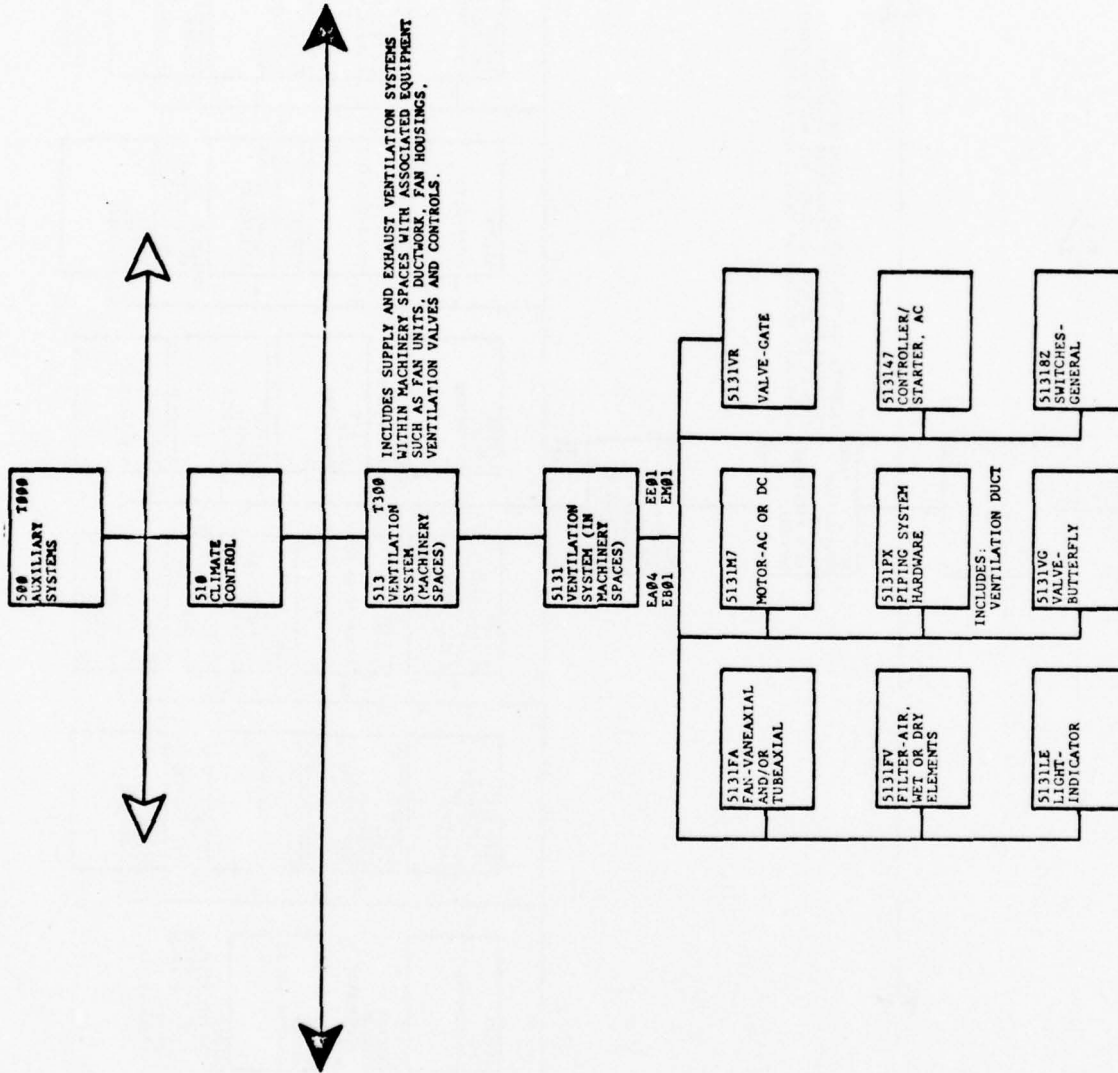

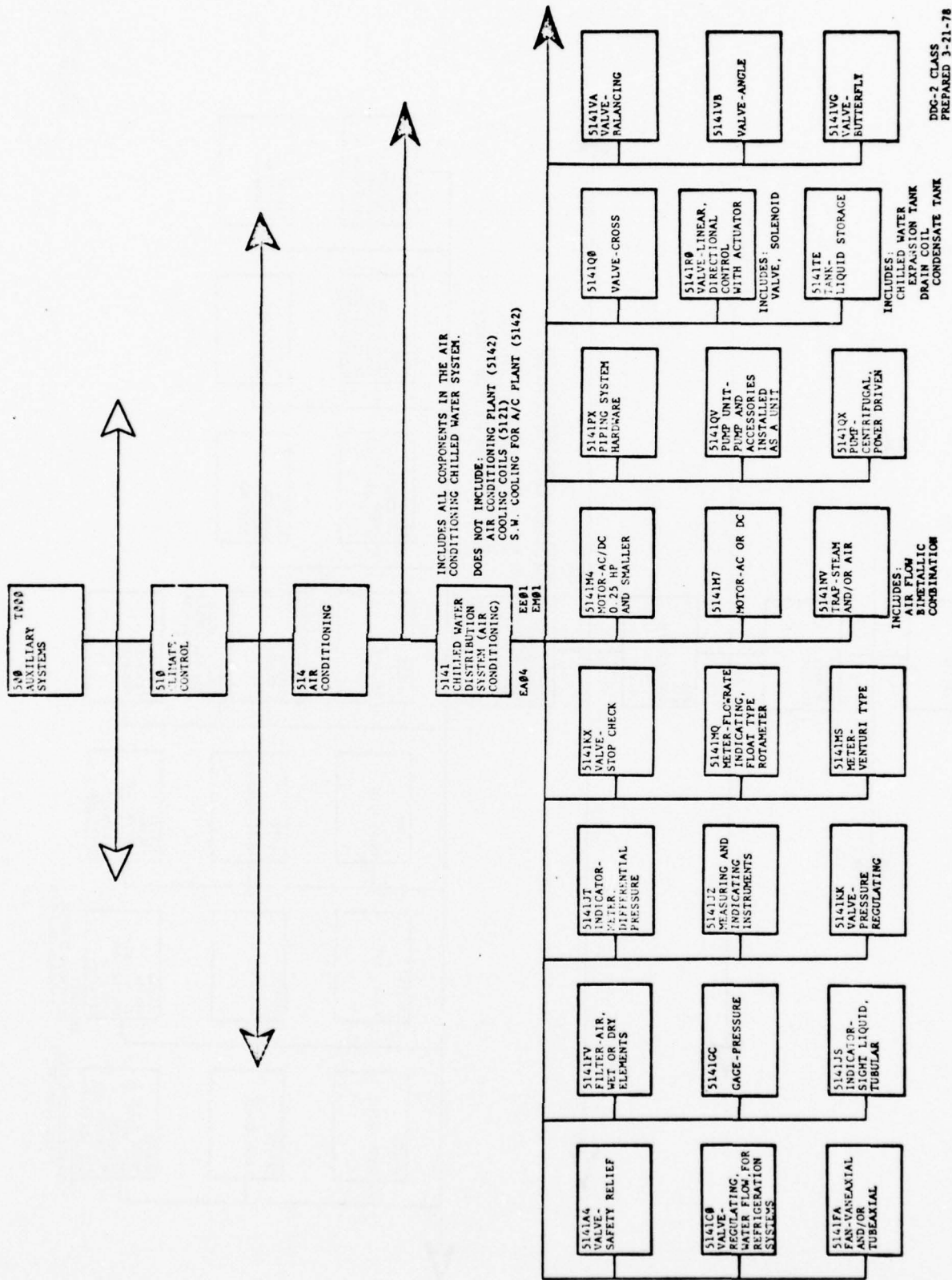

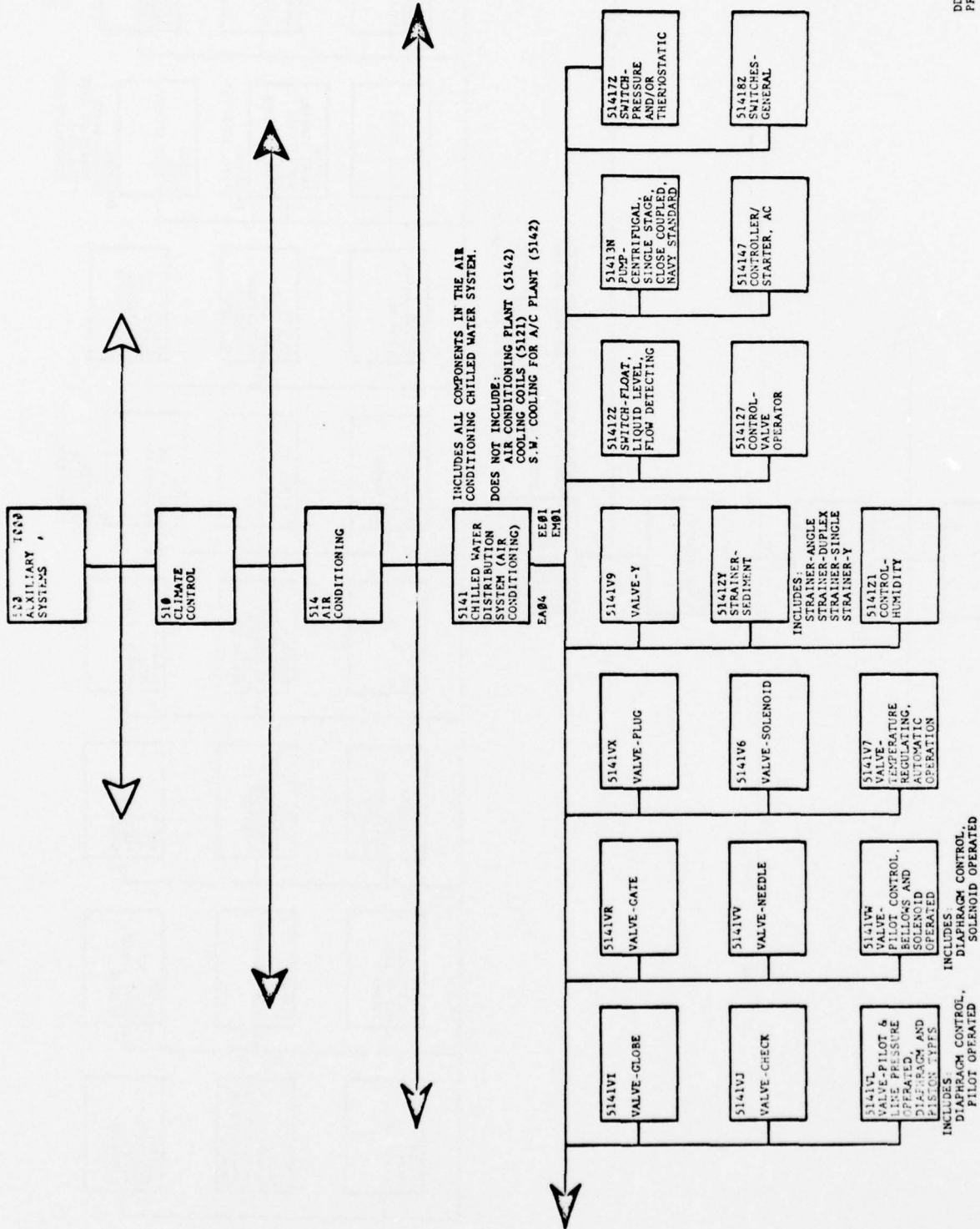

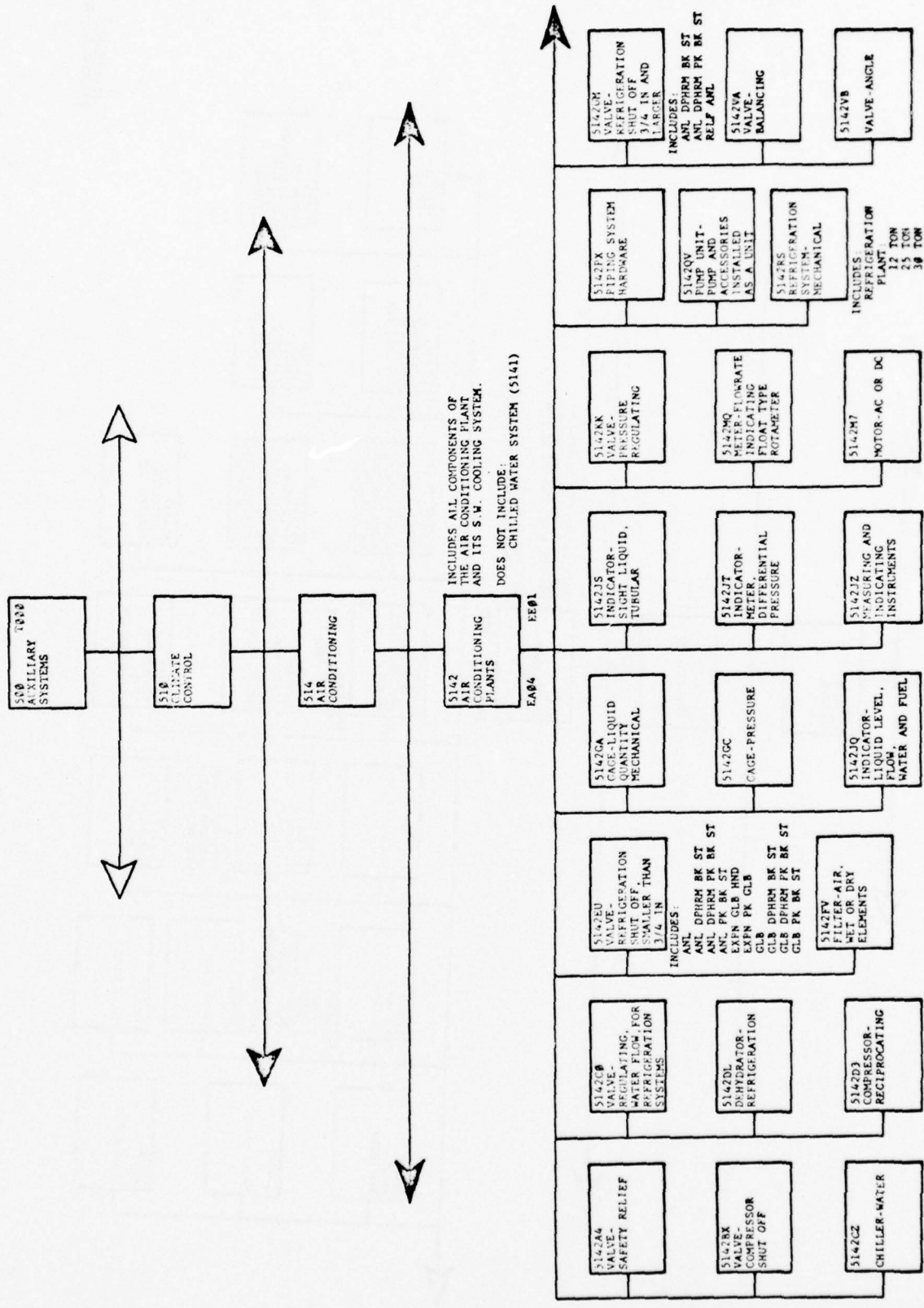

DDG-2 CLASS
PREPARED 3-21-78

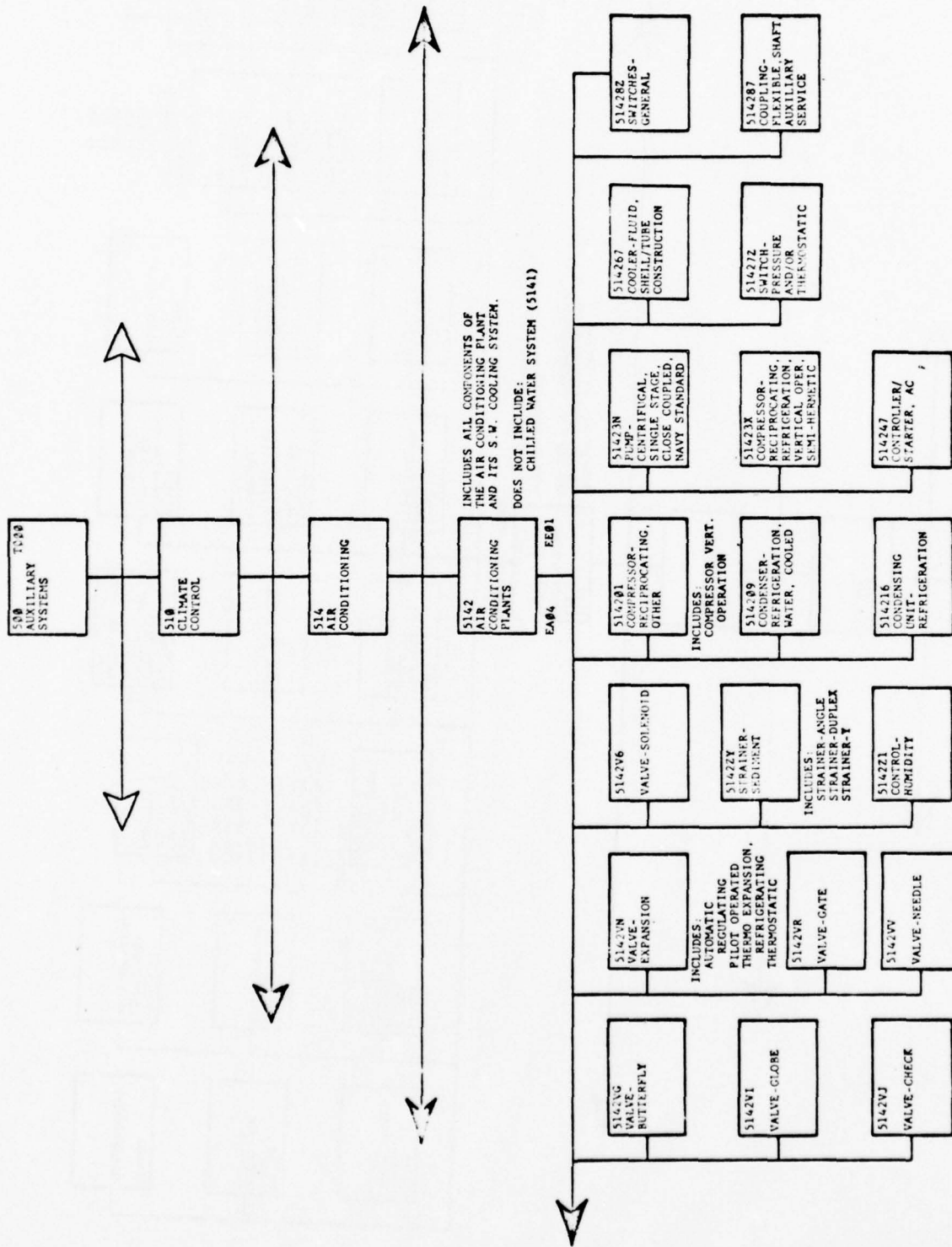

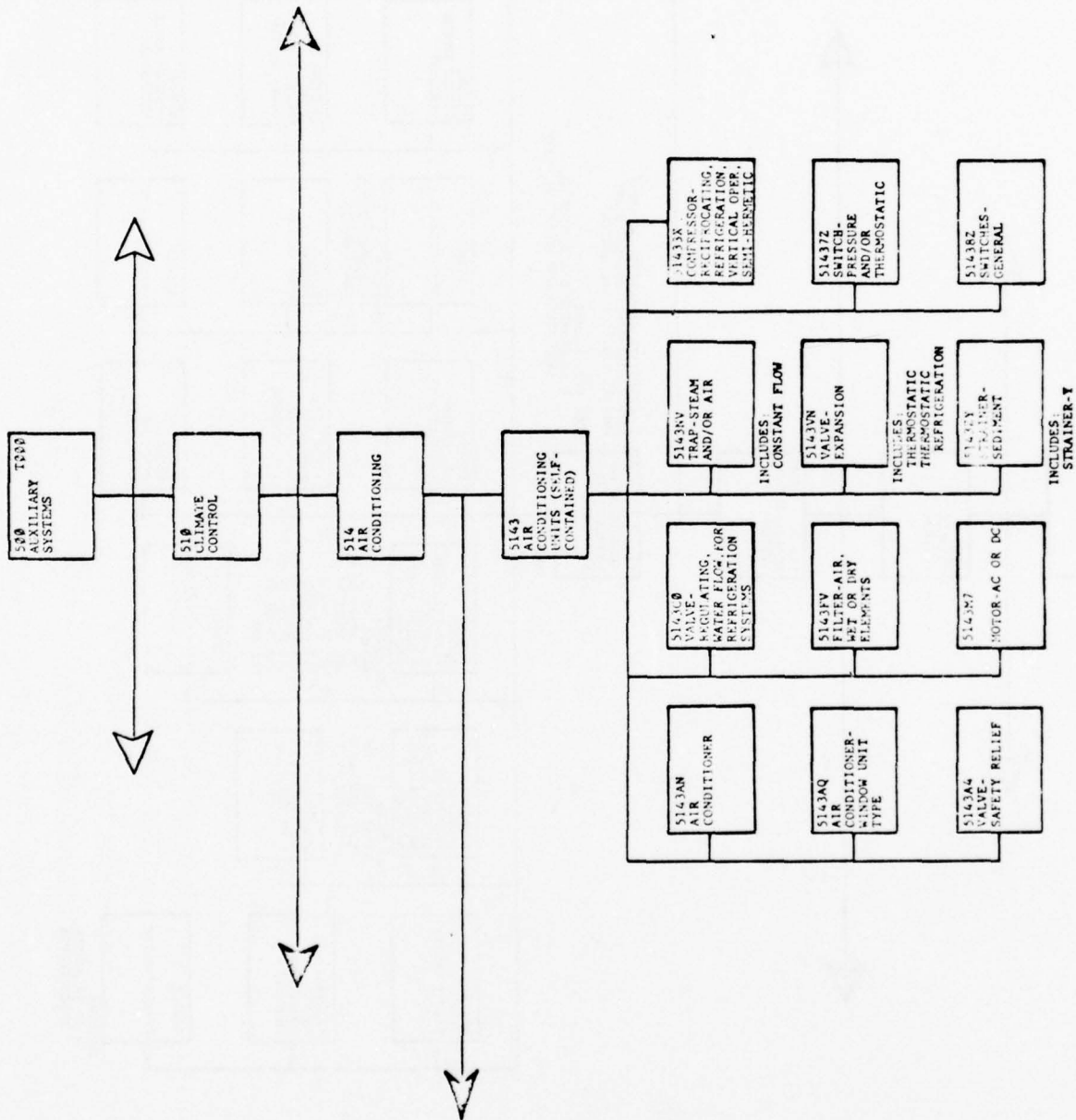

500
AUXILIARY
SYSTEMS
7800

510
CLIMATE
CONTROL

516
REFRIGERATION
SYSTEM
7500

5161
REFRIGERATION
SYSTEM (SHIP
SERVICE)
7503
EE01

INCLUDES ALL COMPONENTS OF THE
SHIP STORES REFRIGERATION PLANT
AND ITS S.W. COOLING SYSTEM.
DOES NOT INCLUDE:
REFRIGERATED SPACE, THERMAL
INSULATION AND SHEATHING (635)

5161A4
VALVE-
SAFETY RELIEF

5161B
VALVE-
COMPRESSOR
SHUT OFF

5161CZ
CHILLER-WATER
INCLUDES
HEAT EXCHANGER,
REFRIGERATOR

5161C0
VALVE-
REGULATING,
WATER FLOW, FOR
REFRIGERATION
SYSTEMS
INCLUDES:
PRESS REG, REG
PRESS REG, SUCT
PRESS REG, WTR

5161D1
VALVE-COR-
REFRIGERATION

5161E0
VALVE-
REFRIGERATION
SHUT OFF,
SMALLER THAN
3/4 IN
INCLUDES:
ANL BK ST
ANL DPHM BK ST
ANL DPHM FK BK ST
ANL P BK ST
EXP GLB BK ST
GLB DPHM BK ST
GLB DPHM FK BK ST
GLB FK BK ST
RLF ANL

5161CC
CAGE-PRESSURE

5161J5
INDICATOR-
SIGHT LIQUID,
TUBULAR

5161JZ
MEASURING
INSTRUMENTS

5161NK
VALVE
PRESSURE
REGULATING

5161KW
TANK-STORAGE
INCLUDES:
RECEIVER, LIQUID
REFRIGERANT

5161KX
VALVE-
STOP CHECK

5161M7
MOTOR-AC OR DC

5161PX
PIPING SYSTEM
HARDWARE

5161QX
PUMP-
CENTRIFUGAL,
POWER DRIVEN

5161QY
REFRIGERATION-
MECHANICAL

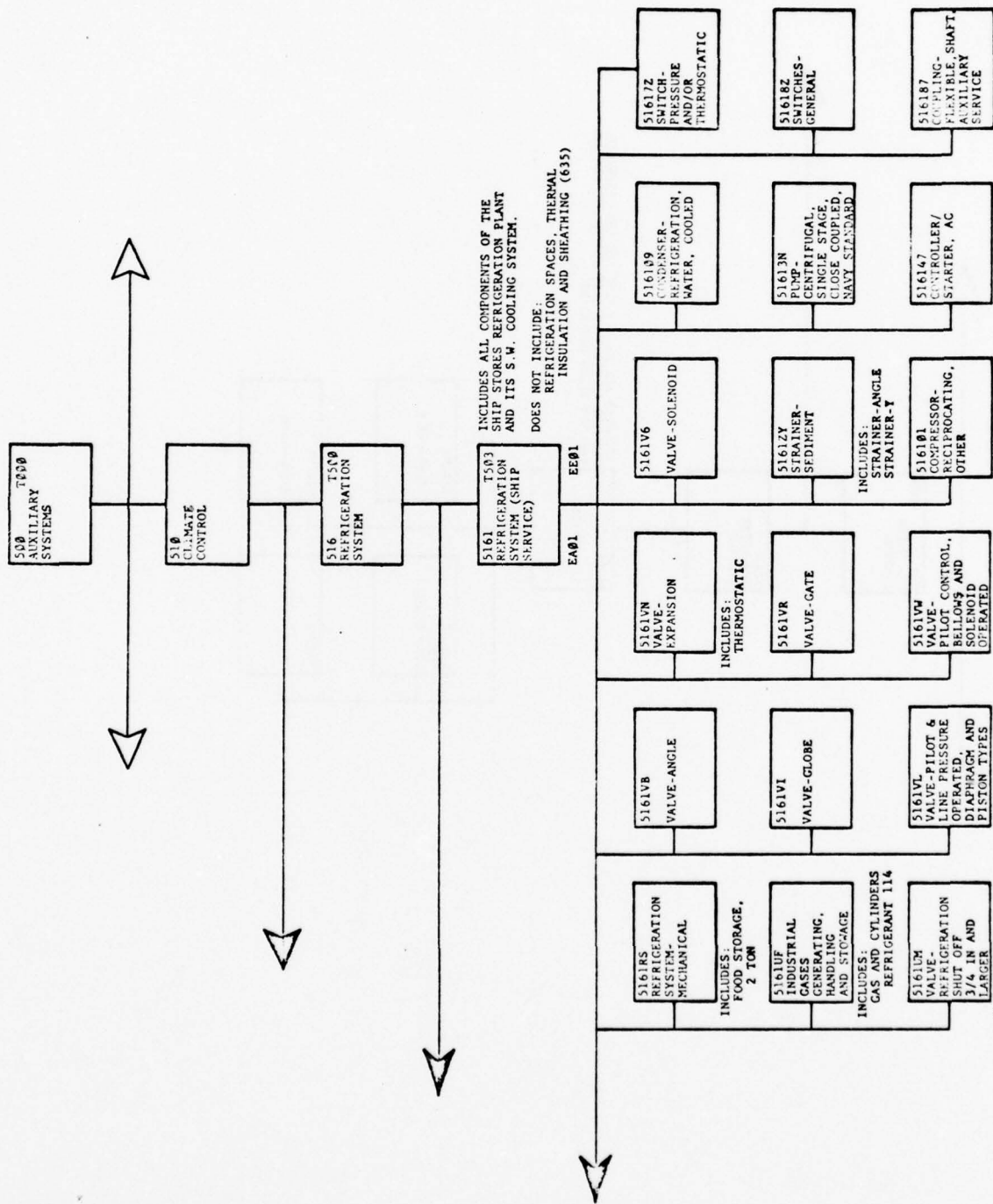

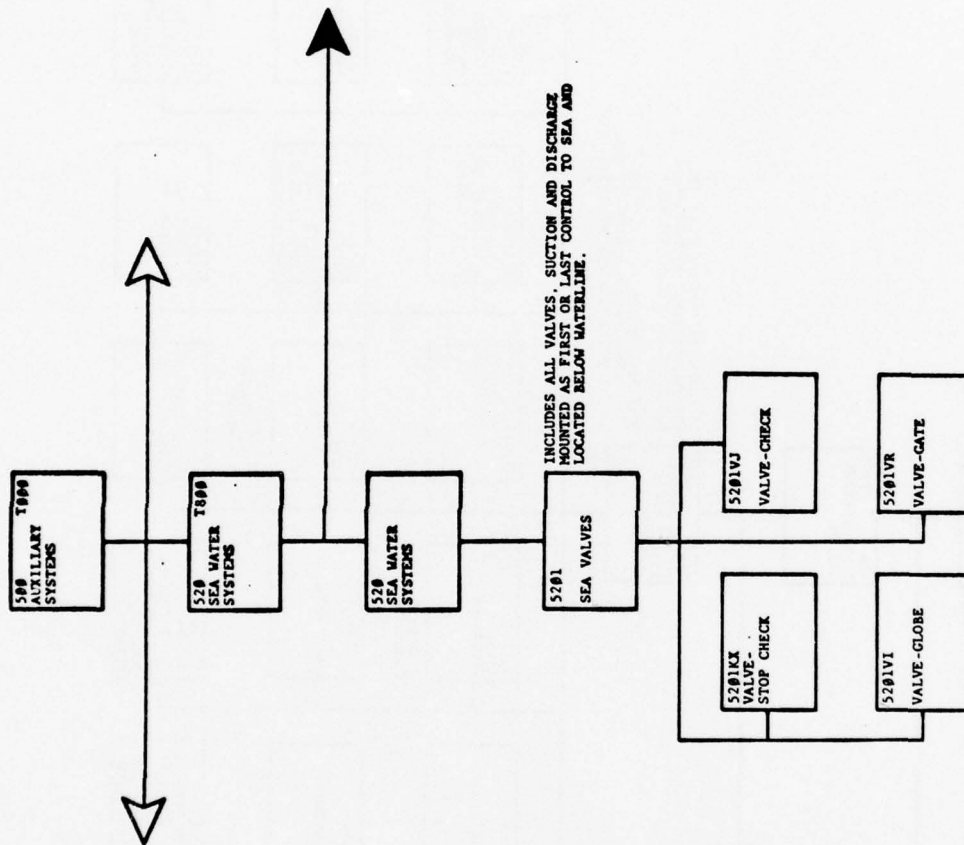

DDG-2 CLASS
PREPARED 6-28-78

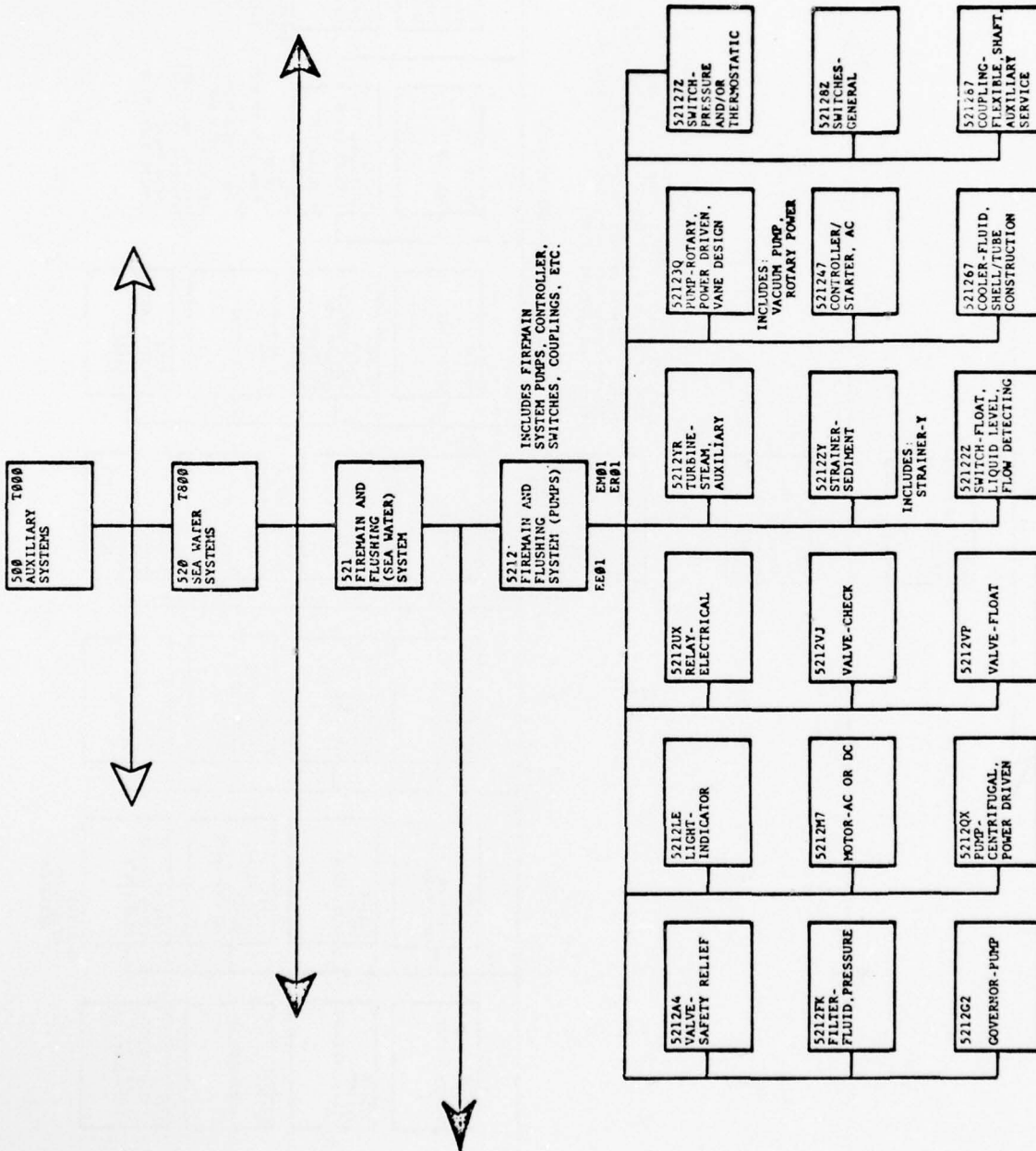

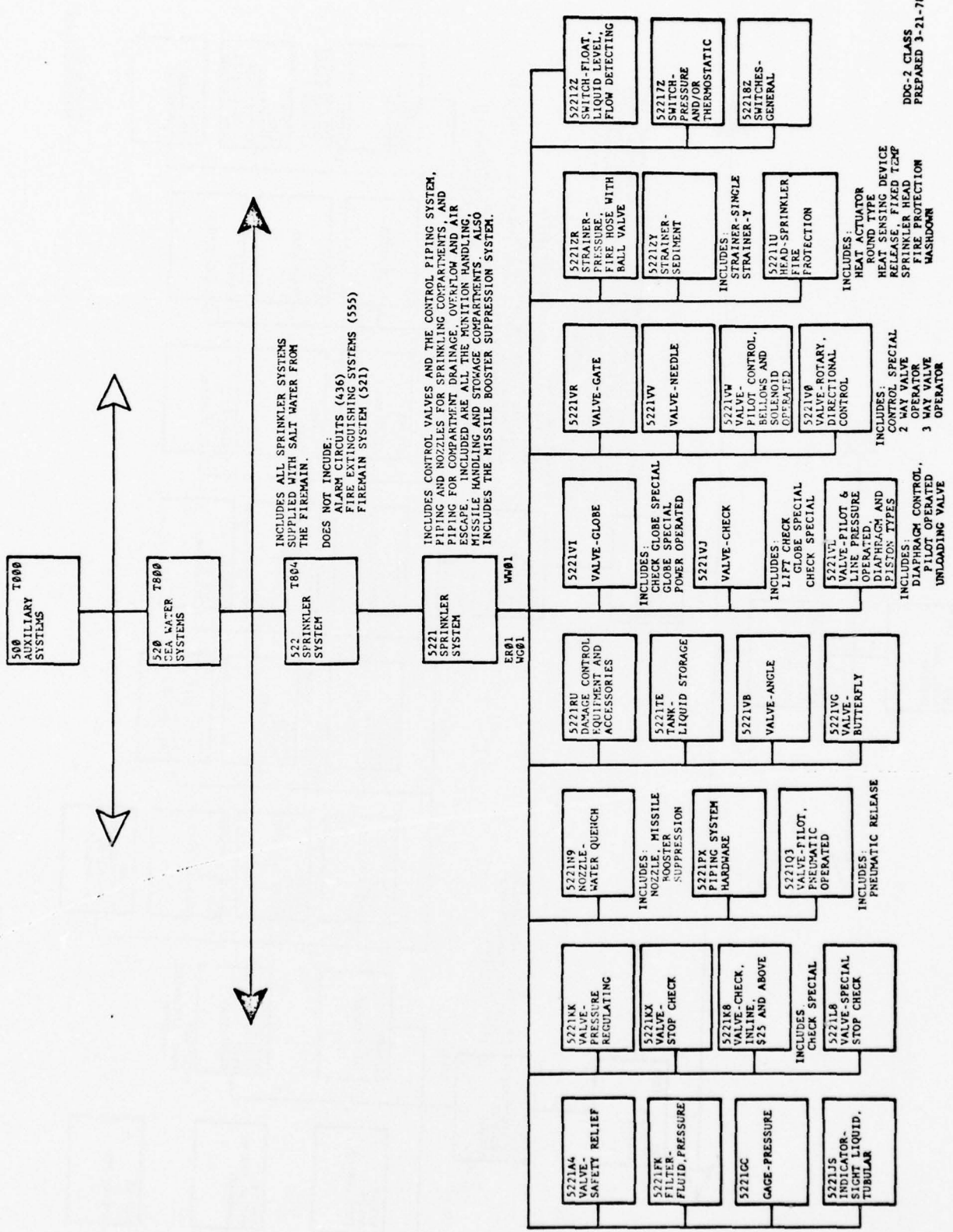

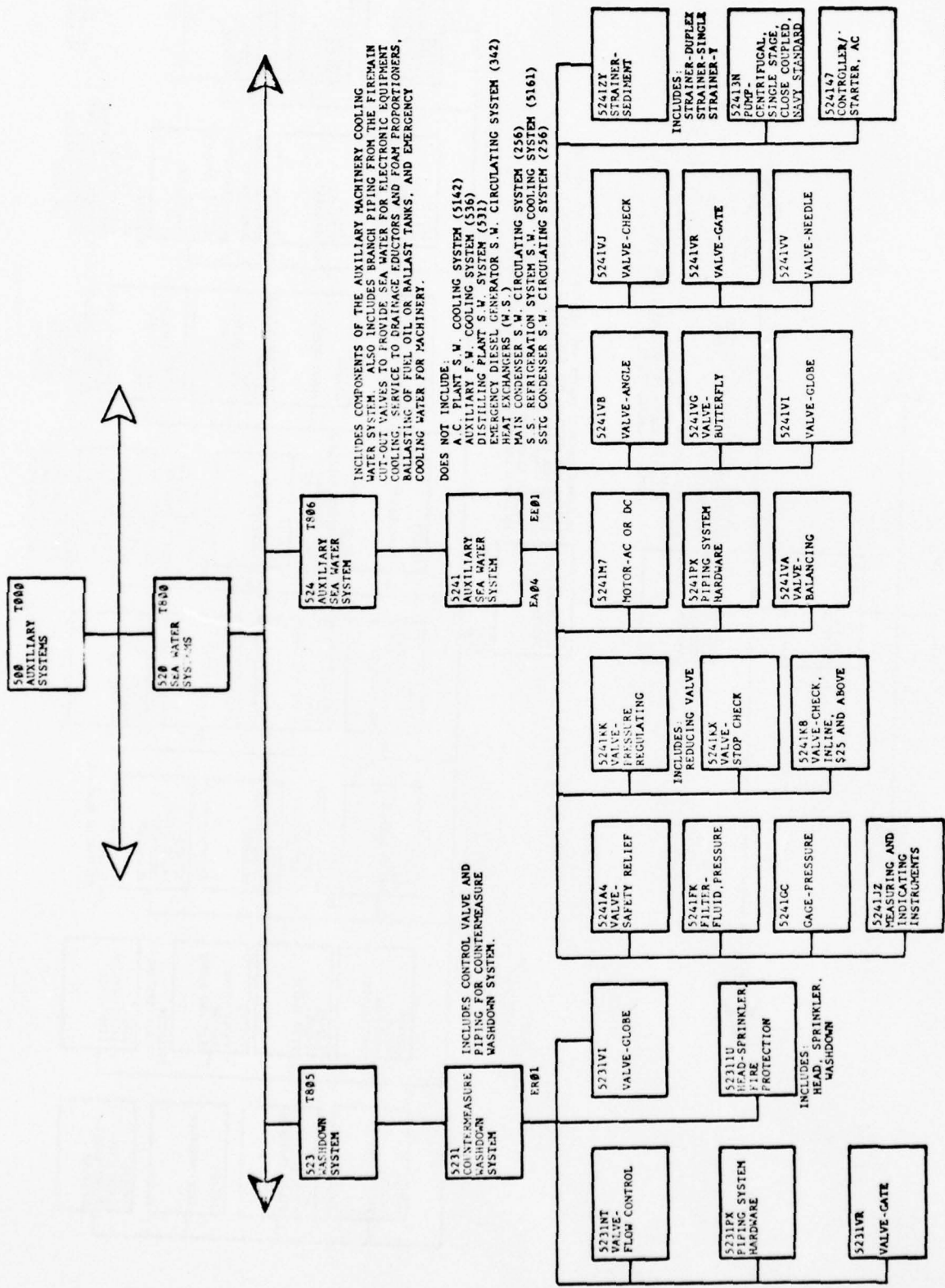

INCLUDES COMPONENTS OF THE AUXILIARY MACHINERY COOLING WATER SYSTEM. ALSO INCLUDES BRANCH PIPING FROM THE FIREMAIN CUT-OUT VALVES TO PROVIDE SEA WATER FOR ELECTRONIC EQUIPMENT COOLING. SUPPLY TO EMERGENCY EXHAUSTORS AND FOAM PROPORIONERS, BOLLING OF FUEL OIL, BALLAST TANKS, AND EMERGENCY COOLING WATER FOR MACHINERY.

DOES NOT INCLUDE:
 A. C. PLANT S. W. COOLING SYSTEM (51422)
 AUXILIARY F. W. COOLING SYSTEM (536)
 DISTILLING PLANT S. W. SYSTEM (531)
 EMERGENCY DIESEL GENERATOR S. W. CIRCULATING SYSTEM (342)
 HEAT EXCHANGERS (W. S.)
 MAIN CONDENSER S. W. CIRCULATING SYSTEM (256)
 S. S. REFRIGERATION SYSTEM S. W. COOLING SYSTEM (5161)
 SSTG CONDENSER S. W. CIRCULATING SYSTEM (256)

INCLUDES:
 STRAINER-DUPLEX
 STRAINER-SINGLE
 STRAINER-Y
 52413N
 CENTRIFUGAL
 SINGLE STAGE
 CLOSE COUPLED
 NAVY STANDARD
 524147
 CONTROLLER/
 STARTER, AC

DOC-2 CLASS
 PREPARED 3-21-78

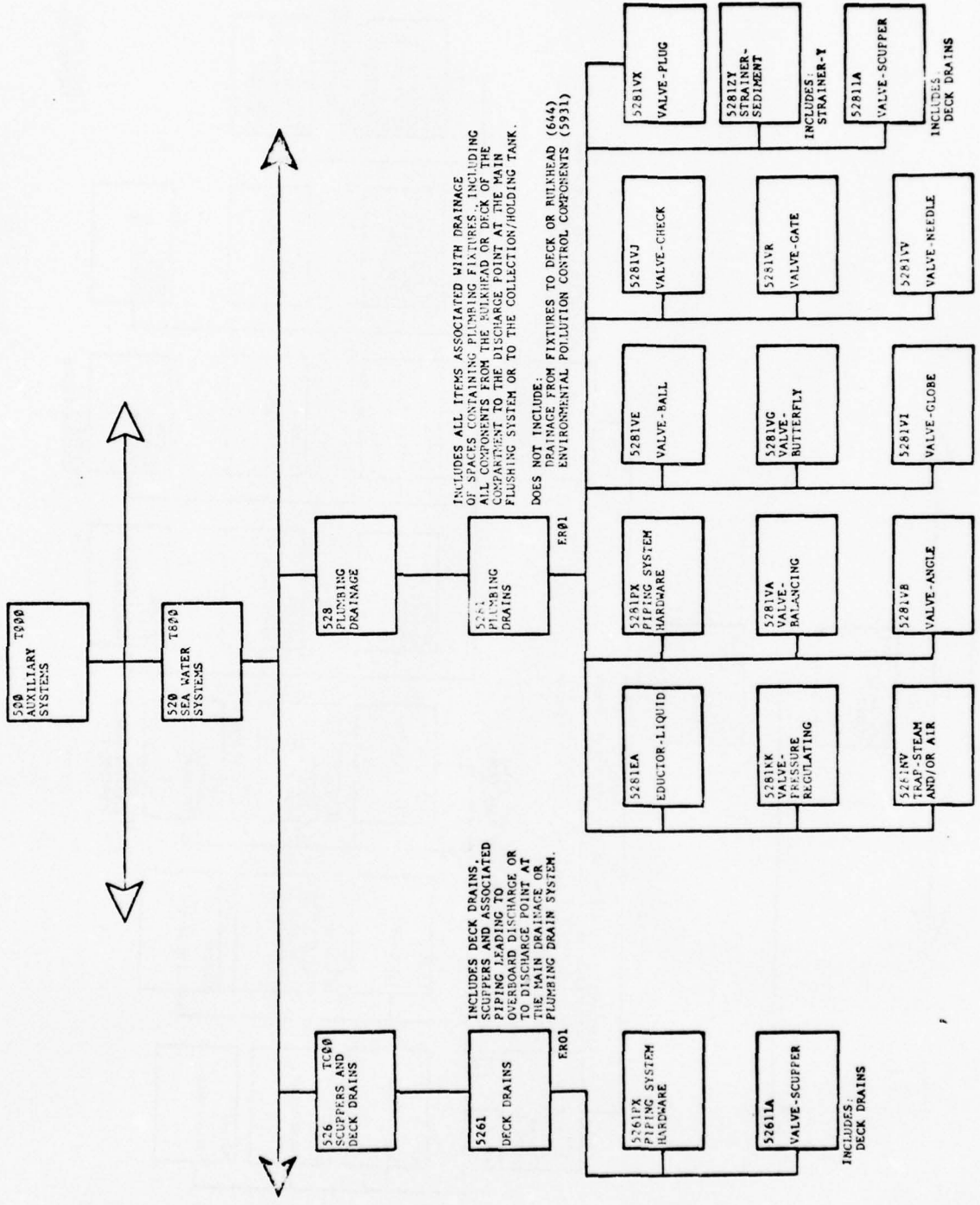

INCLUDES ALL ITEMS ASSOCIATED WITH DRAINAGE OF SPACES, PLUMBING FIXTURES INCLUDING ALL COMPONENTS FROM THE HULLHEAD OR DECK OF THE COMPARTMENT TO THE DISCHARGE POINT AT THE MAIN FLUSHING SYSTEM OR TO THE COLLECTION/HOLDING TANK.

DOES NOT INCLUDE: DRAINAGE FROM FIXTURES TO DECK OR HULLHEAD (644) ENVIRONMENTAL POLLUTION CONTROL COMPONENTS (5931)

INCLUDES DECK DRAINS, SCUPPERS AND ASSOCIATED PIPING AND FITTINGS OVERBOARD DISCHARGE OR TO DISCHARGE POINT AT THE MAIN DRAINAGE OR PLUMBING DRAIN SYSTEM.

INCLUDES: DECK DRAINS

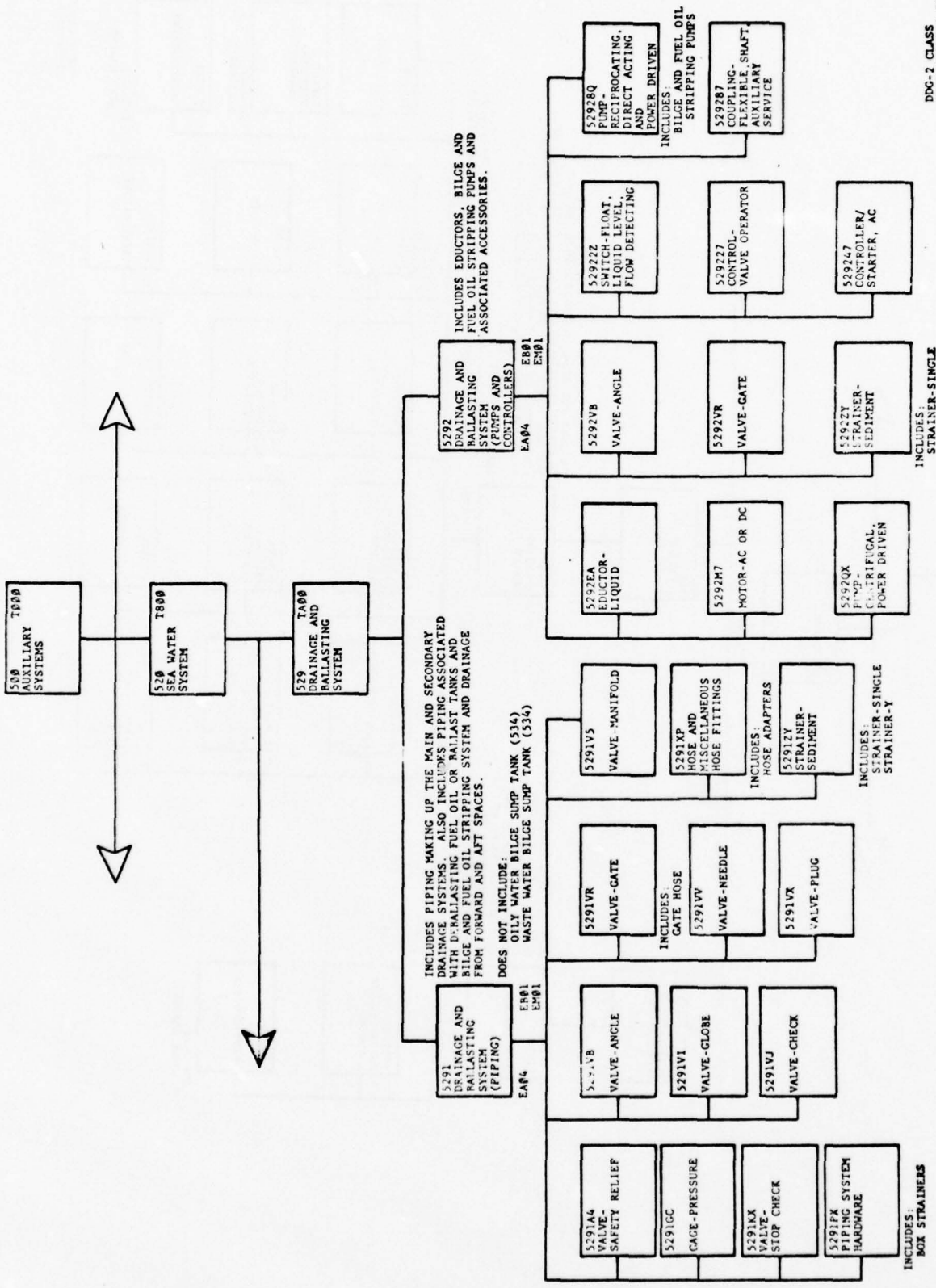

DDG-2 CLASS
PREPARED 4-4-78

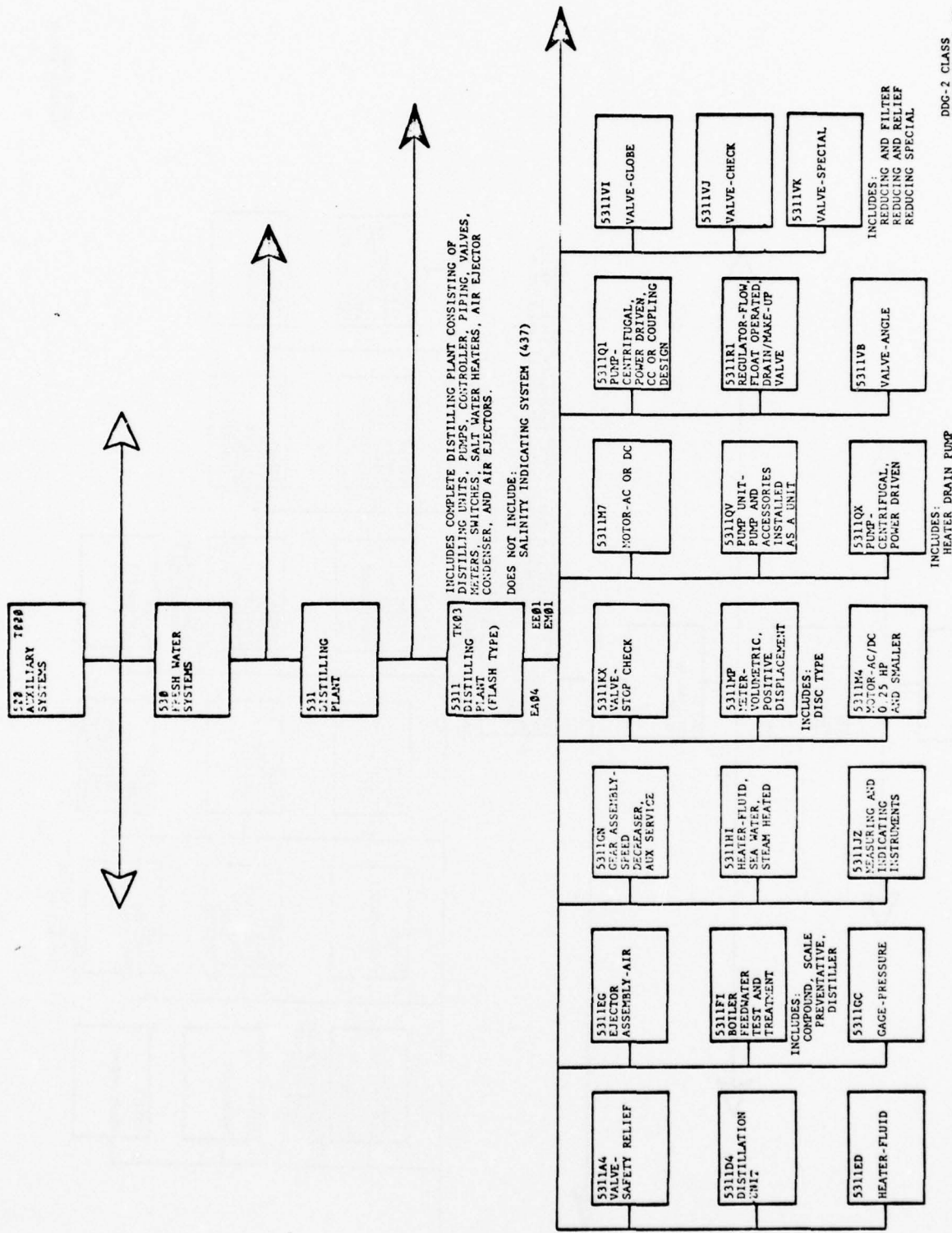

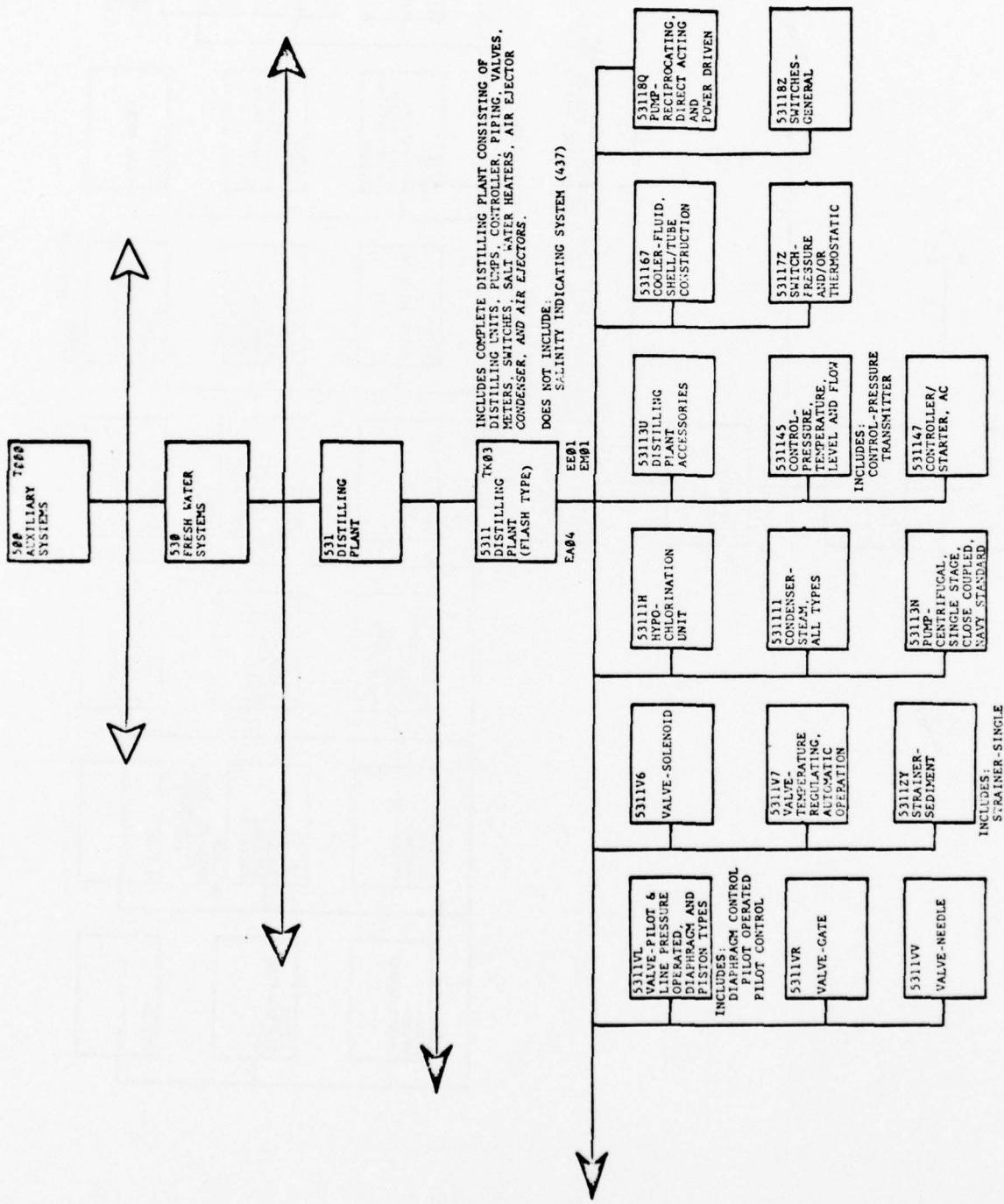

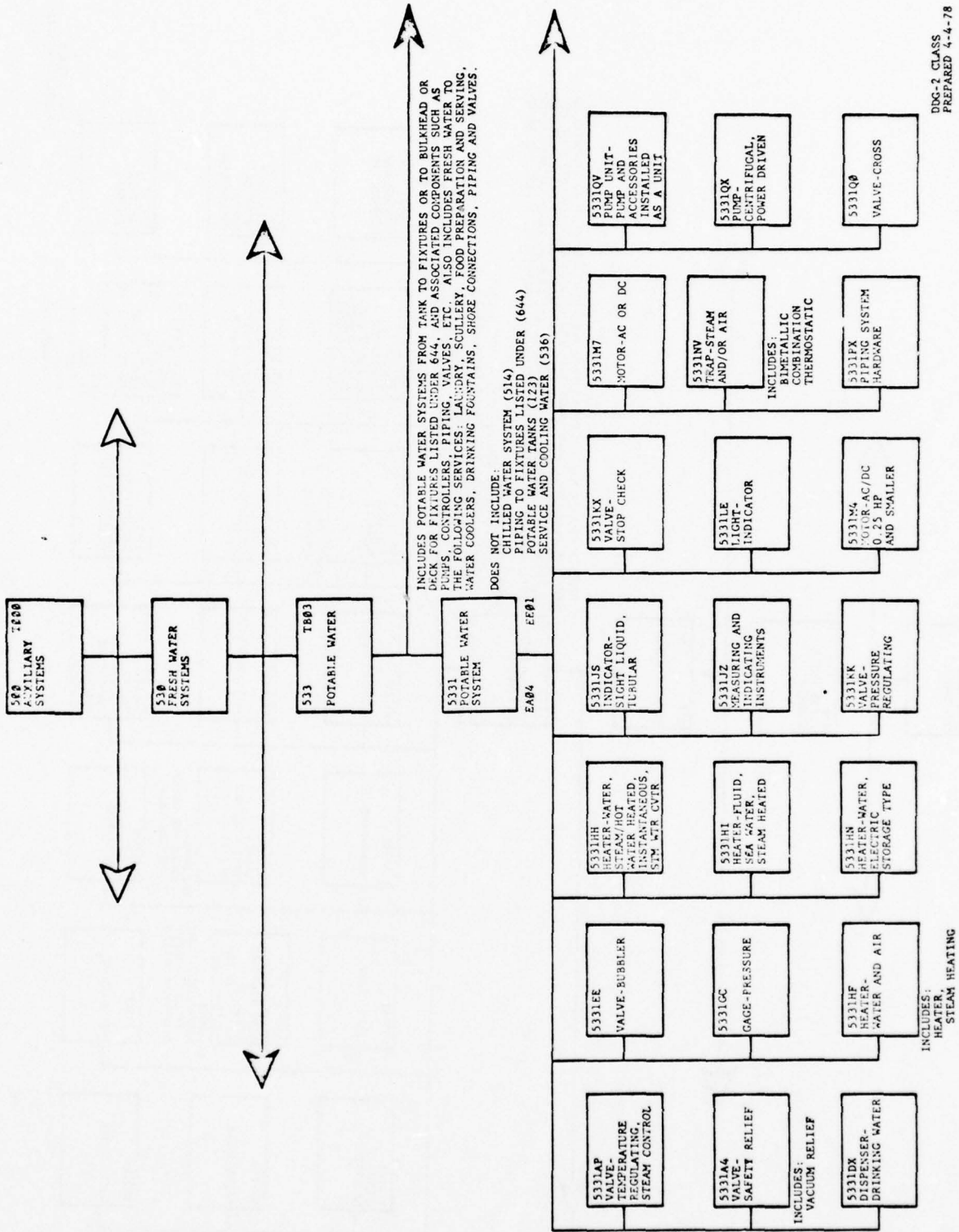

DDG-2 CLASS
PREPARED 4-4-78

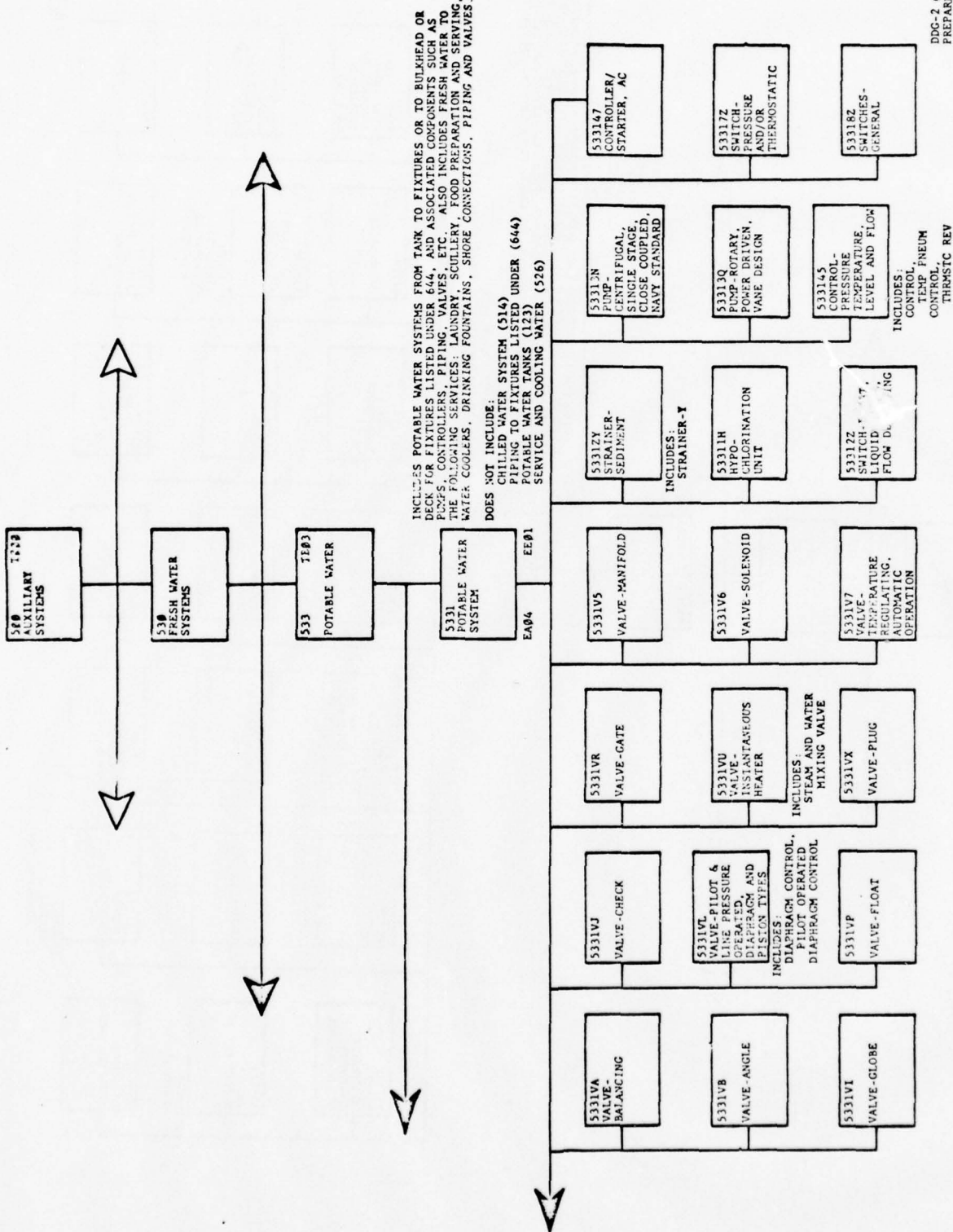

INCLUDES POTABLE WATER SYSTEMS FROM TANK TO FIXTURES OR TO BULKHEAD OR DECK FOR FIXTURES LISTED UNDER 644, AND ASSOCIATED COMPONENTS SUCH AS PUMPS, CONTROLLERS, PIPING, VALVES, ETC. ALSO INCLUDES FRESH WATER TO THE FOLLOWING SERVICES: LAUNDRY, SCULLERY, FOOD PREPARATION AND SERVING, WATER COOLERS, DRINKING FOUNTAINS, SHORE CONNECTIONS, PIPING AND VALVES.

DOES NOT INCLUDE:

CHILLED WATER SYSTEM (514) PIPING TO FIXTURES LISTED UNDER (644) POTABLE WATER TANKS (123) SERVICE AND COOLING WATER (526)

EA04

EA01

INCLUDES:
CONTROL-PNEUMATIC

CONTROL-THRUSTIC REV

DDG-2 CLASS
PREPARED 4-4-78

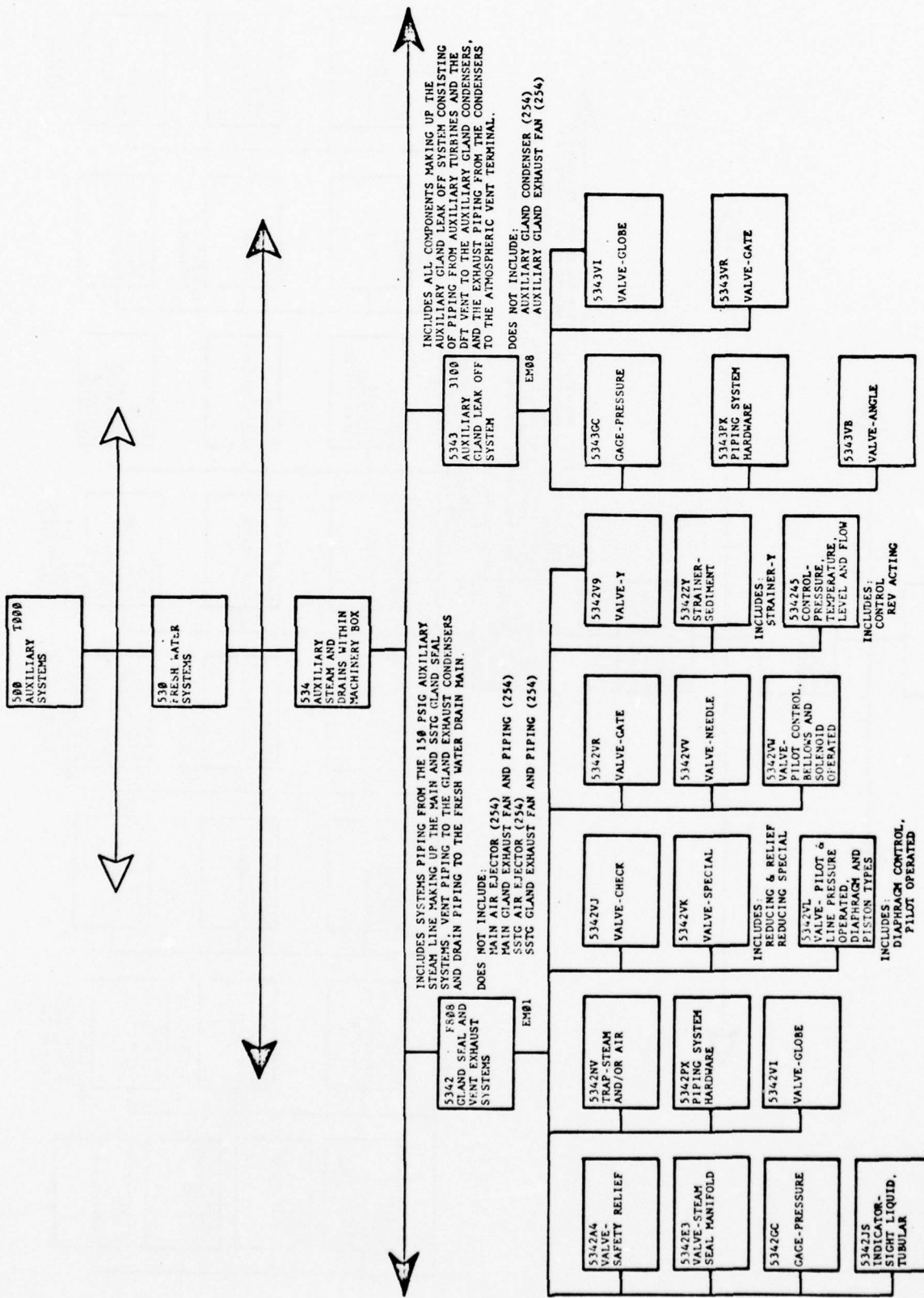

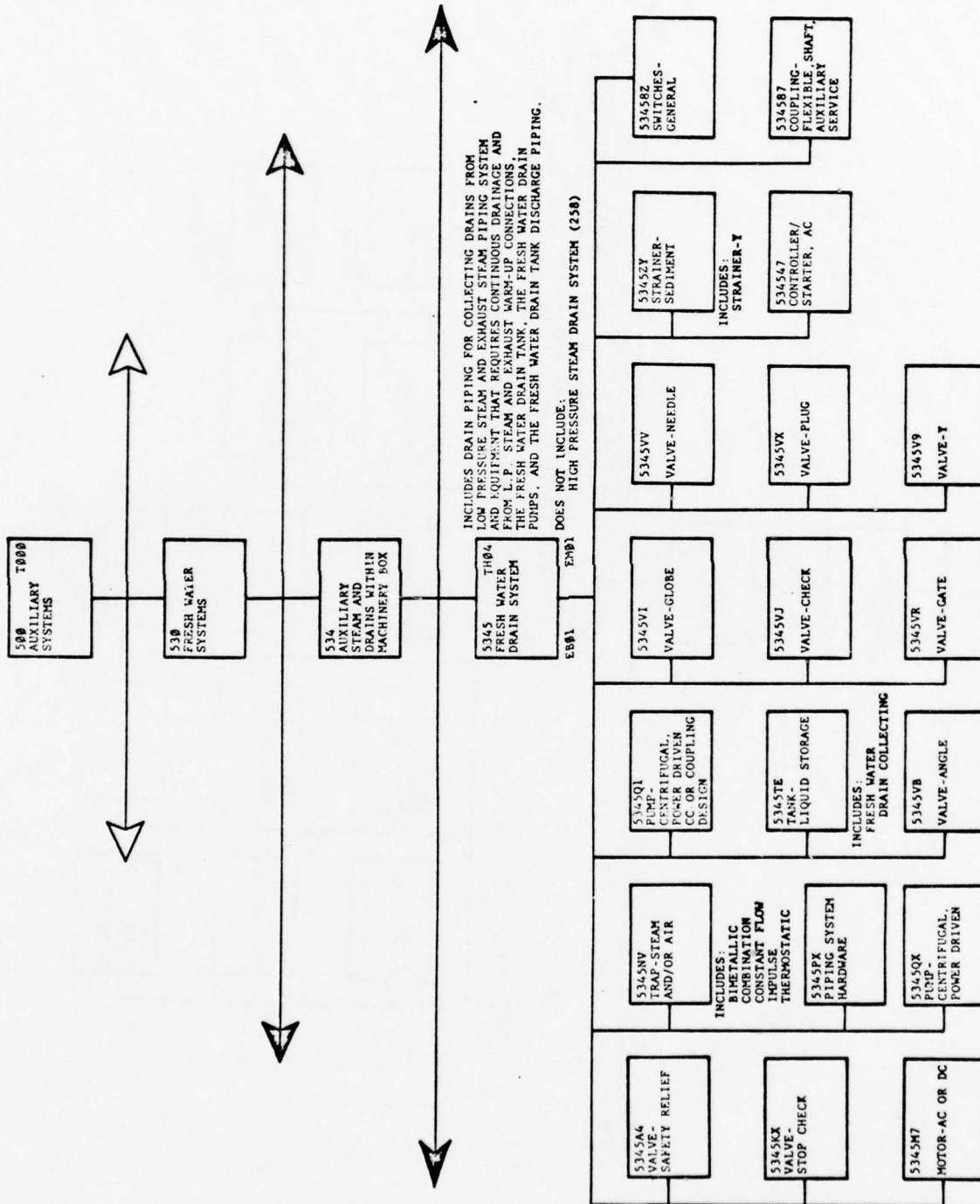

500
AUXILIARY
SYSTEMS

530
FRESH WATER
SYSTEMS

534
AUXILIARY
STEAM AND
DRAINS WITHIN
MACHINERY BOX

INCLUDES THE INSPECTION TANK DRAIN MAIN PIPING SYSTEM WHICH COLLECTS DRAINS FROM EQUIPMENT THAT MAY COME IN CONTACT WITH OIL, THE INSPECTION TANK AND DISCHARGE PIPING TO THE DEAERATING FEED TANK OR CONTAMINATED DRAIN MAIN. ALSO INCLUDES MACHINERY DRAINS FROM EQUIPMENT IN CONTACT OR WORKING WITH OIL TO THE OILY WATER BILGE SUMP AND THE SEA WATER CONTAMINATED DRAINS FOR EQUIPMENT OPERATING IN CONTACT WITH SEA WATER DRAINAGE TO THE WASTE WATER BILGE SUMP TANK.

5346
VALVE-
STOP CHECK
DRAIN SYSTEM

EM01

53464
VALVE-
SAFETY RELIEF

5346CC
GAGE-PRESSURE

5346J5
INDICATOR-
SIGHT LIQUID,
TUBULAR

5346KX
VALVE-
STOP CHECK

5346SV
TRAP-STEAM
AND/OR AIR

INCLUDES:
BIMETALLIC

5346IX
PIPING SYSTEM
HARDWARE

5346TE
TANK-
LIQUID STORAGE

INCLUDES:
DRAIN INSPECTION
TANK
WASTE WATER
BILGE SUMP TANK

5346V9
VALVE-Y

5346VB
VALVE-ANGLE

5346V1
VALVE-GLOBE

5346ZY
STRAINER-
SEDIMENT

INCLUDES:
STRAINER-Y

5346VR
VALVE-GATE

5346VV
VALVE-NEEDLE

5347
LOW PRESSURE
STEAM DRAIN
SYSTEM

EM01

5347A4
VALVE-
SAFETY RELIEF

5347CC
GAGE-PRESSURE

5347KX
VALVE-
STOP CHECK

5347NV
TRAP-STEAM
AND/OR AIR

5347VB
VALVE-ANGLE

5347V1
VALVE-GLOBE

5347FX
PIPING SYSTEM
HARDWARE

5347VJ
VALVE-CHECK

5347VR
VALVE-GATE

5347V9
VALVE-Y

5347ZY
STRAINER-
SEDIMENT

INCLUDES:
STRAINER-Y

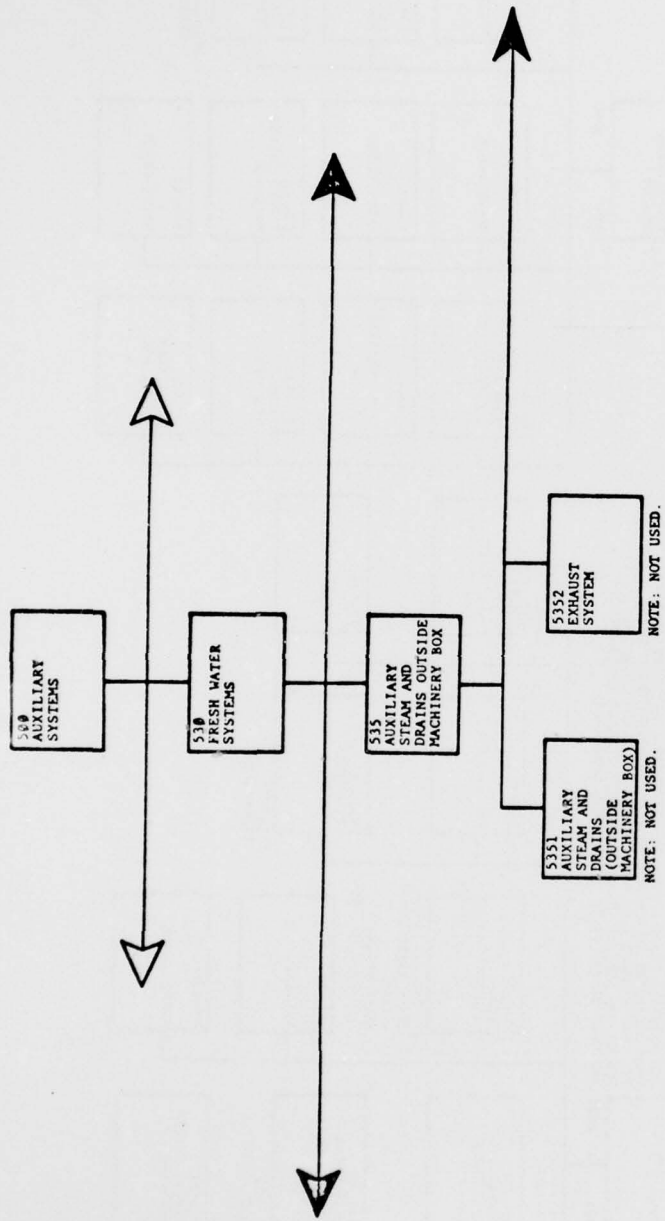

DDC-2 CLASS
PREPARED 3-21-78

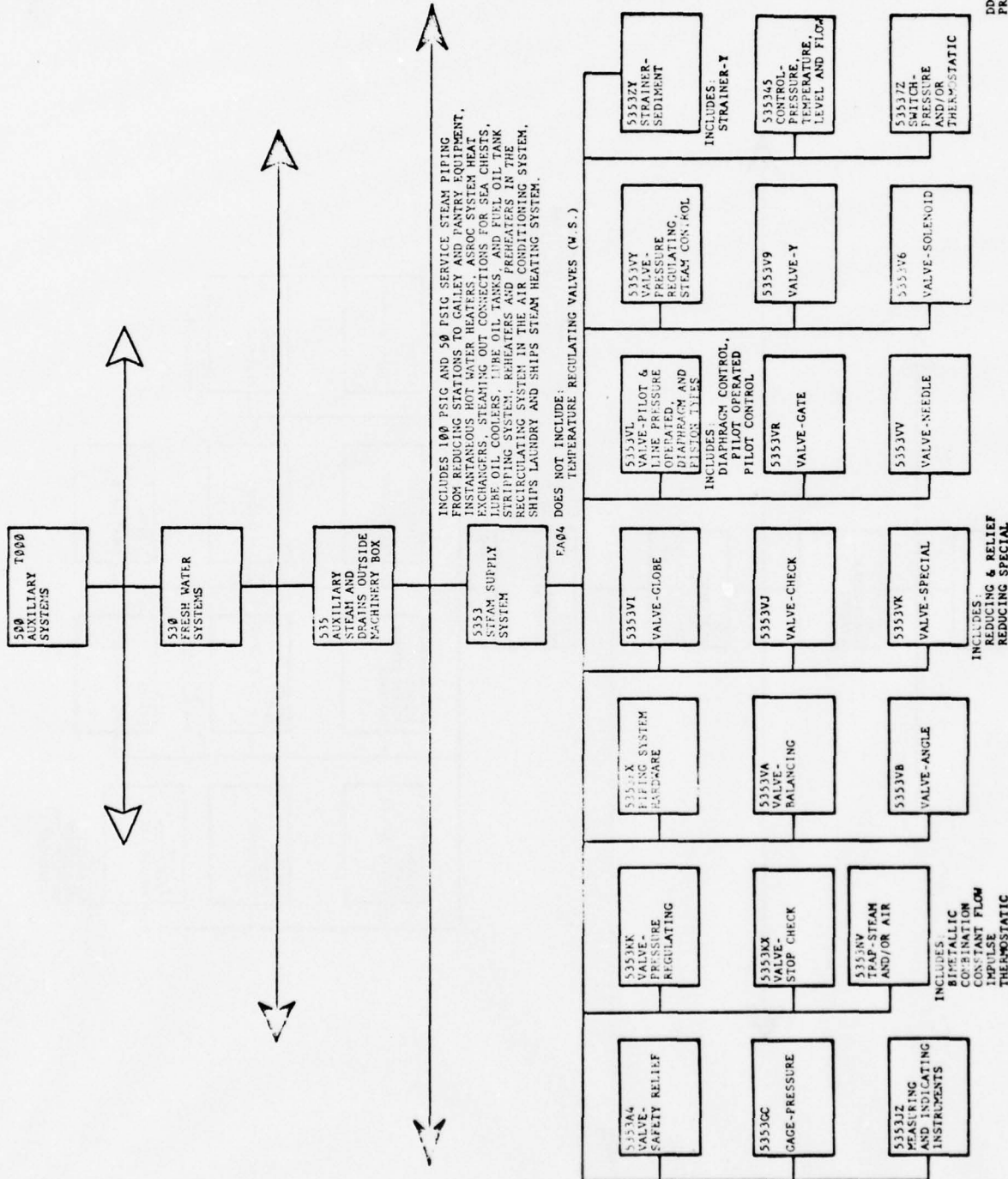

INCLUDES 100 PSIG AND 50 PSIG SERVICE STEAM PIPING FROM MELTING VALVES AND PASTRY EQUIPMENT, INSTANTANEOUS FLOWING HEAT EXCHANGERS, STEAMING OUT CONNECTIONS FOR SEW CHESTS, LUBE OIL COOLERS, LUBE OIL TANKS AND FUEL OIL TANK STRIPPING SYSTEM, REHEATERS AND PREHEATERS IN THE RECIRCULATING SYSTEM IN THE AIR CONDITIONING SYSTEM, SHIPS LAUNDRY AND SHIPS STEAM HEATING SYSTEM.

FA04 DOES NOT INCLUDE: TEMPERATURE REGULATING VALVES (W.S.)

INCLUDES: BIPERALLIC CONNECTION COMPENSATE FLOW IMPULSE THERMOSTATIC

INCLUDES: REDUCING & RELIEF

INCLUDES: STRAINER-Y, CONTROL-PRESSURE, TEMPERATURE, LEVEL AND FLOW, SWITCH-PRESSURE AND/OR THERMOSTATIC

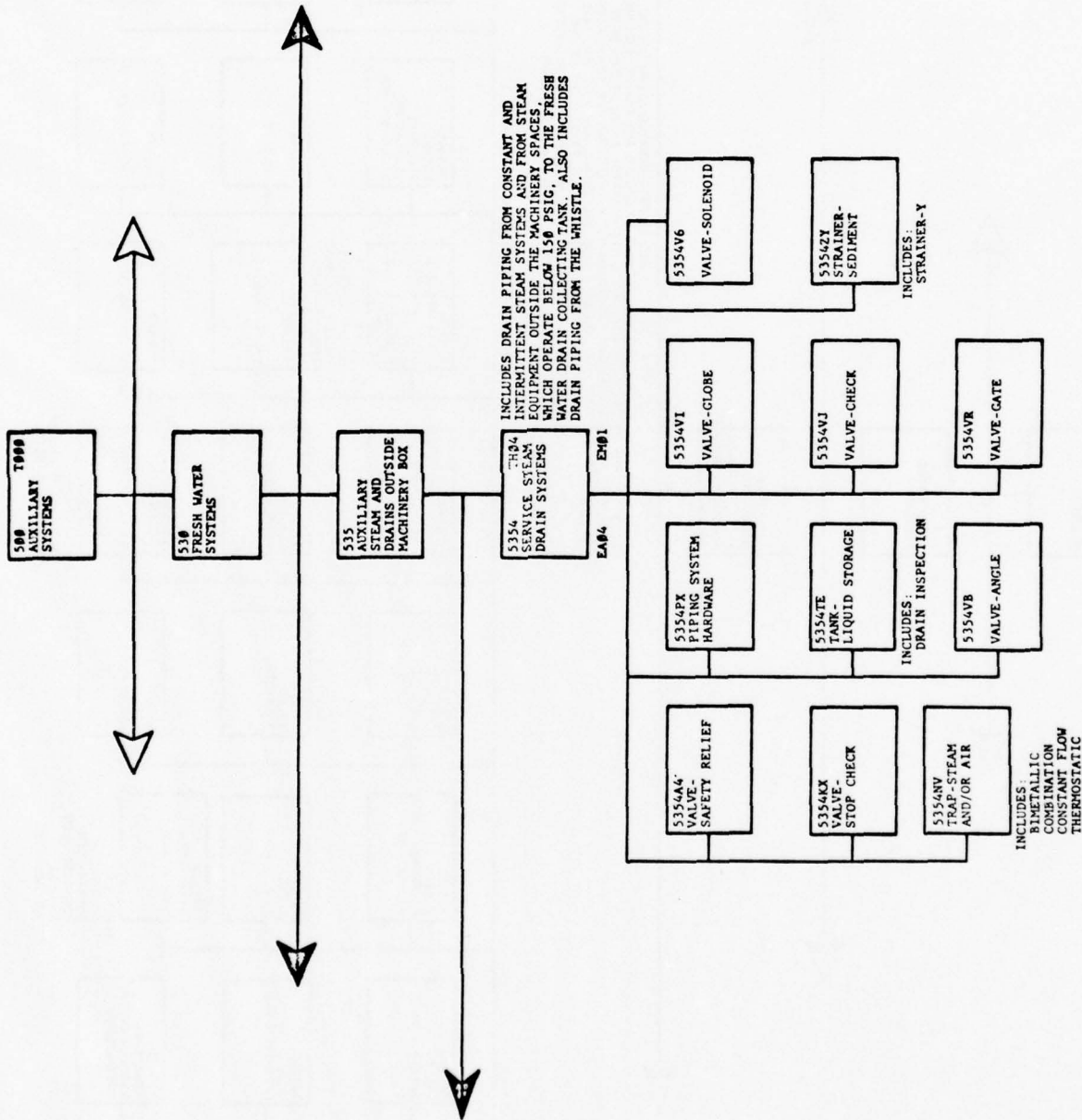

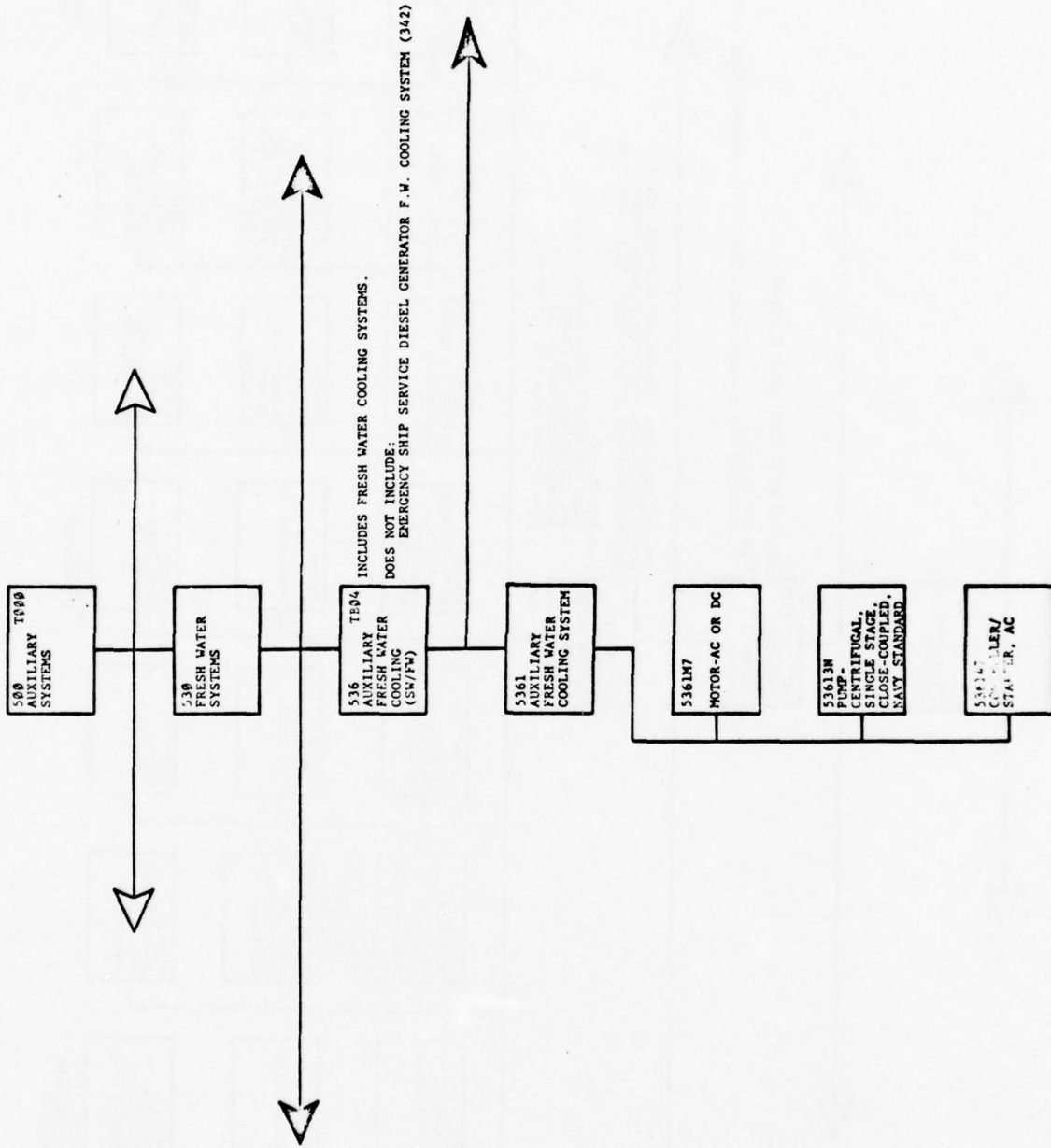

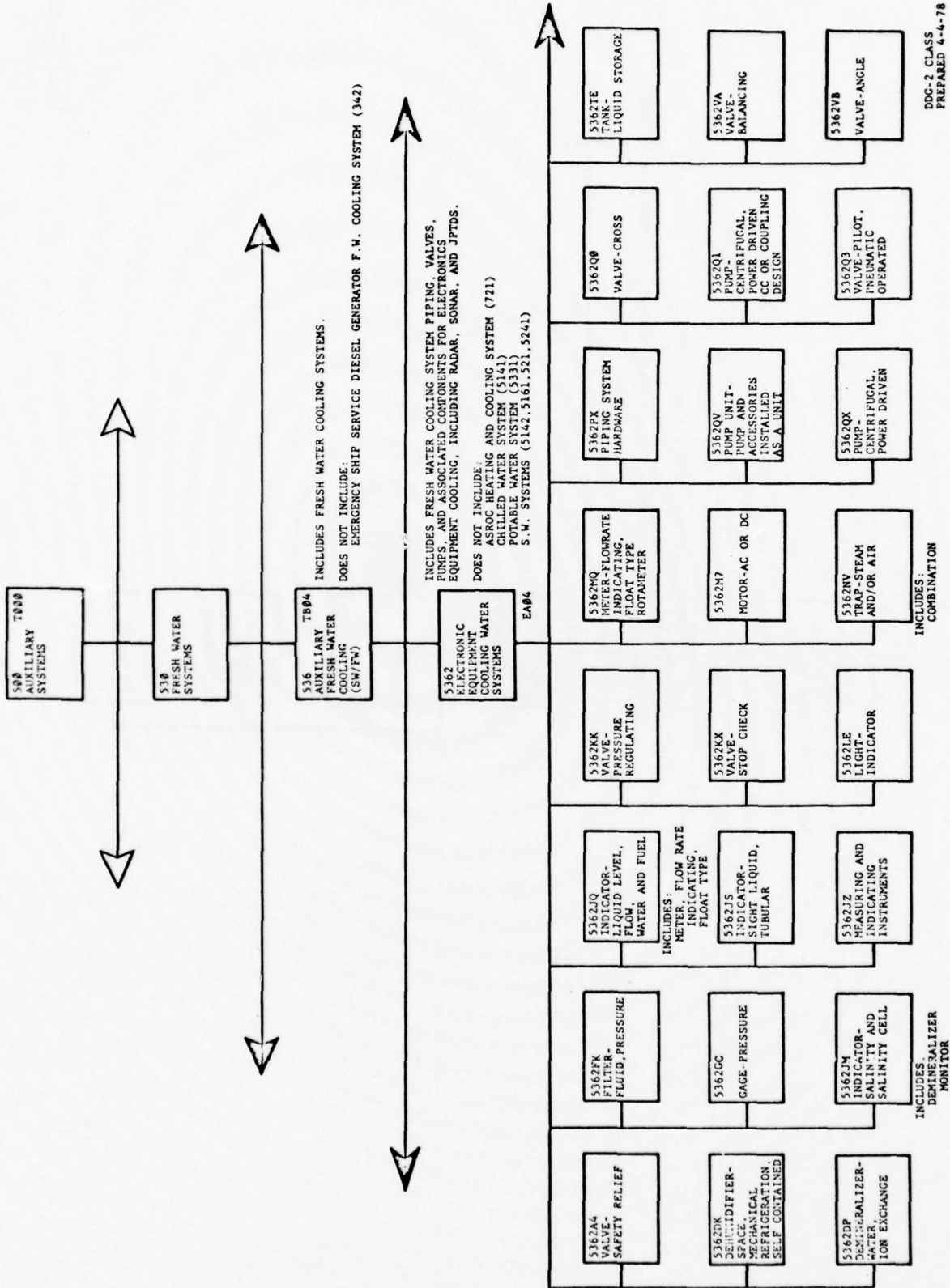

DDG-2 CLASS
 PREPARED 4-4-78

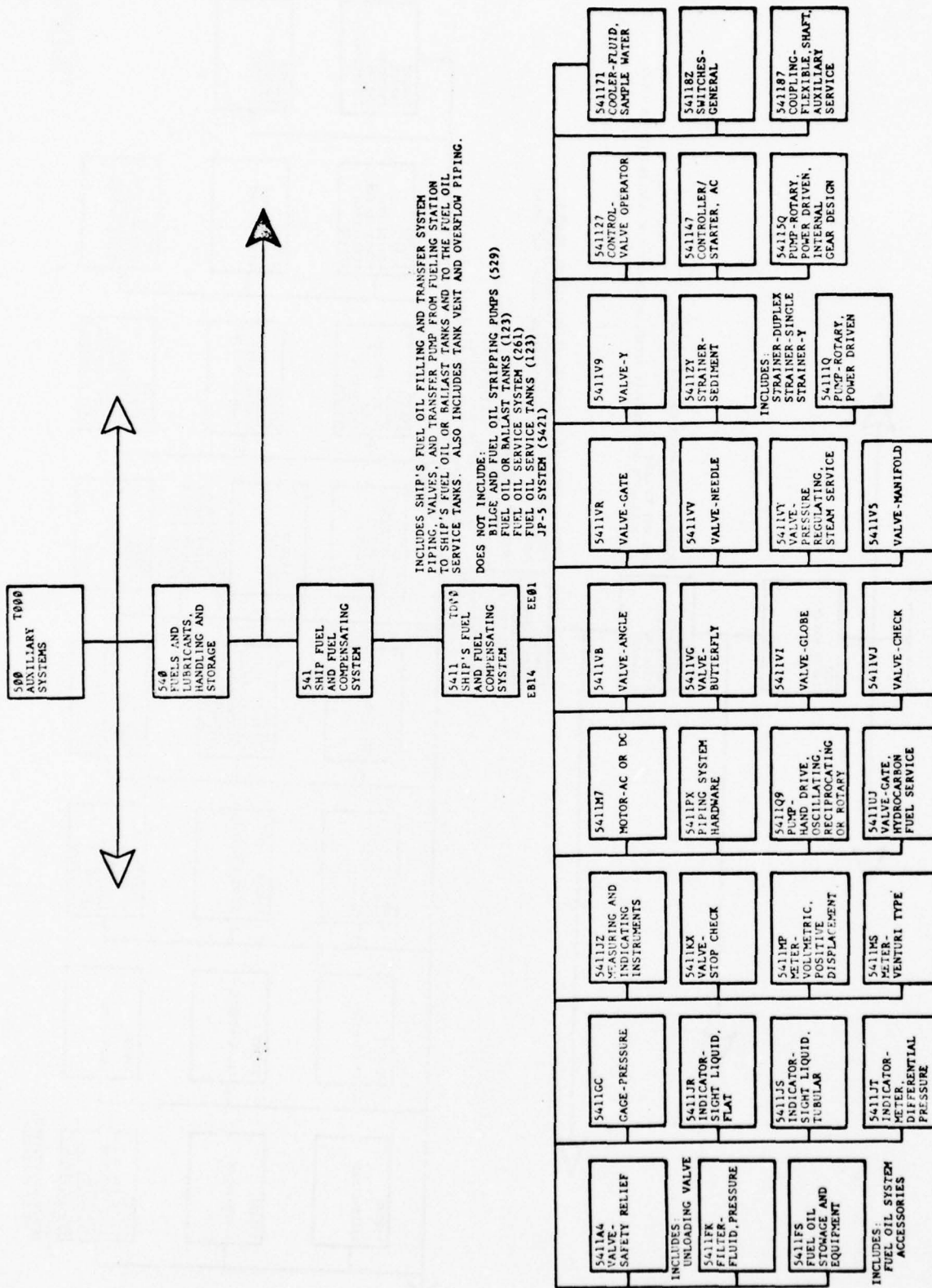

DDC-2 CLASS
PREPARED 3-21-78

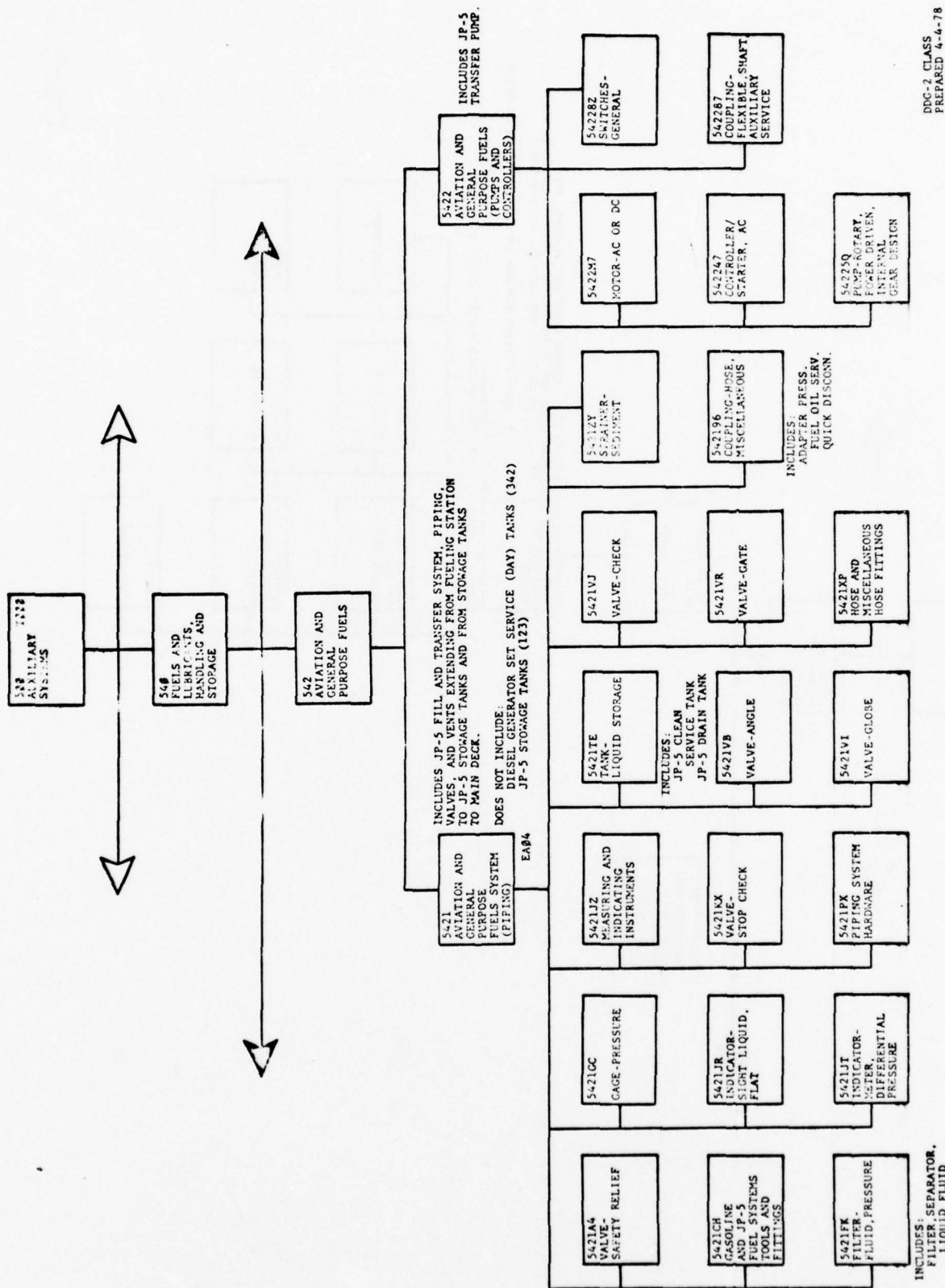

DDC-2 CLASS
PREPARED 4-4-78

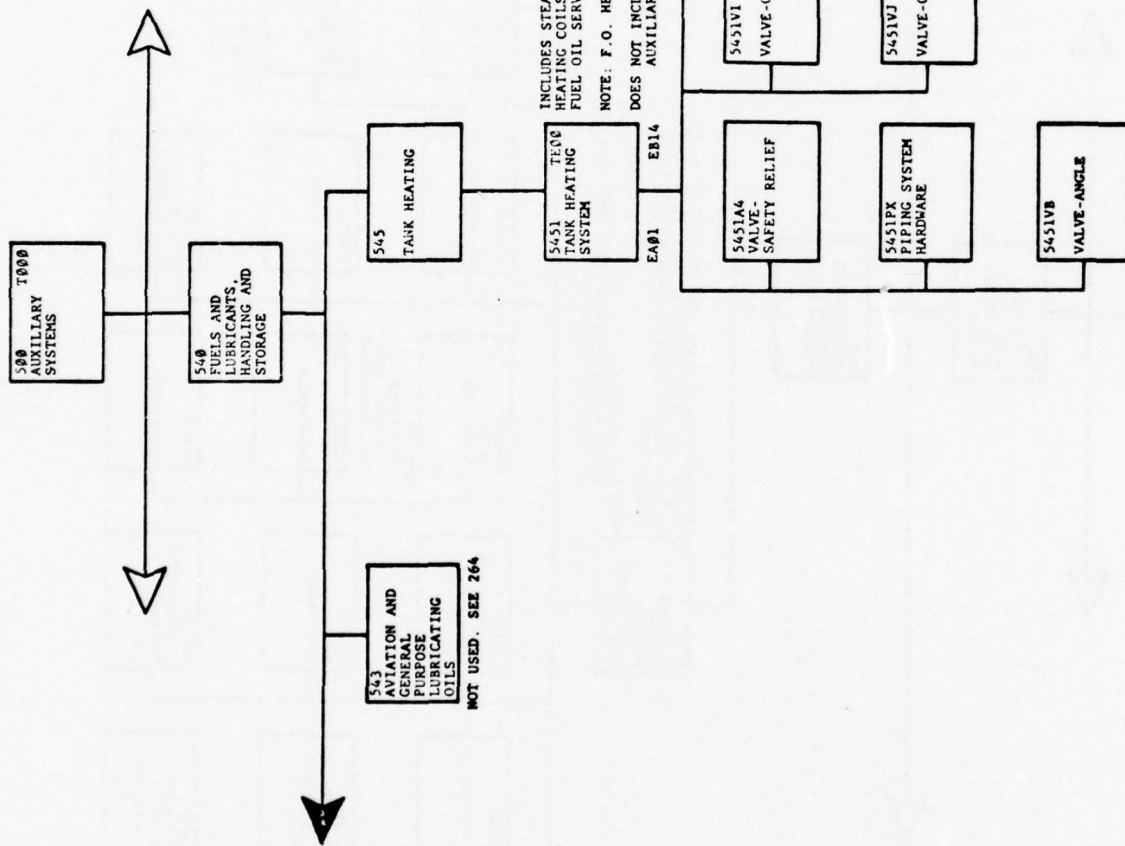

DOC-2 CLASS
PREPARED 3-21-78

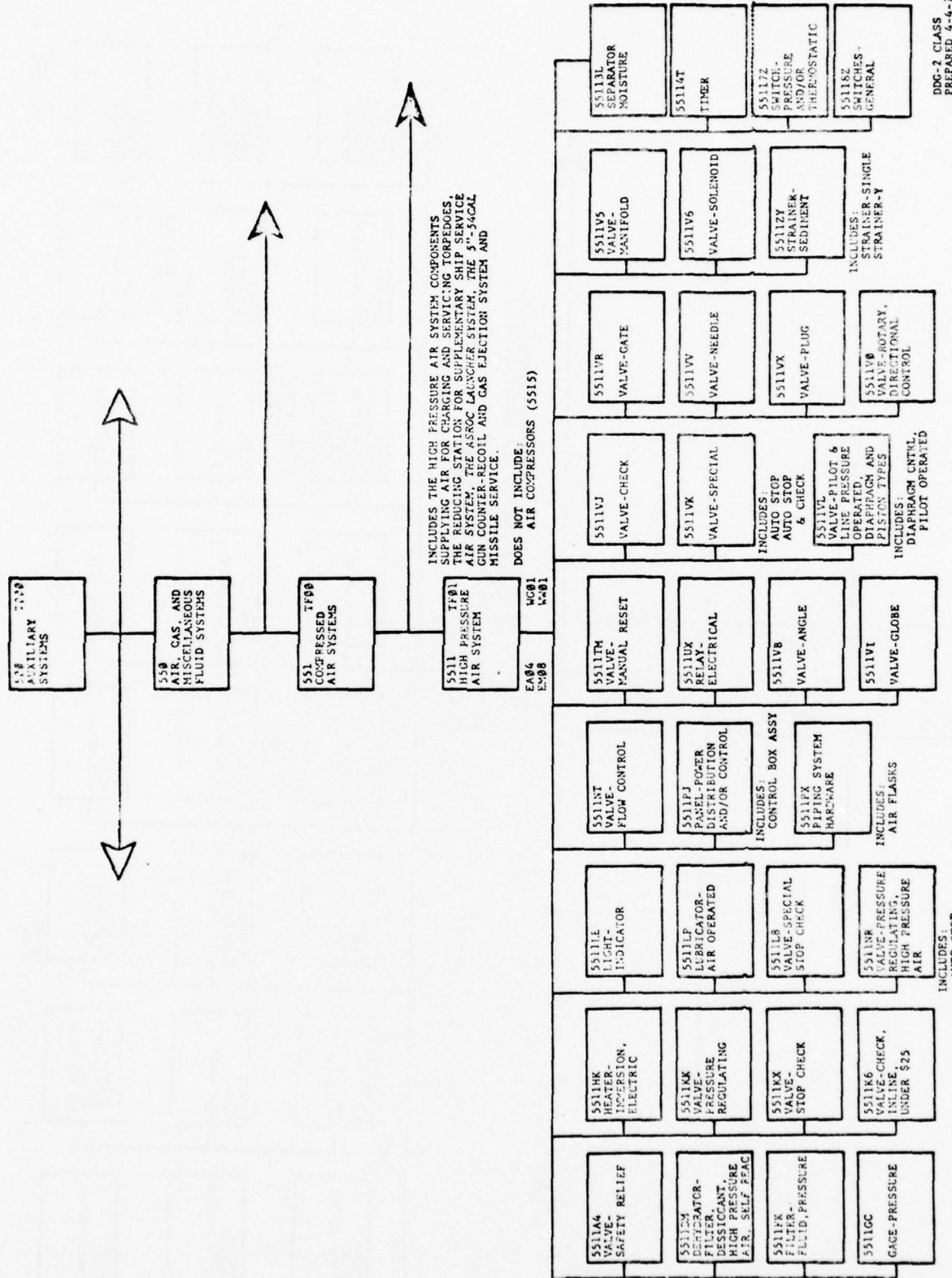

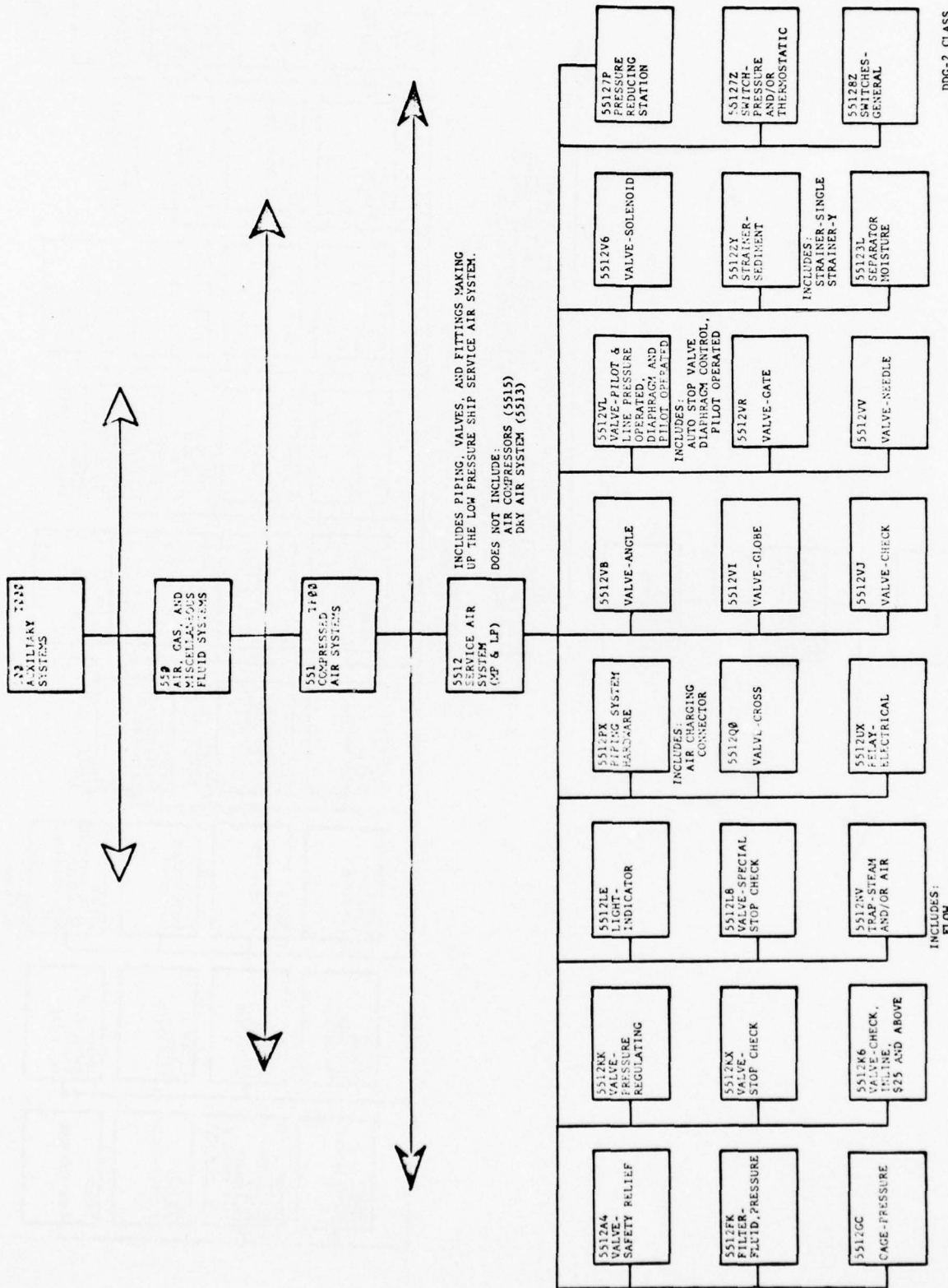

DDG-2 CLASS
PREPARED 4-4-78

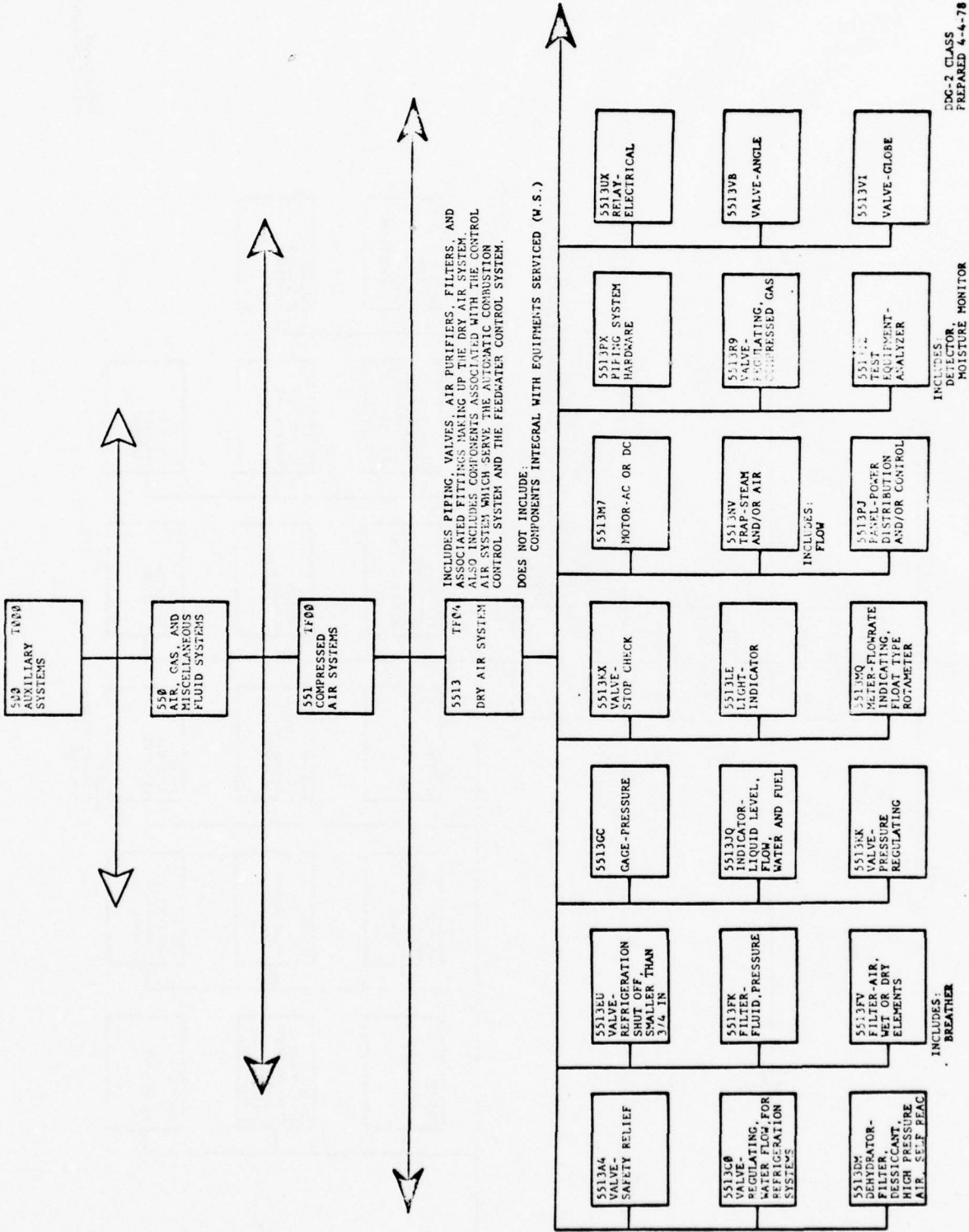

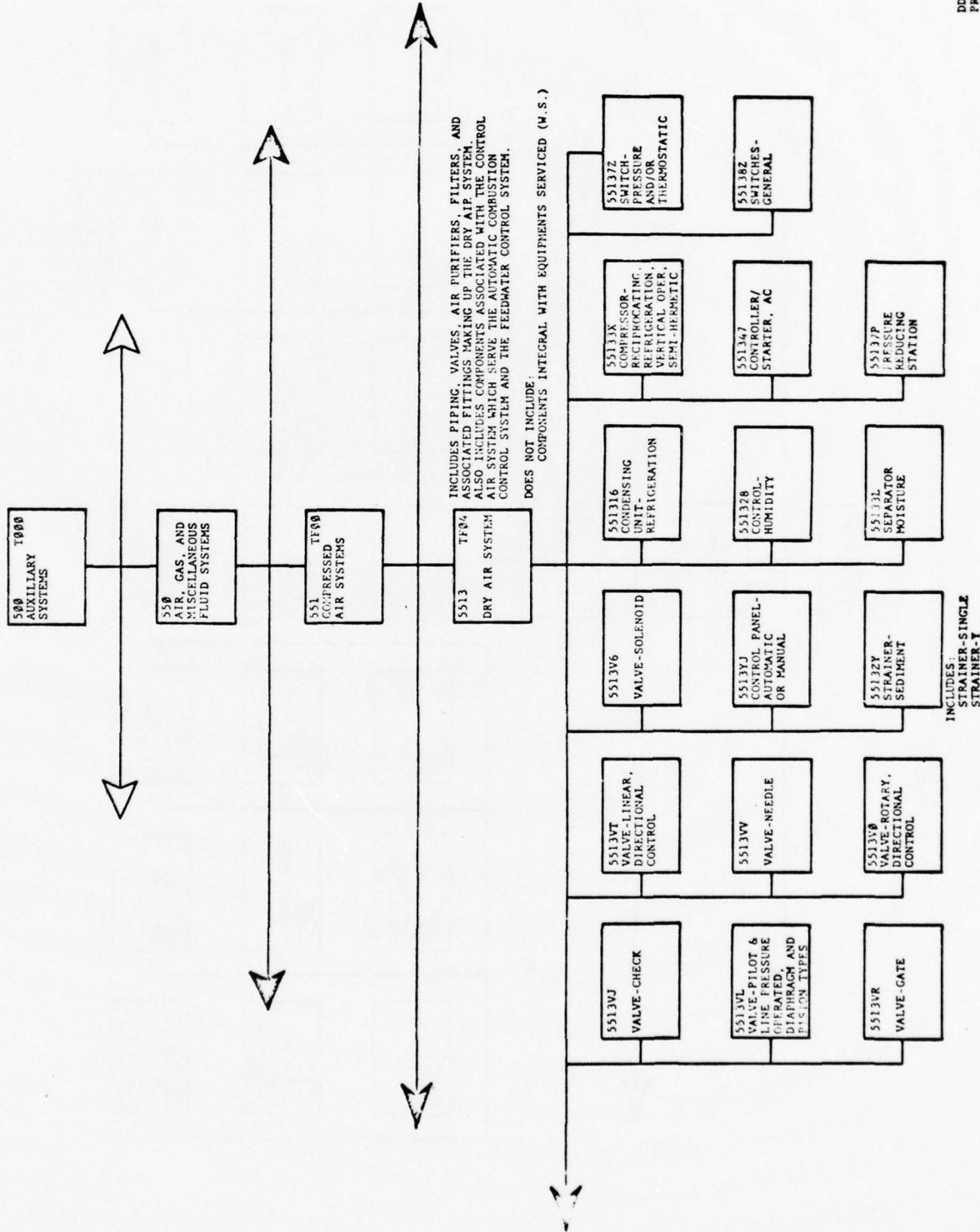

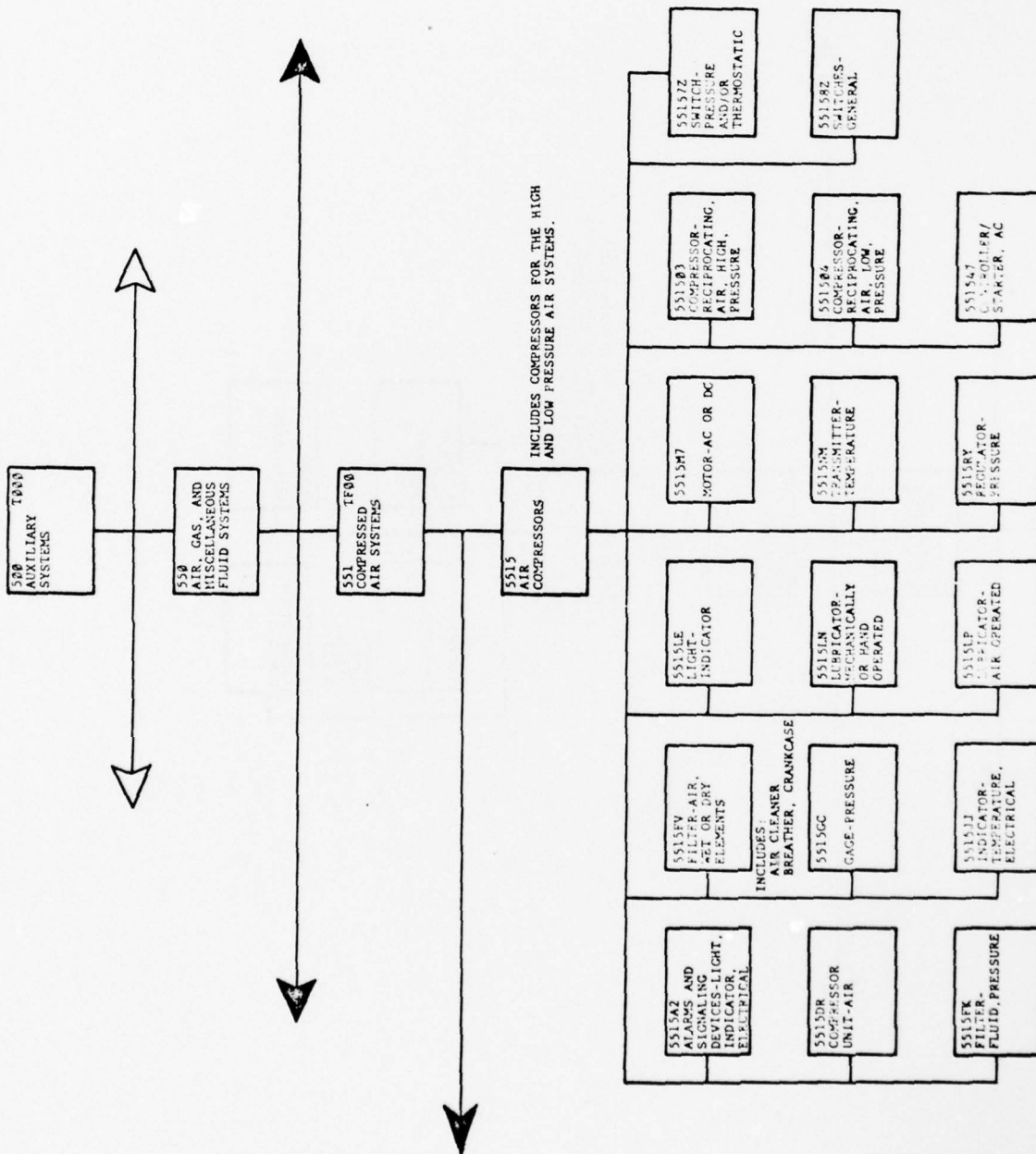

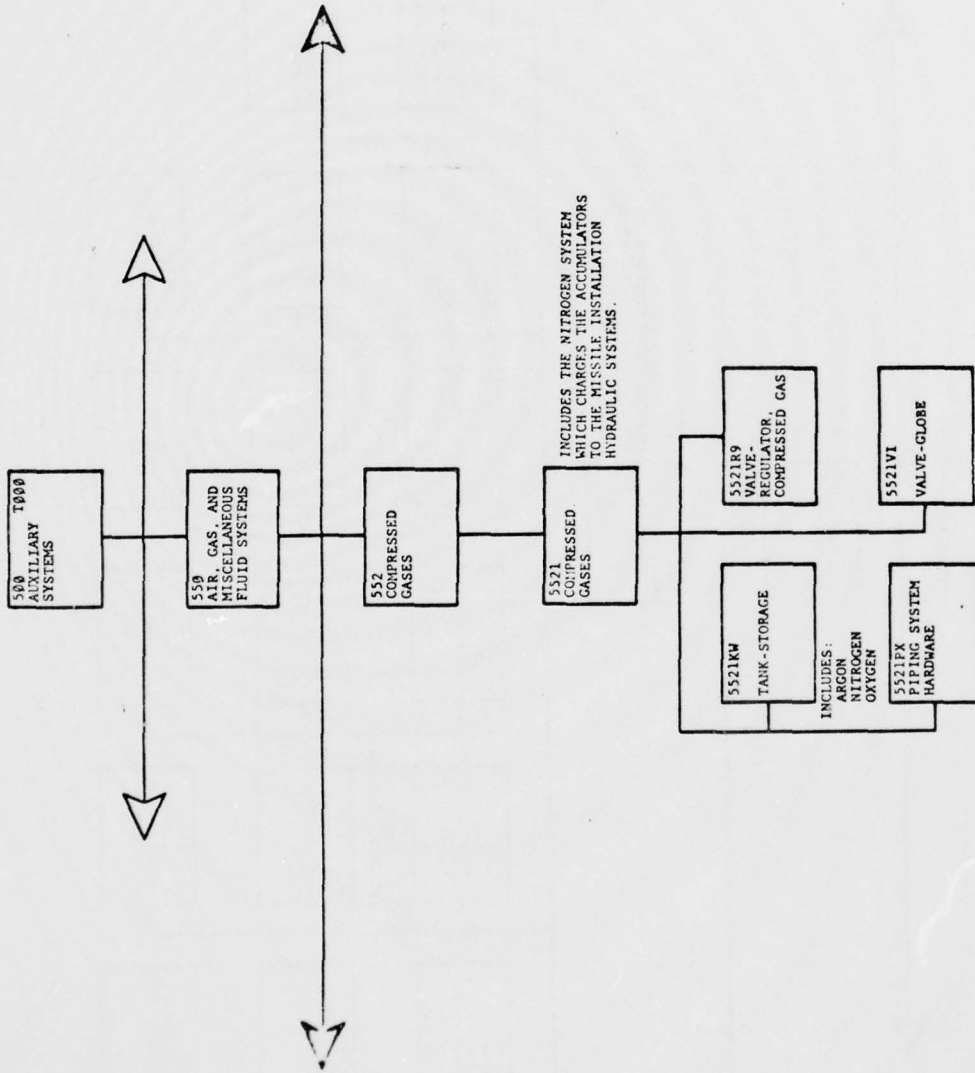

INCLUDES THE NITROGEN SYSTEM WHICH CHARGES THE ACCUMULATORS TO THE MISSILE INSTALLATION HYDRAULIC SYSTEMS.

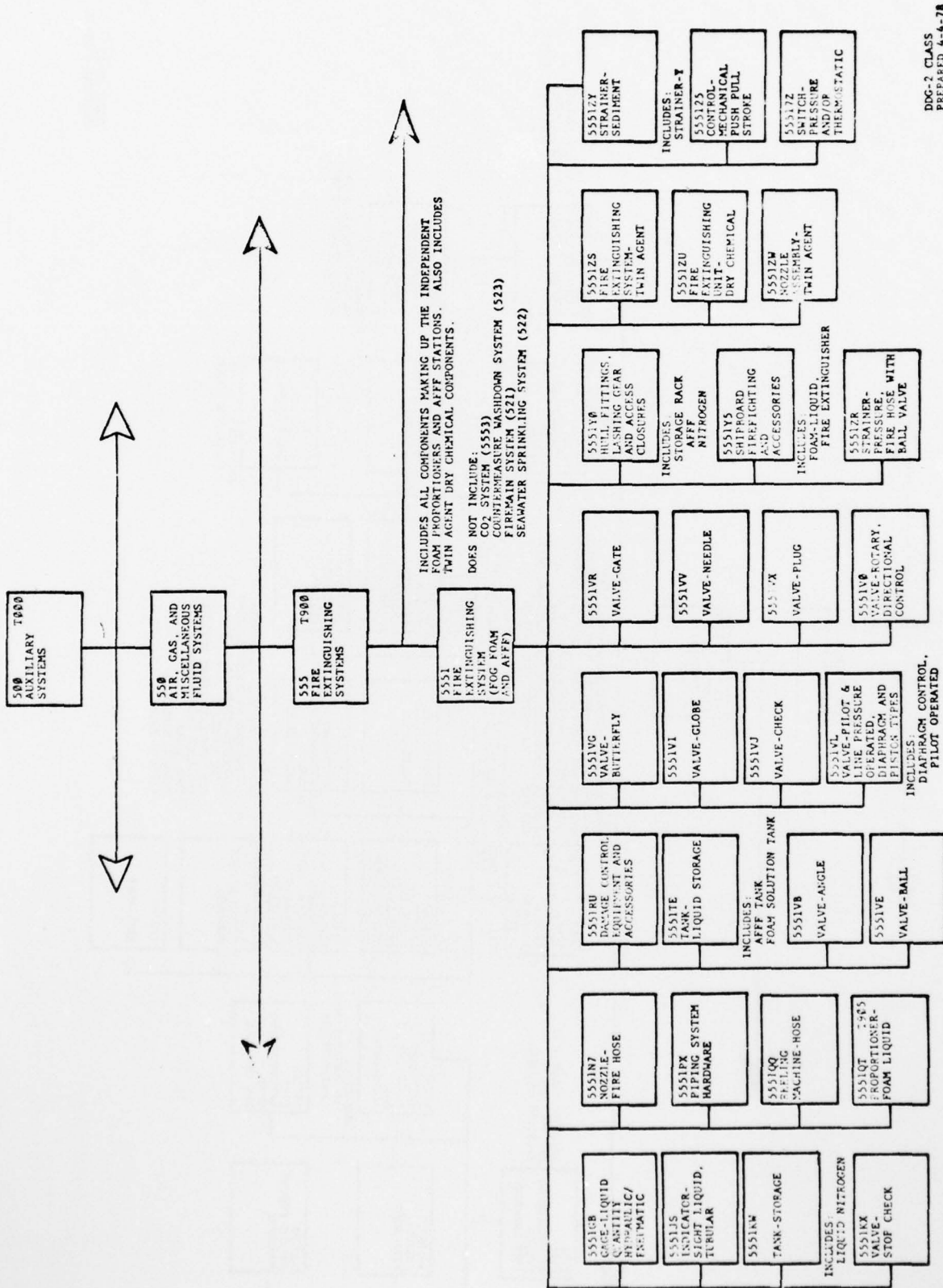

BDC-2 CLASS
PREPARED 4-4-78

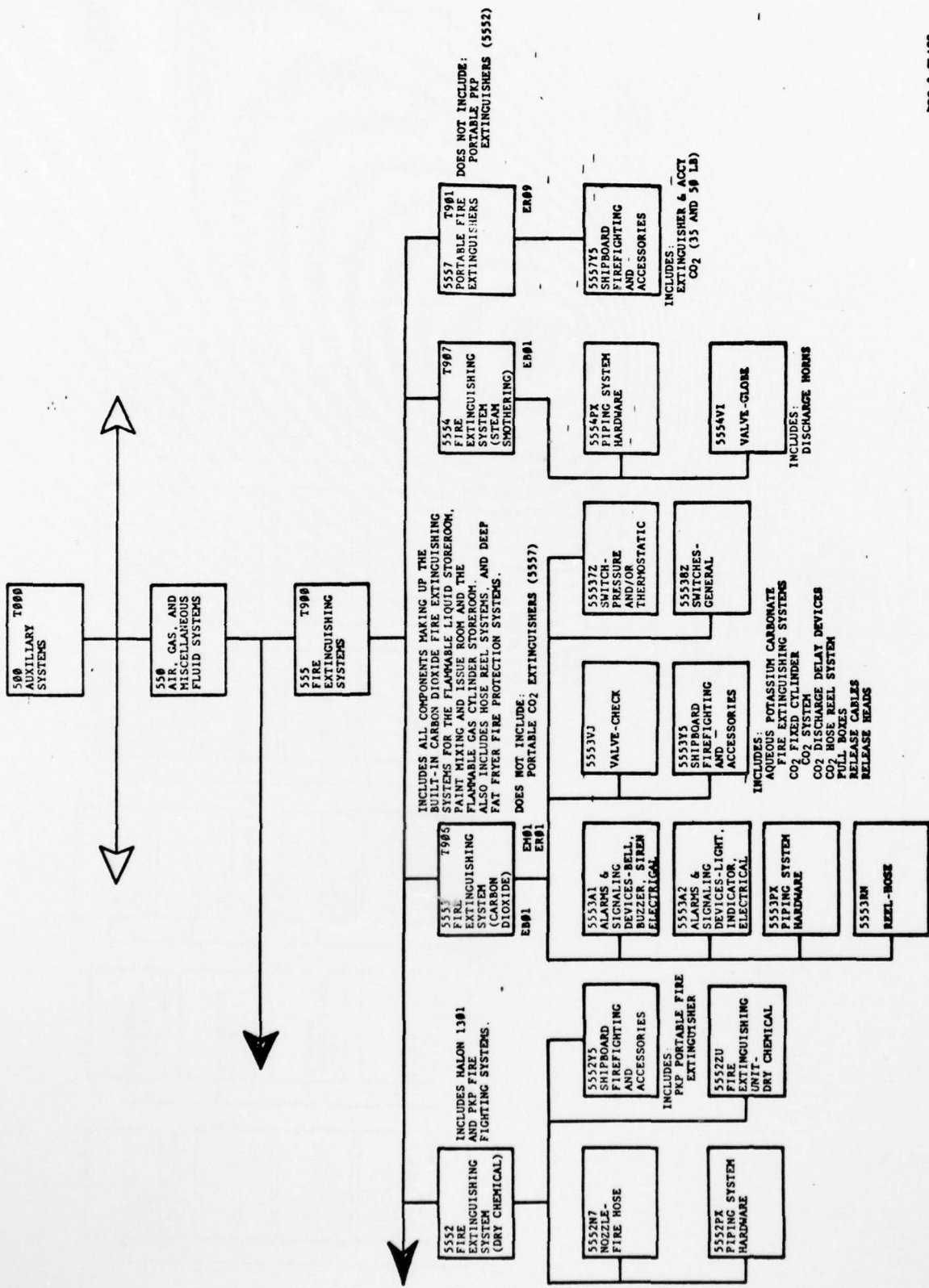

DOC-2 CLASS
PREPARED 6-28-78

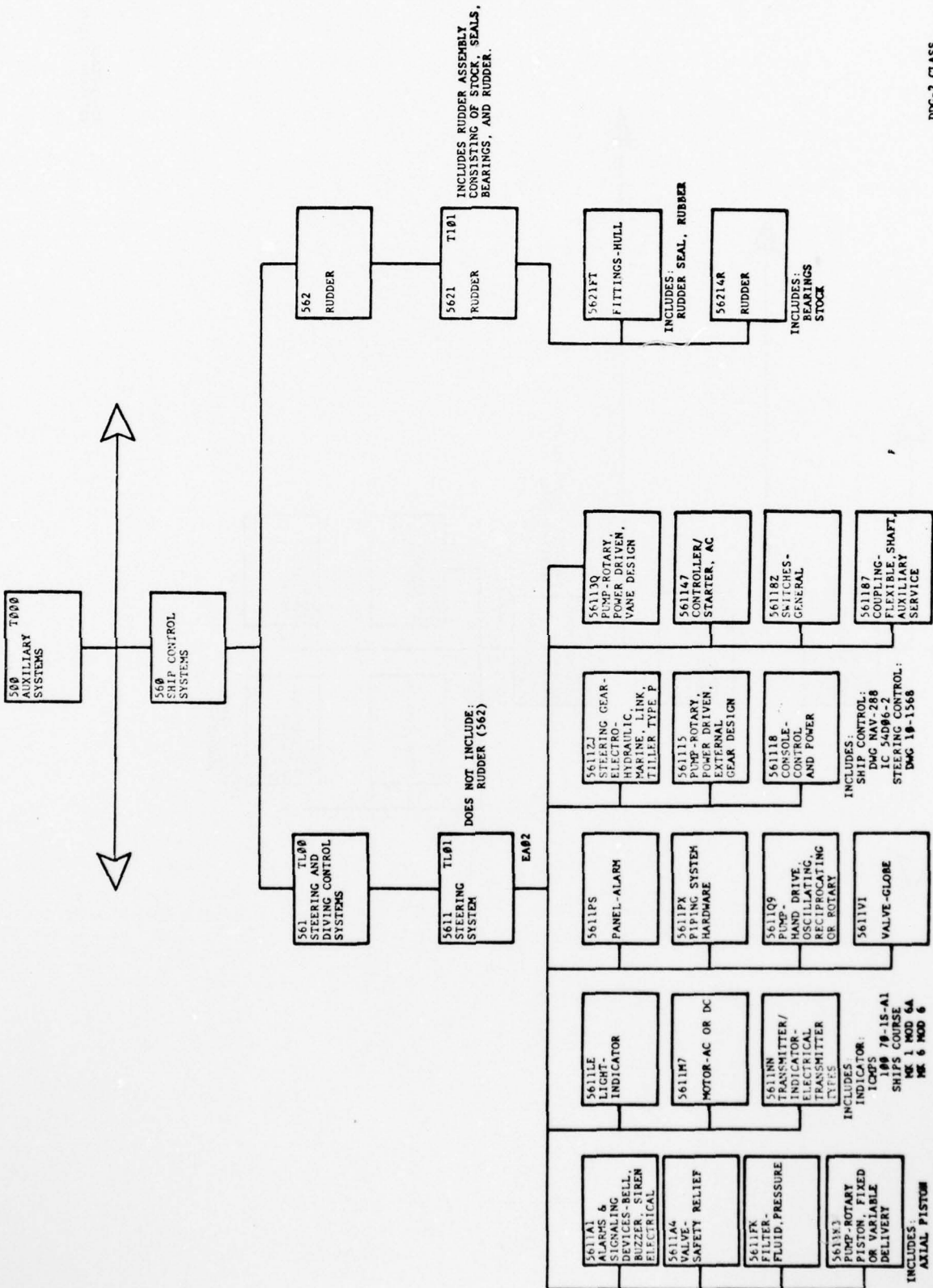

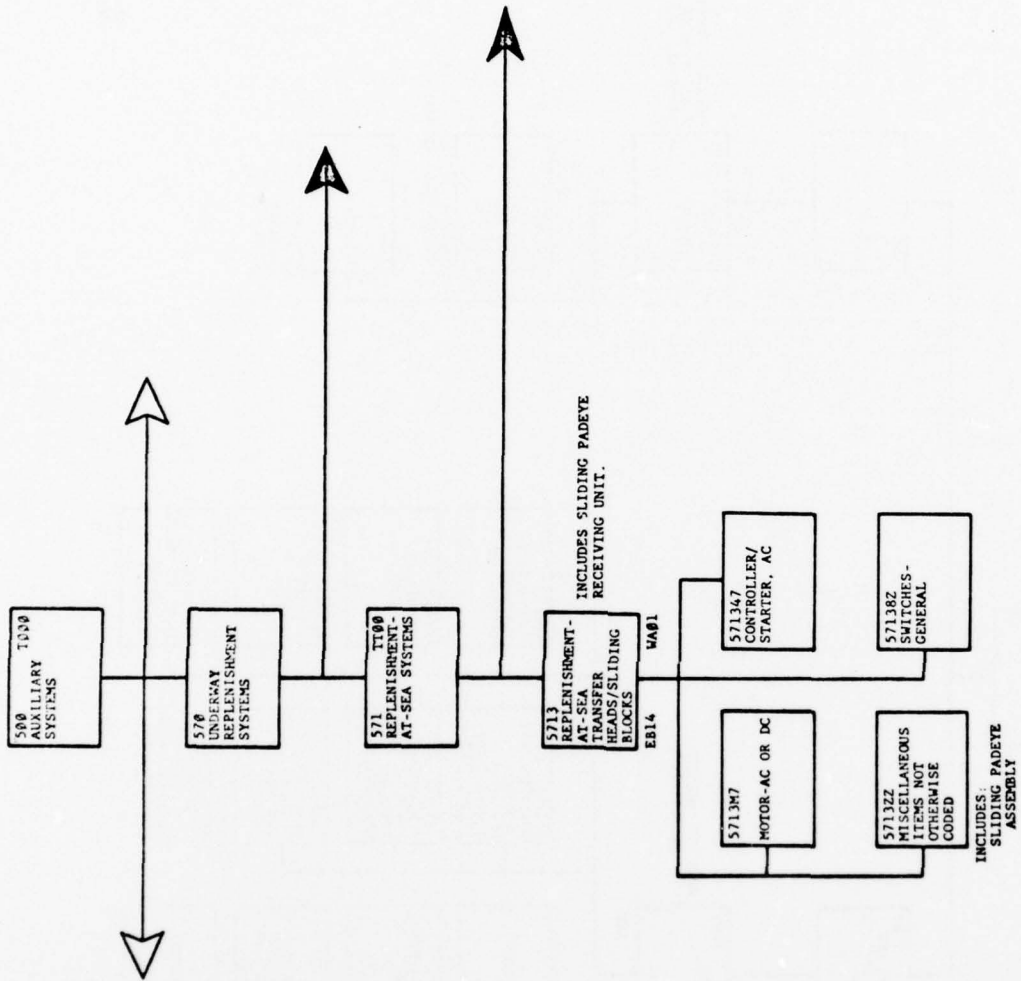

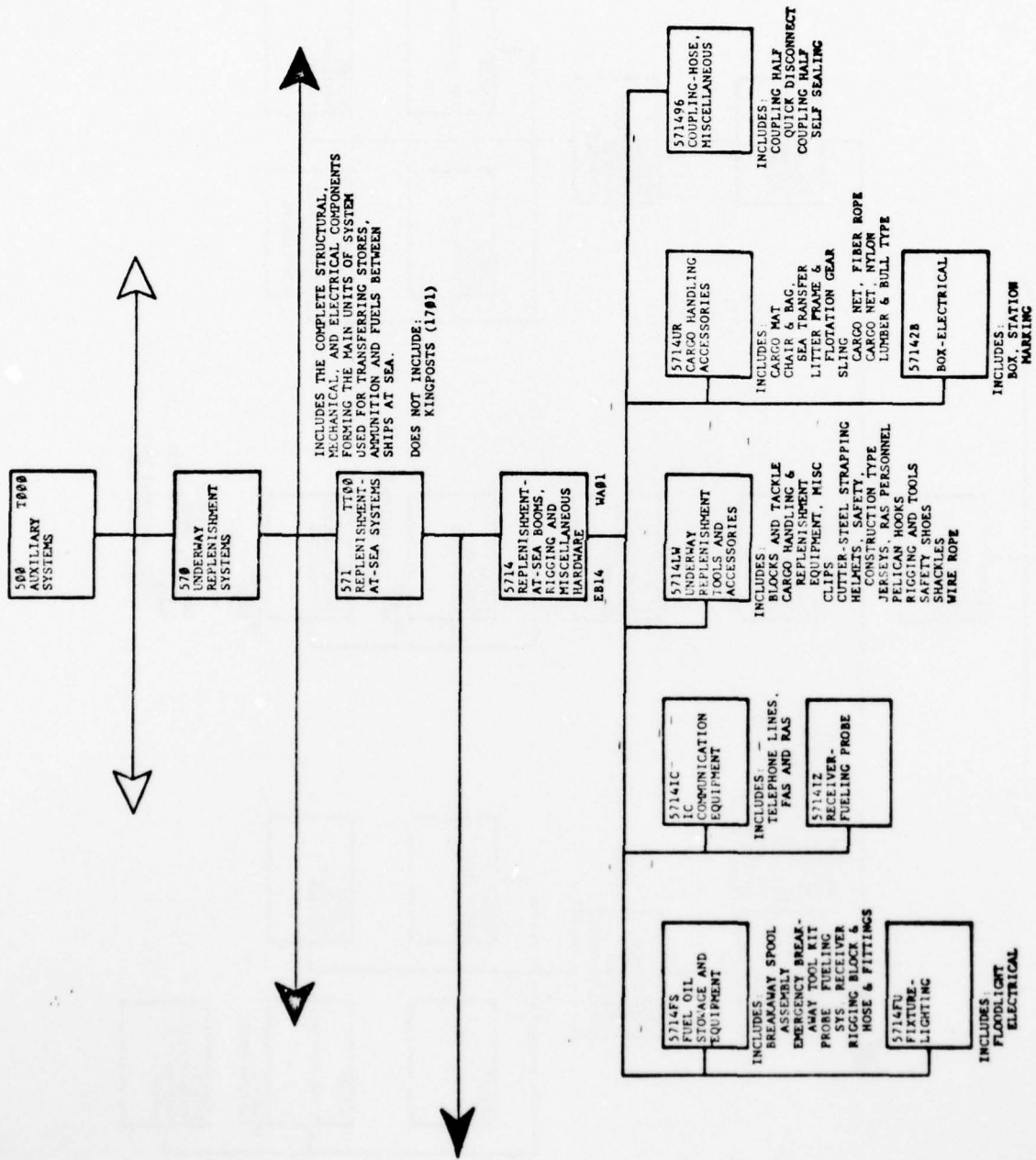

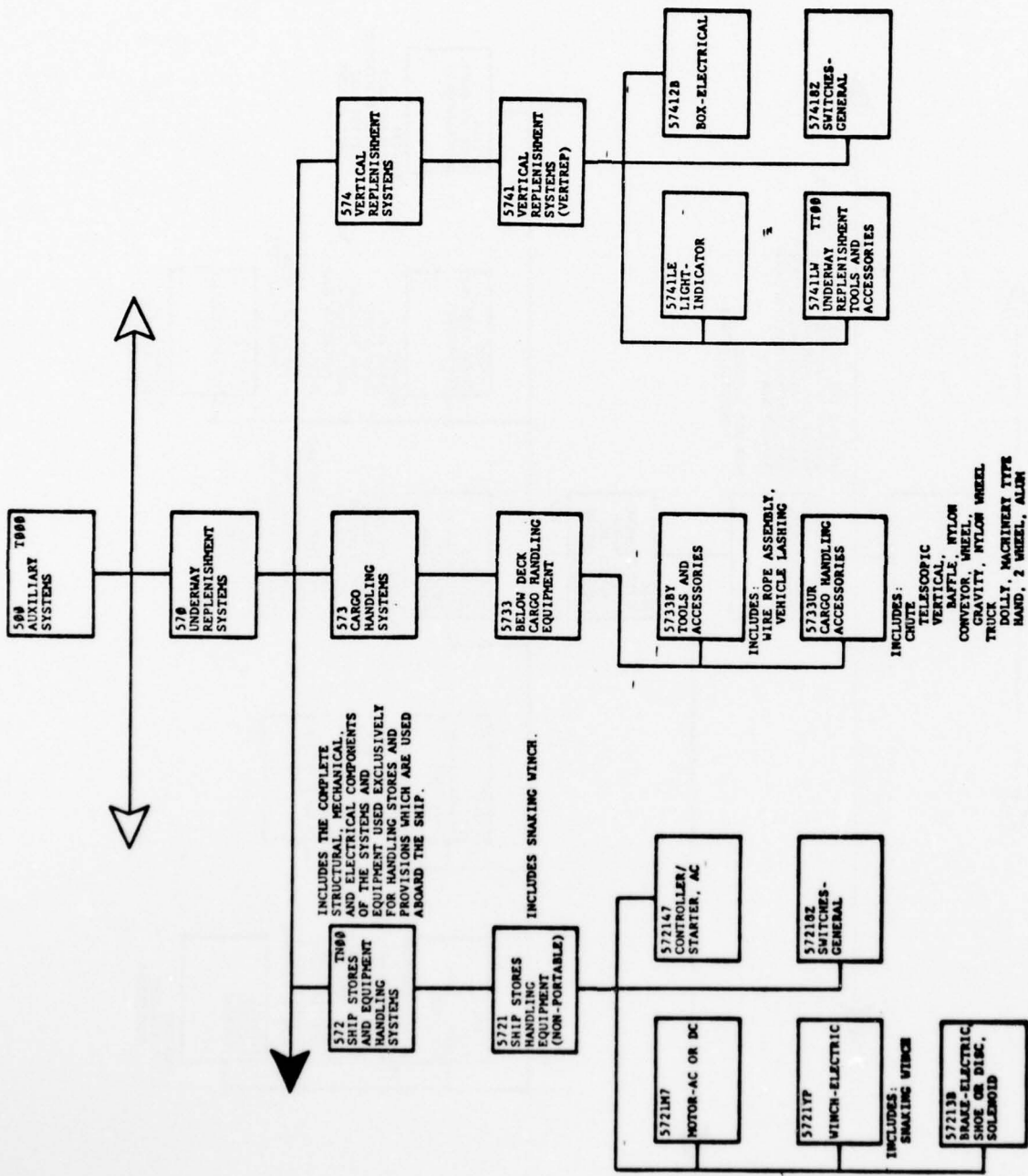

DDC-2 CLASS PREPARED 6-28-78

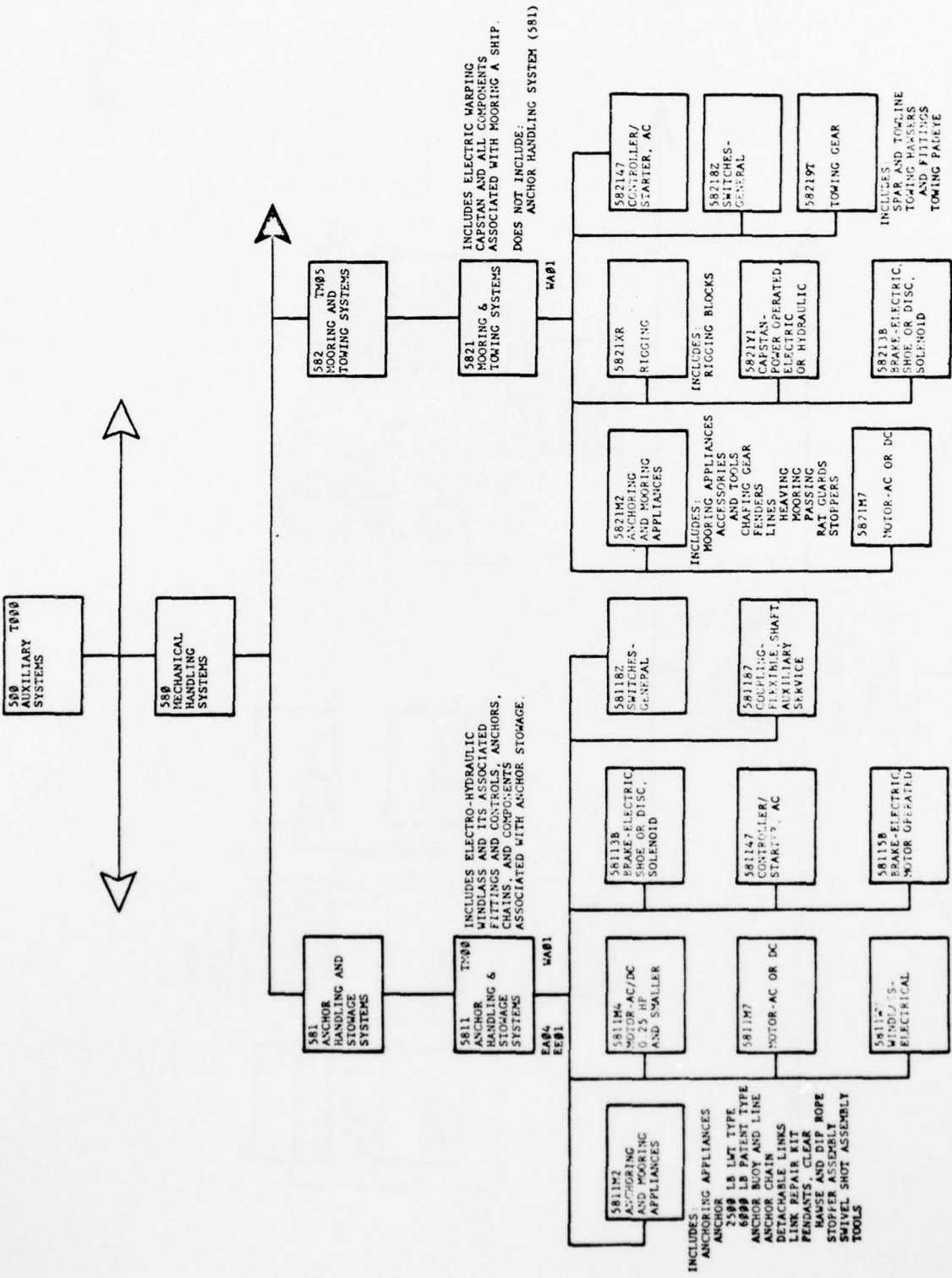

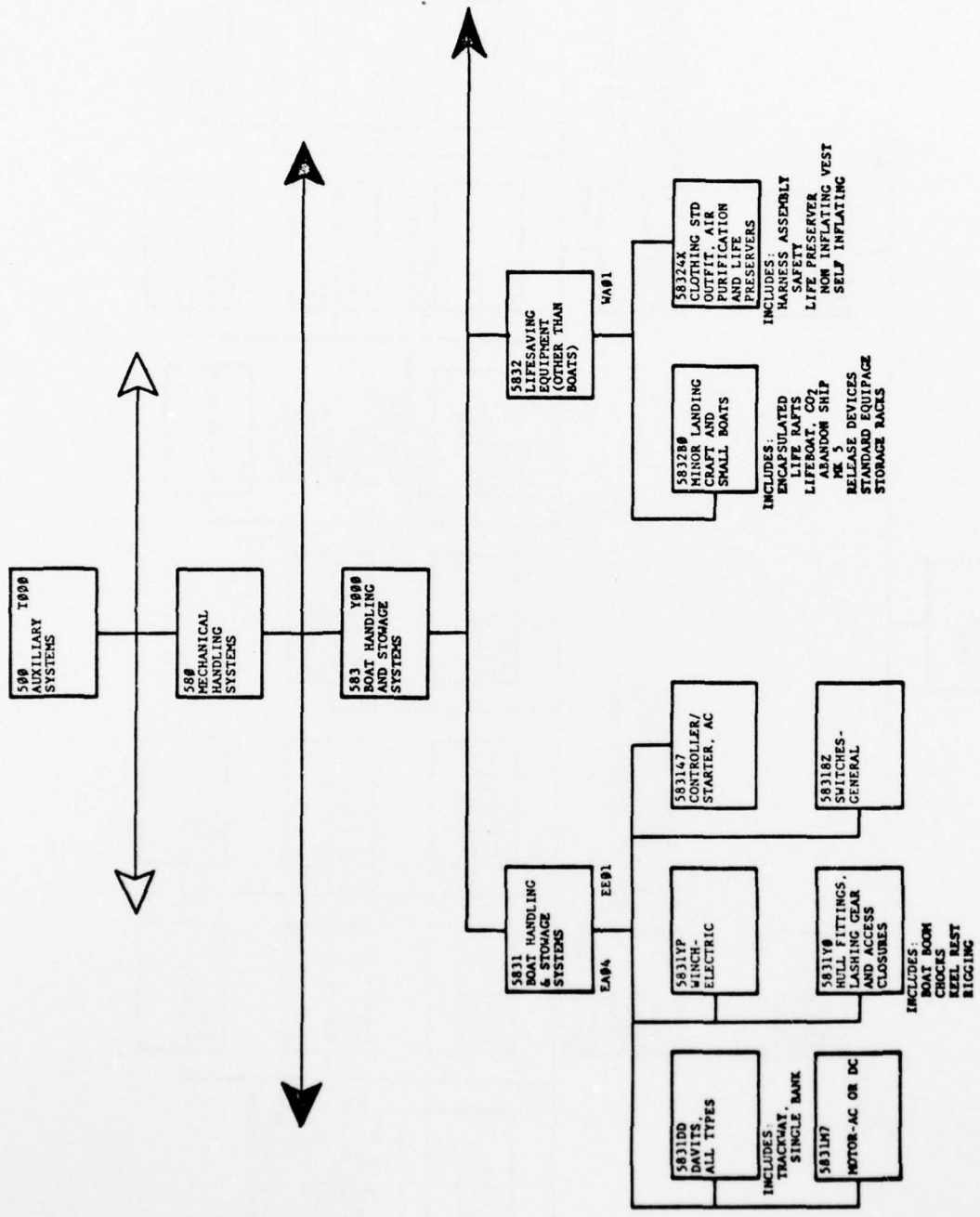

DDC-2 CLASS
PREPARED 3-21-78

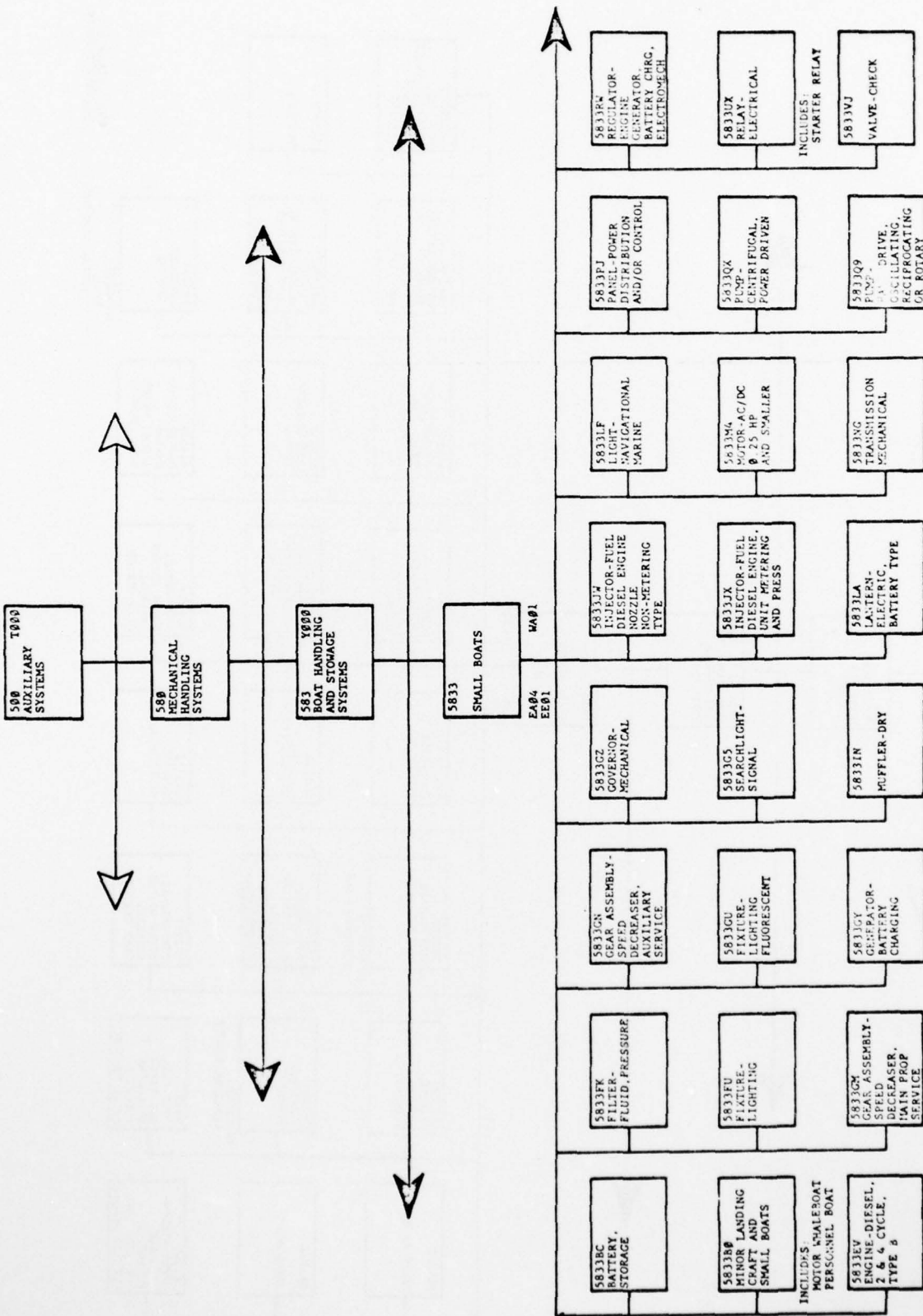

DDG-2 CLASS
 PREPARED 4-4-78

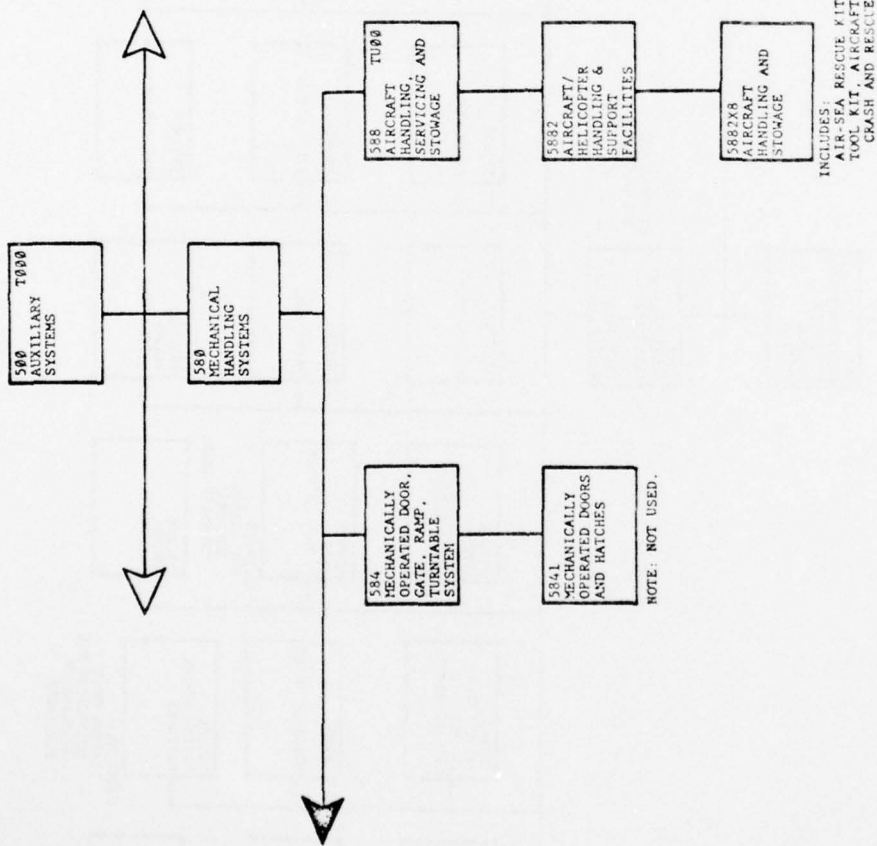

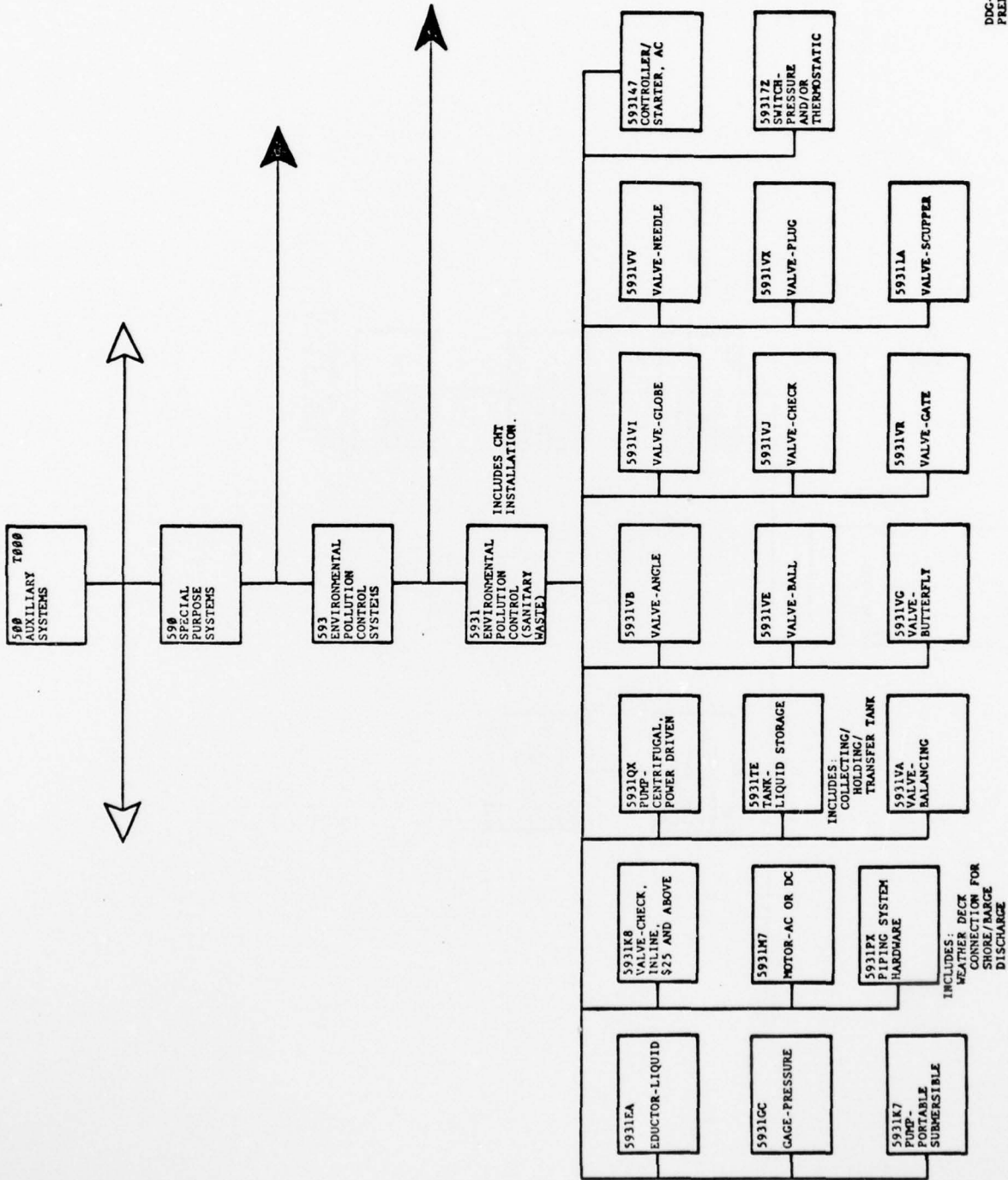

DDC-2 CLASS
PREPARED 3-21-78

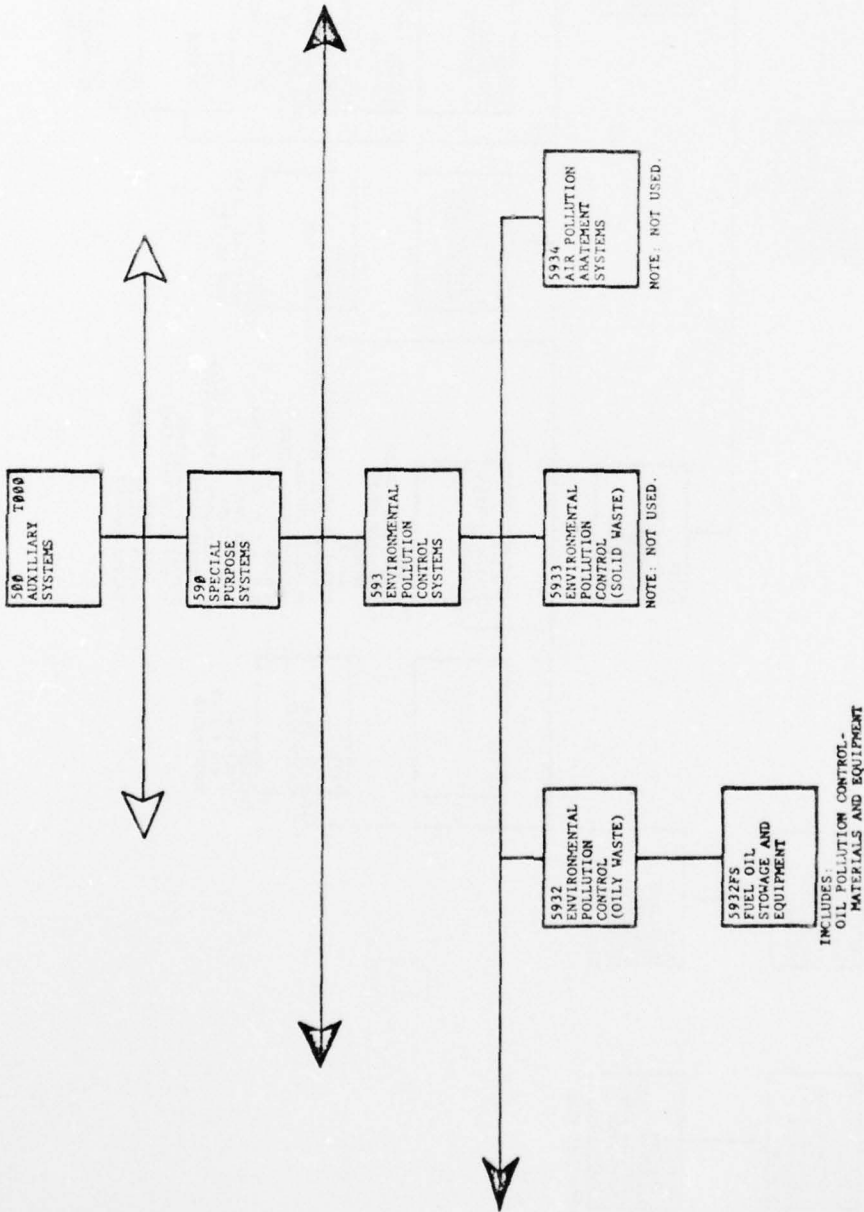

AD-A058 520

ARINC RESEARCH CORP ANNAPOLIS MD
SHIP SYSTEMS STAGING DIAGRAMS FOR DDG-2 CLASS SHIPS.(U)
JUN 78

F/6 13/10

UNCLASSIFIED

1806-01-4-1742

N00140-76-D-0813

NL

3 of 3

AD
4058520



END
DATE
FILMED
11-78
DDC

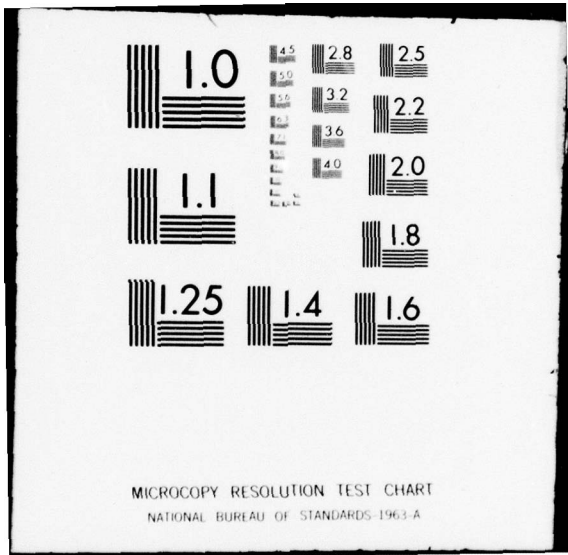

MICROCOPY RESOLUTION TEST CHART
NATIONAL BUREAU OF STANDARDS-1963-A

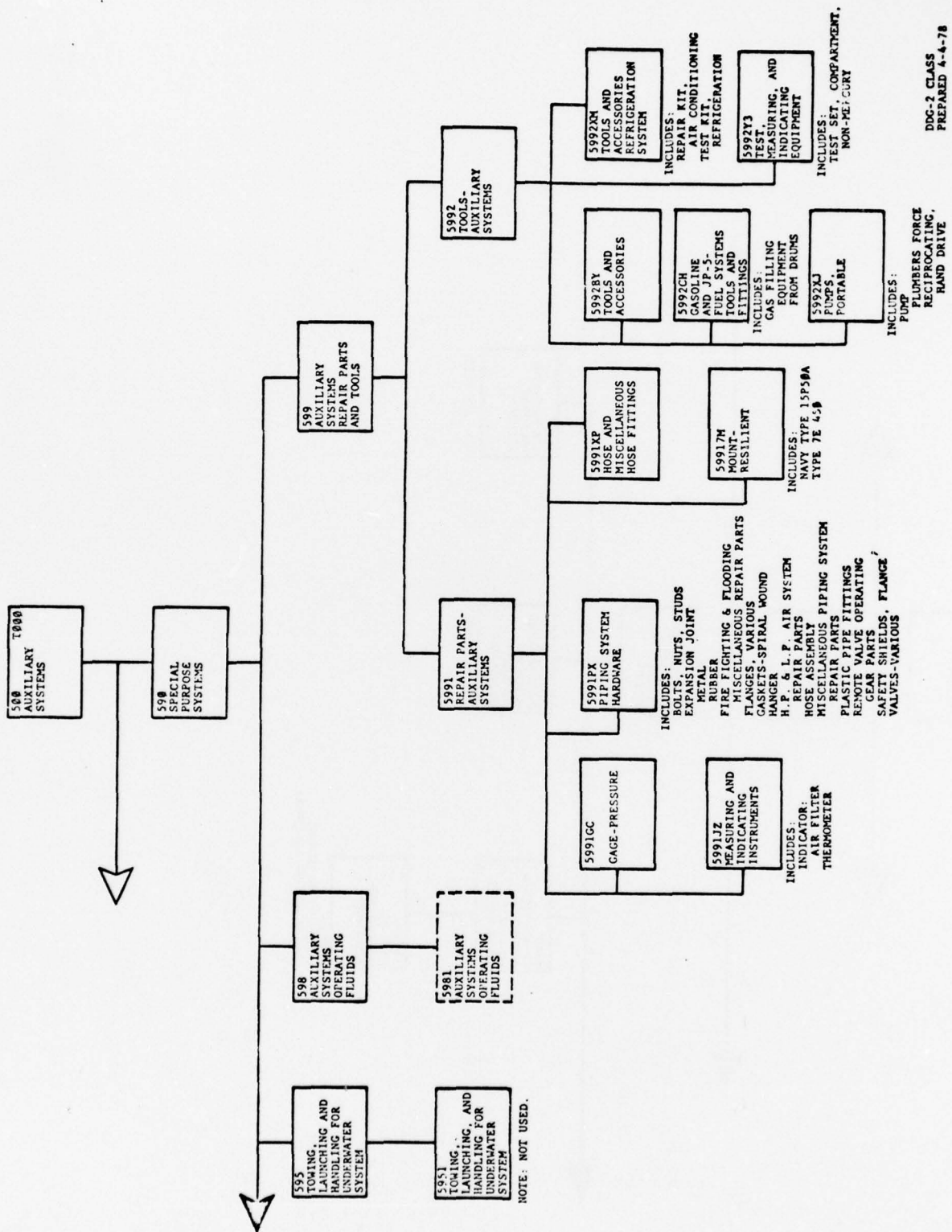

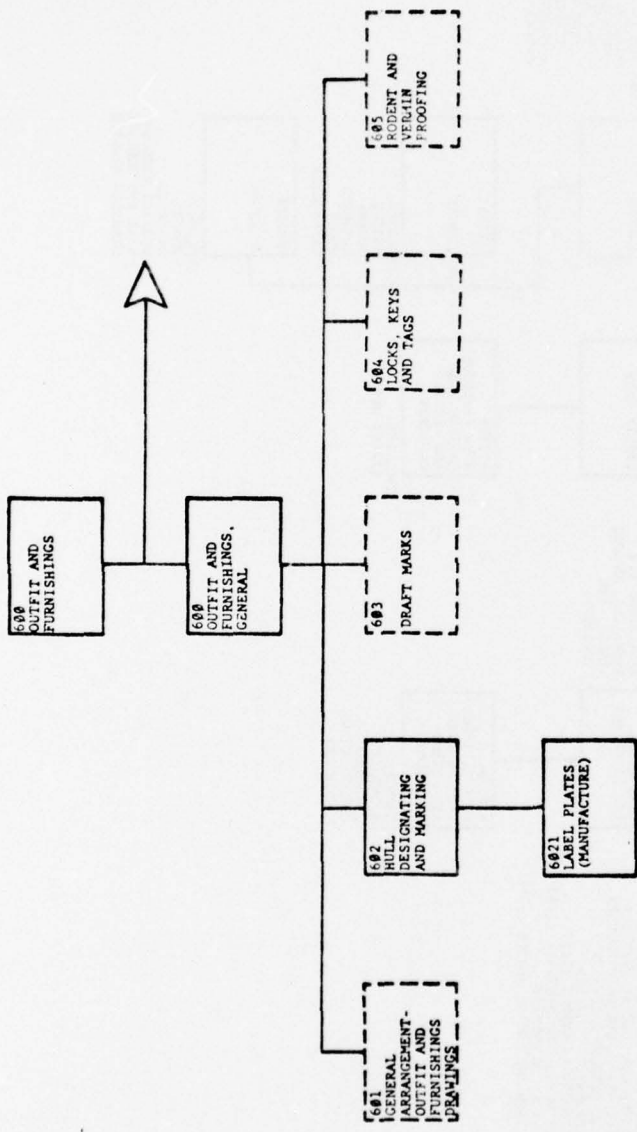

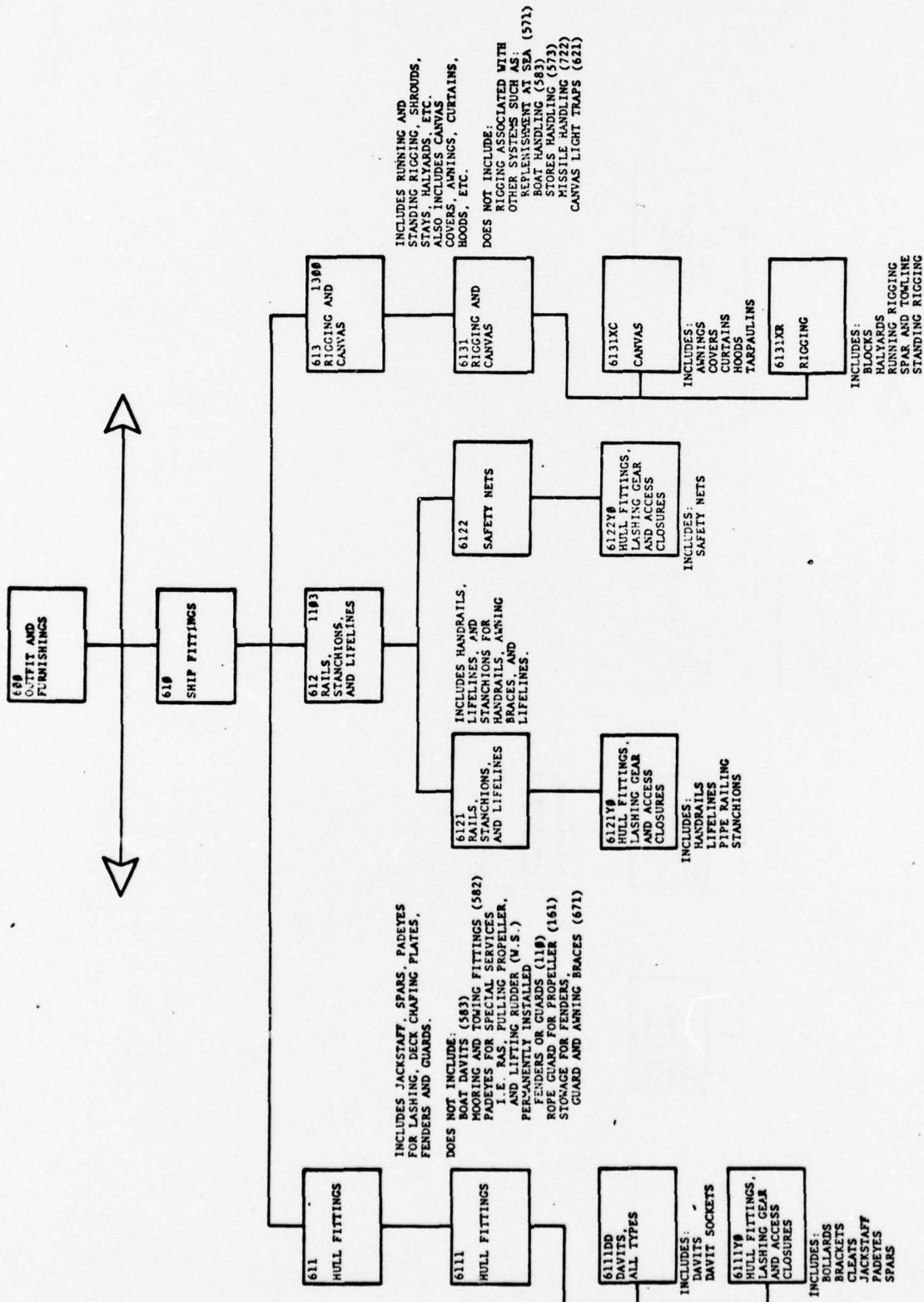

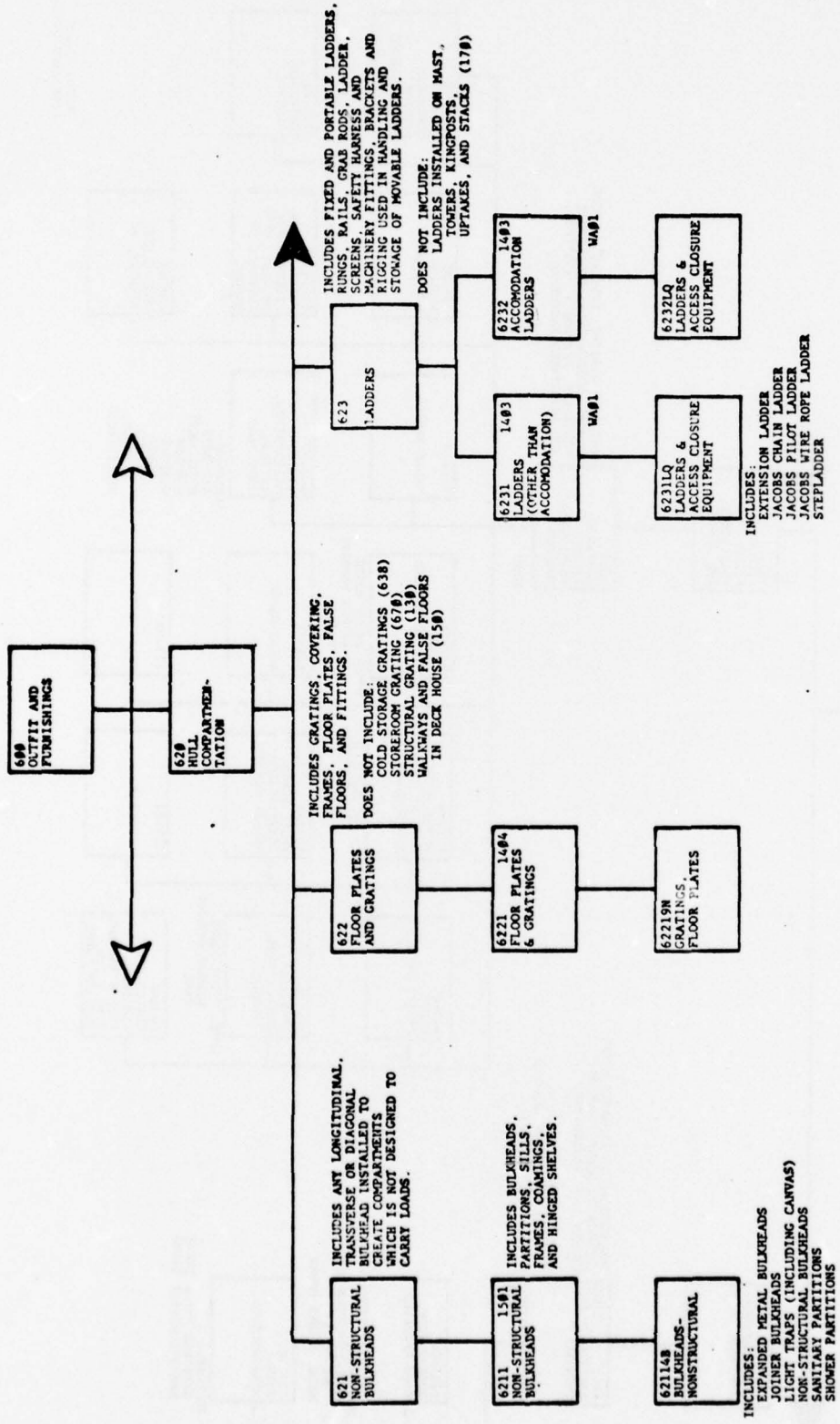

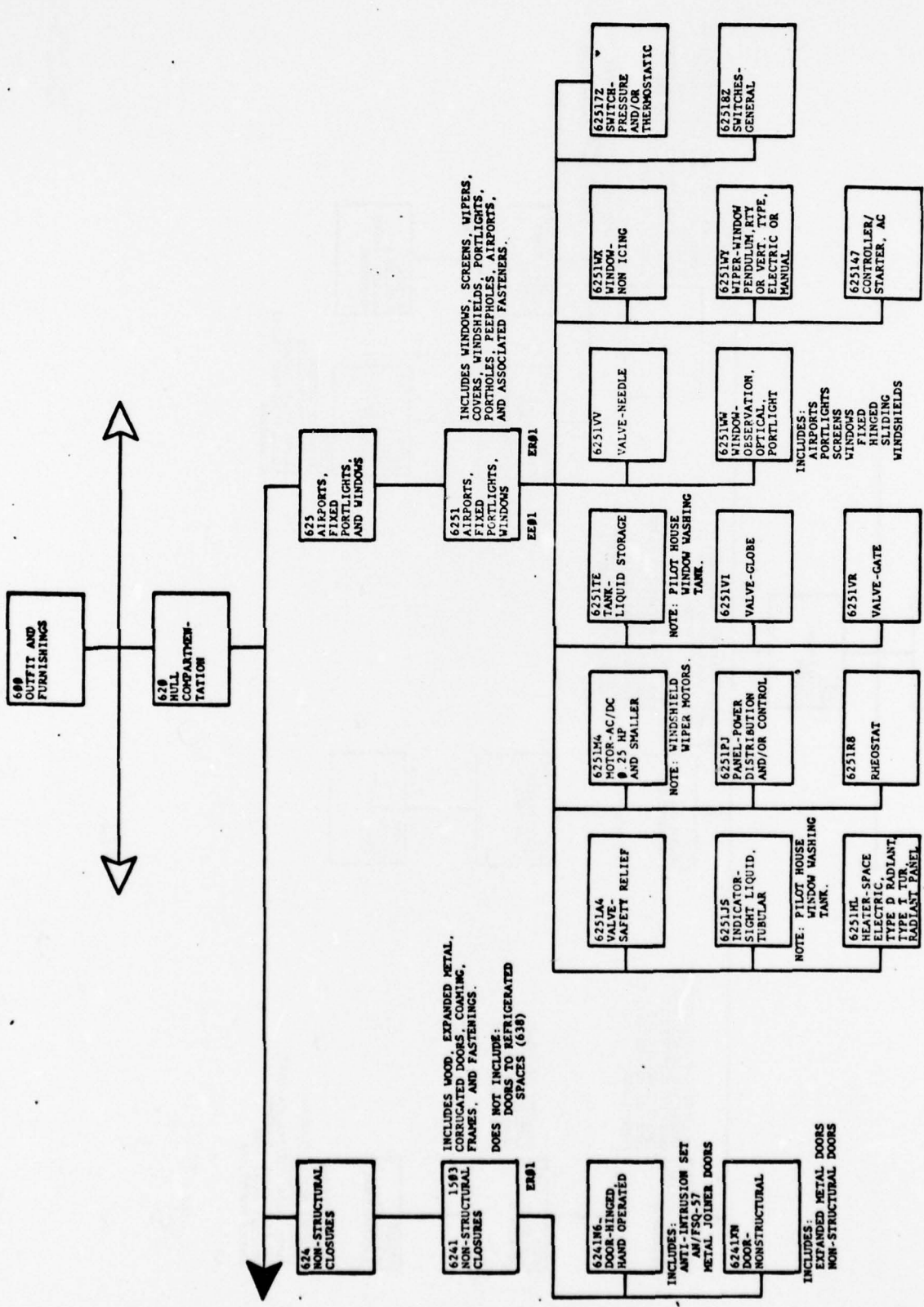

DDG-2 CLASS
PREPARED 2-11-78

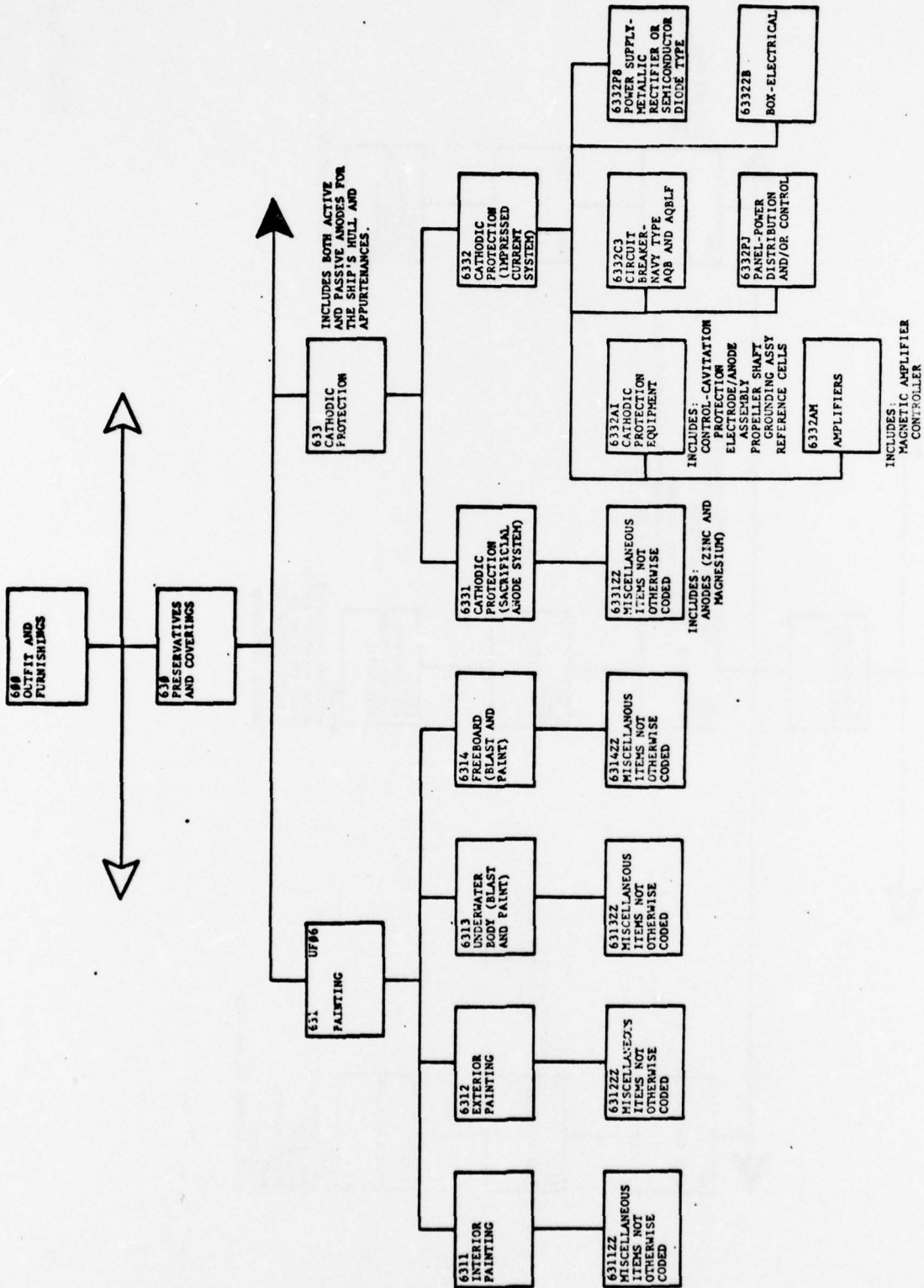

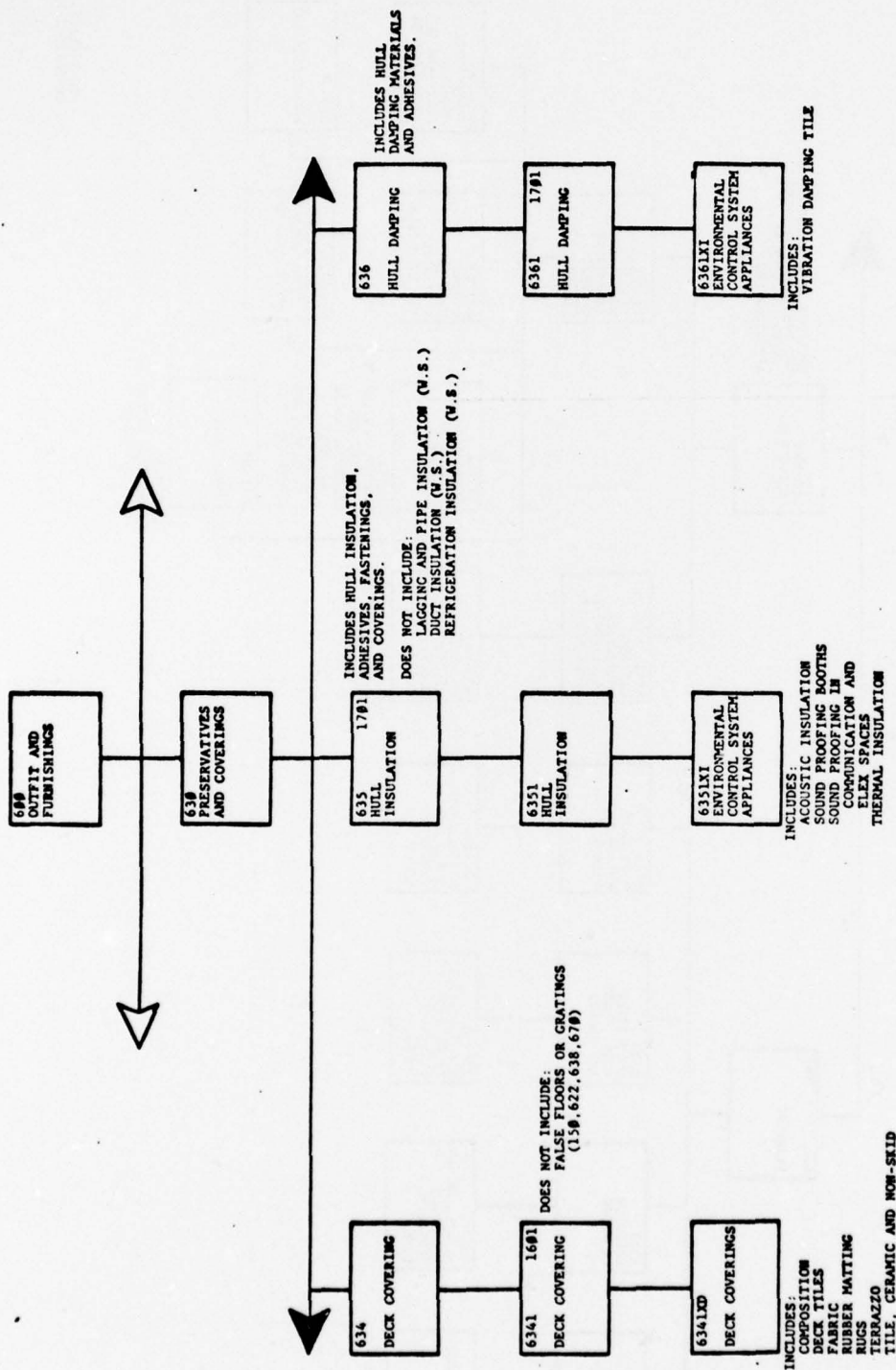

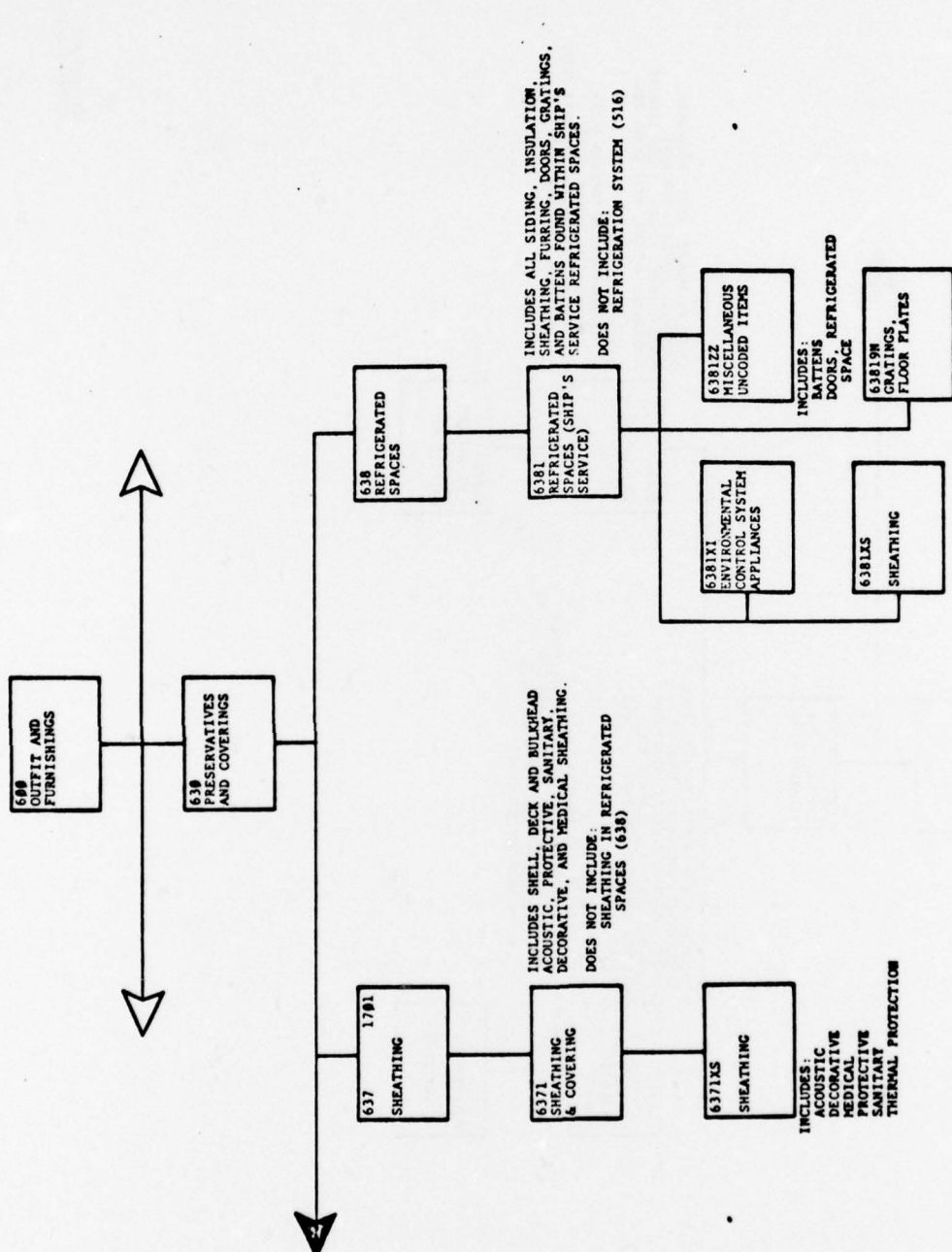

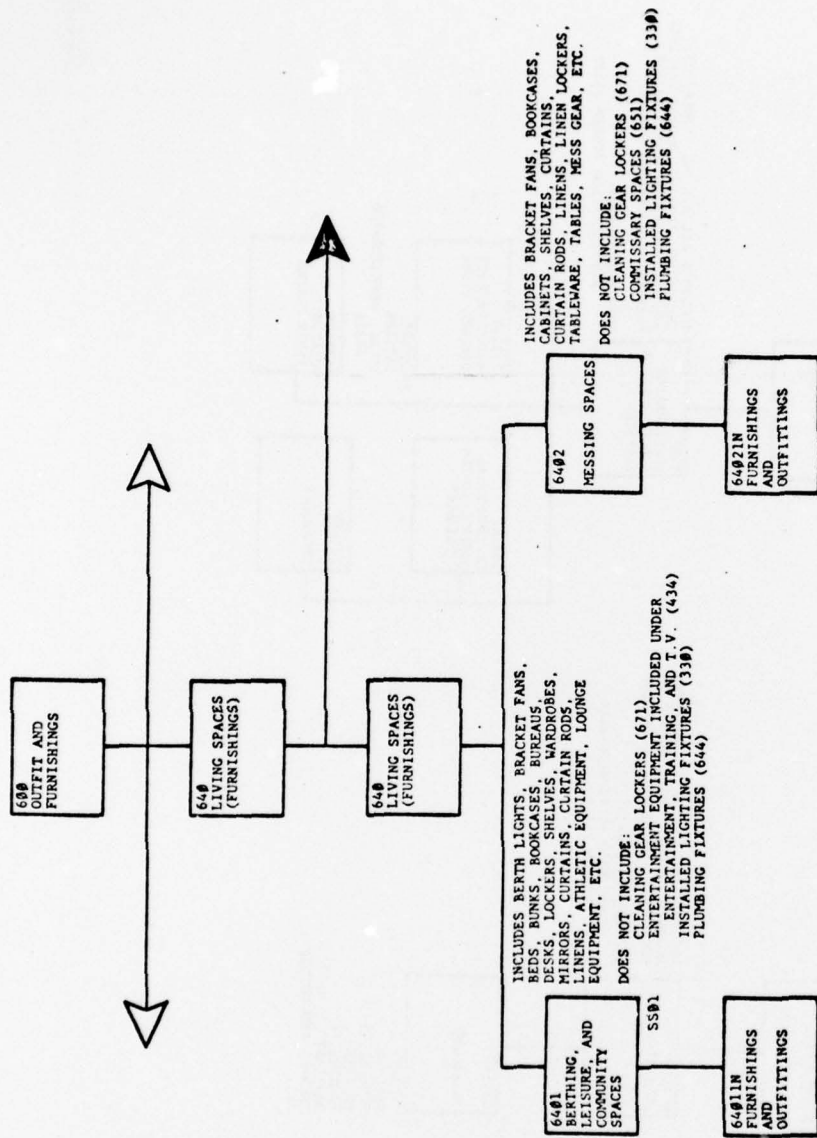

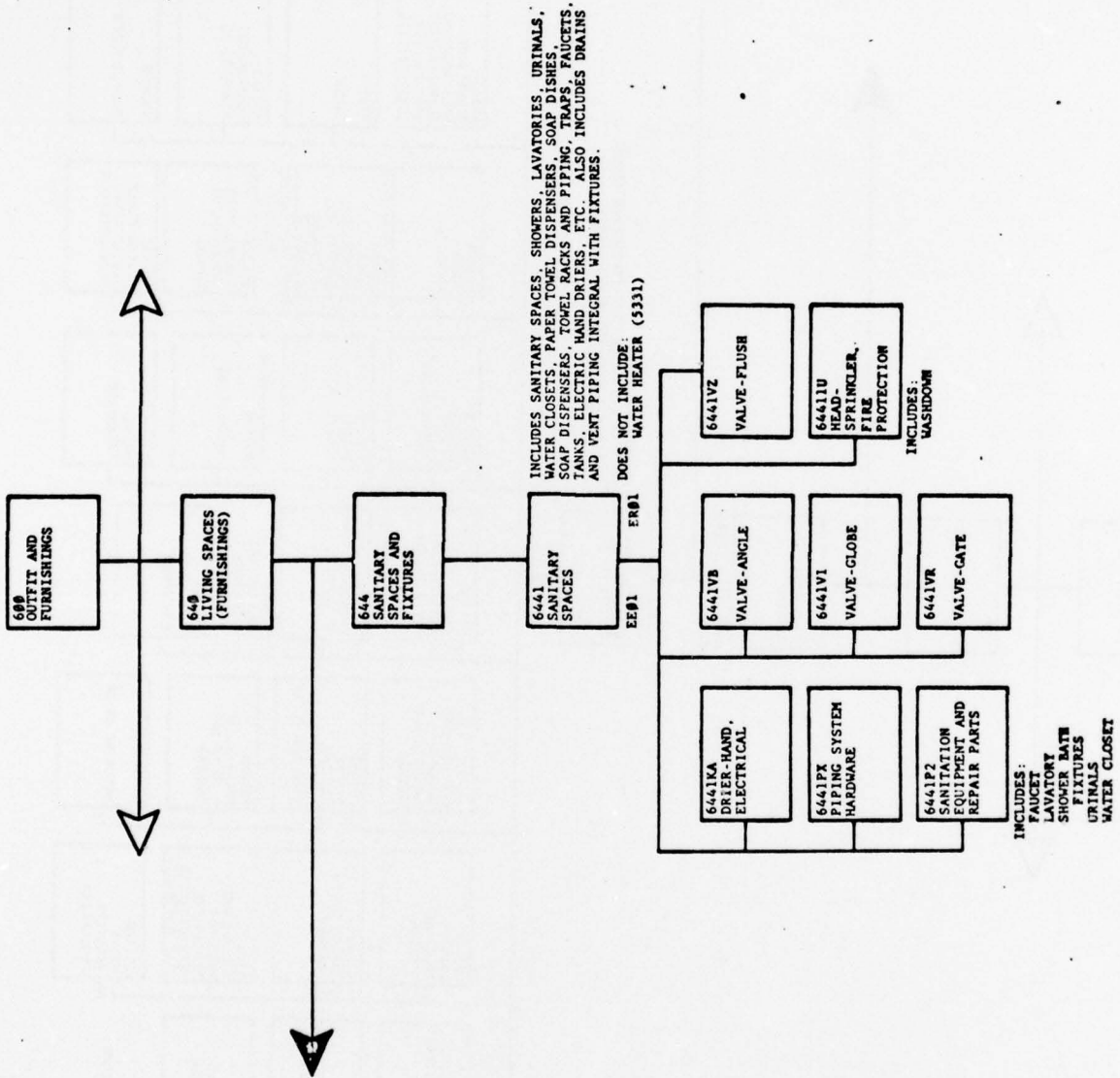

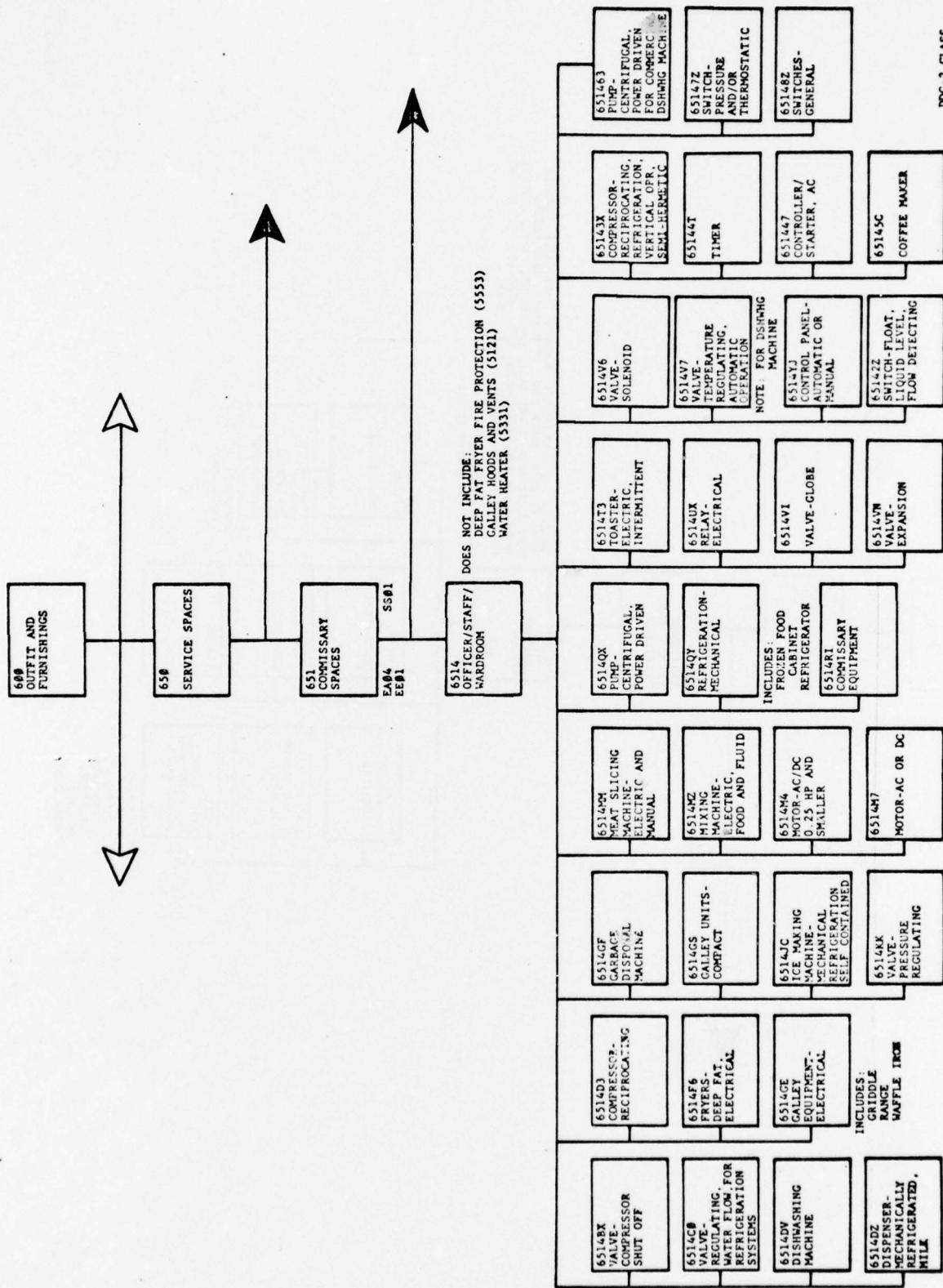

DDG-2 CLASS
PREPARED 2-11-78

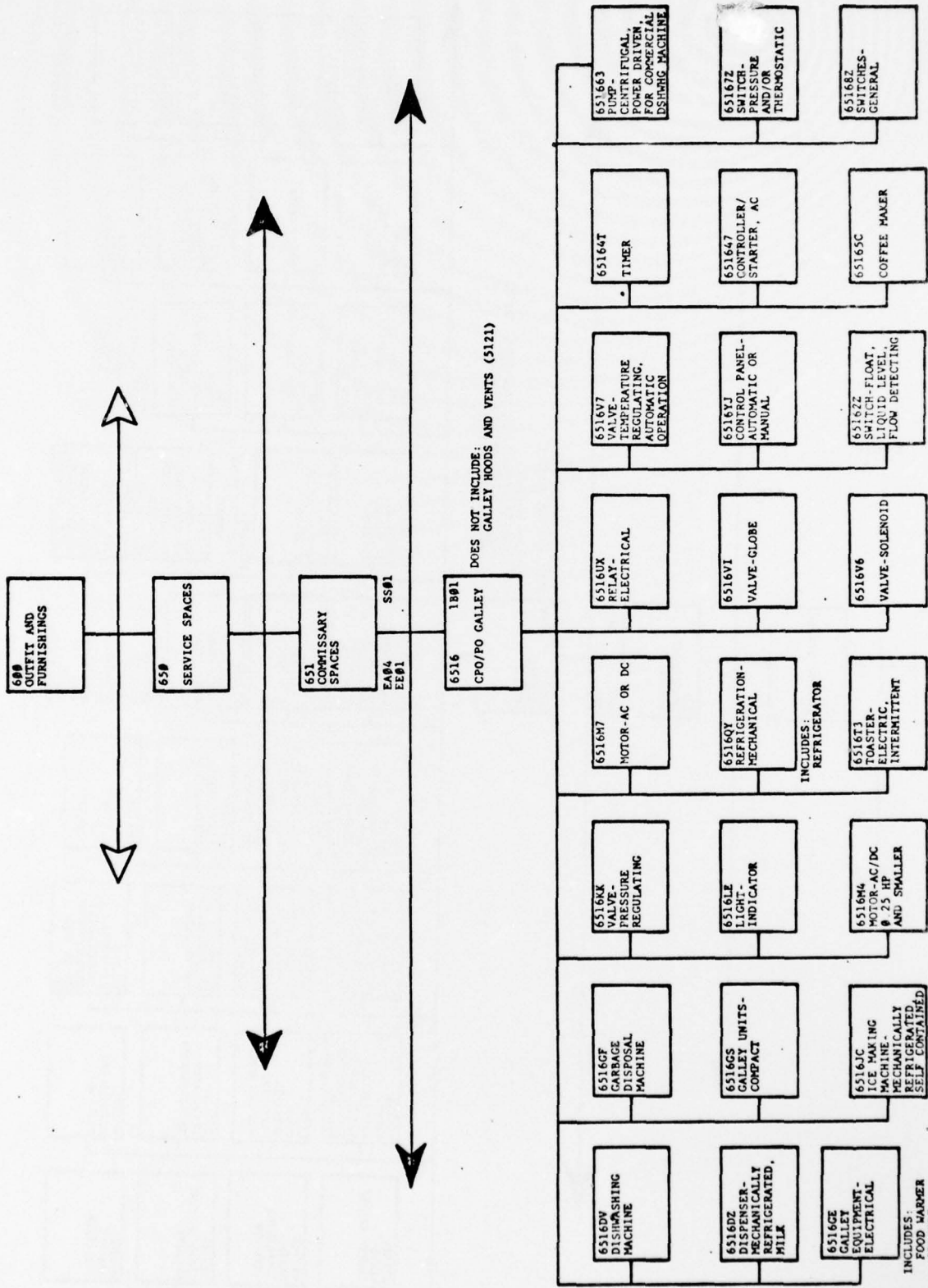

DDG-2 CLASS PREPARED 2-11-78

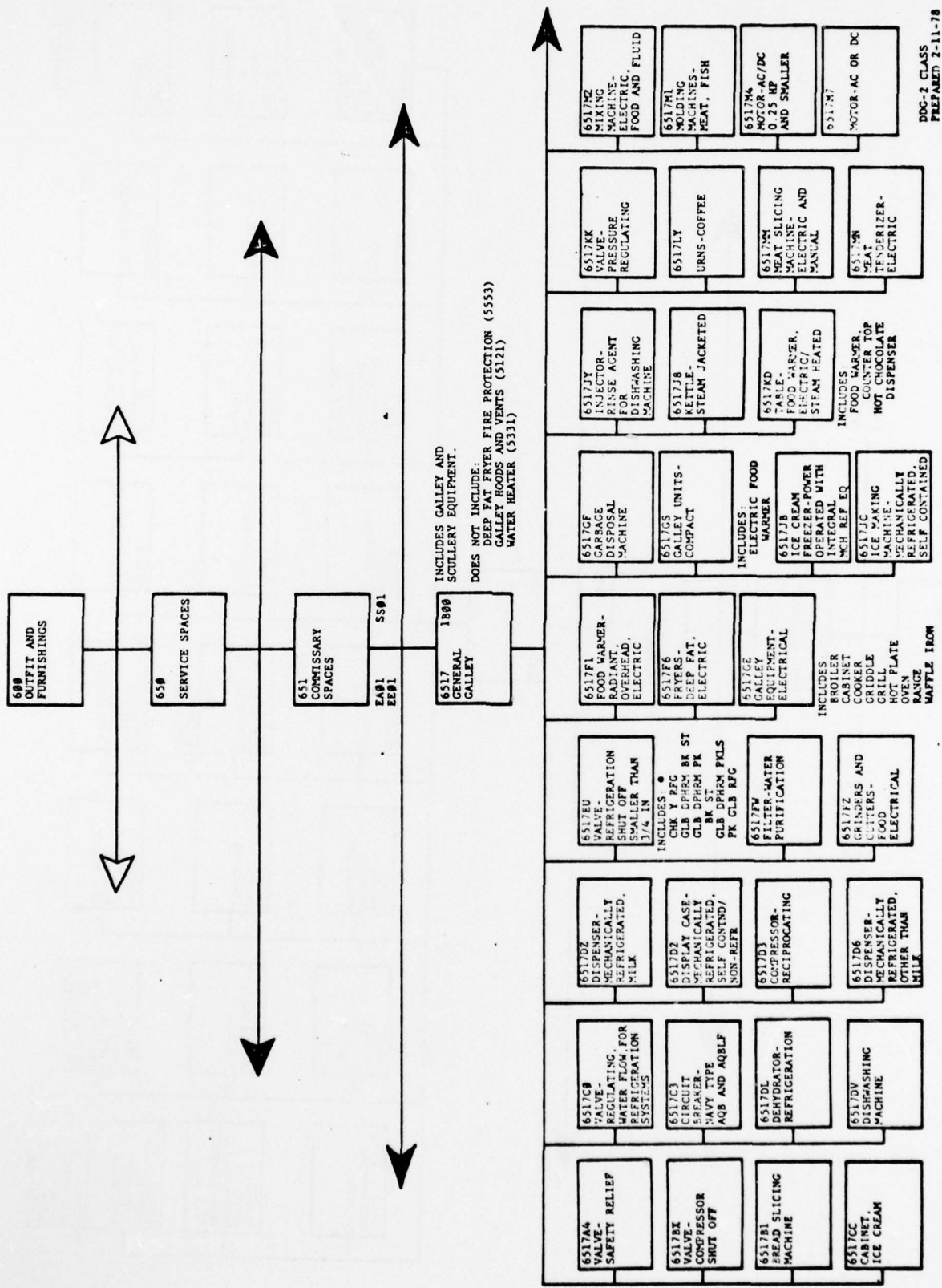

DDG-2 CLASS PREPARED 2-11-78

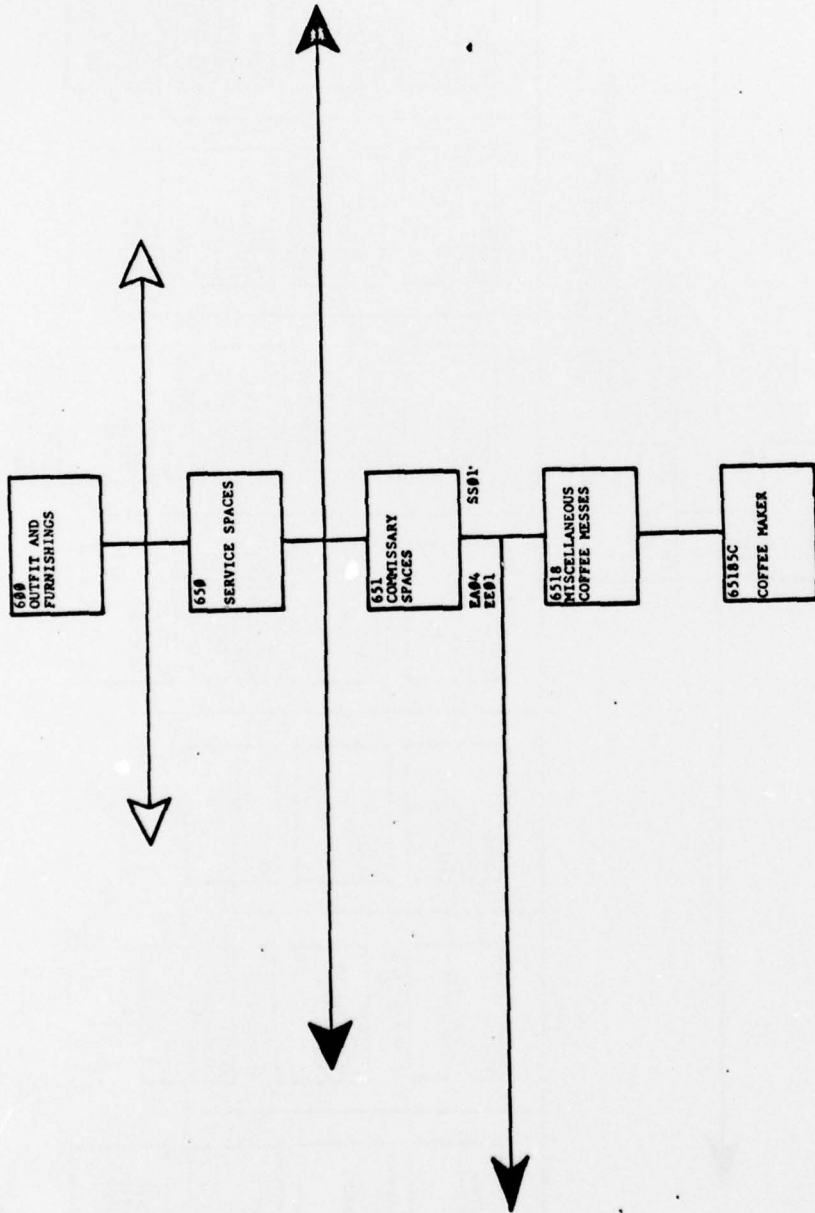

DOC-2 CLASS
PREPARED 2-11-78

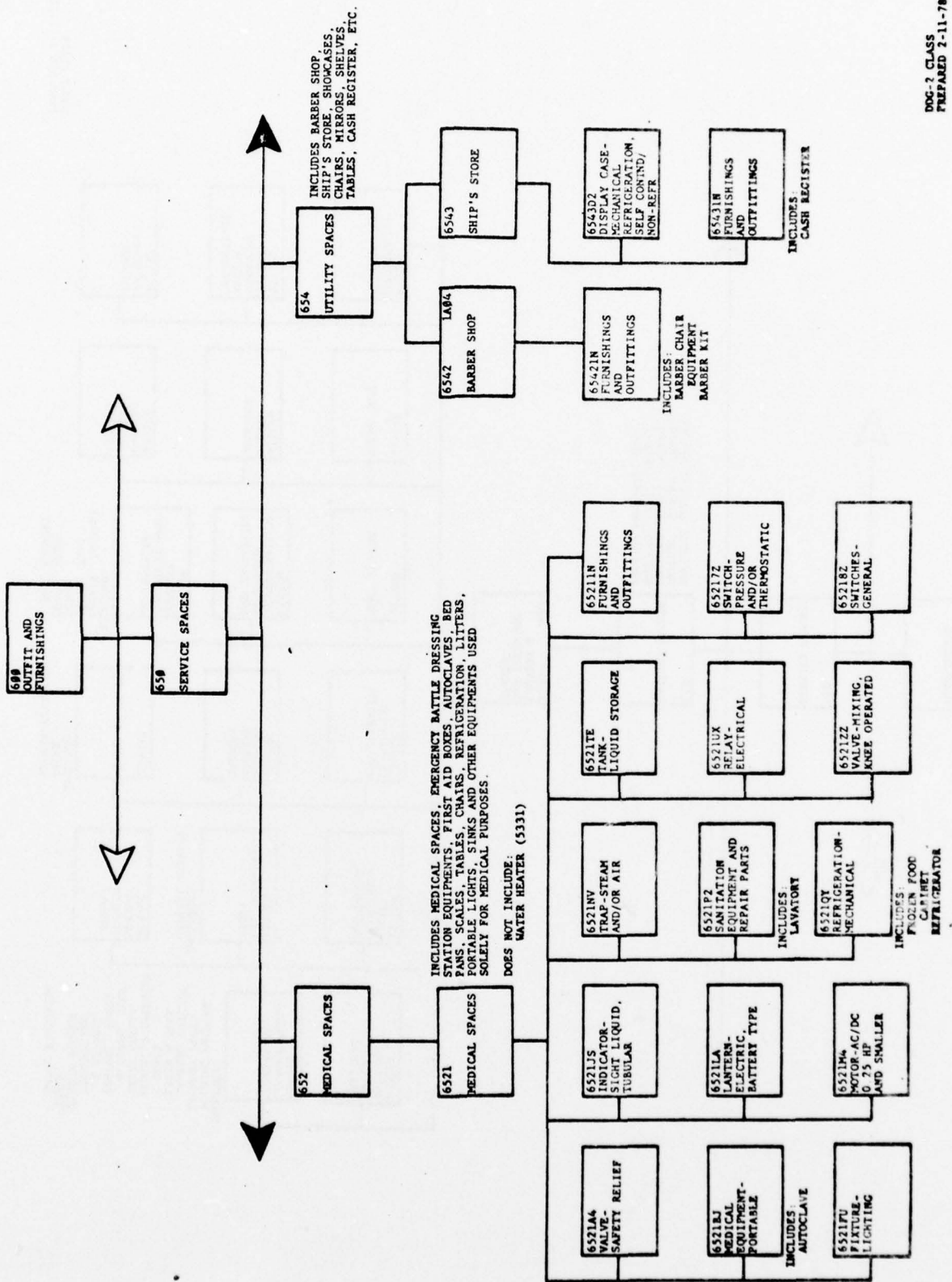

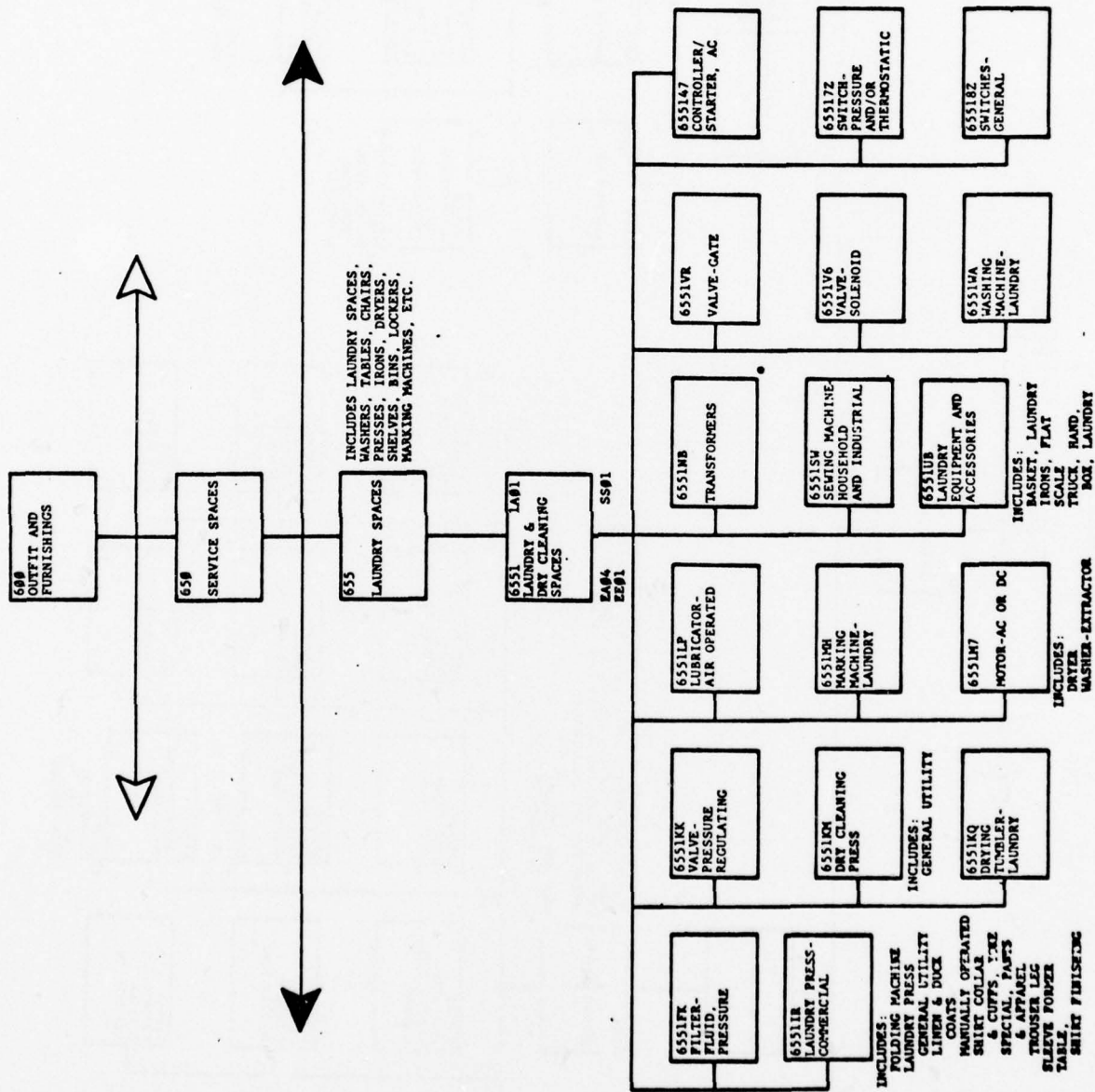

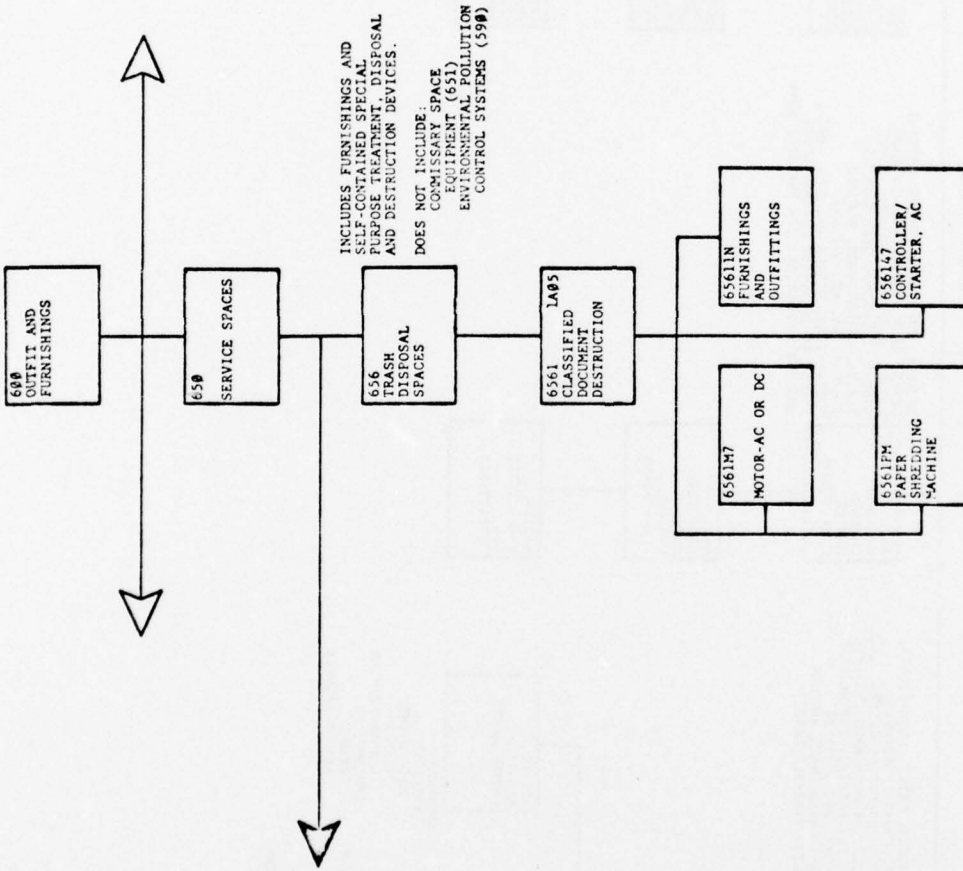

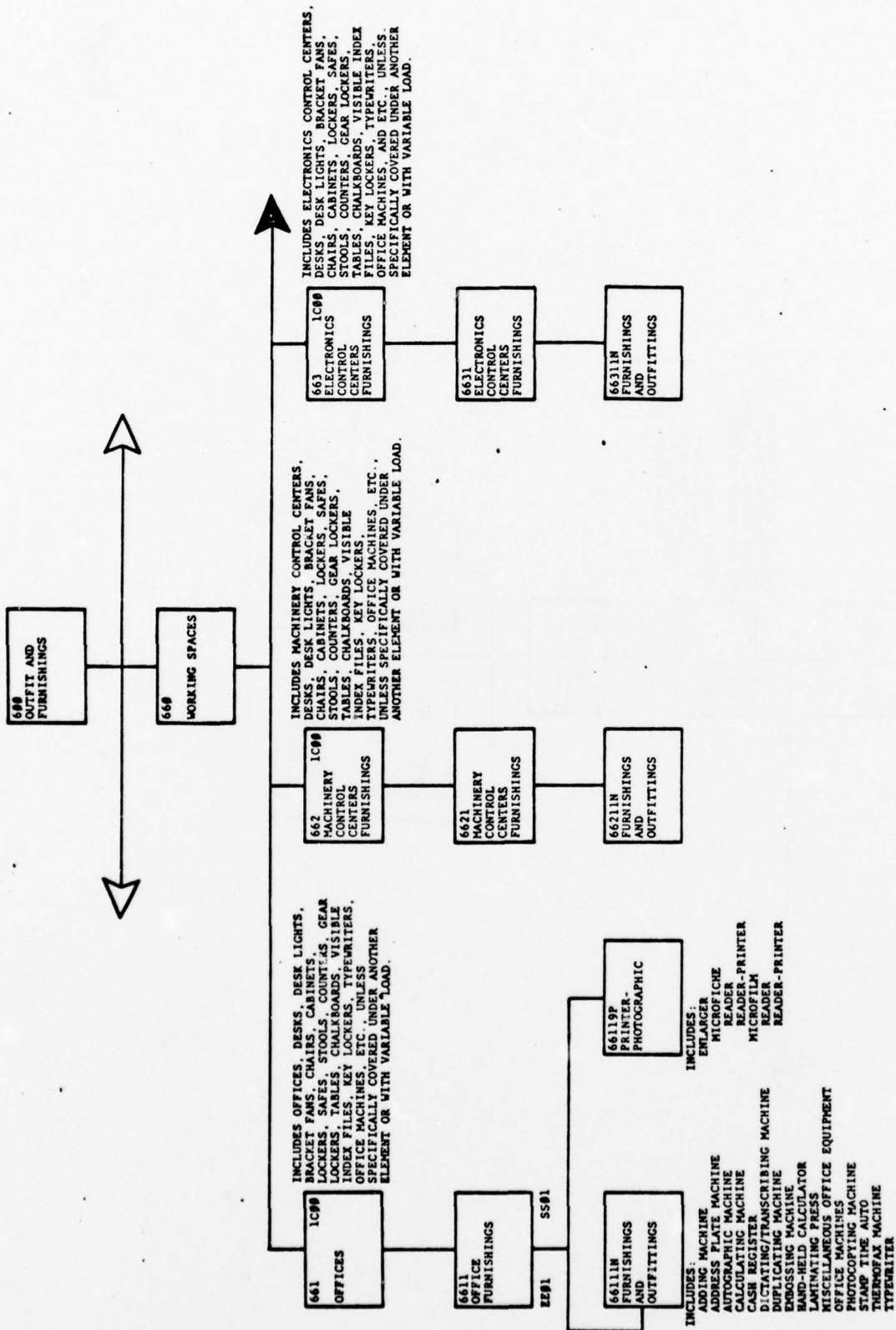

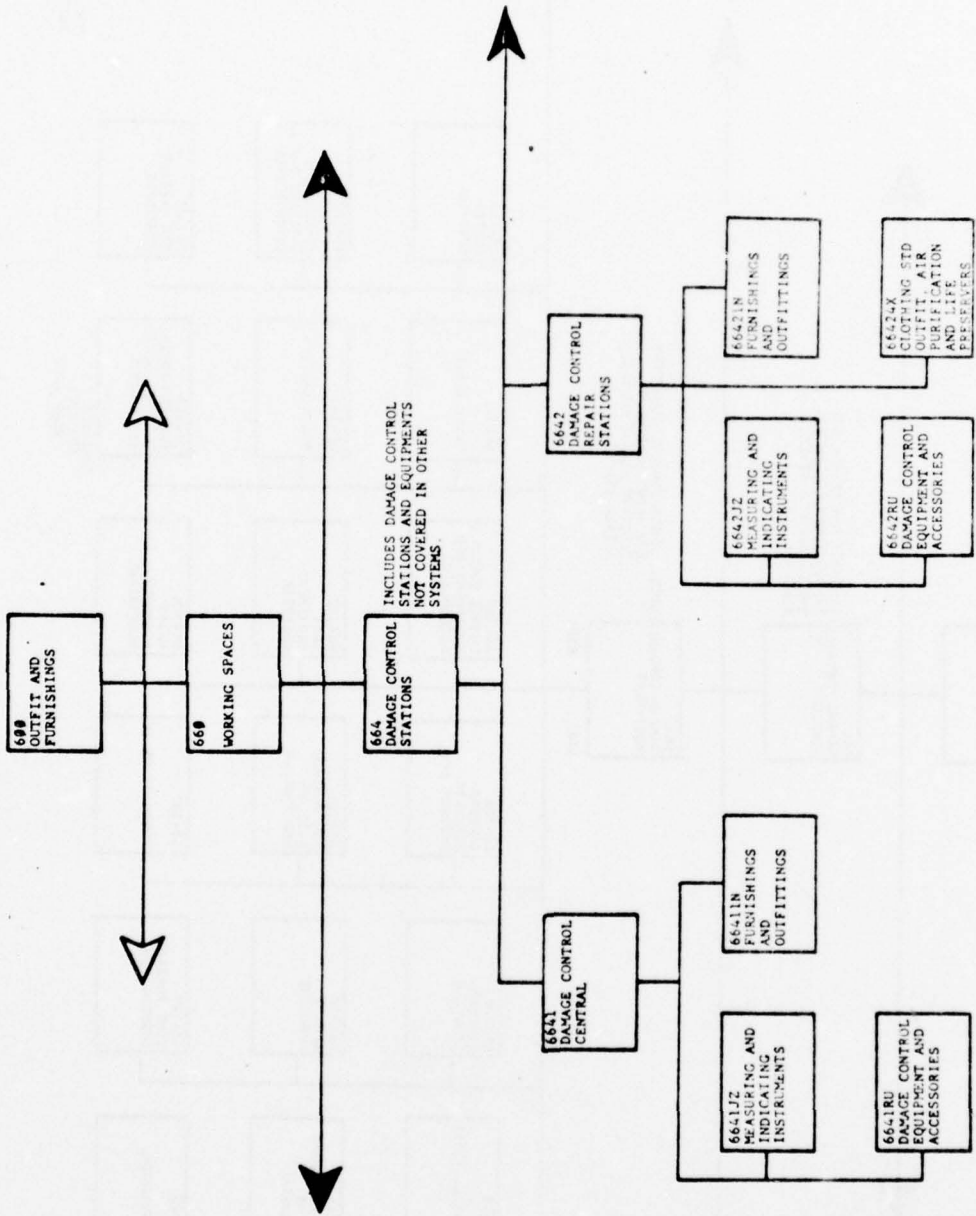

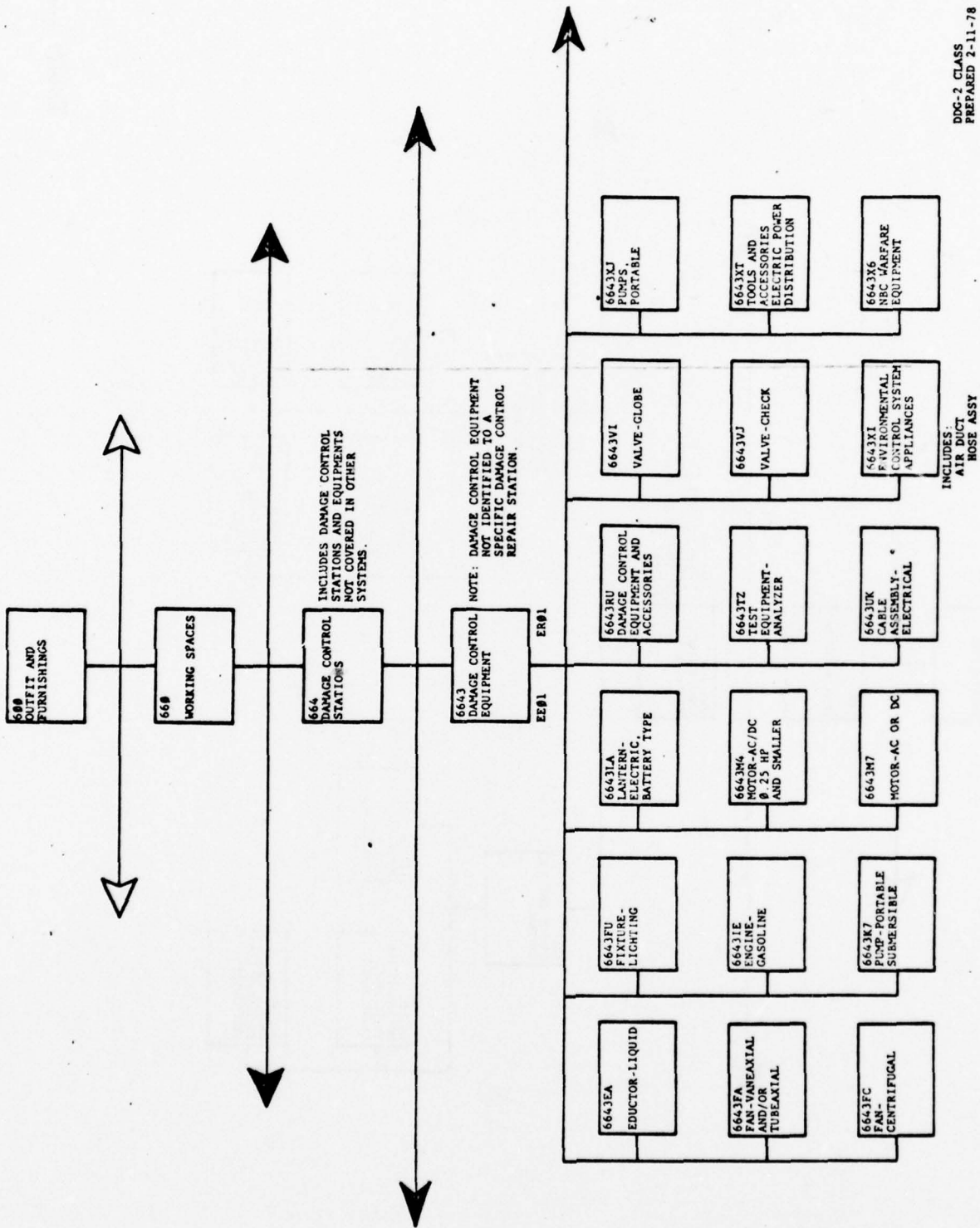

DDG-2 CLASS
PREPARED 2-11-78

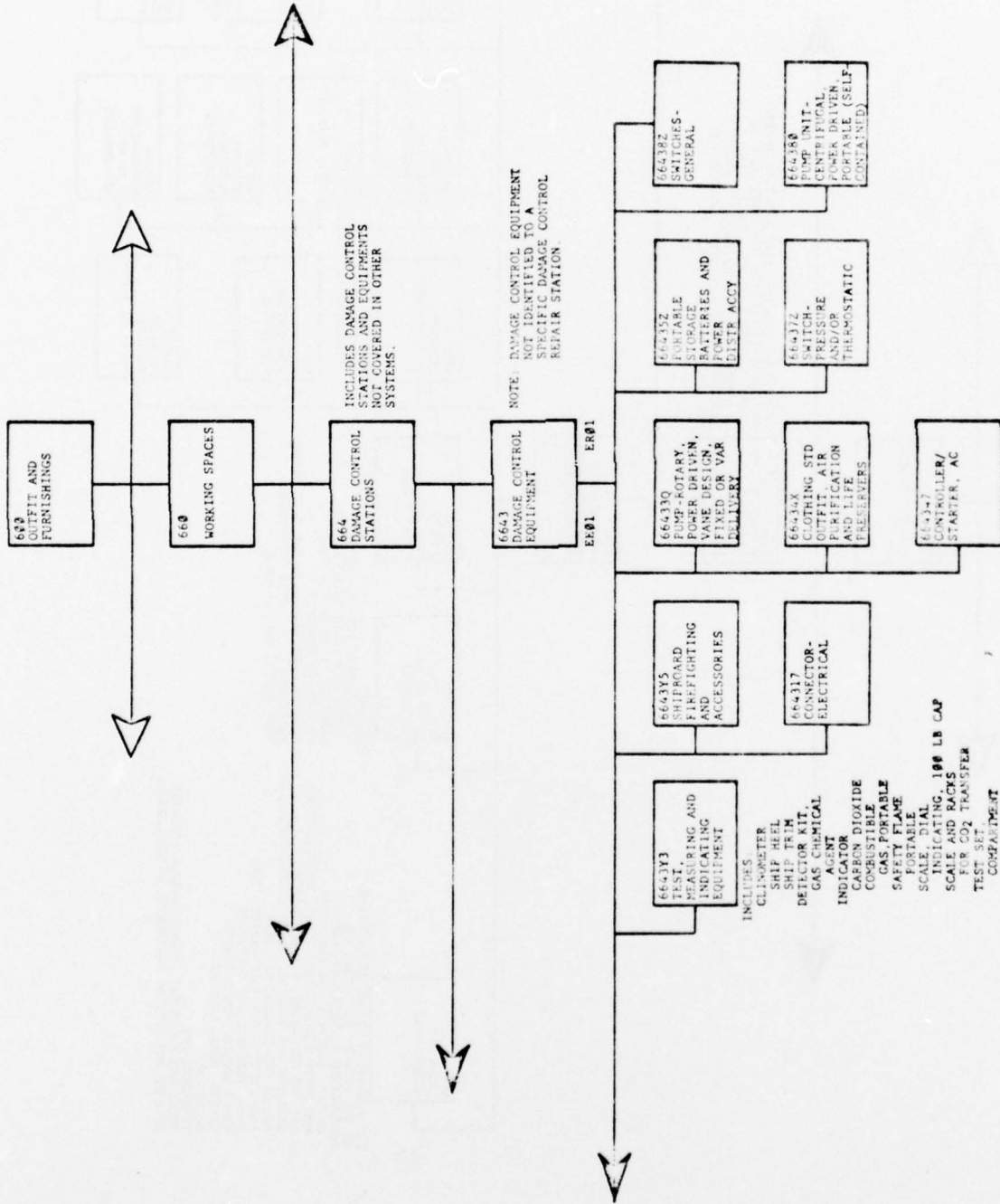

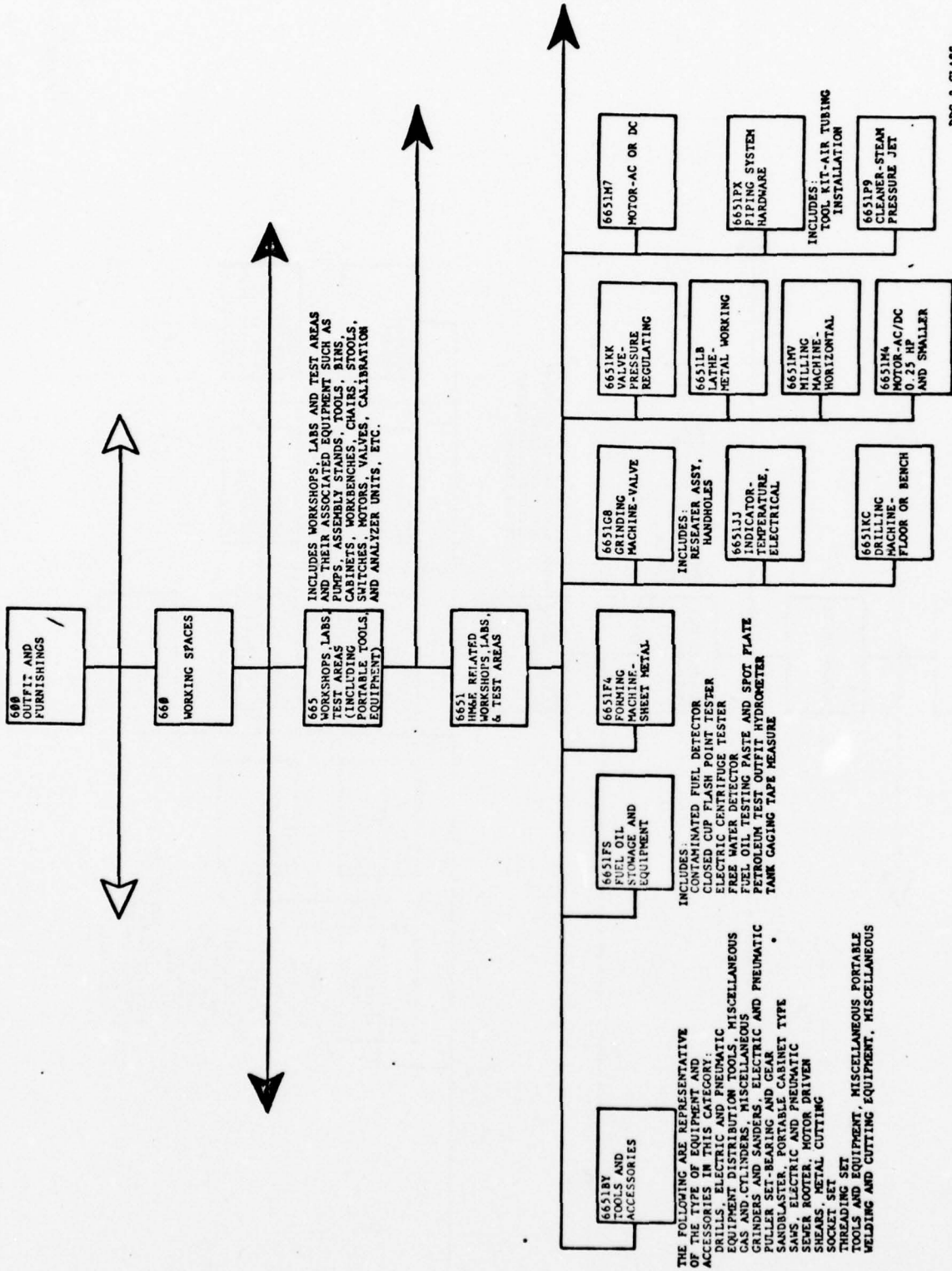

DDG-2 CLASS
 PREPARED 2-11-78

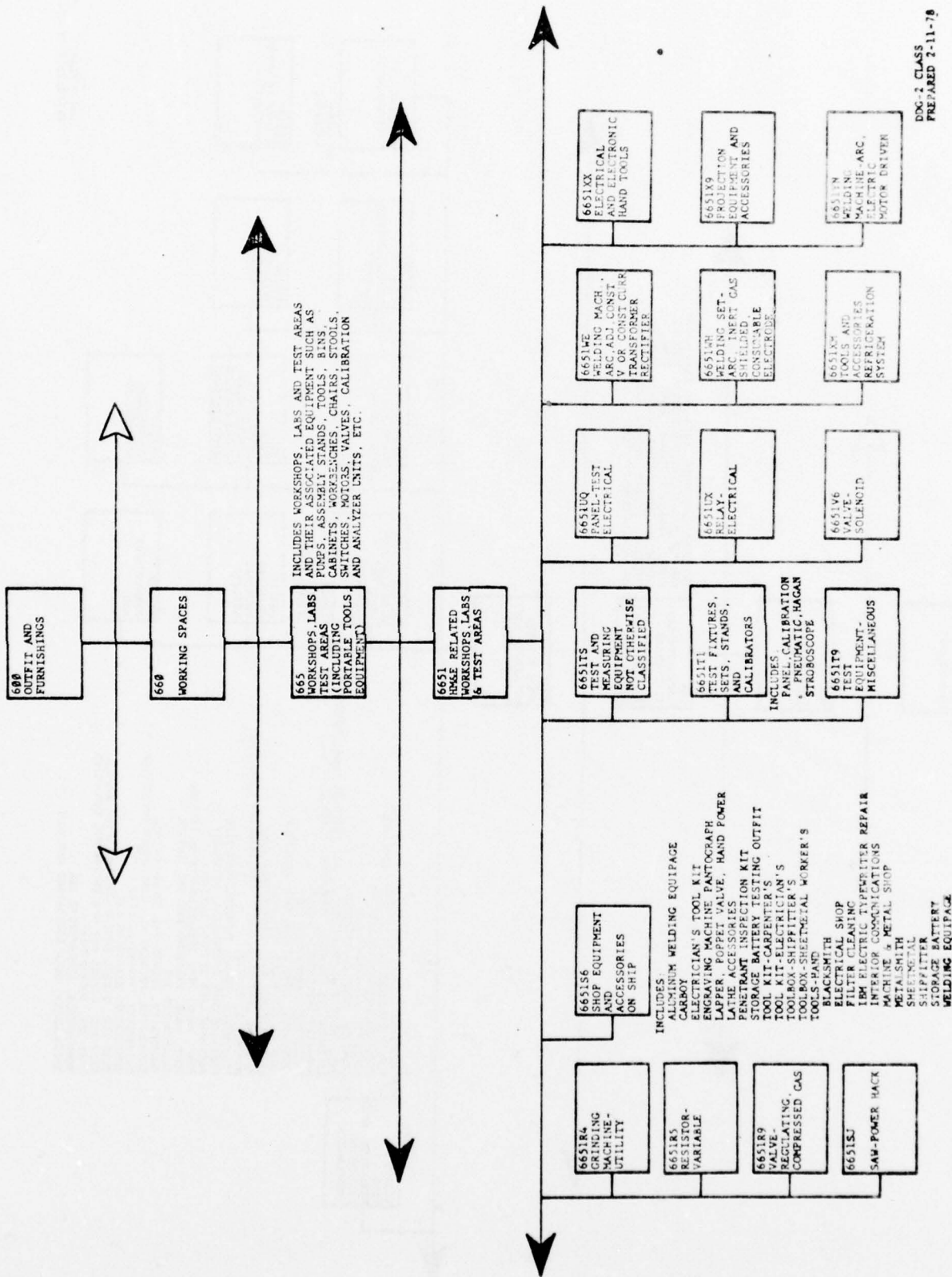

DDC-1 CLASS PREPARED 7-11-78

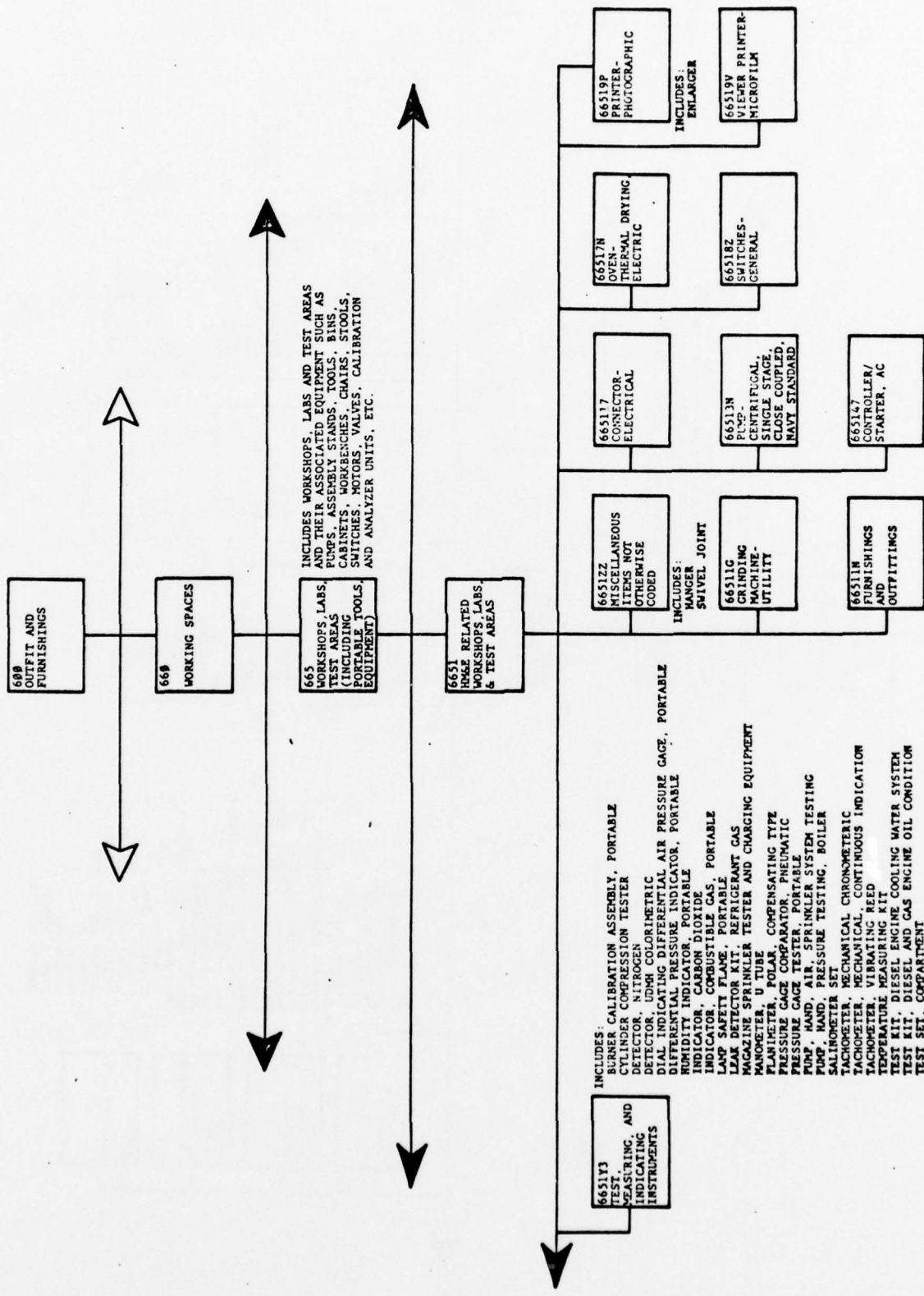

DDG-2 CLASS
PREPARED 2-11-78

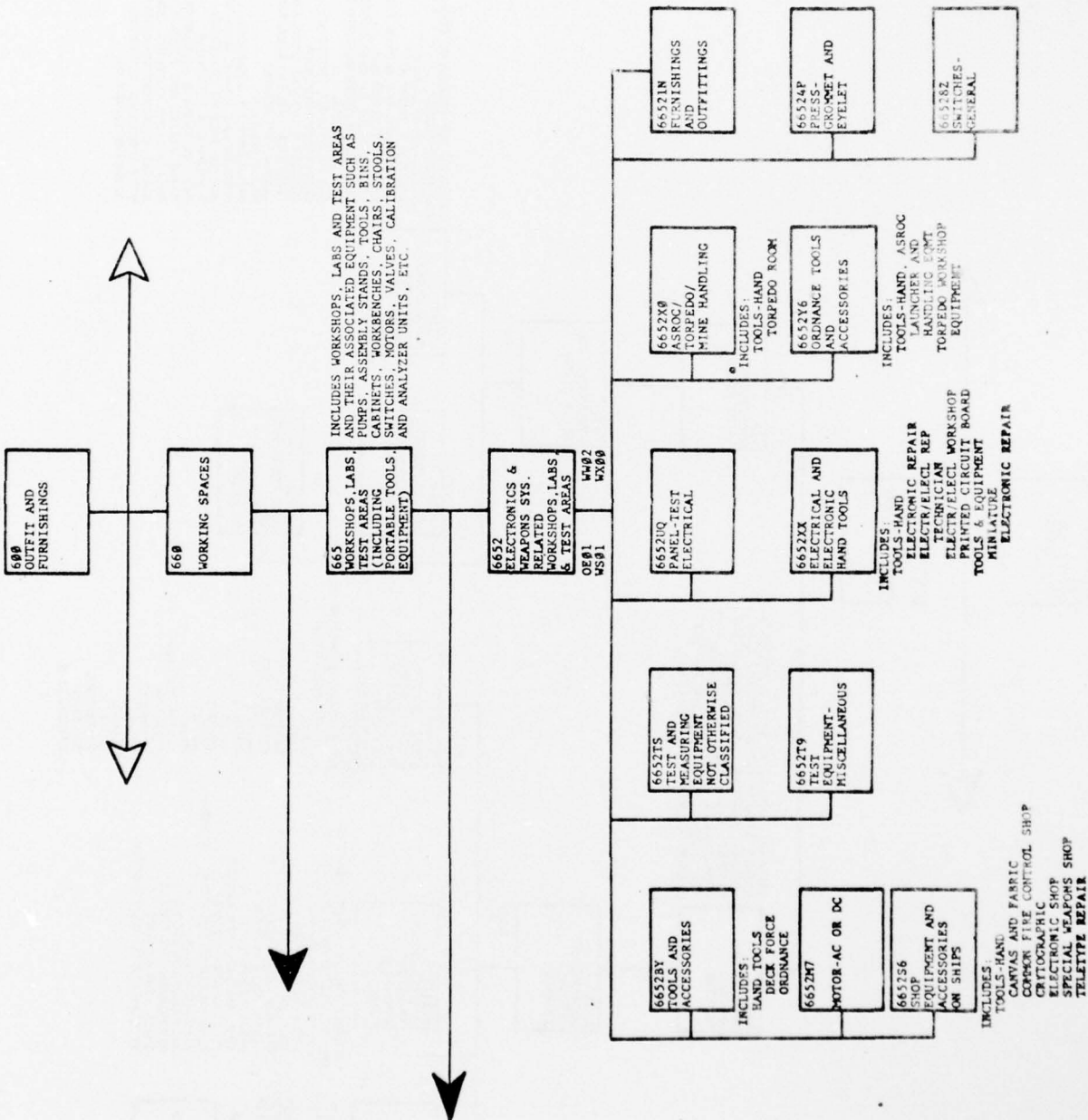

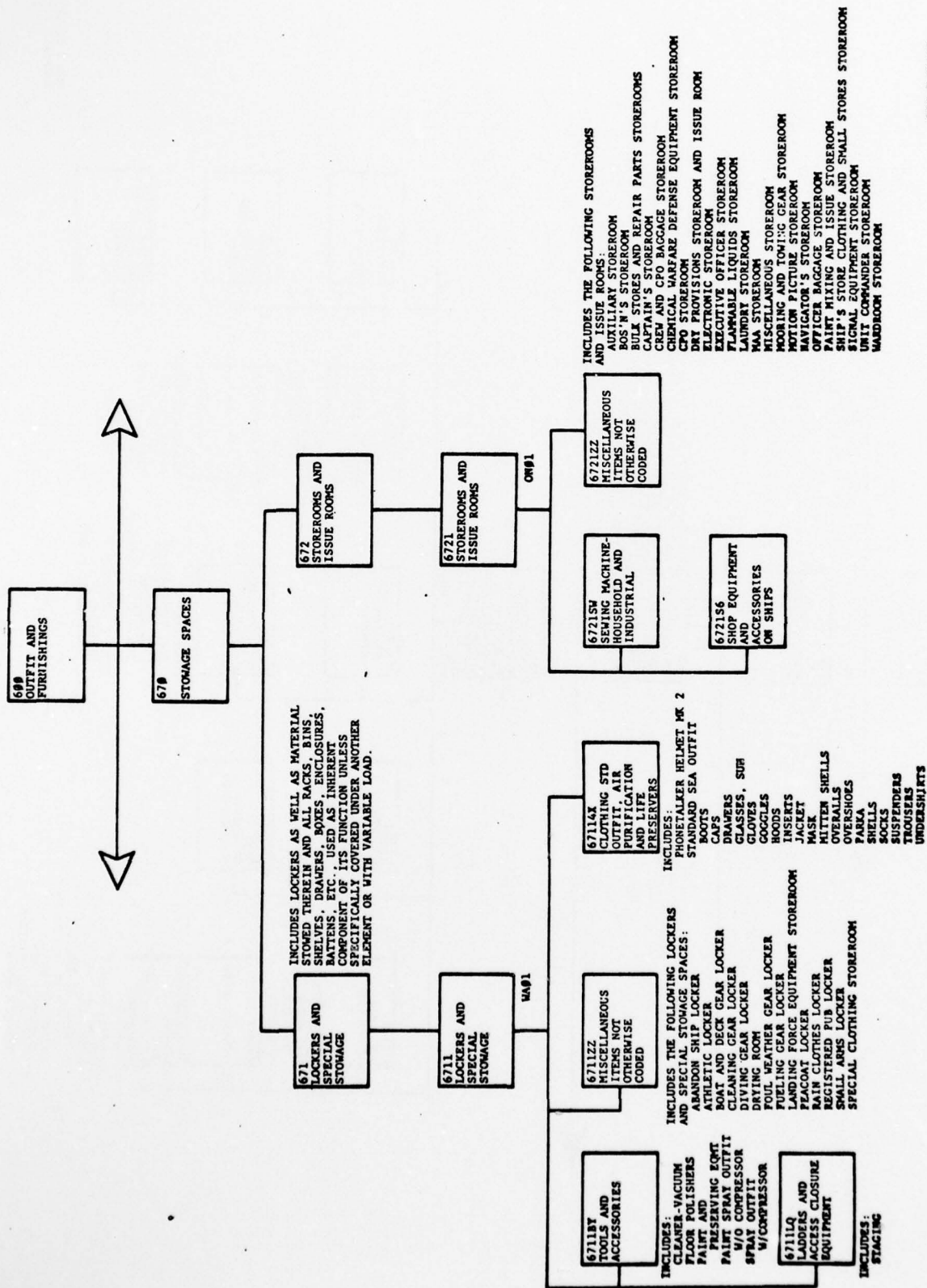

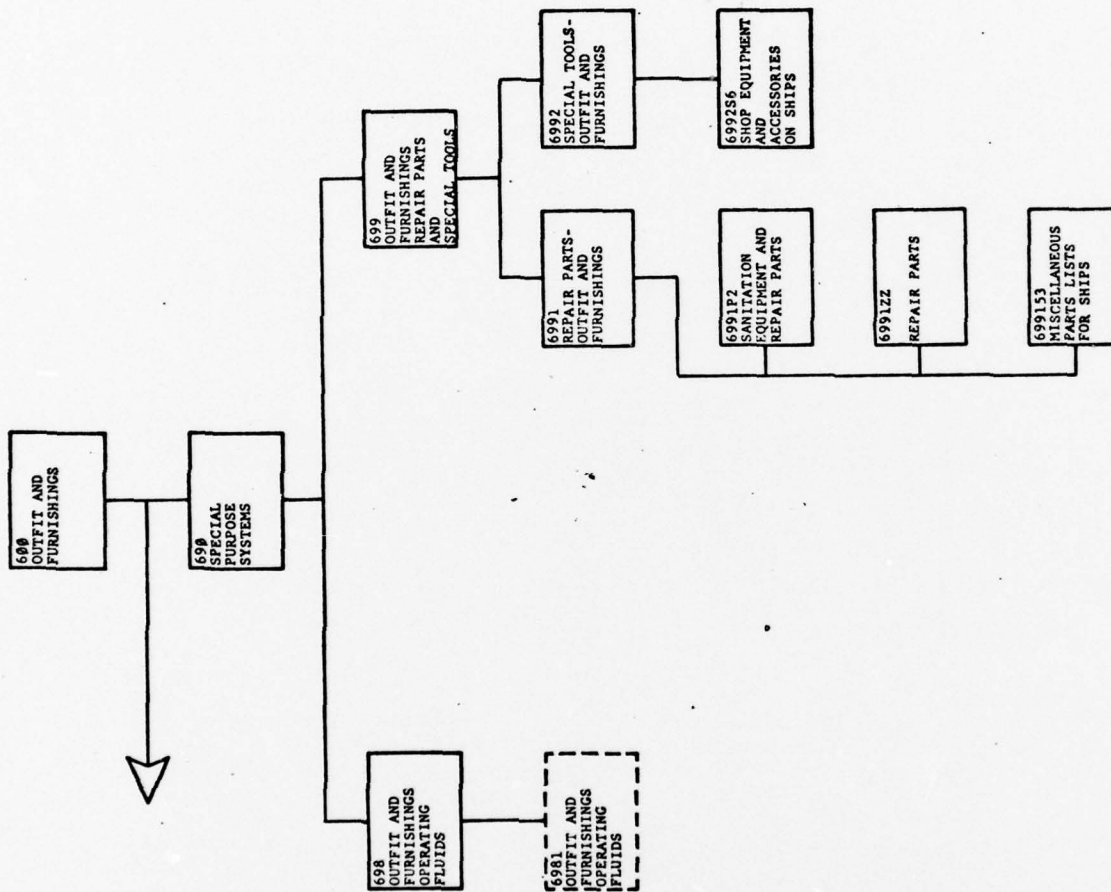

DDC-2 CLASS
PREPARED 2-11-76

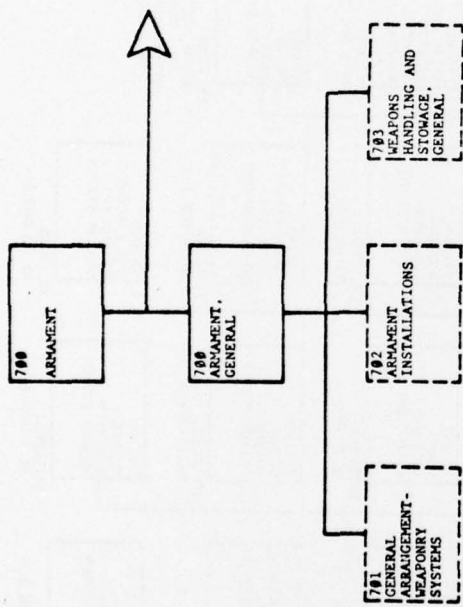

DDG-2 CLASS
PREPARED 2-11-78

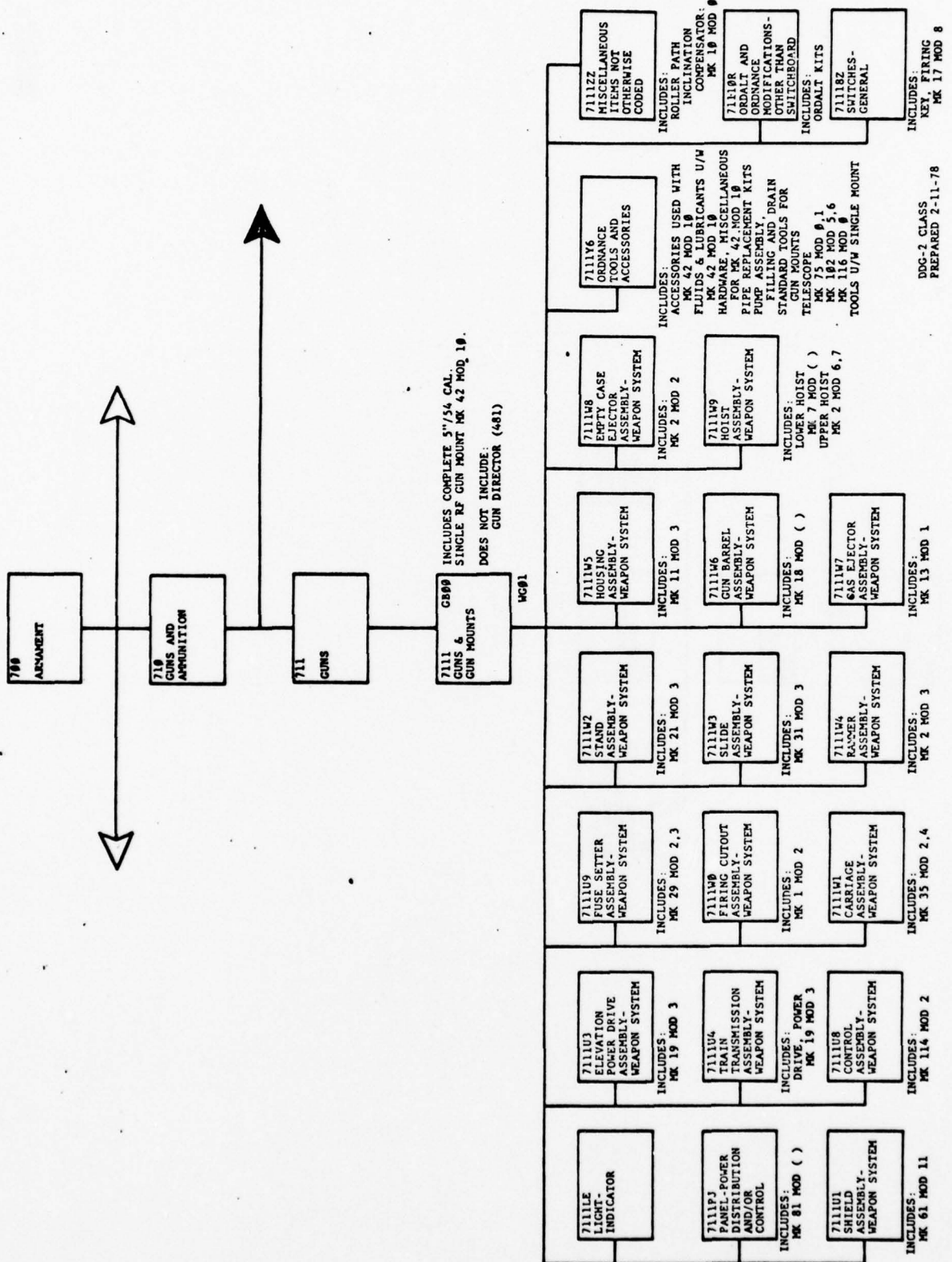

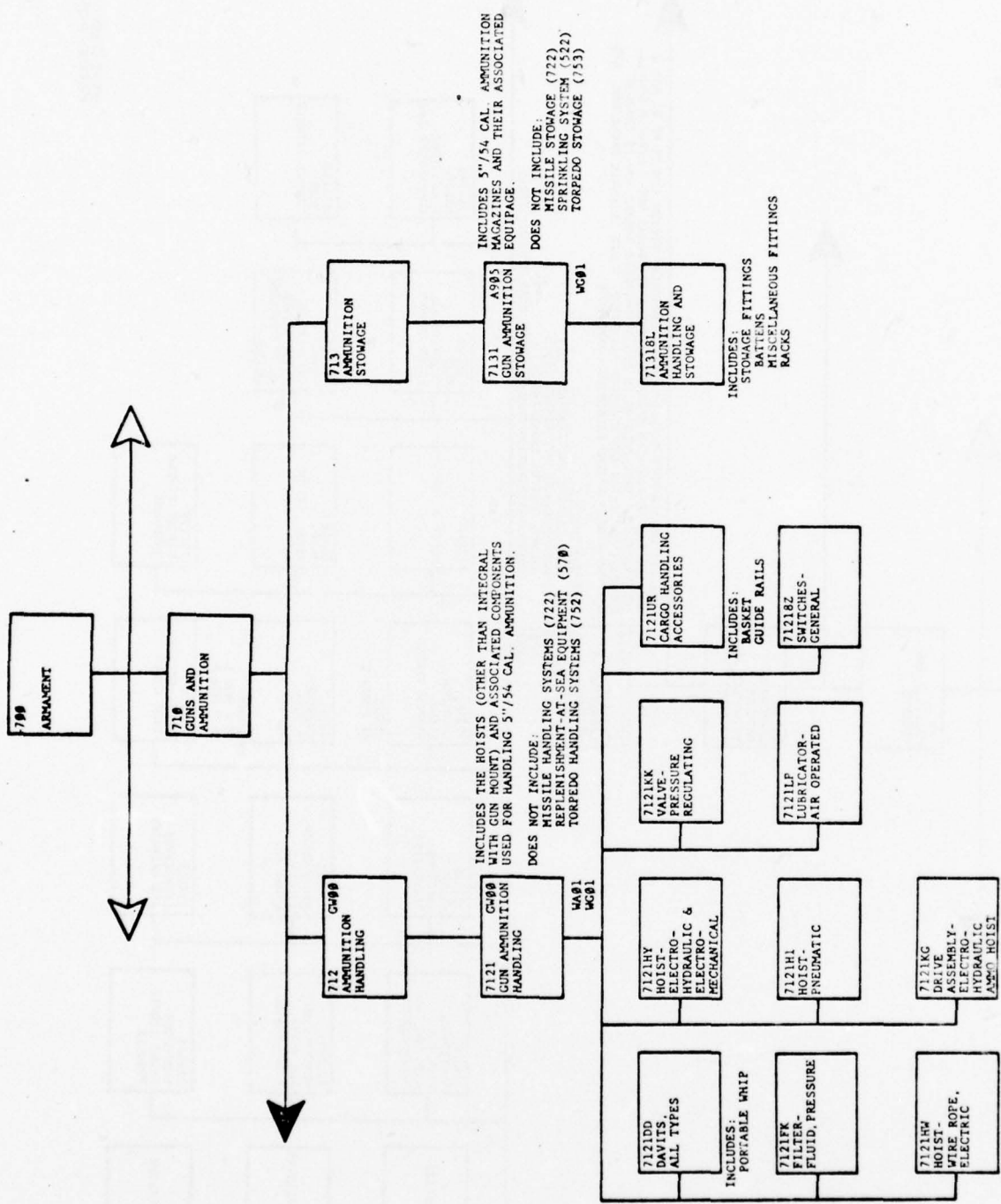

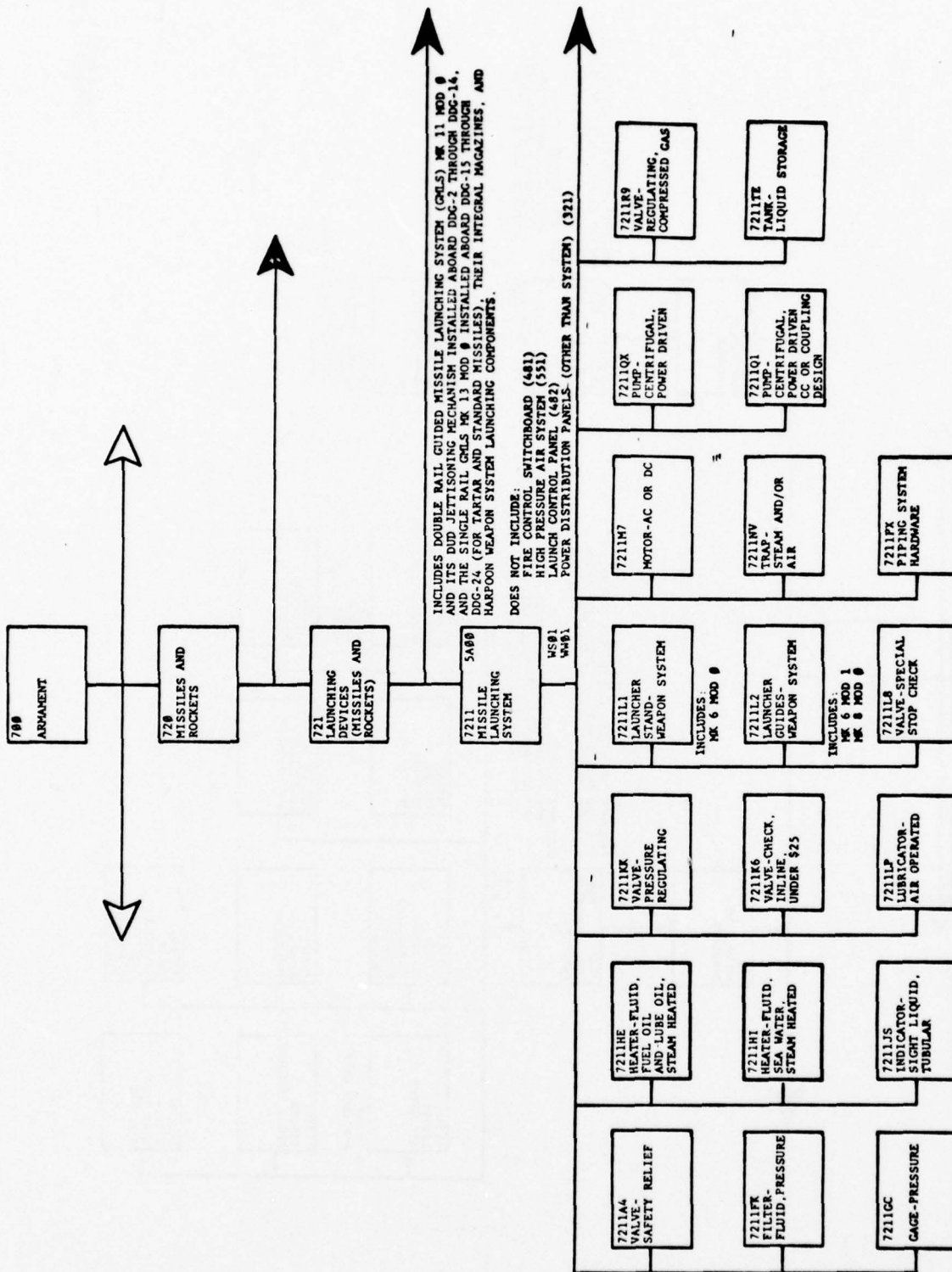

DOC-2 CLASS
PREPARED 6-29-78

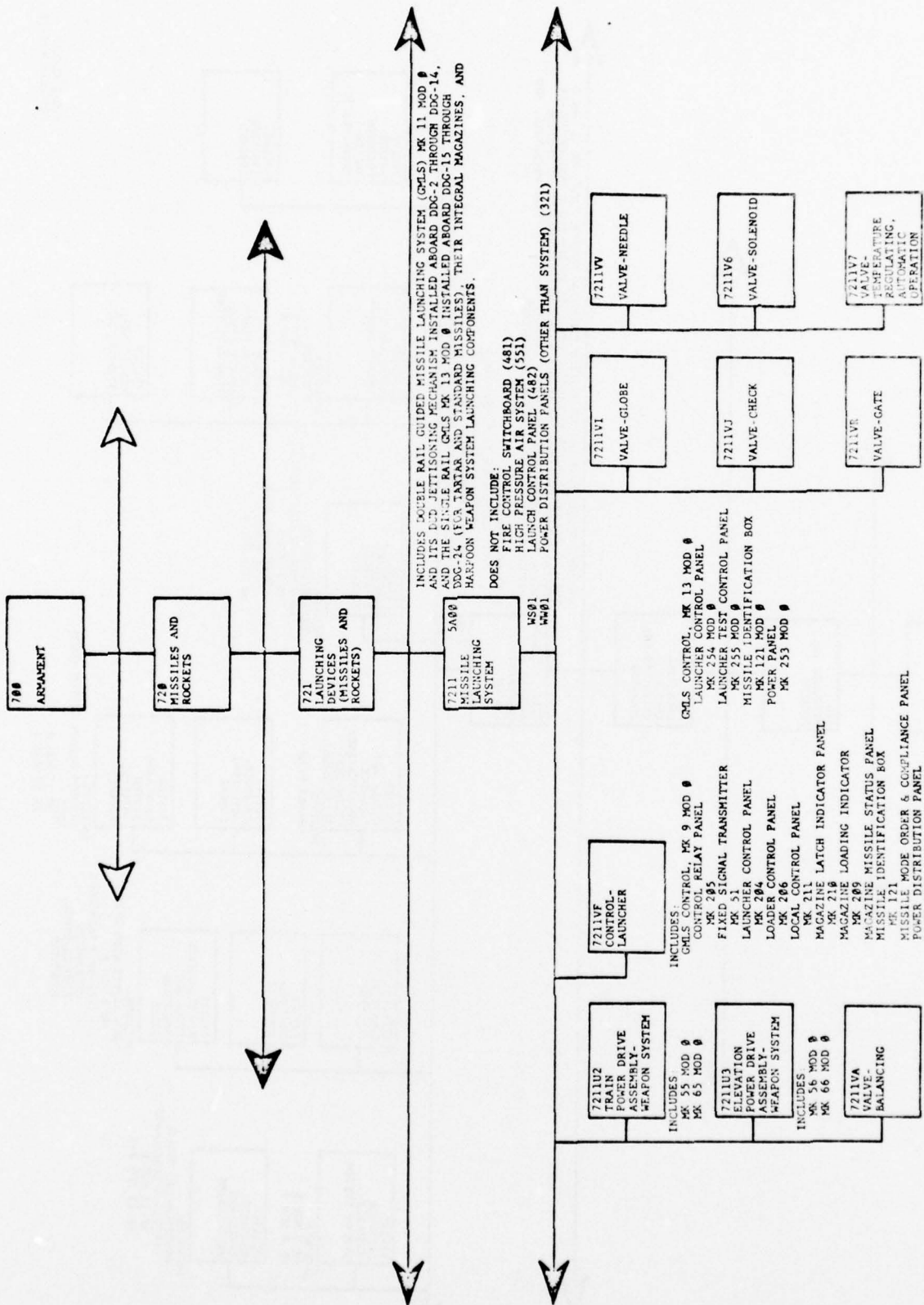

DDG-2 CLASS
 PREPARED 3-21-78

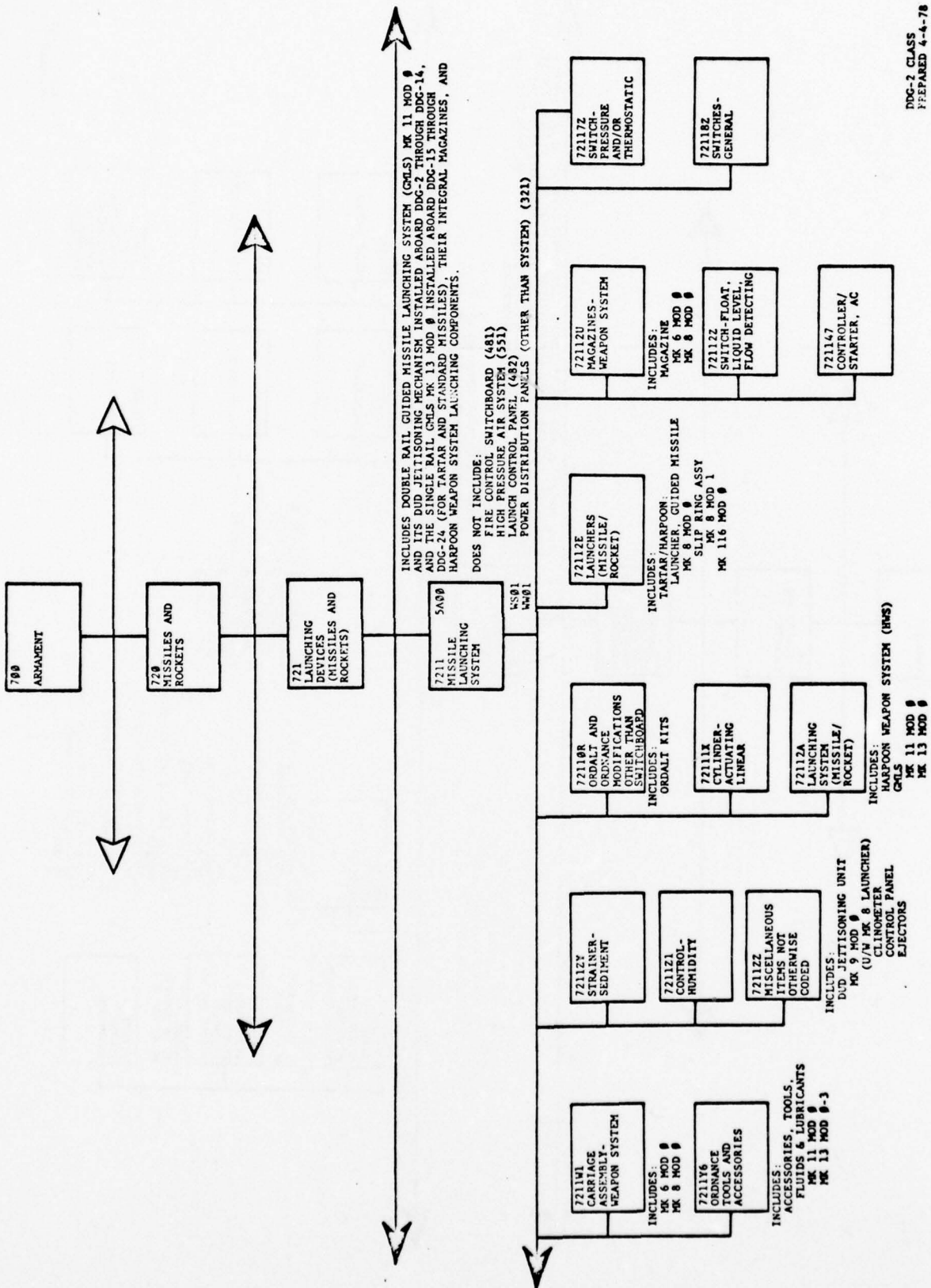

DDG-2 CLASS
 PREPARED 4-4-78

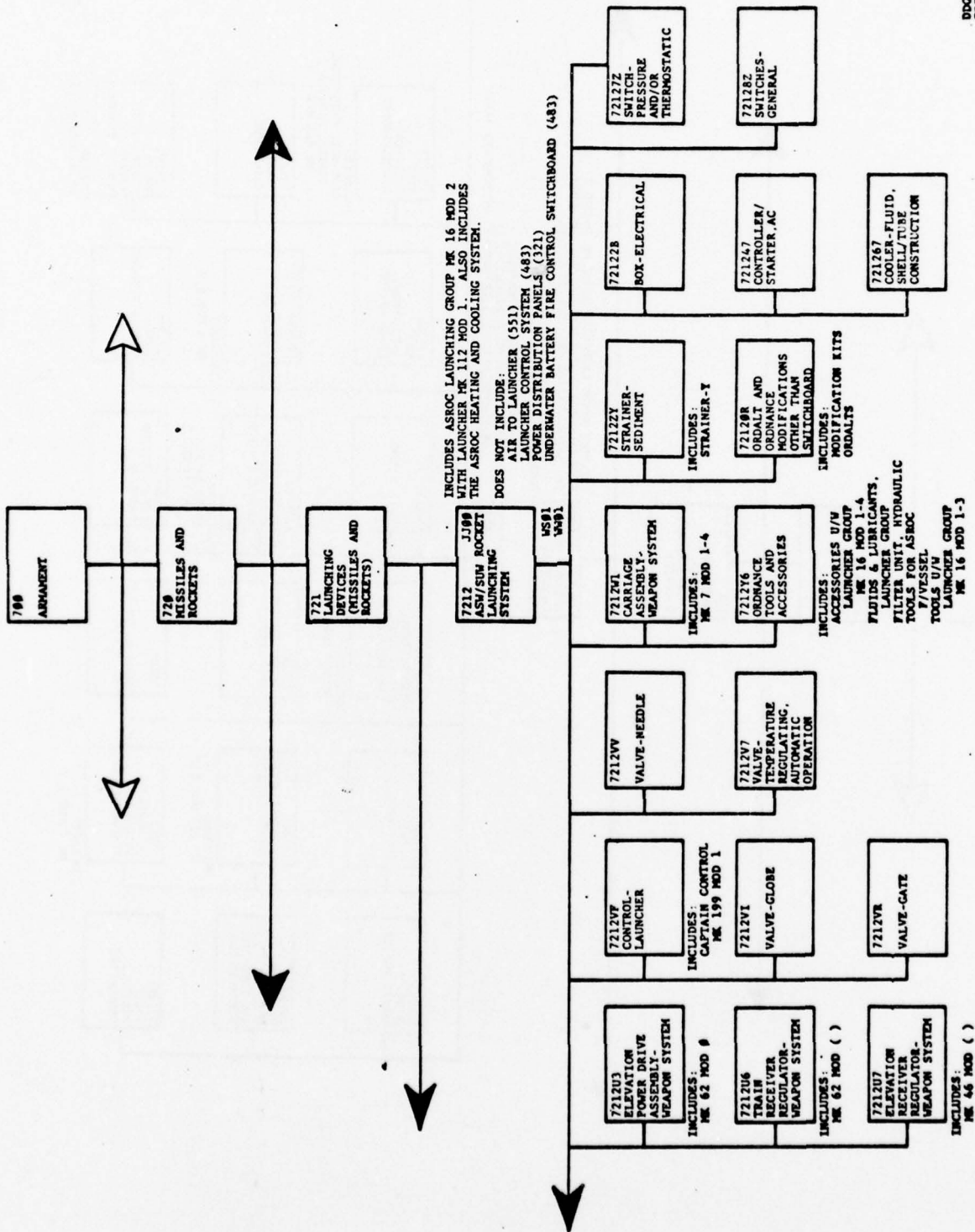

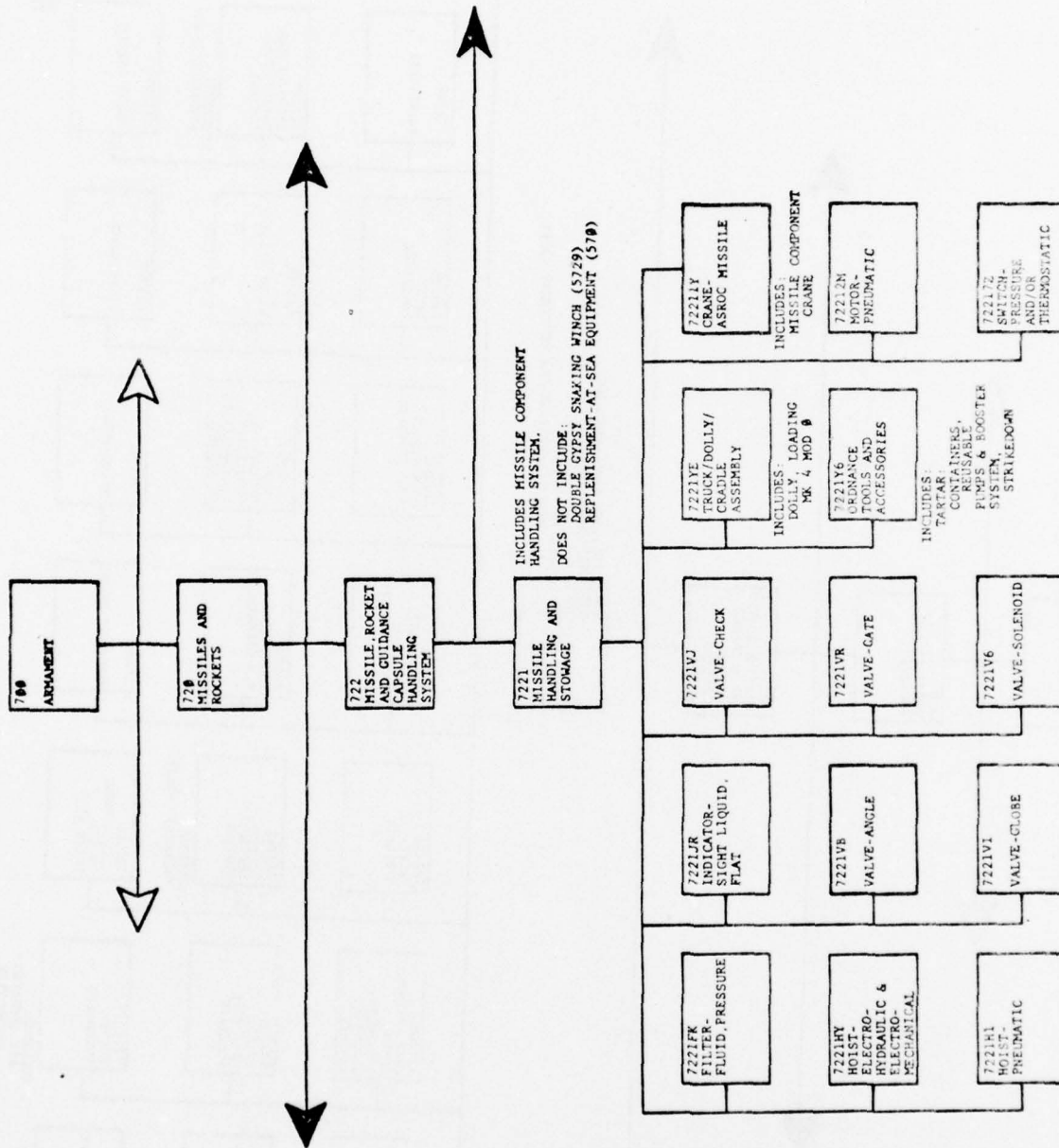

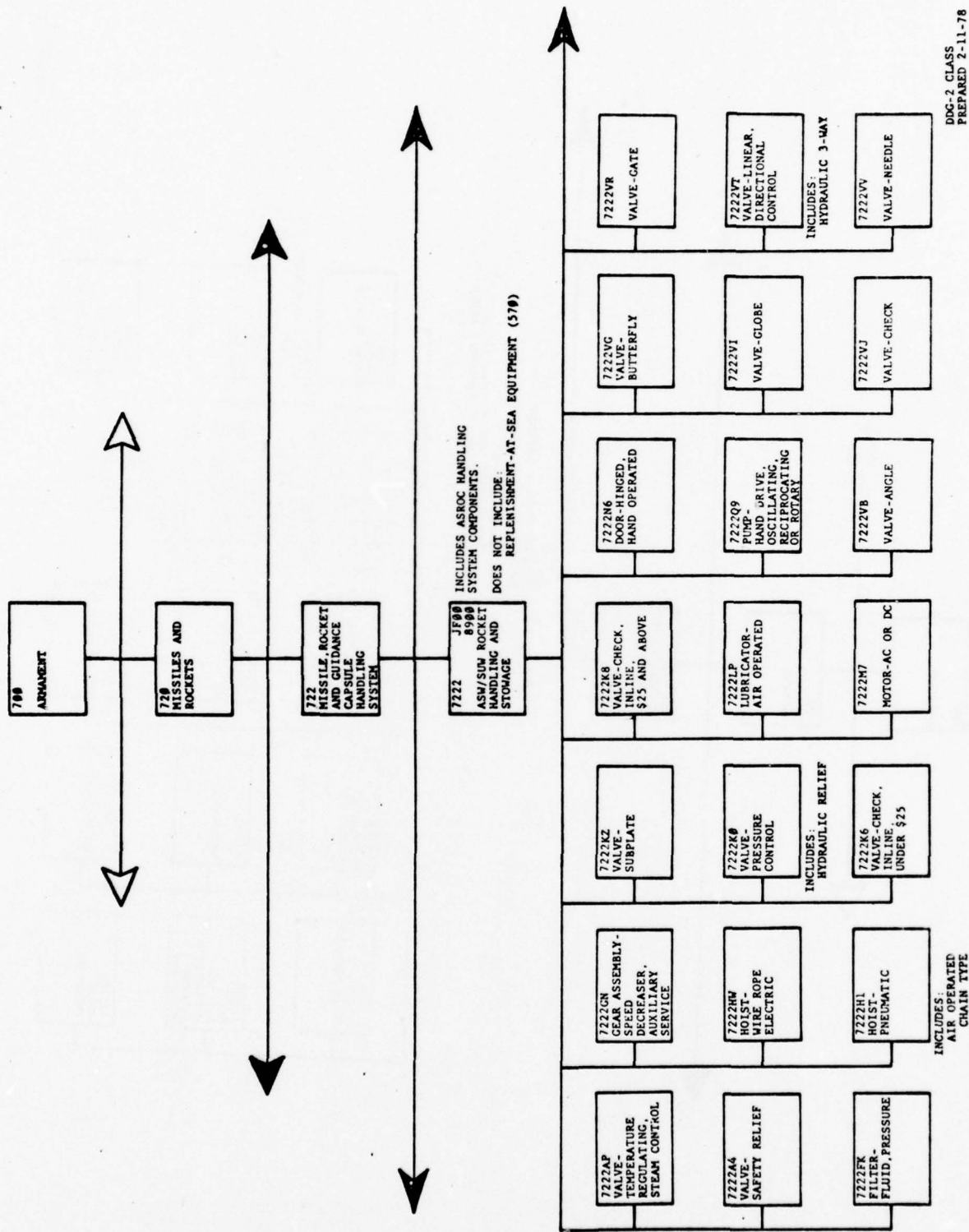

DGC-2 CLASS PREPARED 2-11-78

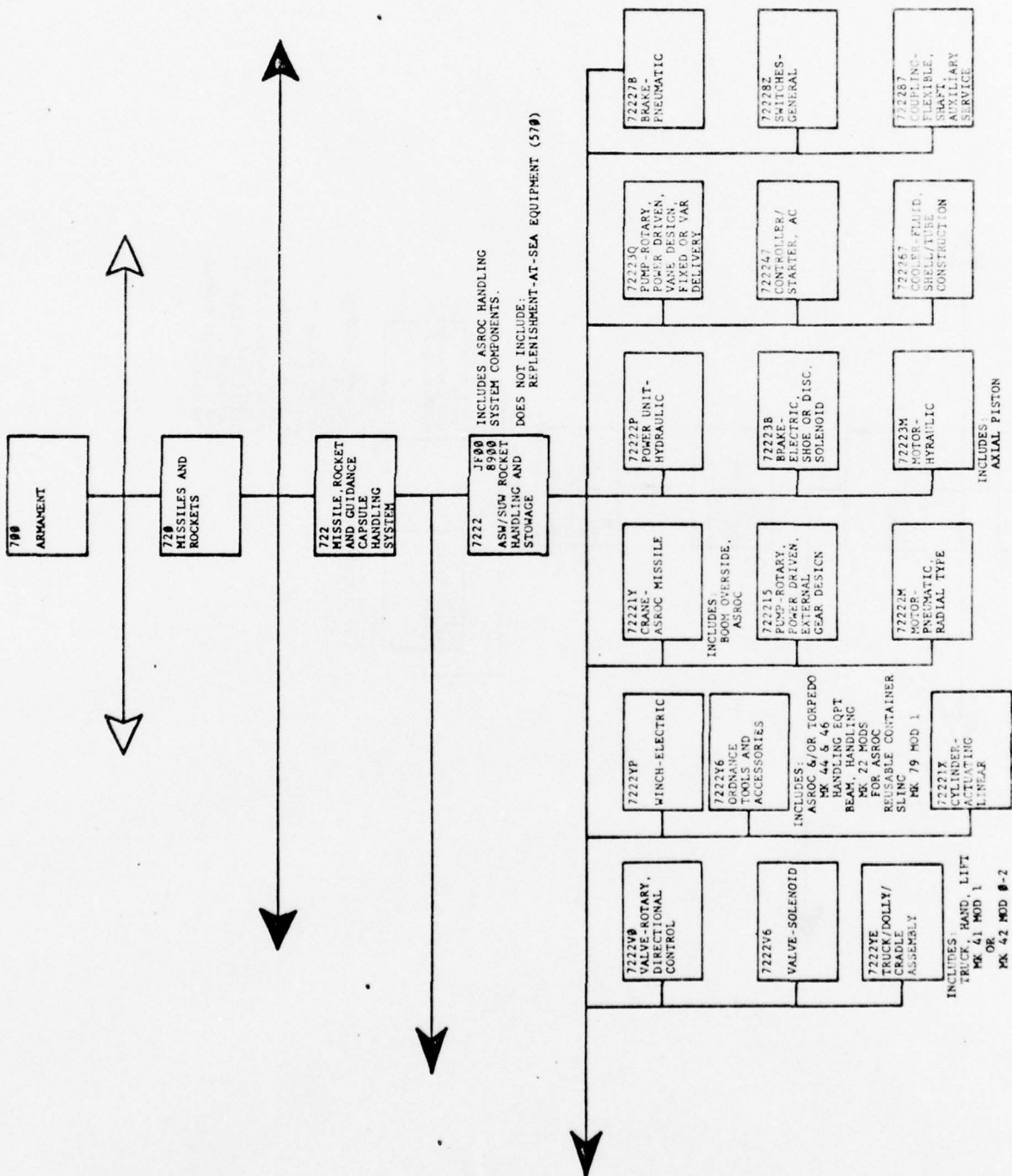

DDC-2 CLASS
PREPARED 1-11-78

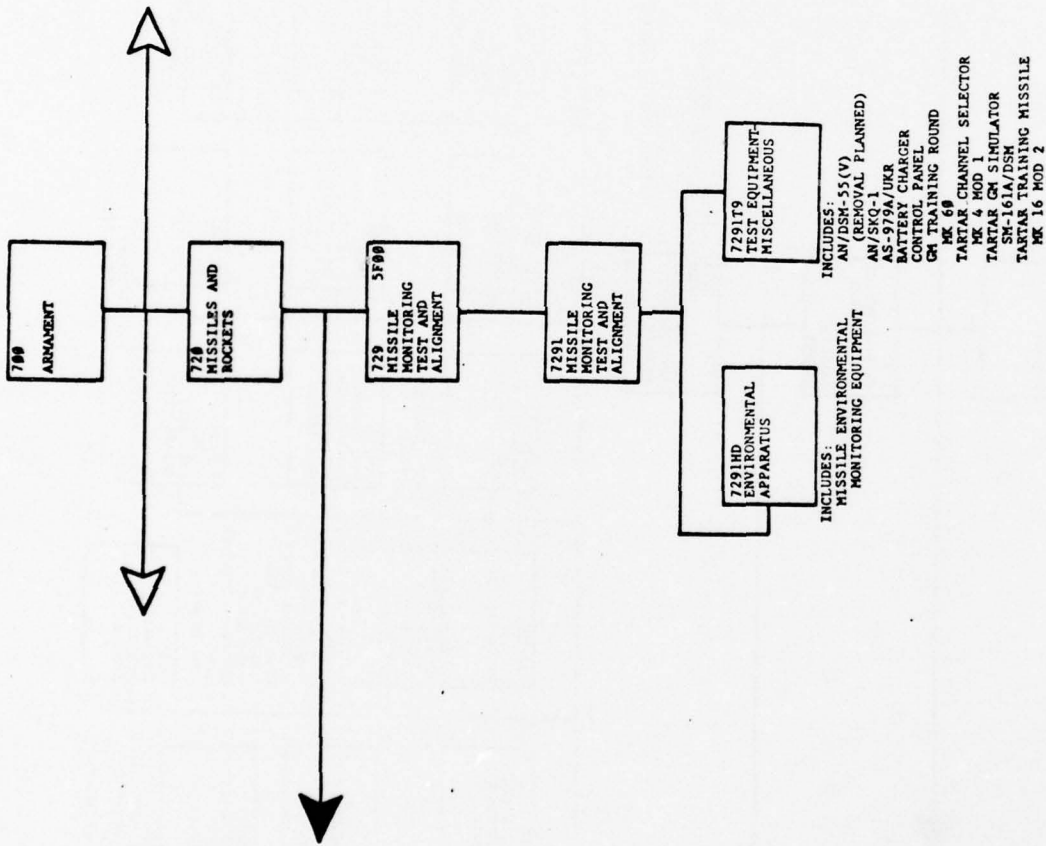

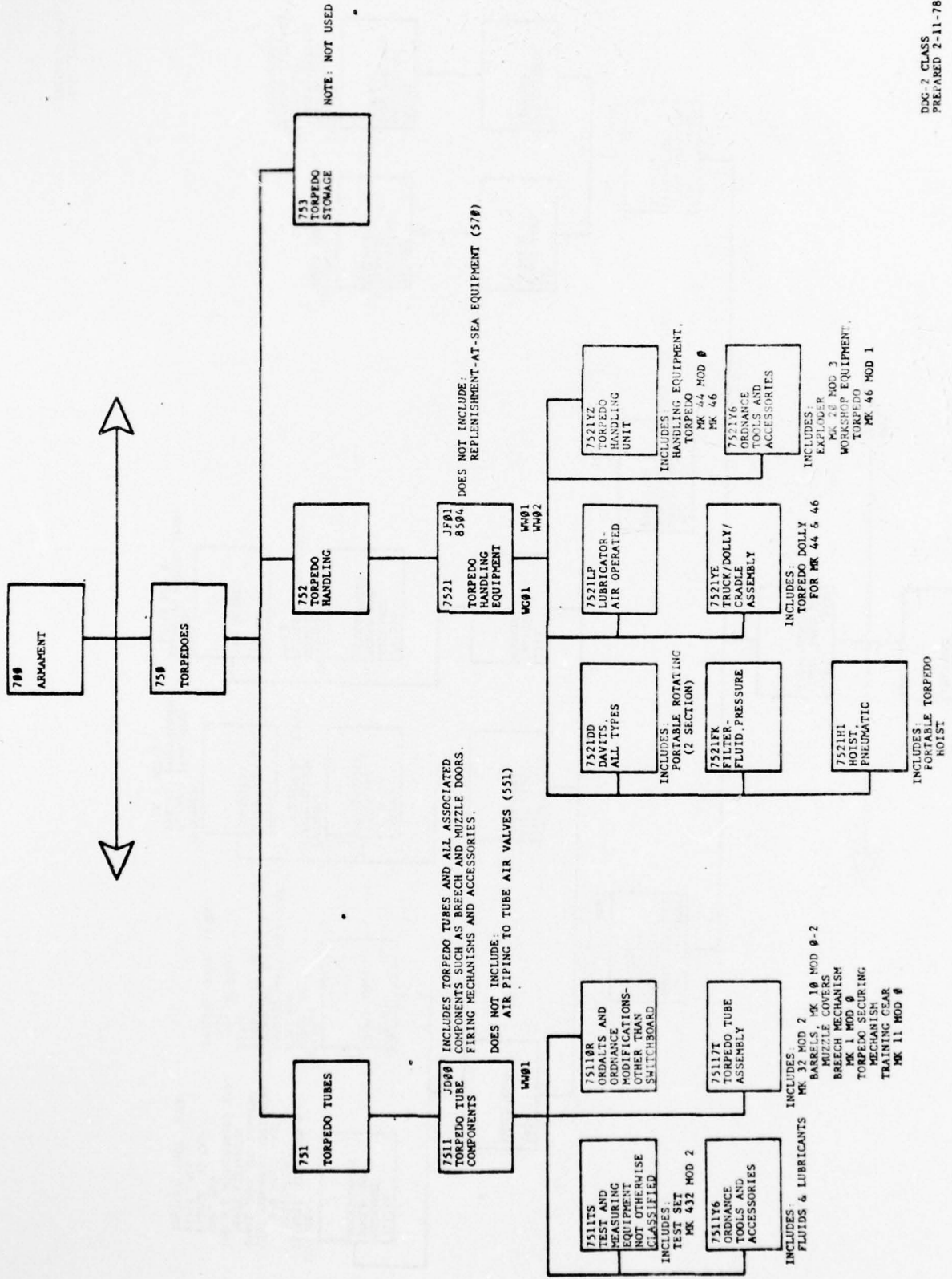

DDG-2 CLASS
PREPARED 2-11-78

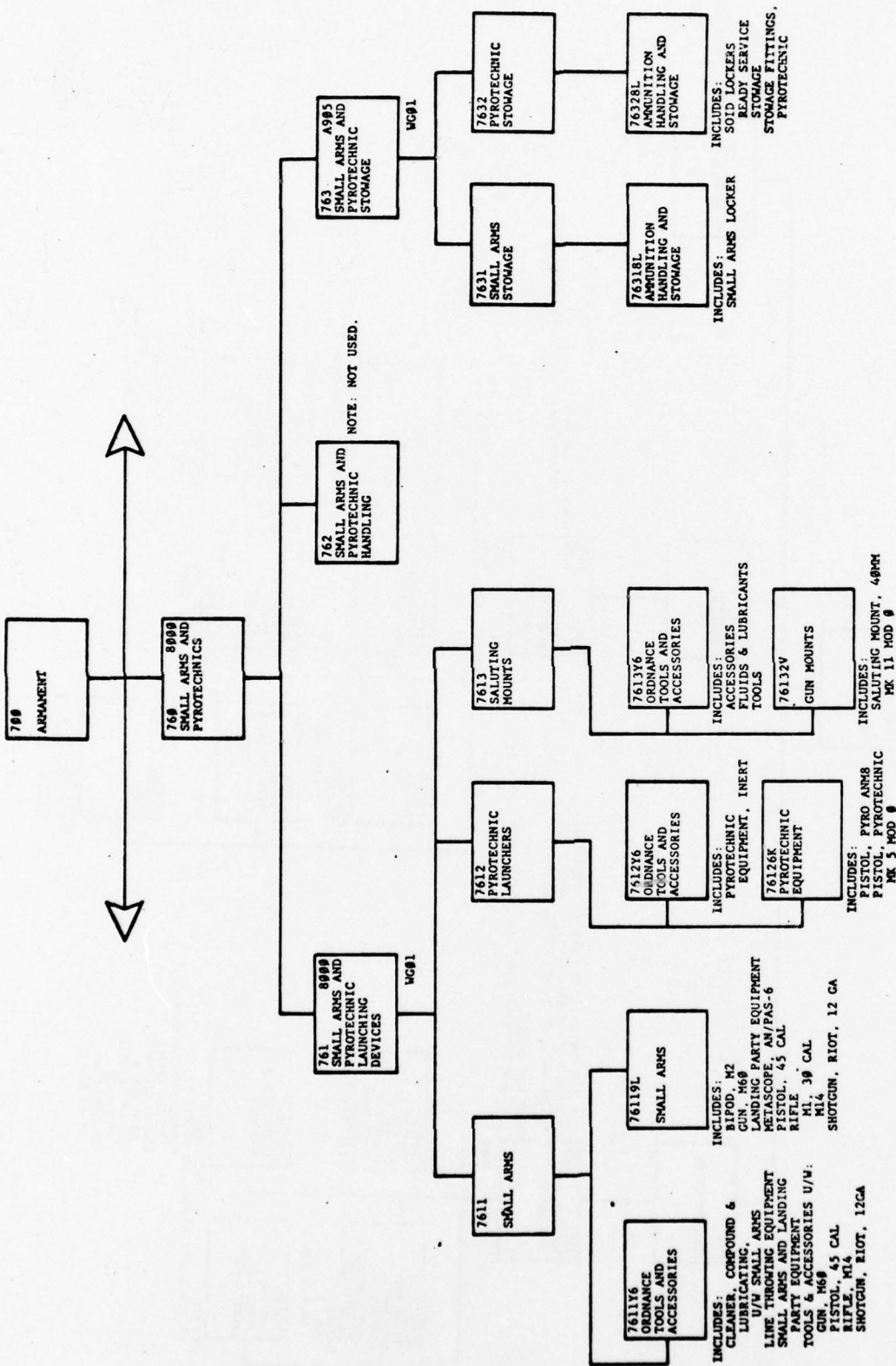

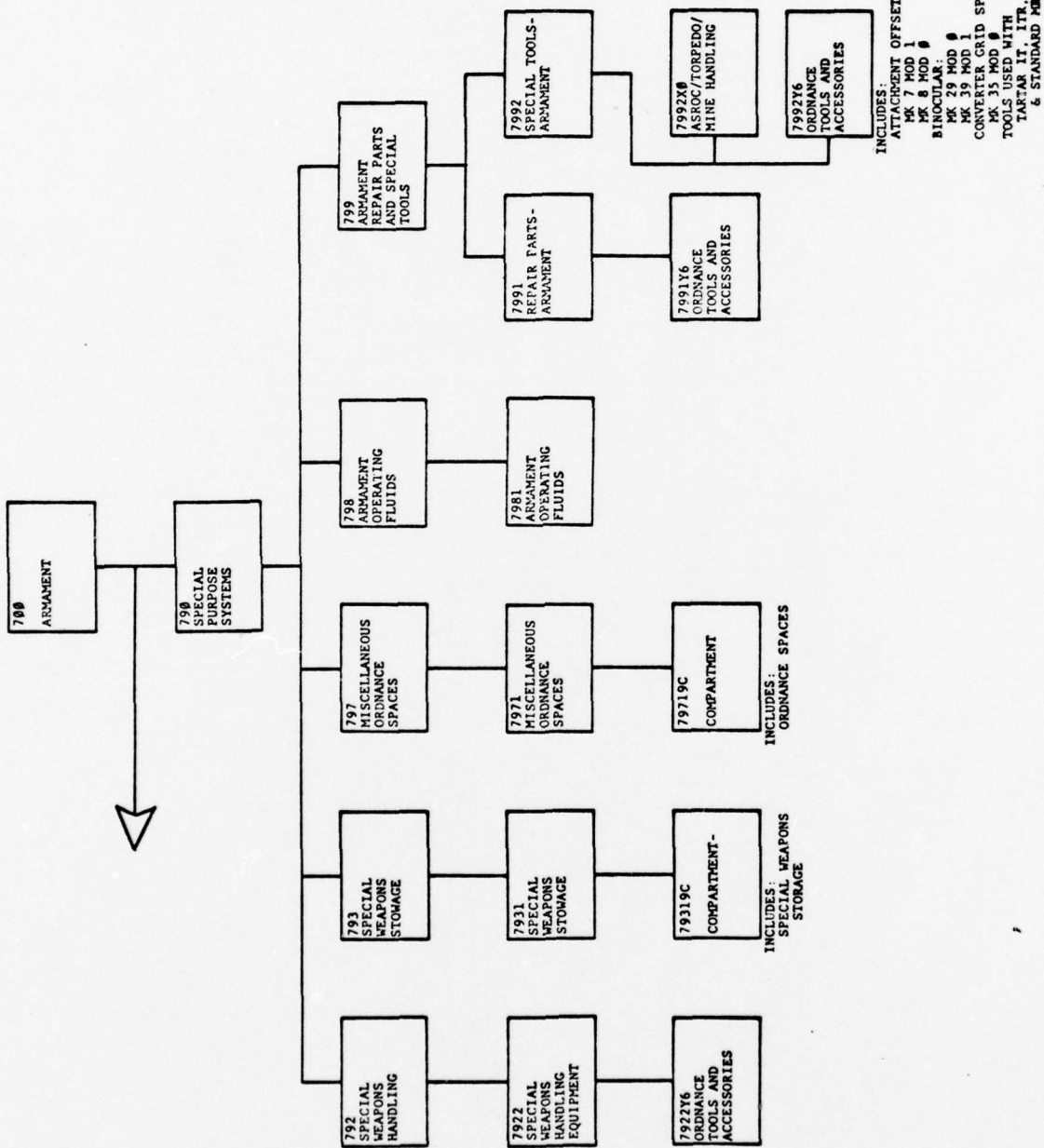

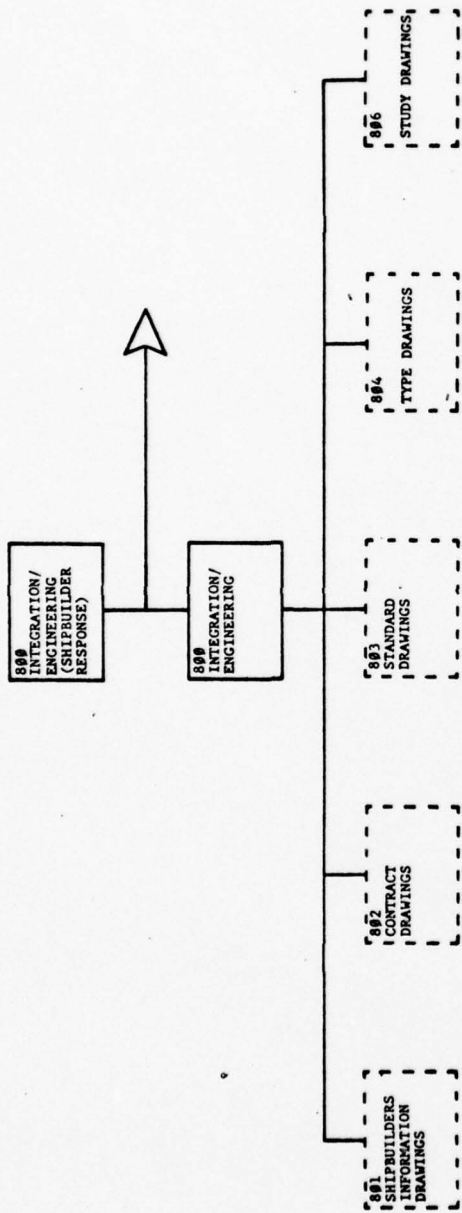

DOC-2 CLASS
PREPARED 2-11-78

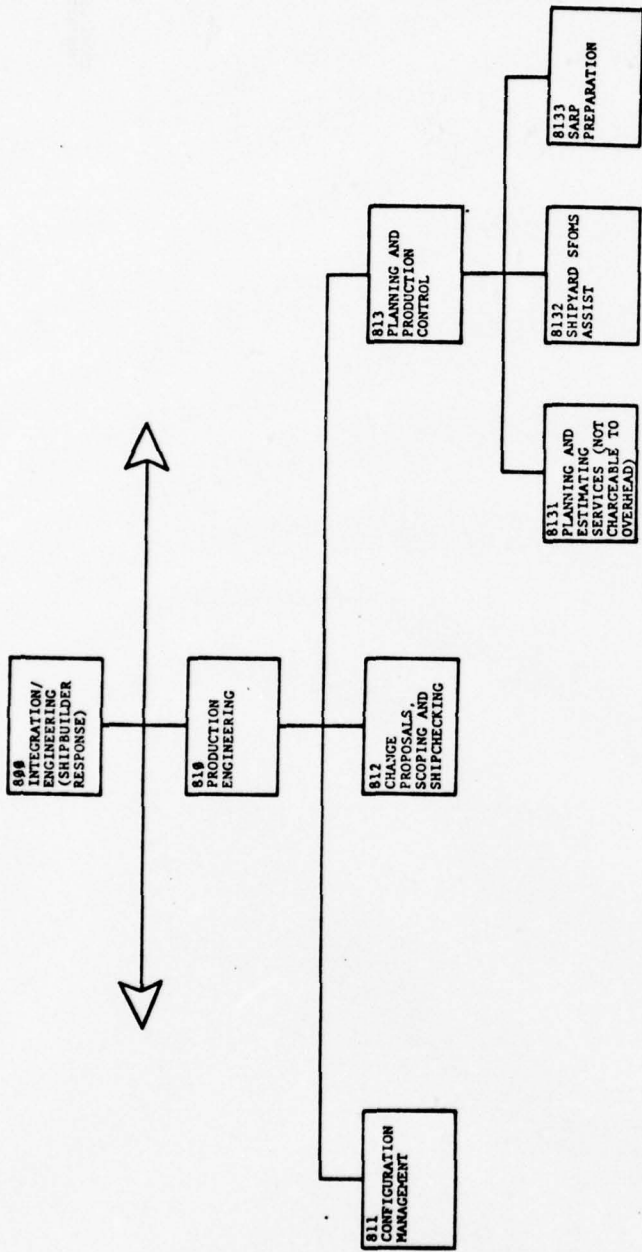

DOC-2 CLASS
PREPARED 2-11-78

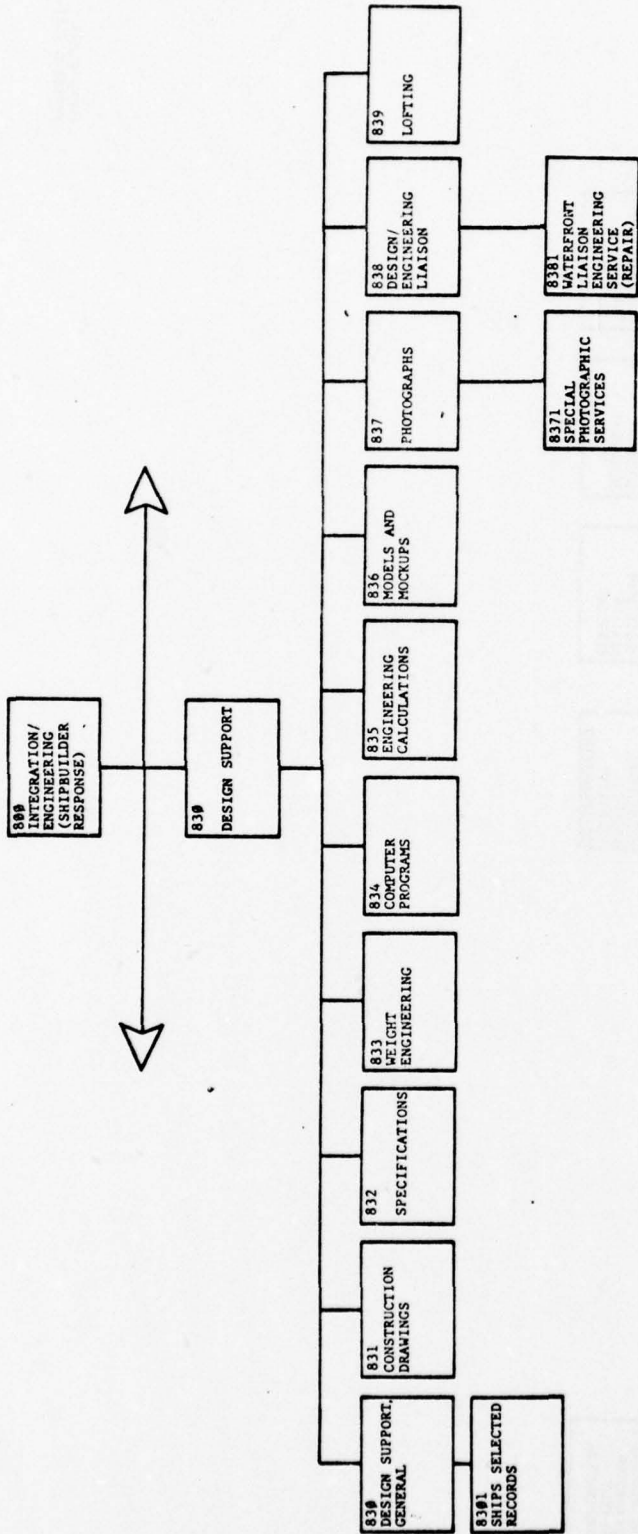

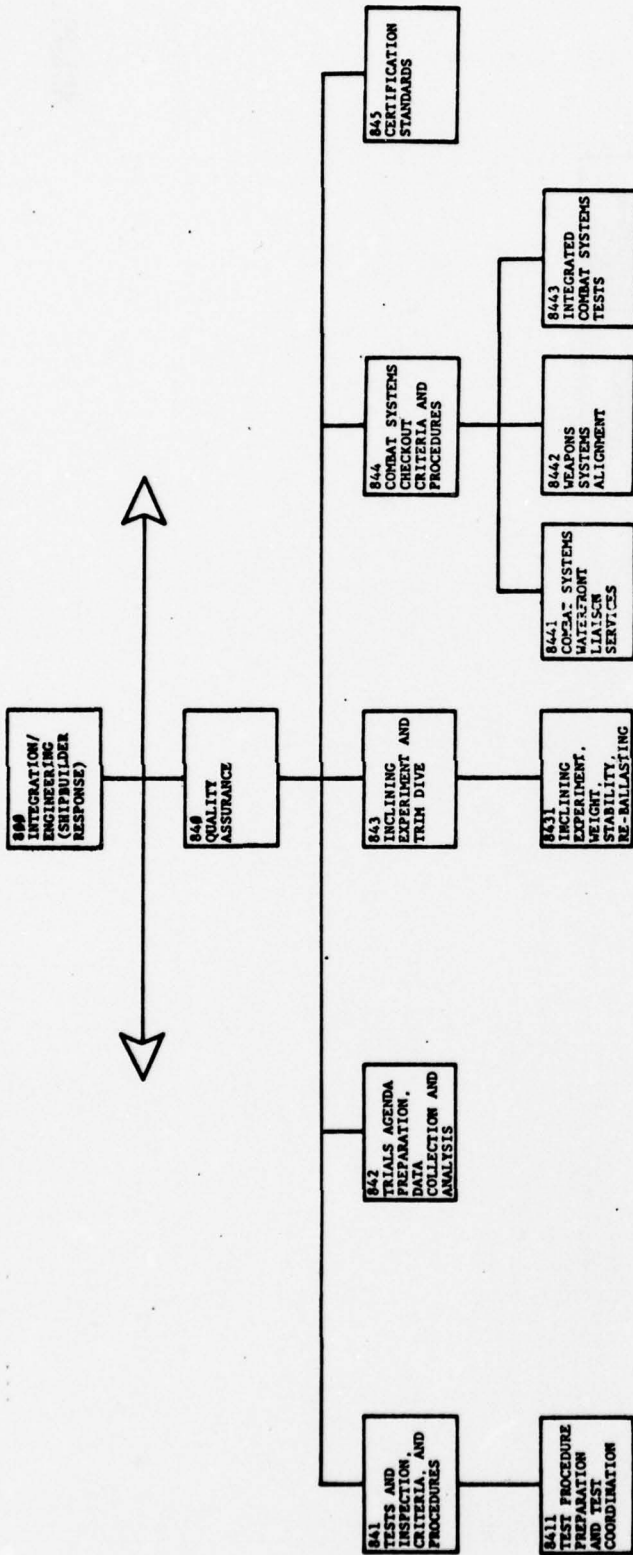

DOC-2 CLASS
PREPARED 2-11-78

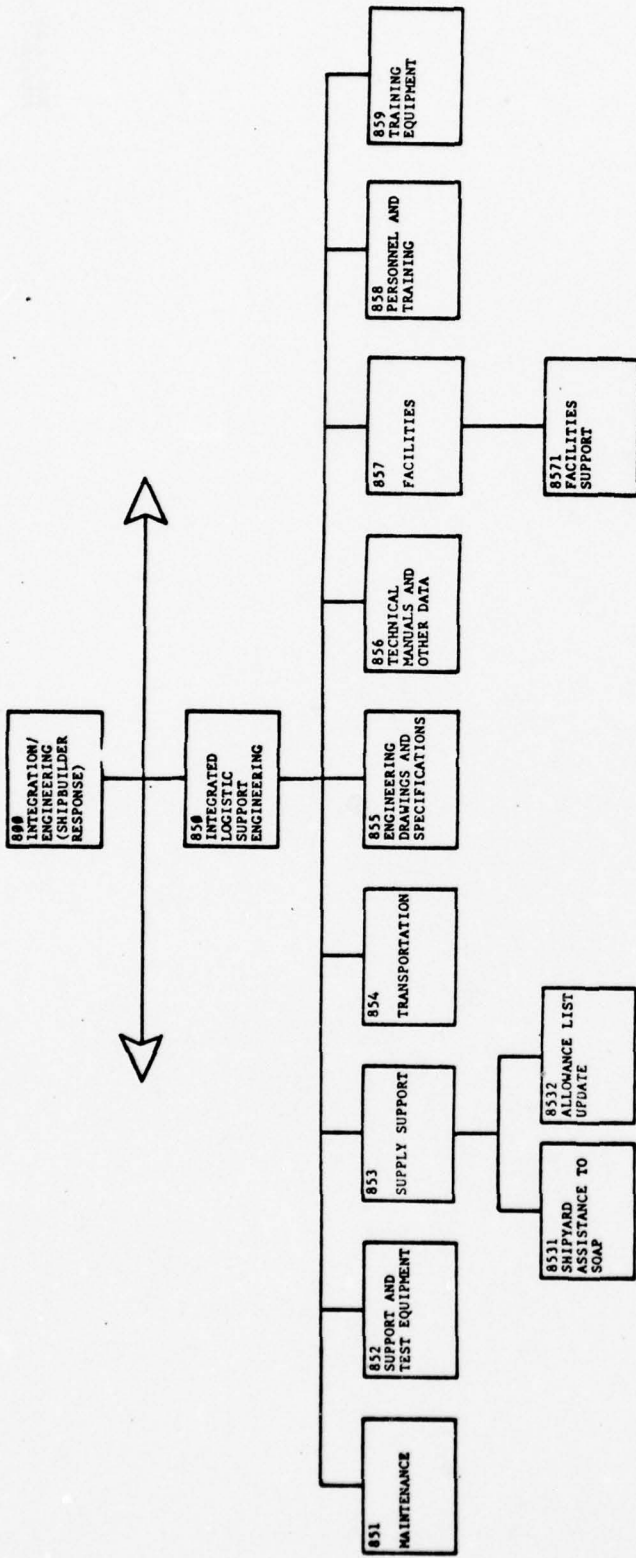

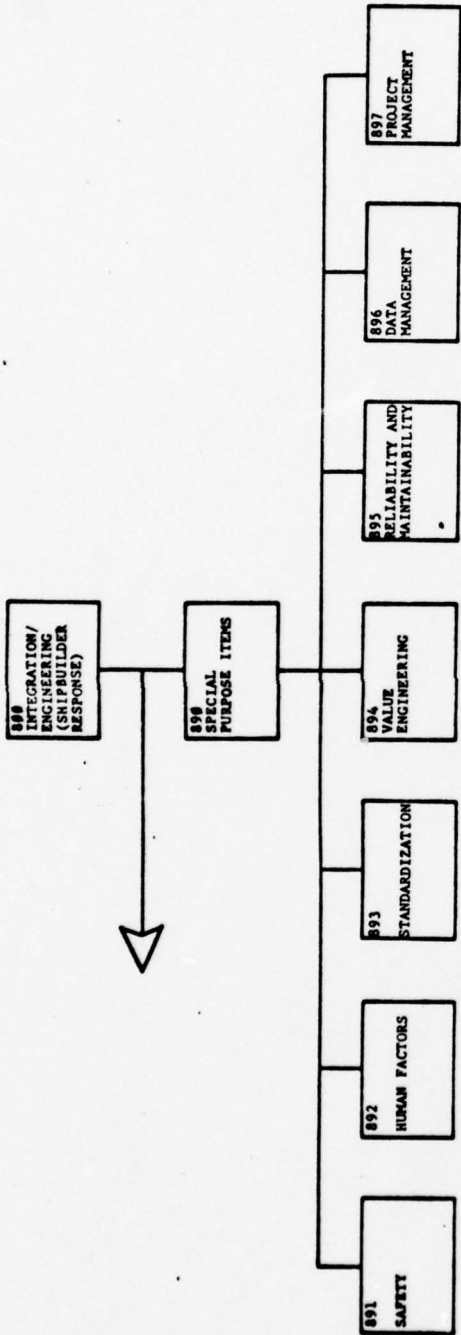

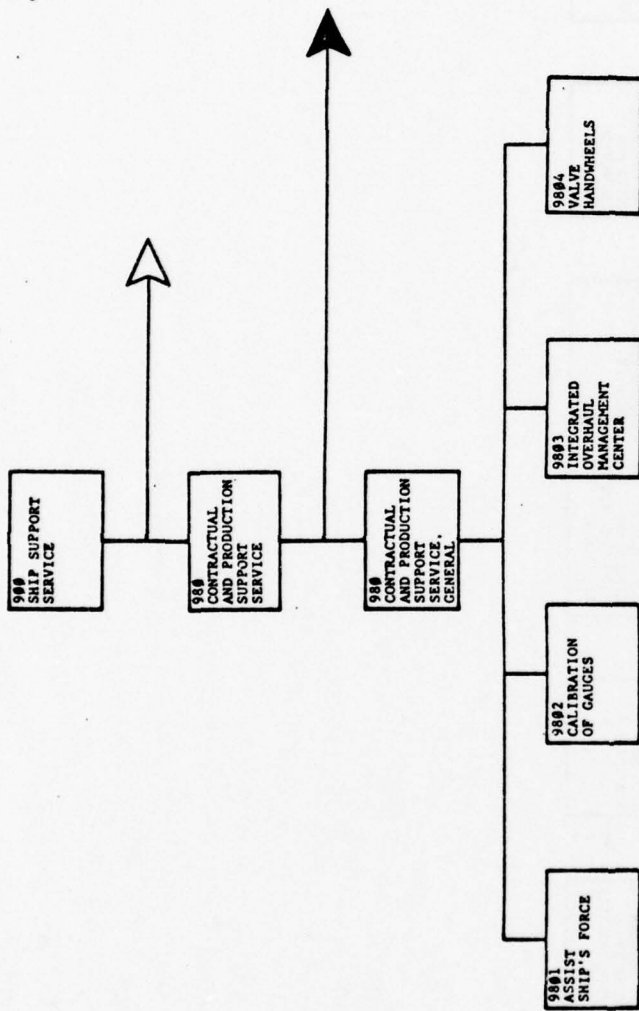

DGC-2 CLASS
PREPARED 2-11-78

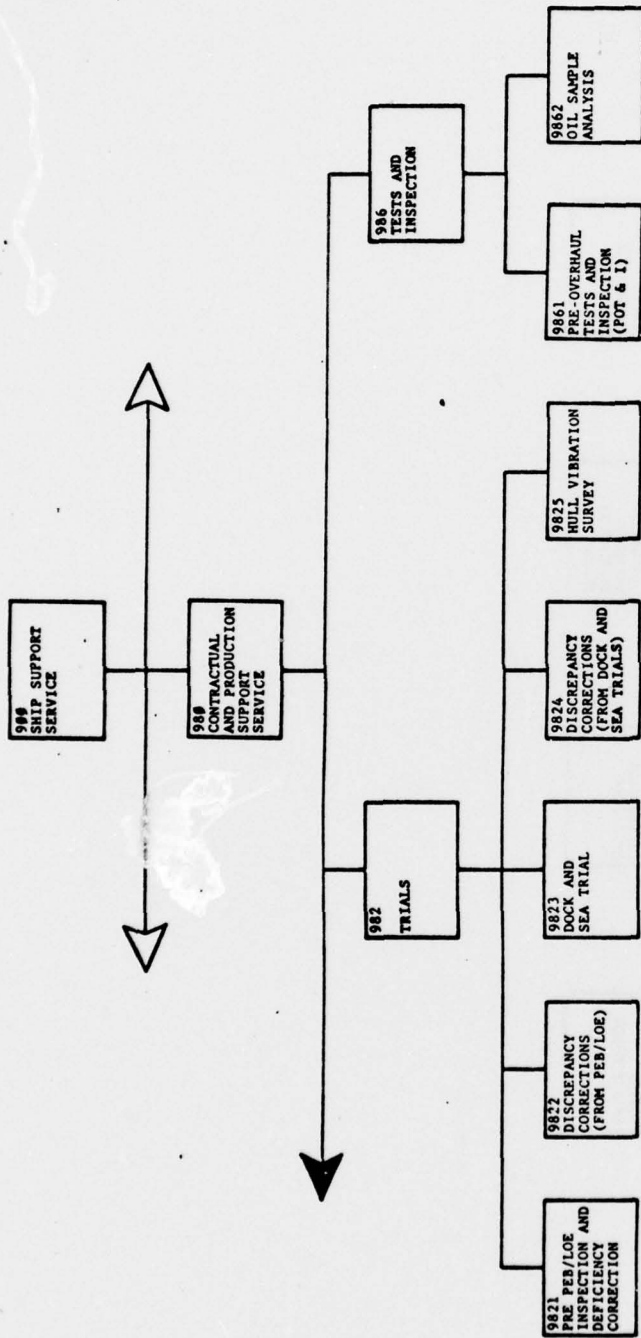

DDG-2 CLASS
PREPARED 2-11-78

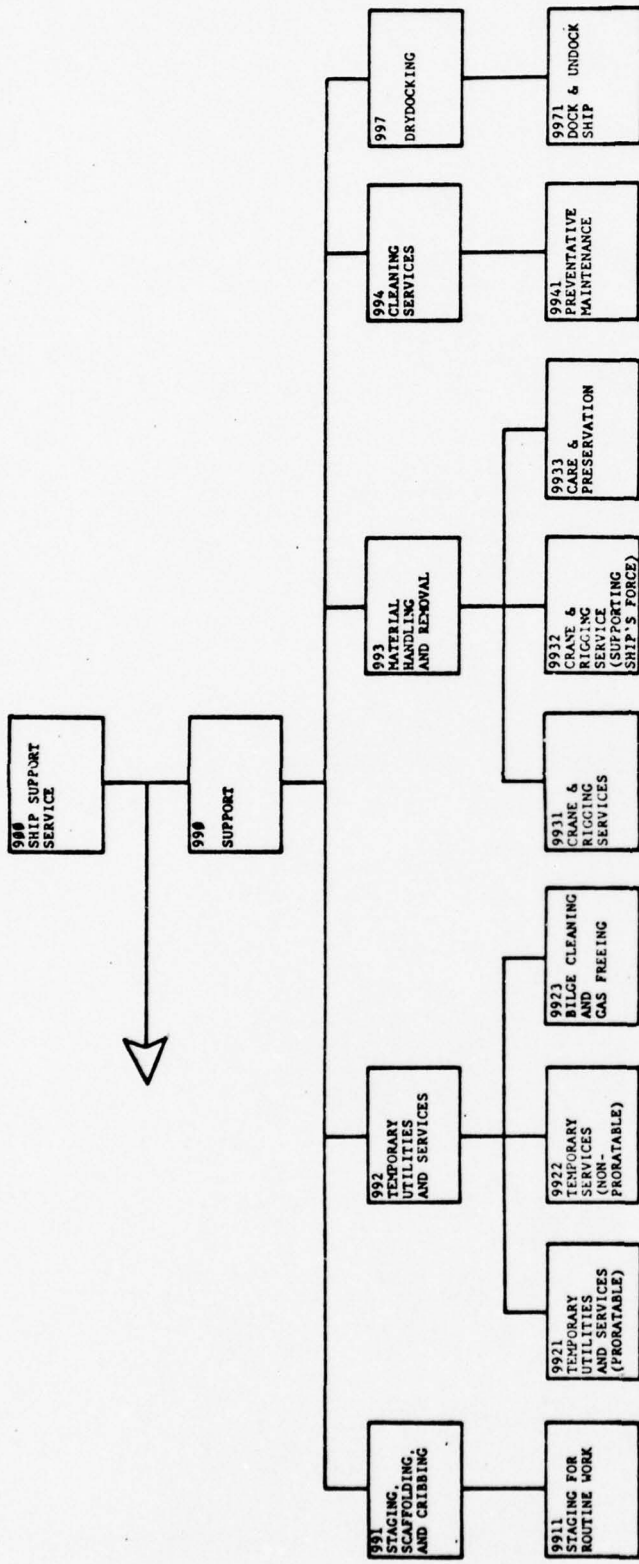

APPENDIX A

COMPONENT DICTIONARY CODE LIST

APPENDIX A
COMPONENT DICTIONARY CODE LIST

CDC LAPL

AA C82 ABANDON SHIP ACCESSORIES AND LIFE BOATS
 AB AB- SUPPORTS, ANTENNA (ELEX)
 AC 94-003 ACOUSTIC DEVICE-SEE ALSO CONTROL ACOUSTIC DEVICE-MINESWEEPING
 AD 02-006 BOILER-AUXILIARY, STEAM, WASTE HEAT
 AE 10-006 METER-ELECTRICAL INDICATING, AC AND DC METERS
 AF 52-013 ACTUATOR-HYDRAULIC SEE ALSO CYL-ACT LINEAR
 AG 61-265 ACTUATOR-PNEUMATIC & ELECTRO-PNEUMATIC
 AH 41-040 CUTTING MACHINE-OXYGEN ACETYLENE
 AI 31-009 CATHODIC PROTECTION EQUIPMENT
 AJ 61-273 ACTUATOR-ELECTRO MECHANICAL
 AK 89-008 ADAPTER-MISSILE HANDLING, CARGO HANDLING
 AL 41-122 AGITATOR-PAINT, SHAKER TYPE
 AM AM- AMPLIFIERS (ELEX/ORD)

 AN 33-002 AIR CONDITIONER
 AO NOT ASSIGNED
 AP 88-011 VALVE-TEMPERATURE REGULATING, STEAM CONTROL
 AQ 33-012 AIR CONDITIONER-WINDOW UNIT TYPE
 AR 09-001 CHARGER-BATTERY, AC
 AS 97-006 ANTENNA ASSEMBLY-BICONICAL OR STUB (HM&E/ELEX)
 AS AS- ANTENNAE-SIMPLE & COMPLEX (HM&E/ELEX)
 AT AT- ANTENNAE-SIMPLE (ELEX)
 AU 36-001 ALARMS & SIGNALING DEVICES-HORNS, SIRENS AND WHISTLES, AIR OR STEAM
 AV 41-006 CHARGER-MAGNET, PORTABLE
 AW 36-005 ALARMS & SIGNALING DEVICES-WHISTLE, STEAM OR AIR
 AX 41-046 CENTERING MACHINE-SINGLE SPINDLE
 AY 03-007 COOLER-AIR
 AZ 83-001 SEAL-STERNTUBE, SUBMARINE APPLICATION
 A0 88-021 VALVE-BOILER BLOW
 A1 36-003 ALARMS & SIGNALING DEVICES-BELL, BUZZER, SIREN ELECTRICAL
 A2 23-009 ALARMS & SIGNALING DEVICES-LIGHT, INDICATOR, ELECTRICAL
 A3 61-079 AMPLIFIER-MAGNETIC
 A4 89-023 VALVE-SAFETY RELIEF, INCLUDING VACUUM BREAKERS
 A5 61-082 AMPLIFIER-HYDRAULIC
 A6 B22 STEERING AND DIVING TOOLS AND REPAIR PARTS
 A7 B23 TOOLS AND EQUIPMENT O2N2 PLANT
 A8 23-006 ANNUNCIATOR-MECHANICAL DROP-AC
 A9 B24 PERISCOPES - HOUSING FITTINGS
 BA BA- BATTERY-PRIMARY TYPE (ELEX)
 BB BB- BATTERY-SECONDARY TYPE (ELEX)
 BC C9-005 BATTERY-STORAGE
 BD 37-001 BEARING ASSEMBLY-STERNTUBE & STRUT
 BE 41-001 BALANCING INSTRUMENT-PORTABLE
 BF 85-037 BALL, NUT, & SCREW ASSEMBLY
 BG C4-C02 CONDENSER CHILLER-REFRIGERATION
 BH 37-011 BEARING ASSEMBLY-THRUST, PIVOTED SEGMENTAL, SINGLE OR DOUBLE
 BI 53-001 CAPSTAN-SEE ALSO MOORING ACCESSORIES
 BJ C37 MEDICAL EQUIPMENT-PORTABLE
 BK 83-011 BRAKE-PROPULSION SHAFT (REGARDLESS OF PRIME MOVER)
 BL 37-013 BEARING ASSEMBLY-THRUST AND JOURNAL WITH RESONANCE CHGR
 BM C5-C23 COOLING UNIT-AIR TURBINE DRIVEN
 BN 37-005 BEARING ASSEMBLY-LINE SHAFT
 BO NOT ASSIGNED

CDC LAPL

BP 25-042 BENCH MARK-OPTICAL
BQ 41-097 BENDING MACHINE-POWER OPERATED
BR 93-003 BLFNDER-AVIATION FUFL
BS 05-030 TURBOSUPERCHARGER-CENTRIFUGAL BOILER
BT 05-031 TURBINE-GAS
BU 02-001 BOILER-MAIN PROPELLSION, HP STEAM
BV 02-005 BOILER-AUXILIARY, HOT WATER
BW 64-017 FIRE EXTINGUISHER-PORTABLE
BX 88-027 VALVE-COMPRESSOR SHUT OFF
BY C92 TOOLS AND ACCESSORIES
BZ BZ- ALARM UNITS (ELEX)
BO MINOR LANDING CRAFT AND SMALL BOATS (INCL ALL COMMODITY CLASS 72)
B1 43-024 BREAD SLICING MACHINE
B2 99-017 BREATHING APPARATUS
B3 89-001 BUOY-MESSENGER SEE ALSO UNDERWAY REPLEN ACC
B4 03-008 COOLER-AIR
B5 30-001 BURNER-OIL, PRESSURE ATOMIZING, BOILER SERVICE
B6 30-002 BURNER-OIL, PRESSURE ATOMIZING, GUN TYPE
B7 30-004 BURNER-OIL, VAPORIZING PCT
B8 30-005 BURNER-OIL, ROTARY HORIZONTAL
B9 30-007 BURNER-CATALYTIC
CA CA- COMMUTATOR ASSEMBLY-SONAR (ELEX)
CB CB- CAPACITOR BANK (ELEX)
CC 32-019 CABINET, ICE CREAM SEE ALSO REFRIGERATOR
CD 28-005 CABINET, RESOLVER CONTROL-AUTOMATIC PLOTTING
CE 41-005 CABINET, BLAST CLEANING
CF 85-038 CABLE MACHINERY-DECK
CG CG- CABLE ASSEMBLY-RF (ELEX)
CH C15 GASOLINE AND JP - FUEL SYSTEMS TOOLS AND FITTINGS
CI 43-027 CABINET, DOUGH PROOFING
CJ 54-006 CAMERA-COPYING, LITHOGRAPHIC
CK CK- CRYSTAL KITS (ELEX)
CL 99-002 CARBON DIOXIDE
CM CM- COMPARATOR (ELEX)
CN CN- COMPENSATOR (ELEX)
CO C- CONTROLS (ELEX/ORD)

CP CP- COMPUTER (ELEX/ORD)

CO 85-042 CARRIAGE/CAR/CART/TRACTOR/TRAILOR
CR CR- CRYSTALS (ELEX)
CS 05-032 BASE/ENCLOSURE-GAS TURBINE
CT 41-147 CARTON MACHINE
CU CU- COUPLER (ELEX)
CV CV- CONVERTER (ELEX/ORD)
CV CONVERTER (ELEX/ORD)
CW CW- RADOMES (ELEX)
CX CX- CABLE ASSEMBLIES, NON RF (ELEX)
CY CY- CASES AND CABINETS (ELEX)
CZ 32-003 CHILLER-WATER
CO 88-029 VALVE-REGULATING, WATER FLOW, FOR REFRIGERATION SYSTEMS
CI 76-004 CHLORINATOR
C2 31-032 CHOCK-ROLLER, DECK AND STERN
C3 14-001 CIRCUIT BREAKER-NAVY TYPE AQB AND AQBFL
C4 14-002 CIRCUIT BREAKER-NAVY TYPE NOB AND NLF
C5 14-003 CIRCUIT BREAKER-NAVY TYPE ACB

CDC LAPL

C6 14-004 CIRCUIT BREAKER-NAVY TYPE ALB
C7 14-006 CIRCUIT BREAKER-OTHER THAN AQB, NQB, ACB,ALB TYPES
C8 41-148 CLEANING MACHINE-ALL TYPES EXCEPT BLAST CLNG CAB
C9 99-006 CLOSER-DOOR HYDRAULIC
DA DA- DUMMY LOAD (ELEX)
DB 33-007 DAMPER-ACTUATOR AND POSITIONER
DC 40-006 DAMPER-VENT, COMBUSTION CONTROL
DD 56-001 DAVITS, ALL TYPES
DE 28-003 DEAD RECKONING EQUIPMENT
DF 85-024 DEFLECTOR, JET BLAST
DG 46-012 DEGAUSSING MAGNETIC MEASUREMENT SYSTEM
DH 41-011 DEGREASER
DI D- DISPENSER-CHAFF (ELEX)
DJ 44-002 DEHUMIDIFIER-DESICCANT ELECTRIC
DK 44-009 DEHUMIDIFIER-SPACE, MECH REFRIG SELF CONTAINED
DL 32-005 DEHYDRATOR-REFRIGERATION
DM 44-001 DEHYDRATOR-FILTER, DESICCANT, HGH PRES AIR, SELF REAC
DN 44-004 DEHYDRATOR-NON REACTIVATING
DO NOT ASSIGNED
DP 08-007 DEMINERALIZER-WATER, ION EXCHANGE
DQ 99-027 DESUPERHEATERS-ALL TYPES
DR 06-205 COMPRESSOR UNIT-AIR
DS 33-005 CAMPER-MECHANICAL EXHAUST VENTILATION SYS
DT DT- DETECTING HEADS (ELEX)
DU 54-021 DEVELOPING MACHINE-BLACK AND WHITE PROCESS
DV 43-001 DISH WASHING MACHINE
DW 41-049 DISINTEGRATING MACH-METAL, ELEC ARC
DX 32-014 DISPENSER-DRINKING WTR SEE ALSO DRNKG FTN(67-006)
DY DY- DYNAMOTORS (ELEX)
DZ 32-032 DISPENSER-MECHANICALLY REFRIGERATED, MILK
DO 09-002 CHARGER-BATTERY, D.C.
D1 41-146 DISPENSER-TAPE, ELECTRIC
D2 32-031 DISPLAY CASE-MECH REF, SELF CONTND/NON-REFR
D3 06-002 COMPRESSOR-RECIPROCATING
D4 08-001 DISTILLATION UNIT
D5 52-015 DESURGER-HYDRAULIC
D6 32-027 DISPENSER-MECH REF, OTHR THN MLK SEE CAB, ICE CR/FREEZR
D7 08-005 DISTILLATION UNIT-VAPOR COMPRESSION
D8 85-011 DOLLY-BOAT STORAGE SEE ALSO TRK/DOLLY/CRADLE ASS
D9 31-034 DOOR-ROLLER CURTAIN, SHIPBRD, HAND CR PWR CPER
EA 74-001 EDUCTOR-LIQUID
EB 49-001 CARBURETOR
EC 73-010 EJECTOR-GARBAGE AND TRASH DISPOSAL
ED 07-011 HEATER-FLUID
EF 88-031 VALVE-BURBLER
EG 73-012 EJECTOR-SIGNAL
EH 73-001 EJECTOR ASSEMBLY-AIR
EI E- HOISTS (ELEX)
EJ NOT ASSIGNED
EK 11-003 CONVERTER
EL 849 NITROGEN CHARGING ASSEMBLY
EM 59-001 ELEVATOR-ELECTRO MECHANICAL
EN 15-013 CONTROLLER-AC
EO 16-010 GENERATOR-GAS
EP NOT ASSIGNED
EQ 59-002 ELEVATOR-AIRCRAFT LIFTING

CDC LAPL

EQ 41-050 EMBOSSEING MACHINE-METAL & CRDBRD ALSO OFF MACH ACC
ER 16-012 BENCH-LIQUID OXYGEN CONVERTER FILL
ES 66-001 ENGINE-DIESEL, SHIP PROPULSION AND SHIP'S SERVICE, 2 & 4 CYCLE
ET 22-022 SWITCHBOARD-MINESWEEPING
EU 89-037 VALVE-REFRIGERATION SHUT OFF, SMALLER THAN 3/4 IN
EV 66-005 ENGINE-DIESEL, 2 & 4 CYC, TYPE B
EW 16-014 BOOSTER-GAS
EX 66-006 ENGINE-DIESEL, NON-MAGNETIC MINESWP PROP & AUX 4 CYC
EY 66-017 ENGINE-GASOLINE AIR OR FLUID COOLED
EZ 18-007 MOTOR GENERATOR
EO 88-042 VALVE-FLCAT, LIQUID LEVEL CONTROL, REFRIGERATION SYSTEMS
E1 66-019 ENGINE-GASOLINE, BOAT PROP, OUTBOARD MOTOR
E2 66-020 ENGINE-STEAM, RECIPROCATING, MN PROP & AUX SERVICE
E3 88-044 VALVE-STEAM SEAL MANIFOLD
E4 88-045 VALVE-GUARDING
E5 41-051 ENGRAVING MACHINE PANTOGRAPH
E6 59-005 ESCALATOR
E7 09-011 EXCHANGER, ION
E8 53-001 EXPANSION JOINTS-PIPE, PACKLESS
E9 88-046 VALVE-TRIP THROTTLE
FA 40-001 FAN-VANEAXIAL AND/OR TUBEAXIAL
FB 18-009 MOTOR GENERATOR
FC 40-002 FAN-CENTRIFUGAL
FD 20-002 RHEOSTAT
FE 40-003 FAN-CIRCULATING
FF 40-009 FAN-CENTRIFUGAL, CARBON DIOXIDE REMOVAL SYS
FG 99-020 FEEDRAIL-BRIDGE CRANE
FH 41-076 FILING MACHINE-SAW, BLADE
FI C56 BOILER FEEDWATER TEST AND TREATMENT
FJ 09-010 FILLER-PORTABLE BATTERY WATER
FK 48-002 FILTER-FLUID, PRESSURE
FL F- FILTER UNITS (ELEX)
FM 20-006 RHEOSTAT
FN FN- FURNITURE (ELEX)
FO NOT ASSIGNED
FP 88-043 VALVE-CROSSOVER AND MANIFOLD
FQ 43-034 FILTER-COOKING GREASE
FR FR- FREQUENCY MEASURING DEVICES (ELEX)
FS C55 FUEL OIL STOWAGE AND EQUIPMENT
FT 31-023 FITTINGS-HULL SEE ALSO TOWING-ACC, MOORING ACC
FU 24-002 FIXTURE-LIGHTING
FV 48-006 FILTER-AIR, WET OR DRY ELEMENTS
FW 76-003 FILTER-WATER PURIFICATION
FX 31-012 FLAME ARRESTER-VENTILATION
FY 54-015 FOLDING MACHINE-PAPER
FZ 43-012 GRINDERS AND CUTTERS-FOOD ELECTRICAL
FO 16-011 FURNACE ASS OXY CANDLE ROUND AND SQUARE
F1 43-059 FOOD WARMER-RADIANT, OVERHEAD, ELECTRIC
F2 41-016 FORGE-OIL BURNING ELEC OR OTHER ALSO FURNACE
F3 41-053 FORGING MACHINE-HAMMER VERTICAL
F4 41-017 FORMING MACHINE-SHEET METAL
F5 54-004 FRAME PRINTING
F6 43-006 FRYERS-DEEP FAT, ELECTRIC
F7 85-046 FUEL DISPERSING SYS
F8 41-019 FURNACE- ELECTRIC
F9 41-020 FURNACE-OIL BURNING

CDC LAPL

GA 45-003 GAGE-LIQUID QNTY MECHANICAL SEE ALSO INDICATOR AND METER
GB 45-004 GAGE-LIQUID QUANTITY HYDRAULIC/PNEUMATIC
GC 45-007 GAGE-PRESSURE
GD 45-009 GAGE-DEPTH SURMARINE
GE 43-002 GALLEY EQUIPMENT-ELECTRICAL
GF 43-009 GARBAGE DISPOSAL MACHINE
GG 31-005 GATE-STERN SFF ALSO DOOR OR HATCH
GH G- GENERATOR-POWER (ELEX)
GI 867 OPERATING GEAR MISCELLANEOUS REPAIR PARTS
GJ 43-047 DOUGHNUT MACHINE-CUTTING AND FRYING
GK 69-028 GEAR-TURNING/JACK DEVICE
GL 69-029 GEAR-TILTING
GM 69-006 GEAR ASSEMBLY-SPEED DECREASER, MAIN PRCP SERVICE
GN 69-016 GEAR ASSEMBLY-SPEED DECREASER, AUX SERVICE
GO 60- GONIOMETERS (ELEX)
GP 6P- GROUND RODS (ELEX)
GQ 851 BOILER FEEDWATER SYSTEM CONTROL FITTINGS
GR 23-008 SEMAPHORE-MECHANICAL SIGNAL
GS 43-044 GALLEY UNITS-COMPACT
GT 16-006 GENERATOR-DC OR AC
GU 24-004 FIXTURE-LIGHTING FLUORESCENT
GV 24-006 FIXTURE-LIGHTING MERCURY VAPOR
GW 16-008 GENERATOR-SMOKE, MECHANICAL
GX 16-009 GENERATOR-OXYGEN/NITROGEN
GY 16-001 GENERATOR-BATTERY CHARGING
GZ 70-001 GOVERNOR-MECHANICAL
G0 FUEL GELLING UNIT MIG - 10
G1 70-005 GOVERNOR-HYDRAULIC
G2 88-072 GOVERNOR-PUMP
G3 70-013 GOVERNOR-ELECTRO HYDRAULIC
G4 70-014 GOVERNOR-ELECTRIC
G5 23-004 SEARCHLIGHT-SIGNAL
G6 41-057 GRINDING MACHINE-CYCLINDRICAL
G7 41-060 GRINDING MACHINE-GLASS
G8 41-063 GRINDING MACHINE-VALVE
G9 41-065 GRINDING MACHINE-SURFACE, RECIPROCATING
HA 85-031 HANDLING GEAR-GUIDANCE CAPSULE
HB 85-045 HANGAR-AIRCRAFT
HC HC- HOLDER, CRYSTAL (ELEX)
HD HD- ENVIRONMENTAL APPARATUS (ELEX)
HE 07-002 HEATER-FLUID, FUEL OIL AND LUBE OIL, STEAM HEATED
HF 07-003 HEATER-WATER AND AIR
HG 26-015 PROJECTOR-MOTION PICTURE, SOUND, SUPER 8MM
HH 07-004 HEATER-WATER, STM/HT WTR HTD, INST, STM WTR CVTR
HI 07-001 HEATER-FLUID, SEA WATER, STEAM HEATED
HJ 07-005 HEATER-FLD, DEAERATING, BOILER FDWTR, TYPES I & II
HK 07-006 HEATER-IMMERSION, ELECTRIC
HL 07-007 HEATER-SPACE ELEC, TYP D RADIANT, TYPE T TUR, RAD PANL
HM 26-016 PROJECTOR-MOTION PICTURE, SOUND, SUPER 16MM
HN 07-013 HEATER-WTR, ELECTRIC STORAGE TYPE
HO NOT ASSIGNED
HP 07-016 HEATER-COOLANT ENGINE, OIL FIRED OR ELECTRIC
HQ 07-022 HEATER-VENTILATION, VENT DUCT, ELEC, TYP 51-61
HR 07-023 HEATER-SPACE ELECTRIC, BLOWER, TYPE B
HS H- HEAD, HAND, AND CHEST SETS (ELEX)
HT 07-017 HEATER-AIR CIRCULATING UNIT, STEAM OR HT WTR HTD

CDC LAPL

HU 07-045 HEATING ELEMENTS-ELEMENTS-ELECTRICAL
HV 07-036 HEATING UNIT-ELEC. CONTRLD TEMP FOR STRSS RELF PRHTG
HW 58-001 HOIST-WIREROPE ELECTRIC
HX 58-002 HOIST-MANUAL
HY 58-003 HOIST-ELECTRO HYDRAULIC & ELECTRO-MECHANICAL
HZ 58-004 HOIST-CHAIN ELECTRIC
HO 61-116 HYDROSTAT, CONTRCL
HI 58-005 HOIST-PNEUMATIC
H2 58-006 HOIST-HYDRAULIC
H3 85-025 HOIST-WINDSCREEN
H4 87-009 HOIST-RODMETER, U/W LOG
H5 52-033 HOIST ASSEMBLY-CYL & RAM TYP FOR COMMUN MAST
H6 41-069 HONING MACHINE-HCRIZONTAL OR VERTICAL
H7 33-010 HUMIDIFIER
H8 52-016 HYDRAULIC MECHANISM SEE ALSO MISSLE FNDG SYS-HYD
H9 31-033 HYDROFOIL ASSEMBLY
IA 64-018 FIRE EXTINGUISHING SYSTEM
IB 66-002 ENGINE-DIESEL, TWO CYCLE
IC 865 IC COMMUNICATION EQUIPMENT
ID ID- INDICATOR-NON CATHODE RAY TUBE (ELEX/CRO)

IE 66-018 ENGINE-GASOLINE
IF 66-021 ENGINE-DIESEL, NONMAGNETIC
IG 66-022 ENGINE-DIESEL, MODEL 645
IH 69-026 GEAR ASSEMBLY-SPEED INCREASER
II 71-001 DISTRIBUTOR-IGNITION SYSTEM
IJ 73-011 EJECTOR-SEWAGE
IK 78-018 COUPLING ASSEMBLY
IL IL- INSULATORS (ELEX)
IM IM- INTENSITY MEASURING DEVICES (ELEX)
IN 79-003 MUFFLER-DRY
IO NOT ASSIGNED
IP IP- INDICATORS-CATHODE RAY TUBE (ELEX)
IQ 83-015 CONTROL BOARD-CONTROLLABLE PITCH PROPELLER, EMER. PITCH CONTROL
IR 91-004 LAUNDRY PRESS-COMMERCIAL
IS 859 AIR CONDITIONING REFRIGERATION TOOLS AND ACCESSORIES
IT 92-020 TANK-LUBE OIL STORAGE AND CONDITIONING ASSEMBLY
IU 94-004 ACOUSTIC DEVICE
IV 94-005 ACOUSTIC DEVICE
IW NOT ASSIGNED
IX 97-012 SUB ASSEMBLIES-PERISCOPE
IY 97-018 CAMERA ACCESSORIES-PERISCOPE
IZ 99-029 RECEIVER-FUELING PROBE
IO NOT ASSIGNED
I1 NOT ASSIGNED
I2 864 NAVIGATIONAL SIGNAL LIGHTS
I3 NOT ASSIGNED
I4 NOT ASSIGNED
I5 NOT ASSIGNED
I6 NOT ASSIGNED
I7 NOT ASSIGNED
I8 NOT ASSIGNED
I9 NOT ASSIGNED
JA 43-028 ICE CREAM CUP FILLING MACHINE- HAND OPERATED
JB 32-017 ICE CREAM FREEZER-PWR OPER WITH INTGRL MCH REF EQ
JC 32-022 ICE MAKING MACHINE-MECH REFRIG SELF CONTAINED

CDC LAPL

JD J- INTERFACE UNITS (ELFX)
JE 32-004 ICE MAKING PLANT
JF 41-032 IMPREGNATING EQUIPMENT
JG 30-006 INCINERATOR SEE ALSO BURNER
JH 27-008 SALINITY INDICATING EQUIPMENT
JI NOT ASSIGNED
JJ 38-002 INDICATOR-TEMPERATURE, ELECTRICAL
JK 28-028 NAVIGATION EQUIPMENT
JL 38-007 INDICATOR-BOILER SMOKE
JM 38-014 INDICATOR-SALINITY & SALINITY CELL
JN 38-015 INDICATOR-PRES DIFFERTL, LIQ/STM LVL, DIR OR REM
JO NOT ASSIGNED
JP 38-016 INDICATOR-MECHANICAL TACHOMETER
JQ 38-020 INDICATOR-LIQ LVL, FLOW, WATER AND FUEL
JR 45-001 INDICATOR-SIGHT LIQUID, FLAT
JS 45-002 INDICATOR-SIGHT LIQUID, TUBULAR
JT 45-005 INDICATOR-METER, DIFFERENTIAL PRESSURE
JU 61-025 INDICATOR-PORTABLE SHIP CONTROL
JV 41-111 VULCANIZER - RUBBER COVERED CABLE
JW 29-001 INJECTOR- FUEL DIESEL ENGINE NOZZLE NON-MET TYP
JX 29-002 INJECTOR-FUEL, DIESEL ENGINE, UNIT METERING AND PRES
JY 43-060 INJECTOR-RINSE AGENT FOR DISHWASHING MACHINE
JZ B87 MEASURING AND INDICATING INSTRUMENTS
JO 31-011 TENSION UNIT-HYDRAULIC RAM
J1 27-009 INTERCOMMUNICATION STATION
J2 97-002 MAST-ANTENNA
J3 97-013 MAST-SNORKEL
J4 689 NUCLEAR POWER PLANT - COOLANT DISCHARGE SYSTEM VALVE
J5 85-035 JACK ASSEMBLY-HAND, SCREW, HYDRAULIC/PNEUMATIC OPR
J6 41-034 JOINTER-WOODWORKING
J7 27-010 TELEPHONE EQUIPMENT-DIAL
J8 43-008 KETTLE-STEAM JACKETED
J9 41-070 KEY DUPLICATING MACHINE
KA 40-004 DRIER-HAND, ELECTRIC
KB 86-003 DRIER-PHOTOGRAPHIC
KC 41-014 DRILLING MACHINE-FLOOR OR BENCH
KD 43-050 TABLE-FOOD WARMER, ELECTRIC/STEAM HEATED
KE 54-014 DRILLING MACHINE-PAPER
KF 67-006 DRINKING FOUNTAIN
KG 52-001 DRIVE ASSEMBLY-ELECTRO HYDRAULIC AMMUN HOIST
KH 52-004 DRIVE ASSEMBLY-ELECTRO HYD HST, VERT TUB, 12.75RKT
KI 16-005 TACHOMETER SEE ALSO INDICATOR-MECHANIC TACHMETER
KJ 52-007 DRIVE ASSEMBLY-ELECTROHYDRAULIC HOIST, 3000# MIS TRAV
KK 88-063 VALVE-PRESSURE REGULATING
KL 85-004 DRIVE ASSEMBLY-SLIDING BLOCK
KM 91-008 DRY CLEANING PRESS
KN 91-007 DRY CLEANING UNIT ASS-AUTO, SYNTHET SOLVENT TYPE
KO NOT ASSIGNED
KP 54-018 DRYING MACHINE BLUEPRINT
KQ 91-002 DRYING TUMBLER-LAUNDRY
KR 59-003 DUMBWAITER
KS 54-002 DUPLICATING MACHINE-OFFSET SEE ALSO CFF MACH ACC
KT 41-015 DYNAMOMETER
KU 41-131 TANK-HOT DIP
KV 92-005 TANK-DIESEL ENGINE, AIR STARTING
KW 92-001 TANK-STORAGE

CDC LAPL

KX 88-104 VALVE-STOP CHECK
KY KY- KEYING DEVICES (ELEX)
KZ 88-117 VALVE SUBPLATE
K0 88-125 VALVE-PRESSURE CONTROL
K1 88-129 VALVE-PRESSURE REGULATING
K2 88-130 VALVE-HYDRAULIC CONTROL
K3 01-010 PUMP, ROTARY PISTON, FIXED OR VARIABLE DELIVERY
K4 88-134 VALVE-SHUTTLE
K5 88-135 VALVE-HYDRAULIC
K6 88-138 VALVE-CHECK, INLINE, UNDER \$25.00
K7 01-025 PUMP, PORTABLE SUBMERSIBLE
K8 88-142 VALVE-CHECK, INLINE, \$25.00 AND ABOVE
K9 88-158 VALVE-TEST CASTING
LA 24-009 LANTERN-ELECTRIC, BATTERY TYPE
LB 41-036 LATHE-METAL WORKING
LC LC- TOOLS-LINE CONSTRUCTION (ELEX)
LD 91-012 LAUNDRY EQUIPMENT
LE 23-002 LIGHT-INDICATOR
LF 24-008 LIGHT-NAVIGATIONAL MARINE
LG 54-024 LIGHT-ARC PHOTOLITHOGRAPHIC
LH 16-015 LIQUIDIFIED GAS STORAGE AND CHARGING SYS
LI NOT ASSIGNED
LJ 54-007 LITHOGRAPHIC, NEGATIVE AND PLATE MAKING
LK 59-020 LOCK-ELECTROMECHANICAL
LL 28-018 LOCKER-BINOCULAR DRYING
LM 26-013 LOUDSPEAKER-MOTION PICTURE PROJECTOR
LN 65-001 LUBRICATOR-MECHANICALLY OR HAND OPERATED
LO NOT ASSIGNED
LP 65-002 LUBRICATOR-AIR OPERATED
LO C16 LADDERS AND ACCESS CLOSURE EQUIPMENT
LR 845 LUBE OIL PIPING SYSTEM REPAIR PARTS
LS LS- LOUDSPEAKERS (ELEX)
LT 41-037 LATHE-WOODWORKING
LU 88-159 VALVE-DISTRIBUTOR LUBRICATION
LV 41-141 UNDERCUTTER - ARMATURE, MICA, ELECTRICAL OPERATED
LW C20 UNDERWAY REPLENISHMENT TOOLS AND ACCESSORIES
LX 32-008 UNION TUBE - REFRIGERATION
LY 43-005 URNS -COFFEE
LZ 88-162 VALVE-SHEARING
L0 88-169 VALVE-LINE BLIND
L1 LAUNCHER STAND-WEAPON SYSTEM
L2 LAUNCHER GUIDES-WEAPON SYSTEM
L3 TRAIN ASSEMBLY-WEAPON SYSTEM
L4 ELEVATION ASSEMBLY-WEAPON SYSTEM
L5 AMPLIFIER, POWER DRIVE-WEAPON SYSTEM
L6 RAMMER-LOADER ASSEMBLY-WEAPON SYSTEM
L7 88-170 VALVE AND TRAP MANIFOLD
L8 88-177 VALVE-SPECIAL STOP CHECK
L9 88-186 VALVE-FLOW FUSE
MA MA- MAGAZINE-MAGNETIC TAPE OR WIRE (ELEX)
MB 68-001 MAGNETO-IGNITION
MC 32-006 MANIFOLD-REFRIGERATION
MD MD- MODULATORS, DEMODULATORS, AND DISCRIMINATORS (ELEX)
ME ME- METERS (ELEX)
MF MF- MAGNETS OR MAGNETIC FIELD GENERATORS (ELEX)
MG 45-008 MANOMETER-U TUBE AND OTHER TYPES

CDC LAPL

MH 91-006 MARKING MACHINE-LAUNDRY
MI M- MICROPHONES (ELEX)
MJ 85-030 MAST-HINGED
MK MK- MISCELLANEOUS KITS (ELEX)
ML ML- METEOROLOGICAL DEVICES (ELEX)
MM 43-016 MEAT SLICING MACH-ELEC & MANUAL SEE ALSO FOOD CUTTER
MN 43-021 MEAT TENDERIZER-ELECTRIC
MO NOT ASSIGNED
MP 10-001 METER-VOLUMETRIC, POS DISPL, FUEL OIL, WTR, GAS, JP-5, AL T
MQ 10-002 METER-FLOWRATE INDICATING, FLOAT TYPE ROTAMETER
MR 10-003 METER-IMPELLER TYPE LIQUID VELOCITY
MS 10-004 METER-VENTURI TYPE
MT MT- MOUNTINGS (ELEX)
MU MU- MEMORY UNITS (ELEX)
MV 41-042 MILLING MACHINE-HORIZONTAL
MW 41-043 MILLING MACHINE-WOODWORKING, VERTICAL, BORING
MX MX- MISCELLANEOUS EQUIPMENT (ELEX)
MY 41-038 MIXER-LIQUID, PORTABLE
MZ 43-004 MIXING MACHINE-ELECTRIC, FOOD AND FLUID
M0 28-031 SEXTANT, MARINE
M1 43-035 MOLDING MACHINES-MEAT, FISH
M2 C26 ANCHORING AND MOORING APPLIANCES
M3 41-088 MORTISER-HOLLOW CHISEL
M4 17-023 MOTOR-AC/DC 0.25 HORSEPOWER AND SMALLER
M5 31-039 SONAR DOME WINDOW SYSTEM
M6 10-005 METER-FLOWRATE INDICATING, VANE TYPE
M7 17-001 MOTOR-AC OR DC
M8 31-040 TENSIONING DEVICE-TORSION BAR
M9 E32 MISCELLANEOUS FLAG ALLOWANCES, OFFICE MACHINES
NA 32-021 CARBONATOR-SODA FOUNTAIN
NB 13-013 TRANSFORMERS-REPAIRABLE AND NON-REPAIRABLE
NC 32-025 ICE CREAM FREEZER
ND 33-004 CHILLER-WATER, AIR CONDITIONING
NE 61-080 AMPLIFIER-ELECTRONIC
NF 52-005 TRANSMISSION-HYDRAULIC, FIXED OR VARIABLE DELIVERY SEE ALSO POWER UNIT
NG 69-011 TRANSMISSION-MECHANICAL
NH 27-005 TRANSMITTER-MECHANICAL
NI NOT ASSIGNED
NJ 27-006 TXMTR-LIQ LVL AND/OR FLOW, CAP, FLOAT, IND, RADIACT, RES AND SONIC TYPE
NK 27-021 TRANSMITTER-LIQUID LEVEL, ELECTRICAL
NL 28-024 TRANSMITTER-NAVIGATIONAL
NM 61-055 TRANSMITTER-TEMPERATURE SEE ALSO INDICATOR - TEMPERATURE, ELEC RESIST
NN 27-001 TRANSMITTER/INDICATOR-ELECTRICAL TRANSMITTER TYPES
NO NOT ASSIGNED
NP 54-022 PRINTING MACHINE-BLUEPRINT
NQ 85-043 STAND-MISSILE
NR 88-192 VALVE-PRESSURE REGULATING, HIGH PRESSURE AIR
NS STEEL PLATE
NT 88-193 VALVE-FLOW CONTRL
NU 88-201 VALVE-OFFICE
NV 77-001 TRAP-STEAM AND/OR AIR
NW 37-016 BEARING-JOURNAL, PIVOTED PAD/SHOE
NX 38-021 INDICATING SYSTEM-LIQUID LEVEL, PNEUMATIC
NY 41-002 BALANCING MACHINE-DYNAMIC, STATIC, HORIZONTAL
NZ 41-031 MACHINE-HOSE ASSEMBLY, REPAIR AND CUTOFF
NO 93-004 NOZZLE-PRESSURE FUEL SERVICING

CDC LAPL

NA C24 NAVIGATION EQUIPMENT AND ACCESSORIES
N2 28-027 NAVIGATION EQUIPMENT-PLOTTING SYS SEE ALSO PLTG TABLE
N3 28-026 NAVIGATION EQUIPMENT-DEAD RECKONING EQUIPMENT
N4 28-001 NAVIGATION PLOTTING BOARDS
N5 28-011 NAVIGATIONAL CLOCKS
N6 31-041 DOOR-HINGED-HAND OPERATED
N7 64-001 NOZZLE-FIRE HOSE SEE ALSO DAMAGE CONTROL ACC
N8 64-003 NOZZLE-MONITOR TYPE
N9 64-004 NOZZLE-WATER QUENCH
CA 0A- MISCELLANEOUS GROUPS (ELEX)
OB 0B- MULTIPLEXER AND/OR DEMULTIPLEXER GROUPS (ELEX)
OC 0C- OCEANOGRAPHIC DEVICES (ELEX)
OD 0D- INDICATOR GROUPS (ELEX/ORD)

OE 0E- ANTENNA GROUPS (ELEX)
OF 0F- ADAPTER GROUPS (ELEX)
OG 0G- AMPLIFIER GROUPS (ELEX)
OH 0H- SIMULATOR GROUPS (ELEX)
OI 0I- OSCILLATORS (ELEX)
OJ 0J- CONSOLES AND CONSOLE GROUPS (ELEX/ORD)

OK 0K- CONTROL GROUPS (ELEX/ORD)
OL 0L- DATA ANALYSIS AND DATA PROCESSING (ELEX)
OM 0M- MODULATOR AND/OR DEMODULATOR GROUPS (ELEX)
ON 0N- INTERCONNECTING GROUPS (ELEX)
OO NOT ASSIGNED

OP 0P- POWER SUPPLY GROUPS (ELEX/ORD)
OQ 0Q- TEST SET GROUPS (ELEX)
OR 0R- RECEIVER GROUPS (ELEX)
OS 0S- OSCILLOSCOPE-TEST (ELEX)
OT 0T- TRANSMITTER GROUPS (ELEX)
OU 0U- CONVERTER GROUPS (ELEX)
OV 0V- GENERATOR GROUPS (ELEX)
OW 0W- TERMINAL GROUPS (ELEX)
OX 0X- CODER, DECODER, INTERROGATOR, TRANSPONDER GROUPS (ELEX)
OY 0Y- RADAR SET GROUPS (ELEX/ORD)

OZ 0Z- RADIO SET GROUPS (ELEX)
CO NOT ASSIGNED
O1 99-A01 NR-1 SUBMERSIBLE RESEARCH SHIP
O2 99-A02 ATS-1, 2, 3 (UNITED KINGDOM)
O3 99-A03 ORDNANCE FIRE CONTROL SWITCHING EQUIPMENT (HM&E/ORD)

O4 99-A04 DEEP DIVING SUBMERGENCE SYSTEM
O5 99-A05 OCEANOGRAPHIC COMPONENTS
O6 TRANSCEIVER GROUPS
O7 SONAR SET GROUPS
O8 97-003 ANTENNA SYSTEM-FLOATING WIRE
O9 97-004 ANTENNA SYSTEM-HELICAL LOOP OR WHIP
PA 50-033 PANEL-REMOTE VALVE OPERATING
PB 88-203 VALVE-MIXING, REFRIGERATION, AIR CONDITIONING AND COOLING
PC 50-001 PANEL-FUSE
PD 50-001 PRIME DRIVERS (ELEX)
PE 50-005 PANEL-COMMUNICATION

CDC LAMPL

PF PF- FITTINGS-POLE (ELEX)
PG PG- PIGEON ARTICLES (ELEX)
PH PH- PHOTOGRAPHIC ARTICLES (ELEX)
PI 97-011 PERISCOPE-STADIMETER
PJ 50-010 PANEL-POWER DISTRIBUTION AND/OR CONTRL (HM&E/ORD)

PK PANEL-INDICATING (HM&E/ORD)
PK 50-025 PANEL-INDICATING (HM&E/ORD)
PL PL- PLUG-IN UNITS (ELEX)
PM 41-072 PAPER SHREDDING MACHINE SEE ALSO OFF MACH ACC
PN 25-004 PELORUS STAND SEE ALSO NAVIGATION EQUIPMENT ACC
PO NOT ASSIGNED
PP PP- POWER SUPPLY-ACNONROTATING MACHINE TYPE (ELEX)
PQ 97-008 PERISCOPE-COLLIMATOR
PR 97-009 DEPLUMERS, FAIRINGS AND SUPPORTS FOR SUBMARINE PERISCOPES AND MASTS
PS 50-009 PANEL-ALARM
PT PT- MAPPING AND PLOTTING UNITS (ELEX)
PU PU- POWER SUPPLY-ROTATING (ELEX)
PV 41-047 CLEANING MACHINE-CLOCK AND WATCH
PW 41-073 PINKING MACHINE
PX B48 PIPING SYSTEM HARDWARE
PY 41-091 PLANER-METAL CUTTING
PZ 97-010 PERISCOPE-SEXTANT
P0 11-009 POWER SUPPLY-AN/SQS-26 SONAR
P1 28-029 PLOTTING TABLE, MK NC2 MOD0.2 & 3 SEE ALSO NAVIG EQ (HM&E/ORD)

P2 B36 SANITATION EQUIPMENT AND REPAIR PARTS
P3 27-011 PNEUMATIC TUBE SYSTEMS-COMMUNICATION
P4 41-093 POLISHER-METALLURGICAL
P5 41-095 POSITIONER-WELDING
P6 41-094 POT-MELTING, ELEC
P7 97-001 PERISCOPE-SUBMARINE
P8 11-001 POWER SUPPLY-METALLIC RECTIFIER OR SEMICONDUCTOR DIODE TYPE
P9 41-008 CLEANER-STEAM PRESSURE JET
QA 54-010 PRINTING MACHINE-HEAT DEVELOPING
QB 54-005 PRINTING PRESS-OFFSET
QC 54-008 PRINTING PRESS-LETTER PRESS
QD 54-019 PRINTING PRESS-LETTER
QE 54-025 PRINTING PRESS-PROOF
QF 99-028 PROBE AND CARRIER-FUELNG SEE ALSO FUEL CIL SYS ACC
QG 54-017 PROCESSING MACHINE-BLUE PRINT
QH 86-013 PROCESSING MACHINE-PHOTOGRAPHIC FILM
QI NOT ASSIGNED
QJ 61-117 PROGRAM CONTROLLER
QK 26-001 PROJECTION EQUIPMENT-MOTION PICTURE
QL 26-002 PROJECTION EQUIPMENT-STILL PICTURE
QM 83-030 PROPELLER ASSEMBLY-CONSTANT PITCH
QN 64-007 RECHARGING UNIT-CO2 PUMPING METHOD
QO NOT ASSIGNED
QP 89-002 RESCUE CHAMBER AND RECOMPRESSION TANK
QQ 55-002 REELING MACHINE-HOSE
QR 32-039 REFRIGERATION SYSTEM-ABSORPTION
QS 83-034 PROPELLER ASSEMBLY-CONTROLLABLE PITCH
QT 64-008 PROPORTIONER-FOAM LIQ SEE ALSO DAMAGE CONTRL ACC
QU 83-043 PROPULSION DRIVE UNIT-STERN
QV 01-038 PUMP UNIT-PUMP AND ACCESSORIES INSTALLED AS A UNIT

CDC LAPL

QW 88-213 VALVE-OVERFLOW
QX C1-011 PUMP-CENTRIFUGAL, POWER DRIVEN
QY 32-023 REFRIGERATION-MECHANICAL
QZ 42-001 REGULATOR-ELECTRICAL (EXCEPT ENGINE GENERATOR)
00 88-231 VALVE-CROSS
C1 01-017 PUMP-CENTRIFUGAL, POWER DRIVEN, CLOSE-COUPLED OR COUPLING DESIGN
Q2 88-245 VALVE-DIRECTIONAL INTERLOCK
Q3 88-248 VALVE-PILOT, PNEUMATIC OPERATED
Q4 01-001 PUMP-CENTRIFUGAL, BOILER FEED
Q5 88-249 VALVE-CONTROL THERMAL
Q6 41-048 CLEANING MACHINE-ELECTRIC AND OILBURNING
Q7 88-251 VALVE-LOW PUMP SECTION, SAFETY TRIP
Q8 88-252 VALVE-CONTROL AIR
Q9 01-014 PUMP-HAND DRIVE, OSCILLATING, RECIPROCATING OR ROTARY
RA 58-007 RACK-READY SERVICE
RB 52-029 RAM-HYDRAULIC
RC RC- REELS (ELEX)
RD RD- RECORDER/REPRODUCERS (ELEX)
RE RE- RELAY ASSEMBLY UNITS (ELEX/ORD)

RF RF- RADIO FREQUENCY COMPONENTS (ELEX)
RG RG- CABLES, RF BULK-(ELEX)
RH 16-013 RECONDENSER SYSTEM-NITROGEN AND OXYGEN
RI B34 COMMISSARY EQUIPMENT
RJ 32-007 REFRIGERATION PURGE UNIT
RK 46-010 RECORDER-PNEUMATIC AND ELECTRO-PNEUMATIC
PL RL- REELING MACHINES (ELEX/ORD)

RM 41-084 CLEANING MACHINE-TANK
RN 55-003 REEL-HOSE
RO RO- RECORDERS (ELEX/ORD)

RP RP- REPRODUCERS (ELEX)
RQ 32-029 REFRIGERATED TANK-FILM PROCESSING
RR RR- REFLECTORS-EXCEPT ANTENNA REFLECTORS (ELEX)
RS 32-001 REFRIGERATION SYSTEM-MECHANICAL
RT RT- RECEIVER & TRANSMITTER (ELEX)
RU C88 DAMAGE CONTROL EQUIPMENT AND ACCESSORIES
RV R- RECEIVERS (ELEX)
RW 42-002 REGULATOR-ENGINE GENERATOR, BATTERY CHRG, ELECTROMECH
RX 42-007 REGULATOR-ENGINE GENERATOR, BATTERY CHRG, ELEX
RY 42-100 REGULATOR-PRESSURE
RZ 42-101 REGULATOR-FLOW, BOILER FEED WATER
P0 88-253 VALVE-LINEAR DIRECTIONAL CONTROL WITH ACTUATOR
R1 42-102 REGULATOR-FLOW, FLOAT OPERATED, DRAIN/MAKE-UP VALVE
R2 42-104 REGULATOR-PRESSURE OXYGEN SERVICE
P3 99-004 RECEPTACLE ASSEMBLY-CO2 ABSORBENT
R4 41-067 GRINDING MACHINE-UTILITY
R5 20-003 RESISTOR-VARIABLE
R6 20-004 RESISTOR-FIXED
R7 41-104 REWINDING AND INSULATION MACHINES
R8 20-001 RHEOSTAT
R9 88-254 VALVE-REGULATING, COMPRESSED GAS
SA SA- SWITCHING UNITS (ELEX)
SB SB- SWITCHBOARDS (ELEX)
SC 41-112 SANDER-BELT, DISK AND SPINDLE

CDC LAPL

SD 67-008 SANITATION EQUIPMENT SEE ALSO TOILET-MARINE
SE 41-114 SAW-ABRASIVE-DISC, MASONRY
SF 41-115 SAW-BAND

SG SG- GENERATOR-SIGNAL (ELEX/ORD)
SH S- SHELTER (ELEX)
SI 54-016 COMPOSING MACHINE-PHOTO PRINTING
SJ 41-120 SAW- POWER HACK
SK 43-017 SAW BAND, MEAT CUTTING
SL 41-078 SAW SETTING MACHINE

SM SM- SIMULATORS (ELEX/ORD)
SN SN- SYNCHRONIZERS (ELEX)
SO NOT ASSIGNED
SP 83-010 SFAL-SWIVEL JOINT TYPE
SQ 41-145 SEALING MACHINE-HEAT
SR 07-029 HEATER-SPACE, MULTI-FUEL WITH BLOWER
SS 87-006 SELECTOR-SPEED SENSITIVITY
ST ST- STRAPS (ELEX)
SU SU- OPTICAL UNITS (ELEX)
SV 67-010 SEWAGE TREATMENT SYSTEM-MULTI TOILETS OR URINALS
SW 41-080 SEWING MACHINE-HOUSEHOLD AND INDUSTRIAL
SX 83-017 SHAFT-PROPULSION, SHIP
SY 41-119 SAW-JIG, WOOD WORKING
SZ 83-002 SFAL-STERN TUBE SHAFT
S0 43-023 SINK-SCULLERY
S1 41-123 SHAPER-METAL CUTTING AND WOODWORKING
S2 41-096 BENDING OR FOLDING MACHINE-MANUAL
S3 99-007 SHELL-MISSILE TUBE
S4 85-014 SHOCK ABSORBER-GAS, CIL OR PNEUMATIC
S5 41-081 SHOE FINISHING AND STITCHING MACHINE
S6 891 SHOP EQUIPMENT AND ACCESSORIES ON SHIPS
S7 40-005 SHUTTER
S8 41-125 STEVE-FCUNDRY
S9 43-052 SIFTING MACHINE-FLOUR, ELECTRIC
TA TA- TELEPHONE APPARATUS (ELEX)
TB TB- TOWED BODY (FLEX)
TC TC- TOWED CABLE (ELEX)
TD TD- TIMING DEVICES (ELEX)
TE 92-007 TANK-LIQUID STORAGE
TF TF- TRANSFORMERS (ELEX)
TG TG- POSITIONING DEVICES-TILT AND/OR TRAIN (ELEX)
TH TH- TELEGRAPH APPARATUS (ELEX)
TI 61-107 TRANSDUCER-MOTIONAL PICKUP
TJ 88-049 VALVE-MANEUVERING AND THROTTLE
TK TK- TOOL KITS (ELEX)
TL TL- TOOLS (ELEX)
TM 88-250 VALVE-MANUAL RESET
TN TN- TUNING UNITS (ELEX)
TO NOT ASSIGNED
TP AN/ A INVISIBLE LIGHT, HEAT RADIATION
TO 52-012 TANK-ACCUMULATOR, HYDRAULIC
TR TR- TRANSDUCERS (ELEX)

TS TS- TEST AND MEASURING EQUIPMENT NOT OTHERWISE CLASSIFIED (ELEX/ORD)
TT TT- TELETYPE WRITER AND FACSIMILE APPARATUS (ELEX)

CDC LAPL

TU 52-048 COMPENSATOR-HYDRAULIC
TV TV- TESTER-TUBE (ELEX)
TW TW- TAPE UNITS-USED FOR OPERATIONAL TEST AND CHECK OUT (ELEX)
TX T- TRANSMITTERS-ALL TYPES EXCEPT TELEPHONE (ELEX)
TY 31-006 TENSIONING DEVICE-COUNTERWEIGHT
TZ 46-002 TEST EQUIPMENT-ANALYZER
TO 41-149 PUMP-AIRLESS SPRAY PAINT
TI 46-006 TEST FIXTURES, SETS, STANDS AND CALIBRATORS, ALL TYPES
T2 41-150 CLEANER-VACUUM, ELECTRIC
T3 43-029 TOASTER-ELECTRIC, INTERMITTENT
T4 43-030 MIXER AND TANK-FLUID ELECTRIC
T5 43-058 FOOD CUTTER AND MIXER-ELECTRICAL
T6 43-061 COMPACTOR-TRASH
T7 46-013 TORSION METER-PROPULSION SHAFTING
T8 48-010 FILTER-AIR, ELECTROSTATIC

T9 41-132 TEST EQUIPMENT-MISCELLANEOUS (HM&E/CRC)
UA U- CONNECTORS-AUDIO AND POWER (ELEX)
UB C35 LAUNDRY EQUIPMENT AND ACCESSORIES
UC C22 STEERING GEAR, EMERGENCY
UD C21 HYDRAULIC FILTER UNIT, PORTABLE
UE C30 PORTABLE CLEATS
UF C23 INDUSTRIAL GASES GENERATING, HANDLING AND STORAGE
UG UG- CONNECTORS-RF (ELEX)
UH DIRECTOR-WEAPON SYSTEM
UI NOT ASSIGNED
UJ 88-014 VALVE-GATE, HYDROCARBON FUEL SERVICE
UK 99-018 CABLE ASSEMBLY-ELECTRICAL
UL 99-031 DISPENSER-CHAFF
UM 88-032 VALVE-REFRIGERATION SHUT OFF 3/4 IN AND LARGER
UN 52-006 MISSILE HANDLING SYSTEM-HYDRAULIC
UO NOT ASSIGNED
UP 41-071 MAGNETIC INSPECTION UNIT PORTABLE
UQ 50-003 PANEL-TEST ELECTRICAL
UR C27 CARGO HANDLING ACCESSORIES
US 50-006 PANEL-INTERIOR COMMUNICATION
UT 50-008 PANEL-GYRO OR DEAD RECKONING CONTROL
UU 86-004 SAFELIGHT-DARKROOM, PHOTOGRAPHIC
UV 28-023 PLOTTING AND TRACING EQUIPMENT
UW 55-004 REEL-CABLE
UX 19-002 RELAY-ELECTRICAL SEE ALSO TEST EQUIPMENT
UY 55-001 REELING MACHINE-CABLE
UZ 46-003 RECORDER-ELECTRICAL AND ELECTRONIC
UO 41-118 SAW-CIRCULAR
U1 SHIELD ASSEMBLY-WEAPON SYSTEM
U2 TRAIN POWER DRIVE ASSEMBLY-WEAPON SYSTEM
U3 ELEVATION POWER DRIVE ASSEMBLY-WEAPON SYSTEM
U4 TRAIN TRANSMISSION ASSEMBLY-WEAPON SYSTEM
U5 ELEVATION TRANSMISSION ASSEMBLY-WEAPON SYSTEM
U6 TRAIN RECEIVER REGULATOR-WEAPON SYSTEM
U7 ELEVATION RECEIVER REGULATOR-WEAPON SYSTEM
U8 CONTROL ASSEMBLY-WEAPON SYSTEM
U9 FUSE SETTER ASSEMBLY-WEAPON SYSTEM
VA 88-103 VALVE-BALANCING
VB 88-149 VALVE-ANGLE
VC 88-039 VALVE-ASTERN

CDC LAPL

VP 838 ENVIRONMENTAL CONTROL SYSTEM SPARES AND REPAIR PARTS
VE 88-001 VALVE-BALL
VF CONTROL-LAUNCHER
VG 88-038 VALVE-BUTTERFLY
VH V- VEHICLES-CARTS, DOLLIES, VANS U/W ELECTRONIC EQUIPMENT (ELEX)
VI 88-057 VALVE-GLOBE
VJ 88-036 VALVE-CHECK
VK 88-175 VALVE-SPECIAL
VL 88-019 VALVE-PILOT AND LINE PRESSURE OPERATED, DIAPHRAGM AND PISTON TYPES
VM 88-171 VALVE-RELAY AIR, DIAPHRAGM AND PISTON TYPES
VN 88-026 VALVE-EXPANSION
VO NOT ASSIGNED
VP 88-212 VALVE-FLOAT
VQ 88-024 VALVE-FUEL OIL REGULATING
VR 88-013 VALVE-GATE, ALL TYPES EXCEPT HYDROCARBON FUEL SERVICE
VS VS- SIGNALING EQUIPMENT-VISUAL (ELEX)
VT 88-124 VALVE-LINEAR, DIRECTIONAL CONTROL
VU 88-189 VALVE-INSTANTANEOUS HEATER
VV 88-071 VALVE-NEEDLE
VW 88-217 VALVE-PILOT CONTROL, BELLOWS AND SOLENOID OPERATED
VX 88-033 VALVE-PLUG
VY 88-020 VALVE-PRESSURE REGULATING, STEAM SERVICE
VZ 88-025 VALVE-FLUSH
V0 88-102 VALVE-ROTARY, DIRECTIONAL CONTROL
V1 88-176 VALVE-EXHAUST AND RELIEF
V2 88-191 VALVE-FEEDWATER REGULATING
V3 87-013 VALVE - SEA, UNDERWATER LOG
V4 88-152 VALVE-MAIN BALLAST
V5 88-144 VALVE-MANIFOLD (EXCLUDES VALVE AND TRAP MANIFOLDS)
V6 88-216 VALVE-SOLENOID
V7 88-010 VALVE-TEMPERATURE REGULATING, AUTOMATIC OPERATION
V8 88-166 VALVE-HINGE TYPE
V9 88-055 VALVE-Y
WA 91-001 WASHING MACHINE - LAUNDRY
WB 41-086 WELDING AND BRAZING MACHINE - BAND SAW BLADE
WC 82-002 WELDING MACHINE - RESISTANCE
WD WD- CABLE, 2 CONDUCTOR, NON-RF (ELEX)
WE 82-005 WELDING MACH-ARC,ADJUST,CONST VLTG CR CONST CURR TRANSFORMER RECTIFIER
WF WF- CABLE, 4 CONDUCTOR, NON-RF (ELEX)
WG 82-001 WELDING SET - TUNGSTEN ARC,INERT GAS SHIELDED,NONCONSUMABLE ELECTRODE
WH 82-004 WELDING SET - ARC,INERT GAS SHIELDED, CONSUMABLE ELECTRODE
WI NOT ASSIGNED
WJ 82-007 WELDING SET - STUD, ELECTRIC ARC
WK 62-001 WINCH - HAND OPERATED
WL 62-002 WINCH - STEAM OPERATED
WM WM- CABLE, MULTIPLE CONDUCTOR, NON-RF (ELEX)
WN 62-004 WINCH - ELECTRIC - HYDRAULIC
WO NOT ASSIGNED
WP 62-006 WINCH - ENGINE DRIVEN, GASOLINE OR DIESEL
WQ 62-007 WINCH - PNEUMATIC DRIVE
WR 41-087 WINDING MACHINE COIL
WS WS- CABLE, SINGLE CONDUCTOR, NON-RF (ELEX)
WT WT- CABLE, 3 CONDUCTOR, NON-RF (ELEX)
WU 63-003 WINDLASS - ELECTRICAL MECHANICAL SEE ALSO ANCHOR HANDLING ACCESSORIES
WV 63-004 WINDLASS - HAND OPERATED SEE ALSO ANCHOR HANDLING ACCESSORIES
WW 31-025 WINDOW - OBSERVATION, OPTICAL, PORTLIGHT

CDC LAPL

WX 99-001 WINDOW - NON ICING
WY 35-001 WIPER-WINDOW PNLM, RTY OR VERT TYPE, ELEC OR MNL (HM&E/ORD)

WZ 35-002 WIPER - WINDOW, PENDULUM TYPE, PNEUMATIC
W0 FIRING CUTOUT ASSY-WEAPON SYSTEM
W1 CARRIAGE ASSEMBLY-WEAPON SYSTEM
W2 STAND ASSEMBLY-WEAPON SYSTEM
W3 SLIDE ASSEMBLY-WEAPON SYSTEM
W4 RAMMER ASSEMBLY-WEAPON SYSTEM
W5 HOUSING ASSEMBLY-WEAPON SYSTEM
W6 GUN BARREL ASSEMBLY-WEAPON SYSTEM
W7 GAS EJECTOR ASSEMBLY-WEAPON SYSTEM
W8 EMPTY CASE EJECTOR ASSY-WEAPON SYSTEM
W9 HOIST ASSEMBLY-WEAPON SYSTEM
XA C00 COMPRESSOR GAS TURBINE REPAIR PARTS
XB BULKHEADS-STRUCTURAL
XC CANVAS
XD DECK COVERINGS
XE E34 MISCELLANEOUS FLAG ALLOWANCES, MESSING GEAR
XF C36 SURVIVAL EQUIPMENT
XG C41 LIFTING AND HANDLING GEAR MAIN AND AUXILIARY MACHINERY
XH C43 TOOLS AND ACCESSORIES MAIN PROPULSION SHAFTING
XI C38 ENVIRONMENTAL CONTROL SYSTEM APPLIANCES
XJ C47 PUMPS, PORTABLE
XK C51 BOILER TOOLS AND ACCESSORIES
XL C58 TOOLS AND ACCESSORIES DISTILLING PLANT
XM C59 TOOLS AND ACCESSORIES REFRIGERATION SYSTEM
XN DOOR-NON STRUCTURAL
XO NOT ASSIGNED
XP C48 HOSE AND MISCELLANEOUS HOSE FITTINGS
XQ C61 TOOLS AND ACCESSORIES GENERATORS
XR C18 RIGGING
XS SHEATHING
XT C62 TOOLS AND ACCESSORIES ELECTRIC POWER DISTRIBUTION
XU C64 LIGHT EXTENSION
XV C65 PORTABLE INTERICR COMMUNICATION EQUIPMENT
XW C66 LIGHT SIGNAL PORTABLE
XX C67 ELECTRICAL AND ELECTRONIC HAND TOOLS
XY C69 IDIC SUPPORT EQUIPMENT
XZ C70 FLAGS AND PENNANTS
X0 C75 ASROC/TORPEDO/MINE HANDLING
X1 DECK
X2 DOME-SONAR(STRUCT AND NON STRUCT)
X3 BALLAST
X4 PLATFORM DECK
X5 FLAT
X6 C77 NBC WARFARE EQUIPMENT
X7 C81 MINESWEEPING EQUIPMENT
X8 C83 AIRCRAFT HANDLING AND STOWAGE
X9 C85 PROJECTION EQUIPMENT AND ACCESSORIES
YA 54-009 TABLE-LITHOGRAPHIC LAYOUT
YB 60-006 STEERING GEAR
YC 46-C11 TRITIUM AIR MONITOR
YD 85-C36 TROLLEY - MONORAIL AND BI-RAIL
YE 85-018 TRUCK/DOLLY/ CRADLE ASSEMBLY SEE ALSO CARGO HNDL ACCY (HM&E/ORD)

CDC LAPL

YF 41-139 TUBE AND FLUE CLEANER - AIR MOTOR DRIVEN
YG 41-140 TUBE AND FLUE CLEANER - ELECTRIC MOTOR DRIVEN
YH 05-001 TURBINE-STEAM, MAIN PROPULSION
YI NOT ASSIGNED
YJ 61-029 CONTROL PANEL-AUTOMATIC OR MANUAL
YK 61-048 ELECTRONICS SUB-ASSEMBLIES
YL 82-003 WELDING MACHINE - ARC, DRIVEN BY GAS OR DIESEL INTERNAL COMBUSTION ENGINE
YM 61-065 INDUCTOR-VERNIER
YN 82-006 WELDING MACHINE - ARC, ELECTRIC MOTOR DRIVEN
YO NOT ASSIGNED
YP 62-003 WINCH - ELECTRIC
YQ 63-001 WINDLASS - STEAM DRIVEN SEE ALSO ANCHOR HANDLING ACCESSORIES
YR 05-006 TURBINE-STEAM, AUXILIARY
YS 05-022 TURBINE - WATER DRIVEN
YT 05-028 TURBINE - GAS, PROPULSION AND AUXILIARY SERVICE OVER 2000 HORSEPOWER
YU 05-029 TURBINE - GAS, PROPULSION AND AUX SERVICE 2000 HORSEPOWER OR UNDER
YV 05-025 TURBINE AND FAN, INTEGRAL FORCED DRAFT AIR SERVICE FOR MAIN BOILER
YW 05-019 TURBINE CONTROL - PROPULSION
YX 05-024 TURBO/SUPERCHARGER - DIESEL ENGINE
YY 85-003 TURNTABLE - TROLLEY OR BALL TYPE, MANUAL OR POWER DRIVEN
YZ 85-009 TORPEDO HANDLING UNIT (HM&E/ORD)

YO C12 HULL FITTINGS, LASHING GEAR AND ACCESS CLOSURES
Y1 53-002 CAPSTAN-POWER OPERATED, ELECTRIC OR HYDRAULIC
Y2 63-002 WINDLASS - ELECTRIC HYDRAULIC SEE ALSO ANCHOR HANDLING ACCESSORIES
Y3 C87 TEST, MEASURING AND INDICATING EQUIPMENT
Y4 C90 RADIATION MONITORING AND COUNTERMEASURES
Y5 C93 SHIPBOARD FIREFIGHTING AND ACCESSORIES

Y6 A00 ORDNANCE TOOLS AND ACCESSORIES (AEL/CRD)
Y7 WELDMENT
Y8 C94 SALVAGE TOOLS AND EQUIPMENT
Y9 C95 DIVING EQUIPMENT
ZA 61-086 STAND, CONTROL-STEERING
ZB 61-087 STAND, CONTROL PROPULSION
ZC 91-009 STARCH COCKER-LAUNDRY
ZD 61-482 VALVE OPERATOR-HYDRAULIC OPERATOR
ZE 34-001 STARTER-ENGINE, ELECTRICAL
ZF 34-002 STARTER-ENGINE, HYDRAULIC
ZG 34-003 STARTER-ENGINE, DIRECT COMBUSTION AND/OR GAS TURBINE
ZH 34-005 STARTER-ENGINE, AIR MOTOR OR AIR TURBINE TYPE
ZI NOT ASSIGNED
ZJ 60-001 STEERING GEAR-ELECTRO-HYDRAULIC, MARINE, LINK, TILLER TYPE
ZK 60-003 STRONG GEAR-ELECTRIC MOTOR, DRUM & CBL/CBLECC, GR&OC, HAND OPERATED TYPE
ZL 60-007 STEERING GEAR-ELECTRIC, STEER MOTOR-CHAIN DRIVE TYPE
ZM ZM- IMPEDANCE MEASURING DEVICES (ELEX)
ZN 60-008 STEERING GEAR-EMERGENCY SUBMERSIBLE TYPE
ZO NOT ASSIGNED
ZP 61-027 STEERING HEAD-GYROPILOT
ZQ 54-020 STITCHER-BOOK AND PAMPHLET
ZR 64-005 STRAINER-PRESSURE, FIRE HOSE WITH BALL VALVE
ZS 64-014 FIRE EXTINGUISHING SYSTEM-TWIN AGENT
ZT C99 TOOLS AND EQUIPMENT MISCELLANEOUS
ZU 64-015 FIRE EXTINGUISHING UNIT-DRY CHEMICAL
ZV D39 DSRV RESCUE CONTROL CENTER
ZW 64-016 NOZZLE ASSEMBLY-TWIN AGENT

CDC LAPL

ZX 41-113 SAND MULLER
ZY 75-001 STRAINER-SEDIMENT
ZZ MISCELLANEOUS ITEMS NOT OTHERWISE CODED
Z0 E24 MISCELLANEOUS FLAG ALLOWANCES, NAVIGATION INSTRUMENTS
Z1 61-072 CONTROL-HUMIDITY
Z2 41-129 SURFACER-WOODWORKING
Z3 85-027 SWAY BRACE ASSEMBLY-ELECTRIC CHAIN HOIST DRIVE
Z4 89-005 SWIMMERS RECOVERY SYSTEM
Z5 E36 MISCELLANEOUS FLAG ALLOWANCES, VACUUM CLEANER
Z6 61-074 COMPUTER-SHIPBOARD
Z7 E85 MISCELLANEOUS FLAG ALLOWANCES, PROJECTION EQUIPMENT
Z8 61-389 BELLOWS ASSEMBLY-PRESSURE RELIEF
Z9 NOT ASSIGNED
0A NOT ASSIGNED
0B NOT ASSIGNED
0C TELEMETRING SETS
0D NOT ASSIGNED
0E NOT ASSIGNED
0F NOT ASSIGNED
0G NOT ASSIGNED
0H NOT ASSIGNED
0I NOT ASSIGNED
0J NOT ASSIGNED
0K NOT ASSIGNED
0L NOT ASSIGNED
0M NOT ASSIGNED
0N NOT ASSIGNED
0O NOT ASSIGNED
0P NOT ASSIGNED
0Q NOT ASSIGNED
OR OR ORDALTS AND ORDNANCE MODIFICATIONS-OTHER THAN SWITCHBOARD
OS RS ORDALTS AND ORDNANCE MODIFICATIONS-SWITCHBOARD ONLY
OT NOT ASSIGNED
OU NOT ASSIGNED
OV NOT ASSIGNED
OW NOT ASSIGNED
OX NOT ASSIGNED
OY NOT ASSIGNED
OZ NOT ASSIGNED
00 NLAPLW NLAPLW-ITEM LISTED BY SPCC AS NOT LAPL WORTHY
00 INCOMP INCOMP-ITEM LISTED BY SPCC AS INCOMPLETE
01 06-001 COMPRESSOR-RECIPROCATING, OTHER
02 06-004 COMPRESSOR-CENTRIFUGAL, REFRIGERATION
03 06-201 COMPRESSOR-RECIPROCATING, AIR, HIGH, PRESSURE
04 06-202 COMPRESSOR-RECIPROCATING, AIR, LOW, PRESSURE
05 06-203 COMPRESSOR-CENTRIFUGAL, AIR, LOW PRESSURE
06 06-204 COMPRESSOR-ROTARY, AIR, LOW PRESSURE
07 06-501 COMPRESSOR-VAPOR ROTARY
08 AVIATION ORDNANCE EQUIPMENT
09 04-001 CONDENSER-REFRIGERATION, WATER, COOLED
1A VALVE-SCUPPER (INCL. DECK DRAIN VALVES)
1B 41-004 BOOTH-SPRAYING
1C 39-005 CLUTCH-FRICTION
1D B37 PROPANE GAS AND CYLINDERS
1E MACK
1F 14-007 FUSE UNIT ASS

CDC LAPL

IG 41-045 GRINDING MACHINE-UTILITY (INCL BUFFNG CAPABILITY)
IH 76-006 HYPOCHLORINATION UNIT
II NOT ASSIGNED
IJ 01-012 PUMP-FUEL, ALL TYPES INCLUDING ELFCTRIC DRIVE DESIGN
IK 54-001 PUNCHING MACHINE-PAPER
IL 61-049 SYNCHRO-RECEIVER, TRANSMITTER, RECEIVER, TRANSMITTER
IM 17-018 MOTOR-AC/DC MAIN PROP, UNLIMITED HORSEPOWER
IN C32 FURNISHINGS AND CUTFITTINGS
IO NOT ASSIGNED
IP 39-003 POWER TAKE OFF-ACCESSORY DRIVE
IQ 01-005 PUMP-ROTARY, POWER DRIVEN
IR 43-057 RINSER-SANITIZER
IS 86-001 SINK-PHOTOGRAPHIC PROCESSING
IT 01-013 PUMPING UNIT-CENTRIFUGAL, POWER DRIVEN, AIRCRAFT FUELING
IU HEAD-SPRINKLER-FIRE PROTECTION
IV 88-004 VALVE-SAFETY RELIEF, MAIN PROPULSION BOILER
IW NOT ASSIGNED
IX 52-014 CYLINDER-ACTUATING LINEAR SEE ALSO JACK ASSEMBLY/SFCK AB
IY 57-008 CRANE-ASROC MISSILE
IZ NOT ASSIGNED
IO NOT ASSIGNED
11 04-100 CONDENSER-STEAM, ALL TYPES
12 01-003 PUMP-CENTRIFUGAL, MAIN CONDENSER CIRCULATING
13 01-004 PUMP-ROTARY, POWER DRIVEN, CAM AND PLUNGER DESIGN
14 01-006 PUMP-ROTARY, POWER DRIVEN, IMPELLER DESIGN WITH TIMING GEARS
15 01-007 PUMP-ROTARY, POWER DRIVEN, EXTERNAL GEAR DESIGN
16 32-009 CONDENSING UNIT-REFRIGERATION
17 99-023 CONNECTOR-ELECTRICAL SEE BOX-ELECTRICAL
18 61-030 CONSOLE-CONTROL AND POWER
19 09-004 CONTROL-BATTERY CHARGER
2A LAUNCHING SYSTEM (MISSILE/ROCKET)

2B 99-008 BOX-ELECTRICAL (HM&E/CRD)
2C 39-006 CLUTCH-MAGNETIC
2D 844 PROPELLER, SPECIAL TOOLS AND HANDLING GEAR
2E LAUNCHERS (MISSILE/ROCKET)
2F 850 GOVERNOR OVERSPEED SPARES
2G 25-024 GYRO COMPASS-ARMA MK 7,8,9,10,21,22,24, & 26
2H 31-003 HATCH COVER
2I NOT ASSIGNED
2J ANTI-ICING SYSTEM
2K 41-074 PUNCHING, SHEARING, AND NIBBLING MACHINE-METAL
2L 32-034 SEPARATOR-OIL, REFRIGERANT
2M 41-089 MOTOR-PNEUMATIC
2N 83-037 OIL DISTRIBUTION BOX OR OIL INJECTOR ASSEMBLY
2O NOT ASSIGNED
2P 52-047 POWER UNIT-HYDRAULIC
2Q 39-001 CLUTCH-POSITIVE DRIVE AND ROTATING ELEMENT
2R 41-075 RIVETING MACHINE-ELECTRIC OR PNEUMATIC
2S 41-082 SKIVING AND BEVELING MACHINE-SHOE, SOLE, HAND OPERATED
2T 41-085 THREADING MACHINE-PIPE AND BOLT SEE ALSO SHOP ACCESSORIES-TOOLS X ECP
2U MAGAZINES-WEAPON SYSTEM
2V GUN MOUNTS
2W NOT ASSIGNED
2X CASTING
2Y 57-009 CRANE-ELECTRIC HYDRAULIC

CDC LAPL

2Z 21-011 SWITCH-FLOAT, LIQUID LEVEL, FLOW DETECTING
20 61-008 CONTROL-STEERING SYSTEM
21 61-009 CONTROL-MECHANICAL
22 NOT ASSIGNED
23 61-015 CONTROL-NAVIGATIONAL LIGHT
24 61-022 CONTROL-ACOUSTIC DEVICE
25 61-024 CONTROL-MECHANICAL PUSH PULL STROKE
26 61-026 CONTROL-ELECTRIC LIGHT
27 61-040 CONTROL-VALVE OPERATOR
28 61-064 CONTROL-HUMIDITY
29 61-067 CONTROL-REMOTE TRANSMITTERS AND RECEIVERS
3A NOT ASSIGNED
3B 80-001 BRAKE-ELECTRIC, SHOE OR DISC, SOLENOID
3C 39-007 CLUTCH-MAGNETIC PARTICLE
3D B41 PROPULSION MAIN DRIVE DIESEL ENGINE EQUIPMENT AND ACCESSORIES
3E NOT ASSIGNED
3F FRAME-STRUCTURAL
3G 25-028 GYRO COMPASS-SPERRY MK 11, 14, 17, 18, & 19
3H NOT ASSIGNED
3I NOT ASSIGNED
3J 21-018 SWITCHING UNIT-POWER TRANSFER
3K 76-001 PURIFIER-CENTRIFUGAL
3L 93-009 SEPARATOR MOISTURE
3M 52-046 MOTOR-HYDRAULIC
3N 01-018 PUMP-CENTRIFUGAL, SINGLE STAGE, CLOSE-COUPLED, NAVY STD
3O NOT ASSIGNED
3P 61-091 POWER UNIT-GYRO PILOT
3Q 01-009 PUMP-ROTARY, POWER DRIVEN, VANE DESIGN, FIXED OR VAR DELIVERY
3R 87-002 ROOMETER-UNDERWATER LOG SYSTEM
3S 32-020 SODA FOUNTAIN
3T 61-056 THRUSTOR-MOTOR DRIVEN, HYDRAULICALLY OPERATED
3U B58 DISTILLING PLANT ACCESSORIES
3V 16-016 VAPORIZER SYSTEM - LIQUID OXYGEN OR NITROGEN
3W AN/ C CARRIER
3X 06-005 COMPRESSOR-RECIPROCATING, REFRIG, VERT OPR, SEMI-HERM
3Y 57-010 CRANE STERN
3Z AN/ D RADIAC
30 61-071 CONTROL-PHOTOELECTRIC CELL
31 61-079 CONTROL-CONSTANT FREQUENCY
32 61-096 CONTROL-TRANSMISSION REVERSING MECHANISM
33 61-108 CONTROL-PERISCOPE
34 61-110 CONTROL-SENSOR, DEPTH AND TRIM
35 61-402 CONTROL-FLAME FAILURE
36 61-444 CONTROL-GENERATOR, COOLER FEEDWATER
37 61-481 CONTROL-SERV, CONTROLLABLE PITCH PROPELLERS
38 87-004 CONTROL-UNDERWATER LOG
39 61-019 CONTROL TRANSMITTER-PRESSURE DIFFERENTIAL
4A AN/ G TELEGRAPH OR TELETYPE
4B BULKHEAD-NONSTRUCTURAL
4C 39-013 CLUTCH- ALL OTHER TYPES
4D 31-019 DOOR-MISSILE TUBE
4E AN/ I INTERPHONE AND PUBLIC ADDRESS
4F FORGING
4G 25-039 GYRO COMPASS-SPERRY MK 23 AND 27
4H AN/ J ELECTROMECHANICAL OR INERTIAL WIRE COVERED
4I NOT ASSIGNED

CDC LAPL

4J 22-001 SWITCHBOARD-DEGAUSSING
4K 61-012 CONTROL-DEGAUSSING
4L 61-011 SERVO GEAR TRAIN
4M 18-001 MOTOR GENERATOR
4N 31-002 OPERATING MECHANISM-DOOR,RAMP,STERNGATE & BRIDGE
4O NOT ASSIGNED
4P 41-069 PRESS-GROMMET AND EYFLET

4Q AN/ K TELEMETERING (ELEX/ORD)
4R 31-018 RUDDER-INCLUDING STOCKS, POSTS AND CARRIERS
4S 41-127 SOLDER AND DESOLDER UNIT-ELECTRIC
4T 61-005 TIMER
4U AN/ L COUNTERMEASURES
4V 43-014 VEGETABLE PEELING MACHINE - ELECTRIC
4W AN/ M METEOROLOGICAL
4X C33 CLOTHING STANDARD OUTFIT, AIR PURIFICATION AND LIFE PRESERVERS
4Y 57-011 CRANE-HEAVY EQUIPMENT
4Z 01-019 PUMP CENTRIFUGAL, POWER DRIVEN, PERIPHERAL DESIGN
40 61-075 CONTROL-STEERING AND DIVING ASSEMBLY
41 61-062 CONTROL-PNEUMATIC
42 61-066 CONTROL-TELE MOTOR STEERING
43 61-089 CONTROL-SPLIT PLANE
44 61-132 CONTROL-FEED WATER SYSTEM
45 61-251 CONTROL- PRESSURE,TEMP,LEVEL AND FLOW
46 83-040 CONTROL-CONTROLLABLE PITCH PROPELLER
47 15-002 CONTROLLER/STARTER, AC
48 AN/ N SOUND IN AIR
49 AN/ P RADAR
5A AN/ Q SONAR AND UNDERWATER SOUND
5B 80-002 BRAKE-ELECTRIC, MOTOR OPERATED
5C 43-015 COFFEE MAKER
5D 31-017 DOOR-HINGED TYPE, POWER OPERATED
5E AN/ R RADIO
5F FOUNDATION
5G 25-008 GYRO COMPASS EQUIPMENT-AMPLIFIER-SYNCHRO SIGNAL
5H AN/ S SPECIAL TYPES MAGNETIC, ETC., OR COMBINATIONS OF TYPES
5I NOT ASSIGNED
5J 22-002 SWITCHBOARD-INTERIOR COMMUNICATION
5K PLATFORM-SERVICE
5L STRUCTURE-DECKHOUSE
5M AN/ T TELEPHONE (WIPE)
5N 28-009 OPTICAL NAVIGATIONAL AIDS ALSO SEE SPECIFIC EQPMT
5O NOT ASSIGNED
5P 41-098 PRESS-HYDRAULIC, MANUAL OR POWER OPERATED
5Q 01-008 PUMP-ROTARY, POWER DRIVEN, INTERNAL GEAR DESIGN
5R B21 HYDRAULIC SYSTEM TOOLS AND REPAIR PARTS
5S 41-126 SOLDERING AND BRAZING OUTFIT, ELECTRIC
5T TRUNK-STRUCTURAL
5U AN/ V VISUAL AND VISIBLE LIGHT
5V 87-007 VENT, AIR - U/W LOG EQUIPMENT
5W AN/ W ARMAMENT (PECULIAR TO ARMAMENT, NOT OTHERWISE COVERED)
5X 01-021 PUMP-CENTRIFUGAL, TURBINE DRIVEN, GASLINE SERVICE
5Y 57-013 CRANE-GANTRY
5Z B62 PORTABLE STORAGE BATTERIES AND POWER DISTRIBUTION ACCESSORIES
50 AN/ X FACSIMILE OR TELEVISION
51 AN/ Y DATA PROCESSING

CDC LAPL

52 AUTOMOTIVE & CONSTRUCTION EQUIPMENT (INCL ALL COMMODITY CLASS 95)
53 MISC. PARTS LISTS FOR SHIPS (INCL ALL APLS STARTING WITH 89000)
54 MAINTENANCE & REPAIR SHIP EQUIPMENT (INCL ALL COMMODITY CLASS 12)
55 CHEMICAL WARFARE EQUIPMENT (INCL ALL COMMODITY CLASS 47)
56 SICK-BAY EQUIPMENT (INCL ALL COMMODITY CLASS 84)
57 01-020 PUMP-CENTRIFUGAL, POWER DRIVEN, HCRIZCNTAL, SPLIT CASE DESIGN
58 RIGGING & RIGGING GEAR (INCL ALL COMMODITY CLASS 90)
59 CONSTRUCTION EQUIPMENT (INCL ALL COMMODITY CLASS 96)
6A 99-015 ARRESTOR-ELECTRICAL
6B 01-028 PUMP-CENTRIFUGAL, TURBINE DRIVEN, HCRIZCNTAL, CLOSE-COUPLED
6C 54-023 COLLATOR
6D 31-008 DOOR-METAL SLIDING
6E SPECIAL POWER PLANT EQUIPMENT (INCL ALL COMMODITY CLASS 98)
6F NOT ASSIGNED
6G 25-010 GYRO COMPASS EQUIPMENT-ALARMS-AUDIBLE & VISIBLE
6H NOT ASSIGNED
6I NOT ASSIGNED
6J 22-004 SWITCHBOARD-PROPULSION
6K PYROTECHNIC EQUIPMENT
6L SEA CHESTS
6M E99 MISCELLANEOUS FLAG ALLOWANCES, FURNITURE AND MISC. EQUIPMENT
6N 87-012 OSCILLATOR AND AMPLIFIER-U/W LOG EQUIPMENT
6O NOT ASSIGNED
6P 41-100 PRESS-ARBOR, MANUAL OPERATION
6Q NOT ASSIGNED
6R NOT ASSIGNED
6S 61-046 SOLENOID-ELECTRIC
6T 43-026 TOASTER-ELECTRIC
6U NOT ASSIGNED
6V 31-020 VENTILATOR - DECK
6W NOT ASSIGNED
6X B16 ACCESS CLOSURES OPERATING SPARES
6Y 57-016 CRANE-KINGPOST
6Z NOT ASSIGNED
60 15-010 CONTROLLER, DC
61 NOT ASSIGNED
62 25-014 CONVERTER-SIGNAL DATA
63 01-022 PUMP-CENTRIFUGAL, POWER DRIVEN, FOR COMMERCIAL DISHWASHING MACHINE
64 01-023 PUMP-CENTRIFUGAL, POWER DRIVEN, SUBMARINE TRIM AND DRAIN SERVICE
65 59-006 CONVEYOR-POWER OPERATED, BELT OR VERTICAL TRAY TYPE
66 NOT ASSIGNED
67 03-001 COOLER-FLUID, SHELL/TUBE CONSTRUCTION
68 01-026 PUMPING UNIT-CENTRIFUGAL, ELECTRIC MOTOR DRIVEN, FOR STEAM SYSTEMS
69 03-002 COOLER-FLUID, TYPE B
7A APPENDAGES-SHELL
7B 80-003 BRAKE-PNEUMATIC
7C 41-009 COLLECTOR UNIT-DUST
7D 43-054 DOUGH INTERMEDIATE PROOFING MACHINES
7E NOT ASSIGNED
7F NOT ASSIGNED
7G 25-011 GYRO COMPASS EQUIPMENT-CABINET-GYRO & GUID COMP STOR
7H NOT ASSIGNED
7I NOT ASSIGNED
7J 22-009 SWITCHBOARD-ALARM
7K NOT ASSIGNED
7L STANCHIONS

CDC LAPL

7M 51-006 MOUNT-RESILIENT
7N 41-090 OVEN-THERMAL DRYING, ELECTRIC
7O NOT ASSIGNED
7P 44-008 PRESSURE REDUCING STATION
7Q NOT ASSIGNED
7R NOT ASSIGNED
7S 81-001 SOOT BLOWERS
7T TORPEDO TUBE ASSEMBLY
7U NOT ASSIGNED
7V 61-054 VERTICAL REFERENCE
7W NOT ASSIGNED
7X NOT ASSIGNED
7Y 41-039 CUT-OFF MACHINE-ABRASIVE DISK, METAL CUTTING
7Z 21-023 SWITCH-PRESSURE AND/OR THERMOSTATIC
70 03-003 COOLER-FLUID, ENGINE JACKET WATER HULL MOUNTED
71 03-004 COOLER, FLD SMPL WTR TYPE I SHL/CL DSN, TYP II DB TB
72 03-006 COOLER, AIR
73 03-011 COOLER-FLUID, RADIATOR ENGINE COOLANT
74 03-015 COOLER-AMINE
75 32-011 COOLER-AIR FLOW UNIT
76 32-010 COOLING COIL-AIR, DUCT TYPE AND GRAVITY TYPE
77 46-005 COUNTERS AND TOTALIZERS
78 NOT ASSIGNED
79 51-001 COUPLING-FLEXIBLE, SOUND ISOLATION
8A NOT ASSIGNED
8B 80-004 BRAKE-MANUAL
8C 28-012 COMPASS COMPENSATING EQUIPMENT
8D 43-018 DOUGH MIXING MACHINES
8E NOT ASSIGNED
8F NOT ASSIGNED
8G 25-021 GYRO COMPASS EQUIPMENT-RELAY TRANSMITTER
8H NOT ASSIGNED
8I NOT ASSIGNED
8J 22-013 SWITCHBOARD-POWER
8K NOT ASSIGNED
8L 878 AMMUNITION HANDLING AND STOWAGE
8M 86-014 MOUNT-FILM SLIDE, PHOTOGRAPHIC
8N 43-019 RANGES AND OVENS-OIL BURNING-SEE ALSO GALLEY EQPMT
8O NOT ASSIGNED
8P 29-003 PRIMER-ENGINE STARTING, ETHER INJECTION
8Q 01-002 PUMP-RECIPROCATING, DIRECT ACTING AND POWER DRIVEN
8R NOT ASSIGNED
8S 25-017 STABILIZER-GYRC
8T 67-009 TOILET-MARINE
8U NOT ASSIGNED
8V 26-004 VIEWER - STILL PICTURE
8W NOT ASSIGNED
8X NOT ASSIGNED
8Y 02-004 BOILER-AUXILIARY, HP STEAM, OIL FIRED
8Z 21-006 SWITCHES-GENERAL
80 01-032 PUMP UNIT-CENTRIFUGAL, POWER DRIVEN, PORTABLE (SELF-CONTAINED)
81 78-001 COUPLING-FLEXIBLE, SHAFT
82 01-034 PUMPING UNIT-HYDRAULIC, AIR DRIVEN
83 NOT ASSIGNED
84 01-035 PUMP-CENTRIFUGAL, PWR DRIVEN, (MULTI-STAGE) VERT DEEPWELL TURB DESIGN
85 01-036 PUMP-JET, MAIN PROPULSION

CDC LAPL

86 01-037 PUMP-RECIPROCATING, AIR DRIVEN, MISCELLANEOUS SERVICE
87 78-004 COUPLING-FLEX, SHFT, AUXILIARY SERVICE
88 02-002 BOILER-AUXILIARY, HP STEAM, WATER TUBE
89 02-003 BOILER-AUXILIARY, HP STEAM, HORIZONTAL FIRE TUBE
9A NOT ASSIGNED
9B 80-005 BRAKE-HYDRAULIC
9C COMPARTMENT
9D 43-032 DOUGH PROCESSING MACHINE-POWER AND MANUAL
9E NOT ASSIGNED
9F NOT ASSIGNED
9G 41-066 GRINDING MACHINE-TOOLS & CUTTERS
9H NOT ASSIGNED
9I NOT ASSIGNED
9J 22-021 SWITCHBOARD-STATIC GROUP CONTROL
9K NOT ASSIGNED
9L SMALL ARMS
9M 79-001 MUFFLER
9N GRATINGS, FLOOR PLATES
9O NOT ASSIGNED
9P 86-002 PRINTER-PHOTOGRAPHIC
9Q NOT ASSIGNED
9R NOT ASSIGNED
9S 31-029 STABILIZER-ACTIV FIN,RETRACTBLE & NCRRETRACTBLE
9T C25 TOWING GEAR
9U NOT ASSIGNED
9V 86-006 VIEWER PRINTER - MICROFILM
9W NOT ASSIGNED
9X NOT ASSIGNED
9Y 54-013 CUTTER-PAPER, GUILLOTINE
9Z NOT ASSIGNED
90 NOT ASSIGNED
91 R20 WINCHES AND CAPSTANS REPAIR PARTS
92 78-011 COUPLING-RIGID, SHAFT
93 78-009 COUPLING-HYDPAULIC
94 78-012 COUPLING-CLAMP PIPE
95 78-013 COUPLING-ELECTRIC INDUCTION
96 93-019 COUPLING-HOSP,MISC SEE ALSO UNWAY REPLEN ACC
97 57-001 CRANE-BRIDGE CR CVERHEAD TRAVELING
98 57-002 CRANE-QUARTER
99 57-003 CRANE-JIB