

AD-A009 482

A NASTRAN VIBRATION MODEL OF THE AH-1G
HELICOPTER AIRFRAME. VOLUME I

James D. Cronkhite, et al

Bell Helicopter Company

Prepared for:

Army Air Mobility Research and Development
Laboratory
Rock Island Arsenal

June 1974

DISTRIBUTED BY:

NTIS

National Technical Information Service
U. S. DEPARTMENT OF COMMERCE

UNCLASSIFIED

SECURITY CLASSIFICATION OF THIS PAGE (When Data Entered)

| REPORT DOCUMENTATION PAGE | | READ INSTRUCTIONS BEFORE COMPLETING FORM |
|---|-----------------------|---|
| 1. REPORT NUMBER R-TK-74-045 | 2. GOVT ACCESSION NO. | 3. RECIPIENT'S CATALOG NUMBER AD-A009 482 |
| 4. TITLE (and Subtitle) A NASTRAN VIBRATION MODEL OF THE AH-1G HELICOPTER AIRFRAME VOLUME I OF TWO VOLUMES | | 5. TYPE OF REPORT & PERIOD COVERED Final Report July 1973 - April 1974 |
| 7. AUTHOR(s) James D. Cronkhite Victor L. Berry John E. Brunken | | 6. PERFORMING ORG. REPORT NUMBER 209-099-432 |
| 9. PERFORMING ORGANIZATION NAME AND ADDRESS Bell Helicopter Company, Div. of Textron Inc. P.O. Box 482 Fort Worth, Texas 76101 | | 8. CONTRACT OR GRANT NUMBER(s) DAAF03-73-C-0122 |
| 11. CONTROLLING OFFICE NAME AND ADDRESS Research Directorate, GEN Thomas J. Rodman Lab. Rock Island Arsenal Rock Island, Illinois 61201 | | 10. PROGRAM ELEMENT, PROJECT, TASK AREA & WORK UNIT NUMBERS DA1F26201DH96 |
| 14. MONITORING AGENCY NAME & ADDRESS (if different from Controlling Office) Langley Directorate U.S. Army Air Mobility Research and Development Laboratory Hampton, Virginia 23665 | | 12. REPORT DATE June 1974 |
| | | 13. NUMBER OF PAGES 425 |
| | | 15. SECURITY CLASS. (of this report) UNCLASSIFIED |
| 16. DISTRIBUTION STATEMENT (of this Report) Approved for public release, distribution unlimited. | | 15a. DECLASSIFICATION DOWNGRADING SCHEDULE |
| 17. DISTRIBUTION STATEMENT (of the abstract entered in Block 20, if different from Report) | | |
| 18. SUPPLEMENTARY NOTES | | |
| 19. KEY WORDS (Continue on reverse side if necessary and identify by block number) | | |
| 1. Structure | 6. NASTRAN | |
| 2. Dynamic | 7. Computer | |
| 3. Vibration | 8. Airframe | |
| 4. Finite Element Model | 9. Helicopter | |
| 5. Mathematical Model | | |
| 20. ABSTRACT (Continue on reverse side if necessary and identify by block number) | | |
| <p>This report documents a NASTRAN finite element model of the AH-1G helicopter airframe. The model was developed for the purpose of representing the low frequency vibration response of the airframe and the structure deflections due to weapon firing. The NASTRAN input data deck for the model is included in the documentation as well as a Normal Modes run on Level 15.1 of the program.</p> <p style="text-align: center;">(over)</p> | | |

D D C
RECEIVED
MAY 9 1975
RECEIVED
D

PRICES SUBJECT TO CHANGE

DD FORM 1473
1 JAN 73

Reproduced by
NATIONAL TECHNICAL
INFORMATION SERVICE
U.S. Department of Commerce
Springfield, VA 22151

UNCLASSIFIED
SECURITY CLASSIFICATION OF THIS PAGE (When Data Entered)

| | |
|---------------------------------|---|
| ACCESSION for | |
| NTIS | White Section <input checked="" type="checkbox"/> |
| DOC | Buff Section <input type="checkbox"/> |
| UNANNOUNCED | <input type="checkbox"/> |
| JUSTIFICATION | |
| BY | |
| DISTRIBUTION/AVAILABILITY CODES | |
| Dist. | Avail. and or SPECIAL |
| A | |

DISCLAIMER

The findings in this report are not to be construed as an official Department of the Army position, unless so designated by other authorized documents.

DISPOSITION INSTRUCTIONS

Destroy this report when it is no longer needed.

UNCLASSIFIED

SECURITY CLASSIFICATION OF THIS PAGE(When Data Entered)

20.

The documentation is aimed at assuring that the government can independently use and modify the model to reflect actual or proposed changes in design. It is assumed that government personnel using this model and documentation have a good understanding of the NASTRAN computer program.

The documentation consists mainly of drawings and sketches of the idealized NASTRAN model with supporting instructions. In addition, the actual structure is identified and the idealization of the structure as a finite element model is explained. The NASTRAN input data deck serves as a major portion of the documentation.

11 UNCLASSIFIED

SECURITY CLASSIFICATION OF THIS PAGE(When Data Entered)

FOREWORD

This report, "A NASTRAN Vibration Model of the Bell AH-1G Helicopter Airframe," was prepared by Bell Helicopter Company, Fort Worth, Texas, for the U. S. Army Armament Command, Rock Island, Illinois, under contract DAAFO3-73-C-0122. Messrs. Carl E. Swindlehurst, Jr. (USAAMRDL-Langley) and Eugene C. Naumann (NASA-Langley) were the contracting officer's technical representatives.

The authors acknowledge the help of Bell Helicopter Company's Mr. David L. Kidd, Dynamics Group Engineer, for his contributions to the study.

TABLE OF CONTENTS

| | <u>Page</u> |
|---|-------------|
| DD FORM 1473 | i |
| FOREWORD | iii |
| VOLUME I | |
| LIST OF ILLUSTRATIONS | x |
| LIST OF TABLES | xi |
| 1. INTRODUCTION | 1-1 |
| 1.1 Background | 1-1 |
| 1.2 How to Use This Report | 1-1 |
| 2. PREFACE | 2-1 |
| 2.1 Description of the AH-1G Helicopter Airframe Structure. | 2-1 |
| 2.2 Idealization of the Airframe Structure | 2-11 |
| 2.3 Modeling Philosophy | 2-16 |
| 2.4 Introduction to the Stiffness Modeling | 2-19 |
| 2.4.1 Symbols and Notation Used in the Stiffness Modeling. | 2-19 |
| 2.4.2 Techniques Used Repetitively in the Stiffness Modeling. | 2-26 |
| 2.4.2.1 Types of Rod and Shear Panel Modeling Techniques | 2-26 |
| 2.4.2.2 Rules for Multi-Point Constraints (MPC) | 2-27 |
| 2.4.2.3 Rules for Single Point Constraints (SPC) | 2-27 |
| 2.4.2.4 Rules for Guyan Reduction (OMIT). | 2-27 |
| 3. STIFFNESS MODELING - FINAL ASSEMBLY. | 3-1 |
| 3.1 Fuselage Major Assembly | 3-2 |
| 3.1.1 Nose Subassembly | 3-3 |
| 3.1.1.1 Bulkhead Sta. 33. Detail | 3-4 |
| 3.1.1.2 Bulkhead Sta. 46. Detail | 3-5 |
| 3.1.1.3 Right Gunner's Floor, Frame, and Battery Shelf (Sta. 33-61) Detail | 3-7 |
| 3.1.1.4 Left Gunner's Floor, Frame, and Battery Shelf (Sta. 33-61) Detail | 3-10 |
| 3.1.1.5 Right Shell Assembly Detail | 3-13 |
| 3.1.1.6 Left Shell Assembly Detail. | 3-16 |
| 3.1.1.7 Right Lower Shell Assembly Detail | 3-19 |
| 3.1.1.8 Left Lower Shell Assembly Detail. | 3-21 |

| | <u>Page</u> |
|---|-------------|
| 3.1.2 Forward Fuselage Subassembly | 3-23 |
| 3.1.2.1 Right Main Beam (Sta. 61-93) Detail | 3-24 |
| 3.1.2.2 Left Main Beam (Sta. 61-93) Detail | 3-29 |
| 3.1.2.3 Right Main Beam (Sta. 93-138) Detail | 3-34 |
| 3.1.2.4 Left Main Beam (Sta. 93-138) Detail | 3-37 |
| 3.1.2.5 Right Main Beam (Sta. 138-148) Detail | 3-40 |
| 3.1.2.6 Left Main Beam (Sta. 138-148) Detail | 3-44 |
| 3.1.2.7 Bulkhead Sta. 61.25 Detail | 3-48 |
| 3.1.2.8 Bulkhead Sta. 93. Detail | 3-51 |
| 3.1.2.9 Bulkhead Sta. 138.7 Detail | 3-55 |
| 3.1.2.10 Right Side Panels Under Canopy (Sta. 61-93) Detail | 3-59 |
| 3.1.2.11 Left Side Panels Under Canopy (Sta. 61-93) Detail | 3-61 |
| 3.1.2.12 Right Side Panels Under Canopy (Sta. 93-138) Detail | 3-63 |
| 3.1.2.13 Left Side Panels Under Canopy (Sta. 93-138) Detail | 3-65 |
| 3.1.2.14 Right Side Panels Under Canopy (Sta. 138-148) Detail | 3-67 |
| 3.1.2.15 Left Side Panels Under Canopy (Sta. 138-148) Detail | 3-69 |
| 3.1.2.16 Ammo Floor (Sta. 93-138, W.L. 27) Detail | 3-71 |
| 3.1.2.17 Ammo Cover (Sta. 93-138, W.L. 46) Detail | 3-73 |
| 3.1.2.18 Gunner's Floor (Sta. 61-93, W.L. 46) Detail | 3-77 |
| 3.1.2.19 Turret and Support Fittings Detail | 3-83 |
| 3.1.2.20 Extension of Ammo Cover (Sta. 138-148, W.L. 35.97) Detail | 3-85 |
| 3.1.2.21 Pilot's Floor (Sta. 93-148, W.L. 55) Detail | 3-86 |
| 3.1.2.22 Right and Left Upper Gunner's Shelves (Sta. 61-93) Detail | 3-90 |
| 3.1.2.23 Right and Left Upper Pilot's Shelves (Sta. 93-148) Detail | 3-93 |
| 3.1.2.24 Right Lower Skins Under Ammo Floor (Sta. 93-148) Detail | 3-96 |
| 3.1.2.25 Left Lower Skins Under Ammo Floor (Sta. 93-148) Detail | 3-99 |
| 3.1.3 Center Fuselage Subassembly | 3-102 |
| 3.1.3.1 Right Main Beam (Sta. 148-186) Detail | 3-103 |
| 3.1.3.2 Left Main Beam (Sta. 148-186) Detail | 3-108 |
| 3.1.3.3 Right Main Beam (Sta. 186-213) Detail | 3-112 |
| 3.1.3.4 Left Main Beam (Sta. 186-213) Detail | 3-116 |
| 3.1.3.5 Bulkhead Sta. 148.5 Detail | 3-120 |
| 3.1.3.6 Partial Belly Bulkhead Sta. 156.41 Detail | 3-125 |
| 3.1.3.7 Bulkhead Sta. 186.25 Detail | 3-127 |

| | <u>Page</u> |
|---|-------------|
| 3.1.3.8 Right Side Panels Under Canopy (Sta. 148-186) Detail | 3-133 |
| 3.1.3.9 Left Side Panels Under Canopy (Sta. 148-186) Detail | 3-136 |
| 3.1.3.10 Forward Fuel Cell Floor (Sta. 148-186, W.L. 35.97) Detail | 3-139 |
| 3.1.3.11 Forward Fuel Cell Cover (Sta. 148-186, W.L. 77.57) Detail | 3-144 |
| 3.1.3.12 Lower Floor Under Pylon (Sta. 186-213, W.L. 35.97) Detail | 3-149 |
| 3.1.3.13 Right and Left Upper Shelves (Sta. 148-186) Detail | 3-153 |
| 3.1.3.14 Right Belly Skins (Sta. 156-218) Detail | 3-155 |
| 3.1.3.15 Left Belly Skins (Sta. 156-218) Detail | 3-158 |
| 3.1.4 Aft Fuselage Subassembly | 3-161 |
| 3.1.4.1 Right Main Beam (Sta. 213-250) Detail | 3-162 |
| 3.1.4.2 Left Main Beam (Sta. 213-250) Detail | 3-165 |
| 3.1.4.3 Right Main Beam (Sta. 250-299) Detail | 3-168 |
| 3.1.4.4 Left Main Beam (Sta. 250-299) Detail | 3-172 |
| 3.1.4.5 Bulkhead Sta. 213.94 Detail | 3-176 |
| 3.1.4.6 Partial Belly Bulkhead Sta. 218.97 Detail | 3-179 |
| 3.1.4.7 Partial Belly Bulkhead Sta. 227.62 Detail | 3-180 |
| 3.1.4.8 Bulkhead Sta. 250. Detail | 3-181 |
| 3.1.4.9 Bulkhead Sta. 268.25 Detail | 3-184 |
| 3.1.4.10 Tailboom Junction Bulkhead Sta. 299. Detail | 3-187 |
| 3.1.4.11 Aft Fuel Cell Floor (Sta. 213-250, W.L. 35.97) Detail | 3-189 |
| 3.1.4.12 Floor Panel (Sta. 250-268, W.O. 35.97) Detail | 3-196 |
| 3.1.4.13 Floor Panel (Sta. 268-299, W.L. 35.97) Detail | 3-198 |
| 3.1.4.14 Engine Deck (Sta. 213-250) Detail | 3-200 |
| 3.1.4.15 Engine Deck (Sta. 250-299) Detail | 3-203 |
| 3.1.4.16 Right Belly Skins (Sta. 227-299) Detail | 3-207 |
| 3.1.4.17 Left Belly Skins (Sta. 227-299) Detail | 3-210 |
| 3.1.5 Main Rotor Pylon Subassembly | 3-213 |
| 3.1.5.1 Main Rotor Mast, Transmission, Mounts, Lift Link - Detail | 3-214 |
| 3.1.5.2 Main Rotor Pylon Support Structure - Detail | 3-218 |
| 3.1.6 Landing Gear Subassembly | 3-221 |

| | <u>Page</u> |
|---|-------------|
| 3.1.6.1 Landing Gear and Mounts - Detail | 3-222 |
| 3.1.6.2 Landing Gear Attach Point Support Structure - Detail | 3-225 |
| 3.1.7 Engine Mounting Subassembly | 3-228 |
| 3.1.7.1 Engine Mounts - Detail. | 3-229 |
| 3.2 Wing and Carry Through - Major Assembly. | 3-231 |
| 3.2.1 Carry Through Subassembly | 3-232 |
| 3.2.1.1 Forward Carry Through Detail. | 3-233 |
| 3.2.1.2 Center Carry Through Detail | 3-239 |
| 3.2.1.3 Aft Carry Through Detail | 3-243 |
| 3.2.2 Right and Left Wing Subassemblies | 3-245 |
| 3.2.2.1 Right Wing Ribs - Detail | 3-246 |
| 3.2.2.2 Left Wing Ribs - Detail | 3-250 |
| 3.2.2.3 Right Wing Spars - Detail. | 3-254 |
| 3.2.2.4 Left Wing Spars - Detail | 3-260 |
| 3.2.2.5 Right Wing Skins - Detail. | 3-266 |
| 3.2.2.6 Left Wing Skins - Detail | 3-269 |
| 3.2.2.7 Right Wing Lugs - Detail | 3-272 |
| 3.2.2.8 Left Wing Lugs - Detail | 3-275 |
| 3.3 Tailboom and Vertical Fin Major Assembly | 3-278 |
| 3.3.1 Tailboom Subassembly and Detail | 3-279 |
| 3.3.1.1 Tailboom Section Properties and Stiffness Distribution | 3-281 |
| 3.3.1.2 Tailboom Bending Stiffness Distributions for Maneuver Conditions | 3-288 |
| 3.3.2 Vertical Fin Subassembly and Detail. | 3-292 |
| 3.3.2.1 Vertical Fin Stiffness Distribution | 3-294 |
| 3.3.3 Elevator Subassembly and Detail | 3-296 |
| 3.3.4 Tail Rotor Mast Subassembly and Detail. | 3-298 |
| 4. WEIGHTS MODELING | 4-1 |
| 4.1 Automatic Weight Distribution Program (SDSNO2) | 4-1 |
| 4.1.1 Weight Regions and NASTRAN Weights Data (CONM2). | 4-2 |

| | <u>Page</u> |
|--|-------------|
| 4.2 Distribution of Large Weights and Useful Loads | 4-2 |
| 4.2.1 Lycoming T53-L13 Engine | 4-2 |
| 4.2.2 XM-28 Gun Turret | 4-3 |
| 4.2.3 Main Rotor and Tail Rotor | 4-3 |
| 4.2.4 Useful Weight Items | 4-4 |
| 5. NASTRAN STRUCTURAL ELEMENT AND GRID POINT INDEX. | 5-1 |
| 6. LITERATURE CITED | 6-1 |
| 7. DISTRIBUTION | 7-1 |
| VOLUME II | |
| 8. NASTRAN DATA | 8-1 |
| 8.1 Input Data Deck. | 8-1 |
| 8.1.1 Organization of the Unsorted Bulk Data Deck | 8-1 |
| 8.1.2 Listing of the Unsorted Bulk Data Deck. | 8-9 |
| 8.2 Normal Modes Output - Rigid Format 3. | 8-146 |
| 8.2.1 NASTRAN Output. | 8-146 |
| 8.2.2 Normal Mode Plots. | 8-620 |

LIST OF ILLUSTRATIONS

| <u>Figure</u> | | <u>Page</u> |
|---------------|---|-------------|
| 1-1 | Bell Model AH-1G Helicopter | 1-2 |
| 2-1 | AH-1G Helicopter - Basic Structural Lines. | 2-2 |
| 2-2 | Bending Sections of the Fuselage Structure | 2-3 |
| 2-3 | Gun Turret Attachment Fittings | 2-5 |
| 2-4 | Main Rotor Pylon Mounts and Lift Link | 2-6 |
| 2-5 | Engine Mounts | 2-7 |
| 2-6 | Skid Landing Gear. | 2-8 |
| 2-7 | Wing and Carry Through Structure. | 2-9 |
| 2-8 | Tailboom and Vertical Fin Structure. | 2-10 |
| 2-9 | Elevator Structure | 2-12 |
| 2-10 | NASTRAN Model of the AH-1G Helicopter Airframe | 2-13 |
| 2-11 | Exploded View Showing Major Areas of the NASTRAN Model | 2-15 |
| 3-1 | SFCR02 Input Geometry for a Typical Tailboom Structure | 3-290 |
| 4-1 | Automatic Weight Distribution Program: SDSN02. | 4-6 |
| 4-2 | Distribution of Useful Weight Items with Artificial Trusses | 4-35 |
| 8-1 | NASTRAN Normal Mode Plots | 8-621 |

LIST OF TABLES

| <u>Table</u> | | <u>Page</u> |
|--------------|---|-------------|
| 2-1 | Element Symbols Used in the Detail Drawings | 2-20 |
| 2-2 | ID Numbering Conventions Used in the Modeling | 2-21 |
| 3-1 | Tailboom Bending Stiffness for Maneuver Conditions | 3-291 |
| 4-1 | Fuselage Section - Regions and CONM2 Data | 4-7 |
| 4-2 | Tailboom and Wings - Regions and CONM2 Data | 4-25 |
| 4-3 | Main Rotor Pylon - Regions and CONM2 Data | 4-31 |
| 4-4 | Basic Mission Useful Weight Items | 4-33 |
| 4-5 | Rod Element Data for Distribution of Useful Weight Items | 4-36 |
| 4-6 | Grid Point Constraint Data for Distribution of Useful Weight Items | 4-37 |
| 8-1 | ID Numbering Conventions Used in the Modeling | 8-4 |

1. INTRODUCTION

1.1 BACKGROUND

The two principal goals of the work reported herein are

- 1) to produce a NASTRAN model of the AH-1G helicopter, Figure 1-1, which will enable the government to determine time dependent deformations of the airframe structure produced by on-board weapon systems, as well as rotor induced vibrations, and
- 2) to provide documentation which is clear and altogether comprehensible, showing in what manner and upon what judgements the actual helicopter is idealized as a NASTRAN finite element model.

Both of these goals satisfy needs stemming from experiences in which results of modern analysis and computation fell short of realizable desires or targets owing to poor analysis management. There has been little aversion to applying scientific management to large hardware programs. But there has been an aversion to applying it to the development and use of large, complex analyses, the NASTRAN development being a notable exception. As a result, many analyses serve only mediocrity for a short time in the locale where they are developed, rather than serving well over a long period and a wide geographical area.

History has shown that a major weapon system which does a good job and can grow stays in the DOD inventory for a long time; 20 years is common. During this period, the system is the object of study and experiment many times. At different times and places many groups are involved representing the prime contractor, subcontractors, and the government. Sometimes the common data being coordinated is as simple as the latest drawing. Increasingly, however, the common data should be a sophisticated computer program, for instance, a NASTRAN model for computing the stress, sighting error, and comfort degradation produced by a larger caliber machine gun on the AH-1G. This procedure can coordinate widely separated teams and "system optimization" becomes a meaningful word and exercise.

Such a program must be rational, visible, teachable, changeable, useable, and accurate; and it must be developed, disseminated, and maintained efficiently. We are well into the period in which such modeling is possible; however, it is not yet commonplace. The study of this report takes two major steps toward this goal.

1.2 HOW TO USE THIS REPORT

The input data deck for the AH-1G airframe model is systematically arranged to be easily used by someone familiar with NASTRAN. The unsorted Bulk Data listing is included in Section 8. of this report and is preceded by an outline describing the organization of the deck. Together, the outline and input data listing should enable someone familiar with NASTRAN to use the model or modify it with a minimum need for reference to the body of this report.

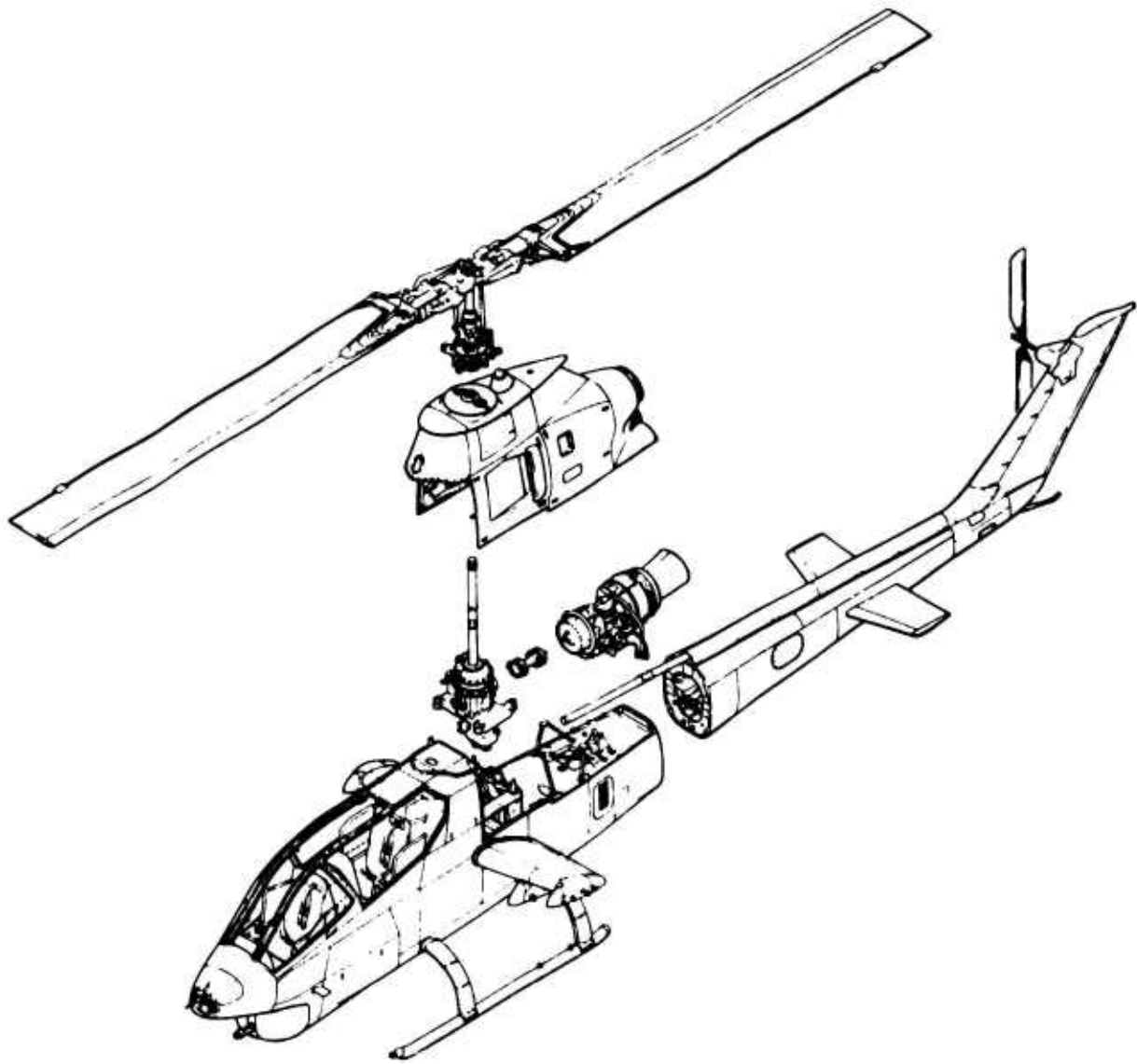

Exploded View

Figure 1-1. Bell Model AH-1G Helicopter

Supplementary computer programs used in developing input data for the NASTRAN model are (1) the weight distribution program, described in Reference 1, and (2) BANDIT, a grid point resequencing program described in Reference 2.

The organization of the report is outlined below.

- (1) The Preface serves as an introduction to the detailed documentation of the stiffness model and includes the following:
 - (a) identification of the actual AH-1G airframe structure used in the modeling,
 - (b) a general discussion of the idealization of parts of the airframe structure into a finite element model,
 - (c) a discussion of modeling philosophy and techniques and assumptions used in the modeling, and
 - (d) a listing of symbols and modeling techniques used in the detailed description of the stiffness model.
- (2) Stiffness Modeling - The stiffness model is described in detail by drawings and sketches organized in a manner similar to the design drawings for the helicopter, however depicting the finite element model instead of the actual structure. The Table of Contents serves as an index to the drawings describing the stiffness model. The drawings are organized as follows:
 - (a) FINAL ASSEMBLY - includes a NASTRAN plot of the complete airframe model showing the major assemblies of the model: Fuselage, Wings and Carry Through, and Tailboom and Vertical Fin.
 - (b) MAJOR ASSEMBLY - includes a NASTRAN plot of the major assembly with subassemblies identified; also included is an illustration of the actual structure represented by the major assembly.
 - (c) SUBASSEMBLY - includes a NASTRAN plot showing the location of the subassembly in the actual structure and is used for reference in locating the detail drawings.
 - (d) DETAIL - refers to a subassembly drawing and includes a symbolized sketch of structural elements and grid points in the model followed by tabular listings of the element properties, grid points and constraints.
- (3) Weights Modeling
 - (a) The weight distribution program used to generate CONM2 cards for the NASTRAN model is described and the data created by the program is listed.

- (b) The separate distribution of large weight items to the grid points of the model is described.
- (4) A Structural Element and Grid Point Index serves as a cross reference for locating where an element or grid point in the NASTRAN data deck is described in the Stiffness Modeling section of the report.
- (5) The Unsorted Input Data Listing for the NASTRAN model and a normal modes run on Rigid Format 3 (see Section 3.1 of the User's Manual, Reference 3) are included in Section 8. Also included are deformed plots of the computed elastic modes below 30 Hertz.

2. PREFACE

In the following sections the actual structure is described, the idealization of the structure is discussed in general, and assumptions and modeling philosophy used in the idealization are presented. Modeling techniques used repetitively are listed and are referenced later in the stiffness modeling section.

2.1 DESCRIPTION OF THE AH-1G HELICOPTER AIRFRAME STRUCTURE

The actual structure for the latest production configuration of the AH-1G helicopter (identified as FY71 AH-1G ship number 21123) is described in this section. The descriptions are intended to be brief with a liberal use of figures to identify the basic structure used in the analysis. The reader can find more detailed descriptions in References 4 through 6. For reference, a basic lines drawing of the AH-1G helicopter is shown in Figure 2-1.

The areas of the airframe structure in the order they are discussed are

- (1) the fuselage,
- (2) the wings and carry through, and
- (3) the tailboom and vertical fin.

2.1.1 Fuselage

The fuselage structure with panels removed is illustrated in Figure 2-2. The section cuts between bulkheads show the basic structure used in the stiffness modeling. Structure assumed not effective in the stiffness of the fuselage follows:

- (1) the canopy
- (2) cowling around the engine and main rotor pylon
- (3) access panels at contour (FS 61.25 to 213.94)
- (4) doors on the ammo bay (FS 93. to 138.7)
- (5) top access door on the nose (FS 33 to 46)
- (6) drive shaft connection of the engine to the main transmission

These assumptions are based on experience with the AH-1G structure and on results from the testing and analysis of the AH-1J helicopter (similar to the AH-1G) described in Reference 7.

The structure is built around the main beams running the length of the fuselage (FS 61 to 300). The beams are made up of vertical webs and upper and lower caps. The left-hand main beam is shown by the shaded area in Figure 2-2. The main beams give the primary vertical bending stiffness in the fuselage structure and differential bending of the main beams provides torsional stiffness in the open sections of the forward fuselage (FS 61 to 138).

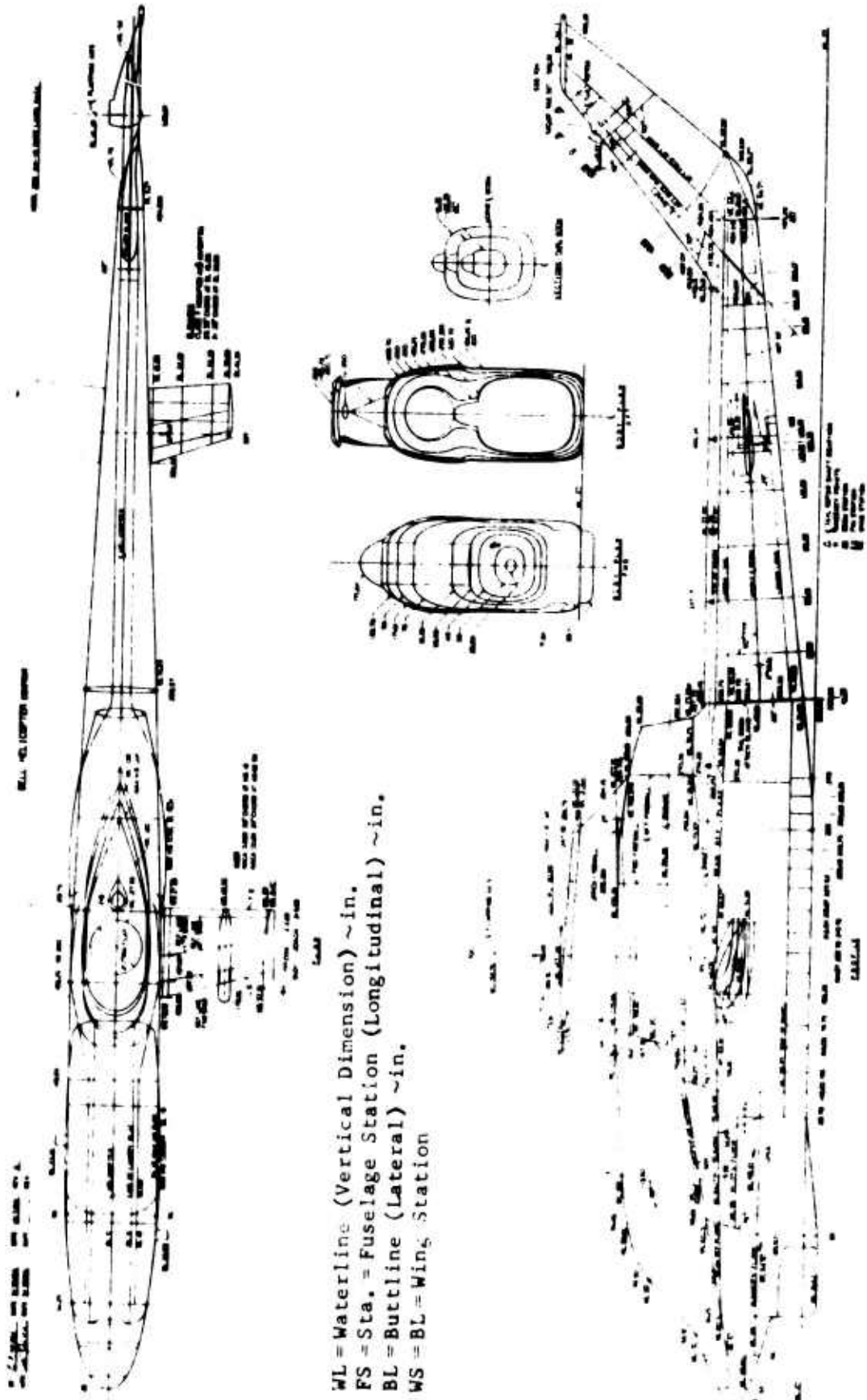

Figure 2-1. AH-1G Helicopter - Basic Lines

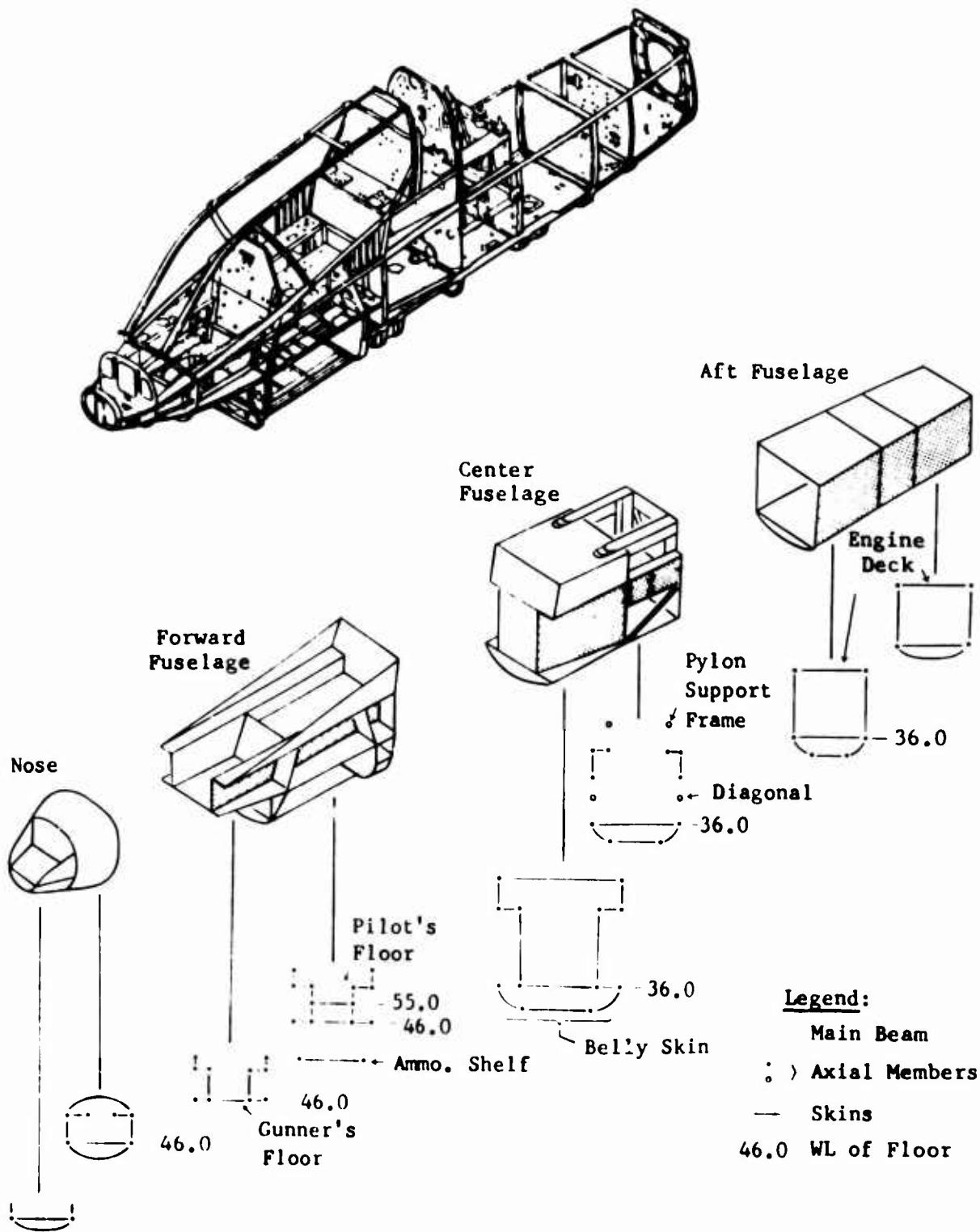

Figure 2-2. Bending Sections of the Fuselage Structure

The main beams are tied together by the lower horizontal floors (FS 46 to 138, WL 46; FS 93 to 138, WL 55; FS 138 to 300, WL 35.97), the forward fuel cell cover (FS 152 to 186, WL 77.), and the engine deck (FS 213 to 300, WL 65) to give the fuselage lateral stiffness. The torsion sections are closed in the forward fuel cell area (FS 148.5 to 186) and the aft fuselage (FS 213 to 300) but open on top of the main beams in the main rotor pylon and wing area (FS 186 to 213).

The ammo shelf (FS 93 to 138, WL 27) does not significantly affect the vertical or lateral bending stiffness of the fuselage structure but does influence the torsional stiffness because of the shear tie at the FS 93 bulkhead.

The XM-28 gun turret shown in Figure 2-3 is mounted under the gunner's floor (FS 61.25 to 93.). Four fittings distribute the recoil loads into the main beams.

The main rotor pylon located at FS 200 above WL 65 provides the structural tie between the main rotor and the fuselage. It is attached to the fuselage through five elastomeric mounts and a lift link. The mounting arrangement is shown in Figure 2-4. This lift link is the primary vertical load path and is pinned to the center wing carry through beam or "lift beam." The elastomeric mounts are designed to produce low pylon rocking frequencies to isolate the main rotor in-plane vibratory loads from the fuselage and to react the main rotor torque.

The engine mounting on the WL 65 deck of the fuselage (FS 228. to 268.) is shown in Figure 2-5. The mounting is statically determinant with a single strut at the forward left-hand mounting pad, a tripod at the aft left-hand mounting pad and a bipod at the right-hand aft mounting pad.

The landing gear connected to the fuselage at FS 152. and 223. is shown in Figure 2-6. It consists of two energy absorbing cross tubes and skids. The skid gear is attached to the fuselage with pinned connections on the cross tubes at BL ± 13.5 .

2.1.2 Wing and Carry Through

The wings on the AH-1G are designed primarily as stores supports, not as aerodynamic lifting surfaces. The wings and carry through structure are shown in Figure 2-7. The stores attachment points are at BL 42.5 and 60.

The wing is a two-cell box structure having aluminum skins, three spars and three ribs. The carry through consists of three beams that are attached to the three wing spars by pinned connections at the fuselage contour. The forward carry through beam is attached to the FS 186.25 bulkhead. The center carry through beam or "lift beam" is attached at the fuselage contour and is pin connected in the center to the lift link. The aft spar carry through is attached to the FS 213.94 bulkhead.

2.1.3 Tailboom and Vertical Fin

The tailboom and vertical fin structure are shown in Figure 2-8. The tailboom is bolted to the fuselage at four attachment fittings located at the four main longerons of the tailboom and the four main beam caps of the fuselage.

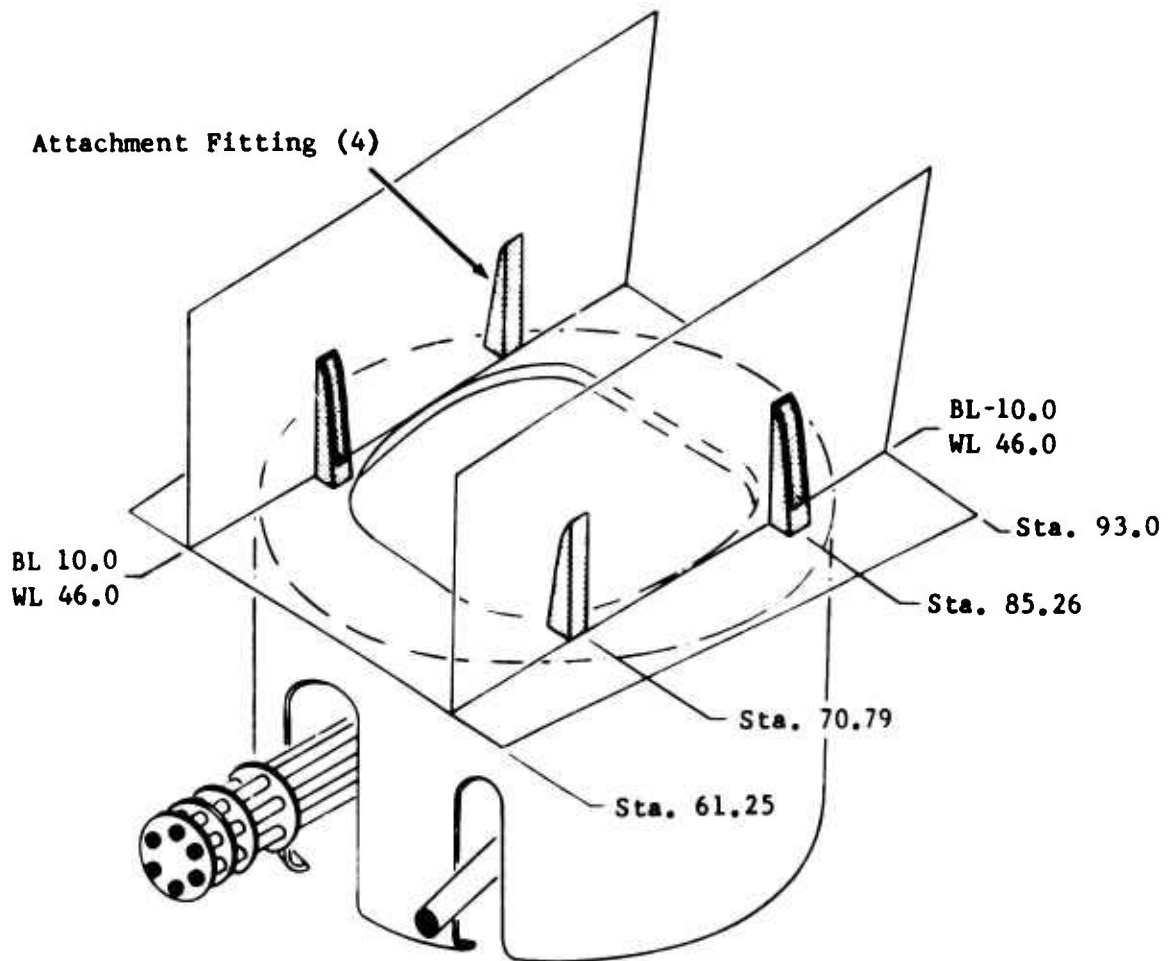

XM-28 Dual Gun Turret System

Figure 2-3. Gun Turret Attachment Fittings

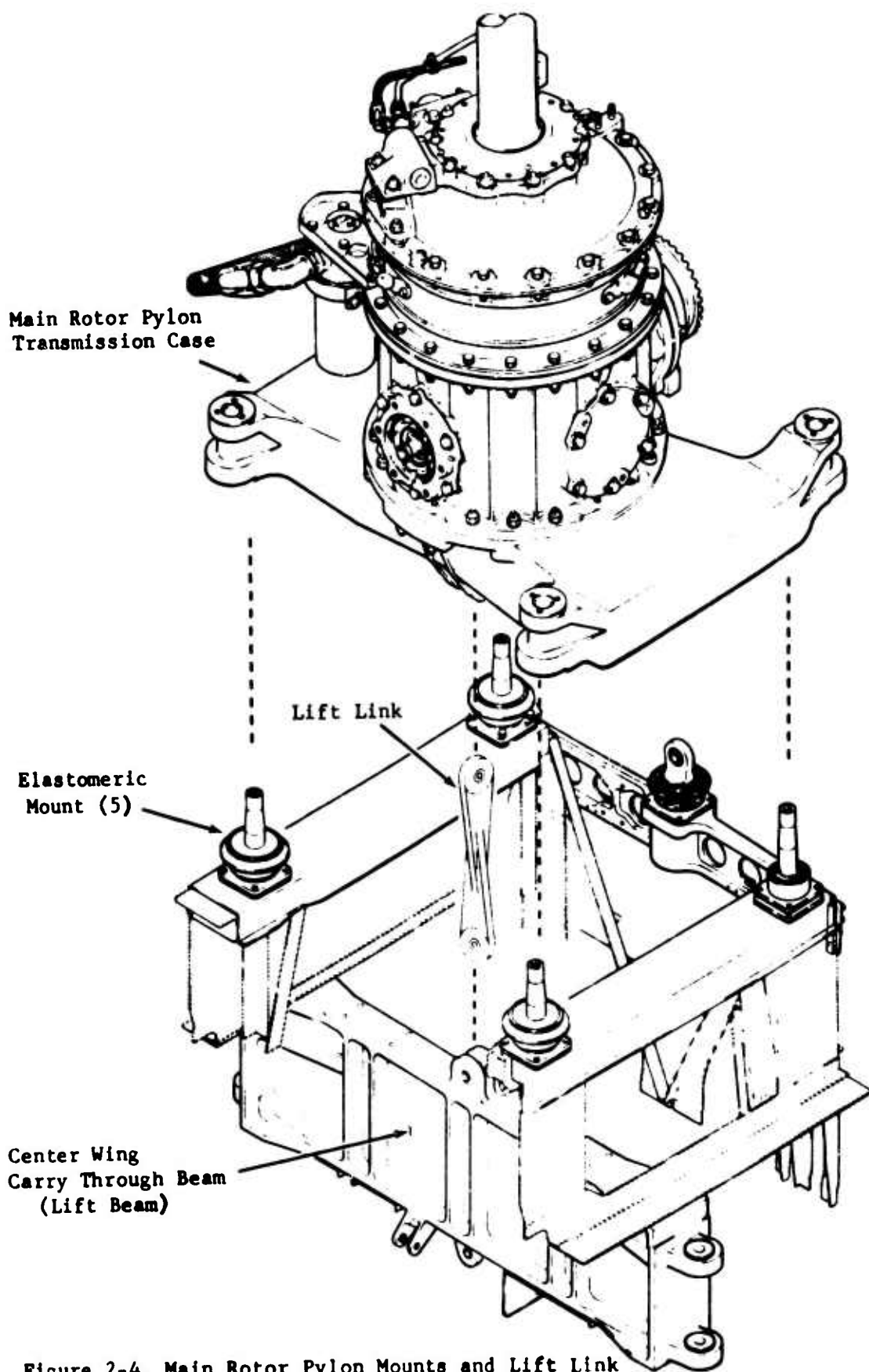

Figure 2-4. Main Rotor Pylon Mounts and Lift Link

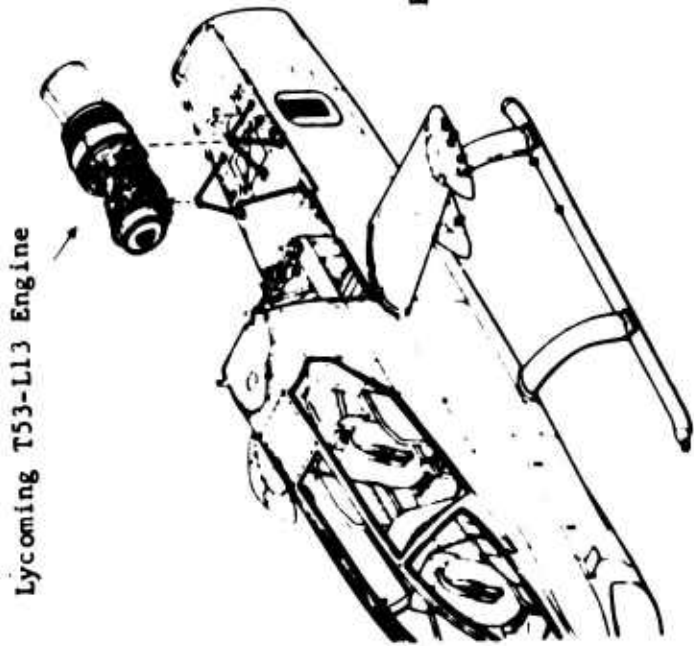
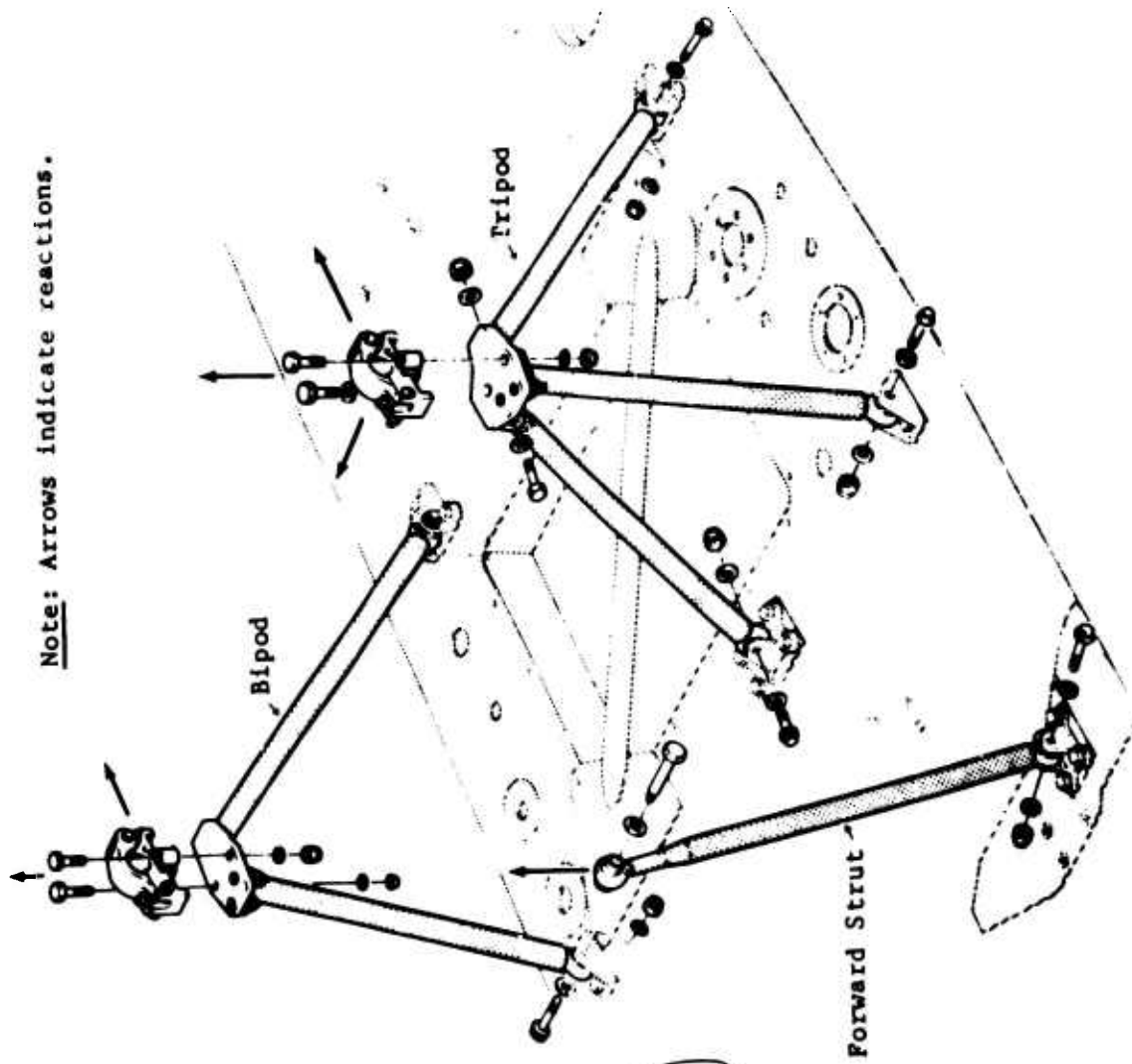

Figure 2-5. Engine Mounts

Note: Arrows indicate attachment points to the fuselage.

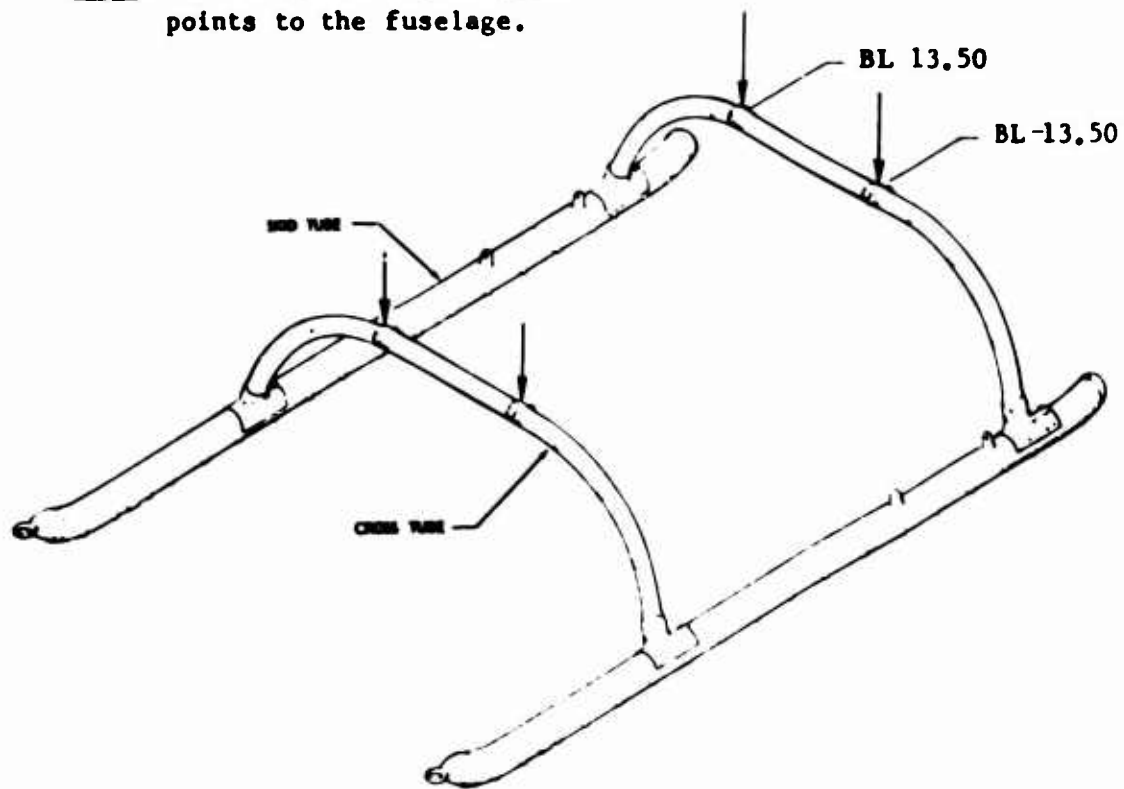

Figure 2-6. Skid Landing Gear

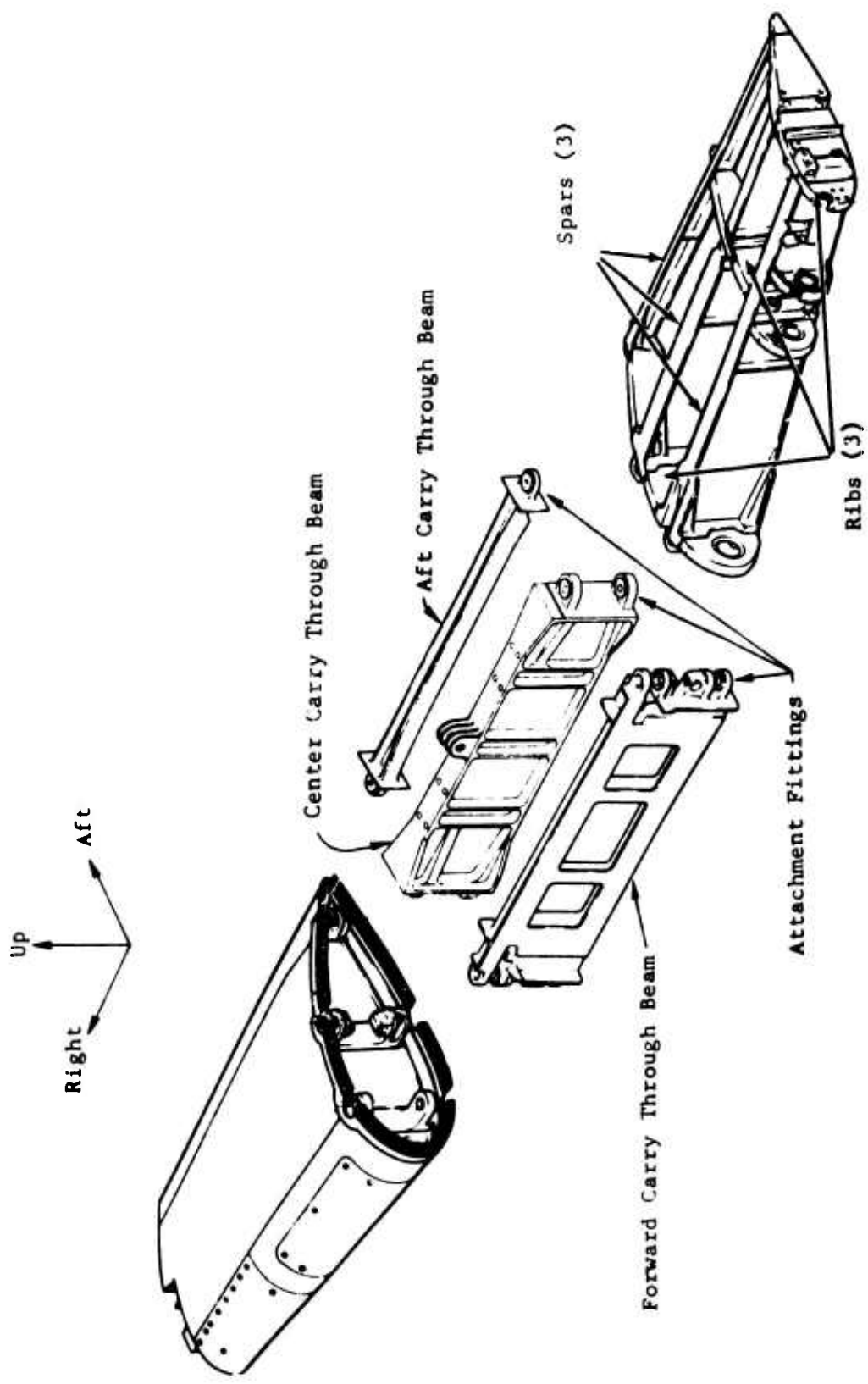

Figure 2-7. Wing and Carry Through Structure

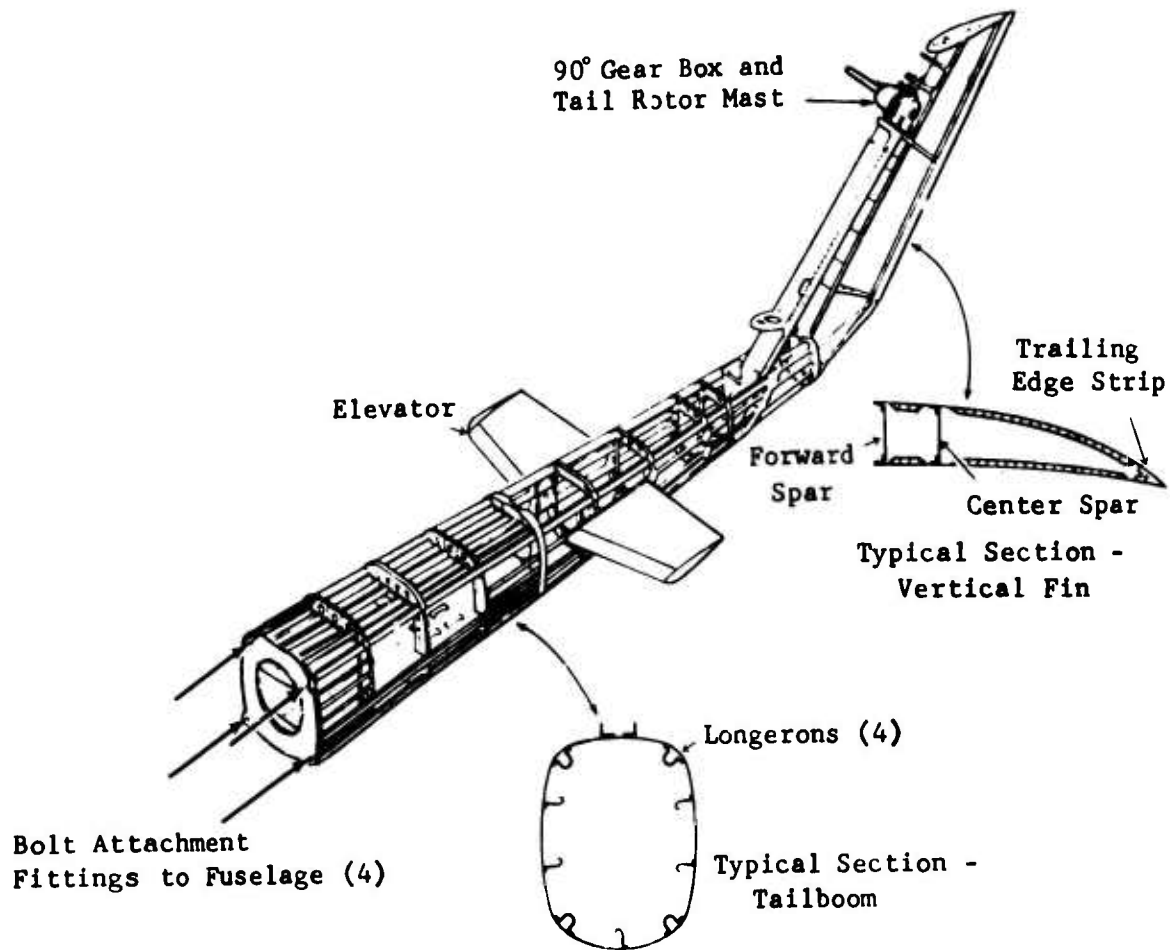

Figure 2-8. Tailboom and Vertical Fin

The tailboom is of semimonocoque construction having aluminum skins, stringers and longerons. The longerons and stringers are supported by bulkhead frames spaced down the length of the boom. A typical cross section of the tailboom is shown in Figure 2-8. The hinged tail rotor drive shaft cover on top of the boom is assumed nonstructural.

The vertical fin has a two cell cambered airfoil section with two spars and a trailing edge strip. The hinged tail rotor drive shaft cover on the front of the fin is assumed nonstructural as well as the top portion of the fin which extends above the 90 degree gearbox. A typical fin cross section is shown in Figure 2-8. The 90 degree gearbox and the tail rotor mast shown in Figure 2-8 provide the connection between the tail rotor and the top of the vertical fin structure. The tail rotor mast is supported on bearings inside the gearbox and the gearbox is bolted to the top of the fin.

The movable elevator is connected to the tailboom by pitch bearings at BS 140.35. The elevator and carry through are shown in Figure 2-9. The elevator and carry through structure consists of a single tubular spar. Four ribs covered by a sheet skin making up each elevator surface are connected to the spar.

2.2 IDEALIZATION OF THE AIRFRAME STRUCTURE

This section contains a basic description of the idealization of the airframe structure into a finite element model. The details of the idealization are presented in the stiffness modeling section.

The emphasis in the idealization is on developing a model adequately representing the low frequency vibration modes of the airframe with the fewest degrees of freedom possible. Representation of the fuselage and wing structures in the areas of the XM-28 gun turret and the wing stores is given special attention. The gun turret and stores themselves are represented as rigid masses, as are the main and tail rotors, the engine, and useful weight items such as the crew, fuel and ammunition.

The complete model, shown in Figure 2-10, consists of structural elements from the NASTRAN library (see section 1.3 of the User's Manual) such as scalar springs, rods, bars, shear panels, triangular and quadrilateral membranes. There was no use of General Elements, substructuring, or DMAPing in the model. Symmetry could not be used because of unsymmetrical sections in the fuselage and the tail rotor offset to the right side. The table below shows the degrees of freedom before and after constraints and partitioning were applied (see section 1.4 of the User's Manual).

| Stiffness Matrix | Degrees of Freedom | Description |
|------------------|--------------------|-----------------------------------|
| K_{gg} | 2940 | Unreduced size |
| K_{nn} | 2699 | After applying MPC equations |
| K_{ff} | 1714 | After applying SPC's |
| K_{aa} | 241 | After partitioning with OMIT's |
| K_{ll} | 235 | After applying free body SUPPORTs |

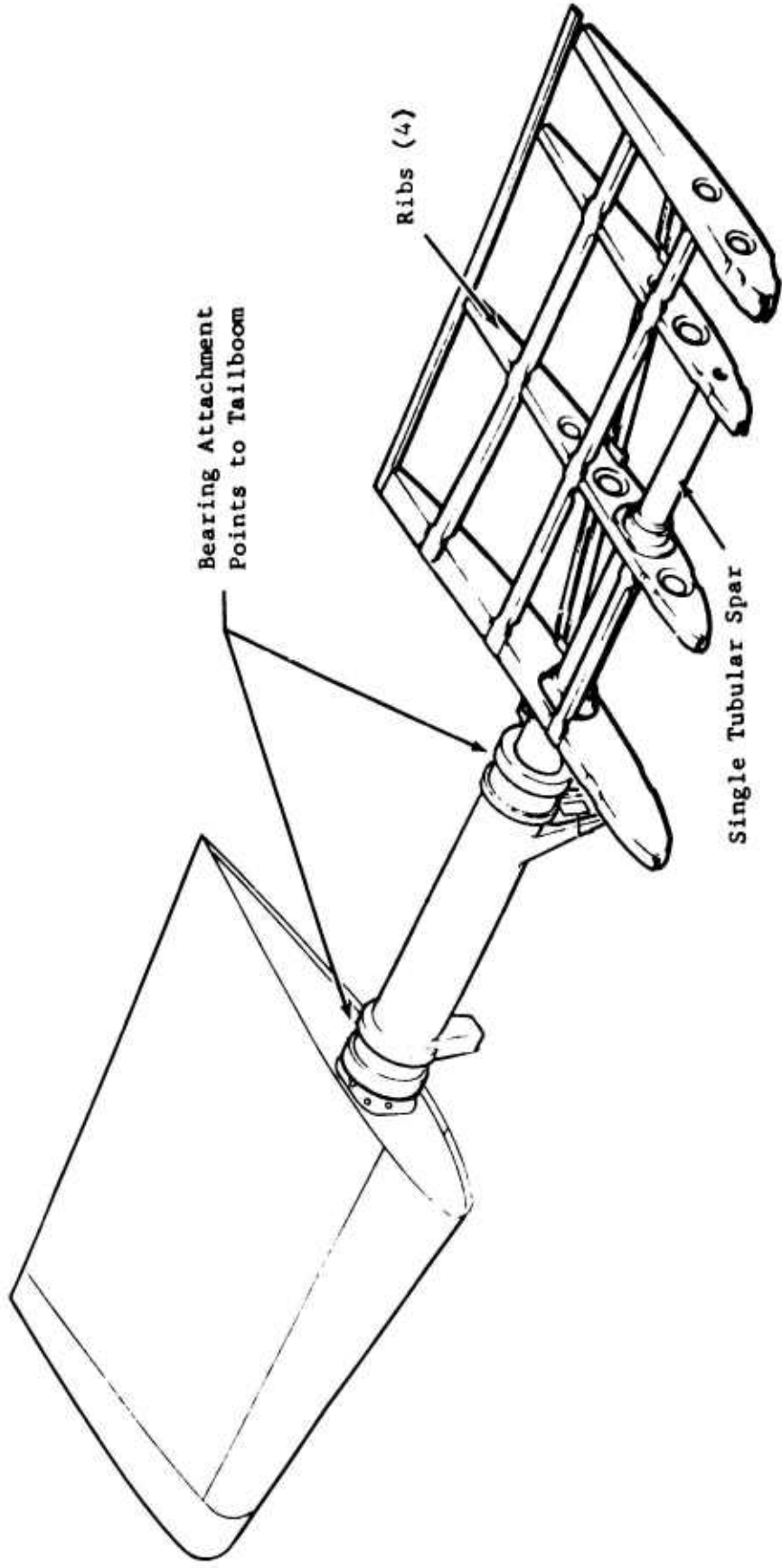
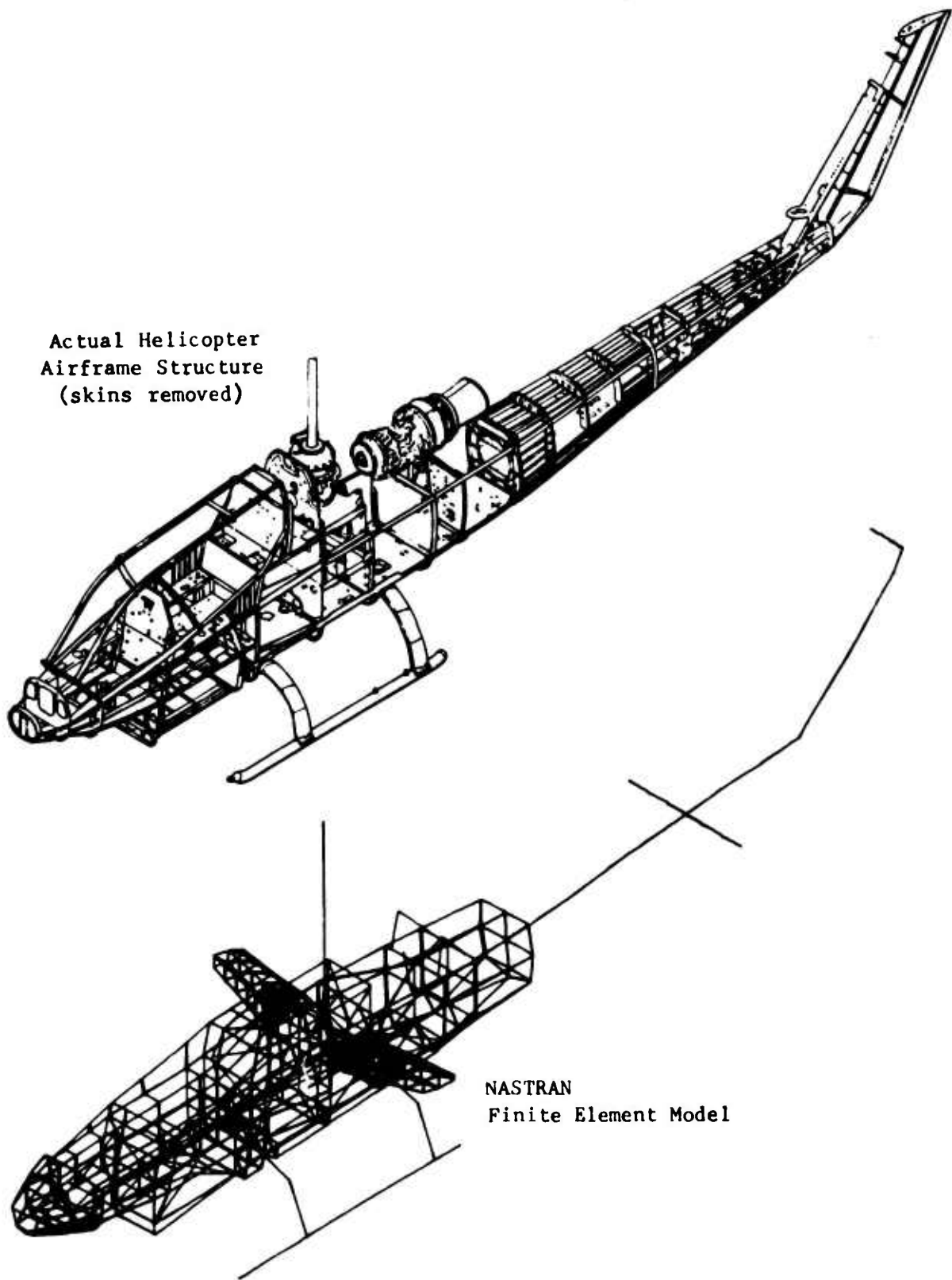

Figure 2-9. Elevator Structure



Actual Helicopter
Airframe Structure
(skins removed)

NASTRAN
Finite Element Model

Figure 2-10. NASTRAN Model of the AH-1G Helicopter Airframe

Idealization of major portions of the airframe structure shown in Figure 2-11 are described below.

- The fuselage is a built-up idealization using primarily rods and shear panels in the bending sections. Instead of using an elastic line or 'beam' representation, build-up modeling is used because of the complex structure in the forward and center fuselage areas. The forward fuselage has open sections making it difficult to calculate the elastic axis and torsional stiffness properties important in determining the structural response to lateral gunfiring. In the center fuselage, where the wing carry through, pylon support and fuselage structures intersect, built-up modeling is required to represent the complex redundant structure. The primary fuselage bending structure is modeled with rods and shear panels. The belly structure is also modeled with rods and shear panels except where triangular membranes are required due to geometry. The nose structure skins are modeled with membranes, and bulkheads are modeled with membranes surrounded by rods. MPC equations representing rigid elements are used to tie the landing gear, tailboom and gun turret mass to the fuselage. Bar elements are used only for the pylon support structure.
- The wings and carry through are built-up idealizations because of the complex interface between these structures involving pinned connections at the fuselage contour. The wing spar caps, carry through beam caps and attachment lugs are modeled with bars and the spar and beam webs with shear panels and rods. The wing skins are represented by quadrilateral membranes which preserve the beamwise (vertical) bending and torsional stiffness but are somewhat too stiff in chordwise (fore-and-aft) bending. The pinned connections at the attachment lugs are modeled with MPC equations.
- The tailboom and vertical fin are modeled as elastic lines using bar elements with calculated bending and torsional stiffness properties. The elastic axis is assumed to be on the geometric center of the tailboom and along the center spar of the vertical fin (refer to Figure 2-8 for typical sections). In the stiffness calculations, all skins are assumed effective. The change in bending section properties for the tailboom under severe maneuver conditions is also calculated and shown in the Stiffness Modeling section. By using an elastic line model, the bending stiffness changes for maneuver conditions can easily be incorporated by changing only the nine bar property cards representing the tailboom. The effective skin for the vertical fin having sandwich panels will not change for maneuver conditions.
- The elevator is modeled with bars and is pin connected to the tailboom at the bearing locations. Stiff bars are used to tie the tailboom elastic line to the bearing supports.
- The tail rotor mast is modeled with bars and pinned at the bearing supports in the 90 degree gearbox. Stiff bars are used to tie the fin elastic line to the bearing supports.

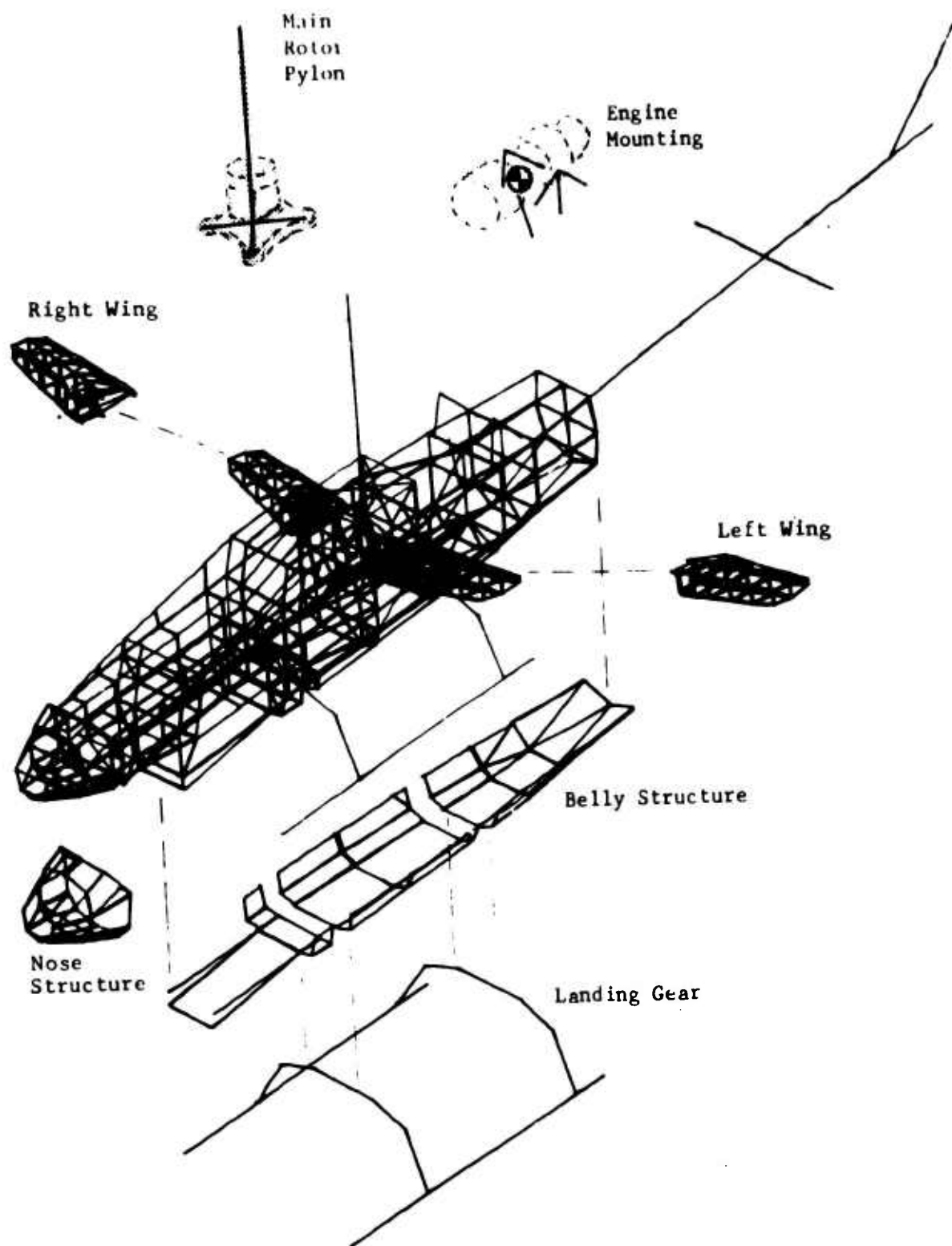

Figure 2-11. Exploded View Showing Major Areas of the NASTRAN Model

- The main rotor pylon is modeled as an elastic line using bar elements. The mast is pinned to the transmission case at mast bearing locations. The elastomeric pylon mounts are modeled with scalar spring elements, and MPC equations are used to tie the transmission elastic line to the mount locations. The lift link is represented with a bar, pinned and rigidly offset from grid points on the transmission and lift beam.
- The engine mounting is modeled with rods and MPC equations. The elastic mounts are represented by rods and tied to the rigid engine c.g. with MPC equations. The bottom attachments of the mounts are related to motions of the plane of the engine deck by MPC equations.
- The landing gear is modeled with bar elements representing the cross tubes and skid tubes. The cross tubes are tied to the fuselage with MPC equations.

The weights modeling is discussed under Modeling Philosophy and the actual mass data (CONM2 cards) and modeling techniques are described in the Weights Modeling Section.

2.3 MODELING PHILOSOPHY

The objectives in the modeling are to preserve the low frequency (below 35 Hertz) vibration modes of the AH-1G airframe and to predict structure deflections when firing the XM-28 gun turret and wing stores.

To meet these objectives it is important that the stiffness of the structure be accurately modeled. This means that much of the stress analysis documentation on the AH-1G cannot be used. A stress model can be conservative without representing the structure stiffness accurately but a dynamic model cannot be. The structure documented in stress analysis reports often does not include such things as

- (1) effective stiffness areas of axial members (usually minimum areas are used),
- (2) doublers,
- (3) angles or flanges tied to primary structure caps or axial members used for attaching nonstructural fairings, cowlings, covers, etc., and
- (4) secondary structure such as: equipment shelves, external structure used to distribute airloads to primary structure, removable panels, etc.

The sections effective in the stiffness of the fuselage structure could be derived only by referring directly to the design drawings rather than using stress reports. The tailboom sections, however, are taken directly from an AH-1G stress report, Reference 5, with all skins effective in the stiffness calculations.

It is difficult to explain all the judgments made in the stiffness idealization of the structure because the basis for each of the judgments often depends on the artistic skill of the modeler and what has been found to work from past experience; an example would be determining how fine the model must be so that an adequate representation is achieved without causing excessive loss of numerical accuracy due to unnecessary computations. However, some guidelines and techniques generally used in the modeling and requiring some explanation are discussed below.

- In the built-up modeling of the fuselage, grid points are located at the intersection of panels. This is done since the axial members (rods) are generally easier to relocate to the grid point than shear panels or membranes.
- In bending sections, such as the main beams, relocating rods with centroids offset from the grid point is done by calculating an effective area that preserves the area moment of inertia of the beam about its neutral axis.
- In sections of the fuselage where the offset of the rod centroid affects both lateral and vertical bending stiffness, the effective rod area is calculated to preserve the vertical bending stiffness. The vertical stiffness which directly affects the vertical vibration of the crew as well as the vertical and pitch vibration of the wing stores is considered more critical than the lateral. Also, preserving the torsional stiffness (primarily differential vertical bending of the main beams) in the open sections of the forward fuselage is important for the structural response to lateral firing of the XM-28 gun turret.
- When modeling bulkheads, where preserving the bending stiffness in the plane of the bulkhead is not significant in the overall airframe bending stiffness, axial members around the periphery were relocated to the grid points with no change in area.
- For caps or axial members with varying cross sectional areas between grid points, average areas were used as the effective rod areas.
- When modeling panels with rods and shear panels, effective rod areas are calculated to preserve either the inplane bending inertia or the total cross sectional area of the panel, or both. The methods used for calculating the rod areas are described under Stiffness Modeling Techniques Used Repetitively.
- When modeling panels where it is important to represent the inplane bending stiffness adequately, shear panels surrounded by rods are used instead of quadrilateral membranes. The shear panel elements in NASTRAN contribute no significant inplane bending stiffness and react only shears. The inplane bending stiffness of the panel is represented by the surrounding rods. The quadrilateral membrane element, on the other hand, is considerably too stiff for inplane bending unless many elements are used. For example, at least three elements are used across the width of a beam or spar web and, as a general rule, the aspect ratio of the element is kept less than 2.0. Triangular membranes are used where geometry prohibits the use of quadrilateral elements.

- The inner skins of joggled sandwich panels are added to the outer skin without considering the offset. The skin in the joggled portion is assumed not effective.

In determining the undamped free vibration modes of the helicopter airframe structure, the weight distribution must be modeled properly as well as the stiffness distribution. The distribution of the hundreds of weight items in the helicopter to the grid points of the finite element model can be a very tedious operation; therefore, the distribution of most of the weight items is done automatically by an in-house computer program (Reference 1). Large weight items that significantly affect the low frequency vibration modes of the airframe are distributed separately by the modeler. These large weight items include the gun turret, main and tail rotors, main transmission, engine, and useful weights such as the crew, fuel, ammunition and stores. A more detailed discussion of the distribution of weights is included in the Weights Modeling section.

After idealizing the structure into a stiffness model and distributing the weights to grid points, constraints are applied to the unreduced NASTRAN model to reduce the number of degrees of freedom to an acceptable analysis size for the Givens eigenvalue solution. Constraints and partitioning techniques (reference Section 1.4 of the User's Manual) applied to the model are summarized below.

- (1) SPC's are applied, removing degrees of freedom having no stiffness.
- (2) MPC equations representing rigid elements, pin connections, etc. remove the dependent degrees of freedom of the equations from the model.
- (3) Guyan Reduction (described in section 3.5.4 of the Theoretical Manual, Reference 8) performed via OMIT cards condenses out degrees of freedom with zero inertia properties or whose inertia properties can be rationally redistributed to others.

After reducing the degrees of freedom sufficiently, the Givens or Tridiagonal method of eigenvalue extraction (explained in the Theoretical Manual, Section 10.2) is used to compute the natural vibration modes and frequencies of the airframe. The Givens method which extracts all the eigenvalues of the analysis set requires a reduction to below 250 degrees of freedom for efficient run times on the IBM 360/65 computer at BHC.

The Inverse Power eigenvalue extraction method (discussed in the Theoretical Manual, Section 10.4) does not require the Guyan Reduction procedure; however, it operates on an analysis size six to ten times larger than Givens and extracts only one mode at a time. The time spent in Guyan Reduction, which is performed only once in an analysis, becomes comparatively small when several modes are required; the AH-1G airframe model has more than 40 modes below 50 Hertz.

A problem, however, lies in the reduction of the large system to the smaller without significant loss in accuracy of the dynamic characteristics of the model. Guidelines for using the Guyan Reduction technique in the modeling are listed under Stiffness Modeling Techniques Used Repetitively.

2.4 INTRODUCTION TO THE STIFFNESS MODELING

2.4.1 Symbols and Notation Used in the Stiffness Modeling

Use of the detailed documentation included in the Stiffness Modeling section has already been described briefly in Section 1.2; however, an explanation of the special symbols and notations used is required for easy reference and use of the detail drawings.

The detail drawings and corresponding data tables provide information about each structural element in the model and constraints at each grid point. The drawings show grid points and structural elements for a local area of the model. The symbols used on the drawing for different types of elements are shown in Table 2-1. The elements are marked with letters referring to one or more specific elements in the following element data tables. In addition to the element data tables, grid point tables provide information about constraints or reduction of specific degrees of freedom. Conventions used for numbering grid point and element ID's are defined in Table 2-2.

The following data tables are used in conjunction with the detail drawings.

- (1) Rod Element tables include the CONROD element identification number (ID), a type, the actual cross sectional area, offsets of the area centroid from the grid point, and the final area used in the model. The types of Rod Elements are the following:
 - (a) Cap - axial load carrying member in a beam or spar
 - (b) RSP1, RSP2, RSP3 - rod used with a shear panel (explained in Section 2.4.2)
 - (c) Doubler
 - (d) Frame - used primarily around bulkheads
 - (e) Fitting - used for the gun turret attachment fittings
- (2) The Shear Panel and Membrane Element tables include CSHEAR, CTRMEM, and CQDMEM element ID's, type, and thickness. The types used are the following.
 - (a) Inner skin
 - (b) Outer skin
 - (c) Interior skin (or doubler)
 - (d) Bulkhead
 - (e) Web
 - (f) Skinfor sandwich panels
- (3) The Bar Element tables include the CBAR element ID, cross sectional area, area moments of inertia, and torsional stiffness constant. References to notes following the tables are used to indicate bar offsets or pin flags.
- (4) The Scalar Spring Element tables include the CELAS2 element ID, the direction of the element, and spring rate.

TABLE 2-1. ELEMENT SYMBOLS USED IN THE DETAIL DRAWINGS





| Symbol | Description |
|---|---|
|  | Grid Point (GRID) |
|  | Rod Element (CONROD) |
|  | Bar Element (CBAR) |
|  | Shear Panel Element (CSHEAR) |
|  | Membrane Plate Element (CQDMEM) (CTRMEM) |
|  | Scalar Spring Element (CELAS2) |
|  | Rigid Element (MPC) |

TABLE 2-2. ID NUMBERING CONVENTIONS USED IN THE MODELING

I. GRID POINTS

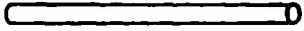
A. Fuselage, tailboom, vertical fin, elevator

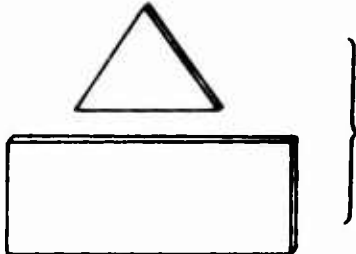

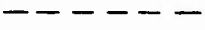
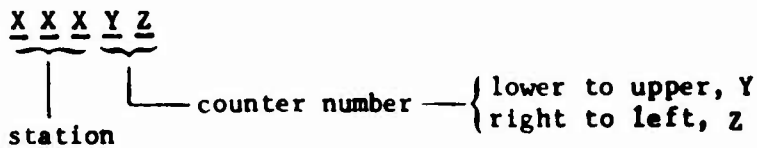
B. Wings

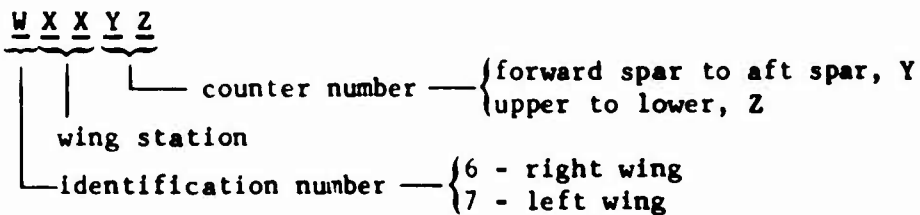

C. Main rotor mast/transmission

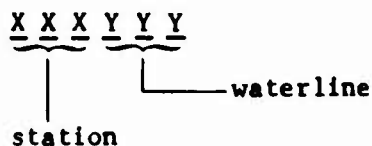

D. Main rotor transmission case support

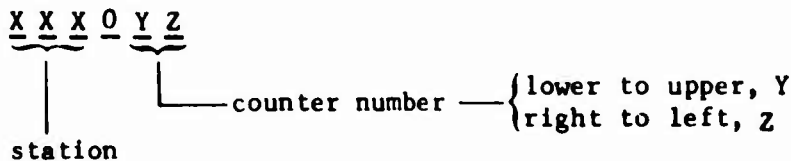

E. Tail rotor mast/gearbox

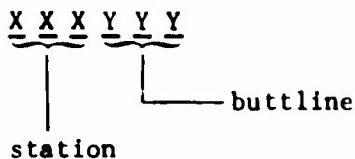

F. Skid landing gear

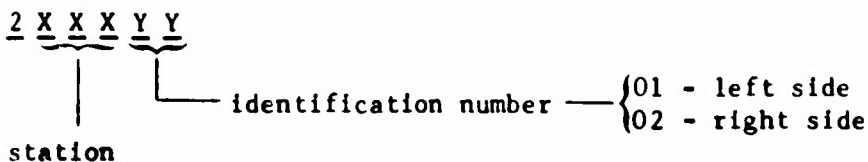

G. Engine mounts

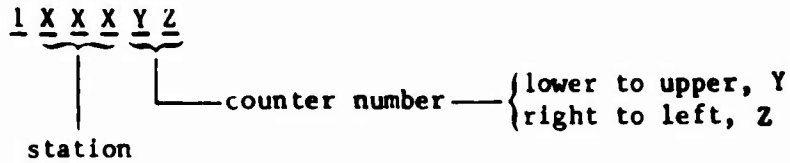

H. Engine

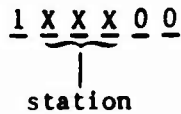

I. Useful load cg's

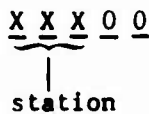

II. STRUCTURAL ELEMENTS

A. Fuselage

1. Doublers, caps, skins, useful load trusses, main rotor mast/transmission, skid landing gear, engine mounts

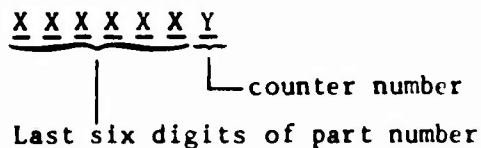

2. Rods for shear panels

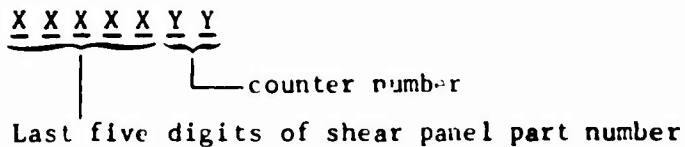

3. Bulkheads

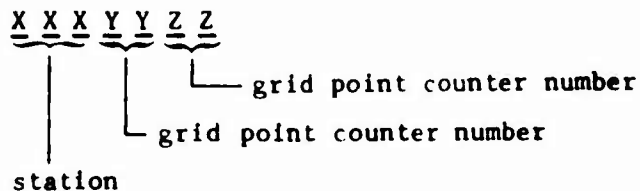

Examples:



4. Wing lugs

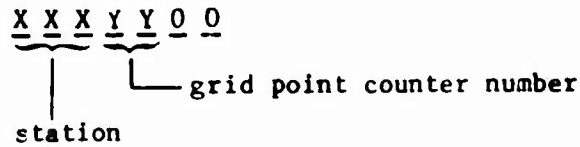

5. Main rotor pylon mount springs

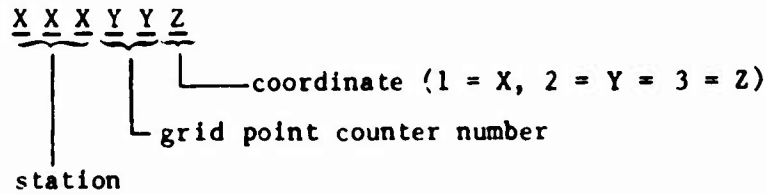

B. Empennage

1. Tailboom/vertical fin

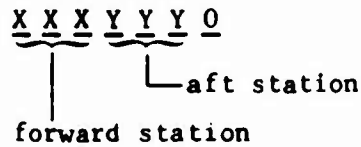

2. Elevator - see II.A.3.

3. Tail rotor mast/gearbox - see II.A.1.

C. Wings

1. Spars caps

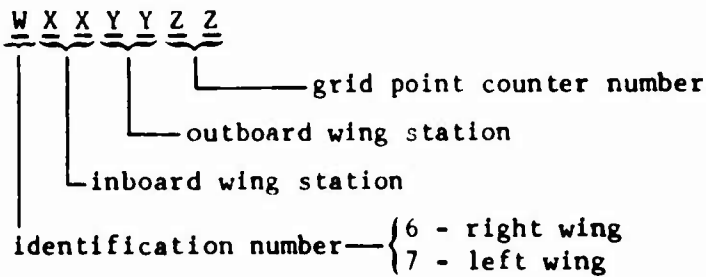

2. Spars webs

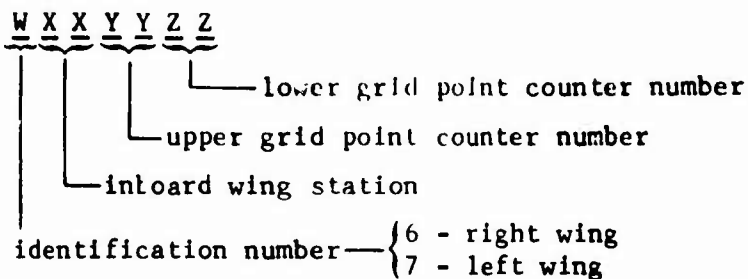

3. Skins

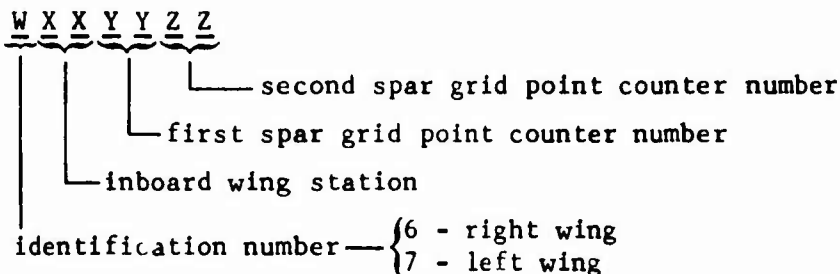

4. Ribs

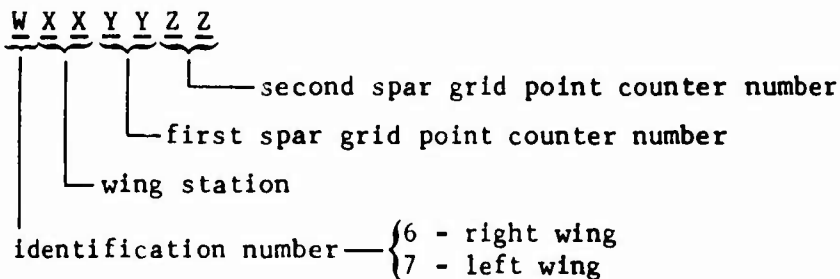

5. Lugs

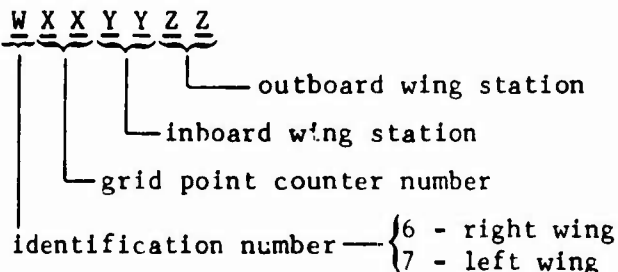

III. MISCELLANEOUS

A. Shear panel/membrane properties

1. Primary

X X X Y Y Y

material identification number
skin thickness in thousandths of an inch

2. Secondary

X X X X X

skin thickness in hundred-thousandths of an inch

B. Bar properties

X X X X X X X

bar element identification number

C. Materials

1. Primary

X X X X

alloy number

2. Secondary

X X

counter number

D. Coordinate systems for SPC's

X X X X X

grid point at which SPC's applied

- (5) The Grid Point tables include information about SPC's, MPC's and OMIT's for the degrees of freedom at the grid points shown on the detail drawing. Rules listed in Section 2.4.2 are referred to in these tables.

Notes are located on the detail drawing or after the data tables to explain modeling techniques that are not clear or need special explanation beyond that given in the tables.

2.4.2 Techniques Used Repetitively in the Stiffness Modeling

2.4.2.1 Types of Rod and Shear Panel Modeling Techniques

Shear panels surrounded by rods are used extensively in the modeling. Since the shear panels can only react shear loads in the plane of the panel, rods are required to react inplane bending and axial loads. Three types of modeling are used to calculate the rod areas surrounding the shear panel:

- (1) RSP1 - is used when a beam web is represented with three rods and two shear panels. The rod areas are calculated to preserve the area, cg and moment of inertia of the web as follows:

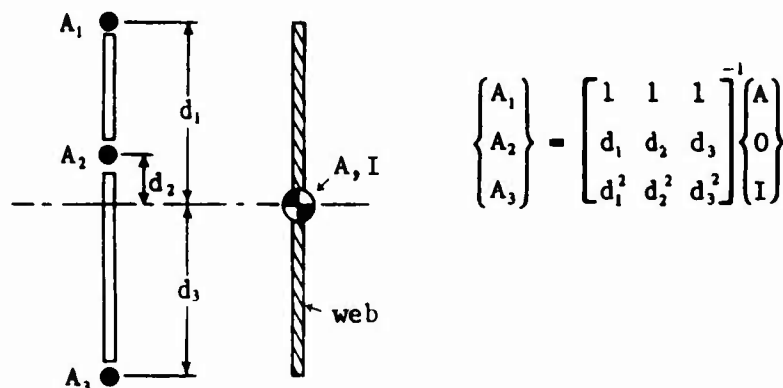

- (2) RSP2 - The shear panel cross sectional area is lumped at the rods to preserve the axial stiffness of the panel.
- (3) RSP3 - The inplane bending moment of inertia of the shear panel or $1/12th^3$ is preserved by giving the rods an area of $1/6th$.

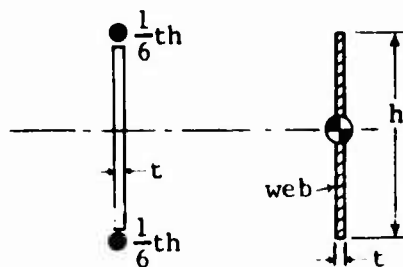

Note that two different types of modeling are often used on one panel.

2.4.2.2 Rules for Multi-Point Constraints (MPC)

Two common rules for using multi-point constraint equations in the modeling are

- A , representation of rigid bar or rod elements, and
- B , representation of pin connections between parts of the structure.

The rule refers to the dependent coordinate in the MPC equation.

2.4.2.3 Rules for Single Point Constraints (SPC)

The rules for using single point constraints in the modeling are

- A , elimination of degrees of freedom with zero stiffness, and
- B , representation of boundary conditions.

Rule B is not used in the modeling of the free helicopter airframe modes. In order to use rule A for eliminating degrees of freedom that are not aligned with the basic coordinate system a coordinate system is defined in the direction of the constraint.

When applying rule A it is important that the structure is not actually constrained by the SPC. As a check on this, the SPC reactions are printed out in the Normal Modes NASTRAN run and checked to ensure that they are negligible.

2.4.2.4 Rules for Guyan Reduction (OMIT)

The Guyan Reduction technique, described in Section 3.5.4 of the Theoretical Manual, is used to condense the degrees of freedom down to a practical size for the Givens eigenvalue solution. As explained in Section 2.3, degrees of freedom are omitted that have negligible inertia properties or whose inertia properties can be rationally redistributed to others. The rules used for omitting degrees of freedom are

- A , the inertia properties are negligible,
- B , for a relatively uniform mass distribution uniform omitting is used which preserves the distribution,
- C , for structure such as panels where relative inplane deflections are insignificant many of the inplane degrees of freedom are omitted, and
- D , knowledge of the mode shapes of importance and the relative stiffness in certain areas of the structure.

Use of rule D depends on knowledge of the relative stiffness and significant mode shapes of the structure. Degrees of freedom in low response areas of a particular mode will not develop inertia loads as large as high response areas and can be omitted without a significant effect on that mode. Degrees of freedom may also be omitted in high stiffness areas where relative deflections are small and inertia loads redistributed to degrees of freedom not omitted will still give accurate results.

3. STIFFNESS MODELING - FINAL ASSEMBLY

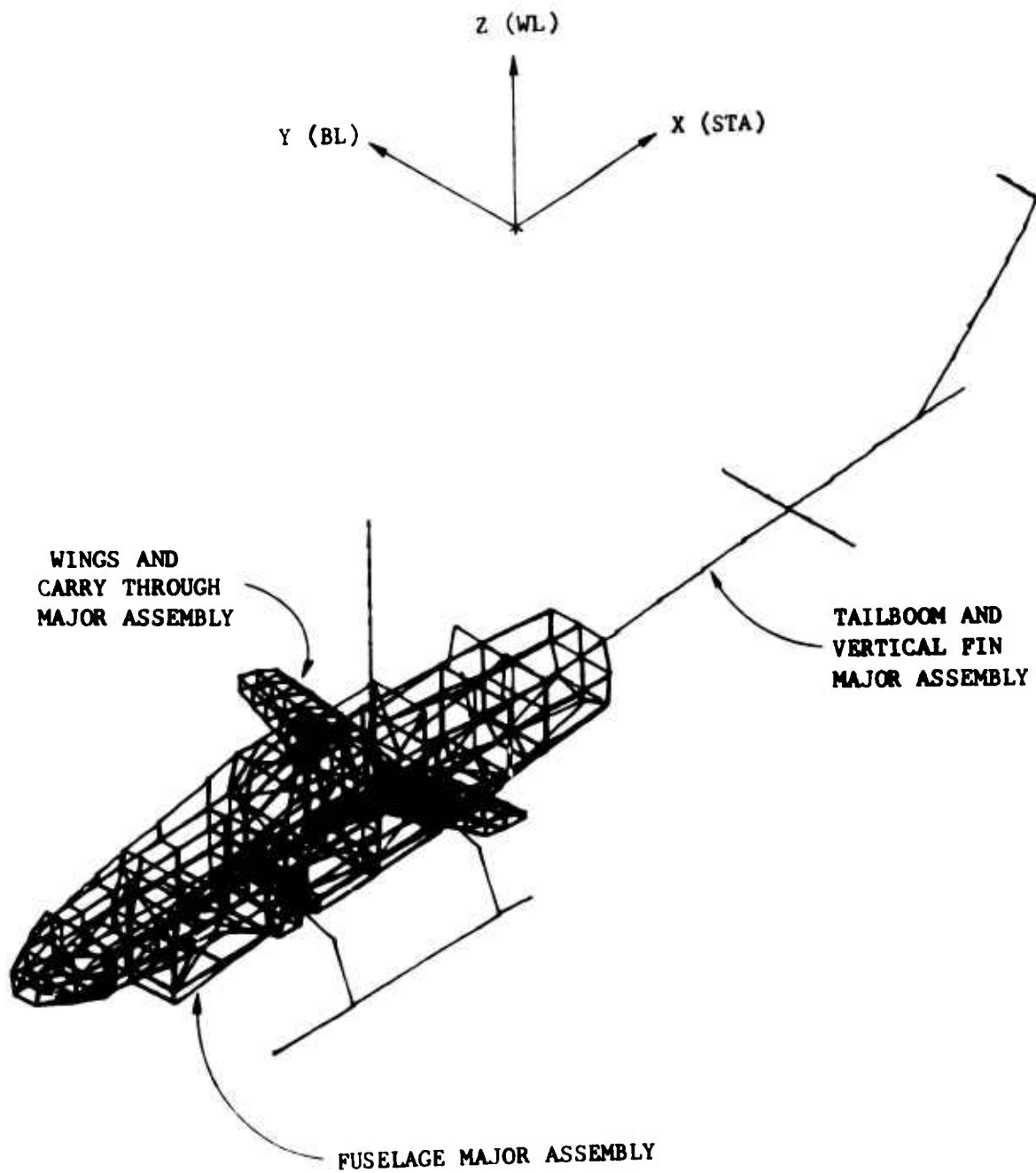

3.1 FUSELAGE MAJOR ASSEMBLY

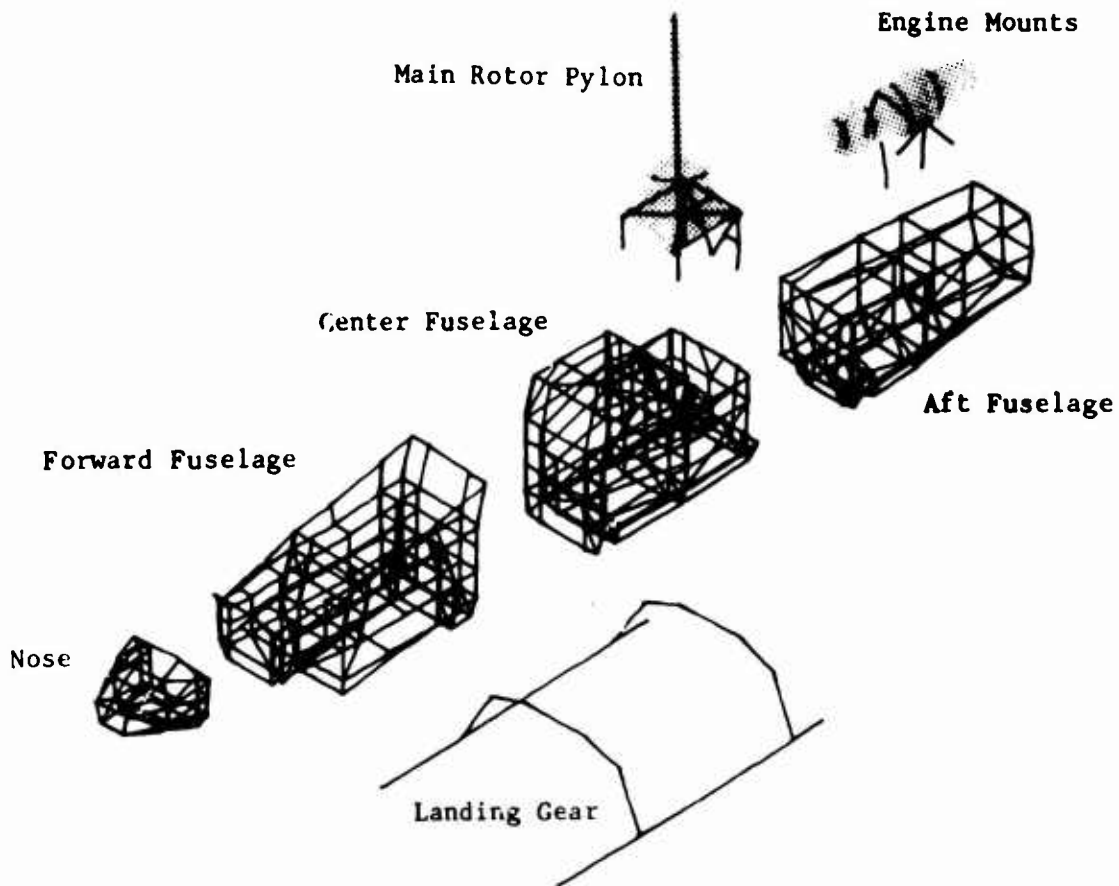
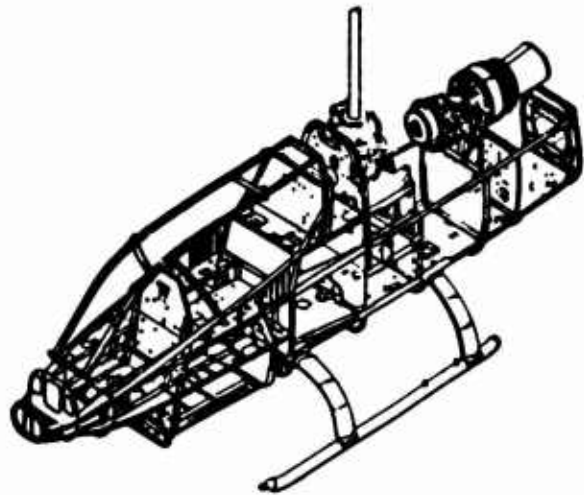

3.1.1 Nose Subassembly

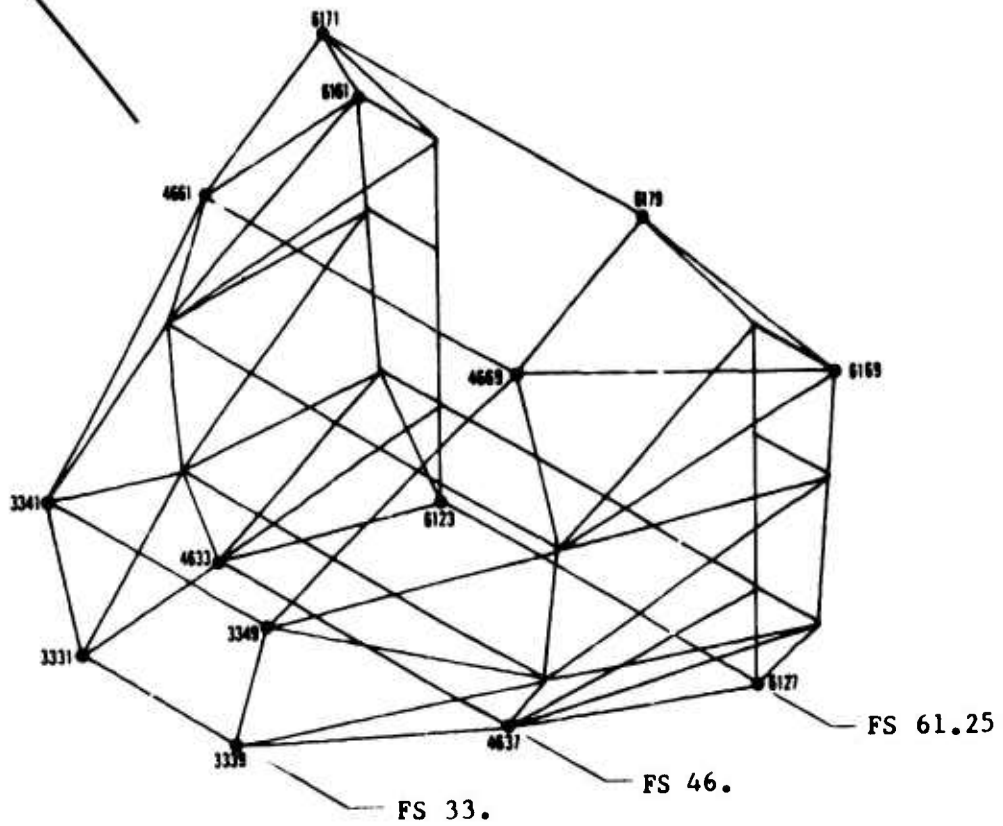
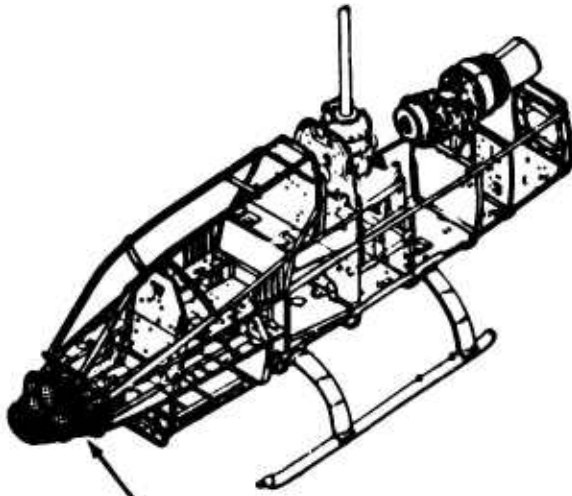

3.1.1.1 Bulkhead Sta. 33. Detail

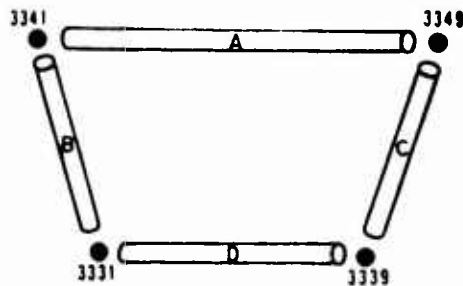

View looking aft

GRID POINT DATA

| GRID POINT | SPC | | MPC | | OMIT | |
|------------|--------|------|--------|------|--------|------|
| | D.O.F. | RULE | D.O.F. | RULE | D.O.F. | RULE |
| 3331 | 456 | AAA | - | - | 2 | C |
| 3339 | 456 | AAA | - | - | 1 | D |
| 3341 | 456 | AAA | - | - | 13 | DC |
| 3349 | 456 | AAA | - | - | 23 | CC |

ROD ELEMENT DATA

| LETTER DESIGNATION | NASTRAN EID | TYPE | ACTUAL AREA (in. ²) | OFFSETS FROM GRIDPOINT | | FINAL AREA (in. ²) |
|--------------------|-------------|---------|---------------------------------|------------------------|---|--------------------------------|
| | | | | Z | Y | |
| A | 334149 | Frame | 0.092 | - | - | 0.092 |
| | 5850754 | Doubler | 0.035 | - | - | 0.035 |
| B | 333141 | Frame | 0.092 | - | - | 0.092 |
| | 5850751 | Doubler | 0.035 | - | - | 0.035 |
| C | 333949 | Frame | 0.092 | - | - | 0.092 |
| | 5850753 | Doubler | 0.035 | - | - | 0.035 |
| D | 333931 | Frame | 0.092 | - | - | 0.092 |
| | 5850752 | Doubler | 0.035 | - | - | 0.035 |

3.1.1.2 Bulkhead Sta. 46. Detail

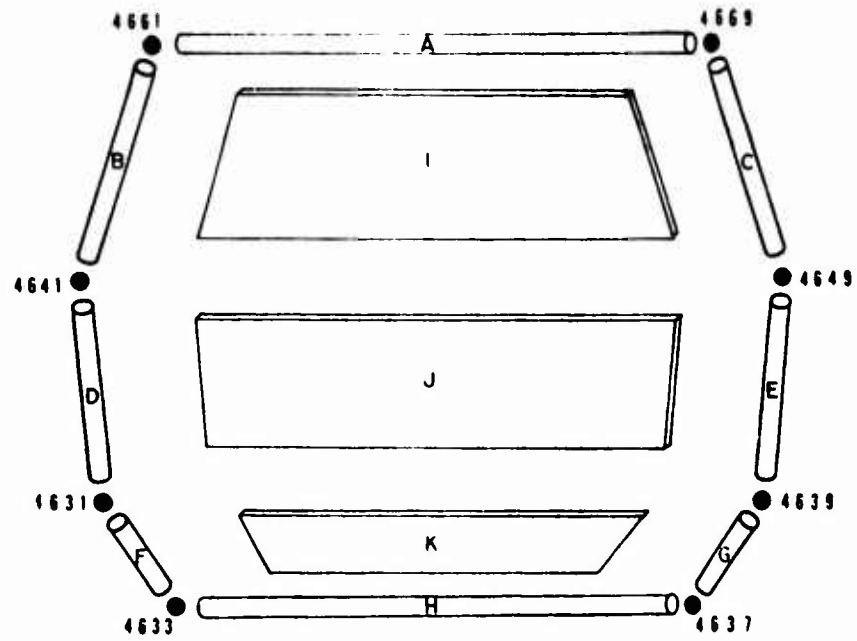

View looking aft

GRID POINT DATA

| GRID POINT | SPC | | MPC | | OMIT | |
|------------|--------|------|--------|------|--------|------|
| | D.O.F. | RULE | D.O.F. | RULE | D.O.F. | RULE |
| 4631 | 456 | AAA | - | - | 123 | DCC |
| 4633 | 456 | AAA | - | - | 13 | DC |
| 4637 | 456 | AAA | - | - | 23 | CC |
| 4639 | 456 | AAA | - | - | 123 | DCC |
| 4641 | 456 | AAA | - | - | 12 | DC |
| 4649 | 456 | AAA | - | - | 12 | DC |
| 4661 | 456 | AAA | - | - | 23 | CC |
| 4669 | 456 | AAA | - | - | 13 | DC |

ROD ELEMENT DATA

| LETTER DESIGNATION | NASTRAN EID | TYPE | ACTUAL AREA (in. ²) | OFFSETS FROM GRIDPOINT | | FINAL AREA (in. ²) |
|--------------------|-------------|---------|---------------------------------|------------------------|---|--------------------------------|
| | | | | Z | Y | |
| A | 5850818 | Doubler | 0.053 | - | - | 0.053 |
| B | 5850811 | Doubler | 0.053 | - | - | 0.053 |
| C | 5850817 | Doubler | 0.053 | - | - | 0.053 |
| D | 5850812 | Doubler | 0.053 | - | - | 0.053 |
| E | 5850816 | Doubler | 0.053 | - | - | 0.053 |
| F | 5850813 | Doubler | 0.053 | - | - | 0.053 |
| G | 5850815 | Doubler | 0.053 | - | - | 0.053 |
| H | 5850814 | Doubler | 0.053 | - | - | 0.053 |

SHEAR PANEL/MEMBRANE ELEMENT DATA

| Letter Designation | NASTRAN EID | Type | Thickness (IN.) |
|--------------------|-------------|----------|-----------------|
| I | 464169 | Bulkhead | .025 |
| J | 463149 | Bulkhead | .025 |
| K | 463137 | Bulkhead | .025 |

3.1.1.3 Right Gunner's Floor, Frame, and Battery Shelf (Sta. 33-61) Detail

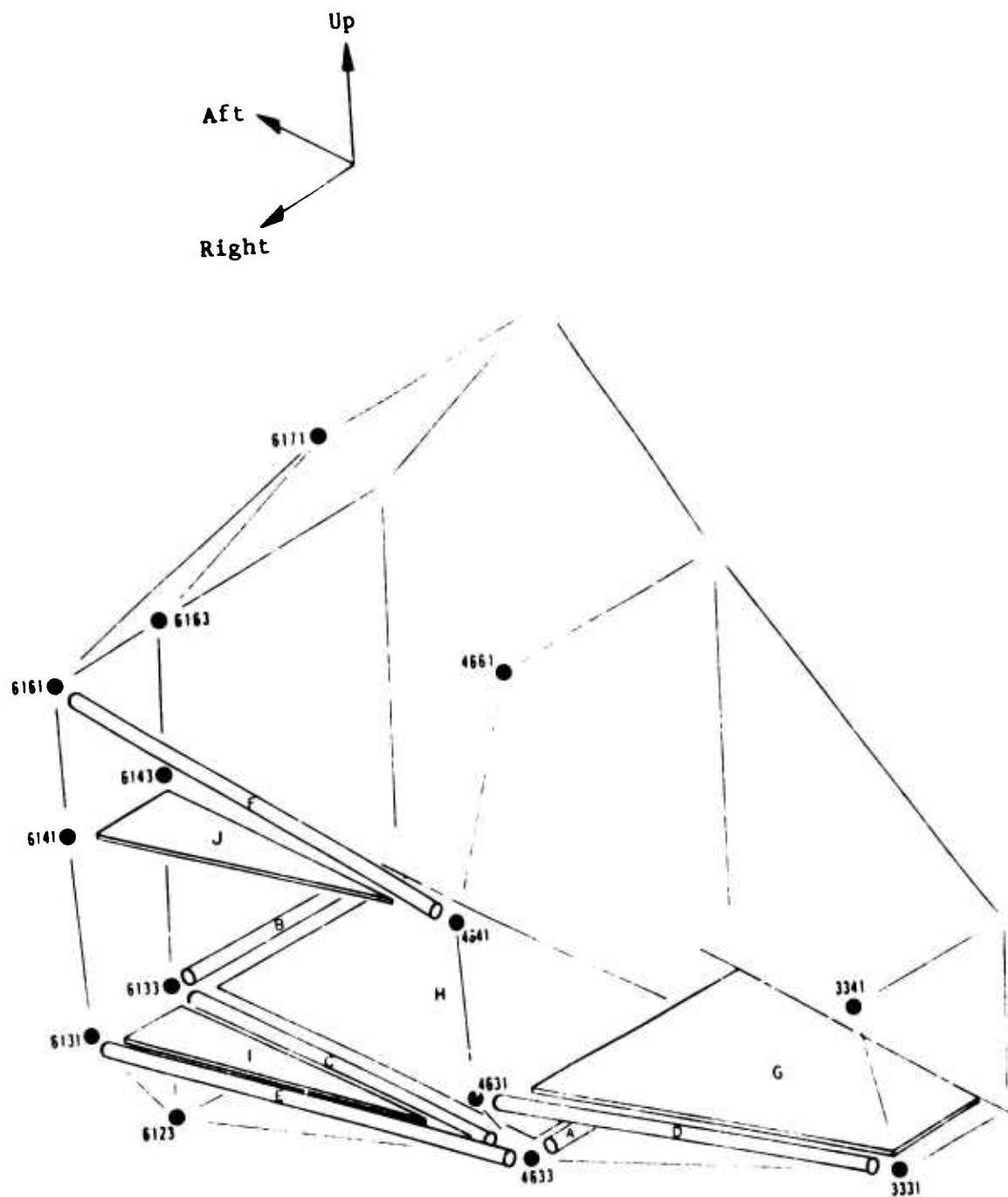

GRID POINT DATA

| GRID POINT | SPC | | MPC | | OMIT | |
|------------|--------|------|--------|------|--------|------|
| | D.O.F. | RULE | D.O.F. | RULE | D.O.F. | RULE |
| 3331 | 456 | AAA | - | - | 2 | C |
| 3341 | 456 | AAA | - | - | 13 | DC |
| 4631 | 456 | AAA | - | - | 123 | DCC |
| 4633 | 456 | AAA | - | - | 13 | DC |
| 4641 | 456 | AAA | - | - | 12 | DC |
| 4661 | 456 | AAA | - | - | 23 | CC |
| 6123 | 456 | AAA | - | - | 123 | DCC |
| 6131 | 456 | AAA | - | - | 123 | DCC |
| 6133 | 456 | AAA | - | - | 23 | CC |
| 6141 | 456 | AAA | - | - | 123 | DCC |
| 6143 | 456 | AAA | - | - | 12 | DC |
| 6161 | 456 | AAA | - | - | 123 | DCC |
| 6163 | 456 | AAA | - | - | 123 | DCC |
| 6171 | 456 | AAA | - | - | 13 | DC |

SHEAR PANEL/MEMBRANE ELEMENT DATA

| Letter Designation | NASTRAN EID | Type | Thickness (IN.) |
|--------------------|-------------|------------|-----------------|
| G | 5950211 | Shelf | .012 |
| | 5950271 | Shelf | .020 |
| H | 2010672 | Lower Skin | .012 |
| | 2010692 | Upper Skin | .020 |
| I | 2010671 | Lower Skin | .012 |
| | 2010691 | Upper Skin | .020 |
| J | 5940041 | Frame | .032 |

ROD ELEMENT DATA

| LETTER DESIGNATION | NASTRAN EID | TYPE | ACTUAL AREA (in. ²) | OFFSETS FROM GRIDPOINT | | FINAL AREA (in. ²) |
|-----------------------|----------------|---------|------------------------------------|---------------------------|-------|-----------------------------------|
| | | | | Z | Y | |
| A | 2016703 | R/SP2 | .079 | - | - | .079 |
| | 2016903 | R/SP2 | .151 | - | - | .151 |
| | 2010211 | Doubler | .022 | 0.0 | -0.85 | .024 |
| B | 2016704 | R/SP2 | .079 | - | - | .079 |
| | 2016904 | R/SP2 | .151 | - | - | .151 |
| C | 2016701 | R/SP2 | .029 | - | - | .029 |
| | 2016901 | R/SP2 | .062 | - | - | .062 |
| D | 5850771 | Doubler | .057 | - | - | .057 |
| | 5810351 | Doubler | .054 | - | - | .054 |
| E | 2110101 | Cap | .059 | - | - | .059 |
| | 585C790 | Doubler | .059 | - | - | .059 |
| | 2010191 | Doubler | .021 | 0.0 | -0.85 | .018 |
| F | 5850851 | Doubler | .053 | - | - | .053 |

3.1.1.4 Left Gunner's Floor, Frame, and Battery Shelf (Sta. 33-61) Detail

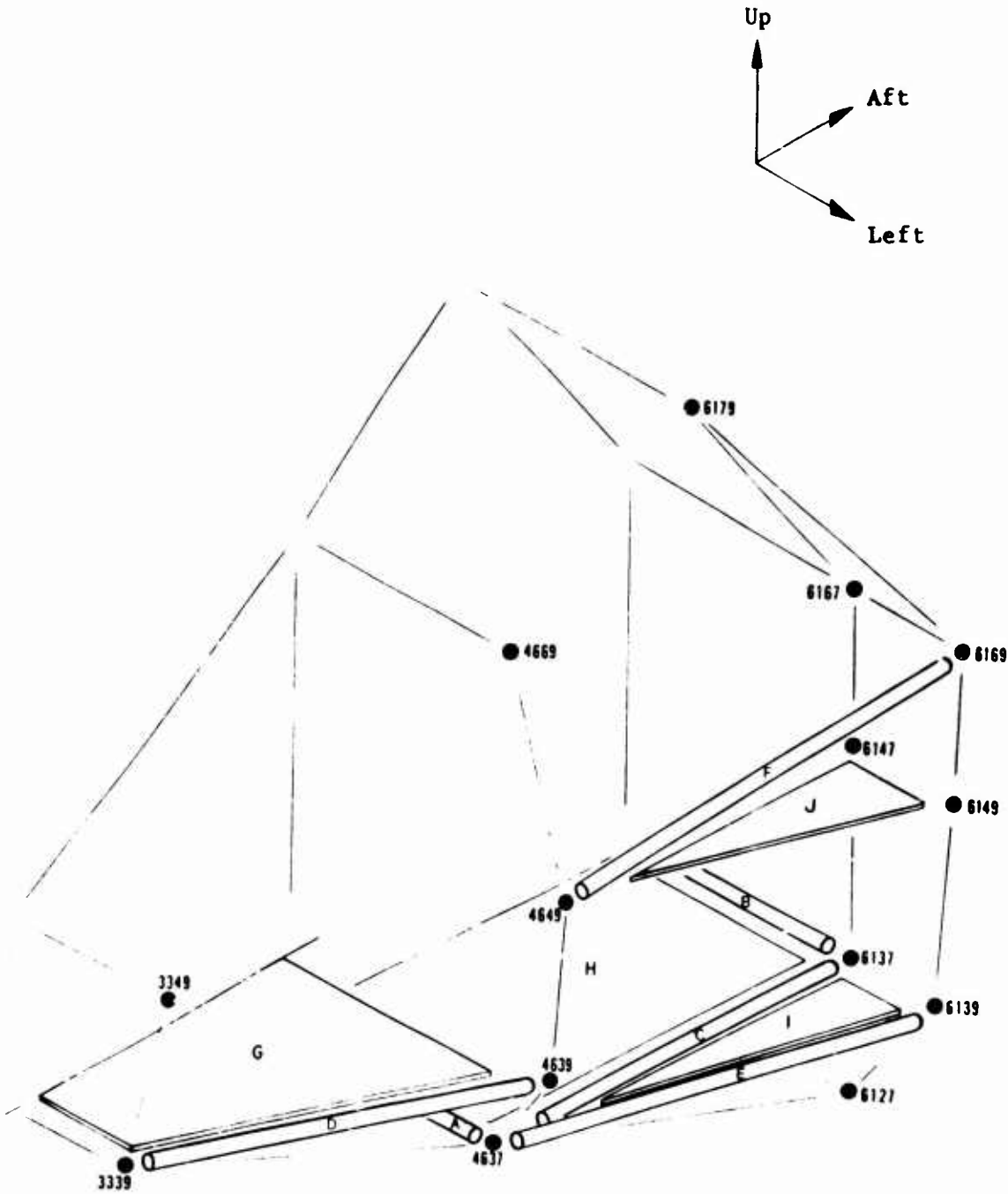

GRID POINT DATA

| GRID POINT | SPC | | MPC | | OMIT | |
|------------|--------|------|--------|------|--------|------|
| | D.O.F. | RULE | D.O.F. | RULE | D.O.F. | RULE |
| 3339 | 456 | AAA | - | - | 1 | D |
| 3349 | 456 | AAA | - | - | 23 | CC |
| 4637 | 456 | AAA | - | - | 23 | CC |
| 4639 | 456 | AAA | - | - | 123 | DCC |
| 4649 | 456 | AAA | - | - | 12 | DC |
| 4669 | 456 | AAA | - | - | 13 | DC |
| 6127 | 456 | AAA | - | - | 13 | DC |
| 6137 | 456 | AAA | - | - | 123 | DCC |
| 6139 | 456 | AAA | - | - | 123 | DCC |
| 6147 | 456 | AAA | - | - | 12 | DC |
| 6149 | 456 | AAA | - | - | 123 | DCC |
| 6167 | 456 | AAA | - | - | 23 | CC |
| 6169 | 456 | AAA | - | - | 123 | DCC |
| 6179 | 456 | AAA | - | - | 123 | DCC |

SHEAR PANEL/MEMBRANE ELEMENT DATA

| Letter Designation | NASTRAN EID | Type | Thickness (IN.) |
|--------------------|-------------|------------|-----------------|
| D | 5950211 | Shelf | .012 |
| | 5950271 | Shelf | .020 |
| E | 2010672 | Lower Skin | .012 |
| | 2010692 | Upper Skin | .020 |
| F | 2010673 | Lower Skin | .012 |
| | 2010693 | Upper Skin | .020 |
| G | 5940171 | Frame | .032 |

ROD ELEMENT DATA

| LETTER DESIGNATION | NASTRAN EID | TYPE | ACTUAL AREA (in. ²) | OFFSETS FROM GRIDPOINT | | FINAL AREA (in. ²) |
|-----------------------|----------------|---------|------------------------------------|---------------------------|------|-----------------------------------|
| | | | | Z | Y | |
| A | 2016703 | R/SP2 | .079 | - | - | .079 |
| | 2016903 | R/SP2 | .151 | - | - | .151 |
| | 2010211 | Doubler | .022 | 0.0 | 0.85 | .024 |
| B | 2016704 | R/SP2 | .079 | - | - | .079 |
| | 2016904 | R/SP2 | .151 | - | - | .151 |
| C | 2016702 | R/SP2 | .029 | - | - | .029 |
| | 2016902 | R/SP2 | .062 | - | - | .062 |
| D | 5850772 | Doubler | .057 | - | - | .057 |
| | 5810251 | Doubler | .054 | - | - | .054 |
| E | 2110531 | Cap | .059 | - | - | .059 |
| | 5850791 | Doubler | .059 | - | - | .059 |
| | 2010192 | Doubler | .021 | 0.0 | 0.85 | .018 |
| F | 5850852 | Doubler | .053 | - | - | .053 |

3.1.1.5 Right Shell Assembly Detail

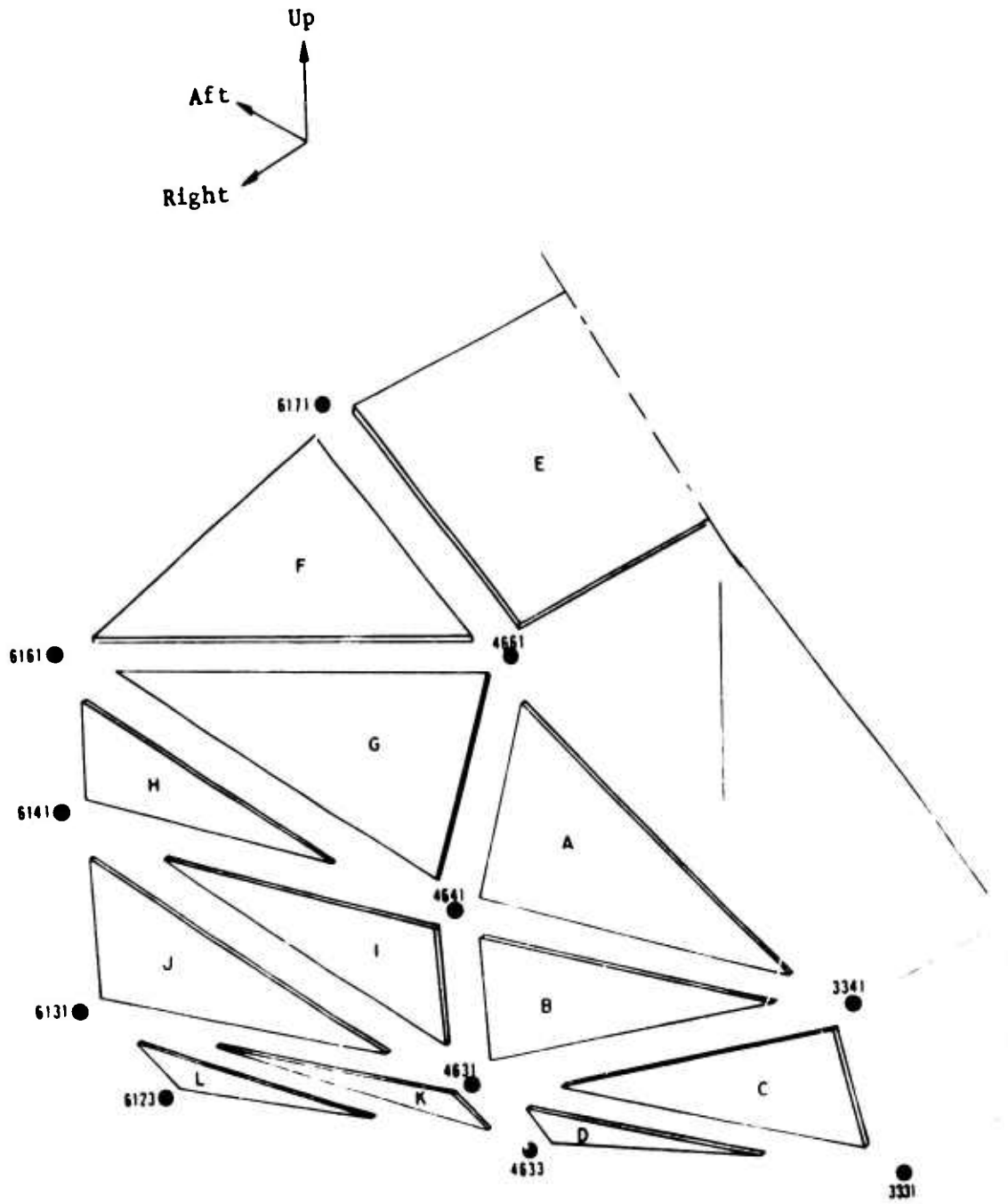

GRID POINT DATA

| GRID POINT | SPC | | MPC | | OMIT | |
|------------|--------|------|--------|------|--------|------|
| | D.O.F. | RULE | D.O.F. | RULE | D.O.F. | RULE |
| 3331 | 456 | AAA | - | - | 2 | C |
| 3341 | 456 | AAA | - | - | 13 | DC |
| 4631 | 456 | AAA | - | - | 123 | DCC |
| 4633 | 456 | AAA | - | - | 13 | DC |
| 4641 | 456 | AAA | - | - | 12 | DC |
| 4661 | 456 | AAA | - | - | 23 | CC |
| 6123 | 456 | AAA | - | - | 123 | DCC |
| 6131 | 456 | AAA | - | - | 123 | DCC |
| 6141 | 456 | AAA | - | - | 123 | DCC |
| 6161 | 456 | AAA | - | - | 123 | DCC |
| 6171 | 456 | AAA | - | - | 13 | DC |

SHEAR PANEL/MEMBRANE ELEMENT DATA

| Letter Designation | NASTRAN EID | Type | Thickness (IN.) |
|--------------------|-------------|---------------|-----------------|
| A | 5858901 | Inner Skin | .010 |
| | 5850501 | Interior Skin | .010 |
| | 5850301 | Outer Skin | .010 |
| B | 5858902 | Inner Skin | .010 |
| | 5850502 | Interior Skin | .010 |
| | 5850302 | Outer Skin | .010 |
| C | 5858903 | Inner Skin | .010 |
| | 5850503 | Interior Skin | .010 |
| | 5850303 | Outer Skin | .010 |
| D | 5858904 | Inner Skin | .010 |
| | 5850504 | Interior Skin | .010 |
| | 5850304 | Outer Skin | .010 |
| E | 5858921 | Inner Skin | .010 |
| | 5850521 | Interior Skin | .010 |
| | 5850321 | Outer Skin | .010 |

SHEAR PANEL/MEMBRANE ELEMENT DATA (CONT.)

| Letter Designation | NASTRAN EID | Type | Thickness (IN.) |
|--------------------|-------------|---------------|-----------------|
| F | 5858922 | Inner Skin | .010 |
| | 5850522 | Interior Skin | .010 |
| | 5850322 | Outer Skin | .010 |
| G | 5858923 | Inner Skin | .010 |
| | 5850523 | Interior Skin | .010 |
| | 5850323 | Outer Skin | .010 |
| H | 5858924 | Inner Skin | .010 |
| | 5850524 | Interior Skin | .010 |
| | 5850324 | Outer Skin | .010 |
| I | 5858925 | Inner Skin | .010 |
| | 5850525 | Interior Skin | .010 |
| | 5850325 | Outer Skin | .010 |
| J | 5858926 | Inner Skin | .010 |
| | 5850526 | Interior Skin | .010 |
| | 5850326 | Outer Skin | .010 |
| K | 5858927 | Inner Skin | .010 |
| | 5850527 | Interior Skin | .010 |
| | 5850327 | Outer Skin | .010 |
| L | 5858928 | Inner Skin | .010 |
| | 5850528 | Interior Skin | .010 |
| | 5850328 | Outer Skin | .010 |

3.1.1.6 Left Shell Assembly Detail

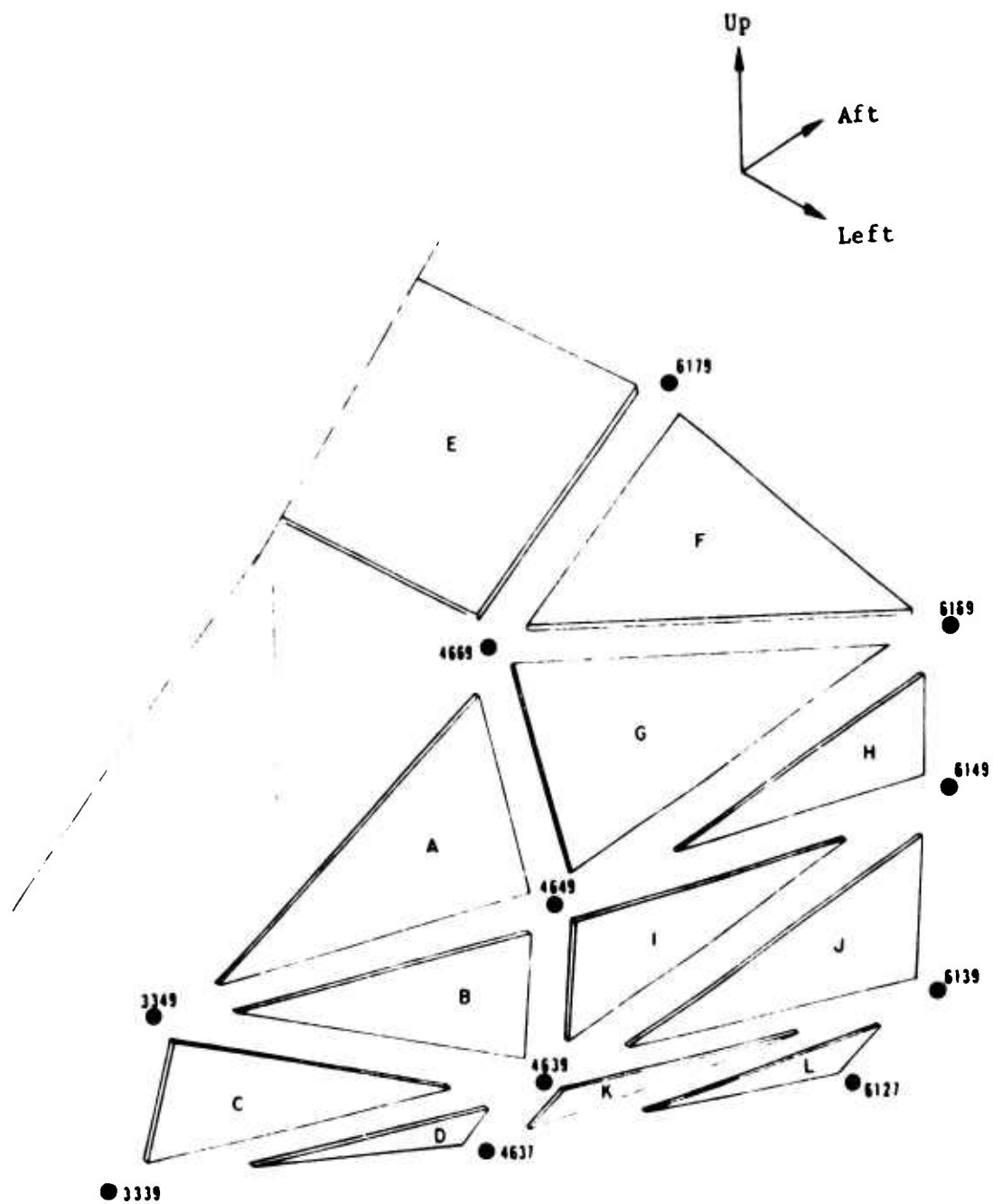

GRID POINT DATA

| GRID POINT | SPC | | MPC | | OMIT | |
|------------|--------|------|--------|------|--------|------|
| | D.O.F. | RULE | D.O.F. | RULE | D.O.F. | RULE |
| 3339 | 456 | AAA | - | - | 1 | D |
| 3349 | 456 | AAA | - | - | 23 | CC |
| 4637 | 456 | AAA | - | - | 23 | CC |
| 4639 | 456 | AAA | - | - | 123 | DCC |
| 4649 | 456 | AAA | - | - | 12 | DC |
| 4669 | 456 | AAA | - | - | 13 | DC |
| 6127 | 456 | AAA | - | - | 13 | DC |
| 6139 | 456 | AAA | - | - | 123 | DCC |
| 6149 | 456 | AAA | - | - | 123 | DCC |
| 6169 | 456 | AAA | - | - | 123 | DCC |
| 6179 | 456 | AAA | - | - | 123 | DCC |

SHEAR PANEL/MEMBRANE ELEMENT DATA

| Letter Designation | NASTRAN EID | Type | Thickness (IN.) |
|--------------------|-------------|---------------|-----------------|
| A | 5858909 | Inner Skin | .010 |
| | 5850509 | Interior Skin | .010 |
| | 5850309 | Outer Skin | .010 |
| B | 5858908 | Inner Skin | .010 |
| | 5850508 | Interior Skin | .010 |
| | 5850308 | Outer Skin | .010 |
| C | 5858907 | Inner Skin | .010 |
| | 5850507 | Interior Skin | .010 |
| | 5850307 | Outer Skin | .010 |
| D | 5858906 | Inner Skin | .010 |
| | 5850506 | Interior Skin | .010 |
| | 5850306 | Outer Skin | .010 |
| E | 5858921 | Inner Skin | .010 |
| | 5850521 | Interior Skin | .010 |
| | 5850321 | Outer Skin | .010 |

SHEAR PANEL/MEMBRANE ELEMENT DATA (CONT.)

| Letter Designation | NASTRAN EID | Type | Thickness (IN.) |
|--------------------|-------------|---------------|-----------------|
| F | 5858936 | Inner Skin | .010 |
| | 5850536 | Interior Skin | .010 |
| | 5850336 | Outer Skin | .010 |
| G | 5858935 | Inner Skin | .010 |
| | 5850535 | Interior Skin | .010 |
| | 5850335 | Outer Skin | .010 |
| H | 5858934 | Inner Skin | .010 |
| | 5850534 | Interior Skin | .010 |
| | 5850334 | Outer Skin | .010 |
| I | 5858933 | Inner Skin | .010 |
| | 5850533 | Interior Skin | .010 |
| | 5850333 | Outer Skin | .010 |
| J | 5858932 | Inner Skin | .010 |
| | 5850532 | Interior Skin | .010 |
| | 5850332 | Outer Skin | .010 |
| K | 5858931 | Inner Skin | .010 |
| | 5850531 | Interior Skin | .010 |
| | 5850331 | Outer Skin | .010 |
| L | 5858930 | Inner Skin | .010 |
| | 5850530 | Interior Skin | .010 |
| | 5850330 | Outer Skin | .010 |

3.1.1.7 Right Lower Shell Assembly Detail

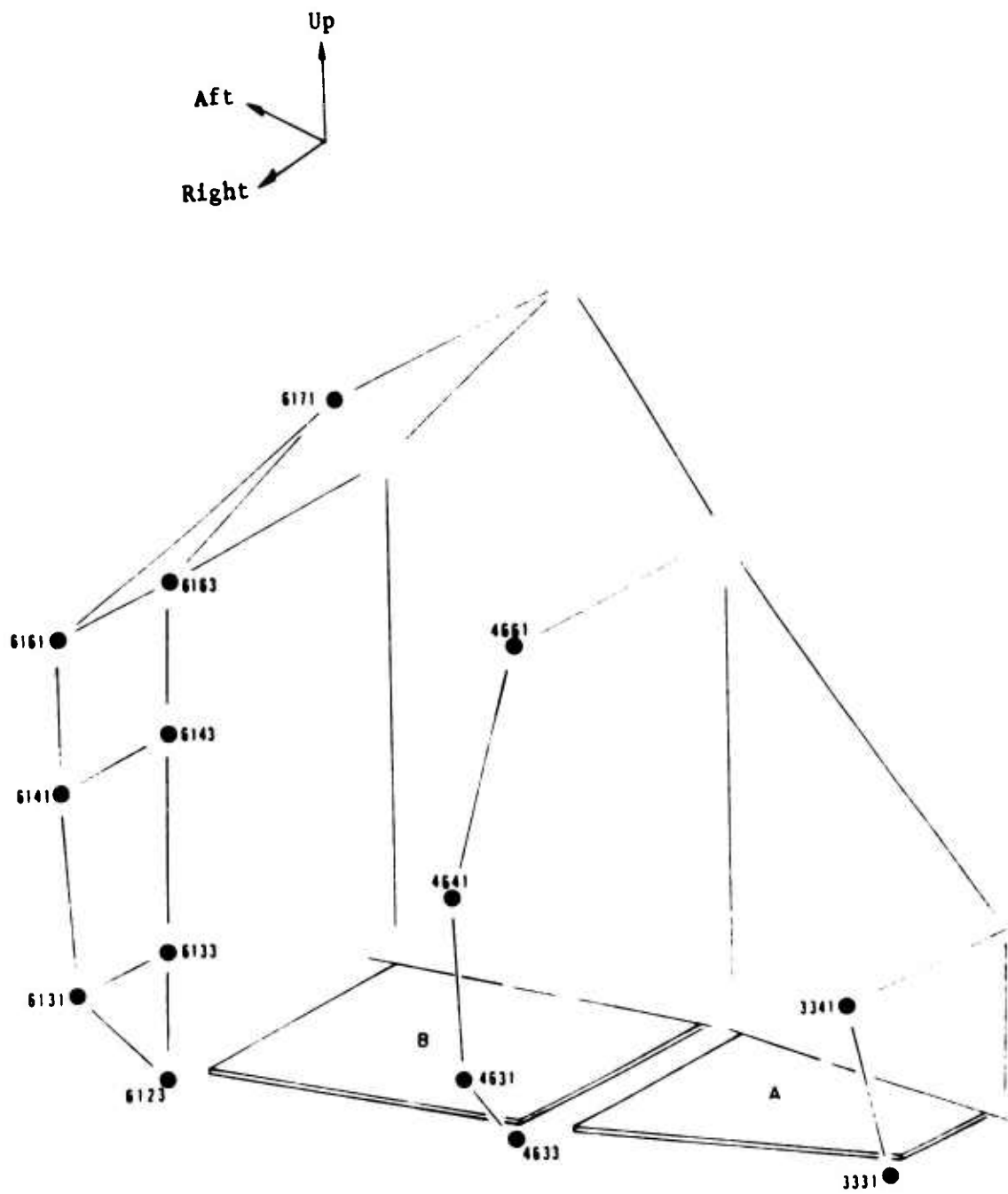

GRID POINT DATA

| GRID POINT | SPC | | MPC | | OMIT | |
|------------|--------|------|--------|------|--------|------|
| | D.O.F. | RULE | D.O.F. | RULE | D.O.F. | RULE |
| 3331 | 456 | AAA | - | - | 2 | C |
| 3341 | 456 | AAA | - | - | 13 | DC |
| 4631 | 456 | AAA | - | - | 123 | DCC |
| 4633 | 456 | AAA | - | - | 13 | DC |
| 4641 | 456 | AAA | - | - | 12 | DC |
| 4661 | 456 | AAA | - | - | 23 | CC |
| 6123 | 456 | AAA | - | - | 123 | DCC |
| 6131 | 456 | AAA | - | - | 123 | DCC |
| 6133 | 456 | AAA | - | - | 23 | CC |
| 6141 | 456 | AAA | - | - | 123 | DCC |
| 6143 | 456 | AAA | - | - | 12 | DC |
| 6161 | 456 | AAA | - | - | 123 | DCC |
| 6163 | 456 | AAA | - | - | 123 | DCC |
| 6171 | 456 | AAA | - | - | 13 | DC |

SHEAR PANEL/MEMBRANE ELEMENT DATA

| Letter Designation | NASTRAN EID | Type | Thickness (IN.) |
|--------------------|-------------|---------------|-----------------|
| A | 5858905 | inner Skin | .010 |
| | 5850505 | Interior Skin | .010 |
| | 5850305 | Outer Skin | .010 |
| B | 5858929 | Inner Skin | .010 |
| | 5850529 | Interior Skin | .010 |
| | 5850329 | Outer Skin | .010 |

3.1.1.8 Left Lower Shell Assembly Detail

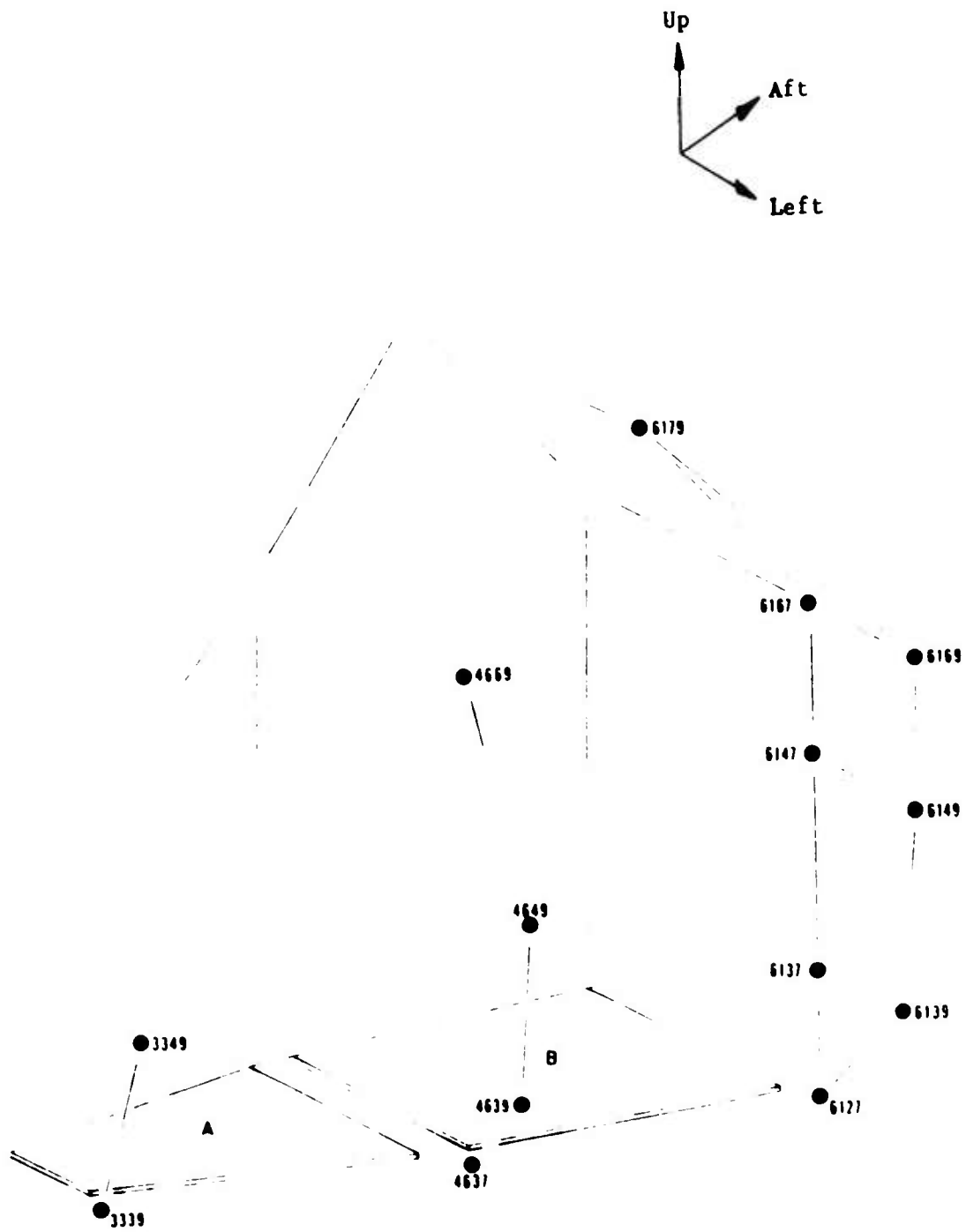

GRID POINT DATA

| GRID POINT | SPC | | MPC | | OMIT | |
|------------|--------|------|--------|------|--------|------|
| | D.O.F. | RULE | D.O.F. | RULE | D.O.F. | RULE |
| 3339 | 456 | AAA | - | - | 1 | D |
| 3349 | 456 | AAA | - | - | 23 | CC |
| 4637 | 456 | AAA | - | - | 23 | CC |
| 4639 | 456 | AAA | - | - | 123 | DCC |
| 4649 | 456 | AAA | - | - | 12 | DC |
| 4669 | 456 | AAA | - | - | 13 | DC |
| 6127 | 456 | AAA | - | - | 13 | DC |
| 6137 | 456 | AAA | - | - | 123 | DCC |
| 6139 | 456 | AAA | - | - | 123 | DCC |
| 6147 | 456 | AAA | - | - | 12 | DC |
| 6149 | 456 | AAA | - | - | 123 | DCC |
| 6167 | 456 | AAA | - | - | 23 | CC |
| 6169 | 456 | AAA | - | - | 123 | DCC |
| 6179 | 456 | AAA | - | - | 123 | DCC |

SHEAR PANEL/MEMBRANE ELEMENT DATA

| Letter Designation | NASTRAN EID | Type | Thickness (IN.) |
|--------------------|-------------|---------------|-----------------|
| A | 5858905 | Inner Skin | .010 |
| | 5850505 | Interior Skin | .010 |
| | 5850305 | Outer Skin | .010 |
| B | 5858929 | Inner Skin | .010 |
| | 5850529 | Interior Skin | .010 |
| | 5850329 | Outer Skin | .010 |

3.1.2 Forward Fuselage Subassembly

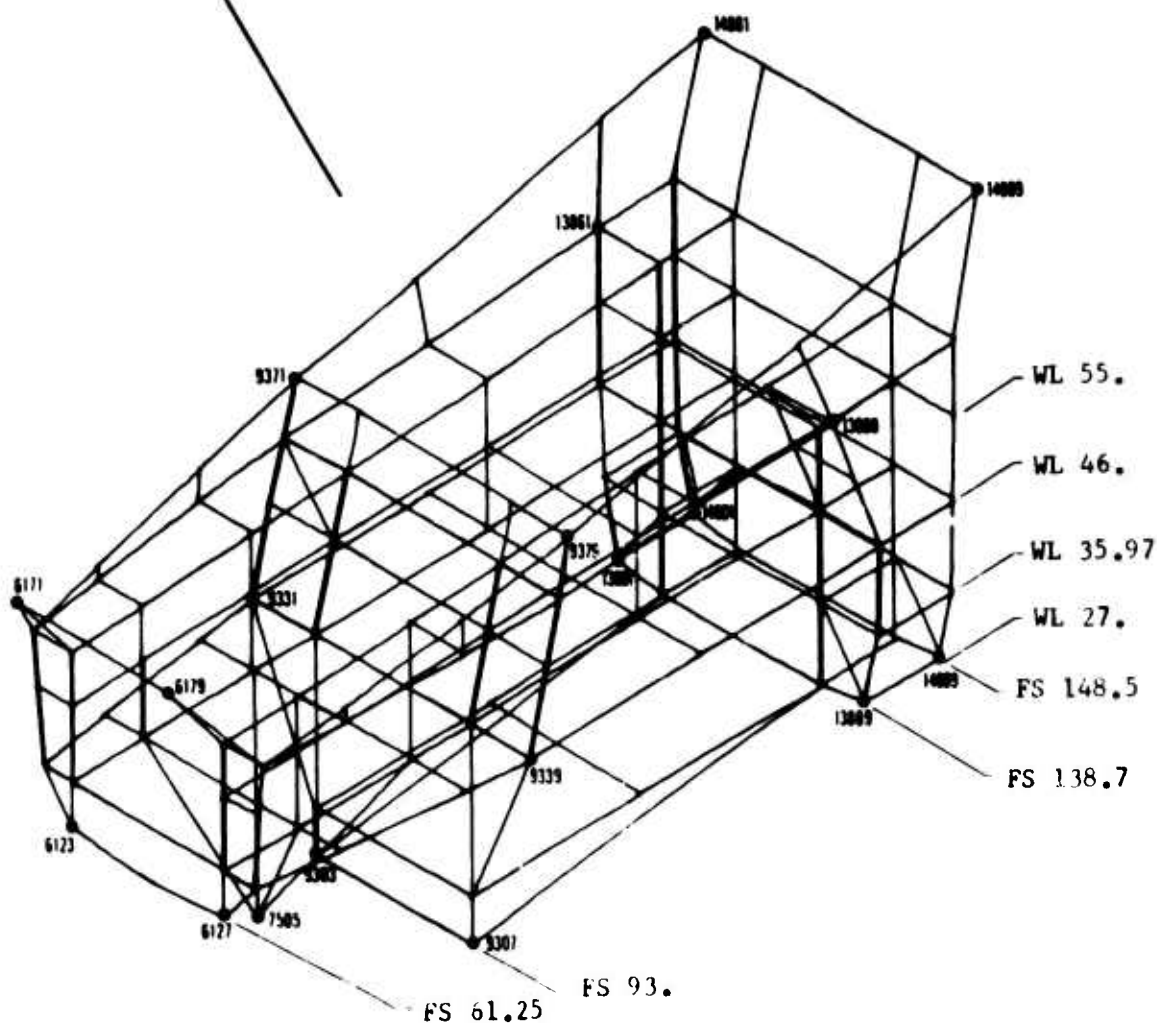
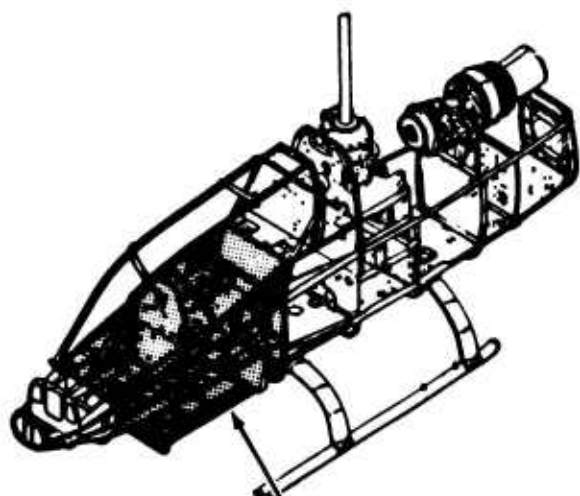

3.1.2.1 Right Main Beam (Sta. 61-93) Detail

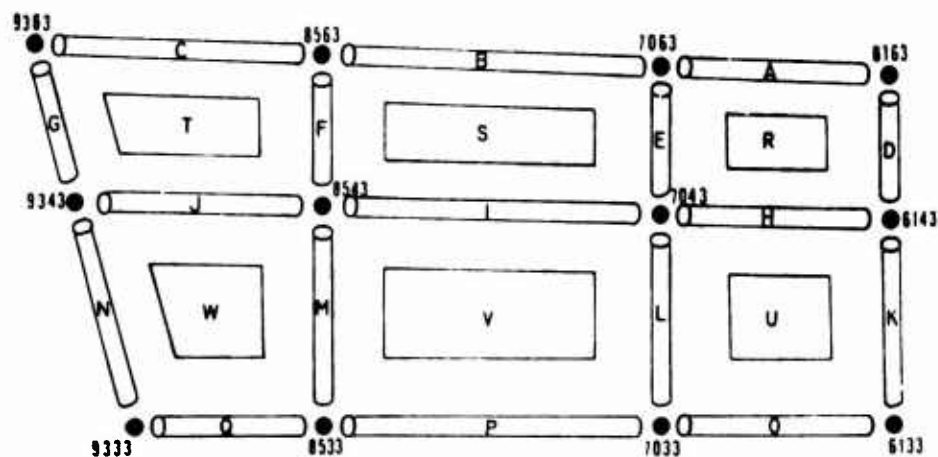

View looking inboard

GRID POINT DATA

| GRID POINT | SPC | | MPC | | OMIT | |
|------------|--------|------|--------|------|--------|------|
| | D.O.F. | RULE | D.O.F. | RULE | D.O.F. | RULE |
| 6133 | 456 | AAA | - | - | 23 | CC |
| 6143 | 456 | AAA | - | - | 12 | DC |
| 6163 | 456 | AAA | - | - | 123 | DCC |
| 7033 | 456 | AAA | 123 | AAA | - | - |
| 7043 | 2456 | AAAA | - | - | 1 | D |
| 7063 | 456 | AAA | - | - | 23 | CC |
| 8533 | 456 | AAA | 123 | AAA | - | - |
| 8543 | 2456 | AAAA | - | - | 1 | D |
| 8563 | 456 | AAA | - | - | 13 | DC |
| 9333 | 456 | AAA | - | - | 1 | D |
| 9343 | 456 | AAA | - | - | 123 | DCC |
| 9363 | 456 | AAA | - | - | 2 | C |

SHEAR PANEL/MEMBRANE ELEMENT DATA

| Letter Designation | NASTRAN EID | Type | Thickness (IN.) |
|--------------------|-------------|---------------|-----------------|
| R | 1292091 | Inner Skin | .025 |
| | 1291832 | Outer Skin | .016 |
| S | 1292093 | Inner Skin | .025 |
| | 1290412 | Interior Skin | .016 |
| | 1291592 | Interior Skin | .016 |
| | 1291834 | Outer Skin | .016 |
| T | 1292095 | Inner Skin | .025 |
| | 1291836 | Outer Skin | .016 |
| U | 1292090 | Inner Skin | .025 |
| | 1291831 | Outer Skin | .016 |
| V | 1292092 | Inner Skin | .025 |
| | 1290411 | Interior Skin | .016 |
| | 1291591 | Interior Skin | .016 |
| | 1291833 | Outer Skin | .016 |
| W | 1292094 | Inner Skin | .025 |
| | 1291835 | Outer Skin | .016 |

ROD ELEMENT DATA

| LETTER DESIGNATION | NASTRAN EID | TYPE | ACTUAL AREA (in. ²) | OFFSETS FROM GRIDPOINT | | FINAL AREA (in. ²) |
|--------------------|-------------|---------|---------------------------------|------------------------|-----|--------------------------------|
| | | | | Z | Y | |
| A | 1570031 | Cap | .213 | -0.26 | 0.0 | .198 |
| | 1290231 | Doubler | .068 | -1.12 | 0.0 | .048 |
| | 1290904 | R/SP1 | .033 | - | - | .033 |
| | 1298304 | R/SP1 | .003 | - | - | .003 |
| B | 1570032 | Cap | .213 | -0.29 | 0.0 | .195 |
| | 1290232 | Doubler | .068 | -1.12 | 0.0 | .047 |
| | 1290924 | R/SP1 | .034 | - | - | .034 |
| | 1294124 | R/SP1 | .001 | - | - | .001 |
| | 1295904 | R/SP1 | .001 | - | - | .001 |
| | 1298324 | R/SP1 | .003 | - | - | .003 |

ROD ELEMENT DATA (CONT.)

| LETTER DESIGNATION | NASTRAN EID | TYPE | ACTUAL AREA (in. ²) | OFFSETS FROM GRIDPOINT | | FINAL AREA (in. ²) |
|-----------------------|----------------|---------|------------------------------------|---------------------------|-----|-----------------------------------|
| | | | | Z | Y | |
| C | 1570033 | Cap | .213 | -0.33 | 0.0 | .192 |
| | 1290233 | Doubler | .068 | -1.12 | 0.0 | .046 |
| | 1290944 | R/SP1 | .035 | - | - | .035 |
| | 1298344 | R/SP1 | .007 | - | - | .007 |
| D | 1290212 | Doubler | .029 | -1.12 | 0.0 | .035 |
| | 1290912 | R/SP2 | .118 | - | - | .118 |
| | 1298312 | R/SP2 | .065 | - | - | .065 |
| E | 1290914 | R/SP2 | .118 | - | - | .118 |
| | 1290932 | R/SP2 | .181 | - | - | .181 |
| | 1294132 | R/SP2 | .116 | - | - | .116 |
| | 1295912 | R/SP2 | .116 | - | - | .116 |
| | 1298314 | R/SP2 | .065 | - | - | .065 |
| | 1298332 | R/SP2 | .116 | - | - | .116 |
| | 1290934 | R/SP2 | .181 | - | - | .181 |
| F | 1290952 | R/SP2 | .123 | - | - | .123 |
| | 1294134 | R/SP2 | .116 | - | - | .116 |
| | 1295914 | R/SP2 | .116 | - | - | .116 |
| | 1298334 | R/SP2 | .116 | - | - | .116 |
| | 1298352 | R/SP2 | .062 | - | - | .062 |
| | 1290272 | Doubler | .084 | -1.12 | 0.0 | .098 |
| G | 1290954 | R/SP2 | .123 | - | - | .123 |
| | 1298354 | R/SP2 | .062 | - | - | .062 |
| | 1290902 | R/SP1 | .122 | - | - | .122 |
| H | 1290903 | R/SP1 | .122 | - | - | .122 |
| | 1298302 | R/SP1 | .071 | - | - | .071 |
| | 1298303 | R/SP1 | .071 | - | - | .071 |
| | 1298303 | R/SP1 | .071 | - | - | .071 |

ROD ELEMENT DATA (CONT.)

| LETTER DESIGNATION | NASTRAN EID | TYPE | ACTUAL AREA (in. ²) | OFFSETS FROM GRIDPOINT | | FINAL AREA (in. ²) |
|--------------------|-------------|---------|---------------------------------|------------------------|-----|--------------------------------|
| | | | | Z | Y | |
| I | 1290922 | R/SP1 | .126 | - | - | .126 |
| | 1290923 | R/SP1 | .126 | - | - | .126 |
| | 1294122 | R/SP1 | .057 | - | - | .057 |
| | 1294123 | R/SP1 | .057 | - | - | .057 |
| | 1295902 | R/SP1 | .071 | - | - | .071 |
| | 1295903 | R/SP1 | .071 | - | - | .071 |
| | 1298322 | R/SP1 | .074 | - | - | .074 |
| | 1298323 | R/SP1 | .074 | - | - | .074 |
| J | 1290942 | R/SP1 | .130 | - | - | .130 |
| | 1290943 | R/SP1 | .130 | - | - | .130 |
| | 1298342 | R/SP1 | .079 | - | - | .079 |
| | 1298343 | R/SP1 | .079 | - | - | .079 |
| K | 1290211 | Doubler | .029 | 1.12 | 0.0 | .035 |
| | 1290911 | R/SP2 | .118 | - | - | .118 |
| | 1298311 | R/SP2 | .065 | - | - | .065 |
| L | 1290913 | R/SP2 | .118 | - | - | .118 |
| | 1290931 | R/SP2 | .181 | - | - | .181 |
| | 1294131 | R/SP2 | .116 | - | - | .116 |
| | 1295911 | R/SP2 | .116 | - | - | .116 |
| | 1298313 | R/SP2 | .065 | - | - | .065 |
| | 1298331 | R/SP2 | .116 | - | - | .116 |
| | 1298331 | R/SP2 | .116 | - | - | .116 |
| M | 1290933 | R/SP2 | .181 | - | - | .181 |
| | 1290951 | R/SP2 | .123 | - | - | .123 |
| | 1294133 | R/SP2 | .116 | - | - | .116 |
| | 1295913 | R/SP2 | .116 | - | - | .116 |
| | 1298333 | R/SP2 | .116 | - | - | .116 |
| | 1298351 | R/SP2 | .062 | - | - | .062 |
| N | 1290271 | Doubler | .084 | 1.12 | 0.0 | .098 |
| | 1290953 | R/SP2 | .123 | - | - | .123 |
| | 1298353 | R/SP2 | .062 | - | - | .062 |

ROD ELEMENT DATA (CONT.)

| LETTER DESIGNATION | NASTRAN EID | TYPE | ACTUAL AREA (in. ²) | OFFSETS FROM GRIDPOINT | | FINAL AREA (in. ²) |
|-----------------------|----------------|---------|------------------------------------|---------------------------|-----|-----------------------------------|
| | | | | Z | Y | |
| O | 1580041 | Cap | .269 | 0.30 | 0.0 | .247 |
| | 1290251 | Doubler | .101 | 1.12 | 0.0 | .072 |
| | 1290901 | R/SP1 | .073 | - | - | .073 |
| | 1298301 | R/SP1 | .026 | - | - | .026 |
| P | 1580042 | Cap | .269 | 0.32 | 0.0 | .248 |
| | 1290252 | Doubler | .101 | 1.12 | 0.0 | .075 |
| | 1290921 | R/SP1 | .076 | - | - | .076 |
| | 1294121 | R/SP1 | .011 | - | - | .011 |
| | 1295901 | R/SP1 | .024 | - | - | .024 |
| | 1298321 | R/SP1 | .028 | - | - | .028 |
| Q | 1580043 | Cap | .269 | 0.34 | 0.0 | .249 |
| | 1290253 | Doubler | .101 | 1.12 | 0.0 | .077 |
| | 1290941 | R/SP1 | .078 | - | - | .078 |
| | 1298341 | R/SP1 | .033 | - | - | .033 |

3.1.2.2 Left Main Beam (Sta. 61-93) Detail

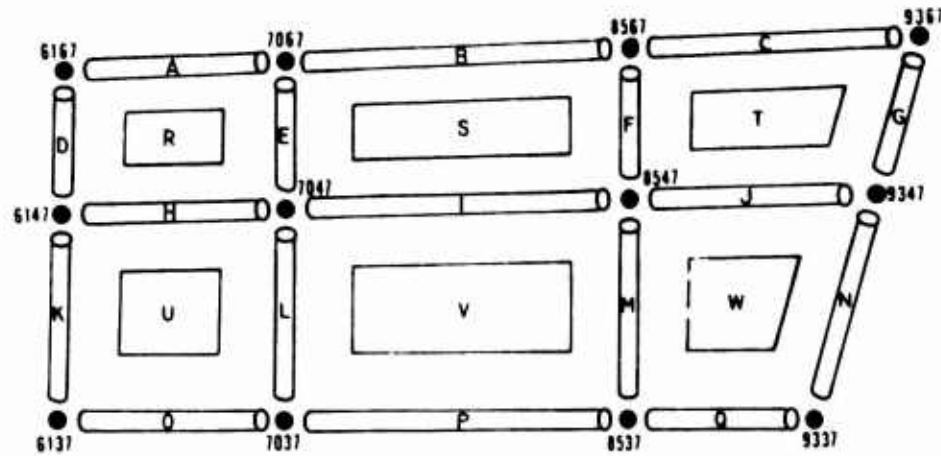

View looking inboard

GRID POINT DATA

| GRID POINT | SPC | | MPC | | OMIT | |
|------------|--------|------|--------|------|--------|------|
| | D.O.F. | RULE | D.O.F. | RULE | D.O.F. | RULE |
| 6137 | 456 | AAA | - | - | 123 | DCC |
| 6147 | 456 | AAA | - | - | 12 | DC |
| 6167 | 456 | AAA | - | - | 23 | CC |
| 7037 | 456 | AAA | 123 | AAA | - | - |
| 7047 | 2456 | AAAA | - | - | 1 | D |
| 7067 | 456 | AAA | - | - | 13 | DC |
| 8537 | 456 | AAA | 123 | AAA | - | - |
| 8547 | 2456 | AAAA | - | - | 1 | D |
| 8567 | 456 | AAA | - | - | 23 | CC |
| 9337 | 456 | AAA | - | - | 2 | C |
| 9347 | 456 | AAA | - | - | 123 | DCC |
| 9367 | 456 | AAA | - | - | 1 | D |

SHEAR PANEL/MEMBRANE ELEMENT DATA

| Letter Designation | NASTRAN EID | Type | Thickness (IN.) |
|--------------------|-------------|---------------|-----------------|
| R | 1292051 | Inner Skin | .025 |
| | 1290752 | Interior Skin | .016 |
| | 1292012 | Outer Skin | .016 |
| S | 1292053 | Inner Skin | .025 |
| | 1290753 | Interior Skin | .016 |
| | 1290771 | Interior Skin | .012 |
| | 1292014 | Outer Skin | .016 |
| T | 1292055 | Inner Skin | .025 |
| | 1292016 | Outer Skin | .016 |
| U | 1292050 | Inner Skin | .025 |
| | 1290751 | Interior Skin | .016 |
| | 1292011 | Outer Skin | .016 |
| V | 1292052 | Inner Skin | .025 |
| | 1292013 | Outer Skin | .016 |
| W | 1292054 | Inner Skin | .025 |
| | 1292015 | Outer Skin | .016 |

ROD ELEMENT DATA

| LETTER DESIGNATION | NASTRAN EID | TYPE | ACTUAL AREA (in. ²) | OFFSETS FROM GRIDPOINT | | FINAL AREA (in. ²) |
|--------------------|-------------|---------|---------------------------------|------------------------|-----|--------------------------------|
| | | | | Z | Y | |
| A | 1570011 | Cap | .213 | -0.26 | 0.0 | .198 |
| | 1290754 | Doubler | .047 | -1.13 | 0.0 | .033 |
| | 1290504 | R/SP1 | .033 | - | - | .033 |
| | 1297504 | R/SP1 | .001 | - | - | .001 |
| | 1290104 | R/SP1 | .002 | - | - | .002 |
| B | 1570012 | Cap | .213 | -0.29 | 0.0 | .194 |
| | 1290755 | Doubler | .047 | -1.05 | 0.0 | .033 |
| | 1290524 | R/SP1 | .034 | - | - | .034 |
| | 1297522 | R/SP1 | .011 | - | - | .011 |
| | 1297702 | R/SP1 | .008 | - | - | .008 |
| | 1290124 | R/SP1 | .003 | - | - | .003 |

ROD ELEMENT DATA (CONT.)

| LETTER DESIGNATION | NASTRAN EID | TYPE | ACTUAL AREA (in. ²) | OFFSETS FROM GRIDPOINT | | FINAL AREA (in. ²) |
|--------------------|-------------|---------|---------------------------------|------------------------|-----|--------------------------------|
| | | | | Z | Y | |
| C | 1570013 | Cap | .213 | -0.33 | 0.0 | .191 |
| | 1290731 | Doubler | .047 | -0.96 | 0.0 | .034 |
| | 1290544 | R/SP1 | .035 | - | - | .035 |
| | 1290144 | R/SP1 | .003 | - | - | .003 |
| D | 1290758 | Doubler | .029 | -1.17 | 0.0 | .035 |
| | 1290512 | R/SP2 | .118 | - | - | .118 |
| | 1297512 | R/SP2 | .061 | - | - | .061 |
| | 1290112 | R/SP2 | .065 | - | - | .065 |
| E | 1290514 | R/SP2 | .118 | - | - | .118 |
| | 1290532 | R/SP2 | .181 | - | - | .181 |
| | 1297514 | R/SP2 | .061 | - | - | .061 |
| | 1297523 | R/SP2 | .102 | - | - | .102 |
| | 1297703 | R/SP2 | .058 | - | - | .058 |
| | 1290114 | R/SP2 | .065 | - | - | .065 |
| | 1290132 | R/SP2 | .116 | - | - | .116 |
| F | 1290534 | R/SP2 | .181 | - | - | .181 |
| | 1290552 | R/SP2 | .123 | - | - | .123 |
| | 1297524 | R/SP2 | .102 | - | - | .102 |
| | 1297704 | R/SP2 | .058 | - | - | .058 |
| | 1290134 | R/SP2 | .116 | - | - | .116 |
| | 1290152 | R/SP2 | .062 | - | - | .062 |
| G | 1290792 | Doubler | .105 | -0.93 | 0.0 | .122 |
| | 1290554 | R/SP2 | .123 | - | - | .123 |
| | 1290154 | R/SP2 | .062 | - | - | .062 |
| H | 1290502 | R/SP1 | .122 | - | - | .122 |
| | 1290503 | R/SP1 | .122 | - | - | .122 |
| | 1297502 | R/SP1 | .069 | - | - | .069 |
| | 1297503 | R/SP1 | .069 | - | - | .069 |
| | 1290102 | R/SP1 | .071 | - | - | .071 |
| | 1290103 | R/SP1 | .071 | - | - | .071 |

ROD ELEMENT DATA (CONT.)

| LETTER DESIGNATION | NASTRAN EID | TYPE | ACTUAL AREA (in. ²) | OFFSETS FROM GRIDPOINT | | FINAL AREA (in. ²) |
|--------------------|-------------|---------|---------------------------------|------------------------|-----|--------------------------------|
| | | | | Z | Y | |
| I | 1290522 | R/SP1 | .126 | - | - | .126 |
| | 1290523 | R/SP1 | .126 | - | - | .126 |
| | 1297521 | R/SP1 | .011 | - | - | .011 |
| | 1297701 | R/SP1 | .008 | - | - | .008 |
| | 1290122 | R/SP1 | .074 | - | - | .074 |
| | 1290123 | R/SP1 | .074 | - | - | .074 |
| J | 1290542 | R/SP1 | .130 | - | - | .130 |
| | 1290543 | R/SP1 | .130 | - | - | .130 |
| | 1290142 | R/SP1 | .077 | - | - | .077 |
| | 1290143 | R/SP1 | .077 | - | - | .077 |
| K | 1290757 | Doubler | .029 | 1.18 | 0.0 | .035 |
| | 1290511 | R/SP2 | .118 | - | - | .118 |
| | 1297511 | R/SP2 | .061 | - | - | .061 |
| | 1290111 | R/SP2 | .065 | - | - | .065 |
| L | 1290513 | R/SP2 | .118 | - | - | .118 |
| | 1290531 | R/SP2 | .181 | - | - | .181 |
| | 1297513 | R/SP2 | .061 | - | - | .061 |
| | 1290113 | R/SP2 | .065 | - | - | .065 |
| | 1290131 | R/SP2 | .116 | - | - | .116 |
| M | 1290533 | R/SP2 | .181 | - | - | .181 |
| | 1290551 | R/SP2 | .123 | - | - | .123 |
| | 1290133 | R/SP2 | .116 | - | - | .116 |
| | 1290151 | R/SP2 | .062 | - | - | .062 |
| N | 1290791 | Doubler | .105 | 1.18 | 0.0 | .122 |
| | 1290553 | R/SP2 | .123 | - | - | .123 |
| | 1290153 | R/SP2 | .062 | - | - | .062 |

ROD ELEMENT DATA (CONT.)

| LETTER DESIGNATION | NASTRAN EID | TYPE | ACTUAL AREA (in. ²) | OFFSETS FROM GRIDPOINT | | FINAL AREA (in. ²) |
|-----------------------|----------------|---------|------------------------------------|---------------------------|-----|-----------------------------------|
| | | | | Z | Y | |
| O | 1580031 | Cap | .269 | 0.30 | 0.0 | .247 |
| | 1290756 | Doubler | .056 | 1.18 | 0.0 | .039 |
| | 1290501 | R/SP1 | .072 | - | - | .072 |
| | 1297501 | R/SP1 | .023 | - | - | .023 |
| | 1290101 | R/SP1 | .026 | - | - | .026 |
| P | 1580032 | Cap | .269 | 0.32 | 0.0 | .248 |
| | 1290991 | Doubler | .056 | 1.18 | 0.0 | .041 |
| | 1290521 | R/SP1 | .075 | - | - | .075 |
| | 1290121 | R/SP1 | .028 | - | - | .028 |
| Q | 1580033 | Cap | .269 | 0.34 | 0.0 | .249 |
| | 1290992 | Doubler | .056 | 1.18 | 0.0 | .042 |
| | 1290541 | R/SP1 | .078 | - | - | .078 |
| | 1290141 | R/CP1 | .029 | - | - | .029 |

3.1.2.3 Right Main Beam (Sta 93-138) Detail

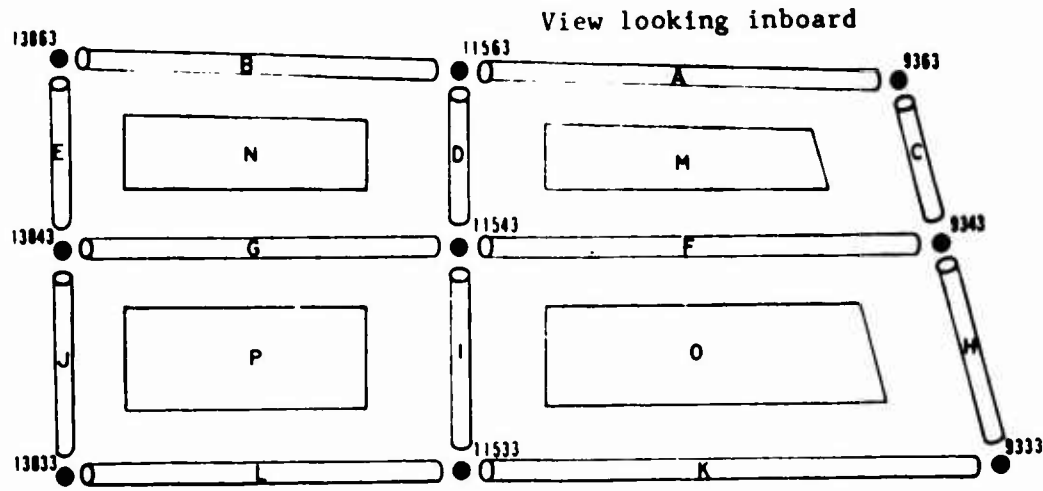

GRID POINT DATA

| GRID POINT | SPC | | MPC | | OMIT | |
|------------|--------|------|--------|------|--------|------|
| | D.O.F. | RULE | D.O.F. | RULE | D.O.F. | RULE |
| 9333 | 456 | AAA | - | - | 1 | D |
| 9343 | 456 | AAA | - | - | 123 | DCC |
| 9363 | 456 | AAA | - | - | 2 | C |
| 11533 | 456 | AAA | - | - | 23 | CC |
| 11543 | 456 | AAA | - | - | 12 | DC |
| 11563 | 456 | AAA | - | - | 13 | DC |
| 13833 | 456 | AAA | - | - | 12 | DC |
| 13843 | 456 | AAA | - | - | 123 | DCC |
| 13863 | 456 | AAA | - | - | 123 | DCC |

SHEAR PANEL/MEMBRANE ELEMENT DATA

| Letter Designation | NASTRAN EID | Type | Thickness (IN.) |
|--------------------|-------------|------------|-----------------|
| M | 1292097 | Inner Skin | .025 |
| | 1291492 | Outer Skin | .016 |
| N | 1292099 | Inner Skin | .025 |
| | 1291494 | Outer Skin | .016 |
| O | 1292096 | Inner Skin | .025 |
| | 1291491 | Outer Skin | .016 |
| P | 1292098 | Inner Skin | .025 |
| | 1291493 | Outer Skin | .016 |

ROD ELEMENT DATA

| LETTER DESIGNATION | NASTRAN EID | TYPE | ACTUAL AREA (in. ²) | OFFSETS FROM GRIDPOINT | | FINAL AREA (in. ²) |
|--------------------|-------------|---------|---------------------------------|------------------------|-----|--------------------------------|
| | | | | Z | Y | |
| A | 1570034 | Cap | .364 | -0.34 | 0.0 | .325 |
| | 1290234 | Doubler | .036 | -1.12 | 0.0 | .024 |
| | 1290964 | R/SP1 | .042 | - | - | .042 |
| | 1294904 | R/SP1 | .007 | - | - | .007 |
| B | 1570035 | Cap | .319 | -0.33 | 0.0 | .284 |
| | 1290235 | Doubler | .036 | -1.12 | 0.0 | .024 |
| | 1290984 | R/SP1 | .054 | - | - | .054 |
| | 1294924 | R/SP1 | .014 | - | - | .014 |
| C | 1290274 | Doubler | .037 | -1.12 | 0.0 | .043 |
| | 1290972 | R/SP2 | .256 | - | - | .256 |
| | 1294912 | R/SP2 | .155 | - | - | .155 |
| D | 1290974 | R/SP2 | .256 | - | - | .256 |
| | 1290994 | R/SP2 | .289 | - | - | .289 |
| | 1294914 | R/SP2 | .155 | - | - | .155 |
| | 1294932 | R/SP2 | .176 | - | - | .176 |
| E | 1291374 | Doubler | .047 | -1.12 | 0.0 | .054 |
| | 1290996 | R/SP2 | .289 | - | - | .289 |
| | 1294934 | R/SP2 | .176 | - | - | .176 |
| F | 1290331 | Doubler | .090 | 0.0 | 0.0 | .090 |
| | 1290962 | R/SP1 | .134 | - | - | .134 |
| | 1290963 | R/SP1 | .134 | - | - | .134 |
| | 1294902 | R/SP1 | .080 | - | - | .080 |
| | 1294903 | R/SP1 | .080 | - | - | .080 |
| G | 1291972 | Doubler | .090 | 0.0 | 0.0 | .090 |
| | 1290982 | R/SP1 | .140 | - | - | .140 |
| | 1290983 | R/SP1 | .140 | - | - | .140 |
| | 1294922 | R/SP1 | .084 | - | - | .084 |
| | 1294923 | R/SP1 | .084 | - | - | .084 |
| H | 1290273 | Doubler | .037 | 1.12 | 0.0 | .043 |
| | 1290971 | R/SP1 | .256 | - | - | .256 |
| | 1294911 | R/SP2 | .155 | - | - | .155 |

ROD ELEMENT DATA (CONT.)

| LETTER DESIGNATION | NASTRAN EID | TYPE | ACTUAL AREA (in. ²) | OFFSETS FROM GRIDPOINT | | FINAL AREA (in. ²) |
|-----------------------|----------------|---------|------------------------------------|---------------------------|-----|-----------------------------------|
| | | | | Z | Y | |
| I | 1290973 | R/SP2 | .256 | - | - | .256 |
| | 1290993 | R/SP2 | .289 | - | - | .289 |
| | 1294913 | R/SP2 | .155 | - | - | .155 |
| | 1294931 | R/SP2 | .176 | - | - | .176 |
| J | 1291373 | Doubler | .047 | 1.12 | 0.0 | .054 |
| | 1290995 | R/SP2 | .289 | - | - | .289 |
| | 1294933 | R/SP2 | .176 | - | - | .176 |
| K | 1580044 | Cap | .370 | 0.34 | 0.0 | .344 |
| | 1290254 | Doubler | .057 | 1.12 | 0.0 | .046 |
| | 1290961 | R/SP1 | .079 | - | - | .079 |
| | 1294901 | R/SP1 | .030 | - | - | .030 |
| L | 1580045 | Cap | .370 | 0.34 | 0.0 | .347 |
| | 1291971 | Doubler | .057 | 1.12 | 0.0 | .044 |
| | 1290981 | R/SP1 | .077 | - | - | .077 |
| | 1294921 | R/SP1 | .028 | - | - | .028 |

3.1.2.4 Left Main Beam (Sta. 93-138) Detail

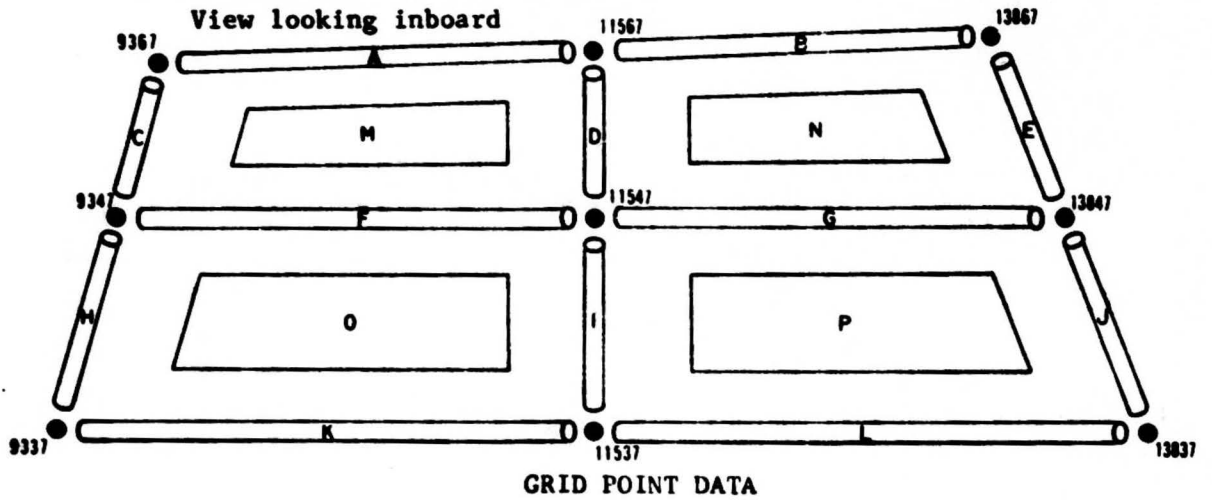

| GRID POINT | SPC | | MPC | | OMIT | |
|------------|--------|------|--------|------|--------|------|
| | D.O.F. | RULE | D.O.F. | RULE | D.O.F. | RULE |
| 9337 | 456 | AAA | - | - | 2 | C |
| 9347 | 456 | AAA | - | - | 123 | DCC |
| 9367 | 456 | AAA | - | - | 1 | D |
| 11537 | 456 | AAA | - | - | 13 | DC |
| 11547 | 456 | AAA | - | - | 12 | DC |
| 11567 | 456 | AAA | - | - | 3 | C |
| 13837 | 456 | AAA | - | - | 12 | DC |
| 13847 | 456 | AAA | - | - | 13 | DC |
| 13867 | 456 | AAA | - | - | 123 | DCC |

SHEAR PANEL/MEMBRANE ELEMENT DATA

| Letter Designation | NASTRAN EID | Type | Thickness (IN.) |
|--------------------|-------------|------------|-----------------|
| M | 1292057 | Inner Skin | .025 |
| | 1291371 | Outer Skin | .016 |
| N | 1292059 | Inner Skin | .025 |
| | 1291372 | Outer Skin | .016 |
| O | 1292056 | Inner Skin | .025 |
| | 1291851 | Outer Skin | .016 |
| P | 1292058 | Inner Skin | .025 |
| | 1291852 | Outer Skin | .016 |

ROD ELEMENT DATA

| LETTER DESIGNATION | NASTRAN EID | TYPE | ACTUAL AREA (in. ²) | OFFSETS FROM CRIDPOINT | | FINAL AREA (in. ²) |
|--------------------|-------------|---------|---------------------------------|------------------------|-----|--------------------------------|
| | | | | Z | Y | |
| A | 1570014 | Cap | .364 | -0.33 | 0.0 | .325 |
| | 1290732 | Doubler | .068 | -1.19 | 0.0 | .044 |
| | 1290564 | R/SP1 | .041 | - | - | .041 |
| | 1293702 | R/SP1 | .012 | - | - | .012 |
| B | 1570015 | Cap | .319 | -0.33 | 0.0 | .285 |
| | 1290733 | Doubler | .068 | -1.19 | 0.0 | .044 |
| | 1290584 | R/SP1 | .052 | - | - | .052 |
| | 1293712 | R/SP1 | .011 | - | - | .011 |
| C | 1290794 | Doubler | .047 | -1.19 | 0.0 | .056 |
| | 1290572 | R/SP2 | .256 | - | - | .256 |
| | 1293703 | R/SP2 | .159 | - | - | .159 |
| D | 1290574 | R/SP2 | .256 | - | - | .256 |
| | 1290592 | R/SP2 | .249 | - | - | .249 |
| | 1293704 | R/SP2 | .159 | - | - | .159 |
| | 1293713 | R/SP2 | .154 | - | - | .154 |
| E | 1290692 | Doubler | .050 | -1.19 | 0.0 | .058 |
| | 1290594 | R/SP2 | .249 | - | - | .249 |
| | 1293714 | R/SP2 | .154 | - | - | .154 |
| F | 1291431 | Doubler | .093 | 0.0 | 0.0 | .093 |
| | 1290562 | R/SP1 | .134 | - | - | .134 |
| | 1290563 | R/SP1 | .134 | - | - | .134 |
| | 1298502 | R/SP1 | .028 | - | - | .028 |
| | 1293701 | R/SP1 | .012 | - | - | .012 |
| G | 1291432 | Doubler | .093 | 0.0 | 0.0 | .093 |
| | 1290582 | R/SP1 | .139 | - | - | .139 |
| | 1290583 | R/SP1 | .139 | - | - | .139 |
| | 1298512 | R/SP1 | .031 | - | - | .031 |
| | 1293711 | R/SP1 | .011 | - | - | .011 |
| H | 1290793 | Doubler | .047 | 1.21 | 0.0 | .056 |
| | 1290571 | R/SP2 | .256 | - | - | .256 |
| | 1298503 | R/SP2 | .159 | - | - | .159 |

ROD ELEMENT DATA (CONT.)

| LETTER DESIGNATION | NASTRAN EID | TYPE | ACTUAL AREA (in. ²) | OFFSETS FROM GRIDPOINT | | FINAL AREA (in. ²) |
|-----------------------|----------------|---------|------------------------------------|---------------------------|-----|-----------------------------------|
| | | | | Z | Y | |
| I | 1290577 | R/SP2 | .256 | - | - | .256 |
| | 1290591 | R/SP2 | .249 | - | - | .249 |
| | 1298504 | R/SP2 | .159 | - | - | .159 |
| | 1298513 | R/SP2 | .154 | - | - | .154 |
| J | 1290591 | Doubler | .050 | 1.21 | 0.0 | .058 |
| | 1290593 | R/SP2 | .249 | - | - | .249 |
| | 1298514 | R/SP2 | .154 | - | - | .154 |
| K | 1580034 | Cap | .370 | 0.34 | 0.0 | .344 |
| | 1291111 | Doubler | .068 | 1.21 | 0.0 | .052 |
| | 1290561 | R/SP1 | .078 | - | - | .078 |
| | 1298501 | R/SP1 | .028 | - | - | .028 |
| L | 1580035 | Cap | .370 | 0.34 | 0.0 | .346 |
| | 1291112 | Doubler | .068 | 1.21 | 0.0 | .052 |
| | 1290581 | R/SP1 | .076 | - | - | .076 |
| | 1298511 | R/SP1 | .031 | - | - | .031 |

3.1.2.5 Right Main Beam (Sta. 138-148) Detail

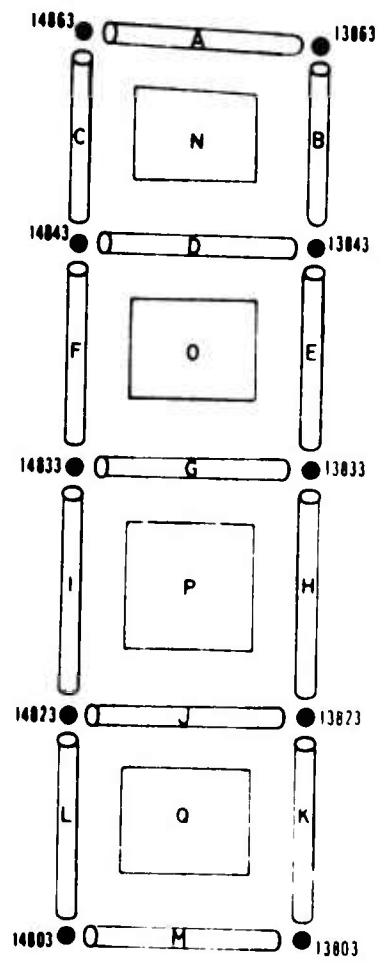

View looking inboard

GRID POINT DATA

| GRID POINT | SPC | | MPC | | OMIT | |
|------------|--------|------|--------|------|--------|------|
| | D.O.F. | RULE | D.O.F. | RULE | D.O.F. | RULE |
| 13803 | 456 | AAA | - | - | 123 | DCC |
| 13823 | 456 | AAA | - | - | 13 | DC |
| 13833 | 456 | AAA | - | - | 12 | DC |
| 13843 | 456 | AAA | - | - | 123 | DCC |
| 13863 | 456 | AAA | - | - | 123 | DCC |
| 14803 | 456 | AAA | 123 | AAA | - | - |
| 14823 | 456 | AAA | 123 | AAA | - | - |
| 14833 | 456 | AAA | - | - | 123 | DCC |
| 14843 | 456 | AAA | - | - | 123 | DCC |
| 14863 | 456 | AAA | - | - | - | - |

SHEAR PANEL/MEMBRANE ELEMENT DATA

| Letter Designation | NASTRAN EID | Type | Thickness (IN.) |
|--------------------|-------------|---------------|-----------------|
| N | 1292104 | Inner Skin | .025 |
| | 1290171 | Outer Skin | .016 |
| O | 1292103 | Inner Skin | .025 |
| | 1291983 | Interior Skin | .040 |
| | 1290191 | Outer Skin | .016 |
| P | 1292102 | Inner Skin | .025 |
| | 1291982 | Interior Skin | .040 |
| | 1291272 | Outer Skin | .020 |
| Q | 1292101 | Inner Skin | .025 |
| | 1291981 | Interior Skin | .040 |
| | 1291271 | Outer Skin | .020 |

ROD ELEMENT DATA

| LETTER DESIGNATION | NASTRAN EID | TYPE | INITIAL AREA (in. ²) | OFFSETS FROM GRIDPOINT | | FINAL AREA (in. ²) |
|--------------------|-------------|---------|----------------------------------|------------------------|-----|--------------------------------|
| | | | | Z | Y | |
| A | 1570036 | Cap | .215 | -0.33 | 0.0 | .301 |
| | 1291985 | Doubler | .090 | -1.25 | 0.0 | .075 |
| | 1291008 | R/SP1 | .063 | - | - | .063 |
| | 1291702 | R/SP1 | .035 | - | - | .035 |
| B | 1291986 | Doubler | .080 | -0.77 | 0.0 | .087 |
| | 1291014 | R/SP2 | .120 | - | - | .120 |
| | 1291703 | R/SP2 | .055 | - | - | .055 |
| C | 1291987 | Doubler | .071 | -1.31 | 0.0 | .083 |
| | 1291018 | R/SP2 | .120 | - | - | .120 |
| | 1291704 | R/SP2 | .055 | - | - | .055 |
| D | 1291984 | Doubler | .179 | -0.31 | 0.0 | .163 |
| | 1291006 | R/SP1 | .144 | - | - | .144 |
| | 1291007 | R/SP1 | .144 | - | - | .144 |
| | 1299806 | R/SP1 | .142 | - | - | .142 |
| | 1291701 | R/SP1 | .035 | - | - | .035 |
| | 1291902 | R/SP1 | .013 | - | - | .013 |
| E | 1291274 | Doubler | .041 | -0.48 | 0.0 | .044 |
| | 1291013 | R/SP2 | .120 | - | - | .120 |
| | 1299813 | R/SP2 | .191 | - | - | .191 |
| | 1291903 | R/SP2 | .055 | - | - | .055 |
| F | 1291275 | Doubler | .036 | 0.0 | 0.0 | .036 |
| | 1291017 | R/SP2 | .120 | - | - | .120 |
| | 1299816 | R/SP2 | .191 | - | - | .191 |
| | 1291904 | R/SP2 | .055 | - | - | .055 |
| G | 1580046 | Cap | .291 | 0.33 | 0.0 | .227 |
| | 1291273 | Doubler | .084 | 0.0 | 0.0 | .084 |
| | 1291004 | R/SP1 | .088 | - | - | .088 |
| | 1291005 | R/SP1 | .078 | - | - | .078 |
| | 1299804 | R/SP1 | .201 | - | - | .201 |
| | 1299805 | R/SP1 | .142 | - | - | .142 |
| | 1292704 | R/SP1 | .034 | - | - | .034 |
| | 1291901 | R/SP1 | .013 | - | - | .013 |

ROD ELEMENT DATA (CONT.)

| LETTER DESIGNATION | NASTRAN EID | TYPE | ACTUAL AREA (in. ²) | OFFSETS FROM GRIDPOINT | | FINAL AREA (in. ²) |
|-----------------------|----------------|-------|------------------------------------|---------------------------|-----|-----------------------------------|
| | | | | Z | Y | |
| H | 1291012 | R/SP2 | .120 | - | - | .120 |
| | 1299812 | R/SP2 | .191 | - | - | .191 |
| | 1292712 | R/SP2 | .096 | - | - | .096 |
| I | 1291016 | R/SP2 | .120 | - | - | .120 |
| | 1299815 | R/SP2 | .191 | - | - | .191 |
| | 1292714 | R/SP2 | .096 | - | - | .096 |
| J | 1590071 | Cap | .278 | 0.34 | 0.0 | .264 |
| | 1291002 | R/SP1 | .158 | - | - | .158 |
| | 1291003 | R/SP1 | .158 | - | - | .158 |
| | 1299802 | R/SP1 | .167 | - | - | .167 |
| | 1299803 | R/SP1 | .201 | - | - | .201 |
| | 1292702 | R/SP1 | .122 | - | - | .122 |
| | 1292703 | R/SP1 | .122 | - | - | .122 |
| K | 1291011 | R/SP2 | .120 | - | - | .120 |
| | 1299811 | R/SP2 | .191 | - | - | .191 |
| | 1292711 | R/SP2 | .096 | - | - | .096 |
| L | 1291015 | R/SP2 | .120 | - | - | .120 |
| | 1299814 | R/SP2 | .191 | - | - | .191 |
| | 1292713 | R/SP2 | .096 | - | - | .096 |
| M | 1291001 | R/SP1 | .056 | - | - | .056 |
| | 1299801 | R/SP1 | .167 | - | - | .167 |
| | 1292701 | R/SP1 | .047 | - | - | .047 |

3.1.2.6 Left Main Beam (Sta. 138-148) Detail

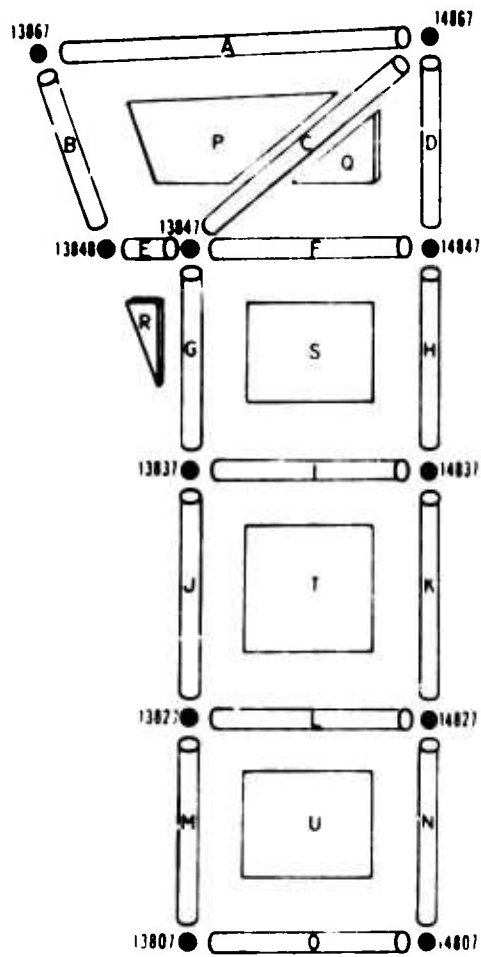

View looking inboard

GRID POINT DATA

| GRID POINT | SPC | | MPC | | OMIT | |
|------------|--------|------|--------|------|--------|------|
| | D.O.F. | RULE | D.O.F. | RULE | D.O.F. | RULE |
| 13807 | 456 | AAA | - | - | 123 | DCC |
| 13827 | 456 | AAA | - | - | 123 | DCC |
| 13837 | 456 | AAA | - | - | 12 | DC |
| 13847 | 456 | AAA | - | - | 13 | DC |
| 13848 | 456 | AAA | - | - | 123 | DCC |
| 13867 | 456 | AAA | - | - | 123 | DCC |
| 14807 | 456 | AAA | 123 | AAA | - | - |
| 14827 | 456 | AAA | 123 | AAA | - | - |
| 14837 | 456 | AAA | - | - | 123 | DCC |
| 14847 | 456 | AAA | - | - | 123 | DCC |
| 14867 | 456 | AAA | - | - | 12 | DC |

SHEAR PANEL/MEMBRANE ELEMENT DATA

| Letter Designation | NASTRAN EID | Type | Thickness (IN.) |
|--------------------|-------------|---------------|-----------------|
| P | 1291415 | Inner Skin | .025 |
| | 1290591 | Outer Skin | .025 |
| Q | 1291416 | Inner Skin | .025 |
| | 1290592 | Outer Skin | .025 |
| R | 1291413 | Inner Skin | .025 |
| | 1290693 | Interior Skin | .040 |
| S | 1291414 | Inner Skin | .025 |
| | 1290694 | Interior Skin | .040 |
| | 1290571 | Outer Skin | .016 |
| T | 1291412 | Inner Skin | .025 |
| | 1290692 | Interior Skin | .040 |
| | 1291252 | Outer Skin | .020 |
| U | 1291411 | Inner Skin | .025 |
| | 1290691 | Interior Skin | .040 |
| | 1291251 | Outer Skin | .020 |

ROD ELEMENT DATA

| LETTER DESIGNATION | NASTRAN EID | TYPE | ACTUAL AREA (in. ²) | OFFSETS FROM GRIDPOINT | | FINAL AREA (in. ²) |
|--------------------|-------------|---------|---------------------------------|------------------------|------|--------------------------------|
| | | | | Z | Y | |
| A | 1570016 | Cap | .288 | -0.33 | 0.0 | .275 |
| | 1290695 | Doubler | .116 | -1.25 | 0.0 | .097 |
| | 1294108 | R/SP1 | .061 | - | - | .061 |
| | 1295922 | R/SP1 | .053 | - | - | .053 |
| B | 1290698 | Doubler | .080 | -1.25 | 0.0 | .090 |
| | 1294114 | R/SP2 | .122 | - | - | .122 |
| | 1295923 | R/SP2 | .094 | - | - | .094 |
| C | 1294118 | R/SP2 | .122 | - | - | .122 |
| | 1295924 | R/SP2 | .094 | - | - | .094 |
| D | 1290699 | Doubler | .072 | -1.25 | 0.0 | .081 |
| E | 1290696 | Doubler | .117 | -0.35 | 0.0 | .104 |
| | 1294107 | R/SP1 | .143 | - | - | .143 |
| | 1295921 | R/SP1 | .053 | - | - | .053 |
| F | 1290697 | Doubler | .117 | -0.35 | 0.0 | .104 |
| | 1294106 | R/SP1 | .143 | - | - | .143 |
| | 1296906 | R/SP1 | .151 | - | - | .151 |
| | 1295702 | R/SP1 | .014 | - | - | .014 |
| G | 1291254 | Doubler | .041 | 0.0 | 0.0 | .041 |
| | 1294113 | R/SP2 | .121 | - | - | .121 |
| | 1296913 | R/SP2 | .194 | - | - | .194 |
| | 1295703 | R/SP2 | .056 | - | - | .056 |
| H | 1291255 | Doubler | .037 | 0.0 | 0.0 | .037 |
| | 1294117 | R/SP2 | .121 | - | - | .121 |
| | 1296916 | R/SP2 | .194 | - | - | .194 |
| | 1295704 | R/SP2 | .056 | - | - | .056 |
| I | 1580036 | Cap | .291 | 0.33 | 0.0 | .221 |
| | 1291253 | Doubler | .090 | 0.0 | 0.0 | .090 |
| | 1294104 | R/SP1 | .088 | - | - | .088 |
| | 1294105 | R/SP1 | .078 | - | - | .078 |
| | 1296904 | R/SP1 | .201 | - | - | .201 |
| | 1296905 | R/SP1 | .151 | - | - | .151 |
| | 1292504 | R/SP1 | .033 | - | - | .033 |
| 1295701 | R/SP1 | .014 | - | - | .014 | |

ROD ELEMENT DATA (CONT.)

| LETTER DESIGNATION | NASTRAN EID | TYPE | ACTUAL AREA (in. ²) | OFFSETS FROM GRIDPOINT | | FINAL AREA (in. ²) |
|-----------------------|----------------|-------|------------------------------------|---------------------------|-----|-----------------------------------|
| | | | | Z | Y | |
| J | 1294112 | R/SP2 | .120 | - | - | .120 |
| | 1296912 | R/SP2 | .191 | - | - | .191 |
| | 1292512 | R/SP2 | .096 | - | - | .096 |
| K | 1294116 | R/SP2 | .120 | - | - | .120 |
| | 1296915 | R/SP2 | .191 | - | - | .191 |
| | 1292514 | R/SP2 | .096 | - | - | .096 |
| L | 1590051 | Cap | .290 | 0.35 | 0.0 | .274 |
| | 1294102 | R/SP1 | .158 | - | - | .158 |
| | 1294103 | R/SP1 | .158 | - | - | .158 |
| | 1296902 | R/SP1 | .169 | - | - | .169 |
| | 1296903 | R/SP1 | .201 | - | - | .201 |
| | 1292502 | R/SP1 | .122 | - | - | .122 |
| | 1292503 | R/SP1 | .122 | - | - | .122 |
| | 1294111 | R/SP2 | .120 | - | - | .120 |
| M | 1296911 | R/SP2 | .191 | - | - | .191 |
| | 1292511 | R/SP2 | .096 | - | - | .096 |
| | 1294115 | R/SP2 | .120 | - | - | .120 |
| N | 1296914 | R/SP2 | .191 | - | - | .191 |
| | 1292513 | R/SP2 | .096 | - | - | .096 |
| | 1294101 | R/SP1 | .057 | - | - | .057 |
| O | 1296901 | R/SP1 | .169 | - | - | .169 |
| | 1292501 | R/SP1 | .048 | - | - | .048 |

3.1.2.7 Bulkhead Sta. 61.25 Detail

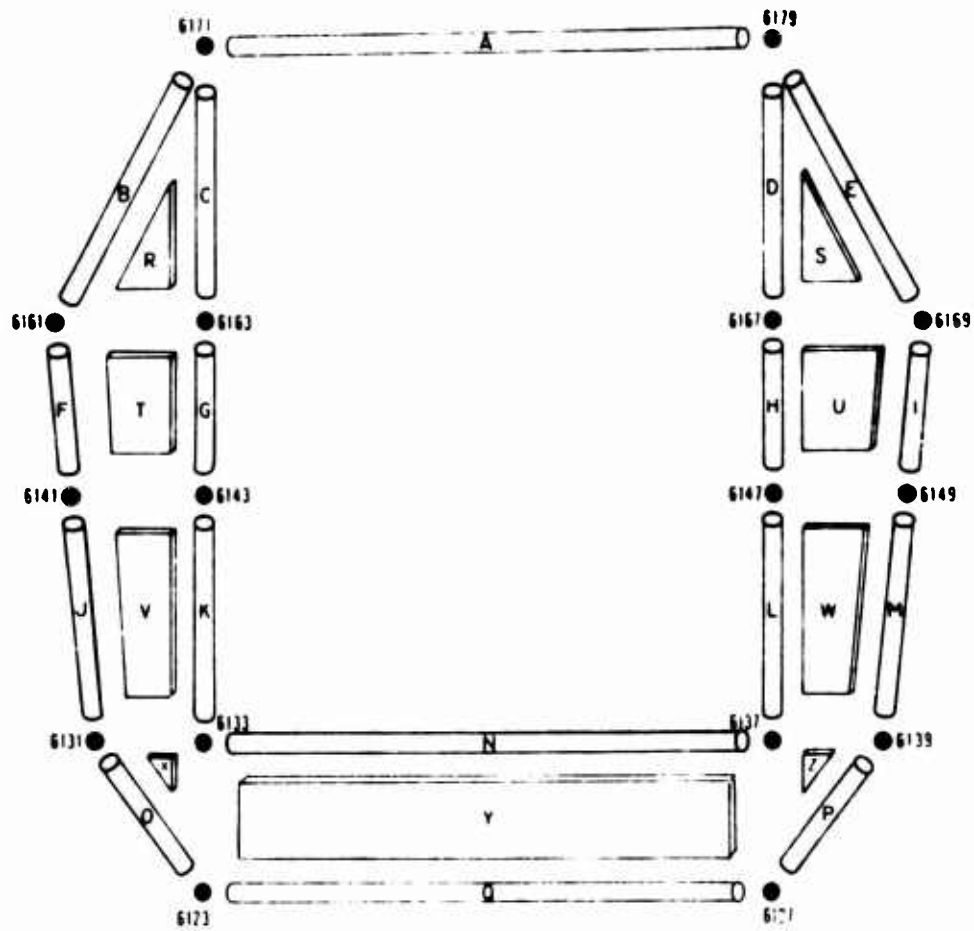

View looking aft

GRID POINT DATA

| GRID POINT | SPC | | MPC | | OMIT | |
|------------|--------|------|--------|------|--------|------|
| | D.O.F. | RULE | D.O.F. | RULE | D.O.F. | RULE |
| 6123 | 456 | AAA | - | - | 123 | DCC |
| 6127 | 456 | AAA | - | - | 13 | DC |
| 6131 | 456 | AAA | - | - | 123 | DCC |
| 6133 | 456 | AAA | - | - | 23 | CC |
| 6137 | 456 | AAA | - | - | 123 | DCC |
| 6139 | 456 | AAA | - | - | 123 | DCC |
| 6141 | 456 | AAA | - | - | 123 | DCC |
| 6143 | 456 | AAA | - | - | 12 | DC |
| 6147 | 456 | AAA | - | - | 12 | DC |
| 6149 | 456 | AAA | - | - | 123 | DCC |
| 6161 | 456 | AAA | - | - | 123 | DCC |
| 6163 | 456 | AAA | - | - | 123 | DCC |
| 6167 | 456 | AAA | - | - | 23 | CC |
| 6169 | 456 | AAA | - | - | 123 | DCC |
| 6171 | 456 | AAA | - | - | 13 | DC |
| 6179 | 456 | AAA | - | - | 123 | DCC |

SHEAR PANEL/MEMBRANE ELEMENT DATA

| Letter Designation | NASTRAN EID | Type | Thickness (IN.) |
|--------------------|-------------|----------|-----------------|
| R | 617161 | Bulkhead | .040 |
| S | 616779 | Bulkhead | .040 |
| T | 614163 | Bulkhead | .040 |
| U | 614769 | Bulkhead | .040 |
| V | 613143 | Bulkhead | .040 |
| W | 613749 | Bulkhead | .040 |
| X | 612331 | Bulkhead | .040 |
| Y | 612337 | Bulkhead | .040 |
| Z | 612737 | Bulkhead | .040 |

ROD ELEMENT DATA (CONT.)

| LETTER DESIGNATION | NASTRAN EID | TYPE | ACTUAL AREA (in. ²) | OFFSETS FROM GRIDPOINT | | FINAL AREA (in. ²) |
|-----------------------|----------------|---------|------------------------------------|---------------------------|---|-----------------------------------|
| | | | | Z | Y | |
| A | 5850871 | Doubler | 0.044 | - | - | 0.044 |
| | 617179 | Frame | 0.282 | - | - | 0.282 |
| B | 5850872 | Doubler | 0.044 | - | - | 0.044 |
| | 616171 | Frame | 0.282 | - | - | 0.282 |
| C | 616371 | Frame | 0.012 | - | - | 0.012 |
| D | 617967 | Frame | 0.012 | - | - | 0.012 |
| E | 5850873 | Doubler | 0.044 | - | - | 0.044 |
| | 616979 | Frame | 0.282 | - | - | 0.282 |
| F | 5850792 | Doubler | 0.034 | - | - | 0.034 |
| | 614161 | Frame | 0.064 | - | - | 0.064 |
| G | 614363 | Frame | 0.030 | - | - | 0.030 |
| H | 614767 | Frame | 0.030 | - | - | 0.030 |
| I | 5850798 | Doubler | 0.034 | - | - | 0.034 |
| | 614969 | Frame | 0.064 | - | - | 0.064 |
| J | 5850793 | Doubler | 0.034 | - | - | 0.034 |
| | 613141 | Frame | 0.064 | - | - | 0.064 |
| K | 613343 | Frame | 0.030 | - | - | 0.030 |
| L | 613747 | Frame | 0.030 | - | - | 0.030 |
| M | 5850797 | Doubler | 0.034 | - | - | 0.034 |
| | 613949 | Frame | 0.064 | - | - | 0.064 |
| N | 613337 | Frame | 0.055 | - | - | 0.055 |
| O | 5850794 | Doubler | 0.034 | - | - | 0.034 |
| | 613123 | Frame | 0.030 | - | - | 0.030 |
| P | 5850796 | Doubler | 0.034 | - | - | 0.034 |
| | 612739 | Frame | 0.030 | - | - | 0.030 |
| Q | 5850795 | Doubler | 0.034 | - | - | 0.034 |
| | 612327 | Frame | 0.108 | - | - | 0.108 |

3.1.2.8 Bulkhead Sta. 93. Detail

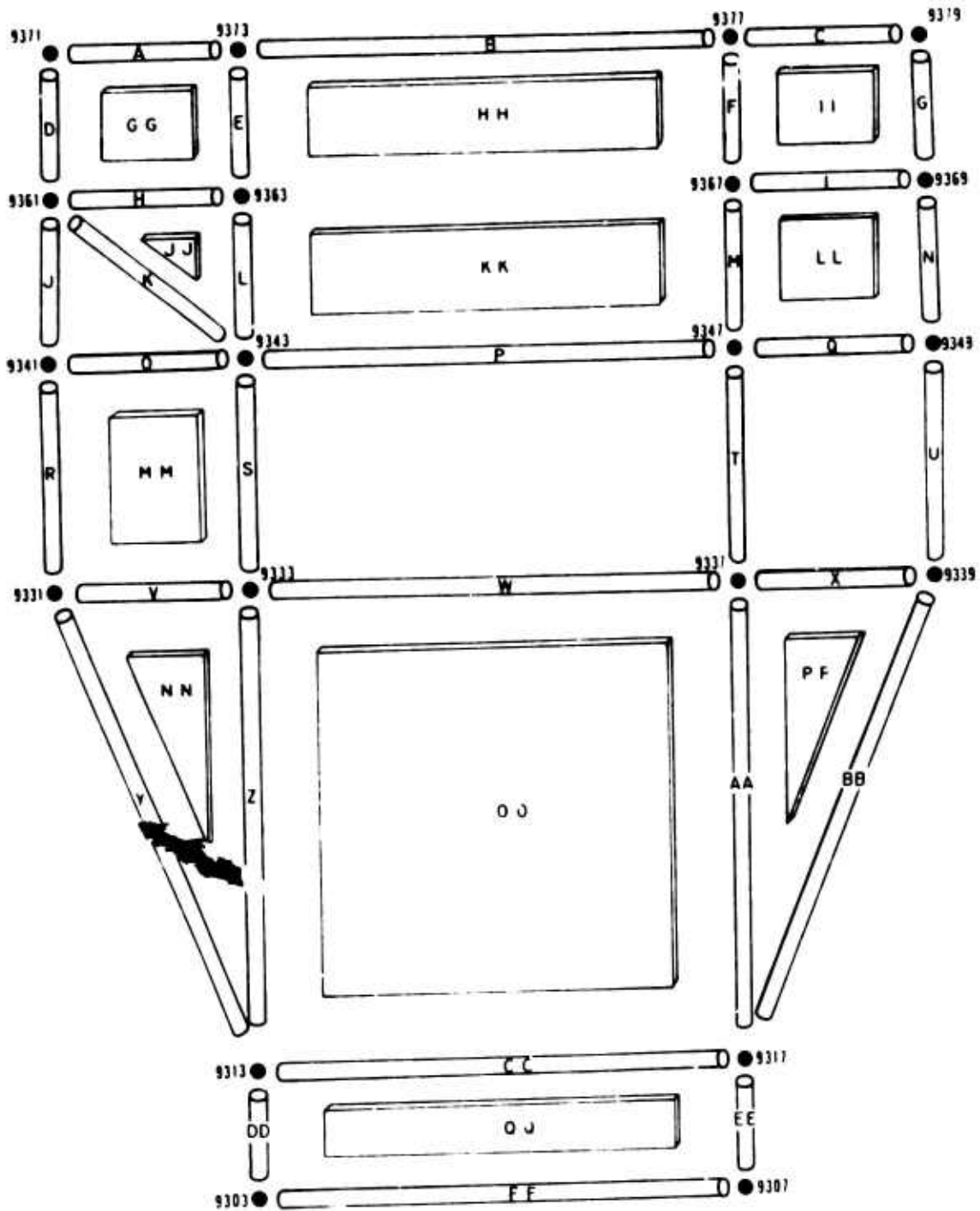

View looking aft

GRID POINT DATA

| GRID POINT | SPC | | MPC | | OMIT | |
|------------|--------|------|--------|------|--------|------|
| | D.O.F. | RULE | D.O.F. | RULE | D.O.F. | RULE |
| 9303 | 456 | AAA | - | - | 123 | DCC |
| 9307 | 456 | AAA | - | - | 123 | DCC |
| 9313 | 456 | AAA | - | - | 123 | DCC |
| 9317 | 456 | AAA | - | - | 13 | DC |
| 9331 | 456 | AAA | - | - | 123 | DC |
| 9333 | 456 | AAA | - | - | 1 | D |
| 9337 | 456 | AAA | - | - | 2 | C |
| 9339 | 456 | AAA | - | - | 123 | DCC |
| 9341 | 1456 | AAAA | - | - | 23 | CC |
| 9343 | 456 | AAA | - | - | 123 | DCC |
| 9347 | 456 | AAA | - | - | 123 | DCC |
| 9349 | 1456 | AAAA | - | - | 23 | CC |
| 9361 | 456 | AAA | - | - | 123 | DCC |
| 9363 | 456 | AAA | - | - | 2 | C |
| 9367 | 456 | AAA | - | - | 1 | D |
| 9369 | 456 | AAA | - | - | 123 | DCC |
| 9371 | 456 | AAA | - | - | 123 | DCC |
| 9373 | 1456 | AAAA | - | - | 23 | CC |
| 9377 | 1456 | AAAA | - | - | 23 | CC |
| 9379 | 456 | AAA | - | - | 123 | DCC |

SHEAR PANEL/MEMBRANE ELEMENT DATA

| Letter Designation | NASTRAN EID | Type | Thickness (IN.) |
|--------------------|-------------|----------|-----------------|
| GG | 936173 | Bulkhead | .049 |
| HH | 936377 | Bulkhead | .024 |
| II | 936779 | Bulkhead | .049 |
| JJ | 934361 | Bulkhead | .040 |
| KK | 934367 | Bulkhead | .024 |
| LL | 934769 | Bulkhead | .040 |
| MM | 933143 | Bulkhead | .085 |
| NN | 931331 | Bulkhead | .024 |
| OO | 931337 | Bulkhead | .024 |
| PP | 931737 | Bulkhead | .024 |
| QQ | 930317 | Bulkhead | .025 |

ROD ELEMENT DATA

| LETTER DESIGNATION | NASTRAN EID | TYPE | ACTUAL AREA (in. ²) | OFFSETS FROM GRIDPOINT | | FINAL AREA (in. ²) |
|-----------------------|----------------|-------|------------------------------------|---------------------------|---|-----------------------------------|
| | | | | Z | Y | |
| A | 937173 | Frame | .202 | - | - | .202 |
| B | 937377 | Frame | .188 | - | - | .188 |
| C | 937779 | Frame | .202 | - | - | .202 |
| D | 936171 | Frame | .092 | - | - | .092 |
| E | 936373 | Frame | .100 | - | - | .100 |
| F | 936777 | Frame | .100 | - | - | .100 |
| G | 936979 | Frame | .092 | - | - | .092 |
| H | 936163 | Frame | .194 | - | - | .194 |
| I | 936769 | Frame | .194 | - | - | .194 |
| J | 934161 | Frame | .333 | - | - | .333 |
| K | 936143 | Frame | .191 | - | - | .191 |
| L | 934363 | Frame | .242 | - | - | .242 |
| M | 934767 | Frame | .374 | - | - | .374 |
| N | 934969 | Frame | .188 | - | - | .188 |
| O | 934143 | Frame | .242 | - | - | .242 |
| P | 934347 | Frame | .374 | - | - | .374 |
| Q | 934749 | Frame | .357 | - | - | .357 |
| R | 933141 | Frame | .333 | - | - | .333 |
| S | 933343 | Frame | .333 | - | - | .333 |
| T | 933747 | Frame | .510 | - | - | .510 |
| U | 933949 | Frame | .314 | - | - | .314 |
| V | 933133 | Frame | .397 | - | - | .397 |
| W | 933337 | Frame | .167 | - | - | .167 |
| X | 933739 | Frame | .261 | - | - | .261 |
| Y | 933113 | Frame | .080 | - | - | .080 |
| Z | 931333 | Frame | .209 | - | - | .209 |
| AA | 933717 | Frame | .209 | - | - | .209 |
| BB | 931739 | Frame | .080 | - | - | .080 |
| CC | 931317 | Frame | .151 | - | - | .151 |
| DD | 930313 | Frame | .051 | - | - | .051 |
| EE | 930717 | Frame | .051 | - | - | .051 |
| FF | 930307 | Frame | .095 | - | - | .095 |

3.1.2.9 Bulkhead Sta. 138.7 Detail

Note: Upper left bulkhead canted forward.

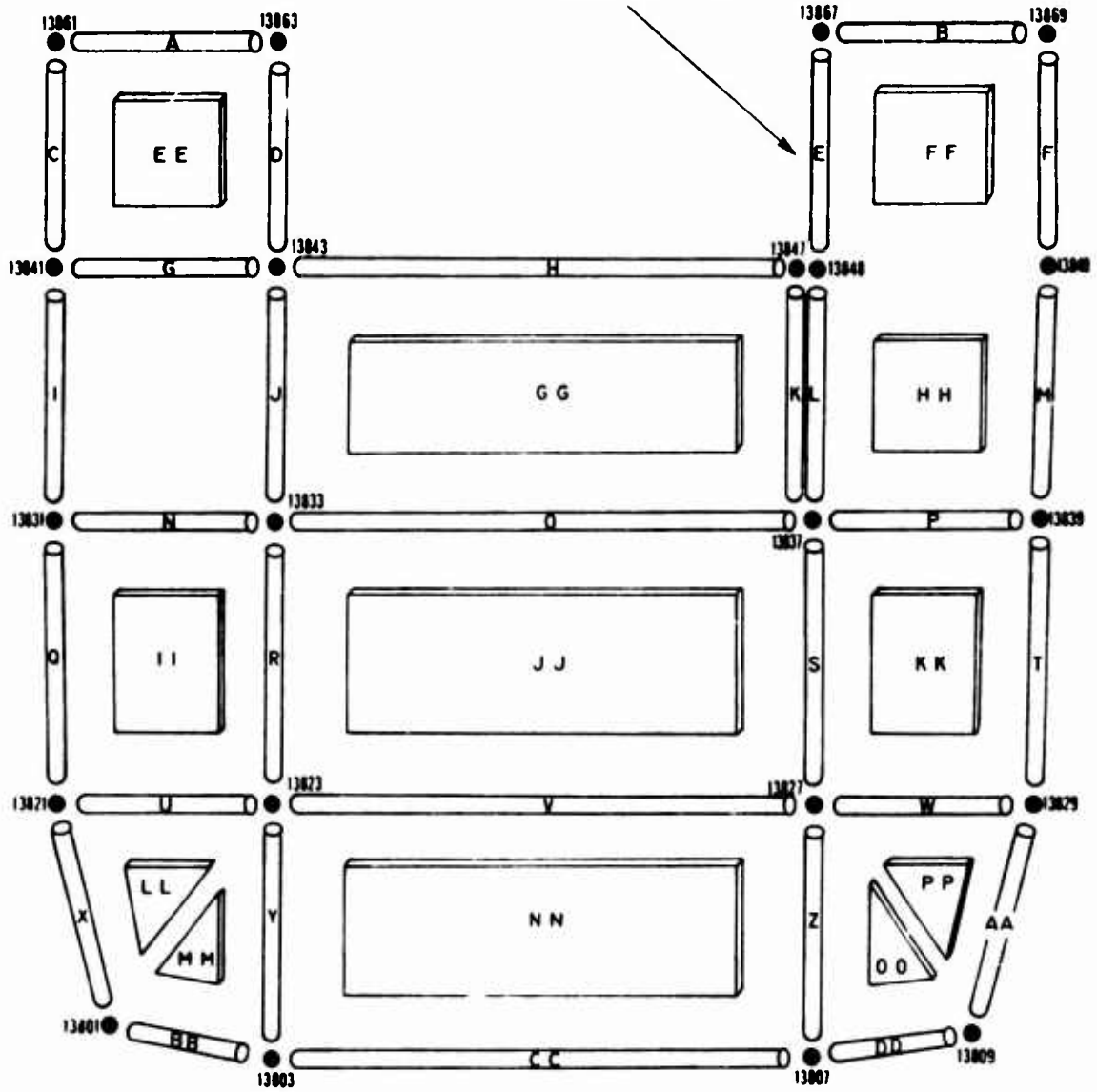

View looking aft

GRID POINT DATA

| GRID POINT | SPC | | MPC | | OMIT | |
|------------|--------|------|--------|------|--------|------|
| | D.O.F. | RULE | D.O.F. | RULE | D.O.F. | RULE |
| 13801 | 456 | AAA | - | - | 123 | DCC |
| 13803 | 456 | AAA | - | - | 123 | DCC |
| 13807 | 456 | AAA | - | - | 123 | DCC |
| 13809 | 456 | AAA | - | - | 123 | DCC |
| 13821 | 456 | AAA | - | - | 123 | DCC |
| 13823 | 456 | AAA | - | - | 13 | DC |
| 13827 | 456 | AAA | - | - | 123 | DCC |
| 13829 | 456 | AAA | - | - | 123 | DCC |
| 13831 | 456 | AAA | - | - | 123 | DCC |
| 13833 | 456 | AAA | - | - | 12 | DC |
| 13837 | 456 | AAA | - | - | 12 | DC |
| 13839 | 456 | AAA | - | - | 123 | DCC |
| 13841 | 1456 | AAAA | - | - | 23 | CC |
| 13843 | 456 | AAA | - | - | 123 | DCC |
| 13847 | 456 | AAA | - | - | 13 | DC |
| 13848 | 456 | AAA | - | - | 123 | DCC |
| 13849 | 1456 | AAAA | - | - | 23 | CC |
| 13861 | 456 | AAA | - | - | 123 | DCC |
| 13863 | 456 | AAA | - | - | 123 | DCC |
| 13867 | 456 | AAA | - | - | 123 | DCC |
| 13869 | 456 | AAA | - | - | 123 | DCC |
| 13871 | 2456 | AAAA | - | - | 13 | DC |
| 13879 | 2456 | AAAA | - | - | 13 | DC |

SHEAR PANEL/MEMBRANE ELEMENT DATA

| Letter Designation | NASTRAN EID | Type | Thickness (IN.) |
|--------------------|-------------|----------|-----------------|
| EE | 1384163 | Bulkhead | .032 |
| FF | 1384869 | Bulkhead | .032 |
| GG | 1383347 | Bulkhead | .040 |
| HH | 1383749 | Bulkhead | .032 |
| II | 1382133 | Bulkhead | .040 |
| JJ | 1382337 | Bulkhead | .040 |
| KK | 1382739 | Bulkhead | .040 |
| LL | 1380121 | Bulkhead | .040 |
| MM | 1380123 | Bulkhead | .040 |
| NN | 1380327 | Bulkhead | .040 |
| OO | 1380727 | Bulkhead | .040 |
| PP | 1380927 | Bulkhead | .040 |

ROD ELEMENT DATA

| LETTER DESIGNATION | NASTRAN EID | TYPE | ACTUAL AREA (in. ²) | OFFSETS FROM GRIDPOINT | | FINAL AREA (in. ²) |
|-----------------------|----------------|-------|------------------------------------|---------------------------|---|-----------------------------------|
| | | | | Z | Y | |
| A | 1386163 | Frame | .056 | - | - | .056 |
| B | 1386769 | Frame | .047 | - | - | .047 |
| C | 1384161 | Frame | .104 | - | - | .104 |
| D | 1384363 | Frame | .128 | - | - | .128 |
| E | 1384867 | Frame | .128 | - | - | .128 |
| F | 1384969 | Frame | .104 | - | - | .104 |
| G | 1384143 | Frame | .056 | - | - | .056 |
| H | 1384347 | Frame | .108 | - | - | .108 |
| I | 1383141 | Frame | .104 | - | - | .104 |
| J | 1383343 | Frame | .244 | - | - | .244 |
| K | 1383747 | Frame | .116 | - | - | .116 |
| L | 1383748 | Frame | .128 | - | - | .128 |
| M | 1383949 | Frame | .104 | - | - | .104 |
| N | 1383133 | Frame | .168 | - | - | .168 |
| O | 1383337 | Frame | .168 | - | - | .168 |
| P | 1383739 | Frame | .224 | - | - | .224 |
| Q | 1382131 | Frame | .057 | - | - | .057 |
| R | 1382333 | Frame | .116 | - | - | .116 |
| S | 1382737 | Frame | .116 | - | - | .116 |
| T | 1382939 | Frame | .061 | - | - | .061 |
| U | 1382123 | Frame | .070 | - | - | .070 |
| V | 1382327 | Frame | .130 | - | - | .130 |
| W | 1382729 | Frame | .070 | - | - | .070 |
| X | 1382101 | Frame | .078 | - | - | .078 |
| Y | 1380323 | Frame | .863 | - | - | .863 |
| Z | 1382707 | Frame | .116 | - | - | .116 |
| AA | 1380929 | Frame | .078 | - | - | .078 |
| BB | 1380103 | Frame | .078 | - | - | .078 |
| CC | 1380307 | Frame | .184 | - | - | .184 |
| DD | 1380709 | Frame | .078 | - | - | .078 |

3.1.2.10 Right Side Panels Under Canopy (Sta. 61-93) Detail

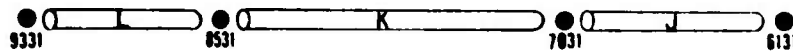
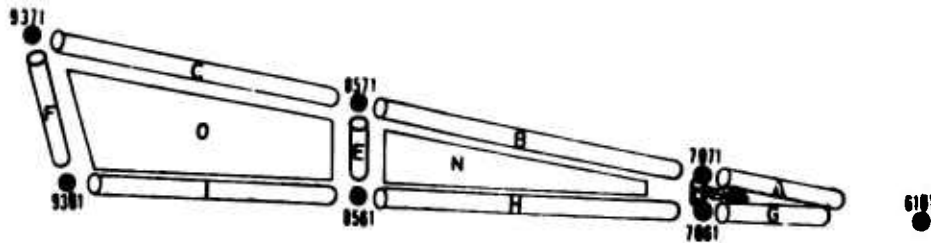

View looking inboard

GRID POINT DATA

| GRID POINT | SPC | | MPC | | OMIT | |
|------------|--------|------|--------|------|--------|------|
| | D.O.F. | RULE | D.O.F. | RULE | D.O.F. | RULE |
| 6131 | 456 | AAA | - | - | 123 | DCC |
| 6161 | 456 | AAA | - | - | 123 | DCC |
| 7031 | 3456 | AAAA | - | - | 12 | DC |
| 7061 | 456 | AAA | - | - | 123 | DCC |
| 7071 | 2456 | AAAA | - | - | 13 | DC |
| 8531 | 3456 | AAAA | - | - | 12 | DC |
| 8561 | 456 | AAA | - | - | 123 | DCC |
| 8571 | 2456 | AAAA | - | - | 13 | DC |
| 9331 | 456 | AAA | - | - | 123 | DCC |
| 9361 | 456 | AAA | - | - | 123 | DCC |
| 9371 | 456 | AAA | - | - | 123 | DCC |

SHEAR PANEL/MEMBRANE ELEMENT DATA

| Letter Designation | NASTRAN EID | Type | Thickness (IN.) |
|--------------------|-------------|------|-----------------|
| M | 1791611 | Skin | .032 |
| N | 1791612 | Skin | .032 |
| O | 1791613 | Skin | .032 |

ROD ELEMENT DATA

| LETTER DESIGNATION | NASTRAN EID | TYPE | ACTUAL AREA (in. ²) | OFFSETS FROM GRIDPOINT | | FINAL AREA (in. ²) |
|--------------------|-------------|-------|---------------------------------|------------------------|-----|--------------------------------|
| | | | | Z | Y | |
| A | 5003111 | Frame | .211 | 0.41 | 0.0 | .234 |
| B | 5003112 | Frame | .211 | 0.41 | 0.0 | .230 |
| | 1796102 | R/SP3 | .040 | - | - | .040 |
| C | 5003113 | Frame | .211 | 0.41 | 0.0 | .227 |
| | 1796112 | R/SP3 | .072 | - | - | .072 |
| D | 1796103 | R/SP2 | .232 | - | - | .232 |
| E | 1796104 | R/SP2 | .232 | - | - | .232 |
| | 1796113 | R/SP2 | .202 | - | - | .202 |
| F | 1796114 | R/SP2 | .202 | - | - | .202 |
| G | 2500171 | Cap | .059 | -0.27 | 0.0 | .054 |
| H | 2500172 | Cap | .059 | -0.27 | 0.0 | .054 |
| | 1796101 | R/SP3 | .040 | - | - | .040 |
| I | 2500173 | Cap | .059 | -0.27 | 0.0 | .054 |
| | 1796111 | R/SP3 | .072 | - | - | .072 |
| J | 2110102 | Cap | .226 | 0.67 | 0.0 | .187 |
| K | 2110103 | Cap | .226 | 0.68 | 0.0 | .189 |
| L | 2110104 | Cap | .226 | 0.68 | 0.0 | .193 |

3.1.2.11 Left Side Panels Under Canopy (Sta. 61-93) Detail

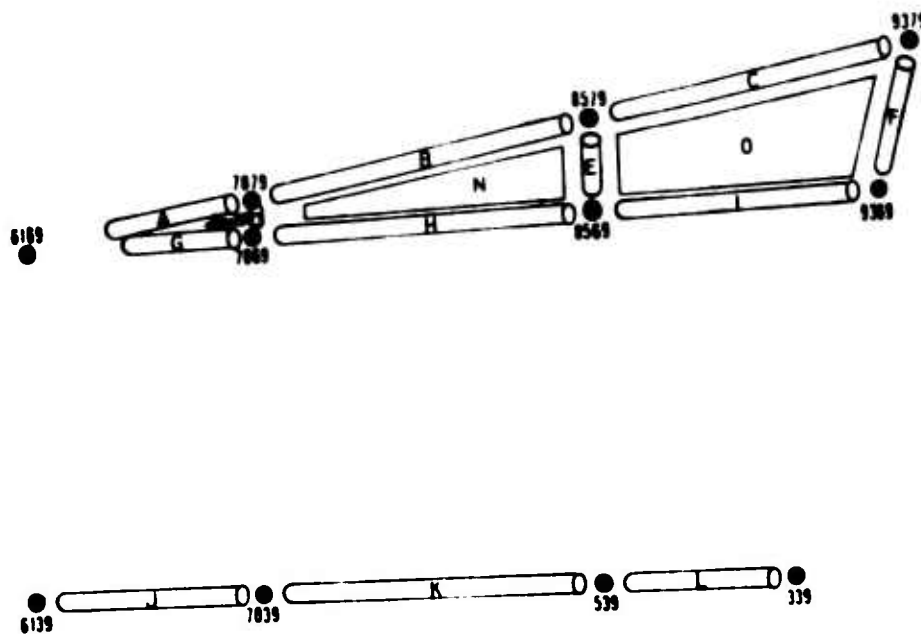

View looking inboard

GRID POINT DATA

| GRID POINT | SPC | | MPC | | OMIT | |
|------------|--------|------|--------|------|--------|------|
| | D.O.F. | RULE | D.O.F. | RULE | D.O.F. | RULE |
| 6139 | 456 | AAA | - | - | 123 | DCC |
| 6169 | 456 | AAA | - | - | 123 | DCC |
| 7039 | 3456 | AAAA | - | - | 12 | DC |
| 7069 | 456 | AAA | - | - | 123 | DCC |
| 7079 | 2456 | AAAA | - | - | 13 | DC |
| 8539 | 3456 | AAAA | - | - | 12 | DC |
| 8569 | 456 | AAA | - | - | 123 | DCC |
| 8579 | 2456 | AAAA | - | - | 13 | DC |
| 9339 | 456 | AAA | - | - | 123 | DCC |
| 9369 | 456 | AAA | - | - | 123 | DCC |
| 9379 | 456 | AAA | - | - | 123 | DCC |

SHEAR PANEL/MEMBRANE ELEMENT DATA

| Letter Designation | NASTRAN EID | Type | Thickness (IN.) |
|--------------------|-------------|------|-----------------|
| M | 1791631 | Skin | .032 |
| N | 1791632 | Skin | .032 |
| O | 1791633 | Skin | .032 |

ROD ELEMENT DATA

| LETTER DESIGNATION | NASTRAN EID | TYPE | ACTUAL AREA (in. ²) | OFFSETS FROM GRIDPOINT | | FINAL AREA (in. ²) |
|--------------------|-------------|-------|---------------------------------|------------------------|-----|--------------------------------|
| | | | | Z | Y | |
| A | 5003091 | Frame | .197 | -0.12 | 0.0 | .191 |
| B | 5003092 | Frame | .197 | -0.12 | 0.0 | .192 |
| | 1796302 | R/SP3 | .040 | - | - | .040 |
| C | 5003093 | Frame | .197 | -0.12 | 0.0 | .193 |
| | 1796312 | R/SP3 | .072 | - | - | .072 |
| D | 1796303 | R/SP2 | .232 | - | - | .232 |
| E | 1796304 | R/SP2 | .232 | - | - | .232 |
| | 1796313 | R/SP2 | .202 | - | - | .202 |
| F | 1796314 | R/SP2 | .202 | - | - | .202 |
| G | 2100451 | Cap | .059 | -0.27 | 0.0 | .055 |
| | 2100452 | Cap | .059 | -0.27 | 0.0 | .054 |
| H | 1796301 | R/SP3 | .040 | - | - | .040 |
| | 2100453 | Cap | .059 | -0.27 | 0.0 | .054 |
| I | 1796311 | R/SP3 | .072 | - | - | .072 |
| | 2110532 | Cap | .226 | 0.66 | 0.0 | .187 |
| K | 2110533 | Cap | .226 | 0.67 | 0.0 | .190 |
| L | 2110534 | Cap | .226 | 0.68 | 0.0 | .193 |

3.1.2.12 Right Side Panels Under Canopy (Sta. 93-138) Detail

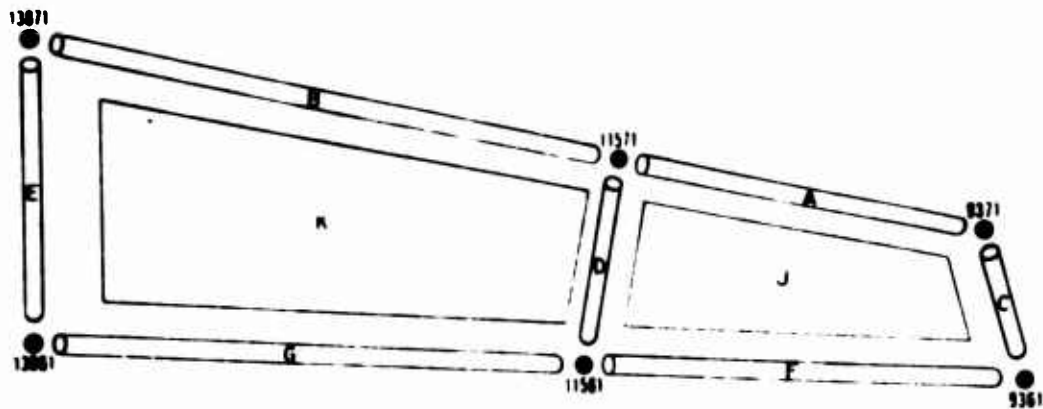

View looking inboard

GRID POINT DATA

| GRID POINT | SPC | | MPC | | OMIT | |
|------------|--------|------|--------|------|--------|------|
| | D.O.F. | RULE | D.O.F. | RULE | D.O.F. | RULE |
| 9331 | 456 | AAA | - | - | 123 | DCC |
| 9361 | 456 | AAA | - | - | 123 | DCC |
| 9371 | 456 | AAA | - | - | 123 | DCC |
| 11531 | 3456 | AAAA | - | - | 12 | DC |
| 11561 | 456 | AAA | - | - | 123 | DCC |
| 11571 | 2456 | AAAA | - | - | 13 | DC |
| 13831 | 456 | AAA | - | - | 123 | DCC |
| 13861 | 456 | AAA | - | - | 123 | DCC |
| 13871 | 2456 | AAAA | - | - | 13 | DC |

SHEAR PANEL/MEMBRANE ELEMENT DATA

| Letter Designation | NASTRAN EID | Type | Thickness (IN.) |
|--------------------|-------------|------|-----------------|
| J | 1791614 | Skin | .032 |
| K | 1791615 | Skin | .032 |

ROD ELEMENT DATA

| LETTER DESIGNATION | NASTRAN EID | TYPE | ACTUAL AREA (in. ²) | OFFSETS FROM GRIDPOINT | | FINAL AREA (in. ²) |
|--------------------|-------------|-------|---------------------------------|------------------------|-----|--------------------------------|
| | | | | Z | Y | |
| A | 5003114 | Frame | .201 | 0.20 | 0.0 | .213 |
| | 1796122 | R/SP3 | .102 | - | - | .102 |
| B | 5003115 | Frame | .201 | 0.0 | 0.0 | .201 |
| | 1796132 | R/SP3 | .104 | - | - | .140 |
| C | 1796123 | R/SP2 | .270 | - | - | .270 |
| D | 1796124 | R/SP2 | .270 | - | - | .270 |
| | 1796133 | R/SP2 | .382 | - | - | .382 |
| E | 1796134 | R/SP2 | .382 | - | - | .382 |
| F | 2500911 | Cap | .059 | -0.28 | 0.0 | .053 |
| | 1796121 | R/SP3 | .102 | - | - | .102 |
| G | 2500912 | Cap | .059 | -0.30 | 0.0 | .050 |
| | 1796131 | R/SP3 | .140 | - | - | .140 |
| H | 2110105 | Cap | .281 | 0.67 | 0.0 | .243 |
| I | 2110106 | Cap | .281 | 0.65 | 0.0 | .248 |

3.1.2.13 Left Side Panels Under Canopy (Sta. 93-138) Detail

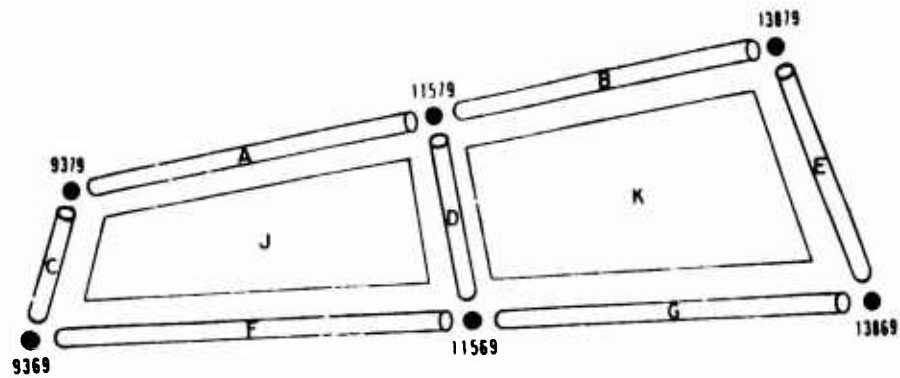

View looking inboard

GRID POINT DATA

| GRID POINT | SPC | | MPC | | OMIT | |
|------------|--------|------|--------|------|--------|------|
| | D.O.F. | RULE | D.O.F. | RULE | D.O.F. | RULE |
| 9339 | 456 | AAA | - | - | 123 | DCC |
| 9369 | 456 | AAA | - | - | 123 | DCC |
| 9379 | 456 | AAA | - | - | 123 | DCC |
| 11539 | 3456 | AAAA | - | - | 12 | DC |
| 11569 | 456 | AAA | - | - | 123 | DCC |
| 11579 | 2456 | AAAA | - | - | 13 | DC |
| 13839 | 456 | AAA | - | - | 123 | DCC |
| 13869 | 456 | AAA | - | - | 123 | DCC |
| 13879 | 2456 | AAAA | - | - | 13 | DC |

SHEAR PANEL/MEMBRANE ELEMENT DATA

| Letter Designation | NASTRAN EID | Type | Thickness (IN.) |
|--------------------|-------------|------|-----------------|
| J | 1791634 | Skin | .032 |
| K | 1791635 | Skin | .032 |

ROD ELEMENT DATA

| LETTER DESIGNATION | NASTRAN EID | TYPE | ACTUAL AREA (in. ²) | OFFSETS FROM GRIDPOINT | | FINAL AREA (in. ²) |
|--------------------|-------------|-------|---------------------------------|------------------------|-----|--------------------------------|
| | | | | Z | Y | |
| A | 5003094 | Frame | .208 | -0.06 | 0.0 | .206 |
| | 1796322 | R/SP3 | .102 | - | - | .102 |
| B | 5003095 | Frame | .208 | 0.0 | 0.0 | .208 |
| | 1796332 | R/SP3 | .130 | - | - | .130 |
| C | 1796323 | R/SP2 | .270 | - | - | .270 |
| D | 1796324 | R/SP2 | .270 | - | - | .270 |
| | 1796333 | R/SP2 | .248 | - | - | .248 |
| E | 1796334 | R/SP2 | .248 | - | - | .248 |
| F | 2100551 | Cap | .059 | -0.27 | 0.0 | .054 |
| | 1796321 | R/SP3 | .102 | - | - | .102 |
| G | 2100552 | Cap | .059 | -0.27 | 0.0 | .054 |
| | 1796331 | R/SP3 | .130 | - | - | .130 |
| H | 2110535 | Cap | .281 | 0.67 | 0.0 | .243 |
| I | 2110536 | Cap | .281 | 0.65 | 0.0 | .247 |

3.1.2.14 Right Side Panels Under Canopy (Sta. 138-148) Detail

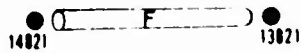
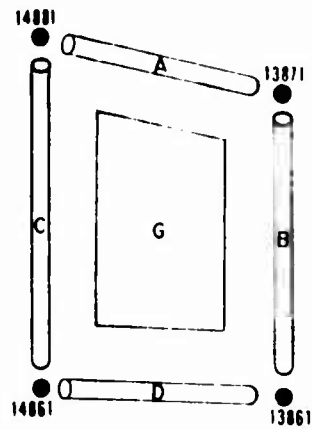

View looking inboard

GRID POINT DATA

| GRID POINT | SPC | | MPC | | OMIT | |
|------------|--------|------|--------|------|--------|------|
| | D.O.F. | RULE | D.O.F. | RULE | D.O.F. | RULE |
| 13821 | 456 | AAA | - | - | 123 | DCC |
| 13831 | 456 | AAA | - | - | 123 | DCC |
| 13861 | 456 | AAA | - | - | 123 | DCC |
| 13871 | 2456 | AAAA | - | - | 13 | DC |
| 14821 | 456 | AAA | - | - | 123 | DCC |
| 14831 | 456 | AAA | - | - | 123 | DCC |
| 14861 | 456 | AAA | - | - | 123 | DCC |
| 14881 | 456 | AAA | - | - | 123 | DCC |

SHEAR PANEL/MEMBRANE ELEMENT DATA

| Letter Designation | NASTRAN EID | Type | Thickness (IN.) |
|--------------------|-------------|------|-----------------|
| G | 1791616 | Skin | .032 |

ROD ELEMENT DATA

| LETTER DESIGNATION | NASTRAN EID | TYPE | ACTUAL AREA (in. ²) | OFFSETS FROM GRIDPOINT | | FINAL AREA (in. ²) |
|--------------------|-------------|-------|---------------------------------|------------------------|-----|--------------------------------|
| | | | | Z | Y | |
| A | 5003116 | Frame | .201 | -0.06 | 0.0 | .200 |
| | 1796142 | R/SP3 | .195 | - | - | .195 |
| B | 1796143 | R/SP2 | .187 | - | - | .187 |
| C | 1796144 | R/SP2 | .187 | - | - | .187 |
| D | 2500913 | Cap | .070 | -0.37 | 0.0 | .067 |
| | 1796141 | R/SP3 | .195 | - | - | .195 |
| E | 2110107 | Cap | .252 | 0.47 | 0.0 | .174 |
| F | 1610151 | Cap | .130 | 0.11 | 0.0 | .128 |

3.1.2.15 Left Side Panels Under Canopy (Sta. 138-148) Detail

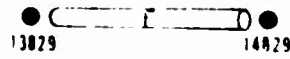
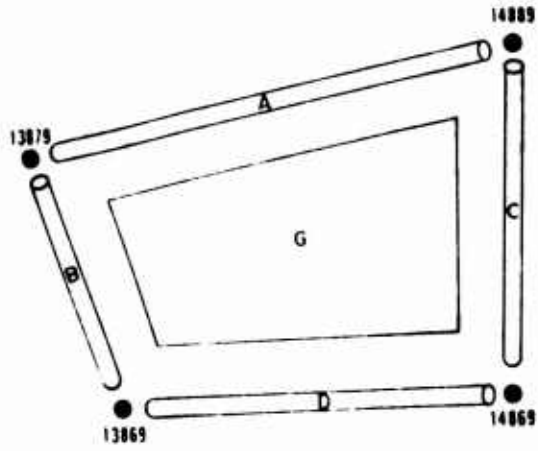

View looking inboard

GRID POINT DATA

| GRID POINT | SPC | | MPC | | OMIT | |
|------------|--------|------|--------|------|--------|------|
| | D.O.F. | RULE | D.O.F. | RULE | D.O.F. | RULE |
| 13829 | 456 | AAA | - | - | 123 | DCC |
| 13839 | 456 | AAA | - | - | 123 | DCC |
| 13869 | 456 | AAA | - | - | 123 | DCC |
| 13879 | 2456 | AAAA | - | - | 13 | DC |
| 14829 | 456 | AAA | - | - | 123 | DCC |
| 14839 | 456 | AAA | - | - | 123 | DCC |
| 14869 | 456 | AAA | - | - | 123 | DCC |
| 14889 | 456 | AAA | - | - | 123 | DCC |

SHEAR PANEL/MEMBRANE ELEMENT DATA

| Letter Designation | NASTRAN EID | Type | Thickness (IN.) |
|--------------------|-------------|------|-----------------|
| G | 1791636 | Skin | .032 |

ROD ELEMENT DATA

| LETTER DESIGNATION | NASTRAN EID | TYPE | ACTUAL AREA (in. ²) | OFFSETS FROM GRIDPOINT | | FINAL AREA (in. ²) |
|--------------------|-------------|-------|---------------------------------|------------------------|-----|--------------------------------|
| | | | | Z | Y | |
| A | 5003096 | Frame | .208 | -0.20 | 0.0 | .205 |
| | 1796342 | R/SP3 | .183 | - | - | .183 |
| B | 1796343 | R/SP2 | .321 | - | - | .321 |
| C | 1796344 | R/SP2 | .321 | - | - | .321 |
| D | 2100553 | Cap | .066 | -0.24 | 0.0 | .064 |
| | 1796341 | R/SP3 | .183 | - | - | .183 |
| E | 2110537 | Cap | .252 | 0.47 | 0.0 | .166 |
| F | 1610131 | Cap | .130 | 0.11 | 0.0 | .128 |

3.1.2.16 Ammo. Floor (Sta. 93-138, W. L. 27) Detail

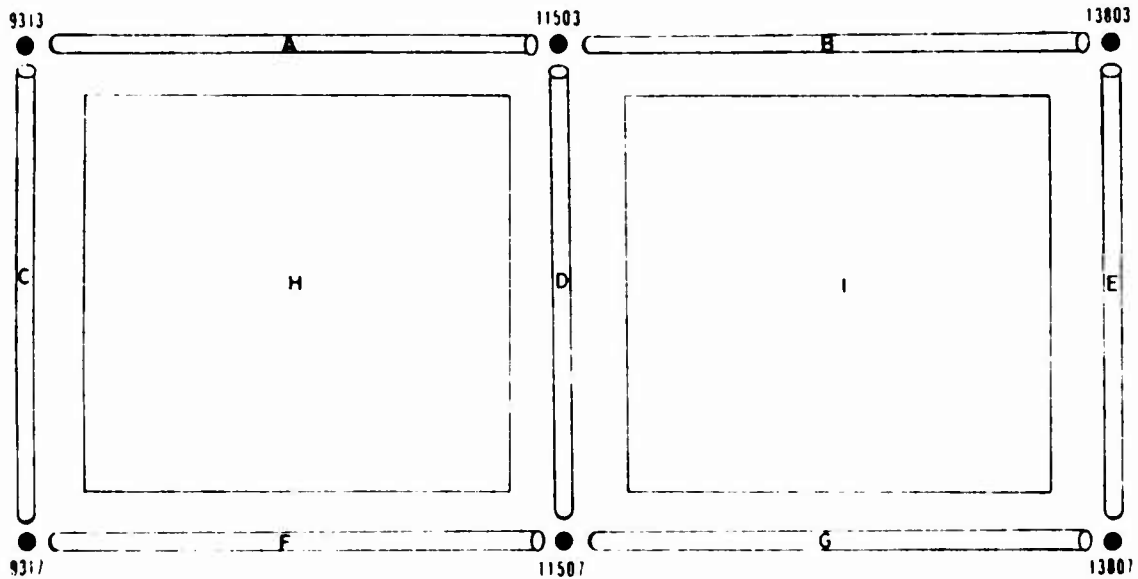

View looking down

GRID POINT DATA

| GRID POINT | SPC | | MPC | | OMIT | |
|------------|--------|------|--------|------|--------|------|
| | D.O.F. | RULE | D.O.F. | RULE | D.O.F. | RULE |
| 9313 | 456 | AAA | - | - | 123 | DCC |
| 9317 | 456 | AAA | - | - | 13 | DC |
| 11503 | 3456 | AAAA | - | - | 12 | DC |
| 11507 | 3456 | AAAA | - | - | 12 | DC |
| 13803 | 456 | AAA | - | - | 123 | DCC |
| 13807 | 456 | AAA | - | - | 123 | DCC |

SHEAR PANEL/MEMBRANE ELEMENT DATA

| Letter Designation | NASTRAN EID | Type | Thickness (IN.) |
|--------------------|-------------|------------|-----------------|
| H | 2190151 | Lower Skin | .020 |
| | 2190191 | Upper Skin | .025 |
| I | 2190152 | Lower Skin | .020 |
| | 2190192 | Upper Skin | .025 |

ROD ELEMENT DATA

| LETTER DESIGNATION | NASTRAN EID | TYPE | ACTUAL AREA (in. ²) | OFFSETS FROM GRIDPOINT | | FINAL AREA (in. ²) |
|--------------------|-------------|---------|---------------------------------|------------------------|-------|--------------------------------|
| | | | | Z | Y | |
| A | 2190311 | Doubler | .151 | 0.0 | 1.38 | .196 |
| | 2191503 | R/SP3 | .186 | - | - | .186 |
| | 2191903 | R/SP3 | .044 | - | - | .044 |
| B | 2190312 | Doubler | .151 | 0.0 | 1.38 | .196 |
| | 2191507 | R/SP3 | .186 | - | - | .186 |
| | 2191907 | R/SP3 | .044 | - | - | .044 |
| C | 2190271 | Doubler | .052 | 0.0 | 2.72 | .046 |
| | 2191501 | R/SP2 | .233 | - | - | .233 |
| | 2191901 | R/SP2 | .272 | - | - | .272 |
| D | 2191502 | R/SP2 | .233 | - | - | .233 |
| | 2191505 | R/SP2 | .238 | - | - | .238 |
| | 2191902 | R/SP2 | .272 | - | - | .272 |
| | 2191905 | R/SP2 | .279 | - | - | .279 |
| E | 2190431 | Doubler | .054 | 0.0 | 2.72 | .047 |
| | 2191506 | R/SP2 | .238 | - | - | .238 |
| | 2191906 | R/SP2 | .279 | - | - | .279 |
| F | 2190313 | Doubler | .151 | 0.0 | -1.38 | .196 |
| | 2191504 | R/SP3 | .186 | - | - | .186 |
| | 2191904 | R/SP3 | .044 | - | - | .044 |
| G | 2190314 | Doubler | .151 | 0.0 | -1.38 | .196 |
| | 2191508 | R/SP3 | .186 | - | - | .186 |
| | 2191908 | R/SP3 | .044 | - | - | .044 |

3.1.2.17 Ammo. Cover (Sta. 93-148, W. L. 46) Detail

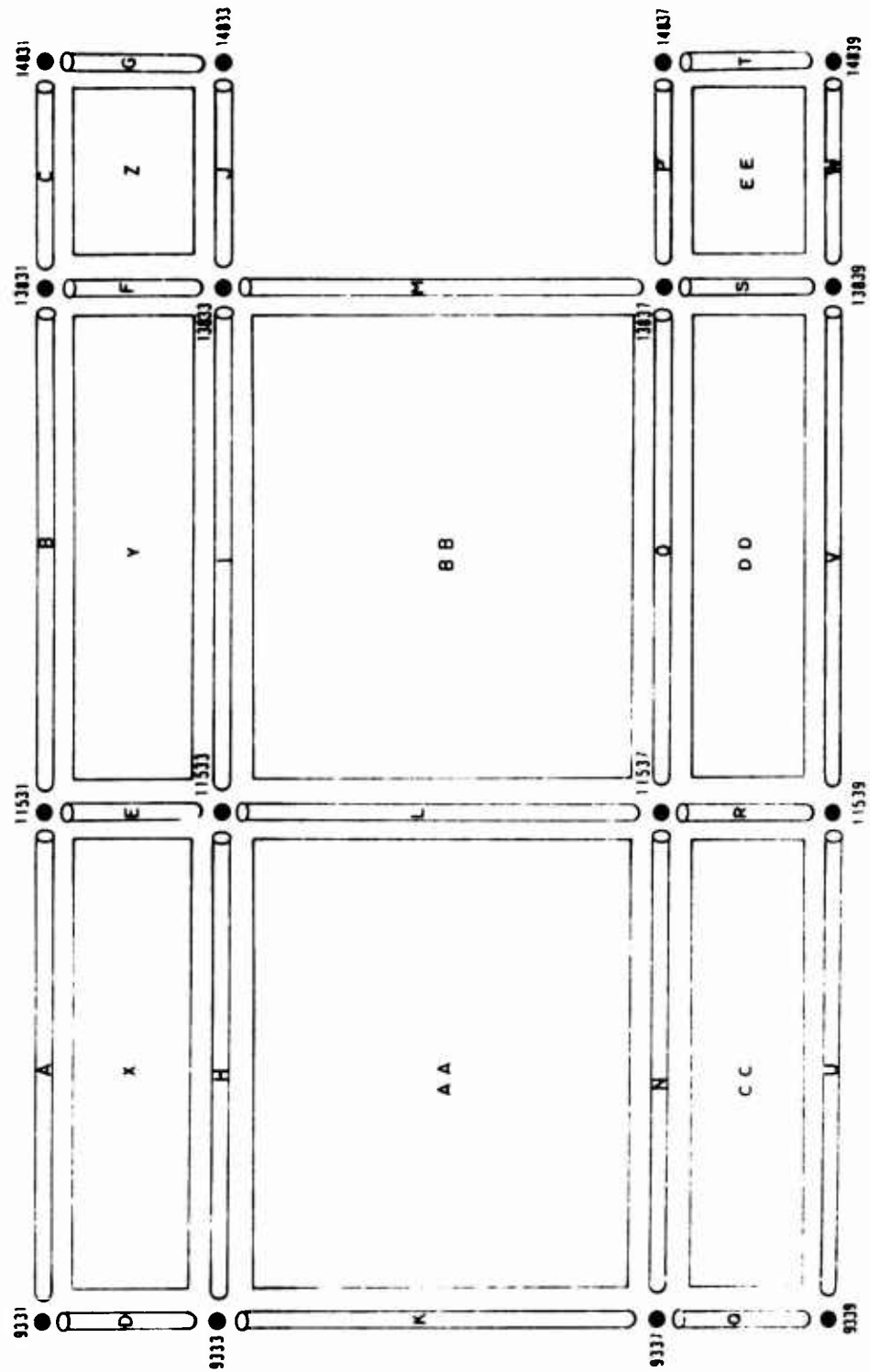

View looking down

GRID POINT DATA

| GRID POINT | SPC | | MPC | | OMIT | |
|------------|--------|------|--------|------|--------|------|
| | D.O.F. | RULE | D.O.F. | RULE | D.O.F. | RULE |
| 9331 | 456 | AAA | - | - | 123 | DCC |
| 9333 | 456 | AAA | - | - | 1 | D |
| 9337 | 456 | AAA | - | - | 2 | C |
| 9339 | 456 | AAA | - | - | 123 | DCC |
| 11531 | 3456 | AAAA | - | - | 12 | DC |
| 11533 | 456 | AAA | - | - | 23 | CC |
| 11537 | 456 | AAA | - | - | 13 | DC |
| 11539 | 3456 | AAAA | - | - | 12 | DC |
| 13831 | 456 | AAA | - | - | 123 | DCC |
| 13833 | 456 | AAA | - | - | 12 | DC |
| 13837 | 456 | AAA | - | - | 12 | DC |
| 13839 | 456 | AAA | - | - | 123 | DCC |
| 14831 | 456 | AAA | - | - | 123 | DCC |
| 14833 | 456 | AAA | - | - | 123 | DCC |
| 14837 | 456 | AAA | - | - | 123 | DCC |
| 14839 | 456 | AAA | - | - | 123 | DCC |

SHEAR PANEL/MEMBRANE ELEMENT DATA

| Letter Designation | NASTRAN EID | Type | Thickness (IN.) |
|--------------------|-------------|------------|-----------------|
| X | 2110071 | Skin | .032 |
| Y | 2110072 | Skin | .032 |
| Z | 2110073 | Skin | .032 |
| AA | 2170111 | Lower Skin | .016 |
| | 2170331 | Upper Skin | .012 |
| BB | 2170112 | Lower Skin | .016 |
| | 2170332 | Upper Skin | .012 |
| CC | 2110051 | Skin | .032 |
| DD | 2110052 | Skin | .032 |
| EE | 2110053 | Skin | .032 |

ROD ELEMENT DATA

| LETTER DESIGNATION | NASTRAN EID | TYPE | ACTUAL AREA (in. ²) | OFFSETS FROM GRIDPOINT | | FINAL AREA (in. ²) |
|--------------------|-------------|---------|---------------------------------|------------------------|-------|--------------------------------|
| | | | | Z | Y | |
| A | 2110701 | R/SP2 | .109 | - | - | .109 |
| B | 2110702 | R/SP2 | .109 | - | - | .109 |
| C | 2110703 | R/SP2 | .109 | - | - | .109 |
| D | 2110707 | R/SP2 | .361 | - | - | .361 |
| E | 2110708 | R/SP2 | .361 | - | - | .361 |
| | 2110709 | R/SP2 | .370 | - | - | .370 |
| F | 2110710 | R/SP2 | .370 | - | - | .370 |
| | 2110711 | R/SP2 | .157 | - | - | .157 |
| G | 2110712 | R/SP2 | .157 | - | - | .157 |
| H | 2170171 | Doubler | .030 | 0.0 | -0.60 | .027 |
| | 2170101 | Doubler | .054 | 0.0 | -0.18 | .052 |
| | 2110704 | R/SP2 | .109 | - | - | .109 |
| | 2171101 | R/SP2 | .053 | - | - | .053 |
| | 2173301 | R/SP2 | .028 | - | - | .028 |
| I | 2170172 | Doubler | .030 | 0.0 | -0.60 | .027 |
| | 2170102 | Doubler | .054 | 0.0 | -0.18 | .052 |
| | 2110705 | R/SP2 | .109 | - | - | .109 |
| | 2171102 | R/SP2 | .053 | - | - | .053 |
| | 2173302 | R/SP2 | .028 | - | - | .028 |
| J | 2110706 | R/SP2 | .109 | - | - | .109 |
| K | 2170191 | Doubler | .030 | 0.0 | -1.20 | .032 |
| | 2360031 | Doubler | .108 | 0.0 | -0.36 | .108 |
| | 2171105 | R/SP2 | .109 | - | - | .109 |
| | 2173305 | R/SP2 | .075 | - | - | .075 |
| L | 2171106 | R/SP2 | .109 | - | - | .109 |
| | 2171107 | R/SP2 | .183 | - | - | .183 |
| | 2173306 | R/SP2 | .075 | - | - | .075 |
| | 2173307 | R/SP2 | .131 | - | - | .131 |
| M | 2170271 | Doubler | .030 | 0.0 | -1.20 | .032 |
| | 2171108 | R/SP2 | .183 | - | - | .183 |
| | 2173308 | R/SP2 | .131 | - | - | .131 |

ROD ELEMENT DATA (CONT.)

| LETTER DESIGNATION | NASTRAN EID | TYPE | ACTUAL AREA (in. ²) | OFFSETS FROM GRIDPOINT | | FINAL AREA (in. ²) |
|-----------------------|----------------|---------|------------------------------------|---------------------------|------|-----------------------------------|
| | | | | Z | Y | |
| N | 2170291 | Doubler | .030 | 0.0 | 0.60 | .027 |
| | 2170091 | Doubler | .054 | 0.0 | 0.18 | .052 |
| | 2110501 | R/SP2 | .109 | - | - | .109 |
| | 2171103 | R/SP2 | .053 | - | - | .053 |
| | 2173303 | R/SP2 | .028 | - | - | .028 |
| O | 2170292 | Doubler | .030 | 0.0 | 0.60 | .027 |
| | 2170092 | Doubler | .054 | 0.0 | 0.18 | .052 |
| | 2110502 | R/SP2 | .109 | - | - | .109 |
| | 2171104 | R/SP2 | .053 | - | - | .053 |
| | 2173304 | R/SP2 | .028 | - | - | .028 |
| P | 2110503 | R/SP2 | .109 | - | - | .109 |
| Q | 2110507 | R/SP2 | .361 | - | - | .361 |
| R | 2110508 | R/SP2 | .361 | - | - | .361 |
| | 2110509 | R/SP2 | .370 | - | - | .370 |
| S | 2110510 | R/SP2 | .370 | - | - | .370 |
| | 2110511 | R/SP2 | .157 | - | - | .157 |
| T | 2110512 | R/SP2 | .157 | - | - | .157 |
| U | 2110504 | R/SP2 | .109 | - | - | .109 |
| V | 2110505 | R/SP2 | .109 | - | - | .109 |
| W | 2110506 | R/SP2 | .109 | - | - | .109 |

3.1.2.18 Gunner's Floor (Sta. 61-93, W. L. 46) Detail

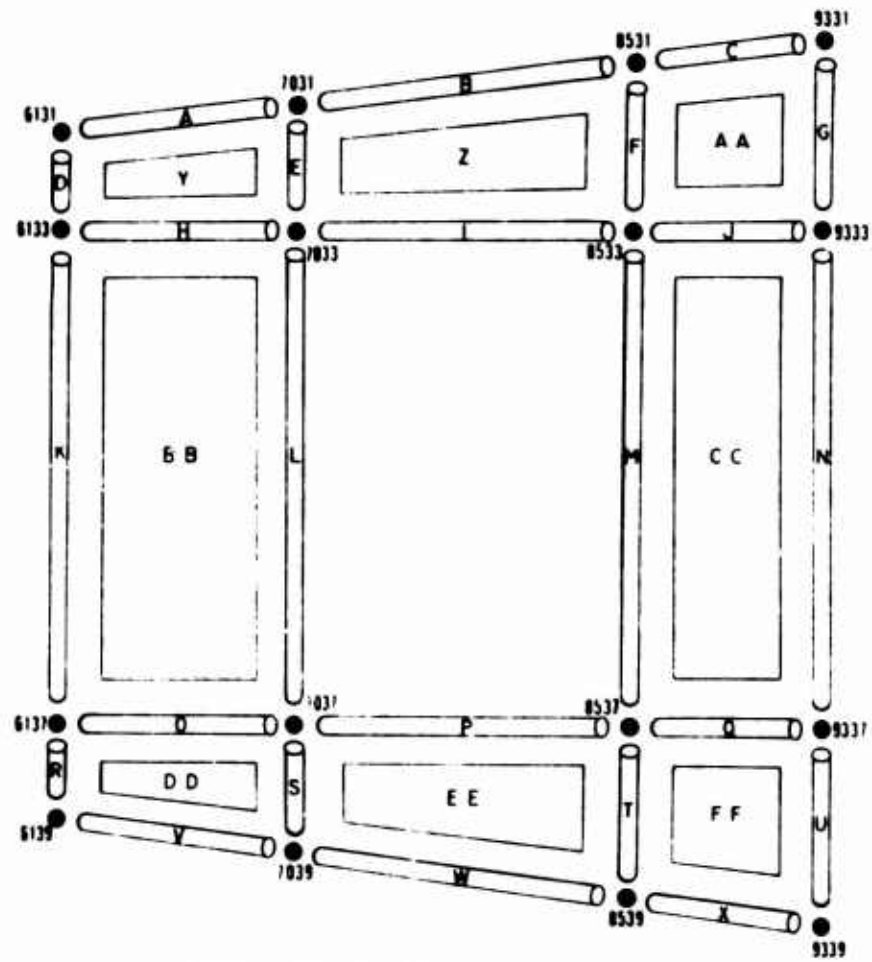

View looking down

GRID POINT DATA

| GRID POINT | SPC | | MPC | | OMIT | |
|------------|--------|------|--------|------|--------|------|
| | D.O.F. | RULE | D.O.F. | RULE | D.O.F. | RULE |
| 6131 | 456 | AAA | - | - | 123 | DCC |
| 6133 | 456 | AAA | - | - | 23 | CC |
| 6137 | 456 | AAA | - | - | 123 | DCC |
| 6139 | 456 | AAA | - | - | 123 | DCC |
| 7031 | 3456 | AAAA | - | - | 12 | DC |
| 7033 | 456 | AAA | 123 | AAA | - | - |
| 7037 | 456 | AAA | 123 | AAA | - | - |
| 7039 | 3456 | AAAA | - | - | 12 | DC |
| 8531 | 3456 | AAAA | - | - | 12 | DC |
| 8533 | 456 | AAA | 123 | AAA | - | - |
| 8537 | 456 | AAA | 123 | AAA | - | - |
| 8539 | 3456 | AAAA | - | - | 12 | DC |
| 9331 | 456 | AAA | - | - | 123 | DCC |
| 9333 | 456 | AAA | - | - | 1 | D |
| 9337 | 456 | AAA | - | - | 2 | C |
| 9339 | 456 | AAA | - | - | 123 | DCC |

SHEAR PANEL/MEMBRANE ELEMENT DATA

| Letter Designation | NASTRAN EID | Type | Thickness (IN.) |
|--------------------|-------------|---------------|-----------------|
| Y | 2010851 | Lower Skin | .032 |
| | 2010531 | Interior Skin | .016 |
| | 2010694 | Upper Skin | .020 |
| Z | 2010854 | Lower Skin | .032 |
| | 2010534 | Interior Skin | .016 |
| | 2010697 | Upper Skin | .020 |
| AA | 2010857 | Lower Skin | .032 |
| | 2010537 | Interior Skin | .016 |
| | 2010701 | Upper Skin | .020 |
| BB | 2010852 | Lower Skin | .032 |
| | 2010532 | Interior Skin | .016 |
| | 2010695 | Upper Skin | .020 |
| CC | 2010858 | Lower Skin | .032 |
| | 2010538 | Interior Skin | .016 |
| | 2010702 | Upper Skin | .020 |
| DD | 2010853 | Lower Skin | .032 |
| | 2010533 | Interior Skin | .016 |
| | 2010696 | Upper Skin | .020 |
| EE | 2010856 | Lower Skin | .032 |
| | 2010536 | Interior Skin | .016 |
| | 2010699 | Upper Skin | .020 |
| FF | 2010859 | Lower Skin | .032 |
| | 2010539 | Interior Skin | .016 |
| | 2010703 | Upper Skin | .020 |

ROD ELEMENT DATA

| LETTER DESIGNATION | NASTRAN EID | TYPE | ACTUAL AREA (in. ²) | OFFSETS FROM GRIDPOINT | | FINAL AREA (in. ²) |
|-----------------------|----------------|-------|------------------------------------|---------------------------|---|-----------------------------------|
| | | | | Z | Y | |
| A | 2018501 | R/SP2 | .032 | - | - | .032 |
| | 2015301 | R/SP2 | .029 | - | - | .029 |
| | 2016911 | R/SP2 | .036 | - | - | .036 |
| B | 2018521 | R/SP2 | .062 | - | - | .062 |
| | 2015321 | R/SP2 | .044 | - | - | .044 |
| | 2016931 | R/SP2 | .055 | - | - | .055 |
| C | 2018531 | R/SP2 | .082 | - | - | .082 |
| | 2015331 | R/SP2 | .054 | - | - | .054 |
| | 2017001 | R/SP2 | .067 | - | - | .067 |
| D | 2018507 | R/SP2 | .127 | - | - | .127 |
| | 2015307 | R/SP2 | .076 | - | - | .076 |
| | 2016917 | R/SP2 | .095 | - | - | .095 |
| E | 2018510 | R/SP2 | .127 | - | - | .127 |
| | 2018525 | R/SP2 | .232 | - | - | .232 |
| | 2015310 | R/SP2 | .076 | - | - | .076 |
| | 2015325 | R/SP2 | .116 | - | - | .116 |
| | 2016920 | R/SP2 | .095 | - | - | .095 |
| | 2016935 | R/SP2 | .148 | - | - | .148 |
| F | 2018527 | R/SP2 | .232 | - | - | .232 |
| | 2018537 | R/SP2 | .098 | - | - | .098 |
| | 2015327 | R/SP2 | .116 | - | - | .116 |
| | 2015337 | R/SP2 | .062 | - | - | .062 |
| | 2016937 | R/SP2 | .148 | - | - | .148 |
| | 2017007 | R/SP2 | .077 | - | - | .077 |
| G | 2018540 | R/SP2 | .098 | - | - | .098 |
| | 2015343 | R/SP2 | .062 | - | - | .062 |
| | 2017010 | R/SP2 | .077 | - | - | .077 |
| H | 2018502 | R/SP2 | .032 | - | - | .032 |
| | 2018503 | R/SP2 | .320 | - | - | .320 |
| | 2015302 | R/SP2 | .029 | - | - | .029 |
| | 2015303 | R/SP2 | .160 | - | - | .160 |

ROD ELEMENT DATA (CONT.)

| LETTER DESIGNATION | NASTRAN EID | TYPE | ACTUAL AREA (in. ²) | OFFSETS FROM GRIDPOINT | | FINAL AREA (in. ²) |
|--------------------|-------------|-------|---------------------------------|------------------------|---|--------------------------------|
| | | | | Z | Y | |
| H (cont.) | 2016912 | R/SP2 | .036 | - | - | .036 |
| | 2016913 | R/SP2 | .200 | - | - | .200 |
| I | 2018522 | R/SP2 | .062 | - | - | .062 |
| | 2015322 | R/SP2 | .044 | - | - | .044 |
| J | 2016932 | R/SP2 | .055 | - | - | .055 |
| | 2018532 | R/SP2 | .082 | - | - | .082 |
| K | 2018533 | R/SP2 | .320 | - | - | .320 |
| | 2015332 | R/SP2 | .054 | - | - | .054 |
| L | 2015333 | R/SP2 | .160 | - | - | .160 |
| | 2017002 | R/SP2 | .067 | - | - | .067 |
| M | 2017003 | R/SP2 | .200 | - | - | .200 |
| | 2018508 | R/SP2 | .127 | - | - | .127 |
| N | 2015308 | R/SP2 | .076 | - | - | .076 |
| | 2016918 | R/SP2 | .095 | - | - | .095 |
| O | 2018511 | R/SP2 | .127 | - | - | .127 |
| | 2015311 | R/SP2 | .076 | - | - | .076 |
| P | 2016921 | R/SP2 | .095 | - | - | .095 |
| | 2018538 | R/SP2 | .098 | - | - | .098 |
| Q | 2015338 | R/SP2 | .062 | - | - | .062 |
| | 2017008 | R/SP2 | .077 | - | - | .077 |
| R | 2018541 | R/SP2 | .098 | - | - | .098 |
| | 2015341 | R/SP2 | .062 | - | - | .062 |
| S | 2017011 | R/SP2 | .077 | - | - | .077 |
| | 2018504 | R/SP2 | .320 | - | - | .320 |
| T | 2018505 | R/SP2 | .032 | - | - | .032 |
| | 2015304 | R/SP2 | .160 | - | - | .160 |
| U | 2015305 | R/SP2 | .029 | - | - | .029 |
| | 2016914 | R/SP2 | .200 | - | - | .200 |
| V | 2016915 | R/SP2 | .036 | - | - | .036 |
| | 2018523 | R/SP2 | .062 | - | - | .062 |
| W | 2015323 | R/SP2 | .044 | - | - | .044 |
| | 2016933 | R/SP2 | .055 | - | - | .055 |

ROD ELEMENT DATA (CONT.)

| LETTER DESIGNATION | NASTRAN EID | TYPE | ACTUAL AREA (in. ²) | OFFSETS FROM GRIDPOINT | | FINAL AREA (in. ²) |
|-----------------------|----------------|-------|------------------------------------|---------------------------|---|-----------------------------------|
| | | | | Z | Y | |
| Q | 2018534 | R/SP2 | .320 | - | - | .320 |
| | 2018535 | R/SP2 | .082 | - | - | .082 |
| | 2015334 | R/SP2 | .160 | - | - | .160 |
| | 2015335 | R/SP2 | .054 | - | - | .054 |
| | 2017004 | R/SP2 | .200 | - | - | .200 |
| | 2017005 | R/SP2 | .067 | - | - | .067 |
| R | 2018509 | R/SP2 | .127 | - | - | .127 |
| | 2015309 | R/SP2 | .076 | - | - | .076 |
| | 2016919 | R/SP2 | .095 | - | - | .095 |
| S | 2018512 | R/SP2 | .127 | - | - | .127 |
| | 2018526 | R/SP2 | .232 | - | - | .232 |
| | 2015312 | R/SP2 | .076 | - | - | .076 |
| | 2015326 | R/SP2 | .116 | - | - | .116 |
| | 2016922 | R/SP2 | .095 | - | - | .095 |
| | 2016936 | R/SP2 | .148 | - | - | .148 |
| T | 2018528 | R/SP2 | .232 | - | - | .232 |
| | 2018539 | R/SP2 | .098 | - | - | .098 |
| | 2015328 | R/SP2 | .116 | - | - | .116 |
| | 2015339 | R/SP2 | .062 | - | - | .062 |
| | 2016938 | R/SP2 | .148 | - | - | .148 |
| | 2017009 | R/SP2 | .077 | - | - | .077 |
| U | 2018542 | R/SP2 | .098 | - | - | .098 |
| | 2015342 | R/SP2 | .062 | - | - | .062 |
| | 2017012 | R/SP2 | .077 | - | - | .077 |
| V | 2018506 | R/SP2 | .032 | - | - | .032 |
| | 2015306 | R/SP2 | .029 | - | - | .029 |
| | 2016916 | R/SP2 | .036 | - | - | .036 |
| W | 2018524 | R/SP2 | .062 | - | - | .062 |
| | 2015324 | R/SP2 | .044 | - | - | .044 |
| | 2016934 | R/SP2 | .055 | - | - | .055 |
| X | 2018536 | R/SP2 | .082 | - | - | .082 |
| | 2015336 | R/SP2 | .054 | - | - | .054 |
| | 2017006 | R/SP2 | .067 | - | - | .067 |

3.1.2.19 Turret and Support Fittings Detail

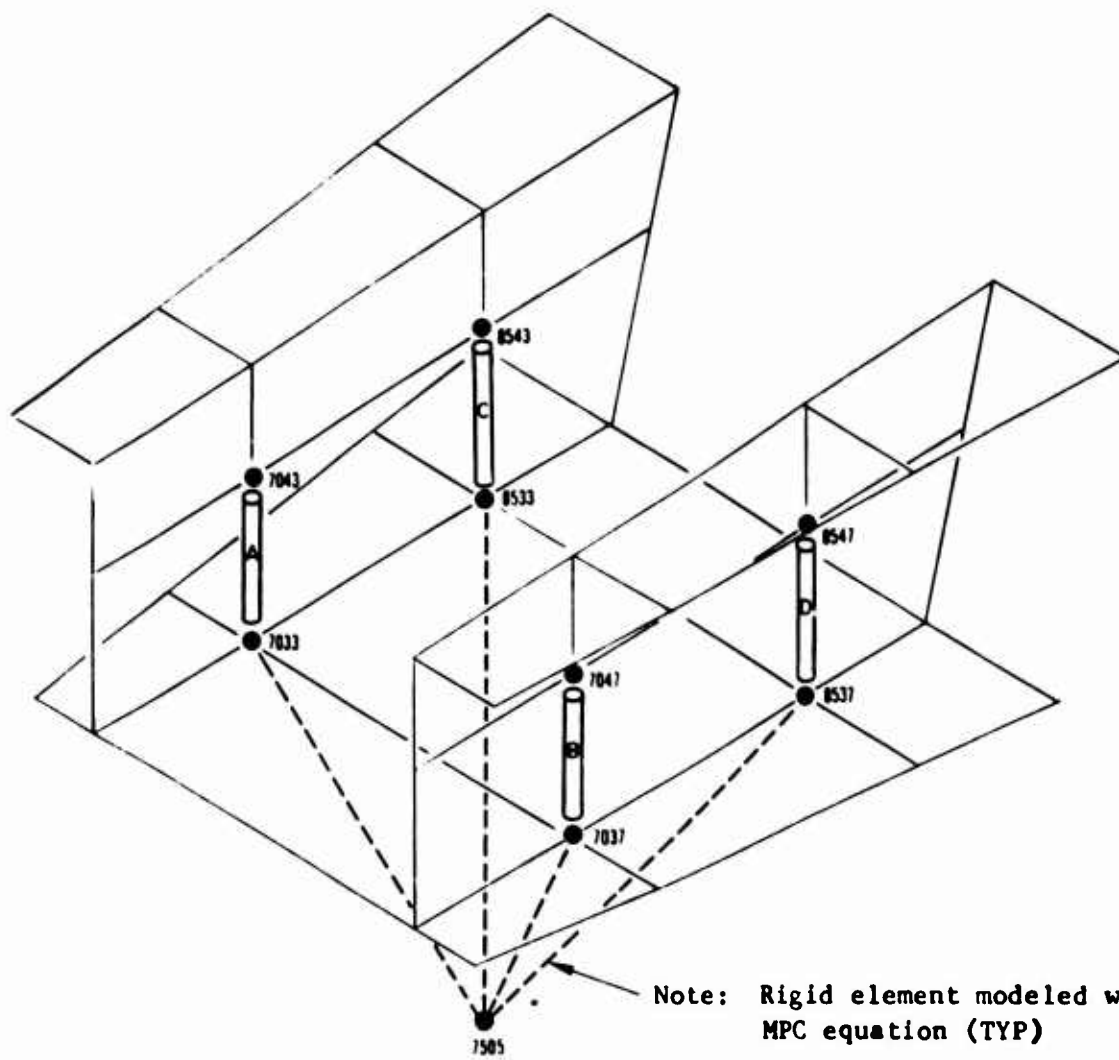

Note: Rigid element modeled with MPC equation (TYP)

GRID POINT DATA

| GRID POINT | SPC | | MPC | | OMIT | |
|------------|--------|------|--------|------|--------|------|
| | D.O.F. | RULE | D.O.F. | RULE | D.O.F. | RULE |
| 7033 | 456 | AAA | 123 | AAA | - | - |
| 7037 | 456 | AAA | 123 | AAA | - | - |
| 7043 | 2456 | AAAA | - | - | 1 | D |
| 7047 | 2456 | AAAA | - | - | 1 | D |
| 7505 | - | - | - | - | 456 | AAA |
| 8533 | 456 | AAA | 123 | AAA | - | - |
| 8537 | 456 | AAA | 123 | AAA | - | - |
| 8543 | 2456 | AAAA | - | - | 1 | D |
| 8547 | 2456 | AAAA | - | - | 1 | D |

ROD ELEMENT DATA

| LETTER DESIGNATION | NASTRAN EID | TYPE | ACTUAL AREA (in. ²) | OFFSETS FROM GRIDPOINT | | FINAL AREA (in. ²) |
|--------------------|-------------|---------|---------------------------------|------------------------|-----|--------------------------------|
| | | | | Z | Y | |
| A | 2510021 | Fitting | .527 | 0.830 | 0.0 | .585 |
| B | 2510022 | Fitting | .495 | 0.830 | 0.0 | .549 |
| C | 1870031 | Fitting | .503 | 1.170 | 0.0 | .581 |
| D | 1870032 | Fitting | .497 | 1.170 | 0.0 | .574 |

3.1.2.20 Extension of Ammo Cover (Sta. 138-148, W. L. 35.97) Detail

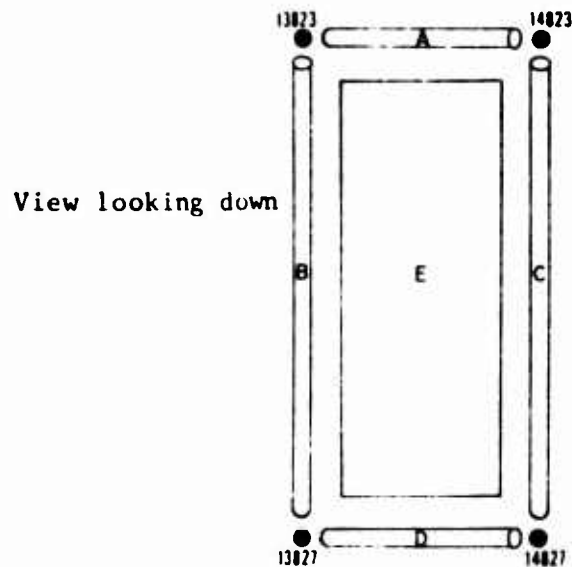

GRID POINT DATA

| GRID POINT | SPC | | MPC | | OMIT | |
|------------|--------|------|--------|------|--------|------|
| | D.O.F. | RULE | D.O.F. | RULE | D.O.F. | RULE |
| 13823 | 456 | AAA | - | - | 13 | DC |
| 13827 | 456 | AAA | - | - | 123 | DCC |
| 14823 | 456 | AAA | 123 | AAA | - | - |
| 14827 | 456 | AAA | 123 | AAA | - | - |

SHEAR PANEL/MEMBRANE ELEMENT DATA

| Letter Designation | NASTRAN EID | Type | Thickness (IN.) |
|--------------------|-------------|------|-----------------|
| E | 2120011 | Skin | .040 |

ROD ELEMENT DATA

| LETTER DESIGNATION | NASTRAN EID | TYPE | ACTUAL AREA (in. ²) | OFFSETS FROM GRIDPOINT | | FINAL AREA (in. ²) |
|--------------------|-------------|-------|---------------------------------|------------------------|---|--------------------------------|
| | | | | Z | Y | |
| A | 2120101 | R/SP3 | .133 | - | - | .133 |
| B | 2120103 | R/SP2 | .392 | - | - | .392 |
| C | 2120104 | R/SP2 | .392 | - | - | .392 |
| D | 2120102 | R/SP3 | .133 | - | - | .133 |

3.1.2.21 Pilot's Floor (Sta. 93-148, W. L. 55) Detail

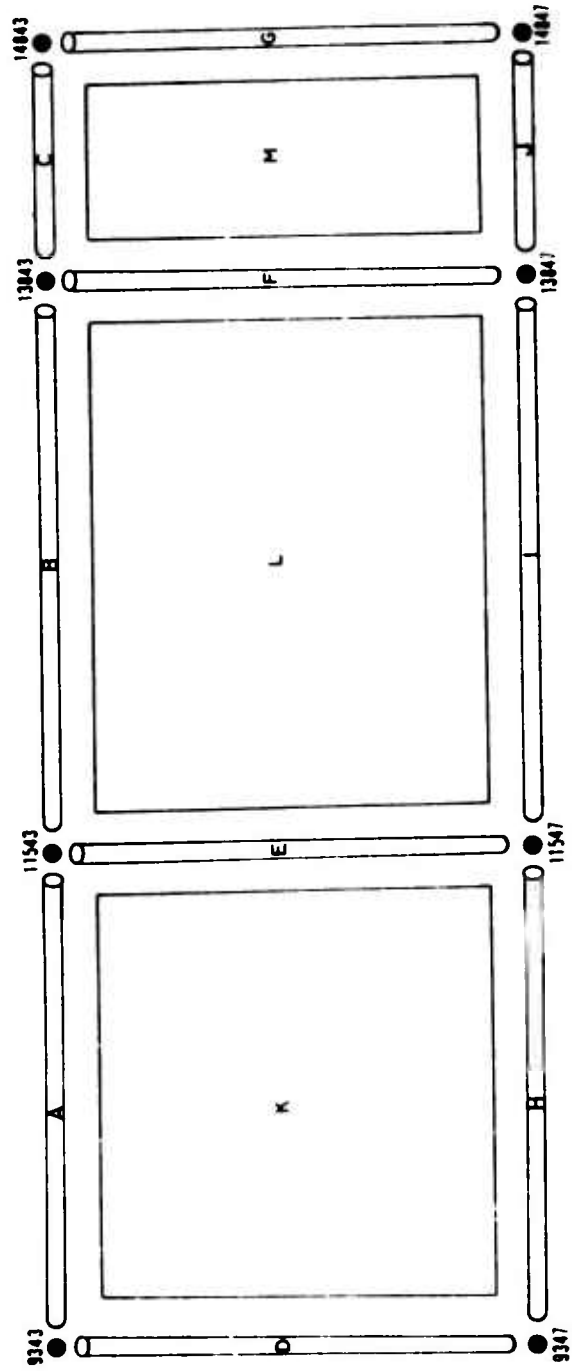

View looking down

GRID POINT DATA

| GRID POINT | SPC | | MPC | | OMIT | |
|------------|--------|------|--------|------|--------|------|
| | D.O.F. | RULE | D.O.F. | RULE | D.O.F. | RULE |
| 9343 | 456 | AAA | - | - | 123 | DCC |
| 9347 | 456 | AAA | - | - | 123 | DCC |
| 11543 | 456 | AAA | - | - | 12 | DC |
| 11547 | 456 | AAA | - | - | 12 | DC |
| 13843 | 456 | AAA | - | - | 123 | DCC |
| 13847 | 456 | AAA | - | - | 13 | DC |
| 14843 | 456 | AAA | - | - | 123 | DCC |
| 14847 | 456 | AAA | - | - | 123 | DCC |

SHEAR PANEL/MEMBRANE ELEMENT DATA

| Letter Designation | NASTRAN EID | Type | Thickness (IN.) |
|--------------------|-------------|------------|-----------------|
| K | 2070771 | Lower Skin | .016 |
| | 2020731 | Upper Skin | .020 |
| L | 2070772 | Lower Skin | .016 |
| | 2020732 | Upper Skin | .020 |
| M | 2070773 | Lower Skin | .016 |
| | 2020733 | Upper Skin | .020 |

ROD ELEMENT DATA

| LETTER DESIGNATION | NASTRAN EID | TYPE | ACTUAL AREA (in. ²) | OFFSETS FROM GRIDPOINT | | FINAL AREA (in. ²) |
|--------------------|-------------|---------|---------------------------------|------------------------|-------|--------------------------------|
| | | | | Z | Y | |
| A | 2020291 | Doubler | .032 | 0.0 | -0.77 | .027 |
| | 1560041 | Doubler | .138 | 0.0 | -0.22 | .132 |
| | 2077701 | R/SP3 | .034 | - | - | .034 |
| | 2027301 | R/SP3 | .065 | - | - | .065 |
| B | 2020292 | Doubler | .032 | 0.0 | -0.88 | .026 |
| | 1560042 | Doubler | .138 | 0.0 | -0.31 | .130 |
| | 2077702 | R/SP3 | .031 | - | - | .031 |
| | 2027302 | R/SP3 | .065 | - | - | .065 |
| C | 2020293 | Doubler | .036 | 0.0 | -0.93 | .030 |
| | 1560043 | Doubler | .205 | 0.0 | -0.27 | .194 |
| | 2077703 | R/SP3 | .029 | - | - | .029 |
| | 2027303 | R/SP3 | .065 | - | - | .065 |
| D | 2020171 | Doubler | .170 | 0.0 | 1.44 | .183 |
| | 2077707 | R/SP2 | .050 | - | - | .150 |
| | 2027307 | R/SP2 | .200 | - | - | .200 |
| E | 2077708 | R/SP2 | .150 | - | - | .150 |
| | 2077709 | R/SP2 | .175 | - | - | .175 |
| | 2027308 | R/SP2 | .200 | - | - | .200 |
| | 2027309 | R/SP2 | .231 | - | - | .231 |
| F | 2020172 | Doubler | .037 | 0.0 | 1.86 | .041 |
| | 2077710 | R/SP2 | .175 | - | - | .175 |
| | 2077711 | R/SP2 | .063 | - | - | .063 |
| | 2027310 | R/SP2 | .231 | - | - | .231 |
| | 2027311 | R/SP2 | .097 | - | - | .097 |
| G | 2020173 | Doubler | .024 | 0.0 | 1.86 | .027 |
| | 2077712 | R/SP2 | .063 | - | - | .063 |
| | 2027312 | R/SP2 | .097 | - | - | .097 |
| H | 2020271 | Doubler | .032 | 0.0 | 0.77 | .027 |
| | 1560031 | Doubler | .130 | 0.0 | 0.22 | .124 |
| | 2077704 | R/SP3 | .034 | - | - | .034 |
| | 2027304 | R/SP3 | .065 | - | - | .065 |

ROD ELEMENT DATA (CONT.)

| LETTER DESIGNATION | NASTRAN EID | TYPE | ACTUAL AREA (in. ²) | OFFSETS FROM GRIDPOINT | | FINAL AREA (in. ²) |
|-----------------------|----------------|---------|------------------------------------|---------------------------|------|-----------------------------------|
| | | | | Z | Y | |
| I | 2020272 | Doubler | .032 | 0.0 | 0.88 | .026 |
| | 1560032 | Doubler | .130 | 0.0 | 0.30 | .122 |
| | 2077705 | R/SP3 | .031 | - | - | .031 |
| | 2027305 | R/SP3 | .065 | - | - | .065 |
| J | 2020273 | Doubler | .036 | 0.0 | 0.93 | .030 |
| | 1560033 | Doubler | .211 | 0.0 | 0.26 | .200 |
| | 2077706 | R/SP3 | .029 | - | - | .029 |
| | 2027306 | R/SP3 | .065 | - | - | .065 |

3.1.2.22 Right and Left Upper Gunner's Shelves (Sta. 61-93) Detail

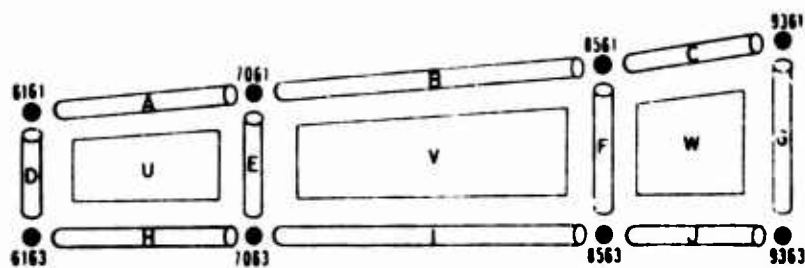

View looking down

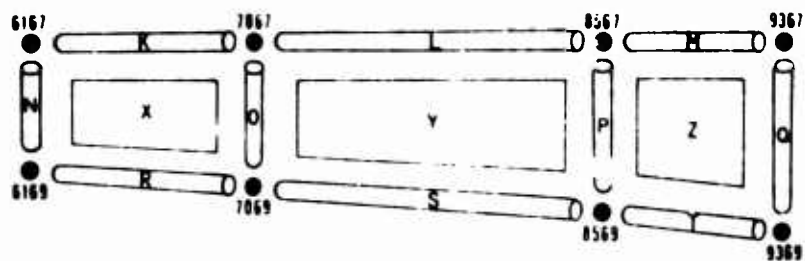

GRID POINT DATA

| GRID POINT | SPC | | MPC | | OMIT | |
|------------|--------|------|--------|------|--------|------|
| | D.O.F. | RULE | D.O.F. | RULE | D.O.F. | RULE |
| 6161 | 456 | AAA | - | - | 123 | DCC |
| 6163 | 456 | AAA | - | - | 123 | DCC |
| 6167 | 456 | AAA | - | - | 23 | CC |
| 6169 | 456 | AAA | - | - | 123 | DCC |
| 7061 | 456 | AAA | - | - | 123 | DCC |
| 7063 | 456 | AAA | - | - | 23 | CC |
| 7067 | 456 | AAA | - | - | 13 | DC |
| 7069 | 456 | AAA | - | - | 123 | DCC |
| 8561 | 456 | AAA | - | - | 123 | DCC |
| 8563 | 456 | AAA | - | - | 13 | DC |
| 8567 | 456 | AAA | - | - | 23 | CC |
| 8569 | 456 | AAA | - | - | 123 | DCC |
| 9361 | 456 | AAA | - | - | 123 | DCC |
| 9363 | 456 | AAA | - | - | 2 | C |
| 9367 | 456 | AAA | - | - | 1 | D |
| 9369 | 456 | AAA | - | - | 123 | DCC |

SHEAR PANEL/MEMBRANE ELEMENT DATA

| Letter Designation | NASTRAN EID | Type | Thickness (IN.) |
|--------------------|-------------|------|-----------------|
| U | 2501771 | Skin | .032 |
| V | 2501772 | Skin | .032 |
| W | 2501773 | Skin | .032 |
| X | 2100891 | Skin | .032 |
| Y | 2100892 | Skin | .032 |
| Z | 2100893 | Skin | .032 |

ROD ELEMENT DATA

| LETTER DESIGNATION | NASTRAN EID | TYPE | ACTUAL AREA (in. ²) | OFFSETS FROM GRIDPOINT | | FINAL AREA (in. ²) |
|-----------------------|----------------|-------|------------------------------------|---------------------------|---|-----------------------------------|
| | | | | Z | Y | |
| A | 2507701 | R/SP3 | .084 | - | - | .084 |
| B | 2507702 | R/SP3 | .098 | - | - | .098 |
| C | 2507703 | R/SP3 | .113 | - | - | .113 |
| D | 2507713 | R/SP2 | .153 | - | - | .153 |
| E | 2507714 | R/SP2 | .153 | - | - | .153 |
| | 2507715 | R/SP2 | .232 | - | - | .232 |
| F | 2507716 | R/SP2 | .232 | - | - | .232 |
| | 2507717 | R/SP2 | .190 | - | - | .190 |
| G | 2507718 | R/SP2 | .190 | - | - | .190 |
| H | 2507707 | R/SP3 | .084 | - | - | .084 |
| I | 2507708 | R/SP3 | .098 | - | - | .098 |
| J | 2507709 | R/SP3 | .113 | - | - | .113 |
| K | 2108901 | R/SP3 | .084 | - | - | .084 |
| L | 2108902 | R/SP3 | .098 | - | - | .098 |
| M | 2108903 | R/SP3 | .113 | - | - | .113 |
| N | 2108913 | R/SP2 | .153 | - | - | .153 |
| O | 2108914 | R/SP2 | .153 | - | - | .153 |
| | 2108915 | R/SP2 | .232 | - | - | .232 |
| P | 2108916 | R/SP2 | .232 | - | - | .232 |
| | 2108917 | R/SP2 | .190 | - | - | .190 |
| Q | 2108918 | R/SP2 | .190 | - | - | .190 |
| R | 2108907 | R/SP3 | .084 | - | - | .084 |
| S | 2108908 | R/SP3 | .098 | - | - | .098 |
| T | 2108909 | R/SP3 | .113 | - | - | .113 |

3.1.2.23 Right and Left Upper Pilot's Shelves (Sta. 93-148) Detail

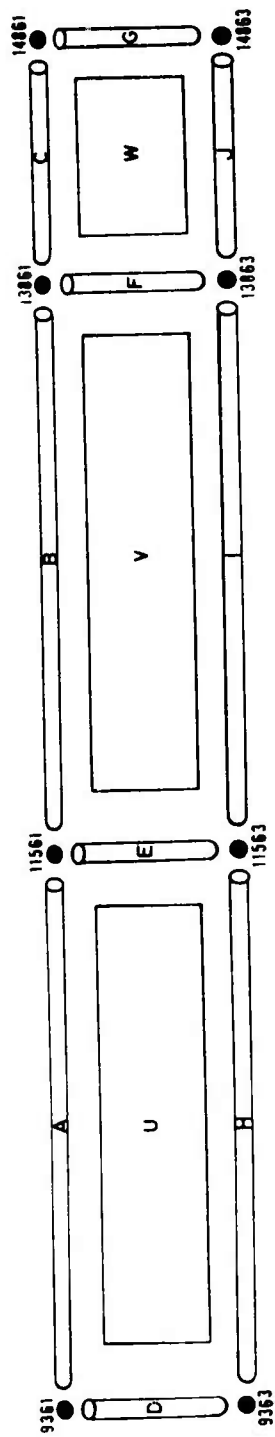

View looking down

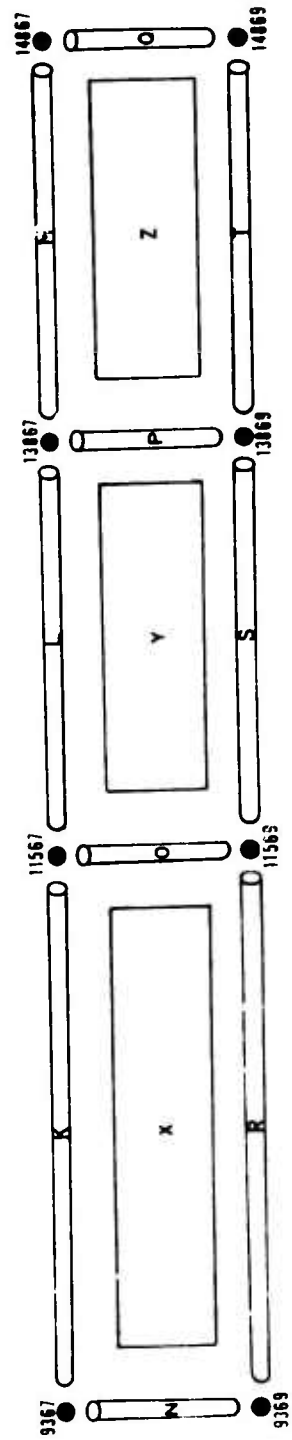

GRID POINT DATA

| GRID POINT | SPC | | MPC | | OMIT | |
|------------|--------|------|--------|------|--------|------|
| | D.O.F. | RULE | D.O.F. | RULE | D.O.F. | RULE |
| 9361 | 456 | AAA | - | - | 123 | DCC |
| 9363 | 456 | AAA | - | - | 2 | C |
| 9367 | 456 | AAA | - | - | 1 | D |
| 9369 | 456 | AAA | - | - | 123 | DCC |
| 11561 | 456 | AAA | - | - | 123 | DCC |
| 11563 | 456 | AAA | - | - | 13 | DC |
| 11567 | 456 | AAA | - | - | 3 | C |
| 11569 | 456 | AAA | - | - | 123 | DCC |
| 13861 | 456 | AAA | - | - | 123 | DCC |
| 13863 | 456 | AAA | - | - | 123 | DCC |
| 13867 | 456 | AAA | - | - | 123 | DCC |
| 13869 | 456 | AAA | - | - | 123 | DCC |
| 14861 | 456 | AAA | - | - | 123 | DCC |
| 14863 | 456 | AAA | - | - | - | - |
| 14867 | 456 | AAA | - | - | 12 | DC |
| 14869 | 456 | AAA | - | - | 123 | DCC |

SHEAR PANEL/MEMBRANE ELEMENT DATA

| Letter Designation | NASTRAN EID | Type | Thickness (IN.) |
|--------------------|-------------|------|-----------------|
| U | 2501774 | Skin | .032 |
| V | 2501775 | Skin | .032 |
| W | 2501776 | Skin | .032 |
| X | 2100894 | Skin | .032 |
| Y | 2100895 | Skin | .032 |
| Z | 2100896 | Skin | .032 |

ROD ELEMENT DATA

| LETTER DESIGNATION | NASTRAN EID | TYPE | ACTUAL AREA (in. ²) | OFFSETS FROM GRIDPOINT | | FINAL AREA (in. ²) |
|-----------------------|----------------|-------|------------------------------------|---------------------------|---|-----------------------------------|
| | | | | Z | Y | |
| A | 2507704 | R/SP3 | .120 | - | - | .120 |
| B | 2507705 | R/SP3 | .121 | - | - | .121 |
| C | 2507706 | R/SP3 | .121 | - | - | .121 |
| D | 2507719 | R/SP2 | .295 | - | - | .295 |
| E | 2507720 | R/SP2 | .295 | - | - | .295 |
| | 2507721 | R/SP2 | .370 | - | - | .370 |
| F | 2507722 | R/SP2 | .370 | - | - | .370 |
| | 2507723 | R/SP2 | .157 | - | - | .157 |
| G | 2507724 | R/SP2 | .157 | - | - | .157 |
| H | 2507710 | R/SP3 | .120 | - | - | .120 |
| I | 2507711 | R/SP3 | .121 | - | - | .121 |
| J | 2507712 | R/SP3 | .121 | - | - | .121 |
| K | 2108904 | R/SP3 | .120 | - | - | .120 |
| L | 2108905 | R/SP3 | .121 | - | - | .121 |
| M | 2108906 | R/SP3 | .121 | - | - | .121 |
| N | 2108919 | R/SP2 | .295 | - | - | .295 |
| O | 2108920 | R/SP2 | .295 | - | - | .295 |
| | 2108921 | R/SP2 | .267 | - | - | .267 |
| P | 2108922 | R/SP2 | .267 | - | - | .267 |
| | 2108923 | R/SP2 | .260 | - | - | .260 |
| Q | 2108924 | R/SP2 | .260 | - | - | .260 |
| R | 2108910 | R/SP3 | .120 | - | - | .120 |
| S | 2108911 | R/SP3 | .121 | - | - | .121 |
| T | 2108912 | R/SP3 | .121 | - | - | .121 |

3.1.2.24 Right Lower Skins Under Ammo Floor (Sta. 93-148) Detail

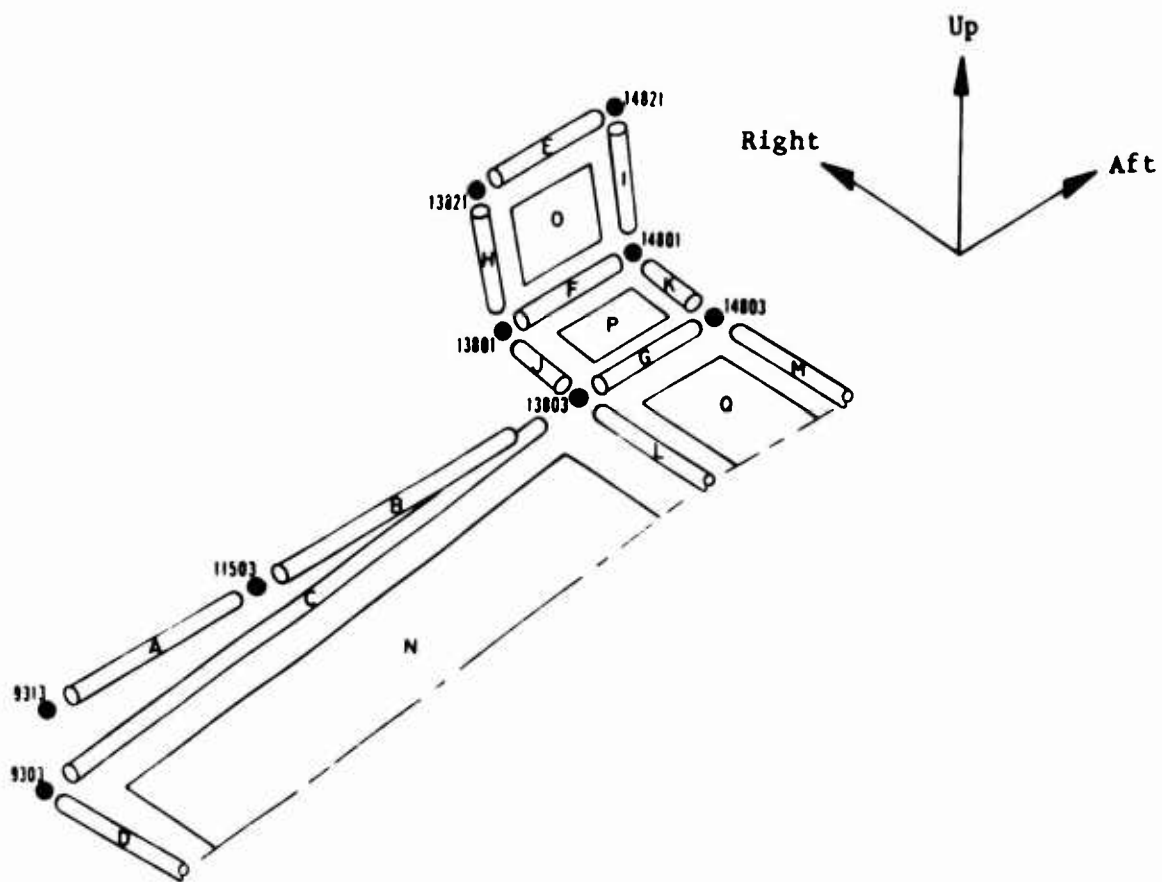

GRID POINT DATA

| GRID POINT | SPC | | MPC | | OMIT | |
|------------|--------|------|--------|------|--------|------|
| | D.O.F. | RULE | D.O.F. | RULE | D.O.F. | RULE |
| 9303 | 456 | AAA | - | - | 123 | DCC |
| 9313 | 456 | AAA | - | - | 123 | DCC |
| 11503 | 3456 | AAAA | - | - | 12 | DC |
| 13801 | 456 | AAA | - | - | 123 | DCC |
| 13803 | 456 | AAA | - | - | 123 | DCC |
| 13821 | 456 | AAA | - | - | 123 | DCC |
| 14801 | 456 | AAA | - | - | 123 | DCC |
| 14803 | 456 | AAA | 123 | AAA | - | - |
| 14821 | 456 | AAA | - | - | 123 | DCC |

SHEAR PANEL/MEMBRANE ELEMENT DATA

| Letter Designation | NASTRAN EID | Type | Thickness (IN.) |
|--------------------|-------------|------|-----------------|
| N | 2030291 | Skin | .025 |
| O | 2200621 | Skin | .032 |
| P | 2201011 | Skin | .025 |
| Q | 2201012 | Skin | .025 |

ROD ELEMENT DATA

| LETTER DESIGNATION | NASTRAN EID | TYPE | ACTUAL AREA (in. ²) | OFFSETS FROM GRIDPOINT | | FINAL AREA (in. ²) |
|--------------------|-------------|---------|---------------------------------|------------------------|---|--------------------------------|
| | | | | Z | Y | |
| A | 2030521 | Doubler | .302 | - | - | .302 |
| B | 2030522 | Doubler | .302 | - | - | .302 |
| C | 2030523 | Doubler | .065 | - | - | .065 |
| | 2032901 | R/SP3 | .250 | - | - | .250 |
| D | 2032903 | R/SP2 | .575 | - | - | .575 |
| E | 2206201 | R/SP2 | .131 | - | - | .131 |
| F | 2200441 | Doubler | .046 | - | - | .046 |
| | 2206202 | R/SP2 | .131 | - | - | .131 |
| | 2200101 | R/SP2 | .074 | - | - | .074 |
| G | 1160311 | Doubler | .521 | - | - | .521 |
| | 2200102 | R/SP2 | .074 | - | - | .074 |
| | 2200111 | R/SP2 | .250 | - | - | .250 |
| H | 2206203 | R/SP2 | .157 | - | - | .157 |
| I | 2206204 | R/SP2 | .157 | - | - | .157 |
| J | 2200103 | R/SP2 | .123 | - | - | .123 |
| K | 2200104 | R/SP2 | .123 | - | - | .123 |
| L | 2032904 | R/SP2 | .575 | - | - | .575 |
| | 2200113 | R/SP2 | .123 | - | - | .123 |
| M | 2200114 | R/SP2 | .123 | - | - | .123 |

3.1.2.25 Left Lower Skins Under Ammo Floor (Sta. 93-148) Detail

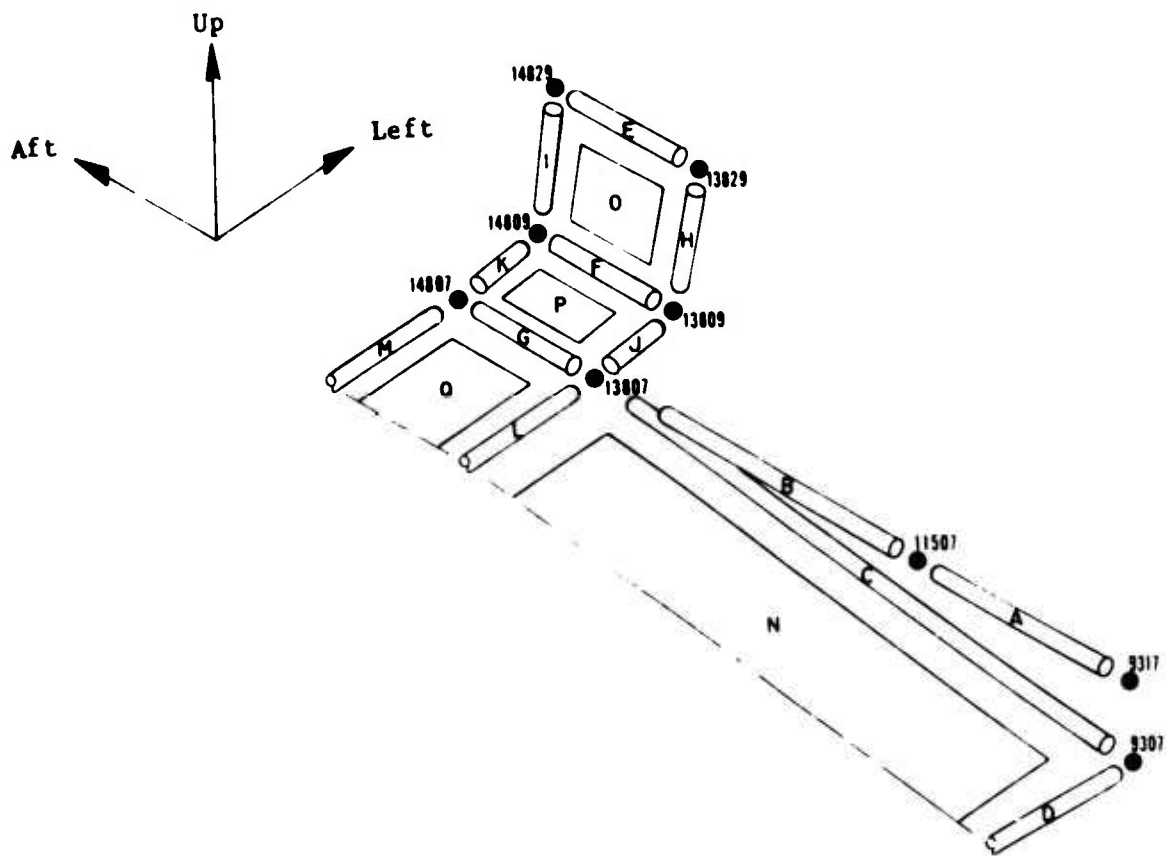

GRID POINT DATA

| GRID POINT | SPC | | MPC | | OMIT | |
|------------|--------|------|--------|------|--------|------|
| | D.O.F. | RULE | D.O.F. | RULE | D.O.F. | RULE |
| 9307 | 456 | AAA | - | - | 123 | DCC |
| 9317 | 456 | AAA | - | - | 13 | DC |
| 11507 | 3456 | AAAA | - | - | 12 | DC |
| 13807 | 456 | AAA | - | - | 123 | DCC |
| 13809 | 456 | AAA | - | - | 123 | DCC |
| 13829 | 456 | AAA | - | - | 123 | DCC |
| 14807 | 456 | AAA | 123 | AAA | - | - |
| 14809 | 456 | AAA | - | - | 123 | DCC |
| 14829 | 456 | AAA | - | - | 123 | DCC |

SHEAR PANEL/MEMBRANE ELEMENT DATA

| Letter Designation | NASTRAN EID | Type | Thickness (IN.) |
|--------------------|-------------|------|-----------------|
| N | 2030291 | Skin | .025 |
| O | 2200611 | Skin | .032 |
| P | 2201013 | Skin | .025 |
| Q | 2201012 | Skin | .025 |

ROD ELEMENT DATA

| LETTER DESIGNATION | NASTRAN EID | TYPE | ACTUAL AREA (in. ²) | OFFSETS FROM GRIDPOINT | | FINAL AREA (in. ²) |
|--------------------|-------------|---------|---------------------------------|------------------------|---|--------------------------------|
| | | | | Z | Y | |
| A | 2030511 | Doubler | .302 | - | - | .302 |
| B | 2030512 | Doubler | .302 | - | - | .302 |
| C | 2030513 | Doubler | .065 | - | - | .065 |
| | 2032902 | R/SP3 | .250 | - | - | .250 |
| D | 2032903 | R/SP2 | .575 | - | - | .575 |
| E | 2206102 | R/SP2 | .131 | - | - | .131 |
| F | 2200431 | Doubler | .046 | - | - | .046 |
| | 2200122 | R/SP2 | .074 | - | - | .074 |
| | 2206101 | R/SP2 | .131 | - | - | .131 |
| G | 1150231 | Doubler | .455 | - | - | .455 |
| | 2200112 | R/SP2 | .250 | - | - | .250 |
| | 2200121 | R/SP2 | .074 | - | - | .074 |
| H | 2206103 | R/SP2 | .157 | - | - | .157 |
| I | 2206104 | R/SP2 | .157 | - | - | .157 |
| J | 2200123 | R/SP2 | .123 | - | - | .123 |
| K | 2200124 | R/SP2 | .123 | - | - | .123 |
| L | 2032904 | R/SP2 | .575 | - | - | .575 |
| | 2200113 | R/SP2 | .123 | - | - | .123 |
| M | 2200114 | R/SP2 | .123 | - | - | .123 |

3.1.3 Center Fuselage Subassembly

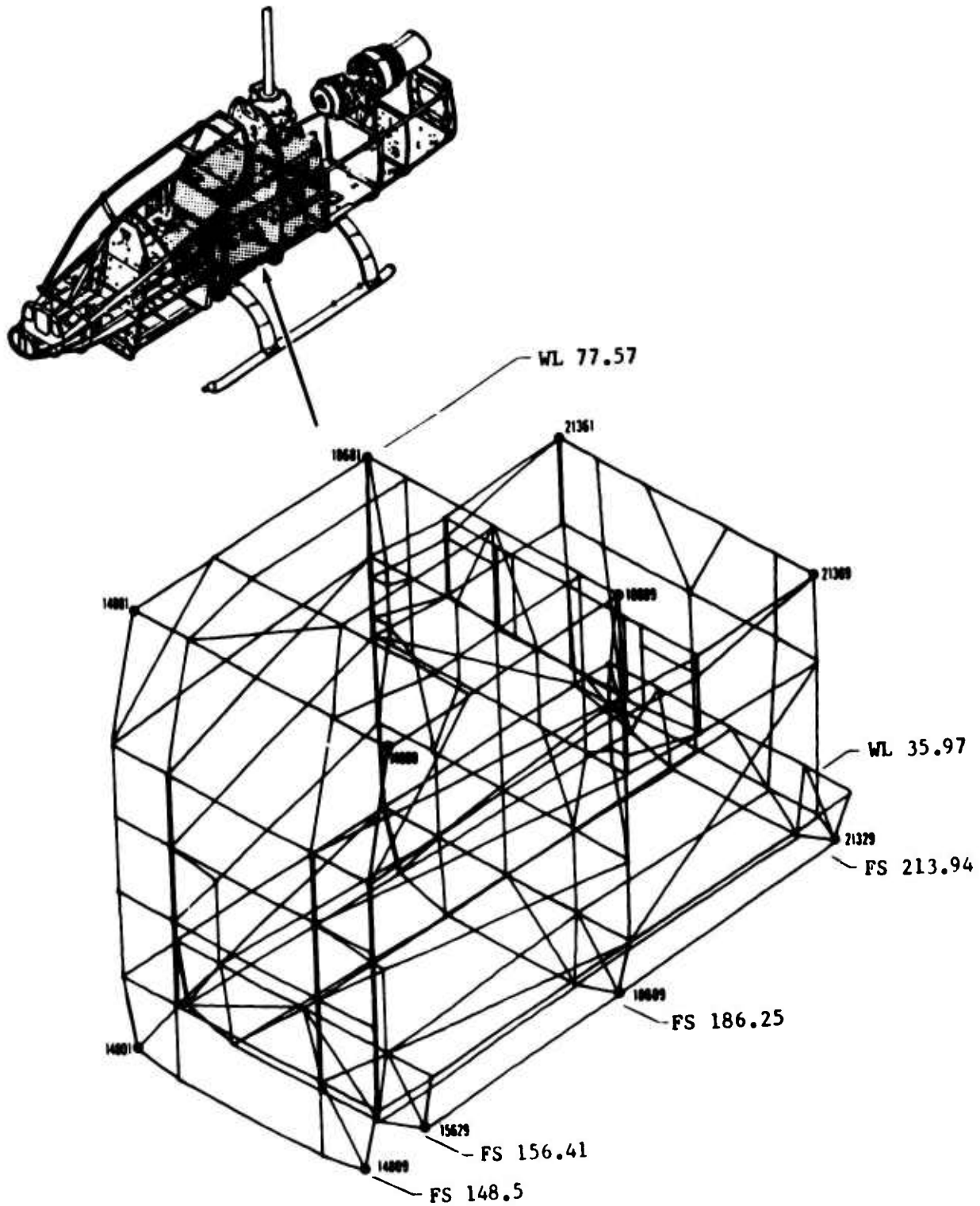

3.1.3.1 Right Main Beam (Sta. 148-186) Detail

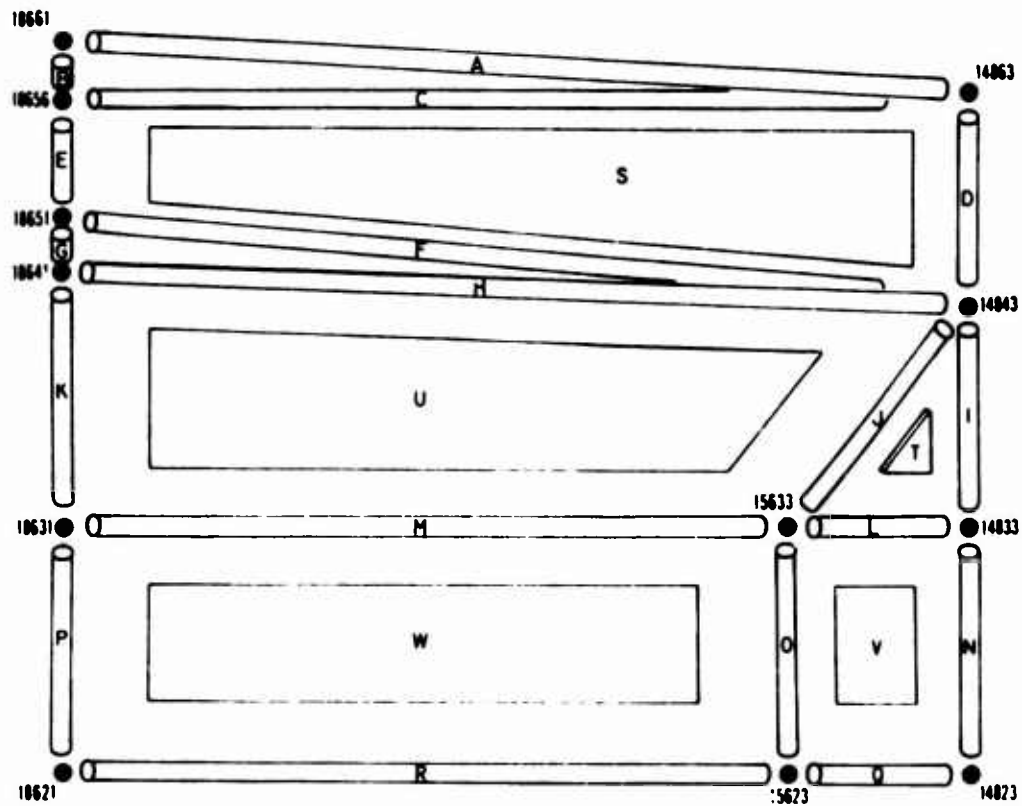

View looking inboard

GRID POINT DATA

| GRID POINT | SPC | | MPC | | OMIT | |
|------------|--------|------|--------|------|--------|--------|
| | D.O.F. | RULE | D.O.F. | RULE | D.O.F. | RULE |
| 14823 | 456 | AAA | 123 | AAA | - | - |
| 14833 | 456 | AAA | - | - | 123 | DCC |
| 14843 | 456 | AAA | - | - | 123 | DCC |
| 14863 | 456 | AAA | - | - | - | - |
| 15623 | 456 | AAA | 123 | AAA | - | - |
| 15633 | 2456 | AAAA | - | - | 13 | DC |
| 18621 | 456 | AAA | - | - | 123 | DCC |
| 18631 | 456 | AAA | - | - | 123 | DCC |
| 18641 | - | - | - | - | 12456 | DCAAA |
| 18651 | - | - | - | - | 123456 | DCCAAA |
| 18656 | - | - | - | - | 123456 | DCCAAA |
| 18661 | - | - | - | - | 123456 | DCCAAA |

SHEAR PANEL/MEMBRANE ELEMENT DATA

| Letter Designation | NASTRAN EID | Type | Thickness (IN.) |
|--------------------|-------------|---------------|-----------------|
| S | 1300395 | Inner Skin | .020 |
| | 1300335 | Outer Skin | .012 |
| T | 1300393 | Inner Skin | .020 |
| | 1300333 | Outer Skin | .012 |
| U | 1300394 | Inner Skin | .020 |
| | 1300334 | Outer Skin | .012 |
| V | 1300391 | Inner Skin | .020 |
| | 1300291 | Interior Skin | .025 |
| | 1300351 | Interior Skin | .032 |
| | 1300331 | Outer Skin | .012 |
| W | 1300392 | Inner Skin | .020 |
| | 1300332 | Outer Skin | .012 |

ROD ELEMENT DATA

| LETTER DESIGNATION | NASTRAN EID | TYPE | ACTUAL AREA (in. ²) | OFFSETS FROM GRIDPOINT | | FINAL AREA (in. ²) |
|--------------------|-------------|---------|---------------------------------|------------------------|-----|--------------------------------|
| | | | | Z | Y | |
| A | 1570037 | Cap | .337 | -0.70 | 0.0 | .285 |
| | 1300231 | Doubler | .098 | -1.74 | 0.0 | .062 |
| B | 1300215 | Doubler | .098 | 0.23 | 0.0 | .108 |
| C | 1303916 | R/SP2 | .083 | - | - | .083 |
| | 1303316 | R/SP2 | .050 | - | - | .050 |
| D | 1300412 | Doubler | .098 | 0.86 | 0.0 | .109 |
| | 1303923 | R/SP2 | .357 | - | - | .357 |
| | 1303323 | R/SP2 | .214 | - | - | .214 |
| E | 1300214 | Doubler | .098 | 0.44 | 0.0 | .108 |
| | 1303926 | R/SP2 | .357 | - | - | .357 |
| | 1303326 | R/SP2 | .214 | - | - | .214 |
| F | 1303915 | R/SP2 | .083 | - | - | .083 |
| | 1303315 | R/SP2 | .050 | - | - | .050 |
| G | 1300213 | Doubler | .098 | 0.20 | 0.0 | .108 |
| H | 1303914 | R/SP2 | .096 | - | - | .096 |
| | 1303314 | R/SP2 | .058 | - | - | .058 |
| I | 1300411 | Doubler | .098 | 0.91 | 0.0 | .109 |
| J | 1303922 | R/SP2 | .320 | - | - | .320 |
| | 1303322 | R/SP2 | .192 | - | - | .192 |
| K | 1300212 | Doubler | .098 | 0.94 | 0.0 | .108 |
| | 1303925 | R/SP2 | .320 | - | - | .320 |
| | 1303325 | R/SP2 | .192 | - | - | .192 |

ROD ELEMENT DATA (CONT.)

| LETTER DESIGNATION | NASTRAN EID | TYPE | ACTUAL AREA (in. ²) | OFFSETS FROM GRIDPOINT | | FINAL AREA (in. ²) |
|--------------------|-------------|---------|---------------------------------|------------------------|-----|--------------------------------|
| | | | | Z | Y | |
| L | 1303902 | R/SP2 | .096 | - | - | .096 |
| | 1302902 | R/SP2 | .050 | - | - | .050 |
| | 1303502 | R/SP2 | .089 | - | - | .089 |
| | 1303302 | R/SP2 | .057 | - | - | .057 |
| M | 1303912 | R/SP2 | .096 | - | - | .096 |
| | 1303913 | R/SP2 | .096 | - | - | .096 |
| | 1303312 | R/SP2 | .057 | - | - | .057 |
| | 1303313 | R/SP2 | .058 | - | - | .058 |
| N | 1300353 | Doubler | .098 | 1.01 | 0.0 | .109 |
| | 1303903 | R/SP2 | .074 | - | - | .074 |
| | 1302903 | R/SP2 | .044 | - | - | .044 |
| | 1303503 | P/SP2 | .090 | - | - | .090 |
| | 1303303 | R/SP2 | .045 | - | - | .045 |
| O | 1303904 | R/SP2 | .074 | - | - | .074 |
| | 1303921 | R/SP2 | .282 | - | - | .282 |
| | 1302904 | R/SP2 | .044 | - | - | .044 |
| | 1303504 | R/SP2 | .090 | - | - | .090 |
| | 1303304 | R/SP2 | .045 | - | - | .045 |
| | 1303321 | R/SP2 | .169 | - | - | .169 |
| | 1300211 | Doubler | .098 | 0.93 | 0.0 | .108 |
| P | 1303924 | R/SP2 | .282 | - | - | .282 |
| | 1303324 | R/SP2 | .169 | - | - | .169 |
| Q | 1590072 | Cap | .297 | 0.35 | 0.0 | .285 |
| | 1300352 | Doubler | .112 | 1.38 | 0.0 | .095 |
| | 1303901 | R/SP2 | .096 | - | - | .096 |
| | 1302901 | R/SP2 | .050 | - | - | .050 |
| | 1303501 | R/SP2 | .089 | - | - | .089 |
| | 1303301 | R/SP2 | .057 | - | - | .057 |

ROD ELEMENT DATA (CONT.)

| LETTER DESIGNATION | NASTRAN EID | TYPE | ACTUAL AREA (in. ²) | OFFSETS FROM GRIDPOINT | | FINAL AREA (in. ²) |
|-----------------------|----------------|---------|------------------------------------|---------------------------|-----|-----------------------------------|
| | | | | Z | Y | |
| R | 1590073 | Cap | .319 | 0.33 | 0.0 | .309 |
| | 1300271 | Doubler | .114 | 1.38 | 0.0 | .097 |
| | 1303911 | R/SP2 | .096 | - | - | .096 |
| | 1303311 | R/SP2 | .057 | - | - | .057 |

3.1.3.2 Left Main Beam (Sta. 148-186) Detail

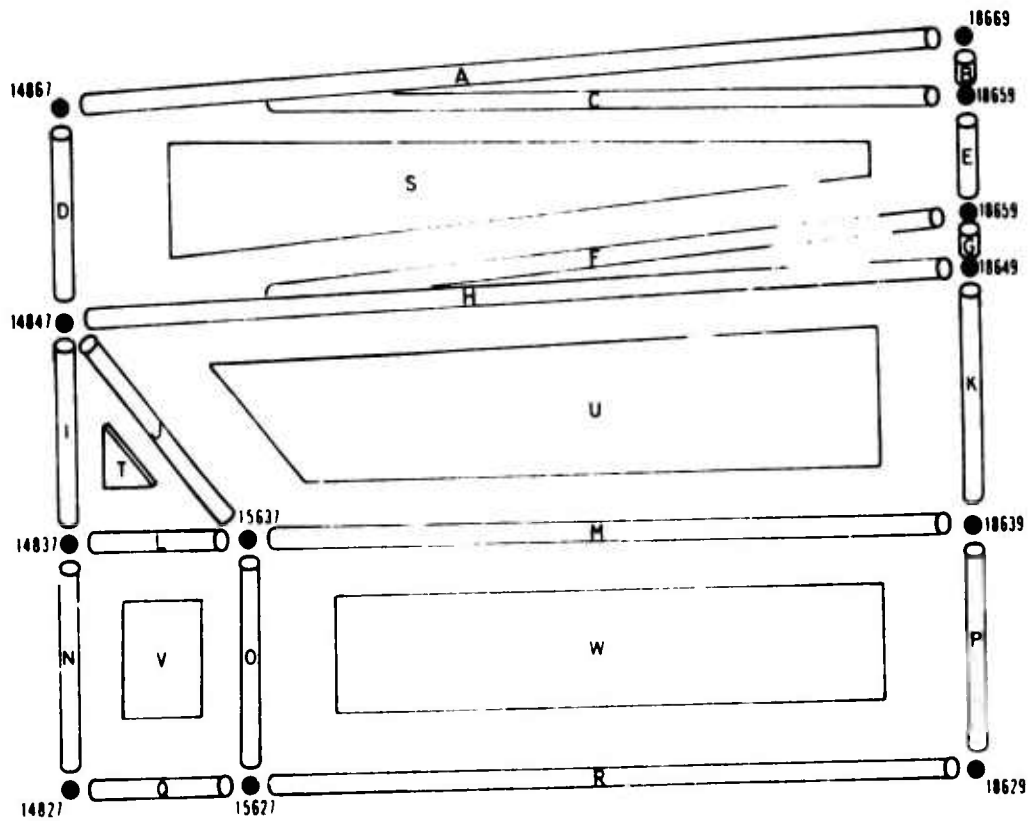

View looking inboard

GRID POINT DATA

| GRID POINT | SPC | | MPC | | OMIT | |
|------------|--------|------|--------|------|--------|--------|
| | D.O.F. | RULE | D.O.F. | RULE | D.O.F. | RULE |
| 14827 | 456 | AAA | 123 | AAA | - | - |
| 14837 | 456 | AAA | - | - | 123 | DCC |
| 14847 | 456 | AAA | - | - | 123 | DCC |
| 14867 | 456 | AAA | - | - | 12 | DC |
| 15627 | 456 | AAA | 123 | AAA | - | - |
| 15637 | 2456 | AAAA | - | - | 13 | DC |
| 18629 | 456 | AAA | - | - | 123 | DCC |
| 18639 | 456 | AAA | - | - | 123 | DCC |
| 18649 | - | - | - | - | 12456 | DCAAA |
| 18654 | - | - | - | - | 123456 | DCCAAA |
| 18659 | - | - | - | - | 123456 | DCCAAA |
| 18669 | - | - | - | - | 123456 | DCCAAA |

SHEAR PANEL/MEMBRANE ELEMENT DATA

| Letter Designation | NASTRAN EID | Type | Thickness (IN.) |
|--------------------|-------------|---------------|-----------------|
| S | 1380415 | Inner Skin | .020 |
| | 1380455 | Outer Skin | .012 |
| T | 1380413 | Inner Skin | .020 |
| | 1380453 | Outer Skin | .012 |
| U | 1380414 | Inner Skin | .020 |
| | 1380454 | Outer Skin | .012 |
| V | 1380411 | Inner Skin | .020 |
| | 1380351 | Interior Skin | .016 |
| | 1380431 | Interior Skin | .040 |
| | 1380451 | Outer Skin | .012 |
| W | 1380412 | Inner Skin | .020 |
| | 1380452 | Outer Skin | .012 |

ROD ELEMENT DATA

| LETTER DESIGNATION | NASTRAN EID | TYPE | ACTUAL AREA (in. ²) | OFFSETS FROM GRIDPOINT | | FINAL AREA (in. ²) |
|-----------------------|----------------|---------|------------------------------------|---------------------------|-----|-----------------------------------|
| | | | | Z | Y | |
| A | 1570017 | Cap | .385 | -0.57 | 0.0 | .346 |
| | 1380291 | Doubler | .212 | -2.01 | 0.0 | .139 |
| B | 1380195 | Doubler | .055 | 0.53 | 0.0 | .070 |
| C | 1384116 | R/SP2 | .075 | - | - | .075 |
| | 1384516 | R/SP2 | .045 | - | - | .045 |
| D | 1380492 | Doubler | .061 | 1.58 | 0.0 | .075 |
| | 1384123 | R/SP2 | .369 | - | - | .369 |
| | 1384523 | R/SP2 | .221 | - | - | .221 |
| E | 1380194 | Doubler | .055 | 1.01 | 0.0 | .070 |
| | 1384126 | R/SP2 | .369 | - | - | .369 |
| | 1384526 | R/SP2 | .221 | - | - | .221 |
| F | 1384115 | R/SP2 | .075 | - | - | .075 |
| | 1384515 | R/SP2 | .045 | - | - | .045 |
| G | 1380193 | Doubler | .055 | 0.47 | 0.0 | .070 |
| H | 1384114 | R/SP2 | .096 | - | - | .096 |
| | 1384514 | R/SP2 | .058 | - | - | .058 |
| I | 1380491 | Doubler | .061 | 1.68 | 0.0 | .075 |
| J | 1384122 | R/SP2 | .334 | - | - | .334 |
| | 1384522 | R/SP2 | .200 | - | - | .200 |
| K | 1380192 | Doubler | .055 | 2.19 | 0.0 | .070 |
| | 1384125 | R/SP2 | .334 | - | - | .334 |
| | 1384525 | R/SP2 | .200 | - | - | .200 |
| L | 1384102 | R/SP2 | .088 | - | - | .088 |
| | 1383502 | R/SP2 | .031 | - | - | .031 |
| | 1384302 | R/SP2 | .096 | - | - | .096 |
| | 1384502 | R/SP2 | .053 | - | - | .053 |

ROD ELEMENT DATA (CONT.)

| LETTER DESIGNATION | NASTRAN EID | TYPE | ACTUAL AREA (in. ²) | OFFSETS FROM GRIDPOINT | | FINAL AREA (in. ²) |
|-----------------------|----------------|---------|------------------------------------|---------------------------|-----|-----------------------------------|
| | | | | Z | Y | |
| M | 1384112 | R/SP2 | .088 | - | - | .088 |
| | 1384113 | R/SP2 | .096 | - | - | .096 |
| | 1384512 | R/SP2 | .053 | - | - | .053 |
| | 1384513 | R/SP2 | .058 | - | - | .058 |
| N | 1380432 | Doubler | .061 | 1.87 | 0.0 | .075 |
| | 1384103 | R/SP2 | .071 | - | - | .071 |
| | 1383503 | R/SP2 | .066 | - | - | .066 |
| | 1384303 | R/SP2 | .183 | - | - | .183 |
| | 1384503 | R/SP2 | .042 | - | - | .042 |
| O | 1384104 | R/SP2 | .071 | - | - | .071 |
| | 1384121 | R/SP2 | .298 | - | - | .298 |
| | 1383504 | R/SP2 | .066 | - | - | .066 |
| | 1384304 | R/SP2 | .183 | - | - | .183 |
| | 1384504 | R/SP2 | .042 | - | - | .042 |
| | 1384521 | R/SP2 | .179 | - | - | .179 |
| P | 1380191 | Doubler | .055 | 2.15 | 0.0 | .070 |
| | 1384124 | R/SP2 | .298 | - | - | .298 |
| | 1384524 | R/SP2 | .179 | - | - | .179 |
| Q | 1590052 | Cap | .316 | 0.36 | 0.0 | .303 |
| | 1380433 | Doubler | .226 | 1.69 | 0.0 | .182 |
| | 1384101 | R/SP2 | .088 | - | - | .088 |
| | 1383501 | R/SP2 | .031 | - | - | .031 |
| | 1384301 | R/SP2 | .096 | - | - | .096 |
| R | 1384501 | R/SP2 | .053 | - | - | .053 |
| | 1590053 | Cap | .326 | 0.33 | 0.0 | .315 |
| | 1380311 | Doubler | .226 | 1.75 | 0.0 | .186 |
| | 1384111 | R/SP2 | .088 | - | - | .088 |
| | 1384511 | R/SP2 | .053 | - | - | .053 |

3.1.3.3 Right Main Beam (Sta. 186-213) Detail

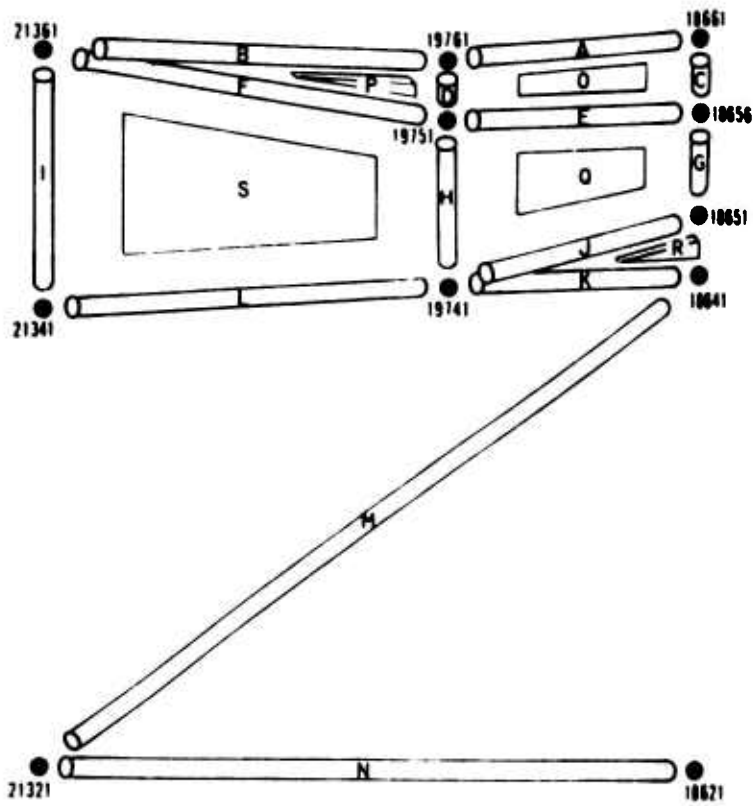

View looking inboard

GRID POINT DATA

| GRID POINT | SPC | | MPC | | OMIT | |
|------------|--------|------|--------|------|--------|--------|
| | D.O.F. | RULE | D.O.F. | RULE | D.O.F. | RULE |
| 18621 | 456 | AAA | - | - | 123 | DCC |
| 18641 | - | - | - | - | 12456 | DCAAA |
| 18651 | - | - | - | - | 123456 | DCCAAA |
| 18656 | - | - | - | - | 123456 | DCCAAA |
| 18661 | - | - | - | - | 123456 | DCCAAA |
| 19741 | - | - | - | - | 123456 | DCCAAA |
| 19751 | - | - | - | - | 12456 | DCAAA |
| 19761 | - | - | - | - | 123456 | DCCAAA |
| 21321 | 456 | AAA | - | - | 23 | CC |
| 21341 | - | - | - | - | 12456 | DCAAA |
| 21361 | 456 | AAA | - | - | 123 | DCC |

SHEAR PANEL/MEMBRANE ELEMENT DATA

| Letter Designation | NASTRAN EID | Type | Thickness (IN.) |
|--------------------|-------------|------------|-----------------|
| O | 1370363 | Inner Skin | .040 |
| | 1370063 | Outer Skin | .040 |
| P | 1370242 | Inner Skin | .012 |
| | 1370065 | Outer Skin | .040 |
| Q | 1370362 | Inner Skin | .040 |
| | 1370062 | Outer Skin | .040 |
| R | 1370361 | Inner Skin | .040 |
| | 1370061 | Outer Skin | .040 |
| S | 1370241 | Inner Skin | .012 |
| | 1370064 | Outer Skin | .040 |

ROD ELEMENT DATA

| LETTER DESIGNATION | NASTRAN EID | TYPE | ACTUAL AREA (in. ²) | OFFSETS FROM GRIDPOINT | | FINAL AREA (in. ²) |
|--------------------|-------------|---------|---------------------------------|------------------------|-----|--------------------------------|
| | | | | Z | Y | |
| A | 1600091 | Cap | .463 | -0.53 | 0.0 | .411 |
| | 1360711 | Cap | .294 | 1.08 | 0.0 | .378 |
| | 1210321 | Cap | .241 | 0.0 | 0.0 | .241 |
| | 1373604 | R/SP1 | .001 | - | - | .001 |
| | 1370604 | R/SP1 | .109 | - | - | .109 |
| B | 1600092 | Cap | .463 | -0.19 | 0.0 | .444 |
| | 1360712 | Cap | .294 | 1.38 | 0.0 | .399 |
| | 1210322 | Cap | .241 | 0.0 | 0.0 | .241 |
| | 1370365 | Doubler | .085 | -0.94 | 0.0 | .067 |
| C | 1373612 | R/SP2 | .213 | - | - | .213 |
| | 1370612 | R/SP2 | .213 | - | - | .213 |
| D | 1370367 | Doubler | .178 | -0.35 | 0.0 | .156 |
| | 1373614 | R/SP2 | .213 | - | - | .213 |
| | 1370614 | R/SP2 | .213 | - | - | .213 |
| E | 1373602 | R/SP1 | .117 | - | - | .117 |
| | 1373603 | R/SP1 | .117 | - | - | .117 |
| | 1370602 | R/SP1 | .095 | - | - | .095 |
| | 1370603 | R/SP1 | .095 | - | - | .095 |
| F | 1372402 | R/SP3 | .020 | - | - | .020 |
| | 1370622 | R/SP3 | .148 | - | - | .148 |
| G | 1373611 | R/SP2 | .213 | - | - | .213 |
| | 1370611 | R/SP2 | .213 | - | - | .213 |
| H | 1370366 | Doubler | .178 | -0.95 | 0.0 | .156 |
| | 1372403 | R/SP2 | .076 | - | - | .076 |
| | 1373613 | R/SP2 | .213 | - | - | .213 |
| | 1370613 | R/SP2 | .213 | - | - | .213 |
| | 1370623 | R/SP2 | .341 | - | - | .341 |
| I | 1370368 | Doubler | .082 | 0.78 | 0.0 | .089 |
| | 1372404 | R/SP2 | .076 | - | - | .076 |
| | 1370624 | R/SP2 | .341 | - | - | .341 |
| J | 1373601 | R/SP1 | .139 | - | - | .139 |
| | 1370601 | R/SP1 | .143 | - | - | .143 |

ROD ELEMENT DATA (CONT.)

| LETTER DESIGNATION | NASTRAN EID | TYPE | ACTUAL AREA (in. ²) | OFFSETS FROM GRIDPOINT | | FINAL AREA (in. ²) |
|-----------------------|----------------|---------|------------------------------------|---------------------------|-----|-----------------------------------|
| | | | | Z | Y | |
| K | 1820051 | Cap | .288 | 0.0 | 0.0 | .288 |
| L | 1820052 | Cap | .288 | 0.0 | 0.0 | .288 |
| | 1370364 | Doubler | .089 | 0.0 | 0.0 | .089 |
| | 1372401 | R/SP3 | .020 | - | - | .020 |
| | 1370621 | R/SP3 | .148 | - | - | .148 |
| M | 1800191 | Brace | .491 | - | - | .491 |
| N | 1610291 | Cap | .521 | 0.41 | 0.0 | .513 |

3.1.3.4 Left Main Beam (Sta. 186-213) Detail

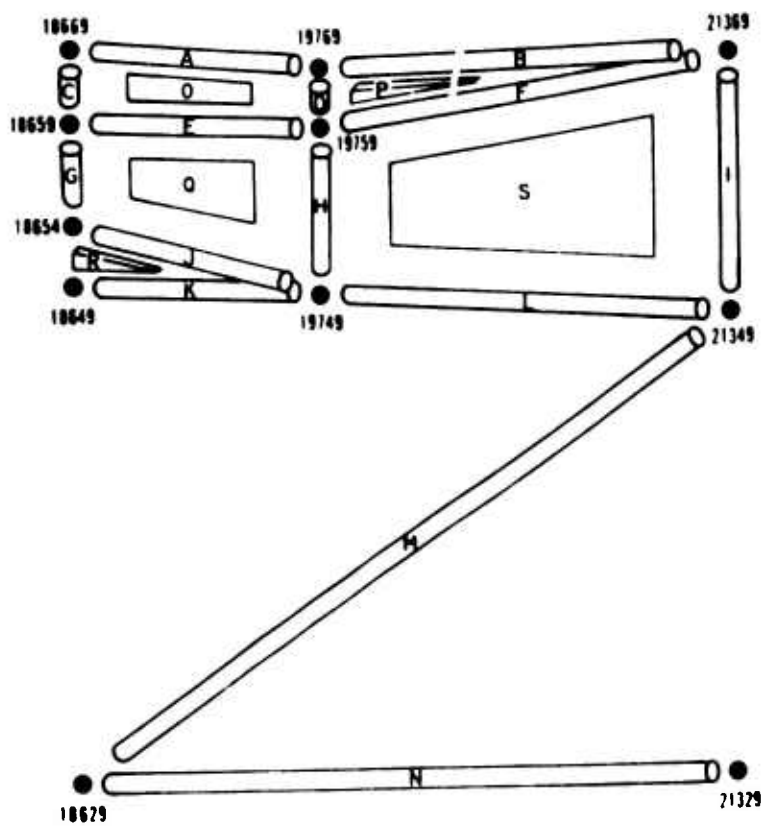

View looking inboard

GRID POINT DATA

| GRID POINT | SPC | | MPC | | OMIT | |
|------------|--------|------|--------|------|--------|--------|
| | D.O.F. | RULE | D.O.F. | RULE | D.O.F. | RULE |
| 18629 | 456 | AAA | - | - | 123 | DCC |
| 18649 | - | - | - | - | 12456 | DCAAA |
| 18654 | - | - | - | - | 123456 | DCCAAA |
| 18659 | - | - | - | - | 123456 | DCCAAA |
| 18669 | - | - | - | - | 123456 | DCCAAA |
| 19749 | - | - | - | - | 123456 | DCCAAA |
| 19759 | - | - | - | - | 12456 | DCAAA |
| 19769 | - | - | - | - | 123456 | DCCAAA |
| 21329 | 456 | AAA | - | - | 123 | DCC |
| 21349 | - | - | - | - | 12456 | DCAAA |
| 21369 | 456 | AAA | - | - | 23 | CC |

SHEAR PANEL/MEMBRANE ELEMENT DATA

| Letter Designation | NASTRAN EID | Type | Thickness (IN.) |
|--------------------|-------------|------------|-----------------|
| O | 1370353 | Inner Skin | .040 |
| | 1370053 | Outer Skin | .040 |
| P | 1370232 | Inner Skin | .012 |
| | 1370055 | Outer Skin | .040 |
| Q | 1370352 | Inner Skin | .040 |
| | 1370052 | Outer Skin | .040 |
| R | 1370351 | Inner Skin | .040 |
| | 1370051 | Outer Skin | .040 |
| S | 1370231 | Inner Skin | .012 |
| | 1370054 | Outer Skin | .040 |

ROD ELEMENT DATA

| LETTER DESIGNATION | NASTRAN EID | TYPE | ACTUAL AREA (in. ²) | OFFSETS FROM GRIDPOINT | | FINAL AREA (in. ²) |
|-----------------------|----------------|---------|------------------------------------|---------------------------|-----|-----------------------------------|
| | | | | Z | Y | |
| A | 1600051 | Cap | .463 | -0.53 | 0.0 | .407 |
| | 1360691 | Cap | .294 | 1.07 | 0.0 | .386 |
| | 1210311 | Cap | .241 | 0.0 | 0.0 | .241 |
| | 1373504 | R/SP1 | .001 | - | - | .001 |
| | 1370504 | R/SP1 | .109 | - | - | .109 |
| B | 1600052 | Cap | .463 | -0.19 | 0.0 | .441 |
| | 1360692 | Cap | .294 | 1.38 | 0.0 | .411 |
| | 1210312 | Cap | .241 | 0.0 | 0.0 | .241 |
| | 1370355 | Doubler | .085 | -1.01 | 0.0 | .064 |
| C | 1373512 | R/SP2 | .213 | - | - | .213 |
| | 1370512 | R/SP2 | .213 | - | - | .213 |
| D | 1370357 | Doubler | .178 | -0.35 | 0.0 | .156 |
| | 1373514 | R/SP2 | .213 | - | - | .213 |
| | 1370514 | R/SP2 | .213 | - | - | .213 |
| E | 1373502 | R/SP1 | .117 | - | - | .117 |
| | 1373503 | R/SP1 | .117 | - | - | .117 |
| | 1370502 | R/SP1 | .095 | - | - | .095 |
| | 1370503 | R/SP1 | .095 | - | - | .095 |
| F | 1372302 | R/SP3 | .016 | - | - | .016 |
| | 1370522 | R/SP3 | .143 | - | - | .143 |
| G | 1373511 | R/SP2 | .213 | - | - | .213 |
| | 1370511 | R/SP2 | .213 | - | - | .213 |
| H | 1370356 | Doubler | .176 | -0.95 | 0.0 | .156 |
| | 1372303 | R/SP2 | .076 | - | - | .076 |
| | 1373513 | R/SP2 | .213 | - | - | .213 |
| | 1370513 | R/SP2 | .213 | - | - | .213 |
| | 1370523 | R/SP2 | .341 | - | - | .341 |
| I | 1370358 | Doubler | .082 | 0.78 | 0.0 | .089 |
| | 1372304 | R/SP2 | .076 | - | - | .076 |
| | 1370524 | R/SP2 | .341 | - | - | .341 |
| J | 1373501 | R/SP1 | .139 | - | - | .139 |
| | 1370501 | R/SP1 | .143 | - | - | .143 |
| K | 1820011 | Cap | .288 | 0.0 | 0.0 | .288 |

ROD ELEMENT DATA (CONT.)

| LETTER DESIGNATION | NASTRAN EID | TYPE | ACTUAL AREA (in. ²) | OFFSETS FROM GRIDPOINT | | FINAL AREA (in. ²) |
|-----------------------|----------------|---------|------------------------------------|---------------------------|-----|-----------------------------------|
| | | | | Z | Y | |
| L | 1820012 | Cap | .288 | 0.0 | 0.0 | .288 |
| | 1370354 | Doubler | .089 | -0.64 | 0.0 | .158 |
| | 1372301 | R/SP3 | .016 | - | - | .016 |
| | 1370521 | R/SP3 | .143 | - | - | .143 |
| M | 1800171 | Brace | .491 | - | - | .491 |
| N | 1610191 | Cap | .427 | 0.38 | 0.0 | .412 |

3.1.3.5 Bulkhead Sta. 148.5 Detail

View looking aft

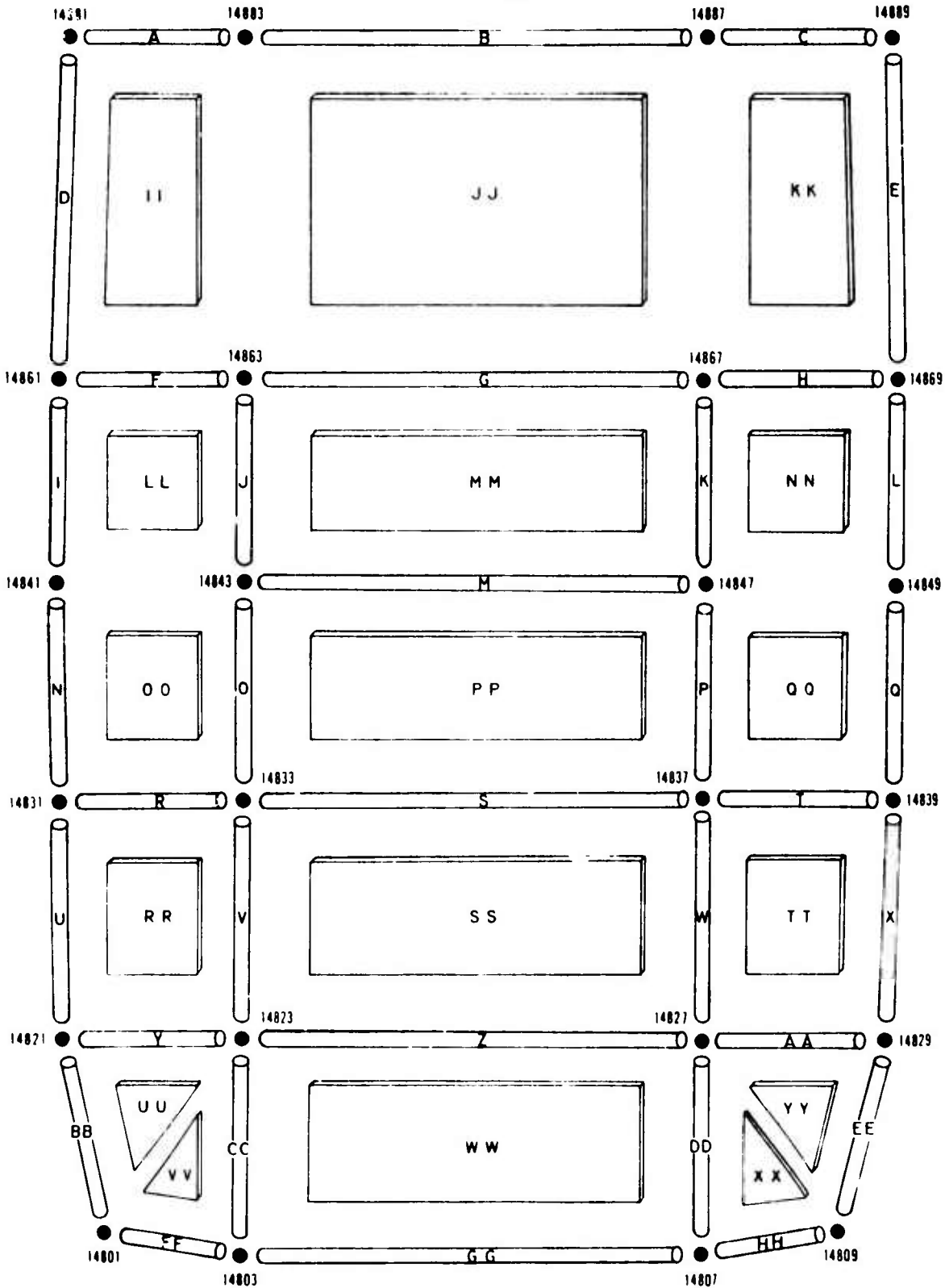

GRID POINT DATA

| GRID POINT | SPC | | MPC | | OMIT | |
|------------|--------|------|--------|------|--------|------|
| | D.O.F. | RULE | D.O.F. | RULE | D.O.F. | RULE |
| 14801 | 456 | AAA | - | - | 123 | DCC |
| 14803 | 456 | AAA | 123 | AAA | - | - |
| 14807 | 456 | AAA | 123 | AAA | - | - |
| 14809 | 456 | AAA | - | - | 123 | DCC |
| 14821 | 456 | AAA | - | - | 123 | DCC |
| 14823 | 456 | AAA | 123 | AAA | - | - |
| 14827 | 456 | AAA | 123 | AAA | - | - |
| 14829 | 456 | AAA | - | - | 123 | DCC |
| 14831 | 456 | AAA | - | - | 123 | DCC |
| 14833 | 456 | AAA | - | - | 123 | DCC |
| 14837 | 456 | AAA | - | - | 123 | DCC |
| 14839 | 456 | AAA | - | - | 123 | DCC |
| 14841 | 1456 | AAAA | - | - | 23 | CC |
| 14843 | 456 | AAA | - | - | 123 | DCC |
| 14847 | 456 | AAA | - | - | 123 | DCC |
| 14849 | 1456 | AAAA | - | - | 23 | CC |
| 14861 | 456 | AAA | - | - | 123 | DCC |
| 14863 | 456 | AAA | - | - | - | - |
| 14867 | 456 | AAA | - | - | 12 | DC |
| 14869 | 456 | AAA | - | - | 123 | DCC |
| 14881 | 456 | AAA | - | - | 123 | DCC |
| 14883 | 456 | AAA | - | - | 123 | DCC |
| 14887 | 456 | AAA | - | - | 123 | DCC |
| 14889 | 456 | AAA | - | - | 123 | DCC |

SHEAR PANEL/MEMBRANE ELEMENT DATA

| Letter Designation | NASTRAN EID | Type | Thickness (IN.) |
|--------------------|-------------|----------|-----------------|
| II | 1486183 | Bulkhead | .022 |
| JJ | 1486387 | Bulkhead | .022 |
| KK | 1486789 | Bulkhead | .022 |
| LL | 1484163 | Bulkhead | .032 |
| MM | 1484367 | Bulkhead | .016 |
| NN | 1484769 | Bulkhead | .032 |
| OO | 1483143 | Bulkhead | .032 |
| PP | 1483347 | Bulkhead | .016 |
| QQ | 1483749 | Bulkhead | .032 |
| RR | 1482133 | Bulkhead | .032 |
| SS | 1482337 | Bulkhead | .016 |
| TT | 1482739 | Bulkhead | .032 |
| UU | 1480121 | Bulkhead | .072 |
| VV | 1480123 | Bulkhead | .072 |
| WW | 1480327 | Bulkhead | .072 |
| XX | 1480727 | Bulkhead | .072 |
| YY | 1480927 | Bulkhead | .072 |

ROD ELEMENT DATA

| LETTER DESIGNATION | NASTRAN EID | TYPE | ACTUAL AREA (in. ²) | OFFSETS FROM GRIDPOINT | | FINAL AREA (in. ²) |
|-----------------------|----------------|-------|------------------------------------|---------------------------|---|-----------------------------------|
| | | | | Z | Y | |
| A | 1488183 | Frame | .155 | - | - | .155 |
| B | 1488387 | Frame | .155 | - | - | .155 |
| C | 1488789 | Frame | .155 | - | - | .155 |
| D | 1486181 | Frame | .121 | - | - | .121 |
| E | 1486989 | Frame | .121 | - | - | .121 |
| F | 1486163 | Frame | .277 | - | - | .277 |
| G | 1486367 | Frame | .249 | - | - | .249 |
| H | 1486769 | Frame | .277 | - | - | .277 |
| I | 1484161 | Frame | .130 | - | - | .130 |
| J | 1484363 | Frame | .334 | - | - | .334 |
| K | 1484767 | Frame | .342 | - | - | .342 |
| L | 1484969 | Frame | .130 | - | - | .130 |
| M | 1484347 | Frame | .152 | - | - | .152 |
| N | 1483141 | Frame | .130 | - | - | .130 |
| O | 1483343 | Frame | .334 | - | - | .334 |
| P | 1483747 | Frame | .342 | - | - | .342 |
| Q | 1483949 | Frame | .130 | - | - | .130 |
| R | 1483133 | Frame | .155 | - | - | .155 |
| S | 1483337 | Frame | .265 | - | - | .265 |
| T | 1483739 | Frame | .155 | - | - | .155 |
| U | 1482131 | Frame | .130 | - | - | .130 |
| V | 1482333 | Frame | .284 | - | - | .284 |
| W | 1482737 | Frame | .292 | - | - | .292 |
| X | 1482939 | Frame | .130 | - | - | .130 |
| Y | 1482123 | Frame | .293 | - | - | .293 |
| Z | 1482327 | Frame | .316 | - | - | .316 |
| AA | 1482729 | Frame | .293 | - | - | .293 |
| BB | 1482101 | Frame | .130 | - | - | .130 |
| CC | 1480323 | Frame | .234 | - | - | .234 |
| DD | 1482707 | Frame | .234 | - | - | .234 |
| EE | 1480929 | Frame | .130 | - | - | .130 |

ROD ELEMENT DATA (CONT.)

| LETTER DESIGNATION | NASTRAN EID | TYPE | ACTUAL AREA (in. ²) | OFFSETS FROM GRIDPOINT | | FINAL AREA (in. ²) |
|-----------------------|----------------|-------|------------------------------------|---------------------------|---|-----------------------------------|
| | | | | Z | Y | |
| FF | 1480103 | Frame | .130 | - | - | .130 |
| GG | 1480307 | Frame | .130 | - | - | .130 |
| HH | 1480709 | Frame | .130 | - | - | .130 |

3.1.3.6 Partial Belly Bulkhead Sta. 156.41 - Detail

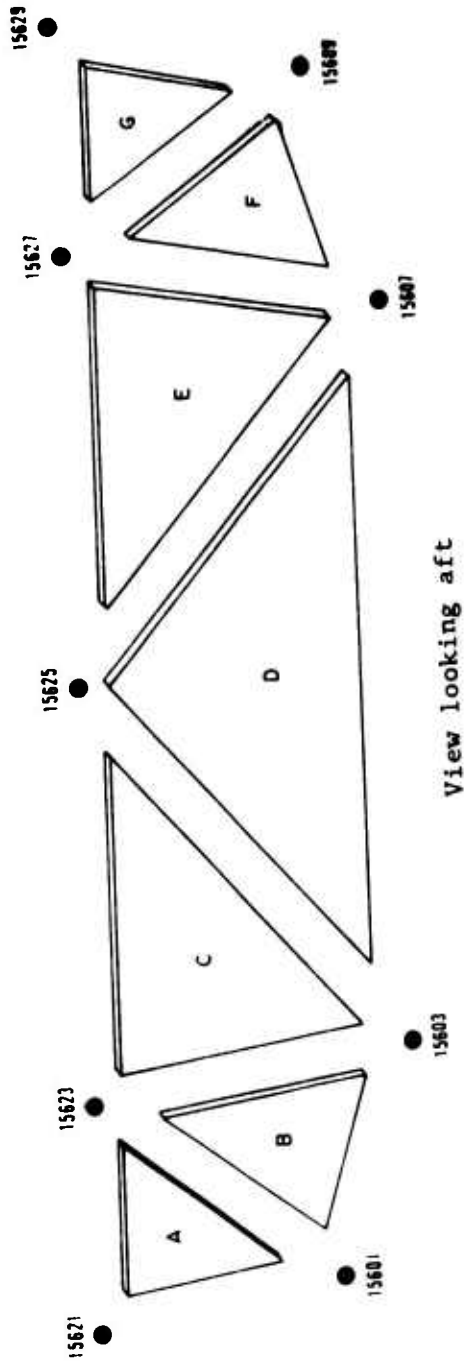

GRID POINT DATA

| GRID POINT | SPC | | MPC | | OMIT | |
|------------|--------|------|--------|------|--------|------|
| | D.O.F. | RULE | D.O.F. | RULE | D.O.F. | RULE |
| 15601 | 456 | AAA | - | - | 123 | DCC |
| 15603 | 456 | AAA | 123 | AAA | - | - |
| 15607 | 456 | AAA | 123 | AAA | - | - |
| 15609 | 456 | AAA | - | - | 123 | DCC |
| 15621 | 456 | AAA | - | - | 123 | DCC |
| 15623 | 456 | AAA | 123 | AAA | - | - |
| 15625 | 456 | AAA | - | - | - | - |
| 15627 | 456 | AAA | 123 | AAA | - | - |
| 15629 | 456 | AAA | - | - | 123 | DCC |
| 15633 | 2456 | AAAA | - | - | 13 | DC |
| 15637 | 2456 | AAAA | - | - | 13 | DC |

SHEAR PANEL/MEMBRANE ELEMENT DATA

| Letter Designation | NASTRAN EID | Type | Thickness (IN.) |
|--------------------|-------------|----------|-----------------|
| A | 1560121 | Bulkhead | .032 |
| B | 1560123 | Bulkhead | .032 |
| C | 1560323 | Bulkhead | .032 |
| D | 1560325 | Bulkhead | .032 |
| E | 1560725 | Bulkhead | .032 |
| F | 1560727 | Bulkhead | .032 |
| G | 1560927 | Bulkhead | .032 |

3.1.3.7 Bulkhead Sta. 186.25 Detail

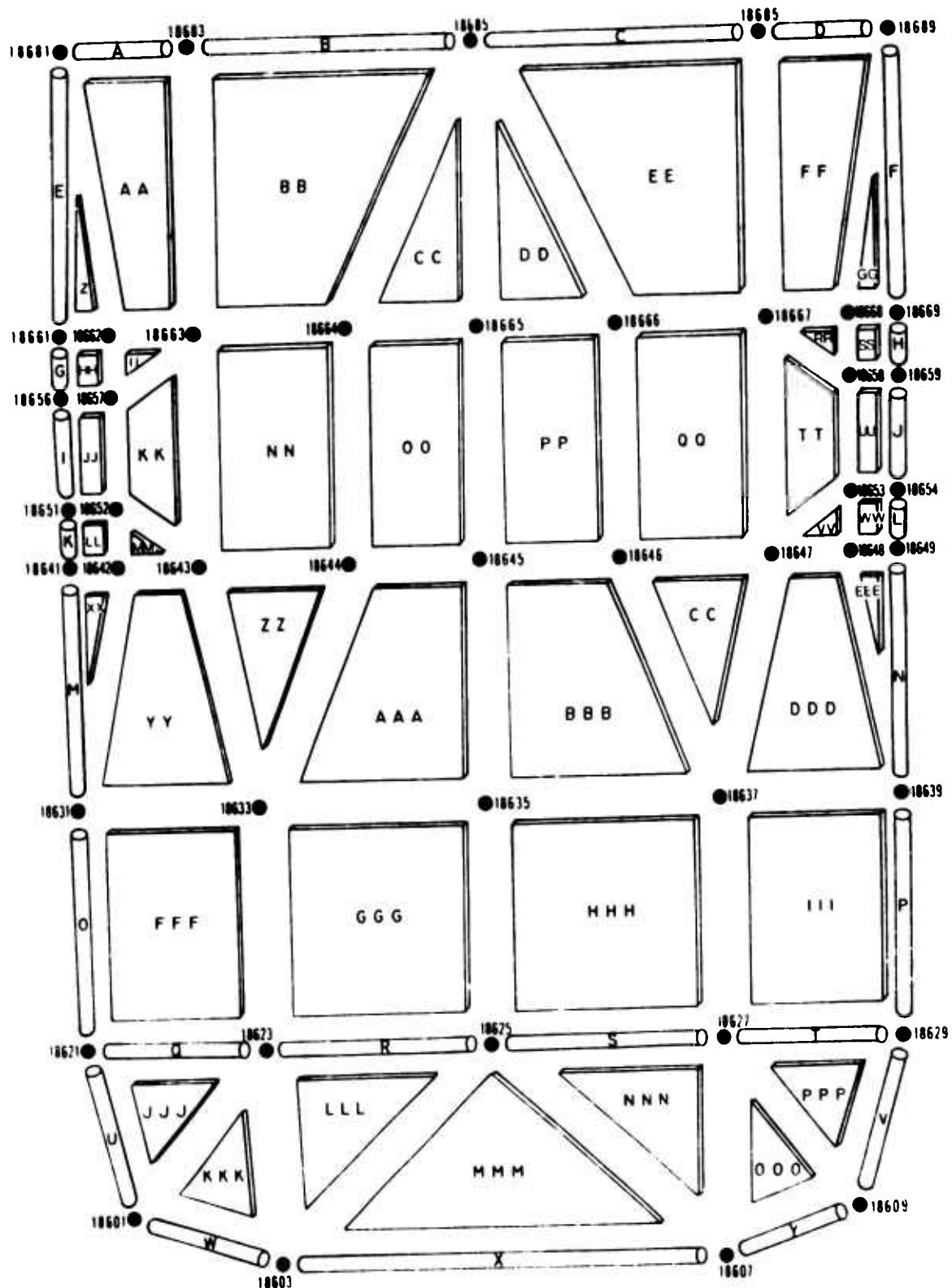

View looking aft

GRID POINT DATA

| GRID POINT | SPC | | MPC | | OMIT | |
|------------|--------|------|--------|------|--------|--------|
| | D.O.F. | RULE | D.O.F. | RULE | D.O.F. | RULE |
| 18601 | 456 | AAA | - | - | 123 | DCC |
| 18603 | 456 | AAA | - | - | 123 | DCC |
| 18607 | 456 | AAA | - | - | 123 | DCC |
| 18609 | 456 | AAA | - | - | 123 | DCC |
| 18621 | 456 | AAA | - | - | 123 | DCC |
| 18623 | 456 | AAA | - | - | 123 | DCC |
| 18625 | 456 | AAA | - | - | 3 | C |
| 18627 | 456 | AAA | - | - | 123 | DCC |
| 18629 | 456 | AAA | - | - | 123 | DCC |
| 18631 | 456 | AAA | - | - | 123 | DCC |
| 18633 | 1456 | AAAA | - | - | 23 | CC |
| 18635 | 1456 | AAAA | - | - | 23 | CC |
| 18637 | 1456 | AAAA | - | - | 23 | CC |
| 18639 | 456 | AAA | - | - | 123 | DCC |
| 18641 | - | - | - | - | 12456 | DCAAA |
| 18642 | - | - | - | - | 23456 | CCAAA |
| 18643 | 4 | A | - | - | 12356 | DCCAA |
| 18644 | 45 | AA | - | - | 1236 | DCCA |
| 18645 | 45 | AA | - | - | 126 | DCA |
| 18646 | 45 | AA | - | - | 1236 | DCCA |
| 18647 | 4 | A | - | - | 12356 | DCCAA |
| 18648 | - | - | - | - | 23456 | CCAAA |
| 18649 | - | - | - | - | 12456 | DCAAA |
| 18651 | - | - | - | - | 123456 | DCCAAA |
| 18652 | - | - | - | - | 23456 | CCAAA |
| 18653 | - | - | - | - | 23456 | CCAAA |
| 18654 | - | - | - | - | 123456 | DCCAAA |
| 18656 | - | - | - | - | 123456 | DCCAAA |
| 18657 | - | - | - | - | 23456 | CCAAA |
| 18658 | - | - | - | - | 23456 | CCAAA |
| 18659 | - | - | - | - | 123456 | DCCAAA |

GRID POINT DATA (CONT.)

| GRID POINT | SPC | | MPC | | OMIT | |
|------------|--------|------|--------|------|--------|--------|
| | D.O.F. | RULE | D.O.F. | RULE | D.O.F. | RULE |
| 18661 | - | - | - | - | 123456 | DCCAAA |
| 18662 | - | - | - | - | 23456 | CCAAA |
| 18663 | - | - | - | - | 123456 | DCCAAA |
| 18664 | 45 | AA | - | - | 1236 | DCCA |
| 18665 | 45 | AA | - | - | 1236 | DCCA |
| 18666 | 45 | AA | - | - | 1236 | DCCA |
| 18667 | - | - | - | - | 123456 | DCCAAA |
| 18668 | - | - | - | - | 23456 | CCAAA |
| 18669 | - | - | - | - | 123456 | DCCAAA |
| 18681 | 456 | AAA | - | - | 123 | DCC |
| 18683 | - | - | 6 | A | 1245 | DCAA |
| 18685 | 456 | AAA | - | - | 13 | DC |
| 18687 | - | - | 6 | A | 1245 | DCAA |
| 18689 | 456 | AAA | - | - | 123 | DCC |

SHEAR PANEL/MEMBRANE ELEMENT DATA

| Letter Designation | NASTRAN EID | Type | Thickness (IN.) |
|--------------------|-------------|----------|-----------------|
| Z | 1866181 | Bulkhead | .095 |
| AA | 1866283 | Bulkhead | .095 |
| BB | 1866385 | Bulkhead | .012 |
| CC | 1866485 | Bulkhead | .012 |
| DD | 1866585 | Bulkhead | .012 |
| EE | 1866687 | Bulkhead | .012 |
| FF | 1866789 | Bulkhead | .095 |
| GG | 1866889 | Bulkhead | .095 |
| HH | 1865662 | Bulkhead | .032 |
| II | 1865762 | Bulkhead | .032 |
| JJ | 1865157 | Bulkhead | .032 |
| KK | 1865263 | Bulkhead | .032 |
| LL | 1864152 | Bulkhead | .032 |
| MM | 1864252 | Bulkhead | .032 |
| NN | 1864364 | Bulkhead | .032 |
| OO | 1864465 | Bulkhead | .032 |
| PP | 1864566 | Bulkhead | .032 |
| QQ | 1864667 | Bulkhead | .032 |
| RR | 1865867 | Bulkhead | .032 |
| SS | 1865869 | Bulkhead | .032 |
| TT | 1864758 | Bulkhead | .032 |
| UU | 1865359 | Bulkhead | .032 |
| VV | 1864753 | Bulkhead | .032 |
| WW | 1864854 | Bulkhead | .032 |
| XX | 1863141 | Bulkhead | .012 |
| YY | 1863143 | Bulkhead | .012 |
| ZZ | 1863343 | Bulkhead | .012 |
| AAA | 1863345 | Bulkhead | .012 |
| BBB | 1863546 | Bulkhead | .012 |
| CCC | 1863746 | Bulkhead | .012 |
| DDD | 1863748 | Bulkhead | .012 |
| EEE | 1863948 | Bulkhead | .012 |
| FFF | 1862133 | Bulkhead | .012 |

SHEAR PANEL/MEMBRANE ELEMENT DATA (CONT.)

| Letter Designation | NASTRAN EID | Type | Thickness (IN.) |
|--------------------|-------------|----------|-----------------|
| GGG | 1862335 | Bulkhead | .012 |
| HHH | 1862537 | Bulkhead | .012 |
| III | 1862739 | Bulkhead | .012 |
| JJJ | 1860121 | Bulkhead | .012 |
| KKK | 1860123 | Bulkhead | .012 |
| LLL | 1860323 | Bulkhead | .012 |
| MMM | 1860325 | Bulkhead | .012 |
| NNN | 1860725 | Bulkhead | .012 |
| OOO | 1860727 | Bulkhead | .012 |
| PPP | 1860927 | Bulkhead | .012 |

ROD ELEMENT DATA

| LETTER DESIGNATION | NASTRAN EID | TYPE | ACTUAL AREA (in. ²) | OFFSETS FROM GRIDPOINT | | FINAL AREA (in. ²) |
|-----------------------|----------------|-------|------------------------------------|---------------------------|---|-----------------------------------|
| | | | | Z | Y | |
| A | 1868183 | Frame | .328 | - | - | .328 |
| B | 1868385 | Frame | .328 | - | - | .328 |
| C | 1868587 | Frame | .328 | - | - | .328 |
| D | 1868789 | Frame | .328 | - | - | .328 |
| E | 1866181 | Frame | .203 | - | - | .203 |
| F | 1866989 | Frame | .203 | - | - | .203 |
| G | 1865661 | Frame | .548 | - | - | .548 |
| H | 1865969 | Frame | .588 | - | - | .588 |
| I | 1865156 | Frame | .548 | - | - | .548 |
| J | 1865459 | Frame | .588 | - | - | .588 |
| K | 1864151 | Frame | .548 | - | - | .548 |
| L | 1864954 | Frame | .588 | - | - | .588 |
| M | 1863141 | Frame | .652 | - | - | .652 |
| N | 1863949 | Frame | .487 | - | - | .487 |
| O | 1862131 | Frame | .652 | - | - | .652 |
| P | 1862939 | Frame | .487 | - | - | .487 |
| Q | 1862123 | Frame | .278 | - | - | .278 |
| R | 1862325 | Frame | .278 | - | - | .278 |
| S | 1862527 | Frame | .278 | - | - | .278 |
| T | 1862729 | Frame | .278 | - | - | .278 |
| U | 1862101 | Frame | .123 | - | - | .123 |
| V | 1860929 | Frame | .123 | - | - | .123 |
| W | 1860103 | Frame | .123 | - | - | .123 |
| X | 1860307 | Frame | .123 | - | - | .123 |
| Y | 1860709 | Frame | .123 | - | - | .123 |

3.1.3.8 Right Side Panel Under Canopy (Sta. 148-186) Detail

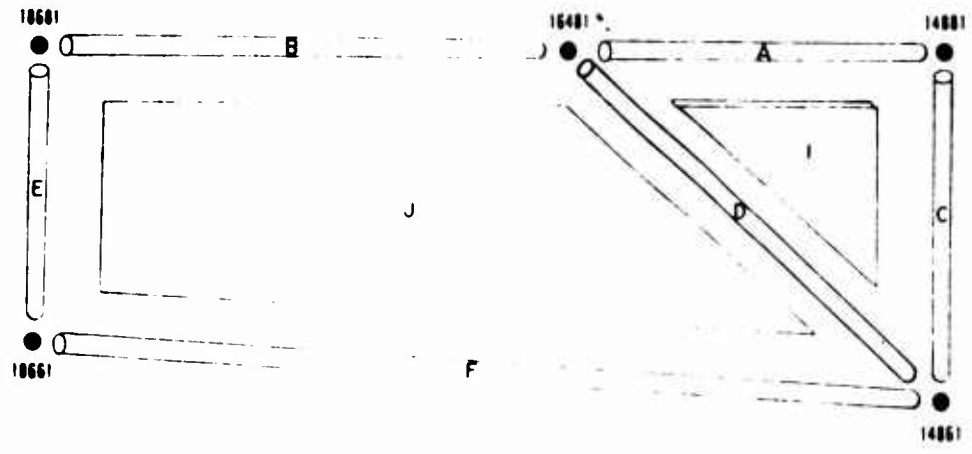

View looking inboard

GRID POINT DATA

| GRID POINT | SPC | | MPC | | OMIT | |
|------------|--------|------|--------|------|--------|--------|
| | D.O.F. | RULE | D.O.F. | RULE | D.O.F. | RULE |
| 14821 | 456 | AAA | - | - | 123 | DCC |
| 14861 | 456 | AAA | - | - | 123 | DCC |
| 14881 | 456 | AAA | - | - | 123 | DCC |
| 15621 | 456 | AAA | - | - | 123 | DCC |
| 16481 | 456 | AAA | - | - | 123 | DCC |
| 18621 | 456 | AAA | - | - | 123 | DCC |
| 18661 | - | - | - | - | 123456 | DCCAAA |
| 18681 | 456 | AAA | - | - | 123 | DCC |

SHEAR PANEL/MEMBRANE ELEMENT DATA

| Letter Designation | NASTRAN EID | Type | Thickness (IN.) |
|--------------------|-------------|------------|-----------------|
| I | 1250271 | Inner Skin | .008 |
| | 3790011 | Outer Skin | .021 |
| J | 1250272 | Inner Skin | .008 |
| | 3790012 | Outer Skin | .021 |

ROD ELEMENT DATA

| LETTER DESIGNATION | NASTR EID | TYPE | ACTUAL AREA (in. ²) | OFFSETS FROM GRIDPOINT | | FINAL AREA (in. ²) |
|-----------------------|--------------|---------|------------------------------------|---------------------------|-----|-----------------------------------|
| | | | | Z | Y | |
| A | 1250571 | Cap | .117 | -0.20 | 0.0 | .115 |
| | 1251571 | Doubler | .121 | -0.88 | 0.0 | .112 |
| B | 1250572 | Cap | .117 | -0.20 | 0.0 | .115 |
| | 1251572 | Doubler | .121 | -0.88 | 0.0 | .111 |
| | 1252702 | R/SP3 | .035 | - | - | .035 |
| | 3790102 | R/SP3 | .121 | - | - | .121 |
| | 1251511 | Doubler | .121 | 0.0 | 0.0 | .121 |
| D | 1252703 | R/SP2 | .120 | - | - | .120 |
| | 3790103 | R/SP2 | .315 | - | - | .315 |
| E | 1251551 | Doubler | .121 | 0.0 | 0.0 | .121 |
| | 1252704 | R/SP2 | .120 | - | - | .120 |
| | 3790104 | R/SP2 | .315 | - | - | .315 |
| F | 2501711 | Cap | .118 | -0.47 | 0.0 | .104 |
| | 1251491 | Doubler | .121 | 0.67 | 0.0 | .140 |
| | 1252701 | R/SP3 | .035 | - | - | .035 |
| | 3790101 | R/SP3 | .121 | - | - | .121 |
| G | 1610152 | Cap | .130 | 0.11 | 0.0 | .128 |
| H | 1610153 | Cap | .130 | 0.11 | 0.0 | .128 |

3.1.3.9 Left Side Panel Under Canopy (Sta. 148-186) Detail

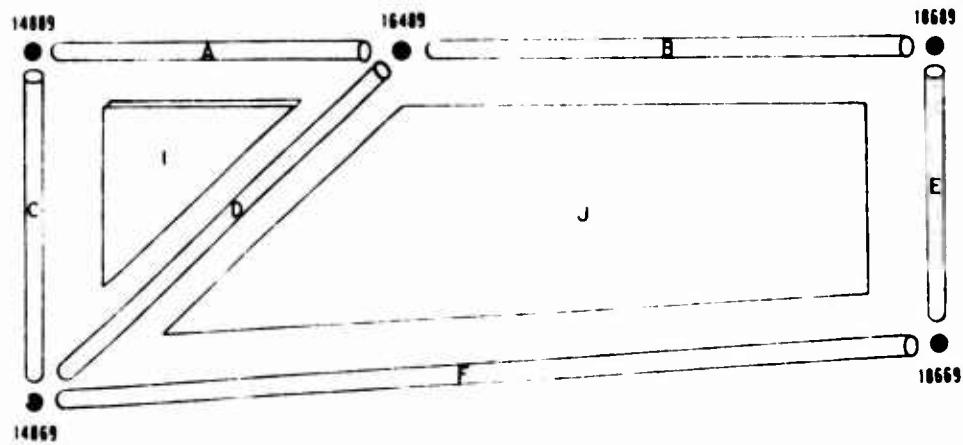

View looking inbound

GRID POINT DATA

| GRID POINT | SPC | | MPC | | OMIT | |
|------------|--------|------|--------|------|--------|--------|
| | D.O.F. | RULE | D.O.F. | RULE | D.O.F. | RULE |
| 14829 | 456 | AAA | - | - | 123 | DCC |
| 14869 | 456 | AAA | - | - | 123 | DCC |
| 14889 | 456 | AAA | - | - | 123 | DCC |
| 15629 | 456 | AAA | - | - | 123 | DCC |
| 16489 | 456 | AAA | - | - | 123 | DCC |
| 18629 | 456 | AAA | - | - | 123 | DCC |
| 18669 | - | - | - | - | 123456 | DCCAAA |
| 18689 | 456 | AAA | - | - | 123 | DCC |

SHEAR PANEL/MEMBRANE ELEMENT DATA

| Letter Designation | NASTRAN EID | Type | Thickness (IN.) |
|--------------------|-------------|------------|-----------------|
| I | 1250231 | Inner Skin | .008 |
| | 1250911 | Outer Skin | .016 |
| J | 1250232 | Inner Skin | .008 |
| | 1250912 | Outer Skin | .016 |

ROD ELEMENT DATA

| LETTER DESIGNATION | NASTRAN EID | TYPE | ACTUAL AREA (in. ²) | OFFSETS FROM GRIDPOINT | | FINAL AREA (in. ²) |
|--------------------|-------------|---------|---------------------------------|------------------------|-----|--------------------------------|
| | | | | Z | Y | |
| A | 1250771 | Cap | .117 | -0.20 | 0.0 | .115 |
| | 1250131 | Doubler | .070 | -1.10 | 0.0 | .064 |
| B | 1250772 | Cap | .117 | -0.20 | 0.0 | .115 |
| | 1250132 | Doubler | .070 | -1.10 | 0.0 | .064 |
| | 1252302 | R/SP3 | .035 | - | - | .035 |
| | 1259102 | R/SP3 | .098 | - | - | .098 |
| C | 1250171 | Doubler | .070 | 0.0 | 0.0 | .070 |
| D | 1252303 | R/SP2 | .120 | - | - | .120 |
| | 1259103 | R/SP2 | .240 | - | - | .240 |
| E | 1250151 | Doubler | .070 | 0.0 | 0.0 | .070 |
| | 1252304 | R/SP2 | .120 | - | - | .120 |
| | 1259104 | R/SP2 | .240 | - | - | .240 |
| F | 2100711 | Cap | .127 | -0.40 | 0.0 | .119 |
| | 1250971 | Doubler | .070 | 0.89 | 0.0 | .084 |
| | 1252301 | R/SP3 | .035 | - | - | .035 |
| | 1259101 | R/SP3 | .098 | - | - | .098 |
| G | 1610132 | Cap | .130 | 0.11 | 0.0 | .128 |
| H | 1610133 | Cap | .130 | 0.11 | 0.0 | .128 |

3.1.3.10 Forward Fuel Cell Floor (Sta. 148-186, W.L. 35.97) Detail

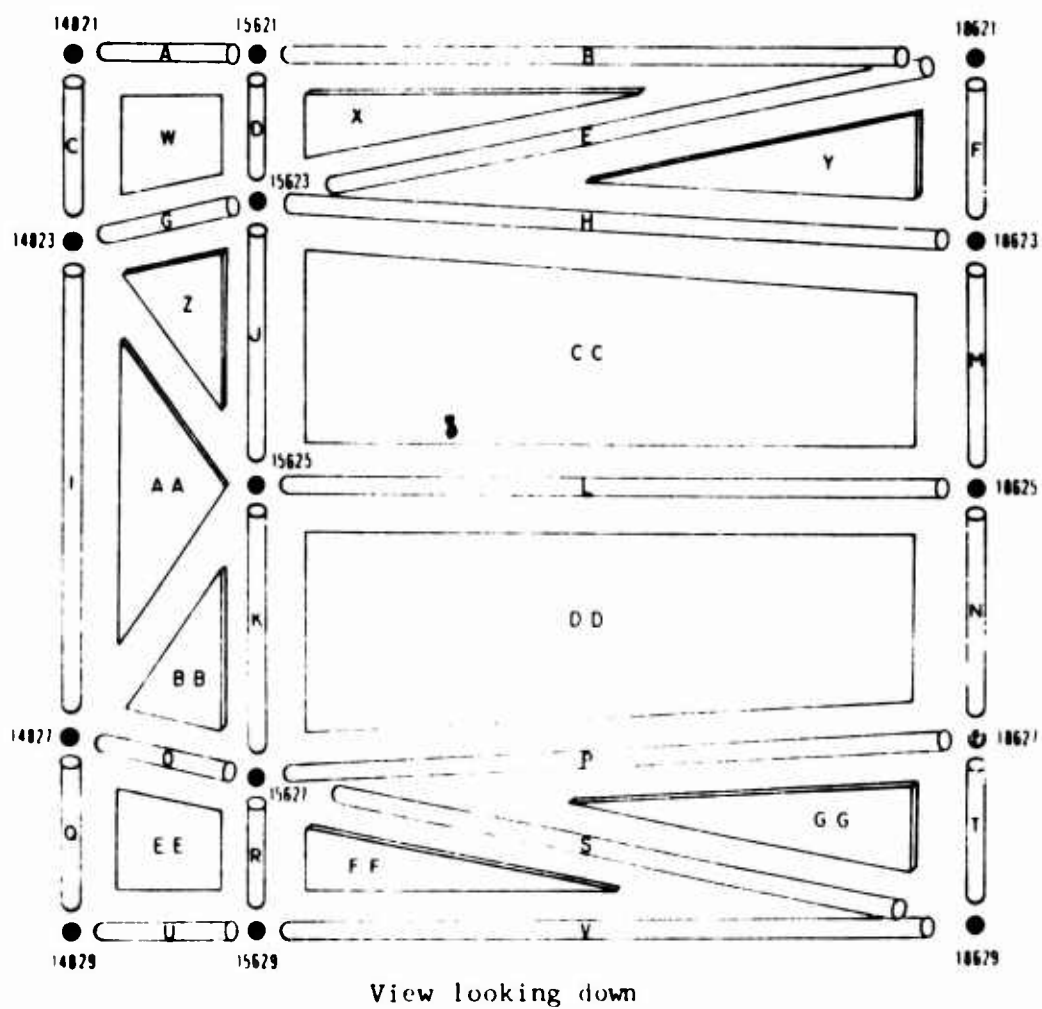

GRID POINT DATA

| GRID POINT | SPC | | MPC | | OMIT | |
|------------|--------|------|--------|------|--------|------|
| | D.O.F. | RULE | D.O.F. | RULE | D.O.F. | RULE |
| 14821 | 456 | AAA | - | - | 123 | DCC |
| 14823 | 456 | AAA | 123 | AAA | - | - |
| 14827 | 456 | AAA | 123 | AAA | - | - |
| 14829 | 456 | AAA | - | - | 123 | DCC |
| 15621 | 456 | AAA | - | - | 123 | DCC |
| 15623 | 456 | AAA | 123 | AAA | - | - |
| 15625 | 456 | AAA | - | - | - | - |
| 15627 | 456 | AAA | 123 | AAA | - | - |
| 15629 | 456 | AAA | - | - | 123 | DCC |
| 18621 | 456 | AAA | - | - | 123 | DCC |
| 18623 | 456 | AAA | - | - | 123 | DCC |
| 18625 | 456 | AAA | - | - | 3 | C |
| 18627 | 456 | AAA | - | - | 123 | DCC |
| 18629 | 456 | AAA | - | - | 123 | DCC |

SHEAR PANEL/MEMBRANE ELEMENT DATA

| Letter Designation | NASTRAN EID | Type | Thickness (IN.) |
|--------------------|-------------|---------------|-----------------|
| W | 2040811 | Lower Skin | .016 |
| | 2040471 | Interior Skin | .050 |
| X | 2040821 | Skin | .016 |
| Y | 2040822 | Lower Skin | .016 |
| | 2040794 | Upper Skin | .020 |
| Z | 2040812 | Lower Skin | .016 |
| | 2040791 | Upper Skin | .020 |
| AA | 2040813 | Lower Skin | .016 |
| | 2040792 | Upper Skin | .020 |
| BB | 2040814 | Lower Skin | .016 |
| | 2040793 | Upper Skin | .020 |
| CC | 2040823 | Lower Skin | .016 |
| | 2040795 | Upper Skin | .020 |
| DD | 2040824 | Lower Skin | .016 |
| | 2040796 | Upper Skin | .020 |
| EE | 2040815 | Lower Skin | .016 |
| | 2040472 | Interior Skin | .050 |
| FF | 2040826 | Skin | .016 |
| GG | 2040825 | Lower Skin | .016 |
| | 2040797 | Upper Skin | .020 |

ROD ELEMENT DATA

| LETTER DESIGNATION | NASTRAN EID | TYPE | ACTUAL AREA (in. ²) | OFFSETS FROM GRIDPOINT | | FINAL AREA (in. ²) |
|--------------------|-------------|---------|---------------------------------|------------------------|-------|--------------------------------|
| | | | | Z | Y | |
| A | 2044711 | Doubler | .020 | 0.0 | -0.54 | .019 |
| | 2048101 | R/SP3 | .050 | - | - | .050 |
| | 2044701 | R/SP3 | .152 | - | - | .152 |
| B | 2044720 | Doubler | .053 | 0.0 | -0.54 | .050 |
| C | 2048105 | R/SP2 | .062 | - | - | .062 |
| | 2044705 | R/SP2 | .195 | - | - | .195 |
| D | 2044716 | Doubler | .285 | 0.0 | 0.23 | .296 |
| | 2048107 | R/SP2 | .062 | - | - | .062 |
| | 2044707 | R/SP2 | .195 | - | - | .195 |
| E | 2044721 | Doubler | .213 | 0.0 | -0.68 | .195 |
| F | 2044724 | Doubler | .174 | 0.0 | 0.25 | .180 |
| G | 2044712 | Doubler | .213 | 0.0 | -0.22 | .205 |
| | 2048102 | R/SP3 | .050 | - | - | .050 |
| | 2044702 | R/SP3 | .152 | - | - | .152 |
| H | 2048201 | R/SP1 | .057 | - | - | .057 |
| | 2047901 | R/SP1 | .072 | - | - | .072 |
| I | 2044715 | Doubler | .174 | 0.0 | 0.24 | .176 |
| J | 2044717 | Doubler | .285 | 0.0 | 0.43 | .294 |
| | 2048205 | R/SP2 | .238 | - | - | .238 |
| | 2047905 | R/SP2 | .298 | - | - | .298 |
| K | 2044718 | Doubler | .285 | 0.0 | 0.43 | .294 |
| | 2048206 | R/SP2 | .238 | - | - | .238 |
| | 2047906 | R/SP2 | .298 | - | - | .298 |
| L | 2048202 | R/SP1 | .115 | - | - | .115 |
| | 2048203 | R/SP1 | .115 | - | - | .115 |
| | 2047902 | R/SP1 | .144 | - | - | .144 |
| | 2047903 | R/SP1 | .144 | - | - | .144 |
| M | 2044725 | Doubler | .174 | 0.0 | 0.33 | .180 |
| | 2048207 | R/SP2 | .238 | - | - | .238 |
| | 2047907 | R/SP2 | .298 | - | - | .298 |

ROD ELEMENT DATA (CONT.)

| LETTER DESIGNATION | NASTRAN EID | TYPE | ACTUAL AREA (in. ²) | OFFSETS FROM GRIDPOINT | | FINAL AREA (in. ²) |
|-----------------------|----------------|---------|------------------------------------|---------------------------|------|-----------------------------------|
| | | | | Z | Y | |
| N | 2044726 | Doubler | .174 | 0.0 | 0.33 | .180 |
| | 2048208 | R/SP2 | .238 | - | - | .238 |
| | 2047908 | R/SP2 | .298 | - | - | .298 |
| O | 2044713 | Doubler | .213 | 0.0 | 0.22 | .205 |
| | 2048103 | R/SP3 | .050 | - | - | .050 |
| | 2044703 | R/SP3 | .152 | - | - | .152 |
| P | 2048204 | R/SP1 | .057 | - | - | .057 |
| | 2047904 | R/SP1 | .072 | - | - | .072 |
| Q | 2048106 | R/SP2 | .062 | - | - | .062 |
| | 2044706 | R/SP2 | .195 | - | - | .195 |
| R | 2044719 | Doubler | .285 | 0.0 | 0.23 | .296 |
| | 2048108 | R/SP2 | .062 | - | - | .062 |
| | 2044708 | R/SP2 | .195 | - | - | .195 |
| S | 2044722 | Doubler | .213 | 0.0 | 0.68 | .195 |
| T | 2044727 | Doubler | .174 | 0.0 | 0.25 | .180 |
| U | 2044714 | Doubler | .020 | 0.0 | 0.54 | .019 |
| | 2048104 | R/SP3 | .050 | - | - | .050 |
| | 2044704 | R/SP3 | .152 | - | - | .152 |
| V | 2044723 | Doubler | .053 | 0.0 | 0.54 | .050 |

3.1.3.11 Forward Fuel Cell Cover (Sta. 148-186, W.L. 77.57) Detail

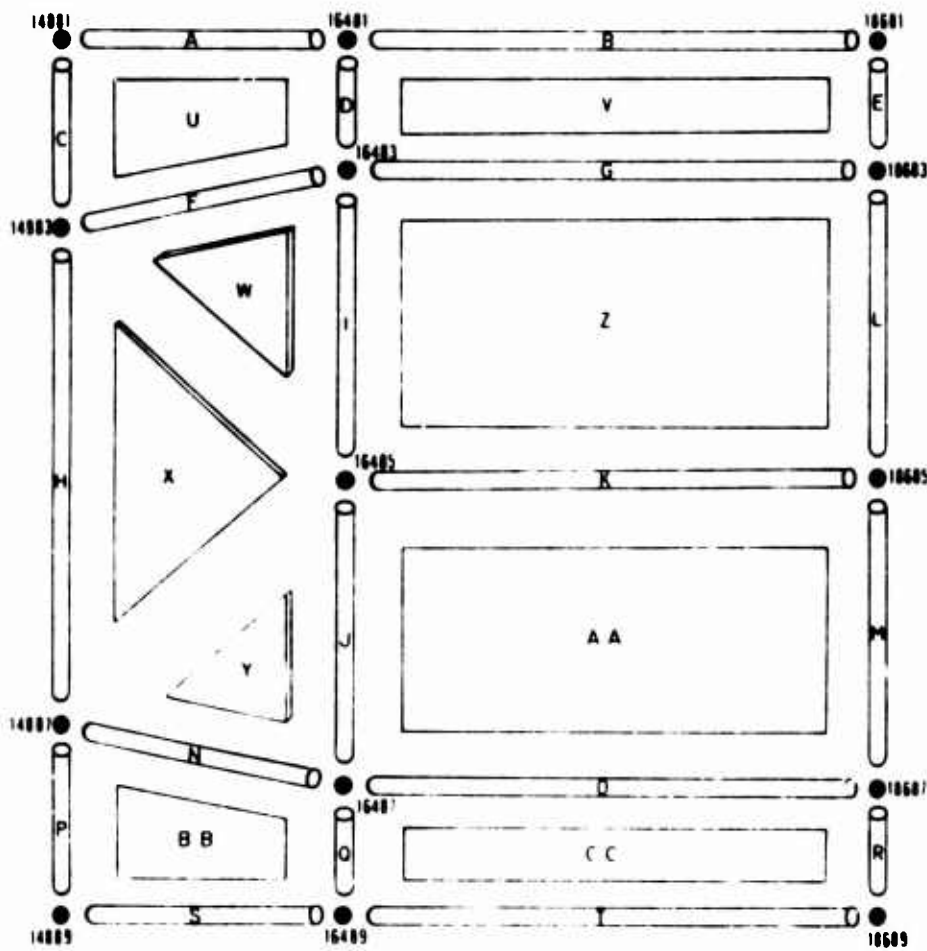

View looking down

GRID POINT DATA

| GRID POINT | SPC | | MPC | | OMIT | |
|------------|--------|------|--------|------|--------|-------|
| | D.O.F. | RULE | D.O.F. | RULE | D.O.F. | RULE |
| 14881 | 456 | AAA | - | - | 123 | DCC |
| 14883 | 456 | AAA | - | - | 123 | DCC |
| 14887 | 456 | AAA | - | - | 123 | DCC |
| 14889 | 456 | AAA | - | - | 123 | DCC |
| 16481 | 456 | AAA | - | - | 123 | DCC |
| 16483 | 3456 | AAAA | - | - | 12 | DC |
| 16485 | 3456 | AAAA | - | - | 12 | DC |
| 16487 | 3456 | AAAA | - | - | 12 | DC |
| 16489 | 456 | AAA | - | - | 123 | DCC |
| 18681 | 456 | AAA | - | - | 123 | DCC |
| 18683 | - | - | - | - | 12456 | DCAAA |
| 18685 | 456 | AAA | - | - | 13 | DC |
| 18687 | - | - | - | - | 12456 | DCAAA |
| 18689 | 456 | AAA | - | - | 123 | DCC |

SHEAR PANEL/MEMBRANE ELEMENT DATA

| Letter Designation | NASTRAN EID | Type | Thickness (IN.) |
|--------------------|-------------|------------|-----------------|
| U | 2080791 | Upper Skin | .016 |
| V | 2080131 | Lower Skin | .008 |
| W | 2080796 | Upper Skin | .016 |
| | 2080111 | Lower Skin | .008 |
| X | 2080792 | Upper Skin | .016 |
| | 2080112 | Lower Skin | .008 |
| Y | 2080793 | Upper Skin | .016 |
| | 2080113 | Lower Skin | .008 |
| Z | 2080794 | Upper Skin | .016 |
| | 2080132 | Lower Skin | .008 |
| AA | 2080797 | Upper Skin | .016 |
| | 2080133 | Lower Skin | |
| BB | 2080798 | Upper Skin | |
| | 2080114 | Lower Skin | |
| CC | 2080795 | Upper Skin | .01 |
| | 2080134 | Lower Skin | .008 |
| | 2080799 | Upper Skin | .016 |

ROD ELEMENT DATA

| LETTER DESIGNATION | NASTRAN EID | TYPE | ACTUAL AREA (in. ²) | OFFSETS FROM GRIDPOINT | | FINAL AREA (in. ²) |
|--------------------|-------------|---------|---------------------------------|------------------------|-------|--------------------------------|
| | | | | Z | Y | |
| A | 2084501 | Doubler | .052 | 0.0 | -1.30 | .045 |
| | 2087901 | R/SP3 | .047 | - | - | .047 |
| B | 2084502 | Doubler | .052 | 0.0 | -1.30 | .045 |
| | 2081301 | R/SP1 | .014 | - | - | .014 |
| | 2087921 | R/SP1 | .040 | - | - | .040 |
| C | 2084521 | Doubler | .072 | 0.0 | 0.59 | .078 |
| | 2087905 | R/SP2 | .093 | - | - | .093 |

ROD ELEMENT DATA (CONT.)

| LETTER DESIGNATION | NASTRAN EID | TYPE | ACTUAL AREA (in. ²) | OFFSETS FROM GRIDPOINT | | FINAL AREA (in. ²) |
|-----------------------|----------------|---------|------------------------------------|---------------------------|------|-----------------------------------|
| | | | | Z | Y | |
| D | 2084531 | Doubler | .083 | 0.0 | 0.41 | .090 |
| | 2081309 | R/SP2 | .075 | - | - | .075 |
| | 2087907 | R/SP2 | .093 | - | - | .093 |
| | 2087929 | R/SP2 | .175 | - | - | .175 |
| E | 2084541 | Doubler | .050 | 0.0 | 0.39 | .054 |
| | 2081313 | R/SP2 | .075 | - | - | .075 |
| | 2087933 | R/SP2 | .175 | - | - | .175 |
| F | 2087902 | R/SP3 | .047 | - | - | .047 |
| G | 2080231 | Doubler | .475 | - | - | .475 |
| | 2081302 | R/SP1 | .014 | - | - | .014 |
| | 2081303 | R/SP1 | .050 | - | - | .050 |
| | 2087922 | R/SP1 | .040 | - | - | .040 |
| | 2087923 | R/SP1 | .062 | - | - | .062 |
| H | 2084522 | Doubler | .072 | 0.0 | 1.54 | .078 |
| I | 2084532 | Doubler | .083 | 0.0 | 0.96 | .090 |
| | 2081310 | R/SP2 | .075 | - | - | .075 |
| | 2087930 | R/SP2 | .175 | - | - | .175 |
| J | 2084533 | Doubler | .083 | 0.0 | 0.96 | .090 |
| | 2081311 | R/SP2 | .075 | - | - | .075 |
| | 2087931 | R/SP2 | .175 | - | - | .175 |
| K | 2081304 | R/SP1 | .050 | - | - | .050 |
| | 2081305 | R/SP1 | .050 | - | - | .050 |
| | 2087924 | R/SP1 | .062 | - | - | .062 |
| | 2087925 | R/SP1 | .062 | - | - | .062 |
| L | 2084542 | Doubler | .050 | 0.0 | 0.92 | .054 |
| | 2081314 | R/SP2 | .075 | - | - | .075 |
| | 2087934 | R/SP2 | .175 | - | - | .175 |

ROD ELEMENT DATA (CONT.)

| LETTER DESIGNATION | NASTRAN EID | TYPE | ACTUAL AREA (in. ²) | OFFSETS FROM GRIDPOINT | | FINAL AREA (in. ²) |
|-----------------------|----------------|---------|------------------------------------|---------------------------|------|-----------------------------------|
| | | | | Z | Y | |
| M | 2084543 | Doubler | .050 | 0.0 | 0.92 | .054 |
| | 2081315 | R/SP2 | .075 | - | - | .075 |
| | 2087935 | R/SP2 | .175 | - | - | .175 |
| N | 2081101 | R/SP3 | .016 | - | - | .016 |
| | 2087903 | R/SP3 | .047 | - | - | .047 |
| O | 2080232 | Doubler | .475 | - | - | .475 |
| | 2081306 | R/SP1 | .050 | - | - | .050 |
| | 2081307 | R/SP1 | .014 | - | - | .014 |
| | 2087926 | R/SP1 | .062 | - | - | .062 |
| | 2087927 | R/SP1 | .040 | - | - | .040 |
| P | 2084523 | Doubler | .072 | 0.0 | 0.59 | .078 |
| | 2081103 | R/SP2 | .036 | - | - | .036 |
| | 2087906 | R/SP2 | .093 | - | - | .093 |
| Q | 2084534 | Doubler | .083 | 0.0 | 0.41 | .090 |
| | 2081104 | R/SP2 | .036 | - | - | .036 |
| | 2081312 | R/SP2 | .075 | - | - | .075 |
| | 2087908 | R/SP2 | .093 | - | - | .093 |
| | 2087932 | R/SP2 | .175 | - | - | .175 |
| R | 2084544 | Doubler | .050 | 0.0 | 0.39 | .054 |
| | 2081316 | R/SP2 | .075 | - | - | .075 |
| | 2087936 | R/SP2 | .175 | - | - | .175 |
| S | 2084511 | Doubler | .052 | 0.0 | 1.30 | .044 |
| | 2081102 | R/SP3 | .016 | - | - | .016 |
| | 2087904 | R/SP3 | .047 | - | - | .047 |
| T | 2084512 | Doubler | .052 | 0.0 | 1.30 | .045 |
| | 2081308 | R/SP1 | .014 | - | - | .014 |
| | 2087928 | R/SP1 | .040 | - | - | .040 |

3.1.3.12 Lower Floor Under Pylon (Sta. 186-213, W.L. 35.97) Detail

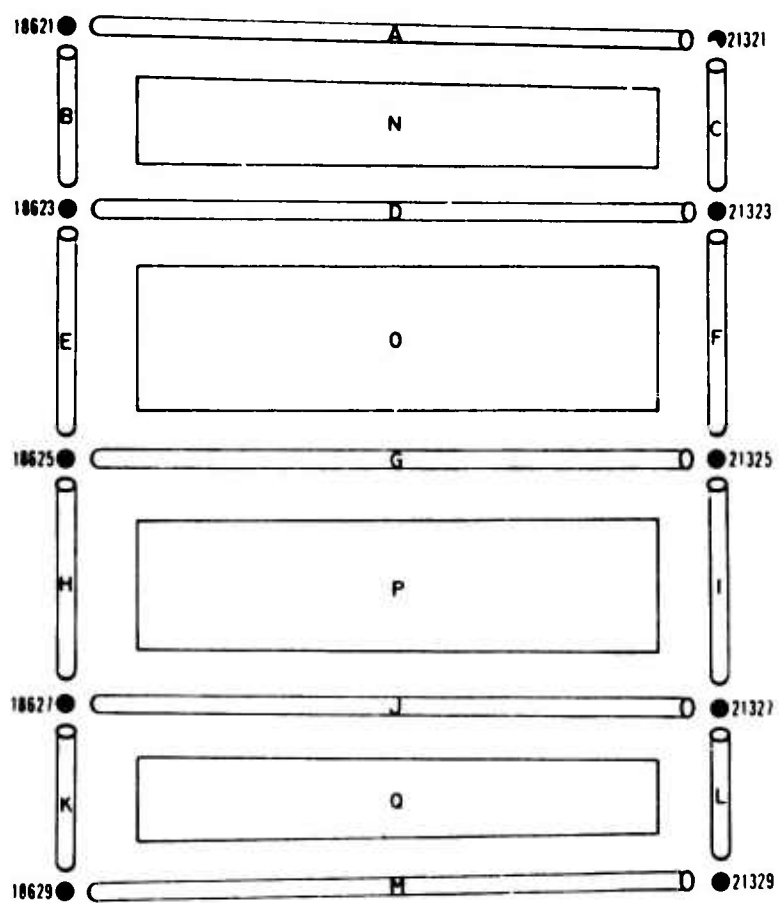

View looking down

GRID POINT DATA

| GRID POINT | SPC | | MPC | | OMIT | |
|------------|--------|------|--------|------|--------|------|
| | D.O.F. | RULE | D.O.F. | RULE | D.O.F. | RULE |
| 18621 | 456 | AAA | - | - | 123 | DCC |
| 18623 | 456 | AAA | - | - | 123 | DCC |
| 18625 | 456 | AAA | - | - | 3 | C |
| 18627 | 456 | AAA | - | - | 123 | DCC |
| 18629 | 456 | AAA | - | - | 123 | DCC |
| 21321 | 456 | AAA | - | - | 23 | CC |
| 21323 | 456 | AAA | - | - | 123 | DCC |
| 21325 | 456 | AAA | - | - | 13 | DC |
| 21327 | 456 | AAA | - | - | 123 | DCC |
| 21329 | 456 | AAA | - | - | 123 | DCC |

SHEAR PANEL/MEMBRANE ELEMENT DATA

| Letter Designation | NASTRAN EID | Type | Thickness (IN.) |
|--------------------|-------------|------------|-----------------|
| N | 2050551 | Lower Skin | .016 |
| | 2050631 | Upper Skin | .012 |
| O | 2050552 | Lower Skin | .016 |
| | 2050632 | Upper Skin | .012 |
| P | 2050553 | Lower Skin | .016 |
| | 2050633 | Upper Skin | .012 |
| Q | 2050554 | Lower Skin | .016 |
| | 2050634 | Upper Skin | .012 |

ROD ELEMENT DATA

| LETTER DESIGNATION | NASTRAN EID | TYPE | ACTUAL AREA (in. ²) | OFFSETS FROM GRIDPOINT | | FINAL AREA (in. ²) |
|--------------------|-------------|---------|---------------------------------|------------------------|-------|--------------------------------|
| | | | | Z | Y | |
| A | 2050431 | Doubler | .028 | 0.0 | -1.46 | .024 |
| | 2055501 | R/SP1 | .018 | - | - | .018 |
| | 2056301 | R/SP1 | .004 | - | - | .004 |
| B | 2050432 | Doubler | .032 | 0.0 | 1.48 | .040 |
| | 2055511 | R/SP2 | .221 | - | - | .221 |
| | 2056311 | R/SP2 | .145 | - | - | .145 |
| C | 2050436 | Doubler | .084 | 0.0 | 1.32 | .104 |
| | 2055515 | R/SP2 | .221 | - | - | .221 |
| | 2056315 | R/SP2 | .145 | - | - | .145 |
| D | 2055502 | R/SP1 | .094 | - | - | .094 |
| | 2055503 | R/SP1 | .094 | - | - | .094 |
| | 2056302 | R/SP1 | .069 | - | - | .069 |
| | 2056303 | R/SP1 | .069 | - | - | .069 |
| E | 2050433 | Doubler | .032 | 0.0 | 2.00 | .040 |
| | 2055512 | R/SP2 | .221 | - | - | .221 |
| | 2056312 | R/SP2 | .145 | - | - | .145 |
| F | 2050437 | Doubler | .084 | 0.0 | 1.92 | .104 |
| | 2055516 | R/SP2 | .221 | - | - | .221 |
| | 2056316 | R/SP2 | .145 | - | - | .145 |
| G | 2055504 | R/SP1 | .059 | - | - | .059 |
| | 2055505 | R/SP1 | .059 | - | - | .059 |
| | 2056304 | R/SP1 | .045 | - | - | .045 |
| | 2056305 | R/SP1 | .045 | - | - | .045 |
| H | 2050434 | Doubler | .032 | 0.0 | 2.00 | .040 |
| | 2055513 | R/SP2 | .221 | - | - | .221 |
| | 2056313 | R/SP2 | .145 | - | - | .145 |
| I | 2050438 | Doubler | .084 | 0.0 | 1.92 | .104 |
| | 2055517 | R/SP2 | .221 | - | - | .221 |
| | 2056317 | R/SP2 | .145 | - | - | .145 |

ROD ELEMENT DATA

| LETTER DESIGNATION | NASTRAN EID | TYPE | ACTUAL AREA (in. ²) | OFFSETS FROM GRIDPOINT | | FINAL AREA (in. ²) |
|-----------------------|----------------|---------|------------------------------------|---------------------------|-------|-----------------------------------|
| | | | | Z | Y | |
| J | 2050651 | Doubler | .124 | 0.0 | -1.96 | .193 |
| | 2055506 | R/SP1 | .094 | - | - | .094 |
| | 2055507 | R/SP1 | .094 | - | - | .094 |
| | 2056306 | R/SP1 | .069 | - | - | .069 |
| | 2056307 | R/SP1 | .069 | - | - | .069 |
| K | 2050435 | Doubler | .032 | 0.0 | 1.48 | .040 |
| | 2055514 | R/SP2 | .221 | - | - | .221 |
| | 2056314 | R/SP2 | .145 | - | - | .145 |
| L | 2050439 | Doubler | .084 | 0.0 | 1.32 | .104 |
| | 2055518 | R/SP2 | .221 | - | - | .221 |
| | 2056318 | R/SP2 | .145 | - | - | .145 |
| M | 2050652 | Doubler | .124 | 0.0 | 5.18 | .053 |
| | 2055508 | R/SP1 | .018 | - | - | .018 |
| | 2056308 | R/SP1 | .005 | - | - | .005 |

3.1.3.13 Right and Left Upper Shelves (Sta. 148-186) Detail

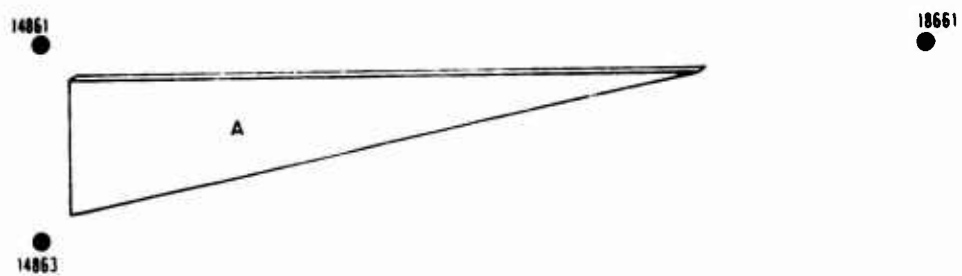

View looking down

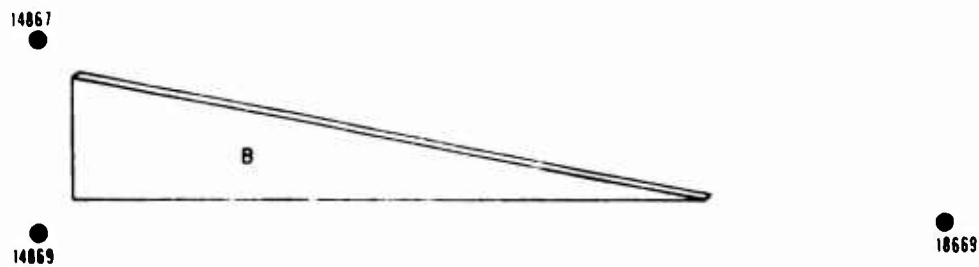

GRID POINT DATA

| GRID POINT | SPC | | MPC | | OMIT | |
|------------|--------|------|--------|------|--------|--------|
| | D.O.F. | RULE | D.O.F. | RULE | D.O.F. | RULE |
| 14861 | 456 | AAA | - | - | 123 | DCC |
| 14863 | 456 | AAA | - | - | - | - |
| 14867 | 456 | AAA | - | - | 12 | DC |
| 14869 | 456 | AAA | - | - | 123 | DCC |
| 18661 | - | - | - | - | 123456 | DCCAAA |
| 18669 | - | - | - | - | 123456 | DCCAAA |

SHEAR PANEL/MEMBRANE ELEMENT DATA

| Letter Designation | NASTRAN EID | Type | Thickness (IN.) |
|--------------------|-------------|------|-----------------|
| A | 2501777 | Skin | .032 |
| B | 2100897 | Skin | .032 |

3.1.3.14 Right Belly Skins (Sta. 156-218) Detail

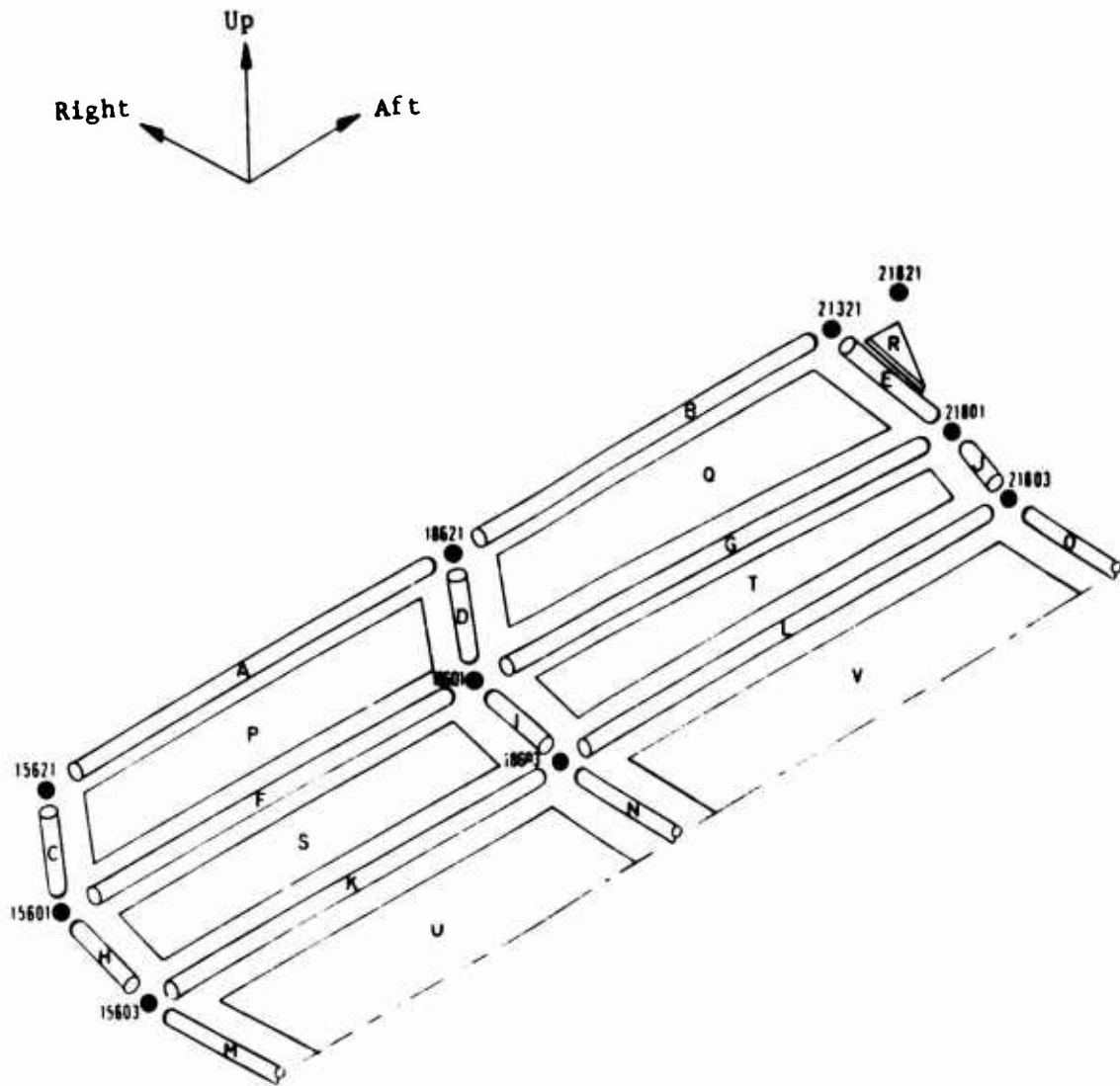

GRID POINT DATA

| GRID POINT | SPC | | MPC | | OMIT | |
|------------|--------|------|--------|------|--------|------|
| | D.O.F. | RULE | D.O.F. | RULE | D.O.F. | RULE |
| 15601 | 456 | AAA | - | - | 123 | DCC |
| 15603 | 456 | AAA | 123 | AAA | - | - |
| 15621 | 456 | AAA | - | - | 123 | DCC |
| 18601 | 456 | AAA | - | - | 123 | DCC |
| 18603 | 456 | AAA | - | - | 123 | DCC |
| 18621 | 456 | AAA | - | - | 123 | DCC |
| 21321 | 456 | AAA | - | - | 23 | CC |
| 21801 | 456 | AAA | - | - | 123 | DCC |
| 21803 | 456 | AAA | - | - | 123 | DCC |
| 21821 | 456 | AAA | - | - | 123 | DCC |

SHEAR PANEL/MEMBRANE ELEMENT DATA

| Letter Designation | NASTRAN EID | Type | Thickness (IN.) |
|--------------------|-------------|------|-----------------|
| P | 2200771 | Skin | .025 |
| Q | 2200721 | Skin | .025 |
| R | 2200722 | Skin | .025 |
| S | 2200772 | Skin | .025 |
| T | 2200723 | Skin | .025 |
| U | 2200773 | Skin | .025 |
| V | 2570011 | Skin | .024 |

ROD ELEMENT DATA

| LETTER DESIGNATION | NASTRAN EID | TYPE | ACTUAL AREA (in. ²) | OFFSETS FROM GRIDPOINT | | FINAL AREA (in. ²) |
|--------------------|-------------|---------|---------------------------------|------------------------|---|--------------------------------|
| | | | | Z | Y | |
| A | 2207701 | R/SP2 | .089 | - | - | .089 |
| B | 2207201 | R/SP2 | .092 | - | - | .092 |
| C | 2207703 | R/SP2 | .373 | - | - | .373 |
| D | 2207704 | R/SP2 | .373 | - | - | .373 |
| | 2207203 | R/SP2 | .378 | - | - | .378 |
| E | 2207204 | R/SP2 | .378 | - | - | .378 |
| F | 2207702 | R/SP2 | .089 | - | - | .089 |
| | 2207711 | R/SP2 | .083 | - | - | .083 |
| G | 2207202 | R/SP2 | .092 | - | - | .092 |
| | 2207211 | R/SP2 | .077 | - | - | .077 |
| H | 2207713 | R/SP2 | .373 | - | - | .373 |
| I | 2207714 | R/SP2 | .373 | - | - | .373 |
| | 2207213 | R/SP2 | .409 | - | - | .409 |
| J | 2207214 | R/SP2 | .409 | - | - | .409 |
| K | 2200561 | Doubler | .117 | - | - | .117 |
| | 2207712 | R/SP2 | .083 | - | - | .083 |
| | 2207721 | R/SP2 | .241 | - | - | .241 |
| L | 2200601 | Doubler | .117 | - | - | .117 |
| | 2207212 | R/SP2 | .077 | - | - | .077 |
| | 2570101 | R/SP2 | .215 | - | - | .215 |
| M | 2207723 | R/SP2 | .373 | - | - | .373 |
| N | 2207724 | R/SP2 | .373 | - | - | .373 |
| | 2570103 | R/SP2 | .393 | - | - | .393 |
| O | 2570104 | R/SP2 | .393 | - | - | .393 |

3.1.3.15 Left Belly Skins (Sta. 156-218) Detail

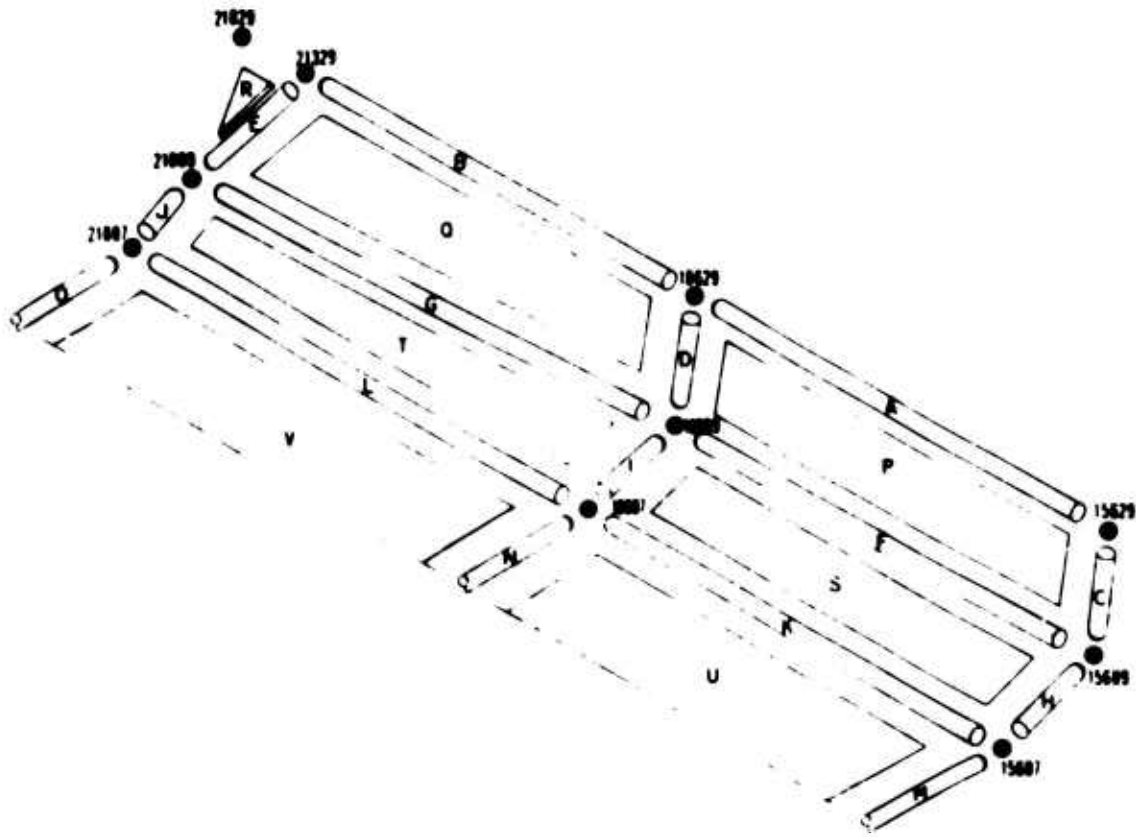
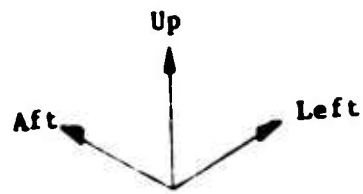

GRID POINT DATA

| GRID POINT | SPC | | MPC | | OMIT | |
|------------|--------|------|--------|------|--------|------|
| | D.O.F. | RULE | D.O.F. | RULE | D.O.F. | RULE |
| 15607 | 456 | AAA | 123 | AAA | - | - |
| 15609 | 456 | AAA | - | - | 123 | DCC |
| 15629 | 456 | AAA | - | - | 123 | DCC |
| 18607 | 456 | AAA | - | - | 123 | DCC |
| 18609 | 456 | AAA | - | - | 123 | DCC |
| 18629 | 456 | AAA | - | - | 123 | DCC |
| 21329 | 456 | AAA | - | - | 123 | DCC |
| 21807 | 456 | AAA | - | - | 123 | DCC |
| 21809 | 456 | AAA | - | - | 123 | DCC |
| 21829 | 456 | A/A | - | - | 123 | DCC |

SHEAR PANEL/MEMBRANE ELEMENT DATA

| Letter Designation | NASTRAN EID | Type | Thickness (IN.) |
|--------------------|-------------|------|-----------------|
| P | 2200775 | Skin | .025 |
| Q | 2200711 | Skin | .025 |
| R | 2200712 | Skin | .025 |
| S | 2200774 | Skin | .025 |
| T | 2200713 | Skin | .025 |
| U | 2200773 | Skin | .025 |
| V | 2570011 | Skin | .024 |

ROD ELEMENT DATA

| LETTER DESIGNATION | NASTRAN EID | TYPE | ACTUAL AREA (in. ²) | OFFSETS FROM GRIDPOINT | | FINAL AREA (in. ²) |
|-----------------------|----------------|---------|------------------------------------|---------------------------|---|-----------------------------------|
| | | | | Z | Y | |
| A | 2207742 | R/SP2 | .089 | - | - | .089 |
| B | 2207112 | R/SP2 | .092 | - | - | .092 |
| C | 2207743 | R/SP2 | .373 | - | - | .373 |
| D | 2207744 | R/SP2 | .373 | - | - | .373 |
| | 2207113 | R/SP2 | .378 | - | - | .378 |
| E | 2207114 | R/SP2 | .378 | - | - | .378 |
| F | 2207732 | R/SP2 | .083 | - | - | .083 |
| | 2207741 | R/SP2 | .089 | - | - | .089 |
| G | 2207102 | R/SP2 | .077 | - | - | .077 |
| | 2207111 | R/SP2 | .092 | - | - | .092 |
| H | 2207733 | R/SP2 | .373 | - | - | .373 |
| I | 2207734 | R/SP2 | .373 | - | - | .373 |
| | 2207103 | R/SP2 | .409 | - | - | .409 |
| J | 2207104 | R/SP2 | .409 | - | - | .409 |
| K | 2200551 | Doubler | .117 | - | - | .117 |
| | 2207722 | R/SP2 | .241 | - | - | .241 |
| | 2207731 | R/SP2 | .083 | - | - | .083 |
| L | 2200591 | Doubler | .117 | - | - | .117 |
| | 2570102 | R/SP2 | .215 | - | - | .215 |
| | 2207101 | R/SP2 | .077 | - | - | .077 |
| M | 2207723 | R/SP2 | .241 | - | - | .241 |
| N | 2207724 | R/SP2 | .373 | - | - | .373 |
| | 2570103 | R/SP2 | .393 | - | - | .393 |
| O | 2570104 | R/SP2 | .393 | - | - | .393 |

3.1.4 Aft Fuselage Subassembly

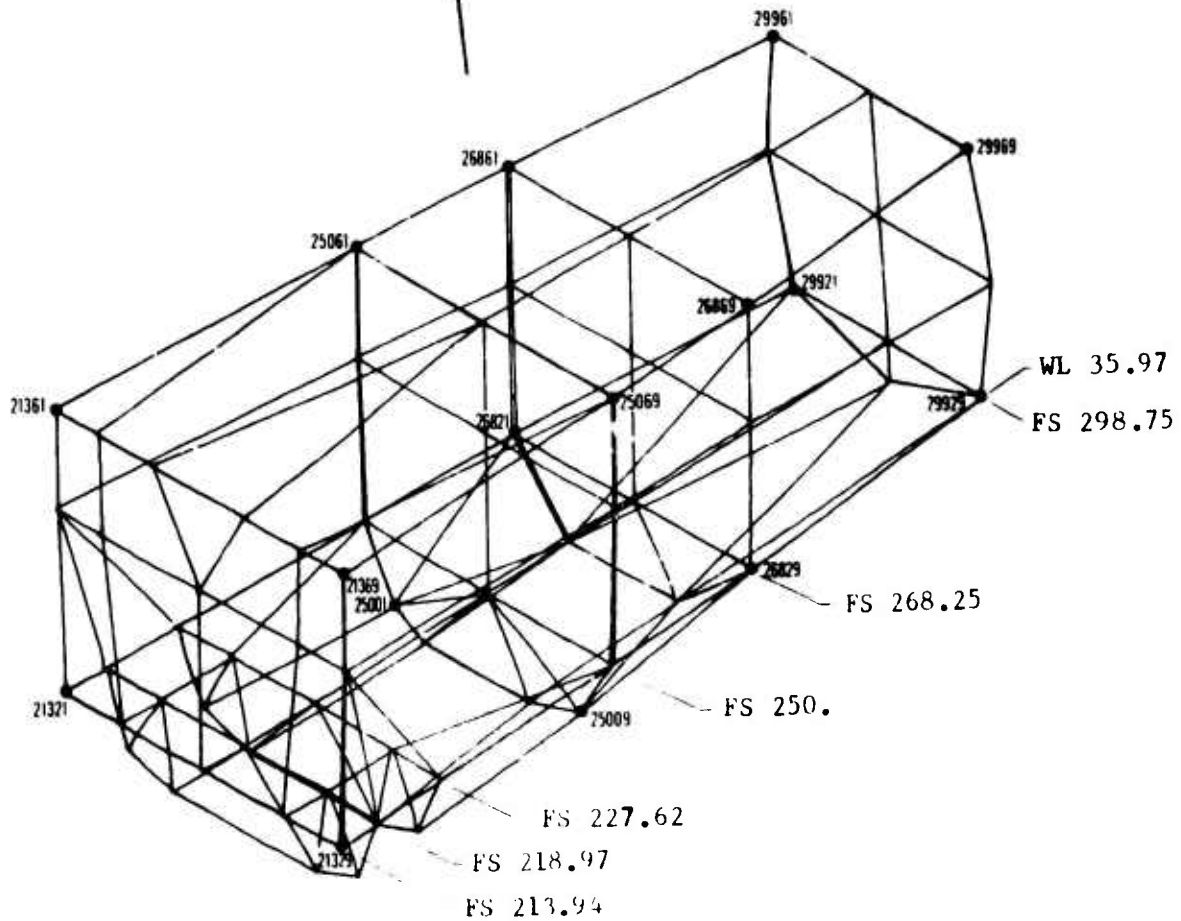
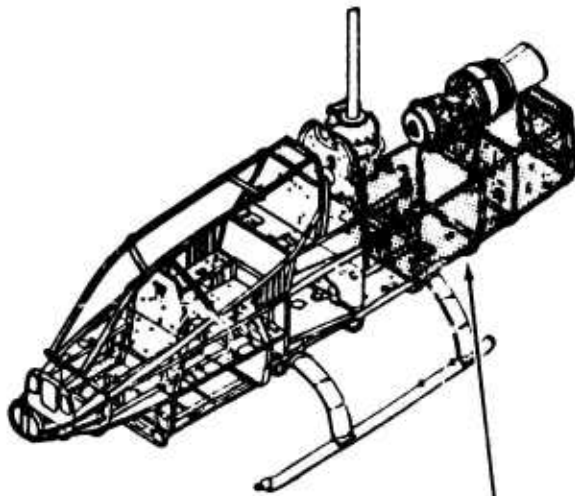

3.1.4.1 Right Main Beam (Sta. 213-250) Detail

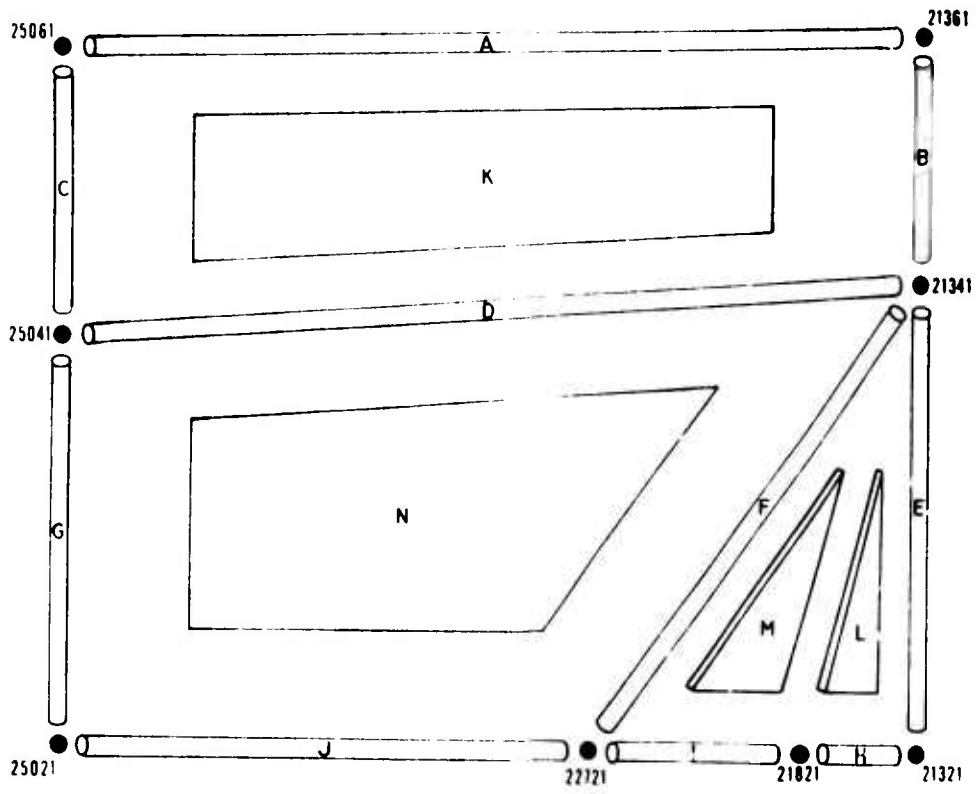

View looking inboard

GRID POINT DATA

| GRID POINT | SPC | | MPC | | OMIT | |
|------------|--------|------|--------|------|--------|-------|
| | D.O.F. | RULE | D.O.F. | RULE | D.O.F. | RULE |
| 21321 | 456 | AAA | - | - | 23 | CC |
| 21341 | - | - | - | - | 12456 | DCAAA |
| 21361 | 456 | AAA | - | - | 123 | DCC |
| 21821 | 456 | AAA | - | - | 123 | DCC |
| 22721 | 456 | AAA | - | - | 123 | DCC |
| 25021 | 456 | AAA | - | - | 123 | DCC |
| 25041 | 456 | AAA | - | - | 12 | DC |
| 25061 | 456 | AAA | - | - | 23 | CC |

SHEAR PANEL/MEMBRANE ELEMENT DATA

| Letter Designation | NASTRAN EID | Type | Thickness (IN.) |
|--------------------|-------------|---------------|-----------------|
| K | 1200074 | Inner Skin | .020 |
| | 1200114 | Outer Skin | .016 |
| L | 1200071 | Inner Skin | .020 |
| | 1200131 | Interior Skin | .032 |
| | 1200111 | Outer Skin | .016 |
| M | 1200072 | Inner Skin | .020 |
| | 1200132 | Interior Skin | .032 |
| | 1200112 | Outer Skin | .016 |
| N | 1200073 | Inner Skin | .020 |
| | 1200113 | Outer Skin | .016 |

ROD ELEMENT DATA

| LETTER DESIGNATION | NASTRAN EID | TYPE | ACTUAL AREA (in. ²) | OFFSETS FROM GRIDPOINT | | FINAL AREA (in. ²) |
|-----------------------|----------------|---------|------------------------------------|---------------------------|-----|-----------------------------------|
| | | | | Z | Y | |
| A | 1600093 | Cap | .425 | -0.35 | 0.0 | .404 |
| | 1360713 | Cap | .162 | 0.0 | 0.0 | .162 |
| | 1200151 | Doubler | .254 | -0.47 | 0.0 | .238 |
| | 1200704 | R/SP1 | .034 | - | - | .034 |
| | 1201104 | R/SP1 | .027 | - | - | .027 |
| B | 1200137 | Doubler | .153 | 1.44 | 0.0 | .178 |
| | 1200712 | R/SP2 | .361 | - | - | .361 |
| | 1201112 | R/SP2 | .288 | - | - | .288 |
| C | 1200092 | Doubler | .153 | 0.70 | 0.0 | .163 |
| | 1200714 | R/SP2 | .361 | - | - | .361 |
| | 1201114 | R/SP2 | .288 | - | - | .288 |
| D | 1200702 | R/SP1 | .203 | - | - | .203 |
| | 1200703 | R/SP1 | .203 | - | - | .203 |
| | 1201102 | R/SP1 | .162 | - | - | .162 |
| | 1201103 | R/SP1 | .162 | - | - | .162 |
| E | 1200136 | Doubler | .153 | 2.64 | 0.0 | .178 |
| F | 1200711 | R/SP2 | .292 | - | - | .292 |
| | 1201111 | R/SP2 | .234 | - | - | .234 |
| G | 1200091 | Doubler | .153 | 1.02 | 0.0 | .163 |
| | 1200713 | R/SP2 | .292 | - | - | .292 |
| | 1201113 | R/SP2 | .234 | - | - | .234 |
| H | 1610292 | Cap | .594 | 0.65 | 0.0 | .545 |
| | 1200133 | Doubler | .475 | 3.45 | 0.0 | .279 |
| I | 1610293 | Cap | .740 | 0.98 | 0.0 | .640 |
| | 1200134 | Doubler | .475 | 2.99 | 0.0 | .294 |
| J | 1610294 | Cap | .461 | 0.63 | 0.0 | .420 |
| | 1200135 | Doubler | .475 | 1.95 | 0.0 | .351 |
| | 1200701 | R/SP1 | .131 | - | - | .131 |
| | 1201101 | R/SP1 | .105 | - | - | .105 |

3.1.4.2 Left Main Beam (Sta. 213-250) Detail

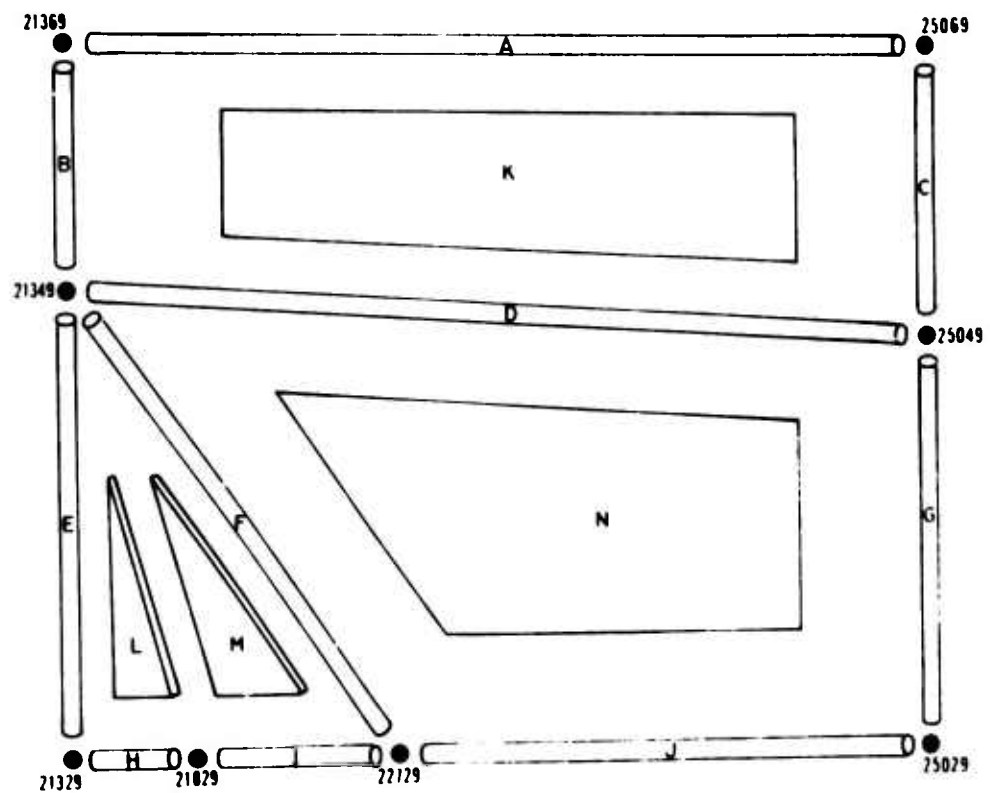

View looking inboard

GRID POINT DATA

| GRID POINT | SPC | | MPC | | OMIT | |
|------------|--------|------|--------|------|--------|-------|
| | D.O.F. | RULE | D.O.F. | RULE | D.O.F. | RULE |
| 21329 | 456 | AAA | - | - | 123 | DCC |
| 21349 | - | - | - | - | 12456 | DCAAA |
| 21369 | 456 | AAA | - | - | 23 | CC |
| 21829 | 456 | AAA | - | - | 123 | DCC |
| 22729 | 456 | AAA | - | - | 123 | DCC |
| 25029 | 456 | AAA | - | - | 123 | DCC |
| 25049 | 456 | AAA | - | - | 12 | DC |
| 25069 | 456 | AAA | - | - | 123 | DCC |

SHEAR PANEL/MEMBRANE ELEMENT DATA

| Letter Designation | NASTRAN EID | Type | Thickness (IN.) |
|--------------------|-------------|---------------|-----------------|
| K | 1190094 | Inner Skin | .020 |
| | 1190054 | Outer Skin | .016 |
| L | 1190091 | Inner Skin | .020 |
| | 1190131 | Interior Skin | .032 |
| | 1190051 | Outer Skin | .016 |
| M | 1190092 | Inner Skin | .020 |
| | 1190132 | Interior Skin | .032 |
| | 1190052 | Outer Skin | .016 |
| N | 1190093 | Inner Skin | .020 |
| | 1190053 | Outer Skin | .016 |

ROD ELEMENT DATA

| LETTER DESIGNATION | NASTRAN EID | TYPE | ACTUAL AREA (in. ²) | OFFSETS FROM GRIDPOINT | | FINAL AREA (in. ²) |
|--------------------|-------------|---------|---------------------------------|------------------------|-----|--------------------------------|
| | | | | Z | Y | |
| A | 1600053 | Cap | .412 | -0.35 | 0.0 | .392 |
| | 1360693 | Cap | .162 | 0.0 | 0.0 | .162 |
| | 1190211 | Doubler | .254 | -0.82 | 0.0 | .229 |
| | 1190904 | R/SP1 | .034 | - | - | .034 |
| | 1190504 | R/SP1 | .027 | - | - | .027 |
| B | 1190232 | Doubler | .153 | 1.44 | 0.0 | .178 |
| | 1190912 | R/SP2 | .361 | - | - | .361 |
| | 1190512 | R/SP2 | .288 | - | - | .288 |
| C | 1190192 | Doubler | .153 | 0.96 | 0.0 | .167 |
| | 1190914 | R/SP2 | .361 | - | - | .361 |
| | 1190514 | R/SP2 | .288 | - | - | .288 |
| D | 1190902 | R/SP1 | .203 | - | - | .203 |
| | 1190903 | R/SP1 | .203 | - | - | .203 |
| | 1190502 | R/SP1 | .162 | - | - | .162 |
| | 1190503 | R/SP1 | .162 | - | - | .162 |
| E | 1190231 | Doubler | .153 | 2.64 | 0.0 | .178 |
| | 1190911 | R/SP2 | .292 | - | - | .292 |
| | 1190511 | R/SP2 | .234 | - | - | .234 |
| G | 1190191 | Doubler | .153 | 1.39 | 0.0 | .167 |
| | 1190913 | R/SP2 | .292 | - | - | .292 |
| | 1190513 | R/SP2 | .234 | - | - | .234 |
| H | 1610192 | Cap | .482 | 0.60 | 0.0 | .445 |
| | 1190171 | Doubler | .475 | 3.45 | 0.0 | .284 |
| I | 1610193 | Cap | .597 | 0.94 | 0.0 | .522 |
| | 1190172 | Doubler | .475 | 2.99 | 0.0 | .300 |
| J | 1610194 | Cap | .379 | 0.60 | 0.0 | .348 |
| | 1190173 | Doubler | .475 | 1.95 | 0.0 | .353 |
| | 1190901 | R/SP1 | .131 | - | - | .131 |
| | 1190501 | R/SP1 | .105 | - | - | .105 |

3.1.4.3 Right Main Beam (Sta. 250-299) Detail

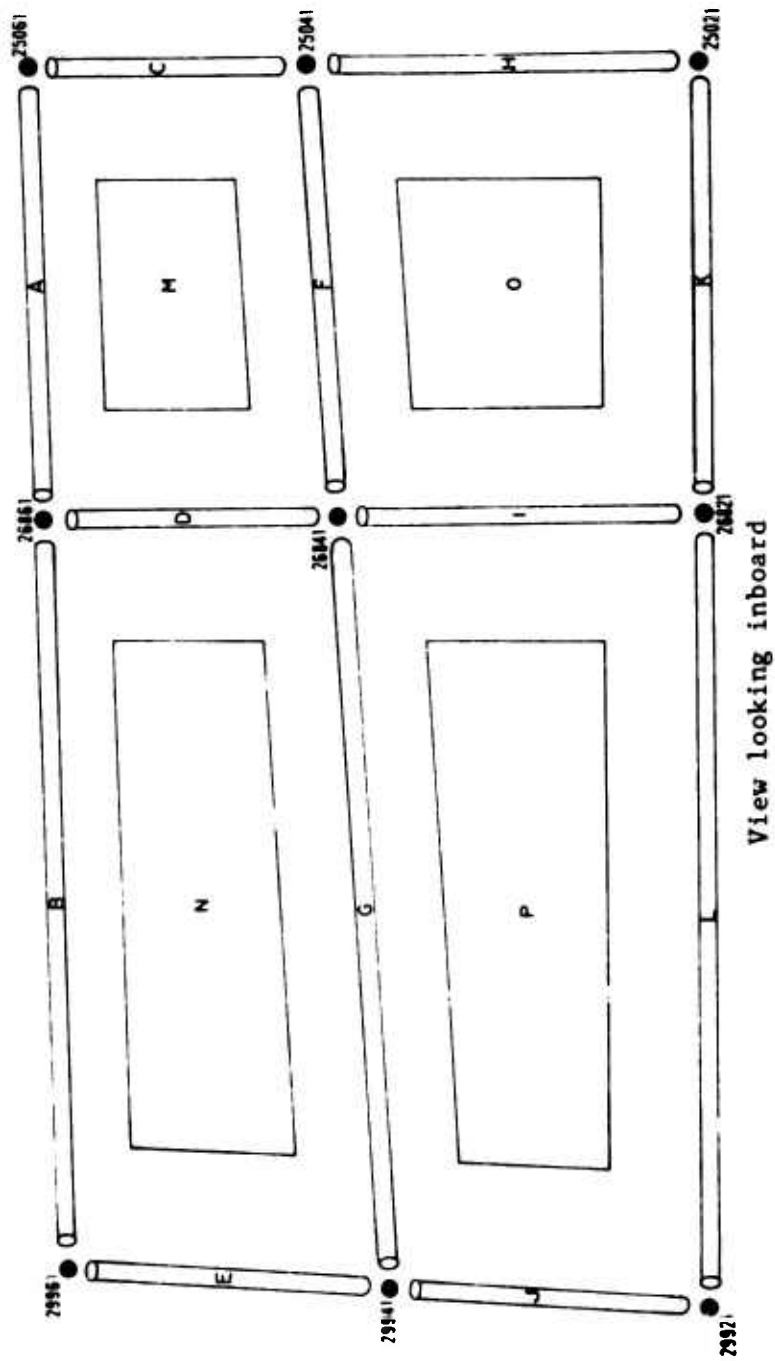

GRID POINT DATA

| GRID POINT | SPC | | MPC | | OMIT | |
|------------|--------|------|--------|------|--------|------|
| | D.O.F. | RULE | D.O.F. | RULE | D.O.F. | RULE |
| 25021 | 456 | AAA | . | - | 123 | DCC |
| 25041 | 456 | AAA | . | - | 12 | DC |
| 25061 | 456 | AAA | - | . | 23 | CC |
| 26821 | 456 | AAA | - | - | 23 | CC |
| 26841 | 456 | AAA | - | - | 12 | DC |
| 26861 | 456 | AAA | - | - | 123 | DCC |
| 29921 | 456 | AAA | 123 | AAA | - | - |
| 29941 | 456 | AAA | - | - | 123 | DCC |
| 29961 | 456 | AAA | 123 | AAA | - | - |

SHEAR PANEL/MEMBRANE ELEMENT DATA

| Letter Designation | NASTRAN EID | Type | Thickness (IN.) |
|--------------------|-------------|------------|-----------------|
| M | 1180712 | Inner Skin | .008 |
| | 1180692 | Outer Skin | .071 |
| N | 1180452 | Inner Skin | .008 |
| | 1180694 | Outer Skin | .071 |
| O | 1180711 | Inner Skin | .008 |
| | 1180691 | Outer Skin | .071 |
| P | 1180451 | Inner Skin | .008 |
| | 1180693 | Outer Skin | .071 |

ROD ELEMENT DATA

| LETTER DESIGNATION | NASTRAN EID | TYPE | ACTUAL AREA (in. ²) | OFFSETS FROM GRIDPOINT | | FINAL AREA (in. ²) |
|-----------------------|----------------|-------|------------------------------------|---------------------------|-----|-----------------------------------|
| | | | | Z | Y | |
| A | 1600094 | Cap | .411 | -0.35 | 0.0 | .390 |
| | 1360714 | Cap | .079 | 0.24 | 0.0 | .082 |
| | 1187104 | R/SP1 | .011 | - | - | .011 |
| | 1186904 | R/SP1 | .209 | - | - | .209 |
| B | 1600095 | Cap | .710 | -0.56 | 0.0 | .647 |
| | 1360715 | Cap | .069 | 0.22 | 0.0 | .071 |
| | 1184504 | R/SP1 | .014 | - | - | .014 |
| | 1186924 | R/SP1 | .276 | - | - | .276 |
| C | 1187112 | R/SP2 | .061 | - | - | .061 |
| | 1186912 | R/SP2 | .646 | - | - | .646 |
| D | 1187114 | R/SP2 | .061 | - | - | .061 |
| | 1184512 | R/SP2 | .118 | - | - | .118 |
| | 1186914 | R/SP2 | .646 | - | - | .646 |
| | 1186932 | R/SP2 | 1.109 | - | - | 1.109 |
| E | 1184514 | R/SP2 | .118 | - | - | .118 |
| | 1186934 | R/SP2 | 1.109 | - | - | 1.109 |
| F | 1187102 | R/SP1 | .074 | - | - | .074 |
| | 1187103 | R/SP1 | .074 | - | - | .074 |
| | 1186902 | R/SP1 | .676 | - | - | .676 |
| | 1186903 | R/SP1 | .676 | - | - | .676 |
| G | 1184502 | R/SP1 | .069 | - | - | .069 |
| | 1184503 | R/SP1 | .069 | - | - | .069 |
| | 1186922 | R/SP1 | .649 | - | - | .649 |
| | 1186923 | R/SP1 | .649 | - | - | .649 |
| H | 1187111 | R/SP2 | .061 | - | - | .061 |
| | 1186911 | R/SP2 | .646 | - | - | .646 |
| I | 1187113 | R/SP2 | .061 | - | - | .061 |
| | 1184511 | R/SP2 | .118 | - | - | .118 |
| | 1186913 | R/SP2 | .646 | - | - | .646 |
| | 1186931 | R/SP2 | 1.109 | - | - | 1.109 |

ROD ELEMENT DATA (CONT.)

| LETTER DESIGNATION | NASTRAN EID | TYPE | ACTUAL AREA (in. ²) | OFFSETS FROM GRIDPOINT | | FINAL AREA (in. ²) |
|-----------------------|----------------|-------|------------------------------------|---------------------------|-----|-----------------------------------|
| | | | | Z | Y | |
| J | 1184513 | R/SP2 | .118 | - | - | .118 |
| | 1186933 | R/SP2 | 1.109 | - | - | 1.109 |
| K | 1610295 | Cap | .427 | 0.28 | 0.0 | .410 |
| | 1187101 | R/SP1 | .034 | - | - | .034 |
| | 1186901 | R/SP1 | .415 | - | - | .415 |
| L | 1610296 | Cap | .436 | 0.27 | 0.0 | .450 |
| | 1184501 | R/SP1 | .023 | - | - | .023 |
| | 1186921 | R/SP1 | .356 | - | - | .356 |

3.1.4.4 Left Main Beam (Sta. 250-299) Detail

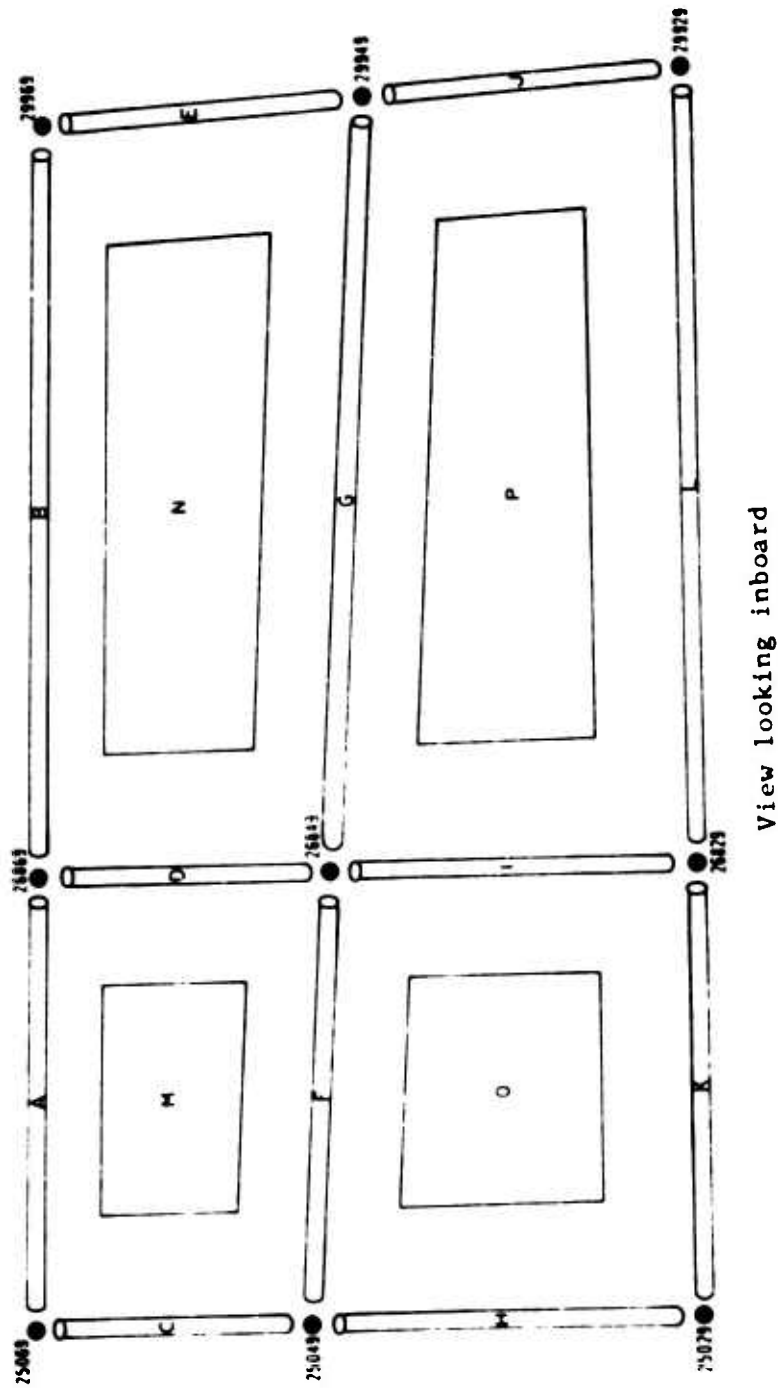

GRID POINT DATA

| GRID POINT | SPC | | MPC | | OMIT | |
|------------|--------|------|--------|------|--------|------|
| | D.O.F. | RULE | D.O.F. | RULE | D.O.F. | RULE |
| 25029 | 456 | AAA | - | - | 123 | DCC |
| 25049 | 456 | AAA | - | - | 12 | DC |
| 25069 | 456 | AAA | - | - | 123 | DCC |
| 26829 | 456 | AAA | - | - | 123 | DCC |
| 26849 | 456 | AAA | - | - | 12 | DC |
| 26869 | 456 | AAA | - | - | 23 | CC |
| 29929 | 456 | AAA | 123 | AAA | - | - |
| 29949 | 456 | AAA | - | - | 123 | DCC |
| 29969 | 456 | AAA | 123 | AAA | - | - |

SHEAR PANEL/MEMBRANE ELEMENT DATA

| Letter Designation | NASTRAN EID | Type | Thickness (IN.) |
|--------------------|-------------|---------------|-----------------|
| M | 1170112 | Inner Skin | .016 |
| | 1170512 | Interior Skin | .040 |
| | 1170052 | Outer Skin | .016 |
| N | 1170392 | Inner Skin | .008 |
| | 1170054 | Outer Skin | .016 |
| O | 1170111 | Inner Skin | .016 |
| | 1170511 | Interior Skin | .040 |
| | 1170051 | Outer Skin | .016 |
| P | 1170391 | Inner Skin | .008 |
| | 1170053 | Outer Skin | .016 |

ROD ELEMENT DATA

| LETTER DESIGNATION | NASTRAN EID | TYPE | ACTUAL AREA (in. ²) | OFFSETS FROM GRIDPOINT | | FINAL AREA (in. ²) |
|--------------------|-------------|---------|---------------------------------|------------------------|-----|--------------------------------|
| | | | | Z | Y | |
| A | 1600054 | Cap | .411 | -0.35 | 0.0 | .390 |
| | 1360694 | Cap | .079 | 0.24 | 0.0 | .082 |
| | 1171104 | R/SP1 | .020 | - | - | .020 |
| | 1175104 | R/SP1 | .118 | - | - | .118 |
| | 1170504 | R/SP1 | .047 | - | - | .047 |
| B | 1600055 | Cap | .710 | -0.56 | 0.0 | .638 |
| | 1360695 | Cap | .069 | 0.22 | 0.0 | .071 |
| | 1170191 | Doubler | .090 | -1.37 | 0.0 | .069 |
| | 1173904 | R/SP1 | .014 | - | - | .014 |
| | 1170524 | R/SP1 | .062 | - | - | .062 |
| C | 1171112 | R/SP2 | .118 | - | - | .118 |
| | 1175112 | R/SP2 | .365 | - | - | .365 |
| | 1170514 | R/SP2 | .146 | - | - | .146 |
| D | 1170512 | Doubler | .043 | 0.0 | 0.0 | .043 |
| | 1171114 | R/SP2 | .118 | - | - | .118 |
| | 1173912 | R/SP2 | .116 | - | - | .116 |
| | 1175114 | R/SP2 | .365 | - | - | .365 |
| | 1170516 | R/SP2 | .146 | - | - | .146 |
| | 1170532 | R/SP2 | .250 | - | - | .250 |
| E | 1170232 | Doubler | .046 | 1.77 | 0.0 | .053 |
| | 1173914 | R/SP2 | .116 | - | - | .116 |
| | 1170534 | R/SP2 | .250 | - | - | .250 |
| F | 1171102 | R/SP1 | .148 | - | - | .148 |
| | 1171103 | R/SP1 | .148 | - | - | .148 |
| | 1175102 | R/SP1 | .381 | - | - | .381 |
| | 1175103 | R/SP1 | .381 | - | - | .381 |
| | 1170502 | R/SP1 | .152 | - | - | .152 |
| | 1170503 | R/SP1 | .152 | - | - | .152 |
| G | 1173902 | R/SP1 | .069 | - | - | .069 |
| | 1173903 | R/SP1 | .069 | - | - | .069 |
| | 1170522 | R/SP1 | .146 | - | - | .146 |
| | 1170523 | R/SP1 | .146 | - | - | .146 |

ROD ELEMENT DATA (CONT.)

| LETTER DESIGNATION | NASTRAN EID | TYPE | ACTUAL AREA (in. ²) | OFFSETS FROM GRIDPOINT | | FINAL AREA (in. ²) |
|-----------------------|----------------|---------|------------------------------------|---------------------------|------|-----------------------------------|
| | | | | Z | Y | |
| H | 1171111 | R/SP2 | .118 | - | - | .118 |
| | 1175111 | R/SP2 | .365 | - | - | .365 |
| | 1170513 | R/SP2 | .146 | - | - | .146 |
| I | 1170511 | Doubler | .043 | 0.0 | 0.0 | .043 |
| | 1171113 | R/SP2 | .118 | - | - | .118 |
| | 1173911 | R/SP2 | .116 | - | - | .116 |
| | 1175113 | R/SP2 | .365 | - | - | .365 |
| | 1170515 | R/SP2 | .146 | - | - | .146 |
| | 1170531 | R/SP2 | .250 | - | - | .250 |
| | J | 1170231 | Doubler | .046 | 1.77 | 0.0 |
| 1173913 | | R/SP2 | .116 | - | - | .116 |
| 1170533 | | R/SP2 | .250 | - | - | .250 |
| K | 1610195 | Cap | .353 | 0.25 | 0.0 | .341 |
| | 1171101 | R/SP1 | .066 | - | - | .066 |
| | 1175101 | R/SP1 | .235 | - | - | .235 |
| | 1170501 | R/SP1 | .094 | - | - | .094 |
| L | 1610196 | Cap | .361 | 0.24 | 0.0 | .351 |
| | 1170211 | Doubler | .082 | 1.46 | 0.0 | .068 |
| | 1173901 | R/SP1 | .023 | - | - | .023 |
| | 1170521 | R/SP1 | .081 | - | - | .081 |

3.1.4.5 Bulkhead Sta. 213.94 Detail

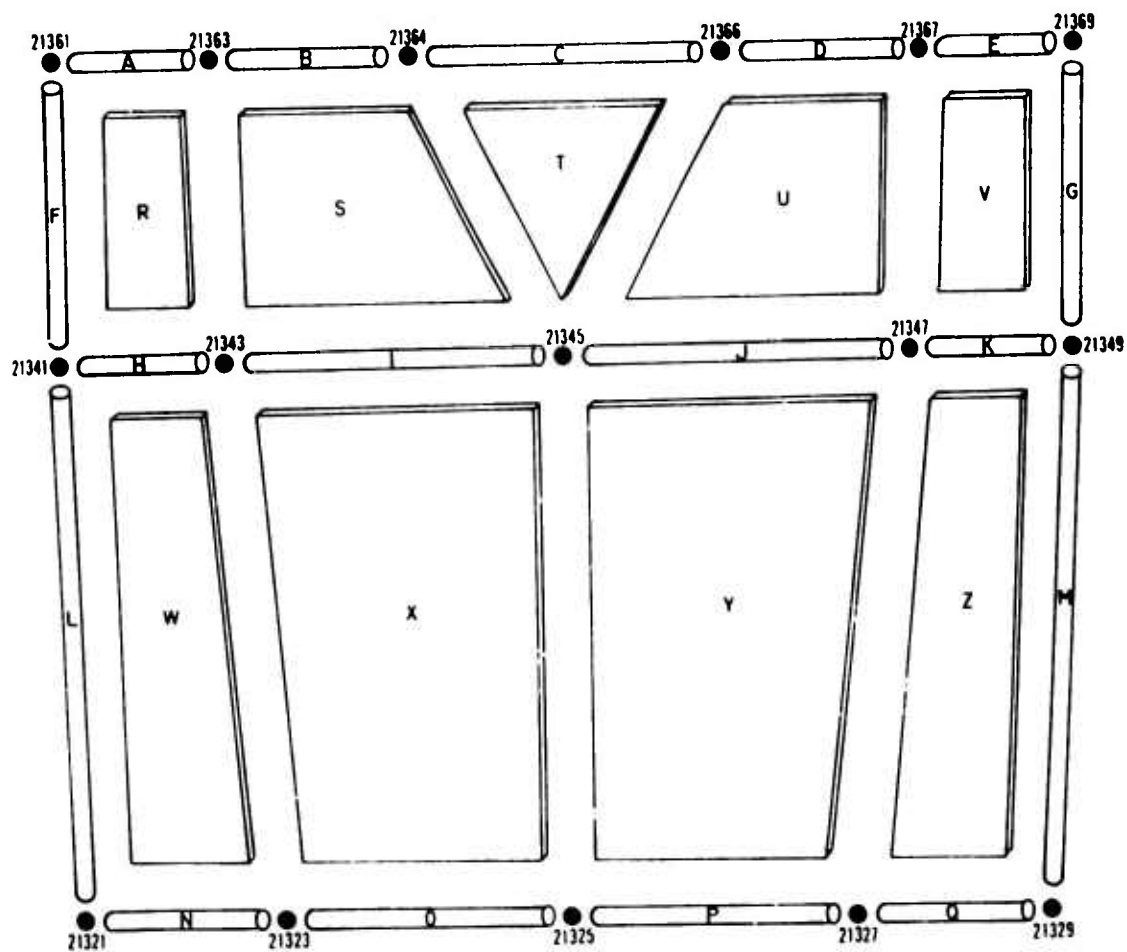

View looking aft

GRID POINT DATA

| GRID POINT | SPC | | MPC | | OMIT | |
|------------|--------|------|--------|------|--------|-------|
| | D.O.F. | RULE | D.O.F. | RULE | D.O.F. | RULE |
| 21321 | 456 | AAA | - | - | 23 | CC |
| 21323 | 456 | AAA | - | - | 123 | DCC |
| 21325 | 456 | AAA | - | - | 13 | DC |
| 21327 | 456 | AAA | - | - | 123 | DCC |
| 21329 | 456 | AAA | - | - | 123 | DCC |
| 21341 | - | - | - | - | 12456 | DCAAA |
| 21343 | 4 | A | - | - | 12356 | DCCAA |
| 21345 | 4 | A | - | - | 12356 | DCCAA |
| 21347 | 4 | A | - | - | 12356 | DCCAA |
| 21349 | - | - | - | - | 12456 | DCAAA |
| 21361 | 456 | AAA | - | - | 123 | DCC |
| 21363 | 6 | A | - | - | 12345 | DCCAA |
| 21364 | 456 | AAA | - | - | 123 | DCC |
| 21366 | 456 | AAA | - | - | 123 | DCC |
| 21367 | 6 | A | - | - | 12345 | DCCAA |
| 21369 | 456 | AAA | - | - | 23 | CC |
| 21383 | - | - | - | - | 12456 | DCAAA |
| 21387 | - | - | - | - | 12456 | DCAAA |

SHEAR PANEL/MEMBRANE ELEMENT DATA

| Letter Designation | NASTRAN EID | Type | Thickness (IN.) |
|--------------------|-------------|----------|-----------------|
| R | 2134163 | Bulkhead | .100 |
| S | 2134366 | Bulkhead | .050 |
| T | 2134564 | Bulkhead | .050 |
| U | 2134567 | Bulkhead | .050 |
| V | 2134769 | Bulkhead | .100 |
| W | 2132143 | Bulkhead | .012 |
| X | 2132345 | Bulkhead | .012 |
| Y | 2132547 | Bulkhead | .012 |
| Z | 2132749 | Bulkhead | .012 |

ROD ELEMENT DATA

| LETTER DESIGNATION | NASTRAN EID | TYPE | ACTUAL AREA (in. ²) | OFFSETS FROM GRIDPOINT | | FINAL AREA (in. ²) |
|-----------------------|----------------|-------|------------------------------------|---------------------------|---|-----------------------------------|
| | | | | Z | Y | |
| A | 2136163 | Frame | .101 | - | - | .101 |
| B | 2136364 | Frame | .101 | - | - | .101 |
| C | 2136466 | Frame | .101 | - | - | .101 |
| D | 2136667 | Frame | .101 | - | - | .101 |
| E | 2136769 | Frame | .101 | - | - | .101 |
| F | 2134161 | Frame | .182 | - | - | .182 |
| G | 2134969 | Frame | .182 | - | - | .182 |
| H | 2134143 | Frame | .131 | - | - | .131 |
| I | 2134345 | Frame | .131 | - | - | .131 |
| J | 2134547 | Frame | .131 | - | - | .131 |
| K | 2134749 | Frame | .131 | - | - | .131 |
| L | 2132141 | Frame | .309 | - | - | .309 |
| M | 2132949 | Frame | .309 | - | - | .309 |
| N | 2132123 | Frame | .302 | - | - | .302 |
| O | 2132325 | Frame | .302 | - | - | .302 |
| P | 2132527 | Frame | .302 | - | - | .302 |
| Q | 2132729 | Frame | .302 | - | - | .302 |

3.1.4.6 Partial Belly Bulkhead Sta. 218.97 Detail

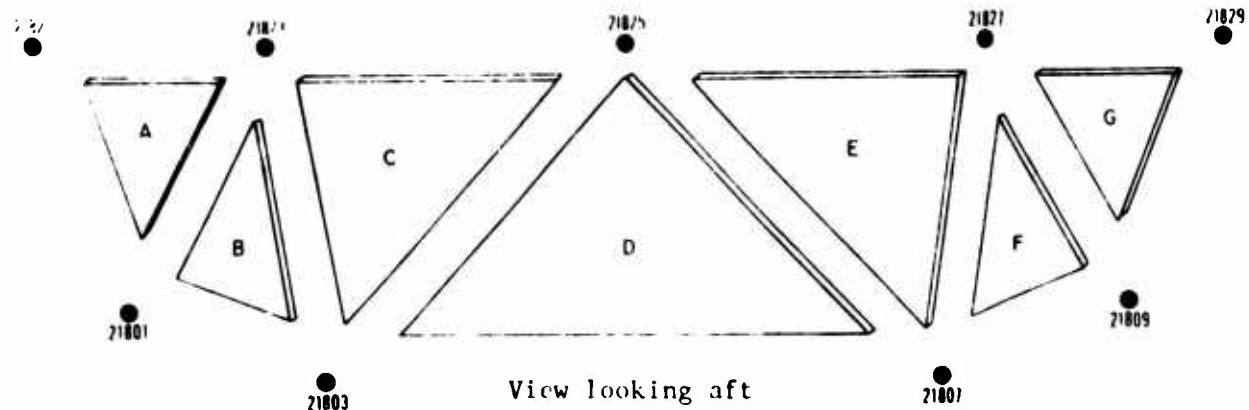

GRID POINT DATA

| GRID POINT | SPC | | MPC | | OMIT | |
|------------|--------|------|--------|------|--------|------|
| | D.O.F. | RULE | D.O.F. | RULE | D.O.F. | RULE |
| 21801 | 456 | AAA | - | - | 123 | DCC |
| 21803 | 456 | AAA | - | - | 123 | DCC |
| 21807 | 456 | AAA | - | - | 123 | DCC |
| 21809 | 456 | AAA | - | - | 123 | DCC |
| 21821 | 456 | AAA | - | - | 123 | DCC |
| 21823 | 456 | AAA | - | - | 123 | DCC |
| 21825 | 456 | AAA | - | - | - | - |
| 21827 | 456 | AAA | - | - | 123 | DCC |
| 21829 | 456 | AAA | - | - | 123 | DCC |

SHEAR PANEL/MEMBRANE ELEMENT DATA

| Letter Designation | NASTRAN EID | Type | Thickness (IN.) |
|--------------------|-------------|----------|-----------------|
| A | 2180121 | Bulkhead | .025 |
| B | 2180123 | Bulkhead | .025 |
| C | 2180323 | Bulkhead | .025 |
| D | 2180325 | Bulkhead | .025 |
| E | 2180725 | Bulkhead | .025 |
| F | 2180727 | Bulkhead | .025 |
| G | 2180927 | Bulkhead | .025 |

3.1.4.7 Partial Belly Bulkhead Sta. 227.62 Detail

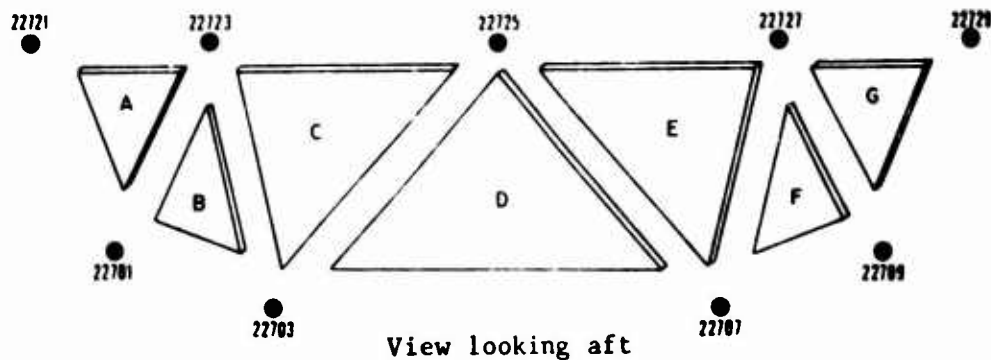

GRID POINT DATA

| GRID POINT | SPC | | MPC | | OMIT | |
|------------|--------|------|--------|------|--------|------|
| | D.O.F. | RULE | D.O.F. | RULE | D.O.F. | RULE |
| 22701 | 456 | AAA | - | - | 123 | DCC |
| 22703 | 456 | AAA | - | - | 123 | DCC |
| 22707 | 456 | AAA | - | - | 123 | DCC |
| 22709 | 456 | AAA | - | - | 123 | DCC |
| 22721 | 456 | AAA | - | - | 123 | DCC |
| 22773 | 456 | AAA | - | - | 123 | DCC |
| 22725 | 456 | AAA | - | - | - | - |
| 22727 | 456 | AAA | - | - | 123 | DCC |
| 22729 | 456 | AAA | - | - | 123 | DCC |

SHEAR PANEL/MEMBRANE ELEMENT DATA

| Letter Designation | NASTRAN EID | Type | Thickness (IN.) |
|--------------------|-------------|----------|-----------------|
| A | 2270121 | Bulkhead | .025 |
| B | 2270123 | Bulkhead | .025 |
| C | 2270323 | Bulkhead | .025 |
| D | 2270325 | Bulkhead | .025 |
| E | 2270725 | Bulkhead | .025 |
| F | 2270727 | Bulkhead | .025 |
| G | 2270927 | Bulkhead | .025 |

3.1.4.8 Bulkhead Sta. 250. Detail

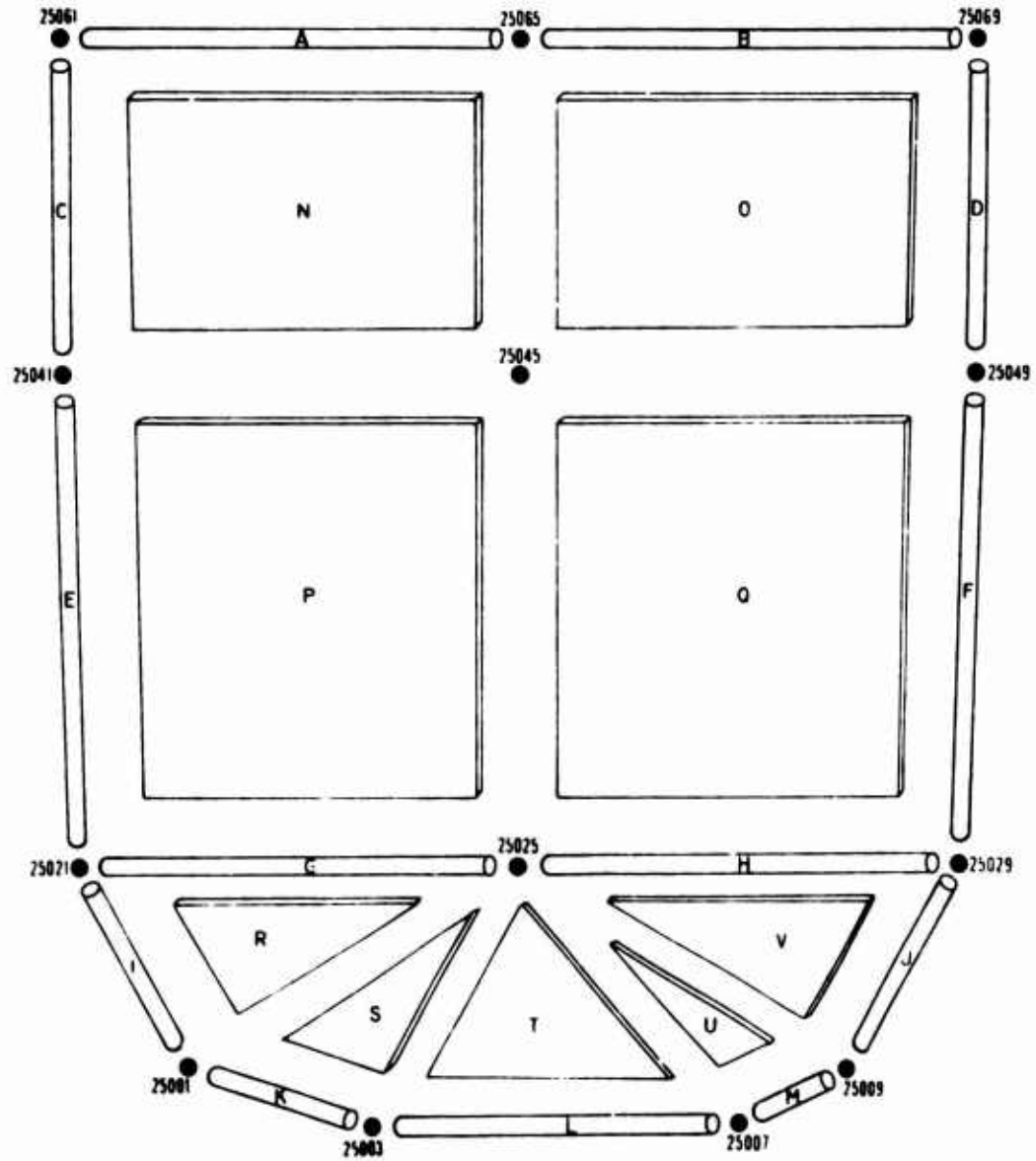

View looking aft

GRID POINT DATA

| GRID POINT | SPC | | MPC | | OMIT | |
|------------|--------|------|--------|------|--------|------|
| | D.O.F. | RULE | D.O.F. | RULE | D.O.F. | RULE |
| 25001 | 456 | AAA | - | - | 123 | DCC |
| 25003 | 456 | AAA | - | - | 123 | DCC |
| 25007 | 456 | AAA | - | - | 123 | DCC |
| 25009 | 456 | AAA | - | - | 123 | DCC |
| 25021 | 456 | AAA | - | - | 123 | DCC |
| 25025 | 456 | AAA | - | - | 13 | DC |
| 25029 | 456 | AAA | - | - | 123 | DCC |
| 25041 | 456 | AAA | - | - | 12 | DC |
| 25045 | 1456 | AAAA | - | - | 23 | CC |
| 25049 | 456 | AAA | - | - | 12 | DC |
| 25061 | 456 | AAA | - | - | 23 | CC |
| 25065 | 456 | AAA | - | - | 13 | DC |
| 25069 | 456 | AAA | - | - | 123 | DCC |

SHEAR PANEL/MEMBRANE ELEMENT DATA

| Letter Designation | NASTRAN EID | Type | Thickness (IN.) |
|--------------------|-------------|----------|-----------------|
| N | 2504165 | Bulkhead | .012 |
| O | 2504569 | Bulkhead | .012 |
| P | 2502145 | Bulkhead | .012 |
| Q | 2502549 | Bulkhead | .012 |
| R | 2500121 | Bulkhead | .025 |
| S | 2500125 | Bulkhead | .025 |
| T | 2500325 | Bulkhead | .025 |
| U | 2500725 | Bulkhead | .025 |
| V | 2500925 | Bulkhead | .025 |

ROD ELEMENT DATA

| LETTER DESIGNATION | NASTRAN EID | TYPE | ACTUAL AREA (in. ²) | OFFSETS FROM GRIDPOINT | | FINAL AREA (in. ²) |
|-----------------------|----------------|-------|------------------------------------|---------------------------|---|-----------------------------------|
| | | | | Z | Y | |
| A | 2506165 | Frame | .489 | - | - | .489 |
| B | 2506569 | Frame | .489 | - | - | .489 |
| C | 2504161 | Frame | .266 | - | - | .266 |
| D | 2504969 | Frame | .266 | - | - | .266 |
| E | 2502141 | Frame | .266 | - | - | .266 |
| F | 2502949 | Frame | .266 | - | - | .266 |
| G | 2502125 | Frame | .299 | - | - | .299 |
| H | 2502529 | Frame | .299 | - | - | .299 |
| I | 2502101 | Frame | .039 | - | - | .039 |
| J | 2500929 | Frame | .039 | - | - | .039 |
| K | 2500103 | Frame | .039 | - | - | .039 |
| L | 2500307 | Frame | .039 | - | - | .039 |
| M | 2500709 | Frame | .039 | - | - | .039 |

3.1.4.9 Bulkhead Sta. 268.25 Detail

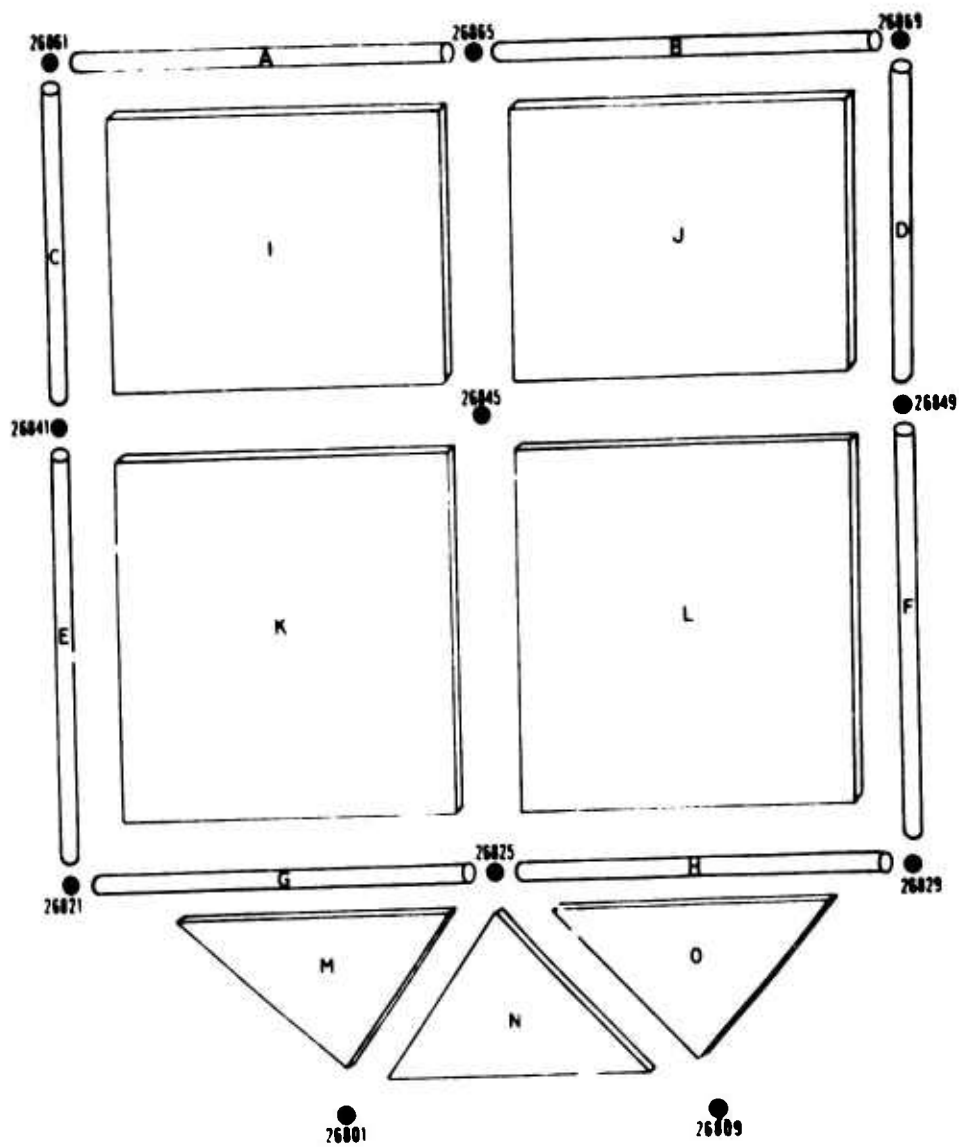

View looking aft

GRID POINT DATA

| GRID POINT | SPC | | MPC | | OMIT | |
|------------|--------|------|--------|------|--------|------|
| | D.O.F. | RULE | D.O.F. | RULE | D.O.F. | RULE |
| 26801 | 456 | AAA | - | - | 123 | DCC |
| 26809 | 456 | AAA | - | - | 123 | DCC |
| 26821 | 456 | AAA | - | - | 23 | CC |
| 26825 | 456 | AAA | - | - | 13 | DC |
| 26829 | 456 | AAA | - | - | 123 | DCC |
| 26841 | 456 | AAA | - | - | 12 | DC |
| 26845 | 1456 | AAAA | - | - | 23 | CC |
| 26849 | 456 | AAA | - | - | 12 | DC |
| 26861 | 456 | AAA | - | - | 123 | DCC |
| 26865 | 456 | AAA | - | - | 13 | DC |
| 26869 | 456 | AAA | - | - | 23 | CC |

SHEAR PANEL/MEMBRANE ELEMENT DATA

| Letter Designation | NASTRAN EID | Type | Thickness (IN.) |
|--------------------|-------------|----------|-----------------|
| I | 2684165 | Bulkhead | .028 |
| J | 2684569 | Bulkhead | .028 |
| K | 2682145 | Bulkhead | .028 |
| L | 2682549 | Bulkhead | .028 |
| M | 2680121 | Bulkhead | .028 |
| N | 2680125 | Bulkhead | .028 |
| O | 2680925 | Bulkhead | .028 |

ROD ELEMENT DATA

| LETTER DESIGNATION | NASTRAN EID | TYPE | ACTUAL AREA (in. ²) | OFFSETS FROM GRIDPOINT | | FINAL AREA (in. ²) |
|-----------------------|----------------|-------|------------------------------------|---------------------------|---|-----------------------------------|
| | | | | Z | Y | |
| A | 2686165 | Frame | .446 | - | - | .446 |
| B | 2686569 | Frame | .446 | - | - | .446 |
| C | 2684161 | Frame | .072 | - | - | .072 |
| D | 2684969 | Frame | .072 | - | - | .072 |
| E | 2682141 | Frame | .072 | - | - | .072 |
| F | 2682949 | Frame | .072 | - | - | .072 |
| G | 2682125 | Frame | .225 | - | - | .225 |
| H | 2682529 | Frame | .225 | - | - | .225 |

3.1.4.10 Tailboom Junction Bulkhead Sta. 299, Detail

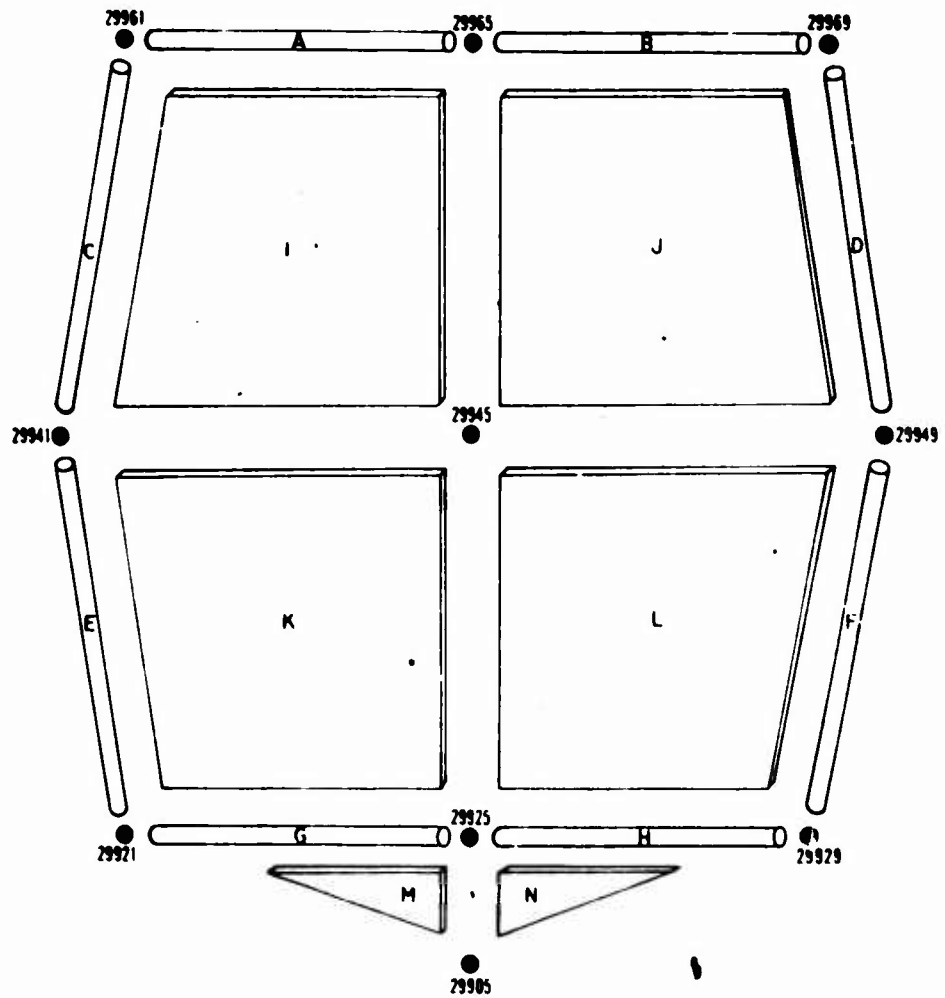

View looking aft

GRID POINT DATA

| GRID POINT | SPC | | MPC | | OMIT | |
|------------|--------|------|--------|------|--------|------|
| | D.O.F. | RULE | D.O.F. | RULE | D.O.F. | RULE |
| 29905 | 456 | AAA | - | - | 123 | DCC |
| 29921 | 456 | AAA | 123 | AAA | - | - |
| 29925 | 456 | AAA | - | - | 123 | DCC |
| 29929 | 456 | AAA | 123 | AAA | - | - |
| 29941 | 456 | AAA | - | - | 123 | DCC |
| 29945 | 1456 | AAAA | - | - | 23 | CC |
| 29949 | 456 | AAA | - | - | 123 | DCC |
| 29961 | 456 | AAA | 123 | AAA | - | - |
| 29965 | 456 | AAA | - | - | 123 | DCC |
| 29969 | 456 | AAA | 123 | AAA | - | - |

SHEAR PANEL/MEMBRANE ELEMENT DATA

| Letter Designation | NASTRAN EID | Type | Thickness (IN.) |
|--------------------|-------------|----------|-----------------|
| I | 2994165 | Bulkhead | .032 |
| J | 2994569 | Bulkhead | .032 |
| K | 2992145 | Bulkhead | .032 |
| L | 2992549 | Bulkhead | .032 |
| M | 2990521 | Bulkhead | .032 |
| N | 2990525 | Bulkhead | .032 |

ROD ELEMENT DATA

| LETTER DESIGNATION | NASTRAN EID | TYPE | ACTUAL AREA (in. ²) | OFFSETS FROM GRIDPOINT | | FINAL AREA (in. ²) |
|--------------------|-------------|-------|---------------------------------|------------------------|---|--------------------------------|
| | | | | Z | Y | |
| A | 2996165 | Frame | .480 | - | - | .480 |
| B | 2996569 | Frame | .480 | - | - | .480 |
| C | 2994161 | Frame | .335 | - | - | .335 |
| D | 2994969 | Frame | .335 | - | - | .335 |
| E | 2992141 | Frame | .335 | - | - | .335 |
| F | 2992949 | Frame | .605 | - | - | .605 |
| G | 2992125 | Frame | .285 | - | - | .285 |
| H | 2992529 | Frame | .285 | - | - | .285 |

3.1.4.11 Aft Fuel Cell Floor (Sta. 213-250, W.L. 35.97) Detail

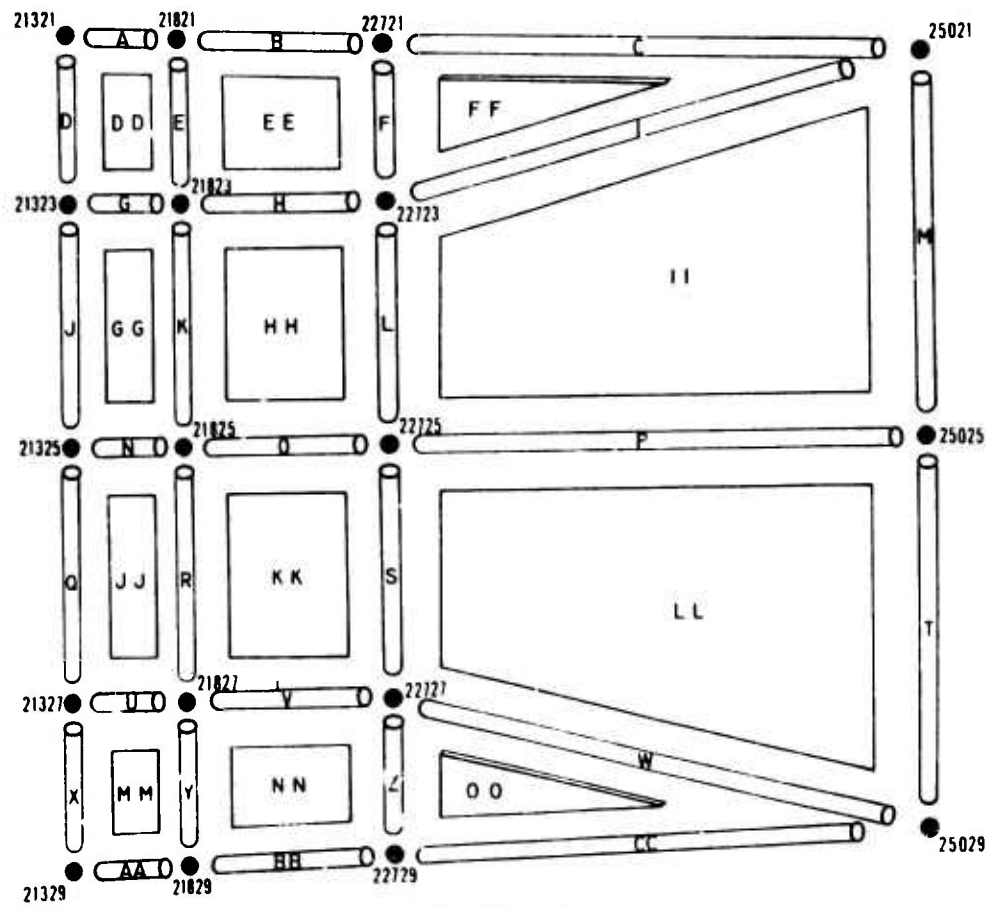

View looking down

GRID POINT DATA

| GRID POINT | SPC | | MPC | | OMIT | |
|------------|--------|------|--------|------|--------|------|
| | D.O.F. | RULE | D.O.F. | RULE | D.O.F. | RULE |
| 21321 | 456 | AAA | - | - | 23 | CC |
| 21323 | 456 | AAA | - | - | 123 | DCC |
| 21325 | 456 | AAA | - | - | 13 | DC |
| 21327 | 456 | AAA | - | - | 123 | DCC |
| 21329 | 456 | AAA | - | - | 123 | DCC |
| 21821 | 456 | AAA | - | - | 123 | DCC |
| 21823 | 456 | AAA | - | - | 123 | DCC |
| 21825 | 456 | AAA | - | - | - | - |
| 21827 | 456 | AAA | - | - | 123 | DCC |
| 21829 | 456 | AAA | - | - | 123 | DCC |
| 22721 | 456 | AAA | - | - | 123 | DCC |
| 22723 | 456 | AAA | - | - | 123 | DCC |
| 22725 | 456 | AAA | - | - | - | - |
| 22727 | 456 | AAA | - | - | 123 | DCC |
| 22729 | 456 | AAA | - | - | 123 | DCC |
| 25021 | 456 | AAA | - | - | 123 | DCC |
| 25025 | 456 | AAA | - | - | 13 | DC |
| 25029 | 456 | AAA | - | - | 123 | DCC |

3

SHEAR PANEL/MEMBRANE ELEMENT DATA

| Letter Designation | NASTRAN EID | Type | Thickness (IN.) |
|--------------------|-------------|---------------|-----------------|
| DD | 2060871 | Lower Skin | .016 |
| | 2060911 | Interior Skin | .010 |
| | 2060891 | Upper Skin | .020 |
| EE | 2060875 | Lower Skin | .016 |
| | 2060895 | Upper Skin | .020 |
| FF | 2060881 | Lower Skin | .016 |
| | 2060901 | Upper Skin | .020 |
| GG | 2060872 | Lower Skin | .016 |
| | 2060912 | Interior Skin | .010 |
| | 2060892 | Upper Skin | .020 |
| HH | 2060876 | Lower Skin | .016 |
| | 2060896 | Upper Skin | .020 |
| II | 2060882 | Lower Skin | .016 |
| | 2060902 | Upper Skin | .020 |
| JJ | 2060873 | Lower Skin | .016 |
| | 2060913 | Interior Skin | .010 |
| | 2060893 | Upper Skin | .020 |
| KK | 2060877 | Lower Skin | .016 |
| | 2060897 | Upper Skin | .020 |
| LL | 2060883 | Lower Skin | .016 |
| | 2060903 | Upper Skin | .020 |
| MM | 2060874 | Lower Skin | .016 |
| | 2060914 | Interior Skin | .010 |
| | 2060894 | Upper Skin | .020 |
| NN | 2060878 | Lower Skin | .016 |
| | 2060898 | Upper Skin | .020 |
| OO | 2060884 | Lower Skin | .016 |
| | 2060904 | Upper Skin | .020 |

ROD ELEMENT DATA

| LETTER DESIGNATION | NASTRAN EID | TYPE | ACTUAL AREA (in. ²) | OFFSETS FROM GRIDPOINT | | FINAL AREA (in. ²) |
|--------------------|-------------|---------|---------------------------------|------------------------|-------|--------------------------------|
| | | | | Z | Y | |
| A | 2060850 | Doubler | .262 | 0.0 | -2.86 | .180 |
| | 2068701 | R/SP1 | .017 | - | - | .017 |
| | 2069101 | R/SP1 | .011 | - | - | .011 |
| | 2068901 | R/SP1 | .021 | - | - | .021 |
| B | 2060501 | Doubler | .250 | 0.0 | -2.75 | .174 |
| | 2068721 | R/SP1 | .014 | - | - | .014 |
| | 2068921 | R/SP1 | .018 | - | - | .018 |
| C | 2060211 | Doubler | .100 | 0.0 | -1.36 | .084 |
| D | 2060852 | Doubler | .170 | 0.0 | 1.17 | .205 |
| | 2068711 | R/SP2 | .040 | - | - | .040 |
| | 2069111 | R/SP2 | .025 | - | - | .025 |
| | 2068911 | R/SP2 | .050 | - | - | .050 |
| E | 2060856 | Doubler | .201 | 0.0 | 1.14 | .242 |
| | 2068715 | R/SP2 | .040 | - | - | .040 |
| | 2068731 | R/SP2 | .069 | - | - | .069 |
| | 2069115 | R/SP2 | .025 | - | - | .025 |
| | 2068915 | R/SP2 | .050 | - | - | .050 |
| | 2068931 | R/SP2 | .087 | - | - | .087 |
| F | 2060231 | Doubler | .133 | 0.0 | 0.53 | .145 |
| | 2068735 | R/SP2 | .069 | - | - | .069 |
| | 2068935 | R/SP2 | .087 | - | - | .087 |
| G | 2068702 | R/SP1 | .093 | - | - | .093 |
| | 2068703 | R/SP1 | .093 | - | - | .093 |
| | 2069102 | R/SP1 | .058 | - | - | .058 |
| | 2069103 | R/SP1 | .058 | - | - | .058 |
| | 2068902 | R/SP1 | .116 | - | - | .116 |
| | 2068903 | R/SP1 | .116 | - | - | .116 |
| H | 2068722 | R/SP1 | .092 | - | - | .092 |
| | 2068723 | R/SP1 | .092 | - | - | .092 |
| | 2068922 | R/SP1 | .115 | - | - | .115 |
| | 2068923 | R/SP1 | .115 | - | - | .115 |

ROD ELEMENT DATA (CONT.)

| LETTER DESIGNATION | NASTRAN EID | TYPE | ACTUAL AREA (in. ²) | OFFSETS FROM GRIDPOINT | | FINAL AREA (in. ²) |
|-----------------------|----------------|---------|------------------------------------|---------------------------|------|-----------------------------------|
| | | | | Z | Y | |
| I | 2068801 | R/SP1 | .065 | - | - | .065 |
| | 2069001 | R/SP1 | .081 | - | - | .081 |
| J | 2060853 | Doubler | .170 | 0.0 | 1.71 | .205 |
| | 2068712 | R/SP2 | .040 | - | - | .040 |
| | 2069112 | R/SP2 | .025 | - | - | .025 |
| | 2068912 | R/SP2 | .050 | - | - | .050 |
| K | 2060857 | Doubler | .201 | 0.0 | 1.69 | .242 |
| | 2068716 | R/SP2 | .040 | - | - | .040 |
| | 2068732 | R/SP2 | .069 | - | - | .069 |
| | 2069116 | R/SP2 | .025 | - | - | .025 |
| | 2068916 | R/SP2 | .050 | - | - | .050 |
| | 2068932 | R/SP2 | .087 | - | - | .087 |
| L | 2060232 | Doubler | .133 | 0.0 | 0.83 | .145 |
| | 2068736 | R/SP2 | .069 | - | - | .069 |
| | 2068811 | R/SP2 | .179 | - | - | .179 |
| | 2068936 | R/SP2 | .087 | - | - | .087 |
| | 2069011 | R/SP2 | .224 | - | - | .224 |
| M | 2060391 | Doubler | .101 | 0.0 | 1.40 | .111 |
| | 2068813 | R/SP2 | .179 | - | - | .179 |
| | 2069013 | R/SP2 | .224 | - | - | .224 |
| N | 2068704 | R/SP1 | .059 | - | - | .059 |
| | 2068705 | R/SP1 | .059 | - | - | .059 |
| | 2069104 | R/SP1 | .037 | - | - | .037 |
| | 2069105 | R/SP1 | .037 | - | - | .037 |
| | 2068904 | R/SP1 | .074 | - | - | .074 |
| | 2068905 | R/SP1 | .074 | - | - | .074 |
| O | 2068724 | R/SP1 | .059 | - | - | .059 |
| | 2068725 | R/SP1 | .059 | - | - | .059 |
| | 2068924 | R/SP1 | .074 | - | - | .074 |
| | 2068925 | R/SP1 | .074 | - | - | .074 |
| P | 2068802 | R/SP1 | .136 | - | - | .136 |

ROD ELEMENT DATA (CONT.)

| LETTER DESIGNATION | NASTRAN EID | TYPE | ACTUAL AREA (in. ²) | OFFSETS FROM GRIDPOINT | | FINAL AREA (in. ²) |
|-----------------------|----------------|---------|------------------------------------|---------------------------|------|-----------------------------------|
| | | | | Z | Y | |
| Q | 2068803 | R/SP1 | .136 | - | - | .136 |
| | 2069002 | R/SP1 | .170 | - | - | .170 |
| | 2069003 | R/SP1 | .170 | - | - | .170 |
| | 2060854 | Doubler | .170 | 0.0 | 1.71 | .205 |
| | 2068713 | R/SP2 | .040 | - | - | .040 |
| | 2069113 | R/SP2 | .025 | - | - | .025 |
| | 2068913 | R/SP2 | .050 | - | - | .050 |
| R | 2060858 | Doubler | .201 | 0.0 | 1.69 | .242 |
| | 2068717 | R/SP2 | .040 | - | - | .040 |
| | 2068733 | R/SP2 | .069 | - | - | .069 |
| | 2069117 | R/SP2 | .025 | - | - | .025 |
| | 2068917 | R/SP2 | .050 | - | - | .050 |
| | 2068933 | R/SP2 | .087 | - | - | .087 |
| | 2060233 | Doubler | .133 | 0.0 | 0.83 | .145 |
| S | 2068737 | R/SP2 | .069 | - | - | .069 |
| | 2068812 | R/SP2 | .179 | - | - | .179 |
| | 2068937 | R/SP2 | .087 | - | - | .087 |
| | 2069012 | R/SP2 | .224 | - | - | .224 |
| | 2060392 | Doubler | .101 | 0.0 | 1.40 | .111 |
| T | 2068814 | R/SP2 | .179 | - | - | .179 |
| | 2069014 | R/SP2 | .224 | - | - | .224 |
| | 2068706 | R/SP1 | .093 | - | - | .093 |
| U | 2068707 | R/SP1 | .093 | - | - | .093 |
| | 2069106 | R/SP1 | .058 | - | - | .058 |
| | 2069107 | R/SP1 | .058 | - | - | .058 |
| | 2068906 | R/SP1 | .116 | - | - | .116 |
| | 2068907 | R/SP1 | .116 | - | - | .116 |
| V | 2068726 | R/SP1 | .092 | - | - | .092 |
| | 2068727 | R/SP1 | .092 | - | - | .092 |
| | 2068926 | R/SP1 | .115 | - | - | .115 |
| | 2068927 | R/SP1 | .115 | - | - | .115 |

ROD ELEMENT DATA (CONT.)

| LETTER DESIGNATION | NASTRAN EID | TYPE | ACTUAL AREA (in. ²) | OFFSETS FROM GRIDPOINT | | FINAL AREA (in. ²) |
|--------------------|-------------|---------|---------------------------------|------------------------|------|--------------------------------|
| | | | | Z | Y | |
| W | 2068804 | R/SP1 | .065 | - | - | .065 |
| | 2069004 | R/SP1 | .081 | - | - | .081 |
| X | 2060855 | Doubler | .170 | 0.0 | 1.17 | .205 |
| | 2068714 | R/SP2 | .040 | - | - | .040 |
| | 2069114 | R/SP2 | .025 | - | - | .025 |
| | 2068914 | R/SP2 | .050 | - | - | .050 |
| Y | 2060859 | Doubler | .201 | 0.0 | 1.14 | .242 |
| | 2068718 | R/SP2 | .040 | - | - | .040 |
| | 2068734 | R/SP2 | .069 | - | - | .069 |
| | 2069118 | R/SP2 | .025 | - | - | .025 |
| | 2068918 | R/SP2 | .050 | - | - | .050 |
| | 2068934 | R/SP2 | .087 | - | - | .087 |
| Z | 2060234 | Doubler | .133 | 0.0 | 0.53 | .145 |
| | 2068738 | R/SP2 | .069 | - | - | .069 |
| | 2068938 | R/SP2 | .087 | - | - | .087 |
| AA | 2060851 | Doubler | .262 | 0.0 | 2.86 | .180 |
| | 2068708 | R/SP1 | .017 | - | - | .017 |
| | 2069108 | R/SP1 | .011 | - | - | .011 |
| | 2068908 | R/SP1 | .021 | - | - | .021 |
| BB | 2060271 | Doubler | .250 | 0.0 | 2.75 | .174 |
| | 2068728 | R/SP1 | .014 | - | - | .014 |
| | 2068928 | R/SP1 | .018 | - | - | .018 |
| CC | 2060191 | Doubler | .100 | 0.0 | 1.36 | .084 |

3.1.4.12 Floor Panel (Sta. 250-268, W.L. 35.97) Detail

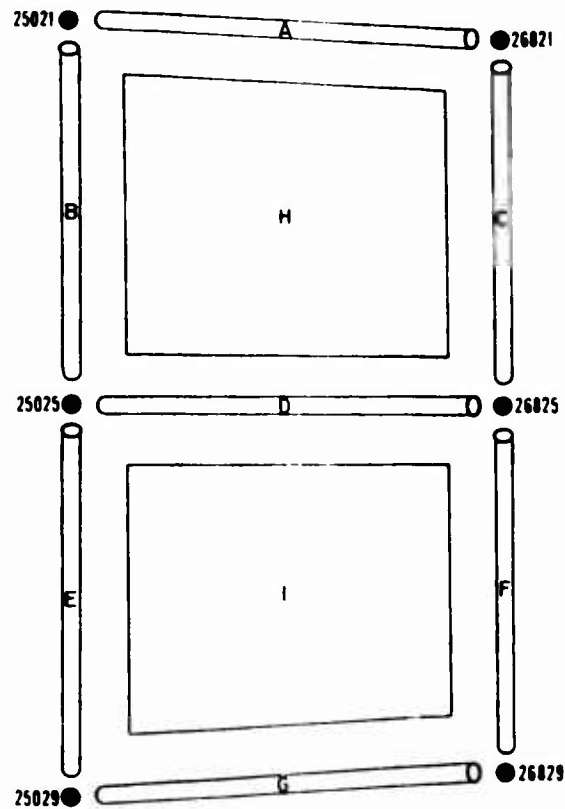

View looking down

GRID POINT DATA

| GRID POINT | SPC | | MPC | | OMIT | |
|------------|--------|------|--------|------|--------|------|
| | D.O.F. | RULE | D.O.F. | RULE | D.O.F. | RULE |
| 25021 | 456 | AAA | - | - | 123 | DCC |
| 25025 | 456 | AAA | - | - | 13 | DC |
| 25029 | 456 | AAA | - | - | 123 | DCC |
| 26821 | 456 | AAA | - | - | 23 | CC |
| 26825 | 456 | AAA | - | - | 13 | DC |
| 26829 | 456 | AAA | - | - | 123 | DCC |

SHEAR PANEL/MEMBRANE ELEMENT DATA

| Letter Designation | NASTRAN EID | Type | Thickness (IN.) |
|--------------------|-------------|------------|-----------------|
| H | 2070271 | Lower Skin | .016 |
| | 2070811 | Upper Skin | .012 |
| I | 2070272 | Lower Skin | .016 |
| | 2070812 | Upper Skin | .012 |

ROD ELEMENT DATA

| LETTER DESIGNATION | NASTRAN EID | TYPE | ACTUAL AREA (in. ²) | OFFSETS FROM GRIDPOINT | | FINAL AREA (in. ²) |
|--------------------|-------------|---------|---------------------------------|------------------------|-------|--------------------------------|
| | | | | Z | Y | |
| A | 2070091 | Doubler | .030 | 0.0 | -1.43 | .025 |
| | 2072701 | R/SP1 | .073 | - | - | .073 |
| | 2078101 | R/SP1 | .040 | - | - | .040 |
| B | 2070231 | Doubler | .034 | 0.0 | 3.53 | .044 |
| | 2072711 | R/SP2 | .144 | - | - | .144 |
| | 2078111 | R/SP2 | .090 | - | - | .090 |
| C | 2070551 | Doubler | .032 | 0.0 | 3.20 | .041 |
| | 2072713 | R/SP2 | .144 | - | - | .144 |
| | 2078113 | R/SP2 | .090 | - | - | .090 |
| D | 2072702 | R/SP1 | .160 | - | - | .160 |
| | 2072703 | R/SP1 | .160 | - | - | .160 |
| | 2078102 | R/SP1 | .118 | - | - | .118 |
| | 2078103 | R/SP1 | .118 | - | - | .118 |
| E | 2070232 | Doubler | .034 | 0.0 | 3.53 | .044 |
| | 2072712 | R/SP2 | .144 | - | - | .144 |
| | 2078112 | R/SP2 | .090 | - | - | .090 |
| F | 2070552 | Doubler | .032 | 0.0 | 3.20 | .041 |
| | 2072714 | R/SP2 | .144 | - | - | .144 |
| | 2078114 | R/SP2 | .090 | - | - | .090 |
| G | 2070511 | Doubler | .175 | 0.0 | 5.19 | .068 |
| | 2072704 | R/SP1 | .073 | - | - | .073 |
| | 2078104 | R/SP1 | .040 | - | - | .040 |

3.1.4.13 Floor Panel (Sta. 268-299, W.L. 35.97) Detail

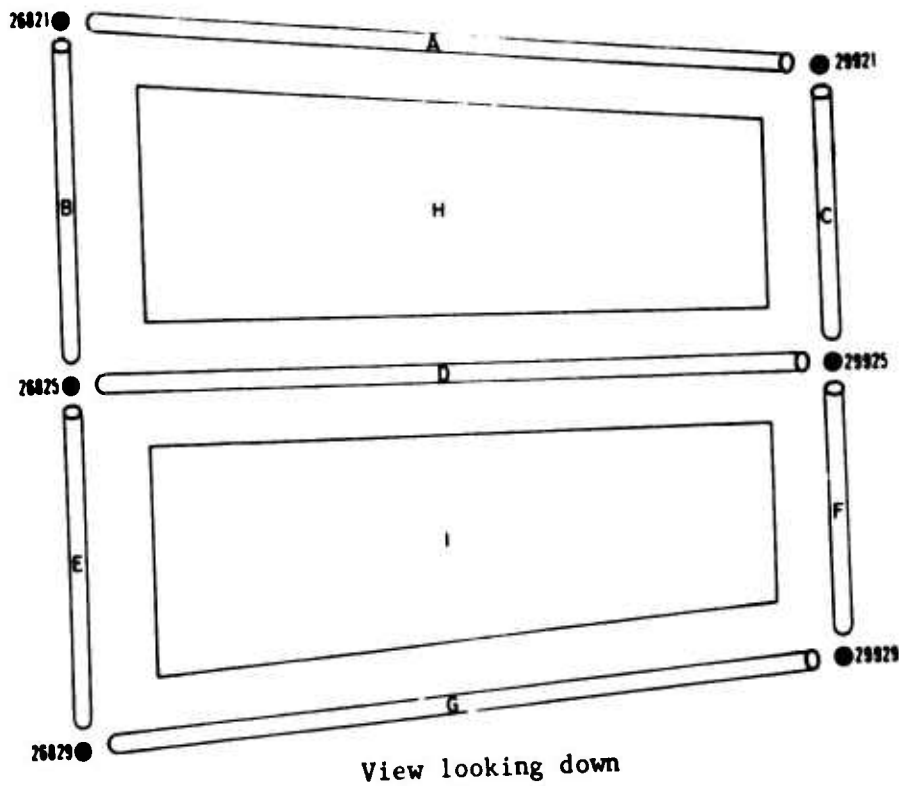

GRID POINT DATA

| GRID POINT | SPC | | MPC | | OMIT | |
|------------|--------|------|--------|------|--------|------|
| | D.O.F. | RULE | D.O.F. | RULE | D.O.F. | RULE |
| 26821 | 456 | AAA | - | - | 23 | CC |
| 26825 | 456 | AAA | - | - | 13 | DC |
| 26829 | 456 | AAA | - | - | 123 | DCC |
| 29921 | 456 | AAA | 123 | AAA | - | - |
| 29925 | 456 | AAA | - | - | 123 | DCC |
| 29929 | 456 | AAA | 123 | AAA | - | - |

SHEAR PANEL/MEMBRANE ELEMENT DATA

| Letter Designation | NASTRAN EID | Type | Thickness (IN.) |
|--------------------|-------------|------------|-----------------|
| H | 2070651 | Lower Skin | .008 |
| | 2070871 | Upper Skin | .016 |
| I | 2070652 | Lower Skin | .008 |
| | 2070872 | Upper Skin | .016 |

ROD ELEMENT DATA

| LETTER DESIGNATION | NASTRAN EID | TYPE | ACTUAL AREA (in. ²) | OFFSETS FROM GRIDPOINT | | FINAL AREA (in. ²) |
|--------------------|-------------|---------|---------------------------------|------------------------|-------|--------------------------------|
| | | | | Z | Y | |
| A | 2070571 | Doubler | .236 | 0.0 | -1.92 | .156 |
| | 2076501 | R/SP1 | .019 | - | - | .019 |
| | 2078701 | R/SP1 | .063 | - | - | .063 |
| B | 2070131 | Doubler | .037 | 0.0 | 1.42 | .041 |
| | 2076511 | R/SP2 | .111 | - | - | .111 |
| | 2078711 | R/SP2 | .248 | - | - | .248 |
| C | 2070211 | Doubler | .031 | 0.0 | 2.45 | .039 |
| | 2076513 | R/SP2 | .111 | - | - | .111 |
| | 2078713 | R/SP2 | .248 | - | - | .248 |
| D | 2076502 | R/SP1 | .065 | - | - | .065 |
| | 2076503 | R/SP1 | .065 | - | - | .065 |
| | 2078702 | R/SP1 | .141 | - | - | .141 |
| | 2078703 | R/SP1 | .141 | - | - | .141 |
| E | 2070132 | Doubler | .037 | 0.0 | 1.42 | .041 |
| | 2076512 | R/SP2 | .111 | - | - | .111 |
| | 2078712 | R/SP2 | .248 | - | - | .248 |
| F | 2070212 | Doubler | .031 | 0.0 | 2.45 | .039 |
| | 2076514 | R/SP2 | .111 | - | - | .111 |
| | 2078714 | R/SP2 | .248 | - | - | .248 |
| G | 2070151 | Doubler | .036 | 0.0 | 1.91 | .028 |
| | 2076504 | R/SP1 | .013 | - | - | .013 |
| | 2078704 | R/SP1 | .063 | - | - | .063 |

3.1.4.14 Engine Deck (Sta. 213-250) Detail

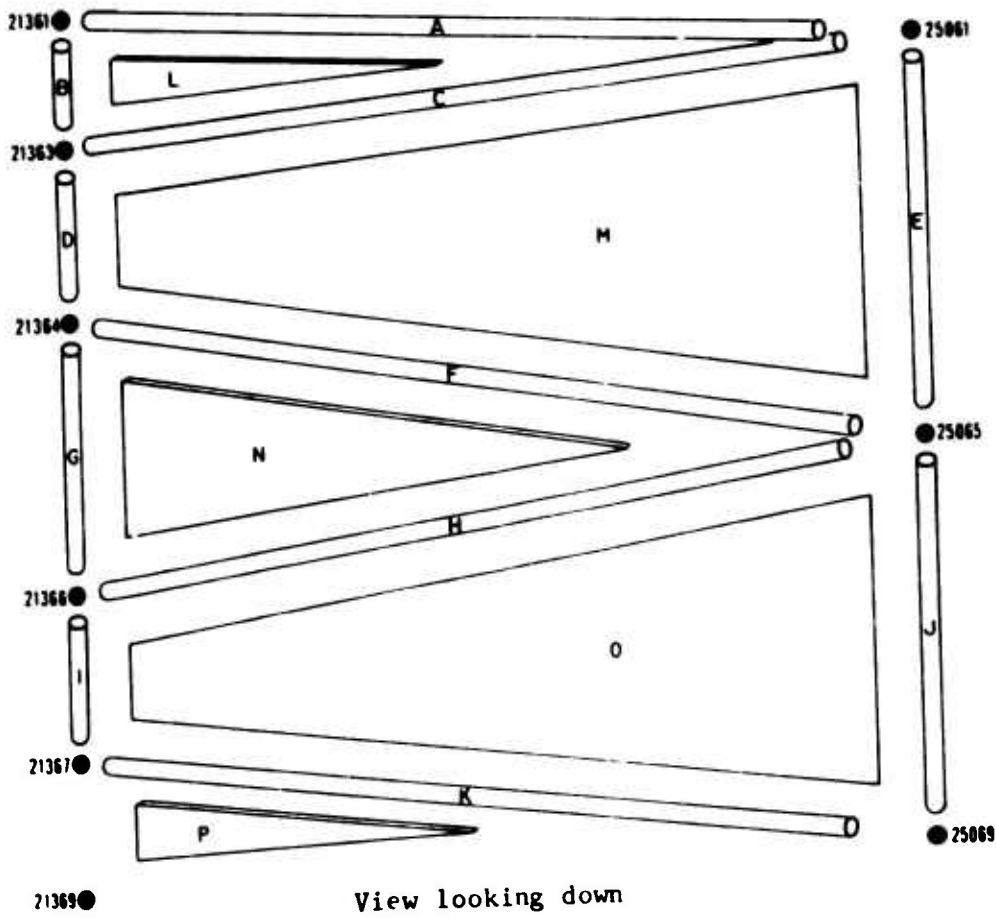

GRID POINT DATA

| GRID POINT | SPC | | MPC | | OMIT | |
|------------|--------|------|--------|------|--------|-------|
| | D.O.F. | RULE | D.O.F. | RULE | D.O.F. | RULE |
| 21361 | 456 | AAA | - | - | 123 | DCC |
| 21363 | 6 | A | - | - | 12345 | DCCAA |
| 21364 | 456 | AAA | - | - | 123 | DCC |
| 21366 | 456 | AAA | - | - | 123 | DCC |
| 21367 | 6 | A | - | - | 12345 | DCCAA |
| 21369 | 456 | AAA | - | - | 23 | CC |
| 25061 | 456 | AAA | - | - | 23 | CC |
| 25065 | 456 | AAA | - | - | 13 | DC |
| 25069 | 456 | AAA | - | - | 123 | DCC |

SHEAR PANEL/MEMBRANE ELEMENT DATA

| Letter Designation | NASTRAN EID | Type | Thickness (IN.) |
|--------------------|-------------|------------|-----------------|
| L | 2091291 | Lower Skin | .020 |
| | 2091251 | Upper Skin | .016 |
| M | 2091292 | Lower Skin | .020 |
| | 2091252 | Upper Skin | .016 |
| N | 2091293 | Lower Skin | .020 |
| | 2091253 | Upper Skin | .016 |
| O | 2091294 | Lower Skin | .020 |
| | 2091254 | Upper Skin | .016 |
| P | 2091295 | Lower Skin | .020 |
| | 2091255 | Upper Skin | .016 |

ROD ELEMENT DATA

| LETTER DESIGNATION | NASTRAN EID | TYPE | ACTUAL AREA (in. ²) | OFFSETS FROM GRIDPOINT | | FINAL AREA (in. ²) |
|-----------------------|----------------|---------|------------------------------------|---------------------------|-------|-----------------------------------|
| | | | | Z | Y | |
| A | 2091270 | Doubler | .044 | 0.0 | -1.31 | .038 |
| B | 2091272 | Doubler | .168 | 0.0 | 0.0 | .168 |
| C | 2092901 | R/SP3 | .085 | - | - | .085 |
| | 2092501 | R/SP3 | .068 | - | - | .068 |
| D | 2091273 | Doubler | .168 | 0.0 | 0.0 | .168 |
| | 2092911 | R/SP2 | .359 | - | - | .359 |
| | 2092511 | R/SP2 | .287 | - | - | .287 |
| E | 2091276 | Doubler | .047 | 0.0 | 1.27 | .051 |
| | 2092913 | R/SP2 | .359 | - | - | .359 |
| | 2092513 | R/SP2 | .287 | - | - | .287 |
| F | 2092902 | R/SP3 | .085 | - | - | .085 |
| | 2092502 | R/SP3 | .068 | - | - | .068 |
| G | 2091274 | Doubler | .168 | 0.0 | 0.0 | .168 |
| H | 2092903 | R/SP3 | .080 | - | - | .080 |
| | 2092503 | R/SP3 | .064 | - | - | .064 |
| I | 2091275 | Doubler | .168 | 0.0 | 0.0 | .168 |
| | 2092912 | R/SP2 | .359 | - | - | .359 |
| | 2092512 | R/SP2 | .287 | - | - | .287 |
| J | 2091277 | Doubler | .047 | 0.0 | 1.27 | .051 |
| | 2092914 | R/SP2 | .359 | - | - | .359 |
| | 2092514 | R/SP2 | .287 | - | - | .287 |
| K | 2091271 | Doubler | .102 | 0.0 | 0.67 | .094 |
| | 2092904 | R/SP3 | .080 | - | - | .080 |
| | 2092504 | R/SP3 | .064 | - | - | .064 |

3.1.4.15 Engine Deck (Sta. 250-299) Detail

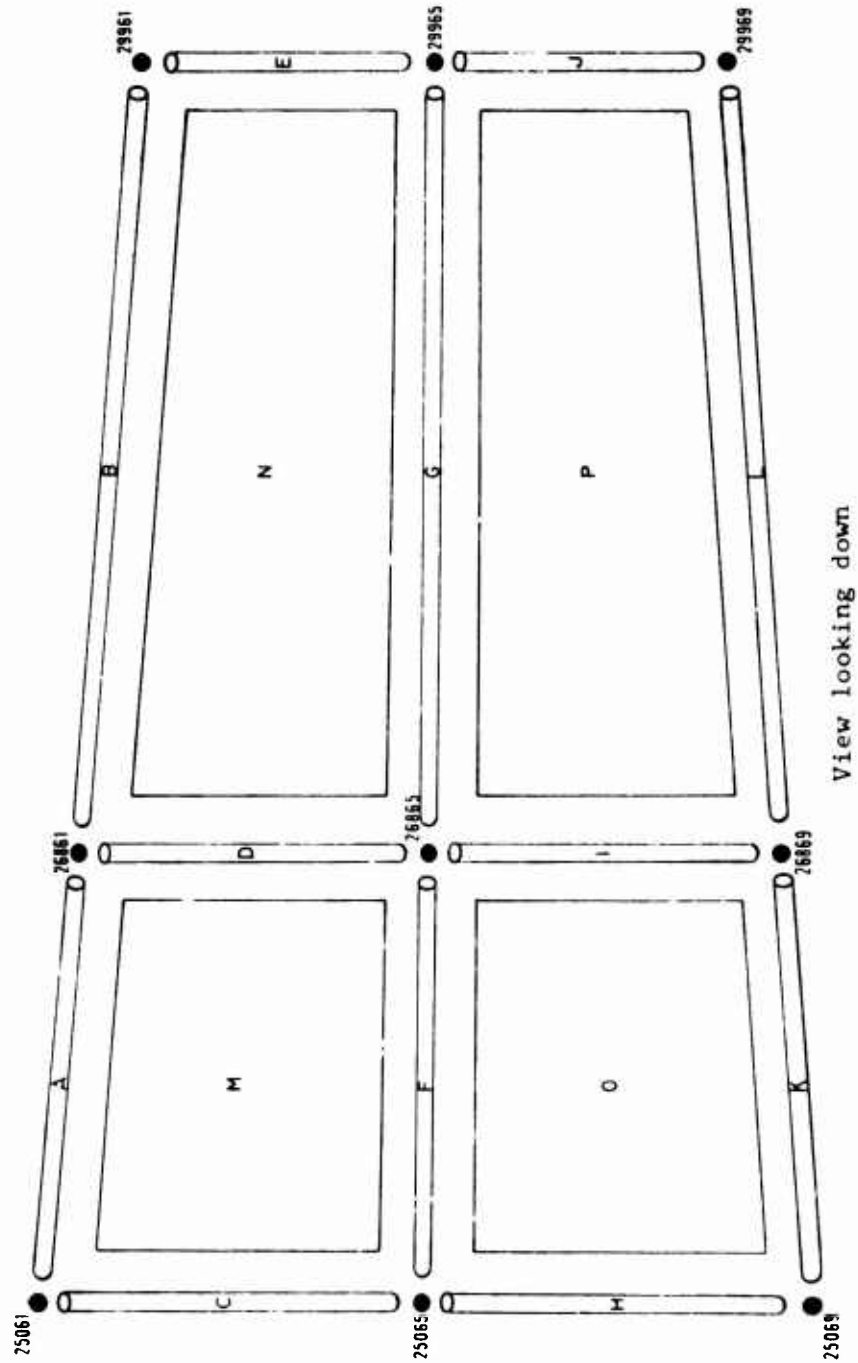

GRID POINT DATA

| GRID POINT | SPC | | MPC | | OMIT | |
|------------|--------|------|--------|------|--------|------|
| | D.O.F. | RULE | D.O.F. | RULE | D.O.F. | RULE |
| 25061 | 456 | AAA | - | - | 23 | CC |
| 25065 | 456 | AAA | - | - | 13 | DC |
| 25069 | 456 | AAA | - | - | 123 | DCC |
| 26861 | 456 | AAA | - | - | 123 | DCC |
| 26865 | 456 | AAA | - | - | 13 | DC |
| 26869 | 456 | AAA | - | - | 23 | CC |
| 29961 | 456 | AAA | 123 | AAA | - | - |
| 29965 | 456 | AAA | - | - | 123 | DCC |
| 29969 | 456 | AAA | 123 | AAA | - | - |

SHEAR PANEL/MEMBRANE ELEMENT DATA

| Letter Designation | NASTRAN EID | Type | Thickness (In.) |
|--------------------|-------------|------------|-----------------|
| M | 2091296 | Lower Skin | .020 |
| | 2091256 | Upper Skin | .016 |
| | 2091278 | Upper Skin | .012 |
| N | 2091298 | Lower Skin | .020 |
| | 2091258 | Upper Skin | .016 |
| O | 2091297 | Lower Skin | .020 |
| | 2091257 | Upper Skin | .016 |
| | 2091279 | Upper Skin | .012 |
| P | 2091299 | Lower Skin | .020 |
| | 2091259 | Upper Skin | .016 |

ROD ELEMENT DATA

| LETTER DESIGNATION | NASTRAN EID | TYPE | ACTUAL AREA (in. ²) | OFFSETS FROM GRIDPOINT | | FINAL AREA (in. ²) |
|-----------------------|----------------|---------|------------------------------------|---------------------------|-------|-----------------------------------|
| | | | | Z | Y | |
| A | 2091031 | Doubler | .229 | 0.0 | -6.25 | .071 |
| | 2090051 | Doubler | .116 | 0.0 | -6.25 | .036 |
| | 2092921 | R/SP1 | .099 | - | - | .099 |
| | 2092521 | R/SP1 | .079 | - | - | .079 |
| | 2092701 | R/SP1 | .060 | - | - | .060 |
| B | 2091281 | Doubler | .047 | 0.0 | -1.77 | .031 |
| | 2092941 | R/SP1 | .086 | - | - | .086 |
| | 2092541 | R/SP1 | .069 | - | - | .069 |
| C | 2090411 | Doubler | .197 | 0.0 | 8.38 | .408 |
| | 2090055 | Doubler | .137 | 0.0 | 8.36 | .283 |
| | 2092931 | R/SP2 | .183 | - | - | .183 |
| | 2092531 | R/SP2 | .146 | - | - | .146 |
| | 2092711 | R/SP2 | .110 | - | - | .110 |
| D | 2090431 | Doubler | .197 | 0.0 | 4.12 | .273 |
| | 2090057 | Doubler | .137 | 0.0 | 6.94 | .258 |
| | 2091283 | Doubler | .049 | 0.0 | 1.37 | .054 |
| | 2092933 | R/SP2 | .183 | - | - | .183 |
| | 2092951 | R/SP2 | .303 | - | - | .303 |
| | 2092533 | R/SP2 | .146 | - | - | .146 |
| | 2092551 | R/SP2 | .242 | - | - | .242 |
| | 2092713 | R/SP2 | .110 | - | - | .110 |
| E | 2091285 | Doubler | .030 | 0.0 | 2.05 | .036 |
| | 2092953 | R/SP2 | .303 | - | - | .303 |
| | 2092553 | R/SP2 | .242 | - | - | .242 |
| F | 2091032 | Doubler | .229 | 0.0 | 9.25 | .071 |
| | 2090052 | Doubler | .116 | 0.0 | 9.25 | .036 |
| | 2091011 | Doubler | .229 | 0.0 | -6.39 | .049 |
| | 2090053 | Doubler | .116 | 0.0 | -6.39 | .025 |
| | 2092922 | R/SP1 | .207 | - | - | .207 |
| | 2092923 | R/SP1 | .207 | - | - | .207 |
| | 2092522 | R/SP1 | .165 | - | - | .165 |

ROD ELEMENT DATA (CONT.)

| LETTER DESIGNATION | NASTRAN EID | TYPE | ACTUAL AREA (in. ²) | OFFSETS FROM GRIDPOINT | | FINAL AREA (in. ²) |
|-----------------------|----------------|---------|------------------------------------|---------------------------|------|-----------------------------------|
| | | | | Z | Y | |
| G | 2092523 | R/SP1 | .165 | - | - | .165 |
| | 2092702 | R/SP1 | .124 | - | - | .124 |
| | 2092703 | R/SP1 | .124 | - | - | .124 |
| | 2092942 | R/SP1 | .181 | - | - | .181 |
| | 2092943 | R/SP1 | .181 | - | - | .181 |
| | 2092542 | R/SP1 | .145 | - | - | .145 |
| | 2092543 | R/SP1 | .145 | - | - | .145 |
| H | 2090412 | Doubler | .197 | 0.0 | 8.38 | .408 |
| | 2090056 | Doubler | .137 | 0.0 | 8.36 | .283 |
| | 2092932 | R/SP2 | .183 | - | - | .183 |
| | 2092532 | R/SP2 | .146 | - | - | .146 |
| | 2092712 | R/SP2 | .110 | - | - | .110 |
| I | 2090432 | Doubler | .197 | 0.0 | 4.12 | .273 |
| | 2090058 | Doubler | .137 | 0.0 | 6.94 | .258 |
| | 2091284 | Doubler | .049 | 0.0 | 1.37 | .054 |
| | 2092934 | R/SP2 | .183 | - | - | .183 |
| | 2092952 | R/SP2 | .303 | - | - | .303 |
| | 2092534 | R/SP2 | .146 | - | - | .146 |
| | 2092552 | R/SP2 | .242 | - | - | .242 |
| J | 2092714 | R/SP2 | .110 | - | - | .110 |
| | 2091286 | Doubler | .030 | 0.0 | 2.05 | .036 |
| | 2092954 | R/SP2 | .303 | - | - | .303 |
| | 2092554 | R/SP2 | .242 | - | - | .242 |
| K | 2091012 | Doubler | .229 | 0.0 | 6.25 | .049 |
| | 2090054 | Doubler | .116 | 0.0 | 6.25 | .025 |
| | 2092924 | R/SP1 | .099 | - | - | .099 |
| | 2092524 | R/SP1 | .079 | - | - | .079 |
| | 2092704 | R/SP1 | .060 | - | - | .060 |
| L | 2091282 | Doubler | .058 | 0.0 | 1.62 | .047 |
| | 2092944 | R/SP1 | .086 | - | - | .086 |
| | 2092544 | R/SP1 | .069 | - | - | .069 |

3.1.4.16 Right Belly Skins (Sta. 227-299) Detail

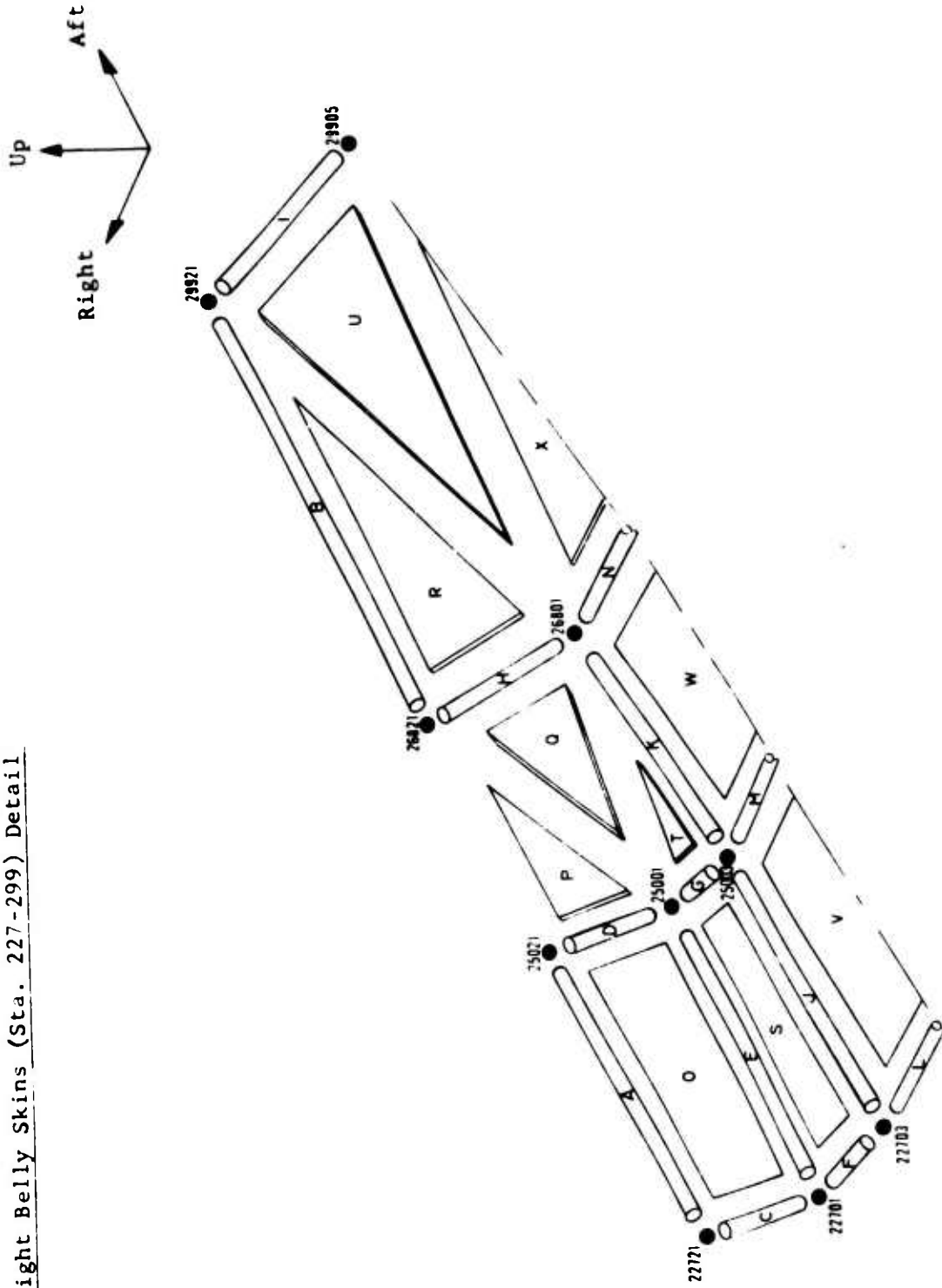

GRID POINT DATA

| GRID POINT | SPC | | MPC | | OMIT | |
|------------|--------|------|--------|------|--------|------|
| | D.O.F. | RULE | D.O.F. | RULE | D.O.F. | RULE |
| 22701 | 456 | AAA | - | - | 123 | DCC |
| 22703 | 456 | AAA | - | - | 123 | DCC |
| 22721 | 456 | AAA | - | - | 123 | DCC |
| 25001 | 456 | AAA | - | - | 123 | DCC |
| 25003 | 456 | AAA | - | - | 123 | DCC |
| 25021 | 456 | AAA | - | - | 123 | DCC |
| 26801 | 456 | AAA | - | - | 123 | DCC |
| 26821 | 456 | AAA | - | - | 23 | CC |
| 29905 | 456 | AAA | - | - | 123 | DCC |
| 29921 | 456 | AAA | 123 | AAA | - | - |

SHEAR PANEL/MEMBRANE ELEMENT DATA

| Letter Designation | NASTRAN EID | Type | Thickness (IN.) |
|--------------------|-------------|------|-----------------|
| O | 2200671 | Skin | .025 |
| P | 2200675 | Skin | .025 |
| Q | 2200676 | Skin | .025 |
| R | 1330011 | Skin | .025 |
| S | 2200672 | Skin | .025 |
| T | 2200677 | Skin | .025 |
| U | 1330012 | Skin | .025 |
| V | 2590011 | Skin | .024 |
| W | 1201211 | Skin | .032 |
| X | 1330013 | Skin | .025 |

ROD ELEMENT DATA

| LETTER DESIGNATION | NASTRAN EID | TYPE | ACTUAL AREA (in. ²) | OFFSETS FROM GRIDPOINT | | FINAL AREA (in. ²) |
|-----------------------|----------------|---------|------------------------------------|---------------------------|---|-----------------------------------|
| | | | | Z | Y | |
| A | 2206701 | R/SP2 | .097 | - | - | .097 |
| B | 1330104 | Doubler | .055 | - | - | .055 |
| C | 2206703 | R/SP2 | .280 | - | - | .280 |
| D | 2206704 | R/SP2 | .280 | - | - | .280 |
| E | 2206702 | R/SP2 | .097 | - | - | .097 |
| | 2206711 | R/SP2 | .064 | - | - | .064 |
| F | 2206713 | R/SP2 | .280 | - | - | .280 |
| G | 2206714 | R/SP2 | .280 | - | - | .280 |
| H | 1330101 | Doubler | .055 | - | - | .055 |
| I | 1330106 | Doubler | .055 | - | - | .055 |
| J | 2200581 | Doubler | .117 | - | - | .117 |
| | 2206712 | R/SP2 | .064 | - | - | .064 |
| | 2590101 | R/SP2 | .172 | - | - | .172 |
| K | 2201171 | Doubler | .116 | - | - | .116 |
| | 1202101 | R/SP3 | .208 | - | - | .208 |
| L | 2590103 | R/SP2 | .269 | - | - | .269 |
| M | 2201151 | Doubler | .119 | - | - | .119 |
| | 2590104 | R/SP2 | .269 | - | - | .269 |
| | 1202103 | R/SP2 | .292 | - | - | .292 |
| N | 1330102 | Doubler | .055 | - | - | .055 |
| | 1202104 | R/SP2 | .292 | - | - | .292 |

3.1.4.17 Left Belly Skins (Sta. 227-299) Detail

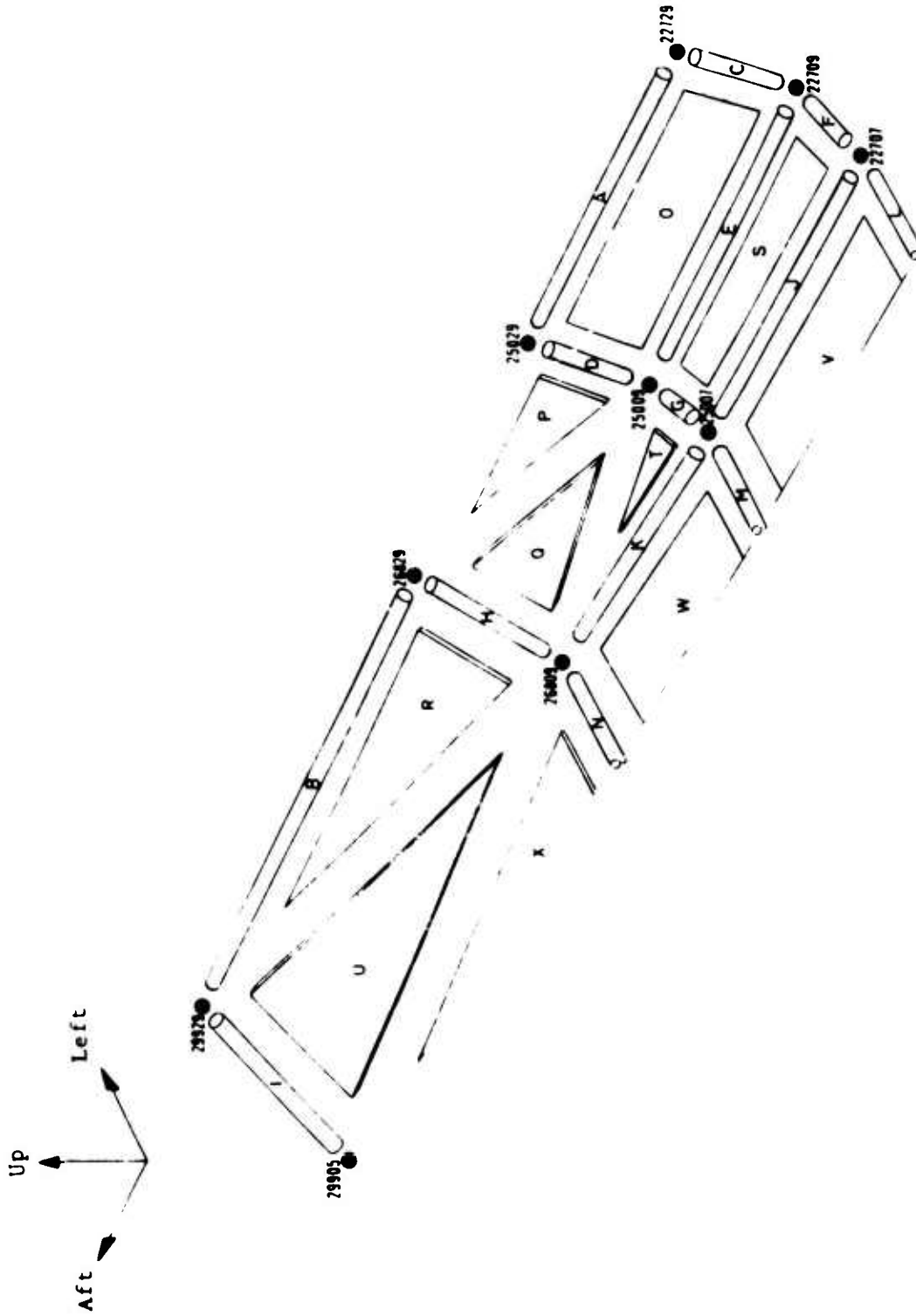

GRID POINT DATA

| GRID POINT | SPC | | MPC | | OMIT | |
|------------|--------|------|--------|------|--------|------|
| | D.O.F. | RULE | D.O.F. | RULE | D.O.F. | RULE |
| 22707 | 456 | AAA | - | - | 123 | DCC |
| 22709 | 456 | AAA | - | - | 123 | DCC |
| 22729 | 456 | AAA | - | - | 123 | DCC |
| 25007 | 456 | AAA | - | - | 123 | DCC |
| 25009 | 456 | AAA | - | - | 123 | DCC |
| 25029 | 456 | AAA | - | - | 123 | DCC |
| 26809 | 456 | AAA | - | - | 123 | DCC |
| 26829 | 456 | AAA | - | - | 123 | DCC |
| 29905 | 456 | AAA | - | - | 123 | DCC |
| 29929 | 456 | AAA | 123 | AAA | - | - |

SHEAR PANEL/MEMBRANE ELEMENT DATA

| Letter Designation | NASTRAN EID | Type | Thickness (IN.) |
|--------------------|-------------|------|-----------------|
| O | 2201031 | Skin | .025 |
| P | 2201035 | Skin | .025 |
| Q | 2201036 | Skin | .025 |
| R | 1330015 | Skin | .025 |
| S | 2201032 | Skin | .025 |
| T | 2201037 | Skin | .025 |
| U | 1330014 | Skin | .025 |
| V | 2590011 | Skin | .024 |
| W | 1201211 | Skin | .032 |
| X | 1330013 | Skin | .025 |

ROD ELEMENT DATA

| LETTER DESIGNATION | NASTRAN EID | TYPE | ACTUAL AREA (in. ²) | OFFSETS FROM GRIDPOINT | | FINAL AREA (in. ²) |
|-----------------------|----------------|---------|------------------------------------|---------------------------|---|-----------------------------------|
| | | | | Z | Y | |
| A | 2200312 | R/SP2 | .097 | - | - | .097 |
| B | 1330105 | Doubler | .055 | - | - | .055 |
| C | 2200313 | R/SP2 | .280 | - | - | .280 |
| D | 2200314 | R/SP2 | .280 | - | - | .280 |
| E | 2200302 | R/SP2 | .079 | - | - | .079 |
| | 2200311 | R/SP2 | .097 | - | - | .097 |
| F | 2200303 | R/SP2 | .280 | - | - | .280 |
| G | 2200304 | R/SP2 | .280 | - | - | .280 |
| H | 1330103 | Doubler | .055 | - | - | .055 |
| I | 1330107 | Doubler | .055 | - | - | .055 |
| J | 2200571 | Doubler | .117 | - | - | .117 |
| | 2590102 | R/SP2 | .172 | - | - | .172 |
| | 2200301 | R/SP2 | .079 | - | - | .079 |
| K | 2201191 | Doubler | .116 | - | - | .116 |
| | 1202102 | R/SP3 | .208 | - | - | .208 |
| L | 2590103 | R/SP2 | .269 | - | - | .269 |
| M | 2201151 | Doubler | .119 | - | - | .119 |
| | 2590104 | R/SP2 | .269 | - | - | .269 |
| | 1202103 | R/SP2 | .292 | - | - | .292 |
| N | 1330102 | Doubler | .055 | - | - | .055 |
| | 1202104 | R/SP2 | .292 | - | - | .292 |

3.1.5 Main Rotor Pylon Subassembly

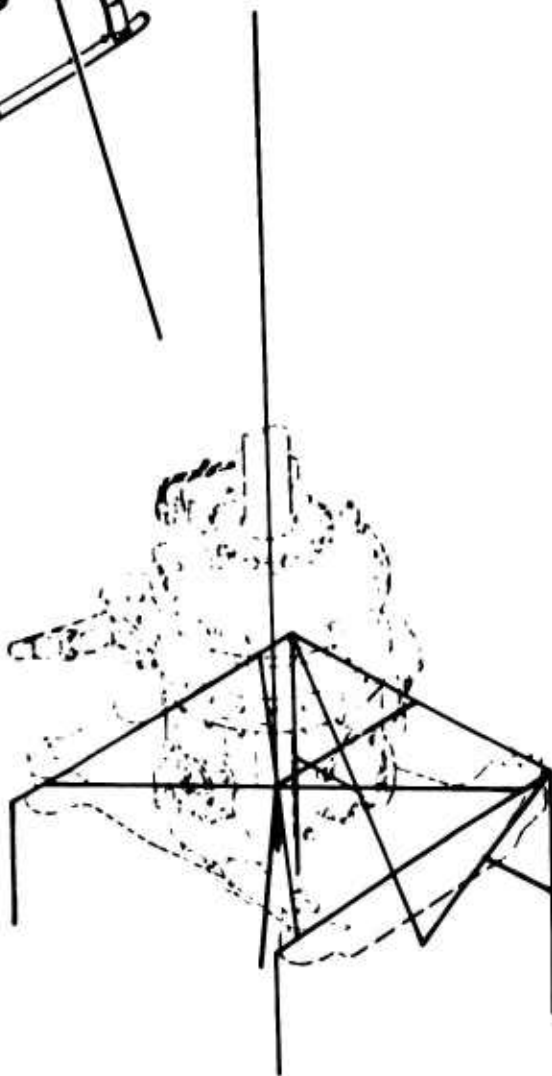
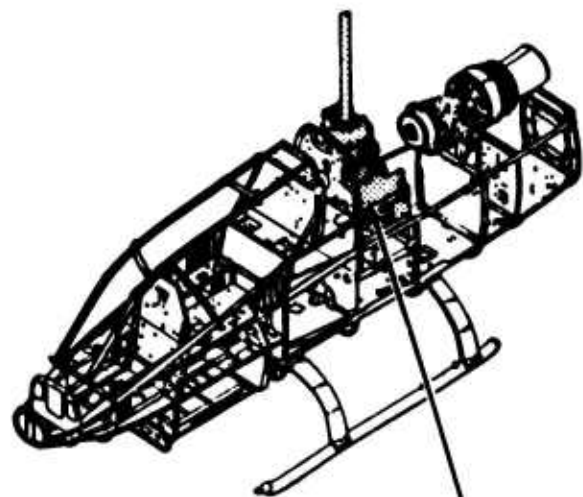

FS 213.94

FS 186.25

3.1.5.1 Main Rotor Mast, Transmission, Mounts, Lift Link - Detail

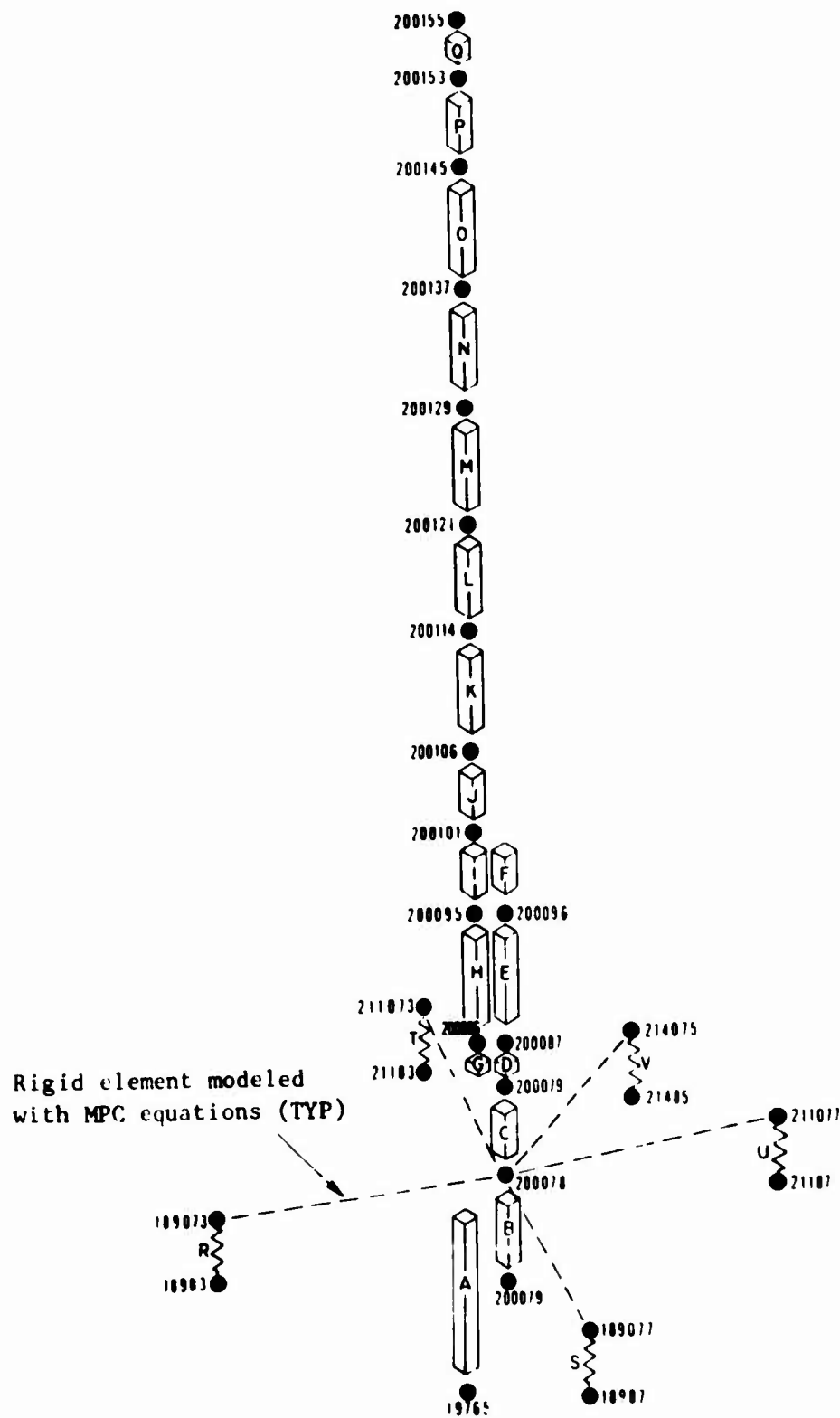

GRID POINT DATA

| GRID POINT | SPC | | MPC | | OMIT | |
|------------|--------|------|--------|--------|--------|--------|
| | D.O.F. | RULE | D.O.F. | RULE | D.O.F. | RULE |
| 18983 | 4 | A | - | - | 12356 | AAAAA |
| 18987 | 4 | A | - | - | 12356 | AAAAA |
| 19765 | 45 | AA | - | - | 16 | DA |
| 21183 | 4 | A | - | - | 12356 | AAAAA |
| 21187 | 4 | A | - | - | 12356 | AAAAA |
| 21485 | 156 | AAA | - | - | 34 | AA |
| 189073 | - | - | 123456 | AAAAAA | - | - |
| 189077 | - | - | 123456 | AAAAAA | - | - |
| 211073 | - | - | 123456 | AAAAAA | - | - |
| 211077 | - | - | 123456 | AAAAAA | - | - |
| 214075 | - | - | 123456 | AAAAAA | - | - |
| 200070 | - | - | - | - | 123456 | BBDAAA |
| 200078 | - | - | - | - | 3456 | DAAA |
| 200079 | - | - | - | - | 123456 | BBDAAA |
| 200086 | - | - | - | - | 13456 | BDAAA |
| 200087 | - | - | - | - | 23456 | BDAAA |
| 200095 | - | - | - | - | 23456 | BDAAA |
| 200096 | - | - | - | - | 13456 | BDAAA |
| 200101 | - | - | - | - | 123456 | BBDAAA |
| 200106 | - | - | - | - | 3456 | DAAA |
| 200114 | - | - | - | - | 123456 | BBDAAA |
| 200121 | - | - | - | - | 3456 | DAAA |
| 200129 | - | - | - | - | 12456 | BBAAA |
| 200137 | - | - | - | - | 3456 | DAAA |
| 200145 | - | - | - | - | 123456 | BBDAAA |
| 200153 | - | - | - | - | 3456 | DAAA |
| 200155 | - | - | - | - | 123456 | BBDAAA |

CBAR ELEMENT DATA

| LETTER DESIGNATION | NASTRAN EID | SECTION PROPERTIES | | | | | | |
|--------------------|-------------|--------------------------|-------------------------------------|-------------------------------------|-----------------------------|-------|-------|------|
| | | AREA (in. ²) | INERTIA-PLANE 1 (in. ⁴) | INERTIA-PLANE 2 (in. ⁴) | TORSION (in. ⁴) | | | |
| A ¹ | 3570001 | 0.890 | 0.0 | 0.0 | 0.0 | | | |
| B | 3530251 | 3.448 | 67.241 | 67.241 | 134.55 | | | |
| C | 3530252 | ↓ | ↓ | ↓ | ↓ | | | |
| D | 3530253 | | | | | | | |
| E | 3530254 | | | | | | | |
| F ² | 3530255 | | | | | | | |
| G ³ | 4500050 | | | | | 4.140 | 4.140 | 8.28 |
| H | 4500070 | | | | | | | |
| I | 4500071 | | | | | | | |
| J | 4500072 | | | | | | | |
| K | 4500073 | | | | | | | |
| L | 4500074 | | | | | | | |
| M | 4500075 | | | | | | | |
| N | 4500076 | | | | | | | |
| O | 4500077 | | | | | | | |
| P | 4500078 | | | | | | | |
| Q | 4500079 | | | | | | | |

NOTES -

- ¹ Offsets at End A: x=-3.1 in., y=0.0 in., z=-1.67 in.
Offsets at End B: x= 0.0 in., y=0.0 in., z= 1.52 in.
- ² Pin flags at End B: 456
- ³ Pin flags at End A: 56

SPRING ELEMENT DATA

| LETTER DESIGNATION | NASTRAN EID | COORDINATE | SPRING RATE (lb/in.) |
|--------------------|-------------|------------|----------------------|
| R | 189831 | 1 | 28125 |
| | 189832 | 2 | 28125 |
| | 189833 | 3 | 4500 |
| S | 189871 | 1 | 28125 |
| | 189872 | 2 | 28125 |
| | 189873 | 3 | 4500 |
| T | 211831 | 1 | 28125 |
| | 211832 | 2 | 28125 |
| | 211833 | 3 | 4500 |
| U | 211871 | 1 | 28125 |
| | 211872 | 2 | 28125 |
| | 211873 | 3 | 4500 |
| V | 214853 | 3 | 20000 |

3.1.5.2 Main Rotor Pylon Support Structure - Detail

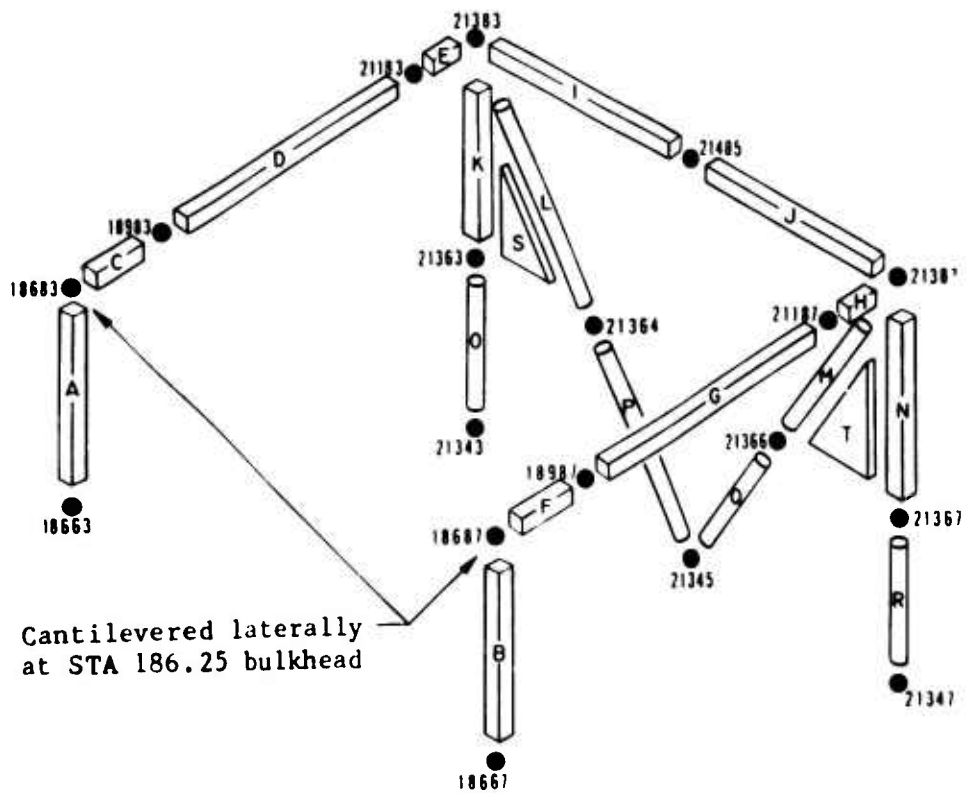

GRID POINT DATA

| GRID POINT | SPC | | MPC | | OMIT | |
|------------|--------|------|--------|------|--------|--------|
| | D.O.F. | RULE | D.O.F. | RULE | D.O.F. | RULE |
| 18663 | - | - | - | - | 123456 | DCCAAA |
| 18667 | - | - | - | - | 123456 | DCCAAA |
| 18683 | - | - | 6 | A | 1245 | DCAA |
| 18687 | - | - | 6 | A | 1245 | DCAA |
| 18983 | 4 | A | - | - | 12356 | AAAAA |
| 18987 | 4 | A | - | - | 12356 | AAAAA |
| 21183 | 4 | A | - | - | 12356 | AAAAA |
| 21187 | 4 | A | - | - | 12356 | AAAAA |
| 21343 | 4 | A | - | - | 12356 | DCCAA |
| 21345 | 4 | A | - | - | 12356 | DCCAA |
| 21347 | 4 | A | - | - | 12356 | DCCAA |
| 21363 | 6 | A | - | - | 12345 | DCCAA |
| 21364 | 456 | AAA | - | - | 123 | DCC |
| 21366 | 456 | AAA | - | - | 123 | DCC |
| 21367 | 6 | A | - | - | 12345 | DCCAA |
| 21383 | - | - | - | - | 12456 | DCAAA |
| 21387 | - | - | - | - | 12456 | DCAAA |
| 21485 | 156 | AAA | - | - | 34 | AA |



SHEAR PANEL/MEMBRANE ELEMENT DATA

| Letter Designation | NASTRAN EID | Type | Thickness (IN.) |
|--------------------|-------------|------|-----------------|
| S | 1210590 | Web | .050 |
| T | 1210470 | Web | .050 |

ROD ELEMENT DATA

| LETTER DESIGNATION | NASTRAN EID | TYPE | ACTUAL AREA (in. ²) | OFFSETS FROM GRIDPOINT | | FINAL AREA (in. ²) |
|--------------------|-------------|-------|---------------------------------|------------------------|---|--------------------------------|
| | | | | Z | Y | |
| L | 1210592 | Brace | .137 | - | - | .137 |
| M | 1210472 | Brace | .137 | - | - | .137 |
| O | 1210102 | Brace | .473 | - | - | .473 |
| P | 1210591 | Brace | .137 | - | - | .137 |
| Q | 1210471 | Brace | .137 | - | - | .137 |
| R | 1210092 | Brace | .707 | - | - | .707 |

CBAR ELEMENT DATA

| LETTER DESIGNATION | NASTRAN EID | SECTION PROPERTIES | | | |
|---|-------------|--------------------------|-------------------------------------|-------------------------------------|-----------------------------|
| | | AREA (in. ²) | INERTIA-PLANE 1 (in. ⁴) | INERTIA-PLANE 2 (in. ⁴) | TORSION (in. ⁴) |
| A | 1070321 | 2.100 | 13.035 | 6.442 | 0.0 |
| B | 1070311 | 2.100 | 13.035 | 6.442 | 0.0 |
| C | 1210611 | 0.643 | 0.342 | 2.081 | 0.0 |
| D | 1210612 | 0.643 | 0.342 | 2.081 | 0.0 |
| E | 1210613 | 0.643 | 0.342 | 2.081 | 0.0 |
| F | 1210211 | 0.643 | 0.342 | 2.081 | 0.0 |
| G | 1210212 | 0.643 | 0.342 | 2.081 | 0.0 |
| H | 1210213 | 0.643 | 0.342 | 2.081 | 0.0 |
| I  | 3440011 | 1.405 | 2.216 | 0.0 | 0.0 |
| J  | 3440012 | 1.405 | 2.216 | 0.0 | 0.0 |
| K | 1210101 | 1.643 | 5.770 | 5.205 | 0.0 |
| N | 1210091 | 1.643 | 5.770 | 5.205 | 0.0 |

NOTES -



Offsets at End A: x=0.56 in., y=0.0 in., z=-2.96 in.
 Offsets at End B: x=0.0 in., y=0.0 in., z=-2.96 in.



Offsets at End A: x=0.0 in., y=0.0 in., z=-2.96 in.
 Offsets at End B: x=0.56 in., y=0.0 in., z=-2.96 in.

3.1.6 Landing Gear Subassembly

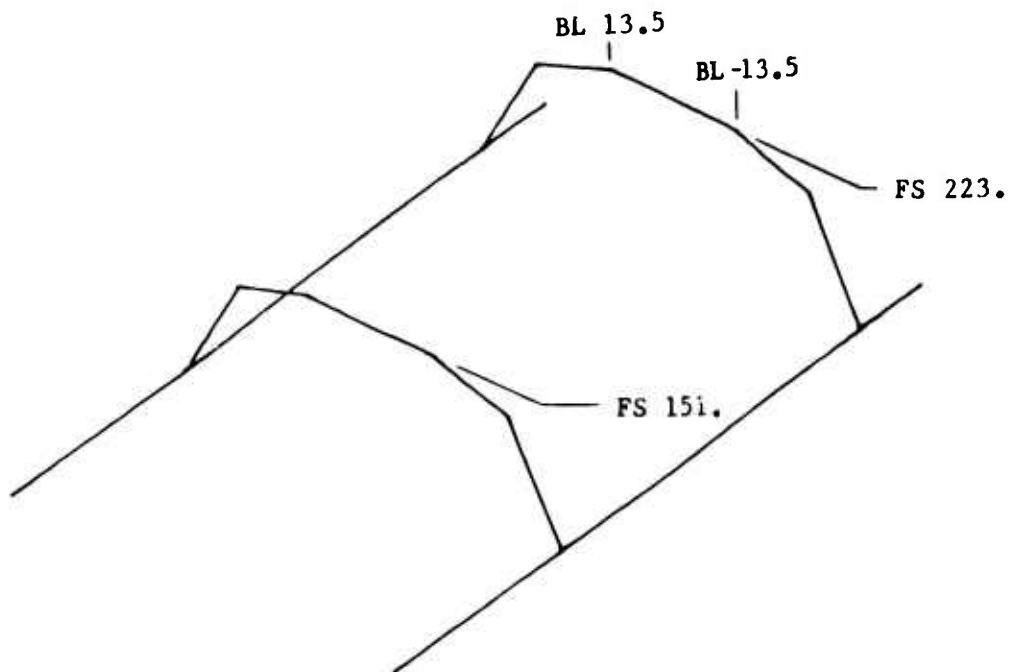
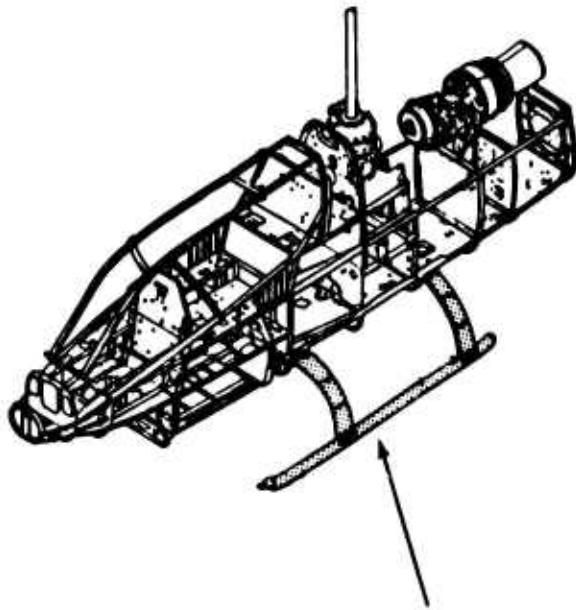

3.1.6.1 Landing Gear and Mounts - Detail

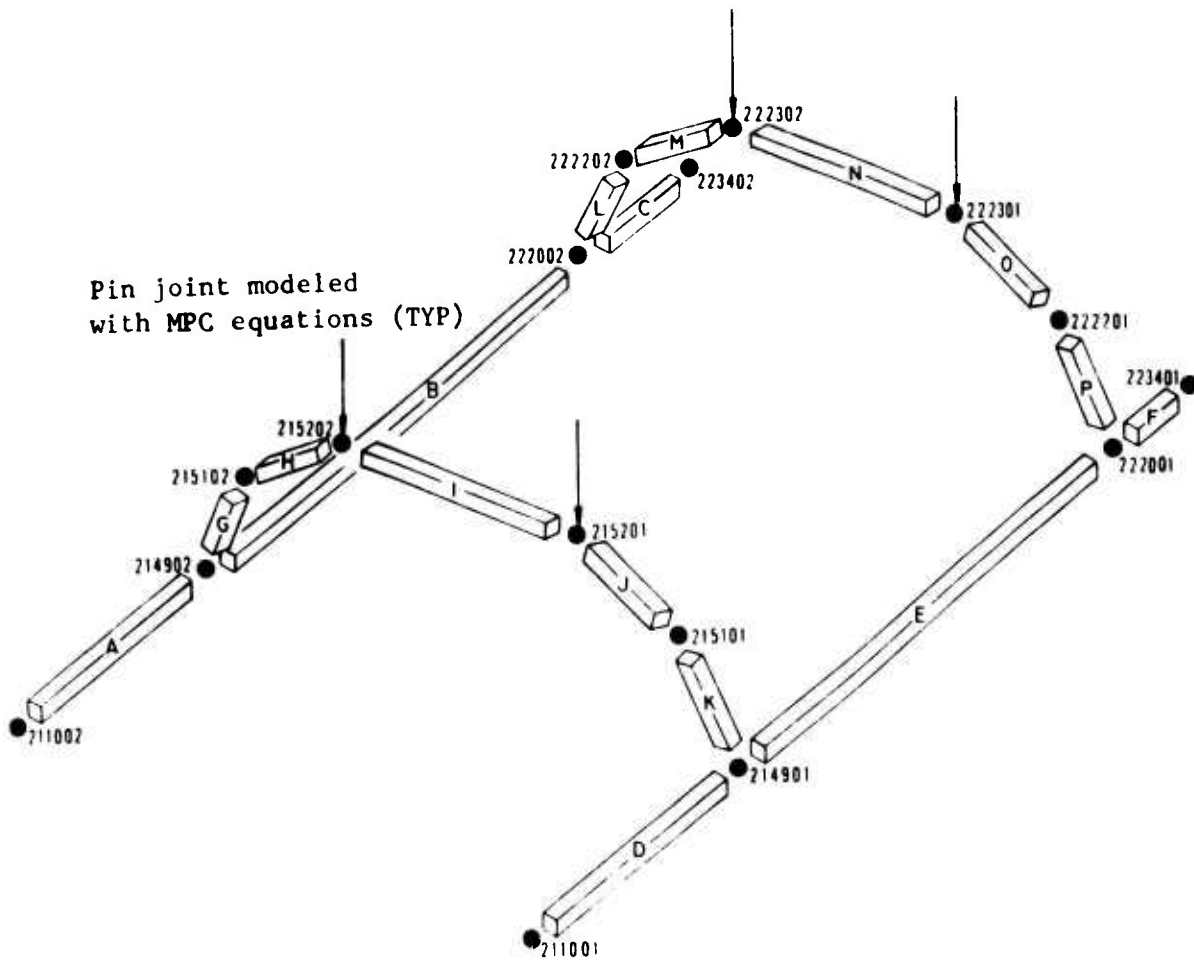

GRID POINT DATA

| GRID POINT | SPC | | MPC | | OMIT | |
|------------|--------|------|--------|------|--------|--------|
| | D.O.F. | RULE | D.O.F. | RULE | D.O.F. | RULE |
| 211001 | - | - | - | - | 123456 | DDDAAA |
| 211002 | - | - | - | - | 123456 | DDDAAA |
| 214901 | - | - | - | - | 456 | AAA |
| 214902 | - | - | - | - | 456 | AAA |
| 215101 | - | - | - | - | 123456 | DDDAAA |
| 215102 | - | - | - | - | 123456 | DDDAAA |
| 215201 | - | - | - | - | 123456 | DDDAAA |
| 215202 | - | - | - | - | 123456 | DDDAAA |
| 222001 | - | - | - | - | 456 | AAA |
| 222002 | - | - | - | - | 456 | AAA |
| 222201 | - | - | - | - | 123456 | DDDAAA |
| 222202 | - | - | - | - | 123456 | DDDAAA |
| 222301 | - | - | - | - | 123456 | DDDAAA |
| 222302 | - | - | - | - | 123456 | DDDAAA |
| 223401 | - | - | - | - | 123456 | DDDAAA |
| 223402 | - | - | - | - | 123456 | DDDAAA |

CBAR ELEMENT DATA

| LETTER DESIGNATION | NASTRAN EID | SECTION PROPERTIES | | | |
|-----------------------|----------------|-----------------------------|--|--|--------------------------------|
| | | AREA (in. ²) | INERTIA-PLANE 1 (in. ⁴) | INERTIA-PLANE 2 (in. ⁴) | TORSION (in. ⁴) |
| A | 0020521 | 0.779 | 1.510 | 1.510 | 3.020 |
| B | 0020522 | ↓ | ↓ | ↓ | ↓ |
| C | 0020523 | ↓ | ↓ | ↓ | ↓ |
| D | 0020511 | ↓ | ↓ | ↓ | ↓ |
| E | 0020512 | ↓ | ↓ | ↓ | ↓ |
| F | 0020513 | ↓ | ↓ | ↓ | ↓ |
| G | 0020451 | 1.132 | 0.836 | 0.836 | 1.672 |
| H | 0020452 | 1.686 | 1.312 | 1.312 | 2.624 |
| I | 0020453 | 1.964 | 1.549 | 1.549 | 3.098 |
| J | 0020454 | 1.686 | 1.312 | 1.312 | 2.624 |
| K | 0020455 | 1.132 | 0.836 | 0.836 | 1.672 |
| L | 0020411 | 1.516 | 1.090 | 1.090 | 2.180 |
| M | 0020412 | 2.371 | 1.712 | 1.712 | 3.424 |
| N | 0020413 | 2.798 | 2.022 | 2.022 | 4.044 |
| O | 0020414 | 2.371 | 1.712 | 1.712 | 3.424 |
| P | 0020415 | 1.516 | 1.090 | 1.090 | 2.180 |

3.1.6.2 Landing Gear Attach Point Support Structure - Detail

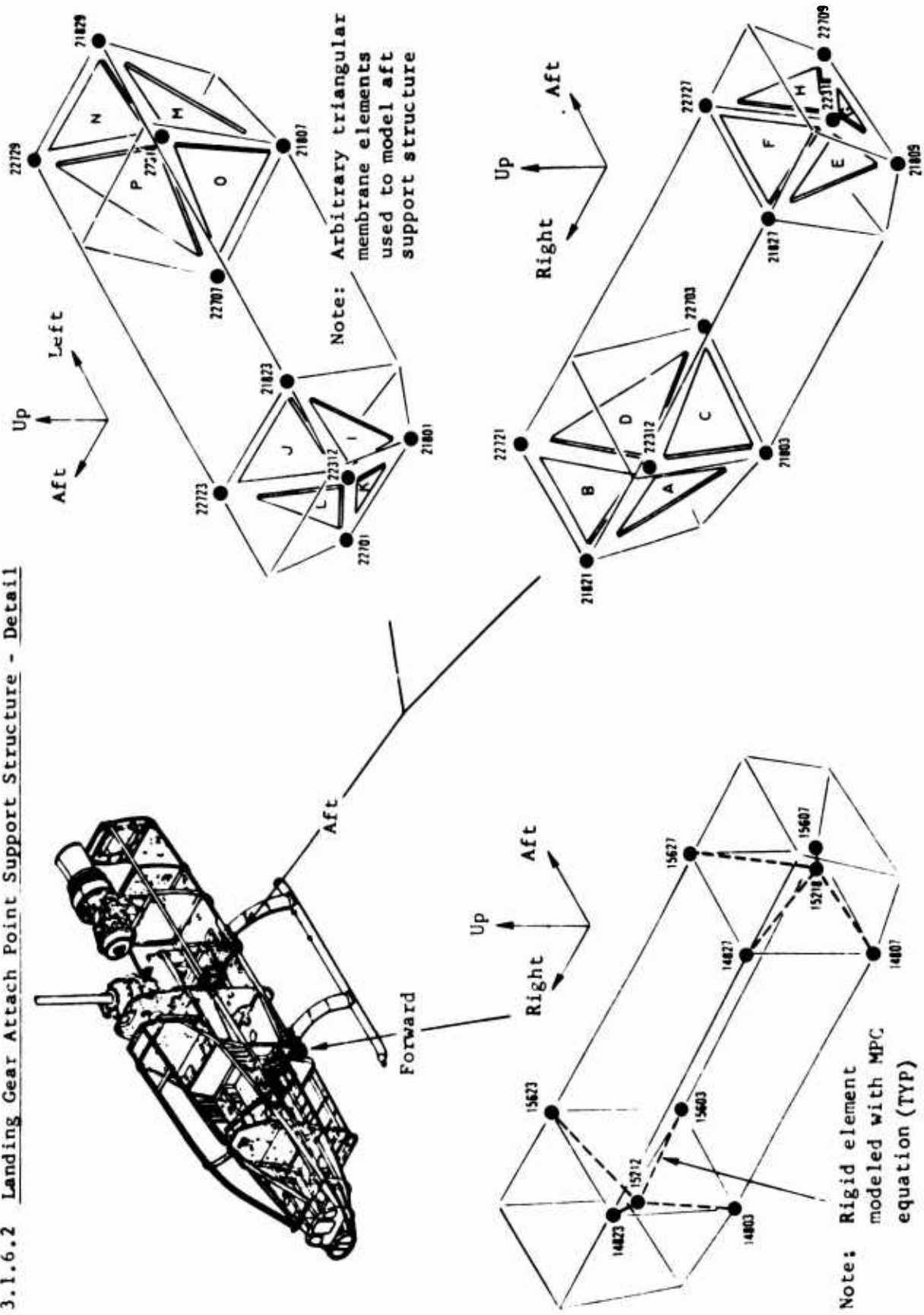

GRID POINT DATA

| GRID POINT | SPC | | MPC | | OMIT | |
|------------|--------|------|--------|------|--------|------|
| | D.O.F. | RULE | D.O.F. | RULE | D.O.F. | RULE |
| 14803 | 456 | AAA | 123 | AAA | - | - |
| 14807 | 456 | AAA | 123 | AAA | - | - |
| 14823 | 456 | AAA | 123 | AAA | - | - |
| 14827 | 456 | AAA | 123 | AAA | - | - |
| 15212 | - | - | 123 | BBB | 456 | AAA |
| 15218 | - | - | 123 | BBB | 456 | AAA |
| 15603 | 456 | AAA | 123 | AAA | - | - |
| 15607 | 456 | AAA | 123 | AAA | - | - |
| 15623 | 456 | AAA | 123 | AAA | - | - |
| 15627 | 456 | AAA | 123 | AAA | - | - |
| 21801 | 456 | AAA | - | - | 123 | DCC |
| 21803 | 456 | AAA | - | - | 123 | DCC |
| 21807 | 456 | AAA | - | - | 123 | DCC |
| 21809 | 456 | AAA | - | - | 123 | DCC |
| 21821 | 456 | AAA | - | - | 123 | DCC |
| 21823 | 456 | AAA | - | - | 123 | DCC |
| 21827 | 456 | AAA | - | - | 123 | DCC |
| 21829 | 456 | AAA | - | - | 123 | DCC |
| 22312 | 456 | AAA | 123 | BBB | - | - |
| 22318 | 456 | AAA | 123 | BBB | - | - |
| 22701 | 456 | AAA | - | - | 123 | DCC |
| 22703 | 456 | AAA | - | - | 123 | DCC |
| 22707 | 456 | AAA | - | - | 123 | DCC |
| 22709 | 456 | AAA | - | - | 123 | DCC |
| 22721 | 456 | AAA | - | - | 123 | DCC |
| 22723 | 456 | AAA | - | - | 123 | DCC |
| 22727 | 456 | AAA | - | - | 123 | DCC |
| 22729 | 456 | AAA | - | - | 123 | DCC |

SHEAR PANEL/MEMBRANE ELEMENT DATA

| Letter Designation | NASTRAN EID | Type | Thickness (IN.) |
|--------------------|-------------|---------|-----------------|
| A | 1720021 | Fitting | 0.155 |
| B | 1720022 | Fitting | 0.155 |
| C | 1720024 | Fitting | 0.155 |
| D | 1720023 | Fitting | 0.155 |
| E | 1720015 | Fitting | 0.155 |
| F | 1720016 | Fitting | 0.155 |
| G | 1720018 | Fitting | 0.155 |
| H | 1720017 | Fitting | 0.155 |
| I | 1720025 | Fitting | 0.155 |
| J | 1720026 | Fitting | 0.155 |
| K | 1720028 | Fitting | 0.155 |
| L | 1720027 | Fitting | 0.155 |
| M | 1720011 | Fitting | 0.155 |
| N | 1720012 | Fitting | 0.155 |
| O | 1720014 | Fitting | 0.155 |
| P | 1720013 | Fitting | 0.155 |

3.1.7 Engine Mounting Subassembly

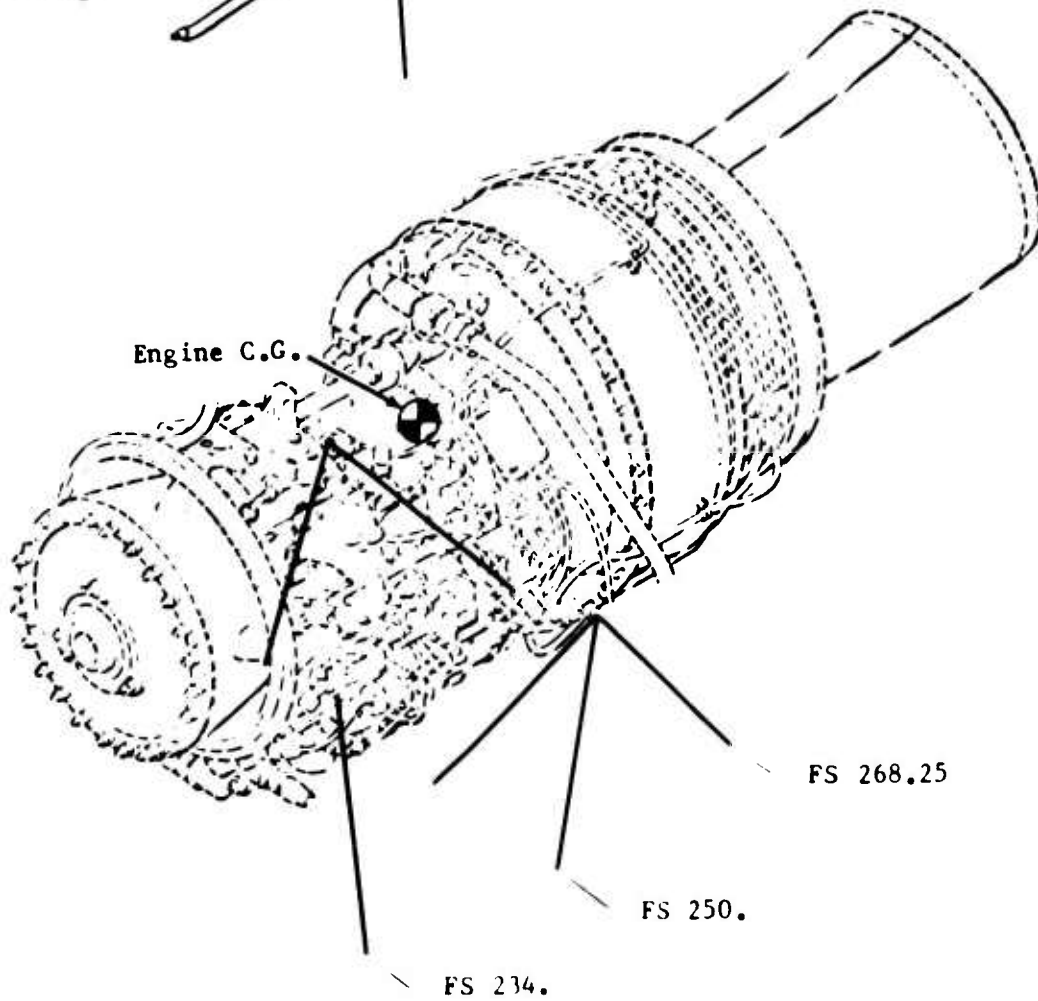
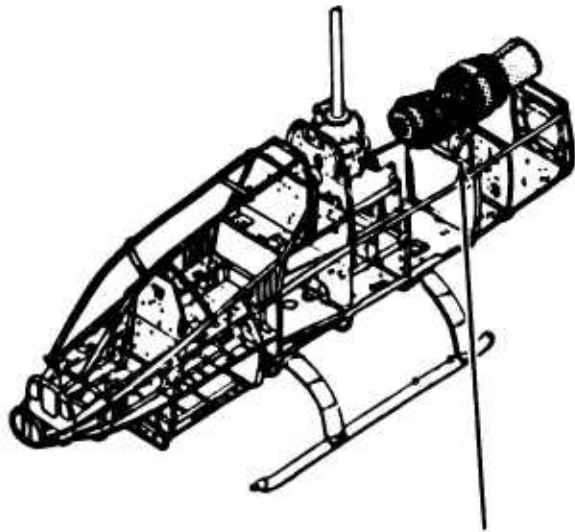

3.1.7.1 Engine Mounts - Detail

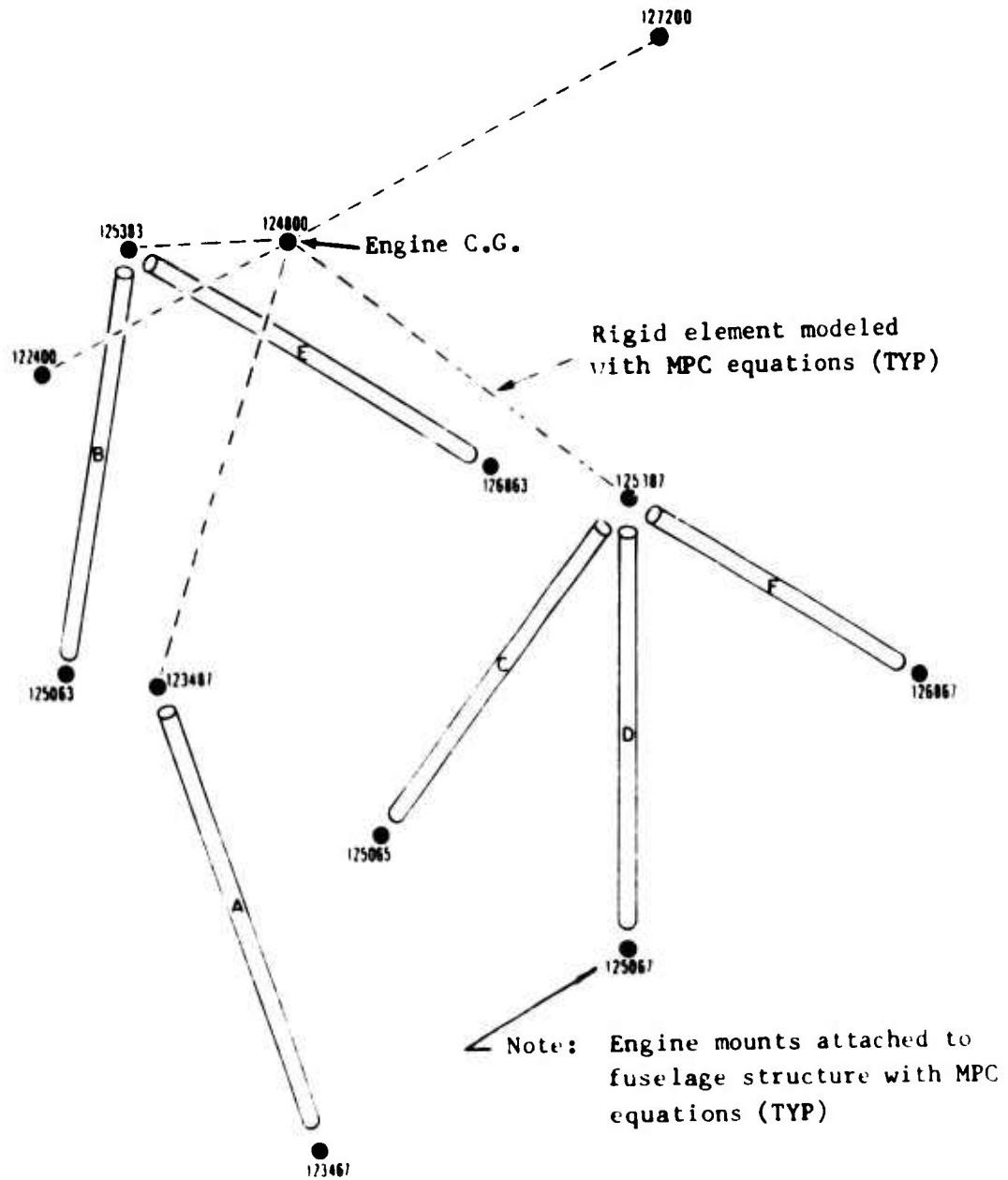

GRID POINT DATA

| GRID POINT | SPC | | MPC | | OMIT | |
|------------|--------|------|--------|--------|--------|------|
| | D.O.F. | RULE | D.O.F. | RULE | D.O.F. | RULE |
| 123467 | 456 | AAA | 123 | AAA | - | - |
| 123487 | 456 | AAA | 123 | AAA | - | - |
| 125063 | 456 | AAA | 123 | AAA | - | - |
| 125065 | 456 | AAA | 123 | AAA | - | - |
| 125067 | 456 | AAA | 123 | AAA | - | - |
| 125383 | 456 | AAA | 123 | AAA | - | - |
| 125387 | 456 | AAA | 123 | AAA | - | - |
| 126863 | 456 | AAA | 123 | AAA | - | - |
| 126867 | 456 | AAA | 123 | AAA | - | - |
| 122400 | - | - | 123456 | AAAAAA | - | - |
| 124800 | - | - | - | - | - | - |
| 127200 | - | - | 123456 | AAAAAA | - | - |

ROD ELEMENT DATA

| LETTER DESIGNATION | NASTRAN EID | TYPE | ACTUAL AREA (in. ²) | OFFSETS FROM GRIDPOINT | | FINAL AREA (in. ²) |
|--------------------|-------------|-------|---------------------------------|------------------------|---|--------------------------------|
| | | | | Z | Y | |
| A | 109001 | Mount | .0887 | - | - | .0887 |
| B | 1070012 | Mount | .1261 | - | - | .1261 |
| C | 107001 | Mount | .1261 | - | - | .1261 |
| D | 1070011 | Mount | .1261 | - | - | .1261 |
| E | 106012 | Mount | .1261 | - | - | .1261 |
| F | 1060011 | Mount | .1261 | - | - | .1261 |

3.2 WINGS AND CARRY THROUGH MAJOR ASSEMBLY

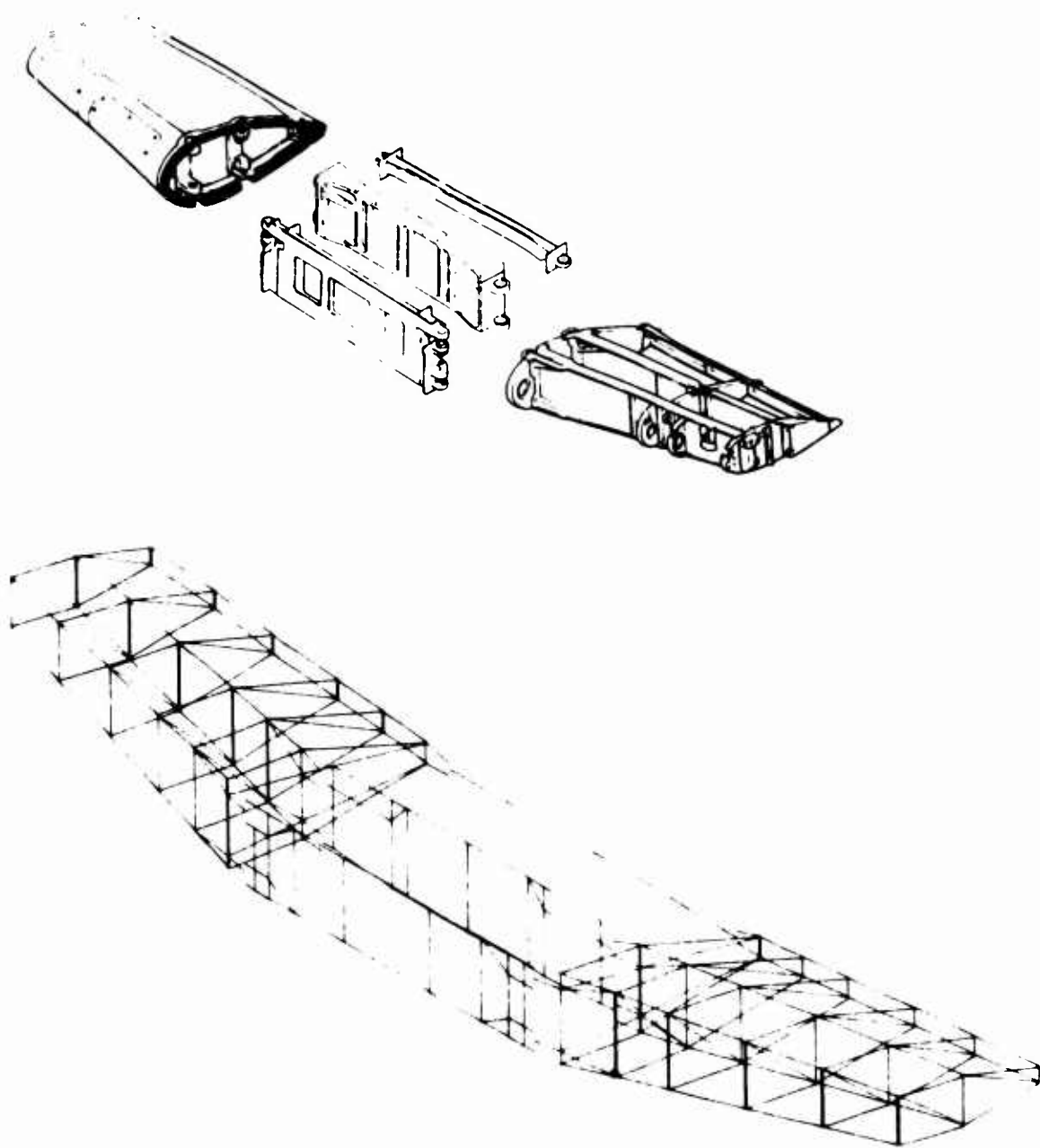

3.2.1 Carry Through Subassembly

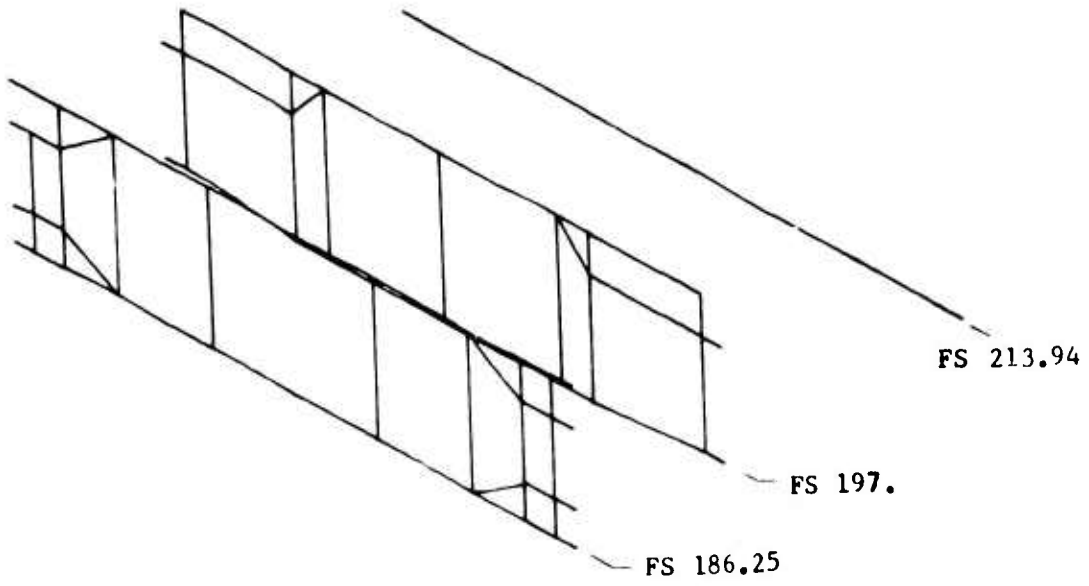
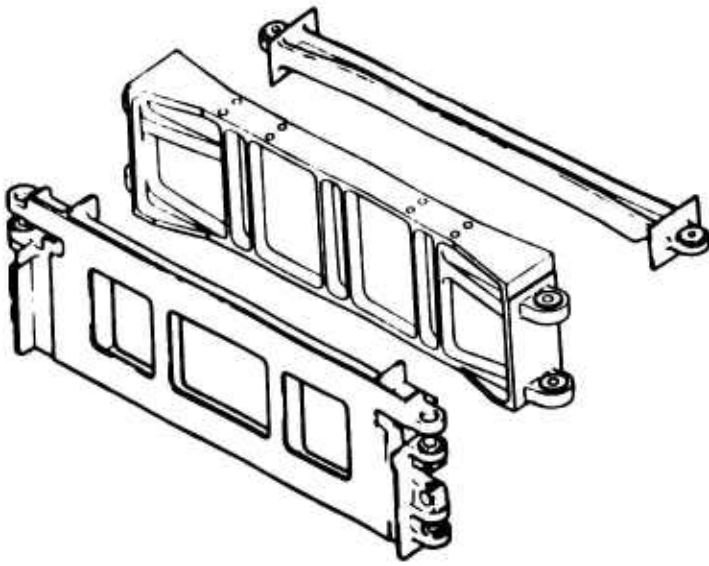

3.2.1.1.1 Forward Carry Through Detail

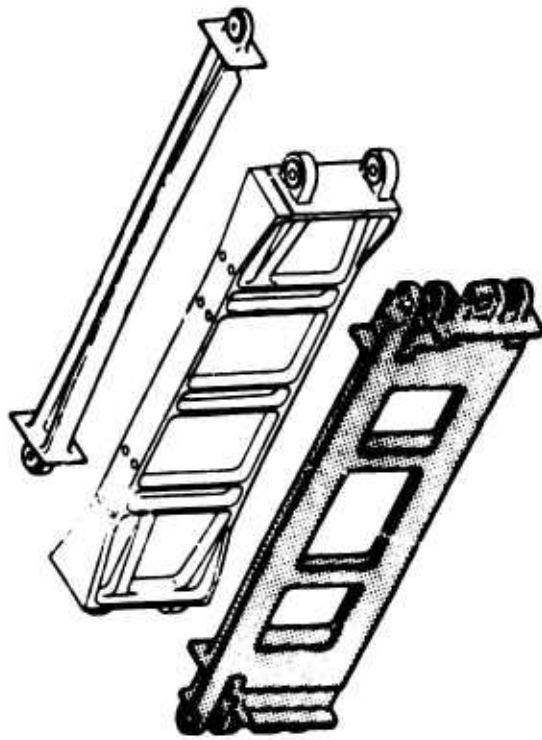

View looking aft

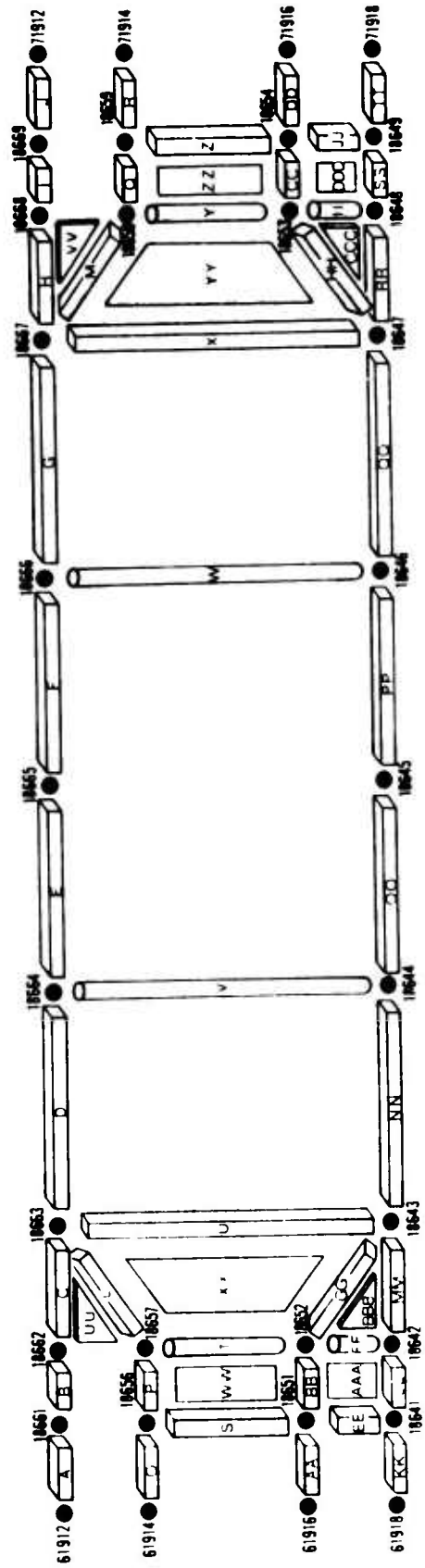

GRID POINT DATA

| GRID POINT | SPC | | MPC | | OMIT | |
|------------|--------|------|--------|------|--------|--------|
| | D.O.F. | RULE | D.O.F. | RULE | D.O.F. | RULE |
| 18641 | - | - | - | - | 12456 | DCAAA |
| 18642 | - | - | - | - | 23456 | CCAAA |
| 18643 | 4 | A | - | - | 12356 | DCCAA |
| 18644 | 45 | AA | - | - | 1236 | DCCA |
| 18645 | 45 | AA | - | - | 126 | DCA |
| 18646 | 45 | AA | - | - | 1236 | DCCA |
| 18647 | 4 | A | - | - | 12356 | DCCAA |
| 18648 | - | - | - | - | 23456 | CCAAA |
| 18649 | - | - | - | - | 12456 | DCAAA |
| 18651 | - | - | - | - | 123456 | DCCAAA |
| 18652 | - | - | - | - | 23456 | CCAAA |
| 18653 | - | - | - | - | 23456 | CCAAA |
| 18654 | - | - | - | - | 123456 | DCCAAA |
| 18656 | - | - | - | - | 123456 | DCCAAA |
| 18657 | - | - | - | - | 23456 | CCAAA |
| 18658 | - | - | - | - | 23456 | CCAAA |
| 18659 | - | - | - | - | 123456 | DCCAAA |
| 18661 | - | - | - | - | 123456 | DCCAAA |
| 18662 | - | - | - | - | 23456 | CCAAA |
| 18663 | - | - | - | - | 123456 | DCCAAA |
| 18664 | 45 | AA | - | - | 1236 | DCCA |
| 18665 | 45 | AA | - | - | 1236 | DCCA |
| 18666 | 45 | AA | - | - | 1236 | DCCA |
| 18667 | - | - | - | - | 123456 | DCCAAA |
| 18668 | - | - | - | - | 23456 | CCAAA |
| 18669 | - | - | - | - | 123456 | DCCAAA |
| 61912 | - | - | 345 | AAA | 126 | DDA |
| 61914 | - | - | 345 | AAA | 126 | DDA |
| 61916 | - | - | 345 | AAA | 126 | DDA |
| 61918 | - | - | 345 | AAA | 126 | DDA |
| 71912 | - | - | 345 | AAA | 126 | DDA |

GRID POINT DATA (CONT.)

| GRID POINT | SPC | | MPC | | OMIT | |
|------------|--------|------|--------|------|--------|------|
| | D.O.F. | RULE | D.O.F. | RULE | D.O.F. | RULE |
| 71914 | - | - | 345 | AAA | 126 | DDA |
| 71916 | - | - | 345 | AAA | 126 | DDA |
| 71918 | - | - | 345 | AAA | 126 | DDA |







SHEAR PANEL/MEMBRANE ELEMENT DATA

| Letter Designation | NASTRAN EID | Type | Thickness (IN.) |
|--------------------|-------------|------|-----------------|
| UU | 1875763 | Web | .125 |
| VV | 1875868 | Web | .125 |
| WW | 1875256 | Web | .125 |
| XX | 1874357 | Web | .125 |
| YY | 1875847 | Web | .125 |
| ZZ | 1875953 | Web | .125 |
| AAA | 1874251 | Web | .125 |
| BBB | 1874352 | Web | .125 |
| CCC | 1874853 | Web | .125 |
| DDD | 1875448 | Web | .125 |



ROD ELEMENT DATA

| LETTER DESIGNATION | NASTRAN EID | TYPE | ACTUAL AREA (in. ²) | OFFSETS FROM GRIDPOINT | | FINAL AREA (in. ²) |
|-----------------------|----------------|-------|------------------------------------|---------------------------|---|-----------------------------------|
| | | | | Z | Y | |
| L | 1876357 | R/SP3 | .147 | - | - | .147 |
| M | 1875867 | R/SP3 | .147 | - | - | .147 |
| P | 1875756 | R/SP1 | .099 | - | - | .099 |
| Q | 1875958 | R/SP1 | .099 | - | - | .099 |
| S | 1875651 | R/SP2 | .125 | - | - | .125 |
| T | 1875752 | R/SP2 | .342 | - | - | .342 |
| U | 1876343 | R/SP2 | .217 | - | - | .217 |
| V | 1874464 | Frame | .681 | - | - | .681 |
| W | 1874666 | Frame | .681 | - | - | .681 |
| X | 1876747 | R/SP2 | .217 | - | - | .217 |
| Y | 1875853 | R/SP2 | .342 | - | - | .342 |
| Z | 1875954 | R/SP2 | .125 | - | - | .125 |
| BB | 1875251 | R/SP1 | .144 | - | - | .144 |
| CC | 1875453 | R/SP1 | .144 | - | - | .144 |
| EE | 1875141 | R/SP2 | .125 | - | - | .125 |
| FF | 1875242 | R/SP2 | .125 | - | - | .125 |
| GG | 1874352 | R/SP3 | .147 | - | - | .147 |
| HH | 1875347 | R/SP3 | .147 | - | - | .147 |
| II | 1875348 | R/SP2 | .125 | - | - | .125 |
| JJ | 1875449 | R/SP2 | .125 | - | - | .125 |
| LL | 1874241 | R/SP1 | .046 | - | - | .046 |
| SS | 1874948 | R/SP1 | .046 | - | - | .046 |





CBAR ELEMENT DATA

| LETTER DESIGNATION | NASTRAN EID | SECTION PROPERTIES | | | |
|--|-------------|--------------------------|-------------------------------------|-------------------------------------|-----------------------------|
| | | AREA (in. ²) | INERTIA-PLANE 1 (in. ⁴) | INERTIA-PLANE 2 (in. ⁴) | TORSION (in. ⁴) |
| A | 1866100 | 0.424 | 0.070 | 0.500 | 0.215 |
| B | 1876162 | 1.828 | 0.087 | 0.574 | 0.260 |
| C  | 1876263 | 2.133 | 0.537 | 1.937 | 0.453 |
| D | 1876364 | 1.133 | 0.0 | 0.497 | 0.0 |
| E | 1876465 | 1.036 | 0.0 | 0.403 | 0.0 |
| F | 1876566 | 1.036 | 0.0 | 0.403 | 0.0 |
| G | 1876667 | 1.133 | 0.0 | 0.497 | 0.0 |
| H  | 1876768 | 2.133 | 0.537 | 1.937 | 0.453 |
| I | 1876869 | 1.828 | 0.087 | 0.574 | 0.260 |
| J | 1866900 | 0.424 | 0.070 | 0.500 | 0.215 |
| L  | 1875763 | 1.500 | 0.070 | 0.500 | 0.215 |
| M  | 1876758 | 1.500 | 0.070 | 0.500 | 0.215 |
| O | 1865600 | 0.424 | 0.070 | 0.500 | 0.215 |
| P | 1875657 | 1.500 | 0.070 | 0.500 | 0.215 |
| Q | 1875859 | 1.500 | 0.070 | 0.500 | 0.215 |
| R | 1865900 | 0.424 | 0.070 | 0.500 | 0.215 |
| S | 1875156 | 0.858 | 0.004 | 1.070 | 0.015 |
| T | 1875257 | 0.512 | 0.003 | 0.179 | 0.010 |
| U | 1874363 | 0.512 | 0.0 | 0.179 | 0.0 |
| X | 1874767 | 0.512 | 0.0 | 0.179 | 0.0 |
| Y | 1875358 | 0.512 | 0.003 | 0.179 | 0.010 |
| Z | 1875459 | 0.858 | 0.004 | 1.070 | 0.015 |
| AA | 1865100 | 0.424 | 0.070 | 0.500 | 0.215 |
| BB | 1875152 | 1.500 | 0.070 | 0.500 | 0.215 |
| CC | 1875354 | 1.500 | 0.070 | 0.500 | 0.215 |
| DD | 1865400 | 0.424 | 0.070 | 0.500 | 0.215 |
| EE | 1874151 | 0.569 | 0.001 | 0.981 | 0.003 |
| GG  | 1875243 | 1.500 | 0.070 | 0.500 | 0.215 |
| HH  | 1874753 | 1.500 | 0.070 | 0.500 | 0.215 |
| JJ | 1874954 | 0.569 | 0.001 | 0.981 | 0.003 |
| KK | 1864100 | 0.367 | 0.046 | 0.433 | 0.146 |
| LL | 1874142 | 1.828 | 0.087 | 0.574 | 0.260 |

CBAR ELEMENT DATA (CONT.)

| LETTER DESIGNATION | NASTRAN EID | SECTION PROPERTIES | | | |
|--|----------------|-----------------------------|--|--|--------------------------------|
| | | AREA (in. ²) | INERTIA-PLANE 1 (in. ⁴) | INERTIA-PLANE 2 (in. ⁴) | TORSION (in. ⁴) |
| MM  | 1874243 | 2.133 | 0.537 | 1.937 | 0.453 |
| NN | 1874344 | 0.928 | 0.0 | 0.407 | 0.0 |
| OO | 1874445 | 0.928 | 0.0 | 0.407 | 0.0 |
| PP | 1874546 | 0.928 | 0.0 | 0.407 | 0.0 |
| QQ | 1874647 | 0.928 | 0.0 | 0.407 | 0.0 |
| RR  | 1874748 | 2.133 | 0.537 | 1.937 | 0.453 |
| SS | 1874849 | 1.828 | 0.087 | 0.574 | 0.260 |
| TT | 1864900 | 0.367 | 0.046 | 0.433 | 0.146 |

NOTES -

-  Pin flags at End B: 6
-  Pin flags at End A: 6
-  Pin flags at End B: 456
-  Pin flags at End A: 456

3.2.1.1.2 Center Carry Through Detail

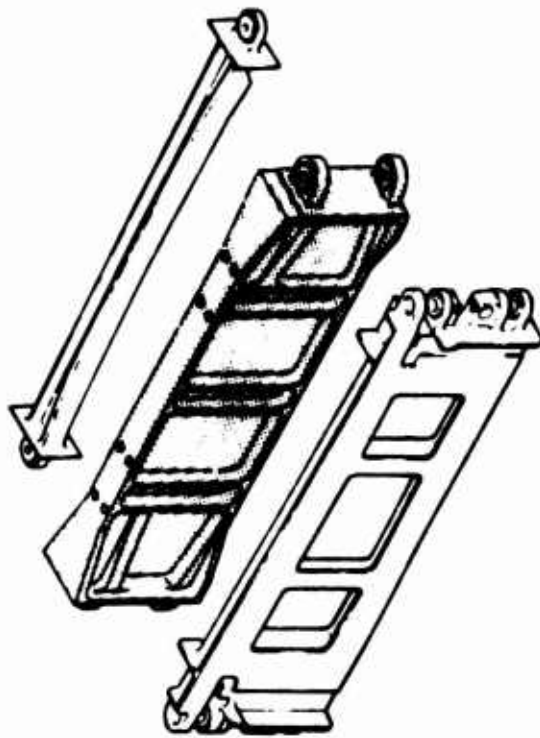

View looking at

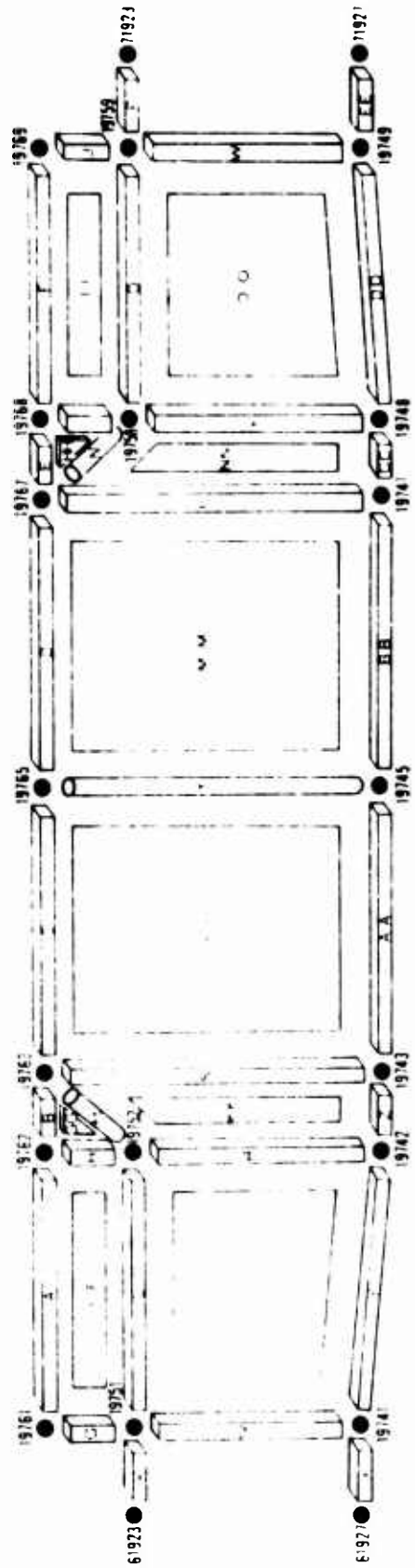

GRID POINT DATA

| GRID POINT | SPC | | MPC | | OMIT | |
|------------|--------|------|--------|------|--------|--------|
| | D.O.F. | RULE | D.O.F. | RULE | D.O.F. | RULE |
| 19741 | - | - | - | - | 123456 | DCCAAA |
| 19742 | - | - | - | - | 23456 | CCAAA |
| 19743 | 4 | A | - | - | 12356 | DCCAA |
| 19745 | 45 | AA | - | - | 136 | DCA |
| 19747 | 4 | A | - | - | 12356 | DCCAA |
| 19748 | - | - | - | - | 23456 | CCAAA |
| 19749 | - | - | - | - | 123456 | DCCAAA |
| 19751 | - | - | - | - | 12456 | DCAAA |
| 19752 | - | - | - | - | 23456 | CCAAA |
| 19758 | - | - | - | - | 23456 | CCAAA |
| 19759 | - | - | - | - | 12456 | DCAAA |
| 19761 | - | - | - | - | 123456 | DCCAAA |
| 19762 | - | - | - | - | 23456 | CCAAA |
| 19763 | 4 | A | - | - | 12356 | DCCAA |
| 19765 | 45 | AA | - | - | 16 | DA |
| 19767 | 4 | A | - | - | 12356 | DCCAA |
| 19768 | - | - | - | - | 23456 | CCAAA |
| 19769 | - | - | - | - | 123456 | DCCAAA |
| 61923 | - | - | 1245 | AAAA | 36 | DA |
| 61927 | - | - | 1245 | AAAA | 36 | DA |
| 71923 | - | - | 1245 | AAAA | 36 | DA |
| 71927 | - | - | 1245 | AA.A | 36 | DA |

SHEAR PANEL/MEMBRANE ELEMENT DATA

| Letter Designation | NASTRAN EID | Type | Thickness (IN.) |
|--------------------|-------------|------|-----------------|
| FF | 1975162 | Web | 0.400 |
| GG | 1975263 | Web | 0.200 |
| HH | 1975867 | Web | 0.200 |
| II | 1975869 | Web | 0.400 |
| JJ | 1974152 | Web | 0.200 |
| KK | 1974352 | Web | 0.200 |
| LL | 1974365 | Web | 0.200 |





SHEAR PANEL/MEMBRANE ELEMENT DATA (CONT.)

| Letter Designation | NASTRAN EID | Type | Thickness (IN.) |
|--------------------|-------------|------|-----------------|
| MM | 1974567 | Web | 0.200 |
| NN | 1974758 | Web | 0.200 |
| OO | 1974859 | Web | 0.200 |



ROD ELEMENT DATA

| LETTER DESIGNATION | NASTRAN EID | TYPE | ACTUAL AREA (in. ²) | OFFSETS FROM GRIDPOINT | | FINAL AREA (in. ²) |
|--------------------|-------------|---------|---------------------------------|------------------------|---|--------------------------------|
| | | | | Z | Y | |
| A | 1976261 | R/SP1 | .165 | - | - | .165 |
| C | 1976563 | R/SP1 | .329 | - | - | .329 |
| D | 1976765 | R/SP1 | .329 | - | - | .329 |
| F | 1976968 | R/SP1 | .165 | - | - | .165 |
| G | 1976151 | R/SP2 | 1.528 | - | - | 1.528 |
| H | 1976252 | R/SP2 | 1.528 | - | - | 1.528 |
| I | 1976858 | R/SP2 | 1.528 | - | - | 1.528 |
| J | 1976959 | R/SP2 | 1.528 | - | - | 1.528 |
| L | 1975251 | R/SP1 | 0.412 | - | - | 0.412 |
| M | 1976352 | R/SP3 | 0.288 | - | - | 0.288 |
| N | 1975867 | R/SP3 | 0.288 | - | - | 0.288 |
| O | 1975958 | R/SP1 | 0.412 | - | - | 0.412 |
| Q | 1975141 | R/SP2 | 0.764 | - | - | 0.764 |
| R | 1975242 | R/SP2 | 0.981 | - | - | 0.981 |
| S | 1976343 | R/SP2 | 1.009 | - | - | 1.009 |
| T | 1974565 | Doubler | 0.825 | - | - | 0.825 |
| | 1976545 | R/SP2 | 1.584 | - | - | 1.584 |
| U | 1976747 | R/SP2 | 1.009 | - | - | 1.009 |
| V | 1975848 | R/SP2 | 0.981 | - | - | 0.981 |
| W | 1975949 | R/SP2 | 0.764 | - | - | 0.764 |
| Y | 1974241 | R/SP1 | 0.247 | - | - | 0.247 |
| Z | 1974342 | R/SP3 | 0.288 | - | - | 0.288 |
| AA | 1974543 | R/SP1 | 0.329 | - | - | 0.329 |
| BB | 1974745 | R/SP1 | 0.329 | - | - | 0.329 |
| CC | 1974847 | R/SP3 | 0.288 | - | - | 0.288 |
| DD | 1974948 | R/SP1 | 0.247 | - | - | 0.247 |

CBAR ELEMENT DATA

| LITTER DESIGNATION | NASTRAN EID | SECTION PROPERTIES | | | |
|--|-------------|--------------------------|-------------------------------------|-------------------------------------|-----------------------------|
| | | AREA (in. ²) | INERTIA-PLANE 1 (in. ⁴) | INERTIA-PLANE 2 (in. ⁴) | TORSION (in. ⁴) |
| A | 1976162 | 2.019 | 0.437 | 13.573 | 0.174 |
| B  | 1976263 | 2.063 | 0.097 | 1.300 | 0.320 |
| C | 1976365 | 2.063 | 0.0 | 1.300 | 0.0 |
| D | 1976567 | 2.063 | 0.0 | 1.300 | 0.0 |
| E  | 1976768 | 2.063 | 0.097 | 1.300 | 0.320 |
| F | 1976869 | 2.019 | 0.437 | 13.573 | 0.174 |
| G | 1975161 | 1.845 | 0.026 | 3.113 | 0.103 |
| H | 1975262 | 0.825 | 0.006 | 0.520 | 0.023 |
| I | 1975868 | 0.825 | 0.006 | 0.520 | 0.023 |
| J | 1975969 | 1.845 | 0.026 | 3.113 | 0.103 |
| K | 1975100 | 0.694 | 0.208 | 1.302 | 0.624 |
| L | 1975152 | 1.283 | 0.113 | 2.156 | 0.075 |
| O | 1975859 | 1.283 | 0.113 | 2.156 | 0.075 |
| P | 1975900 | 0.694 | 0.208 | 1.302 | 0.624 |
| Q | 1974151 | 1.845 | 0.026 | 3.113 | 0.103 |
| R | 1974252 | 0.825 | 0.006 | 0.520 | 0.023 |
| S | 1974363 | 0.825 | 0.0 | 0.520 | 0.0 |
| U | 1974767 | 0.825 | 0.0 | 0.520 | 0.0 |
| V | 1974858 | 0.825 | 0.006 | 0.520 | 0.023 |
| W | 1974959 | 1.845 | 0.026 | 3.113 | 0.103 |
| X | 1974100 | 0.694 | 0.208 | 1.302 | 0.624 |
| Y | 1974142 | 2.453 | 0.965 | 10.405 | 0.497 |
| Z  | 1974243 | 1.650 | 0.050 | 1.040 | 0.171 |
| AA | 1974345 | 1.650 | 0.0 | 1.040 | 0.0 |
| BB | 1974547 | 1.650 | 0.0 | 1.040 | 0.0 |
| CC  | 1974748 | 1.650 | 0.050 | 1.040 | 0.171 |
| DD | 1974849 | 2.453 | 0.965 | 10.405 | 0.497 |
| EE | 1974900 | 0.694 | 0.208 | 1.302 | 0.624 |

NOTES -

-  Pin flags at End B: 6
-  Pin flags at End A: 6

3.2.1.1.3 Aft Carry Through Detail

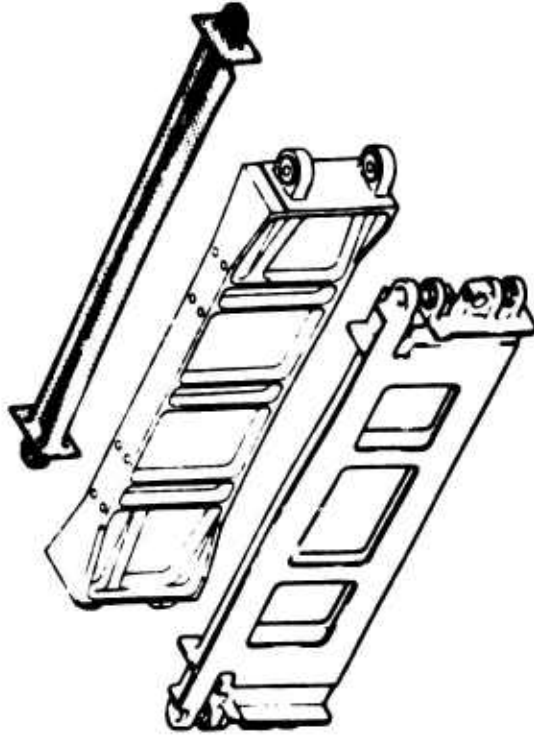



View looking aft





GRID POINT DATA

| GRID POINT | SPC | | MPC | | OMIT | |
|------------|--------|------|--------|------|--------|-------|
| | D.O.F. | RULE | D.O.F. | RULE | D.O.F. | RULE |
| 21341 | - | - | - | - | 12456 | DCAAA |
| 21343 | 4 | A | - | - | 12356 | DCCAA |
| 21345 | 4 | A | - | - | 12356 | DCCAA |
| 21347 | 4 | A | - | - | 12356 | DCCAA |
| 21349 | - | - | - | - | 12456 | DCAAA |
| 61935 | - | - | 1245 | AAAA | 36 | DA |
| 71935 | - | - | 1245 | AAAA | 36 | DA |

CBAR ELEMENT DATA

| LETTER DESIGNATION | NASTRAN EID | SECTION PROPERTIES | | | |
|---|-------------|--------------------------|-------------------------------------|-------------------------------------|-----------------------------|
| | | AREA (in. ²) | INERTIA-PLANE 1 (in. ⁴) | INERTIA-PLANE 2 (in. ⁴) | TORSION (in. ⁴) |
| A | 2134100 | 0.469 | 0.047 | 0.899 | 0.164 |
| B  | 2124143 | 1.562 | 0.725 | 1.422 | 0.063 |
| C | 2124345 | 0.812 | 0.0 | 0.343 | 0.008 |
| D | 2124547 | 0.812 | 0.0 | 0.343 | 0.008 |
| E | 2124749 | 1.562 | 0.725 | 1.422 | 0.063 |
| F  | 2134900 | 0.469 | 0.047 | 0.899 | 0.161 |

NOTES -

-  Pin flags at End B: 6
-  Pin flags at End A: 6

3.2.2 Right and Left Wing Subassemblies

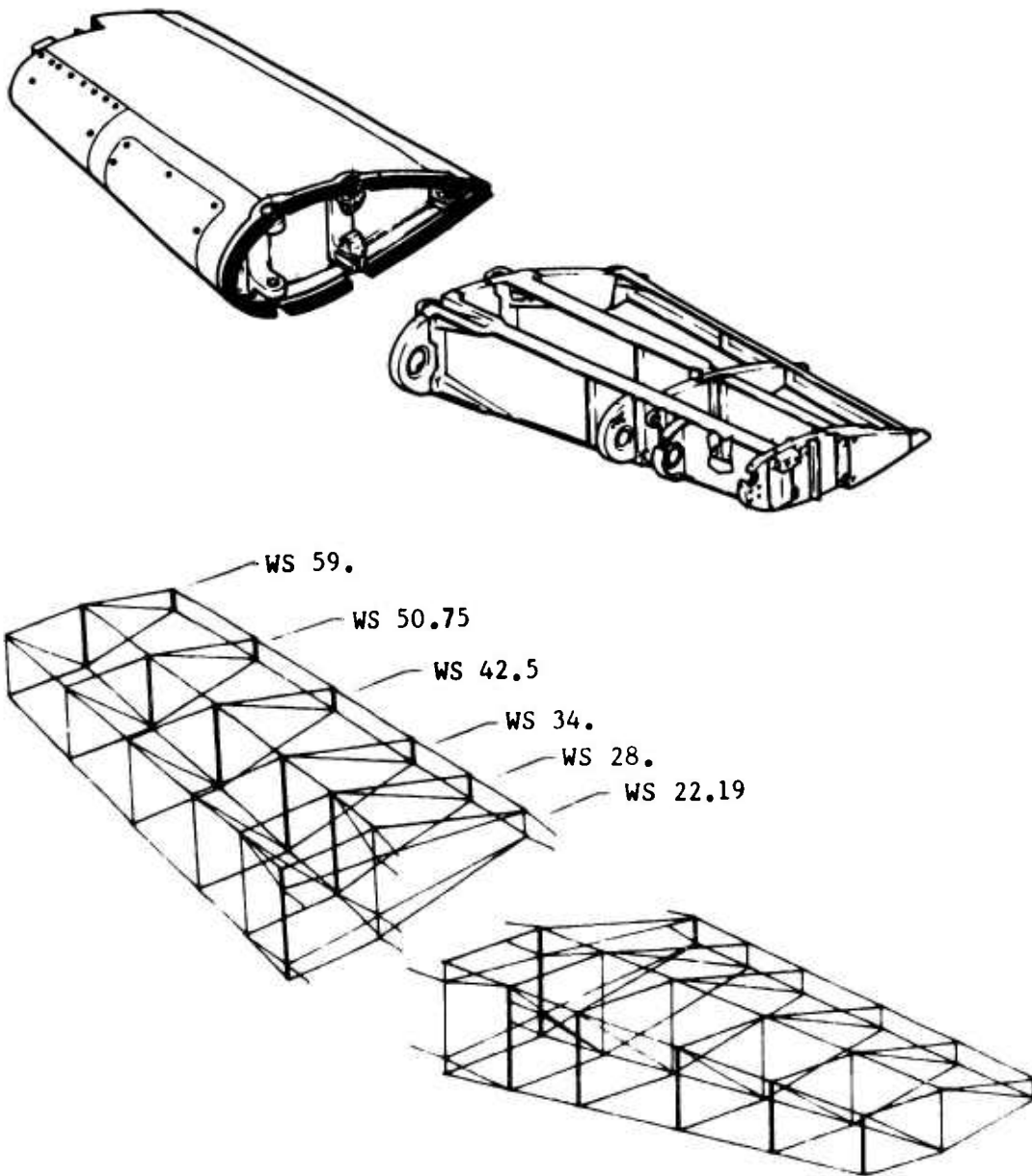

3.2.2.1 Right Wing Ribs - Detail

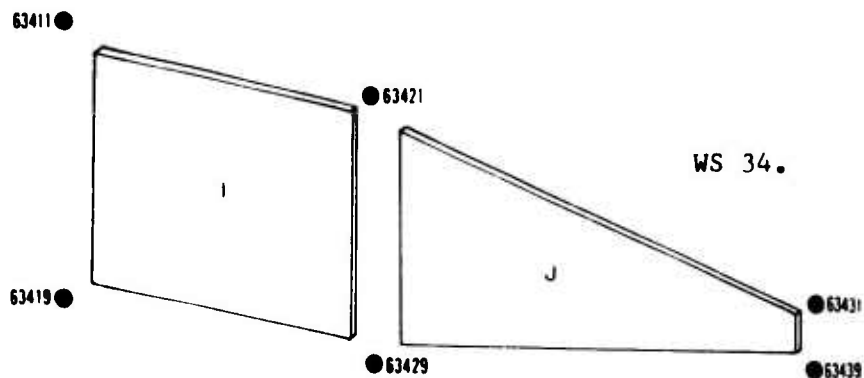
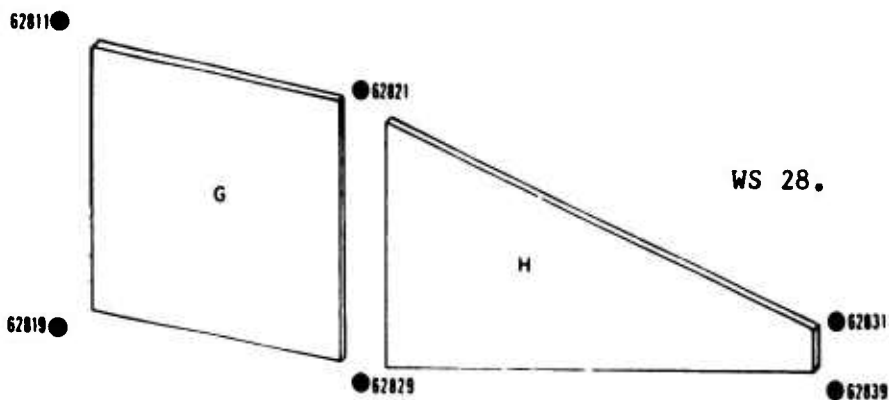
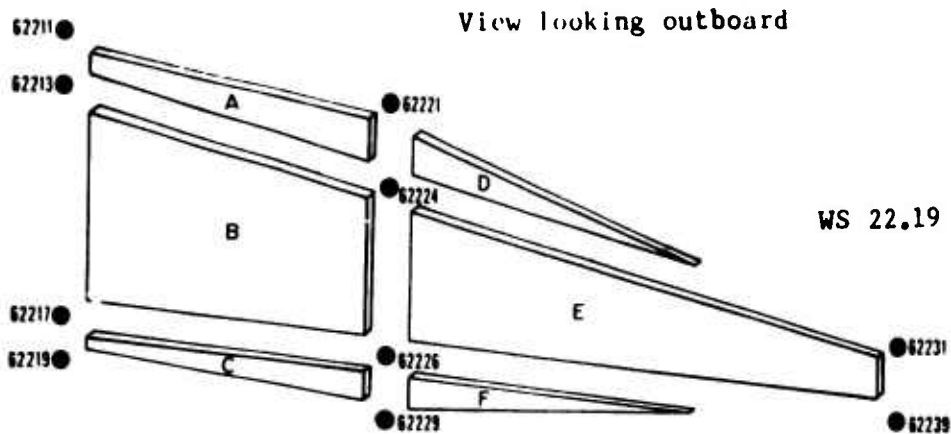

View looking outboard

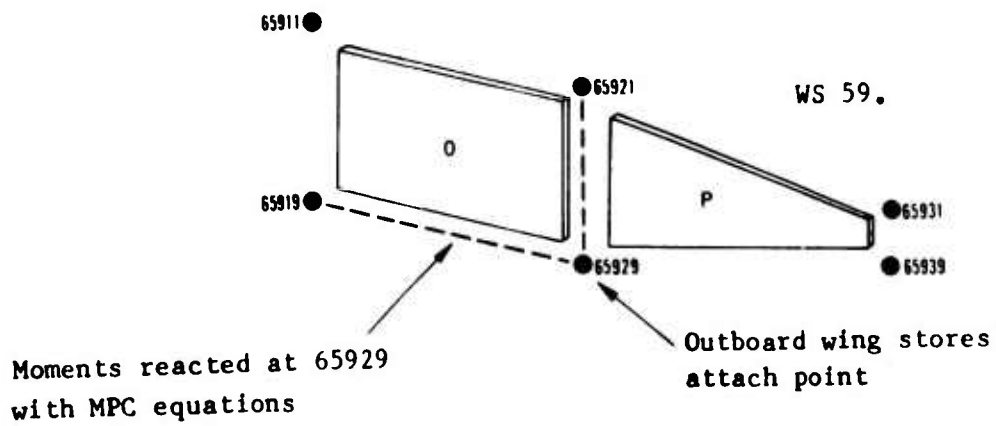
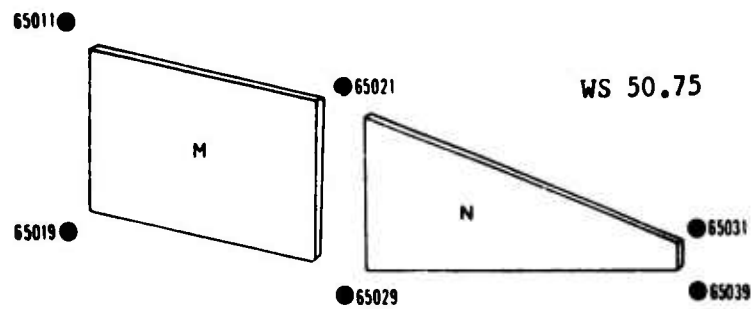
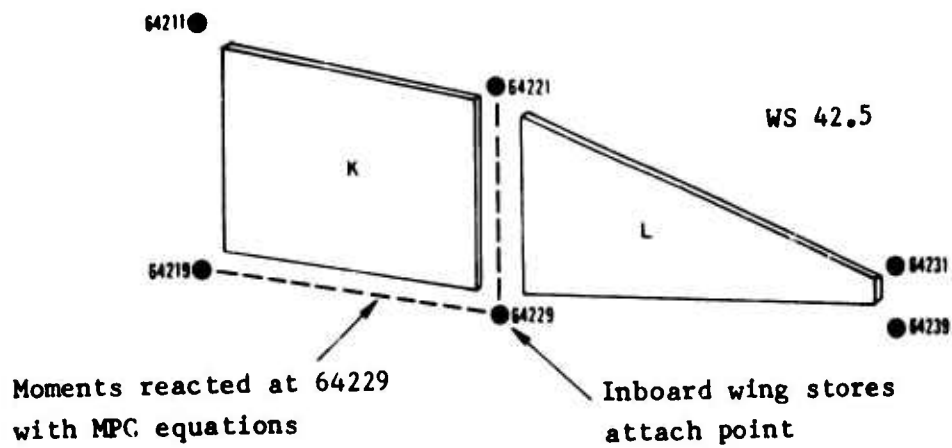

GRID POINT DATA

| GRID POINT | SPC | | MPC | | OMIT | |
|------------|--------|------|--------|------|--------|--------|
| | D.O.F. | RULE | D.O.F. | RULE | D.O.F. | RULE |
| 62211 | 456 | AAA | - | - | 123 | DDD |
| 62213 | - | - | - | - | 123456 | DDDAAA |
| 62217 | - | - | - | - | 123456 | DDDAAA |
| 62219 | 456 | AAA | - | - | 123 | DDD |
| 62221 | - | - | - | - | 123456 | DDDAAA |
| 62224 | - | - | - | - | 123456 | DDDAAA |
| 62226 | - | - | - | - | 123456 | DDDAAA |
| 62229 | - | - | - | - | 123456 | DDDAAA |
| 62231 | - | - | - | - | 123456 | DDDAAA |
| 62239 | - | - | - | - | 123456 | DDDAAA |
| 62811 | 456 | AAA | - | - | 123 | CDC |
| 62819 | 456 | AAA | - | - | 12 | CD |
| 62821 | 456 | AAA | - | - | 123 | CDC |
| 62829 | 456 | AAA | - | - | 3 | C |
| 62831 | 456 | AAA | - | - | 123 | CDC |
| 62839 | 456 | AAA | - | - | 12 | CD |
| 63411 | 456 | AAA | - | - | 123 | CDC |
| 63419 | 456 | AAA | - | - | 123 | CDC |
| 63421 | 456 | AAA | - | - | 3 | C |
| 63429 | 456 | AAA | - | - | 12 | CD |
| 63431 | 456 | AAA | - | - | 123 | CDC |
| 63439 | 456 | AAA | - | - | 123 | CDC |
| 64211 | 456 | AAA | - | - | 123 | CDC |
| 64219 | 456 | AAA | - | - | 12 | CD |
| 64221 | 456 | AAA | - | - | 123 | CDC |
| 64229 | - | - | 456 | AAA | - | - |
| 64231 | 456 | AAA | - | - | 123 | CDC |
| 64239 | 456 | AAA | - | - | 12 | CD |
| 65011 | 456 | AAA | - | - | 123 | CDC |
| 65019 | 456 | AAA | - | - | 123 | CDC |
| 65021 | 456 | AAA | - | - | 3 | C |

GRID POINT DATA (CONT.)

| GRID POINT | SPC | | MPC | | OMIT | |
|------------|--------|------|--------|------|--------|------|
| | D.O.F. | RULE | D.O.F. | RULE | D.O.F. | RULE |
| 65029 | 456 | AAA | - | - | 12 | CD |
| 65031 | 456 | AAA | - | - | 123 | CDC |
| 65039 | 456 | AAA | - | - | 123 | CDC |
| 65911 | 456 | AAA | - | - | 123 | CDC |
| 65919 | 456 | AAA | - | - | 12 | CD |
| 65921 | 456 | AAA | - | - | 123 | CDC |
| 65929 | - | - | 456 | AAA | - | - |
| 65931 | 456 | AAA | - | - | 123 | CDC |
| 65939 | 456 | AAA | - | - | 12 | CD |

SHEAR PANEL/MEMBRANE ELEMENT DATA

| Letter Designation | NASTRAN EID | Type | Thickness (IN.) |
|--------------------|-------------|----------|-----------------|
| A | 6221124 | Bulkhead | .125 |
| B | 6221326 | Bulkhead | .125 |
| C | 6221729 | Bulkhead | .125 |
| D | 6222431 | Bulkhead | .125 |
| E | 6222439 | Bulkhead | .125 |
| F | 6222639 | Bulkhead | .125 |
| G | 6281129 | Bulkhead | .125 |
| H | 6282139 | Bulkhead | .125 |
| I | 6341129 | Bulkhead | .125 |
| J | 6342139 | Bulkhead | .125 |
| K | 6421129 | Bulkhead | .125 |
| L | 6422139 | Bulkhead | .125 |
| M | 6501129 | Bulkhead | .125 |
| N | 6502139 | Bulkhead | .125 |
| O | 6591129 | Bulkhead | .125 |
| P | 6592139 | Bulkhead | .125 |

3.2.2.2 Left Wing Ribs - Detail

View looking outboard

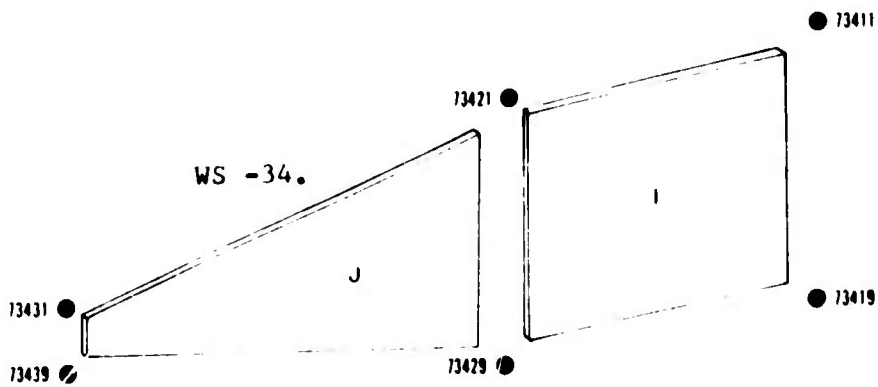
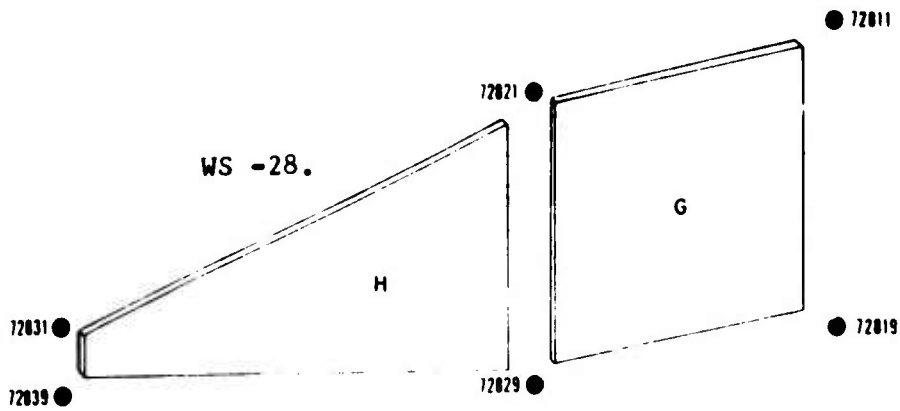
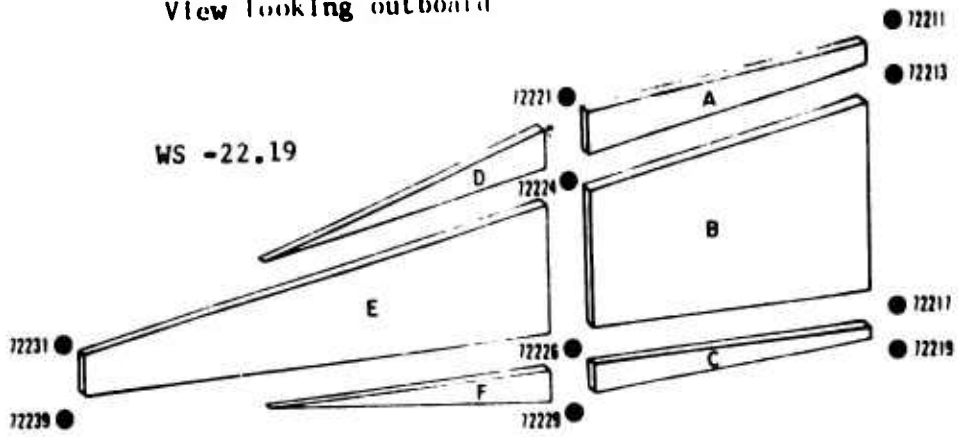

View looking outboard

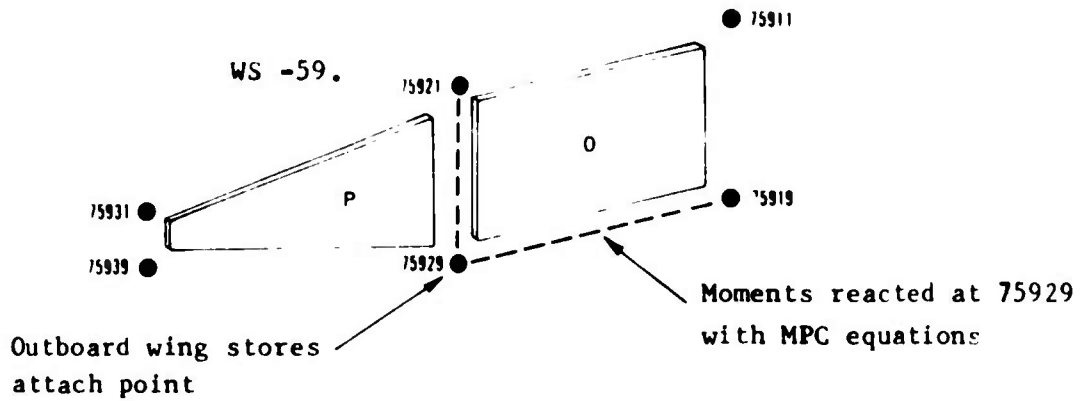
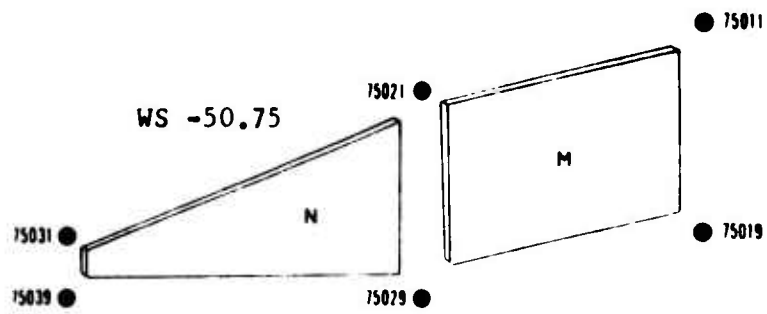
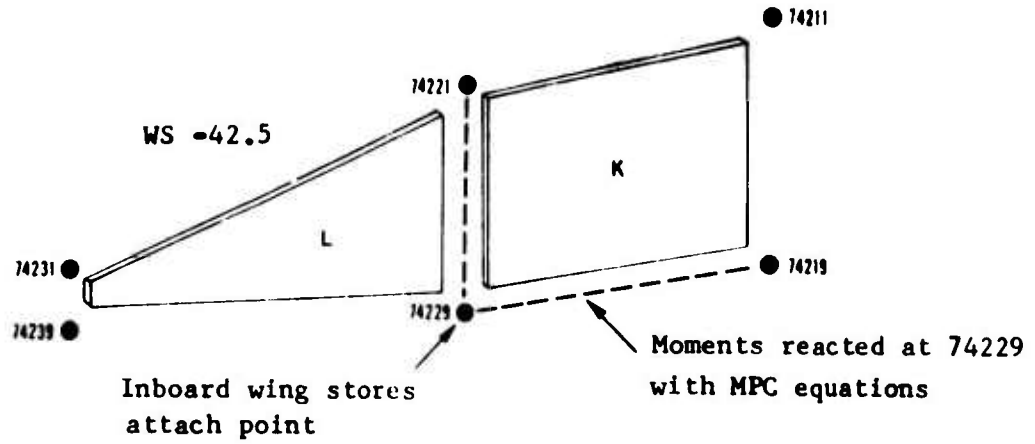

GRID POINT DATA

| GRID POINT | SPC | | MPC | | OMIT | |
|------------|--------|------|--------|------|--------|--------|
| | D.O.F. | RULE | D.O.F. | RULE | D.O.F. | RULE |
| 72211 | 456 | AAA | - | - | 123 | DDD |
| 72213 | - | - | - | - | 123456 | DDDAAA |
| 72217 | - | - | - | - | 123456 | DDDAAA |
| 72219 | 456 | AAA | - | - | 123 | CDC |
| 72221 | - | - | - | - | 123456 | DDDAAA |
| 72224 | - | - | - | - | 123456 | DDDAAA |
| 72226 | - | - | - | - | 123456 | DDDAAA |
| 72229 | - | - | - | - | 123456 | DDDAAA |
| 72231 | - | - | - | - | 123456 | DDDAAA |
| 72239 | - | - | - | - | 123456 | DDDAAA |
| 72811 | 456 | AAA | - | - | 123 | DDD |
| 72819 | 456 | AAA | - | - | 12 | CD |
| 72821 | 456 | AAA | - | - | 123 | CDC |
| 72829 | 456 | AAA | - | - | 3 | C |
| 72831 | 456 | AAA | - | - | 123 | CDC |
| 72839 | 456 | AAA | - | - | 12 | CD |
| 73411 | 456 | AAA | - | - | 123 | CDC |
| 73419 | 456 | AAA | - | - | 123 | CDC |
| 73421 | 456 | AAA | - | - | 3 | C |
| 73429 | 456 | AAA | - | - | 12 | CD |
| 73431 | 456 | AAA | - | - | 123 | CDC |
| 73439 | 456 | AAA | - | - | 123 | CDC |
| 74211 | 456 | AAA | - | - | 123 | CDC |
| 74219 | 456 | AAA | - | - | 12 | CD |
| 74221 | 456 | AAA | - | - | 123 | CDC |
| 74229 | - | - | 456 | AAA | - | - |
| 74231 | 456 | AAA | - | - | 123 | CDC |
| 74239 | 456 | AAA | - | - | 12 | CD |
| 75011 | 456 | AAA | - | - | 123 | CDC |
| 75019 | 456 | AAA | - | - | 123 | CDC |
| 75021 | 456 | AAA | - | - | 3 | C |
| 75029 | 456 | AAA | - | - | 12 | CD |
| 75031 | 456 | AAA | - | - | 123 | CDC |

GRID POINT DATA (CONT.)

| GRID POINT | SPC | | MPC | | OMIT | |
|------------|--------|------|--------|------|--------|------|
| | D.O.F. | RULE | D.O.F. | RULE | D.O.F. | RULE |
| 75039 | 456 | AAA | - | - | 123 | CDC |
| 75911 | 456 | AAA | - | - | 123 | CDC |
| 75919 | 456 | AAA | - | - | 12 | CD |
| 75921 | 456 | AAA | - | - | 123 | CDC |
| 75929 | - | - | 456 | AAA | - | - |
| 75931 | 456 | AAA | - | - | 123 | CDC |
| 75939 | 456 | AAA | - | - | 12 | CD |

SHEAR PANEL/MEMBRANE ELEMENT DATA

| Letter Designation | NASTRAN EID | Type | Thickness (IN.) |
|--------------------|-------------|----------|-----------------|
| A | 7221124 | Bulkhead | .125 |
| B | 7221326 | Bulkhead | .125 |
| C | 7221729 | Bulkhead | .125 |
| D | 7222431 | Bulkhead | .125 |
| E | 7222439 | Bulkhead | .125 |
| F | 7222639 | Bulkhead | .125 |
| G | 7281129 | Bulkhead | .125 |
| H | 7282139 | Bulkhead | .125 |
| I | 7341129 | Bulkhead | .125 |
| J | 7342139 | Bulkhead | .125 |
| K | 7421129 | Bulkhead | .125 |
| L | 7422139 | Bulkhead | .125 |
| M | 7501129 | Bulkhead | .125 |
| N | 7502139 | Bulkhead | .125 |
| O | 7591129 | Bulkhead | .125 |
| P | 7592139 | Bulkhead | .125 |

3.2.2.3 Right Wing Spars Detail

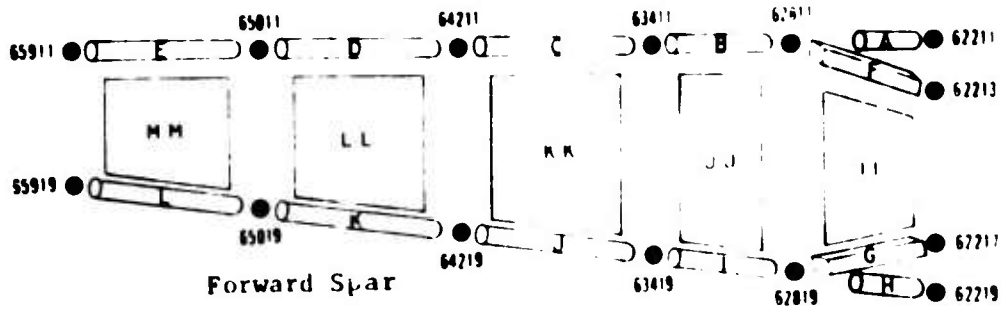
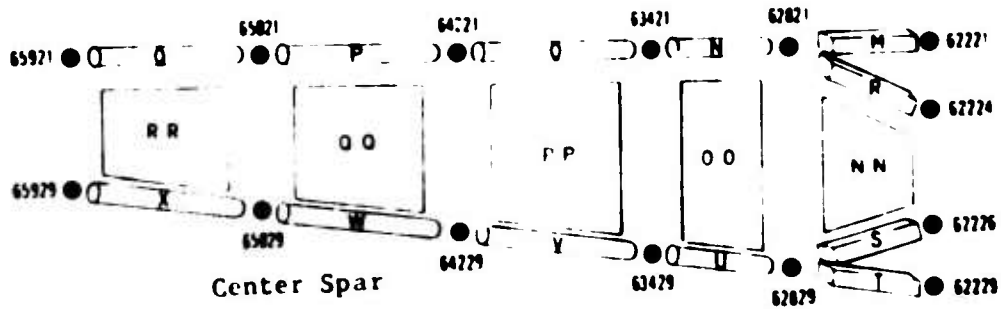
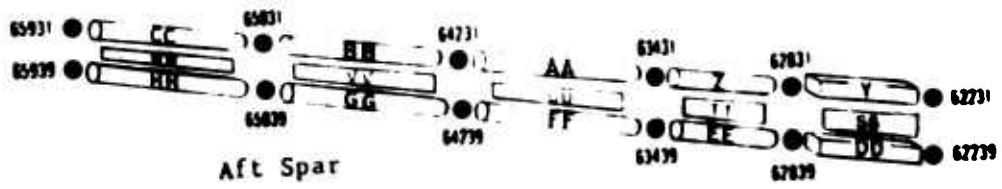

View looking aft

GRID POINT DATA

| GRID POINT | SPC | | MPC | | OMIT | |
|------------|--------|------|--------|------|--------|--------|
| | D.O.F. | RULE | D.O.F. | RULE | D.O.F. | RULE |
| 62211 | 456 | AAA | - | - | 123 | DDD |
| 62213 | - | - | - | - | 123456 | DDDAAA |
| 62217 | - | - | - | - | 123456 | DDDAAA |
| 62219 | 456 | AAA | - | - | 123 | DDD |
| 62221 | - | - | - | - | 123456 | DDDAAA |
| 62224 | - | - | - | - | 123456 | DDDAAA |
| 62226 | - | - | - | - | 123456 | DDDAAA |
| 62229 | - | - | - | - | 123456 | DDDAAA |
| 62231 | - | - | - | - | 123456 | DDDAAA |
| 62239 | - | - | - | - | 123456 | DDDAAA |
| 62811 | 456 | AAA | - | - | 123 | CDC |
| 62819 | 456 | AAA | - | - | 12 | CD |
| 62821 | 456 | AAA | - | - | 123 | CDC |
| 62829 | 456 | AAA | - | - | 3 | C |
| 62831 | 456 | AAA | - | - | 123 | CDC |
| 62839 | 456 | AAA | - | - | 12 | CD |
| 63411 | 456 | AAA | - | - | 123 | CDC |
| 63419 | 456 | AAA | - | - | 123 | CDC |
| 63421 | 456 | AAA | - | - | 3 | C |
| 63429 | 456 | AAA | - | - | 12 | CD |
| 63431 | 456 | AAA | - | - | 123 | CDC |
| 63439 | 456 | AAA | - | - | 123 | CDC |
| 64211 | 456 | AAA | - | - | 123 | CDC |
| 64219 | 456 | AAA | - | - | 12 | CD |
| 64221 | 456 | AAA | - | - | 123 | CDC |
| 64229 | - | - | 456 | AAA | - | - |
| 64231 | 456 | AAA | - | - | 123 | CDC |
| 64239 | 456 | AAA | - | - | 12 | CD |
| 65011 | 456 | AAA | - | - | 123 | CDC |
| 65019 | 456 | AAA | - | - | 123 | CDC |
| 65021 | 456 | AAA | - | - | 3 | C |
| 65029 | 456 | AAA | - | - | 12 | CD |

GRID POINT DATA (CONT.)

| GRID POINT | SPC | | MPC | | OMIT | |
|------------|--------|------|--------|------|--------|------|
| | D.O.F. | RULE | D.O.F. | RULE | D.O.F. | RULE |
| 65031 | 456 | AAA | - | - | 123 | CDC |
| 65039 | 456 | AAA | - | - | 123 | CDC |
| 65911 | 456 | AAA | - | - | 123 | CDC |
| 65919 | 456 | AAA | - | - | 12 | CD |
| 65921 | 456 | AAA | - | - | 123 | CDC |
| 65929 | - | - | 456 | AAA | - | - |
| 65931 | 456 | AAA | - | - | 123 | CDC |
| 65939 | 456 | AAA | - | - | 12 | CD |

SHEAR PANEL/MEMBRANE ELEMENT DATA

| Letter Designation | NASTRAN EID | Type | Thickness (IN.) |
|--------------------|-------------|------|-----------------|
| II | 6221119 | Web | .150 |
| JJ | 6281119 | Web | .130 |
| KK | 6341119 | Web | .127 |
| LL | 6421119 | Web | .124 |
| MM | 6501119 | Web | .119 |
| NN | 6222129 | Web | .182 |
| OO | 6282129 | Web | .177 |
| PP | 6342129 | Web | .175 |
| QQ | 6422129 | Web | .174 |
| RR | 6502129 | Web | .171 |
| SS | 6223139 | Web | .064 |
| TT | 6283139 | Web | .075 |
| UU | 6343139 | Web | .074 |
| VV | 6423139 | Web | .073 |
| WW | 6503139 | Web | .071 |









ROD ELEMENT DATA

| LETTER DESIGNATION | NASTRAN EID | TYPE | ACTUAL AREA (in. ²) | OFFSETS FROM GRIDPOINT | | FINAL AREA (in. ²) |
|-----------------------|----------------|-------|------------------------------------|---------------------------|-----|-----------------------------------|
| | | | | Z | Y | |
| A | 6222611 | Cap | .506 | -0.22 | 0.0 | .438 |
| B | 6283411 | Cap | .506 | -0.22 | 0.0 | .412 |
| | 6283412 | R/SP3 | .193 | - | - | .193 |
| C | 6344211 | Cap | .506 | -0.22 | 0.0 | .407 |
| | 6344212 | R/SP3 | .170 | - | - | .170 |
| D | 6425011 | Cap | .506 | -0.22 | 0.0 | .401 |
| | 6425012 | R/SP3 | .144 | - | - | .144 |
| E | 6505911 | Cap | .506 | -0.22 | 0.0 | .392 |
| | 6505912 | R/SP3 | .118 | - | - | .118 |
| F | 6222812 | R/SP3 | .188 | - | - | .188 |
| G | 6222818 | R/SP3 | .188 | - | - | .188 |
| H | 6222819 | Cap | .506 | 0.21 | 0.0 | .437 |
| I | 6283418 | R/SP3 | .193 | - | - | .193 |
| | 6283419 | Cap | .506 | 0.21 | 0.0 | .408 |
| J | 6344218 | R/SP3 | .170 | - | - | .170 |
| | 6344219 | Cap | .506 | 0.21 | 0.0 | .404 |
| K | 6425018 | R/SP3 | .144 | - | - | .144 |
| | 6425019 | Cap | .506 | 0.21 | 0.0 | .399 |
| L | 6505918 | R/SP3 | .118 | - | - | .118 |
| | 6505919 | Cap | .506 | 0.21 | 0.0 | .391 |
| N | 6283421 | Cap | 1.608 | -0.41 | 0.0 | 1.240 |
| | 6283422 | R/SP3 | .260 | - | - | .260 |
| O | 6344221 | Cap | 1.275 | -0.55 | 0.0 | .944 |
| | 6344222 | R/SP3 | .232 | - | - | .232 |
| P | 6425021 | Cap | .705 | -0.30 | 0.0 | .501 |
| | 6425022 | R/SP3 | .202 | - | - | .202 |
| Q | 6505921 | Cap | .579 | -0.21 | 0.0 | .436 |
| | 6505922 | R/SP3 | .171 | - | - | .171 |
| R | 6222822 | R/SP3 | .216 | - | - | .216 |
| S | 6222828 | R/SP3 | .216 | - | - | .216 |
| U | 6283428 | R/SP3 | .260 | - | - | .260 |
| | 6283429 | Cap | 1.608 | 1.10 | 0.0 | 1.234 |

ROD ELEMENT DATA (CONT.)

| LETTER DESIGNATION | NASTRAN EID | TYPE | ACTUAL AREA (in. ²) | OFFSETS FROM GRIDPOINT | | FINAL AREA (in. ²) |
|-----------------------|----------------|-------|------------------------------------|---------------------------|-----|-----------------------------------|
| | | | | Z | Y | |
| V | 6344228 | R/SP3 | .232 | - | - | .232 |
| | 6344229 | Cap | 1.710 | 0.42 | 0.0 | .966 |
| W | 6425028 | R/SP3 | .202 | - | - | .202 |
| | 6425029 | Cap | .748 | 0.34 | 0.0 | .535 |
| X | 6505928 | R/SP3 | .171 | - | - | .171 |
| | 6505929 | Cap | .595 | 0.24 | 0.0 | .443 |
| Y | 6222832 | R/SP3 | .026 | - | - | .026 |
| Z | 6283431 | Cap | .150 | -0.12 | 0.0 | .103 |
| | 6283432 | R/SP3 | .028 | - | - | .028 |
| AA | 6344231 | Cap | .150 | -0.12 | 0.0 | .102 |
| | 6344232 | R/SP3 | .026 | - | - | .026 |
| BB | 6425031 | Cap | .150 | -0.12 | 0.0 | .101 |
| | 6425032 | R/SP3 | .025 | - | - | .025 |
| CC | 6505931 | Cap | .150 | -0.12 | 0.0 | .100 |
| | 6505932 | R/SP3 | .023 | - | - | .023 |
| DD | 6222838 | R/SP3 | .026 | - | - | .026 |
| EE | 6283438 | R/SP3 | .028 | - | - | .028 |
| | 6283439 | Cap | .200 | 0.11 | 0.0 | .154 |
| FF | 6344238 | R/SP3 | .026 | - | - | .026 |
| | 6344239 | Cap | .200 | 0.11 | 0.0 | .152 |
| GG | 6425038 | R/SP3 | .025 | - | - | .025 |
| | 6425039 | Cap | .200 | 0.11 | 0.0 | .150 |
| HH | 6505938 | R/SP3 | .023 | - | - | .023 |
| | 6505939 | Cap | .200 | 0.11 | 0.0 | .149 |

CBAR ELEMENT DATA

| LETTER DESIGNATION | NASTRAN EID | SECTION PROPERTIES | | | |
|--|-------------|--------------------------|-------------------------------------|-------------------------------------|-----------------------------|
| | | AREA (in. ²) | INERTIA-PLANE 1 (in. ⁴) | INERTIA-PLANE 2 (in. ⁴) | TORSION (in. ⁴) |
| F  | 6222813 | 1.790 | 0.209 | 1.023 | 0.100 |
| G  | 6222817 | 1.355 | 0.072 | 0.680 | 0.046 |
| M  | 6222821 | 1.341 | 0.523 | 0.100 | 0.009 |
| R  | 6222824 | 1.450 | 0.147 | 0.635 | 0.009 |
| S  | 6222826 | 1.410 | 0.150 | 0.656 | 0.009 |
| T  | 6222829 | 0.979 | 0.217 | 0.863 | 0.009 |
| Y  | 6222831 | 0.423 | 0.044 | 0.321 | 0.009 |
| DD  | 6222839 | 0.259 | 0.012 | 0.117 | 0.014 |

NOTES -



Pin flags at End B: 456

3.2.2.4 Left Wing Spars Detail

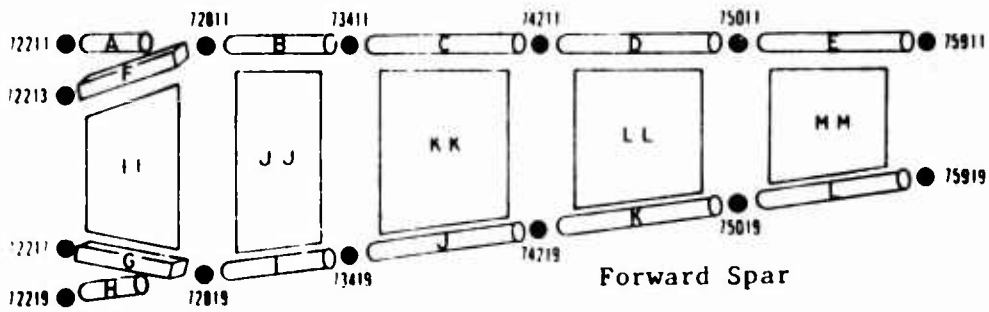
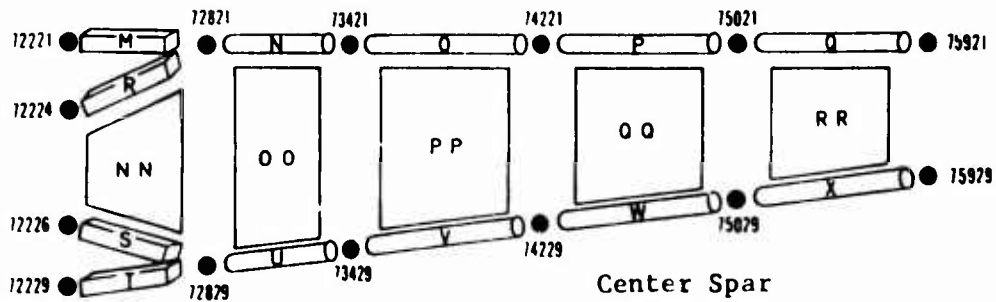
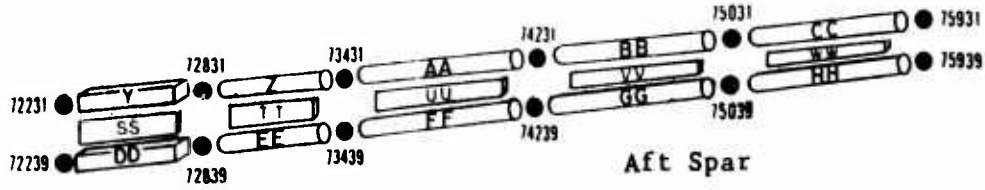

View looking aft

GRID POINT DATA

| GRID POINT | SPC | | MPC | | OMIT | |
|------------|--------|------|--------|------|--------|--------|
| | D.O.F. | RULF | D.O.F. | RULE | D.O.F. | RULE |
| 72211 | 456 | AAA | - | - | 123 | DDD |
| 72213 | - | - | - | - | 123456 | DDDAAA |
| 72217 | - | - | - | - | 123456 | DDDAAA |
| 72219 | 456 | AAA | - | - | 123 | DDD |
| 72221 | - | - | - | - | 123456 | DDDAAA |
| 72224 | - | - | - | - | 123456 | DDDAAA |
| 72226 | - | - | - | - | 123456 | DDDAAA |
| 72229 | - | - | - | - | 123456 | DDDAAA |
| 72231 | - | - | - | - | 123456 | DDDAAA |
| 72239 | - | - | - | - | 123456 | DDDAAA |
| 72811 | 456 | AAA | - | - | 123 | CDC |
| 72819 | 456 | AAA | - | - | 12 | CD |
| 72821 | 456 | AAA | - | - | 123 | CDC |
| 72829 | 456 | AAA | - | - | 3 | C |
| 72831 | 456 | AAA | - | - | 123 | CDC |
| 72839 | 456 | AAA | - | - | 12 | CD |
| 73411 | 456 | AAA | - | - | 123 | CDC |
| 73419 | 456 | AAA | - | - | 123 | CDC |
| 73421 | 456 | AAA | - | - | 3 | C |
| 73429 | 456 | AAA | - | - | 12 | CD |
| 73431 | 456 | AAA | - | - | 123 | CDC |
| 73439 | 456 | AAA | - | - | 123 | CDC |
| 74211 | 456 | AAA | - | - | 123 | CDC |
| 74219 | 456 | AAA | - | - | 12 | CD |
| 74221 | 456 | AAA | - | - | 123 | CDC |
| 74229 | - | - | 456 | AAA | - | - |
| 74231 | 456 | AAA | - | - | 123 | CDC |
| 74239 | 456 | AAA | - | - | 12 | CD |
| 75011 | 456 | AAA | - | - | 123 | CDC |
| 75019 | 456 | AAA | - | - | 123 | CDC |
| 75021 | 456 | AAA | - | - | 3 | C |
| 75029 | 456 | AAA | - | - | 12 | CD |
| 75031 | 456 | AAA | - | - | 123 | CDC |

GRID POINT DATA (CONT.)

| GRID POINT | SPC | | MPC | | OMIT | |
|------------|--------|------|--------|------|--------|------|
| | D.O.F. | RULE | D.O.F. | RULE | D.O.F. | RULE |
| 75039 | 456 | AAA | - | - | 123 | CDC |
| 75911 | 456 | AAA | - | - | 123 | CDC |
| 75919 | 456 | AAA | - | - | 12 | CD |
| 75921 | 456 | AAA | - | - | 123 | CDC |
| 75929 | - | - | 456 | AAA | - | - |
| 75931 | 456 | AAA | - | - | 123 | CDC |
| 75939 | 456 | AAA | - | - | 12 | CD |

SHEAR PANEL/MEMBRANE ELEMENT DATA

| Letter Designation | NASTRAN EID | Type | Thickness (IN.) |
|--------------------|-------------|------|-----------------|
| II | 7221119 | Web | .150 |
| JJ | 7281119 | Web | .130 |
| KK | 7341119 | Web | .127 |
| LL | 7421119 | Web | .124 |
| MM | 7501119 | Web | .119 |
| NN | 7222129 | Web | .182 |
| OO | 7282129 | Web | .177 |
| PP | 7342129 | Web | .175 |
| QC | 7422129 | Web | .174 |
| RR | 7502129 | Web | .171 |
| SS | 7223139 | Web | .064 |
| TT | 7283139 | Web | .075 |
| UU | 7343139 | Web | .074 |
| VV | 7423139 | Web | .073 |
| WW | 7503139 | Web | .071 |









ROD ELEMENT DATA

| LETTER DESIGNATION | NASTRAN EID | TYPE | ACTUAL AREA (in. ²) | OFFSETS FROM GRIDPOINT | | FINAL AREA (in. ²) |
|-----------------------|----------------|-------|------------------------------------|---------------------------|-----|-----------------------------------|
| | | | | Z | Y | |
| A | 7222811 | Cap | .506 | -0.22 | 0.0 | .438 |
| B | 7283411 | Cap | .506 | -0.22 | 0.0 | .412 |
| | 7283412 | R/SP3 | .193 | - | - | .193 |
| C | 7344211 | Cap | .506 | -0.22 | 0.0 | .407 |
| | 7344212 | R/SP3 | .170 | - | - | .170 |
| D | 7425011 | Cap | .506 | -0.22 | 0.0 | .401 |
| | 7425012 | R/SP3 | .144 | - | - | .144 |
| E | 7505911 | Cap | .506 | -0.22 | 0.0 | .392 |
| | 7505912 | R/SP3 | .118 | - | - | .118 |
| F | 7222812 | R/SP3 | .188 | - | - | .188 |
| G | 7222818 | R/SP3 | .188 | - | - | .188 |
| H | 7222819 | Cap | .506 | 0.21 | 0.0 | .437 |
| I | 7283418 | R/SP3 | .193 | - | - | .193 |
| | 7283419 | Cap | .506 | 0.21 | 0.0 | .408 |
| J | 7344218 | R/SP3 | .170 | - | - | .170 |
| | 7344219 | Cap | .506 | 0.21 | 0.0 | .404 |
| K | 7425018 | R/SP3 | .144 | - | - | .144 |
| | 7425019 | Cap | .506 | 0.21 | 0.0 | .399 |
| L | 7505918 | R/SP3 | .118 | - | - | .118 |
| | 7505919 | Cap | .506 | 0.21 | 0.0 | .391 |
| N | 7283421 | Cap | 1.608 | -0.41 | 0.0 | 1.240 |
| | 7283422 | R/SP3 | .260 | - | - | .260 |
| O | 7344221 | Cap | 1.275 | -0.55 | 0.0 | .944 |
| | 7344222 | R/SP3 | .232 | - | - | .232 |
| P | 7425021 | Cap | .705 | -0.30 | 0.0 | .501 |
| | 7425022 | R/SP3 | .202 | - | - | .202 |
| Q | 7505921 | Cap | .579 | -0.21 | 0.0 | .436 |
| | 7505922 | R/SP3 | .171 | - | - | .171 |
| R | 7222822 | R/SP3 | .216 | - | - | .216 |
| S | 7222828 | R/SP3 | .216 | - | - | .216 |
| U | 7283428 | R/SP3 | .260 | - | - | .260 |
| | 7283429 | Cap | 1.608 | 1.10 | 0.0 | 1.234 |

ROD ELEMENT DATA (CONT.)

| LETTER DESIGNATION | NASTRAN EID | TYPE | ACTUAL AREA (in. ²) | OFFSETS FROM GRIDPOINT | | FINAL AREA (in. ²) |
|-----------------------|----------------|-------|------------------------------------|---------------------------|-----|-----------------------------------|
| | | | | Z | Y | |
| V | 7344228 | R/SP3 | .232 | - | - | .232 |
| | 7344229 | Cap | 1.310 | 0.42 | 0.0 | .966 |
| W | 7425028 | R/SP3 | .202 | - | - | .202 |
| | 7425029 | Cap | .748 | 0.34 | 0.0 | .535 |
| X | 7505928 | R/SP3 | .171 | - | - | .171 |
| | 7505929 | Cap | .595 | 0.24 | 0.0 | .443 |
| Y | 7222832 | R/SP3 | .026 | - | - | .026 |
| Z | 7283431 | Cap | .150 | -0.12 | 0.0 | .103 |
| | 7283432 | R/SP3 | .028 | - | - | .028 |
| AA | 7344231 | Cap | .150 | -0.12 | 0.0 | .102 |
| | 7344232 | R/SP3 | .026 | - | - | .026 |
| BB | 7425031 | Cap | .150 | -0.12 | 0.0 | .101 |
| | 7425032 | R/SP3 | .025 | - | - | .025 |
| CC | 7505931 | Cap | .150 | -0.12 | 0.0 | .100 |
| | 7505932 | R/SP3 | .023 | - | - | .023 |
| DD | 7222838 | R/SP3 | .026 | - | - | .026 |
| EE | 7283438 | R/SP3 | .028 | - | - | .028 |
| | 7283439 | Cap | .200 | 0.11 | 0.0 | .154 |
| FF | 7344238 | R/SP3 | .026 | - | - | .026 |
| | 7344239 | Cap | .200 | 0.11 | 0.0 | .152 |
| GG | 7425038 | R/SP3 | .025 | - | - | .025 |
| | 7425039 | Cap | .200 | 0.11 | 0.0 | .150 |
| HH | 7505938 | R/SP3 | .023 | - | - | .023 |
| | 7505939 | Cap | .200 | 0.11 | 0.0 | .149 |

CBAR ELEMENT DATA

| LETTER DESIGNATION | NASTRAN EID | SECTION PROPERTIES | | | |
|--|----------------|-----------------------------|--|--|--------------------------------|
| | | AREA (in. ²) | INERTIA-PLANE 1 (in. ⁴) | INERTIA-PLANE 2 (in. ⁴) | TORSION (in. ⁴) |
| F  | 7222813 | 1.790 | 0.209 | 1.023 | 0.100 |
| G  | 7222817 | 1.355 | 0.072 | 0.680 | 0.046 |
| M  | 7222821 | 1.341 | 0.523 | 0.996 | 0.009 |
| R  | 7222824 | 1.450 | 0.147 | 0.635 | 0.009 |
| S  | 7222826 | 1.410 | 0.150 | 0.656 | 0.009 |
| T  | 7222829 | 0.979 | 0.217 | 0.863 | 0.009 |
| Y  | 7222831 | 0.423 | 0.044 | 0.321 | 0.009 |
| DD  | 7222839 | 0.259 | 0.012 | 0.117 | 0.014 |

NOTES -



Pin flags at End B: 456

3.2.2.5 Right Wing Skins Detail

View looking down

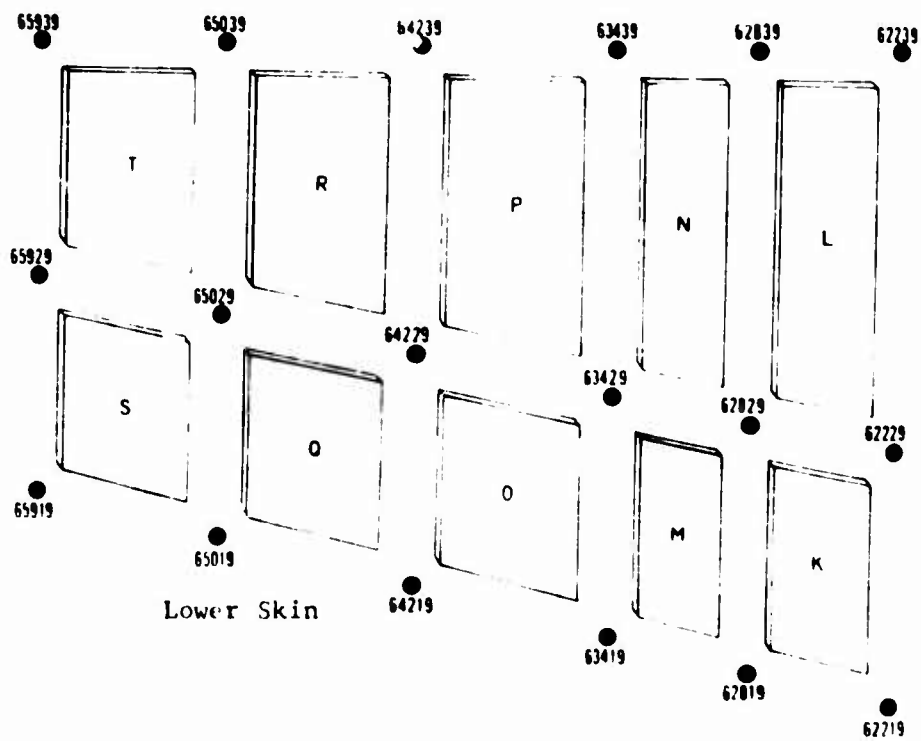
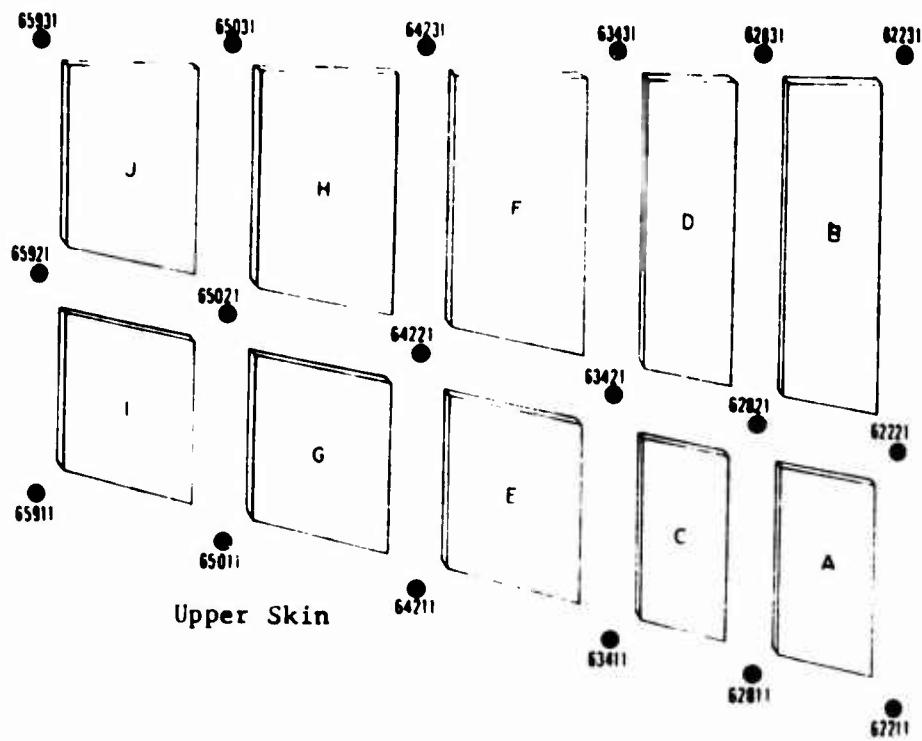

GRID POINT DATA

| GRID POINT | SPC | | MPC | | OMIT | |
|------------|--------|------|--------|------|--------|--------|
| | D.O.F. | RULE | D.O.F. | RULE | D.O.F. | RULE |
| 62211 | 456 | AAA | - | - | 123 | DDD |
| 62219 | 456 | AAA | - | - | 123 | DDD |
| 62221 | - | - | - | - | 123456 | DDDAAA |
| 62229 | - | - | - | - | 123456 | DDDAAA |
| 62231 | - | - | - | - | 123456 | DDDAAA |
| 62239 | - | - | - | - | 123456 | DDDAAA |
| 62811 | 456 | AAA | - | - | 123 | CDC |
| 62819 | 456 | AAA | - | - | 12 | CD |
| 62821 | 456 | AAA | - | - | 123 | CDC |
| 62829 | 456 | AAA | - | - | 3 | C |
| 62831 | 456 | AAA | - | - | 123 | CDC |
| 62839 | 456 | AAA | - | - | 12 | CD |
| 63411 | 456 | AAA | - | - | 123 | CDC |
| 63419 | 456 | AAA | - | - | 123 | CDC |
| 63421 | 456 | AAA | - | - | 3 | C |
| 63429 | 456 | AAA | - | - | 12 | CD |
| 63431 | 456 | AAA | - | - | 123 | CDC |
| 63439 | 456 | AAA | - | - | 123 | CDC |
| 64211 | 456 | AAA | - | - | 123 | CDC |
| 64219 | 456 | AAA | - | - | 12 | CD |
| 64221 | 456 | AAA | - | - | 123 | CDC |
| 64229 | - | - | 456 | AAA | - | - |
| 64231 | 456 | AAA | - | - | 123 | CDC |
| 64239 | 456 | AAA | - | - | 12 | CD |
| 65021 | 456 | AAA | - | - | 123 | CDC |
| 65029 | 456 | AAA | - | - | 123 | CDC |
| 65021 | 456 | AAA | - | - | 3 | C |
| 65029 | 456 | AAA | - | - | 12 | CD |
| 65031 | 456 | AAA | - | - | 123 | CDC |
| 65039 | 456 | AAA | - | - | 123 | CDC |
| 65911 | 456 | AAA | - | - | 123 | CDC |
| 65919 | 456 | AAA | - | - | 12 | CD |
| 65921 | 456 | AAA | - | - | 123 | CDC |

GRID POINT DATA (CONT.)

| GRID POINT | SPC | | MP | | OMIT | |
|------------|--------|------|--------|------|--------|------|
| | D.O.F. | RULE | D.O.F. | RULE | D.O.F. | RULE |
| 65929 | - | - | 456 | AAA | - | - |
| 65931 | 456 | AAA | - | - | 123 | CDC |
| 65939 | 456 | AAA | - | - | 12 | CD |

SHEAR PANEL/MEMBRANE ELEMENT DATA

| Letter Designation | NASTRAN EID | Type | Thickness (IN.) |
|--------------------|-------------|------------|-----------------|
| A | 6221121 | Upper Skin | .063 |
| B | 6222131 | Upper Skin | .063 |
| C | 6281121 | Upper Skin | .063 |
| D | 6282131 | Upper Skin | .063 |
| E | 6341121 | Upper Skin | .063 |
| F | 6342131 | Upper Skin | .063 |
| G | 6421121 | Upper Skin | .063 |
| H | 6422131 | Upper Skin | .063 |
| I | 6501121 | Upper Skin | .063 |
| J | 6502131 | Upper Skin | .063 |
| K | 6221929 | Lower Skin | .063 |
| L | 6222939 | Lower Skin | .063 |
| M | 6281929 | Lower Skin | .063 |
| N | 6282939 | Lower Skin | .063 |
| O | 6341929 | Lower Skin | .063 |
| P | 6342939 | Lower Skin | .063 |
| Q | 6421929 | Lower Skin | .063 |
| R | 6422939 | Lower Skin | .063 |
| S | 6501929 | Lower Skin | .063 |
| T | 6502939 | Lower Skin | .063 |

3.2.2.6 Left Wing Skins Detail

View looking down

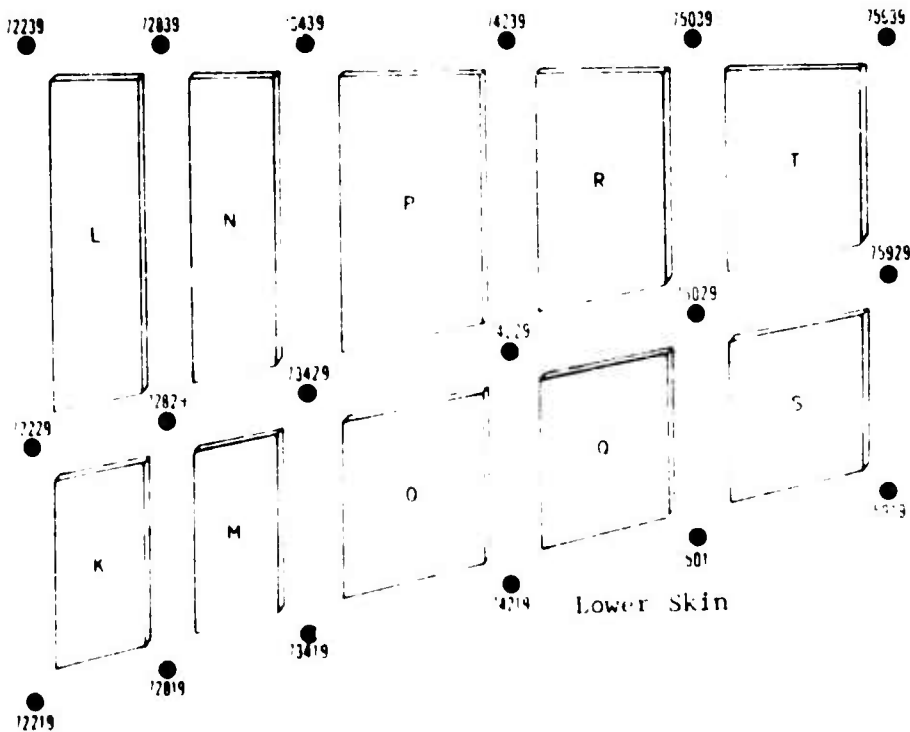
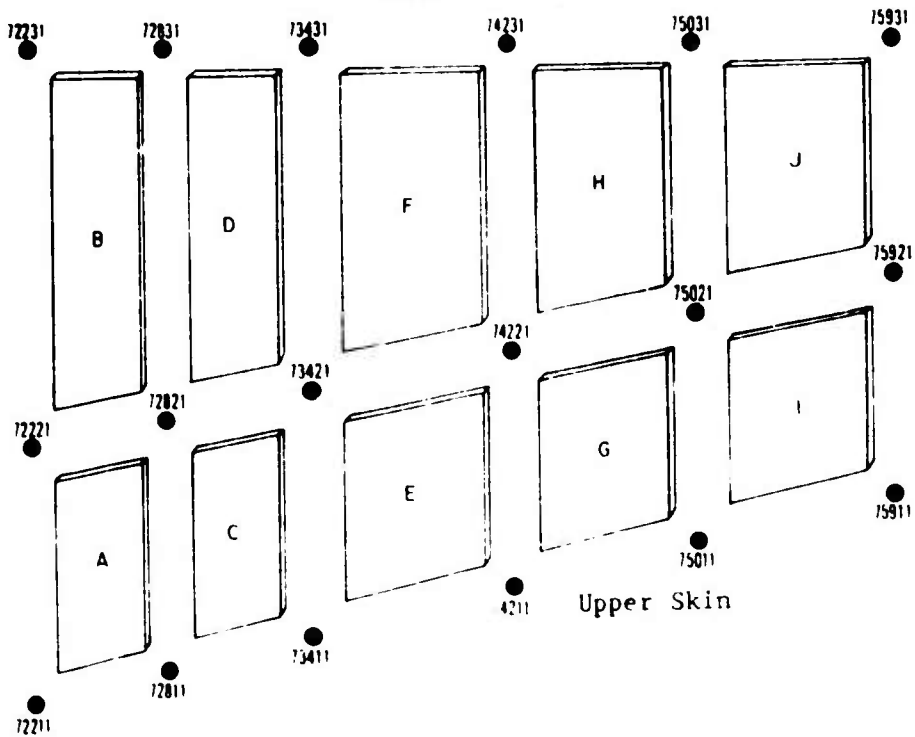

GRID POINT DATA

| GRID POINT | SPC | | MPC | | OMIT | |
|------------|--------|------|--------|------|--------|--------|
| | D.O.F. | RULE | D.O.F. | RULE | D.O.F. | RULE |
| 72211 | 456 | AAA | - | - | 123 | DDD |
| 72219 | 456 | AAA | - | - | 123 | DDD |
| 72221 | - | - | - | - | 123456 | DDDAAA |
| 72229 | - | - | - | - | 123456 | DDDAAA |
| 72231 | - | - | - | - | 123456 | DDDAAA |
| 72239 | - | - | - | - | 123456 | DDDAAA |
| 72811 | 456 | AAA | - | - | 123 | CDC |
| 72819 | 456 | AAA | - | - | 12 | CD |
| 72821 | 456 | AAA | - | - | 123 | CDC |
| 72829 | 456 | AAA | - | - | 3 | C |
| 72831 | 456 | AAA | - | - | 123 | CDC |
| 72839 | 456 | AAA | - | - | 12 | CD |
| 73411 | 456 | AAA | - | - | 123 | CDC |
| 73419 | 456 | AAA | - | - | 123 | CDC |
| 73421 | 456 | AAA | - | - | 3 | C |
| 73429 | 456 | AAA | - | - | 12 | CD |
| 73431 | 456 | AAA | - | - | 123 | CDC |
| 73439 | 456 | AAA | - | - | 123 | CDC |
| 74211 | 456 | AAA | - | - | 123 | CDC |
| 74219 | 456 | AAA | - | - | 12 | CD |
| 74221 | 456 | AAA | - | - | 123 | CDC |
| 74229 | - | - | 456 | AAA | - | - |
| 74231 | 456 | AAA | - | - | 123 | CDC |
| 74239 | 456 | AAA | - | - | 12 | CD |
| 75011 | 456 | AAA | - | - | 123 | CDC |
| 75019 | 456 | AAA | - | - | 123 | CDC |
| 75021 | 456 | AAA | - | - | 3 | C |
| 75029 | 456 | AAA | - | - | 12 | CD |
| 75031 | 456 | AAA | - | - | 123 | CDC |
| 75039 | 456 | AAA | - | - | 123 | CDC |
| 75911 | 456 | AAA | - | - | 123 | CDC |
| 75919 | 456 | AAA | - | - | 12 | CD |
| 75921 | 456 | AAA | - | - | 123 | CDC |

GRID POINT DATA (CONT.)

| GRID POINT | SPC | | MPC | | OMIT | |
|------------|--------|------|--------|------|--------|------|
| | D.O.F. | RULE | D.O.F. | RULE | D.O.F. | RULE |
| 75929 | - | - | 456 | AAA | - | - |
| 75931 | 456 | AAA | - | - | 123 | CDC |
| 75939 | 456 | AAA | - | - | 12 | CD |

SHEAR PANEL/MEMBRANE ELEMENT DATA

| Letter Designation | NASTRAN EID | Type | Thickness (IN.) |
|--------------------|-------------|------------|-----------------|
| A | 7221121 | Upper Skin | .063 |
| B | 7222131 | Upper Skin | .063 |
| C | 7281121 | Upper Skin | .063 |
| D | 7282131 | Upper Skin | .063 |
| E | 7341121 | Upper Skin | .063 |
| F | 7342131 | Upper Skin | .063 |
| G | 7421121 | Upper Skin | .063 |
| H | 7422131 | Upper Skin | .063 |
| I | 7501121 | Upper Skin | .063 |
| J | 7502131 | Upper Skin | .063 |
| K | 7221929 | Lower Skin | .063 |
| L | 7222939 | Lower Skin | .063 |
| M | 7281929 | Lower Skin | .063 |
| N | 7282939 | Lower Skin | .063 |
| O | 7341929 | Lower Skin | .063 |
| P | 7342939 | Lower Skin | .063 |
| Q | 7421929 | Lower Skin | .063 |
| R | 7422939 | Lower Skin | .063 |
| S | 7501929 | Lower Skin | .063 |
| T | 7502939 | Lower Skin | .063 |

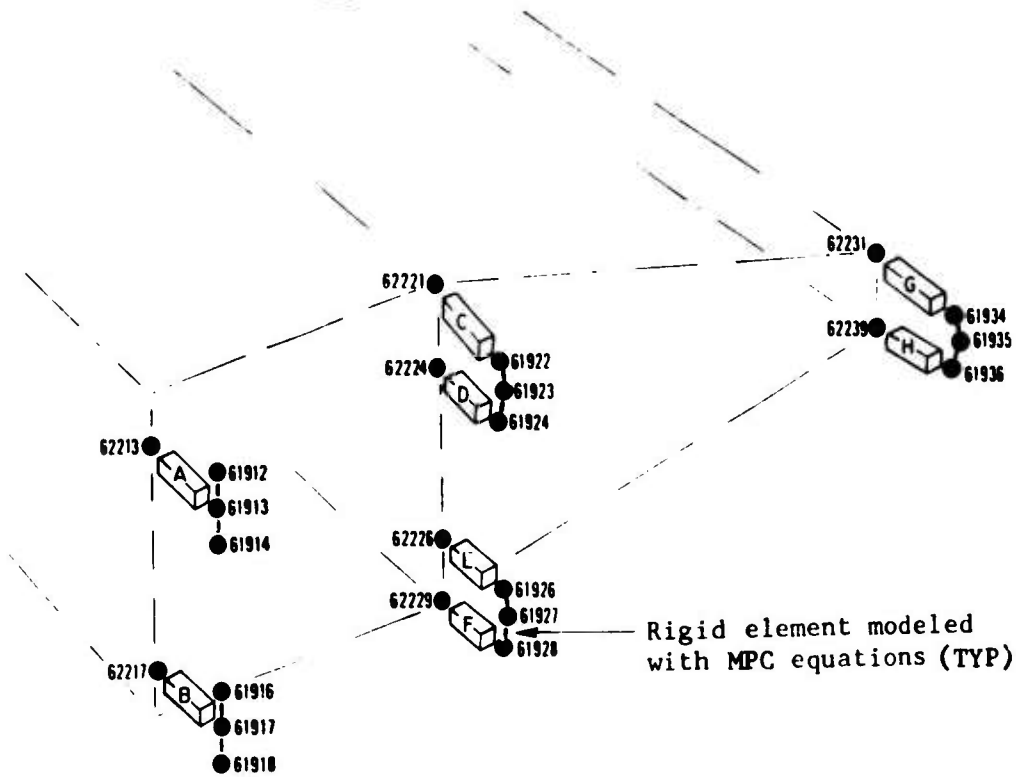
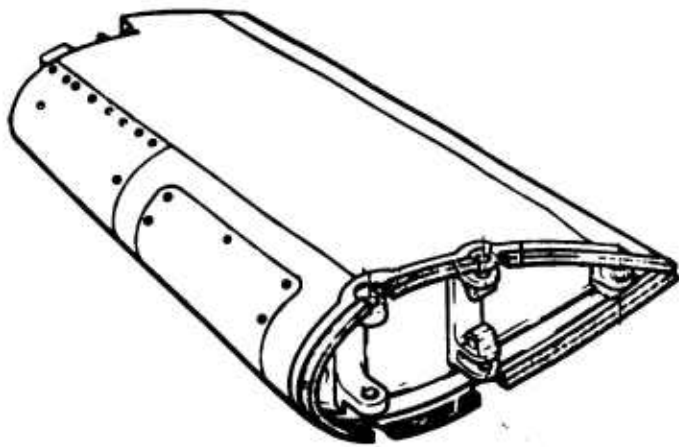

3.2.2.7 Right Wing Lugs Detail





GRID POINT DATA

| GRID POINT | SPC | | MPC | | OMIT | |
|------------|--------|------|--------|------|--------|--------|
| | D.O.F. | RULE | D.O.F. | RULE | D.O.F. | RULE |
| 61912 | - | - | 345 | AAA | 126 | DDA |
| 61913 | - | - | 1245 | AAAA | 36 | DA |
| 61914 | - | - | 345 | AAA | 126 | DDA |
| 61916 | - | - | 345 | AAA | 126 | DDA |
| 61917 | - | - | 1245 | AAAA | 36 | DA |
| 61918 | - | - | 345 | AAA | 126 | DDA |
| 61922 | - | - | 345 | AAA | 126 | DDA |
| 61923 | - | - | 1245 | AAAA | 36 | DA |
| 61924 | - | - | 345 | AAA | 126 | DDA |
| 61926 | - | - | 345 | AAA | 126 | DDA |
| 61927 | - | - | 1245 | AAAA | 36 | DA |
| 61928 | - | - | 345 | AAA | 126 | DDA |
| 61934 | - | - | 345 | AAA | 126 | DDA |
| 61935 | - | - | 1245 | AAAA | 36 | DA |
| 61936 | - | - | 345 | AAA | 126 | DDA |
| 62213 | - | - | - | - | 123456 | DDDDAA |
| 62217 | - | - | - | - | 123456 | DDDDAA |
| 62221 | - | - | - | - | 123456 | DDDDAA |
| 62224 | - | - | - | - | 123456 | DDDDAA |
| 62226 | - | - | - | - | 123456 | DDDDAA |
| 62229 | - | - | - | - | 123456 | DDDDAA |
| 62231 | - | - | - | - | 123456 | DDDDAA |
| 62239 | - | - | - | - | 123456 | DDDDAA |

CBAR ELEMENT DATA

| LETTER DESIGNATION | NASTRAN EID | SECTION PROPERTIES | | | |
|---|-------------|--------------------------|-------------------------------------|-------------------------------------|-----------------------------|
| | | AREA (in. ²) | INERTIA-PLANE 1 (in. ⁴) | INERTIA-PLANE 2 (in. ⁴) | TORSION (in. ⁴) |
| A | 6131922 | 1.321 | 0.433 | 0.916 | 0.995 |
| B | 6171922 | 1.550 | 0.166 | 0.666 | 0.457 |
| C  | 6221922 | 0.543 | 0.026 | 0.651 | 0.091 |
| D | 6241922 | 0.543 | 0.026 | 0.651 | 0.091 |
| E | 6261922 | 0.833 | 0.026 | 0.651 | 0.091 |
| F  | 6281922 | 0.833 | 0.026 | 0.651 | 0.091 |
| G  | 6341922 | 0.532 | 0.028 | 0.320 | 0.091 |
| H | 6361922 | 0.986 | 0.043 | 0.371 | 0.137 |

NOTES -

-  Offsets at End B: x=0.0 in., y=0.0 in., z=-0.91 in.
-  Offsets at End B: x=0.0 in., y=0.0 in., z= 0.27 in.
-  Offsets at End B: x=0.0 in., y=0.0 in., z=-0.93 in.

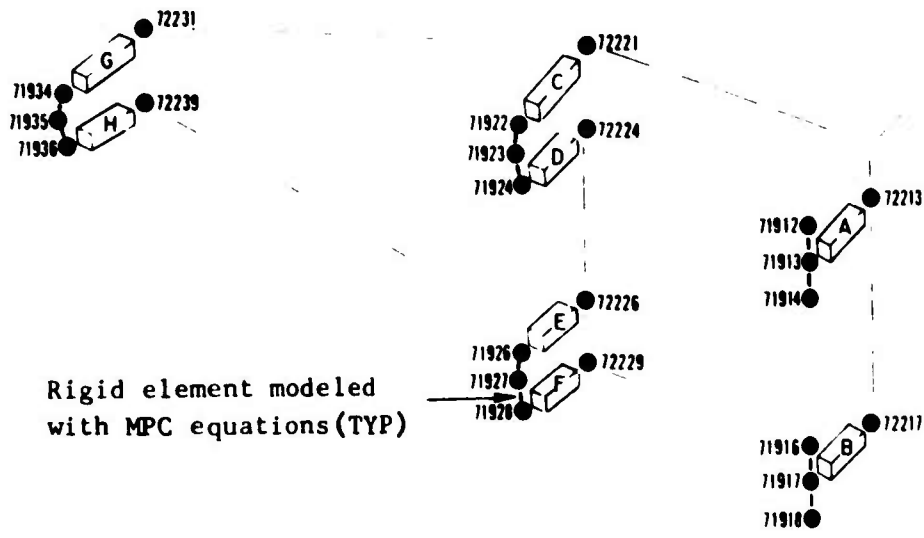
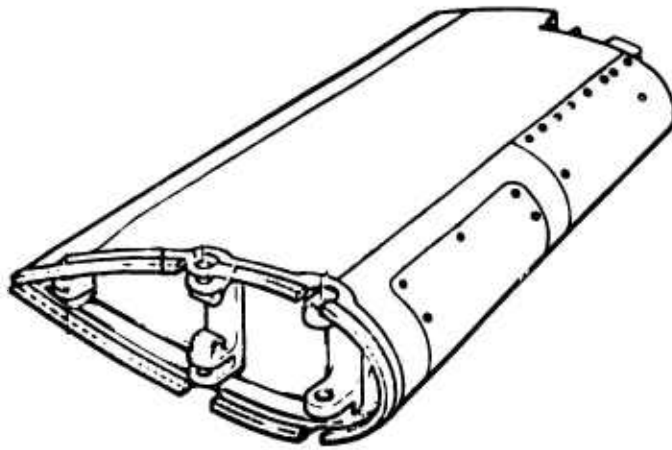

3.2.2.8 Left Wing Lugs Detail



GRID POINT DATA

| GRID POINT | SPC | | MPC | | OMIT | |
|------------|--------|------|--------|------|--------|--------|
| | D.O.F. | RULE | D.O.F. | RULE | D.O.F. | RULE |
| 71912 | - | - | 345 | AAA | 126 | DDA |
| 71913 | - | - | 1245 | AAAA | 36 | DA |
| 71914 | - | - | 345 | AAA | 126 | DDA |
| 71916 | - | - | 345 | AAA | 126 | DDA |
| 71917 | - | - | 1245 | AAAA | 36 | DA |
| 71918 | - | - | 345 | AAA | 126 | DDA |
| 71922 | - | - | 345 | AAA | 126 | DDA |
| 71923 | - | - | 1245 | AAAA | 36 | DA |
| 71924 | - | - | 345 | AAA | 126 | DDA |
| 71926 | - | - | 345 | AAA | 126 | DDA |
| 71927 | - | - | 1245 | AAAA | 36 | DA |
| 71928 | - | - | 345 | AAA | 126 | DDA |
| 71934 | - | - | 345 | AAA | 126 | DDA |
| 71935 | - | - | 1245 | AAAA | 36 | DA |
| 71936 | - | - | 345 | AAA | 126 | DDA |
| 72213 | - | - | - | - | 123456 | DDDDAA |
| 72217 | - | - | - | - | 123456 | DDDDAA |
| 72221 | - | - | - | - | 123456 | DDDDAA |
| 72224 | - | - | - | - | 123456 | DDDDAA |
| 72226 | - | - | - | - | 123456 | DDDDAA |
| 72229 | - | - | - | - | 123456 | DDDDAA |
| 72231 | - | - | - | - | 123456 | DDDDAA |
| 72239 | - | - | - | - | 123456 | DDDDAA |

CBAR ELEMENT DATA

| LETTER DESIGNATION | NASTRAN EID | SECTION PROPERTIES | | | |
|---|-------------|--------------------------|-------------------------------------|-------------------------------------|-----------------------------|
| | | AREA (in. ²) | INERTIA-PLANE 1 (in. ⁴) | INERTIA-PLANE 2 (in. ⁴) | TORSION (in. ⁴) |
| A | 7131922 | 1.321 | 0.433 | 0.916 | 0.995 |
| B | 7171922 | 1.550 | 0.166 | 0.666 | 0.457 |
| C  | 7221922 | 0.543 | 0.026 | 0.651 | 0.091 |
| D | 7241922 | 0.543 | 0.026 | 0.651 | 0.091 |
| E | 7261922 | 0.833 | 0.026 | 0.651 | 0.091 |
| F  | 7281922 | 0.833 | 0.026 | 0.651 | 0.091 |
| G  | 7341922 | 0.532 | 0.028 | 0.320 | 0.091 |
| H | 7361922 | 0.986 | 0.043 | 0.371 | 0.137 |

NOTES -



Offsets at End B: x=0.0 in., y=0.0 in., z=-0.91 in.



Offsets at End B: x=0.0 in., y=0.0 in., z= 0.27 in.



Offsets at End B: x=0.0 in., y=0.0 in., z=-0.93 in.

3.3 TAILBOOM AND VERTICAL FIN MAJOR ASSEMBLY

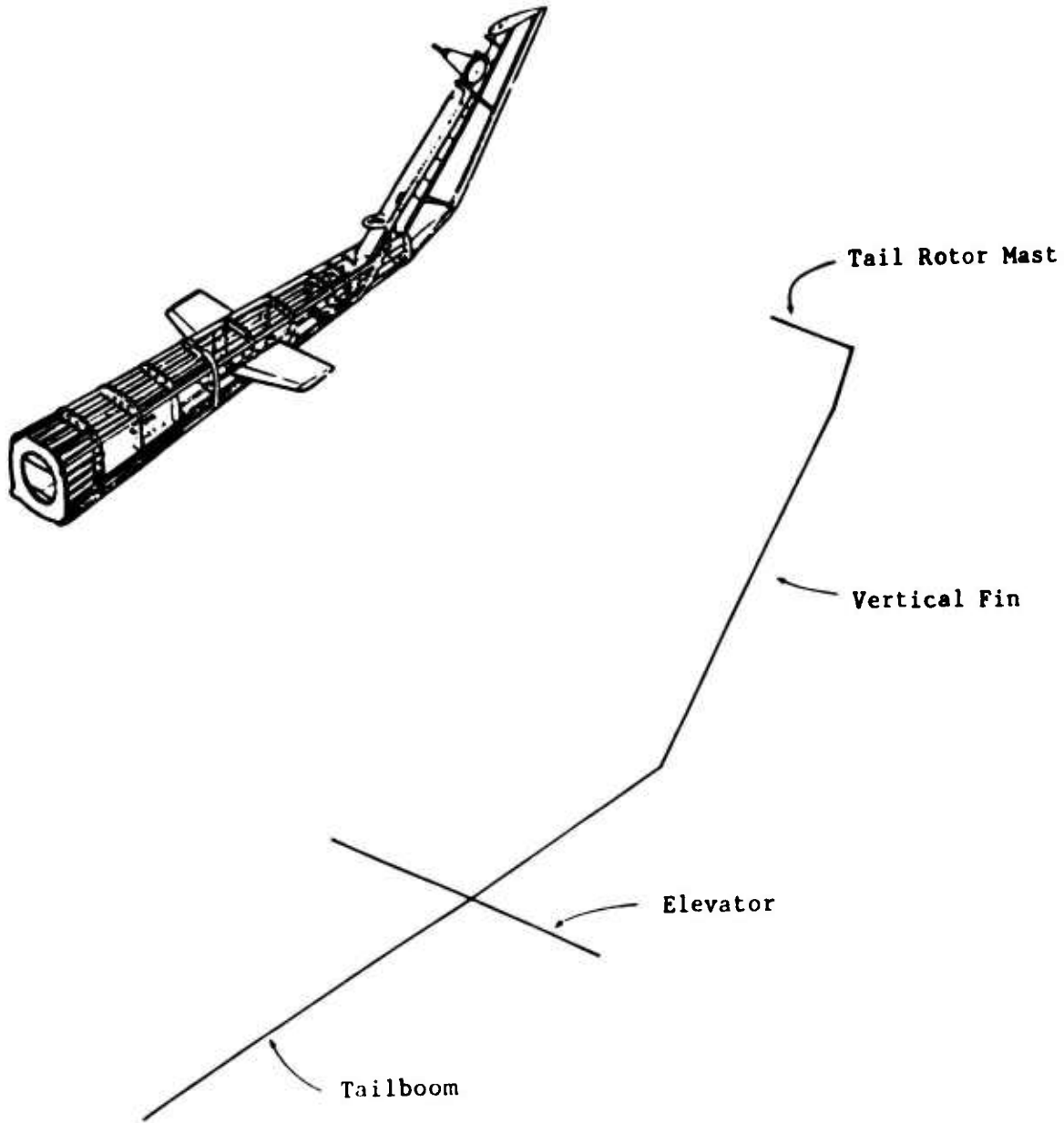

3.3.2 Tailboom Subassembly and Detail

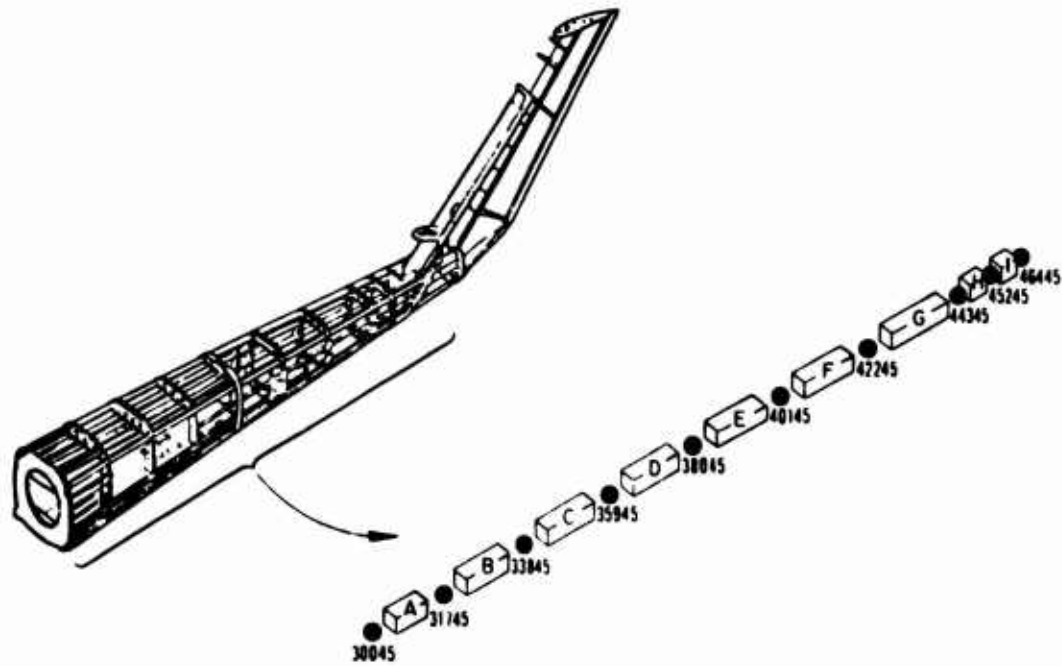

GRID POINT DATA

| GRID POINT | SPC | | MPC | | OMIT | |
|------------|--------|------|--------|------|--------|-------|
| | D.O.F. | RULE | D.O.F. | RULE | D.O.F. | RULE |
| 30045 | - | - | - | - | 456 | AAA |
| 31745 | - | - | - | - | 12456 | DBAAA |
| 33845 | - | - | - | - | 13456 | DBAAA |
| 35945 | - | - | - | - | 12456 | DBAAA |
| 38045 | - | - | - | - | 13456 | DBAAA |
| 40145 | - | - | - | - | 456 | AAA |
| 42245 | - | - | - | - | 12456 | DBAAA |
| 44345 | - | - | - | - | 13456 | DBAAA |
| 45245 | - | - | - | - | 12456 | DBAAA |
| 46445 | - | - | - | - | 456 | AAA |

CBAR ELEMENT DATA

| LETTER DESIGNATION | NASTRAN EID | SECTION PROPERTIES | | | |
|-----------------------|----------------|-----------------------------|--|--|--------------------------------|
| | | AREA (in. ²) | INERTIA-PLANE 1 (in. ⁴) | INERTIA-PLANE 2 (in. ⁴) | TORSION (in. ⁴) |
| A | 3003170 | 4.070 | 594.72 | 489.37 | 831.65 |
| B | 3173380 | 4.520 | 600.01 | 446.37 | 596.95 |
| C | 3383590 | 3.951 | 442.91 | 321.60 | 466.00 |
| D | 3593800 | 3.690 | 316.50 | 266.43 | 355.73 |
| E | 3804010 | 3.577 | 219.23 | 230.38 | 278.33 |
| F | 4014220 | 3.497 | 169.75 | 182.84 | 220.43 |
| G | 4224430 | 3.311 | 125.97 | 135.12 | 158.63 |
| H | 4434520 | 3.294 | 107.66 | 104.24 | 117.30 |
| I | 4524640 | 3.386 | 110.39 | 96.00 | 107.1 |

3.3.2.1 Tailboom Section Properties and Stiffness Distribution

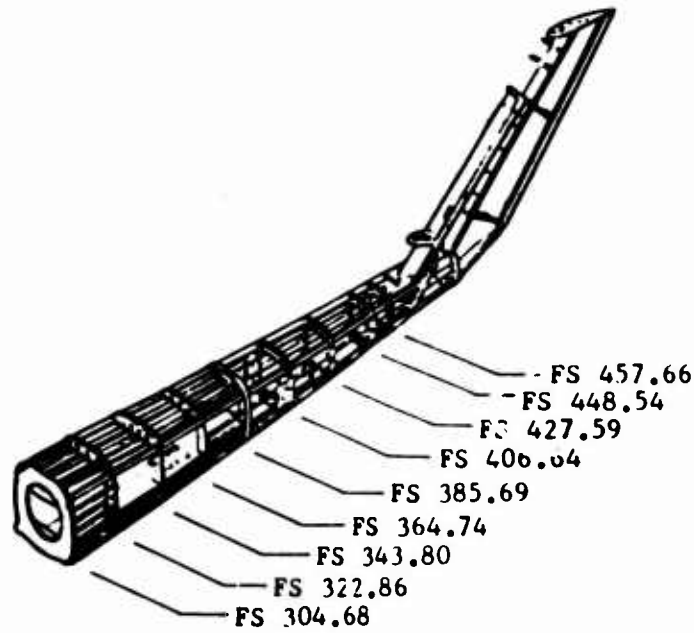

BOOM STATION 41.32 FS 304.68
 REF AXIS AT W.L. 49.590 AND B.L. 0.0

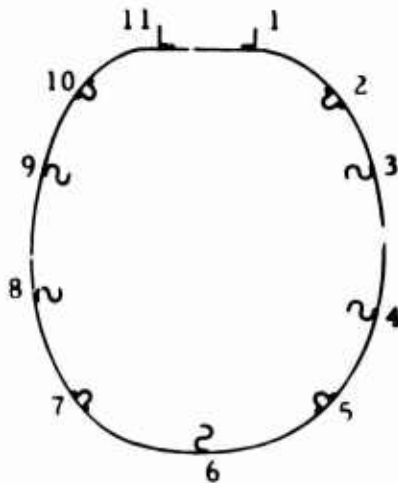

| ELEMENT NUMBER | AREA | Z' | Y' |
|----------------|-------------------|--------------------|--------------------|
| 1 | 0.0 | 19.074 | 3.887 |
| 2 | 0.6602 | 13.274 | 12.278 |
| 3 | 0.0 | 5.174 | 14.128 |
| 4 | 0.0 | -3.276 | 14.108 |
| 5 | 0.8990 | -11.476 | 12.078 |
| 6 | 0.0 | -16.576 | 0.452 |
| 7 | 0.8230 | -11.476 | -11.422 |
| 8 | 0.0 | -3.276 | -13.452 |
| 9 | 0.0 | 5.174 | -13.472 |
| 10 | 0.8254 | 13.274 | -11.622 |
| 11 | 0.0 | 19.194 | -3.762 |

SECTION PROPERTIES

AREA = 3.2052
 IY = 488.25
 IZ = 449.22
 J = 995.51

BOOM STATION 59.50 FS 322.86
 REF AXIS AT W.L. 50.714 AND B.L. 0.0

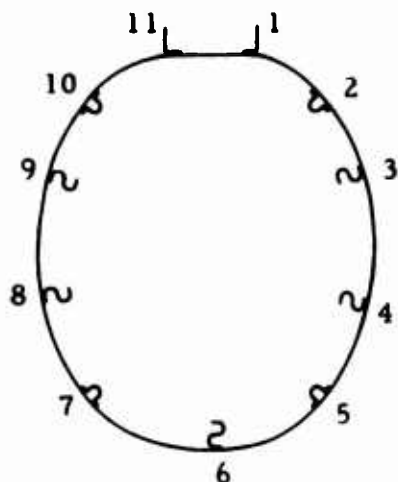

| ELEMENT NUMBER | AREA | Z' | Y' |
|----------------|--------|---------|---------|
| 1 | 0.3259 | 16.808 | 2.869 |
| 2 | 0.5746 | 11.473 | 10.560 |
| 3 | 0.3380 | 3.978 | 12.200 |
| 4 | 0.3381 | -4.067 | 12.220 |
| 5 | 0.8175 | -11.772 | 10.330 |
| 6 | 0.3892 | -16.652 | -0.566 |
| 7 | 0.7385 | -11.792 | -11.740 |
| 8 | 0.3381 | -4.067 | -13.600 |
| 9 | 0.0 | 3.978 | -13.580 |
| 10 | 0.7403 | 11.433 | -11.860 |
| 11 | 0.3355 | 16.928 | -4.280 |

SECTION PROPERTIES

AREA = 4.9358
 IY = 701.20
 IZ = 529.52
 J = 667.80

BOOM STATION 80.44 FS 343.80
 REF AXIS AT W.L. 52.015 AND B.L. 0.0

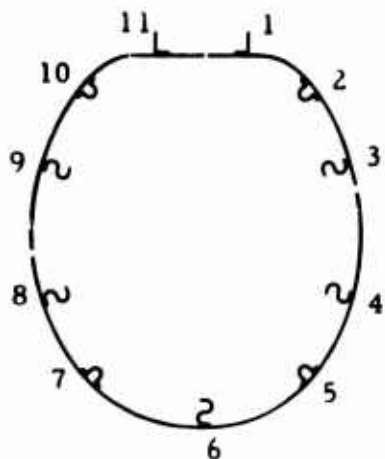

| ELEMENT NUMBER | AREA | Z' | Y' |
|----------------|--------|---------|---------|
| 1 | 0.3083 | 15.288 | 2.250 |
| 2 | 0.5494 | 10.408 | 9.011 |
| 3 | 0.3229 | 3.538 | 10.561 |
| 4 | 0.3233 | -3.912 | 10.596 |
| 5 | 0.5980 | -11.082 | 8.871 |
| 6 | 0.3635 | -15.582 | -1.185 |
| 7 | 0.5601 | -11.082 | -11.489 |
| 8 | 0.3233 | -3.912 | -13.214 |
| 9 | 0.0 | 3.538 | -13.179 |
| 10 | 0.4381 | 10.398 | -11.619 |
| 11 | 0.3179 | 15.408 | -4.899 |

SECTION PROPERTIES

AREA = 4.1048
 IY = 498.81
 IZ = 363.22
 J = 526.11

BOOM STATION 101.38 FS 364.74
 REF AXIS AT W.L. 53.314 AND B.L. 0.0

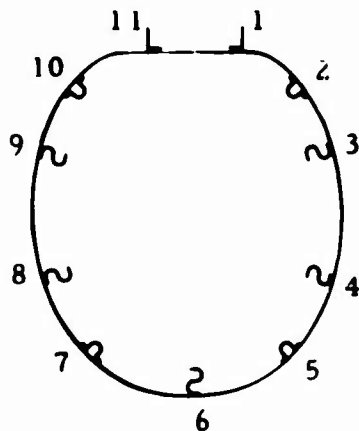

| ELEMENT NUMBER | AREA | Z' | Y' |
|----------------|--------|---------|---------|
| 1 | 0.2912 | 14.082 | 2.222 |
| 2 | 0.5246 | 9.672 | 8.063 |
| 3 | 0.3076 | 3.392 | 9.513 |
| 4 | 0.3083 | -3.468 | 9.563 |
| 5 | 0.5400 | -10.038 | 7.963 |
| 6 | 0.3381 | -14.178 | -1.213 |
| 7 | 0.5400 | -10.038 | -10.637 |
| 8 | 0.3083 | -3.468 | -12.237 |
| 9 | 0.0 | 3.392 | -12.187 |
| 10 | 0.3392 | 9.672 | -10.757 |
| 11 | 0.3008 | 14.212 | -4.927 |

SECTION PROPERTIES

AREA = 3.7979
 IY = 387.02
 IZ = 279.99
 J = 405.83

BOOM STATION 122.33 FS 385.69
 REF AXIS AT W.L. 54.613 AND B.L. 0.0

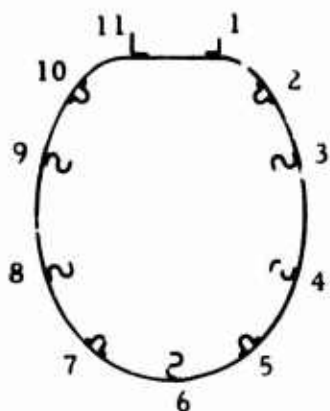

| ELEMENT NUMBER | AREA | Z' | Y' |
|----------------|-------------------|--------------------|---------|
| 1 | 0.2736 | 11.397 | 3.129 |
| 2 | 0.4993 | 7.467 | 8.100 |
| 3 | 0.2925 | 1.797 | 9.425 |
| 4 | 0.2935 | -4.453 | 9.445 |
| 5 | 0.5198 | -10.473 | 7.960 |
| 6 | 0.0 | -14.268 | -0.306 |
| 7 | 0.5198 | -10.473 | -8.820 |
| 8 | 0.2935 | -4.453 | -10.305 |
| 9 | 0.2925 | 1.797 | -10.285 |
| 10 | 0.3139 | 7.467 | -8.960 |
| 11 | 0.2832 | 11.517 | -4.020 |

SECTION PROPERTIES

AREA = 3.5816
 IY = 245.99
 IZ = 252.87
 J = 305.58

BOOM STATION 143.28 FS 406.64
 REF AXIS AT W.L. 55.912 AND B.L. 0.0

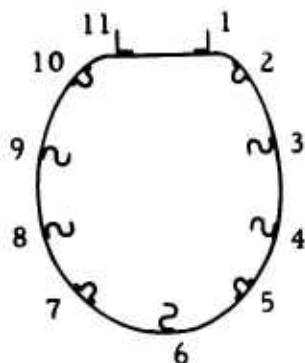

| ELEMENT NUMBER | AREA | Z' | Y' |
|----------------|--------|---------|--------|
| 1 | 0.2565 | 10.461 | 3.308 |
| 2 | 0.4316 | 7.001 | 7.399 |
| 3 | 0.3167 | 1.911 | 8.599 |
| 4 | 0.3185 | -3.719 | 8.629 |
| 5 | 0.5193 | -9.159 | 7.244 |
| 6 | 0.0 | -12.609 | -0.127 |
| 7 | 0.5193 | -9.159 | -7.746 |
| 8 | 0.3185 | -3.719 | -9.131 |
| 9 | 0.3167 | 1.911 | -9.101 |
| 10 | 0.3087 | 7.001 | -7.891 |
| 11 | 0.2661 | 10.581 | -3.841 |

SECTION PROPERTIES

AREA = 3.5728
 IY = 192.47
 IZ = 207.90
 J = 251.09

BOOM STATION 164.23 FS 427.59
 REF AXIS AT W.L. 57.210 AND B.L. 0.0

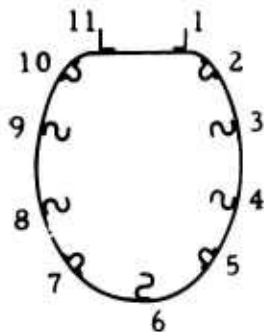

| ELEMENT NUMBER | AREA | Z' | Y' |
|----------------|--------|---------|--------|
| 1 | 0.2389 | 9.420 | 3.325 |
| 2 | 0.4044 | 6.470 | 6.616 |
| 3 | 0.2972 | 1.950 | 7.601 |
| 4 | 0.2996 | -3.070 | 7.626 |
| 5 | 0.5269 | -7.950 | 6.376 |
| 6 | 0.0 | -11.055 | -0.110 |
| 7 | 0.5266 | -7.950 | -6.844 |
| 8 | 0.2996 | -3.070 | -8.094 |
| 9 | 0.2972 | 1.950 | -8.069 |
| 10 | 0.2815 | 6.470 | -7.094 |
| 11 | 0.2485 | 9.540 | -3.824 |

SECTION PROPERTIES

AREA = 3.4206
 IY = 147.03
 IZ = 157.77
 J = 189.76

BOOM STATION 185.18 FS 448.54
 REF AXIS AT W.L. 58.510 AND B.L. 0.0

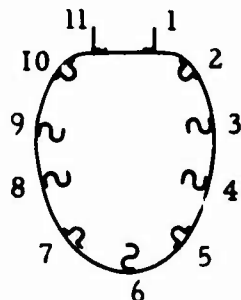

| ELEMENT NUMBER | AREA | Z' | Y' |
|----------------|--------|--------|--------|
| 1 | 0.2217 | 8.227 | 3.347 |
| 2 | 0.3774 | 5.687 | 5.658 |
| 3 | 0.2779 | 1.827 | 6.618 |
| 4 | 0.2804 | -2.588 | 6.658 |
| 5 | 0.5008 | -6.903 | 5.498 |
| 6 | 0.0 | -9.643 | -0.088 |
| 7 | 0.5008 | -6.903 | -5.922 |
| 8 | 0.2804 | -2.588 | -7.082 |
| 9 | 0.2779 | 1.827 | -7.042 |
| 10 | 0.2545 | 5.687 | -6.082 |
| 11 | 0.2313 | 8.352 | -3.802 |

SECTION PROPERTIES

AREA = 3.2031
 IY = 104.92
 IZ = 112.47
 J = 127.49

BOOM STATION 194.30 FS 457.66
 REF AXIS AT W.L. 59.075 AND B.L. 0.0

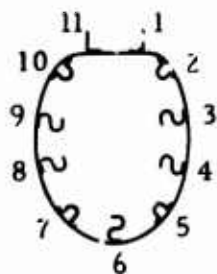

| ELEMENT NUMBER | AREA | Z' | Y' |
|----------------|--------|--------|--------|
| 1 | 0.2142 | 8.435 | 3.362 |
| 2 | 0.3657 | 6.130 | 5.278 |
| 3 | 0.2695 | 2.490 | 6.178 |
| 4 | 0.2729 | -1.665 | 6.233 |
| 5 | 0.4907 | -5.725 | 5.128 |
| 6 | 0.2729 | -8.310 | -0.073 |
| 7 | 0.4907 | -5.725 | -5.522 |
| 8 | 0.2729 | -1.665 | -6.627 |
| 9 | 0.2695 | 2.490 | -6.572 |
| 10 | 0.2428 | 6.130 | -5.672 |
| 11 | 0.2238 | 8.565 | -3.787 |

SECTION PROPERTIES

AREA = 3.3854
 IY = 110.39
 IZ = 96.00
 J = 107.09

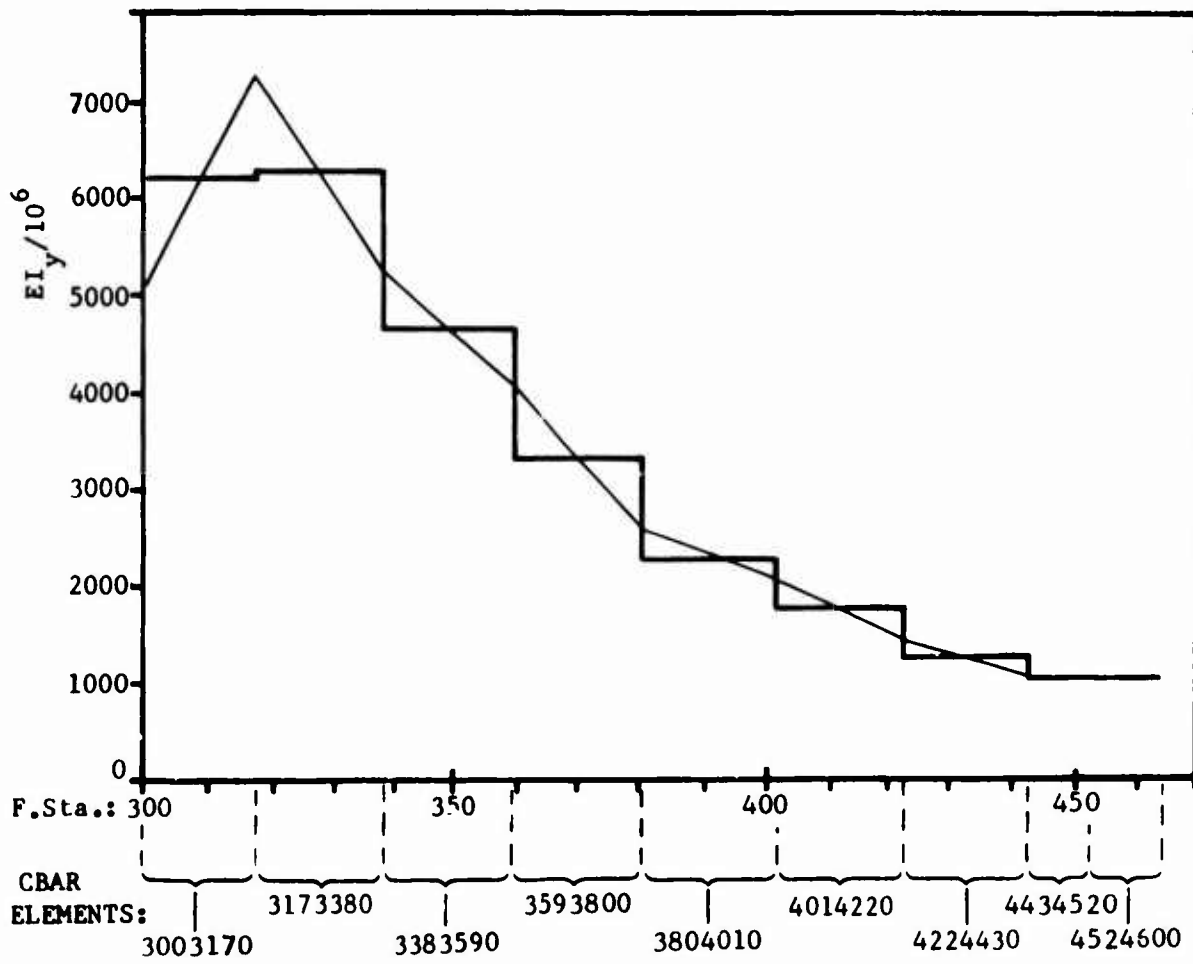
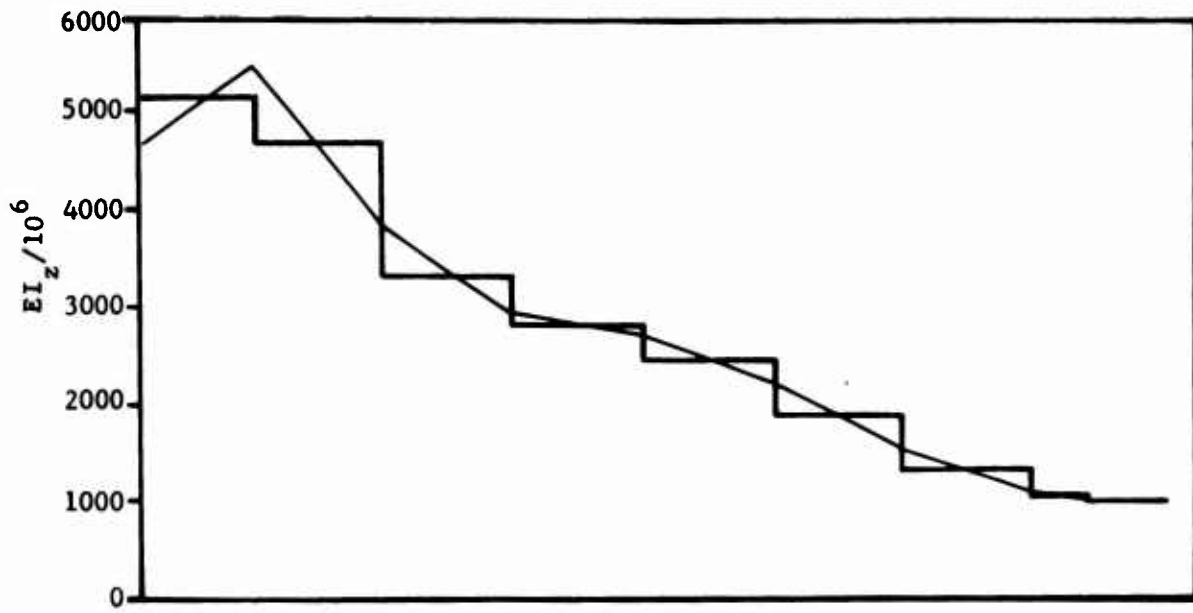

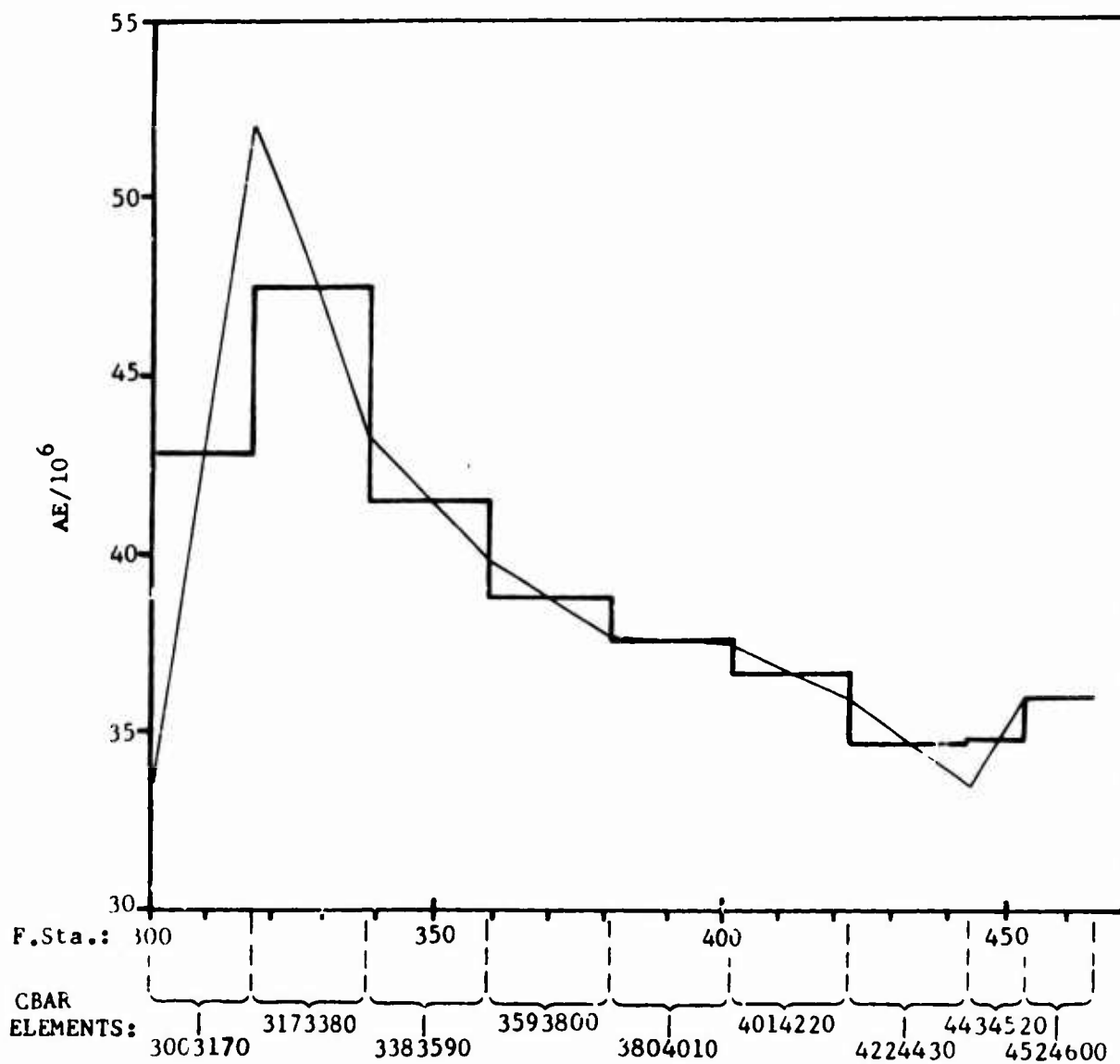
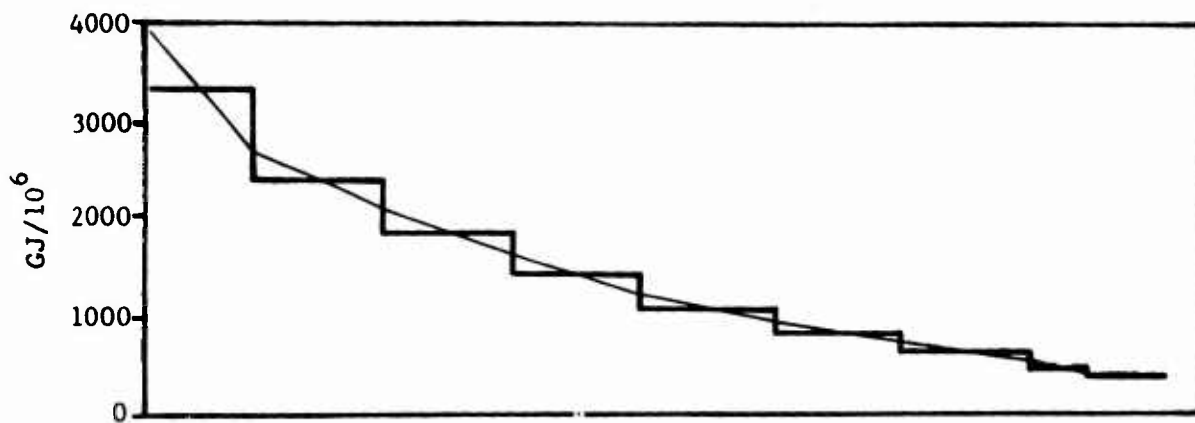

3.3.2.2 Tailboom Bending Stiffness for Maneuver Conditions

A computer program SFCRO2 described in Reference 9, calculates the bending stiffness section properties for a given shear and bending moment distribution due to flight maneuver loads. The tailboom, constructed of longerons, stringers, and aluminum skin, has some skin width on either side of the axial members effective in reacting bending loads. All of the skin is assumed effective when the axial member is in tension and the amount of effective skin decreases as the compressive load in the member increases.

The program determines the section properties, unsymmetrical bending stresses, element loads and shear flows for a single cell torque box. Figure 3-1 shows typical input geometry data defining the skin contour and centroids of axial members (stringers and longerons). Section properties are computed from the input geometry. This includes mounted axis location, shear center location, moments of inertia about the neutral axes, maximum and minimum moments of inertia, angle to principal axis and torsional stiffness. The skin area is lumped at the centroid of the axial members in the neutral axis and moment of inertia calculations which would result in the bending stiffness being slightly low since the skin area should be acting at contour. Bending moments are computed at the neutral axis and torsion is computed at the reference axis for the first condition. Bending stresses are computed by use of the standard unsymmetrical bending equation:

$$f_b = \frac{M'_y I_{yz} - M'_z I_y}{I_y I_z - I_{yz}^2} \cdot Y + \frac{M'_z I_{yz} - M'_y I_z}{I_y I_z - I_{yz}^2} \cdot Z' \quad \text{Ref. (10)}$$

Element loads are then computed at this station. The same process is repeated at the next station aft.

Using the previously calculated stress levels, an effective skin width, W , on either side of each element is found by using the following equation:

$$W = .85t \sqrt{\frac{E_c}{f_c}} \quad \text{Ref. (10)}$$

Where $E_c = 10.5 \times 10^6$ psi (entire structure based on aluminum)

f_c = Computed compression stress

t = Skin thickness in equivalent aluminum

This equation is based on flat sheets and should be conservative for the curved tailboom skin resulting in the bending stiffness calculations being low. A limit of W equals one-half of the arc length between elements is applied to this equation. If f_b is tension (τ) then W equals one-half the arc length. New areas are computed for each element and section properties and bending stresses are calculated. New effective skin widths are found, based on the new stress levels, and compared with the previous widths. If a five percent (5%) difference is evident the process continues up to a maximum of ten (10) iterations.

The computed vertical and lateral bending stiffnesses for the tailboom are listed in Table 3-1 for the following maneuver conditions.

- (1) Maximum speed - power on
- (2) Symmetric pullout
- (3) Rolling pullout - tail rotor thrust, right
- (4) Rolling pullout - tail rotor thrust, left
- (5) Yaw $+15^\circ$ (nose right) and recover - forward cg
- (6) Yaw -15° (nose left) and recover - forward cg

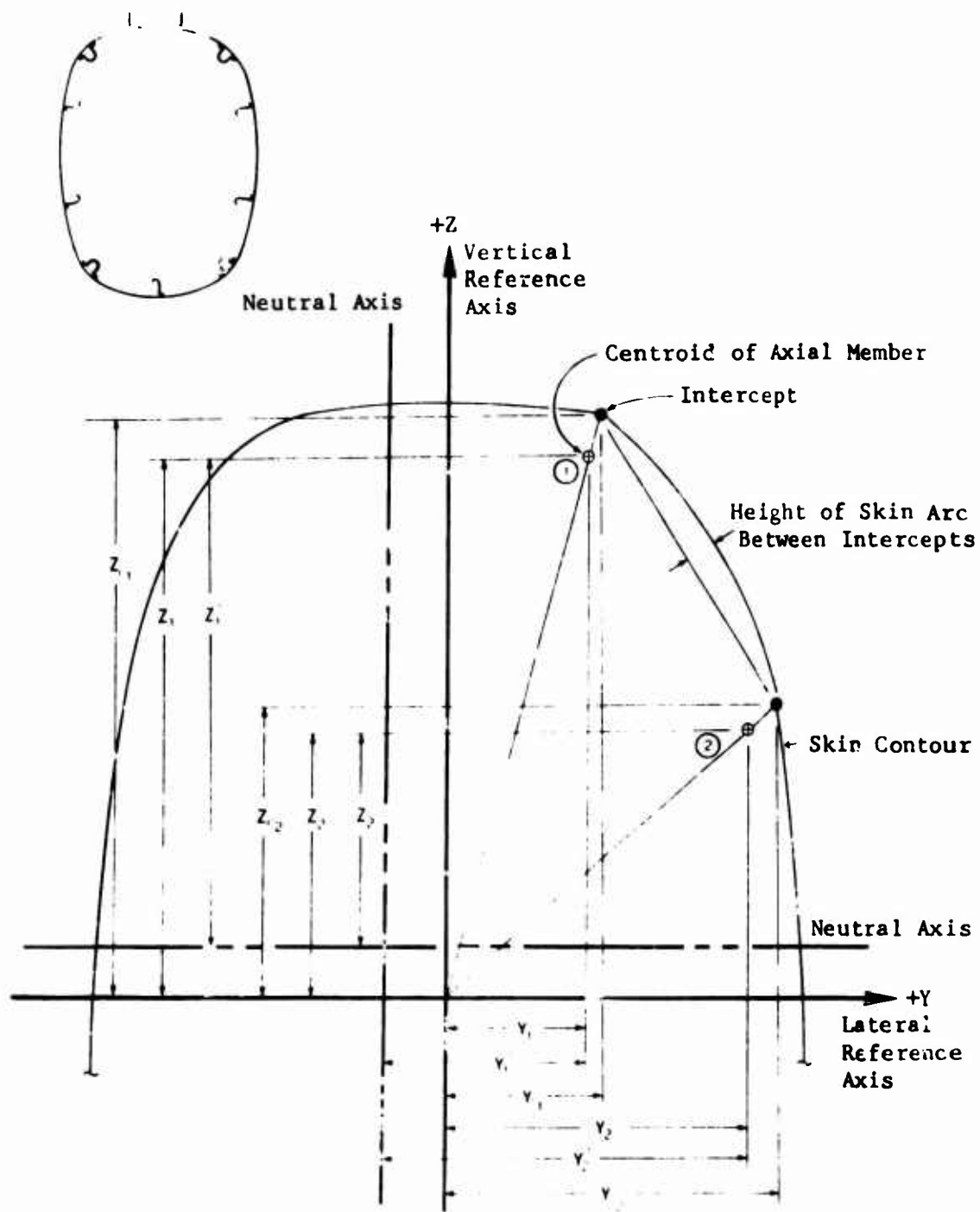

Figure 3-1. SFCR02 Input Geometry for a Typical Tailboom Section

TABLE 3-1. TAILBOOM BENDING STIFFNESS FOR MANEUVER CONDITIONS

$EI_y/10^6$ (Lateral Stiffness)

| FLY. STATION CONDITION | 299.570 | 317.715 | 338.614 | 359.514 | 380.424 | 401.333 | 422.243 | 443.153 | 452.255 |
|---|---------|---------|---------|---------|---------|---------|---------|---------|---------|
| BASELINE | 5126.63 | 7362.60 | 5237.51 | 4063.71 | 2582.90 | 2020.94 | 1543.82 | 1101.62 | 1124.45 |
| MAXSPEED | 4381.86 | 5574.33 | 4022.03 | 3168.80 | 2303.18 | 1835.19 | 1428.32 | 1044.33 | 1090.85 |
| SYMMETRIC PULLOUT | 4130.18 | 5451.60 | 3659.57 | 2920.26 | 2126.88 | 1759.49 | 1396.82 | 1035.51 | 1027.85 |
| ROLLING PULLOUT TAIL ROTOR THRUST RT. | 4215.65 | 5730.85 | 3925.64 | 3085.85 | 2264.33 | 1720.95 | 1335.81 | 969.99 | 965.69 |
| ROLLING PULLOUT TAIL ROTOR THRUST LEFT. | 4169.34 | 5460.32 | 3647.70 | 2930.97 | 2154.39 | 1808.00 | 1434.09 | 1048.43 | 1058.61 |
| YAW +15° AND RECOVER-FWD CG | 4129.44 | 5200.13 | 3572.52 | 2815.08 | 2043.51 | 1602.20 | 1248.56 | 916.23 | 913.19 |
| YAW -15° AND RECOVER-FWD CG | 4187.30 | 5511.35 | 3492.33 | 2717.51 | 2031.96 | 1608.92 | 1253.49 | 921.38 | 938.49 |

$EI_z/10^6$ (Vertical Stiffness)

| FLY. STATION CONDITION | 299.570 | 317.715 | 338.614 | 359.514 | 380.424 | 401.333 | 422.243 | 443.153 | 452.255 |
|---|---------|---------|---------|---------|---------|---------|---------|---------|---------|
| BASELINE | 4716.81 | 5559.96 | 3813.81 | 2939.79 | 2655.14 | 2182.95 | 1656.59 | 1180.94 | 1008.00 |
| MAXSPEED | 3959.97 | 4532.85 | 3086.06 | 2420.57 | 2218.34 | 1877.72 | 1482.39 | 1102.40 | 963.27 |
| SYMMETRIC PULLOUT | 3861.38 | 4436.04 | 2991.87 | 2342.34 | 2187.05 | 1866.48 | 1470.95 | 1094.52 | 953.19 |
| ROLLING PULLOUT TAIL ROTOR THRUST RT. | 3697.79 | 4366.22 | 2970.66 | 2333.94 | 2131.92 | 1753.50 | 1376.55 | 1020.08 | 887.57 |
| ROLLING PULLOUT TAIL ROTOR THRUST LEFT. | 3891.72 | 4507.97 | 2955.02 | 2326.80 | 2203.11 | 1935.89 | 1520.51 | 1115.21 | 967.68 |
| YAW +15° AND RECOVER-FWD CG | 3524.12 | 4177.32 | 2959.36 | 2247.80 | 2039.84 | 1666.88 | 1308.83 | 973.14 | 848.82 |
| YAW -15° AND RECOVER-FWD CG | 3718.47 | 4347.74 | 2619.33 | 1997.94 | 1914.47 | 1619.31 | 1277.64 | 956.86 | 838.22 |

3.3.2 Vertical Fin Subassembly and Detail

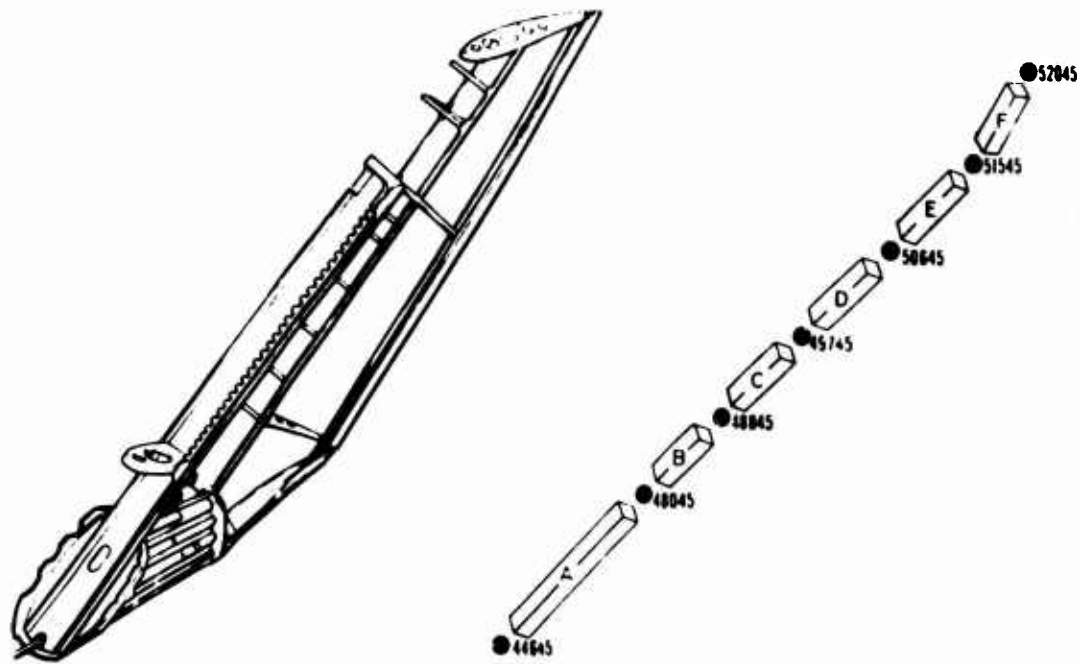

GRID POINT DATA

| GRID POINT | SPC | | MPC | | OMIT | |
|------------|--------|------|--------|------|--------|-------|
| | D.O.F. | RULE | D.O.F. | RULE | D.O.F. | RULE |
| 46445 | - | - | - | - | 456 | AAA |
| 48045 | - | - | - | - | 23456 | DDAAA |
| 48845 | - | - | - | - | 1456 | DAAA |
| 49745 | - | - | - | - | 3456 | DAAA |
| 50645 | - | - | - | - | 12456 | DDAAA |
| 51545 | - | - | - | - | 3456 | DAAA |
| 52045 | - | - | - | - | 456 | AAA |

CBAR ELEMENT DATA

| LETTER DESIGNATION | NASTRAN EID | SECTION PROPERTIES | | | |
|--------------------|-------------|--------------------------|-------------------------------------|-------------------------------------|-----------------------------|
| | | AREA (in. ²) | INERTIA-PLANE 1 (in. ⁴) | INERTIA-PLANE 2 (in. ⁴) | TORSION (in. ⁴) |
| A | 4644800 | 3.667 | 490.48 | 30.50 | 28.375 |
| B | 4804880 | 3.346 | 180.95 | 28.00 | 20.300 |
| C | 4884970 | 3.114 | 154.29 | 25.33 | 17.250 |
| D | 4975060 | 2.881 | 146.67 | 22.50 | 14.200 |
| E | 5065150 | 2.652 | 100.95 | 16.83 | 12.125 |
| F | 5155200 | 2.424 | 61.90 | 12.00 | 10.925 |

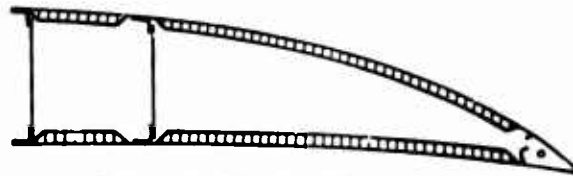

Typical Fin Section



Beading Section Used for Stiffness Calculations

3.3.2.1 Vertical Fin Stiffness Distribution

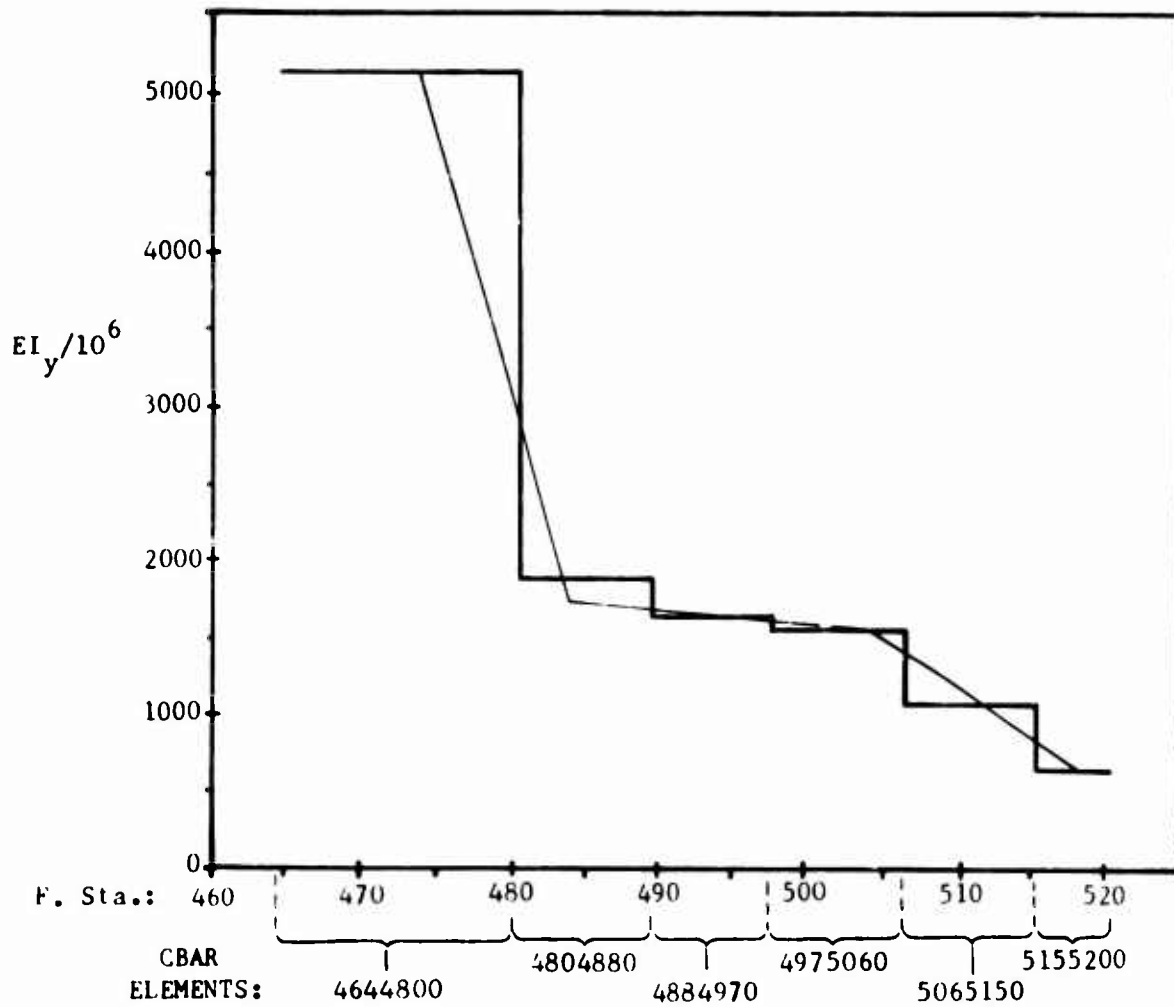
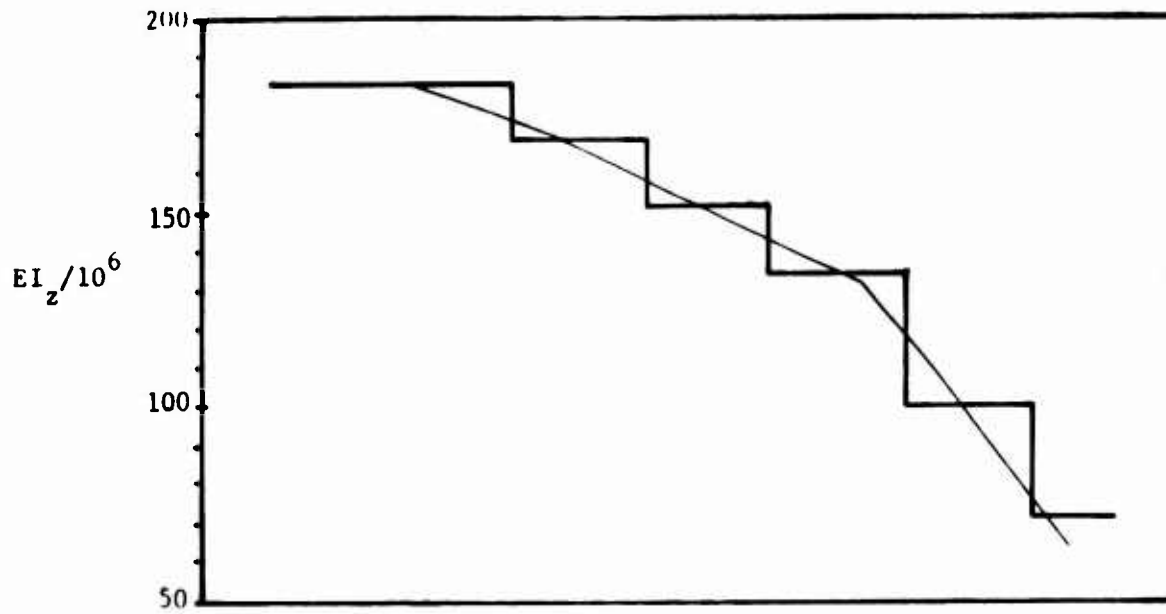

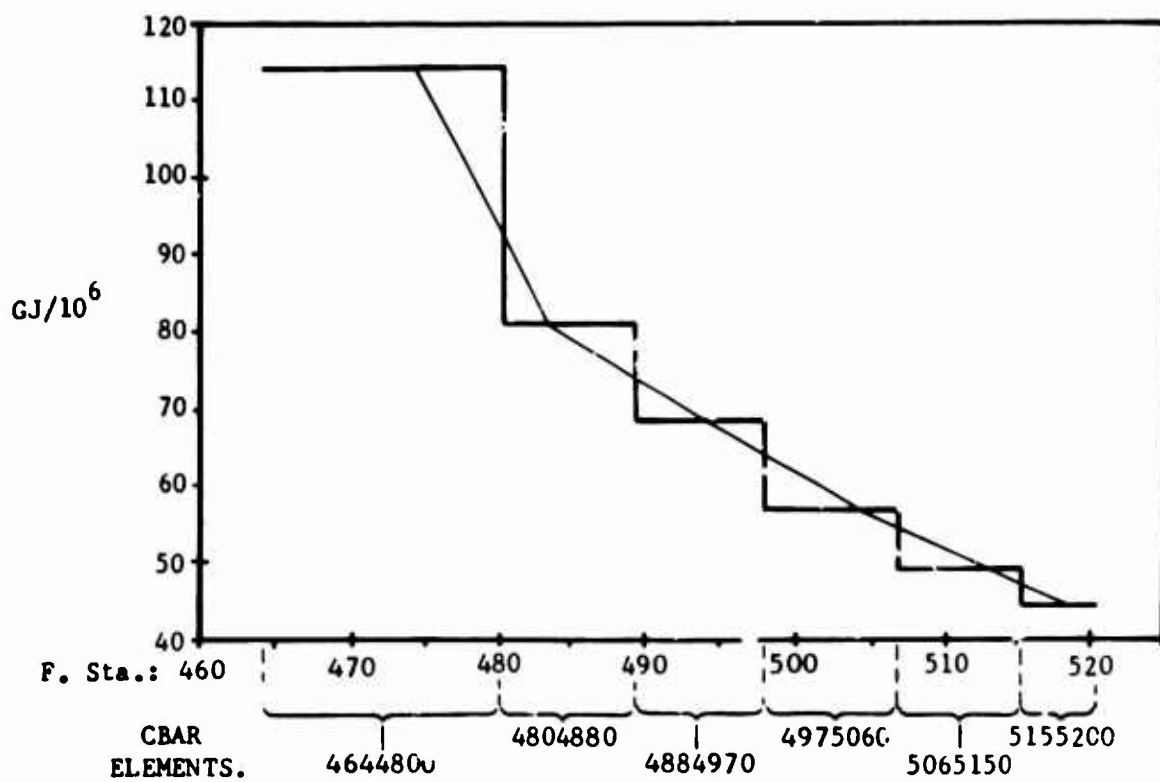
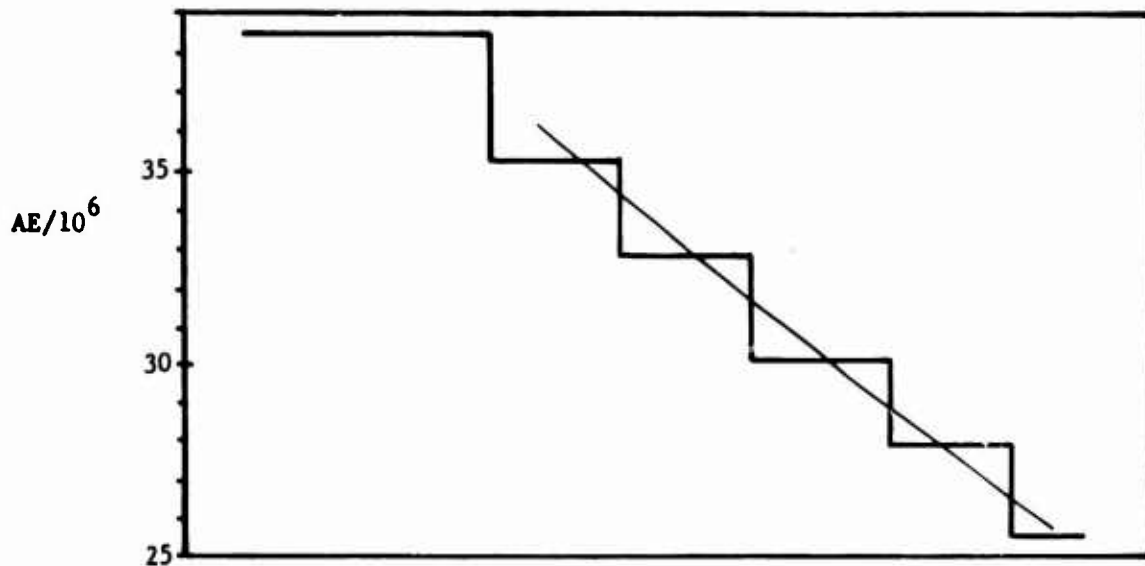

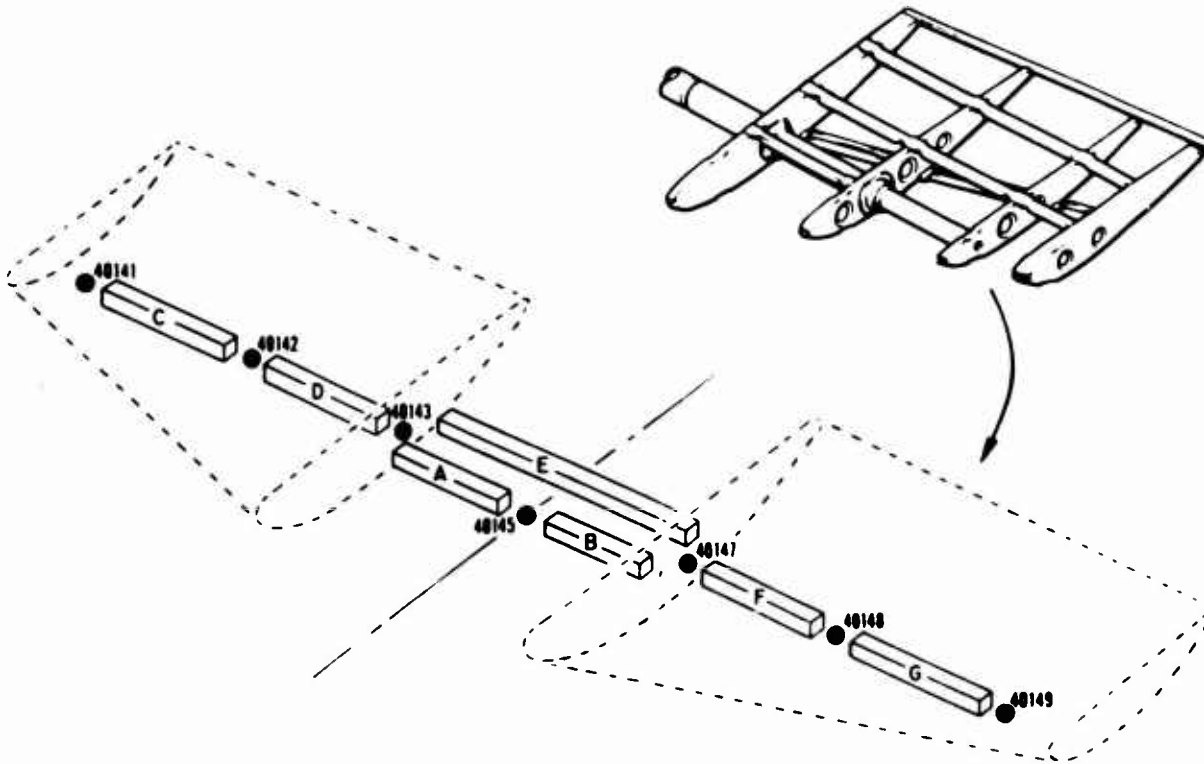

3.3.3 Elevator Subassembly and Detail



GRID POINT DATA

| GRID POINT | SPC | | MPC | | OMIT | |
|------------|--------|------|--------|------|--------|--------|
| | D.O.F. | RULE | D.O.F. | RULE | D.O.F. | RULE |
| 40141 | - | - | - | - | 2456 | DAAA |
| 40142 | - | - | - | - | 123456 | BDBAAA |
| 40143 | - | - | - | - | 123456 | BDBAAA |
| 40145 | - | - | - | - | 456 | AAA |
| 40147 | - | - | - | - | 123456 | BDBAAA |
| 40148 | - | - | - | - | 123456 | BDBAAA |
| 40149 | - | - | - | - | 2456 | DAAA |

CBAR ELEMENT DATA

| LETTER DESIGNATION | NASTRAN EID | SECTION PROPERTIES | | | |
|---|-------------|--------------------------|-------------------------------------|-------------------------------------|-----------------------------|
| | | AREA (in. ²) | INERTIA-PLANE 1 (in. ⁴) | INERTIA-PLANE 2 (in. ⁴) | TORSION (in. ⁴) |
| A  | 4014345 | 2.314 | 1.353 | 1.353 | 2.706 |
| B  | 4014547 | 2.314 | 1.353 | 1.353 | 2.706 |
| C | 4014142 | 0.947 | 0.451 | 0.451 | 0.901 |
| D | 4014243 | 1.675 | 0.894 | 0.894 | 1.788 |
| E | 4014347 | 2.314 | 1.353 | 1.353 | 2.706 |
| F | 4014748 | 1.675 | 0.894 | 0.894 | 1.788 |
| G | 4014849 | 0.947 | 0.451 | 0.451 | 0.901 |

NOTES -



Pin flags at End A: 56



Pin flags at End B: 56

3.3.4 Tail Rotor Mast Subassembly and Detail

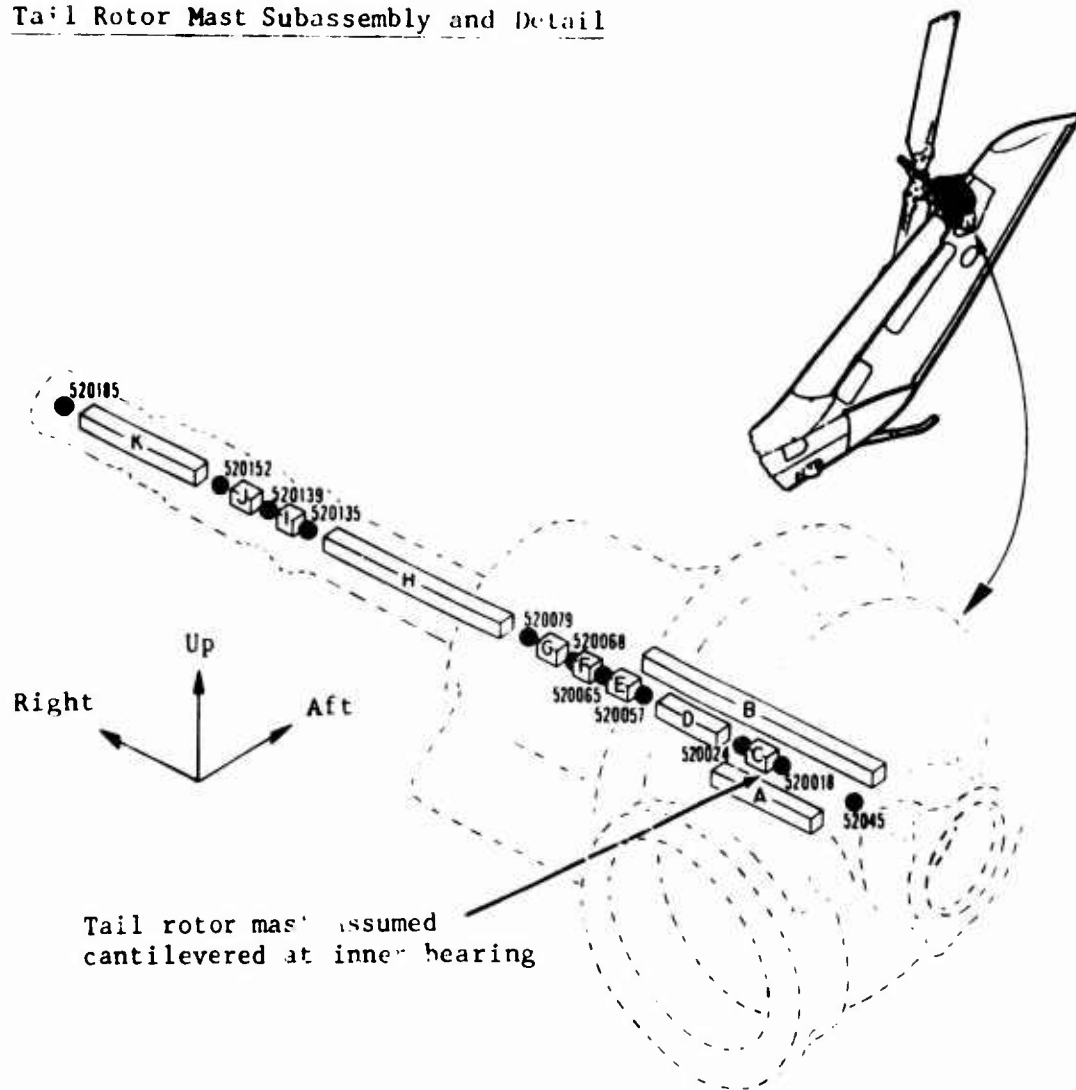

GRID POINT DATA

| GRID POINT | SPC | | MPC | | OMIT | |
|------------|--------|------|--------|------|--------|--------|
| | D.O.F. | RULE | D.O.F. | RULE | D.O.F. | RULE |
| 52045 | - | - | - | - | 456 | AAA |
| 520018 | - | - | - | - | 2456 | DAAA |
| 520024 | - | - | - | - | 123456 | BDBAAA |
| 520057 | - | - | - | - | 2456 | DAAA |
| 520065 | - | - | - | - | 123456 | BDBAAA |
| 520068 | - | - | - | - | 123456 | BDBAAA |
| 520079 | - | - | - | - | 2456 | DAAA |
| 520135 | - | - | - | - | 123456 | BDBAAA |

GRID POINT DATA (CONT.)

| GRID POINT | SPC | | MPC | | OMIT | |
|------------|--------|------|--------|------|--------|--------|
| | D.O.F. | RULE | D.O.F. | RULE | D.O.F. | RULE |
| 520139 | - | - | - | - | 2456 | DAAA |
| 520152 | - | - | - | - | 456 | AAA |
| 520185 | - | - | - | - | 123456 | BDBAAA |

CBAR ELEMENT DATA

| LETTER DESIGNATION | NASTRAN EID | SECTION PROPERTIES | | | |
|---|-------------|--------------------------|-------------------------------------|-------------------------------------|-----------------------------|
| | | AREA (in. ²) | INERTIA-PLANE 1 (in. ⁴) | INERTIA-PLANE 2 (in. ⁴) | TORSION (in. ⁴) |
| A | 4000071 | 10.000 | 3.250 | 3.250 | 6.500 |
| B  | 4000072 | 10.000 | 3.250 | 3.250 | 6.500 |
| C | 4020091 | 1.109 | 0.239 | 0.239 | 0.479 |
| D | 4020092 | 0.936 | 0.191 | 0.191 | 0.382 |
| E | 4020093 | 0.944 | 0.164 | 0.164 | 0.327 |
| F | 4020094 | 1.003 | 0.179 | 0.179 | 0.358 |
| G | 4020095 | 1.124 | 0.184 | 0.184 | 0.368 |
| H | 4020096 | 0.818 | 0.115 | 0.115 | 0.230 |
| I | 4020097 | 0.644 | 0.079 | 0.079 | 0.159 |
| J | 4020098 | 0.651 | 0.081 | 0.081 | 0.162 |
| K | 4020099 | 0.651 | 0.081 | 0.081 | 0.162 |

NOTES -



Pin flags at End B: 450

4. WEIGHTS MODELING

Most of the approximately 5700 weight items in the helicopter are distributed automatically to the grid points of the NASTRAN model; however, useful loads and some large weight items are distributed separately. This section describes a computer program used to generate NASTRAN weights data and methods used for the allocation of useful loads and large weight items in the modeling.

4.1 AUTOMATIC WEIGHT DISTRIBUTION PROGRAM (SDSN02)

The program SDSN02 (Reference 1) computes the distribution of helicopter weight items to grid points in the model and generates NASTRAN concentrated mass data in the form of CONM2 cards. Using the program involves first dividing the helicopter into regions or boxes. Data defining these regions along with the GRID data from the model and the detailed weights tape are input to SDSN02. The center of gravity of all the weight items that lie within each region is computed and the total region weight is distributed to the grid points in the region. The weights distributed to each grid point are summed for all regions and resulting weights are punched on CONM2 cards. The flow of the program is shown schematically in Figure 4-1.

The formula for distributing the total region weight to the j^{th} grid point in the region is given below.

$$W_j = \frac{W_r / L_j}{\sum_{i=1}^n (1/L_i)}$$

where:

W_r = region weight

L_j = distance from region cg to grid point j

L_i = distance from region cg to grid point i

n = number of grid points in the region

This formula preserves the total weight of the region and distributes the weight to each grid point based on its proximity to the cg, i.e., the closer the grid point, the larger the weight. The formula does not necessarily preserve the cg of the region. However, this is not considered to be a problem provided the regions are kept small and are chosen to include a balanced set of grid points within the region.

The detailed weights tape for the FY'71 Model AH-1G used in the modeling is being kept on permanent file at BHC. The tape is identified as follows: Weights Group Data File for the Model 209 (AH-1G) Sorted by AN (Army/Navy) Code - File Number SDSN01-F1G.

4.1.1 Weight Regions and NASTRAN Weights Data (CONM2)

Because of the model size, the AH-1G NASTRAN dynamic model is divided into three major sections, each requiring a separate SDSN02 data deck.

- (1) Fuselage excluding wings and main rotor pylon
- (2) Tailboom and wings
- (3) Main rotor pylon

The fuselage section includes the built-up fuselage structure (station 28 to 300) and skid landing gear and is divided into 194 regions. The engine and XM-28 gun turret weights are not processed with SDSN02. The distribution of these weight items is discussed in Section 4.2. The region locations, grid points within each region, and CONM2 cards generated for this section are listed in Table 4-1.

The tailboom and wings section consists of 48 regions encompassing the tailboom, vertical fin, elevator, tail rotor mast, and wings. The regions, associated grid points and CONM2 cards created for this section are listed in Table 4-2.

The main rotor pylon section has 16 regions and includes the rotating controls, main transmission, and mast. The regions, associated grid points and CONM2 cards generated for this section are listed in Table 4-3.

4.2 DISTRIBUTION OF LARGE WEIGHTS AND USEFUL LOADS

Weight items on the helicopter that are not automatically distributed by the weights program are the following:

- Lycoming T53-L13 Engine
- XM-28 Gun Turret
- Main Rotor and Tail Rotor
- Useful Weights

4.2.1 Lycoming T53-L13 Engine

The engine weight items and corresponding Army/Navy (AN) code number are listed below.

| | | |
|--|---|----------------|
| - Engine (AN 24051) | = | 530.00 lb |
| - Starter-Generator (AN 27225) | = | 48.00 lb |
| - Residual Fluid (AN 24061) | = | 5.00 lb |
| - One-Half Drive Shaft (AN 30051) | = | 1.55 lb |
| - Transmitter Dual Tachometer (AN 32054) | = | <u>0.80 lb</u> |
| Total Engine Weight | = | 585.35 lb |

The weight moments of inertia about the cg of the engine are given below.

$$\begin{aligned} I_{\text{roll}} &= 17,800 \text{ (lb-in}^2\text{)} \\ I_{\text{pitch}} &= 109,500 \text{ (lb-in}^2\text{)} \\ I_{\text{yaw}} &= 94,300 \text{ (lb-in}^2\text{)} \end{aligned}$$

The total weight and inertias of the engine are lumped at grid point 124800 located at the engine cg (station 248., WL 86, and BL 0.). This grid point is tied rigidly to the elastic engine mounts by MPC equations, as explained in Section 3.1.7 of the Stiffness Modeling.

4.2.2 XM-28 Gun Turret

The weight items included in the gun turret system are listed below.

| | | |
|---|---|----------------|
| - Turret Fluid (AN 38051) | = | 1.00 lb |
| - Turret (AN 38051) | = | 124.50 lb |
| - Turret Closure, Right Side (AN 38051) | = | 2.30 lb |
| - Turret Closure, Left Side (AN 38051) | = | 2.30 lb |
| - Turret Rub Strip (AN 38051) | = | 0.10 lb |
| - Launcher (AN 38061) | = | 40.80 lb |
| - Cradle (AN 38061) | = | 10.30 lb |
| - Gearbox and Motor (AN 38061) | = | 9.10 lb |
| - Mirigun (AN 38061) | = | 48.30 lb |
| - Cable (AN 38061) | = | 1.00 lb |
| - Gearbox (AN 38061) | = | 1.50 lb |
| - Motor (AN 38061) | = | 7.70 lb |
| - Feed Tray (AN 38061) | = | <u>4.50 lb</u> |

Total Gun Turret Weight = 253.4 lb

The total weight of the gun turret system represented as a rigid body is concentrated at grid point 7505 located at the turret cg (station 75.5, WL 29, and BL 0.). Grid point 7505 is tied to the turret attachment fittings on the fuselage by MPC equations as shown in Section 3.1.2.19 of the Stiffness Modeling. Moments due to turret rigid body motions are represented by the cg offset from the fuselage structure.

4.2.3 Main Rotor and Tail Rotor

The weights of the main rotor and tail rotor as given below.

| | | |
|-----------------------------------|---|-----------------|
| - Blade Inertia Weights (AN 2486) | = | 110.0 lb |
| - Blade Assembly (AN 2546) | = | 348.0 lb |
| - Hub Assembly (AN 3041-3501) | = | <u>489.5 lb</u> |
| Total Main Rotor Weight | = | 947.5 lb |
| - Tail Rotor Blades (AN 8105) | = | 14.3 lb |
| - Tail Rotor Hub (AN 8206) | = | <u>16.5 lb</u> |
| Total Tail Rotor Weight | = | 30.8 lb |

The main rotor weight is lumped at grid point 200153 located at the rotor cg (station 200., WL 153., and BL 0.). The tail rotor blade weight is lumped at its cg location at grid point 520152 (station 520.67, WL 118.27, and BL 15.19), and the tail rotor hub weight is lumped at its cg location at grid point 520139 (station 520.67, WL 118.27, and BL 13.85). Rotor flapping inertias are not included with the rotor weights because of the Bell teetering hinge rotor system which does not transfer flapping moments to the airframe.

4.2.4 Useful Weight Items

The weight items discussed up to this point, including the weight distributed automatically and those previously mentioned in this section, constitute the empty weight items of the helicopter. The total empty weight of the AH-1G is 5760 lb.

The Basic Mission configuration was selected as a representative flyable weight configuration to be used in the modeling. The useful loads for this configuration total 3173 lb and include crew, fuel, wing stores and ammo. This gives a Basic Mission gross weight of 8933 lb. The useful weight items, their locations, associated grid points and offsets (if any) are listed in Table 4-4.

The Basic Mission total weight, cg, and inertias from the grid point weight generator table in NASTRAN are compared with actual weights tape data below.

| Parameter | NASTRAN | Weights Tape |
|-------------------------------------|-------------------------|-------------------------|
| Center of Gravity - Station (in.) | 193.2 | 195.9 |
| WL (in.) | 69.4 | 71.4 |
| BL (in.) | 0.001 | 0. |
| Total Weight (lb) | 8914.15 | 8930.77 |
| Roll Inertia (lb-in ²) | 13.41 x 10 ⁶ | 13.49 x 10 ⁶ |
| Pitch Inertia (lb-in ²) | 62.14 x 10 ⁶ | 61.64 x 10 ⁶ |
| Yaw Inertia (lb-in ²) | 53.78 x 10 ⁶ | 53.06 x 10 ⁶ |

The discrepancy of about 19 lb in the total weight comes from the portion of the empty weights generated by the computer program and is possibly due to accumulated error resulting from processing the thousands of weight items and distributing them to the grid points.

Grid points associated with the crew, fuel, and ammo are located at their respective cg's and each is tied to the fuselage by four rods as shown in Figure 4-2. This is done to represent the inertia loads distributed into the structure for these particular weight items. For example, the inertia loads due to the weight of the pilot are distributed into the bulkhead at station 148.50 through the seat support structure. The rods properly distribute loads and moments into the bulkhead caused by fore-and-aft, lateral and vertical accelerations of the weight cg offset forward of the bulkhead.

The wing stores consisting of smoke grenades and AN-157A rockets are offset from grid points at the left and right wing tip ribs, grid points 65929 and 75929. MPC equations are used to distribute moments into the wing structure due to the weight offsets and are shown in Section 3.2.2 of the Stiffness Modeling.

The NASTRAN data deck listing and normal modes run included in Section 8, have included the Basic Mission useful weights; however, the useful weights can be readily changed to another weight configuration. The useful weights are all grouped together in one section of the unsorted Bulk Data deck. In addition, all the CONM2 cards representing Basic Mission useful loads have comments in field 10 indicating the weight configuration. These cards can then be easily located and removed and another set of useful load cards inserted. The useful load data cards for the 9500 lb gross weight HOG II configuration which has a heavier wing stores loading than the Basic Mission are included after the Bulk Data deck and can be interchanged with the Basic Mission cards if the user desires.

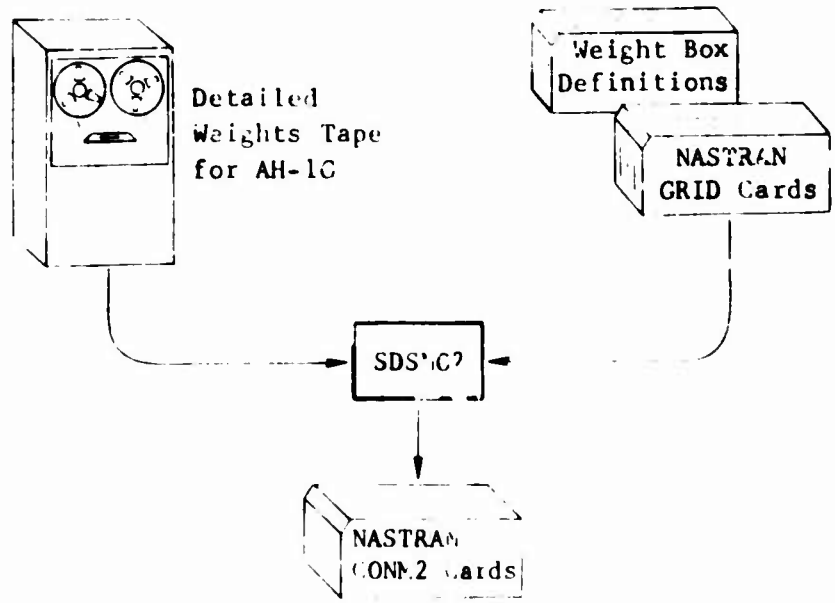
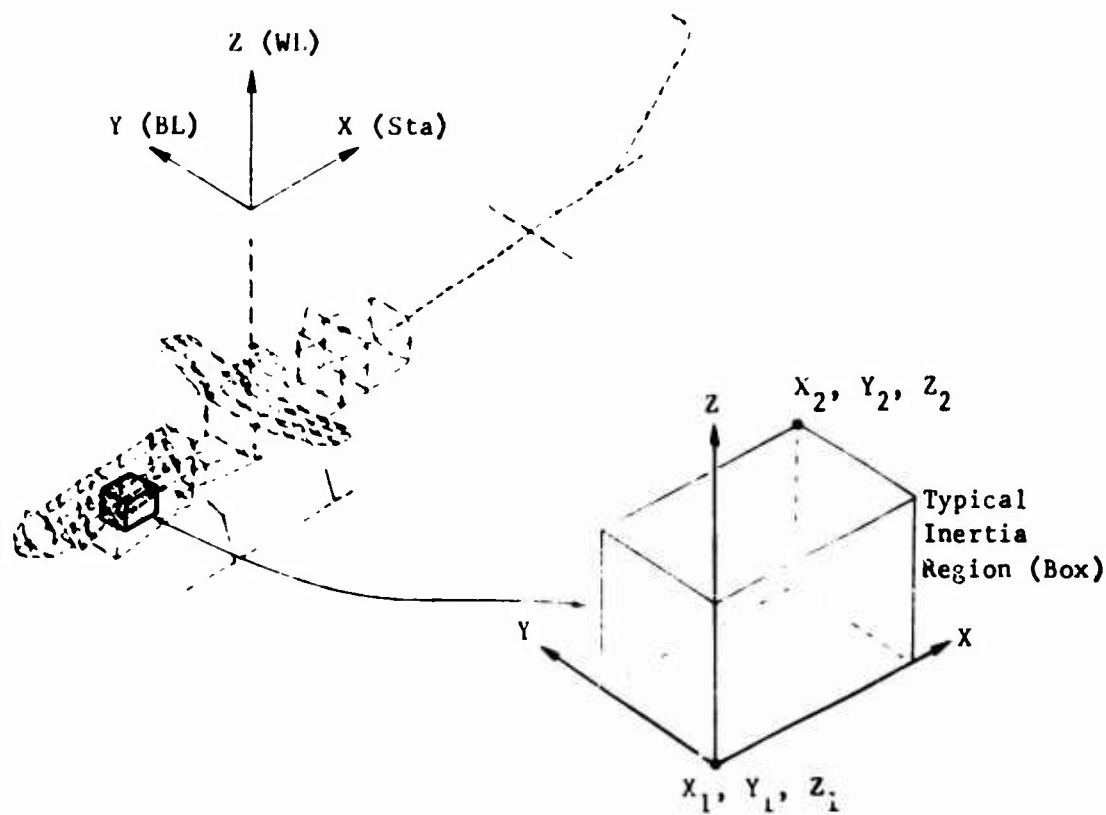

Figure 4-1. Automatic Weight Distribution Program SDSN02

TABLE 4-1. FUSELAGE SECTION - REGIONS AND CONM2 CARDS

| REGION | STATION | | | BUTTLINE | | | WATERLINE | | |
|--------|---------|-------|-------|----------|--------|--------|-----------|--------|--------|
| | X1 | TO | X2 | Y1 | TO | Y2 | Z1 | TO | Z2 |
| 1 | -50.00 | 33.00 | 33.00 | -100.00 | 0.0 | 0.0 | -50.00 | 49.60 | 49.60 |
| 2 | -50.00 | 33.00 | 33.00 | 0.0 | 100.00 | 100.00 | -50.00 | 49.60 | 49.60 |
| 3 | -50.00 | 33.00 | 33.00 | -100.00 | 0.0 | 0.0 | 49.60 | 56.85 | 56.85 |
| 4 | -50.00 | 33.00 | 33.00 | 0.0 | 100.00 | 100.00 | 49.60 | 56.85 | 56.85 |
| 5 | -50.00 | 33.00 | 33.00 | -100.00 | 0.0 | 0.0 | 56.85 | 200.00 | 200.00 |
| 6 | -50.00 | 33.00 | 33.00 | 0.0 | 100.00 | 100.00 | 56.85 | 200.00 | 200.00 |
| 7 | 33.00 | 46.00 | 46.00 | -100.00 | 0.0 | 0.0 | -50.00 | 49.60 | 49.60 |
| 8 | 33.00 | 46.00 | 46.00 | 0.0 | 100.00 | 100.00 | -50.00 | 49.60 | 49.60 |
| 9 | 33.00 | 46.00 | 46.00 | -100.00 | 0.0 | 0.0 | 49.60 | 56.85 | 56.85 |
| 10 | 33.00 | 46.00 | 46.00 | 0.0 | 100.00 | 100.00 | 49.60 | 56.85 | 56.85 |
| 11 | 33.00 | 46.00 | 46.00 | -100.00 | 0.0 | 0.0 | 56.85 | 200.00 | 200.00 |
| 12 | 33.00 | 46.00 | 46.00 | 0.0 | 100.00 | 100.00 | 56.85 | 200.00 | 200.00 |
| 13 | 46.00 | 61.25 | 61.25 | -100.00 | -10.00 | -10.00 | -50.00 | 46.00 | 46.00 |
| 14 | 46.00 | 61.25 | 61.25 | -10.00 | 0.0 | 0.0 | -50.00 | 46.00 | 46.00 |
| 15 | 46.00 | 61.25 | 61.25 | 0.0 | 10.00 | 10.00 | -50.00 | 46.00 | 46.00 |
| 16 | 46.00 | 61.25 | 61.25 | -10.00 | 100.00 | 100.00 | -50.00 | 46.00 | 46.00 |
| 17 | 46.00 | 61.25 | 61.25 | -100.00 | -10.00 | -10.00 | 46.00 | 57.00 | 57.00 |
| 18 | 46.00 | 61.25 | 61.25 | -10.00 | 0.0 | 0.0 | 46.00 | 57.00 | 57.00 |
| 19 | 46.00 | 61.25 | 61.25 | 0.0 | 10.00 | 10.00 | 46.00 | 57.00 | 57.00 |
| 20 | 46.00 | 61.25 | 61.25 | 10.00 | 100.00 | 100.00 | 46.00 | 57.00 | 57.00 |
| 21 | 46.00 | 61.25 | 61.25 | -100.00 | -10.00 | -10.00 | 57.00 | 69.42 | 69.42 |
| 22 | 46.00 | 61.25 | 61.25 | -10.00 | 0.0 | 0.0 | 57.00 | 69.42 | 69.42 |
| 23 | 46.00 | 61.25 | 61.25 | 0.0 | 10.00 | 10.00 | 57.00 | 69.42 | 69.42 |
| 24 | 46.00 | 61.25 | 61.25 | 10.00 | 100.00 | 100.00 | 57.00 | 69.42 | 69.42 |
| 25 | 46.00 | 61.25 | 61.25 | -100.00 | -10.00 | -10.00 | 69.42 | 200.00 | 200.00 |
| 26 | 46.00 | 61.25 | 61.25 | -10.00 | 0.0 | 0.0 | 69.42 | 200.00 | 200.00 |
| 27 | 46.00 | 61.25 | 61.25 | 0.0 | 10.00 | 10.00 | 69.42 | 200.00 | 200.00 |
| 28 | 46.00 | 61.25 | 61.25 | 10.00 | 100.00 | 100.00 | 69.42 | 200.00 | 200.00 |
| 29 | 61.25 | 93.00 | 93.00 | -100.00 | -10.00 | -10.00 | -50.00 | 46.00 | 46.00 |
| 30 | 61.25 | 93.00 | 93.00 | -10.00 | 10.00 | 10.00 | -50.00 | 46.00 | 46.00 |
| 31 | 61.25 | 93.00 | 93.00 | 10.00 | 100.00 | 100.00 | -50.00 | 46.00 | 46.00 |
| 32 | 61.25 | 70.79 | 70.79 | -100.00 | -10.00 | -10.00 | 46.00 | 54.16 | 54.16 |
| 33 | 61.25 | 70.79 | 70.79 | -10.00 | 10.00 | 10.00 | 46.00 | 54.16 | 54.16 |
| 34 | 61.25 | 70.79 | 70.79 | 10.00 | 100.00 | 100.00 | 46.00 | 54.16 | 54.16 |
| 35 | 61.25 | 70.79 | 70.79 | -100.00 | -10.00 | -10.00 | 54.16 | 60.00 | 60.00 |
| 36 | 61.25 | 70.79 | 70.79 | -10.00 | 10.00 | 10.00 | 54.16 | 60.00 | 60.00 |
| 37 | 61.25 | 70.79 | 70.79 | 10.00 | 100.00 | 100.00 | 54.16 | 60.00 | 60.00 |
| 38 | 61.25 | 70.79 | 70.79 | -100.00 | -10.00 | -10.00 | 60.00 | 200.00 | 200.00 |
| 39 | 61.25 | 70.79 | 70.79 | -10.00 | 10.00 | 10.00 | 60.00 | 200.00 | 200.00 |
| 40 | 61.25 | 70.79 | 70.79 | 10.00 | 100.00 | 100.00 | 60.00 | 200.00 | 200.00 |
| 41 | 70.79 | 85.26 | 85.26 | -100.00 | -10.00 | -10.00 | 46.00 | 54.38 | 54.38 |
| 42 | 70.79 | 85.26 | 85.26 | -10.00 | 10.00 | 10.00 | 46.00 | 54.38 | 54.38 |
| 43 | 70.79 | 85.26 | 85.26 | 10.00 | 100.00 | 100.00 | 46.00 | 54.38 | 54.38 |
| 44 | 70.79 | 85.26 | 85.26 | -100.00 | -10.00 | -10.00 | 54.38 | 60.38 | 60.38 |
| 45 | 70.79 | 85.26 | 85.26 | -10.00 | 10.00 | 10.00 | 54.38 | 60.38 | 60.38 |
| 46 | 70.79 | 85.26 | 85.26 | 10.00 | 100.00 | 100.00 | 54.38 | 60.38 | 60.38 |
| 47 | 70.79 | 85.26 | 85.26 | -100.00 | -10.00 | -10.00 | 60.38 | 200.00 | 200.00 |
| 48 | 70.79 | 85.26 | 85.26 | -10.00 | 10.00 | 10.00 | 60.38 | 200.00 | 200.00 |

TABLE 4-1. FUSELAGE SECTION - REGIONS AND CONM2 CARDS (CONT'D)

| | | | | | | |
|-----|--------|--------|---------|--------|--------|--------|
| 49 | 70.79 | 85.26 | 10.00 | 100.00 | 60.33 | 200.00 |
| 50 | 85.26 | 93.00 | -100.00 | -10.00 | 46.00 | 54.72 |
| 51 | 85.26 | 93.00 | -10.00 | 10.00 | 46.00 | 54.72 |
| 52 | 85.26 | 93.00 | 10.00 | 100.00 | 46.00 | 54.72 |
| 53 | 85.26 | 93.00 | -100.00 | -10.00 | 54.72 | 60.96 |
| 54 | 85.26 | 93.00 | -10.00 | 10.00 | 54.72 | 60.96 |
| 55 | 85.26 | 93.00 | 10.00 | 100.00 | 54.72 | 60.96 |
| 56 | 85.26 | 93.00 | -100.00 | -10.00 | 60.96 | 200.00 |
| 57 | 85.26 | 93.00 | -10.00 | 10.00 | 60.96 | 200.00 |
| 58 | 85.26 | 93.00 | 10.00 | 100.00 | 60.96 | 200.00 |
| 59 | 93.00 | 250.00 | -100.00 | 0.0 | -50.00 | 15.00 |
| 60 | 93.00 | 250.00 | 0.0 | 100.00 | -50.00 | 15.00 |
| 61 | 93.00 | 138.70 | -100.00 | -10.00 | 15.00 | 27.00 |
| 62 | 93.00 | 138.70 | -10.00 | 10.00 | 15.00 | 27.00 |
| 63 | 93.00 | 138.70 | 10.00 | 100.00 | 15.00 | 27.00 |
| 64 | 93.00 | 138.70 | -100.00 | -10.00 | 27.00 | 46.00 |
| 65 | 93.00 | 138.70 | -10.00 | 10.00 | 27.00 | 46.00 |
| 66 | 93.00 | 138.70 | 10.00 | 100.00 | 27.00 | 46.00 |
| 67 | 93.00 | 115.58 | -100.00 | -10.00 | 46.00 | 55.00 |
| 68 | 93.00 | 115.58 | -10.00 | 10.00 | 46.00 | 55.00 |
| 69 | 93.00 | 115.58 | 10.00 | 100.00 | 46.00 | 55.00 |
| 70 | 93.00 | 115.58 | -100.00 | -10.00 | 55.00 | 61.44 |
| 71 | 93.00 | 115.58 | -10.00 | 10.00 | 55.00 | 61.44 |
| 72 | 93.00 | 115.58 | 10.00 | 100.00 | 55.00 | 61.44 |
| 73 | 93.00 | 115.58 | -100.00 | -10.00 | 61.44 | 67.23 |
| 74 | 93.00 | 115.58 | -10.00 | 10.00 | 61.44 | 67.23 |
| 75 | 93.00 | 115.58 | 10.00 | 100.00 | 61.44 | 67.23 |
| 76 | 93.00 | 115.58 | -100.00 | -10.00 | 67.23 | 200.00 |
| 77 | 93.00 | 115.58 | -10.00 | 10.00 | 67.23 | 200.00 |
| 78 | 93.00 | 115.58 | 10.00 | 100.00 | 67.23 | 200.00 |
| 79 | 115.58 | 138.70 | -100.00 | -10.00 | 46.00 | 54.90 |
| 80 | 115.58 | 138.70 | -10.00 | 10.00 | 46.00 | 54.90 |
| 81 | 115.58 | 138.70 | 10.00 | 100.00 | 46.00 | 54.90 |
| 82 | 115.58 | 138.70 | -100.00 | -10.00 | 54.90 | 62.17 |
| 83 | 115.58 | 138.70 | -10.00 | 10.00 | 54.90 | 62.17 |
| 84 | 115.58 | 138.70 | 10.00 | 100.00 | 54.90 | 62.17 |
| 85 | 115.58 | 138.70 | -100.00 | -10.00 | 62.17 | 200.00 |
| 86 | 115.58 | 138.70 | -10.00 | 10.00 | 62.17 | 200.00 |
| 87 | 115.58 | 138.70 | 10.00 | 100.00 | 62.17 | 200.00 |
| 88 | 138.70 | 148.50 | -100.00 | -10.00 | 15.00 | 27.00 |
| 89 | 138.70 | 148.50 | -10.00 | 10.00 | 15.00 | 27.00 |
| 90 | 138.70 | 148.50 | -10.00 | 100.00 | 15.00 | 27.00 |
| 91 | 138.70 | 148.50 | -100.00 | -10.00 | 27.00 | 35.97 |
| 92 | 138.70 | 148.50 | -10.00 | 10.00 | 27.00 | 35.97 |
| 93 | 138.70 | 148.50 | -10.00 | 100.00 | 27.00 | 35.97 |
| 94 | 138.70 | 148.50 | -100.00 | -10.00 | 35.97 | 46.00 |
| 95 | 138.70 | 148.50 | -10.00 | 10.00 | 35.97 | 46.00 |
| 96 | 138.70 | 148.50 | 10.00 | 100.00 | 35.97 | 46.00 |
| 97 | 138.70 | 148.50 | -100.00 | -10.00 | 46.00 | 54.90 |
| 98 | 138.70 | 148.50 | -10.00 | 10.00 | 46.00 | 54.90 |
| 99 | 138.70 | 148.50 | 10.00 | 100.00 | 46.00 | 54.90 |
| 100 | 138.70 | 148.50 | -100.00 | -10.00 | 54.90 | 62.17 |

TABLE 4-1. FUSELAGE SECTION - REGIONS AND CONM2 CARDS (CONT'D)

| | | | | | | |
|----------------|-------------------|-------------------|--------------------|-------------------|------------------|-------------------|
| 101 | 138.70 | 148.50 | -10.00 | 10.00 | 54.90 | 62.84 |
| 102 | 138.70 | 148.50 | 10.00 | 100.00 | 54.90 | 62.84 |
| 103 | 138.70 | 148.50 | -100.00 | -10.00 | 62.84 | 200.00 |
| 104 | 138.70 | 148.50 | -10.00 | 10.00 | 62.84 | 200.00 |
| 105 | 138.70 | 148.50 | 10.00 | 100.00 | 62.84 | 200.00 |
| 106 | 148.50 | 156.41 | -100.00 | -10.00 | 15.00 | 27.00 |
| 107 | 148.50 | 156.41 | -10.00 | 10.00 | 15.00 | 27.00 |
| 108 | 148.50 | 156.41 | 10.00 | 100.00 | 15.00 | 27.00 |
| 109 | 148.50 | 156.41 | -100.00 | -10.00 | 27.00 | 35.97 |
| 110 | 148.50 | 156.41 | -10.00 | 10.00 | 27.00 | 35.97 |
| 111 | 148.50 | 156.41 | 10.00 | 100.00 | 27.00 | 35.97 |
| 112 | 156.41 | 186.25 | -100.00 | -10.00 | 15.00 | 27.00 |
| 113 | 156.41 | 186.25 | -10.00 | 10.00 | 15.00 | 27.00 |
| 114 | 156.41 | 186.25 | 10.00 | 100.00 | 15.00 | 27.00 |
| 115 | 156.41 | 186.25 | -100.00 | -10.00 | 27.00 | 35.97 |
| 116 | 156.41 | 186.25 | -10.00 | 10.00 | 27.00 | 35.97 |
| 117 | 156.41 | 186.25 | 10.00 | 100.00 | 27.00 | 35.97 |
| 118 | 186.25 | 218.97 | -100.00 | -10.00 | 15.00 | 27.00 |
| 119 | 186.25 | 218.97 | -10.00 | 10.00 | 15.00 | 27.00 |
| 120 | 186.25 | 218.97 | 10.00 | 100.00 | 15.00 | 27.00 |
| 121 | 186.25 | 218.97 | -100.00 | -10.00 | 27.00 | 35.97 |
| 122 | 186.25 | 218.97 | -10.00 | 10.00 | 27.00 | 35.97 |
| 123 | 186.25 | 218.97 | 10.00 | 100.00 | 27.00 | 35.97 |
| 124 | 218.97 | 227.62 | -100.00 | -10.00 | 15.00 | 27.00 |
| 125 | 218.97 | 227.62 | -10.00 | 10.00 | 15.00 | 27.00 |
| 126 | 218.97 | 227.62 | 10.00 | 100.00 | 15.00 | 27.00 |
| 127 | 218.97 | 227.62 | -100.00 | -10.00 | 27.00 | 35.97 |
| 128 | 218.97 | 227.62 | -10.00 | 10.00 | 27.00 | 35.97 |
| 129 | 218.97 | 227.62 | 10.00 | 100.00 | 27.00 | 35.97 |
| 130 | 227.62 | 250.00 | -100.00 | -10.00 | 15.00 | 27.00 |
| 131 | 227.62 | 250.00 | -10.00 | 10.00 | 15.00 | 27.00 |
| 132 | 227.62 | 250.00 | 10.00 | 100.00 | 15.00 | 27.00 |
| 133 | 227.62 | 250.00 | -100.00 | -10.00 | 27.00 | 35.97 |
| 134 | 227.62 | 250.00 | -10.00 | 10.00 | 27.00 | 35.97 |
| 135 | 227.62 | 250.00 | 10.00 | 100.00 | 27.00 | 35.97 |
| 136 | 148.50 | 186.25 | -10.00 | -10.00 | 35.97 | 46.00 |
| 137 | 148.50 | 186.25 | -10.00 | 10.00 | 35.97 | 46.00 |
| 138 | 148.50 | 186.25 | 10.00 | 19.00 | 35.97 | 46.00 |
| 139 | 148.50 | 186.25 | -10.00 | -10.00 | 46.00 | 55.00 |
| 140 | 148.50 | 186.25 | -10.00 | 10.00 | 46.00 | 55.00 |
| 141 | 148.50 | 186.25 | 10.00 | 19.00 | 46.00 | 55.00 |
| 142 | 148.50 | 186.25 | -10.00 | -10.00 | 55.00 | 63.49 |
| 143 | 148.50 | 186.25 | -10.00 | 10.00 | 55.00 | 63.49 |
| 144 | 148.50 | 186.25 | 10.00 | 19.00 | 55.00 | 63.49 |
| 145 | 148.50 | 186.25 | -10.00 | -10.00 | 63.49 | 77.57 |
| 146 | 148.50 | 186.25 | -10.00 | 10.00 | 63.49 | 77.57 |
| 147 | 148.50 | 186.25 | 10.00 | 19.00 | 63.49 | 77.57 |
| 148 | 148.50 | 186.25 | -10.00 | -10.00 | 77.57 | 200.00 |
| 149 | 148.50 | 186.25 | -10.00 | 10.00 | 77.57 | 200.00 |
| 150 | 148.50 | 186.25 | 10.00 | 19.00 | 77.57 | 200.00 |
| 151 | 186.25 | 213.94 | -10.00 | -10.00 | 35.97 | 54.74 |
| 152 | 186.25 | 213.94 | -10.00 | 0.0 | 35.97 | 54.74 |

TABLE 4-1. FUSELAGE SECTION - REGIONS AND CONM2 CARDS (CONT'D)

| | | | | | | |
|-----|--------|--------|---------|--------|--------|--------|
| 153 | 186.25 | 213.94 | 0.0 | 10.00 | 35.97 | 54.74 |
| 154 | 186.25 | 213.94 | 10.00 | 19.00 | 35.97 | 54.74 |
| 155 | 186.25 | 196.90 | -19.00 | -12.38 | 54.74 | 64.64 |
| 156 | 186.25 | 196.90 | -12.38 | 0.0 | 54.74 | 64.64 |
| 157 | 186.25 | 196.90 | 0.0 | 12.38 | 54.74 | 64.64 |
| 158 | 186.25 | 196.90 | 12.38 | 19.00 | 54.74 | 64.64 |
| 159 | 196.90 | 213.94 | -19.00 | -12.38 | 54.74 | 64.64 |
| 160 | 196.90 | 213.94 | -12.38 | 0.0 | 54.74 | 64.64 |
| 161 | 196.90 | 213.94 | 0.0 | 12.38 | 54.74 | 64.64 |
| 162 | 196.90 | 213.94 | 12.38 | 19.00 | 54.74 | 64.64 |
| 163 | 186.25 | 213.94 | -19.00 | -12.38 | 64.64 | 77.57 |
| 164 | 186.25 | 213.94 | -12.38 | 0.0 | 64.64 | 77.57 |
| 165 | 186.25 | 213.94 | 0.0 | 12.38 | 64.64 | 77.57 |
| 166 | 186.25 | 213.94 | 12.38 | 19.00 | 64.64 | 77.57 |
| 167 | 186.25 | 213.94 | -19.00 | -12.38 | 77.57 | 200.00 |
| 168 | 186.25 | 213.94 | -12.38 | 0.0 | 77.57 | 200.00 |
| 169 | 186.25 | 213.94 | 0.0 | 12.38 | 77.57 | 200.00 |
| 170 | 186.25 | 213.94 | 12.38 | 19.00 | 77.57 | 200.00 |
| 171 | 213.94 | 250.00 | -19.00 | 0.0 | 35.97 | 52.59 |
| 172 | 213.94 | 250.00 | 0.0 | 19.00 | 35.97 | 52.59 |
| 173 | 213.94 | 250.00 | -19.00 | 0.0 | 52.59 | 64.07 |
| 174 | 213.94 | 250.00 | 0.0 | 19.00 | 52.59 | 64.07 |
| 175 | 213.94 | 250.00 | -19.00 | 0.0 | 64.07 | 200.00 |
| 176 | 213.94 | 250.00 | 0.0 | 19.00 | 64.07 | 200.00 |
| 177 | 250.00 | 268.25 | -100.00 | -10.00 | -50.00 | 35.97 |
| 178 | 250.00 | 268.25 | -10.00 | 10.00 | -50.00 | 35.97 |
| 179 | 250.00 | 268.25 | 10.00 | 100.00 | -50.00 | 35.97 |
| 180 | 250.00 | 268.25 | -100.00 | 0.0 | 35.97 | 51.49 |
| 181 | 250.00 | 268.25 | 0.0 | 100.00 | 35.97 | 51.49 |
| 182 | 250.00 | 268.25 | -100.00 | 0.0 | 51.49 | 63.59 |
| 183 | 250.00 | 268.25 | 0.0 | 100.00 | 51.49 | 63.59 |
| 184 | 250.00 | 268.25 | -100.00 | 0.0 | 63.59 | 200.00 |
| 185 | 250.00 | 268.25 | 0.0 | 100.00 | 63.59 | 200.00 |
| 186 | 268.25 | 308.00 | -100.00 | -10.00 | -50.00 | 35.97 |
| 187 | 268.25 | 308.00 | -10.00 | 10.00 | -50.00 | 35.97 |
| 188 | 268.25 | 308.00 | 10.00 | 100.00 | -50.00 | 35.97 |
| 189 | 268.25 | 308.00 | -100.00 | 0.0 | 35.97 | 49.38 |
| 190 | 268.25 | 308.00 | 0.0 | 100.00 | 35.97 | 49.38 |
| 191 | 268.25 | 308.00 | -100.00 | 0.0 | 49.38 | 62.80 |
| 192 | 268.25 | 308.00 | 0.0 | 100.00 | 49.38 | 62.80 |
| 193 | 268.25 | 308.00 | -100.00 | 0.0 | 62.80 | 200.00 |
| 194 | 268.25 | 308.00 | 0.0 | 100.00 | 62.80 | 200.00 |

TABLE 4-1. FUSELAGE SECTION - REGIONS AND CONM2 CARDS (CONT'D)

| REG | #GPTS | GRID POINTS: |
|-----|-------|-------------------------------|
| 1 | 1 | 3339 |
| 2 | 1 | 3331 |
| 3 | 2 | 3339 3349 |
| 4 | 2 | 3331 3341 |
| 5 | 1 | 3349 |
| 6 | 1 | 3341 |
| 7 | 3 | 3339 4637 4639 |
| 8 | 3 | 3331 4631 4633 |
| 9 | 3 | 3339 3349 4639 |
| 10 | 3 | 3331 3341 6431 |
| 11 | 3 | 3349 4649 4669 |
| 12 | 4 | 3341 4641 4661 |
| 13 | 3 | 6127 6137 6139 |
| 14 | 3 | 4637 6127 6137 |
| 15 | 3 | 4633 6123 6133 |
| 16 | 3 | 6123 6131 6133 |
| 17 | 6 | 4639 4649 6137 6139 6147 6149 |
| 18 | 3 | 4637 6137 6147 |
| 19 | 3 | 4633 6133 6143 |
| 20 | 6 | 4631 4641 6131 6133 6141 6143 |
| 21 | 4 | 4649 6167 6169 6179 |
| 22 | 3 | 4669 6167 6179 |
| 23 | 3 | 4661 6163 6171 |
| 24 | 4 | 4641 6161 6163 6171 |

TABLE 4-1. FUSELAGE SECTION - REGIONS AND CONM2 CARDS (CONT'D)

| | | |
|----|----|---|
| 25 | 1 | 6179 |
| 26 | 1 | 6179 |
| 27 | 1 | 6171 |
| 28 | 1 | 6171 |
| 29 | 11 | 6127 6137 6139 7037 7039 8537 8539 9307 9317 9337 9339 |
| 30 | 15 | 6123 6125 6127 6133 6137 7033 7037 8533 8537 9303 9307 9313 9317 9333 9337 |
| 31 | 11 | 6123 6131 6133 7031 7033 8531 8533 9303 9313 9331 9333 |
| 32 | 6 | 6137 6139 6147 6149 7037 7039 |
| 33 | 6 | 6133 6137 6143 6147 7033 7037 |
| 34 | 6 | 6131 6133 6141 6143 7031 7033 |
| 35 | 5 | 6147 6149 6167 6169 7047 |
| 36 | 6 | 6143 6147 6163 6167 7043 7047 |
| 37 | 5 | 6141 6143 6161 6163 7043 |
| 38 | 5 | 6167 6169 7067 7069 7079 |
| 39 | 4 | 6163 6167 7063 7067 |
| 40 | 5 | 6161 6163 7061 7063 7071 |
| 41 | 5 | 7037 7039 7047 8537 8539 |
| 42 | 6 | 7033 7037 7043 7047 8533 8537 |
| 43 | 5 | 7031 7033 7043 8531 8533 |
| 44 | 4 | 7047 7067 7069 8547 |
| 45 | 6 | 7043 7047 7063 7067 8543 8547 |
| 46 | 4 | 7043 7061 7063 8543 |
| 47 | 6 | 7067 7069 7079 8567 8569 8579 |
| 48 | 4 | 7063 7067 8567 8567 |
| 49 | 6 | 7061 7063 7071 8561 8563 8571 |
| 50 | 5 | 8537 8539 8547 9337 9339 |

TABLE 4-1. FUSELAGE SECTION - REGIONS AND CONM2 CARDS (CONT'D)

| | | |
|----|----|---|
| 51 | 6 | 8533 8537 8543 8547 9333 9337 |
| 52 | 5 | 8531 8533 8543 9331 9333 |
| 53 | 3 | 8547 8567 8569 |
| 54 | 4 | 8543 8547 8563 8567 |
| 55 | 3 | 8543 8561 8563 |
| 56 | 3 | 8567 8569 8579 |
| 57 | 2 | 8563 8567 |
| 58 | 3 | 8561 8563 8571 |
| 59 | 4 | 211001 214901 222001 223401 |
| 60 | 4 | 211002 214902 222002 223402 |
| 61 | 4 | 9307 9317 11507 13807 |
| 62 | 8 | 9303 9307 9313 9317 11503 11507 13803 13807 |
| 63 | 4 | 9303 9313 11503 13803 |
| 64 | 12 | 9317 9337 9339 11507 11537 11539 13807 13809 13827 13829 13837 13839 |
| 65 | 14 | 9313 9317 9333 93337 11503 11507 11533 11537 13803 13807 13823 13827 13833 13837 |
| 66 | 12 | 9313 9331 9333 11503 11531 11533 13801 13803 13821 13823 13831 13833 |
| 67 | 7 | 9337 9339 9347 9349 11537 11539 11547 |
| 68 | 8 | 9333 9337 9343 9347 11533 11537 11543 11547 |
| 69 | 7 | 9331 9333 9341 9343 11531 11533 11543 |
| 70 | 5 | 9347 9349 9367 9369 11547 |
| 71 | 6 | 9343 9347 9363 9367 11543 11547 |
| 72 | 5 | 9341 9343 9361 9363 11543 |
| 73 | 6 | 9367 9369 9377 9379 11567 11569 |
| 74 | 6 | 9363 9367 9373 9377 11563 11567 |
| 75 | 6 | 9361 9363 9371 9373 11561 11563 |
| 76 | 3 | 9377 9379 11579 |

TABLE 4-1. FUSELAGE SECTION - REGIONS AND CONM2 CARDS (CONT'D)

| | | |
|-----|---|---|
| 77 | 2 | 9373 9377 |
| 78 | 3 | 9371 9373 11571 |
| 79 | 4 | 11537 11539 13837 13839 |
| 80 | 4 | 11533 11537 13833 13837 |
| 81 | 4 | 11531 11533 13831 13833 |
| 82 | 6 | 11547 11567 11569 13847 13848 13849 |
| 83 | 7 | 11543 11547 11563 11567 13843 13847 13848 |
| 84 | 5 | 11543 11561 11563 13841 13843 |
| 85 | 5 | 11567 11569 13867 13869 13879 |
| 86 | 4 | 11563 11567 13863 13867 |
| 87 | 5 | 11561 11563 13861 13863 13871 |
| 88 | 2 | 13807 14807 |
| 89 | 4 | 13803 13807 14803 14807 |
| 90 | 2 | 13803 14803 |
| 91 | 8 | 13807 13809 13827 13829 14807 14809 14827 14829 |
| 92 | 8 | 13803 13807 13823 13827 14803 14807 14823 14827 |
| 93 | 8 | 13801 13803 13821 13823 14801 14803 14821 14823 |
| 94 | 8 | 13827 13829 13837 13839 14827 14829 14837 14839 |
| 95 | 8 | 13823 13827 13833 13837 14823 14827 14833 14837 |
| 96 | 8 | 13821 13823 13831 13833 14821 14823 14831 14833 |
| 97 | 4 | 13837 13839 14837 14839 |
| 98 | 4 | 13833 13837 14833 14837 |
| 99 | 4 | 13831 13833 14831 14833 |
| 100 | 3 | 13847 14847 14849 |
| 101 | 4 | 13843 13847 14843 14847 |
| 102 | 4 | 13841 13843 14841 14843 |

TABLE 4-1. FUSELAGE SECTION - REGIONS AND CONM2 CARDS (CONT'D)

| | | |
|-----|----|--|
| 103 | 2 | 14867 14869 |
| 104 | 3 | 13863 14863 14867 |
| 105 | 5 | 13861 13863 13871 14861 14863 |
| 106 | 3 | 14807 15607 215101 |
| 107 | 4 | 14803 14807 15603 15607 |
| 108 | 3 | 14803 15603 215102 |
| 109 | 9 | 14807 14809 14827 14829 15607 15609 15627 15629 215201 |
| 110 | 7 | 14803 14807 14823 14827 15603 15607 15625 |
| 111 | 9 | 14801 14803 14821 14823 15601 15603 15621 15623 215202 |
| 112 | 1 | 15607 |
| 113 | 4 | 15603 15607 18603 18607 |
| 114 | 1 | 15603 |
| 115 | 7 | 15607 15609 15627 15629 18609 18627 18629 |
| 116 | 8 | 15603 15607 15625 18603 18607 18625 18625 18627 |
| 117 | 7 | 15601 15603 15621 15623 18601 18621 18623 |
| 118 | 0 | No Grid Points |
| 119 | 4 | 18603 18607 21803 21807 |
| 120 | 0 | No Grid Points |
| 121 | 8 | 18609 18627 18629 21327 21329 21809 21827 21829 |
| 122 | 13 | 18603 18607 18625 18625 18627 21323 21325 21327 21803 21807 21823 21825 21827 |
| 123 | 8 | 18601 18621 18623 21321 21323 21801 21821 21823 |
| 124 | 1 | 222201 |
| 125 | 4 | 21803 21807 22703 22707 |
| 126 | 1 | 222202 |
| 127 | 7 | 21809 21827 21829 22709 22727 227292 22301 |
| 128 | 10 | 21803 21807 21823 21825 21827 22702 22707 22723 22725 22727 |
| 129 | 7 | 21801 21821 21823 22701 22721 227232 22302 |

TABLE 4-1. FUSELAGE SECTION - REGIONS AND CONM2 CARDS (CONT'D)

| | | |
|-----|----|--|
| 130 | 0 | No Grid Points |
| 131 | 4 | 22703 22707 25003 25007 |
| 132 | 0 | No Grid Points |
| 133 | 5 | 22709 22727 22729 25009 25029 |
| 134 | 8 | 22703 22707 22723 22725 22727 25003 25007 25025 |
| 135 | 5 | 22701 22721 22723 25001 25021 |
| 136 | 11 | 14827 14829 14837 14839 15627 15629 15637 18627 18629 18637 18639 |
| 137 | 11 | 14823 14827 14833 14837 15625 18623 18625 18627 18633 18635 18637 |
| 138 | 11 | 14821 14823 14831 14833 15621 15623 15633 18621 18623 18631 18633 |
| 139 | 7 | 14837 14839 14847 14849 15637 18637 18639 |
| 140 | 7 | 14833 14837 14843 14847 18633 18635 18637 |
| 141 | 7 | 14831 14833 14841 14843 15633 18631 18633 |
| 142 | 11 | 14847 14849 14867 14869 18647 18649 18649 18653 18654 18658 18659 |
| 143 | 7 | 14843 14847 14863 14867 18644 18645 18646 |
| 144 | 11 | 14841 14843 14861 14863 18641 18642 18643 18651 18652 18656 18657 |
| 145 | 11 | 14867 14869 14887 14889 16487 16489 18667 18668 18669 18687 18689 |
| 146 | 9 | 14863 14867 14883 14887 16435 18664 18665 18666 18685 |
| 147 | 11 | 14861 14863 14881 14883 16481 16483 18661 18662 18663 18681 18683 |
| 148 | 6 | 14887 14889 16487 16489 18687 18689 |
| 149 | 4 | 14883 14887 16485 18685 |
| 150 | 6 | 14881 14883 16481 16483 18681 18683 |
| 151 | 6 | 18627 18629 18637 18639 21327 21329 |
| 152 | 6 | 18625 18627 18635 18637 21325 21327 |
| 153 | 6 | 18623 18625 18633 18635 21323 21325 |
| 154 | 6 | 18621 18623 18631 18633 21321 21323 |
| 155 | 10 | 18647 18648 18649 18653 18654 18658 18659 19749 19759 17969 |
| 156 | 10 | 18645 18646 18647 19745 19747 19748 19758 19765 19767 19768 |

TABLE 4-1. FUSELAGE SECTION - REGIONS AND CONM2 CARDS (CONT'D)

| | | |
|-----|----|--|
| 157 | 10 | 18643 18644 18645 19742 19743 19745 19752 19762 19763 19765 |
| 158 | 10 | 18641 18642 18643 18651 18652 18656 18657 19741 19751 19761 |
| 159 | 4 | 19749 19759 19769 21349 |
| 160 | 9 | 19745 19747 19748 19758 19765 19767 19768 21345 21347 |
| 161 | 9 | 19742 19743 19745 19752 19762 19763 19765 21343 21345 |
| 162 | 4 | 19741 19751 19761 21341 |
| 163 | 8 | 18667 18668 18669 18687 18689 21367 21369 21387 |
| 164 | 8 | 18665 18666 18667 18685 18687 21366 21367 21387 |
| 165 | 8 | 18663 18664 18665 18683 18685 21365 21364 21383 |
| 166 | 8 | 18661 18662 18663 18681 18683 21361 21363 21383 |
| 167 | 3 | 18687 18689 21387 |
| 168 | 3 | 18685 18687 21387 |
| 169 | 3 | 18683 18685 21383 |
| 170 | 3 | 18681 18683 21383 |
| 171 | 13 | 21325 21327 21329 21825 21827 21829 22725 22727 22729 25025 25029 25045 25049 |
| 172 | 13 | 21321 21323 21325 21821 21823 21825 22721 22723 22725 25021 25025 25041 25045 |
| 173 | 7 | 21345 21347 21349 25045 25049 25065 25069 |
| 174 | 7 | 21341 21343 21345 25041 25045 25061 25065 |
| 175 | 6 | 21366 21367 21369 21387 25065 25069 |
| 176 | 6 | 21361 21363 21364 21383 25061 25065 |
| 177 | 3 | 25009 25029 26829 |
| 178 | 6 | 25003 25007 25025 26801 26809 26825 |
| 179 | 3 | 25001 25021 26821 |
| 180 | 6 | 25025 25029 26825 26829 26845 26849 |
| 181 | 6 | 25021 25025 26821 26825 26841 26845 |
| 182 | 6 | 25045 25049 26845 26849 26865 26869 |

TABLE 4-1. FUSELAGE SECTION - REGIONS AND CONM2 CARDS (CONT'D)

| | | |
|-----|---|---|
| 183 | 6 | 25041 25045 26841 26845 26861 26865 |
| 184 | 4 | 25065 25069 26865 26869 |
| 185 | 4 | 25061 25065 26861 26865 |
| 186 | 2 | 26829 29929 |
| 187 | 5 | 26801 26809 26825 29905 29925 |
| 188 | 2 | 26821 29921 |
| 189 | 6 | 26825 26829 29925 29929 29945 29949 |
| 190 | 6 | 26821 26825 29921 29925 29941 29945 |
| 191 | 7 | 26845 26849 29945 29949 29965 29969 30045 |
| 192 | 7 | 26841 26845 29941 29945 29961 29965 30045 |
| 193 | 4 | 26865 26869 29965 29969 |
| 194 | 4 | 26861 26865 29961 29965 |

TABLE 4-1. FUSELAGE SECTION - REGIONS AND CONM2 CARDS (CONT'D)

| TYPE | NASTRAN EID | GRID POINT | WEIGHT (lb) |
|-------|----------------|---------------|-------------|
| CONM2 | 93331 | 3331 | 1.892 |
| CONM2 | 93339 | 3339 | 3.221 |
| CONM2 | 93341 | 3341 | 1.962 |
| CONM2 | 93349 | 3349 | 2.701 |
| CONM2 | 94631 | 4631 | 0.922 |
| CONM2 | 94633 | 4633 | 4.425 |
| CONM2 | 94637 | 4637 | 5.541 |
| CONM2 | 94639 | 4639 | 2.676 |
| CONM2 | 94641 | 4641 | 0.621 |
| CCNM2 | 94649 | 4649 | 0.925 |
| CONM2 | 94661 | 4661 | 8.249 |
| CONM2 | 94669 | 4669 | 6.663 |
| CONM2 | 96123 | 6123 | 3.694 |
| CONM2 | 96127 | 6127 | 3.545 |
| CCNM2 | 96131 | 6131 | 1.113 |
| CONM2 | 96133 | 6133 | 6.058 |
| CONM2 | 96137 | 6137 | 5.058 |
| CONM2 | 96139 | 6139 | 3.755 |
| CONM2 | 96141 | 6141 | 1.950 |
| CONM2 | 96143 | 6143 | 5.711 |
| CONM2 | 96147 | 6147 | 3.897 |
| CONM2 | 96149 | 6149 | 0.821 |
| CONM2 | 96161 | 6161 | 2.947 |
| CONM2 | 96163 | 6163 | 9.863 |
| CONM2 | 96167 | 6167 | 6.505 |
| CONM2 | 96169 | 6169 | 2.029 |
| CONM2 | 96171 | 6171 | 7.551 |
| CONM2 | 96179 | 6179 | 5.502 |
| CONM2 | 97031 | 7031 | 2.284 |
| CONM2 | 97033 | 7033 | 8.434 |
| CONM2 | 97037 | 7037 | 6.885 |
| CONM2 | 97039 | 7039 | 1.452 |
| CONM2 | 97043 | 7043 | 9.812 |
| CONM2 | 97047 | 7047 | 7.798 |
| CONM2 | 97061 | 7061 | 3.578 |
| CONM2 | 97063 | 7063 | 14.650 |
| CONM2 | 97067 | 7067 | 13.585 |
| CCNM2 | 97069 | 7069 | 2.574 |
| CONM2 | 97071 | 7071 | 2.916 |
| CONM2 | 97079 | 7079 | 1.882 |
| CONM2 | 98531 | 8531 | 2.399 |
| CONM2 | 98533 | 8533 | 10.570 |
| CCNM2 | 98537 | 8537 | 9.864 |
| CCNM2 | 98539 | 8539 | 2.403 |
| CONM2 | 98543 | 8543 | 9.724 |
| CONM2 | 98547 | 8547 | 8.931 |
| CONM2 | 98561 | 8561 | 4.317 |
| CONM2 | 98563 | 8563 | 22.532 |
| CONM2 | 98567 | 8567 | 24.136 |
| CONM2 | 98569 | 8569 | 5.718 |
| CONM2 | 98571 | 8571 | 6.222 |

TABLE 4-1. FUSELAGE SECTION - REGIONS AND CONM2 CARDS (CONT'D)

| | | | |
|-------|--------|-------|--------|
| CONM2 | 98579 | 8579 | 8.408 |
| CONM2 | 99303 | 9303 | 3.970 |
| CONM2 | 99307 | 9307 | 3.957 |
| CONM2 | 99313 | 9313 | 8.087 |
| CONM2 | 99317 | 9317 | 8.088 |
| CONM2 | 99331 | 9331 | 3.170 |
| CONM2 | 99333 | 9333 | 13.973 |
| CONM2 | 99337 | 9337 | 13.744 |
| CONM2 | 99339 | 9339 | 3.147 |
| CCNM2 | 99341 | 9341 | 2.554 |
| CONM2 | 99343 | 9343 | 11.084 |
| CONM2 | 99347 | 9347 | 10.863 |
| CONM2 | 99349 | 9349 | 2.147 |
| CONM2 | 99361 | 9361 | 2.380 |
| CONM2 | 99363 | 9363 | 8.351 |
| CONM2 | 99367 | 9367 | 9.072 |
| CONM2 | 99369 | 9369 | 2.335 |
| CONM2 | 99371 | 9371 | 6.511 |
| CONM2 | 99373 | 9373 | 49.161 |
| CONM2 | 99377 | 9377 | 54.894 |
| CONM2 | 99379 | 9379 | 12.037 |
| CONM2 | 101503 | 11503 | 9.083 |
| CONM2 | 101507 | 11507 | 9.128 |
| CONM2 | 101531 | 11531 | 5.859 |
| CONM2 | 101533 | 11533 | 19.722 |
| CONM2 | 101537 | 11537 | 21.508 |
| CONM2 | 101539 | 11539 | 7.873 |
| CONM2 | 101543 | 11543 | 14.344 |
| CONM2 | 101547 | 11547 | 14.791 |
| CONM2 | 101561 | 11561 | 9.470 |
| CONM2 | 101563 | 11563 | 21.696 |
| CONM2 | 101567 | 11567 | 18.154 |
| CONM2 | 101569 | 11569 | 5.917 |
| CONM2 | 101571 | 11571 | 5.538 |
| CONM2 | 101579 | 11579 | 8.826 |
| CONM2 | 103801 | 13801 | 1.113 |
| CONM2 | 103803 | 13803 | 5.138 |
| CONM2 | 103807 | 13807 | 5.002 |
| CONM2 | 103809 | 13809 | 1.052 |
| CONM2 | 103821 | 13821 | 1.512 |
| CONM2 | 103823 | 13823 | 5.508 |
| CONM2 | 103827 | 13827 | 5.708 |
| CONM2 | 103829 | 13829 | 1.649 |
| CONM2 | 103831 | 13831 | 3.656 |
| CONM2 | 103833 | 13833 | 13.472 |
| CCNM2 | 103837 | 13837 | 15.662 |
| CONM2 | 103839 | 13839 | 5.126 |
| CONM2 | 103841 | 13841 | 1.887 |
| CONM2 | 103843 | 13843 | 7.291 |
| CONM2 | 103847 | 13847 | 9.530 |
| CONM2 | 103848 | 13848 | 4.869 |
| CONM2 | 103849 | 13849 | 2.018 |
| CONM2 | 103861 | 13861 | 9.669 |

TABLE 4-1. FUSELAGE SECTION - REGIONS AND CONM2 CARDS (CONT'D)

| | | | |
|-------|--------|-------|--------|
| CONM2 | 103863 | 13863 | 40.094 |
| CONM2 | 103867 | 13867 | 14.571 |
| CONM2 | 103869 | 13869 | 3.301 |
| CONM2 | 103871 | 13871 | 16.714 |
| CONM2 | 103879 | 13879 | 10.322 |
| CONM2 | 104801 | 14801 | 1.098 |
| CONM2 | 104803 | 14803 | 4.057 |
| CONM2 | 104807 | 14807 | 4.022 |
| CONM2 | 104809 | 14809 | 1.092 |
| CONM2 | 104821 | 14821 | 1.980 |
| CONM2 | 104823 | 14823 | 7.770 |
| CONM2 | 104827 | 14827 | 8.254 |
| CONM2 | 104829 | 14829 | 2.424 |
| CONM2 | 104831 | 14831 | 4.886 |
| CONM2 | 104833 | 14833 | 14.738 |
| CONM2 | 104837 | 14837 | 15.388 |
| CONM2 | 104839 | 14839 | 5.566 |
| CONM2 | 104841 | 14841 | 3.991 |
| CONM2 | 104843 | 14843 | 15.512 |
| CONM2 | 104847 | 14847 | 17.832 |
| CONM2 | 104849 | 14849 | 5.932 |
| CONM2 | 104861 | 14861 | 5.066 |
| CONM2 | 104863 | 14863 | 33.238 |
| CONM2 | 104867 | 14867 | 36.138 |
| CONM2 | 104869 | 14869 | 8.171 |
| CONM2 | 104881 | 14881 | 4.845 |
| CONM2 | 104883 | 14883 | 17.626 |
| CONM2 | 104887 | 14887 | 18.186 |
| CONM2 | 104889 | 14889 | 5.338 |
| CONM2 | 105601 | 15601 | 1.680 |
| CONM2 | 105603 | 15603 | 6.578 |
| CONM2 | 105607 | 15607 | 7.003 |
| CONM2 | 105609 | 15609 | 2.088 |
| CONM2 | 105621 | 15621 | 2.569 |
| CONM2 | 105623 | 15623 | 2.463 |
| CONM2 | 105625 | 15625 | 10.568 |
| CONM2 | 105627 | 15627 | 3.439 |
| CONM2 | 105629 | 15629 | 3.449 |
| CONM2 | 105633 | 15633 | 5.611 |
| CONM2 | 105637 | 15637 | 5.916 |
| CONM2 | 106481 | 16481 | 8.756 |
| CONM2 | 106483 | 16483 | 8.759 |
| CONM2 | 106485 | 16485 | 20.106 |
| CONM2 | 106487 | 16487 | 10.054 |
| CONM2 | 106489 | 16489 | 9.779 |
| CONM2 | 108501 | 18601 | 1.073 |
| CONM2 | 108603 | 18603 | 4.685 |
| CONM2 | 108607 | 18607 | 4.556 |
| CONM2 | 108609 | 18609 | 1.986 |
| CONM2 | 108621 | 18621 | 3.665 |
| CONM2 | 108623 | 18623 | 13.694 |
| CONM2 | 108625 | 18625 | 20.981 |

TABLE 4-1. FUSELAGE SECTION - REGIONS AND CONM2 CARDS (CONT'D)

| | | | |
|-------|--------|-------|--------|
| CONM2 | 108627 | 18627 | 22.897 |
| CONM2 | 108629 | 18629 | 5.552 |
| CONM2 | 108631 | 18631 | 5.946 |
| CONM2 | 108633 | 18633 | 16.895 |
| CONM2 | 108635 | 18635 | 22.634 |
| CCNM2 | 108637 | 18637 | 26.279 |
| CONM2 | 108639 | 18639 | 7.945 |
| CONM2 | 108641 | 18641 | 1.269 |
| CONM2 | 108642 | 18642 | 1.285 |
| CONM2 | 108643 | 18643 | 2.285 |
| CCNM2 | 108644 | 18644 | 8.294 |
| CONM2 | 108645 | 18645 | 8.560 |
| CONM2 | 108646 | 18646 | 8.135 |
| CONM2 | 108647 | 18647 | 2.578 |
| CONM2 | 108648 | 18648 | 1.705 |
| CONM2 | 108649 | 18649 | 1.670 |
| CONM2 | 108651 | 18651 | 1.396 |
| CONM2 | 108652 | 18652 | 1.415 |
| CONM2 | 108653 | 18653 | 1.854 |
| CONM2 | 108654 | 18654 | 1.813 |
| CONM2 | 108656 | 18656 | 1.288 |
| CONM2 | 108657 | 18657 | 1.305 |
| CONM2 | 108658 | 18658 | 1.739 |
| CONM2 | 108659 | 18659 | 1.703 |
| CONM2 | 108661 | 18661 | 2.124 |
| CONM2 | 108662 | 18662 | 2.138 |
| CONM2 | 108663 | 18663 | 7.944 |
| CONM2 | 108664 | 18664 | 8.778 |
| CONM2 | 108665 | 18665 | 13.016 |
| CONM2 | 108666 | 18665 | 8.161 |
| CONM2 | 108667 | 18667 | 7.302 |
| CONM2 | 108668 | 18668 | 2.013 |
| CONM2 | 108669 | 18669 | 1.998 |
| CONM2 | 108681 | 18681 | 8.693 |
| CONM2 | 108683 | 18683 | 32.324 |
| CCNM2 | 108685 | 18685 | 60.323 |
| CONM2 | 108687 | 18687 | 27.285 |
| CONM2 | 108689 | 18689 | 9.604 |
| CONM2 | 109741 | 19741 | 2.346 |
| CONM2 | 109742 | 19742 | 4.409 |
| CONM2 | 109743 | 19743 | 5.156 |
| CONM2 | 109745 | 19745 | 11.232 |
| CONM2 | 109747 | 19747 | 4.251 |
| CONM2 | 109748 | 19748 | 3.642 |
| CONM2 | 109749 | 19749 | 2.399 |
| CCNM2 | 109751 | 19751 | 2.757 |
| CONM2 | 109752 | 19752 | 5.133 |
| CONM2 | 109758 | 19758 | 3.995 |
| CONM2 | 109759 | 19759 | 2.844 |
| CONM2 | 109761 | 19761 | 2.221 |
| CCNM2 | 109762 | 19762 | 4.633 |
| CONM2 | 109763 | 19763 | 5.632 |

TABLE 4-1. FUSELAGE SECTION - REGIONS AND CONM2 CARDS (CONT'D)

| | | | |
|-------|--------|-------|--------|
| CONM2 | 109765 | 19765 | 12.896 |
| CONM2 | 109767 | 19767 | 4.155 |
| CONM2 | 109768 | 19768 | 3.600 |
| CONM2 | 109769 | 19769 | 2.303 |
| CONM2 | 111321 | 21321 | 6.659 |
| CONM2 | 111323 | 21323 | 9.994 |
| CONM2 | 111325 | 21325 | 20.033 |
| CONM2 | 111327 | 21327 | 18.946 |
| CONM2 | 111329 | 21329 | 7.634 |
| CONM2 | 111341 | 21341 | 4.930 |
| CONM2 | 111343 | 21343 | 5.686 |
| CONM2 | 111345 | 21345 | 11.857 |
| CONM2 | 111347 | 21347 | 5.713 |
| CONM2 | 111349 | 21349 | 4.679 |
| CONM2 | 111361 | 21361 | 17.866 |
| CONM2 | 111363 | 21363 | 23.858 |
| CONM2 | 111364 | 21364 | 23.001 |
| CONM2 | 111366 | 21366 | 27.471 |
| CONM2 | 111367 | 21367 | 28.406 |
| CONM2 | 111369 | 21369 | 21.681 |
| CONM2 | 111383 | 21383 | 48.827 |
| CONM2 | 111387 | 21387 | 54.371 |
| CONM2 | 111801 | 21801 | 1.894 |
| CONM2 | 111803 | 21803 | 3.639 |
| CONM2 | 111807 | 21807 | 3.893 |
| CONM2 | 111809 | 21809 | 1.953 |
| CONM2 | 111821 | 21821 | 5.997 |
| CONM2 | 111823 | 21823 | 7.188 |
| CONM2 | 111825 | 21825 | 10.613 |
| CONM2 | 111827 | 21827 | 7.871 |
| CONM2 | 111829 | 21829 | 6.220 |
| CONM2 | 112701 | 22701 | 2.043 |
| CONM2 | 112703 | 22703 | 3.691 |
| CONM2 | 112707 | 22707 | 3.687 |
| CONM2 | 112709 | 22709 | 1.998 |
| CONM2 | 112721 | 22721 | 7.817 |
| CONM2 | 112723 | 22723 | 11.522 |
| CONM2 | 112725 | 22725 | 15.296 |
| CONM2 | 112727 | 22727 | 12.589 |
| CONM2 | 112729 | 22729 | 7.921 |
| CONM2 | 115001 | 25001 | 1.933 |
| CONM2 | 115003 | 25003 | 2.877 |
| CONM2 | 115007 | 25007 | 3.006 |
| CONM2 | 115009 | 25009 | 1.526 |
| CONM2 | 115021 | 25021 | 6.318 |
| CONM2 | 115025 | 25025 | 12.767 |
| CONM2 | 115029 | 25029 | 6.632 |
| CONM2 | 115041 | 25041 | 10.475 |
| CONM2 | 115045 | 25045 | 22.769 |
| CONM2 | 115049 | 25049 | 10.010 |
| CONM2 | 115061 | 25061 | 25.414 |
| CONM2 | 115065 | 25065 | 56.155 |

TABLE 4-1. FUSELAGE SECTION - REGIONS AND CONM2 CARDS (CONT'D)

| | | | |
|-------|--------|--------|--------|
| CONM2 | 115069 | 25069 | 31.959 |
| CONM2 | 116801 | 26801 | 2.583 |
| CONM2 | 116809 | 26809 | 2.896 |
| CONM2 | 116821 | 26821 | 7.919 |
| CONM2 | 116825 | 26825 | 26.633 |
| CONM2 | 116829 | 26829 | 16.380 |
| CONM2 | 116841 | 26841 | 7.840 |
| CONM2 | 116845 | 26845 | 17.307 |
| CONM2 | 116849 | 26849 | 8.427 |
| CONM2 | 116861 | 26861 | 17.663 |
| CONM2 | 116865 | 26865 | 37.880 |
| CONM2 | 116869 | 26869 | 17.941 |
| CONM2 | 119905 | 29905 | 2.139 |
| CONM2 | 119921 | 29921 | 8.430 |
| CCNM2 | 119925 | 29925 | 22.915 |
| CONM2 | 119929 | 29929 | 13.202 |
| CONM2 | 119941 | 29941 | 10.447 |
| CONM2 | 119945 | 29945 | 27.421 |
| CONM2 | 119949 | 29949 | 15.273 |
| CONM2 | 119961 | 29961 | 10.173 |
| CONM2 | 119965 | 29965 | 21.300 |
| CONM2 | 119969 | 29969 | 10.763 |
| CONM2 | 301002 | 211002 | 4.953 |
| CONM2 | 304902 | 214902 | 13.024 |
| CONM2 | 312002 | 222002 | 6.744 |
| CONM2 | 313402 | 223402 | 5.142 |
| CONM2 | 305102 | 215102 | 3.158 |
| CONM2 | 305202 | 215202 | 0.961 |
| CONM2 | 312202 | 222202 | 6.554 |
| CONM2 | 312302 | 222302 | 1.635 |
| CONM2 | 301001 | 211001 | 4.953 |
| CONM2 | 304901 | 214901 | 13.024 |
| CONM2 | 312001 | 222001 | 6.744 |
| CONM2 | 313401 | 223401 | 5.142 |
| CONM2 | 305101 | 215101 | 3.676 |
| CONM2 | 305201 | 215201 | 0.952 |
| CONM2 | 312201 | 222201 | 6.554 |
| CONM2 | 312301 | 222301 | 1.619 |

TABLE 4-2. TAILBOOM AND WINGS - REGIONS AND CONN2 CARDS

| REGION | STATION | | BUTTLINE | | | WATERLINE | | |
|--------|---------|--------|----------|--------|--------|-----------|--|--|
| | X1 | TO X2 | Y1 | TO Y2 | Z1 | TO Z2 | | |
| 1 | 308.00 | 317.71 | -100.00 | 100.00 | -50.00 | 200.00 | | |
| 2 | 317.71 | 338.61 | -100.00 | 100.00 | -50.00 | 200.00 | | |
| 3 | 338.61 | 359.51 | -100.00 | 100.00 | -50.00 | 200.00 | | |
| 4 | 359.51 | 380.42 | -100.00 | 100.00 | -50.00 | 200.00 | | |
| 5 | 380.42 | 401.33 | -9.68 | 9.68 | -50.00 | 200.00 | | |
| 6 | 401.33 | 422.24 | -9.68 | 9.68 | -50.00 | 200.00 | | |
| 7 | 422.24 | 443.15 | -100.00 | 100.00 | -50.00 | 200.00 | | |
| 8 | 443.15 | 452.25 | -100.00 | 100.00 | -50.00 | 200.00 | | |
| 9 | 452.25 | 464.10 | -100.00 | 100.00 | -50.00 | 200.00 | | |
| 10 | 464.10 | 484.89 | -100.00 | 100.00 | -50.00 | 67.50 | | |
| 11 | 484.89 | 600.00 | -100.00 | 100.00 | -50.00 | 67.50 | | |
| 12 | 380.42 | 422.24 | -100.00 | -31.25 | -50.00 | 200.00 | | |
| 13 | 380.42 | 422.24 | -31.25 | -20.87 | -50.00 | 200.00 | | |
| 14 | 380.42 | 422.24 | -20.87 | -9.68 | -50.00 | 200.00 | | |
| 15 | 380.42 | 422.24 | 9.68 | 20.87 | -50.00 | 200.00 | | |
| 16 | 380.42 | 422.24 | 20.87 | 31.25 | -50.00 | 200.00 | | |
| 17 | 380.42 | 422.24 | 31.25 | 100.00 | -50.00 | 200.00 | | |
| 18 | 464.10 | 600.00 | -100.00 | 100.00 | 67.50 | 75.40 | | |
| 19 | 464.10 | 600.00 | -100.00 | 100.00 | 75.40 | 83.82 | | |
| 20 | 464.10 | 600.00 | -100.00 | 100.00 | 83.82 | 92.37 | | |
| 21 | 464.10 | 600.00 | -100.00 | 100.00 | 92.37 | 100.91 | | |
| 22 | 464.10 | 600.00 | -100.00 | 100.00 | 100.91 | 109.46 | | |
| 23 | 464.10 | 600.00 | -100.00 | 0.0 | 109.46 | 200.00 | | |
| 24 | 464.10 | 600.00 | 0.0 | 1.80 | 109.46 | 200.00 | | |
| 25 | 464.10 | 600.00 | 1.80 | 2.42 | 109.46 | 200.00 | | |
| 26 | 464.10 | 600.00 | 2.42 | 5.69 | 109.46 | 200.00 | | |
| 27 | 464.10 | 600.00 | 5.69 | 6.45 | 109.46 | 200.00 | | |
| 28 | 464.10 | 600.00 | 6.45 | 6.82 | 109.46 | 200.00 | | |
| 29 | 464.10 | 600.00 | 6.82 | 7.90 | 109.46 | 200.00 | | |
| 30 | 464.10 | 600.00 | 7.90 | 13.47 | 109.46 | 200.00 | | |
| 31 | 464.10 | 600.00 | 13.47 | 13.88 | 109.46 | 200.00 | | |
| 32 | 464.10 | 600.00 | 13.88 | 15.19 | 109.46 | 200.00 | | |
| 33 | 464.10 | 600.00 | 15.19 | 18.49 | 109.46 | 200.00 | | |
| 34 | 464.10 | 600.00 | 18.49 | 100.00 | 109.46 | 200.00 | | |
| 35 | 148.00 | 250.00 | -100.00 | -59.00 | 35.97 | 200.00 | | |
| 36 | 148.00 | 250.00 | -59.00 | -50.75 | 35.97 | 200.00 | | |
| 37 | 148.00 | 250.00 | -50.75 | -42.50 | 35.97 | 200.00 | | |
| 38 | 148.00 | 250.00 | -42.50 | -34.00 | 35.97 | 200.00 | | |
| 39 | 148.00 | 250.00 | -34.00 | -28.00 | 35.97 | 200.00 | | |
| 40 | 148.00 | 250.00 | -28.00 | -22.19 | 35.97 | 200.00 | | |
| 41 | 148.00 | 250.00 | -22.19 | -19.19 | 35.97 | 200.00 | | |
| 42 | 148.00 | 250.00 | 19.19 | 22.19 | 35.97 | 200.00 | | |
| 43 | 148.00 | 250.00 | 22.19 | 28.00 | 35.97 | 200.00 | | |
| 44 | 148.00 | 250.00 | 28.00 | 34.00 | 35.97 | 200.00 | | |
| 45 | 148.00 | 250.00 | 34.00 | 42.50 | 35.97 | 200.00 | | |
| 46 | 148.00 | 250.00 | 42.50 | 50.75 | 35.97 | 200.00 | | |
| 47 | 148.00 | 250.00 | 50.75 | 59.00 | 35.97 | 200.00 | | |
| 48 | 148.00 | 250.00 | 59.00 | 100.00 | 35.97 | 200.00 | | |

TABLE 4-2. TAILBOOM AND WINGS - REGIONS AND CONM2 CARDS (CONT'D)

| REG | #GPTS | GRID POINTS: |
|-----|-------|-------------------------|
| 1 | 1 | 31745 |
| 2 | 2 | 31745 33845 |
| 3 | 2 | 33845 35945 |
| 4 | 2 | 35945 38045 |
| 5 | 4 | 38045 40145 40143 40147 |
| 6 | 2 | 40145 42245 |
| 7 | 2 | 42245 44345 |
| 8 | 2 | 44345 45245 |
| 9 | 2 | 45245 46445 |
| 10 | 2 | 46445 48445 |
| 11 | 1 | 48445 |
| 12 | 1 | 40149 |
| 13 | 2 | 40148 40149 |
| 14 | 2 | 40147 40148 |
| 15 | 2 | 40142 40143 |
| 16 | 2 | 40141 40142 |
| 17 | 1 | 40141 |
| 18 | 1 | 48045 |
| 19 | 2 | 48045 48845 |
| 20 | 2 | 48845 49745 |
| 21 | 2 | 49745 50645 |
| 22 | 2 | 50645 51545 |
| 23 | 2 | 51545 52045 |
| 24 | 3 | 51545 52045 520013 |
| 25 | 2 | 520018 520024 |

TABLE 4-2. TAILBOOM AND WINGS - REGIONS AND CONM2 CARDS (CONT'D)

| | | |
|----|----|---|
| 26 | 2 | 520024 520057 |
| 27 | 2 | 520057 520065 |
| 28 | 2 | 520065 520068 |
| 29 | 2 | 520068 520079 |
| 30 | 2 | 520079 520135 |
| 31 | 2 | 520135 520139 |
| 32 | 2 | 520139 520152 |
| 33 | 2 | 520152 520185 |
| 34 | 1 | 520185 |
| 35 | 6 | 75911 75919 75921 75929 75931 75939 |
| 36 | 12 | 75011 75010 75021 75029 75031 75039 75911 75919 75921 75929 75931 75939 |
| 37 | 12 | 74211 74219 74221 74229 74231 74239 75011 75019 75021 75029 75031 75039 |
| 38 | 12 | 73411 73419 73421 73429 73431 73439 74211 74219 74221 74229 74231 74239 |
| 39 | 12 | 72811 72819 72821 72829 72831 72839 73411 73419 73421 73429 73431 73439 |
| 40 | 16 | 72211 72213 72217 72219 72221 72224 72226 72229 72231 72239 72811 72819 72821 72829 72831 72839 |
| 41 | 25 | 71912 71913 71914 71916 71917 71918 71922 71923 71924 72224 72226 72229 72231 72239 71926 71927 71928 71934 71935 71936 72211 72213 72217 72219 72221 |
| 42 | 25 | 61912 61913 61914 61916 61917 61918 61922 61923 61924 62224 62226 62229 62231 62239 61926 61927 61928 61934 61935 61936 62211 62213 62217 62219 62221 |
| 43 | 16 | 62211 62213 62217 62219 62221 62224 62226 62229 62231 62239 62811 62819 62821 62829 62831 62839 |
| 44 | 12 | 62811 62819 62821 62829 62831 62839 63411 63419 63421 63429 63431 63439 |
| 45 | 12 | 63411 63419 63421 63429 63431 63439 64211 64219 64221 64229 64231 64239 |
| 46 | 12 | 64211 64219 64221 64229 64231 64239 65011 65019 65021 65029 65031 65039 |
| 47 | 12 | 65011 65019 65021 65029 65031 65039 65911 65919 65921 65929 65931 65939 |
| 48 | 6 | 65911 65919 65921 65929 65931 65939 |

TABLE 4-11 FILLBOOM AND WINGS - REGIONS AND CONM2 CARDS (CONT'D)

| | NASTRAN EID | GRID POINT | WEIGHT (lb) |
|-------|----------------|---------------|-------------|
| CONM2 | 120045 | 30045 | 8.020 |
| CONM2 | 121745 | 31745 | 33.300 |
| CONM2 | 123345 | 33845 | 43.991 |
| CONM2 | 125045 | 35945 | 60.542 |
| CONM2 | 128045 | 38045 | 33.770 |
| CONM2 | 130145 | 40145 | 20.830 |
| CONM2 | 132245 | 42245 | 19.695 |
| CONM2 | 134345 | 44345 | 9.748 |
| CONM2 | 136045 | 45245 | 10.218 |
| CONM2 | 137445 | 46445 | 18.052 |
| CONM2 | 138445 | 48445 | 16.465 |
| CONM2 | 138045 | 48045 | 23.604 |
| CONM2 | 138845 | 48845 | 6.526 |
| CONM2 | 139745 | 49745 | 12.117 |
| CONM2 | 140645 | 50645 | 8.474 |
| CONM2 | 141545 | 51545 | 5.845 |
| CONM2 | 142045 | 52045 | 17.591 |
| CONM2 | 130141 | 40141 | 3.541 |
| CONM2 | 130142 | 40142 | 5.937 |
| CONM2 | 130143 | 40143 | 10.107 |
| CONM2 | 130147 | 40147 | 9.503 |
| CONM2 | 130148 | 40148 | 5.887 |
| CONM2 | 130149 | 40149 | 3.541 |
| CONM2 | 151912 | 61912 | 0.201 |
| CONM2 | 151913 | 61913 | 0.201 |
| CONM2 | 151914 | 61914 | 0.201 |
| CONM2 | 151916 | 61916 | 0.184 |
| CONM2 | 151917 | 61917 | 0.179 |
| CONM2 | 151918 | 61918 | 0.172 |
| CONM2 | 151922 | 61922 | 0.774 |
| CONM2 | 151923 | 61923 | 0.689 |
| CONM2 | 151924 | 61924 | 0.610 |
| CONM2 | 151926 | 61926 | 0.305 |
| CONM2 | 151927 | 61927 | 0.285 |
| CONM2 | 151928 | 61928 | 0.259 |
| CONM2 | 151934 | 61934 | 0.164 |
| CONM2 | 151935 | 61935 | 0.160 |
| CONM2 | 151936 | 61936 | 0.157 |
| CONM2 | 152211 | 62211 | 0.463 |
| CONM2 | 152213 | 62213 | 0.480 |
| CONM2 | 152217 | 62217 | 0.476 |
| CONM2 | 152219 | 62219 | 0.462 |
| CONM2 | 152221 | 62221 | 1.537 |
| CONM2 | 152224 | 62224 | 1.539 |
| CONM2 | 152226 | 62226 | 1.135 |
| CONM2 | 152229 | 62229 | 0.865 |
| CONM2 | 152231 | 62231 | 0.393 |
| CONM2 | 152239 | 62239 | 0.374 |
| CONM2 | 152811 | 62811 | 0.960 |
| CONM2 | 152819 | 62819 | 1.111 |
| CONM2 | 152821 | 62821 | 1.904 |

TABLE 4-2. TAILBOOM AND WINGS - REGIONS AND CONM2 CARDS (CONT'D)

| | | | |
|-------|--------|-------|-------|
| CONM2 | 152829 | 62829 | 1.798 |
| CONM2 | 152831 | 62831 | 0.612 |
| CONM2 | 152839 | 62839 | 0.595 |
| CONM2 | 153411 | 63411 | 1.969 |
| CONM2 | 153419 | 63419 | 2.323 |
| CONM2 | 153421 | 63421 | 3.041 |
| CONM2 | 153429 | 63429 | 2.881 |
| CONM2 | 153431 | 63431 | 1.144 |
| CONM2 | 153439 | 63439 | 1.118 |
| CONM2 | 154211 | 64211 | 2.314 |
| CONM2 | 154219 | 64219 | 3.090 |
| CONM2 | 154221 | 64221 | 3.275 |
| CONM2 | 154229 | 64229 | 3.561 |
| CONM2 | 154231 | 64231 | 1.265 |
| CONM2 | 154239 | 64239 | 1.243 |
| CONM2 | 155011 | 65011 | 1.382 |
| CONM2 | 155019 | 65019 | 2.036 |
| CONM2 | 155021 | 65021 | 1.737 |
| CONM2 | 155029 | 65029 | 2.148 |
| CONM2 | 155031 | 65031 | 0.796 |
| CONM2 | 155039 | 65039 | 0.790 |
| CONM2 | 155911 | 65911 | 0.693 |
| CONM2 | 155919 | 65919 | 0.967 |
| CONM2 | 155921 | 65921 | 1.009 |
| CONM2 | 155929 | 65929 | 1.298 |
| CONM2 | 155931 | 65931 | 0.517 |
| CONM2 | 155939 | 65939 | 0.509 |
| CONM2 | 161912 | 71912 | 0.251 |
| CONM2 | 161913 | 71913 | 0.249 |
| CONM2 | 161914 | 71914 | 0.245 |
| CONM2 | 161916 | 71916 | 0.216 |
| CONM2 | 161917 | 71917 | 0.208 |
| CONM2 | 161918 | 71918 | 0.199 |
| CONM2 | 161922 | 71922 | 0.866 |
| CONM2 | 161923 | 71923 | 0.723 |
| CONM2 | 161924 | 71924 | 0.623 |
| CONM2 | 161926 | 71926 | 0.314 |
| CONM2 | 161927 | 71927 | 0.294 |
| CONM2 | 161928 | 71928 | 0.269 |
| CONM2 | 161934 | 71934 | 0.171 |
| CONM2 | 161935 | 71935 | 0.167 |
| CONM2 | 161936 | 71936 | 0.164 |
| CONM2 | 162211 | 72211 | 0.517 |
| CONM2 | 162213 | 72213 | 0.530 |
| CONM2 | 162217 | 72217 | 0.506 |
| CONM2 | 162219 | 72219 | 0.488 |
| CONM2 | 162221 | 72221 | 1.708 |
| CONM2 | 162224 | 72224 | 1.528 |
| CONM2 | 162226 | 72226 | 1.141 |
| CONM2 | 162229 | 72229 | 0.874 |

TABLE 4-2. FAILBOOM AND WINGS - REGIONS AND CONM2 CARDS (CONT'D)

| | | | |
|-------|--------|--------|--------|
| CONM2 | 162231 | 72231 | 0.400 |
| CONM2 | 162239 | 72239 | 0.381 |
| CONM2 | 162811 | 72811 | 0.960 |
| CONM2 | 162819 | 72819 | 1.111 |
| CONM2 | 162821 | 72821 | 1.904 |
| CONM2 | 162829 | 72829 | 1.798 |
| CONM2 | 162831 | 72831 | 0.612 |
| CONM2 | 162839 | 72839 | 0.595 |
| CONM2 | 163411 | 73411 | 1.969 |
| CONM2 | 163419 | 73419 | 2.323 |
| CONM2 | 163421 | 73421 | 3.041 |
| CONM2 | 163429 | 73429 | 2.881 |
| CONM2 | 163431 | 73431 | 1.144 |
| CONM2 | 163439 | 73439 | 1.118 |
| CONM2 | 164211 | 74211 | 2.314 |
| CONM2 | 164219 | 74219 | 3.090 |
| CONM2 | 164221 | 74221 | 3.275 |
| CONM2 | 164229 | 74229 | 3.561 |
| CONM2 | 164231 | 74231 | 1.265 |
| CONM2 | 164239 | 74239 | 1.243 |
| CONM2 | 165011 | 75011 | 1.382 |
| CONM2 | 165019 | 75019 | 2.036 |
| CONM2 | 165021 | 75021 | 1.737 |
| CONM2 | 165029 | 75029 | 2.148 |
| CONM2 | 165031 | 75031 | 0.796 |
| CONM2 | 165039 | 75039 | 0.790 |
| CONM2 | 165911 | 75911 | 0.693 |
| CONM2 | 165919 | 75919 | 0.967 |
| CONM2 | 165921 | 75921 | 1.009 |
| CONM2 | 165929 | 75929 | 1.298 |
| CONM2 | 165931 | 75931 | 0.517 |
| CONM2 | 165939 | 75939 | 0.509 |
| CONM2 | 610018 | 520018 | 5.662 |
| CONM2 | 610024 | 520024 | 5.937 |
| CONM2 | 610057 | 520057 | 4.420 |
| CONM2 | 610065 | 520065 | 0.0 |
| CONM2 | 610068 | 520068 | 0.819 |
| CONM2 | 610079 | 520079 | 4.374 |
| CONM2 | 610135 | 520135 | 1.007 |
| CONM2 | 610139 | 520139 | 16.749 |
| CONM2 | 610152 | 520152 | 14.868 |
| CONM2 | 610185 | 520185 | 1.583 |

TABLE 4-3. MAIN ROTOR PYLON - REGIONS AND CONM2 CARDS

| REGION | STATION | | BUTTLINE | | | WATERLINE | | |
|--------|---------|--------|----------|-------|--------|-----------|--------|--|
| | X1 | TO X2 | Y1 | TO Y2 | Z1 | T(1) | Z2 | |
| 1 | 187.00 | 213.00 | -13.00 | 13.00 | 75.00 | | 76.00 | |
| 2 | 187.00 | 213.00 | -13.00 | 13.00 | 76.70 | | 77.57 | |
| 3 | 187.00 | 213.00 | -13.00 | 13.00 | 77.57 | | 79.05 | |
| 4 | 187.00 | 213.00 | -13.00 | 13.00 | 79.05 | | 86.25 | |
| 5 | 187.00 | 213.00 | -13.00 | 13.00 | 86.25 | | 95.00 | |
| 6 | 187.00 | 213.00 | -13.00 | 13.00 | 95.00 | | 100.67 | |
| 7 | 187.00 | 213.00 | -13.00 | 13.00 | 100.67 | | 106.00 | |
| 8 | 187.00 | 213.00 | -13.00 | 13.00 | 106.00 | | 114.00 | |
| 9 | 187.00 | 213.00 | -13.00 | 13.00 | 114.00 | | 121.00 | |
| 10 | 187.00 | 213.00 | -13.00 | 13.00 | 121.00 | | 129.00 | |
| 11 | 187.00 | 213.00 | -13.00 | 13.00 | 129.00 | | 137.00 | |
| 12 | 187.00 | 213.00 | -13.00 | 13.00 | 137.00 | | 145.00 | |
| 13 | 187.00 | 213.00 | -13.00 | 13.00 | 145.00 | | 152.76 | |
| 14 | 187.00 | 213.00 | -13.00 | 13.00 | 152.76 | | 154.00 | |
| 15 | 187.00 | 213.00 | -13.00 | 13.00 | 154.00 | | 154.97 | |
| 16 | 187.00 | 213.00 | -13.00 | 13.00 | 154.97 | | 200.00 | |

| REG | #GPTS | GRID POINTS: |
|-----|-------|---------------|
| 1 | 1 | 200070 |
| 2 | 2 | 200070 200078 |
| 3 | 2 | 200078 200079 |
| 4 | 2 | 200079 200086 |
| 5 | 2 | 200086 200095 |
| 6 | 2 | 200095 200101 |
| 7 | 2 | 200101 200106 |
| 8 | 2 | 200106 200114 |
| 9 | 2 | 200114 200121 |
| 10 | 2 | 200121 200129 |
| 11 | 2 | 200129 200137 |
| 12 | 2 | 200137 200145 |

TABLE 4-3. MAIN ROTOR PYLON - REGIONS AND CONM2 CARDS (CONT'D)

| | | |
|----|---|---------------|
| 13 | 2 | 200145 200153 |
| 14 | 1 | 200153 |
| 15 | 1 | 200155 |
| 16 | 1 | 200155 |

| TYPE | NASTRAN EID | GRID POINT | WEIGHT (lb) |
|-------|----------------|---------------|-------------|
| CONM2 | 290070 | 200070 | 34.465 |
| CONM2 | 290078 | 200078 | 22.740 |
| CONM2 | 290079 | 200079 | 51.048 |
| CONM2 | 290086 | 200086 | 60.052 |
| CONM2 | 290087 | 200087 | 60.052 |
| CONM2 | 290095 | 200095 | 64.933 |
| CONM2 | 290096 | 200096 | 64.933 |
| CONM2 | 290101 | 200101 | 57.277 |
| CONM2 | 290106 | 200106 | 47.013 |
| CONM2 | 290114 | 200114 | 66.626 |
| CONM2 | 290121 | 200121 | 54.350 |
| CONM2 | 290129 | 200129 | 13.810 |
| CONM2 | 290137 | 200137 | 9.253 |
| CONM2 | 290145 | 200145 | 12.065 |
| CONM2 | 290153 | 200153 | 953.352 |
| CONM2 | 290155 | 200155 | 6.124 |

TABLE 4-4. BASIC MISSION USEFUL WEIGHT ITEMS

| Description | A/N Code | Weight (lb) | Grid Point | Location | | Offset Distances | |
|-------------------------------------|----------|-------------|------------|----------|--------|------------------|-------|
| | | | | Sta | BL | ΔSta | ΔBL |
| Pilot | 60061 | 200.00 | 13500 | 135.00 | 0.0 | 78.00 | - |
| Gunner | 60071 | 200.00 | 8300 | 83.00 | 0.0 | 70.00 | - |
| Forward Fuel | 60151 | 775.00 | 17100 | 169.00 | 0.0 | 53.00 | - |
| Aft Fuel | 60151 | 825.00 | 23100 | 231.00 | 0.0 | 51.00 | - |
| Trapped Fuel | 60161 | 4.25 | 17100 | 169.00 | 0.0 | 53.00 | - |
| | | 4.25 | 23100 | 231.00 | 0.0 | 51.00 | - |
| Engine Oil | 60181 | 26.70 | 124800 | 248.00 | 0.0 | 86.00 | - |
| Trapped Engine Oil | 60191 | 2.20 | 124800 | 248.00 | 0.0 | 86.00 | - |
| Main Transmission Oil | 60211 | 26.10 | 200070 | 200.00 | 0.0 | 70.00 | - |
| 42° Gearbox Oil | 60211 | 0.30 | 46445 | 464.10 | 0.0 | 59.81 | - |
| 50° Gearbox Oil | 60211 | 0.40 | 52045 | 520.07 | 0.0 | 118.27 | - |
| 40mm Drum and Pallet | 60251 | 75.00 | 11300 | 113.60 | 10.00 | 37.00 | - |
| Grenades 250 Rounds | 60261 | 190.00 | 11300 | 113.60 | 10.00 | 37.00 | - |
| Smoke Grenade Dispenser, Right Wing | 60321 | 17.80 | 65929 | 204.04 | 59.00 | 58.45 | -2.74 |
| Smoke Grenade Dispenser, Left Wing | 60321 | 17.80 | 75979 | 204.04 | -59.00 | 58.45 | -2.74 |
| Smoke Grenades, Right Wing | 60331 | 22.00 | 65929 | 204.04 | 59.00 | 58.45 | -2.74 |
| Smoke Grenades, Left Wing | 60331 | 22.00 | 75929 | 204.04 | -59.00 | 58.45 | -2.74 |
| Mamee Drum, 7.62mm | 60381 | 63.30 | 11700 | 115.80 | -7.20 | 36.00 | - |
| Ammo, 4000 rounds | 60391 | 260.00 | 11700 | 115.80 | -7.20 | 36.00 | - |
| Outboard Pylon Assembly, Left Wing | 60441 | 17.80 | 75929 | 204.04 | -59.00 | 58.45 | - |
| Outboard Pylon Assembly, Right Wing | 60441 | 17.80 | 65929 | 204.04 | 59.00 | 58.45 | - |
| XM-157A Pod, Left Wing | 60491 | 57.00 | 75929 | 204.04 | -59.00 | 58.45 | -7.04 |
| | | | | | | | 0.0 |
| | | | | | | | -7.45 |

TABLE 4-4. Continued

| Description | A/N Code | Weight (lb) | Grid Point | Location | | | Offset Distances | | |
|--------------------------------|----------|-------------|------------|----------|--------|-------|------------------|-------------|-------------|
| | | | | Sta | BL | WL | Δ Sta | Δ BL | Δ WL |
| XM-157A Pod, Right Wing | 60491 | 57.00 | 65929 | 204.04 | 59.00 | 58.45 | -7.04 | 0.0 | -7.45 |
| M-151/XM429 Rockets, Left Wing | 60501 | 145.70 | 75929 | 204.04 | -59.00 | 58.45 | -7.04 | 0.0 | -7.45 |
| M-151/XM429 Rockets Right Wing | 60501 | 145.70 | 65929 | 204.04 | 59.00 | 58.45 | -7.04 | 0.0 | -7.45 |

Note: Elements A through X are CONROD's; ID's and arcs are defined in Table 4-5, and constraints at numbered grid points are listed in Table 4-6. Useful weights and their locations are given in Table 4-4.

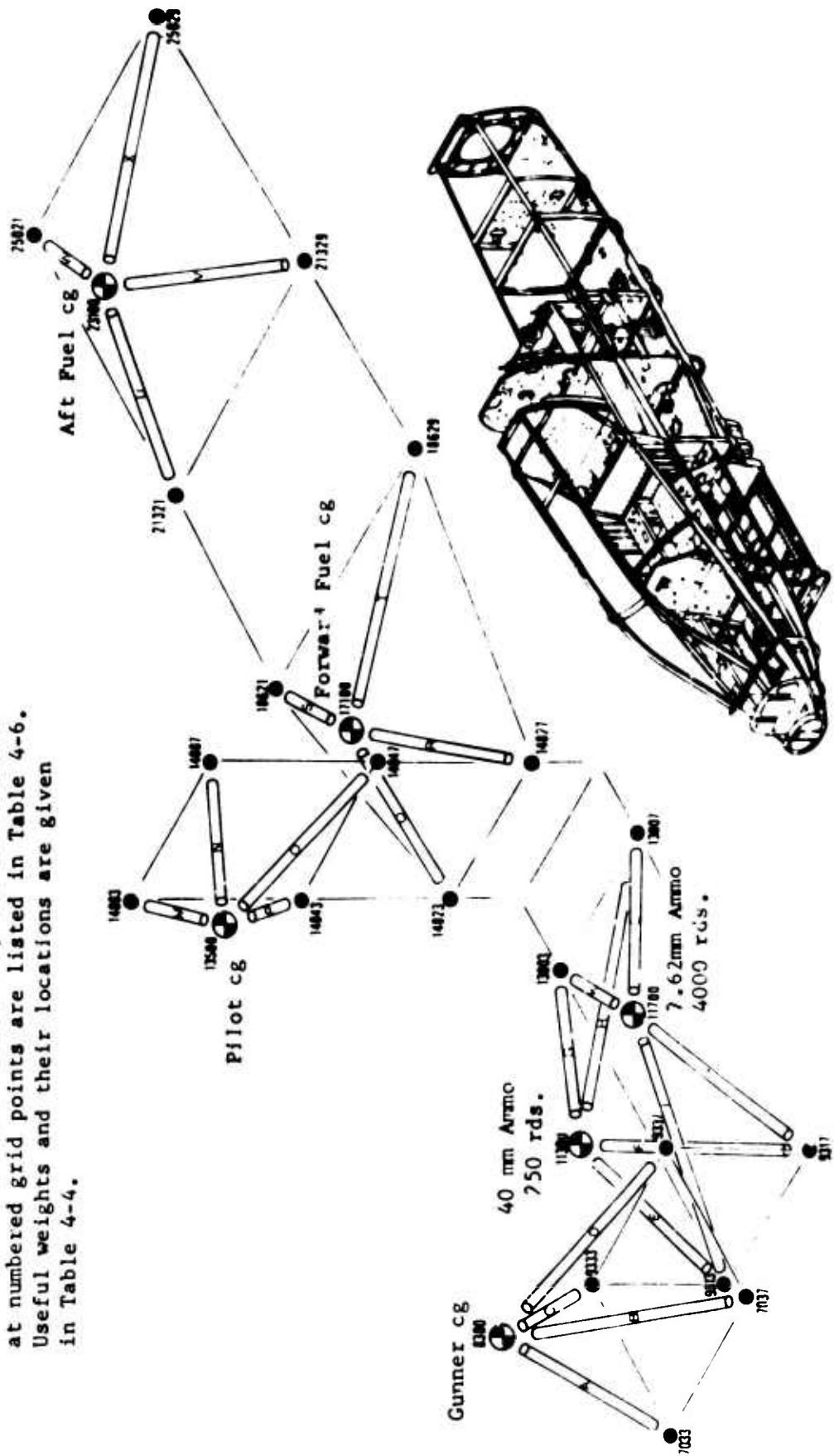

Figure 4-2. Distribution of Useful Weight Items

Table 4-5. Rod Element Data for Distribution of Useful Weight Items

ROD ELEMENT DATA

| LETTER DESIGNATION | NASTRAN EID | TYPE | ACTUAL AREA (in. ²) | OFFSETS FROM GRIDPOINT | | FINAL AREA (in. ²) |
|-----------------------|----------------|-------|------------------------------------|---------------------------|---|-----------------------------------|
| | | | | Z | Y | |
| A | 20081 | Truss | 1.0 | - | - | 1.0 |
| B | 20082 | Truss | 1.0 | - | - | 1.0 |
| C | 20083 | Truss | 1.0 | - | - | 1.0 |
| D | 20084 | Truss | 1.0 | - | - | 1.0 |
| E | 150151 | Truss | 1.0 | - | - | 1.0 |
| F | 150152 | Truss | 1.0 | - | - | 1.0 |
| G | 150153 | Truss | 1.0 | - | - | 1.0 |
| H | 150154 | Truss | 1.0 | - | - | 1.0 |
| I | 150201 | Truss | 1.0 | - | - | 1.0 |
| J | 150202 | Truss | 1.0 | - | - | 1.0 |
| K | 150203 | Truss | 1.0 | - | - | 1.0 |
| L | 150204 | Truss | 1.0 | - | - | 1.0 |
| M | 10093 | Truss | 1.0 | - | - | 1.0 |
| N | 10094 | Truss | 1.0 | - | - | 1.0 |
| O | 10092 | Truss | 1.0 | - | - | 1.0 |
| P | 10091 | Truss | 1.0 | - | - | 1.0 |
| Q | 31071 | Truss | 1.0 | - | - | 1.0 |
| R | 31072 | Truss | 1.0 | - | - | 1.0 |
| S | 31073 | Truss | 1.0 | - | - | 1.0 |
| T | 31074 | Truss | 1.0 | - | - | 1.0 |
| U | 31081 | Truss | 1.0 | - | - | 1.0 |
| V | 31082 | Truss | 1.0 | - | - | 1.0 |
| W | 31083 | Truss | 1.0 | - | - | 1.0 |
| X | 31084 | Truss | 1.0 | - | - | 1.0 |

Table 4-6. Grid Point Constraint Data for Distribution of Useful Weight Items

GRID POINT DATA

| GRID POINT | SPC | | MPC | | OMIT | |
|------------|--------|-------|--------|-------|--------|-------|
| | D.O.F. | RULE* | D.O.F. | RULE* | D.O.F. | RULE* |
| 7033 | 456 | AAA | 123 | AAA | - | - |
| 7037 | 456 | AAA | 123 | AAA | - | - |
| 8300 | - | - | - | - | - | - |
| 9313 | 456 | AAA | - | - | 123 | DCC |
| 9317 | 456 | AAA | - | - | 13 | DC |
| 9333 | 456 | AAA | - | - | 1 | D |
| 9337 | 456 | AAA | - | - | 2 | C |
| 11300 | - | - | - | - | - | - |
| 11700 | - | - | - | - | - | - |
| 13500 | - | - | - | - | - | - |
| 13803 | 456 | AAA | - | - | 123 | DCC |
| 13807 | 456 | AAA | - | - | 123 | DCC |
| 14823 | 456 | AAA | 123 | AAA | - | - |
| 14827 | 456 | AAA | 123 | AAA | - | - |
| 14843 | 456 | AAA | - | - | 123 | DCC |
| 14947 | 456 | AAA | - | - | 123 | DCC |
| 14883 | 456 | AAA | - | - | 123 | DCC |
| 14887 | 456 | AAA | - | - | 123 | DCC |
| 17100 | - | - | - | - | - | - |
| 18621 | 456 | AAA | - | - | 123 | DCC |
| 18629 | 456 | AAA | - | - | 123 | DCC |
| 21321 | 456 | AAA | - | - | 23 | CC |
| 21329 | 456 | AAA | - | - | 123 | DCC |
| 23100 | - | - | - | - | - | - |
| 25021 | 456 | AAA | - | - | 123 | DCC |
| 25029 | 456 | AAA | - | - | 123 | DCC |

* Reference Section 2.4.2

5. NASTRAN STRUCTURAL ELEMENT
AND GRID POINT INDEX

BAR ELEMENT (CBAR) INDEX

| NASTRAN EID | PAGE |
|------------------------|-------------|
| 20411 | 3-224 |
| 20412 | 3-224 |
| 20413 | 3-224 |
| 20414 | 3-224 |
| 20415 | 3-224 |
| 20451 | 3-224 |
| 20452 | 3-224 |
| 20453 | 3-224 |
| 20454 | 3-224 |
| 20455 | 3-224 |
| 20511 | 3-224 |
| 20512 | 3-224 |
| 20513 | 3-224 |
| 20521 | 3-224 |
| 20527 | 3-224 |
| 20523 | 3-224 |
| 1070311 | 3-220 |
| 1070321 | 3-220 |
| 1210091 | 3-220 |
| 1210101 | 3-220 |
| 1210211 | 3-220 |
| 1210212 | 3-220 |
| 1210213 | 3-220 |
| 1210611 | 3-220 |
| 1210612 | 3-220 |
| 1210613 | 3-220 |
| 1864100 | 3-237 |
| 1864900 | 3-238 |
| 1865100 | 3-237 |
| 1865400 | 3-237 |
| 1865600 | 3-237 |
| 1865900 | 3-237 |
| 1866100 | 3-237 |
| 1866900 | 3-237 |
| 1874142 | 3-237 |
| 1874151 | 3-237 |
| 1874243 | 3-238 |
| 1874344 | 3-238 |
| 1874363 | 3-237 |
| 1874445 | 3-238 |
| 1874546 | 3-238 |
| 1874647 | 3-238 |
| 1874748 | 3-238 |
| 1874753 | 3-237 |
| 1874767 | 3-237 |

| NASTRAN EID | PAGE |
|------------------------|-------------|
| 1874849 | 3-238 |
| 1874954 | 3-237 |
| 1875152 | 3-237 |
| 1875156 | 3-237 |
| 1875243 | 3-237 |
| 1875257 | 3-237 |
| 1875354 | 3-237 |
| 1875358 | 3-237 |
| 1875459 | 3-237 |
| 1875657 | 3-237 |
| 1875763 | 3-237 |
| 1875859 | 3-237 |
| 1876162 | 3-237 |
| 1876263 | 3-237 |
| 1876364 | 3-237 |
| 1876465 | 3-237 |
| 1876566 | 3-237 |
| 1876667 | 3-237 |
| 1876758 | 3-237 |
| 1876768 | 3-237 |
| 1876869 | 3-237 |
| 1974100 | 3-242 |
| 1974142 | 3-242 |
| 1974151 | 3-242 |
| 1974243 | 3-242 |
| 1974252 | 3-242 |
| 1974345 | 3-242 |
| 1974363 | 3-242 |
| 1974547 | 3-242 |
| 1974748 | 3-242 |
| 1974767 | 3-242 |
| 1974849 | 3-242 |
| 1974858 | 3-242 |
| 1974900 | 3-242 |
| 1974959 | 3-242 |
| 1975100 | 3-242 |
| 1975152 | 3-242 |
| 1975161 | 3-242 |
| 1975262 | 3-242 |
| 1975859 | 3-242 |
| 1975868 | 3-242 |
| 1975900 | 3-242 |
| 1975969 | 3-242 |
| 1976162 | 3-242 |
| 1976263 | 3-242 |

BAR ELEMENT (CBAR) INDEX (CONT.)

| NASTRAN EID | PAGE |
|----------------|-------|
| 1976365 | 3-242 |
| 1976567 | 3-242 |
| 1976768 | 3-242 |
| 1976869 | 3-242 |
| 2124143 | 3-244 |
| 2124345 | 3-244 |
| 2124547 | 3-244 |
| 2124749 | 3-244 |
| 2134100 | 3-244 |
| 2134900 | 3-244 |
| 3003170 | 3-280 |
| 3173380 | 3-280 |
| 3383590 | 3-280 |
| 3440011 | 3-220 |
| 3440012 | 3-220 |
| 3530251 | 3-216 |
| 3530252 | 3-216 |
| 3530253 | 3-216 |
| 3530254 | 3-216 |
| 3530255 | 3-216 |
| 3570001 | 3-216 |
| 3593800 | 3-280 |
| 3804010 | 3-280 |
| 4000071 | 3-299 |
| 4000072 | 3-299 |
| 4014142 | 3-297 |
| 4014220 | 3-280 |
| 4014243 | 3-297 |
| 4014345 | 3-297 |
| 4014347 | 3-297 |
| 4014547 | 3-297 |
| 4014748 | 3-297 |
| 4014849 | 3-297 |
| 4020091 | 3-299 |
| 4020092 | 3-299 |
| 4020093 | 3-299 |
| 4020094 | 3-299 |
| 4020095 | 3-299 |
| 4020096 | 3-299 |
| 4020097 | 3-299 |
| 4020098 | 3-299 |
| 4020099 | 3-299 |
| 4224430 | 3-280 |
| 4434520 | 3-280 |
| 4500050 | 3-216 |

| NASTRAN EID | PAGE |
|----------------|-------|
| 4500070 | 3-216 |
| 4500071 | 3-216 |
| 4500072 | 3-216 |
| 4500073 | 3-216 |
| 4500074 | 3-216 |
| 4500075 | 3-216 |
| 4500076 | 3-216 |
| 4500077 | 3-216 |
| 4500078 | 3-216 |
| 4500079 | 3-216 |
| 4524640 | 3-280 |
| 4644800 | 3-293 |
| 4804880 | 3-293 |
| 4884970 | 3-293 |
| 4975060 | 3-293 |
| 5065150 | 3-293 |
| 5155200 | 3-293 |
| 6131922 | 3-274 |
| 6171922 | 3-274 |
| 6221922 | 3-274 |
| 6222813 | 3-259 |
| 6222817 | 3-259 |
| 6222821 | 3-259 |
| 6222824 | 3-259 |
| 6222826 | 3-259 |
| 6222829 | 3-259 |
| 6222831 | 3-259 |
| 6222839 | 3-259 |
| 6241922 | 3-274 |
| 6261922 | 3-274 |
| 6281922 | 3-274 |
| 6341922 | 3-274 |
| 6361922 | 3-274 |
| 7131922 | 3-277 |
| 7171922 | 3-277 |
| 7221922 | 3-277 |
| 7222813 | 3-265 |
| 7222817 | 3-265 |
| 7222821 | 3-265 |
| 7222824 | 3-265 |
| 7222826 | 3-265 |
| 7222829 | 3-265 |
| 7222831 | 3-265 |
| 7222839 | 3-265 |

BAR ELEMENT (CBAR) INDEX (CONT.)

| NASTRAN EID | PAGE |
|----------------|-------|
| 7241922 | 3-277 |
| 7261922 | 3-277 |
| 7281922 | 3-277 |
| 7341922 | 3-277 |
| 7361922 | 3-277 |

SCALAR SPRING ELEMENT (CELAS2) INDEX

| NASTRAN EID | PAGE |
|----------------|-------|
| 189831 | 3-217 |
| 189832 | 3-217 |
| 189833 | 3-217 |
| 189871 | 3-217 |
| 189872 | 3-217 |
| 189873 | 3-217 |
| 211831 | 3-217 |
| 211832 | 3-217 |
| 211833 | 3-217 |
| 211871 | 3-217 |
| 211872 | 3-217 |
| 211873 | 3-217 |
| 214853 | 3-217 |

ROD ELEMENT (CONROD) INDEX

| NASTRAN EID | PAGE |
|-------------|-------|
| 10091 | 4-35 |
| 10092 | 4-35 |
| 10093 | 4-35 |
| 10094 | 4-35 |
| 20081 | 4-35 |
| 20082 | 4-35 |
| 20083 | 4-35 |
| 20084 | 4-35 |
| 31071 | 4-35 |
| 31072 | 4-35 |
| 31073 | 4-35 |
| 31074 | 4-35 |
| 31081 | 4-35 |
| 31082 | 4-35 |
| 31083 | 4-35 |
| 31084 | 4-35 |
| 108001 | 3-230 |
| 109001 | 3-230 |
| 150151 | 4-35 |
| 150152 | 4-35 |
| 150153 | 4-35 |
| 150154 | 4-35 |
| 150201 | 4-35 |
| 150202 | 4-35 |
| 150203 | 4-35 |
| 150204 | 4-35 |
| 333141 | 3-4 |
| 333931 | 3-4 |
| 333949 | 3-4 |
| 334149 | 3-4 |
| 612327 | 3-50 |
| 612739 | 3-50 |
| 613123 | 3-50 |
| 613141 | 3-50 |
| 613337 | 3-50 |
| 613343 | 3-50 |
| 613747 | 3-50 |
| 613949 | 3-50 |
| 614161 | 3-50 |
| 614363 | 3-50 |
| 614767 | 3-50 |
| 614969 | 3-50 |
| 616171 | 3-50 |
| 616371 | 3-50 |
| 616979 | 3-50 |

| NASTRAN EID | PAGE |
|-------------|-------|
| 617179 | 3-50 |
| 617967 | 3-50 |
| 930307 | 3-54 |
| 930313 | 3-54 |
| 930717 | 3-54 |
| 931317 | 3-54 |
| 931333 | 3-54 |
| 931730 | 3-54 |
| 933113 | 3-54 |
| 933133 | 3-54 |
| 933141 | 3-54 |
| 933337 | 3-54 |
| 933343 | 3-54 |
| 933717 | 3-54 |
| 933739 | 3-54 |
| 933747 | 3-54 |
| 933949 | 3-54 |
| 934143 | 3-54 |
| 934161 | 3-54 |
| 934347 | 3-54 |
| 934363 | 3-54 |
| 934749 | 3-54 |
| 934767 | 3-54 |
| 934969 | 3-54 |
| 936143 | 3-54 |
| 936163 | 3-54 |
| 936171 | 3-54 |
| 936373 | 3-54 |
| 936769 | 3-54 |
| 936777 | 3-54 |
| 936979 | 3-54 |
| 937173 | 3-54 |
| 937377 | 3-54 |
| 937779 | 3-54 |
| 1060011 | 3-230 |
| 1060012 | 3-230 |
| 1070011 | 3-230 |
| 1070012 | 3-230 |
| 1150231 | 3-101 |
| 1160311 | 3-98 |
| 1170191 | 3-174 |
| 1170211 | 3-175 |
| 1170231 | 3-175 |
| 1170232 | 3-174 |
| 1170501 | 3-175 |

ROD ELEMENT (CONROD) INDEX (CONT.)

| NASTRAN EID | PAGE |
|----------------|-------|
| 1170502 | 3-174 |
| 1170503 | 3-174 |
| 1170504 | 3-174 |
| 1170511 | 3-175 |
| 1170512 | 3-174 |
| 1170513 | 3-175 |
| 1170514 | 3-174 |
| 1170515 | 3-175 |
| 1170516 | 3-174 |
| 1170521 | 3-175 |
| 1170522 | 3-174 |
| 1170523 | 3-174 |
| 1170524 | 3-174 |
| 1170531 | 3-175 |
| 1170532 | 3-174 |
| 1170533 | 3-175 |
| 1170534 | 3-174 |
| 1171101 | 3-175 |
| 1171102 | 3-174 |
| 1171103 | 3-174 |
| 1171104 | 3-174 |
| 1171111 | 3-175 |
| 1171112 | 3-174 |
| 1171113 | 3-175 |
| 1171114 | 3-174 |
| 1173901 | 3-175 |
| 1173902 | 3-174 |
| 1173903 | 3-174 |
| 1173904 | 3-174 |
| 1173911 | 3-175 |
| 1173912 | 3-174 |
| 1173913 | 3-175 |
| 1173914 | 3-174 |
| 1175101 | 3-175 |
| 1175102 | 3-174 |
| 1175103 | 3-174 |
| 1175104 | 3-174 |
| 1175111 | 3-175 |
| 1175112 | 3-174 |
| 1175113 | 3-175 |
| 1175114 | 3-174 |
| 1184501 | 3-171 |
| 1184502 | 3-170 |
| 1184503 | 3-170 |
| 1184504 | 3-170 |

| NASTRAN EID | PAGE |
|----------------|-------|
| 1184511 | 3-170 |
| 1184512 | 3-170 |
| 1184513 | 3-171 |
| 1184514 | 3-170 |
| 1186901 | 3-171 |
| 1186902 | 3-170 |
| 1186903 | 3-170 |
| 1186904 | 3-170 |
| 1186911 | 3-170 |
| 1186912 | 3-170 |
| 1186913 | 3-170 |
| 1186914 | 3-170 |
| 1186921 | 3-171 |
| 1186922 | 3-170 |
| 1186923 | 3-170 |
| 1186924 | 3-170 |
| 1186931 | 3-170 |
| 1186932 | 3-170 |
| 1186933 | 3-171 |
| 1186934 | 3-170 |
| 1187101 | 3-171 |
| 1187102 | 3-170 |
| 1187103 | 3-170 |
| 1187104 | 3-170 |
| 1187111 | 3-170 |
| 1187112 | 3-170 |
| 1187113 | 3-170 |
| 1187114 | 3-170 |
| 1190171 | 3-167 |
| 1190172 | 3-167 |
| 1190173 | 3-167 |
| 1190191 | 3-167 |
| 1190192 | 3-167 |
| 1190211 | 3-167 |
| 1190231 | 3-167 |
| 1190232 | 3-167 |
| 1190501 | 3-167 |
| 1190502 | 3-167 |
| 1190503 | 3-167 |
| 1190504 | 3-167 |
| 1190511 | 3-167 |
| 1190512 | 3-167 |
| 1190513 | 3-167 |
| 1190514 | 3-167 |
| 1190901 | 3-167 |

ROD ELEMENT (CONROD) INDEX (CONT.)

| NASTRAN EID | PAGE |
|----------------|------------|
| 1190902 | 3-167 |
| 1190903 | 3-167 |
| 1190904 | 3-167 |
| 1190911 | 3-167 |
| 1190912 | 3-167 |
| 1190913 | 3-167 |
| 1190914 | 3-167 |
| 1200091 | 3-164 |
| 1200092 | 3-164 |
| 1200133 | 3-164 |
| 1200134 | 3-164 |
| 1200135 | 3-164 |
| 1200136 | 3-164 |
| 1200137 | 3-164 |
| 1200151 | 3-164 |
| 1200701 | 3-164 |
| 1200702 | 3-164 |
| 1200703 | 3-164 |
| 1200704 | 3-164 |
| 1200711 | 3-164 |
| 1200712 | 3-164 |
| 1200713 | 3-164 |
| 1200714 | 3-164 |
| 1201101 | 3-164 |
| 1201102 | 3-164 |
| 1201103 | 3-164 |
| 1201104 | 3-164 |
| 1201111 | 3-164 |
| 1201112 | 3-164 |
| 1201113 | 3-164 |
| 1201114 | 3-164 |
| 1202101 | 3-209 |
| 1202102 | 3-212 |
| 1202103 | 3-209, 212 |
| 1202104 | 3-209, 212 |
| 1210092 | 3-220 |
| 1210102 | 3-220 |
| 1210311 | 3-118 |
| 1210312 | 3-118 |
| 1210321 | 3-114 |
| 1210322 | 3-114 |
| 1210471 | 3-220 |
| 1210472 | 3-220 |
| 1210591 | 3-220 |
| 1210592 | 3-220 |

| NASTRAN EID | PAGE |
|----------------|-------|
| 1250131 | 3-138 |
| 1250132 | 3-138 |
| 1250151 | 3-138 |
| 1250171 | 3-138 |
| 1250571 | 3-135 |
| 1250572 | 3-135 |
| 1250771 | 3-138 |
| 1250772 | 3-138 |
| 1250971 | 3-138 |
| 1251491 | 3-135 |
| 1251511 | 3-135 |
| 1251551 | 3-135 |
| 1251571 | 3-135 |
| 1251572 | 3-135 |
| 1252301 | 3-138 |
| 1252302 | 3-138 |
| 1252303 | 3-138 |
| 1252304 | 3-138 |
| 1252701 | 3-135 |
| 1252702 | 3-135 |
| 1252703 | 3-135 |
| 1252704 | 3-135 |
| 1259101 | 3-138 |
| 1259102 | 3-138 |
| 1259103 | 3-138 |
| 1259104 | 3-138 |
| 1290101 | 3-33 |
| 1290102 | 3-31 |
| 1290103 | 3-31 |
| 1290104 | 3-30 |
| 1290111 | 3-32 |
| 1290112 | 3-31 |
| 1290113 | 3-32 |
| 1290114 | 3-31 |
| 1290121 | 3-33 |
| 1290122 | 3-32 |
| 1290123 | 3-32 |
| 1290124 | 3-30 |
| 1290131 | 3-32 |
| 1290132 | 3-31 |
| 1290133 | 3-32 |
| 1290134 | 3-31 |
| 1290141 | 3-33 |
| 1290142 | 3-32 |
| 1290143 | 3-32 |

ROD ELEMENT (CONROD) INDEX (CONT.)

| NASTRAN EID | PAGE |
|----------------|------|
| 1290144 | 3-31 |
| 1290151 | 3-32 |
| 1290152 | 3-31 |
| 1290153 | 3-32 |
| 1290154 | 3-31 |
| 1290211 | 3-27 |
| 1290212 | 3-26 |
| 1290231 | 3-25 |
| 1290232 | 3-25 |
| 1290233 | 3-26 |
| 1290234 | 3-35 |
| 1290235 | 3-35 |
| 1290251 | 3-28 |
| 1290252 | 3-28 |
| 1290253 | 3-28 |
| 1290254 | 3-36 |
| 1290271 | 3-27 |
| 1290272 | 3-26 |
| 1290273 | 3-35 |
| 1290274 | 3-35 |
| 1290331 | 3-35 |
| 1290501 | 3-33 |
| 1290502 | 3-31 |
| 1290503 | 3-31 |
| 1290504 | 3-30 |
| 1290511 | 3-32 |
| 1290512 | 3-31 |
| 1290513 | 3-32 |
| 1290514 | 3-31 |
| 1290521 | 3-33 |
| 1290522 | 3-32 |
| 1290523 | 3-32 |
| 1290524 | 3-30 |
| 1290531 | 3-32 |
| 1290532 | 3-31 |
| 1290533 | 3-32 |
| 1290534 | 3-31 |
| 1290541 | 3-33 |
| 1290542 | 3-32 |
| 1290543 | 3-32 |
| 1290544 | 3-31 |
| 1290551 | 3-32 |
| 1290552 | 3-31 |
| 1290553 | 3-32 |
| 1290554 | 3-31 |

| NASTRAN EID | PAGE |
|----------------|------|
| 1290561 | 3-39 |
| 1290562 | 3-38 |
| 1290563 | 3-38 |
| 1290564 | 3-38 |
| 1290571 | 3-38 |
| 1290572 | 3-38 |
| 1290573 | 3-39 |
| 1290574 | 3-38 |
| 1290581 | 3-39 |
| 1290582 | 3-38 |
| 1290583 | 3-38 |
| 1290584 | 3-38 |
| 1290591 | 3-39 |
| 1290592 | 3-38 |
| 1290593 | 3-39 |
| 1290594 | 3-38 |
| 1290691 | 3-39 |
| 1290692 | 3-38 |
| 1290695 | 3-46 |
| 1290696 | 3-46 |
| 1290697 | 3-46 |
| 1290698 | 3-46 |
| 1290699 | 3-46 |
| 1290731 | 3-31 |
| 1290732 | 3-38 |
| 1290733 | 3-38 |
| 1290754 | 3-30 |
| 1290755 | 3-30 |
| 1290756 | 3-33 |
| 1290757 | 3-32 |
| 1290758 | 3-31 |
| 1290791 | 3-32 |
| 1290792 | 3-31 |
| 1290793 | 3-38 |
| 1290794 | 3-38 |
| 1290901 | 3-28 |
| 1290902 | 3-26 |
| 1290903 | 3-26 |
| 1290904 | 3-25 |
| 1290911 | 3-27 |
| 1290912 | 3-26 |
| 1290913 | 3-27 |
| 1290914 | 3-26 |
| 1290921 | 3-28 |
| 1290922 | 3-27 |

ROD ELEMENT (CONROD) INDEX (CONT.)

| NASTRAN EID | PAGE |
|----------------|------|
| 1290923 | 3-27 |
| 1290924 | 3-25 |
| 1290931 | 3-27 |
| 1290932 | 3-26 |
| 1290933 | 3-27 |
| 1290934 | 3-26 |
| 1290941 | 3-28 |
| 1290942 | 3-27 |
| 1290943 | 3-27 |
| 1290944 | 3-26 |
| 1290951 | 3-27 |
| 1290952 | 3-26 |
| 1290953 | 3-27 |
| 1290954 | 3-26 |
| 1290961 | 3-36 |
| 1290962 | 3-35 |
| 1290963 | 3-35 |
| 1290964 | 3-35 |
| 1290971 | 3-35 |
| 1290972 | 3-35 |
| 1290973 | 3-36 |
| 1290974 | 3-35 |
| 1290981 | 3-36 |
| 1290982 | 3-35 |
| 1290983 | 3-35 |
| 1290984 | 3-35 |
| 1290991 | 3-33 |
| 1290992 | 3-33 |
| 1290993 | 3-36 |
| 1290994 | 3-35 |
| 1290995 | 3-36 |
| 1290996 | 3-35 |
| 1291001 | 3-43 |
| 1291002 | 3-43 |
| 1291003 | 3-43 |
| 1291004 | 3-42 |
| 1291005 | 3-42 |
| 1291006 | 3-42 |
| 1291007 | 3-42 |
| 1291008 | 3-47 |
| 1291011 | 3-43 |
| 1291012 | 3-43 |
| 1291013 | 3-42 |
| 1291014 | 3-42 |
| 1291015 | 3-43 |

| NASTRAN EID | PAGE |
|----------------|------|
| 1291016 | 3-43 |
| 1291017 | 3-42 |
| 1291018 | 3-42 |
| 1291111 | 3-39 |
| 1291112 | 3-39 |
| 1291253 | 3-46 |
| 1291254 | 3-46 |
| 1291255 | 3-46 |
| 1291273 | 3-42 |
| 1291274 | 3-42 |
| 1291275 | 3-42 |
| 1291373 | 3-36 |
| 1291374 | 3-35 |
| 1291431 | 3-38 |
| 1291432 | 3-38 |
| 1291701 | 3-42 |
| 1291702 | 3-42 |
| 1291703 | 3-42 |
| 1291704 | 3-42 |
| 1291901 | 3-42 |
| 1291902 | 3-42 |
| 1291903 | 3-42 |
| 1291904 | 3-42 |
| 1291971 | 3-36 |
| 1291972 | 3-35 |
| 1291984 | 3-42 |
| 1291985 | 3-42 |
| 1291986 | 3-42 |
| 1291987 | 3-42 |
| 1292501 | 3-47 |
| 1292502 | 3-47 |
| 1292503 | 3-47 |
| 1292504 | 3-46 |
| 1292511 | 3-47 |
| 1292512 | 3-47 |
| 1292513 | 3-47 |
| 1292514 | 3-47 |
| 1292701 | 3-43 |
| 1292702 | 3-43 |
| 1292703 | 3-43 |
| 1292704 | 3-42 |
| 1292711 | 3-43 |
| 1292712 | 3-43 |
| 1292713 | 3-43 |
| 1292714 | 3-43 |

ROD ELEMENT (CONROD) INDEX (CONT.)

| NASTRAN EID | PAGE |
|----------------|------|
| 1293701 | 3-38 |
| 1293702 | 3-38 |
| 1293703 | 3-38 |
| 1293704 | 3-38 |
| 1293711 | 3-38 |
| 1293712 | 3-38 |
| 1293713 | 3-38 |
| 1293714 | 3-38 |
| 1294101 | 3-47 |
| 1294102 | 3-47 |
| 1294103 | 3-47 |
| 1294104 | 3-46 |
| 1294105 | 3-46 |
| 1294106 | 3-46 |
| 1294107 | 3-46 |
| 1294108 | 3-46 |
| 1294111 | 3-47 |
| 1294112 | 3-47 |
| 1294113 | 3-46 |
| 1294114 | 3-46 |
| 1294115 | 3-47 |
| 1294116 | 3-47 |
| 1294117 | 3-46 |
| 1294118 | 3-46 |
| 1294121 | 3-28 |
| 1294122 | 3-27 |
| 1294123 | 3-27 |
| 1294124 | 3-25 |
| 1294131 | 3-27 |
| 1294132 | 3-26 |
| 1294133 | 3-27 |
| 1294134 | 3-26 |
| 1294901 | 3-36 |
| 1294902 | 3-35 |
| 1294903 | 3-35 |
| 1294904 | 3-35 |
| 1294911 | 3-35 |
| 1294912 | 3-35 |
| 1294913 | 3-36 |
| 1294914 | 3-35 |
| 1294921 | 3-36 |
| 1294922 | 3-35 |
| 1294923 | 3-35 |
| 1294924 | 3-35 |
| 1294931 | 3-36 |

| NASTRAN EID | PAGE |
|----------------|------|
| 1294932 | 3-35 |
| 1294933 | 3-36 |
| 1294934 | 3-35 |
| 1295701 | 3-46 |
| 1295702 | 3-46 |
| 1295703 | 3-46 |
| 1295704 | 3-46 |
| 1295901 | 3-28 |
| 1295902 | 3-27 |
| 1295903 | 3-27 |
| 1295904 | 3-25 |
| 1295911 | 3-27 |
| 1295912 | 3-26 |
| 1295913 | 3-27 |
| 1295914 | 3-26 |
| 1295921 | 3-46 |
| 1295922 | 3-46 |
| 1295923 | 3-46 |
| 1295924 | 3-46 |
| 1296901 | 3-47 |
| 1296902 | 3-47 |
| 1296903 | 3-47 |
| 1296904 | 3-46 |
| 1296905 | 3-46 |
| 1296906 | 3-46 |
| 1296911 | 3-47 |
| 1296912 | 3-47 |
| 1296913 | 3-46 |
| 1296914 | 3-47 |
| 1296915 | 3-47 |
| 1296916 | 3-46 |
| 1297501 | 3-33 |
| 1297502 | 3-31 |
| 1297503 | 3-31 |
| 1297504 | 3-30 |
| 1297511 | 3-32 |
| 1297512 | 3-31 |
| 1297513 | 3-32 |
| 1297514 | 3-31 |
| 1297521 | 3-32 |
| 1297522 | 3-30 |
| 1297523 | 3-31 |
| 1297524 | 3-31 |
| 1297701 | 3-32 |
| 1297702 | 3-30 |

ROD ELEMENT (CONROD) INDEX (CONT.)

| NASTRAN EID | PAGE |
|----------------|------|
| 1297703 | 3-31 |
| 1297704 | 3-31 |
| 1298301 | 3-28 |
| 1298302 | 3-26 |
| 1298303 | 3-26 |
| 1298304 | 3-25 |
| 1298311 | 3-27 |
| 1298312 | 3-26 |
| 1298313 | 3-27 |
| 1298314 | 3-26 |
| 1298321 | 3-28 |
| 1298322 | 3-27 |
| 1298323 | 3-27 |
| 1298324 | 3-25 |
| 1298331 | 3-27 |
| 1298332 | 3-26 |
| 1298333 | 3-27 |
| 1298334 | 3-26 |
| 1298341 | 3-28 |
| 1298342 | 3-27 |
| 1298343 | 3-27 |
| 1298344 | 3-26 |
| 1298351 | 3-27 |
| 1298352 | 3-26 |
| 1298353 | 3-27 |
| 1298354 | 3-26 |
| 1298501 | 3-39 |
| 1298502 | 3-38 |
| 1298503 | 3-38 |
| 1298504 | 3-39 |
| 1298511 | 3-39 |
| 1298512 | 3-38 |
| 1298513 | 3-39 |
| 1298514 | 3-39 |
| 1299801 | 3-43 |
| 1299802 | 3-43 |
| 1299803 | 3-43 |
| 1299804 | 3-42 |
| 1299805 | 3-42 |
| 1299806 | 3-42 |
| 1299811 | 3-43 |
| 1299812 | 3-43 |
| 1299813 | 3-42 |
| 1299814 | 3-43 |
| 1299815 | 3-43 |

| NASTRAN EID | PAGE |
|----------------|-------|
| 1299816 | 3-42 |
| 1300211 | 3-106 |
| 1300212 | 3-105 |
| 1300213 | 3-105 |
| 1300214 | 3-105 |
| 1300215 | 3-105 |
| 1300231 | 3-105 |
| 1300271 | 3-107 |
| 1300352 | 3-106 |
| 1300353 | 3-106 |
| 1300411 | 3-105 |
| 1300412 | 3-105 |
| 1302901 | 3-106 |
| 1302902 | 3-106 |
| 1302903 | 3-106 |
| 1302904 | 3-106 |
| 1303301 | 3-106 |
| 1303302 | 3-106 |
| 1303303 | 3-106 |
| 1303304 | 3-106 |
| 1303311 | 3-107 |
| 1303312 | 3-106 |
| 1303313 | 3-106 |
| 1303314 | 3-105 |
| 1303315 | 3-105 |
| 1303316 | 3-105 |
| 1303321 | 3-106 |
| 1303322 | 3-105 |
| 1303323 | 3-105 |
| 1303324 | 3-106 |
| 1303325 | 3-105 |
| 1303326 | 3-105 |
| 1303501 | 3-106 |
| 1303502 | 3-106 |
| 1303503 | 3-106 |
| 1303504 | 3-106 |
| 1303901 | 3-106 |
| 1303902 | 3-106 |
| 1303903 | 3-106 |
| 1303904 | 3-106 |
| 1303911 | 3-107 |
| 1303912 | 3-106 |
| 1303913 | 3-106 |
| 1303914 | 3-105 |
| 1303915 | 3-105 |

ROD ELEMENT (CONROD) INDEX (CONT.)

| NASTRAN EID | PAGE |
|----------------|------------|
| 1303916 | 3-105 |
| 1303921 | 3-106 |
| 1303922 | 3-105 |
| 1303923 | 3-105 |
| 1303924 | 3-106 |
| 1303925 | 3-105 |
| 1303926 | 3-105 |
| 1330101 | 3-209 |
| 1330102 | 3-209, 212 |
| 1330103 | 3-212 |
| 1330104 | 3-209 |
| 1330105 | 3-212 |
| 1330106 | 3-209 |
| 1330107 | 3-212 |
| 1360691 | 3-118 |
| 1360692 | 3-118 |
| 1360693 | 3-167 |
| 1360694 | 3-174 |
| 1360695 | 3-174 |
| 1360711 | 3-114 |
| 1360712 | 3-114 |
| 1360713 | 3-164 |
| 1360714 | 3-170 |
| 1360715 | 3-170 |
| 1370354 | 3-119 |
| 1370355 | 3-118 |
| 1370356 | 3-118 |
| 1370357 | 3-118 |
| 1370358 | 3-118 |
| 1370364 | 3-115 |
| 1370365 | 3-114 |
| 1370366 | 3-114 |
| 1370367 | 3-114 |
| 1370368 | 3-114 |
| 1370501 | 3-118 |
| 1370502 | 3-118 |
| 1370503 | 3-118 |
| 1370504 | 3-118 |
| 1370511 | 3-118 |
| 1370512 | 3-118 |
| 1370513 | 3-118 |
| 1370514 | 3-118 |
| 1370521 | 3-119 |
| 1370522 | 3-118 |
| 1370523 | 3-118 |

| NASTRAN EID | PAGE |
|----------------|-------|
| 1370524 | 3-118 |
| 1370601 | 3-114 |
| 1370602 | 3-114 |
| 1370603 | 3-114 |
| 1370604 | 3-114 |
| 1370611 | 3-114 |
| 1370612 | 3-114 |
| 1370613 | 3-114 |
| 1370614 | 3-114 |
| 1370621 | 3-115 |
| 1370622 | 3-114 |
| 1370623 | 3-114 |
| 1370624 | 3-114 |
| 1372301 | 3-119 |
| 1372302 | 3-118 |
| 1372303 | 3-118 |
| 1372304 | 3-118 |
| 1372401 | 3-115 |
| 1372402 | 3-114 |
| 1372403 | 3-114 |
| 1372404 | 3-114 |
| 1373501 | 3-118 |
| 1373502 | 3-118 |
| 1373503 | 3-118 |
| 1373504 | 3-118 |
| 1373511 | 3-118 |
| 1373512 | 3-118 |
| 1373513 | 3-118 |
| 1373514 | 3-118 |
| 1373601 | 3-114 |
| 1373602 | 3-114 |
| 1373603 | 3-114 |
| 1373604 | 3-114 |
| 1373611 | 3-114 |
| 1373612 | 3-114 |
| 1373613 | 3-114 |
| 1373614 | 3-114 |
| 1380103 | 3-58 |
| 1380191 | 3-111 |
| 1380192 | 3-110 |
| 1380193 | 3-110 |
| 1380194 | 3-110 |
| 1380195 | 3-110 |
| 1380291 | 3-110 |
| 1380307 | 3-58 |

ROD ELEMENT (CONROD) INDEX (CONT.)

| NASTRAN EID | PAGE |
|----------------|-------|
| 1380311 | 3-111 |
| 1380323 | 3-58 |
| 1380432 | 3-111 |
| 1380433 | 3-111 |
| 1380491 | 3-110 |
| 1380492 | 3-110 |
| 1380709 | 3-58 |
| 1380929 | 3-58 |
| 1382101 | 3-58 |
| 1382123 | 3-58 |
| 1382131 | 3-58 |
| 1382327 | 3-58 |
| 1382333 | 3-58 |
| 1382707 | 3-58 |
| 1382729 | 3-58 |
| 1382737 | 3-58 |
| 1382939 | 3-58 |
| 1383133 | 3-58 |
| 1383141 | 3-58 |
| 1383337 | 3-58 |
| 1383343 | 3-58 |
| 1383501 | 3-111 |
| 1383502 | 3-110 |
| 1383503 | 3-111 |
| 1383504 | 3-111 |
| 1383739 | 3-58 |
| 1383747 | 3-58 |
| 1383748 | 3-58 |
| 1383949 | 3-58 |
| 1384101 | 3-111 |
| 1384102 | 3-110 |
| 1384103 | 3-111 |
| 1384104 | 3-111 |
| 1384111 | 3-111 |
| 1384112 | 3-111 |
| 1384113 | 3-111 |
| 1384114 | 3-110 |
| 1384115 | 3-110 |
| 1384116 | 3-110 |
| 1384121 | 3-111 |
| 1384122 | 3-110 |
| 1384123 | 3-110 |
| 1384124 | 3-111 |
| 1384125 | 3-110 |
| 1384126 | 3-110 |

| NASTRAN EID | PAGE |
|----------------|-------|
| 1384143 | 3-58 |
| 1384161 | 3-58 |
| 1384301 | 3-111 |
| 1384302 | 3-110 |
| 1384303 | 3-111 |
| 1384304 | 3-111 |
| 1384347 | 3-58 |
| 1384363 | 3-58 |
| 1384501 | 3-111 |
| 1384502 | 3-110 |
| 1384503 | 3-111 |
| 1384504 | 3-111 |
| 1384511 | 3-111 |
| 1384512 | 3-111 |
| 1384513 | 3-111 |
| 1384514 | 3-110 |
| 1384515 | 3-110 |
| 1384516 | 3-110 |
| 1384521 | 3-111 |
| 1384522 | 3-110 |
| 1384523 | 3-110 |
| 1384524 | 3-111 |
| 1384525 | 3-110 |
| 1384526 | 3-110 |
| 1384867 | 3-58 |
| 1384969 | 3-58 |
| 1386163 | 3-58 |
| 1386760 | 3-58 |
| 1480103 | 3-124 |
| 1480307 | 3-124 |
| 1480323 | 3-123 |
| 1480709 | 3-124 |
| 1480929 | 3-123 |
| 1482101 | 3-123 |
| 1482123 | 3-123 |
| 1482131 | 3-123 |
| 1482327 | 3-123 |
| 1482333 | 3-123 |
| 1482707 | 3-123 |
| 1482729 | 3-123 |
| 1482737 | 3-123 |
| 1482939 | 3-123 |
| 1483133 | 3-123 |
| 1483141 | 3-123 |
| 1483337 | 3-123 |

ROD ELEMENT (CONROD) INDEX (CONT.)

| NASTRAN EID | PAGE |
|----------------|-------|
| 1483343 | 3-123 |
| 1483739 | 3-123 |
| 1483747 | 3-123 |
| 1483949 | 3-123 |
| 1484161 | 3-123 |
| 1484347 | 3-123 |
| 1484363 | 3-123 |
| 1484767 | 3-123 |
| 1484969 | 3-123 |
| 1486163 | 3-123 |
| 1486181 | 3-123 |
| 1486367 | 3-123 |
| 1486769 | 3-123 |
| 1486989 | 3-123 |
| 1488183 | 3-123 |
| 1488387 | 3-123 |
| 1488789 | 3-123 |
| 1560031 | 3-88 |
| 1560032 | 3-89 |
| 1560033 | 3-89 |
| 1560041 | 3-88 |
| 1560042 | 3-88 |
| 1560043 | 3-88 |
| 1570017 | 3-30 |
| 1570018 | 3-30 |
| 1570013 | 3-31 |
| 1570014 | 3-38 |
| 1570015 | 3-38 |
| 1570016 | 3-46 |
| 1570017 | 3-110 |
| 1570031 | 3-25 |
| 1570032 | 3-25 |
| 1570033 | 3-26 |
| 1570034 | 3-35 |
| 1570035 | 3-35 |
| 1570036 | 3-42 |
| 1570037 | 3-105 |
| 1580031 | 3-33 |
| 1580032 | 3-33 |
| 1580033 | 3-33 |
| 1580034 | 3-39 |
| 1580035 | 3-39 |
| 1580036 | 3-46 |
| 1580041 | 3-20 |
| 1580042 | 3-28 |

| NASTRAN EID | PAGE |
|----------------|-------|
| 1560043 | 3-28 |
| 1580044 | 3-36 |
| 1580045 | 3-36 |
| 1580046 | 3-42 |
| 1590051 | 3-47 |
| 1590052 | 3-111 |
| 1590053 | 3-111 |
| 1590071 | 3-43 |
| 1590072 | 3-106 |
| 1590073 | 3-107 |
| 1600051 | 3-118 |
| 1600052 | 3-118 |
| 1600053 | 3-167 |
| 1600054 | 3-174 |
| 1600055 | 3-174 |
| 1600091 | 3-114 |
| 1600092 | 3-114 |
| 1600093 | 3-164 |
| 1600094 | 3-170 |
| 1600095 | 3-170 |
| 1610131 | 3-70 |
| 1610132 | 3-138 |
| 1610133 | 3-138 |
| 1610151 | 3-68 |
| 1610152 | 3-135 |
| 1610153 | 3-135 |
| 1610191 | 3-119 |
| 1610192 | 3-167 |
| 1610193 | 3-167 |
| 1610194 | 3-167 |
| 1610195 | 3-175 |
| 1610196 | 3-175 |
| 1610291 | 3-115 |
| 1610292 | 3-164 |
| 1610293 | 3-164 |
| 1610294 | 3-164 |
| 1610295 | 3-171 |
| 1610296 | 3-171 |
| 1796101 | 3-60 |
| 1796102 | 3-60 |
| 1796103 | 3-60 |
| 1796104 | 3-60 |
| 1796111 | 3-60 |
| 1796112 | 3-60 |
| 1796113 | 3-60 |

ROD ELEMENT (CONROD) INDEX (CONT.)

| NASTRAN EID | PAGE |
|----------------|-------|
| 1796114 | 3-60 |
| 1796121 | 3-64 |
| 1796122 | 3-64 |
| 1796123 | 3-64 |
| 1796124 | 3-64 |
| 1796131 | 3-64 |
| 1796132 | 3-64 |
| 1796133 | 3-64 |
| 1796134 | 3-64 |
| 1796141 | 3-68 |
| 1796142 | 3-68 |
| 1796143 | 3-68 |
| 1796144 | 3-68 |
| 1796301 | 3-62 |
| 1796302 | 3-62 |
| 1796303 | 3-62 |
| 1796304 | 3-62 |
| 1796311 | 3-62 |
| 1796312 | 3-62 |
| 1796313 | 3-62 |
| 1796314 | 3-62 |
| 1796321 | 3-66 |
| 1796322 | 3-66 |
| 1796323 | 3-66 |
| 1796324 | 3-66 |
| 1796331 | 3-66 |
| 1796332 | 3-66 |
| 1796333 | 3-66 |
| 1796334 | 3-66 |
| 1796341 | 3-70 |
| 1796342 | 3-70 |
| 1796343 | 3-70 |
| 1796344 | 3-70 |
| 1800171 | 3-119 |
| 1800191 | 3-115 |
| 1820011 | 3-118 |
| 1820012 | 3-119 |
| 1820051 | 3-115 |
| 1820052 | 3-115 |
| 1860103 | 3-132 |
| 1860307 | 3-132 |
| 1860709 | 3-132 |
| 1860929 | 3-132 |
| 1862101 | 3-132 |
| 1862123 | 3-132 |

| NASTRAN EID | PAGE |
|----------------|-------|
| 1862131 | 3-132 |
| 1862325 | 3-132 |
| 1862527 | 3-132 |
| 1862729 | 3-132 |
| 1862939 | 3-132 |
| 1863141 | 3-132 |
| 1863949 | 3-132 |
| 1864151 | 3-132 |
| 1864454 | 3-132 |
| 1865156 | 3-132 |
| 1865459 | 3-132 |
| 1865661 | 3-132 |
| 1865969 | 3-132 |
| 1866181 | 3-132 |
| 1866989 | 3-132 |
| 1868183 | 3-132 |
| 1868385 | 3-132 |
| 1868587 | 3-132 |
| 1868789 | 3-132 |
| 1870031 | 3-84 |
| 1870032 | 3-84 |
| 1874241 | 3-236 |
| 1874352 | 3-236 |
| 1874464 | 3-236 |
| 1874666 | 3-236 |
| 1874948 | 3-236 |
| 1875141 | 3-236 |
| 1875242 | 3-236 |
| 1875251 | 3-236 |
| 1875347 | 3-236 |
| 1875348 | 3-236 |
| 1875449 | 3-236 |
| 1875453 | 3-236 |
| 1875651 | 3-236 |
| 1875752 | 3-236 |
| 1875756 | 3-236 |
| 1875853 | 3-236 |
| 1875867 | 3-236 |
| 1875954 | 3-236 |
| 1875958 | 3-236 |
| 1876343 | 3-236 |
| 1876357 | 3-236 |
| 1876747 | 3-236 |
| 1974241 | 3-241 |
| 1974342 | 3-241 |

ROD ELEMENT (CONROD) INDEX (CONT.)

| NASTRAN EID | PAGE |
|----------------|--------|
| 1974543 | 3-241 |
| 1974565 | 3-241 |
| 1974745 | 3-241 |
| 1974847 | 3-241 |
| 1974948 | 3-241 |
| 1975141 | 3-241 |
| 1975242 | 3-241 |
| 1975251 | 3-241 |
| 1975848 | 3-241 |
| 1975867 | 3-241 |
| 1975949 | 3-241 |
| 1975958 | 3-241 |
| 1976151 | 3-241 |
| 1976252 | 3-241 |
| 1976261 | 3-241 |
| 1976343 | 3-241 |
| 1976352 | 3-241 |
| 1976545 | 3-241 |
| 1976563 | 3-241 |
| 1976747 | 3-241 |
| 1976765 | 3-241 |
| 1976858 | 3-241 |
| 1976959 | 3-241 |
| 1976968 | 3-241 |
| 2010191 | 3-9 |
| 2010192 | 3-12 |
| 2010211 | 3-9,12 |
| 2015301 | 3-80 |
| 2015302 | 3-80 |
| 2015303 | 3-80 |
| 2015304 | 3-81 |
| 2015305 | 3-81 |
| 2015306 | 3-82 |
| 2015307 | 3-80 |
| 2015308 | 3-81 |
| 2015309 | 3-82 |
| 2015310 | 3-80 |
| 2015311 | 3-81 |
| 2015312 | 3-82 |
| 2015321 | 3-80 |
| 2015322 | 3-81 |
| 2015323 | 3-81 |
| 2015324 | 3-82 |
| 2015325 | 3-80 |
| 2015326 | 3-82 |

| NASTRAN EID | PAGE |
|----------------|--------|
| 2015327 | 3-80 |
| 2015328 | 3-82 |
| 2015331 | 3-80 |
| 2015332 | 3-81 |
| 2015333 | 3-81 |
| 2015334 | 3-82 |
| 2015335 | 3-82 |
| 2015336 | 3-82 |
| 2015337 | 3-80 |
| 2015338 | 3-81 |
| 2015339 | 3-82 |
| 2015341 | 3-81 |
| 2015342 | 3-82 |
| 2015343 | 3-80 |
| 2016701 | 3-9 |
| 2016702 | 3-12 |
| 2016703 | 3-9,12 |
| 2016704 | 3-9,12 |
| 2016901 | 3-9 |
| 2016902 | 3-12 |
| 2016903 | 3-9,12 |
| 2016904 | 3-9,12 |
| 2016911 | 3-80 |
| 2016912 | 3-81 |
| 2016913 | 3-81 |
| 2016914 | 3-81 |
| 2016915 | 3-81 |
| 2016916 | 3-82 |
| 2016917 | 3-80 |
| 2016918 | 3-81 |
| 2016919 | 3-82 |
| 2016920 | 3-80 |
| 2016921 | 3-81 |
| 2016922 | 3-82 |
| 2016931 | 3-80 |
| 2016932 | 3-81 |
| 2016933 | 3-81 |
| 2016934 | 3-82 |
| 2016935 | 3-80 |
| 2016936 | 3-82 |
| 2016937 | 3-80 |
| 2016938 | 3-82 |
| 2017001 | 3-80 |
| 2017002 | 3-81 |
| 2017003 | 3-81 |

ROD ELEMENT (CONROD) INDEX (CONT.)

| NASTRAN EID | PAGE |
|----------------|------|
| 2017004 | 3-82 |
| 2017005 | 3-82 |
| 2017006 | 3-82 |
| 2017007 | 3-80 |
| 2017008 | 3-81 |
| 2017009 | 3-82 |
| 2017010 | 3-80 |
| 2017011 | 3-81 |
| 2017012 | 3-82 |
| 2018501 | 3-80 |
| 2018502 | 3-80 |
| 2018503 | 3-80 |
| 2018504 | 3-81 |
| 2018505 | 3-81 |
| 2018506 | 3-82 |
| 2018507 | 3-80 |
| 2018508 | 3-81 |
| 2018509 | 3-82 |
| 2018510 | 3-80 |
| 2018511 | 3-81 |
| 2018512 | 3-82 |
| 2018521 | 3-80 |
| 2018522 | 3-81 |
| 2018523 | 3-81 |
| 2018524 | 3-82 |
| 2018525 | 3-80 |
| 2018526 | 3-82 |
| 2018527 | 3-80 |
| 2018528 | 3-82 |
| 2018531 | 3-80 |
| 2018532 | 3-81 |
| 2018533 | 3-81 |
| 2018534 | 3-82 |
| 2018535 | 3-82 |
| 2018536 | 3-82 |
| 2018537 | 3-80 |
| 2018538 | 3-81 |
| 2018539 | 3-82 |
| 2018540 | 3-80 |
| 2018541 | 3-81 |
| 2018542 | 3-82 |
| 2020171 | 3-88 |
| 2020172 | 3-88 |
| 2020173 | 3-88 |
| 2020271 | 3-88 |

| NASTRAN EID | PAGE |
|----------------|-----------|
| 2020272 | 3-89 |
| 2020273 | 3-89 |
| 2020291 | 3-88 |
| 2020292 | 3-88 |
| 2020293 | 3-88 |
| 2027301 | 3-88 |
| 2027302 | 3-88 |
| 2027303 | 3-88 |
| 2027304 | 3-88 |
| 2027305 | 3-89 |
| 2027306 | 3-89 |
| 2027307 | 3-88 |
| 2027308 | 3-88 |
| 2027309 | 3-88 |
| 2027310 | 3-88 |
| 2027311 | 3-88 |
| 2027312 | 3-88 |
| 2030511 | 3-101 |
| 2030512 | 3-101 |
| 2030513 | 3-101 |
| 2030521 | 3-98 |
| 2030522 | 3-98 |
| 2030523 | 3-98 |
| 2032901 | 3-98 |
| 2032902 | 3-101 |
| 2032903 | 3-98, 101 |
| 2032904 | 3-98, 101 |
| 2044701 | 3-142 |
| 2044702 | 3-142 |
| 2044703 | 3-143 |
| 2044704 | 3-143 |
| 2044705 | 3-142 |
| 2044706 | 3-143 |
| 2044707 | 3-142 |
| 2044708 | 3-143 |
| 2044711 | 3-142 |
| 2044712 | 3-142 |
| 2044713 | 3-143 |
| 2044714 | 3-143 |
| 2044715 | 3-142 |
| 2044716 | 3-142 |
| 2044717 | 3-142 |
| 2044718 | 3-142 |
| 2044719 | 3-143 |
| 2044720 | 3-142 |

ROD ELEMENT (CONROD) INDEX (CONT.)

| NASTRAN EID | PAGE |
|----------------|-------|
| 2044721 | 3-142 |
| 2044722 | 3-143 |
| 2044723 | 3-143 |
| 2044724 | 3-142 |
| 2044725 | 3-142 |
| 2044726 | 3-143 |
| 2044727 | 3-143 |
| 2047901 | 3-142 |
| 2047902 | 3-142 |
| 2047903 | 3-142 |
| 2047904 | 3-143 |
| 2047905 | 3-142 |
| 2047906 | 3-142 |
| 2047907 | 3-142 |
| 2047908 | 3-143 |
| 2048101 | 3-142 |
| 2048102 | 3-142 |
| 2048103 | 3-143 |
| 2048104 | 3-143 |
| 2048105 | 3-142 |
| 2048106 | 3-143 |
| 2048107 | 3-142 |
| 2048108 | 3-143 |
| 2048201 | 3-142 |
| 2048202 | 3-142 |
| 2048203 | 3-142 |
| 2048204 | 3-143 |
| 2048205 | 3-142 |
| 2048206 | 3-142 |
| 2048207 | 3-142 |
| 2048208 | 3-143 |
| 2050431 | 3-151 |
| 2050432 | 3-151 |
| 2050433 | 3-151 |
| 2050434 | 3-151 |
| 2050435 | 3-152 |
| 2050436 | 3-151 |
| 2050437 | 3-151 |
| 2050438 | 3-151 |
| 2050439 | 3-152 |
| 2050651 | 3-152 |
| 2050652 | 3-152 |
| 2055501 | 3-151 |
| 2055502 | 3-151 |
| 2055503 | 3-151 |

| NASTRAN EID | PAGE |
|----------------|-------|
| 2055504 | 3-151 |
| 2055505 | 3-151 |
| 2055506 | 3-152 |
| 2055507 | 3-152 |
| 2055508 | 3-152 |
| 2055511 | 3-152 |
| 2055512 | 3-151 |
| 2055513 | 3-151 |
| 2055514 | 3-152 |
| 2055515 | 3-151 |
| 2055516 | 3-151 |
| 2055517 | 3-151 |
| 2055518 | 3-152 |
| 2056301 | 3-151 |
| 2056302 | 3-151 |
| 2056303 | 3-151 |
| 2056304 | 3-151 |
| 2056305 | 3-151 |
| 2056306 | 3-152 |
| 2056307 | 3-152 |
| 2056308 | 3-152 |
| 2056311 | 3-151 |
| 2056312 | 3-151 |
| 2056313 | 3-151 |
| 2056314 | 3-152 |
| 2056315 | 3-151 |
| 2056316 | 3-151 |
| 2056317 | 3-151 |
| 2056318 | 3-152 |
| 2060191 | 3-195 |
| 2060211 | 3-192 |
| 2060231 | 3-192 |
| 2060232 | 3-193 |
| 2060233 | 3-194 |
| 2060234 | 3-195 |
| 2060271 | 3-195 |
| 2060391 | 3-193 |
| 2060392 | 3-194 |
| 2060501 | 3-192 |
| 2060850 | 3-192 |
| 2060851 | 3-195 |
| 2060852 | 3-192 |
| 2060853 | 3-193 |
| 2060854 | 3-194 |
| 2060855 | 3-195 |

ROD ELEMENT (CONROD) INDEX (CONT.)

| NASTRAN EID | PAGE |
|----------------|-------|
| 2060856 | 3-192 |
| 2060857 | 3-193 |
| 2060858 | 3-194 |
| 2060859 | 3-195 |
| 2068701 | 3-192 |
| 2068702 | 3-192 |
| 2068703 | 3-192 |
| 2068704 | 3-193 |
| 2068705 | 3-193 |
| 2068706 | 3-194 |
| 2068707 | 3-194 |
| 2068708 | 3-195 |
| 2068711 | 3-192 |
| 2068712 | 3-193 |
| 2068713 | 3-194 |
| 2068714 | 3-195 |
| 2068715 | 3-192 |
| 2068716 | 3-193 |
| 2068717 | 3-194 |
| 2068718 | 3-195 |
| 2068721 | 3-192 |
| 2068722 | 3-192 |
| 2068723 | 3-192 |
| 2068724 | 3-193 |
| 2068725 | 3-193 |
| 2068726 | 3-194 |
| 2068727 | 3-194 |
| 2068728 | 3-195 |
| 2068731 | 3-192 |
| 2068732 | 3-193 |
| 2068733 | 3-194 |
| 2068734 | 3-195 |
| 2068735 | 3-192 |
| 2068736 | 3-193 |
| 2068737 | 3-194 |
| 2068738 | 3-195 |
| 2068801 | 3-193 |
| 2068802 | 3-193 |
| 2068803 | 3-194 |
| 2068804 | 3-195 |
| 2068811 | 3-193 |
| 2068812 | 3-194 |
| 2068813 | 3-193 |
| 2068814 | 3-194 |
| 2068901 | 3-192 |

| NASTRAN EID | PAGE |
|----------------|-------|
| 2068902 | 3-192 |
| 2068903 | 3-192 |
| 2068904 | 3-193 |
| 2068905 | 3-193 |
| 2068906 | 3-194 |
| 2068907 | 3-194 |
| 2068908 | 3-195 |
| 2068911 | 3-192 |
| 2068912 | 3-193 |
| 2068913 | 3-194 |
| 2068914 | 3-195 |
| 2068915 | 3-192 |
| 2068916 | 3-193 |
| 2068917 | 3-194 |
| 2068918 | 3-195 |
| 2068921 | 3-192 |
| 2068922 | 3-192 |
| 2068923 | 3-193 |
| 2068924 | 3-193 |
| 2068925 | 3-193 |
| 2068926 | 3-194 |
| 2068927 | 3-194 |
| 2068928 | 3-195 |
| 2068931 | 3-192 |
| 2068932 | 3-193 |
| 2068933 | 3-194 |
| 2068934 | 3-195 |
| 2068935 | 3-192 |
| 2068936 | 3-193 |
| 2068937 | 3-194 |
| 2068938 | 3-195 |
| 2069001 | 3-193 |
| 2069002 | 3-194 |
| 2069003 | 3-194 |
| 2069004 | 3-195 |
| 2069011 | 3-193 |
| 2069012 | 3-194 |
| 2069013 | 3-194 |
| 2069014 | 3-194 |
| 2069101 | 3-192 |
| 2069102 | 3-192 |
| 2069103 | 3-192 |
| 2069104 | 3-193 |
| 2069105 | 3-193 |
| 2069106 | 3-194 |

ROD ELEMENT (CONROD) INDEX (CONT.)

| NASTRAN EID | PAGE |
|----------------|-------|
| 2069107 | 3-194 |
| 2069108 | 3-195 |
| 2069111 | 3-192 |
| 2069112 | 3-193 |
| 2069113 | 3-194 |
| 2069114 | 3-195 |
| 2069115 | 3-192 |
| 2069116 | 3-193 |
| 2069117 | 3-194 |
| 2069118 | 3-195 |
| 2070091 | 3-197 |
| 2070131 | 3-199 |
| 2070132 | 3-199 |
| 2070151 | 3-199 |
| 2070211 | 3-199 |
| 2070212 | 3-199 |
| 2070231 | 3-197 |
| 2070232 | 3-197 |
| 2070511 | 3-197 |
| 2070551 | 3-197 |
| 2070552 | 3-197 |
| 2070571 | 3-199 |
| 2072701 | 3-197 |
| 2072702 | 3-197 |
| 2072703 | 3-197 |
| 2072704 | 3-197 |
| 2072711 | 3-197 |
| 2072712 | 3-197 |
| 2072713 | 3-197 |
| 2072714 | 3-197 |
| 2076501 | 3-199 |
| 2076502 | 3-199 |
| 2076503 | 3-199 |
| 2076504 | 3-199 |
| 2076511 | 3-199 |
| 2076512 | 3-199 |
| 2076513 | 3-199 |
| 2076514 | 3-199 |
| 2077701 | 3-88 |
| 2077702 | 3-88 |
| 2077703 | 3-88 |
| 2077704 | 3-88 |
| 2077705 | 3-89 |
| 2077706 | 3-89 |
| 2077707 | 3-88 |

| NASTRAN EID | PAGE |
|----------------|-------|
| 2077708 | 3-88 |
| 2077709 | 3-88 |
| 2077710 | 3-88 |
| 2077711 | 3-88 |
| 2077712 | 3-88 |
| 2078101 | 3-197 |
| 2078102 | 3-197 |
| 2078103 | 3-197 |
| 2078104 | 3-197 |
| 2078111 | 3-197 |
| 2078112 | 3-197 |
| 2078113 | 3-197 |
| 2078114 | 3-197 |
| 2078701 | 3-199 |
| 2078702 | 3-199 |
| 2078703 | 3-199 |
| 2078704 | 3-199 |
| 2078711 | 3-199 |
| 2078712 | 3-199 |
| 2078713 | 3-199 |
| 2078714 | 3-199 |
| 2080231 | 3-147 |
| 2080232 | 3-148 |
| 2081101 | 3-148 |
| 2081102 | 3-148 |
| 2081103 | 3-148 |
| 2081104 | 4-148 |
| 2081301 | 3-146 |
| 2081302 | 3-147 |
| 2081303 | 3-147 |
| 2081304 | 3-147 |
| 2081305 | 3-147 |
| 2081306 | 3-148 |
| 2081307 | 3-148 |
| 2081308 | 3-148 |
| 2081309 | 3-147 |
| 2081310 | 3-147 |
| 2081311 | 3-147 |
| 2081312 | 3-148 |
| 2081313 | 3-147 |
| 2081314 | 3-147 |
| 2081315 | 3-148 |
| 2081316 | 3-148 |
| 2084501 | 3-146 |
| 2084502 | 3-146 |

ROD ELEMENT (CONROD) INDEX (CONT.)

| NASTRAN EID | PAGE |
|----------------|-------|
| 2084511 | 3-148 |
| 2084512 | 3-148 |
| 2084521 | 3-146 |
| 2084522 | 3-147 |
| 2084523 | 3-148 |
| 2084531 | 3-147 |
| 2084532 | 3-147 |
| 2084533 | 3-147 |
| 2084534 | 3-148 |
| 2084541 | 3-147 |
| 2084542 | 3-147 |
| 2084543 | 3-148 |
| 2084544 | 3-148 |
| 2087901 | 3-146 |
| 2087902 | 3-147 |
| 2087903 | 3-148 |
| 2087904 | 3-148 |
| 2087905 | 3-146 |
| 2087906 | 3-148 |
| 2087907 | 3-147 |
| 2087908 | 3-148 |
| 2087921 | 3-146 |
| 2087922 | 3-147 |
| 2087923 | 3-147 |
| 2087924 | 3-147 |
| 2087925 | 3-147 |
| 2087926 | 3-148 |
| 2087927 | 3-148 |
| 2087928 | 3-148 |
| 2087929 | 3-147 |
| 2087930 | 3-147 |
| 2087931 | 3-147 |
| 2087932 | 3-148 |
| 2087933 | 3-147 |
| 2087934 | 3-147 |
| 2087935 | 3-148 |
| 2087936 | 3-148 |
| 2090051 | 3-205 |
| 2090052 | 3-205 |
| 2090053 | 3-205 |
| 2090054 | 3-206 |
| 2090055 | 3-205 |
| 2090056 | 3-206 |
| 2090057 | 3-205 |
| 2090058 | 3-206 |

| NASTRAN EID | PAGE |
|----------------|-------|
| 2090411 | 3-205 |
| 2090412 | 3-206 |
| 2090431 | 3-205 |
| 2090432 | 3-206 |
| 2091011 | 3-205 |
| 2091012 | 3-206 |
| 2091031 | 3-205 |
| 2091032 | 3-205 |
| 2091270 | 3-202 |
| 2091271 | 3-202 |
| 2091272 | 3-202 |
| 2091273 | 3-202 |
| 2091274 | 3-202 |
| 2091275 | 3-202 |
| 2091276 | 3-202 |
| 2091277 | 3-202 |
| 2091281 | 3-205 |
| 2091282 | 3-206 |
| 2091283 | 3-205 |
| 2091284 | 3-206 |
| 2091285 | 3-205 |
| 2091286 | 3-206 |
| 2092501 | 3-202 |
| 2092502 | 3-202 |
| 2092503 | 3-202 |
| 2092504 | 3-202 |
| 2092511 | 3-202 |
| 2092512 | 3-202 |
| 2092513 | 3-202 |
| 2092514 | 3-202 |
| 2092521 | 3-205 |
| 2092522 | 3-205 |
| 2092523 | 3-206 |
| 2092524 | 3-206 |
| 2092531 | 3-205 |
| 2092532 | 3-206 |
| 2092533 | 3-205 |
| 2092534 | 3-206 |
| 2092541 | 3-205 |
| 2092542 | 3-206 |
| 2092543 | 3-206 |
| 2092544 | 3-205 |
| 2092551 | 3-205 |
| 2092552 | 3-206 |
| 2092553 | 3-205 |

ROD ELEMENT (CONROD) INDEX (CONT.)

| NASTRAN EID | PAGE |
|----------------|-------|
| 2092554 | 3-206 |
| 2092701 | 3-205 |
| 2092702 | 3-206 |
| 2092703 | 3-206 |
| 2092704 | 3-206 |
| 2092711 | 3-205 |
| 2092712 | 3-206 |
| 2092713 | 3-205 |
| 2092714 | 3-206 |
| 2092901 | 3-202 |
| 2092902 | 3-202 |
| 2092903 | 3-202 |
| 2092904 | 3-202 |
| 2092911 | 3-202 |
| 2092912 | 3-202 |
| 2092913 | 3-202 |
| 2092914 | 3-202 |
| 2092921 | 3-205 |
| 2092922 | 3-205 |
| 2092923 | 3-205 |
| 2092924 | 3-206 |
| 2092931 | 3-205 |
| 2092932 | 3-206 |
| 2092933 | 3-205 |
| 2092934 | 3-206 |
| 2092941 | 3-205 |
| 2092942 | 3-206 |
| 2092943 | 3-206 |
| 2092944 | 3-206 |
| 2092951 | 3-205 |
| 2092952 | 3-206 |
| 2092953 | 3-205 |
| 2092954 | 3-206 |
| 2100451 | 3-62 |
| 2100452 | 3-62 |
| 2100453 | 3-62 |
| 2100551 | 3-66 |
| 2100552 | 3-66 |
| 2100553 | 3-70 |
| 2100711 | 3-138 |
| 2108901 | 3-92 |
| 2108902 | 3-92 |
| 2108903 | 3-92 |
| 2108904 | 3-95 |
| 2108905 | 3-95 |

| NASTRAN EID | PAGE |
|----------------|------|
| 2108906 | 3-95 |
| 2108907 | 3-92 |
| 2108908 | 3-92 |
| 2108909 | 3-92 |
| 2108910 | 3-95 |
| 2108911 | 3-95 |
| 2108912 | 3-95 |
| 2108913 | 3-92 |
| 2108914 | 3-92 |
| 2108915 | 3-92 |
| 2108916 | 3-92 |
| 2108917 | 3-92 |
| 2108918 | 3-92 |
| 2108919 | 3-95 |
| 2108920 | 3-95 |
| 2108921 | 3-95 |
| 2108922 | 3-95 |
| 2108923 | 3-95 |
| 2108924 | 3-95 |
| 2110101 | 3-9 |
| 2110102 | 3-60 |
| 2110103 | 3-60 |
| 2110104 | 3-60 |
| 2110105 | 3-64 |
| 2110106 | 3-64 |
| 2110107 | 3-68 |
| 2110501 | 3-76 |
| 2110502 | 3-76 |
| 2110503 | 3-76 |
| 2110504 | 3-76 |
| 2110505 | 3-76 |
| 2110506 | 3-76 |
| 2110507 | 3-76 |
| 2110508 | 3-76 |
| 2110509 | 3-76 |
| 2110510 | 3-76 |
| 2110511 | 3-76 |
| 2110512 | 3-76 |
| 2110531 | 3-12 |
| 2110532 | 3-12 |
| 2110533 | 3-62 |
| 2110534 | 3-62 |
| 2110535 | 3-66 |
| 2110536 | 3-66 |
| 2110537 | 3-70 |

ROD ELEMENT (CONROD) INDEX (CONT.)

| NASTRAN EID | PAGE |
|----------------|-------|
| 2110701 | 3-75 |
| 2110702 | 3-75 |
| 2110703 | 3-75 |
| 2110704 | 3-75 |
| 2110705 | 3-75 |
| 2110706 | 3-75 |
| 2110707 | 3-75 |
| 2110708 | 3-75 |
| 2110709 | 3-75 |
| 2110710 | 3-75 |
| 2110711 | 3-75 |
| 2110712 | 3-75 |
| 2120101 | 3-85 |
| 2120102 | 3-85 |
| 2120103 | 3-85 |
| 2120104 | 3-85 |
| 2132123 | 3-178 |
| 2132141 | 3-178 |
| 2132325 | 3-178 |
| 2132527 | 3-178 |
| 2132729 | 3-178 |
| 2132949 | 3-178 |
| 2134143 | 3-178 |
| 2134161 | 3-178 |
| 2134345 | 3-178 |
| 2134547 | 3-178 |
| 2134749 | 3-178 |
| 2134969 | 3-178 |
| 2136163 | 3-178 |
| 2136364 | 3-178 |
| 2136466 | 3-178 |
| 2136667 | 3-178 |
| 2136769 | 3-178 |
| 2170091 | 3-76 |
| 2170092 | 3-76 |
| 2170101 | 3-75 |
| 2170102 | 3-75 |
| 2170171 | 3-75 |
| 2170172 | 3-75 |
| 2170191 | 3-75 |
| 2170271 | 3-75 |
| 2170291 | 3-76 |
| 2170292 | 3-76 |
| 2171101 | 3-75 |
| 2171102 | 3-75 |

| NASTRAN EID | PAGE |
|----------------|-----------|
| 2171103 | 3-76 |
| 2171104 | 3-76 |
| 2171105 | 3-75 |
| 2171106 | 3-75 |
| 2171107 | 3-75 |
| 2171108 | 3-75 |
| 2173301 | 3-75 |
| 2173302 | 3-75 |
| 2173303 | 3-76 |
| 2173304 | 3-76 |
| 2173305 | 3-75 |
| 2173306 | 3-75 |
| 2173307 | 3-75 |
| 2173308 | 3-75 |
| 2190271 | 3-72 |
| 2190311 | 3-72 |
| 2190312 | 3-72 |
| 2190313 | 3-72 |
| 2190314 | 3-72 |
| 2190431 | 3-72 |
| 2191501 | 3-72 |
| 2191502 | 3-72 |
| 2191503 | 3-72 |
| 2191504 | 3-72 |
| 2191505 | 3-72 |
| 2191506 | 3-72 |
| 2191507 | 3-72 |
| 2191508 | 3-72 |
| 2191901 | 3-72 |
| 2191902 | 3-72 |
| 2191903 | 3-72 |
| 2191904 | 3-72 |
| 2191905 | 3-72 |
| 2191906 | 3-72 |
| 2191907 | 3-72 |
| 2191908 | 3-72 |
| 2200101 | 3-98 |
| 2200102 | 3-98 |
| 2200103 | 3-98 |
| 2200104 | 3-98 |
| 2200111 | 3-98 |
| 2200112 | 3-101 |
| 2200113 | 3-98, 101 |
| 2200114 | 3-98, 101 |
| 2200121 | 3-101 |

ROD ELEMENT (CONROD) INDEX (CONT.)

| NASTRAN EID | PAGE |
|----------------|------------|
| 2200122 | 3-101 |
| 2200123 | 3-101 |
| 2200124 | 3-101 |
| 2200301 | 3-212 |
| 2200302 | 3-212 |
| 2200303 | 3-212 |
| 2200304 | 3-212 |
| 2200311 | 3-212 |
| 2200312 | 3-212 |
| 2200313 | 3-212 |
| 2200314 | 3-212 |
| 2200431 | 3-101 |
| 2200441 | 3-98 |
| 2200551 | 3-160 |
| 2200561 | 3-157 |
| 2200571 | 3-212 |
| 2200581 | 3-209 |
| 2200591 | 3-160 |
| 2200601 | 3-157 |
| 2201151 | 3-209, 212 |
| 2201171 | 3-209 |
| 2201191 | 3-212 |
| 2206101 | 3-101 |
| 2206102 | 3-101 |
| 2206103 | 3-101 |
| 2206104 | 3-101 |
| 2206201 | 3-98 |
| 2206202 | 3-98 |
| 2206203 | 3-98 |
| 2206204 | 3-98 |
| 2206701 | 3-209 |
| 2206702 | 3-209 |
| 2206703 | 3-209 |
| 2206704 | 3-209 |
| 2206711 | 3-209 |
| 2206712 | 3-209 |
| 2206713 | 3-209 |
| 2206714 | 3-209 |
| 2207101 | 3-160 |
| 2207102 | 3-160 |
| 2207103 | 3-160 |
| 2207104 | 3-160 |
| 2207111 | 3-160 |
| 2207112 | 3-160 |
| 2207113 | 3-160 |

| NASTRAN EID | PAGE |
|----------------|------------|
| 2207114 | 3-160 |
| 2207201 | 3-157 |
| 2207202 | 3-157 |
| 2207203 | 3-157 |
| 2207204 | 3-157 |
| 2207211 | 3-157 |
| 2207212 | 3-157 |
| 2207213 | 3-157 |
| 2207214 | 3-157 |
| 2207701 | 3-157 |
| 2207702 | 3-157 |
| 2207703 | 3-157 |
| 2207704 | 3-157 |
| 2207711 | 3-157 |
| 2207712 | 3-157 |
| 2207713 | 3-157 |
| 2207714 | 3-157 |
| 2207721 | 3-157 |
| 2207722 | 3-160 |
| 2207723 | 3-157, 160 |
| 2207724 | 3-157, 160 |
| 2207731 | 3-160 |
| 2207732 | 3-160 |
| 2207733 | 3-160 |
| 2207734 | 3-160 |
| 2207741 | 3-160 |
| 2207742 | 3-160 |
| 2207743 | 3-160 |
| 2207744 | 3-160 |
| 2360031 | 3-75 |
| 2500103 | 3-183 |
| 2500171 | 3-60 |
| 2500172 | 3-60 |
| 2500173 | 3-60 |
| 2500307 | 3-183 |
| 2500709 | 3-183 |
| 2500911 | 3-64 |
| 2500912 | 3-64 |
| 2500913 | 3-68 |
| 2500929 | 3-135 |
| 2501711 | 3-183 |
| 2502101 | 3-183 |
| 2502125 | 3-183 |
| 2502141 | 3-183 |
| 2502529 | 3-183 |

ROD ELEMENT (CONROD) INDEX (CONT.)

| NASTRAN EID | PAGE |
|----------------|-----------|
| 2502949 | 3-183 |
| 2504161 | 3-183 |
| 2504969 | 3-183 |
| 2506165 | 3-183 |
| 2506569 | 3-183 |
| 2507701 | 3-92 |
| 2507702 | 3-92 |
| 2507703 | 3-92 |
| 2507704 | 3-95 |
| 2507705 | 3-95 |
| 2507706 | 3-95 |
| 2507707 | 3-92 |
| 2507708 | 3-92 |
| 2507709 | 3-92 |
| 2507710 | 3-95 |
| 2507711 | 3-95 |
| 2507712 | 3-95 |
| 2507713 | 3-92 |
| 2507714 | 3-92 |
| 2507715 | 3-92 |
| 2507716 | 3-92 |
| 2507717 | 3-92 |
| 2507718 | 3-92 |
| 2507719 | 3-95 |
| 2507720 | 3-95 |
| 2507721 | 3-95 |
| 2507722 | 3-95 |
| 2507723 | 3-95 |
| 2507724 | 3-95 |
| 2510021 | 3-84 |
| 2510022 | 3-84 |
| 2570101 | 3-157 |
| 2570102 | 3-160 |
| 2570103 | 3-157,160 |
| 2570104 | 3-157,160 |
| 2590101 | 3-209 |
| 2590102 | 3-212 |
| 2590103 | 3-209,212 |
| 2590104 | 3-209,212 |
| 2682125 | 3-186 |
| 2682141 | 3-186 |
| 2682529 | 3-186 |
| 2682949 | 3-186 |
| 2684161 | 3-186 |
| 2684969 | 3-186 |

| NASTRAN EID | PAGE |
|----------------|-------|
| 2686165 | 3-186 |
| 2686569 | 3-186 |
| 2992125 | 3-188 |
| 2992141 | 3-188 |
| 2992529 | 3-188 |
| 2992949 | 3-188 |
| 2994161 | 3-188 |
| 2994969 | 3-188 |
| 2996165 | 3-188 |
| 2996569 | 3-188 |
| 3790101 | 3-135 |
| 3790102 | 3-135 |
| 3790103 | 3-135 |
| 3790104 | 3-135 |
| 5003091 | 3-62 |
| 5003092 | 3-62 |
| 5003093 | 3-62 |
| 5003094 | 3-66 |
| 5003095 | 3-66 |
| 5003096 | 3-70 |
| 5003111 | 3-60 |
| 5003112 | 3-60 |
| 5003113 | 3-60 |
| 5003114 | 3-64 |
| 5003115 | 3-64 |
| 5003116 | 3-68 |
| 5810251 | 3-12 |
| 5810351 | 3-9 |
| 5850751 | 3-4 |
| 5850752 | 3-4 |
| 5850753 | 3-4 |
| 5850754 | 3-4 |
| 5850771 | 3-9 |
| 5850772 | 3-12 |
| 5850790 | 3-9 |
| 5850791 | 3-12 |
| 5850792 | 3-50 |
| 5850793 | 3-50 |
| 5850794 | 3-50 |
| 5850795 | 3-50 |
| 5850796 | 3-50 |
| 5850797 | 3-50 |
| 5850798 | 3-50 |
| 5850811 | 3-6 |
| 5850812 | 3-6 |

ROD ELEMENT (CONROD) INDEX (CONT.)

| NASTRAN EID | PAGE |
|----------------|-------|
| 5850813 | 3-6 |
| 5850814 | 3-6 |
| 5850815 | 3-6 |
| 5850816 | 3-6 |
| 5850817 | 3-6 |
| 5850818 | 3-6 |
| 5850851 | 3-9 |
| 5850852 | 3-12 |
| 5850871 | 3-50 |
| 5850872 | 3-50 |
| 5850873 | 3-50 |
| 6222811 | 3-257 |
| 6222812 | 3-257 |
| 6222818 | 3-257 |
| 6222819 | 3-257 |
| 6222822 | 3-257 |
| 6222828 | 3-257 |
| 6222832 | 3-258 |
| 6222838 | 3-258 |
| 6283411 | 3-257 |
| 6283412 | 3-257 |
| 6283418 | 3-257 |
| 6283419 | 3-257 |
| 6283421 | 3-257 |
| 6283422 | 3-257 |
| 6283428 | 3-257 |
| 6283429 | 3-257 |
| 6283431 | 3-258 |
| 6283432 | 3-258 |
| 6283438 | 3-258 |
| 6283439 | 3-258 |
| 6344211 | 3-257 |
| 6344212 | 3-257 |
| 6344218 | 3-257 |
| 6344219 | 3-257 |
| 6344221 | 3-257 |
| 6344222 | 3-257 |
| 6344228 | 3-258 |
| 6344229 | 3-258 |
| 6344231 | 3-258 |
| 6344232 | 3-258 |
| 6344238 | 3-258 |
| 6344239 | 3-258 |
| 6425011 | 3-257 |
| 6425012 | 3-257 |

| NASTRAN EID | PAGE |
|----------------|-------|
| 6425018 | 3-257 |
| 6425019 | 3-257 |
| 6425021 | 3-257 |
| 6425022 | 3-257 |
| 6425028 | 3-258 |
| 6425029 | 3-258 |
| 6425031 | 3-258 |
| 6425032 | 3-258 |
| 6425038 | 3-258 |
| 6425039 | 3-258 |
| 6505911 | 3-257 |
| 6505912 | 3-257 |
| 6505918 | 3-257 |
| 6505919 | 3-257 |
| 6505921 | 3-257 |
| 6505922 | 3-257 |
| 6505928 | 3-258 |
| 6505929 | 3-258 |
| 6505931 | 3-258 |
| 6505932 | 3-258 |
| 6505938 | 3-258 |
| 6505939 | 3-258 |
| 7222811 | 3-263 |
| 7222812 | 3-263 |
| 7222818 | 3-263 |
| 7222819 | 3-263 |
| 7222822 | 3-263 |
| 7222828 | 3-268 |
| 7222832 | 3-264 |
| 7222838 | 3-264 |
| 7283411 | 3-263 |
| 7283412 | 3-263 |
| 7283418 | 3-263 |
| 7283419 | 3-263 |
| 7283421 | 3-263 |
| 7283422 | 3-263 |
| 7283428 | 3-263 |
| 7283429 | 3-263 |
| 7283431 | 3-264 |
| 7283432 | 3-264 |
| 7283438 | 3-264 |
| 7283439 | 3-264 |
| 7344211 | 3-263 |
| 7344212 | 3-263 |
| 7344218 | 3-263 |

ROD ELEMENT (CONROD) INDEX (CONT.)

| NASTRAN EID | PAGE |
|----------------|-------|
| 7344219 | 3-263 |
| 7344221 | 3-263 |
| 7344222 | 3-263 |
| 7344228 | 3-254 |
| 7344229 | 3-264 |
| 7344231 | 3-264 |
| 7344232 | 3-264 |
| 7344238 | 3-264 |
| 7344239 | 3-264 |
| 7425011 | 3-263 |
| 7425012 | 3-263 |
| 7425018 | 3-263 |
| 7425019 | 3-263 |
| 7425021 | 3-263 |
| 7425022 | 3-263 |
| 7425028 | 3-264 |
| 7425029 | 3-264 |
| 7425031 | 3-264 |
| 7425032 | 3-264 |
| 7425038 | 3-264 |
| 7425039 | 3-264 |
| 7505911 | 3-263 |
| 7505912 | 3-263 |
| 7505918 | 3-263 |
| 7505919 | 3-263 |
| 7505921 | 3-263 |
| 7505922 | 3-263 |
| 7505928 | 3-264 |
| 7505929 | 3-264 |
| 7505931 | 3-264 |
| 7505932 | 3-264 |
| 7505938 | 3-264 |
| 7505939 | 3-264 |

QUADRILATERAL MEMBRANE PLATE ELEMENT (QDMEM) INDEX

| NASTRAN EID | PAGE |
|----------------|-------|
| 463137 | 3-6 |
| 463149 | 3-6 |
| 464169 | 3-6 |
| 612337 | 3-49 |
| 613143 | 3-49 |
| 613749 | 3-49 |
| 614163 | 3-49 |
| 614769 | 3-49 |
| 930317 | 3-53 |
| 931337 | 3-53 |
| 933143 | 3-53 |
| 934367 | 3-53 |
| 934769 | 3-53 |
| 936173 | 3-53 |
| 936377 | 3-53 |
| 936779 | 3-57 |
| 1380327 | 3-57 |
| 1382133 | 3-57 |
| 1382337 | 3-57 |
| 1382739 | 3-57 |
| 1383347 | 3-57 |
| 1383749 | 3-57 |
| 1384163 | 3-57 |
| 1384869 | 3-57 |
| 1480327 | 3-122 |
| 1482133 | 3-122 |
| 1482337 | 3-122 |
| 1482739 | 3-122 |
| 1483143 | 3-122 |
| 1483347 | 3-122 |
| 1483749 | 3-122 |
| 1484163 | 3-122 |
| 1484367 | 3-122 |
| 1484769 | 3-122 |
| 1486183 | 3-122 |
| 1486387 | 3-122 |
| 1486789 | 3-122 |
| 1862133 | 3-130 |
| 1862335 | 3-131 |
| 1862537 | 3-131 |
| 1862739 | 3-131 |
| 1863143 | 3-130 |
| 1863345 | 3-130 |
| 1863546 | 3-130 |
| 1863748 | 3-130 |

| NASTRAN EID | PAGE |
|----------------|----------|
| 1864152 | 3-130 |
| 1864364 | 3-130 |
| 1864465 | 3-130 |
| 1864566 | 3-130 |
| 1864667 | 3-130 |
| 1864758 | 3-130 |
| 1864854 | 3-130 |
| 1865157 | 3-130 |
| 1865263 | 3-130 |
| 1865359 | 3-130 |
| 1865662 | 3-130 |
| 1865869 | 3-130 |
| 1866283 | 3-130 |
| 1866385 | 3-130 |
| 1866687 | 3-130 |
| 1866789 | 3-177 |
| 2132143 | 3-177 |
| 2132345 | 3-177 |
| 2132547 | 3-177 |
| 2132749 | 3-177 |
| 2134163 | 3-177 |
| 2134364 | 3-177 |
| 2134567 | 3-177 |
| 2134769 | 3-177 |
| 2502145 | 3-182 |
| 2502549 | 3-182 |
| 2504165 | 3-182 |
| 2504569 | 3-182 |
| 2682145 | 3-185 |
| 2682549 | 3-185 |
| 2684165 | 3-185 |
| 2684569 | 3-185 |
| 2992145 | 3-188 |
| 2992549 | 3-188 |
| 2994165 | 3-188 |
| 2994569 | 3-188 |
| 5850305 | 3-20, 22 |
| 5850321 | 3-14, 17 |
| 5850329 | 3-20, 22 |
| 5850505 | 3-20, 22 |
| 5850521 | 3-14, 17 |
| 5850529 | 3-20, 22 |
| 5858905 | 3-20, 22 |
| 5858921 | 3-14, 17 |
| 5858929 | 3-20, 22 |

QUADRILATERAL MEMBRANE PLATE ELEMENT (QDMEM) INDEX (CONT.)

| NASTRAN EID | PAGE |
|----------------|---------|
| 5950211 | 3-8, 11 |
| 5950271 | 3-8, 11 |
| 6221121 | 3-268 |
| 6221124 | 3-249 |
| 6221326 | 3-249 |
| 6221729 | 3-249 |
| 6221929 | 3-268 |
| 6222131 | 3-268 |
| 6222439 | 3-249 |
| 6222939 | 3-268 |
| 6281121 | 3-268 |
| 6281129 | 3-249 |
| 6281929 | 3-268 |
| 6282131 | 3-268 |
| 6282139 | 3-249 |
| 6282939 | 3-268 |
| 6341121 | 3-268 |
| 6341129 | 3-249 |
| 6341929 | 3-268 |
| 6342131 | 3-268 |
| 6342139 | 3-249 |
| 6342939 | 3-268 |
| 6421121 | 3-268 |
| 6421129 | 3-249 |
| 6421929 | 3-268 |
| 6422131 | 3-268 |
| 6422139 | 3-249 |
| 6422939 | 3-268 |
| 6501121 | 3-268 |
| 6501129 | 3-249 |
| 6501929 | 3-268 |
| 6502131 | 3-268 |
| 6502139 | 3-249 |
| 6502939 | 3-268 |
| 6591129 | 3-249 |
| 6592139 | 3-249 |
| 7221121 | 3-271 |
| 7221124 | 3-253 |
| 7221326 | 3-253 |
| 7221729 | 3-253 |
| 7221929 | 3-271 |
| 7222131 | 3-271 |
| 7222439 | 3-253 |
| 7222939 | 3-271 |
| 7281121 | 3-271 |

| NASTRAN EID | PAGE |
|----------------|-------|
| 7281129 | 3-253 |
| 7281929 | 3-271 |
| 7282131 | 3-271 |
| 7282139 | 3-253 |
| 7282939 | 3-271 |
| 7341121 | 3-271 |
| 7341129 | 3-253 |
| 7341929 | 3-271 |
| 7342131 | 3-271 |
| 7342139 | 3-253 |
| 7342939 | 3-271 |
| 7421121 | 3-271 |
| 7421129 | 3-253 |
| 7421929 | 3-271 |
| 7422131 | 3-271 |
| 7422139 | 3-253 |
| 7422939 | 3-271 |
| 7501121 | 3-271 |
| 7501129 | 3-253 |
| 7501929 | 3-271 |
| 7502131 | 3-271 |
| 7502139 | 3-253 |
| 7502939 | 3-271 |
| 7591129 | 3-253 |
| 7592139 | 3-253 |

SHEAR PANEL ELEMENT (C.SHEAR) INDEX

| NAST EID | PAGE |
|-------------|------------|
| 1170051 | 3-173 |
| 1170052 | 3-173 |
| 1170053 | 3-173 |
| 1170054 | 3-173 |
| 1170111 | 3-173 |
| 1170112 | 3-173 |
| 1170391 | 3-173 |
| 1170392 | 3-173 |
| 1170511 | 3-173 |
| 1170512 | 3-173 |
| 1180451 | 3-169 |
| 1180452 | 3-169 |
| 1180691 | 3-169 |
| 1180692 | 3-169 |
| 1180693 | 3-169 |
| 1180694 | 3-169 |
| 1180711 | 3-169 |
| 1180712 | 3-169 |
| 1190053 | 3-166 |
| 1190054 | 3-166 |
| 1190093 | 3-166 |
| 1190094 | 3-166 |
| 1200073 | 3-163 |
| 1200074 | 3-163 |
| 1200113 | 3-163 |
| 1200114 | 3-163 |
| 1201211 | 3-208, 211 |
| 1250232 | 3-137 |
| 1250272 | 3-134 |
| 1250912 | 3-137 |
| 1290171 | 3-41 |
| 1290191 | 3-41 |
| 1290411 | 3-25 |
| 1290412 | 3-25 |
| 1290571 | 3-45 |
| 1290591 | 3-45 |
| 1290691 | 3-45 |
| 1290692 | 3-45 |
| 1290694 | 3-45 |
| 1290751 | 3-30 |
| 1290752 | 3-30 |
| 1290753 | 3-30 |
| 1290771 | 3-30 |
| 1291251 | 3-45 |
| 1291252 | 3-45 |

| NASTRAN EID | PAGE |
|----------------|------|
| 1291271 | 3-41 |
| 1291272 | 3-41 |
| 1291371 | 3-37 |
| 1291372 | 3-37 |
| 1291411 | 3-45 |
| 1291412 | 3-45 |
| 1291414 | 3-45 |
| 1291415 | 3-45 |
| 1291491 | 3-34 |
| 1291492 | 3-34 |
| 1291493 | 3-34 |
| 1291494 | 3-34 |
| 1291591 | 3-25 |
| 1291592 | 3-25 |
| 1291831 | 3-25 |
| 1291832 | 3-25 |
| 1291833 | 3-25 |
| 1291834 | 3-25 |
| 1291835 | 3-25 |
| 1291836 | 3-25 |
| 1291851 | 3-37 |
| 1291852 | 3-37 |
| 1291981 | 3-41 |
| 1291982 | 3-41 |
| 1291983 | 3-41 |
| 1292011 | 3-30 |
| 1292012 | 3-30 |
| 1292013 | 3-30 |
| 1292014 | 3-30 |
| 1292015 | 3-30 |
| 1292016 | 3-30 |
| 1292050 | 3-30 |
| 1292051 | 3-30 |
| 1292052 | 3-30 |
| 1292053 | 3-30 |
| 1292054 | 3-30 |
| 1292055 | 3-37 |
| 1292056 | 3-37 |
| 1292057 | 3-37 |
| 1292058 | 3-37 |
| 1292059 | 3-37 |
| 1292090 | 3-25 |
| 1292091 | 3-25 |
| 1292092 | 3-25 |
| 1292093 | 3-25 |

SHEAR PANEL ELEMENT (CSHEAR) INDEX (CONT.)

| NASTRAN EID | PAGE |
|----------------|-------|
| 1292094 | 3-25 |
| 1292095 | 3-25 |
| 1292096 | 3-34 |
| 1292097 | 3-34 |
| 1292098 | 3-34 |
| 1292099 | 3-34 |
| 1292101 | 3-41 |
| 1292102 | 3-41 |
| 1292103 | 3-41 |
| 1292104 | 3-41 |
| 1300291 | 3-104 |
| 1300331 | 3-104 |
| 1300332 | 3-104 |
| 1300334 | 3-104 |
| 1300335 | 3-104 |
| 1300351 | 3-104 |
| 1300391 | 3-104 |
| 1300392 | 3-104 |
| 1300394 | 3-104 |
| 1300395 | 3-104 |
| 1370052 | 3-117 |
| 1370053 | 3-117 |
| 1370054 | 3-117 |
| 1370062 | 3-113 |
| 1370063 | 3-113 |
| 1370064 | 3-113 |
| 1370231 | 3-117 |
| 1370241 | 3-113 |
| 1370352 | 3-117 |
| 1370353 | 3-117 |
| 1370362 | 3-113 |
| 1370363 | 3-113 |
| 1380351 | 3-109 |
| 1380411 | 3-109 |
| 1380412 | 3-109 |
| 1380414 | 3-109 |
| 1380415 | 3-109 |
| 1380431 | 3-109 |
| 1380451 | 3-109 |
| 1380452 | 3-109 |
| 1380454 | 3-109 |
| 1380455 | 3-109 |
| 1791612 | 3-60 |
| 1791613 | 3-60 |
| 1791614 | 3-64 |

| NASTRAN EID | PAGE |
|----------------|---------|
| 1791615 | 3-64 |
| 1791616 | 3-68 |
| 1791632 | 3-62 |
| 1791633 | 3-62 |
| 1791634 | 3-66 |
| 1791635 | 3-66 |
| 1791636 | 3-66 |
| 1874251 | 3-235 |
| 1874357 | 3-235 |
| 1875256 | 3-235 |
| 1875448 | 3-235 |
| 1875847 | 3-235 |
| 1875953 | 3-235 |
| 1974152 | 3-240 |
| 1974352 | 3-240 |
| 1974365 | 3-240 |
| 1974567 | 3-241 |
| 1974758 | 3-241 |
| 1974859 | 3-241 |
| 1975162 | 3-240 |
| 1975869 | 3-240 |
| 2010531 | 3-79 |
| 2010532 | 3-79 |
| 2010533 | 3-79 |
| 2010534 | 3-79 |
| 2010536 | 3-79 |
| 2010537 | 3-79 |
| 2010538 | 3-79 |
| 2010539 | 3-79 |
| 2010672 | 3-8, 11 |
| 2010692 | 3-8, 11 |
| 2010694 | 3-79 |
| 2010695 | 3-79 |
| 2010696 | 3-79 |
| 2010697 | 3-79 |
| 2010699 | 3-79 |
| 2010701 | 3-79 |
| 2010702 | 3-79 |
| 2010703 | 3-79 |
| 2010851 | 3-79 |
| 2010852 | 3-79 |
| 2010853 | 3-79 |
| 2010854 | 3-79 |
| 2010856 | 3-79 |
| 2010857 | 3-79 |

SHEAR PANEL ELEMENT (CSHEAR) INDEX (CONT.)

| NASTRAN EID | PAGE |
|----------------|-----------|
| 2010858 | 3-79 |
| 2010859 | 3-79 |
| 2020731 | 3-87 |
| 2020732 | 3-87 |
| 2020733 | 3-87 |
| 2030291 | 3-97, 100 |
| 2040471 | 3-141 |
| 2040472 | 3-141 |
| 2040795 | 3-141 |
| 2040796 | 3-141 |
| 2040811 | 3-141 |
| 2040815 | 3-141 |
| 2040823 | 3-141 |
| 2040824 | 3-141 |
| 2050551 | 3-150 |
| 2050552 | 3-150 |
| 2050553 | 3-150 |
| 2050554 | 3-150 |
| 2050631 | 3-150 |
| 2050632 | 3-150 |
| 2050633 | 3-150 |
| 2050634 | 3-150 |
| 2060871 | 3-191 |
| 2060872 | 3-191 |
| 2060873 | 3-191 |
| 2060874 | 3-191 |
| 2060875 | 3-191 |
| 2060876 | 3-191 |
| 2060877 | 3-191 |
| 2060878 | 3-191 |
| 2060882 | 3-191 |
| 2060883 | 3-191 |
| 2060891 | 3-191 |
| 2060892 | 3-191 |
| 2060893 | 3-191 |
| 2060894 | 3-191 |
| 2060895 | 3-191 |
| 2060896 | 3-191 |
| 2060897 | 3-191 |
| 2060898 | 3-191 |
| 2060902 | 3-191 |
| 2060903 | 3-191 |
| 2060911 | 3-191 |
| 2060912 | 3-191 |
| 2060913 | 3-191 |

| NASTRAN EID | PAGE |
|----------------|-------|
| 2060914 | 3-191 |
| 2070271 | 3-197 |
| 2070272 | 3-197 |
| 2070651 | 3-199 |
| 2070652 | 3-199 |
| 2070771 | 3-87 |
| 2070772 | 3-87 |
| 2070773 | 3-87 |
| 2070811 | 3-197 |
| 2070812 | 3-197 |
| 2070871 | 3-199 |
| 2070872 | 3-199 |
| 2080114 | 3-146 |
| 2080131 | 3-146 |
| 2080132 | 3-146 |
| 2080133 | 3-146 |
| 2080134 | 3-146 |
| 2080791 | 3-146 |
| 2080795 | 3-146 |
| 2080796 | 3-146 |
| 2080797 | 3-146 |
| 2080798 | 3-146 |
| 2080799 | 3-146 |
| 2091252 | 3-201 |
| 2091254 | 3-201 |
| 2091256 | 3-204 |
| 2091257 | 3-204 |
| 2091258 | 3-204 |
| 2091259 | 3-204 |
| 2091278 | 3-204 |
| 2091279 | 3-204 |
| 2091292 | 3-201 |
| 2091294 | 3-201 |
| 2091296 | 3-204 |
| 2091297 | 3-204 |
| 2091298 | 3-204 |
| 2091299 | 3-204 |
| 2100891 | 3-91 |
| 2100892 | 3-91 |
| 2100893 | 3-91 |
| 2100894 | 3-94 |
| 2100895 | 3-94 |
| 2100896 | 3-94 |
| 2110051 | 3-74 |
| 2110052 | 3-74 |

SHEAR PANEL ELEMENT (CSHEAR) INDEX (CONT.)

| NASTRAN EID | PAGE |
|----------------|------------|
| 2110053 | 3-74 |
| 2110071 | 3-74 |
| 2110072 | 3-74 |
| 2110073 | 3-74 |
| 2120011 | 3-85 |
| 2170111 | 3-74 |
| 2170112 | 3-74 |
| 2170331 | 3-74 |
| 2170332 | 3-74 |
| 2190151 | 3-72 |
| 2190152 | 3-72 |
| 2190191 | 3-72 |
| 2190192 | 3-72 |
| 2200611 | 3-100 |
| 2200621 | 3-97 |
| 2200671 | 3-208 |
| 2200672 | 3-208 |
| 2200711 | 3-159 |
| 2200713 | 3-159 |
| 2200721 | 3-156 |
| 2200723 | 3-156 |
| 2200771 | 3-156 |
| 2200772 | 3-156 |
| 2200773 | 3-156, 159 |
| 2200774 | 3-159 |
| 2200775 | 3-159 |
| 2201011 | 3-97 |
| 2201012 | 3-97, 100 |
| 2201013 | 3-100 |
| 2201031 | 3-211 |
| 2201032 | 3-211 |
| 2501771 | 3-91 |
| 2501772 | 3-91 |
| 2501773 | 3-91 |
| 2501774 | 3-94 |
| 2501775 | 3-94 |
| 2501776 | 3-94 |
| 2570011 | 3-156, 159 |
| 2590011 | 3-208, 211 |
| 3790012 | 3-134 |
| 6221119 | 3-256 |
| 6222129 | 3-256 |
| 6223139 | 3-256 |
| 6281119 | 3-256 |
| 6282129 | 3-256 |

| NASTRAN EID | PAGE |
|----------------|-------|
| 6283139 | 3-256 |
| 6341119 | 3-256 |
| 6342129 | 3-256 |
| 6343139 | 3-256 |
| 6421119 | 3-256 |
| 6422129 | 3-256 |
| 6423139 | 3-256 |
| 6501119 | 3-256 |
| 6502129 | 3-256 |
| 6503139 | 3-256 |
| 7221119 | 3-262 |
| 7222129 | 3-262 |
| 7223139 | 3-262 |
| 7281119 | 3-262 |
| 7282129 | 3-262 |
| 7283139 | 3-262 |
| 7341119 | 3-262 |
| 7342129 | 3-262 |
| 7343139 | 3-262 |
| 7421119 | 3-262 |
| 7422129 | 3-262 |
| 7423139 | 3-262 |
| 7501119 | 3-262 |
| 7502129 | 3-262 |
| 7503139 | 3-262 |

TRIANGULAR MEMBRANE PLATE ELEMENT (CTRMEM) INDEX

| NASTRAN EID | PAGE |
|----------------|------------|
| 612331 | 3-49 |
| 612737 | 3-49 |
| 616779 | 3-49 |
| 617161 | 3-49 |
| 931331 | 3-53 |
| 931737 | 3-53 |
| 934361 | 3-53 |
| 1190051 | 3-166 |
| 1190052 | 3-166 |
| 1190091 | 3-166 |
| 1190092 | 3-166 |
| 1190131 | 3-166 |
| 1190132 | 3-166 |
| 1200071 | 3-163 |
| 1200072 | 3-163 |
| 1200111 | 3-163 |
| 1200112 | 3-163 |
| 1200131 | 3-163 |
| 1200132 | 3-163 |
| 1210470 | 3-219 |
| 1210590 | 3-219 |
| 1250231 | 3-137 |
| 1250271 | 3-134 |
| 1250911 | 3-137 |
| 1290592 | 3-45 |
| 1290693 | 3-45 |
| 1291413 | 3-45 |
| 1291416 | 3-45 |
| 1300333 | 3-104 |
| 1300393 | 3-104 |
| 1330011 | 3-208 |
| 1330012 | 3-208 |
| 1330013 | 3-208, 211 |
| 1330014 | 3-211 |
| 1330015 | 3-211 |
| 1370051 | 3-117 |
| 1370055 | 3-117 |
| 1370061 | 3-113 |
| 1370065 | 3-113 |
| 1370232 | 3-117 |
| 1370242 | 3-113 |
| 1370351 | 3-117 |
| 1370361 | 3-113 |
| 1380121 | 3-57 |
| 1380123 | 3-57 |

| NASTRAN EID | PAGE |
|----------------|-------|
| 1380413 | 3-109 |
| 1380453 | 3-109 |
| 1380727 | 3-57 |
| 1380927 | 3-57 |
| 1480121 | 3-122 |
| 1480123 | 3-122 |
| 1480727 | 3-122 |
| 1480927 | 3-122 |
| 1560121 | 3-126 |
| 1560123 | 3-126 |
| 1560323 | 3-126 |
| 1560325 | 3-126 |
| 1560725 | 3-126 |
| 1560727 | 3-126 |
| 1560927 | 3-126 |
| 1720011 | 3-227 |
| 1720012 | 3-227 |
| 1720013 | 3-227 |
| 1720014 | 3-227 |
| 1720015 | 3-227 |
| 1720016 | 3-227 |
| 1720017 | 3-227 |
| 1720018 | 3-227 |
| 1720021 | 3-227 |
| 1720022 | 3-227 |
| 1720023 | 3-227 |
| 1720024 | 3-227 |
| 1720025 | 3-227 |
| 1720026 | 3-227 |
| 1720027 | 3-227 |
| 1720028 | 3-227 |
| 1791611 | 3-60 |
| 1791631 | 3-62 |
| 1860121 | 3-131 |
| 1860123 | 3-131 |
| 1860323 | 3-131 |
| 1860325 | 3-131 |
| 1860725 | 3-131 |
| 1860727 | 3-131 |
| 1860927 | 3-131 |
| 1863141 | 3-130 |
| 1863343 | 3-130 |
| 1863746 | 3-130 |
| 1863948 | 3-130 |
| 1864252 | 3-130 |

TRIANGULAR MEMBRANE PLATE ELEMENT (CTRMEM) INDEX (CONT.)

| NASTRAN EID | PAGE |
|----------------|-------|
| 1864753 | 3-130 |
| 1865762 | 3-130 |
| 1865867 | 3-130 |
| 1866181 | 3-130 |
| 1866485 | 3-130 |
| 1866585 | 3-130 |
| 1866889 | 3-130 |
| 1874352 | 3-235 |
| 1874853 | 3-235 |
| 1875763 | 3-235 |
| 1875868 | 3-235 |
| 1975263 | 3-240 |
| 1975867 | 3-240 |
| 2010671 | 3-8 |
| 2010673 | 3-11 |
| 2010691 | 3-8 |
| 2010693 | 3-11 |
| 2040791 | 3-141 |
| 2040792 | 3-141 |
| 2040793 | 3-141 |
| 2040794 | 3-141 |
| 2040797 | 3-141 |
| 2040812 | 3-141 |
| 2040813 | 3-141 |
| 2040814 | 3-141 |
| 2040821 | 3-141 |
| 2040822 | 3-141 |
| 2040825 | 3-141 |
| 2040826 | 3-141 |
| 2060881 | 3-191 |
| 2060884 | 3-191 |
| 2060901 | 3-191 |
| 2060904 | 3-191 |
| 2080111 | 3-146 |
| 2080112 | 3-146 |
| 2080113 | 3-146 |
| 2080792 | 3-146 |
| 2080793 | 3-146 |
| 2080794 | 3-146 |
| 2091251 | 3-201 |
| 2091253 | 3-201 |
| 2091255 | 3-201 |
| 2091291 | 3-201 |
| 2091293 | 3-201 |
| 2091295 | 3-201 |

| NASTRAN EID | PAGE |
|----------------|-------|
| 2100897 | 3-154 |
| 2134564 | 3-177 |
| 2180121 | 3-179 |
| 2180123 | 3-179 |
| 2180323 | 3-179 |
| 2180325 | 3-179 |
| 2180725 | 3-179 |
| 2180727 | 3-179 |
| 2180927 | 3-179 |
| 2200675 | 3-208 |
| 2200676 | 3-208 |
| 2200677 | 3-208 |
| 2200712 | 3-159 |
| 2200722 | 3-156 |
| 2201035 | 3-211 |
| 2201036 | 3-211 |
| 2201037 | 3-211 |
| 2270121 | 3-180 |
| 2270123 | 3-180 |
| 2270323 | 3-180 |
| 2270325 | 3-180 |
| 2270725 | 3-180 |
| 2270727 | 3-180 |
| 2270927 | 3-180 |
| 2500121 | 3-182 |
| 2500125 | 3-182 |
| 2500325 | 3-182 |
| 2500725 | 3-182 |
| 2500925 | 3-182 |
| 2501777 | 3-154 |
| 2680121 | 3-185 |
| 2680125 | 3-185 |
| 2680925 | 3-185 |
| 2990521 | 3-188 |
| 2990525 | 3-188 |
| 3790011 | 3-134 |
| 5850301 | 3-14 |
| 5850302 | 3-14 |
| 5850303 | 3-14 |
| 5850304 | 3-14 |
| 5850306 | 3-17 |
| 5850307 | 3-17 |
| 5850308 | 3-17 |
| 5850309 | 3-17 |
| 5850322 | 3-15 |

TRIANGULAR MEMBRANE PLATE ELEMENT (CTRMEM) INDEX (CONT.)

| NASTRAN EID | PAGE |
|----------------|------|
| 5850323 | 3-15 |
| 5850324 | 3-15 |
| 5850325 | 3-15 |
| 5850326 | 3-15 |
| 5850327 | 3-15 |
| 5850328 | 3-15 |
| 5850330 | 3-18 |
| 5850331 | 3-18 |
| 5850332 | 3-18 |
| 5850333 | 3-18 |
| 5850334 | 3-18 |
| 5850335 | 3-18 |
| 5850336 | 3-18 |
| 5850501 | 3-14 |
| 5850502 | 3-14 |
| 5850503 | 3-14 |
| 5850504 | 3-14 |
| 5850506 | 3-17 |
| 5850507 | 3-17 |
| 5850508 | 3-17 |
| 5850509 | 3-17 |
| 5850522 | 3-17 |
| 5850523 | 3-15 |
| 5850524 | 3-15 |
| 5850525 | 3-15 |
| 5850526 | 3-15 |
| 5850527 | 3-15 |
| 5850528 | 3-15 |
| 5850530 | 3-18 |
| 5850531 | 3-18 |
| 5850532 | 3-18 |
| 5850533 | 3-18 |
| 5850534 | 3-18 |
| 5850535 | 3-18 |
| 5850536 | 3-18 |
| 5858901 | 3-14 |
| 5858902 | 3-14 |
| 5858903 | 3-14 |
| 5858904 | 3-14 |
| 5858906 | 3-17 |
| 5858907 | 3-17 |
| 5858908 | 3-17 |
| 5858909 | 3-17 |
| 5858922 | 3-15 |
| 5858923 | 3-15 |

| NASTRAN EID | PAGE |
|----------------|-------|
| 5858924 | 3-15 |
| 5858925 | 3-15 |
| 5858926 | 3-15 |
| 5858927 | 3-15 |
| 5858928 | 3-15 |
| 5858930 | 3-18 |
| 5858931 | 3-18 |
| 5858932 | 3-18 |
| 5858933 | 3-18 |
| 5858934 | 3-18 |
| 5858935 | 3-18 |
| 5858936 | 3-18 |
| 5940041 | 3-8 |
| 5940171 | 3-11 |
| 6222431 | 3-249 |
| 6222639 | 3-249 |
| 7222431 | 3-253 |
| 7222639 | 3-253 |

GRID POINT INDEX

| NASTRAN ID | PAGE |
|------------|--------------------------|
| 3331 | 3-4, 8, 14, 20 |
| 3339 | 3-4, 11, 17, 22 |
| 3341 | 3-4, 8, 14, 20 |
| 3349 | 3-4, 11, 17, 22 |
| 4631 | 3-5, 8, 14, 20 |
| 4633 | 3-5, 8, 14 |
| 4637 | 3-5, 11, 17, 22 |
| 4639 | 3-5, 11, 17, 22 |
| 4641 | 3-5, 8, 14, 20 |
| 4649 | 3-5, 11, 17, 22 |
| 4661 | 3-5, 8, 14 |
| 4669 | 3-5, 11, 22 |
| 6123 | 3-8, 14, 20, 49 |
| 6127 | 3-11, 17, 22, 49 |
| 6131 | 3-8, 14, 20, 49, 59, 78 |
| 6133 | 3-8, 20, 24, 49, 78 |
| 6137 | 3-11, 22, 29, 49, 78 |
| 6139 | 3-11, 17, 22, 49, 61, 78 |
| 6141 | 3-8, 14, 20, 49 |
| 6143 | 3-8, 20, 24, 49 |
| 6147 | 3-11, 22, 29, 49 |
| 6149 | 3-11, 17, 22, 49 |
| 6161 | 3-8, 14, 20, 49, 59, 91 |
| 6163 | 3-8, 20, 24, 49, 91 |
| 6167 | 3-11, 22, 29, 49, 91 |
| 6169 | 3-11, 17, 22, 49, 61, 91 |
| 6171 | 3-8, 14, 20, 49 |
| 6179 | 3-11, 17, 22, 49 |
| 7031 | 3-59, 78 |
| 7033 | 3-59, 78, 84 |
| 7037 | 3-24, 78, 84 |
| 7039 | 3-61, 78 |
| 7043 | 3-24, 84 |
| 7047 | 3-29, 84 |
| 7061 | 3-59, 91 |
| 7063 | 3-24, 91 |
| 7067 | 3-29, 91 |
| 7069 | 3-61, 91 |
| 7071 | 3-59 |
| 7079 | 3-61 |
| 7505 | 3-84 |
| 8300 | 4-36 |
| 8531 | 3-59, 78 |
| 8533 | 3-24, 78, 84 |
| 8537 | 3-29, 78, 84 |

| NASTRAN ID | PAGE |
|------------|----------------------|
| 8539 | 3-61, 78 |
| 8543 | 3-24, 84 |
| 8547 | 3-29, 84 |
| 8561 | 3-59, 91 |
| 8563 | 3-24, 91 |
| 8567 | 3-29, 91 |
| 8569 | 3-61, 91 |
| 8571 | 3-59 |
| 8579 | 3-61 |
| 9303 | 3-52, 97 |
| 9307 | 3-52, 97, 100 |
| 9313 | 3-52, 71 |
| 9317 | 3-52, 71, 100 |
| 9331 | 3-52, 59, 63, 74, 78 |
| 9333 | 3-24, 34, 52, 74, 78 |
| 9337 | 3-29, 37, 52, 74, 78 |
| 9339 | 3-52, 61, 65, 74, 78 |
| 9341 | 3-52 |
| 9343 | 3-24, 34, 52, 87 |
| 9347 | 3-29, 37, 52, 87 |
| 9349 | 3-52 |
| 9361 | 3-52, 59, 63, 91, 94 |
| 9363 | 3-24, 34, 52, 91, 94 |
| 9367 | 3-29, 37, 52, 91, 94 |
| 9369 | 3-52, 61, 65, 91, 94 |
| 9371 | 3-52, 59, 63 |
| 9373 | 3-52 |
| 9377 | 3-52 |
| 9379 | 3-52, 61, 65 |
| 11300 | 4-36 |
| 11503 | 3-71, 97 |
| 11507 | 3-71, 100 |
| 11531 | 3-63, 74 |
| 11533 | 3-34, 74 |
| 11537 | 3-37, 74 |
| 11539 | 3-65, 74 |
| 11543 | 3-34, 87 |
| 11547 | 3-37, 87 |
| 11561 | 3-63, 94 |
| 11563 | 3-34, 94 |
| 11567 | 3-37, 94 |
| 11569 | 3-65, 94 |
| 11571 | 3-63 |
| 11579 | 3-65 |
| 11700 | 4-36 |

GRID POINT INDEX (CONT.)

| NASTRAN ID | PAGE |
|------------|-------------------------|
| 13500 | 4-36 |
| 13801 | 3-56,97 |
| 13803 | 3-41,56,71,97 |
| 13807 | 3-45,56,71,100 |
| 13809 | 3-56,100 |
| 13821 | 3-56,68,97 |
| 13823 | 3-41,56,85 |
| 13827 | 3-45,56,85 |
| 13829 | 3-56,70,100 |
| 13831 | 3-56,63,68,74 |
| 13833 | 3-34,41,56,74 |
| 13837 | 3-37,45,56,74 |
| 13839 | 3-56,65,70,74 |
| 13841 | 3-56 |
| 13843 | 3-34,41,56,87 |
| 13847 | 3-37,45,56,87 |
| 13848 | 3-45,56 |
| 13849 | 3-56 |
| 13861 | 3-56,63,68,94 |
| 13863 | 3-34,41,56,94 |
| 13867 | 3-37,45,56,94 |
| 13869 | 3-56,65,70,94 |
| 13871 | 3-56,63,68 |
| 13879 | 3-56,65,70 |
| 14801 | 3-97,121 |
| 14803 | 3-41,97,121,226 |
| 14807 | 3-45,100,121,226 |
| 14809 | 3-100,121 |
| 14821 | 3-68,97,121,134,140 |
| 14823 | 3-41,85,104,121,140,226 |
| 14827 | 3-45,85,109,121,140,226 |
| 14829 | 3-70,100,121,137,140 |
| 14831 | 3-68,74,121 |
| 14833 | 3-41,74,104,121 |
| 14837 | 3-45,74,109,121 |
| 14839 | 3-70,74,121 |
| 14841 | 3-121 |
| 14843 | 3-41,87,104,121 |
| 14847 | 3-45,87,109,121 |
| 14849 | 3-121 |
| 14861 | 3-68,94,121,134,154 |
| 14863 | 3-41,94,121,154 |
| 14867 | 3-45,94,109,121,154 |
| 14869 | 3-70,94,121,137,154 |
| 14881 | 3-68,121,134,145 |

| NASTRAN ID | PAGE |
|------------|-------------------------------|
| 14883 | 3-121,145 |
| 14887 | 3-121,145 |
| 14889 | 3-70,121,137,145 |
| 15212 | 3-226 |
| 15218 | 3-226 |
| 15601 | 3-126,156 |
| 15603 | 3-126,156,226 |
| 15607 | 3-126,159,226 |
| 15609 | 3-126,159 |
| 15621 | 3-126,134,140,156 |
| 15623 | 3-104,126,140,226 |
| 15625 | 3-126,140 |
| 15627 | 3-109,126,140,226 |
| 15629 | 3-126,137,140,159 |
| 15633 | 3-104,126 |
| 15637 | 3-109,126 |
| 16481 | 3-134,145 |
| 16483 | 3-145 |
| 16485 | 3-145 |
| 16487 | 3-145 |
| 16489 | 3-137,145 |
| 17100 | 4-36 |
| 18601 | 3-128,156 |
| 18603 | 3-128,156 |
| 18607 | 3-128,159 |
| 18609 | 3-128,159 |
| 18621 | 3-104,113,128,134,140,150,156 |
| 18623 | 3-128,140,150 |
| 18625 | 3-128,140,150 |
| 18627 | 3-128,140,150 |
| 18629 | 3-109,117,128,137,140,150,159 |
| 18631 | 3-104,128 |
| 18633 | 3-128 |
| 18635 | 3-128 |
| 18637 | 3-128 |
| 18639 | 3-109,128 |
| 18641 | 3-104,113,128,234 |
| 18642 | 3-128,234 |
| 18643 | 3-128,234 |
| 18644 | 3-128,234 |
| 18645 | 3-128,234 |
| 18646 | 3-128,234 |
| 18647 | 3-128,234 |
| 18648 | 3-128,234 |
| 18649 | 3-109,117,128,234 |

GRID POINT INDEX (CONT.)

| NASTRAN ID | PAGE |
|------------|--------------------------------|
| 18651 | 3-104, 113, 128, 234 |
| 18652 | 3-128, 234 |
| 18653 | 3-128, 234 |
| 18654 | 3-109, 117, 128, 234 |
| 18656 | 3-104, 113, 128, 234 |
| 18657 | 3-128, 234 |
| 18658 | 3-128, 234 |
| 18659 | 3-109, 117, 128, 234 |
| 18661 | 3-104, 113, 129, 134, 154, 234 |
| 18662 | 3-129, 234 |
| 18663 | 3-129, 219, 234 |
| 18664 | 3-129, 234 |
| 18665 | 3-129, 234 |
| 18666 | 3-129, 234 |
| 18667 | 3-129, 219, 234 |
| 18668 | 3-129, 234 |
| 18669 | 3-109, 117, 129, 137, 154, 234 |
| 18681 | 3-129, 134, 145 |
| 18683 | 3-129, 145, 219 |
| 18685 | 3-129, 145 |
| 18687 | 3-129, 145, 219 |
| 18689 | 3-129, 137, 145 |
| 18983 | 3-215, 219 |
| 18987 | 3-215, 219 |
| 19741 | 3-113, 240 |
| 19742 | 3-240 |
| 19743 | 3-240 |
| 19745 | 3-240 |
| 19747 | 3-240 |
| 19748 | 3-240 |
| 19749 | 3-117, 240 |
| 19751 | 3-113, 240 |
| 19752 | 3-240 |
| 19758 | 3-240 |
| 19759 | 3-117, 240 |
| 19761 | 3-113, 240 |
| 19762 | 3-240 |
| 19763 | 3-240 |
| 19765 | 3-215, 240 |
| 19767 | 3-240 |
| 19768 | 3-240 |
| 19769 | 3-117, 240 |
| 21183 | 3-215, 219 |
| 21187 | 3-215, 219 |
| 21321 | 3-113, 150, 156, 163, 177, 190 |

| NASTRAN ID | PAGE |
|------------|--------------------------------|
| 21323 | 3-150, 177, 190 |
| 21325 | 3-150, 177, 190 |
| 21327 | 3-150, 177, 190 |
| 21329 | 3-117, 150, 159, 166, 177, 190 |
| 21341 | 3-113, 163, 177, 244 |
| 21343 | 3-177, 219, 244 |
| 21345 | 3-177, 219, 244 |
| 21347 | 3-177, 219, 244 |
| 21349 | 3-117, 166, 177, 244 |
| 21361 | 3-113, 163, 177, 201 |
| 21363 | 3-177, 201, 219 |
| 21364 | 3-177, 201, 219 |
| 21366 | 3-177, 201, 219 |
| 21367 | 3-177, 201, 219 |
| 21369 | 3-117, 166, 177, 201 |
| 21383 | 3-177, 219 |
| 21387 | 3-177, 219 |
| 21485 | 3-215, 219 |
| 21801 | 3-156, 179, 226 |
| 21803 | 3-156, 179, 226 |
| 21807 | 3-159, 179, 226 |
| 21809 | 3-159, 179, 226 |
| 21821 | 3-156, 163, 179, 190, 226 |
| 21823 | 3-179, 190, 226 |
| 21825 | 3-179, 190 |
| 21827 | 3-179, 190, 226 |
| 21829 | 3-159, 166, 179, 190, 226 |
| 22312 | 3-226 |
| 22318 | 3-226 |
| 22701 | 3-180, 208, 226 |
| 22703 | 3-180, 208, 226 |
| 22707 | 3-180, 211, 226 |
| 22709 | 3-180, 211, 226 |
| 22721 | 3-163, 180, 190, 208, 226 |
| 22723 | 3-180, 190, 226 |
| 22725 | 3-180, 190 |
| 22727 | 3-180, 190, 226 |
| 22729 | 3-166, 180, 190, 211, 226 |
| 23100 | 4-36 |
| 25001 | 3-182, 208 |
| 25003 | 3-182, 208 |
| 25007 | 3-182, 211 |
| 25009 | 3-182, 211 |
| 25021 | 3-163, 169, 182, 190, 196, 208 |
| 25025 | 3-182, 190, 196 |

GRID POINT INDEX (CONT.)

| NASTRAN ID | PAGE |
|------------|---------------------------|
| 25029 | 3-166,173,182,190,196,211 |
| 25041 | 3-163,169,182 |
| 25045 | 3-182 |
| 25049 | 3-166,173,182 |
| 25061 | 3-163,169,182,201,204 |
| 25065 | 3-182,201,204 |
| 25069 | 3-166,173,182,201,204 |
| 26801 | 3-185,208 |
| 26809 | 3-185,211 |
| 26821 | 3-169,185,196,198,208 |
| 26825 | 3-185,196,198 |
| 26829 | 3-173,185,196,198,211 |
| 26841 | 3-169,185 |
| 26845 | 3-185 |
| 26849 | 3-173,185 |
| 26861 | 3-169,185,204 |
| 26865 | 3-185,204 |
| 26869 | 3-173,185,204 |
| 29905 | 3-188,208,211 |
| 29921 | 3-169,188,198,208 |
| 29925 | 3-188,198 |
| 29929 | 3-173,188,198,211 |
| 29941 | 3-169,188 |
| 29945 | 3-188 |
| 29949 | 3-173,188 |
| 29961 | 3-169,188,204 |
| 29965 | 3-188,204 |
| 29969 | 3-173,188,204 |
| 30045 | 3-279 |
| 31745 | 3-279 |
| 33845 | 3-279 |
| 35945 | 4-379 |
| 38045 | 3-279 |
| 40141 | 3-296 |
| 40142 | 3-296 |
| 40143 | 3-296 |
| 40145 | 3-279,296 |
| 40147 | 3-296 |
| 40148 | 3-296 |
| 40149 | 3-296 |
| 42245 | 3-279 |
| 44345 | 3-279 |
| 45245 | 3-279 |
| 46445 | 3-279,292 |
| 48045 | 3-292 |

| NASTRAN ID | PAGE |
|------------|-------------------|
| 48845 | 3-292 |
| 49745 | 3-292 |
| 50645 | 3-292 |
| 51545 | 3-292 |
| 52045 | 3-292,298 |
| 61912 | 3-234,273 |
| 61913 | 3-273 |
| 61914 | 3-234,273 |
| 61916 | 3-234,273 |
| 61917 | 3-273 |
| 61918 | 3-234,273 |
| 61922 | 3-273 |
| 61923 | 3-240,273 |
| 61924 | 3-273 |
| 61926 | 3-273 |
| 61927 | 3-240,273 |
| 61928 | 3-273 |
| 61934 | 3-273 |
| 61935 | 3-244,273 |
| 61936 | 3-273 |
| 62211 | 3-248,255,267 |
| 62213 | 3-248,255,273 |
| 62217 | 3-248,255,273 |
| 62219 | 3-248,255,267 |
| 62221 | 3-248,255,267,273 |
| 62224 | 3-248,255,273 |
| 62226 | 3-248,255,273 |
| 62229 | 3-248,255,267,273 |
| 62231 | 3-248,255,267,273 |
| 62239 | 3-248,255,267,273 |
| 62811 | 3-248,255,267 |
| 62819 | 3-248,255,267 |
| 62821 | 3-248,255,267 |
| 62829 | 3-248,255,267 |
| 62831 | 3-248,255,267 |
| 62839 | 3-248,255,267 |
| 63411 | 3-248,255,267 |
| 63419 | 3-248,255,267 |
| 63421 | 3-248,255,267 |
| 63429 | 3-248,255,267 |
| 63431 | 3-248,255,267 |
| 63439 | 3-248,255,267 |
| 64211 | 3-248,255,267 |
| 64219 | 3-248,255,267 |
| 64221 | 3-248,255,267 |

GRID POINT INDEX (CONT.)

| NASTRAN ID | PAGE |
|------------|----------------------|
| 64229 | 3-248, 255, 267 |
| 64231 | 3-248, 255, 267 |
| 64239 | 3-248, 255, 267 |
| 65011 | 3-248, 255, 267 |
| 65019 | 3-248, 255, 267 |
| 65021 | 3-248, 255, 267 |
| 65029 | 3-249, 255, 267 |
| 65031 | 3-249, 256, 267 |
| 65039 | 3-249, 256, 267 |
| 65011 | 3-249, 256, 267 |
| 65919 | 3-249, 256, 267 |
| 65921 | 3-249, 256, 267 |
| 65929 | 3-249, 256, 268 |
| 65931 | 3-249, 256, 268 |
| 65939 | 3-249, 256, 268 |
| 71912 | 3-234, 276 |
| 71913 | 3-276 |
| 71914 | 3-235, 276 |
| 71916 | 3-235, 276 |
| 71917 | 3-276 |
| 71918 | 3-235, 276 |
| 71922 | 3-276 |
| 71923 | 3-240, 276 |
| 71924 | 3-276 |
| 71926 | 3-276 |
| 71927 | 3-240, 276 |
| 71928 | 3-276 |
| 71934 | 3-276 |
| 71935 | 3-244, 276 |
| 71936 | 3-276 |
| 72211 | 3-252, 261, 270 |
| 72213 | 3-252, 261, 276 |
| 72217 | 3-252, 261, 276 |
| 72219 | 3-252, 261, 270 |
| 72221 | 3-252, 261, 270, 276 |
| 72224 | 3-252, 261, 276 |
| 72226 | 3-252, 261, 276 |
| 72229 | 3-252, 261, 270, 276 |
| 72231 | 3-252, 261, 270, 276 |
| 72239 | 3-252, 261, 270, 276 |
| 72811 | 3-252, 261, 270 |
| 72819 | 3-252, 261, 270 |
| 72821 | 3-252, 261, 270 |
| 72829 | 3-252, 261, 270 |
| 72831 | 3-252, 261, 270 |

| NASTRAN ID | PAGE |
|------------|-----------------|
| 72839 | 3-252, 261, 270 |
| 73411 | 3-252, 261, 270 |
| 73419 | 3-252, 261, 270 |
| 73421 | 3-252, 261, 270 |
| 73429 | 3-252, 261, 270 |
| 73431 | 3-252, 261, 270 |
| 73439 | 3-252, 261, 270 |
| 74211 | 3-252, 261, 270 |
| 74219 | 3-252, 261, 270 |
| 74221 | 3-252, 261, 270 |
| 74229 | 3-252, 261, 270 |
| 74231 | 3-252, 261, 270 |
| 74239 | 3-252, 261, 270 |
| 75011 | 3-252, 261, 270 |
| 75019 | 3-252, 261, 270 |
| 75021 | 3-252, 261, 270 |
| 75029 | 3-252, 261, 270 |
| 75031 | 3-252, 261, 270 |
| 75039 | 3-253, 262, 270 |
| 75911 | 3-253, 262, 270 |
| 75919 | 3-253, 262, 270 |
| 75921 | 3-253, 262, 270 |
| 75929 | 3-253, 262, 271 |
| 75931 | 3-253, 262, 271 |
| 75939 | 3-253, 262, 271 |
| 122400 | 3-230 |
| 123467 | 3-230 |
| 123487 | 3-230 |
| 124800 | 3-230 |
| 125063 | 3-230 |
| 125065 | 3-230 |
| 125067 | 3-230 |
| 125383 | 3-230 |
| 125387 | 3-230 |
| 126863 | 3-230 |
| 126867 | 3-230 |
| 127200 | 3-230 |
| 189073 | 3-215 |
| 189077 | 3-215 |
| 200070 | 3-215 |
| 200078 | 3-215 |
| 200079 | 3-215 |
| 200086 | 3-215 |
| 200087 | 3-215 |
| 200095 | 3-215 |

GRID POINT INDEX (CONT.)

| NASTRAN ID | PAGE |
|---------------|-------|
| 200096 | 3-215 |
| 200101 | 3-215 |
| 200106 | 3-215 |
| 200114 | 3-215 |
| 200121 | 3-215 |
| 200129 | 3-215 |
| 200137 | 3-215 |
| 200145 | 3-215 |
| 200153 | 3-215 |
| 200155 | 3-215 |
| 211001 | 3-223 |
| 211002 | 3-223 |
| 211073 | 3-215 |
| 211077 | 3-215 |
| 214075 | 3-215 |
| 214901 | 3-223 |
| 214902 | 3-223 |
| 215101 | 3-223 |
| 215102 | 3-223 |
| 215201 | 3-223 |
| 215202 | 3-223 |
| 222001 | 3-223 |
| 222002 | 3-223 |
| 222201 | 3-223 |
| 222202 | 3-223 |
| 222301 | 3-223 |
| 222302 | 3-223 |
| 223401 | 3-223 |
| 223402 | 3-223 |
| 520018 | 3-298 |
| 520024 | 3-298 |
| 520057 | 3-298 |
| 520065 | 3-298 |
| 520068 | 3-298 |
| 520079 | 3-298 |
| 520135 | 3-298 |
| 520139 | 3-299 |
| 520152 | 3-299 |
| 520185 | 3-299 |

6. LITERATURE CITED

1. Tisdale, P. R., and Nelson, B. J., SDSN02 - MASS AND INERTIAL DISTRIBUTIONS CALCULATED FROM A WEIGHTS CONTROL TAPE FOR A NASTRAN FINITE ELEMENT MODEL, Report No. 599-162-911, Bell Helicopter Company, Fort Worth, Texas, March 1972.
2. THE BANDIT COMPUTER PROGRAM FOR THE REDUCTION OF MATRIX BAND WIDTH FOR NASTRAN, Department of Applied Mathematics - Naval Ship Research and Development Center, NASA Accession No. 472-10119, COSMIC, Barrows Hall, University of Georgia, Athens, Georgia, January 1970.
3. McCormick, Caleb W., THE NASTRAN USER'S MANUAL, NASA SP-222(01), Computer Software Management and Information Center (COSMIC), Barrows Hall, University of Georgia, Athens, Georgia, June 1972.
4. Alsmiller, G. R., et al., STRUCTURAL ANALYSIS FORWARD FUSELAGE, MODEL 209, Report No. 209-099-055, Bell Helicopter Company, Fort Worth, Texas, April 1967.
5. Ambrose, E., and Clarke, D., TAILBOOM, VERTICAL FIN AND HORIZONTAL STABILIZER STRUCTURAL ANALYSIS MODEL 209, Report No. 209-099-056, Bell Helicopter Company, Fort Worth, Texas, January 1967.
6. McCaskill, O. K., Johnson, J. W., and Ramirez, J., ARMAMENT EXTERNAL STORES AND WING STRUCTURAL ANALYSIS - AH-1G, Report No. 209-099-059, Bell Helicopter Company, Fort Worth, Texas, April 1967.
7. Cronkhite, J. D., and Wilson, W. F., DYNAMIC ANALYSIS OF TWO-PER-REV VIBRATIONS IN THE MODEL AH-1J HELICOPTER, Report No. 299-100-021, Bell Helicopter Company, Fort Worth, Texas, February 1972.
8. MacNeal, Richard H., THE NASTRAN THEORETICAL MANUAL, NASA SP-221(01), COSMIC, Barrows Hall, University of Georgia, Athens, Georgia, June 1972.
9. Alsmiller, G. R., STRUCTURAL ANALYSIS COMPUTER PROGRAMS, Report No. 299-099-252, Bell Helicopter Company, Fort Worth, Texas, March 1964. pp. 14.00 ff.
10. Peery, David J., AIRCRAFT STRUCTURES, McGraw-Hill Book Company, New York, New York, 1950. pp. 158, 374.

DISTRIBUTION LIST UPDATE

- - - FOR YOUR CONVENIENCE - - -

Government regulations require the maintenance of up-to-date distribution lists for technical reports. This form is provided for your convenience to indicate necessary changes or corrections.

If a change in our mailing lists should be made, please check the appropriate boxes below. For changes or corrections, show old address *exactly* as it appeared on the mailing label. Fold on dotted lines, tape or staple the lower edge together, and mail.

Remove Name From List

Change or Correct Address

Old Address:

Corrected or New Address:

COMMENTS

Date: _____ Signature: _____

Technical Report # R-TR-74-045 (VOLUME I)

FOLD HERE

Return Address:

POSTAGE AND FEES PAID
DEPARTMENT OF THE ARMY
DOD 314



OFFICIAL BUSINESS
Penalty for Private Use \$300

Commander
Rock Island Arsenal
Attn: SARRI-LR
Rock Island, Illinois 61201

FOLD HERE