

AD-A183 986

LIGHTWEIGHT TOWED HOWITZER DEMONSTRATOR PHASE 1 AND
PARTIAL PHASE 2 VOLUM (U) FMC CORP MINNEAPOLIS MINN
NORTHERN ORDNANCE DIV R RATHE ET AL APR 87
FMC-E-3041-VOL-C-PT-2 DAAA21-86-C-0047

1/3

UNCLASSIFIED

F/G 19/6

NL

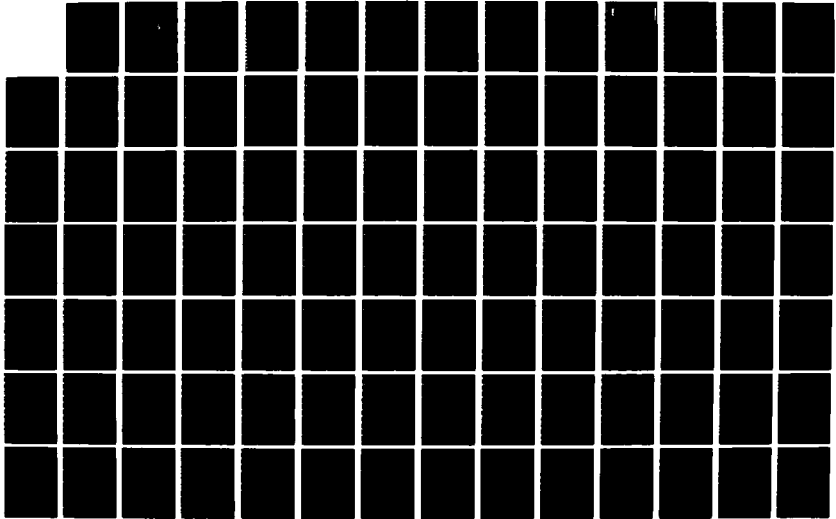

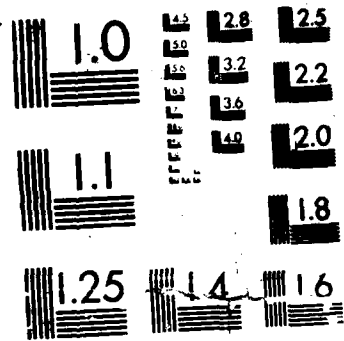

MICROCOPY RESOLUTION TEST CHART

2

DTIC FILE COPY

Lightweight Towed Howitzer Demonstrator

Final Report

Volume C - Part II

Dynamic Analysis Report

April 1987

DTIC
SELECTED
SEP 03 1987
S Q&D D

AD-A183 986

Contract Number DAAA21-86-C-0047

FMC CORPORATION
Northern Ordnance Division
4800 East River Road
Minneapolis, Minnesota 55421

DISTRIBUTION STATEMENT A
Approved for public release;
Distribution Unlimited

"THE VIEWS, OPINIONS, AND/OR FINDINGS CONTAINED IN THIS REPORT ARE
THOSE OF THE AUTHOR(S) AND SHOULD NOT BE CONSTRUED AS AN OFFICIAL
DEPARTMENT OF THE ARMY POSITION, POLICY OR DECISION, UNLESS SO
DESIGNATED BY OTHER DOCUMENTATION."

87 9 1 245

DISCLAIMER NOTICE

THIS DOCUMENT IS BEST QUALITY PRACTICABLE. THE COPY FURNISHED TO DTIC CONTAINED A SIGNIFICANT NUMBER OF PAGES WHICH DO NOT REPRODUCE LEGIBLY.

UNCLASSIFIED

SECURITY CLASSIFICATION OF THIS PAGE (When Data Entered)

REPORT DOCUMENTATION PAGE		READ INSTRUCTIONS BEFORE COMPLETING FORM
1. REPORT NUMBER	2. GOVT ACCESSION NO. AD-A183986	3. RECIPIENT'S CATALOG NUMBER
4. TITLE (and Subtitle) Final report for the Lightweight Towed Howitzer Demonstrator		5. TYPE OF REPORT & PERIOD COVERED Final: 20 December 1985 - 13 March 1987
7. AUTHOR(s) Robert Rathe, FMC Program Manager Bart Anderson, FMC Project Manager		6. PERFORMING ORG. REPORT NUMBER E-3041
9. PERFORMING ORGANIZATION NAME AND ADDRESS FMC CORPORATION, Northern Ordnance Division 4800 East River Road Minneapolis MN 55421		8. CONTRACT OR GRANT NUMBER(s) DAAA21-86-C-0047
11. CONTROLLING OFFICE NAME AND ADDRESS AMCCOM AMSMC-PCW-A(D) Dover NJ 07801-5001		10. PROGRAM ELEMENT, PROJECT, TASK AREA & WORK UNIT NUMBERS Item 0001 LTHD Phase I and Partial Phase II
14. MONITORING AGENCY NAME & ADDRESS (if different from Controlling Office) AMCCOM AMSMC-FSA-F Dover NJ 07801-5001		12. REPORT DATE April 1987
		13. NUMBER OF PAGES 4,856
		15. SECURITY CLASS. (of this report) Unclassified
16. DISTRIBUTION STATEMENT (of this Report) Approved for public release, distribution unlimited.		15a. DECLASSIFICATION/DOWNGRADING SCHEDULE N/A
17. DISTRIBUTION STATEMENT (of the abstract entered in Block 20, if different from Report) Same as Block 16.		
18. SUPPLEMENTARY NOTES None		
19. KEY WORDS (Continue on reverse side if necessary and identify by block number) 155mm towed gun howitzer, advanced weapons, composite cradle, composite hydraulic actuators, composite trails, field artillery weapon, firing stability analysis, howitzers, hydraulic control valves with force feedback, hydraulic joystick control of gun direction, hydraulic inertial rammer, hydraulic opening breech, hydraulic primer autoloader, lightweight towed howitzer demonstrator (LTHD) load out of battery howitzer, mortar howitzer, recoil energy recovery, recoil mechanism, using metal matrix composites, titanium muzzle brake, titanium platform, titanium spade, titanium walking beams, thermal stability, towing stability analysis, unconventional weapons, and weight reduction of artillery		
20. ABSTRACT (Continue on reverse side if necessary and identify by block number) The LTHD (Lightweight Towed Howitzer Demonstrator) was to be a 9,000 lb equivalent to the M198, transportable via Blackhawk helicopter, with reduced emplacement time using fewer personnel. The FMC design achieved weight reduction via a mortar-like configuration, composites structure, and hydraulic actuators. Recovery of power from the recoil system, in turn, facilitated crew reduction via hydraulic emplacement, four-way joystick tube lay, and power ramming. FMC completed Concept Development (Ph I) and two-thirds of Detailed Design (Ph II) prior to funds running out.		

DD FORM 1473
1 JAN 73

EDITION OF 1 NOV 65 IS OBSOLETE

UNCLASSIFIED

SECURITY CLASSIFICATION OF THIS PAGE (When Data Entered)

Vol/Sec	Description
C	Dynamic Analysis
C/050	Table of Contents
C/060	Mass-Coordinate Data File
C/070	Computer File Inventory
C/100	Breech Actuator
C/110	Elevation and Equilibration
C/120	Energy Storage Accumulator
C/130	Equilibration Intensifier
C/140	Firing Stability
C/150	Lanyard Actuator
C/160	Load Position Actuator
C/170	Loading System
C/180	Parking and Service Brakes
C/190	Primer Autoloader
C/200	Recoil System
C/210	Recoil System Abandoned Dec 86 (fixed orifice)
C/220	Reservoir Accumulator
C/230	Towing Stability
C/240	Traverse Actuator
C/250	Tube <i>Interface</i>
C/260	Tube Laying Accuracy
C/270	Walking Beam Actuators



Accession For	
NTIS CRA&I	<input checked="" type="checkbox"/>
DTIC TAB	<input type="checkbox"/>
Unannounced	<input type="checkbox"/>
Justification	
By	
Distribution/	
Availability Codes	
Dist	Avail and/or Special
A-1	

PART NUMBERS: 12585710-275, Compound Actuator Assembly

DESCRIPTION: RECOIL SYSTEM

The recoil system consists of two recoil cylinders, a counter-recoil cylinder, an energy recovery cylinder, and a load position actuator. There are also two counter-recoil accumulators and a reservoir accumulator.

The two recoil cylinders and the energy storage cylinder have a 6 inch free recoil length to keep retardation forces to a minimum until the project exits the barrel.

The recoil system is designed to give a constant 78,000 lbs. retarding force profile when fired from load position with a nitrogen volume of 4800 cu. in., pressure of 2166 psi, and temperature of -25 F.

In normal operation (firing from battery position) the recoil force profile consists of 6 inches of free recoil, then hard recoil of 75,000 lbs until recoil travel is 3.25 feet. Finally, the recoil force is gradually reduced as recoil travel approaches full recoil stroke. This trailing off of retardation force during the last 5.5 feet of recoil travel is to improve firing stability.

STATUS:

All dimensions and mounting requirements have been determined. The final orifice profile was pending completion of weight, CG and inertia analysis to provide optimum firing stability.

AUTHOR: Jeff Ireland

RECOIL SYSTEM SUMMARY

	PISTON ϕ	ROD ϕ
RECOIL	3.000	2.000
C' RECOIL	3.000	2.250
ENERGY STORAGE	3.000	2.250

MOMENTUM INDEX $\beta = 0.7$

$$\text{IMPULSE } IS = IM + (1-\beta)IG = 10,350 \text{ LBF-SEC}$$

$$\text{FINAL RECOILING MASS} = W = 3870 \text{ LBF}$$

$$\text{ENERGY} = \frac{I^2}{2M} = \frac{(10,350 \text{ LBF-SEC})^2 (32.174 \text{ FT/SEC}^2)}{2(3870 \text{ LBF})}$$

$$= 445,300 \text{ FT-LBF}$$

RECOIL SYSTEM IS DESIGNED TO GIVE A FLAT RECOIL FORCE PROFILE (CONSTANT RETARDING FORCE) WHEN FIRED FROM LOAD POSITION

$$\text{RECOIL STROKE FROM BATTERY} = 8.75 \text{ FT}$$

$$\text{RECOIL STROKE FROM LOAD} = 5.75 \text{ FT}$$

$$F \cdot 5.75 \text{ FT} = 445,300 \text{ FT-LBF}$$

$$F = 77,443 \text{ LBF}$$

$$\text{I) } F_{\text{GRAVITY}} = 3870 \text{ LBF} \sin 70^\circ = 3637 \text{ LBF}$$

FORCE COUNTER RECOIL / ENERGY STORAGE

PRECHARGE PRESSURE 70°F = 2640 PSI
 VOLUME (NITROGEN) = 4800 in³
 PRESSURE AT -25°F = 2166 PSI

a) PRESSURE AT LOAD POSITION (3FT. OUT OF BATTERY)

$$\frac{P_0 V_0}{\pi L} = \frac{P_{CR} (V_0 - \Delta V)}{\pi L} \quad \underline{\underline{\text{CONSTANT TEMP}}}$$

$$P_{CR} = \frac{P_0 V_0}{V_0 - \Delta V} = P_0 / (1 - \Delta V / V_0)$$

b) PRESSURE AT LOAD POSITION (3FT. OUT OF BATTERY)

ADIABATIC

$$P_{CR} (V_0 - \Delta V)^k = P_0 V_0^k$$

$$P_{CR} = P_0 \left[\frac{V_0}{V_0 - \Delta V} \right]^k$$

$$P_{CR} = P_0 / (1 - \Delta V / V_0)^k$$

CONSTANT TEMP WILL GIVE LOWER PRESSURE READINGS
 SO WE WILL USE THAT.

$$A_{CR} = A_{ES} = \frac{\pi}{4} [(30 \text{ in})^2 - (2.25 \text{ in})^2] = 3.093 \text{ in}^2$$

$$F_{CR} \dagger F_{ES} = 2(3.093 \text{ in}^2)(2166 \text{ lbf/in}^2) / \left[1 - \frac{3.093(24 \text{ in} + 36 \text{ in})}{4800 \text{ in}^3} \right]$$

$$= 13,938 \text{ LBF.}$$

FORCE RECOIL CYLINDERS

$$2FR = F - (F_{CR} + F_{ES}) + F_{GRAVITY}$$

$$2FR = 77,443 \text{ LBF} - 13,938 \text{ LBF} + 3637 \text{ LBF}$$

$$FR = 33,571 \text{ LBF}$$

$$P_{RECOIL} = \frac{33,571 \text{ LBF}}{\pi/4 [(3.0\text{in})^2 - (2.0\text{in})^2]} = 8,550 \text{ PSI}$$

THIS WOULD REPRESENT MAX RECOIL PRESSURE WHEN BS IS FIRED AT -25°F WITH AN EMPTY ACCUMULATOR 3FT OUT OF BATTERY

IF SYSTEM WAS BROUGHT UP TO 3000 PSI BEFORE FIRING MAX RECOIL PRESSURE FOR 3FT OUT OF BATTERY IS

$$F_{CR} + F_{ES} = 19,000 \text{ LBF}$$

$$FR = (77,443 \text{ LBF} - 19,000 \text{ LBF} + 3637 \text{ LBF}) / 2(\pi/4) [(3.0\text{in})^2 - (2.0\text{in})^2]$$

$$PR = 7,904 \text{ PSI}$$

IF FIRED FROM BATTERY POSITION (NORMAL OPERATION)

$$PR = 7,150 \text{ PSI}$$

FMC

**LTHD RECOIL FORCE
ZONE 8-S**

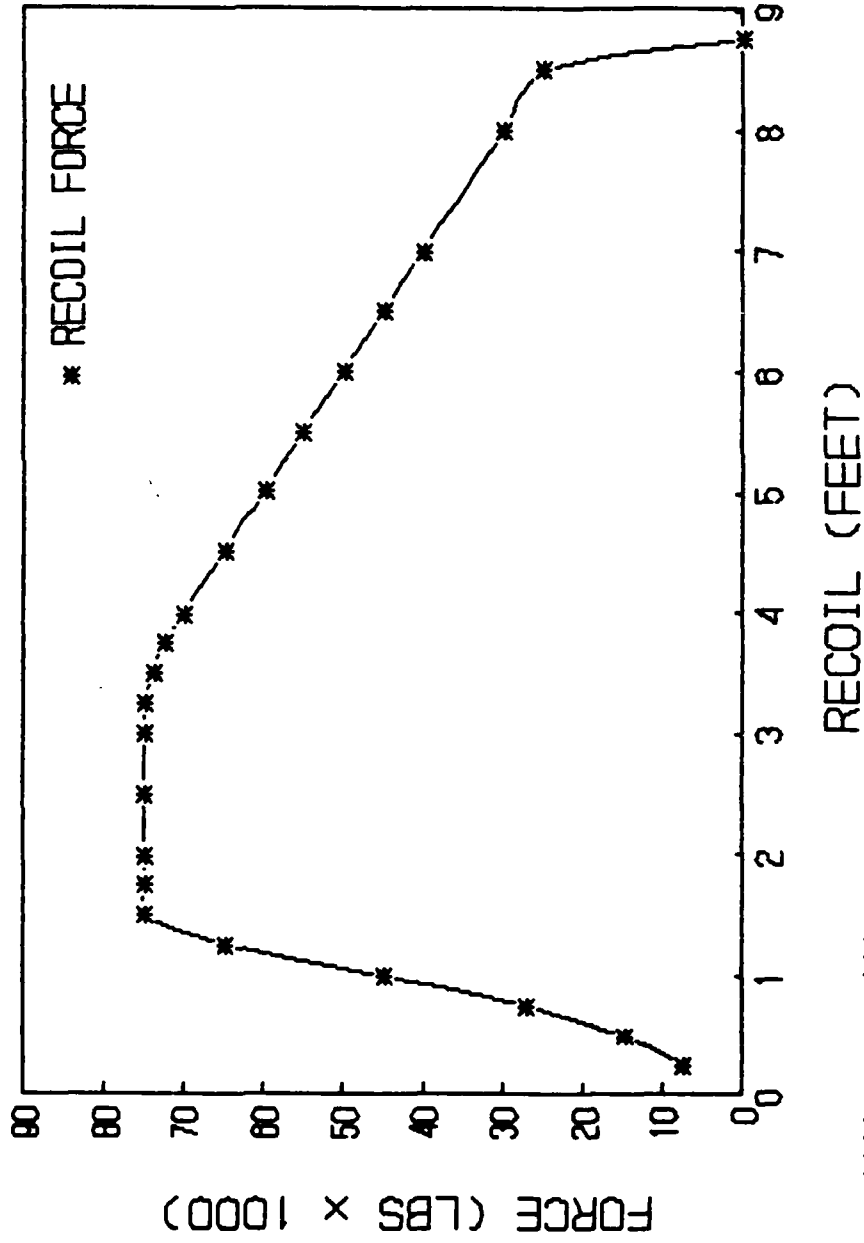

LTHD
15 JANUARY 1987
JI

$$W_R = 3800. \text{ lbs} \quad (\text{RECOILING WEIGHT})$$

$$\gamma = 1.238$$

$$W_P = 96.0 \text{ lbs} \quad (\text{PROJECTILE WEIGHT})$$

$$W_C = 28.0 \text{ lbs} \quad (\text{CHARGE WEIGHT})$$

$$W_A = 4.0 \text{ lbs} \quad (\text{ADDITIVE WEIGHT})$$

$$V_C = 1147 \text{ IN}^3 \quad \text{CHAMBER VOLUME}$$

$$D_B = 6.15 \text{ IN} \quad \text{BORE } \phi$$

$$A_B = \pi/4 (6.15 \text{ IN})^2 \quad \text{BORE AREA}$$

$$U_M = 200.1 \text{ IN} = 16.675 \text{ FT} \quad \text{PROJECTILE TRAVEL IN CANNON}$$

$$\Delta = V_C + A_B U_M \quad \text{CHAMBER + CANNON VOLUME}$$

$$R_{TB} = 11,563,400 \text{ (FT/SEC)}^2 \quad \text{SPECIFIC IMPETUS OF CHARGE}$$

$$K = 1/7$$

$$W_{EFF} = W_P + (W_A + W_C)/2$$

$$P_M = \frac{W_C R_{T0}}{g \Delta} \left(1 + \frac{W_C}{6W_P} \right) \quad \text{PRESSURE WHEN PROSO EXITS MUZZLE}$$

$$V_M = 2710 \text{ FT/SEC} \quad \text{MUZZLE VELOCITY}$$

$$A = V_M / \left[1 - (P_M * A_B * G * U_M) / (U_M * V_M * W_{EFF}) \right]$$

$$B = \left[(A/V_M) - 1.0 \right] * U_M$$

$$T_M = 2. * U_M / V_M \quad \text{TIME FOR PROJECTILE TO EXIT MUZZLE}$$

$$U_0 = e^{[L_0(U_M) - 2. - U_M/B]}$$

$$t = 1/a [b \ln u - u] \Big|_{U_0}^{U_M} \quad U_M = \text{MAX}$$

$$\dot{u} = Au / (B+u)$$

$U =$ PROJECTILE TRAVEL IN G

$\dot{u} =$ PROSO VELOCITY

$$\ddot{u} = \frac{A\dot{u}}{B+u} - \frac{Au\dot{u}}{(B+u)^2} = \frac{A\dot{u}(B+u-u)}{(B+u)^2} = \frac{AB\dot{u}}{(B+u)^2} = \frac{A^2Bu}{(B+u)^3}$$

$$W_R \dot{x}_R = (W_{EFF}) \dot{u}$$

$$\text{CHAMBER VOLUME (M549)} = V_C = 1147 \text{ in}^3$$

Page 160 KAMMERER

$$\text{LENGTH OF PROJECTILE TRAVEL} = L = 200.1 \text{ in}$$

PROJECTILE TRAVEL CALCULA

PAGE 16 KAMMERER

DWG # 11578879-6

$$\text{DIAMETER OF GUN TUBE BORE} = D_B = 6.150 \text{ in}$$

$$\text{BORE AREA} = A_B = \pi D_B^2 / 4 = 29.7057 \text{ in}^2$$

CHARGE M203 ZONE 85

PROPELLANT M30A1

PAGE 112 KAMMERER MIL-P-48367-B

$$\text{MUZZLE VELOCITY} = V_M = 2710 \text{ FT/SEC PAGE 112 KAMMERER MIL-P-48367-E}$$

MUZZLE VELOCITY OF 2710 FT/SEC IS WITH M549 PROJECTILE

$$\text{AVERAGE MAX. CHAMBER PRESSURE} = P_{\text{MAX}} = 47,500 \text{ lb}_f/\text{in}^2 \text{ MIL-P-48367-E}$$

$$\text{PROPELLANT DENSITY} = \rho_C = .06 \text{ lb}_f/\text{in}^3$$

PROPELLANT DATA SHEET M30A1

$$\text{SPECIFIC IMPETUS} = R_{TB} = 4,312,800 \frac{\text{in} \cdot \text{lb}_f}{\text{lb}_m} \text{ PROPELLANT DATA SHEET M30A1}$$

$$R_{TB} = 4,312,800 \frac{\text{in} \cdot \text{lb}_f}{\text{lb}_m} \left(\frac{286 \text{ in} \cdot \text{lb}_f}{\text{lb}_f \cdot \text{sec}^2} \right) \left(\frac{\text{FT}}{12 \text{ IN}} \right)^2$$

$$= 11,563,305.7 \text{ (FT/SEC)}^2$$

$$\sqrt{R_{TB}} = 3400.5 \text{ FT/SEC}$$

$$\text{PROPELLANT WEIGHT (M30A1)} = W_C = 26.0 \text{ lb}_f \text{ PAGE 112 KAMMERER}$$

$$\text{PROPELLANT ADDITIVE WEIGHT} = W_A = 30.0 - 26.0 \text{ lb}_f$$

$$W_A = 4 \text{ lb}_f$$

PAGE 112 KAMMERER

$$\text{M549 PROJECTILE WEIGHT} = W_P = 96.0 \text{ lb}_f \text{ PAGE 76 KAMMERER MIL-P-48367-E}$$

$$\text{PROJECTILE SPIN} = \omega_p = \frac{2\pi V_p}{20 D_B} \quad V_p = \text{PROJECTILE VELOCITY PAGE 16 KAMMERER}$$

$$D_B = 6.150 \text{ in}$$

$$\gamma = 1.2380 - \text{SPECIFIC HEAT RATIO}$$

$V_c = 1147.0 \text{ in}^3$

$L = 200.1 \text{ in}$

$D_B = 6.150 \text{ in}$

$A_B = 29.7057 \text{ in}^2$

$V_M = 2710 \text{ FT/SEC}$

$P_{MAX} = 47,500 \text{ lbs/in}^2$

$S_c = .06 \text{ lbs/in}^3$

$R_{TB} = 4,312,800 \text{ in-lbs/lbm}$

$= 11,563,306 \text{ FT}^2/\text{SEC}^2$

$\sqrt{R_{TB}} = 3400.5 \text{ FT/SEC}$

$W_c = 26.0 \text{ lbs}$

$W_A = 4.0 \text{ lbs}$

$W_p = 96.0 \text{ lbs}$

$\omega_p = \frac{2\pi V_p (r)}{20 D_B}$

$I_p = \text{PROJECTILE INERTIA} = 501 \text{ in}^2 \text{ in}^2 \frac{\text{lbs-sec}^2}{386 \text{ lbm-in}}$

$I_p = 1.2976 \text{ lbs-in-sec}^2$

$.1081 \text{ lbs-FT-sec}^2$

$K = 1/7$

$\gamma = 1.2380$

FROM SIMPLE INTERIOR BALLISTIC CALCULATION

$$P = \frac{(V_c/W_c - 1/S_c) P_{MAX}}{R_{TB}} = \frac{(1147 \text{ in}^3 / 26.0 \text{ lbs} - 1 / .06 \text{ lbs/in}^3) (47,500 \text{ lbs/in}^2)}{4,312,800 \text{ in-lbs/lbm}} = .3023$$

$$X_M = \frac{1 + A_B L}{V_c - W_c/S_c} = \frac{1 + (29.7057 \text{ in}^2)(200.1 \text{ in})}{(1147 \text{ in}^3 - 26.0 \text{ lbs} / .06 \text{ lbs/in}^3)} = 9.3290$$

$$X_B = \frac{1}{\left[\frac{1 - .0451}{P} \right]^{.667}} = \frac{1}{\left[\frac{1 - .0451}{.3023} \right]^{.667}} = 2.9378$$

EQUATION VALID ONLY IF $X_M > X_B$

For $P \leq .3906$ $U_M = 2.582 \sqrt{1 - \frac{1}{X_M^3 \left(1 - \frac{.0451}{P}\right)}} = 1.6300$

$$V_M = U_M \sqrt{R_{TB}} \sqrt{\frac{W_c/W_p}{1 + W_c/3W_p}} = U_M \sqrt{R_{TB}} \sqrt{\frac{W_c}{3W_p + W_c/3}}$$

$$= 1.630 (3400.5 \text{ FT/SEC}) \sqrt{\frac{26 \text{ lbs}}{96 \text{ lbs} + 26 \text{ lbs}/3}} = 2762.7$$

EMC Northern Ordnance Division
Minneapolis

a) CORRECT FOR PROJECTILE SPIN ENERGY

$$\frac{1}{2} \frac{W_p}{g} V_{M \text{ calc}}^2 = \frac{1}{2} I_p \omega_p^2 + \frac{1}{2} \frac{W_p}{g} V_{M \text{ ACT}}^2$$

$$\frac{96.0 \text{ lbs} (2762 \text{ FT/SEC})^2}{32.174 \text{ FT/SEC}^2} = 1.2976 \text{ lbs-IN-SEC}^2 \left(\frac{\text{FT}}{12 \text{ IN}} \right) \left(\frac{2 \pi V_{M \text{ ACT}}}{20 (6.15 \text{ IN})} \left(\frac{12 \text{ IN}}{\text{FT}} \right) \right)^2 + \frac{96.0 \text{ lbs}}{32.174 \text{ FT/SEC}^2} V_{M \text{ ACT}}^2$$

$$22,762,163 = (.0406 + 2.9838) V_{M \text{ ACT}}^2$$

$$V_{M \text{ ACT}} = 2743 \text{ FT/SEC} \quad \text{ACTUAL} = 2710 \text{ FT/SEC}$$

II ADD INFLUENCE OF PROPELLANT ADDITIVES

$$V_M = U_M N R T B \sqrt{\frac{W_c}{W_p + W_A/2 + W_C/3}}$$

$$= 1.6300 (34005 \text{ FT/SEC}) \sqrt{\frac{26.0 \text{ lbs}}{96.0 \text{ lbs} + \left(\frac{40 \text{ lbs}}{2}\right) + \left(\frac{26.0 \text{ lbs}}{3}\right)}$$

$$= 2736.5 \text{ FT/SEC}$$

b) CORRECT FOR PROJECTILE SPIN ENERGY.

$$\frac{(96.0 \text{ lbs} + 2.0 \text{ lbs} + 13.0 \text{ lbs}) (2736.5 \text{ ft/SEC})^2}{32.174 \text{ ft/SEC}^2} = \left[(.1081 \text{ lbs-FT-SEC}^2) \left(\frac{2 \pi (12)}{20 (6.15)} \right)^2 + \frac{(96 + 2 + 13)}{32.174} \right] V_{M \text{ ACT}}^2$$

$$V_{M \text{ ACT}} = 2720.5 \text{ FT/SEC}$$

IMPULSE CALCULATION

$$\Delta = V_c + A_B L$$

$$RT_0 = RT_B - (\gamma - 1) \left[\frac{1}{2} + \left(\frac{1+\gamma}{2} \right) \frac{W_p}{W_c} \right] V$$

$$P_0 = \frac{W_c R T_0}{g \Delta} \left(1 + \frac{W_c}{G W_p} \right)$$

$$K = 1/7$$

$$\phi = \frac{2 \Delta}{A_B (\gamma - 1)} \left[\frac{\left(\frac{\gamma + 1}{2} \right)^{\frac{\gamma + 1}{\gamma - 1}}}{\gamma R T_0 \left(1 + \frac{W_c}{G W_p} \right)} \right]^{1/2}$$

$$P = P_0 \left(1 + \frac{z}{\phi} \right)^{2\gamma / (1 - \gamma)}$$

$$\text{GAS IMPULSE} = I_G = P_0 A_B \int \left(1 + \frac{z}{\phi} \right)^{2\gamma / (1 - \gamma)} dz$$

$$= P_0 A_B \left. \frac{\left(1 + \frac{z}{\phi} \right)^{\frac{2\gamma}{1 - \gamma} + 1}}{\left(\frac{2}{1 - \gamma} + 1 \right)} \right|_0^z$$

$$\frac{2\gamma + 1}{1 - \gamma} = \frac{2\gamma + 1 - \gamma}{1 - \gamma}$$

$$= \frac{P_0 A_B \phi \left(1 - \gamma \right) \left(1 + \frac{z}{\phi} \right)^{\frac{\gamma + 1}{1 - \gamma}}}{\left(\gamma + 1 \right)} \Big|_0^{\infty}$$

$$= \frac{\gamma + 1}{1 - \gamma}$$

$$= \frac{P_0 A_B \phi \left(1 - \gamma \right) \left(0 - 1 \right)}{\left(\gamma + 1 \right)}$$

$$= \frac{P_0 A_B \phi \left(\gamma - 1 \right)}{\left(\gamma + 1 \right)}$$

$$= \frac{W_c R T_0 A_B \left(1 + \frac{W_c}{G W_p} \right) 2 \Delta \left[\frac{\left(\frac{\gamma + 1}{2} \right)^{\frac{\gamma + 1}{\gamma - 1}}}{\gamma R T_0 \left(1 + \frac{W_c}{G W_p} \right)} \right]^{1/2} \left(\gamma - 1 \right)}{g A A_B (\gamma - 1) (\gamma + 1)}$$

$$= \left(\frac{W_c}{g} \right) (R T_0)^{1/2} \left(1 + \frac{W_c}{G W_p} \right)^{1/2} \left(\frac{2}{\gamma + 1} \right) \left[\frac{\left(\frac{\gamma + 1}{2} \right)^{\frac{\gamma + 1}{\gamma - 1}}}{\gamma} \right]^{1/2}$$

$$I_M = \frac{(W_p + W_a/2 + W_c/2) V_M}{g}$$

$$I_G = \left(\frac{W_c}{g} \right) (RT_0)^{1/2} \left(1 + \frac{W_c}{6W_p} \right)^{1/2} \left(\frac{2}{\gamma+1} \right) \left[\frac{(\gamma+1/2)^{\frac{\gamma+1}{\gamma-1}}}{\gamma} \right]^{1/2}$$

$$RT_0 = RT_B - (\gamma-1) \left[\frac{1}{6} + \left(\frac{\gamma-1}{2} \right) \frac{W_p}{W_c} \right] V_M^2$$

$$= 11,563,306 \text{ FT}^2/\text{SEC}^2 - (.238) \left[\frac{1}{6} + \left(\frac{1.4-1}{2} \right) \left(\frac{W_p}{W_c} \right) \right] V_M^2$$

$$RT_0 = 11,563,306 \text{ FT}^2/\text{SEC}^2 - (.238) \left[\frac{1}{6} + 4/7 \left(\frac{W_p}{W_c} \right) \right] V_M^2$$

$$I_G = 1.3627 \left(\frac{W_c}{g} \right) (RT_0)^{1/2} \left(1 + \frac{W_c}{6W_p} \right)^{1/2}$$

$$W_p = 96 \text{ lbs} \quad W_c = 26.0 \text{ lbs} \quad V_M = 2710 \text{ FT/SEC} \quad W_a = 4.0 \text{ lbs}$$

$$(RT_0)^{1/2} = 2,754 \text{ FT/SEC}$$

$$I_G = 3,100 \text{ lbs-SEC}$$

$$I_M = \frac{9,349 \text{ lbs-SEC}}{12,449 \text{ lbs-SEC}}$$

$$\dot{u} = \frac{au}{b+u}$$

$$V_M = 2710 \text{ FT/SEC}$$

$$U_M = 16.675 \text{ FT}$$

$$\ddot{u} = \frac{a\dot{u}}{(b+u)} + \frac{(-1)au\dot{u}}{(b+u)^2}$$

$$\ddot{u} = \frac{a\dot{u}(b+u-u)}{(b+u)^2} = \frac{a^2bu}{(b+u)^3} \left(\frac{u^2}{u^2}\right) \left(\frac{a}{a}\right)$$

$$\ddot{u} = \frac{b\dot{u}^3}{a^2u^2} \quad \ddot{u}_{\text{MAX}} = \frac{a^2b^2/2}{(2b/2)^3} = \frac{4a^2b^2}{27b^3} = \frac{4a^2}{27b}$$

$$\ddot{u}_{\text{EXIT}} = \frac{bV_M^3}{aU_M^2} (\omega_p + \omega_{ah} + \omega_{ch}) = P_0 AB$$

$$P_0 = \frac{W_c R T_0}{g \Delta} \left(1 + \frac{W_c}{G W_p}\right)$$

$$AB = 29.7057 \text{ in}^2$$

$$R T_0 = (2754 \text{ FT/SEC})^2$$

$$\Delta = 1147 \text{ in}^3 + 29.7057 \text{ in}^2 (200.1 \text{ in})$$

$$= 7091.111 \text{ in}^3$$

$$P_0 = 10,840.196 \text{ lbf/in}^2$$

$$W_c = 26 \text{ lbf}$$

$$W_p = 96 \text{ lbf}$$

$$766.8619 b = a$$

$$2710 \text{ ft/sec} = \frac{a \cdot 16.675 \text{ ft}}{(16.675 \text{ ft} + b)}$$

$$2710 \text{ ft/sec} (16.675 \text{ ft} + b) = (766.8619) b (16.675 \text{ ft})$$

$$b = 4.4842 \text{ ft}$$

$$a = 3438.768 \text{ ft/sec}$$

$$P_{\text{MAX}} = 45, 372.754 \text{ PSI}$$

Northern Ordnance Division

$$g = 32.174 \text{ FT/SEC}^2$$

$$V_c = 1147.0 \text{ IN}^3 \quad \checkmark$$

$$L = 200 \phi \text{ IN} \quad \checkmark$$

$$D_B = 6.15 \text{ IN} \quad \checkmark$$

$$A_B = 29.7057 \text{ IN}^2 \quad \checkmark$$

$$V_M = 2710 \text{ FT/SEC} \quad \checkmark$$

$$P_{MAX} = 47,500 \text{ PSI}$$

$$U_M = L/12 \quad \checkmark$$

$$P_c = .06 \text{ LB/IN}^3$$

$$RT_B = 4,312,800 \frac{\text{IN} \cdot \text{LB}}{\text{IN}^2}$$

$$* RT_B = RT_B * 386.087 / 144 \text{ (FT/SEC)}^2$$

$$\sqrt{RT_B} = 3400.5 \text{ FT/SEC}$$

$$11,663,400$$

$$\gamma = 1.2380$$

$$W_c = 26.0 \text{ LB}_f$$

$$W_a = 4.0 \text{ LB}_f$$

$$W_p = 96.0 \text{ LB}_f$$

$$D_1 = 2\pi / 20 * D_B$$

$$W_p = D_1 V_p$$

$$I_p = .1081 \text{ LB}_f \cdot \text{SEC}^2$$

$$K = 1/7$$

$$\Delta = V_c + A_B L$$

$$RT_0 = RT_B - (\gamma - 1) \left[\frac{1}{6} + \frac{(1+K)}{2} \right] \frac{W_p}{W_c} V_M^2$$

$$P_0 = \frac{W_c RT_0}{g \Delta 12} \left(\frac{1 + W_c}{6W_p} \right)$$

$$A_1 = \gamma + 1$$

$$A_2 = \gamma - 1$$

$$A_3 = A_1 / A_2$$

$$\phi = \frac{2\Delta}{A_B A_2} \left[\frac{(A_1/2) ** A_3}{\gamma RT_0 (1 + W_c/6W_p)} \right]^{1/2}$$

$$a = \frac{V_M^3 (W_p + W_c/2 + W_a/2)}{P_0 A_B U_M^2 g} b$$

$$V_M (U_M + b) = a U_M$$

$$a = \frac{V_M}{U_M} (U_M + b)$$

$$\frac{V_M}{U_M} (U_M + b) = \frac{V_M^3 (W_p + W_c/2 + W_a/2)}{P_0 A_B U_M^2 g} b$$

$$U_M = \left(\frac{V_M^3 (W_p + W_c/2 + W_a/2)}{P_0 A_B U_M g} - 1 \right) b$$

$$b = U_M / \left(\frac{V_M^3 (W_p + W_c/2 + W_a/2)}{P_0 A_B U_M g} - 1 \right)$$

$$a = \frac{V_M}{U_M} (U_M + b)$$

$$P_{MAX} = \frac{(W_p + W_c/2 + W_a/2) \cdot 4 a^2}{27 g A_B b}$$

$$u = \frac{a^2 b u}{(b+u)^3}$$

$$m_{\infty} = P_b A_B$$

$$P_b = \frac{m_{\infty}}{A_B} = \frac{(W_p + W_c/2 + W_a/2) a^2 b u}{g A_B (b+u)^3}$$

$$F_{AVE} U_M = \int_0^{U_M} F \delta u = P_b A_B = \frac{(W_p + W_c/2 + W_a/2) a^2 b}{g} \left(\frac{u \delta u}{(b+u)^3} \right)$$

FROM PAGE 413 STD MATHEMATICAL TABLES # 32

$$F_{AVE} U_M = \frac{(W_p + W_c/2 + W_a/2) a^2 b}{g} \left[\frac{-1}{(b+u)} + \frac{b}{2(b+u)^2} \right]_0^{U_M}$$

$$= \frac{(W_p + W_c/2 + W_a/2) a^2 b}{g} \left[\frac{-2(b+u) + b}{2(b+u)^2} \right]_0^{U_M} \quad b+u+u$$

$$= \frac{(W_p + W_c/2 + W_a/2) a^2 b}{g} \left[\frac{-b-2u}{2(b+u)^2} \right]_0^{U_M} - (b+2u)$$

$$= \frac{(W_p + W_c/2 + W_a/2) a^2 b}{g} \left[\frac{-(b+2U_M)}{2(b+U_M)^2} - \frac{-(-b)}{2b^2} \right]$$

$$= \frac{(W_p + W_c/2 + W_a/2) a^2 b}{2g} \left[\frac{-(b+2U_M)b^2 + (b+U_M)^2 b}{b^2(b+U_M)^2} \right]$$

$$= \frac{(W_p + W_c/2 + W_a/2) a^2 b}{2g} \left[\frac{-b^3 - 2U_M b^2 + b^3 + 2U_M b^2 + U_M^2 b}{b^2(b+U_M)^2} \right]$$

$$F_{AVE} U_M = \frac{(W_p + W_c/2 + W_a/2) a^2 b^2 U_M^2}{2g b^2 (b+U_M)^2}$$

$$F_{\text{gross}} = \frac{(W_p + W_c/2 + W_a/2) a^2 U_M}{2g (b + U_M)^2} = \frac{(W_p + W_c/2 + W_a/2) V_M^2}{2g U_M} = \frac{1}{2} \frac{M V^2}{D}$$

$$t_M = \frac{(W_p + W_c/2 + W_a/2) V_M}{g F_{\text{gross}}}$$

$$t_M = \frac{2(b + U_M)^2 V_M}{a^2 U_M} = \frac{2U_M}{V_M}$$

$$\frac{du}{dt} = \frac{au}{b+u}$$

$$\frac{(b+u) du}{a u} = dt$$

$$\int_{u_0}^u dt = \frac{1}{a} \left(b \int_{u_0}^u \frac{du}{u} + \int_{u_0}^u du \right)$$

$$t = \frac{1}{a} [b \ln u + u] \Big|_{u_0}^u$$

$$t = \frac{1}{a} [(b \ln u + u) - (b \ln u_0 + u_0)]$$

$$\frac{(b+U_M) 2U_M}{V_M} = b \ln U_M + U_M - b \ln u_0 - u_0 \quad t = t_M \quad U = U_M$$

$$2b + U_M - b \ln U_M = -b \ln u_0 - u_0$$

$$b(2 - \ln U_M) + U_M = \ln u_0$$

$$\frac{-(2 - \ln U_M + \frac{U_M}{b})}{e} = u_0$$

$$.0548 = u_0$$

ASSUME u_0 INFLUENCE IS
VERY SMALL

$\theta = 32.174^\circ/\text{sec}^2$
 $V_c = \text{CHAMBER VOLUME} = 1147.0 \text{ in}^3$
 $U_m = \text{PROJECTILE TRAVEL} = 200.110 = 16.675 \text{ ft}$
 $V_m = \text{MUZZLE VELOCITY} = 2710 \text{ ft/sec}$
 $A_b = \text{BORE AREA} = 29.7057 \text{ in}^2$
 $\rho_c = \text{PROPELLANT DENSITY} = .06 \text{ lb/in}^3$
 $R_i = \text{SPECIFIC IMPULS} = 11,563,305.7 \text{ (ft/sec)}$
 $W_c = \text{PROPELLANT WEIGHT} = 26.014 \text{ lb}$
 $W_p = \text{PROJECTILE WEIGHT} = 96.014 \text{ lb}$
 $W_a = \text{ADDITIVE WEIGHT} = 4.014 \text{ lb}$
 $W_{sp} = \text{PROJECTILE SPIN RATE} = 27/200 \text{ (rev/ft)}$
 $D_b = \text{BORE DIAMETER} = 6.15 \text{ in}$
 $Y_s = \text{SPECIFIC HEAT RATIO} = 1.238$
 $I_p = \text{PROJECTILE INERTIA} = .1081 \text{ lb-sec}^2$
 $K = .7$

$P_{max} = \text{MAX. CHAMBER PRESSURE} = 47,500 \text{ psi}$
 $\rho_o = \text{DENSITY OF OIL AT } P = 0.84 \text{ lb/in}^3 = 0.308 \text{ lb/in}^3$
 $B = \text{BULK MODULUS OF OIL} = 150,000 \text{ lb/in}^2$
 $W_{eff} = \text{WEIGHT INCLUDING COMBUSTION} = 4,000 \text{ lb}$

CALCULATION OF R_{TO}

$$R_{TO} = R_{TB} - (Y-1) \left[\frac{1}{6} + \left(\frac{1}{2} \right) \left(\frac{W_p}{W_c} \right) \right] V_m^2$$

CALCULATION OF Δ

$$\Delta = V_c + A_b U_m$$

CALCULATION OF ϕ

$$\phi = \frac{Z \Delta}{A_b (Y-1) \left[\frac{1}{6} + \left(\frac{1}{2} \right) \left(\frac{W_p}{W_c} \right) \right] V_m^2}$$

CALCULATION OF MUZZLE PRESSURE P_M

$$P_M = \frac{W_c R_{TO}}{g \Delta} \left(1 + \frac{V_m}{G_{imp}} \right)$$

CALCULATION OF W_{EFF}

$$W_{EFF} = (W_p + (W_a + W_c)/2)$$

CALCULATION OF a & b CONSTANTS

$$b = \frac{P_{max} g U_m^2}{V_m^2 W_{eff}} \quad b = \left(\frac{a}{V_m} - 1 \right) U_m$$

$$\frac{P_{max} g U_m a}{V_m^2 W_{eff}} = a - V_m$$

$$a = V_m / \left[1 - \frac{P_{max} g U_m}{V_m^2 W_{eff}} \right]$$

$$b = \left(\frac{1}{V_m} \left[1 - \frac{P_{max} g U_m}{V_m^2 W_{eff}} \right] - 1 \right) U_m$$

$$P_{MAX} = \frac{(W_{EFF})^2}{A_b g Z^2 b}$$

CALCULATION OF t_m MUZZLE EXIT TIME

$$t_m = \frac{Z U_m}{V_m}$$

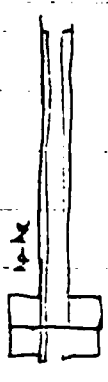

CALCULATION OF U_0

$$U_0 = e^{(g t_m - Z - U_m)}$$

CALCULATION OF F_{GAS}

$$F_{GAS} = \frac{(W_{eff})^2 a b U}{g (b + U^3)}$$

$F_{GUN} = W R \sin \theta$

$F_{FREE} = \mu W R \cos \theta$

F_{SENS}

PROJECTILE	XM795	XM795	M549A1	M107	M107	M483A1	M483A1
Wp (lb)	103.4	103.4	95.2	95.0	95.0	103.3	103.3
Ip. (lb-in)	575.3	575.3	501.0	499.2	499.2	540.0	540.0
It. (lb-in)	7008.4	7008.4	6488.0	4311.0	4311.0	5860.0	5860.0
CG (in FROM BASE)	11.47	11.47	12.82	9.45	9.45	13.2	13.2
CHARGE	M203	105PMP	105PMP	M3A1	M4A2	M3A1	M4A2
PROPELLANT	M30A1	M30A1	M30A1	M1	M1	M1	M1
ZONE	85			3	3	3	3
RT SPECIFIC IMPETUS (ft/sec)	1174E6	1174E6	1174E6	1013E6	1013E6	1013E6	1013E6
Wc (lb)	26.0	30.5	30.5	3.1	4.1	3.1	4.1
Y RATIO SPECIFIC HEATS	1.2380	1.2380	1.2380	1.2593	1.2593	1.2593	1.2593
Pc DENSITY (lb/in ³)	.06	.06	.06	.0567	.0567	.0567	.0567
W/msc (lb)	4.0	4.0	4.0	.4	.4	.4	.4
L PROJECTILE TRAVEL (in)	1985	1985	200.1	200.0	200.0	1985	198.5
Vc CHAMBER VOLUME (in ³)	1188	1188	1147	1151	1151	1188	1188
D BORE DIAMETER (in)	6.133	6.133	6.133	6.133	6.133	6.133	6.133
AB BORE AREA (in ²)	29.542	29.542	29.542	29.542	29.542	29.542	29.542
Pmax (PSI)	49,000	62,000	69,900	7,900	6200	8500	6600
Vm (FT/SEC)	2615	2880	2978	910	960	859	936
TEMP (°F)	70°F	145	145	70	70	70	70

(11)

SEAL FRICTION

90 DUROMETER / ON STEEL DISOGREN

 $\mu = .01 - .02$ BREAKAWAY

FRICTION SHOULD ACCOUNT FOR LESS THAN 5% OF ENERGY

FRICTIONAL FORCE ON SEALS

$$F = \pi D \mu (W_1 S + W_2 P)$$

F = FRICTIONAL LOAD, lbf / LINEAR INCH OF SEAL CONTACT

 μ = COEFFICIENT OF FRICTION W_1 = WIDTH OF SEAL IN CONTACT AS INSTALLED (IN) W_2 = WIDTH OF SEAL EXPOSED TO ENERGIZING PRESSURE (IN)

S = INSTALLED SEAT STRESS (PSI)

P = OPERATING PRESSURE (PSI)

 $\mu = .01 - .02$ USE .05 (BREAKAWAY) $W_1 = .5$ IN $W_2 = .25$ IN

S = 200 PSI (RUBBER) USE 400 PSI

 $P_s = 2500$ PSI $P_T = 200$ PSI

ROD SEALS

$$\begin{aligned} F_{RS} &= \pi D_r (.05) [4(.5 \text{ in})(400 \text{ lb}_f/\text{in}^2) + (.25 \text{ in})(2500 \text{ lb}_f/\text{in}^2 + 3(200 \text{ lb}_f/\text{in}^2))] \\ &= \pi D_r (.05) [1575 \text{ lb}_f/\text{in}] \\ &= 247.4 D_r \text{ lb}_f/\text{in} \end{aligned}$$

OIL PASSAGE SEALS

$$\begin{aligned} F_{PS} &= \pi D_r (.05) [2(.5)(400 \text{ lb}_f/\text{in}^2) + (.25 \text{ in})(2500 \text{ lb}_f/\text{in}^2 + 200 \text{ lb}_f/\text{in}^2)] \\ &= 168.9 D_{RS} \text{ lb}_f/\text{in} \end{aligned}$$

$$F_s = [247.4 D_R + 168.9 D_p] \text{ lbf/in}$$

ASSUME $D_R = 1.375 \text{ in}$
 $D_{P_{25}} = 1.000 \text{ in}$

$$F_s = \underline{510 \text{ lbf}}$$

GUN / SLIDE INTERFACE

$$F_{\text{GRAVITY}} = W \sin \theta = \underline{3,715 \text{ lbf}}$$

$$W = 3845 \text{ lbf}$$

$$\theta = 75^\circ$$

$$F_{\text{FG}} = \text{FORCE FRICTION GUN} = W \mu \cos \theta$$

$$= \underline{250 \text{ lbf}}$$

$$W = 4230 \text{ lbf}$$

$$\mu = .35$$

$$\theta = 75^\circ$$

$$\text{FORCE ACCELERATION} = \frac{1}{2} \ddot{x}_{\text{CR}} t^2 = 69.0$$

$$\ddot{x}_{\text{CR}} = 34.5 \text{ m/sec}^2$$

$$t = 2 \text{ sec}$$

$$\frac{1}{2} \ddot{x}_{\text{CR}} t^2 = 36 \text{ in}$$

$$\ddot{x}_{\text{CR}} = 72 \text{ m/sec}^2$$

$$t = 1 \text{ sec}$$

$$3845 \text{ lbf} \left(\frac{72}{306} \right) = \underline{720 \text{ lbf}}$$

$$\text{TOTAL FORCE NEEDED} = 510 + 3715 + 250 + 720 = 5,200 \text{ lbf}$$

$$\text{PRESSURE} = 2500 \text{ lbf/in}^2$$

$$A_P - A_R = 5,200 \text{ lbf} / 2500 \text{ lbf/in}^2 = 2.080 \text{ in}^2$$

STOW GUN

$$A_R = [510 \text{ lbf} + 3845 \text{ lbf} (.75)] / 2500 \text{ lbf/in}^2 = .5885 \text{ in}^2$$

$$D_R = .894 \text{ in}$$

$$\text{USE } D_R = 1.375$$

$$D_p = 2.25 \text{ in}$$

$$D_{\text{PASSAGE}} = 1.000$$

LIGHT WEIGHT TOWED HOWITZER RECOIL AND COUNTER-RECOIL CYLINDER WEIGHTS FOR VARIOUS DESIGN CRITERIA AND ALUMINUM-SiC METAL MATRIX MATERIAL

DESIGN * CRITERIA	RECOIL CYLINDER			COUNTER RECOIL CYLINDER	
	SECTION	WALL (in) THICKNESS	TOTAL WEIGHT (lbs)	WALL (in) THICKNESS	TOTAL (lbs) WEIGHT
YIELD STRENGTH OF ALUM-SiC 6061-T6 S.F. = 2 $\sigma_{ys} = 50,000$ psi	LARGE DIA.	.41	59.4	.38	42.9
	SMALL DIA.	.36		.31	
DESIGN FOR FATIGUE LIFE 30,000 CYCLES	LARGE DIA.	.35	50.9	.33	37.1
	SMALL DIA.	.31		.27	
7090-T6 ALUM-SiC S.F. = 2	LARGE DIA.	.37	52.7	.34	38.5
	SMALL DIA.	.32		.28	
* STRESSES CALCULATED FOR 4500 PSI			INTERNAL	HYDRAULIC	PRESSURE.
COMPOSITE WAAPPED			75		48

MPL
9-25-86.

RECOIL CYLINDER (BENDING)

$$I.D. = 4.000 \text{ IN}$$

$$O.D. = 4.1875$$

$$I = \frac{\pi [(4.1875 \text{ IN})^4 - (4.0 \text{ IN})^4]}{64} = 2.5271 \text{ IN}^4$$

$$Z = 2I / d_o = 2(2.5271 \text{ IN}^4) / 4.1875 \text{ IN} = 1.2070 \text{ IN}^3$$

$$A = \pi [(4.1875 \text{ IN})^2 - (4.000 \text{ IN})^2] / 4 = 1.2057 \text{ IN}^2$$

$$W = PAL (18.5)$$

18.5 G SHOCK LOAD

FIXED AT BOTH ENDS, UNIFORM LOAD

$$S_F = WL / 12Z$$

$$\delta_F = WL^3 / 384EI$$

$$S_F = 5,500 \text{ lbf/IN}^2$$

$$\delta_F = .034 \text{ IN}$$

STEEL

$$P = .283 \text{ lbf/IN}^3$$

$$E = 30 \times 10^6 \text{ lbf/IN}^2$$

$$L = 112.0 \text{ IN}$$

$$W = 707. \text{ lbf}$$

SUPPORTED AT BOTH ENDS, UNIFORM LOAD

$$S_S = \frac{WL}{8Z}$$

$$\frac{S_S}{S_F} = \frac{WL / 12Z}{WL / 8Z} = 1.5$$

$$S_S = 8,250 \text{ lbf}$$

$$\delta_S = \frac{5WL^3}{384EI}$$

$$\frac{\delta_S}{\delta_F} = \frac{(5WL^3 / 384EI)}{(WL^3 / 384EI)} = 5$$

$$\delta_S = .170 \text{ IN}$$

RECOILING MASS

GUN TUBE	2586 lbf
BREECH	495 lbf
THERMAL WARNING DEVICE	15 lbf
BAND ASSY.	86 lbf
AUTO PRIMER	45 lbf
MUZZLE BRAKE	158 lbf
BREECH ACTUATOR ASSY.	18 lbf
BREECH VALVE	2 lbf
4 RECOIL PISTONS	100 ← 70 lbf
2 WAYS (1 x 4 x 220) 2 (.1)	180 lbf
(COLLAR $\pi/4 [(13.75 \text{ in})^2 - (9.375 \text{ in})^2] (4.0) (.1)$	35 lbf
2 COLLARS $\pi/4 [(13.75 \text{ in})^2 - (8.0 \text{ in})^2] (4.0) (.1) 2$	80 lbf
3 COLLARS $\pi/4 [(13.75 \text{ in})^2 - (10.75 \text{ in})^2] (4.0) (.1) 3$	75 lbf
	<hr/> 3,845 lbf

X_1 (FT)	F_1 (LBS)	$(\frac{dF_1}{dX_1})$ ($\frac{LBS}{FT}$)	X_2 (FT)	F_2 (LBS)	$(\frac{dF_2}{dX_2})$ ($\frac{LBS}{FT}$)	C_1 ($\frac{LBS}{FT}$)	C_2 ($\frac{LBS}{FT}$)	C_3 ($\frac{LBS}{FT}$)	C_4 ($\frac{LBS}{FT}$)	$(\frac{dC_4}{dX})$	F (LBS)
① 0	5,000	0	1.0	45,000	80,000	80,000	80,000	5,000	$C_1 X^2/2 + C_2 X + C_3$	$80,000 X$	$C_1 X^2/6 + C_2 X^2/2 + C_3 X + C_4$
② 1.0	45,000	80,000	1.50	75,000	0	-960,000	1,040,000	165,000	$(\frac{960X^2 + 1040X - 430}{2}) 1000$	$80,000 X$	$(\frac{960X^3 + 1040X^2 - 430X + 165}{2}) 1000$
③ 1.5	75,000	0	3.25	75,000	0	0	0	75,000	0	0	75,000
④ 3.25	75,000	0	4.5	65,000	-10,000	23,040	-97,280	194,480	-175,120	$(\frac{23,040X^2 - 97,280X + 194,480}{2}) 1000$	$(\frac{23,040X^3 - 97,280X^2 + 194,480X - 175,120}{2}) 1000$
⑤ 4.5	65,000	-10,000	8.5	25,000	-10,000	0	0	-10,000	119,000	-10,000	-10,000

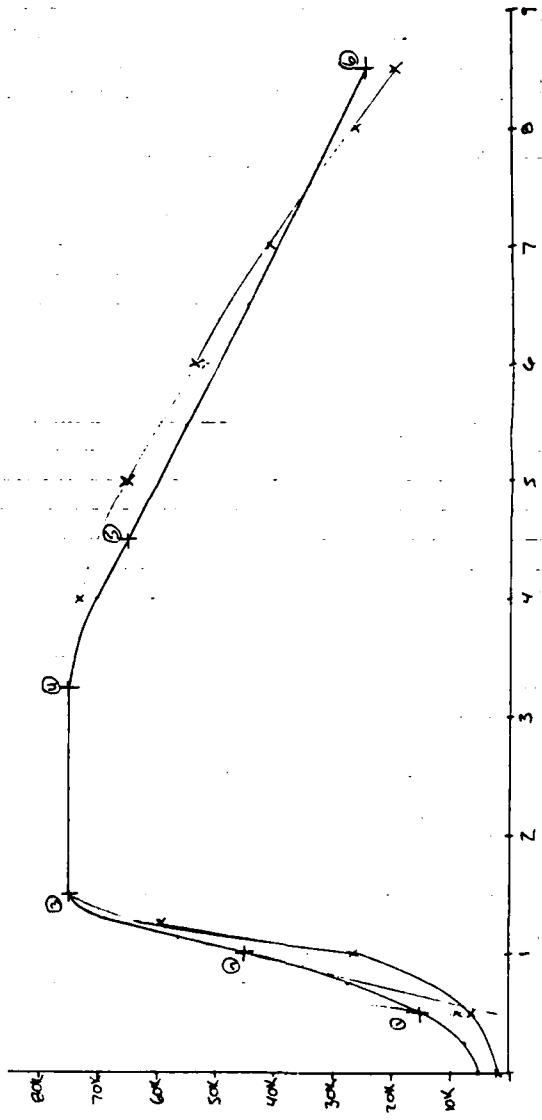

$\frac{dF}{dX} = 119,000$

$$x_1 \leq x \leq x_2$$

$$\partial^2 F / \partial x^2 = c_1 x + c_2$$

$$\partial F / \partial x = c_1 x^2 / 2 + c_2 x + c_3$$

$$x = x_1$$

$$x = x_2$$

$$\begin{aligned} \partial F / \partial x &= (\partial F / \partial x)_1 \\ \partial F / \partial x &= (\partial F / \partial x)_2 \end{aligned}$$

$$\text{I) } (\partial F / \partial x)_1 = c_1 x_1^2 / 2 + c_2 x_1 + c_3$$

$$\text{II) } (\partial F / \partial x)_2 = c_1 x_2^2 / 2 + c_2 x_2 + c_3$$

$$\text{II-I) } (\partial F / \partial x)_2 - (\partial F / \partial x)_1 = c_1 / 2 (x_2^2 - x_1^2) + c_2 (x_2 - x_1)$$

$$\underline{\underline{c_2 = [(\partial F / \partial x)_2 - (\partial F / \partial x)_1 - c_1 / 2 (x_2^2 - x_1^2)] / (x_2 - x_1)}}$$

$$\text{I) } (\partial F / \partial x)_1 = c_1 x_1^2 / 2 + c_2 x_1 + c_3$$

$$c_3 = (\partial F / \partial x)_1 - c_1 x_1^2 / 2 - c_2 x_1$$

$$c_3 = (\partial F / \partial x)_1 - c_1 x_1^2 / 2 - [(\partial F / \partial x)_2 - (\partial F / \partial x)_1 - c_1 / 2 (x_2^2 - x_1^2)] x_1 / (x_2 - x_1)$$

$$c_3 = [(\partial F / \partial x)_1 (x_2 - x_1) - \frac{c_1 x_1^2 (x_2 - x_1)}{2} - (\partial F / \partial x)_2 x_1 + (\partial F / \partial x)_1 x_1 + \frac{c_1 (x_2^2 - x_1^2) x_1}{2}] / (x_2 - x_1)$$

$$\underline{\underline{c_3 = [(\partial F / \partial x)_1 x_2 - (\partial F / \partial x)_2 x_1 + (c_1 / 2) x_1 x_2 (x_2 - x_1)] / (x_2 - x_1)}}$$

$$\partial F / \partial x = c_1 x^2 / 2 + c_2 x + c_3$$

$$F = c_1 x^3 / 6 + c_2 x^2 / 2 + c_3 x + c_4$$

$$x = x_1$$

$$F = F_1$$

$$x = x_2$$

$$F = F_2$$

$$\text{III) } F_1 = c_1 x_1^3 / 6 + c_2 x_1^2 / 2 + c_3 x_1 + c_4$$

$$\text{IV) } F_2 = c_1 x_2^3 / 6 + c_2 x_2^2 / 2 + c_3 x_2 + c_4$$

$$\text{-III) } F_2 - F_1 = (c_1 / 6) (x_2^3 - x_1^3) + (c_2 / 2) (x_2^2 - x_1^2) + c_3 (x_2 - x_1)$$

$$F_2 - F_1 = \frac{C_1(x_2^3 - x_1^3)}{6} + \frac{[(\partial F/\partial x)_2 - (\partial F/\partial x)_1 - C_1/2(x_2^2 - x_1^2)](x_2 - x_1)}{2(x_2 - x_1)} + \frac{[(\partial F/\partial x)_1 x_2 - (\partial F/\partial x)_2 x_1 + (C_1/2)x_1(x_2^2 - x_1^2)](x_2 - x_1)}{(x_2 - x_1)}$$

$$F_2 - F_1 = \frac{C_1(x_2^3 - x_1^3)}{6} + \frac{[(\partial F/\partial x)_2 - (\partial F/\partial x)_1 - C_1/2(x_2^2 - x_1^2)](x_2 + x_1)}{2} + \frac{[(\partial F/\partial x)_1 x_2 - (\partial F/\partial x)_2 x_1 + (C_1/2)x_1(x_2^2 - x_1^2)](x_2 - x_1)}{(x_2 - x_1)}$$

$$F_2 - F_1 = C_1 \left[\frac{(x_2^3 - x_1^3)}{6} - \frac{(x_2^3 - x_1^2 x_2 + x_2^2 x_1 - x_1^3)}{4} + \frac{(x_2^2 x_1 - x_2 x_1^2)}{2} \right] + \frac{[(\partial F/\partial x)_2 + (\partial F/\partial x)_1](x_2 - x_1)}{2}$$

$$F_2 - F_1 = \frac{C_1}{12} [2x_2^3 - 2x_1^3 - 3x_2^3 + 3x_1^2 x_2 - 3x_2^2 x_1 + 3x_1^3 + 6x_2^2 x_1 - 6x_2 x_1^2] + \frac{[(\partial F/\partial x)_2 + (\partial F/\partial x)_1](x_2 - x_1)}{2}$$

$$F_2 - F_1 = (C_1/12) [-x_2^3 + x_1^3 + 3x_2^2 x_1 - 3x_1^2 x_2] + \frac{[(\partial F/\partial x)_2 + (\partial F/\partial x)_1](x_2 - x_1)}{2}$$

$$C_1 = \frac{[F_2 - F_1 - \frac{[(\partial F/\partial x)_2 + (\partial F/\partial x)_1](x_2 - x_1)}{2}](12)}{(x_1 - x_2)^3} \quad \text{lb}_f/\text{FT}^3$$

$$C_2 = \frac{[(\partial F/\partial x)_2 - (\partial F/\partial x)_1](x_2 - x_1) - C_1(x_2 + x_1)/2}{1} \quad \text{lb}_f/\text{FT}^2$$

$$C_3 = \frac{[(\partial F/\partial x)_1 x_2 - (\partial F/\partial x)_2 x_1](x_2 - x_1) + C_1 x_2 x_1/2}{1} \quad \text{lb}_f/\text{FT}$$

OR

$$C_3 = (\partial F/\partial x)_1 - C_1 x_1^2/2 - C_2 x_1$$

$$C_4 = F_1 - C_1 x_1^3/6 - C_2 x_1^2/2 - C_3 x_1$$

$$F = C_1 x^3/6 + C_2 x^2/2 + C_3 x + C_4$$

$$\frac{\partial F}{\partial x} = C_1 x^2/2 + C_2 x + C_3$$

$$C_1 = [F_2 - F_1 - ((\partial F / \partial x)_2 + (\partial F / \partial x)_1)(x_2 - x_1)/2] (1/2) / (x_1 - x_2)^3 \quad \mu_f / FT^3$$

$$C_2 = [(\partial F / \partial x)_2 - (\partial F / \partial x)_1] / (x_2 - x_1) - C_1(x_2 + x_1)/2 \quad \mu_f / FT^2$$

$$C_3 = (\partial F / \partial x)_1 - C_1 x_1^2 / 2 - C_2 x_1$$

$$C_4 = F_1 - C_1 x_1^3 / 6 - C_2 x_1^2 / 2 - C_3 x_1$$

$$F = C_1 x^3 / 6 + C_2 x^2 / 2 + C_3 x + C_4$$

$$\partial F / \partial x = C_1 x^2 / 2 + C_2 x + C_3$$

```
TTTTTTTTTT
TTTTTTTTTT
TTTTTTTTTT
```

```
111111111111111111111111111111111111111111111111111111111111111111111111111111111111111
Digital Equipment Corporation - VAX/VMS Version V4.4
111111111111111111111111111111111111111111111111111111111111111111111111111111111111111
```

```
TTTTTTTTTT
TTTTTTTTTT
TTTTTTTTTT
```

27

```

M   M   222   000   EEEEE   222   000
MM  MM  2    2   0   0   E      2   2   0   0
M   M   2    2   0   00  E      2   2   0   00
M   M   2    0   0   0   EEEE   2   0   0   0
M   M   2    00  0   E      2   00  0
M   M   2    0   0   E      2   0   0
M   M   2222  000  EEEEE  2222  000

```

```

OOOOOO  RRRRRRRR  IIIIII  FFFFFFFFFF  IIIIII
OOOOOO  RRRRRRRR  IIIIII  FFFFFFFFFF  IIIIII
OO    OO  RR      RR      II      FF      II
OO    OO  RR      RR      II      FF      II
OO    OO  RR      RR      II      FF      II
OO    OO  RR      RR      II      FF      II
OO    OO  RRRRRRRR  II      FFFFFFFF  II
OO    OO  RRRRRRRR  II      FFFFFFFF  II
OO    OO  RR  RR    II      FF      II
OO    OO  RR  RR    II      FF      II
OO    OO  RR  RR    II      FF      II
OO    OO  RR  RR    II      FF      II
OOOOOO  RR      RR  IIIIII  FF      IIIIII
OOOOOO  RR      RR  IIIIII  FF      IIIIII

```

```

FFFFFFFFFF  OOOOOO  RRRRRRRR  ;;;  888888
FFFFFFFFFF  OOOOOO  RRRRRRRR  ;;;  888888
FF          OO      OO  RR      RR  ;;;  88      88
FF          OO      OO  RR      RR  ;;;  88      88
FF          OO      OO  RR      RR  ;;;  88      88
FF          OO      OO  RR      RR  ;;;  88      88
FFFFFFFFFF  OO      OO  RRRRRRRR  ;;;  888888
FFFFFFFFFF  OO      OO  RRRRRRRR  ;;;  888888
FF          OO      OO  RR  RR    ;;;  88      88
FF          OO      OO  RR  RR    ;;;  88      88
....      FF          OO      OO  RR  RR    ;;  88      88
....      FF          OO      OO  RR  RR    ;;  88      88
....      FF          OOOOOO  RR  RR    ;;  888888
....      FF          OOOOOO  RR  RR    ;;  888888

```

File HSC000\$DUA9:[M20.IRELAND JV.VMS]ORIFI.FOR;8 (2234,6,2), last revised on 4-MAR-1987 10:34, is a 8 block sequential file owned by UIC [M20,IRELAND JV]. The records are variable length with implied (CR) carriage control. The longest record is 70 bytes.

Job AODAT (375) queued to LN on 24-APR-1987 11:31 by user M20E20, UIC [M20,IRELAND JV], under account M22 at priority 100, started on printer _VENUS\$TXA6: on 24-APR-1987 11:34 from queue TXA6.

```
TTTTTTTTTT
TTTTTTTTTT
TTTTTTTTTT
```

```
111111111111111111111111111111111111111111111111111111111111111111111111111111111111111
Digital Equipment Corporation - VAX/VMS Version V4.4
111111111111111111111111111111111111111111111111111111111111111111111111111111111111111
```

```
TTTTTTTTTT
TTTTTTTTTT
TTTTTTTTTT
```

```

VC=1147.
UM=16.675
DB=6.15
WP=96.
WC=28.
WA=4.
PRINT 5
5 FORMAT(//,1X,'MUZZLE VELOCITY(FT/SEC)=?')
READ(6,*) VM
VM=2710.
RHOC=.06
RTB=11563400.
GAMMA=1.238
CK=1./7.
RL=8.75
DRP=3.
DRR=2.
DCRP=3.
DCRR=2.25
P0=3000.
V0=7000.
CK2=1.3
WR=3800.
BETA=.7
BULK=150000.
RHOIL=.0308
G=32.174
PI=3.141592
AB=PI*DB*DB/4.
D=VC+AB*UM*12.
AR=PI*(DRP*DRP-DRR*DRR)/4.
ACR=PI*(DCRP*DCRP-DCRR*DCRR)/4.
GAMAM=GAMMA-1.
GAMAP=GAMMA+1.
GAMA1=GAMAP/GAMAM
GAMA2=2.*GAMMA/(1.-GAMMA)
RATIO=1.+WC/(6.*WP)
RTO=RTB-GAMAM*(1./6.+(1.+CK)*WP/(2.*WC))*VM*VM
SIG=D*SQRT(((GAMAP/2.)*GAMA1)/(GAMMA*RTO*RATIO))/(AB*GAMAM*6.)
PM=WC*RTO*RATIO*12./(G*D)
C WRITE (*,'(5F13.4)') PM,RATIO,RTO,SIG,D
WEFF=WP+(WC+WA)/2.
A=VM/(1.-(PM*AB*G*UM)/(VM*VM*WEFF))
B=((A/VM)-1.)*UM
TM=2.*UM/VM
U0=EXP(LOG(UM)-2.-UM/B)
XR=0.
XRD=0.
T=0.
U=U0
DT=.001
XRK=0.
XRDL=0.
50 C1=-1.
C2=1.
C3=-1.
DELXR=0.
DELXRD=0.
DO 300 I=1,4
C1=C1+2.*C2
C2=C2-.5
D1=1.5-C1*.5+C3

```

```

C3=0.
XREFF=XR+D1*XRK
XRDEFF=XRD+D1*XRDL
XRK=DT*XRDEFF
IF(T.GT.TM) GO TO 100
DELT=D1*DT/2.
VP=A*U/(B+U)
BB=B+U-(VP+A)*DELT
CC=-((VP+A)*U+VP*B)*DELT
DELU=(-BB+SQRT(BB*BB-4.*CC))/2.
DELT2=(B*LOG(1.+DELU/U)+DELU)/A
UEFF=U+DELU+(D1*DT-DELT2)*A*(U+DELU)/(B+U+DELU)
FGAS=(WEFF/G)*A*A*B*UEFF/(B+UEFF)**3.
GO TO 200
100 TEFF=T-TM+D1*DT
FGAS=PM*AB*(1.-BETA)*(1.+TEFF/SIG)**GAMA2
200 IF(XREFF.LT.1.) GO TO 250
IF(XREFF.LT.1.5) GO TO 260
IF(XREFF.LT.3.25) GO TO 270
IF(XREFF.LT.4.5) GO TO 280
IF(XREFF.LT.8.5) GO TO 290
GO TO 500
250 FR=40000.*XREFF*XREFF+5000.
GO TO 295
260 FR=(-160.*(XREFF**3.)+520.*XREFF*XREFF-480.*XREFF+165.)*1000.
GO TO 295
270 FR=75000.
GO TO 295
280 FR=(3.84*(XREFF**3.)-48.64*XREFF**2.+194.48*XREFF-175.12)*1000.
GO TO 295
290 FR=-10000.*XREFF+110000.
295 XRDL=DT*G*(FGAS-FR)/WR
DELXR=DELXR+C1*XRK
DELXRD=DELXRD+C1*XRDL
300 CONTINUE
XR=XR+DELXR/6.
XRD=XRD+DELXRD/6.
U=UEFF
T=T+DT
IF(XR.LT.1.) GO TO 350
IF(XR.LT.1.5) GO TO 360
IF(XR.LT.3.25) GO TO 370
IF(XR.LT.4.5) GO TO 380
IF(XR.LT.8.5) GO TO 390
GO TO 500
350 FR=40000.*XR*XR+5000.
DFDX=80000.*XR
GO TO 400
360 FR=(-160.*(XR**3.)+520.*XR*XR-480.*XR+165.)*1000.
DFDX=(-480.*XR*XR+1040.*XR-480.)*1000.
GO TO 400
370 FR=75000.
DFDX=0.
GO TO 400
380 FR=(3.84*(XR**3.)-48.64*XR*XR+194.48*XR-175.12)*1000.
DFDX=(11.52*XR*XR-97.28*XR+194.48)*1000.
GO TO 400
390 FR=(-10000.*XR+110000.)
DFDX=-10000.
400 ER=1.
IF(XR.LT..5) ER=0.
DV=ACR*(XR+ER*(XR-.5))*12.

```

```
FCR=P0*ACR*(1.+ER)/(1.-DV/V0)**CK2
DFCRDX=FCR*CK2*12.*ACR*(1.+ER)/(V0-DV)
RECOIL=(FR-FCR)/2.
IF(RECOIL.LE.0.) RECOIL=1.
P=RECOIL/AR
DFRDX=DFDX-DFCRDX
DPDX=DFRDX/(2.*AR)
DPDT=DPDX*XRD
V=AR*(RL-XR)*12.
AO=(-DPDT*V/BULK+AR*XRD*12.)/(115.5*SQRT(P))
IF(AO.GT.1.75) AO=1.75
IF(AO.LT.0.) AO=0.
C   PRINT 450,T,XR,AO,XRD,P,FR
C 450 FORMAT(3X,F4.3,4X,F5.3,4X,F9.7,4X,F5.2,4X,F6.0,4X,F7.0)
    WRITE (*,'(1X,F7.0)') FR
    WRITE (*,'(1X,F5.3)') XR
    IF(XRD.LT.0.) GO TO 500
    IF(XR.GT.8.75) GO TO 500
    GO TO 50
500 STOP
    END
```

000000000
000000000
000000000

11
Digital Equipment Corporation - VAX/VMS Version V4.4
11

000000000
000000000
000000000

M	M	222	000	EEEE	222	000
MM	MM	2 2	0 0	E	2 2	0 0
M M M		2	0 00	E	2	0 00
M	M	2	0 0 0	EEEE	2	0 0 0
M	M	2	00 0	E	2	00 0
M	M	2	0 0	E	2	0 0
M	M	2222	000	EEEE	2222	000

AAAAAA	AAAAAA	OOOOOO	OOOOOO	DDDDDDDD	DDDDDDDD	AAAAAA	AAAAAA	TTTTTTTTTT	TTTTTTTTTT
AA	AA	OO	OO	DD	DD	AA	AA	TT	TT
AA	AA	OO	OO	DD	DD	AA	AA	TT	TT
AA	AA	OO	OO	DD	DD	AA	AA	TT	TT
AA	AA	OO	OO	DD	DD	AA	AA	TT	TT
AA	AA	OO	OO	DD	DD	AA	AA	TT	TT
AAAAA	AAAAA	OO	OO	DD	DD	AAAAA	AAAAA	TT	TT
AAAAA	AAAAA	OO	OO	DD	DD	AAAAA	AAAAA	TT	TT
AA	AA	OO	OO	DD	DD	AA	AA	TT	TT
AA	AA	OO	OO	DD	DD	AA	AA	TT	TT
AA	AA	OOOOO	OOOOO	DDDDDDD	DDDDDDD	AA	AA	TT	TT
AA	AA	OOOOO	OOOOO	DDDDDDD	DDDDDDD	AA	AA	TT	TT

FFFFFFFFF	OOOOO	RRRRRRR	;;;;	33333		
FFFFFFFFF	OOOOO	RRRRRRR	;;;;	33333		
FF	OO	RR	RR	33	33	
FF	OO	RR	RR	33	33	
FF	OO	RR	RR		33	
FF	OO	RR	RR		33	
FFFFFFFFF	OO	RRRRRRR	;;;;	33		
FFFFFFFFF	OO	RRRRRRR	;;;;	33		
FF	OO	RR	RR		33	
FF	OO	RR	RR		33	
.... FF	OO	RR	RR	;;	33	33
.... FF	OO	RR	RR	;;	33	33
.... FF	OOOOO	RR	RR	;;	33333	
.... FF	OOOOO	RR	RR	;;	33333	

File HSC000\$DUA9:(M20.IRELAND JV.VMS)AODAT.FOR;3 (2183,18,2), last revised on 4-MAR-1987 09:26, is a 8 block sequential file owned by UIC [M20, IRELAND JV]. The records are variable length with implied (CR) carriage control. The longest record is 70 bytes.

Job AODAT (375) queued to LN on 24-APR-1987 11:31 by user M20E20, UIC [M20, IRELAND JV], under account M22 at priority 100, started on printer VENUS\$TXA6: on 24-APR-1987 11:31 from queue TXA6.

000000000
000000000
000000000

11
Digital Equipment Corporation - VAX/VMS Version V4.4
11

000000000
000000000
000000000

```

VC=1147.
UM=16.675
DB=6.15
WP=96.
WC=28.
WA=4.
VM=2710.
RHOC=.06
RTB=11563400.
GAMMA=1.238
CK=1./7.
RL=8.75
DRP=3.
DRR=2.
DCRP=3.
DCRR=2.25
P0=3000.
V0=7000.
CK2=1.3
WR=3800.
BETA=.7
BULK=150000.
RHOIL=.0308
G=32.174
PI=3.141592
AB=PI*DB*DB/4.
D=VC+AB*UM*12.
AR=PI*(DRP*DRP-DRR*DRR)/4.
ACR=PI*(DCRP*DCRP-DCRR*DCRR)/4.
GAMAM=GAMMA-1.
GAMAP=GAMMA+1.
GAMA1=GAMAP/GAMAM
GAMA2=2.*GAMMA/(1.-GAMMA)
RATIO=1.+WC/(6.*WP)
RTO=RTB-GAMAM*(1./6.+(1.+CK)*WP/(2.*WC))*VM*VM
SIG=D*SQRT(((GAMAP/2.)*GAMA1)/(GAMMA*RTO*RATIO))/(AB*GAMAM*6.)
PM=WC*RTO*RATIO*12./(G*D)
WRITE (*,'(5F13.4)') PM,RATIO,RTO,SIG,D
WEFF=WP+(WC+WA)/2.
A=VM/(1.-(PM*AB*G*UM)/(VM*VM*WEFF))
B=((A/VM)-1.)*UM
TM=2.*UM/VM
U0=EXP(LOG(UM)-2.-UM/B)
XR=0.
XRD=0.
T=0.
U=U0
DT=.001
XRK=0.
XRDL=0.
DO 300 I=1,4
C1=C1+2.*C2
C2=C2-.5
D1=1.5-C1*.5+C3
C3=0.
XREFF=XR+D1*XRK
XRDEFF=XRD+D1*XRDL

```

C

50

```

XRK=DT*XRDEFF
IF(T.GT.TM) GO TO 100
DELT=D1*DT/2.
VP=A*U/(B+U)
BB=B+U-(VP+A)*DELT
CC=-((VP+A)*U+VP*B)*DELT
DELU=(-BB+SQRT(BB*BB-4.*CC))/2.
DELT2=(B*LOG(1.+DELU/U)+DELU)/A
UEFF=U+DELU+(D1*DT-DELT2)*A*(U+DELU)/(B+U+DELU)
FGAS=(WEFF/G)*A*A*B*UEFF/(B+UEFF)**3.
GO TO 200
100 TEFF=T-TM+D1*DT
FGAS=PM*AB*(1.-BETA)*(1.+TEFF/SIG)**GAMA2
200 IF(XREFF.LT.1.) GO TO 250
IF(XREFF.LT.1.5) GO TO 260
IF(XREFF.LT.3.25) GO TO 270
IF(XREFF.LT.4.5) GO TO 280
IF(XREFF.LT.8.5) GO TO 290
GO TO 500
250 FR=40000.*XREFF*XREFF+5000.
GO TO 295
260 FR=(-160.*(XREFF**3.)+520.*XREFF*XREFF-480.*XREFF+165.)*1000.
GO TO 295
270 FR=75000.
GO TO 295
280 FR=(3.84*(XREFF**3.)-48.64*XREFF**2.+194.48*XREFF-175.12)*1000.
GO TO 295
290 FR=-10000.*XREFF+110000.
295 XRDL=DT*G*(FGAS-FR)/WR
DELXR=DELXR+C1*XRK
DELXRD=DELXRD+C1*XRDL
300 CONTINUE
XR=XR+DELXR/6.
XRD=XRD+DELXRD/6.
U=UEFF
T=T+DT
IF(XR.LT.1.) GO TO 350
IF(XR.LT.1.5) GO TO 360
IF(XR.LT.3.25) GO TO 370
IF(XR.LT.4.5) GO TO 380
IF(XR.LT.8.5) GO TO 390
GO TO 500
350 FR=40000.*XR*XR+5000.
DFDX=80000.*XR
GO TO 400
360 FR=(-160.*(XR**3.)+520.*XR*XR-480.*XR+165.)*1000.
DFDX=(-480.*XR*XR+1040.*XR-480.)*1000.
GO TO 400
370 FR=75000.
DFDX=0.
GO TO 400
380 FR=(3.84*(XR**3.)-48.64*XR*XR+194.48*XR-175.12)*1000.
DFDX=(11.52*XR*XR-97.28*XR+194.48)*1000.
GO TO 400
390 FR=(-10000.*XR+110000.)
DFDX=-10000.
400 ER=1.
IF(XR.LT..5) ER=0.
DV=ACR*(XR+ER*(XR-.5))*12.
FCR=P0*ACR*(1.+ER)/(1.-DV/V0)**CK2
DFCRDX=FCR*CK2*12.*ACR*(1.+ER)/(VO-DV)
RECOIL=(FR-FCR)/2.

```

```
IF(RECOIL.LE.0.) RECOIL=1.
P=RECOIL/AR
DFRDX=DFDX-DFCRDX
DPDX=DFRDX/(2.*AR)
DPDT=DPDX*XRD
V=AR*(RL-XR)*12.
AO=(-DPDT*V/BULK+AR*XRD*12.)/(115.5*SQRT(P))
IF(AO.GT.1.75) AO=1.75
IF(AO.LT.0.) AO=0.
IF(XR.LT.2.9) GO TO 475
PRINT 450,XR
450 FORMAT(1X,F5.3)
PRINT 460,AO
460 FORMAT(1X,F5.4)
C   WRITE (*,'(1X,F7.0)') FR
C   WRITE (*,'(1X,F5.3)') XR
475 IF(XRD.LT.0.) GO TO 500
IF(XR.GT.8.75) GO TO 500
GO TO 50
500 STOP
END
```

$$\text{INPUT IMPULSE} = 12,500 \text{ lbf-SEC}$$

$$\text{AT MUZZLE EXIT} = [96 + (28+4)/2] \text{ lbf} (2710 \text{ ft/sec}) / 32.174 \text{ ft/sec}^2 = 9433.704$$

$$\text{GAS IMPULSE} = (1-.7) (12,500 - 9433.704) \text{ lbf-SEC} = 919.889 \text{ lbf-SEC}$$

$$\text{EFFECTIVE IMPULSE} = 10,353.593 \text{ lbf-SEC}$$

$$\text{VELOCITY} = I/M = 87.662 \text{ FT/SEC}$$

$$\begin{aligned} \text{ENERGY} &= I^2/2M = (10,353.593 \text{ lbf-SEC})^2 (32.174 \text{ FT/SEC}^2) / (2(3800 \text{ lbf})) \\ &= 453,809.539 \text{ FT-lbf} \end{aligned}$$

$$\textcircled{1} \int_0^1 (40x^2 + 5) 1000 \delta x = \left(\frac{40}{3} x^3 + 5x \right) 1000 \Big|_0^1 = \underline{18,333.3 \text{ FT-lbf}}$$

$$\textcircled{2} \int_1^{1.5} \left(\frac{-960x^3}{6} + \frac{1040x^2}{2} - 480x + 165 \right) 1000 \delta x = \left(-40x^4 + \frac{520x^3}{3} - 240x^2 + 165x \right) 1000 \Big|_1^{1.5} = \underline{31,666.666 \text{ FT-lbf}}$$

$$\textcircled{3} \int_{1.5}^{3.25} 75,000 \delta x = 75,000x \Big|_{1.5}^{3.25} = \underline{131,250 \text{ FT-lbf}}$$

$$\textcircled{4} \int_{3.25}^{4.5} \left(\frac{23.04x^3}{6} - \frac{97.28x^2}{2} + 194.48x - 175.12 \right) 1000 \delta x = \left(\frac{96x^4}{3} - \frac{48.64x^3}{3} + 97.24x^2 - 175.12x \right) 1000 \Big|_{3.25}^{4.5} = \underline{88,802.083 \text{ FT-lbf}}$$

$$\textcircled{5} \int_{4.5}^{8.5} (-10,000x + 110,000) \delta x = -5000x^2 + 110,000x \Big|_{4.5}^{8.5} = \underline{180,000 \text{ FT-lbf}}$$

$$\text{(TOTAL ENERGY = } \underline{\underline{450,052.083 \text{ FT-lbf}}}$$

LE

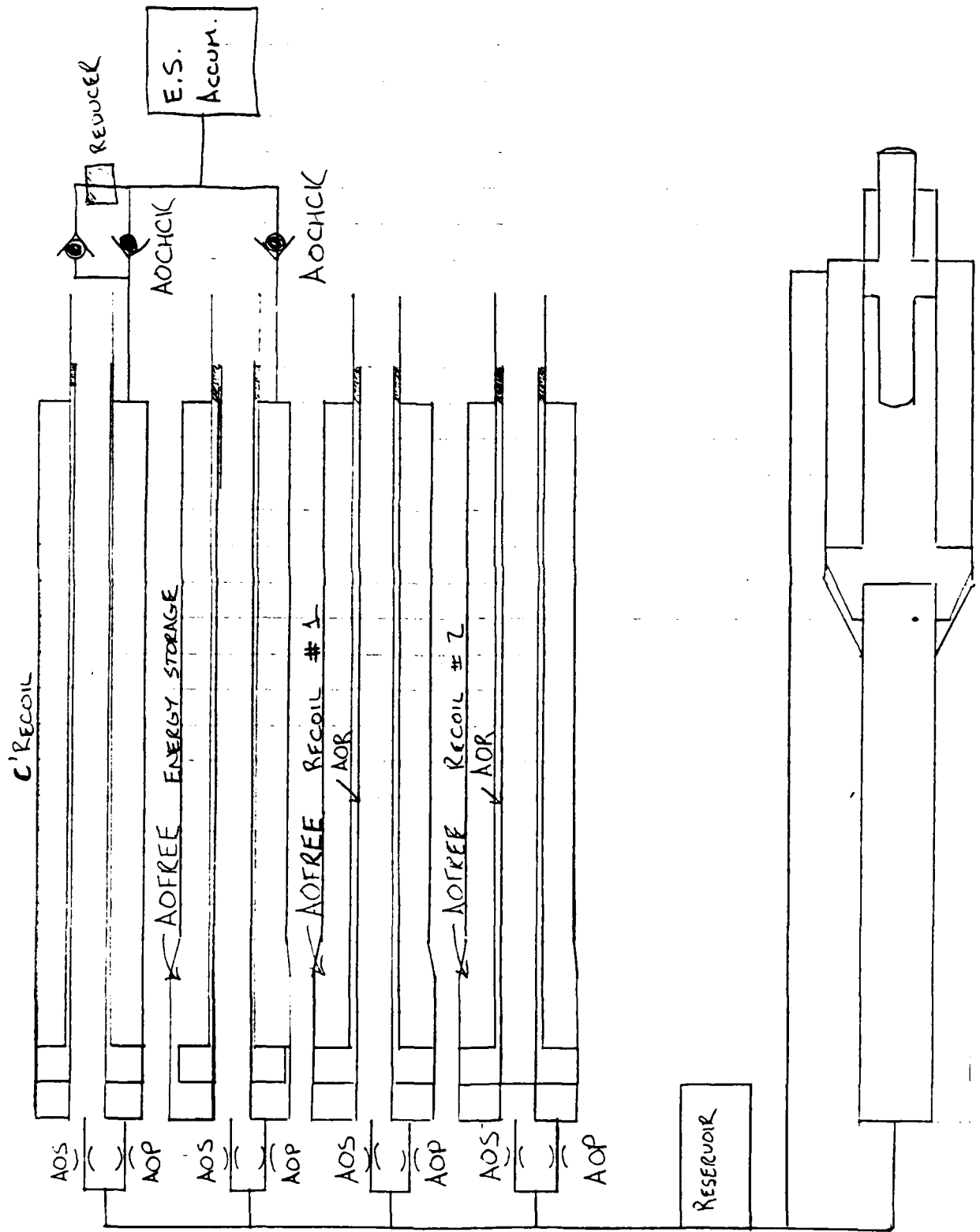

LA

VC=1147.
 UM=16.675
 DS=5.15
 KP=94.
 WC=28.
 WA=4.
 VM=2710.
 PHCC=.06
 PTB=11563400.
 GAMMA=1.238
 CK=1./7.
 PL=8.75
 DRP=3.
 DCR=3.
 DCRP=3.
 DCR2=2.25
 PC=3900.
 VC=4800.
 CR2=1.2
 NP=3900.
 BETA=.7
 PULK=150000.
 PHOBIL=.0303
 G=22.174
 PI=3.141592
 AB=PI*DS*UM/4.
 D=VC+AB*UM*12.
 AF=PI*(DRP*DRP-DRP*DSR)/4.
 ACF=PI*(DCRP*DCRP-DCRP*DCR2)/4.
 GAMMA=GAMMA-1.
 GAMAP=GAMMA+1.
 GAMAL=GAMAP/GAMMA
 GAMAR=2.*GAMMA/(1.-GAMMA)
 RATIO=1.+WC/(G.*PP)
 PTC=PTB-GAMAR*(1./G.+(1.+CK)*NP/(2.*WC))*VM+VM
 SIG=D*SCPT(((GAMAP/2.)*GAMAL)/(GAMMA*RTC*RATIO))/(AB*GAMAM*6.)
 PM=WC*PTC*RATIO*12./(G*D)
 WRITE(8,'(5F13.4)') PM,RATIO,RTC,SIG,D
 WEFF=NP+(WC+WA)/2.
 A=VM/(1.-(PM*AB*WC*UM)/(VM*VM*WEFF))
 B=((1./VM)-1.)*UM
 TX=2.*UM/VM
 UC=EYP(LOG(UM)-2.-UM/5)
 XP=0.
 YRD=0.
 T=0.
 U=UG
 DT=.001
 XRK=0.
 XRDL=0.
 C1=-1.
 C2=1.
 C3=-1.
 DELXP=0.
 DELXSD=0.
 DO 300 I=1.4
 C1=C1+2.*C2
 C2=C2-.5
 D1=1.5-C1*.5+C3
 C3=0.

? ←

DESP = 3.
 DESR = 2.25

$AES = PI * (DESP + DESD - DESR + DESR) / 4.$

50

```

VREFF=V1+D1*YK4
VREFF=xp0+D1*xADL
VK=DT*xADREFF
IF(T.GT.TH) GO TO 100
DELT=D1*DT/L.
VP=VU/(P+U)
ZP=V+U-(VU+U)*DELT
CC=-((VP+U)*U+VP*U)*DELT
DELU=(-V+U*DELT*(P+U+U*DELT))/L.
DELT2=(U*DELU*(1.+DELU/U)+V*DELU)/L.
VREFF=V+DELU+(U*DT-DELT2)*X*(U+DELU)/(U+DELU)
EQAS=V*DELU*(1.+DELU/U)+VREFF/(U+DELU)+U.
GO TO 200
100 T=REFF+DT*DELT
EQAS=V*DELU*(1.+DELU/U)+T*DELU*(U+DELU)/L.
200 Y=VREFF-LT.1.1) *D1) *U
IF(XREFF.LT.1.1) GO TO 250
IF(XREFF.LT.1.25) GO TO 270
IF(XREFF.LT.1.5) GO TO 280
IF(XREFF.LT.1.5) GO TO 290
GO TO 500
250 ER=40000.*XREFF+XREFF+1000.
GO TO 295
260 ER=(-150.*(XREFF*3.)+520.*XREFF+400.*XREFF+150.)*1000.
GO TO 295
270 ER=75000.
GO TO 295
280 ER=(3.84*(XREFF*3.)-48.04*XREFF*2.+194.40*XREFF-175.12)*1000.
GO TO 295
290 ER=-10000.*XREFF+110000.
295 XDELU=DT*U*(EQAS-P)/L.
DELT2=DELU*(1.+D1*U/L.
DELU200=DELU*(1.+D1*U/L.
300 CONTINUE
V=V+DELU200/L.
VRE=VRE+DELU200/L.
U=U*DELU
T=T+DT
IF(X2.LT.1.1) GO TO 370
IF(X2.LT.1.5) GO TO 380
IF(X2.LT.1.5) GO TO 390
IF(X2.LT.1.5) GO TO 390
IF(X2.LT.1.5) GO TO 390
GO TO 500
350 ER=40000.*X2+X2+5000.
DETX=-10000.*X2
GO TO 400
360 ER=(-150.*(X2*3.)+520.*X2+400.*X2+150.)*1000.
DETX=(-470.*X2*2+1540.*X2-400.)*1000.
GO TO 400
370 ER=75000.
DETX=1.
GO TO 400
380 ER=(3.84*(X2*3.)-48.04*X2*2.+194.40*X2-175.12)*1000.
DETX=(11.52*X2*3.-97.20*X2*2.+194.40)*1000.
GO TO 400
390 ER=(-10000.*X2+110000.)
DETX=-10000.
400 ER=1.
IF(X2.LT.1.5) ER=0.

```

```

DV=ACR*(XR+ER*(XP-.5))*12.
FCR=PO*ACR*(1.+ER)/(1.-DV/VO)**CK2
DFCRDX=FCR*CK2*12.*ACR*(1.+ER)/(VO-DV)
RECCIL=(FR-FCR)/2.
IF(RECCIL.LT.0.) RECCIL=1.
P=RECCIL/AF
DFRDX=DFDX-DFCRDX
DPDX=DFRDX/(2.*AR)
DPDT=DPDX*XR5
V=AR*(PL-XP)*12.
AD=(AR*XP5*12.-DPDT*V/BULK)/(115.5*SQRT(P))
IF(AD.GT.1.75) AD=1.75
IF(AD.LT.0.) AD=0.
PRINT 450,T,YR,AD,XRD,P,E
450 FORMAT(3Y,F4.3,4X,F5.3,4X,F7.7,4X,F5.2,4X,F6.0,4X,F7.0)
IF(XRD.LT.0.) GO TO 500
IF(XRD.GT.0.75) GO TO 500
GO TO 50
500 STOP
END

```

12117.1729		1.0465 7047524.5001	0.0669	7091.1138
.001	0.001	0.0000000	0.	5000.
.002	0.004	0.0000000	0.	5001.
.003	0.010	0.0000000	0.	5004.
.004	0.022	0.0000000	0.	5022.
.005	0.044	0.0000000	0.	5061.
.006	0.077	0.0000000	0.	5236.
.007	0.110	1.7500000	0.	5508.
.008	0.171	1.7500000	0.	6169.
.009	0.231	1.7500000	0.	7125.
.010	0.299	1.7500000	0.	8515.
.011	0.367	1.4254437	140.	10400.
.012	0.434	0.8331437	443.	12820.
.013	0.501	1.7500000	0.	15331.
.014	0.568	1.7500000	57.	17400.
.015	0.635	1.7500000	010.	20527.
.016	0.702	0.2017171	1200.	25170.
.017	0.769	0.2007000	1300.	30303.
.018	0.836	0.1754010	2590.	34153.
.019	0.903	0.1500730	3347.	40420.
.020	0.970	0.1270053	4250.	52150.
.021	1.037	0.1055743	5100.	58340.
.022	1.104	0.0723410	5074.	64409.
.023	1.171	0.02114775	5522.	70060.
.024	1.238	0.0200000	6464.	75555.
.025	1.305	0.03350430	7144.	74258.
.026	1.372	0.0413509	7143.	75000.
.027	1.439	0.0429192	7140.	75000.
.028	1.506	0.0455440	7138.	75000.
.029	1.573	0.0487474	7135.	75000.
.030	1.640	0.0457315	7132.	75000.
.031	1.707	0.0410037	7130.	75000.
.032	1.774	0.0327473	7127.	75000.
.033	1.841	0.03413937	7045.	75000.
.034	1.908	0.03410000	7041.	75000.
.035	1.975	0.0293434	7037.	75000.
.036	2.042	0.03303322	7401.	75000.
.037	2.109	0.03370010	7425.	75000.
.038	2.176	0.03055207	7004.	75000.
.039	2.243	0.0333300	7021.	75000.
.040	2.310	0.0320700	7024.	75000.
.041	2.377	0.0302170	7104.	75000.
.042	2.444	0.0302750	7102.	75000.
.043	2.511	0.0252092	7077.	75000.
.044	2.578	0.0241700	7014.	75000.
.045	2.645	0.0220011	59.53	7094.
.046	2.712	0.0190290	58.47	7092.
.047	2.779	0.0170700	58.33	7039.
.048	2.846	0.0152740	57.77	7037.
.049	2.913	0.0135210	57.15	7034.
.050	2.980	0.0135411	56.57	7072.
.051	3.047	0.0134227	55.74	7040.
.052	3.114	0.0132007	55.53	7014.
.053	3.181	0.01300710	54.72	6972.
.054	3.248	0.0128532	54.11	6921.
.055	3.315	0.0125517	63.50	5005.
.056	3.382	0.0122230	52.40	6794.
.057	3.449	0.0115462	52.29	6730.
.058	3.516	0.0114154	51.70	6050.
.059	3.583	0.0104280	61.10	6030.
.060	3.650			71211.

.1484

.040	3.972	0.3103800	50.01	0500.	70604.
.041	4.052	0.3097870	50.03	0414.	69982.
.042	4.092	0.3090847	50.35	0330.	69350.
.043	4.151	0.3082251	50.77	0253.	68714.
.044	4.210	0.3074037	51.21	0175.	68079.
.045	4.269	0.3065534	51.63	5098.	67449.
.046	4.325	0.3056240	51.07	6007.	66820.
.047	4.387	0.3044001	50.52	5427.	66221.
.048	4.438	0.3031870	50.90	5050.	65631.
.049	4.494	0.3018060	55.42	5773.	65063.
.050	4.545	0.3007120	54.87	5704.	64512.
.051	4.603	0.2995500	54.33	5032.	63900.
.052	4.657	0.2980070	53.80	5051.	63425.
.053	4.711	0.2970045	53.27	5041.	62850.
.054	4.764	0.2959014	52.75	5422.	62300.
.055	4.817	0.2944000	52.22	5033.	61800.
.056	4.870	0.2929000	51.70	5235.	61315.
.057	4.922	0.2913000	51.25	5210.	60801.
.058	4.971	0.2892000	50.60	5151.	60291.
.059	5.021	0.2872000	50.27	5035.	59757.
.060	5.071	0.2850000	49.87	5014.	59208.
.061	5.121	0.2834000	49.17	4955.	58744.
.062	5.170	0.2810000	48.63	4091.	58304.
.063	5.219	0.2790000	48.19	4027.	57820.
.064	5.268	0.2760000	47.71	4704.	57341.
.065	5.317	0.2740000	47.22	4702.	56800.
.066	5.366	0.2739454	46.75	4041.	56340.
.067	5.407	0.2729100	46.27	4530.	55831.
.068	5.452	0.2718777	45.80	4514.	55471.
.069	5.498	0.2708450	45.34	4400.	55010.
.070	5.544	0.2700100	44.87	4401.	54504.
.071	5.589	0.2700700	44.42	4042.	54117.
.072	5.632	0.2700700	43.90	4234.	53675.
.073	5.676	0.2700700	43.51	4227.	53250.
.074	5.719	0.2700700	43.00	4175.	52805.
.075	5.762	0.2747000	42.62	4114.	52377.
.076	5.805	0.2736000	42.10	4050.	51953.
.077	5.847	0.2726000	41.74	4000.	51533.
.078	5.889	0.2716000	41.51	3444.	51118.
.079	5.929	0.2706000	40.27	3535.	50707.
.080	5.970	0.2696000	40.45	3042.	50301.
.081	6.010	0.2686000	40.02	2754.	49890.
.082	6.050	0.2676000	39.50	3737.	49500.
.083	6.089	0.2666000	39.19	3035.	49100.
.084	6.128	0.2656000	38.77	3034.	48710.
.085	6.167	0.2646000	38.30	3584.	48331.
.086	6.205	0.2636000	37.96	3534.	47944.
.087	6.243	0.2626000	37.55	3484.	47572.
.088	6.280	0.2615000	37.19	3435.	47140.
.089	6.317	0.2605000	36.78	3387.	46829.
.090	6.354	0.2597000	36.35	3334.	46403.
.091	6.390	0.2587000	35.97	3291.	46101.
.092	6.426	0.2577000	35.58	3244.	45744.
.093	6.461	0.2567000	35.19	3190.	45390.
.094	6.496	0.2557000	34.81	3152.	45040.
.095	6.531	0.2548000	34.43	3107.	44693.
.096	6.565	0.2538000	34.06	3062.	44351.
.097	6.599	0.2528000	33.68	3017.	44012.
.098	6.632	0.2518000	33.31	2973.	43677.
.099	6.665	0.2508000	32.94	2930.	43340.

C

.120	4.640	0.2499175	32.55	2667.	43019.
.121	4.721	0.2489423	32.21	2644.	42045.
.122	4.783	0.2479670	31.86	2602.	42374.
.123	4.744	0.2469930	31.50	2761.	42057.
.124	4.825	0.2460185	31.14	2720.	41744.
.125	4.857	0.2450430	30.79	2679.	41435.
.126	4.867	0.2440678	30.44	2639.	41126.
.127	4.917	0.2430934	30.10	2599.	40826.
.128	4.947	0.2421173	29.75	2550.	40527.
.129	4.977	0.2411405	29.41	2521.	40231.
.130	7.005	0.2401627	29.07	2483.	39936.
.131	7.035	0.2391837	28.75	2445.	39644.
.132	7.063	0.2382036	28.43	2407.	39304.
.133	7.090	0.2372214	28.07	2370.	39001.
.134	7.117	0.2362371	27.74	2334.	38702.
.135	7.147	0.2352506	27.41	2298.	38407.
.136	7.177	0.2342619	27.06	2262.	38104.
.137	7.202	0.2332714	26.74	2227.	37805.
.138	7.228	0.2322791	26.44	2192.	37514.
.139	7.254	0.2312836	26.12	2157.	37225.
.140	7.280	0.2302870	25.81	2123.	36940.
.141	7.307	0.2292884	25.49	2090.	36658.
.142	7.331	0.2282879	25.18	2056.	36385.
.143	7.356	0.2272854	24.87	2023.	36109.
.144	7.381	0.2262807	24.57	1991.	35845.
.145	7.406	0.2252735	24.26	1959.	35585.
.146	7.430	0.2242634	23.95	1927.	35325.
.147	7.453	0.2232506	23.65	1896.	35065.
.148	7.477	0.2222354	23.34	1865.	34805.
.149	7.500	0.2212174	23.03	1835.	34549.
.150	7.523	0.2201967	22.73	1805.	34295.
.151	7.546	0.2191733	22.43	1775.	34043.
.152	7.569	0.2181472	22.13	1746.	33794.
.153	7.592	0.2171184	21.84	1717.	33548.
.154	7.615	0.2160869	21.55	1688.	33305.
.155	7.638	0.2150527	21.26	1660.	33065.
.156	7.661	0.2140158	20.97	1632.	32828.
.157	7.684	0.2129762	20.68	1605.	32594.
.158	7.707	0.2119339	20.40	1578.	32364.
.159	7.730	0.2108888	20.12	1551.	32138.
.160	7.753	0.2098409	19.84	1525.	31915.
.161	7.776	0.2087902	19.56	1499.	31695.
.162	7.799	0.2077367	19.29	1473.	31478.
.163	7.822	0.2066804	19.02	1448.	31264.
.164	7.845	0.2056213	18.75	1423.	31052.
.165	7.868	0.2045594	18.48	1399.	30842.
.166	7.891	0.2034947	18.22	1374.	30635.
.167	7.914	0.2024272	17.96	1351.	30431.
.168	7.937	0.2013570	17.70	1327.	30230.
.169	7.960	0.2002840	17.44	1304.	30032.
.170	7.983	0.1992083	17.19	1281.	29837.
.171	7.999	0.1981299	16.94	1259.	29645.
.172	8.015	0.1970488	16.69	1237.	29456.
.173	8.031	0.1959650	16.45	1215.	29270.
.174	8.047	0.1948784	16.20	1193.	29087.
.175	8.063	0.1937891	15.95	1172.	28907.
.176	8.079	0.1926970	15.70	1152.	28730.
.177	8.095	0.1916021	15.44	1131.	28555.
.178	8.111	0.1905044	15.19	1111.	28383.
.179	8.127	0.1894039	14.94	1091.	28213.

.198	8.061	0.1535029	14.09	1072.	29186.
.191	8.094	0.1523405	14.45	1053.	29040.
.192	8.116	0.1503541	14.20	1034.	28897.
.193	8.124	0.1493477	13.95	1015.	28756.
.194	8.130	0.1477177	13.72	997.	28615.
.195	8.132	0.1462455	13.47	979.	28462.
.196	8.135	0.1449572	13.23	952.	28349.
.197	8.137	0.1438407	12.99	945.	28217.
.198	8.139	0.1428951	12.75	928.	28084.
.199	8.140	0.1421175	12.52	911.	27962.
.200	8.141	0.1415015	12.29	895.	27838.
.201	8.141	0.1410427	12.05	879.	27717.
.202	8.141	0.1407355	11.81	863.	27597.
.203	8.141	0.1404753	11.57	847.	27480.
.204	8.141	0.1402585	11.33	831.	27366.
.205	8.141	0.1400817	11.09	815.	27253.
.206	8.141	0.1399417	10.85	799.	27143.
.207	8.141	0.1398351	10.61	783.	27035.
.208	8.141	0.1397587	10.37	767.	26930.
.209	8.141	0.1397097	10.13	751.	26827.
.210	8.141	0.1396857	9.89	735.	26726.
.211	8.141	0.1396835	9.65	719.	26628.
.212	8.141	0.1397007	9.41	703.	26531.
.213	8.141	0.1397353	9.17	687.	26437.
.214	8.141	0.1397853	8.93	671.	26345.
.215	8.141	0.1398497	8.69	655.	26255.
.216	8.141	0.1399275	8.45	639.	26166.
.217	8.141	0.1399997	8.21	623.	26083.
.218	8.141	0.1399997	7.97	607.	26000.
.219	8.141	0.1399997	7.73	591.	25919.
.220	8.141	0.1399997	7.49	575.	25841.
.221	8.141	0.1399997	7.25	559.	25764.
.222	8.141	0.1399997	7.01	543.	25690.
.223	8.141	0.1399997	6.77	527.	25618.
.224	8.141	0.1399997	6.53	511.	25548.
.225	8.141	0.1399997	6.29	495.	25481.
.226	8.141	0.1399997	6.05	479.	25415.
.227	8.141	0.1399997	5.81	463.	25352.
.228	8.141	0.1399997	5.57	447.	25290.
.229	8.141	0.1399997	5.33	431.	25231.
.230	8.141	0.1399997	5.09	415.	25174.
.231	8.141	0.1399997	4.85	399.	25119.
.232	8.141	0.1399997	4.61	383.	25067.
.233	8.141	0.1399997	4.37	367.	25016.

FOOTPRINT STCF

ENERGY RECOVERY :

$$\frac{\Delta PER}{\Delta t} = [AER * \dot{X}R - 115.5 * AOFREE * SQRT(PER-PEP) + AOERCK * SQRT(PER-PEA)] * BULK / (AER * (RL-YR))$$

$$\frac{\Delta PER}{\Delta t} \frac{\Delta t}{\Delta XR} = [AER - (115.5 / \dot{X}R)] * [AOFREE * SQRT(PER-PEP) + AOERCK * SQRT(PER-PEA)] * BULK / (AER * (RL-YR))$$

$$DFEDXR = [AER * (115.5 / \dot{X}R)] * (AOFREE * SQRT(PER-PEP) + AOERCK * SQRT(PER-PEA)) * BULK / (RL-YR)$$

COUNTER - RECOIL :

$$\frac{\Delta PCR}{\Delta t} = [ACR * \dot{X}R - 115.5 * AOERCK * SQRT(PCR-PEA)] * BULK / (ACR * (RL-YR))$$

$$DFCDXR = [ACR - (115.5 / \dot{X}R)] * AOERCK * SQRT(PCR-PEA)] * BULK / (RL-YR)$$

RECOIL :

$$\frac{\Delta PRR}{\Delta t} = [ARR * \dot{X}R - 115.5 * AOFREE * SQRT(PRR-PRP)] * BULK / (ARR * (RL-YR))$$

$$DFRDXR = 2. * [ARR - (115.5 / \dot{X}R)] * AOFREE * SQRT(PRR-PRP)] * BULK / (RL-YR)$$

ENERGY RECOVERY

$$\frac{\Delta PER}{\delta t} = B [AER \cdot X_R + 115.5 (AOCHEK(PA-PEE))^{1/2} - AOCHEE(PEE-PEP)^{1/2}] / AEP(RL-XR)$$

$$\frac{\Delta PER}{\delta t} = \left(\frac{B}{AER} \right) \left[\left(\frac{AER \cdot X_R + 115.5 (AOCHEK(PA-PEE))^{1/2}}{(PEE-PEP)^{1/2}} - \frac{AOCHEE(PA-PEE)^{1/2}}{(PEE-PEP)^{1/2}} \right) / (RL-XR) + (AER \cdot X_R + 115.5 (AOCHEK(PA-PEE))^{1/2} - AOCHEE(PEE-PEP)^{1/2}) / (RL-XR) \right]$$

$$\frac{\Delta PER}{\delta t} = \left(\frac{B}{AER} \right) \left[\left(\frac{AER \cdot X_R + 115.5 (AOCHEK(PA-PEE))^{1/2}}{(PEE-PEP)^{1/2}} - \frac{AOCHEE(PA-PEE)^{1/2}}{(PEE-PEP)^{1/2}} \right) / (PEE-PEP) + \left(\frac{AER \cdot X_R + 115.5 (AOCHEK(PA-PEE))^{1/2}}{(PEE-PEP)^{1/2}} - \frac{AOCHEE(PEE-PEP)^{1/2}}{(PEE-PEP)^{1/2}} \right) / (RL-XR) \right]$$

$$\frac{\Delta PER}{\delta t} = B [-AEP \cdot X_R + 115.5 (AOCHEE(PEE-PEP))^{1/2} + AOP(PA-PEP)^{1/2}] / AEP(CO+XR)$$

$$\frac{\Delta PER}{\delta t} = \frac{B}{AEP(CO+XR)} \left[-AEP \cdot X_R + 115.5 (AOCHEE(PEE-PEP))^{1/2} + AOP(PA-PEP)^{1/2} \right] + (-AEP \cdot X_C + 115.5 (AOCHEE(PEE-PEP))^{1/2} + AOP(PA-PEP)^{1/2}) / (CO+XR)$$

- TER = PR
- TEP = PR
- TERD = O
- TEPD = O
- TRX = O
- TPX = O
- TRL = O
- TPL = O

- DELTR = O
- DELT = O
- DELTRD = O
- DELTRPD = O

- TREF = TER + DI + TRX
- TPEF = TEP + DI + TPX
- TRDEF = TERD + DI + TRL
- TPDEF = TEPD + DI + TPL
- DTERP = TREF - TREF

- IF (DTERP .LT. 0) DTERP = 0
- DTRK = PRDEF - TREF
- DTRP = PRDEF - TPEF
- QF = VALVES + SORT(DTERP)
- QC = CO + AOCHEK + SORT(DTRK)

QP = VALVE + SORT(DTRP)

DTERPD = TERD - TEPD

DTRERD = - TERD

DTRERPD = - TEPD

IF (QF .LE. 0) DTERP = 1

IF (QC .LE. 0) DTRER = 1

IF (QP .LE. 0) DTRERD = 1

TCRI = (QC + DTRERD / DTRER) - (QF * DTERPD / DTRER)

TCRZ = (AER * XRD1 + QC - QF) * XRD1 / XRI

TCPI = (QF * DTERPD / DTRER) + (QP * DTRERPD / DTRER)

TCPZ = (-AEP * XRD1 + QF + QP) * XRD1 / XRL

TRK = DT + TROEFF

TPX = DT * TPDEFF

AFTER XRD

TRL = BULK * (AER * XRD1 + DT * TCRI / Z + TCRZ) / (AER * XRI)

TPL = BULK * (-AEP * XRD1 + DT * (TCP1 / Z + TCPZ)) / (AEP * XRL)

DELTR = DELTR + CI * TRX

DELT = DELT + CI * TPX

DELTRD = DELTRD + CI * TRL

DELTRPD = DELTRPD + CI * TPL

- AFTER 75
- TER = TER + DELTR / G
- TEP = TEP + DELTP / G
- TERD = TERD + DELTRD / G
- TEPD = TEPD + DELTRPD / G

WRITE (4, (BX, F7.1, M1, F3.1)) TER, TEP

COUNTER RECOIL CYLINDER

$$\frac{\Delta PCR}{\delta t} = [ACR + \dot{x}_R - 115.5 * AOCRCX + \text{SQRT}(PCR - PEA)] * BULK / (ACR + (RL - XR))$$

$$PCP = PR - [ACP + \dot{x}_R / (115.5 * AOP)]^2 \quad PCS = PR - [ACS + \dot{x}_R / (115.5 * AOP)]^2$$

RECOIL CYLINDERS

$$\frac{\Delta PRR}{\delta t} = [ARR + \dot{x}_R - 115.5 * AOFREE + \text{SQRT}(PRR - PRP)] * BULK / (ARR + (RL - XR))$$

$$PRP = PR - [(ARP + \dot{x}_R - 115.5 * AOFREE + \text{SQRT}(PRR - PRP))] / (115.5 * AOP)]^2$$

$$(PR - PRP)(115.5 * AOP)^2 - (ARP + \dot{x}_R)^2 - (115.5 * AOFREE)^2 (PRR - PRP) = -2 * ARP + \dot{x}_R + 115.5 * AOFREE + \text{SQRT}(PRR - PRP)$$

$$(115.5)^2 (AOFREE - AOP)^2 PRP + (115.5)^2 (AOP^2 + PR - AOFREE^2 + PRE) - (ARP + \dot{x}_R)^2 = -2 * 115.5 * ARP + AOFREE + \dot{x}_R + \text{SQRT}(PRR - PRP)$$

$$APRP = (115.5)^2 (AOFREE^2 - AOP^2)$$

$$BPRP = (115.5)^2 (AOP^2 + PR - AOFREE^2 + PRE) - (ARP + \dot{x}_R)^2$$

$$CPRP = -2 * 115.5 * ARP + AOFREE + \dot{x}_R$$

$$A1PRP = APRP + APRP$$

$$B1PRP = 2 * A1PRP + BPRP + CPRP + CPRP$$

$$C1PRP = BPRP + BPRP - CPRP + CPRP + PRP$$

$$PRP = [-B1PRP - \text{SQRT}(B1PRP * B1PRP - 4 * A1PRP * C1PRP)] / (2 * A1PRP)$$

$$PCS = PR - [ARS + \dot{x}_R / (115.5 * AOB)]^2$$

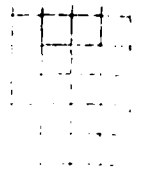

ENERGY RECOVERY CYLINDER

$$\frac{\Delta PER}{\Delta E} = [AER * XR - 115.5 * AOFREE * SQRT(PER - PEP) - 115.5 * AOELOCK + SQRT(PER - PEA)] * BULK / (AER * (RL - XR))$$

$$PEP = PR - [(AEP * XR - 115.5 * AOFREE * SQRT(PER - PEP)) / (115.5 * AOP)]^2$$

$$(PR - PEP)(115.5 * AOP)^2 - (AEP * XR)^2 - ((115.5)^2 * AOFREE^2 + (PER - PEP)) = -2. * AEP * XR + 115.5 * AOFREE * SQRT(PER - PEP)$$

$$(115.5)^2 (AOFREE^2 - AOP^2) PEP + (115.5)^2 (AOP^2 * PR - AOFREE^2 * PER) - (AEP * XR)^2 = -2. * 115.5 * AEP * AOFREE * XR + SQRT(PER - PEP)$$

$$AEP = 115.5 * 115.5 * (AOFREE * AOFREE - AOP * AOP)$$

$$BPEP = 115.5 * 115.5 * (AOP * AOP + PR - AOFREE * AOFREE + PER) - (AEP * AEP * XR + XR)$$

$$CPEP = -2. * 115.5 * AEP * AOFREE * XR$$

$$AEP * PEP + BPEP = CPEP * SQRT(PER - PEP)$$

$$AEP^2 * PEP^2 + 2 * AEP * BPEP * PEP + BPEP^2 = CPEP^2 * (PER - PEP)$$

$$AEP^2 * PEP^2 + (2 * AEP * BPEP + CPEP^2) PEP + (BPEP^2 - CPEP^2 * PER) = 0.$$

$$A1PEP = AEP + APEP$$

$$B1PEP = 2 * AEP * BPEP + BPEP + CPEP + CPEP$$

$$C1PEP = BPEP * BPEP - CPEP * CPEP + PER$$

$$PEP = [-B1PEP - SQRT(B1PEP^2 + B1PEP * B1PEP - 4 * A1PEP * C1PEP)] / (2. * A1PEP)$$

$$PES = PR - [(AES * XR / (115.5 * AOP)]^2$$

RECOIL:

$$\begin{aligned}
 PRR &= \left[ARR \cdot \sqrt{115.5 \cdot (AOFREE)} \right]^2 + PRP \\
 PRP &= PRA - \left[(ARP - ARR) \cdot \sqrt{115.5 \cdot AOP} \right]^2 \\
 PRR &= \left[\frac{ARR \cdot \sqrt{CE}}{115.5 \cdot AOFREE} \right]^2 + PRA
 \end{aligned}$$

ENERGY STORAGE:

$$\begin{aligned}
 PER &= \left[\frac{115.5 \cdot AOCICK \cdot \sqrt{SOET} \cdot (PRA - PER) + AER \cdot \sqrt{RR}}{115.5 \cdot AOFREE} \right]^2 + PEP \\
 PEP &= \left[\frac{AER \cdot \sqrt{RR} - AER \cdot \sqrt{RR} - 115.5 \cdot AOCICK \cdot \sqrt{SOET} \cdot (PRA - PER)}{115.5 \cdot AOP} \right]^2 + PRA \\
 PER &= \left[\frac{115.5 \cdot AOCICK \cdot \sqrt{SOET} \cdot (PRA - PER) + AER \cdot \sqrt{RR}}{115.5 \cdot AOFREE} \right]^2 + PRA - \left[\frac{(AER - AER) \cdot \sqrt{RR} - 115.5 \cdot AOCICK \cdot \sqrt{SOET} \cdot (PRA - PER)}{115.5 \cdot AOP} \right]^2 \\
 (PRA - PER) &= \left[1 + \left(\frac{AOCICK}{AOFREE} \right)^2 - \left(\frac{AOCICK}{AOP} \right)^2 \right] \cdot \left[\frac{RR}{115.5} \right]^2 - \left(\frac{AER - AER}{AOP} \right)^2 \cdot \left[\frac{RR}{115.5} \right]^2 = 2 \cdot \left[\frac{115.5 \cdot AOCICK \cdot \sqrt{SOET} \cdot (PRA - PER) \cdot \sqrt{RR}}{115.5 \cdot AOP} \right]^2 + \frac{AER}{115.5 \cdot AOFREE} \\
 AE &= 1 + (AOCICK / AOFREE) \cdot 2 - (AOCICK / AOP) \cdot 2 \quad AE1 \\
 BE &= \left(\frac{AER}{AOFREE} \right) \cdot 2 - \left(\frac{AER - AER}{AOP} \right) \cdot 2 \quad / COZ \\
 CE &= -2 \cdot AOCICK \cdot \left(\frac{AER - AER}{(AOP + AOP)} \right) + AER / (AOFREE \cdot AOFREE) / CO \\
 AE (PRA - PER) + BE \cdot \sqrt{RR} &= CE \cdot \sqrt{RR} \cdot \sqrt{PRA - PER} \\
 AE^2 (PRA - PER)^2 + 2 \cdot AE \cdot BE \cdot \sqrt{RR} (PRA - PER) + BE^2 \cdot \sqrt{RR}^2 &= CE^2 \cdot \sqrt{RR}^2 (PRA - PER) \\
 AE1 &= AE \cdot AE \\
 BE1 &= 2 \cdot AE \cdot BE - CE \cdot CE \\
 CE1 &= BE \cdot BE \\
 (PRA - PER) &= \frac{-BE1 \cdot \sqrt{RR} \pm \sqrt{SOET} \cdot (BE1 \cdot BE1 \cdot \sqrt{RR}^2 - 4 \cdot AE1 \cdot CE1 \cdot \sqrt{RR}^2)}{2 \cdot AE1} \\
 (PRA - PER) &= \left[(-BE1 \pm \sqrt{SOET} \cdot (BE1 + BE1 - 4 \cdot AE1 \cdot CE1)) / (2 \cdot AE1) \right] \cdot \sqrt{RR}^2 = COE1 \cdot \sqrt{RR}^2
 \end{aligned}$$

ENERGY STORAGE CONTINUED:

IF $PER = 0$

$$PER = \left[\frac{115.5 \text{ AOECC} + \text{SQRT}(\text{PRA} - \text{PER}) + \text{AER} * \text{R}}{115.5 \text{ AOFEEC}} \right]^2$$

$$(115.5 \text{ AOFEEC})^2 PER = (115.5 \text{ AOECC})^2 (\text{PRA} - \text{PER}) + 2(115.5) \text{ AER AOECC} \text{R} \text{SQRT}(\text{PRA} - \text{PER}) + (\text{AER} * \text{R})^2$$

$$PER \left[1 + \left(\frac{\text{AOECC}}{\text{AOFEEC}} \right)^2 \right] + \left[\left(\frac{\text{AOECC}}{\text{AOFEEC}} \right)^2 \text{PRA} + \left(\frac{\text{AER}}{\text{AOFEEC}} \right)^2 \text{R}^2 \right] = \left[2 \text{AER AOECC} \text{R} / (115.5) \right] \sqrt{\text{PRA} - \text{PER}}$$

$$\text{AEZ} = \left[1 + \left(\frac{\text{AOECC}}{\text{AOFEEC}} \right)^2 \right]$$

$$\text{BEZ} = - \left[\left(\frac{\text{AOECC}}{\text{AOFEEC}} \right)^2 \text{PRA} + \left(\frac{\text{AER}}{\text{AOFEEC}} \right)^2 \text{R}^2 / (115.5)^2 \right]$$

$$\text{CEZ} = 2 \text{AER AOECC} \text{R} / (\text{AOFEEC} * 115.5) + \left(\text{R} / (115.5) \right)^2$$

$$\text{AEZ}(\text{PER}) - \text{BEZ} = \text{CEZ} * \sqrt{\text{PRA} - \text{PER}}$$

$$\text{AEZ}^2 \text{PER}^2 - 2 \text{AEZ} \text{BEZ} \text{PER} + \text{BEZ}^2 = \text{CEZ}^2 (\text{PRA} - \text{PER})$$

$$\text{AEZE} = \text{AEZ} + \text{AEZ}$$

$$\text{BEZE} = 2 \text{BEZ} + \text{BEZ} + \text{CEZ} + \text{CEZ}$$

$$\text{CEZE} = \text{BEZ} + \text{BEZ} - \text{CEZ} + \text{CEZ} + \text{PRA}$$

I. $\frac{\Delta PR}{\Delta t} = [ARR + XRDFF * 12. - 115.5 * AOFEE + SQRT(PREFF) \otimes \frac{\Delta PR}{\Delta t} (\frac{\delta t}{2}) - PRPEFF \otimes \frac{\Delta PR}{\Delta t} (\frac{\delta t}{2})] + BULK / ARR + (RL - XR) + 12.$

II. $\frac{\Delta PR}{\Delta t} = [ARR + XRDFF * 12. + 115.5 * AOFEE + SQRT(PREFF) \otimes \frac{\Delta PR}{\Delta t} (\frac{\delta t}{2}) - PRPEFF \otimes \frac{\Delta PR}{\Delta t} (\frac{\delta t}{2})] + BULK / ARR + (OS + XR) + 12.$

I. $\left(\frac{\Delta PR}{\Delta t} \right) * \frac{ARR + (RL - XR) * 12. - ARR + XRDFF * 12. - 115.5 * AOFEE + SQRT(PREFF) \otimes \frac{\Delta PR}{\Delta t} (\frac{\delta t}{2}) - PRPEFF - \frac{\Delta PR}{\Delta t} (\frac{\delta t}{2})}{BULK} = -115.5 * AOFEE + SQRT(PREFF) \otimes \frac{\Delta PR}{\Delta t} (\frac{\delta t}{2}) - PRPEFF - \frac{\Delta PR}{\Delta t} (\frac{\delta t}{2})$

II. $\left(\frac{\Delta PR}{\Delta t} \right) * \frac{ARR + (OS + XR) * 12. + ARR + XRDFF * 12. + 115.5 * AOFEE + SQRT(PREFF) \otimes \frac{\Delta PR}{\Delta t} (\frac{\delta t}{2}) - PRPEFF - \frac{\Delta PR}{\Delta t} (\frac{\delta t}{2})}{BULK} = 115.5 * AOFEE + SQRT(PREFF) \otimes \frac{\Delta PR}{\Delta t} (\frac{\delta t}{2}) - PRPEFF - \frac{\Delta PR}{\Delta t} (\frac{\delta t}{2})$

I, II $\left(\frac{\Delta PR}{\Delta t} \right) * \frac{ARR + (RL - XR) * 12. + (ARR + (OS + XR) * 12. + (ARR - NR) + XRDFF * 12. - 115.5 * AOFEE + SQRT(PREFF) \otimes \frac{\Delta PR}{\Delta t} (\frac{\delta t}{2}) - PRPEFF - \frac{\Delta PR}{\Delta t} (\frac{\delta t}{2})}{BULK} = 115.5 * AOFEE + SQRT(PREFF) \otimes \frac{\Delta PR}{\Delta t} (\frac{\delta t}{2}) - PRPEFF - \frac{\Delta PR}{\Delta t} (\frac{\delta t}{2})$

I. $\left(\frac{\Delta PR}{\Delta t} \right) * \frac{ARR + (RL - XR) * 12. - 2 * (ARR) * \frac{\Delta PR}{\Delta t} (\frac{\delta t}{2})}{BULK} + (ARR + XRDFF * 12.) = (115.5 * AOFEE) * (PREFF + \frac{\Delta PR}{\Delta t} (\frac{\delta t}{2}) - PRPEFF - \frac{\Delta PR}{\Delta t} (\frac{\delta t}{2}))$

II. $\left(\frac{\Delta PR}{\Delta t} \right) * \frac{ARR + (OS + XR) * 12. + 2 * (ARR) * \frac{\Delta PR}{\Delta t} (\frac{\delta t}{2})}{BULK} + (ARR + XRDFF * 12.) = (115.5 * AOFEE) * (PREFF + \frac{\Delta PR}{\Delta t} (\frac{\delta t}{2}) - PRPEFF - \frac{\Delta PR}{\Delta t} (\frac{\delta t}{2}))$

III. $\left(\frac{\Delta PR}{\Delta t} \right) * \frac{ARR + (OS + XR) * 12. + 2 * (ARR) * \frac{\Delta PR}{\Delta t} (\frac{\delta t}{2})}{BULK} + (ARR + XRDFF * 12.) = (115.5 * AOFEE) * (PREFF + \frac{\Delta PR}{\Delta t} (\frac{\delta t}{2}) - PRPEFF - \frac{\Delta PR}{\Delta t} (\frac{\delta t}{2}))$

$\rightarrow 2 * (115.5 * AOFEE) * SQRT(PREFF) \otimes \frac{\Delta PR}{\Delta t} (\frac{\delta t}{2}) - PRPEFF - \frac{\Delta PR}{\Delta t} (\frac{\delta t}{2})$

$E1 (\frac{\Delta PR}{\Delta t}) + E2 (\frac{\Delta PR}{\Delta t}) + E3 = E4 SQRT(PREFF) \otimes \frac{\Delta PR}{\Delta t} (\frac{\delta t}{2}) - PRPEFF - \frac{\Delta PR}{\Delta t} (\frac{\delta t}{2})$

$E1 (\frac{\Delta PR}{\Delta t}) + 2 * E1 * E2 (\frac{\Delta PR}{\Delta t}) + 2 * E1 * E3 (\frac{\Delta PR}{\Delta t}) + E2^2 (\frac{\Delta PR}{\Delta t}) + E3^2 = E4^2 [PREFF + \frac{\Delta PR}{\Delta t} (\frac{\delta t}{2}) - PRPEFF - \frac{\Delta PR}{\Delta t} (\frac{\delta t}{2})] + (PREFF + \frac{\Delta PR}{\Delta t} (\frac{\delta t}{2}))$

DESCRIPTION: RECOIL SYSTEM (WITH FIXED DRIFICE,
ABANDONED DECEMBER, 1986)

Design analysis of this system over Christmas break in 1986 revealed extensive complications due to the combination of temperature fluctuations, energy recovery levels, and possible cookoff at latch (load) position [B/700 pg 14]. Review of cylinders and rods designed and detailed indicated changing to conventional orifice rods was a superior path.

STATUS:

Abandoned in December 1986.

AUTHOR: Jeff Ireland

OIL IS ASSUMED TO FLOW
INTO PASSAGE FAST
ENOUGH TO PREVENT
CAVITATION AND ASSIST
IN PUSHING GUN OUT OF
BATTERY

1ST SHOT 8S

MUZZLE BRAKE $B = .7$

75° ELEVATION

OIL IS ASSUMED TO FLOW INTO PASSAGE
FAST ENOUGH TO PREVENT CAVITATION
ACTUALLY IS PUTTING FORCE IN WHICH
PUSHES GUN OUT OF BATTERY.

$A_0 = 1.375 \text{ in}^2$ SINGLE ORIFICE

$V_0 = N_2 \rightarrow 5000 \text{ in}^3$

$P_0 = N_2 \rightarrow 2500 \text{ PSI}$

(2ND SHOT 8S

$V_0 N_2 = 4135 \text{ in}^3$

$P_0 N_2 = 3200 \text{ PSI}$

```

G=32.174
PI=3.141592
VC=1147.
UM=16.675
DB=5.15
AB=PI*DB*DB/4.
WS=24.*PI/(20.*DB)
D=VC+AB*UM*12.
RL=8.75
PIP=.1081
WP=96.
VM=2710.
PMA=47500.
RHOC=.06
RTP=11562400.
GAMMA=1.235
WC=24.
WA=4.
CK=1./7.
GAMMA=GAMMA-1.
GAMAP=GAMMA+1.
GAMA1=GAMAP/GAMMA
GAMA2=2.*GAMMA/(1.-GAMMA)
RATIO=1.+WC/(5.*WP)
RTO=RTP-GAMMA*(1./5.+(1.+CK)*WP/(2.*WC))*VM*VM
SIG=D*SQRT(((GAMAP/2.)*GAMA1)/(GAMMA*RTO*RATIO))/(AB*GAMMA*5.)
PM=WC*RTO*RATIO*12./(G*D)
WRITE (*,'(5F13.4)') PM,RATIO,RTO,SIG,D
WEFF=WP+(WC+WA)/2.
A=VY/(1.-(PM*AB*G*JM)/(VM*VM*WEFF))
R=((A/VM)-1.)*UM
TM=2.*UM/VM
UD=EXP(LOG(JM)-2.-UM/3)
DR=2.
DP=2.75
DS=1.75
DPASS=1.5
WR=4000.
BULK=150000.
BETA=.7
RHOCIL=.0303
THETA=75.*PI/180.
UB=.25
DT=.001
APR=PI*(DP*DP-DR*DR)/4.
AS=PI*DS*DS/4.
AS=0.
PEQ=2500.
PE=PEQ
PR=100.
WDL=RHOCIL*APR*RL*12.*(4.+(PE+3.*P<)/BULK)
US=.05
W1=.F
W2=.25
S=400.
FGF=WR*(SIN(THETA)-UB*COS(THETA))
PRLF=3500.
E2=0.
AD2=0.
AC1=1.375

```

```

V0=5000.
CK2=1.3
P1=PF
P2=PF
XR=0.
XRD=0.
U=U0
T=0.
P1K=0.
P2K=0.
XRK=0.
XRDL=0.
TM1=TM+DT
TM2=TM-DT
50 C1=-1.
C2=1.
C3=-1.
DELP1=0.
DELP2=0.
DELXR=0.
DELXRD=0.
IF(T.GT.TM) GO TO 60
IF(T.LE.TM2) GO TO 70
IF(T.LT.TM) DT=TM-T
IF(T.LT.TM) GO TO 70
DT=TM1-TM-DT
GO TO 70
60 DT=TM1-TM
70 DO 300 I=1.4
C1=C1+2.*C2
C2=C2-.5
D1=1.5-C1*.5+C3
C3=0.
P1EFF=P1+D1*P1K
P2EFF=P2+D1*P2K
XREFF=XR+D1*XRK
XRDEFF=XRD+D1*XRDL
IF(P2EFF.GE.PE) E2=.75
E1=1.-E2
DP1=P1EFF-PE
IF(DP1.GE.PKLF) AD2=0.
DP2=P2EFF-PE
IF(DP2.LE.0.) DP2=0.
AD=AD1+AD2
R1=115.5*AD
D31=(B1*E1/(12.*APR))**2.
A3=((RL-XREFF)/(DT*BULK))**2.
B31=-((2.*XRDEFF*SQR(A3)+D31/2.))
C31=XRDEFF**2.-D31*DP1
P1K=(-B31-SQR(B31*B31-4.*A3*C31))/(2.*A3)
D32=(B1*E2/(36.*APR))**2.
B32=-((2.*XRDEFF*SQR(A3)+D32/2.))
C32=XRDEFF**2.-D32*DP2
FLOWND=B32*B32-4.*A3*C32
IF(FLOWND.LE.0.) FLOWND=0.
P2K=(-B32-SQR(FLOWND))/(2.*A3)
XRK=DT*XRDEFF
IF(T.GE.TM) GO TO 100
DELT=D1*DT/2.
VP=A*U/(B+U)

```

```

PB=B+U-(VF+A)*DELT
CC=-((VP+A)*J+VP*3)*DELT
DELU=(-BB+SQR(BR*B5-4.*CC))/2.
DELT2=(B*LOG(1.+DELU/J)+DELU)/A
UEFF=U+DELU+(D1*DT-DELT2)*A*(U+DELU)/(B+U+DELU)
FGAS=(UEFF/B)*A*A*B*UEFF/(B+UEFF)**3.
GO TO 200
100 TEFF=T-TM+D1*DT
FGAS=PM*ZE*(1.-BETA)*(1.+TEFF/SIG)**GAMA2
200 FSEAL1=PI*US*DR+(W1*S*4.+W2*(P1EFF+3.*P2EFF))
FSEAL2=PI*JS*DS*(W1*S*2.+W2*(PE+PK))
FSEAL=FSEAL1
YRDL=DT*(G/WR)*(FGAS-APK*(P1EFF+3.*P2EFF)+AS*(PE+PR)-FSEAL+FGF)
DELP1=DELP1+C1*P1K
DELP2=DELP2+C1*P2K
DELXR=DELXR+C1*XRK
DELXRD=DELXRD+C1*XRD
300 CONTINUE
P1=P1+DELP1/B.
P2=P2+DELP2/B.
XR=XR+DELXR/B.
XRD=XRD+DELXRD/B.
U=UEFF
T=T+DT
DWDIL=RHDIL*APR*(RL-XR)*12.*(4.+(P1+3.*P2)/BULK)-WDIL
RHDE=RHDIL*(1.+PE/BULK)
DV=DWDIL/KHJE+AS*XR*12.
PE=PE0/(1.+DV/VD)**CK2
PRINT 400,T,U,XR,XRD,P1,P2,PE
400 FORMAT(5X,F5.4,5X,F5.2,5X,F5.3,5X,F5.1,5X,F5.0,5X,F5.0,5X,F6.0)
IF(XRD.LE.0.) GO TO 500
IF(XR.GE.0.75) GO TO 500
GO TO 50
500 STOP
END

```

10859.7507		1.0451 7584215.0000		0.0905		7091.1138	
.0010	0.12	0.001	1.2	2500.		109.	2500.
.0020	0.24	0.003	3.7	2500.		149.	2500.
.0030	0.49	0.009	8.2	2502.		248.	2500.
.0040	0.95	0.020	15.6	2507.		448.	2500.
.0050	1.74	0.041	25.3	2519.		797.	2500.
.0060	2.89	0.071	35.0	2540.		1326.	2500.
.0070	4.43	0.112	45.8	2570.		2037.	2500.
.0080	6.29	0.152	53.9	2689.		2823.	2501.
.0090	8.42	0.220	60.3	3160.		3257.	2502.
.0100	10.75	0.282	65.1	3582.		3656.	2505.
.0110	13.26	0.349	68.7	3968.		4026.	2508.
.0120	15.89	0.419	71.5	4323.		4369.	2511.
.0123	16.71	0.441	72.2	4433.		4476.	2512.
.0130	16.71	0.492	72.4	4653.		4691.	2514.
.0140	16.71	0.554	72.7	4919.		4950.	2518.
.0150	16.71	0.637	72.9	5143.		5166.	2522.
.0160	16.71	0.710	73.0	5333.		5354.	2527.
.0170	16.71	0.783	73.0	5493.		5510.	2531.
.0180	16.71	0.856	72.9	5628.		5643.	2536.
.0190	16.71	0.929	72.8	5741.		5754.	2541.
.0200	16.71	1.002	72.7	5836.		5846.	2545.
.0210	16.71	1.074	72.5	5913.		5921.	2550.
.0220	16.71	1.147	72.3	5975.		5982.	2555.
.0230	16.71	1.219	72.0	6025.		6031.	2561.
.0240	16.71	1.291	71.7	6063.		6067.	2566.
.0250	16.71	1.352	71.4	6090.		6094.	2571.
.0260	16.71	1.433	71.1	6109.		6112.	2576.
.0270	16.71	1.504	70.7	6119.		6122.	2581.
.0280	16.71	1.575	70.3	6122.		6125.	2587.
.0290	16.71	1.645	70.0	6119.		6121.	2592.
.0300	16.71	1.715	69.6	6111.		6113.	2597.
.0310	16.71	1.784	69.1	6048.		6099.	2602.
.0320	16.71	1.853	68.7	6080.		6081.	2608.
.0330	16.71	1.922	68.3	6059.		6060.	2613.
.0340	16.71	1.990	67.9	6035.		6035.	2618.
.0350	16.71	2.057	67.4	6008.		6009.	2624.
.0360	16.71	2.124	67.0	5979.		5979.	2629.
.0370	16.71	2.191	66.5	5948.		5948.	2634.
.0380	16.71	2.258	66.1	5915.		5915.	2639.
.0390	16.71	2.323	65.6	5881.		5881.	2645.
.0400	16.71	2.389	65.2	5846.		5846.	2650.
.0410	16.71	2.454	64.7	5810.		5810.	2655.
.0420	16.71	2.518	64.3	5773.		5773.	2660.
.0430	16.71	2.582	63.8	5736.		5735.	2665.
.0440	16.71	2.646	63.4	5698.		5698.	2671.
.0450	16.71	2.709	62.9	5661.		5661.	2676.
.0460	16.71	2.772	62.5	5623.		5623.	2681.
.0470	16.71	2.834	62.0	5585.		5585.	2686.
.0480	16.71	2.896	61.5	5547.		5547.	2691.
.0490	16.71	2.957	61.1	5510.		5510.	2696.
.0500	16.71	3.018	60.7	5472.		5472.	2701.
.0510	16.71	3.078	60.2	5435.		5435.	2706.
.0520	16.71	3.138	59.8	5399.		5399.	2711.
.0530	16.71	3.198	59.3	5363.		5363.	2716.
.0540	16.71	3.257	58.9	5327.		5327.	2721.
.0550	16.71	3.315	58.4	5291.		5291.	2726.
.0560	16.71	3.374	58.0	5256.		5255.	2731.
.0570	16.71	3.432	57.6	5222.		5222.	2736.
.0580	16.71	3.489	57.1	5188.		5185.	2740.

.0590	16.71	3.545	55.7	5154.	5154.	2745.
.0600	16.71	3.502	55.3	5121.	5121.	2750.
.0610	16.71	3.658	55.9	5089.	5089.	2755.
.0620	16.71	3.714	55.4	5057.	5057.	2759.
.0630	16.71	3.759	55.0	5025.	5025.	2764.
.0640	16.71	3.824	54.6	4994.	4994.	2769.
.0650	16.71	3.879	54.2	4963.	4963.	2773.
.0660	16.71	3.933	53.8	4933.	4933.	2778.
.0670	16.71	3.985	53.4	4904.	4904.	2783.
.0680	16.71	4.039	53.0	4874.	4874.	2787.
.0690	16.71	4.092	52.6	4846.	4846.	2792.
.0700	16.71	4.144	52.2	4818.	4815.	2796.
.0710	16.71	4.196	51.8	4790.	4790.	2801.
.0720	16.71	4.248	51.4	4763.	4763.	2805.
.0730	16.71	4.299	51.0	4736.	4736.	2810.
.0740	16.71	4.350	50.6	4709.	4709.	2814.
.0750	16.71	4.400	50.2	4683.	4683.	2818.
.0760	16.71	4.450	49.8	4658.	4658.	2823.
.0770	16.71	4.500	49.4	4632.	4632.	2827.
.0780	16.71	4.549	49.0	4608.	4605.	2832.
.0790	16.71	4.598	48.6	4583.	4583.	2836.
.0800	16.71	4.646	48.2	4559.	4559.	2840.
.0810	16.71	4.694	47.9	4536.	4536.	2844.
.0820	16.71	4.742	47.5	4513.	4513.	2849.
.0830	16.71	4.789	47.1	4490.	4490.	2853.
.0840	16.71	4.836	46.7	4467.	4467.	2857.
.0850	16.71	4.883	46.4	4445.	4445.	2851.
.0860	16.71	4.929	46.0	4423.	4423.	2865.
.0870	16.71	4.975	45.6	4402.	4402.	2869.
.0880	16.71	5.020	45.3	4381.	4381.	2873.
.0890	16.71	5.065	44.9	4360.	4360.	2877.
.0900	16.71	5.110	44.5	4340.	4340.	2881.
.0910	16.71	5.154	44.2	4320.	4320.	2885.
.0920	16.71	5.198	43.8	4300.	4300.	2889.
.0930	16.71	5.242	43.5	4280.	4280.	2893.
.0940	16.71	5.285	43.1	4261.	4261.	2897.
.0950	16.71	5.328	42.8	4242.	4242.	2901.
.0960	16.71	5.371	42.4	4224.	4224.	2905.
.0970	16.71	5.413	42.1	4205.	4205.	2909.
.0980	16.71	5.455	41.7	4187.	4187.	2913.
.0990	16.71	5.496	41.4	4170.	4170.	2917.
.1000	16.71	5.538	41.0	4152.	4152.	2920.
.1010	16.71	5.578	40.7	4135.	4135.	2924.
.1020	16.71	5.519	40.3	4118.	4115.	2928.
.1030	16.71	5.559	40.0	4101.	4101.	2932.
.1040	16.71	5.599	39.7	4085.	4085.	2935.
.1050	16.71	5.738	39.3	4069.	4069.	2939.
.1060	16.71	5.778	39.0	4053.	4053.	2942.
.1070	16.71	5.816	38.7	4037.	4037.	2946.
.1080	16.71	5.855	38.3	4022.	4022.	2950.
.1090	16.71	5.893	38.0	4007.	4007.	2953.
.1100	16.71	5.931	37.7	3992.	3992.	2957.
.1110	16.71	5.968	37.3	3977.	3977.	2960.
.1120	16.71	6.006	37.0	3962.	3962.	2964.
.1130	16.71	6.042	36.7	3948.	3948.	2967.
.1140	16.71	6.079	36.4	3934.	3934.	2971.
.1150	16.71	6.115	36.0	3920.	3920.	2974.
.1160	16.71	6.151	35.7	3906.	3905.	2977.
.1170	16.71	6.187	35.4	3893.	3893.	2981.
.1180	16.71	6.222	35.1	3880.	3880.	2984.

.1190	16.71	6.257	34.8	3857.	3857.	2987.
.1200	16.71	6.241	34.4	3854.	3854.	2991.
.1210	16.71	6.326	34.1	3841.	3841.	2994.
.1220	16.71	6.350	33.8	3828.	3828.	2997.
.1230	16.71	6.373	33.5	3816.	3816.	3000.
.1240	16.71	6.427	33.2	3804.	3804.	3004.
.1250	16.71	6.450	32.9	3792.	3792.	3007.
.1260	16.71	6.472	32.6	3780.	3780.	3010.
.1270	16.71	6.525	32.3	3769.	3769.	3013.
.1280	16.71	6.557	31.9	3757.	3757.	3016.
.1290	16.71	6.539	31.6	3746.	3746.	3019.
.1300	16.71	6.520	31.3	3735.	3735.	3022.
.1310	16.71	6.591	31.0	3724.	3724.	3025.
.1320	16.71	6.562	30.7	3713.	3713.	3028.
.1330	16.71	6.713	30.4	3703.	3703.	3031.
.1340	16.71	6.743	30.1	3692.	3692.	3034.
.1350	16.71	6.773	29.8	3682.	3682.	3037.
.1360	16.71	6.803	29.5	3672.	3672.	3040.
.1370	16.71	6.832	29.2	3662.	3662.	3043.
.1380	16.71	6.851	28.9	3652.	3652.	3046.
.1390	16.71	6.890	28.6	3642.	3642.	3048.
.1400	16.71	6.918	28.3	3633.	3633.	3051.
.1410	16.71	6.946	28.0	3623.	3623.	3054.
.1420	16.71	6.974	27.7	3614.	3614.	3057.
.1430	16.71	7.002	27.4	3605.	3605.	3059.
.1440	16.71	7.029	27.2	3596.	3596.	3062.
.1450	16.71	7.056	26.9	3587.	3587.	3065.
.1460	16.71	7.083	26.6	3579.	3579.	3067.
.1470	16.71	7.109	26.3	3570.	3570.	3070.
.1480	16.71	7.135	26.0	3562.	3562.	3073.
.1490	16.71	7.151	25.7	3553.	3553.	3075.
.1500	16.71	7.167	25.4	3545.	3545.	3078.
.1510	16.71	7.212	25.1	3537.	3537.	3080.
.1520	16.71	7.257	24.8	3529.	3529.	3083.
.1530	16.71	7.252	24.6	3521.	3521.	3085.
.1540	16.71	7.265	24.3	3514.	3514.	3088.
.1550	16.71	7.310	24.0	3506.	3506.	3090.
.1560	16.71	7.334	23.7	3499.	3499.	3092.
.1570	16.71	7.358	23.4	3491.	3491.	3095.
.1580	16.71	7.381	23.1	3484.	3484.	3097.
.1590	16.71	7.404	22.9	3477.	3477.	3099.
.1600	16.71	7.427	22.6	3470.	3470.	3102.
.1610	16.71	7.449	22.3	3463.	3463.	3104.
.1620	16.71	7.471	22.0	3456.	3456.	3106.
.1630	16.71	7.493	21.7	3450.	3450.	3108.
.1640	16.71	7.515	21.5	3443.	3443.	3110.
.1650	16.71	7.535	21.2	3437.	3437.	3113.
.1660	16.71	7.557	20.9	3430.	3430.	3115.
.1670	16.71	7.578	20.6	3424.	3424.	3117.
.1680	16.71	7.598	20.4	3418.	3418.	3119.
.1690	16.71	7.519	20.1	3412.	3412.	3121.
.1700	16.71	7.539	19.8	3406.	3406.	3123.
.1710	16.71	7.558	19.5	3400.	3400.	3125.
.1720	16.71	7.578	19.3	3395.	3395.	3127.
.1730	16.71	7.547	19.0	3389.	3389.	3129.
.1740	16.71	7.716	18.7	3384.	3384.	3131.
.1750	16.71	7.734	18.4	3378.	3378.	3133.
.1760	16.71	7.752	18.2	3373.	3373.	3135.
.1770	16.71	7.770	17.9	3368.	3368.	3136.
.1780	16.71	7.783	17.6	3362.	3362.	3136.

.1740	16.71	7.806	17.4	3357.	3357.	3140.
.1800	16.71	7.823	17.1	3352.	3352.	3142.
.1810	16.71	7.840	16.8	3348.	3348.	3144.
.1820	16.71	7.857	16.5	3343.	3343.	3145.
.1830	16.71	7.873	16.3	3338.	3338.	3147.
.1840	16.71	7.889	16.0	3334.	3334.	3149.
.1850	16.71	7.905	15.7	3329.	3329.	3150.
.1860	16.71	7.921	15.5	3325.	3325.	3152.
.1870	16.71	7.936	15.2	3320.	3320.	3153.
.1880	16.71	7.951	14.9	3316.	3316.	3155.
.1890	16.71	7.966	14.7	3312.	3312.	3156.
.1900	16.71	7.980	14.4	3308.	3308.	3158.
.1910	16.71	7.995	14.1	3304.	3304.	3159.
.1920	16.71	8.009	13.9	3300.	3300.	3161.
.1930	16.71	8.022	13.6	3296.	3296.	3162.
.1940	16.71	8.036	13.4	3292.	3292.	3164.
.1950	16.71	8.049	13.1	3289.	3289.	3165.
.1960	16.71	8.052	12.3	3285.	3285.	3166.
.1970	16.71	8.075	12.6	3282.	3282.	3168.
.1980	16.71	8.087	12.3	3278.	3278.	3169.
.1990	16.71	8.099	12.0	3275.	3275.	3170.
.2000	16.71	8.111	11.8	3272.	3272.	3172.
.2010	16.71	8.123	11.5	3268.	3268.	3173.
.2020	16.71	8.134	11.3	3265.	3265.	3174.
.2030	16.71	8.145	11.0	3262.	3262.	3175.
.2040	16.71	8.156	10.7	3259.	3259.	3176.
.2050	16.71	8.167	10.5	3256.	3256.	3177.
.2060	16.71	8.177	10.2	3254.	3254.	3178.
.2070	16.71	8.187	10.0	3251.	3251.	3179.
.2080	16.71	8.197	9.7	3248.	3248.	3180.
.2090	16.71	8.207	9.4	3246.	3246.	3181.
.2100	16.71	8.216	9.2	3243.	3243.	3182.
.2110	16.71	8.225	8.9	3241.	3241.	3183.
.2120	16.71	8.234	8.7	3238.	3238.	3184.
.2130	16.71	8.242	8.4	3236.	3236.	3185.
.2140	16.71	8.251	8.1	3234.	3234.	3186.
.2150	16.71	8.259	7.9	3232.	3232.	3187.
.2160	16.71	8.266	7.6	3230.	3230.	3188.
.2170	16.71	8.274	7.4	3228.	3228.	3189.
.2180	16.71	8.281	7.1	3226.	3226.	3189.
.2190	16.71	8.288	6.9	3224.	3224.	3190.
.2200	16.71	8.295	6.6	3222.	3222.	3191.
.2210	16.71	8.301	6.3	3220.	3220.	3191.
.2220	16.71	8.308	6.1	3219.	3219.	3192.
.2230	16.71	8.314	5.8	3217.	3217.	3193.
.2240	16.71	8.319	5.6	3216.	3216.	3193.
.2250	16.71	8.325	5.3	3214.	3214.	3194.
.2260	16.71	8.330	5.1	3213.	3213.	3194.
.2270	16.71	8.335	4.8	3212.	3212.	3195.
.2280	16.71	8.339	4.5	3210.	3210.	3195.
.2290	16.71	8.344	4.3	3209.	3209.	3196.
.2300	16.71	8.348	4.0	3208.	3208.	3196.
.2310	16.71	8.352	3.8	3207.	3207.	3197.
.2320	16.71	8.356	3.5	3206.	3206.	3197.
.2330	16.71	8.359	3.3	3205.	3205.	3197.
.2340	16.71	8.362	3.0	3204.	3204.	3198.
.2350	16.71	8.365	2.8	3204.	3204.	3198.
.2360	16.71	8.368	2.5	3203.	3203.	3198.
.2370	16.71	8.370	2.2	3202.	3202.	3199.
.2380	16.71	8.372	2.0	3202.	3202.	3199.

.2390	16.71	8.374	1.7	3201.	3201.	3199.
.2400	16.71	8.376	1.5	3201.	3201.	3199.
.2410	16.71	8.377	1.2	3200.	3200.	3199.
.2420	16.71	8.378	1.0	3200.	3200.	3199.
.2430	16.71	8.379	0.7	3200.	3200.	3200.
.2440	16.71	8.379	0.5	3200.	3200.	3200.
.2450	16.71	8.380	0.2	3200.	3200.	3200.
.2460	16.71	8.380	-0.1	3200.	3200.	3200.

FORTRAN STOP

$$P_o V_o^K = P_F V_c^K \quad K=1.3$$

$$V_o \left(\frac{P_o}{P_F} \right)^{1/K} = V_F$$

$$V_c = 12 = 4.5^3$$

$P_o = 2500 \text{ PSI}$
 $P_F = 3200 \text{ PSI}$
 $V_o = 5000$

```

G=32.174
PI=3.141592
VC=1147.
UM=16.675
DB=5.15
AB=PI*DB*DB/4.
WS=24.*PI/(20.*DB)
D=VC+AB*UM*12.
RL=8.75
PIP=.1061
WP=96.
VM=2710.
PMAX=47500.
RHDC=.05
RTB=11563400.
GAMMA=1.238
WC=26.
WA=4.
CK=1./7.
GAMAM=GAMMA-1.
GAMAP=GAMMA+1.
GAMA1=GAMAP/GAMAM
GAMA2=2.*GAMMA/(1.-GAMMA)
RATIO=1.+WC/(5.*WP)
RTO=PTB-GAMAM*(1./6.+(1.+CK)*WP/(2.*WC))*VM*VM
SIG=D*SQRT(((GAMAP/2.)**GAMA1)/(GAMMA*RTO*RATIO))/(AB*GAMAM*6.)
PM=WC*RTO*RATIO*12./(G*D)
WRITE (*,'(5F13.4)') PM,RATIO,RTO,SIG,D
WEFF=(P+(WC+WA))/2.
A=VM/(1.-(PM*AB*G*UM)/(VM*VM*WEFF))
B=((A/VM)-1.)*UM
TM=2.*UM/VM
UD=EXP(LOG(JM)-2.-JM/B)
DR=2.
DP=2.75
DS=1.75
DPASS=1.5
WR=4000.
BULK=150000.
BETA=.7
RHODIL=.0305.
THETA=75.*PI/180.
UB=.25
DT=.001
APR=PI*(DP*DP-DR*DR)/4.
ASP=PI*(DS*DS-DPASS*DPASS)/4.
PEO=3200.
PE=PEO
PR=100.
WOIL=RHODIL*APR*RL*12.*(4.+(PE+3.*PR)/BULK)
US=.05
W1=.5
W2=.75
S=400.
FGF=WR*(SIN(THETA)-JB*COS(THETA))
PRLF=3500.
E2=0.
AD2=0.
AD1=1.375
VO=4135.

```

```

CK2=1.3
P1=PE
P2=PP
XR=0.
XRD=0.
U=UJ
T=0.
P1K=0.
P2K=0.
XRK=0.
XRDL=0.
TM1=TM+DT
TM2=TM-DT
50 C1=-1.
C2=1.
C3=-1.
DELP1=0.
DELP2=0.
DELXR=0.
DELXRD=C.
IF(T.GT.TM) GO TO 50
IF(T.LE.TM2) GO TO 70
IF(T.LT.TM) DT=TM-T
IF(T.LT.TM) GO TO 70
DT=TM1-TM-DT
GO TO 70
60 DT=TM1-TM
70 DO 300 I=1,4
C1=C1+2.*C2
C2=C2-.5
D1=1.5-C1*.5+C3
C3=0.
P1EFF=P1+D1*P1K
P2EFF=P2+D1*P2K
XREFF=XK+D1*XRK
XRDEFF=XRD+D1*XRDL
IF(P2EFF.GE.PE) E2=.75
E1=1.-E2
DP1=P1EFF-PE
IF(DP1.GE.PRLF) AD2=0.
DP2=P2EFF-PE
IF(DP2.LE.0.) DP2=0.
AD=AD1+AD2
B1=115.5*AD
D31=(B1*E1/(12.*APR))**.2.
A3=((RL-XREFF)/(DT*BULK))**.2.
B31=-((2.*XRDEFF*SQRT(A3)+D31/2.))
C31=XRDEFF**.2.-D31*DP1
P1K=(-B31-SQRT(B31*B31-4.*A3*C31))/(2.*A3)
D32=(B1*E2/(35.*APR))**.2.
B32=-((2.*XRDEFF*SQRT(A3)+D32/2.))
C32=XRDEFF**.2.-D32*DP2
FLOWND=B32*B32-4.*A3*C32
IF(FLOWND.LE.0.) FLJWND=0.
P2K=(-B32-SQRT(FLOWND))/(2.*A3)
XRK=DT*XRDEFF
IF(T.GE.TM) GO TO 100
DELT=D1*DT/2.
VP=A*U/(B+J)
BB=B+U-(VP+A)*DELT

```

```

CC=-((VP+A)*J+VP*3)*DELT
DELU=(-BB+SQRT(BB*BB-4.*CC))/2.
DELT2=(B*LOG(1.+DELU/U)+DELU)/A
UEFF=J+DELU+(D1*DT-DELT2)*A*(J+DELU)/(B+U+DELU)
FGAS=(WEFF/G)*A*A*B*JEFF/(B+UEFF)**3.
GO TO 200
100 TEFF=T-TM+D1*DT
FGAS=PM*AB*(1.-BETA)*(1.+TEFF/SIG)**GAMA2
200 FSEAL1=FI*JS*DR*(W1*S*4.+W2*(PIEFF+3.*P2EFF))
FSEAL2=PI*JS*DS*(W1*S*2.+W2*(PE+PR))
FSEAL=FSEAL1+FSEAL2
XRDL=DT*(G/WR)*(FGAS-APR*(PIEFF+3.*P2EFF)+ASP*(PE+PR)-FSEAL+FGF)
DELP1=DELP1+C1*P1K
DELP2=DELP2+C1*P2K
DELXR=DELXR+C1*XRK
DELXRD=DELXRD+C1*XRDL
300 CONTINUE
P1=P1+DELP1/6.
P2=P2+DELP2/6.
XR=XR+DELXR/6.
XRD=XRD+DELXRD/6.
U=UEFF
T=T+DT
DWDIL=RHDJIL*APR*(RL-XR)*12.*(4.+(P1+3.*P2)/BULK)-WDJIL
RHGE=RHDJIL*(1.+PE/BULK)
DV=DWDIL/RHGE+PI*DS*DS*XR*3.
PE=PE0/(1.+DV/VJ)**CK2
PRINT 400,T,U,XR,XRD,P1,P2,PE
400 FORMAT(3X,F5.4,5X,F5.2,5X,F5.3,5X,F5.1,5X,F5.0,5X,F5.0,5X,F6.0)
IF(XRD.LE.0.) GO TO 500
IF(XR.GE.8.75) GO TO 500
GO TO 50
500 STOP
END

```

10839.7507		1.0451 7584215.0000		0.0905	7091.1138	
.0010	0.12	0.001	1.2	3200.	109.	3200.
.0020	0.24	0.003	3.7	3200.	149.	3200.
.0030	0.49	0.009	8.2	3202.	247.	3200.
.0040	0.96	0.020	15.5	3206.	447.	3200.
.0050	1.74	0.040	25.3	3218.	794.	3200.
.0060	2.89	0.071	35.9	3240.	1322.	3200.
.0070	4.43	0.112	45.7	3270.	2031.	3200.
.0080	6.29	0.162	53.8	3304.	2901.	3201.
.0090	8.42	0.219	50.1	3741.	3547.	3202.
.0100	10.75	0.282	54.9	4190.	4046.	3205.
.0110	13.25	0.348	58.5	4594.	4482.	3209.
.0120	15.89	0.413	71.2	4960.	4871.	3214.
.0123	15.71	0.440	71.9	5074.	4991.	3216.
.0130	16.71	0.490	72.1	5300.	5229.	3219.
.0140	15.71	0.553	72.4	5571.	5513.	3225.
.0150	16.71	0.535	72.5	5749.	5751.	3231.
.0160	16.71	0.707	72.5	5991.	5952.	3238.
.0170	16.71	0.780	72.5	6153.	6120.	3245.
.0180	16.71	0.852	72.4	6289.	6261.	3252.
.0190	16.71	0.925	72.2	6402.	6379.	3259.
.0200	15.71	0.997	72.0	6495.	6476.	3267.
.0210	16.71	1.059	71.8	5571.	6555.	3274.
.0220	16.71	1.140	71.5	6632.	6619.	3282.
.0230	16.71	1.212	71.2	6680.	6659.	3290.
.0240	16.71	1.283	70.8	6716.	6706.	3297.
.0250	16.71	1.353	70.5	6741.	6733.	3305.
.0260	16.71	1.424	70.1	6757.	6751.	3313.
.0270	16.71	1.494	69.7	5765.	6750.	3322.
.0280	16.71	1.553	69.2	6766.	6751.	3330.
.0290	16.71	1.632	68.8	6760.	6757.	3338.
.0300	16.71	1.701	58.3	5749.	6746.	3346.
.0310	16.71	1.759	57.9	5734.	6731.	3354.
.0320	16.71	1.836	57.4	5714.	6712.	3362.
.0330	16.71	1.903	56.9	6690.	6694.	3370.
.0340	16.71	1.970	55.4	6654.	6652.	3378.
.0350	16.71	2.036	65.9	6635.	6634.	3387.
.0360	16.71	2.102	65.4	6603.	6602.	3395.
.0370	16.71	2.167	64.9	6570.	6559.	3403.
.0380	16.71	2.232	64.4	6535.	6535.	3411.
.0390	16.71	2.296	63.9	6500.	6499.	3419.
.0400	16.71	2.350	63.4	6463.	6452.	3427.
.0410	16.71	2.423	62.9	6425.	6425.	3435.
.0420	16.71	2.485	62.4	6387.	6387.	3443.
.0430	16.71	2.548	61.9	6348.	6348.	3451.
.0440	16.71	2.609	61.4	6309.	6309.	3459.
.0450	16.71	2.570	60.9	6271.	6270.	3467.
.0460	16.71	2.731	60.4	6232.	6232.	3474.
.0470	16.71	2.791	59.9	6193.	6193.	3482.
.0480	16.71	2.851	59.4	6154.	6154.	3490.
.0490	16.71	2.910	58.9	6116.	6116.	3498.
.0500	15.71	2.958	58.4	6078.	6078.	3505.
.0510	16.71	3.025	57.9	6041.	6041.	3513.
.0520	16.71	3.084	57.4	6003.	6003.	3520.
.0530	16.71	3.141	56.9	5967.	5957.	3528.
.0540	16.71	3.198	56.4	5931.	5931.	3535.
.0550	16.71	3.254	55.9	5895.	5895.	3543.
.0560	16.71	3.310	55.4	5860.	5860.	3550.
.0570	16.71	3.355	54.9	5825.	5825.	3558.
.0580	16.71	3.419	54.4	5791.	5791.	3565.

.0590	16.71	3.474	53.9	5757.	5757.	3572.
.0600	16.71	3.527	53.5	5724.	5724.	3579.
.0610	16.71	3.530	53.0	5692.	5692.	3587.
.0620	16.71	3.533	52.5	5660.	5660.	3594.
.0630	16.71	3.685	52.0	5629.	5629.	3501.
.0640	16.71	3.737	51.6	5598.	5598.	3508.
.0650	16.71	3.789	51.1	5567.	5567.	3615.
.0660	16.71	3.840	50.6	5538.	5538.	3622.
.0670	16.71	3.890	50.2	5508.	5508.	3629.
.0680	16.71	3.940	49.7	5480.	5480.	3636.
.0690	16.71	3.989	49.3	5451.	5451.	3642.
.0700	16.71	4.038	48.8	5424.	5424.	3649.
.0710	16.71	4.087	48.4	5397.	5397.	3656.
.0720	16.71	4.135	47.9	5370.	5370.	3662.
.0730	16.71	4.183	47.5	5343.	5343.	3669.
.0740	16.71	4.230	47.0	5318.	5318.	3676.
.0750	16.71	4.277	46.6	5292.	5292.	3682.
.0760	16.71	4.323	46.1	5267.	5267.	3689.
.0770	16.71	4.359	45.7	5243.	5243.	3695.
.0780	16.71	4.415	45.2	5219.	5219.	3702.
.0790	16.71	4.450	44.8	5195.	5195.	3708.
.0800	16.71	4.504	44.4	5172.	5172.	3714.
.0810	16.71	4.548	43.9	5149.	5149.	3720.
.0820	16.71	4.592	43.5	5127.	5127.	3727.
.0830	16.71	4.635	43.1	5105.	5105.	3733.
.0840	16.71	4.678	42.7	5084.	5084.	3739.
.0850	16.71	4.721	42.2	5062.	5062.	3745.
.0860	16.71	4.763	41.8	5042.	5042.	3751.
.0870	16.71	4.804	41.4	5021.	5021.	3757.
.0880	16.71	4.845	41.0	5001.	5001.	3763.
.0890	16.71	4.886	40.6	4981.	4981.	3769.
.0900	16.71	4.927	40.1	4962.	4962.	3775.
.0910	16.71	4.967	39.7	4943.	4943.	3780.
.0920	16.71	5.006	39.3	4924.	4924.	3786.
.0930	16.71	5.045	38.9	4906.	4906.	3792.
.0940	16.71	5.084	38.5	4888.	4888.	3798.
.0950	16.71	5.122	38.1	4870.	4870.	3803.
.0960	16.71	5.150	37.7	4853.	4853.	3809.
.0970	16.71	5.193	37.3	4835.	4835.	3814.
.0980	16.71	5.235	36.9	4819.	4819.	3820.
.0990	16.71	5.271	36.5	4802.	4802.	3825.
.1000	16.71	5.308	36.1	4786.	4786.	3830.
.1010	16.71	5.343	35.7	4770.	4770.	3836.
.1020	16.71	5.379	35.3	4754.	4754.	3841.
.1030	16.71	5.414	34.9	4739.	4739.	3846.
.1040	16.71	5.449	34.5	4724.	4724.	3851.
.1050	16.71	5.483	34.1	4709.	4709.	3857.
.1060	16.71	5.517	33.7	4694.	4694.	3862.
.1070	16.71	5.551	33.3	4680.	4680.	3867.
.1080	16.71	5.584	32.9	4666.	4666.	3872.
.1090	16.71	5.616	32.6	4652.	4652.	3877.
.1100	16.71	5.649	32.2	4638.	4638.	3881.
.1110	16.71	5.681	31.8	4625.	4625.	3886.
.1120	16.71	5.712	31.4	4612.	4612.	3891.
.1130	16.71	5.744	31.0	4599.	4599.	3896.
.1140	16.71	5.774	30.6	4586.	4586.	3900.
.1150	16.71	5.805	30.3	4574.	4574.	3905.
.1160	16.71	5.835	29.9	4562.	4562.	3910.
.1170	16.71	5.865	29.5	4550.	4550.	3914.
.1180	16.71	5.894	29.1	4538.	4538.	3919.

.1190	16.71	5.923	28.8	4527.	4527.	3923.
.1200	16.71	5.951	28.4	4515.	4515.	3927.
.1210	16.71	5.950	28.0	4504.	4504.	3932.
.1220	16.71	6.007	27.6	4493.	4493.	3936.
.1230	16.71	6.035	27.3	4482.	4482.	3940.
.1240	16.71	6.052	26.9	4472.	4472.	3944.
.1250	16.71	6.089	26.5	4462.	4462.	3949.
.1260	16.71	6.115	26.2	4451.	4451.	3953.
.1270	16.71	6.141	25.8	4442.	4442.	3957.
.1280	16.71	6.157	25.4	4432.	4432.	3961.
.1290	16.71	6.192	25.1	4422.	4422.	3965.
.1300	16.71	6.217	24.7	4413.	4413.	3968.
.1310	16.71	6.241	24.3	4404.	4404.	3972.
.1320	16.71	6.255	24.0	4395.	4395.	3976.
.1330	16.71	6.259	23.6	4386.	4386.	3980.
.1340	16.71	6.313	23.3	4377.	4377.	3983.
.1350	16.71	6.336	22.9	4368.	4368.	3987.
.1360	16.71	6.358	22.5	4360.	4360.	3991.
.1370	16.71	6.361	22.2	4352.	4352.	3994.
.1380	16.71	6.403	21.8	4344.	4344.	3998.
.1390	16.71	6.424	21.5	4336.	4336.	4001.
.1400	16.71	6.446	21.1	4328.	4328.	4004.
.1410	16.71	6.467	20.8	4321.	4321.	4008.
.1420	16.71	6.487	20.4	4313.	4313.	4011.
.1430	16.71	6.507	20.0	4306.	4306.	4014.
.1440	16.71	6.527	19.7	4299.	4299.	4017.
.1450	16.71	6.547	19.3	4292.	4292.	4020.
.1460	16.71	6.555	19.0	4285.	4285.	4023.
.1470	16.71	6.565	18.6	4279.	4279.	4026.
.1480	16.71	6.603	18.3	4272.	4272.	4029.
.1490	16.71	6.621	17.9	4266.	4266.	4032.
.1500	16.71	6.639	17.6	4260.	4260.	4035.
.1510	16.71	6.657	17.2	4254.	4254.	4038.
.1520	16.71	6.674	16.9	4248.	4248.	4041.
.1530	16.71	6.690	16.5	4242.	4242.	4043.
.1540	16.71	6.707	16.2	4236.	4236.	4046.
.1550	16.71	6.723	15.8	4231.	4231.	4048.
.1560	16.71	6.738	15.5	4225.	4225.	4051.
.1570	16.71	6.754	15.2	4220.	4220.	4053.
.1580	16.71	6.759	14.8	4215.	4215.	4056.
.1590	16.71	6.783	14.5	4210.	4210.	4058.
.1600	16.71	6.798	14.1	4205.	4205.	4061.
.1610	16.71	6.812	13.8	4201.	4201.	4063.
.1620	16.71	6.825	13.4	4196.	4196.	4065.
.1630	16.71	6.838	13.1	4191.	4191.	4067.
.1640	16.71	6.851	12.7	4187.	4187.	4069.
.1650	16.71	6.854	12.4	4183.	4183.	4071.
.1660	16.71	6.876	12.1	4179.	4179.	4073.
.1670	16.71	6.838	11.7	4175.	4175.	4075.
.1680	16.71	6.900	11.4	4171.	4171.	4077.
.1690	16.71	6.911	11.0	4167.	4167.	4079.
.1700	16.71	6.922	10.7	4164.	4164.	4081.
.1710	16.71	6.932	10.4	4160.	4160.	4082.
.1720	16.71	6.942	10.0	4157.	4157.	4084.
.1730	16.71	6.952	9.7	4154.	4154.	4086.
.1740	16.71	6.952	9.3	4150.	4150.	4087.
.1750	16.71	6.971	9.0	4147.	4147.	4089.
.1760	16.71	6.980	8.7	4145.	4145.	4090.
.1770	16.71	6.988	8.3	4142.	4142.	4091.
.1780	16.71	6.996	8.0	4139.	4139.	4093.

.1790	16.71	7.004	7.7	4137.	4137.	4094.
.1800	16.71	7.012	7.3	4134.	4134.	4095.
.1810	16.71	7.019	7.0	4132.	4132.	4096.
.1820	16.71	7.026	6.6	4130.	4130.	4098.
.1830	16.71	7.032	6.3	4127.	4127.	4099.
.1840	16.71	7.038	6.0	4125.	4125.	4100.
.1850	16.71	7.044	5.6	4124.	4124.	4101.
.1860	16.71	7.050	5.3	4122.	4122.	4101.
.1870	16.71	7.055	5.0	4120.	4120.	4102.
.1880	16.71	7.059	4.6	4119.	4119.	4103.
.1890	16.71	7.064	4.3	4117.	4117.	4104.
.1900	16.71	7.068	3.9	4116.	4116.	4105.
.1910	16.71	7.072	3.6	4115.	4115.	4105.
.1920	16.71	7.075	3.3	4113.	4113.	4106.
.1930	16.71	7.078	2.9	4112.	4112.	4106.
.1940	16.71	7.081	2.6	4112.	4112.	4107.
.1950	16.71	7.084	2.3	4111.	4111.	4107.
.1960	16.71	7.086	1.9	4110.	4110.	4107.
.1970	16.71	7.087	1.6	4110.	4110.	4108.
.1980	16.71	7.089	1.3	4109.	4109.	4108.
.1990	16.71	7.090	0.9	4109.	4109.	4108.
.2000	16.71	7.091	0.6	4108.	4108.	4108.
.2010	16.71	7.091	0.3	4108.	4108.	4108.
.2020	16.71	7.091	-0.1	4108.	4108.	4108.

FORTRAN STOP

TOTAL CAVITATION
ASSUMED

1ST SHOT BSMUZZLE BRAKE $B=0.7$

75° ELEVATION

NO OIL FLOWS INTO PASSAGE
 NO FORCE ACTING AT SLEEVE DUE TO PRESSURE
 (ASSUME FLOW RATE IS SMALL)

$$A_0 = 1.375 \text{ IN}^2$$

$$V_0 = N_2 \Rightarrow 5000 \text{ IN}^3$$

$$P_0 = N_2 \Rightarrow 2500 \text{ PSI}$$

2ND SHOT BS

$$V_0 = N_2 \Rightarrow 3950 \text{ IN}^3$$

$$P_0 = N_2 \Rightarrow 3400 \text{ PSI}$$

10939.7507	1.0451 7584215.0000	0.0905	7091.1136			
.0010	0.12	0.001	1.2	2500.	109.	2500.
.0020	0.24	0.003	3.7	2500.	149.	2500.
.0030	0.49	0.009	8.2	2502.	247.	2500.
.0040	0.96	0.020	15.5	2507.	447.	2500.
.0050	1.74	0.040	25.3	2519.	795.	2501.
.0060	2.59	0.071	35.9	2541.	1323.	2502.
.0070	4.43	0.112	45.8	2571.	2032.	2502.
.0080	6.29	0.152	53.9	2690.	2817.	2504.
.0090	8.42	0.219	60.2	3161.	3252.	2507.
.0100	10.75	0.252	65.0	3502.	3652.	2510.
.0110	13.25	0.349	68.6	3908.	4023.	2514.
.0120	15.89	0.419	71.3	4322.	4306.	2519.
.0123	15.71	0.441	72.0	4432.	4473.	2520.
.0130	15.71	0.491	72.3	4552.	4585.	2524.
.0140	16.71	0.553	72.5	4917.	4945.	2529.
.0150	16.71	0.635	72.7	5141.	5155.	2535.
.0160	16.71	0.709	72.8	5331.	5350.	2540.
.0170	16.71	0.731	72.8	5491.	5507.	2546.
.0180	16.71	0.854	72.8	5626.	5640.	2552.
.0190	16.71	0.927	72.6	5739.	5750.	2559.
.0200	16.71	0.999	72.5	5833.	5843.	2565.
.0210	16.71	1.072	72.3	5910.	5915.	2571.
.0220	16.71	1.144	72.0	5973.	5977.	2578.
.0230	16.71	1.216	71.8	6022.	6026.	2584.
.0240	16.71	1.257	71.5	6060.	6065.	2591.
.0250	16.71	1.359	71.1	6088.	6092.	2598.
.0260	16.71	1.430	70.8	6106.	6110.	2604.
.0270	16.71	1.500	70.4	6117.	6120.	2611.
.0280	16.71	1.571	70.0	6121.	6123.	2618.
.0290	16.71	1.640	69.6	6118.	6120.	2625.
.0300	16.71	1.710	69.2	6110.	6112.	2631.
.0310	16.71	1.779	68.8	6097.	6095.	2638.
.0320	16.71	1.847	68.4	6080.	6081.	2645.
.0330	16.71	1.915	67.9	6059.	6050.	2652.
.0340	16.71	1.983	67.5	6036.	6035.	2659.
.0350	16.71	2.051	67.0	6009.	6010.	2666.
.0360	16.71	2.117	66.6	5981.	5981.	2672.
.0370	16.71	2.184	66.1	5950.	5950.	2679.
.0380	16.71	2.250	65.7	5918.	5915.	2686.
.0390	16.71	2.315	65.2	5884.	5884.	2693.
.0400	16.71	2.380	64.7	5850.	5850.	2699.
.0410	16.71	2.445	64.3	5814.	5814.	2706.
.0420	16.71	2.509	63.8	5778.	5773.	2713.
.0430	16.71	2.572	63.3	5742.	5742.	2720.
.0440	16.71	2.635	62.9	5705.	5705.	2726.
.0450	16.71	2.698	62.4	5668.	5666.	2733.
.0460	16.71	2.750	61.9	5631.	5631.	2740.
.0470	16.71	2.822	61.5	5594.	5594.	2746.
.0480	16.71	2.853	61.0	5557.	5557.	2753.
.0490	16.71	2.944	60.5	5520.	5520.	2759.
.0500	16.71	3.004	60.1	5483.	5483.	2766.
.0510	16.71	3.054	59.6	5447.	5447.	2772.
.0520	16.71	3.123	59.2	5411.	5411.	2779.
.0530	16.71	3.182	58.7	5376.	5376.	2785.
.0540	16.71	3.241	58.3	5341.	5341.	2792.
.0550	16.71	3.299	57.8	5306.	5305.	2798.
.0560	16.71	3.355	57.4	5272.	5272.	2804.
.0570	16.71	3.413	56.9	5238.	5233.	2811.
.0580	16.71	3.470	56.5	5205.	5205.	2817.

.0590	16.71	3.525	56.0	5172.	5172.	2823.
.0600	16.71	3.552	55.6	5140.	5140.	2830.
.0610	16.71	3.538	55.1	5106.	5106.	2836.
.0620	16.71	3.592	54.7	5077.	5077.	2842.
.0630	16.71	3.747	54.3	5046.	5046.	2848.
.0640	16.71	3.801	53.8	5016.	5016.	2854.
.0650	16.71	3.855	53.4	4987.	4987.	2860.
.0660	16.71	3.908	53.0	4957.	4957.	2866.
.0670	16.71	3.951	52.5	4929.	4929.	2872.
.0680	16.71	4.013	52.1	4900.	4900.	2878.
.0690	16.71	4.065	51.7	4872.	4872.	2884.
.0700	16.71	4.116	51.3	4845.	4845.	2890.
.0710	16.71	4.168	50.9	4818.	4818.	2896.
.0720	16.71	4.219	50.5	4792.	4792.	2902.
.0730	16.71	4.255	50.1	4755.	4755.	2908.
.0740	16.71	4.318	49.7	4740.	4740.	2914.
.0750	16.71	4.368	49.2	4715.	4715.	2920.
.0760	16.71	4.417	48.8	4690.	4690.	2925.
.0770	16.71	4.465	48.4	4666.	4666.	2931.
.0780	16.71	4.514	48.0	4642.	4642.	2937.
.0790	16.71	4.552	47.6	4619.	4619.	2943.
.0800	16.71	4.599	47.2	4596.	4596.	2948.
.0810	16.71	4.656	46.8	4573.	4573.	2954.
.0820	16.71	4.703	46.5	4551.	4551.	2959.
.0830	16.71	4.749	46.1	4529.	4529.	2965.
.0840	16.71	4.795	45.7	4507.	4507.	2971.
.0850	16.71	4.840	45.3	4486.	4486.	2976.
.0860	16.71	4.885	44.9	4465.	4465.	2982.
.0870	16.71	4.930	44.5	4445.	4445.	2987.
.0880	16.71	4.974	44.1	4424.	4424.	2992.
.0890	16.71	5.018	43.8	4405.	4405.	2998.
.0900	16.71	5.052	43.4	4385.	4385.	3003.
.0910	16.71	5.105	43.0	4366.	4366.	3008.
.0920	16.71	5.148	42.6	4347.	4347.	3014.
.0930	16.71	5.190	42.2	4328.	4328.	3019.
.0940	16.71	5.232	41.9	4310.	4310.	3024.
.0950	16.71	5.274	41.5	4292.	4292.	3029.
.0960	16.71	5.315	41.1	4274.	4274.	3034.
.0970	16.71	5.356	40.8	4257.	4257.	3040.
.0980	16.71	5.397	40.4	4240.	4240.	3045.
.0990	16.71	5.437	40.0	4223.	4223.	3050.
.1000	16.71	5.477	39.7	4207.	4207.	3055.
.1010	16.71	5.517	39.3	4190.	4190.	3060.
.1020	16.71	5.555	39.0	4174.	4174.	3065.
.1030	16.71	5.594	38.6	4158.	4158.	3070.
.1040	16.71	5.633	38.2	4143.	4143.	3074.
.1050	16.71	5.671	37.9	4128.	4128.	3079.
.1060	16.71	5.709	37.5	4113.	4113.	3084.
.1070	16.71	5.746	37.2	4098.	4098.	3089.
.1080	16.71	5.783	35.8	4083.	4083.	3094.
.1090	16.71	5.820	35.5	4069.	4069.	3098.
.1100	16.71	5.856	36.1	4055.	4055.	3103.
.1110	16.71	5.892	35.8	4041.	4041.	3108.
.1120	16.71	5.928	35.4	4028.	4028.	3112.
.1130	16.71	5.963	35.1	4014.	4014.	3117.
.1140	16.71	5.998	34.8	4001.	4001.	3121.
.1150	16.71	6.032	34.4	3988.	3988.	3126.
.1160	16.71	6.067	34.1	3975.	3975.	3130.
.1170	16.71	6.100	33.7	3963.	3963.	3135.
.1180	16.71	6.134	33.4	3950.	3950.	3139.

.1190	15.71	6.157	33.1	3938.	3935.	3144.
.1200	16.71	6.200	32.7	3926.	3926.	3148.
.1210	16.71	6.233	32.4	3914.	3914.	3152.
.1220	16.71	6.265	32.0	3903.	3903.	3156.
.1230	16.71	6.297	31.7	3891.	3891.	3161.
.1740	16.71	6.328	31.4	3880.	3880.	3165.
.1250	16.71	6.350	31.0	3869.	3869.	3169.
.1260	16.71	6.390	30.7	3858.	3858.	3173.
.1270	16.71	6.421	30.4	3846.	3846.	3177.
.1280	16.71	6.451	30.1	3837.	3837.	3181.
.1290	16.71	6.481	29.7	3827.	3827.	3185.
.1300	16.71	6.511	29.4	3817.	3817.	3189.
.1310	16.71	6.540	29.1	3807.	3807.	3193.
.1320	16.71	6.559	28.8	3797.	3797.	3197.
.1330	16.71	6.597	28.4	3787.	3787.	3201.
.1340	16.71	6.626	28.1	3776.	3776.	3205.
.1350	16.71	6.654	27.8	3768.	3768.	3209.
.1360	16.71	6.681	27.5	3759.	3759.	3212.
.1370	16.71	6.709	27.1	3750.	3750.	3216.
.1380	16.71	6.736	25.8	3741.	3741.	3220.
.1390	16.71	6.762	25.5	3732.	3732.	3223.
.1400	16.71	6.789	25.2	3724.	3724.	3227.
.1410	16.71	6.815	25.9	3715.	3715.	3231.
.1420	16.71	6.840	25.6	3707.	3707.	3234.
.1430	16.71	6.866	25.2	3699.	3699.	3238.
.1440	16.71	6.891	24.9	3691.	3691.	3241.
.1450	16.71	6.916	24.6	3683.	3683.	3245.
.1460	16.71	6.940	24.3	3675.	3675.	3248.
.1470	16.71	6.954	24.0	3667.	3667.	3251.
.1480	16.71	6.988	23.7	3660.	3660.	3255.
.1490	16.71	7.011	23.4	3653.	3653.	3258.
.1500	16.71	7.035	23.0	3645.	3645.	3261.
.1510	16.71	7.058	22.7	3638.	3638.	3264.
.1520	16.71	7.080	22.4	3631.	3631.	3268.
.1530	16.71	7.102	22.1	3624.	3624.	3271.
.1540	16.71	7.124	21.8	3618.	3618.	3274.
.1550	16.71	7.146	21.5	3611.	3611.	3277.
.1560	16.71	7.157	21.2	3605.	3605.	3280.
.1570	16.71	7.188	20.9	3598.	3598.	3283.
.1580	16.71	7.209	20.6	3592.	3592.	3286.
.1590	16.71	7.230	20.3	3586.	3586.	3289.
.1600	16.71	7.250	20.0	3580.	3580.	3291.
.1610	16.71	7.270	19.7	3574.	3574.	3294.
.1620	16.71	7.289	19.4	3568.	3568.	3297.
.1630	16.71	7.308	19.1	3562.	3562.	3300.
.1640	16.71	7.327	18.8	3557.	3557.	3302.
.1650	16.71	7.346	18.5	3551.	3551.	3305.
.1660	16.71	7.364	18.2	3546.	3546.	3308.
.1670	16.71	7.382	17.9	3540.	3540.	3310.
.1680	16.71	7.400	17.6	3535.	3535.	3313.
.1690	16.71	7.417	17.3	3530.	3530.	3315.
.1700	16.71	7.434	17.0	3525.	3525.	3318.
.1710	16.71	7.451	16.7	3520.	3520.	3320.
.1720	16.71	7.458	16.4	3516.	3516.	3323.
.1730	15.71	7.434	15.1	3511.	3511.	3325.
.1740	16.71	7.500	15.8	3506.	3506.	3327.
.1750	16.71	7.515	15.5	3502.	3502.	3329.
.1760	16.71	7.531	15.2	3498.	3498.	3332.
.1770	16.71	7.546	14.9	3493.	3493.	3334.
.1780	16.71	7.550	14.6	3489.	3489.	3336.

.1790	16.71	7.575	14.3	3485.	3485.	3338.
.1800	16.71	7.584	14.0	3481.	3481.	3340.
.1810	16.71	7.603	13.7	3477.	3477.	3342.
.1820	16.71	7.616	13.4	3473.	3473.	3344.
.1830	16.71	7.630	13.1	3470.	3470.	3346.
.1840	16.71	7.543	12.8	3466.	3466.	3348.
.1850	16.71	7.555	12.5	3463.	3463.	3350.
.1860	16.71	7.558	12.2	3459.	3459.	3352.
.1870	16.71	7.550	11.9	3456.	3456.	3353.
.1880	16.71	7.591	11.6	3453.	3453.	3355.
.1890	16.71	7.703	11.3	3449.	3449.	3357.
.1900	16.71	7.714	11.0	3446.	3446.	3358.
.1910	16.71	7.725	10.8	3443.	3443.	3360.
.1920	16.71	7.736	10.5	3440.	3440.	3362.
.1930	16.71	7.746	10.2	3438.	3438.	3363.
.1940	16.71	7.755	9.9	3435.	3435.	3365.
.1950	16.71	7.766	9.6	3432.	3432.	3366.
.1960	16.71	7.775	9.3	3430.	3430.	3367.
.1970	16.71	7.784	9.0	3427.	3427.	3369.
.1980	16.71	7.793	8.7	3425.	3425.	3370.
.1990	16.71	7.802	8.4	3422.	3422.	3371.
.2000	16.71	7.810	8.1	3420.	3420.	3372.
.2010	16.71	7.818	7.9	3418.	3418.	3374.
.2020	16.71	7.826	7.6	3416.	3416.	3375.
.2030	16.71	7.833	7.3	3414.	3414.	3376.
.2040	16.71	7.840	7.0	3412.	3412.	3377.
.2050	16.71	7.847	6.7	3410.	3410.	3378.
.2060	16.71	7.854	6.4	3408.	3408.	3379.
.2070	16.71	7.860	6.1	3407.	3407.	3380.
.2080	16.71	7.866	5.8	3405.	3405.	3381.
.2090	16.71	7.872	5.5	3404.	3404.	3382.
.2100	16.71	7.877	5.3	3402.	3402.	3382.
.2110	16.71	7.882	5.0	3401.	3401.	3383.
.2120	16.71	7.887	4.7	3400.	3400.	3384.
.2130	16.71	7.892	4.4	3398.	3398.	3385.
.2140	16.71	7.896	4.1	3397.	3397.	3385.
.2150	16.71	7.900	3.8	3396.	3396.	3386.
.2160	16.71	7.903	3.5	3395.	3395.	3386.
.2170	16.71	7.907	3.2	3394.	3394.	3387.
.2180	16.71	7.910	3.0	3393.	3393.	3387.
.2190	16.71	7.913	2.7	3393.	3393.	3388.
.2200	16.71	7.915	2.4	3392.	3392.	3388.
.2210	16.71	7.917	2.1	3391.	3391.	3388.
.2220	16.71	7.919	1.8	3391.	3391.	3389.
.2230	16.71	7.921	1.5	3391.	3391.	3389.
.2240	16.71	7.922	1.2	3390.	3390.	3389.
.2250	16.71	7.924	0.9	3390.	3390.	3389.
.2260	16.71	7.924	0.7	3390.	3390.	3389.
.2270	16.71	7.925	0.4	3390.	3390.	3389.
.2280	16.71	7.925	0.1	3389.	3389.	3389.
.2290	16.71	7.925	-0.2	3389.	3389.	3389.

FORTRAN STOP

```

G=32.174
PI=3.141592
VC=1147.
UM=16.675
DB=5.15
AF=PI*DB*DB/4.
WS=24.*PI/(20.*DB)
D=VC+AB*UM*12.
RL=5.75
PIP=.1051
WP=45.
VM=2710.
PMA=47500.
RHDC=.05
RTB=11563400.
GAMMA=1.235
WC=26.
WA=4.
CK=1./7.
GAMMA=GAMMA-1.
GAMAP=GAMMA+1.
GAMA1=GAMAP/GAMMA
GAMA2=2.*GAMMA/(1.-GAMMA)
RATIO=1.+WC/(5.*WP)
RTD=RTB-GAMMA*(1./5.+(1.+CK)*WP/(2.*WC))*VM*VM
SIG=D*SQRT(((GAMAP/2.)*GAMA1)/(GAMMA*RTD*RATIO))/(AB*GAMMA*5.)
PM=WC*RTD*RATIO*12./(G*D)
WRITE (*,'(5F13.4)') PM,RATIO,RTD,SIG,D
WFFF=WP+(WC+WA)/2.
A=VM/(1.-(PM*AB*G*UM)/(VM*VM*WFFF))
P=((A/VM)-1.)*UM
TM=2.*UM/VM
UG=EXP(LOG(UM)-2.-UM/3)
DP=2.
DP=2.75
DS=1.75
DPASS=1.5
WR=4000.
BULK=150000.
RETA=.7
PHDUIL=.0305
THETA=75.*PI/180.
UB=.25
DT=.001
APR=PI*(DP*DP-DR*DR)/4.
AS=PI*DS*DS/4.
AS=0.
PEQ=3400.
PE=PEQ
PR=100.
WUIL=RHDDUIL*APR*RL*12.*(4.+(PE+3.*PR)/BULK)
US=.05
W1=.5
W2=.25
S=400.
FGF=WR*(SIN(THETA)-UB*COS(THETA))
PRLF=3500.
F2=0.
AD2=0.
AD1=1.375

```

```

VC=3050.
CK2=1.3
P1=PF
P2=PR
XR=0.
YRD=0.
U=UR
T=0.
P1K=0.
P2K=0.
XPK=0.
XRDL=0.
TM1=TM+UT
TM2=TM-UT
50 C1=-1.
C2=1.
C3=-1.
DELP1=0.
DELP2=0.
DELXR=0.
DELXRD=0.
IF(T.GT.TM) GO TO 50
IF(T.LE.TM2) GO TO 70
IF(T.LT.TM) DT=TM-T
IF(T.LT.TM) GO TO 70
DT=TM1-TM-DT
GO TO 70
60 DT=TM1-TM
70 DO 300 I=1,4
C1=C1+2.*C2
C2=C2-.5
C1=1.5-C1*.5+C3
C3=0.
P1EFF=P1+U1*P1K
P2EFF=P2+U1*P2K
YREFF=XR+U1*XPK
XRDEFF=XRD+U1*XRDL
IF(P2EFF.GE.PE) E2=.75
F1=1.-E2
DP1=P1EFF-PE
IF(DP1.GE.PRLF) AD2=0.
DP2=P2EFF-PE
IF(DP2.LE.0.) DP2=0.
AD=AD1+AD2
R1=115.5*AD
DB1=(B1*E1/(12.*APR))**2.
A3=((RL-YREFF)/(DT*BJLK))**2.
B31=(-(2.*XRDEFF*SQRT(A3)+DB1/2.))
C31=YREFF**2.-DB1*U1
P1K=(-B31-SQRT(B31*B31-4.*A3*C31))/(2.*A3)
DB2=(B1*E2/(35.*APR))**2.
B32=(-(2.*XRDEFF*SQRT(A3)+DB2/2.))
C32=YRDEFF**2.-DB2*U2
FLOWND=B32*B32-4.*A3*C32
IF(FLOWND.LE.0.) FLOWND=0.
P2K=(-B32-SQRT(FLOWND))/(2.*A3)
YRK=DT*XRDEFF
IF(T.GE.TM) GO TO 100
DELT=D1*DT/2.
VP=A*U/(B+U)

```

```

RR=B+U-(VP+A)*DELT
CC=-((VP+A)*U+VP*B)*DELT
DELU=(-BR+SQRT(BB*BB-4.*CC))/2.
DELT2=(B*LOG(1.+DELU/J)+DELU)/A
UEFF=U+DELU+(D1*DT-DELT2)*A*(U+DELU)/(B+U+DELU)
FGAS=(UEFF/S)*A*A*B*UEFF/(B+UEFF)**3.
GO TO 200
100 TEFF=T-TM+D1*DT
FGAS=P*A*A*(1.-BETA)*(1.+TEFF/SIG)**GAMA2
200 FSEAL1=PI*US*DR*(N1*S*4.+N2*(P1EFF+3.*P2EFF))
FSEAL2=PI*US*DS*(N1*S*2.+N2*(PE+PK))
FSEAL=FSEAL1
XRDL=DT*(S/NK)*(FGAS-APK*(P1EFF+3.*P2EFF)+AS*(PE+PK)-FSEAL+FGF)
DELP1=DELP1+C1*P1K
DELP2=DELP2+C1*P2K
DELP3=DELP3+C1*P3K
DELP4=DELP4+C1*P4K
300 CONTINUE
P1=P1+DELP1/6.
P2=P2+DELP2/6.
P3=P3+DELP3/6.
P4=P4+DELP4/6.
U=UEFF
T=T+DT
DWDIL=RHDIL+4PR*(RL-XR)*12.*(4.+(P1+3.*P2)/BULK)-WJIL
PHDE=RHDIL*(1.+PE/BULK)
DV=DWJIL/RHJE+AS*XR*12.
PE=PE0/(1.+DV/VJ)**CK2
PRINT 400,T,U,XR,XRD,P1,P2,PE
400 FORMAT(3X,F5.4,5X,F5.2,5X,F5.3,5X,F5.1,5X,F5.0,5X,F5.0,5X,F5.0)
IF(XR.LE.0.) GO TO 500
IF(XR.GE.8.75) GO TO 500
GO TO 50
500 STOP
END

```

10839.7507		1.0451	7584215.0000	0.0905	7091.1138	
.0010	0.12	0.001	1.2	3400.	109.	3400.
.0020	0.24	0.003	3.6	3400.	148.	3400.
.0030	0.49	0.008	8.2	3402.	240.	3400.
.0040	0.95	0.020	15.4	3407.	444.	3401.
.0050	1.74	0.040	25.2	3419.	790.	3401.
.0060	2.89	0.071	35.8	3441.	1315.	3403.
.0070	4.43	0.111	45.6	3472.	2023.	3404.
.0080	6.29	0.151	53.7	3507.	2891.	3406.
.0090	8.42	0.218	50.0	3638.	3795.	3409.
.0100	10.75	0.251	54.7	4156.	4281.	3414.
.0110	13.25	0.347	58.3	4619.	4703.	3420.
.0120	15.89	0.417	71.0	5020.	5090.	3428.
.0123	15.71	0.439	71.6	5143.	5208.	3430.
.0130	15.71	0.459	71.8	5337.	5443.	3430.
.0140	15.71	0.551	72.0	5677.	5723.	3445.
.0150	15.71	0.553	72.1	5920.	5955.	3454.
.0150	15.71	0.705	72.1	6124.	6155.	3464.
.0170	15.71	0.777	72.1	6296.	6321.	3474.
.0180	15.71	0.849	71.9	6439.	6460.	3484.
.0190	15.71	0.921	71.8	6558.	6575.	3495.
.0200	15.71	0.992	71.5	6557.	6672.	3506.
.0210	15.71	1.054	71.2	6738.	6750.	3517.
.0220	15.71	1.135	70.9	6802.	6812.	3528.
.0230	15.71	1.205	70.5	6853.	6651.	3539.
.0240	15.71	1.276	70.2	6891.	6635.	3550.
.0250	15.71	1.346	59.8	6918.	6924.	3562.
.0260	15.71	1.415	59.4	5936.	6941.	3573.
.0270	15.71	1.455	53.9	5946.	6950.	3585.
.0280	15.71	1.553	58.5	5948.	6951.	3597.
.0290	15.71	1.622	58.0	5944.	6945.	3608.
.0300	15.71	1.659	57.5	5934.	6930.	3620.
.0310	15.71	1.757	57.0	5919.	6921.	3631.
.0320	15.71	1.823	55.5	5900.	6902.	3643.
.0330	15.71	1.889	55.0	5878.	6879.	3655.
.0340	15.71	1.955	65.5	6853.	6854.	3666.
.0350	15.71	2.020	54.9	6824.	6825.	3678.
.0360	15.71	2.085	54.4	6794.	6795.	3690.
.0370	15.71	2.149	53.9	6762.	6763.	3701.
.0380	15.71	2.213	53.3	6728.	6727.	3713.
.0390	15.71	2.276	52.8	6694.	6694.	3724.
.0400	15.71	2.338	52.2	6658.	6655.	3736.
.0410	15.71	2.400	61.7	6621.	6622.	3747.
.0420	15.71	2.462	61.2	6584.	6585.	3759.
.0430	15.71	2.523	50.6	6547.	6547.	3770.
.0440	15.71	2.583	50.1	6510.	6510.	3782.
.0450	15.71	2.643	59.5	6472.	6472.	3793.
.0460	15.71	2.702	59.0	6435.	6435.	3804.
.0470	15.71	2.751	58.5	6398.	6398.	3815.
.0480	15.71	2.819	57.9	6361.	6361.	3827.
.0490	15.71	2.877	57.4	6324.	6324.	3838.
.0500	15.71	2.934	55.8	6288.	6288.	3849.
.0510	15.71	2.990	55.3	6252.	6252.	3860.
.0520	15.71	3.045	55.8	6216.	6215.	3871.
.0530	15.71	3.102	55.3	6181.	6181.	3882.
.0540	15.71	3.157	54.7	6147.	6147.	3892.
.0550	15.71	3.211	54.2	6113.	6113.	3903.
.0560	15.71	3.255	53.7	6079.	6079.	3914.
.0570	15.71	3.319	53.2	6046.	6046.	3925.
.0580	15.71	3.372	52.5	6014.	6014.	3935.

.0590	16.71	3.424	52.1	5982.	5982.	3946.
.0600	16.71	3.475	51.5	5951.	5951.	3956.
.0610	16.71	3.527	51.1	5921.	5921.	3967.
.0620	15.71	3.578	50.5	5891.	5891.	3977.
.0630	16.71	3.528	50.1	5851.	5851.	3987.
.0640	16.71	3.578	49.5	5832.	5832.	3997.
.0650	16.71	3.727	49.1	5804.	5804.	4008.
.0660	16.71	3.775	48.6	5776.	5776.	4018.
.0670	16.71	3.825	48.1	5749.	5749.	4028.
.0680	15.71	3.872	47.6	5722.	5722.	4038.
.0690	16.71	3.920	47.1	5696.	5696.	4047.
.0700	16.71	3.965	46.5	5670.	5670.	4057.
.0710	16.71	4.013	46.1	5645.	5645.	4067.
.0720	16.71	4.059	45.5	5620.	5620.	4077.
.0730	16.71	4.104	45.1	5596.	5596.	4086.
.0740	15.71	4.149	44.6	5572.	5572.	4096.
.0750	16.71	4.193	44.1	5549.	5549.	4105.
.0760	16.71	4.237	43.6	5526.	5526.	4115.
.0770	16.71	4.280	43.2	5503.	5503.	4124.
.0780	16.71	4.323	42.7	5482.	5482.	4133.
.0790	16.71	4.366	42.2	5460.	5460.	4143.
.0800	16.71	4.408	41.7	5439.	5439.	4152.
.0810	16.71	4.449	41.3	5418.	5418.	4161.
.0820	16.71	4.490	40.8	5398.	5398.	4170.
.0830	16.71	4.531	40.3	5378.	5378.	4179.
.0840	16.71	4.571	39.8	5359.	5359.	4187.
.0850	16.71	4.611	39.4	5339.	5339.	4196.
.0860	16.71	4.650	38.9	5321.	5321.	4205.
.0870	16.71	4.688	38.5	5302.	5302.	4213.
.0880	16.71	4.727	38.0	5284.	5284.	4222.
.0890	16.71	4.764	37.5	5267.	5267.	4230.
.0900	15.71	4.802	37.1	5250.	5250.	4239.
.0910	16.71	4.839	36.6	5233.	5233.	4247.
.0920	16.71	4.875	36.2	5216.	5216.	4255.
.0930	16.71	4.911	35.7	5200.	5200.	4263.
.0940	16.71	4.946	35.3	5184.	5184.	4271.
.0950	16.71	4.981	34.8	5168.	5168.	4279.
.0960	16.71	5.016	34.4	5153.	5153.	4287.
.0970	16.71	5.050	33.9	5138.	5138.	4295.
.0980	16.71	5.084	33.5	5123.	5123.	4303.
.0990	16.71	5.117	33.0	5109.	5109.	4310.
.1000	16.71	5.150	32.5	5095.	5095.	4318.
.1010	16.71	5.182	32.1	5081.	5081.	4325.
.1020	16.71	5.214	31.7	5068.	5068.	4333.
.1030	16.71	5.245	31.2	5054.	5054.	4340.
.1040	15.71	5.276	30.8	5041.	5041.	4347.
.1050	16.71	5.307	30.4	5029.	5029.	4355.
.1060	16.71	5.337	29.9	5016.	5016.	4362.
.1070	16.71	5.367	29.5	5004.	5004.	4369.
.1080	16.71	5.396	29.1	4992.	4992.	4376.
.1090	15.71	5.425	28.6	4981.	4981.	4382.
.1100	16.71	5.453	28.2	4969.	4969.	4389.
.1110	16.71	5.481	27.8	4958.	4958.	4396.
.1120	16.71	5.509	27.3	4947.	4947.	4402.
.1130	16.71	5.536	26.9	4936.	4936.	4409.
.1140	16.71	5.563	26.5	4926.	4926.	4415.
.1150	16.71	5.589	25.0	4916.	4916.	4421.
.1160	16.71	5.615	25.6	4906.	4906.	4428.
.1170	16.71	5.640	25.2	4896.	4896.	4434.
.1180	16.71	5.665	24.8	4886.	4886.	4440.

.1190	16.71	5.590	24.3	4877.	4877.	4446.
.1200	16.71	5.714	23.9	4868.	4868.	4452.
.1210	16.71	5.737	23.5	4859.	4859.	4457.
.1220	16.71	5.751	23.1	4850.	4850.	4463.
.1230	16.71	5.784	22.6	4842.	4842.	4468.
.1240	16.71	5.805	22.2	4833.	4833.	4474.
.1250	16.71	5.823	21.8	4825.	4825.	4479.
.1260	16.71	5.850	21.4	4817.	4817.	4485.
.1270	16.71	5.871	21.0	4809.	4809.	4490.
.1280	16.71	5.892	20.5	4802.	4802.	4495.
.1290	16.71	5.912	20.1	4794.	4794.	4500.
.1300	16.71	5.932	19.7	4787.	4787.	4505.
.1310	16.71	5.951	19.3	4780.	4780.	4510.
.1320	16.71	5.970	18.9	4773.	4773.	4514.
.1330	16.71	5.989	18.5	4767.	4767.	4519.
.1340	16.71	6.007	18.1	4760.	4760.	4524.
.1350	16.71	6.025	17.6	4754.	4754.	4528.
.1360	16.71	6.043	17.2	4748.	4748.	4532.
.1370	16.71	6.060	15.8	4742.	4742.	4537.
.1380	16.71	6.076	16.4	4736.	4736.	4541.
.1390	16.71	6.092	15.0	4730.	4730.	4545.
.1400	16.71	6.108	15.5	4725.	4725.	4549.
.1410	16.71	6.124	15.2	4720.	4720.	4553.
.1420	16.71	6.139	14.8	4714.	4714.	4556.
.1430	16.71	6.153	14.4	4709.	4709.	4560.
.1440	16.71	6.167	13.9	4705.	4705.	4564.
.1450	16.71	6.181	13.5	4700.	4700.	4567.
.1460	16.71	6.194	13.1	4695.	4695.	4570.
.1470	16.71	6.207	12.7	4691.	4691.	4574.
.1480	16.71	6.220	12.3	4687.	4687.	4577.
.1490	16.71	6.232	11.9	4683.	4683.	4580.
.1500	16.71	6.244	11.5	4679.	4679.	4583.
.1510	16.71	6.255	11.1	4675.	4675.	4586.
.1520	16.71	6.256	10.7	4671.	4671.	4589.
.1530	16.71	6.275	10.3	4668.	4668.	4591.
.1540	16.71	6.286	9.9	4664.	4664.	4594.
.1550	16.71	6.296	9.5	4661.	4661.	4596.
.1560	16.71	6.305	9.1	4658.	4658.	4599.
.1570	16.71	6.314	8.7	4655.	4655.	4601.
.1580	16.71	6.323	8.3	4652.	4652.	4603.
.1590	16.71	6.331	7.9	4650.	4650.	4605.
.1600	16.71	6.338	7.5	4647.	4647.	4607.
.1610	16.71	6.346	7.1	4645.	4645.	4609.
.1620	16.71	6.353	6.7	4643.	4643.	4611.
.1630	16.71	6.359	6.3	4640.	4640.	4612.
.1640	16.71	6.355	5.8	4638.	4638.	4614.
.1650	16.71	6.371	5.4	4637.	4637.	4615.
.1660	16.71	6.376	5.0	4635.	4635.	4617.
.1670	16.71	6.381	4.6	4633.	4633.	4618.
.1680	16.71	6.385	4.2	4632.	4632.	4619.
.1690	16.71	6.389	3.8	4631.	4631.	4620.
.1700	16.71	6.393	3.4	4629.	4629.	4621.
.1710	16.71	6.396	3.0	4628.	4628.	4622.
.1720	16.71	6.399	2.6	4627.	4627.	4623.
.1730	16.71	6.401	2.2	4627.	4627.	4623.
.1740	16.71	6.403	1.8	4626.	4626.	4624.
.1750	16.71	6.405	1.4	4626.	4626.	4624.
.1760	16.71	6.406	1.0	4625.	4625.	4625.
.1770	16.71	6.407	0.6	4625.	4625.	4625.
.1780	16.71	6.408	0.2	4625.	4625.	4625.

.1790
FORTRAN STOP

16.71

6.404

-0.2

4525.

4625.

4625. 31

1 SHOT BS

MUZZLE BRAKE BETA = .7

~~75°~~
75° ELEVATION ANGLE

SERVEE ADDS FORCE OUT OF BATTERY

OIL FLOWS INTO PASSAGE (KEEPS UP
WITH RECOIL)

$$A_0 = 1.250 \text{ in}^2$$

SINGLE ORIFICE

$$V_0 = 6000 \text{ in}^3$$

$$P_0 = 2500 \text{ PSI}$$

```
G=32.174
PI=3.141592
VC=1147.
UM=16.675
DB=6.15
AB=PI*DB*DB/4.
WS=24.*PI/(20.*DB)
D=VC+AB*UM*12.
RL=8.75
PIP=.1081
WP=96.
VM=2710.
PMAx=47500.
RHOC=.06
RTB=11563400.
GAMMA=1.238
WC=26.
WA=4.
CK=1./7.
GAMAM=GAMMA-1.
GAMAP=GAMMA+1.
GAMA1=GAMAP/GAMAM
GAMA2=2.*GAMMA/(1.-GAMMA)
RATIO=1.+WC/(5.*WP)
RTO=RTB-GAMAM*(1./6.+(1.+CK)*WP/(2.*WC))*VM*VM
SIG=D*SQRT(((GAMAP/2.)*GAMA1)/(GAMMA*RTO*RATIO))/(AB*GAMAM*6.)
PM=WC*RTO*RATIO*12./(5*D)
WRITE (*,'(5F13.4)') PM,RATIO,RTO,SIG,D
WEFF=WP+(WC+WA)/2.
A=VM/(1.-(PM*AB*G*UM)/(VM*VM*WEFF))
B=((A/VM)-1.)*UM
TM=2.*UM/VM
UD=EXP(LOG(JM)-2.-JM/B)
DR=2.
DP=2.75
DS=1.75
DPASS=1.5
WR=4000.
BULK=150000.
BETA=.7
RHOJIL=.0308
THETA=75.*PI/180.
UB=.25
DT=.001
APR=PI*(DP*DP-DK*DR)/4.
ASP=PI*(DS*DS-DPASS*DPASS)/4.
PED=2500.
PE=PED
PR=100.
WDIL=RHOJIL*APR*RL*12.*(4.+(PE+3.*PR)/BULK)
US=.05
W1=.5
W2=.25
S=400.
FGF=WR*(SIN(THETA)-UB*COS(THETA))
PRLF=3000.
E2=0.
A02=0.
A01=1.25
V0=6000.
```

```

CK2=1.3
P1=PE
P2=PR
XR=0.
XRD=0.
U=UJ
T=0.
P1K=0.
P2K=0.
XRK=0.
XRDL=0.
TM1=TM+DT
TM2=TM-DT
50 C1=-1.
C2=1.
C3=-1.
DELP1=0.
DELP2=0.
DELXR=0.
DELXRD=0.
IF(T.GT.TM) GO TO 60
IF(T.LE.TM2) GO TO 70
IF(T.LT.TM) DT=TM-T
IF(T.LT.TM) GO TO 70
DT=TM1-TM-DT
GO TO 70
60 DT=TM1-TM
70 DO 300 I=1,4
C1=C1+2.*C2
C2=C2-.5
D1=1.5-C1*.5+C3
C3=0.
P1EFF=P1+D1*P1K
P2EFF=P2+D1*P2K
XREFF=XR+D1*XRK
XRDEFF=XRD+D1*XKDL
IF(P2EFF.GE.PE) E2=.75
E1=1.-E2
DP1=P1EFF-PE
IF(DP1.GE.PRLF) A02=0.
DP2=P2EFF-PE
IF(DP2.LE.0.) DP2=0.
A0=A01+A02
B1=115.5*A0
D31=(B1*E1/(12.*APR))**2.
A3=((RL-XREFF)/(DT*BULK))**2.
B31=(-(2.*XRDEFF*SQRT(A3)+D31/2.))
C31=XRDEFF**2.-D31*DP1
P1K=(-B31-SQRT(B31*B31-4.*A3*C31))/(2.*A3)
D32=(B1*E2/(36.*APR))**2.
B32=(-(2.*XRDEFF*SQRT(A3)+D32/2.))
C32=XRDEFF**2.-D32*DP2
FLOWND=B32*B32-4.*A3*C32
IF(FLOWND.LE.0.) FLOWND=0.
P2K=(-B32-SQRT(FLOWND))/(2.*A3)
XRK=DT*XRDEFF
IF(T.GE.TM) GO TO 100
DELT=D1*DT/2.
VP=A*U/(B+J)
BB=B+U-(VP+A)*DELT

```

```

CC=-((VP+A)*U+VP*3)*DELT
DELU=(-BB+SQRT(BB*BB-4.*CC))/2.
DELT2=(B*LJG(1.+DELU/U)+DELU)/A
UEFF=U+DELU+(D1*DT-DELT2)*A*(U+DELU)/(B+U+DELU)
FGAS=(UEFF/G)*A*A*B*UEFF/(B+UEFF)**3.
GO TO 200
100 TEFF=T-TM+D1*DT
FGAS=PM*AB*(1.-BETA)*(1.+TE=F/SIG)**GAMA2
200 FSEAL1=PI*JS*JR*(W1*S*4.+W2*(P1EFF+3.*P2EFF))
FSEAL2=PI*JS*JS*(W1*S*2.+W2*(PE+PR))
FSEAL=FSEAL1+FSEAL2
XRDL=DT*(G/WR)*(FGAS-APR*(P1EFF+3.*P2EFF)+ASP*(PE+PR)-FSEAL+FGF)
DELP1=DELP1+C1*P1K
DELP2=DELP2+C1*P2K
DELXR=DELXR+C1*XR<
DELXRD=DELXRD+C1*XRDL
300 CONTINUE
P1=P1+DELP1/6.
P2=P2+DELP2/6.
XR=XR+DELXR/6.
XRD=XRD+DELXRD/6.
U=UEFF
T=T+DT
DWJIL=RHOJIL*APR*(RL-XR)*12.*(4.+(P1+3.*P2)/BULK)-WJIL
RHDE=RHOJIL*(1.+PE/BULK)
DV=DWJIL/RHJE+PI*DS*DS*XR*3.
PE=PEO/(1.+DV/VO)**CK2
PRINT 400,T,U,XR,XRD,P1,P2,PE
400 FORMAT(3X,F5.4,5X,F5.2,5X,F5.3,5X,F5.1,5X,F5.0,5X,F6.0,5X,F6.0)
IF(XRD.LE.0.) GO TO 500
IF(XR.GE.8.75) GO TO 500
GO TO 50
500 STOP
END

```

10839.7507		1.0451 7584215.0000		0.0905	7091.1138	
.0010	0.12	0.001	1.2	2500.	109.	2500.
.0020	0.24	0.003	3.7	2500.	149.	2500.
.0030	0.49	0.009	8.2	2502.	248.	2500.
.0040	0.96	0.020	15.6	2508.	448.	2500.
.0050	1.74	0.041	25.3	2522.	797.	2500.
.0060	2.89	0.071	36.0	2548.	1326.	2500.
.0070	4.43	0.112	45.8	2584.	2037.	2500.
.0080	6.29	0.162	53.9	2711.	2829.	2501.
.0090	8.42	0.220	50.3	3212.	3300.	2502.
.0100	10.75	0.292	55.1	3671.	3741.	2504.
.0110	13.25	0.349	58.7	4099.	4154.	2506.
.0120	15.89	0.419	71.4	4496.	4542.	2508.
.0123	15.71	0.441	72.1	4620.	4653.	2509.
.0130	16.71	0.492	72.4	4871.	4909.	2511.
.0140	16.71	0.564	72.6	5180.	5212.	2514.
.0150	16.71	0.637	72.8	5446.	5473.	2517.
.0160	16.71	0.710	72.8	5676.	5699.	2521.
.0170	16.71	0.782	72.8	5874.	5894.	2524.
.0180	16.71	0.855	72.7	6044.	6061.	2528.
.0190	16.71	0.928	72.6	6189.	6204.	2532.
.0200	16.71	1.000	72.4	6313.	6325.	2536.
.0210	16.71	1.073	72.2	6416.	6427.	2540.
.0220	16.71	1.145	71.9	6502.	6511.	2544.
.0230	16.71	1.216	71.6	6572.	6579.	2548.
.0240	16.71	1.288	71.3	6627.	6633.	2552.
.0250	16.71	1.359	70.9	6669.	6675.	2556.
.0260	16.71	1.430	70.5	6699.	6704.	2561.
.0270	16.71	1.500	70.1	6719.	6723.	2565.
.0280	16.71	1.570	59.6	6729.	6733.	2569.
.0290	16.71	1.539	59.2	6731.	6734.	2574.
.0300	16.71	1.709	58.7	6725.	6727.	2578.
.0310	16.71	1.777	68.3	6712.	6714.	2582.
.0320	16.71	1.845	67.8	6692.	6694.	2587.
.0330	16.71	1.912	67.3	6668.	6669.	2591.
.0340	15.71	1.979	65.8	6639.	6640.	2595.
.0350	16.71	2.046	66.3	6605.	6605.	2600.
.0360	16.71	2.112	65.8	6558.	6559.	2604.
.0370	16.71	2.178	65.3	6528.	6529.	2608.
.0380	16.71	2.243	64.8	6486.	6485.	2612.
.0390	16.71	2.307	64.3	6441.	6441.	2617.
.0400	16.71	2.371	63.8	6394.	6394.	2621.
.0410	16.71	2.435	63.3	6346.	6345.	2625.
.0420	16.71	2.498	62.8	6296.	6295.	2629.
.0430	16.71	2.561	62.3	6246.	6245.	2634.
.0440	16.71	2.623	61.8	6195.	6195.	2638.
.0450	16.71	2.684	61.3	6143.	6143.	2642.
.0460	16.71	2.745	60.8	6091.	6092.	2646.
.0470	16.71	2.806	60.3	6040.	6040.	2650.
.0480	16.71	2.866	59.8	5988.	5985.	2654.
.0490	16.71	2.925	59.3	5936.	5936.	2658.
.0500	16.71	2.984	58.8	5885.	5885.	2662.
.0510	16.71	3.043	58.4	5834.	5834.	2666.
.0520	16.71	3.101	57.9	5784.	5784.	2670.
.0530	16.71	3.159	57.4	5734.	5734.	2674.
.0540	16.71	3.216	56.9	5685.	5685.	2678.
.0550	16.71	3.273	56.5	5637.	5637.	2682.
.0560	16.71	3.329	56.0	5589.	5589.	2686.
.0570	16.71	3.385	55.5	5542.	5542.	2690.
.0580	16.71	3.440	55.1	5496.	5495.	2693.

.0590	16.71	3.445	54.6	5450.	5450.	2697.
.0600	16.71	3.549	54.2	5405.	5405.	2701.
.0610	16.71	3.603	53.7	5361.	5361.	2705.
.0620	16.71	3.657	53.3	5318.	5318.	2708.
.0630	16.71	3.710	52.8	5276.	5276.	2712.
.0640	16.71	3.752	52.4	5234.	5234.	2716.
.0650	16.71	3.814	51.9	5193.	5193.	2719.
.0660	16.71	3.855	51.5	5153.	5153.	2723.
.0670	16.71	3.917	51.1	5114.	5114.	2727.
.0680	16.71	3.968	50.6	5075.	5075.	2730.
.0690	16.71	4.019	50.2	5038.	5038.	2734.
.0700	16.71	4.059	49.8	5000.	5000.	2737.
.0710	16.71	4.118	49.4	4964.	4964.	2741.
.0720	16.71	4.168	49.0	4928.	4928.	2744.
.0730	16.71	4.216	48.6	4893.	4893.	2748.
.0740	16.71	4.265	48.2	4859.	4859.	2751.
.0750	16.71	4.313	47.7	4825.	4825.	2754.
.0760	16.71	4.350	47.3	4792.	4792.	2758.
.0770	16.71	4.407	46.9	4759.	4759.	2751.
.0780	16.71	4.454	46.5	4727.	4727.	2764.
.0790	16.71	4.500	46.2	4696.	4696.	2768.
.0800	16.71	4.546	45.8	4665.	4665.	2771.
.0810	16.71	4.592	45.4	4635.	4635.	2774.
.0820	16.71	4.637	45.0	4605.	4605.	2777.
.0830	16.71	4.682	44.6	4576.	4576.	2780.
.0840	16.71	4.726	44.2	4547.	4547.	2784.
.0850	16.71	4.770	43.8	4519.	4519.	2787.
.0860	16.71	4.814	43.5	4491.	4491.	2790.
.0870	16.71	4.857	43.1	4464.	4464.	2793.
.0880	16.71	4.900	42.7	4438.	4438.	2796.
.0890	16.71	4.943	42.4	4411.	4411.	2799.
.0900	16.71	4.985	42.0	4386.	4386.	2802.
.0910	16.71	5.027	41.6	4360.	4360.	2805.
.0920	16.71	5.068	41.3	4336.	4336.	2808.
.0930	16.71	5.109	40.9	4311.	4311.	2811.
.0940	16.71	5.150	40.5	4287.	4287.	2814.
.0950	16.71	5.190	40.2	4264.	4264.	2817.
.0960	16.71	5.230	39.8	4241.	4241.	2820.
.0970	16.71	5.270	39.5	4218.	4218.	2823.
.0980	16.71	5.309	39.1	4195.	4195.	2826.
.0990	16.71	5.348	38.8	4173.	4173.	2828.
.1000	16.71	5.387	38.4	4152.	4152.	2831.
.1010	16.71	5.425	38.1	4130.	4130.	2834.
.1020	16.71	5.463	37.8	4109.	4109.	2837.
.1030	16.71	5.501	37.4	4089.	4089.	2840.
.1040	16.71	5.538	37.1	4069.	4069.	2842.
.1050	16.71	5.575	36.7	4049.	4049.	2845.
.1060	16.71	5.611	36.4	4029.	4029.	2848.
.1070	16.71	5.648	36.1	4010.	4010.	2850.
.1080	16.71	5.684	35.8	3991.	3991.	2853.
.1090	16.71	5.719	35.4	3972.	3972.	2856.
.1100	16.71	5.754	35.1	3954.	3954.	2858.
.1110	16.71	5.789	34.8	3936.	3936.	2861.
.1120	16.71	5.824	34.4	3918.	3918.	2863.
.1130	16.71	5.858	34.1	3901.	3901.	2866.
.1140	16.71	5.892	33.8	3884.	3884.	2868.
.1150	16.71	5.926	33.5	3867.	3867.	2871.
.1160	16.71	5.959	33.2	3850.	3850.	2873.
.1170	16.71	5.992	32.9	3834.	3834.	2876.
.1180	16.71	6.025	32.5	3818.	3818.	2878.

.1190	16.71	6.057	32.2	3802.	3802.	2881.
.1200	16.71	6.089	31.9	3786.	3786.	2883.
.1210	16.71	6.121	31.6	3771.	3771.	2885.
.1220	16.71	6.153	31.3	3756.	3756.	2888.
.1230	16.71	6.184	31.0	3741.	3741.	2890.
.1240	16.71	6.215	30.7	3726.	3726.	2892.
.1250	16.71	6.245	30.4	3712.	3712.	2895.
.1260	16.71	6.275	30.1	3698.	3698.	2897.
.1270	16.71	6.305	29.8	3684.	3684.	2899.
.1280	16.71	6.335	29.5	3670.	3670.	2901.
.1290	16.71	6.354	29.2	3657.	3657.	2904.
.1300	16.71	6.393	28.9	3643.	3643.	2906.
.1310	16.71	6.422	28.6	3630.	3630.	2908.
.1320	16.71	6.450	28.3	3617.	3617.	2910.
.1330	16.71	6.479	28.0	3605.	3605.	2912.
.1340	16.71	6.506	27.7	3592.	3592.	2914.
.1350	16.71	6.534	27.4	3580.	3580.	2916.
.1360	16.71	6.551	27.1	3568.	3568.	2919.
.1370	16.71	6.588	26.8	3556.	3556.	2921.
.1380	16.71	6.615	26.5	3544.	3544.	2923.
.1390	16.71	6.641	26.3	3533.	3533.	2925.
.1400	16.71	6.557	25.0	3522.	3522.	2927.
.1410	16.71	6.593	25.7	3510.	3510.	2929.
.1420	16.71	6.719	25.4	3499.	3499.	2931.
.1430	16.71	6.744	25.1	3489.	3489.	2932.
.1440	16.71	6.759	24.8	3478.	3478.	2934.
.1450	16.71	6.794	24.5	3468.	3468.	2936.
.1460	16.71	6.818	24.3	3457.	3457.	2938.
.1470	16.71	6.842	24.0	3447.	3447.	2940.
.1480	16.71	6.856	23.7	3437.	3437.	2942.
.1490	16.71	6.890	23.4	3427.	3427.	2944.
.1500	16.71	6.913	23.2	3418.	3418.	2945.
.1510	16.71	6.936	22.9	3408.	3408.	2947.
.1520	16.71	6.959	22.6	3399.	3399.	2949.
.1530	16.71	6.981	22.3	3390.	3390.	2951.
.1540	16.71	7.003	22.1	3381.	3381.	2952.
.1550	16.71	7.025	21.8	3372.	3372.	2954.
.1560	16.71	7.047	21.5	3363.	3363.	2956.
.1570	16.71	7.068	21.2	3355.	3355.	2957.
.1580	16.71	7.089	21.0	3346.	3346.	2959.
.1590	16.71	7.110	20.7	3338.	3338.	2961.
.1600	16.71	7.131	20.4	3330.	3330.	2962.
.1610	16.71	7.151	20.2	3322.	3322.	2964.
.1620	16.71	7.171	19.9	3314.	3314.	2965.
.1630	16.71	7.191	19.6	3306.	3306.	2967.
.1640	16.71	7.210	19.4	3298.	3298.	2968.
.1650	16.71	7.230	19.1	3291.	3291.	2970.
.1660	16.71	7.249	18.8	3284.	3284.	2971.
.1670	16.71	7.257	18.6	3276.	3276.	2973.
.1680	16.71	7.286	18.3	3269.	3269.	2974.
.1690	16.71	7.304	18.1	3262.	3262.	2976.
.1700	16.71	7.322	17.8	3255.	3255.	2977.
.1710	16.71	7.340	17.5	3249.	3249.	2978.
.1720	16.71	7.357	17.3	3242.	3242.	2980.
.1730	16.71	7.374	17.0	3236.	3236.	2981.
.1740	16.71	7.391	16.8	3229.	3229.	2982.
.1750	16.71	7.408	16.5	3223.	3223.	2984.
.1760	16.71	7.424	16.2	3217.	3217.	2985.
.1770	16.71	7.440	15.0	3211.	3211.	2986.
.1780	16.71	7.456	15.7	3205.	3205.	2987.

.1790	16.71	7.472	15.5	3199.	3199.	2989.
.1800	16.71	7.487	15.2	3193.	3193.	2990.
.1810	16.71	7.502	15.0	3188.	3188.	2991.
.1820	16.71	7.517	14.7	3182.	3182.	2992.
.1830	16.71	7.531	14.4	3177.	3177.	2993.
.1840	16.71	7.546	14.2	3172.	3172.	2995.
.1850	16.71	7.560	13.9	3167.	3167.	2996.
.1860	16.71	7.574	13.7	3162.	3162.	2997.
.1870	16.71	7.587	13.4	3157.	3157.	2998.
.1880	16.71	7.500	13.2	3152.	3152.	2999.
.1890	16.71	7.613	12.9	3147.	3147.	3000.
.1900	16.71	7.626	12.7	3142.	3142.	3001.
.1910	16.71	7.639	12.4	3138.	3138.	3002.
.1920	16.71	7.651	12.2	3133.	3133.	3003.
.1930	16.71	7.563	11.9	3129.	3129.	3004.
.1940	16.71	7.575	11.7	3125.	3125.	3005.
.1950	16.71	7.587	11.4	3121.	3121.	3006.
.1960	16.71	7.598	11.2	3117.	3117.	3007.
.1970	16.71	7.709	10.9	3113.	3113.	3007.
.1980	16.71	7.720	10.7	3109.	3109.	3008.
.1990	16.71	7.730	10.4	3105.	3105.	3009.
.2000	16.71	7.741	10.2	3102.	3102.	3010.
.2010	16.71	7.751	9.9	3098.	3098.	3011.
.2020	16.71	7.751	9.7	3094.	3094.	3011.
.2030	16.71	7.770	9.5	3091.	3091.	3012.
.2040	16.71	7.779	9.2	3088.	3088.	3013.
.2050	16.71	7.789	9.0	3085.	3085.	3014.
.2060	16.71	7.797	8.7	3082.	3082.	3014.
.2070	16.71	7.806	8.5	3079.	3079.	3015.
.2080	16.71	7.814	8.2	3076.	3076.	3016.
.2090	16.71	7.822	8.0	3073.	3073.	3016.
.2100	16.71	7.830	7.7	3070.	3070.	3017.
.2110	16.71	7.838	7.5	3067.	3067.	3018.
.2120	16.71	7.845	7.3	3065.	3065.	3018.
.2130	16.71	7.852	7.0	3062.	3062.	3019.
.2140	16.71	7.859	6.8	3060.	3060.	3019.
.2150	16.71	7.866	6.5	3058.	3058.	3020.
.2160	16.71	7.872	6.3	3055.	3055.	3020.
.2170	16.71	7.879	6.0	3053.	3053.	3021.
.2180	16.71	7.884	5.8	3051.	3051.	3021.
.2190	16.71	7.890	5.6	3049.	3049.	3022.
.2200	16.71	7.896	5.3	3047.	3047.	3022.
.2210	16.71	7.901	5.1	3046.	3046.	3023.
.2220	16.71	7.906	4.8	3044.	3044.	3023.
.2230	16.71	7.910	4.6	3042.	3042.	3023.
.2240	16.71	7.915	4.4	3041.	3041.	3024.
.2250	16.71	7.919	4.1	3039.	3039.	3024.
.2260	16.71	7.923	3.9	3038.	3038.	3024.
.2270	16.71	7.927	3.6	3037.	3037.	3025.
.2280	16.71	7.930	3.4	3035.	3035.	3025.
.2290	16.71	7.934	3.1	3034.	3034.	3025.
.2300	16.71	7.937	2.9	3033.	3033.	3026.
.2310	16.71	7.940	2.7	3032.	3032.	3026.
.2320	16.71	7.942	2.4	3031.	3031.	3026.
.2330	16.71	7.944	2.2	3030.	3030.	3026.
.2340	16.71	7.946	1.9	3030.	3030.	3026.
.2350	16.71	7.948	1.7	3029.	3029.	3026.
.2360	16.71	7.950	1.5	3029.	3029.	3027.
.2370	16.71	7.951	1.2	3028.	3028.	3027.
.2380	16.71	7.952	1.0	3028.	3028.	3027.

.2390	16.71	7.953	0.7	3027.	3027.	3027.
.2400	16.71	7.954	0.5	3027.	3027.	3027.
.2410	16.71	7.954	0.3	3027.	3027.	3027.
.2420	16.71	7.954	0.0	3027.	3027.	3027.
.2430	16.71	7.954	-0.2	3027.	3027.	3027.

FORTRAN STOP

FIRE FROM LOAD
POSITION (3' OUT
OF BATTERY)

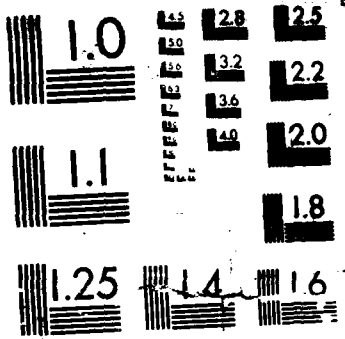

MICROCOPY RESOLUTION TEST CHART

```

G=32.174
PI=3.141592
VC=1147.
UM=16.675
DB=6.15
AB=PI*DB*DB/4.
WS=24.*PI/(20.*DB)
D=VC+AB*UM*12.
RL=8.75
PIP=.1081
WP=96.
VM=2710.
PMA=47500.
RHOC=.06
RTB=11563400.
GAMMA=1.238
WC=26.
WA=4.
CK=1./7.
GAMAM=GAMMA-1.
GAMAP=GAMMA+1.
GAMA1=GAMAP/GAMAM
GAMA2=2.*GAMMA/(1.-GAMMA)
RATIO=1.+WC/(5.*WP)
RTO=RTB-GAMAM*(1./6.+(1.+CK)*WP/(2.*WC))*VM*VM
SIG=D*SQRT(((GAMAP/2.)*GAMA1)/(GAMMA*RTO*RATIO))/(AB*GAMAM*6.)
PM=WC*RTO*RATIO*12./(G*D)
WRITE (*,'(5F13.4)') PM,RATIO,RTO,SIG,D
WEFF=WP+(WC+WA)/2.
A=VM/(1.-(PM*AB*G*UM)/(VM*VM*WEFF))
B=((A/VM)-1.)*UM
TM=2.*UM/VM
UD=EXP(LOG(JM)-2.-UM/B)
DR=2.
DP=2.75
DS=1.75
DPASS=1.5
WR=4000.
BULK=150000.
BETA=.7
RHOOIL=.0308.
THETA=75.*PI/180.
UB=.25
DT=.001
APR=PI*(DP*DP-DR*DR)/4.
AS=PI*DS*DS/4.
AS=0.
PEO=2500.
PE=PEO
PR=100.
WOIL=RHOIL*APR*RL*12.*(4.+(PE+3.*PR)/BULK)
US=.05
W1=.5
W2=.25
S=400.
FGF=WR*(SIN(THETA)-JB*CJS(THETA))
PRLF=3500.
E2=0.
AO2=0.
AO1=.875

```

```

VO=5000.
CK2=1.3
P1=PE
P2=PR
XR=0.
XRD=0.
U=UJ
T=0.
P1K=0.
P2K=0.
XRK=0.
XRDL=0.
TM1=TM+DT
TM2=TM-DT
50 C1=-1.
C2=1.
C3=-1.
DELP1=0.
DELP2=0.
DELXR=0.
DELXRD=0.
IF(T.GT.TM) GO TO 60
IF(T.LE.TM2) GO TO 70
IF(T.LT.TM) DT=TM-T
IF(T.LT.TM) GO TO 70
DT=TM1-TM-DT
GO TO 70
60 DT=TM1-TM
70 DO 300 I=1,4
C1=C1+2.*C2
C2=C2-.5
D1=1.5-C1*.5+C3
C3=0.
P1EFF=P1+D1*P1K
P2EFF=P2+D1*P2K
XREFF=XR+D1*XRK
XRDEFF=XRD+D1*XRDL
IF(P2EFF.GE.PE) E2=.75
E1=1.-E2
DP1=P1EFF-PE
IF(DP1.GE.PRLF) A02=0.
DP2=P2EFF-PE
IF(DP2.LE.0.) DP2=0.
A0=A01+A02
B1=115.5*A0
D31=(B1*E1/(12.*APR))**2.
A3=((RL-XREFF)/(DT*BJLK))**2.
B31=-((2.*XRDEFF*SQRT(A3)+D31/2.))
C31=XRDEFF**2.-D31*DP1
P1K=(-B31-SQRT(B31*B31-4.*A3*C31))/(2.*A3)
D32=(B1*E2/(36.*APR))**2.
B32=-((2.*XRDEFF*SQRT(A3)+D32/2.))
C32=XRDEFF**2.-D32*DP2
FLOWND=B32*B32-4.*A3*C32
IF(FLOWND.LE.0.) FLOWND=0.
P2K=(-B32-SQRT(FLOWND))/(2.*A3)
XRK=DT*XRDEFF
IF(T.GE.TM) GO TO 100
DELT=D1*DT/2.
VP=A*U/(B+J)

```

```

BR=B+U-(VP+A)*DELT
CC=-((VP+A)*U+VP*B)*DELT
DELU=(-BB+SQR(BB*BB-4.*CC))/2.
DELT2=(B*LOG(1.+DELU/U)+DELU)/A
UEFF=U+DELU+(D1*DT-DELT2)*A*(U+DELU)/(B+U+DELU)
FGAS=(UEFF/G)*A*A*B*UEFF/(B+UEFF)**3.
GO TO 200
100 TEFF=T-TM+D1*DT
FGAS=PM*AB*(1.-BETA)*(1.+TEFF/SIG)**GAMA2
200 FSEAL1=PI*JS*DR*(W1*S*4.+W2*(PIEFF+3.*P2EFF))
FSEAL2=PI*US*DS*(W1*S*2.+W2*(PE+PR))
FSEAL=FSEAL1
XRDL=DT*(G/WR)*(FGAS-APR*(PIEFF+3.*P2EFF)+AS*(PE+PR)-FSEAL+FGF)
DELP1=DELP1+C1*P1K
DELP2=DELP2+C1*P2K
DELXR=DELXR+C1*XRK
DELXRD=DELXRD+C1*XRDL
300 CONTINUE
P1=P1+DELP1/6.
P2=P2+DELP2/6.
XR=XR+DELXR/6.
XRD=XRD+DELXRD/6.
U=UEFF
T=T+DT
DWOIL=RHOIL*APR*(RL-XR)*12.*(4.+(P1+3.*P2)/BULK)-WJIL
RHOE=RHOIL*(1.+PE/BULK)
DV=DWOIL/RHOE+AS*XR*12.
PE=PEO/(1.+DV/VO)**CK2
PRINT 400,T,U,XR,XRD,P1,P2,PE
400 FORMAT(3X,F5.4,5X,F5.2,5X,F5.3,5X,F5.1,5X,F6.0,5X,F6.0,5X,F6.0)
IF(XRD.LE.0.) GO TO 500
IF(XR.GE.5.75) GO TO 500
GO TO 50
500 STOP
END

```

10839.7507		1.0451 7584215.0000		0.0905	7091.1138	
.0010	0.12	0.001	1.2	2500.	109.	2500.
.0020	0.24	0.003	3.7	2501.	149.	2500.
.0030	0.49	0.009	8.2	2504.	247.	2500.
.0040	0.96	0.020	15.5	2515.	447.	2500.
.0050	1.74	0.040	25.3	2542.	795.	2501.
.0060	2.89	0.071	35.9	2589.	1323.	2501.
.0070	4.43	0.112	45.7	2656.	2032.	2502.
.0080	6.29	0.152	53.8	2825.	2844.	2503.
.0090	8.42	0.219	59.1	3427.	3443.	2506.
.0100	10.75	0.282	54.9	4017.	4030.	2508.
.0110	13.25	0.349	68.5	4594.	4606.	2511.
.0120	15.89	0.418	71.2	5153.	5164.	2515.
.0123	16.71	0.440	71.9	5328.	5338.	2516.
.0130	16.71	0.490	72.0	5699.	5703.	2519.
.0140	16.71	0.562	72.2	6183.	6192.	2523.
.0150	16.71	0.635	72.2	6625.	6633.	2527.
.0160	16.71	0.707	72.2	7028.	7035.	2532.
.0170	16.71	0.779	72.0	7396.	7402.	2537.
.0180	16.71	0.851	71.8	7730.	7735.	2542.
.0190	16.71	0.922	71.5	8032.	8038.	2547.
.0200	16.71	0.994	71.1	8305.	8310.	2553.
.0210	16.71	1.055	70.7	8550.	8554.	2558.
.0220	16.71	1.135	70.2	8768.	8772.	2564.
.0230	16.71	1.205	59.6	8960.	8953.	2570.
.0240	16.71	1.274	69.0	9127.	9131.	2576.
.0250	16.71	1.343	68.4	9272.	9275.	2582.
.0260	16.71	1.411	67.8	9393.	9396.	2588.
.0270	15.71	1.479	57.1	9494.	9497.	2594.
.0280	16.71	1.545	55.4	9574.	9577.	2600.
.0290	16.71	1.511	55.7	9635.	9638.	2606.
.0300	16.71	1.577	64.9	9678.	9680.	2613.
.0310	16.71	1.741	64.2	9704.	9705.	2619.
.0320	16.71	1.805	53.4	9713.	9714.	2625.
.0330	16.71	1.858	52.6	9706.	9708.	2631.
.0340	16.71	1.930	51.9	9685.	9687.	2638.
.0350	16.71	1.992	61.1	9651.	9652.	2644.
.0360	16.71	2.052	60.3	9604.	9605.	2650.
.0370	16.71	2.112	59.5	9545.	9546.	2657.
.0380	16.71	2.171	58.7	9476.	9477.	2663.
.0390	16.71	2.230	57.9	9397.	9398.	2669.
.0400	16.71	2.287	57.1	9309.	9310.	2676.
.0410	16.71	2.344	56.3	9213.	9213.	2682.
.0420	16.71	2.400	55.6	9110.	9110.	2688.
.0430	16.71	2.455	54.8	9000.	9000.	2694.
.0440	16.71	2.510	54.0	8885.	8885.	2700.
.0450	16.71	2.553	53.3	8765.	8765.	2706.
.0460	16.71	2.616	52.5	8641.	8641.	2712.
.0470	16.71	2.658	51.8	8514.	8514.	2718.
.0480	16.71	2.720	51.0	8384.	8384.	2724.
.0490	16.71	2.770	50.3	8253.	8253.	2730.
.0500	16.71	2.820	49.6	8120.	8120.	2736.
.0510	16.71	2.859	48.9	7986.	7986.	2742.
.0520	16.71	2.918	48.2	7852.	7852.	2747.
.0530	16.71	2.956	47.6	7719.	7719.	2753.
.0540	16.71	3.013	46.9	7586.	7586.	2759.
.0550	16.71	3.050	46.2	7454.	7455.	2764.
.0560	16.71	3.105	45.6	7325.	7325.	2769.
.0570	16.71	3.151	45.0	7197.	7197.	2775.
.0580	16.71	3.195	44.3	7071.	7071.	2780.

.0590	16.71	3.240	43.7	6947.	6946.	2785.
.0600	16.71	3.283	43.1	6827.	6827.	2791.
.0610	16.71	3.326	42.5	6709.	6709.	2796.
.0620	16.71	3.368	42.0	6594.	6594.	2801.
.0630	16.71	3.410	41.4	6482.	6482.	2806.
.0640	16.71	3.451	40.8	6374.	6374.	2811.
.0650	16.71	3.491	40.3	6269.	6269.	2815.
.0660	16.71	3.531	39.7	6167.	6167.	2820.
.0670	16.71	3.571	39.2	6068.	6068.	2825.
.0680	16.71	3.610	38.7	5972.	5972.	2830.
.0690	16.71	3.648	38.2	5880.	5880.	2834.
.0700	16.71	3.685	37.6	5791.	5791.	2839.
.0710	16.71	3.723	37.1	5705.	5705.	2843.
.0720	16.71	3.760	36.7	5622.	5622.	2848.
.0730	16.71	3.797	36.2	5542.	5542.	2852.
.0740	16.71	3.833	35.7	5465.	5455.	2856.
.0750	16.71	3.868	35.2	5390.	5390.	2860.
.0760	16.71	3.903	34.7	5319.	5319.	2865.
.0770	16.71	3.938	34.3	5250.	5250.	2869.
.0780	16.71	3.972	33.8	5183.	5183.	2873.
.0790	16.71	4.005	33.4	5118.	5118.	2877.
.0800	16.71	4.038	32.9	5056.	5056.	2881.
.0810	16.71	4.071	32.5	4996.	4996.	2885.
.0820	16.71	4.104	32.1	4938.	4938.	2889.
.0830	16.71	4.135	31.7	4882.	4882.	2892.
.0840	16.71	4.167	31.2	4828.	4828.	2896.
.0850	16.71	4.198	30.8	4776.	4776.	2900.
.0860	16.71	4.228	30.4	4725.	4725.	2904.
.0870	16.71	4.259	30.0	4676.	4676.	2907.
.0880	16.71	4.288	29.6	4628.	4628.	2911.
.0890	16.71	4.318	29.2	4582.	4582.	2914.
.0900	16.71	4.347	28.8	4538.	4538.	2918.
.0910	16.71	4.375	28.4	4495.	4495.	2921.
.0920	16.71	4.404	28.0	4453.	4453.	2925.
.0930	16.71	4.432	27.7	4412.	4412.	2928.
.0940	16.71	4.459	27.3	4372.	4372.	2931.
.0950	16.71	4.486	26.9	4334.	4334.	2935.
.0960	16.71	4.513	26.5	4297.	4297.	2938.
.0970	16.71	4.539	26.2	4260.	4260.	2941.
.0980	16.71	4.565	25.8	4225.	4225.	2944.
.0990	16.71	4.591	25.4	4191.	4191.	2947.
.1000	16.71	4.616	25.1	4157.	4157.	2950.
.1010	16.71	4.641	24.7	4125.	4125.	2954.
.1020	16.71	4.665	24.4	4093.	4093.	2956.
.1030	16.71	4.690	24.0	4062.	4052.	2959.
.1040	16.71	4.713	23.7	4032.	4032.	2962.
.1050	16.71	4.737	23.3	4003.	4003.	2965.
.1060	16.71	4.760	23.0	3975.	3975.	2968.
.1070	16.71	4.783	22.6	3947.	3947.	2971.
.1080	16.71	4.805	22.3	3920.	3920.	2974.
.1090	16.71	4.828	22.0	3894.	3894.	2976.
.1100	16.71	4.849	21.6	3868.	3868.	2979.
.1110	16.71	4.871	21.3	3843.	3843.	2982.
.1120	16.71	4.892	21.0	3819.	3819.	2984.
.1130	16.71	4.913	20.7	3795.	3795.	2987.
.1140	16.71	4.933	20.3	3772.	3772.	2989.
.1150	16.71	4.953	20.0	3749.	3749.	2992.
.1160	16.71	4.973	19.7	3727.	3727.	2994.
.1170	16.71	4.993	19.4	3706.	3706.	2997.
.1180	16.71	5.012	19.1	3685.	3685.	2999.

.1190	16.71	5.031	18.8	3665.	3655.	3001.
.1200	16.71	5.050	18.4	3645.	3645.	3004.
.1210	16.71	5.068	18.1	3625.	3625.	3006.
.1220	16.71	5.086	17.8	3606.	3606.	3008.
.1230	16.71	5.103	17.5	3588.	3588.	3010.
.1240	16.71	5.121	17.2	3570.	3570.	3013.
.1250	16.71	5.138	16.9	3552.	3552.	3015.
.1260	16.71	5.155	16.6	3535.	3535.	3017.
.1270	16.71	5.171	15.3	3519.	3519.	3019.
.1280	16.71	5.187	15.0	3502.	3502.	3021.
.1290	16.71	5.203	15.7	3487.	3487.	3023.
.1300	16.71	5.219	15.4	3471.	3471.	3025.
.1310	16.71	5.234	15.1	3456.	3456.	3027.
.1320	16.71	5.249	14.8	3441.	3441.	3029.
.1330	16.71	5.264	14.5	3427.	3427.	3030.
.1340	16.71	5.278	14.3	3413.	3413.	3032.
.1350	16.71	5.292	14.0	3400.	3400.	3034.
.1360	16.71	5.306	13.7	3386.	3386.	3036.
.1370	16.71	5.320	13.4	3374.	3374.	3037.
.1380	16.71	5.333	13.1	3361.	3361.	3039.
.1390	16.71	5.346	12.8	3349.	3349.	3041.
.1400	16.71	5.358	12.5	3337.	3337.	3042.
.1410	16.71	5.371	12.3	3325.	3325.	3044.
.1420	16.71	5.383	12.0	3314.	3314.	3045.
.1430	16.71	5.395	11.7	3303.	3303.	3047.
.1440	16.71	5.406	11.4	3293.	3293.	3048.
.1450	16.71	5.418	11.1	3282.	3282.	3050.
.1460	16.71	5.429	10.9	3272.	3272.	3051.
.1470	16.71	5.439	10.6	3263.	3263.	3052.
.1480	16.71	5.450	10.3	3253.	3253.	3054.
.1490	16.71	5.450	10.0	3244.	3244.	3055.
.1500	16.71	5.470	9.8	3235.	3235.	3056.
.1510	16.71	5.480	9.5	3227.	3227.	3058.
.1520	16.71	5.489	9.2	3219.	3219.	3059.
.1530	16.71	5.498	9.0	3211.	3211.	3060.
.1540	16.71	5.507	8.7	3203.	3203.	3061.
.1550	16.71	5.515	8.4	3195.	3195.	3062.
.1560	16.71	5.524	8.2	3188.	3188.	3063.
.1570	16.71	5.532	7.9	3181.	3181.	3064.
.1580	16.71	5.540	7.6	3174.	3174.	3065.
.1590	16.71	5.547	7.4	3158.	3158.	3066.
.1600	16.71	5.554	7.1	3152.	3152.	3067.
.1610	16.71	5.561	6.8	3156.	3156.	3058.
.1620	16.71	5.568	6.6	3150.	3150.	3069.
.1630	16.71	5.574	6.3	3144.	3144.	3070.
.1640	16.71	5.580	6.0	3139.	3139.	3070.
.1650	16.71	5.585	5.8	3134.	3134.	3071.
.1660	16.71	5.592	5.5	3129.	3129.	3072.
.1670	16.71	5.597	5.2	3125.	3125.	3073.
.1680	16.71	5.603	5.0	3120.	3120.	3073.
.1690	16.71	5.607	4.7	3116.	3116.	3074.
.1700	16.71	5.612	4.5	3112.	3112.	3074.
.1710	16.71	5.616	4.2	3109.	3109.	3075.
.1720	16.71	5.620	3.9	3105.	3105.	3075.
.1730	16.71	5.624	3.7	3102.	3102.	3076.
.1740	16.71	5.628	3.4	3099.	3099.	3076.
.1750	16.71	5.631	3.2	3096.	3096.	3077.
.1760	16.71	5.634	2.9	3093.	3093.	3077.
.1770	16.71	5.637	2.6	3091.	3091.	3078.
.1780	16.71	5.639	2.4	3089.	3089.	3078.

.1790	16.71	5.642	2.1	3087.	3087.	3078.
.1800	16.71	5.644	1.9	3085.	3085.	3078.
.1810	16.71	5.645	1.6	3084.	3084.	3079.
.1820	16.71	5.647	1.3	3083.	3083.	3079.
.1830	16.71	5.648	1.1	3081.	3081.	3079.
.1840	16.71	5.649	0.8	3081.	3081.	3079.
.1850	16.71	5.650	0.6	3080.	3080.	3079.
.1860	16.71	5.650	0.3	3080.	3080.	3079.
.1870	16.71	5.650	0.1	3079.	3079.	3079.
.1880	16.71	5.650	-0.2	3079.	3079.	3079.

FORTRAN STOP

PART NUMBER: 12585720-003, Reservoir Accumulator

DESCRIPTION:

The reservoir accumulator size and pressure requirements were determined from the following oil displacement analysis.

Nitrogen volume: 8000 cu. in.
Pre-Charge Pressure: 120 psi at 70 F

STATUS:

Mounting and dimensional requirements have been provided to York for finalized design.

AUTHOR: Jeff Ireland

ACTUATOR	EXTEND LENGTH (IN)	RETRACT LENGTH (IN)	STROKE (IN)	PISTON ϕ (IN)	ROD ϕ (IN)	EXTEND VOLUME (IN ³)	RETRACT VOLUME (IN ³)
TRANSVERSE (27, 832)	51.676	37.000	14.676	4.250	2.500	208.740	136.185
ELEVATION	55.002	40.323	14.679	3.000	1.500	311.905	217.001
WHEEL ACTUATOR (REAR)	121.512	67.059	54.453	3.250	3.000	199.549	14.726
WHEEL ACTUATOR (FRONT)	112.827	64.781	48.046	2.375	2.250	66.452	6.811
EQUILIBRATION	38.088	25.278	12.810	2.500	2.500		
	40.719	25.243	15.476	2.000	1.750		
RAMMER	226.438	139.793	86.735	1.875	1.500	8.455	3.044
BREECH	11.188	8.125	3.062	.937	.875	3.103	.397
PRIMER	13.374	8.874	4.500	.969 (87500)	.375	.068	.314
LAMNARD	2.875	3.375	.500	2.125 IN	1.875	126.676	
LOAD POSITION			26.000				
ACCUMULATOR	Volume IN ³	RECHARGE PRESSURE 70°F PSI	PEAK PSI	LOAD CYCLE = ZONE 3			
EQUILIBRATION	1200	2015 2090	6800	LOAD POS		127.676	
RESERVOIR	8000	2280	5600	RAMMER		34.785	
ENERGY STORAGE	4800	120	360	DRIVER		11.499	
		2640	5600	PRIMER		8.377	
				LAMNARD		.068	
						172.478	

NORMALLY 5400 PSI

RESERVOIR ACCUMULATOR

ΔV_{OIL} IN ENERGY STORAGE AT 435°R & 3800PSI RELIEF = 2064. IN³

II EQUILIBRATOR CIRCUIT

EQUILIBRATION CYLINDER OIL = $(5.7 \text{ IN}^2)(44.671 \text{ IN}) = 254.625 \text{ IN}^3$

OIL ADDED AT -25°F = ~~377 IN³~~

OIL ADDED AT +160°F = ~~95 IN³~~

Δ = 282 IN³

407.6 IN³
~~433 IN³~~

426.4
 179.4

IF ALL OF THE OIL IN THE EQUILIBRATION CIRCUIT IS IN RESERVOIR ACCUMULATOR

V_{EC} = 377 IN³ + 254.625 IN³ = 631.625 IN³

ΔV_{EC} = 282. IN³

(ROD VOLUME OF ACTUATORS

TOW MODE

A. RECOIL = $2(\pi/4)(2.0 \text{ IN})^2(105 \text{ IN}) = 659.734 \text{ IN}^3$

0.

B. C. RECOIL = $2(\pi/4)(2.25 \text{ IN})^2(105 \text{ IN}) = 834.976 \text{ IN}^3$

0.

C. TRAVERSE = $(\pi/4)(2.5 \text{ IN})^2(14.679 \text{ IN}) = 72.055 \text{ IN}^3$

≈ 36.

D. ELEVATION = $(\pi/4)(1.5 \text{ IN})^2(48.046 \text{ IN}) = 84.904 \text{ IN}^3$

≈ 20.

3586
 3720

E. WHEEL (REAR) = $2(\pi/4)(3.0 \text{ IN})^2(12.0 \text{ IN}) = 169.646 \text{ IN}^3$

31.5

F. WHEEL (FRONT) = $2(\pi/4)(2.25 \text{ IN})^2(15.0 \text{ IN}) = 119.282 \text{ IN}^3$

27.5

G. RAMMER = $(\pi/4)[(1.75 \text{ IN})^2 - (1.25 \text{ IN})^2](87 \text{ IN}) = 102.494 \text{ IN}^3$

0.

H. BREECH = $(\pi/4)(1.5 \text{ IN})^2(3.0 \text{ IN}) = 2.356 \text{ IN}^3$ 5.411

5.411

I. PRIMER = $(\pi/4)(.875 \text{ IN})^2(4.5 \text{ IN}) = 2.706 \text{ IN}^3$

2.706

J. LANYARD = $(\pi/4)[(.875 \text{ IN})^2 - (.375 \text{ IN})^2](5 \text{ IN}) = .245 \text{ IN}^3$

.245

K. LOAD POSITION = $(\pi/4)(1.875 \text{ IN})^2(36.0 \text{ IN}) = 99.402 \text{ IN}^3$

L. L.P. BUFFER = $(\pi/4)(1.375 \text{ IN})^2(6.0 \text{ IN}) = 8.909 \text{ IN}^3$

TOTAL ROD VOLUME OF ACTUATORS 2,156.709 IN³ ≈ 125 IN³

MAX. OPERATING OIL IN ACCUMULATOR = 2064. IN³ + 282. IN³ + 2156.709 IN³
 = 4500 IN³

$$\begin{aligned} P_L &= 100. \text{PSI} \\ T_L &= -25^\circ\text{F} = 439 \\ T_C &= 70^\circ\text{F} = 530 \\ T_H &= 160^\circ\text{F} = 620 \\ \Delta V &= 4500 \text{ IN}^3 \end{aligned}$$

$$\frac{P_L V_0}{T_L} = \frac{P_H V_0}{T_H}$$

$$\underline{P_H = (T_H/T_L) P_L}$$

$$\frac{P_{MAX} (V_0 - \Delta V)}{T_H} = \frac{P_H V_0}{T_H}$$

$$\underline{P_{MAX} = P_H \left[\frac{V_0}{(V_0 - \Delta V)} \right]} = \underline{P_L \left(\frac{T_H}{T_L} \right) \left(\frac{V_0}{V_0 - \Delta V} \right)} = \frac{P_L \left(\frac{T_H}{T_L} \right)}{(1 - \Delta V/V_0)}$$

$$\text{IF } V_0 = 7000. \text{ IN}^3 \quad P_{MAX} = 399. \text{ PSI}$$

$$\text{IF } \underline{V_0 = 8000. \text{ IN}^3} \quad \underline{P_{MAX} = 325. \text{ PSI}} \quad \left. \vphantom{\underline{P_{MAX} = 325. \text{ PSI}}} \right\} \text{ OPERATING}$$

$$\text{PEAK PRESSURE } \Delta V = 4500 \text{ IN}^3 + 631.625 \text{ IN}^3 - 282. \text{ IN}^3 = 4850 \text{ IN}^3$$

$$\underline{\underline{P_{PEAK} = 362. \text{ PSI}}}$$

$$\text{PRECHARGE} = P_C$$

$$\frac{P_C V_0}{T_C} = \frac{P_L V_0}{T_L}$$

$$P_C = (T_C/T_L) P_L = 120. \text{ PSI}$$

OIL IN ACCUMULATOR DURING TOW

ACTUATORS $\approx 125 \text{ IN}^3$
 EQUIL $\approx 282 \text{ IN}^3$
 DV ENERGY $\approx 2064 \text{ IN}^3$
 $2471 \text{ IN}^3 \Rightarrow 2500. \text{ IN}^3$

$$\text{ACCUMULATOR PRESSURE} = \frac{120 \text{ PSI } (8000 \text{ IN}^3)}{530^\circ\text{R}} = \frac{P_{\text{TOW}} (8000 \text{ IN}^3 - 2500 \text{ IN}^3)}{620^\circ\text{R}}$$

$$\underline{\underline{P_{\text{TOW}} = 200 \text{ PSI}}}$$

DESCRIPTION: TOWING STABILITY

STATUS:

The following section is exerpted from the Phase I Dynamic Analysis Report. All towing stability analysis was performed in Phase I since it was felt that the results of the analysis would not change significantly with the configuration changes.

AUTHOR: Scott Dacko

Towing Stability

Extensive work has been performed in the area of towing stability. The objective is to maximize LTHD stability and ensure that its performance in towing is equal to or greater than that of the M198. Both static and dynamic responses are examined, with considerable effort placed on dynamic analysis. Advanced simulation and animation software was used for the dynamic analysis, and the results currently exist in the form of graphs in Appendix F and animations on videotape. The analysis is presented in the following sections.

9.1 Static

Static stability for both the LTHD and M198 were analyzed. The center of gravity heights for both vehicles were estimated and compared and the distances between wheels were also compared. The results are shown in Table 9-1. The data used to determine these values can be found Appendix F. The important result for comparison purposes is the tipping angle. This is the angle at which each vehicle would begin to tip over sideways, since the center of gravity would be over the wheel centers. As we can see, the M198 tipping angle is better by 3.7 degrees. This is attributed to its wider wheel base. The LTHD purposely had a narrower wheel base to allow it to track in the tow vehicle's track (M813). The LTHD track was increased to about 87 inches (from 73 inches) to eliminate this problem on June 3.

9.2 Dynamic

For comparison purposes, more important system characteristics exist than those described in the static analysis. These include the responses of the vehicles at various speeds to various road conditions. Before these are presented, however, lumette loads are briefly covered. Then the responses to bumps on flat road and bumps on roads while rounding a corner are described.

9.2.1 Lumette Loads

The maximum loads to be experienced by the lumette were determined for designing a lumette with the best size and shape and to determine the impact on barrel deflection. Load conditions were estimated by accounting for the LTHD moment of inertia for yaw and pitch, maximum deceleration by the M813, jack-knifing situations, and the effect of large bumps on a typical truck suspension. It was determined that the barrel can easily withstand these forces, which are considered worst-case conditions.

<u>Load Condition</u>	<u>Max Load</u>	<u>Factor of Safety</u>	<u>Design to:</u>
Forward-back load	9,000 lbs	2	18,000 lbs
Vertical load	2,200 lbs	4	8,800 lbs
Lateral load	6,750 lbs	2	13,500 lbs
Vertical & lateral	7,100 lbs	2.27	16,115 lbs

TOWING STABILITY - STATIC

	M198	
	TOW	LTHD
	----	----
C.G. HEIGHT. IN.	53.84	48.29
DIST. BETW. WHEELS CENTERS. IN	93.0	73.0
TIPPING ANGLE. DEG'S	40.8	37.1

Table 9-1

9.2.2 Dynamic Analysis Model

4

This section documents dynamic towing stability analyses performed comparing the FMC LTHD and the M198. The work was performed by Don Cronquist, FMC Central Engineering Laboratories. Important dynamic parameters are found in Table 9-2.

The purpose of the dynamic analysis and simulation is to provide preliminary towing stability comparisons of the LTHD and M198 using simplified models. The results also demonstrate FMC's capabilities for performing such analyses.

9.2.2.1 Computer Models

Towing stability simulations were run with computer models of the LTHD and M198. The simulations were run using version 84 of the ADAMS computer program, a program for simulation of three-dimensional non-linear mechanical systems of rigid bodies. This program is currently in use by a number of companies in the automotive industry and elsewhere.

Figures 9-1 and 9-2 illustrate the computer models of both towed howitzers obtained using the graphics provided by the ADAMS program. Each towed howitzer model consists of the following:

- . A model data file which provides the mass and inertial properties, geometric data including force location and direction, part-to-part connection data, and graphics. Some of the terrain/obstacle data is also provided in the model file.
- . A set of user-written subroutines, written in FORTRAN, which include the tire/terrain model, and a subroutine used to guide the trailers in the cornering simulations.

Standard ADAMS elements were used in most portions of the vehicle model. The tire/terrain model is not a standard element, however. This model is a point contact tire capable of running in any direction on a cross-country terrain surface. A tire obstacle of rectangular cross section may be superimposed on the of the terrain surface. The tire model computes approximate force of interaction between the tire and obstacle in both the horizontal and vertical directions. The tire obstacle is a new feature which was added to the tire model for this dynamic analysis project.

The effect of the obstacle-enveloping capability of the tire is included in the tire/obstacle interaction model, but is not included in the tire/terrain interaction model. In this way, vehicle maneuvering may be done with efficient use of computer resources, but obstacle-enveloping characteristics may be included when the tire is interacting with an obstacle of rectangular cross-section.

Previous simulations using the tire model used a wash-board shaped terrain in which the terrain height varied only along one dimension of the model. Future simulations may be performed in which terrain height is a function of both horizontal coordinates.

TOWING STABILITY - DYNAMIC

	M198	
	TOW	LTHD
	----	----
TIRE SPRING CONSTANT, LB/IN	4.507	1.312
DAMPING COEFFICIENT ROLLING: NEGLIGIBLE	.019	.019
TOW WEIGHT, LBS	15.600	8.982
MOMENT OF INERTIA ABOUT ROLL AXIS, FT-LB-SEC ²	2096.5	562.7
TOW SPEED: 25 MPH		

Table 9-2

TIME=0

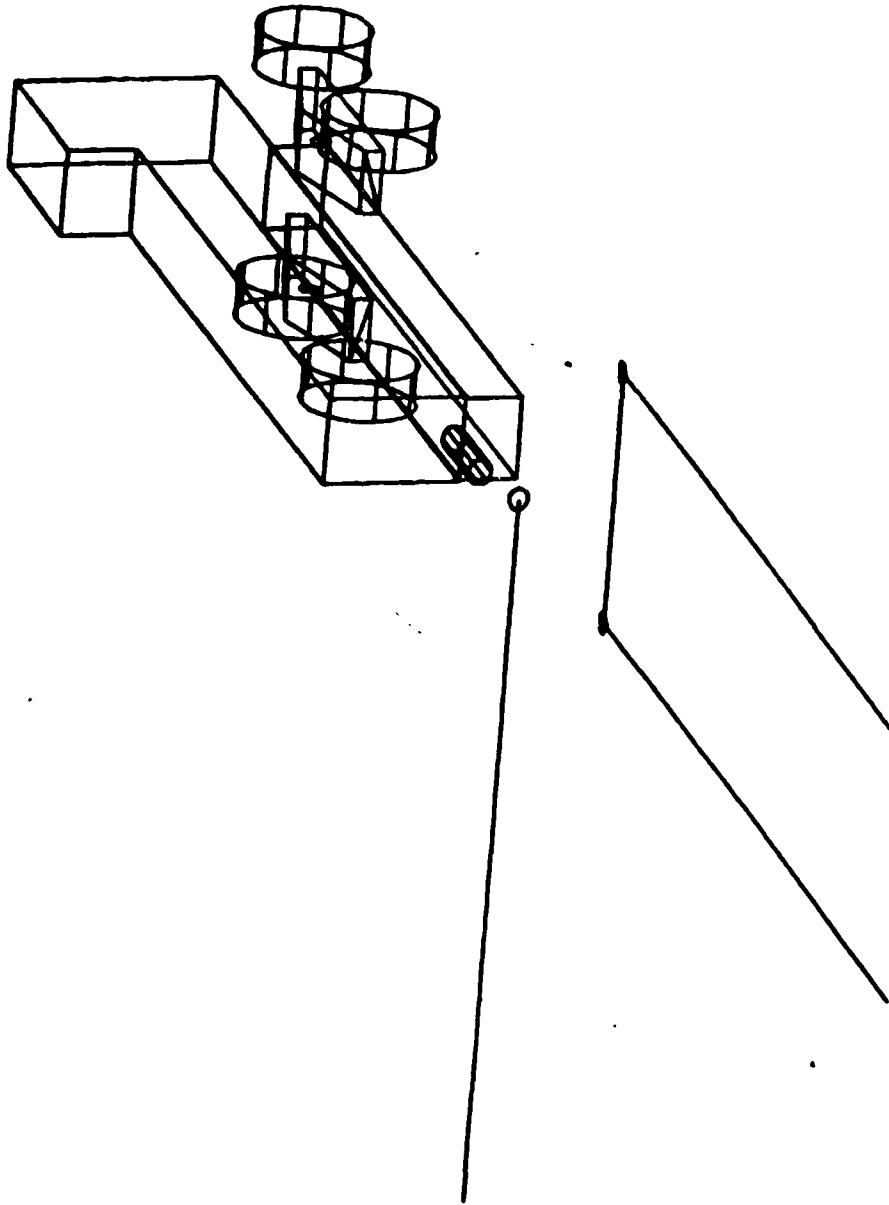

Figure 9-1

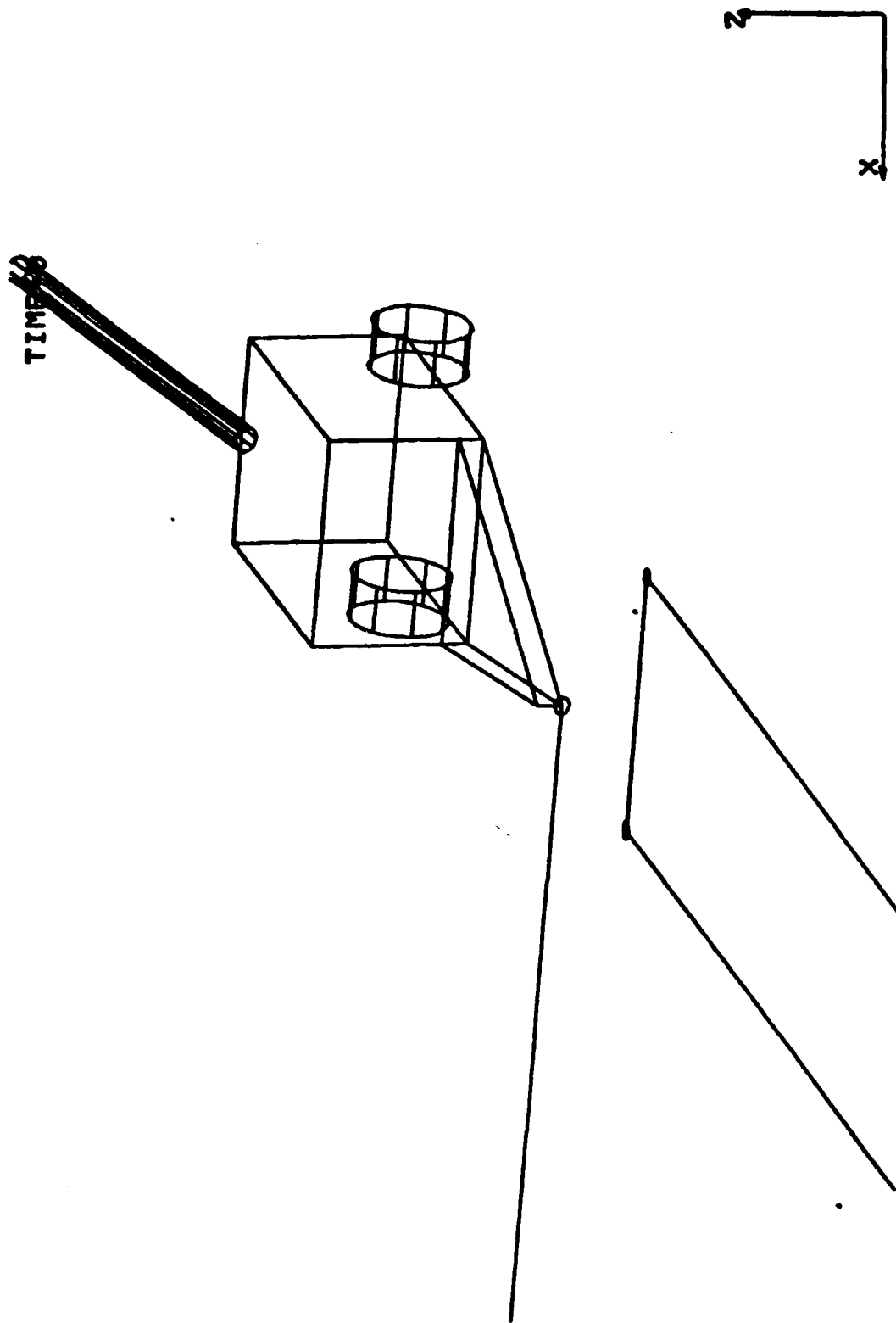

Figure 9-2

In the present computer simulations, the base terrain was flat, but an obstacle of rectangular cross section was superimposed on the terrain surface to test the vehicle stability limits. For this phase of the project, approximate tire/obstacle force equations were used. However, tire test data may be used to improve the accuracy of the tire/obstacle forces for future work.

Representative model data files for the LTHD and M198 are shown in Appendix L. The input data is included in the appendix with each tire model.

The tire/terrain model is not shown in this report due to its proprietary nature. This program was already in use at FMC before its use in the LTHD program. As part of the LTHD and M198 study, the tire model was enhanced to compute horizontal and vertical force of interaction of the tire with an obstacle of rectangular cross-section. The portion of the tire model is shown in Appendix L.

It should be noted that an error was detected in the equations for the horizontal force between the tire and the obstacle. This error allowed a rearward force between the tire and the trailing corner of the bump. The error is documented in Appendix L.

The effects of the error in horizontal obstacle force were generally very small in the cases where the simulations were re-run. The largest effect occurred in the LTHD straight road simulations in which the maximum roll angle increased from roughly 23.5 degrees to 25.5 degrees in one case and in another case the maximum roll angle decreased from roughly 13 degrees to 11.2 degrees. These comparisons are documented in Appendix H.

9.2.2.2 Assumptions

The following assumptions were made in this analysis:

- . All parts are rigid bodies.
- . All joints are ideal kinematic joints without looseness or flexibility.
- . The tires have constant spring rates up to the rim radius, at which the spring rate increases by a factor of 5. The tire forces were computed based on the position of the center of the tire spindles relative to the terrain surface and relative to the obstacle.

- . These simulations do not include the effects of rolling resistance or lateral spring rate.
- . The tow hitch of the towing vehicle had the following idealized motion: constant speed in either a straight path or a straight path followed by a constant radius. There is a 30 inch transition between the straight path to the radius. The tow hitch was represented by a spherical joint without friction or looseness.
- . Zero tire damping was assumed in the straight path bump simulations. Damping in the tire/terrain forces was 1.9% of critical in the cornering simulations (based on the appropriate tire mass and spring rate). In all cases, no tire damping was applied during the tire/obstacle interaction.
- . The terrain surface was rigid and flat. A rigid rectangular bump was superimposed on the terrain surfaces.

9.2.2.3 Results

The simulations show that the LTHD tolerates larger terrain obstacles that the M198 when being towed along a straight road. However, in cornering simulations the M198 tolerated larger tire obstacles that the LTHD at 18 and 20 mph, while the LTHD tolerated larger obstacles at 15 mph.

A modified version of the LTHD with the width between tire centers increased from 73 inches to 87.25 inches was able to tolerate a higher bump than the M198 in a cornering simulation at 20 mph.

Figures 9-3 and 9-4 summarize the simulation results. Figure 9-3 shows a plot of maximum roll angle versus bump height for the straight road towing simulations. This plot compares the performance of the LTHD and M198 and reveals that for equally sized bumps the the LTHD does not roll as far as the M198. The simulations also show that the M198 rolls over for a 12 inch obstacle while the LTHD returned to an upright position.

Figure 9-4 summarizes the results for cornering maneuvers. This is a plot of towing speed versus maximum obstacle height without rollover. Where an obstacle height is indicated on this plot it means that a simulation was run at this bump height and at the next higher bump height and that the towed howitzer rolled over only at the higher bump height. The bump height increment for these simulations was 2 inches, except that simulations were also run with a bump height of 1 inch.

Figure 9-4 shows that at 18 and 20 miles per hour the M198 trailer tolerated higher bumps than the LTHD. However, at 15 miles per hour the LTHD tolerated a higher bump than the M198. These simulations were performed with a 500 inch radius at the tow hitch. Figures L-1 and L-2 in Appendix L, are plots of roll angle vs. time for the LTHD and M198 straight road towing simulations. Each figure shows the response for three different obstacle heights. Figures L-3 through L-5 are plots of roll angle vs. time for the cornering simulations. Figure L-3 shows the

STRAIGHT LINE TOWING SIMULATION ROLL ANGLE VERSUS BUMP HEIGHT

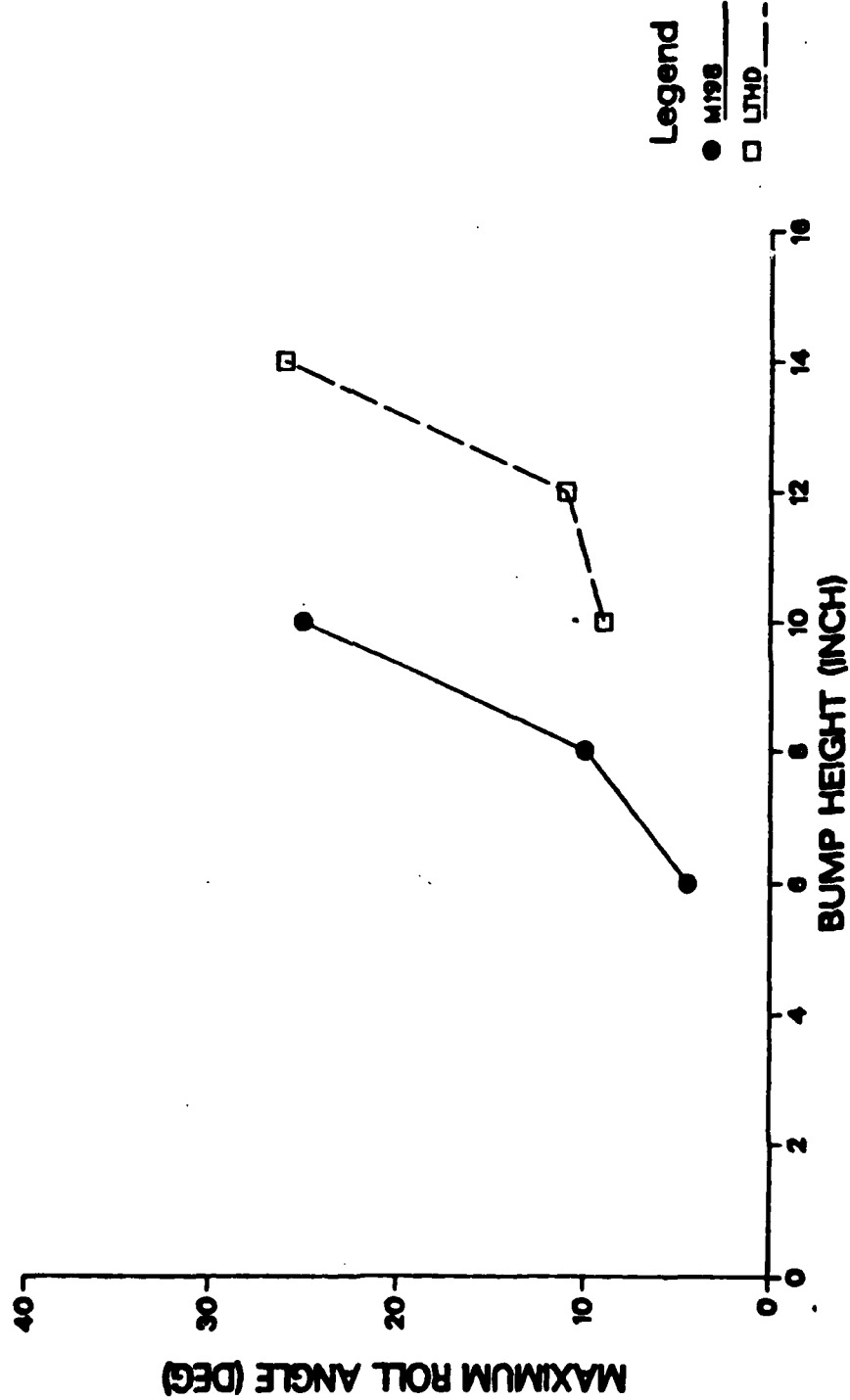

Legend

- M198
- LJHD

Figure 9-3

**CORNERING MANEUVERS
500 INCH TOW HITCH RADIUS**

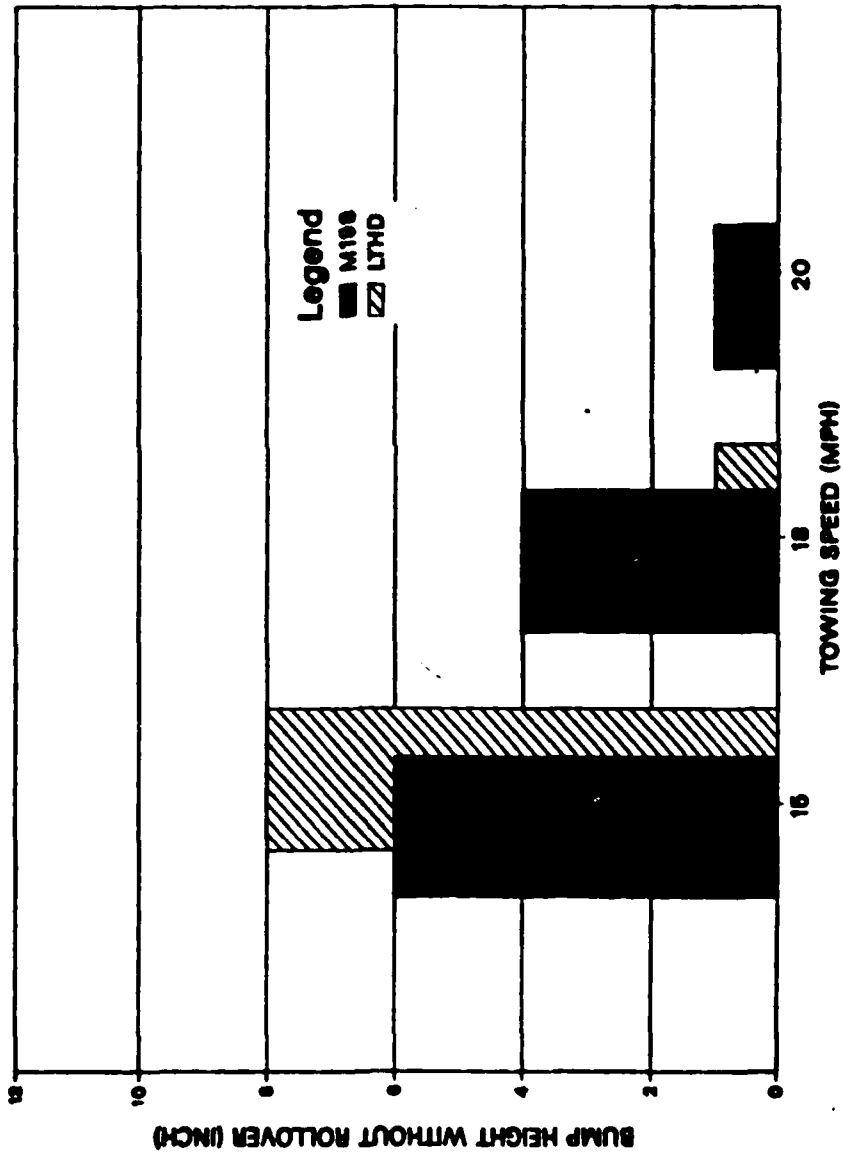

Figure 9-4

stable response of the LTHD to an 8 inch obstacle and an unstable response to a 10 inch obstacle at 15 miles per hour. Figure L-4 shows the stable response of the M198 to a 6 inch obstacle and an unstable response to an 8 inch obstacle at 15 mph. Figure L-5 shows the stable response of the M198 to a 1 inch obstacle and the unstable response to a 2 inch obstacle at 20 mph.

Two modifications of the initial LTHD configuration were also simulated:

- . Lowered CG 6.0 inches from 48.29 inches to 42.29 inches. This is a 12.4% reduction in CG height. Note that these CG heights are measured relative to the bottom of the tires at their unloaded radii.
- . Width between tire centerlines increased from 73 inches to 87.25 inches. This is a 19.5% increase in width. This modification was simulated both with the original tire spring rate of 1500 lb/in per tire and with a higher spring rate of 3000 lb/in per tire.

The LTHD with the first modification (lowered CG) was found to roll over with 1 and 2 inch obstacle heights in the 20 mph cornering maneuvers. This is the same as with the initial LTHD configuration. The increment between these obstacle heights (1 inch) was thus too large to detect an improvement due to this modification.

The LTHD with the second modification (greater width between tire centerlines) was found to be stable with a 2 inch obstacle height at 20 mph. Note that the original LTHD rolled over with a 1 inch obstacle and the M198 rolled over with a 2 inch obstacle. Thus the cornering stability of the LTHD with increased width between tires was superior to both the original LTHD and the M198.

Appendix L documents the error in the horizontal component of force while the tire is interacting with the tail end of the bump. In most of the cases checked, this error did not significantly affect the maximum roll angles. The largest effect was found in the case of the LTHD straight road towing simulations in which one maximum roll angle was decreased from 10.7 degrees to 9.2 degrees and in another case the maximum roll angle was increased from 23.5 degrees to 25.5 degrees. (See Figures L-8, L-9 and L-10 in Appendix L.) However, in the M198 straight road simulations there were much smaller changes in the maximum roll angle simulations in the cases where both tire models were simulated and the results compared. (See Figures L-6, L-7, L-11 and L-12 in Appendix L.)

The maximum roll angle versus bump height plot of Figure 9-3 is based on the corrected bump force subroutine except for the M198 simulation at the 6 inch bump height. At the data in the cornering maneuver plot of Figure 9-4 was based on the original subroutine. However, it is not likely that the results of Figure 9-4 will be affected by the error because of the small effect this error has on maximum roll angle in the cornering simulations checked and because of the large increment in obstacle heights in Figure 9-4.

It should be noted that both the LTHD and M198 became highly sensitive to tire obstacle as the cornering speed approached their respective stability limits.

9.2.2.4 Considerations for Additional Analysis

13

The following ideas surfaced upon performing the towing stability analysis. The ideas are not necessarily recommended; rather, they could be considered as options for further study.

- . Strong consideration could be given to reducing the ratio of the CG height to width between tire centerlines for the LTHD, such as in the case of the LTHD with 87.25 inches width between tire centers. Note that a 6 inch (12.4%) reduction in CG height did not produce a significant improvement in stability, while a 14.24 inch (19.5%) increase in width between tire centerlines did produce a significant improvement. This recommendation is intended to increase the speeds and obstacle heights required to overturn the vehicle.
- . Consideration could be given to using the tow hitch to restrain the LTHD from rolling to large angles. The writer believes that a small restraining torque at the tow hitch could prevent the LTHD from overturning in cases when small obstacles are encountered at speeds near the stability limits. If this restraint is provided by means of a slip clutch, a suitable maximum torque could be selected which will prevent damage to either vehicle and which would be unlikely to overturn the tow vehicle.

The second option is intended to make the LTHD less prone to rollover without warning as the turning stability limit is approached. Not only will larger obstacles be required to overturn the towed howitzer, but the driver will be somewhat able to feel the torsional response of the towed howitzer in instances in which it almost turned over. The driver will thereby be able to learn about the howitzer's towing stability limits without a howitzer rollover actually occurring.

In this section, towing stability concerns have been examined. A detailed analysis has been performed on the LTHD's towing stability and by estimating the M198's CG location and inertial properties, a similar analysis was performed. More complex models, which build upon the models presented here, can be developed for further work in the area of towing stability.

Appendix L

Towing Stability Data, Models and Results

All figures are Roll Angle vs. Time:

Figure L-1	LTHD, 25 mph, straight direction	L-2
Figure L-2	M198, 25 mph, straight direction	L-3
Figure L-3	LTHD, 15 mph, cornering	L-4
Figure L-4	M198, 15 mph, cornering	L-5
Figure L-5	M198, 20 mph, cornering	L-6
Figure L-6	M198, 25 mph, straight, corrected	L-7
Figure L-7	M198, 25 mph, straight, corrected	L-8
Figure L-8	LTHD, 25 mph, straight, corrected, 10 inch .	L-9
Figure L-9	LTHD, 25 mph, straight, corrected, 12 inch .	L-10
Figure L-10	LTHD, 25 mph, straight, corrected, 14 inch .	L-11
Figure L-11	M198, 15 mph, cornering, corrected	L-12
Figure L-12	M198, 15 mph, straight, corrected	L-13
LTHD Model		L-14
LTHD Data		L-15
LTHD Program, ADAMS Model		L-17
M198 Model		L-21
M198 Data		L-22
M198 Program, ADAMS Model		L-23
FORTTRAN Subroutines for Tire/Obstacle Force		L-25

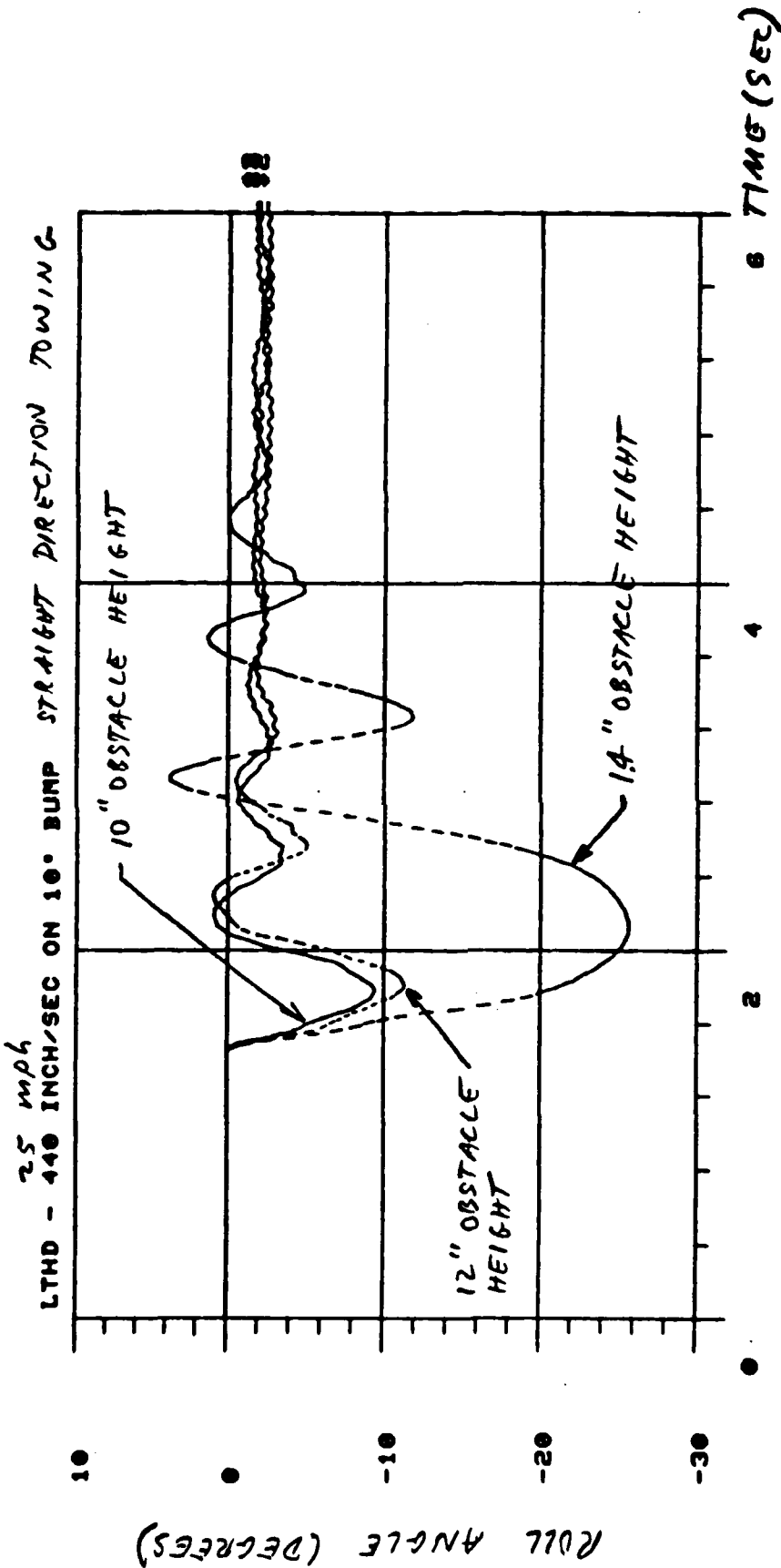

Plot No	X Axis		Y Axis		Req#	Run file
	Comp	Type	Comp	Type		
1.		TIME	ANG3	DISP	1	12 LTMD - E3
2		TIME	ANG3	DISP	1	13 LTMD - F3
3		TIME	ANG3	DISP	1	14 LTMD - G3

Figure L-1

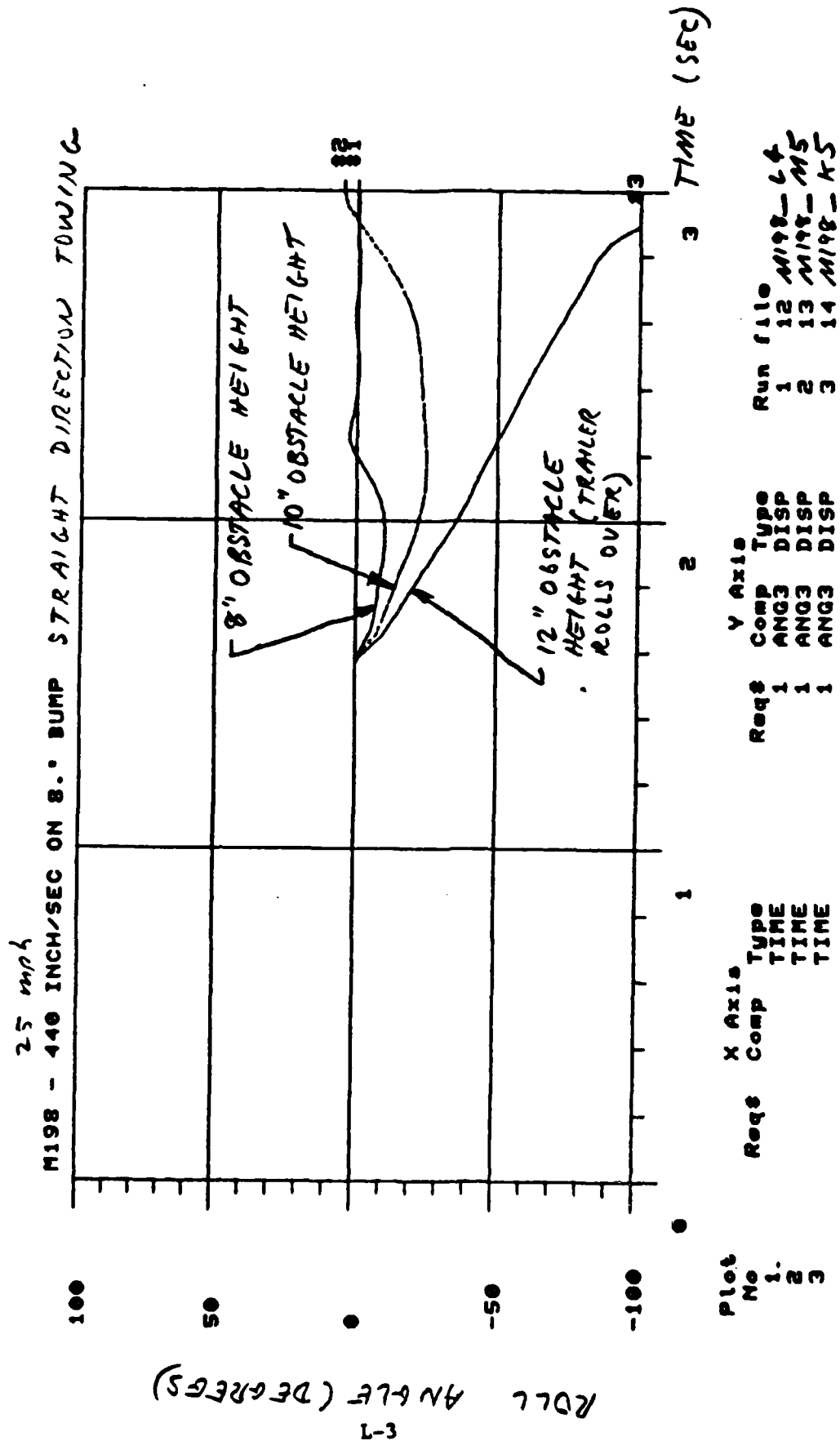
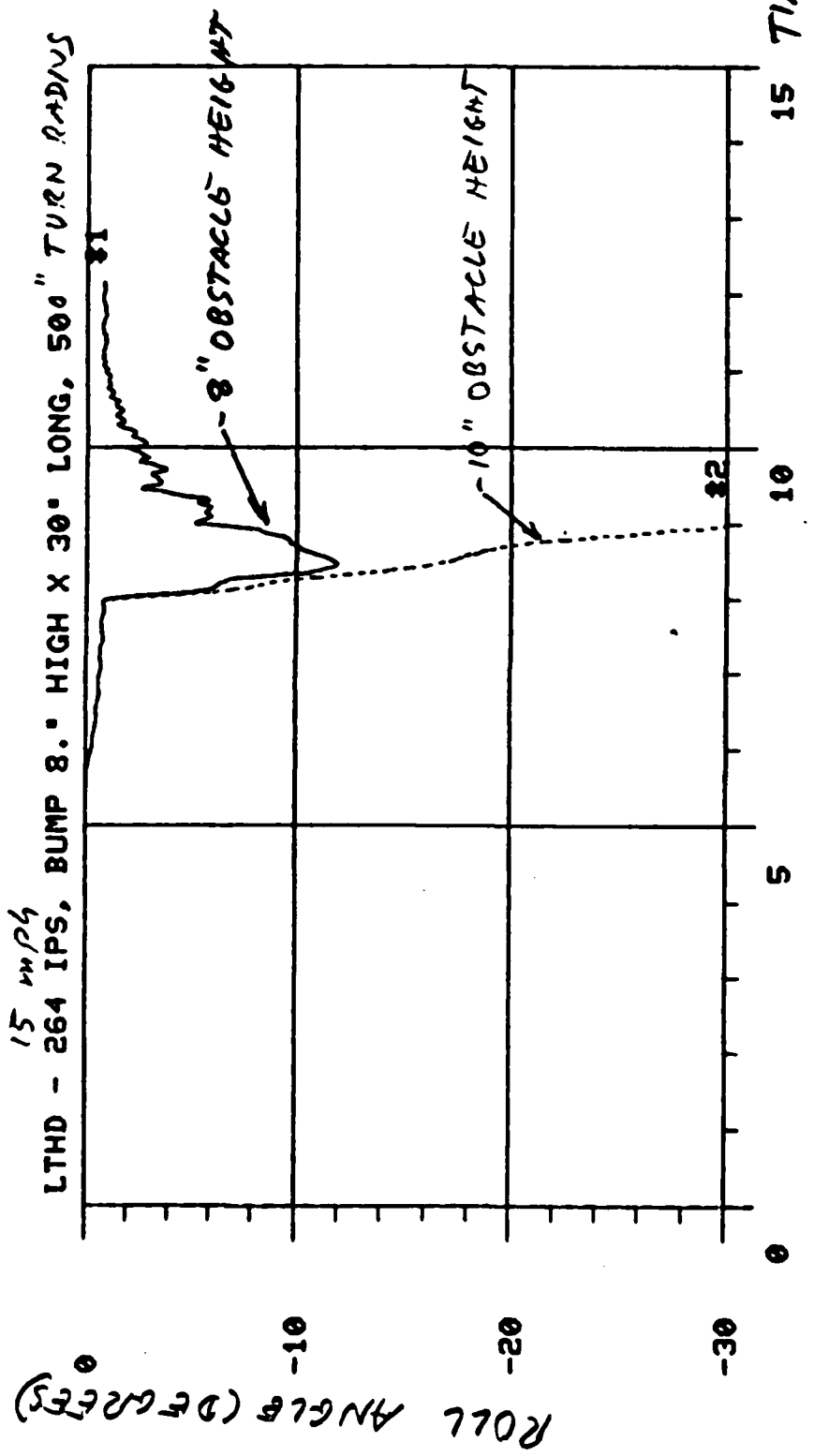

Figure L-2



Plot. No. 1. 2.

X Axis Req# Comp Type TIME TIME

Y Axis Req# Comp Type DISP DISP

Run file 1 12 LTHD - A1
2 13 LTHD - B2

Figure L-3

15 mph
 WM198 - 264 INCH/SEC, 500' RADIUS TURN, BUMP 6" HIGH & 8" HIGH

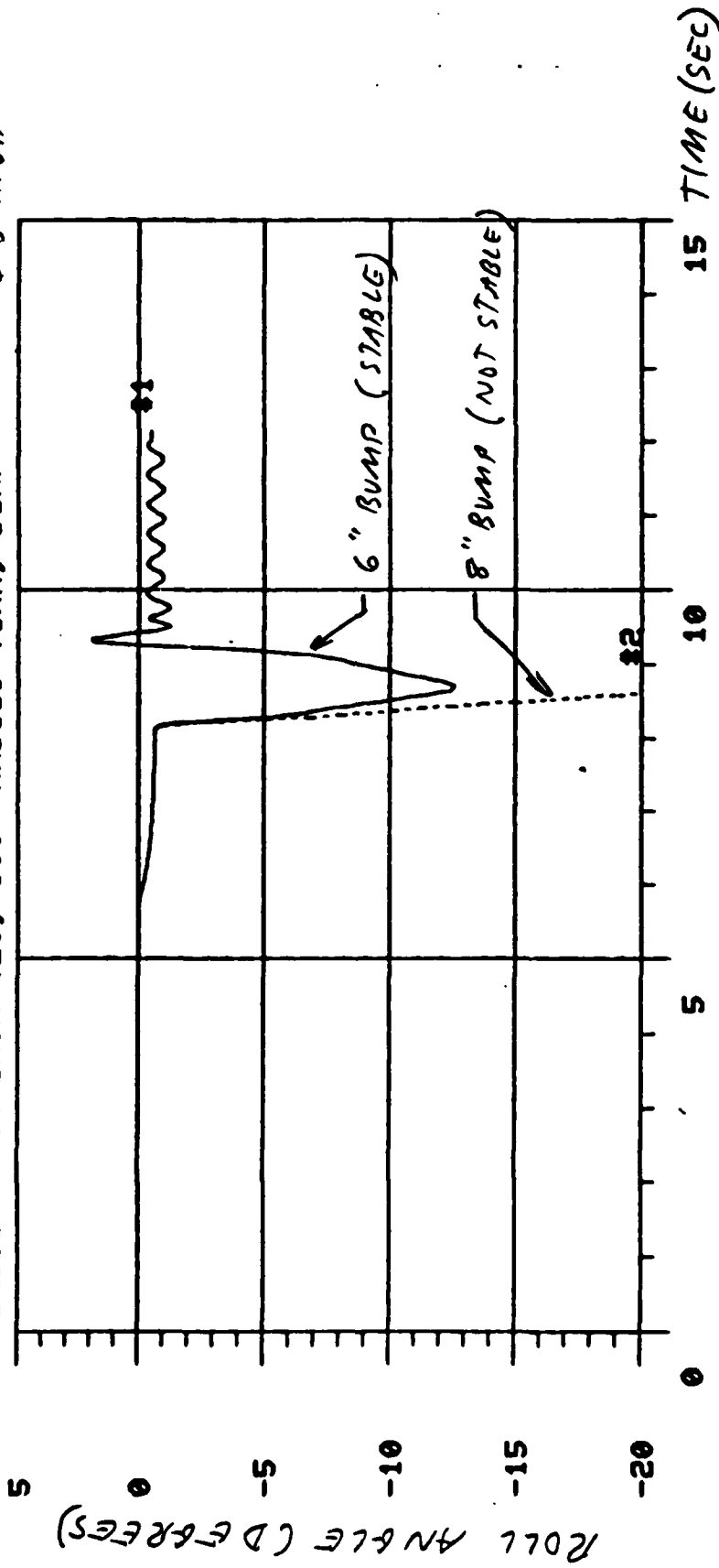

Plot No.	X Axis		Y Axis		Run file
	Req#	Comp	Req#	Comp	
1.		TIME	1	ANG3	12 M198-A
2.		TIME	1	ANG3	13 M198-G

Figure L-4

20 mph
WM198 - 352 INCH/SEC, 500' RADIUS TURN, BUMPS 1" AND 2" HIGH

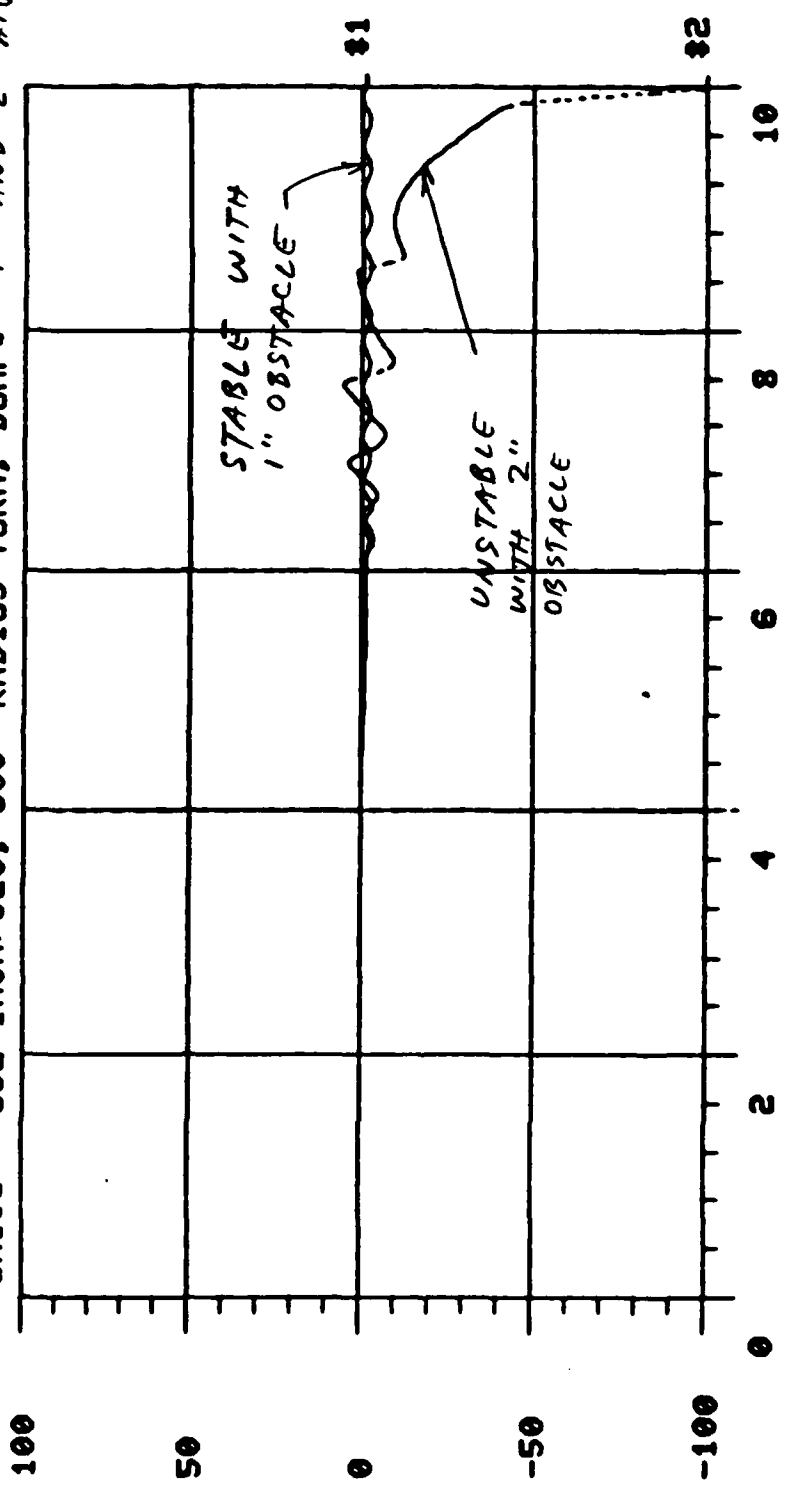

Plot No	X Axis		Y Axis		Run file	
	Req#	Comp	Req#	Comp	1	2
1			1	ANG3	12	MI98-CC
2			1	ANG3	13	MI98-Y

Figure L-5

ROLL ANGLE (DEGREES)

M198 - 440 INCH/SEC ON 8.° BUMP STRAIGHT DIRECTION TOWING

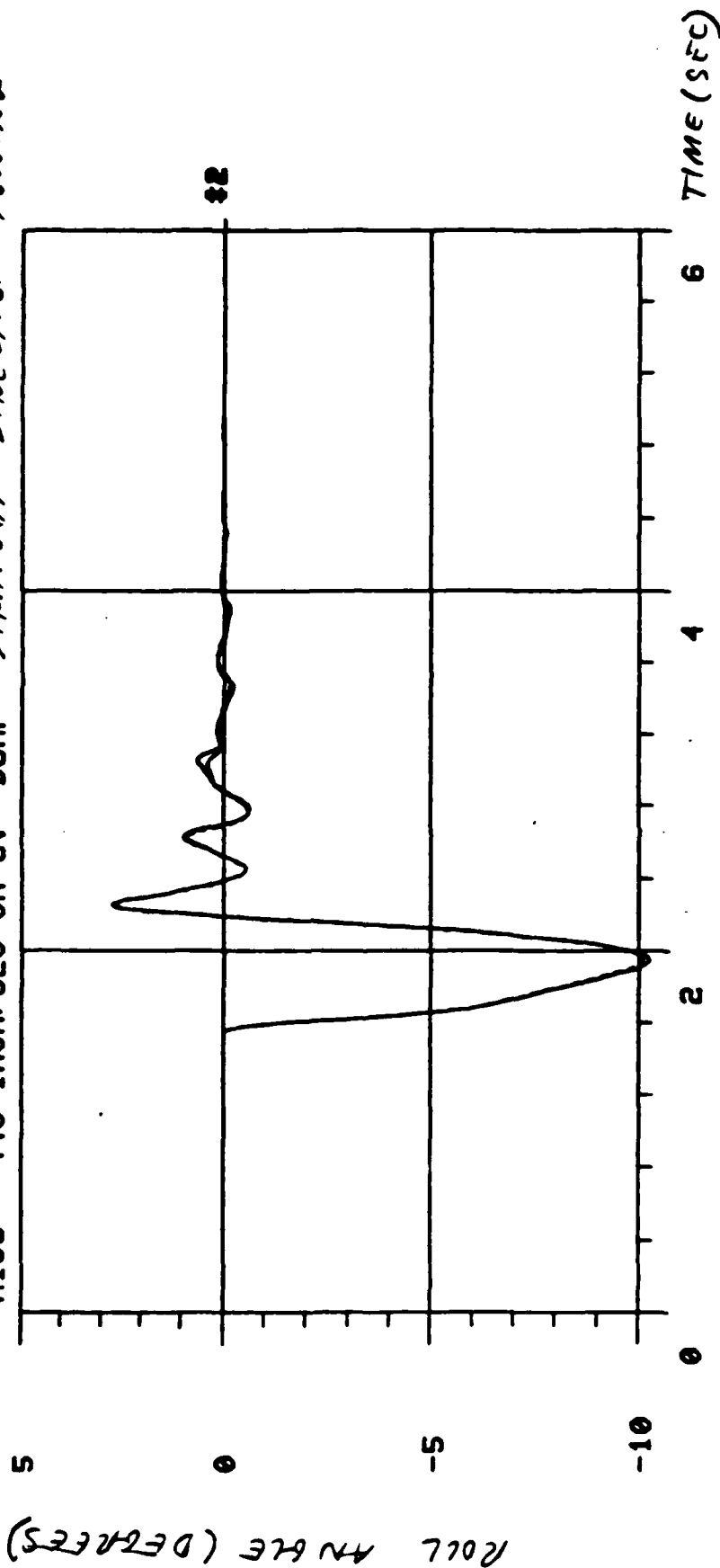

Plot No
1
2

X Axis
Req# 1
Comp TIME
Type TIME

Req# 1
Comp ANG3
Type DISP
Type DISP

Run file
1 12 M198-L3
2 13 M198-L4

EFFECT OF CORRECTED HORIZONTAL
COMPONENT OF TIRE/BUMP FORCE

Figure L-6

M198 - 440 INCH/SEC ON 10° BUMP STRAIGHT DIRECTION TOWING

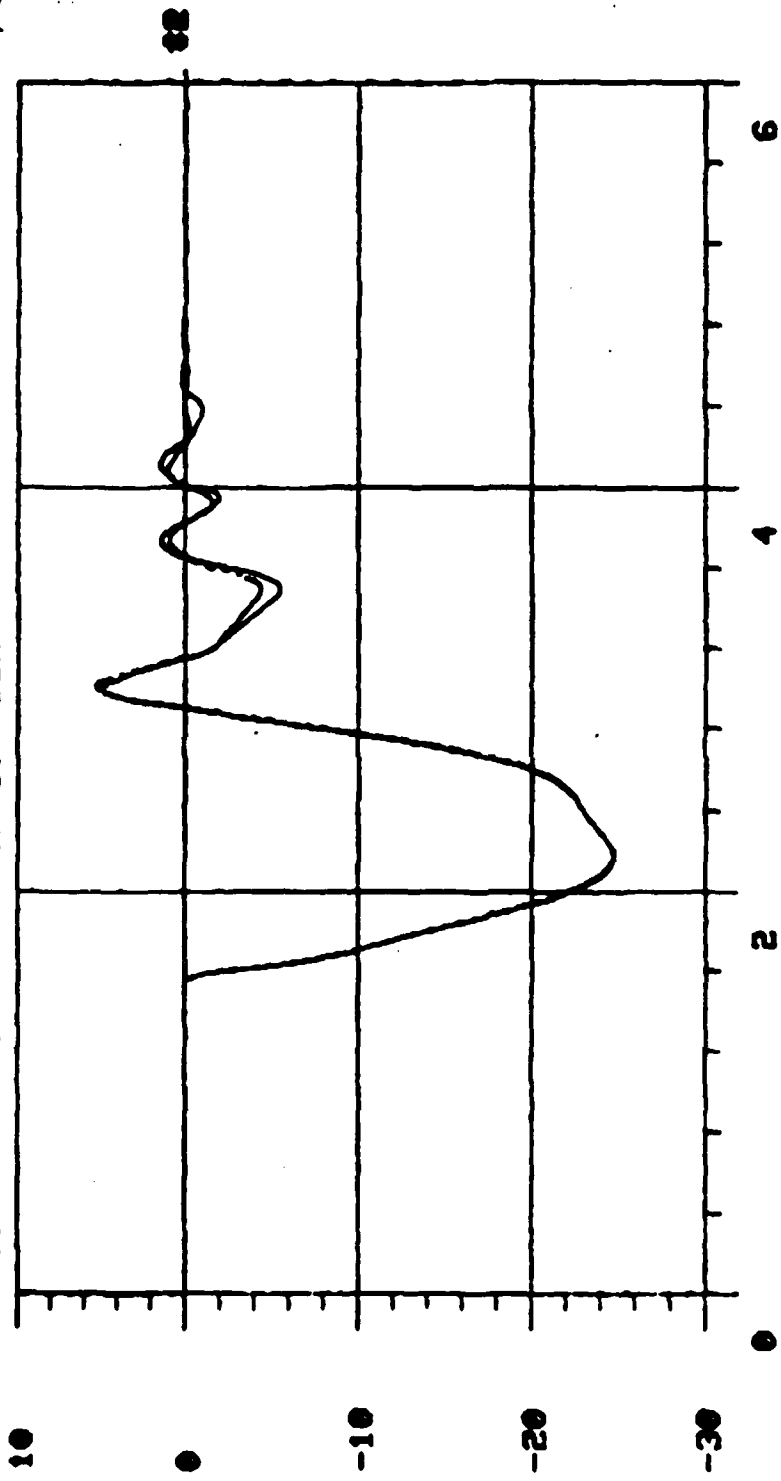

ROLL ANGLE (DEGREES)

Plot No	X Axis		Y Axis		Run file	
	Reqd	Comp	Type	Comp	Type	Run file
1			TIME	ANG3	DISP	1 12 11/98-M3
2			TIME	ANG3	DISP	2 13 11/98-M5

LIST OF CORRECTED ORIGINAL COMPONENT OF INSTANTANEOUS FORCE

Figure L-7

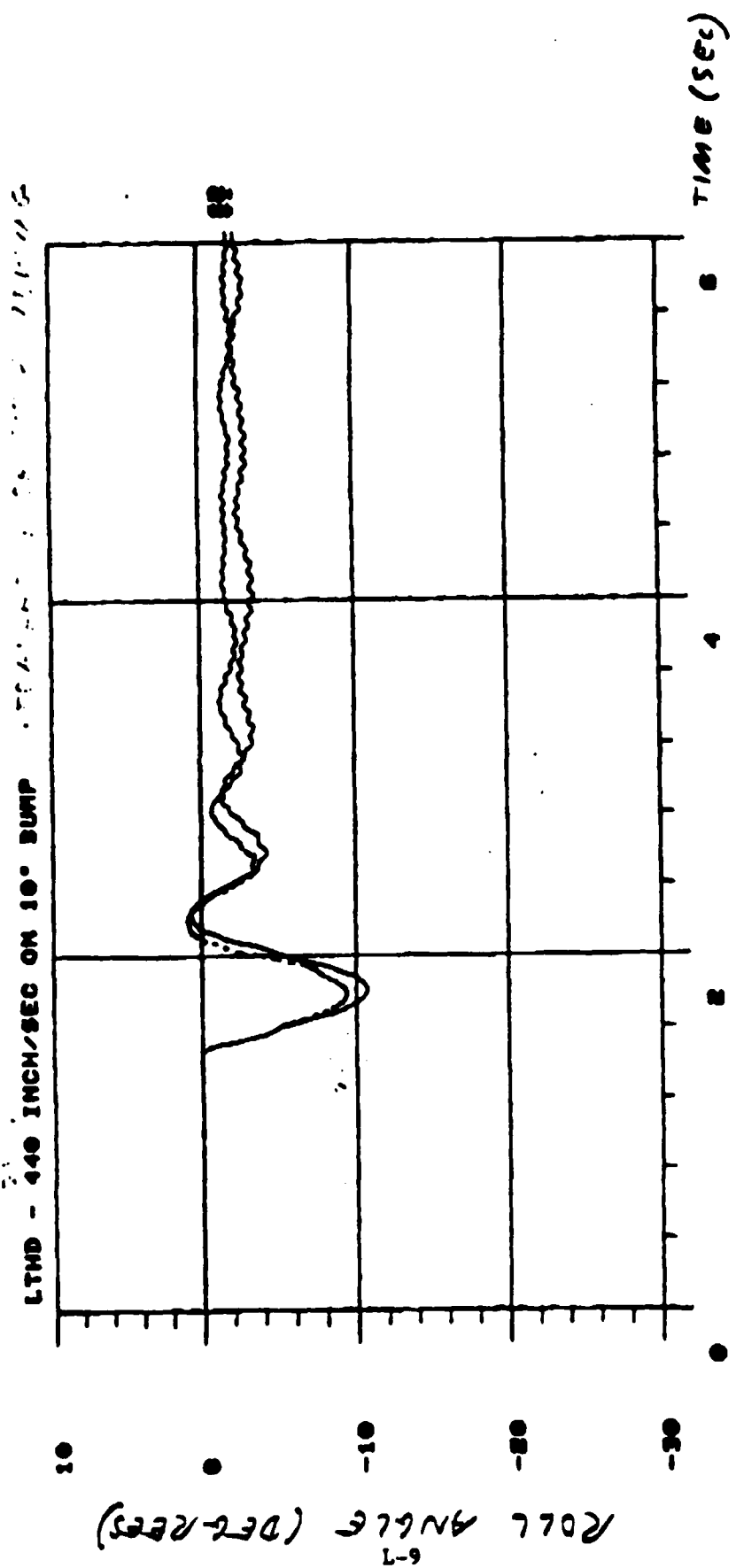

X Axis		Y Axis		Run file	
Reqd	Comp	Reqd	Comp	1	2
TIME	TIME	ANG3	DISP	LTND-62	LTND-63
1	1	1	1		
2	2	1	1		

EFFICIENCY OF CORRECTED HORIZONTAL
 COMPONENT IN THE OBSTACLE FORCE

Figure L-8

LTND - 440 INCH/SEC ON 12' BUMP 57.0 INCH DISPLACEMENT TOWING

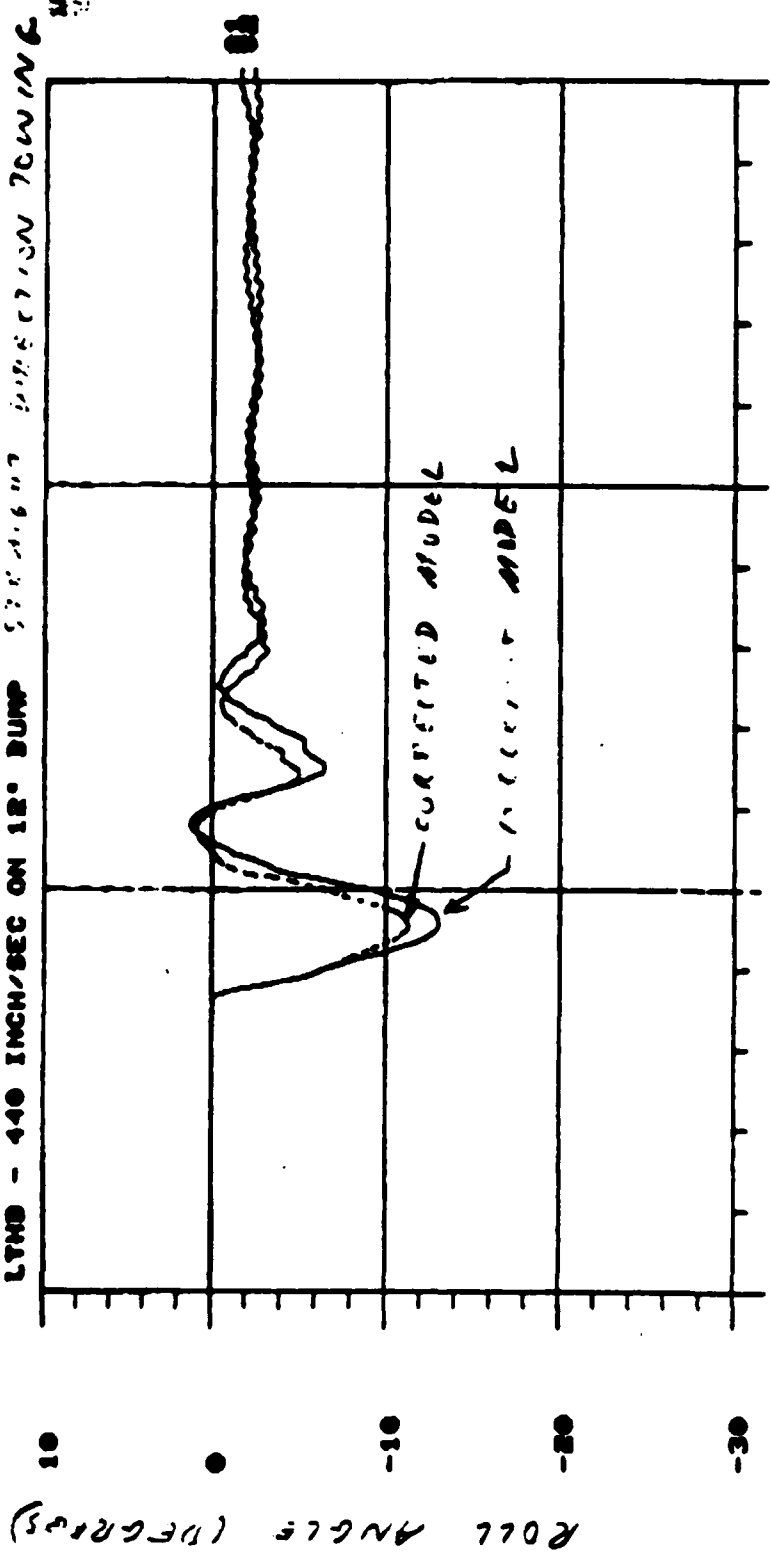

Plot No	X Axis		Y Axis		Run File	
	Reqd	Type	Reqd	Type	1	2
1		TIME	1	ANG3 DISP	1	12 1100-F2
2		TIME	1	ANG3 DISP	2	13 1100-F3

EFFECT OF CORRECTED DISPLACEMENT
ON TIRE/SPRING FORCE

Figure L-9

25 MPH
 LTHD - 440 INCH/SEC ON 14° BUMP STRAIGHT DIRECTION TOWING

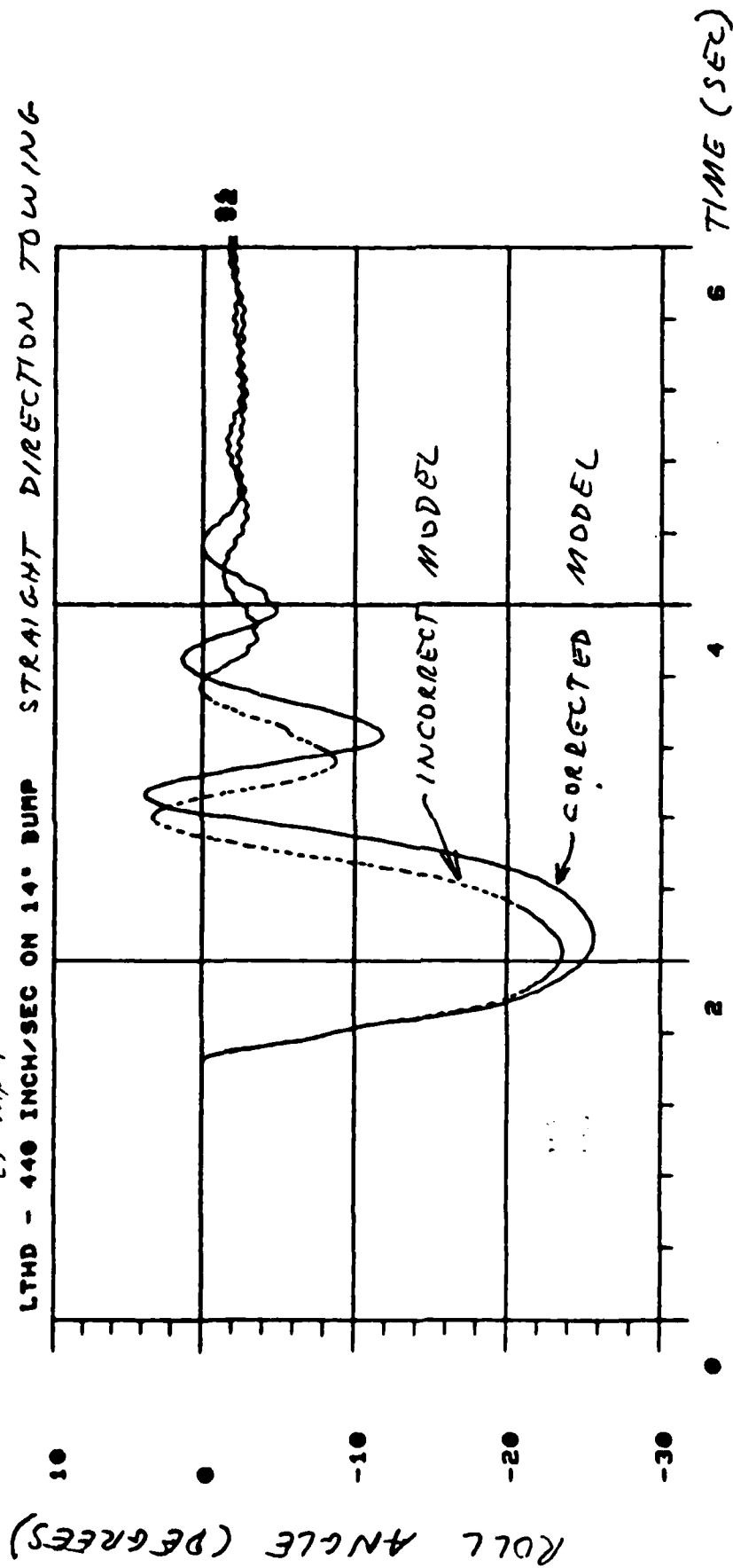

Plot No	X Axis		Y Axis		Run file	
	Req	Comp	Req	Comp	1	2
1		TIME	1	ANG3	1	12 LTHD - G-3
2		TIME	1	ANG3	2	13 LTHD - G-2

EFFECT OF CORRECTED HORIZONTAL COMPONENT OF TIRE/OBSTACLE FORCE

Figure L-10

UM198 - 264 INCH/SEC, 500" RADIUS TURN, F = 100"

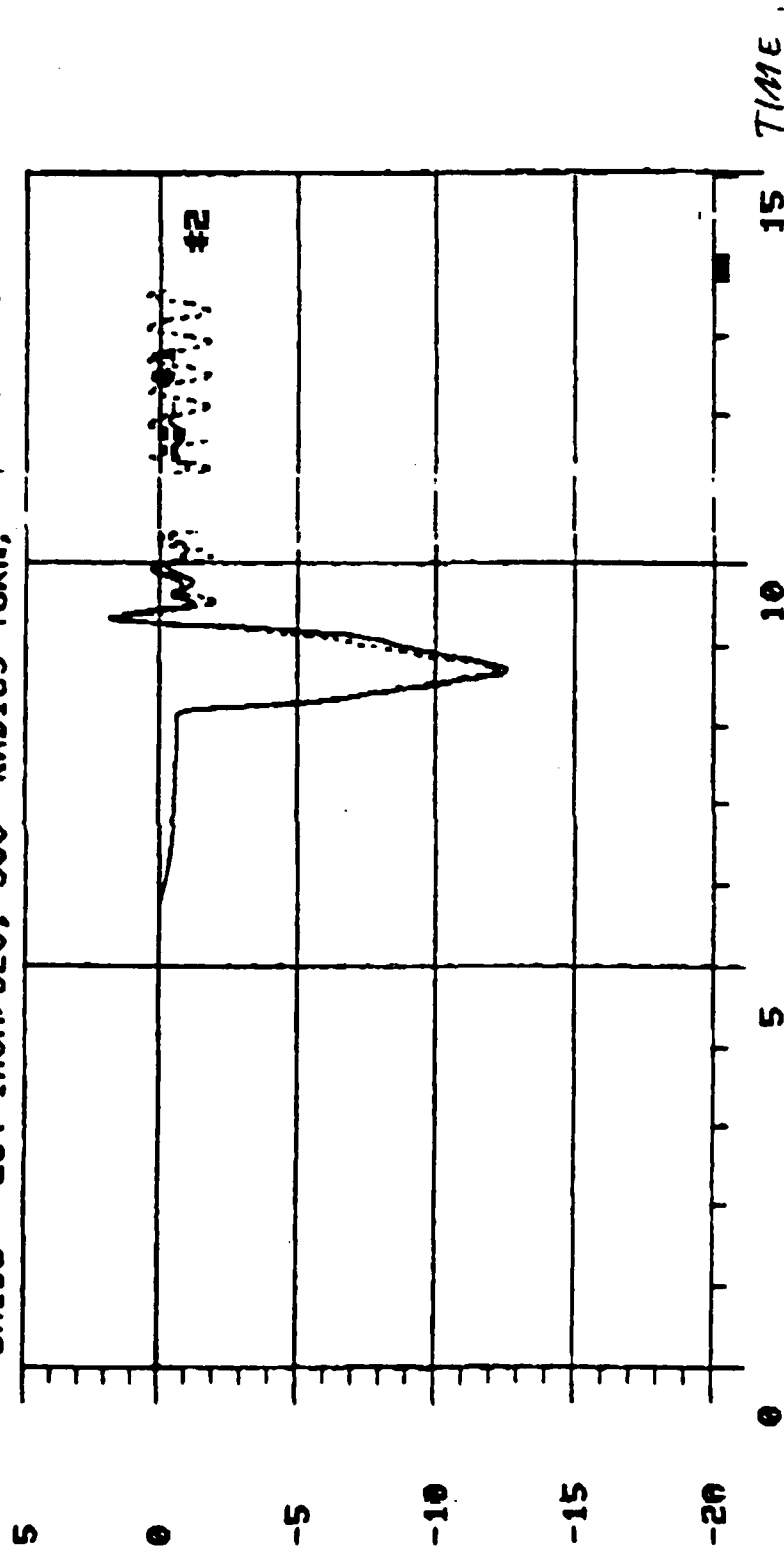

Plot No	X Axis Comp	Type	Reqd	Y Axis Comp	Reqd	EF	Rt	F110
1	TIME	TIME	1	ANG3	1	1	1	11/19-2X
2	TIME	TIME	1	ANG3	1	1	1	11/19-2

L-12

Figure L-11

ENTER COMMAND *15 mph*
 LTHD - 264 IPS, BUMP 8." HIGH X 30" LONG, 50

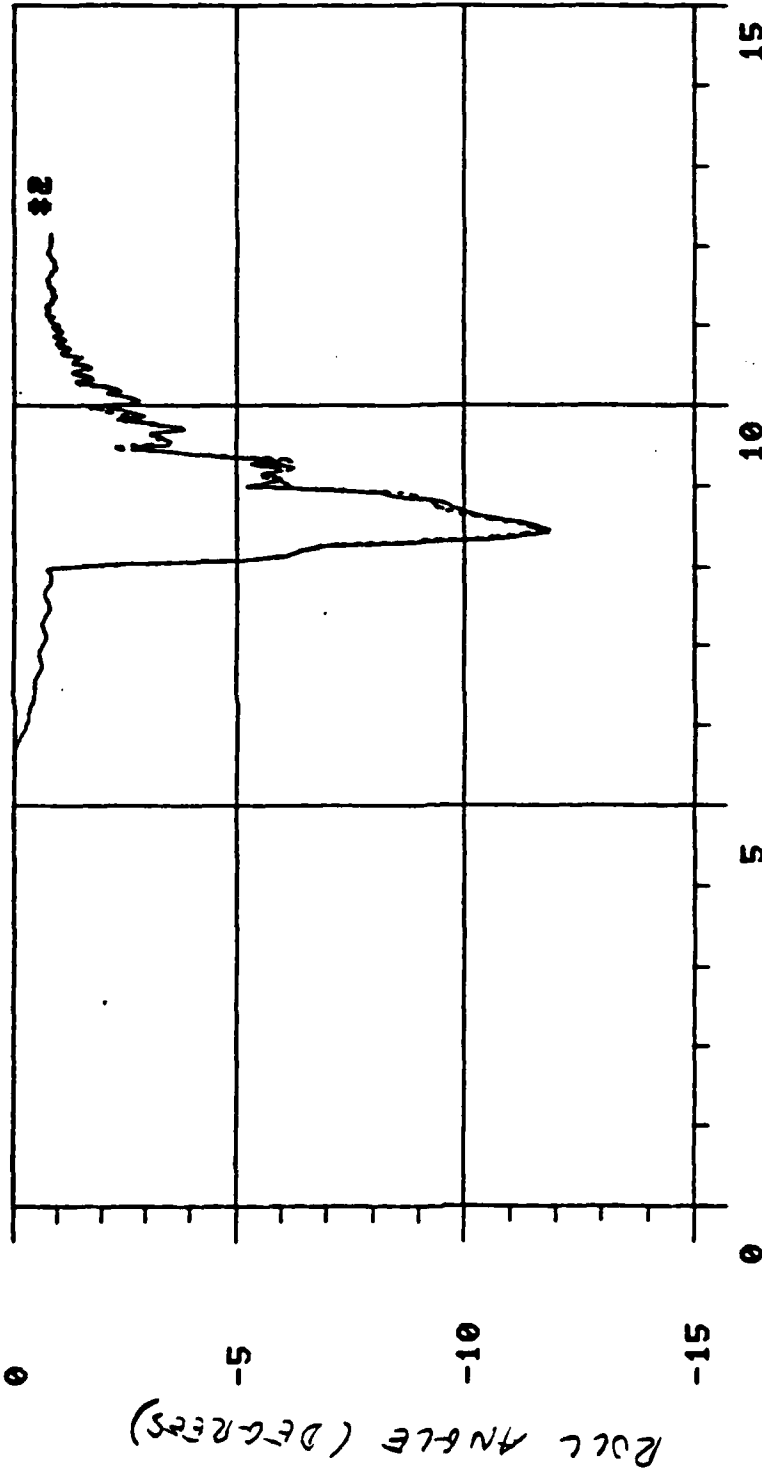

Plot No	X Axis Comp	X Axis Type	Req#	Y Axis Comp	Y Axis Type	Req#	Run file
1	TIME	TIME	1	ANG3	DISP	1	12 LTHD-AA
2	TIME	TIME	1	ANG3	DISP	2	13 LTHD-AA2

EFFECT OF CORRECTED HORIZONTAL COMPONENT
 OF TIRE/Obstacle FORCE

Figure L-12

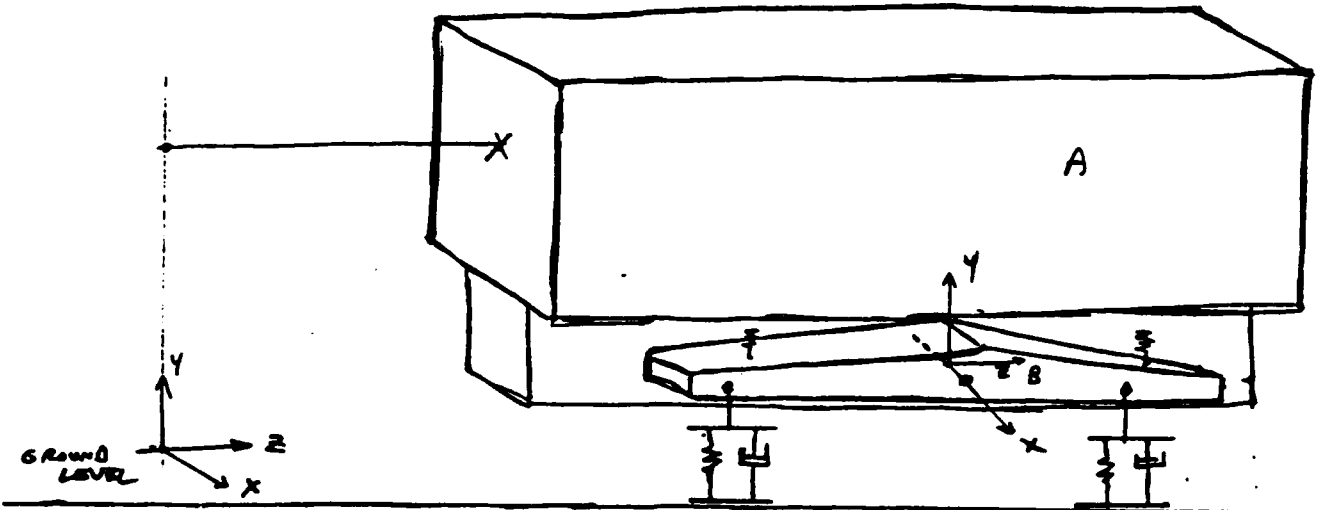

LTHD MODEL FOR TOWING STABILITY
- INITIAL REPRESENTATION

CG AND MMI OF LTHD TOWED - PART A ONLY
 TOTAL WEIGHT = 8379
 C.G. X COORD (IN) = .859291E-01
 C.G. Y COORD (IN) = 3.11609
 C.G. Z COORD (IN) = 91.7685
 JYZ (FT-LB-S²) = 24701.7
 JXY (FT-LB-S²) = 362.078
 JXZ (FT-LB-S²) = 24729.2

DESCRIPTION	WEIGHT	X	Y	Z
CANNON	2600	0	0	102
BREECH	500	.5	.5	8.16
BAND	86	0	0	14.5
AUTOPR	45	0	0	-1
MBRKASSEM	137	0	-.25	260
ASSTGUN	59	0	22	-21
GUNNER	115	0	22	-21
SLIDEUNIT	396	0	2	134
SLUNITLP	182	0	2	134
PLATFORM	265	0	9	-19
SPADES	190	0	-6	-28
SPLKBLTS	8	0	-12	-28
TSHFTUPR	10	0	42	-16.5
TSHFTLWR	30	0	-18	-16.5
TRLLKPR	16	0	24	-20
WRSKPLTFM	20	0	-12	-19
LFTGEYES	14	0	44	-28
GIMBALASSY	256	0	14	-13
PULLYASSY	16	0	36.75	2
LTRYLASSY	18	0	14	-13
TRLASSYLH	215	-36	12	75
TRLASSYRH	215	36	12	75
MNFASSYG	95	0	16	-22
TRVCYL	50	31	36	-30
HDLNSL	40	-18	0	134
HOSETSG	20	-18	10	-12
MNFOLD	190	0	6	241
LFTEYSMF	16	0	14	241
TRLLKPF	14	0	0	241
ELVCYLLH	25	-14	21	-3
ELVCYLRH	25	14	21	-3
COMPCBL	25	0	18	72
IBCUSH	26	0	0	238
ACCBNKASSY	300	0	13	185
HFLUID	150	0	13	185
RCYLREC	440	0	0	67.5
RCYLNREC	160	0	0	185.5
CRCYLREC	220	0	0	67.5
CRCYLNREC	160	0	0	185.5
FVDYK	100	0	0	127
REARYOK	100	0	0	22
LTBUNGY	10	0	0	112
DMF	68	0	-16	61
DCTWB	38	0	-19	52
DLWB	48	-27	-22	52
DRVB	48	27	-22	52
DTPIN	8	0	-15	92
DTHANDL	3	0	-15	117
DFWDLPIN	4	0	-8	128
DBRKCAL	44	0	-26	52

AOVEROILAC	15	0	-26	52
DBKROTOR	42	0	-26	52
DHUBS	36	0	-26	52
DBRGSBLTS	16	0	-26	52
EQUILCYLLH	225	-21	12	192
EQUILCYLRH	225	21	12	192

LTHD - 440 INCH/SEC ON 10" BUMP

FILE LTHD.DAT

INITIAL VELOCITY = 440 INCHES/SEC

NOTE: EULER ANGLE DISPLACEMENT OUTPUT IS YAW, PITCH, ROLL

PA/1,GR

A/9, EU= 90., 90., 0.

MARKER/11,EU=90,90,0Z-AXIS PAR.W/X-AXIS

MARKER/12,EU=0,-90,0Z-AXIS PAR.W/Y-AXIS

MARKER/13,EU=0,0,0Z-AXIS PAR.W/Z-AXIS

GRAPHICS OF TERRAIN:

MA/5001, QP=0., 36.5, 0.

MA/5011, QP=2000., 36.5, 0.

GR/14,OU=5001,5011

MA/5002, QP=0., -36.5, 0.

MA/5004, QP=440., -36.5, 0.

MA/5006, QP=440., -36.5, 10.

MA/5008, QP=470., -36.5, 10.

MA/5010, QP=470., -36.5, 0.

MA/5012, QP=2000., -36.5, 0.

GR/15, OU=5001,5002,5004,5006,5008,5010,5012,5011

HOWITZER BODY

PA/2,MA=8484.,CM=200,IP= 53.48E6, 53.31E6, 2.33E6

,QG=0.,0.,0.,EU=90,90,0,VX=440

MA/200,QP=0.,48.29,-216.5

MA/223, QP=0., 48.29, -216.5, EU=0., -90., -90. INITIALLY PARALLEL W/ GLOBAL
ON GROUND, INITIALLY AT VEHICLE C.G.

MA/10, PA=1, QP= -216.5, 0., 48.29

MA/201,QP=12.5,76.5,-51.6

MA/203,QP=12.5,76.5,-265.5

MA/205,QP=12.5,99.,-265.5

MA/207,QP=12.5,99.,-326.35

MA/209,QP=12.5,33.,-326.35

MA/211,QP=12.5,33.,-51.6

MA/202,QP=-12.5,76.5,-51.6

MA/204,QP=-12.5,76.5,-265.5

MA/206,QP=-12.5,99.,-265.5

MA/208,QP=-12.5,99.,-326.35

MA/210,QP=-12.5,33.,-326.35

MA/212,QP=-12.5,33.,-51.6

MA/215,QP=12,33.,-51.6

MA/217,QP=12,15.,-51.6

MA/219,QP=12,15.,-267.6

MA/221,QP=12,33.,-267.6

MA/216,QP= -12, 33., -51.6

MA/218,QP= -12, 15., -51.6

MA/220,QP= -12, 15., -267.6

MA/222,QP= -12, 33., -267.6

GR/1,OU=201,203,205,207,209,211,201

,202,204,206,208,210,212

,202/203,204/205,206/207,208/209,210/211

,212/215,217,218,216,222,220,219,221

,215/217,218/219,220/221,222

MA/213,QP=0.,35.75,-51.6

GR/2,CY,CM=213,LENGTH=28.85,RADIUS=3.75,SIDES=8

LEFT SIDE WALKING BEAM:

PA/3,MA=244.,CM=300,IP= 2.78E5,2.78E5,4.64E4

,QG= -243.6, 21.5,24.75, EU=90,90,0,VX=440

WALKING BEAM GRAPHICS:

MA/300,QP=11.34, -5.38, 0.

MA/301, QP= 9., -9., 36.

MA/303, QP= 9., -3., 36.
 MA/305, QP= 9., 7., 0.
 MA/307, QP= 9., -3., -36.
 MA/309, QP= 9., -9., -36.
 MA/311, QP= -9., -9., 36.
 A/313, QP= -9., -3., 36.
 A/315, QP= -9., 7., 0.
 MA/317, QP= -9., -3., -36.
 MA/319, QP= -9., -9., -36
 GR/3, OU=301,303,305,307,309,301,311,313,315,317,319,311
 ,303,313/305,315/307,317/309,319

RIGHT SIDE WALKING BEAM:

PA/4, MA=244., CM=400, IP=2.78E5, 2.78E5, 4.64E4
 , QG= -243.6, -21.5, 24.75
 , EU=90, 90, 0, VX=440

WALKING BEAM GRAPHICS:

MA/400, QP= -11.34, -5.38, 0.
 MA/401, QP= -9., -9., 36.
 MA/403, QP= -9., -3., 36.
 MA/405, QP= -9., 7., 0.
 MA/407, QP= -9., -3., -36.
 MA/409, QP= -9., -9., -36
 MA/411, QP= 9., -9., 36.
 MA/413, QP= 9., -3., 36.
 MA/415, QP= 9., 7., 0.
 MA/417, QP= 9., -3., -36.
 MA/419, QP= 9., -9., -36
 GR/4, OU=401,403,405,407,409,401,411,413,415,417,419,411
 ,403,413/405,415/407,417/409,419

TOWING VEHICLE:

PA/5, MA=10., CM=500, IP=1.E3, 1.E3, 1.E3, QG=0, 0, 0
 , EU=90, 90, 0, VX=440
 MA/500, QP=0, 0, 0

JO/1, RE, I=1001, J=1002
 MA/1001, PA=3, QP=0, 0, 0, EU=90., 90., 0.
 MA/1002, PA=2, QP=21.5, 24.75, -243.6, EU= 90., 90., 0.
 GR/9, CI, CM=1002, RADIUS=3.

JO/2, RE, I=2001, J=2002
 MA/2001, PA=4, QP=0, 0, 0, EU=90., 90., 0.
 MA/2002, PA=2, QP=-21.5, 24.75, -243.6, EU= 90., 90., 0.
 GR/10, CI, CM=2002, RADIUS=3.

JO/3, SP, I=3001, J=3002
 MA/3001, PA=5, QP=0, 32, 0
 MA/3002, PA=2, QP=0, 32, 0
 GR/11, CI, CM=3002, RADIUS=3.

JO/4, TR, I=4002, J=4001
 MA/4001, PA=1, QP=10., 0., 32., EU=90., 90., 0.
 MA/4002, PA=5, QP=0., 32., 10.
 GR/12, CI, CM=4001, RADIUS=3.
 GR/13, CI, CM=4002, RADIUS=3.

JE/1, CO, JO=4, PAR= 440., 0.

LEFT FRONT TIRE:

MA/1, PA=3, QP=15., -6.75, 36.
 MA/5, PA=3, QP=14., -6.75, 36
 FO/11, AOF, I=1, J=11, PAR= 1500., 10., 1, 5, 0.
 FO/21, AOF, I=1, J=12; PAR= 1500., 10., 1, 5, 0.
 FO/31, AOF, I=1, J=13, PAR= 1500., 10., 1, 5, 0.

TIRE GRAPHICS:

A/320, PA=3, QP= 9., -6.75, 36., EU=90,90,0
 GR/5, CY, CM=320, LENGTH=12, RADIUS=18., SIDES=8

RIGHT FRONT TIRE:

MA/2, PA=4, QP=-15., -6.75, 36.
 MA/6, PA=4, QP=-16., -6.75, 36.
 FO/12, AOF, I=2, J=11, PAR= 1500., 10., 2, 6, 0.
 FO/22, AOF, I=2, J=12, PAR= 1500., 10., 2, 6, 0.
 FO/32, AOF, I=2, J=13, PAR= 1500., 10., 2, 6, 0.

TIRE GRAPHICS:

MA/420, PA=4, QP= -9., -6.75, 36., EU=90,-90,0
 GR/7, CY, CM=420, LENGTH=12, RADIUS=18., SIDES=8

LEFT REAR TIRE:

MA/3, PA=3, QP=15., -6.75, -36.
 MA/7, PA=3, QP=14., -6.75, -36.
 FO/13, AOF, I=3, J=11, PAR= 1500., 10., 3, 7, 0.
 FO/23, AOF, I=3, J=12, PAR= 1500., 10., 3, 7, 0.
 FO/33, AOF, I=3, J=13, PAR= 1500., 10., 3, 7, 0.

TIRE GRAPHICS:

MA/321, PA=3, QP= 9., -6.75, -36., EU=90,90,0
 GR/6, CY, CM=321, LENGTH=12, RADIUS=18., SIDES=8

RIGHT REAR TIRE:

A/4, PA=4, QP=-15., -6.75, -36.
 A/8, PA=4, QP=-16., -6.75, -36.
 FO/14, AOF, I=4, J=11, PAR= 1500., 10., 4, 8, 0.
 FO/24, AOF, I=4, J=12, PAR= 1500., 10., 4, 8, 0.
 FO/34, AOF, I=4, J=13, PAR= 1500., 10., 4, 8, 0.

TIRE GRAPHICS:

MA/421, PA=4, QP= -9., -6.75, -36., EU=90,-90,0
 GR/8, CY, CM=421, LENGTH=12, RADIUS=18., SIDES=8

TIRE MOMENTS, LEFT FRONT:

FO/41, AOT, I=1, J=11
 FO/51, AOT, I=1, J=12
 FO/61, AOT, I=1, J=13

TIRE MOMENTS, RIGHT FRONT:

FO/42, AOT, I=2, J=11
 FO/52, AOT, I=2, J=12
 FO/62, AOT, I=2, J=13

TIRE MOMENTS, LEFT REAR:

FO/43, AOT, I=3, J=11
 FO/53, AOT, I=3, J=12
 FO/63, AOT, I=3, J=13

TIRE MOMENTS, RIGHT REAR:

FO/44, AOT, I=4, J=11
 J/54, AOT, I=4, J=12
 J/64, AOT, I=4, J=13

LEFT FRONT BUMP STOP:

L-19

F0/1, CO, I=323, J=223, K=10.E3, L=6.
MA/323, PA=3, QP=-5., 0., 36.
MA/223, PA=2, QP= 16.5, 40.7, -208.82

LEFT REAR BUMP STOP:

O/3, CO, I=325, J=225, K=10.E3, L=6.
1/325, PA=3, QP= -5., 0., -36.
MA/225, PA=2, QP= 16.5, 40.7, -278.38

RIGHT FRONT BUMP STOP:

F0/2, CO, I=324, J=224, K=10.E3, L=6.
MA/324, PA=4, QP= 5., 0., 36.
MA/224, PA=2, QP= -16.5, 40.7, -208.82

RIGHT REAR BUMP STOP:

F0/4, CO, I=326, J=226, K=10.E3, L=6.
MA/326, PA=4, QP= 5., 0., -36.
MA/226, PA=2, QP= -16.5, 40.7, -278.38

SPLINES (LATERAL FORCE CHARACTERISTIC)

SP/1, X=0., 1., 2., 3., 4., 5., 20., 90.
.Y= .0, .16, .30, .40, .49, .57, .75, .85

SLIP ANGLES IN DEGREES
RATIO: FSIDE/FLOAD

SYSTEM AND OUTPUT CARDS:

SYSTEM/ GC=386.088, KGRAV= -386.088
OUTPUT/SCIENTIFIC, GRSAVE, SAVEREQ, YPR

RE/1, D, I= 223, J=10, :DISP OF CG (YAW, PITCH, ROLL)
RE/2, V, I= 200, J=10, :VEL OF CG
RE/3, A, I= 200, J=10, :ACCEL OF CG

E/41, F, I=1, :LEFT FRONT TIRE
RE/42, F, I=2, :RIGHT FRONT TIRE
RE/43, F, I=3, :LEFT REAR TIRE
RE/44, F, I=4, :RIGHT REAR TIRE

RE/21, D, I=1, J=9
RE/22, D, I=2, J=9
RE/23, D, I=3, J=9
RE/24, D, I=4, J=9

END CARD:

END

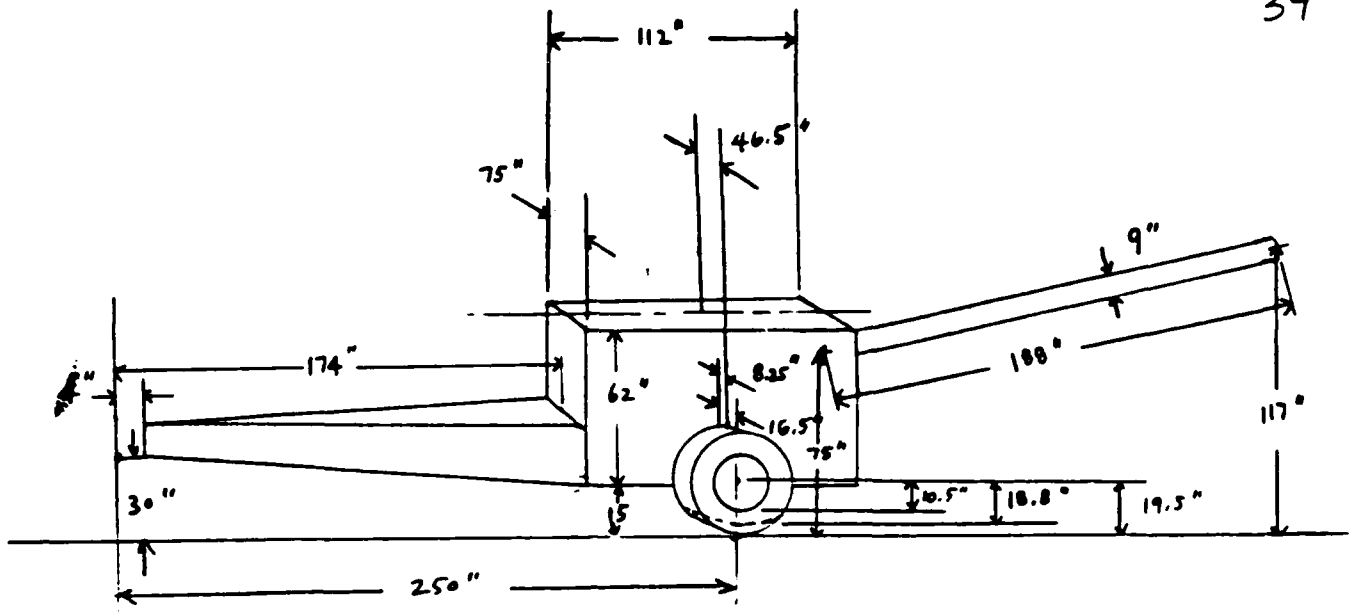

M19B MODEL FOR TOWING STABILITY
- GRAPHIC REPRESENTATION

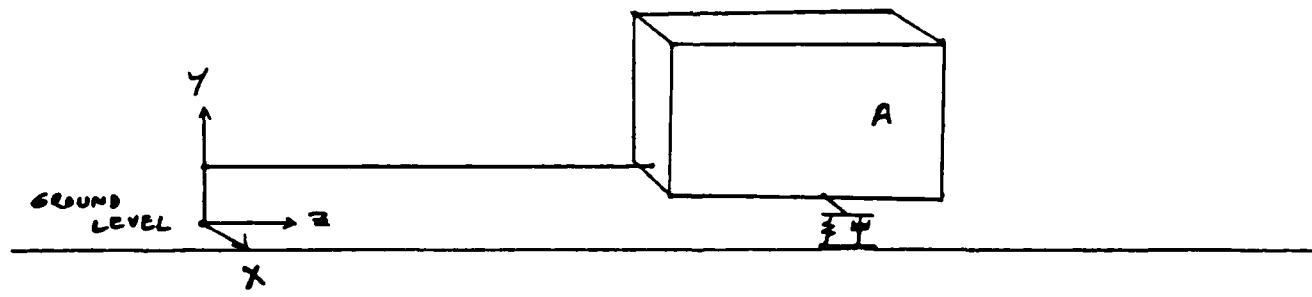

MMI OF M198 IN TOW 860507
 TOTAL WEIGHT = 15780
 C.G. X COORD (IN) = -.106084E-01
 C.G. Y COORD (IN) = .883412E-02
 C.G. Z COORD (IN) = 21.9205
 JYZ (FT-LB-S²) = 14136.1
 JXY (FT-LB-S²) = 2096.5
 JXZ (FT-LB-S²) = 12935.7

DESCRIPTION	WEIGHT	X	Y	Z
WHEELR	263	-46.5	-34.34	7
WHELL	263	46.5	-34.34	7
PIRING BASE	74	0	-8.94	-157
SPADERT	184	-36	-17.14	-96
SPADEL	184	36	-17.14	-96
TRAILRT	674	-18.6	-36.64	-48
TRAILL	665	18.6	-36.64	-48
BOTTCAR	1555	0	-24.14	6
BBANDB	5008	0	21.86	84
RECSYS	2105	0	16.86	46
CRADLE	1020	0	17.86	56
INTCOMP	1276	0	-3.64	-2
REMAINDER	2509	0	-18.64	-51

FILE: M198.DAT,53

M198 - 440 INCH/SEC ON 10" BUMP

FILE M198.DAT

INITIAL VELOCITY = 440 INCHES/SEC

NOTE: EULER ANGLE DISPLACEMENTS IN YAW, PITCH, ROLL

36

PA/1,GR

A/9, EU= 90., 90., 0.

MARKER/11,EU=90,90,0

.....Z-AXIS PAR.W/X-AXIS

MARKER/12,EU=0,-90,0

.....Z-AXIS PAR.W/Y-AXIS

MARKER/13,EU=0,0,0

.....Z-AXIS PAR.W/Z-AXIS

GRAPHICS OF TERRAIN:

MA/5001, QP=0., 46.5, 0.

MA/5011, QP=2000., 46.5, 0.

GR/14,OU=5001,5011

MA/5002, QP=0., -46.5, 0.

MA/5004, QP=440., -46.5, 0.

MA/5006, QP=440., -46.5, 10.

MA/5008, QP=470., -46.5, 10.

MA/5010, QP=470., -46.5, 0.

MA/5012, QP=2000., -46.5, 0.

GR/15, OU=5001,5002,5004,5006,5008,5010,5012,5011

HOWITZER BODY

PA/2,MA= 15600.,CM=200,IP= 58.71E6, 53.14E6, 9.72E6

,QG=0.,0.,0.,EU=90,90,0,VX=440

MA/200, QP= 0., 53.84, -242.

MA/223, QP= 0., 53.84, -242., EU=0., -90., -90.

MA/10, PA=1, QP= -242., 0., 53.84 FOR VEHICLE C.G.

MA/201, QP= 37.5, 77., -174.

MA/203, QP= 37.5, 77., -286.

MA/205, QP= 37.5, 15., -286.

MA/207, QP= 37.5, 15., -174.

MA/209, QP= 37.5, 25., -174.

MA/211, QP= 0., 40., 0.

MA/213, QP= 0., 30., 0.

MA/215, QP= 0., 75., -286., EU= 0., -167., 0.

MA/202, QP= -37.5, 77., -174.

MA/204, QP= -37.5, 77., -286.

MA/206, QP= -37.5, 15., -286.

MA/208, QP= -37.5, 15., -174.

MA/210, QP= -37.5, 25., -174.

GR/1, OU= 207,201,203,205,207,213,211,209,210,211,213

,208,202,204,206,208/201,202/203,204/205,206/207,208

GR/2,CY, CM=215, LENGTH= 188., RADIUS= 4.5, SIDES=8

BARREL

TOWING VEHICLE:

PA/5,MA=10.,CM=500,IP=1.E3,1.E3,1.E3,QG=0,0,0

,EU=90,90,0,VX=440

MA/500, QP=0,0,0

JO/3, SP, I=3001, J=3002

MA/3001, PA=5, QP=0,30,0

MA/3002, PA=2, QP=0,30,0

GR/11, CI, CM=3002, RADIUS=3.

JO/4, TR, I=4002, J=4001

A/4001, PA=1, QP=10., 30., 0., EU=90., 90., 0.

A/4002, PA=5, QP=0., 30., 10.

GR/12, CI, CM=4001, RADIUS=3.

GR/13, CI, CM=4002, RADIUS=3.

GE/1, CO, JO=4, PAR= 440., 0.

LEFT TIRE FORCE:

MA/1, PA= 2, QP= 46.5, 19.5, -250.
A/5, PA= 2, QP= 45.5, 19.5, -250.
J/11, AOF, I=1, J=11, PAR= 5150., 10., 1, 5, 0.
FO/21, AOF, I=1, J=12, PAR= 5150., 10., 1, 5, 0.
FO/31, AOF, I=1, J=13, PAR= 5150., 10., 1, 5, 0.

TIRE GRAPHICS:

MA/320, PA=2, QP= 37.5, 19.5, -250., EU=90., 90., 0.
GR/5, CY, CM=320, LENGTH= 16.5, RADIUS= 19.5, SIDES=8

RIGHT TIRE FORCES:

MA/2, PA=2, QP= -46.5, 19.5, -250.
MA/6, PA=2, QP= -47.5, 19.5, -250
FO/12, AOF, I=2, J=11, PAR= 5150., 10., 2, 6, 0.
FO/22, AOF, I=2, J=12, PAR= 5150., 10., 2, 6, 0.
FO/32, AOF, I=2, J=13, PAR= 5150., 10., 2, 6, 0.

TIRE GRAPHICS:

MA/420, PA=2, QP= -37.5, 19.5, -250., EU=90., -90., 0.
GR/7, CY, CM=420, LENGTH= 16.5, RADIUS= 19.5, SIDES=8

TIRE MOMENTS, LEFT:

FO/41, AOT, I=1, J=11
FO/51, AOT, I=1, J=12
FO/61, AOT, I=1, J=13

TIRE MOMENTS, RIGHT:

FO/42, AOT, I=2, J=11
FO/52, AOT, I=2, J=12
FO/62, AOT, I=2, J=13

SPLINES (LATERAL FORCE CHARACTERISTIC)

SP/1, X=0., 1., 2., 3., 4., 5., 20., 90.
Y= .0, .16, .30, .40, .49, .57, .75, .85

SLIP ANGLES IN DEGREES
RATIO: FSIDE/FLOAD

SYSTEM AND OUTPUT CARDS:

SYSTEM/ GC=386.088, KGRAV= -386.088, HMAX=.005, ERR=.00008
OUTPUT/SCIENTIFIC, GRSAVE, SAVEREQ, YPR

RE/1, D, I= 223, J=10, :DISP OF CG (YAW, PITCH, ROLL)
RE/2, V, I= 200, J=10, :VEL OF CG
RE/3, A, I= 200, J=10, :ACCEL OF CG

RE/41, F, I=1, :LEFT FRONT TIRE
RE/42, F, I=2, :RIGHT FRONT TIRE

RE/21, D, I=1, J=9
RE/22, D, I=2, J=9

RE/11, V, I=1, J=9
RE/12, V, I=2, J=9

RE/31, A, I=1, J=9
RE/32, A, I=2, J=9

END CARD:

END

Subroutine Model After Double Contact (pg 1/2)

```

SUBROUTINE FGROUND (FVERT,PEN,VDOOTU,RTIRE,RRIM,DAMP,VSTIF)
IMPLICIT REAL*8 (A-H,O-Z)
IF (PEN.LT.0.) THEN
  FVERT = 0.
ELSE IF (PEN.LT. (RTIRE-RRIM)) THEN
  FVERT = (PEN) * VSTIF - DAMP * VDOTU
ELSE
  FVERT = (RTIRE-RRIM)*VSTIF + (PEN-(RTIRE-RRIM))*5.*VSTIF
  $ - DAMP*VDOTU
END IF
IF (FVERT.LT.0.) FVERT = 0.
RETURN
END

```

```

SUBROUTINE FBUMP(FVERT,FH,XS,YS,ZS,VDOOTU
,MG,X2,X3,HBUMP,RTIRE,RRIM,XL,VSTIF,DAMP)
IMPLICIT REAL*8 (A-H,O-Z)

```

```

**VERTICAL GROUND FORCE:
PEN = HG - (ZS - RTIRE)
CALL FGROUND(FGV,PEN,VDOOTU,RTIRE,RRIM,DAMP,VSTIF)

**MAX VERTICAL BUMP FORCE:
CALL FGROUND(FBVMAX,PEN+HBUMP,VDOOTU,RTIRE,RRIM,DAMP,VSTIF)

```

```

**LEADING AND TRAILING ENDS OF TIRE PATCH:
A = XS - XL/2
B = XS + XL/2

```

```

**PROPORTION VERTICAL FORCE BY FRACTION OF TIRE/GROUND CONTACT
**PATCH OFF BUMP AND FRACTION OF TIRE/GROUND CONTACT PATCH ON BUMP:
IF (B.LE.X2) THEN
  **TIRE CONTACT PATCH NOT YET ON BUMP:
  FVERT = FGV
ELSE IF (B.GE.X2.AND.B.LE.X3.AND.A.LE.X2) THEN
  **TIRE PARTLY ON BUMP:
  FVERT = ((X2-A)/XL)*FGV + ((B-X2)/XL)*FBVMAX
ELSE IF (A.LE.X2.AND.B.GT.X3) THEN
  **TIRE HAS ENVELOPED BUMP COMPLETELY:
  FVERT = ((X2-A+X3)/XL)*FGV + ((X3-X2)/XL)*FBVMAX
ELSE IF (A.GT.X2.AND.B.LE.X3) THEN
  **TIRE CONTACT PATCH IS FULLY ON BUMP:
  FVERT = FBVMAX
ELSE IF (A.GE.X2.AND.A.LE.X3.AND.B.GE.X3) THEN
  **TIRE CONTACT PATCH IS PARTLY OFF BUMP:
  FVERT = ((X3-A)/XL)*FBVMAX + ((B-X3)/XL)*FGV
ELSE IF (A.GE.X3) THEN
  **TIRE CONTACT PATCH IS FULLY OFF BUMP:
  FVERT = FGV

```

```

ELSE PRINT *, 'NO TIRE POSITION FOUND IN FBUMP.FOR'
STOP
END IF

```

```

**HORIZONTAL BUMP FORCE:
IF (XS.LE.X2) THEN
  IF (ZS.GE.HG+HBUMP) THEN
    THETA = ATAN((X2-XS)/(ZS-HG-HBUMP))
    RPEN = RTIRE - SQRT((XS - X2)**2 + (ZS-HBUMP-HG)**2)
    IF (RPEN.LT.0.CO) RPEN=0.00

```

BUMP FORCE MODEL AFTER CORRECTION (Pg 2/2)

```

C
C
FH = VSTIF*(1-COS(THETA))*SIN(THETA))*SIN(THETA))*(RPEN)
ELSE
  RPEN = (RTIRE + X3) - X2
  CALL FGROUND(FH,RPEN,O.,RTIRE,RRIM,DAMP,VSTIF)
END IF
***REDUCTION OF HORIZONTAL BUMP FORCE WHEN PART OF TIRE TREAD IS
***SUPPORTED ON HORIZONTAL GROUND ADJACENT TO BUMP:
FH = FH*(HBUMP/(HBUMP + MAX(PEN,0.00)))
ELSE IF (XS.GT.X2.AND.XS.LE.X3) THEN
  ELSE IF (XS.GT.X3) THEN
  ELSE IF (XS.GE.HG+HBUMP) THEN
    THETA = ATAN((XS-X3)/(ZS-HG-HBUMP))
    RPEN = RTIRE - SQRT((XS - X3)**2 + (ZS-HBUMP-HG)**2)
    IF (RPEN.LT.0.00) RPEN=0.00
    FH = VSTIF*(1-COS(THETA))*SIN(THETA))*SIN(THETA))*(RPEN)
    FH = -FH
  ELSE
    RPEN = X3 - (XS - RTIRE)
    CALL FGROUND (FH,RPEN,O.,RTIRE,RRIM,DAMP,VSTIF)
    FH = -FH
  END IF
***REDUCTION OF HORIZONTAL BUMP FORCE WHEN PART OF TIRE TREAD IS
***SUPPORTED ON HORIZONTAL GROUND ADJACENT TO BUMP:
FH = FH*(HBUMP/(HBUMP + MAX(PEN,0.00)))
END IF
RETURN
END

```

```

SUBROUTINE FGROUND (FVERT,PEN,VDOU,RTIRE,RRIM,DAMP,VSTIF)
IMPLICIT REAL*8 (A-H,O-Z)
IF (PEN.LT.0.) THEN
  FVERT = 0.
ELSE IF (PEN.LT.(RTIRE-RRIM)) THEN
  FVERT = (PEN)*VSTIF - DAMP * VDOU
ELSE
  FVERT = (RTIRE-RRIM)*VSTIF + (PEN-(RTIRE-RRIM))*5.*VSTIF
  DAMP*VDOU
END IF
IF (FVERT.LT.0.) FVERT = 0.
RETURN
END

```

```

SUBROUTINE FBUMP(FH,XS,YS,ZS,VDOU,
  HG,X2,X3,HBUMP,RTIRE,RRIM,XL,VSTIF,DAMP)
IMPLICIT REAL*8 (A-H,O-Z)

```

```

**VERTICAL GROUND FORCE:
PEN = HG - (ZS - RTIRE)
CALL FGROUND(FGV,PEN,VDOU,RTIRE,RRIM,DAMP,VSTIF)
**MAX VERTICAL BUMP FORCE:
CALL FGROUND(FBVMAX,PEN+HBUMP,VDOU,RTIRE,RRIM,DAMP,VSTIF)
**LEADING AND TRAILING ENDS OF TIRE PATCH:
A = XS - XL/2
B = XS + XL/2

```

```

**PROPORTION VERTICAL FORCE BY FRACTION OF TIRE/GROUND CONTACT
**PATCH OFF BUMP AND FRACTION OF TIRE/GROUND CONTACT PATCH ON BUMP:
IF (B.LE.X2) THEN
  **TIRE CONTACT PATCH NOT YET ON BUMP:
  FVERT = FGV
ELSE IF (B.GE.X2.AND.B.LE.X3.AND.A.LE.X2) THEN
  **TIRE PARTLY ON BUMP:
  **TIRE = ((X2-A)/XL)*FGV + ((9-X2)/XL)*FBVMAX
ELSE IF (A.LE.X2.AND.B.GT.X3) THEN
  **TIRE HAS ENVELOPED BUMP COMPLETELY:
  FVERT = ((X2-A+B-X3)/XL)*FGV + ((X3-X2)/XL)*FBVMAX
ELSE IF (A.GT.X2.AND.B.LE.X3) THEN
  **TIRE CONTACT PATCH IS FULLY ON BUMP:
  FVERT = FBVMAX
ELSE IF (A.GE.X2.AND.A.LE.X3.AND.B.GE.X3) THEN
  **TIRE CONTACT PATCH IS PARTLY OFF BUMP:
  **TIRE = ((X3-A)/XL)*FBVMAX + ((8-X3)/XL)*FGV
ELSE IF (A.GE.X3) THEN
  **TIRE CONTACT PATCH IS FULLY OFF BUMP:
  FVERT = FGV

```

```

ELSE PRINT *, 'NO TIRE POSITION FOUND IN FBUMP.FOR'
STOP
END IF

```

```

**HORIZONTAL BUMP FORCE:
IF (XS.LE.X2) THEN
  IF (ZS.GE.HG+HBUMP) THEN
    THETA = ATAN((X2-XS)/(ZS-HG-HBUMP))
    RPEN = RTIRE - SQRT((XS - X2)**2 + (ZS-HBUMP-HG)**2)
    FH = VSTIF*(1-COS(THETA))*SIN(THETA)*SIN(THETA)*(RPEN)

```

IF (RPEN.LT.0.DO) RPEN = 0.DO



BUMP FORCE MODEL BEFORE DEFORMATION (PG 2/2)

```

C
ELSE RPEN = (RTIRE + XS) - X2
CALL FGROUND(FH,RPEN,0.,RTIRE,RRIM,DAMP,VSTIF)
END IF
***REDUCTION OF HORIZONTAL BUMP FORCE WHEN PART OF TIRE TREAD IS
***SUPPORTED ON HORIZONTAL GROUND ADJACENT TO BUMP:
FH = FH*(HBUMP/(HBUMP + MAX(PEN,0.00)))
ELSE IF (XS.GT.X2.AND.XS.LE.X3) THEN
FH = 0.
ELSE IF (XS.GT.X3) THEN
IF(ZS.GE.HG+HBUMP) THEN
THETA = ATAN((XS-X3)/(ZS-HG-HBUMP))
RPEN = RTIRE - SQRT((XS - X3)**2 + (ZS-HBUMP-HG)**2)*(RPEN)
FH = VSTIF*(1-COS(THETA))*SIN(THETA)*SIN(THETA)*(RPEN)
ELSE RPEN = X3 - (XS - RTIRE)
CALL FGROUND (FH,RPEN,0.,RTIRE,RRIM,DAMP,VSTIF)
FH = -FH
END IF
***REDUCTION OF HORIZONTAL BUMP FORCE WHEN PART OF TIRE TREAD IS
***SUPPORTED ON HORIZONTAL GROUND ADJACENT TO BUMP:
FH = FH*(HBUMP/(HBUMP + MAX(PEN,C.00)))
END IF
RETURN
END

```

IF (RPEN.LT.0.00) RPEN = 0.00

FH = -FH

PART NUMBER: 12585714, Traverse Actuator

DESCRIPTION: TRAVERSE ACTUATOR

Piston Diameter: 4.25 inches
Rod Diameter: 2.5 inches
Bear Loc Force: 30,000 lbs

This actuator was sized based on firing on a 10% side slope, with hurricane force winds, a muzzle brake imbalance, and the rifling torque input into the gimbal, traverse actuator and platform assembly.

The reader is also referred to Section C/260, Tube Laying Accuracy for additional work performed in finalizing the traverse cylinder design.

STATUS:

Mounting and size requirements for the traverse actuator have been determined and were provided to York to be finalized.

AUTHOR: Jeff Ireland

TRAV. CYL
T 12585714

87-2-1A
Tent

TRAVERSE STICTION

LOCK FRICTION

= 5% BEAR LOCK

= 1500 lbf

EXTEND LENGTH = 51.676
RETRACTED LENGTH = 37.000

STROKE = 14.676

BUFFERS AT 38.125" & 50.551" EXTENSIONS.

SPHERICAL BEARINGS

TORRINGTON: 12SFL22 (BOTH ENDS)

1.250 DIA I.D.

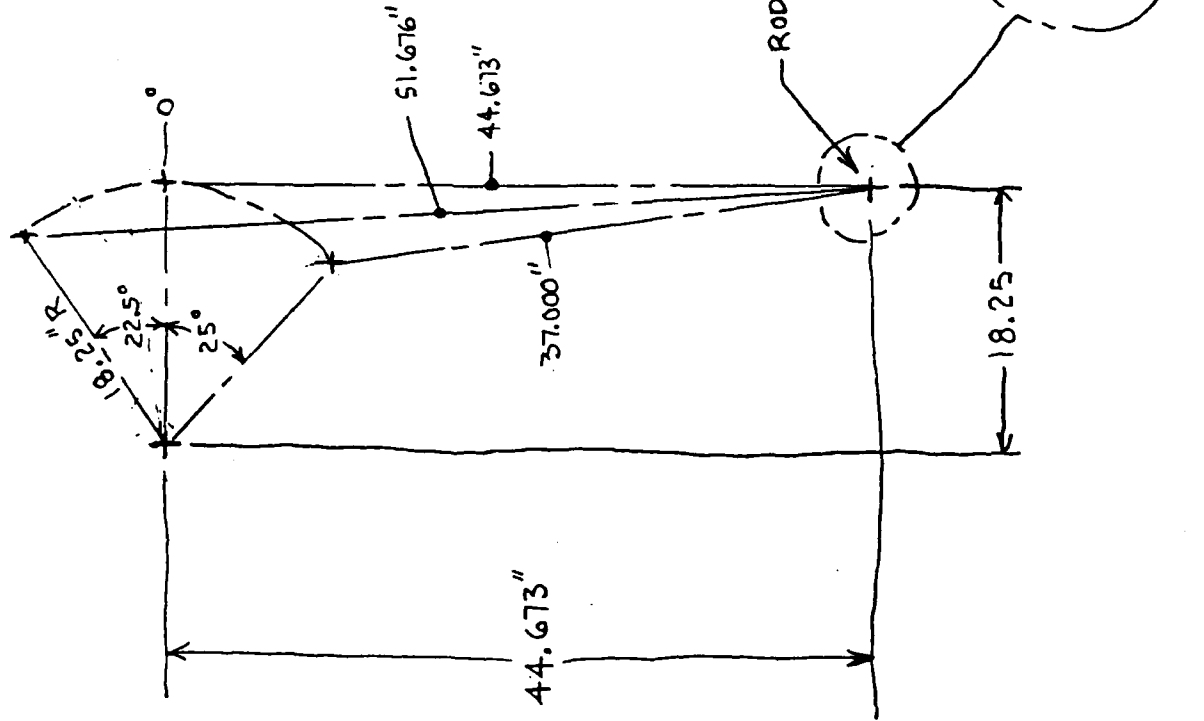

TRAVERSE ACTUATOR 3

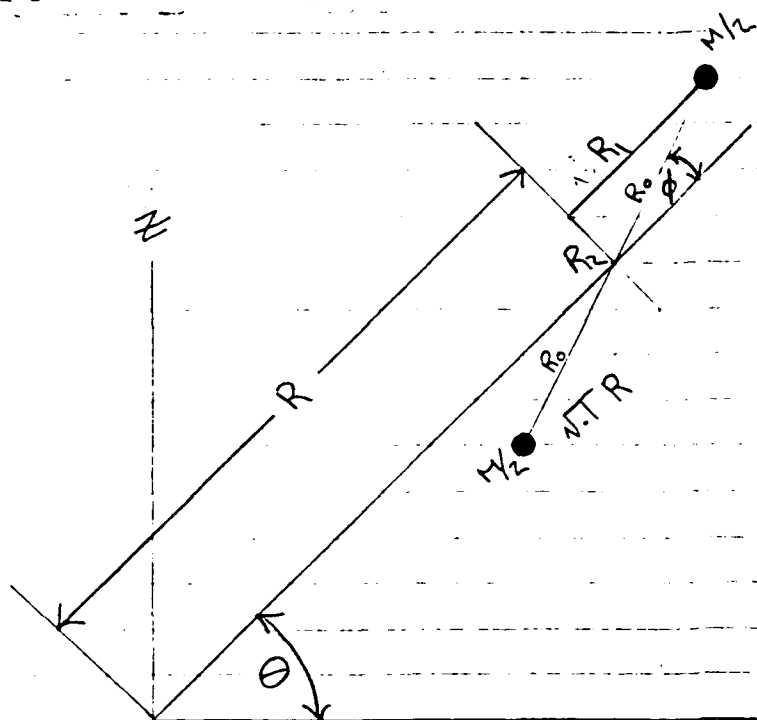

$$I_{\parallel} = MR^2$$

$$R_2 = 8.0 \text{ IN}$$

$$I_0 = .1 I_{\parallel} \quad (\text{ASSUMPTION})$$

$$\frac{MR_1^2}{2} + \frac{MR_2^2}{2} = .1 MR^2$$

$$R_1^2 = .1 R^2$$

$$R_1 = \sqrt{.1} R$$

$$W = 6311.0 \text{ lbf}$$

$$R = 193.34 \text{ IN}$$

$$R_0 = \left[(\sqrt{.1} (193.34 \text{ IN}))^2 + (8.0 \text{ IN})^2 \right]^{1/2} = 61.661 \text{ IN}$$

$$\phi = \text{ARC TAN} \left[\frac{8.0}{\sqrt{.1} (193.34)} \right] = 7.455^\circ$$

$$I_{zz} = \frac{W}{g} R_0^2 \cos^2(\theta + \phi) + \frac{W}{g} R^2 \cos^2 \theta = \left(\frac{W}{g} \right) \left[(R \cos \theta)^2 + (R_0 \cos(\theta + \phi))^2 \right]$$

$$I_{zz} = \left(\frac{W}{g} \right) \left[(R \cos \theta)^2 + (R_0 \cos(\theta + \phi))^2 \right]$$

$$\dot{\theta} = \text{IMP}_{\text{RMB}} R_{\text{MB}} \cos \theta / I_{zz}$$

$$\text{ENERGY} = \frac{1}{2} I_{zz} \dot{\theta}^2 = \frac{1}{2} I_{zz} \left[\text{IMP}_{\text{RMB}} R_{\text{MB}} \cos \theta / I_{zz} \right]^2$$

$$\underline{\underline{\text{ENERGY} = \left[\text{IMP}_{\text{RMB}} R_{\text{MB}} \cos \theta \right]^2 / 2 I_{zz}}}$$

II.) IMP_{RMB} CALCULATION

$$\underline{\underline{\text{TOTAL DESIGN IMPULSE} = 12,500 \text{ lbf-SEC}}}$$

$$\text{IMPULSE AT PROSECTILE EXIT} = (W_p + (W_A + W_c)/2) V_M / g$$

$$\underline{\underline{\text{IMP}_{\text{EXIT}} = 9433.704 \text{ lbf-SEC}}}$$

$$W_p = 960$$

$$W_A = 4.0$$

$$W_c = 28.0$$

$$V_M = 2710$$

$$g = 32.174 \text{ FT/SEC}^2$$

$$\text{IMP}_{\text{GAS}} = 12,500 \text{ lbf-SEC} - 9433.704 \text{ lbf-SEC}$$

$$\underline{\underline{\text{IMP}_{\text{GAS}} = 3,066.296 \text{ lbf-SEC}}}$$

$$\underline{\underline{\text{MOMENTUM INDEX} = .7 = .35 \text{ TO EACH SIDE OF MUZZLE BRAKE}}}$$

$\text{IMP}_{\text{RMB}} = \text{IMPULSE } \perp \text{ TO BORE AXIS DUE TO 5\% SIDE TO SIDE MISMATCH IN MUZZLE BRAKE EXIT AREA.}$

$$\underline{\underline{\text{IMP}_{\text{RMB}} = 3,066.296 \text{ lbf-SEC} (.35)(.05) = 53.66 \text{ lbf-SEC}}}$$

$$E = \text{ENERGY} = \left[\text{IMP}_{\text{RMB}} R_{\text{MB}} \cos \theta \right]^2 / 2 I_{zz}$$

$$= \left[\text{IMP}_{\text{RMB}} R_{\text{MB}} \cos \theta \right]^2 / 2 (W/g) \left[(R \cos \theta)^2 + (R \cos(\theta + \phi))^2 \right]$$

$$\frac{\partial E}{\partial \theta} = \frac{\text{IMP}_{\text{RMB}}^2 R_{\text{MB}}^2}{2 (W/g)} \left[\frac{-2 \cos \theta \sin \theta}{\left[(R \cos \theta)^2 + (R \cos(\theta + \phi))^2 \right]} - \frac{\cos^2 \theta \left[-2 R \cos \theta \sin \theta - 2 R \cos(\theta + \phi) \sin(\theta + \phi) \right]}{\left[(R \cos \theta)^2 + (R \cos(\theta + \phi))^2 \right]^2} \right]$$

$$\frac{\delta E}{\delta \theta} = 0 = -[\cos \theta \sin \theta [(R \cos \theta)^2 + (R_0 \cos(\theta + \phi))^2]] + \cos^2 \theta [R^2 \cos \theta \sin \theta + R_0^2 \cos(\theta + \phi) \sin(\theta + \phi)]$$

$$0 = R_0^2 \cos \theta \cos(\theta + \phi) [\cos \theta \sin(\theta + \phi) - \sin \theta \cos(\theta + \phi)]$$

$$0 = \cos \theta \cos(\theta + \phi) \sin(\phi)$$

MAX / MIN occur

$$\begin{aligned} \cos \theta &= 0 \\ \cos(\theta + \phi) &= 0 \end{aligned}$$

$$\begin{aligned} \theta &= 90^\circ \\ \theta + \phi &= 90^\circ \quad \theta = 90^\circ - 7.455^\circ = 82.545^\circ \end{aligned}$$

$$E = \frac{[I_{PR} R_{MB} \cos \theta]^2}{2(w/g) [(R \cos \theta)^2 + (R_0 \cos(\theta + \phi))^2]}$$

- $I_{PR} R_{MB} = 53.66 \text{ lbs-sec}$
- $R_{MB} = 383.2 \text{ IN}$
- $W = 6311.0 \text{ lbs}$
- $g = 386.087 \text{ in/sec}^2$
- $\phi = 7.455^\circ$
- $R = 193.34 \text{ IN}$
- $R_0 = 61.661 \text{ IN}$

θ	E
90°	0
82.545°	345.992 lbs-IN
0	314.538 lbs-IN
75°	337.165 lbs-IN

MIN } DON'T EXIST
 MAX } OUTSIDE RANGE
 } THESE CONDITIONS DUE EXIST

IMPULSE DUE TO RIFLING TORQUE

ASSUME CONSERVATIVE CASE OF USING A HYPOTHETICAL RIGID, MASSLESS CANNON MOUNTED VERTICALLY ON TRAVERSE C/L. USE MINIMUM INERTIA OF TRAVERSING COMPONENTS (CANNON ELEVATED TO 75°).

ANGULAR MOMENTUM PROJO = ANGULAR MOMENTUM TRAVERSING COMPO

$$\underline{I_{PROJO}} = \frac{501 \text{ lbs-in}^2}{386.087 \text{ in/sec}^2} = \underline{1.298 \text{ lbs-w-sec}^2}$$

$$I_{TRAV} = (W/g) [(R \cos \theta)^2 + (R_0 \cos(\theta + \phi))^2]$$

$$W = 6311.0 \text{ lbs}$$

$$R = 193.34 \text{ in}$$

$$R_0 = 61.661 \text{ in}$$

$$\phi = 7.455^\circ$$

$$\underline{I_{T75} = 47,002.182 \text{ lbs-in-sec}^2}$$

$$\theta_1 = 75^\circ$$

$$\underline{I_{T0} = 672,124.169 \text{ lbs-in-sec}^2}$$

$$\theta_2 = 0^\circ$$

ANGULAR VELOCITY OF PROJO = ω_{PROJO}

TWIST OF RIFLING R.H. 1-TURN IN 20 CALIBERS

$$\frac{\Delta \theta}{\Delta u} = 2\pi \text{ RAD} / (20 \text{ DB})$$

$$DB = 6.15 \text{ in}$$

$$VM = 2710 \text{ FT/SEC}$$

$$\frac{\Delta \theta}{\Delta t} = \frac{\Delta \theta}{\Delta u} \frac{\Delta u}{\Delta t} = \frac{2\pi \text{ RAD}}{20(6.15 \text{ in})} \left(\frac{2710 \text{ FT}}{\text{SEC}} \right) \left(\frac{12 \text{ in}}{\text{FT}} \right)$$

$$\underline{\omega_{PROJO} = \frac{\Delta \theta}{\Delta t} = 1,661.213}$$

$$I_{PROJO} \omega_{PROJO} = I_{T75} \omega_T$$

$$\omega_T = \left(\frac{I_{PROJO}}{I_{T75}} \right) \omega_{PROJO}$$

$$\omega_T = .051 \text{ RAD/SEC}$$

$$\underline{E_{RT} = \frac{1}{2} I_{T75} \omega_T^2 = \frac{1}{2} (47,002.182 \text{ lbs-in}) (.051 \text{ RAD/SEC})^2 = \underline{55.348 \text{ lbs-in}}}$$

10% SLOPE = 5.71°

W = 6311.0 lbf

R = 19334 IN

θ = ELEVATION ANGLE

$T_{SLOPE} = 6311 \text{ lbf} (\sin 5.71^\circ) (193.34 \text{ IN}) \cos \theta$

$T_{SLOPE}(\theta = 75^\circ) = 31,420 \text{ IN-lbf}$

$T_{SLOPE}(\theta = 0^\circ) = 121,400 \text{ IN-lbf}$

$T_{WIND} = F_{WIND} R_{WIND} \cos \theta$

$F_{WIND} = 618 \text{ lbf}$

$R_{WIND} = 383.2 \text{ IN}$

θ = ELEVATION ANGLE

$T_{WIND}(\theta = 75^\circ) = 61,292.905 \text{ lbf-IN}$

$T_{WIND}(\theta = 0^\circ) = 236,817.6 \text{ lbf-IN}$

INITIAL TORQUE PRIOR TO FIRING = $T_0 = T_{WIND} + T_{SLOPE}$

$T_0(75^\circ) = 92,713.0 \text{ lbf-IN}$

$F_0(75^\circ) = T_0(75^\circ) / R = 5,723.0 \text{ lbf}$ $R = 16.7 \text{ IN}$

$T_0(0^\circ) = 358,218.0 \text{ lbf-IN}$

$F_0(0^\circ) = T_0(0^\circ) / R = 22,113.0 \text{ lbf}$

ELEVATION ANGLE	0°	75°
F ₀ (lbf)	22,113.0	5,723.0
E _{MB} (IN-lbf)	315.0	338.0
E _{RT} (IN-lbf)	0.0	56.0
E _{TOT} (IN-lbf)	315.0	394.0

$$P_{CR} = n \pi^2 EI / L_{EXTEND}^2$$

$$E_{TIT} = 15 \times 10^6 \text{ lb}_f/\text{in}^2$$

$$E_{STL} = 30 \times 10^6 \text{ lb}_f/\text{in}^2$$

$$D_{OR} = 2.5 \text{ in} \quad D_{IR} = 2.0 \text{ in}$$

$$n = 1 \text{ PIN/PIN}$$

$$L_{EXTEND} = 55.002 \text{ in}$$

$$I = \pi [(2.5 \text{ in})^4 - (2.0 \text{ in})^4] / 64 = \underline{\underline{1.132 \text{ in}^4}}$$

$$A = \pi [(2.5 \text{ in})^2 - (2.0 \text{ in})^2] / 4 = \underline{\underline{1.767 \text{ in}^2}}$$

$$P_{CR_{TIT}} = \underline{\underline{55,396.263 \text{ lb}_f}}$$

$$P_{CR_{STL}} = \underline{\underline{110,792.526 \text{ lb}_f}}$$

$$K = EA / L_{ROD}$$

$$L_{ROD} = 15.0 \text{ in}$$

$$K_{TIT} = \underline{\underline{1,767,000 \text{ lb}_f/\text{in}}}$$

$$K_{STL} = \underline{\underline{3,534,000 \text{ lb}_f/\text{in}}}$$

$$F_0 = K X_0$$

$$X_0 = F_0 / K$$

$K X_F \leq \text{FORCE BEARLOK}$
 $K X_F \leq 50,000 \text{ lb}_f$

$$\int_{X_0}^{X_F} K X \delta X = E_{TOT}$$

$$\frac{1}{2} K X^2 \Big|_{F_0/K}^{X_F} = E_{TOT}$$

$$(\frac{1}{2}) K (X_F^2 - (F_0/K)^2) = E_{TOT}$$

$$\frac{1}{2} [(K X_F)^2 - F_0^2] = E_{TOT} K$$

$$K X_F = [2 E_{TOT} K + F_0^2]^{1/2}$$

THESE FORCES ARE FURTHER REDUCED WHEN YOU INCLUDE SPRING RATES OF GIMBAL & PLATE FORM.

$$K X_{F_0} (TIT) = \underline{\underline{40,030 \text{ lb}_f}}$$

$$K X_{F_5} (TIT) = \underline{\underline{37,750 \text{ lb}_f}}$$

$$K X_{F_0} (STL) = \underline{\underline{52,110 \text{ lb}_f}}$$

$$K X_{F_5} (STL) = \underline{\underline{53,080 \text{ lb}_f}}$$

ACTUATOR SIZE

DESIGN FOR HOWITZER BEING ABLE TO MOVE ON 10% SLOPE WITH WIND FORCE WORKING AGAINST YOU.

$$F_{\text{MOVE}} = 22,113 \text{ lbf} + F_{\text{BEAR-LOK DRAG}} + \text{FRICTION}$$

$$F_{\text{MOVE}} = 22,113 \text{ lbf} + 2500 \text{ lbf} + 2,211 \text{ lbf}$$

$$F_{\text{MOVE}} = 26,824 \text{ lbf}$$

$$F_{\text{BEAR-LOK DRAG}} = 2500 \text{ lbf}$$

$$\text{FRICTION} = 10\% \ 22,113$$

$$DOR = 2.5 \text{ IN}$$

$$\pi/4 [(D_p)^2 - (2.5 \text{ IN})^2] 3000 \text{ lbf/IN}^2 = 26,824 \text{ lbf}$$

$$D_p = 4.199 \text{ IN}$$

$$\text{YORK'S DESIGN} = D_p = 4.25 \text{ IN}$$

$$\ddot{\theta} = \frac{[(4.25 \text{ IN})^2 - (4.199 \text{ IN})^2] \pi/4 (3000 \text{ lbf/IN}^2) (16.2 \text{ IN})}{672,124.169 \text{ lbf-IN-SEC}^2}$$

$$\ddot{\theta} = .024 \text{ RAD/SEC}^2$$

TRAVERSE ACTUATOR

$$D_p = 4.25 \text{ IN}$$

$$D_r = 2.5 \text{ IN}$$

$$\underline{\text{EXTEND VOLUME}} = \pi/4 (4.25 \text{ IN})^2 14.679 \text{ IN} = \underline{208.240 \text{ IN}^3} \quad \text{STROKE} = 14.679 \text{ IN}$$

$$\underline{\text{RETRACT VOLUME}} = \pi/4 [(4.25 \text{ IN})^2 - (2.5 \text{ IN})^2] 14.679 \text{ IN} = \underline{136.185 \text{ IN}^3}$$

PART NUMBER: 12585767, Tube Interface

DESCRIPTION: TUBE INTERFACE

The tube is a modified XM284 in shape and was chosen to provide the lightest weight tube possible. The drawing specifies FMC's requested tube weight of 2,480 lbs.

The tube OD contains five raised flat areas for interfacing with the collar sets via torsional and alignment keys. The rear-most flat has a machined-in keyway to anchor the collars and rails. The other flats do not have keyways to allow the collar-rail set to "float" axially when temperature changes cause thermal expansion. The locations of the first flat (closest to the breech) and the fourth flat allow the front sides of the first and fourth collar sets to be 0.75 inches in front of the front sides of the manifolds in fire position. This provides a straight path for the transmission of rifling torque from the collars to the manifolds at the time of maximum torque. The second flat is positioned to perform this same function in the load position to directly transmit rifling torque in a cookoff situation. The fifth flat position allows the front-most collar set to be flush with the front manifold when the tube is in tow position.

The alignment keys (on top and bottom of tube) between the tube and collars maintains side-to-side alignment of the tube. The torsional keys transmit the rifling torque from the tube to the collars. Space between the alignment and torsional keys and the collars allows the pressure-induced radial tube growth at the time of firing prevents stressing of the collars

STATUS:

A finalized Tube Interface drawing (TDF, Dwg. 12585767) has been provided to and accepted by Benet.

AUTHOR: Scott Dacko, Joe Turek, Bart Anderson

DESCRIPTION: TUBE LAYING ACCURACY

The reader is referred to the enclosed Gun Laying Accuracy Report for details of the analysis performed.

STATUS:

The tube laying accuracy study is current and complete. No additional work in this area is anticipated in Phase II.

AUTHOR: Sean Marek

GUN LAYING ACCURACY
Critical Parameter Identification

26 FEB 1987

S. MAREK

LTHD Gun Laying Accuracy

The following pages summarize the results from the analysis of the LTHD's gun laying accuracy. Example results are contained in Appendix A, the initial model parameter calculations are contained in Appendix B and the DADS' model is in Appendix C. The analysis uses a DADS mechanism model to simulate the gun during laying exercises. The model includes the effects of the hydraulic cylinders, control valves, mechanism geometry and friction for both the traversal and elevation systems. Since only small motions were simulated the equilibration system is modeled as a constant unbalanced torque operating on the gun.

Friction

No major problems due to frictional losses in the system were discovered and in fact some beneficial effects were found. The friction present in the system provides a significant degree of damping which will enhance the system's controllability. Furthermore, there is enough friction in the system to prevent typical unbalanced torques from moving the gun when the locking system is released. This makes the timing between joystick motion and lock release less critical.

Valves

The control valve size appears to be the most critical factor affecting the operator's ability to accurately lay the gun. For precise gun laying motion rates of 0.3 to 0.5 mil/sec are necessary. The flow rates corresponding to these velocities can create significant lags between initial motion of the joystick and the motion of the gun. The lag is due to the time it takes for the pressure rise in the cylinder to overcome unbalanced loads such as friction. A lag of 1 to 3 seconds is common and lags up to 8 seconds are possible when the gun's direction is reversed or extended inactivity has allowed the cylinder pressures to leak down. Much smaller time lags occur if motion in a direction has just occurred and resumption of that motion in the same direction is attempted.

Basic Problem

The time lag between initial joystick motion and initial gun motion will cause the operator to open the valve more than necessary. Then when motion does occur it will be too quick and he will overshoot the desired position because of his reaction time and the gun's delayed response when the joystick is

returned to the null position. The size of the time lag has a strong dependence on the friction present, the volume under compression, the effective bulk modulus and the flow rate through the valve consequently, the time lag cannot be eliminated and a way to deal with it must be found.

Possible Solution

The operator displaces the joystick enough to create motion in a reasonable time. As soon as the motion starts he lets go of the joystick so that the gun's motion is stopped. The cylinder is now pressurized to the point at which motion will occur. To resume the motion the operator can either use a smaller joystick motion or more likely he can pulse the joystick until the desired position is reached.

System requirements

For the preceding procedure to work the system must be configured such that;

A.) The slowest controlled motion rate possible with the valve is about 0.3 to 0.5 mil/sec when a small constant joystick displacement is used in precise gun laying. This value can be doubled if the joystick is pulsed.

B.) The dynamic flow response of the valve should be nearly proportional to the joystick position for small stick displacements. That is there should be no damping of small valve motions near its' closed position.

Secondary Problems

Flexible hydraulic lines and other design factors which lower the system's effective bulk modulus compound the delay problem. The time it takes to pressurize a cylinder before motion occurs is inversely proportional to the bulk modulus while the system's rate of motion is independent of the bulk modulus. Therefore as the bulk modulus is decreased it takes longer for the gun to start moving but once it does start its motion rate depends mainly on the joystick position. This will add to the operator's tendency to use too large of a joystick displacement when initiating motion.

Friction and other unbalanced loads such as equilibration also increase the delay between joystick and gun motion. Frictional losses provide a significant damping force to the gun and their elimination could create other difficulties. Without this damping there is a much better chance that pulsing the

joystick near the gun's natural frequency could lead to an instability due to resonance. Since too much friction can be a problem some optimum frictional force is possible but determination of that optimum is difficult.

Valve Sizes

For traversal the maximum desired rate is 80 mil/sec. Taking into account the losses in the system and the unbalanced loads, a valve that provides 5 gpm of flow at 3000 psi with no pressure drop across the load produces the desired rate. The equations used for this estimation and their deviation are included as the next three pages. To generate a .3 mil/sec minimum velocity the minimum valve opening should be 0.25 percent of full open. Since 0.1 percent is possible no problem with this valve size is apparent.

For elevation the valve size is highly dependent on the equilibration system. The last time the valve was sized it needed to be capable of delivering 40 gpm at 3000 psi with no pressure drop across the load. Generating a motion rate of 0.3 mil/sec to 0.5 mil/sec requires a valve opening of 0.04 to 0.06 percent of full open. This is a 2000 to 1 ratio between maximum and minimum controlled flow which could be outside of the valve's practical limits therefore potential problems may exist for this valve. Either some degree of controllability must be sacrificed or some time must be added to the time cycle and the valve down sized.

Calculation of Maximum Velocity

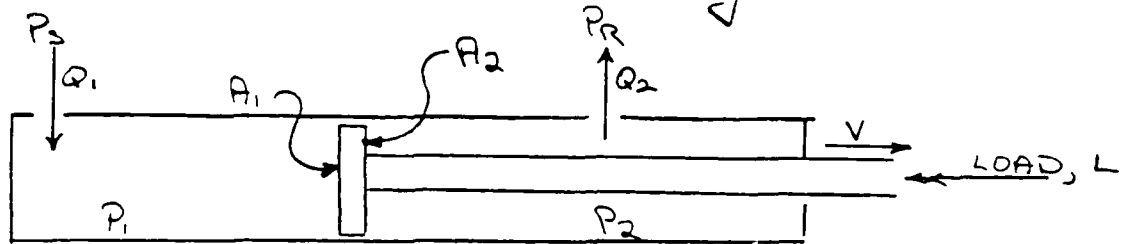

IF the piston is being driven in the direction of v by the pressure P_1 , then the following equations apply. If v is reversed A_1 and A_2 must also be reversed in the equations 1, 2 and 4.

$$\textcircled{1} P_2 = \left[\frac{A_1}{A_1^3 + A_2^3} \right] (A_2^2 P_s - L A_2^2 / A_1 + A_1^2 P_r)$$

$$\textcircled{2} P_1 = L / A_1 + P_2 A_2 / A_1$$

$$\textcircled{3} C_d = Q_R \sqrt{2} / \sqrt{P_s - P_r} \quad Q_R \text{ IN IN}^3/\text{SEC}$$

$$C_d = 5.445 Q_R / \sqrt{P_s - P_r} \quad Q_R \text{ IN GPM}$$

$$\textcircled{4} v = (C_d / A_1) \sqrt{P_s - P_1} \quad \text{OR} \quad (C_d / A_2) \sqrt{P_2 - P_r}$$

A_1 - AREA of piston SIDE 1.

A_2 - AREA of piston SIDE 2

C_d - VALVE flow COEFFICIENT

L - LOAD FORCE

Q_R - VALVE'S RATED FLOW

Q_1 - Flow into CHAMBER 1

Q_2 - Flow out of CHAMBER 2

P_R - RETURN LINE PRESSURE

P_S - SUPPLY LINE PRESSURE

P_1 - PRESSURE IN CHAMBER 1

P_2 - PRESSURE IN CHAMBER 2

V - PISTON VELOCITY

DERIVATIONS

$$\textcircled{1} \quad Q_1 = VA_1 = C_d \sqrt{P_S - P_1}$$

$$\textcircled{2} \quad Q_2 = VA_2 = C_d \sqrt{P_2 - P_R}$$

$$\textcircled{3} \quad P_1 A_1 - P_2 A_2 = L \quad (\text{at a constant velocity})$$

$$\textcircled{4} \quad P_1 = L/A_1 + P_2 A_2/A_1$$

Substitute P_1 in Eq ①

$$VA_1 = C_d \sqrt{P_s - L/A_1 - P_2 A_2/A_1} \quad \text{OR}$$

$$\textcircled{5} \quad V = C_d/A_1 \sqrt{P_s - L/A_1 - P_2 A_2/A_1}$$

From Eq ②

$$\textcircled{6} \quad V = C_d/A_2 \sqrt{P_2 - P_R}$$

Equate ⑤ and ⑥

$$\textcircled{7} \quad C_d/A_1 \sqrt{P_s - L/A_1 - P_2 A_2/A_1} = C_d/A_2 \sqrt{P_2 - P_R} \quad \text{OR}$$

$$A_2^2 (P_s - L/A_1 - P_2 A_2/A_1) = A_1^2 (P_2 - P_R) \quad \text{OR}$$

$$A_2^2 P_s - LA_2^2/A_1 - P_2 A_2^3/A_1 = A_1^2 P_2 - A_1^2 P_R \quad \text{OR}$$

Bring all P_2 terms to one side

$$A_2^2 P_s - LA_2^2/A_1 + A_1^2 P_R = P_2 (A_1^2 + A_2^3/A_1) = P_2 \left(\frac{A_1^3 + A_2^3}{A_1} \right)$$

Solve for P_2

$$P_2 = \frac{A_1}{(A_1^3 + A_2^3)} (A_2^2 P_s - LA_2^2/A_1 + A_1^2 P_R)$$

Appendix A

Examples of Results from Analysis

In figure 1 the green lines represent the elevation system's response at 72 degrees QE to two constant valve openings of 0.5 and 0.05 percent of full open. The first vertical red line marks the time when the valve is first opened. The second vertical red line marks the time when the 0.5 percent valve opening was closed. The target position is $0.5E-3$ radians. The valve is not closed until sometime after the target position is reached because of the mechanical and human delays in the system. The horizontal red line and the third vertical red line show the valve position when a 0.05 constant valve opening was used.

Attention should be paid to the time lag between when the valve is opened and when gun motion starts. For the first curve this lag is about 0.1 seconds and for the second curve this lag is about 1 second. Attention should also be paid to the amount of overshoot that is present. For the first curve it is about $0.9E-3$ radians, (0.9 mils) and for the second curve the overshoot is only about $0.15E-3$ radians, (0.15 mils). The overshoot could be reduced further with a smaller valve opening but then the initial time lag would become excessive.

Elevation .5% and .05% value openings 72 deg OE

x E -3

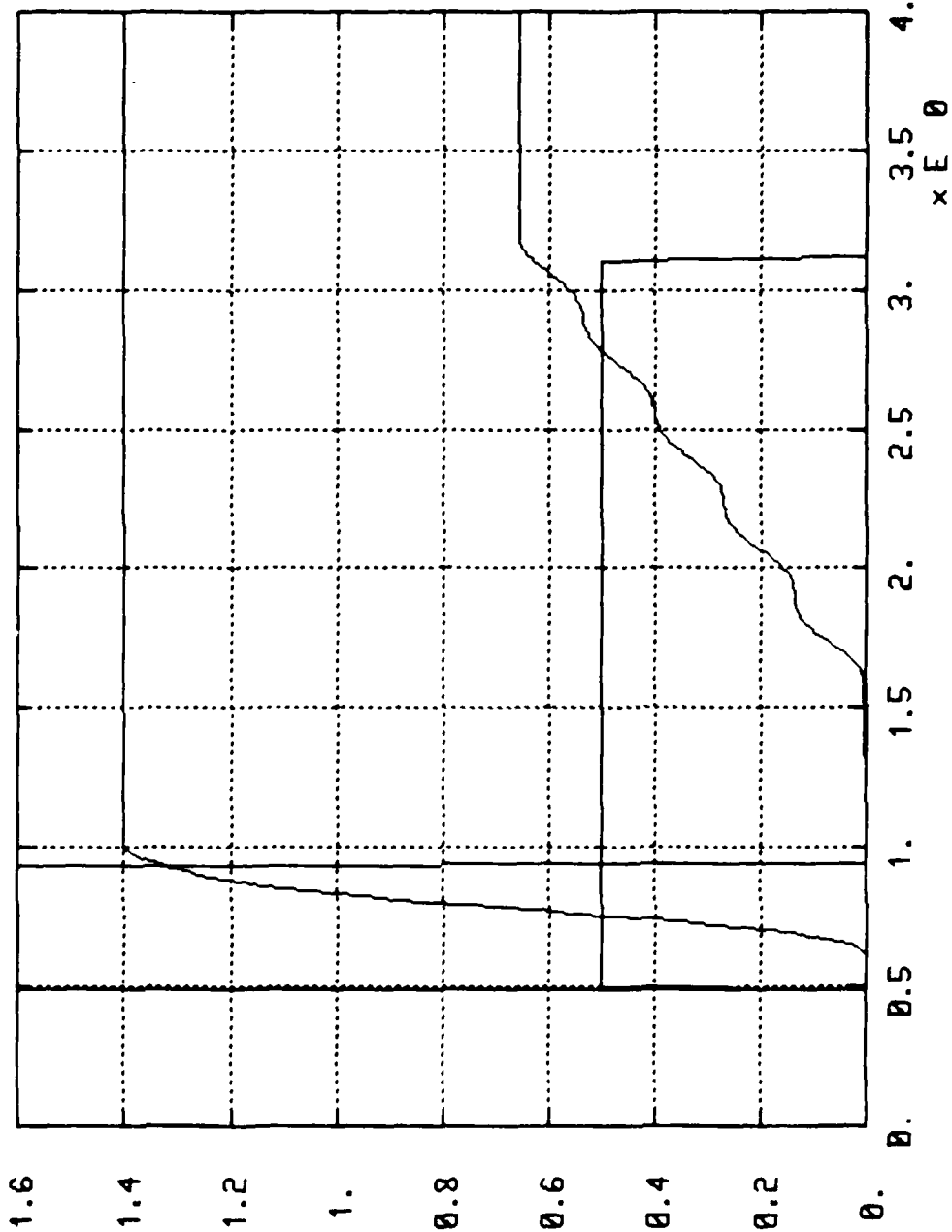

E L E V A T I O N

Time sec

(Figure 1)

Figures 2 and 3 go together, figure 2 is the traversal response of the gun to pulses of the joystick and figure 3 shows those pulses. The pulses occur every 0.5 seconds with a 0.5 percent magnitude and a 0.1 second duration. In reality these pulses could be smoother in nature and different in frequency and duration however these differences should not have a significant effect on the gun behavior shown in figure 2.

As shown the gun takes over 2 seconds to get moving and another 5 to 6 seconds to traverse 0.5 mils. In many cases this response would be too slow however this can be corrected by using pulses that are larger in magnitude and/or longer in duration. The important point made by figure 2 is that a lower precision valve can be used for accurate positioning if a pulsing technique is used. Recall that for precise gun traversal the recommended lower limit for a steady controlled valve opening is 0.25 percent of full open yet it appears that at least twice this value is acceptable when the valve is pulsed.

Gun position .5% joystick "blips" every .5 second

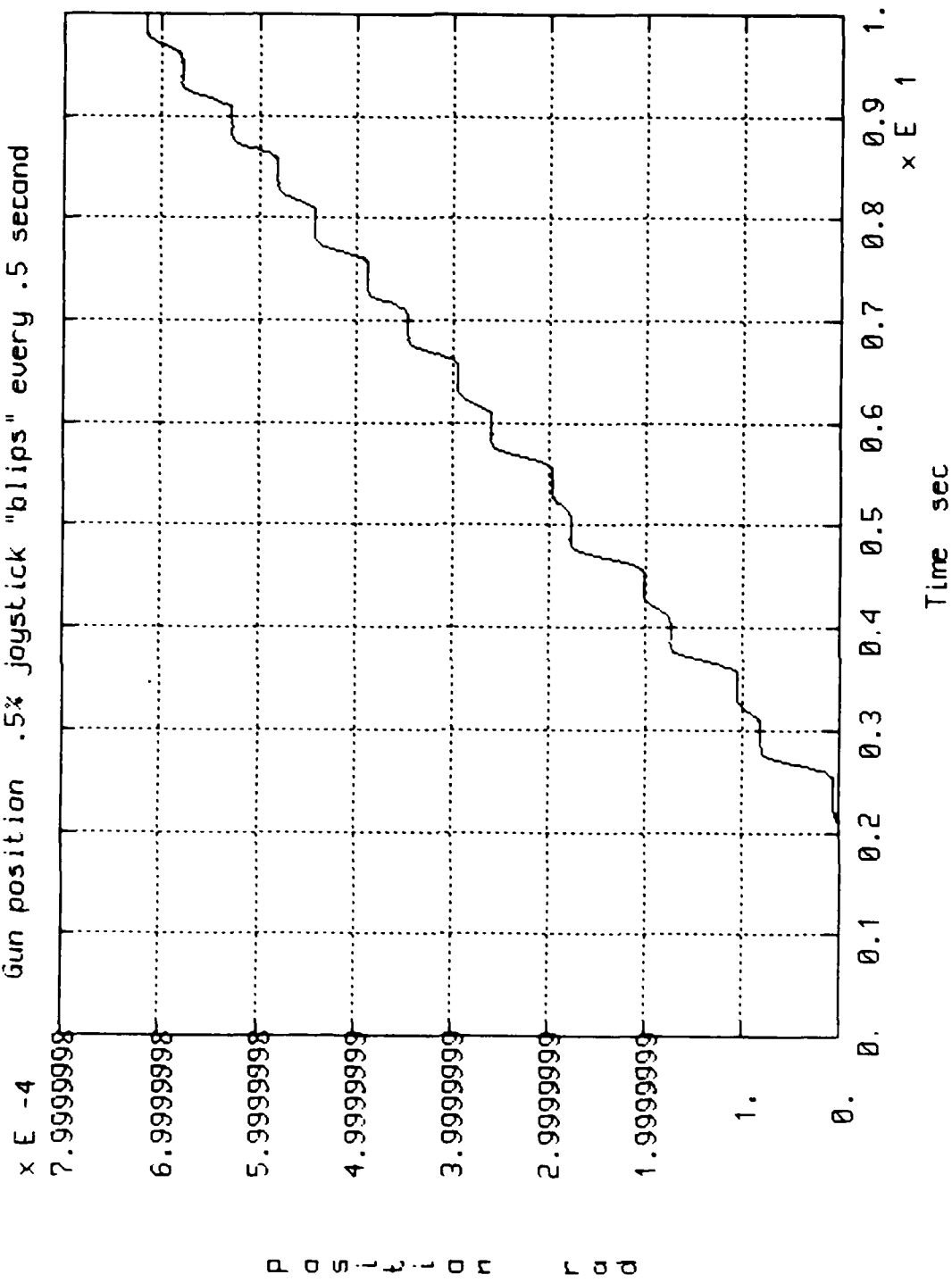

(Figure 2)

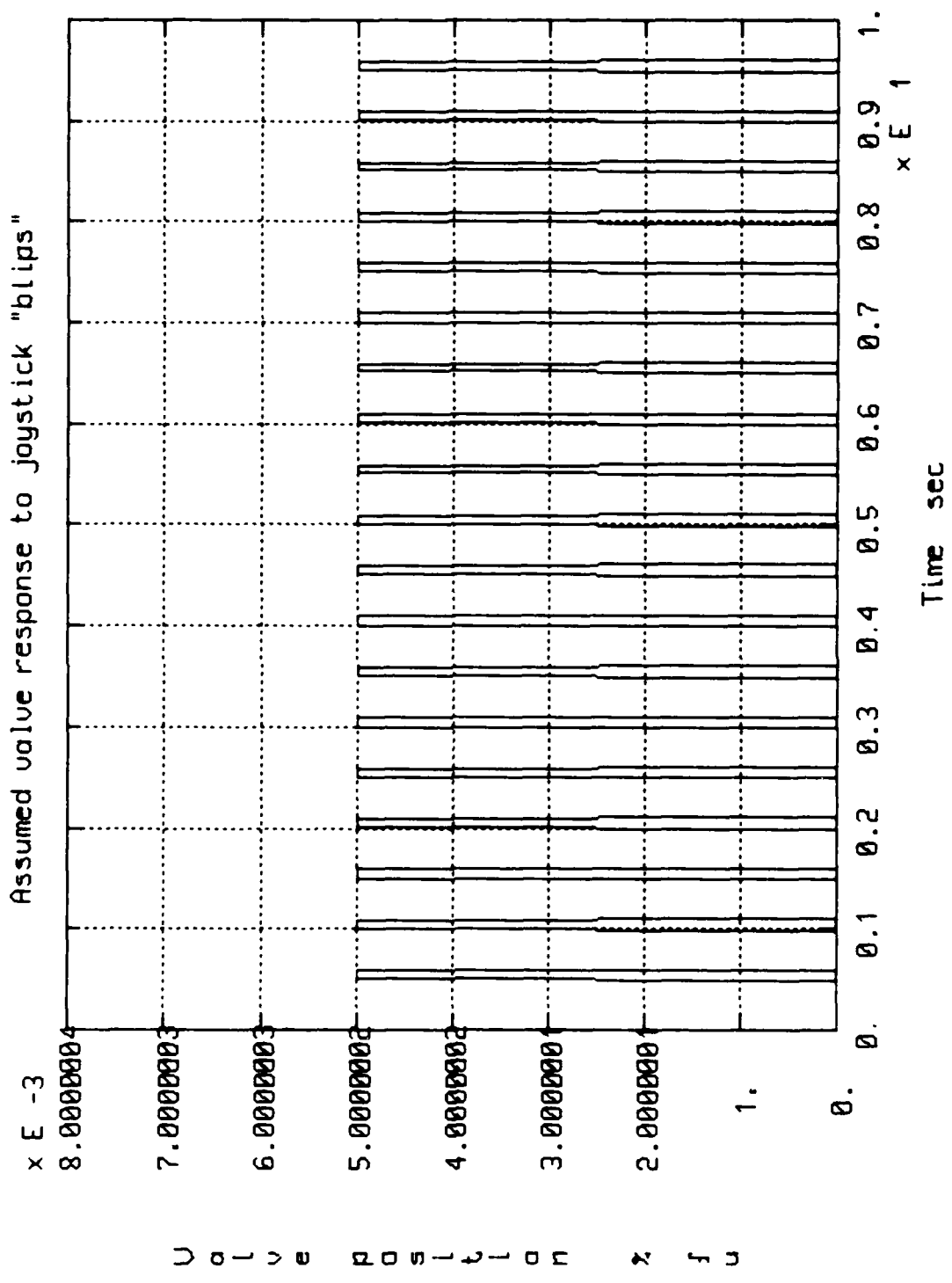

(Figure 3)

Figure 4 shows the gun's traversal response to a 1.0 percent valve opening when the effective bulk modulus is 175000 psi and 50,000 psi. The first value is typical for a system that uses steel hydraulic lines and has mild air entrainment. The second value is typical for a system that contains flexible hydraulic lines or excessive air entrainment. The first vertical green line marks when the valve was first opened, the vertical red line marks when the valve was closed for the 175000 psi bulk modulus system and the second vertical green line marks when the valve was closed for the 50000 psi bulk modulus system. In both cases the target position was 0.5 mils.

Two observations are easily made from this figure. First, as the bulk modulus decreases the initial time lag increases proportionately. Second, the average elevation rate is unchanged as demonstrated by the equal average slope of the two traces. Consequently, as the bulk modulus decreases the minimum valve opening necessary to provide adequate reaction time is unchanged but the gun's response becomes sluggish. This can lead to excessive joystick motion by the operator.

Gun position Red beta=175000 Green beta=500000

x E -3

1.200000

1.100000

1.

0.9

0.8

0.7

0.6

0.5

0.4

0.3

0.2

0.1

0.

P o s i t i o n r a d

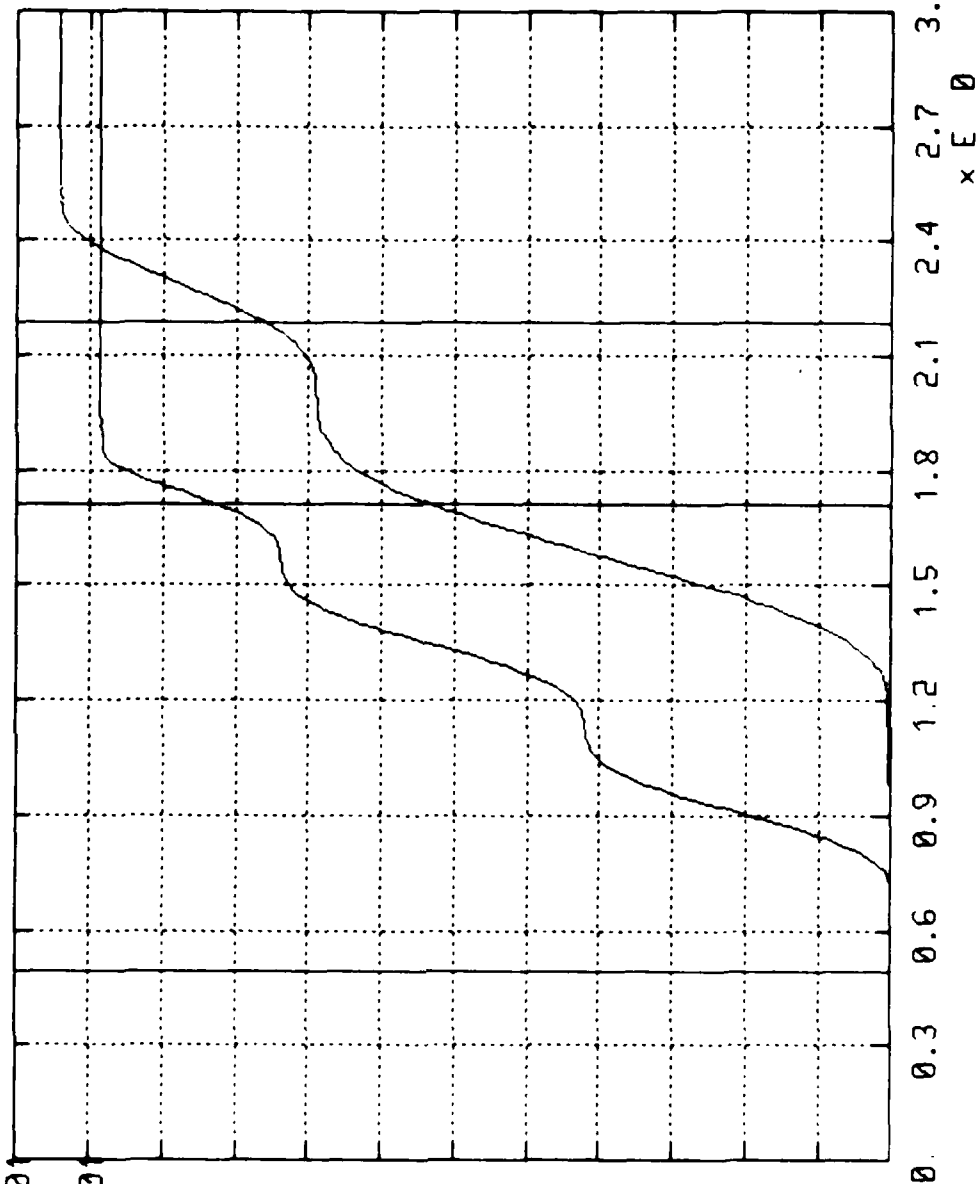

Time sec

(Figure 4)

Appendix B
Gun Laying System Parameters
and
Calculation of Model Parameters

TRAVERSE CYLINDER:

$$R = 14.000 \text{ IN (TORQUE } \frac{1}{2} \text{ ARM)}$$

$$S = [(12.938)^2 + (27.5)^2]^{\frac{1}{2}}$$

$$L^2 = R^2 + S^2 - 2RS \cos(\theta + \Delta)$$

$$L^2 = (14.000)^2 + (12.938)^2 + (27.5)^2 - 2(14.000)[(12.938)^2 + (27.5)^2]^{\frac{1}{2}} \cos(64.80429483 + \Delta)$$

$$L^2 = 1,119.64344 - 850.9613420 \cos(64.80429483 + \Delta)$$

$$\text{EXTEND } L(\Delta = +22.5^\circ) = 32.858 \text{ IN}$$

$$\text{RETRACT } L(\Delta = -25.0^\circ) = 21.584 \text{ IN}$$

NEED BUFFER WHEN CANNON IS AT 17° TRAVERSE EXTENDS

$$L = 31.596 \text{ IN}$$

$$L = 22.858 - 31.596 \text{ IN} = 1.262 \text{ IN}$$

NEED BUFFER WHEN CANNON IS AT $L = 21.584 + 1.262 = 22.846 \text{ IN}$

$$\theta = -19.423^\circ \text{ RETRACT}$$

$$\text{STROKE} = L(22.5^\circ) - L(-25.0^\circ) = 32.858 \text{ IN} - 21.584 \text{ IN} = 11.274 \text{ IN}$$

$$\text{PISTON DIA} = 3.000 \text{ IN}$$

$$\text{ROD DIA} = 1.250 \text{ IN}$$

BEAR-LOCK HOLDING FORCE 41,000 lbf

USE 50,000 lbf

$$L(\Delta = 0) = 27.5 \text{ IN}$$

TRAVERSE CYL MOUNTING

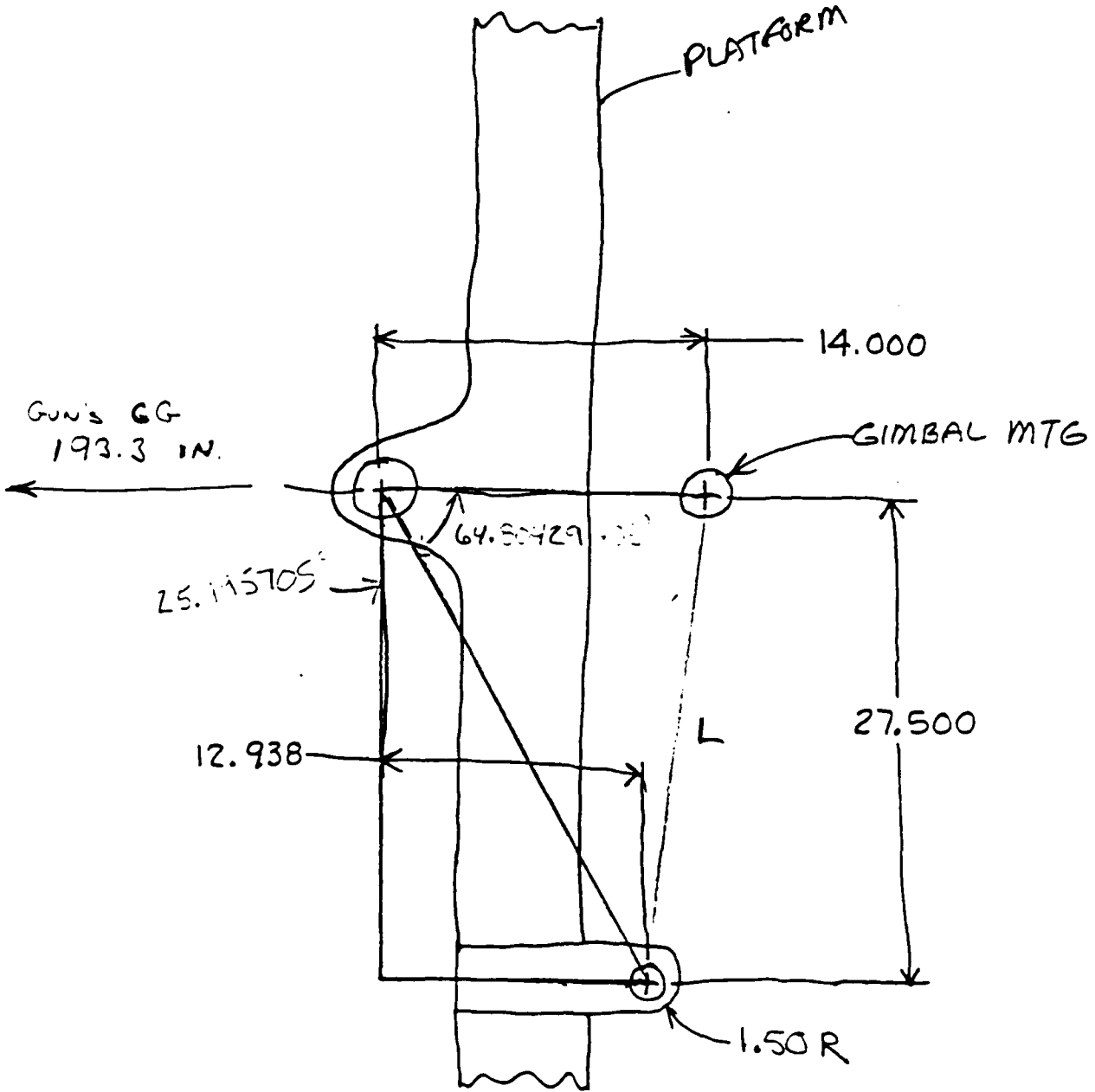

Summary of loads into gimbal bearings
(NCSIRAN model 12 Nov.)

<u>0° QE</u>		<u>2 directions</u>	<u>XY-plane</u>
bottom bearing	98,552	+	98,360
top bearing	21,264		21,264
 <u>72° QE</u>			
bottom bearing	109,640		72,350
top bearing	36,830	+	36,830

TORRINGTON

19

BEARING DIMENSIONS

construction

Type SFL self-lubricating lined Spherical Plain Radial Bearings are unit assemblies, each consisting of an inner ring with a spherical outer surface and an outer ring with a spherical inner surface. Both rings are manufactured from through-hardened steel. The outer ring has a single fracture to permit assembly. The spherical inner surface of the outer ring is lined with a mixture of solid lubricant TFE fibers and a phenolic resin binder. The spherical outer surface of the inner ring is chrome plated. Each bearing has two seals made of reinforced nitrile rubber.

CHECK FOR AVAILABILITY

dimensions

The controlling dimensions for type SFL bearings are in inches. Inch-metric conversions given are for the convenience of the user.

For tolerances of nominal dimensions see Tables 2 and 2A on page 3.

α is the maximum tilting angle for effective sealing. If this angle is exceeded, the seal lips will slide off the spherical surface.

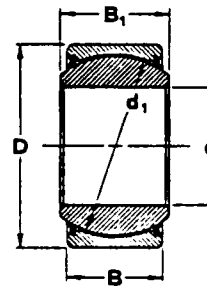
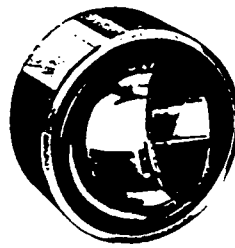

Type SFL bearing

	d		D		bearing designation	B ₁		B		d ₁		load ratings radial		mass (appr.)	α tilting angle (max.)
	mm	inch	mm	inch		mm	inch	mm	inch	mm	inch	lbf	lbf		
	19.050	.7500	31.750	1.2500	7SFL12	16.66	.656	14.27	.562	27.43	1.080	21000	10500	.126	6.0
	22.225	.8750	36.512	1.4375	8SFL14	19.43	.765	16.66	.656	31.95	1.258	29200	14600	.193	6.0
	25.400	1.0000	41.275	1.6250	10SFL16	22.22	.875	19.05	.750	36.50	1.437	38800	19400	.276	6.0
	31.750	1.2500	50.800	2.0000	12SFL20	27.76	1.093	23.80	.937	45.59	1.795	61900	31000	.516	6.0
	34.925	1.3750	55.562	2.1875	13SFL22	30.15	1.187	26.19	1.031	49.20	1.937	74800	37400	.770	5.5
	38.100	1.5000	61.912	2.4375	15SFL24	33.32	1.312	28.58	1.125	54.74	2.155	89300	44600	.934	6.0
TOP	44.450	1.7500	71.438	2.8125	17SFL28	38.89	1.531	33.32	1.312	63.88	2.515	124000	62200	1.43	6.0
GUMBAL	50.800	2.0000	80.962	3.1875	20SFL32	44.45	1.750	38.10	1.500	73.02	2.875	157000	78400	2.07	6.0
	57.150	2.2500	90.488	3.5625	22SFL36	50.01	1.969	42.85	1.687	82.17	3.235	203000	102000	2.92	6.0
	63.500	2.5000	100.012	3.9375	25SFL40	55.55	2.187	47.62	1.875	91.19	3.590	251000	126000	4.09	6.0
*	69.850	2.7500	111.125	4.3750	27SFL44	61.11	2.406	52.37	2.062	100.33	3.950	332000	166000	5.38	6.0
BOTTOM	76.200	3.0000	120.650	4.7500	30SFL48	66.68	2.625	57.15	2.250	109.52	4.312	394000	197000	6.87	6.0
GUMBAL	82.550	3.2500	130.175	5.1250	32SFL52	72.24	2.844	61.90	2.437	118.74	4.675	462000	231000	8.63	6.0
	88.900	3.5000	139.700	5.5000	35SFL56	77.77	3.062	66.68	2.625	128.02	5.040	536000	268000	10.7	6.0
	95.250	3.7500	149.225	5.8750	37SFL60	83.34	3.281	71.42	2.812	136.91	5.390	606000	303000	13.0	6.0
	101.600	4.0000	158.750	6.2500	40SFL64	88.90	3.500	76.20	3.000	146.05	5.750	695000	347000	15.6	6.0
	114.300	4.5000	177.800	7.0000	45SFL72	100.00	3.937	85.72	3.375	164.46	6.475	873000	436000	21.9	6.0
	120.650	4.7500	187.325	7.3750	47SFL78	105.56	4.156	90.47	3.562	173.36	6.825	969000	484000	25.6	6.0
	127.000	5.0000	196.850	7.7500	50SFL80	111.12	4.375	95.25	3.750	182.63	7.190	1080000	540000	29.7	6.0
	152.400	6.0000	222.250	8.7500	60SFL96	120.65	4.750	104.78	4.125	207.16	8.156	1380000	694000	38.8	5.0

* order bearings shown above this line from
THE TORRINGTON COMPANY / BEARINGS DIVISION
Torrington, Connecticut 06790

ELEVATION SYSTEM MODEL CALCS.

5-FEB

20

(1)

Elevation cyl.

2.875" dia bore

1.5" dia rod

A_1 , largest area away from barrel end

$$A_1 = 6.492 \text{ in}^2 = \frac{1}{4} (2.875)^2 \pi$$

$$A_2 = \frac{1}{4} \pi (2.875^2 - 1.5^2) = 4.725 \text{ in}^2$$

$$P_1 = 1300$$

$$P_1 A_1 = P_2 A_2 = 0$$

$$P_2 = P_1 A_1 / A_2$$

$$P_2 = 1786.2$$

@ 0° WE CYLINDER HAS EXTENDED $107.3' - 64.8'' = 42.5''$

$$\text{VOL}_1 = 1.05 (42.5) 6.492 = 289.7 \text{ in}^3$$

TOTAL STROKE IS 48.0" SO RETRACT SIDE OIL COLUMN IS

$$48.0 - 42.5 = 5.5 \text{ in long}$$

$$\text{VOL}_2 = 1.05 (5.5) 4.725 = 23.3 \text{ in}^3$$

6-FEB 21

(2)

① 72° QE CYLINDER HAS EXTENDED $64.8 - 64.8 = 0''$

ASSUME 3" BUFFER ON END OF CYLINDER.

$$\text{VOL. 1} = 3(6.492) = \underline{19.5 \text{ in}^3}$$

TOTAL STROKE IS 48.0" SO RETRACT SIDE OIL COLUMN IS 42.0"

$$\text{VOL. 2} = 42(4.725) = \underline{226.8 \text{ in}^3}$$

② 33° QE

$$\text{CYLINDER LENGTH} = \sqrt{67.7^2 + 70.4^2} = 97.7 \text{ in}$$

CYLINDER WAS EXTENDED $97.7 - 64.8 = 32.9 \text{ in}$

$$\text{VOL. 1} = (32.9 + 3) 6.492 = \underline{232.9}$$

TOTAL STROKE IS 48.0" SO RETRACT SIDE OIL COLUMN IS $48.0 - 32.9 \text{ in} = 15.1 \text{ in}$

$$\text{VOL. 2} = (15.1) 4.725 = \underline{71.3 \text{ in}^3}$$

5-FEB 27

(3)

GUN MODEL FOR ELEVATION

$$I_T = 37,540 \text{ ft-lb-s}^2 + 10\% \quad (\text{ABOUT TRUNNION})$$

$$I_T = 41300 \text{ ft-lb-s}^2 = 495,500 \text{ in-lb-s}^2$$

$$I_T = m r^2 + I_{CG}$$

$$m = 15.74$$

$$r = 161.75''$$

$$I_{CG} = 495,500 - 15.74 (161.75)^2 = \underline{23,700 \text{ in-lb-s}^2}$$

FOR 0° QE ASSUME 10,000 ft-lb OF
OVER EQUILIBRATION IS POSSIBLE.

120,000 in-lb "CONSTANT" TORQUE

330 QE

$$\text{TORQUE INBALANCE} \approx 67,100 - 43,700 = 23,400 \text{ ft-lb}$$

OR LOAD IS UNDER EQUILIBRATED BY

230,800 in-lb.

72° QE

UNDER EQUIL. BY 87,000

MOMENT ARM
(FOR ELEVATION cyl)

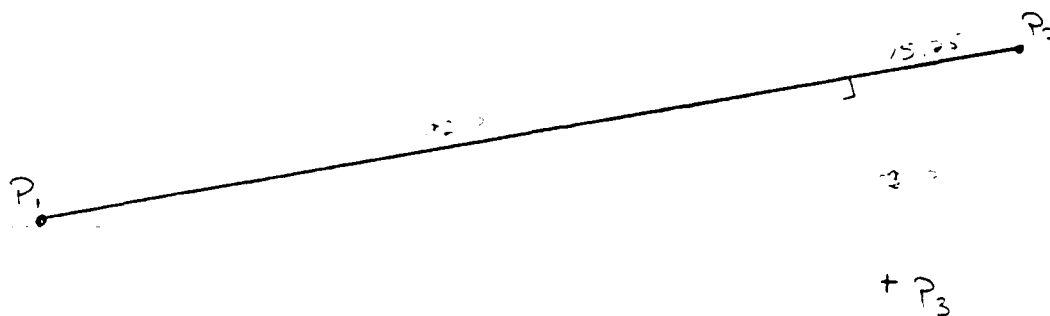

EQ OF LINE $y = mx + b$ OR $mx - y - b = 0$

$$m = \frac{P_{2y} - P_{1y}}{P_{2x} - P_{1x}}$$

$$b = \frac{(P_{2x} P_{1y} - P_{1x} P_{2y})}{(P_{2x} - P_{1x})}$$

NORMAL DISTANCE TO LINE, ma

$$ma = \frac{m P_{3x} - P_{3y} - b}{\sqrt{m^2 + 1}}$$

$$P_1 = (18.5, 96)$$

$$P_2 = (35, -10)$$

$$P_3 = (0, 0)$$

$$m = -6.424$$

$$b = 24.85$$

$$ma = 33.05''$$

Estimation of INITIAL CYLINDER PRESSURES

(4a)

(+ FORCE \rightarrow - TORQUE)

FORCE * MOMENT_ARM = -TORQUE UNBALANCE

$$\text{FORCE} = P_1 A_1 - P_2 (A_2)$$

@ 0° QE

$$\text{Torq} = 120,000 \quad m_a = 33.05$$

$$P_1 A_1 - P_2 A_2 = -120,000 / 33.05$$

$$P_2 = (P_1 A_1 + 120,000 / 33.05) / A_2$$

$$P_1 = \underline{1000} \quad P_2 = \underline{2237.6} \quad 2142.4$$

@ 33° QE

$$\text{Torq} = -280,000$$

$$m_a = 36.2$$

$$P_1 = \underline{2000}$$

$$P_2 = \underline{1301.4} \quad 1110.9$$

@ 72° QE

$$\text{Torq} = -87,000$$

$$m_a = 21.2$$

$$P_1 = \underline{1700}$$

$$P_2 = \underline{1629.1} \quad 1467.2$$

MOMENT ARM
ELEVATION CYL.

33° QE

$P_0 = (35, -10)$

$P_3 = (0, 0)$

NEED P_1

$(97.7 \sin(\omega_E + 10.9^\circ), 97.7 \cos(\omega_E + 10.9^\circ))$
 $(67.7, 70.4)$

$(8.5, 96)$

$(0, 97.7)$

$(0, 0)$

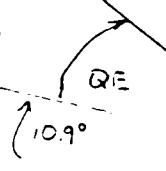

$m = 2.459$

$b = 96.06$

$ma = 36.2$

72° QE

$P_1 = (97.7 \sin(82.9), 97.7 \cos(82.9)) = (97.0, 12.1)$

$P_2 = (35, -10)$

$m = 3.52$

$b = 22.48$

$ma = 21.2$

MOMENT ARM
(FOR EQUILIBRATION cyl.)

0° QE

$$P_1 = (-8.5, 242.25)$$

$$P_2 = (35.5, -2)$$

$$P_3 = (0, 0)$$

$$m = 5.55$$

$$b = 195.07$$

$$\underline{ma = 34.58''}$$

33° QE

NEED P1

$$P_2 = (35.5, -2)$$

$$m = 2.346$$

$$\cdot (242.05 \sin(33^\circ - 2^\circ), 242.05 \cos(33^\circ - 2^\circ)) \\ = (124.97, 207.99) = P_1$$

$$b = 85.296$$

$$\underline{ma = 33.44}$$



MOMENT ARM EQUILIBRATION Cal.
72° WE

⑦

$$P_1 = (242.65 \sin(WE-2), 242.65 \cos(WE-2)) \\ = (228.02, 82.99)$$

$$P_2 = (35.5, -2)$$

$$P_3 = 0.0$$

$$m = .442$$

$$ma = \underline{16.17''}$$

$$c = 17.675$$

MAX - FRICTION VALUE

⑧

FRICTION IS DUE TO
BEAR-LOCS IN EQUILIBRATION CYLINDERS
JOURNAL BEARINGS IN TRUNNION

JOURNAL BEARINGS

at 0° QE

$$\text{STATIC FORCE} = \sqrt{34,000^2 + 1400^2} = 34,000 \text{ lb}$$

$$\begin{aligned} \text{BEARING RADIUS TO BEARING SURFACE} &= 2.875/2 \\ &= 1.438 \text{ "} \end{aligned}$$

ASSUME COEFF OF FRICTION = .185

$$\begin{aligned} \text{BEARING FRICTION TORQUE} &= 34,000 \times .185 \times 1.438 \\ &= \underline{6100 \text{ in-lb.}} \end{aligned}$$

72° QE

$$\text{STATIC FORCE} = 35,900 \text{ lb}$$

$$\text{BEARING FRICTION} = \frac{35.9}{34.0} 6100 = \underline{6450 \text{ in-lb.}}$$

FRICTION DUE TO BEAR-LOCKS

⑨

BEAR-LOCK SIZE 2 - 50,000 lb. holding FORCE

$$\text{lock drag} = .05 (\text{holding force})$$

$$\text{drag} = 5000 \text{ lbs.}$$

AT 0° QE

$$\text{MOMENT - ARM} = 34.6''$$

$$\text{EQUIVALENT FRICTION TORQUE} = \underline{173,000 \text{ in-lb}}$$

AT 33° QE

$$M - A = 33.4$$

$$\underline{T_f = 167,000 \text{ in-lb.}}$$

AT 72° QE

$$M - a = 16.2''$$

$$\underline{T_f = 81,000 \text{ in-lb.}}$$

5-FEB
30

TOTAL FRICTION

(10)

0° QE

$$T_{fTOT} = 6100 + 173000 = \underline{179,000 \text{ in-lb}}$$

33° QE

$$T_{fTOT} = 6300 + 167,000 = \underline{173,000 \text{ in-lb}}$$

72° QE

$$T_{fTOT} = 6500 + 81,000 = \underline{87,000 \text{ in-lb}}$$

2/3/87
S. DAKOTA 31

ELEVATION w/ BARREL IN LOAD POSITION.

$$WT = 6077$$

$$CG_z = 161.748$$

$$J_y z = 37,539.5 \text{ ft} \cdot \text{lb} \cdot \text{s}^2 + 10^6$$

ABOUT TRUNNION

MAX_FRICTION

→ DEPENDS ON BEARING FORCES
& BEAR LOC SIZE.

2 - 50,000 lb HO'ING FORCE EQUILIBRATION CT.

2 - BEARING DIA 2.875"

	STATIC FORCE N BEARINGS
0° OE	$\sqrt{34,000^2 + 1700^2}$
70° OE	$\sqrt{10,700^2 + 34,300^2}$

AD-A183 986

LIGHTWEIGHT TOWED HOWITZER DEMONSTRATOR PHASE 1 AND
PARTIAL PHASE 2 VOLUM (U) FMC CORP MINNEAPOLIS MINN
NORTHERN ORDNANCE DIV R RATHE ET AL APR 87
FMC-E-3041-VOL-C-PT-2 DAAA21-86-C-0047

3/3

UNCLASSIFIED

F/G 19/6

NL

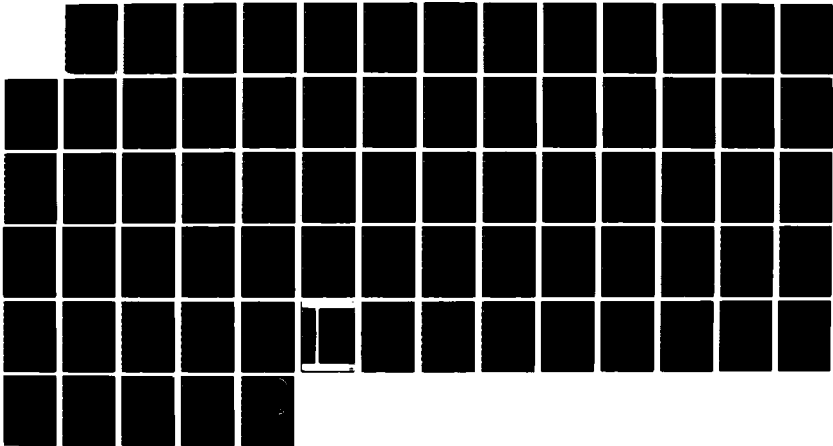

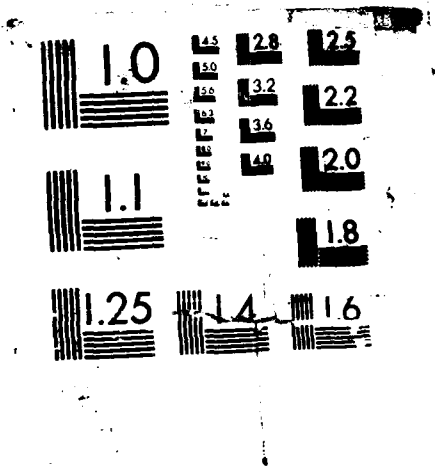

MICROCOPY RESOLUTION TEST CHART

TITLE STATIC ANALYSIS RESULTS - Nitrogen
 SUBTITLE ENERGY RECOVERY 05-Feb-87 10:57 AM
 HORIZONTAL LABEL THETA (degrees)
 VERTICAL LABEL TORQUE (ft-lb)
 Y_LEGEND gravity
 Y_LEGEND equilibration
 Y_LEGEND elevation
 Y_LEGEND dyn equil

TGRAV - DYNEQUIL = TORQUE
 IN BALANCE

TYPICAL VALUES FOR DYNAMIC
 OPERATION.

C	THETA	TGRAV	TEQUIL	TELEV	DYNEQUIL
-5.00	81600.2	83341.2	31017.6	84407.5	
-4.00	81712.4	83446.8	31294.4	83221.1	
-3.00	81799.6	82290.4	31566.3	82947.0	
-2.00	81862.0	82230.1	31832.9	82660.5	
-1.00	81899.4	82150.0	32094.2	82361.6	
0.00	81911.9	82050.2	32350.1	82050.4	
1.00	81899.4	81930.9	32600.4	81727.0	
2.00	81862.0	81792.3	32845.0	81391.5	
3.00	81799.6	81634.5	33083.7	81044.1	
4.00	81712.4	81457.8	33316.4	80684.7	
5.00	81600.2	81262.2	33542.9	79092.1	
6.00	81463.2	81047.9	33763.1	78428.6	
7.00	81301.3	80815.1	33976.8	77762.5	
8.00	81114.7	80563.8	34183.8	77093.5	
9.00	80903.4	80294.2	34384.0	76421.6	
10.00	80667.5	80006.4	34577.1	75746.8	
11.00	80406.9	78524.7	34763.1	74297.9	
12.00	80121.9	78087.4	34941.7	73265.7	
13.00	79812.5	77634.4	35112.7	72245.1	
14.00	79478.8	77165.9	35276.0	71235.5	
15.00	79120.8	76682.0	35431.2	70236.4	
16.00	78738.8	76183.1	35578.4	69247.4	
17.00	78332.7	75669.1	35717.1	68267.8	
18.00	77902.8	75140.3	35847.2	67297.3	
19.00	77449.2	74596.8	35968.5	64793.0	
20.00	76972.0	74038.9	36080.8	63443.7	
21.00	76471.3	73466.5	36183.8	62123.9	
22.00	75947.4	72879.9	36277.2	60832.4	
23.00	75400.3	71393.6	36360.9	58282.3	
24.00	74830.2	70680.7	36434.5	56485.1	
25.00	74237.4	69956.8	36497.9	54751.1	
26.00	73621.9	69222.1	36550.7	53077.1	
27.00	72984.0	68476.8	36592.6	49626.8	
28.00	72323.9	67721.0	36623.5	47225.4	
29.00	71641.7	66955.0	36643.0	48384.0	
30.00	70937.8	66178.8	36650.9	46920.3	
31.00	70212.2	65392.7	36646.7	45502.7	
32.00	69465.2	64596.8	36630.3	44129.2	
33.00	68697.1	63791.1	36601.3	42797.7	
34.00	67908.0	62976.0	36559.5	44239.7	
35.00	67098.3	62151.4	36504.4	43722.5	
36.00	66268.1	61317.6	36435.8	43197.0	
37.00	65417.7	59740.1	36353.3	42663.0	
38.00	64547.4	58816.1	36256.6	42120.7	
39.00	63657.5	57886.6	36145.4	41570.1	
40.00	62748.1	56951.6	36019.3	41011.2	
41.00	61819.7	56011.4	35877.9	40444.1	
42.00	60872.4	55066.0	35721.0	39868.9	
43.00	59906.5	54115.7	35548.1	39285.6	
44.00	58922.5	53160.4	35358.9	38694.1	
45.00	57920.4	52200.3	35153.1	38094.7	
46.00	56900.8	51235.7	34930.3	37487.3	

47.00	55863.8	50266.5	34690.1	36872.0
48.00	54809.7	49292.8	34432.2	36248.9
49.00	53739.0	48314.9	34156.1	35618.0
50.00	52651.9	47332.7	33861.7	34979.4
51.00	51548.8	46346.4	33548.5	34333.2
52.00	50430.0	44849.9	33216.1	33679.4
53.00	49295.8	43814.3	32864.3	32527.3
54.00	48146.6	42778.2	32492.7	31814.6
55.00	46982.7	41741.5	32101.1	31098.5
56.00	45804.5	40704.3	31689.0	30378.9
57.00	44612.4	39666.8	31256.3	29656.0
58.00	43406.7	38629.0	30802.6	28929.7
59.00	42187.7	37590.9	30327.7	28200.0
60.00	40955.9	36552.6	29831.3	27466.9
61.00	39711.6	35514.1	29313.4	26730.6
62.00	38455.3	34475.5	28773.6	25990.9
63.00	37187.2	33436.8	28211.8	25248.0
64.00	35907.8	32398.0	27627.9	24501.9
65.00	34617.4	31359.2	27021.8	23752.6
66.00	33316.5	30320.5	26393.5	23000.2
67.00	32005.5	29281.7	25742.9	22244.8
68.00	30684.7	28243.0	25070.1	21486.3
69.00	29354.5	27204.4	24375.1	20724.9
70.00	28015.5	26165.8	23658.1	19960.6
71.00	26667.8	25127.4	22919.2	19193.6
72.00	25312.1	24089.1	22158.6	18072.7

ELEV. CYL

107.277" @ 70W

97.073" @ 300 MPa (16.875°)

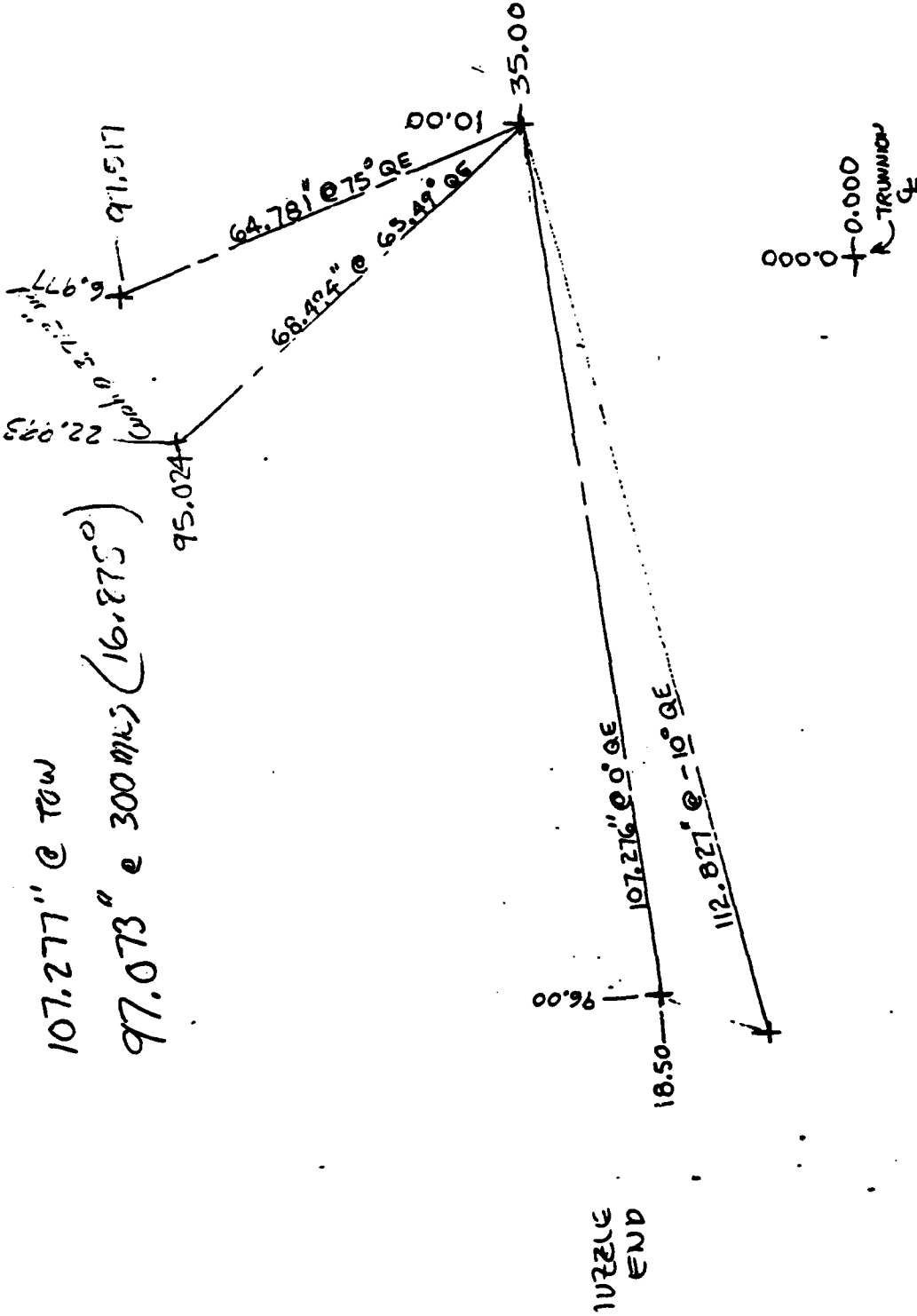

EXTEND LENGTH = 112.827
 RETRACTED LENGTH = 64.781

STROKE = 48.046"

NEED BUFFER AT 3.713" EXTENSION

FORCES
 EXTEND : 18,844
 RETRACT : 14,132

WORKING PRESSURE = 3000 PSI

EQUILIBRATION CTL *STR LH

7604

36

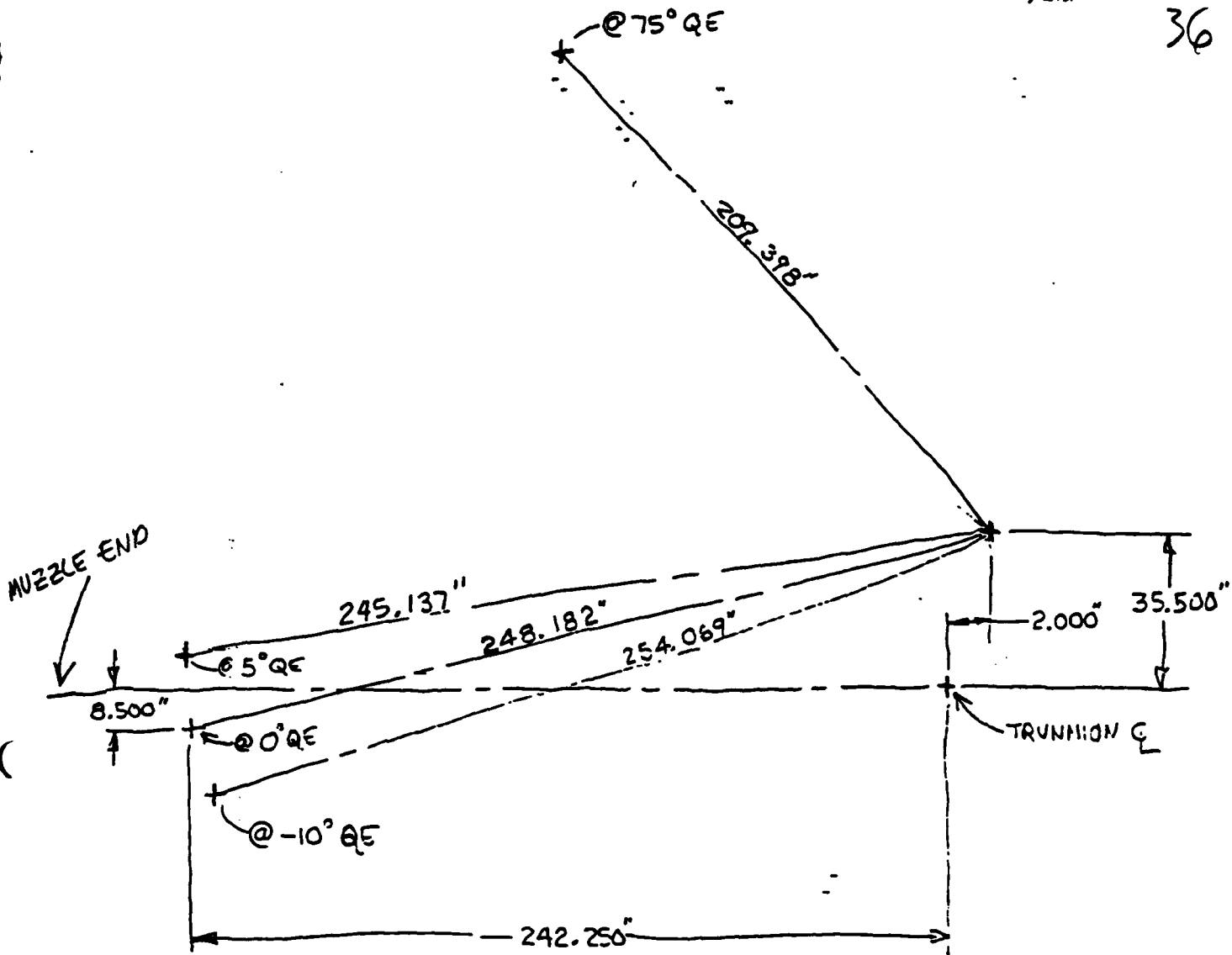

STROKE = 44.671"

NEED BUFFER AT 5° (35.739" EXTENSION)

Appendix C

DADS Model

Includes a description of the DADS software,
the input data for the model and
the user written supplementary code for the model.

Introduction to DADS Software

Purpose and Use of DADS

The Dynamic Analysis and Design System software is a set of general purpose computer programs that can be used to model and predict the motion of a variety of real world mechanical systems. Using a set of data that describes the machine to be modeled, DADS builds a mathematical model of the real system that calculates positions, velocities, and accelerations of the various parts of the machine, as well as resultant forces that act in the system. By using such a computer program to analyze a machine, the designer can simulate the behavior of a wide range of alternate designs prior to building and testing prototypes.

Types of Machines That Can Be Modeled

DADS contains a large library of mechanical elements that can be used to build a model. These include rigid and flexible bodies, joints and other constraints, force- and torque-producing elements, as well as control and hydraulic elements. Models can be created in two or three dimensions. Any machine whose motion is entirely planar can be modeled more easily in 2D and can be analyzed much more quickly by the analysis program, because of the smaller number of variables required. The 3D version is used to model any machine whose motion is not contained within a plane, allowing complete generality. If desired, planar systems can also be modeled in 3D.

The control elements can be used in any rigid or flexible body model that is analyzed using the dynamic option, or can be used independently to create a control system model without any bodies in it. The control elements can be used to apply forces, torques, or constraints to the rigid or flexible body system. The control elements define a system of first order differential equations that are solved along with the set of second order differential equations associated with the rigid or flexible body equations of motion.

The ability to model the flexibility effect allows much more detailed mechanical models to be built. Data for flexible bodies are generated by using the DADS Intermediate Processor to process data from a finite element program. Any elements in the finite element model can be used, not just simple beam elements between nodes. DADS uses modal coordinates, which are synthesized from the finite element data, to represent the flexibility effects of all flexible bodies in the model. This approach allows the most generality for modeling flexible bodies within the mechanical system.

Physical data entered into model**System geometry:**

- joint locations
- CG locations

Inertial properties:

- body weights
- rotational inertia about CG

Descriptions of hydraulic components

- accumulator volume and charge pressure
- control valve size
- amount of lapping in the valve
- actuator size
 - trapped volumes on either side of the piston
 - area of each side of the piston
- connectivity of hydraulic circuit

Hydraulic system parameters

- oil bulk modulus
- supply pressure
- return line pressure
- valve position

Miscellaneous

- gravity vector
- initial values of state variables
- error tolerances for simulation
- initial integration time step
- integration technique

Output available from the model**Forces**

- reaction forces at joints
- forces acting on body CGs
- forces produced by actuators

Kinematic information

- body position and orientation
- linear and angular velocity of bodies
- linear and angular acceleration of bodies

Hydraulic system information

- actuator pressures and pressure rates
- actuator motion
- state variables and their derivatives

Input data for the DADS model of the traversal system

CREATE HEADER

TRAVERSAL SYSTEM

This is a model of the LTHD traversal system. It contains the main valve, the traversal cylinder, energy accumulator, the gun body the friction in the gimbal bearing and locking mechanisms and a model of the man which is a first order system representing the delay due to his reaction time.

ANALYSIS

CREATE SYSTEM.DATA

```

UNITS                               := 'INCH-LB-SEC'
ANALYSIS.TYPE                       := 'DYNAMIC'
STARTING.TIME                       := '0.0'
ENDING.TIME                         := '3'
PRINT.INTERVAL                      := '.01'
GRAVITY.SEA.LEVEL                   := '386'
X.GRAVITY                           := '0.0'
Y.GRAVITY                           := '0.0'
Z.GRAVITY                           := '-1.0'
SCALE.GRAVITY.COEFF                 := '1.0'
MATRIX.OPERATIONS                   := 'SPARSE'
REDUNDANCY.CHECK                     := 'TRUE'
LU.TOL                              := '1.0D-12'
ASSEMBLY.TOL                        := '1.0D-3'
BYPASS.ASSEMBLY                     := 'FALSE'
OUTPUT.FILE                         := 'BINARY'
REFERENCE.FRAME                     := 'GLOBAL'
DEBUG.FLAG                          := 'TRUE'

```

UP

CREATE DYNAMIC.DATA

```

REACTION.FORCES                     := 'FALSE'
FORCE.COORDINATES                   := 'GLOBAL'
PRINT.METHOD                       := 'ACTUAL'
MAX.INT.STEP                        := '.01'
SOLUTION.TOL                        := '0.001'
INTEGRATION.TOL                     := '0.0001'

```

UP

UP

JOINTS

CREATE REVOLUTE.JOINT

```

NAME                                 := 'GIMBAL REV'
BODY.1.NAME                         := 'GND_BOD'
BODY.2.NAME                         := 'GUN_BOD'
P.ON.BODY.1                         := ( 0, -16, 0 )
P.ON.BODY.2                         := ( 0, -16, 0 )
Q.ON.BODY.1                         := ( 0, -16, 1 )
Q.ON.BODY.2                         := ( 0, -16, 1 )
R.ON.BODY.1                         := ( 1, -16, 0 )
R.ON.BODY.2                         := ( 1, -16, 0 )
NODE.1                              := '0'
NODE.2                              := '0'

```

UP

UP

CONTROLS

CREATE ACCUMULATOR

```

NAME                                 := 'ENERGY ACCUMULATOR'
INPUT.NODE                          := 'ACC PSI'
GAMMA                               := '1.4'
INITIAL.PRESSURE                    := '3000'
VOLUME                              := '4500'
CHARGE.PRESSURE                     := '2500'
ATMOS.PRESSURE                      := '14.7'

```

```

UP
CREATE AMPLIFIER
  NAME                := 'AMP SWITCH'
  INPUT.NODE          := 'SWITCH VALUE'
  OUTPUT.NODE         := 'AMP OUTPUT'
  TYPE                := 'CONSTANT'
  GAIN                := '.01'
  CURVE.NAME          := 'NONE'
UP
CREATE DOUBLE.ACTUATOR
  NAME                := 'TRAVERSE CYL'
  INPUT.NODE.1        := 'EXT_PSI'
  INPUT.NODE.2        := 'RET_PSI'
  OUTPUT.NODE         := 'CYL_FORCE'
  BODY.1.NAME         := 'GND_BOD'
  BODY.2.NAME         := 'GUN_BOD'
  PRESSURE.1          := '1500'
  PRESSURE.2          := '2000'
  AREA.1              := '14.186'
  AREA.2              := '9.276'
  VOLUME.1            := '85.118'
  VOLUME.2            := '49.708'
  COULOMB.COEFF       := '0.0'
  VISCOUS.COEFF      := '10'
  P.ON.BODY.1         := ( 27.5, -28.938, 0 )
  P.ON.BODY.2         := ( 0, -30, 0 )
  FLEXIBLE.NODE.1    := '0'
  FLEXIBLE.NODE.2    := '0'
UP
CREATE FIRST.ORDER
  NAME                := 'MAN MODEL'
  INPUT.NODE          := 'GUN_POSITION'
  OUTPUT.NODE         := 'MAN_OUTPUT'
  D.FIRST.ORDER.COEFF := '.3'
  D.CONSTANT.TERM     := '1'
  N.FIRST.ORDER.COEFF := '0'
  N.CONSTANT.TERM     := '1.0'
  S.ZERO              := '0.0'
UP
CREATE INPUT.FUNCTION
  NAME                := 'VELOCITY FEEDBACK'
  NODE.NAME           := 'GUN_VELOCITY'
  TYPE                := 'ZL_OMEGA'
  BODY.1.NAME         := 'GUN_BOD'
  BODY.2.NAME         := 'NONE'
  FUNCTION.PARAMETERS := ( 0.0, 0.0, 0.0, 0.0 )
  P.ON.BODY.1         := ( 0.0, 0.0, 0.0 )
  P.ON.BODY.2         := ( 0.0, 0.0, 0.0 )
  Q.ON.BODY.1         := ( 1.0, 0.0, 0.0 )
  Q.ON.BODY.2         := ( 1.0, 0.0, 0.0 )
  CURVE.NAME          := 'NONE'
  JOINT.NAME          := 'NONE'
  FLEXIBLE.NODE.1    := '0'
  FLEXIBLE.NODE.2    := '0'
  ANGULAR.UNITS       := 'DEGREES'
UP
CREATE INPUT.FUNCTION
  NAME                := 'TANK_PRESSURE'
  NODE.NAME           := 'TANK_PSI'
  TYPE                := 'POLYNOMIAL'
  BODY.1.NAME         := 'NONE'
  BODY.2.NAME         := 'NONE'

```

```

FUNCTION.PARAMETERS      := ( 300, 0, 0, 0 )
P.ON.BODY.1              := ( 0.0, 0.0, 0.0 )
P.ON.BODY.2              := ( 0.0, 0.0, 0.0 )
Q.ON.BODY.1              := ( 1.0, 0.0, 0.0 )
Q.ON.BODY.2              := ( 1.0, 0.0, 0.0 )
CURVE.NAME               := 'NONE'
JOINT.NAME               := 'NONE'
FLEXIBLE.NODE.1         := '0'
FLEXIBLE.NODE.2         := '0'
ANGULAR.UNITS           := 'DEGREES'

UP
CREATE INPUT.FUNCTION
NAME                     := 'VALVE_INPUT'
NODE.NAME               := 'VALVE_INPUT'
TYPE                    := 'STEP'
BODY.1.NAME             := 'NONE'
BODY.2.NAME             := 'NONE'
FUNCTION.PARAMETERS     := ( .5, .01, 0, 0 )
P.ON.BODY.1             := ( 0.0, 0.0, 0.0 )
P.ON.BODY.2             := ( 0.0, 0.0, 0.0 )
Q.ON.BODY.1             := ( 1.0, 0.0, 0.0 )
Q.ON.BODY.2             := ( 1.0, 0.0, 0.0 )
CURVE.NAME              := 'NONE'
JOINT.NAME              := 'NONE'
FLEXIBLE.NODE.1        := '0'
FLEXIBLE.NODE.2        := '0'
ANGULAR.UNITS           := 'DEGREES'

UP
CREATE INPUT.FUNCTION
NAME                     := 'DUMMY_INPUT'
NODE.NAME               := 'DUMMY_OUTPUT'
TYPE                    := 'STEP'
BODY.1.NAME             := 'NONE'
BODY.2.NAME             := 'NONE'
FUNCTION.PARAMETERS     := ( 0.0, 0.0, 0.0, 0.0 )
P.ON.BODY.1             := ( 0.0, 0.0, 0.0 )
P.ON.BODY.2             := ( 0.0, 0.0, 0.0 )
Q.ON.BODY.1             := ( 1.0, 0.0, 0.0 )
Q.ON.BODY.2             := ( 1.0, 0.0, 0.0 )
CURVE.NAME              := 'NONE'
JOINT.NAME              := 'NONE'
FLEXIBLE.NODE.1        := '0'
FLEXIBLE.NODE.2        := '0'
ANGULAR.UNITS           := 'DEGREES'

UP
CREATE INTEGRATOR
NAME                     := 'POSITION FEEDBACK'
INPUT.NODE              := 'GUN_VELOCITY'
OUTPUT.NODE             := 'GUN_POSITION'
S.ZERO                  := '0.0'

UP
CREATE OUTPUT
NAME                     := 'DUMMY_OUTPUT'
OUTPUT.NODE             := 'DUMMY_OUTPUT'
TYPE                    := 'FORCE.DIFF'
BODY.1.NAME             := 'GND_BOD'
BODY.2.NAME             := 'GUN_BOD'
P.ON.BODY.1             := ( 27.5, -28.938, 0 )
P.ON.BODY.2             := ( 0, -30, 0 )
JOINT.NAME              := 'NONE'
FLEXIBLE.NODE.1        := '0'
FLEXIBLE.NODE.2        := '0'

```

```

UP
CREATE PARAMETER
  NAME                               := 'BULK MODULUS'
  BULK.MODULUS                       := '175000'
UP
CREATE SUMMER
  NAME                               := 'SUMMER'
  OUTPUT.NODE                        := 'VALVE_POSITION'
  INPUT.NODE.1                       := 'VALVE_INPUT'
  INPUT.NODE.2                       := 'AMP_OUTPUT'
  INPUT.NODE.3                       := 'NONE'
  COEFFICIENT.1                     := '+'
  COEFFICIENT.2                     := '-'
  COEFFICIENT.3                     := '+'
UP
CREATE SWITCH
  NAME                               := 'SWITCH'
  INPUT.NODE                         := 'MAN_OUTPUT'
  OUTPUT.NODE                        := 'SWITCH_VALUE'
  ON.VALUE                           := '.0005'
UP
CREATE VALVE
  NAME                               := 'MAIN VALVE'
  INPUT.NODE                         := 'VALVE_POSITION'
  TYPE                               := '4WAY'
  CHAMBER.1.NODE                    := 'ACC_PSI'
  CHAMBER.2.NODE                    := 'EXT_PSI'
  CHAMBER.3.NODE                    := 'RET_PSI'
  CHAMBER.4.NODE                    := 'TANK_PSI'
  FLOW.COEFFICIENT                  := '.4'
  MAX.SPOOL                         := '1'
  LAP.SPOOL                         := '0.0'
UP
UP
CREATE BODY
  NAME                               := 'GND BOD'
  CENTER.OF.GRAVITY                 := ( 0.0, 0.0, 0.0 )
  TYPE.ANGULAR.COORD                := 'EULER'
  ANGLE.1                           := '0.0'
  ANGLE.2                           := '0.0'
  ANGLE.3                           := '0.0'
  FIXED.TO.GROUND                   := 'TRUE'
  MASS                               := '1.0'
  INERTIA.XXL                       := '1.0'
  INERTIA.YYL                       := '1.0'
  INERTIA.ZZL                       := '1.0'
  INERTIA.XYL                       := '0.0'
  INERTIA.XZL                       := '0.0'
  INERTIA.YZL                       := '0.0'
  XG.FORCE                          := '0.0'
  YG.FORCE                          := '0.0'
  ZG.FORCE                          := '0.0'
  XL.TORQUE                         := '0.0'
  YL.TORQUE                         := '0.0'
  ZL.TORQUE                         := '0.0'
  CURVE.XGF                         := 'NONE'
  CURVE.YGF                         := 'NONE'
  CURVE.ZGF                         := 'NONE'
  CURVE.XLT                         := 'NONE'
  CURVE.YLT                         := 'NONE'
  CURVE.ZLT                         := 'NONE'
  SIGN.E0                           := 'POSITIVE'

```

```

ANGULAR.UNITS      := 'DEGREES'
FLEXIBLE           := 'FALSE'
SUPERELEMENT      := 'FALSE'
UP
CREATE BODY
NAME               := 'GUN_BOD'
CENTER.OF.GRAVITY := ( 0, 177.3, 0 )
TYPE.ANGULAR.COORD := 'EULER'
ANGLE.1            := '0.0'
ANGLE.2            := '0.0'
ANGLE.3            := '0.0'
FIXED.TO.GROUND   := 'FALSE'
MASS               := '16.34'
INERTIA.XXL       := '1.0'
INERTIA.YYL       := '1.0'
INERTIA.ZZL       := '69250'
INERTIA.XYL       := '0.0'
INERTIA.XZL       := '0.0'
INERTIA.YZL       := '0.0'
XG.FORCE          := '0.0'
YG.FORCE          := '0.0'
ZG.FORCE          := '0.0'
XL.TORQUE         := '0.0'
YL.TORQUE         := '0.0'
ZL.TORQUE         := '0.0'
CURVE.XGF         := 'NONE'
CURVE.YGF         := 'NONE'
CURVE.ZGF         := 'NONE'
CURVE.XLT         := 'NONE'
CURVE.YLT         := 'NONE'
CURVE.ZLT         := 'NONE'
SIGN.E0           := 'POSITIVE'
ANGULAR.UNITS     := 'DEGREES'
FLEXIBLE           := 'FALSE'
SUPERELEMENT      := 'FALSE'
UP
CREATE INITIAL.CONDITION
NAME               := 'GUN_X_IC'
BODY.1.NAME       := 'GUN_BOD'
BODY.2.NAME       := 'NONE'
ELEMENT.NAME      := 'NONE'
TYPE.INITIAL.COND := 'X'
INITIAL.VALUE     := '0.0'
TIME.DERIVATIVE   := '0.0'
OMEGA.Y           := '0.0'
OMEGA.Z           := '0.0'
P.ON.BODY.1       := ( 0.0, 0.0, 0.0 )
P.ON.BODY.2       := ( 0.0, 0.0, 0.0 )
EXTRA.COORD       := '0'
ANGULAR.UNITS     := 'DEGREES'
UP

```

Input data for the DADS model of the elevation system

CREATE HEADER

ELEVATION SYSTEM

This is a model of the LTHD elevation system. It contains the main valve, the elevation cylinder, the energy accumulator, the gun body the friction in the trunnion bearings and locking mechanism, a constant torque which represents the inbalance between equilibration and gravity at a point of elevation and a model of the man which is a first order system that represents the delay due to his reaction time.

ANALYSIS

CREATE SYSTEM.DATA

```

UNITS                := 'INCH-LB-SEC'
ANALYSIS.TYPE        := 'DYNAMIC'
STARTING.TIME        := '0.0'
ENDING.TIME          := '3'
PRINT.INTERVAL       := '.01'
GRAVITY.SEA.LEVEL    := '386'
X.GRAVITY            := '1'
Y.GRAVITY            := '0.0'
Z.GRAVITY            := '0'
SCALE.GRAVITY.COEF   := '1.0'
MATRIX.OPERATIONS   := 'SPARSE'
REDUNDANCY.CHECK     := 'TRUE'
LU.TOL               := '1.0D-12'
ASSEMBLY.TOL         := '1.0D-3'
BYPASS.ASSEMBLY      := 'FALSE'
OUTPUT.FILE          := 'BINARY'
REFERENCE.FRAME      := 'GLOBAL'
DEBUG.FLAG           := 'TRUE'

```

UP

CREATE DYNAMIC.DATA

```

REACTION.FORCES      := 'FALSE'
FORCE.COORDINATES    := 'GLOBAL'
PRINT.METHOD        := 'ACTUAL'
MAX.INT.STEP         := '.01'
SOLUTION.TOL         := '0.001'
INTEGRATION.TOL      := '0.0001'

```

UP

UP

JOINTS

CREATE REVOLUTE.JOINT

```

NAME                 := 'TRUNNION'
BODY.1.NAME          := 'GND_BOD'
BODY.2.NAME          := 'GUN_BOD'
P.ON.BODY.1          := ( 0, 0, 0 )
P.ON.BODY.2          := ( 0, 0, 0 )
Q.ON.BODY.1          := ( 1, 0, 0 )
Q.ON.BODY.2          := ( 1, 0, 0 )
R.ON.BODY.1          := ( 0, 1, 0 )
R.ON.BODY.2          := ( 0, 1, 0 )
NODE.1               := '0'
NODE.2               := '0'

```

UP

UP

CONTROLS

CREATE ACCUMULATOR

```

NAME                 := 'ENERGY ACCUMULATOR'
INPUT.NODE           := 'ACC PSI'
GAMMA                := '1.47'
INITIAL.PRESSURE     := '3000'
VOLUME               := '4500'
CHARGE.PRESSURE      := '2500'

```

```

      ATMOS.PRESSURE                := '14.7'
UP
CREATE AMPLIFIER
  NAME                             := 'AMP_SWITCH'
  INPUT.NODE                        := 'SWITCH_VALUE'
  OUTPUT.NODE                       := 'AMP_OUTPUT'
  TYPE                              := 'CONSTANT'
  GAIN                              := '.01'
  CURVE.NAME                        := 'NONE'
UP
CREATE DOUBLE.ACTUATOR
  NAME                             := 'ELEVATION_CYL'
  INPUT.NODE.1                     := 'EXT_PSI'
  INPUT.NODE.2                     := 'RET_PSI'
  OUTPUT.NODE                       := 'CYL_FORCE'
  BODY.1.NAME                      := 'GND_BOD'
  BODY.2.NAME                      := 'GUN_BOD'
  PRESSURE.1                       := '1000'
  PRESSURE.2                       := '2237.6'
  AREA.1                           := '6.492'
  AREA.2                           := '4.725'
  VOLUME.1                         := '289.7'
  VOLUME.2                         := '23.3'
  COULOMB.COEFF                   := '0.0'
  VISCOUS.COEFF                   := '10'
  P.ON.BODY.1                      := ( 0, -10, 35 )
  P.ON.BODY.2                      := ( 0, 96, 18.5 )
  FLEXIBLE.NODE.1                  := '0'
  FLEXIBLE.NODE.2                  := '0'
UP
CREATE FIRST.ORDER
  NAME                             := 'MAN_MODEL'
  INPUT.NODE                        := 'GUN_POSITION'
  OUTPUT.NODE                       := 'MAN_OUTPUT'
  D.FIRST.ORDER.COEFF              := '.3'
  D.CONSTANT.TERM                  := '1'
  N.FIRST.ORDER.COEFF              := '0'
  N.CONSTANT.TERM                  := '1.0'
  S.ZERO                           := '0.0'
UP
CREATE INPUT.FUNCTION
  NAME                             := 'VELOCITY_FEEDBACK'
  NODE.NAME                         := 'GUN_VELOCITY'
  TYPE                              := 'XL_OMEGA'
  BODY.1.NAME                      := 'GUN_BOD'
  BODY.2.NAME                      := 'NONE'
  FUNCTION.PARAMETERS              := ( 0.0, 0.0, 0.0, 0.0 )
  P.ON.BODY.1                      := ( 0.0, 0.0, 0.0 )
  P.ON.BODY.2                      := ( 0.0, 0.0, 0.0 )
  Q.ON.BODY.1                      := ( 1.0, 0.0, 0.0 )
  Q.ON.BODY.2                      := ( 1.0, 0.0, 0.0 )
  CURVE.NAME                       := 'NONE'
  JOINT.NAME                       := 'NONE'
  FLEXIBLE.NODE.1                  := '0'
  FLEXIBLE.NODE.2                  := '0'
  ANGULAR.UNITS                    := 'DEGREES'
UP
CREATE INPUT.FUNCTION
  NAME                             := 'TANK_PRESSURE'
  NODE.NAME                         := 'TANK_PSI'
  TYPE                              := 'POLYNOMIAL'
  BODY.1.NAME                      := 'NONE'

```

```

BODY.2.NAME                := 'NONE'
FUNCTION.PARAMETERS        := ( 300, 0, 0, 0 )
P.ON.BODY.1                := ( 0.0, 0.0, 0.0 )
P.ON.BODY.2                := ( 0.0, 0.0, 0.0 )
Q.ON.BODY.1                := ( 1.0, 0.0, 0.0 )
Q.ON.BODY.2                := ( 1.0, 0.0, 0.0 )
CURVE.NAME                 := 'NONE'
JOINT.NAME                 := 'NONE'
FLEXIBLE.NODE.1            := '0'
FLEXIBLE.NODE.2            := '0'
ANGULAR.UNITS              := 'DEGREES'

UP
CREATE INPUT.FUNCTION
NAME                        := 'VALVE_INPUT'
NODE.NAME                   := 'VALVE_INPUT'
TYPE                        := 'STEP'
BODY.1.NAME                 := 'NONE'
BODY.2.NAME                 := 'NONE'
FUNCTION.PARAMETERS        := ( .5, .01, 0, 0 )
P.ON.BODY.1                 := ( 0.0, 0.0, 0.0 )
P.ON.BODY.2                 := ( 0.0, 0.0, 0.0 )
Q.ON.BODY.1                 := ( 1.0, 0.0, 0.0 )
Q.ON.BODY.2                 := ( 1.0, 0.0, 0.0 )
CURVE.NAME                 := 'NONE'
JOINT.NAME                 := 'NONE'
FLEXIBLE.NODE.1            := '0'
FLEXIBLE.NODE.2            := '0'
ANGULAR.UNITS              := 'DEGREES'

UP
CREATE INPUT.FUNCTION
NAME                        := 'DUMMY_INPUT'
NODE.NAME                   := 'DUMMY_OUTPUT'
TYPE                        := 'STEP'
BODY.1.NAME                 := 'NONE'
BODY.2.NAME                 := 'NONE'
FUNCTION.PARAMETERS        := ( 0.0, 0.0, 0.0, 0.0 )
P.ON.BODY.1                 := ( 0.0, 0.0, 0.0 )
P.ON.BODY.2                 := ( 0.0, 0.0, 0.0 )
Q.ON.BODY.1                 := ( 1.0, 0.0, 0.0 )
Q.ON.BODY.2                 := ( 1.0, 0.0, 0.0 )
CURVE.NAME                 := 'NONE'
JOINT.NAME                 := 'NONE'
FLEXIBLE.NODE.1            := '0'
FLEXIBLE.NODE.2            := '0'
ANGULAR.UNITS              := 'DEGREES'

UP
CREATE INTEGRATOR
NAME                        := 'POSITION FEEDBACK'
INPUT.NODE                  := 'GUN_VELOCITY'
OUTPUT.NODE                 := 'GUN_POSITION'
S.ZERO                      := '0.0'

UP
CREATE OUTPUT
NAME                        := 'DUMMY_OUTPUT'
OUTPUT.NODE                 := 'DUMMY_OUTPUT'
TYPE                        := 'FORCE.DIFF'
BODY.1.NAME                 := 'GND_BOD'
BODY.2.NAME                 := 'GUN_BOD'
P.ON.BODY.1                 := ( 0, -10, 35 )
P.ON.BODY.2                 := ( 0, 96, 18.5 )
JOINT.NAME                 := 'NONE'
FLEXIBLE.NODE.1            := '0'

```

```

        FLEXIBLE.NODE.2           := '0'
UP
CREATE PARAMETER
    NAME                          := 'BULK MODULUS'
    BULK.MODULUS                  := '175000'
UP
CREATE SUMMER
    NAME                          := 'SUMMER'
    OUTPUT.NODE                   := 'VALVE_POSITION'
    INPUT.NODE.1                  := 'VALVE_INPUT'
    INPUT.NODE.2                  := 'AMP_OUTPUT'
    INPUT.NODE.3                  := 'NONE'
    COEFFICIENT.1                 := '+'
    COEFFICIENT.2                 := '-'
    COEFFICIENT.3                 := '+'
UP
CREATE SWITCH
    NAME                          := 'SWITCH'
    INPUT.NODE                    := 'MAN_OUTPUT'
    OUTPUT.NODE                   := 'SWITCH_VALUE'
    ON.VALUE                       := '.0005'
UP
CREATE VALVE
    NAME                          := 'MAIN VALVE'
    INPUT.NODE                    := 'VALVE_POSITION'
    TYPE                          := '4WAY'
    CHAMBER.1.NODE                := 'ACC_PSI'
    CHAMBER.2.NODE                := 'EXT_PSI'
    CHAMBER.3.NODE                := 'RET_PSI'
    CHAMBER.4.NODE                := 'TANK_PSI'
    FLOW.COEFFICIENT              := '.4'
    MAX.SPOOL                     := '1'
    LAP.SPOOL                     := '0.0'
UP
UP
CREATE BODY
    NAME                          := 'GND BOD'
    CENTER.OF.GRAVITY             := ( 0.0, 0.0, 0.0 )
    TYPE.ANGULAR.COORD            := 'EULER'
    ANGLE.1                       := '0.0'
    ANGLE.2                       := '0.0'
    ANGLE.3                       := '0.0'
    FIXED.TO.GROUND               := 'TRUE'
    MASS                          := '1.0'
    INERTIA.XXL                   := '1.0'
    INERTIA.YYL                   := '1.0'
    INERTIA.ZZL                   := '1.0'
    INERTIA.XYL                   := '0.0'
    INERTIA.XZL                   := '0.0'
    INERTIA.YZL                   := '0.0'
    XG.FORCE                      := '0.0'
    YG.FORCE                      := '0.0'
    ZG.FORCE                      := '0.0'
    XL.TORQUE                     := '0.0'
    YL.TORQUE                     := '0.0'
    ZL.TORQUE                     := '0.0'
    CURVE.XGF                     := 'NONE'
    CURVE.YGF                     := 'NONE'
    CURVE.ZGF                     := 'NONE'
    CURVE.XLT                     := 'NONE'
    CURVE.YLT                     := 'NONE'
    CURVE.ZLT                     := 'NONE'

```

```

SIGN.E0                := 'POSITIVE'
ANGULAR.UNITS          := 'DEGREES'
FLEXIBLE                := 'FALSE'
SUPERELEMENT           := 'FALSE'

UP
CREATE BODY
NAME                   := 'GUN_BOD'
CENTER.OF.GRAVITY     := ( 0, 161.75, 0 )
TYPE.ANGULAR.COORD    := 'EULER'
ANGLE.1                := '0.0'
ANGLE.2                := '0.0'
ANGLE.3                := '0.0'
FIXED.TO.GROUND       := 'FALSE'
MASS                   := '15.74'
INERTIA.XXL           := '83700'
INERTIA.YYL           := '1.0'
INERTIA.ZZL           := '1'
INERTIA.XYL           := '0.0'
INERTIA.XZL           := '0.0'
INERTIA.YZL           := '0.0'
XG.FORCE              := '0.0'
YG.FORCE              := '0.0'
ZG.FORCE              := '0.0'
XL.TORQUE              := '120000'
YL.TORQUE              := '0.0'
ZL.TORQUE              := '0.0'
CURVE.XGF             := 'NONE'
CURVE.YGF             := 'NONE'
CURVE.ZGF             := 'NONE'
CURVE.XLT             := 'NONE'
CURVE.YLT             := 'NONE'
CURVE.ZLT             := 'NONE'
SIGN.E0                := 'POSITIVE'
ANGULAR.UNITS          := 'DEGREES'
FLEXIBLE                := 'FALSE'
SUPERELEMENT           := 'FALSE'

UP
CREATE INITIAL.CONDITION
NAME                   := 'GUN_Z_IC'
BODY.1.NAME            := 'GUN_BOD'
BODY.2.NAME            := 'NONE'
ELEMENT.NAME           := 'NONE'
TYPE.INITIAL.COND     := 'Z'
INITIAL.VALUE         := '0.0'
TIME.DERIVATIVE       := '0.0'
OMEGA.Y                := '0.0'
OMEGA.Z                := '0.0'
P.ON.BODY.1           := ( 0, 10, 0 )
P.ON.BODY.2           := ( 0.0, 0.0, 0.0 )
EXTRA.COORD            := '0'
ANGULAR.UNITS          := 'DEGREES'

UP

```

FRC32_3D.FOR

The following routine calculates forces defined by the DADS user. The top part of the routine is the basic template provided to the user, the bottom part is the code necessary for the friction calculations

C-----Author and Modification Section-----

C
C Author: Chuck Mead
C
C Date written: December 5, 1985
C
C Modifications:
C
C Copyright (c) CADSI 1985
C

C-----Algorithm Description-----

C
C Purpose and use:
C This subroutine is used to calculate the components of any user-
C defined forces defined in the model. Any of the various input
C variables can be used in these calculations, with the results
C being added to the generalized coordinate force array, FRC. In
C addition, the subroutine SPL32 can be used to reference curve
C data elements for use in the calculations.
C The various input arguments are described and declared in three
C separate groups: read-only arguments, arguments read and modi-
C fied, and return-only arguments.
C Read-only arguments are passed in with meaningful values which
C should not be changed within this subroutine. This constitutes
C the largest group of arguments passed. Consult the documentation
C on user-defined force elements for a description of the structure
C and contents of the various variables and arrays passed in.
C Arguments read and modified are also passed in with meaningful
C values which may be changed within this subroutine. This group
C includes the user-defined force element data arrays, UDF and IUDF,
C and the two generalized coordinate force arrays, FRC and XFRC.
C The final group of arguments, return-only arguments, are passed
C in with unknown values and should therefore be assigned some value
C within this subroutine before they are used in any other computa-
C tion. The only variable in this group is ERRCOD. Since this
C variable's value is used in the calling routine to determine the
C success of the computations performed in FRC32, it is suggested
C that ERRCOD be initialized to zero before beginning any other
C computations.
C
C Error conditions:
C Error conditions are reported via the variable ERRCOD. A zero
C value indicates no error; a positive value indicates some fatal
C error, i.e., files will be closed and execution aborted upon
C return to the calling routine; negative values are reserved for
C future use.
C
C Machine dependencies: none known
C

```

SUBROUTINE FRC32 ( UDF, IUDF, NUDF, NPTRS, MPTRS, TIME,
& Q, QD, QDD, XQ, XQD, XQDD, NXCRD, FRC,
& XFRC, RB, NRB, NPRB, NTPES, NELEMS,
& A, NMAX, IA, MMAX, IPRDCT, INFOF, ERRCOD )

```

-----Variable Descriptions-----

C
C
C---Read-only arguments-----

- C NUDF.....Number of user-defined force elements in the input data.
C (This variable has a minimum value of 1 for array dec-
C laration purposes.)
- C NPTRS....Number of real (double precision) data stored for each
C user-defined force element. (This variable has a minimum
C value of 1 for array declaration purposes.)
- C MPTRS....Number of integer data stored for each user-defined force
C element. (This variable has a minimum value of 1 for
C array declaration purposes.)
- C TIME.....Current time in the model simulation.
- C Q.....Array of displacement values for all rigid body coor-
C dinates in the model.
- C QD.....Array of velocities of all rigid body coordinates.
- C QDD.....Array of accelerations of all rigid body coordinates.
- C XQ.....Array of displacement values for all extra generalized
C coordinates in the model.
- C XQD.....Array of velocities of all extra generalized coordinates.
- C XQDD....Array of accelerations of all extra generalized coor-
C dinates.
- C NXCRD....Number of extra generalized coordinates in the model.
C (This variable has a minimum value of 1 for array dec-
C laration purposes.)
- C RB.....Array of real (double precision) data for each rigid body
C in the model.
- C NRB.....Number of rigid bodies in the model.
- C NPRB....Number of real (double precision) data stored for each
C rigid body in the model.
- C NTPES...Number of different element types available in DADS.
- C NELEMS..Number of occurrences of each element type in the model.
- C A.....Array of all real (double precision) data used in the
C analysis.
- C NMAX....Length of the A array.
- C IA.....Array of all integer data used in the analysis.
- C MMAX....Length of the IA array.
- C IPRDCT...Flag used to identify the type of integration step cur-
C rently being performed:
C If IPRDCT = 0, this is a corrector step.
C If IPRDCT >= 1, this is a predictor step.
- C INFOF....FORTRAN file unit number for the DADS information file.
C Error, warning, or other informational messages can be
C written to this file if so desired.

```

INTEGER NUDF, NPTRS, MPTRS, NXCRD, NRB, NPRB, NTPES,
& NELEMS(NTPES), NMAX, MMAX, IA(0:MMAX), IPRDCT,
& INFOF

```

```

DOUBLE PRECISION TIME, Q(7,NRB), QD(7,NRB), QDD(7,NRB),
& XQ(NXCRD), XQD(NXCRD), XQDD(NXCRD),
& RB(NPRB,NRB), A(0:NMAX)

```



```

C
C---Arguments read and modified-----
C
C   UDF.....Array of real (double precision) data for all user-
C             defined force elements in the model.
C   IUDF.....Array of integer data for all user-defined force elements
C             in the model.
C   FRC.....Array of forces for each rigid body coordinate in the
C             model.
C   XFRC.....Array of forces for each extra generalized coordinate in
C             the model.
C
C           INTEGER  IUDF(MPTRS,NUDF)
C
C           DOUBLE PRECISION  UDF(NPTRS,NUDF), FRC(7,NRB), XFRC(NXCRD)
C
C---Return-only arguments-----
C
C   ERRCOD...Error condition flag.
C
C           INTEGER  ERRCOD
C
C---COMMON blocks-----
C   none
C
C---Local variables-----
C   none
C
C---Functions and subroutines-----
C
C   SPL32....Function used to return various values associated with a
C             a point on a particular curve data element.
C
C           EXTERNAL  SPL32
C
C           DOUBLE PRECISION  SPL32
C
C---DATA statements-----
C   none
C-----
C * * * * *
C * * * * *
C
C           Remaining Code Supplied By User
C * * * * *
C * * * * *
C
C           common /fric/ friction, velocity, accel, ext_torque
C           common /hook/ act_force, p1, p2
C           integer body_axis, body_number
C
C           double precision act_force, p1(3), p2(3)
C           double precision friction, dt, fudge_factor, inertia, torque,one
C           double precision last_vel, last_time, step_flag, velocity
C           double precision max_friction, stopping_torque, accel,ext_torque
C           double precision euler_params(4), euler_torques(4),
C           1         euler_accel(4), jt_loc(3), torque_arm(3)
C           double precision euler_velocity(4)

```

```

      double precision local_torques(3), local_velocity(3),
1      local_accel(3)
      double precision forc(3), unit(3),
&      pterm1(3), pterm2(3),
&      torq2(4), dist, pos1(3), pos2(3),
&      value, tterm1(3), tterm2(3)

      save /hook/
      save /fric/

```

C ##### V A R I A B L E S #####

- C accel -- Acceleration of body about joint axis
- C act_force -- Force produced by the actuator, value entered into FRC32_3D through a common block, value in common Block set by modified FR3520 routine
- C body_axis -- Axis number about which the torque is applied
- C body_number -- Number of the body of interest
- C dist -- Distance between the actuator's end points
- C dt -- Size of simulation's calculation time step
- C ext_torque -- Total external torque excluding friction that is acting on the body about the joint axis
- C friction -- Value used for friction
- C fudge_factor -- Value used to adjust the stopping torque when the friction torque is sufficient to stop the inertia in a time step
- C inertia -- Inertia of the body in motion in the direction of the torque
- C last_time -- Value of time at last completed simulation time step
- C last_vel -- Value of the body's velocity at the last completed time step
- C max_friction -- Maximum torque due to friction
- C moment_arm -- Distance from body CG to pivot point
- C step_flag -- Flag used to determine if a time step has been completed, (= -1 if yes, = time if no)
- C stopping_torque -- Approximate torque necessary to stop body's motion in the next time step
- C torque -- Torque applied to the body about the friction axis
- C velocity -- Velocity of the body

C ##### A R R A Y S #####

- C euler_accel -- Angular acceleration of body in euler c-sys.
- C euler_params -- Euler parameters for body of interest
- C euler_torques -- Global euler/cartesian torques acting on body
- C forc -- Force vector in global coordinates from end 1 to end 2 of actuator
- C jt_loc -- Global location of the joint axis
- C local_accel -- Acceleration of body 2 in its coordinate system
- C local_torques -- Body fixed torques acting on the body
- C local_velocity -- Velocity of body 2 in its coordinate system
- C pos1 -- Global location of actuator's first end
- C pos2 -- Global location of actuator's second end
- C pterm1 -- Location of actuator's first end on body one with respect to that body's CG
- C pterm2 -- Location of actuator's second end on body two with respect to that body's CG
- C torque_arm -- Vector from joint location to actuator's second end on body 2, in global coordinates

```

C   torq2           -- One half of the resultant torque acting on
C                   body 2 because of the actuator, in Euler
C                   parameter coordinate system
C   tterm2          -- Resultant torque acting on body 2 because of
C                   the actuator, in global coordinate system
C   unit            -- Unit vector along actuator from end one to
C                   end two, in global coordinates

```

```

C-----Process Block-----

```

```

C---First zero out the error condition flag to indicate that no errors
C   have occurred yet.

```

```

ERRCOD = 0

```

```

if (time .eq. 0) then           ! do one time calcs

```

```

    max_friction = udf(1,1)
    fudge_factor = udf(2,1)
    body_number   = int(udf(3,1))
    body_axis     = int(udf(4,1))
    moment_arm    = udf(5,1)
    jt_loc(1)     = udf(7,1)
    jt_loc(2)     = udf(8,1)
    jt_loc(3)     = udf(9,1)

```

```

C *** Calculation of inertia about joint axis

```

```

1      inertia      = RB(body_axis+1, body_number) +
          RB(1, body_number)*moment_arm**2

      step_flag     = 0
      dt            = 1
      one           = 1

```

```

endif

```

```

C *** If/then/else statement used to capture simulation time and body's
C *** velocity about joint axis at last COMPLETED time step

```

```

if (time .eq. step_flag) then
    step_flag = -1
    last_vel  = velocity
    last_time = time

```

```

else
    step_flag = time
    dt = time - last_time
    if (time .eq. 0) dt = 1

```

```

endif

```

```

do i = 1, 4
    j = i + 3

```

```

    euler_params(i) = Q(j, body_number)
    euler_torques(i) = FRC(j, body_number)
    euler_accel(i) = QDD(j, body_number)

```

enddo

C---Transform p1 and p2 from local to global coordinates.

```
call asp( RB(38,1), p1(1), pterm1(1) )
call asp( RB(38,body_number), p2(1), pterm2(1) )
```

```
pos1(1) = Q(1,1) + pterm1(1)
pos1(2) = Q(2,1) + pterm1(2)
pos1(3) = Q(3,1) + pterm1(3)
```

```
pos2(1) = Q(1,body_number) + pterm2(1)
pos2(2) = Q(2,body_number) + pterm2(2)
pos2(3) = Q(3,body_number) + pterm2(3)
```

C *** Calculate actuator length

```
dist = ( pos2(1) - pos1(1) )**2 + ( pos2(2) - pos1(2) )**2
&      + ( pos2(3) - pos1(3) )**2
```

```
if ( dist .gt. 1.d-10 ) then
  dist = sqrt(dist)
```

```
else
```

```
write(INFOF,1000)
1000 format(/,' Error from the control output element.',
&      /,' The distance is near zero, a value of',
&      ' 1.D-5 will be used. ' )
```

```
dist = 1.d-5
endif
```

C---Define the unit vector from P1 to P2 in global space.

```
unit(1) = ( pos2(1) - pos1(1) ) / dist
unit(2) = ( pos2(2) - pos1(2) ) / dist
unit(3) = ( pos2(3) - pos1(3) ) / dist
```

C *** Calculate the force vector acting in body 2 due to the actuator

```
forc(1) = act_force * unit(1)
forc(2) = act_force * unit(2)
forc(3) = act_force * unit(3)
```

C *** Calculate the torque acting on body 2 due to the actuator and
C *** convert to the euler parameter c-sys

```
do i = 1, 3
  torque_arm(i) = pos2(i) - jt_loc(i)
enddo
```

```
call WCS( torque_arm(1), forc(1), tterm2(1))
call ETS( Q(4,body_number), tterm2(1), torq2(1) )
```

C *** Add the estimate of the actuator torque to the other torques
C *** already acting on the body

```
do i = 1, 4
```

```

        euler_torques(i) = euler_torques(i) + 2.d0 * torq2(i)
    enddo

C *** Calculate the torques and accelerations of the body in its c-sys
    call GV4(euler_params, euler_accel, local_accel)
    call GV4(euler_params, euler_torques, local_torques)

    do i = 1, 3
        local_accel(i) = local_accel(i)/2
        local_torques(i) = local_torques(i)/2
        local_velocity(i) = RB(34+i, body_number)
    enddo

C *** Set the variables to be used in the friction calculation

    velocity = local_velocity(body_axis)
    accel = local_accel(body_axis)
    torque = local_torques(body_axis)
    ext_torque = torque

C *****
C ***                               Calculation of Friction                               ***
C *****

    if (abs(torque) .ge. max_friction) then
        if (velocity .eq. 0) then
C == Set friction to its max value and in the opposite direction of the
C net external torque if the body is stopped otherwise set it in
C opposition to the body's motion
            friction = -sign(one, torque)*max_friction
        else
            friction = -sign(one, velocity)*max_friction
        endif
    else
        if (velocity .eq. 0) then      ! Cancel out the external torque
            friction = -torque
        else
C *** Estimate the torque necessary to stop the body in one time step
            stopping_torque = -torque - velocity *
1                               inertia*fudge_factor/dt
C *** Set the value of friction to that torque value unless it exceeds
C *** friction's maximum possible value
            if (abs(stopping_torque) .ge. max_friction) then
                friction = -sign(one, velocity)*max_friction
            else
                friction = stopping_torque
            endif
        endif
    endif

```

```
                endif
            endif
        endif

C *** Set the local torque vector to be equal to the friction present
        do i = 1, 3
            local_torques(i) = 0
        enddo

        local_torques(body_axis) = friction

C *** Convert the frictional torque to the euler parameter c-sys and
C *** add it to the external torques already acting on the body

        call GTS (euler_params, local_torques, euler_torques)

        do i = 1, 4
            j = i + 3
            frc(j, body_number) = 2*euler_torques(i) +
1             frc(j, body_number)
            frc(j, 1) = -2*euler_torques(i) + frc(j, 1)
        enddo

        return
    end
```

FR3520.FOR

This routine is used to apply forces calculated by DADS control module elements to bodies in the model. Typically it is not modified by the user. To model friction it was modified only to gain access to some model variables that where needed and that where not available to the user written force calculation routine. The variables were made available through the addition of a common block to the two routines.

C FR3520: Transfer forces due the control elements to DADS.

C-----Author and Modification Section-----

C Author: Dick Kading

C Date written: April 1986

C Written on: MicroVax, VMS

C Modifications:

C 1) 6/2/86 Changed the TORQ1,2 vectors dimension from 3 to 4.
C Dick Kading

C 2) 7/7/86 Changed this routine so it could be used or modified
C by customers wanting special access to control forces.
C Dick Kading

C Copyright (c) CADSI 1986

C-----Algorithm Description-----

C Purpose and use:

C This routine appends the forces calculated by the control elements to the generalized force vector. There are 8 possible options in this element that apply forces, some to one body, some to both. This routine has the common blocks locally declared, not "INCLUDED", so that it can be edited, recompiled and linked as a "user" routine. It provides access to all rigid body position, velocities, accelerations, and forces along with the control node and state variables.

C Error conditions: none

C Machine dependencies: none

SUBROUTINE FR3520 (ENS, IC, RC, Q, QD, QDD, FRC, NEL, RB, RVL, CYL, S, SD)

C-----Variable Descriptions-----

C---Arguments passed-----

```

C
C NEL.....Number of outputs to the rigid body program.
C IC.....Integer array of output element data.
C ENS.....Vector of node variable values.
C RC.....Real array of control element data.
C Q.....Real array of rigid body generalized coordinates.
C QD.....Real array of rigid body velocities.
C QDD.....Real array of rigid body accelerations.
C FRC.....Real array of generalized forces.
C RB.....Array of rigid body real data.
C RVLTL.....Array of revolute joint real data.
C CYL.....Array of cylindrical joint real data.
C S.....Vector of state variables.
C SD.....Vector of state variable time derivatives.
C
      INTEGER NEL,IC(NEL,1)
      DOUBLE PRECISION ENS(1), RC(NEL,1), Q(7,1), FRC(7,1), RB(65,1),
      &                   RVLTL(36,1), CYL(36,1), QD(7,1), QDD(7,1), S(1),
      &                   SD(1)
C
C-----COMMON blocks-----
C
C INPUTF...File unit the input data is in.
C INFOF....File unit of the information output file.
C OUTPF....File unit of the standard output file.
C BINRYF...File unit of the unformatted or "binary" output file.
C CRTIN....File unit for reading from the user's terminal.
C CRTOUT...File unit for writing to the user's terminal.
C NXTREC...Next record available in the binary output file.
C
      INTEGER  INPUTF, INFOF, OUTPF, BINRYF, CRTIN, CRTOUT, NXTREC
      COMMON  / IOUNIT /  INPUTF, INFOF, OUTPF, BINRYF, CRTIN, CRTOUT,
      &                   NXTREC
      SAVE  /IOUNIT/
C
C-----Controls COMMON Block.
C
      COMMON /STAT35/ IEVAL,IMODUL,IBLOCK,IFN
      INTEGER IEVAL,IMODUL,IBLOCK,IFN
      SAVE /STAT35/
C
C-----Local variables-----
C
C I.....Loop index.
C IOUT.....Output node number.
C TYPE.....Type of coordinate force is appended to,
C
      TYPE = 1, X
      = 2, Y
      = 3, Z
      = 4, Force difference
      = 5, Torque difference
      = 6, X torque, local
      = 7, Y torque
      = 8, Z torque
C
C BODY1.....Body 1.
C BODY2.....Body 2.

```

```

C FORCE.....Value of the force output from the control system.
C FORC.....Vector of forces in global space.
C UNIT.....Unit vector.
C SLP1.....Vector locating P1 on body 1, in local coordinates.
C SLP2..... " P2 on body 2.
C PTERM1.....Global value of SLP1.
C PTERM2..... " SLP2.
C TORQ1.....Torque on body 1, transformed into the Euler parameter
C              coordinate system.
C TORQ2..... " body 2.
C DIST.....Distance from P1 on body1 to P2 on body 2.
C POS1.....Global position of P1 on body 1.
C POS2..... " P2 on body 2.
C VALUE.....Temporary value used to test the SQRT argument.
C TTERM1.....Torque term, result of cross product of Force and
C              moment arm.
C TTERM2..... " body 2.
C AXIS1L.....Revolute or cylindrical axis about which the actuator
C              torque is applied on body 1.
C AXIS2L..... " body 2.
C JNTNUM.....Joint number, either a revolute or cylindrical.
C JNTTYP.....Type of joint, revolute = 1, cylindrical = 3.

```

```

      INTEGER I, IOUT, BODY1, BODY2, TYPE, JNTNUM, JNTTYP

```

```

      DOUBLE PRECISION FORCE, FORC(3), UNIT(3), AXIS1L(3), AXIS2L(3),
&          SLP1(3), SLP2(3), PTERM1(3), PTERM2(3),
&          TORQ1(4), TORQ2(4), DIST, POS1(3), POS2(3),
&          VALUE, TTERM1(3), TTERM2(3)

```

```

C
C-----Functions and subroutines-----
C

```

```

      INTRINSIC ABS, SQRT
      EXTERNAL ASP, WCS, ETS, GTS

```

```

C
C-----

```

```

C * * * * *
C# * * * * *

```

USER MODIFICATIONS

```

      common /hook/ act_force, p1, p2
      double precision act_force, p1(3), p2(3)
      save /hook/

```

```

C * * * * *
C# * * * * *

```

```

C-----Process Block-----

```

```

C---If this isn't the right analysis phase return.

```

```

      IF ( IEVAL .NE. 4 ) RETURN

```

```

C * * * * *

```

```

C * * * * *
      U S E R   M O D I F I C A T I O N S

      act_force = ens(13)
      do I = 1, 3

          p1(i) = rc(1,i)
          p2(i) = rc(1,i+3)

      enddo

C * * * * *
C * * * * *

C---Go through the loop for each output required.

      DO 100 I = 1,NEL

C---Define local variables for convenience.

          IOUT   = IC(I,1)
          TYPE   = IC(I,2)
          BODY1  = IC(I,3)
          BODY2  = IC(I,4)
          JNTNUM = IC(I,7)
          JNTTYP = IC(I,8)

C---Define the vectors locating points P1 and P2.

          SLP1(1) = RC(I,1)
          SLP1(2) = RC(I,2)
          SLP1(3) = RC(I,3)

          SLP2(1) = RC(I,4)
          SLP2(2) = RC(I,5)
          SLP2(3) = RC(I,6)

C---Define the output value of the node.

          FORCE = ENS(IOUT)

C---Transform SLP1 and 2 from local to global coordinates.

          CALL ASP( RB(38,BODY1), SLP1(1), PTERM1(1) )
          CALL ASP( RB(38,BODY2), SLP2(1), PTERM2(1) )

          POS1(1) = Q(1,BODY1) + PTERM1(1)
          POS1(2) = Q(2,BODY1) + PTERM1(2)
          POS1(3) = Q(3,BODY1) + PTERM1(3)

          POS2(1) = Q(1,BODY2) + PTERM2(1)
          POS2(2) = Q(2,BODY2) + PTERM2(2)
          POS2(3) = Q(3,BODY2) + PTERM2(3)

C---Update generalized force with control element forces. Note these
C   force terms are "action only" types of forces since they act on only
C   one body. The first type is on X of P1 on body 1.

          IF ( TYPE .EQ. 1 ) THEN

```

```

FORC(1) = FORCE
FORC(2) = 0.0
FORC(3) = 0.0

```

C---Call WCS to calc. the cross product of thte moment arm and the
C force. Use ETS to transform the the torque to the Euler parameter
C coordinate system.

```

CALL WCS( PTERM1(1), FORC(1), TTERM1(1) )
CALL ETS( Q(4,BODY1), TTERM1(1), TORQ1(1) )

```

C---Update the generalized force vector.

```

FRC(1,BODY1) = FRC(1,BODY1) + FORCE
FRC(4,BODY1) = FRC(4,BODY1) + 2.D0 * TORQ1(1)
FRC(5,BODY1) = FRC(5,BODY1) + 2.D0 * TORQ1(2)
FRC(6,BODY1) = FRC(6,BODY1) + 2.D0 * TORQ1(3)
FRC(7,BODY1) = FRC(7,BODY1) + 2.D0 * TORQ1(4)

```

C---This is the Y of point P1 option.

```

ELSE IF ( TYPE .EQ. 2 ) THEN

```

```

FORC(1) = 0.0
FORC(2) = FORCE
FORC(3) = 0.0

```

```

CALL WCS( PTERM1(1), FORC(1), TTERM1(1) )
CALL ETS( Q(4,BODY1), TTERM1(1), TORQ1(1) )

```

```

FRC(2,BODY1) = FRC(2,BODY1) + FORCE
FRC(4,BODY1) = FRC(4,BODY1) + 2.D0 * TORQ1(1)
FRC(5,BODY1) = FRC(5,BODY1) + 2.D0 * TORQ1(2)
FRC(6,BODY1) = FRC(6,BODY1) + 2.D0 * TORQ1(3)
FRC(7,BODY1) = FRC(7,BODY1) + 2.D0 * TORQ1(4)

```

C---This is the Z of point P1 option.

```

ELSE IF ( TYPE .EQ. 3 ) THEN

```

```

FORC(1) = 0.0
FORC(2) = 0.0
FORC(3) = FORCE

```

```

CALL WCS( PTERM1(1), FORC(1), TTERM1(1) )
CALL ETS( Q(4,BODY1), TTERM1(1), TORQ1(1) )

```

```

FRC(3,BODY1) = FRC(3,BODY1) + FORCE
FRC(4,BODY1) = FRC(4,BODY1) + 2.D0 * TORQ1(1)
FRC(5,BODY1) = FRC(5,BODY1) + 2.D0 * TORQ1(2)
FRC(6,BODY1) = FRC(6,BODY1) + 2.D0 * TORQ1(3)
FRC(7,BODY1) = FRC(7,BODY1) + 2.D0 * TORQ1(4)

```

C---Update generalized force with force difference between the 2
C bodies connected. This is to apply force at P1 on body 1 and
C P2 on body 2.

```

ELSE IF ( TYPE .EQ. 4 ) THEN

```

```

VALUE = ( POS2(1) - POS1(1) )**2 + ( POS2(2) - POS1(2) )**2
        + ( POS2(3) - POS1(3) )**2

```

```

IF ( VALUE .GT. 1.D-10 ) THEN
  DIST = SQRT(VALUE)
ELSE
  WRITE(INFOF,1000)
  FORMAT(//,' Error from the control output element.',
        &      //,' The distance is near zero, a value of',
        &      ' 1.D-5 will be used. ' )
  DIST = 1.D-5
END IF

```

C---Define the unit vector from P1 to P2 in global space.

```

UNIT(1) = ( POS2(1) - POS1(1) ) / DIST
UNIT(2) = ( POS2(2) - POS1(2) ) / DIST
UNIT(3) = ( POS2(3) - POS1(3) ) / DIST

FORC(1) = FORCE * UNIT(1)
FORC(2) = FORCE * UNIT(2)
FORC(3) = FORCE * UNIT(3)

```

C---Calculate the torques and convert to the Euler parameter system.

```

CALL WCS( PTERM1(1), FORC(1), TTERM1(1) )
CALL ETS( Q(4,BODY1), TTERM1(1), TORQ1(1) )

CALL WCS( PTERM2(1), FORC(1), TTERM2(1) )
CALL ETS( Q(4,BODY2), TTERM2(1), TORQ2(1) )

```

C---Update the generalized force vector.

```

FRC(1,BODY1) = FRC(1,BODY1) - FORC(1)
FRC(2,BODY1) = FRC(2,BODY1) - FORC(2)
FRC(3,BODY1) = FRC(3,BODY1) - FORC(3)
FRC(4,BODY1) = FRC(4,BODY1) - 2.D0 * TORQ1(1)
FRC(5,BODY1) = FRC(5,BODY1) - 2.D0 * TORQ1(2)
FRC(6,BODY1) = FRC(6,BODY1) - 2.D0 * TORQ1(3)
FRC(7,BODY1) = FRC(7,BODY1) - 2.D0 * TORQ1(4)

FRC(1,BODY2) = FRC(1,BODY2) + FORC(1)
FRC(2,BODY2) = FRC(2,BODY2) + FORC(2)
FRC(3,BODY2) = FRC(3,BODY2) + FORC(3)
FRC(4,BODY2) = FRC(4,BODY2) + 2.D0 * TORQ2(1)
FRC(5,BODY2) = FRC(5,BODY2) + 2.D0 * TORQ2(2)
FRC(6,BODY2) = FRC(6,BODY2) + 2.D0 * TORQ2(3)
FRC(7,BODY2) = FRC(7,BODY2) + 2.D0 * TORQ2(4)

```

C---Update generalized force with rotational actuator force. This
C option applies torque on the 2 bodies connected by revolute or
C cylindrical joints. The torque is applied about the rev or cyl
C joint Z axes.

```

ELSE IF ( TYPE .EQ. 5 ) THEN

```

C---If this is a revolute joint, use the RFLT data to define the
C local joint Z axis. The force term is included at this step;
C it could be applied at the last step equivalently.

```

IF ( JNTTYP .EQ. 1 ) THEN

  AXIS1L(1) = RFLT(25,JNTNUM) * FORCE
  AXIS1L(2) = RFLT(26,JNTNUM) * FORCE
  AXIS1L(3) = RFLT(27,JNTNUM) * FORCE

```

```

    AXIS2L(1) = RVLT(34,JNTNUM) * FORCE
    AXIS2L(2) = RVLT(35,JNTNUM) * FORCE
    AXIS2L(3) = RVLT(36,JNTNUM) * FORCE

```

C---If this is a cylindrical joint, use the CYL data.

```

ELSE IF ( JNTTYP .EQ. 3 ) THEN

```

```

    AXIS1L(1) = CYL(25,JNTNUM) * FORCE
    AXIS1L(2) = CYL(26,JNTNUM) * FORCE
    AXIS1L(3) = CYL(27,JNTNUM) * FORCE

```

```

    AXIS2L(1) = CYL(34,JNTNUM) * FORCE
    AXIS2L(2) = CYL(35,JNTNUM) * FORCE
    AXIS2L(3) = CYL(36,JNTNUM) * FORCE

```

```

END IF

```

C---Transform the torque to the Euler parameter system.

```

CALL GTS( Q(4,BODY1), AXIS1L(1), TORQ1(1) )
CALL GTS( Q(4,BODY2), AXIS2L(1), TORQ2(1) )

```

```

FRC(4,BODY1) = FRC(4,BODY1) - 2.D0 * TORQ1(1)
FRC(5,BODY1) = FRC(5,BODY1) - 2.D0 * TORQ1(2)
FRC(6,BODY1) = FRC(6,BODY1) - 2.D0 * TORQ1(3)
FRC(7,BODY1) = FRC(7,BODY1) - 2.D0 * TORQ1(4)

```

```

FRC(4,BODY2) = FRC(4,BODY2) + 2.D0 * TORQ2(1)
FRC(5,BODY2) = FRC(5,BODY2) + 2.D0 * TORQ2(2)
FRC(6,BODY2) = FRC(6,BODY2) + 2.D0 * TORQ2(3)
FRC(7,BODY2) = FRC(7,BODY2) + 2.D0 * TORQ2(4)

```

C---This option applies a torque about the local X axis directly.

```

ELSE IF ( TYPE .EQ. 6 ) THEN

```

```

TTERM1(1) = FORCE
TTERM1(2) = 0.0
TTERM1(3) = 0.0

```

```

CALL GTS( Q(4,BODY1), TTERM1(1), TORQ1(1) )

```

```

FRC(4,BODY1) = FRC(4,BODY1) + 2.D0 * TORQ1(1)
FRC(5,BODY1) = FRC(5,BODY1) + 2.D0 * TORQ1(2)
FRC(6,BODY1) = FRC(6,BODY1) + 2.D0 * TORQ1(3)
FRC(7,BODY1) = FRC(7,BODY1) + 2.D0 * TORQ1(4)

```

C---This option applies a torque about the local Y axis directly.

```

ELSE IF ( TYPE .EQ. 7 ) THEN

```

```

TTERM1(1) = 0.0
TTERM1(2) = FORCE
TTERM1(3) = 0.0

```

```

CALL GTS( Q(4,BODY1), TTERM1(1), TORQ1(1) )

```

```

FRC(4,BODY1) = FRC(4,BODY1) + 2.D0 * TORQ1(1)
FRC(5,BODY1) = FRC(5,BODY1) + 2.D0 * TORQ1(2)
FRC(6,BODY1) = FRC(6,BODY1) + 2.D0 * TORQ1(3)

```

```
FRC(7,BODY1) = FRC(7,BODY1) + 2.D0 * TORQ1(4)
```

C---This option applies the torque about the local Z axis directly.

```
ELSE IF ( TYPE .EQ. 8 ) THEN
```

```
TTERM1(1) = 0.0
```

```
TTERM1(2) = 0.0
```

```
TTERM1(3) = FORCE
```

```
CALL GTS( Q(4,BODY1), TTERM1(1), TORQ1(1) )
```

```
FRC(4,BODY1) = FRC(4,BODY1) + 2.D0 * TORQ1(1)
```

```
FRC(5,BODY1) = FRC(5,BODY1) + 2.D0 * TORQ1(2)
```

```
FRC(6,BODY1) = FRC(6,BODY1) + 2.D0 * TORQ1(3)
```

```
FRC(7,BODY1) = FRC(7,BODY1) + 2.D0 * TORQ1(4)
```

```
END IF
```

```
100 CONTINUE
```

```
RETURN
```

```
END
```

IN32_3D.FOR

This routine allows the user to input parameters that are to be used with their force calculations. Most of this routine is a vendor supplied template, the modifications done by the appear near its end and are designated as such.

C IN32: Reads and stores input data for user-defined forces (3D).

C-----Author and Modification Section-----

C
 C Author: Chuck Mead
 C
 C Date written: December 5, 1985
 C
 C Modifications:
 C
 C Copyright (c) CADSI 1985
 C
 C-----

C-----Algorithm Description-----

C
 C Purpose and use:
 C This subroutine reads the user-defined force input data from the
 C internal file HLDINP, checks it for errors, and stores it in the
 C user-defined force data areas: UDF for real (double precision)
 C data and IUDF for integer data. Note that the first record of
 C each user-defined force element must have the string "USERFORCE "
 C in columns 1 through 10 in order to be identified as such.
 C The number of records of data required for each user-defined
 C force element is defined by the array element REC3D(32). The
 C number of real and integer data stored for each user-defined force
 C element are defined by the array elements NPTRS3(32) and
 C MPTRS3(32), respectively. These three values are initialized in
 C the block data routine BLOCKD. For use within this routine, the
 C array elements NPTRS3(32) and MPTRS3(32) are passed in via the
 C argument list as the variables NPTRS and MPTRS, respectively.
 C The various input arguments are described and declared in three
 C separate groups: read-only arguments, arguments read and modi-
 C fied, and return-only arguments.
 C Read-only arguments are passed in with meaningful values which
 C should not be changed within this subroutine. This constitutes
 C the largest group of arguments passed. Consult the documentation
 C on user-defined force elements for a description of the structure
 C and contents of the various variables and arrays passed in.
 C Arguments read and modified are also passed in with meaningful
 C values which may be changed within this subroutine. There are no
 C read-and-modify arguments passed to IN32.
 C The final group of arguments, return-only arguments, are passed
 C in with unknown values and should therefore be assigned some value

C within this subroutine before they are used in any other computa-
 C tion. The variables in this group are the two user-defined force
 C element data arrays, UDF and IUDF, and the error condition flag
 C ERRCOD. Since the value of ERRCOD is used in the calling routine
 C to determine the success of the computations performed in IN32, it
 C is suggested that ERRCOD be initialized to zero before beginning
 C any other computations.

C Error conditions:

C Error conditions are reported via the variable ERRCOD. A zero
 C value indicates no error; a positive value indicates some fatal
 C error, i.e., files will be closed and execution aborted upon
 C return to the calling routine; negative values are reserved for
 C future use.

C Machine dependencies: none known
 C

C-----

SUBROUTINE IN32 (UDF, IUDF, NUDF, NPTRS, MPTRS, HLDINP, MAXLNS,
 & HLDLNK, STARTU, INFOF, BODMOD, CRVMOD, ERRCOD)

C-----Variable Descriptions-----

C---Read-only arguments-----

C NUDF....Number of user-defined force elements in the input data.
 C (This variable has a minimum value of 1 for array dec-
 C laration purposes.)
 C NPTRS....Number of real (double precision) data stored for each
 C user-defined force element. (This variable has a minimum
 C value of 1 for array declaration purposes.)
 C MPTRS....Number of integer data stored for each user-defined force
 C element. (This variable has a minimum value of 1 for
 C array declaration purposes.)
 C HLDINP...Array of character data read into memory from the DADS
 C input file. This is used as a FORTRAN internal file in
 C this subroutine in order to read any user-defined force
 C element data and store it in the appropriate data arrays.
 C MAXLNS...The maximum number of lines storable in HLDINP.
 C HLDLNK...Array of pointers used to link together the locations of
 C various occurrences of each element type in the input
 C data.
 C STARTU...Pointer to the line in HLDINP at which the data for the
 C first user-defined force element starts.
 C INFOF....FORTRAN file unit number for the DADS information file.
 C Error, warning, or other informational messages can be
 C written to this file if so desired.
 C BODMOD...Element type number of the rigid body module. Can be
 C used to map body names to body numbers via the GETNUM
 C function.
 C CRVMOD...Element type number of the curve data module. Can be
 C used to map curve data element names to curve data
 C element numbers via the GETNUM function.

C INTEGER NUDF, NPTRS, MPTRS, MAXLNS, HLDLNK(MAXLNS), STARTU,
 & INFOF, BODMOD, CRVMOD

C CHARACTER*80 HLDINP(MAXLNS)
 C CHARACTER*20 UDFNAM

C

```

C---Arguments read and modified-----
C   none
C
C---Return-only arguments-----
C
C   UDF.....Array of real (double precision) data for all user-
C             defined force elements in the model.
C   IUDF....Array of integer data for all user-defined force elements
C             in the model.
C   ERRCOD...Error condition flag.
C
C       INTEGER  IUDF(MPTRS,NUDF),  ERRCOD
C
C       DOUBLE PRECISION  UDF(NPTRS,NUDF)
C
C---COMMON blocks-----
C   none
C
C---Local variables-----
C
C   PNTR.....Pointer used to step through the internal file HLDINP and
C             point to the location of the first record for each user-
C             defined force element in the input data.
C   IOSTAT...FORTRAN I/O error flag.  A zero value indicates no error
C             encountered in the execution of a I/O statement.
C   I.....Loop counter.
C
C       INTEGER  PNTR, IOSTAT, I
C       CHARACTER*60  MNAME,MNAMEX
C
C---Functions and subroutines-----
C
C   GETNUM...Given the element type number (i.e., module number) and
C             an element name, this function returns the element num-
C             ber.  A zero function value means either the named ele-
C             ment doesn't exist or the input values are invalid.
C
C       EXTERNAL  GETNUM
C
C       INTEGER  GETNUM
C
C---DATA statements-----
C   none
C
C=====
C-----Process Block-----
C
C---No errors have been detected yet.
C
C       ERRCOD = 0
C
C---If one or more extra output files will be used to report user-
C   defined force output data, they could be opened at this point.
C
C---Set the pointer to the first line of data for the first user-
C   defined force element.
C
C       PNTR = STARTU
C
C---Loop to read in and process the data for each user-defined force

```

C element in the input data.

C#####
C#####

USER MODIFICATIONS

(START AT THIS POINT AND APPEAR AS lower case CODE.)

C *** OPEN A FILE FOR ADDITIONAL OUTPUT SPECIFIED BY THE USER IN
C *** ROUTINE RPT32_3D

write (*,'(lx, a, \$)') 'EXTRA DATA FILE NAME? '
read (*,'(a)') mname

nn = index(mname,' ')
mname(nn:nn+4) = '.pll'

open(unit = 11, file = mname,status = 'unknown', iostat=ios)
rewind(11)

DO 1000 I = 1, NUDF

C---Read the data on the first record for this user-defined force
C element.

15 READ (HLDINP(PNTR), 15, ERR=100, IOSTAT=IOSTAT) udfnam
FORMAT (BN,10X,A20)

C---If there was a READ error, report it and return to the calling
C routine.

100 CONTINUE
if (iostat .ne. 0) then
write (infof, 115) i, udfnam
115 format (/, 'Error in reading data for a user-defined ',
& 'force element # ',I2,' ',A,/
ERRCOD = 31032
RETURN
ENDIF

C---Read the data on the second record for this user-defined force
C element.

C!!!!!!!!!!!!!! REMEMBER TO INCREMENT PNTR POINTER FOR THE NEXT RECORD !!!

C *** READING OF ADDITIONAL DATA

read (hldinp(pntr+1), 125, err=200, iostat=iostat)
1 (udf(j,i), j = 1, 3)
read (hldinp(pntr+2), 125, err=200, iostat=iostat)
1 (udf(j,i), j = 4, 6)
read (hldinp(pntr+3), 125, err=200, iostat=iostat)
1 (udf(j,i), j = 7, 9)
125 FORMAT (BN,3(g20.14))

C---If there was a READ error, report it and return to the calling

C routine.

```
200 CONTINUE
    if ( iostat .ne. 0 ) then
      write ( infof, 215 ) i, udfnam
215   FORMAT (/, 'Error in reading data for a user-defined ',
      &      'force element', I2, ' ', A, /)
      ERRCOD = 31032
      RETURN
    ENDIF
```

END OF USER MODIFICATIONS

```
C #####
C#####
```

C---Continue to read data from however many records exist for each
C user-defined force element. Following this, any input data error
C checking can be performed.

C---Set the pointer to the first record for the next user-defined
C force element.

```
PNTR = HLDLNK (PNTR)
1000 CONTINUE
```

```
RETURN
END
```

BLOCKD. FOR

This block of code sets up how data is stored in DADS for its model elements, it must be modified by the user to define how data is stored in the input file for his force calculation routine FRC32_3D. The modification appears at the end of the block.

C BLOCKD: Initialization for common block data.

C-----Author and Modification Section-----

C
C Author: Chuck Mead
C
C Date written: December 14, 1984
C
C Written on: PR1ME 750, PR1MOS Rev. 19.1, compiled by F77 Rev. 19.1
C
C Copyright (c) CADSI 1986
C

C-----

C-----Algorithm Description-----

C
C Purpose and use:
C This routine is used to initialize any common block variables.
C
C Error conditions: none
C
C Machine dependencies: none known
C

C-----

BLOCKDATA BLOCKD

C-----Variable Descriptions-----

C

C---COMMON blocks-----

C

C Harwel.blk

C

C LIRN....array length of IRN for position and velocity analysis

C LICN....array length of ICN for position and velocity analysis

C LIRN2....array length of IRN for acceleration analysis

C LICN2....array length of ICN for acceleration analysis

C MREGE1...matrix regeneration for position and velocity analysis

C ISCAL1...rescaling of the matrix for position and velocity analysis

C MREGE2...matrix regeneration for acceleration analysis

C ISCAL2...rescaling of the matrix for acceleration analysis

C IDISP1...position of free space of ICN for position and velocity

C analysis

C IDISP2...position of free space of ICN for acceleration analysis

C U.....pivoting value of sparce matrix recomended value 0.1 - 0.25

```

C
  INTEGER  LIRN, LICN, LIRN2, LICN2, MREG1, ISCAL1,
  &        MREG2, ISCAL2, IDISP1(2), IDISP2(2)
  DOUBLE PRECISION  U

  COMMON /HARWEL/ LIRN, LICN, LIRN2, LICN2, U, MREG1, ISCAL1,
  &        MREG2, ISCAL2, IDISP1, IDISP2
  SAVE /HARWEL/

```

```

C Integv.blk
C
C IFAIL...Flag for prediction failure
C NORDER...Order of integration
C IDIVG...Flag for integration step controller from DYNAM2
C IPOSIT..Position iteration counter
C IVELOC..Velocity analysis counter
C IACCEL..Acceleration analysis counter
  COMMON /INTEGV/ IFAIL,NORDER, IDIVG, IPOSIT, IVELOC, IACCEL
  INTEGER IFAIL,NORDER, IDIVG, IPOSIT, IVELOC, IACCEL
  SAVE /INTEGV/

```

```

C Iounit.blk
C
C INPUTF...File unit the input data is in.
C INFOF....File unit of the information output file.
C OUTPF....File unit of the standard output file.
C BINRYF...File unit of the unformatted or "binary" output file.
C NXTREC...Next record available in the binary output file.

```

```

  INTEGER          INPUTF, INFOF, OUTPF, BINRYF, NXTREC
  COMMON / IOUNIT / INPUTF, INFOF, OUTPF, BINRYF, NXTREC
  SAVE /IOUNIT/

```

```

C
C Ptrs.blk
C
C NPTRS2...Vector containing the number of real data required for an
C           element of each module in 2D.
C NPTRS3...Same vector for 3D modules.
C MPTRS2...Vector containing the number of integer data required for
C           an element of each module in 2D.
C MPTRS3...Same vector for 3D modules.
C
  INTEGER NPTRS2(50), NPTRS3(50), MPTRS2(50), MPTRS3(50)
  COMMON / PTRS / NPTRS2, NPTRS3, MPTRS2, MPTRS3
  SAVE / PTRS /

```

```

C
C Steps.blk
C
C NS.....Number of steps taken with size H
C NORND...Logical value for too small error tolerance in STEP
C PHASE1..Logical value of prediction failure in STEP
C ALPHA...Integration parameter
C BETA....Integration parameter

```



```

C SIG.....Integration parameter
C G.....Integration parameter
C
C   INTEGER NS
C   DOUBLE PRECISION ALPHA(12), BETA(12), SIG(13), G(13), V(12),
C   & W(12)
C   LOGICAL NORND, PHASE1
C
C   COMMON / STEPS / ALPHA, BETA, SIG, G, V, W, NS, NORND, PHASE1
C   SAVE / STEPS /
C
C Timing.blk
C
C DOTIME....Logical variable that is .TRUE. if the user wants to call
C           the system timing routines.
C
C   LOGICAL DOTIME
C   COMMON / TIMING / DOTIME
C
C Rcdnum.blk
C
C REC2D....Vector of the number of records for each 2D module.
C REC3D....Vector of the number of records for each 3D module.
C
C   INTEGER REC2D(50), REC3D(50)
C
C   COMMON / RCDNUM / REC2D, REC3D
C
C   SAVE / RCDNUM /
C
C Multip.blk
C
C   COMMON /MULTIP/ IIN(40),IOU(40),ILN(40)
C   INTEGER IIN,IOU,ILN
C   SAVE / MULTIP /
C
C Crcrds.blk
C
C   COMMON / CRCRDS / CREC2D, CREC3D
C   INTEGER CREC2D(29), CREC3D(29)
C   SAVE / CRCRDS /
C
C---Local variables-----
C
C I.....Loop index.
C
C   INTEGER I
C
C---DATA statements-----
C
C---Initialization of variables in the HARWEL common block.
C
C   DATA U / 0.25 /
C
C---Initialization of variables in the INTEGV common block.
C
C   DATA IPOSIT, IVELOC, IACCEL / 0, 0, 0 /
C
C---Added data for MULTIP. This is control element data, 1/17/86.

```

```

DATA IIN /0,3,1,1,1,1,1,1,1,1,1,1,1,1,1,1,0,1,1,
&         0,0,0,1,0,0,0,2,0,0,0,0,0,0,0,0,0,0,5/
DATA IOU /1,1,1,1,1,1,1,1,1,1,1,1,1,1,1,1,2,0,
&         1,0,1,0,3,1,0,1,0,0,0,0,0,0,0,0,0,0,5/
DATA ILN /1,1,1,2,2,2,2,1,1,1,1,1,1,1,1,1,1,3,1,
&         1,1,1,1,5,3,2,3,2,0,0,0,0,0,0,0,0,0,3/

```

C---Define the number of records per control element, input data.

```

DATA CREC2D / 6, 2, 2, 3, 3,
&            2, 0, 2, 2, 2,
&            2, 0, 2, 0, 0,
&            0, 0, 0, 5, 3,
&            0, 1, 5, 3, 5,
&            2, 2, 3, 2 /

```

```

DATA CREC3D / 8, 2, 2, 3, 3,
&            2, 0, 2, 2, 2,
&            2, 0, 2, 0, 0,
&            0, 0, 0, 6, 5,
&            0, 1, 6, 3, 6,
&            2, 2, 3, 2 /

```

C---Initialization of variables in the IOUNIT common block.

```

DATA INPUTF, INFOF, OUTPF / 100, 102, 101 /
DATA BINRYF / 103 /

```

C---Initialization of variables in the PTRS common block, except for C array elements number 32, defined below for the user-defined C force element module.

```

DATA (NPTRS2(I),I=1,31) / 0, 0, 20, 6, 7,
&                        10, 14, 11, 2, 19,
&                        9, 2, 11, 1, 6,
&                        10, 11, 13, 10, 0,
&                        7, 9, 4, 8, 6,
&                        0, 0, 0, 0, 0,
&                        0 /
DATA (NPTRS2(I),I=33,50) / 16*0, 14, 6 /

DATA (NPTRS3(I),I=1,31) / 0, 0, 65, 19, 21,
&                        36, 36, 37, 36, 43,
&                        26, 3, 37, 1, 36,
&                        36, 37, 36, 37, 0,
&                        39, 37, 36, 36, 0,
&                        0, 0, 0, 0, 0,
&                        30 /
DATA (NPTRS3(I),I=33,50) / 11*0, 62, 4*0, 40, 10 /

DATA (MPTRS2(I),I=1,31) / 0, 0, 10, 3, 2,
&                        5, 5, 3, 3, 7,
&                        6, 3, 3, 1, 4,
&                        4, 4, 3, 5, 0,
&                        3, 3, 3, 4, 3,
&                        0, 0, 0, 0, 21,
&                        0 /
DATA (MPTRS2(I),I=33,50) / 16*0, 6, 4 /

DATA (MPTRS3(I),I=1,31) / 0, 0, 10, 3, 2,
&                        5, 5, 5, 5, 7,
&                        7, 3, 5, 1, 5,

```

```

&          5, 6, 3, 3, 0,
&          4, 3, 3, 3, 0,
&          0, 0, 0, 0, 21,
&          7
DATA (MPTRS3(I),I=33,50) / 11*0, 6, 4*0, 8, 5 /

```

C---Initialization of variables in the RCDNUM common block, except for
C array elements number 32, defined below for the user-defined
C force element module.

```

DATA (REC2D(I),I=1,31) / 0, 4, 5, 2,
&          3, 3, 3, 4,
&          2, 5, 3, 2,
&          4, 0, 3, 2,
&          4, 4, 3, 0,
&          2, 3, 2, 3,
&          3, 2, 1, 1,
&          1, 0, 0 /
DATA (REC2D(I),I=33,50) / 16*0, 5, 3 /

```

```

DATA (REC3D(I),I=1,31) / 0, 4, 9, 4,
&          5, 7, 7, 8,
&          7, 9, 3, 2,
&          8, 0, 7, 7,
&          8, 7, 8, 0,
&          8, 8, 7, 7,
&          0, 2, 1, 1,
&          1, 0, 6 /
DATA (REC3D(I),I=33,50) / 2, 10*0, 10, 4*0, 9, 5 /

```

C---Initialization of variables in the STEPS common block.

```

DATA G(1), G(2) / 1.0, 0.5 /
DATA SIG(1) / 1.0 /

```

C---Initialization of variables in the TIMING common block.

```

DATA DOTIME / .FALSE. /

```

C
C-----
C
C---Initialization of variables required for implementation of a user-
C defined force element module.
C
C-----

C---NPTRS2(32) defines the number of real (double precision) data
C stored for each user-defined force element in DADS-2D.

```

DATA NPTRS2(32) / 0 /

```

C---NPTRS3(32) defines the number of real (double precision) data
C stored for each user-defined force element in DADS-3D.

C * * * * *
C * * * * *

USER MODIFICATION

The value of NPTR32(32) for this problem has been changed from
a 0 to a 9.

DATA NPTRS3(32) / 9 /

C---MPTRS2(32) defines the number of integer data stored for each user-
C defined force element in DADS-2D.

DATA MPTRS2(32) / 0 /

C---MPTRS3(32) defines the number of integer data stored for each user-
C defined force element in DADS-3D.

DATA MPTRS3(32) / 0 /

C---REC2D(32) defines the number of records in the input file for each
C user-defined force element in DADS-2D.

DATA REC2D(32) / 1 /

C---REC3D(32) defines the number of records in the input file for each
C user-defined force element in DADS-3D.

C * * * * *
C * * * * *

USER MODIFICATION

The value of REC3D(32) for this problem has been changed from
a 1 to a 4.

DATA REC3D(32) / 4 /

END

RPT32_3D.FOR

This routine allows the user to output additional data that is calculated by their force calculation routine FRC32_3D. Most of this routine is a vendor supplied template, the user's modifications appear at its end and are designated as such.

C RPT32: Reports user-defined force data at each output time step (3D).

C-----Author and Modification Section-----

C

C Author: Chuck Mead

C

C Date written: December 5, 1985

C

C Modifications:

C

C Copyright (c) CADSI 1985

C

C-----

C-----Algorithm Description-----

C

C Purpose and use:

C This subroutine reports any data associated with the user-defined force elements in the model. Any of the various input arguments for this subroutine can be reported or used to calculate reported values. The output data can be written to the standard DADS ASCII output file (FORTRAN file unit OUTPF) or to some other user-defined output file(s). The function GETNAM can be used to convert an element number into the corresponding element name for writing out to the output file(s). This function can be used to retrieve the name of each user-defined force element processed if the first input record of each user-defined force element contains such a name in columns 11 through 30.

C The various input arguments are described and declared in three separate groups: read-only arguments, arguments read and modified, and return-only arguments.

C Read-only arguments are passed in with meaningful values which should not be changed within this subroutine. This constitutes the largest group of arguments passed. Consult the documentation on user-defined force elements for a description of the structure and contents of the various variables and arrays passed in.

C Arguments read and modified are also passed in with meaningful values which may be changed within this subroutine. There are no read-and-modify arguments passed to RPT32.

C The final group of arguments, return-only arguments, are passed in with unknown values and should therefore be assigned some value within this subroutine before they are used in any other computation. The only variable in this group is ERRCOD. Since this variable's value is used in the calling routine to determine the success of the computations performed in RPT32, it is suggested that ERRCOD be initialized to zero before beginning any other

```

C      computations.
C
C      Error conditions:
C      Error conditions are reported via the variable ERRCOD. A zero
C      value indicates no error; a positive value indicates some fatal
C      error, i.e., files will be closed and execution aborted upon
C      return to the calling routine; negative values are reserved for
C      future use.
C
C      Machine dependencies: none known
C
C-----

```

```

      SUBROUTINE RPT32 ( UDF, IUDF, NUDF, NPTRS, MPTRS, TIME,
&                      Q, QD, QDD, XQ, XQD, XQDD, NXCRD, FRC,
&                      XFRC, RB, NRB, NPRB, NTYPES, NELEMS,
&                      INFOF, OUTPF, BODMOD, ERRCOD )

```

```

C-----Variable Descriptions-----
C
C---Read-only arguments-----
C
C      UDF.....Array of real (double precision) data for all user-
C              defined force elements in the model.
C      IUDF.....Array of integer data for all user-defined force elements
C              in the model.
C      NUDF.....Number of user-defined force elements in the input data.
C              (This variable has a minimum value of 1 for array dec-
C              laration purposes.)
C      NPTRS....Number of real (double precision) data stored for each
C              user-defined force element. (This variable has a minimum
C              value of 1 for array declaration purposes.)
C      MPTRS....Number of integer data stored for each user-defined force
C              element. (This variable has a minimum value of 1 for
C              array declaration purposes.)
C      TIME.....Current time in the model simulation.
C      Q.....Array of displacement values for all rigid body coor-
C              dinates in the model.
C      QD.....Array of velocities of all rigid body coordinates.
C      QDD.....Array of accelerations of all rigid body coordinates.
C      XQ.....Array of displacement values for all extra generalized
C              coordinates in the model.
C      XQD.....Array of velocities of all extra generalized coordinates.
C      XQDD.....Array of accelerations of all extra generalized coor-
C              dinates.
C      NXCRD....Number of extra generalized coordinates in the model.
C              (This variable has a minimum value of 1 for array dec-
C              laration purposes.)
C      FRC.....Array of forces for each rigid body coordinate in the
C              model.
C      XFRC.....Array of forces for each extra generalized coordinate in
C              the model.
C      RB.....Array of real (double precision) data for each rigid body
C              in the model.
C      NRB.....Number of rigid bodies in the model.
C      NPRB.....Number of real (double precision) data stored for each
C              rigid body in the model.
C      NTYPES...Number of different element types available in DADS.
C      NELEMS...Number of occurrences of each element type in the model.
C      INFOF....FORTRAN file unit number for the DADS information file.

```

```

C          Error, warning, or other informational messages can be
C          written to this file if so desired.
C      OUTPF...FORTRAN file unit number for the standard DADS ASCII
C          output file.
C      BODMOD...Element type number of the rigid body module.  Can be
C          used to map body numbers to body names via the GETNAM
C          function.
C
C          INTEGER  NUDF, NPTRS, MPTRS, IUDF(MPTRS,NUDF), NXCRD, NRB, NPRB,
C          &          NTYPES, NELEMS(NTYPES), INFOF, OUTPF, BODMOD
C
C          DOUBLE PRECISION  UDF(NPTRS,NUDF), TIME, Q(7,NRB), QD(7,NRB),
C          &                  QDD(7,NRB), XQ(NXCRD), XQD(NXCRD), XQDD(NXCRD),
C          &                  FRC(7,NRB), XFRC(NXCRD), RB(NPRB,NRB)
C
C-----Arguments read and modified-----
C      none
C
C-----Return-only arguments-----
C
C      ERRCOD...Error condition flag.
C
C          INTEGER  ERRCOD
C
C-----COMMON blocks-----
C      none
C
C-----Local variables-----
C      none
C
C-----Functions and subroutines-----
C
C      GETNAM...Given the element type number (i.e., module number) and
C          the element number, this function returns the element
C          name.  A blank function value means that either or both
C          of the input values are invalid.
C
C          EXTERNAL  GETNAM
C
C          CHARACTER*20  GETNAM
C
C-----DATA statements-----
C      none
C
C=====

```

```

C#####
C#####

```

U S E R M O D I F A C A T I O N

```

common /fric/ friction, velocity, accel, ext_torque
double precision friction, velocity, accel, ext_torque
save /fric/

```

```

C-----Process Block-----

```



```

C---First zero out the error condition flag to indicate that no errors
C   have occurred yet.

```

```

ERRCOD = 0

```

```

1  write (11, '(5(2x, pe12.5))')
    time, friction, velocity, accel, ext_torque

```

```

C # # # # # # # # # # # # # # # # # # # # # # # # # # # # # # # # #
C# # # # # # # # # # # # # # # # # # # # # # # # # # # # # # # # #

```

```

RETURN
END

```

PART NUMBER: 12585721-5724, Walking Beam (Wheel) Actuators

DESCRIPTION: WALKING BEAM ACTUATORS

STATUS:

All functional and dimensional requirements have been determined by FMC for each of the four wheel (walking beam) actuators and based on this information, York has completed preliminary drawings (TDP, Dwgs. 12585721-12585724).

It should be noted that the rear actuators are designed to not only lift the rear of the LTHD off the ground during routine displacement but can lift a "stuck" spade out of muddy ground as well.

Also note that the wheel actuators are designed to act as "shock absorbers" in the LTHD's travel mode and will allow the walking beams to walk freely. If the LTHD encounters a large obstacle at a high speed, however, the limited flow rate of the cylinders may cause the shock absorbing system to be unnecessarily stiff and decrease towing stability. Possible solutions to this problem are listed in this section.

AUTHOR: Jeff Ireland, Scott Dacko

WHEEL ACTUATORS

87-2-6

FRONT ACTUATOR

EXTEND LENGTH = 40.719"
 RETRACT LENGTH = 25.243"
 STROKE = 15.476"

REAR ACTUATOR

EXTEND LENGTH = 38.088"
 RETRACT LENGTH = 25.278"
 STROKE = 12.810"

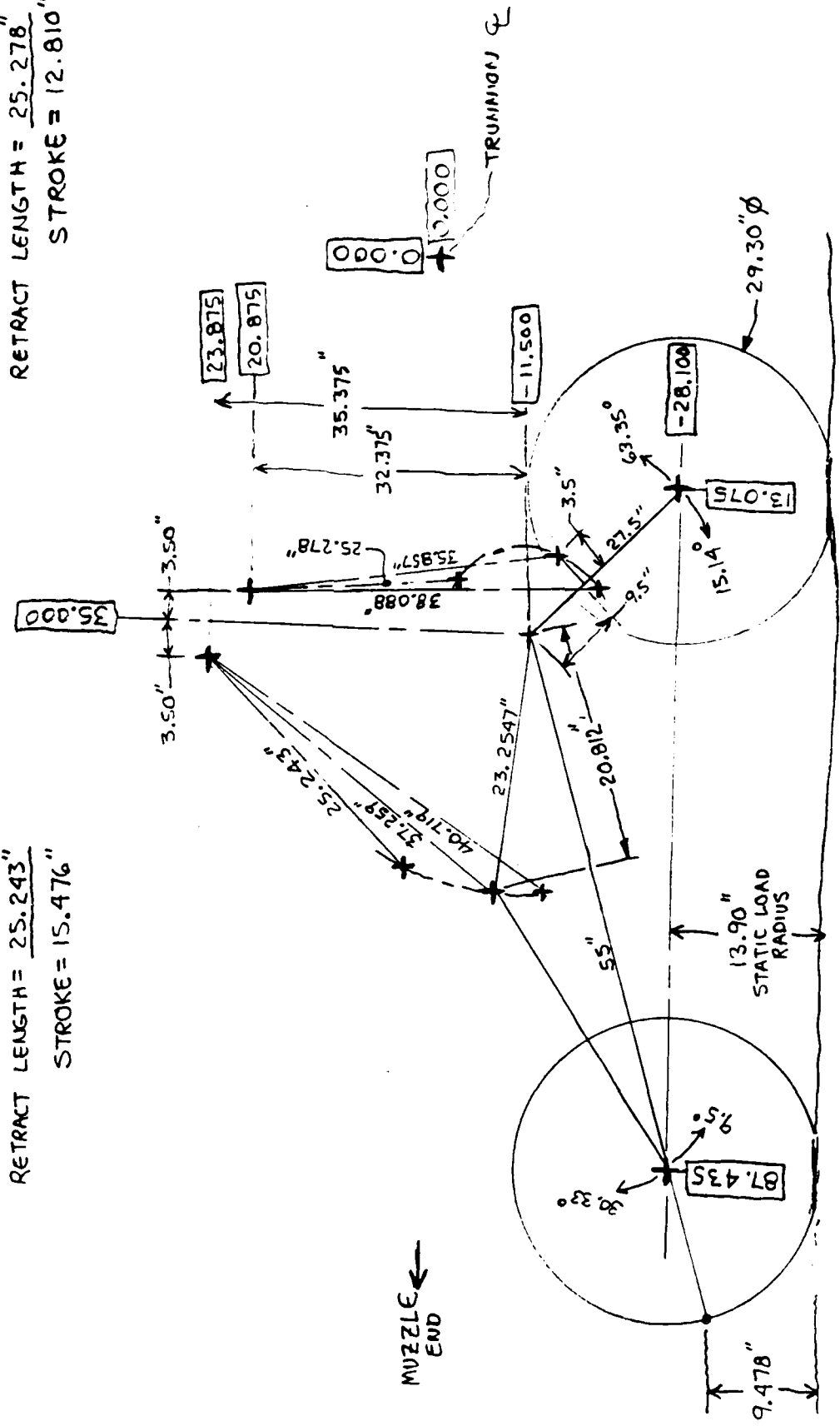

MUZZLE
END

86-1-18
87-1-19

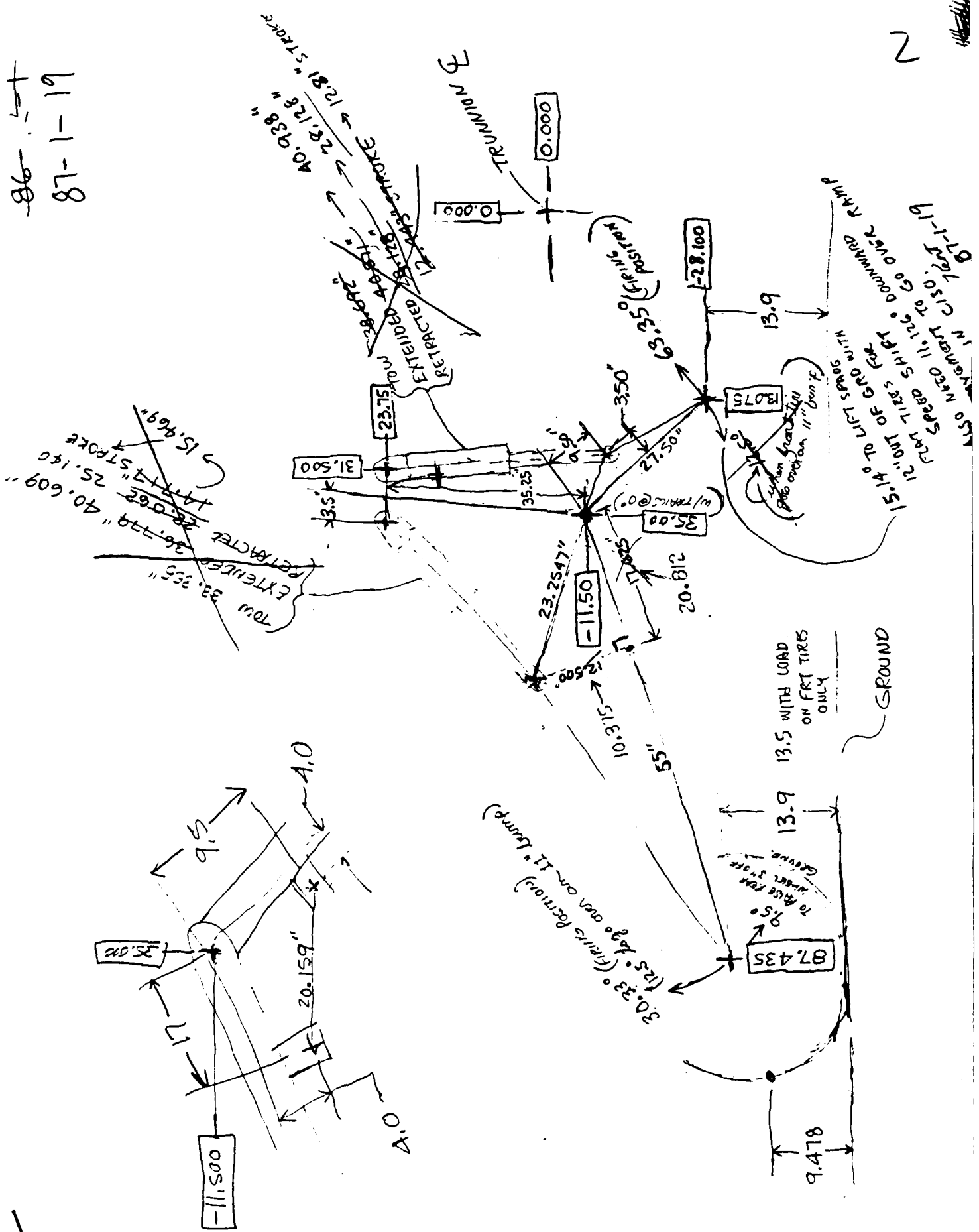

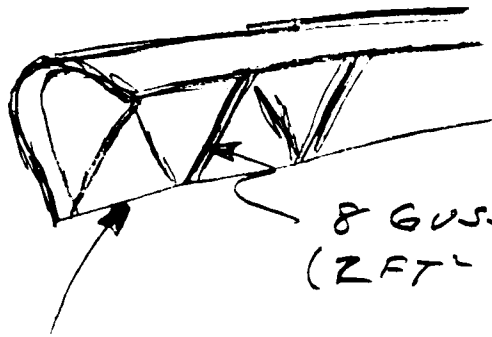
SPADE WITHDRAWAL FORCES1/28/87
J.A.8 GUSSETS
(2 FT² SURFACE AREA)BLADE
(18 FT² SURFACE AREA)34 FT² TOTAL SURFACE AREA

$$F = c A_1 + f A_2$$

A₁ = FRICTIONAL AREA OF BLADE & GUSSETSA₂ = SHEAR AREA OF SOILc = COHESION FORCE = 180 #/FT²f = SHEAR UNIT FORCE = 500 #/FT²

$$F = 180(34) + 500(9) = 10620 \#$$

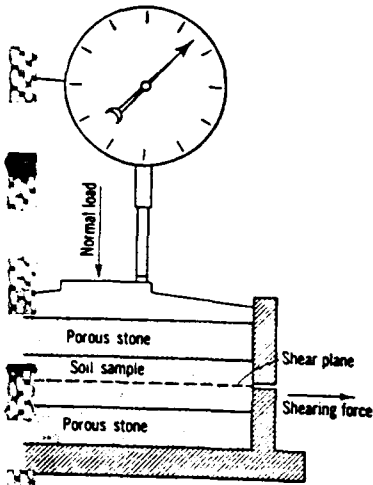

atus for Direct Shear Test

of failure of the sample along the
 required to produce continuous move-
 length of the specimen under the
 is test.
 maximum applied shearing force
 at the shear plane gives the
 ss failure of the sample. These
 gram like that in Fig. 18-6. The
 int on the graph representing the
 th. In order to obtain sufficient
 tional tests must be performed on
 rates of the first. The procedure in
 the first, except that a different
 generalization, the plotted points
 ure of the various specimens will
 there will be deviations due to
 niformity of the specimens. Also,
 e clay soils in the undrained test,
 en normal stress and shearing
 ecially at low values of normal
 practice to draw the best straight
 the Coulomb graph and equation
 ction angle and cohesion can be

panying data were obtained in tests
 glacial drift. Determine the cohesion

4

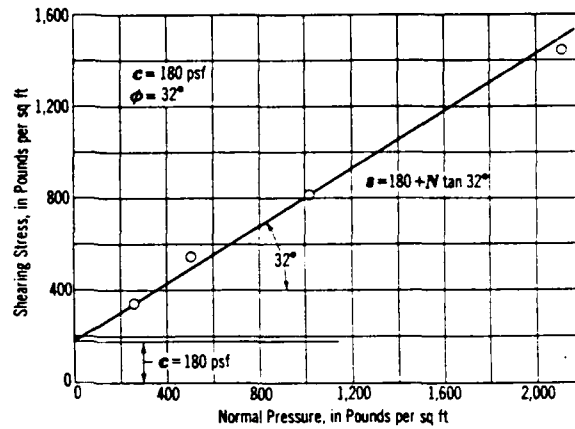

Fig. 18-8. Shear Diagram for Example 18-1

Specimen No.	Failure Stresses, in Pounds per sq ft	
	Normal Load	Shearing Force
1	255	345
2	505	550
3	1010	820
4	2080	1450

Solution: The data are plotted on the shear diagram in Fig. 18-8. A straight line through the plotted points makes an angle of 32° with the horizontal, and the intercept on the vertical axis represents 180 psf. Therefore, the shearing strength properties of the soil are designated as $c = 180$ psf and $\phi = 32^\circ$.

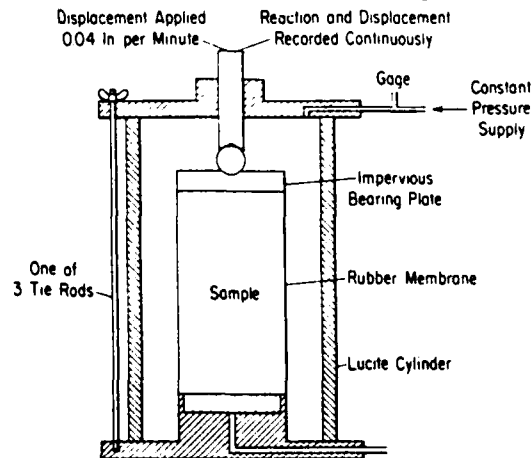
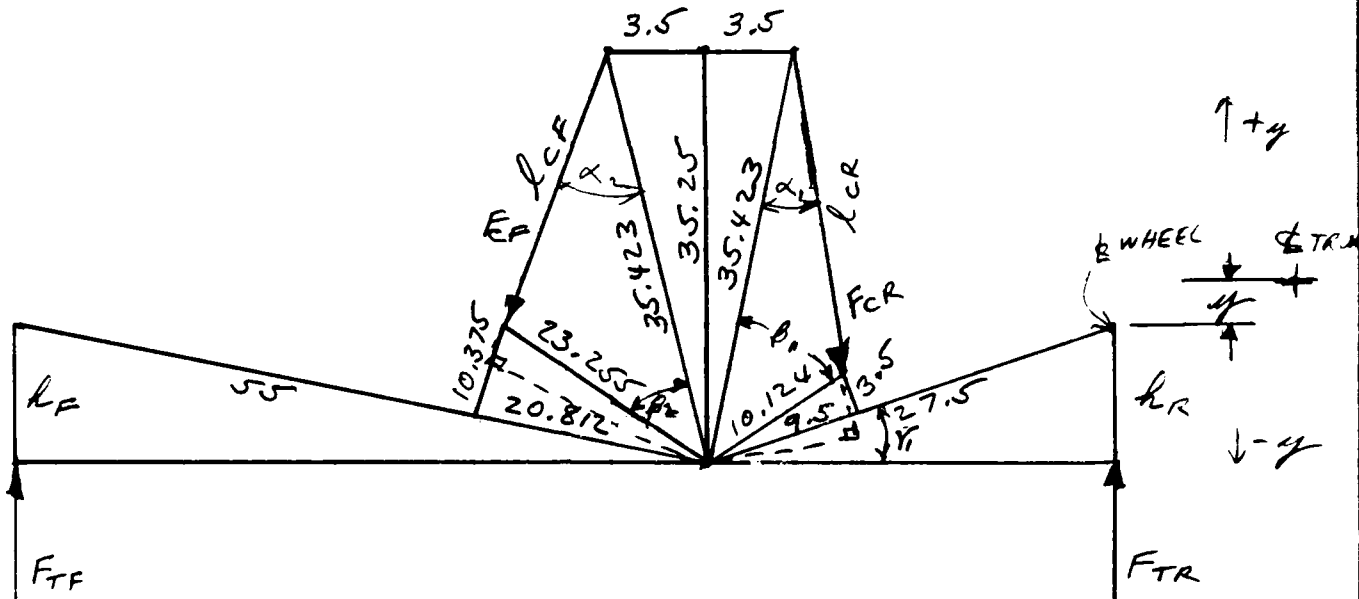

Fig. 18-9. Schematic Diagram of Triaxial Compression Device

SOIL ENGINEERING 2ND EDITION
 M.G. SPANGLER
 INTERNATIONAL TEXTBOOK COMPANY

WALKING BEAM CYLINDER/TIRE REACTIONS



$$F_{CR} (35.423) \sin \alpha_1 = F_{TR} (27.5) \cos \gamma_1$$

$$\cos \beta_1 = \frac{(35.423)^2 + (10.124)^2 - l_{CR}^2}{2(35.423)(10.124)} = \frac{1357.28 - l_{CR}^2}{717.24}$$

$$\cos \alpha_1 = \frac{(35.423)^2 + l_{CR}^2 - (10.124)^2}{2(35.423)l_{CR}} = \frac{1152.29 + l_{CR}^2}{70.85 l_{CR}}$$

$$\gamma_1 = 90 - \tan^{-1} \frac{3.5}{35.25} - \beta_1 - \tan^{-1} \frac{3.5}{9.5} = 64.105 - \beta_1$$

$$\frac{F_{CR}}{F_{TR}} = \frac{27.5 \cos (64.105 - \beta_1)}{35.423 \sin \alpha_1} = \frac{.7763 \cos (64.105 - \beta_1)}{\sin \alpha_1}$$

$$\cos \beta_2 = \frac{(35.423)^2 + (23.255)^2 - l_{CF}^2}{2(35.423)(23.255)} = \frac{1795.58 - l_{CF}^2}{1647.52}$$

$$\cos \alpha_2 = \frac{(35.423)^2 - (23.255)^2 + l_{CF}^2}{2(35.423)l_{CF}} = \frac{713.99 + l_{CF}^2}{70.85 l_{CF}}$$

$$\gamma_2 = 90 - \tan^{-1} \frac{3.5}{35.25} - \beta_2 - \tan^{-1} \frac{10.375}{20.812} = 57.833 - \beta_2$$

$$\frac{F_{CF}}{F_{TF}} = \frac{55 \cos (57.833 - \beta_2)}{35.423 \sin \alpha_2} = \frac{1.5527 \cos (57.833 - \beta_2)}{\sin \alpha_2}$$

<u>Lc</u>	<u>F_{CR}/F_{TR}</u>	<u>y_R</u>	<u>F_{CF}/F_{TE}</u>	<u>y_F</u>
25.469	7.0965	11.08	2.3172	-0.11
25.5	6.6789	10.87	2.3177	-.18
26.5	3.8085	6.20	2.3332	-2.51
27.5	3.3065	2.68	2.3489	-4.85
28.5	3.0784	-.51	2.3642	-7.21
29.5	2.9462	-3.52	2.3790	-9.58
30.5	2.8586	-6.42	2.3928	-11.96
31.5	2.7946	-9.25	2.4055	-14.36
32.5	2.7433	-12.02	2.4168	-16.77
33.5	2.6982	-14.74	2.4264	-19.20
34.5	2.6547	-17.42	2.4342	-21.63
35.5	2.6094	-20.05	2.4398	-24.06
36.5	2.5587	-22.64	2.4430	-26.51
37.5	2.4990	-25.17	2.4434	-28.95
38.5	2.4257	-27.64	2.4409	-31.39
39.5	2.3323	-30.02	2.4349	-33.83
40.5	2.2091	-32.30	2.4251	-36.26
40.938	2.1417	-33.25	2.4195	-37.32



$\theta = 37.13$
 $y = -11.5 - 27.5 \sin \theta = -28.1$

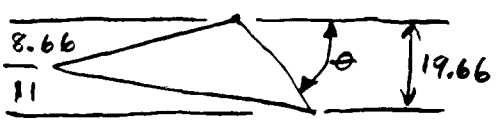

$\theta = 37.13 + \sin^{-1} \frac{11}{74.36} = 45.637$
 $y_R = -11.5 - 27.5 \sin \theta = -31.16$ *1A
 $y_F = y_R + 11 = -20.16$

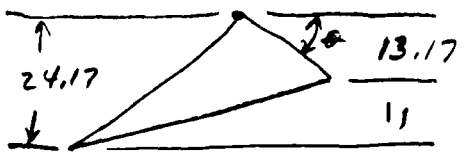

$\theta = 37.13 - \sin^{-1} \frac{11}{74.36} = 28.623$
 $y_R = -11.5 - 27.5 \sin \theta = -24.67$
 $y_F = y_R - 11 = -35.67$ *MA

$y_R (REQ.) = 0 \approx -31.16$
 $L_{CR} (REQ.) = 28.32 \approx 40$ (11.68 stroke) 12

$y_F (REQ.) = 0 \approx -35.67$
 $L_{CF} (REQ.) = 25.42 \approx 40.26$ (14.84 stroke) 15

REVISED

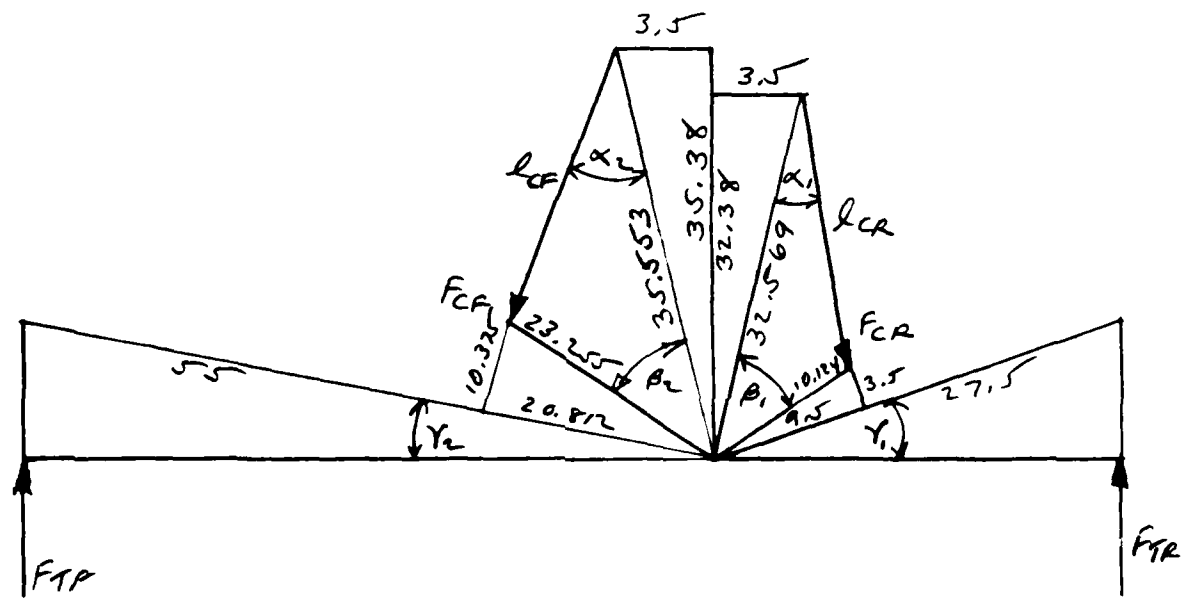

$$\cos \beta_1 = \frac{1163.24 - l_{CP}^2}{659.46}$$

$$\cos \alpha_1 = \frac{958.24 + l_{CP}^2}{65.138 l_{CP}}$$

$$Y_1 = 63.606 - \beta_1$$

$$\frac{F_{CR}}{F_{TR}} = .8444 \frac{\cos Y_1}{\sin \alpha_1}$$

$$\cos \beta_2 = \frac{1804.81 - l_{CF}^2}{1653.57}$$

$$\cos \alpha_2 = \frac{723.22 + l_{CF}^2}{71.106 l_{CF}}$$

$$Y_2 = 57.854 - \beta_2$$

$$\frac{F_{CF}}{F_{TP}} = 1.547 \frac{\cos Y_2}{\sin \alpha_2}$$

rear cyl.

retracted	25.5
extended	37.5
stroke	12.0

front cyl.

retracted	25.5
extended	40.5
stroke	15.0

<u>Lc</u>	<u>F_{CR}/F_{TR}</u>	<u>Y_R</u>	<u>F_{CR}/F_{TE}</u>	<u>Y_R</u>
25.5	3,0754	-.02	2,3166	.07
26.5	2,9402	-3.02	2,3318	-2.26
27.5	2,8542	-5.92	2,3472	-4.60
28.5	2,7935	-8.74	2,3623	-6.95
29.5	2,7463	-11.51	2,3769	-9.32
30.5	2,7057	-14.23	2,3907	-11.71
31.5	2,6669	-16.92	2,4033	-14.10
32.5	2,6262	-19.57	2,4146	-16.51
33.5	2,5801	-22.17	2,4243	-18.93
34.5	2,5251	-24.72	2,4321	-21.36
35.5	2,4564	-27.22	2,4378	-23.80
36.5	2,3681	-29.63	2,4411	-26.24
37.5	2,2505	-31.94	2,4418	-28.68
38.5			2,4395	-31.12
39.5			2,4339	-33.56
40.5			2,4245	-35.98

2-3-87
J.T.'9

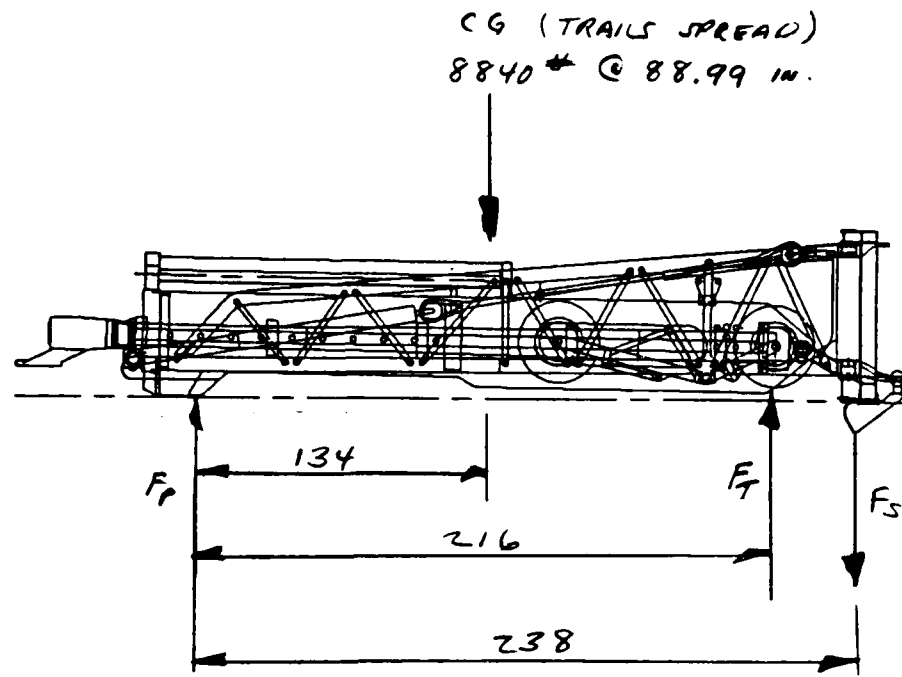

$$F_s = 10620 \#$$

$$F_T = \frac{10620(238) + 8840(134)}{216} = 17186 \#$$

$$F_T = 8593 \# / \text{TIRE}$$

$$F_p = 8840 + 10620 - 17186 = 2274 \#$$

F_{CR} = FORCE ON REAR CYLINDER TO BREAK OUT SPADE

$$F_{CR} = 2.9 F_T = 24920 \# / \text{CYLINDER}$$

2-3-87
J.T. 10

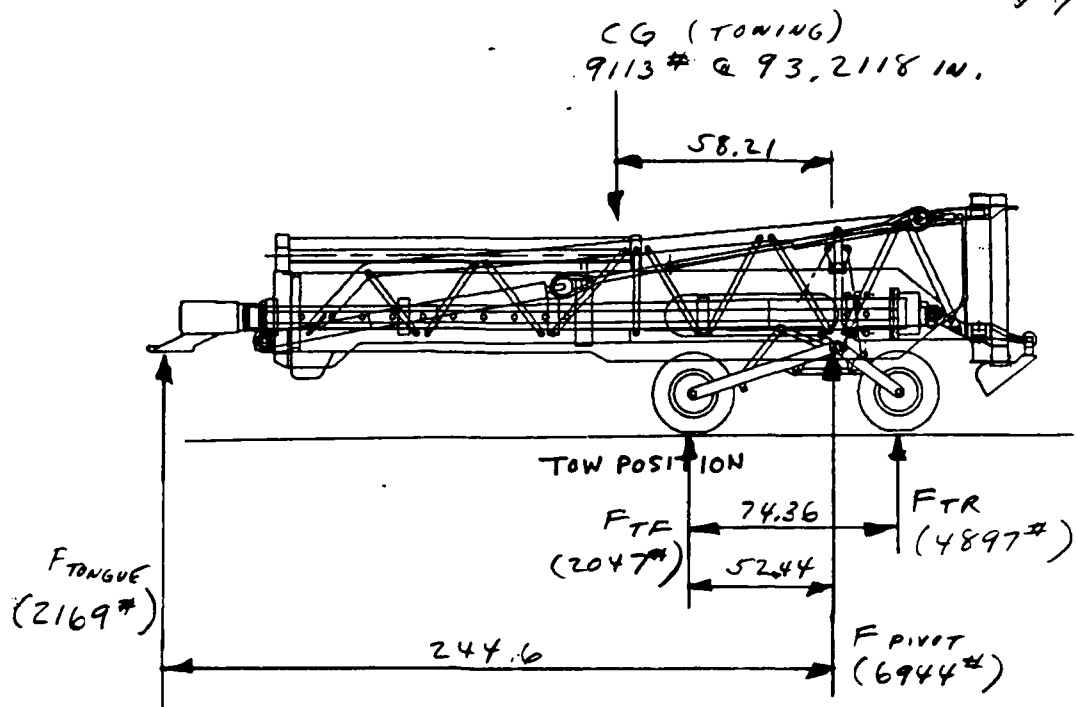

$$F_{PIVOT} = \frac{9113(244.6 - 58.21)}{244.6} = 6944\#$$

$$F_{TONGUE} = 9113 - 6944 = 2169\#$$

$$F_{TR} = \frac{6944(52.44)}{74.36} = 4897\# \quad (2449\#/\text{TIRE})$$

$$F_{TA} = 6944 - 4897 = 2047\# \quad (1023\#/\text{TIRE})$$

WALKING BEAM MOTION

J. V.
2/15/87

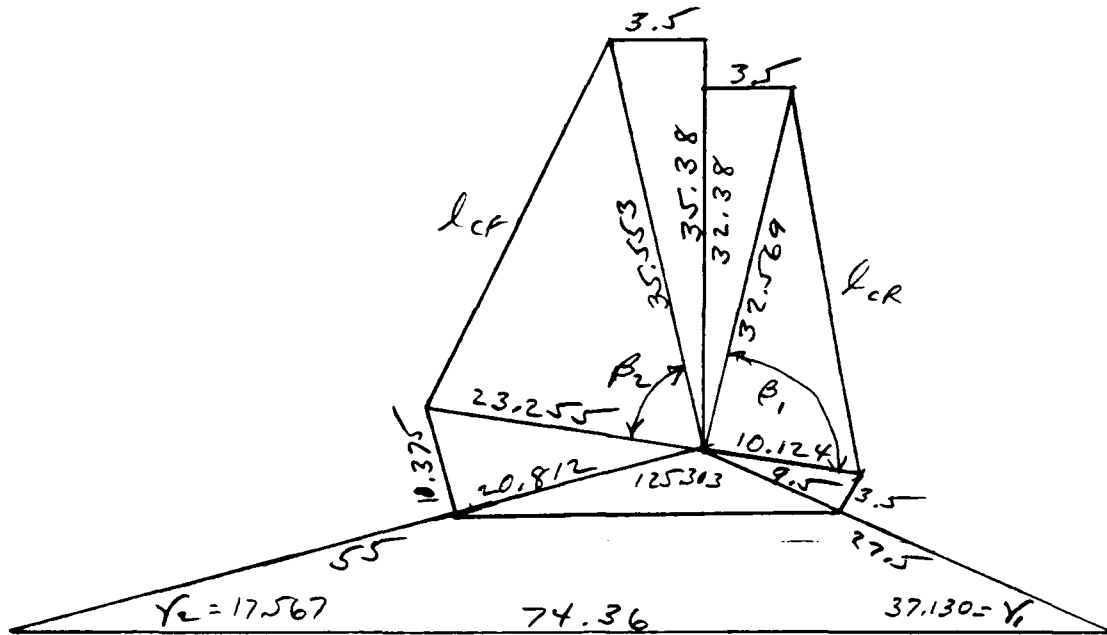

$$\beta_1 + \beta_2 = 360 - \tan^{-1} \frac{3.5}{35.38} - \tan^{-1} \frac{3.5}{32.38} - \tan^{-1} \frac{3.5}{9.5} - \tan^{-1} \frac{10.375}{20.812} - 180 + \gamma_1 + \gamma_2$$

$$\beta_1 + \beta_2 = 121.46 + \gamma_1 + \gamma_2 = 176.157$$

$$\beta_1 = \cos^{-1} \left[\frac{(32.569)^2 + (10.124)^2 - l_{cf}^2}{2(32.569)(10.124)} \right] = \cos^{-1} \left[\frac{1163.235 - l_{cf}^2}{659.457} \right]$$

$$\beta_2 = \cos^{-1} \left[\frac{(35.553)^2 + (23.255)^2 - l_{cf}^2}{2(35.553)(23.255)} \right] = \cos^{-1} \left[\frac{1804.811 - l_{cf}^2}{1653.57} \right]$$

$$\cos^{-1} \left[\frac{1163.235 - l_{cf}^2}{659.457} \right] = 176.157 - \cos^{-1} \left[\frac{1804.811 - l_{cf}^2}{1653.57} \right]$$

$$\frac{1163.235 - l_{cf}^2}{659.457} = \cos 176.157 \left[\frac{1804.811 - l_{cf}^2}{1653.57} \right] + \sin 176.157 \sin \cos^{-1} \left[\frac{1804.811 - l_{cf}^2}{1653.57} \right]$$

$$1163.235 - l_{cf}^2 = -718.155 + .398 l_{cf}^2 + 44.199 \sin \cos^{-1} \left(1.0915 - \frac{l_{cf}^2}{1653.57} \right)$$

$$l_{cf}^2 = 1881.39 - .398 l_{cf}^2 - 44.199 \sin \cos^{-1} \left(1.0915 - \frac{l_{cf}^2}{1653.57} \right)$$

J.F.V.
2/5/87

$R_{10} = 100.736$

$l_{CR0} = (1163.24 - 659.46 \cos \beta_{10})^{1/2} = 35.862$

$R_{20} = 75.421$

$l_{CF0} = (1854.81 - 1653.57 \cos \beta_{20})^{1/2} = 37.264$

$\beta_1 = 100.736 \pm \sin^{-1}(\mu_{BUMP} / 74.36)$

$\beta_2 = 75.421 \pm \sin^{-1}(\mu_{BUMP} / 74.36)$

<u>y</u>	<u>l_{CR1}</u>	<u>ΔR1</u>	<u>l_{CR2}</u>	<u>ΔR2</u>	<u>l_{CF1}</u>	<u>ΔF1</u>	<u>l_{CF2}</u>	<u>ΔF2</u>
0	35.862	0	35.862	0	37.264	0	37.264	0
1	35.983	.12	35.740	-.12	36.974	-.29	37.552	.29
2	36.104	.24	35.618	-.24	36.684	-.58	37.839	.57
3	36.223	.36	35.494	-.37	36.392	-.87	38.125	.86
4	36.342	.48	35.370	-.49	36.099	-1.17	38.409	1.15
5	36.461	.60	35.246	-.62	35.804	-1.46	38.693	1.43
6	36.578	.72	35.120	-.74	35.508	-1.76	38.975	1.71
7	36.695	.83	34.994	-.87	35.211	-2.05	39.257	1.99
8	36.811	.95	34.866	-1.00	34.912	-2.35	39.537	2.27
9	36.927	1.07	34.739	-1.12	34.611	-2.65	39.816	2.55
10	37.042	1.18	34.610	-1.25	34.310	-2.95	40.095	2.83
11	37.156	1.29	34.480	-1.38	34.006	-3.26	40.372	3.11
* 12	37.270	1.41	34.350	-1.51	33.701	-3.56	40.648	3.38

3.00 O.D. R00

2.50 I.D. R00

2.25 O.D. R00

1.75 I.D. R00

*

+3.05 IN³

-3.26 IN³

-5.59 IN³

+5.31 IN³

6.31 IN³
(2.50 DIA. X 1.28 LG.)

10.90 IN³
(1.75 DIA. X 4.53 LG.)

L.J.V.
2-7-87

13

This device allows movement of a cylinder rod in an actuator over a limited range with no external flow or transfer of oil. This is accomplished with a shuttle spool having diameters sized to accommodate the internal differential flows.

This device or something similar is required on the LTHD to allow the walking beam to operate over bumps without generating excessive hydraulic flows through the control valves and connecting lines.

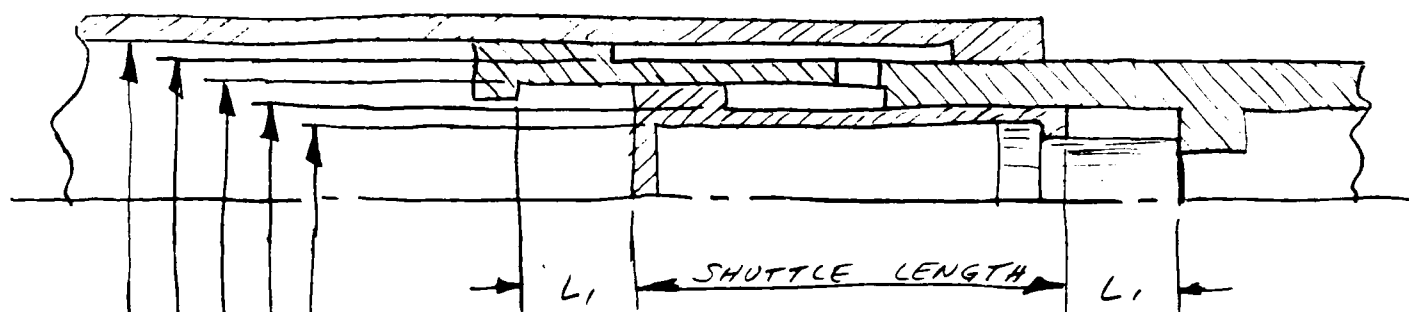

$D_5 = \text{ACCUMULATOR DIA.} = 2.25 \text{ DIA.}$
 $D_4 = \text{SPOOL BODY DIA.} = 2.538 \text{ DIA.}$
 $D_3 = \text{SPOOL O.D.} = 2.75 \text{ DIA.}$
 $D_2 = \text{ROD DIA.} = 3.00 \text{ DIA.}$
 $D_1 = \text{CYLINDER BORE} = 3.25 \text{ DIA.}$

$L_1 = \text{REQUIRED FREE TRAVEL OF PISTON IN EITHER DIRECTION FOR WALKING BEAM MOTION} = 2.00 \text{ IN.}$

J.H. 14
2-7-87

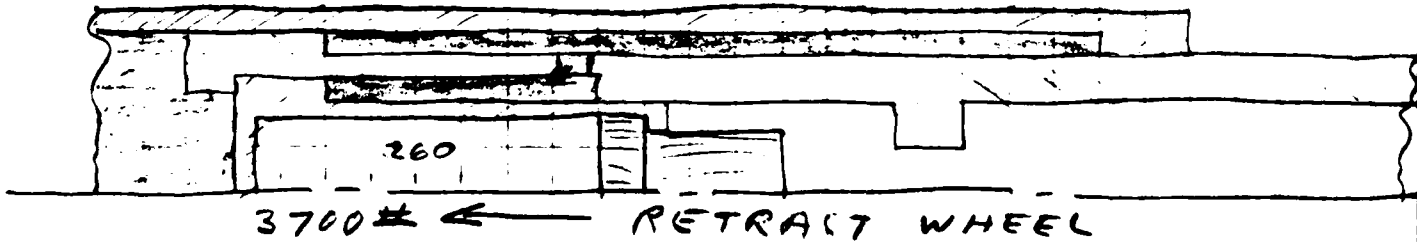
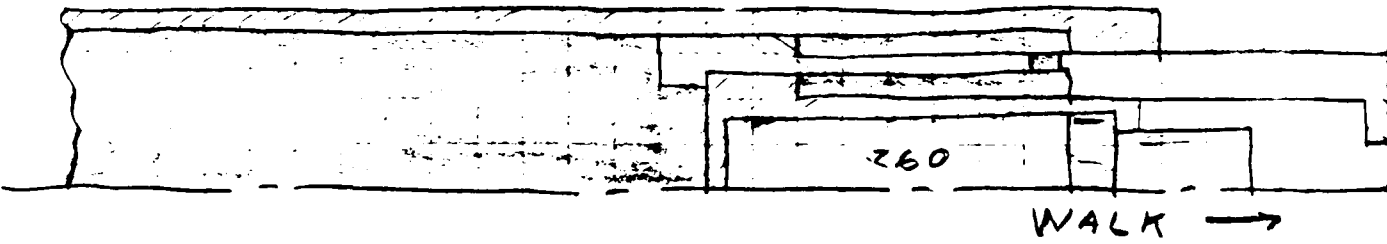
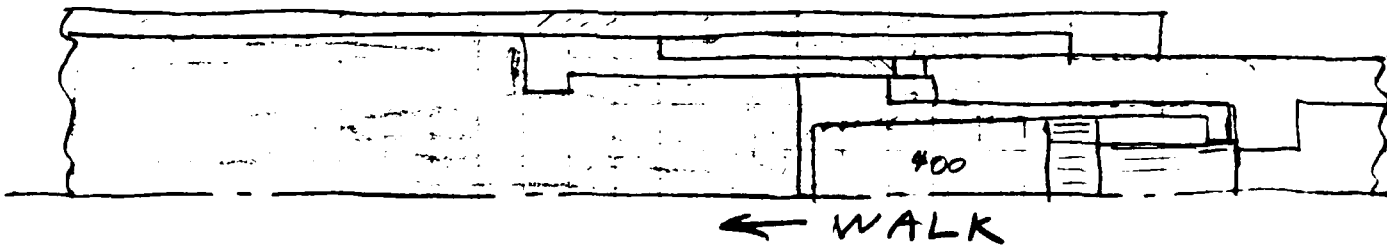
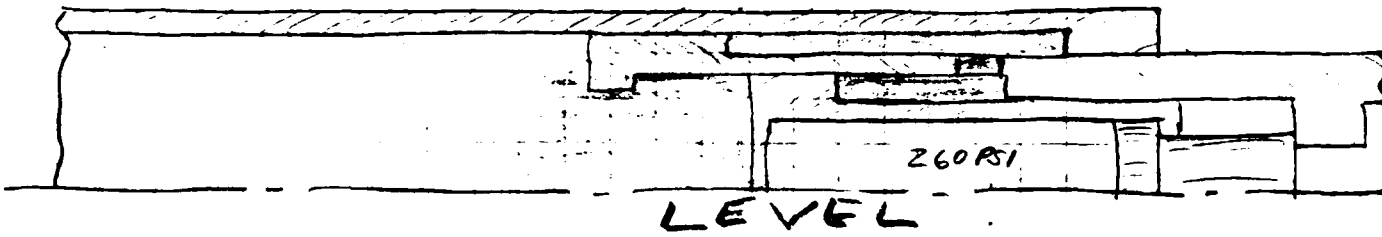
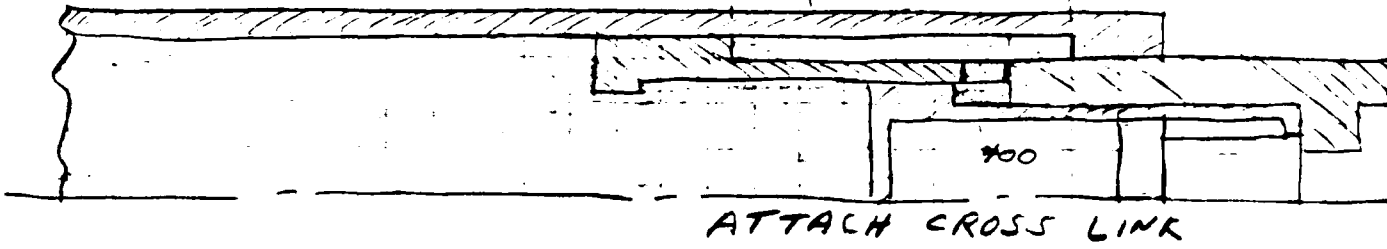
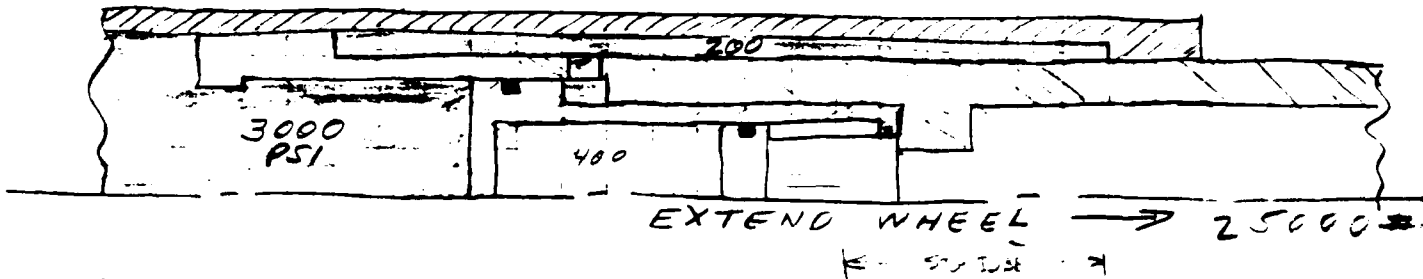

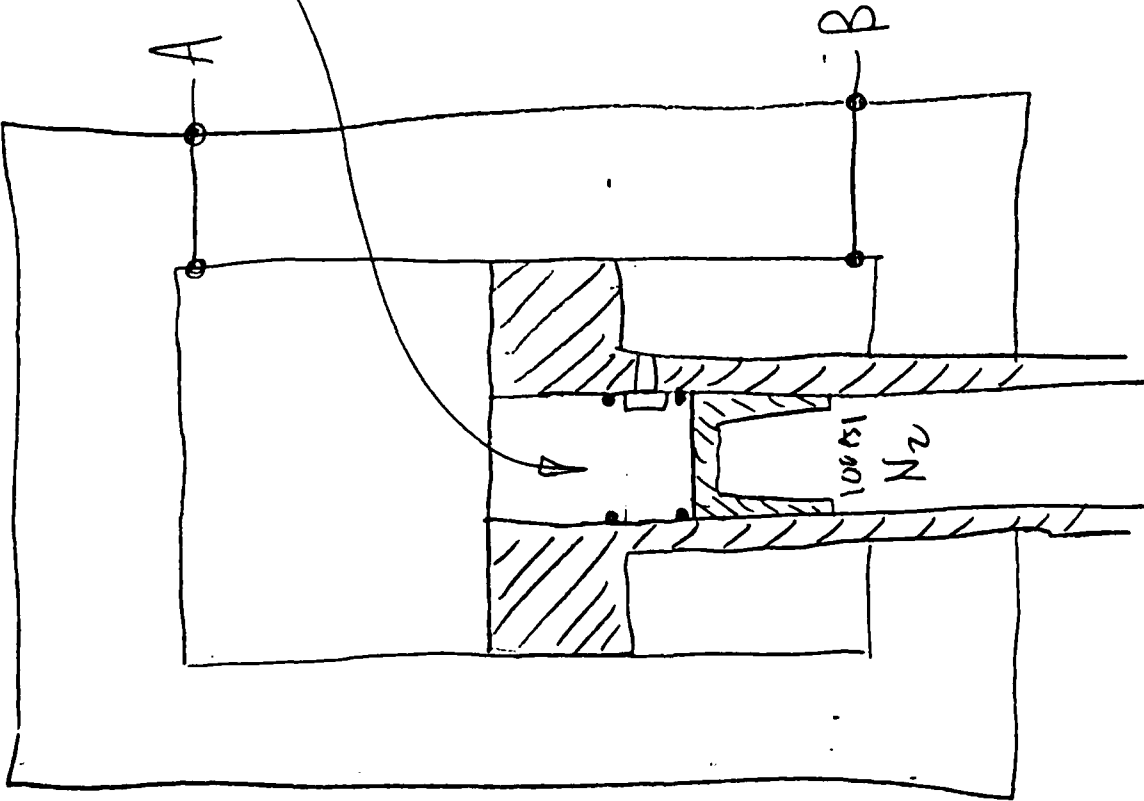

NORMALLY OPEN 1" VALVE BY
 YOAK OR MAROTTA. WHEN
 B IS PRESSURIZED, VALVE
 CLOSES & CONSERVES
 OIL.

	A	B	B IS PRESSURIZED FIRST
EXTEND	P	P	
RETRACT	P	R	
HOLD	LOCKED	LOCKED	
Tow	R	R	

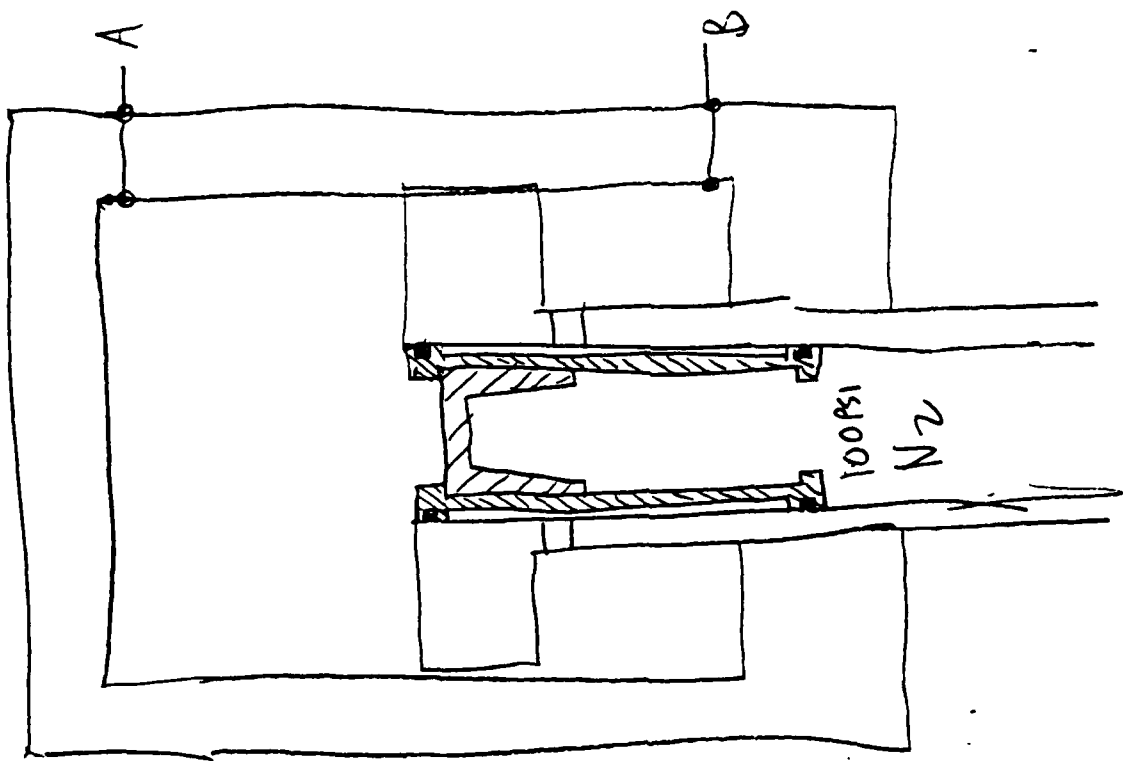

B IS PRESSURIZED FIRST,
APPLYING BEAR LOC TO
ACCUM PISTON.

	A	B
EXTEND	P	P
RETRACT	P	R
HOLD	LOCKED	LOCKED
TOW	R	R

END

10-87

DTIC