

AD-A103 201

VOUGHT CORP DALLAS TX
HYDRAULIC SYSTEM SEAL DEVELOPMENT. (U)
JUN 81 K E WHITFILL

F/G 1/3

DAAK51-78-C-0028

UNCLASSIFIED

USAAVRADCOM-TR-81-0-17

NL

1 of 2
AD-A
103 201



USAAVRADCOM-TR-81-D-17

AD A103201

LEVEL



12

HYDRAULIC SYSTEM SEAL DEVELOPMENT

Keith E. Whitfill
VOUGHT CORPORATION
P. O. Box 225907
Dallas, Tex. 75265

DTIC
AUG 24 1981
H

June 1981

Final Report for Period September 1978 - October 1980

Approved for public release;
distribution unlimited.

Prepared for
APPLIED TECHNOLOGY LABORATORY
U. S. ARMY RESEARCH AND TECHNOLOGY LABORATORIES (AVRADCOM)
Fort Eustis, Va. 23604

DTIC FILE COPY

31 8 21 1981

APPLIED TECHNOLOGY LABORATORY POSITION STATEMENT

This report has been reviewed by the Applied Technology Laboratory, US Army Research and Technology Laboratory (AVRADCOM), and is considered to be technically sound.

This research effort resulted from the need to reduce or eliminate leakage from hydraulic systems actuators used on military helicopters and other vehicles. Hydraulic fluid leakage has been a continuous and serious problem resulting in increased maintenance costs and in many cases unwarranted down time for helicopters.

This program was to investigate multiple cascaded seals and to develop new and improved seals and seal configurations for hydraulic systems and actuators, thereby favorably impacting hydraulic systems reliability, maintainability, safety, and cost by significantly reducing leakage.

Mr. George Fosdick of the Applied Aeronautics Technical Area, Aeronautical Systems Division, served as Project Engineer for this effort.

DISCLAIMERS

The findings in this report are not to be construed as an official Department of the Army position unless so designated by other authorized documents.

When Government drawings, specifications, or other data are used for any purpose other than in connection with a definitely related Government procurement operation, the United States Government thereby incurs no responsibility nor any obligation whatsoever, and the fact that the Government may have formulated, furnished, or in any way supplied the said drawings, specifications, or other data is not to be regarded by implication or otherwise as in any manner licensing the holder or any other person or corporation, or conveying any rights or permission, to manufacture, use, or sell any patented invention that may in any way be related thereto.

Trade names cited in this report do not constitute an official endorsement or approval of the use of such commercial hardware or software.

DISPOSITION INSTRUCTIONS

Destroy this report when no longer needed. Do not return it to the originator.

Unclassified

SECURITY CLASSIFICATION OF THIS PAGE (When Data Entered)

REPORT DOCUMENTATION PAGE		READ INSTRUCTIONS BEFORE COMPLETING FORM
1. REPORT NUMBER USAAVRADCOM, IR-81-D-17	2. GOVT ACCESSION NO. 4D-205-01	3. RECIPIENT'S CATALOG NUMBER
4. TITLE (and Subtitle) HYDRAULIC SYSTEM SEAL DEVELOPMENT	5. TYPE OF REPORT & PERIOD COVERED Final Report Sep 1978 - Oct 1980	
	6. PERFORMING ORG. REPORT NUMBER	
7. AUTHOR(s) Keith E. Whitfill	8. CONTRACT OR GRANT NUMBER(s) DAAK51-78-C-0028	
9. PERFORMING ORGANIZATION NAME AND ADDRESS Vought Corporation P. O. Box 225907 Dallas, Texas 75265	10. PROGRAM ELEMENT PROJECT, TASK AREA & WORK UNIT NUMBERS 62209A 1L162209AH7600 251 FK	
11. CONTROLLING OFFICE NAME AND ADDRESS Applied Technology Laboratory, U.S. Army Research and Technology Laboratories (AVRADCOM) Fort Eustis, Virginia 23604	12. REPORT DATE June 1981	
14. MONITORING AGENCY NAME & ADDRESS (if different from Controlling Office)	13. NUMBER OF PAGES 334	
	15. SECURITY CLASS. (of this report) Unclassified	
16. DISTRIBUTION STATEMENT (of this Report) Approved for public release; distribution unlimited.		
17. DISTRIBUTION STATEMENT (of the abstract entered in Block 20, if different from Report)		
18. SUPPLEMENTARY NOTES		
19. KEY WORDS (Continue on reverse side if necessary and identify by block number) Hydraulic Sealing Systems Rotor Feedback Test High Pressure Long Life Cascaded Seals Dynamic Testing Hydraulic System Reliability Multiple Seals Vented Seals Surface Finish Unvented Seals		
20. ABSTRACT (Continue on reverse side if necessary and identify by block number) The objectives of this program were to investigate multiple cascaded seals and to develop new and improved seals and seal configurations for hydraulic systems and actuators, thereby favorably impacting hydraulic systems reliability, maintainability, safety, and cost by significantly reducing leakage.		

FOREWORD

This report was prepared by the Vought Corporation division of LTV Inc., Dallas, Texas under U. S. Army Contract DAAK51-78-C-0028 with the Applied Technology Laboratory, U. S. Army Research and Technology Laboratory (AVRADCOM), Fort Eustis, Virginia. Mr. George Fosdick, Applied Aeronautics Technical Area, was Project Engineer.

The author expresses his appreciation to those individuals and companies who supplied materials or specimens for investigation.

Accession For	
NTIS CLASS	<input checked="" type="checkbox"/>
DTIC TAB	<input type="checkbox"/>
Unannounced	<input type="checkbox"/>
Justification	
By _____	
Distribution of _____	
Availability Codes	
Avail and/or	
Dist _____	

TABLE OF CONTENTS

	<u>Page</u>
INTRODUCTION.	8
TECHNICAL PROGRAM	9
Task I - Design Investigation.	9
Task II - Seal Design and Developmental Testing.	24
Task III - Testing	41
CONCLUSIONS	103
RECOMMENDATIONS	106
Appendix A - Task I Data	
Seal Evaluation Parameters.	110
Rod Finish Evaluation Parameters.	124
Seals Selected for Task II Test	128
Appendix B - Task II Data	
Task II Seals	130
Task II Seal Performance Summary.	134
Process Specification 208-1-7	151
Task III Test Plan.	157
Measured Critical Dimensions and Finishes	170
Appendix C - TASK III Data	
Task III Seal Performance Summary	185
Measured Critical Dimensions Before and After Task III Test	227
Photographs of Task III Actuator Rods and Seals	233

LIST OF ILLUSTRATIONS

<u>FIGURE</u>		<u>Page</u>
1	Stage 1 Seal Selection Flow Diagram	17
2	Stage 2, 3 & 4 Seal Selection Flow Diagram. . .	18
3	Seals Selected for Task II Test	23
4	Seals Installed at Start of Task II Test. . . .	26
5	Pressurized Friction of Task II Seals	30
6	Task II Seal Leakage.	33
7	Seals Selected for Task III Test.	34
8	Pressurized Friction of Task III Seals.	99
9	Task III Seal Leakage	100
10	Comparison of Seal Failures by Stage.	101
11	Comparison of Vented and Unvented Seal Failures	102
12	Recommended Installation of Backup Rings. . . .	109
B-1	Seal Evaluation Test Fixture.	149
B-2	Specimen and Load Hydraulic Systems	150

LIST OF TABLES

<u>Table</u>		<u>Page</u>
1	High Pressure Seal Evaluation Matrix.	13
2	Low Pressure Seal Evaluation Matrix	15
3	Seal Configurations	19
4	Rating Matrix for Rod Finishes.	22
5	Task II Tests Summary	27
6	Unpressurized Friction of Task II Seals	29
7	Task III Rod Seal Description	35
8	Task III Test Summary	43
9	Leakage and Interstage Pressure Data During Endurance Test.	44
10	Leakage and Interstage Pressure Data During Rotor Feedback Test	68
11	Unpressurized Friction of Task III Seals.	98
12	Recommended Seals	109
A-1	Seal Evaluation Parameters.	110
A-2	Rod Finish Evaluation Parameters.	124
A-3	Seals Selected for Task II Test	128
B-1	Task II Seals	130
B-2	Task II Seal Performance Summary.	134
B-3	Measured Critical Dimensions and Finishes Before and (After) Task II Test	179
C-1	Task III Seal Performance Summary	185
C-2	Measured Critical Dimensions and Finishes Before and (After) Task III Test.	227

INTRODUCTION

Modern Army Helicopters utilize single- or two-stage hydraulic actuator rod seals that must be capable of operating over the temperature range of -65°F to $+275^{\circ}\text{F}$. These actuators are usually exposed to a high concentration of dust during takeoff and/or landing maneuvers and during very low level hover maneuvers. The rotor control actuators are subjected to a large number of small amplitude feedback cycles caused by the load imposed by each rotor blade. Helicopter actuators exposed to the environment described have not provided the desired reliability, maintainability, or safety.

The objective of this program was to investigate and develop new and improved multiple cascaded seal configurations for hydraulic systems and actuators, thereby favorably impacting hydraulic system reliability, maintainability, safety, and cost by significantly reducing seal system leakage.

The program objective was achieved by: (1) devising an Evaluation Matrix that allowed each seal to be rated for performance based on 14 evaluation parameters, (2) testing the seals selected for 2×10^6 cycles at high temperature in single-stage, two-stage and three-stage configurations, and (3) performing a 5×10^6 cycle endurance test and a 20×10^6 cycle rotor feedback test at high temperature with a contaminated environment, for single-, two-, three- and four-stage seal installations.

The program clearly demonstrated the superiority of the multiple cascaded seal over the single-stage seal and provided data that can be used as a guideline for selection of the optimum number of seals in a given installation.

TECHNICAL PROGRAM

The program contained three major tasks.

Task I - Design Investigation

Task II - Seal Design and Developmental Testing.

Task III - Testing

TASK I - DESIGN INVESTIGATION

Task I investigated existing and newly devised hydraulic servo-actuator seals. In order to take advantage of the knowledge and experience of the seal industry, a number of potential seal suppliers were invited to suggest possible configurations. Their proposals furnished several promising seal ideas. Ten different test reports were reviewed to (a) help establish the requirements for long life tests, (b) to locate seal designs that had passed long life and/or 8000 psig tests, and (c) to identify and eliminate those seal designs that had failed similar tests. Significant data from each report was summarized on index cards for use in preparing Seal Evaluation parameters.

After the test report review was completed, 14 parameters were established as being applicable for seal evaluation. Each parameter had a clear rationale so that it could be used to rate a seal as being Excellent, Average, or Poor with a minimum amount of bias from the evaluator. These parameters and the application thesis are listed below. The rationale used for each parameter is shown in Appendix A.

- | | |
|---------------|--|
| Sealing | - Is the sealing predictable, with uniform loading, have high and low pressure sealing for static and/or dynamic pressure? |
| Wear | - Are the materials wear resistant yet nonabrasive? |
| Friction | - Is friction minimized? |
| Temperature | - Does it meet -65°F to +275°F requirement? |
| Extrusion Gap | - How well does the design bridge the extrusion gap? |
| Installation | - How is the ease of installation compared to an O-ring installation with two backup rings? |
| Space | - How does space compare to a MIL-G-5514F ¹ gland for an O-ring with two backup rings? |

¹MIL-G-5514F - Military Specification - Gland Design; Packings, Hydraulic, General Requirements for, dtd 15 January 1969.

- Seal Deflection- Does the seal flex or work when pressure changes so that fatigue failures are likely?
- Orientation - Can the seal be installed backwards or improperly? Can the proper orientation be easily recognized?
- Complexity - Are there parts, few interfaces? Are gland requirements simple?
- Compatibility - Are all of the materials compatible with both MIL-H-5606 and MIL-H-83282?
- Producibility - Is it producible? Are there an excessive number of close tolerances that must be held?
- Pressure Level - Is the configuration suitable for 8000 psi?
- Pressure Trap - Does the configuration trap an unacceptable pressure level between seal stages?

Seal Evaluation Matrix

After the Seal Evaluation Criteria were established, parameters (Appendix A) were used to rate the seals in a matrix format, shown in Table 1. In this table a rating of Excellent (E) was awarded 3 points, a rating of Average (A) was awarded 2 points and a rating of Poor (P) was awarded 1 point. This matrix assumed that the seals were exposed to high pressure and did not give a realistic rating to elastomeric seals that could be used at low pressure in a vented seal. To give the elastomeric seals a fair rating at low pressure, the seals were all evaluated in Table 2. In this table the wear and friction rating of each elastomeric seal was increased by one level.

Each table has a subtotal rating for the parameters of Sealing, Wear, Friction, and Pressure Trap. These parameters were believed to be the most important for meeting the desired life on a helicopter servo actuator and were used as the main guide for locating each seal in the multi-stage seals. The ratings of the other parameters were totaled (including the subtotal) and this total was used as a tie breaker when necessary. The last row in each table is the estimated cost in dollars for each seal installation.

Seal Selection Flow Diagrams

While establishing the seal evaluation criteria and the seal evaluation matrix, it became apparent that each stage of a multi-stage seal had slightly different requirements and that the requirements were also slightly different, depending upon whether the seal was vented or unvented. For example, a single-stage seal for this program must withstand 3000 to 8000 psig operating pressure while maintaining very low leakage for 25 million cycles without showing excessive wear. The

pressure requirement and the leakage requirement can be met by an O-ring type seal, but some of the reference material reviewed showed that 5 million cycles of operation produced significant wear when only 3000 psig operating pressure was applied to the O-ring type seals and the elastomer was simultaneously exposed to rod motion. It was obvious that increasing the number of cycles or the applied pressure would cause the wear to increase substantially. The addition of a pressure-resistant second-stage seal inside of the O-ring type seal would allow leakage from the second-stage seal to be vented to return. This, in turn, would relieve the pressure on the O-ring type seal and improve its wear resistance while maintaining the desired low leakage characteristics. If the vent between the two seals was undesirable, then the individual seal requirements would change again. In the vented case, the second-stage seal could be an asymmetric design since high pressure could only be applied from one direction. In an unvented two-stage seal the second-stage (inside) seal must be symmetrical or pressure resistant so that it would not be damaged at hydraulic system shutdown by the pressure that was trapped between the two stages, which has been shown to be approximately half the cylinder pressure. In both the vented and unvented case, the first-stage (outside) seal can be asymmetric since pressure was applied from only one side, but in the unvented case the O-ring type seal would not provide satisfactory service because of the excessive wear caused by the high trapped pressure. The addition of a second stage would increase friction in both the vented and unvented case. In the unvented case it was desirable to use seals that were self-venting if possible to reduce pressure friction forces during manual reversion. The Bal Seal, Configuration R4 in Table 3 was one example of this design. Other vendors contacted also had self-venting seal designs.

When the third and fourth stages were added inside the second stage, the same arguments shown above for the second stage were applicable. The inside stage would carry most of the pressure load and could be a sacrificial element which could conceivably double the life of the seal assembly.

The requirements for each stage were codified in the form of flow diagrams that are shown in Figures 1 and 2. These diagrams were applied to Tables 1 and 2 to select the seals to be used in this test. The stage selection was done in the following manner.

Selected stage 1 seal for end 1 and end 2 for actuators 1 thru 5 in chronological order using Figure 1.

Selected stage 2 seals for end 1 and end 2 for actuators 2 thru 5 in chronological order using Figure 2.

Selected stage 3 seal for end 2 of actuator 3 and ends 1 and 2 for actuators 4 and 5 in chronological order using Figure 2.

Selected stage 4 seal for end 1 and end 2 of actuator 5 using Figure 2.

Specified seals for actuator 6 to fulfill finish comparison requirements.

For the purpose of selection only, the outside seal was stage 1, with higher stage numbers on the inside. For the rest of this report, the inside stage is stage 1, with the higher number stages added on the outside.

The only exceptions to this process were as follows. Configuration R15 gave unsatisfactory results in a test after only 23,814 cycles so it was dropped from consideration. Configuration R17 was considered similar to R3 so it was not selected for test. Configuration R9 was not selected for test because it was considered similar to R2, which is available in this country. Configuration R14 had a very high rating, but since it cannot withstand long-term exposure at 275°F it was not selected for testing during Task II.

The final seal selections for the Task II Test are shown in Figure 3. Four-stage seals were not selected for Task II tests so that a greater variety of two-stage seals could be tested during Task II tests. Four-stage seals were evaluated during Task III tests.

In Figure 3, as in all successive figures that show the seal installations, the ports into the actuator end caps were identified as A, B, C, and D. The groove adjacent to and outboard from a port had the same letter identification as the port. For example, the innermost groove was adjacent to and outboard from Port A, so that groove was referred to as groove A. Pressure was supplied to ports B, C, and D only if 90 psig was shown at the port. In all other cases the ports were used either to monitor pressure and/or leakage to provide a vent back to the inboard side of the seal groove, or they were not needed and were plugged.

Rating Values
E = 3, A = 2, P = 1

TABLE 1. HIGH PRESSURE SEAL EVALUATION MATRIX
(SEAL EVALUATION PARAMETERS - APPENDIX A)

CONFIGURATION	WT	R1	R2	R3	R4	R5	R6	R7	R8	R9	R10	R11
Sealing	5	E	E	A	A	A	E	E	E	E	A	P
Wear	6	P	A	E	E	E	A	A	P	A	E	F
Friction	2	P	P	A	A	A	P	P	P	P	A	A
Pressure Trap	1	P	P	A	E	A	P	P	P	P	A	E
Subtotal		24	30	34	35	34	30	30	24	30	34	30
Temperature	1	A	A	A	E	A	A	A	A	A	A	F
Extrusion Gap	1	E	E	E	P	E	P	E	F	F	A	E
Installation	1	A	A	A	P	A	A	A	A	A	P	A
Space	1	A	A	E	P	A	A	A	A	E	E	E
Seal Deflection	1	P	A	A	A	A	P	A	A	A	A	E
Orientation	1	A	E	E	A	P	A	A	A	A	A	E
Complexity	1	E	P	E	P	E	E	E	E	E	E	E
Compatibility	1	E	E	E	E	E	E	E	E	E	E	E
Producibility	1	A	A	A	A	A	A	A	A	A	A	P
Pressure Level	1	P	P	E	E	A	P	P	P	P	A	A
Total		45	51	60	54	56	49	52	46	53	56	56
ESTIMATED COST PER INSTL		2	5	2	2	2	2	2	2	2	2	2

TABLE 1. CONTINUED

CONFIGURATION	WT	R12	R13	R14	R15	R16	R17	R18	R19	R20	R21	R22
Sealing	5	P	A	E	A	A	A	A	E	A	A	A
Wear	6	E	E	A	E	E	E	E	A	E	E	E
Friction	2	E	A	A	A	A	A	A	P	A	A	A
Pressure Trap	1	E	P	E	E	A	A	A	E	A	A	A
Subtotal	32	33	34	35	34	34	34	34	32	34	34	34
Temperature	1	E	A	P	A	A	A	A	A	A	A	A
Extrusion Gap	1	E	A	E	E	E	E	E	E	E	E	E
Installation	1	E	A	E	A	A	A	A	P	P	A	E
Space	1	E	E	P	E	A	E	A	A	E	A	A
Seal Deflection	1	E	A	A	P	A	P	E	A	A	E	E
Orientation	1	E	A	A	A	E	E	E	A	P	A	A
Complexity	1	E	A	E	E	E	E	P	P	P	P	E
Compatibility	1	E	E	E	E	E	F	E	E	E	E	E
Producibility	1	A	A	A	A	A	A	A	A	A	A	A
Pressure Level	1	A	A	A	P	A	A	E	P	A	A	A
Total	60	55	56	57	58	58	58	58	51	54	56	59
ESTIMATED COST PER INSTL	5	2	2	3	2	4	4	4	2	2	4	4

TABLE 2. LOW PRESSURE SEAL EVALUATION MATRIX

CONFIGURATION	WT	R1	R2	R3	R4	R5	R6	R7	R8	R9	R10	R11
Sealing	5	E	E	A	A	A	E	E	E	E	A	P
Wear	6	A	E	E	F	E	E	E	A	E	E	E
Friction	2	A	A	A	A	A	A	A	A	A	A	A
Pressure Trap	1	P	P	A	E	A	P	P	P	P	A	E
Subtotal		32	38	34	35	34	38	38	32	38	34	30
Temperature	1	A	A	A	E	A	A	A	A	A	A	E
Extrusion Gap	1	E	E	E	P	E	P	E	E	E	A	E
Installation	1	A	A	A	P	A	A	A	A	A	P	A
Space	1	A	A	E	P	A	A	A	A	E	E	E
Seal Deflection	1	P	A	A	A	A	P	A	A	A	A	E
Orientation	1	A	E	E	A	P	A	A	A	A	A	E
Complexity	1	E	P	E	P	E	E	E	E	E	E	E
Compatibility	1	E	E	E	E	E	E	E	F	E	E	E
Producibility	1	A	A	A	A	A	A	A	A	A	A	P
Pressure Level	1	P	P	E	E	A	P	P	P	P	A	A
Total		53	59	60	54	56	57	60	54	61	56	56
ESTIMATED COST PER INSTL		2	5	2	2	2	2	2	2	2	2	2

TABLE 2. CONTINUED

CONFIGURATION	WT	R12	R13	R14	R15	R16	R17	R18	R19	R20	R21	R22
Sealing	5	P	A	E	A	A	A	A	E	A	A	A
Wear	6	E	E	F	E	E	E	E	E	E	E	E
Friction	2	E	A	F	A	A	A	A	A	A	A	A
Pressure Trap	1	E	P	E	E	A	A	A	E	A	A	A
Subtotal	32	33	42	42	35	34	34	34	40	34	34	34
Temperature	1	E	A	P	A	A	A	A	A	A	A	A
Extrusion Gap	1	F	A	E	E	F	E	F	F	F	E	E
Installation	1	E	A	F	A	A	A	A	P	P	A	E
Space	1	E	E	P	E	A	E	A	A	E	A	A
Seal Deflection	1	E	A	A	P	A	P	F	A	A	E	E
Orientation	1	E	A	A	A	E	E	E	A	P	A	A
Complexity	1	E	A	E	E	E	E	P	P	P	P	E
Compatibility	1	E	E	E	E	E	F	F	F	F	F	E
Producibility	1	A	A	A	A	A	A	A	A	A	A	A
Pressure Level	1	A	A	A	P	A	A	F	P	A	A	A
Total	60	55	64	64	57	58	58	58	59	54	56	59
ESTIMATED COST PER INSTL	5	2	3	2	4	4	4	4	2	2	4	4

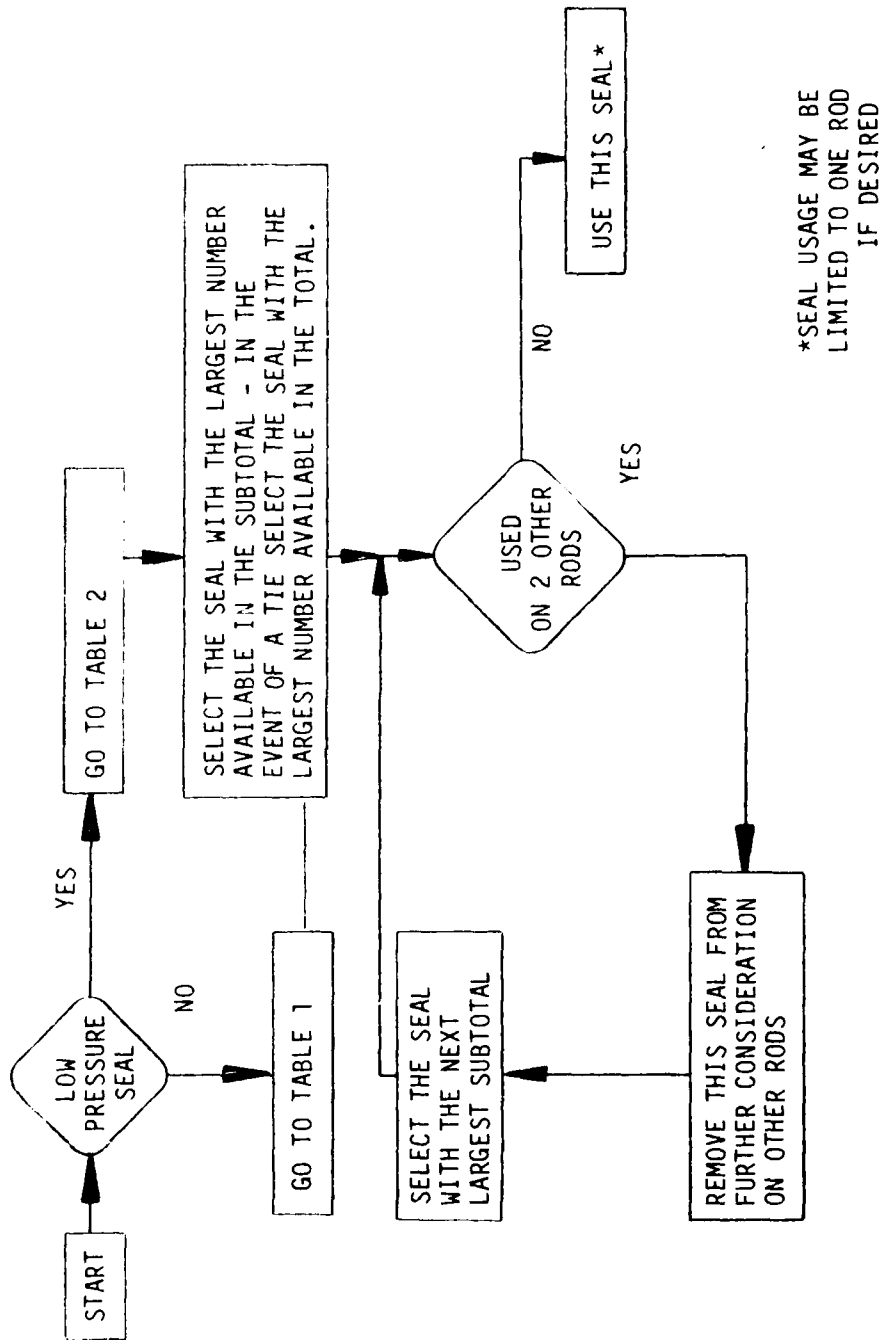

*SEAL USAGE MAY BE LIMITED TO ONE ROD IF DESIRED

FIGURE 1. STAGE 1 SEAL SELECTION FLOW DIAGRAM

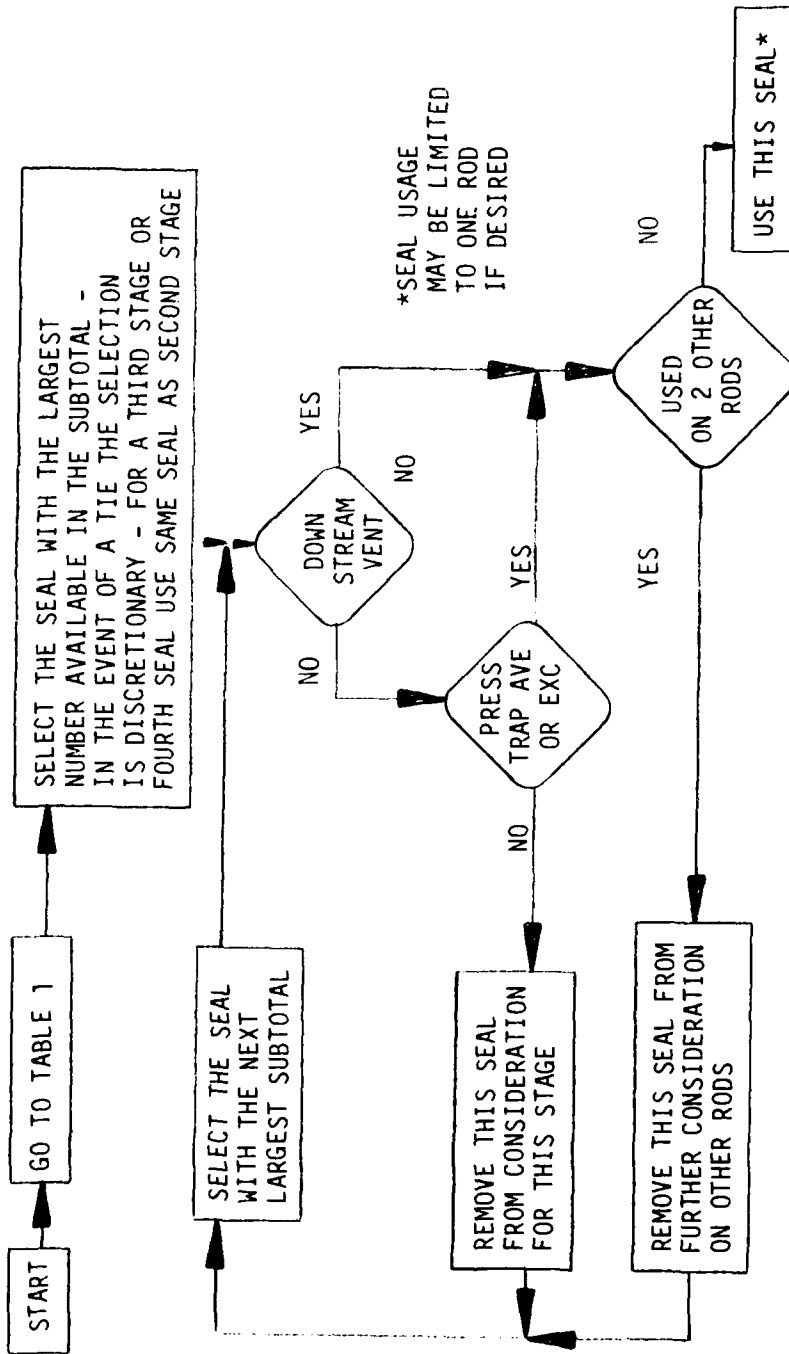

FIGURE 2. STAGE 2, 3 & 4 SEAL SELECTION FLOW DIAGRAM

TABLE 3. SEAL CONFIGURATION













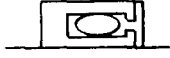
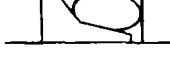

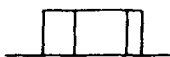

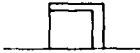

Number	Cross Section	Description
R1		MIL-P-83461 O-ring with uncut thick backup ring.
R2		G.T. "T" ring with staged backup rings.
R3		Channel seal (double delta)
R4		Bal Seal (heavy duty)
R5		Foot seal (delta)
R6		O-ring with triangular backup ring
R7		Trapezoidal seal
R8		Square ring with uncut thick backup ring
R9		"L" seal
R10		Shamban Excluder
R11		2-piece metal rod seal

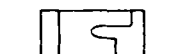
TABLE 3. Continued

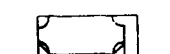
Number	Cross Section	Description
R12		Step cut Teflon buffer
R13		Hex seal
R14		Urethane "U" seal with backup
R15		Step seal
R16		Plus seal
R17		Slipper seal
R18		Double delta with two backups
R19		Hat Seal
R20		DC Excluder
R21		Delta seal with staged backup ring
R22		Rubber spring actuated seal

Rod Finish Evaluation

The rod finishes were evaluated in Table 4. The rating rationale used for each parameter is shown in Appendix A. Table 4 shows the tungsten carbide to be the clear winner insofar as performance, but the cost for this finish is approximately ten times the cost of conventional chromium plating and it must be applied by a Detonation Gun. The phosphate coating gives low cost performance, but does not provide an adequate amount of corrosion resistance. The abusively ground chromium plating is expected to cause leakage to increase. All other finishes were judged to provide approximately equal performance.

Materials Evaluation

The material evaluation was aimed primarily at rating physical configurations. Each of the configurations that uses Teflon type non-elastomers can be obtained with the non-elastomer produced from a wide variety of proprietary compounds. Comparative data on these proprietary compounds is generally not available, but the seal manufacturers contacted strongly recommended the use of Teflon blends, bronze-filled Teflon, and graphite-filled Teflon for the capstrip type seals for this test. The same general recommendations were made for the backup rings except that polyimide materials were also recommended. Based on the manufacturers recommendations, the non-elastomers used in this test were Teflon blends and filled Teflon. The particular blend depended upon the manufacturer supplying the seal. Shamban, Fluorocarbon, Parker, Dowty, Hercules, Disogrin, Bal Seal Engineering, American Variseal, Tetrafluor, Conover, and Greene Tweed supplied seals for these tests.

Compounds to be tested were selected just prior to the initiation of the tests. The Navy-sponsored Lightweight Hydraulic System Screening Tests had tested materials at 8000 psig, and the results of those tests were used as the final guide for the material selection for this test.

Table 4. RATING MATRIX FOR ROD FINISHES

Parameter	4 RMS	8 - 16 RMS		Abusively Ground 16 RMS	Tungsten Carbide	Iron Phosphate
		8 - 16 RMS	16 RMS			
Cost to Prepare	A	A	A	A	U	A
Relative Corrosion Resistance	A	A	A	A	A	U
Potential For Reducing Leakage	A	A	A	P	E	E
Wear Resistance	A	A	A	A	E	A

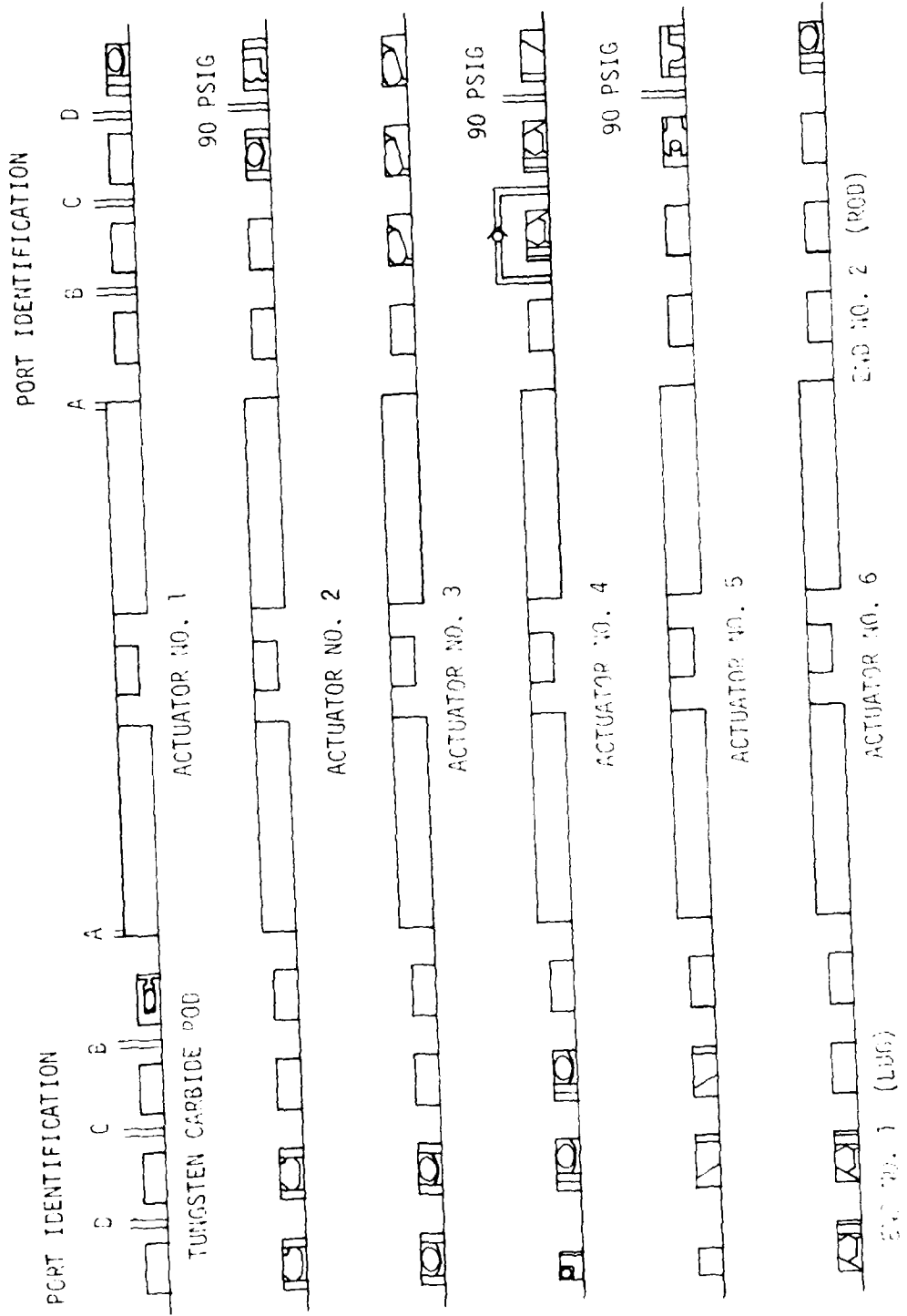

FIGURE 3. SEALS SELECTED FOR TASK II TEST

TASK II - SEAL DESIGN AND DEVELOPMENT TESTING

Task II included the design and manufacture of test equipment and test seals as well as the test itself. All seals were manufactured by seal vendors that were familiar with the processes and problems involved. One of the seals was designed by G. K. Fling of Vought and one was designed by B. Brent of Bell Helicopter. All of the other seals were vendor designs. The test actuators and test rig were designed and manufactured by Vought. Where possible, commercial parts were used to reduce costs. A gland design per MIL-G-5514-214 was used with the following changes for the seals that used a standard gland.

<u>Item</u>	<u>MIL-G-5514</u>	<u>Test Parts</u>
Rod OD	.998 +.000 -.002	.998 +.000 -.001
Groove ID	1.241 +.002 -.000	1.241 +.001 -.000
Rod Bore	1.000 +.001 -.000	.999 +.001 -.000
Eccentricity	.002	.001
Groove Angle	0° +5° -0°	0° +/- 1/2°
Groove Edge	Break Edge .005 +.005 -.000	Break Edge .002 +.005 -.000
Rod Finish	16 RMS	2 RMS - 8 RMS

One nonstandard gland was designed and manufactured to accommodate a "Bal Seal" and one was designed to accommodate a Shamban "Excluder". These gland designs were used later in Task III tests using different seals.

The changes in the Rod OD, Groove ID, Rod Bore, and Eccentricity were made as a result of Vought's experience with the 8000 psi hydraulic system design for the U. S. Navy "Lightweight Hydraulic System" program. Vought discovered that a reduced extrusion gap is necessary for good performance at 8000 psi. The groove angle was modified to reduce friction due to pressure and to improve the fit between the seal and/or backup ring and the rod. The groove edge was sharpened to reduce seal extrusion. The rod finish was improved from a maximum of 16 RMS to a maximum of 8 RMS by a machining error, but the change appears to have been beneficial with most of the seals tested.

All of the actuators were produced from 15 - 5 PH CRES that was aged to H925 (170,000 psi). All rods except one were hard chrome plated

and then ground per Vought Spec 208-1-7 (See Appendix B). The grinding process is believed to be very important in producing a good sealing surface and Vought Spec 208-1-7 was specifically set up to assure proper control of surface grinding of hydraulic actuator parts so that chromium plating cracking caused by the grinding would not occur. The one rod that was not chromium plated had a Tungsten Carbide coating, LW-1N40, applied and ground to a 2 RMS finish by the Linde Division of the Union Carbide Corporation.

During installation of the seals that had been selected for the Task II test it became apparent that some of the seals could not be installed in one-piece glands. Those seals were replaced by alternate seals. The seal configurations that were installed for the Task II test are shown on Figure 4. A seal description for each of the seals is shown in Table B-1 in Appendix B. In this table, the innermost groove is designated as groove A, the next groove is labeled groove B and so on. The Seal Evaluation Test Fixture is shown in Figure B-1 in Appendix B. The Specimen and Load Hydraulic Systems are shown in Figure B-2 in Appendix B.

The Task II test was performed as shown in Table 5. The long stroke cycles were +/- 1.75 inches with a maximum load of 2318 pounds per actuator. The short stroke cycles were +/- .04 inch with a maximum load of 58 pounds per actuator. The unpressurized friction for the seals is shown in Table 6. The pressurized friction for each seal is shown in Figure 5. The total measured leakage for the seals that survived the test is shown in Figure 6.

The individual results for each seal in the Task II test are given in Appendix B along with the measured critical dimensions, and finishes for each actuator which are given in Table B-2 in Appendix B.

All of the seals that failed the Task II test failed during the high temperature portions of the test. The low pressure Trapezoid Seal (Rod End, Actuator No. 4) failed after 694,111 cycles. The return pressure was removed from the seal and cycling was continued using only the inside two stages. During the remaining 307,582 cycles with MIL-H-5606 hydraulic fluid the two inside stages leaked a total of 28.07 cc. Slight leakage was also shown by the Double Delta Seal (lug end actuator no. 1, lug end actuator no. 4, and rod end actuator no. 6) the Hat Seal (rod end actuator no. 2), the Trapezoid Seal (lug end actuator no. 5) and the Hex Seal (lug end actuator no. 6), but the leakage was well within acceptable limits.

During the test the Bal Seal (rod seal in actuator no. 1) began leaking erratically. The seal would leak on some days, but not on others. During 45,000 cycles, the seal leaked as much as 38 cc in one hour. After a short shutdown, the leakage stopped, but it reoccurred the next day and the seal was designated as a failure.

PORT IDENTIFICATION

PORT IDENTIFICATION

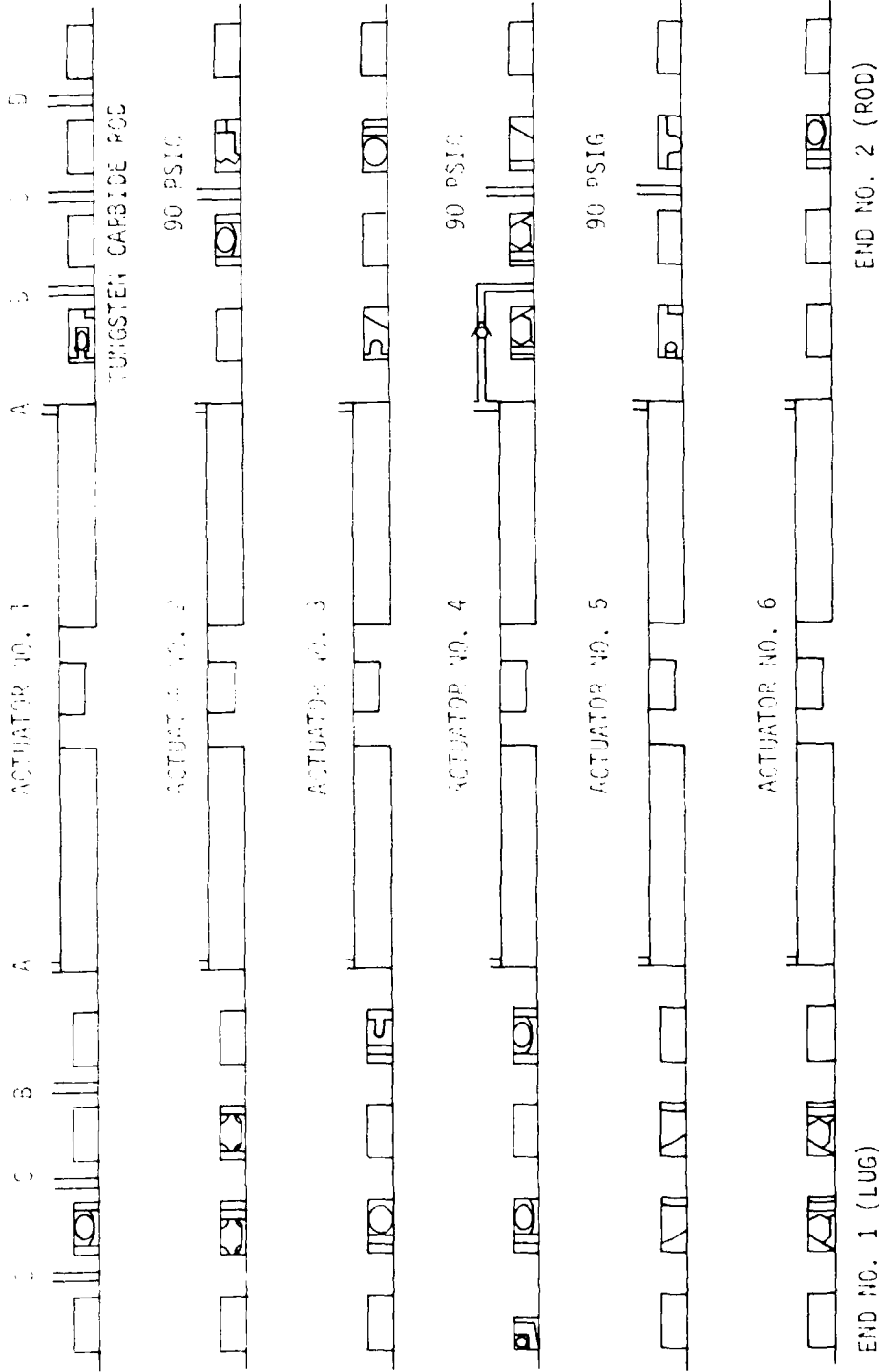

FIGURE 4. SEALS INSTALLED AT START OF TASK II TESTS

TABLE 5. TASK II TESTS SUMMARY

<u>Type of Test</u>	<u>Ambient Temperature</u>	<u>Fluid Temperature</u>	<u>Cycles</u>
Acceptance	Room Ambient	Room Ambient	25 LS
Unpressurized Friction	Room Ambient	Room Ambient	--
Pressurized Friction MIL-H-5606	Room Ambient	Room Ambient	--
Low Temp. 3000 psig test MIL-H-5606	-65°F	-65°F	5 LS
Intermediate Temp 3000 psig test MIL-H-5606	80°F +/- 20°F	160°F +/- 5°F	5,670 LS 96,000 SS
High Temp 3000 psig test MIL-H-5606	80°F +/-20°F for 500,000 cycles 200°-250°F For Remainder	275°F + 0°F -10°F	45,018 LS 855,000 SS
<u>Fluid Change</u>			
Acceptance MIL-H-83282	Room Ambient	Room Ambient	25 LS
Low Temp. 3000 psig test MIL-H-83282	-40°F	-40°F	5 LS

TABLE 5. CONTINUED

<u>Type of Test</u>	<u>Ambient Temperature</u>	<u>Fluid Temperature</u>	<u>Cycles</u>
Intermediate Temp 3000 psig test MIL-H-83282	80°F +/- 25°F	160°F +/- 5°F	3,970 LS 48,000 SS
High Temp 3000 psig test MIL-H-83282	225°F +/- 25°F	275°F + 0° -10° F	22,538 LS 444,150 SS
Static Leakage	Room Ambient	Room Ambient	--
Acceptance MIL-H-83282 8000 psig	Room Ambient	Room Ambient	25 LS
Low Temperature MIL-H-83282 8000 psig	-40°F	-40°F	5 LS
Intermediate Temp MIL-H-83282 8000 psig	80°F +/- 20°F	160°F +/- 5°F	20,450 LS 427,680 SS
High Temp MIL-H-83282 8000 psig	200°F to 275°F	200°F to 250°F	22,500 LS 429,120 SS
Static Leakage MIL-H-83282	Room Ambient	Room Ambient	---

TABLE 6. UNPRESSURIZED FRICTION OF TASY II SEALS

ACTUATOR NUMBER	LUG END	ROD END	AVG. BREAKOUT FRICTION LBS		LBS AVG. RUNNING FRICTION	
			EXTEND	RETRACT	EXTEND	RETRACT
1	X	X	7.69	8.44	6.28	6.58
			6.12	7.02	2.70	3.48
2	X	X	8.63	6.01	5.25	6.25
			15.98	12.36	15.40	11.80
3	X	X	8.48	7.58	5.16	5.00
			8.12	6.64	6.75	7.25
4	X	X	30.64	25.98	21.00	21.00
			34.18	22.64	45.00*	27.00
5	X	X	58.96	34.22	56.90	35.50
			46.68	39.30	43.25	22.00
6	X	X	26.40	20.88	27.00*	8.00*
			14.44	10.66	11.50	11.00

* Erratic

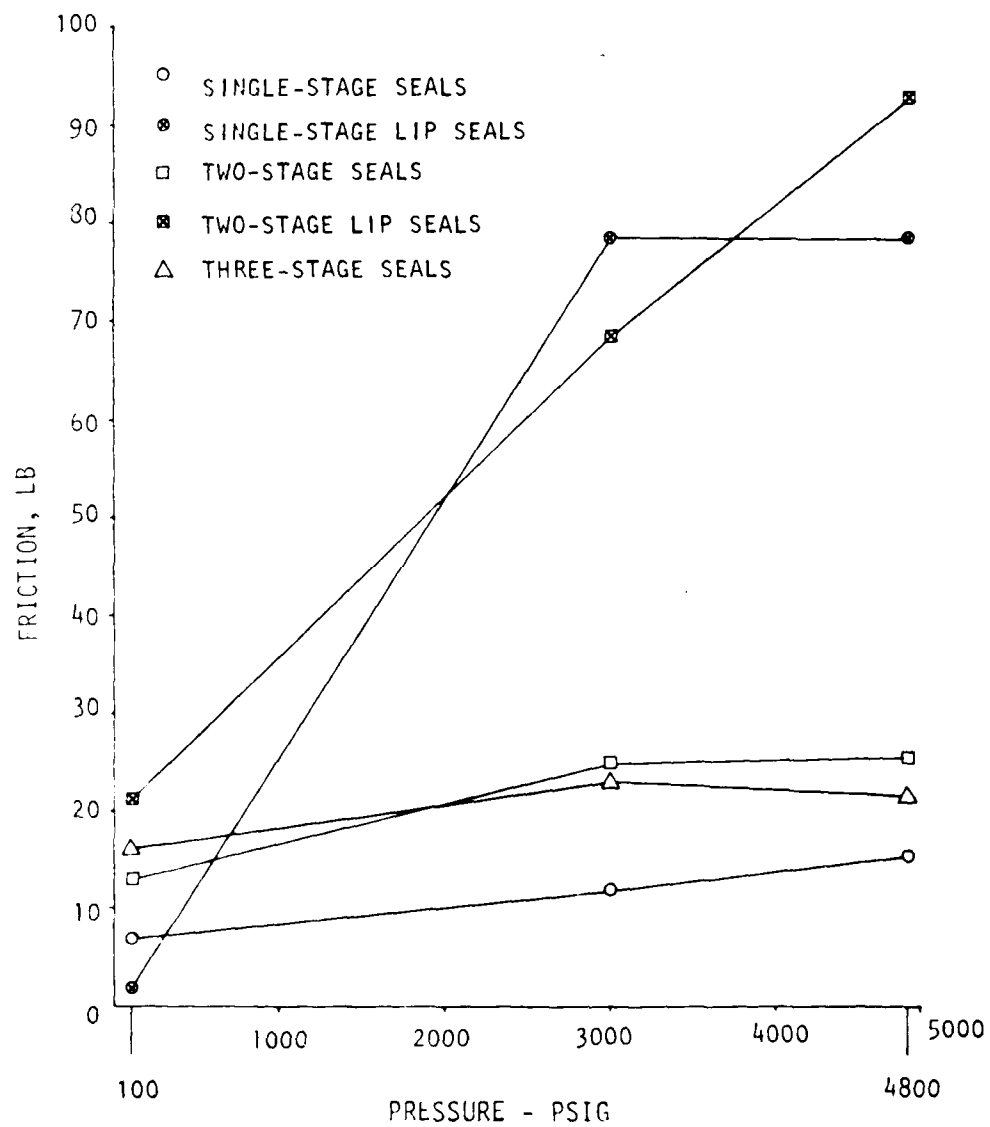

FIGURE 5. PRESSURIZED FRICTION OF TASK II SEALS

Another seal had excessive leakage during this test, but it was not designated as a failure. The Greene, Tweed Seals (rod seal in actuator no. 5) began leaking after 353,897 cycles. This leakage slowly increased until after 988,925 cycles, 135 cc of leakage was measured in one day. This seal used 2 stages that were vented to return, so the return path was shut off and the leakage was dramatically reduced. After 1,001,693 cycles, the actuator was removed from the test setup. It was discovered that the rod had contacted the end cap and the chrome plating had been worn through. It is believed that the rod failure which caused the seal failure was caused by the contact with the end cap and not by the seal itself.

Since the rod in actuator no. 5 was not useable until it could be reworked and the rod end seal in actuator no. 1 had been designated as a failure, the two actuators were combined into a new actuator that was designated as 5A. The lug end cap (-5 S/N 001) from actuator no. 5 was combined with the lug end cap (-5 S/N 007), barrel (-8 S/N 001) and Piston and Rod (012 S/N 007) from actuator no. 1. The combined assembly was installed in the no. 5 actuator position to minimize plumbing changes in the test setup.

After 1,054,811 cycles (53,118 with MIL-H-83282 hydraulic fluid), the drier in the central hot air supply malfunctioned and a large volume of sandy residue was blown into the insulated box. A layer of contaminant approximately 1/4 in. thick was deposited on the actuators. The lab technician saw the dust cloud emerging from the box and turned off the hydraulic pressure to the setup. The box and the test cell were thoroughly contaminated with this substance, but they were thoroughly cleaned before any further cycling was attempted. The contaminant was analyzed and identified as a mixture of silica gel and oil absorber. Both of these substances were from the drier in the hot air source. The hot air source was completely refurbished before any more cycling was attempted.

After 193,635 additional cycles with MIL-H-83282, the central hot air supply malfunction occurred again and a thin layer of contaminant was deposited in the box. The technician monitoring the test immediately turned off the hydraulic pressure to the setup. The contamination was much less than it was the first time, but since the entire hot air setup had been refurbished after the first incident and the refurbishment did not prevent the second incident, it was decided to use a portable air heater instead of the central hot air source. The contaminant was analyzed and identified as silica gel from the drier in the hot air source. The test setup was thoroughly cleaned and a portable hot air source was installed.

During the Intermediate Temperature Test at 8000 psig with MIL-H-83282, an error resulted in a total of 427,680 two-percent stroke cycles and 20,450 full stroke cycles being run at the intermediate temperature requirements. The test required 47,500 short stroke cycles and 2500 long stroke cycles. The 2 percent stroke cycles and full stroke cycles that were run in excess of the requirements were documented and all

data was recorded, but the additional cycles were not counted toward meeting the 2×10^6 total cycle requirements.

During the High Temperature Test at 8000 psig with IIL-H-83282, after 1,975,578 cycles, the single-stage double-delta seal in the rod end of actuator no. 6 failed. The seal was removed and a replacement seal of similar configuration, from C. E. Conover & Co., was installed. The visual inspection summary for each seal is shown in Table B-2 in Appendix B. The seal test summary for the failed seal is shown in Table B-3 in Appendix B. There were no additional seal replacements during the Task II Test.

The seals to be tested in Task III were chosen based on the results of the Task II Test. Since the Shamban Plus Seal had delivered the best performance, it was chosen to be installed in a one-stage seal, a two-stage seal, a three-stage seal and in both a vented and an unvented four-stage seal installation. The Shamban Hat Seal and Double Delta Seal were chosen to be installed in a two-stage seal. The Conover/Brent Hex Seal was chosen for a three-stage seal and the Conover/Fling Trapezoid backup with an H83461 O-ring was chosen for both a vented and an unvented seal. The Shamban Double Delta seal continued as the baseline for comparison purposes.

All of the pressure loaded lip seal designs were removed from consideration for the Task III test. The Bal Seal was removed because it had shown excessive leakage. The Tetrafluor rod seal showed good leakage characteristics, as did the Variseal, but both caused minor rod scoring. The Greene Tweed Hytrel seal was not considered for further testing because concurrent testing of this seal in the Air Force Dynamic Seals for Advanced Hydraulic Systems program showed the seal to have relatively high leakage. All of the lip seals require a two-piece gland, which complicates actuator design.

Both Greene Tweed and Tetrafluor submitted elastomeric loaded seals that were included in the Task III test. All of the seals used in the Task III test are shown in Figure 7 and described in Table 7.

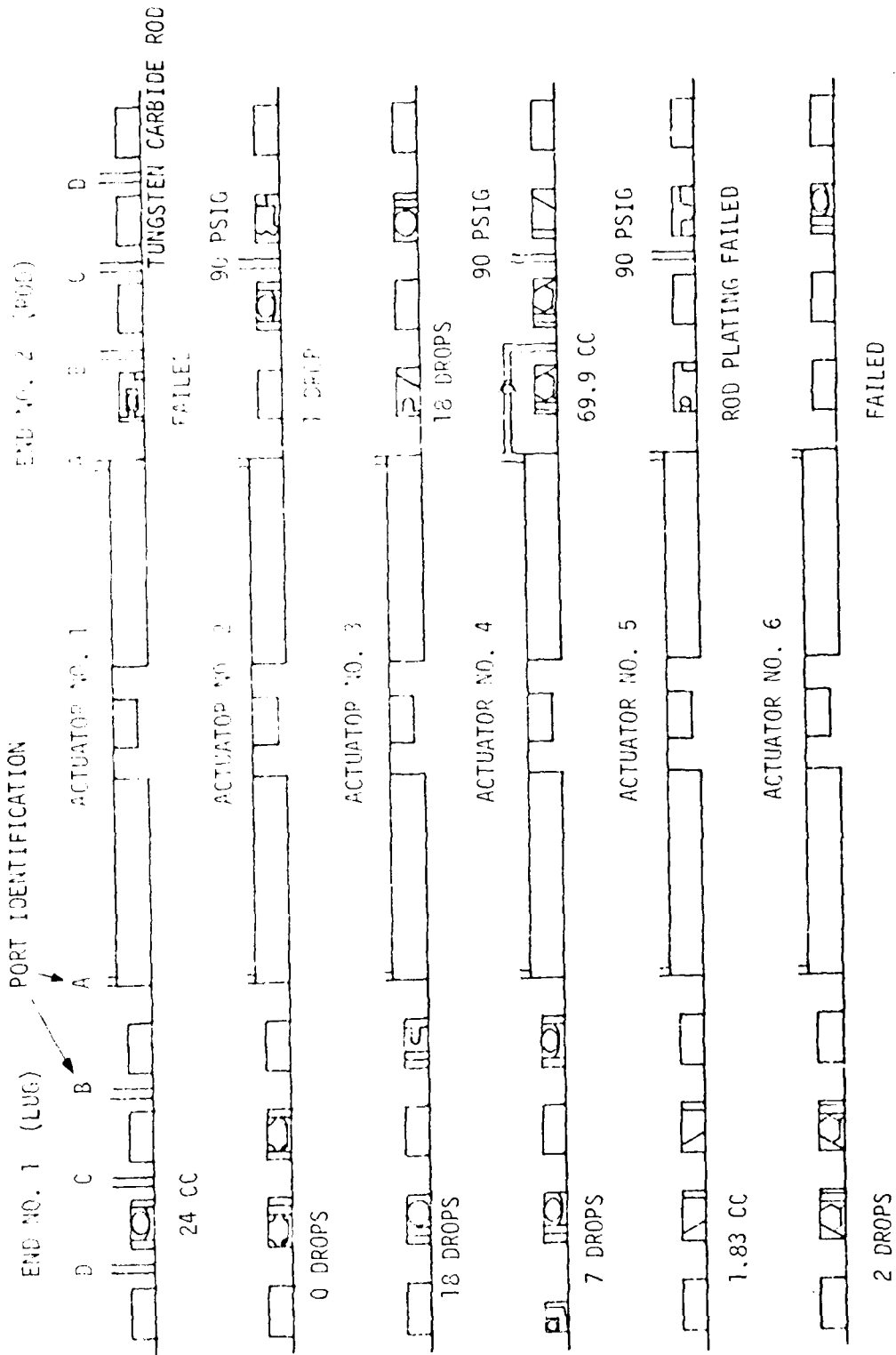

FIGURE 6. TASK II SEAL LEAKAGE

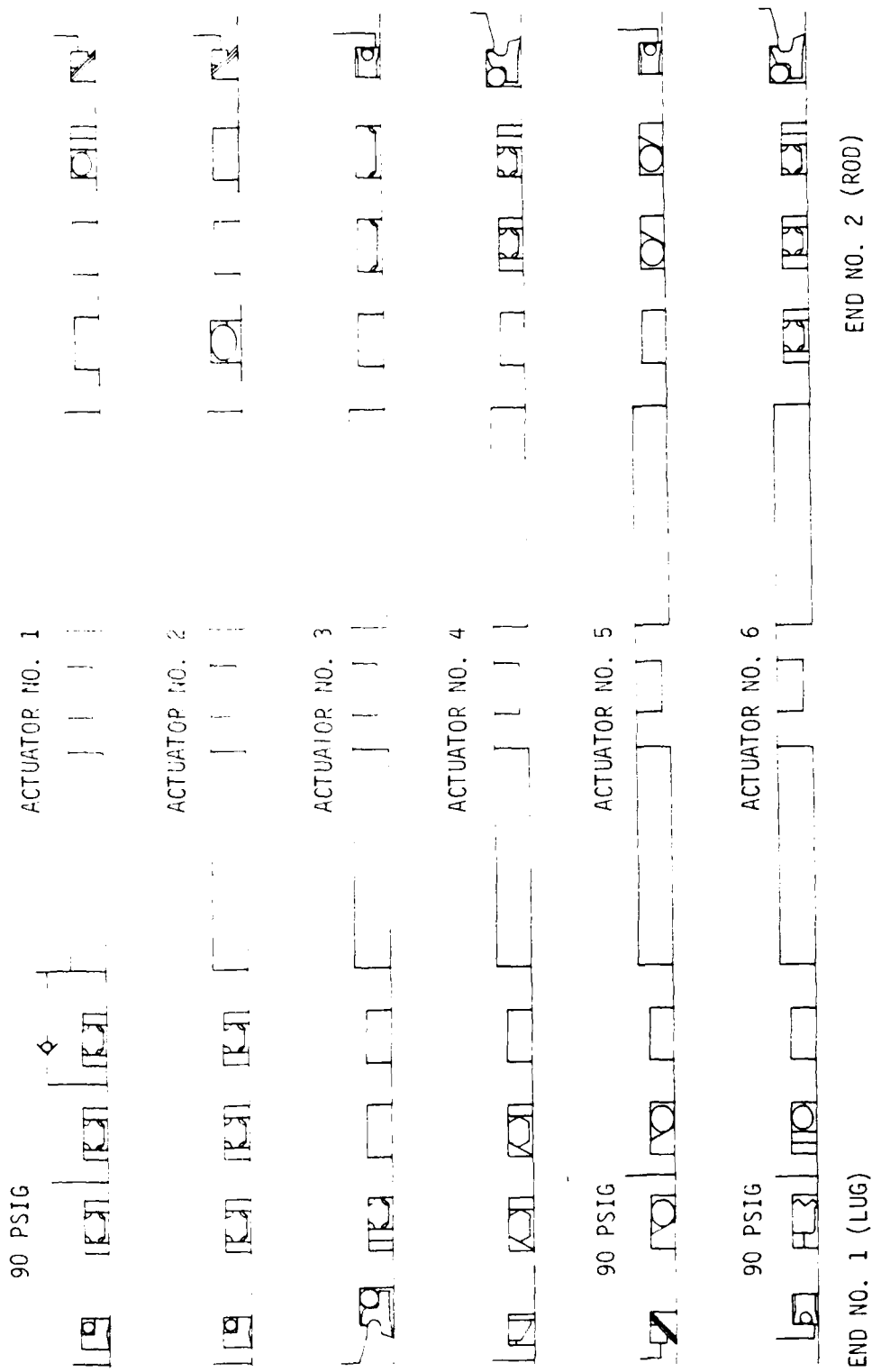

FIGURE 7. SEALS SELECTED FOR TASK III TEST

TABLE 7. TASK III ROD SEAL DESCRIPTION #1

ACT NO.	LUG END	ROD END	GROOVE			SFAL NAME & PART NUMBER	MANUFACTURER	MATERIAL
			A	B	C			
1	X		X	X	X	Plus Seal S30775-214P-19	W. S. Shamban	Turcon with proprietary MoS ₂ filler. Elastomer per MIL-P-83461.
			X	X	X	Backup Ring (2) S33157-214-19	W. S. Shamban	Turcon with proprietary MoS ₂ filler.
					X	Excluder S32925-9P-19	W. S. Shamban	Turcon with proprietary MoS ₂ filler.
					X	O-Ring M83461/1-121	Parker	MIL-P-83461
1		X			X	Double Delta S30650-214-14	W. S. Shamban	Turcon with glass and proprietary MoS ₂ filler
					X	O-Ring M83461/1-214	Parker	MIL-P-83461
					X	Backup Ring (2) S33157-214-14	W. S. Shamban	Turcon with glass and proprietary MoS ₂ filler
					X	Seal Guard S-34-20	Hercules	Bronze with a Nitrile Load Ring

TABLE 7. CONTINUED

#2

ACT NO.	LUG END	ROD END	GROOVE				SEAL NAME & PART NUMBER	MANUFACTURER	MATERIAL
			A	B	C	D			
2	X		X	X	X	Plus Seal S30775-214P-19	W. S. Shamban	Turcon with proprietary MoS ₂ filler. Elastomer per MIL-P-83461.	
			X	X	X	Backup Ring (2) S33157-214-19	W. S. Shamban	Turcon with proprietary MoS ₂ filler.	
						Excluder S32925-9P-19	W. S. Shamban	Turcon with proprietary MoS ₂ filler.	
						O-Ring M83461/1-121	Parker	MIL-P-83461	
2		X	X			Maxi-Flex Seal TF831M-7214	Tetrafluor	Tetralon 720	
			X			O-Ring M83461/1-318	Parker	MIL-P-83461	
						Seal Guard S-34-20	Hercules	Bronze with a Nitrile Load Ring	

TABLE 7. CONTINUED

#3

ACT NO.	LUG END	ROD END	GROOVE				SEAL NAME & PART NUMBER	MANUFACTURER	MATERIAL
			A	B	C	D			
3	X			X			Plus Seal S30775-214P-19	W. S. Shamban	Turcon with proprietary MoS2 filler. Elastomer per MIL-P-83461.
						X	Wiper/Scraper 120-218-1709	Dowty Seals Limited	Acetal Resin
						X	O-Ring 100-218-0074	Dowty Seals Limited	Nitrile
3		X		X	X		Enercap Seal 595-21400-160 -PX1	Greene Tweed	Ekanol filled TFE Proprietary Nitrile
						X	Polypak 1870100074651053	Parker Packing	Polymyte

TABLE 7. CONTINUEE

#4

ACT NO.	LUG END	POD END	GROOVE			SEAL NAME & PART NUMBER	MANUFACTURER	MATERIAL
			A	B	C			
4	X		X	X		Con-O-flex; CEC 6001-214	C. E. Conover & Co.	Revonoc 6200 Proprietary 70 Durometer Nitrile
			X	X		Backup Ring CEC5110-214	C. E. Conover & Co.	Revonoc 6200
					X	Scraper CEC5091-998-55 and Spacer	C. E. Conover & Co.	Revonoc 18159
4		X	X	X		Plus Seal S30775-214P-19	W. S. Shamban	Turcon with proprietary MoS ₂ filler. Elastomer per MIL-P-83461
			X	X		Backup Ring (2) S33157-214-19	W. S. Shamban	Turcon with proprietary MoS ₂ filler.
					X	Wiper/Scraper 120-218-1709	Dovty Seals Limited	Acetal Resin
					X	O-Ring 100-218-0074	Dovty Seals Limited	Nitrile

TABLE 7. CONTINUED

#5

ACT NO.	LUG END	ROD END	GROOVE				SEAL NAME & PART NUMBER	MANUFACTURER	MATERIAL
			A	B	C	D			
5	X		X	X			Trapezoid Seal CEC5065-214	C. E. Conover	Revonoc 6200
			X	X			O-Ring M83461/1-214	Parker	MIL-P-83461
					X		Seal Guard S-34-20	Hercules	Bronze with a nitrile Load Ring.
5		X	X	X			Trapezoid Seal CEC 5065-214	C. E. Conover	Revonoc 6200
			X	X			O-Ring M83461/1/214	Parker	MIL-P-83461
					X		Polypak 18701000Z 4651D53	Parker	Polymyte

TABLE 7. CONTINUED

#6

ACT NO.	LUG END	ROD END	GROOVE				SEAL NAME & PART NUMBER	MANUFACTURER	MATERIAL
			A	B	C	D			
6	X		X				Double Delta S30650-214-19	W. S. Shamban	Turcon with proprietary MoS ₂ filler.
			X				O-Ring M83461/1-214	Parker	MIL-P-83461
			X				Backup Ring (2) S33157-214-19	W. S. Shamban	Turcon with proprietary MoS ₂ filler.
				X			Hat Seal S33051-214-99	W. S. Shamban	Turcon with MoS ₂ filler.
					X		Polypak 18701000Z4651D53	Parker	Polymyte
6		X	X	X	X		Plus Seal S30775-214P-19	W. S. Shamban	Turcon with proprietary MoS ₂ filler. Elastomer per MIL-P-83461.
			X	X	X		Backup Ring (2) S33157-214-19	W. S. Shamban	Turcon with proprietary MoS ₂ filler.
					X		Wiper/Scraper 120-218-1709	Dowty Seals Limited	Acetal Resin
					X		O-Ring 100-218-0074	Dowty Seals Limited	Nitrile

TASK III - TESTING

Task III consisted of a 5 million a cycle endurance test and a 20 million cycle rotor feedback test. A summary of the Task III test is shown in Table 8.

Before the test could be performed, the test actuators were reworked to include press fit bronze inserts that were machined to accept four different kinds of scrapers. All rods were ground to restore the proper finish, and where necessary, replated and ground.

During the Task III test, the 2% stroke cycles at 8.33 Hz were superimposed on the 10% stroke cycles at 1.67 Hz, the 50% stroke cycles at .42 Hz and the full stroke cycles at .15 Hz by electrically combining the two sinusoidal wave forms electronically to form the command signal to the Electro-Hydraulic Servo Actuator that drove the hydraulic servo-valve. During the 2% stroke cycles at 8.33 Hz, a 0.15 Hz, +/- 1-inch stroke was superimposed in the same manner to prevent artificially overheating a seal and to more closely simulate flight conditions.

During the endurance test, 5,561,850 cycles were imposed on the seals. Of these, 5000 were full stroke, 25,000 were half stroke, 70,000 were 10% stroke and 5,461,850 were 2% stroke. During the 8000 psi tests the pressure from the pump started to decay during the short stroke cycles. The cause of decay was not known so cycling continued while the setup was monitored and parts were checked to isolate the problem. The pump was finally identified as the problem, so it was replaced on 28 July. An additional 440,500 of the short stroke cycles were run to assure that the test had met all requirements. During the rotor feedback test an additional 20,586,870 cycles were imposed. Of the 20,586,870 cycles, 10,634,940 cycles imposed a compression load and 9,951,930 imposed a tension load. A fully reversing sinusoidal load could not be imposed during rotor feedback because of stroke limitations of the Electro Mechanical Shaker, but the position of the actuators was varied sinusoidally at 0.15 Hz with a 2-inch double amplitude. The load imposed during rotor feedback tests was 33.3 - 966.6 lbs. per actuator, with a stroke of .015 - .02-inch.

The average pressurized friction for the Task III seals is shown in Figure 8. The unpressurized friction for the seals is shown in Table 11. The daily leakage for the seals is shown in Tables 9 and 10. A performance summary for each seal is given in Table C-1 in Appendix C. The measured critical dimensions for each actuator are given in Table C-2 in Appendix C.

All of the seals that failed the Task III test failed during the rotor feedback test. The Double Delta Seal (Rod End, Actuator No. 1) failed after 6,035,850 cycles. It was replaced by an O-ring with two Tetrafluor backup rings which failed after an additional 4,650,540 cycles. The O-ring was replaced by a Shamban Plus Seal with no backup rings. At the same time, the Greene Tweed Enercap Seals (rod end,

Actuator No. 3) were replaced because of excessive leakage. They were replaced by a two-stage Omni Seal installation. There were no additional failures during the rotor feedback test.

During the performance test at the end of the Task III test, it became obvious that the 25 cycles required would not produce measurable leakage. The technician was instructed to cycle the actuators for 2000 long stroke (+/- 1.75 in) cycles. After 1620 cycles the test stand reservoir was depleted by a massive failure of the replacement Plus Seal in the rod end of actuator no. 1. The test was terminated at that point since all requirements had been satisfied. The leakage results for the seals that completed the entire test are shown in Figure 9.

TABLE 8. TASK III TEST SUMMARY

<u>TYPE OF TEST</u>	<u>AMBIENT TEMPERATURE</u>	<u>FLUID TEMPERATURE</u>	<u>CYCLES</u>
Unpressurized Friction	Room Ambient	----	---
Pressurized Friction	Room Ambient	---	----
Acceptance	Room Ambient	Room Ambient	25 LS
High Temp. 3000 psig test MIL-H-5606	60°F to 275°F	225°F+/-25°F	2.56 x 10 ⁶
Performance Test	Room Ambient	Room Ambient	25 LS
<u>Fluid Change</u>	6-24-80		
Performance Test	Room Ambient	Room Ambient	25 LS
High Temp 3000 psig Test MIL-H-83282	60°F to 275°F	225°F+/-25°F	2.0 x 10 ⁶
Performance Test	Room Ambient	Room Ambient	25 LS
High Temp 8000 psig Test MIL-H-83282	60°F to 275°F	225°F+/-25°F	998,250
Performance Test	Room Ambient	Room Ambient	25 LS
Rotor Feedback	60°F to 275°F	225°F+/-25°F	20.5 x 10 ⁶
Performance Test	Room Ambient	Room Ambient	1620 LS

TABLE 9. LEAKAGE AND INTERSTAGE PRESSURE DATA DURING ENDURANCE TEST

ACTUATOR NUMBER 1

DATE	START UP TEMP.	OVER NIGHT LKG.	NUMBER OF CYCLES		END NUMBER 1 (LUG) LEAKAGE			END NUMBER 2 (ROD) LEAKAGE											
			SHORT STROKE	LONG STROKE	(END OF DAY) CC	(END OF DAY) DROPS	(END OF DAY) PRESSURE (MAX) PORT B	(END OF DAY) PRESSURE (MAX) PORT C	(END OF DAY) PRESSURE (MAX) PORT D	(END OF DAY) CC	(END OF DAY) DROPS	(END OF DAY) PRESSURE (MAX) PORT B	(END OF DAY) PRESSURE (MAX) PORT C	(END OF DAY) PRESSURE (MAX) PORT D					
1980																			
29 May	86°	0		500FS 2500HS	0	0	0	90	0	0	0	0	0	0	0	0	0	0	0
30 May	79°	0	84600	7000TS	0	0	0	90	0	0	0	0	0	0	0	0	0	0	0
2 June	80°	0	115000		0	0	0	90	0	0	0	0	0	0	0	0	0	0	0
3 June	80°	0	105000		0	0	0	90	0	0	0	0	0	0	0	0	0	0	0
4 June	80°	0	189000		0	0	0	90	0	0	0	0	0	0	0	0	0	0	0
5 June	80°	0	50000 90000	500FS 2500HS 7000TS	0	0	0	90	0	0	0	0	0	0	0	0	0	0	0
6 June	81°	0	180000		0	0	0	90	0	0	0	0	0	0	0	0	0	0	0
9 June	74°	0	180000		0	0	0	90	0	0	0	0	0	0	0	0	0	0	0
10 June	75°	0	50000 10000	500FS 2500HS 7000TS	0	0	0	90	0	0	0	0	0	0	0	0	0	0	0
11 June	76°	0	202500		0	0	0	90	0	0	0	0	0	0	0	0	0	0	0

3000 psig Test

FS = Full Stroke
 HS = Half Stroke
 TS = 10% Stroke
 Short Stroke = 2% stroke

TABLE 9. CONTINUED

ACTUATOR NUMBER 1

DATE	START UP TEMP.	OVER NIGHT LKG.	NUMBER OF CYCLES		END NUMBER 1 (LUG) LEAKAGE			END NUMBER 2 (ROD) LEAKAGE										
			SHORT STROKE	LONG STROKE	CC	DROPS	B	C	T	CC	DROPS	B	C	D				
1980																		
12 June	78°	0	137500		0	0	0	0	90	0	0	0	0	0	0	-	-	
13 June	78°	0	140000	500FS 2500HS	0	0	0	0	0	0	0	0	0	0	0	-	-	
16 June	80°	0	195000	7000TS	0	0	0	0	0	0	0	0	0	0	0	-	-	
17 June	81°	0	202500		0	0	0	0	0	0	0	0	0	0	0	-	-	
18 June	82°	0	92500	500FS 2500HS 7000TS	0	0*	0	0	0	0	0	0	0	0	0*	-	-	
19 June	82°	0	175000		0	0	0	0	0	0	0	0	0	0	0	-	-	
20 June	83°	0	200000		0	0	0	0	0	0	0	0	0	0	0	-	-	
23 June	83	0	65000		0	0	0	0	0	0	0	0	0	0	0	-	-	
24 June	NO CYCLING FLUID CHANGE																	
25 June	82	0	50000	500FS 2500HS	0	0	0	0	0	0	0	0	0	0	0	0	-	-
26 June	78	0	122500	7000TS	0	0	0	0	0	0	0	0	0	0	0	0	-	-

3000 psig test

* Some fluid on rod

TABLE 9. CONTINUED

ACTUATOR NUMBER 1

DATE	START UP TEMP.	OVER NIGHT LKG.	NUMBER OF CYCLES		END NUMBER 1 (LUG) LEAKAGE			END NUMBER 2 (ROD) LEAKAGE												
			SHORT STROKE	LONG STROKE	(END OF DAY) CC	(END OF DAY) DROPS	(MAX) PORT C	(MAX) PORT D	(END OF DAY) CC	(END OF DAY) DROPS	(MAX) PORT C	(MAX) PORT D								
1980																				
27 June	85	0	190000				0	0	0	90	0	0	0	0	0	0	0	0	0	0
30 June	83	0	127500	500FS 1890HS			0	0	0	90	0	0	0	0	0	0	0	0	0	0
1 July	87	0	180000	610 HS 7000 TS			0	0	0	90	0	0	0	0	0	0	0	0	0	0
2 July	86	0	200000				0	0	0	90	0	0	0	0	0	0	0	0	0	0
3 July	85	0	50000 110000	500 FS 2500 HS			0	0	0	90	0	0	0	0	0	0	0	0	0	0
7 July	84	0	162500	7000 TS			0	0	0	90	0	0	0	0	0	0	0	0	0	0
8 July	84	Rod .6cc	202500				0	0	0	90	0	0	0	0	0	0	0	0	0	0
		Rod	75000	500 FS																
9 July	84	3 drops	50000	2500 HS 7000 TS			0	0	0	90	0	0	0	0	0	0	0	0	0	0
10 July	86	Trace	202500				0	0	0	90	0	0	0	0	0	0	0	0	0	0
11 July	85		80000				0	0	0	90	0	0	0	0	0	0	0	0	0	0
14 July	85	Trace	157500				0	0	0	90	0	0	0	0	0	0	0	0	0	0

3000 psig Tests

TABLE 9. CONTINUED

ACTUATOR NUMBER 1

DATE	START UP TEMP.	OVER NIGHT LKG.	NUMBER OF CYCLES		END NUMBER 1 (LUG) LEAKAGE (END OF DAY)	PRESSURE (MAX) PORT		END NUMBER 2 (ROD) LEAKAGE (END OF DAY)	PRESSURE (MAX) PORT	
			SHORT STROKE	LONG STROKE		CC	DROPS		CC	DROPS
17 July 1980	-	0		500FS	0	0	0	0	0	0
18 July	86	0	50000	7000TS 2500HS	0	0	0	0	0	0
21 July	86	0	96250		0	0	0	0	0	0
22 July	82	0	30000		0	0	0	0	0	0
23 July	82	0	157500		0	0	0	0	0	0
24 July	83	0	154000		0	0	0	0	0	0
25 July	85	0	60000		0	0	0	0	0	0
28 July	80	1 Dp Rod	42500		0	0	0	0	0	0
29 July	80	0	85000		0	0	0	0	0	0
30 July	82			No	Running	~	No cooling water			
31 July	83	TR Rod	200000		0	0	0	0	0	0
1 Aug	83	0	113000		0	0	0	0	0	0

8000 psig Test

TABLE 9. CONTINUED

ACTUATOR NUMBER 2

DATE	START UP TEMP.	OVER NIGHT LKG.	NUMBER OF CYCLES		END NUMBER 1 (LUG) LEAKAGE			END NUMBER 2 (ROD) LEAKAGE					
			SHORT STROKE	LONG STROKE	(TEND OF DAY) CC	(TEND OF DAY) DROPS	(MAX) PORT C	(MAX) PORT P	(TEND OF DAY) CC	(TEND OF DAY) DROPS	(MAX) PORT C	(MAX) PORT D	
1980 29 May	86°	0		500FS 2500HS	0	0	0	0	0	0	0	-	-
30 May	79°	0	84600	7000TS	0	0	0	0	0	0	0	-	-
2 June	80°	0	115000	0	0	0	0	0	0	0	0	-	-
3 June	80°	0	105000	0	0	0	0	0	0	0	0	-	-
4 June	80°	0	189000	0	0	0	0	0	0	0	0	-	-
5 June	80°	0	50000	500FS	0	0	0	0	0	0	0	-	-
			90000	2500HS									
				7000TS									
6 June	81°	0	180000		0	0	0	0	0	0	0	-	-
9 June	74°	0	180000		0	0	0	0	0	0	0	-	-
			50000	500FS									
10 June	75°	0	10000	2500HS	0	0	0	0	0	0	0	-	-
				7000TS									
11 June	76°	0	202500		0	0	0	0	0	0	0	-	-

3000 psig Test

TABLE 9. CONTINUED

ACTUATOR NUMBER 2

DATE	START UP TEMP.	OVER NIGHT LKG.	NUMBER OF CYCLES		END NUMBER 1 (LUG) LEAKAGE			END NUMBER 2 (ROD) LEAKAGE											
			SHORT STROKE	LONG STROKE	CC	DROPS	B	C	D	CC	DROPS	B	C	D					
1980																			
12 June	78°	0	137500		0	0	0	0	0	0	0	0	0	0	0	0	0	0	0
13 June	78°	0	140000	500FS 2500HS	0	0	0	0	0	0	0	0	0	0	0	0	0	0	0
16 June	80°	0	95000	7000TS	0	0	0	0	0	0	0	0	0	0	0	0	0	0	0
17 June	81°	0	202500		0	0	0	0	0	0	0	0	0	0	0	0	0	0	0
18 June	82°	0	92500	500FS 2500HS 7000TS	0	0*	0	0	0	0	0	0	0	0	0	0	0	0	0
19 June	82°	0	175000		0	0	0	0	0	0	0	0	0	0	0	0	0	0	0
20 June	83°	0	200000		0	0	0	0	0	0	0	0	0	0	0	0	0	0	0
23 June	83	0	65000		0	0	0	0	0	0	0	0	0	0	0	0	0	0	0
24 June	NO CYCLING FLUID CHANGE																		
25 June	82	0	50000	500 FS 2500 HS	0	0	0	0	0	0	0	0	0	0	0	0	0	0	0
26 June	78	0	122500	7000 TS	0	0	0	0	0	0	0	0	0	0	0	0	0	0	0

3000 psig Test

* Some fluid on rod

TABLE 9. CONTINUED

ACTUATOR NUMBER 2

DATE	START UP TEMP.	OVER NIGHT LKG.	NUMBER OF CYCLES		END NUMBER 1 (LUG) LEAKAGE			END NUMBER 2 (ROD) LEAKAGE												
			SHORT STROKE	LONG STROKE	(END OF DAY) CC	(MAX) PORT B	(MAX) PORT C	(END OF DAY) CC	(MAX) PORT B	(MAX) PORT C										
1980																				
27 June	85	0	190000				0	0	0	0	0	0	0	0	0	0	0	0	0	0
30 June	83	0	127500	500 FS 1890 HS			0	0	0	0	0	0	0	0	0	0	0	0	0	0
1 July	87	0	180000	610 HS 7000 TS			0	0	0	0	0	0	0	0	0	0	0	0	0	0
2 July	86	0	200000				0	0	0	0	0	0	0	0	0	0	0	0	0	0
3 July	85	0	50000 110000	500 FS 2500 HS			0	0	0	0	0	0	0	0	0	0	0	0	0	0
7 July	84	0	162500	7000 TS			0	0	0	0	0	0	0	0	0	0	0	0	0	0
8 July	84	0	202500 75000	500 FS			0	0	0	0	0	0	0	0	0	0	0	0	0	0
9 July	84	0	50000	2500 HS 7000 TS			0	0	0	0	0	0	0	0	0	0	0	0	0	0
10 July	86	0	202500				0	0	0	0	0	0	0	0	0	0	0	0	0	0
11 July	85	0	80000				0	0	0	0	0	0	0	0	0	0	0	0	0	0
14 July	85	0	157500				0	0	0	0	0	0	0	0	0	0	0	0	0	0

3000 psig Test

TABLE 9. CONTINUED

ACTUATOR NUMBER 2

DATE	START UP TEMP.	OVER NIGHT LKG.	NUMBER OF CYCLES		END NUMBER 1 (LUG) LEAKAGE			END NUMBER 2 (ROD) LEAKAGE										
			SHORT STROKE	LONG STROKE	(END OF DAY) CC	(END OF DAY) DROPS	(MAX) PORT C	(MAX) PORT D	(END OF DAY) CC	(END OF DAY) DROPS	(MAX) PORT C	(MAX) PORT D						
17 July 1980		0		500FS	0	0	0	0	0	0	0	0	0	0	0	0	0	0
18 July	86	0	50000	7000TS 2500HS	0	0	0	0	0	0	0	0	0	0	0	0	0	0
21 July	86	0	96250		0	0	0	0	0	0	0	0	0	0	0	0	0	0
22 July	82	0	30000		0	0	0	0	0	0	0	0	0	0	0	0	0	0
23 July	82	0	157500		0	0	0	0	0	0	0	0	0	0	0	0	0	0
24 July	83	0	154000		0	0	0	0	0	0	0	0	0	0	0	0	0	0
25 July	83	0	60000		0	0	0	0	0	0	0	0	0	0	0	0	0	0
28 July	80	0	42500		0	0	0	0	0	0	0	0	0	0	0	0	0	0
29 July	80	0	85000		0	0	0	0	0	0	0	0	0	0	0	0	0	0
30 July	82		No Running	No Cooling water														
31 July	83	0	200000		0	0	0	0	0	0	0	0	0	0	0	0	0	0
1 Aug	83	0	113000		0	0	0	0	0	0	0	0	0	0	0	0	0	0

8000 psig Test

TABLE 9. CONTINUED
ACTUATOR NUMBER 3

DATE	START UP TEMP.	OVER NIGHT LKG.	NUMBER OF CYCLES		END NUMBER 1 (LUG) LEAKAGE			END NUMBER 2 (ROD) LEAKAGE						
			SHORT STROKE	LONG STROKE	(END OF DAY) CC	(END OF DAY) DROPS	PRESSURE (MAX) PORT B	PRESSURE (MAX) PORT C	PRESSURE (MAX) PORT D	(END OF DAY) CC	(END OF DAY) DROPS	PRESSURE (MAX) PORT B	PRESSURE (MAX) PORT C	PRESSURE (MAX) PORT D
1980 29 May	86°	0	0	500FS 2500HS	0	6	-	-	0	0	-	-	0	0
30 May	79°	0	84600	7000TS	0	0	-	-	0	0	-	-	0	0
2 June	80°	0	115000	0	0	0	-	-	0	0	-	-	0	0
3 June	80°	0	105000	0	0	0	-	-	0	0	-	-	0	0
4 June	80°	0	189000	0	0	0	-	-	0	0	-	-	0	0
5 June	80°	0	50000	500FS	0	0	-	-	0	0	-	-	0	0
			90000	2500HS 7000TS										
6 June	81°	0	180000		0	0	-	-	0	0	-	-	0	0
7 June	74°	0	180000		0	0	-	-	0	0	-	-	0	0
			50000	500FS										
10 June	75°	0	10000	2500HS 7000TS	0	0	-	-	0	0	-	-	0	0
11 June	76°	0	202500		0	0	-	-	0	0	-	-	0	0

TABLE 9. CONTINUED

ACTUATOR NUMBER 3

DATE	START UP TEMP.	OVER NIGHT LKG.	NUMBER OF CYCLES		END NUMBER 1 (LUG) LEAKAGE (END OF DAY)	END NUMBER 2 (ROD) LEAKAGE (END OF DAY)						
			SHORT STROKE	LONG STROKE		CC	DROPS	B	C	D		
12 June 1980	78°	0	137500		0	0	0	0	0	0	0	0
13 June	78°	0	140000	500FS 2500HS	0	0	0	0	0	0	0	0
16 June	80°	0	95000		0	0	0	0	0	0	0	0
17 June	81°	0	202500		0	0	0	0	0	0	0	0
18 June	82°	0	92500	500FS 2500HS 7000TS	0	0	0	0	0	0	0	0
19 June	82°	0	175000		0	0	0	0	0	0	0	0
20 June	83°	0	200000		0	0	0	0	0	0	0	0
23 June	83	0	65000		0	0	0	0	0	0	0	0
24 June	NO CYCLING FLUID CHANGE											
25 June	82	0	50000	500 FS 2500 HS	0	0	0	0	0	0	0	0
26 June	78	0	122500	7000 TS	0	0	0	0	0	0	0	0

3000 psig Test

TABLE 9. CONTINUED

ACTUATOR NUMBER 3

DATE	START UP TEMP.	OVER NIGHT LKG.	NUMBER OF CYCLES		END NUMBER 1 (LUG) LEAKAGE			END NUMBER 2 (ROD) LEAKAGE					
			SHORT STROKE	LONG STROKE	(END OF DAY) CC	(END OF DAY) DROPS	(MAX) PORT C	(MAX) PORT D	(END OF DAY) CC	(END OF DAY) DROPS	(MAX) PORT C	(MAX) PORT D	
27 June 1980	85	0	190000		0	0	-	0	0	0	0	0	0
30 June	83	0	127500	500 FS: 1890 HS	0	0	-	0	0	0	0	0	0
1 July	87	0	180000	610 HS: 7000 TS	0	0	-	0	0	0	0	0	0
2 July	86	0	200000		0	0	-	0	0	0	0	0	0
3 July	85	0	50000 110000	500 FS: 2500 HS	0	0	-	0	0	0	0	0	0
7 July	84	0	162500	7000 TS	0	0	-	0	0	0	0	0	0
8 July	84	0	202500 75000		0	0	-	0	0	0	0	0	0
9 July	84	0	50000	500FS: 2500HS: 7000TS	0	0	-	0	0	0	0	0	0
10 July	86	0	202500		0	0	-	0	0	0	0	0	0
11 July	85		80000		0	0	-	0	0	0	0	0	0
14 July	85	0	157500		0	0	-	0	0	0	0	0	0

3000 psig Test

TABLE 9. CONTINUED

ACTUATOR NUMBER 3

DATE	START UP TEMP.	OVER NIGHT LKG.	NUMBER OF CYCLES		END NUMBER 1 (LUG) LEAKAGE			END NUMBER 2 (ROD) LEAKAGE								
			SHORT STROKE	LONG STROKE	CC	DROPS	B	C	D	CC	DROPS	B	C	D		
17 July 1980	-	0		500	0	0	-	-	-	0	0	-	-	0	0	
18 July	86	0	50000	2500	0	0	-	-	-	0	0	-	-	0	0	
21 July	86	LUG TRACE	96250		0	0	-	-	-	0	0	-	-	0	0	
22 July	82	0	30000		0	0	-	-	-	0	0	-	-	0	0	
23 July	82	TR LUG TR ROD	157500		0	0	-	-	-	0	0	-	-	0	0	
24 July	83	0	154000		0	0	-	-	-	0	0	-	-	0	0	
25 July	85	0	60000		0	0	-	-	-	0	0	-	-	0	0	
28 July	80	0	42500		0	0	-	-	-	0	0	-	-	0	0	
29 July	80	0	85000		0	0	-	-	-	0	0	-	-	0	0	
30 July			No Running - No Cooling water													
31 July	83	TRACE ROD	200000		0	0	-	-	-	0	0	-	-	0	0	
1 Aug	83	0	113000		0	0	-	-	-	0	0	-	-	0	0	

8000 psig Test

TABLE 9. CONTINUED

ACTUATOR NUMBER 4

DATE	START UP TEMP.	OVER NIGHT LKG.	NUMBER OF CYCLES		END NUMBER 1 (LUG) LEAKAGE			END NUMBER 2 (ROD) LEAKAGE												
			SHORT STROKE	LONG STROKE	(END OF DAY) CC	(END OF DAY) DROPS	(END OF DAY) PRESSURE (MAX) PORT B	(END OF DAY) PRESSURE (MAX) PORT C	(END OF DAY) PRESSURE (MAX) PORT D											
1980																				
29 May	86°	0	0	0	500FS	0	0	0	0	0	0	0	0	0	0	0	0	0	0	0
30 May	79°	0	84600	7000TS	7000TS	0	0	0	0	0	0	0	0	0	0	0	0	0	0	0
2 June	80°	0	115000	0	0	0	0	0	0	0	0	0	0	0	0	0	0	0	0	0
3 June	80°	0	105000	0	0	0	0	0	0	0	0	0	0	0	0	0	0	0	0	0
4 June	80°	0	189000	0	0	0	0	0	0	0	0	0	0	0	0	0	0	0	0	0
5 June	80°	0	50000	500FS	0	0	0	0	0	0	0	0	0	0	0	0	0	0	0	0
			90000	2500HS	0	0	0	0	0	0	0	0	0	0	0	0	0	0	0	0
6 June	81°	0	180000	7000TS	0	0	0	0	0	0	0	0	0	0	0	0	0	0	0	0
			180000	0	0	0	0	0	0	0	0	0	0	0	0	0	0	0	0	0
6/09/80	74°	0	180000	500FS	0	0	0	0	0	0	0	0	0	0	0	0	0	0	0	0
			50000	2500HS	0	0	0	0	0	0	0	0	0	0	0	0	0	0	0	0
10 June	75°	0	10000	7000TS	0	0	0	0	0	0	0	0	0	0	0	0	0	0	0	0
			202500	0	0	0	0	0	0	0	0	0	0	0	0	0	0	0	0	0
11 June	76°	0	202500	0	0	0	0	0	0	0	0	0	0	0	0	0	0	0	0	0

3000 psig Test

TABLE 9. CONTINUED

ACTUATOR NUMBER 4

DATE	START UP TEMP.	OVER NIGHT LKG.	NUMBER OF CYCLES		END NUMBER 1 (LUG) LEAKAGE			END NUMBER 2 (ROD) LEAKAGE						
			SHORT STROKE	LONG STROKE	TEND OF DAY CC	DROPS	PRESSURE (MAX) PORT B	C	D	TEND OF DAY CC	DROPS	PRESSURE (MAX) PORT B	C	D
12 June 1980	78°	0	137500		0	0	-	0	0	0	-	0	0	0
13 June	78°	0	140000	500FS 2500HS	0	0	-	0	0	0	-	0	0	0
16 June	80°	0	95000	50000	0	0	-	0	0	0	-	0	0	0
17 June	81°		202500		0	0	-	0	0	0	-	0	0	0
18 June	82°	0	92500	500FS 2500HS 7000TS	0	0	-	0	0	0	-	0	0	0
19 June	82°	0	175000		0	0	-	0	0	0	-	0	0	0
20 June	83°	0	200000		0	0	-	0	0	0	-	0	0	0
23 June	83	0	65000		0	0	-	0	0	0	-	0	0	0
24 June	NO CYCLING FLUID CHANGE						NO CYCLING							
25 June	82	0	50000	500 FS 2500 HS	0	0	-	0	0	0	-	0	0	0
26 June	78	LUG END TRACE	122500	7000 TS	0	0	-	0	0	0	-	0	0	0

3000 psig Test

TABLE 9. CONTINUED

ACTUATOR NUMBER 4

DATE	START UP TEMP.	OVER NIGHT LKG.	NUMBER OF CYCLES		END NUMBER 1 (LUG) LEAKAGE			END NUMBER 2 (POD) LEAKAGE						
			SHORT STROKE	LONG STROKE	(END OF DAY) CC	(END OF DAY) DROPS	(END OF DAY) PRESSURE (MAX) PORT B	(END OF DAY) PRESSURE (MAX) PORT C	(END OF DAY) PRESSURE (MAX) PORT D	(END OF DAY) CC	(END OF DAY) DROPS	(END OF DAY) PRESSURE (MAX) PORT B	(END OF DAY) PRESSURE (MAX) PORT C	(END OF DAY) PRESSURE (MAX) PORT D
1980 27 June	85	0	190000		0	0	-	0	0	0	-	0	0	0
30 June	83	0	127500	500 FS 1890 HS	0	0	-	0	0	0	-	0	0	0
1 July	87	0	180000	610 HS 7000 TS	0	0	-	0	0	0	-	0	0	0
2 July	86	0	200000		0	0	-	0	0	0	-	0	0	0
3 July	85	0	50000 110000	500 FS 2500 HS	0	0	-	0	0	0	-	0	0	0
7 July	84	0	162500	7000 TS	0	0	-	0	0	0	-	0	0	0
8 July	84	0	202500 75000		0	0	-	0	0	0	-	0	0	0
9 July	84	0	50000	500 FS 2500 HS 7000 TS	0	0	-	0	0	0	-	0	0	0
10 July	86	0	202500		0	0	-	0	0	0	-	0	0	0
11 July	85		80000		0	0	-	0	0	0	-	0	0	0
14 July	85	0	157500		0	0	-	0	0	0	-	0	0	0

3000 psig Test

TABLE 9. CONTINUED
ACTUATOR NUMBER 4

DATE	START UP TEMP.	OVER NIGHT LKG.	NUMBER OF CYCLES		END NUMBER 1 (LUG) LEAKAGE			END NUMBER 2 (ROD) LEAKAGE						
			SHORT STROKE	LONG STROKE	(END OF DAY) CC	(END OF DAY) DROPS	(MAX) PORT B	(MAX) PORT C	(MAX) PORT D	(END OF DAY) CC	(END OF DAY) DROPS	(MAX) PORT B	(MAX) PORT C	(MAX) PORT D
17 July 1980	-	0		500FS	0	0	-	0	0	0	-	0	0	0
18 July	86	0	50000	7000TS 2500HS	0	0	-	0	0	0	-	0	0	0
21 July	86	0	96250		0	0	-	0	0	0	-	0	0	0
22 July	82	0	30000		0	0	-	0	0	0	-	0	0	0
23 July	82	0	157500		0	0	-	0	0	0	-	0	0	0
24 July	83	0	154000		0	0	-	0	0	0	-	0	0	0
25 July	85	0	60000		0	0	-	0	0	0	-	0	0	0
28 July	80	0	42500		0	0	-	0	0	0	-	0	0	0
29 July	80	0	85000		0	0	-	0	0	0	-	0	0	0
30 July	82		No	Running - No Cooling water										
31 July	83	0	200000		0	0	-	0	0	0	-	0	0	0
1 Aug	83		113000		0	0	-	0	0	0	-	0	0	0

8000 psig Test

TABLE 9. CONTINUED

ACTUATOR NUMBER 5

DATE	START UP TEMP.	OVER NIGHT LKG.	NUMBER OF CYCLES		LONG STROKE	END NUMBER 1 (LUG) LEAKAGE			END NUMBER 2 (ROD) LEAKAGE										
			SHORT STROKE	LONG STROKE		CC	DROPS	B	C	D	CC	DROPS	B	C	D				
1980					500FS														
29 May	86°	0			2500HS	0	0		90	-	-	0	0	-	-	0	0	0	0
30 May	70°	0	84600		7000TS	0	0		90	-	-	0	0	-	-	0	0	0	0
2 June	80°	0	115000			0	0		90	-	-	0	0	-	-	0	0	0	0
3 June	80°	0	105000			0	0		90	-	-	0	0	-	-	0	0	0	0
4 June	80°	0	189000			0	0		90	-	-	0	0	-	-	0	0	0	0
			50000		500FS														
5 June	80°	0	90000		2500HS	0	0		90	-	-	0	0	-	-	0	0	0	0
					7000TS														
6 June	81°	0	180000			0	0		90	-	-	0	0	-	-	0	0	0	0
9 June	74°	0	180000			0	0		90	-	-	0	0	-	-	0	0	0	0
			50000		500FS														
10 June	75°	0	100000		2500HS	0	0		90	-	-	0	0	-	-	0	0	0	0
					7000TS														
11 June	76°	0	202500			0	0		90	-	-	0	0	-	-	0	0	0	0

3000 psig Test

TABLE 9. CONTINUED

ACTUATOR NUMBER 5

DATE	START UP TEMP.	OVER NIGHT LKG.	NUMBER OF CYCLES		END NUMBER 1 (LUG) LEAKAGE			END NUMBER 2 (ROD) LEAKAGE						
			SHORT STROKE	LONG STROKE	(END OF DAY) CC	(END OF DAY) DROPS	(END OF DAY) PRESSURE (MAX) PORT C	(END OF DAY) D	(END OF DAY) CC	(END OF DAY) DROPS	(END OF DAY) PRESSURE (MAX) PORT C	(END OF DAY) D		
12 June 1980	78°	0	137500		0	0	-	90	-	0	0	-	0	0
13 June	78°	0	140000	500FS: 2500HS:	0	0	-	90	-	0	0	-	0	0
16 June	80°	0	195000	50000 195000	0	0	-	90	-	0	0	-	0	0
17 June	81°	0	202500		0	0	-	90	-	0	0	-	0	0
18 June	82°	0	92500	500FS: 2500HS: 7000TS:	0	0	-	90	-	0	0*	-	0	0
19 June	82°	0	175000		0	0	-	90	-	0	0	-	0	0
20 June	83°	0	200000		0	0	-	90	-	0	0	-	0	0
23 June	83	0	65000		0	0	-	90	-	0	0	-	0	0
24 June	NO CYCLING FLUID CHANGE													
25 June	82	0	50000	500 FS: 2500 HS:	0	0	-	90	-	0	0	-	0	0
26 June	78	0	122500	7000TS:	0	0	-	90	-	0	0	-	0	0

3000 psig Test

* Some fluid on rod.

TABLE 9. CONTINUED

ACTUATOR NUMBER 5

DATE	START UP TEMP.	OVER NIGHT LKG.	NUMBER OF CYCLES		END NUMBER 1 (LUG) LEAKAGE			END NUMBER 2 (ROD) LEAKAGE					
			SHORT STROKE	LONG STROKE	(END OF DAY) CC	(END OF DAY) DROPS	(END OF DAY) PRESSURE (MAX) PORT B	(END OF DAY) PRESSURE (MAX) PORT C	(END OF DAY) PRESSURE (MAX) PORT D				
27 June 1980	85	0	190000		0	0	-	90	-	0	0	0	0
30 June	83	0	127500	500 FS	0	0	-	90	-	0	0	0	0
				1890 HS									
1 July	87	0	180000	610 HS	0	0	-	90	-	0	0	0	0
				7000 TS									
2 July	86	0	200000		0	0	-	90	-	0	0	0	0
				50000									
3 July	85	0	110000	500 FS	0	0	-	90	-	0	0	0	0
				2500 HS									
7 July	84	0	162500	7000 TS	0	0	-	90	-	0	0	0	0
9 July	84	0	202500		0	0	-	90	-	0	0	0	0
				75000									
9 July	84	0	50000	500 FS	0	0	-	90	-	0	0	0	0
				2500 HS									
10 July	86	0	202500	7000 TS	0	0	-	90	-	0	0	0	0
11 July	85	0	80000		0	0	-	90	-	0	0	0	0
14 July	85	0	157500		0	0	-	90	-	0	0	0	0

3000 psig Test

TABLE 9. CONTINUED

ACTUATOR NUMBER 5

DATE	START UP TEMP.	OVER NIGHT LKG.	NUMBER OF CYCLES		END NUMBER 1 (LUG) LEAKAGE			END NUMBER 2 (ROD) LEAKAGE						
			SHORT STROKE	LONG STROKE	CC	DROPS	B	C	n	CC	DROPS	B	C	n
17 July 1980	-	0		500FS	0	0	-	90	-	0	0	-	0	0
18 July	86	0	50000	7000TS 2500HS	0	0	-	90	-	0	0	-	0	0
21 July	86	0	96250		0	0	-	90	-	0	0	-	0	0
22 July	82	0	30000		0	0	-	90	-	0	0	-	0	0
23 July	82	0	157500		0	0	-	90	-	0	0	-	0	0
24 July	83	0	154000		0	0	-	90	-	0	0	-	0	0
25 July	85	0	60000		0	0	-	90	-	0	0	-	0	0
28 July	80	0	42500		0	0	-	90	-	0	0	-	0	0
29 July	80	0	85000		0	0	-	90	-	0	0	-	0	0
30 July	82		No Running - No Cooling water											
31 July	83	0	20000		0	0	-	90	-	0	0	-	0	0
1 Aug	83	0	113000		0	0	-	90	-	0	0	-	0	0

8000 psig Test

TABLE 9. CONTINUED

ACTUATOR NUMBER 6

DATE	START UP TEMP.	OVER NIGHT LKG.	NUMBER OF CYCLES		END NUMBER 1 (LUG) LEAKAGE			END NUMBER 2 (POD) LEAKAGE											
			SHORT STROKE	LONG STROKE	(END OF DAY) CC	(END OF DAY) DROPS	(END OF DAY) PRESSURE (MAX) PORT B	(END OF DAY) PRESSURE (MAX) PORT C	(END OF DAY) PRESSURE (MAX) PORT D	(END OF DAY) CC	(END OF DAY) DROPS	(END OF DAY) PRESSURE (MAX) PORT B	(END OF DAY) PRESSURE (MAX) PORT C	(END OF DAY) PRESSURE (MAX) PORT D					
1980																			
12 June	78°	0	137500			0	0	-	90	0	0	0	0	0	0	0	0	0	0
13 June	78°	0	140000	500FS 2500HS		0	0	-	90	0	0	0	0	0	0	0	0	0	0
16 June	80°	0	195000	7000TS		0	0	-	90	0	0	0	0	0	0	0	0	0	0
17 June	81°	0	202500			0	0	-	90	0	0	0	0	0	0	0	0	0	0
18 June	82°	0	92500	500FS 2500HS 7000TS		0	0	-	90	0	0	0	0	0	0	0	0	0	0
6/19/80	83°	0	175000			0	0	-	90	0	0	0	0	0	0	0	0	0	0
6/20/80	83°	0	200000			0	0	-	90	0	0	0	0	0	0	0	0	0	0
June 23	83	0	65000			0	0	-	90	0	0	0	0	0	0	0	0	0	0
24 June	NO CYCLING FLUID CHANGE																		
25 June	82	0	50000	500 FS 2500 HS		0	0	-	90	0	0	0	0	0	0	0	0	0	0
26 June	78	0	122500	7000 TS		0	0	-	90	0	0	0	0	0	0	0	0	0	0

3000 psig Test

TABLE 9. CONTINUED

ACTUATOR NUMBER 6

DATE	START UP TEMP.	OVER NIGHT LKG.	NUMBER OF CYCLES		END NUMBER 1 (LUG) LEAKAGE			END NUMBER 2 (ROD) LEAKAGE						
			SHORT STROKE	LONG STROKE	CC	DROPS	B	C	D	CC	DROPS	B	C	D
17 July 1980	-	0		500FS	0	0	-	90	0	0	0	0	0	0
				7000FS										
18 July	86	0	50000	2500HS	0	0	-	90	0	0	0	0	0	0
21 July	86	0	96250		0	0	-	90	0	0	0	0	0	0
22 July	82	0	30000		0	0	-	90	0	0	0	0	0	0
23 July	82	0	157500		0	0	-	90	0	0	0	0	0	0
24 July	83	0	154000		0	0	-	90	0	0	0	0	0	0
25 July	85	0	60000		0	0	-	90	0	0	0	0	0	0
28 July	80	0	42500		0	0	-	90	0	0	0	0	0	0
29 July	80	0	85000		0	0	-	90	0	0	0	0	0	0
30 July	82		No. Running	No Cooling water										
31 July	83	0	200000		0	0	-	90	0	0	0	0	0	0
1 Aug	83	0	113000		0	0	-	90	0	0	0	0	0	0

8000 psig Test

TABLE 10. LEAKAGE AND INTERSTAGE PRESSURE DATA DURING ROTOR FEEDBACK TEST

ACTUATOR NUMBER 1

DATE	ROTOR FEEDBACK CYCLES		END NUMBER 1 (LUG) LEAKAGE				END NUMBER 2 (ROD) LEAKAGE					
	DAILY	CUMUL	(END OF DAY) CC	(END OF DAY) DROPS	PRESSURE (MAX) B	PRESSURE (MAX) C	PRESSURE (MAX) D	(END OF DAY) CC	(END OF DAY) DROPS	PRESSURE (MAX) B	PRESSURE (MAX) C	PRESSURE (MAX) D
1980												
25 Aug *	117000	*:117000	0	0	0	90	0	0	0	-	-	-
26 Aug *	353400	*:470400	0	0	0	90	0	35+	0	-	-	-
27 Aug *	3600	*:474000	0	0	0	90	0	30	0	-	-	-
REPLACED ROD END SEAL IN ACTUATOR #1												
28 Aug *	486000	*:960000	0	0	0	90	0	0	0	-	-	-
29 Aug *	483000	*:1443600	0	TR	0	90	0	0	0	-	-	-
2 Sept *	508800	*:1952400	0	0	0	90	0	0	0	-	-	-
3 Sept #:	87600	*:2040000	0	0	0	90	0	0	0	-	-	-
	446250	#:2486250	0	0	0	90	0	0	0	-	-	-
4 Sept	637500	:3123750	0	0	0	90	0	0	0	TR	-	-
5 Sept	656250	:3780000	0	0	0	90	0	0	0	-	-	-

* 10 Hertz
Change to negative load

TABLE 10. CONTINUED

ACTUATOR NUMBER 1

DATE	ROTOR FEEDBACK		END NUMBER 1 (LUG) LEAKAGE			END NUMBER 2 (ROD) LEAKAGE			
	DAILY	CUMUL	(END OF DAY) CC	DROPS	PRESSURE (MAX) PORT	(END OF DAY) CC	DROPS	PRESSURE (MAX) PORT	
				B	C	D	B	C	D
8 Sept	:542250	:4322250	0	0	90	0	0	-	-
9 Sept **	:667500	:4989750	0	0	90	0	0	-	-
10 Sept #:	:792960	:5782710	0	0	90	0	0	-	-
11 Sept	:806400	:6589110	0	0	90	0	0	-	-
12 Sept	:801600	:7390710	0	0	90	0	0	-	-
15 Sept *	:674880	:8065590	0	0	90	0	TR	-	-
16 Sept	:760320	:8825910	0	0	90	0	0	-	-
17 Sept	:812160	:9638070	0	0	90	0	0	-	-
18 Sept	:753600	:10391670	0	0	90	0	TR	-	-
19 Sept	:294720	:10686390	0	0	90	0	TR	-	-
22-24 Sept	:REPLACED ROD END SEALS IN ACT. NO. 1 AND ACT. NO. 3:								

** Change to positive load
 # Change to 16.0 Hertz

TABLE 10. CONTINUED

ACTUATOR NUMBER 1

DATE	ROTOR FEEDBACK		END NUMBER 1 (LUG) LEAKAGE			END NUMBER 2 (ROD) LEAKAGE							
	DAILY	CYCLES CUMUL	(END OF DAY) : PRESSURE (MAX) PORT			(END OF DAY) : PRESSURE (MAX) PORT							
			CC	DROPS	B C D	CC	DROPS	B C D					
25 Sept	:651840	:11338230	0	TR	0	90	0	0	0	1	-	-	-
26 Sept	:872640	:12210870	0	TR	0	90	0	0	0	0	-	-	-
29 Sept **	:854400	:13065270	0	TR	0	90	0	0	0	TR	-	-	-
30 Sept	:849600	:13914870	0	0	0	90	0	0	0	0	-	-	-
1 Oct	:765120	:14679990	0	0	0	90	0	0	0	TR	-	-	-
2 Oct	:831360	:15511350	0	0	0	90	0	0	0	0	-	-	-
3 Oct	:316800	:15828150	0	0	0	90	0	0	0	0	-	-	-
6 Oct	:369600	:16197750	0	0	0	90	0	0	0	0	-	-	-
7 Oct	:379200	:16576950	0	0	0	90	0	0	0	0	-	-	-

* Change to Negative Load
 ** Change to Positive Load

TABLE 10. CONTINUED

ACTUATOR NUMBER 1

DATE	ROTOR FEEDBACK		END NUMBER 1 (LUG) LEAKAGE			END NUMBER 2 (ROD) LEAKAGE					
	DAILY	CUMUL	(END OF DAY) CC	(END OF DAY) DROPS	PRESSURE (MAX) PORT B	PRESSURE (MAX) PORT C	PRESSURE (MAX) PORT D	(END OF DAY) DROPS	PRESSURE (MAX) PORT B	PRESSURE (MAX) PORT C	PRESSURE (MAX) PORT D
1980											
8 Oct	403200	16980150	0	0	0	90	0	0	0	-	-
9 Oct	412800	17392950	0	0	0	90	0	0	0	-	-
10 Oct	395520	17788470	0	0	0	90	0	0	0	-	-
13 Oct	398400	18186870	0	0	0	90	0	0	0	-	-
14 Oct	86400	18273270	0	0	0	90	0	0	0	-	-
**	86400	18359670	0	0	0	90	0	0	0	-	-
15 Oct	456000	18815670	0	0	0	90	0	0	0	-	-
16 Oct	441600	19257270	0	0	0	30	0	0	0	-	-
17 Oct	446400	19703670	0	0	0	90	0	0	0	-	-

** Change to positive load

TABLE 10. CONTINUED

ACTUATOR NUMBER 1

DATE	ROTOR FEEDBACK		END NUMBER 1 (LUG) LEAKAGE			END NUMBER 2 (ROD) LEAKAGE		
	DAILY	CUMUL	CC	DROPS	END OF DAY) : PRESSURE (MAX) PORT	CC	DROPS	END OF DAY) : PRESSURE (MAX) PORT
			B	C	D	B	C	D
20 Oct	446400	20150070	0	0	90	0	4	-
21 Oct	436800	20586870	0	0	90	0	0	-
21 Oct		1620LS	0	3	90	0	35+	0
TOTAL	20586870							
	+ 1620LS							
	+ 141480	+/-1.0 STROKE						

TABLE 10. CONTINUED

ACTUATOR NUMBER 2

DATE	ROTOR FEEDBACK		END NUMBER 1 (LUG) LEAKAGE			END NUMBER 2 (ROD) LEAKAGE						
	DAILY	CUMUL	CC	DROPS	B	C	D	CC	DROPS	B	C	D
1980												
25 Aug *	117000	117000	0	0	0	0	0	0	0	-	-	-
26 Aug *	353400	470400	0	0	0	0	0	0	0	-	-	-
27 Aug *	3600	474000	0	0	0	0	0	0	0	-	-	-
REPLACED ROD END SEAL IN ACTUATOR #1												
28 Aug *	486000	960000	0	0	0	0	0	0	0	-	-	-
29 Aug *	483000	1443600	0	TR	0	0	0	0	0	-	-	-
2 Sept *	508800	1952400	0	0	0	0	0	0	0	-	-	-
3 Sept *#	87600	2040000	0	0	0	0	0	0	0	-	-	-
	446250	#2486250	0	0	0	0	0	0	0	-	-	-
4 Sept	637500	3123750	0	0	0	0	0	0	0	-	-	-
5 Sept	656250	3780000	0	0	0	0	0	0	0	-	-	-

* 10 Hertz
Change to negative load

TABLE 10. CONTINUED

ACTUATOR NUMBER 2

DATE	ROTOR FEEDBACK		END NUMBER 1 (LUG) LEAKAGE			END NUMBER 2 (ROD) LEAKAGE						
	DAILY	CUMUL	CC	DROPS	B	C	D	CC	DROPS	B	C	D
8 Sept	:542250	:4322250	0	0	0	0	0	0	0	0	0	0
9 Sept **	:667500	:4989750	0	0	0	0	0	0	0	0	0	0
10 Sept #:	:792960	:5782710	0	0	0	0	0	0	0	0	0	0
11 Sept	:806400	:6589110	0	0	0	0	0	0	0	0	0	0
12 Sept	:801600	:7390710	0	0	0	0	0	0	0	0	0	0
15 Sept *	:674880	:8065590	0	0	0	0	0	0	0	0	0	0
16 Sept	:760320	:8825910	0	0	0	0	0	0	0	0	0	0
17 Sept	:812160	:9638070	0	0	0	0	0	0	0	0	0	0
18 Sept	:753600	:10391670	0	0	0	0	0	0	0	0	0	0
19 Sept	:294720	:10686390	0	0	0	0	0	0	0	0	0	0

** Change to positive load
 # Change to 16.0 Hertz
 * Change to negative load

TABLE 10. CONTINUED

ACTUATOR NUMBER 2

DATE	ROTOR FEEDBACK		END NUMBER 1 (LUG) LEAKAGE			END NUMBER 2 (ROD) LEAKAGE				
	DAILY	CUMUL	(END OF DAY) CC	(END OF DAY) DROPS	(END OF DAY) PRESSURE (MAX) PORT B	(END OF DAY) PRESSURE (MAX) PORT C	(END OF DAY) PRESSURE (MAX) PORT D	(END OF DAY) DROPS B	(END OF DAY) DROPS C	(END OF DAY) DROPS D
22-24 Sept	REPLACED ROD END SEALS IN ACT. NO. 1 AND ACT. NO. 3									
25 Sept	:651840	:11338230	:0	:0	:0	:0	:0	:0	:0	-
26 Sept	:872640	:12210870	:0	:0	:0	:0	:0	:0	:0	-
29 Sept **	:854400	:13065270	:0	:0	:0	:0	:0	:0	:0	-
30 Sept	:849600	:13914870	:0	:0	:0	:0	:0	:0	:0	-
1 Oct	:765120	:14679990	:0	:0	:0	:0	:0	:0	:0	0
2 Oct	:831360	:15511350	:0	:0	:0	:0	:0	:0	:0	-
3 Oct*	:316800	:15828150	:0	:0	:0	:0	:0	:0	TR	-
6 Oct	:369600	:16197750	:0	:0	:0	:0	:0	:0	:0	-
7 Oct	:379200	:16576950	:0	:0	:0	:0	:0	:0	:0	-

* Change to negative Load

** Change to positive Load

TABLE 10. CONTINUED

ACTUATOR NUMBER 2

DATE	ROTOR FEEDBACK		END NUMBER 1 (LUG) LEAKAGE			END NUMBER 2 (ROD) LEAKAGE				
	DAILY	CUMUL	(END OF DAY) CC	(END OF DAY) DROPS	PRESSURE (MAX) PORT B	PRESSURE (MAX) PORT C	(END OF DAY) CC	(END OF DAY) DROPS	PRESSURE (MAX) PORT B	PRESSURE (MAX) PORT C
1980										
8 Oct	403200	16980150	0	0	0	0	0	0	-	-
9 Oct	412800	17392950	0	0	0	0	0	0	-	-
10 Oct	395520	17788470	0	0	0	0	0	0	-	-
13 Oct	398400	18186870	0	0	0	0	0	0	-	-
14 Oct	86400	18273270	0	0	0	0	0	0	-	-
**	86400	18359670	0	0	0	0	0	0	-	-
15 Oct	456000	18815670	0	0	0	0	0	0	-	-
16 Oct	441600	19257270	0	0	0	0	0	0	-	-
17 Oct	446400	19703670	0	0	0	0	0	0	-	-

** Change to positive load

TABLE 10. CONTINUED

ACTUATOR NUMBER 2

DATE	ROTOR FEEDBACK		END NUMBER 1 (LUG) LEAKAGE				END NUMBER 2 (ROD) LEAKAGE						
	DAILY	CUMUL	(END OF DAY)		(END OF DAY)		(END OF DAY)		(END OF DAY)				
			CC	DROPS	CC	DROPS	CC	DROPS	CC	DROPS			
20 Oct	446400	20150070	0	0	0	0	0	0	0	0	0	0	0
21 Oct	436800	20586870	0	0	0	0	0	0	0	0	0	0	0
21 Oct		1620LS	0	0	0	0	0	0	0	0	0	0	0
TOTAL	20586870												
	+ 1620LS												
	+ 141480	+/-1.0 STROKE											

TABLE 10. CONTINUED

ACTUATOR NUMBER 3

DATE	ROTOR FEEDBACK CYCLES	END NUMBER 1 (LUG) LEAKAGE			END NUMBER 2 (ROD) LEAKAGE								
		DAILY	CUMUL	(END OF DAY) CC	DROPS	B	C	D	(END OF DAY) CC	DROPS	B	C	D
1980													
25 Aug *	117000	*	117000	0	0	-	-	0	0	0	-	0	0
26 Aug *	353400	*	470400	0	0	-	-	0	0	0	-	0	0
27 Aug *	3600	*	474000	0	0	-	-	0	0	0	-	0	0
REPLACED ROD END SEAL IN ACTUATOR #1													
28 Aug *	486000	*	960000	0	0	-	-	0	0	0	-	0	0
29 Aug *	483000	*	1443600	0	TR	-	-	0	1.5	0	-	225	0
2 Sept *	508800	*	1952400	0	TR	-	-	0	1.3	0	-	1500	0
3 Sept #:	87600	*	2040000	0	0	-	-	0	0.7	0	-	1500	0
	446250	#:	2486250	0	0	-	-	0	-	0	-	1500	0
4 Sept	637500		3123750	0	0	-	-	0	1.0	0	-	1500	0
5 Sept	656250		3780000	0	0	-	-	0	11.0	0	-	1500	0

* 10 Hertz
Change to negative load

TABLE 10. CONTINUED

ACTUATOR NUMBER 3

DATE	ROTOR FEEDBACK		END NUMBER 1 (LUG) LEAKAGE			END NUMBER 2 (ROD) LEAKAGE				
	DAILY	CUMUL	(END OF DAY) CC	DROPS	PRESSURE (MAX) PORT	(END OF DAY) CC	DROPS	PRESSURE (MAX) PORT		
					B			B		
					C			C		
					D			D		
8 Sept	:542250	:4322250	0	0	-	0	13.0	0	1500	0
9 Sept **	:667500	:4989750	0	0	-	0	19.25	0	1500	0
10 Sept #:	:792960	:5782710	0	0	-	0	10.0	0	1300	0
11 Sept	:806400	:6589110	0	0	-	0	14.25	0	1300	0
12 Sept	:801600	:7390710	0	0	-	0	16.0	0	1300	0
15 Sept *	:674880	:8065590	0	0	-	0	17.25	0	1300	0
16 Sept	:760320	:8825910	0	0	-	0	11.25	0	1850	0
17 Sept	:812160	:9638070	0	0	-	0	68	0	1850	0
18 Sept	:753600	:10391670	0	0	-	0	61.9	0	No Data	0
19 Sept	:294720	:10686390	0	0	-	0	9	0	No Data	0

** Change to positive load
 # Change to 16.0 Hertz
 * Change to negative load

TABLE 10. CONTINUED

ACTUATOR NUMBER 3

DATE	ROTOR FEEDBACK CYCLES		END NUMBER 1 (LUG) LEAKAGE (TEND OF DAY)			END NUMBER 2 (ROD) LEAKAGE (TEND OF DAY)						
	DAILY	CUMUL	CC	DROPS	B	C	D	CC	DROPS	B	C	D
22-24 Sept	REPLACED ROD END SEALS IN ACT. NO. 1 AND ACT. NO. 3											
25 Sept	:651840	:11338230	0	0	-	-	0	0	1	-	0	0
26 Sept	:872640	:12210870	0	TR	-	-	0	11	-	-	0	0
29 Sept **	:854400	:13065270	0	0	-	-	0	31	-	-	0	0
30 Sept	:849600	:13914870	0	0	-	-	0	0.4	-	-	0	0
1 Oct	:765120	:14679990	0	0	-	-	0	3.2	-	-	0	0
2 Oct	:831360	:15511350	.4	0	-	-	0	6.0	-	-	0	0
3 Oct *	:316800	:15828150	0	0	-	-	0	5.8	-	-	0	0
6 Oct	:369600	:16197750	0	0	-	-	0	1.2	0	-	0	0
7 Oct	:379200	:16576950	0	0	-	-	0	2.6	0	-	0	0

* Change to negative Load
 ** Change to positive Load

TABLE 10. CONTINUED

ACTUATOR NUMBER 3

DATE	ROTOR FEEDBACK		END NUMBER 1 (LUG) LEAKAGE			END NUMBER 2 (ROD) LEAKAGE		
	DAILY	CUMUL	CC	PROPS	(END OF DAY) PRESSURE (MAX) PORT C	D	(END OF DAY) PRESSURE (MAX) PORT C	D
1980								
8 Oct	403200	16980150	0	0	-	0	1.3	0
9 Oct	412800	17392950	0	0	-	0	3.55	0
10 Oct	395520	17788470	0	0	-	0	1.55	0
13 Oct	398400	18186870	0	0	-	0	3.3	0
14 Oct	86400	18273270	0	0	-	0	0.9	0
**	86400	18359670	0	0	-	0	-	-
15 Oct	456000	18815670	0	0	-	0	0	3
16 Oct	441600	19257270	0	0	-	0	1.2	0
17 Oct	446400	19703670	0	0	-	0	1.2	0

** Change to positive load

TABLE 10. CONTINUED

ACTUATOR NUMBER 3

DATE	ROTOR FEEDBACK		END NUMBER 1 (LUG) LEAKAGE		END NUMBER 2 (ROD) LEAKAGE	
	DAILY	CUMUL	(END OF DAY) CC	(MAX) PORT B	(END OF DAY) CC	(MAX) PORT C
20 Oct	446400	20150070	0	0	0	0
21 Oct	436800	20586870	0	0	10	0
21 Oct		1620LS	0	5	0	0
TOTAL	20586870					
	+ 1620LS					
	+ 141480					
	+/-1.0 STROKE					

TABLE 10. CONTINUED

ACTUATOR NUMBER 4

DATE	ROTOR FEEDBACK CYCLES		END NUMBER 1 (LUG) LEAKAGE			END NUMBER 2 (ROD) LEAKAGE						
	DAILY	CUMUL	(END OF DAY) CC	DROPS	PRESSURE (MAX) PORT B	C	D	(END OF DAY) DROPS	PRESSURE (MAX) PORT B	C	D	
1980												
25 Aug *	117000	* 117000	0	0	-	0	0	0	-	0	0	0
26 Aug *	353400	* 470400	0	0	-	0	0	0	-	0	0	0
27 Aug *	3600	* 474000	0	0	-	0	0	0	-	0	0	0
REPLACED ROD END SEAL IN ACTUATOR #1												
28 Aug *	486000	* 960000	0	0	-	0	0	0	-	0	0	0
29 Aug *	483000	* 1443600	0	TR	-	0	0	0	-	0	0	0
2 Sept *	508800	* 1952400	0	0	-	0	0	0	-	0	0	0
3 Sept *#	87600	* 2040000	0	0	-	0	0	0	-	0	0	0
	446250	# 2486250	0	0	-	0	0	0	-	0	0	0
4 Sept	637500	3123750	0	0	-	0	0	0	-	0	0	0
5 Sept	656250	3780000	0	0	-	0	0	0	-	0	0	0

* 10 Hertz
Change to negative load

TABLE 10. CONTINUED

ACTUATOR NUMBER 4

DATE	ROTOR FEEDBACK		END NUMBER 1 (LUG) LEAKAGE			END NUMBER 2 (ROD) LEAKAGE		
	DAILY	CUMUL	(END OF DAY) CC	(END OF DAY) DROPS	(END OF DAY) PRESSURE (MAX) PORT B	(END OF DAY) PRESSURE (MAX) PORT C	(END OF DAY) PRESSURE (MAX) PORT D	(END OF DAY) DROPS
8 Sept	:542250	:4322250	:0	:0	-	:0	:0	:0
9 Sept **	:667500	:4989750	:0	:0	-	:0	:0	:0
10 Sept #:	:792960	:5782710	:0	:0	-	:0	:0	:0
11 Sept	:806400	:6589110	:0	:0	-	:0	:0	:0
12 Sept	:801600	:7390710	:0	:0	-	:0	:0	:0
15 Sept *	:674880	:8065590	:0	:0	-	:0	:0	:0
16 Sept	:760320	:8825910	:0	:0	-	:0	:0	:0
17 Sept	:812160	:9638070	:0	:0	-	:0	:0	:0
18 Sept	:753600	:10391670	:0	:0	-	:0	:0	:0
19 Sept	:294720	:10686390	:0	:0	-	:0	:0	:0

** Change to positive load
 ## Change to 16.0 Hertz
 * Change to negative load

TABLE 10. CONTINUED

ACTUATOR NUMBER 4

DATE	ROTOR FEEDBACK		END NUMBER 1 (LUG) LEAKAGE			END NUMBER 2 (ROD) LEAKAGE		
	DAILY	CUMUL	(END OF DAY) CC	(END OF DAY) PROPS	(END OF DAY) PRESSURE (MAX) PORT C	(END OF DAY) PROPS	(END OF DAY) PRESSURE (MAX) PORT C	
1980								
22-24 Sept		REPLACED ROD END SEALS IN ACT. NO. 1 AND ACT. NO. 3						
25 Sept	:651840	:11338230	0	0	-	0	0	
26 Sept	:872640	:12210870	0	0	-	0	0	
29 Sept **	:854400	:13065270	0	0	-	0	0	
30 Sept	:849600	:13914870	0	0	-	0	0	
1 Oct	:765120	:14679990	0	0	-	0	0	
2 Oct	:831360	:15511350	0	0	-	0	0	
3 Oct *	:316800	:15828150	0	0	-	0	0	
6 Oct	:369600	:16197750	0	0	-	0	0	
7 Oct	:379200	:16576950	0	0	-	0	0	

* Change to negative Load
 ** Change to positive Load

TABLE 10. CONTINUED

ACTUATOR NUMBER 4

DATE	ROTOR FEEDBACK CYCLES			END NUMBER 1 (LUG) LEAKAGE (END OF DAY)			END NUMBER 2 (ROD) LEAKAGE (END OF DAY)					
	DAILY	CUMUL	CC	DROPS	B	C	D	CC	DROPS	B	C	D
1980												
8 Oct	403200	16980150	0	0	-	0	0	0	0	-	0	0
9 Oct	412800	17392950	0	0	-	0	0	0	0	-	0	0
10 Oct	395520	17788470	0	0	-	0	0	0	0	-	0	0
13 Oct	398400	18186870	0	0	-	0	0	0	0	-	0	0
14 Oct	86400	18273270	0	0	-	0	0	0	0	-	0	0
**	86400	18359670	0	0	-	0	0	0	0	-	0	0
15 Oct	456000	18815670	0	0	-	0	0	0	0	-	0	0
16 Oct	441600	19257270	0	0	-	0	0	0	0	-	0	0
17 Oct	446400	19703670	0	0	-	0	0	0	0	-	0	0

** Change to positive load

TABLE 10. CONTINUED

ACTUATOR NUMBER 4

DATE	ROTOR FEEDBACK CYCLES		END NUMBER 1 (LUG) LEAKAGE			END NUMBER 2 (ROD) LEAKAGE				
	DAILY	CUMUL	CC	DROPS	END OF DAY PRESSURE (MAX) PORT B	C	D	(END OF DAY) PRESSURE (MAX) PORT B	C	D
20 Oct	446400	20150070	0	0	-	0	0	0	0	0
21 Oct	436800	20586870	0	0	-	0	0	0	0	0
21 Oct		1620LS	0	0	-	0	0	0	0	0
TOTAL	20586870									
	+ 1620LS									
	+ 141480									
	+/-1.0 STROKE									

TABLE 10. CONTINUED

ACTUATOR NUMBER 5

DATE	ROTOR FEEDBACK		END NUMBER 1 (LUG) LEAKAGE			END NUMBER 2 (ROD) LEAKAGE		
	DAILY	CUMUL	CC	DROPS	CC	DROPS	CC	DROPS
1980 *								
25 Aug *	117000 *	117000	0	0	0	0	0	0
26 Aug *	353400 *	470400	0	0	0	0	0	0
27 Aug *	3600 *	474000	0	0	0	0	0	0
REPLACED ROD END SEAL IN ACTUATOR #1								
28 Aug *	486000 *	960000	0	0	0	0	0	0
29 Aug *	483000 *	1443600	0	0	0	0	0	0
2 Sept *	508800 *	1952400	0	0	0	0	0	0
3 Sept **	87600 *	2040000	0	0	0	0	0	0
	446250 #	2486250	0	0	0	0	0	0
4 Sept	637500	3123750	0	0	0	0	0	0
5 Sept	656250	3780000	0	0	0	0	0	0

* 10 Hertz
 # Change to negative load

TABLE 10. CONTINUED

ACTUATOR NUMBER 5

DATE	ROTOR FEEDBACK			END NUMBER 1 (LUG) LEAKAGE			END NUMBER 2 (ROD) LEAKAGE		
	DAILY	CUMUL	CYCLES	(END OF DAY) CC	DROPS	PRESSURE (MAX) PORT	(END OF DAY) CC	DROPS	PRESSURE (MAX) PORT
8 Sept	:542250	:4322250		0	0	-	0	0	-
9 Sept **	:667500	:4989750		0	0	-	0	0	-
10 Sept #:	:792960	:5782710		0	0	-	0	0	-
11 Sept	:806400	:6589110		0	0	-	0	0	-
12 Sept	:801600	:7390710		0	0	-	0	0	-
15 Sept *	:674880	:8065590		0	0	-	0	0	-
16 Sept	:760320	:8825910		0	0	-	0	0	-
17 Sept	:812160	:9638070		0	0	-	0	0	-
18 Sept	:753600	:10391670		0	0	-	0	0	-
19 Sept	:294720	:10686390		0	0	-	0	0	-

** Change to positive load
 # Change to 16.0 Hertz
 * Change to negative load

TABLE 10. CONTINUED

ACTUATOR NUMBER 5

DATE	ROTOR FEEDBACK CYCLES	END NUMBER 1 (LUG) LEAKAGE			END NUMBER 2 (ROD) LEAKAGE		
		DAILY	CUMUL	(END OF DAY) CC	:(END OF DAY) CC	:(END OF DAY) CC	:(END OF DAY) CC
				:(END OF DAY) DROPS	:(END OF DAY) DROPS	:(END OF DAY) DROPS	:(END OF DAY) DROPS
				:(END OF DAY) PRESSURE (MAX) PORT B C D	:(END OF DAY) PRESSURE (MAX) PORT B C D	:(END OF DAY) PRESSURE (MAX) PORT B C D	:(END OF DAY) PRESSURE (MAX) PORT B C D
1980							
22-24 Sept	REPLACED ROD END SEALS IN ACT. NO. 1 AND ACT. NO. 3						
25 Sept	:651840	:11338230	0	0	-	90	-
26 Sept	:872640	:12210870	0	0	-	90	-
29 Sept **	:854400	:13065270	0	0	-	90	-
30 Sept	:849600	:13914870	0	0	-	90	-
1 Oct	:765120	:14679990	0	0	-	90	-
2 Oct	:831360	:15511350	0	0	-	90	-
3 Oct *	:316800	:15828150	0	0	-	90	-
6 Oct	:369600	:16197750	0	0	-	90	-

* Change to negative Load

** Change to positive Load

TABLE 10. CONTINUED

ACTUATOR NUMBER 5

DATE	ROTOR FEEDBACK		END NUMBER 1 (LUG) LEAKAGE			END NUMBER 2 (ROD) LEAKAGE		
	DAILY	CUMUL	(END OF DAY) CC	DROPS	PRESSURE (MAX) PORT B C D	(END OF DAY) CC	DROPS	PRESSURE (MAX) PORT B C D
1980								
7 Oct	379200	16576950	0	0	- 90 -	0	0	- 0 0
8 Oct	403200	16980150	0	0	- 90 -	0	0	- 0 0
9 Oct	412800	17392950	0	0	- 90 -	0	0	- 0 0
10 Oct	395520	17788470	0	0	- 90 -	0	0	- 0 0
13 Oct	398400	18186870	0	0	- 90 -	0	0	- 0 0
14 Oct	86400	18273270	0	0	- 90 -	0	0	- 0 0
**	86400	18359670	0	0	- 90 -	0	0	- 0 0
15 Oct	456000	18815670	0	0	- 90 -	0	0	- 0 0
16 Oct	441600	19257270	0	0	- 90 -	0	0	- 0 0
17 Oct	446400	19703670	0	0	- 90 -	0	0	- 0 0

** Change to positive load

TABLE 10. CONTINUED

ACTUATOR NUMBER 5

DATE	ROTOR FEEDBACK		END NUMBER 1 (LUG) LEAKAGE				END NUMBER 2 (ROD) LEAKAGE			
	DAILY	CUMUL	(END OF DAY) : PRESSURE (MAX) PORT		(END OF DAY) : DROPS		(END OF DAY) : PRESSURE (MAX) PORT		(END OF DAY) : DROPS	
			B	C	D	CC	B	C	D	CC
20 Oct	446400	20150070	-	90	-	0	-	0	-	0
21 Oct	436800	20586870	-	90	-	0	-	0	-	0
21 Oct		1620LS	-	90	-	0	-	0	-	0
TOTAL	20586870									
	+ 1620LS									
	+ 141480									
	+/-1.0 STROKE									

TABLE 10. CONTINUED

ACTUATOR NUMBER 6

DATE	ROTOR FEEDBACK		END NUMBER 1 (LUG) LEAKAGE			END NUMBER 2 (ROD) LEAKAGE						
	CYCLES		(END OF DAY)		(END OF DAY)	(END OF DAY)		(END OF DAY)				
	DAILY	CUMUL	CC	DROPS	B	C	D	CC	DROPS	B	C	D
1980												
25 Aug *	:117000	*:117000	0	0	-	90	-	0	0	0	0	-
26 Aug *	:353400	*:470400	0	0	-	90	-	0	0	0	0	-
27 Aug *	:3600	*:474000	0	0	-	90	-	0	0	0	0	-
REPLACED ROD END SEAL IN ACTUATOR #1												
28 Aug *	:486000	*:960000	0	0	-	90	-	0	0	0	0	-
29 Aug *	:483000	*:1443600	0	0	-	90	-	0	0	0	0	-
2 Sept *	:508800	*:1952400	0	0	-	90	-	0	0	0	0	-
3 Sept *#:	:87600	*:2040000	0	0	-	90	-	0	0	0	0	-
	:446250	*:2486250	0	0	-	90	-	0	0	0	0	-
4 Sept	:637500	:3123750	0	0	-	90	-	0	0	0	0	-
5 Sept	:656250	:3780000	0	0	-	90	-	0	0	0	0	-

* 10 Hertz
Change to negative load

TABLE 10. CONTINUED

ACTUATOR NUMBER 6

DATE	ROTOR FEEDBACK CYCLES DAILY CUMUL	END NUMBER 1 (LUG) LEAKAGE				END NUMBER 2 (ROD) LEAKAGE							
		: (END OF DAY)		: PRESSURE (MAX)		: (END OF DAY)		: PRESSURE (MAX)					
		CC	DROPS	B	C	D	CC	DROPS	B	C	D		
8 Sept	:542250	:4322250	0	0	-	90	-	0	0	0	0	0	-
9 Sept **	:667500	:4989750	0	0	-	90	-	0	0	0	0	0	-
10 Sept #	:792960	:5782710	0	0	-	90	-	0	0	0	0	0	-
11 Sept	:806400	:6589110	0	0	-	90	-	0	0	0	0	0	-
12 Sept	:801600	:7390710	0	0	-	90	-	0	0	0	0	0	-
15 Sept *	:674880	:8065590	0	0	-	90	-	0	0	0	0	0	-
16 Sept	:760320	:8825910	0	0	-	90	-	0	0	0	0	0	-
17 Sept	:812160	:9638070	0	0	-	90	-	0	0	0	0	0	-
18 Sept	:753600	:10391670	0	0	-	90	-	0	0	0	0	0	-
19 Sept	:294720	:10686390	0	0	-	90	-	0	0	0	0	0	-

** Change to positive load
 ## Change to 16.0 Hertz
 * Change to negative load

TABLE 10. CONTINUED

ACTUATOR NUMBER 6

DATE	ROTOR FEEDBACK		END NUMBER 1 (LUG) LEAKAGE			END NUMBER 2 (ROD) LEAKAGE			
	DAILY	CUMUL	(END OF DAY) CC	(END OF DAY) DROPS	(PRESSURE (MAX) PORT) B	(PRESSURE (MAX) PORT) C	(PRESSURE (MAX) PORT) D	(END OF DAY) DROPS	
1980									
22-24 Sept			REPLACED ROD END SEALS IN ACT. NO. 1 AND ACT. NO. 3						
25 Sept	:651840	:11338230	0	0	-	90	-	0	
26 Sept	:872640	:12210870	0	0	-	90	-	0	
29 Sept **	:854400	:13065270	0	0	-	90	-	0	
30 Sept	:849600	:13914870	0	0	-	90	-	0	
1 Oct	:765120	:14679990	0	0	-	90	-	0	
2 Oct	:831360	:15511350	0	0	-	90	-	0	
3 Oct *	:316800	:15828150	0	0	-	90	-	0	
6 Oct	:369600	:16197750	0	0	-	90	-	0	
7 Oct	:379200	:16576950	0	0	-	90	-	0	

* Change to negative Load

** Change to positive Load

TABLE 10. CONTINUED

ACTUATOR NUMBER 6

DATE	ROTOR FEEDBACK CYCLES		END NUMBER 1 (LUG) LEAKAGE (END OF DAY)			END NUMBER 2 (ROD) LEAKAGE (END OF DAY)			
	DAILY	CUMUL	CC	DROPS		CC	DROPS		
				B	C		B	C	
1980									
8 Oct	403200	16980150	0	0	-	90	-	0	0
9 Oct	412800	17392950	0	0	-	90	-	0	0
10 Oct	395520	17788470	0	0	-	90	-	0	0
13 Oct	398400	18186870	0	0	-	90	-	0	0
14 Oct	86400	18273270	0	0	-	90	-	0	0
**	86400	18359670	0	0	-	90	-	0	0
15 Oct	456000	18815670	0	0	-	90	-	0	0
16 Oct	441600	19257270	0	0	-	90	-	0	0
17 Oct	446400	19703670	0	0	-	90	-	0	0

** Change to positive load

AD-A103 201

VOUGHT CORP DALLAS TX
HYDRAULIC SYSTEM SEAL DEVELOPMENT. (U)
JUN 81 K E WHITFILL

F/G 1/3

DAAK51-78-C-0028

USAAVRADCOM-TR-81-D-17

NL

UNCLASSIFIED

2 of 4
AD-A
103-201

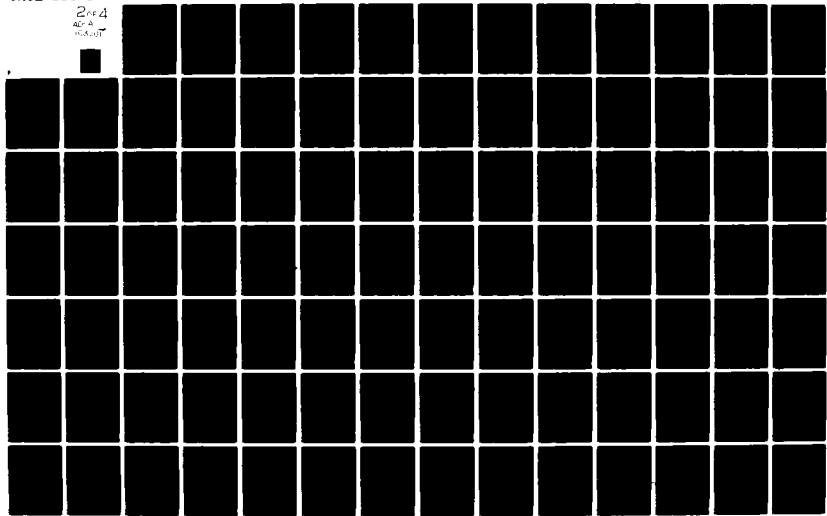

TABLE 10. CONTINUED

ACTUATOR NUMBER 6

DATE	ROTOR FEEDBACK		END NUMBER 1 (LUG) LEAKAGE			END NUMBER 2 (ROD) LEAKAGE				
	DAILY	CUMUL	(END OF DAY) CC	DROPS	PRESSURE (MAX) R	PORT C	(END OF DAY) CC	DROPS	PRESSURE (MAX) R	PORT C
20 Oct	446400	20150070	0	0	-	90	-	0	0	0
21 Oct	436800	20586870	0	0	-	90	-	0	0	0
21 Oct		1620LS	0	0	-	90	-	0	0	0
TOTAL	20586870									
	+ 1620LS									
	+ 141480									

TABLE 11. UNPRESSURIZED FRICTION OF TASK III SEALS

ACTUATOR NUMBER	LUG END	ROD END	AVG. BREAKOUT		FRICTION LB		AVG. RUNNING		FRICTION LB	
			EXTEND	RETRACT	RETRACT	EXTEND	EXTEND	RETRACT		
1	X	X	33.7	27.1	19.6	19.0				
			24.2	22.1	17.8	16.2				
2	X	X	35.5	28.6	21.0	19.9				
			17.0	15.5	10.0	10.0				
3	X	X	29.6	27.0	15.4	15.2				
			37.2	36.3	19.6	19.2				
4	X	X	33.8	26.8	18.8	16.0				
			43.6	40.8	20.2	18.8				
5	X	X	17.2	16.8	9.2	10.4				
			36.4	38.6	19.8	22.0				
6	X	X	44.8	39.5	27.0	24.6				
			41.4	42.5	27.2	26.8				

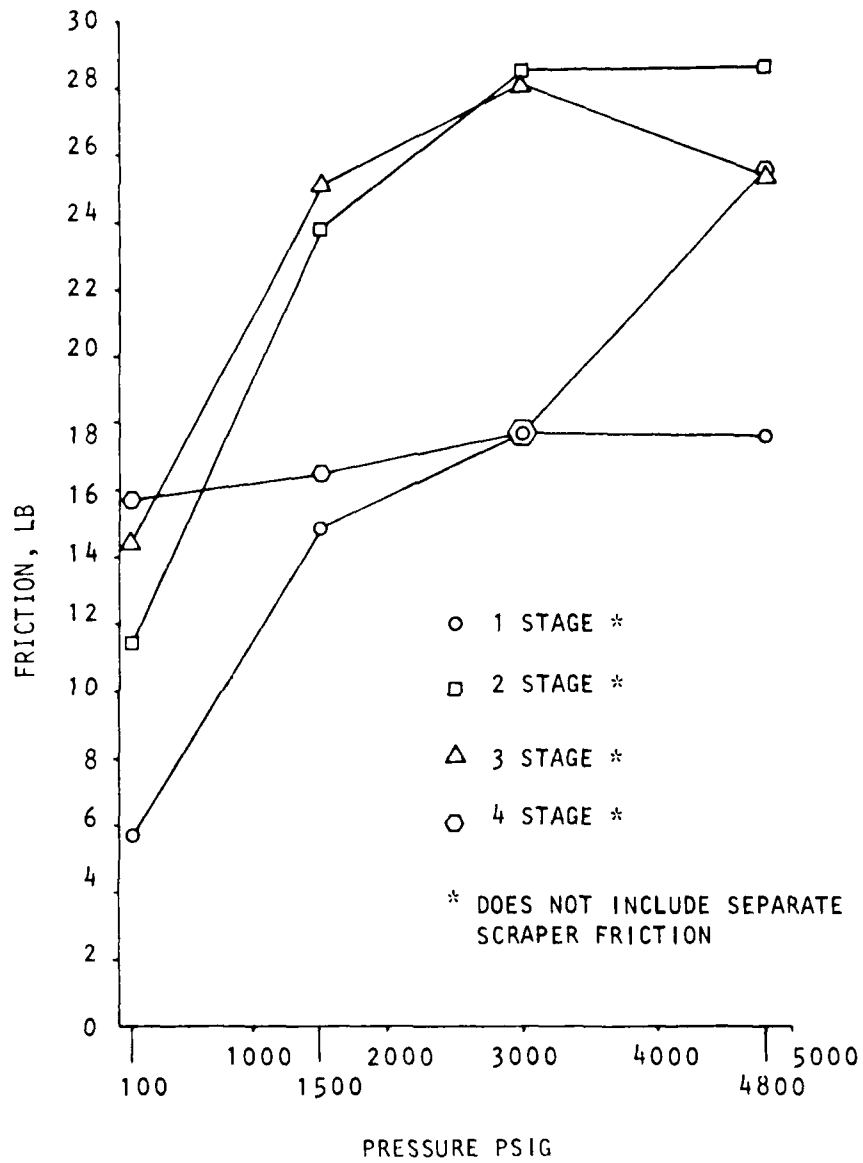

FIGURE 8. PRESSURIZED FRICTION OF TASK III SEALS

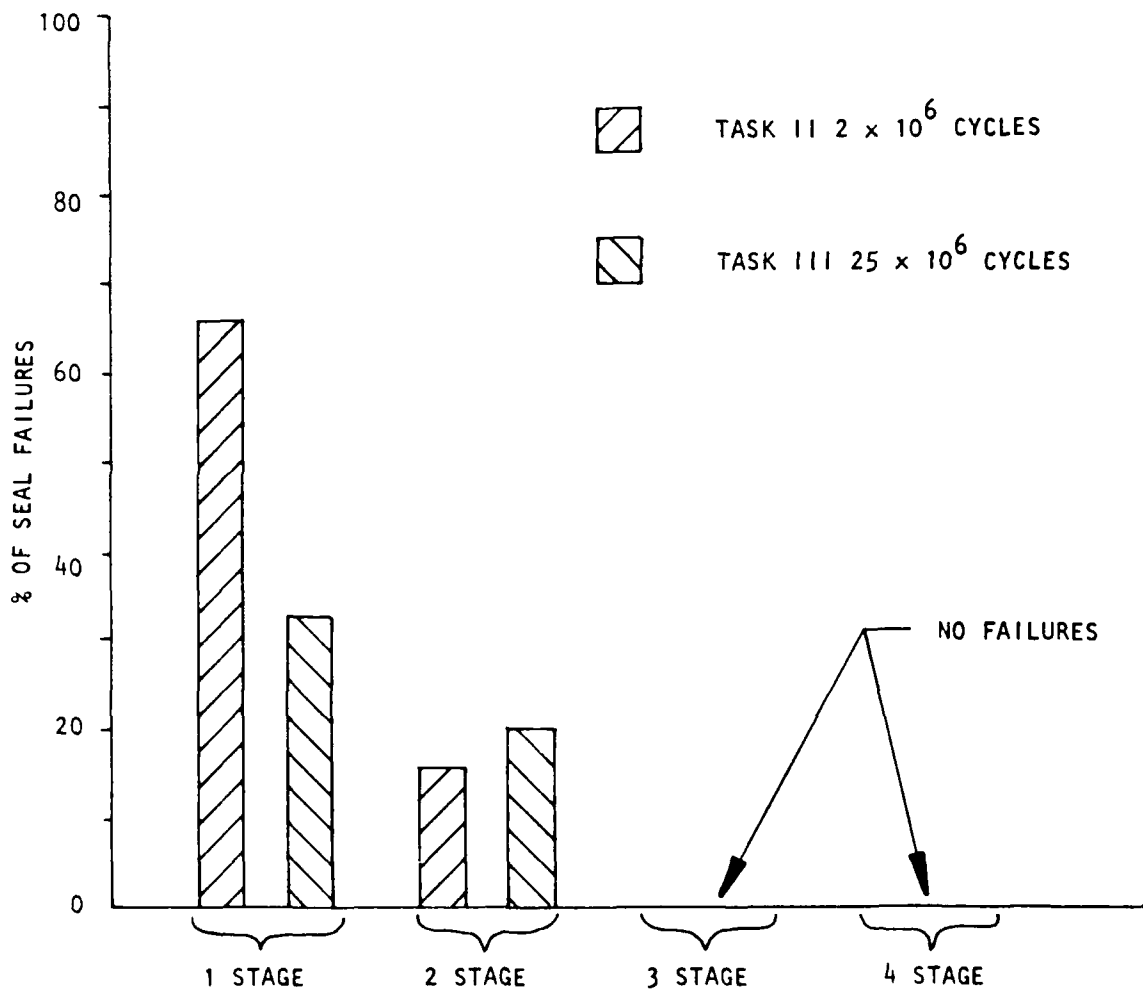

FIGURE 10. COMPARISON OF SEAL FAILURES BY STAGE

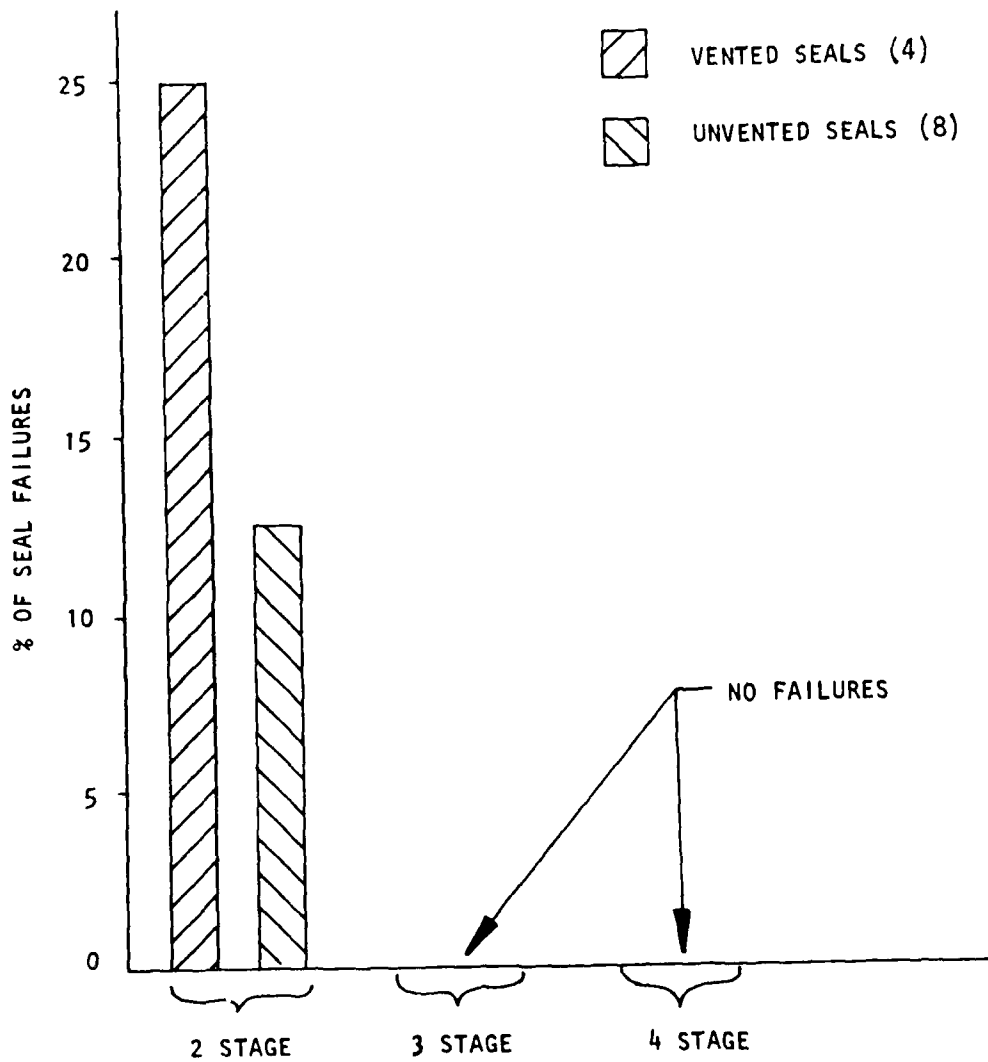

FIGURE 11. COMPARISON OF VENTED AND UNVENTED SEAL FAILURES

CONCLUSIONS

SURFACE FINISH

The Task III test has shown that plastic seals have good leakage performance when the surface finish is better than the 8-16 RMS finish that is usually specified for elastomeric seals. The rods used in the Task III test had surface finishes that ranged from 2 RMS to 6 RMS at the start of the test. After 25×10^6 cycles, with daily applications of Arizona coarse road dust directly onto the rods, the surface finishes were in the range of 2 RMS to 12 RMS. The leakage of the seals on these rods during a 1620 long stroke (± 1.75 in.) test at the end of the Task III test varied from zero leakage for 8 seals to a maximum of 1 drop per 324 cycles.

MATERIALS

The Task III test has also shown the importance of selecting a seal material that has good wear resistance and is not abrasive. The glass-filled materials used in Task II were almost all deleted from the Task III tests since they showed rod abrasion on the chromium plated rods during only 2×10^6 cycles. The Shamban backup rings and one of the Double Delta seals were changed from a material that had 15% glass to the same material with no glass to reduce abrasiveness. The new material, Shamban Composition 19, showed very good results in all except scraper applications although there was some liberation of MoS_2 . The Conover backup rings were changed from Revonoc 18158 to Revonoc 6200 to improve wear resistance. The Revonoc 6200 material showed very good results in all applications.

The Ekanol-filled TFE used in the Greene Tweed Enercap and the polymer-filled Tetrafluor Maxi Flex seal did not provide adequate life. The Enercap seal failed during the rotor feedback tests and the Maxi Flex seal was on the verge of failure at the end of the test.

The only glass-filled TFE in the Task III test was the single-stage Double Delta seal in Actuator No. 1, rod end. This seal, which used 15% glass and was tested on a Tungsten Carbide rod, was the first seal to fail in the test.

Most of the elastomers used in this test were O-rings per M83461/1-XXX, or specially shaped elastomers per MIL-P-83461. These elastomers performed well in this test. The O-ring used with the Dowty scraper was a proprietary compound that took a severe permanent set. The proprietary nitrile elastomer used with the Hercules scraper performed well in this test. The addition of aluminum bronze inserts in both ends of each actuator was apparently beneficial. Although there was some evidence of hard contact between the actuator rods and the end caps in some of the actuators, as shown by wearing away of the aluminum bronze, there were no failures of the chrome plating on the rod as had been the case in the Task II test.

ROD COATINGS

The rod coatings tested in this program were Chromium plating and Tungsten Carbide which were applied by a detonation gun. The Chromium plated rods, used with aluminum bronze bearing surfaces, gave the lowest leakage and the longest seal life if the seal material was not abrasive. The Tungsten Carbide coated rod was almost indestructible, but every seal that was tested on the Tungsten Carbide coated rod for any length of time failed by excessive wear. The rods were examined with a 40X microscope and the Tungsten Carbide coating appeared to be significantly smoother than the Chromium plating. Since the measured surface roughness on the Tungsten Carbide coating was the same as the measured surface roughness on some of the Chromium plated rods, the seal failures may be caused by a lack of "wettability" on the part of the Tungsten Carbide coating.

VENTED AND UNVENTED SEALS

Vented and unvented seals were tested during this program. The vented seal installations had a slightly higher failure rate than the unvented seal installations, as shown in Figure 11, but there was only one failure of each type, so the failure rate is somewhat misleading. Pressure buildup between stages in unvented installations was infrequent and sporadic. The maximum pressure observed between stages was 50% of the system pressure. There was no evidence of seal damage caused by pressure buildup between stages. Based upon the data from this test, it is not necessary to vent the cavity between seals in an actuator if the seal installations are self venting or protected by a backup ring on the upstream side. This type of installation is exemplified by the two-stage seal on the rod end of Actuator No. 4 in Figure 9. The 1st-stage seal has backup rings on both sides of the Plus Seal.

SINGLE-STAGE VERSUS MULTI-STAGE SEALS

The advantage of multi-stage seals over single-stage seals has been clearly demonstrated by this test. The failure pattern of multi-stage seals in the Task III test has shown that the seal exposed to high pressure will have the most wear. The inside seal will fail and pressure will be applied to the next stage seal, which will fail and so on. This type of failure was demonstrated by the two-stage seal in the rod end of Actuator No. 3. The inside stage failed at 5,561,850 endurance plus 1,443,600 Rotor Feedback cycles; the second-stage did not fail until 5,561,850 endurance plus 10,391,670 Rotor Feedback cycles. The life increase from 7,005,450 cycles to 15,953,520 cycles shows a 127% increase in life that can be attributed to the addition of a second-stage seal.

Since none of the three- or four-stage seals tested in Task III failed, the further proof of this failure pattern was not as complete as desired, but the wear on the seals did provide supporting evidence. If the before and after dimensions of the Shamban backup rings on the downstream side are added and are averaged for the 1st-stage, 2nd-stage

and third-stage seals (no BU used in 4th stage), the change in ID is as shown below

	<u>1st Stage</u>	<u>2nd Stage</u>	<u>3rd Stage</u>	<u>4th Stage</u>
Delta I.D.	.01192	.00185	.0024	.0139

This data indicates that the 1st stage has experienced significantly more wear than the 2nd and third stages, which are almost equal. The fourth stage data, which represents scraper ID change instead of backup ring ID change, shows the most change, but this stage was exposed to daily applications of Arizona coarse road dust and more wear would be expected there.

The additional life provided by the multi-stage seals can also be seen in the failure data for the seals in the Task II and Task III tests as shown below.

<u>No. Of Stages</u>	<u>No. of Samples</u>		<u>No. of Failures</u>		<u>% Failures</u>	
	<u>Task II</u>	<u>Task III</u>	<u>Task II</u>	<u>Task III</u>	<u>Task II</u>	<u>Task III</u>
1	3	3	2	1*	66.7	33.3
2	7	5	1	1	14.3	20
3	2	2	0**	0	0	0
4	0	2	0	0	0	0

* One single-stage seal was on the verge of failure, but it did not fail during the test.

** The outer stage of one three-stage seal failed, but if the return line had a check valve installed, there would have been no system leakage.

The multiple stage installations have been much more reliable than the single-stage installations tested. The improvements in rod finish, rod clearances, groove angle, and seal materials have combined so favorably that it appears possible to design and build a hydraulic actuator that will last the life of the helicopter without removals due to leakage. A slight weight and cost penalty is exacted for these benefits, but the reduction in downtime and overhaul costs would be significant.

RECOMMENDATIONS

Based on the results of this effort, it is recommended that:

ROD SEALS

1. Rod seals in all new hydraulic actuators have a minimum of two unvented seals. If the actuator is to be used with a manual reversion system, vented seals should be used. If life, or leakage requirements are severe, three or more seals should be used. The space between seal stages should have a "catch basin" for wear particles.
2. The surface finish on rods for plastic seals be in the 2-8 RMS range. The rod surface should be ground in accordance with Process Specification 208-1-7 (Appendix B) or equivalent.
3. The end cap material that contacts the rod be relatively soft like the aluminum bronze used in this test.
4. Rod to bore clearances be reduced from those specified in MIL-G-5514 to prevent seal extrusion. The diametral rod-bore clearance specified for this test and recommended for future use is .001 - .003 inch.
5. The sides of the O-ring grooves be as near perpendicular to the rod as is economically possible. The sides of the O-ring grooves in this test were perpendicular to the rod within $\pm 1/2^\circ$.
6. The edge of the O-ring groove be sharper than the .005-inch minimum break specified in MIL-G-5514 to help prevent extrusion. The minimum edge break specified for the test was .002 inch.
7. Plastic Seals be made from a nonabrasive material. Conover's Revonoc 6200 and Shamban's Compositions 19 and 99 have proven to be both nonabrasive and wear resistant. All plastic seals should have a positive interference with the rod. The seals in this test had positive interference with the rod of from .004 to .014 inch. Recommended seals are shown in Table 12. All seals should be used with backup rings.
8. Backup rings be uncut and of the same material as the plastic seal. The backup rings should be installed as shown in Figure 12. The outside seal should have both backup rings on the outside. The inside seals should have a backup ring on each side. If the Con-O-Hex seal is used, the triangular backup ring takes the place of one regular backup ring. All backup rings should have a positive interference with the rod. The trapezoid backup ring is recommended for use with O-rings.

9. O-rings always be the "dynamic" size, and be the largest cross-section possible. The .070 inch cross-section O-ring, or its equivalent in another seal, should never be used since this size seal takes too much compression set. O-ring squeeze should be 5% minimum except that the groove should not be so shallow that the backup ring will be mashed when the rod is against the side of the bore. O-ring squeeze should always be calculated using the worst possible combination of O-ring cross-section and stretch, rod bore, rod size and groove size. If worst-case conditions are used to assure proper squeeze, some wear can occur without causing leakage. The O-rings used in this test were almost exclusively .139 inch cross-section, but one .210-inch cross-section O-ring was used with Maxi-Flex seal.

The O-ring material should be per MIL-P-83461 if hydraulic fluid per MIL-H-5606 or MIL-H-83282 is used.

SCRAPERS

1. Plastic scrapers be used rather than metallic scrapers. The plastic scrapers produced less rod wear and provide better dirt exclusion than the metallic scrapers.

Scrapers must have a positive interference with the rod and with the scraper groove inside diameter at all operating temperatures so that contamination cannot enter the actuator. All of the plastic scrapers tested met this requirement when new, but the Conover scraper was the only scraper that met this requirement at the end of the test.

It is desirable to have a scraper that can also act as a seal. The Conover scraper and the Shamban D. C. Excluder both provided this service.

QUALIFICATION TESTS

1. All future actuator qualification tests for Helicopter Rotor Control Actuators include a realistic Rotor Feedback Test. The Rotor Feedback Cycles and Endurance Cycles should be applied in blocks of cycles at realistic operating temperatures. Each block of cycles should be followed by a full stroke test, preferably 1000 cycles, at 80°F +/- 20°F to show useable leakage data. It would be desirable to perform a 5-cycle test at low temperature, -40°F or -65°F, depending upon the fluid chosen, at the end of each block of cycles. Measurable leakage during any of these tests should be considered to be a failure of the actuator.

ADDITIONAL TESTS

1. Additional multiple seal tests be performed under the conditions stated above until all seals in the test fail, so that the true value of the multiple-stage seal can be demonstrated. This type of testing should concentrate on a single-seal design in any given test so that the increased life/stage can be measured.

2. Additional scraper tests be performed with all competing scrapers designed to fit a standard groove. At the present time many vendors use unique groove and test costs increase with each nonstandard groove required. Scrapers should be tested at realistic operating temperatures and must be tested in a setup that will allow measurement of the quantity of contaminant that bypasses the scraper.

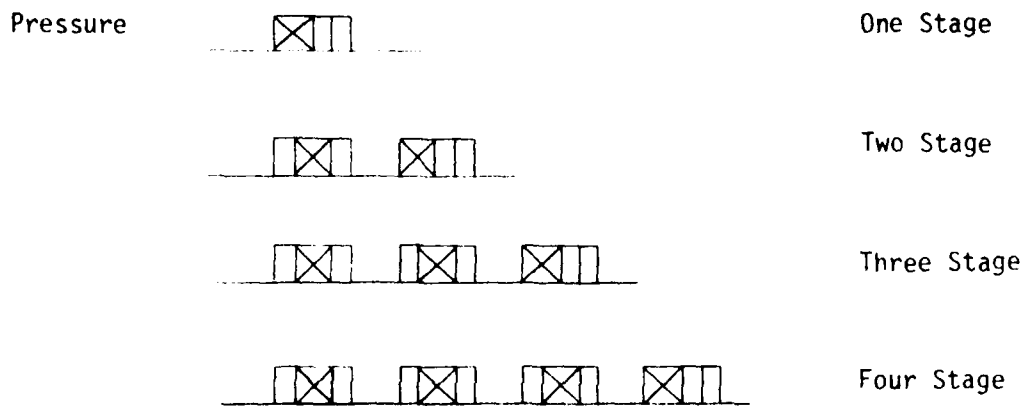







FIGURE 12. RECOMMENDED INSTALLATION OF BACKUP RINGS

TABLE 12. RECOMMENDED SEALS

	<u>Name</u>	<u>Manufacturer</u>	<u>Material</u>
Press. 	Con-O-Hex	C. E. Conover	Revonoc 6200
	Trapezoid Seal	C. E. Conover	Revonoc 6200
	Plus Seal	W. S. Shamban	Comp 19
	Double Delta with 1183461/ 1-XXX O-ring	W. S. Shamban	Comp 19
	Hat Seal	W. S. Shamban	Comp 19
	Maxi-Flex* with 1183461/ 1-XXX O-ring	Tetrafluor	Tetralon 720

* Requires a two-piece groove

APPENDIX A
TASK I DATA

TABLE A.1. SEAL EVALUATION PARAMETERS

SEALING

- Sealing - Predictable, uniform, high- and low-pressure sealing, static and/or dynamic.
- Excellent - One or more continuous elastomer sealing surfaces in contact with the rod surface.
- Average - One or more Teflon or other non-elastomer continuous sealing surface in contact with the rod surface.
- Poor - One or more interrupted sealing surface in contact with the rod surface.

JUSTIFICATION - The principal purpose of the program is to prevent leakage.

TABLE A.1. CONTINUED

WEAR

- Wear - Are the materials wear resistant yet nonabrasive.
- Excellent - No elastomer exposed to high pressure is in contact with the rod. Not abrasive.
- Average - Elastomer is exposed to high pressure and contacts the rod but is partially supported by non-elastomer. May be mildly abrasive.
- Poor - Elastomer is exposed to high pressure, contacts the rod, and may be abrasive.

NOTE: Elastomer contacting rod may be acceptable at system return pressure (100 psi or less), five million cycle life has been demonstrated.

JUSTIFICATION - Seal tests have shown that elastomers exposed to both high pressure and rod motion have a shorter life than non-elastomers exposed to the same conditions. Wear resistant materials are necessary for long life.

TABLE A.1. CONTINUED

FRICITION

- Friction - Minimize
- Excellent - Virgin Teflon in contact with rod. No elastomer contact with rod.
- Average - Blended Teflon or other non-elastomer in contact with rod. No elastomer contact with rod.
- Poor - Elastomer in contact with rod.

JUSTIFICATION -

<u>Material</u>	<u>Static Friction Coefficient</u>	<u>Dynamic Friction Coefficient</u>	<u>Source</u>
Buna-N	1.35	1.20	Greene, Tweed Catalogue
Teflon	.15	.05	Shamban Catalog and "Journal of Teflon"
	.05	.04	Bal Seal Data
Teflon Blend	.12	.10	Bal Seal Data
Turcon (Teflon Blend)	40 percent of Buna-N O-ring (.54 calculated)	40 percent of Buna-N O-ring (.48 calculated)	Shamban Catalog

TABLE A.1. CONTINUED

PRESSURE TRAP

- | | |
|---------------|--|
| Pressure Trap | - Does the configuration trap an unacceptable pressure level between seal stages. |
| Excellent | - Seal does not trap pressure. |
| Average | - Seal traps pressure but the pressure does not have an adverse effect on the seal. |
| Poor | - Seal traps pressure that can cause seal damage. Pressure must be relieved by an auxiliary vent. |
| JUSTIFICATION | - Some asymmetric seals can be damaged by high pressure on the downstream side. (Reverse Pressurization) |

TABLE A.1. CONTINUED

TEMPERATURE

- Temperature - Meets -65°F to $+275^{\circ}\text{F}$ requirement.
- Excellent - Exceeds -65°F to $+275^{\circ}\text{F}$ temperature range.
- Average - Meets -65°F to $+275^{\circ}\text{F}$ temperature range
- Poor - Does not meet -65°F to $+275^{\circ}\text{F}$ temperature range, but could be considered for use where that requirement is not strictly applicable.

- JUSTIFICATION - Temperature requirements should be met unless outstanding capability can be shown at a useable temperature range that is slightly deficient.

8
B

TABLE A.1. CONTINUED

EXTRUSION GAP

- | | |
|---------------|---|
| Extrusion Gap | - How well does the design bridge the extrusion gap. |
| Excellent | - Virgin Teflon thicker than .17 in. or other material at (material shear stress)/4.0 or less (applied) at 275°F. |
| Average | - Virgin Teflon thicker than .145 in. or other material at (material shear stress)/3.38 or less (applied) at 275°F. |
| Poor | - Virgin Teflon thicker than .120 in. or other material at (material shear stress)/2.76 or less (applied) at 275°F (this should give the same performance as an MS28774 backup ring at 3000 psi). |
| JUSTIFICATION | - Extrusion can cause seal failure for a rod moved to the limit of its radial motion. |

TABLE A.1. CONTINUED

INSTALLATION

- Installation - Ease of installation compared to an O-ring installation with two backup rings.
- Excellent - Easier to install than an O-ring with two backup rings. One-piece gland. No special tools.
- Average - Equivalent installation difficulty as an O-ring with two backup rings. One-piece gland. No special tools.
- Poor - Installation more difficult than an O-ring with two backup rings or uses a two-piece gland. Special tools may be required.
- JUSTIFICATION - Cascaded seals require more installation time than a single O-ring with two backup rings.

TABLE A.1. CONTINUED

SPACE

- Space - Space required compared to MIL-G-5514F gland for an O-ring with two backup rings.
- Excellent - Requires less space than two backup groove.
- Average - Requires same space as two backup groove.
- Poor - Requires more space than two backup groove.

JUSTIFICATION - Cascaded seals should occupy as little space as is practical.

TABLE A.1. CONTINUED

SEAL DEFLECTION

- Seal Deflection - Does the seal flex or work when pressure changes so that fatigue failures are likely.
- Excellent - After initial pressure application little or no deflection is required. Seal cross-section does not change its basic shape as pressure changes.
Example: Metal rod seal.
- Average - After initial pressure application some deflection is required. Seal cross-section may undergo slight change in its basic shape as pressure changes.
Example: GT Seal.
- Poor - After initial pressure application the seal cross-section changes shape to conform to seal gland.
Example: O-ring.
- JUSTIFICATION - The 25 million cycle requirement mandates that seal deflection be minimized.

TABLE A.1. CONTINUED

ORIENTATION

- | | |
|-------------|---|
| Orientation | - Can the seal be installed backwards or improperly?
Can the proper orientation be easily recognized? |
| Excellent | - Seal is symmetrical or if not improper orientation is not possible. |
| Average | - Seal can be installed improperly but improper orientation can be observed by visual inspection after installation. |
| Poor | - Seal can be installed improperly. Orientation is difficult to check visually and may require partial disassembly to verify. |

- | | |
|---------------|---|
| JUSTIFICATION | - Improper installation of nonsymmetrical seals will cause leakage failure. |
|---------------|---|

TABLE A.1. CONTINUED

COMPLEXITY

Complexity	- Few parts, few interfaces, simple gland requirements.
Excellent	- One or two pieces to install in a one-piece gland.
Average	- Three separate pieces to install in a one-piece gland.
Poor	- More than three separate pieces to install or uses a two-piece gland.
JUSTIFICATION	- A two-piece gland complicates and penalizes a design. A complex seal is more easily damaged than a simple seal during installation.

TABLE A.1. CONTINUED

COMPATIBILITY

- Compatibility - Are all of the materials compatible with both MIL-H-5606 and MIL-H-83282.
- Excellent - All materials are compatible with both fluids.
- Average - All materials are compatible with one fluid and marginal with the other.
- Poor - Materials are not compatible with either fluid.

JUSTIFICATION - The seals must be tested in both MIL-H-5606 and MIL-H-83282.

NOTE: Fluid compatibility will be estimated if it is unknown.

TABLE A.1. CONTINUED

PRODUCIBILITY

- Producibility - Is it producible? Is there an excessive number of close tolerances that must be held?
- Excellent - Rod, Rod bore, and groove surfaces and tolerances are more liberal than MIL-G-5514F. Seal tolerances are more liberal than MS28775.
- Average - Rod, rod bore, and groove surfaces and tolerances are equivalent to those in MIL-G-5514F. Seal tolerances are equivalent to those in MS28775.
- Poor - Rod, rod bore, and groove surfaces and tolerances stricter than MIL-G-5514F. Seal tolerances stricter than MS28775.

JUSTIFICATION - MIL-G-5514F and MS28775 are recognized standards in Aerospace Industry and provide a good baseline for purposes of comparison.

For A - 214 seal	MIL-G-5514F specifies	&	MS28775 specifies
	+ .001		
Rod bore	- .000		ID +/- .006
	+ .000		
Rod	- .002	16 ✓	T +/- .004
	+ .002		
Groove	- .000	32 ✓	

TABLE A.1. CONTINUED

PRESSURE LEVEL

- Pressure Level - Is the configuration suitable for 8000 psi?
- Excellent - Seal has been tested at 8000 psi and has demonstrated its capability.
- Average - Seal has been tested at 3000 psi and appears to be good for 8000 psi.
- Poor - Seal has been tested at 3000 psi but appears to be marginal for 8000 psi.
- JUSTIFICATION - All seals tested will be exposed to 8000 psi for 25 percent of the test cycles.

TABLE A.2. ROD FINISH EVALUATION PARAMETERS

COST TO PREPARE

- | | |
|--------------|--|
| Excellent | - Cost is less than that necessary to produce a $\sqrt[16]{}$ on a chromium-plated rod. |
| Average | - Cost is approximately the same as that necessary to produce a $\sqrt[16]{}$ on a chromium-plated rod. |
| Poor | - Cost is greater than that necessary to produce a $\sqrt[16]{}$ on a chromium-plated rod. |
| UNACCEPTABLE | - Cost is significantly greater than that necessary to produce a $\sqrt[16]{}$ on a chromium-plated rod. |

TABLE A.2. CONTINUED

RELATIVE CORROSION RESISTANCE

- | | |
|--------------|--|
| Excellent | - Corrosion resistance is better than a chromium plated rod. |
| Average | - Corrosion resistance is approximately the same as a chromium-plated rod. |
| Poor | - Corrosion resistance is less than a chromium-plated rod. |
| UNACCEPTABLE | - Corrosion resistance is inadequate for normal environmental exposure. |

TABLE A.2. CONTINUED

POTENTIAL FOR REDUCING LEAKAGE

- | | |
|-----------|---|
| Excellent | - Surface cracks are smaller and less numerous than a normal $\sqrt[16]{}$ chromium-plated rod. |
| Average | - Surface cracks are approximately the same size and number as those in a normal $\sqrt[16]{}$ chromium-plated rod. |
| Poor | - Surface cracks are larger and/or more numerous than those in a normal $\sqrt[16]{}$ chromium-plated rod. |

TABLE A.2. CONTINUED

WEAR RESISTANCE

- | | |
|-----------|---|
| Excellent | - Provides better wear resistance than a chromium-plated rod. |
| Average | - Provides approximately the same wear resistance as a chromium-plated rod. |
| Poor | - Provides less wear resistance than a chromium-plated rod. |

TABLE A-3. SEALS SELECTED FOR TASK II TEST

ACTUATOR NO.	END NO.	STAGE NO.	SEAL CONFIGURATION	SEAL DESIGNATION	SEAL MATERIAL (ELASTOMER)
1	2	1	R3	Double Delta	Filled Teflon (MIL-P-83461 O-Ring)
2	1	1,2	R16	Plus Seal	Filled Teflon (MIL-P-83461 Elastomer)
2	2	1	R19	Hat Seal	Filled Teflon (MIL-P-83461 Elastomer)
2	2	2	R18	Double Delta with two backups	Filled Teflon (MIL-P-83461 O-ring)
3	1	1,2	R18	Double Delta with two backups	Filled Teflon (MIL-P-83461 O-ring)
3	2	1,2,3	R5	Foot Seal	Filled Teflon (MIL-P-83461 O-ring)
4	1	1	R10	Excluder	Filled Teflon (MIL-P-83461 O-ring)
4	1	2,3	R21	Double Delta Staged Backups	Filled Teflon (MIL-P-83461 O-ring)
4	2	1	P7	Trapezoidal Seal	Filled Teflon (MIL-P-83461 Elastomer)
4	2	2,3	R13	Hex Seal	Filled Teflon (Proprietary Compound)

TABLE A-3. CONTINUED

ACTUATOR NO.	END NO.	STAGE NO.	SEAL CONFIGURATION	SEAL DESIGNATION	SEAL MATERIAL (ELASTOMER)
5	1	2,3	R7	Trapezoidal Seal	Filled Teflon (MIL-P-83461 Elastomer)
5	2	1	R2	GT "T" Ring	Filled Teflon (Proprietary Elastomer)
5	2	2	R22	Rubber Spring Actuated Seal	Hytrel (Proprietary Elastomer)
6	1	1,2	R13	Hex Seal	Filled Teflon (Proprietary Elastomer)
6	2	1	R3	Double Delta	Filled Teflon (MIL-P-83461 O-ring)

APPENDIX B
TASK II DATA

TABLE B-1. TASK II SFALS

ACT LUG NO. FHD	ROD END	GROOVE				PART NUMBER	SEAL NAME & MANUFACTURER	MATERIAL	
		A	B	C	D				
1	X	X	X	X	Double Delta S30650-214-14	W. S. Shanban	Turcon with glass, and Proprietary MoS ₂ filler		
					O-Ring 183461/1-214			Parker	NIL-P-83461
					Backup Ring (2) S33012-214-14				
1	X	X			Ball Seal 2A1H506-0321	Ball Seal Eng. Co.	Graphite-Carbon Glass Teflon		
2	X	X	X	X	Plus Seal S30775-214P-19	W. S. Shanban	Turcon with proprietary MoS ₂ Filler		
2	X	X	X	X	Double Delta S30650-214-14	W. S. Shanban	Turcon with glass and Proprietary MoS ₂ filler		
					O-Ring 183461/1-214			Parker	NIL-P-83461
					Backup Ring (2) S33012-214-14				
					Hat Seal S33050-214P-14	W. S. Shanban	Turcon with glass and Proprietary MoS ₂ filler		

TABLE B-1. CONTINUED

ACT LUG NO. END	ROD END	GROOVE				SEAL NAME & PART NUMBER	MANUFACTURER	MATERIAL
		A	B	C	D			
3	X	X				Rod Seal TF-1009-214	Tetrafluor	Glass filled TFE
			X			O-Ring M83461/1-214	Parker	MIL-P-83461
			X			Backup Ring (2) CEC5065-214 Uncut	Conover	Revonoc 18158
3	X	X				Varipak M S61200	American Variseal Corp	Turcite 42, glass reinforced PTFE
		X				Cam Ring S61202		Turcite 57, bronze reinforced PTFE
			X			O-Ring M83461/1-214	Parker	MIL-P-83461
			X			Backup Ring (2) CEC5065-214 Uncut	C. E. Conover & Co.	Revonoc 18158

Table B-1. CONTINUED

ACT LUG NO. END	ROD END	GROOVE			SEAL NAME & PART NUMBER	MANUFACTURER	MATERIAL
		A	B	C D			
4	X	X	X	X	Double Delta S30650-214-14	W. S. Shamban	Turcon with glass and Proprietary MoS ₂ filler
		X	X	X	O-Ring M83461/1-214	Parker	MIL-P-83461
		X	X	X	Backup Ring (2) S33012-214-14	W. S. Shamban	Turcon with glass and Proprietary MoS ₂ filler
			X	X	Excluder S30395-9G-8	W. S. Shamban	Turcon with bronze
			X	X	O-Ring M83461/1-121	Parker	MIL-P-83461
4	X	X	X	X	Con-O-Hex CEC6001-214	C. E. Conover & Co.	Revonoc 18158 Revonoc 6200 Proprietary Nitrile
		X	X	X	Backup Ring CEC5065-214	C. E. Conover & Co.	Revonoc 18158
			X	X	Trapezoid Seal CEC5056-214	C. E. Conover & Co.	Revonoc 18158 MIL-P-83461 (Elastomer)
5	X	X	X	X	Trapezoid Seal CEC5056-214	C. E. Conover	Revonoc 18158 MIL-P-83461 (Elastomer)

Table B-1. CONTINUED

ACT LUG NO. END	ROD END	GROOVE				SEAL NAME & PART NUMBEP	MANUFACTURER	MATERIAL
		A	B	C	D			
5	X	X				RSA Seal, 3694- -00998-0122-0304	Greene Tweed	Hytrel
			X			G. T. Ring 7214FT-000-P3	Greene Tweed	Proprietary Nitrile Compound
6	X	X	X			Con-O-Hex CEC6001-214	C. E. Conover & Co.	Revonoc 18158 Revonoc 6200 Proprietary Nitrile
		X	X			Backup Ring CEC5065-214	C. E. Conover & Co.	Revonoc 18158
6	X		X			Double Delta S30650-214-14	W. S. Shamban	Turcon with glass and Molybdenum Disulfide
			X			O-Ring M83461/1-214	Parker	MIL-P-83461

TABLE B-2. TASK II SEAL PERFORMANCE SUMMARY

#1 Rod End

CONFIGURATION SKETCH	PART NUMBER	DESIGNER/ SUPPLIER	SATISFACTORY PERFORMANCE	COMMENTS
P 	2A1H506-0321	Ba1 Seal Eng. Co.	No	This seal was removed for leakage after 1 x 10 ⁶ cycles. The seal appeared to be in good condition. The sealing lips had been mashed flat with the adjacent surfaces. The seal ID showed light wear, but the seal cavity had many seal wear particles.

Single-Stage
Seal Installation

TABLE B-2. CONTINUED

#2 Rod End

CONFIGURATION SKETCH	PART NUMBER	DESIGNER/SUPPLIER	SATISFACTORY PERFORMANCE	COMMENTS
P 	S30775-214P Plus Seal	Shamban	Yes	No leakage in 2.4 x 10 ⁶ cycles. In a 2-stage unvented installation, the Plus Seal extruded approx .15 inch under the backup ring and had minor axial wear on the I.D. There was no visible extrusion of the backup ring. Elastomer was in excellent condition.
INSIDE SEAL in a 2-stage unvented instl	S33012-214-14 Backup on inside modified as a spacer			
P 	S30775-214P Plus Seal	Shamban	Yes	Faint axial wear on ID of plus seal, but no extrusion. Elastomer was in excellent condition. The chromium rod had been discolored and polished by the seals.
OUTSIDE SEAL in a 2-stage unvented instl	S33012-214-14 Backup rings (2) on inside modified as spacers			

TABLE B-2. CONTINUED

#2 Lug End

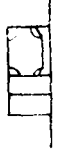

CONFIGURATION SKETCH	PART NUMBER	DESIGNER/SUPPLIER	SATISFACTORY PERFORMANCE	COMMENTS
 P	S30650-214-14 Double Delta	Shamban	Yes	One drop total rod leakage in 2.4 x 10 ⁶ cycles in a 2-stage vented installation. The outside backup ring extruded approx. .03-inch. The Double Delta seal inside backup ring and O-ring were in excellent condition
 INSIDE SEAL in a 2-Stage Vented Instl. (90 psi.)	S33012-214-14 Backup ring M83461/1-214 O-ring Parker			
 P OUTSIDE SEAL in a 2-stage vented instl. (90 psi)	S33050-214P-14 Hat Seal	Shamban	Yes	Turcon parts were in excellent condition. Elastomer was in good condition but had a 120-degree circumferential crack on the ID in the lip just inside of the flat section.

TABLE B-2. CONTINUED

#3 Lug End

CONFIGURATION SKETCH	PART NUMBER	DESIGNER/ SUPPLIER	SATISFACTORY PERFORMANCE	COMMENTS
<p>P </p> <p>INSIDE STAGE in a 2-Stage unvented instl.</p>	<p>TF-1009-214 Rod Seal CEC 5065-214 Qty 2, Backup Ring modified as spacers</p>	Tetrafluor	Yes	<p>This seal instl. leaked 18 drops at the rod in 2.4 x 10⁶ cycles. This seal instl. was exceptionally clean and free of wear particles. The outside backup ring had approx. an .03 inch extrusion (The spacers were accidentally installed as Backup Rings)</p>
<p>P </p> <p>OUTSIDE STAGE in a 2-Stage unvented instl</p>	<p>M83461/1-214 O-Ring CEC 5065-214 Backup ring Qty 2</p>	Parker	Yes	<p>The O-ring shows some wear from passing over a damaged area on the rod, but it shows no sign of nibbling. It had taken a slight permanent set. The 2 backup rings had fused together. The outside ring shows very light extrusion. The inside backup ring has a slightly concave shape where it contacted the O-ring.</p> <p>The rod showed light wear but a fragment of the chrome plate had flaked off.</p>

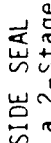
TABLE B-2. CONTINUED

#3 Rod End

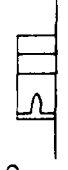
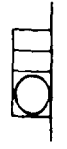

CONFIGURATION SKETCH	PART NUMBER	DESIGNER/SUPPLIER	SATISFACTORY PERFORMANCE	COMMENTS
	S61200 Varipak M	American Variseal	Conditionally Yes	This seal instl. leaked only 18 drops at the rod in 2.4 x 10 ⁶ cycles, but the bronze particles worn off of the cam ring might cause problems in some applications. The OD & ID lips on the Varipak M are now almost flat surfaces.
INSIDE STAGE of a 2-stage unvented instl.	S61202 Cam Ring			
	M83461/1-214 O-Ring	Parker	Yes	The O-ring has been nibbled slightly and shows some wear. It has taken a permanent set. The two backup rings had fused together and were coated with bronze particles.
OUTSIDE STAGE of a 2-stage unvented instl	CEC5065-214 Backup rings Qty. 2	Conover		The rod shows moderate wear and scoring.

TABLE B-2. CONTINUED

#4 Lug End



CONFIGURATION SKETCH	PART NUMBER	DESIGNER/SUPPLIER	SATISFACTORY PERFORMANCE	COMMENTS
 <p>INSIDE STAGE OF a 3-stage unvented seal instl.</p>	S30650-214-14 Double Delta	Shamban	Conditionally Yes	This seal instl had 7 drops total rod leakage in 2.4×10^6 cycles. Inside backup ring is in excellent condition. Double delta shows minor wear but is in good condition. O-ring has taken a permanent set but is in good condition. The outside backup ring is in good condition, but has extruded approx. .06 inch.
	M83461/1-214 O-ring	Parker	The seals look good but the chrome finish on the rod was moderately worn with light axial scratches	
	S33012-214-14 Backup ring Qty. 2	Shamban		
 <p>CENTER STAGE of a 3-Stage Unvented Seal Instl.</p>	S30650-214-14 Double Delta	Shamban	Conditionally Yes	Both backup rings are in good condition. No extrusion is visible. The double delta seal shows minor wear but is in good condition. The O-ring has taken a permanent set but is in good condition.
	M83461/1-214 O-ring	Parker	The seals look good but the chrome finish on the rod was moderately worn with light axial scratches	
	S33012-214-24 Backup Ring Qty. 2	Shamban		

TABLE B-2. CONTINUED

#4 Lug End
Continued

CONFIGURATION SKETCH	PART NUMBER	DESIGNER/ SUPPLIER	SATISFACTORY PERFORMANCE	COMMENTS
P 	S30395-9G-8 Excluder	Shamban	Conditionally Yes	The excluder is in good condition. The wear pattern is on the outside edge as desired. Bronze particles have separated from the Turcon and are present in the seal cavity. The O-ring has taken a permanent set but is in good condition.
OUTSIDE STAGE of a 3-Stage Unvented Seal Instl.	M83461-121 O-Ring	Parker	The seals look good but the chrome finish on the rod was moderately worn with light axial scratches	

TABLE B-2. CONTINUED

#4 Rod End



CONFIGURATION SKETCH	PART NUMBER	DESIGNER/SUPPLIER	SATISFACTORY PERFORMANCE	COMMENTS
P 	CEC6001-214 Con-0-Hex	Bob Brent/ Conover	Yes, but outside stage failed	This seal leaked 69.9 cc in 2.4 x 10 ⁶ cycles because the outside seal failed. For the last 1.4 x 10 ⁶ cycles, return pressure was removed from the outside seal and rod leakage was 9.23 cc. The seal cavity was clean but wear particles from the 18158 Revonoc were present in the fluid collection grooves. The inside backup ring showed wear, but no extrusion. The special cap strip showed slight wear, but was in good condition. The hex shaped elastomer was in excellent condition. The outside triangular backup was in good condition but had approx. an .02 inch extrusion.
INSIDE STAGE in a 3-Stage Vented Instl.	CEC5065-214 Backup Ring			
P 	CEC6001-214 Con-0-Hex	Bob Brent/ Conover		The inside backup was flattened on the OD prior to instl so that it would act as a spacer. It showed slight wear but was in good condition. The hex shaped elastomer was in excellent condition. The outside triangular backup was in good condition but had approx. an .02 inch extrusion.
CENTER STAGE in a 3-Stage Vented Instl.	CEC5065-214 Backup Ring modified as a spacer		Yes, but outside stage failed	The inside backup was flattened on the OD prior to instl so that it would act as a spacer. It showed slight wear but was in good condition. The hex shaped elastomer was in excellent condition. The outside triangular backup was in excellent condition.

TABLE B-2. CONTINUED

#4 Rod End
Continued

CONFIGURATION SKETCH	PART NUMBER	DESIGNER/ SUPPLIER	SATISFACTORY PERFORMANCE	COMMENTS
<p>P</p>  <p>OUTSIDE STAGE in a 3-Stage Vented Instl.</p>	CEC5056-214 Trapezoid Seal	G. K. Fling /Conover	No	The trapezoid shaped elastomer failed in a delamination manner. The trapezoid shaped backup showed minor wear but no extrusion and was in good condition

TABLE B-2. CONTINUED

#5 Rod End



CONFIGURATION SKETCH	PART NUMBER	DESIGNER/ SUPPLIER	SATISFACTORY PERFORMANCE	COMMENTS
<p>P </p> <p>INSIDE STAGE of a Two- Stage Vented Seal Instl. (90 psig)</p>	3694-00998- 0122-0304 RSA Seal	Greene Tweed	No. Friction was excessive	This seal instl. was removed for leakage after 1 x 10 ⁶ cycles. It was discovered that the chrome plating on the rod had flaked. The seal ID showed heavy wear from passing over the damaged rod
<p>P </p> <p>OUTSIDE STAGE of a Two- Stage Vented Seal Instl. (90 psi)</p>	7214FT-000-P3	Greene Tweed	No. Friction was excessive	The inside backup ring was in good condition and showed only light wear. The elastomer showed heavy wear on the outside edge by the rod. The outside backup showed light wear but was extruded approx. .02 inch.

TABLE B-2. CONTINUED

#5A Lug End

CONFIGURATION SKETCH	PART NUMBER	DESIGNER/ SUPPLIER	SATISFACTORY PERFORMANCE	COMMENTS
P 	S30650-214-14 Double Delta	Shamban	Yes	This seal instl leaked 24 cc in 2.4 x 10 ⁶ cycles. This installation was very clean. The inside backup ring was in excellent condition. The double delta seal was in good condition with light wear, but had approx. a .02 inch extrusion. The O-ring had taken a slight permanent set but was in good condition. The outside backup ring was in good condition but had approx. a .04 inch extrusion.
	M83461/1-214 O-Ring	Parker		
	S33012-214-14 Backup Ring Qty. 2	Shamban		

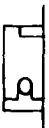
TABLE B-2. CONTINUED

#5A Rod End



CONFIGURATION SKETCH	PART NUMBER	DESIGNER/ SUPPLIER	SATISFACTORY PERFORMANCE	COMMENTS
<p>P </p> <p>INSIDE STAGE of a 2-Stage Unvented Instl.</p>	CEC5056-214 Trapezoid Seal	G.K.Fling /Conover	Yes	This seal instl. leaked 1.83 cc in 2.4×10^6 cycles. This was the only seal instl that used an elastomer that was exposed to high pressure and the moving rod surface. The trapezoid shaped elastomer had a partial failure that did not affect the sealing surface. A small piece of elastomer had separated from the back of the seal. There was light nibbling close to the rod. The trapezoid shaped backup had experienced a considerable amount of wear on one side and had extruded approx .05 inch.
<p>P </p> <p>OUTSIDE STAGE of a 2-Stage Unvented Instl.</p>	CEC5056-214 Trapezoid Seal	G.K.Fling /Conover	Yes	The elastomer had some circumferential cracking at approx. 50% axial depth on the I.D. There was some very light nibbling. The backup ring was in good condition. There was no extrusion, but there was minor wear on the I.D. These seals were cycled 1×10^6 cycles on the lug end of Act. No. 5 and 1.4×10^6 cycles on the rod end of Act. No. 5A. The leakage rate was lowest on the tungsten carbide rod in 5A.

TABLE B-2. CONTINUED

#6 Rod End

CONFIGURATION SKETCH	PART NUMBER	DESIGNER/ SUPPLIER	SATISFACTORY PERFORMANCE	COMMENTS
P 	S30650-214-14 Double Delta	Shamban	No	The seal failed the leakage requirement after 1.9 x 10 ⁶ cycles. The backup rings were flattened prior to instl. to serve as spacers. They were in good condition. The outside lip of the delta seal had been worn away over a 60-degree continuous arc. The double delta had extruded approx. .05 inch in two places on either side of the arc. The elastomer had come into contact with the rod in that arc and approx. 20% of the outside thickness of the elastomer had been worn away. The rod was in good condition.
	M83461/1-214 O-Ring	Parker		
	CEC5065-214 Backup Ring (Spacer) Qty. 2	Conover		

TABLE B-2. CONTINUED

#6 Lug End



CONFIGURATION SKETCH	PART NUMBER	DESIGNER/ SUPPLIER	SATISFACTORY PERFORMANCE	COMMENTS
P 	CEC6001-214 Con-0-Hex	Bob Brent /Conover	Yes	The seal instl leaked 2 drops in 2.4 x 10 ⁶ cycles. The seal cavity was very clean. The inside backup ring was in excellent condition with no visible wear. The special cap was in good condition with light wear. The hex-shaped elastomer was in excellent condition. The triangular-shaped backup ring was in good condition but had approx. a .03 inch extrusion.
INSIDE STAGE of a Two Stage Unvented Instl.	CEC5065-214 Backup Ring			
P 	CEC6001-214 Con-0-Hex	Bob Brent /Conover	Yes	The inside backup ring was flattened prior to instl. so that it could be used as a spacer. It was in excellent condition with no visible wear. The special cap was in good condition but showed a slight accumulation of contamination under its thickest section. The hex-shaped elastomer was in excellent condition. The outside triangular-shaped backup ring was in excellent condition.
OUTSIDE STAGE of a Two Stage Vented Instl	CEC5065-214 Backup Ring modified as a spacer			

TABLE B-2. CONTINUED

#6 Rod End

CONFIGURATION SKETCH	PART NUMBER	DESIGNER/ SUPPLIER	SATISFACTORY PERFORMANCE	COMMENTS
	CEC5058-214	Conover	Yes	<p>This seal instl. was very clean. This was a replacement seal and leaked 13.7 cc in 444,537 cycles at 8000 psig. The cap strip was in good condition and showed slight wear. The O-ring had taken a permanent set but was in good condition. The two backup rings had fused together and were in good shape, but the one on the outside had extruded approx .04 inch.</p>

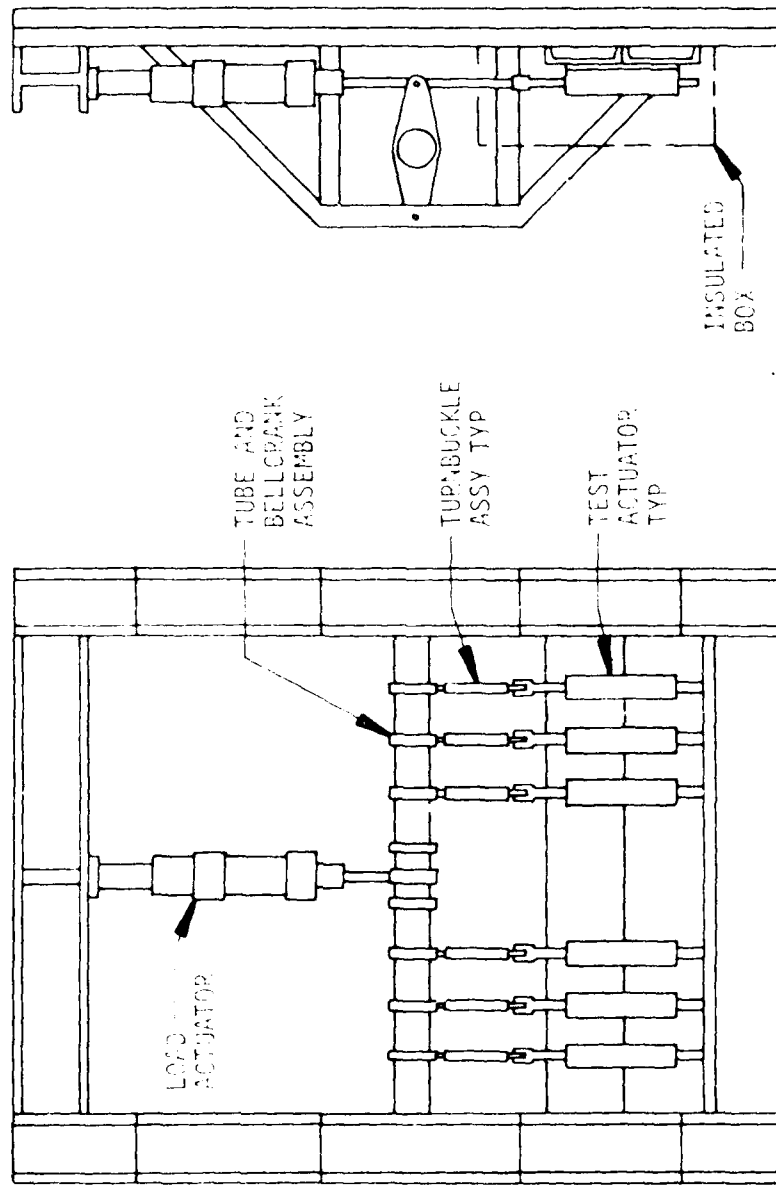

FIGURE B-1. SEAL EVALUATION TEST FIXTURE

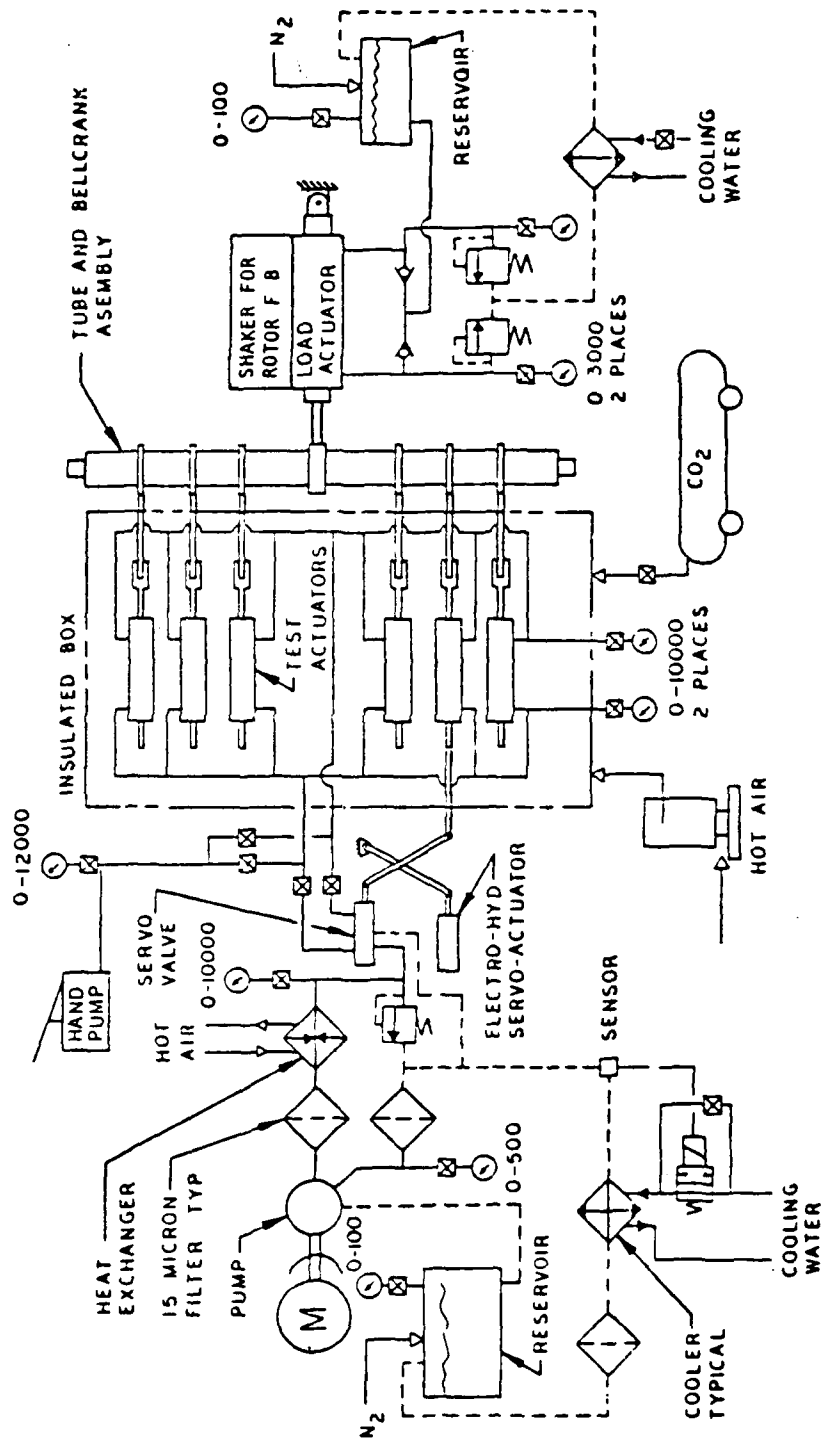

FIGURE B-2. SPECIMEN AND LOAD HYDRAULIC SYSTEMS

PROCESS SPECIFICATION
208-1-7

STEEL PARTS,
UNPLATED AND CHROME PLATED,
GRINDING OF

1. SCOPE - This specification establishes the requirements and procedures for grinding of unplated and chrome plated steel parts.

2. APPLICABLE DOCUMENTS

2.1 The applicable provisions of the following documents are incorporated herein by reference:

SPECIFICATIONS

MILITARY

MIL-I-6868	Inspection Process, Magnetic Particles
MIL-C-16173	Corrosion Preventive Compound, Solvent Cutback, Cold Application

VSD

CVA 1-372	Heat Treatment of Steels
CVA 9-96	Corrosion Preventives, Temporary for Metallic Parts Application of
CVA 13-23	Nital Etching for Carbon and Low Alloy Steels
208-13-40	Peening, Shot and Glass Bead

2.2 In the event this specification does not meet or exceed the requirements of any applicable government specification, the government specification shall take precedence unless a deviation has been granted.

3. MATERIALS AND EQUIPMENT

3.1 MATERIALS

3.1.1 GRINDING COOLANTS - Water soluble, commercial grade.

3.1.2 CORROSION PREVENTIVE COMPOUND - MIL-C-16173, Grade II.

3.2 EQUIPMENT

PROCESS SPECIFICATION. CONTINUED

3.2.1 Ovens for baking and stress relieving, controlled in accordance with CVA 1-372.

3.2.2 Grinding Wheels.

4. REQUIREMENTS

4.1 GRINDING EQUIPMENT

4.1.1 GRINDING MACHINES - Grinding machines shall be capable of maintaining grinding speed, work speed (spindle or traverse), cross feed and down feed in increments necessary to avoid surface degradation of the part. Provisions shall be made to supply a constant application of coolant to the working surface of the wheel.

4.1.2 COOLING - The machine shall be capable of continuously supplying coolant to the work area at a rate of 2 gallons per minute per inch of wheel width. The coolant nozzle shall be of a configuration which shall flood the entire width of the wheel with coolant and shall direct the coolant at the point of contact between the grinding wheel and the work piece in the direction of motion of the grinding wheel.

4.1.2.1 GRINDING COOLANTS - A suitable coolant shall be used which does not have an adverse effect on the part being ground. Recirculated coolants shall be either gravity separated of contaminants or continuously filtered to minimize recycling grinding residue.

4.2 GRINDING WHEELS

4.2.1 MARKING - Grinding wheels shall be labeled or numbered as to abrasive type and grade, grit size, bond type, density and wheel hardness.

4.2.2 CHARACTERISTICS - Unless otherwise specified, aluminum oxide grinding wheels having a grit size of 46 to 90, a grade or hardness designation between G and K, a structural density between 6 and 12, and a vitrified bond shall be used for all grinding operations.

4.3 PROCESSING

4.3.1 CLEANING - Protective coatings and other foreign materials shall be removed from parts prior to grinding to preclude contamination of coolant and wheels. Coolants and grinding residuals that have a deleterious effect on the part shall be removed after grinding. Cleaning materials shall not corrode or otherwise degrade the surfaces of the part. Where process delay time is such that corrosion might occur, parts shall be adequately protected after cleaning.

PROCESS SPECIFICATION. CONTINUED

4.3.2 WHEEL DRESSING AND TRUING - Wheel dressing and truing shall be performed as required in the specific grinding requirements.

- (a) The dressing or truing operation shall simulate the actual grinding as far as wheel speed and use of coolant are concerned.
- (b) The edges of the wheel shall be rounded off with a hard stone or precision tool to prevent chipping the wheel edges.
- (c) The nib in the diamond shall be turned frequently to present a sharp edge for dressing.
- (d) The cross feed of the nib shall be 7 to 15 inches per minute when dressing the wheel.
- (e) Each time the wheel is dressed, the dressing infeed shall total 0.003 inch, accomplished in controlled infeeds of 0.0005 inch per pass plus four multidirection sparkout passes after the last infeed pass.

4.3.3 GRINDING

- (a) The grinding process shall be controlled so as to result in low stress grinding.
- (b) Dry grinding or grinding with the side of the grinding wheel is prohibited.
- (c) Parts shall be traversed for high spots in order to avoid inadvertent violation of the down feed requirements of this specification.
- (d) There shall be no contact between a rotating grinding wheel and a non-rotating cylindrical part.
- (e) Parts shall meet all previous operation requirements before grinding is attempted.
- (f) Finish ground parts and parts in process where processing delay time is such that surface corrosion might occur shall be protected with MIL-C-16173, Grade II corrosion preventive compound per CVA 9-96.

PROCESS SPECIFICATION. CONTINUED

5. PROCEDURES

5.1 GRINDING PROCESS - The grinding process shall be performed in accordance with Table I to result in metallurgically sound parts. All feeds, speeds, and stock removal parameters are actual and not necessarily machine or indicator readings.

5.2 POST GRINDING PROCESSING

5.2.1 UNPLATED STEEL PARTS

- (a) Nital etch parts in accordance with CVA 13-23.
- (b) Stress relieve parts in accordance with CVA 1-372.
- (c) Vapor blasting or dry blasting using 120 grit aluminum oxide at 40 psi pressure may be used to remove the scale produced by the baking operation. This method of scale removal also removes 0.00006 to 0.00015 inch of base metal.
- (d) Magnetic particle inspect in accordance with MIL-I-6868.
- (e) Parts heat treated to 260,000 psi and above and those required to be shot peened in accordance with the Engineering drawing shall be shot peened in accordance with 208-13-40 after they have been nital etched, stress relieved and magnetic particle inspected.

5.2.2 CHROME PLATED STEEL PARTS

- (a) Bake parts for 3 hours at 375°F \pm 25°F.
- (b) Magnetic particle inspect in accordance with MIL-I-6868.

6. QUALITY ASSURANCE PROVISIONS

6.1 QUALIFICATION - Vought Quality Assurance shall determine and control qualification of Vought personnel, equipment and grinding process. A Quality Assurance program shall be developed and implemented to ensure that all requirements of this specification are met.

6.2 PROCESS CONTROL

6.2.1 WORK INSTRUCTIONS - Detailed instructions (shop planning) shall be written for each part number for use by the operator and inspector. They shall incorporate all parameters required for a controlled operation, as directed in this specification.

PROCESS SPECIFICATION. CONTINUED

6.3 INSPECTION

6.3.1 FINAL INSPECTION

6.3.1.1 After grinding, all parts shall be inspected as follows:

- (a) Visually inspect for cracks, chatter marks, or other obvious discrepant conditions.
- (b) Dimensionally inspect in accordance with the applicable Engineering drawing. In cases where the final part is chrome plated, the following additional data shall be taken:
 - (1) Measure and record unplated steel part dimensions after completion of final grinding operation performed prior to plating.
 - (2) After grinding, measure and record final plated part dimensions.
 - (3) Compare (1) and (2) to assure compliance with required chrome plate thickness.
 - (4) Compliance with chrome plating thickness requirements shall be verified using suitable nondestructive instruments, such as Accudern, Magnegage, Dermatron, etc.
- (c) Nital etch inspect for grinder burns (unplated parts) in accordance with CVA 13-23.
- (d) After each finish grind operation, prior to and following chrome plate, magnetic particle inspect for cracks in accordance with MIL-I-6868.

TABLE I. Grinding Parameters

GRINDING METHOD	RECOMMENDED GRINDING WHEEL CHARACTERISTICS		MAX. WHEEL SPEEDS	WORK SPEED RANGE	CROSS FEED OR TRANSVERSE	MAXIMUM DOWN (IN) FEED		MIN. STOCK LEFT FOR FINISH
	GRIT	GRADE				STRUCTURE **	S.F.M.	
SURFACE (FLAT) BARE STEEL	46/80	G - K	6 - 12	6500	30 - 100	1/8 - 1/2	.001" .0005"	.003"
CYLINDRICAL BARE STEEL	46/80	G - K	6 - 12	6500	30 - 100	1/8 - 1/4*	.001" .0005"	.003"
INTERNAL BARE STEEL	46/80	G - K	6 - 12	6500	30 - 200	1/8 - 1/4*	.0005" .0002"	.001"
SURFACE (FLAT) CHROME PLATED	46/90	G - K	6 - 12	6500	30 - 200	1/8 - 1/4	.0005" .0002"	.001"
CYLINDRICAL CHROME PLATED	46/120	G - K	6 - 12	6500	30 - 200	1/8 - 1/4*	.0005" .0002"	.001"
INTERNAL CHROME PLATED	46/120	G - K	6 - 12	12000	30 - 300	1/8 - 1/4	.0005" .0002"	.001"

THESE CHARACTERISTICS REFER TO THE INDUSTRY STANDARD DESIGNATORS FOR GRINDING WHEELS.

Examples: 32** Type Abrasive A Abrasive Grain Size 100 H Grade 9** Structure V Bond RG** Bond Type
 (Verified)

* Per Part Revolution

** May vary with manufacturer (code symbol not standardized)

TASK III TEST PLAN

1.0 INTRODUCTION

The objectives of this program are to investigate multiple cascaded seals and to develop new and improved seals and seal configurations for hydraulic systems and actuators, thereby favorably impacting hydraulic system reliability, maintainability, safety and cost by significantly reducing leakage. The test plan for all Vought Corporation testing will be included in this report and will be divided into the following sections:

I. Acceptance Tests

II Seal Development Tests

2.0 REFERENCES

2.1 Contract No. DAAK51-78-C-0028.

2.2 Report No. 2-51700-C/8R-3527, Hydraulic System Seal Development Task II Test Report, Vought Corporation.

3.0 LIST OF ILLUSTRATIONS

3.1 List of Tables

3.1.1 Measured Critical Dimensions and Finishes

3.1.2 Leakage and interstage pressure data.

3.1.3 Rod seal description

3.2 List of Figures.

3.2.1 Seal Evaluation Test Figure Sketch.

3.2.2 Specimen and Loading Actuator Hydraulic Schematic.

3.2.3 Rod Seal Configurations to be Tested.

3.2.4 Critical Dimensions and Finishes.

3.2.5 Pressurized Friction Test Set-Up.

4.0 TEST PLAN

4.1 Seal Development Program.

4.1.1 Test Requirements and Objectives.

Requirements for these tests are established by Section F of Reference 2.1. The purpose of this program is to test seals, seal combinations and rod finishes to determine the best rod seals and finishes for use in actuators designed for a 3,000 psig or an 8,000 psig hydraulic system. To accomplish this Vought will evaluate the best known seal combinations, as indicated by Reference 2.2 and approved by the Contracting Officer under adverse but controlled, test environments.

4.1.2 Test Specimens

The seals will be tested in six double ended cylinders that were designed and manufactured especially for this program. Both ends of each cylinder have multiple rod seal grooves. The space between each set of grooves is equipped with a port so that pressure and/or leakage can be monitored. The rod seals to be tested and the ports are identified in Figure 3.2.3. The scrapers shown in this figure were the best performers in recent contamination tests at Vought at the time this test plan was written. The scraper tests were performed under Contract No. F33615-78-C-2027, Project 3145, Dynamic Seals for Advanced Hydraulic Systems.

4.1.3 Test Set-Up.

The housings of the six specimen actuators will be grounded to a test fixture with each piston rod tied to a common output. The output bellcrank will in turn be loaded by a load actuator so that realistic loads will be imposed on the test specimens during each stroking cycle. A shaker will replace the load actuator to simulate rotor feedback loads. A sketch of the general arrangement of the test fixture is shown in Figure 3.2.1. A schematic of the hydraulic system used in cycling the test specimen actuators is shown in Figure 3.2.2.

4.1.4 Test Procedures

4.1.4.1 Inspection. The critical dimensions of each actuator not measured in Reference 2.2 will be measured and recorded (scraper groove dimensions). All critical dimensions recorded will be shown in the final report.

4.1.4.2 Friction.

4.1.4.2.1 Unpressurized Friction. Each seal assembly will be checked for static and dynamic unpressurized friction prior to final cylinder assembly. For this test the cylinder will be assembled with rod seals in one end only and with no piston seals. The rod/piston will be moved 5 times in each direction. The static and dynamic friction in each direction will be recorded.

4.1.4.2.2 Pressurized Friction. Each seal assembly will be checked for breakout friction at 100, 1500, 3000 and 4800 psig. For this test the cylinder will be assembled with the Shamban Double Delta Seal in one end and the test seal configuration in the other end. The set-up for this test is shown in Figure 3.2.5. Friction shall be measured as follows.

- a. Pressurize both ends to 100 psig.
- b. Slowly decrease the pressure at End 1 until the rod moves. Record the delta pressure.
- c. Repeat a.
- d. Slowly decrease the pressure at End 2 until the rod moves. Record the delta pressure.
- e. Repeat a through d for a total of 5 sets of data.
- f. Repeat a through e with the test pressure at 1500 psig.
- g. Repeat a through e with the test pressure at 3000 psig.
- h. Repeat a through e with the test pressure at 4800 psig.
- j. Repeat a through h for all seal configurations.
- k. Subtract tare breakout pressure and calculate the average breakout friction at each pressure level.

4.1.4.3 Acceptance Test.

4.1.4.3.1 Static Leakage. Apply static pressures of 5 psig, 90 psig, and 3000 psig to both cylinder ports for 5 minutes. There shall be no leakage from the external rod seal. Each seal vent shall be opened (one at a time) and the leakage checked for 3 minutes after a two minute wait. Temperature shall be 80 degrees F. +/- 20 degrees F.

4.1.4.3.2 Dynamic Leakage and Operation. Each cylinder will be cycled through at least 25 complete cycles with 3000 psig fluid to demonstrate satisfactory operation and leakage characteristics. Leakage at external rod seals shall not exceed 1 drop per 25 cycles. All leakage values will be recorded.

4.1.4.3.3 Proof Test.

4.1.4.3.3.1 3000 psig Proof Test. Apply 4500 psig to both cylinder ports for five minutes. There shall be no evidence of external leakage.

4.1.4.3.3.2 8000 psig Proof Test. Apply 12,000 psig to both cylinder ports for five minutes. There shall be no evidence of external leakage.

4.1.4.4 Development Testing. The cylinders will be placed in a test fixture (Figure 3.2.1) that uses a load actuator to simulate the actual cylinder loading. The fixture will be equipped with an insulated box so that the ambient temperature for the cylinders can be varied and controlled from test cell ambient to 275 degrees F. The actuators will be controlled by a servo-valve that is driven by an electro-hydraulic actuator through a scissors linkage.

Any seals that exhibit an external leakage of more than 1 drop per 25 cycles at full load and stroke, 1 drop per 50 cycles at 50% load and stroke, 1 drop per 250 cycles at 10% load and stroke, or 1 drop per hour at 2% load and stroke will be replaced with alternate seals at the first opportunity. If the seals in both ends of a cylinder fail that cylinder will be removed from the test. The total number of cycles to failure will be recorded for each seal. Leakage will be measured at the start and end of each day. The cylinders will be cycled at the rates shown in Paragraph 4.1.4.4.1.2. This rate will be reduced if seal temperatures become excessive or if max. fluid temperature cannot be met.

During all development tests the following parameters will be periodically monitored and their results recorded.

- . specimen actuator cycles
- . actuator strokes
- . loads
- . gland rod seal area temperatures
- . specimen actuator fluid temperatures
- . pump suction (pressure and temperature)
- . pump discharge (pressure and temperature).
- . pump case drain (pressure and temperature)
- . specimen actuator rod end leakage
- . specimen actuator pressures between seals
- . elapsed test time
- . specimen actuator pressures

4.1.4.4.1 3000 psig Tests.

4.1.4.4.1.1 High Temperature, 3,000 psig Test, MIL-H-5606. Cycle the actuators through 2.5×10^6 input cycles. Ambient temperature shall be 60 degrees F to 275 degrees F as required to obtain a fluid temperature at the test actuators of 225 degrees F +/- 25 degrees F. This cycling shall be performed in 5 blocks. Block definition is shown in 4.1.4.4.1.2. At

the start of each day 9 ML of AC coarse Arizona road dust will be placed on each rod to simulate a soil laden environment. Cycling will be started with the insulated box at test cell ambient temperature so that the dust will not be blown from the rods by the hot air that is used for heat. After 5 to 10 minutes of cycling, the hot air will be introduced into the insulated box to allow the fluid temperature to stabilize at 225 degrees F. +/- 25 degrees F.

4.1.4.4.1.2 Block Definition.

<u>Input Cycles</u>	<u>Description</u>	<u>Approximate Rate</u>
500 cycles	Full stroke and load	9 - 15 cpm
2500 cycles	50% stroke and load	18 - 30 cpm
7000 cycles	10% stroke and load	60 - 90 cpm
490000 cycles	2% stroke and load (+/- .04 in)	240 - 500 cpm

During the 2% cycling a .15 Hz, +/- 1-inch stroke shall be superimposed by electronically combining the two signals to prevent artificially overheating the seal.

4.1.4.4.1.3 Performance Test. Rerun tests of paragraph 4.1.4.3.1 and 4.1.4.3.2.

4.1.4.4.1.4 Fluid Change. The entire test set-up, including the lines and cylinders, shall have all MIL-H-5606 fluid removed by draining. After all of the MIL-H-5606 fluid has been removed, the entire test set-up shall be filled with MIL-H-83282 hydraulic fluid. The system will be cycled until it is free of air.

4.1.4.4.1.4.1 Performance Test. Rerun tests of paragraphs 4.1.4.3.1 and 4.1.4.3.2.

4.1.4.4.1.5 High Temperature, 3,000 psig Test, MIL-H-83282. Cycle the actuators through 2×10^6 input cycles. Ambient temperature shall be 60 degrees F. to 275 degrees F. as required to obtain a fluid temperature at the test actuators of 225 degrees F +/- 25 degrees F. This cycling shall be performed in 4 blocks. Block definition is shown in 4.1.4.4.1.2. At the start of each day 9 ML of AC coarse Arizona road dust will be placed on each rod to simulate a soil laden environment. Cycling will be started with the insulated box at test cell ambient temperature so that the dust will not be blown from the rods by the hot air that is used for heat. After 5 to 10 minutes of cycling the hot air will be introduced into the insulated box to allow the fluid temperature to stabilize at 225 degrees F. +/- 25 degrees F.

4.1.4.4.1.6 Performance Test.

4.1.4.4.1.6.1 Static Leakage. Apply static pressures of 5 psig, 90 psig, 3,000 psig and 8,000 psig to both cylinder ports for 5 minutes. There shall be no leakage from the external rod seal. Each seal vent shall be opened (one at a time) and the leakage will be checked for 3 minutes after a two minute wait. Temperature shall be the test cell ambient temperature.

4.1.4.4.1.6.2 Dynamic Leakage and Operation. Each cylinder will be cycled through at least 25 complete cycles with 8,000 psig fluid to demonstrate satisfactory operation and leakage characteristics. Leakage at the external rod seal shall not exceed 1 drop per 25 cycles. All leakage values will be recorded.

4.1.4.4.2 High Temperature, 8,000 psig Test, MIL-H-83282. Cycle the actuator through 500,000 input cycles. Ambient temperature shall be 60 degrees F. to 275 degrees F. as required to obtain a fluid temperature at the test actuators of 225 degrees F. +/- 25 degrees F. This cycling shall be performed in one block. Block definition is shown in 4.1.4.4.1.2. At the start of each day 9 ML of AC coarse Arizona road dust will be placed on each rod to simulate a soil laden environment. Cycling will be started with the insulated box at test cell ambient temperature so that the dust will not be blown from the rods by the hot air that is used for heat. After 5 to 10 minutes of cycling, the hot air will be introduced into the insulated box to allow the fluid temperature to stabilize at 225 degrees F. +/- 25 degrees F.

4.1.4.4.3 Performance Test. Rerun tests of paragraph 4.1.4.4.1.6.1 and 4.1.4.4.1.6.2.

11
B

4.1.4.5 Rotor Feedback Test. Replace the load actuator with an electromechanical shaker and apply 20×10^6 output feedback cycles at a rate of 16 +/- 3 CPS.. System pressure for this test shall be MIL-H-83282 hydraulic fluid at 3000 psig. Ambient temperature in the insulated box shall be 60 degrees F. to 275 degrees F. as required to obtain a fluid temperature at the test actuators of 225 degrees F. +/- 25 degrees F. The amplitude of the feedback cycles will be .010 +/- .005 in. The output of the actuators will be 800 +/- 200 pounds. At the start of each day 9 ML of AC coarse Arizona road dust will be placed on each rod to simulate a soil laden environment. Cycling will be started with the insulated box at test cell ambient temperature so that the dust will not be blown from the rods by the hot air that is used for heat. After 5 to 10 minutes of cycling, the hot air will be introduced into the insulated box to allow the fluid temperature to stabilize at 225 degrees F.

Rod position shall be varied sinusoidally at .15 Hz +/- .05 Hz with a 2-inch double amplitude to simulate helicopter loads and to reduce rod wear.

4.1.4.6 Performance Test. For those actuators that survive all cycling tests, rerun tests of paragraph 4.1.4.3.1 and 4.1.4.3.2.

4.1.5 Disassembly and Final Inspection. Following all tests the cylinders will be disassembled and all seal conditions evaluated and recorded. Photographs will be taken to show each seal configuration that is tested. The data on Tables 3.1.1 and 3.1.3 will be recorded.

5.0 TEST PARAMETERS

Unless otherwise specified the test parameters shall be as follows.

5.1 Test Fluid.

Fluid shall be filtered by a non-bypassing 3 or 5 micron absolute filter in the pressure line immediately downstream of the pump.

5.2 Temperature.

Unless otherwise specified the ambient temperature shall be 175 degrees +/- 100 degrees F. (as required to control the fluid temperature). Test fluid temperatures at the test actuator shall be 225 degrees F. +/- 25 degrees F.

5.3 Pressures.

Test pressures are specified for each test

5.4 Tolerances.

Temperature - as specified for each test.

Pressure - +/- 2% of the full scale reading.

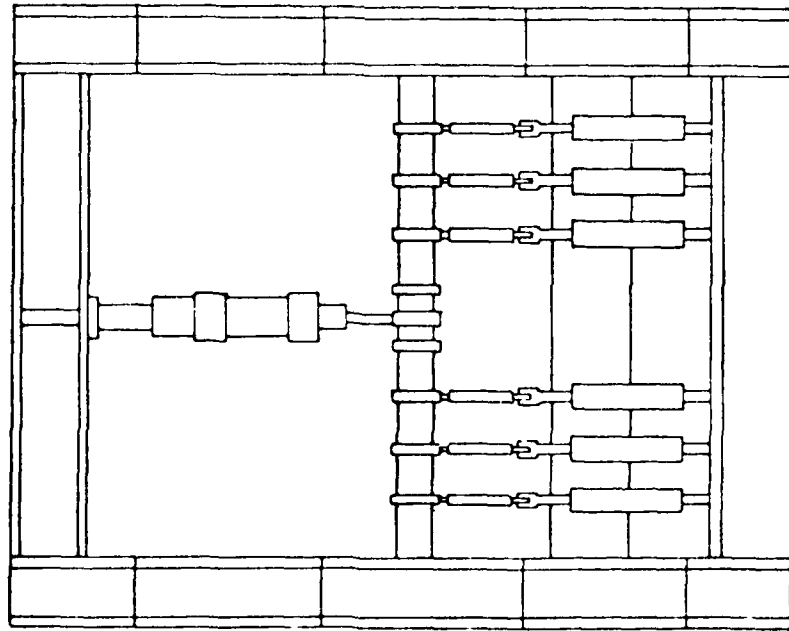
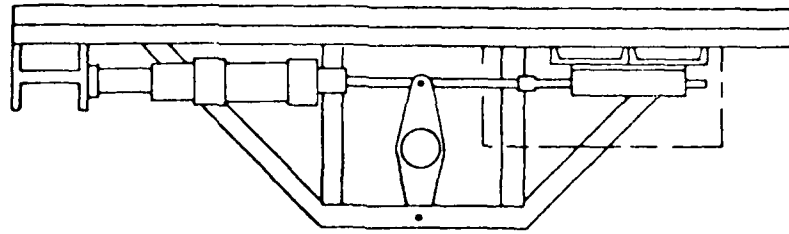

FIGURE 3.2.1. SEAL EVALUATION TEST FIGURE SKETCH

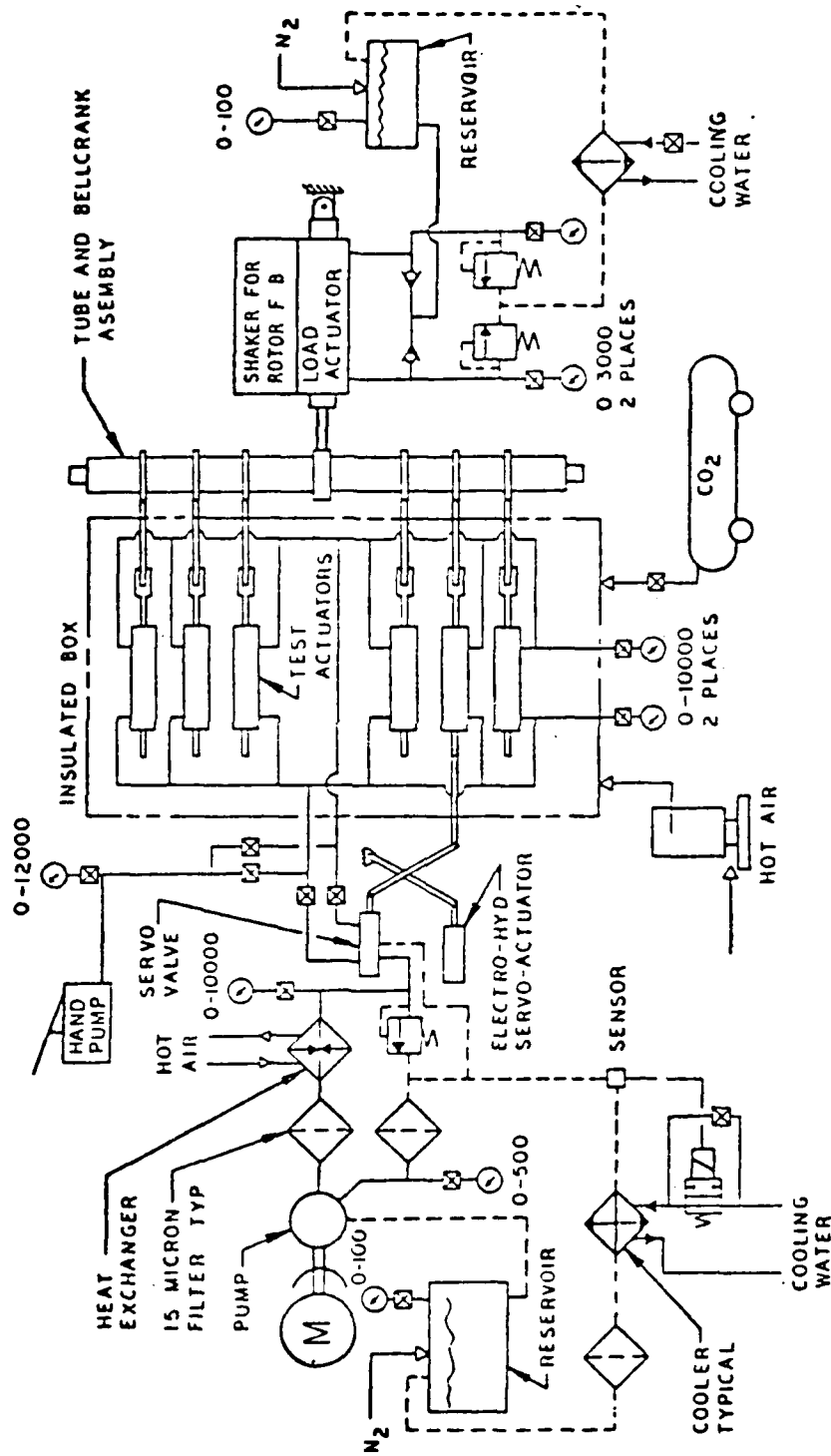

FIGURE 3.2.2. SPECIMEN AND LOAD HYDRAULIC SYSTEMS

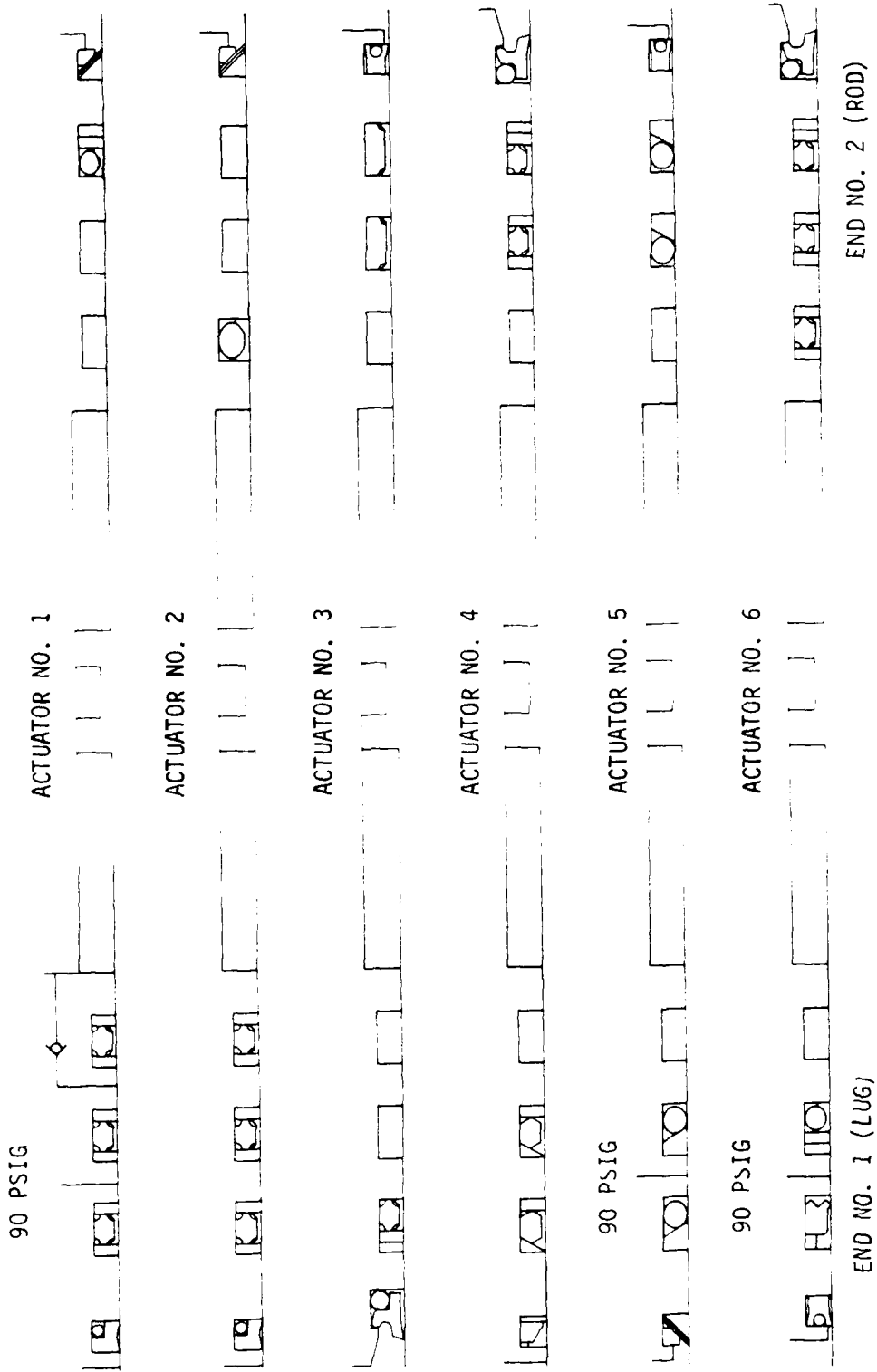

FIGURE 3.2.3. ROD SEAL CONFIGURATIONS TO BE TESTED

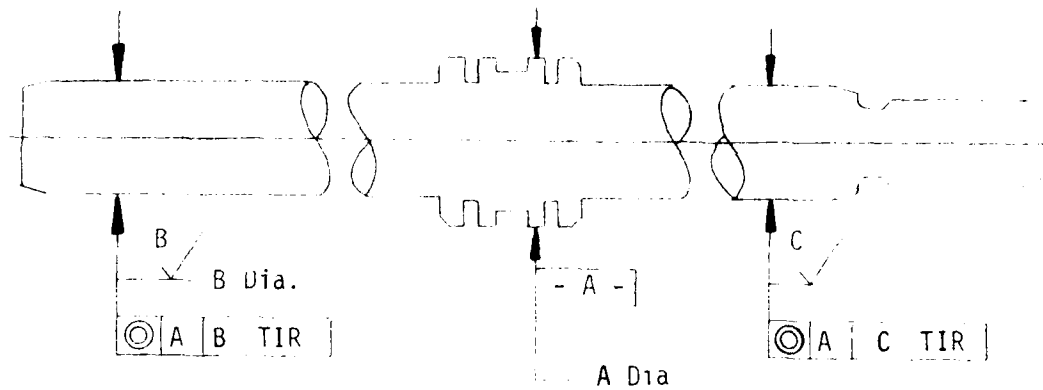

FIGURE 3.2.4A ROD CRITICAL DIMENSIONS

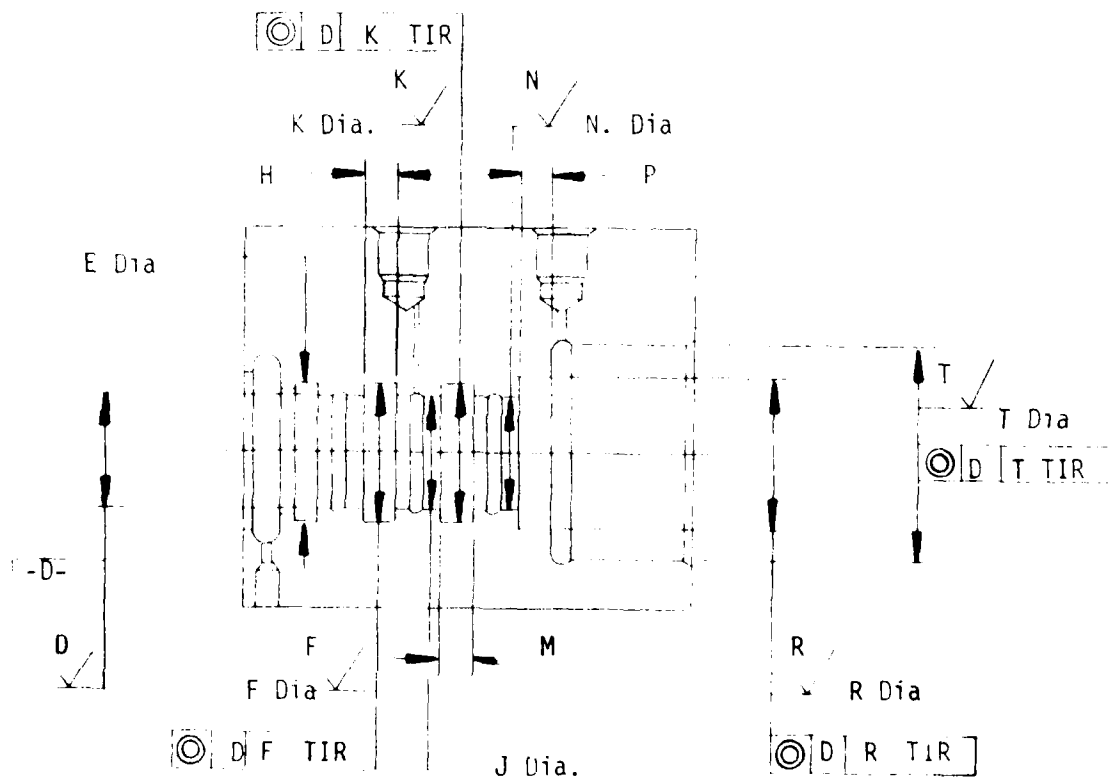
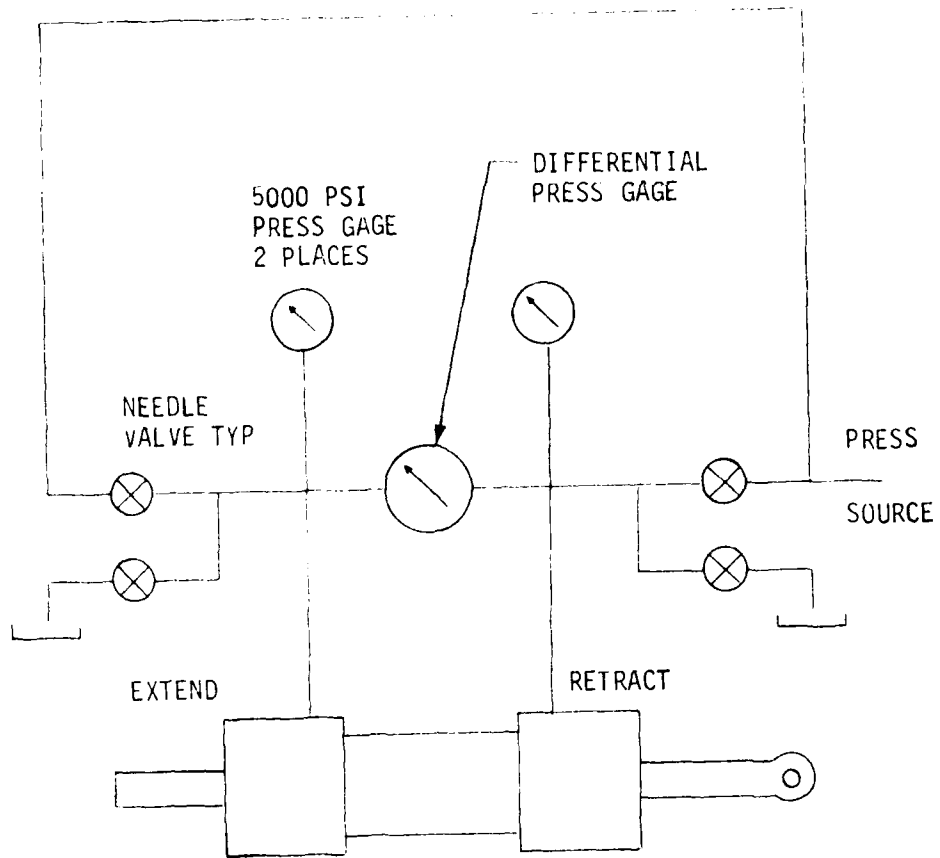

FIGURE 3.2.4B. END CAP CRITICAL DIMENSIONS



PRESSURIZED FRICTION SET-UP
 FIGURE 3.2.5

TABLE 3.1.1
MEASURED CRITICAL DIMENSIONS AND FINISHES

Actuator No. _____

DIMENSION	PISTON & ROD MEASUREMENT	LUG END CAP MEASUREMENT	ROD END CAP MEASUREMENT
A DIA			
B DIA			
B RMS			
B TIR			
C DIA			
C RMS			
C TIR			
<hr/>			
D DIA			
D RMS			
E DIA			
F DIA			
F RMS			
F TIR			
H			
J DIA			
K DIA			
K RMS			
K TIR			
M			
N DIA			
N RMS			
P			
R DIA			
R RMS			
R TIR			
T DIA			
T RMS			
T TIR			

TABLE 3.1.1A

MEASURED CRITICAL DIMENSIONS AND FINISHES AFTER TEST
Actuator No.

DIMENSION	PISTON & ROD MEASUREMENT	LUG END CAP MEASUREMENT	ROD END CAP MEASUREMENT
B Dia.			
B RMS Finish			
C Dia.			
C RMS Finish			
D Dia.			
N Dia.			

TABLE 3.1.2
LEAKAGE AND INTERSTAGE PRESSURE DATA
ACTUATOR NUMBER

DATE	START UP TEMP.	OVER NIGHT LKG.	NUMBER OF CYCLES		END NUMBER 1 (LUG) LEAKAGE			END NUMBER 2 (ROD) LEAKAGE													
			SHORT STROKE	LONG STROKE	(END OF DAY) CC	PRESSURE (MAX) B	PORT C	PORT D	(END OF DAY) CC	PRESSURE (MAX) B	PORT C	PORT D									

TABLE 3.1.3
ROD SEAL DESCRIPTION

#1

ACT NO.	LUG END	ROD END	GROOVE			SEAL NAME & PART NUMBER	MANUFACTURER	MATERIAL
			A	B	C			
1	X		X	X	X	Plus Seal S30775-214P-19	W. S. Shamban	Turcon with proprietary MoS ₂ Filler. Elastomer per MIL-P-83461.
			X	X	X	Back-up Ring (2) S33157-214-19	W. S. Shamban	Turcon with proprietary MoS ₂ Filler.
					X	Excluder S32925-9P-19	W. S. Shamban	Turcon with proprietary MoS ₂ Filler.
					X	O-Ring M83461/1-121	Parker	MIL-P-83461
1	X			X		Double Delta S30650-214-14	W. S. Shamban	Turcon with glass and Proprietary MoS ₂ Filler
				X		O-Ring M83461/1-214	Parker	MIL-P-83461
				X		Back-Up Ring (2) S33157-214-14	W. S. Shamban	Turcon with glass and Proprietary MoS ₂ Filler
					X	Seal Guard S-34-20	Hercules	Bronze with a Nitrile Load Ring

TABLE 3.1.3
ROD SEAL DESCRIPTION

#2

ACT NO.	LUG END	ROD END	GROOVE				SEAL NAME & PART NUMBER	MANUFACTURER	MATERIAL
			A	B	C	D			
2	X		X	X	X	Plus Seal S30775-214P-19	W. S. Shamban	Turcon with proprietary MoS ₂ Filler. Elastomer per MIL-P-83461.	
			X	X	X	Backup Ring (2) S33157-214-19	W. S. Shamban	Turcon with proprietary MoS ₂ Filler.	
						Excluder S32925-9P-19	W. S. Shamban	Turcon with proprietary MoS ₂ Filler.	
						O-Ring M83461/1-121	Parker	MIL-P-83461	
2		X	X			Maxi-Flex Seal TF831M-7214	Tetrafluor	Tetraon 720	
			X			O-Ring M83461/1-318	Parker	MIL-P-83461	
						Seal Guard S-34-20	Hercules	Bronze with a Nitrite Load Ring	

TABLE 3.1.3
ROD SEAL DESCRIPTION #3

ACT NO.	LUG END	ROD END	GROOVE				SEAL NAME & PART NUMBER	MANUFACTURER	MATERIAL
			A	B	C	D			
3	X				X		Plus Seal S30775-214P-19	W. S. Shamban	Turcon with Proprietary MoS2 Filler. Elastomer per MIL-P-83461.
						X	Wiper/Scraper 120-218-1709	Dowty Seals Limited	Acetal Resin
						X	O-Ring 100-218-0074	Dowty Seals Limited	Nitrile
3		X		X	X		Enercap Seal 595-21400-160 -PX1	Greene Tweed	Ekano1 filled TFE Proprietary Nitrile
						X	Polypak 18701000Z4651D53	Parker Packing	Polymyte

TABLE 3.1.3
ROD SEAL DESCRIPTION

#4

ACT FIG.	LUG END	ROD END	GROOVE				SEAL TYPE & PART NUMBER	MANUFACTURER	MATERIAL
			A	B	C	D			
4	X		X	X			C. E. Conover & Co.	Revonoc 6200 Proprie- tary 70 Durometer Nitrile	
			X	X			C. E. Conover & Co.	Revonoc 6200	
					X		C. E. Conover & Co.	Revonoc 18158	
4		X	X	X		Plus Seal S30775-214P-19	W. S. Shamban	Turcon with proprietary MoS ₂ Filler. Elastomer per MIL-P-83461	
			X	X		Backup Ring (2) S33157-214-19	W. S. Shamban	Mineral Filled TFE Comp 18016	
				X		Wiper/Scraper 120-218-1709	Dowty Seals Limited	Acetal Resin	
				X		O-Ring 100-218-0074	Dowty Seals Limited	Nitrile	

TABLE 3.1.3
ROD SEAL DESCRIPTION

#6

ACT NO.	LUG END	ROD END	GROOVE			SEAL NAME & PART NUMBER	MANUFACTURER	MATERIAL
			A	B	C			
5	X		X	X		Trapezoid Backup Seal CEC 50560-214	C. F. Gonover Revonoc 6200	Revonoc 6200
			X			O-Ring M83461/1-214	Parker	MIL-P-83461
					X	Seal Guard S-34-20	Hercules	Bronze with a nitrile load ring.
5		X	X			Trapezoid Backup Seal CEC 50560-214	C. F. Gonover	Revonoc 6200
			X	X		O-Ring M83461/1/214	Parker	MIL-P-83461
					X	Polypak 187010007 4651D53	Parker	Polymyte

TABLE 3.1.3
ROD SEAL DESCRIPTION

#6

ACT NO.	LUG END	ROD END	GROOVE			SEAL NAME & PART NUMBER	MANUFACTURER	MATERIAL
			A	B	C			
6	X		X			Double Delta S30650-214-19	W. S. Shamban	Turcon with Proprietary MoS ₂ Filler.
			X			O-Ring M83461/1-214	Parker	MIL-P-83461
			X			Backup Ring (2) S33157-214-19	W. S. Shamban	Turcon with Proprietary MoS ₂ Filler.
			X			Hat Seal S33051-214-99	W. S. Shamban	Turcon with MoS ₂ Filler
6		X				Polypak 18701000Z4651D53	Parker	Polymyte
			X	X	X	Plus Seal S30775-214P-19	W. S. Shamban	Turcon with Proprietary MoS ₂ Filler. Elastomer per MIL-P-83461.
			X	X	X	Backup Ring (2) S33157-214-19	W. S. Shamban	Turcon with Proprietary MoS ₂ Filler.
			X			Wiper/Scraper 120-218-1709	Dowty Seals Limited	Acetal Resin
			X		O-Ring 100-218-0074	Dowty Seals Limited	Nitrile	

TABLE B-3

MEASURED CRITICAL DIMENSIONS AND FINISHES
BEFORE AND (AFTER) TASK II TEST

Actuator No. 1

DIMENSION*	PISTON & ROD -12 S/N 007 MEASUREMENT	LUG END CAP -5 S/N 001 MEASUREMENT	ROD END CAP -2 S/N 001 MEASUREMENT
A DIA	1.488	---	---
B DIA	.998 (.9975)	---	---
B RMS	6 (4)	---	---
B TIR	.000	---	---
C DIA	.997 (.9972)	---	---
C RMS	2 (4)	---	---
C TIR	.000	---	---
D DIA	---	1.0004 (1.0005)	1.0006 (1.0004)
D RMS	---	16	16
E DIA	---	NA	NA
F DIA	---	1.241	1.241
F RMS	---	32	32
F TIR	---	.0002	.0002
H	---	.305	.3118
J DIA	---	1.0005	1.0007
K DIA	---	1.241	1.241
K RMS	---	32	32
K TIR	---	.0002	.0001
M	---	.304	.3106
N DIA	---	1.0006 (1.0005)	1.0003 (1.00115)
N RMS	---	16	16
P	---	.312	.3084
R DIA	---	1.241	1.3965
R RMS	---	32	32
R TIR	---	.0002	Not Recorded
T DIA	---	1.930	1.930
T RMS	---	32	32
T TIR	---	.0002	Not Recorded

* See Figures 3.2.4A and 3.2.4B in Task III Test Plan.

TABLE B-3. Continued

Actuator No. 2

DIMENSION	PISTON & ROD -1 S/N 007 MEASUREMENT	LUG END CAP -5 S/N 008 MEASUREMENT	ROD END CAP -5 S/N 003 MEASUREMENT
A DIA	1.488	---	---
B DIA	.9975 (.998)	---	---
B RMS	6 (8)	---	---
B TIR	.000	---	---
C DIA	.997 (.9972)	---	---
C RMS	6 (8)	---	---
C TIR	.000	---	---
D DIA	---	1.0004 (1.00075)	1.0005 (1.0004)
D RMS	---	16	16
E DIA	---	NA	NA
F DIA	---	1.241	1.241
F RMS	---	16	32
F TIR	---	.0001	.0002
H	---	.3041	.3058
J DIA	---	1.0006	1.0008
K DIA	---	1.241	1.241
K RMS	---	32	32
K TIR	---	.0002	.0002
M	---	.3041	.304
N DIA	---	1.0004 (1.00075)	1.0005 (1.0004)
N RMS	---	32	16
P	---	.307	.3084
R DIA	--	1.241	1.2412
R RMS	---	32	32
R TIR	---	.0003	.0002
T DIA	---	1.930	Not Recorded
T RMS	---	32	32
T TIR	---	.0002	.0002

TABLE B-3. Continued

Actuator No. 3

DIMENSION	PISTON & ROD -1 S/N 002 MEASUREMENT	LUG END CAP -5 S/N 004 MEASUREMENT	ROD END CAP -5 S/N 005 MEASUREMENT
A DIA	1.488	---	---
B DIA	.9975 (.9975)	---	---
B RMS	6 (6)	---	---
B TIR	.000	---	---
C DIA	.9980 (.9972)	---	---
C RMS	6 (8)	---	---
C TIR	.000	---	---
D DIA	---	1.0003 (1.0004)	1.0004 (1.0010)
D RMS	---	16	16
E DIA	---	NA	NA
F DIA	---	1.241	1.241
F RMS	---	32	32
F TIR	---	.0002	.0002
H	---	.3041	.306
J DIA	---	1.0006	1.0006
K DIA	---	1.241	1.241
K RMS	---	32	32
K TIR	---	.0002	.0002
M	---	.3048	.304
N DIA	---	1.0006 (1.0004)	1.0005 (1.0006)
N RMS	---	16	16
P	---	.3094	.311
R DIA	---	1.2412	1.2415
R RMS	---	32	32
R TIR	---	.0002	.0002
T DIA	---	1.930	1.930
T RMS	---	32	32
T TIR	---	.0002	.0002

TABLE B-3. Continued

Actuator No. 4

DIMENSION	PISTON & ROD -1 S/N 003 MEASUREMENT	LUG END CAP -6 S/N 001 MEASUREMENT	ROD END CAP -5 S/N 006 MEASUREMENT
A DIA	1.489	---	---
B DIA	.9977 (.9970)	---	---
B RMS	4 (16)	---	---
B TIR	.001	---	---
C DIA	.998 (.9975)	---	---
C RMS	4 (4)	---	---
C TIR	.000	---	---
D DIA	---	1.0007 (1.0006)	1.0004 (1.0008)
D RMS	---	16	16
E DIA	---	1.275	NA
F DIA	---	1.242	1.2413
F RMS	---	16	32
F TIR	---	Not Recorded	.0002
H	---	.310	.305
J DIA	---	1.0006	1.0006
K DIA	---	1.241	1.2413
K RMS	---	16	32
K TIR	---	.0001	.0002
M	---	.3084	.3059
N DIA	---	1.0004 (1.00055)	1.0005 (1.0004)
N RMS	---	16	16
P	---	.3143	.3075
R DIA	---	1.2412	Not Recorded
R RMS	---	16	32
R TIR	---	.0001	.0002
T DIA	---	1.930	1.930
T RMS	---	32	32
T TIR	---	.0001	.0001

TABLE B-3. Continued

Actuator No. 5

DIMENSION	PISTON & ROD -1 S/N 004 MEASUREMENT	LUG END CAP -5 S/N 007 MEASUREMENT	ROD END CAP -5 S/N 008 MEASUREMENT
A DIA	1.4888	---	---
B DIA	.998	---	---
B RMS	4	---	---
B TIR	.000	---	---
C DIA	.998	---	---
C RMS	4	---	---
C TIR	.000	---	---
D DIA	---	1.0004 (1.0032)	1.0003 (1.00075)
D RMS	---	16	16
E DIA	---	NA	NA
F DIA	---	1.2415	1.2415
F RMS	---	32	32
F TIR	---	.0003	.0002
H	---	.3065	.3063
J DIA	---	1.0005	1.0005
K DIA	---	1.2413	1.243
K RMS	---	32	32
K TIR	---	.0003	.0002
M	---	.3051	.3065
N DIA	---	1.0006 (1.00055)	1.0006 (1.0004)
N RMS	---	16	16
P	---	.3135	.3136
R DIA	---	1.2412	1.2416
R RMS	---	32	32
R TIR	---	.0003	.0002
T DIA	---	1.930	1.930
T RMS	---	32	32
T TIR	---	.0003	.0003

TABLE B-3. Continued

Actuator No. 6

DIMENSION	PISTON & ROD -1 S/N 005 MEASUREMENT	LUG END CAP -5 S/N 009 MEASUREMENT	ROD END CAP -5 S/N 010 MEASUREMENT
A DIA	1.4885	---	---
B DIA	.998 (.9980)	---	---
B RMS	4 (4)	---	---
B TIR	.000	---	---
C DIA	.998 (.9976)	---	---
C RMS	4 (4)	---	---
C TIR	.000	---	---
D DIA	---	1.0006 (1.00055)	1.0004 (1.00078)
D RMS	---	16	16
E DIA	---	NA	NA
F DIA	---	1.242	1.243
F RMS	---	32	32
F TIR	---	.0001	.0002
H	---	.3055	.3051
J DIA	---	1.0007	1.0007
K DIA	---	1.242	1.243
K RMS	---	32	32
K TIR	---	.0001	.0002
M	---	.3083	.304
N DIA	---	1.0008 (1.00065)	1.0007 (1.00083)
N RMS	---	16	16
P	---	.3111	.3078
R DIA	---	1.2416	1.2415
R RMS	---	32	32
R TIR	---	.0001	.0002
T DIA	---	1.930	1.930
T RMS	---	32	32
T TIR	---	.0001	.0002

APPENDIX C
TASK III DATA

TABLE C-1. TASK III SEAL PERFORMANCE SUMMARY

CONFIGURATION/ SKETCH	PART NUMBER	DESIGNER/ SUPPLIER	SATISFACTORY PERFORMANCE	COMMENTS																		
P 	S30775-214P-19 plus Seal	W. S. Shamban	Yes	Cap Strip and backup rings are in good condition. Outside backup ring has approximately .04 in. extrusion. Elastomer has minor deformation away from pressure. The seal survived the entire test.																		
	S33157-214-19 Backup Ring (2)		3 drops total rod leakage																			
FIRST-STAGE SEAL IN A FOUR-STAGE VENTED INSTALLATION NO. 1 LUG, GROOVE "A"																						
				<table border="0"> <tr> <td>Inside</td> <td>Cap</td> <td>Outside</td> </tr> <tr> <td>Bu I.D.</td> <td>I.D.</td> <td>Bu I.D.</td> </tr> <tr> <td>New .9903</td> <td>LT.982</td> <td>.9903</td> </tr> <tr> <td>Used .994</td> <td>.994</td> <td>1.0042</td> </tr> </table> <table border="0"> <tr> <td>Rod Dia</td> <td>Rod Finish</td> </tr> <tr> <td>New .998</td> <td>3 RMS</td> </tr> <tr> <td>Used .9974-.9978</td> <td>4-7 RMS</td> </tr> </table>	Inside	Cap	Outside	Bu I.D.	I.D.	Bu I.D.	New .9903	LT.982	.9903	Used .994	.994	1.0042	Rod Dia	Rod Finish	New .998	3 RMS	Used .9974-.9978	4-7 RMS
Inside	Cap	Outside																				
Bu I.D.	I.D.	Bu I.D.																				
New .9903	LT.982	.9903																				
Used .994	.994	1.0042																				
Rod Dia	Rod Finish																					
New .998	3 RMS																					
Used .9974-.9978	4-7 RMS																					

TABLE C-1. CONTINUED

CONFIGURATION PART SKETCH	DESIGNER/ SUPPLIER	SATISFACTORY PERFORMANCE	COMMENTS																									
<p>P </p> <p>S30775-214P-19 Plus Seal</p>	W. S. Shamban	Yes 3 drops total rod leakage	Cap strip and backup rings are in very good condition. Elastomer has minor deformation away from pressure. This seal survived the entire test.																									
<p>S33157-214-19 Backup Ring (2)</p> <p>SECOND-STAGE SEAL IN A FOUR STAGE VENTED INSTALLATION NO. 1 LUG GROOVE "B"</p>			<table border="0"> <tr> <td></td> <td>Inside</td> <td>Cap</td> <td>Outside</td> </tr> <tr> <td></td> <td>Bu I.D.</td> <td>I.D.</td> <td>Ru I.D.</td> </tr> <tr> <td>New</td> <td>.9903</td> <td>LT.982</td> <td>.9903</td> </tr> <tr> <td>Used</td> <td>.994</td> <td>.9903</td> <td>.994</td> </tr> </table> <table border="0"> <tr> <td></td> <td>Rod Dia</td> <td>Rod Finish</td> </tr> <tr> <td>New</td> <td>.998</td> <td>3 RMS</td> </tr> <tr> <td>Used</td> <td>.9974-.9978</td> <td>4-7 RMS</td> </tr> </table>		Inside	Cap	Outside		Bu I.D.	I.D.	Ru I.D.	New	.9903	LT.982	.9903	Used	.994	.9903	.994		Rod Dia	Rod Finish	New	.998	3 RMS	Used	.9974-.9978	4-7 RMS
	Inside	Cap	Outside																									
	Bu I.D.	I.D.	Ru I.D.																									
New	.9903	LT.982	.9903																									
Used	.994	.9903	.994																									
	Rod Dia	Rod Finish																										
New	.998	3 RMS																										
Used	.9974-.9978	4-7 RMS																										

TABLE C-1. CONTINUED

CONFIGURATION PART SKETCH	NUMBER	DESIGNER/SUPPLIER	SATISFACTORY PERFORMANCE	COMMENTS																
	S30775-214P-19 Plus Seal	W. S. Shanban	Yes 3 drops total Rod Leakage	Cap strip and backup rings are in very good condition. Elastomer has minor deformation away from pressure. This seal survived the entire test.																
	S33157-214-19 Backup Ring (2)																			
THIRD-STAGE SEAL IN A FOUR-STAGE VENTED INSTALLATION NO. 1 LUG, GROOVE "C"																				
				<table border="0"> <tr> <td></td> <td>Inside</td> <td>Cap</td> <td>Outside</td> </tr> <tr> <td></td> <td>Bu I.D.</td> <td>I.D.</td> <td>Bu I.D.</td> </tr> <tr> <td>New</td> <td>.9903</td> <td>[T-.982</td> <td>.9903</td> </tr> <tr> <td>Used</td> <td>.994</td> <td>.9903</td> <td>.994</td> </tr> </table>		Inside	Cap	Outside		Bu I.D.	I.D.	Bu I.D.	New	.9903	[T-.982	.9903	Used	.994	.9903	.994
	Inside	Cap	Outside																	
	Bu I.D.	I.D.	Bu I.D.																	
New	.9903	[T-.982	.9903																	
Used	.994	.9903	.994																	
				<table border="0"> <tr> <td></td> <td>Rod Dia</td> <td>Rod Finish</td> </tr> <tr> <td>New</td> <td>.998</td> <td>3 RMS</td> </tr> <tr> <td>Used</td> <td>.9974-.9978</td> <td>4-7 RMS</td> </tr> </table>		Rod Dia	Rod Finish	New	.998	3 RMS	Used	.9974-.9978	4-7 RMS							
	Rod Dia	Rod Finish																		
New	.998	3 RMS																		
Used	.9974-.9978	4-7 RMS																		

TABLE C-1. CONTINUED



CONFIGURATION SKETCH	PART NUMBER	DESIGNER/SUPPLIER	SATISFACTORY PERFORMANCE	COMMENTS															
P 	S32925-9P-19 Excluder	W. S. Shamban	No -- Excessive Wear	Both I.D. crowns of the Excluder show contact and wear, with the most wear under the O-ring. Contaminant was trapped in the "V" groove.															
	M83461/1-121 O-Ring	Parker																	
FOURTH-STAGE SEAL/SCRAPER IN A FOUR-STAGE VENTED INSTALLATION. NO. 1 LUG GROOVE "D".																			
				<table border="0"> <tr> <td></td> <td style="text-align: center;"><u>Excluder I.D.</u></td> </tr> <tr> <td>New</td> <td style="text-align: center;">.9903</td> </tr> <tr> <td>Used</td> <td style="text-align: center;">1.0042</td> </tr> </table> <p>The wear exhibited by this excluder would prevent it acting as a seal or as an effective scraper. The contaminant trapped by the Excluder scratched the rod.</p> <table border="0" style="margin-left: auto; margin-right: auto;"> <tr> <td></td> <td style="text-align: center;"><u>Rod Dia</u></td> <td style="text-align: center;"><u>Rod Finish</u></td> </tr> <tr> <td>New</td> <td style="text-align: center;">.998</td> <td style="text-align: center;">3 RMS</td> </tr> <tr> <td>Used</td> <td style="text-align: center;">.9974-.9978</td> <td style="text-align: center;">4-7 RMS</td> </tr> </table>		<u>Excluder I.D.</u>	New	.9903	Used	1.0042		<u>Rod Dia</u>	<u>Rod Finish</u>	New	.998	3 RMS	Used	.9974-.9978	4-7 RMS
	<u>Excluder I.D.</u>																		
New	.9903																		
Used	1.0042																		
	<u>Rod Dia</u>	<u>Rod Finish</u>																	
New	.998	3 RMS																	
Used	.9974-.9978	4-7 RMS																	

TABLE C-1. CONTINUED

CONFIGURATION PART SKETCH	DESIGNER/SUPPLIER	SATISFACTORY PERFORMANCE	COMMENTS
<p>P</p> 	<p>S30650-214-14 Double Delta</p> <p>M83461/1-214 Parker</p> <p>S33157-214-14 W. S. Shamban Backup Ring (2)</p>	<p>No. The Seal Failed</p>	<p>This seal failed during the rotor feedback test. The failure occurred after 5.5 x 10⁶ endurance cycles and 474,000 rotor feedback cycles</p> <p>The outside lip of the double delta had been worn away and the O-ring wear area had a polished appearance.</p> <p>This seal was tested on a tungsten carbide coated rod. All seals tested on the tungsten carbide coated rod failed.</p>

SINGLE-STAGE SEAL INSTALLATION
NO. 1 ROD, GROOVE "C".

TABLE C-1. CONTINUED

CONFIGURATION PART SKETCH	DESIGNER/ SUPPLIER	SATISFACTORY PERFORMANCE	COMMENTS
<p>P</p>  <p>S-34-20 Seal Guard</p>	Hercules	No	The scraper was in good condition but it had allowed a significant quantity of dirt to bypass it on the rod.

SCRAPER FOR A SINGLE-STAGE
SEAL INSTALLATION
NO. 1 ROD, GROOVE "D".

TABLE C-1. CONTINUED

CONFIGURATION PART SKETCH	DESIGNER/ SUPPLIER	SATISFACTORY PERFORMANCE	COMMENTS
	S30775-214P-19 Plus Seal W. S. Shamban	Yes, zero leakage during entire test	Cap strip and inside backup ring are in very good condition. The outside backup ring has approx. .04 in. extrusion, but is in good condition. The elastomer has minor deformation away from pressure. The seal survived the entire test.
	S33157-214-19 Backup Ring (2)		Inside Cap Outside Bu I.D. I.D. Bu I.D. New <u>.994</u> <u>LT.982</u> <u>.994</u> Used .994 .994 1.0042
			Rod Dia Rod Finish New <u>.998</u> <u>2 RMS</u> Used .9973-.9979 2-3 RMS

FIRST-STAGE SEAL IN A FOUR-STAGE
 UNVENTED INSTALLATION
 NO. 2 LUG, GROOVE "A"

TABLE C-1. CONTINUED

CONFIGURATION PART SKETCH	PART NUMBER	DESIGNER/SUPPLIER	SATISFACTORY PERFORMANCE	COMMENTS												
P <u>214</u>	S30775-214P-19 Plus Seal	W. S. Shanban	Yes, zero leakage during test	Cap strip and backup rings are in very good condition with no extrusion. Elastomer has minor deflection away from pressure.												
	S33157-214-19 Backup Ring (2)															
SECOND-STAGE SEAL IN A FOUR-STAGE INVENTED INSTALLATION NO. 2 LUG, GROOVE "B".																
				<table border="0"> <tr> <td></td> <td>Inside Cap</td> <td>Outside</td> </tr> <tr> <td></td> <td>Ru I.D.</td> <td>Ru I.D.</td> </tr> <tr> <td>New</td> <td>.994</td> <td>.982</td> </tr> <tr> <td>Used</td> <td>.994</td> <td>.994</td> </tr> </table>		Inside Cap	Outside		Ru I.D.	Ru I.D.	New	.994	.982	Used	.994	.994
	Inside Cap	Outside														
	Ru I.D.	Ru I.D.														
New	.994	.982														
Used	.994	.994														
				<table border="0"> <tr> <td></td> <td>Pod Dia</td> <td>Pod Finish</td> </tr> <tr> <td>New</td> <td>.998</td> <td>2 RMS</td> </tr> <tr> <td>Used</td> <td>.9973-.9979</td> <td>2-3 RMS</td> </tr> </table>		Pod Dia	Pod Finish	New	.998	2 RMS	Used	.9973-.9979	2-3 RMS			
	Pod Dia	Pod Finish														
New	.998	2 RMS														
Used	.9973-.9979	2-3 RMS														

AD-A103 201

VOUGHT CORP DALLAS TX
HYDRAULIC SYSTEM SEAL DEVELOPMENT. (U)
JUN 81 K E WHITFILL

F/6 1/3

DAAK51-78-C-0028
NL

UNCLASSIFIED

USAAVRADCOM-TR-81-D-17

3 of 4
AD-A
103-07

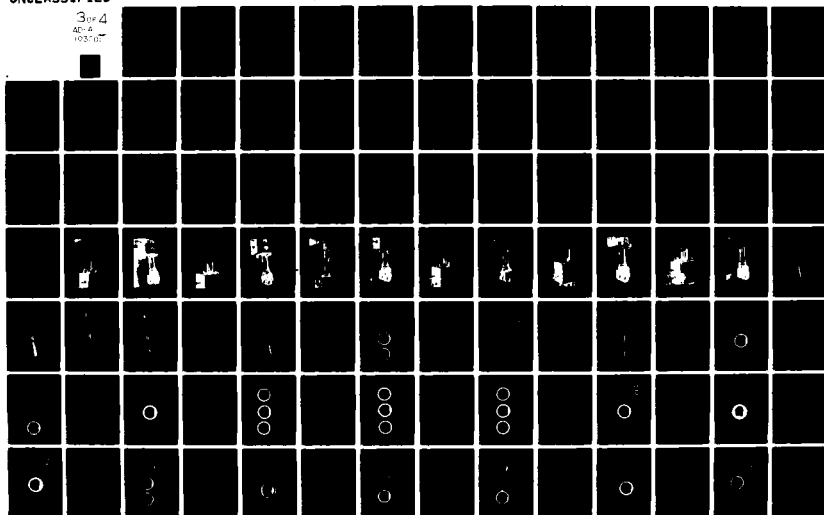

TABLE C-1. CONTINUED



CONFIGURATION PART SKETCH	DESIGNER/SUPPLIER	SATISFACTORY PERFORMANCE	COMMENTS
	S30775-214P-19 Plus Seal W. S. Shamban	Yes, zero leakage during test	Cap strips and backup rings are in very good condition. Elastomer has minor deformation away from pressure.
S33157-214-19 Backup Ring (2)			
THIRD-STAGE SEAL IN A FOUR-STAGE UNVENTED INSTALLATION NO. 2 LUG, GROOVE "C".			
	Inside Cap Ru I.D. I.D. .994 .982 Used .994 .994		Outside Bu I.D. .994
	Rod Dia New .998 Used .9973-.9979		Rod Finish ? RMS 2-3 RMS

TABLE C-1. CONTINUED

CONFIGURATION PART SKETCH	DESIGNER/ SUPPLIER	SATISFACTORY PERFORMANCE	COMMENTS									
P 	W. S. Shamban Ho, Excessive Wear	Ho, Excessive Wear	Both ID crowns of the Excluder show contact and wear with the most wear under the O-ring. Contaminant was trapped in the "V" groove.									
S32925-9P-19 Excluder			<table border="0"> <tr> <td></td> <td><u>Excluder I.D.</u></td> </tr> <tr> <td>New</td> <td>.9903</td> </tr> <tr> <td>Used</td> <td>1.0042</td> </tr> </table>		<u>Excluder I.D.</u>	New	.9903	Used	1.0042			
	<u>Excluder I.D.</u>											
New	.9903											
Used	1.0042											
1183461/1-121 O-ring	Parker		<p>The wear exhibited by this Excluder would prevent it acting as a seal or as an effective scraper. The contaminant trapped by the excluder scratched the rod. The rod under the scraper had a blue appearance as if it had been overheated.</p> <table border="0"> <tr> <td></td> <td><u>Rod Dia</u></td> <td><u>Rod Finish</u></td> </tr> <tr> <td>New</td> <td>.998</td> <td>2 RMS</td> </tr> <tr> <td>Used</td> <td>.9973-.9979</td> <td>2-3 RMS</td> </tr> </table>		<u>Rod Dia</u>	<u>Rod Finish</u>	New	.998	2 RMS	Used	.9973-.9979	2-3 RMS
	<u>Rod Dia</u>	<u>Rod Finish</u>										
New	.998	2 RMS										
Used	.9973-.9979	2-3 RMS										

FOURTH-STAGE SEAL/SCRAPER IN A
FOUR-STAGE UNVENTED INSTALLATION.
NO. 2 LUG, GROOVE "D".

TABLE C-1. CONTINUED

CONFIGURATION PART SKETCH	DESIGNER/SUPPLIER	SATISFACTORY PERFORMANCE	COMMENTS																								
P 	Tetrafluor Parker	No. Seal was on the verge of failure despite zero 1kg during the test.	Cap strip is worn through on approximately 200° of the outside lip. The cap strip has extruded approx. .06 in. on the entire down-stream circumference. The O-ring is abraded over an area approx. .20 in. wide on the downstream side. The seal survived the entire test with zero measurable leakage.																								
SINGLE-STAGE SEAL INSTALLATION NO. 2 ROD, GROOVE "A"																											
			<table border="0"> <tr> <td></td> <td>Cap I.D.</td> <td></td> <td></td> </tr> <tr> <td>New</td> <td>LT .982</td> <td></td> <td></td> </tr> <tr> <td>Used</td> <td>.994</td> <td></td> <td></td> </tr> <tr> <td></td> <td></td> <td>Rod Dia</td> <td>Rod Finish</td> </tr> <tr> <td>New</td> <td>.998</td> <td></td> <td>2 RMS</td> </tr> <tr> <td>Used</td> <td>.9976-.9978</td> <td></td> <td>3-5 RMS</td> </tr> </table>		Cap I.D.			New	LT .982			Used	.994					Rod Dia	Rod Finish	New	.998		2 RMS	Used	.9976-.9978		3-5 RMS
	Cap I.D.																										
New	LT .982																										
Used	.994																										
		Rod Dia	Rod Finish																								
New	.998		2 RMS																								
Used	.9976-.9978		3-5 RMS																								

TABLE C-1. CONTINUED

CONFIGURATION PART SKETCH	DESIGNER/ SUPPLIER	SATISFACTORY PERFORMANCE	COMMENTS																					
P 	S-34-20 Seal Guard Hercules	No.	The scraper was in good condition but it had allowed a significant quantity of contamination to bypass it on the rod.																					
SCRAPER FOR A SINGLE STAGE SEAL INSTALLATION NO. 2 ROD, GROOVE "D".																								
			<table border="0"> <tr> <td></td> <td>Scraper I.D.</td> <td></td> </tr> <tr> <td>New</td> <td><u>.994</u></td> <td></td> </tr> <tr> <td>Used</td> <td>.998</td> <td></td> </tr> <tr> <td></td> <td></td> <td>Rod Dia</td> </tr> <tr> <td>New</td> <td><u>.998</u></td> <td>Rod Finish</td> </tr> <tr> <td>Used</td> <td>.9976-.9978</td> <td>2 RMS</td> </tr> <tr> <td></td> <td></td> <td>3-5 RMS</td> </tr> </table>		Scraper I.D.		New	<u>.994</u>		Used	.998				Rod Dia	New	<u>.998</u>	Rod Finish	Used	.9976-.9978	2 RMS			3-5 RMS
	Scraper I.D.																							
New	<u>.994</u>																							
Used	.998																							
		Rod Dia																						
New	<u>.998</u>	Rod Finish																						
Used	.9976-.9978	2 RMS																						
		3-5 RMS																						

TABLE C-1. CONTINUED

CONFIGURATION PART SKETCH	NUMBER	DESIGNER/ SUPPLIER	SATISFACTORY PERFORMANCE	COMMENTS																								
	S30775-214P-19 Plus Seal	W. S. Shamban	Yes; 17 drops leakage during the test.	The cap strip and inside backup ring were in very good condition. The outside backup ring was in good condition but had approx. .02 in. extrusion. This seal survived the entire test.																								
	S33157-214-19 Backup Ring (2)																											
SINGLE-STAGE SEAL INSTALLATION NO. 3 LUG, GROOVE "C".																												
				<table border="0" style="width: 100%;"> <tr> <td style="width: 33%;"></td> <td style="width: 33%; text-align: center;">Inside Cap</td> <td style="width: 33%; text-align: center;">Outside</td> </tr> <tr> <td></td> <td style="text-align: center;">Bu I.D.</td> <td style="text-align: center;">Bu I.D.</td> </tr> <tr> <td style="text-align: center;">New</td> <td style="text-align: center;"><u>LT .982</u></td> <td style="text-align: center;"><u>.9903</u></td> </tr> <tr> <td style="text-align: center;">Used</td> <td style="text-align: center;">.994</td> <td style="text-align: center;">1.0042</td> </tr> <tr> <td></td> <td></td> <td></td> </tr> <tr> <td></td> <td style="text-align: center;"><u>Rod Dia</u></td> <td style="text-align: center;"><u>Rod Finish</u></td> </tr> <tr> <td style="text-align: center;">New</td> <td style="text-align: center;">.9975</td> <td style="text-align: center;">6 RMS</td> </tr> <tr> <td style="text-align: center;">Used</td> <td style="text-align: center;">.9972-.9973</td> <td style="text-align: center;">5-11 RMS</td> </tr> </table>		Inside Cap	Outside		Bu I.D.	Bu I.D.	New	<u>LT .982</u>	<u>.9903</u>	Used	.994	1.0042					<u>Rod Dia</u>	<u>Rod Finish</u>	New	.9975	6 RMS	Used	.9972-.9973	5-11 RMS
	Inside Cap	Outside																										
	Bu I.D.	Bu I.D.																										
New	<u>LT .982</u>	<u>.9903</u>																										
Used	.994	1.0042																										
	<u>Rod Dia</u>	<u>Rod Finish</u>																										
New	.9975	6 RMS																										
Used	.9972-.9973	5-11 RMS																										

TABLE C-1. CONTINUED



CONFIGURATION PART SKETCH	NUMBER	DESIGNER/ SUPPLIER	SATISFACTORY PERFORMANCE	COMMENTS
P 	120-218-1709 Wiper/Scraper	Dowty Seals Limited	Yes	The scraper was in good condition, but had allowed the passage of a small amount of dirt on the rod. The O-ring had taken a permanent set. This scraper survived the entire test.
	100-218-0074 O-ring	Dowty Seals Limited		
<u>Scraper I.D.</u>				
		New .982 Used .998		
<p>SCRAPER FOR A SINGLE-STAGE SEAL INSTALLATION NO. 3 (LUG) GROOVE D</p> <p>This scraper could not be removed without damage from a one-piece gland, and it was difficult to install in a one-piece gland.</p>				
		New .9975 Used .9972-.9973		Rod Dia 6 RMS Rod Finish 5-11 RMS

TABLE C-1. CONTINUED

CONFIGURATION PART SKETCH	DESIGNER/ SUPPLIER	SATISFACTORY PERFORMANCE	COMMENTS
<p>P</p>  <p>595-21400 - 160-PX1 Enercap</p>	Greene Tweed	No	<p>The cap strip cracked through axially and the downstream side wore away. This seal did not survive the test. The approximate failure point for this seal was after 16,248,240 cycles. The elastomer was in good condition.</p> <p style="text-align: center;"><u>Cap Strip I.D.</u></p> <p>New .982 Used Could not be measured because of cracks in the cap strip.</p> <p style="text-align: center;"><u>Rod Dia</u> <u>Rod Finish</u></p> <p>New .9975 3 RMS Used .9972-.9976 3-5 RMS</p>

FIRST-STAGE SEAL IN A TWO-STAGE UNVENTED INSTALLATION NO. 3 ROD, GROOVE "B"

TABLE C-1. CONTINUED

CONFIGURATION PART SKETCH	DESIGNER/ SUPPLIER	SATISFACTORY PERFORMANCE	COMMENTS
<p>P</p>  <p>595-21400- 160-PX1 Enercap</p>	Greene Tweed	No.	<p>The cap strip cracked through axially and the downstream side wore away. This seal did not survive the test. This seal failed after 16,248,240 cycles. The elastomer was in good condition.</p>
<p>SECOND-STAGE SEAL IN A TWO-STAGE UNVENTED INSTALLATION NO. 3 ROD, GROOVE "C"</p>			
			<p>Cap Strip I.D. .982</p>
		<p>New Used</p>	<p>Could not be measured because of crack in the cap strip.</p>
			<p>Rod Dia Rod Finish</p> <p>New .9975 3 RMS</p> <p>Used .9972-.9976 3-5 RMS</p>

TABLE C-1. CONTINUED



CONFIGURATION PART SKETCH	DESIGNER/SUPPLIER	SATISFACTORY PERFORMANCE	COMMENTS
P 	18701000Z 4651053 Polypak Parker Packing	Yes	Scraper was in good condition but allowed some dirt to pass. This scraper survived the entire test.
SCRAPER FOR A TWO-STAGE SEAL UNVENTED INSTALLATION NO. 3 ROD, GROOVE "D"			
			Scraper I.D.
			New .982
			Used .994
			Rod Dia
			New .9975
			Used .9972-.9976
			Rod Finish
			3 RMS
			3-5 RMS

TABLE C-1. CONTINUED

CONFIGURATION PART SKETCH	DESIGNER/ SUPPLIER	SATISFACTORY PERFORMANCE	COMMENTS																
P 	C. E Conover & Co.	Yes; zero leakage during test	This seal produced no visible wear particles. The inside backup ring, cap and elastomer look very good. The outside triangular backup has approx. .02 in. extrusion. This seal survived the entire test.																
			<table border="0"> <tr> <td></td> <td>Inside</td> <td>Cap</td> <td>Outside</td> </tr> <tr> <td></td> <td>Bu I.D.</td> <td>I.D.</td> <td>Bu I.D.</td> </tr> <tr> <td>New</td> <td>.9903</td> <td>17.982</td> <td>.998</td> </tr> <tr> <td>Used</td> <td>.9903</td> <td>.998</td> <td>.998+</td> </tr> </table>		Inside	Cap	Outside		Bu I.D.	I.D.	Bu I.D.	New	.9903	17.982	.998	Used	.9903	.998	.998+
	Inside	Cap	Outside																
	Bu I.D.	I.D.	Bu I.D.																
New	.9903	17.982	.998																
Used	.9903	.998	.998+																
			<table border="0"> <tr> <td></td> <td>Rod Dia</td> <td>Rod Finish</td> </tr> <tr> <td>New</td> <td>.9975</td> <td>3 RMS</td> </tr> <tr> <td>Used</td> <td>.9973-.9975</td> <td>3-4 RMS</td> </tr> </table>		Rod Dia	Rod Finish	New	.9975	3 RMS	Used	.9973-.9975	3-4 RMS							
	Rod Dia	Rod Finish																	
New	.9975	3 RMS																	
Used	.9973-.9975	3-4 RMS																	

FIRST-STAGE SEAL IN A THREE-STAGE
UNVENTED INSTALLATION
NO. 4 LUG, GROOVE "B"

TABLE C-1. CONTINUED

CONFIGURATION PART SKETCH	DESIGNER/ SUPPLIER	SATISFACTORY PERFORMANCE	COMMENTS																
P 	C. E. Conover & Co.	Yes; zero leakage during the test	This seal produced no visible wear particles. Both backup rings, the cap, and the elastomer were in very good condition. This seal survived the entire test.																
			<table border="0"> <tr> <td></td> <td>Inside</td> <td>Cap</td> <td>Outside</td> </tr> <tr> <td>New</td> <td>Bu I.D.</td> <td>I.D.</td> <td>Bu I.D.</td> </tr> <tr> <td>Used</td> <td>.9907</td> <td>LT.982</td> <td>.994</td> </tr> <tr> <td></td> <td>.9903</td> <td>.986</td> <td>.994</td> </tr> </table>		Inside	Cap	Outside	New	Bu I.D.	I.D.	Bu I.D.	Used	.9907	LT.982	.994		.9903	.986	.994
	Inside	Cap	Outside																
New	Bu I.D.	I.D.	Bu I.D.																
Used	.9907	LT.982	.994																
	.9903	.986	.994																
			<table border="0"> <tr> <td></td> <td>Rod Dia</td> <td>Rod Finish</td> </tr> <tr> <td>New</td> <td>.9975</td> <td>3 RMS</td> </tr> <tr> <td>Used</td> <td>.9973-.9975</td> <td>3-4 RMS</td> </tr> </table>		Rod Dia	Rod Finish	New	.9975	3 RMS	Used	.9973-.9975	3-4 RMS							
	Rod Dia	Rod Finish																	
New	.9975	3 RMS																	
Used	.9973-.9975	3-4 RMS																	

SECOND-STAGE SEAL IN A THREE-STAGE
UNVENTED INSTALLATION
NO. 4 LUG, GROOVE "C"

TABLE C-1. CONTINUED

CONFIGURATION PART SKETCH	DESIGNER/ SUPPLIER	SATISFACTORY PERFORMANCE	COMMENTS
P 	CEC5091-998-55 C. E. Conover Scraper	Yes	This scraper did not allow contaminant to bypass on the rod. It produced the least visible rod wear of all scrapers tested.
THIRD-STAGE SEAL/SCRAPER IN A THREE-STAGE UNVENTED INSTALLATION NO. 4 LUG, GROOVE "D"			
			Scraper I.D. New <u>LT .982</u> Used .9903
			Rod Dia <u>Pod Finish</u> New .9975 <u>3 RMS</u> Used .9973-.9975 <u>3-4 RMS</u>

TABLE C-1. CONTINUED

CONFIGURATION PART SKETCH	DESIGNER/ SUPPLIER	SATISFACTORY PERFORMANCE	COMMENTS								
P 	S30775-214P-19 Plus Seal W. S. Shamban	Yes; zero leakage during test	Backup rings are in good condition. Outside backup ring has approx. .04 in. extrusion. Cap strip is in very good condition. Elastomer has minor deformation away from pressure. This seal survived the entire test.								
S33157-214-19 Backup Ring (2)			<table border="0"> <tr> <td>Inside Cap</td> <td>Outside</td> </tr> <tr> <td>Bu I.D. I.D.</td> <td>Bu I.D.</td> </tr> <tr> <td>New .9903</td> <td>LT.982 .9903</td> </tr> <tr> <td>Used .994</td> <td>.994 1.0042</td> </tr> </table>	Inside Cap	Outside	Bu I.D. I.D.	Bu I.D.	New .9903	LT.982 .9903	Used .994	.994 1.0042
Inside Cap	Outside										
Bu I.D. I.D.	Bu I.D.										
New .9903	LT.982 .9903										
Used .994	.994 1.0042										
FIRST-STAGE SEAL IN A TWO-STAGE UNVENTED INSTALLATION NO. 4 ROD, GROOVE "B"			<table border="0"> <tr> <td>Inside Cap</td> <td>Outside</td> </tr> <tr> <td>Bu I.D. I.D.</td> <td>Bu I.D.</td> </tr> <tr> <td>New .9903</td> <td>LT.982 .9903</td> </tr> <tr> <td>Used .994</td> <td>.994 1.0042</td> </tr> </table>	Inside Cap	Outside	Bu I.D. I.D.	Bu I.D.	New .9903	LT.982 .9903	Used .994	.994 1.0042
Inside Cap	Outside										
Bu I.D. I.D.	Bu I.D.										
New .9903	LT.982 .9903										
Used .994	.994 1.0042										
			<table border="0"> <tr> <td>Rod Dia</td> <td>Rod Finish</td> </tr> <tr> <td>New .9975</td> <td>3 RMS</td> </tr> <tr> <td>Used .9972-.9973</td> <td>2-4 RMS</td> </tr> </table>	Rod Dia	Rod Finish	New .9975	3 RMS	Used .9972-.9973	2-4 RMS		
Rod Dia	Rod Finish										
New .9975	3 RMS										
Used .9972-.9973	2-4 RMS										

TABLE C-1. CONTINUED

CONFIGURATION PART SKETCH	DESIGNER/SUPPLIER	SATISFACTORY PERFORMANCE	COMMENTS																
<p>P</p>  <p>S30775-214P-19 Plus Seal</p> <p>S33157-214-19 Backup Ring (2)</p>	W. S. Shamban	Yes; zero leakage during test	Both backup rings and the cap strip are in very good condition. The elastomer has minor deformation away from pressure. This seal survived the entire test.																
<p>SECOND-STAGE SEAL IN A TWO-STAGE UNVENTED INSTALLATION NO. 4 ROD, GROOVE "C"</p>																			
			<table border="0"> <tr> <td style="text-align: right;">New</td> <td style="text-align: right;">Inside</td> <td style="text-align: right;">Cap</td> <td style="text-align: right;">Outside</td> </tr> <tr> <td style="text-align: right;">Used</td> <td style="text-align: right;">Bu I.D.</td> <td style="text-align: right;">I.D.</td> <td style="text-align: right;">Bu I.D.</td> </tr> <tr> <td></td> <td style="text-align: right;">LT</td> <td style="text-align: right;">.9903</td> <td style="text-align: right;">.9903</td> </tr> <tr> <td></td> <td style="text-align: right;">.9903</td> <td style="text-align: right;">.9903</td> <td style="text-align: right;">.9903</td> </tr> </table>	New	Inside	Cap	Outside	Used	Bu I.D.	I.D.	Bu I.D.		LT	.9903	.9903		.9903	.9903	.9903
New	Inside	Cap	Outside																
Used	Bu I.D.	I.D.	Bu I.D.																
	LT	.9903	.9903																
	.9903	.9903	.9903																
			<table border="0"> <tr> <td style="text-align: right;">New</td> <td style="text-align: right;">Rod Dia</td> <td style="text-align: right;">Rod Finish</td> </tr> <tr> <td style="text-align: right;">Used</td> <td style="text-align: right;">.9975</td> <td style="text-align: right;">3 RMS</td> </tr> <tr> <td></td> <td style="text-align: right;">.9972-.9973</td> <td style="text-align: right;">2-4 RMS</td> </tr> </table>	New	Rod Dia	Rod Finish	Used	.9975	3 RMS		.9972-.9973	2-4 RMS							
New	Rod Dia	Rod Finish																	
Used	.9975	3 RMS																	
	.9972-.9973	2-4 RMS																	

TABLE C-1. CONTINUED

CONFIGURATION PART SKETCH	NUMBER	DESIGNER/SUPPLIER	SATISFACTORY PERFORMANCE	COMMENTS																		
	120-218-1709 Wiper/Scraper	Dowty Seals Limited	Yes	The scraper was in good condition, but had allowed the passage of a small amount of dirt on the rod. The O-ring had taken a permanent set. This scraper survived the entire test.																		
	100-218-0074 O-ring																					
SCRAPER FOR A TWO-STAGE UNVENTED INSTALLATION NO. 4 ROD, GROOVE "D"																						
				<table border="0"> <tr> <td></td> <td>Scraper I.D.</td> <td></td> </tr> <tr> <td>New</td> <td>.982</td> <td></td> </tr> <tr> <td>Used</td> <td>.994</td> <td></td> </tr> </table> <p>This scraper could not be removed without damage from a one-piece gland and it was difficult to install in a one-piece gland.</p> <table border="0"> <tr> <td></td> <td>Rod Dia</td> <td>Rod Finish</td> </tr> <tr> <td>New</td> <td>.9975</td> <td>3 RMS</td> </tr> <tr> <td>Used</td> <td>.9972-.9973</td> <td>2-4 RMS.</td> </tr> </table>		Scraper I.D.		New	.982		Used	.994			Rod Dia	Rod Finish	New	.9975	3 RMS	Used	.9972-.9973	2-4 RMS.
	Scraper I.D.																					
New	.982																					
Used	.994																					
	Rod Dia	Rod Finish																				
New	.9975	3 RMS																				
Used	.9972-.9973	2-4 RMS.																				

TABLE C-1. CONTINUED



CONFIGURATION PART SKETCH	DESIGNER/SUPPLIER	SATISFACTORY PERFORMANCE	COMMENTS									
P 	G. K. Fling/ C. E. Conover	Yes; zero leakage during test	The O-ring was in very good condition with no nibbling. The trapezoidal backup ring was in very good condition with no visible wear particles. This seal survived the entire test									
M83461/1-214 O-Ring	Parker		<table border="0"> <tr> <td></td> <td>O-Ring I.D.</td> <td>Backup I.D.</td> </tr> <tr> <td>New</td> <td>.982</td> <td>.9903</td> </tr> <tr> <td>Used</td> <td>.994</td> <td>1.0042</td> </tr> </table>		O-Ring I.D.	Backup I.D.	New	.982	.9903	Used	.994	1.0042
	O-Ring I.D.	Backup I.D.										
New	.982	.9903										
Used	.994	1.0042										
FIRST-STAGE SEAL IN A TWO-STAGE VENTED INSTALLATION NO. 5 LUG, GROOVE "B".												
			<table border="0"> <tr> <td></td> <td>Rod Dia</td> <td>Rod Finish</td> </tr> <tr> <td>New</td> <td>.998</td> <td>7 RMS</td> </tr> <tr> <td>Used</td> <td>.9976-.9979</td> <td>5-9 RMS</td> </tr> </table>		Rod Dia	Rod Finish	New	.998	7 RMS	Used	.9976-.9979	5-9 RMS
	Rod Dia	Rod Finish										
New	.998	7 RMS										
Used	.9976-.9979	5-9 RMS										

TABLE C-2. CONTINUED

CONFIGURATION PART SKETCH	NUMBER	DESIGNER	SUPPLIER	FACTORY PERFORMANCE	COMMENTS									
P 	CEC5056C-214 Trapezoid Backup Ring	G. K. Fling/ C. E. Conover		Yes, Zero leakage during test	The O-ring was in very good condition with no nibbling. The trapezoidal backup ring was in very good condition with no visible wear particles. This seal survived the entire test.									
	M83461/1-214 O-Ring	Parker												
					<table border="0"> <tr> <td></td> <td>O-Ring I.D.</td> <td>Backup I.D.</td> </tr> <tr> <td>New</td> <td>.986</td> <td>.9903</td> </tr> <tr> <td>Used</td> <td>.994</td> <td>.998</td> </tr> </table>		O-Ring I.D.	Backup I.D.	New	.986	.9903	Used	.994	.998
	O-Ring I.D.	Backup I.D.												
New	.986	.9903												
Used	.994	.998												
					<table border="0"> <tr> <td></td> <td>Rod Dia</td> <td>Rod Finish</td> </tr> <tr> <td>New</td> <td>.998</td> <td>4 RMS</td> </tr> <tr> <td>Used</td> <td>.9976-.9979</td> <td>5-9 RMS</td> </tr> </table>		Rod Dia	Rod Finish	New	.998	4 RMS	Used	.9976-.9979	5-9 RMS
	Rod Dia	Rod Finish												
New	.998	4 RMS												
Used	.9976-.9979	5-9 RMS												

SECOND-STAGE SEAL IN A TWO-STAGE
VENTED INSTALLATION
NO. 5 LUG, GROOVE "C".

TABLE C-1. CONTINUED

CONFIGURATION PART SKETCH	DESIGNER/ SUPPLIER	SATISFACTORY PERFORMANCE	COMMENTS										
<p>P</p>  <p>S-34-20 Seal Guard</p>	Hercules	No	<p>The scraper was in good condition but it had allowed contamination to bypass it on the rod. The rod had a frosted appearance.</p> <p>Scraper I.D.</p> <table> <tr> <td>New</td> <td>.994</td> </tr> <tr> <td>Used</td> <td>.994+</td> </tr> </table> <table> <tr> <td>Rod Dia</td> <td>Rod Finish</td> </tr> <tr> <td>New .998</td> <td>4 RMS</td> </tr> <tr> <td>Used .9976-.9979</td> <td>5-9 RMS</td> </tr> </table>	New	.994	Used	.994+	Rod Dia	Rod Finish	New .998	4 RMS	Used .9976-.9979	5-9 RMS
New	.994												
Used	.994+												
Rod Dia	Rod Finish												
New .998	4 RMS												
Used .9976-.9979	5-9 RMS												

SCRAPER FOR A TWO-STAGE
VENTED INSTALLATION
NO. 5 LUG, GROOVE "D"

TABLE C-1. CONDITION

CONFIGURATION PART SKETCH	DESIGNER/ SUPPLIER	SATISFACTORY PERFORMANCE	COMMENTS																		
P 	G. K. Fling/ C. E. Conover	Yes; zero leakage during test	The O-ring was in very good condition with no nibbling. The trapezoidal backup ring was in very good condition with no visible wear particles. This seal survived the entire test.																		
M83461/1-214 O-ring	Parker		<table border="0"> <tr> <td></td> <td><u>O-Ring I.D.</u></td> <td><u>Backup I.D.</u></td> </tr> <tr> <td>New</td> <td>.986</td> <td>.9903</td> </tr> <tr> <td>Used</td> <td>.998</td> <td>1.0042</td> </tr> </table> <table border="0"> <tr> <td></td> <td><u>Rod Dia</u></td> <td><u>Rod Finish</u></td> </tr> <tr> <td>New</td> <td>.9978</td> <td>6 RMS</td> </tr> <tr> <td>Used</td> <td>.9972-.9976</td> <td>8-10 RMS</td> </tr> </table>		<u>O-Ring I.D.</u>	<u>Backup I.D.</u>	New	.986	.9903	Used	.998	1.0042		<u>Rod Dia</u>	<u>Rod Finish</u>	New	.9978	6 RMS	Used	.9972-.9976	8-10 RMS
	<u>O-Ring I.D.</u>	<u>Backup I.D.</u>																			
New	.986	.9903																			
Used	.998	1.0042																			
	<u>Rod Dia</u>	<u>Rod Finish</u>																			
New	.9978	6 RMS																			
Used	.9972-.9976	8-10 RMS																			

FIRST-STAGE SEAL IN A TWO-STAGE
UNVENTED INSTALLATION
NO. 5 ROD, GROOVE "B"

TABLE C-1. CONTINUED

CONFIGURATION PART SKETCH	NUMBER	DESIGNER/ SUPPLIER	SATISFACTORY PERFORMANCE	COMMENTS									
P 	CEC5056C-214 Trapezoid Backup Ring	G. K. Fling/ Conover	Yes; zero leakage during test	The O-ring was in very good condition with no nibbling. The trapezoid backup ring was in very good condition with no visible wear particles. This seal survived the entire test.									
	M83461/1-214 O-ring			<table border="0"> <tr> <td></td> <td>O-Ring I.D.</td> <td>Backup I.D.</td> </tr> <tr> <td>New</td> <td>.982</td> <td>.9903</td> </tr> <tr> <td>Used</td> <td>.994</td> <td>.998</td> </tr> </table>		O-Ring I.D.	Backup I.D.	New	.982	.9903	Used	.994	.998
	O-Ring I.D.	Backup I.D.											
New	.982	.9903											
Used	.994	.998											
				<table border="0"> <tr> <td></td> <td>Rod Dia</td> <td>Rod Finish</td> </tr> <tr> <td>New</td> <td>.9978</td> <td>6 RMS</td> </tr> <tr> <td>Used</td> <td>.9972-.9976</td> <td>8-10 RMS</td> </tr> </table>		Rod Dia	Rod Finish	New	.9978	6 RMS	Used	.9972-.9976	8-10 RMS
	Rod Dia	Rod Finish											
New	.9978	6 RMS											
Used	.9972-.9976	8-10 RMS											

212 SECOND-STAGE SEAL IN A TWO-STAGE UNVENTED INSTALLATION NO. 5 ROD, GROOVE "C"

TABLE C-1. CONTINUED

CONFIGURATION PART SKETCH	DESIGNER/SUPPLIER	SATISFACTORY PERFORMANCE	COMMENTS
P 	Parker Packing 18701000Z 4651D53 Polypak	Yes	Scraper was in good condition, but allowed some contamination to pass. This scraper survived the entire test Scraper I.D. New <u>LT .982</u> Used .994 Rod Dia New <u>.9978</u> Used .9972 - .9976 Rod Finish New <u>6 RMS</u> Used 8-10 RMS

SCRAPER FOR A TWO-STAGE UNVENTED INSTALLATION NO. 5 ROD, GROOVE "D".

TABLE C-1. CONTINUED

CONFIGURATION PART SKETCH	NUMBER	DESIGNER/SUPPLIER	SATISFACTORY PERFORMANCE	COMMENTS																
P 	S30650-214-19 Double Delta	W. S. Shamban	Yes; zero leakage during test	The cap strip and both back-up rings are in very good condition. The O-ring is in good condition but has slight deformation. This seal survived the entire test																
	S33157-214-19 Backup Ring (2)																			
	M83461/1-214 O-Ring	Parker																		
				<table border="0"> <tr> <td></td> <td>Inside</td> <td>Cap</td> <td>Outside</td> </tr> <tr> <td></td> <td>Bu I.D.</td> <td>I.D.</td> <td>Ru I.D.</td> </tr> <tr> <td>New</td> <td><u>.982</u></td> <td><u>.994</u></td> <td><u>.994</u></td> </tr> <tr> <td>Used</td> <td>.9903</td> <td>1.0042</td> <td>1.0042</td> </tr> </table>		Inside	Cap	Outside		Bu I.D.	I.D.	Ru I.D.	New	<u>.982</u>	<u>.994</u>	<u>.994</u>	Used	.9903	1.0042	1.0042
	Inside	Cap	Outside																	
	Bu I.D.	I.D.	Ru I.D.																	
New	<u>.982</u>	<u>.994</u>	<u>.994</u>																	
Used	.9903	1.0042	1.0042																	
				<table border="0"> <tr> <td></td> <td>Rod Dia</td> <td>Rod Finish</td> </tr> <tr> <td>New</td> <td><u>.9977</u></td> <td>3 RMS</td> </tr> <tr> <td>Used</td> <td>.9973-.9975</td> <td>3 RMS-4 RMS</td> </tr> </table>		Rod Dia	Rod Finish	New	<u>.9977</u>	3 RMS	Used	.9973-.9975	3 RMS-4 RMS							
	Rod Dia	Rod Finish																		
New	<u>.9977</u>	3 RMS																		
Used	.9973-.9975	3 RMS-4 RMS																		

FIRST-STAGE SEAL IN A TWO-STAGE VENTED INSTALLATION NO. 6 LUG, GROOVE "B"

TABLE C-1. CONTINUED

CONFIGURATION PART SKETCH	NUMBER	DESIGNER/ SUPPLIER	SATISFACTORY PERFORMANCE	COMMENTS
P 	S33051-214-99 Hat Seal	W. S. Shamban	Yes; zero leakage during test	The cap strip and elastomer are in very good condition. This seal survived the entire test.
				Cap I.D. Elastomer I.D.
			New	.994 LT .982
			Used	.994+ LT .982
				Pod Dia Rod Finish
			New	.9977 3 RMS
			Used	.9973-.9975 3 RMS-4 RMS

SECOND-STAGE SEAL IN A TWO-STAGE
VENTED INSTALLATION
NO. 6 LUG, GROOVE "C"

TABLE C-1. CONTINUED

CONFIGURATION PART SKETCH	DESIGNER/ SUPPLIER	SATISFACTORY PERFORMANCE	COMMENTS												
P 	Parker Packing	Yes	This scraper allowed very little contamination to bypass on the rod. The scraper was in good condition and survived the entire test.												
			<table border="0"> <tr> <td></td> <td>Scraper I.D.</td> </tr> <tr> <td></td> <td><u>.982</u></td> </tr> <tr> <td>New</td> <td></td> </tr> <tr> <td>Used</td> <td>.998</td> </tr> </table>		Scraper I.D.		<u>.982</u>	New		Used	.998				
	Scraper I.D.														
	<u>.982</u>														
New															
Used	.998														
			<table border="0"> <tr> <td></td> <td>Pod Dia</td> <td>Pod Finish</td> </tr> <tr> <td></td> <td><u>.9977</u></td> <td><u>3 RMS</u></td> </tr> <tr> <td>New</td> <td></td> <td></td> </tr> <tr> <td>Used</td> <td>.9973-.9975</td> <td>3 PMS-4 RMS</td> </tr> </table>		Pod Dia	Pod Finish		<u>.9977</u>	<u>3 RMS</u>	New			Used	.9973-.9975	3 PMS-4 RMS
	Pod Dia	Pod Finish													
	<u>.9977</u>	<u>3 RMS</u>													
New															
Used	.9973-.9975	3 PMS-4 RMS													

SCRAPER FOR A TWO-STAGE
VENTED INSTALLATION
NO. 6 LUG, GROOVE "D".

TABLE C-1. CONTINUED

CONFIGURATION PART SKETCH	DESIGNER/ SUPPLIER	SATISFACTORY PERFORMANCE	COMMENTS																					
P 	S30775-214P-19 Plus Seal W. S. Shamban	Yes; zero leakage during test	The inside backup ring was in very good condition. The Plus Seal was in good condition but had approx. .02 in. extrusion. The outside backup ring was in good condition, but had approx. .01 in. extrusion. The elastomer was in good condition, but had minor deformation away from pressure. This seal survived the entire test.																					
	S33157-214-19 Backup Ring (2)																							
			<table border="0"> <tr> <td>Inside</td> <td>Cap</td> <td>Outside</td> </tr> <tr> <td>Bu I.D.</td> <td>I.D.</td> <td>Bu I.D.</td> </tr> <tr> <td>New .9903</td> <td>LT.982</td> <td>.9903</td> </tr> <tr> <td>Used .9904</td> <td>.9903</td> <td>.998</td> </tr> <tr> <td></td> <td>Rod Dia</td> <td>Rod Finish</td> </tr> <tr> <td></td> <td>New .9975</td> <td>3 RMS</td> </tr> <tr> <td></td> <td>Used .9973-.9975</td> <td>3-10 RMS</td> </tr> </table>	Inside	Cap	Outside	Bu I.D.	I.D.	Bu I.D.	New .9903	LT.982	.9903	Used .9904	.9903	.998		Rod Dia	Rod Finish		New .9975	3 RMS		Used .9973-.9975	3-10 RMS
Inside	Cap	Outside																						
Bu I.D.	I.D.	Bu I.D.																						
New .9903	LT.982	.9903																						
Used .9904	.9903	.998																						
	Rod Dia	Rod Finish																						
	New .9975	3 RMS																						
	Used .9973-.9975	3-10 RMS																						

FIRST-STAGE SEAL III A THREE-STAGE
UNVENTED INSTALLATION
NO 6 ROD, GROOVE "A"

TABLE C-1. CONTINUED

CONFIGURATION PART SKETCH	DESIGNER/ SUPPLIER	SATISFACTORY PERFORMANCE	COMMENTS																									
P 	S30775-214P-19 Plus Seal W. S. Shamban	Yes; zero leakage during test	Both backup rings and the cap were in very good condition. The elastomer was in good condition but had minor deformation away from pressure. This seal survived the entire test.																									
	S33157-214-19 Backup Ring (2)		<table border="0"> <tr> <td></td> <td>Inside</td> <td>Cap</td> <td>Outside</td> </tr> <tr> <td></td> <td>Bu I.D.</td> <td>I.D.</td> <td>Ru I.D.</td> </tr> <tr> <td>New</td> <td>.9903</td> <td>LT.982</td> <td>.9903</td> </tr> <tr> <td>Used</td> <td>.994</td> <td>.9903</td> <td>.994</td> </tr> </table> <table border="0"> <tr> <td></td> <td>Rod Dia</td> <td>Rod Finish</td> </tr> <tr> <td>New</td> <td>.9975</td> <td>3 RMS</td> </tr> <tr> <td>Used</td> <td>.9973-.9975</td> <td>3-10 RMS</td> </tr> </table>		Inside	Cap	Outside		Bu I.D.	I.D.	Ru I.D.	New	.9903	LT.982	.9903	Used	.994	.9903	.994		Rod Dia	Rod Finish	New	.9975	3 RMS	Used	.9973-.9975	3-10 RMS
	Inside	Cap	Outside																									
	Bu I.D.	I.D.	Ru I.D.																									
New	.9903	LT.982	.9903																									
Used	.994	.9903	.994																									
	Rod Dia	Rod Finish																										
New	.9975	3 RMS																										
Used	.9973-.9975	3-10 RMS																										

SECOND-STAGE SEAL IN A THREE-STAGE
UNVENTED INSTALLATION.
NO. 6 ROD, GROOVE "B"

TABLE C-1. CONTINUED

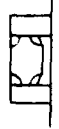
CONFIGURATION PART SKETCH	NUMBER	DESIGNER/ SUPPLIER	SATISFACTORY PERFORMANCE	COMMENTS																									
	S30775-214P-19 Plus Seal	W. S. Shamban	Yes; zero leakage during test	Both backup rings and the cap were in very good condition. The elastomer was in good condition but had minor deformation away from pressure. This seal survived the entire test.																									
	S33157-214-19 Backup Ring (2)			<table border="0"> <tr> <td></td> <td>Inside</td> <td>Cap</td> <td>Outside</td> </tr> <tr> <td>New</td> <td>.9903</td> <td>I.D.</td> <td>Ru I.D.</td> </tr> <tr> <td>Used</td> <td>.994</td> <td>LT.982</td> <td>.9903</td> </tr> <tr> <td></td> <td></td> <td>.9903</td> <td>.994</td> </tr> </table> <table border="0"> <tr> <td></td> <td>Rod Dia</td> <td>Rod Finish</td> </tr> <tr> <td>New</td> <td>.9975</td> <td>3 RMS</td> </tr> <tr> <td>Used</td> <td>.9973-.9975</td> <td>3-10 RMS</td> </tr> </table>		Inside	Cap	Outside	New	.9903	I.D.	Ru I.D.	Used	.994	LT.982	.9903			.9903	.994		Rod Dia	Rod Finish	New	.9975	3 RMS	Used	.9973-.9975	3-10 RMS
	Inside	Cap	Outside																										
New	.9903	I.D.	Ru I.D.																										
Used	.994	LT.982	.9903																										
		.9903	.994																										
	Rod Dia	Rod Finish																											
New	.9975	3 RMS																											
Used	.9973-.9975	3-10 RMS																											

SECOND-STAGE SEAL IN A THREE-STAGE UNVENTED INSTALLATION.
NO. 6 ROD, GROOVE "B"

TABLE C-1. CONTINUED

CONFIGURATION PART SKETCH	DESIGNER/SUPPLIER	SATISFACTORY PERFORMANCE	COMMENTS
<p>P</p>  <p>S30775-214P-19 Plus Seal</p>	W. S Shamban	Yes; zero leakage during test	Both backup rings and the cap were in very good condition. The elastomer was in good condition but had minor deformation away from pressure. This seal survived the entire test
<p>S33157-214-19 Backup Ring (2)</p>			<p>Inside Cap Outside Bu I.D. I.D. Bu I.D. LT .982 .9903 .9903 Used .9903 .994 .994</p>
<p>THIRD-STAGE SEAL IN A THREE-STAGE UNVENTED INSTALLATION NO. 6 ROD, GROOVE "C"</p>			<p>Rod Dia Rod Finish New .9975 3 RMS Used .9973-.9975 3-10 RMS</p>

TABLE C-1. CONTINUED



CONFIGURATION PART SKETCH	DESIGNER/SUPPLIER	SATISFACTORY PERFORMANCE	COMMENTS									
<p>P</p> 	Dowty Seals Limited	Yes	This scraper allowed a small amount of contamination to bypass on the rod. This scraper survived the entire test.									
100-218-1709 Wiper/Scraper												
100-218-0074 O-ring												
<p>SCRAPER FOR A THREE-STAGE UNVENTED INSTALLATION NO. 6 ROD, GROOVE "D"</p>												
			<p>Scraper I.D.</p> <table> <tr> <td>New</td> <td>.982</td> </tr> <tr> <td>Used</td> <td>.9903</td> </tr> </table>	New	.982	Used	.9903					
New	.982											
Used	.9903											
			<table> <tr> <td></td> <td>Pod Dia</td> <td>Pod Finish</td> </tr> <tr> <td>New</td> <td>.9975</td> <td>3 RMS</td> </tr> <tr> <td>Used</td> <td>.9973-.9975</td> <td>3-10 RMS</td> </tr> </table>		Pod Dia	Pod Finish	New	.9975	3 RMS	Used	.9973-.9975	3-10 RMS
	Pod Dia	Pod Finish										
New	.9975	3 RMS										
Used	.9973-.9975	3-10 RMS										

TABLE C-1. CONTINUED

CONFIGURATION PART SKETCH	NUMBER	DESIGNER/ SUPPLIER	SATISFACTORY PERFORMANCE	COMMENTS
P 	TF830-214-2 Backup Ring (2)	Tetrafluor	No; seal failed on tungsten carbide rod	The seal failed after 4,650,540 cycles of rotor feedback. The O-ring was worn away and rolled over approx. 150° of outer surface. The worn area had a polished look. The backup rings had medium local wear caused by the O-Ring getting on top.
	M83461/1-214 O-Ring	Parker		No seal measurements were taken.

SINGLE-STAGE SEAL (1ST REPLACEMENT)
ACT. NO. 1, ROD, GROOVE "C".

TABLE C-1. CONTINUED

CONFIGURATION PART SKETCH	NUMBER	DESIGNER/SUPPLIER	SATISFACTORY PERFORMANCE	COMMENTS
	S-34-20 Seal Guard	Hercules	No	The scraper was in good condition, but it had allowed contamination to bypass it on the rod.
<p>SCRAPER FOR THE 1ST REPLACEMENT SEAL IN ACT NO. 1, ROD, GROOVE "D"</p> <p>Scraper I.D. New Not measured Used Could not be measured because of distortion at disassembly.</p>				

TABLE C-1. CONTINUED

CONFIGURATION PART SKETCH	DESIGNER/ SUPPLIER	SATISFACTORY PERFORMANCE	COMMENTS
<p>P</p>	<p>S30775-214P-19 Plus Seal</p> <p>W. S. Shamban</p>	<p>No; seal failed on tungsten carbide rod</p>	<p>The seal failed after 15,462,330 rotor feedback cycles and 1620 long stroke cycles. The outer lip of the cap was worn away over a 90° arc. The elastomer was exposed to the rod and worn heavily in the same area.</p>
<p>SINGLE-STAGE SEAL (2ND REPLACEMENT) ACT NO. 1 ROD, GROOVE "C"</p>			
<p>No seal measurements were taken.</p>			

TABLE C-1. CONTINUED



CONFIGURATION PART SKETCH	NUMBER	DESIGNER/ SUPPLIER	SATISFACTORY PERFORMANCE	COMMENTS
	S-34-20 Seal Guard	Hercules	No	The scraper was in good condition, but it had allowed contamination to bypass it on the rod.
<p>SCRAPER FOR THE 2ND REPLACEMENT SEAL IN ACT. NO. 1 ROD, GROOVE "D".</p> <p>No measurements were taken.</p>				

TABLE C-1. CONTINUED

CONFIGURATION PART SKETCH	DESIGNER/ SUPPLIER	SATISFACTORY PERFORMANCE	COMMENTS
P 	ARI103-214P-11 Fluorocarbon Omni Seal	No; excessive leakage	This seal was tested for 15,462,330 rotor feedback cycles and 1620 long stroke cycles. Leakage was <u>43.56 cc.</u> Seal I.D. <u>.982</u> New Used <u>.9903</u>

FIRST-STAGE SEAL IN A TWO-STAGE UNVENTED
REPLACEMENT INSTALLATION
ACT. NO. 3 POD, GROOVE "A".

TABLE C-1. CONTINUED

CONFIGURATION PART SKETCH	DESIGNER/ SUPPLIER	SATISFACTORY PERFORMANCE	COMMENTS												
P 	AR141337 Rod Seal	Fluorocarbon No	This seal was tested for 15,462,330 rotor feedback cycles and long stroke cycles. Leakage was excessive and the elastomer cracked and nibbled. The backup rings were in good condition.												
CEC5056-214 Backup Ring (?)	C. E. Conover	Yes													
SECOND-STAGE SEAL IN A TWO-STAGE UNVENTED REPLACEMENT INSTALLATION ACTUATOR NO. 3 ROD, GROOVE "C"															
			<table border="0"> <tr> <td>Seal</td> <td>Inside</td> <td>Outside</td> </tr> <tr> <td>.I.D.</td> <td>Bu I.D</td> <td>Bu I.D.</td> </tr> <tr> <td>New LT.982</td> <td>.9903</td> <td>.9903</td> </tr> <tr> <td>Used LT.982</td> <td>.994</td> <td>.9903+</td> </tr> </table>	Seal	Inside	Outside	.I.D.	Bu I.D	Bu I.D.	New LT.982	.9903	.9903	Used LT.982	.994	.9903+
Seal	Inside	Outside													
.I.D.	Bu I.D	Bu I.D.													
New LT.982	.9903	.9903													
Used LT.982	.994	.9903+													

TABLE C-2. MEASURED CRITICAL DIMENSIONS AND FINISHES
BEFORE AND (AFTER) TASK III TEST

Actuator No. 1

DIMENSION**	PISTON & ROD -12 S/N 007 MEASUREMENT	LUG END CAP -5C S/N 001 MEASUREMENT	ROD END CAP -5A S/N 003 MEASUREMENT
B Dia	.998		
Lug End	(.9974-.9978)		
B RMS	3 (4 - 7)		
C Dia	.9975		
Rod End	(.9972-.9975)		
C RMS	2 (3 - 12)		
D Dia		.9998	.9998
Outside Seal		(1.0126)	(1.0036)
N Dia		1.0005	1.0004
Inside Seal		(1.0007)	(1.0025)

ROD CLEARANCE	START OF TEST	END OF TEST	DIAMETRAL WEAR
Lug End Inside Seal	.0025	.0031	.0006
Outside Seal	.0018	.0148	.013*
Rod End Inside Seal	.0029	.0051	.0022*
Outside Seal	.0023	.0062	.0039*

* Almost exclusively end cap wear

** See Figure 3.2.4A and 3.2.4B in Task III Test Plan.

TABLE C-2. CONTINUED

Actuator No. 2

DIMENSION	PISTON & ROD -1 S/N 001 MEASUREMENT	LUG END CAP -5C S/N 002 MEASUREMENT	ROD END CAP -2A S/N 001 MEASUREMENT
B Dia	.998		
Lug End	(.9973 - .9979)		
B RMS	2 (2 - 4)		
C Dia	.998		
Rod End	(.9976 - .9978)		
C RMS	2 (3 - 5)		
D Dia		.9996	.9995
Outside Seal		(.9995)	(1.0008)
N Dia		1.0005	1.00115
Inside Seal		(1.0005)	(1.0007)

ROD CLEARANCE	START OF TEST	END OF TEST	DIAMETRAL WEAR
Lug End Inside Seal	.0025	.0030	.0005
Outside Seal	.0016	.0020	.0004
Rod End Inside Seal	.00315	.00345	.0003
Outside Seal	.0015	.0032	.0017*

*Almost Exclusively End Cap Wear

TABLE C-2. CONTINUED

Actuator No. 3

DIMENSION	PISTON & ROD -1 S/N 002 MEASUREMENT	LUG END CAP -5D S/N 004 MEASUREMENT	ROD END CAP -5B S/N 005 MEASUREMENT
B Dia	.9975		
Lug End	(.9972 - .9973)		
B RMS	6 (5 - 11)		
C Dia.	.9975		
Rod End	(.9972 - .9975)		
C RMS	3 (3 - 5)		
D Dia		.9996	.9996/.9997
Outside Seal		(1.0013)	(.9995)
N Dia		1.0004	1.0006
Inside Seal		(1.0004)	(1.0003)

<u>ROD CLEARANCE</u>	<u>START OF TEST</u>	<u>END OF TEST</u>	<u>DIAMETRICAL WEAR</u>
Lug End Inside Seal	.0029	.0032	.0003
Outside Seal	.0021	.0040	.0019*
Rod End Inside Seal	.0031	.0033	.0002
Outside Seal	.0020	.0020	- 0 -

*Almost exclusively End Cap Wear

TABLE C-2. CONTINUED

Actuator No. 4

DIMENSION	PISTON & ROD -1 S/N 003 MEASUREMENT	LUG END CAP -6C S/N 001 MEASUREMENT	ROD END CAP -5D S/N 006 MEASUREMENT
B Dia	.9975		
Lug End	(.9973-.9975)		
B RMS	3 (3-4)		
C Dia	.9975		
Rod End	(.9972-.9973)		
C RMS	3 (2-4)		
D Dia		.9996	.9996
Outside Seal		(.9996)	(.9996)
M Dia		1.00055	1.0004
Inside Seal		(1.0008)	(1.0007)

ROD CLEARANCE	START OF TEST	END OF TEST	DIAMETRAL WEAR
Lug End Inside Seal	.00305	.00340	.00035
Outside Seal	.00210	.00230	.0002
Rod End Inside Seal	.0029	.0035	.0006
Outside Seal	.0021	.0023	.0002

TABLE C-2. CONTINUED

Actuator No. 5

DIMENSION	PISTON & ROD -1 S/N 004 MEASUREMENT	LUG END CAP -5A S/N 007 MEASUREMENT	ROD END CAP -5B S/N 008 MEASUREMENT
B Dia	.998		
Lug End	(.9976-.9979)		
B RMS	4 (5-9)		
C Dia	.9978		
Rod End	(.9972-.9976)		
C RMS	6 (8-10)		
D Dia		1.0017	.9997
Outside Seal		(1.0005)	(.9997)
N Dia		1.0013	1.00075
Inside Seal		(1.0014)	(1.0008)

<u>ROD CLEARANCE</u>	<u>START OF TEST</u>	<u>END OF TEST</u>	<u>DIAMETRAL WEAR</u>
Lug End Inside Seal	.0033	.0038	.0005
Outside Seal	.0037	.0039	.0002
Rod End Inside Seal	.00295	.0033	.00035
Outside Seal	.0019	.0021	.0002

TABLE C-2. CONTINUED

Actuator No. 6

DIMENSION	PISTON & ROD -1 S/N 005 MEASUREMENT	LUG END CAP -5B S/N 009 MEASUREMENT	ROD END CAP -5A S/N 010 MEASUREMENT
B Dia	.9977		
Lug End	(.9973-.9975)		
B RMS	3 (3-4)		
C Dia	.9975		
Rod End	(.9972-.9976)		
C RMS	3 (4-10)		
D Dia		.9997	.9995
Outside Seal		(.9995)	(.9999)
N Dia		1.00065	1.00083
Inside Seal		(1.0006)	(1.0008)

ROD CLEARANCE	START OF TEST	END OF TEST	DIAMETRAL WEAR
Lug End Inside Seal	.00295	.00315	.0002
Outside Seal	.0020	.0024	.0004
Rod End Inside Seal	.00333	.00363	.0003
Outside Seal	.0020	.0026	.0006

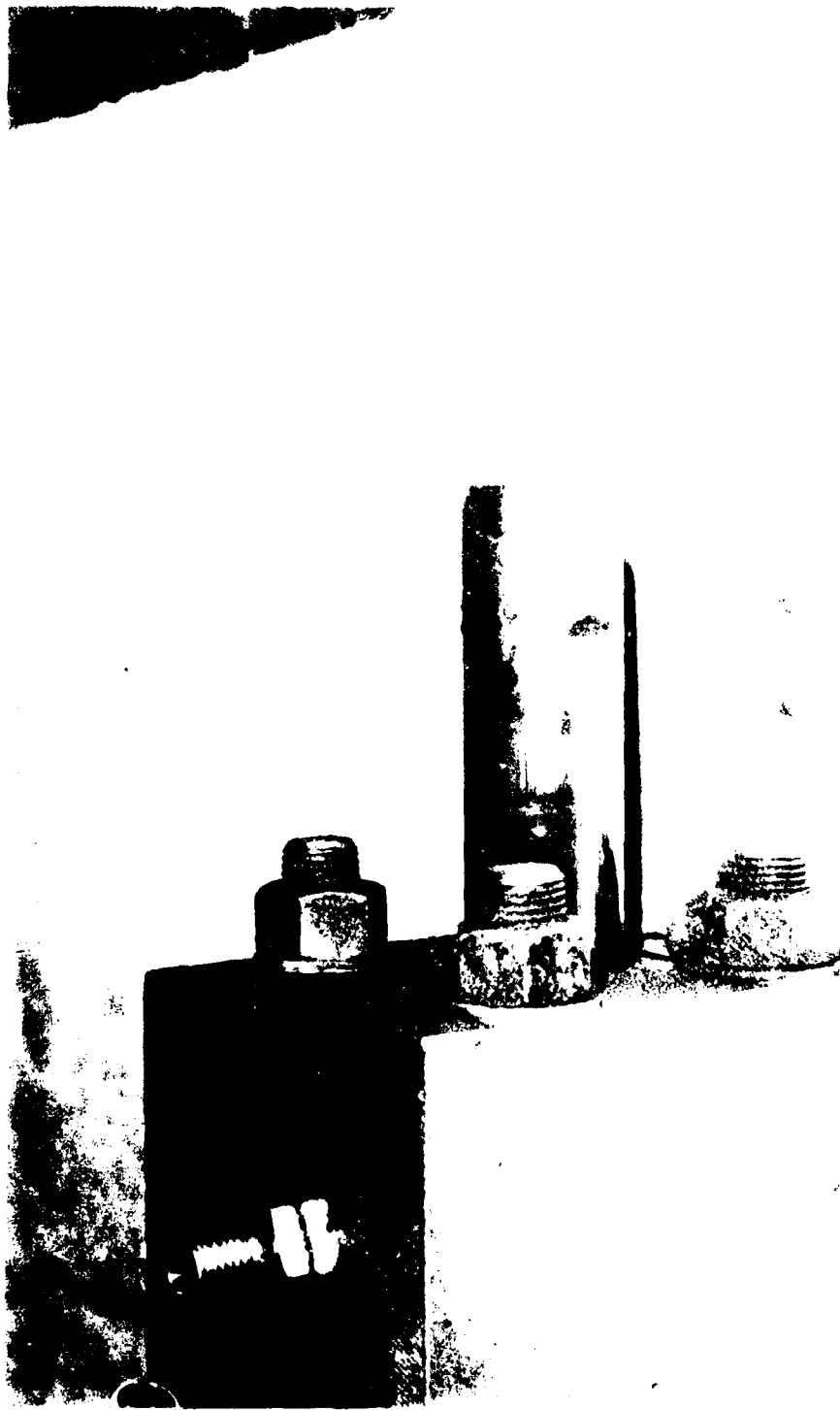

ACTUATOR HG. 7, LUG END POD AT COMPLETION OF TASK III TEST



1R

ACTUATOR NO. 1, ROD END ROD AT CONCLUSION OF TASK III TESTS

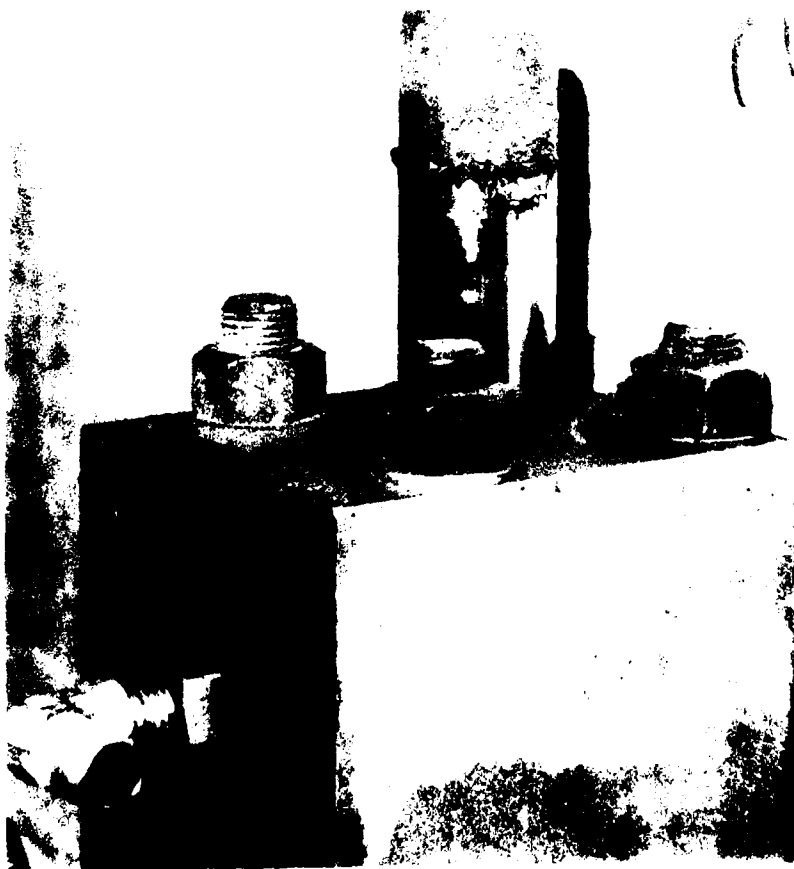

ACTUATOR NO. 2, LUG END ROD AT CONCLUSION OF TASK III TESTS



2R

ACTUATOR NO. 2, POD END ROD AT CONCLUSION OF TASK III TESTS

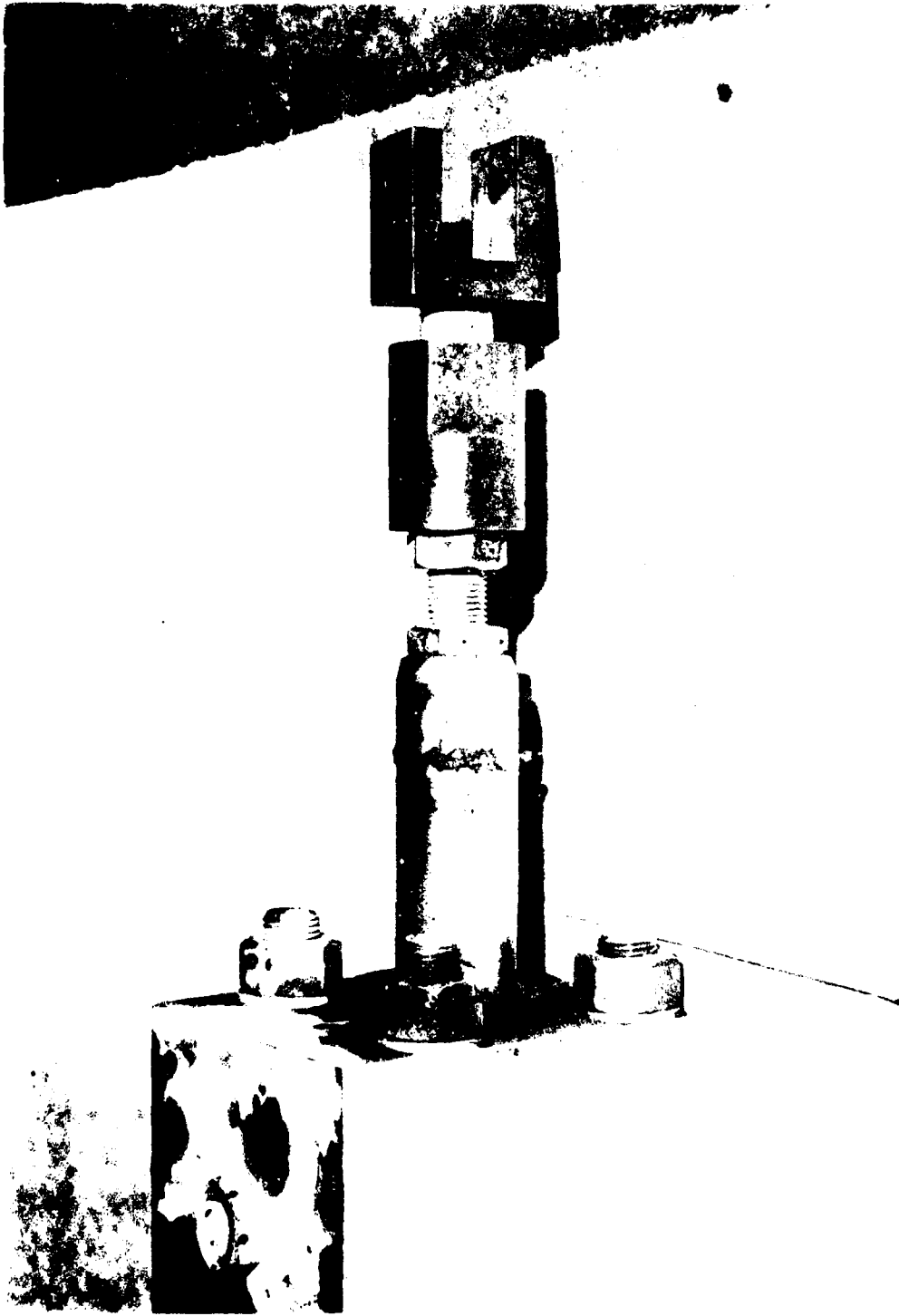

ACTUATOR NO. 3, LUG END ROD AT CONCLUSION OF TASK III TESTS

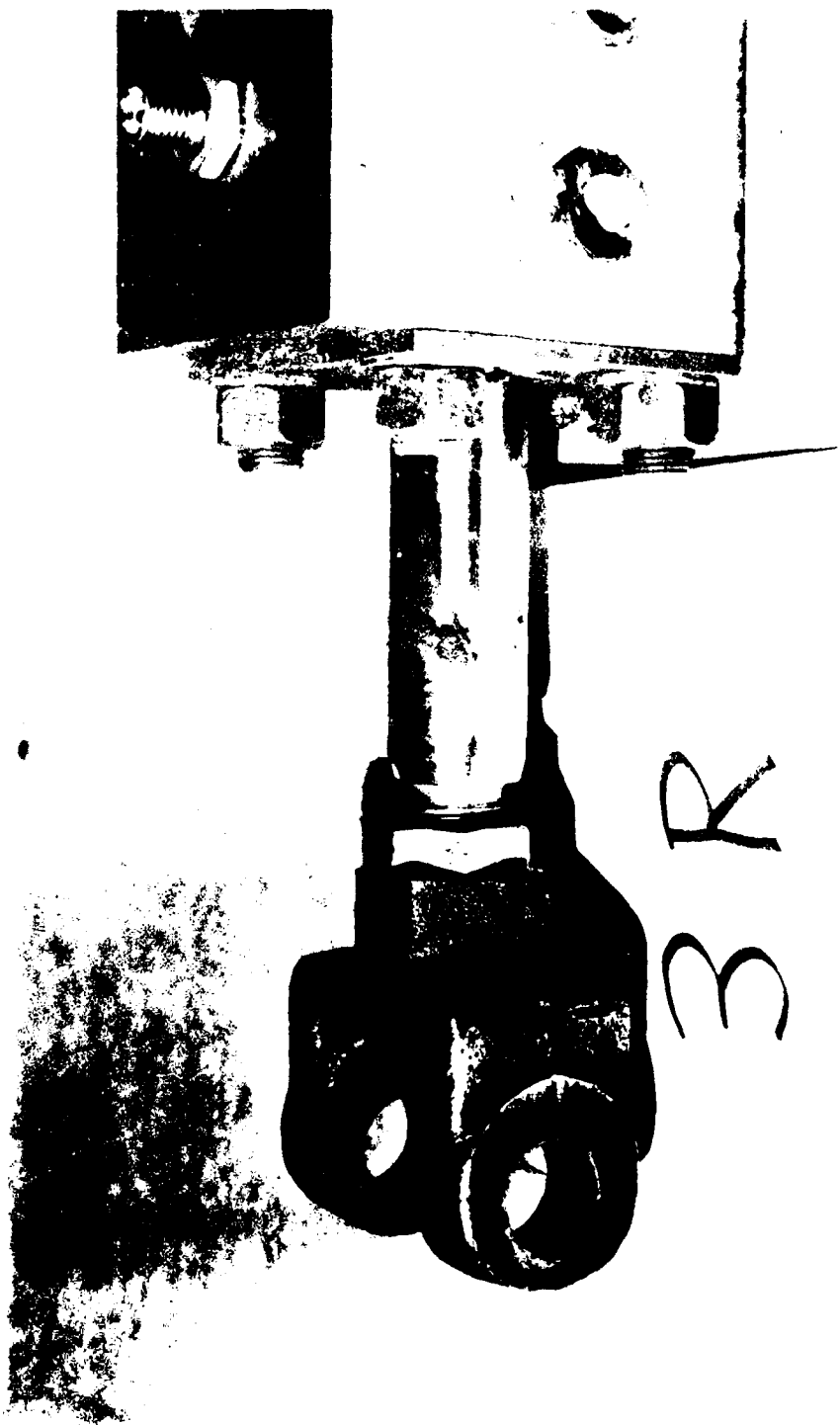

3R

ACTUATOR NO. 3, ROD END ROD AT CONCLUSION OF TASK III TESTS

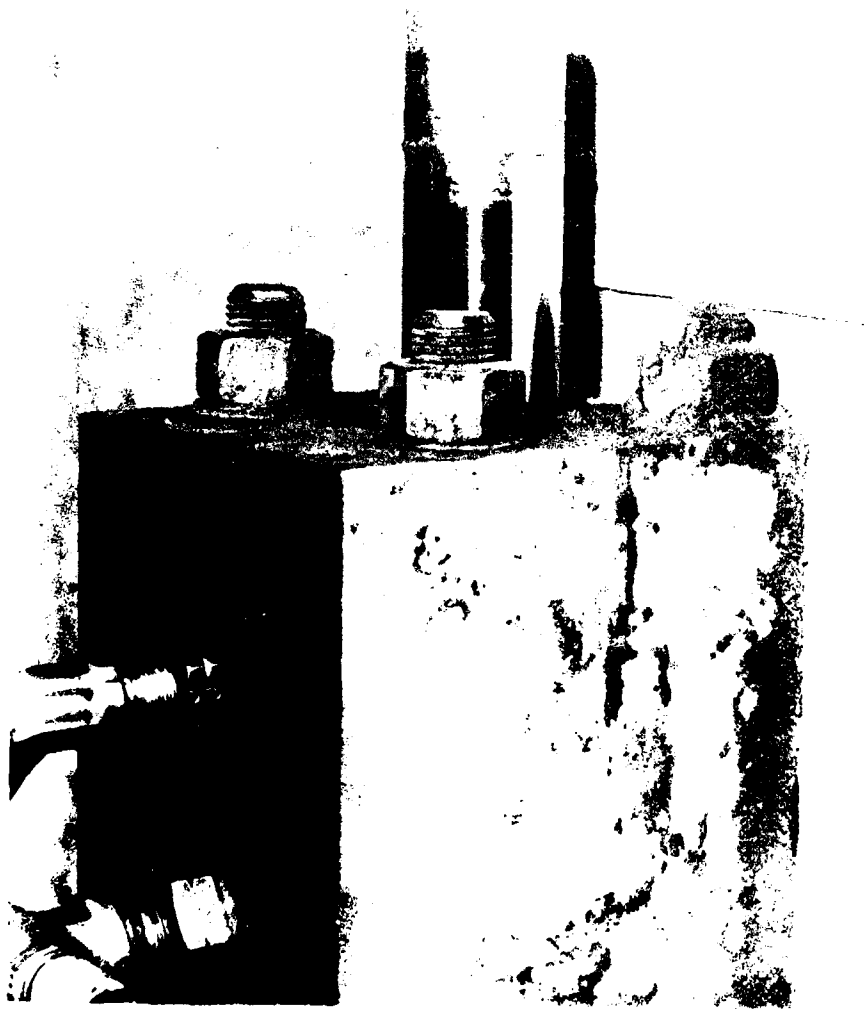

ACTUATOR NO. 4, LUG END ROD AT CONCLUSION OF TASK III TESTS

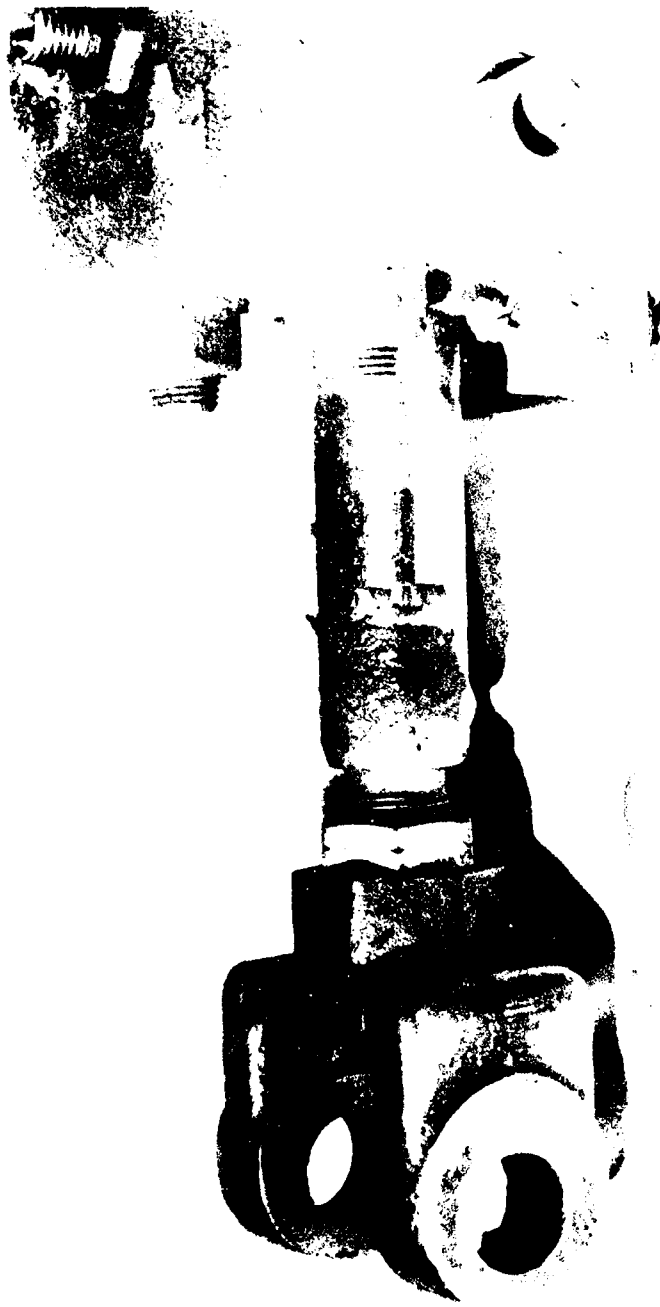

ACTUATOR NO. 4, ROD END POD AT COMPLETION OF TASK III TESTS



57

ACTUATOR NO. 5, LUG END ROD AT CONCLUSION OF TASK III TESTS



ACTUATOR NO. 5, ROD END ROD AT CONCLUSION OF TASK III TESTS

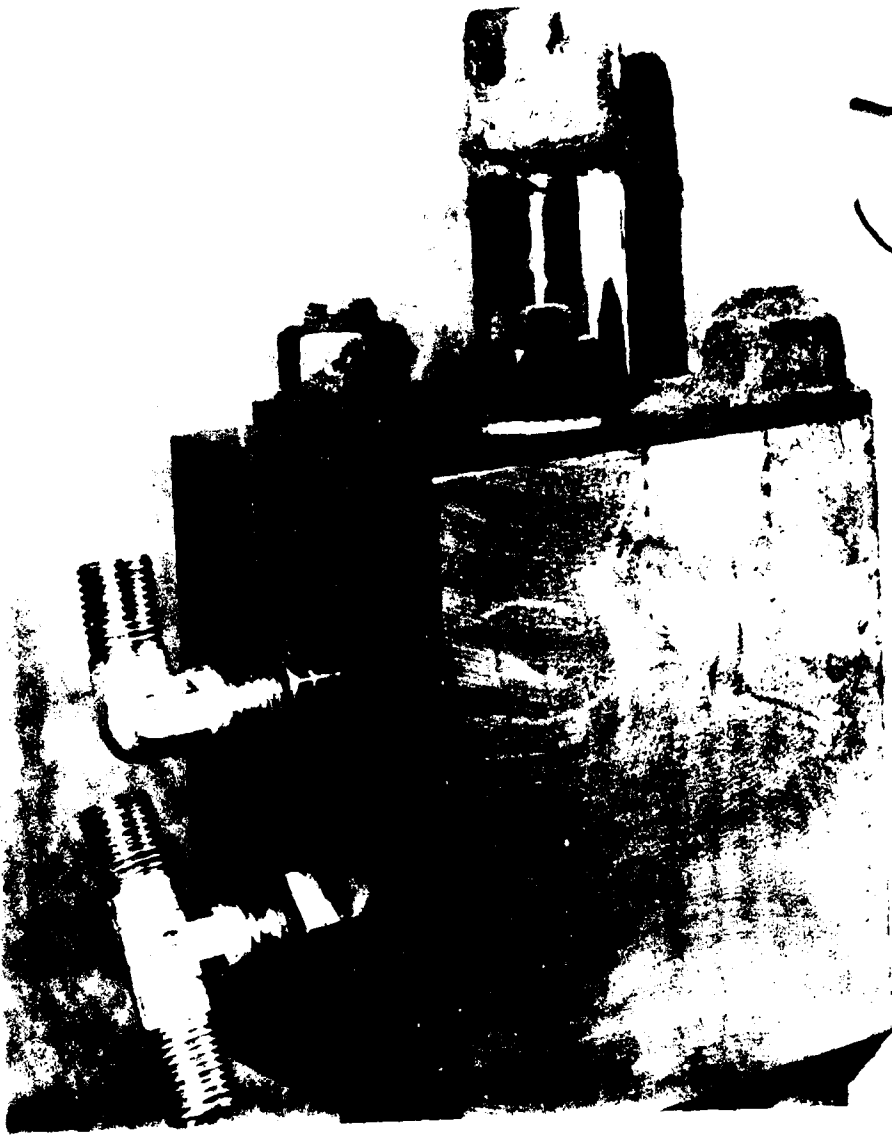

6L

ACTUATOR NO. 6, LUG END ROD AT CONCLUSION OF TASK III TESTS



GR

ACTUATOR NO. 6, ROD END ROD AT CONCLUSION OF TASK III TESTS

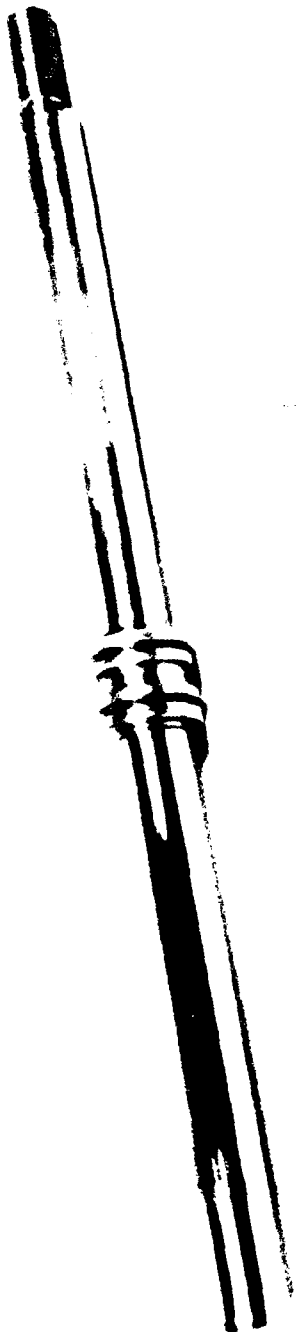

ACTUATOR NO. 1, PISTON AND ROD AT CONCLUSION OF TASK III TESTS (ROD END IS ON THE RIGHT).



2

ACTUATOR NO. 2, PISTON AND ROD AT CONCLUSION OF TASK III TESTS (ROD END IS ON THE RIGHT).

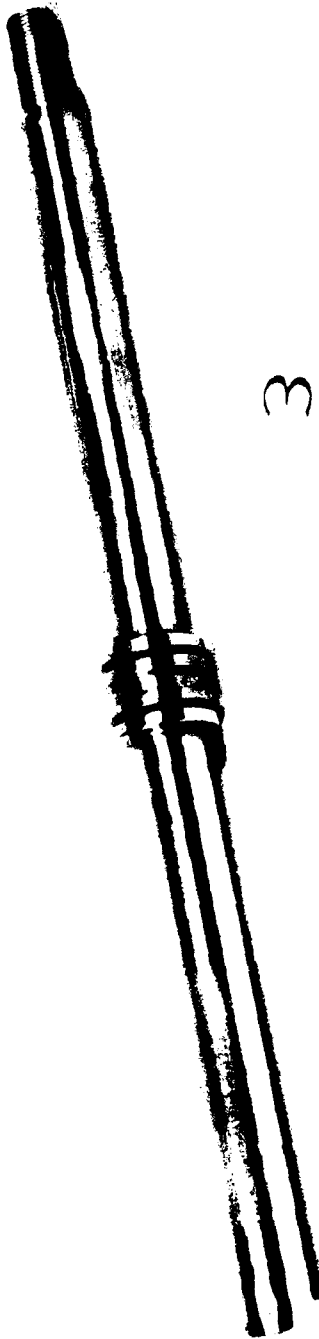

3

ACTUATOR NO. 3, PISTON AND ROD AT CONCLUSION OF TASK III TESTS (POD END IS ON THE RIGHT).

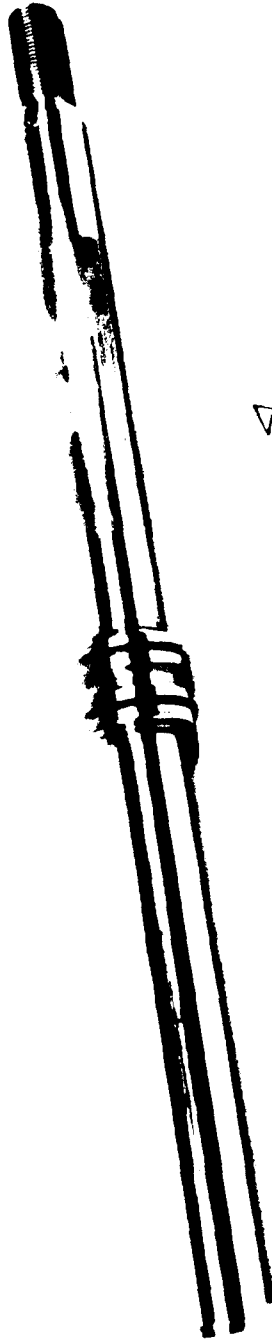

7

ACTIATOP NO. 4, PISTON AND ROD AT CONCLUSION OF TASK III TESTS (ROD END IS ON THE PIGHT).

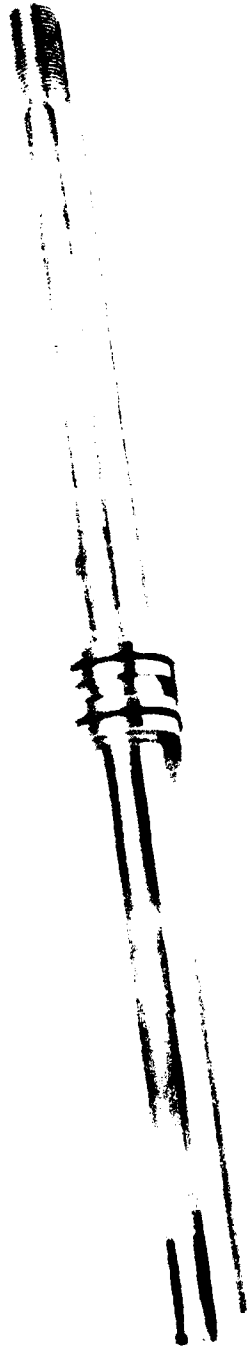

ACTUATOR NO. 5, PISTON AND ROD AT CONCLUSION OF TASK III TESTS (ROD END IS ON THE RIGHT).



6

ACTUATOR NO. 6, PISTON AND ROD AT CONCLUSION OF TASK III TESTS (ROD END IS ON THE RIGHT).

HYDRAULIC SYSTEM SEAL DEVELOPMENT
SEAL DATA

ACTUATOR NO. 1
 ROD END _____ GLAND A B C D
 LUG END X _____ GLAND A B C D
 TOTAL STAGES 4
 TOTAL ROD LEAKAGE 3 Drops

SEAL DATA

SEAL NAME Plus Seal Backup Ring (2)
 SEAL MFG. W. S. Shamban W. S. Shamban
 SEAL P/N S30775-214P-19 S33157-214-19
 MATERIAL Turcon with proprietary MoS2 filler, Flastoner per MIL-P-83461 Turcon with proprietary MoS2 filler

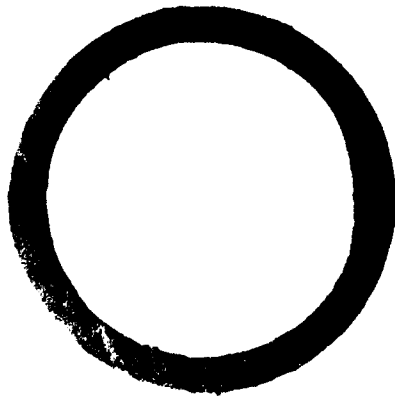
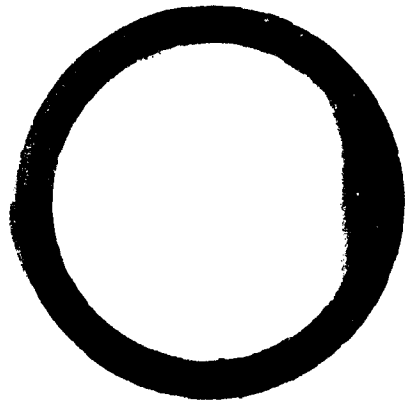
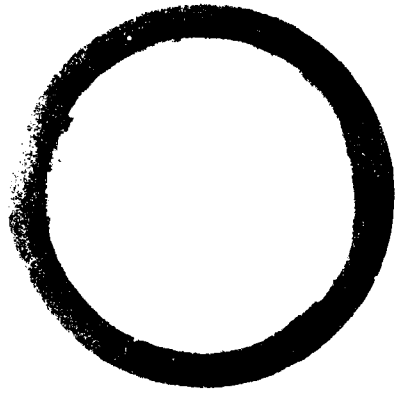

ILA

PLUS SEAL (ACT NO. 1, LUG END, GROOVE A)

HYDRAULIC SYSTEM SEAL DEVELOPMENT
SEAL DATA

ACTUATOR NO. 1
ROD END _____
LUG END X
TOTAL STAGES 4
TOTAL ROD LEAKAGE 3 Drops

GLAND A B C D
GLAND A B C D

SEAL DATA

SEAL NAME Plus Seal Backup Ring (2)
SEAL MFG. W. S. Shamban W. S. Shamban
SEAL P/N S30775-214P-19 S33157-214-19

MATERIAL Turcon with proprietary MoS₂ Filler, Elastomer per MIL-P-83451
Turcon with proprietary MoS₂ Filler

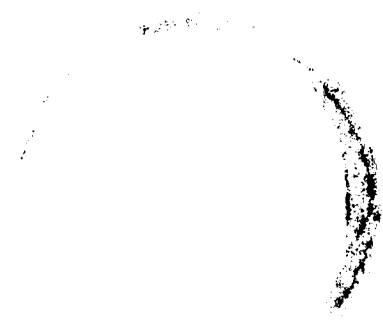
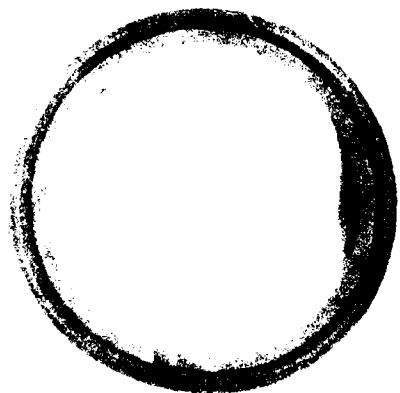
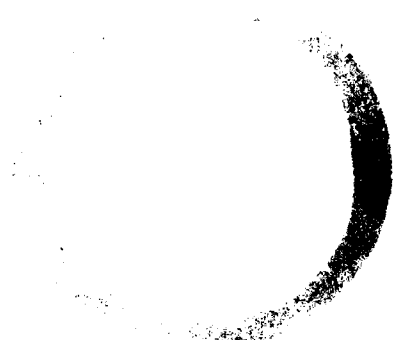

11LB

PLUS SEAL (ACT NO. 1, LUG END, GROOVE B)

HYDRAULIC SYSTEM SEAL DEVELOPMENT
SEAL DATA

ACTUATOR NO. 1
ROD END _____
LUG END X
TOTAL STAGES 4
TOTAL ROD LEAKAGE 3 Drops

GLAND A B C D
GLAND A B C D

SEAL DATA

SEAL NAME Plus Seal Backup Ring _____
SEAL MFG. W. S. Shamban W. S. Shamban _____
SEAL P/N S30775-214P-19 S33157-214-19 _____
MATERIAL Turcon with proprietary MoS2 filler Elastomer per MIL-P-83461 Turcon with proprietary MoS2 filler _____

TLC

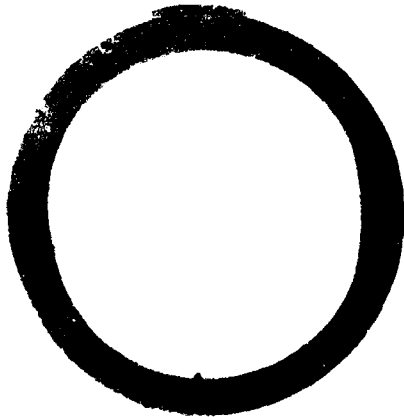
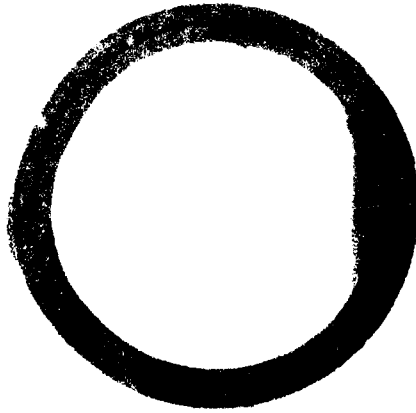
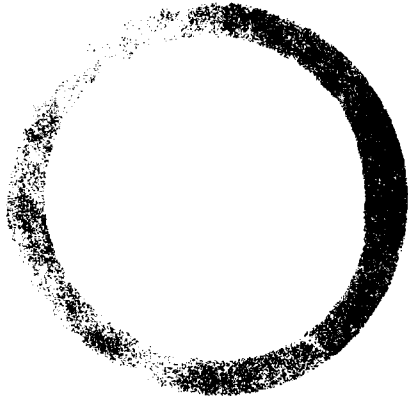

11C

PLUS SEAL (ACT NO. 1, LUG END, GROOVE C)

HYDRAULIC SYSTEM SEAL DEVELOPMENT
SEAL DATA

ACTUATOR NO. 1
 ROD END _____
 LUG END X
 TOTAL STAGES 4
 TOTAL ROD LEAKAGE 3 Drops

GLAND A B C D
 GLAND A B C D

SEAL DATA

SEAL NAME D. C. Excluder O-Ring _____
 SEAL MFG. W. S. Shamban Parker _____
 SEAL P/N S32925-9P-19 M83461/1-121 _____
 MATERIAL Turcon with proprietary MIL-P-83461 _____
MoS₂ filler _____

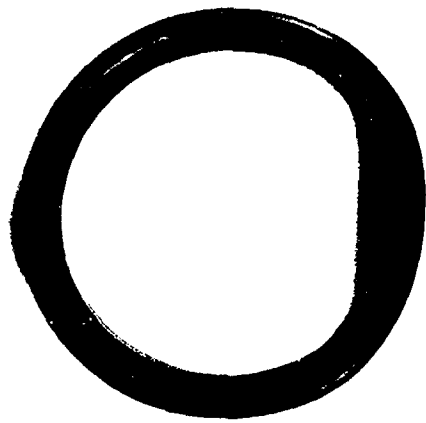

17D

D. C. EXCLUDER (ACT. NO. 1, LUG END, GROOVE D)

17
B

HYDRAULIC SYSTEM SEAL DEVELOPMENT
SEAL DATA

ACTUATOR NO. 1
 ROD END X
 LUG END _____
 TOTAL STAGES 1
 TOTAL ROD LEAKAGE 65 cc - Failed at 6,035,850 cycles
(474000 Rotor Feedback Cycles)

GLAND A B C D
 GLAND A B C D

SEAL DATA
 SEAL NAME Double Delta
 SEAL MFG. W. S. Shamban
 SEAL P/N S30650-214-14
 MATERIAL Turcon with glass and
proprietary MoS2 filler

O-Ring
 Parker
 1R3461/1-214
 MIL-P-83461

Backup Ring (2)
 W. S. Shamban
 S33157-214-14
 Turcon with glass
 and proprietary
 MoS2 filler

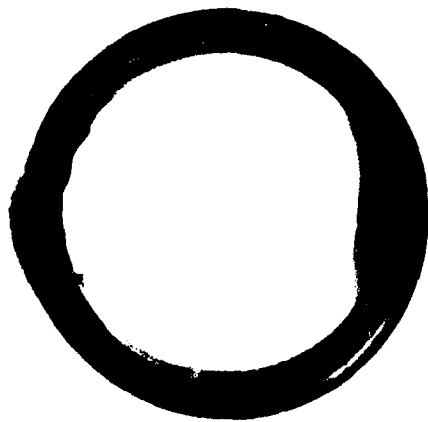
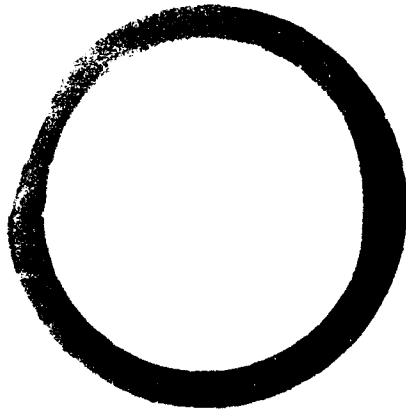
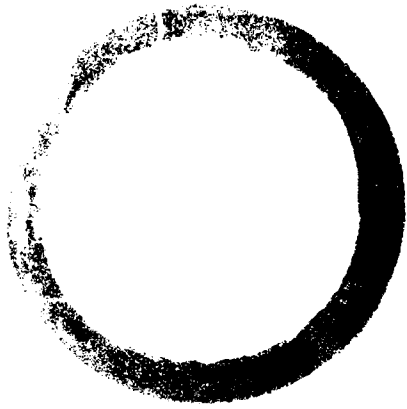

IRC

DOUBLE DELTA (ACT. NO. 7, ROD END, GROOVE C)

HYDRAULIC SYSTEM SEAL DEVELOPMENT
SEAL DATA

ACTUATOR NO. 1
ROD END X
LUG END _____
TOTAL STAGES 1
TOTAL ROD LEAKAGE 65 cc - Seal Failed at 6,035,850 cycles
(474000 Rotor Feedback cycles)

GLAND A B C D
GLAND A B C D

SEAL DATA

SEAL NAME Seal Guard
SEAL MFG. Hercules
SEAL P/N S-34-20
MATERIAL Bronze with a
nitrile load ring

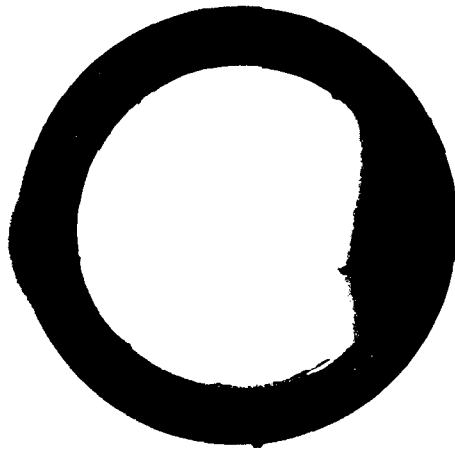

JRD

SEAL GUARD (ACT. NO. 1, ROD END, GROOVE D)

HYDRAULIC SYSTEM SEAL DEVELOPMENT
SEAL DATA

ACTUATOR NO. 2
 ROD END _____
 LUG END X
 TOTAL STAGES 4
 TOTAL ROD LEAKAGE No Measurable Leakage

GLAND A B C D
 GLAND A B C D

SEAL DATA

SEAL NAME Plus Seal
 SEAL MFG. W. S. Shamban
 SEAL P/N S30775-214P-19

Backup Ring (2)
W. S. Shamban
S33157-214-19

MATERIAL Turcon with proprietary
 MoS2 filler
 Elastomer per MIL-P-83461

Turcon with proprietary
 MoS2 filler

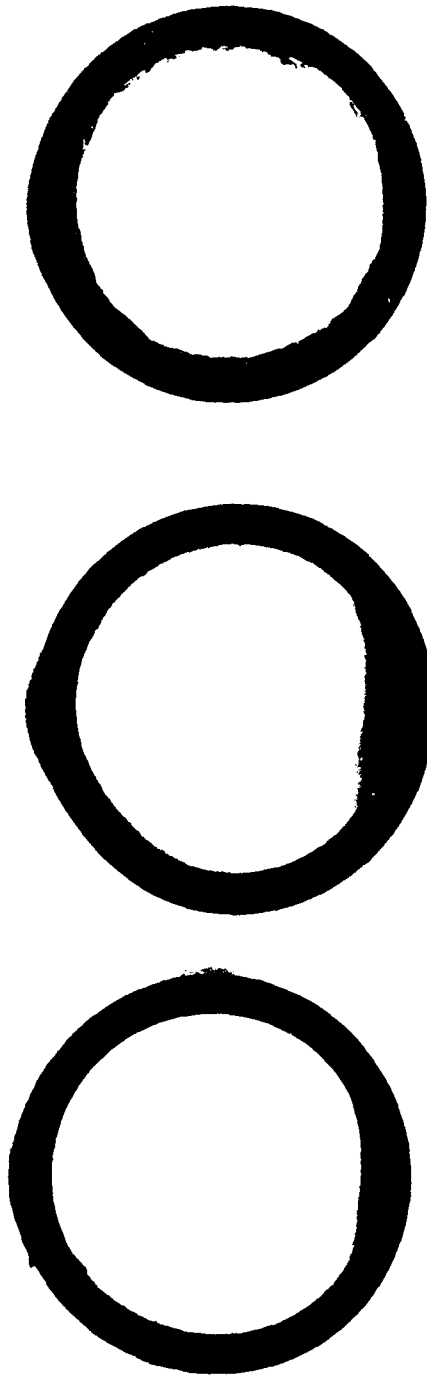

1
1
03

PLUS SFAL (ACT. NO. 2, LUG END, GROOVE A)

HYDRAULIC SYSTEM SEAL DEVELOPMENT
SEAL DATA

ACTUATOR NO. 2
ROD END _____ GLAND A B C D
LUG END X _____ GLAND A B C D
TOTAL STAGES 4
TOTAL ROD LEAKAGE No Measurable Leakage

SEAL DATA

SEAL NAME Plus Seal _____ Backup Ring (2) _____
SEAL MFG. W. S. Shamban _____ W. S. Shamban _____
SEAL P/N S30775-214P-19 _____ S33157-214-19 _____
MATERIAL Turcon with proprietary MoS₂ filler Elastomer per MIL-P-83461
Turcon with proprietary MoS₂ filler

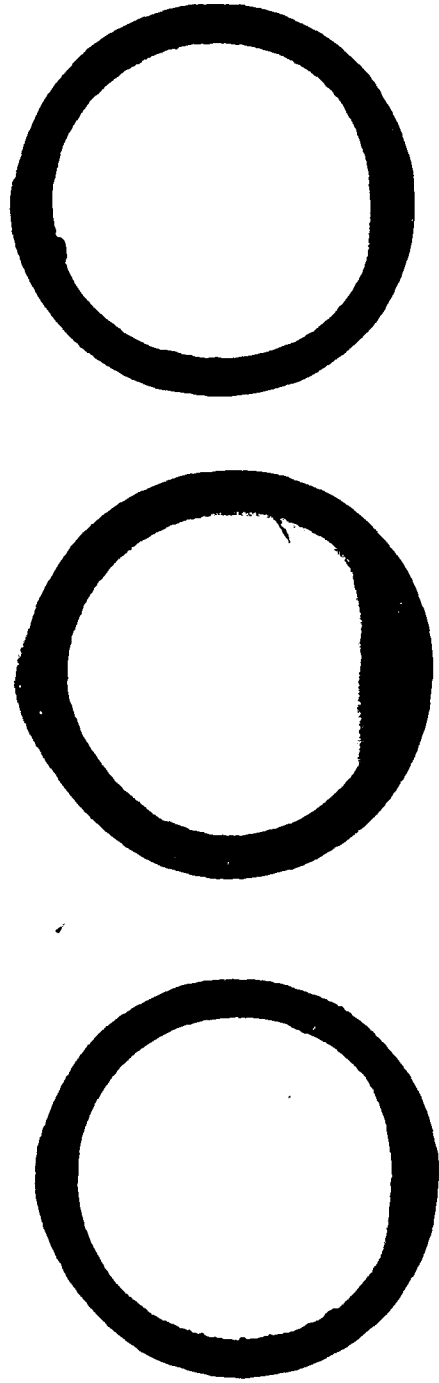

2LB

PLUS SEAL (ACT. NO. 2, LUG END, GROOVE B)

HYDRAULIC SYSTEM SEAL DEVELOPMENT
SEAL DATA

ACTUATOR NO. 2

ROD END _____

LUG END X _____

TOTAL STAGES 4

TOTAL ROD LEAKAGE No Measurable Leakage

GLAND A B C D

GLAND A B C D

SEAL DATA

SEAL NAME Plus Seal

SEAL MFG. W. S. Shamban

SEAL P/N S30775-214P-19

MATERIAL Turcon with proprietary
MoS₂ filler
Elastomer per MIL-P-83461

Backup Ring (2)

W. S. Shamban

S33157-214-19

Turcon with proprietary
MoS₂ filler

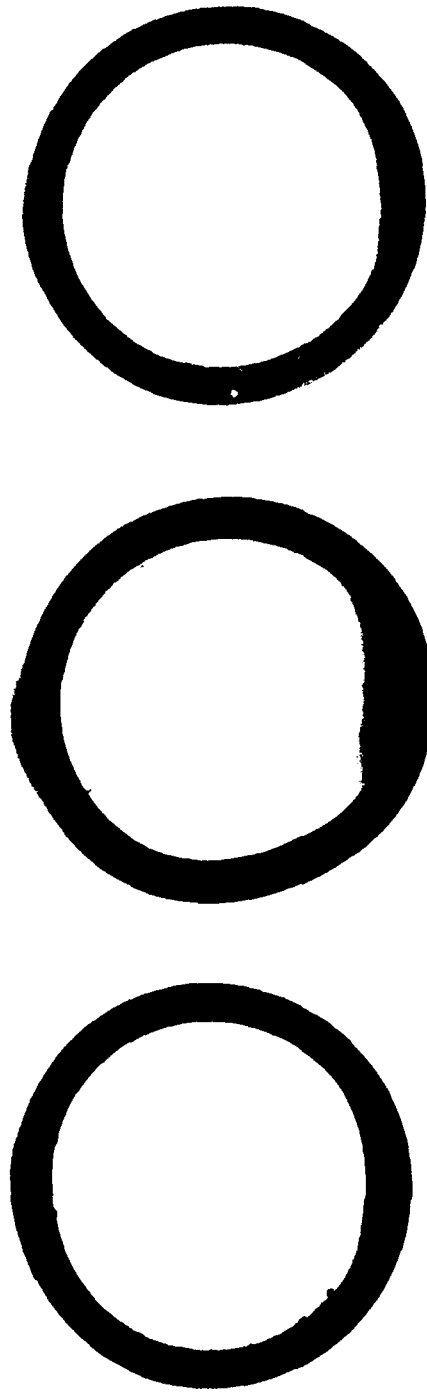

272

PLUS SEAL (ACT. NO. 2, LUG END, GROOVE C)

HYDRAULIC SYSTEM SEAL DEVELOPMENT
SEAL DATA

ACTUATOR NO. 2
ROD END _____
LUG END X
TOTAL STAGES 4

GLAND A B C D
GLAND A B C D

TOTAL ROD LEAKAGE No Measurable Leakage

SEAL DATA

SEAL NAME D. C. Excluder _____
SEAL MFG. W. S. Shamban _____
SEAL P/N S32925-9P-19 _____
MATERIAL Turcon with proprietary _____
MoS₂ filler _____
O-ring _____
Parker _____
M83461/1-121 _____
MIL-P-83461 _____

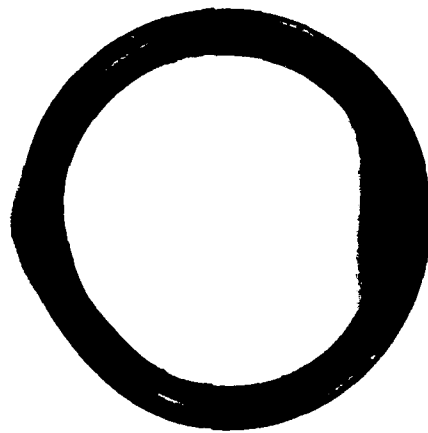

2LD

D. C. EXCLUDER (ACT. NO. 2, LUG END, GROOVE D)

HYDRAULIC SYSTEM SEAL DEVELOPMENT
SEAL DATA

ACTUATOR NO. 2
ROD END X GLAND A B C D
LUG END _____ GLAND A B C D
TOTAL STAGES 1
TOTAL ROD LEAKAGE No measurable leakage, but the seal was on the
verge of failure

SEAL DATA
SEAL NAME Maxi-Flex O-Ring
SEAL MFG. Tetrafluor Parker
SEAL P/N TF831M-7214 M83461/1-318
MATERIAL TetraIon 720 MIL-P-83461



2RA

MAXI-FLEX (ACT. NO. 2, ROD END, GROOVE A)

HYDRAULIC SYSTEM SEAL DEVELOPMENT
SEAL DATA

ACTUATOR NO. 2

ROD END X

LUG END _____

TOTAL STAGES 1

TOTAL ROD LEAKAGE No measurable leakage

GLAND A B C D

GLAND A B C D

SEAL DATA

SEAL NAME Seal Guard

SEAL MFG. Hercules

SEAL P/N S-34-20

MATERIAL Bronze with a
Nitrile Load Ring

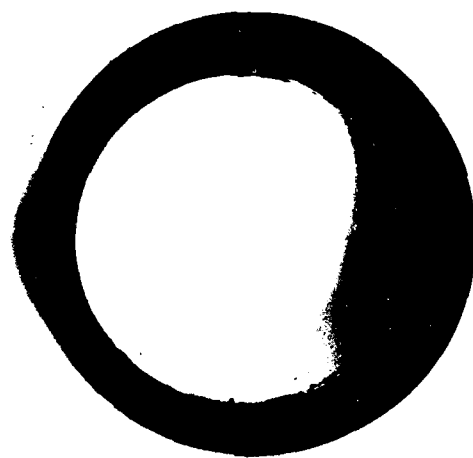

2RD

SEAL GUARD (ACT. NO. 2, ROD END, GROOVE D)

18

B

HYDRAULIC SYSTEM SEAL DEVELOPMENT
SEAL DATA

ACTUATOR NO. 3

ROD END _____

LUG END X

TOTAL STAGES 1

TOTAL ROD LEAKAGE 1.13 cc (17 drops)

GLAND A B C D

GLAND A B C D

SEAL DATA

SEAL NAME Plus Seal

SEAL MFG. W. S. Shamban

SEAL P/N S30775-214P-19

MATERIAL Turcon with proprietary
MoS₂ filler
Elastomer per MIL-P-83461

Backup Ring (2)

W. S. Shamban

S33157-214-19

Turcon with proprietary
MoS₂ filler

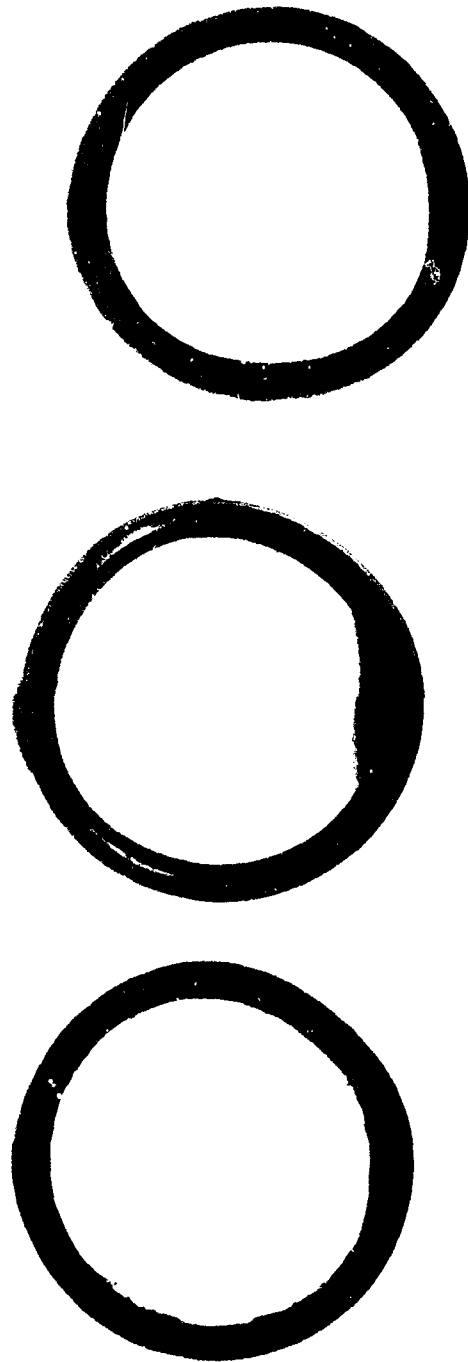

3LC

PLUS SEAL (ACT. NO. 3, LUG END, GROOVE C)

HYDRAULIC SYSTEM SEAL DEVELOPMENT
SEAL DATA

ACTUATOR NO. 3
ROD END _____
LUG END X
TOTAL STAGES 1
TOTAL ROD LEAKAGE 1.13 cc (17 Drops)

GLAND A B C D
GLAND A B C D

SEAL DATA

SEAL NAME Wiper/Scraper O-ring
SEAL MFG. Dowty Seals Ltd. Dowty Seals Ltd.
SEAL P/N 120-218-1709 100-218-0074
MATERIAL Acetal Resin Proprietary Nitrile

The scraper was broken during removal.

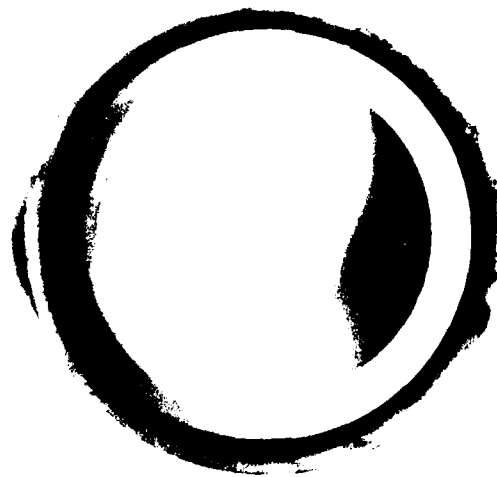

3LD

WIPER/SCRAPER (ACT. NO. 3, LUG END, GROOVE D)

HYDRAULIC SYSTEM SEAL DEVELOPMENT
SEAL DATA

ACTUATOR NO. 3
ROD END X
LUG END _____
TOTAL STAGES 2

GLAND A B C D
GLAND A B C D

TOTAL ROD LEAKAGE 255.4 cc - Failed at 16,248,240 cycles
10,686,390 cycles of rotor feedback

SEAL DATA

SEAL NAME Enercap
SEAL MFG. Greene Tweed
SEAL P/N 595-21400-160-PX1
MATERIAL Ekano1 Filled TFE
Proprietary Nitrile

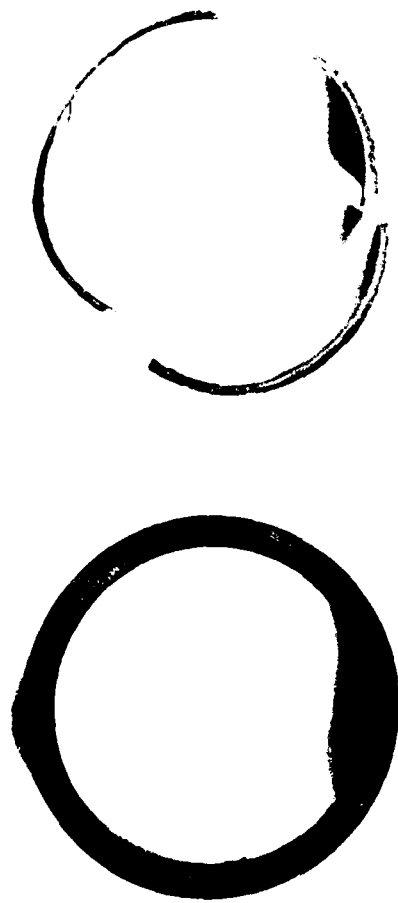

3RB

ENERCAP (ACT. NO. 3, ROD END, GROOVE B)

HYDRAULIC SYSTEM SEAL DEVELOPMENT
SEAL DATA

ACTUATOR NO. 3
ROD END X GLAND A B C D
LUG END _____ GLAND A B C D
TOTAL STAGES 2
TOTAL ROD LEAKAGE 255.4 cc - Failed at 16,248,240 cycles
(10,686,390 cycles of rotor feedback)

281

SEAL DATA
SEAL NAME Enercap _____
SEAL MFG. Greene Tweed _____
SEAL P/N 595-21400-160-PX1 _____
MATERIAL Ekano1 Filled TFE _____
Proprietary Nitrile _____

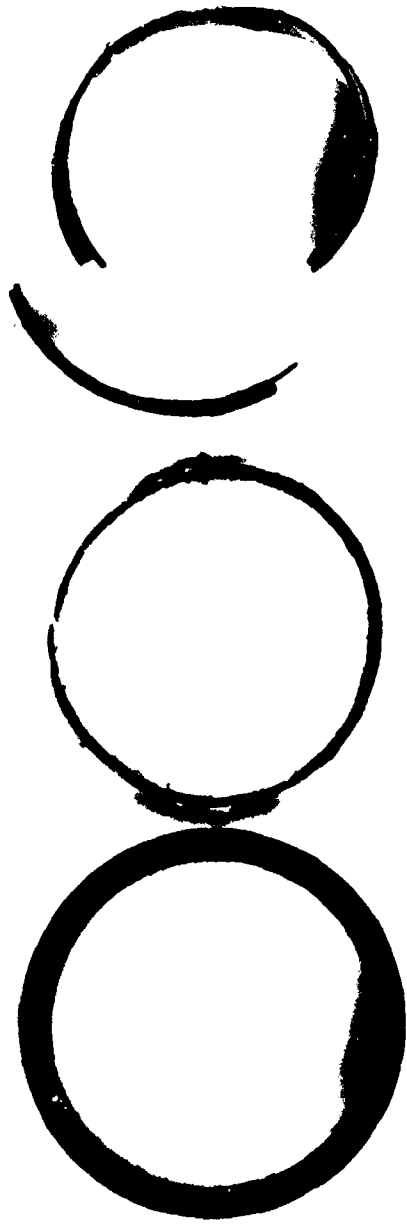

3RC

ENERCAP (ACT. NO. 3, ROD END, GROOVE C)

HYDRAULIC SYSTEM SEAL DEVELOPMENT
SEAL DATA

ACTUATOR NO. 3
ROD END X
LUG END _____
TOTAL STAGES 2

GLAND A B C D
GLAND A B C D

TOTAL ROD LEAKAGE 255.4 cc - Seal failed at 16,248,240 cycles. This scraper survived the entire test. (10,686,390 cycles of rotor feedback)

SEAL DATA

SEAL NAME Polypak
SEAL MFG. Parker Packing
SEAL P/N 1870 100074651D53
MATERIAL Polymyte

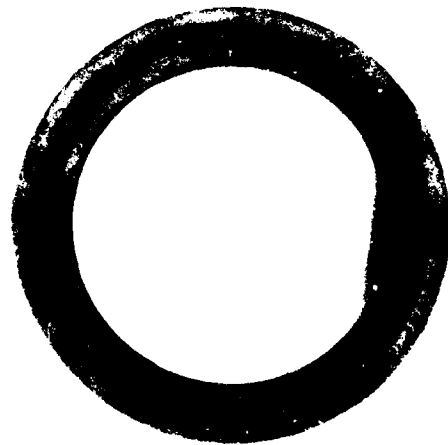

3KD

POLYPAK (ACT. NO. 3, ROD END, GROOVE D)

HYDPAULIC SYSTEM SEAL DEVELOPMENT
SEAL DATA

ACTUATOR NO. 4

ROD END _____

GLAND A B C D

LUG END X

GLAND A B C D

TOTAL STAGES 3

TOTAL ROD LEAKAGE No measurable leakage

SEAL DATA

SEAL NAME Con-O-Hex

Backup Ring

SEAL MFG. C. E. Conover

C. E. Conover

SEAL P/N CEC6001-214

CEC5110-214

MATERIAL Revonoc 6200

Revonoc 6200

4 LB

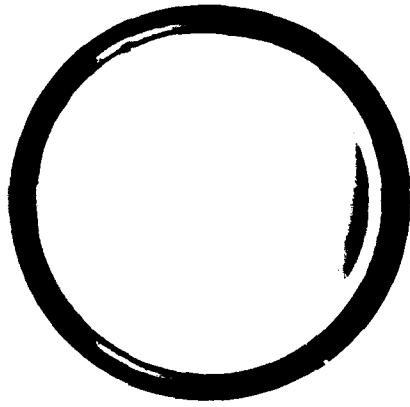

4LB

CON-O-HEX (ACT. NO. 4, LUG END, GROOVE B)

HYDRAULIC SYSTEM SEAL DEVELOPMENT
SEAL DATA

ACTUATOR NO. 4
ROD END _____
LUG END X
TOTAL STAGES 3
TOTAL ROD LEAKAGE No measurable leakage

GLAND A B C D
GLAND A B C D

SEAL DATA

SEAL NAME Con-0-Hex Backup Ring
SEAL MFG. C. E. Conover C. E. Conover
SEAL P/N CEC6001-214 CEC 5110-214
MATERIAL Revonoc 6200 Revonoc 6200

AD-A103 201

VOUGHT CORP DALLAS TX
HYDRAULIC SYSTEM SEAL DEVELOPMENT.(U)
JUN 81 K E WHITFILL

F/6 1/3

DAAK51-78-C-0028

USAAVRADCOM-TR-81-D-17

NL

UNCLASSIFIED

4 of 4

40 8

104017

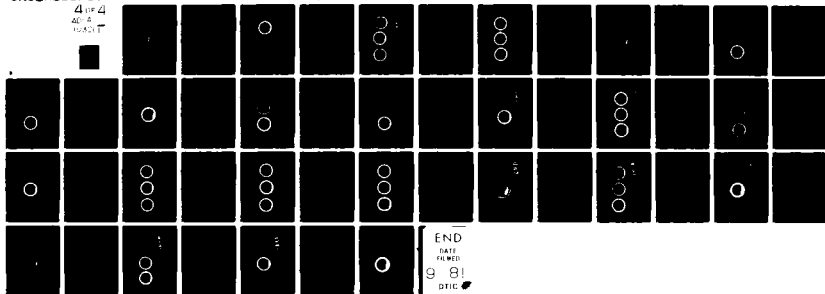

END
DATE
FILMED
8 81
DTIC

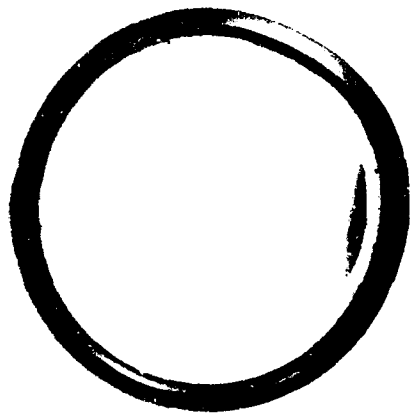

41C

CON-O-HEX (ACT. NO. 4, LUG END, GROOVE C)

HYDRAULIC SYSTEM SEAL DEVELOPMENT
SEAL DATA

ACTUATOR NO. 4
ROD END _____
LUG END X
TOTAL STAGES 3
TOTAL ROD LEAKAGE 0

GLAND A B C D
GLAND A B C D

289

SEAL DATA

SEAL NAME Scraper
SEAL MFG. C. E. Conover
SEAL P/N CEC5091-998-55
MATERIAL Revonoc 18158

4LD

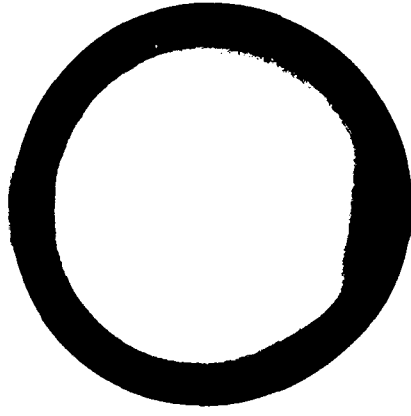

4LD



SCRAPER (ACT. NO. 4, LUG END, GROOVE D)

14

HYDRAULIC SYSTEM SEAL DEVELOPMENT
SEAL DATA

ACTUATOR NO. 4

ROD END X

LUG END _____

TOTAL STAGES 2

TOTAL ROD LEAKAGE No measurable leakage

GLAND A B C D

GLAND A B C D

291

SEAL DATA

SEAL NAME Plus Seal

SEAL MFG. W. S. Shamban

SEAL P/N S30775-214P-19

MATERIAL Turcon with proprietary
MoS₂ filler
Elastomer per MIL-P-83461

Backup Ring (2)

W. S. Shamban

S33157-214-19

Turcon with proprietary
MoS₂ filler

4RB

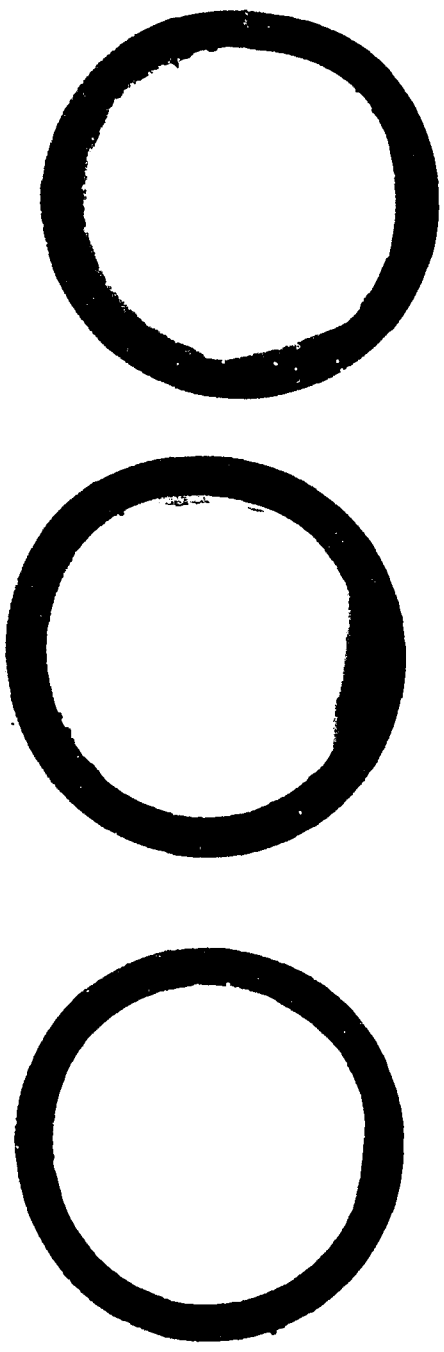

4RB

PLUS SEAL (ACT. NO. 4, ROD END, GROOVE B)

HYDRAULIC SYSTEM SEAL DEVELOPMENT
SEAL DATA

ACTUATOR NO. 4

ROD END X

LUG END _____

TOTAL STAGES 2

TOTAL ROD LEAKAGE No measurable leakage

GLAND A B C D

GLAND A B C D

SEAL DATA

SEAL NAME Plus Seal Backup Ring

SEAL MFG. W. S. Shamban W. S. Shamban

SEAL P/N S30775-214P-19 S33157-214-19

MATERIAL Turcon with proprietary MoS2 filler Elastomer per MIL-P-83461 Turcon with proprietary MoS2 filler

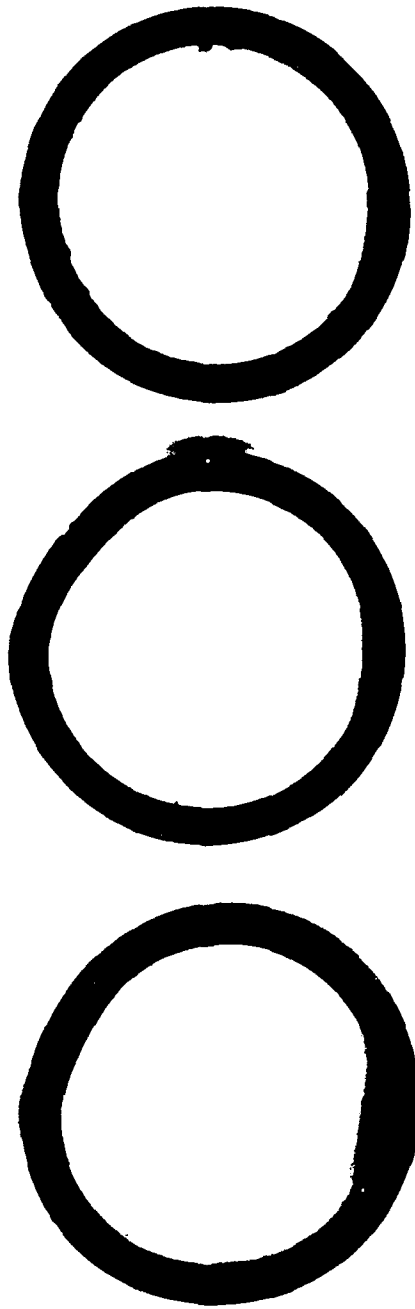

4RC

PLUS SEAL (ACT. NO. 4, ROD END, GROOVE C)

HYDRAULIC SYSTEM SEAL DEVELOPMENT
SEAL DATA

ACTUATOR NO. 4
 ROD END X GLAND A B C D
 LUG END _____ GLAND A B C D
 TOTAL STAGES 2
 TOTAL ROD LEAKAGE No measurable leakage

SEAL DATA

SEAL NAME	<u>Wiper/Scraper</u>	<u>0-ring</u>
SEAL MFG.	<u>Dowty Seals Ltd.</u>	<u>Dowty Seals Ltd</u>
SEAL P/N	<u>120-218-1709</u>	<u>100-218-0074</u>
MATERIAL	<u>Acetal Resin</u>	<u>Proprietary Nitrile</u>

THE SCRAPER WAS BROKEN DURING REMOVAL.



V R D

WIPER/SCRAPER (ACT. NO. 4, ROD END, GROOVE D)

HYDRAULIC SYSTEM SEAL DEVELOPMENT
SEAL DATA

ACTUATOR NO. 5
ROD END _____
LUG END X
TOTAL STAGES 2
TOTAL ROD LEAKAGE No measurable leakage

GLAND A B C D
GLAND A B C D

SEAL DATA

SEAL NAME O-ring Trapezoid Backup Ring
SEAL MFG. Parker C. E. Conover
SEAL P/N M83461/1-214 CEC5056C-214
MATERIAL MIL-P-83461 Revonoc 6200

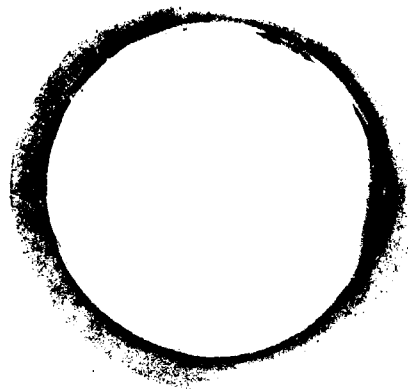
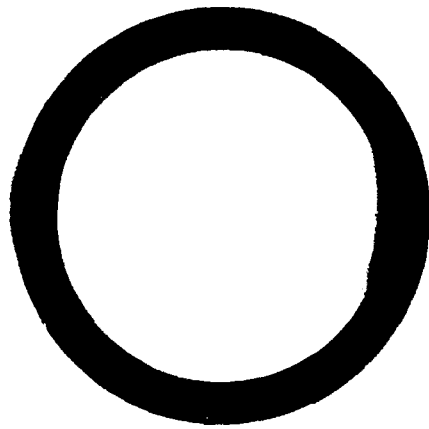

5 L B

O-RING AND TRAPEZOID BACK-UP RING (ACT. NO. 5, LUG END, GROOVE B)

HYDRAULIC SYSTEM SEAL DEVELOPMENT
SEAL DATA

ACTUATOR NO. 5
ROD END _____
LUG END X
TOTAL STAGES 2
TOTAL ROD LEAKAGE No measurable Leakage

GLAND A B C D
GLAND A B C D

SEAL DATA

SEAL NAME O-Ring
SEAL MFG. Parker
SEAL P/N M83461/1-214
MATERIAL MIL-P-83461

Trapezoid Backup Ring
C. E. Conover
CEC5056C-214
Revonoc 6200

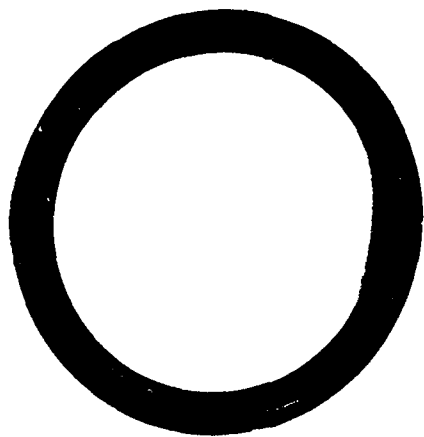

5LC

O-RING AND TRAPEZOID BACK-UP RING (ACT. NO. 5, LUG END, GROOVE C)

HYDRAULIC SYSTEM SEAL DEVELOPMENT
SEAL DATA

ACTUATOR NO. 5
ROD END _____
LUG END X
TOTAL STAGES 2
TOTAL ROD LEAKAGE No measurable leakage

GLAND A B C D
GLAND A B C D

SEAL DATA

SEAL NAME Seal Guard
SEAL MFG. Hercules
SEAL P/N S-34-20
MATERIAL Bronze with a nitrile load ring

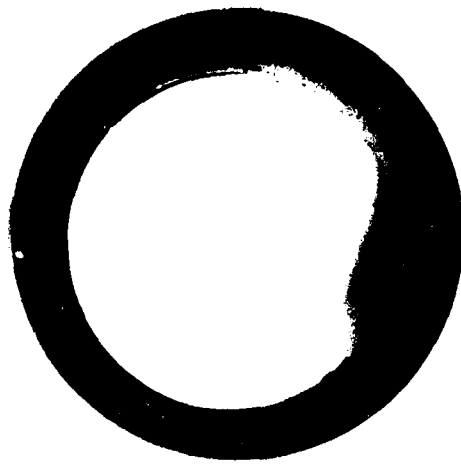

575
5LD

SEAL GUARD (ACT. NO. 5, LUG END, GROOVE D)

HYDRAULIC SYSTEM SEAL DEVELOPMENT
SEAL DATA

ACTUATOR NO. 5
ROD END X GLAND A B C D
LUG END _____ GLAND A B C D
TOTAL STAGES 2
TOTAL ROD LEAKAGE No measurable leakage

SEAL DATA
SEAL NAME O-ring Trapezoid backup ring
SEAL MFG. Parker C. E. Conover
SEAL P/N M83461/1-214 CEC5056C-214
MATERIAL MIL-P-83461 Revonoc 6200

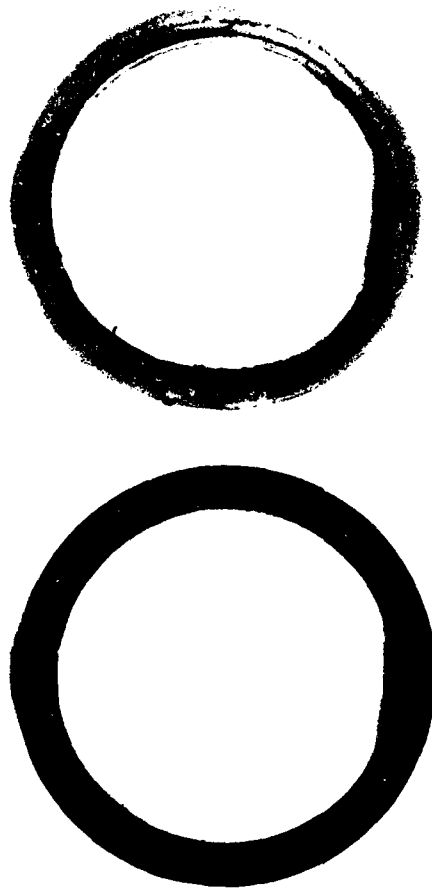

5RB

O-RING AND TRAPEZOID BACK-UP RING (ACT. NO. 5, ROD END, GROOVE B)

HYDRAULIC SYSTEM SEAL DEVELOPMENT
SEAL DATA

ACTUATOR NO. 5

ROD END X

LUG END _____

TOTAL STAGES 2

TOTAL ROD LEAKAGE No measurable leakage

GLAND A B C D

GLAND A B C D

SEAL DATA

SEAL NAME O-ring

SEAL MFG. Parker

SEAL P/N M83461/1-214

MATERIAL MIL-P-83461

Trapezoid backup ring

C. E. Conover

CEC5056C-214

Revonoc 6200

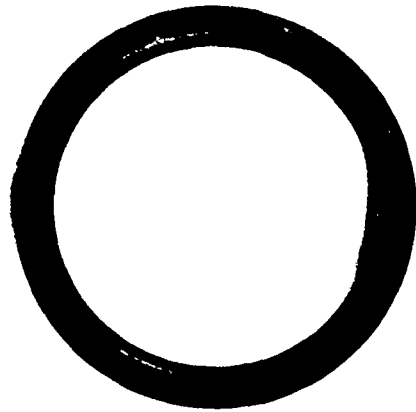

SRC

O-RING AND TRAPEZOID BACK-UP RING (ACT. NO. 5, ROD END, GROOVE C)

HYDRAULIC SYSTEM SEAL DEVELOPMENT
SEAL DATA

ACTUATOR NO. 5
ROD END X
LUG END _____
TOTAL STAGES 2
TOTAL ROD LEAKAGE No measurable leakage

GLAND A B C D
GLAND A B C D

SEAL DATA

SEAL NAME Polypak
SEAL MFG. Parker Packing
SEAL P/N 18701000Z4651D53
MATERIAL Polymyte

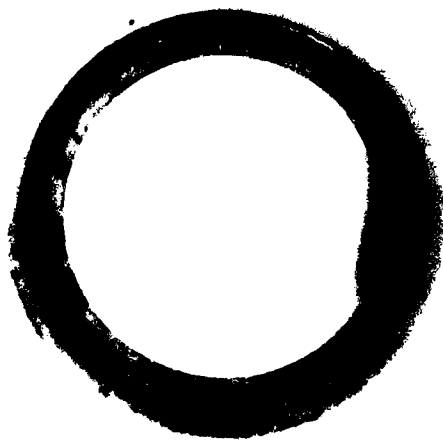

5RD

POLYPAK (ACT. NO. 5, ROD END, GROOVE D)

HYDRAULIC SYSTEM SEAL DEVELOPMENT
SEAL DATA

ACTUATOR NO. 6
ROD END _____
LUG END X
TOTAL STAGES 2
TOTAL ROD LEAKAGE No measurable leakage

GLAND A B C D
GLAND A B C D

SEAL DATA

SEAL NAME	<u>Double Delta</u>	O-ring	<u>Backup ring (2)</u>
SEAL MFG.	<u>W. S. Shamban</u>	<u>Parker</u>	<u>W. S. Shamban</u>
SEAL P/N	<u>S30650-214-19</u>	<u>M83461/1-214</u>	<u>S33157-214-19</u>
MATERIAL	<u>Turcon with proprietary MoS2 filler</u>	<u>MIL-P-83461</u>	<u>Turcon with proprietary MoS2 filler</u>

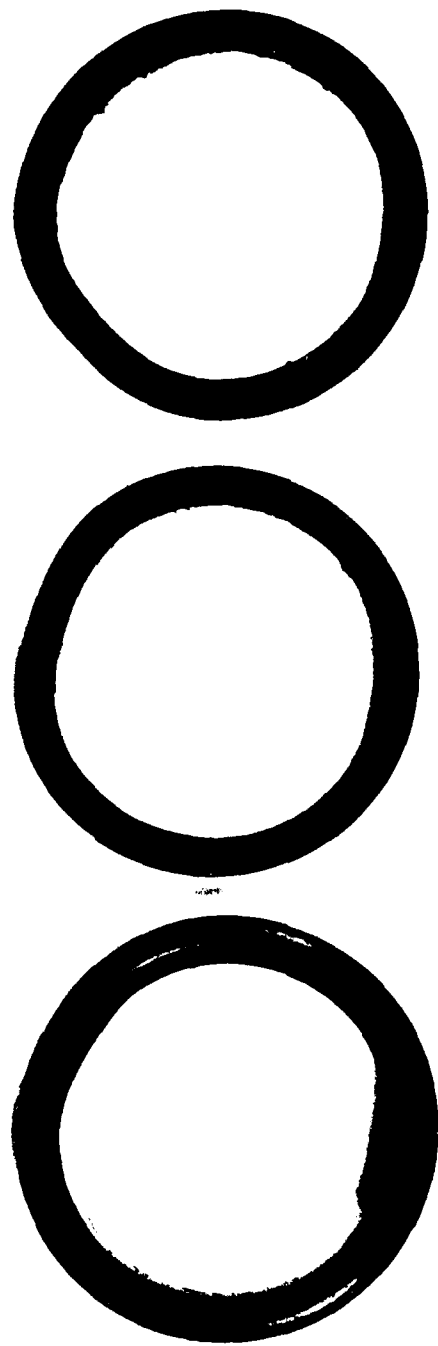

6LB

DOUBLE DELTA (ACT. NO. 6, LUG END, GROOVE B)

HYDRAULIC SYSTEM SEAL DEVELOPMENT
SEAL DATA

ACTUATOR NO. 6
ROD END _____
LUG END X
TOTAL STAGES 2
TOTAL ROD LEAKAGE No measurable leakage

GLAND A B C D
GLAND A B C D

SEAL DATA

SEAL NAME Hat seal
SEAL MFG. W. S. Shamban
SEAL P/N S33051-214-99
MATERIAL Turcon with proprietary
MoS₂ filler
Elastomer per MIL-P-83461

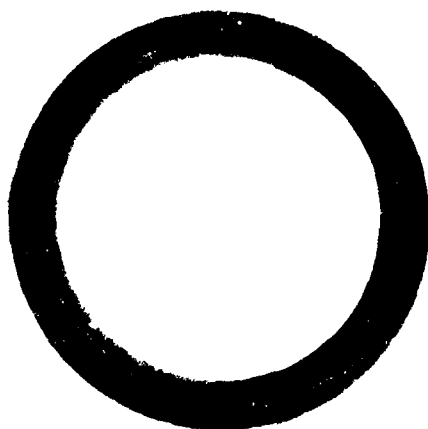
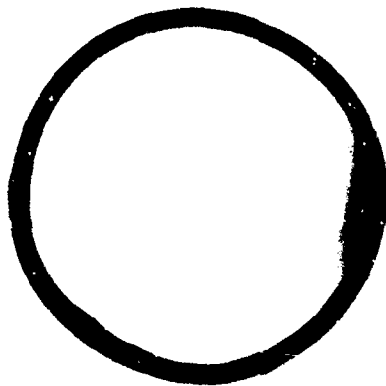
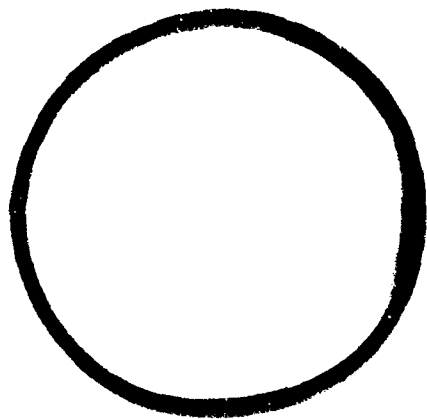

679

HAT SEAL (ACT. NO. 6, LUG END, GROOVE C)

HYDRAULIC SYSTEM SEAL DEVELOPMENT
SEAL DATA

ACTUATOR NO. 6

ROD END _____

LUG END X _____

TOTAL STAGES 2

GLAND A B C D

GLAND A B C D

TOTAL ROD LEAKAGE No measurable leakage

SEAL DATA

SEAL NAME Polypak

SEAL MFG. Parker Packing

SEAL P/N 18701000Z4651053

MATERIAL Polymyte

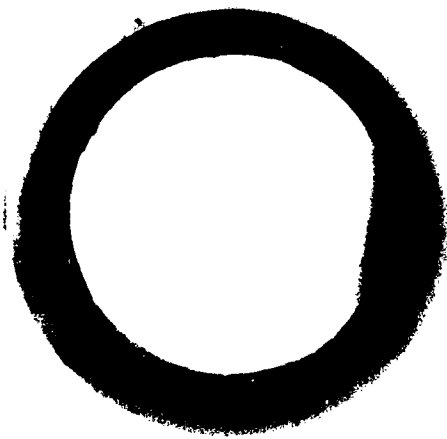

6LD

POLYPAK (ACT. NO. 6, LUG END, GROOVE D)

HYDRAULIC SYSTEM SEAL DEVELOPMENT
SEAL DATA

ACTUATOR NO. 6

ROD END X GLAND A B C D

LUG END _____ GLAND A B C D

TOTAL STAGES 3

TOTAL ROD LEAKAGE No measurable leakage

SEAL DATA

SEAL NAME Plus seal Backup ring (2) _____

SEAL MFG. W. S. Shamban W. S. Shamban _____

SEAL P/N S30775-214P-19 S33157-214-19 _____

MATERIAL Turcon with proprietary Turcon with proprietary _____
MoS2 filler MoS2 filler _____
Elastomer per MIL-P-83461 _____

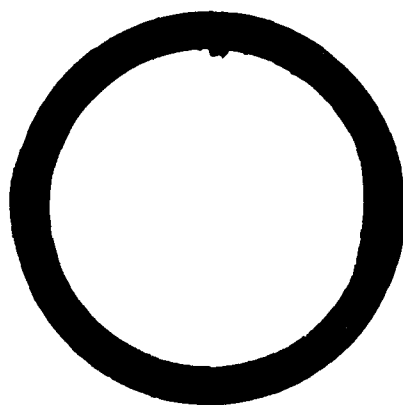
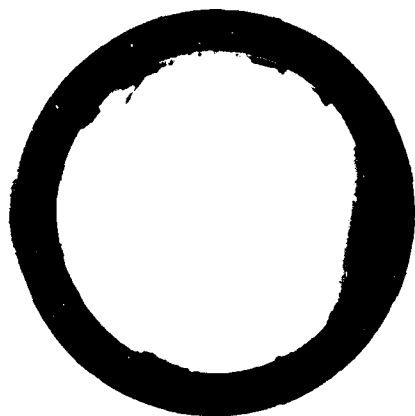
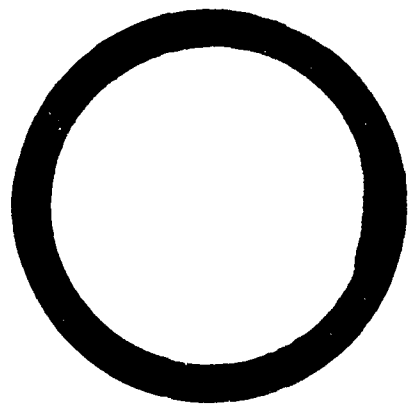

GRA

PLUS SEAL (ACT. NO. 6, ROD END, GROOVE A)

HYDRAULIC SYSTEM SEAL DEVELOPMENT
SEAL DATA

ACTUATOR NO. 6

ROD END X GLAND A B C D

LUG END _____ GLAND A B C D

TOTAL STAGES 3

TOTAL ROD LEAKAGE No measurable leakage

SEAL DATA

SEAL NAME Plus seal Backup ring (2)

SEAL MFG. W. S. Shamban W. S. Shamban

SEAL P/N S30775-214P-19 S33157-214-19

MATERIAL Turcon with proprietary Turcon with proprietary
MoS₂ filler MoS₂ filler
Elastomer per MIL-P-83461

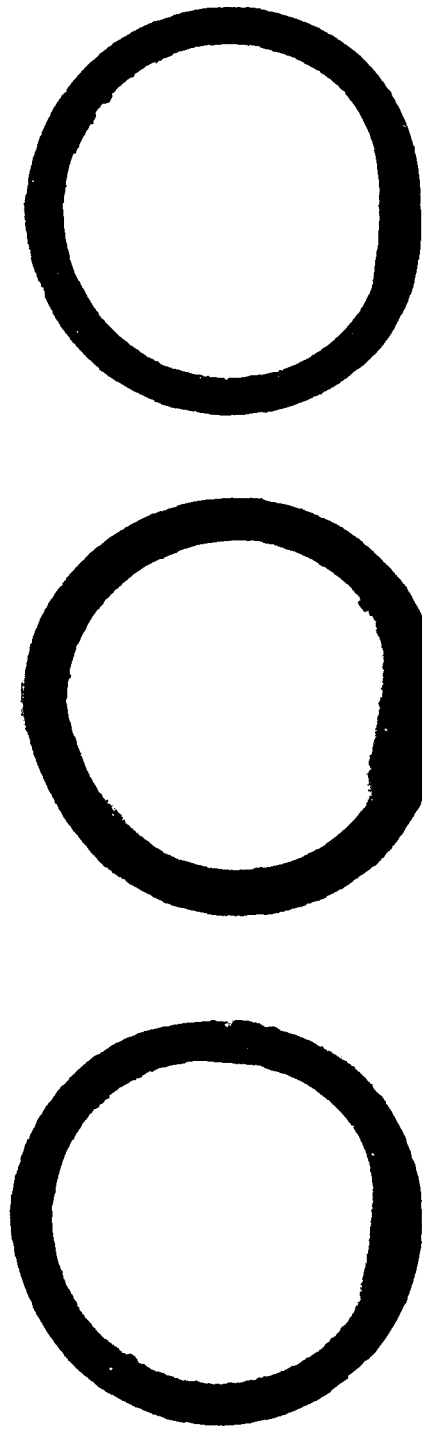

6RB

PLUS SEAL (ACT. NO. 6, ROD END, GROOVE B)

HYDRAULIC SYSTEM SEAL DEVELOPMENT
SEAL DATA

ACTUATOR NO. 6

ROD END X GLAND A B C D

LUG END _____ GLAND A B C D

TOTAL STAGES 3

TOTAL ROD LEAKAGE No measurable leakage

SEAL DATA

SEAL NAME Plus seal Backup ring (2)

SEAL MFG. W. S. Shamban W. S. Shamban

SEAL P/N S30775-214P-19 S33157-214-19

MATERIAL Turcon with proprietary Turcon with proprietary
MoS2 filler MoS2 filler
Elastomer per MIL-P-83461

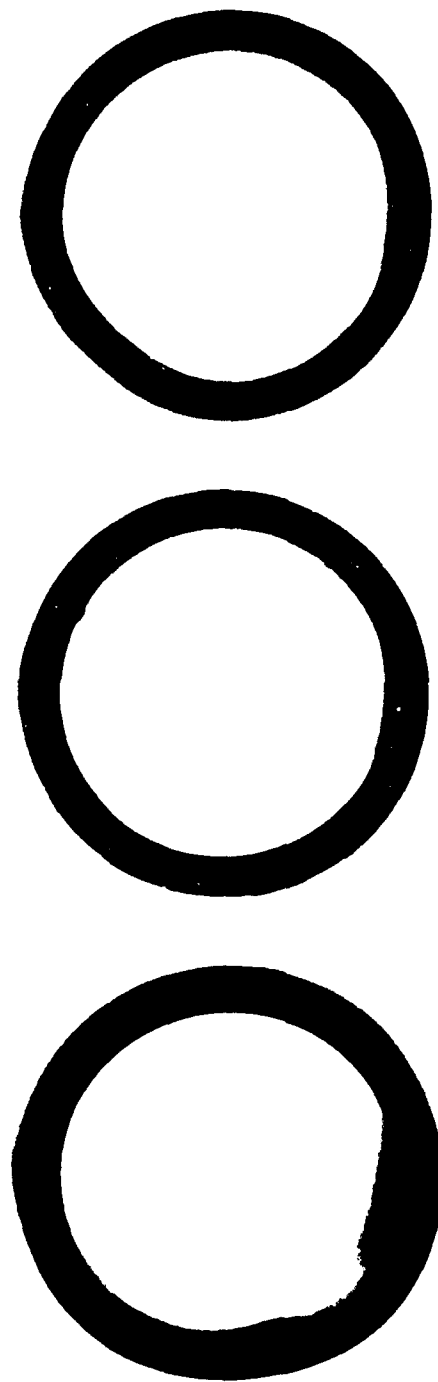

6RC

PLUS SEAL (ACT. NO. 6, ROD END GROOVE C)

HYDRAULIC SYSTEM SEAL DEVELOPMENT
SEAL DATA

ACTUATOR NO. 6
ROD END X
LUG END _____
TOTAL STAGES 3
TOTAL ROD LEAKAGE No measurable leakage

GLAND A B C D
GLAND A B C D

SEAL DATA

SEAL NAME Wiper/Scraper _____
SEAL MFG. Dowty Seals Ltd _____
SEAL P/N 120-218-1709 _____
MATERIAL Acetal Resin _____
O-ring _____
Dowty Seals Ltd _____
100-218-0074 _____
Proprietary Nitrile _____

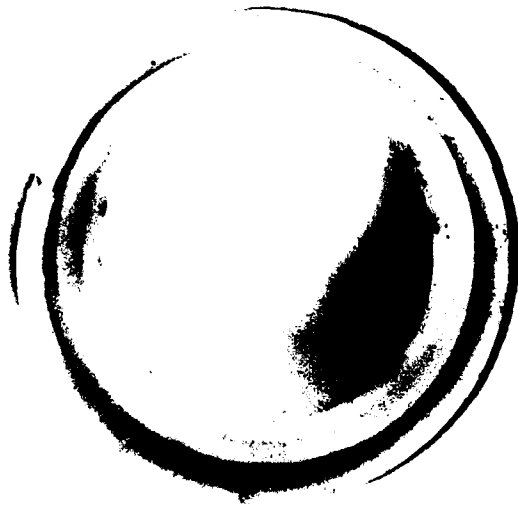

6RD

WIPER SCRAPER (ACT. NO. 6, ROD END, GROOVE D)

21
F

HYDRAULIC SYSTEM SEAL DEVELOPMENT
SEAL DATA

ACTUATOR NO. 1

ROD END X

LUG END _____

TOTAL STAGES 1

GLAND A B C D

GLAND A B C D

TOTAL ROD LEAKAGE Failed after 4,650,540 rotor feedback cycles - massive leak

SEAL DATA

SEAL NAME O-ring

SEAL MFG. Parker

SEAL P/N M83461/1-214

MATERIAL MIL-P-83461

Backup ring (2)

Tetrafluor

TF830-214-2

TRCR

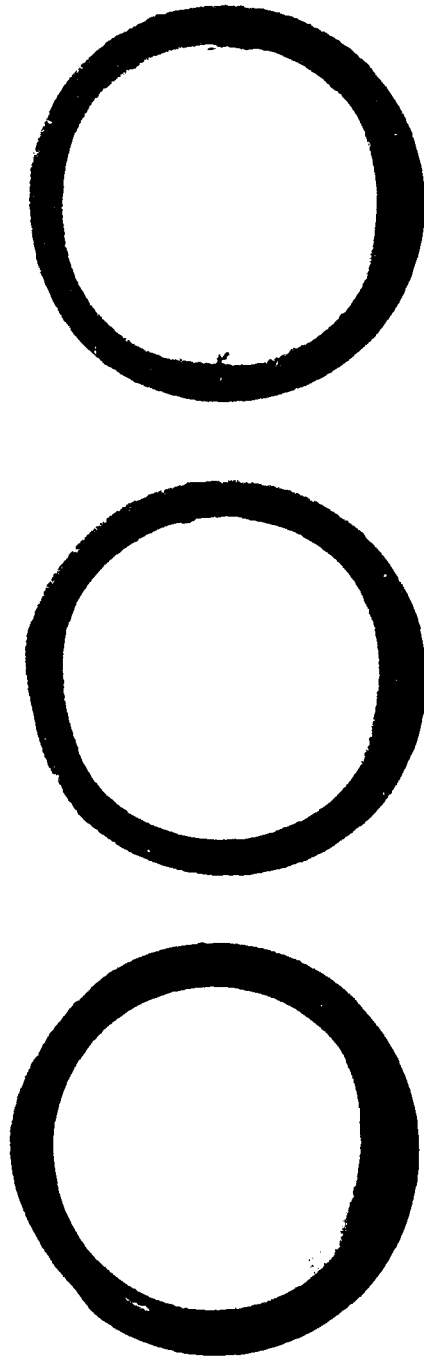

IRCB

O-RING AND TWO BACKUP RINGS (REPLACEMENT SEAL IN ACT. NO. 1, ROD END, GROOVE C).

HYDRAULIC SYSTEM SEAL DEVELOPMENT
SEAL DATA

ACTUATOR NO. 1

ROD END X

LUG END _____

TOTAL STAGES 1

GLAND A B C D

GLAND A B C D

TOTAL ROD LEAKAGE Single stage seal inside the scraper failed after
4,650,540 rotor feedback cycles

SEAL DATA

SEAL NAME Seal Guard

SEAL MFG. Hercules

SEAL P/N S-34-20

MATERIAL Bronze with a
nitrile load ring

JL
1RDR



JL
J R D R

SEAL GUARD (REPLACEMENT SCRAPER IN ACT. NO. 1, ROD END, GROOVE D)

HYDRAULIC SYSTEM SEAL DEVELOPMENT
SEAL DATA

ACTUATOR NO. 3

ROD END X

LUG END _____

TOTAL STAGES 2

GLAND A B C D

GLAND A B C D

TOTAL ROD LEAKAGE 43.56 cc in 9,900,480 rotor feedback cycles
and 1620 long stroke cycles

SEAL DATA

SEAL NAME Omni Seal

SEAL MFG. Fluorocarbon

SEAL P/N ARI0103-214P11

MATERIAL Filled TFE

3RAR

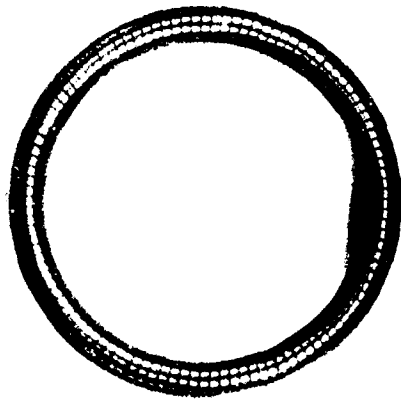

3RAR

OMNI SEAL (REPLACEMENT SEAL IN ACT. NO. 3, ROD END, GROOVE A)

HYDRAULIC SYSTEM SEAL DEVELOPMENT
SEAL DATA

ACTUATOR NO. 3

ROD END X

LUG END _____

GLAND A B C D

GLAND A B C D

TOTAL STAGES _____

TOTAL ROD LEAKAGE 43.56 cc in 9,900,480 rotor feedback cycles
and 1620 long stroke cycles

SEAL DATA

SEAL NAME Rod Seal

SEAL MFG. Fluorocarbon

SEAL P/N ARI41337

MATERIAL Spring loaded
nitrile

Backup Ring (2)

CEC5056-214

C. E. Conover

Revonoc 6200

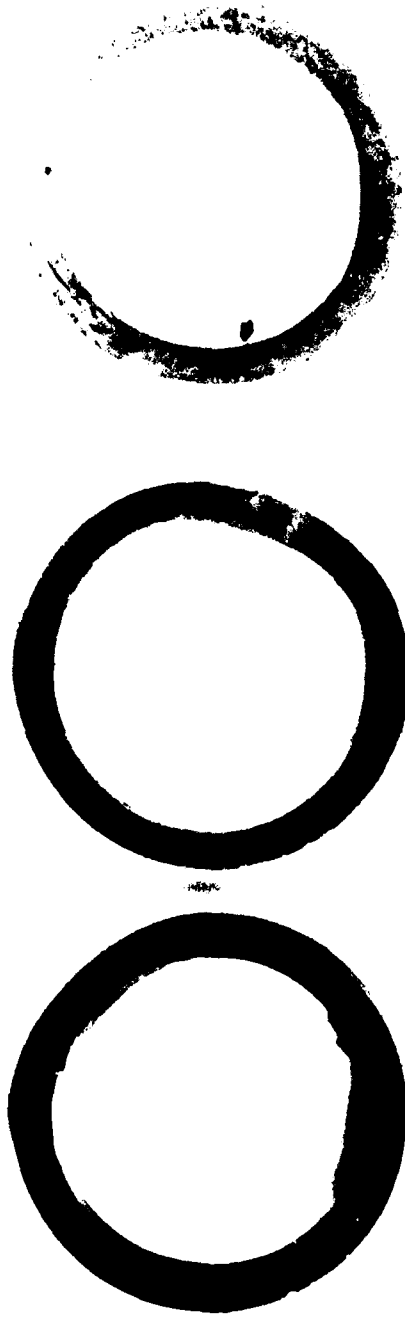

3RCR

ROD SEAL (REPLACEMENT SEAL IN ACT. NO. 3, ROD END, GROOVE C)

HYDRAULIC SYSTEM SEAL DEVELOPMENT
SEAL DATA

ACTUATOR NO. 1
ROD END X GLAND A B C D
LUG END _____ GLAND A B C D
TOTAL STAGES 1
TOTAL ROD LEAKAGE Failed after 9,900,480 rotor feedback cycles and
1620 long stroke cycles. Massive leak

SEAL DATA

SEAL NAME Plus Seal No backup rings were used
SEAL MFG. W. S. Shamban
SEAL P/N S30775-214P-19
MATERIAL Mineral Filled TFE
Comp 19
Elastomer per MIL-P-83461

1RBR

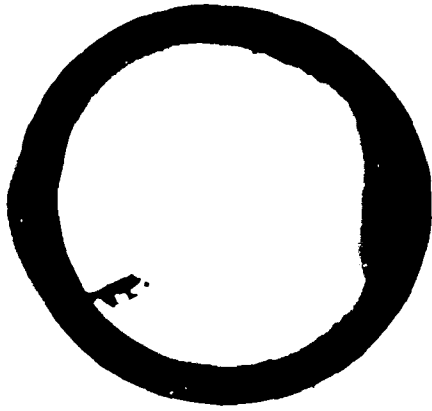

1 R B R

PLUS SEAL (SECOND REPLACEMENT SEAL IN ACT. NO. 1, ROD END, GROOVE B)

HYDRAULIC SYSTEM SEAL DEVELOPMENT
SEAL DATA

ACTUATOR NO. 1

ROD END X

LUG END _____

TOTAL STAGES 1

GLAND A B C D

GLAND A B C D

TOTAL ROD LEAKAGE Single stage seal inside the scraper failed after 9,900,480 rotor feedback cycles
and 1620 long stroke cycles. Massive leak

SEAL DATA

SEAL NAME Seal guard

SEAL MFG. Hercules

SEAL P/N S-34-20

MATERIAL Bronze with a nitrile load ring

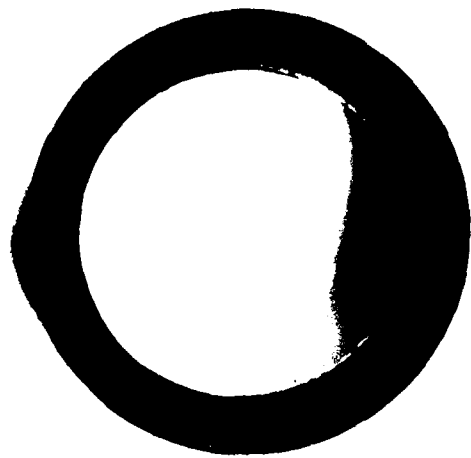

JRDR

SEAL GUARD (SECOND REPLACEMENT SCRAPER IN ACT. NO. 1, ROD END, GROOVE D)

DATE
FILMED
— 8