

UNCLASSIFIED

AD NUMBER
AD878619
NEW LIMITATION CHANGE
TO Approved for public release, distribution unlimited
FROM Distribution authorized to U.S. Gov't. agencies and their contractors; Critical Technology; JAN 1970. Other requests shall be referred to Naval Ship Systems Command, Washington, DC.
AUTHORITY
USNSRDC ltr, 15 Jul 1971

THIS PAGE IS UNCLASSIFIED

AD878619

AD No. \_\_\_\_\_  
DDC FILE COPY

# NAVAL SHIP RESEARCH AND DEVELOPMENT CENTER

Washington, D.C. 20034



*Handwritten initials/signature*

## ENGINEERING GUIDE AND COMPUTER PROGRAMS FOR DETERMINING TURBULENCE-INDUCED VIBRATION AND RADIATION OF PLATES

by

Ralph C. Leibowitz  
and  
Dolores R. Wallace

DDC  
RECEIVED  
JAN 18 1971  
B

This document is subject to special export controls and each transmittal to foreign governments or foreign nationals may be made only with prior approval of Naval Ship Systems Command, SHIPS 037.

DEPARTMENTS OF ACOUSTICS AND VIBRATION  
AND APPLIED MATHEMATICS  
RESEARCH AND DEVELOPMENT REPORT

January 1970

Report 2976

The Naval Ship Research and Development Center is a U.S. Navy center for laboratory effort directed at achieving improved sea and air vehicles. It was formed in March 1967 by merging the David Taylor Model Basin at Carderock, Maryland and the Marine Engineering Laboratory (now Naval Ship R & D Laboratory) at Annapolis, Maryland. The Mine Defense Laboratory (now Naval Ship R & D Laboratory) Panama City, Florida became part of the Center in November 1967.

Naval Ship Research and Development Center  
Washington, D.C. 20034

MAJOR NSRDC ORGANIZATIONAL COMPONENTS

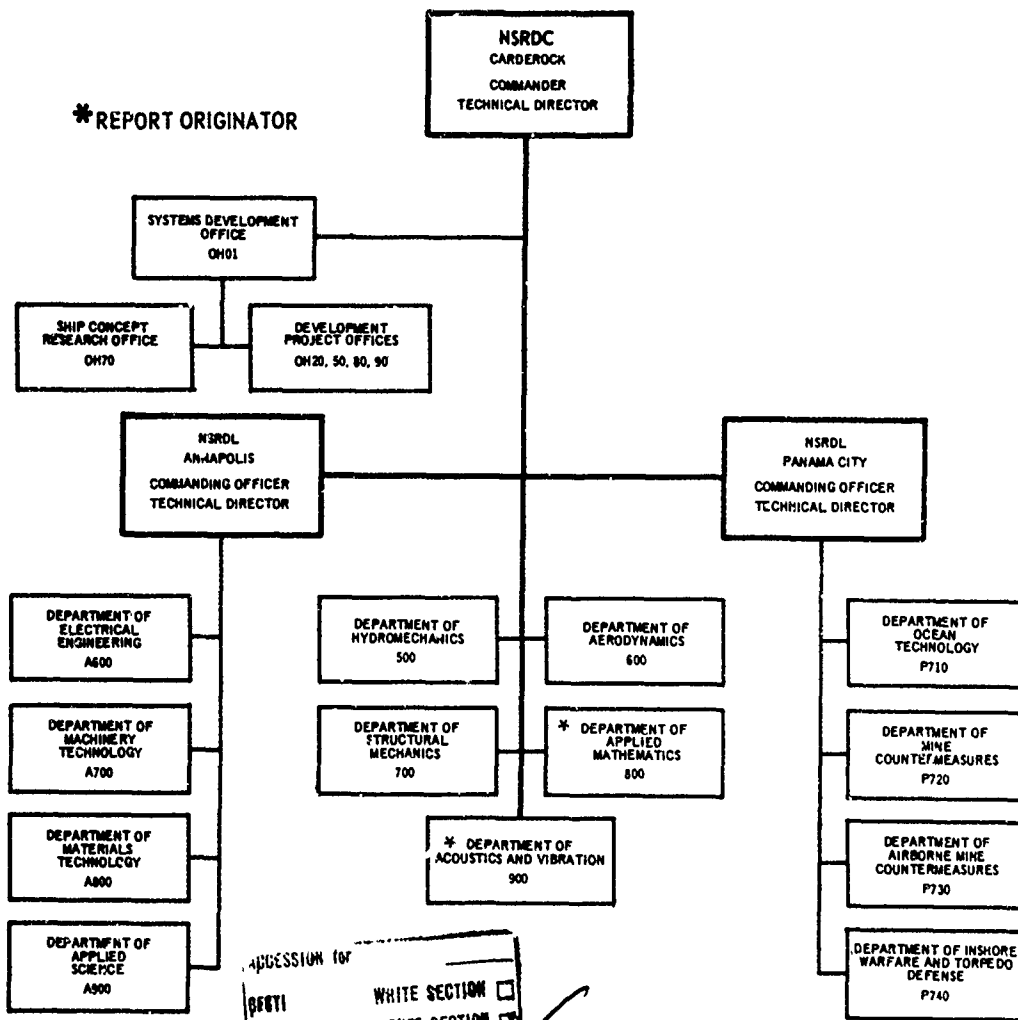

\*REPORT ORIGINATOR

APPROSSION FOR

ORGTI  WHITE SECTION

SDC  BUFF SECTION

UNANNOUNCED

JUSTIFICATION

BY

DISTRIBUTION/AVAILABILITY CODES

BIST.	AVAIL. and/or SPEC.
<i>[Signature]</i>	

DEPARTMENT OF THE NAVY  
NAVAL SHIP RESEARCH AND DEVELOPMENT CENTER  
WASHINGTON, D.C. 20034

ENGINEERING GUIDE AND COMPUTER PROGRAMS  
FOR DETERMINING TURBULENCE-INDUCED  
VIBRATION AND RADIATION OF PLATES

by  
Ralph C. Leibowitz  
and  
Dolores R. Wallace

This document is subject to special export controls  
and each transmittal to foreign governments or foreign  
nationals may be made only with prior approval of Na-  
val Ship Systems Command, SHIPS 037.

*Wash, D.C. 20360*

January 1970

Report 2976



## TABLE OF CONTENTS

	Page
ABSTRACT .....	1
ADMINISTRATIVE INFORMATION .....	1
INTRODUCTION .....	1
DISCUSSION AND RECOMMENDATIONS .....	2
CONCLUSION .....	5
ACKNOWLEDGMENTS .....	5
APPENDIX A – BOLT BERANEK AND NEWMAN MANUAL METHOD (DYER) .....	7
APPENDIX A1 – MATHEMATICAL ANALYSIS .....	12
APPENDIX A2 -- SAMPLE PROBLEMS .....	26
APPENDIX A3 – METHOD FOR DETERMINING INPUT DATA .....	32
APPENDIX B – BOEING PROGRAM I (MAESTRELLO) .....	33
APPENDIX B1 – MATHEMATICAL ANALYSIS .....	37
APPENDIX B2 – METHOD FOR DETERMINING INPUT DATA .....	60
APPENDIX B3 – PROGRAM IDENTIFICATION .....	63
APPENDIX B4 – TEST RUNS .....	93
APPENDIX C – ELECTRIC BOAT PROGRAM (IZZO) .....	117
APPENDIX C1 – MATHEMATICAL ANALYSIS .....	121
APPENDIX C2 – METHOD FOR DETERMINING INPUT DATA .....	137
APPENDIX C4 – TEST RUNS .....	153
APPENDIX D – UNDERWATER SOUND LABORATORY PROGRAM (STRAWDERMAN) .....	201
APPENDIX D1 – MATHEMATICAL ANALYSIS .....	206
APPENDIX D2 – METHOD FOR DETERMINING INPUT DATA .....	229
APPENDIX D3 – PROGRAM IDENTIFICATION .....	231
APPENDIX D4 – TEST RUNS .....	243
APPENDIX E – BOEING PROGRAM II – FINITE ELEMENT (JACOBS AND LAGERQUIST) .....	266
APPENDIX E1 – MATHEMATICAL ANALYSIS .....	271
APPENDIX E2 – METHOD FOR DETERMING INPUT DATA .....	300
APPENDIX E3 – PROGRAM IDENTIFICATION .....	306
APPENDIX E4 – TEST RUNS .....	307
REFERENCES .....	313

## LIST OF FIGURES

	Page
Figure 1 – Geometry and Coordinate System for Boundary Layer Excitation .....	13
Figure 2 – Coordinate Systems and Regions of Integration in the Time Domain .....	19
Figure 3 – Modal Lattice and Constant Wave Number Contour for Simply Supported Plate .....	29
Figure 4 – Transformation of Transverse Coordinates and Region of Integration .....	46
Figure 5 – Transformation of Longitudinal Coordinates and Region of Integration .....	47
Figure 6 – Transformation of Time Coordinates and Region of Integration .....	49
Figure 7 – Variation of Modal Mean Square Displacement with Eddy Lifetime for a 36- × 6.5- × 0.04-Inch Panel .....	64
Figure 8 – Computed Modal Mean Square Displacement for a 36- × 6.5- × 0.04-Inch Panel .....	65
Figure 9 – Contours of Constant Turbulence Pressure Spectrum Level for Convected Semifrozen Pattern .....	65
Figure 10 – Computed Displacement Spectral Density for a 12- × 6- × 0.062- Inch Titanium Panel .....	66
Figure 11 – Coordinate System .....	122
Figure 12 – Longitudinal Space-Time Correlation Function for a 2-Foot × 2.33-Foot × 3/8-Inch Steel Plate .....	154
Figure 13 – Longitudinal Correlation Function for a 2-Foot × 2.33-Foot × 3/8-Inch Steel Plate .....	155
Figure 14 – Computed Power Spectrum for a 2-Foot × 2.33-Foot × 3/8-Inch Steel Plate .....	156
Figure 15 – Illustration of the Theoretical Model .....	207
Figure 16 – Computed Response of a 3.5 × 3.5 × 0.1-Inch Steel Plate to Turbulent Boundary Layer Excitation .....	244
Figure 17 – Computed Dimensionless Plate Velocity Power Spectrum at Dimensionless Coordinates (1/5, 1/3); 10 Percent Critical Damping .....	245

	Page
Figure 18 – Computed Dimensionless Cavity Acoustic Pressure Power Spectrum at Dimensionless Cavity Coordinates (1/2, 1/3, 0) .....	245
Figure 19 – Random Pressure Loads .....	272
Figure 20 – Geometry of a Pair of Finite Plate Elements .....	289
Figure 21 – Coordinates and Separation Distances in the x-Direction .....	289
Figure 22 – Summary of Boundary Layer RMS Pressure Fluctuations .....	302
Figure 23 – Dimensionless Pressure Power Spectra .....	303
Figure 24 – Convection Speed Ratio .....	304
Figure 25 – Characteristic Length .....	304
Figure 26 – Eddy Lifetime .....	305
Figure 27 – Computed Displacement Power Spectral Density for a 12.0- × 7.0- × 0.08-Inch Aluminum Alloy Panel .....	310
Figure 28 – Computed Mean Square Displacement for a 12.0- × 7.0- × 0.08-Inch Aluminum Alloy Panel .....	311
Figure 29 – Cyclic Ordering of Nodes .....	312

#### LIST OF TABLES

Table 1 – Comparison of the Computational Methods .....	3
Table 2 – Identification for Subprograms A, B, C, and D - Maestrello .....	68
Table 3 – Computer Listings for Subprograms A, B, C, and D - Maestrello .....	94
Table 4 – Identification for Electric Boat Program - Izzo .....	139
Table 5 – Computer Listings for Electric Boat Program - Izzo .....	157
Table 6 – Identification for USL Subprograms I and II - Strawderman .....	232
Table 7 – Computer Listings for USL Subprograms I and II - Strawderman .....	246
Table 8 – Sample Printouts of Boundary Layer Input Data and Computed Force Co-Power Spectral Density Matrix - Jacobs .....	308

## ABSTRACT

This report is an engineering guide to the use of the Dyer method of manual computation and to several computer programs for determining turbulence-induced vibration and radiation of finite plates in air and in water. Both simple and clamped boundary conditions are treated. The Dyer method and the computer programs are presented in a series of appendixes:

- A. Bolt Beranek and Newman Manual Method (Dyer)
- B. Boeing Program I (Masestrello)
- C. Electric Boat Program (Izzo)
- D. Underwater Sound Laboratory Program (Strawderman)
- E. Boeing Program II - Finite Element (Jacobs and Lagerquist)

The documentation is intended to facilitate the performance of flow-induced vibroacoustic computations as well as to furnish the groundwork for future research. It should also act as a theoretical guide for experimentalists. In the broader view, the documentation represents the initial steps of an effort to use computer programs to bridge the gap between vibroacoustic research results and design needs for structures that are subject to excitation by turbulence. Research tending to improve and extend the present program is recommended.

## ADMINISTRATIVE INFORMATION

This study was sponsored by the Naval Ship Systems Command (NAVSHIPS) Code 037. Funding was provided by NAVSHIPS 0311 under Subproject S-R003 10 01, Task 11701.

## INTRODUCTION

For several years, the Naval Ship Research and Development Center (NSRDC) has been concerned with computing the vibration and acoustic radiation of plates excited by fully developed turbulence. As indicated in Reference 1, the naval need for achieving accurate methods of computation exceeds the current state of the art for performing such computations.\* Accurate computational methods for plates can provide a useful foundation for extension to more complex naval structures, e.g., ribbed sonar domes.

It is of interest to document the flow-induced vibroacoustic digital computer solutions that have been the subject of investigation by researchers outside NSRDC and that are germane to naval needs. These constitute a convenient reference for application and a base for

---

\*References are listed on page 313. Technical notes are ordinarily not used as formal references in NSRDC reports. However, Reference 1 was authorized for inclusion by the Head, Department of Acoustics and Vibration and is releasable on request to him. This review of the state of the art shows that accurate methods of prediction have not yet been confirmed because of the lack of experimental data, particularly for plates in water. The rationale motivating the present study is discussed and corresponding experimental studies are recommended.

further development. Accordingly, the primary objective of this report is to present a documentation that provides

1. Theoretical methods of computation for immediate application by researchers who are interested in comparing theory and experiment, observing trends, etc.
2. Theoretical methods of computation for use as a guide in designing experiments.
3. Computational frameworks that can be modified and extended through additional research to meet naval needs in an increasingly realistic manner.
4. Initial steps of an effort to use computer programs to bridge the gap between vibro-acoustic research results and design needs for structures that are subject to excitation by turbulence.

The documentation is essentially a user's guide to the Dyer method of manual computation and to several digital computer programs for determining turbulence-induced vibration and radiation of finite plates. Simple and clamped boundary conditions are treated, and the fluid medium surrounding a plate is either air or water. The following titles identify the manual method and the computer programs treated and indicate their location in the report:

Appendix A -- Bolt Beranek and Newman Manual Method (Dyer)

Appendix B -- Boeing Program I (Maestrello)

Appendix C -- Electric Boat Program (Izzo)

Appendix D -- Underwater Sound Laboratory Program (Strawderman)

Appendix E -- Boeing Program II -- Finite Element -- (Jacobs and Lagerquist)

Each appendix includes the appropriate notation, the mathematical development of the equations underlying the program, descriptions of input and output data and of units, computer program listings, the time required to run particular computations, flow charts and operations and rules of the computer program. Methods are also presented for determining computer program input data from either experimental or analytical results. Test runs are included to verify the results (published response curves) of the original developers of the programs and hence to indicate the successful operation of the programs at NSRDC.

The physical foundations on which the development of the equations rest are not included. The references cited in the present report direct the interested reader to appropriate literature.

The report has been organized to meet the needs of the program user.

## DISCUSSION AND RECOMMENDATIONS

For convenience, the salient features of the documentation are summarized in Table 1 which identifies and compares the various methods. This table makes it easy for the potential user to identify the various features of a program that are of interest to him and to select the

TABLE 1  
Comparison of the Computational Methods

Program Description	Location in Report	Theoretical Approach	Major Assumptions	Plate Boundary Conditions
Belt Branch and Newman Manual Method (Dyer)	Appendix A	Green function-normal mode analysis (Lyon-Dyer theoretical model)	<ol style="list-style-type: none"> <li>The turbulent field is not affected by plate motion, this is based on the provision that the plate vibratory displacements are small compared to the boundary layer displacement thickness.</li> <li>The boundary layer pressure field has the following characteristics: <ol style="list-style-type: none"> <li>The pressure field is a stationary random process.</li> <li>The pressure correlation decays with time.</li> <li>The pressure correlation has a spatial extent small compared with the plate size of interest, i.e., <math>\bar{r} \ll L_p</math>, where <math>\bar{r}</math> is essentially the greatest distance in the convection direction along which the forcing field is correlated.</li> <li>The pressure correlation is convected along the surface of the plate in the direction of the free-stream velocity.</li> <li>The spatial correlation is homogeneous depending on the difference in the spatial coordinates as a frame of reference moving with the mean convection speed.</li> </ol> </li> <li>The correlation area is much smaller than the plate area. This permits the boundary layer pressure field to be formulated in terms of delta functions which are analytically simple but inherently approximate. Moreover, as a consequence, the modes are statistically independent.</li> <li>r or low density fluids (only), e.g., air, the radiation reaction on the plate may be neglected, i.e., <math>\rho_2 \ll \rho_1</math>. Then, the sound field external to the plate and the vibration field on the plate can be considered independently. For high density fluids, e.g., water, the radiation reaction on the plate is included in the analysis.</li> <li>Damping restrictions are <math>\eta &lt; 1/3</math> and <math>\frac{\rho_2}{2\rho_1 m} &lt; 1/3</math></li> <li>Orthogonal modes.</li> <li>Convection velocity is a constant given by <math>v = 0.8 U_\infty</math>.</li> </ol>	Simple supports
Buzzing Program I (Moore)	Appendix B	Green function-normal mode analysis (Lyon-Dyer theoretical model) and Fourier transform relationships between cross spectral density and cross correlation of the exciting pressures	<ol style="list-style-type: none"> <li>Same as Items 1, 2, and 3 of Dyer assumptions, model representing turbulence excitation consists of convected wall pressure pattern, space and time dependent which retains the characteristics of the superposition of a wave system, with phase and amplitude associated with wavenumber and frequency spectrum</li> <li>Lightly damped panel</li> <li>Orthogonal modes (except for case of coupled modes, Item 4)</li> <li>Negligible cross-modal effect (except that in obtaining the displacement cross power spectral density the modal cross coupling can be included).</li> <li>Convection velocity is a constant given by <math>U_c = 0.8 U_\infty</math></li> </ol>	Simple supports and that in obtaining the displacement cross spectral density, all damped modes are included.
Electric Seat Program (Izzo et al.)	Appendix C	Green function-normal mode analysis (Lyon-Dyer theoretical model), Rayleigh formulation for acoustic pressure-plate acceleration relationship, and Fourier Transform relationship between cross spectral density and cross correlation of the acoustic field pressures	<ol style="list-style-type: none"> <li>Same as Items 1, 2, 3, 5, 6, and 7 of Dyer assumptions.</li> <li>Viscous and radiation damping are negligible.</li> </ol>	Simple and clamped supports
Underwater Sound Laboratory Program (Svendsen)	Appendix D	Frequency domain analysis of spectral properties of the random variables	<ol style="list-style-type: none"> <li>Same as Item 1 of Dyer assumptions, boundary layer thickness over the plate is considered constant.</li> <li>Turbulent boundary layer is a homogeneous stationary random process.</li> <li>Zero (or small) pressure gradient.</li> <li>Cavity acoustic pressure provides negligible excitation to the plate, i.e., the only forces exciting the plate are those associated with the turbulent boundary layer pressure fluctuations.</li> <li>Convection velocity is a constant given by <math>U_c = 0.8 U_\infty</math>.</li> <li>The effective mass and damping, due to the combined effect of plate and water, is assumed constant; acoustic damping effects are neglected in the derivation of the cavity acoustic spectral density, the only damping effects being associated with the plate.</li> </ol>	Simple supports
Buzzing Program II Finite Element (Jacobs and Lagerquist)	Appendix E	Finite element matrix structural analysis in the frequency domain	<ol style="list-style-type: none"> <li>Same as Item 1, 3, and 4 of Moore's assumptions; a frozen turbulence model (Taylor hypothesis) and small-scale distributed and convected random loading of the turbulent boundary layer on a simple panel are assumed, the loading is considered to be a stationary ergodic and homogeneous random process.</li> <li>Lightly damped panel; damping proportional to inertia, stiffness or both.</li> <li>Mass of the panel is assumed to be concentrated at the node points.</li> <li>Convection velocity is a constant given by <math>U_c = 0.8 U_\infty</math>.</li> </ol>	Simple and clamped supports

	Flat - Boundary Conditions	Fluid Media	Excitation Function Cross Correlation Function and/or Cross Spectral Density for Pressure (no distinction between normalized and unnormalized forms)	Response Function Most General Computer Output Data	Geometry and Coordinate System for Theoretical Model	Test Plans (Specific Computations)
<p>is the premise that the plate vibratory thickness...</p> <p>is the plate size of interest, i.e., <math>v \ll L_p</math> along which the forcing field is correlated.</p> <p>is in the direction of the free-stream velocity.</p> <p>is in the spatial coordinates in a frame of...</p> <p>is the boundary layer pressure field to be at subsonic speeds. Moreover, as a...</p> <p>is the plate may be neglected, i.e., <math>p_1 - p_2 \ll 1</math>.</p> <p>is the plate can be considered independently.</p> <p>is included in the analysis.</p>	Simple supports	Air and Water	$\langle R(r, t)   r' = (r', t') \rangle = A t^2 \delta(\xi - v\tau) \delta(\eta) e^{-\frac{r}{\delta}}$	Space-time correlation of displacement. Mean square pressure within a closed space (Figure 1)	Figure 1	See sample problem
<p>turbulence excitation consists of convected structures of the superposition of a wave frequency spectrum</p> <p>is the cross power spectral density the model</p>	Simple supports except that in obtaining the displacement cross-power spectral density, simple and clamped supports are included.	Air	<p>1. Model A - convected semi-frozen pattern</p> $R(\xi, \eta, \tau) = \frac{\sum_{\gamma=1}^3 \frac{A_\gamma K_\gamma}{K_\gamma^2 + \left(\frac{1}{FU_c}\right)^2 [(t - U_c \tau)^2 + \eta^2]}}{\sum_{\gamma=1}^3 \frac{A_\gamma}{K_\gamma}}$ $P(k_1, \omega) = \frac{\theta}{1 + \theta^2 (\omega + K_1 U_c)^2} \left( \frac{FU_c}{2\pi} \right) \sum_{\gamma=1}^3 A_\gamma e^{-1/\omega K_\gamma F}$ $P(k_1, \omega) = \frac{\sum_{\gamma=1}^3 \frac{A_\gamma}{K_\gamma}}{\sum_{\gamma=1}^3 \frac{A_\gamma}{K_\gamma}}$ <p>Note: The more general expression <math>p(k_1, k_2, \omega)</math> has been derived and was presented in Reference 15, but was not used in computation. Moreover, in deriving the displacement cross power spectral density, Model A was slightly modified in accordance with recent data for a flat smooth plate (Reference 22).</p> <p>2. Model B - unsteady convection</p> <p>Note: Expressions for <math>R(\xi, \eta, \tau)</math> and <math>P(k_1, k_2, \omega)</math> are presented in this report. Programming of these equations can be easily done at the users request.</p>	Mean square displacements Cross-power spectral density of turbulence pressure, i.e., cross pressure spectra in $k, \omega$ space Displacement cross-power spectral density (only the case of model uncoupling has been run)	Same geometry as Figure 1	Figures 7 - 10
	Simple and clamped supports	Air and Water	Same as Dyer equation, but different notation	Space-time correlation of acoustic pressure Power spectrum of acoustic pressure	Figure 11	Figures 12 - 14
<p>is the plate is considered constant.</p> <p>is the only forces exciting the plate system.</p> <p>is the air and water, is assumed constant; acoustic spectral density, the only</p>	Simple supports	Air and Water	$S_{pD}(\xi, \eta, \omega) = 0.75 \times 10^{-5} \alpha^2 \rho^2 U_0^3 \delta^{\alpha} \left[ e^{-0.115 \left  \frac{\omega \xi}{U_c} \right } \right] \left[ e^{-0.7 \left  \frac{\omega \eta}{U_c} \right } \right] e^{-1 \left( \frac{\omega \xi}{U_c} \right)}$ $\omega < 1.256 \frac{U_0}{\delta^{\alpha}}$ $= 1.5 \times 10^{-5} \alpha^2 \frac{\rho^2 U_0^6}{\omega^3 \delta^{\alpha}} \left[ e^{-0.115 \left  \frac{\omega \xi}{U_c} \right } \right] \left[ e^{-0.7 \left  \frac{\omega \eta}{U_c} \right } \right] e^{-1 \left( \frac{\omega \xi}{U_c} \right)}$ $\omega > 1.256 \frac{U_0}{\delta^{\alpha}}$ <p>where <math>\alpha = 1.0</math> for water <math>\alpha = 3.0</math> for air</p>	Plate velocity power spectrum Cavity acoustic pressure power spectrum	Figure 15	Figures 16 - 18
<p>is the model (Taylor hypothesis) and small boundary layer on a simple panel are assumed, random pressure.</p> <p>is both.</p>	Simple and clamped supports	Air	<p>Same as Maertrallo equation (Model A), but different notation</p> $\rho(\xi, \eta, \tau) = \frac{e^{-\frac{r}{\delta}} \left\{ \sum_{n=1}^3 \frac{A_n K_n}{K_n^2 + B^2 [(t - U_c \tau)^2 + \eta^2]} \right\}}{\sum_{n=1}^3 \frac{A_n}{K_n}}$ <p>Note: The pressure cross-power spectral density is given in various forms in Appendix E.</p>	Mean square displacements Power spectral density of displacement Cross power spectral density of turbulence pressure Cross spectral density of displacement	Figures 19, 20, 21	Figures 27, 28

program that most nearly meets his needs. Of course evaluation of the capability of a program for making accurate predictions with respect to naval problems requires comparison between theory and actual experiments in water.

Based on an evaluation of the computer program presented herein as well as the investigation made in Reference 1, the following recommendations are made:

1. Immediate application should be made of the programs considered to be most relevant to naval needs. A range of geometric, structural, and flow data representing naval plating under actual operating (or scaled) conditions should be submitted as input to the programs. The results of a variation in parameters should be analyzed and evaluated. Comparison of such results from different programs may yield meaningful *qualitative* information or trends. The conclusions drawn from such trends may provide insight into the physical nature of the problem and/or act as a guide to the design of associated experiments. Moreover, when compared with corresponding experimental results, the theoretical results will yield *quantitative* information on the degree of accuracy of the methods of computation. Thus, the theory in conjunction with the experimental results may lead either to modification of the existing analysis or to determination of correction factors for the theoretical results. It may also lead to determination of scaling factors for different geometries and media.

2. The methods considered to be most useful for solving naval problems should be modified and extended to include improvements that enable incorporation of the following parameters, structures, and effects:

- a. Radiation resistance
- b. Internal damping
- c. Fluid loading (added or virtual mass)
- d. Shear and rotary inertia (thick plate theory)
- e. Convection velocity
- f. Ribs
- g. Rough plates, protuberances, openings, and indentations
- h. Orthotropic plates and inhomogeneous plates
- i. Combination of plate materials (composite plates)
- j. Complex structures
- k. Boundary conditions (other than fixed or simply supported)
- l. Cross-modal coupling
- m. Surface curvature and fairness
- n. Reverberant and nonreverberant (anechoic) media

Improvements in the theory should result in the evolution of design data for selecting plate materials and geometry and structural arrangements for sonar domes and submarine hulls that will have minimum vibratory and acoustic response to turbulence excitation. In particular, design charts of vibroacoustic response as a function of structural parameters (properties and geometry) can be obtained by using a computer. These charts can be useful in establishing acoustical design criteria.



## CONCLUSION

The Dyer manual method and several computer programs for determining fully developed turbulence-induced vibration and radiation of finite plates have been documented. The treatments include simple and clamped boundaries, and the environment of the plates is either air or water. Methods have also been given for determining computer input data from either experimental results or analysis. The methods are useful for immediate application by theoretical and experimental researchers and also provide a basis for modification and extension to more accurate programs that are capable of meeting naval needs in an increasingly realistic and practical manner. These achievements can be attained (1) through a better understanding of the physical foundations of the problem and hence an improved representation of the models used and the quantities to be included in the analyses, (2) through improved (new) methods of mathematical analysis as well as practical extension of presently used methods of analysis, and (3) through improvements in computer programming techniques and computer capabilities.

## ACKNOWLEDGMENTS

Various personnel played significant roles in the successful completion of this project. The authors are indebted for the supervisory aid and encouragement of Messrs. G.J. Franz and G. H. Gleissner and Drs. E. H. Cuthill, F. N. Frenkiel, and F. Theilheimer. In the initial stages of the work, Dr. Theilheimer also provided mathematical assistance with respect to many phases of the computer program and so merits special appreciation.

For the provision of computer programs and additional assistance relevant to their successful operation, the authors gratefully acknowledge the help of Mr. L. Maestrello, Mrs. F. Gasche, Mr. L. Jacobs, Mr. D. Lagerquist, Mr. K. Tsurusaki, and Mr. M. C. Young of Boeing Company; Mr. Budzyk and the members of his staff at the Electric Boat Division of General Dynamics Corporation; Dr. W. A. Strawderman of the U. S. Navy Underwater Sound Laboratory; and Messrs. Dave Smith, Nelson Wolfe, Mel Eifert, and Ralph Shemovitz of Wright-Patterson Air Force Base.

**APPENDIX A**

**BOLT BERANEK AND NEWMAN MANUAL METHOD (DYER)**

**APPENDIX A1 – MATHEMATICAL ANALYSIS**

**APPENDIX A2 – SAMPLE PROBLEM**

**APPENDIX A3 – METHOD FOR DETERMINING INPUT DATA**

## NOTATION

$A$	Correlation area
$A_{mn}(r_0, \omega)$	A coefficient
$a'_{mn}$	Total modal damping due to structure and fluid coupling
$a_{mn}$	Modal structural damping, positive and real
$B$	Bending stiffness equal to $\frac{Ek^3}{12(1-\sigma^2)}$
$C_B$	Free flexural phase velocity for a thin plate equal to $\omega^{\frac{1}{2}}(B/M)^{\frac{1}{4}}$
$c$	Velocity of sound in fluid
$c_L$	Longitudinal bar velocity (17,000 ft/sec in steel or aluminum)
$D_{pq}$	A coefficient
$d$	Displacement boundary thickness
$E$	Young's modulus
$F$	Force on plate due to external and sound pressure fields
$f$	External pressure field
$f_c$	Sound coincidence frequency
$f_{rms}, f^2$	Root-mean-square and mean-square boundary-layer pressure, respectively
$G(r, r_0, \omega)$	Green function, which is Fourier transform of impulse response $g$
$g$	Acceleration due to gravity
$g\left(\frac{r, t}{r_0, t_0}\right)$ or $g\left(\frac{x, y, t}{x_0, y_0, t_0}\right)$	Impulse response of plate
$H_{mn}$	A coefficient
$h$	Plate thickness
$I_{mn}(\tau)$	Time correlation integral
$k$	Acoustic wave number equal to $\omega/c$
$k_{mn}$	Wave number equal to $\sqrt{k^2 - \Gamma_{mn}^2}$
$L$	Equal to $\frac{1}{2}(L_x L_y)^{\frac{1}{2}}$
$L_x, L_y, L_z$	Dimensions of plate along $x, y,$ and $z,$ respectively, as shown in Figure 1.

$M$	Plate structural mass per unit area
$M'$	Total effective mass per unit area of plate due to structure and fluid coupling
$M_1$	Free-space added mass per unit area
$M_2$	Added mass per unit area associated with coupling to sound waves in the closed liquid-filled volume
$m, n$ or $p, q$ or $\mu, \nu$	Mode numbers
$N(\Gamma_{mn}), \Delta N(\Gamma_{mn})$	Number of modes included up to wave number $\Gamma_{mn}$ and average number of modes in a frequency band $\Delta\nu$ , respectively
$n(\Gamma_{mn})$	Modal density
$P_{mn}^2$	Modal mean-square pressure (a time averaged quantity)
$\overline{P_{mn}^2}$	Spatial average of the modal mean-square pressure $P_{mn}^2$ (a space-time average quantity)
$\overline{p^2}$	Equal to $\overline{P_{mn}^2} \Delta N$ , the average mean square pressure for all modes $\Delta N$ in a frequency band $\Delta\nu$
$p_j$	Sound pressure on either side of plate at $z = L_z$
$r$	Represents coordinate position $x, y$
$S, ds$	Area, differential area equal to $dx dy$
$s$	Radiation efficiency
$t$	Time
$U_\infty$	Free stream velocity of fluid external to plate
$U(t - t_0)$	Unit step function
$V(x, y, z, \omega)$	Equal to the sum of the plate modal velocities
$V_{mn}$	Plate modal velocity
$v$	Mean convection speed along the positive $x$ direction
$v_0$	Hydrodynamic coincidence speed
$W_{m, n}(x, y, t)$	Normal mode for plate
$w(r, t)$ or $w(x, y, t)$	Displacement of neutral plane of plate
$w_s$	Weight of steel plate per square foot
$x, y, z$	Coordinate system for plate (see Figure 1)
$Z_{mn}$	Plate modal impedance

$\alpha_m$	Convection frequency equal to $m\pi v/L_x$ and interpreted as the frequency at which the turbulent field is convected past a length of plate equal to the $m$ modal wavelength
$\beta$	Damping coefficient, including both viscous and hysteretic damping
$\beta_0$	Damping coefficient, representing viscous damping of plate structure only
$\beta_1$	Damping coefficient, representing added viscous damping due to radiation of energy in the fluid away from plate
$\Gamma_{mn}$	Eigenvalue for plate, taken to be real
$\gamma, \mu$	Coordinate system for plate (see Figure 2)
$\delta$	Dirac delta function
$\delta_{\mu\nu}$	Kronecker delta function
$\epsilon, \eta$	Positive quantities
$\zeta$	Equals $x - x'$
$\eta$	Loss factor
$\theta$	Mean statistical lifetime of the turbulent state
$\kappa$	Measure of the inverse radius of the turbulence eddy
$\nu, \Delta\nu$	Frequency and frequency band, respectively
$\xi$	Equals $y - y'$
$\rho$	Fluid density
$\rho_s$	Density of plate steel
$\sigma$	Poisson's ratio
$\tau$	Equals $t - t'$
$\phi_{mn}(x, y)$	Plate eigenfunction
$\psi_i(x, y, z, t)$	Velocity potential; the space $i = 1$ is taken to be free from boundaries except at $z = L_z$ and the space $i = 2$ is a closed space with reflective boundaries
$\Psi_i(x, y, z, \omega)$	Fourier transform of $\psi_i(x, y, z, t)$
$\omega$	Circular frequency of vibration
$\omega_c$	Sound coincidence circular frequency of vibration
$\omega_{mn}$	Damped resonance frequency, positive and real

$\omega_0$	Characteristic frequency
$\langle \dots \rangle$	Symbols for time average operation
*	Denotes complex conjugate
$\mathcal{F}$	Symbol for Fourier transformation

## APPENDIX A1 – MATHEMATICAL ANALYSIS

The differential equation governing displacement of a thin plate due to turbulent boundary layer pressure excitation on the plate surface (Figure 1) is <sup>2-4</sup>

$$B \nabla^4 w + M \frac{\partial^2 w}{\partial t^2} + \beta \frac{\partial w}{\partial t} = -f - (p_1 - p_2)_{z=L_z} = -F(x, y, t) \quad (\text{A1})$$

The solution of Equation (A1) is <sup>5</sup>

$$w(r, t) = \int_{-\infty}^t dt_0 \int_s dS_0 g(r, t/r_0, t_0) F(r_0, t_0) \quad (\text{A2})$$

where  $g$ , the impulse response of the plate, is the solution to <sup>5,6</sup> the equation

$$B \nabla^4 g + M \frac{\partial^2 g}{\partial t^2} + \beta \frac{\partial g}{\partial t} = -\delta(x - x_0) \delta(y - y_0) \delta(z - z_0) \quad (\text{A3})$$

The normal mode  $W_{mn}$  for the plate, which has the form

$$W_{mn}(x, y, t) = \phi_{mn}(x, y) e^{[-a_{mn}t - i\omega_{mn}t]} \quad (\text{A4})$$

satisfies the homogeneous equation for the freely vibrating plate

$$B(1 - i\eta) \nabla^4 W_{mn} + M \frac{\partial^2 W_{mn}}{\partial t^2} + \beta_0 \frac{\partial W_{mn}}{\partial t} = 0 \quad (\text{A5})$$

where explicit division is shown of the damping into its hysteretic and viscous components.

The solution to the nonhomogeneous Equation (A1) will be found by obtaining  $g$ , for inclusion in Equation (A2), in terms of a superposition of the normal modes or eigenfunctions, Equation (A4), satisfying the homogeneous Equation (A5).

Substitution of Equation (A4) in (A5) yields the following equation for the eigenfunctions  $\phi_{mn}$

$$\nabla^4 \phi_{mn} - \Gamma_{mn}^4 \phi_{mn} = 0 \quad (\text{A6a})$$

where

$$\Gamma_{mn}^4 = - \frac{[M(a_{mn} + i\omega_{mn})^2 - \beta_0(a_{mn} + i\omega_{mn})]}{B(1 - i\eta)} \quad (\text{A6b})$$

The eigenvalue  $\Gamma_{mn}$  is taken to be a real quantity. Multiplying both sides of Equation (A6b) by  $B(1 - i\eta)$  and equating imaginary and real numbers, we obtain

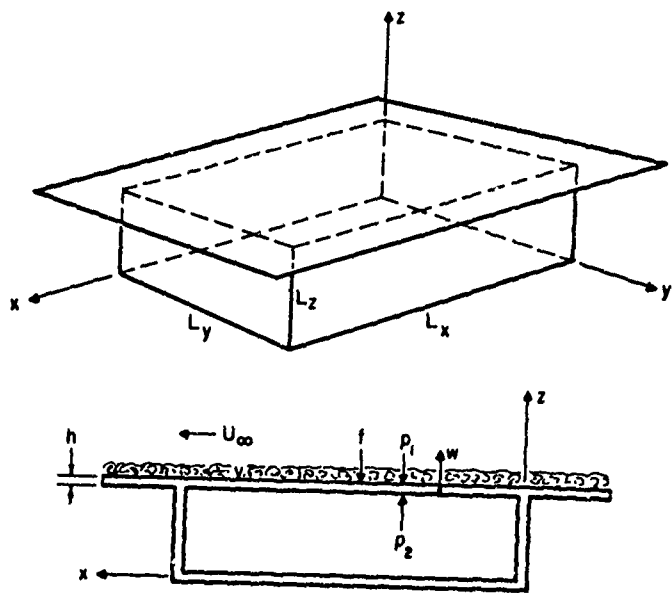

Figure 1 - Geometry and Coordinate System for Boundary Layer Excitation



$$a_{mn} = \frac{\beta_0}{2M} + \frac{\Gamma_{mn}^4 B \eta}{2M \omega_{mn}} \quad (\text{A7})$$

$$\omega_{mn}^2 = \frac{B}{M} \Gamma_{mn}^4 - a_{mn}^2 \approx \frac{B}{M} \Gamma_{mn}^4 \quad (\text{A8})$$

Equations (A7) and (A8) represent two simultaneous equations for  $a_{mn}$  and  $\omega_{mn}$  as functions of the eigenvalues  $\Gamma_{mn}^4$ , which, as will be shown, are determined by the boundary conditions. Equation (A1) is also to obey these conditions.

The Fourier transform pair relating the impulse response  $g$  to the Green function  $G$  is

$$g(r, t / r_0, t_0) = \frac{1}{2\pi} \int_{-\infty}^{\infty} G(r, r_0, \omega) e^{-i\omega(t-t_0)} d\omega \quad (\text{A9a})$$

$$G(r, r_0, \omega) = \int_{-\infty}^{\infty} g(r, t / r_0, t_0) e^{i\omega(t-t_0)} dt \quad (\text{A9b})$$

Taking Fourier transforms of both sides of Equation (A3)\* and noting that  $\mathcal{F}\left(\frac{d^n g}{dt^n}\right) \rightarrow$

$p^n G(\omega)$ , where  $p = -i\omega$ , and  $\int_{-\infty}^{\infty} \delta(t-t_0) e^{-i\omega(t-t_0)} dt = 1$ , we obtain

$$\nabla^4 G - \Gamma^4 G = \frac{-\delta(x-x_0) \delta(y-y_0)}{B(1-i\eta)} \quad (\text{A10a})$$

where

$$\Gamma^4 = \frac{\omega^2 M + i\omega \beta_0}{B(1-i\eta)} \quad (\text{A10b})$$

Assume that the Green function  $G$  can be expanded in terms of the eigenfunctions  $\phi_{mn}$ . Then

$$G(r, r_0, \omega) = \sum_{m,n} A_{mn}(r_0, \omega) \phi_{mn}(r) \quad (\text{A11})$$

To evaluate the coefficients  $A_{mn}$ , substitute Equation (A11) in (A10a); using Equation (A6a), multiply by  $\phi_{pq}$  and integrate over  $S$ , interchanging the summation and integral and normalizing the eigenvalues for convenience thus:

$$\int \phi_{mn}(r) \phi_{pq}(r) dS = \delta_{mp} \delta_{nq} \quad (\text{A12})$$

\*Equation (A3) modified to show explicit division of damping as in Equation (A5).

where

$$\begin{aligned}\delta_{mp} \delta_{nq} &= 0 & m \neq p \text{ or } n \neq q \\ \delta_{mp} \delta_{nq} &= 1 & m = p, n = q\end{aligned}$$

These steps give (noting that the summation is dropped, since the final expression is true for all  $m, n$ )

$$A_{mn} = \frac{1}{B(1-i\eta)} \frac{\phi_{mn}(r_0)}{\Gamma_{mn}^4 - \Gamma^4} \quad (\text{A13})$$

Substituting Equation (A13) in (A11), we obtain

$$G(r, r_0, \omega) = \frac{1}{B(1-i\eta)} \sum_{m,n} \frac{\phi_{mn}(r) \phi_{mn}(r_0)}{\Gamma_{mn}^4 - \Gamma^4} \quad (\text{A14})$$

Using Equations (A6b) and (A10b), it can be shown that

$$\frac{1}{B(1-i\eta)} \frac{1}{\Gamma_{mn}^4 - \Gamma^4} = \frac{1}{M(p-ia) [p - (-ia + \beta_0/M)]}$$

where

$$a = \omega_{mn} - ia_{mn}$$

We also use the approximation, which ignores the hysteretic term  $\beta_0/M = 2a_{mn}$ ; see Equation (A7). Fourier transform tables<sup>7</sup> can now be used to find

$$g(r, t/r_0, t_0) = \sum_{m,n} \frac{\phi_{mn}(r) \phi_{mn}(r_0)}{\omega_{mn} M} e^{-a_{mn}(t-t_0)} \sin \omega_{mn}(t-t_0) U(t-t_0) \quad (\text{A15})$$

where the unit step function  $U(t-t_0)$  corresponds to  $\delta(t-t_0)$  in the excitation.

For a finite plate immersed in a low-density fluid (e.g., air), the radiation reaction on the plate may be neglected, i.e.,  $p_1 - p_2 \ll f$ . Thus, for zero fluid load, Equation (A2) becomes

$$w(r, t) = \int_{-\infty}^t dt_0 \int_S dS_0 g(r, t/r_0, t_0) f(r_0, t_0) \quad (\text{A16})$$

The cross correlation of the displacement is<sup>8</sup>

$$\langle w(r,t) w^*(r',t') \rangle = \int_{-\infty}^t dt_0 \int_{-\infty}^{t'} dt'_0 \int_s dS_0 \int_s dS'_0 g(r, t/r_0, t_0) g^*(r', t'/r'_0, t'_0) \langle f(r_0, t_0) f^*(r'_0, t'_0) \rangle \quad (\text{A17})$$

where Dyer used<sup>2-4</sup>

$$\langle f(r,t) f^*(r',t') \rangle = Af^2 \delta(\zeta - v\tau) \delta(\xi) e^{-\frac{|\tau|}{\theta}} \quad (\text{A18})$$

We assume simply supported boundaries at the plate edge

$$w = \frac{\partial^2 w}{\partial x^2} = 0 \quad \text{at } x = 0, L_x$$

$$w = \frac{\partial^2 w}{\partial y^2} = 0 \quad \text{at } y = 0, L_y \quad (\text{A19})$$

The eigenfunctions (normalized solutions of Equation (A6a) that obey Equation (A19)) and the corresponding eigenvalues, neglecting the effect of damping, are<sup>9</sup>

$$\phi_{mn}(r) = \frac{2}{(L_x L_y)^{1/2}} \sin \frac{m\pi x}{L_x} \sin \frac{n\pi y}{L_y} \quad (\text{A20})$$

$$\Gamma_{mn}^2 = \left(\frac{m\pi}{L_x}\right)^2 + \left(\frac{n\pi}{L_y}\right)^2 \quad (\text{A21})$$

Equations (A18), (A20), and (A21) are now used to determine the plate vibrations, Equation (A17). Equation (A17) involves the product of two doubly infinite sums; a typical term is represented by the cross product of two modes  $(m,n)$  and  $(p,q)$

$$\langle w(r,t) w^*(r',t') \rangle_{mn,pq} = \frac{Af^2 \phi_{mn}(r) \phi_{pq}(r')}{\omega_{mn} \omega_{pq} M^2} \int_{-\infty}^t dt_0 \int_{-\infty}^{t'} dt'_0 \int_s dS_0 \int_s dS'_0 \phi_{mn}(r_0) \phi_{pq}(r'_0) \left[ e^{-a_{mn}(t-t_0) - a_{pq}(t'-t'_0) - \frac{|\tau_0|}{\theta}} \right] \cdot \sin \omega_{mn}(t-t_0) \sin \omega_{pq}(t'-t'_0) \delta(\zeta_0 - v\tau_0) \delta(\xi_0) \quad (\text{A22})$$

If the slope of the plate displacement is small compared to unity, then Equation (A22) is essentially the correlation of the plate normal displacement. Because of the delta function  $\delta(\xi_0) = \delta(y_0 - y_0')$ , the  $y_0, y_0'$  space integrations readily yield the term  $(\delta_{nq} L_y)/2$ . Further, if it is assumed that  $v\theta \ll L_x$ , the  $x_0, x_0'$  integrations yield the term  $\delta_{mp} \frac{L_x}{2} \cos \alpha_m \tau_0$ , where

$$\alpha_m = \frac{m\pi v}{L_x} \quad (\text{A23})$$

Thus the result for the spatial integration is  $\frac{4}{(L_x L_y)} \left[ \frac{(\delta_{nq} L_y)}{2} \right] (\delta_{mp} \frac{L_x}{2} \cos \alpha_m \tau_0)$   
 $= \cos \alpha_m \tau_0 \delta_{mp} \delta_{nq}$ , and Equation (A22) may now be written

$$\begin{aligned} \langle w(r, t) w^*(r', t') \rangle_{mn, pq} &= \frac{Af^2 \phi_{mn}(r) \phi_{pq}(r')}{\omega_{mn} \omega_{pq} M^2} \int_{-\infty}^t dt_0 \int_{-\infty}^{t'} dt'_0 \\ &\cdot \left[ e^{-a_{mn}(t-t_0) - a_{pq}(t'-t'_0) - \frac{|\tau_0|}{\theta}} \right] \\ &\cdot \sin \omega_{mn}(t-t_0) \sin \omega_{pq}(t'-t'_0) \delta_{mn} \delta_{pq} \cos \alpha_m \tau_0 \end{aligned} \quad (\text{A24})$$

To facilitate integration, a new coordinate system  $\gamma, \mu$  is introduced, where  $\gamma$  and  $\mu$  are related to the coordinates  $t_0, t'_0$  as follows

$$\gamma = (t' - t'_0) - (t - t_0) = \tau_0 - \tau$$

$$\mu = (t' - t'_0) + (t - t_0) \quad (\text{A25})$$

The differentials of the  $\gamma, \mu$  and  $t_0, t'_0$  coordinate systems are related by means of the Jacobian

$$\begin{aligned} dt_0 dt'_0 &= \left| \frac{\partial(t_0, t'_0)}{\partial(\mu, \gamma)} \right| dy d\mu = \left| \begin{array}{cc} \frac{\partial t_0}{\partial \mu} & \frac{\partial t'_0}{\partial \mu} \\ \frac{\partial t_0}{\partial \gamma} & \frac{\partial t'_0}{\partial \gamma} \end{array} \right| dy d\mu \begin{vmatrix} -\frac{1}{2} & -\frac{1}{2} \\ +\frac{1}{2} & -\frac{1}{2} \end{vmatrix} dy d\mu \\ dt_0 dt'_0 &= \frac{1}{2} dy d\mu \end{aligned} \quad (\text{A26})$$

Determination of the limits of integration for  $\mu$  and  $\gamma$  is intricate. The limits are determined from construction of the  $\mu, \gamma$  coordinate system as shown in Figure 2. The figure shows that the limits are  $-\mu$  to  $\mu$  for  $\gamma$  and  $0$  to  $\infty$  for  $\mu$ .

Then (letting  $\frac{p}{q} \rightarrow \frac{m}{n}$  by virtue of the delta functions) Equation (A24) becomes

$$\langle w(r, t) w^*(r', t') \rangle_{mn} = \frac{A^2 \phi_{mn}(r) \phi_{mn}(r')}{4\omega_{mn}^2 M^2} I_{mn}(\tau) \quad (\text{A27})$$

where for the correlation integral  $I_{mn}(\tau)$

$$I_{mn}(\tau) = \int_0^\infty d\mu \int_{-\mu}^\mu d\gamma e^{\left[-a_{mn}\mu - \frac{|\gamma + \tau|}{\theta}\right]} \cos \alpha(\gamma + \tau) [\cos \omega_{mn}\gamma - \cos \omega_{mn}\mu] \quad ; \quad \tau \geq 0 \quad (\text{A28})$$

Because of the absolute value sign in the integrand, Equation (A28) must be integrated in separate regions, depending in part on whether  $\gamma$  is greater or less than  $-\tau$  (i.e.,  $\tau_0 > 0$  or  $\tau_0 < 0$ ). Figure 2 shows the regions within which the integral must be evaluated. Thus, Equation (A28) becomes

$$I_{mn}(\tau) = \left\{ \int_\tau^\infty d\mu \int_{-\mu}^{-\tau} d\gamma e^{\left[\frac{\gamma + \tau}{\theta}\right]} + \int_\tau^\infty d\mu \int_{-\tau}^\mu d\gamma e^{\left[\frac{-\gamma - \tau}{\theta}\right]} + \int_0^\tau d\mu \int_{-\mu}^\mu d\gamma e^{\left[\frac{-\gamma - \tau}{\theta}\right]} \right\} e^{-a_{mn}\mu} \quad (\text{A29})$$

$$\cdot \cos \alpha(\gamma + \tau) [\cos \omega_{mn}\gamma - \cos \omega_{mn}\mu], \quad \tau \geq 0$$

For  $\tau < 0$ ,  $\tau$  is replaced by  $-\tau$  in Equation (A29).

Equation (A29) is laborious to evaluate in generality. Dyer gives the following results for  $I_{mn}(\tau)$  for special cases. The results are not directly applicable to underwater problems because the plate is assumed to be immersed in a low-density fluid. However, with modification, they can be used for underwater problems.

### MEAN-SQUARE RESPONSE AT COINCIDENCE

The time integral is now specialized to  $\tau = 0$  as well as  $\alpha_m = \omega_{mn}$ , i.e.,  $v = v_0 = C_B$

$$\left[ 1 + \left( \frac{nL_x}{mL_y} \right)^2 \right]^{1/2} \quad \text{where } v_0 \text{ is the hydrodynamic coincidence speed and } C_B = \omega^{1/2} \left( \frac{B}{M} \right)^{1/4}.$$

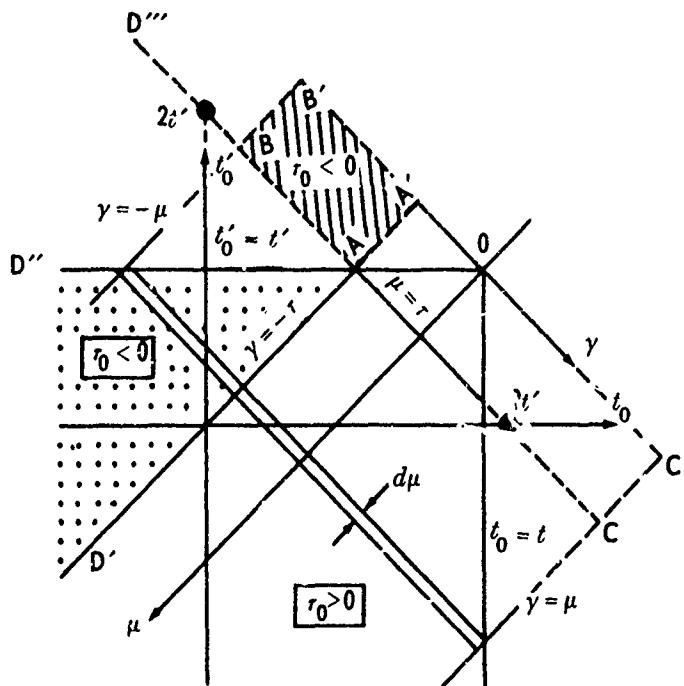

Figure 2 -- Coordinate Systems and Regions of Integration in the Time Domain

Note to Figure 2:

$$\gamma = (t' - t'_0) - (t - t_0) = r_0 - r; r_0 = t_0 - t'_0$$

$$\mu = (t' - t'_0) + (t - t_0); r = t - t'$$

Hence  $\gamma = \mu = 0$  corresponds to  $t_0 = t, t'_0 = t'$ . The line corresponding to  $\mu = 0$  is  $t' - t'_0 = t_0 - t$  which has the slope  $\left(\frac{dt'_0}{dt_0}\right)_{\mu=0} = -1$ . The line corresponding to  $\gamma = 0$  is  $t' - t'_0 = t - t_0$  which has the slope  $\left(\frac{dt'_0}{dt_0}\right)_{\gamma=0} = +1$ .

The lines are perpendicular because  $\left(\frac{dt'_0}{dt_0}\right)_{\mu=0} \left(\frac{dt'_0}{dt_0}\right)_{\gamma=0} = (-1)(1) = -1$ . Since  $\left(\frac{\partial \gamma}{\partial t_0}\right) = +1, \left(\frac{\partial \mu}{\partial t_0}\right) = -1$  the positive

directions are those shown in Figure 2. When  $\mu = r = t - t' = (t' - t'_0) + (t - t_0)$  then  $t'_0 = 2t' - t_0$  represents a line with intercepts  $t_0 = 2t', t'_0 = 2t'$  and slope  $\frac{dt'_0}{dt_0} = -1$ .

When  $\gamma = \mu$  or  $(t' - t'_0) - (t - t_0) = (t' - t'_0) + (t - t_0)$  then  $t_0 = t$ . Similarly when  $\gamma = -\mu$  then  $t'_0 = t'$ . When  $\gamma = -r, r_0 = 0$  or  $t'_0 = t'$ .

$$\text{Consider Region AA'BB' } \begin{cases} \mu = r - \epsilon, \epsilon > 0 \\ \gamma = -r - \eta, \eta > 0 \end{cases}$$

$\gamma + \mu = 2(t' - t'_0)$  or  $\gamma = -\mu + 2(t' - t'_0)$  or  $-r - \eta = -(r - \epsilon) + 2(t' - t'_0)$  or  $t' - t'_0 = \frac{-(\eta + \epsilon)}{2}$  a negative number.

Hence  $t'_0 > t'$ . Figure 2 shows that  $t'_0 > t', \mu = r - \epsilon, \gamma < -r$  defines the region AA'BB'. Since  $r_0 = \gamma + r$  then  $\gamma < -r$  implies  $r_0 < 0$  for this region.

Notes for Figure 2 (Continued)

$$\text{Consider Region OA'ACC'} \begin{cases} \mu = r - \epsilon; \epsilon > 0 \\ \gamma = -r + \eta; \eta > 0 \end{cases}$$

$\gamma = -\mu + 2(t' - t'_0)$  or  $-r + \eta = -(r - \epsilon) + 2(t' - t'_0)$  or  $t' - t'_0 = \frac{\eta - \epsilon}{2}$   $t'_0 > t'$ ,  $\mu = r - \epsilon$ ,  $\gamma = -r + \eta$  corresponds to region OA'A  $t'_0 < t'$ ,  $\mu = r - \epsilon$ ,  $\gamma = -r + \eta$  corresponds to region OACC'. Since  $r_0 = \gamma + r$  then  $\gamma > -r$  implies  $r_0 > 0$  for region OA'ACC'.

$$\text{Consider Region ACDD'} \begin{cases} \mu = r + \epsilon; \epsilon > 0 \\ \gamma = -r + \eta; \eta > 0 \end{cases}$$

$\gamma = -\mu + 2(t' - t'_0)$ ;  $-r + \eta = -r - \epsilon + 2(t' - t'_0)$ ;  $t' - t'_0 = \frac{\eta + \epsilon}{2}$  a positive number. Hence  $t'_0 < t'$ ,  $\mu = r + \epsilon$ ,  $\gamma = -r + \eta$  define the region. Since  $r_0 = \gamma + r$  then  $\gamma > -r$  implies  $r_0 > 0$ .

$$\text{Consider Region (AD'D'' + AD''D''')} \begin{cases} \mu = r + \epsilon; \epsilon > 0 \\ \gamma = -r - \eta; \eta > 0 \end{cases}$$

$\gamma = -\mu + 2(t' - t'_0)$ ;  $t' - t'_0 = \frac{\epsilon - \eta}{2}$ ;  $t'_0 < t'$ ,  $\mu = r + \epsilon$ ,  $\gamma = -r - \eta$  corresponds to region AD'D''. Since  $r_0 = \gamma + r$  then  $\gamma < -r$  implies  $r_0 < 0$ . If  $t'_0 < t'$  then  $\gamma > -\mu$  (see Figure 2). If  $t'_0 > t'$  then  $\gamma < -\mu$  which is an invalid condition since  $\gamma = -\mu$  is the lower limit in the integral, Equation (A28), corresponding to  $t'_0 = t'$ . Hence region AD'D''' is excluded in the integration. From the Figure it is clear that the limits of  $\gamma$  depend on the upper limits of both  $t_0$  and  $t'_0$ . Thus when  $t_0 = t$  (a limit in Equation (A24)),  $\gamma = \mu$  and when  $t'_0 = t'$ ,  $\gamma = -\mu$ . The limits of  $\mu$  in Equation (A28) are obviously from 0 to  $\infty$  as  $t_0$  and  $t'_0$  range from the upper limit  $t_0 = t$ ,  $t'_0 = t'$  to the lower limit  $t_0 = -\infty$ ,  $t'_0 = -\infty$  in Equation (A24). That is, the limits are:

$$\begin{aligned} &-\mu \text{ to } \mu \text{ for } \gamma \\ &0 \text{ to } \infty \text{ for } \mu \end{aligned}$$

Then

$$I_{mn}(0) = \frac{\theta}{a_{mn}(a_{mn}\theta + 1)} + \frac{\theta^2}{(a_{mn}\theta + 1)^2 + 4\omega_{mn}^2\theta^2} \left[ \frac{2 - a_{mn}\theta}{4\omega_{mn}^2\theta^2} \right], \quad \omega_{mn}\theta > 1 \quad (\text{A30})$$

$$I_{mn}(0) = \frac{\theta}{a_{mn}}, \quad a_{mn}\theta \ll 1 \text{ (low damping)} \quad (\text{A31})$$

$$I_{mn}(0) = \frac{\theta}{a_{mn}(a_{mn}\theta + 1)}, \quad \omega_{mn}\theta \gg 1 \text{ (high frequencies)} \quad (\text{A32})$$

### MEAN-SQUARE RESPONSE BELOW COINCIDENCE

The time integral is specialized to  $\tau = 0$  as well as  $\alpha_m \ll \omega_{mn}$  (i.e.,  $v \ll v_0$ ). We get

$$I_{mn}(0) = \frac{2\theta^2}{1 + \omega_{mn}^2\theta^2} \left[ \frac{\omega_{mn}^2\theta^2 - (a_{mn}\theta + 1)}{\omega_{mn}^2\theta^2 + (a_{mn}\theta + 1)^2} + \frac{1}{a_{mn}\theta} \right] + \frac{2\theta^2}{1 + \alpha_m^2\theta^2} \left[ \frac{a_{mn}\theta + 1}{\omega_{mn}^2\theta^2 + (a_{mn}\theta + 1)^2} - \frac{a_{mn}}{\omega_{mn}^2\theta} \right], \quad \alpha_m \ll \omega_{mn} \quad (\text{A33})$$

$$I_{mn}(0) = \frac{2\theta}{a_{mn}} \frac{1}{1 + \omega_{mn}^2\theta^2}, \quad a_{mn}\theta \ll 1 \text{ (low damping)} \quad (\text{A34})$$

$$I_{mn}(0) = \frac{2}{\omega_{mn}^2} \left[ 1 + \frac{1}{a_{mn}\theta} + \frac{1}{1 + \alpha_m^2\theta^2} \right], \quad \omega_{mn}\theta \gg 1 \text{ (high frequencies)} \quad (\text{A35})$$

### DISPLACEMENT CORRELATION BELOW COINCIDENCE

Here,  $\tau \neq 0$  and  $\alpha \ll \omega_{mn}$  is considered.

$$I_{mn}(\tau) = \frac{2\theta}{a_{mn}} \frac{e^{-a_{mn}|\tau|} \cos \omega_{mn}\tau}{1 + \omega_{mn}^2\theta^2}, \quad a_{mn}\theta \ll 1 \text{ (low damping)} \quad (\text{A36a})$$

When substituted in Equation (A27) the results give the cross correlation of (if  $\tau = 0$ ) mean-square displacement. For the latter case ( $\tau = 0$ )



$$I_{mn}(0) = \frac{2\theta}{a_{mn}} \cdot \frac{1}{1 + \omega_{mn}^2 \theta^2}, \quad a_{mn}\theta \ll 1 \text{ (low damping)} \quad (\text{A36b})$$

Now the radiation of boundary layer noise into the closed space shown in Figure 1 is considered, particularly the *underwater case*. The sound field on either side of the plate is governed by the nondissipative linear wave equation of acoustics for a homogeneous, loss- and source-free medium at rest.

$$\nabla^2 \psi_j - \frac{1}{c^2} \frac{\partial^2 \psi_j}{\partial t^2} = 0 \quad (\text{A37})$$

Within the closed space, let  $j = 2$ . The Fourier transform  $\Psi_2(x, y, z, \omega) = \frac{1}{2\pi} \int_{-\infty}^{\infty} \psi_2(x, y, z, t) e^{-i\omega t} dt$  of the velocity potential  $\psi_2$  satisfies the Helmholtz equation

$$\nabla^2 \Psi_2 + k^2 \Psi_2 = \frac{\partial^2 \Psi_2}{\partial x^2} + \frac{\partial^2 \Psi_2}{\partial y^2} + \frac{\partial^2 \Psi_2}{\partial z^2} + k^2 \Psi_2 = 0 \quad (\text{A38})$$

since  $\mathcal{F}\left(\frac{\partial^2 \psi_2}{\partial t^2}\right) \rightarrow -\omega^2 \Psi_2$  and  $k = \frac{\omega}{c}$ .

Except for the plate, all interior surfaces are assumed to be pressure release surfaces. Therefore, the boundary conditions are

$$\Psi_2 = 0 \begin{cases} x = 0, & L_x \\ y = 0, & L_y \\ z = 0 \end{cases} \quad (\text{A39})$$

Assume a general solution for Equation (A38) in the form of normal modes  $p, q$

$$\Psi_2(x, y, z, \omega) = \sum_{p, q} D_{p, q} \phi_{p, q}(r) \sin k_{p, q} z \quad (\text{A40})$$

It will be shown that Equation (A40) satisfies the boundary conditions in Equation (A39). Substitution of Equation (A20) in Equation (A40) and the resultant equation in Equation (A38) gives

$$k_{pq}^2 = k^2 - \left[ \left( \frac{p\pi}{L_x} \right)^2 + \left( \frac{q\pi}{L_y} \right)^2 \right] = k^2 - \Gamma_{pq}^2 \quad (\text{A41})$$

where  $\phi_{pq}$  and  $\Gamma_{pq}$  are the eigenfunctions and eigenvalues given in Equations (A20) and (A21), respectively.

Equation (A37) is coupled to Equation (A1) by the continuity condition on velocity

$$\frac{\partial w}{\partial t} = \frac{\partial \psi_1}{\partial z} \Big|_{z=L_z} = - \frac{\partial \psi_2}{\partial z} \Big|_{z=L_z} \quad (\text{A42})$$

Hence

$$\begin{aligned} - \frac{\partial \Psi_2}{\partial z} \Big|_{z=L_z} &= \frac{1}{2\pi} \int \frac{\partial w}{\partial t}(x, y, z, t) e^{-i\omega t} dt \Big|_{z=L_z} \\ &= V(x, y, z, \omega) = \sum_{m,n} V_{mn} = - \sum_{m,n} H_{mn} \phi_{mn} \end{aligned} \quad (\text{A43})$$

where  $H_{mn} \phi_{mn}$  is the plate modal velocity. Using Equation (A40) in Equation (A43)

$$D_{mn} = - \frac{H_{mn}}{k_{mn} \cos k_{mn} L_z} \quad (\text{A44})$$

Substitution of Equations (A44) and (A20) in Equation (A40) gives

$$\Psi_2(x, y, z, \omega) = - \frac{2}{(L_x L_y)^{1/2}} \sum_{m,n} \frac{H_{mn}}{k_{mn} \cos k_{mn} L_z} \sin \frac{m\pi x}{L_x} \sin \frac{n\pi y}{L_y} \sin k_{mn} z \quad (\text{A45})$$

which satisfies the boundary conditions Equation (A39).

Since the pressure  $p_2(x, y, z, t) = \rho \frac{\partial \psi_2(x, y, z, t)}{\partial t}$ , then the modal pressure transform is

$$\begin{aligned} [P_2(x, y, z, \omega)]_{mn} &= \frac{1}{2\pi} \left[ \int_{-\infty}^{\infty} \rho \frac{\partial \psi_2}{\partial t} e^{-i\omega t} dt \right]_{mn} \\ &= -i\omega \rho [\Psi_2(x, y, z, \omega)]_{mn} \end{aligned}$$

Using these equations as well as Equations (A40), (A43), and (A44), the plate modal impedance (at  $z = L_z$ ) is obtained

$$Z_{mn}(x, y, z, \omega) = \frac{P_{mn}(x, y, z, \omega)}{V_{mn}} = \frac{P_{mn}(x, y, z, \omega)}{-H_{mn} \phi_{mn}} = \frac{-i\omega \rho [\Psi_2]_{mn}}{-H_{mn} \phi_{mn}} = \frac{-i\omega \rho}{k_{mn}} \tan k_{mn} L_z = -i\omega M_2 \quad (\text{A46})$$

From Equations (A41) and (A8) as well as the definition of  $C_B$

$$k_{mn}^2 = k^2 - \Gamma_{mn}^2 = k^2 - \left(\frac{M}{B}\right)^{1/2} \omega_{mn} = \frac{\omega^2}{c^2} - \frac{\omega \omega_{mn}}{C_B^2}$$

Defining a sound coincidence frequency  $\omega = \omega_c$ , corresponding to  $c = C_B$  then

$$k_{mn} = \pm \frac{\omega_c}{C_B} \sqrt{1 - \frac{\omega_{mn}}{\omega_c}}$$

which is real for  $\omega_{mn} < \omega_c$  and imaginary for  $\omega_{mn} > \omega_c$ . Equation (A46) then yields

$$M_2 = \frac{\rho \tanh |k_{mn} L_z|}{|k_{mn}|}, \quad \omega_{mn} > \omega_c \quad (\text{A47a})$$

$$M_2 = \frac{\rho}{k_{mn}} \tan k_{mn} L_z, \quad \omega_{mn} < \omega_c \quad (\text{A47b})$$

The added mass  $M_1$  of the free space external to the cavity, provided the mode number is not too low, is taken to be

$$M_1 = \frac{\rho}{|k_{mn}|}, \quad \omega_{mn} < \omega_c \quad (\text{A48})$$

When the mode number is low, the resistive impedance (viscous damping coefficient) is taken to be

$$\beta_1 = \rho c s \quad (\text{A49})$$

where

$$s = \frac{2}{\pi m} + \frac{2}{\pi n} \frac{\left(\frac{\omega_{mn} L}{c}\right)^2}{1 + \left(\frac{\omega_{mn} L}{c}\right)^2}, \quad \omega_{mn} < \omega_c$$

$$L = \frac{1}{2} (L_x L_y)^{1/2}$$

Equation (A27) gave the modal displacement correlation for a plate in a low-density fluid. The correlation for a high-density fluid is obtained by replacing the structural mass in Equation (A27) by the total mass

$$M' = M + M_1 + M_2 \quad (\text{A50})$$

where  $M$  is the plate mass,

$M_1$  is the free space added mass given by Equation (A48), and

$M_2$  is the added mass due to the enclosed fluid given by either Equation (A47a) or (47b).

*Analogously, the damping in Equation (A7) and, hence, in Equation (A27) becomes for a high-density fluid*

$$a'_{mn} = \frac{\beta_0}{2M'} + \frac{\Gamma_{mn}^4 B \eta}{2M' \omega_{mn}} + \frac{\beta_1}{2M} \quad (\text{A51})$$

where the first two terms represent the original viscous and hysteretic damping for the plate, except that now  $M \rightarrow M'$ , and the last term is the added viscous damping where  $\beta_1$  is given by Equation (A49).

## APPENDIX A2 - SAMPLE PROBLEM

An example will be given to show how to determine the mean-square pressure ( $\tau = 0$ ) in the liquid-filled cavity ( $M \rightarrow M'$ ) adjacent to the plate. Two alternative methods of computation will be treated.

### DISCRETE FREQUENCY METHOD

The modal mean-square pressure  $P_{mn}^2$  at the plate is determined from Equations (A46), (A27), (A28), and (A20) as a *time-average* quantity.

$$P_{mn}^2 = \langle P_{mn} P_{mn} \rangle = V_{mn}^2 Z_{mn}^2 = (-i\omega W_{mn})^2 (-i\omega M_2)^2 = W_{mn}^2 \omega_{mn}^4 M_2^2$$

$$= f^2 \frac{A}{L_x L_y} \left( \frac{M_2}{M'} \right)^2 \left[ \sin^2 \frac{m\pi x}{L_x} \sin^2 \frac{n\pi y}{L_y} \right] \omega_{mn}^2 I_{mn}(0)$$

The *spatial average* of  $P_{mn}^2$  is

$$\overline{P_{mn}^2} = f^2 \frac{A}{4L_x L_y} \left( \frac{M_2}{M'} \right)^2 \omega_{mn}^2 I_{mn}(0)$$

where\*  $f^2 = (6 \times 10^{-3} \cdot \frac{1}{2} \rho U_\infty^2)^2$ ,

$$A = \frac{2\pi}{\kappa^2}, \text{ and}$$

$$\kappa = \frac{2}{d}.$$

For a steel structure in water, let

$$h = \frac{1}{2} \text{ in.},$$

$$L_x = L_y = 5 \text{ ft},$$

$$L_z = 1 \text{ ft},$$

$$U_\infty = 20 \text{ ft/sec} \doteq 12 \text{ knots},$$

$$d = 0.02 \text{ ft},$$

$$\theta \doteq 3 \times 10^{-2} \text{ sec},$$

---

\*See Appendix A3.

$\eta = 10^2$  ( $Q = 100$ ), and

$\rho = 64.2 \text{ lb/ft}^3$ .

At coincidence ( $C_B = c$ ,  $\omega = \omega_c$ )

$$C_B^4 = c^4 = \omega_c^2 \frac{B}{M} = \omega_c^2 \frac{B}{w_s/g} = \omega_c^2 \frac{B}{\rho_s h/g}$$

Hence, ignoring Poisson's ratio  $\sigma$ , the sound coincidence frequency is

$$f_c = \frac{c^2}{2\pi} \sqrt{\frac{\rho_s h/g}{Eh^3/12}} = \frac{c^2}{2\pi h} \sqrt{\frac{12\rho_s}{gE}}$$

$$= \frac{(4910 \text{ ft/sec})^2}{2\pi(1/24 \text{ ft})} \sqrt{\frac{12(490 \text{ lb/ft}^3)}{(32.2 \text{ ft/sec}^2)(0.4175 \times 10^{10} \text{ lb/ft}^2)}} \approx 19,230 \text{ cps}$$

Now

$$k_{mn}^2 = k^2 - \Gamma_{mn}^2$$

see Equation (A41). From page 174 of Reference 10, we see that for  $\omega_{mn} < \omega_c$ ,  $C_B < c$  and  $\Gamma_{mn} > k$  (note:  $k_b$  and  $k_a$  in Reference 10 respectively become  $\Gamma_{mn}$  and  $k$  here.) Hence, for frequencies less than 10,000 cps,  $|k_{mn}|$  may be approximated by  $\Gamma_{mn}$ . Further, restricting attention to frequencies greater than 200 cps, from Equations (A47b), (A48), and (A50)

$$M' = M + M_1 + M_2 = M + \frac{\rho}{|k_{mn}|} + \frac{\rho}{k_{mn}} \tan k_{mn} L_z$$

But

$$k_{mn} = i\Gamma_{mn}, i \tan x = \tanh ix, \tanh x = -\tanh -x$$

Hence,

$$M_2 = \frac{\rho}{i\Gamma_{mn}} \tan i\Gamma_{mn} L_z = \frac{-\rho}{\Gamma_{mn}} \tanh (-\Gamma_{mn} L_z) = \frac{\rho}{\Gamma_{mn}} \tanh \Gamma_{mn} L_z$$

$$= \frac{\rho}{|k_{mn}|} \tanh \sqrt{\left(\frac{M}{B}\right)^{1/2}} \omega_{mn} L_z$$

for  $\omega_{mn}$  sufficiently high  $\tanh \sqrt{\left(\frac{M}{B}\right)^{1/2}} \omega_{mn} L_z \rightarrow 1$  and  $M_2 \rightarrow \frac{\rho}{|k_{mn}|}$  (Note: In the NSRDC system of units,  $M_2 = \frac{\rho}{g|k_{mn}|}$  is used when making computations.) Thus

$$M' = M + \frac{2\rho}{\Gamma_{mn}} \approx M$$

Also, as can be calculated from Equation (A49), for  $\omega_{mn}$  sufficiently high, we get  $\beta_1 \approx 0$ .

For these conditions and using Equation (A8),

$$\left(\frac{M_2}{M'}\right)^2 = \left(\frac{\rho/\Gamma_{mn}g}{M}\right)^2 = \left(\frac{\rho}{M\Gamma_{mn}g}\right)^2 = \left[\frac{\rho/g}{M\left(\frac{M}{B}\right)^{1/4}\omega_{mn}^{1/2}}\right]^2 = \frac{\rho^2/g^2}{\left(\frac{M}{B}\right)^{1/2}\omega_{mn}M^2}$$

but <sup>11</sup>

$$c_L = \left(\frac{E}{\rho_s \cdot \frac{1}{g}}\right)^{1/2} = \sqrt{\frac{12B(1-\sigma^2)}{\rho_s h^3}} \approx \frac{\sqrt{12}}{h} \left(\frac{B}{M}\right)^{1/2} \quad (\text{ignoring } \sigma)$$

Hence,

$$\left(\frac{M}{B}\right)^{1/2} = \frac{\sqrt{12}}{c_L h}$$

and

$$\left(\frac{M_2}{M'}\right)^2 = \frac{1}{\sqrt{12}} \frac{\rho^2 c_L h}{\omega_{mn} M^2} = \frac{1}{\sqrt{12}} \frac{\rho^2 c_L h}{\omega_{mn} \frac{\rho_s^2 h^2}{g^2}} = \frac{1}{\sqrt{12}} \frac{\rho^2 c_L h}{\omega_{mn} \rho_s^2 h^2}$$

Finally, from Equations (A8) and (A21) for any mode

$$\omega_{mn}^2 \approx \left(\frac{B}{M}\right) \Gamma_{mn}^4 = \left(\frac{B}{M}\right) \left[ \left(\frac{m\pi}{L_x}\right)^2 + \left(\frac{n\pi}{L_y}\right)^2 \right]^2$$

is calculated, and  $I_{mn}(0)$  can be calculated from either Equation (A33) or (A34). In these equations, Equation (A51) is used, noting that in this problem  $\beta_1 \approx 0$ ,  $M' \approx M$ ,  $B \approx E h^3 / 12$ , and  $\beta_0 = 0$ ; see page 170 of Reference 2.

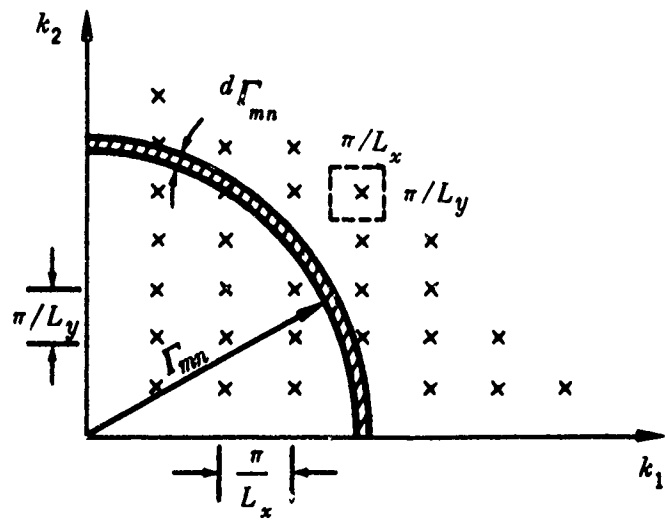

Figure 3 - Modal Lattice and Constant Wave Number Contour for Simply Supported Plate



There is now sufficient data to compute all of the quantities in the equation for  $\overline{P_{mn}^2}$ .

Finally, from Equations (A46) and (A40) and using  $k_{mn} = -i\Gamma_{mn}$

$$\begin{aligned} P_{mn}(x, y, z, \omega) &= -i\omega\rho\Psi_{mn}(x, y, z, \omega) = -i\omega\rho D_{mn}\phi_{mn} \sin(-i\Gamma_{mn}z) \\ &= \omega\rho D_{mn}\phi_{mn} \sinh\Gamma_{mn}z \end{aligned}$$

Hence,  $P_{mn}^2 \propto \sinh^2\Gamma_{mn}z$ ; therefore, the modal mean-square pressure for a location away from the excited plate would be reduced by the factor

$$\frac{\left[ P_{mn}^2 \right]_{z < L_z}}{\left[ P_{mn}^2 \right]_{z = L_z}} = \left[ \frac{\sinh\Gamma_{mn}z}{\sinh\Gamma_{mn}L_z} \right]^2$$

### MODAL DENSITY METHOD

We now determine  $\overline{P^2}$ , the mean-square pressure as measured by frequency analysis in bands of width  $\Delta\nu$ . The modal density of a plate found by considering the area included by the quarter circle of radius  $\Gamma_{mn}$  (Figure (3)) is

$$n(\Gamma_{mn}) = \frac{dN(\Gamma_{mn})}{d\Gamma_{mn}} = \frac{\Gamma_{mn}L_xL_y}{2\pi}$$

see page 135 of Reference 10. Hence, using Equation (A8) and the relation  $c_L = \frac{\sqrt{12}}{h} \left( \frac{B}{M} \right)^{1/2}$ , previously shown, the number of modes included up to wave number  $\Gamma_{mn}$  is

$$dN(\Gamma_{mn}) = \Gamma_{mn} d\Gamma_{mn} \frac{L_xL_y}{2\pi} = \frac{\left( \frac{M}{B} \right)^{1/2} L_xL_y}{4\pi} d\omega = \frac{\sqrt{3} L_xL_y}{c_L h} d\nu$$

where  $d\omega = 2\pi d\nu$ .

Thus, the average number of modes  $\Delta N$  in a band  $\Delta\nu$  is approximately

$$\Delta N = \frac{\sqrt{3} L_xL_y}{c_L h} \Delta\nu$$

Using the relation  $c_L h = \sqrt{3} L_xL_y \frac{\Delta\nu}{\Delta N}$  and the relation for  $\left( \frac{M_2}{M'} \right)$ , previously derived, the equation for the modal mean-square pressure per mode is

$$\begin{aligned} \overline{P_{mn}^2} &= \frac{f^2 A}{4L_x L_y} \left( \frac{M_2}{M'} \right)^2 \omega_{mn}^2 I_{mn}(0) = \frac{f^2 A}{4L_x L_y} \left( \frac{1}{\sqrt{12}} \frac{\rho^2 c_L \hbar}{\omega_{mn} \rho_s^2 \hbar^2} \right) \omega_{mn}^2 I_{mn}(0) \\ &= \frac{f^2 A}{4L_x L_y} \frac{1}{\sqrt{12}} \frac{\rho^2 \sqrt{3} L_x L_y \Delta \nu}{\omega_{mn} \rho_s^2 \hbar^2} \omega_{mn}^2 I_{mn}(0) \end{aligned}$$

For all modes  $\Delta N$  in the band, the average mean-square pressure is

$$\overline{P^2} = \overline{P_{mn}^2} \Delta N = \frac{f^2 A}{8 \hbar^2} \left( \frac{\rho}{\rho_s} \right)^2 \omega_{mn} I_{mn}(0) \Delta \nu$$

where  $\omega_{mn}$  is now considered to be a continuous frequency variable.

Since all data are known (see Discrete Frequency Method), then for a given frequency bandwidth  $\Delta \nu$ ,  $\overline{P^2}$  can be computed. The results of the computation are given for  $\Delta \nu = 1$

in terms of spectrum level,  $SL = 10 \log_{10} \frac{\overline{P^2}}{P_0^2} \text{ db}$ , where reference pressure  $p_0 = 1 \mu \text{ bar} = 1 \text{ dyn/cm}^2$  in Reference 2, Figure 7.

### APPENDIX A3 – METHOD FOR DETERMINING INPUT DATA

Dyer used the following estimates of input data for the boundary-layer pressure field

$$f_{r.m.s.} = 6 \times 10^{-3} \frac{1}{2} \rho U_{\infty}^2$$

based on measurements by Willmarth<sup>12</sup>

$$\kappa d \approx 2$$

$$\theta \approx 30 \frac{d}{U_{\infty}}$$

$$v \approx 0.8 U_{\infty}$$

$$\omega_0 \approx \kappa v$$

based on a comparison of Equations (A18) and its Fourier transform, which is the spectral

density  $s(\omega) = 2 \int_{-\infty}^{\infty} \langle f(r,t) f^*(r',t') \rangle e^{i\omega\tau} d\tau$  with measurements.<sup>12,13</sup>

To determine the cross correlation or mean square pressures, geometric and structural data must also be given as in the sample problem.

**APPENDIX B**

**BOEING PROGRAM 1 (MAESTRELLO)**

- APPENDIX B1 – MATHEMATICAL ANALYSIS**
- APPENDIX B2 – METHOD FOR DETERMINING INPUT DATA**
- APPENDIX B3 – PROGRAM IDENTIFICATION**
- APPENDIX B4 – TEST RUNS**

## NOTATION

$A_i$	Constants
$a, b$	Length of panel sides
$a_{m a}$	Plate modal damping
$a_1, a_2$	Amplitude of temporal fluctuation for unsteady convection
$B$	Bending stiffness
$c$	Speed of sound in fluid
$E$	Young's modulus
$F$	Equals $\frac{\delta^*}{U_c}$
$g$	Plate input-response function
$g_i$	A function
$h$	Panel thickness
$I_\nu, K_\nu$	Integrals
$i$	Equals $\sqrt{-1}$
$J_g$	Jacobian
$K_a$	Bending-wave speed
$K_i, K_\nu, K_\gamma$	Constants; wave numbers
$L_\xi$	Characteristic length of pressure field for semifrozen flow (length over which a given turbulent pressure pattern remains distinguishable)
$M$	Plate mass
$m, n$	Mode numbers
$N$	Constant, for piston radiation $N = 4$
$P_p$	Panel perimeter
$P_r$	Total length of panel ribs
$PWL_{mn}$	Sound power level for $mn$ mode
$p(x, y, t)$	Turbulence wall pressure fluctuation
$\overline{p^2}$	Mean-square pressure
$R(\xi, \eta, \tau)$	Correlation coefficient for pressures
$R(\tau)$	Normalized autocorrelation for pressures
$t, t'$	Time; times at which displacements are measured at points $x, y$ , and $x', y'$ , respectively

$t_0, t_0'$	Times at which pressure measurements are made at points $x_0, y_0$ and $x_0', y_0'$ , respectively
$U_c$	Broadband convection velocity
$U, U_\infty$	Free-stream velocity
$u$	Local flow velocity
$u(t - t_0)$	Unit step function
$u_\tau$	Frictional velocity
$\text{Vol}_{mn}$	Volume displacement for a mode
$x$	Distance from leading edge of plate
$(x, y), (x', y')$	Points on the panel at which displacements are measured
$(x_0, y_0), (x_0', y_0')$	Points on panel at which turbulence pressures are measured
$Y(x, y, t)$	Panel displacement
$\bar{Y}$	Root-mean-square of displacement
$\overline{Y^2}$	Mean square displacement
$Y_{mn}$	Eigenfunction or orthogonal mode of plate oscillation
$y$	Distance from wall normal to flow direction
$\beta_{ac}$	Acoustic-damping coefficient
$\beta_c$	Critical damping
$\beta_{st}$	Structural damping coefficient
$\Gamma_{mn}$	Eigenvalue
$\delta^*$	Boundary layer displacement thickness
$\delta_{mn}$	Total damping ratio
$\eta$	Equals $y - y'$ , lateral partial separation
$\eta'$	Equals $y_0 + y_0'$
$\theta, \theta_1, \theta_2$	Eddy lifetime for steady convection, i.e., time in which value of correlation coefficient obtained from envelope of correlation maxima (maxima-maximorum) drops to $1/e$
$\overline{\theta_1}, \overline{\theta_2}$	Eddy lifetime for unsteady convection
$\nu, \nu_w$	Kinematic viscosity of fluid near wall
$\xi$	Equals $x - x'$ , longitudinal partial separation
$\xi'$	Equals $x_0 + x_0'$
$\rho$	Density of fluid
$\rho_w$	Density of fluid near wall

$\sigma_1, \sigma_2$	Standard deviation of distribution
$\tau$	Equals $t - t'$ , time delay
$\tau_0$	Equals $t_0 - t_0'$
$\tau_0'$	Equals $t_0 + t_0'$
$\tau_w$	Local wall-shear stress
$\phi_{mn}(x,y)$ or $\phi(x)\phi(y)$	Plate eigenfunctions
$\omega$	Circular frequency equal to $2\pi f$
$\omega_t$	Circular frequency of temporal fluctuation
$\omega_{mn}$	Plate modal frequency
$\nabla^4$	Equals $\frac{\partial^4 Y}{\partial x^4} + \frac{2\partial^4 Y}{\partial x^2 \partial y^2} + \frac{\partial^4 Y}{\partial y^4}$
$\langle \dots \rangle$	Symbol for time-average operation

## APPENDIX B1 – MATHEMATICAL ANALYSIS

Two models were taken from experimental data<sup>14,15</sup> to represent the cross correlation of the turbulence wall-pressure fluctuations in a broad frequency band. The models, designated as Model A-convected semifrozen pattern and Model B-unsteady convection-will be considered in turn.

### MODEL A-CONVECTED SEMIFROZEN PATTERN ( $U_c = \text{CONSTANT}$ )

The normalized cross-correlation function of the pressure fluctuations for this model in a moving frame of reference is represented by the sum of two Gaussian distributions

$$R(\xi, \eta, \tau) = \frac{\langle p(x, y, t) p(x + \xi, y + \eta, t + \tau) \rangle}{p^2} = e^{-\frac{|\tau|}{\theta}} \left\{ A_1 e^{-\frac{[(\xi - U_c \tau)^2 + \eta^2]}{2\sigma_1^2}} + A_2 e^{-\frac{[(\xi - U_c \tau)^2 + \eta^2]}{2\sigma_2^2}} \right\} \quad (\text{B1})$$

corresponding to measurements made with a series of constant time delays and variable spatial separation; see Reference 16 Figure 4. The convection velocity, obtained from Equation (B1), is defined by

$$\frac{\partial R(\xi, \tau)}{\partial \xi} = 0, \quad \text{when } U_c = \frac{\xi_{\max}}{\tau} \quad (\text{B2})$$

Alternatively, the normalized cross-correlation function may also be represented by

$$R(\xi, \eta, \tau) = e^{-\frac{|\xi|}{U_c \theta}} \left\{ A_1 e^{-\frac{[(\xi - U_c \tau)^2 + \eta^2]}{2\sigma_1^2}} + A_2 e^{-\frac{[(\xi - U_c \tau)^2 + \eta^2]}{2\sigma_2^2}} \right\} \quad (\text{B3})$$

corresponding to measurements made with constant spatial separation and variable time delay; see Reference 16 Figure 3. The convection velocity obtained from Equation (B3) is defined by



$$\frac{\partial R(\xi, \tau)}{\partial \tau} = 0, \quad \text{when } U_c = \frac{\xi}{\tau_{\max}}. \quad (\text{B4})$$

Since most data were taken at constant spatial separation, the autocorrelation function obtained from Equation (B3) by setting  $\xi = \eta = 0$  is

$$R(\tau) = A_1 e^{-\frac{U_c^2 \tau^2}{2\sigma_1^2}} + A_2 e^{-\frac{U_c^2 \tau^2}{2\sigma_2^2}} \quad (\text{B5})$$

and the corresponding power spectrum is (use Fourier transform Pairs 708 of Reference 7)

$$P(\omega) = \frac{1}{2\pi} \int_{-\infty}^{\infty} R(\tau) e^{-i\omega\tau} d\tau = \frac{A_1 \sigma_1}{U_c \sqrt{2\pi}} e^{-\frac{\sigma_1^2 \omega^2}{2U_c^2}} + \frac{A_2 \sigma_2}{U_c \sqrt{2\pi}} e^{-\frac{\sigma_2^2 \omega^2}{2U_c^2}} \quad (\text{B6})$$

Comparison of theory and experiment shows that the high-frequency resolution of Equation (B3) is poor; see Reference 14 Figure 1. Hence a more satisfactory empirical representation of the cross correlation of the pressures is constructed as follows from the autocorrelation obtained from the measured power spectral density, with decay in a moving frame of reference. This representation corresponds to a broader range of frequency components than the previous one; see Reference 14 Figure 2. The measured dimensionless power spectral density can be represented by

$$\frac{P(\omega)U}{\tau_w^2 \delta^*} = A_1 e^{-K_1 \omega F} + A_2 e^{-K_2 \omega F} + A_3 e^{-K_3 \omega F} \quad (\text{B7})$$

where

$$A_1 = 1.6$$

$$A_2 = 7.2$$

$$A_3 = 12.0$$

$$F = \delta^*/U$$

$$K_1 = 0.470$$

$$K_2 = 3.0$$

$$K_3 = 14.0$$

Using Fourier Pair 632 of Reference 7, the normalized autocorrelation is found

$$R(\tau) = \frac{R(\tau)_{\text{unnormalized}}}{R(0)}$$

$$= \frac{\left[ \frac{A_1 K_1}{K_1^2 + (\tau/F)^2} + \frac{A_2 K_2}{K_2^2 + (\tau/F)^2} + \frac{A_3 K_3}{K_3^2 + (\tau/F)^2} \right]}{\left( \frac{A_1}{K_1} + \frac{A_2}{K_2} + \frac{A_3}{K_3} \right)} \quad (\text{B8})$$

By introducing the spatial decay  $e^{-|\xi|/U_c \theta}$  and moving frame of reference  $(\xi - U_c \tau)$ , the normalized cross-correlation function of the pressure becomes (by analogy with Equation (B3)) with respect to symmetry about the  $\xi$  and  $\tau$  axes:

$$R(\xi, \eta, \tau) = e^{-|\xi|/U_c \theta} \left\{ \frac{\sum_{\gamma=1}^3 \frac{A_\gamma K_\gamma}{K_\gamma^2 + (1/FU_c)^2 [(\xi - U_c \tau)^2 + \eta^2]} \right\} \frac{\sum_{\gamma=1}^3 \frac{A_\gamma}{K_\gamma}}{\quad} \quad (\text{B9})$$

By changing the decay rate from  $\frac{|\xi|}{U_c \theta}$  to  $\frac{|\tau|}{\theta}$  in Equation (B9), (the Taylor hypothesis), the functional form of  $R(\xi, \eta, \tau)$  still fits the experimental results.<sup>17</sup> Hence either form of the exponential may be used to describe the decay of the wall pressure correlation.

#### MODEL B-UNSTEADY CONVECTION ( $U_c \neq \text{CONSTANT}$ )

For unsteady convection, the normalized cross correlation has the form

$$R(\xi, \eta, \tau) = A_1 \left( e^{-\frac{|\tau|}{\theta_1}} + a_1 e^{-\frac{|\tau|}{\theta_1}} \sin \omega_1 |\tau| \right) e^{-\frac{[(\xi - U_c \tau)^2 + \eta^2]}{2\sigma_1^2}}$$

$$+ A_2 \left( e^{-\frac{|\tau|}{\theta_2}} + a_2 e^{-\frac{|\tau|}{\theta_2}} \cos \omega_2 |\tau| \right) e^{-\frac{[(\xi - U_c \tau)^2 + \eta^2]}{2\sigma_2^2}} \quad (\text{B10})$$

and the normalized autocorrelation ( $\eta = \xi = 0$ ) becomes

$$\begin{aligned}
 R(\tau) = & A_1 \left( e^{-\frac{|\tau|}{\theta_1}} + a_1 e^{-\frac{|\tau|}{\bar{\theta}_1}} \sin \omega_1 |\tau| \right) e^{-\frac{U_c^2 \tau^2}{2\sigma_1^2}} \\
 & + A_2 \left( e^{-\frac{|\tau|}{\theta_2}} + a_2 e^{-\frac{|\tau|}{\bar{\theta}_2}} \cos \omega_2 \tau \right) e^{-\frac{U_c^2 \tau^2}{2\sigma_2^2}}
 \end{aligned} \tag{B11}$$

### STRUCTURAL RESPONSE TO TURBULENCE EXCITATION

The displacement cross correlation of a plate due to the cross correlation of a random pressure  $\langle p(x_0, y_0, t_0) p(x'_0, y'_0, t'_0) \rangle$  has been given by Dyer;<sup>2</sup> see Appendix A

$$\begin{aligned}
 \overline{\langle Y(x, y, t) Y(x', y', t') \rangle} &= \int_{-\infty}^t dt_0 \int_{-\infty}^{t'} dt'_0 \int_0^a dx_0 \int_0^b dy_0 \int_0^a dx'_0 \int_0^b dy'_0 \\
 &\cdot g(x, y, t / x_0, y_0, t_0) g(x', y', t' / x'_0, y'_0, t'_0) \\
 &\cdot \langle p(x_0, y_0, t_0) p(x'_0, y'_0, t'_0) \rangle
 \end{aligned} \tag{B12}$$

Using Equation (B9) with  $\frac{|\xi|}{U_c} = |\tau| = |t_0 - t'_0|$ , the unnormalized cross correlation for *semifrozen* flow becomes

$$\begin{aligned}
 \overline{\langle p(x_0, y_0, t_0) p(x'_0, y'_0, t'_0) \rangle} &= \frac{\overline{p^2} e^{-\frac{|t_0 - t'_0|}{\theta}}}{\sum_{\nu=1}^3 \frac{A_\nu}{K_\nu}} \\
 \sum_{\nu=1}^3 \frac{A_\nu K_\nu}{K_\nu^2 + (1/FU_c)^2 \left\{ [l(x_0 - x'_0) - U_c(t_0 - t'_0)]^2 + (y_0 - y'_0)^2 \right\}} & \tag{B13}
 \end{aligned}$$

As in Appendix A1, the homogeneous equation for plate vibrations has the form

$$B \nabla^4 Y(x, y, t) + M \frac{\partial^2 Y(x, y, t)}{\partial t^2} + (\beta_{ac} + \beta_{st}) \frac{\partial Y(x, y, t)}{\partial t} = 0 \quad (\text{B14})$$

where

$$Y_{mn}(x, y, t) \sim \phi_{mn}(x, y) e^{[-a_{mn}t + i\omega_{mn}t]} \quad (\text{B15})$$

is the normal mode solution to Equation (B14). Substitution of Equation (B15) in Equation (B14) yields

$$\nabla^4 \phi_{mn}(x, y) - \Gamma_{mn} \phi_{mn}(x, y) = 0 \quad (\text{B16})$$

where

$$\Gamma_{mn}^4 = \frac{-M(-a_{mn} + i\omega_{mn})^2 - (\beta_{ac} + \beta_{st})(-a_{mn} + i\omega_{mn})}{B} \quad (\text{B17})$$

Equating imaginary and real quantities in Equation (B17),\*

$$a_{mn} = \frac{\beta_{ac} + \beta_{st}}{2M} = \frac{\delta_{mn}\omega_{mn}}{2} \quad (\text{B18})$$

and

$$\omega_{mn}^2 \approx \frac{B}{M} \Gamma_{mn}^4 \quad (\text{B19})$$

---

\* *Forced response of a mode to a sinusoidal force or 3-dB method* was used to measure damping. For small damping, if  $\beta = \beta_{ac} + \beta_{st}$ , the decay ratio  $= \frac{\beta}{\beta_c} = \frac{1}{2} \frac{\omega_+ - \omega_-}{\omega_{mn}} = \frac{1}{2} \frac{\Delta\omega}{\omega_{mn}}$ , where  $\omega_+$  and  $\omega_-$  are circular frequencies of vibration, when response differs from extreme value by ratio of  $\sqrt{2}$  (equivalent to 3dB). In Reference 14, Equation (13) Maestrello defined the total damping ratio by  $\delta_{mn} = \frac{\Delta\omega}{\omega_{mn}}$ . Hence

$$\frac{\beta}{\beta_c} = \frac{1}{2} \frac{\Delta\omega}{\omega_{mn}} = \frac{\delta_{mn}}{2} = \frac{\beta}{2M\omega_{mn}} = \frac{a_{mn}}{\omega_{mn}} \quad \text{and} \quad a_{mn} = \frac{\delta_{mn}\omega_{mn}}{2}$$

see Reference 18, pages 14-16.

For low damping, the impulse response function was found (see Appendix A1) to be

$$g(x, y, t / x_0, y_0, t_0) \doteq \sum_{mn} \frac{\phi_{mn}(x, y) \phi_{mn}(x_0, y_0)}{\omega_{mn} M} \cdot \left[ e^{-a_{mn}(t-t_0)} \sin \omega_{mn}(t-t_0) \right] u(t-t_0) \quad (\text{B20})$$

Substituting Equations (B13) and (B20) in Equation (B12) and ignoring cross-coupling terms,

$$\begin{aligned} \frac{\langle Y(x, y, t) Y(x', y', t') \rangle}{\sum_{\nu=1}^3 \frac{A_{\nu}}{K_{\nu}} M^2} &= \frac{\overline{p^2}}{\sum_{mn} \frac{\phi_{mn}(x, y) \phi_{mn}(x', y')}{\omega_{mn}^2}} \\ &\cdot \int_{-\infty}^t dt_0 \int_{-\infty}^{t'} dt'_0 \int_0^a dx_0 \int_0^b dy_0 \int_0^a dx'_0 \int_0^b dy'_0 e^{-a_{mn}(t'-t'_0)} \\ &\cdot [\sin \omega_{mn}(t'-t'_0) u(t'-t'_0)] e^{-a_{mn}(t-t_0)} [\sin \omega_{mn}(t-t_0) u(t-t_0)] \\ &\cdot \frac{-|t_0 - t'_0|}{\theta} \\ &\sum_{\nu=1}^3 \frac{\phi_{mn}(x_0, y_0) \phi_{mn}(x'_0, y'_0) A_{\nu} K_{\nu} e^{-\frac{|t_0 - t'_0|}{\theta}}}{K_{\nu}^2 + (1/FU_c)^2 \left\{ [(x_0 - x'_0) - U_c(t_0 - t'_0)]^2 + (y_0 - y'_0)^2 \right\}} \end{aligned} \quad (\text{B21})$$

Also (see Appendix A1)

$$\phi_{mn} = \frac{2}{(ab)^{1/2}} \sin \frac{m\pi x}{a} \sin \frac{n\pi y}{b} \quad (\text{B22})$$

By trigonometric manipulation,

$$\begin{aligned} \phi_{mn}(x_0, y_0) \phi_{mn}(x'_0, y'_0) &= \frac{1}{ab} \left[ \cos \frac{m\pi(x_0 - x'_0)}{a} - \cos \frac{m\pi(x_0 + x'_0)}{a} \right] \\ &\cdot \left[ \cos \frac{n\pi(y_0 - y'_0)}{b} - \cos \frac{n\pi(y_0 + y'_0)}{b} \right] \end{aligned} \quad (\text{B23})$$

The space integral in Equation (B21) may then be written

$$\begin{aligned}
 I_V &= \int_0^b dy_0 \int_0^b dy'_0 \int_0^a dx_0 \int_0^a dx'_0 \\
 &= \frac{1}{ab} \left[ \cos \frac{m\pi(x_0 - x'_0)}{a} - \cos \frac{m\pi(x_0 + x'_0)}{a} \right] \left[ \cos \frac{n\pi(y_0 - y'_0)}{b} - \cos \frac{n\pi(y_0 + y'_0)}{b} \right] \\
 &\quad \frac{1}{K_V^2 + (1/FCU_c)^2 \left\{ [(x_0 - x'_0) - U_c(t_0 - t'_0)]^2 + (y_0 - y'_0)^2 \right\}} \\
 &= \int_0^b dy_0 \int_0^b dy'_0 \int_0^a dx_0 \int_0^a dx'_0 f(y_0, y'_0, x_0, x'_0) \quad (B24)
 \end{aligned}$$

To simplify computation of Equation (B21), the variable of integration is changed, thus reducing the number of operations for the integral.

Let

$$\begin{aligned}
 \eta' &= y_0 + y'_0 & \eta' + \eta &= 2y_0 & y_0 &= \frac{\eta' + \eta}{2} = g_1(\eta, \eta', \xi = 0, \xi' = 0) \\
 \eta &= y_0 - y'_0 & \eta' - \eta &= 2y'_0 & y'_0 &= \frac{\eta' - \eta}{2} = g_2(\eta, \eta', \xi = 0, \xi' = 0) \\
 \xi' &= x_0 + x'_0 & \xi' + \xi &= 2x_0 & x_0 &= \frac{\xi' + \xi}{2} = g_3(\eta = 0, \eta' = 0, \xi, \xi') \\
 \xi &= x_0 - x'_0 & \xi' - \xi &= 2x'_0 & x'_0 &= \frac{\xi' - \xi}{2} = g_4(\eta = 0, \eta' = 0, \xi, \xi')
 \end{aligned}$$

In Appendix A1, following Dyer, the transformation of two variables in a multiple integral had the following form. Let

$$x = \phi(u, v), \quad y = \psi(u, v)$$

Then

$$\iint f(x, y) dx dy = \iint f[\phi(u, v), \psi(u, v)] \begin{vmatrix} \frac{\partial x}{\partial u} & \frac{\partial x}{\partial v} \\ \frac{\partial y}{\partial u} & \frac{\partial y}{\partial v} \end{vmatrix} du dv$$

A similar formulation may be made for any number of variables of transformation.<sup>19, 20</sup>

$$I_V = \int_{\bar{x}} f(x) dx = \int_{g^{-1}(\bar{x})} f[g(t)] J_g(t) dt \quad (\text{B25})$$

where  $x = g(t)$  and  $t = g^{-1}(x)$  (the inverse function). In this case, from Equation (B24)

$$f(x) = f(y_0, y_0', x_0, x_0')$$

$$= \frac{\frac{1}{ab} \left[ \cos \frac{m\pi(x_0 - x_0')}{a} - \cos \frac{m\pi(x_0 + x_0')}{a} \right] \left[ \cos \frac{n\pi(y_0 - y_0')}{b} - \cos \frac{n\pi(y_0 + y_0')}{b} \right]}{K_V^2 + (1/FU_c)^2 \left[ \left( (x_0 - x_0') - U_c(t_0 - t_0') \right)^2 + (y_0 - y_0')^2 \right]}$$

also

$$\begin{aligned} f[g(t)] &= f[g_1(\eta, \eta', \xi, \xi'), g_2(\eta, \eta', \xi, \xi'), g_3(\eta, \eta', \xi, \xi'), g_4(\eta, \eta', \xi, \xi')] \\ &= f\left[ \frac{(\eta' + \eta)}{2}, \frac{(\eta' - \eta)}{2}, \frac{(\xi' + \xi)}{2}, \frac{(\xi' - \xi)}{2} \right] \end{aligned}$$

Substitute in  $f(x)$

$$x_0 - x_0' = \xi, \quad x_0 + x_0' = \xi', \quad y_0 - y_0' = \eta, \quad y_0 + y_0' = \eta'$$

to obtain

$$f[g(t)] = \frac{\frac{1}{ab} \left[ \cos \frac{m\pi\xi}{a} - \cos \frac{m\pi\xi'}{a} \right] \left[ \cos \frac{n\pi\eta}{b} - \cos \frac{n\pi\eta'}{b} \right]}{K_V^2 + (1/FU_c)^2 \left[ \left( \xi - U_c(t_0 - t_0') \right)^2 + \eta^2 \right]} \quad (\text{B26})$$

also

$$J_g(t) = \frac{\partial(g_1, g_2, g_3, g_4)}{\partial(\eta, \eta', \xi, \xi')} = \begin{vmatrix} \frac{\partial g_1}{\partial \eta} & \frac{\partial g_1}{\partial \eta'} & \frac{\partial g_1}{\partial \xi} & \frac{\partial g_1}{\partial \xi'} \\ \frac{\partial g_2}{\partial \eta} & \frac{\partial g_2}{\partial \eta'} & \frac{\partial g_2}{\partial \xi} & \frac{\partial g_2}{\partial \xi'} \\ \frac{\partial g_3}{\partial \eta} & \frac{\partial g_3}{\partial \eta'} & \frac{\partial g_3}{\partial \xi} & \frac{\partial g_3}{\partial \xi'} \\ \frac{\partial g_4}{\partial \eta} & \frac{\partial g_4}{\partial \eta'} & \frac{\partial g_4}{\partial \xi} & \frac{\partial g_4}{\partial \xi'} \end{vmatrix} = \begin{vmatrix} \frac{1}{2} & \frac{1}{2} & 0 & 0 \\ -\frac{1}{2} & \frac{1}{2} & 0 & 0 \\ 0 & 0 & \frac{1}{2} & \frac{1}{2} \\ 0 & 0 & -\frac{1}{2} & \frac{1}{2} \end{vmatrix} = \frac{1}{4} \quad (\text{B27})$$

To obtain the new limits, transform the limits in the  $y_0, y'_0$  plane (for the transverse coordinates) to corresponding quantities in the  $\eta, \eta'$  plane and the limits in the  $x_0, x'_0$  plane (for the longitudinal coordinates) to corresponding quantities in  $\xi, \xi'$  plane. The transformation is shown in Figures 4 and 5. From these figures, the limits for the  $\bar{x}$  to  $T$  planes are set to

$$x = g(t) = (y_0, y'_0, x_0, x'_0) : 0 \leq y_0 \leq b, 0 \leq y'_0 \leq b, 0 \leq x_0 \leq a, 0 \leq x'_0 \leq a$$

$$t = g^{-1}(x) = (\eta, \eta', \xi, \xi') : -b \leq \eta \leq b, |\eta| \leq \eta' \leq 2b - |\eta|, -a \leq \xi \leq a, |\xi| \leq \xi' \leq 2a - |\xi|$$

(Note: For  $\eta \geq 0$ ,  $\eta' = 2b + \eta$ , respectively, or equal  $2b - |\eta|$  along upper branch. For  $\eta < 0$ ,  $\eta' = \pm \eta$ , respectively, or equal  $|\eta|$  along lower branch. Similarly for  $\xi'$ .)

Substituting Equations (B26) and (B27) in Equation (B25) and using the limits for  $\xi, \xi', \eta, \eta'$  derived above, we get

$$I_\nu = \frac{1}{4ab} \int_{-a}^a d\xi \int_{-b}^b d\eta \int_{|\xi|}^{2a-|\xi|} -d\xi' \int_{|\eta|}^{2b-|\eta|} -d\eta' \frac{\left[ \cos \frac{m\pi\xi}{a} - \cos \frac{n\pi\xi'}{a} \right] \left[ \cos \frac{n\pi\eta}{b} - \cos \frac{n\pi\eta'}{b} \right]}{K_\nu^2 + (1/FU_c)^2 \left[ \left\{ \xi - U_c(t_0 - t'_0) \right\}^2 + \eta^2 \right]}$$

Integration with respect to  $\eta'$  and  $\xi'$ , in turn, reduces the integral to

$$I_\nu = \frac{2}{ab} \int_{-a}^a \left[ \int_0^b \frac{\left[ (a - |\xi|) \cos \frac{m\pi\xi}{a} + \frac{a}{m\pi} \sin \frac{m\pi|\xi|}{a} \right] \left[ (b - |\eta|) \cos \frac{n\pi\eta}{b} + \frac{b}{n\pi} \sin \frac{n\pi|\eta|}{b} \right]}{\left[ K_\nu^2 + (1/FU_c)^2 \right] \left[ \left\{ \xi - U_c(t_0 - t'_0) \right\}^2 + \eta^2 \right]} d\eta \right] d\xi \quad (\text{B28})$$

where

$$\int_{-b}^b \rightarrow 2 \int_0^b \text{ since the trigonometric functions are even functions of their argument and are thus}$$

unaffected by the signs of  $\xi, \eta$ .

Equation (B21) is rewritten

$$\overline{\langle Y(x, y, t) Y(x', y', t') \rangle} = \frac{\bar{p}^2}{\sum_{\nu=1}^3 \left( \frac{A_\nu}{K_\nu} \right) M^2} \sum_{mn} \frac{\phi_{mn}(x, y) \phi_{mn}(x', y')}{\omega_{mn}^2}$$

(Equation continued on top of page 48.)



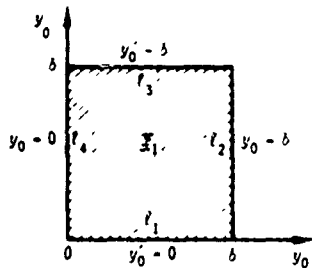

Figure 4A - Original Coordinates and Region of Integration

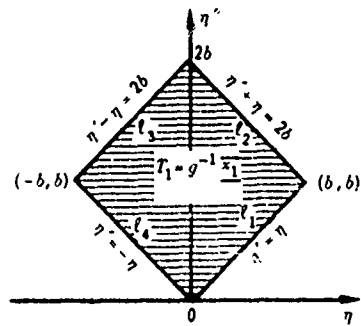

Figure 4b - Transformed Coordinates and Region of Integration

Figure 4 - Transformation of Transverse Coordinates and Region of Integration

Note to Figure 4:

- Line  $l_1$  where  $y'_0 = 0$  transforms to  $\eta' = \eta$
  - Line  $l_2$  where  $y_0 = b$  transforms to  $\eta' = \eta - 2b$
  - Line  $l_3$  where  $y'_0 = b$  transforms to  $\eta' = \eta + 2b$
  - Line  $l_4$  where  $y_0 = 0$  transforms to  $\eta' = -\eta$
- because  $\eta' = y_0 + y'_0 = g_1^{-1}(y_0, y'_0, x_0, x'_0)$   
 $\eta = y_0 - y'_0 = g_2^{-1}(y_0, y'_0, x_0, x'_0)$

Thus these limit points of Equation (B24) for the region  $y_0, y'_0$  denoted by  $\bar{X}_1$  in Figure 4a transform into the lines enclosing the region  $T$ , shown in Figure 4b. The limits for  $\eta, \eta'$  obtained from the later are based on the following relationships.

$$\text{Along } l_1: \begin{cases} 0 \leq y_0 \leq b \\ y'_0 = 0 \end{cases} \left\{ \begin{array}{l} \eta' = \eta \frac{d\eta'}{d\eta} = 1 \\ \eta' = y_0 + y'_0 = y_0 \end{array} \right.$$

Hence  $\eta'$  ranges from 0 to  $b$  with slope  $\frac{d\eta'}{d\eta} = 1$ .

Where  $\eta|_{y_0=0} = y_0 - y'_0|_{y_0=0} = 0$  then  $\eta'|_{y_0=0} = 0$ ;

where  $\eta|_{y_0=b} = y_0 - y'_0|_{y_0=b} = b$  then  $\eta' = b$ .

$$\text{Along } l_2: \begin{cases} 0 \leq y'_0 \leq b \\ y_0 = b \end{cases} \left\{ \begin{array}{l} \eta' + \eta = 2b \text{ or } \eta' = 2b - \eta \text{ and } \frac{d\eta'}{d\eta} = -1 \\ \eta' = y_0 + y'_0 = b + y'_0 \end{array} \right.$$

Hence  $\eta'$  ranges from  $b$  to  $2b$  with slope  $\frac{d\eta'}{d\eta} = -1$ .

Where  $\eta|_{y'_0=0} = y_0 - y'_0|_{y'_0=0} = y_0 = b$  then  $\eta'|_{y'_0=0} = b$ ;

where  $\eta|_{y'_0=b} = y_0 - y'_0|_{y'_0=b} = b - b = 0$  then  $\eta'|_{y'_0=b} = 2b$ .

$$\text{Along } l_3: \begin{cases} 0 \leq y_0 \leq b \\ y'_0 = b \end{cases} \left\{ \begin{array}{l} \eta' - \eta = 2b \text{ and } \frac{d\eta'}{d\eta} = 1 \\ \eta' = y_0 + y'_0 = y_0 + b \end{array} \right.$$

Hence  $\eta'$  ranges from  $b$  to  $2b$  with slope  $\frac{d\eta'}{d\eta} = 1$ .

Where  $\eta|_{y_0=0} = y_0 - y'_0|_{y_0=0} = -b$  then  $\eta'|_{y_0=0} = b$ ;

where  $\eta|_{y_0=b} = y_0 - y'_0|_{y_0=b} = b - b = 0$  then  $\eta'|_{y_0=b} = 2b$ .

$$\text{Along } l_4: \begin{cases} 0 \leq y'_0 \leq b \\ y_0 = 0 \end{cases} \left\{ \begin{array}{l} \eta' = -\eta \text{ and } \frac{d\eta'}{d\eta} = -1 \\ \eta' = y_0 + y'_0 = y'_0 \end{array} \right.$$

Hence  $\eta'$  ranges from 0 to  $b$  with slope  $\frac{d\eta'}{d\eta} = -1$ .

Where  $\eta|_{y'_0=0} = y_0 - y'_0|_{y'_0=0} = 0$  then  $\eta'|_{y'_0=0} = 0$ ;

where  $\eta|_{y'_0=b} = y_0 - y'_0|_{y'_0=b} = -b$  then  $\eta'|_{y'_0=b} = b$ .

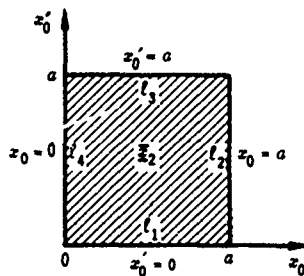

Figure 5a - Original Coordinates and Region of Integration

$$\begin{aligned} \leftarrow z = g(t) \\ \rightarrow t = g^{-1}(z) \end{aligned}$$

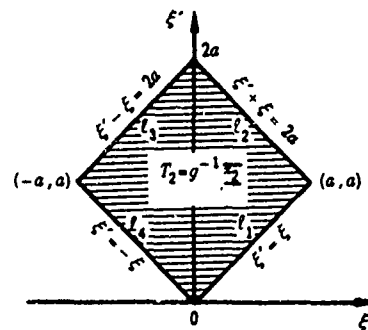

Figure 5b - Transformed Coordinates and Region of Integration

### Figure 5 - Transformation of Longitudinal Coordinates and Region of Integration

Notes to Figure 5:

Line  $l_1$  where  $x_0 = 0$  transforms to  $\xi' = \xi$

Line  $l_2$  where  $x_0 = a$  transforms to  $\xi' + \xi = 2a$  because  $\xi' = x_0 + x_0' = g_3^{-1}(y_0, y_0', x_0, x_0')$

Line  $l_3$  where  $x_0' = a$  transforms to  $\xi' - \xi = 2a$  because  $\xi = x_0 - x_0' = g_4^{-1}(y_0, y_0', x_0, x_0')$

Line  $l_4$  where  $x_0 = 0$  transforms to  $\xi' = -\xi$

Thus the limit points of Equation (B24) for the region  $x_0, x_0'$  denoted by  $\bar{x}_2$  in Figure 5a transform into the lines enclosing the region  $T_2$  shown in Figure 5b. The limits for  $\xi, \xi'$  obtained from the latter are based on the following relationships:

$$\text{Along } l_1: \left. \begin{array}{l} 0 < x_0 \leq a \\ x_0' = 0 \end{array} \right\} \begin{array}{l} \xi' = \xi \text{ and } \frac{d\xi'}{d\xi} = 1. \\ \xi' = x_0 + x_0' = x_0 \end{array}$$

Hence  $\xi'$  ranges from 0 to  $a$  with slope  $\frac{d\xi'}{d\xi} = 1$ .

Where  $\xi|_{x_0=0} = x_0 - x_0'|_{x_0=0} = 0$  then  $\xi'|_{x_0=0} = 0$ ;

where  $\xi|_{x_0=a} = x_0 - x_0'|_{x_0=a} = a$  then  $\xi' = a$ .

$$\text{Along } l_2: \left. \begin{array}{l} 0 \leq x_0' \leq a \\ x_0 = a \end{array} \right\} \begin{array}{l} \xi' + \xi = 2a \text{ or } \xi' = 2a - \xi \text{ and } \frac{d\xi'}{d\xi} = -1 \\ \xi' = x_0 + x_0' = a + x_0' \end{array}$$

Hence  $\xi'$  ranges from  $a$  to  $2a$  with slope  $\frac{d\xi'}{d\xi} = -1$ .

Where  $\xi|_{x_0'=0} = x_0 - x_0'|_{x_0'=0} = a$  then  $\xi'|_{x_0'=0} = a$ ;

where  $\xi|_{x_0'=a} = x_0 - x_0'|_{x_0'=a} = a - a = 0$  then  $\xi'|_{x_0'=a} = 2a$ .

$$\text{Along } l_3: \left. \begin{array}{l} 0 \leq x_0 \leq a \\ x_0' = a \end{array} \right\} \begin{array}{l} \xi' - \xi = 2a \text{ and } \frac{d\xi'}{d\xi} = 1 \\ \xi' = x_0 + x_0' = x_0 + a \end{array}$$

Hence  $\xi'$  ranges from  $a$  to  $2a$  with slope  $\frac{d\xi'}{d\xi} = 1$ .

Where  $\xi|_{x_0=0} = x_0 - x_0'|_{x_0=0} = -a$  then  $\xi'|_{x_0=0} = a$ ;

where  $\xi|_{x_0=a} = x_0 - x_0'|_{x_0=a} = a - a = 0$  then  $\xi'|_{x_0=a} = 2a$ .

$$\text{Along } l_4: \left. \begin{array}{l} 0 < x_0' \leq a \\ x_0 = 0 \end{array} \right\} \begin{array}{l} \xi' = -\xi \text{ and } \frac{d\xi'}{d\xi} = -1 \\ \xi' = x_0 + x_0' = x_0' \end{array}$$

Hence  $\xi'$  ranges from 0 to  $a$  with slope  $\frac{d\xi'}{d\xi} = -1$ .

Where  $\xi|_{x_0'=0} = x_0 - x_0'|_{x_0'=0} = 0$  then  $\xi'|_{x_0'=0} = 0$ ;

where  $\xi|_{x_0'=a} = x_0 - x_0'|_{x_0'=a} = -a$  then  $\xi'|_{x_0'=a} = a$ .

$$\int_{-\infty}^t dt_0 \int_{-\infty}^{t'} dt'_0 \left\{ e^{-a_{mn}(t-t_0)} \sin \omega_{mn}(t-t_0) u(t-t_0) e^{-a_{mn}(t'-t'_0)} \sin \omega_{mn}(t'-t'_0) u(t'-t'_0) \right\}$$

$$\cdot \sum_{\nu=1}^3 \left[ A_{\nu} K_{\nu} \int_0^a dx_0 \int_0^b dy_0 \int_0^a dx'_0 \int_0^b dy'_0 \frac{\phi_{mn}(x_0, y_0) \phi_{mn}(x'_0, y'_0) e^{-\frac{|t_0 - t'_0|}{\theta}}}{K_{\nu}^2 + (1/FU_c)^2 \left\{ [(x_0 - x'_0) - U_c(t_0 - t'_0)]^2 + (y_0 - y'_0)^2 \right\}} \right]$$

(B29)

where the space integrals are given by Equation (B28).

Having transformed the space coordinates, now transform the time coordinates. First, change the variable of integration and find the Jacobian

$$\begin{aligned} \tau'_0 &= t_0 + t'_0 & 2t_0 &= \tau_0 + \tau'_0 & t_0 &= \frac{\tau'_0 + \tau_0}{2} = g_1(\tau_0, \tau'_0) \\ \tau_0 &= t_0 - t'_0 & 2t'_0 &= \tau'_0 - \tau_0 & t'_0 &= \frac{\tau'_0 - \tau_0}{2} = g_2(\tau_0, \tau'_0) \end{aligned} \quad (\text{B30})$$

$$J(\tau_0, \tau'_0) = \frac{\partial(g_1, g_2)}{\partial(\tau_0, \tau'_0)} = \begin{vmatrix} \frac{\partial g_1}{\partial \tau_0} & \frac{\partial g_1}{\partial \tau'_0} \\ \frac{\partial g_2}{\partial \tau_0} & \frac{\partial g_2}{\partial \tau'_0} \end{vmatrix} = \begin{vmatrix} \frac{1}{2} & \frac{1}{2} \\ -\frac{1}{2} & \frac{1}{2} \end{vmatrix} = \frac{1}{2} \quad (\text{B31})$$

As for the space variables, now obtain the limits of  $\tau_0, \tau'_0$  in the transformed ( $T_{cd}$ ) plane. The transformation of the limits in the  $t_0, t'_0$  plane to corresponding quantities in the  $\tau_0, \tau'_0$  plane is given in Figures 6a and 6b where the limits from the  $\bar{x}_{cd}$  to  $T_{cd}$  plane are shown to be

$$\bar{x}_{cd} = \left\{ (t_0, t'_0) : -\infty \leq t_0 \leq t, -\infty \leq t'_0 \leq t' \right\}$$

$$T_{cd} = \left\{ (\tau_0, \tau'_0) : \tau'_0 - 2t' \leq \tau_0 \leq 2t - \tau'_0, -\infty \leq \tau'_0 \leq t + t' \right\} \quad (\text{B32})$$

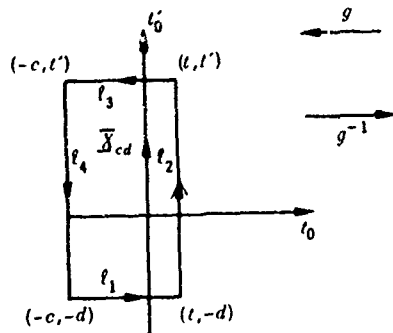

Figure 6a - Original Coordinates and Region of Integration

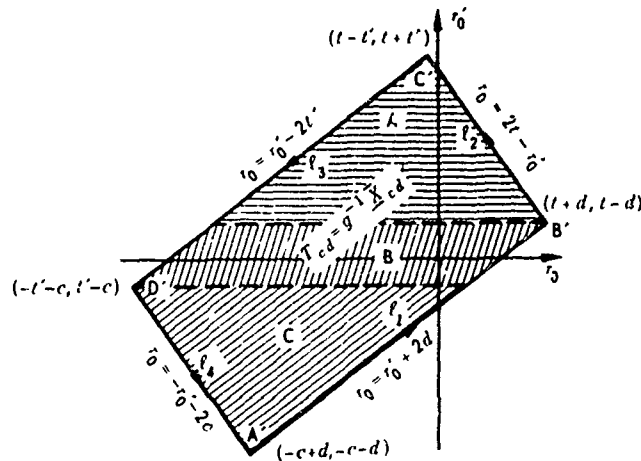

Figure 6b - Transformed Coordinates and Region of Integration

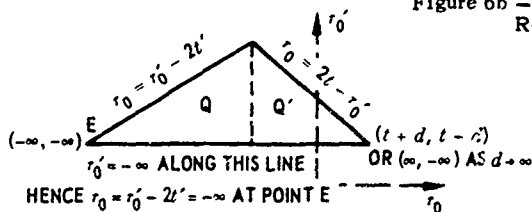

Figure 6c - Subdivision of Region A into Two Parts, Q and Q'

Figure 6 - Transformation of Time Coordinates and Region of Integration

The time limit points of Equation (B29) for the region  $t_0, t'_0$  denoted by  $\bar{X}_{cd}$  in Figure 6a, where  $c \rightarrow \infty, d \rightarrow \infty$ , transform into the lines enclosing the region  $T_{cd}$  in Figure 6b. The limits obtained from the latter are based on the following relationships, using Equation (B30):

Line  $l_1$  where  $t'_0 = -d, -c \leq t_0 \leq t$  transforms to  $r'_0 = t_0 - d, r_0 = t_0 + d, r'_0 = r_0 - 2d$

Line  $l_2$  where  $t_0 = t, -d \leq t'_0 \leq t'$  transforms to  $r_0 = t - t'_0, r'_0 = t + t'_0, r_0 = 2t - r'_0$

Line  $l_3$  where  $t'_0 = t', t \geq t_0 \geq -c$  transforms to  $r_0 = t_0 - t', r'_0 = t_0 + t', r'_0 = r_0 + 2t'$

Line  $l_4$  where  $t_0 = -c, t' \geq t'_0 \geq -d$  transforms to  $r_0 = -c - t'_0, r'_0 = -c + t'_0, r'_0 = -2c - r_0$

In Figure 6b, the points of intersection (corners) representing the new limits are found by solving simultaneous equations thus:

Point A':  $r_0 = -r'_0 - 2c = r'_0 + 2d$  yields  $r'_0 = -c - d, r_0 = -c + d$

Point B':  $r_0 = r'_0 + 2d = 2t - r'_0$  yields  $r'_0 = t - d, r_0 = t + d$

Point C':  $r_0 = 2t - r'_0 = r'_0 - 2t'$  yields  $r'_0 = t + t', r_0 = t - t'$

Point D':  $r_0 = r'_0 - 2t' = -r'_0 - 2c$  yields  $r'_0 = t' - c, r_0 = -t' - c$

The limits for the transformed variables  $r_0, r'_0$  are now obtained from Figure 6b by subdividing the rectangular region into three regions A, B, C, over which the integrations are to be performed. From the figure and letting  $c \rightarrow \infty, d \rightarrow \infty$ , we have:

$$\text{For Region A } \begin{cases} r'_0 - 2t' \leq r_0 \leq 2t - r'_0 \\ t - d \leq r'_0 \leq t + t' \text{ becomes } -\infty \leq r'_0 \leq t + t' \end{cases}$$

$$\text{For Region B } \begin{cases} r'_0 - 2t' \leq r_0 \leq r'_0 + 2d \\ t' - c \leq r'_0 \leq t - d + \infty \leq r'_0 \leq -\infty. \text{ Since the limits for } \\ r'_0 \text{ coincide they will yield a zero contribution to the total} \\ \text{integral. Therefore these limits are not considered.} \end{cases}$$

$$\text{For Region C } \begin{cases} -r'_0 - 2c \leq r_0 \leq r'_0 + 2d \\ -c - d \leq r'_0 \leq t' - c \text{ becomes } -\infty \leq r'_0 \leq -\infty. \end{cases}$$

Again, these limits are not considered.

Since only the limits for Region A contribute to the total integral, they alone are to be considered.

The limits for  $T_{cd}$  shown in Figure 6 correspond to integrations for Region A only, which is the only region that need be treated. To perform the integration in Region A, it is convenient to subdivide the region in two, Q and Q' as shown in Figure 6c. The limits are then reestablished so that the first is integrated with respect to  $\tau'_0$  in Region Q (the inner integral) and then with respect to  $\tau_0$  in Region A; similar action is taken for Region Q'. The limits are (letting  $t - t' = \tau$ )

$$\text{In Region Q } \begin{cases} -\infty \leq \tau'_0 \leq \tau_0 + 2t' \\ -\infty \leq \tau_0 \leq t - t' = \tau \end{cases}$$

$$\text{In Region Q' } \begin{cases} -\infty \leq \tau'_0 \leq 2t - \tau'_0 \\ t - t' = \tau \leq \tau_0 \leq \infty \end{cases}$$

The transformed time integral is now obtained from Equation (B25)

$$I' = \int_{\bar{x}_{cd}} f(x) dx = \int_{g^{-1}(\bar{x})} f[g(t)] J_g(t) dt \quad (\text{B33})$$

using Equation (B29) to obtain

$$\begin{aligned} f[g(t)] &= e^{-\frac{|t_0 - t'_0|}{\theta}} e^{-\alpha_{mn}|t - t_0|} \sin \omega_{mn}(t - t_0) u(t - t_0) e^{-\alpha_{mn}(t' - t'_0)} \sin \omega_{mn}(t' - t'_0) u(t' - t'_0) \\ &= -\frac{1}{2} e^{-\frac{|t_0 - t'_0|}{\theta}} e^{-\alpha_{mn}(t + t' - t_0 - t'_0)} [\cos \omega_{mn}(t + t' - t_0 - t'_0) - \cos \omega_{mn}(t - t' - t_0 + t'_0)] \cdot u(t - t_0) u(t' - t'_0) \\ &= -\frac{1}{2} e^{-\frac{|t_0 - t'_0|}{\theta}} e^{-\alpha_{mn}(t + t' - \tau'_0)} [\cos \omega_{mn}(t + t' - \tau'_0) - \cos \omega_{mn}(\tau - \tau_0)] \cdot u\left[t - \frac{(\tau'_0 + \tau_0)}{2}\right] u\left[t' - \frac{(\tau'_0 - \tau_0)}{2}\right] \end{aligned} \quad (\text{B34})$$

and Equation (B31) to obtain

$$J_g(t) = \frac{1}{2} \quad (\text{B35})$$

The time integral  $I'$  then becomes

$$\begin{aligned} I' = I'_1 + I'_2 &= \underbrace{\frac{1}{2} \int_{-\infty}^{\tau} \left[ \int_{-\infty}^{\tau_0 + 2t'} f[g(t)] d\tau'_0 \right]}_{\text{For Q}} d\tau_0 + \underbrace{\frac{1}{2} \int_{\tau}^{\infty} \left[ \int_{-\infty}^{2t - \tau_0} f[g(t)] d\tau'_0 \right]}_{\text{For Q'}} d\tau_0 \\ &= -\frac{1}{4} \int_{-\infty}^{\tau} \left\{ \left[ \int_{-\infty}^{\tau_0 + 2t'} e^{-a_{mn}(t+t'-\tau'_0)} \cos \omega_{mn}(t+t'-\tau'_0) - \int_{-\infty}^{\tau_0 + 2t'} \right. \right. \\ &\quad \left. \left. \cdot e^{-a_{mn}(t+t'-\tau'_0)} \cos \omega_{mn}(\tau - \tau_0) \right] e^{\frac{-|\tau|}{\theta}} d\tau'_0 \right\} d\tau_0 \\ &\quad - \frac{1}{4} \int_{\tau}^{\infty} \left\{ \left[ \int_{-\infty}^{2t - \tau_0} e^{-a_{mn}(t+t'-\tau'_0)} \cos \omega_{mn}(t+t'-\tau'_0) - \int_{-\infty}^{2t - \tau_0} \right. \right. \\ &\quad \left. \left. \cdot e^{-a_{mn}(t+t'-\tau'_0)} \cos \omega_{mn}(\tau - \tau_0) \right] e^{\frac{-|\tau|}{\theta}} d\tau'_0 \right\} d\tau_0 \end{aligned}$$

(For convenience the  $u$ 's are omitted.)

Using Formula 414 of Reference 21 to obtain the first and third integrals (the second and fourth integrations are simply performed) and noting that  $t + t' - \tau_0 - 2t' = t - t' - \tau_0 = \tau - \tau_0$  and  $t + t' - 2t + \tau_0 = -t + t' + \tau_0 = \tau_0 - \tau$ , we get

$$\begin{aligned} I' = I'_1 + I'_2 &= -\frac{1}{4} \int_{-\infty}^{\tau} e^{-a_{mn}(\tau - \tau_0)} \frac{[a_{mn} \cos \omega_{mn}(\tau - \tau_0) - \omega_{mn} \sin \omega_{mn}(\tau - \tau_0)]}{a_{mn}^2 + \omega_{mn}^2} e^{\frac{-|\tau|}{\theta}} d\tau_0 \\ &\quad + \frac{1}{4 a_{mn}} \int_{-\infty}^{\tau} e^{-a_{mn}(\tau_0 - \tau)} \cos \omega_{mn}(\tau - \tau_0) e^{\frac{-|\tau_0|}{\theta}} d\tau_0 \end{aligned}$$

We define

$$f_1(\xi) = (a - |\xi|) \cos \frac{m\pi\xi}{a} + \frac{a}{m\pi} \sin \frac{m\pi|\xi|}{a}$$

$$f_2(\eta) = (b - |\eta|) \cos \frac{n\pi\eta}{b} + \frac{b}{n\pi} \sin \frac{n\pi|\eta|}{b} \quad (\text{B38})$$

Then

$$\overline{\langle Y(x, y, t) Y(x', y', t') \rangle} = \frac{\overline{p^2}}{\sum_{\nu=1}^3 \left(\frac{A_\nu}{K_\nu}\right) M^2} \sum_{mn} \frac{\phi_{mn}(x, y) \phi_{mn}(x', y')}{\omega_{mn}^2}$$

$$\sum_{\nu=1}^3 A_\nu K_\nu \frac{2}{ab} \int_{-a}^a f_1(\xi) \int_0^b f_2(\eta) \frac{d\eta d\xi [I'_1 + I'_2]}{K_\nu^2 + (1/FU_c)^2 \left[ \left\{ \xi - U_c(t_0 - t'_0) \right\}^2 + \eta^2 \right]} \quad (\text{B39})$$

or

$$\overline{\langle Y(x, y, t) Y(x', y', t') \rangle} = \frac{\overline{p^2}}{\sum_{\nu=1}^3 \left(\frac{A_\nu}{K_\nu}\right) M^2} \sum_{mn} \frac{\phi_{mn}(x, y) \phi_{mn}(x', y')}{2ab \omega_{mn}^2} [I'_1 + I'_2] \quad (\text{B40})$$

where

$$I_1 = \sum_{\nu=1}^3 A_\nu K_\nu \int_{-a}^a f_1(\xi) \left[ \int_0^b f_2(\eta) d\eta \right] d\xi \frac{4I'_1}{K_\nu^2 + (1/FU_c)^2 \left[ \left\{ \xi - U_c(t_0 - t'_0) \right\}^2 + \eta^2 \right]}$$

$$= \frac{\omega_{mn}}{a_{mn}^2 + \omega_{mn}^2} \int_{-a}^a f_1(\xi) \left[ \int_0^b f_2(\eta) \sum_{\nu=1}^3 A_\nu K_\nu \right]$$

$$\left[ \int_{-\infty}^{\tau} \frac{e^{-a_{mn}(\tau - \tau_0)} \left\{ \sin \omega_{mn}(\tau - \tau_0) + \frac{\omega_{mn}}{a_{mn}} \cos \omega_{mn}(\tau - \tau_0) \right\} e^{-\frac{|\tau_0|}{\theta}}}{K_\nu^2 + (1/FU_c)^2 \left[ \left\{ \xi - U_c(t_0 - t'_0) \right\}^2 + \eta^2 \right]} d\tau_0 \right] d\eta \right] d\xi \quad (\text{B41})$$

$$I_2 = \sum_{\nu=1}^3 A_{\nu} K_{\nu} \int_{-a}^a f_1(\xi) \left[ \int_0^b f_2(\eta) d\eta \right] d\xi \frac{4I_2'}{K_{\nu}^2 + (1/FU_c)^2 \left[ \left\{ \xi - U_c(t_0 - t_0') \right\}^2 + \eta^2 \right]}$$

$$= \frac{\omega_{mn}}{a_{mn}^2 + \omega_{mn}^2} \int_{-a}^a f_1(\xi) \left[ \int_0^b f_2(\eta) \sum_{\nu=1}^3 A_{\nu} K_{\nu} \right]$$

$$\cdot \left[ \int_{\tau}^{\infty} \frac{e^{-a_{mn}(\tau_0 - \tau)} \left\{ \sin \omega_{mn}(\tau_0 - \tau) + \frac{\omega_{mn}}{a_{mn}} \cos \omega_{mn}(\tau_0 - \tau) \right\} e^{-\frac{|\tau_0|}{\theta}}}{K_{\nu}^2 + (1/FU_c)^2 \left[ \left\{ \xi - U_c(t_0 - t_0') \right\}^2 + \eta^2 \right]} d\tau_0 \right] d\eta \right] d\xi \quad (B42)$$

The time integral in  $I_1$  and  $I_2$  can be further simplified by changing the limits of integration. In Equation (B41), for  $I_1$  let

$$\bar{K}_1 = \int_{-\infty}^{\tau} \frac{e^{-a_{mn}(\tau - \tau_0)} \left\{ \sin \omega_{mn}(\tau - \tau_0) + \frac{\omega_{mn}}{a_{mn}} \cos \omega_{mn}(\tau - \tau_0) \right\} e^{-\frac{|\tau_0|}{\theta}}}{K_{\nu}^2 + (1/FU_c)^2 \left[ (\xi - U_c \tau_0)^2 + \eta^2 \right]} d\tau_0$$

let

$$\bar{x} = \tau - \tau_0 \quad \tau_0 = \tau - \bar{x} \quad d\bar{x} = -d\tau_0$$

when

$$\tau_0 = \tau, \bar{x} = 0$$

$$\tau_0 = -\infty, \bar{x} = \infty$$

substituting the previously mentioned quantities in  $\bar{K}_1$  and noting that  $-\int_{\infty}^0 = \int_0^{\infty}$

$$\bar{K}_1 = \int_0^{\infty} \frac{e^{-a_{mn}\bar{x}} \left\{ \sin \omega_{mn}\bar{x} + \frac{\omega_{mn}}{a_{mn}} \cos \omega_{mn}\bar{x} \right\} e^{-\frac{|\tau - \bar{x}|}{\theta}}}{K_{\nu}^2 + (1/FU_c)^2 \left[ (\xi - U_c \tau) + U_c \bar{x} \right]^2 + \eta^2} d\bar{x} \quad (B43)$$



Similarly, for the time integral in  $I_2$ , set  $\bar{x} = \tau_0 - \tau$ ,  $\tau_0 = \tau + \bar{x}$   $d\bar{x} = d\tau_0$ , and note that when  $\tau_0 = \infty$ ,  $\bar{x} = \infty$  whereas when  $\tau_0 = \tau$ ,  $\bar{x} = 0$ . The substitutions yield

$$\bar{K}_2 = \int_0^\infty \frac{e^{-a_{mn}\bar{x}} \left\{ \sin \omega_{mn}\bar{x} + \frac{\omega_{mn}}{a_{mn}} \cos \omega_{mn}\bar{x} \right\} e^{-\frac{|\tau+\bar{x}|}{\theta}}}{K_\nu^2 + (1/FU_c)^2 \left[ (\xi - U_c\tau) - U_c\bar{x} \right]^2 + \eta^2} d\bar{x} \quad (\text{B44})$$

When Equations (B43) and (B44) are substituted into Equations (B41) for  $I_1$  and (B42) for  $I_2$ , respectively, Equation (B40) becomes

$$\begin{aligned} \overline{\langle Y(x,y,t) Y(x',y',t') \rangle} &= \frac{\bar{p}^2}{2ab \sum_{\nu=1}^3 \left( \frac{A_\nu}{K_\nu} \right) M^2} \sum_{mn} \frac{\phi_{mn}(x,y) \phi_{mn}(x',y')}{\omega_{mn}(a_{mn}^2 + \omega_{mn}^2)} \\ &\cdot \int_{-a}^a f_1(\xi) \left[ \int_0^b f_2(\eta) \left[ \int_0^\infty g_1(\bar{x}) \sum_{\nu=1}^3 \left\{ \frac{A_\nu K_\nu e^{-\frac{|\tau-x|}{\theta}}}{K_\nu^2 + (1/FU_c)^2 \left[ (\xi - U_c\tau) + U_c\bar{x} \right]^2 + \eta^2} \right. \right. \right. \\ &\quad \left. \left. \left. + \frac{A_\nu K_\nu e^{-\frac{|\tau+\bar{x}|}{\theta}}}{K_\nu^2 + (1/FU_c)^2 \left[ (\xi - U_c\tau) - U_c\bar{x} \right]^2 + \eta^2} \right\} d\bar{x} \right] d\eta \right] d\xi \end{aligned} \quad (\text{B45})$$

where

$$g_1(\bar{x}) = e^{-a_{mn}\bar{x}} \left\{ \sin \omega_{mn}\bar{x} + \frac{\omega_{mn}}{a_{mn}} \cos \omega_{mn}\bar{x} \right\} \quad (\text{B46})$$

and it is important to note that

$$\bar{x} = \tau - \tau_0; \quad d\bar{x} = d\tau_0 \quad \text{for the first terms in the time integral}$$

$$\bar{x} = \tau_0 - \tau; \quad d\bar{x} = d\tau_0 \quad \text{for the second terms in the time integral} \quad (\text{B47})$$

Let

$$\bar{y} = \frac{n\pi\eta}{b} \text{ or } \eta = \frac{b\bar{y}}{n\pi}; \quad \bar{z} = \frac{m\pi\xi}{a} \text{ or } \xi = \frac{a\bar{z}}{m\pi} \quad (\text{B48})$$

then

$$\begin{aligned} \frac{f_1(\xi)}{a} &= \cos \frac{m\pi\xi}{a} - \frac{1}{m\pi} \left( \frac{m\pi|\xi|}{a} \right) \cos \frac{m\pi\xi}{a} + \frac{1}{m\pi} \sin \frac{m\pi|\xi|}{a} \\ f_{11}(\bar{z}) &= \frac{f_1\left(\frac{a\bar{z}}{m\pi}\right)}{a} = \cos \bar{z} + \frac{1}{m\pi} (-|\bar{z}| \cos \bar{z} + \sin |\bar{z}|) \\ \frac{f_2(\eta)}{b} &= \cos \frac{n\pi\eta}{b} - \frac{1}{n\pi} \left( \frac{n\pi|\eta|}{b} \right) \cos \frac{n\pi\eta}{b} + \frac{1}{n\pi} \sin \frac{n\pi|\eta|}{b} \\ f_{21}(\bar{y}) &= \frac{f_2\left(\frac{b\bar{y}}{n\pi}\right)}{b} = \cos \bar{y} + \frac{1}{n\pi} (\sin |\bar{y}| - |\bar{y}| \cos \bar{y}) \end{aligned} \quad (\text{B49})$$

Note that  $f_1(\xi) = af_{11}(\bar{z})$  and  $f_2(\eta) = bf_{21}(\bar{y})$

also when

$$\begin{aligned} \xi &= -a, \bar{z} = -m\pi \\ \xi &= a, \bar{z} = m\pi \\ \eta &= 0, \bar{y} = 0 \\ \eta &= b, \bar{y} = n\pi \end{aligned} \quad (\text{B50})$$

and

$$d\eta = \frac{b}{n\pi} d\bar{y}, \quad d\xi = \frac{a}{m\pi} d\bar{z}, \quad d\eta d\xi = \frac{ab}{mn\pi^2} d\bar{y} d\bar{z} \quad (\text{B51})$$

Substituting Equations (B48) through (B51) in Equation (B45), the final result for the displacement cross correlation is

$$\begin{aligned}
\overline{\langle Y(x, y, t) Y(x', y', t') \rangle} &= \frac{\overline{p^2} ab}{2\pi^2 \left[ \sum_{\nu=1}^3 \left( \frac{A_\nu}{K_\nu} \right) \right] M^2} \sum_{mn} \frac{\phi_{mn}(xy) \phi_{mn}(x', y')}{mn \omega_{mn} (a_{mn}^2 + \omega_{mn}^2)} \\
&\cdot \int_{-m\pi}^{m\pi} f_{11}(\bar{z}) \left[ \int_0^{n\pi} f_{21}(\bar{y}) \left[ \int_0^\infty g_1(\bar{x}) \sum_{\nu=1}^3 \left\{ \frac{A_\nu K_\nu e^{-\frac{|\tau - \bar{x}|}{\theta}}}{K_\nu^2 + (1/FU_c)^2 \left[ \left[ \left( \frac{a\bar{z}}{m\pi} - U_c \tau \right) + U_c \bar{x} \right]^2 + \left( \frac{b\bar{y}}{n\pi} \right)^2 \right]} \right. \right. \right. \\
&+ \left. \left. \frac{A_\nu K_\nu e^{-\frac{|\tau + \bar{x}|}{\theta}}}{K_\nu^2 + (1/FU_c)^2 \left[ \left[ \left( \frac{a\bar{z}}{m\pi} - U_c \tau \right) - U_c \bar{x} \right]^2 + \left( \frac{b\bar{y}}{n\pi} \right)^2 \right]} \right\} d\bar{x} \right] d\bar{y} \right] d\bar{z} \quad (\text{B52})
\end{aligned}$$

(Note that in Reference 15, Equation (28),  $f_{11}(\bar{z}) \rightarrow f(\bar{z})$ ,  $f_{21}(\bar{y}) \rightarrow f(\bar{y})$  and  $g_1(\bar{x}) \rightarrow g(\bar{x})$ .)

If the second form of decay is used (for constant partial separation and variable time delay) for the cross correlation of the wall pressure for *semifrozen flow*, then in Equation (B13)

$$e^{-\frac{|\tau_0 - \tau'_0|}{\theta}} \rightarrow e^{-\frac{|x - x'_0|}{U_c \theta}} = e^{-\frac{|\xi|}{U_c \theta}} = e^{-\left| \frac{a\bar{z}}{m\pi U_c \theta} \right|}$$

so that following a procedure similar to that used in deriving Equation (B52), for this case

$$\begin{aligned}
\overline{\langle Y(x, y, t) Y(x', y', t') \rangle} &= \frac{\overline{p^2} ab}{2\pi^2 \sum_{\nu=1}^3 M^2} \sum_{mn} \frac{\phi_{mn}(x, y) \phi_{mn}(x', y')}{mn \omega_{mn} (a_{mn}^2 + \omega_{mn}^2)} \\
&\cdot \int_{-m\pi}^{m\pi} f_{11}(\bar{z}) \left[ \int_0^{n\pi} f_{21}(\bar{y}) \left[ \int_0^\infty g_1(\bar{x}) \sum_{\nu=1}^3 \left\{ \frac{A_\nu K_\nu}{K_\nu^2 + (1/FU_c)^2 \left[ \left[ \left( \frac{a\bar{z}}{m\pi} - U_c \tau \right) + U_c \bar{x} \right]^2 + \left( \frac{b\bar{y}}{n\pi} \right)^2 \right]} \right. \right. \right. \\
&+ \left. \left. \frac{A_\nu K_\nu}{K_\nu^2 + (1/FU_c)^2 \left[ \left[ \left( \frac{a\bar{z}}{m\pi} - U_c \tau \right) - U_c \bar{x} \right]^2 + \left( \frac{b\bar{y}}{n\pi} \right)^2 \right]} \right\} d\bar{x} \right] d\bar{y} \right] d\bar{z} \quad (\text{B53})
\end{aligned}$$

where

$$f_{11}(\bar{z}) = \frac{f\left(\frac{a\bar{z}}{m\pi}\right)}{b} = \frac{\cos \bar{z} + \frac{1}{m\pi} (-|\bar{z}| \cos \bar{z} + \sin |\bar{z}|)}{e^{-\left|\frac{a\bar{z}}{m\pi U_c \theta}\right|}}$$

$$f_{21}(\bar{z}) = \frac{f\left(\frac{b\bar{y}}{n\pi}\right)}{b} = \cos \bar{y} + \frac{1}{n\pi} (\sin |\bar{y}| - |\bar{y}| \cos \bar{y})$$

$$g_1(\bar{x}) = e^{-a_{mn}\bar{x}} \left[ \sin \omega_{mn}\bar{x} + \frac{\omega_{mn}}{a_{mn}} \cos \omega_{mn}\bar{x} \right]$$

Equations (B52) and (B53) have similar numerical results.

If the pressure covariance is used for *unsteady convection* (Model B) given in Equation (B10), the response of a panel including modal couplings is given by

$$\begin{aligned} \overline{\langle Y(x, Y, t) Y(x', y', t') \rangle} &= \int_{-\infty}^t dt_0 \int_{-\infty}^{t'} dt'_0 \int_0^a dx_0 \int_0^a dx'_0 \int_0^b dy_0 \int_0^b dy'_0 \\ &\cdot \left\{ \frac{\phi_{mn}(x, y) \phi_{mn}(x_0, y_0)}{\omega_{mn} M} e^{-a_{mn}(t-t_0)} [\sin \omega_{mn}(t-t_0) u(t-t_0)] \right\} \\ &\cdot \left\{ \frac{\phi_{p,q}(x', y') \phi_{p,q}(x'_0, y'_0)}{\omega_{pq} M} e^{-a_{pq}(t'-t'_0)} [\sin \omega_{pq}(t'-t'_0) u(t'-t'_0)] \right\} \\ &\cdot \left\{ A_1 \left[ e^{\frac{-|t_0-t'_0|}{\theta_1}} + a_1 e^{\frac{-|t_0-t'_0|}{\bar{\theta}_1}} \cdot \sin \omega_1 |t_0-t'_0| \right] \right. \\ &\cdot \left. \frac{e^{-\left\{ [(x_0-x'_0) - U_c(t_0-t'_0)]^2 + (y_0-y'_0)^2 \right\}}}{2\sigma_1^2} + A_2 \left[ e^{\frac{-|t_0-t'_0|}{\theta_2}} + a_2 e^{\frac{-|t_0-t'_0|}{\bar{\theta}_2}} \cdot \cos \omega_2(t_0-t'_0) \right] \right. \\ &\cdot \left. \frac{e^{-\left\{ [(x_0-x'_0) - U_c(t_0-t'_0)]^2 + (y_0-y'_0)^2 \right\}}}{2\sigma_2^2} \right\} \end{aligned} \quad (B54)$$

Using the modal volume displacement

$$\text{Vol}_{mn} = \sqrt{2} \bar{Y} \int_0^a \int_0^b \phi(x) \phi(y) dx dy \quad (\text{B55})$$

the modal acoustic power radiated in a reverberant field can be calculated

$$\text{PWL}_{mn} = \frac{N\omega^2 \rho c K_a^2}{4\pi} \frac{1}{Y^2} \frac{2P_r + P_p}{P_p} \left[ \int_0^a \int_0^b |\phi_m(x)| |\phi_n(y)| dx dy \right] \quad (\text{B56})$$

Finally, using Equation B9, the normalized power spectrum of the turbulence pressures is computed for case of  $\eta = 0$ . The normalized correlation coefficient is defined as

$$R_y(\xi, \eta, \tau) = \frac{Y(x, y, t) Y(x', y', t')}{\left[ Y(x, y, t)^2 Y(x', y', t')^2 \right]^{1/2}}$$

The normalized power spectrum is then

$$\begin{aligned} P(K_1, \omega) &= \frac{1}{(2\pi)^2} \int_{-\infty}^{\infty} \int_{-\infty}^{\infty} R(\xi, 0, \tau) e^{-(K_1 \xi + \omega \tau)} d\xi d\tau \quad (\text{B57}) \\ &= \frac{1}{(2\pi)^2} \int_{-\infty}^{\infty} \frac{e^{-|\xi|}}{\sum_{\gamma=1}^3 \frac{A_\gamma}{K_\gamma}} \sum_{\gamma=1}^3 A_\gamma K_\gamma F^2 \left[ \int_{-\infty}^{\infty} \frac{e^{-i\omega \tau} d\tau}{K_\gamma^2 F^2 + \left(\tau - \frac{\xi}{U_c}\right)^2} \right] e^{-iK_1 \xi} d\xi \quad (\text{B58}) \end{aligned}$$

From Pair 632.2 of Reference 7, with  $p = i\omega$  and  $\beta = K_\gamma F$ , the quantity in brackets equals

$$\frac{\pi}{K_\gamma F} e^{-K_\gamma F |\omega| - i\xi \omega / U_c}. \text{ Hence}$$

$$P(K_1, \omega) = \frac{F}{4\pi \sum_{\gamma=1}^3 \frac{A_\gamma}{K_\gamma}} \sum_{\gamma=1}^3 A_\gamma e^{-|\omega| K_\gamma F} \int_{-\infty}^{\infty} \frac{e^{-|\xi|}}{U_c} e^{-iK_1' \xi} d\xi \quad (\text{B59})$$

where  $K_1' = \frac{\omega}{U_c} + K_1$ .

Using Pair 444 of Reference 7, with  $p = iK_1' = i\left(\frac{\omega}{U_c} + K_1\right)$ , and  $\beta = \frac{1}{U_c\theta}$ , the integral

$$\text{equals } \frac{-2' U_c \theta}{-(K_1')^2 - (1' U_c \theta)^2} = \frac{2U_c \theta}{1 + \theta^2 (\omega + K_1 U_c)^2}$$

Hence

$$P(K_1, \omega) = \frac{\theta}{1 + \theta^2 (\omega + K_1 U_c)^2} (FU_c / 2\pi) \frac{\sum_{\gamma=1}^3 A_\gamma e^{-|\omega| K_\gamma F}}{\left(\sum_{\gamma=1}^3 \frac{A_\gamma}{K_\gamma}\right)} \quad (\text{B60})$$

which agrees with Reference 16, Equation (6).

## COMPUTER PROGRAMS

Computer programs for either Equation (B52) or (B53) and Equation (B60) are designated as Subprograms A and B, respectively. Reference 22 presents equations similar to Equations (B52) and (B53) and gives Fourier transforms to yield the displacement cross spectral density; (see Reference 22, Equation (27)). Since the method of derivation is similar to the method presented in this report, the details are omitted here.\* The corresponding computer subprograms are designated as Subprograms C (modal coupling excluded) and D (modal coupling included). The latter subprograms treat simple and clamped supports and uncoupled and coupled modes.

## APPENDIX B2 - METHOD FOR DETERMINING INPUT DATA

The following data are furnished to the computer

Flow data:  $U_c, \tau_w, \delta^* = FU, \omega, \overline{p^2}, \theta, A_\nu, K_\nu$  where  $\nu = 1, 2, 3$

Panel data:  $a, b, h, \delta_{mn}, E, M, \phi_{mn}, \omega_{mn}, \xi, \eta, \tau, m, n, \bar{Y}, N, \rho c K_a^2, \frac{2P_r + P_p}{P_p}, x, y, x', y'$

The method for determining the data is now described. Either the data are arbitrarily selected by the user, i.e., the values are chosen to represent the range of interest, or the selections may correspond to experimental values for a parameter.

---

\*The mathematical form of the model representing turbulence excitation pressures used in Reference 22 is slightly different from that used by Maestrello in his earlier works.

Parameter	Description
$A_\nu, K_\nu$	Prescribed constants used in Equation (B7)
$a, b, h$	Prescribed quantities
$E$	A prescribed quantity
$M$	A prescribed quantity
$m, n$	Prescribed data
$N$	Determined as described on page 434 of Reference 15. Maestrello assumed piston radiation for which $N = 4$ .
$\frac{2P_r + P_p}{P_p}$	Equal to 1 for a plate without ribs
$\overline{p^2}$	Equals $\int_0^\infty P(\omega) d\omega$ , where $P(\omega)$ is obtained from Equation (B7). This quantity can also be measured directly.
$U_c$	A parameter whose values are prescribed by the user, $U_c = 0.8 U_\infty$ ; see Reference 15 page 427. A method for measuring this quantity by experimentation is given by Equations (B2) and (B4) or alternately for $K, \omega$ space by equations given in Reference 15, page 414.
$x, y, x', y'$	Prescribed points; the cross correlation of the displacements are computed for these points.
$\overline{Y}$	Determined by taking the square root of the calculated mean-square displacement.
$\delta^* (=FU)$	Equals $0.37/8 (U_\infty x/\nu)^{-1/5}$ ; see Reference 25, Equations (21.6) and (21.8). Tables 1.1 and 2.1 of that reference give values of $\nu$ in air and water. Using this equation, values of $\delta^*$ for a given fluid can be prescribed over a range of $U_\infty$ .
$\delta_{mn}$	Total damping ratio obtained in accordance with the methods of Section 3.4 of Reference 14 and further described in the footnote to statement preceding Equation (B18). Note that in Reference 15 Figure 19, $a_{mn} = \delta_{mn} \omega_{mn} / 2$ , whereas determination of $a_{mn}$ in Figure 16 of the same reference is made from the formula $a_{mn} = 0.5(\omega_{mn})^{1/3}$ , which is based on <i>El Baroudis</i> data. The latter was considered acceptable for thin plates. In general it is preferable to use the former method in making a theoretical calculation. Value of $a_{mn}$ may be prescribed by the user to determine the effects of damping variations.

\*Our equation agrees with that given by Jacobs in Equation (59), of Reference 34 letting  $U_c = 0.8 Mc$  ( $M = \text{Mach Number}$  and  $c = \text{sound velocity}$ ) and noting that  $\theta$  should be in milliseconds in that equation. Our equation differs from that given in Reference 14, Equation 7, by a factor of  $10^{-3}$ , see also Appendix E.

$\theta$

Corresponds to the time in which the value of the measured correlation coefficient of the fluctuating pressures at the wall, obtained from the envelope of the correlation maxima, drop to  $1/e$ . Plots of  $\theta$  versus Mach number for broad- and narrow-band frequencies are given in Reference 14, Figure 5. From Figure 5\*  $\theta = 1.37 \times 10^{-3} U_c + 1.15$  where  $\theta$  is in milliseconds and  $U_c$  in feet per second. Thus,  $\theta = \theta(U_c)$  may also be prescribed for various values of  $U_c$ ;  $\theta$  may also be obtained from the plot of  $U_c \theta / \delta^*$  versus the Mach number given in Reference 15, Figure 6.

$\xi, \eta, \tau$

Prescribed data

$\rho C K_a^2$

The numerical value of this quantity for air has been computed and included in the program. For a water medium, it is necessary to modify this value in the ratio of  $(\rho C)_{\text{water}} / (\rho C)_{\text{air}}$  by adding an instruction to the program.

$\tau_w$

Determination of this quantity is based on the law of the wall described in detail and shown in Reference 23, Figure 1. The Maestrello data given in Reference 24, Figure 2, lie along the universal curve representing this law. (Note that for incompressible flow, the vertical coordinate of this figure equals  $u/u_\tau$ ).

From either of the figures,  $\frac{y u_\tau}{\nu_w} / \frac{u}{u_\tau} = \frac{y u_\tau^2}{u \nu_w} = \text{constant} = \text{inverse}$

slope of the curve, which is measured. Hence if the velocity profile of the users data agrees with the universal curve, then for a known value of  $\nu_w$ , selecting a value of  $u$  corresponding to a value of  $y$  yields the value of  $u_\tau$ . By definition  $\tau_w = \rho_w u_\tau^2$ .

$\phi_{mn}(xy) \phi_{mn}(x',y')$

The data required for the computer program are calculated by the digital computer for a range of prescribed values of  $m, n, x, y, x',$  and  $y'$ .

$\omega$

Prescribed in Equation (B7) to obtain  $P(\omega)$

$\omega_{mn}$

For a plate of given geometry and structural properties, this quantity is computed by hand for a plate with rigid or fixed boundaries using Equation (A7) of Reference 14. For a simply supported plate, use Equation (IV.5.16) of Reference 10.



### APPENDIX B3 – PROGRAM IDENTIFICATION

A program is presented for computing mean-square displacement (Subprogram A) of a simply supported rectangular panel excited by a turbulent boundary layer and the modal acoustic-power radiation of the plate in a reverberant field. The program also computes the turbulent pressures on the plate (Subprogram B) and the cross spectral density of the displacement for simple or clamped boundaries without modal cross coupling (Subprogram C) and with modal cross coupling (Subprogram D); see Tables 2 and 3. Computer running times for sample problems are as follows:

Subprogram	Computer	Time
A	IBM 7090 at NSRDC	The Simpson rule of integration 4 modes ( $m = 1, 3, 5, 7$ , with $n = 1$ ) 1 convection velocity $U_c$ Approximately 28 min
B	IBM 7090 at NSRDC	48 frequencies 8 spatial separations Approximately 2 min
C	IBM 360/91 at Applied Physics Laboratory Johns Hopkins University	Gaussian quadrature (9 point) 4 modes ( $m = 1, 3, 5, 7$ , with $n = 1$ ) 1 $U_c$ Approximately 9 sec

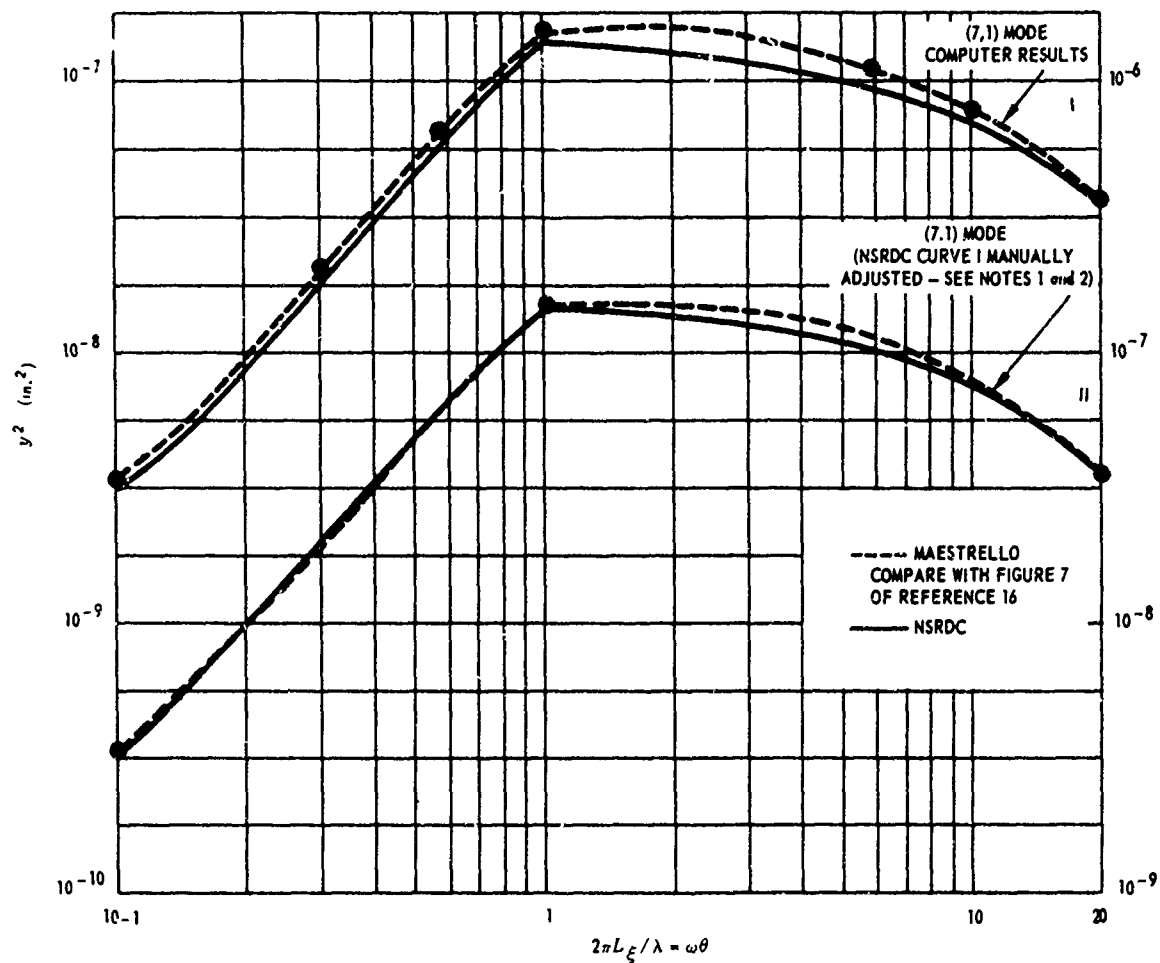

Note 1: For Curves I and II, use ordinate scales to left and right, respectively.

Note 2: NSRDC Curve I was obtained by selection of a value of  $\bar{p}^2 = 13.72 \text{ lb/in.}^4$  which yielded a curve approximating that of Maestrello Curve I. Maestrello's actual value of  $\bar{p}^2$  (Figure 7, Reference 16) is unknown. NSRDC Curve I was then manually adjusted to give the same value of  $y^2$  as that given by

Maestrello at  $\frac{2\pi L\xi}{\lambda_{mn}} = 1$ . (This should be equivalent to using the same value of  $\bar{p}^2$  as Maestrello.)

The replot is shown as Curve II. Observe that in view of the scaling errors involved in copying the Maestrello curve, the curves shown in the replot are in good agreement.

Figure 7 – Variation of Modal Mean Square Displacement with Eddy Lifetime for a 36- × 6.5- × 0.04-Inch Panel

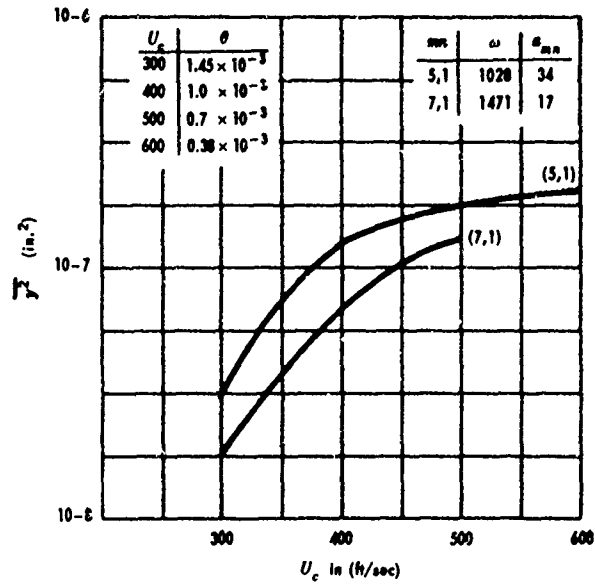

Figure 8 - Computed Modal Mean Square Displacement for a 36- x 6.5- x 0.04-Inch Panel

Compare with Figure 19 of Reference 15. The trend of curves there is similar to curves drawn here, but differences appear to be due either to a normalization factor of  $4\pi^2$  or to the use of different values of  $p^2$  than those used here.

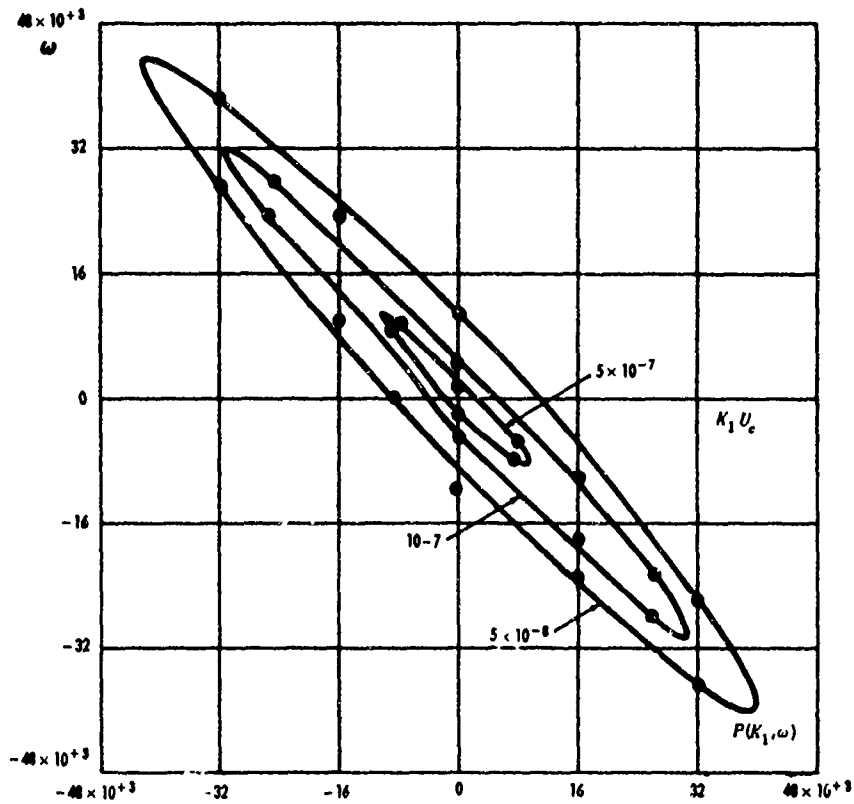

Figure 9 - Contours of Constant Turbulence Pressure Spectrum Level for Convected Semifrozen Pattern

Compare with Figure 5 of Reference 15.

Figure 10 – Computed Displacement Spectral Density for a 12- × 6- × 0.062-Inch Titanium Panel  
Compare with Figure 20 of Reference 22.

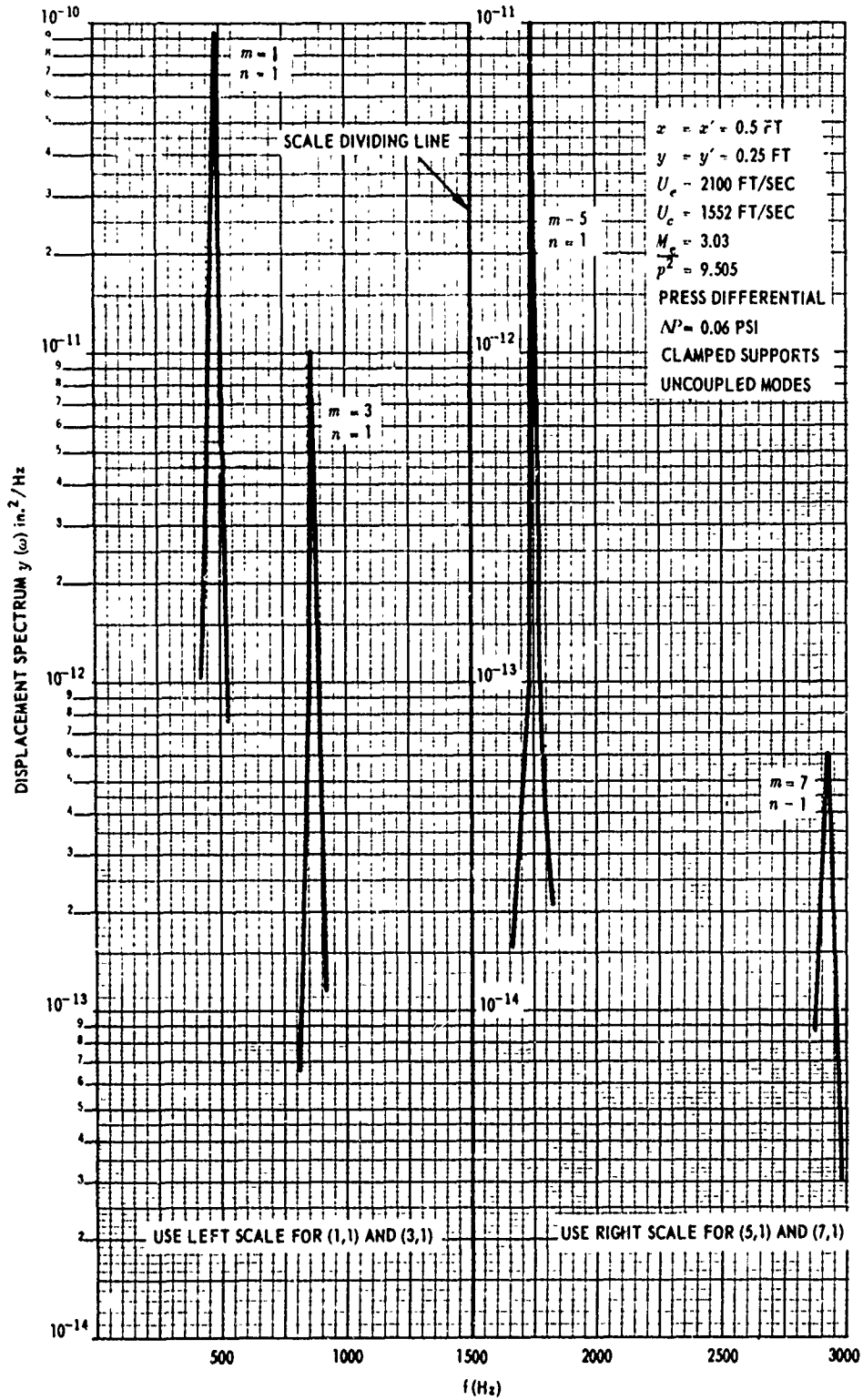

Figure 10a – Result Using Both Parts of Subprogram C

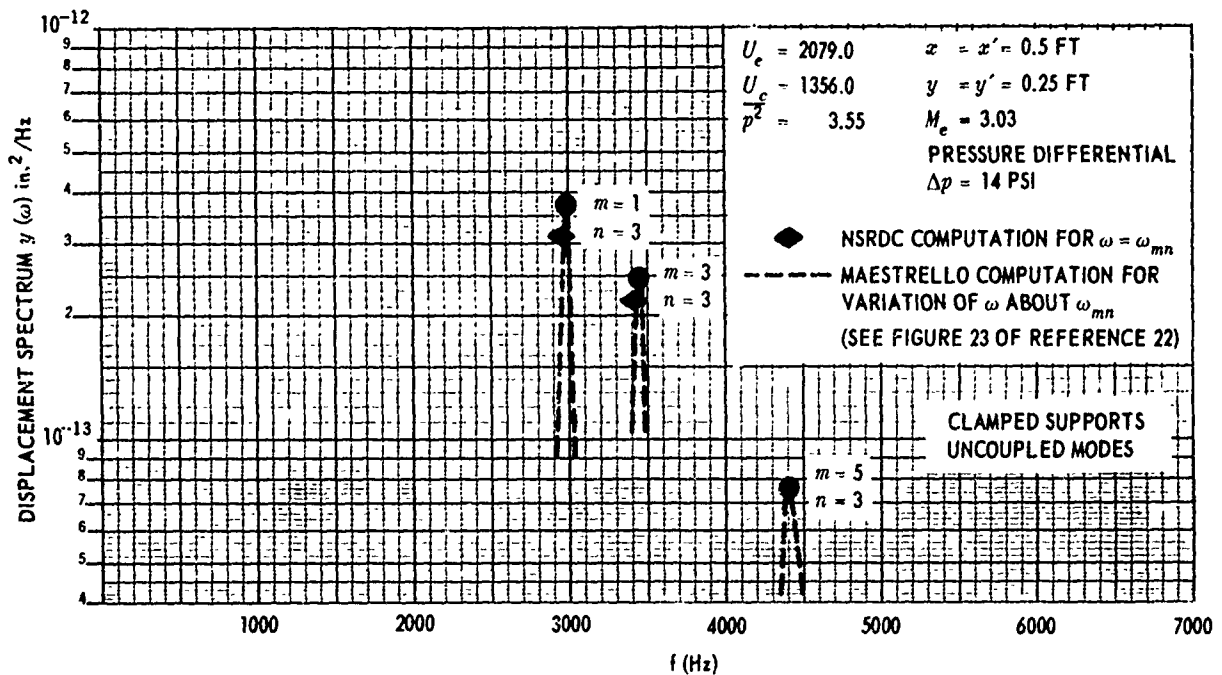

Figure 10b - Results Ignoring the First Part of the Solution

Notes for Figures 10a and 10b:

To compute the power spectrum, without coupling, Subprogram C first uses the Warburton method to determine the eigenfunctions and eigenvalues. Hence the user must submit the coefficients for the boundary conditions he desires. The program comes in two parts: the first solves for the peak response at  $\omega = \omega_{mn}$  and the second solves for the spectrum, varying  $\omega$  around  $\omega_{mn}$ .

Figure 10a shows a narrow bandwidth for some modes, such as (5,1). This means that if the user were to run the program only for  $\omega \neq \omega_{mn}$ , (as in Figure 10b which ignores the first part of the solution) he could bypass the peak response. The curve shown in Figure 10a is a result of both programs, where DW, the interval used in the computer program, was 100, for the case  $\omega \neq \omega_{mn}$ . The curve was then extrapolated to its peak value at  $\omega = \omega_{mn}$ .

Input data for Figures 10a and 10b were obtained from Maestrello, he computed his modal frequencies for  $\Delta p = 0.06$  and 14 psi and used experimentally obtained values of damping. The relations  $U_c = 0.8 U_e$  and  $p^2 \approx 12 \tau_w^2$  were used. Input dimensions of length are in units of feet, whereas by means of a conversion factor in the program, the corresponding output is in inch units.

In Figure 10b the static pressure  $\Delta p = 14$  psi is introduced into the program by modifying the value of  $\omega_{res}$  obtained at  $\Delta p = 0.06$  psi  $\approx 0$  psi from the Warburton equation for clamped boundaries. Since  $\omega_{res} \approx \sqrt{\frac{k}{m}}$  and approximately  $k \propto E$ , then  $\omega_{res}$  is proportional to the square root of  $E$  and therefore the stiffness  $k$ . If originally we have  $E_{\Delta p = 0} = 0.21 \times 10^8$  psi, then modifying  $E$  in proportion to the change in stiffness which was measured with a strain gage on the panel under static loading, we get  $E_{\Delta p = 14 \text{ psi}} = 0.33 \times 10^8$  psi. We then recompute the value of  $\omega_{res}$  corresponding to this value of  $E$ .

## APPENDIX B

TABLE 2

### Identification of Subprograms A, B, C, and D – Maestrello

This table includes identification input and output data units (in foot – pound – seconos), flow charts, order of data, and sample data. Computer subprogram listings are given at the end of this appendix as Table 3.

- |               |  |
|---------------|--|
| Subprogram A: | Computation of Plate Vibration and Acoustic Response for Model A (Semifrozen Convection)         |
| Subprogram B: | Computation of Cross Spectral Density of Turbulent Pressures for Model A (Semifrozen Convection) |
| Subprogram C: | Computation of Cross Spectral Density of Displacement  |
| Subprogram D: | Generalization of Subprogram C to Include Modal Cross Coupling                                   |

TABLE 2 A

Input Required for *Subprogram A* to Compute the Plate Vibration and Acoustic Response for the Semifrozen Convection (*Model A*) and Corresponding Output

(Units are given in foot-pound-seconds)

Data	Description	Type	Symbol Used in Program
<i>Flow Characteristics</i> (Subprogram A)			
$U_c$	Broadband convection velocity	Decimal	UC(I)
$\overline{p^2}$	Mean-square wall-pressure fluctuations, which vary with $U_c^*$	Decimal	PB2*DPB2(I)
$(FU_c)^2$	Quantity $\left(\frac{\delta^* U_c}{U}\right)$ squared where: $\delta^*$ = boundary-layer displacement thickness $U$ = free stream velocity	Decimal	FUCSQ
$K_1, K_2, K_3$	Universal constants: $K_1 = 0.470$ $K_2 = 3.0$ $K_3 = 14.0$	Decimal	AK
$A_1, A_2, A_3$	Universal constants: $A_1 = 1.6$ $A_2 = 7.2$ $A_3 = 12.0$	Decimal	AN
(*PB2 would represent a unique value of $\overline{p^2}$ if $\overline{p^2}$ were independent of $U_c$ . It enters the program (i.e., data cards) once only. Since $\overline{p^2}$ actually varies with $U_c$ , a correction factor DPB2(I) is entered with every value of $U_c$ . Thus $\overline{p^2}$ as a function of $U_c$ is accounted for by the quantity PB2* DPB2(I).			

TABLE 2A (Continued)

Data	Description	Type	Symbol Used in Program
<i>Plate Characteristics</i>			
$h$	Panel thickness	Decimal	$H$
$\eta^2$	Square of plate mass	Decimal	FM2
$a, b$	Lengths of panel sides	Decimal	ZUP, YUP
$\delta_{m,n}$	Total damping ratio	Decimal	DAMP
$\omega_{m,n}$	Modal frequencies of the plate	Decimal	OMEGA
<i>Additional Quantities</i>			
Range of plate mode numbers for which calculations are desired	First $m$ mode number, last $m$ mode number, interval between $m$ mode number, total number of $m$ 's  Same information as previously described, with respect to $n$ mode numbers	Integer Integer Integer  Integer Integer Integer Integer	MLOW MUP DM  MSTEPS  NLOW NUP DN NSTEPS
$\tau$	Time delay	Decimal	TAU
Number of values of $U_c$ to be calculated		Integer	KUC
Set of reference points against which mean-square displacement and acoustic power will be tabulated	$\frac{2U_c\theta}{\lambda_{m,n}}$ where $\theta$ -- eddy lifetime; $\lambda_{m,n}$ -- acoustic wave length for mode $(m,n)$	Decimal	PARAM
Number of values of PARAM specified		Integer	NP
$x_0, y_0$	Coordinates of a point on plate at which mean-square displacement and acoustic power are calculated	Decimal	XO, YO
$x'_0, y'_0$	any point on plate different from $x_0, y_0$	Decimal	XOP, YOP



TABLE 2A (Continued)

Data	Description	Type	Symbol Used in Program
<i>Calculated Output in Inch-Pound-Seconds</i>			
$\phi_{m,n}$	Value of eigenfunctions of mean-square displacement  A value of EIGEN is computed for each mode (m,n) with three values of total damping; 1/10 $a_{m,n}$ ; $a_{m,n}$ ; $10a_{m,n}$	Decimal	EIGEN
$a_{m,n}$	Values of total damping associated with each mode (m,n)	Decimal	FA (m,n,1) for computation; A (m,n, DAMP) in output
$\frac{\text{Vol}_{m,n}}{\sqrt{2Y}}$	Volume under each eigenfunction	Decimal	VOL
$I(m,n)$	Triple integral of Equation I.13: integral of cross correlation	Decimal	IXY2 I(m,n)
$\overline{y^2}$	Mean-square displacement for values of 1/10 $a_{m,n}$ ; $a_{m,n}$ ; $10a_{m,n}$	Decimal	ANS

Output is printed for a given convection velocity  $U_c$  for the modes of interest. The last four columns of the output respectively represent  $\overline{Y^2}$  for  $1/10 a_{m,n}$ ,  $\overline{Y^2}$  for  $a_{m,n}$ , and  $\overline{Y^2}$  for  $10 a_{m,n}$  for chosen PARAM. Since this program was written, Maestrello has developed methods of computing damping, but here he chooses the magnitude of  $a_{m,n}$  according to the  $\omega \theta$  region of the curve that interests him. For example, Figure 7 plots  $\overline{Y^2}$  against  $\omega \cdot \theta$ . In the region  $\omega \cdot \theta = 10^{-1}$  to 1.0 he uses  $a_{m,n}/10$ ; however, for  $\omega \cdot \theta = 1.0$  to 40, he uses  $a_{m,n}$ . Also,  $\overline{Y^2}$  corresponds to the value of PARAM closest to  $\omega \theta$  where  $\theta$  corresponds to  $U_c$ .

TABLE 2A (Continued)

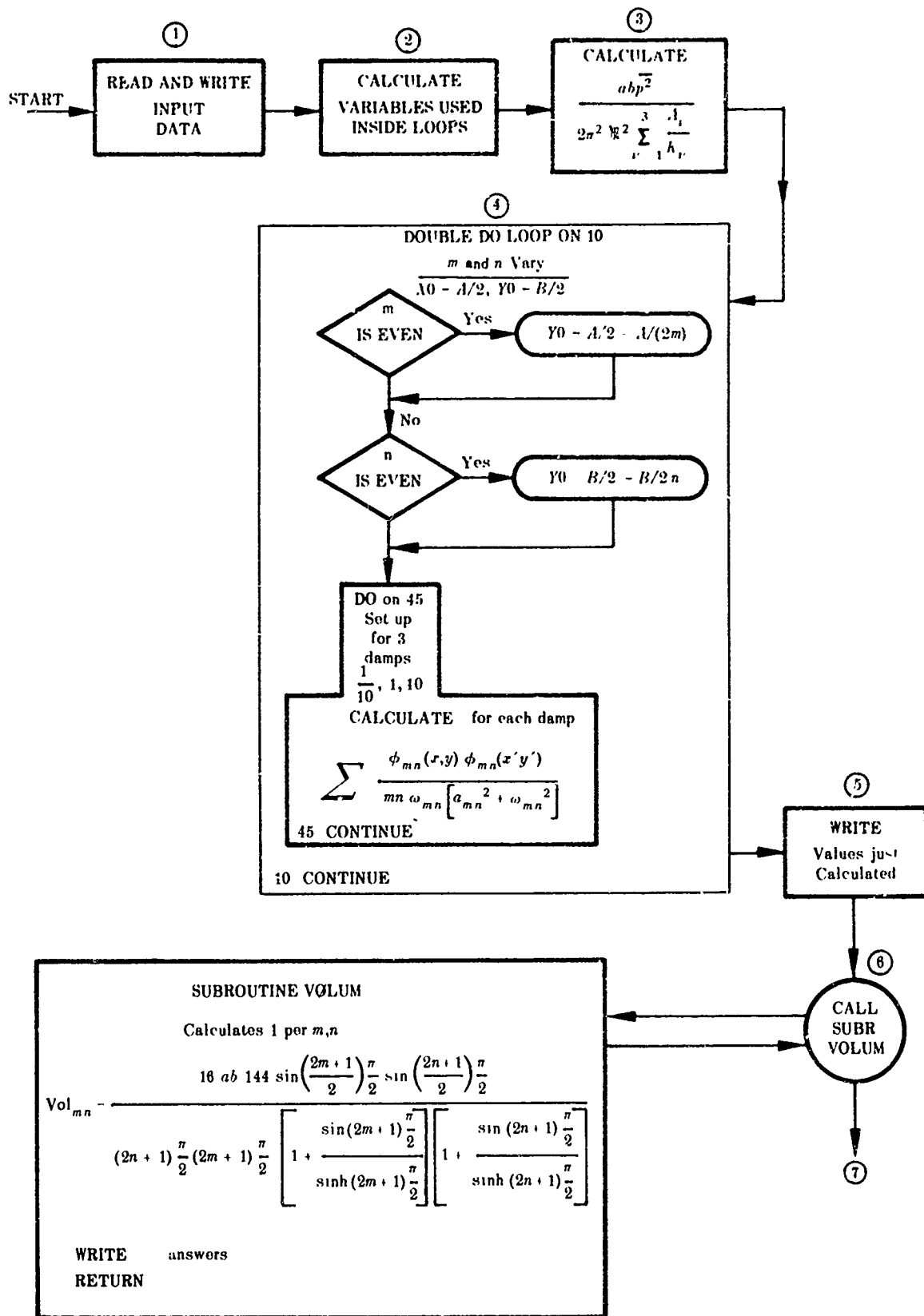

TABLE 2A (Continued)

⑦ DO 777 Vary  $U_c$   
 CONST ③ • DPB2(KU)  
 WRITE  $U_c$  AND CONST

⑧ DO 778 m Values

⑨ DO 779 Set up  $\theta$ 's  
 779  $\theta_i$  PARAM (i)/m/ $U_c$  • A

⑩ Set upper and lower limits for x, y, z integrals; determine no. of steps for each integral and the step size for each

⑪ DO 11  
 Calculates coefficients for Simpsons Rule

⑫ z  
 Set variable of integration - lower limit on z  
 Calculates function of z values  

$$f(z) = \int_{-a}^a \cos \frac{m\pi z}{a} + \frac{1}{m\pi} \left[ \sin \left| \frac{m\pi z}{a} \right| - \left| \frac{m\pi z}{a} \right| \cos \left( \frac{m\pi z}{a} \right) \right] dz$$

⑬ y  
 Set variable of integration - lower limit on y  
 Calculates function of y values  

$$f(y) = \int_0^b f(z) \left[ \cos \frac{n\pi y}{b} + \frac{1}{n\pi} \left[ \sin \left( \frac{n\pi y}{b} \right) - \frac{n\pi y}{b} \cos \left( \frac{n\pi y}{b} \right) \right] \right] dy$$

⑭ Set up and initialize to zero, the array for summing on outside integral

⑮ x  
 Set variable of integration - lower limit on X  
 Calculates function of X varying y and z and summing up parts previously calculated  

$$f(x) = \int_0^{\infty} f(y) \left[ \frac{mn}{ab} e^{-amx} \left[ \sin(\omega_{mn}|x|) + \frac{\omega_{mn}}{a_{mn}} \cos(\omega_{mn}|x|) \right] e^{-|x/\theta|} \right. \\ \left. + \sum_{\nu=1}^3 \frac{A_{\nu} K_{\nu}}{K_{\nu}^2 + \frac{1}{FU_c} (z - U_c (t-x)^2 + y^2)} \right] dx$$

⑯ WRITE  
 Answers of triple integral → IXYZ

⑰ COMPUTE AND WRITE  
 ANS = IXYZ • EGEN AND CONST

778 CONTINUE  
 777 CONTINUE

↓  
 STOP

TABLE 2A (Continued)

COLUMN HEADINGS FOR INPUT FORMS ON DATA CARDS

TAU	15	20	30	40	50	60	70
H	10	20	30	40	50	60	70
XO	10	20	30	40	50	60	70
YO	10	20	30	40	50	60	70
XOP	10	20	30	40	50	60	70
YOP	10	20	30	40	50	60	70
FUCSQ	10	20	30	40	50	60	70
PB2	10	20	30	40	50	60	70
FM2	10	20	30	40	50	60	70
AK(1)	10	20	30	40	50	60	70
AK(2)	10	20	30	40	50	60	70
AK(3)	10	20	30	40	50	60	70
AN(1)	10	20	30	40	50	60	70
AN(2)	10	20	30	40	50	60	70

TABLE 2A (Continued)

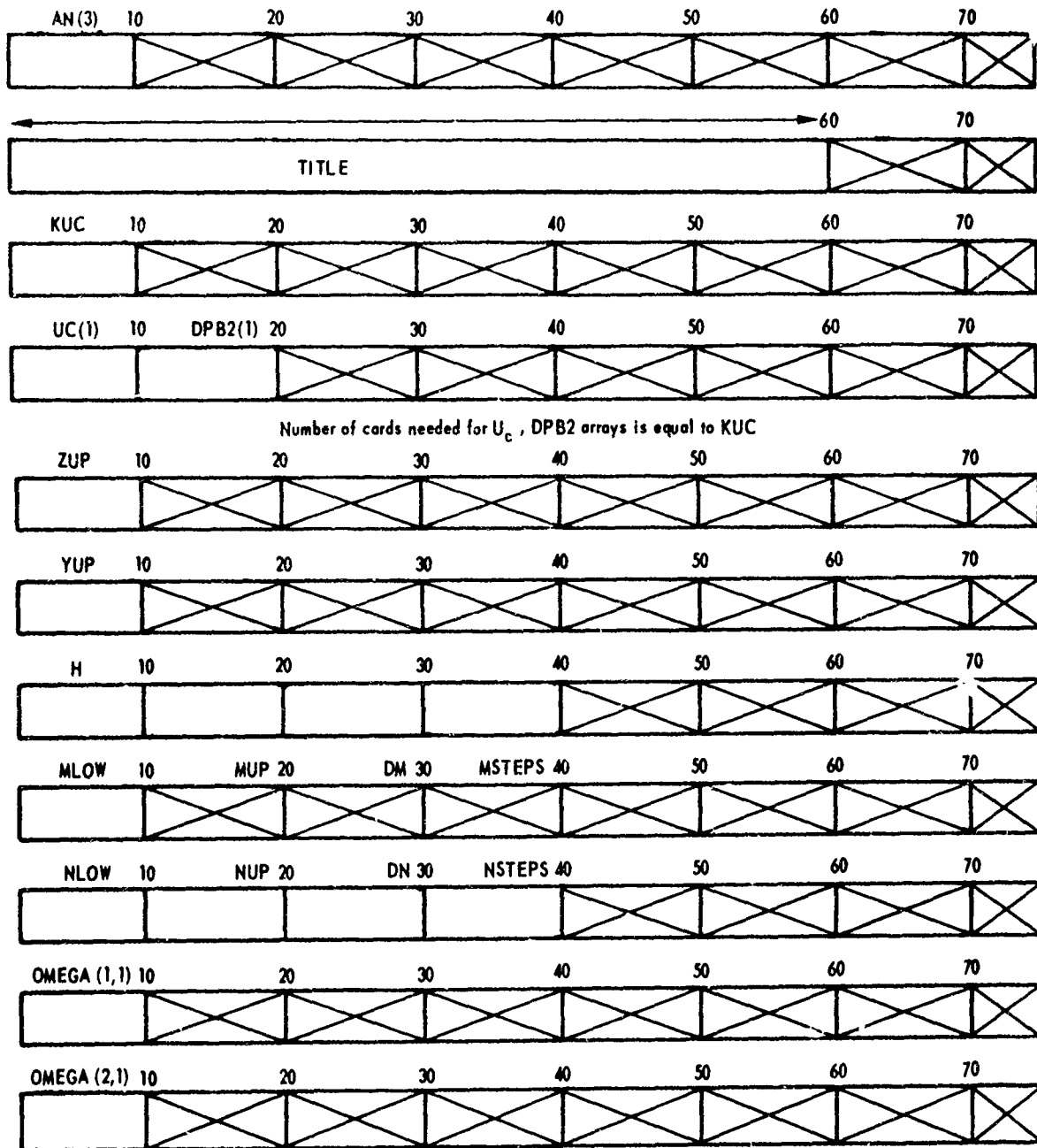

Number of cards needed for  $U_c$ , DPB2 arrays is equal to KUC

With the order of cards (1,1), (2,1), ..., (M,1), (1,2), ..., (M,2), ..., (1,N), ..., (m,N) to complete OMEGA (m,n) array.

TABLE 2A (Continued)

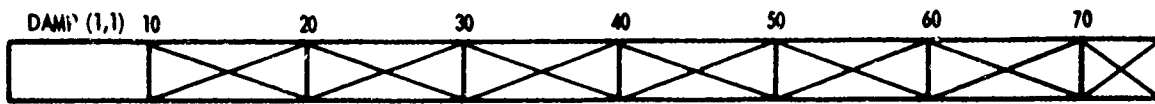

With the order of cards (1,1), (2,1), . . . (m,1), (1,2), . . . (m,2), . . . (1,n), . . . (m,n) to complete the DAMP (m,n) array.



The number of cards needed to complete PARAM array is equal to NP.

TABLE 2B

Input Required for *Subprogram B* to Compute the Cross Spectral Density of Turbulence Pressures for the Semifrozen Convection (*Model A*) and Corresponding Output

(Units are given in foot-pound-seconds)

Data	Description	Type	Symbols Used in Program
<i>Flow Characteristics</i>			
$\theta$	Eddy Lifetime	Decimal	THETA
$\xi$	$x - x'$ (Plate separation in $x$ direction)	Decimal	SI
$\tau_w$	Wall shear stress	Decimal	TW
$\omega$	Frequency	Decimal	FR
$\delta^*$	Boundary-layer displacement thickness	Decimal	DSTAR
$K_1, K_2, K_3$	Universal constants: $K_1 = 0.470, K_2 = 3.0,$ $K_3 = 14.0$	Decimal	D
$A_1, A_2, A_3$	Universal constants: $A_1 = 1.6, A_2 = 7.2,$ $A_3 = 12.0$	Decimal	A
$U_c$	Broadband convection velocity	Decimal	UC
<i>Calculated Output in Foot-Pound-Seconds</i>			
$R(r)$	Normalized autocorrelation of the pressure; see Equation (B8)	Decimal	RAUTO
$R(\xi, n, r)$	Normalized cross correlation of the pressure; see Equation (B9)	Decimal	RCROSS
$\frac{P(\omega) U}{\tau_w^2 \delta^*}$	Dimensionless power spectrum of wall-pressure fluctuations; see Equation (B7)	Decimal	POW
$P(\omega)$	Power spectrum; see Equation (B7)	Decimal	PDW
$P(K_1, \omega)$	Normalized cross-power spectral density, using longitudinal space-time cross correlation of semifrozen model	Decimal	PKW
$P(\omega)$	Power spectrum, corresponding to $P(K_1, \omega)$	Decimal	PW



TABLE 2B (Continued)

AUTOCORRELATION EQUATION (B8)  
 CROSS CORRELATION EQUATION (B9)  
 POWER SPECTRUM EQUATION (B7)  
 $P(K_1, \omega)$  FIGURE 9

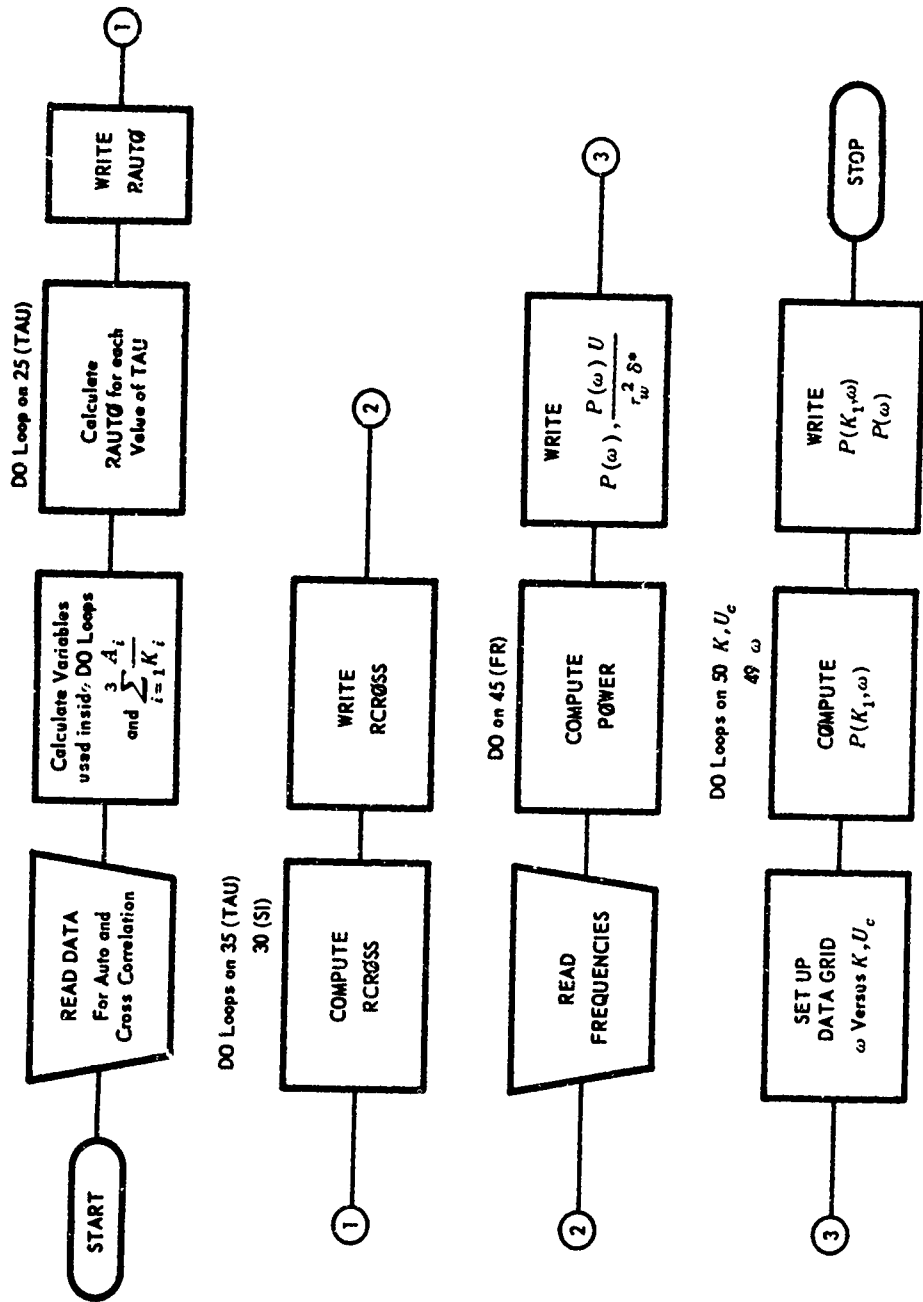

TABLE 2B (Continued)

COLUMN HEADINGS FOR INPUT FORMS ON DATA CARDS

TITLE	10	20	30	40	50	60	70	72	80						
A(1)	8	A(2)	16	A(3)	24	30	42	54	66	80					
D(1)	8	D(2)	16	D(3)	24	30	42	54	66	80					
THETA	12	DSTAR	24	UC	36	42	54	66	80						
SI(1)	9	SI(2)	18	SI(3)	27	SI(4)	36	SI(5)	45	SI(6)	54	SI(7)	63	SI(8)	72
FR(1)	6	FR(2)	12	18	24	30	36	42	48	54	60	66	72	80	
As many cards as needed to complete array FR (25)															
TW	6	18	30	42	54	66	80								

TABLE 2C

Input Required for Subprogram C to Compute Cross Density Displacement  
and Corresponding Output

(Units are given in foot-pound-seconds)

Symbol	Description	Program Symbol
<i>Flow and Plate Characteristics and Additional Quantities</i>		
ARG (I)	Gaussian quadrature	ARG (I)
WGT (I)	Weights and arguments; NW of them; in this problem 9 points	WGT (I)
NW	Number of points in Gaussian integration	NW
K A	Universal constants; NAK of each; in this case, 4 (supersonic)	AK (I) AN (I)
NAK	Number of A's and K's; 4 (supersonic)	NAK
TITLE	Alphanumeric title -- labels the output; User's choice of words	TITLE (I)
$x$	$x$ Coordinate position on plate	X
$x'$	Second $x$ coordinate: $\xi = x - x'$	XP
$y$	$y$ Coordinate position on plate	Y
$y'$	Second $y$ coordinate: $\eta = y - y'$	YP
$a$	Plate size - $x$ direction	A
$b$	Plate size - $y$ direction	B
$U_e$	Free-stream velocity	UE
$M$	Plate mass	FM
$\delta^*$	Boundary layer displacement thickness	DEL
$\overline{p^2}$	Mean-square wall pressure fluctuation	PB2
$U_c$	Convection velocity	UC
$\theta$	Eddy lifetime	TH
MLOW	First mode of interest for $m$	MLOW
MUP	Last mode of interest for $m$	MUP
DM	Increment between $m$ modes	DM
NLOW	Same as described but for $n$ modes	NLOW
NUP	Same as described but for $n$ modes	NUP
DN	Same as described but for $n$ modes	DN

TABLE 2C (Continued)

Symbol	Description	Program Symbol
$\left. \begin{array}{l} y_m \\ k_m \\ y_n \\ k_n \end{array} \right\}$	Warburton $\left. \begin{array}{l} y \\ k \end{array} \right\}$ for $\theta(x)$ to define plates with fixed edges, for $m, n$ modes, respectively.	$\left\{ \begin{array}{l} \text{GM} \\ \text{KM} \\ \text{GN} \\ \text{KN} \end{array} \right.$
$\omega_{mn}$	Plate modal frequencies	WMN (M,N)
$a_{mn}$	Acoustical damping, obtained experimentally	FA (M,N)
Following Symbols Are Used Only in Program for $\omega \neq \omega_{mn}$		
WI	Lower limit of frequency to vary around a given $\omega_{mn}$	WI
WF	Upper limit for $\omega \neq \omega_{mn}$	WF
DW	Increment size for intervals between WI and WF	DW
<i>Calculated Output in Inch-Pound-Seconds</i>		
$\frac{4}{abm^2n^2\phi(x)\phi(x')\phi(y)\phi(y')}$ $P(\omega)$ $Y(x,y;x',y',\omega)$	<p>Plate shapes, by Warburton method</p> <p>Power spectrum:</p> $\sum_i (A_i e^{(-K_i \omega \delta^* / U_e)}) \frac{\overline{p^2 \delta^*}}{U_e}$ <p>Equation 27 of Reference 21: cross spectral density, assuming panel modes well separated.</p> <p>Equation 27 <math>\times \omega^4</math></p> $(AMN^2 + (\omega_{mn} - \omega)^2)(AMN^2 + (\omega_{mn} + \omega)^2)$	<p>EIGEN (M,N)</p> <p>POFW*</p> <p>ANS*</p> <p>PWRSD*</p> <p>DEN</p>
*POFW, ANS PWRSD have real and imaginary parts printed out.		

TABLE 2C (Continued)

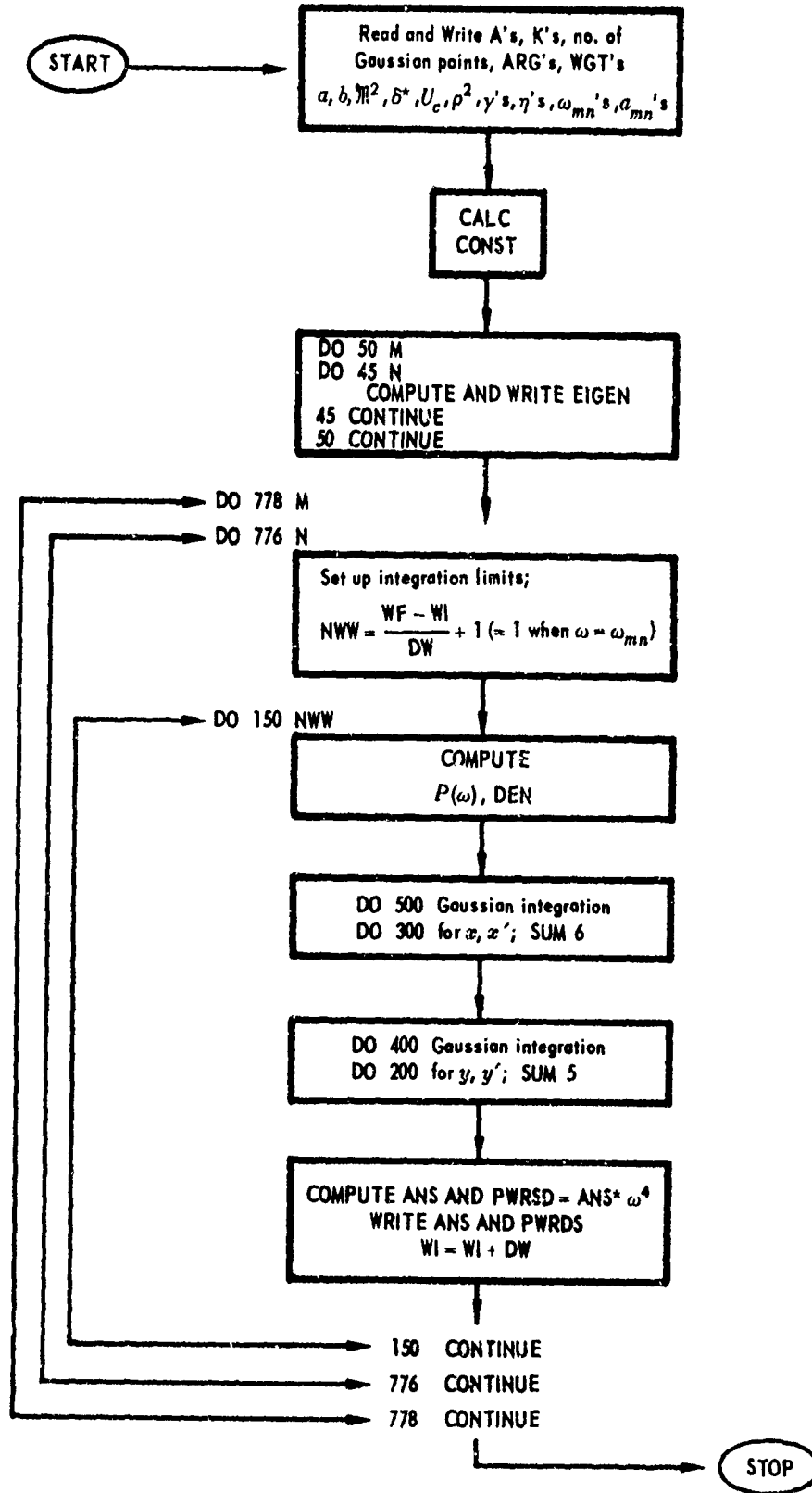
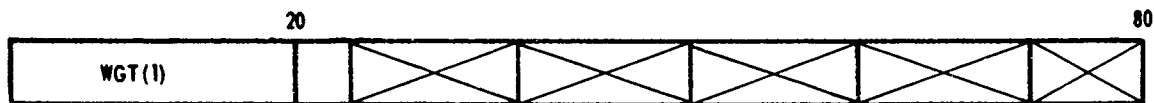

TABLE 2C (Continued)

Column Headings for Input Forms on Data Cards



And as many cards as needed to complete the ARG(NW) array (NW cards).



And as many cards as needed to complete the WGT(NW) array (NW cards).

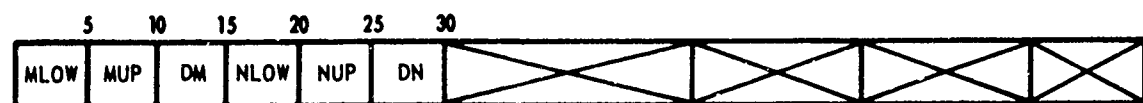
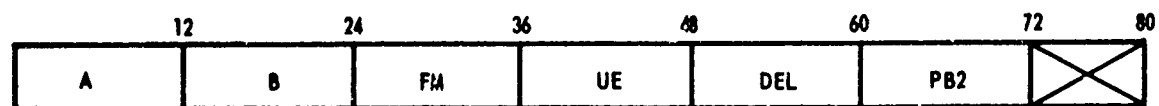
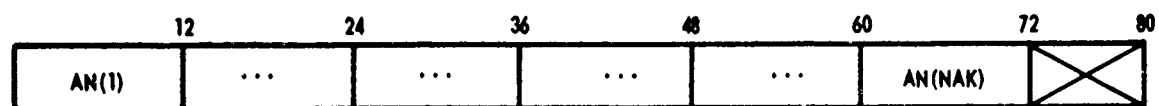
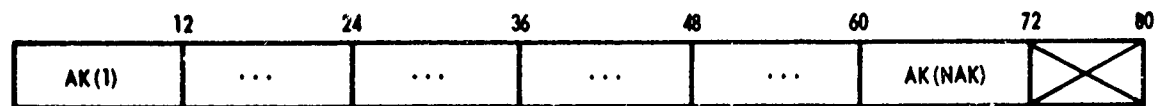
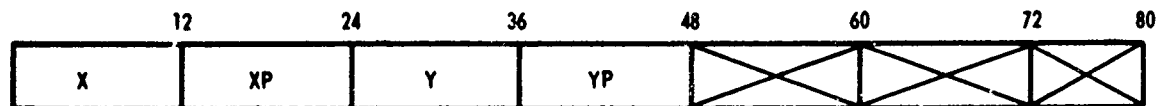
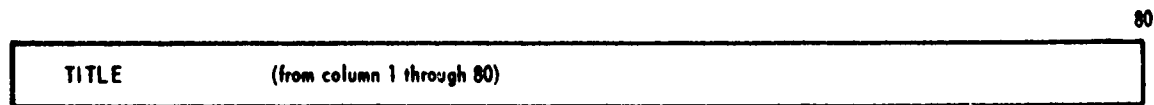
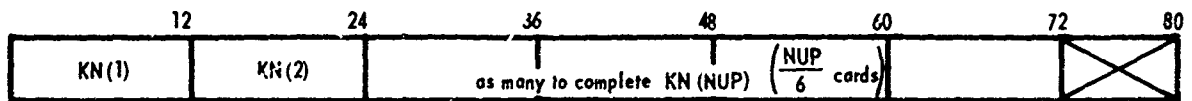
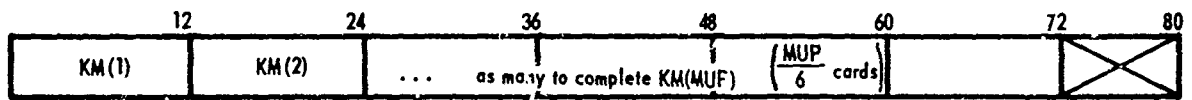
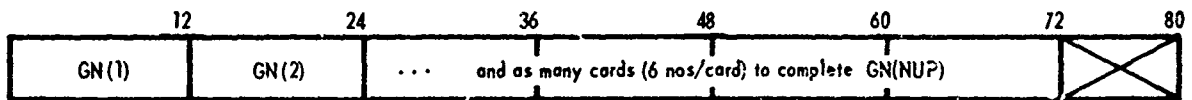
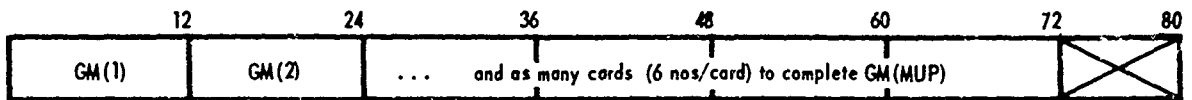

TABLE 2C (Continued)



WMN(MUP,2), and so on, until MUP x NUP cards are used to complete WMN(MUP,NUP) array



FA(1,2), and so on, in WMN array, i.e., use MUP x NUP to complete FA(MUP,NUP) array

For case  $\omega \neq \omega_{mn}$  only: 1 card for each (M,i): (1,1), (1,2), ... (1,N), (2,1), ... so on



## SUBPROGRAM D

Subprogram D represents a generalization of Subprogram C to include modal-cross coupling. Data descriptions of the subprograms are identical, except that Subprogram D requires a second set of modal input data. These data are:

TABLE 2D

### Generalization of Subprogram C to Include Modal Cross Coupling

(Data descriptions of Subprograms C and D are identical except that Subprogram D requires a second set of modal input data as indicated below)

Symbol for Cross-Coupled Modes		Symbols for Uncoupled Modes*
PLOW	for $p$ modes	MLOW
PUP	for $p$ modes	MUP
DP	for $p$ modes	DM
QLOW	for $q$ modes	NLOW
QUP	for $q$ modes	NUP
DQ	for $q$ modes	DN
GP	for $p$ modes	GM
GQ	for $q$ modes	GN
KP	for $p$ modes	KM
KQ	for $q$ modes	KN
WPQ(P,Q)		WMN(M,N)
APQ(P,Q)		FA(M,N).

\*Analogous to data in Subprogram C.  
 Note: The output will now include the additional eigenvalues EIGN(P,Q) for the (P,Q) modes. DENCOM is the denominator of Equation (26), Reference 22.



TABLE 2D (Continued)

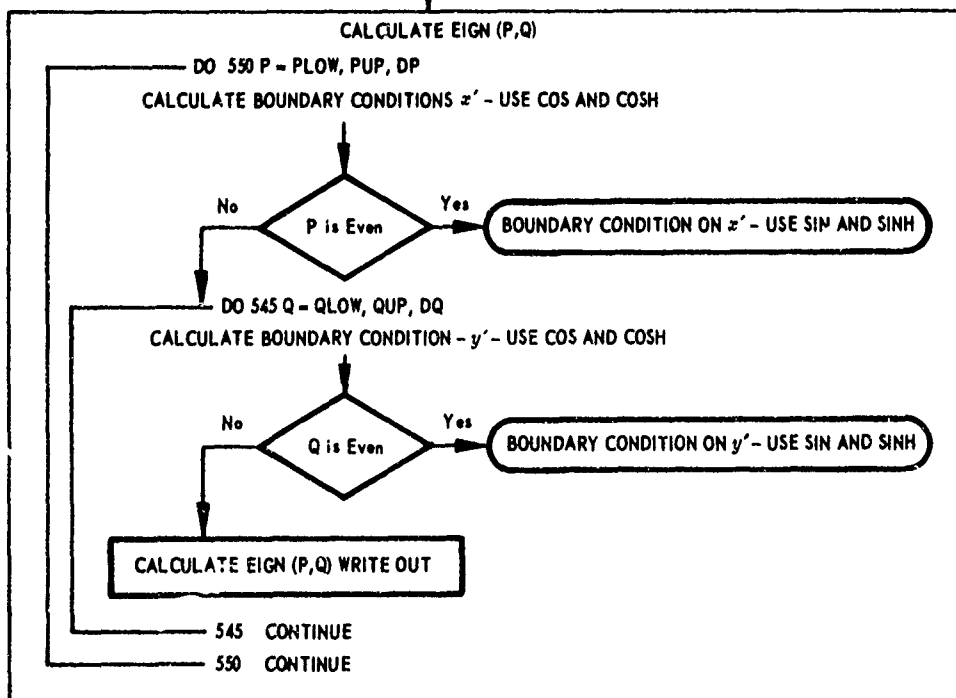
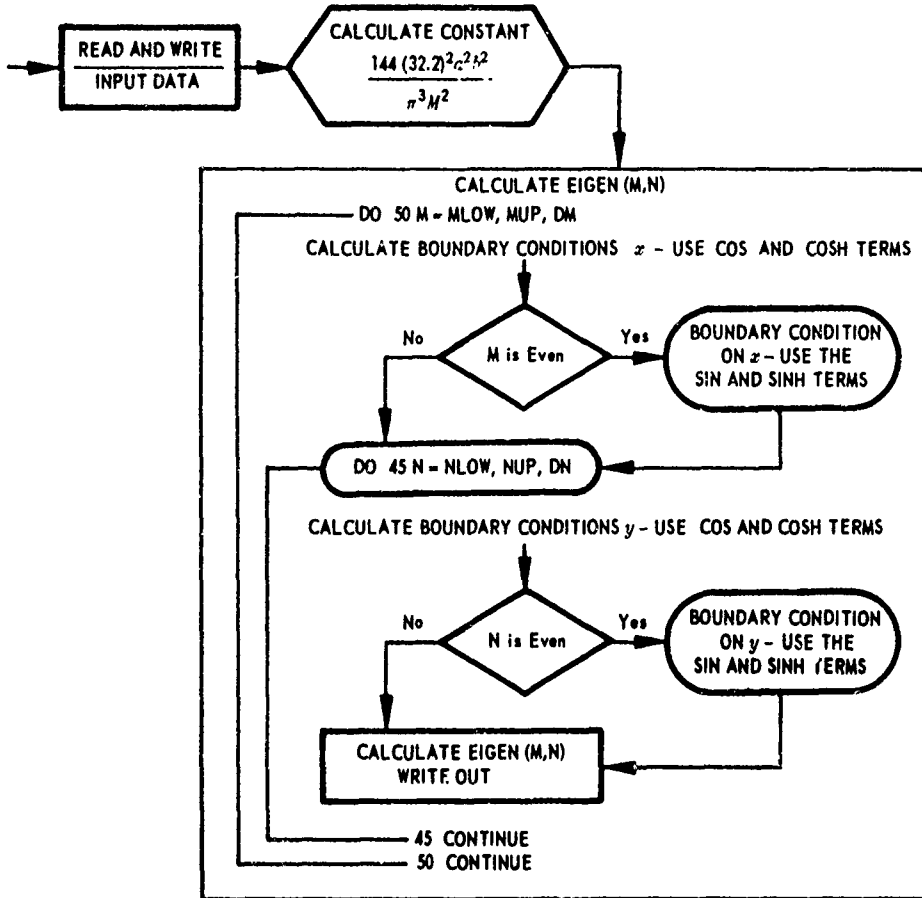

TABLE 2D (Continued)

DO 778 M = MLOW, MUP, DM  
 DO 7781 P = PLOW, PUP, DP  
 DO 776 N = NLOW, NUP, DN  
 DO 7761 Q = QLOW, QUP, DQ

READ  
 $\omega, \Lambda\omega, \omega_f$

CALCULATE  
 $n\omega, nx_0, nx_0^2,$   
 $ny_0, ny_0^1, \omega^2, a^2$

DO 150 MM1 = 1, NWW  
 Initialize answer to 0  
 Calculate DENCOM

$$\left[ \frac{(a_{mn} + i\omega) \left[ \omega_{mn} \omega_{pq} \left( \frac{a_{mn} + a_{pq}}{2} \right) \right] + \omega_{mn} \omega_{pq} \left\{ \left( \frac{a_{mn} + a_{pq}}{2} \right)^2 - \left[ \left( \frac{\omega_{mn}}{2} \right)^2 - \left( \frac{\omega_{pq}}{2} \right)^2 \right] \right\}}{(a_{mn} + i\omega)^2 + \omega_{mn}^2} \right]$$

$$+ \frac{(a_{pq} - i\omega) \left[ \omega_{mn} \omega_{pq} \left( \frac{a_{mn} + a_{pq}}{2} \right) \right] + \omega_{pq} \omega_{mn} \left( \frac{a_{mn} + a_{pq}}{2} \right)^2 + \left( \frac{\omega_{mn}}{2} \right)^2 - \left( \frac{\omega_{pq}}{2} \right)^2}{(a_{pq} - i\omega)^2 + \omega_{pq}^2} \right]$$

$$/ \left( (mn pq) \omega_{mn} \omega_{pq} \left\{ \left[ \left( \frac{a_{mn} + a_{pq}}{2} \right)^2 + \left( \frac{\omega_{mn}}{2} \right)^2 + \left( \frac{\omega_{pq}}{2} \right)^2 \right]^2 - \frac{\omega_{mn}^2 \omega_{pq}^2}{4} \right\} \right)$$

$$P(\omega) = \frac{\overline{p^2} \delta}{U_r} \sum_{k=1}^4 A_k e^{-\frac{k\omega\delta}{U_e}}$$

TABLE 2D (Continued)

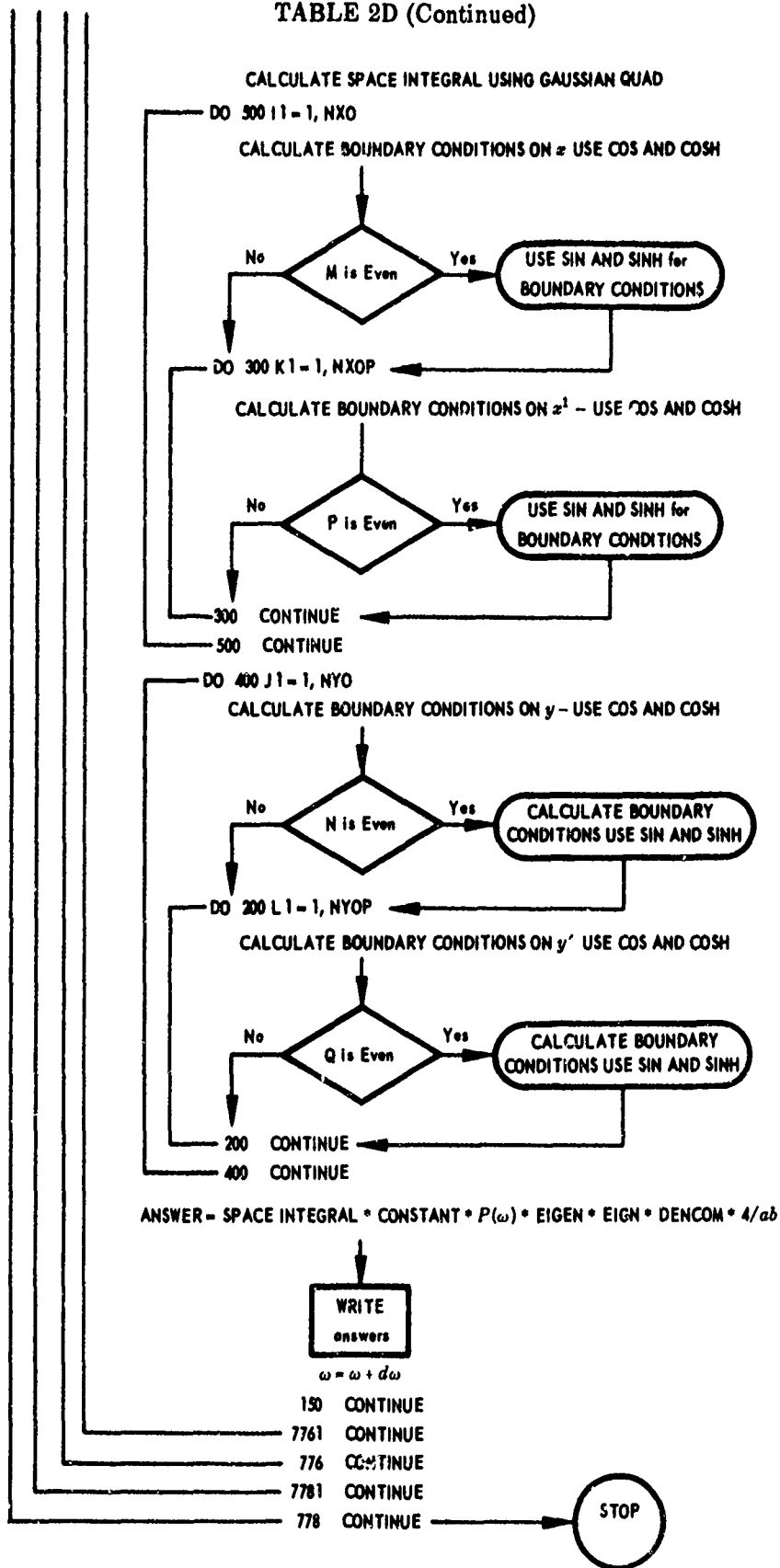



TABLE 2D (Continued)

5	10	15	20	25	30					80										
PLOW	PUP	DP	QLOW	QUP	DQ	X														
		12			24			36			48			60			72			80
GM (1)		GM (2)		GM (3)		And so on, six numbers per card, to have MUP values of GM.						X								
		12			24			36			48			60			72			80
GN (1)		GN (2)		And so on, six numbers per card, to have NUP values of GN.						X										
		12			24			36			48			60			72			80
GQ (1)		GQ (2)		And so on, six numbers per card, to have QUP values of GQ.						X										
		12			24			36			48			60			72			80
KM (1)		KM (2)		And so on, six numbers per card, for MUP values of KM.						X										
		12			24			36			48			60			72			80
KP (1)		KP (2)		And so on, six numbers per card, for PUP values of KP.						X										
		12			24			36			48			60			72			80
KN (1)		KN (2)		And so on, six numbers per card, for NUP values of KN						X										
		12			24			36			48			60			72			80
KQ (1)		KQ (2)		And so on, six numbers per card, for QUP values of KQ.						X										
		12			24			36			48			60			72			80
GP (1)		GP (2)		And so on, six numbers per card, to have PUP values of GP.						X										
		12			24			36			48			60			72			80
WMN (1,1)		X				X				X				X		80				
⋮		X				X				X				X		80				
WMN (MUP,1)		X				X				X				X		80				
⋮		X				X				X				X		80				
WMN (1,2)		X				X				X				X		80				

TABLE 2D (Continued)



And so on, to WPQ(PUP, QUP), i.e., PUP x QUP cards.

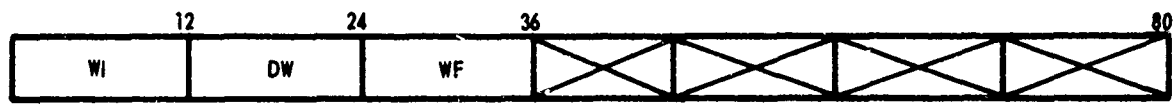
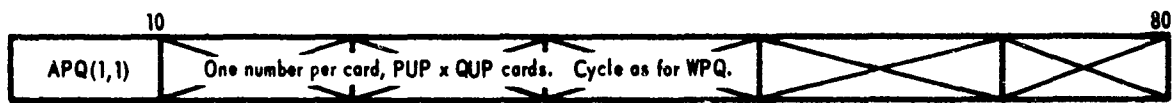
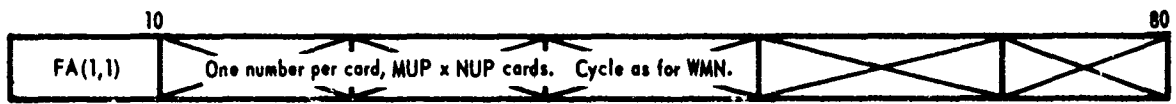

One card for each cross mode of interest; cycling for (m, n, p, q).

## APPENDIX B4 - TEST RUNS

Results obtained from the computer programs of Table 2 are indicated in Figures 7-10. Figures 7 and 8 are obtained from Subprogram A, Figure 9 from Subprogram B, and Figure 10 from Subprogram C. The figures show test runs for modal mean square displacement, turbulence pressure spectrum levels, and displacement spectral density.

TABLE 3

## Computer Listings for Subprograms A, B, C, and D - Maestrello

Table 3A - Computer Listing for Subprogram A  
(Semifrozen Convection - Model A)

3IBFTC TURAD	00 *
C REORGANISED PROGRAM FOR COMPUTING TRIFLE	0010
C INTEGRAL	20
C USING SIMPSONS RULE	30
DIMENSION VOL(20,10)	40
DIMENSION F3(3),ANS(3)	50
DIMENSION IXYZ(10,1,50,3),IYZ(20,1),IY(1),	0060
IG2(401,20),G3(11,1),YY(11),TEMP1(11),G5(4000)	0070
DIMENSION PARAM(101),THETA(101)	0 80
DIMENSION AK(3),AN(3),TITLE(20)	0090
DIMENSION OMEGA(20,10),DAMP(20,10)	0100
DIMENSION FA(20,10,3),FC(20,10,3),EIGEN(20,10,3),FUDGE(20,10,3)	0110
DIMENSION UC(20),DPB2(20)	0120
REAL IXYZ,IYZ,IY	0130
INTEGER DM,DN	0140
READ(5,13) TAU	0150
13 FORMAT(F10,0)	0160
WRITE(6,801) TAU	0170
801 FORMAT(1H1, /5H TAU=E15,6)	0180
READ(5,103) H,XO,YO,XOP,YOP,FUCSQ,PB2,FM2,AK,	0190
1AN,TITLE	200
103 FORMAT(14(F10,0/), (10A6))	0210
WRITE(6,201) TITLE	0220
201 FORMAT(20A6)	0230
WRITE(6,203) FUCSQ,PB2,FM2,AK,AN,XO,YO,	0240
1XOP,YOP	0250
203 FORMAT(14H0FUC SQUARED= E16,8,	0260
X 8H RHO-BAR 9H SQUARED=E16,8,	0270
1 11H M-SQUARED=E16,8/	0280
24H0K1=E16,8,4H K2=E16,8,4H K3=E16,8/	0290
34H A1=E16,6,4H A2=E16,8,4H A3=E16,8/	0300
44H XO=E16,8,4H YO=E16,8,5H XOP=E16,8,5H YOP=E16,8)	0310
READ(5,102) KUC,(UC(I),DPB2(I),I = 1,KUC)	0320
102 FORMAT(110/(2F10,0))	0330
WRITE(6,204) (UC(I),DPB2(I),I = 1,KUC)	0340
204 FORMAT(1H07X2HUC13X4HDPB2/(1H 2E16,8))	0350
99 READ(5,1) ZUP,YUP,H,MLOW,MUP,DM,MSTEPS,NLOW,NUP,DN,NSTEPS	0360



TABLE 3A (Continued)

1	FORMAT(3(F10.0/),(4I10))	0370
	WRITE(6,2)MLOW,MUP,DM,MSTEPS,NLOW,NUP,DN,NSTEPS	0380
2	FORMAT(9HOM FROM I5,4H TOI5,7H DM=I5,	0390
	112H A TOTAL OF I5,7H STEPS/9H N FROM I5,	0400
	24H TOI5,7H DN=I5,12H A TOTAL OF I5,7H STEPS)	0410
	WRITE(6,202) ZUP,YUP,H	0420
202	FORMAT(3H A=E16.8,5H B=E16.8,5H H=E16.8)	0430
	READ(5,101) ((OMEGA(M,N),M=1,20),N=1,3)	0440
101	FORMAT(F10.0)	0450
	WRITE(6,205)((OMEGA(M,N),M=MLOW,MUP,DM),	0460
	1N=NLOW,NUP,DN)	0470
205	FORMAT(7H00MEGA=/(8E16.8))	0480
	DO 7 N=1,NUP,DN	0490
	DO 7 M=1,MUP,DM	0500
7	DAMP(M,N)=.01	0510
	READ(5,104) ((DAMP(M,N),M=1,20),N=1,3)	0520
104	FORMAT(F10.0)	0530
	WRITE(6,206) ((DAMP(M,N),M=MLOW,MUP,DM),	0540
	1N=NLOW,NUP,DN)	0550
206	FORMAT(6H0DAMP=/(8E16.8))	0560
	N1=8	570
	READ(5,207) NP,(PARAM(IP),IF = 1,NP)	0580
207	FORMAT(I10/(6F10.0))	0590
	A=ZUP	600
	B=YUP	610
	B1=AK(1)**2*FUCSG	0620
	B2=AK(2)**2*FUCSQ	0630
	B3=AK(3)**2*FUCSQ	0640
	B4=AN(1)*AK(1)*FUCSQ	0650
	B5=AN(2)*AK(2)*FUCSQ	0660
	B6=AN(3)*AK(3)*FUCSQ	0670
	B7=AN(1)/AK(1)	0680
	B8=AN(2)/AK(2)	0690
	B9=AN(3)/AK(3)	0700
	C1=4.0/(A*B)	0710
	C2=3.14159265	0720
	C3=1./C2	*730

TABLE 3A (Continued)

	C4=C2*C2	740
	C5=(A*B*PB2)/(2.0*C4*FM2*(B7+B8+B9))	0750
	C5=C5*32.2*32.2*12.*12.	0760
	C6=C4/(A*B)	0770
	DO 10 M=MLOW,MUP,DM	0780
	DO 10 N=NLOW,NUP,DN	0790
	XM=M	800
	XN=N	810
	XO=A/2.	820
	YO=B/2.	830
	IF(M-M/2*2.NE.0)GO TO 43	0840
	XO=A/2.-A/(XM*2.)	0850
43	IF(N-N/2*2.NE.0)GO TO 44	0860
	YO=B/2.-B/(XN*2.)	0870
44	XOP=XO	380
	YOP=YO	390
	DAMP(M,N)=DAMP(M,N)/10.	0900
	DO 45 L=1,3	0910
	FA(M,N,L)=DAMP(M,N)/2.*OMEGA(M,N)	0920
	FA(M,N,L)=FA(M,N,L)*0.5	0930
	FC(M,N,L)=OMEGA(M,N)/FA(M,N,L)	0940
	FUDGE(M,N,L)=XM*XN*OMEGA(M,N)*(FA(M,N,L)**2.+OMEGA(M,N)**2.*0)	0950
	EIGEN(M,N,L)=C1/FUDGE(M,N,L)*SIN(XM*C2*XO/A)*SIN(XN*C2*YO/B)*	0960
	1SIN(XM*C2*XOP/A)*SIN(XN*C2*YOP/B)	0970
45	DAMP(M,N)=DAMP(M,N)*10.	0980
10	CONTINUE	990
	WRITE(6,1003)	1000
1003	FORMAT(33H0XO=XOP,YO=YOP,AND THEY VARY WITH	1010
	117H THE MODE NUMBERS)	1020
	DO 46 L=1,3	1030
	WRITE(6,3)((EIGEN(M,N,L),M=MLOW,MUP,DM),N=NLOW,NUP,DN)	1040
3	FORMAT(7H0EIGEN=/(8E16.8))	1050
46	CONTINUE	1060
	DO 47 L=1,3	1070
	WRITE(6,48)((FA(M,N,L),M=MLOW,MUP,DM),N=NLOW,NUP,DN)	1080
48	FORMAT(13H0A(M,N,DAMP)=/(8E16.8))	1090
47	CONTINUE	1100

TABLE 3A (Continued)

	CALL VOLUM(A,B,MLOW,MUP,DM,NLOW,NUP,DN,VOL)	1110
	NUPM=NUP-1	1120
	DO 777 KU=1,KUC	1130
	CONST=C5*DPB2(KU)	1140
	WRITE(6,303) UC(KU),CONST	1150
303	FORMAT(4H UC=,E16.8,8H CONST=,E16.8)	1160
	DO 778 M=MLOW,MUP,DM	1170
	XM=M	1180
	DO 779 IP=1,NP	1190
779	THETA(IP)=PARAM(IP)/XM/UC(KU)*A	1200
	WRITE(6,780) (THETA(IP),IP = 1,NP)	1210
780	FORMAT(7H THETA=/(7E16.8))	1220
	IF(THETA(IP).GT.100.) GO TO 999	1230
	XLOW=0.	1240
	DX=1./(20.*OMEGA(M,NUPM)/2./3.14159265)	1250
	IUP=5./DX*THETA(NP)+1.	1260
	IF(IUP.GT.3599) IUP=3599	
	IF(IUP-IUP/2*2) 501,500,501	1270
500	IUP=IUP+1	1280
501	IUP = IUP +400	1290
502	DX=(THETA(2)-THETA(1))/2.	1300
	ZLOW=-A	1310
	JUP=20*M+1	1320
	ZJUP=JUP-1	1330
	DZ=2.*A/ZJUP	1340
	YLOW=0.	1350
	KUP = 10* NUPM + 1	1360
	YKUP=KUP-1	1370
	DY=B/YKUP	1380
	DO 11 I=1,IUP	1390
	G5(I)=1.	1400
	IF(I.EQ.401)GO TO 11	1410
	IF(I.NE.1.AND.I.NE.IUP) GO TO 510	1420
	GO TO 511	1430
510	G5(I)=G5(I)*2.	1440
511	IF(I-I/2*2.EQ.0) GO TO 513	1450
	GO TO 11	1460
513	G5(I)=G5(I)*2.	1470

TABLE 3A (Continued)

11	CONTINUE	1480
	Z=ZLOW	1490
	DO 21 J=1,JUP	1500
	XM=M	1510
	D1=XM*C2*Z/A	1520
	D2=COS(D1)	1530
	G2(J,M)=D2+1./(XM*C2)*(SIN(ABS(D1))-ABS(D1)	1540
	1*D2)	1550
	IF(J.NE.1.AND.J.NE.JUP) GO TO 520	1560
	GO TO 521	1570
520	G2(J,M)=G2(J,M)*2.	1580
521	IF(J-J/2*2.EQ.0) GO TO 525	1590
	GO TO 21	1600
525	G2(J,M)=G2(M,M)*2.	1610
21	Z=Z+DZ	1620
	Y=YLOW	1630
	DO 31 K=1,KUP	1640
	DO 30 N=NLOW,NUP,DN	1650
	XN=N	1660
	D3=XN*C2*Y/B	1670
	D4=COS(D3)	1680
	G3(K,N)=D4+1./(XN*C2)*(SIN(D3)-D3*D4)	1690
	IF(K.NE.1.AND.K.NE.KUP) GO TO 530	1700
	GO TO 531	1710
530	G3(K,N)=G3(K,N)*2.	1720
531	IF(K-K/2*2.EQ.0) GO TO 533	1730
	GO TO 30	1740
533	G3(K,N)=G3(K,N)*2.	1750
30	CONTINUE	1760
31	Y=Y+DY	1770
	Y=YLOW	1780
	DO 39 K=1,KUP	1790
	YY(K)=Y*Y	1800
39	Y=Y+DY	1810
	DO 40 L1=1,3	1820
	DO 40 N=NLOW,NUP,DN	1830
	DO 40 IT=1,NP	1840

TABLE 3A (Continued)

40	IYZ(M,N;IT,L1)=0.	1850
	KAPPA=0	1860
	X=XLOW	1870
	DO 160 I=1,IUP	1880
	IF(TAU.EQ.0.0) GO TO 630	1890
	E1 = UC(KU)*(TAU-X)	1900
	GO TO 632	1910
630	E1 = UC(KU)*X	1920
632	CONTINUE	1930
	DO 50 N=NLOW,NUP,DN	1940
50	IYZ(M,N)=0.	1950
	Z=ZLOW	1960
	DO 120 J=1,JUP	1970
	E2=(Z-E1)*(Z-E1)	1980
	E4=B1+E2	1990
	E5=B2+E2	2000
	E6=B3+E2	2010
	DO 60 K=1,KUP	2020
60	TEMP1(K)=B4/(E4+YY(K))+B5/(E5+YY(K))+B6/(E6+YY(K))	2030
	DO 70 N=NLOW,NUP,DN	2040
70	IY(N)=0.	2050
	DO 90 K=1,KUP	2060
	DO 90 N=NLOW,NUP,DN	2070
90	IY(N)=IY(N)+G3(K,N)*TEMP1(K)	2080
	DO 100 N=NLOW,NUP,DN	2090
100	IY(N)=IY(N)*DY/3.	2100
	DO 110 N=NLOW,NUP,DN	2110
	TEMP=IY(N)	2120
110	IYZ(M,N)=IYZ(M,N)+G2(J,M)*TEMP	2130
120	Z=Z+DZ	2140
	DO 130 N=NLOW,NUP,DN	2150
130	IYZ(M,N)=IYZ(M,N)*DZ/3.	2160
1001	CONTINUE	2170
	DO 140 N=NLOW,NUP,DN	2180
	TEMP=IYZ(M,N)	2190
	XM=M	2200
	XN=N	2210

TABLE 3A (Continued)

	F1=XM* $\pi$ *C6	2220
	F2=OMEGA(M,N)*ABS(X)	2230
	DO 142 L1=1,3	2240
	F3(L1)=FA(M,N,L1)*ABS(X)	2250
	IF(F3(L1).GT.5.)GO TO 140	2260
	F6=F1*EXP(-F3(L1))*(SIN(F2)+FC(M,N,L1)*COS(F2))	2270
	DO 137 IT=1,NP	2280
	IF(X.GT.5.*THETA(IT))GO TO 137	2290
	IF(TAU.EQ.0.0) GO TO 634	2300
	G6 = DEXP(-DABS((TAU-X)/THETA(IT)))	2310
	GO TO 636	2320
634	G6=DEXP(-DABS(X/THETA(IT)))	2330
636	CONTINUE	2340
	G1=2.*F6*G1/G5(I)	2350
	IXYZ(M,N,IT,L1)=IXYZ(M,N,IT,L1)+G1*TEMP*DX/3.	2360
137	CONTINUE	2370
140	CONTINUE	2380
	IF(KAPPA.NE.0)GO TO 160	2390
	IF(I.NE.401)GO TO 160	2400
	KAPPA=1	2410
	DX=1./(20.*OMEGA(M,NUPM)/2./3.14159265)	2420
	GO TO 1001	2430
160	X=X+DX	2440
	DO 601 N=NLOW,NUP,DN	2450
	IF(THETA(IT).GT.100.) GO TO 999	2460
	WRITE(6,141) M,N	2470
141	FORMAT(3H1M=I5,3H N=I5//45X6HI(M,N)38X,18HI(M,N)*EIGEN*CONST//	2480
	12X5HTHETA4X11HOMEGA*THETA6X11HDAMP=1./10.5X7HDAMP=1.9X8HDAMP=10.	2490
	28X11HDAMP=1./10.5X7HDAMP=1.9X8HDAMP=10.7X5HPARAM)	2500
	DO 601 IT=1,NP	2510
	DO 602 L2=1,3	2520
602	ANS(L2)=IXYZ(M,N,IT,L2)*EIGEN(M,N,L2)*CONST	2530
	T=THETA(IT)*OMEGA(M,N)	2540
	WRITE(6,142)THETA(IT),T,(IXYZ(M,N,IT,L2),L2=1,3),(ANS(L2),L2=1,3),	2550
	IPARAM(IT)	2560
142	FORMAT(1X,F9.6,E14.6,6E16.8,2X,F10.5)	2570
601	CONTINUE	2580

TABLE 3A (Continued)

778	CONTINUE	2590
777	CONTINUE	2600
999	STOP	2610
	END	2620
\$1BFTC	VOLUME	2630
	SUBROUTINE VOLUM(A,B,MLOW,MUP,DM,NLOW,NUP,DN,VOL)	2640
	INTEGER DM, DN	2650
	DIMENSION VOL(20,10)	2660
	PI=3.14159265	2670
	DO 10 N=NLOW,NUP, DN	2680
	XN=N	2690
	DO 10 M=MLOW,MUP, DM	2700
	XM=M	2710
	VOL(M,N)=0.	2720
	IF(N=N/2*2.EQ.0)GO TO 10	2730
	IF(M=M/2*2.EQ.0)GO TO 10	2740
	GAMMAN=(2.*XN+1.)*PI/2.	2750
	GAMMAM=(2.*XM+1.)*PI/2.	2760
	XKN=SIN(GAMMAN/2.)/SINH(GAMMAN/2.)	2770
	XKM=SIN(GAMMAM/2.)/SINH(GAMMAM/2.)	2780
	VOL(M,N)=16.*A*B/GAMMAM/GAMMAN/(1.+XKM)*144.	2790
	1/(1.+XKN)*SIN(GAMMAM/2.)*SIN(GAMMAN/2.)	2800
10	CONTINUE	2810
	WRITE(6,20)((VOL(M,N),M=MLOW,MUP,DM),N=NLOW,NUP, DN)	2820
20	FORMAT(28H0VOLUME UNDER EIGENFUNCTION=//	2830
	1(8E16.8))	2840
	RETURN	2850
	END	2860

Table 3B - Computer Listings for Subprogram B  
(Semifrozen Convection - Model A)

```

$IBFTC ACCROS                                00 *
      DIMENSION RAUTO(100),RCROSS(8,100),POW(25),CAK(3)          0010
      DIMENSION RCRO(8,100),CROSS(8,100)                        0020
      DIMENSION PDW(25)                                          30
      DIMENSION SI(10),          TAU(100),FR(25),D(3),A(3),AD(3),ADD(3),DA 0040
      X(3),XCORD(25),TITLE(12)                                  * 50
      DIMENSION P(2500)                                          60
      DIMENSION SKNE(500),W(1000)                                0*70
1000 FORMAT(12A6)                                               80
1001 FORMAT(3F8.4)                                              90
1002 FORMAT(3F8.4)                                             0100
1003 FORMAT(3F12.6)                                           0110
1010 FORMAT(8F9.6)                                             0120
1011 FORMAT(12F6.0)                                           0130
1014 FORMAT(I4)                                               0140
1015 FORMAT(6F12.5)                                           0150
1016 FORMAT(F6.2)                                             0160
2000 FORMAT(1H1,12A6)                                          0170
2001 FORMAT(//7H A(1) = F8.4,8H A(2) = F8.4,8H A(3) = F8.4)   0180
2002 FORMAT(7H D(1) = F8.4,7H D(2) = F8.4,8H D(3) = F8.4)   0190
2003 FORMAT(8H THETA = F12.6,9H DSTAR = F12.6,8H UC = F12.6)  0200
2004 FORMAT(8H1 TAU ,17H AUTOCORRELATION /(F9.6,2X,F12.8))    0210
2007 FORMAT(1H1,2X,1HJ,3X,19H CROSS CORRELATION /(3X,13,2X,8F8.4)) 0220
2010 FORMAT(10X,3H SI/(8F9.6))                                 0230
2012 FORMAT(1X,10F6.0)                                         0240
2015 FORMAT(1H1,2X,10H K-WAVE NO,2X,10H 2PI*FREQ.,2X,10H K-WAVE NO,2X,
      110H 2PI*FREQ.,2X,10H K-WAVE NO,2X,10H 2PI*FREQ./ (1X,6F12.5) ) 0250
2016 FORMAT(//6H TW = F6.2)                                     0270
2020 FORMAT(1H1,4X,7H XCORD ,18X,5H PSD ,18X,7H POWER )      0280
2022 FORMAT(4X,F9.6,14X,F9.6,14X,F9.6)                        0290
2030 FORMAT(//2X,3H I,5X,9H POWER K ,9X,9H POWER W )         0300
2031 FORMAT(3X,3F12.6)                                         0310
2032 FORMAT(3X,15,4X,F12.9,7X,F12.9)                          0320
2041 FORMAT(15,4E15.6)                                         0330
C      LIST OF VARIABLES AND CONSTANTS                          0340
C      RAUTO = R(TAU)                                          0350
C      RCROSS = R(SI,ETA,TAU)                                  0360

```



TABLE 3B (Continued)

C	POW = P(W)U/(TAU**2*DELTA-STAR)	0370
C	DSTAR = DELTA-STAR	0380
C	D(I) = K(I)	0390
C	FR = FREQUENCY	0400
	PI = 3.1415925	0410
	READ(5,1000) (TITLE(I),I=1,12)	0420
	WRITE(6,2000) (TITLE(I),I=1,12)	0430
	READ(5,1001) (A(I),I=1,3)	0440
	READ(5,1002) (D(I), I=1,3)	0450
	READ(5,1003) THETA,DSTAR,UC	0460
	WRITE(6,2001) (A(I),I=1,3)	0470
	WRITE(6,2002) (D(I),I =1,3)	0480
	WRITE(6,2003) THETA,DSTAR,UC	0490
	READ(5,1010) (SI(I),I=1,8)	0500
	WRITE(6,2010) (SI(I),I =1,8)	0510
C	COMPUTE AUTOCORRELATION	0520
C	SI = 0, ETA = 0	530
	AKC = 0.0	0540
	DO 10 I=1,3	0550
	CAK(I) = A(I)/D(I)	0560
10	AKC = AKC + CAK(I)	0570
	U = UC/0.8	0580
	F = DSTAR/U	05 0
	FDUC = (1./(F*UC))**2	0600
	GO TO 400	*610
	TAU(1) =0.0	0620
	DO 25 J=1,100	0630
	RAUT = 0.0	0640
	DO 20 I =1,3	0650
	ADD(I) = (A(I)*D(I))/(D(I)**2+(TAU(J)/F)**2)	0660
20	RAUT = ADD(I) + RAUT	0670
	RAUTO(J) = RAUT/AKC	0680
	TAU(J+1) = TAU(J) + 0.00001	0690
25	CONTINUE	0700
	WRITE(6,2004) (TAU(J),RAUTO(J),J=1,100)	0710
C	COMPUTE CROSS CORRELATION	0720
C	ETA = 0.0	0730

TABLE 3B (Continued)

	DO 16 I = 1, 8	0740
16	SI(I) = SI(I)/12.	0750
	DO 35 J = 1,100	0760
	DO 33 I = 1,8	0770
	RCRO(I,J) = 0.0	0780
	DO 30 IM = 1,3	0790
	AD(IM) = (A(IM)*D(IM))/(D(IM)**2+FDUC*(SI(I)-UC*TAU(J))**2)	0800
30	RCRO(I,J) = RCRO(I,J)+AD(IM)	0810
	CROSS(I,J) = RCRO(I,J)*EXP(-ABS(SI(I))/(UC*THETA))	0820
	RCROSS(I,J) = CROSS(I,J)/AKC	0830
	TAU(J+1) = TAU(J) + 0.00001	0840
33	CONTINUE	0850
35	CONTINUE	0860
	WRITE(6,2007) (J,(RCROSS(I,J),I=1,8),J=1,100)	0870
COMMENT	FIG.2 EQTN. 4 SEMI-FRPZEN CASE	0880
C	COMPUTE POWER	0890
400	CONTINUE	0900
	READ(5,1012) (FR(I),I=1,25)	0910
	WRITE(6,2012) (FR(I),I = 1,25)	0920
	READ(5,1016) TW	0930
	WRITE(6,2016) TW	0940
	TW = TW**2	0950
	WRITE(6,2020)	0960
	DO 45 J = 1,25	0970
	POW(J) = 0.0	0980
	DO 40 I = 1,3	0990
	DA(I) = A(I)*EXP(-D(I)*6.2832*FR(J)*F)	1000
	POW(J) = POW(J) + DA(I)	1010
40	CONTINUE	1020
	XCORD(J)=(6.2832*FR(J)*DSTAR)/U	1030
	PDW(J) = POW(J)*DSTAR*TW/U	1040
45	CONTINUE	1050
	WRITE(6,2022) (XCORD(J),POW(J),PDW(J),J =1,25)	1060
	GO TO 500	1070
COMMENT	COMPUTE P(K1,W)	1080
COMMENT	SKNE IS WAVE NUMBER K-ONE	1090
COMMENT	CORRESPONDS TO GRAPH IN MAESTRELLO, PAGE 415, FIG.5, FOR 2*PI	1100

TABLE 3B (Continued)

C	*FR VS P(K=ONE,2*PI*FR)	1110
	WI = -48000.	1120
	SKI = WI	1130
	WF = 48000.	1140
	SKF = WF	1150
	DW = 2000.	1160
	M = (WF-WI)/DW + 1.	1170
	DSK = DW	1180
	N = M	1190
	SK = SKI	1200
	DO 50 I = 1,M	1210
	SKNE(I) = SK	1220
	WW = WI	1230
	DO 49 K = 1,N	1240
	W(K) = WW	1250
	FAC = (THETA*F*UC)/((1.+THETA*THETA*(W(K)+SKNE(I))**2)*2.*PI)	1260
	ARF = 0.0	1270
	DO 55 J = 1,3	1280
	FAR = A(J)*EXP(-ABS(W(K))*D(J)*F)	1290
	ARF = ARF + FAR	1300
55	CONTINUE	1310
	PKW = FAC*ARF/AKC	1320
	PW = PKW*PI*(1.+THETA*THETA*(W(K)+SKNE(I))**2/THETA)	1330
	WRITE(6,2041) I,PKW,PW,W(K),SKNE(I)	1340
	WW = WW + DW	1350
49	CONTINUE	1360
	SK = SK + DSK	1370
50	CONTINUE	1380
500	CONTINUE	1390
	STOP	1400
	END	1410

Table 3C -- Computer Listings for Subprogram C  
(Semifrozen Convection -- Model A)

```

COMMENT REMOVE CARD 1030...READ(5,3*)WI,DW,WF ... FOR CASE W = WMN
COMMENT NO IBFTC CARD FOR RUN AT APL
COMMENT NOW RUNNING AT APL ON IBM 360/91
C      MULTIPLE INTEGRAL PROGRAM NO.    FOR LM BY FG
C      USES GAUSSIAN QUADRATURFON FOUR INTEGRALS
C      GENERAL CASE WITH NO COUPLING
C      ANSWER IS IN INCHES SQUARED PER SEC.
C
      IMPLICIT REAL*8(A-H,O-Z)
      INTEGER DM,DM
      REAL KN,KM
      COMPLEX *16 ARGCOM,E2,FV4,SUM4,FV5,SUM5,FV6,SUM6,ANS,ANSINT,PWRSD
      DIMENSION GM(20),GN(10),KN(10),KM(20)
      DIMENSION TITLE(20),AK(4),AN(4),WMN(20,10),FA(20,10),FC(20,10),
      IEIGEN(20,10),WGT(21),ARG(21)
C      READ AND WRITE INPUT DATA
C      NO. OF GAUSSIAN POINTS AND NO OF TERMS IN SUM OF A AND K
      READ(5,9)NW,NAK
      READ(5,33)(ARG(I),I=1,NW)
      READ(5,33)(WGT(I),I=1,NW)
33  FORMAT(D20.8)
      PI=3.14159265358979323
      PI2=2.*PI
      PI3=PI**3
      READ(5,1)(TITLE(I),I=1,20)
1  FORMAT(20A4)
      WRITE(6,2)(TITLE(I),I=1,20)
2  FORMAT(1H1,20A4)
      READ(5,3)X,XP,Y,YP
      READ(5,3)(AK(I),I=1,NAK)
      READ(5,3)(AN(I),I=1,NAK)
      READ(5,3)A,B,FM,UE,DEL,PB2
3  FORMAT(6F12.6)
      FM2=FM*FM
      READ(5,3)UC,TH
      ALPH1=.02*750./DEL
      ALPH2=3.8/DEL

```

0000  
0010  
0020  
0030  
0040  
70  
0 80  
90  
0100  
0110  
0120  
0130  
0140  
0150  
0160  
0170  
0180  
0190  
0200  
0210  
0220  
0230  
0240  
0250  
0260  
0270  
0280  
0290  
0300  
0310  
0320  
0330  
0340  
0350  
0360

TABLE 3C (Continued)

TH=1./(ALPH1*UC*DEL)	0370
WRITE(6,7)A,B,FM2,UE,DEL,PB2,UC,TH	0380
7 FORMAT(3HOA=F10.4,5H B=F10.4,15H MASS SQUARED= E15.6,	0390
111H U SUB E= E15.6/5H DEL=E15.6,17H P BAR SQUARED= E15.6,	0400
26H UC=E15.6,4H TH=E15.6/)	0410
READ(5,9)MLOW,MUP,DM,NLOW,NUP,DN	0420
9 FORMAT(16I5)	0430
READ(5,3)(GM(M),M=1,MUP)	0440
READ(5,3)(GN(N),N=1,NUP)	0450
READ(5,3)(KM(M),M=1,MUP)	0460
READ(5,3)(KN(N),N=1,NUP)	0470
DO 2000 M=1,MUP	0480
2000 GM(M)=GM(M)*PI	0490
DO 2001 N=1,NUP	0500
2001 GN(N)=GN(N)*PI	0510
READ(5,12)((WMN(M,N),M=1,MUP),N=1,NUP)	0520
12 FORMAT(F10.2)	0530
WRITE(6,13)((WMN(M,N),M=MLOW,MUP,DM),N=NLOW,NUP,DN)	0540
13 FORMAT(7HOOMEGA=/(1X,8D14.5))	0550
READ(5,12)((FA(M,N),M=1,MUP),N=1,NUP)	0560
WRITE(6,18)((FA(M,N),M=1,MUP),N=1,NUP)	0570
18 FORMAT(8HOA(M,N)=/(8E14.6))	0580
C1=4./(A*B)	0590
17 FORMAT(7H CONST= E15.6)	0600
CONST=144.*32.2*32.2*4.*A*A*B*B/(PI3*FM2)	0610
WRITE(6,17)CONST	0620
DO 50 M=MLOW,MUP,DM	0630
XM=M	640
XMPI=XM*PI	0650
GMXA2=GM(M)*(X/A-.5)	0660
GMXPA2=GM(M)*(XP/A-.5)	0670
SXMC2A=DCOS(GMXA2)+KM(M)*DCOSH(GMXA2)	0680
IF(M-M/2*2.EQ.0)SXMC2A=DSIN(GMXA2)+KM(M)*DSINH(GMXA2)	0690
SXOPCA=DCOS(GMXPA2)+KM(M)*DCOSH(GMXPA2)	0700
IF(M-M/2*2.EQ.0)SXOPCA=DSIN(GMXPA2)+KM(M)*DSINH(GMXPA2)	0710
SINXPA=SXMC2A*SXOPCA	0720
DO 45 N=NLOW,NUP,DN	0730

TABLE 3C (Continued)

XN=N	740
XNPI=XN*PI	0750
OGA=WMN(M,N)	0760
FC(M,N)=OGA/FA(M,N)	0770
FUDGE=XM*XM*XN*XN	0780
GNYPB2=GN(N)*(Y/B-.5)	0790
GNYPB2=GN(N)*(YP/B-.5)	0800
EIGEN(M,N)=C1/FUDGE*SINXXP*(DCOS(GNYPB2)+KN(N)*DCOSH(GNYPB2))*	0810
1(DCOS(GNYPB2)+KN(N)*DCOSH(GNYPB2))	0820
IF(N=N/2*.EQ.0)EIGEN(M,N)=C1/FUDGE*SINXXP*	0830
1(DSIN(GNYPB2)+KN(N)*DSINH(GNYPB2))*(DSIN(GNYPB2)+KN(N)*DSINH	0840
2(GNYPB2))	0850
WRITE(6,16)X,Y,M,N,EIGEN(M,N),FA(M,N)	0860
16 FORMAT(1H02F12.6,2I4.6E13.6)	0870
45 CONTINUE	0880
50 CONTINUE	0890
WRITE(6,19)	0900
19 FORMAT(1H1,3X,1HM,3X,1HN,14X,1HW,11X,4HPOFW,12X,3HWMN,12X,3HDEN,	0910
1/18X,8HANSINT R, 7X,8HANSINT I,10X,5HANS R,10X,5HANS I,8X,7HPWRS	0920
2R,8X,7HPWRS I /)	0930
UCTH=UC*TH	0940
DO 776 M=NLOW,MUP,DM	0950
XM=M	960
XMPI=XM*PI	0970
AMPI=A/(XMPI*UCTH)	0980
DO 776 N=NLOW,NUP,DN	0990
XN=N	1000
XNPI=XN*PI	1010
BNPI=B/(XNPI*UCTH)	1020
READ(5,3)WI,DW,WF	1030
NWW=(WF-WI)/DW+1.	1040
NXO=NW*M	1050
NYO=NW*N	1060
NXOP=NW*M	1070
NYOP=NW*N	1080
OGA=WMN(M,N)	1090
OGA2=OGA*OGA	1100

TABLE 3C (Continued)

	FAL1=FA(M,N)	1110
	FAL12=FAL1*FAL1	1120
	W=W1	1130
	DO 150 MM1=1,NWW	1140
	ANSINT=0.	1150
	W2=W**W	1160
	DEN=(FAL12+(OGA-W)**2)*(FAL12+(OGA+W)**2)	1170
	SUMAK=0.	1180
	DO 120 IS=1,NAK	1190
120	SUMAK=SUMAK+AN(IS)*DEXP(-AK(IS)*W*DEL/UE)	1200
	POFW=SUMAK*PB2*DEL/UE	1210
	SUM6=0.	1220
	DO 500 I1=1,NXO	1230
	I1Q=(I1-1)/NW	1240
	I1R=I1-NW*I1Q	1250
	XO=PI*(.5+.5*ARG(I1R)+FLOAT(I1Q))	1260
	XOA=GM(M)*(XO/XMPI-.5)	1270
	SFXO=DCOS(XOA)+KM(M)*DCOSH(XOA)	1280
	IF(M-M/2*2.EQ.0)SFXO=DSIN(XOA)+KM(M)*DSINH(XOA)	1290
	SUM4=0.	1300
	DO 300 K1=1,NXOP	1310
	K1Q=(K1-1)/NW	1320
	K1R=K1-NW*K1Q	1330
	XOP=PI*(.5+.5*ARG(K1R)+FLOAT(K1Q))	1340
	XOXOP=XO-XOP	1350
	E1=DEXP(-A/XMPI*ALPH1*DABS(XOXOP))	1360
	ARGCOM=DCMPLX(0.,0,-W*A/(UC*XMPI)*XOXOP)	1370
	E2=CDEXP(ARGCOM)	1380
	XOPA=GM(M)*(XOP/XMPI-.5)	1390
	SFXOP=DCOS(XOPA)+KM(M)*DCOSH(XOPA)	1400
	IF(M-M/2*2.EQ.0)SFXOP=DSIN(XOPA)+KM(M)*DSINH(XOPA)	1410
	FV4= SFXOP*E1**E2	1420
	SUM4=SUM4+FV4*WGT(K1R)*PI/2.	1430
300	CONTINUE	1440
	FV6=SUM4*SFXO	1450
	SUM6=SUM6+FV6*WGT(I1R)*PI/2.	1460
500	CONTINUE	1470

TABLE 3C (Continued)

SUM5=0.	1480
DO 400 J1=1,NYO	1490
J1Q=(J1-1)/NW	1500
J1R=J1-NW*J1Q	1510
YO=PI*(.5+.5*ARG(J1R)+FLOAT(J1Q))	1520
YOB=GN(N)*(YO/XNPI-.5)	1530
SFYO=DCOS(YOB)+KN(N)*DCOSH(YOB)	1540
IF(N-N/2*.EQ.0)SFYU=DSIN(YOB)+KN(N)*DSINH(YOB)	1550
SUM3=0.	1560
DO 200 L1=1,NYOP	1570
L1Q=(L1-1)/NW	1580
L1R=L1-NW*L1Q	1590
YOP=PI*(.5+.5*ARG(L1R)+FLOAT(L1Q))	1600
YOYOP=YO-YOP	1610
BNPI=B/(XNPI*UCTH)	1620
E3=DEXP(-B/XNPI*ALPH2*DABS(YOYOP))	1630
YOPB=GN(N)*(YOP/XNPI-.5)	1640
SFYOP=DCOS(YOPB)+KN(N)*DCOSH(YOPB)	1650
IF(N-N/2*.EQ.0)SFYOP=DSIN(YOPB)+KN(N)*DSINH(YOPB)	1660
FV3=SFYOP*E3	1670
SUM3=SUM3+FV3*WGT(L1R)*PI/2.	1680
200 CONTINUE	1690
FV5=SUM3*SFYO	1700
SUM5=SUM5+FV5*WGT(J1R)*PI/2.	1710
400 CONTINUE	1720
ANSINT=SUM6*SUM5	1730
ANS=ANSINT*CONST*POFW*EIGEN(M,N)/DEN *C1	1740
PWRSD=ANS*W**4	1750
WRITE(6,20)M,N,W,POFW,EIGEN(M,N),DEN	1760
20 FORMAT(1X,2I4,6E15.6)	1770
WRITE(6,21)ANSINT,ANS,PWRSD	1780
21 FORMAT(11X,6E15.6/)	1790
W=W*DW	1800
150 CONTINUE	1810
776 CONTINUE	1820
778 CONTINUE	1830
STOP	1840

END

1850



Table 3D - Computer Listings for Subprogram D  
(Semifrozen Convection - Model A)

```

C   MULTIPLE INTEGRAL PROGRAM NO.   FOR LM BY FG           0000
C   USES GAUSSIAN QUADRATURE ON FOUR INTEGRALS           0010
COMMENT GENERAL CASE WMN AND WPQ           0020
C   ANSWER IS IN INCHES SQUARED PER SEC.           0030
C
C   IMPLICIT REAL*8(A-H,O-Z)           40
C   INTEGER GLOW,QUP,DO,PLOW,PUP,DP,P,Q           0 50
C   INTEGER DM,DN           0060
C   REAL KP,KQ           70
C   REAL KN,KM           80
C   REAL KN,KM           90
C   COMPLEX*16 DENCOM           0100
C   COMPLEX * 16 COM1,COM2,XNMTR           0110
C   COMPLEX *16 ARGCOM,E2,FV4,SUM4,FV5,SUM5,FV6,SUM6,ANS,ANSINT,PWRSD           0120
C   DIMENSION EIGN(20,10)           0130
C   DIMENSION APQ(20,10),WPQ(20,10),GP(20),GQ(10),KP(20),KQ(1,1)           0140
C   DIMENSION GM(20),GN(10),KN(10),KM(20)           0150
C   DIMENSION TITLE(20),AK(4),AN(4),WMN(20,10),FA(20,10),FC(20,10),           0160
C   1EIGEN(20,10),WGT(21),ARG(21)           0170
C   READ AND WRITE INPUT DATA           0180
C   NO. OF GAUSSIAN POINTS AND NO OF TERMS IN SUM OF A AND K           0190
C   READ(5,9)NW,NAK           0200
C   READ(5,33)(ARG(I),I=1,NW)           0210
C   READ(5,33)(WGT(I),I=1,NW)           0220
33  FORMAT(D20,8)           0230
C   PI=3.14159265358979323           0240
C   PI2=2.*PI           0250
C   PI3=PI**3           0260
C   READ(5,1)(TITLE(I),I=1,20)           0270
1  FORMAT(20A4)           0280
C   WRITE(6,2)(TITLE(I),I=1,20)           0290
2  FORMAT(1H1,20A4)           0300
C   READ(5,3)X,XP,Y,YP           0310
C   READ(5,3)(AK(I),I=1,NAK)           0320
C   READ(5,3)(AN(I),I=1,NAK)           0330
C   READ(5,3)A,B,FM,UE,DEL,PB2           0340
3  FORMAT(6F12,6)           0350
C   FM2=FM*FM           0360

```

TABLE 3D (Continued)

READ(5,3)UC,TH	0370
ALPH1=.02*750./DEL	0380
ALPH2=3.8/DEL	0390
TH=1./(ALPH1*UC*DEL)	0400
WRITE(6,7)A,B,FM2,UE,DEL,PB2,UC,TH	0410
7 FORMAT(3H0A=F10.4,5H B=F10.4,15H MASS SQUARED= E15.6,	0420
111H U SUB E= E15.6/5H DEL=E15.6,17H P BAR SQUARED= E15.6,	0430
26H UC=E15.6,4H TH=E15.6/)	0440
READ(5,9)MLOW,MUP,DM,NLOW,NUP,DN	0450
READ(5,9)PLOW,PUP,DP,QLOW,QUP,DQ	0460
9 FORMAT(16I5)	0470
READ(5,3)(GM(M),M=1,MUP)	0480
READ(5,3)(GP(P),P=1,PUP)	0490
READ(5,3)(GN(N),N=1,NUP)	0500
READ(5,3)(GQ(Q),Q=1,QUP)	0510
READ(5,3)(KM(M),M=1,MUP)	0520
READ(5,3)(KP(P),P=1,PUP)	0530
READ(5,3)(KN(N),N=1,NUP)	0540
READ(5,3)(KQ(Q),Q=1,QUP)	0550
DO 2000 M=1,MUP	0560
2000 GM(M)=GM(M)*PI	0570
DO 2001 N=1,NUP	0580
2001 GN(N)=GN(N)*PI	0590
DO 2002 P=1,PUP	0600
2002 GP(P)=GP(P)*PI	0610
DO 2003 Q=1,QUP	0620
2003 GQ(Q)=GQ(Q)*PI	0630
READ(5,12)((WMN(M,N),M=1,MUP),N=1,NUP)	0640
READ(5,12)((WPO(P,Q),P=1,PUP),Q=1,QUP)	0650
12 FORMAT(F10.2)	0660
WRITE(6,13)((WMN(M,N),M=MLOW,MUP,DM),N=NLOW,NUP,DN)	0670
13 FORMAT(12HOOMEGA(M,N)=/(1X,8D14.5))	0680
WRITE(6,23)((WPO(P,Q),P=PLOW,PUP,DP),Q=QLOW,QUP,DQ)	0690
23 FORMAT(12HOOMEGA(P,Q)=/(1X,8D14.5))	0700
READ(5,12)((FA(M,N),M=1,MUP),N=1,NUP)	0710
WRITE(6,18)((FA(M,N),M=1,MUP),N=1,NUP)	0720
18 FORMAT(8H0A(M,N)=/(8E14.6))	0730

TABLE 3D (Continued)

READ(5,12)((APQ(P,Q),P=1,PUP),Q=1,QUP)	0740
WRITE(6,18)((FA(M,N),M=MLOW,MUP,DM),N=NLOW,NUP,DN)	0750
WRITE(6,28)((APQ(P,Q),P=PLOW,PUP,DP),Q=QLOW,QUP,DP)	0760
28 FORMAT(8H0A(P,Q)=/(1X,8E14.6))	0770
C1=2./DSQRT(A*B)	0780
17 FORMAT(7H CONST= E15.6)	0790
CONST=144.*32.2*32.2 *A*A*B*B/(PI3*FM2)	0800
WRITE(6,17)CONST	0810
DO 50 M=MLOW,MUP,DM	0820
XM=M	0830
XMPI=XM*PI	0840
GMXA2=GM(LM)*(X/A-.5)	0850
SXMC2A=DCOS(GMXA2)+KM(M)*DCOSH(GMXA2)	0860
IF(M-M/2*.EQ.0)SXMC2A=DSIN(GMXA2)+KM(M)*DSINH(GMXA2)	0870
DO 45 N=NLOW,NUP,DN	0880
XN=N	0890
XNPI=XN*PI	0900
OGA=WMN(M,N)	0910
FC(M,N)=OGA/FA(M,N)	0920
GNYB2=GN(N)*(Y/B-.5)	0930
FUDGE=YM*XN	0940
EIGEN(N,N)=C1/FUDGE*SXMC2A*(DCOS(GNYB2)+KN(N)*DCOSH(GNYB2))	0950
IF(N-N/2*.EQ.0)EIGEN(M,N)=C1/FUDGE*SXMC2A*	0960
1(DSIN(GNYB2)+KN(N)*DSINH(GNYB2))	0970
WRITE(6,16)X,Y,M,N,EIGEN(M,N),FA(M,N)	0980
16 FORMAT(1H02F12.6,2I4,6E13.6)	0990
45 CONTINUE	1000
50 CONTINUE	1010
DO 550 P=PLOW,PUP,DP	1020
XXP=P	1030
XPPI=XXP*PI	1040
GMXPA2=GP(P)*(XP/A-.5)	1050
SXOPCA=DCOS(GMXPA2)+KP(P)*DCOSH(GMXPA2)	1060
IF(P-P/2*.EQ.0)SXOPCA=DSIN(GMXPA2)+KP(P)*DSINH(GMXPA2)	1070
DO 545 Q=QLOW,QUP,DP	1080
XQ=Q	1090
XQPI=XQ*PI	1100

TABLE 3D (Continued)

OGP=WPO(P,Q)	1110
OGP2=OGP*OGP	1120
FUDGE=XXP*XQ	1130
GNYPB2=GQ(Q)*(YP/B-.5)	1140
EIGN(P,Q)=C1/FUDGE*SXOPCA*(DCOS(GNYPB2)+KQ(Q)*DCOSH(GNYPB2))	1150
IF(Q-Q/2*2.EQ.0)EIGN(P,Q)=C1/FUDGE*SXOPCA*(DSIN(GNYPB2)+KQ(Q)*DSIN	1160
1H(GNYPB2))	1170
WRITE(6,26)XP,YP,P,Q,EIGN(P,Q),APQ(P,Q)	1180
26 FORMAT(1H 2F12.6,2I4.6E13.6)	1190
545 CONTINUE	1200
550 CONTINUE	1210
WRITE(6,19)	1220
19 FORMAT(1H1,3X,1HM,3X,1HN,14X,1HW,11X,4HPOFW,12X,3HWMM,12X,3HDEN,	1230
1/18X,8HANSINT R, 7X,8HANSINT I,10X,5HANS R,10X,5HANS I,8X,7HPWRSD	1240
2R,8X,7HPWRSD I /)	1250
UCTH=UC*TH	1260
DO 778 M=MLOW,MUP,DM	1270
XM=M	1280
XMPI=XM*PI	1290
AMPI=A/(XMPI*UCTH)	1300
DO 7781 P=PLOW,PUP,DP	1310
XXP=P	1320
XPPI=XXP*PI	1330
DO 776 N=NLOW,NUP,DN	1340
XN=N	1350
XNPI=XN*PI	1360
BNPI=B/(XNPI*UCTH)	1370
DO 7761 Q=QLOW,QUP,DQ	1380
XQ=Q	1390
XQPI=XQ*PI	1400
READ(5,3)WI,DW,WF	1410
NWW=(WF-WI)/DW+1.	1420
NXO=NW*M	1430
NYO=NW*N	1440
NXOP=NW*P	1450
NYOP=NW*Q	1460
OGA=WMN(M,N)	1470

TABLE 3D (Continued)

OGA2=OGA*OGA	1480
FAL1=FA(M,N)	1490
FAL12=FAL1*FAL1	1500
OGP=WPQ(P,Q)	1510
OGP2=OGP*OGP	1520
FAL2=APQ(P,Q)	1530
FAL22=FAL2*FAL2	1540
W=WI	1550
DO 150 MM1=1,NWW	1560
ANSINT=0.	1570
W2=W*W	1580
DEN={(((FAL1+FAL2)/2.)**2+OGA2/4.+OGP2/4.)**2	1590
1-CGA2*OGP2/4.)*OGA*OGP	1600
COM1=FAL1+DCMLX(0,DO,W)	1610
COM2=FAL2-DCMLX(0,DO,W)	1620
FALL12=(FAL1+FAL2)/2.	1630
XNMRTR=(COM1*(OGA*OGP*FALL12)+OGA*OGP*(FALL12*FALL12-	1640
1/OGA2/4. -OGP2/4.) )/(COM1*COM1+OGA2)+(COM2*	1650
2(OGA*OGP*FALL12)+OGA*OGP*(FALL12*FALL12+OGA2/4.-OGP2/4.) )/(COM2*CO	1660
3M2+OGP2)	1670
DENCOM=XNMRTR/DEN	1680
SUMAK=0.	1690
DO 120 IS=1,NAK	1700
120 SUMAK=SUMAK+AN(IS)*DEXP(-AK(IS)*W*DEL/UE)	1710
POFW=SUMAK*PB2*DEL/UE	1720
SUM6=0.	1730
DO 500 I1=1,NXO	1740
I1Q=(I1-1)/NW	1750
I1R=I1-NW*I1Q	1760
XO=PI*(.5+.5*ARG(I1R)+FLOAT(I1Q))	1770
XOA=GM(M)*(XO/XMPI-.5)	1780
SFXO=DCOS(XOA)+KM(M)*DCOSH(XOA)	1790
IF(M=M/2*2.EQ.0)SFXO=DSIN(XOA)+KM(M)*DSINH(XOA)	1800
SUM4=0.	1810
DO 300 K1=1,NXOP	1820
K1 Q=(K1-1)/NW	1830
K1R=K1-NW*K1Q	1840

TABLE 3D (Continued)

	XOP=PI*(.5+.5*ARG(K1R))+FLOAT(K1Q)	1850
	XOXOP=XO-XOP	1860
	E1=DEXP(-A/PI*ALPH1 *DABS(XO/XM-XOP/XXP))	1870
	ARGCOM=DCMPLX(0.00,-W*A/(UC*PI))*(XO/XM-XOP/XXP)	1880
	F2=CDEXP(ARGCOM)	1890
	XOPA=GP(P)*(XOP/XPPI-.5)	1900
	SFXOP=DCOS(XOPA)+KP(P)*DCOSH(XOPA)	1910
	IF(P-P/2*.EQ.0)SFXOP=DSIN(XOPA)+KP(P)*DSINH(XOPA)	1920
	FV4=SFXOP*E1*E2	1930
	SUM4=SUM4+FV4*WGT(K1R)*PI/2.	1940
300	CONTINUE	1950
	FV6=SUM4*SFXO	1960
	SUM6=SUM6+FV6*WGT(I1R)*PI/2.	1970
500	CONTINUE	1980
	SUM5=0.	1990
	DO 400 J1=1,NYO	2000
	J1Q=(J1-1)/NW	2010
	J1R=J1-NW*J1Q	2020
	YO=PI*(.5+.5*ARG(J1R))+FLOAT(J1Q)	2030
	YOB=GN(N)*(YO/XNPI-.5)	2040
	SFYO=DCOS(YOB)+KN(N)*DCOSH(YOB)	2050
	IF(N-N/2*.EQ.0)SFYO=DSIN(YOB)+KN(N)*DSINH(YOB)	2060
	SUM3=0.	2070
	DO 200 L1=1,NYOP	2080
	L1Q=(L1-1)/NW	2090
	L1R=L1-NW*L1Q	2100
	YOP=PI*(.5+.5*ARG(L1R))+FLOAT(L1Q)	2110
	YOYOP=Y0-YOP	2120
	BNPI=B/(XNPI*UCTH)	2130
	E3=DEXP(-B/PI * ALPH2*DABS(YO/XN-YOP/XQ))	2140
	YOPB=GQ(Q)*(YOP/XQPI-.5)	2150
	SFYOP=DCOS(YOPB)+KQ(Q)*DCOSH(YOPB)	2160
	IF(Q-Q/2*.EQ.0)SFYOP=DSIN(YOPB)+KQ(Q)*DSINH(YOPB)	2170
	FV3=SFYOP*E3	2180
	SUM3=SUM3+FV3*WGT(L1R)*PI/2.	2190
200	CONTINUE	2200
	FV5=SUM3*SFYO	2210

TABLE 3D (Continued)

	SUM5=SUM5+FV5*WGT(J1R)*PI/2.	2220
400	CONTINUE	2230
	ANSINT=SUM5*SUM5	2240
	ANS=ANSINT*CONST*POFW*EIGEN(M,N)*EIGN(P,Q)*DENCOM*C1*C1	2250
	PWRSD=ANS*W**4	2260
	WRITE(6,20)M,N,W,POFW,EIGEN(M,N),DEN	2270
	WRITE(6,20)P,Q,XNMRTR,EIGN(P,Q),DENCOM	2280
20	FORMAT(1X,2I4,6E15.6)	2290
	WRITE(6,21)ANSINT,ANS,PWRSD	2300
21	FORMAT(11X,6E15.6/)	2310
	W=W+DW	2320
150	CONTINUE	2330
7761	CONTINUE	2340
776	CONTINUE	2350
7781	CONTINUE	2360
778	CONTINUE	2370
	STOP	2380
	END	2390

**APPENDIX C**

**ELECTRIC BOAT PROGRAM (IZZO)**

**APPENDIX C1 – MATHEMATICAL ANALYSIS**

**APPENDIX C2 – METHOD FOR DETERMINING INPUT DATA**

**APPENDIX C3 – PROGRAM IDENTIFICATION**

**APPENDIX C4 – TEST RUNS**

## NOTATION

$A$	Correlation area of turbulence over which the mean square pressure $\overline{p^2}$ is constant
$A_{mn}, A_{rs}$	Coefficient used in series representation of deflection
$A_n, A'_n$	Normal acceleration of plate
$a_i$	Speed of sound in water
$a_m, b_m, c_m, d_m$	Constants
$a_n, b_n, c_n, d_n$	
$a_{mn}$	Modal damping function
$B$	Equal to $\eta/2$
$b$	Bending stiffness
$C_{mn}, D_{mn}$	Constants defined in Equation (C27)
$C_{mn}^{rs}$	Coefficient in Equation (C34)
$g(\ )$	Greens function (impulse response of plate at point $r_0$ due to forcing function $P$ at $r_0$ ) defined by Equation (C10)
$h$	Plate thickness
$l, i$	Refers to properties on the side of the plate where the fluid is in motion (i.e., turbulent) and where the fluid is stagnant, respectively, as shown in Figure 11.
$l_{mn}(\tau)$	Time correlation integral defined by Equation (C24)
$K$	Constant
$K'(\omega_{mn})$	Modal amplitude factor
$\bar{K}_{mn}, K_{mn}$	Constants defined in Equation (C27) and (C28), respectively
$L(\ )$	Linear differential operator defined in Equation (C12)
$L_x, L_y$	Lateral dimensions of plate along the $x$ and $y$ axes, respectively
$M$	Mass per unit area of plate
$m, n; p, q; r, s$	Mode numbers
$P_i$	Acoustic pressure
$\overline{p^2}$	Mean square pressure at surface beneath turbulent boundary layer



$\varphi(r, t)$	Surface pressure beneath turbulent boundary layer
$R_A(\ )$	Space-time correlation of plate accelerations
$R_p(r, r', \tau)$	Space-time correlation of acoustic pressures
$R_p(\tau_0, \tau'_0, \tau)$	Space-time correlation of turbulence pressures
$R_v(\ )$	Space-time correlation of plate velocities
$R_z(\ )$	Space-time correlation of plate displacements
$r, r', \tau_0, \tau'_0$	Radius vectors defined in Figure 11
$\vec{r}_0(\vec{x}_0, \vec{y}_0, \vec{z}_0), \vec{t}_0$ $\omega, \vec{r}'_0, \vec{t}'_0$	Space-time coordinates of the forcing function $p$
$S, S_0, S'_0$	Surface area of plate ( $dS_0 = dx_0 dy_0$ etc)
$S_p(r, r', \omega)$	Cross-spectral density of acoustic pressures
$S_p(r, \omega)$	Power spectrum of acoustic pressures at a point $r$ along the normal through the center of the plate
$S_z(r, r', \omega)$	Cross-spectral density of plate displacements
$T$	Kinetic energy of plate
$t, t', t_0, t'_0, \overline{t_0}, \overline{t'_0}$	Time variables
$U(t - \overline{t_0})$	Unit step function
$U_c$	Average convective speed of turbulent pressure field (or pattern)
$U_0$	Ship speed; free stream velocity
$u$	Velocity component, at any point $y$ in the boundary layer, parallel to the $x$ axis; see Figure 11
$V$	Potential energy of plate
$V_n, V'_n$	Normal velocity of plate
$w$	Plate displacement
$X_m(x), Y_n(y)$	Mode shapes of the plate along $x$ and $y$ , respectively
$x, x', x_0, x'_0$	
$y, y', y_0, y'_0$	Space coordinates defined in Figure 11
$Z_n, Z'_n, z, z'$	Normal displacement of plate

$\alpha$	Equal to $m\pi U_e' L_x$
$\beta_0$	Plate viscous damping (resistance coefficient)
$\beta_1$	Radiation damping coefficient
$\gamma, \mu$	Functions of the time variables as defined by Equation (C 22)
$\delta, \delta^*$	Boundary layer thickness and boundary layer displacement thickness, respectively
$\delta(\ )$	Dirac delta function
$\delta_{mn}, \delta_{pq}$	Kronecker delta equal to $\begin{matrix} 1 \text{ for } m = n \text{ or } p = q \\ 0 \text{ for } m \neq n \text{ or } p \neq q \end{matrix}$
$\delta_{mn}$	Kronecker delta equal to $\begin{matrix} 1 \text{ for } mn = rs \\ 0 \text{ for } mn \neq rs \end{matrix}$
$\eta$	Loss factor (plate hysteretic damping)
$\theta$	Temporal decay factor of turbulent boundary layer associated with eddy decay
$\kappa$	Measure of the inverse radius of the turbulence eddy
$\lambda_{mn}$	Eigenvalue
$\mu$	Poisson's ratio
$\rho$	Density of plate material
$\rho_i$	Fluid density
$r, r', r_0$	Delay times equal to $t' - t, t' - t + \frac{r_0 - r_0'}{a_i}$ , and $\overline{t_0} - \overline{t_0'}$ , respectively
$\Phi\left(\frac{\omega}{\omega_{mn}}\right)$	Spectrum shape factor
$\phi_{mn}, \phi_{pq}$	Eigenfunction
$\omega$	Circular frequency, equal to $2\pi f$
$\omega_{mn}$	Undamped natural modal frequency
*	Symbol representing the complex conjugate
< >	Symbol representing cross (space-time) correlation function

## APPENDIX C1 – MATHEMATICAL ANALYSIS

Equations are now derived for the space-time correlation and spectral density of the acoustic pressure in the near and far field on both sides of a turbulence excited vibrating plate.<sup>26</sup>

The Rayleigh formulation<sup>27</sup> of the velocity potential in the acoustic field resulting from a vibrating plane is

$$\phi(r, t) = -\frac{1}{2\pi} \iint \frac{dS_0}{r} V_n \left( r_0, t - \frac{r_0}{a_i} \right) \quad (C1a)$$

The corresponding acoustic pressure is

$$P_i(r, t) = -\rho_i \frac{\partial \phi}{\partial t} = \frac{\rho_i}{2\pi} \int \frac{dS_0}{r_0} \frac{\partial V_n}{\partial t} \left( r_0, t - \frac{r_0}{a_i} \right) \quad (C1b)$$

Figure 11 shows the coordinate system used for this formulation. The space-time correlation of the acoustic pressures are

$$\begin{aligned} \langle P_i(r, t) P_i(r', t') \rangle &= R_p(r, r', r) = \left\langle \frac{\rho_i}{2\pi} \int_S \frac{dS_0}{r_0} \frac{\partial V_n}{\partial t} \left( r_0, t - \frac{r_0}{a_i} \right) \right. \\ &\quad \left. \frac{\rho_i}{2\pi} \int_S \frac{dS'_0}{r'_0} \frac{\partial V_n}{\partial t} \left( r'_0, t' - \frac{r'_0}{a_i} \right) \right\rangle \end{aligned} \quad (C2)$$

where  $t' = t + \tau$ .

The integration and ensemble averaging processes may be interchanged to give

$$R_p(r, r', r) = \frac{\rho_i^2}{4\pi^2} \iint_S \frac{dS_0}{r_0} \frac{dS'_0}{r'_0} \left\langle \frac{\partial V_n}{\partial t} \left( r_0, t - \frac{r_0}{a_i} \right) \frac{\partial V_n}{\partial t} \left( r'_0, t' - \frac{r'_0}{a_i} \right) \right\rangle \quad (C3)$$

Now

$$\left\langle \frac{\partial^2 Z_n}{\partial t^2} \frac{\partial^2 Z'_n}{\partial t'^2} \right\rangle = \left\langle \frac{\partial V_n}{\partial t} \frac{\partial V'_n}{\partial t'} \right\rangle = \langle A A' \rangle$$

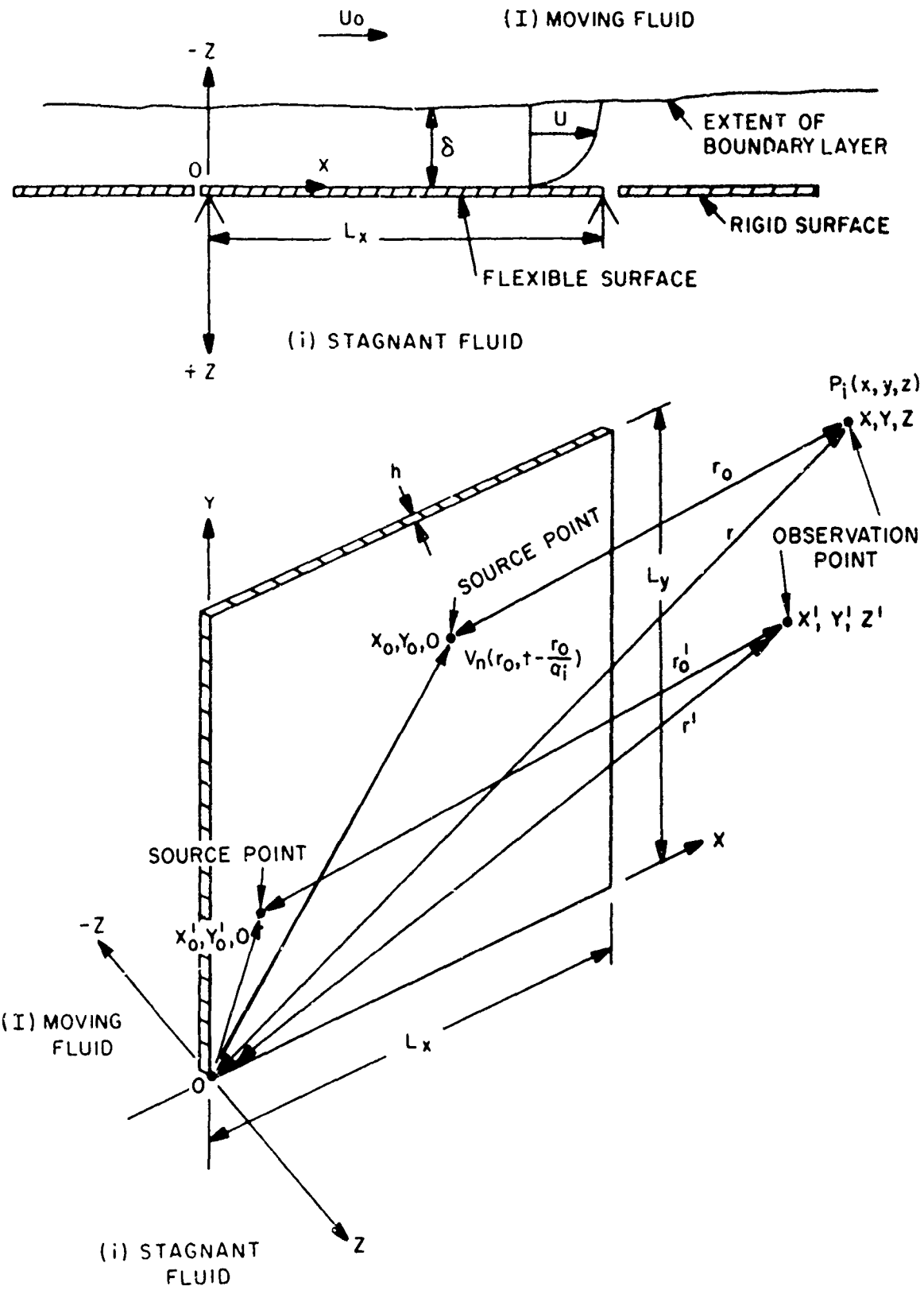

Figure 11 - Coordinate System

may be written as<sup>28</sup>

$$\begin{aligned} \frac{\partial^4}{\partial r^4} R_z \left( r_0, t - \frac{r_0}{a_i}; r_0', t' - \frac{r_0'}{a_i} \right) &= \frac{\partial^2 R_v}{\partial r^2} \left( r_0, t - \frac{r_0}{a_i}; r_0', t' - \frac{r_0'}{a_i} \right) \\ &= R_A \left( r_0, t - \frac{r_0}{a_i}; r_0', t' - \frac{r_0'}{a_i} \right) \end{aligned} \quad (C4)$$

Hence

$$R_p(r, r', \tau) = \frac{\rho_i^2}{4\pi^2} \iint_S \frac{dS_0}{r_0} \frac{dS_0'}{r_0'} \frac{\partial^4}{\partial r^4} R_z \left( r_0, t - \frac{r_0}{a_i}; r_0', t - \frac{r_0'}{a_i} \right) \quad (C5)$$

Assuming a stationary random process, we can shift the time origin by an amount  $r_0/a_i$  without changing the results of averaging. We get

$$R_p(r, r', \tau) = \frac{\rho_i^2}{4\pi^2} \iint_S \frac{dS_0}{r_0} \frac{dS_0'}{r_0'} \frac{\partial^4}{\partial r^4} R_z(r_0, t; r_0', t + r') \quad (C6)$$

where  $r' = r + \frac{r_0 - r_0'}{a_i}$ .

The Wiener-Khinchine relations between the cross-correlation and cross-spectral density of the acoustic pressures are

$$S_p(r, r', \omega) = \frac{1}{2\pi} \int_{-\infty}^{\infty} d\tau R_p(r, r', \tau) e^{-i\omega\tau} \quad (C7a)$$

$$R_p(r, r', \tau) = \int_{-\infty}^{\infty} d\omega S_p(r, r', \omega) e^{i\omega\tau} \quad (C7b)$$

Substituting Equation (C5) in (C7a), we obtain\*

$$S_p(r, r', \omega) = \frac{\omega^4 \rho_i^2}{4\pi^2} \int_S \int_S \frac{dS_0}{r_0} \frac{dS_0'}{r_0'} S_z(r, r', \omega) \quad (C8)$$

Equation (C6), (C7), and (C8) describe the acoustic pressure resulting from the vibration of a plane surface in a semi-infinite medium. The equations are a function of  $R_z$  only and are applicable to any type of plate with any type of boundaries.

The method for determining plate response to turbulence excitation is *identical* to that of Dyer except that more general boundary conditions are included here. However, because the notation is somewhat different, the relevant equations are outlined for the benefit of the computer program user. The reader is referred to Appendix A1 for a more detailed development. The differential equation of motion of the linear system  $Lz = -p$  has the solution

$$Z(r_0, t) = \int_{-\infty}^t dt_0 \int_S dS_0 g(r_0, t; \bar{r}_0, \bar{t}_0) p(\bar{r}_0, \bar{t}_0) \quad (C9)$$

where

$$Lg = -\delta(r - \bar{r}_0) \delta(t_0 - \bar{t}_0) = -\delta(x_0 - \bar{x}_0) \delta(y_0 - \bar{y}_0) \delta(t_0 - \bar{t}_0) \quad (C10)$$

For turbulence excitation (random pressures), the ensemble average or cross correlation of the plate displacements can then be expressed in terms of the correlation of the turbulent pressure forces by

$$\begin{aligned} \langle z(r_0, t) Z^*(r_0', t') \rangle &= R_z(r_0, r_0', r) = \int_{-\infty}^t dt_0 \int_{-\infty}^{t'} dt_0' \int_S dS_0 \int_{S_0'} dS_0' \cdot \\ &\langle g(r_0, t; \bar{r}_0, \bar{t}_0) g^*(r_0', t'; \bar{r}_0', \bar{t}_0') \rangle \langle p(\bar{r}_0, \bar{t}_0) p^*(\bar{r}_0', \bar{t}_0') \rangle \\ &= \int_{-\infty}^t dt_0 \int_{-\infty}^{t'} dt_0' \int_S dS_0 \int_S dS_0' g(r_0, t; \bar{r}_0, \bar{t}_0) g^*(r_0', t'; \bar{r}_0', \bar{t}_0') \\ &\quad \cdot R_{tp}(r_0, r_0', r) \end{aligned} \quad (C11)$$

\*

$$\mathfrak{F} \left( \frac{\partial^4 R_z}{\partial r^4} \right) = \omega^4 S_z$$

For thin plate vibration

$$b(1 - i\eta) \nabla^4 ( ) + M \frac{\partial^2 ( )}{\partial t^2} + \beta_0 \frac{\partial ( )}{\partial t} = L ( ) \quad (C12)$$

The Green function satisfying Equation (C12) has been shown to be represented by

$$g(\vec{r}_0, t; \vec{r}_0, t_0) = \sum_{mn} \frac{\phi_{mn}(\vec{r}_0) \phi_{mn}(\vec{r}_0)}{\omega_{mn} M} e^{-a_{mn}(t-t_0)} \sin \omega_{mn}(t-t_0) U(t-t_0) \quad (C13)$$

where  $\phi_{mn} ( )$ , the orthonormal set of eigenfunctions, satisfies the conditions:

$$L \phi_{mn} = 0 \quad (C14)$$

and

$$\int_S \phi_{mn} \phi_{pq} dS = \delta_{mn} \delta_{pq} \quad (C15)$$

and where\*

$$a_{mn} = \frac{\omega_{mn}}{\eta} \left[ \left( 1 + \frac{\eta\beta}{\omega_{mn} M} + \eta^2 \right)^{1/2} - 1 \right] \quad (C16)$$

$$\omega_{mn} = \left( \frac{b}{M} \right)^{1/2} \lambda_{mn}^2 \quad (C17)$$

---

\*Equation (A7) of Appendix A can be written in the present notation as

$$a_{mn} = \frac{\omega_{mn}}{\eta} \left\{ \left[ \left( \frac{\beta\eta}{2M\omega_{mn}} + \frac{\lambda_{mn}^4 b\eta^2}{2M\omega_{mn}^2} + 1 \right)^2 \right] - 1 \right\}$$

Expanding this equation and assuming, with Dyer (Equation (12) of Reference 2), that  $\eta \leq 1/3$  and  $\frac{\beta}{2\omega_{mn} M} \leq 1/3$

as well as using Equation (A8) in the expansion, we obtain Equation (C16).

When radiation damping is also included, we write

$$a_{mn} = \frac{\beta_0}{2M} + \frac{\eta}{2} \omega_{mn} + \frac{\beta_1}{2M} \quad (C18)$$

In this analysis, it is assumed that  $\beta_0$  and  $\beta_1$  are negligible\* so that

$$a_{mn} = \frac{\eta}{2} \omega_{mn} = B \omega_{mn} \quad (C19)$$

Using Dyer's equation for the pressure correlation

$$R_{tp}(r, r) = \overline{p^2} A \delta[(x_0 - x_0') - U_c \tau] \delta(y_0 - y_0') e^{-\frac{|r|}{\theta}} \quad (C20)$$

Using Equations (C12), (C13), and (C20), we obtain the working expression for the displacement correlation function for a plate excited by a turbulent boundary layer. It is applicable to arbitrary boundary conditions provided expressions can be obtained for the eigenvalues and normalized eigenfunctions.

$$\begin{aligned} R_z(r_0, r_0', r) = & \sum_{pq} \sum_{mn} \frac{A \overline{p^2} \phi_{pq}(r_0)}{\omega_{mn} \omega_{pq} M^2} \phi_{mn}(r_0') \int_{-\infty}^t d\overline{t_0} \int_{-\infty}^{t'} d\overline{t_0'} \int_S d\overline{S_0} \\ & \cdot \int_S d\overline{S_0'} \phi_{mn}(\overline{r_0}) \phi_{pq}(\overline{r_0'}) e^{\left[ -a_{mn}(t - \overline{t_0}) - a_{pq}(t' - \overline{t_0'}) - \frac{|r_0|}{\theta} \right]} \\ & \cdot \sin \omega_{mn}(t - \overline{t_0}) \sin \omega_{pq}(t' - \overline{t_0'}) \delta[(x_0 - x_0') - U_c \tau] \delta(y_0 - y_0') \quad (C21) \end{aligned}$$

Performing a spatial integration of Equation (C21), then introducing the transformation used by Dyer

$$\begin{aligned} \gamma &= (t' - \overline{t_0'}) - (t - \overline{t_0}) = r_0 - r \\ \mu &= (t' - \overline{t_0'}) + (t - \overline{t_0}) \quad (C22) \end{aligned}$$

\*If values or relations for  $\beta_0, \beta_1$  are known, we can include these terms in the analysis and program.



followed by a temporal integration yields

$$R_z(\tau_0, \tau_0', \tau) = \sum_m \sum_n \frac{\overline{Ap^2}}{4\omega_{mn}^2 M^2} \phi_{mn}(\tau_0) \phi_{mn}(\tau_0') I_{mn}(\tau) \quad (C23)$$

where

$$I_{mn}(\tau) = \int_0^\infty d\mu \int_{-\mu}^\mu dy e^{\left[ -a_{mn}\mu - \frac{|\gamma+\tau|}{\theta} \right]} \cos \alpha (y+\tau) [\cos \omega_{mn}\gamma - \cos \omega_{mn}\mu], \quad \tau \geq 0 \quad (C24)$$

where  $\alpha = m\pi U_c / L_x$ .

Since  $\theta$  is small, then for  $|\tau_0| > 0$ ,  $e^{-\frac{|\tau_0|}{\theta}} \rightarrow 0$  so that from Equation (C21)  $R_z(\tau_0, \tau_0', \tau) \rightarrow 0$ .

Hence, with small error, we need consider only the value  $\tau_0 = (\overline{t_0} - \overline{t_0}') = 0$ . With this approximation we perform the integration in Equation (C21) to obtain the displacement correlation below coincidence. To render the analysis tractable for the integration, it is also

assumed that  $U_c \theta \ll L_x$ ,  $\frac{m\pi U_c}{L_x} \ll \omega_{mn}$ , i.e. the correlation length of the pressure field is much smaller than the length of the plate and the convection speed of the turbulence is small compared to the modal wavelength, and  $a_{mn}\theta \ll 1$  (low damping); see (A22), (A23), (A36), and (A36b) of Appendix A1. The result for the displacement correlation function, which is independent of plate boundary conditions, is\*

\*It is important to note that although the same symbols  $\phi_{mn}(\tau_0)$  and  $\phi_{mn}(\tau_0')$  are used,

$$\left. \phi_{mn}(\tau_0) \right|_{\text{Eq (C25)}} = \frac{(L_x L_y)^{1/2}}{2} \left. \phi_{mn}(\tau_0) \right|_{\text{Eq (C21)}} ; \left. \phi_{mn}(\tau_0') \right|_{\text{Eq (C25)}} = \frac{(L_x L_y)^{1/2}}{2} \left. \phi_{mn}(\tau_0') \right|_{\text{Eq (C21)}}$$

The value of the normalized eigenfunction  $\phi_{mn}$  used in Equation (C21) agrees with that used by Dyer. That the value of  $\phi_{mn}$  used in Equation (C25) differs from Dyer's results by a factor  $\frac{(L_x L_y)^{1/2}}{2}$  can be seen by comparing Equations (C35) and (A20) for the case of a simply supported plate. Thus, we see that Equations (C25) and Equation (A27), where  $I_{mn}(\tau)$  is given by Equation (A36), are in agreement.

$$R_z(r_0, r_0', r) = \sum_m \sum_n \frac{2A\theta\bar{p}^2}{L_x L_y \omega_{mn}^2 a_{mn} M^2 (1 + \omega_{mn}^2 \theta^2)} \cdot \phi_{mn}(r_0) \phi_{mn}(r_0') e^{-[a_{mn}|\tau|]} \cos \omega_{mn} r \quad (C25)$$

For the plate mode shape, assume that

$$\phi_{mn}(r) = X_m(x) Y_n(y) \quad (C26)$$

where

$$X_m(x) = a_m \cos \alpha_m x + b_m \sin \alpha_m x + c_m \cosh \alpha_m x + d_m \sinh \alpha_m x$$

$$Y_n(y) = a_n \cos \alpha_n y + b_n \sin \alpha_n y + c_n \cosh \alpha_n y + d_n \sinh \alpha_n y \quad (C26a)$$

From Equations (C4) and (C6), we see that  $R_p(r, r', r)$  is a function of

$$\frac{\partial^4}{\partial r^4} R_z(r_0, r_0', r) = R_A(r_0, r_0', r) \cdot$$

Page 99 of Reference 28 shows that the correlation of the plate acceleration for  $r > 0$  can be expressed as\*

$$R_A(r_0, r_0', r) = \sum_{m,n} \bar{K}_{mn} \phi_{mn}(r_0) \phi_{mn}(r_0') e^{-a_{mn}r} [C_{mn} \cos \omega_{mn} r + D_{mn} \sin \omega_{mn} r] \quad (C27)$$

;  $r > 0$

where

$$\bar{K}_{mn} = \frac{2A\theta\bar{p}^2}{L_x L_y \omega_{mn}^2 M^2 (1 + \omega_{mn}^2 \theta^2)}$$

$$C_{mn} = \omega_{mn}^4 - 6 \omega_{mn} a_{mn}^2 + a_{mn}^4$$

$$D_{mn} = 4 a_{mn} \omega_{mn} (a_{mn}^2 - \omega_{mn}^2)$$

\*Footnote on following page.

\*Footnote to preceding page. Using Equation (C25) and the relationship between  $R_A$  and  $R_z$  we have

$$R_A = \frac{\partial^4}{\partial r^4} R_z = K \frac{\partial^4}{\partial r^4} \left[ e^{-a_{mn}|\tau|} \right] \cos \omega_{mn} \tau$$

where

$$K = \sum_m \sum_n \frac{2A\theta p^2}{L_x L_y \omega_{mn}^2 a_{mn} M^2 (1 + \omega_{mn}^2 \theta^2)} \phi_{mn}(r_0) \phi_{mn}(r_0')$$

Let  $a_{mn} = a$ ,  $\omega_{mn} = b$ . Then

$$\begin{aligned} f(\tau) &= e^{-a|\tau|} \cos b\tau = e^{a\tau} \cos b\tau \text{ for } \tau < 0 \\ &= e^{-a\tau} \cos b\tau \text{ for } \tau > 0 \end{aligned}$$

or

$$= e^{-a\tau} \cos b\tau = u \cdot v \text{ where } a = -a \text{ for } \tau < 0$$

$$a = a \text{ for } \tau > 0$$

$$u(\tau) = e^{-a\tau} \text{ and } v(\tau) = \cos b\tau$$

The Leibniz theorem is obtained by differentiating  $u v$ , with respect to  $\tau$ ,  $n$  times. When  $n = 4$ , corresponding to the fourth derivative, the theorem gives

$$\begin{aligned} f^{(4)}(\tau) &= u^{(4)} v + 4 u^{(3)} v' + 6 u'' v'' + 4 u' v''' + u v^{(4)} \\ &= a^4 e^{-a\tau} \cos b\tau + 4(-a^3) e^{-a\tau} (-b \sin b\tau) + 6a^2 e^{-a\tau} (-b^2) \cos b\tau \\ &\quad + 4(-a) e^{-a\tau} b^3 \sin b\tau + b^4 e^{-a\tau} \cos b\tau \\ &= (a^4 - 6a^2 b^2 + b^2) f(\tau) + 4ab(a^2 - b^2) g(\tau) \\ &= (a^4 - 6a^2 b^2 + b^4) f(\tau) + 4ab(a^2 - b^2) g(\tau) \text{ for } \tau > 0 \\ &= (a^4 - 6a^2 b^2 + b^4) f(\tau) - 4ab(a^2 - b^2) g(\tau) \text{ for } \tau < 0 \end{aligned}$$

where  $f(\tau) = e^{-a\tau} \cos b\tau$  and  $g(\tau) = e^{-a|\tau|} \sin b\tau = e^{-a|\tau|} \sin b\tau$ .

The results agree with those in Appendix II of Reference 29 determined there by use of Heavside functions. We note that the first derivative of  $f(\tau)$  has a finite discontinuity at the origin so that the second and higher order derivatives will have infinite discontinuities at this point.

Reference 29 also shows that Equation (C27) satisfies the Wiener-Khinchine relations, Equations (C7a) and (C7b), thereby establishing the derived expression for  $R_A(r_0, r'_0, r)$  as a valid correlation function.\*

\*To show that  $\frac{\partial^4 f(r)}{\partial r^4}$  and therefore  $R_A$  satisfies the Wiener-Khinchine relations, consider the Fourier cosine transform of  $\frac{\partial^4 f(r)}{\partial r^4}$ . Because  $\frac{\partial^4 f(r)}{\partial r^4}$  is an even function, the Fourier sine transform of this function vanishes. Since the fourth derivative is a continuous function, we integrate by parts to find

$$\int_0^{\infty} \frac{\partial^4 f(r)}{\partial r^4} \cos \omega r dr = \left[ \frac{\partial^3 f(r)}{\partial r^3} \cos \omega r dr + \omega \frac{\partial^2 f(r)}{\partial r^2} \sin \omega r - \omega^2 \frac{\partial f(r)}{\partial r} \cos \omega r \right]_0^{\infty} - \omega^3 \int_0^{\infty} \frac{\partial f(r)}{\partial r} \sin \omega r dr$$

$f(r)$  and all of its derivatives are zero at  $r = \infty$ . Also, odd derivatives of  $f(r)$  over the range  $-\infty \leq r \leq \infty$  are odd functions of  $r$  so that the value of these derivatives at the point of discontinuity (i.e., origin  $r = 0$ ) is zero. Hence, this equation reduces to

$$\int_0^{\infty} \frac{\partial^4 f(r)}{\partial r^4} \cos \omega r dr = -\omega^3 \int_0^{\infty} \frac{\partial f(r)}{\partial r} \sin \omega r dr - \omega^4 \int_0^{\infty} f(r) \cos \omega r dr$$

after integration by parts of the bracketed integral. Substituting  $f(r) = e^{-a|r|} \cos br$  in the last integral we obtain

$$\int_0^{\infty} \frac{\partial^4 f(r)}{\partial r^4} \cos \omega r dr = \frac{a}{2} \left[ \frac{\omega^4}{a^2 + (b + \omega)^2} + \frac{\omega^4}{a^2 + (b - \omega)^2} \right]$$

The inverse Fourier cosine transform of this expression is

$$\frac{1}{2\pi} \int_0^{\infty} \frac{a}{2} \left[ \frac{\omega^4}{a^2 + (b + \omega)^2} + \frac{\omega^4}{a^2 + (b - \omega)^2} \right] \cos \omega r dr = (a^4 - 6a^2 b^2 + b^4) f(r) + 4ab(a^2 - b^2) g(r)$$

which we have previously shown to be  $\frac{d^4 f(r)}{dr^4}$  for  $r > 0$ . Thus, the terms  $\frac{d^4 f(r)}{dr^4}$  and  $\frac{a}{2} \left[ \frac{\omega^4}{a^2 + (b + \omega)^2} + \frac{\omega^4}{a^2 + (b - \omega)^2} \right]$  are Fourier pairs. These results are obtained with somewhat more rigor in Reference 29.

Substitution of Equation (C27) in (C6) yields the following expression for the cross correlation of acoustic pressures\*

$$R_p(r, r', r) = \sum_{mn} K_{mn} \iint_S \frac{dS_0}{r_0} \frac{dS'_0}{r'_0} \phi_{mn}(r_0) \phi_{mn}(r'_0) e^{-\alpha_{mn} r'} \cdot [C_{mn} \cos \omega_{mn} r' + D_{mn} \sin \omega_{mn} r'] \quad (C28)$$

where

$$K_{mn} = \frac{\rho_i^2}{4\pi^2} K_{mn}$$

and

$$r' = r + \frac{(r_0 - r'_0)}{a_i}$$

Equations (C28) and (C7) represent working expressions for determining anywhere in the field the desired statistical properties of the acoustic pressure resulting from the vibrations of a turbulence-excited finite plate of arbitrary boundary conditions. The mode shapes of the plate  $\phi_{mn}(r)$  in these equations implicitly represent the dependence of the acoustic field on the boundary conditions.

The method of analysis used by Young<sup>(30)</sup> (the Ritz method) is used to determine the eigenfunctions and eigenvalues of vibrating rectangular plates with continuous spring-type boundary conditions. This treatment allows for various combinations of clamped and free boundaries.

The Ritz method consists of equating the maximum potential energy of the plate

$$V = \frac{b}{2} \iint_{\text{plate area}} \left[ \left( \frac{\partial^2 w}{\partial x^2} \right)^2 + \left( \frac{\partial^2 w}{\partial y^2} \right)^2 + 2\mu \frac{\partial^2 w}{\partial x^2} \frac{\partial^2 w}{\partial y^2} + 2(1-\mu) \left( \frac{\partial^2 w}{\partial x \partial y} \right)^2 \right] dx dy \quad (C29)$$

---

\*Note that whereas in the statement below Equation (C26a) the term  $\frac{r_0 - r'_0}{a_i}$  was implicitly included in the variables  $r_0, r'_0$  of the function  $R_A(r_0, r'_0, r)$ , in Equation (C27) the term  $\frac{r_0 - r'_0}{a_i}$  is linked with  $r$  to form  $r'$ .

to the maximum kinetic energy of the plate

$$T = \omega^2 \frac{\rho h}{2} \iint_{\text{plate area}} w^2 dx dy \quad (\text{C30})$$

to obtain an expression for the frequency of the vibrating system

$$\omega^2 = \frac{2}{\rho h} \frac{V}{\iint_{\text{plate area}} w^2 dx dy} \quad (\text{C31})$$

The natural frequencies are determined by finding expressions for  $w$  that satisfy the boundary conditions and minimize Equation (C31). The Ritz method consists of assuming the deflection  $w(x, y)$  as a linear series of "admissible" functions (see Reference 30) and adjusting the coefficients in the series so as to minimize Equation (C31).

For a rectangular plate with edges parallel to the  $x$ - and  $y$ -axes, the series approximation for the displacement function is taken in the form

$$w(x, y) = \sum_{m=1}^p \sum_{n=1}^q A_{mn} X_m(x) Y_n(y) \quad (\text{C32})$$

and substituted in Equation (C31). We get

$$\omega^2 = \frac{2}{\rho h} \frac{V}{\iint_{\text{plate}} \sum \sum A_{mn} X_m(x) Y_n(y) dx dy}$$

or

$$V = \frac{\omega^2 \rho h}{2} \iint_{\text{plate}} \sum \sum A_{mn} X_m(x) Y_n(y) dx dy$$

This expression is minimized by setting the partial derivative with respect to each coefficient equal to zero. This yields

$$\frac{\partial V}{\partial A_{rs}} - \frac{\omega^2 \rho h}{2} \frac{\partial}{\partial A_{rs}} \iint_{\text{plate}} w^2 dx dy = 0 \quad (\text{C33})$$

where  $A_{rs}$  is any of the coefficients  $A_{mn}$ . Equation (C33) represents a system of linear homogeneous equations in the unknowns  $A_{mn}$ . The approximate natural frequencies of the plate  $\omega_1, \omega_2, \dots$  are obtained from Equation (C33) by setting the determinant of the system equal to zero.

The functions  $X_m(x)$  and  $Y_n(y)$  inserted in Equation (C33) are the mode shapes of a beam supported by torsional and transverse linear springs along its boundaries. The characteristics of the springs along each side are constant. These spring-type edge conditions allow the effects of edge rotational and edge translational constraints to be analyzed on a quantitative basis. Once the mode shapes are known or determined — for the clamped-clamped plate, we use the functions given by Equation (C26) and (C26a) as the mode shapes  $X(x)$  and  $Y(y)$  of a beam with its ends clamped in the Ritz method — all of the integrals in Equation (C33) can be calculated. Then as explained in Reference (30), the set of integral Equations (C33) can be reduced to a set of linear algebraic equations of the form\*

$$\sum_{m=1}^p \sum_{n=1}^q [C_{mn}^{rs} - \lambda \delta_{mn}^{rs}] A_{mn} = 0 \quad (\text{C34})$$

where

$$\delta_{mn}^{rs} = \begin{cases} 1 & \text{for } mn = rs \\ 0 & \text{for } mn \neq rs \end{cases}$$

$$\lambda = \omega^2 \rho h L_x^3 L_y / b \quad (\text{proportional to } \omega^2)$$

In Equation (C34),  $r$  assumes all values between 1 and  $p$  and  $s$  assumes all values between 1 and  $q$ . The eigenvalues and therefore the natural frequencies  $\omega_{rs}$  are found from the condition that the determinant of the system of Equation (C34) must vanish for nontrivial solutions  $A_{mn}$ . Once the eigenmatrices of Equation (C34) have been determined, the mode shapes of the plate are obtained from Equation (C32).

Reference 29 compares the spectrum of the sound pressure level for a clamped-clamped plate with that of a simply supported plate. The comparison suggests that a *simplified and realistic approach to the investigation of plates with nonsimple supports would be to calculate the modal frequencies considering the true (clamped-clamped) end conditions but to use the mode shapes considering the end conditions as simple supports*. Comparison runs using this approach, which requires much less computation, and the exact approach (clamped-clamped

---

\*The general functional form for  $C_{mn}^{rs}$  is given in Reference 30.

frequencies and mode shapes) produced results in very good agreement.<sup>29</sup> In connection with this aspect of the problem, the following equations were developed to obtain the sound radiated from *simply supported* plates.

For a simply supported plate of dimensions  $L_x, L_y$  and thickness  $h$ , the normalized eigenfunctions (mode shapes) and corresponding modal frequencies are <sup>2</sup> (see footnote for paragraph preceding equation (C25))

$$\phi_{mn} = \sin \frac{m\pi x}{L_x} \sin \frac{n\pi y}{L_y} \quad (C35)$$

$$\omega_{mn}^2 = \left(\frac{b}{M}\right)^{1/2} \lambda_{mn}^2 \quad (C36)$$

where

$$\lambda_{mn}^2 = \left(\frac{m\pi}{L_x}\right)^2 + \left(\frac{n\pi}{L_y}\right)^2$$

Substituting Equation (C35) in (C28), we obtain for *locations in the far field on a normal through the center of the plate* ( $r_0 - r_0' \approx 0$ ; more generally  $r_0 \approx r_0' \approx r$ , see Figure C1, and consequently  $r' \approx r$ )

$$R_p = \sum_m \sum_n \frac{K_{mn}}{r^2} e^{-a_{mn}r} \left[ C_{mn} \cos \omega_{mn}r + D_{mn} \sin \omega_{mn}r \right] \cdot$$

$$\int_0^{L_x} \sin \frac{m\pi x}{L_x} dx \int_0^{L_x} \sin \frac{m\pi x}{L_x} dx \int_0^{L_y} \sin \frac{n\pi y}{L_y} dy \int_0^{L_y} \sin \frac{n\pi y}{L_y} dy$$

Now

$$\int_0^{L_x} \sin \frac{m\pi x}{L_x} dx = \frac{L_x}{m\pi} \left[ -\cos m\pi - 1 \right] = \frac{L_x}{m\pi} \left[ -1(-1)^m - 1 \right]$$

and similarly for the other three integrals. Hence, the product of the four integrals yields the term  $\frac{L_x}{m^2 \pi^2} \left[ -1(-1)^m - 1 \right]^2 \cdot \frac{L_y}{n^2 \pi^2} \left[ -1(-1)^n - 1 \right]^2$  and the auto correlation of the acoustic pressure at  $r$  is



$$R_p(r, \tau) = \sum_m \sum_n \frac{K_{mn}}{r^2} [C_{mn} \cos \omega_{mn} \tau + D_{mn} \sin \omega_{mn} \tau] \cdot e^{-a_{mn} \tau} \frac{L_x^2 L_y^2}{\pi^4 m^2 n^2} [(-1)^m - 1]^2 [(-1)^n - 1]^2 \quad (C37)$$

The power spectrum of the pressure at  $r$  is

$$S_p(r, \omega) = \frac{1}{2\pi} \int_{-\infty}^{\infty} R_p(r, \tau) e^{-i\omega \tau} d\tau = \frac{L_x^2 L_y^2}{r^2 \pi^4} \sum_m \sum_n \frac{K_{mn}}{m^2 n^2} [(-1)^m - 1]^2 [(-1)^n - 1]^2 \frac{1}{2\pi} \cdot \int_{-\infty}^{\infty} e^{-a_{mn} |\tau|} [C_{mn} \cos \omega_{mn} \tau + D_{mn} \sin \omega_{mn} |\tau|] e^{-i\omega \tau} d\tau$$

Note that Equation (C27) and what followed held for  $\tau > 0$ . To obtain  $S_p$  here, we treat  $\tau$  in the infinite range  $(-\infty, \infty)$  hence  $\tau \rightarrow |\tau|$  above. Using Table 3.3 of Reference 31 we obtain directly the value of the integral as\*

$$= \left[ \frac{a_{mn} c_{mn} + d_{mn} (\omega + \omega_{mn})}{a_{mn}^2 + (\omega + \omega_{mn})^2} + \frac{a_{mn} c_{mn} - d_{mn} (\omega - \omega_{mn})}{a_{mn}^2 + (\omega - \omega_{mn})^2} \right]$$

and from Equations (C19) and (C27)

$$a_{mn} = B \omega_{mn}$$

$$C_{mn} = \omega_{mn}^4 - 6\omega_{mn}^2 a_{mn}^2 + a_{mn}^4 = \omega_{mn}^4 - 6B\omega_{mn}^4 + B^4 \omega_{mn}^4 = \omega_{mn}^4 (1 - 6B^2 + B^4)$$

$$D_{mn} = 4a_{mn} \omega_{mn} (a_{mn}^2 - \omega_{mn}^2) = 4B\omega_{mn}^2 (B^2 \omega_{mn}^2 - \omega_{mn}^2)$$

Substituting the values of  $a_{mn}$ ,  $C_{mn}$ , and  $D_{mn}$  in the equation directly above and dropping terms of higher order in  $B$ , i.e.,  $O(B^5)$  and  $O(B^3)$  reduces this equation to

---

\*We take one-half the value given in this table since we use  $-\infty \leq \omega < \infty$  here whereas Reference 31 gives the one-sided power spectral density function.

$$\omega_{mn}^3 B \left[ \frac{4 \frac{\omega}{\omega_{mn}} - 3}{B^2 + \left(1 + \frac{\omega}{\omega_{mn}}\right)^2} - \frac{3 + 4 \frac{\omega}{\omega_{mn}}}{B^2 + \left(1 - \frac{\omega}{\omega_{mn}}\right)^2} \right]$$

Using this value and the value of  $K_{mn}$ ,  $\bar{K}_{mn}$  given by Equations (C28) and (C27), respectively, we get

$$S_p(r, \omega) = \frac{1}{4\pi^7} \left( \frac{L_x L_y}{r^2} \right) \frac{\rho_i^2 A \theta p^2}{M^2} \sum_m \sum_n [1 - (-1)^m]^2 [1 - (-1)^n]^2 .$$

$$\cdot \frac{1}{(1 + \omega_{mn}^2 \theta^2) m^2 n^2} \left[ \frac{4 \frac{\omega}{\omega_{mn}} - 3}{B^2 + \left(1 - \frac{\omega}{\omega_{mn}}\right)^2} - \frac{3 + 4 \frac{\omega}{\omega_{mn}}}{B^2 + \left(1 + \frac{\omega}{\omega_{mn}}\right)^2} \right]$$

In accordance with Reference 2, we take

$$A = \frac{2\pi}{\kappa^2} = \frac{2\pi}{(2/\delta^*)^2} = \frac{\pi(\delta^*)^2}{2}, \quad \theta = \frac{30\delta^*}{U_0}, \quad p^2 = (3 \times 10^{-3})^2 \rho_i^2 U_0^4$$

Substituting these values in the equation for  $S_p(r, \omega)$ , the nondimensional power spectrum at  $r$  is then represented by\*

$$\frac{S_p(r, \omega)}{\rho_i^2 U_0^3 \delta^*} = \underbrace{\frac{33.75 \times 10^{-6}}{\pi^6}}_{= K} \left( \frac{L_x L_y}{r^2} \right) \left( \frac{\rho_i \delta^*}{M} \right)^2 \sum_m \sum_n [1 - (-1)^m]^2 [1 - (-1)^n]^2$$

$$\cdot \frac{1}{(1 + \omega_{mn}^2 \theta^2) m^2 n^2} \left[ \frac{4 \frac{\omega}{\omega_{mn}} - 3}{B^2 + \left(1 - \frac{\omega}{\omega_{mn}}\right)^2} - \frac{3 + 4 \frac{\omega}{\omega_{mn}}}{B^2 + \left(1 + \frac{\omega}{\omega_{mn}}\right)^2} \right] \quad (C38)$$

\*Note that Equation (C38) does not agree with Equation (6-38) of Reference 26 which appears to contain a typographical error.

or

$$\bar{S}_p(r, \omega) = \sum_m \sum_n K'(\omega_{mn}) \Phi\left(\frac{\omega}{\omega_{mn}}\right) \quad (C39)$$

Thus  $\bar{S}_p(r, \omega)$  is the product of a modal amplitude factor  $K'(\omega_{mn})$  and a spectrum shape factor  $\Phi\left(\frac{\omega}{\omega_{mn}}\right)$ .

## APPENDIX C2 – METHOD FOR DETERMINING INPUT DATA

The method for determining input data for the Electric Boat Computer Program is the same as the Dyer method (Appendix A), and the system of units is consistent with Dyer.

## APPENDIX C3 – PROGRAM IDENTIFICATION

This program computes the space-time cross correlation and cross-spectral density of the acoustic pressures resulting from the vibration of a turbulence-excited finite plate of arbitrary boundary conditions.

## APPENDIX C

### TABLE 4

#### Identification for Electric Boat Program – IZZO

This table includes input and output data identification, flow chart, order of input data, and computer running times. Computer program listings are given in Table 5.

Table 4A: Input Data

Table 4B: Output Data

Table 4C: Flow Chart (Electric Boat) for Turbulence – Excited  
Clamped and Simply Supported Plate Problem

Table 4D: Input Formats

TABLE 4A

Input Data

Input Data	Description	Type	Program Symbol
<i>Description for Main Program</i>			
M	Order of m-mode numbers	Integer	MM
N	Order of n-mode numbers	Integer	NN
IM	= 1: m's and n's are read as a vector = MM: m's and n's are read as a matrix such as A(1,1), A(1,2), A(1,3), A(2,1), A(2,2), A(2,3)	Integer	IM
IN	NN	Integer	IN
NXYZ	Number of cases in autocorrelation	Integer	NXYZ
KXYZ	Number of cases in CROSS1-correlation	Integer	KXYZ
LXYZ	Number of cases in CROSS2-correlation	Integer	LXYZ
NAUTO	1: Access to autocorrelation 0: No	Integer	NAUTO
NCROSS	1: Access to CROSS1-correlation 0: No	Integer	NCROSS
NCROST	1: Access to CROSS2-correlation 0: No	Integer	NCROST
XL1	Upper-first-integration limit (plate dimension x)	Decimal	XL1
XL0	Lower-first-integration limit	Decimal	XL0
YL1	Upper-second-integration limit (plate dimension y)	Decimal	YL1
YL0	Lower-second-integration limit	Decimal	YL0
AI	Speed of sound in fluid	Decimal	AI
B	$\beta\omega_{m,n}$ = damping coefficient - $a_{m,n}$	Decimal	B
C	Constant a) simply supported plate b) nonsimply supported	Decimal	C
$\theta$	Decay constant = $\delta^*/U_\infty$	Decimal	THETA
$p^{2*}$	$(\text{mass pressure})^2$ $(\text{lb}/\text{ft}^2)^2 = (6 \times 10^{-3} \cdot 1/2 \rho U_\infty^2)^2$ where $\rho$ = mass density of fluid	Decimal	P2
$\omega_{m,n}$	Frequencies for (m,n) modes (radians)	Decimal	W
MAM	m-mode shape numbers	Integer	MAM
NAN	n-mode shape numbers (MAX-50)	Integer	NAN
$a_m$	Normalized eigenfunction parameters; used only in the general (i.e., clamped) case; for m-mode	Decimal	ALMM
$a_m$		Decimal	AMM
$b_m$		Decimal	BMM
$c_m$		Decimal	CMM
$d_m$		Decimal	DMM
$a_n$	Same as above, only for n-mode	Decimal	ALNN
$a_n$		Decimal	ANN
$b_n$		Decimal	BNN
$c_n$		Decimal	CNN
$d_n$		Decimal	DNN

\*Force = lb, hence mass =  $\frac{\text{force}}{\text{acceleration}} = \frac{\text{lb}}{\text{ft}/\text{sec}^2}$ ; also length = ft and time = sec.  
This system of units is consistent with that of Dyer.

TABLE 4A (Continued)

Input Data	Description	Type	Program Symbol
<i>Description for Subroutine Autocorrelation (Time and Frequency Dependent)</i>			
$x$	Coordinates of point for correlation measurement	Decimal	X
$y$		Decimal	Y
$z$		Decimal	Z
$r_0$	Initial value of $r$	Decimal	TAU
$\Delta r$	Increment of $r$	Decimal	DTAU
NTAU	Number of $r$ 's	Integer	NTAU
EPS	Convergence constant (test value)	Decimal	EPS
NMAX	Maximum number of iterations	Integer	NMAX
NWA	Number of specified frequencies	Integer	NWA
WA	Specified frequencies (radians) chosen by user according to his boundary specifications	Decimal	WA
Comment: There are NXYZ sets of data cards for this subroutine.			
<i>Description for Subroutine Cross Correlation Space Dependent</i>			
$x$	Coordinates of fixed point	Decimal	XX
$y$		Decimal	YY
$z$		Decimal	ZZ
MXP	Number of variable points	Integer	MXP
MTAU	Number of $r$ 's	Integer	MTAU
EPS	Convergence constant	Decimal	EPS
NMAX	Maximum number of iterations	Integer	NMAX
$r$	Value of $r$	Decimal	TAU
$x'$	Coordinates of variable points	Decimal	XP(I)
$y'$		Decimal	YP(I)
$z'$		Decimal	ZP(I)
NOR	= 0	Integer	NOR
Comment: There are KXYZ sets of input cards for this subroutine.			
<i>Description for CROSS 2 Correlation (Time and Frequency Dependent)</i>			
$x$	Coordinate of fixed point	Decimal	XX
$y$		Decimal	YY
$z$		Decimal	ZZ
MXP	Number of variable points	Integer	MXP
TAU	Initial value of $r$	Decimal	TAU
DTAU	Increment of $\Delta r$	Decimal	DTAU
NTAU	Number of $r$ 's	Integer	NTAU
EPS	Convergence constant	Decimal	EPS
NMAX	Maximum number of iterations	Integer	NMAX
NWA	Number of frequencies	Integer	NWA
$x'$	Coordinate of variable point	Decimal	XP(I)
$y'$		Decimal	YP(I)
$z'$		Decimal	ZP(I)
NOR	= 0		NOR
WA	Different frequencies (radians) chosen by user		
Comment: There must be LXYZ sets of input cards.			

TABLE 4B

## Output Data

Description	Program Label	Output Label
<i>Description for AUTO 1 Autocorrelation with Two Options</i> (1. NTAU - no. points of time; 2. NWS - no. frequencies)		
Number of time increments	K	NTAU
Point of time at which autocorrelation taken	ATAU	TAU
Normalized autocorrelation of acoustic pressure over time, i.e., $RP(x_1 - x_2, t) / RP(x_1 - x_2, 0)$	RPBAR(K)	NORM. COR. OF ACC. PRES.
Autocorrelation normalized by rms pressure	PRP(K)	RP(K)/P2
Normalized factor RP(1) for RPBAR(K), i.e., $RP(x_1 - x_2, 0)$ or $R_{11}(0,0)$	RP(1)	NORM. FACTOR
Comment: Above not printed out if NTAU = 0		
Number of frequency	K	K
Specified frequencies	WA(K)	FREQ
$WA(K) / 2\pi$	RAD	RAD/SEC
Cross spectral density	FI(K)	CROSS SPEC. DENS.
$10 \text{ LOG}(FI(K)) + 127.6$	PHI	DB(RE0.0002)
Comment: Above not printed out if NWA = 0		
<i>Description for CROSS 1 (for Various Times in Space)</i>		
Indicates time	I	I
Point of time at which cross-correlation computed	TAU(I)	TAU
Indicates space	J	J
	XP(J)	XP(J)
Space coordinates	YP(J)	YP(J)
	ZP(J)	ZP(J)
Normalized cross-correlation	CRPBAR(I,J)	CRPBAR(I,J)
Normalization factor - CRPBAR(1,1)	CNORM	CNORM
<i>Description for CROSS 2 (Time Variable)</i>		
Number of time point	K	NTAU
Point of time	TAU	TAU
Normalized correlation of acoustic pressure, by $RP(x_1 - x_2, 0)$ or $R_{12}(0,0)$	RPBAR(K)	NORM. CORR. OF ACC. PRESS.
Correlation normalized by rms pressure	RP(K)/P2	PRP(K)
Normalization factor $RP(x_1 - x_2, 0)$	RP(1)	NORM. FACTOR
Number of frequency	K	K
Specified frequency	WA(K)	FREQ
Frequency / $2\pi$	RAD	RAD/SEC
Cross spectral density	FI(K)	CROSS SPEC. DENS.
$10 \text{ LOG}(FI(K)) + 127.6$	PHI	DB(RE0.0002)



*Interpretation of Data Output and Computer Running Times*

The following information is useful in interpreting the program.

The program generally yields results normalized by  $p^2$  or by the correlation of two points at  $\tau = 0$ .

The Electric Boat program consists of two parts which represent the simple case and the general case. The simple case, Equation (C(35)), uses only simply supported boundaries for the plate modal function although frequencies for clamped boundaries may be used. This procedure yielded Figure 12 (see page 154). The general case uses mode shapes represented by Equation (C(26)). In addition the program requires either of the following values for C

$$C = \frac{P_0^2 A p^2}{2 \pi^2 M^2 L_x L_y} \quad (\text{simply supported boundaries})$$

$$C = \frac{P_0^2 A p^2}{8 \pi^2 M^2} \quad (\text{clamped-clamped boundaries})$$

Figure 12 (Figure 17 in Reference 26), is normalized by  $R_{11}(0,0)$ , that is, the auto-correlation function of the fixed point  $x_1$  at  $\tau = 0$ . Therefore, the nonnormalized correlation for each  $\Delta x, \tau$  desired was abstracted from the program and divided by  $R_{11}(0,0)$  to yield this curve. Similarly, calculations were necessary to obtain the data in the form used in Figure 13 (Figure 15 in Reference 26); see page 207 of this report. The program yields a normalized answer in CROSS2, which is not in suitable form for representing the curve as shown. Therefore, the normalized program result is manually multiplied by the NORM FACTOR to give a non-normalized quantity  $R_{12}(\Delta X, \tau)$ ; see equation below. More precisely, this is accomplished by first multiplying the number in the upper right corner labeled "NORM FACTOR=" by the corresponding quantity in the column labeled "NORM. CORR. OF ACC. PRESS,". Only  $\tau = 0$  was used for this curve so that the corresponding quantity would appear in the line for TAU = 0. The second step is to get the normalization factors from AUTO 1, which must have as many cases as there are variable points in CROSS2.  $R_{11}(0,0)$  refers to  $R(x_1 - x_1, \tau = 0)$  for all cases where 11 is a fixed reference point in the longitudinal direction, but  $R_{22}(0,0)$  refers to  $R(x_2 - x_2, \tau = 0)$  where 22 is any other point in the longitudinal direction. The corresponding cross points are denoted by 12 in the correlation function, i.e.,  $R_{12}(\Delta x, \tau)$ . The quantity to be used from AUTO 1 is labeled "NORM.FACTOR=".

The total function plotted then becomes

$$\frac{\text{NORM.CORR. OF ACC.PRESS. (from (CROSS2))} \times \text{NORM.FACTOR (CROSS2)}}{\sqrt{\text{NORM.FACTOR (AUTO1 with } X_1) \times \text{NORM.FACTOR (AUTO1 with } X_2)}}$$

The major subroutines results and running times on the IBM 7090 are:

AUTO 1	CROSS 1	CROSS 2
1. Autocorrelation	1. Cross correlation keeping time constant	1. Cross correlation, varying time and/or space
2. Auto power spectrum	2. Not Applicable	2. Power spectrum for first point
Approximately 3 min per case (i.e., point)	Approximately 3 min for 1 point, 1 time (see CROSS2)	Approximately 1.5 min per variable point over 120 time increments

The printout yields intermediate results, such as integration sums and nonnormalized, noncumulative results for each mode. For example, 37 modes would imply 37 sets of these results, followed by the normalized answers for each of the major subroutines. For the auto-spectrum final results, the labels **FREQ.** and **RAD/SEC** should be interchanged.

TABLE 4C

Flow-Chart (Electric Boat) Turbulence-Excited, Clamped and Simply Supported Plate Problem

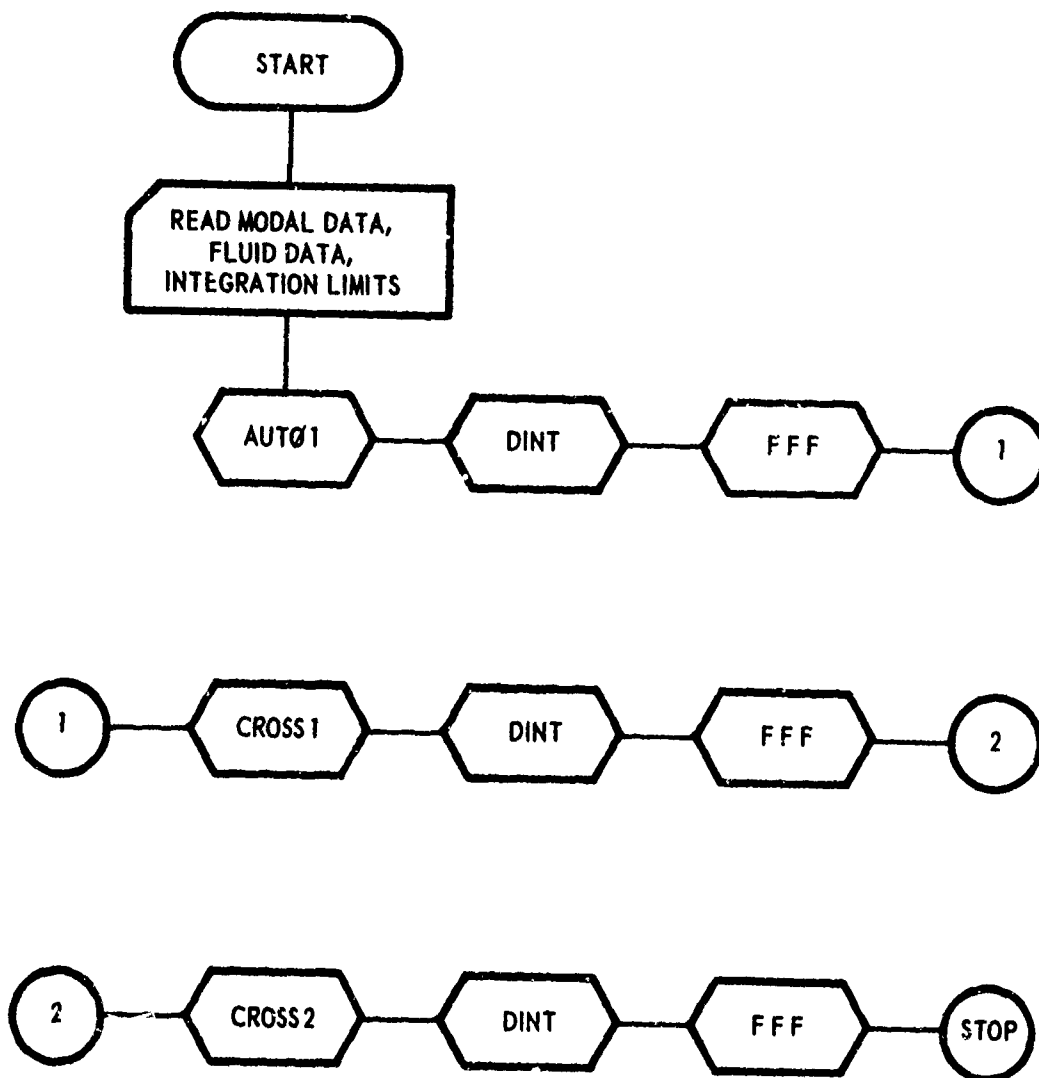

TABLE 4C (Continued)

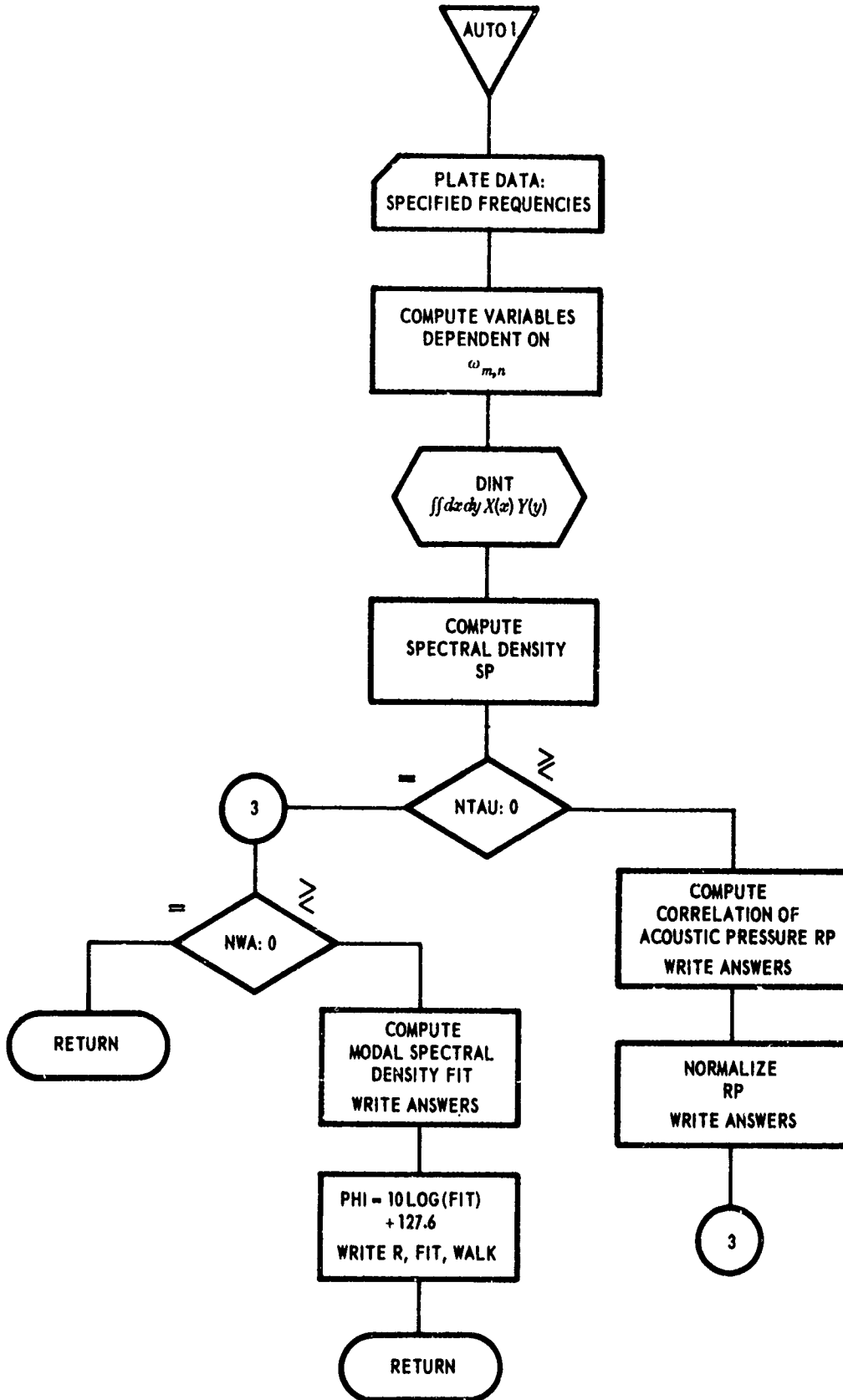

TABLE 4C (Continued)

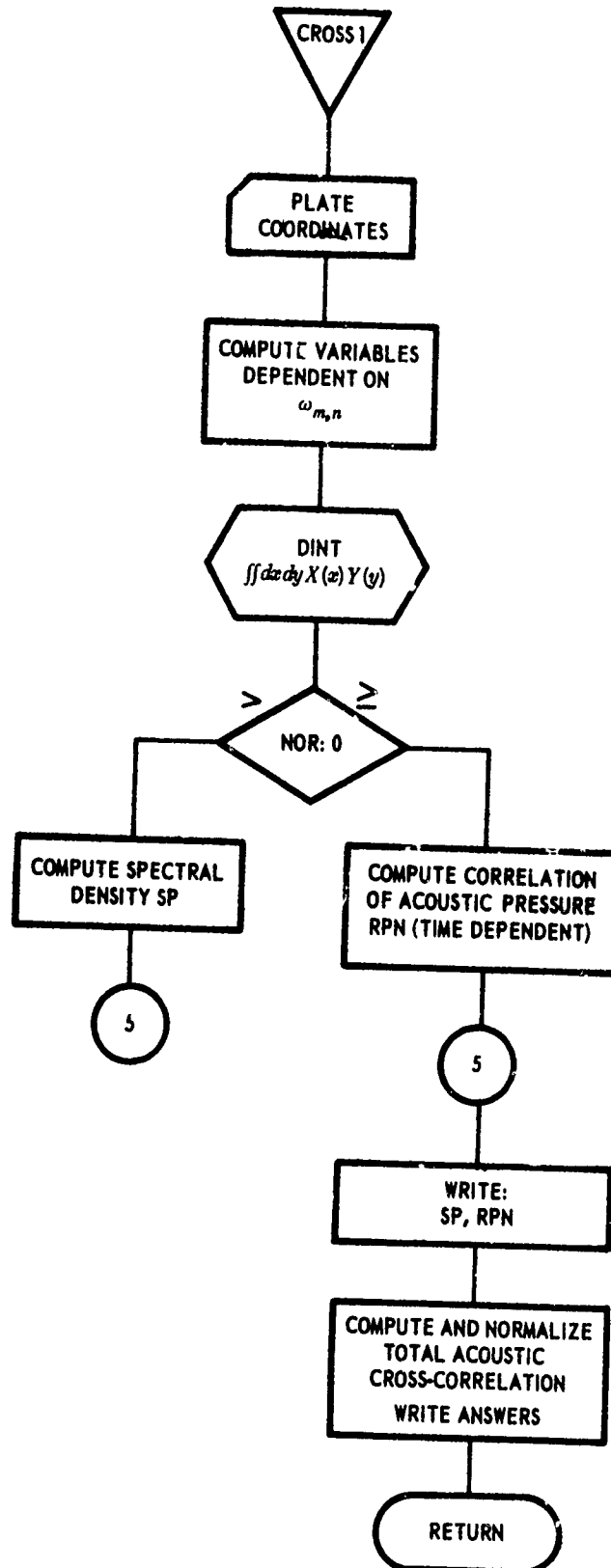

TABLE 4C (Continued)

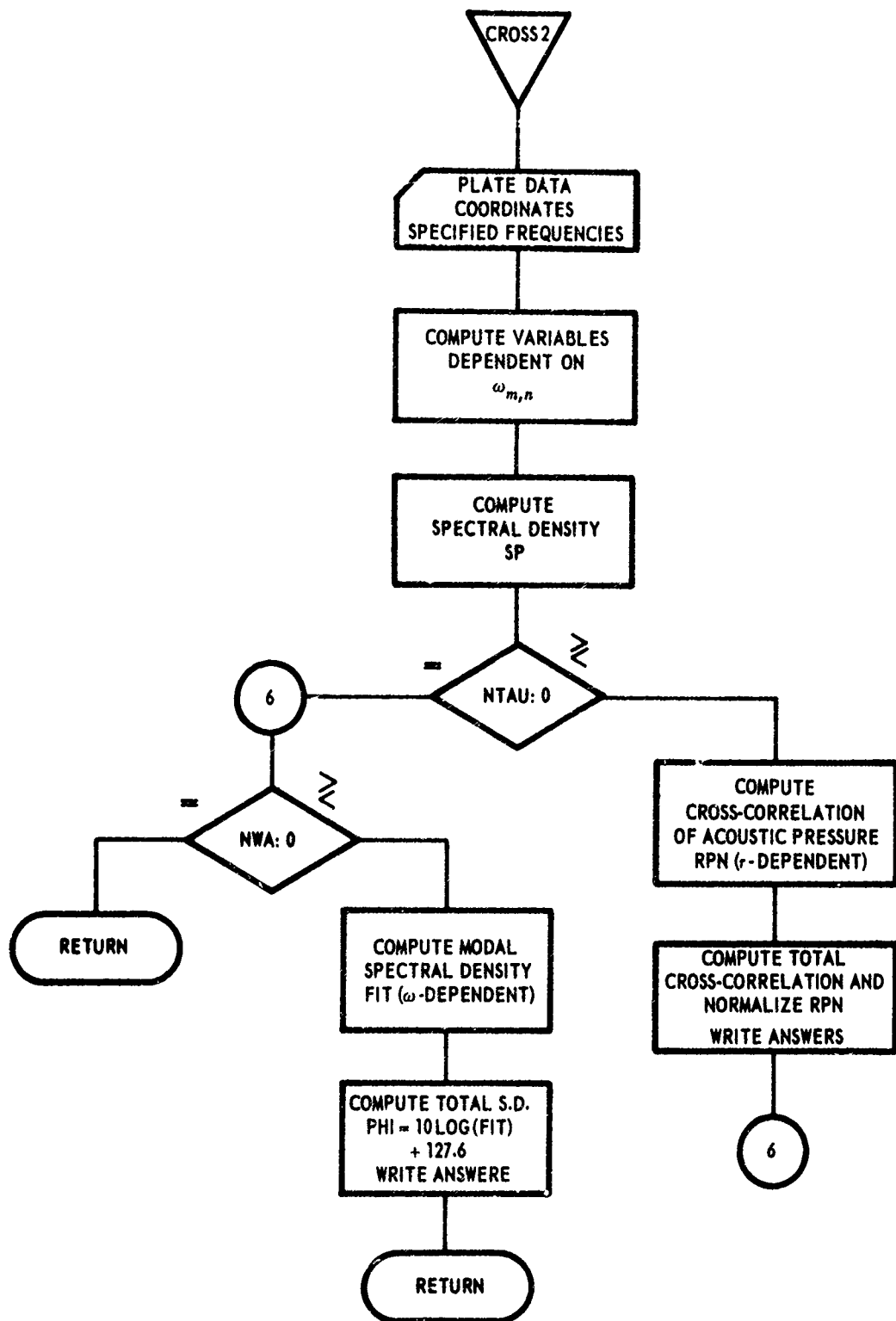

TABLE 4C (Continued)

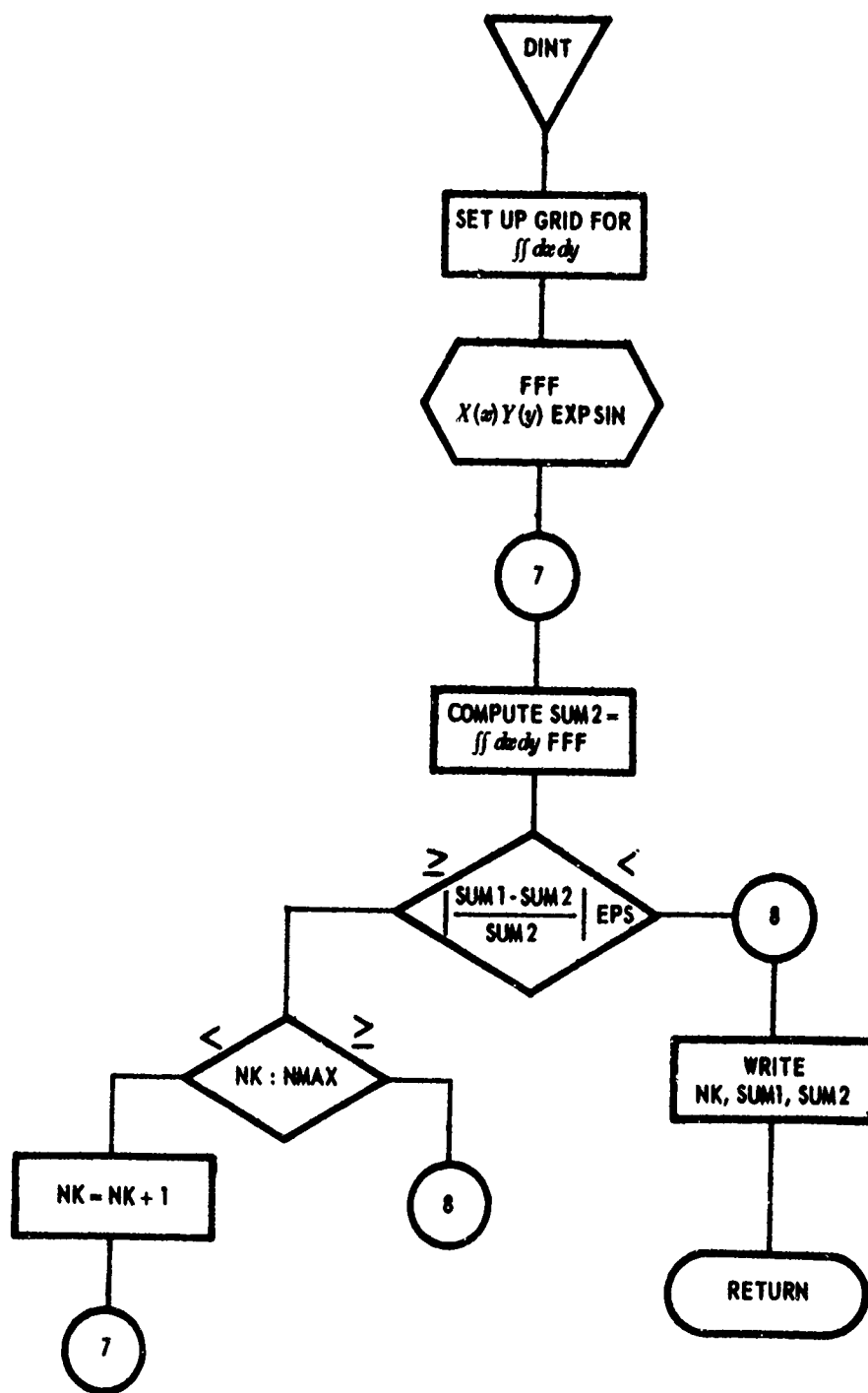
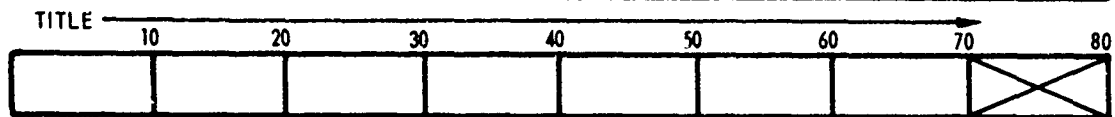
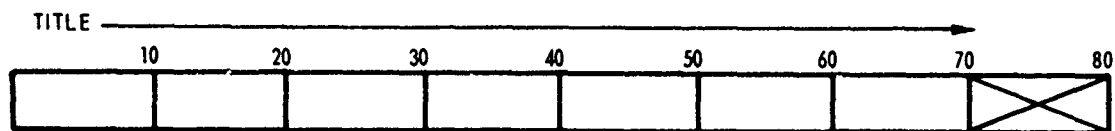
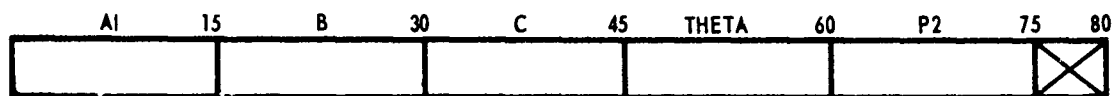
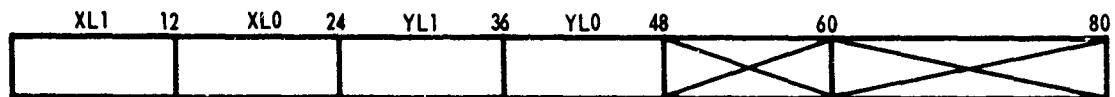
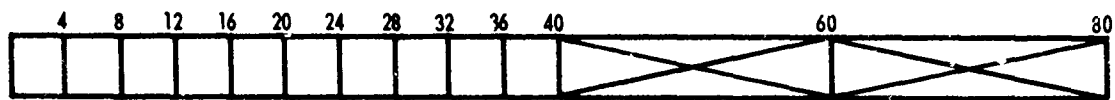

TABLE 4D

Input Format for Main Program, General Case



Columns 1-40, below, contain respectively, in 4-column blocks: MM; NN; IM; IN; NXYZ; KXYZ, LXYZ; NAUTO; NCROSS: NCROST



IMxIN sets of 6-column blocks are needed for the W(IM,IN) array: w(1,1); w(1,2); . . . ; w(1,IN); w(2,1); . . . ; w(2,IN); . . . ; w(IM,IN)

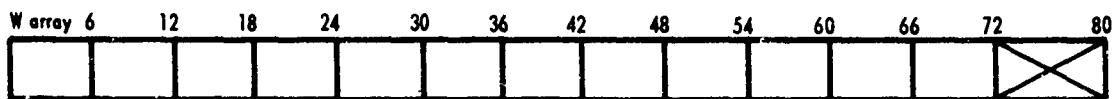

(MM + NN) / 20 cards are needed to complete arrays MAM(MM) and NAN(NN): MAM(1); MAM(2); . . . ; MAM(MM); NAN(1); NAN(2); . . . ; NAN(NN)

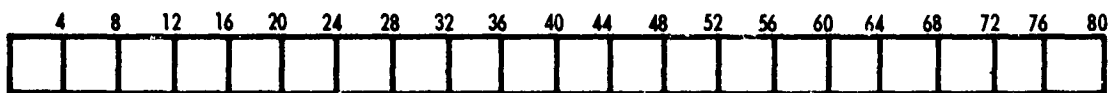

MM cards are needed to complete the following arrays: (used in general case only)

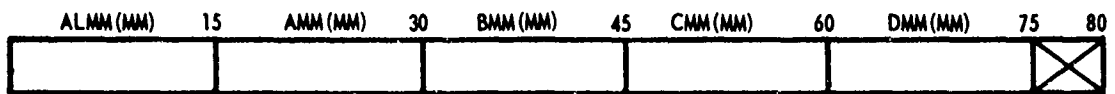
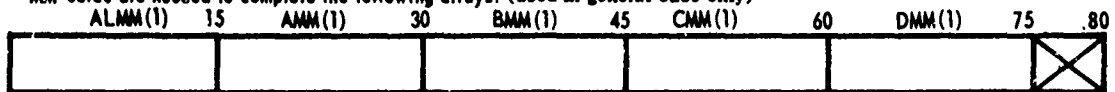

NN cards are needed to complete the following arrays: (used in general case only)

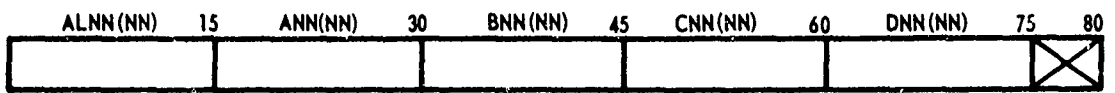
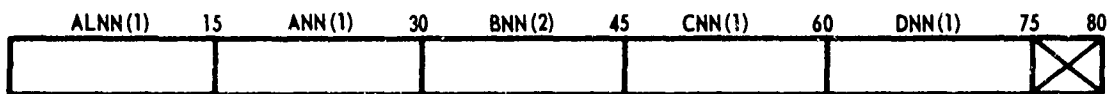



TABLE 4D (Continued)

INPUT FORMAT FOR SUBROUTINE AUTO 1

X	12	Y	24	Z	36	TAU	48	DTAU	60	64	70	74	78	80
														X

NWA/12 cards are needed to complete the WA(NWA) array:

WA(1)	WA(2)	...	...	...	...	...	...	...	...	...	...	...	...	...	...
6	12	18	24	30	36	42	48	54	60	66	72	78	84	90	96
															X

INPUT FORMAT FOR SUBROUTINE CROSS 1

XX	12	YY	24	ZZ	36	MXP	42	48	EPS	60	NMAX	66	72	80
													X	X

MTAU/6 cards are needed to complete the TAU(MTAU) array:

TAU(1)	12	TAU(2)	24	...	36	...	48	...	60	TAU(6)	72	80
												X

MXP/2 cards are needed to complete the following arrays:

XP(1)	12	YP(1)	24	ZP(1)	36	40	52	YP(2)	64	ZP(2)	76	80

TABLE 4D (Continued)

INPUT FORMAT FOR SUBROUTINE CROSS 2

XX	12	YY	24	ZZ	MXP		TAU	51	DTAU	NTAU		NMAX NWA					
					36	39				63	66	EPS	72	75	78	80	
																	X

MXP/2 cards are needed to complete the following arrays:

				NOR(1)				NOR(2)					
XP(1)	12	YP(1)	24	ZP(1)	36	40	XP(2)	52	YP(2)	64	ZP(2)	76	80

NWA/12 cards are needed to complete the WA(NWA) array:

WA(1)	WA(2)	...	...	...	...	...	...	...	...	...	WA(12)	
6	12	18	24	30	36	42	48	54	60	66	72	80
												X

## APPENDIX C4 – TEST RUNS

Test runs for the power spectrum, longitudinal correlation function, and longitudinal space-time correlation function of the acoustic pressures are plotted in Figures 12, 13, and 14. The computer programs used to obtain these results have been given in Table 4, and the computer listings are presented in Table 5.

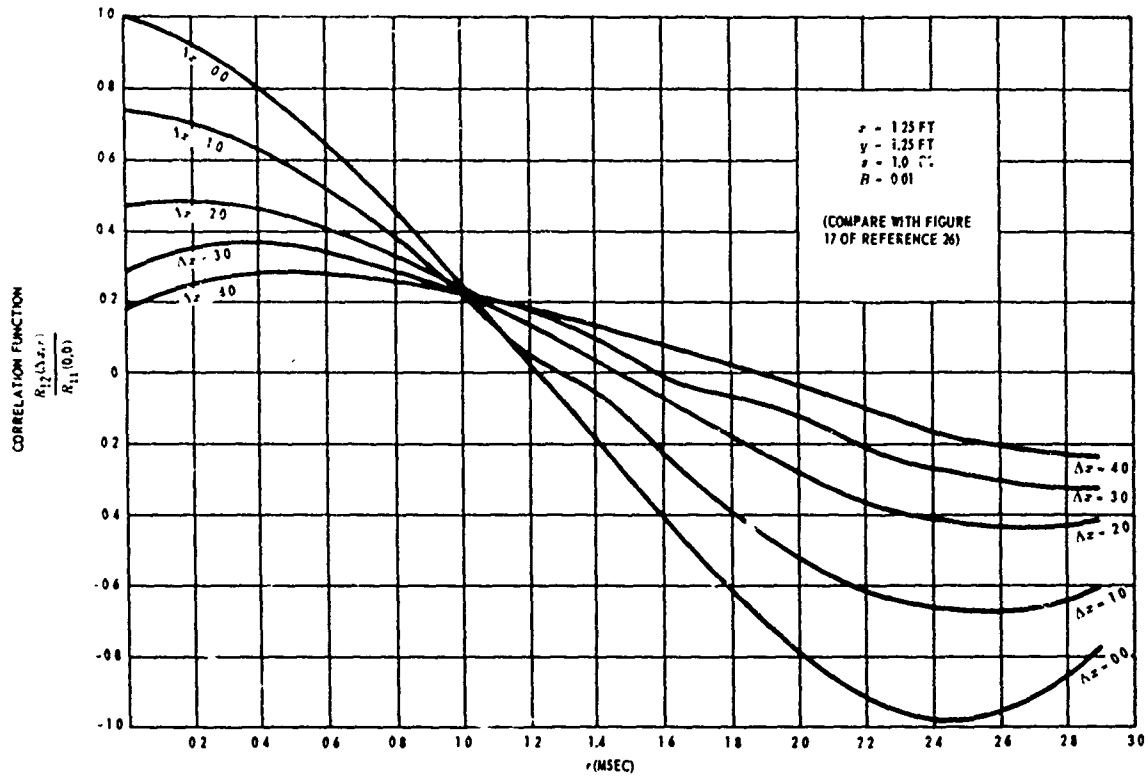

Figure 12a - Clamped-Clamped Steel Plate

This subfigure is based on the use of frequencies obtained for a clamped-clamped plate but modes obtained for a simply supported plate. (see statement following Equation (C34))

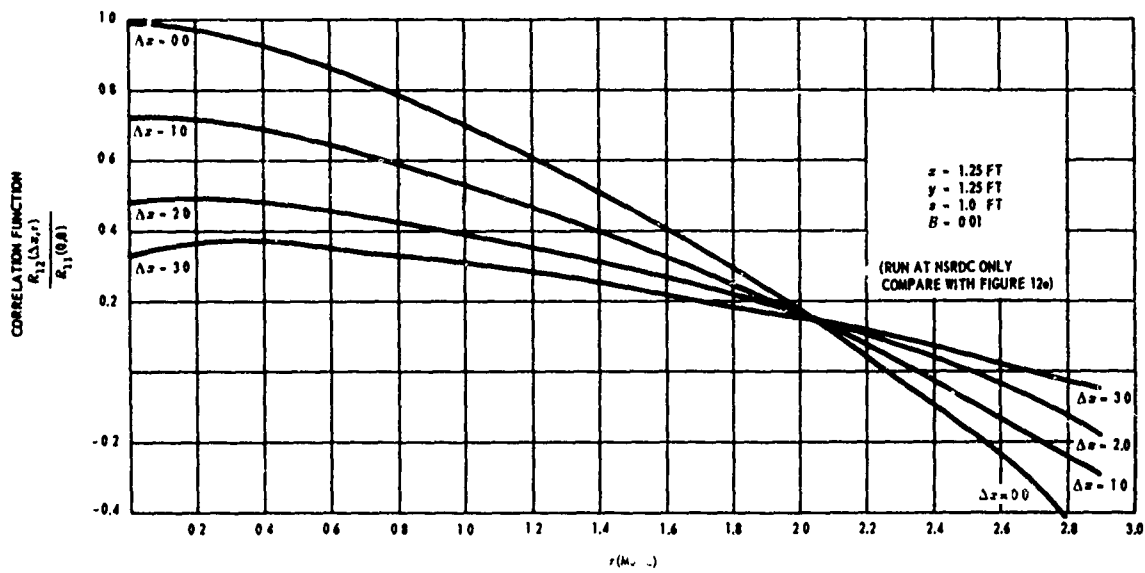

Figure 12b - Simply Supported Steel Plate

This subfigure is based on the use of frequencies and mode shapes obtained for a simply supported plate.

Figure 12 - Longitudinal Space-Time Correlation Function for a 2-Foot  $\times$  2.33-Foot  $\times$  3/8-Inch Steel Plate

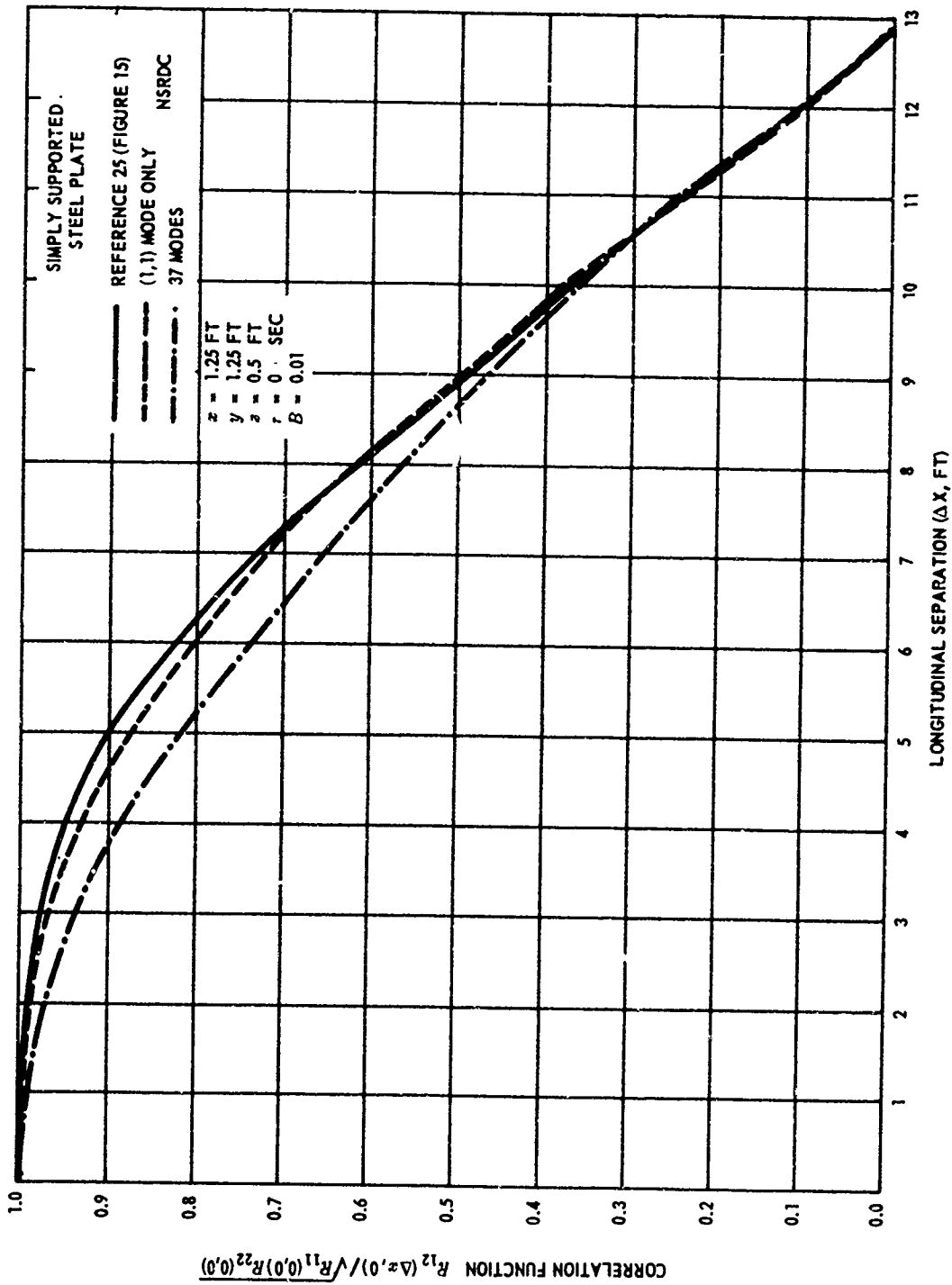

Figure 13 - Longitudinal Correlation Function for a 2-Foot x 2.33-Foot x 3/8-Inch Steel Plate  
 Comparison of the results obtained using the (1,1) mode only and using 37 modes shows the error involved, over the longitudinal range, in neglecting the contributions of the higher modes to the correlation.

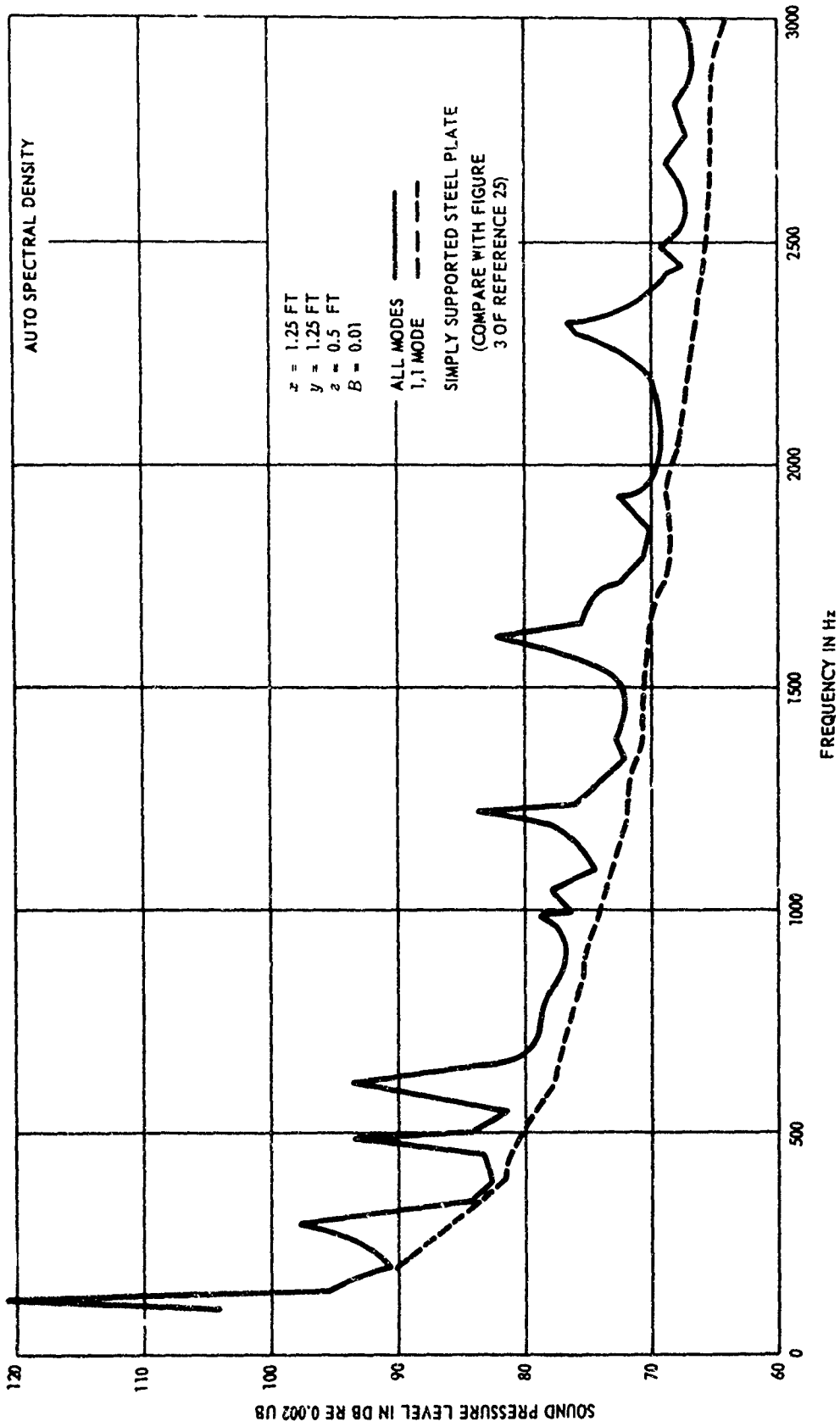

Figure 14 - Computed Power Spectrum for a 2-Foot x 2.33-Foot x 3/8-Inch Steel Plate

TABLE 5

Computer Listings for Electric Boat Program - Izzo

Table 5A - Simply Supported Boundaries

\$IBFTC TURAD2	0000
C	10
C	20
1000 FORMAT(12A6)	30
1001 FORMAT(10I4)	40
1002 FORMAT(4E12.6/5E15.8)	0#50
1003 FORMAT(12F6.0)	0 60
1004 FORMAT(20I4)	0 70
1005 FORMAT(5E15.8)	0 80
C	90
2000 FORMAT(1H1,10X,6HF,P.5,15X,12A6/22X,12A6////)	0100
2001 FORMAT (1H0,29X,45HORDER OF M (MODE NUMBERS) ..... MM =,I	0110
16/30X,45HORDER OF N (MODE NUMBERS) ..... NN =,I6/30X,	0120
245HNUMBER OF CASES (XYZ) IN AUTO CORR.. NXYZ =,I6/30X,45HNUMBER	0130
30F CASES (XYZ) IN CROSS CORR.. KXYZ =,I6 / 30X,45HAUTO CO	0140
4RRELATION CONSTANT ..... NAUTO =,I6/30X,45HCROSS CORRELATION	0150
5CONSTANT ..... NCROSS =,I6/30X,45HLIMITS OF THE 1-ST INTEGRAL	0160
6 ..... XL1 =,F11.4/30X,45H	0170
7 XLO =,F11.4/30X,45HLIMITS OF THE 2-ND INTEGRAL ..... Y	0180
8L1 =,F11.4/30X,45H YLO =,F1	0190
91.4/30X,45HSPEED OF SOUND IN WATER ..... AI =,F13.6/30X	0200
A,45HDAMPING CONSTANT ..... B =,F13.6/30X,45HC	0210
BCONSTANT ..... C =,F13.6/30X,45HTEMPORAL D	0220
CECAY FACTOR OF TURBULENCE THETA =,F11.4/30X,45HR.M.S. PRESSURE .	0230
D..... P2 =,F13.6//30X,2I10)	0240
2002 FORMAT(1H0,40X,35HUNDAMPED NATURAL FREQUENCIES W(M;N)/(10X,10F8.0	0250
X))	0260
2003 FORMAT(1H0,50X,12HMODE NUMBERS//(40X,10I5))	0270
2005 FORMAT(1H0,40X,35HNORMALIZED EIGENFUNCTION PARAMETERS //(15X,5E18.	0280
18) )	0290
2006 FORMAT(1H0,29X,45HNUMBER OF CASES IN CROSS CORR. (TIME).. LXYZ=,	0300
1I6/30X,45HCROSS CORR. (TIME) CONSTANT ..... NCROST=,I6//	0310
230X,2I10)	0320
C	0330
C	0340
COMMON /AAA/A(4000)	0350
C	0360

TABLE 5A (Continued)

	EQUIVALENCE (A(1),MM),(A(2),NN),(A(3),IM),(A(4),IN),(A(5),NXYZ),	0370
	1(A(6),KXYZ),(A(7),NAUTO),(A(8),NCROSS),(A(9),M),(A(10),N),	0380
	2(A(11),LXYZ),(A(12),NCROST,	0390
C		0400
	EQUIVALENCE (A(21),XL1),(A(22),XLO),(A(23),YL1),(A(24),YLO),	0410
	1(A(25),AI),(A(26),B),(A(27),C),(A(28),THETA),(A(29),P2),(A(30),PI)	0420
	2,(A(31),X),(A(32),Y),(A(33),Z),(A(34),EPS),(A(35),NMAX),	0430
	3(A(36),WMN),(A(37),AMN),(A(38),SUM1),(A(39),SUM2)	0440
C		0450
	EQUIVALENCE (A(101),MAM),(A(151),NAN),(A(1001),W)	0460
C		0470
C		0480
	DIMENSION TITLE(24),W(20,50),MAM(50),NAN(50)	0490
C		0500
	REAL KMN	0510
C		0520
	READ AND PRINT TITLE	0530
C		0540
	READ (5,1000) (TITLE(I),I=1,24)	0550
	WRITE(6,2000) (TITLE(I),I=1,24)	0560
C		0570
	READ AND PRINT GENERAL INPUT CONSTANTS	0580
C		0590
	READ (5,1001) MM,NN,IM,IN,NXYZ,KXYZ,LXYZ,NAUTO,NCROSS,NCROST	0600
	READ(5,1002) XL1,XLO,YL1,YLO,AI,B,C,THETA,P2	0610
	READ (5,1003) ((W(I,J),J=1,IN),I=1,IM)	0620
	READ (5,1004) (MAM(I),I=1,MM),(NAN(I),I=1,NN)	0630
C		0640
	WRITE(6,2001) MM,NN,NXYZ,KXYZ,NAUTO,NCROSS,XL1,XLO,YL1,YLO,AI,B,	0650
	1C,THETA,P2	0660
	WRITE(6,2006) LXYZ,NCROST,IM,IN	0670
	WRITE(6,2002) ((W(I,J),J=1,IN),I=1,IM)	0680
	WRITE(6,2003) (MAM(I),I=1,MM),(NAN(I),I=1,NN)	0690
C		0700
C		0710
	PI=3.14159	0720
C		0730



TABLE 5A (Continued)

C	AUTO CORRELATION	0740
C		0750
	IF (NAUTO.EQ.1) CALL AUTO1	0760
C		0770
C	CROSS CORRELATION	0780
C		0790
	IF (NCROSS.EQ.1) CALL CROSS1	0800
C		0810
C		0820
C	CROSS CORRELATION (TIME)	0830
C		0840
	IF (NCROST.EQ.1) CALL CROSS2	0850
C		0860
C		0870
	STOP	0880
	END	08 0
	\$IBFTC XAUTO1	0900
	SUBROUTINE AUTO1	0910
C		0920
C		0930
C		0940
C		0950
C	AUTO CORRELATION) X=XP , Y=YP , Z=ZP	0960
C		0970
C		0980
	3000 FORMAT(5E12.6,I4,E6.2,2I4)	0990
	3001 FORMAT(12F6.0)	1000
C		1010
	4000 FORMAT(1H1,50X,16HAUTO CORRELATION//30X,1HX,30X,1HY,30X,1HZ//	1020
	122X,E14.8,17X,E14.8,17X,E14.8//10X,5HTAU =,E14.8,5X,6HDTAU =,E14.8	1030
	2,5X,6HNMTAU =,I4,5X,5HEPS =,E14.8,5X,6HNMAX =,I4 ,5X,5HNWA =,I4 //)	1040
	4002 FORMAT(1H1,8H PNT CNT,12X,1HX,12X,1HY,12X,1HZ,12X,1HM,4X,1HN,5X,	1050
	1 4HFREQ,5X,21HM.S. SPECTRAL DENSITY,4X,20H DB(RE.0002) //	1060
	2I6,10X,F9.4,4X,F9.4,4X,F9.4,110,I5,3X,F6.0,5X,E16.8,6X,E16.8///	1070
	X40X	1080
	3,1HK,8X,3HTAU,15X,9HRPMN(TAU) //)	1090
		1100

TABLE 5A (Continued)

4003	FORMAT(1H,30X,I10,E16.8,E20.8)	1110
4004	FORMAT(1H0,50X,12HINTEGRATIONS // 33X,9HINT, NUM,5X, 8H MESH , 15X,6HM N,10X, 4HSUM2,16X, 4HSUM1)	1120
4005	FORMAT(1H1,30X,44HNORMALIZED CORRELATION OF ACCOUSTIC PRESSURE/// 110X, 4HNTAU,10X, 3HTAU,10X,25HNORM, CORR. OF ACC. PRES.,10X, 28HRP(K)/P2,12X,14HNORM, FACTOR =,E14.8//)	1130 1140 1150 1160
4006	FORMAT(1H, 8X,I4,8X,F8.6,10X,E16.8,11X,E16.8)	1170
4010	FORMAT(1H1,7E16.8)	1180
4011	FORMAT(1H1,30X,23HAUTO SPECTRAL DENSITY ///12X,1HK,10X, 4HFREQ, 110X, 7HRAD/SEC,10X,17HCROSS SPEC. DENS.,10X,11HDB(RE.0002)/// 10X, 8X,I4, 8X,F6.0,8X,F9.4,2(10X,E14.8))	1190 1200 1210
4012	FORMAT(1H,8X,I4, 8X,F6.0,8X,F9.4,2(10X,E14.8))	1220
4013	FORMAT(1H0,30X,18HCHOSEN FREQUENCIES //(10X,10F10.0))	1230
4014	FORMAT(1H1,30X,1HK,10X,4HFREQ,10X,7HRAD/SEC,10X,17HMODAL SPEC. DEN 1S.,10X,11HDB(RE.0002) //)	1240
4015	FORMAT(1H, 21X,I10,8X,F6.0,8X,F9.4,2(8X,E16.9))	1250
C		1260
C		1270
	COMMON /AAA/A(4000)	1280
C		1290
	EQUIVALENCE (A(1),MM),(A(2),NN),(A(3),IM),(A(4),IN),(A(5),NXYZ), 1(A(6),KXYZ),(A(7),NAUTO),(A(8),NCROSS),(A(9),M),(A(10),N) EQUIVALENCE (A(21),XL1),(A(22),XL0),(A(23),YL1),(A(24),YLO), 1(A(25),AI),(A(26),B),(A(27),C),(A(28),THETA),(A(29),P2),(A(30),PI) 2,(A(31),X),(A(32),Y),(A(33),Z),(A(34),EPS),(A(35),NMAX), 3(A(36),WMN),(A(37),AMN),(A(38),SUM1),(A(39),SUM2), 4(A(40),JA),(A(41),JB) EQUIVALENCE (A(101),MAM),(A(151),NAN),(A(1001),W)	1300 1310 1320 1330 1340 1350 1360 1370
C		1380
	DIMENSION MAM(50),NAN(50),W(20,50),RP(110),RPBAR(110),PRP(110) , 1WA(110),FI(110)	1390 1400
C		1410
	REAL KMN	1420
C		1430
	CONVT = 60000.	1440
C		1450
C		1460
	DO 5 II=1,NXYZ	1470

TABLE 5A (Continued)

C	READ (5,3000) X,Y,Z,TAU,DTAU,NTAU,EPS,NMAX,NWA	1480
C		1490
C	WRITE(6,4000) X,Y,Z,TAU,DTAU,NTAU,EPS,NMAX,NWA	1500
C		1510
C	IF (NWA) 2,1,2	1520
C		1530
C	2 READ (5,3001) (WA(K),K=1,NWA)	1540
C	WRITE(6,4013) (WA(K),K=1,NWA)	1550
C		1560
C		1570
C	1 ATAU = TAU	1580
C		1590
C	DO 6 IA=1,NTAU	1600
C	6 RP(IA) = 0.	1610
C		1620
C	DO 7 IA=1,NWA	1630
C	7 FI(IA) = 0.	1640
C		1650
C	DO 10 I=1,IM	1660
C	DO 10 J=1,IN	1670
C	JA = J	1680
C	JB = J	1690
C	IF (IM,EQ,MM) JA=I	1700
C	M=MAM(JA)	1710
C	N = NAN(J)	1720
C		1730
C	WMN = W(I,J)	1740
C		1750
C	KMN = C*THETA / (B*(1+W(I,J)**2*THETA**2))	1760
C	AMN = B*W(I,J)	1770
C	CMN = W(I,J)*(1-6.*B**2 + B**4)	1780
C	DMN = 4.*B*W(I,J)*(B**2-1.)	1790
C		1800
C	WBAR1=(B**2+2.) / (B*W(I,J)*(B**2+4.))	1810
C	WBAR2 = B*WBAR1 / (B**2+2. )	1820
C	CBAR = KMN*W(I,J)*P2	1830
C		1840

TABLE 5A (Continued)

C	WRITE(6,4010) KMN,AMN,CMN,DMN,WBAR1,WBAR2,CBAR	1850
	WRITE(6,4004)	1860
C	PHASE=1,5708	1870
	KKK=2	1880
	CALL DINT (AMN,PHASE,KKK)	1890
	CAP2=SUM2	1900
C	KKK=1	1910
	AMN=-AMN	1920
	CALL DINT (AMN,PHASE,KKK)	1930
	CAP1=SUM2	1940
C	KKK=5	1950
	PHASE=0.	1960
	CALL DINT (AMN,PHASE,KKK)	1970
	CAP5=SUM2	1980
C	KKK=4	1990
	AMN=-AMN	2000
	CALL DINT (AMN,PHASE,KKK)	2010
	CAP4=SUM2	2020
C		2030
C		2040
	SP = CBAR* (WBAR1*CAP1*CAP2 + WBAR2*CAP1*CAP4 - WBAR2*CAP5*CAP2 +	2050
	1WBAR1*CAP5*CAP4 )	2060
		2070
C		2080
	IF (SP) 11,11,12	2090
11	PHI = 0.	2100
	GO TO 13	2110
12	PHI = 10.* ALOG10(SP) + 127.6	2120
13	WRITE(6,4002)II,X,Y,Z,M,N,W(I,J),SP,PHI	2130
	IF (NTAU) 22,21,22	2140
22	TAU = ATAU	2150
C		2160
	DO 15 K=1,NTAU	2170
		2180
		2190
		2200
		2210

TABLE 5A (Continued)

C		2220
	TH1 = CMN*COS(W(I,J)*TAU) + DMN * SIN(W(I,J)*TAU)	2230
	TH2=CMN*SIN(W(I,J)*TAU)-DMN*COS(W(I,J)*TAU)	2240
C		2250
C		2260
	RPN=KMN*EXP(-AMN*TAU) * (TH1*CAP1*CAP2 + TH2*CAP1*CAP4 - TH2	2270
	1*CAP5*CAP2 + TH1*CAP5*CAP4)	2280
	RP(K)=RP(K)+RPN	2290
C		2300
	WRITE(6,4003) K,TAU,RPN	2310
C		2320
	15 TAU = TAU + DTAU	2330
C		2340
	21 IF (NWA) 14,10,14	2350
	14 WRITE(6,4014)	2360
C		2370
	DO 20 K=1,NWA	2380
	RAD = WA(K)/(2.*PI)	2390
	DD = (B**2*W(I,J)**2 + (W(I,J)-WA(K))**2)* (B**2*W(I,J)**2 +	2400
	1(W(I,J) + WA(K))**2)	2410
C		2420
	AAMN = (B*W(I,J)*(B**2*W(I,J)**2 + W(I,J)**2 + WA(K)**2)) / DD	2430
	BBMN = (W(I,J)*(B**2*W(I,J)**2 + W(I,J)**2 - WA(K)**2)) / DD	2440
C		2450
	TW1 = CMN*AAMN + DMN*BBMN	2460
	TW2 = CMN*BBMN - DMN*AAMN	2470
C		2480
	FIT = KMN * (TW1*CAP1*CAP2 + TW2*CAP1*CAP4 - TW2*CAP5*CAP2 +	2490
	1TW1*CAP5*CAP4)	2500
C		2510
	FAT = FIT	2520
	IF (FIT) 19,19,17	2530
19	PHI = 0.	2540
	FIT = 0.	2550
	GO TO 18	2560
	17 PHI = 10.*ALOG10(FIT) + 127.6	2570
	18 WRITE(6,4015) K,WA(K),RAD,FAT,PHI	2580

TABLE 5A (Continued)

C		2590
	20 FI(K) = FI(K) + FIT	2600
C		2610
	10 CONTINUE	2620
C		2630
	IF (NTAU) 52,51,52	2640
C		2650
	52 WRITE(6,4005) RP(1)	2660
C		2670
	DO 30 K=1,NTAU	2680
	RPBAR(K)=RP(K)/RP(1)	2690
	PRP(K) = RP(K)/P2	2700
	WRITE(6,4006) K,ATAU,RPBAR(K),PRP(K)	2710
	30 ATAU=ATAU+DTAU	2720
C		2730
	51 IF (NWA) 61,5,61	2740
C		2750
	61 WRITE(6,4011)	2760
C		2770
	DO 40 K=1,NWA	2780
	RAD = WA(K)/(2.*PI)	2790
	IF (FI(K)) 71,71,41	2800
	71 PHI = 0.	2810
	GO TO 40	2820
C		2830
	41 PHI = 10.* ALOG10(FI(K)) + 127.6	2840
	40 WRITE(6,4012) K,WA(K),RAD,FI(K),PHI	2850
	5 CONTINUE	2860
C		2870
	RETURN	2880
C		2890
	END	2900
	\$IBFTC XCROSS1	2910
	SUBROUTINE CROSS1	2920
C		2930
		2940
C		2950
	CROSS CORRELATION) TIME = CONSTANT	

TABLE 5A (Continued)

C		2960
C		2970
C		2980
	1000 FORMAT(3E12.6,2I6,E12.6,I6/(6E12.8))	2990
	1001 FORMAT(2(3E12.6,I4))	3000
C		3010
	2000 FORMAT(1H1,50X,17HCROSS CORRELATION///20X,1HX,20X,1HY,20X,1HZ,20X, 13HMXP,10X,4HMTAU,10X, 3HEPS,10X, 4HNMAX //12X,E14.8,2(7X,E14.8), 214X,I4,9X,I4, 5X,E12.6,7X,I3// 5X,7HTAU(I)=,5E16.8//12X,5E16.8//)	3020
	2001 FORMAT(1H0,30X,2HXP,20X,2HYP,20X,2HZP,10X,3HNOR//(23X,E14.8,8X,E14 1.8,8X,E14.8,5X,I3 )	3030
	2002 FORMAT(1H0,1HI ,4X,3HTAU,4X, 7HPNT CNT,5X,2HXP,10X,2HYP,10X,2HZP, 110X, 6HM N,4X,4HFREQ , 5X,17HCROSS SPEC. DENS.,5X,11HDB(RE.0002 2),5X, 9HRPMN(TAU)//I2,E11.5,I4,E14.6,E12.6,E12.6,2X,2I5,2X,F6.0, 36X,E14.8,4X,2E14.8 )	3040
	2004 FORMAT(1H1,4X,1HI,8X, 3HTAU,12X,1HJ,10X,5HXP(J),9X,5HYP(J), 9X, 15HZP(J),12X,11HCRPBAR(I,J),10X,12HNORM. FACTOR/// 16,5X,E10.5, 24X,I5,3X,3E14.6,E20.8,E22.8/(25X,I5,3X,3E14.6,E20.8,E22.8))	3050
	2005 FORMAT(1H0,50X,12HINTEGRATIONS // 33X,9HINT. NUM.,5X, 8H MESH , 15X,6HM N,10X, 4HSUM2,16X, 4HSUM1)	3060
	2010 FORMAT(1H1,7E16.8)	3070
C		3080
C		3090
	COMMON /AAA/A(4000)	3100
C		3110
	EQUIVALENCE (A(1),MM),(A(2),NN),(A(3),IM),(A(4),IN),(A(5),NXYZ), 1(A(6),KXYZ),(A(7),NAUTO),(A(8),NCROSS),(A(9),M),(A(10),N)	3120
	EQUIVALENCE (A(21),XL1),(A(22),XLO),(A(23),YL1),(A(24),YLO), 1(A(25),AI),(A(26),B),(A(27),C),(A(28),THETA),(A(29),P2),(A(30),PI)	3130
	2,(A(31),X),(A(32),Y),(A(33),Z),(A(34),EPS),(A(35),NMAX), 3(A(36),WMN),(A(37),AMN),(A(38),SUM1),(A(39),SUM2), 4(A(40),JA),(A(41),JB)	3140
	EQUIVALENCE (A(101),MAM),(A(151),NAN),(A(1001),W),(A(2001),DIX1), 1(A(3001),DIX5)	3150
C		3160
	DIMENSION TAV(110),XP(50),YP(50),ZP(50),MOR(50),MAM(50), INAN(50),W(20,50),DIX1(20,50),DIX5(20,50),CRPBAR(50)	3170
		3180
		3190
		3200
		3210
		3220
		3230
		3240
		3250
		3260
		3270
		3280
		3290
		3300
		3310
		3320

TABLE 5A (Continued)

C		3330
	REAL KMN	3340
C		3350
C		3360
C		3370
	CONVT = 60000.	3380
C		3390
C		3400
	DO 5 II=1,KXYZ	3410
C		3420
	READ (5,1000)XX,YY,ZZ,MXP,MTAV,EPS,NMAX,(TAV(I),I=1,MTAV)	3430
	WRITE(6,2000)XX,YY,ZZ,MXP,MTAV,EPS,NMAX,(TAV(I),I=1,MTAV)	3440
C		3450
	READ (5,1001)(XP(I),YP(I),ZP(I),NOR(I), I=1,MXP)	3460
	WRITE(6,2001)(XP(I),YP(I),ZP(I),NOR(I), I=1,MXP)	3470
C		3480
	DO 10 I=1, MTAV	3490
C		3500
	DO 20 J=1,MXP	3510
	CRP = 0.	3520
C		3530
C		3540
	DO 30 K=1,IM	3550
	DO 30 L=1,IN	3560
	JA=L	3570
	JB=L	3580
	IF (IM.EQ.MM) JA=K	3590
	M=MAM(JA)	3600
	N=MAN(L)	3610
	WMN= W(K,L)	3620
C		3630
	KMN = C*THETA / (B*(1.+W(K,L)**2*THETA**2))	3640
	AMN = B*W(K,L)	3650
	CMN = W(K,L)*(1.-6.*B**2 + 8**4)	3660
	DMN = 4.*B*W(K,L)*(B**2-1.)	3670
	WBAR1=(B**2+2.)/(B*W(K,L)*(B**2+4.))	3680
	WBAR2= B* WBAR1 / (B**2+2.)	3690



TABLE 5A (Continued)

	CBAR = KMN * W(K,L) * P2	3700
C		3710
	WRITE(6,2010) KMN,AMN,CMN,DMN,WBAR1,WBAR2,CBAR	3720
	WRITE(6,2005)	3730
C		3740
	IF (J.NE.1) GO TO 31	3750
C		3760
	X=XX	3770
	Y=YY	3780
	Z=ZZ	3790
C		3800
	PHASE =1.5708	3810
	KKK=1	3820
	AMN =-AMN	3830
	CALL DINT(AMN,PHASE,KKK)	3840
	DIX1(K,L) = SUM2	3850
C		3860
	PHASE = 0.	3870
	KKK= 5	3880
	CALL DINT(AMN,PHASE,KKK)	3890
	DIX5(K,L) = SUM2	3900
C		3910
	AMN = -AMN	3920
C		3930
	31 X=XP(J)	3940
	Y=YP(J)	3950
	Z=ZP(J)	3960
C		3970
	PHASE =1.5708	3980
	KKK = 2	3990
	CALL DINT(AMN,PHASE,KKK)	4000
	CAP2 = SUM2	4010
C		4020
	PHASE = 0.	4030
	KKK = 4	4040
	CALL DINT(AMN,PHASE,KKK)	4050
	CAP4 = SUM2	4060

TABLE 5A (Continued)

C	SP = .5E+20	4070
	PHI = .5E+20	4080
C		4090
	IF (NOR(J)) 39,32,32	4100
39	SP = CBAR * (WBAR1*DIX1(K,L)*CAP2 + WBAR2*DIX1(K,L)*CAP4 -WBAR2*	4110
	1DIX5(K,L)*CAP2 + WBAR1*DIX5(K,L)*CAP4 )	4120
C		4130
	IF (SP) 37,37,33	4140
37	PHI = 0.	4150
	GO TO 32	4160
C		4170
	33 PHI = 10.* ^LOG10(SP) + 127.6	4180
C		4190
	32 TH1 = CMN*COS(W(K,L)*TAV(I)) + DMN*SIN(W(K,L)*TAV(I))	4200
	TH2 = CMN*SIN(W(K,L)*TAV(I)) - DMN*COS(W(K,L)*TAV(I))	4210
C		4220
	RPN = KMN*EXP(-AMN*TAV(I))*(TH1*DIX1(K,L)*CAP2 + TH2*DIX1(K,L)*	4230
	1CAP4 - TH2*DIX5(K,L)*CAP2 + TH1*DIX5(K,L)*CAP4)	4240
C		4250
	CRP = CRP + RPN	4260
C		4270
	34 WRITE(6,2002) I,TAV(I),J,XP(J),YP(J),ZP(J),M,N,W(K,L),SP,PHI,RPN	4280
C		4290
	30 CONTINUE	4300
C		4310
	IF ((I+J).EQ.2) CNORM =CRP	4320
	CRPBAR(J) = CRP / CNORM	4330
20	CONTINUE	4340
C		4350
	WRITE(6,2004) I,TAV(I),(J,XP(J),YP(J),ZP(J),CRPBAR(J),CNORM,	4360
	1J=1,MXP)	4370
C		4380
	10 CONTINUE	4390
C		4400
	5 CONTINUE	4410
C		4420
		4430

TABLE 5A (Continued)

C		4440
C		4450
C		4460
	RETURN	4470
	END	4480
\$IBFTC	XCROSS2	4490
	SUBROUTINE CROSS2	4500
C		4510
C		4520
C		4530
C	CROSS CORRELATION (TIME) (AUTO CORRELATION INCLUDED FOR THE FIRST POINT)	4540
C		4550
	1000 FORMAT(3E12.6,I3,2E12.8,I3,E6.2,2I3)	4560
	1001 FORMAT(2(3E12.6,I4))	4570
	1002 FORMAT(12F6.0)	4580
C		4590
	2000 FORMAT(1H1,50X,24HCROSS CORRELATION (TIME)///30X,1HX,30X,1HY,30X, 11HZ,///4X,3E31.8///4X, 5HMXP =,I4,4X, 5HTAU =,E14.8,4X, 6HDTAU =, 2E14.8,4X, 6HNTAU =,I4,4X, 5HEPS =,E14.8,4X, 6HNMAX =,I4,4X,5HNWA = 3,I4 /)	4600 4610 4620 4630
	2001 FORMAT(1H0,30X,2HXP,20X,2HYP,20X,2HZP,10X,3HNOR//(23X,E14.8,8X,E14 1.8,8X,E14.8,5X,I3 ))	4640 4650
	2002 FORMAT(1H0, 9HCASE NUM.,5X,11HINTEG. PNT., 5X,2HXP,10X,2HYP,10X, 12HZP,10X, 6HM N,5X,4HFREQ ,5X,21HM.S. SPECTRAL DENSITY,5X, 211HDB(RE,0002)///15,10X,I5,3X,3(3X,F9.4),4X,2I5,3X,F6.0,3X,2E20.8 3///40X,1HK,8X,3HTAU,15X, 9HRPMN(TAU)///)	4660 4670 4680 4690
	2003 FORMAT(1H0, 9HCASE NUM.,5X,11HINTEG. PNT., 5X,2HXP,10X,2HYP,10X, 12HZP,10X, 6HM N,5X,4HFREQ //15,10X,I5, 3X,3(3X,F9.4);4X,2I5,3X, 2F6.0,///40X,1HK,8X,3HTAU,15X,9HRPMN(TAU)///)	4700 4710 4720
	2004 FORMAT(1H ,30X,I10,E16.8,E20.8)	4730
	2005 FORMAT(1H1,50X,12HINTEGRATIONS // 33X,9HINT. NUM.,5X, 8H MESH , 15X,6HM N,10X, 4HSUM2,16X, 4HSUM1)	4740 4750
	2007 FORMAT(1H1,30X,44HNORMALIZED CORRELATION OF ACCOUSTIC PRESSURE/// 110X, 4HNTAU,10X, 3HTAU,10X,25HNORM. CORR. OF ACC. PRES.,10X, 28HRP(K)/P2,12X,14HNORM. FACTOR =,E14.8//)	4760 4770 4780
	2008 FORMAT(1H , 8X,I4,8X,F8.6,10X,E16.8,11X,E16.8)	4790
	2010 FORMAT(1H0,30X,18HCHOSEN FREQUENCIES //(10X,10F10.0))	4800

TABLE 5A (Continued)

2011	FORMAT(1H1,30X,23HCROSS SPECTRAL DENSITY ///12X,1HK,10X, 4HFREQ,	4810
	110X, 7HRAD/SEC,10X,17HCROSS SPEC. DENS.,10X,11HDB(RE.0002)///)	4820
2012	FORMAT(1H ,8X,I4,8X,F6.0,8X,F9.4,2(10X,E14.8))	4830
2013	FORMAT(1H1,30X,1HK,10X,4HFREQ,10X,7HRAD/SEC,10X,17HMODAL SPEC. DEN	4840
	1S.,10X,11HDB(RE.0002) ///	4850
2014	FORMAT(1H ,21X,I10, 8X,F6.0,8X,F9.4,2(8X,E16.8))	4860
C		4870
	COMMON /AAA/A(4000)	4880
C		4890
	EQUIVALENCE (A(1),MM),(A(2),NN),(A(3),IM),(A(4),IN),(A(5),NXYZ),	4900
	1(A(6),KXYZ),(A(7),NAUTO),(A(8),NCROSS),(A(9),M),(A(10),N) ,	4910
	2(A(11),LXYZ),(A(12),NCROST)	4920
	EQUIVALENCE (A(21),XL1),(A(22),XLO),(A(23),YL1),(A(24),YLO),	4930
	1(A(25),AI),(A(26),B),(A(27),C),(A(28),THETA),(A(29),P2),(A(30),PI)	4940
	2,(A(31),X),(A(32),Y),(A(33),Z),(A(34),EPS),(A(35),NMAX),	4950
	3(A(36),WMN),(A(37),AMN),(A(38),SUM1),(A(39),SUM2),	4960
	4(A(40),JA),(A(41),JB)	4970
	EQUIVALENCE (A(101),MAM),(A(151),NAN),(A(1001),W),(A(2001),DIX1),	4980
	1(A(3001),DIX5)	4990
C		5000
	DIMENSION MAM(50),NAN(50),W(20,50),RP(110),RPBAR(110),PRP(110),	5010
	1WA(110),FI(110)	5020
	DIMENSION XP(50),YP(50),ZP(50),DIX1(20,50),DIX5(20,50),NOR(50)	5030
C		5040
	REAL KMN	5050
C		5060
C		5070
C		5080
	CONVT = 60000.	5090
C		5100
C		5110
	DO 5 II=1,LXYZ	5120
C		5130
	READ (5,1000) XX,YY,ZZ,MXP,TAU,DTAU,NTAU,EPS,NMAX,NWA	5140
C		5150
	WRITE(6,2000) XX,YY,ZZ,MXP,TAU,DTAU,NTAU,EPS,NMAX,NWA	5160
C		5170

TABLE 5A (Continued)

C		5180
	ATAU = TAU	5190
C		5200
	READ (5,1001) (XP(I),YP(I),ZP(I),NOR(I), I=1,MXP)	5210
	WRITE(6,2001) (XP(I),YP(I),ZP(I),NOR(I), I=1,MXP)	5220
C		5230
	IF (NWA) 8,1,8	5240
8	READ (5,1002) (WA(K),K=1,NWA)	5250
	WRITE(6,2010) (WA(K),K=1,NWA)	5260
C		5270
	1 DO 10 JJ=1,MXP	5280
C		5290
	DO 6 IA=1,NTAU	5300
	6 RP(IA) = 0.	5310
C		5320
	DO 7 IA=1,NWA	5330
	7 FI(IA) = 0.	5340
C		5350
	DO 20 I=1,IM	5360
	DO 20 J=1,IN	5370
	JA = J	5380
	JB=J	5390
	IF (IM.EQ.MM) JA=I	5400
	M=MAM(JA)	5410
	N = NAN(J)	5420
C		5430
	WMN = W(I,J)	5440
C		5450
	KMN = C*THETA / (B*(1.+W(I,J)**2*THETA**2))	5460
	AMN = B*W(I,J)	5470
	CMN = W(I,J)*(1.-6.*B**2 + B**4)	5480
	DMN = 4.*B*W(I,J)*(B**2-1.)	5490
C		5500
C		5510
	WRITE(6,2005)	5520
	IF (JJ.NE.1) GO TO 21	5530
C		5540

TABLE 5A (Continued)

	X=XX	5550
	Y=YY	5560
	Z=ZZ	5570
C	PHASE =1.5708	5580
	KKK=1	5590
	AMN =-AMN	5600
	CALL DINT(AMN,PHASE,KKK)	5610
	DIX1(I,J) = SUM2	5620
C	PHASE = 0.	5630
	KKK= 5	5640
	CALL DINT(AMN,PHASE,KKK)	5650
	DIX5(I,J) = SUM2	5660
C		5670
	AMN = -AMN	5680
C		5690
	21 X=XP(JJ)	5700
	Y=YP(JJ)	5710
	Z=ZP(JJ)	5720
C		5730
	PHASE =1.5708	5740
	KKK = 2	5750
	CALL DINT(AMN,PHASE,KKK)	5760
	CAP2 = SUM2	5770
C		5780
	PHASE = 0.	5790
	KKK = 4	5800
	CALL DINT(AMN,PHASE,KKK)	5810
	CAP4 = SUM2	5820
C		5830
	IF (JJ.NE.1) GO TO 24	5840
	WBAR1=(B**2+2.) / (B*W(I,J)*(B**2+4.))	5850
	WBAR2 = 8*WBAR1 / (B**2+2. )	5860
	CBAR = KMN*W(I,J)*P2	5870
C		5880
	SP = CBAR * (WBAR1*DIX1(I,J)*CAP2 + WBAR2*DIX1(I,J)*CAP4 -WBAR2*	5890
		5900
		5910

TABLE 5A (Continued)

	1DIX5(I,J)*CAP2 + WBAR1*DIX5(I,J)*CAP4	5920
	IF (SP) 28,28,22	5930
28	PHI = 0,	5940
	GO TO 23	5950
22	PHI = 10.* ALOG10(SP) + 127.6	5960
23	WRITE(6,2002) II,JJ,XP(JJ),YP(JJ),ZP(JJ),M,N,W(I,J),SP,PHI	5970
	GO TO 25	5980
24	WRITE(6,2003) II,JJ,XP(JJ),YP(JJ),ZP(JJ),M,N,W(I,J)	5990
25	IF (NTAU) 39,31,39	6000
39	TAU = ATAU	6010
C		6020
	DO 30 K=1,NTAU	6030
C		6040
	TH1 = CMN*COS(W(I,J)*TAU) + DMN * SIN(W(I,J)*TAU)	6050
	TH2=CMN*SIN(W(I,J)*TAU)-DMN*COS(W(I,J)*TAU)	6060
C		6070
	RPN=KMN*EXP(-AMN*TAU)*(TH1*DIX1(I,J)*CAP2+TH2*DIX1(I,J)*CAP4-TH2*	6080
	1DIX5(I,J)*CAP2 + TH1*DIX5(I,J)*CAP4)	6090
	RP(K)=RP(K)+RPN	6100
C		6110
	WRITE(6,2004) K,TAU,RPN	6120
C		6130
30	TAU = TAU + DTAU	6140
C		6150
31	IF (NWA) 29,20,29	6160
29	WRITE(6,2013)	6170
C		6180
	DO 19 K=1,NWA	6190
	RAD = WA(K)/(2.*PI)	6200
	DD = (B**2*W(I,J)**2 + (W(I,J)-WA(K))**2)* (B**2*W(I,J)**2 +	6210
	1(W(I,J) + WA(K))**2)	6220
C		6230
	AAMN = (B*W(I,J)*(B**2*W(I,J)**2 + W(I,J)**2 + WA(K)**2)) / DD	6240
	BBMN = (W(I,J)*(B**2*W(I,J)**2 + W(I,J)**2 - WA(K)**2)) / DD	6250
C		6260
	TW1 = CMN*AAMN + DMN*BBMN	6270
	TW2 = CMN*BBMN - DMN*AAMN	6280

TABLE 5A (Continued)

C	FIT = KMN * (TW1*DIX1(I,J)*CAP2 + TW2*DIX1(I,J)*CAP4 - TW2*DIX5(I,	6290
	1J)*CAP2 + TW1*DIX5(I,J)*CAP4)	6300
C	FAT = FIT	6310
	IF (FIT) 71,71,17	6320
71	PHI = 0.	6330
	FIT = 0.	6340
	GO TO 18	6350
17	PHI = 10.*ALOG10(FIT) + 127.6	6360
18	WRITE(6,2014) K,WA(K),RAD,FAT,PHI	6370
C	19 FI(K) = FI(K) + FIT	6380
C	20 CONTINUE	6390
C	IF (NTAU) 47,45,47	6400
47	WRITE(6,2007) RP(1)	6410
	TAU = ATAU	6420
C	DO 40 K=1,NTAU	6430
	RPBAR(K)=RP(K)/ RP(1)	6440
	PRP(K) = RP(K)/P2	6450
C	WRITE(6,2008) K, TAU,RPBAR(K),PRP(K)	6460
40	TAU = TAU + DTAU	6470
C	45 IF (NWA) 74,10,74	6480
74	WRITE(6,2011)	6490
C	DO 50 K=1,NWA	6500
	RAD = WA(K)/(2.*PI)	6510
	IF (FI(K)) 75,75,51	6520
75	PHI = 0.	6530
	GO TO 50	6540
C	51 PHI = 10.* ALOG10(FI(K)) + 127.6	6550
		6560
		6570
		6580
		6590
		6600
		6610
		6620
		6630
		6640
		6650



TABLE 5A (Continued)

50 WRITE(6,2012) K,WA(K),RAD,FI(K),PHI	6660
C	6670
C	6680
10 CONTINUE	6690
C	6700
C	6710
5 CONTINUE	6720
C	6730
C	6740
C	6750
RETURN	6760
END	6770
SIBFTC XDINT	6780
SUBROUTINE DINT (SAMN,SPHASE,KKS)	6790
C	6800
C	6810
DOUBLE INTEGRATION SUBROUTINE	6820
C	6830
C	6840
COMMON /AAA/A(4000)	6850
C	6860
EQUIVALENCE (A(9),M),(A(10),N),(A(21),XL1),(A(22),XLO),(A(23),YL1)	6870
1,(A(24),YLO),(A(34),EPS),(A(35),NMAX),(A(38),SUM1),(A(39),SUM2)	6880
C	6890
C	6900
DIMENSION P(5),WW(5)	6910
C	6920
DATA (P(I),I=1,5),(WW(I),I=1,5) /,453089923,~,453089923,.,269234655	6930
1,~.,269234655,0.0,2*.118463443,2*.239314335,.,284444444 /	6940
C	6950
2000 FORMAT(1H0,28H ***** NO CONVERGENCE ***** ,5X,I4,10X,I4,5X,I4,I5,	6960
12E18.8)	6970
2002 FORMAT(1H0,33X,I4,10X,I4,4X,I5,I5,2E18.8)	6980
C	6990
C	7000
C	7010
NK=2	7020

TABLE 5A (Continued)

	BINC1=XL1-XL0	7030
	BINC2=YL1-YL0	7040
C		7050
	DO 25 K=1,NMAX	7060
	SUM1=SUM2	7070
	SUM2=0.0	7080
	CNK = NK	7090
	DINC1 = BINC1/CNK	7100
	DINC2 = BINC2/CNK	7110
	H1 = XL0 + DINC1/2.	7120
C		7130
	DO 26 I=1,NK	7140
	H2 = YL0 + DINC2/2.	7150
C		7160
	DO 27 J=1,NK	7170
	DO 28 II=1,5	7180
	ABS1=DINC1*P(II)+H1	7190
	DO 29 JJ=1,5	7200
	ABS2=DINC2*P(JJ)+H2	7210
	29 SUM2=SUM2+WW(II)*WW(JJ)*FFF(ABS1,ABS2,SAMN,SPHASE)	7220
	28 CONTINUE	7230
	27 H2=H2+DINC2	7240
	26 H1=H1+DINC1	7250
	SUM2=SUM2+DINC1*DINC2	7260
C		7270
C		7280
	IF (K.EQ.1) GO TO 30	7290
	IF (ABS((SUM1-SUM2)/SUM2)-EPS) 31,31,30	7300
	30 NK=NK + 1	7310
	25 CONTINUE	7320
C		7330
	WRITE(6,2000) KKS,NK,M,N,SUM2,SUM1	7340
	SUM2 = 0.	7350
C		7360
	GO TO 32	7370
C		7380
C		7390

TABLE 5A (Continued)

C	31 WRITE(6,2002) KKS,NK,M,N,SUM2,SUM1	7400
	32 RETURN	7410
	END	7420
	\$IBFTC XFFF	7430
	FUNCTION FFF(X0,Y0,FAMN,FPHASE)	7440
C		7450
C		7460
C	DOUBLE INTEGRATION FUNCTION	7470
C		7480
C		7490
C		7500
	COMMON /AAA/A(4000)	7510
C		7520
	EQUIVALENCE (A(7),NAUTO),(A(8),NCROSS),(A(9),M),(A(10),N),	7530
	1(A(21),XL1),(A(22),XLO),(A(23),YL1),(A(24),YLO),(A(25),AI),	7540
	2(A(30),PI),(A(31),X),(A(32),Y),(A(33),Z),(A(36),WMN),(A(40),JA),	7550
	3(A(41),JB)	7560
C		7570
C		7580
C	INTEGER W,WMN	7590
C		7600
C		7610
	RO=SQRT((X-X0)**2+(Y-Y0)**2 + Z**2)	7620
C		7630
	CM = M	7640
	CN = N	7650
	PHX = SIN(CM*PI*X0/XL1)	7660
	PHY = SIN(CN*PI*Y0/YL1)	7670
C		7680
	FFF = PHX * PHY * EXP((FAMN/AI)*RO) * SIN((WMN/AI)*RO+FPHASE)/ RO	7690
C		7700
	RETURN	7710
	END	7720
		7730

Table 5B - Clamped-Clamped Boundaries

\$IBFTC TURGEN	10
C	20
1000 FORMAT(12A6)	0 30
1001 FORMAT(10I4)	0 40
1002 FORMAT(4E12.6/5E15.8)	0050
1003 FORMAT(12F6.0)	0060
1004 FORMAT(20I4)	0070
1005 FORMAT(5E15.8)	0080
C	90
2000 FORMAT(1H1,10X,6HF,P,S.,15X,12A6/22X,12A6////)	0100
2001 FORMAT (1H0,29X,45HORDER OF M (MODE NUMBERS) ..... MM =,I	0110
16/30X,45HORDER OF N (MODE NUMBERS) ..... NN =,I6/30X,	0120
245HNUMBER OF CASES (XYZ) IN AUTO CORR... NXYZ =,I6/30X,45HNUMBER	0130
30F CASES (XYZ) IN CROSS CORR.. KXYZ =,I6 / 30X,45HAUTO CO	0140
4RRELATION CONSTANT ..... NAUTO =,I6/30X,45HCROSS CORRELATION	0150
5CONSTANT ..... NCROSS =,I6/30X,45HLIMITS OF THE 1-ST INTEGRAL	0160
6 ..... XL1 =,F11.4/30X,45H	0170
7 XLO =,F11.4/30X,45HLIMITS OF THE 2-ND INTEGRAL ..... Y	0180
8L1 =,F11.4/30X,45H YLO =,F1	0190
91.4/30X,45HSPEED OF SOUND IN WATER ..... AI =,F13.6/30X	0200
A,45HDAMPING CONSTANT ..... B =,F13.6/30X,45HC	0210
BCONSTANT ..... C =,F13.6/30X,45HTEMPORAL D	0220
CECAV FACTOR OF TURBULENCE THETA =,F11.4/30X,45HR,M.S. PRESSURE .	0230
D..... P2 =,F13.6//30X,2110)	0240
2002 FORMAT(1H0,40X,35HUNDAMPED NATURAL FREQUENCIES W(M,N)/(10X,10F8.0	0250
X))	0260
2003 FORMAT(1H0,50X,12HMODE NUMBERS//(40X,10I5))	0270
2005 FORMAT(1H0,40X,35HNORMALIZED EIGENFUNCTION PARAMETERS //(15X,5E18.	0280
18) )	0290
2006 FORMAT(1H0,29X,45HNUMBER OF CASES IN CROSS CORR. (TIME).. LXYZ=,	0300
116/30X,45HCROSS CORR. (TIME) CONSTANT ..... NCROST=,I6//	0310
230X,2110)	0320
C	0330
C	0340
COMMON /AAA/A(4000)	0350
C	0360

TABLE 5B (Continued)

	EQUIVALENCE (A(1),MM),(A(2),NN),(A(3),IM),(A(4),IN),(A(5),NXYZ),	0370
	1(A(6),KXYZ),(A(7),NAUTO),(A(8),NCROSS),(A(9),M),(A(10),N),	0380
	2(A(11),LXYZ),(A(12),NCROST)	0390
C		0400
	EQUIVALENCE (A(21),XL1),(A(22),XL0),(A(23),YL1),(A(24),YLO),	0410
	1(A(25),AI),(A(26),B),(A(27),C),(A(28),THETA),(A(29),P2),(A(30),PI)	0420
	2,(A(31),X),(A(32),Y),(A(33),Z),(A(34),EPS),(A(35),NMAX),	0430
	3(A(36),WMN),(A(37),AMN),(A(38),SUM1),(A(39),SUM2)	0440
C		0450
	EQUIVALENCE (A(101),MAM),(A(151),NAN),(A(1001),W)	0460
C		0470
	EQUIVALENCE (A(201),AMM),(A(251),ANN),(A(301),BMM),(A(351),BNN),	0480
	1(A(401),CMM),(A(451),CNN),(A(501),DMM),(A(551),DNN),(A(601),ALMM),	0490
	2(A(651),ALNN)	0500
C		0510
C		0520
	DIMENSION TITLE(24),W(20,50),MAM(50),NAN(50)	0530
	DIMENSION AMM(50),ANN(50),BMM(50),BNN(50),CMM(50),CNN(50),DMM(50),	0540
	1DNN(50),ALMM(50),ALNN(50)	0550
C		0560
	REAL KMN	0570
C		0580
	INTEGER W	0590
C		0600
C		0610
	CALL STARTR	0620
C		0630
	IF ACCUMULATOR OVERFLOW ,	0640
C		0650
	READ AND PRINT TITLE	0660
C		0670
	READ(5,1000) (TITLE(I),I=1,24)	0680
	WRITE(6,2000) (TITLE(I),I=1,24)	0690
C		0700
	READ AND PRINT GENERAL INPUT CONSTANTS	0710
C		0720
	READ (5,1001) MM,NN,IM,IN,NXYZ,KXYZ,LXYZ,NAUTO,NCROSS,NCROST	0730
	READ (5,1002) XL1,XL0,YL1,YL0,AI,B,C,THETA,P2	

TABLE 5B (Continued)

	READ (5,1003) ((W(I,J),J=1,IN),I=1,IM)	0740
	READ (5,1004) (MAM(I),I=1,MM),(NAN(I),I=1,NN)	0750
C		0760
	WRITE(6,2001) MM,NN,NXYZ,KXYZ,NAUTO,NCROSS,XL1,XLO,YL1,YLO,AI,B,	0770
	1C,THETA,P2	0780
	WRITE(6,2006) LXYZ,NCROST,IM,IN	0790
	WRITE(6,2002) ((W(I,J),J=1,IN),I=1,IM)	0800
	WRITE(6,2003) (MAM(I),I=1,MM),(NAN(I),I=1,NN)	0810
C		0820
C		0830
	PI=3.14159	0840
C		0850
C	AUTO CORRELATION	0860
C		0870
	IF (NAUTO) 13,3,13	0880
C		0890
	13 READ (5,1005) (ALMM(I),AMM(I),BMM(I),CMM(I),DMM(I),I=1,MM),	0900
	1(ALNN(I),ANN(I),BNN(I),CNN(I),DNN(I),I=1,NN)	0910
	WRITE(6,2005) (ALMM(I),AMM(I),BMM(I),CMM(I),DMM(I),I=1,MM),	0920
	1(ALNN(I),ANN(I),BNN(I),CNN(I),DNN(I),I=1,NN)	0930
C		0940
	CALL AUTO1	0950
C		0960
C	CROSS CORRELATION (SPACE)	0970
C		0980
	3 IF (NCROSS) 10,6,10	0990
	10 IF (NAUTO.EQ. 1) GO TO 5	1000
C		1010
	READ (5,1005) (ALMM(I),AMM(I),BMM(I),CMM(I),DMM(I),I=1,MM),	1020
	1(ALNN(I),ANN(I),BNN(I),CNN(I),DNN(I),I=1,NN)	1030
	WRITE(6,2005) (ALMM(I),AMM(I),BMM(I),CMM(I),DMM(I),I=1,MM),	1040
	1(ALNN(I),ANN(I),BNN(I),CNN(I),DNN(I),I=1,NN)	1050
C		1060
	5 CALL CROSS1	1070
C		1080
C		1090
C	CROSS CORRELATION (TIME)	1100

TABLE 5B (Continued)

C		1110
	6 IF (NCROST) 18,8,18	1120
	18 IF ((NAUTO.EQ.1).OR.(NCROSS.EQ.1)) GO TO 7	1130
	READ (5,1005) (ALMM(I),AMM(I),BMM(I),CMM(I),DMM(I),I=1,MM),	1140
	1(ALNN(I),ANN(I),BNN(I),CNN(I),DNN(I),I=1,NN)	1150
	WRITE(6,2005) (ALMM(I),AMM(I),BMM(I),CMM(I),DMM(I),I=1,MM),	1160
	1(ALNN(I),ANN(I),BNN(I),CNN(I),DNN(I),I=1,NN)	1170
C		1180
	7 CALL CROSS2	1190
C		1200
		1210
	8 STOP	1220
	END	1230
	\$IBFTC XAUTO:	1240
	SUBROUTINE AUTO1	1250
C		1260
C		1270
C		1280
C		1290
C	AUTO CORRELATION) X=XP , Y=YP , Z=ZP	1300
C		1310
C		1320
	3000 FORMAT(5E12.6,14,E6.2,2I4)	1330
	3001 FORMAT(12F6.0)	1340
C		1350
	4000 FORMAT(1H1,50X,16HAUTO CORRELATION///30X,1HX,30X,1HY,30X,1HZ//	1360
	122X,E14.8,17X,E14.8,17X,E14.8//10X,5HTAU =,E14.8,5X,6HDTAU =,E14.8	1370
	2,5X,6HNTAU =,I4,5X,5HEPS =,E14.8,5X,6HNMAL =,I4 ,5X,5HNWA =,I4 /)	1380
	4002 FORMAT(1H1,8H PNT CNT,12X,1HX,12X,1HY,12X,1HZ,12X,1HM,4X,1HN,5X,	1390
	1 4HFREQ,5X,21HM.S. SPECTRAL DENSITY,4X,20H DB(RE,0002) //	1400
	2I6,10X,F9.4,4X,F9.4,4X,F9.4,I10,15,3X,F6.0,5X,E16.8,6X,E16.8///	1410
	X40X	1420
	3,1HK,8X,3HTAU,15X,9HRPMN(TAU) //)	1430
	4003 FORMAT(1H ,30X,I10,E16.8,E20.8)	1440
	4004 FORMAT(1H0,50X,12HINTEGRATIONS // 33X,9HINT. NUM.,5X, 8H MESH ,	1450
	15X,6HM N,10X, 4HSUM2,16X, 4HSUM1)	1460
	4005 FORMAT(1H1,30X,44HNORMALIZED CORRELATION OF ACCOUSTIC PRESSURE///	1470

TABLE 5B (Continued)

110X, 4HNTAU, 10X, 3HTAU, 10X, 25HNORM, CORR. OF ACC. PRES., 10X,	1480
28HRP(K)/P2, 12X, 14HNORM, FACTOR =, E14.5 ///	1490
4006 FORMAT(1H, 8X, I4, 8X, F8.6, 10X, E16.8, 11X, E16.8)	1500
4007 FORMAT(1H1, 40X, 40HTIME ELAPSED IN AUTO CORRELATION (MIN.), F10.4)	1510
4010 FORMAT(1H1, 7E16.8)	1520
4011 FORMAT(1H1, 30X, 23HAUTO SPECTRAL DENSITY ///12X, 1HK, 10X, 4HFREQ,	1530
110X, 7HRAD/SEC, 10X, 17MCROSS SPEC. DENS., 10X, 11HDB(RE.0002) ///	1540
4012 FORMAT(1H, 8X, I4, 8X, I6, 8X, F9.4, 2(10X, E14.8))	1550
4013 FORMAT(1H0, 30X, 18HCHOSEN FREQUENCIES //(10X, 10F10.0))	1560
4014 FORMAT(1H1, 30X, 1HK, 10X, 4HFREQ, 10X, 7HRAD/SEC, 10X, 17HMODAL SPEC. DEN	1570
1S., 10X, 11HDB(RE.0002) ///	1580
4015 FORMAT(1H, 21X, I10, 8X, F6.0, 8X, F9.4, 2(8X, E16.8))	1590
C	1600
C	1610
COMMON /AAA/A(4000)	1620
C	1630
EQUIVALENCE (A(1),MM), (A(2),NN), (A(3),IM), (A(4),IN), (A(5),NXYZ),	1640
1(A(6),KXYZ), (A(7),NAUTO), (A(8),NCROSS), (A(9),M), (A(10),N)	1650
EQUIVALENCE (A(21),XL1), (A(22),XLO), (A(23),YL1), (A(24),YLO),	1660
1(A(25),AI), (A(26),B), (A(27),C), (A(28),THETA), (A(29),P2), (A(30),PI)	1670
2, (A(31),X), (A(32),Y), (A(33),Z), (A(34),EPS), (A(35),NMAX),	1680
3(A(36),WMN), (A(37),AMN), (A(38),SUM1), (A(39),SUM2),	1690
4(A(40),JA), (A(41),JB)	1700
EQUIVALENCE (A(101),MAM), (A(151),NAN), (A(1001),W)	1710
C	1720
DIMENSION MAM(50), NAN(50), W(20,50), RP(110), RPBAR(110), PRP(110),	1730
1WA(110), FI(110)	1740
C	1750
C	1760
INTEGER W, WMN, WA	1770
REAL KMN	1780
C	1790
CONVT = 60000.	1800
C	1810
C	1820
CALL CLOCK(MTIME)	1830
C	1840
DO 5 II=1, NXYZ	1840



TABLE 5B (Continued)

	READ (5,3000) X,Y,Z,TAU,DTAU,NTAU,EPS,NMAX,NWA	1850
C		1860
	WRITE(6,4000) X,Y,Z,TAU,DTAU,NTAU,EPS,NMAX,NWA	1870
C		1880
	IF (NWA) 11,1,11	1890
C		1900
11	READ (5,3001) (WA(K),K=1,NWA)	1910
	WRITE(6,4013) (WA(K),K=1,NWA)	1920
C		1930
C		1940
	1 ATAU = TAU	1950
C		1960
	DO 6 IA=1,NTAU	1970
6	RP(IA) = 0.	1980
C		1990
	DO 7 IA=1,NWA	2000
7	FI(IA) = 0.	2010
C		2020
	DO 10 I=1,IM	2030
	DO 10 J=1,IN	2040
	JA = J	2050
	JB=J	2060
	IF (IM.EQ.MM) JA=I	2070
	M=MAM(JA)	2080
	N = NAN(J)	2090
C		2100
	WMN = W(I,J)	2110
C		2120
	KMN = C*THETA / (B*(1+W(I,J)**2*THETA**2))	2130
	AMN = B*W(I,J)	2140
	CMN = W(I,J)*(1-6.*B**2 + B**4)	2150
	DMN = 4.*B*W(I,J)*(B**2-1.)	2160
C		2170
	WBAR1=(B**2+2.) / (B*W(I,J)*(B**2+4.))	2180
	WBAR2 = B*WBAR1 / (B**2+2. )	2190
	CBAR = KMN*W(I,J)*P2	2200
C		2210

TABLE 5B (Continued)

	WRITE(6,4010) KMN,AMN,CMN,DMN,WBAR1,WBAR2,CBAR	2220
	WRITE(6,4004)	2230
C		2240
C	PHASE=1.5708	2250
	KKK=2	2260
	CALL DINT (AMN,PHASE,KKK)	2270
	CAP2=SUM2	2280
C		2290
	KKK=1	2300
	AMN=-AMN	2310
	CALL DINT (AMN,PHASE,KKK)	2320
	CAP1=SUM2	2330
C		2340
	KKK=5	2350
	PHASE=0.	2360
	CALL DINT (AMN,PHASE,KKK)	2370
	CAP5=SUM2	2380
C		2390
	KKK=4	2400
	AMN=-AMN	2410
	CALL DINT (AMN,PHASE,KKK)	2420
	CAP4=SUM2	2430
C		2440
C		2450
	SP = CBAR* (WBAR1*CAP1*CAP2 + WBAR2*CAP1*CAP4 - WBAR2*CAP5*CAP2 +	2460
	1WBAR1*CAP5*CAP4 )	2470
C		2480
	IF (SP) 9,9,12	2490
9	PHI = 0.	2500
	GO TO 13	2510
12	PHI = 10.* ALOG10(SP) + 127.6	2520
C		2530
C		2540
C		2550
	13 WRITE(6,4002) I,I,X,Y,Z,M,N,W(I,J),SP,PHI	2560
	IF (NTAU) 22,21,22	2570
		2580

TABLE 5B (Continued)

22	TAU = ATAU	2590
C		2600
	DO 15 K=1,NTAU	2610
C		2620
	TH1 = CMN*COS(W(I,J)*TAU) + DMN * SIN(W(I,J)*TAU)	2630
	TH2=CMN*SIN(W(I,J)*TAU)-DMN*COS(W(I,J)*TAU)	2640
C		2650
C		2660
	RPN=KMN*EXP(-AMN*TAU) * (TH1*CAP1*CAP2 + TH2*CAP1*CAP4 - TH2	2670
	1*CAP5*CAP2 + TH1*CAP5*CAP4)	2680
	RP(K)=RP(K)+RPN	2690
C		2700
	WRITE(6,4003) K,TAU,RPN	2710
C		2720
15	TAU = TAU + DTAU	2730
C		2740
21	IF(NWA) 25,10,25	2750
25	WRITE(6,4014)	2760
C		2770
	DO 20 K=1,NWA	2780
	RAD = WA(K)/(2.*PI)	2790
	DD = (B**2*W(I,J)**2 + (W(I,J)-WA(K))**2)* (B**2*W(I,J)**2 +	2800
	1(W(I,J) + WA(K))**2)	2810
C		2820
	AAMN = (B*W(I,J)*(B**2*W(I,J)**2 + W(I,J)**2 + WA(K)**2)) / DD	2830
	BBMN = (W(I,J)*(B**2*W(I,J)**2 + W(I,J)**2 - WA(K)**2)) / DD	2840
C		2850
	TW1 = CMN*AAMN + DMN*BBMN	2860
	TW2 = CMN*BBMN - DMN*AAMN	2870
C		2880
	FIT = KMN * (TW1*CAP1*CAP2 + TW2*CAP1*CAP4 - TW2*CAP5*CAP2 +	2890
	1TW1*CAP5*CAP4)	2900
C		2910
	FAT = FIT	2920
	IF (FIT) 19,19,17	2930
19	PHI = 0.	2940
	FIT = 0.	2950

TABLE 5B (Continued)

	GO TO 18	2960
	17 PHI = 10.*ALOG10(FIT) + 127.6	2970
	18 WRITE(6,4015) K,WA(K),RAD,FAT,PHI	2980
C		2990
	20 FI(K) = FI(K) + FIT	3000
C		3010
	10 CONTINUE	3020
C		3030
	IF (NTAU) 52,51,52	3040
C		3050
	52 WRITE(6,4005) RP(1)	3060
C		3070
	DO 30 K=1,NTAU	3080
	RPBAR(K)=RP(K)/RP(1)	3090
	PRP(K) = RP(K)/P2	3100
	WRITE(6,4006) K,ATAU,RPBAR(K),PRP(K)	3110
	30 ATAU=ATAU+DTAU	3120
C		3130
C		3140
	51 IF (NWA) 27,5,27	3150
	27 WRITE(6,4011)	3160
C		3170
	DO 40 K=1,NWA	3180
	RAD = WA(K)/(2.*PI)	3190
	IF (FI(K)) 45,45,41	3200
	45 PHI = 0.	3210
	GO TO 40	3220
C		3230
	41 PHI = 10.* ALOG10(FI(K)) + 127.6	3240
	40 WRITE(6,4012) K,WA(K),RAD,FI(K),PHI	3250
	5 CONTINUE	3260
C		3270
C	CALL CLOCK(NTIME)	3280
C	TIME = (NTIME-MTIME)/CONVT	3290
C		3300
C	WRITE(6,4002) TIME	3310
C		3320

TABLE 5B (Continued)

RETURN	3330
END	3340
\$IBFTC XCROSS1	3350
SUBROUTINE CROSS1	3360
C	3370
C	3380
C	3390
C CROSS CORRELATION) TIME = CONSTANT	3400
C	3410
C	3420
C	3430
1000 FORMAT(3E12.6,2I6,E12.6,I6/(6E12.8))	3440
1001 FORMAT(2(3E12.6,I4))	3450
C	3460
2000 FORMAT(1H1,50X,17HCROSS CORRELATION///20X,1HX,20X,1HY,20X,1HZ,20X,	3470
13HMXP,10X,4HMTAU,10X, 3HEPS,10X, 4HNMAX //12X,E14.8,2(7X,E14.8),	3480
214X,I4,9X,I4, 5X,E12.6,7X,I3// 5X,7HTAU(I)=,5E16.8//12X,5E16.8//)	3490
2001 FORMAT(1H0,30X,2HXP,20X,2HYP,20X,2HZP,10X,3HNOR//(23X,E14.8,8X,E14	3500
1.8,8X,E14.8,5X,I3 )	3510
2002 FORMAT(1H0,1HI ,4X,3HTAU,4X, 7HPNT CNT,5X,2HXP,10X,2HYP,10X,2HZP,	3520
110X, 6HM N,4X,4HFREQ , 5X,17HCROSS SPEC. DENS.,5X,11HDB(RE=0002	3530
2),5X, 9HRPMN(TAU)//I2,E11.5,I4,E14.6,E12.6,E12.6,2X,2I5,2X,F6.0,	3540
36X,E14.8,4X,2E14.8 )	3550
2004 FORMAT(1H1,4X,1HI,8X, 3HTAU,12X,1HJ,10X,5HXP(J),9X,5HYP(J), 9X,	3560
15HZP(J),12X,11HCRPBAR(I,J),10X,12HNORM. FACTOR/// I6,5X,E10.5,	3570
24X,I5,3X,3E14.6,E20.8,E22.8/(25X,I5,3X,3E14.6,E20.8,E22.8))	3580
2005 FORMAT(1H0,50X,12HINTEGRATIONS // 33X,9HINT. NUM.,5X, 8H MESH ,	3590
15X,6HM N,10X, 4HSUM2,16X, 4HSUM1)	3600
2010 FORMAT(1H1,7E16.8)	3610
2100 FORMAT(1H1,40X,4IHTIME ELAPSED IN CROSS CORRELATION (MIN.),F10.4)	3620
C	3630
C	3640
COMMON /AAA/A(4000)	3650
C	3660
EQUIVALENCE (A(1),MM),(A(2),NN),(A(3),IM),(A(4),IN),(A(5),NXYZ),	3670
1(A(6),KXYZ),(A(7),NAUTO),(A(8),NCROSS),(A(9),M),(A(10),N)	3680
EQUIVALENCE (A(21),XL1),(A(22),XLO),(A(23),YL1),(A(24),YLO),	3690

TABLE 5B (Continued)

	1(A(25),A1),(A(26),B),(A(27),C),(A(28),THETA),(A(29),P2),(A(30),PI)	3700
	2,(A(31),X),(A(32),Y),(A(33),Z),(A(34),EPS),(A(35),NMAX),	3710
	3(A(36),WMN),(A(37),AMN),(A(38),SUM1),(A(39),SUM2),	3720
	4(A(40),JA),(A(41),JB)	3730
	EQUIVALENCE (A(101),MAM),(A(151),NAN),(A(1001),W),(A(2001),DIX1),	3740
	1(A(3001),DIX5)	3750
C		3760
	DIMENSION TAV(110),XP(50),YP(50),ZP(50),NOR(50),MAM(50),	3770
	1NAN(50),W(20,50),DIX1(20,50),DIX5(20,50),CRPBAR(50)	3780
C		3790
C	INTEGER W,WMN	3800
C	REAL KMN	3810
C		3820
C	CALL CLOCK(MTIME)	3830
C		3840
C		3850
	CONVT = 60000.	3860
C		3870
C		3880
	DO 5 II=1,KXYZ	3890
C		3900
	READ (5,1000)XX,YY,ZZ,MXP,MTAV,EPS,NMAX,(TAV(I),I=1,MTAV)	3910
	WRITE(6,2000)XX,YY,ZZ,MXP,MTAV,EPS,NMAX,(TAV(I),I=1,MTAV)	3920
C		3930
	READ (5,1001)(XP(I),YP(I),ZP(I),NOR(I), I=1,MXP)	3940
	WRITE(6,2001)(XP(I),YP(I),ZP(I),NOR(I), I=1,MXP)	3950
C		3960
	DO 10 I=1, MTAV	3970
C		3980
	DO 20 J=1,MXP	3990
	CRP = 0.	4000
C		4010
	DO 30 K=1,IM	4020
	DO 30 L=1,IN	4030
	JA=L	4040
	JB=L	4050
	IF (IM.EQ.MM) JA=K	4060

TABLE 5B (Continued)

	M=MAM(JA)	4070
	N=NAN(L)	4080
	WMN= W(K,L)	4090
C		4100
	KMN = C*THETA / (B*(1.0+W(K,L)**2*THETA**2))	4110
	AMN = B*W(K,L)	4120
	CMN = W(K,L)*(1.0-6.0*B**2 + B**4)	4130
	DMN = 4.0*B*W(K,L)*(B**2-1.0)	4140
	WBAR1=(B**2+2.0)/(B*W(K,L)*(B**2+4.0))	4150
	WBAR2= B* WBAR1 / (B**2+2.0)	4160
	CBAR = KMN * W(K,L) * P2	4170
C		4180
	WRITE(6,2010) KMN,AMN,CMN,DMN,WBAR1,WBAR2,CB1R	4190
	WRITE(6,2005)	4200
C		4210
	IF (J.NE.1) GO TO 31	4220
C		4230
	X=XX	4240
	Y=YY	4250
	Z=ZZ	4260
C		4270
	PHASE =1.5708	4280
	KKK=1	4290
	AMN =-AMN	4300
	CALL DINT(AMN,PHASE,KKK)	4310
	DIX1(K,L) = SUM2	4320
C		4330
	PHASE = 0.	4340
	KKK= 5	4350
	CALL DINT(AMN,PHASE,KKK)	4360
	DIX5(K,L) = SUM2	4370
C		4380
	AMN = -AMN	4390
C		4400
31	X=XP(J)	4410
	Y=YP(J)	4420
	Z=ZP(J)	4430

TABLE 5B (Continued)

C	PHASE = 1.5708	4440
	KKK = 2	4450
	CALL DINT(AMN,PHASE,KKK)	4460
	CAP2 = SUM2	4470
C		4480
	PHASE = 0.	4490
	KKK = 4	4500
	CALL DINT(AMN,PHASE,KKK)	4510
	CAP4 = SUM2	4520
C		4530
	SP = .5E+20	4540
	PHI = .5E+20	4550
C		4560
	IF (NOR(J)) 39,32,32	4570
C		4580
39	SP = CBAR * (WBAR1*DIX1(K,L)*CAP2 + WBAR2*DIX1(K,L)*CAP4 - WBAR2*	4590
	DIX5(K,L)*CAP2 + WBAR1*DIX5(K,L)*CAP4 )	4600
C		4610
	IF (SP) 38,38,33	4620
C		4630
38	PHI = 0.	4640
	GO TO 32	4650
C		4660
33	PHI = 10.0 ALOG10(SP) + 127.6	4670
C		4680
32	TH1 = CMN*COS(W(K,L)*TAV(I)) + DMN*SIN(W(K,L)*TAV(I))	4690
	TH2 = CMN*SIN(W(K,L)*TAV(I)) - DMN*COS(W(K,L)*TAV(I))	4700
C		4710
	RPN = KMN*EXP(-AMN*TAV(I))*(TH1*DIX1(K,L)*CAP2 + TH2*DIX1(K,L)*	4720
	1CAP4 - TH2*DIX5(K,L)*CAP2 + TH1*DIX5(K,L)*CAP4)	4730
C		4740
	CRP = CRP + RPN	4750
C		4760
34	WRITE(6,2002) I,TAV(I),J,XP(J),YP(J),ZP(J),M,N,W(K,L),SP,PHI,RPN	4770
C		4780
30	CONTINUE	4790
		4800



TABLE 5B (Continued)

C		4810
	IF ((I+J).EQ.2) CNORM =CRP	4820
	CRPBAR(J) = CRP / CNORM	4830
20	CONTINUE	4840
C		4850
	WRITE(6,2004) I,TAV(I),(J,XP(J),YP(J),ZP(J),CRPBAR(J),CNORM,	4860
	1J=1,MXP)	4870
C		4880
10	CONTINUE	4890
C		4900
5	CONTINUE	4910
C		4920
C		4930
C	CALL CLOCK(NTIME)	4940
C	TIME = (NTIME -MTIME)/ CONV	4950
C	WRITE(6,2100) TIME	4960
C		4970
C		4980
	RETURN	4990
	END	5000
SIBFTC	XCROSS2	5010
	SUBROUTINE CROSS2	5020
C		5030
C		5040
C		5050
C	CROSS CORRELATION (TIME) (AUTO CORRELATION INCLUDED FOR THE FIRST POINT)	5060
C		5070
1000	FORMAT(3E12.6,I3,2E12.8,I3,E6.2,2I3)	5080
1001	FORMAT(2(3E12.6,I4))	5090
1002	FORMAT(12F6.0)	5100
C		5110
2000	FORMAT(1H1,50X,24HCROSS CORRELATION (TIME)///30X,1HX,30X,1HY,30X,	5120
	11HZ,///4X,3E31.8///4X, 5HMXP =,I4,4X, 5HTAU =,E14.8,4X, 6HDTAU =,	5130
	2E14.8,4X, 6HNTAU =,I4,4X, 3HEPS =,E14.8,4X, 6HNMMA =,I4,4X,5HNWA =	5140
	3,I4 /)	5150
2001	FORMAT(1H0,30X,2HXP,20X,2HYP,20X,2HZP,10X,3HNOR//(23X,E14.8,8X,E14	5160
	1.8,8X,E14.8,5X,I3 )	5170

TABLE 5B (Continued)

2002	FORMAT(1H0, 9HCASE NUM, 5X, 11HINTEG. PNT, 5X, 2HXP, 10X, 2HYP, 10X, 12HZP, 10X, 6HM N, 5X, 4HFREQ, 5X, 21HM, S. SPECTRAL DENSITY, 5X, 21HDB(RE.0002)//15, 10X, 15, 3X, 3(3X, F9.4), 4X, 2I5, 3X, F6.0, 3X, 2E20.8 3///40X, 2HK, 8X, 3HTAU, 15X, 9HRPMN(TAU)//)	5180 5190 5200 5210
2003	FORMAT(1H0, 9HCASE NUM, 5X, 11HINTEG. PNT, 5X, 2HXP, 10X, 2HYP, 10X, 12HZP, 10X, 6HM N, 5X, 4HFREQ //15, 10X, 15, 3X, 3(3X, F9.4), 4X, 2I5, 3X, 2I6 ///40X, 1HK, 8X, 3HTAU, 15X, 9HRPMN(TAU)//)	5220 5230 5240
2004	FORMAT(1H, 30X, I10, E16.8, E20.8)	5250
2005	FORMAT(1H1, 50X, 12HINTEGRATIONS // 33X, 9HINT. NUM, 5X, 8H MESH 15X, 6HM N, 10X, 4HSUM2, 16X, 4HSUM1)	5260 5270
2007	FORMAT(1H1, 30X, 44HNORMALIZED CORRELATION OF ACCOUSTIC PRESSURE/// 110X, 4HN TAU, 10X, 3HTAU, 10X, 25HNORM. CORR. OF ACC. PRES., 10X, 28HRP(K)/P2, 12X, 14HNO <sup>2</sup> M. FACTOR =, E14.8//)	5280 5290 5300
2008	FORMAT(1H, 8X, I4, 8X, F8.6, 10X, E16.8, 11X, E16.8)	5310
2009	FORMAT(1H1, 40X, 40HTIME ELAPSED IN CROSS CORR. (TIME) (MIN.), F10.4)	5320
2010	FORMAT(1H0, 30X, 18HCHOSEN FREQUENCIES //(10X, 10F10.0))	5330
2011	FORMAT(1H1, 30X, 23HCROSS SPECTRAL DENSITY ///12X, 1HK, 10X, 4HFREQ, 110X, 7HRAD/SEC, 10X, 17HCROSS SPEC. DENS., 10X, 11HDB(RE.0002)//)	5340 5350
2012	FORMAT(1H, 8X, I4, 8X, I6, 8X, F9.4, 2(10X, E14.8))	5360
2013	FORMAT(1H1, 30X, 1HK, 10X, 4HFREQ, 10X, 7HRAD/SEC, 10X, 17HMODAL SP <sup>2</sup> C. DEN 1S., 10X, 11HDB(RE.0002) //)	5370 5380
2014	FORMAT(1H, 21X, I10, 8X, F6.0, 8X, F9.4, 2(3X, E16.8))	5390
C	COMMON /AAA/A(4000)	5400
C	EQUIVALENCE (A(1),MM), (A(2),NN), (A(3),IM), (A(4),IN), (A(5),NXYZ), 1(A(6),KXYZ), (A(7),NAUTO), (A(8),NCROSS), (A(9),M), (A(10),N), 2(A(11),LXYZ), (A(12),NCROST) EQUIVALENCE (A(21),XL1), (A(22),XL0), (A(23),YL1), (A(24),YL0), 1(A(25),A1), (A(26),B), (A(27),C), (A(28),THETA), (A(29),P2), (A(30),P1) 2,(A(31),X), (A(32),Y), (A(33),Z), (A(34),EPS), (A(35),NMAX), 3(A(36),WMN), (A(37),AMN), (A(38),SUM1), (A(39),SUM2), 4(A(40),JA), (A(41),JB) EQUIVALENCE (A(101),MAM), (A(151),NAN), (A(1001),W), (A(2001),DIX1), 1(A(3001),DIX5)	5410 5420 5430 5440 5450 5460 5470 5480 5490 5500 5510 5520
C	DIMENSION MAM(50), NAN(50), W(20,50), RP(110), RPBAR(110), PRP(110),	5530 5540

TABLE 5B (Continued)

	1WA(110),FI(210)	5550
	DIMENSION XP(50),YP(50),ZP(50),DIX1(20,50),DIX5(20,50),NOR(50)	5560
C		5570
C	INTEGER W,WMN,WA	5580
	REAL KMN	5590
C		5600
C	CALL CLOCK(MTIME)	5610
C		5620
C		5630
	CONVT = 60000.	5640
C		5650
C		5660
	DO 5 II=1,LXYZ	5670
C		5680
	READ (5,1000) XX,YY,ZZ,MXP,TAU,DTAU,NTAU,EPS,NMAX,NWA	5690
C		5700
	WRITE(6,2000) XX,YY,ZZ,MXP,TAU,DTAU,NTAU,EPS,NMAX,NWA	5710
C		5720
C		5730
	ATAU = TAU	5740
C		5750
	READ (5,1001) (XP(I),YP(I),ZP(I),NOR(I), I=1,MXP.	5760
	WRITE(6,2001) (XP(I),YP(I),ZP(I),NOR(I), I=1,MXP)	5770
C		5780
	IF (NWA) 2,1,2	5790
C		5800
2	READ (5,1002) (WA(K),K=1,NWA)	5810
	WRITE(6,2010) (WA(K),K=1,NWA)	5820
C		5830
	1 DO 10 JJ=1,MXP	5840
C		5850
	DO 6 IA=1,NTAU	5860
	6 RP(IA) = 0.	5870
C		5880
	DO 7 IA=1,NWA	5890
	7 FI(IA) = 0.	5900
C		5910

TABLE 5B (Continued)

DO 20 I=1,IM	5920
DO 20 J=1,IN	5930
JA = J	5940
JB=J	5950
IF (IM.EQ.MM) JA=I	5960
M=MAM(JA)	5970
N = NAN(J)	5980
	5990
WMN = W(I,J)	6000
	6010
KMN = C*THETA / (B*(1.+W(I,J)**2*THETA**2))	6020
AMN = B*W(I,J)	6030
CMN = W(I,J)*(1.-6.*B**2 + B**4)	6040
DMN = 4.*B*W(I,J)*(B**2-1.)	6050
	6060
	6070
WRITE(6,2005)	6080
IF (JJ.NE.1) GO TO 21	6090
	6100
X=XX	6110
Y=YY	6120
Z=ZZ	6130
	6140
PHASE =1.5708	6150
KKK=1	6160
AMN =-AMN	6170
CALL DINT(AMN,PHASE,KKK)	6180
DIX1(I,J) = SUM2	6190
	6200
PHASE = 0.	6210
KKK= 5	6220
CALL DINT(AMN,PHASE,KKK)	6230
DIX5(I,J) = SUM2	6240
	6250
AMN = -AMN	6260
	6270
21 X=XP(JJ)	6280

TABLE 5B (Continued)

	Y=YP(JJ)	6290
	Z=ZP(JJ)	6300
C		6310
	PHASE =1.5708	6320
	KKK = 2	6330
	CALL DINT(AMN,PHASE,KKK)	6340
	CAP2 = SUM2	6350
C		6360
	PHASE = 0.	6370
	KKK = 4	6380
	CALL DINT(AMN,PHASE,KKK)	6390
	CAP4 = SUM2	6400
C		6410
	IF (JJ.NE.1) GO TO 24	6420
	WBAR1=(B**2+2.)/(B*W(I,J)*(B**2+4.))	6430
	WBAR2 = B*WBAR1 / (B**2+2. )	6440
	CBAR = KMN*W(I,J)*P2	6450
C		6460
	SP = CBAR * (WBAR1*DIX1(I,J)*CAP2 + WBAR2*DIX1(I,J)*CAP4 -WBAR2*	6470
	10DIX5(I,J)*CAP2 + WBAR1*DIX5(I,J)*CAP4 )	6480
	IF (SP) 11,11,22	6490
11	PHI = 0.	6500
C		6510
	GO TO 23	6520
C		6530
	22 PHI = 10.* ALOG10(SP) + 127.6	6540
C		6550
	23 WRITE(6,2002) II,JJ,XP(JJ),YP(JJ),ZP(JJ),M,N,W(I,J),SP,PHI	6560
	GO TO 25	6570
C		6580
	24 WRITE(6,2003) II,JJ,XP(JJ),YP(JJ),ZP(JJ),M,N,W(I,J)	6590
C		6600
	25 IF (NTAU) 32,31,32	6610
	32 TAU = ATAU	6620
C		6630
	DO 20 K=1,NTAU	6640
C		6650

TABLE 5B (Continued)

	TH1 = CMN * COS(W(I,J) * TAU) + DMN * SIN(W(I,J) * TAU)	6660
	TH2 = CMN * SIN(W(I,J) * TAU) - DMN * COS(W(I,J) * TAU)	6670
C		6680
	RPN = KMN * EXP(-AMN * TAU) * (TH1 * DIX1(I,J) * CAP2 + TH2 * DIX1(I,J) * CAP4 - TH2 * DIX5(I,J) * CAP2 + TH1 * DIX5(I,J) * CAP4)	6690
	RP(K) = RP(K) + RPN	6700
		6710
C		6720
	WRITE(6,2004) K,TAU,RPN	6730
C		6740
	30 TAU = TAU + DTAU	6750
C		6760
	31 IF (NWA) 33,20,33	6770
C		6780
	33 WRITE(6,2013)	6790
C		6800
	DO 19 K=1,NWA	6810
	RAD = WA(K) / (2 * PI)	6820
	DD = (B**2 * W(I,J)**2 + (W(I,J) - WA(K))**2) * (B**2 * W(I,J)**2 + 1(W(I,J) + WA(K))**2)	6830
		6840
C		6850
	AAMN = (B * W(I,J) * (B**2 * W(I,J)**2 + W(I,J)**2 + WA(K)**2)) / DD	6860
	BBMN = (W(I,J) * (B**2 * W(I,J)**2 + W(I,J)**2 - WA(K)**2)) / DD	6870
C		6880
	TW1 = CMN * AAMN + DMN * BBMN	6890
	TW2 = CMN * BBMN - DMN * AAMN	6900
C		6910
	FIT = KMN * (TW1 * DIX1(I,J) * CAP2 + TW2 * DIX1(I,J) * CAP4 - TW2 * DIX5(I,J) * CAP2 + TW1 * DIX5(I,J) * CAP4)	6920
		6930
C		6940
	FAT = FIT	6950
	IF (FIT) 77,77,17	6960
77	PHI = 0.	6970
	FIT = 0.	6980
	GO TO 18	6990
	17 PHI = 10 * ALOG10(FIT) + 127.5	7000
	18 WRITE(6,2014) K,WA(K),RAD,FAT,PHI	7010
	19 FI(K) = FI(K) + FIT	7020

TABLE 5B (Continued)

20	CONTINUE	7030
	IF (NTAU) 47,45,47	7040
C		7050
47	WRITE(6,2007) RP(1)	7060
	TAU = ATAU	7070
C		7080
	DO 40 K=1,NTAU	7090
	RPBAR(K)=RP(K)/ RP(1)	7100
	PRP(K) = RP(K)/P2	7110
C		7120
	WRITE(6,2008) K, TAU,RPBAR(K),PRP(K)	7130
40	TAU = TAU + DTAU	7140
C		7150
45	IF (NWA) 49,10,49	7160
49	WRITE(6,2011)	7170
C		7180
	DO 50 K=1,NWA	7190
	RAD = WA(K)/(2.*PI)	7200
	IF (FI(K)) 53,53,51	7210
53	PHI = 0.	7220
	GO TO 50	7230
C		7240
51	PHI = 10.* ALOG10(FI(K)) + 127.6	7250
50	WRITE(6,2012) K,WA(K),RAD,FI(K),PHI	7260
C		7270
C		7280
10	CONTINUE	7290
C		7300
C		7310
5	CONTINUE	7320
C		7330
C	CALL CLOCK(NTIME)	7340
C	TIME = (NTIME-MTIME)/CONVT	7350
C		7360
C	WRITE(6,2009) TIME	7370
C		7380
	RETURN	7390

TABLE 5B (Continued)

END	7400
\$IBFTC X0INT	7410
SUBROUTINE DIN? (SAMN,SPHASE,KKS)	7420
C	7430
C	7440
C DOUBLE INTEGRATION SUBROUTINE	7450
C	7460
C	7470
COMMON /AAA/A(4000)	7480
C	7490
EQUIVALENCE (A(9),M),(A(10),N),(A(21),XL1),(A(22),XL0),(A(23),YL1),	7500
1,(A(24),YLO),(A(34),EPS),(A(35),NMAX),(A(38),SUM1),(A(39),SUM2)	7510
C	7520
C	7530
DIMENSION P(5),WW(5)	7540
C	7550
DATA (P(I),I=1,5),(WW(I),I=1,5) /,453089923,-.453089923,.269234655	7560
1,-.269234655,0.0,2*.118463443,2*.239314335,.284444444 /	7570
C	7580
2000 FORMAT(1H0,2BH ***** NO CONVERGENCE ***** ,5X,I4,10X,I4,5X,I4,I5,	7590
12E18.8)	7600
2002 FORMAT(1H0,35X,I4,10X,I4,4X,I5,I5,2E18.8)	7610
C	7620
C	7630
C	7640
NK=2	7650
BINC1=XL1-XL0	7660
BINC2=YL1-YL0	7670
C	7680
DO 25 K=1,NMAX	7690
SUM1=SUM2	7700
SUM2=0.0	7710
CNK = NK	7720
DINC1 = BINC1/CNK	7730
DINC2 = BINC2/CNK	7740
H1 = XL0 + DINC1/2.	7750
C	7760



TABLE 5B (Continued)

	DO 26 I=1,NK	7770
C	H2 = YLO + DINC2/2.	7780
	DO 27 J=1,NK	7790
	DO 28 II=1,5	7800
	ABS1=DINC1*P(II)+H1	7810
	DO 29 JJ=1,5	7820
	ABS2=DINC2*P(JJ)+H2	7830
	29 SUM2=SUM2+WW(II)*WW(JJ)*FFF(ABS1,ABS2,SAMN,SPHASE)	7840
	28 CONTINUE	7850
	27 H2=H2+DINC2	7860
	26 H1=H1+DINC1	7870
	SUM2=SUM2*DINC1*DINC2	7880
C		7890
C		7900
	IF (K.EQ.1) GO TO 30	7910
	IF (ABS((SUM1-SUM2)/SUM2)-EPS) 31,31,30	7920
	30 NK=NK + 1	7930
	25 CONTINUE	7940
C		7950
	WRITE(6,2000) KKS,HK,M,N,SUM2,SUM1	7960
	SUM2 = 0.	7970
C		7980
	GO TO 32	7990
C		8000
C		8010
	31 WRITE(6,2002) KKS,NK,M,N,SUM2,SUM1	8020
C		8030
	32 RETURN	8040
	END	8050
	SIBFTC XFFF	8060
	FUNCTION FFF(X0,Y0,FAMN,FPHASE)	8070
C		8080
C		8090
C	DOUBLE INTEGRATION FUNCTION	8100
C		8110
C		8120
		8130

TABLE 5B (Continued)

C		8140
	COMMON /AAA/A(4000)	8150
C		8160
	EQUIVALENCE (A(7),NAUTO),(A(8),NCROSS),(A(9),M),(A(10),N),	8170
	1(A(21),XL1),(A(22),XL0),(A(23),YL1),(A(24),YL0),(A(25),AI),	8180
	2(A(30),PI),(A(31),X),(A(32),Y),(A(33),Z),(A(36),WMN),(A(40),JA),	8190
	3(A(41),JB)	8200
C		8210
	EQUIVALENCE (A(201),AMM),(A(251),ANN),(A(301),BMM),(A(351),BNN),	8220
	1(A(401),CMM),(A(451),CNN),(A(501),DMM),(A(551),DNN),(A(601),ALMM),	8230
	2(A(651),ALNN)	8240
C		8250
	DIMENSION AMM(50),ANN(50),BMM(50),BNN(50),CMM(50),CNN(50),DMM(50),	8260
	1DNN(50),ALMM(50),ALNN(50)	8270
C		8280
C	INTEGER W,WMN	8290
C		8300
C		8310
	RO=SQRT((X-X0)**2+(Y-Y0)**2 + Z**2)	8320
C		8330
	PHX = AMM(JA)*SIN(ALMM(JA)*X0) + BMM(JA)*COS(ALMM(JA)*X0) +	8340
	1CMM(JA)*SINH(ALMM(JA)*X0) + DMM(JA)*COSH(ALMM(JA)*X0)	8350
C		8360
	PHY= ANN(JB)*SIN(ALNN(JB)*Y0) + BNN(JB)*COS(ALNN(JB)*Y0) +	8370
	1CNN(JB)*SINH(ALNN(JB)*Y0) + DNN(JB)*COSH(ALNN(JB)*Y0)	8380
C		8390
	FFF = PHX * PHY * EXP((FAMN/AI)*RO) * SIN((WMN/AI)*RO+FPHASE) / RO	8400
C		8410
	RETURN	8420
	END	8430

**APPENDIX D**

**UNDERWATER SOUND LABORATORY PROGRAM (STRAWDERMAN)**

**APPENDIX D1 – MATHEMATICAL ANALYSIS**

**APPENDIX D2 – METHOD FOR DETERMINING INPUT DATA**

**APPENDIX D3 – PROGRAM IDENTIFICATION**

**APPENDIX D4 – TEST RUNS**

## NOTATION

$A$	Equal to $0.75 \times 10^{-5} a^2 \rho_f^2 U_0^3 \delta^*$
$a$	Plate and acoustic cavity dimension in $x$ -coordinate (longitudinal) direction
$b$	Plate and acoustic cavity dimension in $y$ -coordinate (lateral) direction
$b^+$	Dimensionless plate and acoustic cavity dimension defined in Equation (D68)
$C_i$	Arbitrary constants
$c$	Speed of sound in acoustic medium
$c^+$	Dimensionless speed of sound defined in Equation (D77)
$D$	Plate flexural rigidity
$D^+$	Dimensionless plate flexural rigidity
$d$	Acoustic cavity dimension in $z$ -coordinate (depth) direction
$d^+$	Dimensionless cavity dimension defined in Equation (D77)
$E[ \ ]$	Denotes ensemble average
$F_{qrst}(x_1, x_2, y_1, y_2)$	Defined by Equation (D51)
$f_{qrst}(\Omega)$	Defined by Equation (D52)
$G_{ns}$	Defined subsequent to Equation (D21b)
$G_{mn}^+(\omega^+)$	Defined by Equation (D72)
$G_{jkmn}(x_1, x_2, y_1, y_2)$	Defined by Equation (D54)
$g_{jkmn}(z_1, z_2, \omega)$	Defined by Equation (D55)
$H(x, x', y, y', \omega)$	Complex frequency response of plate
$h(x, x', y, y', \theta)$	Plate displacement response to a unit impulsive force
$i$	Square root of $-1$
$K_{jkmnqrst}$	Defined by Equation (D60)
$k$	Acoustic wave number defined in Equation (D33)
$k_x$	Acoustic wave number in the $x$ -coordinate direction
$k_y$	Acoustic wave number in the $y$ -coordinate direction
$k_z, k_{z,k}(\omega)$	Acoustic wave number in the $z$ -coordinate direction

$k_{zjk}^+(\omega^+)$	Dimensionless acoustic wave number in the $z$ -coordinate direction
$M$	Dimensionless fluid mass defined by Equation (D68)
$m, n, \text{ etc.}$	Mode numbers
$P_n$	Defined subsequent to Equation (D21b)
$P_n^+(\omega^+)$	Defined by Equation (D73)
$P_t$	Turbulent boundary layer wall pressure
$p_a$	Cavity acoustic pressure
$Q_{aa}(x_1, x_2, y_1, y_2, z_1, z_2, t_1, t_2)$	Cavity acoustic pressure cross correlation
$Q_{pp}(x_1, x_2, y_1, y_2, t)$	Plate pressure cross correlation
$Q_{\phi\phi}(x_1, x_2, y_1, y_2, t_1, t_2)$	Plate velocity cross correlation
$R_m$	Defined subsequent to Equation (D21b)
$R_m^+(\omega^+)$	Defined by Equation (D69)
$r$	Effective plate damping coefficient per unit area
$r_{c_{mn}}$	Critical plate damping coefficient for the $m$ - $n$ <sup>th</sup> mode
$r^+$	Dimensionless plate damping coefficient defined in Equation (D68)
$r_{c_{mn}}^+$	Dimensionless critical plate damping coefficient for the $m$ - $n$ <sup>th</sup> mode
$S_{aa}(x_1, x_2, y_1, y_2, z_1, z_2, \omega)$	Cavity acoustic pressure cross spectral density
$S_{pp}(\xi, \eta, \omega)$	Turbulent wall pressure cross spectral density
$S_{\phi\phi}(x_1, x_2, y_1, y_2, \omega)$	Plate velocity cross spectral density
$T_{mn}$	Defined subsequent to Equation (D21b)
$T_{mn}^+(\omega^+)$	Defined by Equation (D74)
$t$	Time coordinate
$t'$	Time at which impulsive force occurs
$U_0$	Free stream velocity of flowing fluid in $x$ -coordinate direction

$U_c$	Mean convection velocity of turbulent boundary layer
$U^+$	Dimensionless free stream velocity defined by Equation (D68)
$U_{jkmn}^+(\omega^+)$	Defined by Equation (D78)
$\vec{u}$	Acoustic phase velocity vector
$u_x$	Acoustic phase velocity in the $x$ -coordinate direction
$u_y$	Acoustic phase velocity in the $y$ -coordinate direction
$u_z$	Acoustic phase velocity in the $z$ -coordinate direction
$V_{mngs}$	Defined subsequent to Equation (D21b)
$W_{mngs}$	Defined by Equation (D23)
$W_{mngs}^+(\omega^+)$	Defined by Equation (D75)
$w$	Plate displacement in the $z$ -coordinate direction
$X_{j\ell}(\omega)$	Defined by Equation (D40)
$x$	Longitudinal spacial coordinate
$x^+$	Dimensionless longitudinal spacial coordinate defined by Equation (D68)
$y$	Lateral spacial coordinate
$y^+$	Dimensionless lateral spacial coordinate defined by Equation (D68)
$z$	Spacial coordinate normal to the plate
$z^+$	Dimensionless spacial coordinate defined by Equation (D77)
$\alpha$	A dimensionless constant
$\alpha_{mn}(x, y)$	Plate normalized natural mode shapes
$\delta_{j\ell}$	Kronecker delta
$\delta(\omega - \Omega)$	Dirac delta function
$\delta^*$	Turbulent boundary layer displacement thickness
$\delta^+$	Dimensionless turbulent boundary layer displacement thickness defined by Equation (D68)
$\xi(x, x', y, y', \theta)$	Plate velocity response to a suit impulsive force
$\eta$	Relative lateral coordinate $(y - y')$
$\theta$	Relative time coordinate $(t - t')$

$\lambda_{mn}$	Phase angle defined subsequent to Equation (D21b)
$\mu$	Effective mass of plate per unit area
$\nu_m$	Phase angle defined subsequent to Equation (D21b)
$\xi$	Relative longitudinal coordinate ( $x - x'$ )
$\rho_f$	Mass density of flowing fluid
$\rho_{a0}$	Time average mass density of acoustic medium
$\rho_a$	Instantaneous mass density of acoustic medium
$\tau$	Time difference ( $t_2 - t_1$ )
$\Phi(\omega)$	Turbulent wall pressure spectral density
$\phi^+(\omega)$	Dimensionless turbulent wall pressure spectral density
$\Phi_\phi(x, y, \omega)$ or $\Phi(x^+, y^+, \omega^+)$	Plate velocity spectral density
$\Phi_\phi^+(x^+, y^+, \omega^+)$	Dimensionless plate velocity spectral density
$\Phi_a(x, y, z, \omega)$ or $\Phi_a(x^+, y^+, z^+, \omega^+)$	Cavity acoustic pressure spectral density
$\Phi_a^+(x^+, y^+, z^+, \omega^+)$	Dimensionless cavity acoustic pressure spectral density
$\phi$	Plate velocity
$\psi$	Acoustic velocity potential
$\omega$	Radial frequency
$\omega^+$	Dimensionless radial frequency
$\omega_{mn}$	Natural frequency of $m$ - $n$ mode of plate
$\omega_{mn}^+$	Dimensionless natural frequency of $m$ - $n$ mode of plate
$\nabla^4$	Biharmonic operator
$X(\omega)$	Defined by Equation (D53)
$\Omega$	Radial frequency

## APPENDIX D1 - MATHEMATICAL ANALYSIS

The equations for the plate velocity and cavity acoustic pressure spectral densities and cross correlations are now derived<sup>32</sup> for a plate (Figure 15) subject to turbulence excitation.

The differential equation governing the displacement of the plate due to turbulent boundary layer pressure excitation on the plate surface is

$$D \nabla^4 w + r \frac{\partial w}{\partial t} + \mu \frac{\partial^2 w}{\partial t^2} = p_t(x, y, z) \quad (D1)$$

Following Dyer (see Appendix A), the equation for the free undamped plate

$$D \nabla^4 w + \mu \frac{\partial^2 w}{\partial t^2} = 0 \quad (D2)$$

has the normal mode solution, satisfying the simply supported edge conditions (Figure 15), given by

$$w(x, y, t) = a_{mn}(x, y) \sin \omega_{mn} t \quad (D3)$$

where

$$a_{mn}(x, y) = \frac{2}{\sqrt{ab}} \sin \frac{m\pi y}{a} \sin \frac{n\pi x}{a} \quad (D4)$$

$$\omega_{mn} = \sqrt{\frac{D}{\mu}} \left[ \left( \frac{m\pi}{a} \right)^2 + \left( \frac{n\pi}{b} \right)^2 \right] \quad (D5)$$

and

$$\int_0^b \int_0^a a_{mn}(x, y) a_{qr}(x, y) dx dy = \delta_{mq} \delta_{nr} \quad (D6)$$

The solution to Equation (D1) for any *deterministic* pressure is then assumed to be

$$w(x, y, t) = \sum_{\substack{m=1 \\ n=1}}^{\infty} a_{mn}(x, y) T_{mn}(t) \quad (D7)$$



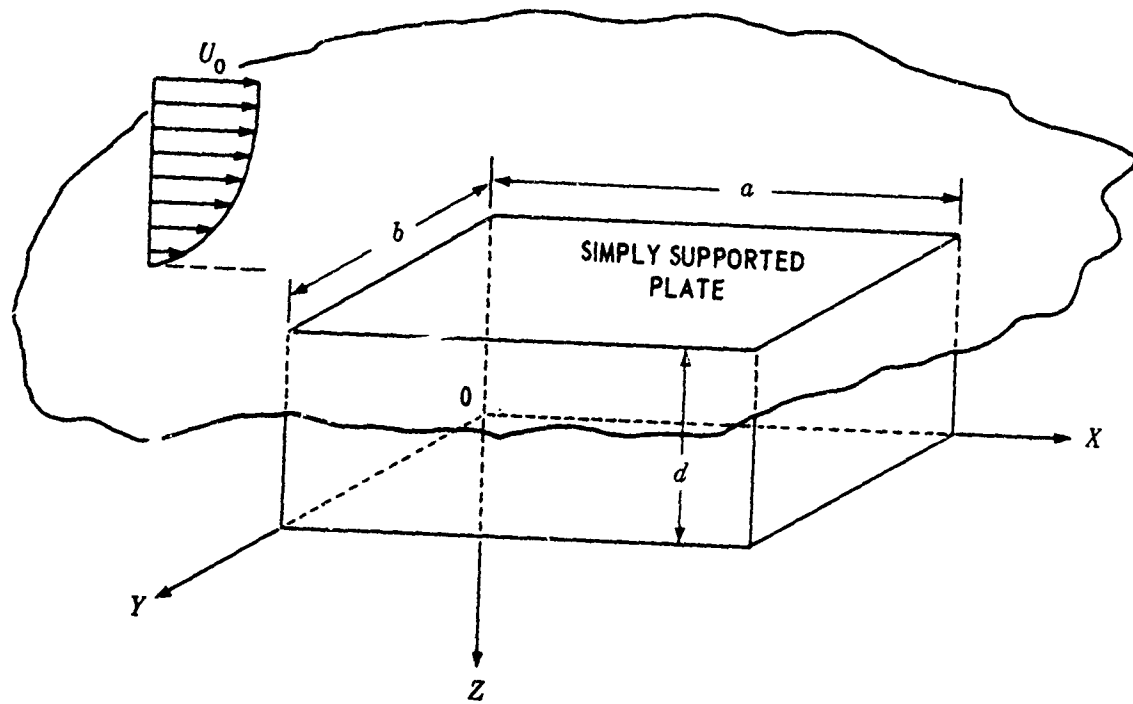

Figure 15 - Illustration of the Theoretical Model

Substituting Equation (D7) in (D1) and using Equation (D6), we find  $T_{mn}(t)$  must satisfy

$$\frac{d^2 T_{mn}}{dt^2} + \frac{r}{\mu} \frac{dT_{mn}}{dt} + \omega_{mn}^2 T_{mn} = \frac{1}{\mu} \int_0^b \int_0^a p_t(x, y, t) a_{mn}(x, y) dx dy \quad (D8)$$

For later use, we consider the following two cases.

CASE I: Concentrated load applied at  $(x', y')$  varying sinusoidally in time

$$p_t(x, y, t) = \delta(x - x') \delta(y - y') e^{i\omega t} \quad (D9)$$

Substituting Equation (D9) in (D8) results in the following solution for Equation (D7):

$$w(x, y, t) = \sum_{\substack{m=1 \\ n=1}}^{\infty} \frac{a_{mn}(x, y) a_{mn}(x', y')}{\mu \left[ (\omega_{mn}^2 - \omega^2) + \frac{ir\omega}{\mu} \right]} e^{i\omega t} = H(x, x', y, y', \omega) e^{i\omega t} \quad (D10)$$

where  $H(x, x', y, y', \omega)$ , the complex frequency response,<sup>32</sup> is

$$H(x, x', y, y', \omega) = \frac{1}{\mu} \sum_{\substack{m=1 \\ n=1}}^{\infty} \frac{a_{mn}(x, y) a_{mn}(x', y')}{\left[ (\omega_{mn}^2 - \omega^2) + \frac{ir\omega}{\mu} \right]} \quad (D11)$$

CASE II: Impulsive loading at time  $t'$  applied at  $(x', y')$

$$p_t(x, y, t) = \delta(x - x') \delta(y - y') \delta(t - t') \quad (D12)$$

Define

$$\theta = t - t'$$

$$h(x, x', y, y', \theta) = \begin{cases} w(x, y, t) & \theta > 0 \\ 0 & \theta \leq 0 \end{cases}$$

Substituting Equation (D12) in (D8) results in the following solution for Equation (D7):

$$h(x, x', y, y', \theta) = w(x, y, t) \cdot \frac{e^{-\frac{r\theta}{2\mu}}}{\mu} \sum_{\substack{m=1 \\ n=1}}^{\infty} \frac{a_{mn}(x, y) a_{mn}(x', y')}{\sqrt{\omega_{mn}^2 - \left(\frac{r}{2\mu}\right)^2}} \sin \sqrt{\omega_{mn}^2 - \left(\frac{r}{2\mu}\right)^2} \theta \quad \theta \geq 0 \quad (\text{D18})$$

By superposition, the response for any deterministic pressure field may be written

$$w(x, y, t) = \int_{-\infty}^t \int_0^b \int_0^a p_t(x', y', t') h(x, x', y, y', \theta) dx' dy' dt' = \int_0^{\infty} \int_0^b \int_0^a p_t(x', y', t-\theta) h(x, x', y, y', \theta) dx' dy' d\theta \quad (\text{D14})$$

Since the velocity of the plate, rather than displacement, is required for the boundary value in the *acoustic* problem, we define the *velocity response* of the plate to impulse loading thus

$$\zeta(x, x', y, y', \theta) = \frac{\partial h(x, x', y, y', \theta)}{\partial t} = \frac{e^{-\frac{r\theta}{2\mu}}}{\mu} \sum_{\substack{m=1 \\ n=1}}^{\infty} \frac{a_{mn}(x, y) a_{mn}(x', y')}{\sqrt{\omega_{mn}^2 - \left(\frac{r}{2\mu}\right)^2}} \cdot \left\{ \sqrt{\omega_{mn}^2 - \left(\frac{r}{2\mu}\right)^2} \cos \sqrt{\omega_{mn}^2 - \left(\frac{r}{2\mu}\right)^2} \theta - \frac{r}{2\mu} \sin \sqrt{\omega_{mn}^2 - \left(\frac{r}{2\mu}\right)^2} \theta \right\} \theta \geq 0 \quad (\text{D15})$$

And we define the *velocity field* of the plate as

$$\phi(x, y, t) = \frac{\partial w(x, y, t)}{\partial t} = \int_0^{\infty} \int_0^b \int_0^a p_t(x', y', t-\theta) \delta(x, x', y, y', \theta) dx' dy' d\theta \quad (\text{D16})$$

We define the *turbulent wall pressure cross correlation* by ( $E$  denotes the ensemble average):

$$Q_{pp}(x_1, x_2, y_1, y_2, t) = E[p_t(x_1, y_1, t) p_t(x_2, y_2, t)] \quad (\text{D17})$$

The plate velocity cross correlation is then

$$\begin{aligned}
 Q_{\phi\phi}(x_1, x_2, y_1, y_2, t_1, t_2) &= E[\phi(x_1, y_1, t_1)\phi(x_2, y_2, t_2)] = E\left[\int_0^b \int_0^a \int_0^b \int_0^a \int_0^\infty \int_0^\infty \cdot \right. \\
 &\quad \cdot p_t(x'_1, y'_1, t_1 - \theta_1) p_t(x'_2, y'_2, t_2 - \theta_2) \delta(x_1, x'_1, y_1, y'_1, \theta_1) \cdot \\
 &\quad \left. \cdot \zeta(x_2, x'_2, y_2, y'_2, \theta_2) d\theta_1 d\theta_2 dx'_1 dy'_1 dx'_2 dy'_2 \right] \\
 &= \int_0^b \int_0^a \int_0^b \int_0^a \int_0^\infty \int_0^\infty Q_{pp}(x'_1, x'_2, y'_1, y'_2, t_1 - \theta_1, t_2 - \theta_2) \zeta(x_1, x'_1, y_1, y'_1, \theta_1) \\
 &\quad \cdot \zeta(x_2, x'_2, y_2, y'_2, \theta_2) d\theta_1 d\theta_2 dx'_1 dy'_1 dx'_2 dy'_2 \\
 &= \int_0^b \int_0^a \int_0^b \int_0^a \int_0^\infty \int_0^\infty Q_{pp}(\zeta', \eta', \tau + \theta_1 - \theta_2) \zeta(x_1, x'_1, y_1, y'_1, \theta_1) \\
 &\quad \zeta(x_2, x'_2, y_2, y'_2, \theta_2) d\theta_1 d\theta_2 dx'_1 dy'_1 dx'_2 dy'_2 \tag{D18}
 \end{aligned}$$

In obtaining Equation (D18), we took account of the fact that since the plate velocity impulse function is not a random quantity, the ensemble average applied only to the turbulent pressure field. Also, since the turbulent boundary layer pressure is assumed to be a homogeneous stationary process,  $Q_{pp}$  is a function of the difference between the spatial and temporal coordinates rather than the coordinates themselves<sup>33</sup>.

The plate velocity cross spectral density is then (multiplying and dividing Equation (D18) by  $e^{-i\omega(\theta_1 - \theta_2)}$  to obtain the third member below):

$$\begin{aligned}
S_{\phi\phi}(x_1, x_2, y_1, y_2, \omega) &= \frac{1}{\sqrt{2\pi}} \int_{-\infty}^{\infty} Q_{\phi\phi}(x_1, x_2, y_1, y_2, \tau) e^{-i\omega\tau} d\tau = \\
&\int_0^b \int_0^a \int_0^b \int_0^a \int_0^{\infty} \int_0^{\infty} \left\{ \frac{1}{\sqrt{2\pi}} \int_{-\infty}^{\infty} Q_{pp}(\xi', \eta', \tau + \theta_1 - \theta_2) e^{-i\omega(\tau + \theta_1 - \theta_2)} \cdot \right. \\
&\left. \cdot d(\tau + \theta_1 - \theta_2) \right\} \zeta(x_1, x_1', y_1, y_1', \theta_1) e^{i\omega\theta_1} \zeta(x_2, x_2', y_2, y_2', \theta_2) \cdot \\
&\quad \cdot e^{-i\omega\theta_2} d\theta_1 d\theta_2 dx_1' dy_1' dx_2' dy_2' \\
&= \int_0^b \int_0^a \int_0^b \int_0^a S_{pp}(\xi', \eta', \omega) \int_0^{\infty} \zeta(x_1, x_1', y_1, y_1', \theta_1) e^{i\omega\theta_1} d\theta_1 \cdot \\
&\quad \cdot \int_0^{\infty} \zeta(x_2, x_2', y_2, y_2', \theta_2) e^{-i\omega\theta_2} d\theta_2 dx_1' dy_1' dx_2' dy_2' \\
&= \int_0^b \int_0^a \int_0^b \int_0^a \omega^2 S_{pp}(\xi', \eta', \omega) H(x_1, x_1', y_1, y_1' - \omega) H(x_2, x_2', y_2, y_2' - \omega) dx_1' dy_1' dx_2' dy_2'
\end{aligned}$$

(D19)

where, since  $\zeta(x, x', y, y', \omega)$  is zero for  $\theta \leq 0$ , the semi-infinite limits in  $\theta_1$  and  $\theta_2$  have been replaced by infinite limits and as can be shown (see Equation 2.11 of Reference 33)

$$\int_0^{\infty} \zeta(x_2, x_2', y_2, y_2', \theta_2) e^{-i\omega\theta_2} d\theta_2 = i\omega H(x_2, x_2', y_2, y_2' - \omega)$$

$$\int_{-\infty}^{\infty} \zeta(x_1, x_1', y_1, y_1', \theta_1) e^{i\omega\theta_1} d\theta_1 = -i\omega H(x_1, x_1', y_1, y_1' - \omega)$$

(D20)

The mathematical model for  $S_{pp}$  used by Strawderman and discussed in detail in Reference 32 is\*

$$\begin{aligned}
 S_{pp}(\xi, \eta, \omega) &= 0.75 \times 10^{-5} a^2 \rho_f^2 U_0^3 \delta^* \left[ e^{-0.115 \left| \frac{\omega \xi}{U_c} \right|} \right] \left[ e^{-0.7 \left| \frac{\omega \eta}{U_c} \right|} \right] e^{-i \left( \frac{\omega \xi}{U_c} \right)} ; \omega \leq 1.256 \frac{U_0}{\delta^*} \\
 &= 1.5 \times 10^{-5} a^2 \frac{\rho_f^2 U_0^6}{\omega^3 \delta^{*2}} \left[ e^{-0.115 \left| \frac{\omega \xi}{U_c} \right|} \right] \left[ e^{-0.7 \left| \frac{\omega \eta}{U_c} \right|} \right] e^{-i \left( \frac{\omega \xi}{U_c} \right)} ; \omega > 1.256 \frac{U_0}{\delta^*}
 \end{aligned}
 \tag{D21a}$$

where  $a = 1.0$  for water and  $a = 3.0$  for air.

Substituting Equation (D21a) in (D19) and using Equations (D11) and (D4), we obtain after extensive, but routine, simplification (see Reference 32 for details):

$$\begin{aligned}
 S_{\phi\phi}(x_1, x_2, y_1, y_2) &= \frac{16A\omega^2}{\mu^2 a^2 \delta^2} \sum_{m=1}^{\infty} \sum_{n=1}^{\infty} \sum_{q=1}^{\infty} \sum_{s=1}^{\infty} \frac{\sin \frac{m\pi x_1}{a} \sin \frac{n\pi y_1}{b} \sin \frac{q\pi x_2}{a} \sin \frac{s\pi y_2}{b}}{T_{mn} T_{qs} P_n P_s R_m R_q} \\
 &\quad \cdot G_{ns} V_{mnqs} ; \omega \leq 1.256 \frac{U_0}{\delta^*} \\
 S_{\phi\phi}(x_1, x_2, y_1, y_2) &= \frac{32A\omega^2}{\mu^2 a^2 b^2} \left( \frac{\omega \delta^*}{U_0} \right)^{-3} \sum_{m=1}^{\infty} \sum_{n=1}^{\infty} \sum_{q=1}^{\infty} \sum_{s=1}^{\infty} \frac{\sin \frac{m\pi x_1}{a} \sin \frac{n\pi y_1}{b} \sin \frac{q\pi x_2}{a} \sin \frac{s\pi y_2}{b}}{T_{mn} T_{qs} P_n P_s R_m R_q} \\
 &\quad \cdot G_{ns} V_{mnqs} ; \omega > 1.256 \frac{U_0}{\delta^*}
 \end{aligned}
 \tag{D21b}$$

\*Equation (D21a) represents a mathematical fit to the Corcos model which is based on experimental data. The Skudrzyk and Haddle expression for the turbulent wall pressure spectral density  $\phi(\omega)$  is incorporated in this model. See Equation (3.1) of Reference 32.

where

$$A = 0.75 \times 10^{-5} a^2 \rho_f^2 U_0^3 \delta^*$$

$$T_{mn} = \sqrt{(\omega_{mn}^2 - \omega^2)^2 + \left(\frac{r\omega}{\mu}\right)^2} ; \text{ similarly for } T_{qs}$$

$$P_n = \left(0.7 \frac{\omega}{U_c}\right)^2 + \left(\frac{n\pi}{b}\right)^2 ; \text{ similarly for } P_s$$

$$R_m = \sqrt{\left(\frac{m\pi}{a}\right)^2 - 0.987 \left(\frac{\omega}{U_c}\right)^2 + 0.0529 \left(\frac{\omega}{U_c}\right)^4} ; \text{ similarly for } R_q$$

$$G_{ns} = 0.35 \frac{\omega b}{U_c} \delta_{ns} \left[ 2 \left(0.7 \frac{\omega}{U_c}\right)^2 + \left(\frac{n\pi}{b}\right)^2 + \left(\frac{s\pi}{b}\right)^2 \right]$$

$$+ \frac{ns\pi^2}{b^2} [1 - \delta_{ns}] \left[ (-1)^n (-1)^s - 1 \right]$$

$$+ \frac{ns\pi^2}{b^2} \left\{ 2 - \left[ (-1)^n + (-1)^s \right] e^{-0.7 \left(\frac{\omega b}{U_c}\right)} \right\}$$

$$V_{mnqs} = \left\{ \delta_{mq} 1.0066 \frac{\omega a}{U_c} R_m (\nu_m - 0.463\pi) \right.$$

$$+ (1 - \delta_{mq}) \frac{mq\pi^2 [(-1)^m (-1)^q - 1]}{a^2 \left[ \left(\frac{m\pi}{a}\right)^2 - \left(\frac{q\pi}{a}\right)^2 \right]} \left[ R_m e^{i\nu_q} - R_q e^{-i\nu_m} \right] + \frac{2mq\pi^2}{a^2} \cdot \cos(\nu_q + \nu_m)$$

$$- \frac{m\pi^2}{a^2} e^{-0.115 \left(\frac{\omega a}{U_c}\right)} \left[ (-1)^m e^{i \left(\frac{\omega a}{U_c} + \nu_q + \nu_m\right)} + (-1)^q e^{-i \left(\frac{\omega a}{U_c} + \nu_q + \nu_m\right)} \right] \left. \right\} e^{i(\lambda_{mn} - \lambda_{qs})}$$

$$\nu_m = \tan^{-1} \frac{0.23 \left(\frac{\omega}{U_c}\right)^2}{\left[ \left(\frac{m\pi}{a}\right)^2 - 0.987 \left(\frac{\omega}{U_c}\right)^2 \right]} ; \text{ similarly for } \nu_q$$

$$\lambda_{mn} = \tan^{-1} \frac{r\omega}{\omega_{mn}^2 - \omega^2}; \text{ similarly for } \lambda_{qs}$$

The power spectrum of the plate velocity  $\Phi_\phi(x, y, \omega)$  is found as follows. First let  $x_1 = x_2 = x$ ,  $y_1 = y_2 = y$  in Equations (D21b); since  $\Phi(x, y, \omega)$  must be a real, even function then the summations in the resultant equations must be real if they are to be considered as valid solutions for  $\Phi_\phi(x, y, \omega)$ . Then substitute  $V_{mnqs}$  from Equation (D21b) in the equation for  $\Phi_\phi(x, y, \omega)$ . After rearranging this equation and taking  $G_{ns} = G_{sn}$ , since  $G_{ns}$  is a symmetrical matrix, we find (see Reference 32 for details):

$$\Phi_\phi(x, y, \omega) = S_\phi(x_1, x_1, y_1, y_1; \omega) = \frac{16A\omega^2}{\mu^2 a^2 b^2} \sum_{n=1}^{\infty} \sum_{s=1}^{\infty} \frac{\sin \frac{m\pi x}{a} \sin \frac{n\pi y}{b} \sin \frac{q\pi x}{a} \sin \frac{s\pi y}{b}}{T_{mn} T_{qs} P_n P_s R_m R_q} G_{ns} W_{mnqs}; \omega \leq 1.256 \frac{U_0}{\delta^*}$$

$$= \frac{32A\omega^2}{\mu^2 a^2 b^2} \left( \frac{\omega \delta^*}{U_0} \right)^{-3} \sum_{n=1}^{\infty} \sum_{s=1}^{\infty} \frac{\sin \frac{m\pi x}{a} \sin \frac{n\pi y}{b} \sin \frac{q\pi x}{a} \sin \frac{s\pi y}{b}}{T_{mn} T_{qs} P_n P_s R_m R_q} G_{ns} W_{mnqs}; \omega > 1.256 \frac{U_0}{\delta^*}$$

(D22)

where

$$W_{mnqs} = 1.0066 \frac{\omega a}{U_e} \delta_{mq} R_m \cos(\nu_m - 0.463\pi) \cos(\lambda_{mn} - \lambda_{qs})$$

$$+ \frac{2mq\pi^2}{a^2} \cos(\nu_m + \nu_q) (\cos \lambda_{mn} - \lambda_{qs}) + (1 - \delta_{mq}) \frac{mq\pi^2}{a^2} \frac{[(-1)^m (-1)^q - 1]}{\left[ \left( \frac{m\pi}{a} \right)^2 - \left( \frac{q\pi}{a} \right)^2 \right]}$$

$$+ [R_m \cos(\lambda_q + \lambda_{mn} - \lambda_{qs}) - R_q \cos(\nu_m + \lambda_{qs} - \lambda_{mn})]$$



$$\begin{aligned}
& -\frac{mqn^2}{a^2} e^{-0.115 \frac{\omega a}{U_c}} \left[ (-1)^m \cos\left(\frac{\omega a}{U_c} + \nu_q + \nu_m + \lambda_{mn} - \lambda_{qs}\right) \right. \\
& \left. + (-1)^q \cos\left(\frac{\omega a}{U_c} + \nu_q + \nu_m + \lambda_{qs} - \lambda_{mn}\right) \right] \quad (D23)
\end{aligned}$$

We now find the cavity acoustic pressure due to an arbitrary plate velocity distribution. From this we will obtain the cavity acoustic pressure cross correlation and spectral density.

We start with the equations governing acoustic phenomena and the boundary conditions for Figure 12.

$$\text{Momentum equation: } \rho_a \frac{\partial \bar{u}}{\partial t} + \nabla p_a = 0 \quad (D24)$$

$$\text{Continuity equation: } \frac{\partial \rho_a}{\partial t} + \rho_{a_0} \nabla \cdot \bar{u} = 0 \quad (D25)$$

$$\text{Equation of state: } p_a = c^2 \rho_a \quad (D26)$$

$$\text{Boundary conditions: } u_x(0, y, z, t) = 0 \quad (D27a)$$

$$u_x(a, y, z, t) = 0 \quad (D27b)$$

$$u_y(x, 0, z, t) = 0 \quad (D27c)$$

$$u_y(x, b, z, t) = 0 \quad (D27d)$$

$$u_z(x, y, 0, t) = 0 \quad (D27e)$$

$$u_z(x, y, -d, t) = \phi(x, y, t) \quad (D27f)$$

Since Equation (D24) was derived for an inviscid fluid, the acoustic field may be assumed to be irrotational. Hence the acoustic phase velocity may be defined in terms of the velocity potential

$$\bar{u}(x, y, z, t) = \nabla \psi(x, y, z, t) \quad (D28)$$

Equation (D28) specifies  $\psi$  to within an arbitrary function of time. To uniquely specify  $\psi$  define, in addition

$$p_a(x, y, z, t) = -\rho_{a_0} \frac{\partial \psi(x, y, z, t)}{\partial t} \quad (D29)$$

Substitution of Equations (D28) and (D29) into (D24) satisfies the latter equation. To satisfy Equations (D25) and (D26), we proceed as follows:

Substitute Equation (D26) into (D25) to obtain

$$\frac{1}{c^2} \frac{\partial p_a}{\partial t} + \rho_{a_0} \nabla \cdot \vec{u} = 0 \quad (D30)$$

Substitute Equations (D28) and (D29) into (D30) to obtain the scalar wave equation in  $\psi$

$$\nabla^2 \psi - \frac{1}{c^2} \frac{\partial^2 \psi}{\partial t^2} = 0 \quad (D31)$$

which, by virtue of the separation of variables technique, has the solution

$$\begin{aligned} \psi(x, y, z, t) = & [C_1 \sin k_x x + C_2 \cos k_x x] [C_3 \sin k_y y + C_4 \cos k_y y] \\ & [C_5 \sin k_z z + C_6 \cos k_z z] C_7 e^{ikct} \end{aligned} \quad (D32)$$

where

$$k_x^2 + k_y^2 + k_z^2 = k^2 \quad (D33)$$

Substituting the boundary conditions, Equations (D27a-e), into Equation (D32), using Equation (D28), we obtain

$$C_1 = C_3 = C_5 = 0 \quad (D34)$$

$$k_x = \frac{j\pi}{a} \quad j = \text{integer} \quad (D35)$$

$$k_y = \frac{\ell\pi}{b} \quad \ell = \text{integer} \quad (D36)$$

Defining  $\omega = k C$  (D37)

and using Equations (D34), (D35), and (D36), we have

$$\psi(x, y, z, t) = \sum_{\substack{j=0 \\ \ell=0}}^{\infty} C_{2j} \cos \frac{j\pi x}{a} C_{4\ell} \cos \frac{\ell\pi y}{b} C_6 \cos(k_{zj\ell} z) C_7 e^{i\omega t} \quad (D38a)$$

Combining the constants, we assume that the solution for  $\psi(x, y, z, t)$  has the form

$$\psi(x, y, z, t) = \sum_{\substack{j=0 \\ \ell=0}}^{\infty} \cos \frac{j\pi x}{a} \cos \frac{\ell\pi y}{b} \int_{-\infty}^{\infty} Y_{j\ell}(\omega) \cos(k_{z,j\ell} z) e^{i\omega t} \frac{d\omega}{\sqrt{2\pi}} \quad (\text{D38b})$$

Equation (D38b) satisfies the wave Equation (D31) as can be seen by substituting Equation (D38b) in (D31). Also, by applying the above arguments, Equations (D27a-e) are satisfied. It remains only to satisfy the boundary condition (D27f),  $u_z(x, y, -d, t) = \phi(x, y, t)$

$$= \left. \frac{\partial \psi(x, y, z, t)}{\partial z} \right|_{z=-d}$$

Hence

$$\begin{aligned} \phi(x, y, t) &= \sum_{\substack{j=0 \\ \ell=0}}^{\infty} \cos \frac{j\pi x}{a} \cos \frac{\ell\pi y}{b} \int_{-\infty}^{\infty} Y_{j\ell}(\omega) \left\{ -k_{z,j\ell} \sin [k_{z,j\ell} (-d)] \right\} e^{i\omega t} \frac{d\omega}{\sqrt{2\pi}} \\ &= \sum_{\substack{j=0 \\ \ell=0}}^{\infty} \cos \frac{j\pi x}{a} \cos \frac{\ell\pi y}{b} \int_{-\infty}^{\infty} X_{j\ell}(\omega) e^{i\omega t} \frac{d\omega}{\sqrt{2\pi}} \end{aligned} \quad (\text{D39})$$

where

$$X_{j\ell}(\omega) = K_{z,j\ell}(\omega) Y_{j\ell}(\omega) \sin(k_{z,j\ell} d) \quad (\text{D40})$$

Multiplying both sides of Equation (D39) by  $\cos \frac{j\pi x}{a} \cos \frac{\ell\pi y}{b}$  and integrating over the area of the plate, we find by virtue of the orthogonality principle that\*

$$\int_{-\infty}^{\infty} X_{j\ell}(\omega) e^{i\omega t} \frac{d\omega}{\sqrt{2\pi}} = \frac{4}{ab(1 + \delta_{0j})(1 + \delta_{0\ell})} \int_0^b \int_0^a \phi(x, y, t) \cos \frac{j\pi x}{a} \cos \frac{\ell\pi y}{b} dx dy \quad (\text{D41a})$$

\*By L' Hôpital's rule,  $\lim_{j \rightarrow 0} \frac{\sin 2j\pi}{2j\pi} = \frac{2\pi}{2\pi} = 1$ , hence  $\frac{\sin 2j\pi}{2j\pi} = \delta_{0j}$ . Similarly for  $\delta_{0\ell}$ .

Transformation of Equation (D41a) yields

$$X_{j\ell}(\omega) = \frac{4}{ab(1+\delta_{0j})(1+\delta_{0\ell})} \int_{-\infty}^{\infty} \int_0^b \int_0^a \phi(x,y,t) \cos \frac{j\pi x}{a} \cos \frac{\ell\pi y}{b} \cdot e^{-i\omega t} dx dy \frac{dt}{\sqrt{2\pi}} \quad (\text{D41b})$$

Thus, from Equation (D40)

$$Y_{j\ell}(\omega) = \frac{4}{ab(1+\delta_{0j})(1+\delta_{0\ell})k_{zj\ell} \sin k_{zj\ell} d} \int_{-\infty}^{\infty} \int_0^b \int_0^a \phi(x,y,t) \cos \frac{j\pi x}{a} \cos \frac{\ell\pi y}{b} e^{-i\omega t} dx dy \frac{dt}{\sqrt{2\pi}} \quad (\text{D42})$$

Substitution of Equation (D42) in (D38b) yields

$$\psi(x,y,z,t) = \frac{2}{\pi ab} \sum_{\substack{j=0 \\ \ell=0}}^{\infty} \cos \frac{j\pi x}{a} \cos \frac{\ell\pi y}{b} \int_{-\infty}^{\infty} \frac{\cos k_{zj\ell} z}{(1+\delta_{0j})(1+\delta_{0\ell})k_{zj\ell} \sin k_{zj\ell} d} \left\{ \int_{-\infty}^{\infty} \int_0^b \int_0^a \phi(x,y,t) \cos \frac{j\pi x}{a} \cos \frac{\ell\pi y}{b} e^{-i\omega t} dx dy dt \right\} e^{i\omega t} d\omega \quad (\text{D43})$$

Substitution of Equation (D43) in (D29) yields the cavity acoustic pressure for an arbitrary, deterministic plate velocity

$$p_a(x,y,z,t) = \frac{-2ip_{a_0}}{\pi ab} \sum_{\substack{j=0 \\ \ell=0}}^{\infty} \cos \frac{j\pi x}{a} \cos \frac{\ell\pi y}{b} \int_{-\infty}^{\infty} \frac{\omega \cos k_{zj\ell} z}{(1+\delta_{0j})(1+\delta_{0\ell})k_{zj\ell} \sin k_{zj\ell} d} \left\{ \int_{-\infty}^{\infty} \int_0^b \int_0^a \phi(x,y,t) \cos \frac{j\pi x}{a} \cos \frac{\ell\pi y}{b} e^{-i\omega t} dx dy dt \right\} e^{-i\omega t} d\omega \quad (\text{D44})$$

If now  $\phi(x,y,t)$  is considered to be the only random quantity in  $p_a$ , then the *cavity acoustic pressure cross correlation* is

$$Q_{aa}(x_1, x_2, y_1, y_2, z_1, z_2, t_1, t_2) = E[p_a(x_1, y_1, z_1, t_1) p_a(x_2, y_2, z_2, t_2)]$$

$$= \frac{-4\rho^2 a_0}{\pi^2 a^2 b^2} \sum_{j=0}^{\infty} \sum_{\ell=0}^{\infty} \sum_{r=0}^{\infty} \sum_{t=0}^{\infty} \cos \frac{j\pi x_1}{a} \cos \frac{\ell\pi y_1}{b} \cos \frac{r\pi x_2}{a} \cos \frac{t\pi y_2}{b}$$

$$\left\{ \int_{-\infty}^{\infty} \int_{-\infty}^{\infty} \frac{\omega \Omega \cos k_{z_j \ell} z_1 \cos k_{z_r t} z_2}{(1+\delta_{0j})(1+\delta_{0\ell})(1+\delta_{0r})(1+\delta_{0t}) k_{z_r t} (\Omega) \sin k_{z_j \ell} d \sin k_{z_r t} d} \right.$$

$$\left[ \int_{-\infty}^{\infty} \int_{-\infty}^{\infty} \int_0^b \int_0^a \int_0^b \int_0^a E \left[ \phi(x_1, y_1, t_1) \phi(x_2, y_2, t_2) \right] \cos \frac{j\pi x_1}{a} \cos \frac{\ell\pi y_1}{b} \cos \frac{r\pi x_2}{a} \right.$$

$$\left. \left. \cos \frac{t\pi y_2}{b} e^{-i\omega t_1} e^{-i\Omega t_1} dx_1 dy_1 dx_2 dy_2 dt_1 dt_2 \right] e^{i\omega t_1} e^{i\Omega t_2} d\omega d\Omega \right\}$$

(D45)

In Equation (D45), we note that from Equation (D18)

$$E[\phi(x_1, y_1, t_1) \phi(x_2, y_2, t_2)] = Q_{\phi\phi}(x_1, x_2, y_1, y_2, r) \quad (D46)$$

Also, since  $r = t_2 - t_1$ , then using Equation (D19) and noting that  $\int_{-\infty}^{\infty} e^{-i(\omega + \Omega)t_1} dt_1 = 2\pi \delta(\omega + \Omega)$

$$\int_{-\infty}^{\infty} \int_{-\infty}^{\infty} Q_{\phi\phi}(x_1, x_2, y_1, y_2, r) e^{-i\omega t_1} e^{-i\Omega t_2} dt_1 dt_2$$

$$= \int_{-\infty}^{\infty} Q_{\phi\phi}(x_1, x_2, y_1, y_2, r) e^{-i\Omega r} \int_{-\infty}^{\infty} e^{-i(\omega + \Omega)t_1} dt_1$$

$$= \sqrt{2\pi} S_{\phi\phi}(x_1, x_2, y_1, y_2, \omega) \int_{-\infty}^{\infty} e^{-i(\omega + \Omega)t_1} dt_1 = (2\pi)^{3/2} S_{\phi\phi}(x_1, x_2, y_1, y_2, \Omega) \delta(\omega + \Omega)$$

(D47)

Substituting Equation (D47) in (D45), integrating over  $\omega$ , and using the identity  $r = t_2 - t_1$  yields

$$Q_{aa}(x_1, x_2, y_1, y_2, z_1, z_2, \tau) = \frac{-8\sqrt{2}\rho_{a0}^2}{\sqrt{\pi a^2 b^2}} \sum_{j=0}^{\infty} \sum_{l=0}^{\infty} \sum_{r=0}^{\infty} \sum_{t=0}^{\infty} \cos \frac{j\pi x_1}{a} \cos \frac{l\pi y_1}{b} \cos \frac{r\pi x_2}{a} \cos \frac{t\pi y_2}{b}$$

$$\int_{-\infty}^{\infty} \frac{\Omega^2 \cos k_{z_{j\ell}} z_1 \cos k_{z_{rt}} z_2}{(1+\delta_{0j})(1+\delta_{0l})(1+\delta_{0r})(1+\delta_{0t}) k_{z_{j\ell}} (-\Omega) k_{z_{rt}} (\Omega) \sin k_{z_{j\ell}} d \sin k_{z_{rt}} d}$$

$$\left\{ \int_0^b \int_0^a \int_0^b \int_0^a S_{\phi\phi}(x_1, x_2, y_1, y_2, \Omega) \cos \frac{j\pi x_1}{a} \cos \frac{l\pi y_1}{b} \cos \frac{r\pi x_2}{a} \cos \frac{t\pi y_2}{b} \right.$$

$$\left. dx_1 dy_1 dx_2 dy_2 \right\} e^{i\Omega\tau} d\Omega \quad (D48a)$$

where from Equations (D33), (D35), (D36), and (D37)

$$k_{z_{j\ell}}(\omega) = \left[ \frac{\omega^2}{c^2} - \left(\frac{j\pi}{a}\right)^2 - \left(\frac{l\pi}{b}\right)^2 \right]^{1/2} \quad (D48b)$$

Hence

$$k_{z_{j\ell}}(\omega) = k_{z_{j\ell}}(-\omega) \quad (D48c)$$

The cavity acoustic pressure cross spectral density is

$$S_{aa}(x_1, x_2, y_1, y_2, z_1, z_2, \omega) = \frac{1}{\sqrt{2\pi}} \int_{-\infty}^{\infty} Q_{aa}(x_1, x_2, y_1, y_2, z_1, z_2, \tau) e^{-i\omega\tau} d\tau \quad (D49)$$

Substitution of Equation (D48a) in (D49) with  $S_{\phi\phi}$  given by Equation (D21b) yields (after reassigning the subscripts such that  $j, k, m, n$  apply to the acoustics problem and  $q, r, s$  and  $t$  to the plate)

$$S_{aa}(x_1, x_2, y_1, y_2, z_1, z_2, \omega) = \frac{8\rho_{a_0}^2}{\pi a^2 b^2} \sum_{\substack{j=0 \\ k=0}}^{\infty} \sum_{\substack{m=0 \\ n=0}}^{\infty} G_{jkmn}(x_1, x_2, y_1, y_2)$$

$$\int_{-\infty}^{\infty} \left\{ \int_{-\infty}^{\infty} \frac{g_{jkmn}(z_1, z_2, \Omega)}{(1+\delta_{0j})(1+\delta_{0k})(1+\delta_{0m})(1+\delta_{0n})} X(\Omega) \right.$$

$$\left. \sum_{\substack{q=1 \\ r=1}}^{\infty} \sum_{\substack{s=1 \\ t=1}}^{\infty} \left[ \int_0^b \int_0^a \int_0^b \int_0^a F_{qrst}(x_1, x_2, y_1, y_2) f_{qrst}(\Omega) G_{jkmn}(x_1, x_2, y_1, y_2) \right. \right.$$

$$\left. \left. dx_1 dy_1 dx_2 dy_2 \right] e^{i\Omega r} d\Omega \right\} e^{-i\omega r} dr$$

$$= \frac{8\rho_{a_0}^2}{\pi a^2 b^2} \sum_{\substack{j=0 \\ k=0}}^{\infty} \sum_{\substack{m=0 \\ n=0}}^{\infty} \sum_{\substack{q=1 \\ r=1}}^{\infty} \sum_{\substack{s=1 \\ t=1}}^{\infty} \frac{G_{jkmn}(x_1, x_2, y_1, y_2)}{(1+\delta_{0j})(1+\delta_{0k})(1+\delta_{0m})(1+\delta_{0n})}$$

$$\left[ \int_0^b \int_0^a \int_0^b \int_0^a F_{qrst}(x_1, x_2, y_1, y_2) G_{jkmn}(x_1, x_2, y_1, y_2) dx_1 dy_1 dx_2 dy_2 \right]$$

$$\int_{-\infty}^{\infty} \left\{ \int_{-\infty}^{\infty} g_{jkmn}(z_1, z_2, \Omega) X(\Omega) f_{qrst}(\Omega) e^{i\Omega r} d\Omega \right\} e^{-i\omega r} dr \quad (D50)$$

where

$$F_{qrst}(x_1, x_2, y_1, y_2) = \sin \frac{qn x_1}{a} \sin \frac{rn y_1}{b} \sin \frac{sn x_2}{a} \sin \frac{tn y_2}{b} \quad (D51)$$

$$f_{qrst}(\Omega) = \frac{G_{rt}(\Omega) V_{qrst}(\Omega)}{T_{qr}(\Omega) T_{st}(\Omega) P_r(\Omega) P_t(\Omega) R_q(\Omega) R_s(\Omega)} \quad (D52)$$

$$X(\Omega) = \begin{cases} \frac{16A\Omega^2}{\mu^2 a^2 b^2} & \Omega \leq 1.256 \frac{U_0}{\delta^*} \\ \frac{32A\Omega^2}{\mu^2 a^2 b^2} \left(\frac{\Omega\delta^*}{U_0}\right)^{-3} & \Omega > 1.256 \frac{U_0}{\delta^*} \end{cases} \quad (\text{D53})$$

$$G_{jkmn}(x_1, x_2, y_1, y_2) = \cos \frac{j\pi x_1}{a} \cos \frac{k\pi y_1}{b} \cos \frac{m\pi x_2}{a} \cos \frac{n\pi y_2}{b} \quad (\text{D54})$$

$$g_{jkmn}(z_1, z_2, \Omega) = \frac{\Omega^2 \cos k_{z_{jk}} z_1 \cos k_{z_{mn}} z_2}{k_{z_{jk}}(\Omega) k_{z_{mn}}(\Omega) \sin k_{z_{jk}} d \sin k_{z_{mn}} d} \quad (\text{D55})$$

Integration over frequency  $\Omega$  of the bracketed term in the right member of Equation (D50) results in

$$\sqrt{2\pi} g_{jkmn}(z_1, z_2, r) X(r) f_{qrst}(r) \quad (\text{D56})$$

where

$$f(r) = \frac{1}{\sqrt{2\pi}} \int_{-\infty}^{\infty} F(\omega) e^{i\omega r} d\omega \quad (\text{D57})$$

Substitution of Equation (D56) in (D50) and integration over  $r$  yields the final expression for the cavity acoustic cross spectral density:

$$S_{aa}(x_1, x_2, y_1, y_2, z_1, z_2, \omega) = \frac{16\rho_{a_0}^2}{a^2 b^2} \sum_{j=0}^{\infty} \sum_{k=0}^{\infty} \sum_{m=0}^{\infty} \sum_{n=0}^{\infty} \sum_{q=1}^{\infty} \sum_{r=1}^{\infty} \sum_{s=1}^{\infty} \sum_{t=1}^{\infty}$$

$$G_{jkmn}(x_1, x_2, y_1, y_2) g_{jkmn}(z_1, z_2, \omega) X(\omega) f_{qrst}(\omega)$$



$$\cdot \left[ \frac{1}{(1+\delta_{0j})(1+\delta_{0k})(1+\delta_{0m})(1+\delta_{0n})} \int_0^b \int_0^a \int_0^b \int_0^a F_{qrst}(x_1, x_2, y_1, y_2) G_{jkmn}(x_1, x_2, y_1, y_2) dx_1 dy_1 dx_2 dy_2 \right] \quad (D58)$$

Integrating over the spatial coordinates, using Equations (D51) and (D54), we obtain by means of standard integration techniques

$$S_{\alpha\alpha}(x_1, x_2, y_1, y_2, z_1, z_2, \omega) = \frac{16\rho_{a_0}^2}{\pi^4} X(\omega) \sum_{j=0}^{\infty} \sum_{k=0}^{\infty} \sum_{m=0}^{\infty} \sum_{n=0}^{\infty} \sum_{q=1}^{\infty} \sum_{r=1}^{\infty} \sum_{s=1}^{\infty} \sum_{t=1}^{\infty} \quad (D59)$$

$$G_{jkmn}(x_1, x_2, y_1, y_2) g_{jkmn}(z_1, z_2, \omega) f_{qrst}(\omega) K_{jkmnqrst} \quad (D59)$$

where  $G_{jkmn}$ ,  $g_{jkmn}$ ,  $f_{qrst}$ , and  $X(\omega)$  are defined in Equations (D54), (D55), (D52), and (D53), respectively, and where

$$K_{jkmnqrst} = \frac{(1-\delta_{qj})(1-\delta_{rk})(1-\delta_{sm})(1-\delta_{tn}) f_{qrst} \left[ 1 - (-1)^q (-1)^j \right] \left[ 1 - (-1)^r (-1)^k \right]}{(1+\delta_{0j})(1+\delta_{0k})(1+\delta_{0m})(1+\delta_{0n})(q^2-j^2)(r^2-k^2)} \cdot \frac{\left[ 1 - (-1)^s (-1)^m \right] \left[ 1 - (-1)^t (-1)^n \right]}{(s^2-m^2)(t^2-n^2)} \quad (D60)$$

The cavity acoustic pressure spectral density obtained from Equation (D58) is

$$\Phi_{\alpha}(x_1, y_1, z_1, \omega) = S_{\alpha\alpha}(x_1, x_1, y_1, y_1, z_1, z_1, \omega) = \frac{16\rho_{a_0}^2}{\pi^4} X(\omega) \cdot$$

$$\sum_{j=0}^{\infty} \sum_{k=0}^{\infty} \sum_{m=0}^{\infty} \sum_{n=0}^{\infty} \sum_{q=1}^{\infty} \sum_{r=1}^{\infty} \sum_{s=1}^{\infty} \sum_{t=1}^{\infty} G_{jkmn}(x_1, x_1, y_1, y_1) g_{jkmn}(z_1, z_1, \omega) f_{qrst}(\omega) K_{jkmnqrst} \quad (D61)$$

Setting  $x_1 = x_2$ ,  $y_1 = y_2$  in Equation (D54) and  $z_1 = z_2$  in Equation (D55), we have

$$G_{jkmn}(x_1, x_1, y_1, y_1) = G_{mnlk}(x_1, x_1, y_1, y_1) = G_{jkmn}(x_1, y_1) \quad (D62)$$

$$g_{jkmn}(z_1, z_1, \omega) = g_{mnlk}(z_1, z_1, \omega) = g_{jkmn}(z_1, \omega) \quad (D63)$$

Also

$$K_{jkmnqrst} = K_{mnlkstqr} \quad (D64)$$

Hence using (D52), (D53), (D62), and (D63) in Equation (D61) and dropping the subscripts on spatial coordinates, we obtain

$$\begin{aligned} \Phi_a(x, y, z, \omega) &= \frac{256A\rho_a^2 \omega^2}{\pi^4 \mu^2 a^2 b^2} \sum_{j=0}^{\infty} \sum_{m=0}^{\infty} \sum_{k=0}^{\infty} \sum_{n=0}^{\infty} \frac{G_{jkmn}(x, y) g_{jkmn}(z, \omega) G_{rt}(\omega)}{T_{qr}(\omega) T_{st}(\omega) P_r(\omega) P_t(\omega) R_q(\omega) R_s(\omega)} \\ &\quad \cdot K_{jkmnqrst} V_{qrst}(\omega); \quad \omega \leq 1.256 \frac{U_0}{\delta^*} \\ &= \frac{512A\rho_a^2 \omega^2}{\pi^4 \mu^2 a^2 b^2} \left( \frac{\omega \delta^*}{U_0} \right)^{-3} \sum_{j=0}^{\infty} \sum_{m=0}^{\infty} \sum_{k=0}^{\infty} \sum_{n=0}^{\infty} \frac{G_{jkmn}(x, y) g_{jkmn}(z, \omega) G_{rt}(\omega)}{T_{qr}(\omega) T_{st}(\omega) P_r(\omega) P_t(\omega) R_q(\omega) R_s(\omega)} \\ &\quad \cdot K_{jkmnqrst} V_{qrst}(\omega) \quad \omega > 1.256 \frac{U_0}{\delta^*} \quad (D65) \end{aligned}$$

As for the case of the plate velocity spectral density, the cavity acoustic pressure spectral density must be a real, even function of frequency. Thus by substituting  $V_{qrst}$  (as given below Equation (D21b)) in Equation (D65), rearranging Equation (D65) first for the frequency range  $\omega \leq 1.256 \frac{U_0}{\delta^*}$ , (see Reference 32 for details) and then for  $\omega > 1.256 \frac{U_0}{\delta^*}$ , and using Equations (D62), (D63), and (D64), we finally obtain

$$\Phi_a(x, y, z, \omega) = \frac{256A\rho_{a_0}^2 \omega^2}{\pi^4 \mu^2 a^2 b^2} \sum_{\substack{j=0 \\ k=0}}^{\infty} \sum_{\substack{m=0 \\ n=0}}^{\infty} \sum_{\substack{q=1 \\ r=1}}^{\infty} \sum_{\substack{s=1 \\ t=1}}^{\infty} \frac{G_{jkmn}(x, y) g_{jkmn}(z, \omega) G_{rt}(\omega)}{T_{qr}(\omega) T_{st}(\omega) P_r(\omega) P_t(\omega) R_q(\omega) R_s(\omega)} \cdot W_{qrst}(\omega) K_{jkmnqrst}; \quad \omega \leq 1.256 \frac{U_0}{\delta^*}$$

$$\Phi_a(x, y, z, \omega) = \frac{512A\rho_{a_0}^2 \omega^2}{\pi^4 \mu^2 a^2 b^2} \left(\frac{\omega \delta^*}{U_0}\right)^{-3} \sum_{\substack{j=0 \\ k=0}}^{\infty} \sum_{\substack{m=0 \\ n=0}}^{\infty} \sum_{\substack{q=1 \\ r=1}}^{\infty} \sum_{\substack{s=1 \\ t=1}}^{\infty} \frac{G_{jkmn}(x, y) g_{jkmn}(z, \omega) G_{rt}(\omega)}{T_{qr}(\omega) T_{st}(\omega) P_r(\omega) P_t(\omega) R_q(\omega) R_s(\omega)} \cdot W_{qrst}(\omega) K_{jkmnqrst} \quad \omega > 1.256 \frac{U_0}{\delta^*} \quad (D66)$$

For practical utility, the plate velocities and cavity acoustic pressures are expressed in nondimensional form. The nondimensional expressions given below are the working expressions used in the computer program.

The nondimensional form of the plate spectral velocity is defined as

$$\Phi_{\phi}^+(x^+, y^+, \omega^+) = \frac{\Phi_{\phi}(x^+, y^+, \omega^+)}{a^2 U_c a} = 4.38 \times 10^{-4} M^2 \delta^+ \omega^{+2}$$

$$\sum_{\substack{m=1 \\ n=1}}^{\infty} \sum_{\substack{q=1 \\ s=1}}^{\infty} \frac{\sin m\pi x^+ \sin q\pi x^+ \sin \frac{n\pi y^+}{b^+} \sin \frac{s\pi y^+}{b^+} G_{ns}^+(\omega^+) W_{mnqs}^+(\omega^+)}{T_{mn}^+(\omega^+) T_{qs}^+(\omega^+) P_n^+(\omega^+) P_s^+(\omega^+) R_m^+(\omega^+) R_q^+(\omega^+)}; \quad \omega^+ \delta^+ \leq 1.932$$

$$= 3.2 \times 10^{-3} M^2 \delta^{+2} \omega^{+5} \sum_{\substack{m=1 \\ n=1}}^{\infty} \sum_{\substack{q=1 \\ s=1}}^{\infty}$$

$$\frac{\sin m\pi x^+ \sin q\pi x^+ \sin \frac{n\pi y^+}{b^+} \sin \frac{s\pi y^+}{b^+} G_{ns}^+(\omega^+) W_{mnqs}^+(\omega^+)}{T_{mn}^+(\omega^+) T_{qs}^+(\omega^+) P_n^+(\omega^+) P_s^+(\omega^+) R_m^+(\omega^+) R_q^+(\omega^+)}; \quad \omega^+ \delta^+ > 1.932 \quad (D67)$$

where the dimensionless input parameters and spatial and frequency variables are defined as follows

$$\begin{aligned}
 M &= \frac{\rho_f a}{\mu} & x^+ &= \frac{x}{a} \\
 U^+ &= \frac{U_0}{U_c} & y^+ &= \frac{y}{a} \\
 \delta^+ &= \frac{\delta^*}{a} & \omega^+ &= \frac{\omega a}{U_c} \\
 b^+ &= \frac{b}{a} \\
 \omega_{mn}^+ &= \frac{\omega_{mn} a}{U_c} \\
 r^+ &= \frac{ra}{\mu U_c} \\
 r_{c_{mn}}^+ &= \frac{r_{c_{mn}} a}{\mu U_c} = \frac{2\omega_{mn} a}{U_c} \\
 D^+ &= \frac{D}{\mu U_c^2 a^2}
 \end{aligned} \tag{D68}$$

The quantities defined below Equation (D21) for  $R_m, R_q, \nu_m, \nu_q, \lambda_{mn}, \lambda_{qs}, G_{ns}, P_n, P_s, T_{mn}, T_{qs}$ , and Equation (D23) have been rewritten in dimensionless terms as follows:

$$R_m^+(\omega^+) = \left\{ \left[ (m\pi)^2 - 0.987 \omega^{+2} \right]^2 + 0.0529 \omega^{+4} \right\}^{1/2} \tag{D69}$$

$$\nu_m = \tan^{-1} \left[ \frac{0.23 \omega^{+2}}{(m\pi)^2 - 0.987 \omega^{+2}} \right] \tag{D70}$$

$$\lambda_{mn} = \tan^{-1} \left[ \frac{r^+ \omega^+}{(\omega_{mn}^+)^2 - (\omega^+)^2} \right] \tag{D71}$$

$$G_{mn}^+(\omega^+) = 0.35 \omega^+ b^+ \delta_{mn} \left[ 2(0.7 \omega^+ b^+)^2 + (m\pi)^2 + (n\pi)^2 \right] \\ + mn\pi^2 \left[ (-1)^m (-1)^n - 1 \right] \left[ 1 - \delta_{mn} \right] + mn\pi^2 \left\{ 2 - \left[ (-1)^m + (-1)^n \right] e^{-0.7 \omega^+ b^+} \right\} \quad (D72)$$

$$P_m^+(\omega^+) = (m\pi)^2 + (0.7 \omega^+ b^+)^2 \quad (D73)$$

$$T_{mn}^+(\omega^+) = \left\{ \left[ \left( \frac{\omega_{mn}^+}{\omega^+} \right)^2 - 1 \right]^2 + \left[ 2 \frac{r^+}{r_{c_{mn}}^+} \frac{\omega_{mn}^+}{\omega^+} \right]^2 \right\}^{1/2} \quad (D74)$$

$$W_{jkmn}^+(\omega^+) = 1.0066 \omega^+ + \delta_{jm} R_m^+ \cos(\nu_j - 0.463\pi) \cos(\lambda_{jk} - \lambda_{mn}) \\ + 2jm\pi^2 \cos(\nu_j + \nu_m) \cos(\lambda_{jk} - \lambda_{mn}) + (1 - \delta_{jm}) \cdot \frac{jm\pi^2 [(-1)^j (-1)^m - 1]}{[(jn)^2 - (m\pi)^2]} \\ \cdot \left[ R_j^+ \cos(\nu_m + \lambda_{jk} - \lambda_{mn}) - R_m^+ \cos(\nu_j + \lambda_{mn} - \lambda_{jk}) \right] - jm\pi^2 e^{-0.115 \omega^+} \\ \cdot \left[ (-1)^j \cos(\omega^+ + \nu_j + \nu_m + \lambda_{jk} - \lambda_{mn}) + (-1)^m \cos(\omega^+ + \nu_j + \nu_m + \lambda_{mn} - \lambda_{jk}) \right] \quad (D75)$$

The nondimensional form of the cavity acoustic pressure spectral density is defined as

$$\Phi_a^+(x^+, y^+, z^+, \omega^+) = \frac{\Phi_a(x^+, y^+, z^+, \omega^+) a}{a^2 \mu^2 U_c^3} = \frac{7.008 \times 10^{-3}}{\pi^4} \rho^+ M^2 \delta^+ .$$

$$\sum_{\substack{j=0 \\ k=0}}^{\infty} \sum_{\substack{m=0 \\ n=0}}^{\infty} \sum_{\substack{q=1 \\ r=1}}^{\infty} \sum_{\substack{s=1 \\ t=1}}^{\infty} \left\{ \frac{G_{rt}^+(\omega^+) W_{qrst}^+(\omega^+) K_{jkmnqrst}}{U_{jkmn}^+(\omega^+)} \right\} .$$

$$\frac{\cos j\pi x^+ \cos m\pi x^+ \cos \frac{k\pi y^+}{b^+} \cos \frac{n\pi y^+}{b^+} \cos k_{z_{jk}}^+ z^+ \cos k_{z_{mn}}^+ z^+}{T_{qr}^+(\omega^+) T_{st}^+(\omega^+) P_r^+(\omega^+) P_t^+(\omega^+) R_q^+(\omega^+) R_s^+(\omega^+)} ; \omega^+ \delta^+ \leq 1.932$$

$$= \frac{5.112 \times 10^{-2}}{\pi^4} \rho^{+2} M^2 \delta^{+2} \omega^{+3} \sum_{j=0}^{\infty} \sum_{k=0}^{\infty} \sum_{m=0}^{\infty} \sum_{n=0}^{\infty} \sum_{q=1}^{\infty} \sum_{r=1}^{\infty} \sum_{s=1}^{\infty} \sum_{t=1}^{\infty}$$

$$\left\{ \frac{G_{rt}^+(\omega^+) W_{qrst}^+(\omega^+) K_{jkmnqrst}}{U_{jkmn}^+(\omega^+)} \right\}$$

$$\frac{\cos j\pi x^+ \cos m\pi x^+ \cos \frac{k\pi y^+}{b^+} \cos \frac{n\pi y^+}{b^+} \cos k_{z_{jk}}^+ z^+ \cos k_{z_{mn}}^+ z^+}{T_{qr}^+(\omega^+) T_{st}^+(\omega^+) P_r^+(\omega^+) P_t^+(\omega^+) R_q^+(\omega^+) R_s^+(\omega^+)} ; \omega^+ \delta^+ > 1.932$$

(D76)

Equation (D76) is obtained from Equations (D66), (D69) through (D75), and the following definitions for the dimensionless input parameters and spatial variable:

$$\begin{aligned} c^+ &= \frac{c}{U_c} & \rho^+ &= \frac{\rho a_0 a}{\mu} \\ d^+ &= \frac{d}{a} & z^+ &= \frac{z}{a} \end{aligned} \quad (D77)$$

which are used to form the following dimensionless quantities

$$k_{z_{jk}}^+(\omega^+) = \left[ \left( \frac{\omega^+}{c^+} \right)^2 - (j\pi)^2 - \left( \frac{k\pi}{b^+} \right)^2 \right]^{1/2}$$

$$U_{jkmn}^+(\omega^+) = k_{z_{jk}}^+(\omega^+) k_{z_{mn}}^+(\omega^+) \sin k_{z_{jk}}^+ d^+ \sin k_{z_{mn}}^+ d^+ \quad (D78)$$

## APPENDIX D2 - METHOD FOR DETERMINING INPUT DATA

The following data are furnished to the computer:

1. Dimensionless input parameters to determine the dimensionless plate velocity spectral density:

$$M = \frac{\rho_f a}{\mu}$$

$$U^+ = \frac{U_0}{U_c} \quad (\text{See Figure 4 of Reference 32; } U^+ \text{ was taken to be constant, equal to 1.54 in Reference 32.)}$$

$$\delta^+ = \frac{\delta^*}{\mu}$$

$$b^+ = \frac{b}{a}$$

$$D^+ = \frac{D}{\mu U_c a^2}$$

$$r^+ = \frac{ra}{\mu U_c}$$

The values for the data used in determining the input parameters may be either arbitrarily prescribed or measured by methods similar to those presented in Appendix C.\*

The range must also be specified for the spacial and frequency variables  $x^+ = \frac{x}{a}$ ,

$$y^+ = \frac{y}{a}, \text{ and } \omega^+ = \omega a / U_c$$

2. Dimensionless input parameters to determine the dimensionless cavity acoustic pressure spectral density.

In addition to the foregoing parameters, it is necessary to specify the following additions:

$$c^+ = \frac{c}{U_c}$$

---

\*Additional input parameters  $\omega_{mn}^+ = \frac{\omega_{mn} a}{U_c}$  and  $r_{c_{mn}}^+ = \frac{r_{c_{mn}} a}{\mu U_c} = \frac{2\omega_{mn} a}{U_c}$  are functions of  $D^+$  and  $b^+$  only,

hence need not be independently specified.

$$d^+ = \frac{d}{a}$$

$$\rho^+ = \frac{\rho_a a}{\mu}$$

and the range for  $z^+ = \frac{z}{a}$ .

The values for these data are either known from the geometry and properties of the actual structure and fluid or are arbitrarily specified.

Reference 32 gives dimensionless input parameters which fall in the range of interest for submarine sonar applications.



### APPENDIX D3 - PROGRAM IDENTIFICATION

This program computes the plate velocity power spectrum and cavity acoustic pressure power spectrum resulting from the vibrations of a turbulence excited finite plate with simply supported boundaries. The program is designated as TURB3. It consists of two subprograms, I and II. Subprogram I computes the plate velocity power spectrum and Subprogram II the cavity acoustic pressure power spectrum. Both use similar notation. There are slight differences in their inputs and in the interpretation of their output. See identification below. A time estimate of the computer running times on the IBM 7090 is given below.

Figure No.	Subprogram	Frequency Range	Running Time min
16	I	$1 \leq \omega^+ \leq 1000$	9.13
17	I	$1 \leq \omega^+ \leq 1000$	12.0
18	II	$1 \leq \omega^+ \leq 1500$	442.0

## APPENDIX D

### TABLE 6

#### Identification for Subprograms I and II - Strawderman

This table includes input and output data identification, flow chart, and order of input data. Computer running times have been given on the previous page. Computer program listings are presented in Table 7.

TABLE 6A: Input Data

TABLE 6B: Output Data

TABLE 6C: Flow Charts

TABLE 6D: Input Format

TABLE 6A

Input Data  
(Dimensionless Units)

Symbol	Identification	Program
$x^+$	Dimensionless longitudinal spacial coordinate $x/a$	X
$y^+$	Dimensionless lateral spacial coordinate $y/a$	Y
$z^+$	Dimensionless spatial coordinate $z/a$	ZP
$b^+$	Dimensionless plate and acoustic cavity dimension $b/a$	BP
$d^+$	Dimensionless cavity dimension $d/a$ where $d$ is acoustic cavity dimension in $z$ -direction	DEPTH
$\frac{r^+}{r_{c_{m,n}}^+}$	Dimensionless plate damping coefficient divided by dimensionless critical plate damping for the $m$ - $n$ th mode	DAMP
$\omega^+$	Dimensionless radial frequency	OMEGA
$c^+ = \frac{c}{U_c} = \frac{cU^+}{U_0}$	Dimensionless speed of sound	CP
$D^+$	Dimensionless plate flexural rigidity	DP
$M$	Dimensionless fluid mass	CAPM
$\delta^+$	Dimensionless turbulent boundary layer displacement thickness	DELTA
$\alpha$	Constant mult. factor; changes for different fluids; $\alpha = 1.0$ for water $\alpha = 3.0$ for air (See Interpretation of Data Output)	ALFA
	Largest frequency of interest, i.e., cutoff frequency at which program is to stop	TIP
	Convergence criterion in Equation (D76) with TOLH > 1.0 (Case I only)	TOLH
	Convergence criterion in Equation (D76) with TOLL < 1.0 (Case I only)	TOLL
$\rho^+$	Dimensionless fluid density equal to $\rho_{a_0} a / \mu$	RHO

TABLE 6B

Output Data

Symbol	Identification	Program
$\omega_{mn}$	Modal natural frequencies $\omega_{mn} = \sqrt{\frac{D}{\mu} \left[ \left(\frac{m\pi}{a}\right)^2 + \left(\frac{n\pi}{b}\right)^2 \right]}$	PNOME (I,J)
$\phi_a^+(x^+, y^+, z^+, \omega^+)$	Subprogram II: Equation (D76) Dimensionless form of the cavity acoustic spectral density. NOTE: PHIP was multiplied by $(\rho^+)^2 =$ $\left(\frac{\rho_{a_0} a}{\mu}\right)^2$ to agree with (D76); see Interpretation of Data Output below  10.0 LOG <sub>e</sub> (PHIP)/2.302589  Corresponding frequency to PHIP and PHIDB  Subprogram I. Equation (D67) Dimensionless plate velocity spectral density  10.0 LOG <sub>e</sub> (PHIP)/2.302589  Number of terms needed for conver- gence for each PHIP  Subscript indicating how many times summation gone through before convergence.	PHIDB  OMEGA  PHIP  PHIDB  ITOP  MU

Interpretation of Data Output

Comment: Subprogram I involves eight nested do-loops which means that the inner operations are done a minimum of  $2^8$  times; the next index on the loop would be  $4^8, 6^8, \dots$  etc. until convergence. Case I involves only four nested loops.

Special Instruction: Sense Switch 4 is turned on by operator at beginning of program.

Curves - Three Examples

Example 1 (Figure 16): Subprogram I, Equation (D67) is used for this curve. The computer results for the plate velocity spectrum were then changed to dimensional form and finally converted to the ratio of displacement spectral density to turbulent pressure spectral

density. The subprogram uses Bull data. The form of the final response is  $10 \text{ Log}_{10} [(\Phi_d(\omega) / \Phi_t(\omega))] \text{ plotted against } f$ . The following conversions were made manually.

- a. Use the program to compute  $\phi_{\phi}^+(\omega)$  Equation (D67) multiplied by  $a^2$
- b. Convert  $\phi_{\phi}^+(\omega) = \frac{\phi_{\phi}(\omega)}{U_c a}$ , where  $a^2 \phi_{\phi}^+(\omega)$  is the quantity appearing in the program. This quantity is then multiplied by  $U_c a$  to yield  $\phi_{\phi}(\omega)$ .
- c.  $\Phi_d(\omega) = \frac{\phi_{\phi}(\omega)}{\omega^2}$  (from velocity to displacement).
- d.  $\Phi_t(\omega) = \phi_p$ , Equations 3.1 of Reference 32. Use first of Equations 3.1 of Reference

32 since the Bull data yield maximum frequency  $\omega = 12,566 \text{ cps}$  but  $\omega = \frac{1.258 U_0}{\delta^*} =$

47,272 is cutoff point in this equation.

- e. Other unit conversions:

$$(1) \quad \omega^+ \text{ to } f \text{ by } \omega^+ = \frac{2\pi f a}{U_c}$$

$$(2) \quad \delta^* = a \delta^+$$

$$(3) \quad U_c = \frac{U_0}{U^+}$$

$$f. \quad \frac{\Phi_d(\omega)}{\Phi_t(\omega)} = \frac{\phi_{\phi}(\omega)}{\omega^2 \phi_p(\omega)} \Rightarrow 10 \text{ Log } \frac{\Phi_d(\omega)}{\Phi_t(\omega)} = 10 \text{ Log } \frac{\phi_{\phi}(\omega)}{\omega^2 \phi_p(\omega)} =$$

$$10 \text{ Log } (\phi_{\phi}(\omega)) - 10 \text{ Log } (\omega^2 \phi_p(\omega)) =$$

$$10 \text{ Log } (U_c a \phi_{\phi}^+(\omega)) - 10 \text{ Log } (\omega^2 \phi_p(\omega)) =$$

$$[10 \text{ Log } (U_c a) + 10 \text{ Log } (\phi_{\phi}^+(\omega)) - 10 \text{ Log } (\omega^2 \phi_p(\omega))] ]$$

$$[10 \text{ Log } (U_c a) + 10 \text{ Log } (\phi_{\phi}^+(\omega)) - 20 \text{ Log } \omega - 10 \text{ Log } \phi_p(\omega)] .$$

Plot this versus  $f$ .

As an alternative, the foregoing results may be obtained by a simplified procedure. This option eliminates most but not all of the manual computations.

For subprogram use, the Bull data are nondimensionalized (see Figure 16). Note that for this frequency range in the figure, the value of  $\phi_p$  is a constant. This makes the correction simpler. The following FORTRAN lines, in which the constants are dependent on the Bull data, are inserted into the Strawderman program to yield direct results for plotting Figure 16. These lines are inserted immediately after Statement 212 in the program. The curve was plotted with RESP (PHISUBD/PHISUBT) against FREQ. It should be noted that the curve is about 6 dB lower than Strawderman's, since he originally used 116 (an arithmetic error which he corrected following publication of Reference 32) instead of 110.392; see subroutine above.

Col. 7

```

PHIC=PHIDB+110.392
OF=OMEGA*190.986
OFW=OF*6.2318
WRITE(6,240)PHIC,OF,OFW
240  FORMAT(1X,6HΔPHIC=E17.8,6HΔFREO=E17.8,10HΔ20LOG(W)=E17.8)
RESP=PHIC-OFW
WRITE(6,241)RESP
241  FORMAT(1X,17HPHISUBD/PHISUBT=E17.8)

```

Example 2 (Figure 17): Subprogram I is used. Computer result PHIDB is plotted against OMEGA. This gives representation of Equation (D67) directly, i.e., PHIDB represents the dimensionless plate velocity spectral density corresponding to values of  $\omega^+$ .

Example 3 (Figure 18): Subprogram I is used. Computer result PHIDB is plotted against OMEGA. Note: for agreement with Equation (D76) (cavity acoustic spectral density), the result PHIP must be multiplied by  $(\rho^+)^2 = (\rho_{a_0} a / \mu)^2$  or  $20 \text{ Log}_{10} \rho^+$  must be added to  $10.0 \text{ Log}_e (\text{PHIP}) / 2.302589 = \text{PHIDB}$ .<sup>\*</sup> In Figure D4 the convergence criterion was a tolerance of 20 percent, with TOLL = 0.8 and TOLH = 1.2.

It is important to note that the original subprograms gave the following results:

$a^2 \Phi_\phi^+(x^+, y^+, \omega^+)$  and  $a^2 \Phi_a^+(x^+, y^+, z^+, \omega^+)$  rather than  $\Phi_\phi^+(x^+, y^+, \omega^+)$  and  $\Phi_a^+(x^+, y^+, z^+, \omega^+)$ . By setting  $a = 1$ , the subprograms have now been modified to yield the *normalized results*  $\Phi_\phi^+(x^+, y^+, \omega^+)$  and  $\Phi_a^+(x^+, y^+, z^+, \omega^+)$ . The *unnormalized results*  $\Phi_\phi(x^+, y^+, \omega^+) = a^2 U_c a \Phi_\phi^+(x^+, y^+, \omega^+)$  and  $\Phi_a(x^+, y^+, z^+, \omega^+) = a^2 \mu^2 U_c^3 \Phi_a^+(x^+, y^+, z^+, \omega^+)$  are then obtained *manually* for water ( $a = 1$ ) or air ( $a = 3$ ), i.e., set  $a = 1$  or 3, accordingly.

<sup>\*</sup>This operation was performed in order to manually compensate for the inadvertent omission of  $(\rho^+)^2$  from the program. Subsequent to the computation of Figure 18, the program was corrected to include  $(\rho^+)^2$ . Hence manual compensation is no longer necessary since the true results are obtained directly from the computer.

Flow Chart for Subprogram I - Plate Velocity Power Spectrum

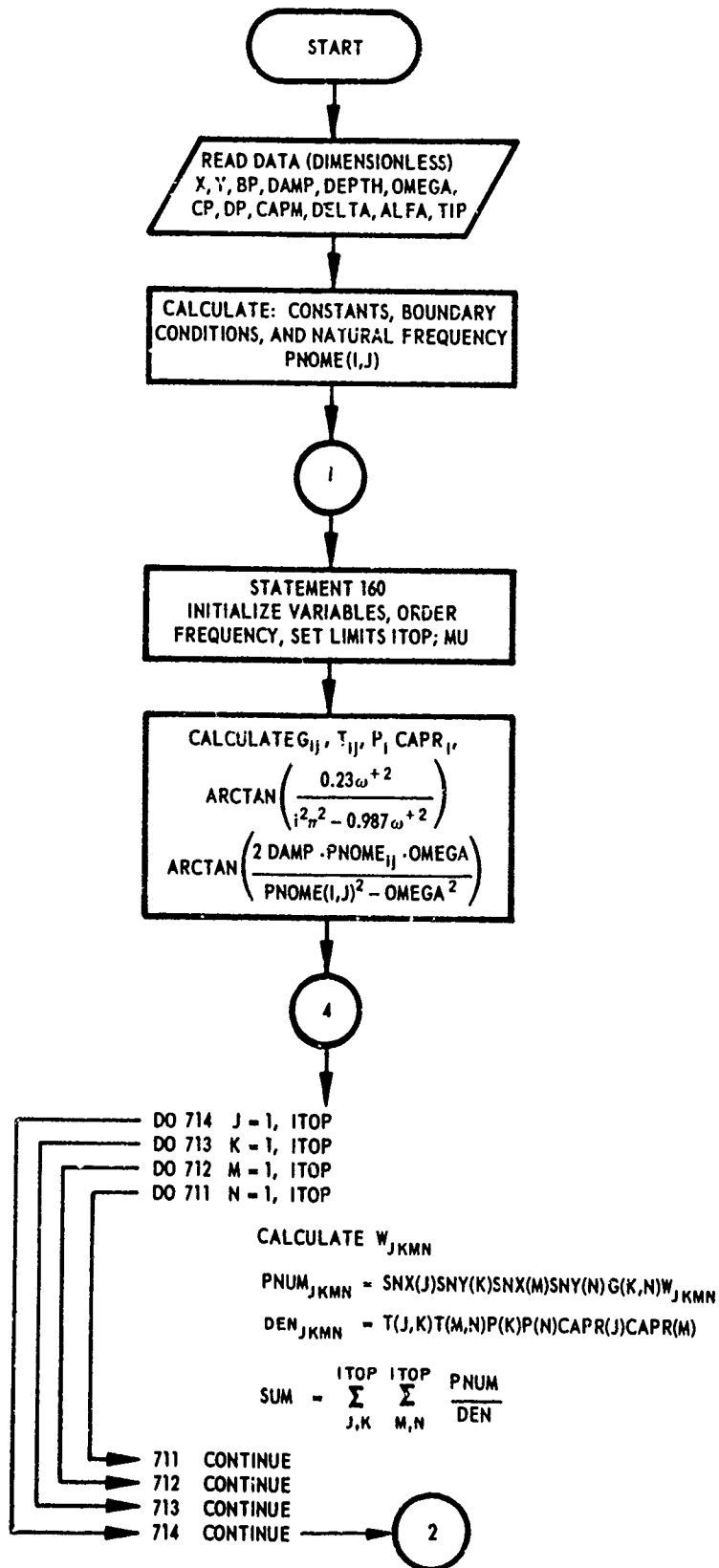

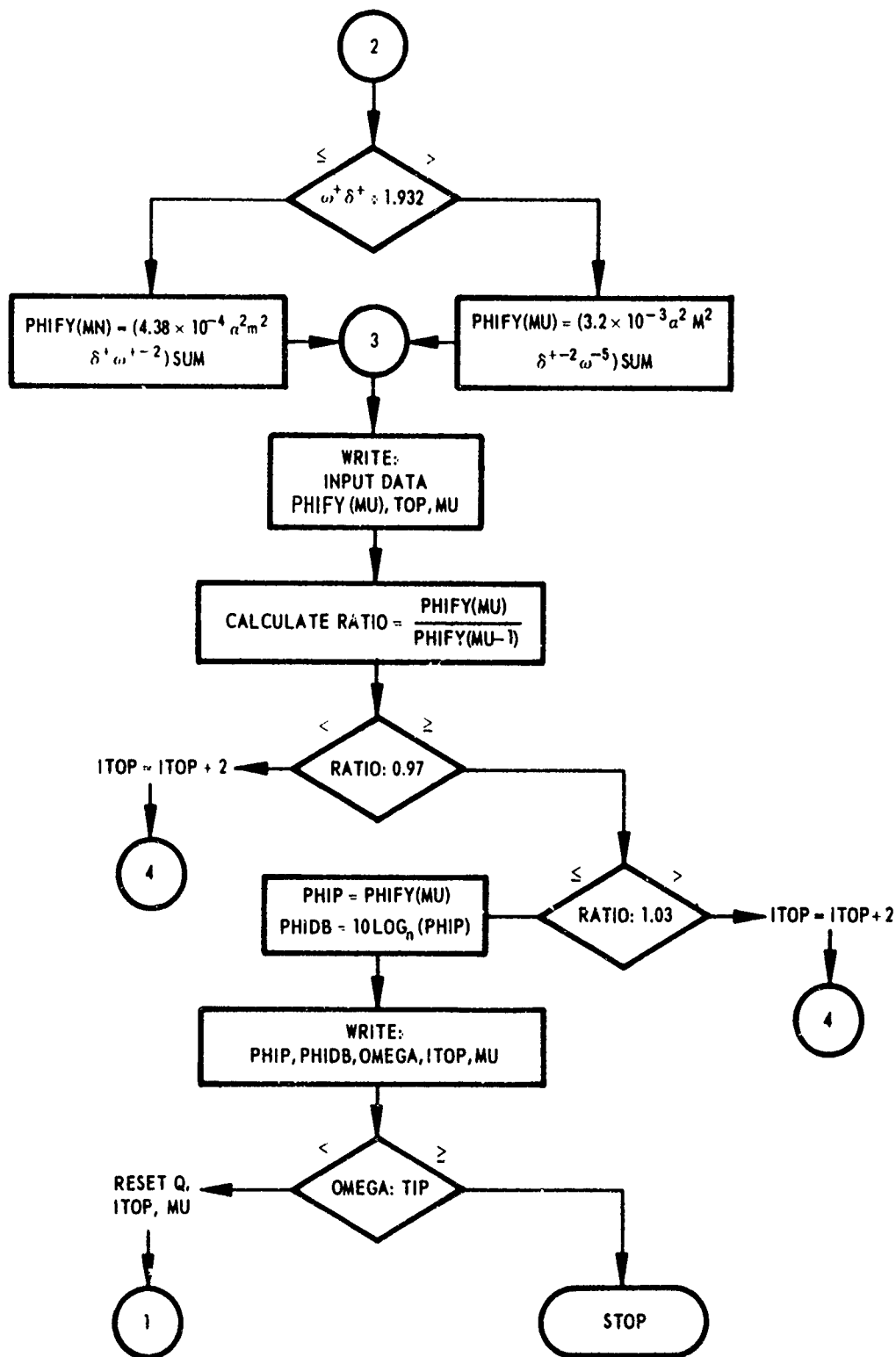



Flow Chart for Subprogram II – Cavity Acoustic Pressure Spectrum

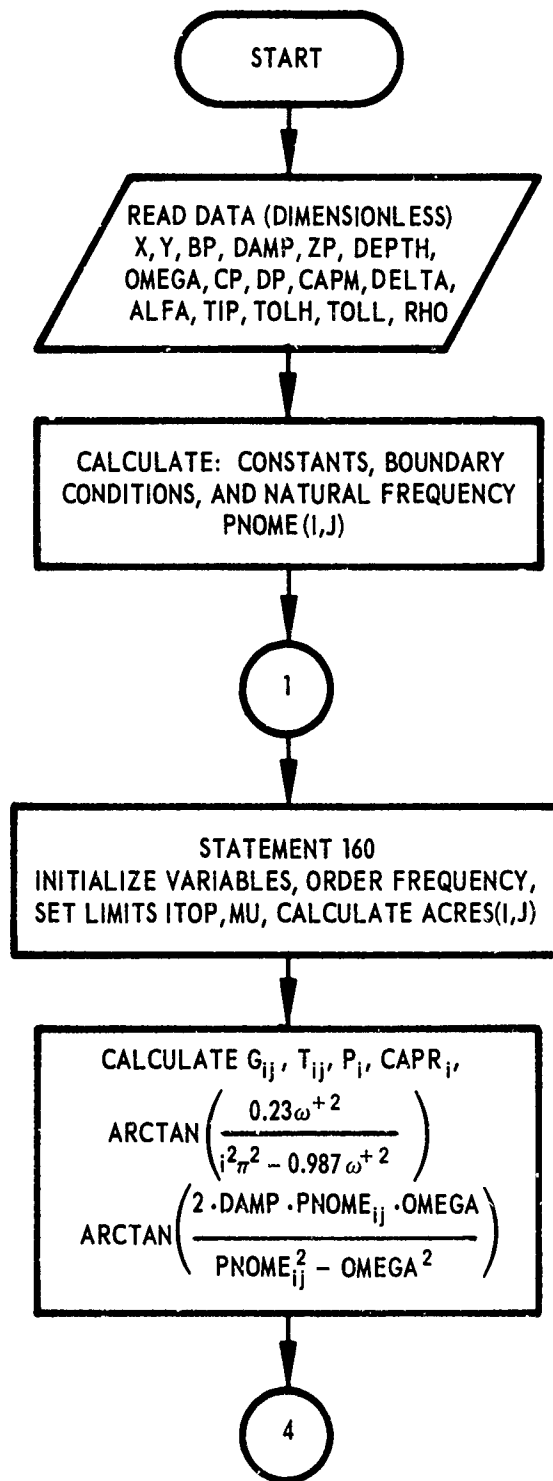

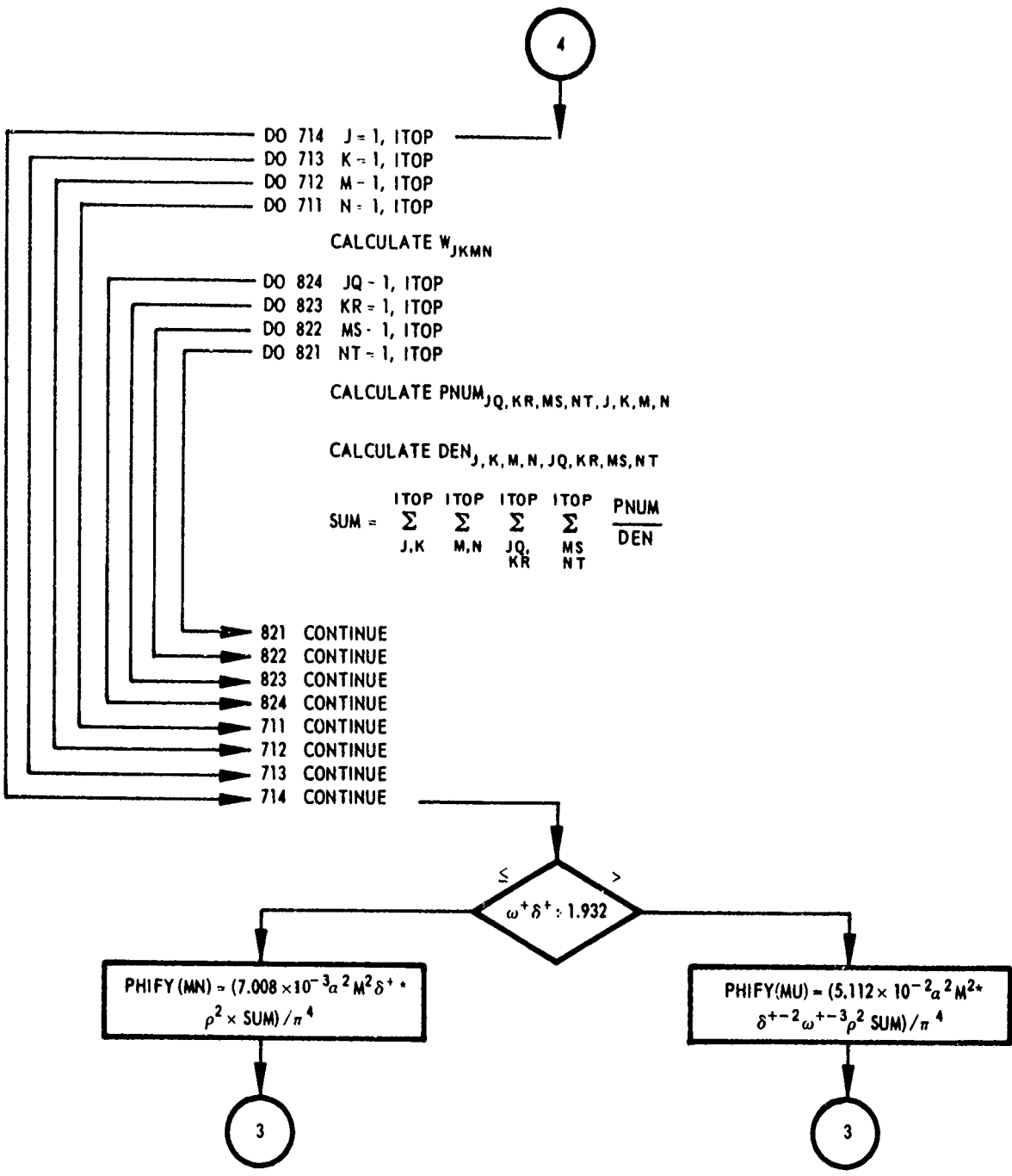

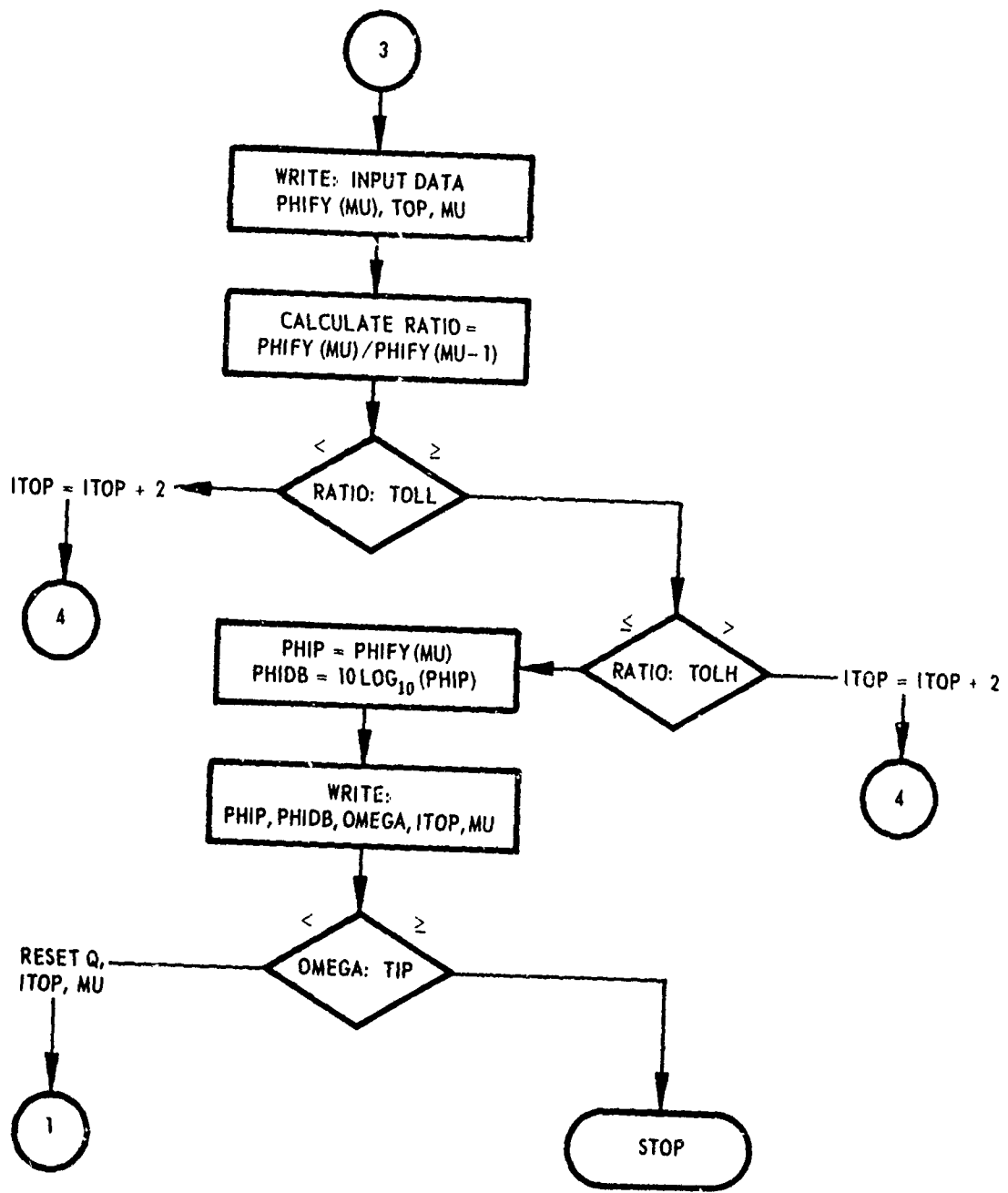
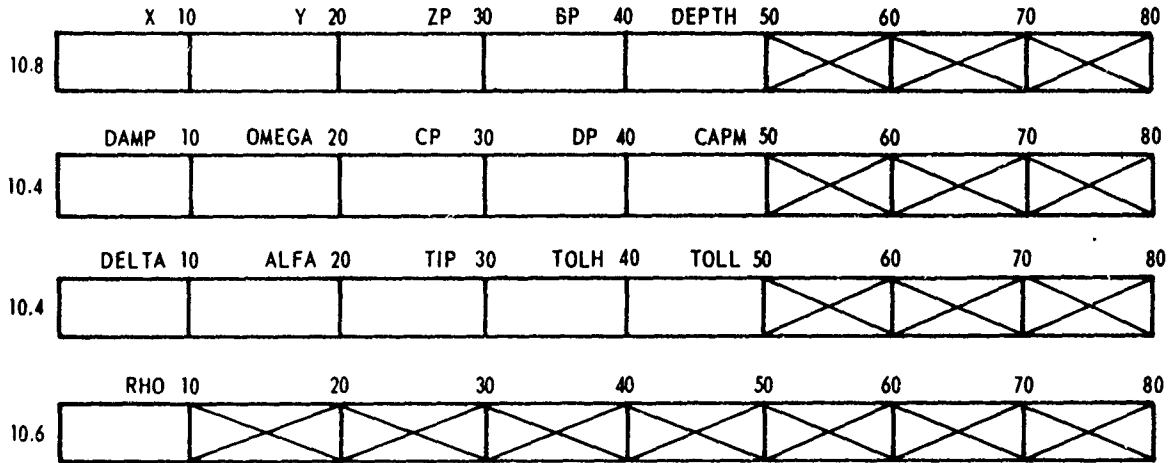

TABLE 6D

Input Format

CASE 1



CASE 2

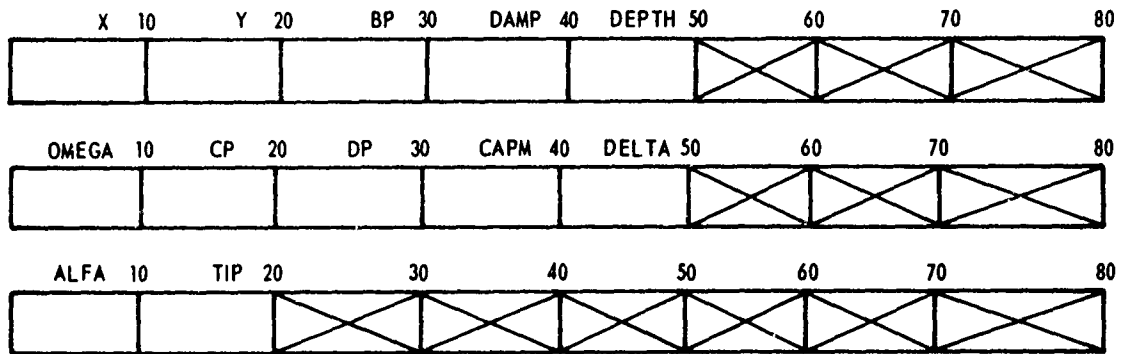

#### APPENDIX D4 – TEST RUNS

Results obtained from the computer programs of Table 6 are given in Figures 16–18.

A test run for the dimensionless plate velocity spectral density  $\phi_{\phi}^+(x^+, y^+, \omega^+)$  converted to the ratio of displacement spectral density to turbulent pressure spectral density  $(\phi_d(\omega)/\phi_f(\omega))$  is plotted logarithmically in Figure 16. Test runs for the plate velocity power spectrum and the cavity acoustic pressure power spectrum are plotted in Figures 17 and 18, respectively. Computer listings are given in Table 7.

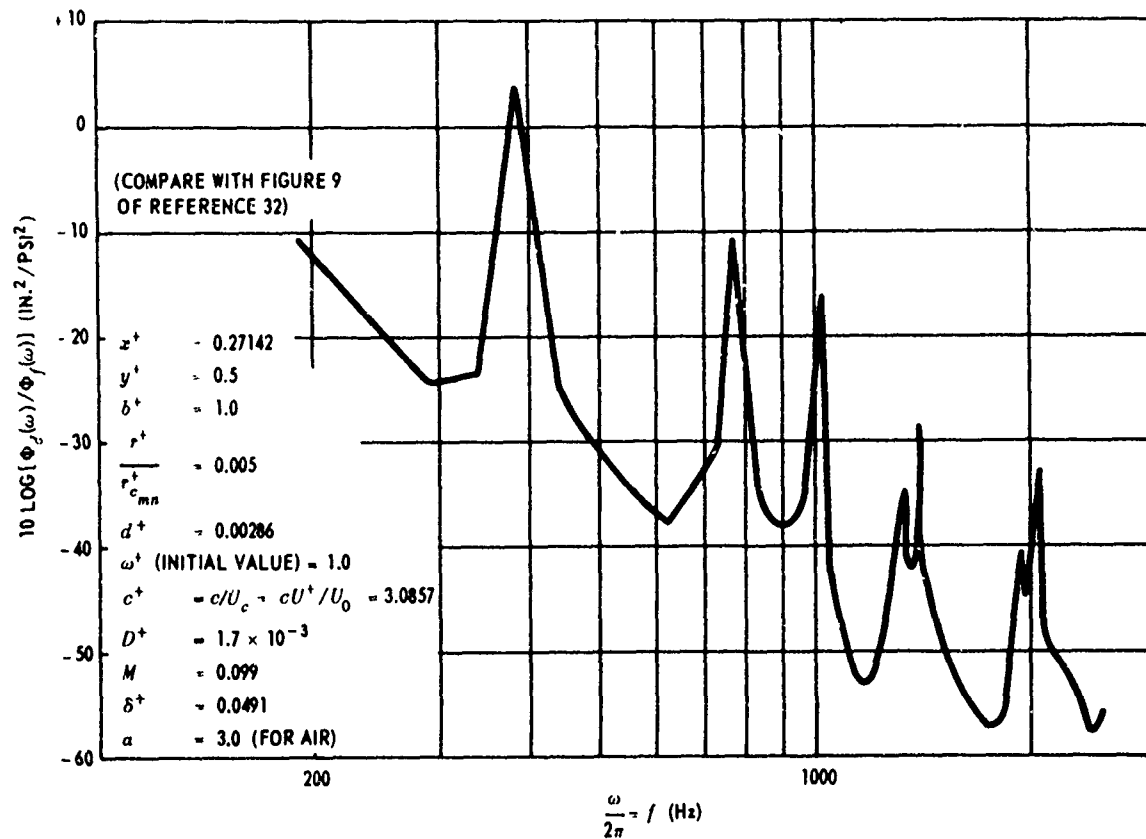

Figure 16 - Computed Response of a 3.5 x 3.5 x 0.1-Inch Steel Plate to Turbulent Boundary Layer Excitation

See pages 56-57 of Reference 32 for source of data used here.

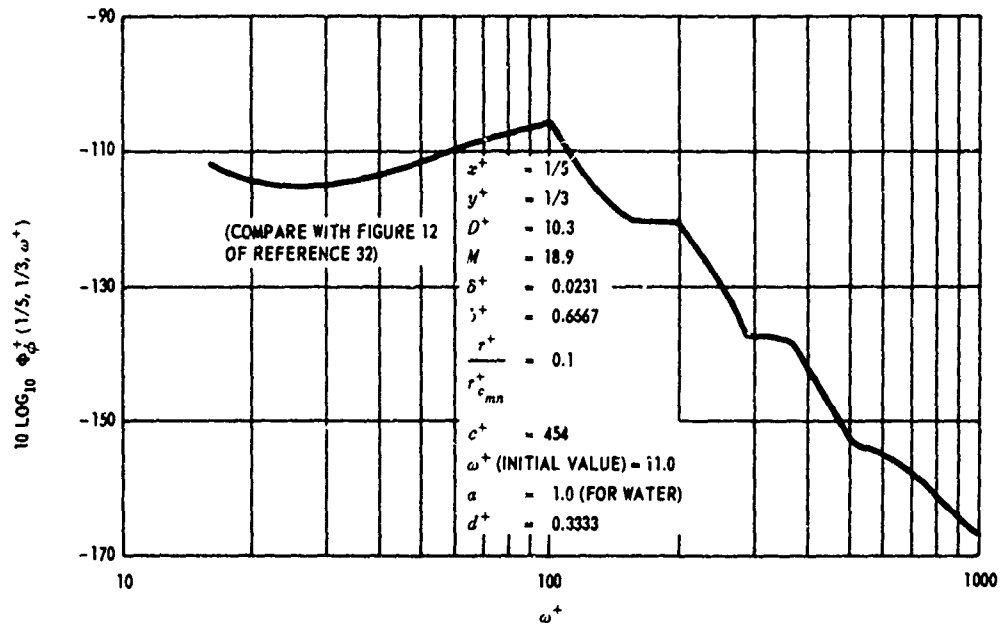

Figure 17 – Computed Dimensionless Plate Velocity Power Spectrum at Dimensionless Coordinates (1/5, 1/3); 10 Percent Critical Damping

See pages 60, 61 and 75 (Table 2, Case 1) of Reference 32 for source of data used here.

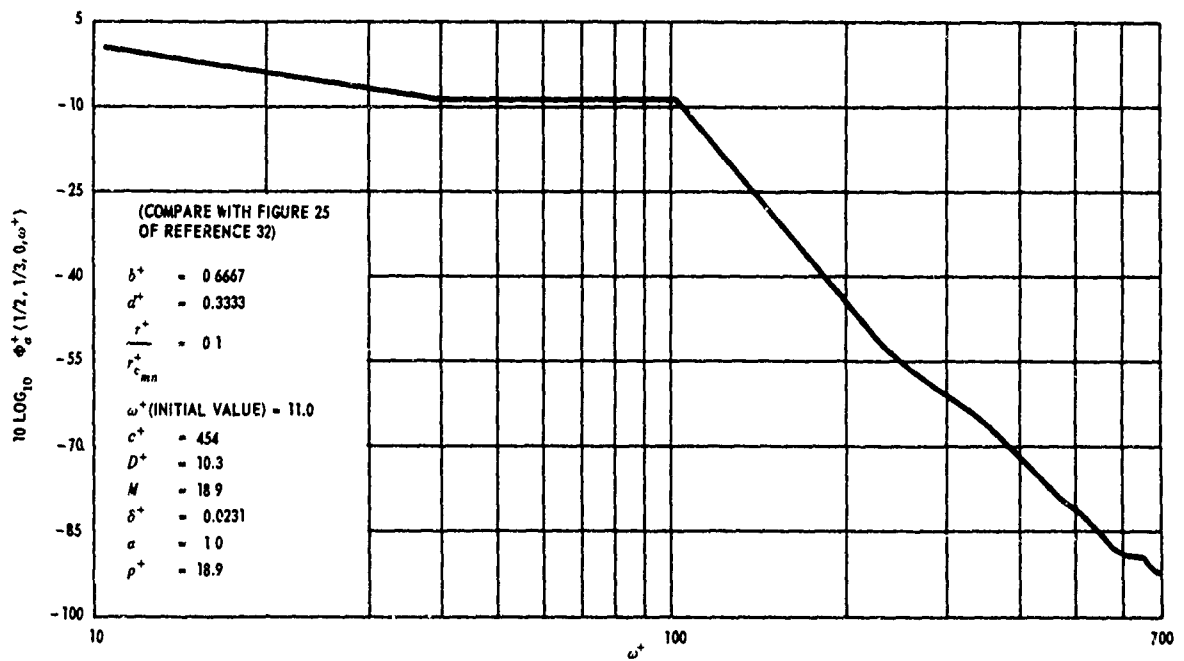

Figure 18 – Computed Dimensionless Cavity Acoustic Pressure Power Spectrum at Dimensionless Cavity Coordinates (1/2, 1/3, 0)

See page 75 (Table 2, Case 1) of Reference 32 for source of data used here.

TABLE 7

Computer Listings for USL Subprograms I and II - Strawderman

Table 7A - Plate Velocity Power Spectrum

\$IBFTC STRTR2	0* *
DIMENSION PNOME(20,20),FREQ(20,20),TMINO(20),PHIFY(100),SNX(20),	0020
ISNY(20),CSX(20),CSY(20),G(20,20),T(20,20),P(20),CAPR(20)	0030
DIMENSION PNOND(20,20),GNU(20),PLDA(20,20)	0040
DIMENSION IDUMP(18)	0 50
402 READ (5,403) X,Y,BP,DAMP,DEPTH,OMEGA,CP,DP,CAPM,DELTA,	0060
ALFA,TIP	70
403 FORMAT(5F10.8/5F10.4/2F10.4)	0080
406 Q=0.0	90
PI=3.14159265	0100
PISQ=PI**2.0	0110
E=2.71828183	0120
IPEN=+80000	*130
SINEX=SIN(PI*X)	0140
COSEX = COS(PI*X)	0150
SINEY = SIN((PI*Y)/BP)	0160
COSEY = COS((PI*Y)/BP)	0170
IF (ABS(SINEX)-10.0**(-7.0)) 800,800,801	0180
800 SINEX=0.0	0190
801 IF (ABS(SINEY)-10.0**(-7.0))802,802,803	0200
802 SINEY=0.0	0210
803 IF (ABS(COSEX)-10.0**(-7.0))804,804,805	0220
804 COSEX=0.0	0230
805 IF (ABS(COSEY)-10.0**(-7.0))806,806,807	0240
806 COSEY=0.0	0250
807 CONTINUE	0260
SNX(1)=SINEX	0270
SNY(1)=SINEY	0280
CSX(1)=COSEX	0290
CSY(1)=COSEY	0300
DO 701 I=2,20	0310
J=I-1	0320
SNX(I)=SNX(J)*COSEX+CSX(J)*SINEX	0330
SNY(I)=SNY(J)*COSEY+CSY(J)*SINEY	0340
CSX(I)=CSX(J)*COSEX-SNX(J)*SINEX	0350
CSY(I)=CSY(J)*COSEY-SNY(J)*SINEY	0360
IF (ABS(SNY(I))-10.0**(-7.0)) 80,80,81	0370



TABLE 7A (Continued)

80	SNY(I)=0.0	0380
81	IF (ABS(SNX(I))-10.0**(-7.0))82,82,83	0390
82	SNX(I)=0.0	0400
83	IF (ABS(CSY(I))-10.0**(-7.0))84,84,85	0410
84	CSY(I)=0.0	0420
85	IF (ABS(CSX(I))-10.0**(-7.0))86,86,87	0430
86	CSX(I)=0.0	0440
87	CONTINUE	0450
701	CONTINUE	0460
	WRITE(6,7)	0470
	7 FORMAT(1H1/26HW. STRAWDERMAN JOB NO 0775)	0480
	DO 100 I=1,20	0490
	DO 101 J=1,20	0500
	F=I	0510
	H=J	0520
	PNOME(I,J)=(DP**0.5)*(((F*PI)**2.0)+((H*PI/BP)**2.0))	0530
101	CONTINUE	0540
100	CONTINUE	0550
	CALL SSWTCH(4,KOOOFX)	0560
	IF(KOOOFX.EQ.2) GO TO 521	0570
520	WRITE(6,522)X,Y,BP,DAMP,DEPTH,OMEGA,CP,DP,CAPM,DELTA ,	0580
	IALFA,TIP	590
522	FORMAT(5F10.8/5F10.4/2F10.4)	0600
521	CONTINUE	0610
	WRITE(6,142)((PNOME(I,J),J=1,10),I=1,10)	0620
142	FORMAT(10E12.4)	0630
160	DO 106 K=1,20	0640
	DO 107 L=1,20	0650
	FREQ(K,L)=0.0	0660
107	CONTINUE	0670
106	CONTINUE	0680
	DO 102 I=1,20	0690
	DO 103 J=1,20	0700
	IF(OMEGA-PNOME(I,J))104,103,103	0710
104	K=I	0720
	L=J	-730
	FREQ(K,L)=PNOME(K,L)	0740

TABLE 7A (Continued)

GO TO 102	0750
103 CONTINUE	0760
102 CONTINUE	0770
DO 700 I=1,20	0780
TMINO(I)=0.0	0790
700 CONTINUE	0800
M=0	*810
DO 109 I=1,20	0820
DO 108 J=1,20	0830
IF(FREQ(I,J))99,110,111	0840
111 M=M+1	0850
TMINO(M)=FREQ(I,J)	0860
110 CONTINUE	0870
108 CONTINUE	*880
109 CONTINUE	0890
S=TMINO(I)	0900
DO 112 L=1,19	0910
IF(S-TMINO(L+1))112,121,121	0920
121 S=TMINO(L+1)	0930
112 CONTINUE	0940
DO 130 L=1,20	0950
IF(S-TMINO(L))130,132,130	0960
132 N=L	970
GO TO 180	980
130 CONTINUE	990
180 OMEG=(S-OMEGA)/4.0	1000
Z=N	1010
ITOP=Z+1.5	1020
MU=1	1030
300 CONTINUE	1040
DO 2171 I=1,100	1050
PHIFY(I)=0.0	1060
2171 CONTINUE	1070
217 CONTINUE	1080
SUM=0.00	1090
TOP=0.0	1100
EXPB=E**(-0.7*OMEGA*BP)	1110

TABLE 7A (Continued)

DO 702 I=1,20	1120
DO 703 J=1,20	1130
B=I	1140
D=J	1150
IF(B=D)11,12,11	1160
11 G(I,J)=B*D*PISC*(((-1.0)**I)*((-1.0)**J)-1.0)+(2.0-((-1.0)**I)	1170
1+((-1.0)**J))*EXPB))	1180
GO TO 703	1190
12 G(I,J)=(0.35*OMEGA*BP)*(2.0*(0.7*OMEGA*BP)**2.0)+PISQ*(B**2.0)+	1200
1(D**2.0))+B*D*PISQ*(2.0-((-1.0)**I)+((-1.0)**J))*EXPB)	1210
703 CONTINUE	1220
702 CONTINUE	1230
CALL OVERFL(J)	1240
IF(J.EQ.2) GO TO 751	1250
750 WRITE(6,752)EXPB	1260
752 FORMAT(012)	1270
751 CONTINUE	1280
DO 705 I=1,20	1290
DO 704 J=1,20	1300
PNOND(I,J)=PNOME(I,J)/OMEGA	1310
T(I,J)=((((PNOND(I,J)**2 )-1.0)**2 )+(2.0*DAMP*PNOND(I,J))**2 )	1320
1**0.5	1330
704 CONTINUE	1340
705 CONTINUE	1350
DO 706 I=1,20	1360
A=I	1370
P(I)=(A**2 )*PISQ+(0.7*OMEGA*BP)**2	1380
706 CONTINUE	1390
DO 707 I=1,20	1400
A=I	1410
CAPR(I)=((((A**2 )*PISQ-0.987*(OMEGA**2 ))**2 )+0.0529*(OMEGA**	1420
14 )**0.5	1430
707 CONTINUE	1440
PNGNU=0.23*(OMEGA**2)	1450
DO 708 I=1,20	1460
A=I	1470
DGNU =(A**2 )*PISQ-0.987*(OMEGA**2 )	1480

TABLE 7A (Continued)

CALL ACTN(DGNU ,PNGNU,GNU(I),IOTA)	1490
IF(IOTA)13,14,13	1500
13 GO TO 216	1510
14 CONTINUE	1520
708 CONTINUE	1530
DO 710 I=1,20	1540
DO 709 J=1,20	1550
PNLDA=2.0*DAMP*PNOME(I,J)*OMEGA	1560
DLDA=(PNOME(I,J)**2 )-(OMEGA**2 )	1570
CALL ACTN(DLDA,PNLDA,PLDA(I,J),ILDA)	1580
IF(ILDA)19,20,19	1590
19 GO TO 216	1600
20 CONTINUE	1610
709 CONTINUE	1620
710 CONTINUE	1630
740 CONTINUE	1640
DO 714 J=1,ITOP	1650
DO 713 K=1,ITOP	1660
DO 712 M=1,ITOP	1670
DO 711 N=1,ITOP	1680
A=J	1690
B=K	1700
C=M	1710
D=N	1720
TMAX = AMAX1(A,B,C,D)	1730
IF(TMAX-TOP)711,711,737	1740
737 CONTINUE	1750
IF(SNY(N))716,715,716	1760
715 PNUM=0.0	1770
DEN=1.0	1780
GO TO 310	1790
716 IF(SNX(M))718,717,718	1800
717 PNUM=0.0	1810
DEN=1.0	1820
GO TO 310	1830
718 IF(SNY(K))720,719,720	1840
719 PNUM=0.0	1850

TABLE 7A (Continued)

DEN=1.0	1860
GO TO 310	1870
720 IF(SNX(J))722,721,722	1880
721 PNUM=0.0	1890
DEN=1.0	1900
GO TO 310	1910
722 CONTINUE	1920
IF(J-M)21,22,21	1930
21 W=A*C*PISQ*(2.0*(COS(GNU(J)+GNU(M)))*(COS	1940
X(PLDA(J,K)-PLDA(M,N)))+	1950
1((( (-1.0)**J)*((-1.0)**M)-1.0)*(CAPR(J)*(COS(GNU(M)+PLDA(J,K)-	1960
2PLDA(M,N)))-CAPR(M)*(COS(GNU(J)+PLDA(M,N)-PLDA(J,K))))	1970
X/(PISQ*(	1980
3(A**2.0)-(C**2.0)))-((E**(-0.115*OMEGA))*	1990
X((( (-1.0)**J)*COS(OMEGA	2000
4+GNU(J)+GNU(M)+PLDA(J,K)-PLDA(M,N)))+((-1.0)**	2010
XM)*(COS(OMEGA+GNU(J	2020
5)+GNU(M)+PLDA(M,N)-PLDA(J,K))))))	2030
GO TO 33	2040
22 W = 1.0066*OMEGA*CAPR(J)*(COS(GNU(J)-0.463*PI))	2050
X*(COS(PLDA(J,K)-	2060
1PLDA(M,N))+A*C*PISQ*(2.0*(COS(GNU(J)+	2070
XGNU(M)))*(COS(PLDA(J,K)-	2080
2PLDA(M,N)))-((E**(-0.115*OMEGA))*((( (-1.0)**J)*	2090
X(COS(OMEGA+GNU(J)+	2100
3GNU(M)+PLDA(J,K)-PLDA(M,N)))+((-1.0)**M)*(COS	2110
X(OMEGA+GNU(J)+GNU(N)	2120
4+PLDA(M,N)-PLDA(J,K))))))	2130
33 CONTINUE	2140
PNUM=SNX(J)*SNY(K)*SNX(M)*SNY(N)*G(K,N)*W	2150
DEN=T(J,K)*T(M,N)*P(K)*P(N)*CAPR(J)*CAPR(M)	2160
310 SUM=SUM+(PNUM/DEN)	2170
CALL SSWTCH(2,K000FX)	2180
IF(K000FX.EQ.2) GO TO 501	2190
500 WRITE(6,23) SUM,PNUM,DEN,G(K,N),W,T(J,K),T(M,N),P(K),	2200
1P(N),CAPR(J),CAPR(M),A,B,C,D	2210
23 FORMAT(5E17.8/5E17.8/5E17.8//)	2220

TABLE 7A (Continued)

501	CONTINUE	2230
	CALL SSWTCH(6,K000FX)	2240
	IF(K000FX.EQ.2) GO TO 51	2250
50	WRITE(6,52)SNX(J),SNY(K),SNX(M),SNY(N)	2260
52	FORMAT(4E17.8)	2270
51	CONTINUE	2280
711	CONTINUE	2290
712	CONTINUE	2300
713	CONTINUE	2310
714	CONTINUE	2320
	IF((OMEGA*DELTA)-1.932)202,202,203	2330
202	PHIFY(MU)=4.38*(10.0**(-4.0))*(ALFA**2.0)*(CAPM**2.0)*DELTA*(OMEGA	2340
	1**(-2.0))*SUM	2350
	GO TO 204	2360
203	PHIFY(MU)=3.2*(10.0**(-3.0))*(ALFA**2.0)*(CAPM**2.0)*(DELTA**(-2.0	2370
	1))*(OMEGA**(-5.0))*SUM	2380
204	CONTINUE	2390
	CALL SSWTCH(4,K000FX)	2400
	IF(K000FX.EQ.2) GO TO 531	2410
530	WRITE(6,532)X,Y,BP,DAMP,DEPTH,OMEGA,CP,DP,CAPM,DELTA,	2420
	1ALFA,TIP	2430
532	FORMAT(5F10.8/5F10.4/2F10.4)	2440
531	CONTINUE	2450
	CALL SSWTCH(4,K000FX)	2460
	IF(K000FX.EQ.2) GO TO 505	2470
504	WRITE(6,502)PHIFY(MU),TOP,MU	2480
502	FORMAT(2E17.8,1I2)	2490
505	CONTINUE	2500
	IF(TOP)206,205,206	2510
205	CONTINUE	2520
	TOP=ITOP	2530
	MU=MU+1	2540
	ITOP=ITOP+2	2550
	GO TO 740	2560
206	CONTINUE	2570
	K=MU-1	2580
	RATIO=ABS((PHIFY(MU))/PHIFY(K))	2590

TABLE 7A (Continued)

CALL SSWTCH(4,KOOOFX)	2600
IF(KOOOFX.EQ.2) GO TO 511	2610
510 WRITE(6,512)RATIO,PHIFY(MU),PHIFY(K),MU,K	2620
512 FORMAT(3E17.8,2I2)	2630
WRITE(6,515)(PHIFY(J),J=1,10)	2640
515 FORMAT(5E17.8)	2650
511 CONTINUE	2660
IF(RATIO-0.97)207,208,208	2670
207 CONTINUE	2680
TOP=TOP+2.0	2690
ITOP=ITOP+2	2700
MU=MU+1	2710
GO TO 740	2720
208 CONTINUE	2730
IF(RATIO-1.03)209,209,210	2740
209 CONTINUE	2750
GO TO 211	2760
210 CONTINUE	2770
TOP=TOP+2.0	2780
ITOP=ITOP+2	2790
MU=MU+1	2800
GO TO 740	2810
211 CONTINUE	2820
PHIP=PHIFY(MU)	2830
CALL SSWTCH(1,KOOOFX)	2840
IF(KOOOFX.EQ.2) GO TO 4002	2850
4001 WRITE(6,4000)PHIP,OMEGA	2860
4000 FORMAT(2E17.8)	2870
4002 CONTINUE	2880
PHIDB = (10.0*ALOG(PHIP))/2.30258509	2890
WRITE(6,212)PHIP,PHIDB,OMEGA,ITOP,MU	2900
212 FORMAT(3E17.8,2I2)	2910
IF(PHIDB)3001,3000,3000	3010
3000 PHIDB=0.0	3020
3001 CONTINUE	3030
IF(OMEGA-TIP)215,216,216	3040
215 CONTINUE	3050

TABLE 7A (Continued)

	IF(Q=3.0)213,214,214	3060
213	OMEGA=OMEGA+DOMEQ	3070
	Q=Q+1.0	3080
	ITOP=Z+1.5	3090
	MU=1	3100
	GO TO 300	3110
214	OMEGA=S+0.001*DAMP	3120
	Q=0.0	3130
	GO TO 160	3140
216	END FILE 4	3150
	WRITE(6,3009)IPEN,IPEN	3160
3009	FORMAT(2I6)	3170
	END FILE 5	3180
	END FILE 5	3190
	STOP 5	3200
99	STOP 7	3210
	END	3220
\$IBFTC	ACTN REF	ACTN0010
CACTN		ACTN0020
	SUBROUTINE ACTN (A,B,THETA,I)	ACTN0030
	I=0	ACTN0040
	IF (ABS(A)+ABS(B)) 27,28,27	ACTN0050
27	THETA= ATAN(ABS(B/A))	ACTN0060
	IF (A) 22,21,23	ACTN0070
22	IF (B) 32,24,31	ACTN0080
23	IF (B) 33,25,34	ACTN0090
24	THETA=3.1415927	ACTN0100
	GO TO 34	ACTN0110
25	THETA=0.0	ACTN0120
	GO TO 34	ACTN0130
21	IF (B) 26,28,29	ACTN0140
26	THETA=4.7123890	ACTN0150
	GO TO 34	ACTN0160
29	THETA=1.5707963	ACTN0170
	GO TO 34	ACTN0180
31	THETA=3.1415927-THETA	ACTN0190
	GO TO 34	ACTN0200
32	THETA=THETA+3.1415927	ACTN0210
	GO TO 34	ACTN0220
33	THETA=6.283154-THETA	ACTN0230
	GO TO 34	ACTN0240
28	WRITE (6,315)	ACTN0250
315.	FORMAT (40HOPROGRAM-CANNOT-CONTINUE,ARCTAN OF (0/0) )	ACTN0260
	I=1	ACTN0270
34	RETURN	ACTN0280
	END	ACTN0290



Table 7B - Subprogram II - Cavity Acoustic Pressure Power Spectrum

```

$IBFTC STRTR1
  DIMENSION PNAME(20,20),FREQ(20,20),TMINO(20),PHIFY(100),SNX(20),
  1SNY(20),CSX(20),CSY(20),G(20,20),T(20,20),P(20),CAPR(20)
  DIMENSION PNOND(20,20),GNU(20),PLDA(20,20),CKAYZ(20,20),SINKD(20,
  120),COSKZ(20,20),ACRES(10,10),COKAP(20,20),COGNU(20,20)
  DIMENSION IDUMP(18)
402 READ(5,403) X,Y,ZP,BP,DEPTH,DAMP,OMEGA,CP,DP,CAPM,DELTA,
  1ALFA,TIP,TOLH,TOLL
403 FORMAT(5F10.8/5F10.4/5F10.4)
  READ(5,410) RHO
410 FORMAT(F10.6)
406 Q=0.0
  PI=3.14159265
  PISQ=PI**2.0
  E=2.71828183
  EXPA=E**(-0.115*OMEGA)
  IPEN=+80000
  SINEX=SIN(PI*X)
  COSEX = COS(PI*X)
  SINEY = SIN((PI*Y)/BP)
  COSEY = COS((PI*Y)/BP)
  IF (ABS(SINEX)-10.0**(-7.0)) 800,800,801
800 SINEX=0.0
801 IF (ABS(SINEY)-10.0**(-7.0))802,802,803
802 SINEY=0.0
803 IF (ABS(COSEX)-10.0**(-7.0))804,804,805
804 COSEX=0.0
805 IF (ABS(COSEY)-10.0**(-7.0))806,806,807
806 COSEY=0.0
807 CONTINUE
  SNX(1)=0.0
  SNY(1)=0.0
  CSX(1)=1.0
  CSY(1)=1.0
  DO 701 I=2,20
  J=I-1
  SNX(I)=SNX(J)*COSEX+CSX(J)*SINEX

```

```

00 0
0010
0020
0030
0040
* 50
0060
* 70
0080
0 85
86
90
0100
0110
0120
0130
0140
0150
0160
0170
0180
0190
0200
0210
0220
0230
0240
0250
0260
0270
0280
0290
0300
0310
0320
0330
0340

```

TABLE 7B (Continued)

SNY(I)=SNY(J)*COSEY+CSY(J)*SINEY	0350
CSX(I)=CSX(J)*COSEX-SNX(J)*SINEX	0360
CSY(I)=CSY(J)*COSEY-SNY(J)*SINEY	0370
IF (ABS(SNY(I))-10.0**(-7.0)) 80,80,81	0380
80 SNY(I)=0.0	0390
81 IF (ABS(SNX(I))-10.0**(-7.0))82,82,83	0400
82 SNX(I)=0.0	0410
83 IF (ABS(CSY(I))-10.0**(-7.0))84,84,85	0420
84 CSY(I)=0.0	0430
85 IF (ABS(CSX(I))-10.0**(-7.0))86,86,87	0440
86 CSX(I)=0.0	0450
87 CONTINUE	0460
701 CONTINUE	0470
WRITE(6,7)	0480
7 FORMAT(1H1/26HW. STRAWDERMAN JOB NO 0775)	0490
DO 100 I=1,20	0500
DO 101 J=1,20	0510
F=I	0520
H=J	0530
PNOME(I,J)=(DP**0.5)*(((F*PI)**2.0)+((H*PI/BP)**2.0))	0540
101 CONTINUE	0550
100 CONTINUE	0560
CALL SSMTCH(4,JSSTCH)	0570
IF(JSSTCH.EQ.2) GO TO 521	0580
520 WRITE(6,522) X,Y,ZP,BP,DEPTH,DAMP,OMEGA,CP,DP,CAPM,	0590
DELTA,ALFA,TIP	0600
522 FORMAT(5F10.8/5F10.4/3F10.4)	0610
WRITE(6,590) RHO	0615
590 FORMAT(1X,F10.6)	0616
521 CONTINUE	0620
WRITE(6,142)((PNOME(I,J),J=1,10),I=1,10)	0630
142 FORMAT(10E12.4)	0640
160 DO 106 K=1,20	0650
DO 107 L=1,20	0660
FREQ(K,L)=0.0	0670
107 CONTINUE	0680
106 CONTINUE	0690

TABLE 7B (Continued)

DO 102 I=1,20	0760
DO 103 J=1,20	0710
IF(Omega=PNOME(I,J))104,103,103	0720
104 K=I	0730
L=J	0740
FREQ(K,L)=PNOME(K,L)	0750
GO TO 102	0760
103 CONTINUE	0770
102 CONTINUE	0780
DO 700 I=1,20	0790
TMINO(I)=0.0	0800
700 CONTINUE	0810
M=0	0820
DO 109 I=1,20	0830
DO 108 J=1,20	0840
IF(FREQ(I,J))99,110,111	0850
111 M=M+1	0860
TMINO(M)=FREQ(I,J)	0870
110 CONTINUE	0880
108 CONTINUE	0890
109 CONTINUE	0900
S=TMINO(1)	0910
DO 112 L=1,19	0920
IF(S-TMINO(L+1))112,121,121	0930
121 S=TMINO(L+1)	0940
112 CONTINUE	0950
DO 130 L=1,20	0960
IF(S-TMINO(L))130,132,130	0970
132 N=L	0980
GO TO 180	0990
130 CONTINUE	1000
180 DOMEQ=(S-OMEGA)/3.0	1010
Z=N	1020
ITOP=Z+1.5	1030
MU=1	1040
DO 901 I=1,10	1050
DO 900 J=1,10	1060

TABLE 7B (Continued)

A=I-1	1070
B=J-1	1080
ACRES(I,J)=PI*CP*((A**2 )+((B/BP)**2 ))**0.5	1090
900 CONTINUE	1100
901 CONTINUE	1110
WRITE(6,902) ((ACRES(I,J),J=1,10),I=1,10)	1120
902 FORMAT(//10E12.4)	1130
300 CONTINUE	1140
DO 2171 I=1,100	1150
PHIFY(I)=0.0	1160
2171 CONTINUE	1170
217 CONTINUE	1180
SUM=0.00	1190
TOP=0.0	1200
EXPB=E**(-0.7*OMEGA*BP)	1210
DO 702 I=1,20	1220
DO 703 J=1,20	1230
B=I	1240
D=J	1250
IF(B-D)11,12,11	1260
11 G(I,J)=B*D*PISQ*((( -1.0)**I)*((-1.0)**J)-1.0)+(2.0-((( -1.0)**I)+	1270
1+((-1.0)**J))*EXPB)	1280
GO TO 703	1290
12 G(I,J)=(0.35*OMEGA*BP)*(2.0*((0.7*OMEGA*BP)**2 )+PISQ*((B**2 )+	1300
1(D**2 )))+B*D*PISQ*(2.0-((( -1.0)**I)+((-1.0)**J))*EXPB)	1310
703 CONTINUE	1320
702 CONTINUE	1330
CALL OVERFL(J)	1340
IF(J.EQ.2) GO TO 751	1350
750 WRITE(6,752)EXPB	1360
752 FORMAT(012)	1370
751 CONTINUE	1380
DO 705 I=1,20	1390
DO 704 J=1,20	1400
PNOND(I,J)=PNOME(I,J)/OMEGA	1410
T(I,J)=(((PNOND(I,J)**2 )-1.0)**2 )+(2.0*DAMP*PNOND(I,J))**2 )	1420
I**0.5	1430

TABLE 7B (Continued)

704	CONTINUE	1440
705	CONTINUE	1450
	DO 706 I=1,20	1460
	A=I	1470
	P(I)=(A**2 )*PISQ+(0.7*OMEGA*BP)**2	1480
706	CONTINUE	1490
	DO 707 I=1,20	1500
	A=I	1510
	CAPR(I)=(((A**2 )*PISQ-0.987*(OMEGA**2 ))**2 )+0.0529*(OMEGA**	1520
	14 )**0.5	1530
707	CONTINUE	1540
	PNGNU=0.23*(OMEGA**2)	1550
	DO 708 I=1,20	1560
	A=I	1570
	DGNU =(A**2 )*PISQ-0.987*(OMEGA**2 )	1580
	CALL ACTN(DGNU ,PNGNU,GNU(I),IOTA)	1590
	IF(IOTA)13,14,13	1600
13	GO TO 216	1610
14	CONTINUE	1620
708	CONTINUE	1630
	DO 7080 I=1,20	1640
	DO 7081 J=1,20	1650
	COGNU(I,J) = COS(GNU(I)+GNU(J))	1660
7081	CONTINUE	1670
7080	CONTINUE	1680
	DO 710 I=1,20	1690
	DO 709 J=1,20	1700
	PNLDA=2.0*DAMP*PNOME(I,J)*OMEGA	1710
	DLDA=(PNOME(I,J)**2 )-(OMEGA**2 )	1720
	CALL ACTN(DLDA,PNLDA,PLDA(I,J),ILDA)	1730
	IF(ILDA)19,20,19	1740
19	GO TO 216	1750
20	CONTINUE	1760
709	CONTINUE	1770
710	CONTINUE	1780
	CQR=(OMEGA/CP)**2	1790
	DO 811 I=1,20	1800

TABLE 7B (Continued)

DO 810 J=1,20	1810
A=I-1	1820
B=J-1	1830
EQR=PI SQ*((A**2 )+((B/BP)**2 ))	1840
IF(EQR-CQR)812,812,813	1850
812 CKAYZ(I,J)=(CQR-EQR)**0.5	1860
ARGD=CKAYZ(I,J)*DEPTH	1870
ARGZ=CKAYZ(I,J)*ZP	1880
SINKD(I,J)=SIN(ARGD)	1890
COSKZ(I,J)=COS(ARGZ)	1900
GO TO 810	1910
813 CKAYZ(I,J)=(EQR-CQR)**0.5	1920
ARGD=CKAYZ(I,J)*DEPTH	1930
ARGZ=CKAYZ(I,J)*ZP	1940
SINKD(I,J)=(0.5)*((E**ARGD)- (E**(-ARGD)))	1950
COSKZ(I,J)=(0.5)*((E**ARGZ)+ (E**(-ARGZ)))	1960
810 CONTINUE	1970
811 CONTINUE	1980
DO 5002 I=1,20	1990
DO 5001 J=1,20	2000
A=I	2010
B=J-1	2020
K=I	2030
L=J-1	2040
IF(A-B)5003,5004,5003	2050
5004 COKAP(I,J)=0.0	2060
GO TO 5001	2070
5003 AHAF=(A+B)/2.0	2080
IHAF=AHAF	2090
AIH=IHAF	2100
IF(AHAF-AIH)4001,4002,4001	2110
4002 COKAP(I,J)=0.0	2120
GO TO 5001	2130
4001 IF(B) 5005,5006,5005	2140
5005 DIJ=1.0	2150
GO TO 5007	2160
5006 DIJ=2.0	2170

TABLE 7B (Continued)

5007	COKAP(I,J)=A*(1.0-((-1.0)**K)*((-1.0)**L))/(DIJ*((A**2)-(B**2)))	2180
5001	CONTINUE	2190
5002	CONTINUE	2200
740	CONTINUE	2210
	DO 714 J=1,ITOP	2220
	DO 713 K=1,ITOP	2230
	DO 712 M=1,ITOP	2240
	DO 711 N=1,ITOP	2250
	A=J	2260
	B=K	2270
	C=M	2280
	D=N	2290
	IF(J-M)21,22,21	2300
21	W=A*C*PISQ*(2.0*COGNUM(J,M)*(COS(PLDA(J,K)-PLDA(M,N)))+	2310
	1(((((-1.0)**J)*((-1.0)**M)-1.0)*(CAPR(J)*(COS(GNUM(M)+PLDA(J,K)-	2320
	2PLDA(M,N)))-CAPR(M)*(COS(GNUM(J)+PLDA(M,N)-PLDA(J,K))))/(PISQ*(	2330
	3(A**2)-(C**2)))-((EXPA*(((1.0)**J)*(COS(OMEGA	2340
	4+GNUM(J)+GNUM(M)+PLDA(J,K)-PLDA(M,N)))+((-1.0)**M)*(COS(OMEGA+GNUM(J)	2350
	5)+GNUM(M)+PLDA(M,N)-PLDA(J,K))))	2360
	GO TO 33	2370
22	W=1.0066*OMEGA*CAPR(J)*(COS(GNUM(J)-0.463*PI))*(COS(PLDA(J,K)-	2380
	1PLDA(M,N)))+A*C*PISQ*(2.0*COGNUM(J,M)*(COS(PLDA(J,K)-	2390
	2PLDA(M,N)))-((EXPA*(((1.0)**J)*(COS(OMEGA+GNUM(J)+	2400
	3GNUM(M)+PLDA(J,K)-PLDA(M,N)))+((-1.0)**M)*(COS(OMEGA+GNUM(J)+GNUM(N)	2410
	4+PLDA(M,N)-PLDA(J,K))))	2420
33	CONTINUE	2430
	DO 824 JQ=1,ITOP	2440
	DO 823 KR=1,ITOP	2450
	DO 822 MS=1,ITOP	2460
	DO 821 NT=1,ITOP	2470
	AQ=JQ	2480
	BR=KR	2490
	CS=MS	2500
	DT=NT	2510
	TMAX = AMAX1(A,B ,C,D,AQ,BR,CS,DT)	2520
	IF(TMAX=TOP)821,821,737	2530
737	CONTINUE	2540

TABLE 7B (Continued)

IF(CSY(NT))716,715 ,716	2550
715 PNUM=0.0	2560
DEN=1.0	2570
GO TO 310	2580
716 IF(CSX(MS))718,717,718	2590
717 PNUM=0.0	2600
DEN=1.0	2610
GO TO 310	2620
718 IF(CSY(KR))720,719,720	2630
719 PNUM=0.0	2640
DEN=1.0	2650
GO TO 310	2660
720 IF(CSX(JQ))722,721,722	2670
721 PNUM=0.0	2680
DEN=1.0	2690
GO TO 310	2700
722 CONTINUE	2710
IF(COKAP(J,JQ)) 602,601,602	2720
601 CKAPA=0.0	2730
PNUM=0.0	2740
DEN=1.0	2750
GO TO 310	2760
602 IF(COKAP(K,KR)) 604,603,604	2770
603 CKAPA=0.0	2780
PNUM=0.0	2790
DEN=1.0	2800
GO TO 310	2810
604 IF(COKAP(M,MS))606,605,606	2820
605 CKAPA=0.0	2830
PNUM=0.0	2840
DEN=1.0	2850
GO TO 310	2860
606 IF(COKAP(N,NT))608,607,608	2870
607 CKAPA=0.0	2880
PNUM=0.0	2890
DEN=1.0	2900
GO TO 310	2910



TABLE 7B (Continued)

608	CONTINUE	2920
	CKAPA=COKAP(J,JQ)*COKAP(K,KR)*COKAP(M,MS)*COKAP(N,NT)	2930
	UQRST=CKAYZ(JQ,KR)*CKAYZ(MS,NT)*SINKD(JQ,KR)*SINKD(MS,NT)	2940
	PNUM=CSX(JQ)*CSY(KR)*CSX(MS)*CSY(NT)*COSKZ(JQ,KR)*COSKZ(MS,NT)	2950
	1*G(K,N)*W*CKAPA	2960
	DEN=T(J,K)*T(M,N)*P(K)*D:N)*CAPR(J)*CAPR(M)*UQRST	2970
310	SUM=SJM+(PNUM/DEN)	2980
	CALL SSWTCH(2,JSSTCH)	2990
	IF(JSSTCH.EQ.2) GO TO 501	3000
500	WRITE(6,23) SUM,PNUM,DEN,G(K,N),W,T(J,K),T(M,N),P(K),	3010
	1P(N),CAPR(J),CAPR(M),CKAPA,UQRST,JQ,KR,MS,NT,J,K,M,N	3020
	23 FORMAT(5E17.8/5E17.8/3E17.8/8I10//)	3030
501	CONTINUE	3040
821	CONTINUE	3050
822	CONTINUE	3060
823	CONTINUE	3070
824	CONTINUE	3080
711	CONTINUE	3090
712	CONTINUE	3100
713	CONTINUE	3110
714	CONTINUE	3120
	IF((OMEGA*DELTA)-1.932)202,202,203	3130
202	PHIFY(MU)=7.0C8*(10.0**(-3.0))*(ALFA**2.0)*(CAPM**2.0)*DELTA*SUM	3140
	1*(RHO**2)/(PISQ**2)	3150
	GO TO 204	3160
203	PHIFY(MU)=5.112*(10.0**(-2.0))*(ALFA**2.0)*(CAPM**2.0)*(DELTA**	3170
	1(-2.0))*OMEGA**(-3.0))*SUM *(RHO**2)/(PISQ**2)	3180
204	CONTINUE	3190
	CALL SSWTCH(4,JSSTCH)	3200
	IF(JSSTCH.EQ.2) GO TO 531	3210
530	WRITE(6,532) X,Y,ZP,BP,DEPTH,DAMP,OMEGA,CP,DP,CAPM,	3220
	1DELTA,ALFA,TIP	3230
	532 FORMAT(5F10.8/5F10.4/3F10.4)	3240
531	CONTINUE	3250
	CALL SSWTCH(4,JSSTCH)	3260
	IF(JSSTCH.EQ.2) GO TO 505	3270
504	WRITE(6,502) PHIFY(MU),TOP,MU	3280

TABLE 7B (Continued)

502	FORMAT(2E17.8,112)	3290
	CALL SSWTCH(4,JSSTCH)	3300
	IF(JSSTCH.EQ.2) GO TO 99	3310
505	CONTINUE	3320
	IF(TOP)206,205,206	3330
205	CONTINUE	3340
	TOP=ITOP	3350
	MU=MU+1	3360
	ITOP=ITOP+2	3370
	GO TO 740	3380
206	CONTINUE	3390
	K=MU-1	3400
	RATIO = ABS((PHIFY(MU))/(PHIFY(K)))	3410
	CALL SSWTCH(4,JSSTCH)	3420
	IF(JSSTCH.EQ.2) GO TO 511	3430
510	WRITE(6,512) RATIO,PHIFY(MU),PHIFY(K),MU,K	3440
512	FORMAT(3E17.8,212)	3450
	WRITE(6,515) (PHIFY(J),J=1,10)	3460
515	FORMAT(5E17.8)	3470
	CALL SSWTCH(4,JSSTCH)	3480
	IF(JSSTCH.EQ.2) GO TO 99	3490
511	CONTINUE	3500
	IF(RATIO-TOLL)207,208,208	3510
207	CONTINUE	3520
	TOP=TOP+2.0	3530
	ITOP=ITOP+2	3540
	MU=MU+1	3550
	GO TO 740	3560
208	CONTINUE	3570
	IF(RATIO-TOLH)209,209,210	3580
209	CONTINUE	3590
	GO TO 211	3600
210	CONTINUE	3610
	TOP=TOP+2.0	3620
	ITOP=ITOP+2	3630
	MU=MU+1	3640
	GO TO 740	3650

TABLE 7B (Continued)

211	CONTINUE		3660
	PHIP=PHIFY(MU)		3670
	PHIDB = (10.0*ALOG(PHIP))/2.30258509		3680
	WRITE(6,212) PHIP,PHIDB,OMEGA,ITOP,MU		3690
212	FORMAT(3E17,P,212)		3700
	CALL SSWTC(4,JSSTCH)		3710
	IF(JSSTCH.EQ.2) GO TO 99		3720
	IF(PHIDB)3001,3000,3000		3730
3000	PHIDB=0.0		3740
3001	CONTINUE		3750
	IF(OMEGA-TIP)215,216,216		3760
215	CONTINUE		3770
	IF(Q-2.0)213,214,214		3780
213	OMEGA=OMEGA+DOMEQ		3790
	Q=Q+1.0		3800
	ITOP=Z+1.5		3810
	MU=1		3820
	GO TO 300		3830
214	OMEGA=S+0.001*DAMP		3840
	0.0		3850
	1 TO 160		3860
216	END FILE 4		3870
	WRITE(6,3009) IPEN,IPEN		3880
3009	FORMAT(2I6)		3890
	END FILE 5		3900
	END FILE 5		3910
	STOP 5		3920
99	STOP 7		3930
	END		3940
SIBFTC	ACTN	REF	
CACTN			ACTN0010
	SUBROUTINE ACTN (A,B,THETA,I)		ACTN0020
	I=0		ACTN0030
	IF (ABS(A)+ABS(B)) 27,28,27		ACTN0040
27	THETA= ATAN(ABS(B/A))		ACTN0050
	IF (A) 22,21,23		ACTN0060
22	IF (B) 32,24,31		ACTN0070
			ACTN0080
23	IF (B) 33,25,34		ACTN0090
24	THETA=3.1415927		ACTN0100
	GO TO 34		ACTN0110
25	THETA=0.0		ACTN0120
	GO TO 34		ACTN0130
21	IF (B) 26,28,29		ACTN0140
26	THETA=4.7123890		ACTN0150
	GO TO 34		ACTN0160
29	THETA=1.5707963		ACTN0170
	GO TO 34		ACTN0180
31	THETA=3.1415927-THETA		ACTN0190
	GO TO 34		ACTN0200
32	THETA=THETA+3.1415927		ACTN0210
	GO TO 34		ACTN0220
33	THETA=6.283154-THETA		ACTN0230
	GO TO 34		ACTN0240
28	WRITE (6,315)		ACTN0250
315	FORMAT (40HOPROGRAM-CANNOT-CONTINUE,ARCTAN OF (0/0) )		ACTN0260
	I=1		ACTN0270
34	RETURN		ACTN0280
	END		ACTN0290

**APPENDIX E**

**BOEING PROGRAM II (JACOBS AND LAGERQUIST)**

**APPENDIX E1 – MATHEMATICAL ANALYSIS**

**APPENDIX E2 – METHOD FOR DETERMINING INPUT DATA**

**APPENDIX E3 – PROGRAM IDENTIFICATION**

**APPENDIX E4 – TEST RUNS**

## NOTATION

$[A]$	Diagonal matrix of elemental areas on structure associated with nodal points
$A_i, A_j, A_k$	Elemental area on structure associated with $i, j$ , and $k$ node points (in. <sup>2</sup> )
$A_n$	A constant, $A_1 = 26.5, A_2 = 7.20, A_3 = 0.5$
$a$	$1/U_c \theta$ (in. <sup>-1</sup> )
$B$	$1/0.8\delta^*$ (in. <sup>-1</sup> )
$b$	$\omega/U_c$ (in. <sup>-1</sup> )
$[C]$	Damping matrix
$[C_F(\omega)]$	Force co-power spectral density matrix (lb <sup>2</sup> · sec)
$C_{F_{ij}}(\omega)$	Force co-power spectral density (co-PSD) acting on plate pairs $i$ and $j$ (lb <sup>2</sup> · sec)
$C_f$	Local coefficient of frictions $r_w/q$
$C_p(\xi, \eta; \omega)$	Pressure co-power spectral density function (psi <sup>2</sup> · sec)
$[C_p(\omega)]$	Pressure co-power spectral density matrix (psi <sup>2</sup> · sec)
$[C_\delta(\omega)]$	Deflection co-power spectral density matrix (in. <sup>2</sup> · sec)
$[D]$	Diagonal matrix, real factor in admittance matrix
$[E]$	Diagonal matrix, imaginary factor in admittance matrix
$\{F(t)\}$	Column force matrix (lb)
$g$	Structural damping coefficient
$H_j^{(i)}(i\omega), H_j^{(k)}(i\omega)$	Complex frequency response function defining deflection at $j$ due to unit harmonic forcing at $i$ and $k$ , respectively
$\{I\}$	Column matrix, Laplace transform of force column matrix with unit impulse at particular point, zero forces at other points
$[H(i\omega)]$	Complex frequency response matrix
$i$	$\sqrt{-1}$
$i, j$	Finite node points
$[K]$	Stiffness matrix
$K^2$	Equals $\frac{\bar{p}^2}{r_w^2}$ ; also equals $\sum_{n=1}^3 \frac{A_n}{K_n} = 9.56$ (a normalization constant for power spectral density)

$K_n$	A constant; $K_1 = 6.1$ , $K_2 = 0.91$ , $K_3 = 0.26$
$k(r)$	Impulse response function defined at time $t$ due to a unit impulse applied $r$ time units earlier
$[L(\delta)]$	Matrix of the Laplace transform of the deflection
$M$	Mach number
$[M]$	Mass matrix
$M_i$	Generalized mass
$m_{ij}, n_{ij}$	Integers used to denote separation distance between the $i$ and $j$ node in $x$ and $y$ -directions respectively
$N$	Number of frequencies used to define the pressure cross power spectral density
$n$	Integer denoting spectral component; allowable values are 1, 2, and 3
$p_j(t), p_1(t), p_2(t)$	Pressure at positions $j$ , 1, and 2, respectively
$\overline{p^2}$ or $\langle p^2 \rangle$	Mean square fluctuating pressure at the wall in turbulent boundary layer ( $\text{psi}^2$ )
$[Q_F(\omega)]$	Force quad power spectral density matrix ( $\text{lb}^2 \cdot \text{sec}$ )
$Q_{F_{ij}}(\omega)$	Force quad-power spectral density acting on plate pairs $i$ and $j$ ( $\text{lb}^2 \cdot \text{sec}$ )
$Q_p(\xi, \eta; \omega)$	Pressure quad-power spectral density function
$[Q_p(\omega)]$	Pressure quad-power spectral density matrix ( $\text{psi}^2 \cdot \text{sec}$ )
$[Q_\delta(\omega)]$	Deflection quad-power spectral density matrix ( $\text{in.}^2 \cdot \text{sec}$ )
$q(t)$	Dynamic pressure ( $\text{psi}$ )
$\{q(t)\}$	Column matrix of principal coordinates
$R_{p_{jk}}(r)$	Cross correlation of pressures at points $j$ and $k$ ( $\text{psi}^2$ )
$R_{\delta_q^j \delta_r^k}(r)$	Cross correlation of deflections at points $q$ and $r$ resulting from loads at points $j$ and $k$ respectively ( $\text{in.}^2$ )
$S$	$\omega \delta^* / U$ , Strouhal number, dimensionless frequency
$s$	Laplace dummy variable
$t$	Time ( $\text{sec}$ )
$U$	Free-stream air flow velocity or aircraft speed ( $\text{in./sec}$ )
$U_c$	Convection velocity ( $\text{in./sec}$ )
$x, y$	Cartesian coordinates ( $\text{in.}$ )

$x_i, y_i$	Cartesian coordinates of $i$ th node point (in.)
$Y_n(K_n S), Y_n\left(\frac{\omega K_n}{BU_c}\right)$	A correction factor (equals 1 unless otherwise defined)
$\gamma$	$C_p/C_v$ , ratio of specific heats of air, 1.41 when $p_a = 14.7$ psi
$\zeta$	Critical damping ratio
$\{\zeta(t)\}$	Column matrix of deflection distance of structure normal to the surface of the structural plate (in.)
$\delta^*$	Boundary layer displacement thickness (in.)
$n$	Separation distance in $y$ -direction (in.)
$\hat{\eta}$	$\eta/0.8K_n\delta^*$ , normalized separation distance
$\eta'$	$\eta + \eta_j - \eta_i$ (in.)
$\eta_i, \eta_j$	Distance in $y$ -direction between node and dummy variable on $i$ th and $j$ th nodal areas respectively (in.)
$\hat{\eta}_i, \hat{\eta}_j$	$\eta_i/0.8K_n\delta^*, \eta_j/0.8K_n\delta^*$ , normalized separation distance
$\eta_0$	Smallest basic separation distance in $y$ -direction (in.)
$\hat{\eta}_0$	$\eta_0/0.8K_n\delta^*$ , normalized separation distance
$\theta$	Eddy lifetime ( $\text{sec}^{-1}$ )
$\kappa_0(K_n S), \kappa_0\left(\frac{\omega K_n}{BU_c}\right)$	Modified Bessel function of order zero with argument $K_n S$ and $\omega K_n / BU_c$ respectively
$\lambda, \mu$	Proportionality factor between damping and stiffness and inertias respectively
$\xi$	Separation distance in $x$ -direction (in.)
$\xi'$	$\xi + \xi_j - \xi_i$ (in.)
$\xi_i, \xi_j$	Distance in $x$ -direction between node and dummy variable on $i$ th and $j$ th nodal areas respectively (in.)
$\xi_0$	Smallest basic separation distance in $x$ -direction
$\Pi_{F_{ij}}(i\omega)$	Normalized cross power spectral density of forces acting on plate pair $i$ and $j$ , a complex function of $\omega$ (sec)
$\Pi_{F^{(n)}}(i\omega)_{ij}$	$n$ th component of normalized cross power spectral density of forces acting on plate pair $i$ and $j$ , a complex function of $\omega$ (sec)
$\Pi_n(\xi, \eta; i\omega)$	$n$ th component of the normalized pressure cross power spectral density, a complex function of $\omega$ (sec)
$\Pi(\xi, \eta; i\omega)$	Normalized pressure cross power spectral density, a complex function of $\omega$ (sec)
$\Pi(\omega), \Pi_n(\omega)$	Normalized pressure power spectral density and the $n$ th component of normalized pressure power spectral density respectively

$\rho_n(\xi, \eta; \tau)$	$n$ th component of pressure cross-correlation coefficient ( $\text{psi}^2$ )
$\rho(\xi, \eta; \tau)$	Cross-correlation coefficient, $-1 \leq \rho(\xi, \eta; \tau) \leq +1$
$\tau$	Time delay (sec)
$\tau_u$	Local fluid shearing stress of air measured at wall (psi)
$[\Phi_F(i\omega)]$	Force cross power spectral density matrix ( $\text{lb}^2 \cdot \text{sec}$ )
$\Phi_{F_{ii}}(\omega)$	Force power spectral density acting on the $i$ th structural plate ( $\text{lb}^2 \cdot \text{sec}$ )
$\Phi_{F_{ij}}(i\omega)$	Cross power spectral density of forces acting on plate pair $i$ and $j$ , a complex function of $\omega$ ( $\text{lb}^2 \cdot \text{sec}$ )
$\Phi_p(\xi, \eta; i\omega)$	Pressure cross power spectral density function ( $\text{psi}^2 \cdot \text{sec}$ )
$\Phi_p(\omega)$	Pressure power spectral density ( $\text{psi}^2 \cdot \text{sec}$ )
$[\phi]$	Matrix of eigenvectors
$\{\phi^{(r)}\}$	Eigenvector column matrix ( $r$ th normal mode shape)
$\psi$	Phase angle (radians)
$\omega$	Angular frequency, $2\pi f$ (radians/sec)
$\omega_i$	Eigenfrequency of $i$ th mode of structure, modal frequency (radians/sec)
$\omega_k, \{\omega_k\}$	Frequency and a set of frequencies respectively at which pressure cross power spectral density is defined (radians/sec)
$\omega_r$	Angular eigenfrequency or eigenvalue (radians/sec)
$[ ]^T$	Transpose of matrix
$( )^*$	Complex conjugate
$( \dot{\ } )$	First derivative with respect to time
$( \ddot{\ } )$	Second derivative with respect to time
$( \bar{\ } )$	Time average
$( \vec{\ } )$	Vector
$[\diagdown( )\diagup]$ or $[\diagup( )\diagdown]$	Denotes diagonal matrix



## APPENDIX E1 – MATHEMATICAL ANALYSIS

This section presents equations developed by means of a finite element analysis<sup>34-37</sup> for the deflection cross power spectral density response of a simple *clamped* panel to a turbulent boundary layer.

Consider a plate idealized into a finite number of discrete structural elements connected at node points having prescribed freedoms (Figure 19). The physical properties of the plate are assumed to be lumped into individual elements. The equations of motion of each panel element is written in the form of a matrix equation<sup>18</sup>

$$[M] \{\ddot{\delta}(t)\} + [C] \{\dot{\delta}(t)\} + [K] \{\delta(t)\} = \{F(t)\} \quad (E1)$$

where  $\delta(t)$  and  $F(t)$  are column matrices of time dependent *nodal* displacements and applied forces, respectively.

The square matrices  $[M]$ ,  $[C]$ , and  $[K]$  are inertia, viscous damping, and stiffness coefficients, respectively.

Elements of the inertia matrix  $[M]$  correspond to inertia forces associated with the freedoms at each node. For small panel deflections, rotary and inplane inertia forces are small in comparison to the forces corresponding to translational freedoms. Hence the inertia of the elements are treated by assuming their masses to be concentrated at their respective nodes, thereby *diagonalizing* the inertia matrix. The accuracy of the concentrated mass assumption depends primarily on the number of elements used to represent the panel; accuracy increases with the number of elements used (for some quantitative data on accuracy, see pages 22, 23 and 34 of Reference 34).

The *viscous* damping is assumed to be proportional to inertia and stiffness; the significance of this assumption is discussed below.\* Hence

$$[C] = \mu[M] + \lambda[K] \quad (E2)$$

where  $\mu$  and  $\lambda$  are proportionality factors.

For the  $j$ th mode:

$$C_j = \mu M_j + \lambda K_j$$

It is convenient to represent the damping factor  $\zeta_j$ , which represents the fraction of critical viscous damping for the  $j$ th mode

$$2\zeta_j \equiv \frac{C_j}{\sqrt{K_j M_j}} = \frac{C_j}{M_j \omega_j} = \frac{\mu M_j + \lambda K_j}{M_j \omega_j} = \frac{\mu}{\omega_j} + \lambda \omega_j \quad (E3)$$

or

$$2\zeta_j \omega_j = \mu + \lambda \omega_j^2$$

---

\*Viscous and structural damping are forms of damping which allow the equations of motion to be uncoupled when displacements are expressed in terms of normal mode shapes.

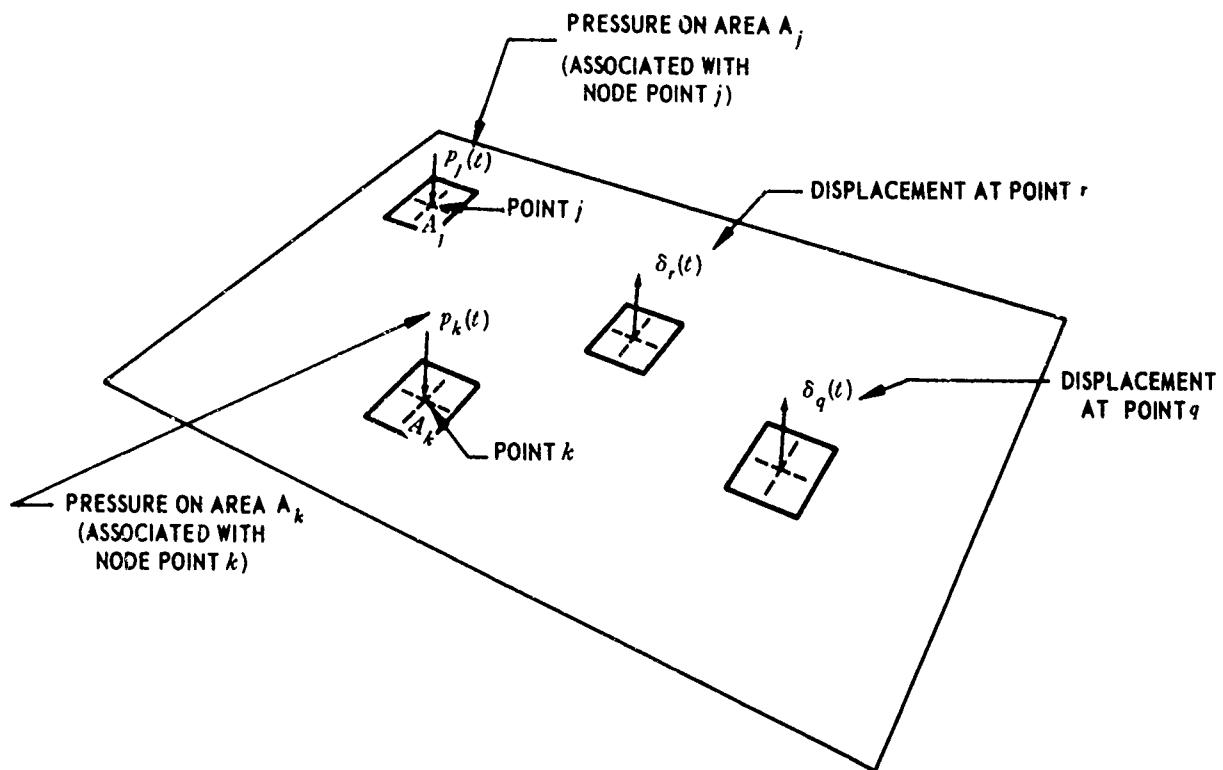

Figure 19 – Random Pressure Loads

Alternatively, when *structural* damping is used, the equations of motion for this damping are (see pages 83–86 of Reference 18)\*

$$[M] \{\ddot{\delta}(t)\} + (1 + ig) [K] \{\delta(t)\} = \{F(t)\} \quad (\text{E4})$$

When the structural damping coefficient is small ( $g \ll 1$ ), then (see page 88, Equation XI and page 16, Equation (27) of Reference 18) the coefficient  $g$  is related to an equivalent viscous damping factor

$$g \approx 2 \zeta, \quad (\text{E5})$$

Total panel damping includes both acoustic radiation and structural damping. This total damping based on *experimental* panel-displacement power spectral density measurements is assumed to have the following mass-proportional viscous-damping representation as in Equations (E2) and (E3) (see pages 24–25 and 34 of Reference 34)

$$\zeta = \frac{\Delta f}{2f} = \frac{7.5}{f}$$

The symmetric stiffness matrix  $[K]$  for the plate is generated by a computer program based on the displacement or stiffness method of static matrix structural analysis.<sup>37</sup> Both applied loading and inertia forces of the panel correspond only to translational freedoms, but the stiffness matrix is formulated with all freedoms included. Through matrix manipulation, the stiffness matrix can also be expressed solely in terms of translational deflections of the panel. Obtaining this “reduced” stiffness matrix in no way restrains the displacements of the unloaded freedoms;<sup>37</sup> thus the accuracy of the stiffness coefficients is unaffected. In the displacement method the panel is idealized as a system of finite plate elements connected at node points. For any point on the plate

$$F_r = K_{r1} \delta_1 + K_{r2} \delta_2 + \dots + K_{rr} \delta_r + \dots + K_{rn} \delta_n$$

where the  $K_r$ 's are force influence coefficients that relate the external force at one point on the plate to deflections at that and other points. The collection of these force equations is represented as

$$\begin{Bmatrix} F_1 \\ F_2 \\ \cdot \\ \cdot \\ F_n \end{Bmatrix} = \begin{bmatrix} K_{11} & K_{12} & \dots & K_{1n} \\ K_{21} & K_{22} & \dots & K_{2n} \\ \cdot & \cdot & \dots & \cdot \\ \cdot & \cdot & \dots & \cdot \\ K_{n1} & K_{n2} & \dots & K_{nn} \end{bmatrix} \begin{Bmatrix} \delta_1 \\ \delta_2 \\ \cdot \\ \cdot \\ \delta_n \end{Bmatrix} \quad (\text{E6})$$

\*See footnote on page 271.

or

$$\{F\} = \{K\} \{\delta\} \quad (\text{E6})$$

where the matrix of force influence coefficients is called the stiffness matrix and the individual terms in the matrix are called the stiffness coefficients. The coefficient (or element)  $K_{rs}$  of  $\{K\}$  is the static force at nodal point  $i$  corresponding to a unit displacement at point  $j$ , all other points held fixed. The foregoing is more fully discussed in Reference 37.

We determine the system response from the equations of motion, (E1) or (E4), for an excitation random in time using the frequency response method of analysis. The method specifies the characteristics of the systems behavior by a matrix of complex frequency response functions, i.e., the admittance matrix now derived.

Let  $\delta(t)$ , the response at time  $t$  due to a unit impulse applied at an earlier time  $t'$ , be expressed by a unit impulse function  $h(t-t')$ .<sup>33</sup> Then the response to an arbitrary input  $F(t')$  is, by use of the superposition or convolution integral

$$\delta(t) = \int_0^t F(t') h(t-t') dt'$$

since  $h(t-t') = 0$  for  $t' > t$  and since  $F(t')$  can be defined for all negative  $t'$ , the limits of integration can be extended (see Equation 2.8 of Reference 33) so that

$$\delta(t) = \int_{-\infty}^{\infty} F(t') h(t-t') dt'$$

If  $F(t') = e^{i\omega t'}$ , then

$$\delta(t) = \int_{-\infty}^{\infty} h(t-t') e^{i\omega t'} dt'$$

Let  $r = t - t'$ ,  $-dr = dt'$ . Then since  $-\int_{\infty}^{-\infty} \dots dr = \int_{-\infty}^{\infty} \dots dr$ ,

$$\delta(t) = e^{i\omega t} \int_{-\infty}^{\infty} h(r) e^{-i\omega r} dr = e^{i\omega t} H(i\omega)$$

where  $H(i\omega) = \int_{-\infty}^{\infty} h(r) e^{-i\omega r} dr$  is defined as the complex frequency response function

=  $2\pi$  times the Fourier transform of the unit impulse response function.

The Laplace transform of Equation (E1) is

$$\mathcal{L} \left[ [M] \{\dot{\delta}(t)\} + [C] \{\dot{\delta}(t)\} + [K] \{\delta(t)\} \right] = \mathcal{L} \{F(t)\}$$

where  $\mathcal{L} \{F(t)\} = \int_0^{\infty} F(t) e^{-st} dt$ ,  $s$  being the Laplace dummy variable.

For a system at rest at time  $t = 0$ , this may be written

$$\left[ s^2 [M] + s [C] + [K] \right] \mathcal{L} \{ \delta(t) \} = \mathcal{L} \{ F(t) \}$$

If a unit impulse is applied at time  $t = 0$  to *one* load point of the structure, then since the Laplace function of a unit impulse function is unity

$$\left[ s^2 [M] + s [C] + [K] \right] \mathcal{L} \{ \delta(t) \} = \{ I \}$$

where  $\{ I \}$  is a null column matrix except for a *unit entry* corresponding to the excitation point. If a unit impulse is consecutively applied to *each* load point and the resulting displacement column matrices are arranged in a square matrix, then<sup>38</sup>

$$\left[ \mathcal{L}(\delta) \right] = \left[ s^2 [M] + s [C] + [K] \right]^{-1}$$

Let  $s \rightarrow i\omega$ . Then  $\mathcal{L}(\delta) = \int_0^{\infty} \delta(t) e^{-i\omega t} dt = \int_0^{\infty} \delta(r) e^{-i\omega r} dr$  and  $H(i\omega) =$

$$\int_{-\infty}^{\infty} h(r) e^{i\omega r} dr = \int_{-\infty}^{\infty} \delta(r) e^{-i\omega r} dr = \int_0^{\infty} \delta(r) e^{-i\omega r} dr$$
 since as previously stated  $h(r) =$

$\delta(r) = 0$  for  $t' > t$  or  $r < 0$ . Thus,

$$\left[ H(i\omega) \right] = \lim_{s \rightarrow i\omega} \left[ L(\delta) \right] = \left[ -\omega^2 [M] + i\omega [C] + [K] \right]^{-1} \quad (E7)$$

is the admittance matrix which is a square complex matrix dependent on frequency  $\omega$ . In general (for a large number of elements), the evaluation of this matrix inversion involves extensive computer time. The inversion can be avoided if we assume the damping to be proportional to inertia, to stiffness, or to both (see Equation (E2)). This assumption permits the displacements to be expressed in terms of the normal modes, thereby uncoupling the equations of motion. The decoupling of the equations of motion results in the diagonalization of the admittance matrix, thus eliminating matrix inversion.

The following procedure is used to find an admittance matrix  $[H(i\omega)]$  which will not involve matrix inversion when the equations of motion are decoupled, the displacements being expressed in terms of the normal mode shapes. The mode shapes are determined from the undamped, unforced equations of motion<sup>18</sup>

$$[M]\{\ddot{\delta}(t)\} + [K]\{\delta(t)\} = 0$$

The solutions to this equation are expressed in terms of normal modes

$$\{\delta(t)\} = \{\phi^{(j)}\} e^{i(\omega_j t + \psi)}$$

Substitution of the latter into the former equation yields

$$\left[ [K] - \omega_j^2 [M] \right] \{\phi^{(j)}\} e^{i(\omega_j t + \psi)} = 0$$

Equating the determinant of the square matrix to zero yields the nontrivial solutions to the *classic eigenvalue equation*, i.e., set

$$|[K] - \omega_j^2 [M]| = 0$$

Corresponding to each degree of freedom of the system, we can solve for an eigenvalue  $\omega_j^2$ . Associated with each eigenfrequency  $\omega_j$  is an eigenvector  $\{\phi^{(j)}\}$ .

By use of a coordinate transformation,<sup>18</sup> we write

$$\{\delta(t)\} = [\phi] [q(t)]$$

where each *column* of  $[\phi]$  is a normal mode  $\{\phi^{(j)}\}$  and  $\{q(t)\}$  is a column matrix of coordinates called principal (or generalized) coordinates<sup>18</sup>. Substituting this equation into Equation (E1)\* and premultiplying by the transpose of  $[\phi]$  results in

$$[\phi]^T [M] [\phi] \{\ddot{q}(t)\} + [\phi]^T [C] [\phi] \{\dot{q}(t)\} + [\phi]^T [K] [\phi] \{q(t)\} = [\phi]^T \{F(t)\} .$$

Since the modes are assumed orthogonal with respect to inertia and stiffness, the generalized inertia and stiffness matrices become diagonal (see page 132 of Reference 18). Since the damping matrix  $[C]$  is proportional to  $[M]$ ,  $[K]$ , or both (Equation (E2)), it also results in a diagonal matrix, i.e.,

$$\begin{aligned} [\phi]^T [M] [\phi] &= [M_j] \\ [\phi]^T [K] [\phi] &= [K_j] = [\omega_j^2 M_j] \\ [\phi]^T [C] [\phi] &= [C_j] \end{aligned}$$

where  $M_j$ ,  $K_j = \omega_j^2 M_j$ , and  $C_j$  are the generalized mass, stiffness, and damping, respectively.

Hence, substituting these quantities into the previous equation of motion, we get the decoupled equation of motion

---

\*Recall that Equation (E1) includes *viscous* damping.

$$[M_j] \{\ddot{q}(t)\} + [C_j] \{\dot{q}(t)\} + [\omega_j^2 M_j] \{q(t)\} = [\phi]^T \{F(t)\}$$

Thus, if *viscous damping* is used, then by means of the unit impulse excitations and the Laplace transform as in the derivation of Equation (E7), the admittance matrix is found from the foregoing equation to be

$$\begin{aligned} [H(i\omega)] &= [\phi] \left[ \frac{1}{-\omega^2 M_j + i\omega C_j + \omega_j^2 M_j} \right] [\phi]^T \\ &= [\phi] \left[ \frac{1}{M_j(-\omega^2 + i\omega(\mu + \lambda\omega_j^2) + \omega_j^2)} \right] [\phi]^T \end{aligned} \quad \begin{array}{l} \text{(viscous damping)} \\ \text{(E8)} \end{array}$$

where  $\mu$  and  $\lambda$  are constants,  $\omega_j$  is the  $j$ th natural circular frequency of the plate, and each column of  $[\phi]$  is a normal mode  $\{\phi^{(j)}\}$ . The term  $M_j$  is the  $j$ th generalized mass defined by

$$M_j = \{\phi^{(j)}\}^T [M] \{\phi^{(j)}\} \quad \text{(E9)}$$

Since  $\omega_j$  and  $\phi_j$  (and therefore  $[\phi]$  and  $[\phi]^T$ ) are solutions to the classic eigenvalue problem and  $[M]$  is a known quantity, then for each value  $j$ ,  $M_j$  is computed from Equation (E9) as a number lying along a diagonal<sup>18</sup> and  $H(i\omega)$  is obtained from Equation (E8). Note that in Equation (E8) the quotient of a scalar quantity, i.e.,  $1/[M_j(-\omega^2 + i\omega(\mu + \lambda\omega_j^2) + \omega_j^2)]$ , for a given value of  $j$  is quite easily determined by a computer for a range of  $\omega$ 's. Hence evaluation of the product of the three matrices in Equation (E8) is generally much simpler (requires less computer time) than the evaluation of the inverse matrix, Equation (E7).

If *structural damping* is used as in Equation (E4), then since  $\omega_j^2 M_j = K_j$ , the quotient in the first of Equations (E8) becomes

$$\frac{1}{-\omega^2 M_j + \omega_j^2 M_j(1 + ig)} = \frac{1}{M_j(-\omega^2 + ig\omega_j^2 + \omega_j^2)}$$

so that

$$[H(i\omega)] = [\phi] \left[ \frac{1}{M_j(-\omega^2 + ig\omega_j^2 + \omega_j^2)} \right] [\phi]^T \quad \begin{array}{l} \text{(structural damping)} \\ \text{(E10)} \end{array}$$

Equations (E8) or (E10) are *decoupled* admittance matrices and do not involve matrix inversions.

The admittance function will now be used in determining the response to turbulence excitation which is treated as an ergodic stationary random process. For such processes the relationship between response cross spectral density and pressure-loading cross spectral density of the turbulent boundary layer pressures is obtained as follows:

As in the derivation of  $H(i\omega)$ , the displacement of point  $q$  of a plate to a pressure  $p_j$  applied over an area  $A_j$  at point  $j$  is (see Figure 19)

$$\delta_q^j(t) = A_j \int_{-\infty}^{\infty} p_j(t_1') h_q^j(t-t_1') dt'$$

Similarly the displacement at point  $r$  due to pressure at point  $k$  is

$$\delta_r^k(t) = A_k \int_{-\infty}^{\infty} p_k(t_2') h_r^k(t-t_2') dt'$$

The cross correlation of the two responses is

$$\begin{aligned} R_{\delta_q^j \delta_r^k}(\tau) &= \lim_{T \rightarrow \infty} \frac{1}{2T} \int_{-T}^T \delta_q^j(t) \delta_r^k(t+\tau) dt \\ &= A_j A_k \int_{-\infty}^{\infty} \int_{-\infty}^{\infty} \left[ \lim_{T \rightarrow \infty} \frac{1}{2T} \int_{-T}^T p_j(t-\xi_1) p_k(t+\tau-\xi_2) dt \right] \cdot h_q^j(\xi_1) h_r^k(\xi_2) d\xi_1 d\xi_2 \\ &= A_j A_k \int_{-\infty}^{\infty} \int_{-\infty}^{\infty} R_{p_{jk}}(\tau-\xi_2+\xi_1) h_q^j(\xi_1) h_r^k(\xi_2) d\xi_1 d\xi_2 \end{aligned}$$

where the order of the integrations has been interchanged and  $\xi_1 = t - t_1'$ ,  $\xi_2 = t - t_2' + \tau$  and  $R_{p_{jk}}$  is the cross correlation of the pressures at points  $j$  and  $k$ .

The cross spectral density of the two displacements is the Fourier transform of this quantity

$$\begin{aligned} \Phi_{\delta_q^j \delta_r^k}(i\omega) &= \frac{1}{2\pi} \int_{-\infty}^{\infty} R_{\delta_q^j \delta_r^k}(\tau) e^{-i\omega\tau} d\tau \\ &= A_j A_k \frac{1}{2\pi} \int_{-\infty}^{\infty} R_{p_{jk}}(\tau-\xi_2+\xi_1) d\tau e^{-i\omega(\tau-\xi_2+\xi_1)} \int_{-\infty}^{\infty} h_q^j(\xi_1) e^{i\omega\xi_1} d\xi_1 \int_{-\infty}^{\infty} h_r^k(\xi_2) e^{-i\omega\xi_2} d\xi_2 \end{aligned}$$



$$= A_j A_k \Phi_{p_{jk}}(i\omega) H_q^{j*}(i\omega) \cdot H_r^k(i\omega)$$

where  $\Phi_{p_{jk}}$  is the cross spectral density of pressures  $j$  and  $k$  and  $H_q^{j*}$  is the complex conjugate of  $H_q^j$ .

When all points of the structure are loaded, the displacement at point  $q$  is the sum of the components resulting from each load

$$\delta_q(t) = \sum_{j=1}^n \delta_q^j(t)$$

where  $n$  is the number of load points. The cross correlation of two displacements when all points are loaded is therefore

$$R_{\delta_{qr}}(\tau) = \sum_{j=1}^n \sum_{k=1}^n R_{\delta_r^j \delta_s^k}(\tau)$$

and the corresponding cross spectral density function for displacements at  $q$  and  $r$  is

$$\Phi_{\delta_{qr}}(i\omega) = \sum_{j=1}^n \sum_{k=1}^n A_j A_k \Phi_{p_{jk}}(i\omega) H_q^{j*}(i\omega) H_r^k(i\omega)$$

which can be expressed conveniently in matrix form for *all* pairs of node displacements\*

$$[\Phi_{\delta}(i\omega)] = [H^*(i\omega)] [A] [\phi_p(i\omega)] [A] [H(i\omega)]^T \quad (E11)$$

where  $[\phi_{\delta}(i\omega)]$  and  $[\phi_p(i\omega)]$  are cross power spectral density matrices of displacement and pressure, respectively. The diagonal elements of the resulting matrix in Equation (E11) are power spectral density functions of the displacements. The off-diagonal terms are displacement cross power spectral density terms.

Now substituting Equation (E3) into (E8) we get

$$\begin{aligned} H(i\omega) &= [\phi] \left[ \frac{1}{M_j \left( (\omega_j^2 - \omega^2) + i\omega (2\zeta_j \omega_j) \right)} \right] [\phi]^T \\ &= [\phi] \left[ \frac{(\omega_j^2 - \omega^2) - 2\zeta_j \omega_j \omega}{M_j (\omega_j^2 - \omega^2)^2 + (2\zeta_j \omega_j \omega)^2} \right] [\phi]^T \end{aligned}$$

\*The matrices in Equation (E11) are easily expanded to yield the foregoing summation.

$$= \{\phi\} \left[ \begin{matrix} \Gamma & D \\ & -i \Gamma & E \end{matrix} \right] \{\phi\}^T \quad (\text{E12})$$

where

$$D_j = \frac{1}{M_j} \frac{\omega_j^2 - \omega^2}{(\omega_j^2 - \omega^2)^2 + (2\zeta_j \omega_j \omega)^2}$$

$$E_j = \frac{1}{M_j} \frac{2\zeta_j \omega_j \omega}{(\omega_j^2 - \omega^2)^2 + (2\zeta_j \omega_j \omega)^2}$$

Both pressure and deflection cross power spectral density matrices are Hermitian matrices which can be decomposed into a real symmetric matrix (co-power spectral density)  $[C(\omega)]$  and a skew symmetric imaginary matrix (quad-power spectral density)  $i[Q(\omega)]$

$$[\phi_p(\omega)] = [C_p(\omega)] + i[Q_p(\omega)] \quad (\text{E13})$$

$$[\phi_\delta(\omega)] = [C_\delta(\omega)] + i[Q_\delta(\omega)] \quad (\text{E14})$$

Pre-and post-multiplying by  $\begin{bmatrix} \Gamma & A \\ & \end{bmatrix}$ , we have

$$[\Phi_F(\omega)] = [C_F(\omega)] + i[Q_F(\omega)] \quad (\text{E15})$$

where

$$[\Phi_F(\omega)] = \begin{bmatrix} \Gamma & A \\ & \end{bmatrix} [\phi_p(\omega)] \begin{bmatrix} \Gamma & A \\ & \end{bmatrix}$$

$$[C_F(\omega)] = \begin{bmatrix} \Gamma & A \\ & \end{bmatrix} [C_p(\omega)] \begin{bmatrix} \Gamma & A \\ & \end{bmatrix}$$

$$[Q_F(\omega)] = \begin{bmatrix} \Gamma & A \\ & \end{bmatrix} [Q_p(\omega)] \begin{bmatrix} \Gamma & A \\ & \end{bmatrix}$$

Substituting Equations (E12) and (E15) into Equation (E11), we get (noting that  $\{\phi\}$ ,  $\{\phi\}^T$  are real quantities)

$$\begin{aligned} [\Phi_\delta(i\omega)] &= [C_\delta(\omega)] + i[Q_\delta(\omega)] \\ &= \left[ \{\phi\} \begin{bmatrix} \Gamma & D \\ & -i \Gamma & E \end{bmatrix} \{\phi\}^T \right]^* [C_F(\omega) + iQ_F(\omega)] \cdot \left[ \{\phi\} \begin{bmatrix} \Gamma & D \\ & -i \Gamma & E \end{bmatrix} \{\phi\}^T \right]^T \\ &= \{\phi\} \left[ \begin{matrix} \Gamma & D \\ & \Gamma & E \end{matrix} \right] \{\phi\}^T [C_F + iQ_F] \{\phi\} \left[ \begin{matrix} \Gamma & D \\ & \Gamma & E \end{matrix} \right] \{\phi\}^T \end{aligned}$$

The equation consists of the sum of eight terms. Consider one of these terms  $[\phi] \lceil D \rceil [\phi]^T [C_F] [\phi] \lceil D \rceil [\phi]^T$ . For convenience we treat the term as a  $3 \times 3$  matrix. The results can then be extended to an  $m \times m$  matrix.

Thus

$$\begin{aligned} [\phi] \lceil D \rceil [\phi]^T &= \phi \begin{pmatrix} D_1 & 0 & 0 \\ 0 & D_2 & 0 \\ 0 & 0 & D_3 \end{pmatrix} \phi^T = [\phi] \begin{pmatrix} D_1 & 0 & 0 \\ 0 & 0 & 0 \\ 0 & 0 & 0 \end{pmatrix} [\phi]^T + \\ & [\phi] \begin{pmatrix} 0 & 0 & 0 \\ 0 & D_2 & 0 \\ 0 & 0 & 0 \end{pmatrix} [\phi]^T + [\phi] \begin{pmatrix} 0 & 0 & 0 \\ 0 & 0 & 0 \\ 0 & 0 & D_3 \end{pmatrix} [\phi]^T \\ &= D_1 [\phi] \begin{pmatrix} 1 & 0 & 0 \\ 0 & 0 & 0 \\ 0 & 0 & 0 \end{pmatrix} [\phi]^T + D_2 [\phi] \begin{pmatrix} 0 & 0 & 0 \\ 0 & 1 & 0 \\ 0 & 0 & 0 \end{pmatrix} [\phi]^T + \\ & D_3 [\phi] \begin{pmatrix} 0 & 0 & 0 \\ 0 & 0 & 0 \\ 0 & 0 & 1 \end{pmatrix} [\phi]^T \end{aligned}$$

If

$$[\phi] = \begin{bmatrix} \phi_{11} & \phi_{12} & \phi_{13} \\ \phi_{21} & \phi_{22} & \phi_{23} \\ \phi_{31} & \phi_{32} & \phi_{33} \end{bmatrix} = \left( \phi^{(1)} \quad \phi^{(2)} \quad \phi^{(3)} \right)$$

where

$$\left\{ \phi^{(1)} \right\} = \begin{pmatrix} \phi_{11} \\ \phi_{12} \\ \phi_{13} \end{pmatrix}, \left\{ \phi^{(2)} \right\} = \begin{pmatrix} \phi_{21} \\ \phi_{22} \\ \phi_{23} \end{pmatrix}, \left\{ \phi^{(3)} \right\} = \begin{pmatrix} \phi_{31} \\ \phi_{32} \\ \phi_{33} \end{pmatrix}$$

$$\left\{ \phi^{(1)} \right\}^T = \left( \phi_{11} \quad \phi_{12} \quad \phi_{13} \right), \left\{ \phi^{(2)} \right\}^T = \left( \phi_{21} \quad \phi_{22} \quad \phi_{23} \right), \left\{ \phi^{(3)} \right\}^T = \left( \phi_{31} \quad \phi_{32} \quad \phi_{33} \right)$$

then

$$[\phi]^T = \begin{bmatrix} \phi_{11} & \phi_{21} & \phi_{31} \\ \phi_{12} & \phi_{22} & \phi_{32} \\ \phi_{13} & \phi_{23} & \phi_{33} \end{bmatrix} = \begin{bmatrix} \left\{ \phi^{(1)} \right\}^T \\ \left\{ \phi^{(2)} \right\}^T \\ \left\{ \phi^{(3)} \right\}^T \end{bmatrix}; \quad \phi_{jk} = \phi_{kj}$$

Hence

$$\begin{aligned}
 \{\phi\} [D] \{\phi\}^T &= D_1 \begin{pmatrix} \phi_{11} & \phi_{12} & \phi_{13} \\ \phi_{21} & \phi_{22} & \phi_{23} \\ \phi_{31} & \phi_{32} & \phi_{33} \end{pmatrix} \begin{pmatrix} 1 & 0 & 0 \\ 0 & 0 & 0 \\ 0 & 0 & 0 \end{pmatrix} \begin{pmatrix} \phi_{11} & \phi_{21} & \phi_{31} \\ \phi_{12} & \phi_{22} & \phi_{32} \\ \phi_{13} & \phi_{23} & \phi_{33} \end{pmatrix} + \dots \\
 &= D_1 \begin{pmatrix} \phi_{11} & 0 & 0 \\ \phi_{21} & 0 & 0 \\ \phi_{31} & 0 & 0 \end{pmatrix} \begin{pmatrix} \phi_{11} & \phi_{21} & \phi_{31} \\ \phi_{12} & \phi_{22} & \phi_{32} \\ \phi_{13} & \phi_{23} & \phi_{33} \end{pmatrix} + \dots \\
 &= D_1 \begin{pmatrix} \phi_{11}^2 & \phi_{11} \phi_{21} & \phi_{11} \phi_{31} \\ \phi_{21} \phi_{11} & \phi_{21}^2 & \phi_{21} \phi_{31} \\ \phi_{31} \phi_{11} & \phi_{31} \phi_{21} & \phi_{31}^2 \end{pmatrix} + \dots \\
 &= D_1 \begin{pmatrix} \phi_{11} \\ \phi_{12} \\ \phi_{13} \end{pmatrix} \begin{pmatrix} \phi_{11} & \phi_{12} & \phi_{13} \end{pmatrix} + \dots \\
 &= D_1 \{\phi^{(1)}\} \{\phi^{(1)}\}^T + D_2 \{\phi^{(2)}\} \{\phi^{(2)}\}^T + D_3 \{\phi^{(3)}\} \{\phi^{(3)}\}^T
 \end{aligned}$$

which is the sum of dyadic products.\* Hence

\*We have shown that if  $A, B, C, D, E, F$  are vectors and  $a, b, c$  are scalars in a diagonal matrix then

$$(ABC) \begin{pmatrix} a & 0 & 0 \\ 0 & b & 0 \\ 0 & 0 & c \end{pmatrix} \begin{pmatrix} D^T \\ E^T \\ F^T \end{pmatrix} = aAD^T + bBE^T + cCF^T. \text{ And the dyadic product } p \cdot q^T \text{ of two vectors}$$

$$p = \begin{pmatrix} p_1 \\ p_2 \\ p_3 \end{pmatrix}, \quad q = \begin{pmatrix} q_1 \\ q_2 \\ q_3 \end{pmatrix} \text{ is } p \cdot q^T = \begin{pmatrix} p_1 \\ p_2 \\ p_3 \end{pmatrix} (q_1 \ q_2 \ q_3) = \begin{pmatrix} p_1 q_1 & p_1 q_2 & p_1 q_3 \\ p_2 q_1 & p_2 q_2 & p_2 q_3 \\ p_3 q_1 & p_3 q_2 & p_3 q_3 \end{pmatrix}. \text{ The dyadic product should}$$

not be confused with the inner product of two vectors  $p \cdot q = p_1 q_1 + p_2 q_2 + p_3 q_3 = (p_1 p_2 p_3) \begin{pmatrix} q_1 \\ q_2 \\ q_3 \end{pmatrix} = p^T \cdot q.$

$$\begin{aligned}
[\phi] \Gamma D^{-1} [\phi]^T [C_F] [\phi] \Gamma \dots \Gamma^{-1} \Gamma^{-1} \Gamma^{-1} T &= (D_1 \{\phi^{(1)}\} \{\phi^{(1)}\}^T + D_2 \{\phi^{(2)}\} \{\phi^{(2)}\}^T + D_3 \{\phi^{(3)}\} \{\phi^{(3)}\}^T) \\
\cdot [C_F] (D_1 \{\phi^{(1)}\} \{\phi^{(1)}\}^T + D_2 \{\phi^{(2)}\} \{\phi^{(2)}\}^T + D_3 \{\phi^{(3)}\} \{\phi^{(3)}\}^T) \\
&= \sum_{j=1}^3 \sum_{k=1}^3 D_j D_k C_F^{(jk)}(\omega)
\end{aligned}$$

$$\text{where } [C_F^{(jk)}(\omega)] = \{\phi^{(j)}\} \{\phi^{(j)}\}^T [C_F(\omega)] \{\phi^{(k)}\} \{\phi^{(k)}\}^T$$

Extending these results to an  $m \times m$  matrix or summation and treating the remaining seven terms of  $[\phi_\delta(i\omega)]$  in a similar manner, we get

$$\begin{aligned}
[\Phi_\delta(i\omega)] &= [C_\delta(\omega)] + i[Q_\delta(\omega)] \\
&= \sum_{j=1}^m \sum_{k=1}^m \left\{ (D_j D_k + E_j E_k) [C_F^{(jk)}(\omega)] \right. \\
&\quad + D_j E_k \left( [Q_F^{(jk)}(\omega)] + [Q_F^{(jk)}(\omega)]^T \right) \\
&\quad + i \left[ D_k E_j \left( [C_F^{(jk)}(\omega)] - [C_F^{(jk)}(\omega)]^T \right) \right. \\
&\quad \left. \left. + (D_j D_k + E_j E_k) [Q_F^{(jk)}(\omega)] \right] \right\} \quad (E16)
\end{aligned}$$

where

$$[C_F^{(jk)}(\omega)] = \{\phi^{(j)}\} \{\phi^{(j)}\}^T [C_F(\omega)] \{\phi^{(k)}\} \{\phi^{(k)}\}^T$$

$$[Q_F^{(jk)}(\omega)] = \{\phi^{(j)}\} \{\phi^{(j)}\}^T [Q_F(\omega)] \{\phi^{(k)}\} \{\phi^{(k)}\}^T$$

The summation in Equation (E16) is over  $m$  normal modes.

Equation (E16) can be approximated for lightly damped systems. The cross product terms ( $j \neq k$ )  $D_j D_k$ ,  $E_j E_k$ , and  $D_j E_k$ , which involve coupling between modes, are considered insignificant for small damping. Neglecting these terms and since  $[Q_F^{(ii)}] = 0$  due to the skew symmetry of  $[Q_F]$ , whereas  $[C_F^{(ii)}] = [C_F^{ii}]^T$  due to the real symmetry of  $[C_F]$  (this will be shown later), we have

$$[\Phi_{\delta}(\omega)] \approx [C_{\delta}(\omega)] = \sum_{j=1}^m (D_j^2 + E_j^2) \{\phi^{(j)}\} \{\phi^{(j)}\}^T C_F(\omega) \{\phi^{(j)}\} \{\phi^{(j)}\}^T \quad (\text{E17})$$

The average value of the product of two distinct responses at locations  $q$  and  $r$  is

$$\overline{\delta_q \delta_r} = \int_0^{\infty} \Phi_{\delta_{qr}}(\omega) d\omega$$

where  $\overline{\delta_q \delta_r}$  is called the joint deflection moment of the two responses  $q$  and  $r$  and denotes the space cross correlation (zero time delay) of the two responses.\* The joint deflection moments for all responses can be considered at once and written as a matrix integration

$$\overline{\delta_q \delta_r} = \int_0^{\infty} [\Phi_{\delta}(\omega)] d\omega \quad (\text{E18})$$

where the elements of  $[\overline{\delta_q \delta_r}]$  are joint deflection moments for all pairs of structural node points. The diagonal elements are mean square values of the deflections, and the off-diagonal terms are time averages of products of deflections at different node points. For small uncoupled damping,  $[\phi_{\delta}]$  is given by Equation (E17) and the response is predominantly narrow-band occurring in the regions of the natural frequencies. If broad-band excitation is assumed, the variation of the excitation cross spectral density is small compared to the response variation near the natural frequencies and the force cross power spectral density can be treated as a constant near each natural frequency. Thus we have

$$[\overline{\delta_q \delta_r}] = \sum_{j=1}^m \{\phi^{(j)}\} \{\phi^{(j)}\}^T [C_F(\omega_j)] \{\phi^{(j)}\} \{\phi^{(j)}\}^T \int_0^{\infty} (D_j^2 + E_j^2) d\omega \quad (\text{E19})$$

For small damping, and from the definitions of  $D_j$  and  $E_j$ , this equation is evaluated as (see page 63, Equation (2.14) and page 72, Equation (ii) of Reference 18).

$$[\overline{\delta_q \delta_r}] = \sum_{j=1}^m \{\phi^{(j)}\} \{\phi^{(j)}\}^T [C_F(\omega_j)] \{\phi^{(j)}\} \{\phi^{(j)}\}^T \frac{\pi}{4\eta_j^2 \omega_j^3 \zeta_j} \quad (\text{E20})$$

The Maestrello mathematical model for the space-time cross correlation of the fluctuating turbulence boundary layer pressures measured in broad frequency bands for Mach numbers ranging from 0.52 to 0.57 is (see Equation (B9) and the corresponding notation as well as Equation (E23) below)

\* For  $j \neq k$ , evaluation of the joint responses is given in Appendix II of Reference 37.

$$\rho(\xi, \eta; \tau) = \frac{e^{-|\tau|/\theta}}{\sum_{n=1}^3 \frac{A_n}{K_n}} \left\{ \sum_{n=1}^3 \frac{A_n K_n}{K_n^2 + B^2 [(\xi - U_c \tau)^2 + \eta^2]} \right\} \quad (\text{E21})$$

where

$$-1 \leq \rho(\xi, \eta; \tau) \leq 1$$

$$\sum_{n=1}^3 \frac{A_n}{K_n} = K^2 = 9.56$$

and the mean (broad band) values of  $\theta$  as a function of Mach number  $M$  is given in Figure 16 of Reference 34\*; see also the method given later in this Appendix for determining computer program output.

The corresponding normalized pressure cross power spectral density is

$$\left. \begin{aligned} \pi(\xi, \eta; i\omega) &= \frac{1}{\pi} \int_{-\infty}^{\infty} \rho(\xi, \eta; \tau) e^{-i\omega\tau} d\tau; (0 \leq \omega \leq \infty) \\ &= \frac{1}{2\pi} \int_{-\infty}^{\infty} \rho(\xi, \eta; \tau) e^{-i\omega\tau} d\tau; (-\infty \leq \omega \leq +\infty) \end{aligned} \right\} \quad (\text{E22})$$

(multiplying the second of Equations (E22) by 2 yields the cross power spectral density in the positive frequency domain).

It has not been possible to solve Equation (E22) using  $\rho$  as defined by Equation (E21). However a solution is possible if we take an alternate approach which makes use of the frozen turbulence model known as the Taylor hypothesis, i.e., assume space and time variations are interrelated according to

$$\frac{|\tau|}{\theta} = \frac{|\xi|}{U_c \theta} \quad (\text{E23})$$

Thus if the time decay is described as a spacial decay, the Maestrello space-time correlation function  $\rho$  has the form

---

\*Measured values of  $\theta$  for frequency band width centered at 1200 and 4800 cps are also plotted in Figure 16 of Reference (34).

$$\rho(\xi, \eta; r) = \frac{e^{-|\xi|/U_c \theta}}{9.56} \left\{ \sum_{n=1}^3 \frac{A_n K_n}{K_n^2 + B^2 [(\xi - U_c r)^2 + \eta^2]} \right\}$$

$$= \sum_{n=1}^3 \rho_n(\xi, \eta; r) \quad (\text{E24})$$

where

$$\rho_n(\xi, \eta; r) = \frac{A_n K_n e^{-|\xi|/U_c \theta}}{9.56 \left\{ K_n^2 + B^2 [(\xi - U_c r)^2 + \eta^2] \right\}} \quad (\text{E25})$$

Then

$$\Pi(\xi, \eta; i\omega) = \sum_{n=1}^3 \frac{1}{\pi} \int_{-\infty}^{\infty} \rho_n(\xi, \eta; r) e^{-i\omega r} dr \quad (0 \leq \omega \leq +\infty) \quad (\text{E26})$$

and the  $n$ th component of the cross power spectral density is

$$\Pi_n(\xi, \eta; i\omega) = \frac{1}{\pi} \int_{-\infty}^{\infty} \rho_n(\xi, \eta; r) e^{-i\omega r} dr \quad (0 \leq \omega \leq +\infty) \quad (\text{E27})$$

Substituting Equation (E25) in (E27) and putting Equation (E25) in the form

$$\rho_n = \frac{A_n K_n e^{-|\xi|/U_c \theta}}{9.56 B^2 U_c^2} \cdot \left[ \frac{1}{\frac{K_n^2 + B^2 \eta^2}{B^2 U_c^2} + \left(r - \frac{\xi}{U_c}\right)^2} \right] \text{ yields upon taking the Fourier}$$

transform

$$\Pi_n(\xi, \eta; i\omega) = \frac{A_n K_n e^{-\frac{i|\xi|}{U_c \theta} - \frac{\omega}{B U_c} [K_n^2 + B^2 \eta^2]^{1/2} - \frac{i\omega \xi}{U_c}}}{9.56 B U_c [K_n^2 + B^2 \eta^2]^{1/2}}$$

$$(0 \leq \omega \leq +\infty) \quad (\text{E28})$$

Dimensionless forms of  $\pi_n$  are plotted in Figures 19 and 20 of Reference 34. The three components defined in Equation (E28) are used in Equation (E26) to define the fluctuating pressure loading function.



From Equation (B7) we have

$$\Pi(\omega) = \frac{\Phi_p(\omega) U}{\tau_w^2 \delta^*}$$

and by definition

$$\int_0^\infty \Pi(\omega) d\omega = 1 = \frac{U}{\tau_w^2 \delta^*} \int_0^\infty \Phi_p(\omega) d\omega = \frac{U}{\tau_w^2 \delta^*} \bar{p}^2$$

Hence

$$\frac{\tau_w^2 \delta^*}{U} = \bar{p}^2$$

or

$$\Pi(\omega) = \frac{\Phi_p(\omega)}{\bar{p}^2} \quad \text{or} \quad \Phi_p(\omega) = \bar{p}^2 \Pi(\omega)$$

but in accordance with the experimental results shown in Figure 14 of Reference 34,  $[(\bar{p}^2)^{1/2} / \tau_w] = K(M)$  is a function of the Mach  $M$  so that  $\bar{p}^2 = K_m^2 \tau_w^2$ . Thus, the power spectrum in nondimensional form is described by:

$$\frac{\Phi_p(\omega) U}{\tau_w^2 \delta^*} = \frac{\bar{p}^2 \Pi(\omega) U}{\tau_w^2 \delta^*} = \frac{\Pi(\omega) U K^2}{\delta^*} = \sum_{n=1}^3 A_n e^{-K_n(\omega \delta^* / U)}$$

(see Equation (B7) and note that Figure 2 of Reference 15 and Figure 2 of Reference 39 are equivalent.); however, see Appendix E2 with respect to the value  $K$  used in practice.

Hence, using Equation (E28) and noting that  $1/9.56 \approx 0.105$

$$\Phi_p(\xi, \eta; i\omega) = C_p(\xi, \eta; \omega) + iQ_p(\xi, \eta; \omega) = \bar{p}^2 \Pi(\xi, \eta; i\omega)$$

$$= \frac{[K(M)\tau_w]^2}{BU_c} e^{-\frac{|\xi|}{U_c \theta} - \frac{i\omega\xi}{U_c}} \left[ 0.105 \sum_{n=1}^3 \frac{A_n K_n e^{-\frac{\omega}{BU_c}(K_n^2 + B^2 \eta^2)^{1/2}}}{(K_n^2 + B^2 \eta^2)^{1/2}} \right]$$

$$(0 \leq \omega \leq +\infty)$$

(E29)

Figure 3 of Reference 34 shows graphs of this function.

The complex pressure cross power spectral density describes pressure loading as a continuous function of separation distances in the  $x$ - and  $y$ -directions. Pressure loads from boundary layers are small in spacial scale. The load can change appreciably within a few inches or even less. Figure 21 of Reference (34) shows the variation of cross power spectral density over an element.\* These rapid variations cause problems in using  $\Phi_p(\xi, \eta; i\omega)$  to define a loading matrix for use with finite element structural methods. Matrix finite structural analysis methods generally assume that the pressure loads vary slowly over the distance of one element, i.e., that approximately constant pressure acts over the element. When this is true, pressure at the node points can be multiplied by area to approximate forces on the elements. But when the loads vary rapidly over an element, as do boundary layer pressure loads, the method is invalid since it results in large overestimates of the total forces on the element.

This rapid variation causes problems in trying to define a matrix of cross power spectral densities acting on pairs of finite element node points; proper application of the matrix would require a very fine grid of elements. Hence an alternate method has been developed to correctly calculate the cross power spectral density of net forces acting on pairs of finite structural elements. Terms of this type are gathered into a cross power spectral density matrix that is compatible with the structural idealization; the number of elements chosen is such that the desired number of modes can be adequately resolved. The infinitesimal forces are then summed to calculate the net force cross power spectral density on finite element pairs, i.e., the elemental loads are determined by summing the contribution of each infinitesimal area within an elemental pair.

We now evaluate the force cross power spectral density and construct matrices for its real and imaginary coefficients.

Consider the geometry of a pair of finite plate elements (Figure 20) and the more detailed drawing of  $\xi$ -direction separation distances (Figure 21); similar relations hold for  $\eta$ -direction separation distances. Let  $\xi_0$  and  $\eta_0$  be the dimensions of the finite elements in the  $x$ - and  $y$ -directions, respectively. The area of the structure represented at each node is  $(\xi_0 \eta_0)$ . The separation distances between the nodes are

$$\xi = (x_j - x_i) = n_{ij} \xi_0$$

$$\eta = (y_j - y_i) = m_{ij} \eta_0$$

The infinitesimal normalized cross power spectral density of the net forces acting on the infinitesimal areas  $dA_i$  and  $dA_j$  (which are on the finite areas  $A_i$  and  $A_j$  associated with the node points, i.e., nodal areas) is

---

\*In Mach 0.52 ( $\delta^* = 0.155$  in.) flow in the Boeing boundary layer facility, the 990-cps frequency cross power spectral density varies by a factor of more than ten between pairs of points on an 0.75-in.-long finite element.

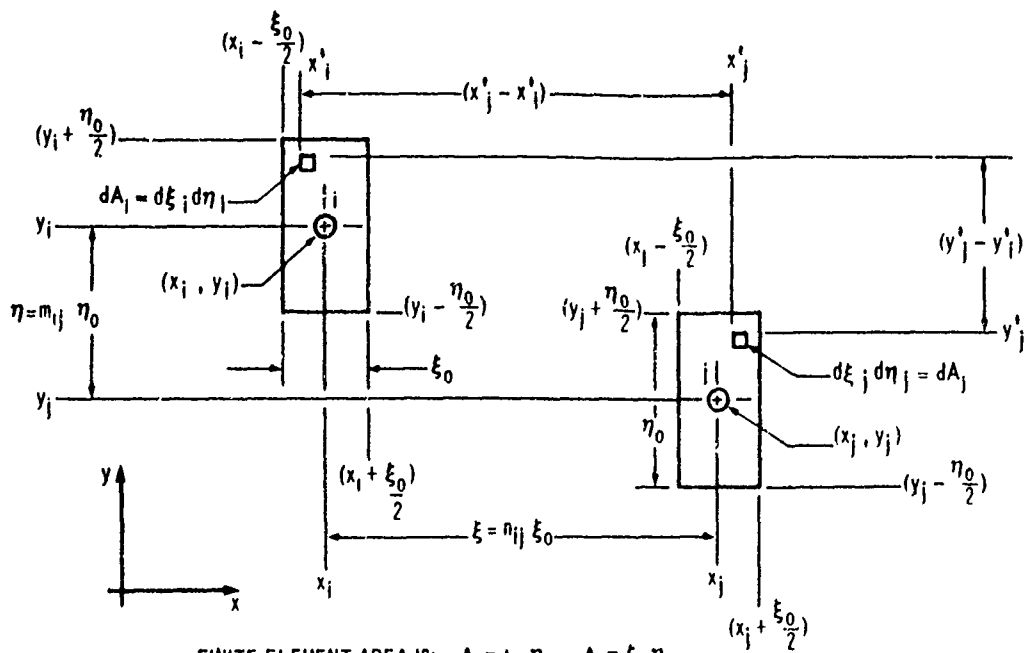

FINITE ELEMENT AREA IS:  $A_i = \xi_0 \eta_0$ ,  $A_j = \xi_0 \eta_0$   
 $\xi = (x_j - x_i) = n_{ij} \xi_0$ ,  $\eta = (y_j - y_i) = m_{ij} \eta_0$ ;  $i, j$  represent structural nodes

Figure 20 - Geometry of a Pair of Finite Plate Elements

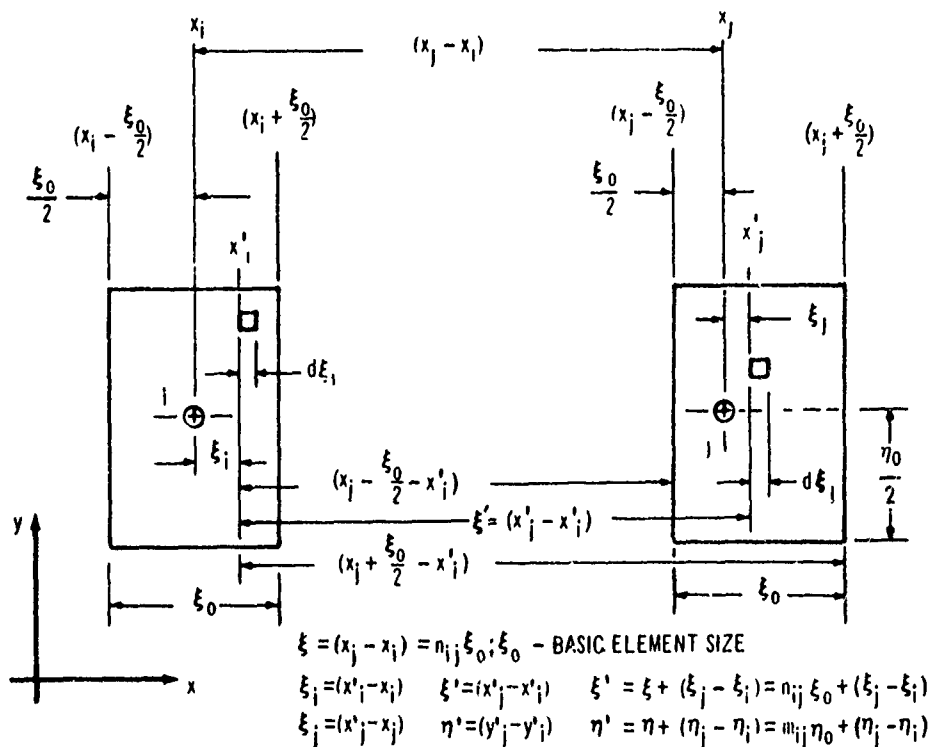

$\xi = (x_j - x_i) = n_{ij} \xi_0$ ;  $\xi_0$  - BASIC ELEMENT SIZE  
 $\xi_i = (x'_i - x_i)$      $\xi'_i = (x'_i - x'_i)$      $\xi' = \xi + (\xi_j - \xi_i) = n_{ij} \xi_0 + (\xi_j - \xi_i)$   
 $\xi_j = (x'_j - x_j)$      $\eta' = (y'_j - y'_j)$      $\eta' = \eta + (\eta_j - \eta_i) = m_{ij} \eta_0 + (\eta_j - \eta_i)$

Figure 21 - Coordinates and Separation Distances in the x-Direction

$$d(\Pi_{F_{ij}}) = \Pi[(x'_j - x'_i), (y'_j - y'_i), i\omega] (dx'_j dy'_j) (dx'_i dy'_i)$$

where  $\Pi[(x'_j - x'_i), (y'_j - y'_i)]$  is the normalized pressure cross spectral density;  $(x'_i, y'_i)$  and  $(x'_j, y'_j)$  are points on the  $i$ th and  $j$ th elements, respectively, whose elemental areas are

$$dA_i = dx'_i dy'_i = d\xi_i d\eta_i$$

$$dA_j = dx'_j dy'_j = d\xi_j d\eta_j$$

The net force cross power spectral density on the  $(i,j)$  pair of nodes is then

$$\Pi_{F_{ij}}(i\omega) = \int_{A_i} \int_{A_j} \Pi[(x'_j - x'_i)(y'_j - y'_i)i\omega] dA_j dA_i \quad (\text{E30})$$

where  $A_i$  and  $A_j$  are areas associated with the  $i$  and  $j$  nodes.

Figures 19 and 20 show that

$$\xi' = (x'_j - x'_i) = n_{ij}\xi_0 + (\xi_j - \xi_i); \quad \xi = n_{ij}\xi_0$$

$$\eta' = (y'_j - y'_i) = m_{ij}\eta_0 + (\eta_j - \eta_i); \quad \eta = m_{ij}\eta_0$$

where  $n_{ij}$  and  $m_{ij}$  are the integral numbers of incremental separation distances in the  $x$ - and  $y$ -directions, respectively.

Hence the force cross power spectral density of the net forces acting on the  $(i,j)$  pair of nodes is

$$\Pi_{F_{ij}}(i\omega) = \int_{-\frac{\eta_0}{2}}^{\frac{\eta_0}{2}} \int_{-\frac{\eta_0}{2}}^{\frac{\eta_0}{2}} \int_{-\frac{\xi_0}{2}}^{\frac{\xi_0}{2}} \int_{-\frac{\xi_0}{2}}^{\frac{\xi_0}{2}} \Pi[(\xi + \xi_j - \xi_i), (\eta + \eta_j - \eta_i); i\omega] d\xi_j d\xi_i d\eta_j d\eta_i \quad (\text{E31})$$

Now rewrite Equation (E28) using the variables of Equation (E31), i.e., *replace the separation between nodes  $\xi, \eta$  by the separation between infinitesimal areas  $\xi + \xi_j - \xi_i, \eta + \eta_j - \eta_i$ , respectively.* Then

$$\Pi_n[(\xi + \xi_j - \xi_i), (\eta + \eta_j - \eta_i); i\omega] = \underbrace{\frac{A_n K_n}{9.56 B U_c}}_{\textcircled{3}} e^{-\underbrace{\left\{ \frac{|\xi + \xi_j - \xi_i|}{U_c \theta} \right\}}_{\textcircled{2}}} - \underbrace{\left\{ i \frac{\omega}{U_c} (\xi + \xi_j - \xi_i) \right\}}_{\textcircled{2}} \frac{e^{-\left\{ \frac{\omega}{B U_c} [K_n^2 + B^2 (\eta + \eta_j - \eta_i)^2]^{1/2} \right\}}}{\underbrace{[K_n^2 + B^2 (\eta + \eta_j - \eta_i)^2]^{1/2}}_{\textcircled{1}}} \quad (0 \leq \omega \leq \infty) \quad \text{E32}$$

is the  $n$ th component of the pressure cross spectral density. Equation (E32) shows that the integrand of Equation (E31) is divided into parts so that the integration is over  $\textcircled{1}$   $\eta$  only,  $\textcircled{2}$   $\xi$  only,  $\textcircled{3}$  constant. The first two parts are now discussed.

The integral of  $\textcircled{1}$  in Equation [E32], which involves  $\eta$  integration only, is

$$\int_{-\frac{\eta_0}{2}}^{+\frac{\eta_0}{2}} \int_{-\frac{\eta_0}{2}}^{+\frac{\eta_0}{2}} e^{-\frac{\omega}{B U_c} [K_n^2 + B^2 (\eta + \eta_j - \eta_i)^2]^{1/2}} \frac{d\eta_j d\eta_i}{[K_n^2 + B^2 (\eta + \eta_j - \eta_i)^2]^{1/2}} \quad \text{E33}$$

To generalize the analysis, the following dimensionless separation distances are defined

$$\hat{\eta} = \frac{\eta}{0.8 K_n \delta^*} = \frac{m_{ij} \eta_0}{0.8 K_n \delta^*}$$

$$\hat{\eta}_0 = \frac{\eta_0}{0.8 K_n \delta^*}$$

$$\hat{\eta}_i = \frac{\eta_i}{0.8 K_n \delta^*}$$

$$\hat{\eta}_j = \frac{\eta_j}{0.8 K_n \delta^*}$$

$$y = \hat{\eta}_j - \hat{\eta}_i$$

Since  $\frac{\omega}{BU_c} - \frac{\omega}{0.8\delta^* U_c} = \frac{\omega\delta^*}{U} = S$ , Equation (E33) may be rewritten as

$$\int_{-\frac{\eta_0}{2}}^{+\frac{\eta_0}{2}} \int_{-\frac{\eta_0}{2}}^{+\frac{\eta_0}{2}} \frac{e^{-K_n S \left[ 1 + \frac{B^2}{K_n^2} \eta^2 \left( 1 + \frac{\eta_j - \eta_i}{\eta} \right)^2 \right]^{1/2}}}{K_n \left[ 1 + \frac{B^2}{K_n^2} \eta^2 \left( 1 + \frac{\eta_j - \eta_i}{\eta} \right)^2 \right]^{1/2}} d\eta_j d\eta_i$$

but

$$\frac{B^2}{K_n^2} \eta^2 = \frac{\left( \frac{1}{0.8\delta^*} \right)^2}{K_n^2} (0.8K_n \delta^* \hat{\eta})^2 = \hat{\eta}^2$$

$$\frac{\eta_j - \eta_i}{\eta} = \frac{\hat{\eta}_j - \hat{\eta}_i}{\hat{\eta}} = \frac{y}{\hat{\eta}}$$

$$d\eta_j d\eta_i = (0.8K_n \delta^*)^2 d\hat{\eta}_j d\hat{\eta}_i$$

and the variables of integration are transformed by use of the Jacobian

$$d\hat{\eta}_i d\hat{\eta}_j = \left| \frac{\partial(\hat{\eta}_i, \hat{\eta}_j)}{\partial(\hat{\eta}_i, y)} \right| dy d\hat{\eta}_i = \begin{vmatrix} \frac{\partial \hat{\eta}_i}{\partial \hat{\eta}_i} & \frac{\partial \hat{\eta}_j}{\partial \hat{\eta}_i} \\ \frac{\partial \hat{\eta}_i}{\partial y} & \frac{\partial \hat{\eta}_j}{\partial y} \end{vmatrix} dy d\hat{\eta}_i$$

$$= \begin{vmatrix} 1 & 0 \\ -1 & 1 \end{vmatrix} dy d\hat{\eta}_i = dy d\hat{\eta}_i$$

Hence  $d\eta_j d\eta_i \rightarrow (0.8K_n \delta^*)^2 dy d\hat{\eta}_i$ .

For the limits when  $\eta_i = \pm \frac{\eta_0}{2}$ ,  $\hat{\eta}_i = \pm \frac{\eta_i}{0.8K_n \delta^*} = \pm \frac{\eta_0}{2(0.8K_n \delta^*)} = \pm \frac{\hat{\eta}_0}{2}$ . Similarly

the upper and lower limits of  $\eta_j$  are  $\pm \hat{\eta}_0 / 2$  respectively. Hence for the  $y (= \hat{\eta}_j - \hat{\eta}_i)$  variable of integration, since  $\hat{\eta}_i$  remains as a variable in the inner limits, the inner limits, the inner limits are  $y = \pm \frac{\hat{\eta}_0}{2} - \hat{\eta}_i$ .

Hence the previous integral in terms of the new coordinates  $y, \hat{\eta}_i$  is

$$(0.8K_n \delta^*)^2 \int_{-\frac{\hat{\eta}_0}{2}}^{+\frac{\hat{\eta}_0}{2}} \int_{\left[\frac{-\hat{\eta}_0}{2} - \hat{\eta}_i\right]}^{\left[\frac{\hat{\eta}_0}{2} - \hat{\eta}_i\right]} \frac{e^{-K_n S [1 + (\hat{\eta} + y)^2]^{1/2}}}{K_n [1 + (\hat{\eta} + y)^2]^{1/2}} dy d\hat{\eta}_i$$

Now let

$$y' = \hat{\eta} + y$$

$$dy' = dy$$

when  $y = \pm \frac{\hat{\eta}_0}{2} - \hat{\eta}_i$ ,  $y' = \pm \frac{\hat{\eta}_0}{2} + \hat{\eta} - \hat{\eta}_i$ , hence the equation becomes

$$(0.8K_n \delta^*)^2 \int_{-\frac{\hat{\eta}_0}{2}}^{+\frac{\hat{\eta}_0}{2}} \int_{\left[\frac{-\hat{\eta}_0}{2} + \hat{\eta} - \hat{\eta}_i\right]}^{\left[\frac{\hat{\eta}_0}{2} + \hat{\eta} - \hat{\eta}_i\right]} \frac{e^{-K_n S [1 + (y')^2]^{1/2}}}{K_n [1 + (y')^2]^{1/2}} dy' d\hat{\eta}_i$$

Since  $y'$  is a dummy variable, we let  $y' \rightarrow y$  so that the equation and symbols conform to those in Reference 34. The integral is then:

$$(0.8K_n \delta^*)^2 \int_{-\frac{\hat{\eta}_0}{2}}^{+\frac{\hat{\eta}_0}{2}} \int_{\left[\frac{-\hat{\eta}_0}{2} + \hat{\eta} - \hat{\eta}_i\right]}^{\left[\frac{\hat{\eta}_0}{2} + \hat{\eta} - \hat{\eta}_i\right]} \frac{e^{-K_n S [1 + y^2]^{1/2}}}{K_n [1 + y^2]^{1/2}} dy d\hat{\eta}_i \quad (\text{E34})$$

Equation (E33) or its equivalent Equation (E34) cannot be integrated in closed form. For the general case, a numerical approximation of this integral is necessary. For the special case of the integrand approaching small values within one incremental separation, a closed-form approximation is possible. Thus for  $S$  and  $\hat{\eta}_0$  not too small and assuming  $\hat{\eta} = 0$ , the integrand of Equation (E34) is a rapidly decaying function. That is, we assume that the sphere of influence of all pressure points on the  $i$ th finite element does not extend beyond the element; the approximation is good when the boundary layer thickness is small compared

to the element size. We can then extend the limits of integration from  $-\infty$  to  $+\infty$  and take

$\int_{-\infty}^{\infty} = 2 \int_0^{\infty}$  since the integrand is an even function. With these approximations, Equation

(E34) is equal to

$$2(0.8K_n\delta^*)^2 \int_{-\frac{\hat{\eta}_0}{2}}^{\frac{\hat{\eta}_0}{2}} \int_0^{\infty} \frac{e^{-K_n S [1+y^2]^{1/2}}}{K_n [1+y^2]^{1/2}} dy d\hat{\eta}_i \quad (\text{E35})$$

Equation (E35) may then be written as

$$1.28K_n(\delta^*)^2 \int_{-\frac{\hat{\eta}_0}{2}}^{\frac{\hat{\eta}_0}{2}} d\hat{\eta}_i \int_0^{\infty} \frac{e^{-K_n S [1+y^2]^{1/2}}}{K_n [1+y^2]^{1/2}} dy$$

The value of the first integral is  $\hat{\eta}_0$  and the value of the second integral obtained from Reference 40 (page 342, item 3.479.1 with  $x = y^2$ ,  $\beta = K_n S$  and  $\nu = \frac{1}{2}$ ) is  $\kappa_0(K_n S)$  the modified

Bessel function of order zero with argument  $K_n S$ . Hence the solution to Equation (E35) is

$$1.28 K_n (\delta^*)^2 \hat{\eta}_0 \kappa_0 (K_n S) \quad (\text{E36})$$

When the Bessel function approximation is used, it is assumed that the force cross power spectral density is approximately zero for all  $(i,i)$  pairs of finite elements except pairs  $(i,i)$ .

The integral of (2) in Equation (E32) which involves  $\xi$  integration only, must be handled as two special cases

Case I:  $\xi = 0$

Case II:  $\xi > 0, \xi < 0$

When  $\xi = 0$ , the region of integration is divided into two regions to properly represent the function with absolute value sign. The  $\xi > 0$  and  $\xi < 0$  cases have been reduced to a single expression which describes both cases.

Now rewriting Equation (E29)

$$\Phi_p(\xi, \eta; i\omega) = \overline{p^2} \Pi(\xi, \eta; i\omega) \quad (\text{E29})$$



Similarly, using  $\Pi_{F_{ij}}(i\omega)$  as defined in Equation (E31)

$$\Phi_{F_{ij}}(i\omega) = \bar{p}^2 \Pi_{F_{ij}}(i\omega)$$

where  $i$  and  $j$  are node points with incremental separation distance in the  $x$  and  $y$ -directions

such that  $\xi = n_{ij}\xi_0$ ,  $\eta = m_{ij}\eta_0$ , where  $n_{ij} = \frac{x_j - x_i}{\xi_0}$  and  $m_{ij} = \frac{y_j - y_i}{\eta_0}$ ;  $n_{ij}$  and  $m_{ij}$  are

integers so that all nodes are separated by increments of length  $\xi_0$  and  $\eta_0$  in the  $x$ -directions, respectively. But the force power spectral density is the sum of three spectral components as defined by Equations (E31) and (E32)

$$\Phi_{F_{ij}}(i\omega) = \bar{p}^2 \Pi_{F_{ij}}(i\omega) = \bar{p}^2 \left[ \sum_{n=1}^3 \Pi_{F^{(n)}_{ij}}(i\omega) \right] \quad (\text{E37})$$

where

$$\Pi_{F^{(n)}_{ij}}(i\omega) = \frac{A_n K_n}{9.56 B U_c} \int_{-\frac{\xi_0}{2}}^{+\frac{\xi_0}{2}} \int_{-\frac{\xi_0}{2}}^{+\frac{\xi_0}{2}} \int_{-\frac{\eta_0}{2}}^{+\frac{\eta_0}{2}} \int_{-\frac{\eta_0}{2}}^{+\frac{\eta_0}{2}} \frac{|n_{ij}\xi_0 + \xi_j - \xi_i|}{U_c \theta} - \frac{i\omega}{U_c} (n_{ij}\xi_0 + \xi_j - \xi_i) - \frac{\omega}{B U_c} \left[ K_n^2 + B^2 (m_{ij}\eta_0 + \eta_j - \eta_i)^2 \right]^{1/2} \cdot d\eta_j d\eta_i d\xi_j d\xi_i \cdot \frac{e}{\left[ K_n^2 + B^2 (m_{ij}\eta_0 + \eta_j - \eta_i)^2 \right]^{1/2}} \quad (\text{E38})$$

$$(0 \leq \omega \leq +\infty)$$

The integral of Equation (E38) is determined as discussed above. *Final equations* for the power and cross power spectral density of force acting on node points of a structure are summarized below <sup>41</sup> (because of the presence of the absolute value signs, evaluation of the integrals requires separate consideration of the various domains; see statement preceding Equation (E29).\*

\*Correction of the boundary layer load equations originally presented in Reference 34 were made by the authors of the present report. These corrections as well as certain other minor modifications were adopted in Reference 41 and the correct final results are given here.

FORCE POWER SPECTRAL DENSITY ( $n_{ij} = m_{ij} = 0$ )

$$\begin{aligned}\Phi_{F_{ii}}(\omega) &= \Phi(\omega) = \hat{K}' \hat{P}(\omega) \hat{\Phi} \\ C_{F_{ii}}(\omega) &= \hat{K}' \hat{P}(\omega) \hat{\Phi}; \quad Q_{F_{ii}}(\omega) = 0\end{aligned}\quad (\text{E39})$$

FORCE CROSS POWER SPECTRAL DENSITY ( $n_{ij} \neq 0, m_{ij} \neq 0$ )\*

$$\Phi_{F_{ij}}(i\omega) = \Phi(n_{ij}, m_{ij}; i\omega) = C_{F_{ij}}(\omega) + i Q_{F_{ij}}(\omega) \quad (\text{E40})$$

FORCE CO-POWER SPECTRAL DENSITY ( $n_{ij} \neq 0, m_{ij} \neq 0$ )

$$C_{F_{ij}}(\omega) = C_F(n_{ij}, m_{ij}; \omega) = \hat{K}' \hat{C} \hat{\Phi} e^{-|n_{ij} a \xi_0|} \quad (\text{E41})$$

FORCE QUAD-POWER SPECTRAL DENSITY ( $n_{ij} \neq 0, m_{ij} \neq 0$ )

$$Q_{F_{ij}}(\omega) = Q_F(n_{ij}, m_{ij}; \omega) = \hat{K}' \hat{Q} \hat{\Phi} e^{-|n_{ij} a \xi_0|} \quad (\text{E42})$$

where  $\hat{K}' = \text{constant} = \overline{p^2} \eta_0 / 4.78 U_c B^2$ .

PRESSURE POWER SPECTRAL DENSITY

Setting  $\xi = \eta = 0$  and letting  $[K(m) \tau(\omega)]^2 = \overline{p^2}$  in Equation (E29) and using the foregoing equation for  $\hat{K}'$ , we obtain

$$\Phi_p(\omega) = \frac{\overline{p^2}}{9.56 B U_c} \sum_{n=1}^{n=3} A_n e^{-\frac{K_n \omega}{B U_c}} = \frac{\hat{K}' B}{2 \eta_0} \sum_{n=1}^n e^{-\frac{K_n \omega}{B U_c}} \quad (\text{E42A})$$

$P(\omega)$  (power spectral density, dependent on  $\xi$ )

$$= \frac{2}{(a^2 + b^2)^2} \{ a \xi_0 (a^2 + b^2) + (b^2 - a^2) [1 - e^{-a \xi_0} \cos(b \xi_0)] - 2 a b e^{-a \xi_0} \sin(b \xi_0) \} \quad (\text{E43})$$

$\Phi$  = that part of Equation (E37) with dependence on  $\eta$ .

\*If  $n_{ij} = 0, m_{ij} \neq 0$ , then  $C_{F_{ij}}(\omega) = \hat{K}' \hat{P} \hat{\Phi}$  and  $Q_{F_{ij}} = 0$ .

There are two options for  $\varphi$  thus:

1.  $\Phi(\omega)$  (uses Bessel function approximation)

$$= \sum_{n=1}^N A_n K_n Y_n \left( \frac{\omega K_n}{BU_c} \right) \kappa_0 \left( \frac{\omega K_n}{BU_c} \right) \quad (\text{Phi Hat Option 1}) \quad (\text{E44})$$

2.  $\hat{\Phi}(\omega)$  (uses numerical methods)

$$= \frac{B}{2n_0} \sum_{n=1}^N A_n K_n Z_n(m_{ij}, \omega) \quad (\text{Phi Hat Option 2}) \quad (\text{E45})$$

$$Z_n(m_{ij}, \omega) = \int_{-\frac{\eta_0}{2}}^{+\frac{\eta_0}{2}} \int_{-\frac{\eta_0}{2}}^{+\frac{\eta_0}{2}} e^{-\frac{\omega}{BU_c} [K_n^2 + B^2(m_{ij}n_0 + \eta_j - \eta_i)^2]^{1/2}} \frac{d\eta_j d\eta_i}{[K_n^2 + B^2(m_{ij}n_0 + \eta_j - \eta_i)^2]^{1/2}} \quad (\text{E46})$$

$\hat{C}, \hat{Q}$  = those parts of Equation (E37) with dependence on  $\xi$

$$\hat{C} = \frac{4}{(a^2 + b^2)^2} [V \cos(n_{ij} b \xi_0) + W \sin(n_{ij} b \xi_0)] \quad (\text{E47})$$

$$\hat{Q} = \frac{4}{(a^2 + b^2)^2} [W \cos(n_{ij} b \xi_0) - V \sin(n_{ij} b \xi_0)] \quad (\text{E48})$$

or

$$\begin{pmatrix} \hat{C} \\ \hat{Q} \end{pmatrix} = \frac{4}{(a^2 + b^2)^2} \begin{bmatrix} V & W \\ W & -V \end{bmatrix} \begin{bmatrix} \cos(n_{ij} b \xi_0) \\ \sin(n_{ij} b \xi_0) \end{bmatrix}$$

$$V = ab \sin(b \xi_0) \sinh(a \xi_0) + \frac{(b^2 - a^2)}{2} [1 - \cos(b \xi_0) \cosh(a \xi_0)]$$

$$\cdot \frac{(a^2 - b^2)}{2} \sin(b \xi_0) \sinh(a \xi_0) + ab [1 - \cos(b \xi_0) \cosh(a \xi_0)] \quad (\text{E49})$$

$$= \frac{1}{U_c \theta}, \quad b = \frac{\omega}{U_c} \quad (\text{E50})$$

The  $C_F$  and  $Q_F$  matrices are each constructed separately by ordering terms to match the ordering of terms in the structural stiffness matrix, thus making the final expressions for the turbulent boundary layer loading function compatible with the finite element methods of structural analysis. If  $\{\omega_k\}$  is the set of frequencies with  $N_\omega$  total frequencies, then there are  $N_\omega$  matrices  $[C_F(\omega_k)]$  and  $[Q_F(\omega_k)]$  as follows (for simplicity, the  $F$  subscript is dropped in the terms in the matrices so that  $C_{F_{ij}}(\omega_k) \rightarrow C_{ij}(\omega_k)$  etc.).

$$[C_F(\omega_k)] = \begin{bmatrix} C_{11}(\omega_k) & C_{12}(\omega_k) & C_{13}(\omega_k) & \dots & C_{1m}(\omega_k) \\ C_{21}(\omega_k) & C_{22}(\omega_k) & C_{23}(\omega_k) & \dots & C_{2m}(\omega_k) \\ C_{31}(\omega_k) & C_{32}(\omega_k) & C_{33}(\omega_k) & \dots & C_{3m}(\omega_k) \\ \vdots & \vdots & \vdots & \ddots & \vdots \\ C_{m1}(\omega_k) & C_{m2}(\omega_k) & C_{m3}(\omega_k) & \dots & C_{mm}(\omega_k) \end{bmatrix} \quad (\text{E51})$$

$$[Q_F(\omega_k)] = \begin{bmatrix} Q_{11}(\omega_k) & Q_{12}(\omega_k) & Q_{13}(\omega_k) & \dots & Q_{1m}(\omega_k) \\ Q_{21}(\omega_k) & Q_{22}(\omega_k) & Q_{23}(\omega_k) & \dots & Q_{2m}(\omega_k) \\ Q_{31}(\omega_k) & Q_{32}(\omega_k) & Q_{33}(\omega_k) & \dots & Q_{3m}(\omega_k) \\ \vdots & \vdots & \vdots & \ddots & \vdots \\ Q_{m1}(\omega_k) & Q_{m2}(\omega_k) & Q_{m3}(\omega_k) & \dots & Q_{mm}(\omega_k) \end{bmatrix} \quad (\text{E52})$$

Since  $[\Phi_F(i\omega)]$  is Hermitian, then  $[\Phi_F(i\omega)] = [\Phi_F^*(i\omega)]^T$  or  $[C_F(\omega_k)] = [C_F(\omega_k)]^T$ ;  $[Q_F(\omega)] = -[Q_F(\omega)]^T$  and terms in the matrices have the following properties

$$C_{F_{ii}}(\omega_k) = C_{F_{jj}}(\omega_k) = \Phi_F(\omega_k) \quad (\text{E53})$$

$$C_{F_{ij}}(\omega_k) = C_{F_{ji}}(\omega_k) = C(n_{ij}, m_{ij}; \omega_k) = C(n_{ji}, m_{ji} = -m_{ij}; \omega_k) \quad (\text{E54})$$

$$Q_{F_{ij}}(\omega_k) = Q_{F_{jj}}(\omega_k) = 0 \quad (\text{E55})$$

$$Q_{F_{ij}}(\omega_k) = -Q_{F_{ji}}(\omega_k) \quad (\text{E56})$$

Hence

$$[C_F(\omega_k)] = \begin{bmatrix} \Phi(\omega_k) & C_{12}(\omega_k) & C_{13}(\omega_k) & - & - & C_{1m}(\omega_k) \\ C_{12}(\omega_k) & \Phi(\omega_k) & C_{23}(\omega_k) & - & - & C_{2m}(\omega_k) \\ C_{13}(\omega_k) & C_{23}(\omega_k) & \Phi(\omega_k) & - & - & C_{3m}(\omega_k) \\ \vdots & \vdots & \vdots & & & \vdots \\ \vdots & \vdots & \vdots & & & \vdots \\ C_{1m}(\omega_k) & C_{2m}(\omega_k) & C_{3m}(\omega_k) & - & - & \Phi(\omega_k) \end{bmatrix} \quad (\text{E57})$$

$$[Q_F(\omega_k)] = \begin{bmatrix} 0 & Q_{12}(\omega_k) & Q_{13}(\omega_k) & - & - & Q_{1m}(\omega_k) \\ -Q_{12}(\omega_k) & 0 & Q_{23}(\omega_k) & - & - & Q_{2m}(\omega_k) \\ -Q_{13}(\omega_k) & -Q_{23}(\omega_k) & 0 & - & - & Q_{3m}(\omega_k) \\ \vdots & \vdots & \vdots & & & \vdots \\ \vdots & \vdots & \vdots & & & \vdots \\ -Q_{1m}(\omega_k) & -Q_{2m}(\omega_k) & -Q_{3m}(\omega_k) & - & - & 0 \end{bmatrix} \quad (\text{E58})$$

Diagonal terms of  $C_F$  are the collections of power spectral densities at all node points. Because the turbulent boundary layer is approximately a homogeneous random process and its thickness changes very slowly within a panel length, these diagonal terms are all equal.

The  $[C_F(\omega)]$  and  $[Q_F(\omega)]$  matrices are symmetric and skew symmetric, respectively. The diagonal terms of the  $[\Phi_F(i\omega)]$  matrix are the diagonal terms of the  $[C_F(\omega)]$  matrix, Equation (E57); hence the diagonal terms of the  $[Q_F(\omega)]$  matrix are zero.

## APPENDIX E2 – METHOD FOR DETERMINING INPUT DATA

In using the program described herein, it is necessary to calculate numerical values for boundary layer parameters  $\delta^*$ ,  $\theta$ ,  $\langle p^2 \rangle$ , and  $U_c$ .<sup>41</sup> These parameters and the associated quantities required for their calculation are defined below. The definitions assume incompressible flow and, therefore, are restricted to subsonic conditions. The Maestrello method (Appendix B2) may be used for computing additional input data.

Parameter	Description
$c$	Free-stream speed of sound (in./sec)
$C_f$	Local coefficient of skin friction (dimensionless), equal to $0.059 R_x^{-1/5}$
$K$	Ratio of rms fluctuating pressure to local wall shearing stress (i.e., $\langle p^2 \rangle^{1/2} / \tau_w = 3.1$ )
$M$	Mach number of the free stream
$P_A$	Ambient pressure (psi)
$\langle p^2 \rangle$	Mean square fluctuating pressure (psi) <sup>2</sup> , equal to $K^2 \tau_w^2$
$q$	Dynamic pressure (psi), equal to $\rho U^2 / 2$
$R_x$	Reynolds number based on $x$ (dimensionless), equal to $xU / \nu$
$R_{\epsilon} \delta^*$	Reynolds number based on $\delta^*$ (dimensionless), equal to $\delta^* U / \nu$
$U_c$	Mean convection velocity of pressure fluctuations in the boundary layer (in./sec)
$x$	Distance from leading edge, or nose, of body (in.)
$\gamma$	Ratio of specific heats, 1.4 at sea level; equal to $c_p / c_v$
$\delta$	Boundary layer thickness (in.), equal to $0.37 x R_x^{-1/5}$
$\delta^*$	Boundary layer displacement thickness (in.), equal to $\delta / 8$
$\theta$	Mean eddy lifetime (sec)
$\mu$	Viscosity (lb force sec/in. <sup>2</sup> )
$\nu$	Kinematic viscosity (in <sup>2</sup> /sec), equal to $\mu / \rho$
$\rho$	Density of free stream (lb force sec <sup>2</sup> /in. <sup>4</sup> )
$\tau_w$	Local wall shearing stress (psi), equal to $C_f q = \frac{\gamma}{2} C_f P_A M^2$
$\sum_{n=1}^3 \frac{A_n}{K_n}$	Equal to 9.56

The system of units is in inch-pound-seconds.

Measurements of the rms fluctuating pressure  $\langle p^2 \rangle^{1/2}$  nondimensionalized with respect to the wall shear stress  $\tau_w$  show considerable scatter (Figure 22). Different investigations show different relationships between  $\langle p^2 \rangle^{1/2}/\tau_w$  and Mach number  $M$ , so it is difficult to predict the influence of Mach number on the rms pressure. It is assumed here that  $\langle p^2 \rangle^{1/2}/\tau_w$  has the value 3.1 for all subsonic and low supersonic Mach numbers, and the model for the pressure power spectral density function, as shown in Figure 23, has been chosen accordingly. The value of  $(\langle p^2 \rangle)^{1/2}/\tau_w$  was chosen to be close to the values measured in the majority of the investigations.

In the frequency domain, the convection velocity  $U_c$  and the eddy lifetime  $\theta$  are functions of frequency. When the overall values of  $U_c$  and  $\theta$  are considered, it is found that the effective values change with distance from the reference point. Complete representations of  $U_c$  and  $\theta$ , which describe the spacial variation, greatly complicate the boundary layer model and, as a simple alternative, values of  $U_c$  and  $\theta$  are chosen for a particular separation distance. Corrections to  $U_c$  and  $\theta$  are proposed, depending on the frequency range of interest for the particular structure under consideration.

The mean convection velocity ratio  $U_c/U$ , taken as the asymptotic value for large separation distances, is not very sensitive to Mach number in subsonic and low supersonic flow. A value of  $U_c/U = 0.82$  can be assumed for subsonic conditions as shown in Figure 24. This figure also indicates variation of subsonic convection velocity with frequency. The mean value is much closer to the low frequency value than it is to the high frequency value.

The mean eddy lifetime is shown in nondimensional form  $U_c \theta / \delta^*$  in Figure 25 as a function of Reynolds number based on displacement thickness  $\delta^*$ . The variation of  $\theta$  with frequency is shown in Figure 26 where the results refer to measurements by Maestrello in fully developed turbulent pipe flow. The data in Figure 26 show that the low-frequency eddy lifetime will be longer by factors of 1.5 or greater than the mean lifetimes predicted in Figure 25.

- KISTLER AND CHEN, REFERENCE 16
- \* HERON AND WEBB, REFERENCE 22
- × BULL, REFERENCE 20
- MAESTRELLO, REFERENCE 6
- △ MAESTRELLO, REFERENCE 23
- ▽ SERAFINI, REFERENCE 17
- ▲ SPEAKER AND AILMAN, REFERENCE 18
- ▷ CHYU AND HANLY, REFERENCE 21
- ◇ BELCHER, REFERENCE 19
- ◊ WILLMARTH AND WOOLDRIDGE, REFERENCE 15
- + MAESTRELLO, REFERENCE 9
- MODEL

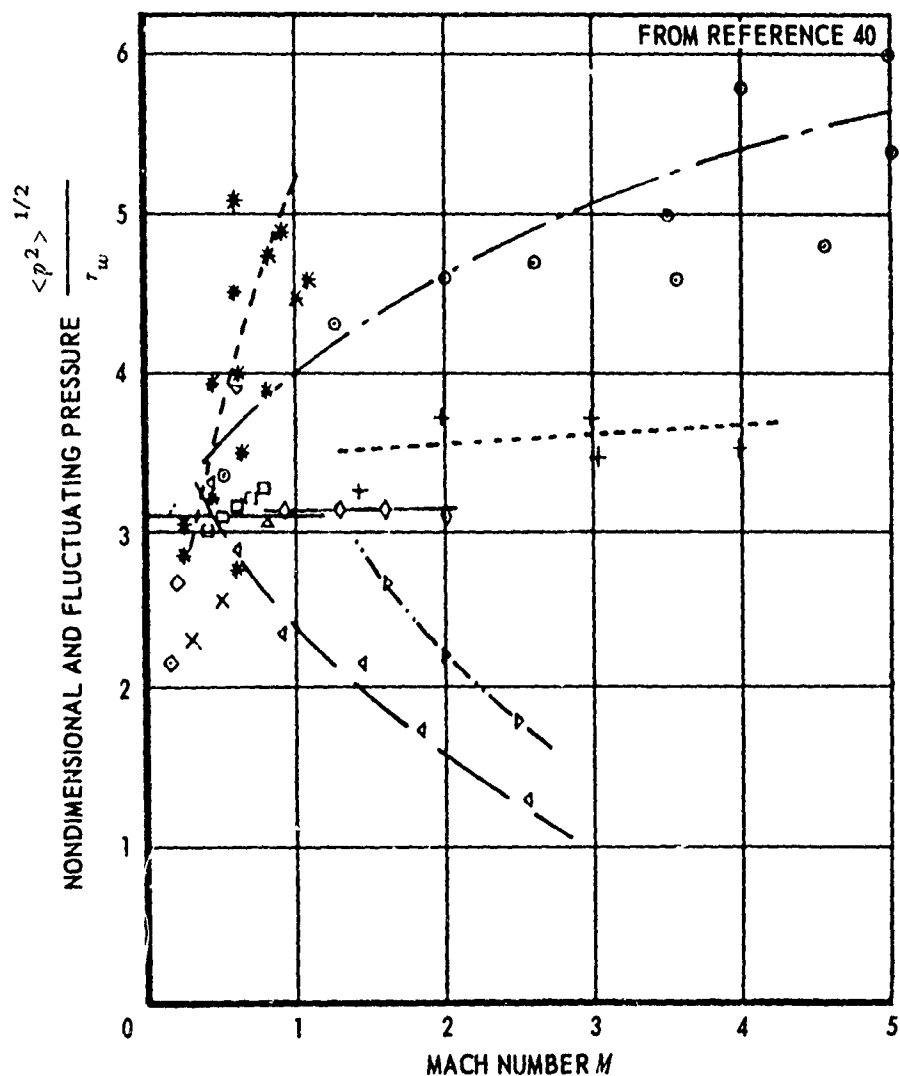

Figure 22 - Summary of Boundary Layer RMS Pressure Fluctuations

This figure is reproduced from Reference 41. The reference numbers indicated on this figure are those given in Reference 41.



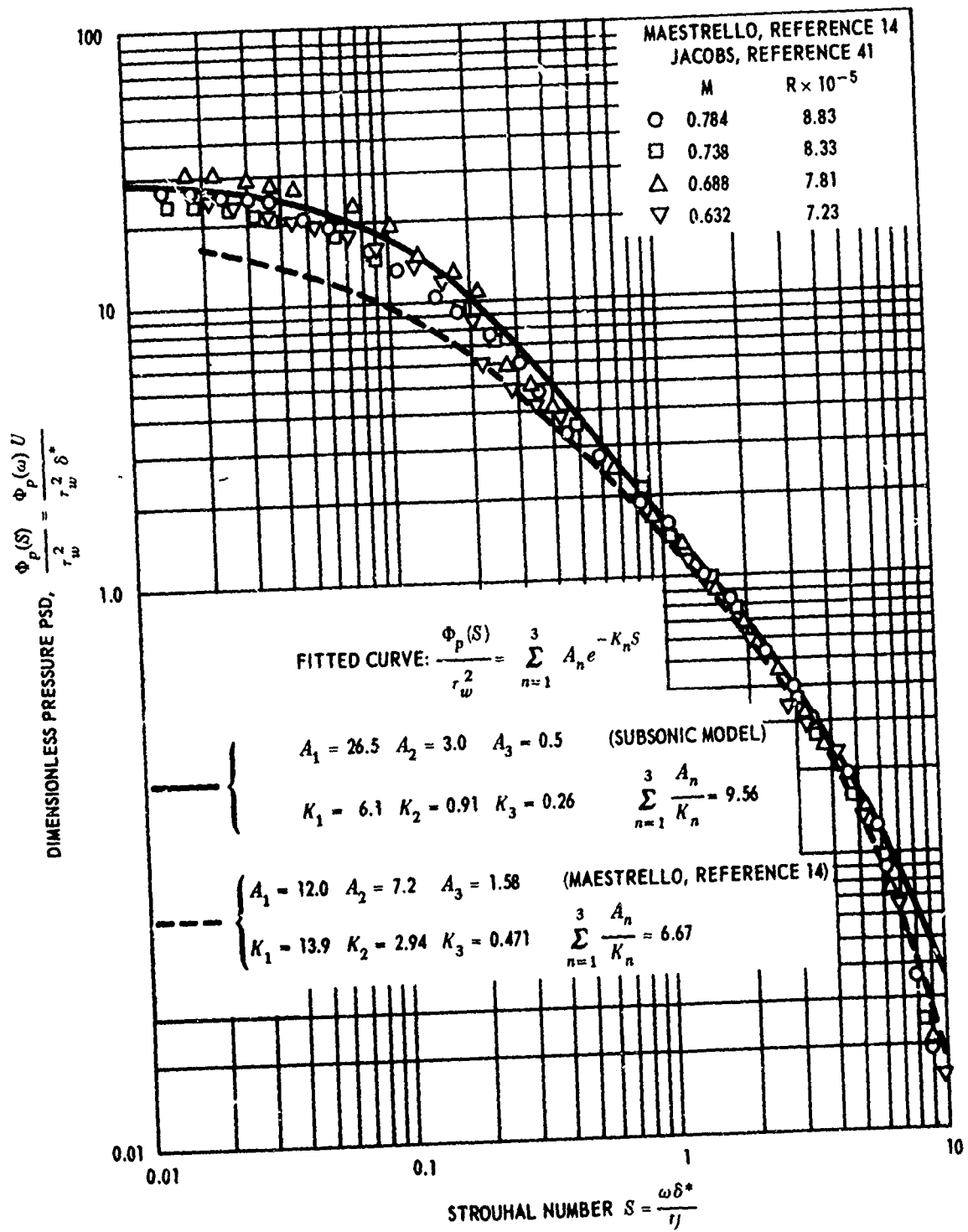

Figure 23 - Dimensionless Pressure Power Spectra

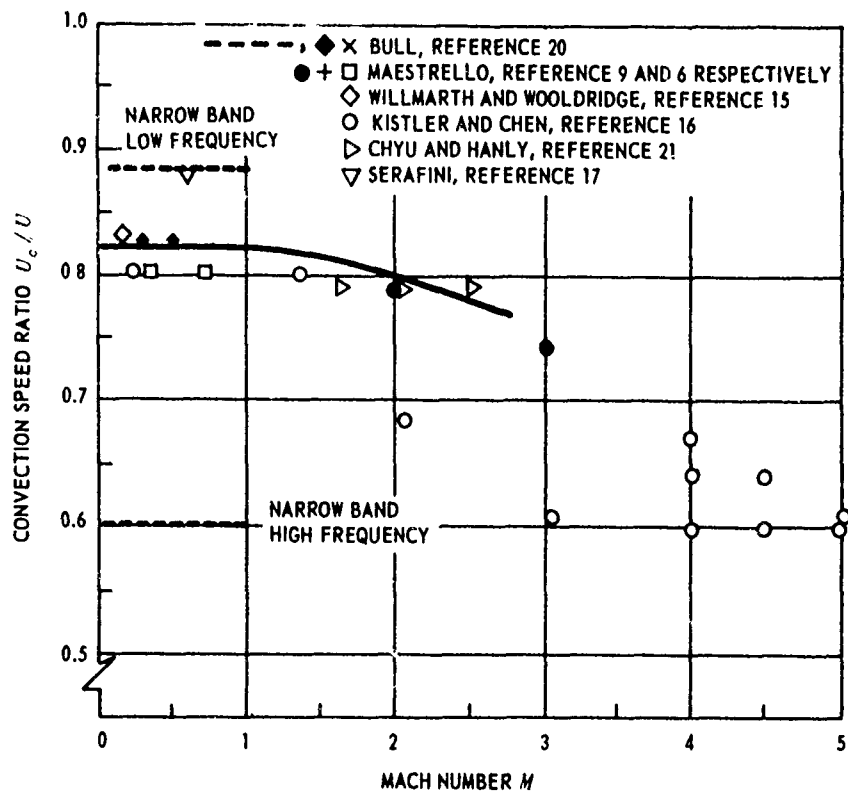

Figure 24 - Convection Speed Ratio

This figure is reproduced from Reference 41. The reference numbers indicated on the figure are those given in Reference 41.

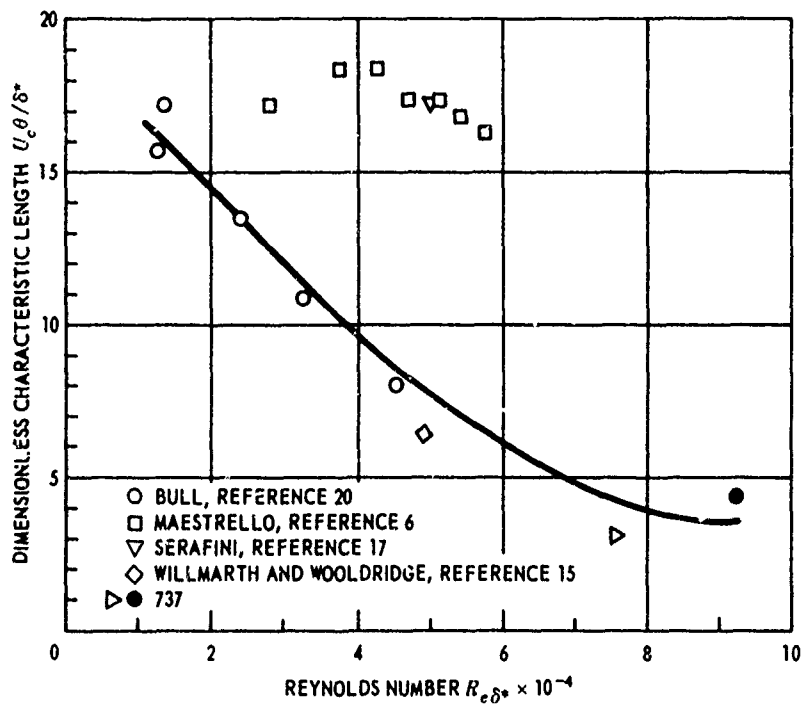

Figure 25 - Characteristic Length

This figure is reproduced from Reference 41. The reference numbers indicated on the figure are those given in Reference 41.

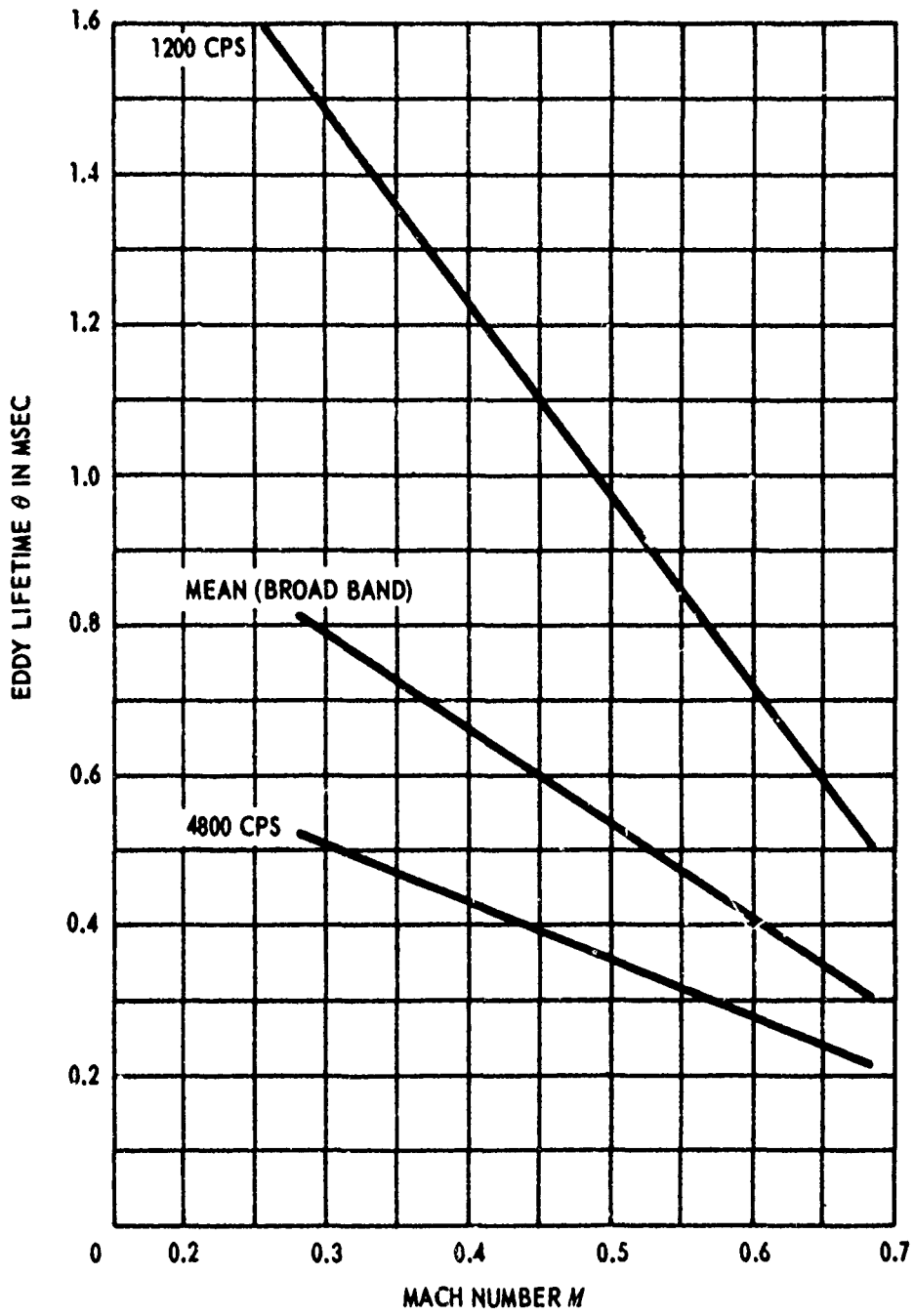

Figure 26 - Eddy Lifetime  
 Taken from Reference 14.

## APPENDIX E3 – PROGRAM IDENTIFICATION

The reader is referred to References 36, 37, and 41 which present an extensive and detailed document of the computer program.

## APPENDIX E4 – TEST RUNS

The computer printout of boundary layer input data is shown in Table 8a. Corresponding sample printouts of the computed force co-power spectral density matrix generated by these data are shown in Table 8b and 8c; note that the frequency associated with one sample differs from that of the other sample. The mean square displacement and displacement power spectral density of a 2024 aluminum alloy rectangular plate subject to this excitation are shown in Figures 27 and 28, respectively.\*

\*The set of force cross-PSD matrices defines loads on a structure with certain geometric characteristics. Compatibility between the terms of both the loading and structural flexibility matrices can be achieved by using some of the structural geometry information and by specifying flow direction and the direction of cyclic structural node numbering (see page 25 of Reference 41 and References 36 and 37). For the convenience of the reader, a description of the numbering schemes used to achieve compatibility is given in Figure 29.

TABLE 8

Sample Printouts of Boundary Layer Input Data and Computed Force  
Co-Power Spectral Density Matrix - Jacobs

INPUT DATA

JACOBS BOUNDARY LAYER PLATE - AIAA PAPER 69-20 (SEE REFERENCE 42)

BOUNDARY LAYER FLOW MODEL OPTION - OPTION= 1  
 NUMBER OF FREQUENCIES FOR WHICH FORCE-CROSS-PSD MATRICES ARE TO BE PRINTED - NPRINT= 33  
 CYCLIC NODE NUMBERING DIRECTION - NCYCL= 2  
 FLOW DIRECTION - NFLOW= 1  
 ROW PRINT OPTION - RPRINT= -0  
 DISPLACEMENT THICKNESS - DELTA= 0.1550000E-00 IN.  
 MEAN EDDY CONVECTION VELOCITY - UC= 0.6200000E 04 IN./SEC  
 INCREMENTAL SEPARATION DISTANCE IN FLOW DIRECTION - XI= 0.1000000E 01 IN.  
 INCREMENTAL SEPARATION DISTANCE IN DIRECTION PERPENDICULAR TO FLOW - ETA= 0.1167000E 01 IN.  
 MEAN EDDY LIFETIME - THETA= 0.9100000E-03 SEC  
 NUMBER OF STRUCTURAL COORDINATES IN DIRECTION OF CYCLIC NODE NUMBERING -NI= 7  
 NUMBER OF STRUCTURAL COORDINATES IN DIRECTION PERPENDICULAR TO CYCLIC NODE NUMBERING DIRECTION - N2= 13  
 MEAN SQUARE FLUCTUATING PRESSURE RATIO - FPR= 0.4070000E-03 SQ. LBS

\*\*\*\*\* END OF INPUT DATA PRINTOUT \*\*\*\*\*

(Table 8A is used in Phase II of the RANVIB program with the ABLN load module. The force matrix CF(I,J) for this case is a 55x55 matrix, determined by the number of retained freedoms in Phase I, computed for frequencies specified by the user-36,37,41. For any frequency, the number of rows of the matrix that are to be printed is either the first row or the total matrix.)

Table 8A - Turbulent Boundary Layer Pressure Loading on Finite Structural Elements

TABLE 8 (Continued)

FREQUENCY NO. 1 CF(I,J) MATRIX OMEGA = 0.27371982E 04

1	1.8343294E-08	9.5847473E-09	3.3228221E-09	1.3477665E-09	6.0726272E-10	1.4841135E-08
	7.7547979E-09	2.6884187E-09	1.0904468E-09	4.9132225E-10	8.8130685E-09	4.6050093E-09
	1.5964559E-09	6.4753686E-10	2.9176047E-10	2.9361496E-09	1.5341984E-09	5.3187302E-10
	2.1573248E-10	9.7202513E-11	-1.7357673E-09	-9.0697405E-10	-3.1442805E-10	-1.2753484E-10
	-5.7463333E-11	-4.6886978E-09	-2.4499409E-09	-8.4934087E-10	-3.4450029E-10	-1.5522138E-10
	-5.8835098E-09	-3.0742546E-09	-1.0657768E-09	-4.3228864E-10	-1.9477616E-10	-5.6215132E-09
	-2.9373560E-09	-1.0183170E-09	-4.1303854E-10	-1.8610265E-10	-4.3865067E-09	-2.2920398E-09
	-7.9460003E-10	-3.2229691E-10	-1.4521722E-10	-2.6998423E-09	-1.4107230E-09	-4.8906679E-10
	-1.9836989E-10	-8.9379456E-11	-1.0111725E-09	-5.2864721E-10	-1.8327041E-10	-7.4336127E-11
	-3.3493605E-11					

Table 8B - First Row 755 x 55 Matrix of the Forcing Function for the Frequency  $\omega = 0.27371882E04$

FREQUENCY NO. 1 CF(I,J) MATRIX OMEGA = 0.20000000E 04

1	2.0364450E-08	1.1205248E-08	4.3956819E-09	2.0430298E-09	1.0565845E-09	1.7238963E-08
	9.4854932E-09	3.7210431E-09	1.7294705E-09	8.9442241E-10	1.2212589E-08	6.7198030E-09
	2.6360966E-09	1.2252079E-09	6.3363521E-10	7.3090158E-09	4.0216816E-09	1.5776566E-09
	7.3326495E-10	3.7921931E-10	3.0446401E-09	1.6752698E-09	6.5718786E-10	3.0544850E-10
	1.5796741E-10	-2.9035879E-10	-1.5976578E-10	-6.2674164E-11	-2.9129767E-11	-1.5064910E-11
	-2.5972299E-09	-1.4290887E-09	-5.6061403E-10	-2.6056280E-10	-1.3475408E-10	-3.9226527E-09
	-2.1583837E-09	-8.4670755E-10	-3.9353366E-10	-2.0352202E-10	-4.4100677E-09	-2.4265769E-09
	-9.5191646E-10	-4.4243278E-10	-2.2881095E-10	-4.2546174E-09	-2.3410425E-09	-9.1836239E-10
	-4.2683748E-10	-2.2074561E-10	-3.6657070E-09	-2.0170030E-09	-7.9124563E-10	-3.6775602E-10
	-1.9019071E-10					

Table 8C - First Row of 55 x 55 Matrix of the Forcing Function for the Frequency  $\omega = 0.20000000E04$





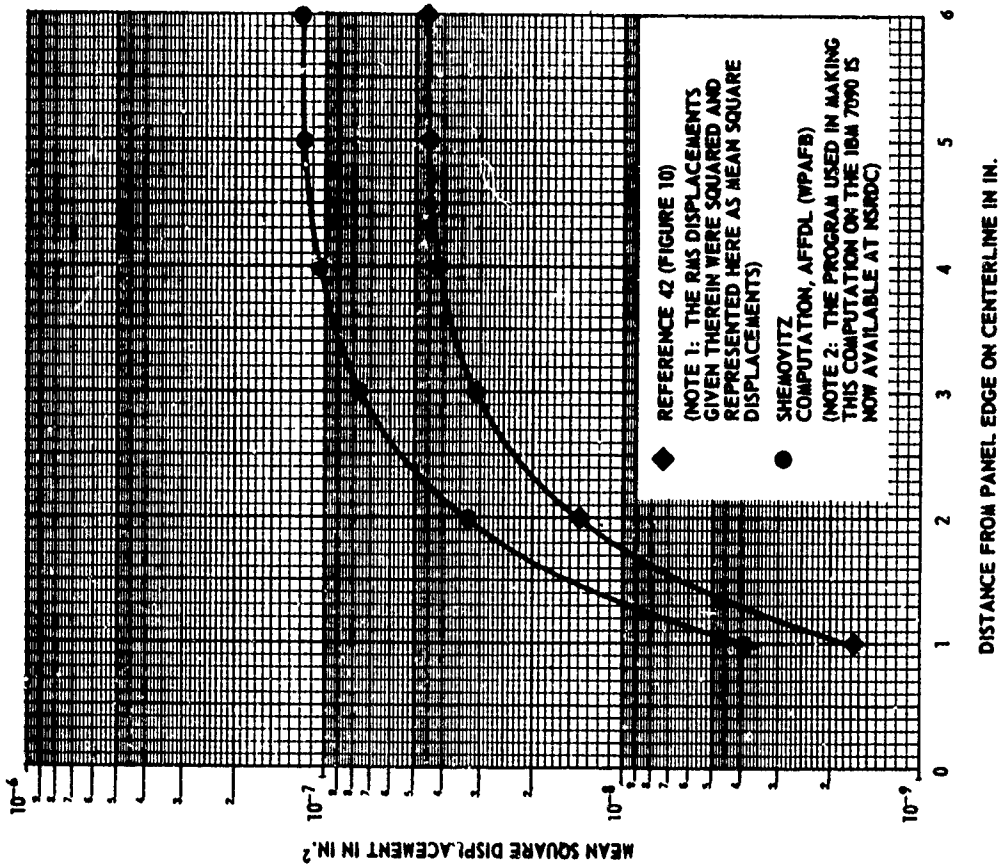

THE BOUNDARY LAYER AND PLATE PARAMETERS USED IN OBTAINING THE CENTERLINE RESPONSE SHOWN IN FIGURE 28 ARE\*

FLOW DATA:  $\langle p^2 \rangle = 4.07 \times 10^{-4}$  (PSI)²  
 $\delta^* = 0.155$  IN.  
 $U_c = 0.88U = 8900$  IN./SEC  
 $M = 0.52$   
 $Q = 9.1 \times 10^{-4}$  SEC  
 $\zeta_0 = 1.00$  IN. (SEPARATION DISTANCE BETWEEN NODE POINTS)  
 $\tau_0 = 1.167$  IN.  
 FLOW IN  $x$ -DIRECTION

PLATE DATA:  $12 \times 7 \times 0.08$ -IN. PLATE

$t_0 = 1.00$  IN.  
 $\tau_0 = 1.67$  IN.  
 MASS =  $0.00024$  LB-SEC²/IN.  
 $E$  (YOUNG'S MODULUS) =  $1.05 \times 10^7$  PSI  
 $\nu$  OR  $\gamma$  (POISSON'S RATIO) = 0.33  
 $I_x$  (MOMENT OF INERTIA) =  $4.967 \times 10^{-5}$  IN.³

SEE PAGE 72 OF REFERENCE 38

$I_x = 0$   
 $I_y = 0$   
 $I_z = 0$

$I_x = 0$   
 $I_y = 0$   
 $I_z = 0$

\*ELEMENT WEIGHT =  $(1.000)$  IN.  $\times$   $(1.167)$  IN.  $\times$   $(0.080)$  IN.  $\times$   $(0.1$  LB./IN.³)

$= 0.009336$  LB  
 $= 0.009336$  LB  
 MASS =  $\frac{0.009336 \text{ LB}}{386 \text{ IN./SEC}^2} = 0.000024 \frac{\text{LB-SEC}^2}{\text{IN.}}$

Figure 28 — Computed Mean Square Displacement for a  $12.0 \times 7.0 \times 0.08$ -Inch Aluminum Alloy Panel

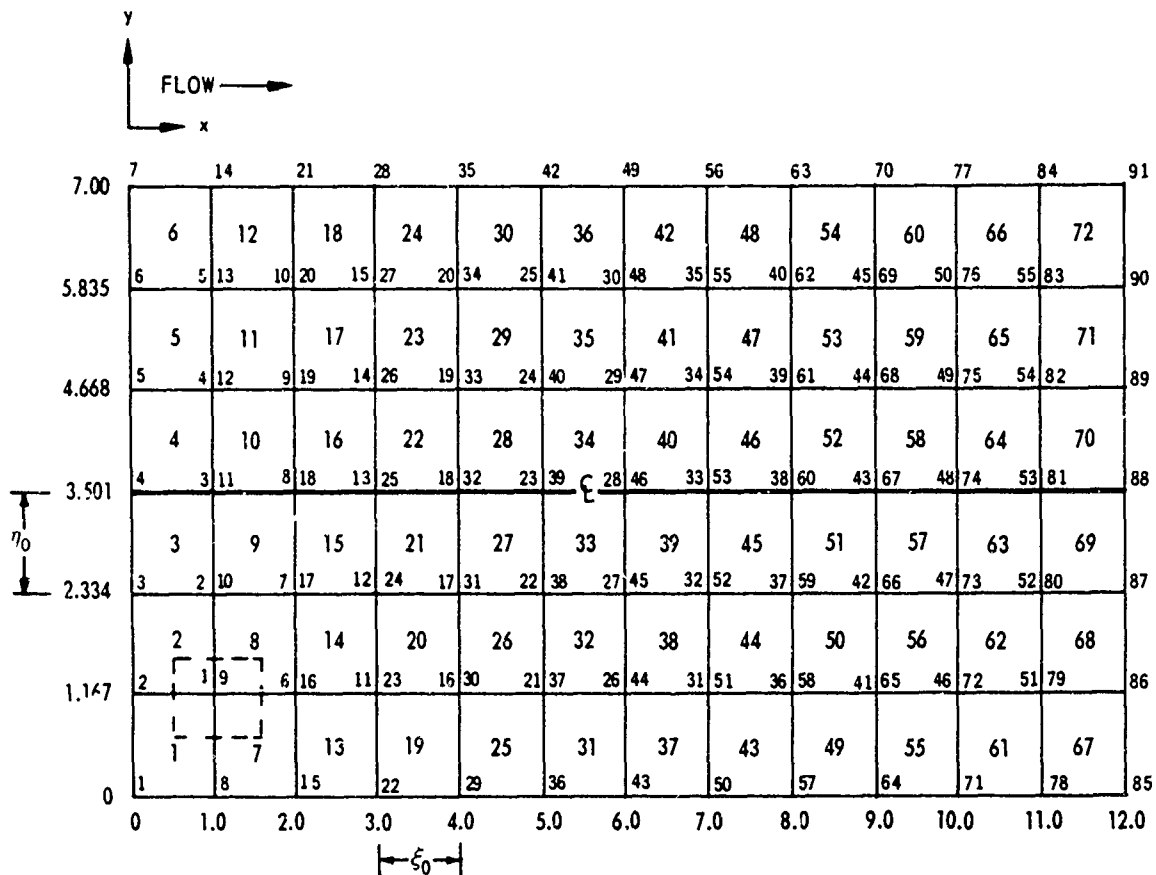

Note to Figure 29:

The area ( $12 \times 7 \text{ in.}^2$ ) of the rectangular plate used in obtaining the results in Figures 27 and 28 was divided into 72 equal rectangles ( $1 \times 1.167 \text{ in.}$ ) numbered consecutively in the  $y$ -direction as shown (1 through 72). The constraint conditions for each of the six degrees of freedom ( $\theta_x, \theta_y, \theta_z, \delta_x, \delta_y, \delta_z$ ) are given for each node (free, fixed or attached to a spring).<sup>36, 37, 41</sup> The present example originally had 91 nodal points as shown (1 through 91), but only 55 of these nodes (inner nodes) have deflection  $\delta_z$  free, which represent the retained freedoms. These (retained) nodes are renumbered in the  $y$ -direction as shown (1 through 55). The sizes of the solution matrices are determined by the number of retained freedoms, 55 in this example. Thus we use a 55 by 55 matrix. Note that the heavy line (centerline) in Figure 29 is the line along which the responses shown in Figures 27 and 28 were obtained.

The grid size ( $\xi_0 \times \eta_0$ ) and the number of retained freedoms must be identical in Phases I and II of the computer program for compatibility to exist between the terms of both the loading and structural flexibility matrices. In the absence of compatibility, only the force co-power spectral matrices (Table 8) are generated, i.e., the computer will not generate response data, e.g., Figures 27 and 28.

Figure 29 - Cyclic Ordering of Nodes  
(Area =  $\xi_0 \times \eta_0 = 1.167 \text{ in.}^2$ )

## REFERENCES

1. Leibowitz, Ralph C., "Turbulence-Induced Vibrations and Radiations--A Projection of the State of the Art to Naval Research Needs," Acoustics and Vibrations Laboratory Technical Note AVL-185-942 (Jun 1967).\*
2. Dyer, I., "Sound Radiation into a Closed Space from Boundary Layer Turbulence," Bolt Beranek and Newman, Inc., Report 602, ONR Contract Nonr-2321(00), Task NR 062-205 (Dec 1958).
3. Dyer, I., "Response of Plates to a Decaying and Convecting Random Pressure Field," Journal of the Acoustical Society of America, Vol. 31, No. 7 (Jul 1959).
4. Lin, Y.K., "Probabilistic Theory of Structural Dynamics," McGraw-Hill Book Company, New York (1967).
5. Morse, P.M. and Feshbach, H., "Methods of Theoretical Physics," Part 1, McGraw-Hill Book Company, New York (1953).
6. Dettman, J.W., "Mathematical Methods in Physics and Engineering," Chapter 4, McGraw-Hill Book Company, New York (1962).
7. Campbell, G.A. and Foster R.M., "Fourier Integrals for Practical Applications," D. Van Nostrand Company, Inc., Princeton, N.J. (1951).
8. Lyon, R.H., "Propagation of Correlation Functions in Continuous Media," Journal of the Acoustical Society of America, Vol. 28, No. 1 (Jan 1956).
9. Nowacki, W., "Dynamics of Elastic Systems," John Wiley and Sons, Inc., New York (1963).
10. Smith, P.W., Jr., and Lyon, R.H., "Sound and Structural Vibration," National Aeronautics and Space Administration CR-160 (Mar 1965).
11. Kolsky, H., "Stress Waves in Solids," Dover Publications, Inc., New York (1963).
12. Willmarth, W.W., "Space-Time Correlations and Spectra of Wall Pressure in a Turbulent Boundary Layer," National Aeronautics and Space Administration Memorandum, 3-17-59W (Mar 1959).
13. Harrison, M.J., "Journal of the Acoustical Society of America 20:1252 (Abstract)" (1957). Also, "Pressure Fluctuations on the Wall Adjacent to a Turbulent Boundary Layer," TMB Report 1260 (Dec 1958).
14. Maestrello, L., "Measurement and Analysis of the Response Field of Turbulent Boundary Layer Excited Panels," Journal of Sound and Vibration, Vol. 2, No. 3, pp. 270-292 (1965).

---

\*Reference 1 is available upon request to Dr. Don Ross, Head, Acoustics and Vibration Laboratory, Naval Ship Research and Development, Washington, D.C. 20007.

15. Maestrello, L., "Use of Turbulent Model to Calculate the Vibration and Radiation Responses of a Panel, with Practical Suggestions for Reducing Sound Level," *Journal of Sound and Vibration*, Vol. 15, No. 3, pp. 407-448 (1967).
16. Maestrello, L., "Design Criterion for Minimum Structural Response and Sound Radiation of a Panel Excited by a Turbulent Boundary Layer," Fifth Aerospace Sciences Meeting, American Institute of Aeronautics and Astronautics Paper 67-12 (23-26 Jan 1967).
17. Maestrello, L., "Test Results from the Boundary Layer Facility (Theory and Experimental Comparison)," Boeing Company Report D-6-9944 Vol. 3 (Jun 1966).
18. Tong, K.N., "Theory of Mechanical Vibration," John Wiley and Sons, Inc., New York (Jun 1963).
19. Apostol, T.M., "Mathematical Analysis," Addison-Wesley, Publishing Company, Inc., Reading, Mass. (1957).
20. Courant, R., "Differential and Integral Calculus," Vol. 2, formerly Interscience Publications, Inc., now John Wiley and Sons, Inc., New York (1947).
21. Pierce, B.O., "A Short Table of Integrals," Ginn and Company, Boston, Mass. (1929).
22. Maestrello, L., "Radiation from and Panel Response to a Supersonic Turbulent Boundary Layer," Boeing Scientific Research Laboratories Document D1-82-0719 (Sep 1968).
23. Coles, D., "The Law of the Wake in the Turbulent Boundary Layer," *J. Fluid Mech.*, Vol. 1 (1956).
24. Maestrello, L., "Measurement of Noise Radiated by Boundary Layer Excited Panels," *J. Sound Vib.*, 2(2), 100-115 (1965).
25. Schlichting, H., "Boundary Layer Theory," McGraw-Hill (1960).
26. Izzo, A.J. et al., "Sound Radiated from Turbulence Excited Finite Plates with Arbitrary Boundary Conditions," Report U411-67-045, General Dynamics/Electric Boat Division, Groton, Conn. (22 Aug 1967); also, *U.S. Navy Journal of Underwater Acoustics*, Vol. 18, No. 1 (Jan 1968).
27. Rayleigh J.W.S., "The Theory of Sound," Vol. 2, p. 107, Dover Publications, New York (1945).
28. Lee, Y.M., "Statistical Theory of Communication," John Wiley and Sons, Inc., New York (1963).
29. Izzo, A.J. et al., "Sound Radiated from Finite Plates Excited by a Turbulent Boundary Layer," Interim Report, General Dynamics/Electric Boat Division, Groton, Conn. (1 Sep 1966).
30. Young, D., "Vibration of Rectangular Plates by the Ritz Method," *Trans. American Society of Mechanical Engineer*, Vol. 72 (1956).

31. Bendat, J.S. et al., "Measurement and Analysis of Random Data," John Wiley and Sons, Inc., New York (1966).
32. Strawderman, W.A., "The Acoustic Field in a Closed Space Behind a Rectangular Simply Supported Plate Excited by Boundary Layer Turbulence," U.S. Navy Underwater Sound Laboratory Report 827 (11 May 1967).
33. Crandall, S.H. and Mark, W.D., "Random Vibration in Mechanical Systems," Academic Press, Inc., New York (1963).
34. Jacobs, L.D. and Lagerquist, D.R., "A Finite Element Analysis of Simple Panel Response to Turbulent Boundary Layers," Technical Report AFFDL-TR-67-81, The Boeing Company, Commercial Airplane Division, Renton, Wash. (Jul and Dec 1967).
35. Jacobs, L.D. and Lagerquist, D.R., "Finite-Element Analysis of Complex Panel Response to Random Loads," Technical Report AFFDL-TR-68-44, The Boeing Company, Commercial Airplane Division, Renton, Wash. (Apr 1968).
36. Lagerquist, D.R., and Jacobs, L.D., "Random-Vibration Analysis System for Complex Structures," Technical Report AFFDL-TR-68-43, Part 1, Engineering Users Guide, The Boeing Company, Commercial Airplane Division, Renton, Wash. (Apr 1968).
37. Tsurusaki, K. and Wallace, F.S. "Random-Vibration Analysis System for Complex Structures," Technical Report AFFDL-TR-68-43, Part 2, Computer Program Description, The Boeing Company, Commercial Airplane Division, Renton, Wash. (Apr 1968).
38. Perlis, S., "Theory of Matrices," Addison-Wesley Publishing Company, Inc., Reading, Mass. (Mar 1956).
39. Maestrello, L., "Design Criterion of Panel Structure Excited by Turbulent Boundary Layer," Journal of Aircraft, Vol. 5, No. 4 (Jul-Aug 1968).
40. Gradshteyn, I.S. and Ryzhik, I.M., "Table of Integrals Series and Products," Academic Press, Inc., New York (1965).
41. Jacobs, L.D. et al., "A Computer Program on Turbulent Boundary Layer Loads for Use with Finite-Element Structural Analysis Systems," Boeing Commercial Airplane Division, Renton, Wash. D6-23769 (May 1969).
42. Jacobs, L. D. et al., "Response of Complex Structures to Turbulent Boundary Layers," American Institute of Aeronautics and Astronautics Seventh Aerospace Sciences Meeting, New York (20 Jan 1969).

**BLANK PAGE**

UNCLASSIFIED

Security Classification

DOCUMENT CONTROL DATA - R & D		
<i>(Security classification of title, body of abstract and indexing annotation must be entered when the overall report is classified)</i>		
1. ORIGINATING ACTIVITY (Corporate author) Naval Ship Research and Development Center Washington, D.C. 20034		2a. REPORT SECURITY CLASSIFICATION <b>UNCLASSIFIED</b>
		2b. GROUP
3. REPORT TITLE <b>ENGINEERING GUIDE AND COMPUTER PROGRAMS FOR DETERMINING TURBULENCE-INDUCED VIBRATION AND RADIATION OF PLATES</b>		
4. DESCRIPTIVE NOTES (Type of report and inclusive dates) Final Report 6/67 - 9/69		
5. AUTHOR(S) (First name, middle initial, last name) Ralph C. Leibowitz and Dolores R. Wallace		
6. REPORT DATE January 1970	7a. TOTAL NO. OF PAGES 322	7b. NO. OF REFS 42
8a. CONTRACT OR GRANT NO.	9a. ORIGINATOR'S REPORT NUMBER(S) Report 2976	
b. PROJECT NO S-R003 1001	9b. OTHER REPORT NO(S) (Any other numbers that may be assigned this report)	
c. Task 11701		
d.		
10. DISTRIBUTION STATEMENT This document is subject to special export controls and each transmittal to foreign governments or foreign nationals may be made only with prior approval of Naval Ship Systems Command, SHIPS 037.		
11. SUPPLEMENTARY NOTES	12. SPONSORING MILITARY ACTIVITY Naval Ship Systems Command, SHIPS 037	
13. ABSTRACT <p>This report is an engineering guide to the use of the Dyer method of manual computation and to several computer programs for determining turbulence-induced vibration and radiation of finite plates in air and in water. Both simple and clamped boundary conditions are treated. The Dyer method and the computer programs are presented in a series of appendixes:</p> <ul style="list-style-type: none"> <li>A. Bolt Beranek and Newman Manual Method (Dyer)</li> <li>B. Boeing Program I (Maestrello)</li> <li>C. Electric Boat Program (Izzo)</li> <li>D. Underwater Sound Laboratory Program (Strawderman)</li> <li>E. Boeing Program II - Finite Element (Jacobs and Lagerquist)</li> </ul> <p>The documentation is intended to facilitate the performance of flow-induced vibroacoustic computations as well as to furnish the groundwork for future research. It should also act as a theoretical guide for experimentalists. In the broader view, the documentation represents the initial steps of an effort to use computer programs to bridge the gap between vibroacoustic research results and design needs for structures that are subject to excitation by turbulence. Research tending to improve and extend the present program is recommended.</p>		

**UNCLASSIFIED**

Security Classification

14 KEY WORDS	LINK A		LINK B		LINK C	
	ROLE	WT	ROLE	WT	ROLE	WT
Turbulence-induced Vibration and Radiation of Plates 1. Simply Supported and Clamped Boundaries 2. Air and Water Fluid Media Manual Computation Digital Computer Programs Continuum and Finite Element Approach Theoretical and Experimental Recommendation Engineering Guide						