



9400 Holly Ave NE, Bldg 3, Ste B, Albuquerque, NM 87122 / P 505.266.6611 / trinityconsultants.com

December 14, 2022

Permit Programs Manager
NMED Air Quality Bureau
525 Camino de los Marquez Suite 1
Santa Fe, NM 87505-1816

RECEIVED

DEC 16 2022

Air Quality Bureau

RE: *Application for Significant Revision to NSR Permit 7200-M3
Targa Northern Delaware LLC; Road Runner Gas Processing Plant*

Permit Program Manager:

On behalf of Targa Northern Delaware LLC, Trinity Consultants is submitting an NSR Significant Revision application for the Road Runner Gas Processing Plant, currently authorized to operate under NSR Permit No. 7200-M3. With this application, Targa seeks to authorize the removal of proposed Train 4, update representations for proposed Trains 2 and 3, and update other process design, throughput, and equipment representation submitted with the previous application for this facility.

The modeling files and modeling report associated with this application will be sent to the NMED as a separate submittal package.

The format and content of this application are consistent with the Bureau's current policy regarding significant revision applications. Please feel free to contact me by email at rliles@trinityconsultants.com if you have any questions regarding this application.

Sincerely,

TRINITY CONSULTANTS

Robert Liles
Director

Cc: Tammy Wallace (Targa Midstream Services LLC, twallace@targaresources.com)
Charles Bates (Targa Midstream Services LLC, cbates@targaresources.com)
Jaimy Karacaoglu (Trinity Consultants, jaimy.karacaoglu@trinityconsultants.com)

Trinity Project File: 223201.0205

HEADQUARTERS

12700 Park Central Dr, Ste 2100, Dallas, TX 75251 / P 800.229.6655 / P 972.661.8100 / F 972.385.9203

ORIGINAL

**NMED AIR QUALITY BUREAU
NSR SIGNIFICANT REVISION APPLICATION**

**TARGA NORTHERN DELAWARE LLC
Road Runner Gas Processing Plant**

RECEIVED

DEC 16 2022

Air Quality Bureau



TARGA

Prepared By:

TRINITY CONSULTANTS
9400 Holly Ave NE
Building 3, Suite B
Albuquerque, NM 87122
(505) 266-6611

December 2022

Project 223201.0205

Trinity
Consultants

<p>Mail Application To:</p> <p>New Mexico Environment Department Air Quality Bureau Permits Section 525 Camino de los Marquez, Suite 1 Santa Fe, New Mexico, 87505</p> <p>Phone: (505) 476-4300 Fax: (505) 476-4375 www.env.nm.gov/aqb</p>		<p>For Department use only:</p> <p style="font-size: 2em; color: blue; font-weight: bold;">RECEIVED</p> <p style="color: red; font-weight: bold;">DEC 16 2022</p> <p style="color: blue; font-weight: bold;">Air Quality Bureau</p>
---	---	--

Universal Air Quality Permit Application

Use this application for NOI, NSR, or Title V sources.

Use this application for: the initial application, modifications, technical revisions, and renewals. For technical revisions, complete Sections, 1-A, 1-B, 2-E, 3, 9 and any other sections that are relevant to the requested action; coordination with the Air Quality Bureau permit staff prior to submittal is encouraged to clarify submittal requirements and to determine if more or less than these sections of the application are needed. Use this application for streamline permits as well.

This application is submitted as (check all that apply): Request for a No Permit Required Determination (no fee)
 Updating an application currently under NMED review. Include this page and all pages that are being updated (no fee required).
 Construction Status: Not Constructed Existing Permitted (or NOI) Facility Existing Non-permitted (or NOI) Facility
 Minor Source: a NOI 20.2.73 NMAC 20.2.72 NMAC application or revision 20.2.72.300 NMAC Streamline application
 Title V Source: Title V (new) Title V renewal TV minor mod. TV significant mod. TV Acid Rain: New Renewal
 PSD Major Source: PSD major source (new) minor modification to a PSD source a PSD major modification

Acknowledgements:

I acknowledge that a pre-application meeting is available to me upon request. Title V Operating, Title IV Acid Rain, and NPR applications have no fees.
 \$500 NSR application Filing Fee enclosed **OR** The full permit fee associated with 10 fee points (required w/ streamline applications).
 Check No.: 5729500127 in the amount of \$500
 I acknowledge the required submittal format for the hard copy application is printed double sided 'head-to-toe', 2-hole punched (except the Sect. 2 landscape tables is printed 'head-to-head'), numbered tab separators. Incl. a copy of the check on a separate page.
 I acknowledge there is an annual fee for permits in addition to the permit review fee: www.env.nm.gov/air-quality/permit-fees-2/.
 This facility qualifies for the small business fee reduction per 20.2.75.11.C. NMAC. The full \$500.00 filing fee is included with this application and I understand the fee reduction will be calculated in the balance due invoice. The Small Business Certification Form has been previously submitted or is included with this application. (Small Business Environmental Assistance Program Information: www.env.nm.gov/air-quality/small-biz-eap-2/.)

Citation: Please provide the **low level citation** under which this application is being submitted: **20.2. 72.219.D NMAC** (e.g. application for a new minor source would be 20.2.72.200.A NMAC, one example for a Technical Permit Revision is 20.2.72.219.B.1.b NMAC, a Title V acid rain application would be: 20.2.70.200.C NMAC)

Section 1 – Facility Information

Section 1-A: Company Information		AI # if known (see 1 st 3 to 5 #s of permit IDEA ID No.): 36536	Updating Permit/NOI #: 7200-M3
1	Facility Name: Road Runner Gas Processing Plant	Plant primary SIC Code (4 digits): 1321 Plant NAIC code (6 digits): 211112	
a	Facility Street Address (If no facility street address, provide directions from a prominent landmark): From Allsup's store in Loving, go South on Pecos Hwy to Higby Hole Road to Bounds Road. Turn West for 0.5 miles to facility on North side of road.		
2	Plant Operator Company Name: Targa Northern Delaware, LLC	Phone/Fax: (575) 631-7093 / (575) 396-7702	
a	Plant Operator Address: PO Box 1689, Lovington, NM 88260		

b	Plant Operator's New Mexico Corporate ID or Tax ID: 1948249	
3	Plant Owner(s) name(s): Targa Northern Delaware, LLC	Phone/Fax: (575) 631-7093 / (575) 396-7702
a	Plant Owner(s) Mailing Address(s): PO Box 1689, Lovington, NM 88260	
4	Bill To (Company): Targa Northern Delaware, LLC	Phone/Fax: (575) 631-7093 / (575) 396-7702
a	Mailing Address: PO Box 1689, Lovington, NM 88260	E-mail: Jaylen.fuente@targaresources.com
5	<input checked="" type="checkbox"/> Preparer: Rob Liles <input checked="" type="checkbox"/> Consultant: Trinity Consultants, Inc.	Phone/Fax: (505) 266-6611
a	Mailing Address: 9400 Holly Ave NE, Building 3, Suite B, Albuquerque, NM 87122	E-mail: rliles@trinityconsultants.com
6	Plant Operator Contact: James Aguilar	Phone/Fax: (575) 810-6093 / (575) 396-7702
a	Address: 201 South 4 th Street, NM 88210	E-mail: james.aguilar@targaresources.com
7	Air Permit Contact: Tammy Wallace	Title: Sr. Environmental Specialist
a	E-mail: twallace@targaresources.com	Phone/Fax: (713) 584-1292 / (713) 584-1522
b	Mailing Address: 811 Louisiana Street, Ste 2100, Houston, TX 77002	
c	The designated Air permit Contact will receive all official correspondence (i.e. letters, permits) from the Air Quality Bureau.	

Section 1-B: Current Facility Status

1.a	Has this facility already been constructed? <input checked="" type="checkbox"/> Yes <input type="checkbox"/> No	1.b If yes to question 1.a, is it currently operating in New Mexico? <input checked="" type="checkbox"/> Yes <input type="checkbox"/> No
2	If yes to question 1.a, was the existing facility subject to a Notice of Intent (NOI) (20.2.73 NMAC) before submittal of this application? <input type="checkbox"/> Yes <input checked="" type="checkbox"/> No	If yes to question 1.a, was the existing facility subject to a construction permit (20.2.72 NMAC) before submittal of this application? <input checked="" type="checkbox"/> Yes <input type="checkbox"/> No
3	Is the facility currently shut down? <input type="checkbox"/> Yes <input checked="" type="checkbox"/> No	If yes, give month and year of shut down (MM/YY): N/A
4	Was this facility constructed before 8/31/1972 and continuously operated since 1972? <input type="checkbox"/> Yes <input checked="" type="checkbox"/> No	
5	If Yes to question 3, has this facility been modified (see 20.2.72.7.P NMAC) or the capacity increased since 8/31/1972? <input type="checkbox"/> Yes <input type="checkbox"/> No <input checked="" type="checkbox"/> N/A	
6	Does this facility have a Title V operating permit (20.2.70 NMAC)? <input type="checkbox"/> Yes <input checked="" type="checkbox"/> No	If yes, the permit No. is: N/A
7	Has this facility been issued a No Permit Required (NPR)? <input type="checkbox"/> Yes <input checked="" type="checkbox"/> No	If yes, the NPR No. is: N/A
8	Has this facility been issued a Notice of Intent (NOI)? <input type="checkbox"/> Yes <input checked="" type="checkbox"/> No	If yes, the NOI No. is: N/A
9	Does this facility have a construction permit (20.2.72/20.2.74 NMAC)? <input checked="" type="checkbox"/> Yes <input type="checkbox"/> No	If yes, the permit No. is: 7200-M3
10	Is this facility registered under a General permit (GCP-1, GCP-2, etc.)? <input type="checkbox"/> Yes <input checked="" type="checkbox"/> No	If yes, the register No. is: N/A

Section 1-C: Facility Input Capacity & Production Rate

1	What is the facility's maximum input capacity, specify units (reference here and list capacities in Section 20, if more room is required)			
a	Current	Hourly: 36.66 MMscf	Daily: 880 MMscf	Annually: 321,200 MMscf
b	Proposed	Hourly: 30.63 MMscf	Daily: 735 MMscf	Annually: 268,275 MMscf
2	What is the facility's maximum production rate, specify units (reference here and list capacities in Section 20, if more room is required)			
a	Current	Hourly: 36.66 MMscf	Daily: 880 MMscf	Annually: 321,200 MMscf
b	Proposed	Hourly: 30.63 MMscf	Daily: 735 MMscf	Annually: 268,275 MMscf

Section 1-D: Facility Location Information

1	Section: 32	Range: 28E	Township: 23S	County: Eddy	Elevation (ft): 3,124
2	UTM Zone: <input type="checkbox"/> 12 or <input checked="" type="checkbox"/> 13			Datum: <input type="checkbox"/> NAD 27 <input checked="" type="checkbox"/> NAD 83 <input type="checkbox"/> WGS 84	
a	UTM E (in meters, to nearest 10 meters): 583,982.0			UTM N (in meters, to nearest 10 meters): 3,570,216.0	
b	AND Latitude (deg., min., sec.): 32 deg 15 min 56.71 sec			Longitude (deg., min., sec.): -104 deg 06 min 29.97 sec	
3	Name and zip code of nearest New Mexico town: Loving, NM 88256				
4	Detailed Driving Instructions from nearest NM town (attach a road map if necessary): From Allsup's store in Loving, go South on Pecos Hwy to Higby Hole Road to Bounds Road. Turn West for 0.5 miles to facility on North side of road.				
5	The facility is 1.5 (distance) miles southwest (direction) of Loving , NM (nearest town).				
6	Status of land at facility (check one): <input checked="" type="checkbox"/> Private <input type="checkbox"/> Indian/Pueblo <input type="checkbox"/> Federal BLM <input type="checkbox"/> Federal Forest Service <input type="checkbox"/> Other (specify)				
7	List all municipalities, Indian tribes, and counties within a ten (10) mile radius (20.2.72.203.B.2 NMAC) of the property on which the facility is proposed to be constructed or operated: Loving, NM; Eddy County, NM;				
8	20.2.72 NMAC applications only: Will the property on which the facility is proposed to be constructed or operated be closer than 50 km (31 miles) to other states, Bernalillo County, or a Class I area (see www.env.nm.gov/air-quality/modeling-publications/)? <input checked="" type="checkbox"/> Yes <input type="checkbox"/> No (20.2.72.206.A.7 NMAC) If yes, list all with corresponding distances in kilometers: Lea County (37 km east); Texas 30.6 km south); Carlsbad Caverns National Park (26 km west southwest)				
9	Name nearest Class I area: Carlsbad Caverns National Park (26 km)				
10	Shortest distance (in km) from facility boundary to the boundary of the nearest Class I area (to the nearest 10 meters): 25.97 km				
11	Distance (meters) from the perimeter of the Area of Operations (AO is defined as the plant site inclusive of all disturbed lands, including mining overburden removal areas) to nearest residence, school or occupied structure: 760 meters				
12	Method(s) used to delineate the Restricted Area: Continuous fencing "Restricted Area" is an area to which public entry is effectively precluded. Effective barriers include continuous fencing, continuous walls, or other continuous barriers approved by the Department, such as rugged physical terrain with steep grade that would require special equipment to traverse. If a large property is completely enclosed by fencing, a restricted area within the property may be identified with signage only. Public roads cannot be part of a Restricted Area.				
13	Does the owner/operator intend to operate this source as a portable stationary source as defined in 20.2.72.7.X NMAC? <input type="checkbox"/> Yes <input checked="" type="checkbox"/> No A portable stationary source is not a mobile source, such as an automobile, but a source that can be installed permanently at one location or that can be re-installed at various locations, such as a hot mix asphalt plant that is moved to different job sites.				
14	Will this facility operate in conjunction with other air regulated parties on the same property? <input checked="" type="checkbox"/> No <input type="checkbox"/> Yes If yes, what is the name and permit number (if known) of the other facility?				

Section 1-E: Proposed Operating Schedule (The 1-E.1 & 1-E.2 operating schedules may become conditions in the permit.)

1	Facility maximum operating ($\frac{\text{hours}}{\text{day}}$): 24	($\frac{\text{days}}{\text{week}}$): 7	($\frac{\text{weeks}}{\text{year}}$): 52	($\frac{\text{hours}}{\text{year}}$): 8,760
2	Facility's maximum daily operating schedule (if less than 24 $\frac{\text{hours}}{\text{day}}$)? Start: N/A	<input type="checkbox"/> AM <input type="checkbox"/> PM	End: N/A	<input type="checkbox"/> AM <input type="checkbox"/> PM
3	Month and year of anticipated start of construction: Upon permit issuance (estimated April 2023)			
4	Month and year of anticipated construction completion: October 2023			
5	Month and year of anticipated startup of new or modified facility: October 2023			
6	Will this facility operate at this site for more than one year? <input checked="" type="checkbox"/> Yes <input type="checkbox"/> No			

Section 1-F: Other Facility Information

1	Are there any current Notice of Violations (NOV), compliance orders, or any other compliance or enforcement issues related to this facility? <input checked="" type="checkbox"/> Yes <input type="checkbox"/> No If yes, specify: Site is part of an approved environmental audit under AQB Civil Penalty Policy, Appendix D. Approval letter is dated October 26, 2022.
---	--

a	If yes, NOV date or description of issue: October 26, 2022 audit approval letter from NMED	NOV Tracking No:
b	Is this application in response to any issue listed in 1-F, 1 or 1a above? <input type="checkbox"/> Yes <input checked="" type="checkbox"/> No If Yes, provide the 1c & 1d info below:	
c	Document Title: N/A	Date: N/A Requirement # (or page # and paragraph #): N/A
d	Provide the required text to be inserted in this permit: N/A	
2	Is air quality dispersion modeling or modeling waiver being submitted with this application? <input checked="" type="checkbox"/> Yes <input type="checkbox"/> No	
3	Does this facility require an "Air Toxics" permit under 20.2.72.400 NMAC & 20.2.72.502, Tables A and/or B? <input type="checkbox"/> Yes <input checked="" type="checkbox"/> No	
4	Will this facility be a source of federal Hazardous Air Pollutants (HAP)? <input checked="" type="checkbox"/> Yes <input type="checkbox"/> No	
a	If Yes, what type of source? <input type="checkbox"/> Major (<input type="checkbox"/> ≥ 10 tpy of any single HAP OR <input type="checkbox"/> ≥ 25 tpy of any combination of HAPS) OR <input checked="" type="checkbox"/> Minor (<input checked="" type="checkbox"/> < 10 tpy of any single HAP AND <input checked="" type="checkbox"/> < 25 tpy of any combination of HAPS)	
5	Is any unit exempt under 20.2.72.202.B.3 NMAC? <input type="checkbox"/> Yes <input checked="" type="checkbox"/> No	
a	If yes, include the name of company providing commercial electric power to the facility: N/A Commercial power is purchased from a commercial utility company, which specifically does not include power generated on site for the sole purpose of the user.	

Section 1-G: Streamline Application (This section applies to 20.2.72.300 NMAC Streamline applications only)

1	<input type="checkbox"/> I have filled out Section 18, "Addendum for Streamline Applications." <input checked="" type="checkbox"/> N/A (This is not a Streamline application.)
---	--

Section 1-H: Current Title V Information - Required for all applications from TV Sources

(Title V-source required information for all applications submitted pursuant to 20.2.72 NMAC (Minor Construction Permits), or 20.2.74/20.2.79 NMAC (Major PSD/NNSR applications), and/or 20.2.70 NMAC (Title V))

1	Responsible Official (R.O.) (20.2.70.300.D.2 NMAC): Jimmy Oxford	Phone: (940) 220-2493
a	R.O. Title: Vice President Operations	R.O. e-mail: JOxford@targaresources.com
b	R. O. Address: 4401 North I-35, Suite 303 Denton, Texas 76207	
2	Alternate Responsible Official (20.2.70.300.D.2 NMAC): N/A	Phone: N/A
a	A. R.O. Title: N/A	A. R.O. e-mail: N/A
b	A. R. O. Address: N/A	
3	Company's Corporate or Partnership Relationship to any other Air Quality Permittee (List the names of any companies that have operating (20.2.70 NMAC) permits and with whom the applicant for this permit has a corporate or partnership relationship): Targa Resources, Inc.	
4	Name of Parent Company ("Parent Company" means the primary name of the organization that owns the company to be permitted wholly or in part.): Targa Resources, Inc.	
a	Address of Parent Company: 811 Louisiana Suite 2100, Houston, TX 77002-1400	
5	Names of Subsidiary Companies ("Subsidiary Companies" means organizations, branches, divisions or subsidiaries, which are owned, wholly or in part, by the company to be permitted.): None	
6	Telephone numbers & names of the owners' agents and site contacts familiar with plant operations: Jaylen Fuentes – (575) 810-6051 and James Aguilar – (575) 810-6093	
7	Affected Programs to include Other States, local air pollution control programs (i.e. Bernalillo) and Indian tribes: Will the property on which the facility is proposed to be constructed or operated be closer than 80 km (50 miles) from other states, local pollution control programs, and Indian tribes and pueblos (20.2.70.402.A.2 and 20.2.70.7.B)? If yes, state which ones and provide the distances in kilometers: Texas 30.6 km	

Section 1-I – Submittal Requirements

Each 20.2.73 NMAC (NOI), a 20.2.70 NMAC (Title V), a 20.2.72 NMAC (NSR minor source), or 20.2.74 NMAC (PSD) application package shall consist of the following:

Hard Copy Submittal Requirements:

- 1) One hard copy **original signed and notarized application package printed double sided ‘head-to-toe’ 2-hole punched** as we bind the document on top, not on the side; except Section 2 (landscape tables), which should be **head-to-head**. Please use **numbered tab separators** in the hard copy submittal(s) as this facilitates the review process. For NOI submittals only, hard copies of UA1, Tables 2A, 2D & 2F, Section 3 and the signed Certification Page are required. **Please include a copy of the check on a separate page.**
- 2) If the application is for a minor NSR, PSD, NNSR, or Title V application, include one working hard **copy** for Department use. This **copy** should be printed in book form, 3-hole punched, and **must be double sided**. Note that this is in addition to the head-to-toe 2-hole punched copy required in 1) above. Minor NSR Technical Permit revisions (20.2.72.219.B NMAC) only need to fill out Sections 1-A, 1-B, 3, and should fill out those portions of other Section(s) relevant to the technical permit revision. TV Minor Modifications need only fill out Sections 1-A, 1-B, 1-H, 3, and those portions of other Section(s) relevant to the minor modification. NMED may require additional portions of the application to be submitted, as needed.
- 3) The entire NOI or Permit application package, including the full modeling study, should be submitted electronically. Electronic files for applications for NOIs, any type of General Construction Permit (GCP), or technical revisions to NSRs must be submitted with compact disk (CD) or digital versatile disc (DVD). For these permit application submittals, **two CD** copies are required (in sleeves, not crystal cases, please), with additional CD copies as specified below. NOI applications require only a **single CD** submittal. Electronic files for other New Source Review (construction) permits/permit modifications or Title V permits/permit modifications can be submitted on CD/DVD or sent through AQB’s secure file transfer service.

Electronic files sent by (check one):

- CD/DVD attached to paper application
 secure electronic transfer.

Air Permit Contact Name: Rob Liles

Email: rliles@trinityconsultants.com

Phone number: (505) 266-6611

a. If the file transfer service is chosen by the applicant, after receipt of the application, the Bureau will email the applicant with instructions for submitting the electronic files through a secure file transfer service. Submission of the electronic files through the file transfer service needs to be completed within 3 business days after the invitation is received, so the applicant should ensure that the files are ready when sending the hard copy of the application. The applicant will not need a password to complete the transfer. **Do not use the file transfer service for NOIs, any type of GCP, or technical revisions to NSR permits.**

- 4) Optionally, the applicant may submit the files with the application on compact disk (CD) or digital versatile disc (DVD) following the instructions above and the instructions in 5 for applications subject to PSD review.
- 5) If **air dispersion modeling** is required by the application type, include the **NMED Modeling Waiver** and/or electronic air dispersion modeling report, input, and output files. The dispersion modeling **summary report only** should be submitted as hard copy(ies) unless otherwise indicated by the Bureau.
- 6) If the applicant submits the electronic files on CD and the application is subject to PSD review under 20.2.74 NMAC (PSD) or NNSR under 20.2.79 NMC include,
 - a. one additional CD copy for US EPA,
 - b. one additional CD copy for each federal land manager affected (NPS, USFS, FWS, USDI) and,
 - c. one additional CD copy for each affected regulatory agency other than the Air Quality Bureau.

If the application is submitted electronically through the secure file transfer service, these extra CDs do not need to be submitted.

Electronic Submittal Requirements [in addition to the required hard copy(ies)]:

- 1) All required electronic documents shall be submitted as 2 separate CDs or submitted through the AQB secure file transfer service. Submit a single PDF document of the entire application as submitted and the individual documents comprising the application.
- 2) The documents should also be submitted in Microsoft Office compatible file format (Word, Excel, etc.) allowing us to access the text and formulas in the documents (copy & paste). Any documents that cannot be submitted in a Microsoft Office compatible

format shall be saved as a PDF file from within the electronic document that created the file. If you are unable to provide Microsoft office compatible electronic files or internally generated PDF files of files (items that were not created electronically: i.e. brochures, maps, graphics, etc.), submit these items in hard copy format. We must be able to review the formulas and inputs that calculated the emissions.

- 3) It is preferred that this application form be submitted as 4 electronic files (**3 MSWord docs**: Universal Application section 1 [UA1], Universal Application section 3-19 [UA3], and Universal Application 4, the modeling report [UA4]) and **1 Excel file** of the tables (Universal Application section 2 [UA2]). Please include as many of the 3-19 Sections as practical in a single MS Word electronic document. Create separate electronic file(s) if a single file becomes too large or if portions must be saved in a file format other than MS Word.
- 4) The **electronic file names** shall be a maximum of 25 characters long (including spaces, if any). The format of the electronic Universal Application shall be in the format: "A-3423-FacilityName". The "A" distinguishes the file as an application submittal, as opposed to other documents the Department itself puts into the database. Thus, all electronic application submittals should begin with "A-". Modifications to existing facilities should use the **core permit number** (i.e. '3423') the Department assigned to the facility as the next 4 digits. Use 'XXXX' for new facility applications. The format of any separate electronic submittals (additional submittals such as non-Word attachments, re-submittals, application updates) and Section document shall be in the format: "A-3423-9-description", where "9" stands for the **section #** (in this case Section 9-Public Notice). Please refrain, as much as possible, from submitting any scanned documents as this file format is extremely large, which uses up too much storage capacity in our database. Please take the time to fill out the **header information** throughout all submittals as this will identify any loose pages, including the Application Date (date submitted) & Revision number (0 for original, 1, 2, etc.; which will help keep track of subsequent partial update(s) to the original submittal. Do not use special symbols (#, @, etc.) in file names. The footer information should not be modified by the applicant.

Table of Contents

Section 1:	General Facility Information
Section 2:	Tables
Section 3:	Application Summary
Section 4:	Process Flow Sheet
Section 5:	Plot Plan Drawn to Scale
Section 6:	All Calculations
Section 7:	Information Used to Determine Emissions
Section 8:	Map(s)
Section 9:	Proof of Public Notice
Section 10:	Written Description of the Routine Operations of the Facility
Section 11:	Source Determination
Section 12:	PSD Applicability Determination for All Sources & Special Requirements for a PSD Application
Section 13:	Discussion Demonstrating Compliance with Each Applicable State & Federal Regulation
Section 14:	Operational Plan to Mitigate Emissions
Section 15:	Alternative Operating Scenarios
Section 16:	Air Dispersion Modeling
Section 17:	Compliance Test History
Section 18:	Addendum for Streamline Applications (streamline applications only)
Section 19:	Requirements for the Title V (20.2.70 NMAC) Program (Title V applications only)
Section 20:	Other Relevant Information
Section 21:	Addendum for Landfill Applications
Section 22:	Certification Page

Table 2-A: Regulated Emission Sources

Unit and stack numbering must correspond throughout the application package. If applying for a NOI under 20.2.73 NMAC, equipment exemptions under 2.72.202 NMAC do not apply.

Unit Number ¹	Source Description	Make	Model #	Serial #	Manufacturer's Rated Capacity ³ (Specify Units)	Requested Permitted Capacity ³ (Specify Units)	Date of Manufacture ²	Controlled by Unit #	Source Classification Code (SCC)	For Each Piece of Equipment, Check One	RICE Ignition Type (CI, SI, 4SLB, 4SRB, 2SLB) ⁴	Replacing Unit No.
							Date of Construction/Reconstruction ²	Emissions vented to Stack #				
EP-1	Emergency Flare (Pilot with auto ignition)	Zeeeco Inc.	FL5100	31927	240.025 MMscf/yr	240.025 MMscf/yr	2017	NA	31000205	<input type="checkbox"/> Existing (unchanged) <input type="checkbox"/> To Be Removed <input type="checkbox"/> New/Additional <input type="checkbox"/> Replacement Unit <input checked="" type="checkbox"/> To Be Modified <input type="checkbox"/> To Be Replaced	NA	NA
2/3-EP-1	Emergency Flare (Pilot with auto ignition)	Zeeeco Inc.	FL5100	TBD	240.025 MMscf/yr	240.025 MMscf/yr	TBD	NA	31000205	<input type="checkbox"/> Existing (unchanged) <input type="checkbox"/> To Be Removed <input type="checkbox"/> New/Additional <input type="checkbox"/> Replacement Unit <input type="checkbox"/> To Be Modified <input checked="" type="checkbox"/> To Be Replaced	NA	NA
2-EP-1	Emergency Flare (Pilot with auto ignition)	TBD	TBD	TBD	240.025 MMscf/yr	240.025 MMscf/yr	TBD	NA	31000205	<input type="checkbox"/> Existing (unchanged) <input type="checkbox"/> To Be Removed <input type="checkbox"/> New/Additional <input checked="" type="checkbox"/> Replacement Unit <input type="checkbox"/> To Be Modified <input type="checkbox"/> To Be Replaced	NA	2/3-EP-1
4-EP-1	Emergency Flare (Pilot with auto ignition)	Zeeeco Inc.	FL5100	TBD	240.025 MMscf/yr	240.025 MMscf/yr	TBD	NA	31000205	<input type="checkbox"/> Existing (unchanged) <input checked="" type="checkbox"/> To Be Removed <input type="checkbox"/> New/Additional <input type="checkbox"/> Replacement Unit <input type="checkbox"/> To Be Modified <input type="checkbox"/> To Be Replaced	NA	NA
3-EP-1	Emergency Flare (Pilot with auto ignition)	TBD	TBD	TBD	240.025 MMscf/yr	240.025 MMscf/yr	TBD	NA	31000205	<input type="checkbox"/> Existing (unchanged) <input type="checkbox"/> To Be Removed <input checked="" type="checkbox"/> New/Additional <input type="checkbox"/> Replacement Unit <input type="checkbox"/> To Be Modified <input type="checkbox"/> To Be Replaced	NA	NA
EP-2	Trim Reboiler	Fabsco Shell & Tube	E-207	516-11764-2/HI14-149	26.5 MMBtu/hr	26.5 MMBtu/hr	2017	NA	31000404	<input type="checkbox"/> Existing (unchanged) <input type="checkbox"/> To Be Removed <input type="checkbox"/> New/Additional <input type="checkbox"/> Replacement Unit <input checked="" type="checkbox"/> To Be Modified <input type="checkbox"/> To Be Replaced	NA	NA
2-EP-2	Trim Reboiler	Fabsco Shell & Tube	E-207	TBD	26.5 MMBtu/hr	26.5 MMBtu/hr	TBD	NA	31000404	<input type="checkbox"/> Existing (unchanged) <input type="checkbox"/> To Be Removed <input type="checkbox"/> New/Additional <input type="checkbox"/> Replacement Unit <input checked="" type="checkbox"/> To Be Modified <input type="checkbox"/> To Be Replaced	NA	NA
3-EP-2	Trim Reboiler	Fabsco Shell & Tube	E-207	TBD	26.5 MMBtu/hr	26.5 MMBtu/hr	TBD	NA	31000404	<input type="checkbox"/> Existing (unchanged) <input type="checkbox"/> To Be Removed <input type="checkbox"/> New/Additional <input type="checkbox"/> Replacement Unit <input checked="" type="checkbox"/> To Be Modified <input type="checkbox"/> To Be Replaced	NA	NA
4-EP-2	Trim Reboiler	Fabsco Shell & Tube	E-207	TBD	17.55 MMBtu/hr	17.55 MMBtu/hr	TBD	NA	31000404	<input type="checkbox"/> Existing (unchanged) <input checked="" type="checkbox"/> To Be Removed <input type="checkbox"/> New/Additional <input type="checkbox"/> Replacement Unit <input type="checkbox"/> To Be Modified <input type="checkbox"/> To Be Replaced	NA	NA
EP-3A	Amine Reboiler Heater	Patrick	2BKU30/5A-312/2687200 20A	TBD	70.28 MMBtu/hr	70.28 MMBtu/hr	2017	NA	31000404	<input type="checkbox"/> Existing (unchanged) <input type="checkbox"/> To Be Removed <input type="checkbox"/> New/Additional <input type="checkbox"/> Replacement Unit <input checked="" type="checkbox"/> To Be Modified <input type="checkbox"/> To Be Replaced	NA	NA
EP-3B	Amine Reboiler Heater	Patrick	TBD	TBD	84.77 MMBtu/hr	84.77 MMBtu/hr	TBD	NA	31000404	<input type="checkbox"/> Existing (unchanged) <input type="checkbox"/> To Be Removed <input type="checkbox"/> New/Additional <input type="checkbox"/> Replacement Unit <input checked="" type="checkbox"/> To Be Modified <input type="checkbox"/> To Be Replaced	NA	NA
EP-4	Glycol Reboiler Heater	Reset Energy	H-2801	F-9	3.9 MMBtu/hr	3.9 MMBtu/hr	2017	NA	31000302	<input type="checkbox"/> Existing (unchanged) <input type="checkbox"/> To Be Removed <input type="checkbox"/> New/Additional <input type="checkbox"/> Replacement Unit <input checked="" type="checkbox"/> To Be Modified <input type="checkbox"/> To Be Replaced	NA	NA
2-EP-4	Glycol Reboiler Heater	TBD	TBD	TBD	3.9 MMBtu/hr	3.9 MMBtu/hr	TBD	NA	31000302	<input type="checkbox"/> Existing (unchanged) <input type="checkbox"/> To Be Removed <input type="checkbox"/> New/Additional <input type="checkbox"/> Replacement Unit <input checked="" type="checkbox"/> To Be Modified <input type="checkbox"/> To Be Replaced	NA	NA
3-EP-4	Glycol Reboiler Heater	TBD	TBD	TBD	3.9 MMBtu/hr	3.9 MMBtu/hr	TBD	NA	31000302	<input type="checkbox"/> Existing (unchanged) <input type="checkbox"/> To Be Removed <input type="checkbox"/> New/Additional <input type="checkbox"/> Replacement Unit <input checked="" type="checkbox"/> To Be Modified <input type="checkbox"/> To Be Replaced	NA	NA
4-EP-4	Glycol Reboiler Heater	TBD	TBD	TBD	3 MMBtu/hr	3 MMBtu/hr	TBD	NA	31000302	<input type="checkbox"/> Existing (unchanged) <input checked="" type="checkbox"/> To Be Removed <input type="checkbox"/> New/Additional <input type="checkbox"/> Replacement Unit <input type="checkbox"/> To Be Modified <input type="checkbox"/> To Be Replaced	NA	NA
EP-5	Regen Reboiler Heater	Heatec	HCI5010-40-G	HI16-201	9.5 MMBtu/hr	9.5 MMBtu/hr	2/2017	NA	31000404	<input type="checkbox"/> Existing (unchanged) <input type="checkbox"/> To Be Removed <input type="checkbox"/> New/Additional <input type="checkbox"/> Replacement Unit <input checked="" type="checkbox"/> To Be Modified <input type="checkbox"/> To Be Replaced	NA	NA
2-EP-5	Regen Reboiler Heater	TBD	TBD	TBD	9.5 MMBtu/hr	9.5 MMBtu/hr	TBD	NA	31000404	<input type="checkbox"/> Existing (unchanged) <input type="checkbox"/> To Be Removed <input type="checkbox"/> New/Additional <input type="checkbox"/> Replacement Unit <input checked="" type="checkbox"/> To Be Modified <input type="checkbox"/> To Be Replaced	NA	NA
3-EP-5	Regen Reboiler Heater	TBD	TBD	TBD	9.5 MMBtu/hr	9.5 MMBtu/hr	TBD	NA	31000404	<input type="checkbox"/> Existing (unchanged) <input type="checkbox"/> To Be Removed <input type="checkbox"/> New/Additional <input type="checkbox"/> Replacement Unit <input checked="" type="checkbox"/> To Be Modified <input type="checkbox"/> To Be Replaced	NA	NA
4-EP-5	Regen Reboiler Heater	TBD	TBD	TBD	5.61 MMBtu/hr	5.61 MMBtu/hr	TBD	NA	31000404	<input type="checkbox"/> Existing (unchanged) <input checked="" type="checkbox"/> To Be Removed <input type="checkbox"/> New/Additional <input type="checkbox"/> Replacement Unit <input type="checkbox"/> To Be Modified <input type="checkbox"/> To Be Replaced	NA	NA
EP-6	Stabilizer Heater	Phoenix	PX-180	17169	23.4 MMBtu/hr	23.4 MMBtu/hr	2017	NA	31000404	<input type="checkbox"/> Existing (unchanged) <input type="checkbox"/> To Be Removed <input type="checkbox"/> New/Additional <input type="checkbox"/> Replacement Unit <input checked="" type="checkbox"/> To Be Modified <input type="checkbox"/> To Be Replaced	NA	NA
2-EP-6	Stabilizer Heater	TBD	TBD	TBD	23.4 MMBtu/hr	23.4 MMBtu/hr	TBD	NA	31000404	<input type="checkbox"/> Existing (unchanged) <input type="checkbox"/> To Be Removed <input type="checkbox"/> New/Additional <input type="checkbox"/> Replacement Unit <input checked="" type="checkbox"/> To Be Modified <input type="checkbox"/> To Be Replaced	NA	NA

Unit Number ¹	Source Description	Make	Model #	Serial #	Manufacturer's Rated Capacity ³ (Specify Units)	Requested Permitted Capacity ³ (Specify Units)	Date of Manufacture ²	Controlled by Unit #	Source Classification Code (SCC)	For Each Piece of Equipment, Check One	RICE Ignition Type (CI, SI, 4SLB, 4SRB, 2SLB) ⁴	Replacing Unit No.
							Date of Construction/Reconstruction ²	Emissions vented to Stack #				
EP-7	Glycol Dehydrator Still Vent	Reset Energy	T-2707	153	240 MMscf/d	240 MMscf/d	2017	EP-9	31000301	<input type="checkbox"/> Existing (unchanged) <input type="checkbox"/> To Be Removed <input type="checkbox"/> New/Additional <input type="checkbox"/> Replacement Unit <input checked="" type="checkbox"/> To Be Modified <input type="checkbox"/> To be Replaced	NA	NA
2-EP-7	Glycol Dehydrator Still Vent	TBD	TBD	TBD	240 MMscf/d	240 MMscf/d	TBD	EP-9	31000301	<input type="checkbox"/> Existing (unchanged) <input type="checkbox"/> To Be Removed <input type="checkbox"/> New/Additional <input type="checkbox"/> Replacement Unit <input checked="" type="checkbox"/> To Be Modified <input type="checkbox"/> To be Replaced	NA	NA
3-EP-7	Glycol Dehydrator Still Vent	TBD	TBD	TBD	240 MMscf/d	240 MMscf/d	TBD	EP-9	31000301	<input type="checkbox"/> Existing (unchanged) <input type="checkbox"/> To Be Removed <input type="checkbox"/> New/Additional <input type="checkbox"/> Replacement Unit <input checked="" type="checkbox"/> To Be Modified <input type="checkbox"/> To be Replaced	NA	NA
4-EP-7	Glycol Dehydrator Still Vent	TBD	TBD	TBD	220 MMscf/d	220 MMscf/d	TBD	EP-9	31000301	<input type="checkbox"/> Existing (unchanged) <input checked="" type="checkbox"/> To Be Removed <input type="checkbox"/> New/Additional <input type="checkbox"/> Replacement Unit <input type="checkbox"/> To Be Modified <input type="checkbox"/> To be Replaced	NA	NA
EP-8	Amine Still Vent	PBP Fabrication	V-5520	493	245 MMscf/d	245 MMscf/d	2017	EP-9	31000305	<input type="checkbox"/> Existing (unchanged) <input type="checkbox"/> To Be Removed <input type="checkbox"/> New/Additional <input type="checkbox"/> Replacement Unit <input checked="" type="checkbox"/> To Be Modified <input type="checkbox"/> To be Replaced	NA	NA
2-EP-8	Amine Still Vent	TBD	TBD	TBD	245 MMscf/d	245 MMscf/d	2017	EP-9	31000305	<input type="checkbox"/> Existing (unchanged) <input type="checkbox"/> To Be Removed <input checked="" type="checkbox"/> New/Additional <input type="checkbox"/> Replacement Unit <input type="checkbox"/> To Be Modified <input type="checkbox"/> To be Replaced	NA	NA
3-EP-8	Amine Still Vent	TBD	TBD	TBD	245 MMscf/d	245 MMscf/d	2017	EP-9	31000305	<input type="checkbox"/> Existing (unchanged) <input type="checkbox"/> To Be Removed <input checked="" type="checkbox"/> New/Additional <input type="checkbox"/> Replacement Unit <input type="checkbox"/> To Be Modified <input type="checkbox"/> To be Replaced	NA	NA
EP-9	Thermal Oxidizer	Zeeco Inc	TO-55	32339	71 MMBtu/hr	71 MMBtu/hr	2017	NA	31000209	<input type="checkbox"/> Existing (unchanged) <input type="checkbox"/> To Be Removed <input type="checkbox"/> New/Additional <input type="checkbox"/> Replacement Unit <input checked="" type="checkbox"/> To Be Modified <input type="checkbox"/> To be Replaced	NA	NA
SSM	Startup, Shutdown, Malfunction Emissions	TBD	TBD	TBD	NA	NA	TBD	N/A	31088811	<input type="checkbox"/> Existing (unchanged) <input type="checkbox"/> To Be Removed <input type="checkbox"/> New/Additional <input type="checkbox"/> Replacement Unit <input checked="" type="checkbox"/> To Be Modified <input type="checkbox"/> To be Replaced	NA	NA
COMB-1	Combustor	Zeeco Inc	VCU-7.5.40 Flare System	31974-001	12.75 MMscf/yr	12.75 MMscf/yr	2017	NA	31000209	<input type="checkbox"/> Existing (unchanged) <input type="checkbox"/> To Be Removed <input type="checkbox"/> New/Additional <input type="checkbox"/> Replacement Unit <input checked="" type="checkbox"/> To Be Modified <input type="checkbox"/> To be Replaced	NA	NA
LOAD	Condensate Loadout Emissions	TBD	TBD	TBD	2,920,000 bbl/yr	2,920,000 bbl/yr	TBD	N/A	40600132	<input type="checkbox"/> Existing (unchanged) <input type="checkbox"/> To Be Removed <input type="checkbox"/> New/Additional <input type="checkbox"/> Replacement Unit <input checked="" type="checkbox"/> To Be Modified <input type="checkbox"/> To be Replaced	NA	NA
HAUL	Haul Road Emissions	TBD	TBD	TBD	4380 trips/yr	4380 trips/yr	TBD	N/A	31088811	<input type="checkbox"/> Existing (unchanged) <input type="checkbox"/> To Be Removed <input type="checkbox"/> New/Additional <input type="checkbox"/> Replacement Unit <input checked="" type="checkbox"/> To Be Modified <input type="checkbox"/> To be Replaced	NA	NA
FUG	Fugitive Emissions	TBD	TBD	TBD	NA	NA	TBD	N/A	31000220	<input type="checkbox"/> Existing (unchanged) <input type="checkbox"/> To Be Removed <input type="checkbox"/> New/Additional <input type="checkbox"/> Replacement Unit <input checked="" type="checkbox"/> To Be Modified <input type="checkbox"/> To be Replaced	NA	NA
FUG2	Fugitive Emissions	TBD	TBD	TBD	NA	NA	TBD	N/A	31000220	<input type="checkbox"/> Existing (unchanged) <input checked="" type="checkbox"/> To Be Removed <input type="checkbox"/> New/Additional <input type="checkbox"/> Replacement Unit <input type="checkbox"/> To Be Modified <input type="checkbox"/> To be Replaced	NA	NA
T-1	Condensate Storage Tank	Tank & Vessel Boilers LP	NA	201723	1000 bbl	1000 bbl	2017	COMB-1	40400311	<input type="checkbox"/> Existing (unchanged) <input type="checkbox"/> To Be Removed <input type="checkbox"/> New/Additional <input type="checkbox"/> Replacement Unit <input checked="" type="checkbox"/> To Be Modified <input type="checkbox"/> To be Replaced	NA	NA
T-2	Condensate Storage Tank	Tank & Vessel Boilers LP	NA	201724	1000 bbl	1000 bbl	2017	COMB-1	40400311	<input type="checkbox"/> Existing (unchanged) <input type="checkbox"/> To Be Removed <input type="checkbox"/> New/Additional <input type="checkbox"/> Replacement Unit <input checked="" type="checkbox"/> To Be Modified <input type="checkbox"/> To be Replaced	NA	NA
T-3	Condensate Storage Tank	Tank & Vessel Boilers LP	NA	201720	1000 bbl	1000 bbl	2017	COMB-1	40400311	<input type="checkbox"/> Existing (unchanged) <input type="checkbox"/> To Be Removed <input type="checkbox"/> New/Additional <input type="checkbox"/> Replacement Unit <input checked="" type="checkbox"/> To Be Modified <input type="checkbox"/> To be Replaced	NA	NA
T-4	Condensate Storage Tank	Tank & Vessel Boilers LP	NA	201721	1000 bbl	1000 bbl	2017	COMB-1	40400311	<input type="checkbox"/> Existing (unchanged) <input type="checkbox"/> To Be Removed <input type="checkbox"/> New/Additional <input type="checkbox"/> Replacement Unit <input checked="" type="checkbox"/> To Be Modified <input type="checkbox"/> To be Replaced	NA	NA
T-5	Condensate Storage Tank	Tank & Vessel Boilers LP	NA	201722	1000 bbl	1000 bbl	2017	COMB-1	40400311	<input type="checkbox"/> Existing (unchanged) <input type="checkbox"/> To Be Removed <input type="checkbox"/> New/Additional <input type="checkbox"/> Replacement Unit <input checked="" type="checkbox"/> To Be Modified <input type="checkbox"/> To be Replaced	NA	NA
T-6	Produced Water Tank	Palmer	NA	ST-1711323	400 bbl	400 bbl	8/2017	NA	40400315	<input type="checkbox"/> Existing (unchanged) <input type="checkbox"/> To Be Removed <input type="checkbox"/> New/Additional <input type="checkbox"/> Replacement Unit <input checked="" type="checkbox"/> To Be Modified <input type="checkbox"/> To be Replaced	NA	NA
D-1	Electric Driven Residue Compressor	Ariel	KBZ/6	F54680	60 MMscf/d	60 MMscf/d	9/2017	NA	31000203	<input checked="" type="checkbox"/> Existing (unchanged) <input type="checkbox"/> To Be Removed <input type="checkbox"/> New/Additional <input type="checkbox"/> Replacement Unit <input type="checkbox"/> To Be Modified <input type="checkbox"/> To be Replaced	NA	NA
D-2	Electric Driven Residue Compressor	Ariel	KBZ/6	F54701	60 MMscf/d	60 MMscf/d	9/2017	NA	31000203	<input checked="" type="checkbox"/> Existing (unchanged) <input type="checkbox"/> To Be Removed <input type="checkbox"/> New/Additional <input type="checkbox"/> Replacement Unit <input type="checkbox"/> To Be Modified <input type="checkbox"/> To be Replaced	NA	NA
D-3	Electric Driven Residue Compressor	Ariel	KBZ/6	F54720	60 MMscf/d	60 MMscf/d	9/2017	NA	31000203	<input checked="" type="checkbox"/> Existing (unchanged) <input type="checkbox"/> To Be Removed <input type="checkbox"/> New/Additional <input type="checkbox"/> Replacement Unit <input type="checkbox"/> To Be Modified <input type="checkbox"/> To be Replaced	NA	NA
D-4	Electric Driven Residue Compressor	Ariel	KBZ/6	F54750	60 MMscf/d	60 MMscf/d	9/2017	NA	31000203	<input checked="" type="checkbox"/> Existing (unchanged) <input type="checkbox"/> To Be Removed <input type="checkbox"/> New/Additional <input type="checkbox"/> Replacement Unit <input type="checkbox"/> To Be Modified <input type="checkbox"/> To be Replaced	NA	NA

Unit Number ¹	Source Description	Make	Model #	Serial #	Manufacturer's Rated Capacity ³ (Specify Units)	Requested Permitted Capacity ³ (Specify Units)	Date of Manufacture ²	Controlled by Unit #	Source Classification Code (SCC)	For Each Piece of Equipment, Check One	RICE Ignition Type (CI, SI, 4SLB, 4SRB, 2SLB) ⁴	Replacing Unit No.	
							Date of Construction/Reconstruction ²	Emissions vented to Stack #					
D-5	Electric Driven Refrigeration Compressor	GEA	XCR-XC26555-18	XC0507	4500 hp	4500 hp	2017 TBD	NA NA	31000203	<input type="checkbox"/> Existing (unchanged) <input checked="" type="checkbox"/> New/Additional <input type="checkbox"/> To Be Modified	<input type="checkbox"/> To be Removed <input type="checkbox"/> Replacement Unit <input type="checkbox"/> To be Replaced	NA	NA
D-6	Electric Driven Refrigeration Compressor	GEA	XCR-XC26555-18	XC0508	4500 hp	4500 hp	2017 TBD	NA NA	31000203	<input type="checkbox"/> Existing (unchanged) <input checked="" type="checkbox"/> New/Additional <input type="checkbox"/> To Be Modified	<input type="checkbox"/> To be Removed <input type="checkbox"/> Replacement Unit <input type="checkbox"/> To be Replaced	NA	NA
D-7	Electric Driven Refrigeration Compressor	GEA	XCR-XC26555-18	XC0510	4500 hp	4500 hp	2017 TBD	NA NA	31000203	<input type="checkbox"/> Existing (unchanged) <input checked="" type="checkbox"/> New/Additional <input type="checkbox"/> To Be Modified	<input type="checkbox"/> To be Removed <input type="checkbox"/> Replacement Unit <input type="checkbox"/> To be Replaced	NA	NA
2-D-1	Electric Driven Flash Gas Compressor	Ariel	JGH/4	F54483	40 MMscf/d	40 MMscf/d	8/2017 2017	NA NA	31000203	<input type="checkbox"/> Existing (unchanged) <input type="checkbox"/> New/Additional <input type="checkbox"/> To Be Modified	<input checked="" type="checkbox"/> To be Removed <input type="checkbox"/> Replacement Unit <input type="checkbox"/> To be Replaced	NA	NA
2-D-2	Electric Driven Flash Gas Compressor	Ariel	JGH/4	F54484	40 MMscf/d	40 MMscf/d	8/2017 2017	NA NA	31000203	<input type="checkbox"/> Existing (unchanged) <input type="checkbox"/> New/Additional <input type="checkbox"/> To Be Modified	<input checked="" type="checkbox"/> To be Removed <input type="checkbox"/> Replacement Unit <input type="checkbox"/> To be Replaced	NA	NA
2-D-3	Electric Driven Flash Gas Compressor	Ariel	KBZ/6	TBD	TBD	TBD	TBD	NA	31000203	<input type="checkbox"/> Existing (unchanged) <input type="checkbox"/> New/Additional <input type="checkbox"/> To Be Modified	<input checked="" type="checkbox"/> To be Removed <input type="checkbox"/> Replacement Unit <input type="checkbox"/> To be Replaced	NA	NA
2-D-4	Electric Driven Flash Gas Compressor	Ariel	KBZ/6	TBD	TBD	TBD	TBD	NA	31000203	<input type="checkbox"/> Existing (unchanged) <input type="checkbox"/> New/Additional <input type="checkbox"/> To Be Modified	<input checked="" type="checkbox"/> To be Removed <input type="checkbox"/> Replacement Unit <input type="checkbox"/> To be Replaced	NA	NA
2-D-1	Electric Driven Residue Compressor	Ariel	KBZ4	TBD	TBD	TBD	2012 TBD	NA NA	31000203	<input type="checkbox"/> Existing (unchanged) <input checked="" type="checkbox"/> New/Additional <input type="checkbox"/> To Be Modified	<input type="checkbox"/> To be Removed <input type="checkbox"/> Replacement Unit <input type="checkbox"/> To be Replaced	NA	NA
2-D-2	Electric Driven Residue Compressor	Ariel	KBZ4	TBD	TBD	TBD	2012 TBD	NA NA	31000203	<input type="checkbox"/> Existing (unchanged) <input checked="" type="checkbox"/> New/Additional <input type="checkbox"/> To Be Modified	<input type="checkbox"/> To be Removed <input type="checkbox"/> Replacement Unit <input type="checkbox"/> To be Replaced	NA	NA
2-D-3	Electric Driven Residue Compressor	Ariel	KBZ4	TBD	TBD	TBD	2012 TBD	NA NA	31000203	<input type="checkbox"/> Existing (unchanged) <input checked="" type="checkbox"/> New/Additional <input type="checkbox"/> To Be Modified	<input type="checkbox"/> To be Removed <input type="checkbox"/> Replacement Unit <input type="checkbox"/> To be Replaced	NA	NA
2-D-4	Electric Driven Residue Compressor	Ariel	KBZ4	TBD	TBD	TBD	2012 TBD	NA NA	31000203	<input type="checkbox"/> Existing (unchanged) <input checked="" type="checkbox"/> New/Additional <input type="checkbox"/> To Be Modified	<input type="checkbox"/> To be Removed <input type="checkbox"/> Replacement Unit <input type="checkbox"/> To be Replaced	NA	NA
2-D-5	Electric Refrigeration Compressor	Frick	RWF546E	TBD	TBD	TBD	2012 TBD	NA NA	31000203	<input type="checkbox"/> Existing (unchanged) <input checked="" type="checkbox"/> New/Additional <input type="checkbox"/> To Be Modified	<input type="checkbox"/> To be Removed <input type="checkbox"/> Replacement Unit <input type="checkbox"/> To be Replaced	NA	NA
2-D-6	Electric Refrigeration Compressor	Frick	RWF546E	TBD	TBD	TBD	2012 TBD	NA NA	31000203	<input type="checkbox"/> Existing (unchanged) <input checked="" type="checkbox"/> New/Additional <input type="checkbox"/> To Be Modified	<input type="checkbox"/> To be Removed <input type="checkbox"/> Replacement Unit <input type="checkbox"/> To be Replaced	NA	NA
2-D-7	Electric Refrigeration Compressor	Frick	RWF546E	TBD	TBD	TBD	2012 TBD	NA NA	31000203	<input type="checkbox"/> Existing (unchanged) <input checked="" type="checkbox"/> New/Additional <input type="checkbox"/> To Be Modified	<input type="checkbox"/> To be Removed <input type="checkbox"/> Replacement Unit <input type="checkbox"/> To be Replaced	NA	NA
2-D-8	Electric Refrigeration Compressor	Frick	RWF546E	TBD	TBD	TBD	2012 TBD	NA NA	31000203	<input type="checkbox"/> Existing (unchanged) <input checked="" type="checkbox"/> New/Additional <input type="checkbox"/> To Be Modified	<input type="checkbox"/> To be Removed <input type="checkbox"/> Replacement Unit <input type="checkbox"/> To be Replaced	NA	NA
3-D-1	Electric Driven Residue Compressor	Ariel	KBZ4	TBD	60 MMscf/d	60 MMscf/d	2023 TBD	NA NA	31000203	<input checked="" type="checkbox"/> Existing (unchanged) <input type="checkbox"/> New/Additional <input type="checkbox"/> To Be Modified	<input type="checkbox"/> To be Removed <input type="checkbox"/> Replacement Unit <input type="checkbox"/> To be Replaced	NA	NA
3-D-2	Electric Driven Residue Compressor	Ariel	KBZ4	TBD	60 MMscf/d	60 MMscf/d	2023 TBD	NA NA	31000203	<input checked="" type="checkbox"/> Existing (unchanged) <input type="checkbox"/> New/Additional <input type="checkbox"/> To Be Modified	<input type="checkbox"/> To be Removed <input type="checkbox"/> Replacement Unit <input type="checkbox"/> To be Replaced	NA	NA
3-D-3	Electric Driven Residue Compressor	Ariel	KBZ4	TBD	60 MMscf/d	60 MMscf/d	2023 TBD	NA NA	31000203	<input checked="" type="checkbox"/> Existing (unchanged) <input type="checkbox"/> New/Additional <input type="checkbox"/> To Be Modified	<input type="checkbox"/> To be Removed <input type="checkbox"/> Replacement Unit <input type="checkbox"/> To be Replaced	NA	NA
3-D-4	Electric Driven Residue Compressor	Ariel	KBZ4	TBD	60 MMscf/d	60 MMscf/d	2023 TBD	NA NA	31000203	<input checked="" type="checkbox"/> Existing (unchanged) <input type="checkbox"/> New/Additional <input type="checkbox"/> To Be Modified	<input type="checkbox"/> To be Removed <input type="checkbox"/> Replacement Unit <input type="checkbox"/> To be Replaced	NA	NA
3-D-5	Electric Driven Refrigeration Compressor	Frick	RWF856E	TBD	TBD	TBD	2023 TBD	NA NA	31000203	<input type="checkbox"/> Existing (unchanged) <input checked="" type="checkbox"/> New/Additional <input type="checkbox"/> To Be Modified	<input type="checkbox"/> To be Removed <input type="checkbox"/> Replacement Unit <input type="checkbox"/> To be Replaced	NA	NA
3-D-6	Electric Driven Refrigeration Compressor	Frick	RWF856E	TBD	TBD	TBD	2023 TBD	NA NA	31000203	<input type="checkbox"/> Existing (unchanged) <input checked="" type="checkbox"/> New/Additional <input type="checkbox"/> To Be Modified	<input type="checkbox"/> To be Removed <input type="checkbox"/> Replacement Unit <input type="checkbox"/> To be Replaced	NA	NA

Unit Number ¹	Source Description	Make	Model #	Serial #	Manufact-urer's Rated Capacity ³ (Specify Units)	Requested Permitted Capacity ³ (Specify Units)	Date of Manufacture ²	Controlled by Unit #	Source Classification Code (SCC)	For Each Piece of Equipment, Check One	RICE Ignition Type (CI, SI, 4SLB, 4SRB, 2SLB) ⁴	Replacing Unit No.
							Date of Construction/Reconstruction ²	Emissions vented to Stack #				
3-D-7	Electric Driven Refrigeration Compressor	Frick	RWF856E	TBD	TBD	TBD	2023	NA	31000203	<input type="checkbox"/> Existing (unchanged) <input type="checkbox"/> To be Removed <input checked="" type="checkbox"/> New/Additional <input type="checkbox"/> Replacement Unit <input type="checkbox"/> To Be Modified <input type="checkbox"/> To be Replaced	NA	NA
							TBD	NA				
3-D-8	Electric Driven Refrigeration Compressor	Frick	RWF856E	TBD	TBD	TBD	2023	NA	31000203	<input type="checkbox"/> Existing (unchanged) <input type="checkbox"/> To be Removed <input checked="" type="checkbox"/> New/Additional <input type="checkbox"/> Replacement Unit <input type="checkbox"/> To Be Modified <input type="checkbox"/> To be Replaced	NA	NA
							TBD	NA				
4-D-1	Electric Driven Residue Compressor	Ariel	KBZ/6	TBD	TBD	TBD	TBD	NA	31000203	<input type="checkbox"/> Existing (unchanged) <input checked="" type="checkbox"/> To be Removed <input type="checkbox"/> New/Additional <input type="checkbox"/> Replacement Unit <input type="checkbox"/> To Be Modified <input type="checkbox"/> To be Replaced	NA	NA
							TBD	NA				
4-D-2	Electric Driven Residue Compressor	Ariel	KBZ/6	TBD	TBD	TBD	TBD	NA	31000203	<input type="checkbox"/> Existing (unchanged) <input checked="" type="checkbox"/> To be Removed <input type="checkbox"/> New/Additional <input type="checkbox"/> Replacement Unit <input type="checkbox"/> To Be Modified <input type="checkbox"/> To be Replaced	NA	NA
							TBD	NA				
4-D-3	Electric Driven Residue Compressor	Ariel	KBZ/6	TBD	TBD	TBD	TBD	NA	31000203	<input type="checkbox"/> Existing (unchanged) <input checked="" type="checkbox"/> To be Removed <input type="checkbox"/> New/Additional <input type="checkbox"/> Replacement Unit <input type="checkbox"/> To Be Modified <input type="checkbox"/> To be Replaced	NA	NA
							TBD	NA				
4-D-4	Electric Driven Residue Compressor	Ariel	KBZ/6	TBD	TBD	TBD	TBD	NA	31000203	<input type="checkbox"/> Existing (unchanged) <input checked="" type="checkbox"/> To be Removed <input type="checkbox"/> New/Additional <input type="checkbox"/> Replacement Unit <input type="checkbox"/> To Be Modified <input type="checkbox"/> To be Replaced	NA	NA
							TBD	NA				

¹ Specify dates required to determine regulatory applicability.

³ To properly account for power conversion efficiencies, generator set rated capacity shall be reported as the rated capacity of the engine in horsepower, not the kilowatt capacity of the generator set.

⁴ "4SLB" means four stroke lean burn engine, "4SRB" means four stroke rich burn engine, "2SLB" means two stroke lean burn engine, "CI" means compression ignition, and "SI" means spark ignition

Table 2-B: Insignificant Activities¹ (20.2.70 NMAC) OR Exempted Equipment (20.2.72 NMAC)

All 20.2.70 NMAC (Title V) applications must list all Insignificant Activities in this table. All 20.2.72 NMAC applications must list Exempted Equipment in this table. If equipment listed on this table is exempt under 20.2.72.202.B.5, include emissions calculations and emissions totals for 20.2.B.5 "similar functions" units, operations, and activities in Section 6, Calculations. Equipment and activities exempted under 20.2.72.202 NMAC may not necessarily be Insignificant under 20.2.70 NMAC (and vice versa). Unit & stack numbering must be consistent throughout the application package. Per Exemptions Policy 02-012.00 (see http://www.env.nm.gov/aqb/permit/aqb_pol.html), 20.2.72.202.B NMAC Exemptions do not apply, but 20.2.72.202.A NMAC exemptions do apply to NOI facilities under 20.2.73 NMAC. List 20.2.72.301.D.4 NMAC Auxiliary Equipment for Streamline applications in Table 2-A. The List of Insignificant Activities (for TV) can be found online at <https://www.env.nm.gov/wp-content/uploads/sites/2/2017/10/InsignificantListTitleV.pdf>. TV sources may elect to enter both TV Insignificant Activities and Part 72 Exemptions on this form.

Unit Number	Source Description	Manufacturer	Model No.	Max Capacity	List Specific 20.2.72.202 NMAC Exemption (e.g. 20.2.72.202.B.5)	Date of Manufacture /Reconstruction ²	For Each Piece of Equipment, Check One
			Serial No.	Capacity Units	Insignificant Activity citation (e.g. IA List Item #1.a)	Date of Installation /Construction ²	
T-7	Used Oil/Slop Oil/Skid Runoff	N/A	N/A	400	20.72.202.B(2)(a) NMAC	2020	<input checked="" type="checkbox"/> Existing (unchanged) <input type="checkbox"/> To be Removed <input type="checkbox"/> New/Additional <input type="checkbox"/> Replacement Unit <input type="checkbox"/> To Be Modified <input type="checkbox"/> To be Replaced
			N/A	bbbl		TBD	
T-8	Used Oil/Slop Oil/Skid Runoff	N/A	N/A	400	20.72.202.B(2)(a) NMAC	2020	<input checked="" type="checkbox"/> Existing (unchanged) <input type="checkbox"/> To be Removed <input type="checkbox"/> New/Additional <input type="checkbox"/> Replacement Unit <input type="checkbox"/> To Be Modified <input type="checkbox"/> To be Replaced
			N/A	bbbl		TBD	
LOAD-2	Produced Water Loading	N/A	N/A	1,032,064	20.72.202.B(5) NMAC	TBD	<input type="checkbox"/> Existing (unchanged) <input type="checkbox"/> To be Removed <input checked="" type="checkbox"/> New/Additional <input type="checkbox"/> Replacement Unit <input type="checkbox"/> To Be Modified <input type="checkbox"/> To be Replaced
			N/A	gal/yr		TBD	
T-9	Methanol Tank	N/A	N/A	1,000	20.72.202.B(5) NMAC	TBD	<input type="checkbox"/> Existing (unchanged) <input type="checkbox"/> To be Removed <input checked="" type="checkbox"/> New/Additional <input type="checkbox"/> Replacement Unit <input type="checkbox"/> To Be Modified <input type="checkbox"/> To be Replaced
			N/A	gallons		2020	
T-10	Methanol Tank	N/A	N/A	1,500	20.72.202.B(5) NMAC	TBD	<input type="checkbox"/> Existing (unchanged) <input type="checkbox"/> To be Removed <input checked="" type="checkbox"/> New/Additional <input type="checkbox"/> Replacement Unit <input type="checkbox"/> To Be Modified <input type="checkbox"/> To be Replaced
			N/A	gallons		2020	
T-11	Diesel Tote	N/A	N/A	520	20.72.202.B(2)(a) NMAC	TBD	<input type="checkbox"/> Existing (unchanged) <input type="checkbox"/> To be Removed <input checked="" type="checkbox"/> New/Additional <input type="checkbox"/> Replacement Unit <input type="checkbox"/> To Be Modified <input type="checkbox"/> To be Replaced
			N/A	gallons		TBD	
T-12	Diesel Tote	N/A	N/A	520	20.72.202.B(2)(a) NMAC	TBD	<input type="checkbox"/> Existing (unchanged) <input type="checkbox"/> To be Removed <input checked="" type="checkbox"/> New/Additional <input type="checkbox"/> Replacement Unit <input type="checkbox"/> To Be Modified <input type="checkbox"/> To be Replaced
			N/A	gallons		TBD	
							<input type="checkbox"/> Existing (unchanged) <input type="checkbox"/> To be Removed <input type="checkbox"/> New/Additional <input type="checkbox"/> Replacement Unit <input type="checkbox"/> To Be Modified <input type="checkbox"/> To be Replaced
							<input type="checkbox"/> Existing (unchanged) <input type="checkbox"/> To be Removed <input type="checkbox"/> New/Additional <input type="checkbox"/> Replacement Unit <input type="checkbox"/> To Be Modified <input type="checkbox"/> To be Replaced
							<input type="checkbox"/> Existing (unchanged) <input type="checkbox"/> To be Removed <input type="checkbox"/> New/Additional <input type="checkbox"/> Replacement Unit <input type="checkbox"/> To Be Modified <input type="checkbox"/> To be Replaced
							<input type="checkbox"/> Existing (unchanged) <input type="checkbox"/> To be Removed <input type="checkbox"/> New/Additional <input type="checkbox"/> Replacement Unit <input type="checkbox"/> To Be Modified <input type="checkbox"/> To be Replaced
							<input type="checkbox"/> Existing (unchanged) <input type="checkbox"/> To be Removed <input type="checkbox"/> New/Additional <input type="checkbox"/> Replacement Unit <input type="checkbox"/> To Be Modified <input type="checkbox"/> To be Replaced

¹ Insignificant activities exempted due to size or production rate are defined in 20.2.70.300.D.6, 20.2.70.7.Q NMAC, and the NMED/AQB List of Insignificant Activities, dated September 15, 2008. Emissions from these insignificant activities do not need to be reported, unless specifically requested.

² Specify date(s) required to determine regulatory applicability.

Table 2-C: Emissions Control Equipment

Unit and stack numbering must correspond throughout the application package. Only list control equipment for TAPs if the TAP's maximum uncontrolled emissions rate is over its respective threshold as listed in 20.2.72 NMAC, Subpart V, Tables A and B. In accordance with 20.2.72.203.A(3) and (8) NMAC, 20.2.70.300.D(5)(b) and (e) NMAC, and 20.2.73.200.B(7) NMAC, the permittee shall report all control devices and list each pollutant controlled by the control device regardless if the applicant takes credit for the reduction in emissions.

Control Equipment Unit No.	Control Equipment Description	Date Installed	Controlled Pollutant(s)	Controlling Emissions for Unit Number(s) ¹	Efficiency (% Control by Weight)	Method used to Estimate Efficiency
BTEX-1	Condenser	2017	VOC, HAP	EP-7, 2-EP-7, 3-EP-7	98%	Engineering Estimate
COMB-1	Combustor	2017	VOC, HAP, H ₂ S	T-1, T-2, T-3, T-4, T-5	95%	Manufacturer Spec
EP-9	Thermal Oxidizer	2017	VOC, HAP, H ₂ S	EP-8, 2-EP-8, 3-EP-8, EP-7, 2-EP-7, 3-EP-7	99.9%	Manufacturer Spec
EP-1	SSM Flare	2017	VOC, HAP, H ₂ S	Train 1 inlet gas and residue gas	98%	Manufacturer Spec
2-EP-1	SSM Flare	TBD	VOC, HAP, H ₂ S	Train 2 inlet gas and residue gas	98%	Manufacturer Spec
3-EP-1	SSM Flare	TBD	VOC, HAP, H ₂ S	Train 3 inlet gas and residue gas	98%	Manufacturer Spec

¹ List each control device on a separate line. For each control device, list all emission units controlled by the control device.

Table 2-D: Maximum Emissions (under normal operating conditions)

This Table was intentionally left blank because it would be identical to Table 2-E.

Maximum Emissions are the emissions at maximum capacity and prior to (in the absence of) pollution control, emission-reducing process equipment, or any other emission reduction. Calculate the hourly emissions using the worst case hourly emissions for each pollutant. For each pollutant, calculate the annual emissions as if the facility were operating at maximum plant capacity without pollution controls for 8760 hours per year, unless otherwise approved by the Department. List Hazardous Air Pollutants (HAP) & Toxic Air Pollutants (TAPs) in Table 2-I. Unit & stack numbering must be consistent throughout the application package. Fill all cells in this table with the emission numbers or a "-" symbol. A "-" symbol indicates that emissions of this pollutant are not expected. Numbers shall be expressed to at least 2 decimal points (e.g. 0.41, 1.41, or 1.41E-4).

Unit No.	NOx		CO		VOC		SOx		PM ¹		PM10 ¹		PM2.5 ¹		H ₂ S		Lead	
	lb/hr	ton/yr	lb/hr	ton/yr	lb/hr	ton/yr	lb/hr	ton/yr	lb/hr	ton/yr	lb/hr	ton/yr	lb/hr	ton/yr	lb/hr	ton/yr	lb/hr	ton/yr
EP-2	2.60	11.38	2.18	9.56	0.14	0.63	0.022	0.10	0.20	0.86	0.20	0.86	0.20	0.86	-	-	-	-
2-EP-2	0.84	3.68	2.18	9.56	0.14	0.63	0.022	0.10	0.20	0.86	0.20	0.86	0.20	0.86	-	-	-	-
3-EP-2	0.84	3.68	2.18	9.56	0.14	0.63	0.022	0.10	0.20	0.86	0.20	0.86	0.20	0.86	-	-	-	-
EP-3A	2.23	9.77	4.53	19.83	0.38	1.66	0.06	0.26	0.52	2.29	0.52	2.29	0.52	2.29	-	-	-	-
EP-3B	0.34	1.49	3.48	15.22	1.61	7.05	0.07	0.31	1.10	4.83	1.10	4.83	1.10	4.83	-	-	-	-
EP-4	0.38	1.67	0.32	1.41	0.021	0.092	0.0032	0.014	0.029	0.127	0.029	0.127	0.029	0.127	-	-	-	-
2-EP-4	0.38	1.67	0.32	1.41	0.021	0.092	0.0032	0.014	0.029	0.127	0.029	0.127	0.029	0.127	-	-	-	-
3-EP-4	0.38	1.67	0.32	1.41	0.021	0.092	0.0032	0.014	0.029	0.127	0.029	0.127	0.029	0.127	-	-	-	-
EP-5	0.93	4.08	0.78	3.43	0.051	0.22	0.008	0.035	0.071	0.31	0.071	0.31	0.071	0.31	-	-	-	-
2-EP-5	0.93	4.08	0.78	3.43	0.051	0.22	0.008	0.035	0.071	0.31	0.071	0.31	0.071	0.31	-	-	-	-
3-EP-5	0.93	4.08	0.78	3.43	0.051	0.22	0.008	0.035	0.071	0.31	0.071	0.31	0.071	0.31	-	-	-	-
EP-6	2.29	10.05	1.93	8.44	0.126	0.55	0.019	0.09	0.17	0.76	0.17	0.76	0.17	0.76	-	-	-	-
2-EP-6	2.29	10.05	1.93	8.44	0.126	0.55	0.019	0.09	0.17	0.76	0.17	0.76	0.17	0.76	-	-	-	-
EP-7	-	-	-	-	102.15	447.40	-	-	-	-	-	-	-	-	2.15E-05	9.42E-05	-	-
2-EP-7	-	-	-	-	102.15	447.40	-	-	-	-	-	-	-	-	2.15E-05	9.42E-05	-	-
3-EP-7	-	-	-	-	102.15	447.40	-	-	-	-	-	-	-	-	2.15E-05	9.42E-05	-	-
EP-8	-	-	-	-	74.67	327.04	-	-	-	-	-	-	-	-	4.72	20.68	-	-
2-EP-8	-	-	-	-	74.67	327.04	-	-	-	-	-	-	-	-	4.72	20.68	-	-
3-EP-8	-	-	-	-	74.67	327.04	-	-	-	-	-	-	-	-	4.72	20.68	-	-
EP-9	No emissions from this unit in an uncontrolled scenario																	
EP-1	0.22	0.96	0.44	1.91	-	-	0.0093	0.041	-	-	-	-	-	-	2.65E-05	1.16E-04	-	-
2-EP-1	0.17	0.72	0.33	1.45	-	-	0.0082	0.036	-	-	-	-	-	-	2.00E-05	8.76E-05	-	-
3-EP-1	0.03	0.14	0.065	0.28	-	-	0.0016	0.0071	-	-	-	-	-	-	1.40E-06	6.11E-06	-	-
T-1	-	-	-	-	32.12	16.87	-	-	-	-	-	-	-	-	0.0038	0.0023	-	-
T-2	-	-	-	-	32.12	16.87	-	-	-	-	-	-	-	-	0.0038	0.0023	-	-
T-3	-	-	-	-	32.12	16.87	-	-	-	-	-	-	-	-	0.0038	0.0023	-	-
T-4	-	-	-	-	32.12	16.87	-	-	-	-	-	-	-	-	0.0038	0.0023	-	-
T-5	-	-	-	-	32.12	16.87	-	-	-	-	-	-	-	-	0.0038	0.0023	-	-
T-6	-	-	-	-	0.14	0.63	-	-	-	-	-	-	-	-	5.19E-03	0.0096	-	-
COMB-1	-	-	-	-	-	-	-	-	-	-	-	-	-	-	-	-	-	-
LOAD	-	-	-	-	257.50	1088.27	-	-	-	-	-	-	-	-	-	-	-	-
FUG	-	-	-	-	26.37	115.48	-	-	-	-	-	-	-	-	0.0007	0.0031	-	-
HAUL	-	-	-	-	-	-	-	-	0.41	1.46	0.11	0.37	0.011	0.037	-	-	-	-
SSM-TO	-	-	-	-	326.15	3.26	-	-	-	-	-	-	-	-	14.17	0.142	-	-
MSSM	-	-	-	-	276.81	4.84	-	-	-	-	-	-	-	-	-	-	-	-
MSSB	-	-	-	-	590.99	11.82	-	-	-	-	-	-	-	-	-	-	-	-
M	-	-	-	-	*	10.00	-	-	-	-	-	-	-	-	-	-	-	-
Totals	15.80	69.19	22.55	98.75	2,022.56	3,000.52	0.29	1.25	3.28	14.02	2.97	12.93	2.88	12.59	18.91	20.85	0.00	0.00

¹Condensable Particulate Matter: Include condensable particulate matter emissions for PM10 and PM2.5 if the source is a combustion source. Do not include condensable particulate matter for PM unless PM is set equal to PM10 and PM2.5. Particulate matter (PM) is not subject to an ambient air quality standard, but PM is a regulated air pollutant under PSD (20.2.74 NMAC) and Title V (20.2.70 NMAC).

Table 2-E: Requested Allowable Emissions

Unit & stack numbering must be consistent throughout the application package. Fill all cells in this table with the emission numbers or a "-" symbol. A "--" symbol indicates that emissions of this pollutant are not expected. Numbers shall be expressed to at least 2 decimal points (e.g. 0.41, 1.41, or 1.41E⁻⁴).

Unit No.	NOx		CO		VOC		SOx		PM ¹		PM10 ¹		PM2.5 ¹		H ₂ S		Lead	
	lb/hr	ton/yr	lb/hr	ton/yr	lb/hr	ton/yr	lb/hr	ton/yr	lb/hr	ton/yr	lb/hr	ton/yr	lb/hr	ton/yr	lb/hr	ton/yr	lb/hr	ton/yr
EP-2	2.60	11.38	2.18	9.56	0.14	0.63	0.022	0.10	0.20	0.86	0.20	0.86	0.20	0.86	-	-	-	-
2-EP-2	0.84	3.68	2.18	9.56	0.14	0.63	0.022	0.10	0.20	0.86	0.20	0.86	0.20	0.86	-	-	-	-
3-EP-2	0.84	3.68	2.18	9.56	0.14	0.63	0.022	0.10	0.20	0.86	0.20	0.86	0.20	0.86	-	-	-	-
EP-3A	2.23	9.77	4.53	19.83	0.38	1.66	0.06	0.26	0.52	2.29	0.52	2.29	0.52	2.29	-	-	-	-
EP-3B	0.34	1.49	3.48	15.22	1.61	7.05	0.07	0.31	1.10	4.83	1.10	4.83	1.10	4.83	-	-	-	-
EP-4	0.38	1.67	0.32	1.41	0.021	0.092	0.0032	0.014	0.029	0.127	0.029	0.127	0.029	0.127	-	-	-	-
2-EP-4	0.38	1.67	0.32	1.41	0.021	0.092	0.0032	0.014	0.029	0.127	0.029	0.127	0.029	0.127	-	-	-	-
3-EP-4	0.38	1.67	0.32	1.41	0.021	0.092	0.0032	0.014	0.029	0.127	0.029	0.127	0.029	0.127	-	-	-	-
EP-5	0.93	4.08	0.78	3.43	0.051	0.22	0.008	0.035	0.071	0.31	0.071	0.31	0.071	0.31	-	-	-	-
2-EP-5	0.93	4.08	0.78	3.43	0.051	0.22	0.008	0.035	0.071	0.31	0.071	0.31	0.071	0.31	-	-	-	-
3-EP-5	0.93	4.08	0.78	3.43	0.051	0.22	0.008	0.035	0.071	0.31	0.071	0.31	0.071	0.31	-	-	-	-
EP-6	2.29	10.05	1.93	8.44	0.126	0.55	0.019	0.09	0.17	0.76	0.17	0.76	0.17	0.76	-	-	-	-
2-EP-6	2.29	10.05	1.93	8.44	0.126	0.55	0.019	0.09	0.17	0.76	0.17	0.76	0.17	0.76	-	-	-	-
EP-7	Emissions represented at the thermal oxidizer (Unit EP-9)																	
2-EP-7	Emissions represented at the thermal oxidizer (Unit EP-9)																	
3-EP-7	Emissions represented at the thermal oxidizer (Unit EP-9)																	
EP-8	Emissions represented at the thermal oxidizer (Unit EP-9)																	
2-EP-8	Emissions represented at the thermal oxidizer (Unit EP-9)																	
3-EP-8	Emissions represented at the thermal oxidizer (Unit EP-9)																	
EP-9	6.12	26.81	2.98	13.05	0.53	2.32	26.66	116.79	0.60	2.63	0.60	2.63	0.60	2.63	0.014	0.062	-	-
T-1	Emissions represented at the combustor (Unit COMB-1)																	
T-2	Emissions represented at the combustor (Unit COMB-1)																	
T-3	Emissions represented at the combustor (Unit COMB-1)																	
T-4	Emissions represented at the combustor (Unit COMB-1)																	
T-5	Emissions represented at the combustor (Unit COMB-1)																	
T-6	-	-	-	-	0.14	0.63	-	-	-	-	-	-	-	-	0.0052	0.0096	-	-
COMB-1	7.83	3.08	15.63	6.16	37.61	4.26	0.16	0.0038	0.42	0.17	0.42	0.17	0.42	0.17	0.0035	0.0006	-	-
LOAD	-	-	-	-	12.88	54.41	-	-	-	-	-	-	-	-	-	-	-	-
FUG	-	-	-	-	26.37	115.48	-	-	-	-	-	-	-	-	0.0007	0.0031	-	-
HAUL	-	-	-	-	-	-	-	-	0.41	1.46	0.11	0.37	0.011	0.037	-	-	-	-
M	-	-	-	-	*	10.00	-	-	-	-	-	-	-	-	-	-	-	-
Totals	29.33	97.26	40.33	114.32	80.41	199.75	27.09	117.96	4.30	16.81	3.99	15.72	3.90	15.39	0.024	0.075	-	-

¹ **Condensable Particulate Matter:** Include condensable particulate matter emissions for PM10 and PM2.5 if the source is a combustion source. Do not include condensable particulate matter for PM unless PM is set equal to PM10 and PM2.5. Particulate matter (PM) is not subject to an ambient air quality standard, but it is a regulated air pollutant under PSD (20.2.74 NMAC) and Title V (20.2.70 NMAC).

"*" denotes that an hourly emission rate is not requested.

Table 2-F: Additional Emissions during Startup, Shutdown, and Routine Maintenance (SSM)

This table is intentionally left blank since all emissions at this facility due to routine or predictable startup, shutdown, or scheduled maintenance are no higher than those listed in Table 2-E and a malfunction emission limit is not already permitted or requested. If you are required to report GHG emissions as described in Section 6a, include any GHG emissions during Startup, Shutdown, and/or Scheduled Maintenance (SSM) in Table 2-P. Provide an explanation of SSM emissions in Section 6 and 6a.

All applications for facilities that have emissions during routine or predictable startup, shutdown or scheduled maintenance (SSM)¹, including NOI applications, must include in this table the Maximum Emissions during routine or predictable startup, shutdown and scheduled maintenance (20.2.7 NMAC, 20.2.72.203.A.3 NMAC, 20.2.73.200.D.2 NMAC). In Section 6 and 6a, provide emissions calculations for all SSM emissions reported in this table. Refer to "Guidance for Submittal of Startup, Shutdown, Maintenance Emissions in Permit Applications (https://www.env.nm.gov/aqb/permit/aqb_pol.html) for more detailed instructions. Numbers shall be expressed to at least 2 decimal points (e.g. 0.41, 1.41, or 1.41E-4).

Unit No.	NOx		CO		VOC		SOx		PM ²		PM10 ²		PM2.5 ²		H ₂ S		Lead	
	lb/hr	ton/yr	lb/hr	ton/yr	lb/hr	ton/yr	lb/hr	ton/yr	lb/hr	ton/yr	lb/hr	ton/yr	lb/hr	ton/yr	lb/hr	ton/yr	lb/hr	ton/yr
EP-1	1,578.35	19.90	3,150.97	39.72	2,484.70	29.82	828.55	9.98	-	-	-	-	-	-	8.98	0.11	-	-
2-EP-1	1,578.29	19.66	3,150.87	39.26	2,484.70	29.82	828.55	9.98	-	-	-	-	-	-	8.98	0.11	-	-
3-EP-1	1,578.16	19.08	3,150.60	38.09	2,484.70	29.82	828.54	9.95	-	-	-	-	-	-	8.98	0.11	-	-
SSM-TO	-	-	-	-	326.15	3.26	-	-	-	-	-	-	-	-	14.17	0.142	-	-
MSSM	-	-	-	-	276.81	4.84	-	-	-	-	-	-	-	-	0.011	0.00016	-	-
MSSB	Emissions represented at the combustor (Unit COMB-1)																	
Totals	4,734.80	58.64	9,452.44	117.07	8,057.07	97.55	2,485.63	29.91	0.00	0.00	0.00	0.00	0.00	0.00	41.13	0.47	0.00	0.00

¹ For instance, if the short term steady-state Table 2-E emissions are 5 lb/hr and the SSM rate is 12 lb/hr, enter 7 lb/hr in this table. If the annual steady-state Table 2-E emissions are 21.9 TPY, and the number of scheduled SSM events result in annual emissions of 31.9 TPY, enter 10.0 TPY in the table below.

² **Condensable Particulate Matter:** Include condensable particulate matter emissions for PM10 and PM2.5 if the source is a combustion source. Do not include condensable particulate matter for PM unless PM is set equal to PM10 and PM2.5. Particulate matter (PM) is not subject to an ambient air quality standard, but it is a regulated air pollutant under PSD (20.2.74 NMAC) and Title V (20.2.70 NMAC).

Table 2-G: Stack Exit and Fugitive Emission Rates for Special Stacks

I have elected to leave this table blank because this facility does not have any stacks/vents that split emissions from a single source or combine emissions from more than one source listed in table 2-A. Additionally, the emission rates of all stacks match the Requested allowable emission rates stated in Table 2-E.

Use this table to list stack emissions (requested allowable) from split and combined stacks. List Toxic Air Pollutants (TAPs) and Hazardous Air Pollutants (HAPs) in Table 2-I. List all fugitives that are associated with the normal, routine, and non-emergency operation of the facility. Unit and stack numbering must correspond throughout the application package. Refer to Table 2-E for instructions on use of the “-“ symbol and on significant figures.

Stack No.	Serving Unit Number(s) from Table 2-A	NOx		CO		VOC		SOx		PM		PM10		PM2.5		<input checked="" type="checkbox"/> H ₂ S or <input type="checkbox"/> Lead	
		lb/hr	ton/yr	lb/hr	ton/yr	lb/hr	ton/yr	lb/hr	ton/yr	lb/hr	ton/yr	lb/hr	ton/yr	lb/hr	ton/yr	lb/hr	ton/yr
Totals:																	

Table 2-H: Stack Exit Conditions

Unit and stack numbering must correspond throughout the application package. Include the stack exit conditions for each unit that emits from a stack, including blowdown venting parameters and tank emissions. If the facility has multiple operating scenarios, complete a separate Table 2-H for each scenario and, for each, type scenario name here:

Stack Number	Serving Unit Number(s) from Table 2-A	Orientation (H=Horizontal V=Vertical)	Rain Caps (Yes or No)	Height Above Ground (ft)	Temp. (F)	Flow Rate		Moisture by Volume (%)	Velocity (ft/sec)	Inside Diameter (ft)
						(acfs)	(dscfs)			
EP-1	EP-1	V	No	100.00	1832	51.52	-	-	65.60	1.00
2-EP-1	2-EP-1	V	No	199.00	1832	51.52	-	-	65.60	1.00
3-EP-1	3-EP-1	V	No	150.00	1832	51.52	-	-	65.60	1.00
EP-2	EP-2	V	No	22.50	624	589.87	-	-	51.12	3.83
2-EP-2	2-EP-2	V	No	25.80	624	217.97	-	-	51.12	2.33
3-EP-2	3-EP-2	V	No	25.80	624	217.97	-	-	51.12	2.33
EP-3A	EP-3A	V	No	24.80	624	1694.47	-	-	176.12	3.50
EP-3B	EP-3B	V	No	32.70	624	2213.19	-	-	176.12	4.00
EP-4	EP-4	V	No	25.00	624	243.70	-	-	77.57	2.00
2-EP-4	2-EP-4	V	No	31.80	624	243.70	-	-	77.57	2.00
3-EP-4	3-EP-4	V	No	31.80	624	243.70	-	-	77.57	2.00
EP-5	EP-5	V	No	15.80	624	27.54	-	-	5.61	2.50
2-EP-5	2-EP-5	V	No	22.00	550	59.33	-	-	42.71	1.33
3-EP-5	3-EP-5	V	No	22.00	550	59.33	-	-	42.71	1.33
EP-6	EP-6	V	No	24.90	624	503.62	-	-	118.11	2.33
2-EP-6	2-EP-6	V	No	24.90	624	503.62	-	-	118.11	2.33
EP-9	EP-7, 2-EP-7, 3-EP-7, EP-8, 2-EP-8, 3-EP-8	V	No	76.00	1600	951.12	-	-	12.11	10.0
COMB-1	T-1 through T-5	V	No	50.00	1500	708.50	-	-	18.41	7.00

Table 2-I: Stack Exit and Fugitive Emission Rates for HAPs and TAPs

In the table below, report the Potential to Emit for each HAP from each regulated emission unit listed in Table 2-A, only if the entire facility emits the HAP at a rate greater than or equal to one (1) ton per year. For each such emission unit, HAPs shall be reported to the nearest 0.1 tpy. Each facility-wide Individual HAP total and the facility-wide Total HAPs shall be the sum of all HAP sources calculated to the nearest 0.1 ton per year. Per 20.2.72.403.A.1 NMAC, facilities not exempt [see 20.2.72.402.C NMAC] from TAP permitting shall report each TAP that has an uncontrolled emission rate in excess of its pounds per hour screening level specified in 20.2.72.502 NMAC. TAPs shall be reported using one more significant figure than the number of significant figures shown in the pound per hour threshold corresponding to the substance. Use the HAP nomenclature as it appears in Section 112 (b) of the 1990 CAAA and the TAP nomenclature as it listed in 20.2.72.502 NMAC. Include tank-flashing emissions estimates of HAPs in this table. For each HAP or TAP listed, fill all cells in this table with the emission numbers or a "-" symbol. A "-" symbol indicates that emissions of this pollutant are not expected or the pollutant is emitted in a quantity less than the threshold amounts described above.

Stack No.	Unit No.(s)	Total HAPs		Benzene <input checked="" type="checkbox"/> HAP or <input type="checkbox"/> TAP		Hexane <input checked="" type="checkbox"/> HAP or <input type="checkbox"/> TAP		Provide Pollutant Name Here <input type="checkbox"/> HAP or <input type="checkbox"/> TAP		Provide Pollutant Name Here <input type="checkbox"/> HAP or <input type="checkbox"/> TAP		Provide Pollutant Name Here <input type="checkbox"/> HAP or <input type="checkbox"/> TAP		Provide Pollutant Name Here <input type="checkbox"/> HAP or <input type="checkbox"/> TAP		Provide Pollutant Name Here <input type="checkbox"/> HAP or <input type="checkbox"/> TAP	
		lb/hr	ton/yr	lb/hr	ton/yr	lb/hr	ton/yr	lb/hr	ton/yr	lb/hr	ton/yr	lb/hr	ton/yr	lb/hr	ton/yr	lb/hr	ton/yr
		EP-2	EP-2	0.0021	0.0092	5.46E-05	2.39E-04	-	-								
2-EP-2	2-EP-2	0.0021	0.0092	5.46E-05	2.39E-04	-	-										
3-EP-2	3-EP-2	0.0021	0.0092	5.46E-05	2.39E-04	-	-										
EP-3A	EP-3A	0.0055	0.024	1.45E-04	6.34E-04	-	-										
EP-3B	EP-3B	0.0067	0.029	0.00E+00	0.00E+00	-	-										
EP-4	EP-4	0.00031	0.0013	8.03E-06	3.52E-05	-	-										
2-EP-4	2-EP-4	0.00031	0.0013	8.03E-06	3.52E-05	-	-										
3-EP-4	3-EP-4	0.00031	0.0013	8.03E-06	3.52E-05	-	-										
EP-5	EP-5	0.00075	0.0033	1.96E-05	8.57E-05	-	-										
2-EP-5	2-EP-5	0.00075	0.0033	1.96E-05	8.57E-05	-	-										
3-EP-5	3-EP-5	0.00075	0.0033	1.96E-05	8.57E-05	-	-										
EP-6	EP-6	0.0018	0.0081	4.82E-05	2.11E-04	-	-										
2-EP-6	2-EP-6	0.0018	0.0081	4.82E-05	2.11E-04	-	-										
EP-7	EP-9	-	-	-	-	-	-										
2-EP-7	EP-9	-	-	-	-	-	-										
3-EP-7	EP-9	-	-	-	-	-	-										
EP-8	EP-9	-	-	-	-	-	-										
2-EP-9	EP-9	-	-	-	-	-	-										
3-EP-8	EP-9	-	-	-	-	-	-										
EP-9	EP-9	0.28	1.24	0.133	0.584	-	-										
EP-1	EP-1	58.10	0.70	-	-	47.72	0.57										
2-EP-1	2-EP-2	58.10	0.70	-	-	47.72	0.57										
3-EP-1	3-EP-1	58.10	0.70	-	-	47.72	0.57										
T-1	COMB-1	-	-	-	-	-	-										
T-2	COMB-1	-	-	-	-	-	-										
T-3	COMB-1	-	-	-	-	-	-										
T-4	COMB-1	-	-	-	-	-	-										
T-5	COMB-1	-	-	-	-	-	-										
T-6	T-6	0.0050	0.022	0.0036	0.016	3.06E-04	1.34E-03										
COMB-1	COMB-1	3.43	4.74	3.43	4.74	0.67	0.066										
LOAD	COMB-1	1.16	4.58	-	-	0.053	0.21										
FUG	N/A	1.83	8.03	-	-	1.12	4.92										
HAUL	N/A	-	-	-	-	-	-										
SSM-TO	N/A	216.77	2.17	104.82	1.05	11.07	0.11										
MSSM	N/A	15.05	0.22	-	-	-	-										
MSSB	COMB-1	-	-	-	-	-	-										
M	N/A	*	1.00	-	-	-	-										
Totals:		412.8	24.21	108.38	6.39	156.07	7.02	-	-	-	-	-	-	-	-	-	-

Table 2-J: Fuel

Specify fuel characteristics and usage. Unit and stack numbering must correspond throughout the application package.

Unit No.	Fuel Type (low sulfur Diesel, ultra low sulfur diesel, Natural Gas, Coal, ...)	Fuel Source: purchased commercial, pipeline quality natural gas, residue gas, raw/field natural gas, process gas (e.g. SRU tail gas) or other	Specify Units				
			Lower Heating Value BTU/scf	Hourly Usage scf/hr	Annual Usage MMscf/yr	Sulfur gr/dscf	% Ash
EP-1	Natural Gas	Residue Gas	1071.8	500.00	4.38	2.00	NA
2-EP-1	Natural Gas	Residue Gas	1071.8	78.00	0.68	2.00	NA
3-EP-1	Natural Gas	Residue Gas	1071.8	219.00	1.92	2.00	NA
EP-2	Natural Gas	Residue Gas	1020	25980.39	227.59	2.00	NA
2-EP-2	Natural Gas	Residue Gas	1020	25980.39	227.59	2.00	NA
3-EP-2	Natural Gas	Residue Gas	1020	25980.39	227.59	2.00	NA
EP-3A	Natural Gas	Residue Gas	1020	68901.96	603.58	2.00	NA
EP-3B	Natural Gas	Residue Gas	1020	83107.84	728.02	2.00	NA
EP-4	Natural Gas	Residue Gas	1020	3823.53	33.49	2.00	NA
2-EP-4	Natural Gas	Residue Gas	1020	3823.53	33.49	2.00	NA
3-EP-4	Natural Gas	Residue Gas	1020	3823.53	33.49	2.00	NA
EP-5	Natural Gas	Residue Gas	1020	9313.73	81.59	2.00	NA
2-EP-5	Natural Gas	Residue Gas	1020	9313.73	81.59	2.00	NA
3-EP-5	Natural Gas	Residue Gas	1020	9313.73	81.59	2.00	NA
EP-6	Natural Gas	Residue Gas	1020	22941.18	200.96	2.00	NA
2-EP-6	Natural Gas	Residue Gas	1020	22941.18	200.96	2.00	NA
EP-9	Natural Gas	Residue Gas	1020	29411.76	257.65	2.00	NA
COMB-1	Natural Gas	Residue Gas	1020	65.00	0.57	2.00	NA

Table 2-K: Liquid Data for Tanks Listed in Table 2-L

For each tank, list the liquid(s) to be stored in each tank. If it is expected that a tank may store a variety of hydrocarbon liquids, enter "mixed hydrocarbons" in the Composition column for that tank and enter the corresponding data of the most volatile liquid to be stored in the tank. If tank is to be used for storage of different materials, list all the materials in the "All Calculations" attachment, run the newest version of TANKS on each, and use the material with the highest emission rate to determine maximum uncontrolled and requested allowable emissions rate. The permit will specify the most volatile category of liquids that may be stored in each tank. Include appropriate tank-flashing modeling input data. Use additional sheets if necessary. Unit and stack numbering must correspond throughout the application package.

Tank No.	SCC Code	Material Name	Composition	Liquid Density (lb/gal)	Vapor Molecular Weight (lb/lb*mol)	Average Storage Conditions		Max Storage Conditions	
						Temperature (°F)	True Vapor Pressure (psia)	Temperature (°F)	True Vapor Pressure (psia)
T-1	40400311	Condensate	Condensate	3.66	52.44	63.2	6.82	95	4.69
T-2	40400311	Condensate	Condensate	3.66	52.44	63.2	6.82	95	4.69
T-3	40400311	Condensate	Condensate	3.66	52.44	63.2	6.82	95	4.69
T-4	40400311	Condensate	Condensate	3.66	52.44	63.2	6.82	95	4.69
T-5	40400311	Condensate	Condensate	3.66	52.44	63.2	6.82	95	4.69
T-6	40400315	Produced Water	Produced Water	8.29	27.30	63.4	0.82	95	0.42

Table 2-L: Tank Data

Include appropriate tank-flashing modeling input data. Use an addendum to this table for unlisted data categories. Unit and stack numbering must correspond throughout the application package. Use additional sheets if necessary. See reference Table 2-L2. Note: 1.00 bbl = 10.159 M3 = 42.0 gal

Tank No.	Date Installed	Materials Stored	Seal Type <small>(refer to Table 2-LR below)</small>	Roof Type <small>(refer to Table 2-LR below)</small>	Capacity		Diameter (M)	Vapor Space (M)	Color <small>(from Table VI-C)</small>		Paint Condition <small>(from Table VI-C)</small>	Annual Throughput <small>(gal/yr)</small>	Turn-overs <small>(per year)</small>
					(bbl)	(M ³)			Roof	Shell			
T-1	2017	Condensate	NA	FX	1,000	119.2	6.55	8.0	White	White	Good	24,528,000	584
T-2	2017	Condensate	NA	FX	1,000	119.2	6.55	8.0	White	White	Good	24,528,000	584
T-3	2017	Condensate	NA	FX	1,000	119.2	6.55	8.0	White	White	Good	24,528,000	584
T-4	2017	Condensate	NA	FX	1,000	119.2	6.55	8.0	White	White	Good	24,528,000	584
T-5	2017	Condensate	NA	FX	1,000	119.2	6.55	8.0	White	White	Good	24,528,000	584
T-6	2017	Produced Water	NA	FX	400	47.7	3.7	10.00	White	White	Good	1,030,097	61

Table 2-L2: Liquid Storage Tank Data Codes Reference Table

Roof Type	Seal Type, Welded Tank Seal Type		Seal Type, Riveted Tank Seal Type		Roof, Shell Color	Paint Condition
FX: Fixed Roof	Mechanical Shoe Seal	Liquid-mounted resilient seal	Vapor-mounted resilient seal	Seal Type	WH: White	Good
IF: Internal Floating Roof	A: Primary only	A: Primary only	A: Primary only	A: Mechanical shoe, primary only	AS: Aluminum (specular)	Poor
EF: External Floating Roof	B: Shoe-mounted secondary	B: Weather shield	B: Weather shield	B: Shoe-mounted secondary	AD: Aluminum (diffuse)	
P: Pressure	C: Rim-mounted secondary	C: Rim-mounted secondary	C: Rim-mounted secondary	C: Rim-mounted secondary	LG: Light Gray	
					MG: Medium Gray	
					BL: Black	
					OT: Other (specify)	

Note: 1.00 bbl = 0.159 M³ = 42.0 gal

Table 2-M: Materials Processed and Produced (Use additional sheets as necessary.)

Material Processed				Material Produced			
Description	Chemical Composition	Phase (Gas, Liquid, or Solid)	Quantity (specify units)	Description	Chemical Composition	Phase	Quantity (specify units)
Natural Gas	Natural Gas	Gas	735 MMscfd	Natural Gas	Natural Gas	Gas	735 MMscfd
				Condensate	Condensate	Liquid	8000 bopd
				Produced Water	Produced Water	Liquid	303 bwpd

Table 2-N: CEM Equipment

Enter Continuous Emissions Measurement (CEM) Data in this table. If CEM data will be used as part of a federally enforceable permit condition, or used to satisfy the requirements of a state or federal regulation, include a copy of the CEM's manufacturer specification sheet in the Information Used to Determine Emissions attachment. Unit and stack numbering must correspond throughout the application package. Use additional sheets if necessary.

Stack No.	Pollutant(s)	Manufacturer	Model No.	Serial No.	Sample Frequency	Averaging Time	Range	Sensitivity	Accuracy
Not Applicable									

Table 2-O: Parametric Emissions Measurement Equipment

Unit and stack numbering must correspond throughout the application package. Use additional sheets if necessary.

Unit No.	Parameter/Pollutant Measured	Location of Measurement	Unit of Measure	Acceptable Range	Frequency of Maintenance	Nature of Maintenance	Method of Recording	Averaging Time
Not Applicable								

Section 3

Application Summary

The **Application Summary** shall include a brief description of the facility and its process, the type of permit application, the applicable regulation (i.e. 20.2.72.200.A.X, or 20.2.73 NMAC) under which the application is being submitted, and any air quality permit numbers associated with this site. If this facility is to be collocated with another facility, provide details of the other facility including permit number(s). In case of a revision or modification to a facility, provide the lowest level regulatory citation (i.e. 20.2.72.219.B.1.d NMAC) under which the revision or modification is being requested. Also describe the proposed changes from the original permit, how the proposed modification will affect the facility's operations and emissions, de-bottlenecking impacts, and changes to the facility's major/minor status (both PSD & Title V).

The **Process Summary** shall include a brief description of the facility and its processes.

Startup, Shutdown, and Maintenance (SSM) routine or predictable emissions: Provide an overview of how SSM emissions are accounted for in this application. Refer to "Guidance for Submittal of Startup, Shutdown, Maintenance Emissions in Permit Applications (http://www.env.nm.gov/aqb/permit/app_form.html) for more detailed instructions on SSM emissions.

Targa Resources, LLC (Targa) owns and operates the Road Runner Gas Processing Plant located near Loving in Eddy County, NM. The site was acquired by Targa on August 1, 2022 from Lucid Energy. The most recent New Source Review (NSR) permit No. 7200-M3 was issued on February 19, 2021. Targa is proposing a significant revision to NSR Permit No. 7200-M3 to authorize design changes for proposed processing trains 2 and 3 and to update representations and permit limits for existing processes at the site, including processing train 1.

The primary function of the Road Runner Gas Processing Plant is to separate natural gas (methane) from heavier (liquid) hydrocarbons, raw sweet field gas so that the gas can meet pipeline specifications. The plant has been designated a primary Standard Industrial Classification (SIC) Code of 1311. The gas is treated to remove CO₂, H₂S, water and heavy (liquid) hydrocarbons from the gas stream. Stabilized condensate is removed from the site via pipeline with the option to truck it out as needed. Produced water is trucked out from the site. The amine treater vent flows to a thermal oxidizer to remove volatile organic compound (VOC) and hazardous air pollutant (HAP) emissions.

Following is a summary of changes being proposed in this application:

- Remove processing train 4 and associated equipment from the permit. Train 4 has not been constructed.
- Increase site processing throughput.
- Update specifications and permit limits for proposed processing trains 2 and 3.
- Increase permit limits to allow the ability to process gas containing up to 5 ppm H₂S.
- Update the permit representation for heaters to be equal to maximum heat output as opposed to design heat duty output.
- Add 10 tpy VOC and 1 tpy HAPs for upsets.
- Reduce the amount of routine SSM emissions represented in the permit.
- Add exempt methanol tanks.
- Increase plant fugitives to use updated counts.
- Update tank emission calculations to account for maximum hourly emissions.
- Update the number of electric compressors initially installed on existing train 1 and renumber the compressors in Form UA-2 Table 2-A for all electric compressors.
- Update representations to separately list the amine sweetening unit for each train.

This project will not trigger Prevention of Significant Deterioration (PSD) review, as the facility is currently a minor NSR source and the proposed emission changes are less than 250 tons per year (tpy) for each criteria pollutant and will remain an area source of HAPs.

Section 4

Process Flow Sheet

A **process flow sheet** and/or block diagram indicating the individual equipment, all emission points and types of control applied to those points. The unit numbering system should be consistent throughout this application.

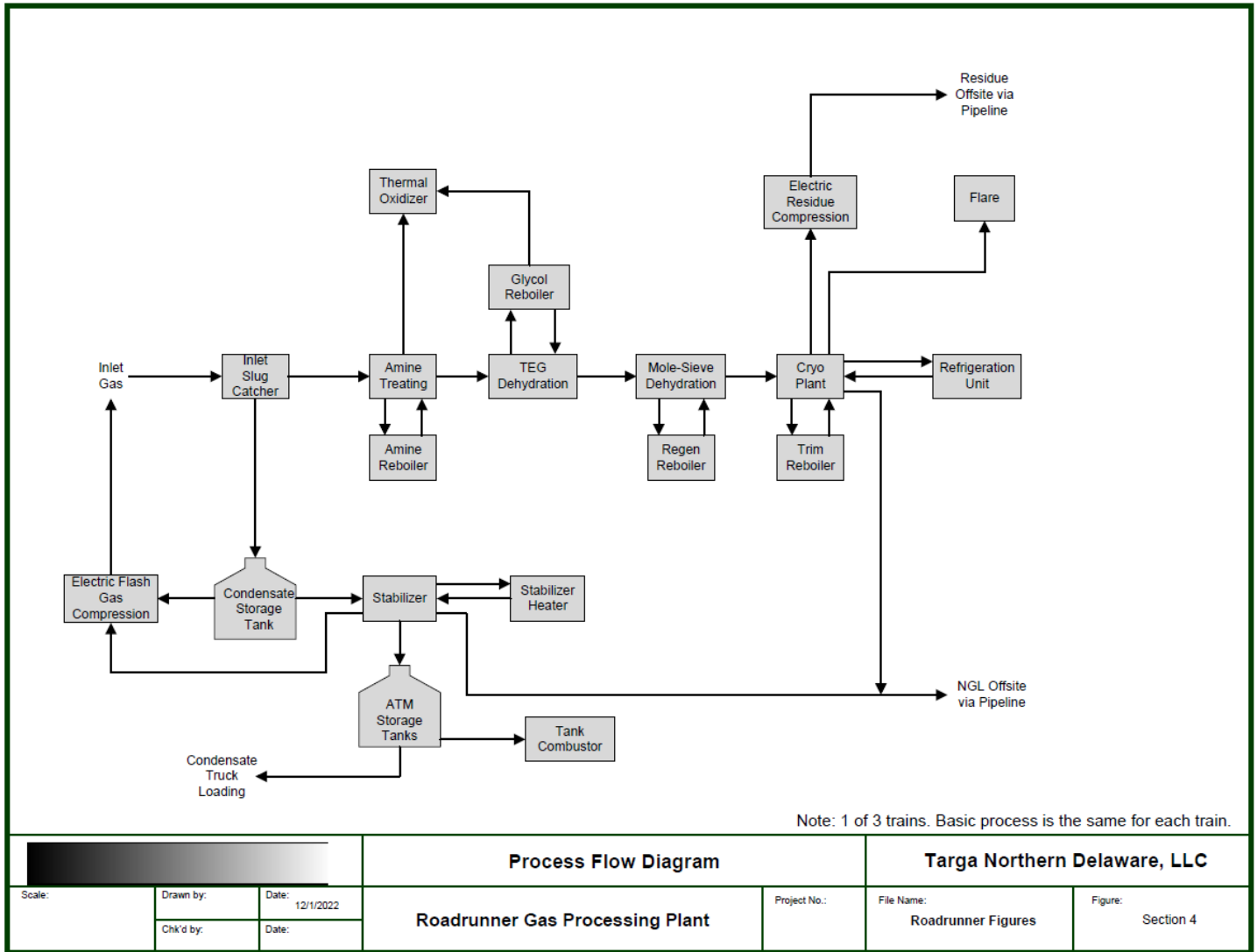

Section 5

Plot Plan Drawn To Scale

A **plot plan drawn to scale** showing emissions points, roads, structures, tanks, and fences of property owned, leased, or under direct control of the applicant. This plot plan must clearly designate the restricted area as defined in UA1, Section 1-D.12. The unit numbering system should be consistent throughout this application.

A plot plan is attached.

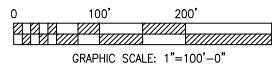
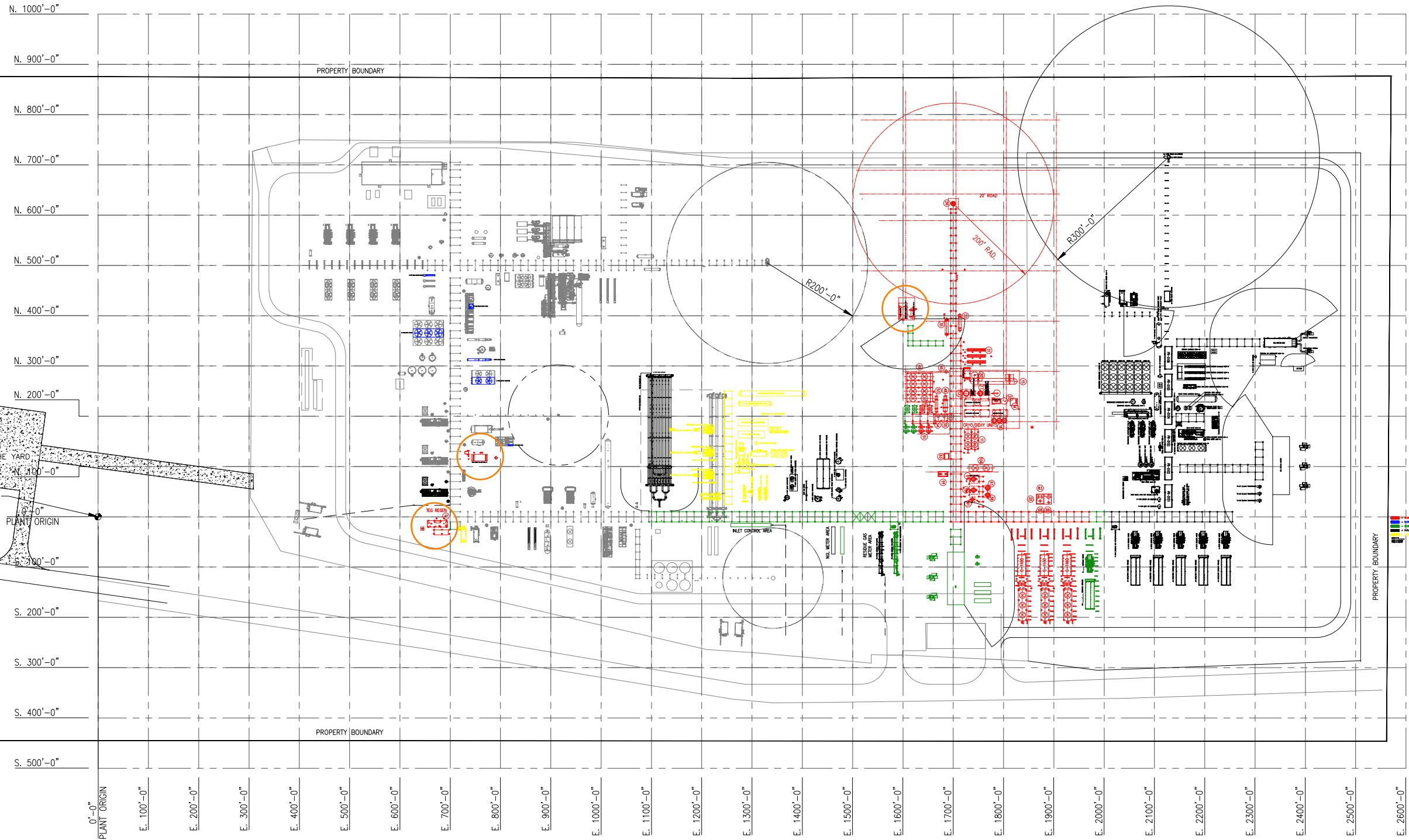

REV	CKD	APP	DATE	DESCRIPTION
P2	MLD	TP	11/09/22	ISSUED FOR INFORMATION ONLY
P1	MLD	TP	11/07/22	ISSUED FOR INFORMATION ONLY

THIS INFORMATION IS PROPRIETARY AND CONFIDENTIAL INFORMATION OF SELECT ENGINEERING AND IS INTENDED ONLY FOR THE USE OF THE CUSTOMER DESIGNATED. ANY DISSEMINATION, DISTRIBUTION, OR COPYING OF THIS INFORMATION IS UNAUTHORIZED AND STRICTLY PROHIBITED.



OVERALL SITE PLAN		Rev P2
ROADRUNNER GAS PLANT		
TARGA No.:	P4956-000-1001	
DWG No.:	P4956-000-1001	

Section 6

All Calculations

Show all calculations used to determine both the hourly and annual controlled and uncontrolled emission rates. All calculations shall be performed keeping a minimum of three significant figures. Document the source of each emission factor used (if an emission rate is carried forward and not revised, then a statement to that effect is required). If identical units are being permitted and will be subject to the same operating conditions, submit calculations for only one unit and a note specifying what other units to which the calculations apply. All formulas and calculations used to calculate emissions must be submitted. The "Calculations" tab in the UA2 has been provided to allow calculations to be linked to the emissions tables. Add additional "Calc" tabs as needed. If the UA2 or other spread sheets are used, all calculation spread sheet(s) shall be submitted electronically in Microsoft Excel compatible format so that formulas and input values can be checked. Format all spread sheets and calculations such that the reviewer can follow the logic and verify the input values. Define all variables. If calculation spread sheets are not used, provide the original formulas with defined variables. Additionally, provide subsequent formulas showing the input values for each variable in the formula. All calculations, including those calculations are imbedded in the Calc tab of the UA2 portion of the application, the printed Calc tab(s), should be submitted under this section.

Tank Flashing Calculations: The information provided to the AQB shall include a discussion of the method used to estimate tank-flashing emissions, relative thresholds (i.e., NOI, permit, or major source (NSPS, PSD or Title V)), accuracy of the model, the input and output from simulation models and software, all calculations, documentation of any assumptions used, descriptions of sampling methods and conditions, copies of any lab sample analysis. If Hysis is used, all relevant input parameters shall be reported, including separator pressure, gas throughput, and all other relevant parameters necessary for flashing calculation.

SSM Calculations: It is the applicant's responsibility to provide an estimate of SSM emissions or to provide justification for not doing so. In this Section, provide emissions calculations for Startup, Shutdown, and Routine Maintenance (SSM) emissions listed in the Section 2 SSM and/or Section 22 GHG Tables and the rationale for why the others are reported as zero (or left blank in the SSM/GHG Tables). Refer to "Guidance for Submittal of Startup, Shutdown, Maintenance Emissions in Permit Applications (http://www.env.nm.gov/aqb/permit/app_form.html) for more detailed instructions on calculating SSM emissions. If SSM emissions are greater than those reported in the Section 2, Requested Allowables Table, modeling may be required to ensure compliance with the standards whether the application is NSR or Title V. Refer to the Modeling Section of this application for more guidance on modeling requirements.

Glycol Dehydrator Calculations: The information provided to the AQB shall include the manufacturer's maximum design recirculation rate for the glycol pump. If GRI-Glycalc is used, the full input summary report shall be included as well as a copy of the gas analysis that was used.

Road Calculations: Calculate fugitive particulate emissions and enter haul road fugitives in Tables 2-A, 2-D and 2-E for:

1. If you transport raw material, process material and/or product into or out of or within the facility and have PER emissions greater than 0.5 tpy.
2. If you transport raw material, process material and/or product into or out of the facility more frequently than one round trip per day.

Significant Figures:

A. All emissions standards are deemed to have at least two significant figures, but not more than three significant figures.

B. At least 5 significant figures shall be retained in all intermediate calculations.

C. In calculating emissions to determine compliance with an emission standard, the following rounding off procedures shall be used:

- (1) If the first digit to be discarded is less than the number 5, the last digit retained shall not be changed;
- (2) If the first digit discarded is greater than the number 5, or if it is the number 5 followed by at least one digit other than the number zero, the last figure retained shall be increased by one unit; **and**
- (3) If the first digit discarded is exactly the number 5, followed only by zeros, the last digit retained shall be rounded upward if it is an odd number, but no adjustment shall be made if it is an even number.
- (4) The final result of the calculation shall be expressed in the units of the standard.

Control Devices: In accordance with 20.2.72.203.A(3) and (8) NMAC, 20.2.70.300.D(5)(b) and (e) NMAC, and 20.2.73.200.B(7) NMAC, the permittee shall report all control devices and list each pollutant controlled by the control device regardless if the applicant takes credit for the reduction in emissions. The applicant can indicate in this section of the

application if they chose to not take credit for the reduction in emission rates. For notices of intent submitted under 20.2.73 NMAC, only uncontrolled emission rates can be considered to determine applicability unless the state or federal Acts require the control. This information is necessary to determine if federally enforceable conditions are necessary for the control device, and/or if the control device produces its own regulated pollutants or increases emission rates of other pollutants.

Heaters and Reboilers

The facility will be equipped with several heaters and reboilers of various heat input capacities. For units EP-2, EP-4, 2-EP-4, 3-EP-4, EP-5, 2-EP-5, 3-EP-5, EP-6, and 2-EP-6, AP-42 Chapter 1.4 *Natural Gas Combustion* was used to determine emissions of nitrogen oxides (NO_x), carbon monoxide (CO), volatile organic compounds (VOC), particulate matter (PM), and hazardous air pollutants (HAPs). Sulfur dioxide emissions were calculated stoichiometrically assuming that the natural gas used as fuel in the heaters and reboilers contains a maximum H₂S content of 5 ppm based on pipeline specifications.

For unit EP-3B, manufacturer specifications were used to determine emissions of nitrogen oxides (NO_x), carbon monoxide (CO), volatile organic compounds (VOC), and particulate matter (PM). AP-42 Chapter 1.4 *Natural Gas Combustion* was used to determine emissions of and hazardous air pollutants (HAPs). Sulfur dioxide emissions were calculated stoichiometrically assuming that the natural gas used as fuel in the heaters and reboilers contains a maximum H₂S content of 5 ppm based on pipeline specifications.

For units 2-EP-2 and 3-EP-2, AP-42 Chapter 1.4 *Natural Gas Combustion* was used to determine emissions of carbon monoxide (CO), volatile organic compounds (VOC), particulate matter (PM), and hazardous air pollutants (HAPs). Sulfur dioxide emissions were calculated stoichiometrically assuming that the natural gas used as fuel in the heaters and reboilers contains a maximum H₂S content of 5 ppm based on pipeline specifications. Emissions of nitrogen oxides (NO_x) are based on the emission factor presented in 20.2.50.119.B(1) NMAC to comply with 20.2.50.119.B(3) NMAC as these units will be considered new units and must comply upon startup.

Greenhouse gas emissions from all heaters and reboilers were calculated using 40 CFR 98 Subpart C Table C-1 and Table C-2.

TEG Glycol Dehydrators

BR&E ProMax was used to determine emissions from the glycol still vent and non-condensable overheads from the BTEX condenser. Emissions from EP-7, 2-EP-7, and 3-EP-7 are controlled by the thermal oxidizer with a 99.9% destruction efficiency. Controlled emissions from the glycol dehydrators are represented at EP-7, 2-EP-7, and 3-EP-7.

Amine Units

BR&E ProMax was used to determine emissions from the amine units. Contactor overheads are routed to the glycol dehydrators for further treatment. The regenerator overheads are routed to the thermal oxidizer with a 99.9% destruction efficiency.

Thermal Oxidizer

The thermal oxidizer will control the waste gas from the glycol dehydrators as well as the waste gas from the amine units. Additional supplemental fuel is routed to the thermal oxidizer at a rate of 29,412 scf/hr. Emissions of nitrogen oxides (NO_x), carbon monoxide (CO), and particulate matter (PM) are based on manufacturer guaranteed emission factors. The thermal oxidizer operates with a destruction efficiency of 99.9%. Greenhouse gas emissions from the thermal oxidizer were calculated using 40 CFR 98 Subpart C Table C-1 and Table C-2.

Thermal Oxidizer SSM

The facility will conduct routine maintenance on the thermal oxidizer during which the thermal oxidizer will be taken offline, and emissions routed to the thermal oxidizer will instead be vented to atmosphere.

Flares

The flares at the facility (EP-1, 2-EP-1, and 3-EP-1) will flare both inlet and residue gas. The expected composition and maximum expected volumes of inlet gas and residue gas were used as the basis of the flare calculation. TNRCC RG-109 flare emission factors for low Btu gas were used to calculate emissions of nitrogen oxides (NO_x) and carbon monoxide (CO). VOC, H₂S, and SO₂ emissions are calculated based on the VOC and H₂S content of the inlet and residue gas. An assumed 98% destruction efficiency is applied to the VOC and H₂S emissions. Greenhouse gas emissions from the flares were calculated using 40 CFR 98 Subpart C Table C-1 and Table C-2 with the methodology outlined in 40 CFR 98.233(n).

Condensate Storage Tanks

Emissions from condensate storage tanks, T-1 through T-5, were determined using BR&E ProMax and a site-specific condensate analysis, dated February 3, 2022. Emissions from the condensate tanks are controlled by a combustor with a 95% destruction efficiency.

Produced Water Storage Tanks

Emissions from the produced water storage tank, T-6, were determined using BR&E ProMax. Emissions from the produced water storage tank are uncontrolled and are vented to the atmosphere.

Condensate Loading

Condensate loading emissions were calculated using the loading loss equation and variables from AP-42 Section 5.2, *Transportation and Marketing of Petroleum Liquids*. True vapor pressure of loaded liquid, molecular weight of vapor, temperature of bulk liquid, and volatile organic compound (VOC), hazardous air pollutants (HAP), and hydrogen sulfide (H₂S) mass percentage were determined with BR&E ProMax. Condensate loading is vapor balanced with the condensate tanks with a 95% capture efficiency.

Tank Combustor

The tank combustor controls emissions from the condensate tanks, condensate loading vapor balance which is routed to the condensate tanks, tank MSS which includes tank cleanings at a frequency of five tank cleanings once per year with a duration of one hour, and blowdowns. The combustor operates with a destruction efficiency of 95%. Emissions of nitrogen oxides (NO_x), carbon monoxide (CO), and particulate matter (PM) were calculated using TNRCC RG-109 and AP-42 Table 1.4-1 and Table 1.4-2. Greenhouse gas emissions from the tank combustor were calculated using 40 CFR 98 Subpart C Table C-1 and Table C-2 with the methodology outlined in 40 CFR 98.233(n).

Fugitives

The emissions from fugitive components associated with this project are calculated using emission factors from Table 2-4 of the EPA Protocol for Equipment Leak Emission estimates, November 1995. Site specific analyses for inlet gas, residue gas, and condensate were used.

Haul Road Emissions

Unpaved haul road emissions were calculated using constants from AP-42 Table 13.2.2-2 and the methodology outlined in AP-42 Chapter 13.2.2.

Miscellaneous MSS

Miscellaneous MSS emissions include routine pigging activities, routine replacement of glycol solution used in dehydration units, routine replacement of solution used in amine units, use of aerosol lubricants, piping components, and calibration activities.

MSS Blowdowns

MSS Blowdown emissions include venting emissions from blowdowns, starter vents, and any gas operated controllers present at the facility, if any.

Section 6.a

Green House Gas Emissions

(Submitting under 20.2.70, 20.2.72 20.2.74 NMAC)

Title V (20.2.70 NMAC), Minor NSR (20.2.72 NMAC), and PSD (20.2.74 NMAC) applicants must estimate and report greenhouse gas (GHG) emissions to verify the emission rates reported in the public notice, determine applicability to 40 CFR 60 Subparts, and to evaluate Prevention of Significant Deterioration (PSD) applicability. GHG emissions that are subject to air permit regulations consist of the sum of an aggregate group of these six greenhouse gases: carbon dioxide (CO₂), nitrous oxide (N₂O), methane (CH₄), hydrofluorocarbons (HFCs), perfluorocarbons (PFCs), and sulfur hexafluoride (SF₆).

Calculating GHG Emissions:

1. Calculate the ton per year (tpy) GHG mass emissions and GHG CO₂e emissions from your facility.
2. GHG mass emissions are the sum of the total annual tons of greenhouse gases without adjusting with the global warming potentials (GWPs). GHG CO₂e emissions are the sum of the mass emissions of each individual GHG multiplied by its GWP found in Table A-1 in 40 CFR 98 Mandatory Greenhouse Gas Reporting.
3. Emissions from routine or predictable start up, shut down, and maintenance must be included.
4. Report GHG mass and GHG CO₂e emissions in Table 2-P of this application. Emissions are reported in **short** tons per year and represent each emission unit's Potential to Emit (PTE).
5. All Title V major sources, PSD major sources, and all power plants, whether major or not, must calculate and report GHG mass and CO₂e emissions for each unit in Table 2-P.
6. For minor source facilities that are not power plants, are not Title V, and are not PSD there are three options for reporting GHGs in Table 2-P: 1) report GHGs for each individual piece of equipment; 2) report all GHGs from a group of unit types, for example report all combustion source GHGs as a single unit and all venting GHGs as a second separate unit; 3) or check the following By checking this box, the applicant acknowledges the total CO₂e emissions are less than 75,000 tons per year.

Sources for Calculating GHG Emissions:

- Manufacturer's Data
- AP-42 Compilation of Air Pollutant Emission Factors at <http://www.epa.gov/ttn/chief/ap42/index.html>
- EPA's Internet emission factor database WebFIRE at <http://cfpub.epa.gov/webfire/>
- 40 CFR 98 Mandatory Green House Gas Reporting except that tons should be reported in short tons rather than in metric tons for the purpose of PSD applicability.
- API Compendium of Greenhouse Gas Emissions Methodologies for the Oil and Natural Gas Industry. August 2009 or most recent version.
- Sources listed on EPA's NSR Resources for Estimating GHG Emissions at <http://www.epa.gov/nsr/clean-air-act-permitting-greenhouse-gases>:

Global Warming Potentials (GWP):

Applicants must use the Global Warming Potentials codified in Table A-1 of the most recent version of 40 CFR 98 Mandatory Greenhouse Gas Reporting. The GWP for a particular GHG is the ratio of heat trapped by one unit mass of the GHG to that of one unit mass of CO₂ over a specified time period.

"Greenhouse gas" for the purpose of air permit regulations is defined as the aggregate group of the following six gases: carbon dioxide, nitrous oxide, methane, hydrofluorocarbons, perfluorocarbons, and sulfur hexafluoride. **(20.2.70.7 NMAC, 20.2.74.7 NMAC)**. You may also find GHGs defined in 40 CFR 86.1818-12(a).

Metric to Short Ton Conversion:

Short tons for GHGs and other regulated pollutants are the standard unit of measure for PSD and title V permitting programs. 40 CFR 98 Mandatory Greenhouse Reporting requires metric tons.

1 metric ton = 1.10231 short tons (per Table A-2 to Subpart A of Part 98 – Units of Measure Conversions)



Targa Midstream Services LLC - Roadrunner Gas Processing Plant

Emission Summary

Controlled Emissions

Unit ID	Equipment Description	NO _x		CO		VOC		SO ₂		TSP ²		PM ₁₀ ²		PM _{2.5} ²		H ₂ S		Total HAP		Benzene		CO ₂	CH ₄	N ₂ O	CO ₂ e	
		lb/hr	ton/yr	lb/hr	ton/yr	lb/hr	ton/yr	lb/hr	ton/yr	lb/hr	ton/yr	lb/hr	ton/yr	lb/hr	ton/yr	lb/hr	ton/yr	lb/hr	ton/yr	lb/hr	ton/yr	lb/hr	ton/yr	lb/hr	ton/yr	lb/hr
EP-2	Trim Reboiler	2.60	11.38	2.18	9.56	0.14	0.63	0.022	0.10	0.20	0.86	0.20	0.86	0.20	0.86	-	-	<0.01	<0.01	<0.01	<0.01	13,577.41	0.26	0.03	13,591.44	
2-EP-2	Trim Reboiler	0.84	3.68	2.18	9.56	0.14	0.63	0.022	0.10	0.20	0.86	0.20	0.86	0.20	0.86	-	-	<0.01	<0.01	<0.01	<0.01	13,577.41	0.26	0.03	13,591.44	
3-EP-2	Trim Reboiler	0.84	3.68	2.18	9.56	0.14	0.63	0.022	0.10	0.20	0.86	0.20	0.86	0.20	0.86	-	-	<0.01	<0.01	<0.01	<0.01	13,577.41	0.26	0.03	13,591.44	
EP-3A	Amine Reboiler	2.23	9.77	4.53	19.83	0.38	1.66	0.06	0.26	0.52	2.29	0.52	2.29	0.52	2.29	-	-	<0.01	0.02	<0.01	<0.01	36,008.32	0.68	0.07	36,045.51	
EP-3B	Amine Reboiler	0.34	1.49	3.48	15.22	1.61	7.05	0.07	0.31	1.10	4.83	1.10	4.83	1.10	4.83	-	-	<0.01	0.03	<0.01	<0.01	43,432.35	0.82	0.08	43,477.21	
EP-4	Glycol Reboiler	0.38	1.67	0.32	1.41	0.021	0.092	<0.01	0.01	0.029	0.13	0.029	0.13	0.029	0.13	-	-	<0.01	<0.01	<0.01	<0.01	1,998.19	0.04	<0.01	2,000.25	
2-EP-4	Glycol Reboiler	0.38	1.67	0.32	1.41	0.021	0.092	<0.01	0.014	0.029	0.13	0.029	0.13	0.029	0.13	-	-	<0.01	<0.01	<0.01	<0.01	1,998.19	0.04	<0.01	2,000.25	
3-EP-4	Glycol Reboiler	0.38	1.67	0.32	1.41	0.021	0.092	<0.01	0.014	0.029	0.13	0.029	0.13	0.029	0.13	-	-	<0.01	<0.01	<0.01	<0.01	1,998.19	0.04	<0.01	2,000.25	
EP-5	Regen Reboiler	0.93	4.08	0.78	3.43	0.05	0.22	<0.01	0.035	0.071	0.31	0.071	0.31	0.071	0.31	-	-	<0.01	<0.01	<0.01	<0.01	4,867.37	0.09	<0.01	4,872.40	
2-EP-5	Regen Reboiler	0.93	4.08	0.78	3.43	0.05	0.22	<0.01	0.035	0.071	0.31	0.071	0.31	0.071	0.31	-	-	<0.01	<0.01	<0.01	<0.01	4,867.37	0.09	<0.01	4,872.40	
3-EP-5	Regen Reboiler	0.93	4.08	0.78	3.43	0.05	0.22	<0.01	0.035	0.071	0.31	0.071	0.31	0.071	0.31	-	-	<0.01	<0.01	<0.01	<0.01	4,867.37	0.09	<0.01	4,872.40	
EP-6	Stabilizer Heater	2.29	10.05	1.93	8.44	0.13	0.55	0.02	0.09	0.17	0.76	0.17	0.76	0.17	0.76	-	-	<0.01	<0.01	<0.01	<0.01	11,989.11	0.23	0.02	12,001.49	
2-EP-6	Stabilizer Heater	2.29	10.05	1.93	8.44	0.13	0.55	0.02	0.09	0.17	0.76	0.17	0.76	0.17	0.76	-	-	<0.01	<0.01	<0.01	<0.01	11,989.11	0.23	0.02	12,001.49	
EP-7	Glycol Dehydrator (99.9% Control)																									
2-EP-7	Glycol Dehydrator (99.9% Control)																									
3-EP-7	Glycol Dehydrator (99.9% Control)																									
EP-8	Amine Vent (99.9% Control)																									
2-EP-8	Amine Vent (99.9% Control)																									
3-EP-8	Amine Vent (99.9% Control)																									
EP-9	Thermal Oxidizer	6.12	26.81	2.98	13.05	0.53	2.32	26.66	116.79	0.60	2.63	0.60	2.63	0.60	2.63	0.014	0.062	0.28	1.24	0.13	0.58	38,426.64	0.72	0.07	38,466.33	
EP-1	Flare (SSM)	1,578.35	19.90	3,150.97	39.72	2,484.70	29.82	828.55	9.98	-	-	-	-	-	-	8.98	0.11	58.10	0.70	-	-	68,089.84	65.18	0.03	69,727.81	
2-EP-1	Flare (SSM)	1,578.29	19.66	3,150.87	39.26	2,484.70	29.82	828.55	9.98	-	-	-	-	-	-	8.98	0.11	58.10	0.70	-	-	68,089.84	65.18	0.03	69,727.81	
3-EP-1	Flare (SSM)	1,578.16	19.08	3,150.60	38.09	2,484.70	29.82	828.54	9.95	-	-	-	-	-	-	8.98	0.11	58.10	0.70	-	-	68,089.84	65.18	0.03	69,727.81	
T-1	Condensate Storage Tank (95% Control)																									
T-2	Condensate Storage Tank (95% Control)																									
T-3	Condensate Storage Tank (95% Control)																									
T-4	Condensate Storage Tank (95% Control)																									
T-5	Condensate Storage Tank (95% Control)																									
T-6	Waste Water Tank	-	-	-	-	0.14	0.63	-	-	-	-	-	-	-	-	<0.01	<0.01	<0.01	0.022	<0.01	0.02	1.06	1.01	-	26.32	
COMB-1	Tank Combustor	7.83	3.08	15.63	6.16	37.61	4.26	0.16	<0.01	0.42	0.17	0.42	0.17	0.42	0.17	<0.01	<0.01	3.43	4.74	3.43	4.74	2,990.42	0.02	<0.01	2,991.33	
LOAD	Condensate Loading Emissions	-	-	-	-	12.88	54.41	-	-	-	-	-	-	-	-	-	-	1.16	4.58	-	-	-	-	-	-	
FUG	Fugitive Emissions	-	-	-	-	26.37	115.48	-	-	-	-	-	-	-	-	<0.01	<0.01	1.83	8.03	-	-	2.71	331.02	<0.01	8,278.14	
HAUL	Haul	-	-	-	-	-	-	-	-	0.41	1.46	0.11	0.37	0.011	0.037	-	-	-	-	-	-	-	-	-	-	
SSM-TO	SSM Thermal Oxidizer	-	-	-	-	326.15	3.26	-	-	-	-	-	-	-	-	14.17	0.14	216.77	2.17	-	-	852.77	0.82	-	873.39	
MSSM	MSS Miscellaneous	-	-	-	-	276.81	4.84	-	-	-	-	-	-	-	-	0.01	<0.01	15.05	0.22	-	-	0.94	10.88	-	272.89	
MSSB	MSS Blowdowns																									
M	Malfunction	-	-	-	-	*	10.00	-	-	-	-	-	-	-	-	-	-	*	1.00	-	-	-	-	-	-	
Totals		4,764.13	155.90	9,492.77	231.39	8,137.48	297.30	2,512.72	147.88	4.30	16.81	3.99	15.72	3.90	15.39	41.15	0.54	412.85	24.21	3.56	5.34	411,291.88	543.12	0.47	425,009.81	
Totals without Fugitives		4,764.13	155.90	9,492.77	231.39	8,111.11	181.82	2,512.72	147.88	4.30	16.81	3.99	15.72	3.90	15.39	41.15	0.54	411.02	16.18	3.56	5.34	411,289.17	212.10	0.47	416,731.67	

Uncontrolled Emissions

Unit ID	Equipment Description	NO _x		CO		VOC		SO ₂		TSP ²		PM ₁₀ ²		PM _{2.5} ²		H ₂ S		Total HAP		Benzene		CO ₂	CH ₄	N ₂ O	CO ₂ e		
		lb/hr	ton/yr	lb/hr	ton/yr	lb/hr	ton/yr	lb/hr	ton/yr	lb/hr	ton/yr	lb/hr	ton/yr	lb/hr	ton/yr	lb/hr	ton/yr	lb/hr	ton/yr	lb/hr	ton/yr	lb/hr	ton/yr	ton/yr	ton/yr	ton/yr	ton/yr
EP-2	Trim Reboiler	2.60	11.38	2.18	9.56	0.14	0.63	0.02	0.10	0.20	0.86	0.20	0.86	0.20	0.86	-	-	<0.01	<0.01	<0.01	<0.01	13,577.41	0.26	0.03	13,591.44		
2-EP-2	Trim Reboiler	0.84	3.68	2.18	9.56	0.14	0.63	0.02	0.10	0.20	0.86	0.20	0.86	0.20	0.86	-	-	<0.01	<0.01	<0.01	<0.01	13,577.41	0.26	0.03	13,591.44		
3-EP-2	Trim Reboiler	0.84	3.68	2.18	9.56	0.14	0.63	0.02	0.10	0.20	0.86	0.20	0.86	0.20	0.86	-	-	<0.01	<0.01	<0.01	<0.01	13,577.41	0.26	0.03	13,591.44		
EP-3A	Amine Reboiler	2.23	9.77	4.53	19.83	0.38	1.66	0.06	0.26	0.52	2.29	0.52	2.29	0.52	2.29	-	-	<0.01	0.02	<0.01	<0.01	36,008.32	0.68	0.07	36,045.51		
EP-3B	Amine Reboiler	0.34	1.49	3.48	15.22	1.61	7.05	0.07	0.31	1.10	4.83	1.10	4.83	1.10	4.83	-	-	<0.01	0.03	<0.01	<0.01	43,432.35	0.82	0.08	43,477.21		
EP-4	Glycol Reboiler	0.38	1.67	0.32	1.41	0.02	0.09	<0.01	0.01	0.03	0.13	0.03	0.13	0.03	0.13	-	-	<0.01	<0.01	<0.01	<0.01	1,998.19	0.04	<0.01	2,000.25		
2-EP-4	Glycol Reboiler	0.38	1.67	0.32	1.41	0.02	0.09	<0.01	0.01	0.03	0.13	0.03	0.13	0.03	0.13	-	-	<0.01	<0.01	<0.01	<0.01	1,998.19	0.04	<0.01	2,000.25		
3-EP-4	Glycol Reboiler	0.38	1.67	0.32	1.41	0.02	0.09	<0.01	0.01	0.03	0.13	0.03	0.13	0.03	0.13	-	-	<0.01	<0.01	<0.01	<0.01	1,998.19	0.04	<0.01	2,000.25		
EP-5	Regen Reboiler	0.93	4.08	0.78	3.43	0.05	0.22	<0.01	0.03	0.07	0.31	0.07	0.31	0.07	0.31	-	-	<0.01	<0.01	<0.01	<0.01	4,867.37	0.09	<0.01	4,872.40		
2-EP-5	Regen Reboiler	0.93	4.08	0.78	3.43	0.05	0.22	<0.01	0.03	0.07	0.31	0.07	0.31	0.07	0.31	-	-	<0.01	<0.01	<0.01	<0.01	4,867.37	0.09	<0.01	4,872.40		
3-EP-5	Regen Reboiler	0.93	4.08	0.78	3.43	0.05	0.22	<0.01	0.03	0.07	0.31	0.07	0.31	0.07	0.31	-	-	<0.01	<0.01	<0.01	<0.01	4,867.37	0.09	<0.01	4,872.40		
EP-6	Stabilizer Heater	2.29	10.05	1.93	8.44	0.13	0.55	0.02	0.09	0.17	0.76	0.17	0.76	0.17	0.76	-	-	<0.01	<0.01	<0.01	<0.01	11,989.11	0.23	0.02	12,001.49		
2-EP-6	Stabilizer Heater	2.29	10.05	1.93	8.44	0.13	0.55	0.02	0.09	0.17	0.76	0.17	0.76	0.17	0.76	-	-	<0.01	<0.01	<0.01	<0.01	11,989.11	0.23	0.02	12,001.49		
EP-7	Glycol Dehydrator (99.9% Control)	-	-	-	-	102.15	447.40	-	-	-	-	-	-	-	-	<0.01	<0.01	33.28	145.74	14.19	62.16	-	20.09	-	502.18		
2-EP-7	Glycol Dehydrator (99.9% Control)	-	-	-	-	102.15	447.40	-	-	-	-	-	-	-	-	<0.01	<0.01	33.28	145.75	14.19	62.15	-	20.12	-	502.99		
3-EP-7	Glycol Dehydrator (99.9% Control)	-	-	-	-	102.15	447.40	-	-	-	-	-	-	-	-	<0.01	<0.01	33.28	145.74	14.19	62.16	-	20.09	-	502.18		
EP-8	Amine Vent (99.9% Control)	-	-	-	-	74.67	327.04	-	-	-	-	-	-	-	-	4.72	20.68	61.17	267.90	<0.01	<0.01	124,504.53	114.30	-	127,361.95		
2-EP-8	Amine Vent (99.9% Control)	-	-	-	-	74.67	327.04	-	-	-	-	-	-	-	-	4.72	20.68	61.17	267.90	<0.01	<0.01	124,504.53	114.30	-	127,361.95		
3-EP-8	Amine Vent (99.9% Control)	-	-	-	-	74.67	327.04	-	-	-	-	-	-	-	-	4.72	20.68	61.17	267.90	<0.01	<0.01	124,504.53	114.30	-	127,361.95		
EP-9	Thermal Oxidizer	-	-	-	-	-	-	-	-	-	-	-	-	-	-	-	-	-	-	-	-	-	-	-	-		
No emissions from this unit in an uncontrolled scenario																											
EP-1	Flare (Pilot and Purge)	0.22	0.96	0.44	1.91	-	-	<0.01	0.04	-	-	-	-	-	-	<0.01	<0.01	-	-	-	-	-	-	-	-	-	
2-EP-1	Flare (Pilot and Purge)	0.17	0.72	0.33	1.45	-	-	<0.01	0.04	-	-	-	-	-	-	<0.01	<0.01	-	-	-	-	-	-	-	-	-	
3-EP-1	Flare (Pilot and Purge)	0.03	0.14	0.06	0.28	-	-	<0.01	<0.01	-	-	-	-	-	-	<0.01	<0.01	-	-	-	-	-	-	-	-	-	
T-1	Condensate Storage Tank (95% Control)	-	-	-	-	32.12	16.87	-	-	-	-	-	-	-	-	<0.01	<0.01	2.89	1.42	-	-	-	-	-	-	-	
T-2	Condensate Storage Tank (95% Control)	-	-	-	-	32.12	16.87	-	-	-	-	-	-	-	-	<0.01	<0.01	2.89	1.42	-	-	-	-	-	-	-	
T-3	Condensate Storage Tank (95% Control)	-	-	-	-	32.12	16.87	-	-	-	-	-	-	-	-	<0.01	<0.01	2.89	1.42	-	-	-	-	-	-	-	
T-4	Condensate Storage Tank (95% Control)	-	-	-	-	32.12	16.87	-	-	-	-	-	-	-	-	<0.01	<0.01	2.89	1.42	-	-	-	-	-	-	-	
T-5	Condensate Storage Tank (95% Control)	-	-	-	-	32.12	16.87	-	-	-	-	-	-	-	-	<0.01	<0.01	2.89	1.42	-	-	-	-	-	-	-	
T-6	Waste Water Tank	-	-	-	-	0.14	0.63	-	-	-	-	-	-	-	-	<0.01	<0.01	<0.01	0.02	<0.01	0.02	1.06	1.01	-	26.32		
COMB-1	Tank Combustor	-	-	-	-	-	-	-	-	-	-	-	-	-	-	-	-	-	-	-	-	2,990.42	0.02	<0.01	2,991.33		
LOAD	Condensate Loading Emissions	-	-	-	-	257.50	1,088.27	-	-	-	-	-	-	-	-	-	-	23.116	91.63	-	-	-	-	-	-	-	
FUG	Fugitive Emissions	-	-	-	-	26.37	115.48	-	-	-	-	-	-	-	-	<0.01	<0.01	1.83	8.03	-	-	2.71	331.02	<0.01	8,278.14		
HAUL	Haul	-	-	-	-	-	-	-	-	0.41	1.46	0.11	0.37	0.011	0.037	-	-	-	-	-	-	-	-	-	-	-	
SSM-TO	SSM Thermal Oxidizer	-	-	-	-	326.15	3.26	-	-	-	-	-	-	-	-	14.17	0.14	216.77	2.17	-	-	852.77	0.82	-	873.39		
MSSM	MSS Miscellaneous	-	-	-	-	276.81	4.84	-	-	-	-	-	-	-	-	-	-	-	-	-	-	-	-	-	-	-	
MSSB	MSS Blowdowns	-	-	-	-	590.99	11.82	-	-	-	-	-	-	-	-	-	-	1.17	0.01	32.16	0.64	-	-	-	-		
M	Malfunction	-	-	-	-	*	10.00	-	-	-	-	-	-	-	-	-	-	*	1.00	-	-	-	-	-	-		
Totals		15.80	69.19	22.55	98.75	2,171.89	3,654.60	0.29	1.25	3.28	14.02	2.97	12.93	2.88	12.59	28.36	62.21	540.67	1,351.02	74.73	187.12	542,108.36	739.16	0.31	560,680.35		



TARGA

Targa Midstream Services LLC - Roadrunner Gas Processing Plant

Heaters

Emission Unit: EP-3B			
Description:			
Heater/Boiler rating (MMBtu/hr):	84.77		
Rating above is (select from list):	<i>below 100 MMBtu/hr, uncontrolled</i> (assume uncontrolled, unless specifically stated otherwise)		
Operating hours/year:	8,760		
Fuel Heat Value, LHV (Btu/SCF):	1020.0		
pollutant	emission factor (lb/MMBTU)	lb/hr	tpy
VOC	0.019	1.611	7.055
NOx	0.004	0.339	1.485
CO	0.041	3.476	15.223
PM	0.013	1.102	4.827
Benzene	2.10E-03	1.75E-04	7.64E-04
Toluene	3.40E-03	2.83E-04	1.24E-03
Formaldehyde	7.50E-02	6.23E-03	2.73E-02
SO ₂	0	0.00E+00	0.00E+00

If the heater/boiler is fueled by Sour Gas, <u>cannot</u> use emission factors above to calculate SO₂ emissions, must use SO₂ mass balance:			
SO₂ Mass Balance calculation:			
Fuel H ₂ S content (mol %) =	0.0005		assumptions:
SO ₂ produced (lb/hr) =	0.0703		SO ₂ MW 64.06 lb/lb-mole
SO ₂ produced (tpy) =	0.3080		Ideal Gas Law 378.61 SCF/lb-mole

EP-2 Emissions Calculations (fueled by natural gas)

Heater/Boiler rating (MMBtu/hr):	26.5		
Rating above is (select from list):	<i>below 100 MMBtu/hr, uncontrolled</i>	(assume uncontrolled, unless specifically stated otherwise)	
Operating hours/year:	8760		
Fuel Heat Value, LHV (Btu/SCF):	1020.0		

pollutant	emission factor (lb/MMCF)	lb/hr	tpy
VOC	5.5	0.143	0.626
NOx	100	2.598	11.379
CO	84	2.182	9.559
PM	7.6	0.197	0.865
Benzene	2.10E-03	5.46E-05	2.39E-04
Toluene	3.40E-03	8.83E-05	3.87E-04
Formaldehyde	7.50E-02	1.95E-03	8.53E-03
SO ₂	0	0.00E+00	0.00E+00

If the heater/boiler is fueled by Sour Gas, cannot use emission factors above to calculate SO₂ emissions, must use SO₂ mass balance:

SO ₂ Mass Balance calculation:			
Fuel H ₂ S content (mol %) =	0.0005	assumptions:	
SO ₂ produced (lb/hr) =	0.0220	SO2 MW	64.06 lb/lb-mole
SO ₂ produced (tpy) =	0.0963	Ideal Gas Law	378.61 SCF/lb-mole

2-EP-2, 3-EP-2 and Emissions Calculations (fueled by natural gas)

Heater/Boiler rating (MMBtu/hr):	26.5	
Flow Rate (dscfm):	3846.92	
Rating above is (select from list):	<i>below 100 MMBtu/hr, uncontrolled</i>	(assume uncontrolled, unless specifically stated otherwise)
Operating hours/year:	8760	
Fuel Heat Value, LHV (Btu/SCF):	1020.0	

pollutant	emission factor (lb/MMCF)	emission factor (ppmv)	lb/hr	tpy
VOC	5.5		0.143	0.626
NOx		30	0.841	3.685
CO	84		2.182	9.559
PM	7.6		0.197	0.865
Benzene	2.10E-03		5.46E-05	2.39E-04
Toluene	3.40E-03		8.83E-05	3.87E-04
Formaldehyde	7.50E-02		1.95E-03	8.53E-03
SO ₂	0		0.00E+00	0.00E+00

If the heater/boiler is fueled by Sour Gas, cannot use emission factors above to calculate SO₂ emissions, must use SO₂ mass balance:

SO ₂ Mass Balance calculation:	
Fuel H ₂ S content (mol %) =	0.0005
SO ₂ produced (lb/hr) =	0.0220
SO ₂ produced (tpy) =	0.0963

assumptions:

SO ₂ MW	64.06 lb/lb-mole
NO ₂ MW	46 lb/lb-mole
CO MW	28 lb/lb-mole
Ideal Gas Law	378.61 SCF/lb-mole
F _d ²	8710 dscf/MMBtu

EP-3A Emissions Calculations (fueled by natural gas)

Heater/Boiler rating (MMBtu/hr):	70.28	
Flow Rate (dscfm):	10202.31	
Rating above is (select from list):	<i>below 100 MMBtu/hr, uncontrolled</i>	(assume uncontrolled, unless specifically stated otherwise)
Operating hours/year:	8760	
Fuel Heat Value, LHV (Btu/SCF):	1020.0	

pollutant	emission factor (lb/MMCF)	emission factor (ppmv)	lb/hr	tpy
VOC	5.5		0.379	1.660
NOx ¹	-	30	2.231	9.773
CO ¹	-	100	4.527	19.829
PM	7.6		0.524	2.294
Benzene	2.10E-03		1.45E-04	6.34E-04
Toluene	3.40E-03		2.34E-04	1.03E-03
Formaldehyde	7.50E-02		5.17E-03	2.26E-02
SO ₂	0		0.00E+00	0.00E+00

If the heater/boiler is fueled by Sour Gas, cannot use emission factors above to calculate SO₂ emissions, must use SO₂ mass balance:

SO ₂ Mass Balance calculation:		calculation factors	
Fuel H ₂ S content (mol %) =	0.0005	SO2 MW	64.06 lb/lb-mole
SO ₂ produced (lb/hr) =	0.0583	NO2 MW	46 lb/lb-mole
SO ₂ produced (tpy) =	0.2553	CO MW	28 lb/lb-mole
		Ideal Gas Law	378.61 SCF/lb-mole
		F _d ²	8710 dscf/MMBtu

¹ Manufacturer specific emission factors per Devco corrected for 3% O₂

² Factor per 40 CFR 40 Appx A Method 19 Table 19-2

EP-4 Emissions Calculations (fueled by natural gas)

Heater/Boiler rating (MMBtu/hr):	3.90
Rating above is (select from list):	<i>below 100 MMBtu/hr, uncontrolled</i>
Operating hours/year:	8760
Fuel Heat Value, LHV (Btu/SCF):	1020.0

(assume uncontrolled, unless specifically stated otherwise)

pollutant	emission factor (lb/MMCF)	lb/hr	tpy
VOC	5.5	0.021	0.092
NOx	100	0.382	1.675
CO	84	0.321	1.407
PM	7.6	0.029	0.127
Benzene	2.10E-03	8.03E-06	3.52E-05
Toluene	3.40E-03	1.30E-05	5.69E-05
Formaldehyde	7.50E-02	2.87E-04	1.26E-03
SO ₂	0	0.00E+00	0.00E+00

If the heater/boiler is fueled by Sour Gas, cannot use emission factors above to calculate SO₂ emissions, must use SO₂ mass balance:

SO₂ Mass Balance calculation:	
Fuel H ₂ S content (mol %) =	0.0005
SO ₂ produced (lb/hr) =	0.0032
SO ₂ produced (tpy) =	0.0142

assumptions:
 SO₂ MW 64.06 lb/lb-mole
 Ideal Gas Law 378.61 SCF/lb-mole

2-EP-4 and 3-EP-4 Emissions Calculations (fueled by natural gas)

Heater/Boiler rating (MMBtu/hr):	3.90
Rating above is (select from list):	<i>below 100 MMBtu/hr, uncontrolled</i>
Operating hours/year:	8760
Fuel Heat Value, LHV (Btu/SCF):	1020.0

(assume uncontrolled, unless specifically stated otherwise)

pollutant	emission factor (lb/MMCF)	lb/hr	tpy
VOC	5.5	0.021	0.092
NOx	100	0.382	1.675
CO	84	0.321	1.407
PM	7.6	0.029	0.127
Benzene	2.10E-03	8.03E-06	3.52E-05
Toluene	3.40E-03	1.30E-05	5.69E-05
Formaldehyde	7.50E-02	2.87E-04	1.26E-03
SO ₂	0	0.00E+00	0.00E+00

If the heater/boiler is fueled by Sour Gas, cannot use emission factors above to calculate SO₂ emissions, must use SO₂ mass balance:

SO₂ Mass Balance calculation:	
Fuel H ₂ S content (mol %) =	0.0005
SO ₂ produced (lb/hr) =	0.0032
SO ₂ produced (tpy) =	0.0142

assumptions:

SO₂ MW 64.06 lb/lb-mole
 Ideal Gas Law 378.61 SCF/lb-mole

EP-5 Emissions Calculations (fueled by natural gas)

Heater/Boiler rating (MMBtu/hr):	9.5
Rating above is (select from list):	<i>below 100 MMBtu/hr, uncontrolled</i>
Operating hours/year:	8760
Fuel Heat Value, LHV (Btu/SCF):	1020.0

(assume uncontrolled, unless specifically stated otherwise)

pollutant	emission factor (lb/MMCF)	lb/hr	tpy
VOC	5.5	0.051	0.224
NOx	100	0.931	4.079
CO	84	0.782	3.427
PM	7.6	0.071	0.310
Benzene	2.10E-03	1.96E-05	8.57E-05
Toluene	3.40E-03	3.17E-05	1.39E-04
Formaldehyde	7.50E-02	6.99E-04	3.06E-03
SO ₂	0	0.00E+00	0.00E+00

If the heater/boiler is fueled by Sour Gas, cannot use emission factors above to calculate SO₂ emissions, must use SO₂ mass balance:

SO₂ Mass Balance calculation:	
Fuel H ₂ S content (mol %) =	0.0005
SO ₂ produced (lb/hr) =	0.0079
SO ₂ produced (tpy) =	0.0345

assumptions:

SO₂ MW 64.06 lb/lb-mole
 Ideal Gas Law 378.61 SCF/lb-mole

2-EP-5 and 3-EP-5 Emissions Calculations (fueled by natural gas)

Heater/Boiler rating (MMBtu/hr):	9.5
Rating above is (select from list):	<i>below 100 MMBtu/hr, uncontrolled</i>
Operating hours/year:	8760
Fuel Heat Value, LHV (Btu/SCF):	1020.0

(assume uncontrolled, unless specifically stated otherwise)

pollutant	emission factor (lb/MMCF)	lb/hr	tpy
VOC	5.5	0.051	0.224
NOx	100	0.931	4.079
CO	84	0.782	3.427
PM	7.6	0.071	0.310
Benzene	2.10E-03	1.96E-05	8.57E-05
Toluene	3.40E-03	3.17E-05	1.39E-04
Formaldehyde	7.50E-02	6.99E-04	3.06E-03
SO ₂	0	0.00E+00	0.00E+00

If the heater/boiler is fueled by Sour Gas, cannot use emission factors above to calculate SO₂ emissions, must use SO₂ mass balance:

SO ₂ Mass Balance calculation:	
Fuel H ₂ S content (mol %) =	0.0005
SO ₂ produced (lb/hr) =	0.0079
SO ₂ produced (tpy) =	0.0345

assumptions:

SO₂ MW 64.06 lb/lb-mole
 Ideal Gas Law 378.61 SCF/lb-mole

EP-6 and 2-EP-6 Emissions Calculations (fueled by natural gas)

Heater/Boiler rating (MMBtu/hr):	23.4
Rating above is (select from list):	<i>below 100 MMBtu/hr, uncontrolled</i>
Operating hours/year:	8760
Fuel Heat Value, LHV (Btu/SCF):	1020.0

(assume uncontrolled, unless specifically stated otherwise)

pollutant	emission factor (lb/MMCF)	lb/hr	tpy
VOC	5.5	0.126	0.553
NOx	100	2.294	10.048
CO	84	1.927	8.441
PM	7.6	0.174	0.764
Benzene	2.10E-03	4.82E-05	2.11E-04
Toluene	3.40E-03	7.80E-05	3.42E-04
Formaldehyde	7.50E-02	1.72E-03	7.54E-03
SO ₂	0	0.00E+00	0.00E+00

If the heater/boiler is fueled by Sour Gas, cannot use emission factors above to calculate SO₂ emissions, must use SO₂ mass balance:

SO₂ Mass Balance calculation:	
Fuel H ₂ S content (mol %) =	0.0005
SO ₂ produced (lb/hr) =	0.0194
SO ₂ produced (tpy) =	0.0850

assumptions:
 SO₂ MW 64.06 lb/lb-mole
 Ideal Gas Law 378.61 SCF/lb-mole



Targa Midstream Services LLC - Roadrunner Gas Processing Plant

Fugitive Emissions

Emission unit number(s): FUG
 Source description: Facility-wide Fugitive Emissions
 Total Operating Hours: 8,760
 Number of Treatment Trains: 3

Component		Emission factor ¹	VOC Content ²	HAP Content ²	Hexane ² (wt%)	H ₂ S Content ²	CO ₂ Content ²	CH ₄ Content ²	Subcomponent Count ³	VOC Emissions ^{4,5}		HAP Emissions ^{4,5}		Hexane Emissions ^{4,5}		H ₂ S Emissions ^{4,5}		CO ₂ Emissions ^{4,5}		CH ₄ Emissions ^{4,5}	
		(lb/hr/source)	(wt%)	(wt%)	(wt%)	(wt%)	(wt%)	(wt%)		(wt%)	lb/hr	ton	lb/hr	ton	lb/hr	ton	lb/hr	ton	lb/hr	ton	lb/hr
Valves	Inlet Gas	9.92E-03	22.12%	0.52%	0.42%	0.0008%	0.68%	58.06%	6714	14.73	64.53	0.35	1.52	0.28	1.23	5.58E-04	2.45E-03	0.45	1.99	38.67	169.39
	Residue Gas	9.92E-03	3.91%	1.2291%	0.0190%	0.0000%	0.14%	78.82%	2962	1.16	5.06	0.36	1.59	0.01	0.02	0.00E+00	0.00E+00	0.04	0.18	23.32	102.13
	Light Oil	5.51E-03	99.98%	14.99%	11.72%	0.0000%	0.00%	0.00%	0.00%	819	4.51	19.77	0.68	2.95	0.53	0.00E+00	0.00E+00	0.00	0.00	0.00	0.00
Connectors	Inlet Gas	4.41E-04	22.12%	0.52%	0.42%	0.0008%	0.68%	58.06%	18342	1.79	7.84	0.04	0.18	0.03	0.15	6.78E-05	2.97E-04	0.06	0.24	4.70	20.57
	Residue Gas	4.41E-04	3.91%	1.2291%	0.0190%	0.0000%	0.14%	78.82%	0	0.00	0.00	0.00	0.00	0.00	0.00	0.00E+00	0.00E+00	0.00	0.00	0.00	0.00
	Light Oil	4.63E-04	99.98%	14.99%	11.72%	0.0000%	0.00%	0.00%	2000	0.93	4.05	0.14	0.61	0.11	0.47	0.00E+00	0.00E+00	0.00	0.00	0.00	0.00
Flanges	Inlet Gas	8.60E-04	22.12%	0.52%	0.42%	0.0008%	0.68%	58.06%	3156	0.60	2.63	0.01	0.06	0.01	0.05	2.27E-05	9.96E-05	0.02	0.08	1.58	6.90
	Residue Gas	8.60E-04	3.91%	1.2291%	0.0190%	0.0000%	0.14%	78.82%	5406	0.18	0.80	0.06	0.25	0.00	0.00	0.00E+00	0.00E+00	0.01	0.03	3.66	16.05
	Light Oil	2.43E-04	99.98%	14.99%	11.72%	0.0000%	0.00%	0.00%	255	0.06	0.27	0.01	0.04	0.01	0.03	0.00E+00	0.00E+00	0.00	0.00	0.00	0.00
Pump Seals	Inlet Gas	5.29E-03	22.12%	0.52%	0.42%	0.0008%	0.68%	58.06%	0	0.00	0.00	0.00	0.00	0.00	0.00	0.00E+00	0.00E+00	0.00	0.00	0.00	0.00
	Residue Gas	5.29E-03	3.91%	1.2291%	0.0190%	0.0000%	0.14%	78.82%	0	0.00	0.00	0.00	0.00	0.00	0.00	0.00E+00	0.00E+00	0.00	0.00	0.00	0.00
	Light Oil	2.87E-02	99.98%	14.99%	11.72%	0.0000%	0.00%	0.00%	29	0.82	3.58	0.12	0.54	0.10	0.42	0.00E+00	0.00E+00	0.00	0.00	0.00	0.00
Other	Inlet Gas	1.94E-02	22.12%	0.52%	0.42%	0.0008%	0.68%	58.06%	324	1.39	6.09	0.03	0.14	0.03	0.12	5.27E-05	2.31E-04	0.04	0.19	3.65	15.99
	Residue Gas	1.94E-02	3.91%	1.2291%	0.0190%	0.0000%	0.14%	78.82%	0	0.00	0.00	0.00	0.00	0.00	0.00E+00	0.00E+00	0.00	0.00	0.00	0.00	
	Light Oil	1.65E-02	99.98%	14.99%	11.72%	0.0000%	0.00%	0.00%	12	0.20	0.87	0.03	0.13	0.02	0.10	0.00E+00	0.00E+00	0.00	0.00	0.00	0.00
Total:										26.37	115.48	1.83	8.03	1.12	4.92	7.01E-04	3.07E-03	0.62	2.71	75.57	331.02

¹ Emission factors from Table 2-4 of EPA Protocol for Equipment Leak Emission Estimates, 1995.

² Weight percent of gas and liquid components from site specific liquids and gas analyses.

³ Component counts are based on facility design.

⁴ Hourly Emissions [lb/hr] = Emissions Factor [lb/hr/component] * Weight Content of Chemical Component [%] * Subcomponent Count.

⁵ Annual Emissions [ton/yr] = Hourly Emissions [lb/hr] * Operating Hours [hr/yr] * 1/2000 [ton/lb].



Targa Midstream Services LLC - Roadrunner Gas Processing Plant

Glycol Dehydrator

Emission Unit: EP-7 and 3-EP-7
 Source Description: TEG Dehydrator emissions
 Thermal Oxidizer Control Efficiency: 99.9%
 Operating Hours: 8760 hrs/yr

	VOC		H ₂ S		Total HAP		Benzene		Toluene		Ethylbenzene		Xylene		Methane	
	lb/hr	tpy	lb/hr	tpy	lb/hr	tpy	lb/hr	tpy	lb/hr	tpy	lb/hr	tpy	lb/hr	tpy	lb/hr	tpy
Uncontrolled Emissions from ProMax	102.15	447.40	2.15E-05	9.42E-05	33.28	145.74	14.19	62.16	6.56	28.73	1.47	6.46	1.03	4.51	4.59	20.09
TOTAL Controlled Emissions	0.10	0.45	2.15E-08	9.42E-08	0.0333	0.1457	0.0142	0.0622	0.0066	0.0287	0.0015	0.0065	0.0010	0.0045	2.29E-05	1.00E-04
Uncontrolled Emissions Per Unit	102.15	447.40	2.15E-05	9.42E-05	33.28	145.74	14.19	62.16	6.56	28.73	1.47	6.46	1.03	4.51	4.59	20.09
Controlled Emissions Per Unit	0.10	0.45	2.15E-08	9.42E-08	0.0333	0.1457	0.0142	0.0622	0.0066	0.0287	0.0015	0.0065	0.0010	0.0045	2.29E-05	1.00E-04

Note: Controlled methane based on 99.9995% destruction (based on 0.001 kg/MMBtu emission EF in 40 CFR Part 98).

Emissions estimated using BR&E ProMax.

TEG Dehydrator controlled by thermal oxidizer unit EP-9

TEG Dehydrator controlled emissions exit via stack EP-9 but are listed as EP-7 and 3-EP-7 emission unit emissions



Targa Midstream Services LLC - Roadrunner Gas Processing Plant

Glycol Dehydrator

Emission Unit: 2-EP-7
 Source Description: TEG Dehydrator emissions
 Thermal Oxidizer Control Efficiency: 99.9%
 Operating Hours: 8760 hrs/yr

	VOC		H ₂ S		Total HAP		Benzene		Toluene		Ethylbenzene		Xylene		Methane	
	lb/hr	tpy	lb/hr	tpy	lb/hr	tpy	lb/hr	tpy	lb/hr	tpy	lb/hr	tpy	lb/hr	tpy	lb/hr	tpy
Uncontrolled Emissions from ProMax	102.15	447.40	2.24E-05	9.81E-05	33.28	145.75	14.19	62.15	6.56	28.73	1.47	6.46	1.03	4.51	4.59	20.12
TOTAL Controlled Emissions	0.10	0.45	2.24E-08	9.81E-08	0.033	0.15	0.014	0.062	0.0066	0.029	0.0015	0.0065	0.0010	0.0045	2.30E-05	1.01E-04
Uncontrolled Emissions Per Unit	102.15	447.40	2.24E-05	9.81E-05	33.28	145.75	14.19	62.15	6.56	28.7	1.47	6.46	1.03	4.51	4.59	20.12
Controlled Emissions Per Unit	0.10	0.45	2.24E-08	9.81E-08	0.033	0.15	0.014	0.062	0.0066	0.0287	0.0015	0.0065	0.0010	0.0045	2.30E-05	1.01E-04

Note: Controlled methane based on 99.9995% destruction (based on 0.001 kg/MMBtu emission EF in 40 CFR Part 98).

Emissions estimated using BR&E ProMax.

TEG Dehydrator controlled by thermal oxidizer unit EP-9

TEG Dehydrator controlled emissions exit via stack EP-9 but are listed as 2-EP-7 emission unit emissions



Targa Midstream Services LLC - Roadrunner Gas Processing Plant

Amine Gas Treatment

Emission Unit: EP-8, 2-EP-8, 3-EP-8
 Source Description: Amine vent controlled by thermal oxidizer unit EP-9
 Thermal Oxidizer Control Efficiency: 99.9%
 Operating Hours: 8760 hrs/yr

Components	Uncontrolled ¹		Thermal Oxidizer Control Efficiency	Controlled ⁴	
	EP-8 Amine Vent (lb/hr)	EP-8 Amine Vent (ton/yr)		EP-8 Amine Vent (lb/hr)	EP-8 Amine Vent (ton/yr)
H2S ²	14.17	62.05	99.9%	0.014	0.062
SO2 ³	-	-	-	28.331	124.09
CO2	85,277.07	373,513.58	-	85,277.074	373513.58
N2	0.13	0.57	-	0.131	0.57
Methane	78.29	342.89	99.9%	0.078	0.34
Ethane	57.56	252.11	99.9%	0.058	2.52E-01
Propane	24.52	107.41	99.9%	0.025	0.11
i-Butane	2.53	11.07	99.9%	0.003	0.011
n-Butane	11.35	49.70	99.9%	0.011	0.050
i-Pentane	0.71	3.12	99.9%	0.001	<0.01
n-Pentane	1.26	5.52	99.9%	0.001	<0.01
n-Hexane	0.72	3.15	99.9%	0.00072	<0.01
n-Heptane	0.11	0.47	99.9%	0.000	<0.01
n-Octane	0.02	0.11	99.9%	0.000	<0.01
n-Nonane	0.00E+00	0.00E+00	99.9%	-	0.00E+00
n-Decane	0.00E+00	0.00E+00	99.9%	-	0.00E+00
Undecane	0.00E+00	0.00E+00	99.9%	-	0.00E+00
Benzene	90.79	397.67	99.9%	0.091	0.40
Toluene	5.62E+01	2.46E+02	99.9%	0.056	0.25
Ethylbenzene	18.11	79.33	99.9%	0.018	0.08
m-Xylene	17.67	77.39	99.9%	0.018	0.08
Water	2,506.19	10,977.09	-	2,506.185	10.98
MDEA	8.27E-05	3.62E-04	-	0.000	<0.01
Piperazine	9.05E-05	3.97E-04	-	0.000	<0.01
TEG	0.00E+00	0.00E+00	-	-	0.00
TOTALS:	88,157	386,129	-	87812.10	373650.86
TOTAL VOCs:	224.00	981.12	-	0.22	0.98
TOTAL HAPs:	183.50	803.71	-	0.18	0.80

Notes:

¹ Emissions from the amine vent are calculated using BR&E ProMax. Hourly emissions are based on the maximum emissions determined from ProMax runs conducted at varying gas flowrates.

² Controlled H₂S emissions assume conversion to SO₂ based on control efficiency.

³ Controlled SO₂ emissions assumed 100% conversion of H₂S to SO₂.

⁴ Controlled emissions are represented at the exit via stack EP-9 but are listed as EP-8 emission unit emissions except for SO₂ and H₂S.



Targa Midstream Services LLC - Roadrunner Gas Processing Plant

Condensate Storage Tanks

Emission unit number(s):

Source description: Condensate Tanks

Annual Operating Hours: 8,760
 Control Efficiency: 95%
 Number of Tanks: 5
 Capacity of Tanks: 1,000 bbl
 Hourly Throughput: 333.33 bbl/hr
 Daily Throughput: 8000.00 bbl/d
 Annual Throughput: 2920000 bbl/yr
 Hourly Throughput per Tank: 67 bbl/hr
 Daily Throughput per Tank: 1600 bbl/d
 Annual Throughput per Tank: 584000 bbl/yr

Condensate Tank Emissions ^{1,2}								
Component	Uncontrolled Emissions (hourly basis)			Uncontrolled Emissions (annual basis)			Controlled Emissions	
	Total Flash (lb/hr)	Total Working and Breathing (lb/hr)	Total per Tank (lb/hr)	Total Flash (lb/hr)	Total Working and Breathing (lb/hr)	Total Emissions Per Tank (tpy)	Total Emissions per Tank (lb/hr)	Total Emissions Per Tank (tpy)
Carbon Dioxide	0.00E+00	0.00E+00	0.00E+00	0.00E+00	0.00E+00	0.00E+00	0.00E+00	0.00E+00
Hydrogen Sulfide	2.88E-04	1.86E-02	0.00	0.00E+00	2.68E-03	2.35E-03	1.88E-04	1.17E-04
Nitrogen	7.73E-01	2.29E+00	0.61	0.00E+00	6.18E-01	5.42E-01	6.13E-01	5.42E-01
Methane	3.78E-03	6.10E-02	0.01	0.00E+00	1.29E-02	1.13E-02	6.48E-04	5.67E-04
Ethane	1.85E-03	1.84E-01	0.04	0.00E+00	2.83E-02	2.48E-02	1.86E-03	1.24E-03
Propane	6.92E-03	5.67E-01	0.11	0.00E+00	8.03E-02	7.04E-02	5.74E-03	3.52E-03
i-Butane	1.34E-02	9.91E-01	0.20	0.00E+00	1.34E-01	1.17E-01	1.00E-02	5.85E-03
n-Butane	1.81E-01	1.37E+01	2.78	0.00E+00	1.82E+00	1.59E+00	1.39E-01	7.96E-02
i-Pentane	5.92E-01	4.15E+01	8.42	0.00E+00	5.21E+00	4.57E+00	4.21E-01	2.28E-01
n-Pentane	7.24E-01	5.07E+01	10.28	0.00E+00	6.23E+00	5.46E+00	5.14E-01	2.73E-01
i-Hexane	3.42E-01	2.37E+01	4.82	0.00E+00	2.78E+00	2.44E+00	2.41E-01	1.22E-01
Hexane	1.91E-01	1.31E+01	2.67	0.00E+00	1.51E+00	1.32E+00	1.33E-01	6.60E-02
Heptane	9.96E-02	6.81E+00	1.38	0.00E+00	7.25E-01	6.35E-01	6.91E-02	3.18E-02
Cyclopentane	0.00E+00	0.00E+00	0.00	0.00E+00	0.00E+00	0.00E+00	0.00E+00	0.00E+00
Benzene	1.58E-02	7.06E-01	0.14	0.00E+00	7.84E-02	6.87E-02	7.22E-03	3.44E-03
Cyclohexane	6.37E-02	3.96E+00	0.80	0.00E+00	4.45E-01	3.90E-01	4.02E-02	1.95E-02
Methylcyclohexane	0.00E+00	0.00E+00	0.00	0.00E+00	0.00E+00	0.00E+00	0.00E+00	0.00E+00
2,2,4-Trimethylpentane	0.00E+00	0.00E+00	0.00	0.00E+00	0.00E+00	0.00E+00	0.00E+00	0.00E+00
Toluene	6.58E-03	3.04E-01	0.06	0.00E+00	3.17E-02	2.78E-02	3.11E-03	1.39E-03
Ethylbenzene	2.84E-04	1.37E-02	0.00	0.00E+00	1.33E-03	1.17E-03	1.40E-04	5.85E-05
o-Xylene	9.52E-04	4.02E-02	0.01	0.00E+00	3.84E-03	3.36E-03	4.12E-04	1.68E-04
Octane	3.42E-02	2.13E+00	0.43	0.00E+00	2.08E-01	1.82E-01	2.16E-02	9.09E-03
VOC	2.27	158.34	32.12	0.00	19.26	16.87	1.61	0.84
Total HAPS	0.21	14.21	2.89	0.00	1.62	1.42	0.14	0.07
H₂S	2.88E-04	1.86E-02	3.77E-03	0.00E+00	2.68E-03	2.35E-03	1.88E-04	1.17E-04

¹ Emissions from the condensate tanks are controlled by the combustor (COMB-1) with an assumed 95% DRE.

² Emissions are calculated using BR&E ProMax. Hourly loading emissions are based on the maximum hourly throughput of the facility. Annual emissions are



Targa Midstream Services LLC - Roadrunner Gas Processing Plant

Produced Water Storage Tank

Emission unit number(s): T-6
 Source description: Produced Water Storage Tank

Annual Operating Hours: 8,760
 Control Efficiency: 0%
 Number of Tanks: 1
 Capacity of Tanks: 400 bbl
 Hourly Throughput: 12.64 bbl/hr
 Daily Throughput: 303.32 bbl/d
 Annual Throughput: 24526 bbl/yr

Produced Water Tank Emissions ^{1,2}								
Component	Uncontrolled Emissions (hourly basis)			Uncontrolled Emissions (annual basis)			Controlled Emissions	
	Flash (lb/hr)	Working and Breathing (lb/hr)	Total per Tank (lb/hr)	Flash (lb/hr)	Working and Breathing (lb/hr)	Total Emissions Per Tank (tpy)	Total Emissions per Tank (lb/hr)	Total Emissions Per Tank (tpy)
Carbon Dioxide	2.29E-01	3.04E-01	5.32E-01	2.29E-01	1.31E-02	1.06E+00	5.32E-01	1.06E+00
Hydrogen Sulfide	2.08E-03	3.11E-03	0.01	2.08E-03	1.17E-04	9.62E-03	5.19E-03	9.62E-03
Nitrogen	1.38E-03	5.16E-06	0.00	1.38E-03	1.08E-06	6.05E-03	1.39E-03	6.05E-03
Methane	2.30E-01	3.23E-03	0.23	2.30E-01	5.00E-04	1.01E+00	2.33E-01	1.01E+00
Ethane	1.92E-01	4.10E-03	0.20	1.92E-01	4.84E-04	8.45E-01	1.97E-01	8.45E-01
Propane	9.70E-02	3.11E-04	0.10	9.70E-02	4.16E-05	4.25E-01	9.73E-02	4.25E-01
i-Butane	1.03E-02	6.10E-06	0.01	1.03E-02	1.08E-06	4.53E-02	1.03E-02	4.53E-02
n-Butane	2.40E-02	1.73E-05	0.02	2.40E-02	2.25E-06	1.05E-01	2.40E-02	1.05E-01
i-Pentane	3.72E-03	5.71E-07	0.00	3.72E-03	9.22E-08	1.63E-02	3.72E-03	1.63E-02
n-Pentane	1.23E-03	5.38E-08	0.00	1.23E-03	9.07E-09	5.40E-03	1.23E-03	5.40E-03
Hexane	3.06E-04	2.42E-09	0.00	3.06E-04	4.40E-10	1.34E-03	3.06E-04	1.34E-03
Heptane	6.65E-05	1.05E-10	0.00	6.65E-05	2.05E-11	2.91E-04	6.65E-05	2.91E-04
Cyclopentane	1.07E-03	9.22E-07	0.00	1.07E-03	6.87E-08	4.69E-03	1.07E-03	4.69E-03
Benzene	3.54E-03	7.15E-05	0.00	3.54E-03	2.81E-06	1.55E-02	3.61E-03	1.55E-02
Cyclohexane	9.89E-04	2.48E-07	0.00	9.89E-04	1.78E-08	4.33E-03	9.89E-04	4.33E-03
Methylcyclohexane	2.20E-04	7.47E-09	0.00	2.20E-04	7.79E-10	9.65E-04	2.20E-04	9.65E-04
2,2,4-Trimethylpentane	1.17E-05	2.31E-11	0.00	1.17E-05	6.23E-12	5.11E-05	1.17E-05	5.11E-05
Toluene	8.44E-04	3.94E-06	0.00	8.44E-04	1.45E-07	3.70E-03	8.48E-04	3.70E-03
Ethylbenzene	1.44E-04	1.90E-07	0.00	1.44E-04	7.39E-09	6.29E-04	1.44E-04	6.29E-04
o-Xylene	8.35E-05	1.20E-07	0.00	8.35E-05	4.46E-09	3.66E-04	8.36E-05	3.66E-04
Octane	1.60E-06	3.22E-13	0.00	1.60E-06	5.76E-14	7.03E-06	1.60E-06	7.03E-06
Water	1.26E-02	6.01E-01	0.61	1.26E-02	2.85E-02	1.80E-01	6.14E-01	1.80E-01
VOC	0.14	4.12E-04	0.14	0.14	4.81E-05	0.63	0.14	0.63
Total HAPS	4.93E-03	7.57E-05	5.00E-03	4.93E-03	2.97E-06	2.16E-02	5.00E-03	2.16E-02
H₂S	2.08E-03	3.11E-03	5.19E-03	2.08E-03	1.17E-04	9.62E-03	5.19E-03	9.62E-03

¹ Emissions from the produced water tank are uncontrolled.

² Emissions are calculated using BR&E ProMax. Hourly loading emissions are based on the maximum hourly throughput of the facility. Annual emissions are based on the average daily throughput of the facility.

General Information		
Flare functions as emergency control device. When streams are fed to flare it will be treated as an emission event.		
(1) Flare Name:	TO 1	
(2) Flare EPN:	EP-9	
(3) What kind of device is this? Pick from list.	Thermal Oxidizer	
Emission Factors for Waste Gas Stream(s) (ppmv)		
	NOx	50
	CO	40
(4) Is there one or more pilot streams fired with pipeline quality natural gas or propane? Pick Yes or No. Follow instructions below.	No	
Please move on to next question below.		
Emission Factors for Pilot Stream (lb/MMscf)		
	NOx	0
	CO	0
(5) Is there one or more pilot streams fired with field gas? Pick Yes or No. Follow instructions below.	No	
Please move on to next question below.		
Emission Factors for Pilot Stream (ppmv)		
	NOx	0
	CO	0
(6) Is there an added fuel stream made up of pipeline quality natural gas or propane? Pick Yes or No. Follow instructions below.	Yes	
Enter added fuel stream information into the boxes in the column for Steam No. 2 below.		
Emission Factors for Added Fuel Stream (ppmv)		
	NOx	
	CO	
(7) Is there an added fuel stream made up of field gas? Pick Yes or No. Follow instructions below.	No	
Please move on to next question below.		
Emission Factors for Added Fuel Stream (lb/MMBtu)		
	NOx	0
	CO	0
(8) VOC percent destruction efficiency (%)	99.9	
(9) propane percent destruction efficiency (%) *OPTIONAL*		
(10) H ₂ S percent destruction efficiency (%)	99.9	
(11) Which is utilized for this device?	automatic ignition system	

Emission Factors					
² Emission Factors from Zeeco Guarantee (lb/MMBtu)					
PM (Total)	0.008 lb/MMBtu				
¹ Manufacturers Guaranteed Outlet Concentration					
Pollutant	(ppmv)				
NOx	50				
CO	40				
calculation factors:					
NO2 MW	46.006	lb/lb-mole			
CO MW	28	lb/lb-mole			
Ideal Gas Law	379.43	SCF/lb-mole			
Exhaust Stream per Zeeco Guarantee					
Component	lb/hr	lb/lbmol	lbmol/hr	L/hr	vol%
CO2	33421	44	759.57	32,349,756	32%
H2O	7086.1	18	393.67	16,766,369	17%
N2	31261.58	28	1110.93	47,314,154	47%
SO2	15.47	64	0.24	10,283	0.0102%
O2	3158.75	32	98.7109375	4,204,066	4.1771%
				100%	
Supplemental Fuel Gas per Zeeco Guarantee			30 MMBtu/hr		
Maximum Heating Value per Zeeco Guarantee			75 MMBtu/hr		
PV=nRT					
T=	1600 F		1,144 K		
n=	2,363 lbmol/hr		1,071,889 gmol/hr		
P=	1 atm		29.92 in Hg		
R=	0.082057 atm-L/mol-K				
V	100,644,628 L/hr		3,554,212 ft ³ /hr		
T (act)	1600 F		2059.67 R		
T (std)			327.67 R		
V (std)			759,040 dscfh		
V (std)			12,651 dscfm		
Safety Factor				1.33	
V (std) with safety factor				1,009,523 dscfh	
Emission Factors from AP-42 Table 1.4-3 (lb/MMscf)					
SO ₂	0.6				
VOC	5.5				
benzene	2.10E-03				
propane	1.60				

Controlled Emissions													
Hourly (lb/hr)													
Stream Sent to Flare/Vapor Combustor No.	1	2	3	4	5	6	7	8	9	10	11	12	Total
Stream Sent to Flare/Vapor Combustor Name		Waste Gas from Dehy	Waste Gas from Amine	Supplemental Fuel									
NOx	0.000	... ¹	... ¹	... ¹	0.000	0.000	0.000	0.000	0.000	0.000	0.000	0.000	6.12
CO	0.000	... ¹	... ¹	... ¹	0.000	0.000	0.000	0.000	0.000	0.000	0.000	0.000	2.98
PM2.5	0.000	... ²	... ²	... ²	0.000	0.000	0.000	0.000	0.000	0.000	0.000	0.000	0.60
PM10	0.000	... ²	... ²	... ²	0.000	0.000	0.000	0.000	0.000	0.000	0.000	0.000	0.60
H2S	0.000	0.000	0.014	0.000	0.000	0.000	0.000	0.000	0.000	0.000	0.000	0.000	0.01
SO2	0.000	0.000	26.665	0.000	0.000	0.000	0.000	0.000	0.000	0.000	0.000	0.000	26.66
Crude or Condensate VOC	-	-	0.000	0.000	0.000	0.000	0.000	0.000	0.000	0.000	0.000	0.000	0.00
Natural Gas VOC	0.00	0.31	0.224	0.000	0.000	0.000	0.000	0.000	0.000	0.000	0.000	0.000	0.53
Total VOC	0.00	0.31	0.224	0.000	0.000	0.000	0.000	0.000	0.000	0.000	0.000	0.000	0.53
benzene	0.000	0.04257	0.091	0.000	0.000	0.000	0.000	0.000	0.000	0.000	0.000	0.000	0.13
Annual (tpy)													
Stream Sent to Flare/Vapor Combustor No.	1	2	3	4	5	6	7	8	9	10	11	12	Total
Stream Sent to Flare/Vapor Combustor Name		Waste Gas from Dehy	Waste Gas from Amine	Supplemental Fuel									
NOx	0.000	... ¹	... ¹	... ¹	0.000	0.000	0.000	0.000	0.000	0.000	0.000	0.000	26.81
CO	0.000	... ¹	... ¹	... ¹	0.000	0.000	0.000	0.000	0.000	0.000	0.000	0.000	13.05
PM2.5	0.000	... ²	... ²	... ²	0.000	0.000	0.000	0.000	0.000	0.000	0.000	0.000	2.63
PM10	0.000	... ²	... ²	... ²	0.000	0.000	0.000	0.000	0.000	0.000	0.000	0.000	2.63
H2S	0.000	0.000	0.062	0.000	0.000	0.000	0.000	0.000	0.000	0.000	0.000	0.000	0.06
SO2	0.000	0.001	116.792	0.000	0.000	0.000	0.000	0.000	0.000	0.000	0.000	0.000	116.79
Crude or Condensate VOC	-	-	0.000	0.000	0.000	0.000	0.000	0.000	0.000	0.000	0.000	0.000	0.00
Natural Gas VOC	0.000	1.342	0.981	0.000	0.000	0.000	0.000	0.000	0.000	0.000	0.000	0.000	2.32
Total VOC	0.000	1.342	0.981	0.000	0.000	0.000	0.000	0.000	0.000	0.000	0.000	0.000	2.32
benzene	0.000	0.0000	0.398	0.000	0.000	0.000	0.000	0.000	0.000	0.000	0.000	0.000	0.40

¹ CO and NOx emissions calculated based on the emission guarantees from manufacturer and the exhaust flue from the TO.

² PM₁₀/PM_{2.5} emissions based on the emission guarantee from the manufacturer and the maximum heating rate of the TO.

Flare/Vapor Combustor Total Emissions (Each TO)		
	Hourly Emissions (lb/hr)	Annual Emissions (tpy)
Crude or Condensate VOC	0.00	0.00
Natural Gas VOC	0.53	2.32
Total VOC	0.53	2.32
NOx	6.12	26.81
CO	2.98	13.05
PM2.5	0.60	2.63
PM10	0.60	2.63
H2S	0.01	0.06
SO2	26.66	116.79
benzene	0.13	0.40



Targa Midstream Services LLC - Roadrunner Gas Processing Plant

Thermal Oxidizer Downtime

Emission Unit: SSM-TO
 Source Description: Thermal Oxidizer downtime during scheduled maintenance events.
 Annual Downtime: 20 hrs/yr

Components	Uncontrolled Emissions		Thermal Oxidizer Downtime	
	EP-8, 2-EP-8, 3-EP-8	EP-7, 2-EP-7, and 3-EP-7	Total	
	lb/hr	lb/hr	lb/hr	ton/yr
H2S ²	14.17	0.000017	14.17	0.14
SO ₂	0.00	0.00014	1.42E-04	1.42E-06
CO ₂	85,277.07	0.000011	85277.07	852.77
N ₂	0.13	0.0063	0.14	0.001
Methane	78.29	4.20	82.48	0.82
Ethane	57.56	11.02	68.58	0.69
Propane	24.52	20.18	44.71	0.45
i-Butane	2.53	4.90	7.43	0.07
n-Butane	11.35	19.25	30.60	0.306
i-Pentane	0.71	7.44	8.15	0.082
n-Pentane	1.26	9.88	11.14	0.111
n-Hexane	0.72	10.35	11.07	0.111
n-Heptane	0.11	6.51	6.62	0.0662
n-Octane	0.02	0.70	7.24E-01	7.24E-03
n-Nonane	0.00	0.00E+00	0.00E+00	0.00E+00
n-Decane	0.00	0.00E+00	0.00E+00	0.00E+00
Undecane	0.00	0.00E+00	0.00	0.00
Benzene	90.79	14.02	104.82	1.05
Toluene	56.20	6.45	62.65	0.63
Ethylbenzene	18.11	1.46	19.57	0.196
m-Xylene	17.67	0.99	18.66	0.19
Water	2,506.19	4.87	2511.05	25.11
MDEA	8.27E-05	1.72E-04	2.55E-04	2.55E-06
Piperazine	9.05E-05	5.68E-06	9.62E-05	9.62E-07
TEG	0.00E+00	0.00E+00	0.00E+00	0.00E+00
Total VOC:	224.00	102.15	326.15	3.26
Total HAPs:	183.50	33.28	216.77	2.17
Total H₂S:	14.17	0.00	14.17	0.14



Targa Midstream Services LLC - Roadrunner Gas Processing Plant
Flare- Inlet Gas Flare Stream Analysis

Emission Unit: EP-1, 2-EP-1, and 3-EP-1
 Source Description: Process Flares
 Destruction Efficiency: 98%

Annual Inlet Gas Flared Gas Volume:¹

Estimated Total Annual Gas (MSCF/yr):	240,000.0	Requested Annual Volume per Train
Manuf. Daily Gas Volume (MSCF/day):	240,000.0	Hourly Treatment Train Gas Flowrate
Max Hourly Flared Gas (MSCF/hr):	10,000.0	

Component	Mol Wt (lb/lb-mol) ²	Component Net Heating Value (BTU/scf) ²	Inlet Gas Analysis Date: 11/20/2019 mol%
Nitrogen	28.013	0	1.39700%
Methane	16.043	909	76.98300%
Carbon Dioxide	44.010	0	0.33000%
Hydrogen Sulfide*	34.081	587	0.05000%
Ethane	30.069	1,619	12.23400%
Propane	44.096	2,315	5.66800%
Iso-Butane	58.122	3,000	0.71700%
n-Butane	58.122	3,011	1.59500%
Iso-Pentane	72.149	3,699	0.28700%
n-Pentane	72.149	3,707	0.28800%
i-Hexanes	86.175	4,404	0.17900%
n-Hexane	86.175	4,404	0.10500%
Benzene	78.112	3,591	0.01700%
Cyclohexane	84.160	4,180	0.04800%
i-Heptanes	100.202	5,100	0.09100%
n-Heptane	100.202	5,100	0.01700%
Toluene	92.138	4,273	0.00700%
i-Octanes	114.229	5,796	0.03400%
n-Octane	114.229	5,796	0.00200%
i-Nonanes	128.255	6,493	0.00100%
TOTAL =	21.30	1143.57	100.05%

*Hydrogen Sulfide conservatively assumed to be 5 ppm.

Stream Emission Calculation:

Components	Hourly Emissions (pph) ³	Annual Emissions (tpy) ³	Hourly MMBTU Rate ⁴ (MMBTU/hr)	Total Net MMBTU ⁴ (MMBTU/yr)
Nitrogen	10314.75	123.78	0.00	0.00
Methane	32524.06	3906.29	7000.83	168020.02
Hydrogen Sulfide*	449.14	5.39	2.93	70.41
Carbon Dioxide	3827.97	45.94	0.00	0.00
Ethane	96959.45	1163.51	1980.68	47536.43
Propane	65876.68	790.52	1312.14	31491.41
Iso-Butane	10984.05	131.81	215.10	5162.40
n-Butane	24434.53	293.21	480.25	11526.11
Iso-Pentane	5457.77	65.49	106.16	2547.87
n-Pentane	5476.78	65.72	106.76	2562.28
i-Hexanes	4065.72	48.79	78.83	1891.96
n-Hexane	2384.92	28.62	46.24	1109.81
Benzene	350.00	4.20	6.10	146.51
Cyclohexane	1064.75	12.78	20.06	481.54
i-Heptanes	2403.37	28.84	46.41	1113.84
n-Heptane	448.98	5.39	8.67	208.08
Toluene	170.00	2.04	2.99	71.79
i-Octanes	1023.67	12.28	19.71	472.95
n-Octane	60.22	0.72	1.16	27.82
i-Nonanes	33.80	0.41	0.65	15.58
Total BTU Values =			11,435.70	274,456.81

*Hydrogen Sulfide conservatively assumed to be 10 ppm.

Gas Flaring Summary

	pph	tpy
Total =	561,310.58	6,735.73
Total VOC =	124,235.22	1,490.82
Total HAP =	2,904.91	34.859
Total Hexane =	2,384.92	28.619
Total H₂S =	449.14	5.39

Controlled Flaring Stream⁵

	pph	tpy
Total VOC =	2,484.70	29.82
Total HAP =	58.10	0.70
Total Hexane =	47.70	0.57
Total H₂S =	8.98	0.11

Notes:

- Conservatively estimated annual gas volume. Max anticipated hourly volume based on manufacturer rated capacity.
- Component Molecular Weights from the following source: BR&E Promax
 Component Net Heating Values from the following source: BR&E Promax
- Hourly and Annual Event gas emissions calculated as follows:
 Hourly Emissions (lb/hr) = Hourly Gas Volume (scf/hr) * Component Mol Wt (lb/lb-mol) * Component Mole% / 379.4 ft³/lb mol
 Annual Emissions (tpy) = Annual Gas Volume (scf/yr) * Component Mol Wt (lb/lb-mol) * Component Mole% / 379.4 ft³/lb mol / 2000 lb/ton
- Component MMBTU/hr = [Component Hourly Emissions (pph) * Component Net Heating Value (BTU/scf) * 379.4 ft³/lb-mol] / Component Mol Wt (lb/lb-mol)
 Component MMBTU/yr = [Component Annual Emissions (tpy) * 2000 lb/ton * Component Net Heating Value (BTU/scf) * 379.4 ft³/lb-mol] / Component Mol Wt (lb/lb-mol)
 Total Net MMBTU/event = Sum of all Individual Component MMBTU/event
- VOC, HAP and H₂S emissions estimated based on event stream routed to flare and 98% efficiency.



Targa Midstream Services LLC - Roadrunner Gas Processing Plant
Flare- Residue Gas Flare Stream Analysis

Emission Unit: EP-1, 2-EP-1, and 3-EP-1
 Source Description: Process Flares
 Destruction Efficiency: 98%

Annual Residue Gas Flared Gas Volume:¹

Estimated Total Annual Gas (MSCF/yr):	25.0	Requested Annual Volume per Train
Manuf. Daily Gas Volume (MSCF/day):	600.0	Hourly Treatment Train Gas Flowrate
Max Hourly Flared Gas (MSCF/hr):	25.0	

Component	Mol Wt (lb/lb-mol) ²	Component Net Heating Value (BTU/scf) ²	Residue Gas Analysis Date: 9/21/2021 mol%
Helium	4.003	0	0.0071%
Nitrogen	28.013	0	1.2421%
Carbon Dioxide	44.010	0	0.0560%
Oxygen	31.999	0	0.0047%
Hydrogen Sulfide	34.081	587	0.0000%
Methane	16.043	909	88.3783%
Ethane	30.069	1,619	9.0801%
Propane	44.096	2,315	0.6880%
i-Butane	58.122	3,000	0.0644%
n-Butane	58.122	3,011	0.1371%
i-Pentane	72.149	3,699	0.0350%
n-Pentane	72.149	3,707	0.0481%
Neopentane	72.149	3,707	0.0013%
Hexanes+	87.090	4,475	0.1144%
n-Hexane	86.175	4,404	0.0190%
Benzene	78.112	3,591	0.0918%
Toluene	92.138	4,273	0.0272%
2,2,4-Trimethylpentane	114.229	5,796	0.0045%
Ethylbenzene	106.165	4,971	0.0004%
O-Xylene	106.165	4,905	0.0004%
TOTAL =	17.98	986.55	100.00%

Stream Emission Calculation:

Components	Hourly Emissions (pph) ³	Annual Emissions (tpy) ³	Hourly MMBTU Rate ⁴ (MMBTU/hr)	Total Net MMBTU ⁴ (MMBTU/yr)
Helium	0.02	9.36E-06	0.00E+00	0.00E+00
Nitrogen	22.93	1.15E-02	0.00E+00	0.00E+00
Oxygen	1.62	8.12E-04	0.00E+00	0.00E+00
Carbon Dioxide	0.10	4.96E-05	0.00E+00	0.00E+00
Hydrogen Sulfide	0.00	0.00E+00	0.00E+00	0.00E+00
Methane	934.27	4.67E-01	2.01E+01	2.01E+01
Ethane	179.91	9.00E-02	3.68E+00	3.68E+00
Propane	19.99	1.00E-02	3.98E-01	3.98E-01
i-Butane	2.47	1.23E-03	4.83E-02	4.83E-02
n-Butane	5.25	2.63E-03	1.03E-01	1.03E-01
i-Pentane	1.66	8.32E-04	3.24E-02	3.24E-02
n-Pentane	2.29	1.14E-03	4.46E-02	4.46E-02
Neopentane	0.06	3.09E-05	1.20E-03	1.20E-03
Hexanes+	6.56	3.28E-03	1.28E-01	1.28E-01
n-Hexane	1.08	5.40E-04	2.09E-02	2.09E-02
Benzene	4.73	2.36E-03	8.25E-02	8.25E-02
Toluene	1.65	8.24E-04	2.90E-02	2.90E-02
2,2,4-Trimethylpentane	0.34	1.71E-04	6.58E-03	6.58E-03
Ethylbenzene	0.03	1.48E-05	5.27E-04	5.27E-04
O-Xylene	0.03	1.55E-05	5.44E-04	5.44E-04
Total BTU Values =			24.66	24.66

Gas Flaring Summary

	pph	tpy
Total =	1,184.99	0.59
Total VOC =	46.14	0.023
Total HAP =	7.86	0.0039
Total Hexane =	1.08	0.001
Total H₂S =	0.00E+00	0.00E+00

Controlled Flaring Stream⁵

	pph	tpy
Total VOC =	0.92	4.61E-04
Total HAP =	0.16	7.86E-05
Total Hexane =	0.022	1.08E-05
Total H₂S =	0.00E+00	0.00E+00

Notes:

- Conservatively estimated annual gas volume. Max anticipated hourly volume based on manufacturer rated capacity.
- Component Molecular Weights from the following source: BR&E Promax
 Component Net Heating Values from the following source: BR&E Promax
- Hourly and Annual Event gas emissions calculated as follows:
 Hourly Emissions (lb/hr) = Hourly Gas Volume (scf/hr) * Component Mol Wt (lb/lb-mol) * Component Mole% / 379.4 ft³/lb mol
 Annual Emissions (tpy) = Annual Gas Volume (scf/yr) * Component Mol Wt (lb/lb-mol) * Component Mole% / 379.4 ft³/lb mol / 2000 lb/ton
- Component MMBTU/hr = [Component Hourly Emissions (pph) * Component Net Heating Value (BTU/scf) * 379.4 ft³/lb-mol] / Component Mol Wt (lb/lb-mol)
 Component MMBTU/yr = [Component Annual Emissions (tpy) * 2000 lb/ton * Component Net Heating Value (BTU/scf) * 379.4 ft³/lb-mol] / Component Mol Wt (lb/lb-mol)
 Total Net MMBTU/event = Sum of all Individual Component MMBTU/event
- VOC, HAP and H₂S emissions estimated based on event stream routed to flare and 98% efficiency.



Targa Midstream Services LLC - Roadrunner Gas Processing Plant

Process Flares

Emission Units: EP-1, 2-EP-1, and 3-EP-1
 Source Description: Process Flares
 Destruction Efficiency: 98%

Flare Information	
Unit(s):	EP-1, 2-EP-1, and 3-EP-1
Unit Count:	3
Annual Operating Hours:	8,760
Combustion Efficiency (%):	98%

Pilot Input Information ¹				
Activity	Parameters	Value	Unit	Notes:
EP-1 Pilot	Hourly Volume Flow Rate	500.0	scf/hr	Design Specification
	Natural Gas Heat Value	1071.8	BTU/scf	Fuel Gas Heat Value
	Annual Volume Flow Rate	4.38	MMscf/yr	
	Hourly Heat Rate	0.536	MMBtu/hr	
	Annual Heat Rate	4694.48	MMBtu/yr	
EP-1 Purge Gas	Hourly Volume Flow Rate	980.0	scf/hr	Design Specification
	Natural Gas Heat Value	1071.8	BTU/scf	Fuel Gas Heat Value
	Annual Volume Flow Rate	8.58	MMscf/yr	
	Hourly Heat Rate	1.050	MMBtu/hr	
	Annual Heat Rate	9201.19	MMBtu/yr	
2-EP-1 Pilot	Hourly Volume Flow Rate	78.0	scf/hr	Design Specification
	Natural Gas Heat Value	1071.8	BTU/scf	Fuel Gas Heat Value
	Annual Volume Flow Rate	0.68	MMscf/yr	
	Hourly Heat Rate	0.084	MMBtu/hr	
	Annual Heat Rate	732.34	MMBtu/yr	
2-EP-1 Purge Gas	Hourly Volume Flow Rate	1040.0	scf/hr	Design Specification
	Natural Gas Heat Value	1071.8	BTU/scf	Fuel Gas Heat Value
	Annual Volume Flow Rate	9.11	MMscf/yr	
	Hourly Heat Rate	1.115	MMBtu/hr	
	Annual Heat Rate	9764.53	MMBtu/yr	
3-EP-1 Pilot	Hourly Volume Flow Rate	219.0	scf/hr	Design Specification
	Natural Gas Heat Value	1071.8	BTU/scf	Fuel Gas Heat Value
	Annual Volume Flow Rate	1.92	MMscf/yr	
	Hourly Heat Rate	0.235	MMBtu/hr	
	Annual Heat Rate	2056.18	MMBtu/yr	

¹ Pilot and Purge rates for EP-1, 2-EP-2, and 3-EP-3 based on manufacturer specification sheet for each flare.

Pilot Emission Calculation

Description	NO _x ¹	CO ¹	VOC	SO ₂ ¹	H ₂ S ¹	HAPs	Units	Notes
Emission Factors	0.138	0.2755					lb/MMBTU	TNRCC RG-109 (high Btu; other)
Fuel Sulfur and H ₂ S Content				2.0	1.00E+01		gr S/100scf lb S/ Mscf ppm gr H ₂ S /100scf lb H ₂ S/Mscf	Conservative assumption for fuel sulfur content (gr/100scf) Gr S/100 scf * (1 lb/7000 gr) * (1000scf/Mscf) Pipeline Specification Pilot gas H ₂ S content
EP-1 Pilot Emissions	0.074	0.15	-	0.0037	8.95E-06	-	lb/hr	
2-EP-1 Pilot Emissions	0.32	0.65	-	0.016	3.92E-05	-	tpy	
3-EP-1 Pilot Emissions	0.012	0.023	-	0.00057	1.40E-06	-	lb/hr	
EP-1 Purge Emissions	0.05	0.10	-	0.0025	6.11E-06	-	tpy	
2-EP-1 Purge Emissions	0.032	0.065	-	0.0016	1.40E-06	-	lb/hr	
3-EP-1 Purge Emissions	0.14	0.28	-	0.0071	6.11E-06	-	tpy	
2-EP-1 Purge Emissions	0.14	0.29	-	0.0056	1.75E-05	-	lb/hr	
3-EP-1 Purge Emissions	0.63	1.27	-	0.025	7.68E-05	-	tpy	
2-EP-1 Purge Emissions	0.15	0.31	-	0.0077	1.86E-05	-	lb/hr	
3-EP-1 Purge Emissions	0.67	1.35	-	0.034	8.15E-05	-	tpy	
Process Emissions per Flare	1578.13	3150.54	2484.70	828.54	8.98	58.10	lb/hr	Process emissions represent inlet and residue gas flaring when gas can not be sent to sales.
	18.94	37.81	29.82	9.94	0.108	0.70	tpy	
Total EP-1 Flare Emissions	1578.35	3150.97	2484.70	828.55	8.98	58.10	lb/hr	
	19.90	39.72	29.82	9.98	0.108	0.70	tpy	
Total 2-EP-1 Flare Emissions	1578.29	3150.87	2484.70	828.55	8.98	58.10	lb/hr	
	19.66	39.26	29.82	9.98	0.108	0.70	tpy	
Total 3-EP-1 Flare Emissions	1578.16	3150.60	2484.70	828.54	8.98	58.10	lb/hr	
	19.08	38.09	29.82	9.95	0.108	0.70	tpy	

Inlet Gas Flaring Emissions Calculations per Flare

Unit ID	Pollutant	Emission Factors (lb/MMBTU) ¹	Emissions lb/hr	tons/yr
EP-1, 2-EP-1, 3-EP-1	NO _x	0.138	1578.13	18.938
	CO	0.2755	3150.54	37.806
	VOC	Mass Balance ²	2484.70	29.82
	HAP	Mass Balance ²	58.10	0.697
	H ₂ S	Mass Balance ²	8.98	0.108
	SO ₂	Stoichiometric ³	828.54	9.94

Flare Stream ¹: 11,435.70 Max Net Hourly MMBTU Value (MMBTU/hr)
 274,456.81 Net Annual MMBTU Value (MMBTU/yr)

Residue Gas Flaring Emissions Calculations per Flare

Unit ID	Pollutant	Emission Factors (lb/MMBTU) ¹	Emissions lb/hr	tons/yr
EP-1, 2-EP-1, 3-EP-1	NO _x	0.138	3.40	1.70E-03
	CO	0.2755	6.79	3.40E-03
	VOC	Mass Balance ²	0.92	4.61E-04
	HAP	Mass Balance ²	0.16	7.86E-05
	H ₂ S	Mass Balance ²	0.00	0.00E+00
	SO ₂	Stoichiometric ³	0.00	0.00E+00

Flare Stream ¹: 24.66 Max Net Hourly MMBTU Value (MMBTU/hr)
 24.66 Net Annual MMBTU Value (MMBTU/yr)

Notes:

- (1) Flare NO_x and CO emission factors: TNRCC RG-109 (high Btu; other); SO₂: Mass balance assuming 98% combustion of H₂S and 100% conversion of combusted H₂S to SO₂.
 Pilot Gas SO₂ Emissions (lb/hr) = (Pilot Gas Flow (Mscf/hr) * Fuel Gas Sulfur Content (lb S/Mscf) * (64 lb/mol SO₂ / 32 lb/mol S)) + (Pilot Gas Flow (Mscf/hr) * Fuel Gas H₂S Content (lb H₂S/mol SO₂ / 34 lb/mol H₂S) * (DRE))
 Pilot Gas H₂S Emissions (lb/hr) = (Pilot Gas Flow Rate (Mscf/hr) * Fuel Gas H₂S Content (lb H₂S/mol SO₂ / 34 lb/mol H₂S) * (1 - DRE))
 Process SO₂ Emissions (lb/hr) = [H₂S Mass Flow Rate (lb/hr) * DRE * (64 lb/mol SO₂ / 34 lb/mol H₂S)]
 Process SO₂ Emissions (tpy) = [H₂S Mass Flow Rate (tpy) * DRE * (64 lb/mol SO₂ / 34 lb/mol H₂S)]
- (2) VOC, HAP and H₂S emissions estimated based on event stream routed to flare and 98% efficiency.
- (3) Flare stream includes inlet and residue gas.

Emission Unit	MSSM
Name	Condensate Tanks
Tank No.:	5
Product stored:	Condensate
Type of tank roof	Fixed Roof
Tank Capacity (bbl)	1,000
Tank Diameter (ft) (D)	21.50
Vapor Molecular Wt. (lb/lb mol) (M _v)	72.77
Number of events/yr	5
Height of the roof (ft)	16.00
Saturation factor (S)	1.0

Vapor Space Volume (ft ³) (V _v)	5808.80
Height of Vapor Space under roof (ft)* (h _v)	16.00

	Max. hourly emissions lb/hr	Avg. Annual emissions tpy	
Duration of activity (hrs/event)	1	1	
True Vapor Pressure (psia) (P)	11.23	6.79	Max > Avg
Day time temperature (°F)	95.00	63.20	Max > Avg
Night time temperature (°F)	68.00	49.10	
Temperature Expansion %	4.86	2.69	
Emissions (lb/event)	797.06	511.07	
Max. Hourly Emissions (lb/hr)	38.78		
Avg. Hourly Emissions (lb/hr)		13.77	
Avg. Annual emissions (tpy)		0.03	

VOC Wt%	0.98
H ₂ S Wt%	-
Benzene Wt%	0.0044

Type of Control Device	
Are tank vapors (A) uncontrolled; (B) controlled by a flare, vapor combustor, thermal oxidizer, or vapor recovery unit (VRU); or (C) controlled by another type of control device?	(B) cont. by flare/ VC/TO/VRU
VOC Control Efficiency	95
H ₂ S Control Efficiency	95

VOC Type: (pick from list)
Natural Gas VOC

Emission Type: (pick from list)
Low Pressure Periodic

Emissions before control and before wt% reduction		
Type of Losses	Max. hourly emissions lb/hr	Avg. Annual emissions tpy
Thermal / Passive Expansion	38.78	0.03
Vapors Captured by Control Device		
Air Contaminant	Max. hourly emissions lb/hr	Avg. Annual emissions tpy
Total VOC	0.36	0.00
Total H ₂ S	0.00	0.00
Total Benzene	0.00	0.00
Planned MSS Emissions		
Air Contaminant	Max. hourly emissions lb/hr	Avg. Annual emissions tpy
Total VOC	0.02	<0.01
Benzene	<0.01	-
Toluene	-	-
Ethylbenzene	<0.01	<0.01
Xylene	<0.01	0.00
Hexane	<0.01	<0.01
2,2,4-Trimethylpentane	-	-
Total H ₂ S	-	-
Total Benzene	<0.01	<0.01

Notes: Calculations based on five tanks being cleaned once a year for the duration of one hour. True vapor pressure calculated from Reid vapor pressure using AP-42 Figure 7.1-14a. Reid vapor pressure collected from Promax simulation.



Targa Midstream Services LLC - Roadrunner Gas Processing Plant
 Condensate Truck Loading

Equation:

$$L_L = \frac{12.46 \cdot SPM}{T}$$

Variables:
 L_L - Loading Loss (lbs/1000 gal loaded)
 S - Saturation Factor (From Table 5.2-1 of AP-42, Section 5.2)
 P - True Vapor Pressure of Loaded Liquid (psia)
 M - Molecular Weight of Vapor (lb/lb mol)
 T - Temperature of Bulk Liquid (°R = [°F + 460])

Unit	Material Loaded ²	Loading Method	S	P _{max} ³ (psia)	M ³ (lb/lbmol)	T _{max} ⁴ (°R)	L _L (lbs/1000 gal)	Hourly Throughput ⁵ (gal/hr)	Capture Efficiency (%)	VOC Wt %	HAP Wt %	H ₂ S Wt %	VOC Vapor Loading Losses (lb/hr)	HAP Vapor Loading Losses (lb/hr)	H ₂ S Vapor Loading Losses (lb/hr)	LOAD-1			DRE (%)
																Uncaptured Hourly VOC Emissions ⁷ (lb/hr)	Uncaptured Hourly HAP Emissions ^{3,7} (lb/hr)	Uncaptured Hourly H ₂ S Emissions ^{3,7} (lb/hr)	
LOAD	Condensate	Submerged	1.0	14.70	52.44	555	17.31	15,120	95.0%	98.41%	8.83%	0.01%	257.50	23.12	0.030	12.88	1.16	1.509E-03	95%
TOTAL													257.50	23.12	0.030	12.88	1.16	1.509E-03	

Unit	Material Loaded ²	Loading Method	S	P _{avg} ³ (psia)	M ³ (lb/lbmol)	T _{avg} ⁴ (°R)	L _L (lbs/1000 gal)	Annual Throughput ⁶ (gal/yr)	Capture Efficiency (%)	VOC Wt %	HAP Wt %	H ₂ S Wt %	VOC Vapor Loading Losses (tpy)	HAP Vapor Loading Losses (tpy)	H ₂ S Vapor Loading Losses (tpy)	LOAD-1			DRE (%)
																Uncaptured Annual VOC Emissions ⁷ (tpy)	Uncaptured Annual HAP Emissions ^{3,7} (tpy)	Uncaptured Annual H ₂ S Emissions ^{3,7} (tpy)	
LOAD	Condensate	Submerged	1.0	14.70	52.44	523	18.36	122,640,000	95.0%	96.68%	8.14%	0.01%	1,088.27	91.63	0.151	54.41	4.581	7.57E-05	95%
TOTAL													1,088.27	91.63	0.151	54.41	4.581	7.57E-05	

¹ Loading loss equation and variables are from AP-42, Section 5.2, Transportation and Marketing of Petroleum Liquids.
² Material loaded is 100% condensate.
³ Vapor pressure, molecular weight, HAP content, and H₂S content is obtained from ProMax run.
⁴ Maximum temperature is 95° F and the average temperature is 63.5° F.
⁵ The maximum hourly throughput is based on the capability of the tank truck to load liquids in one hour.
⁶ Annual throughput for each loading spot represents site-wide throughput; therefore, total annual emissions is the maximum emissions of each loading spot.
⁷ Controlled loading emissions are based on normal operations which account for a capture efficiency of 95% for vapor balanced loading, and a DRE of 95% at the flare. Captured vapors are balanced to the tanks which are controlled by the flare and are thus included in the flare emission totals.

Emission Unit: COMB-1

Emission Factors			
<u>Emission Factors from AP-42 Table 1.4-1 and 1.4-2 (lb/MMscf) and TNRCC RG-109</u>			
	NOx	100	0.138 lb/MMBtu
	CO	84	0.276 lb/MMBtu
	PM (Total)	7.6	0.0075 lb/MMBtu
<u>Emission Factors from AP-42 Table 1.4-2 (lb/MMscf)</u>			
	SO ₂	0.6	
	VOC	5.5	0.0054 lb/MMBtu

Constants	
Btu/MMBtu	1,000,000
scf/MMscf	1,000,000
lb/ton	2,000
molecular	34.08
SO ₂	64.06
seconds/hour	3,600
inches/ft	12
DRE	95%

Stream Sent to Flare/Vapor Combustor Name (Enter Names of Each Stream Here)	BD MSS	Tank MSS	Tank Working/Breathing	Loading Vapor Balance to Tanks	-
Maximum Expected Hourly Volumetric Flow Rate of Stream (scf/hr)	50000	348.6243292	838.99	418.45	51606.06384
Amount of Time Stream Fired (hrs/yr)	40	5	8760	8111.11	-
Maximum Expected Annual Volumetric Flow Rate of Stream (scf/yr)	2,000,000.00	1,743.12	7,349,572.28	3,394,072.08	12745387.48
Heat Value of Stream - from program results or gas analysis (Btu/scf)	1,020.00	2164.99	3,970.23	3,970.23	-
propane weight percent of total stream (%) *OPTIONAL*					-
VOC weight percent of total stream (%) *OPTIONAL*					-

Hourly (lb/hr)					
Stream Sent to Flare/Vapor Combustor Name	BD MSS	Tank MSS	Tank Working/Breathing	Loading Vapor Balance to Tanks	-
VOC	590.9874909	0.36	160.61	244.63	996.59
HAPS	32.16	1.62E-03	14.43	21.96	68.55
H ₂ S	0.023	0.00E+00	0.02	0.03	0.07
Annual (tpy)					
VOC	11.81974982	3.22E-04	84.35	1033.86	1130.03
HAPS	0.643127351	1.44E-06	7.10	87.05	94.79
H ₂ S	0.00046	0.00E+00	0.01	0.00	0.01

Controlled Emissions

Hourly (lb/hr)					
Stream Sent to Flare/Vapor Combustor Name	BD MSS	Tank MSS	Tank Working/Breathing	Loading Vapor Balance to Tanks	-
NOx	7.038	0.104	0.460	0.229	7.83
CO	14.051	0.208	0.918	0.458	15.63
PM2.5	0.380	0.003	0.025	0.012	0.42
PM10	0.380	0.003	0.025	0.012	0.42
H2S	1.16E-03	0.00E+00	9.42E-04	1.43E-03	3.53E-03
SO2	0.071	2.09E-04	3.42E-02	5.15E-02	0.16
Natural Gas VOC	29.549	0.018	8.030	0.009	37.61
Total VOC	29.549	0.018	8.030	0.009	37.61
Total HAPs	1.608	0.000	0.721	1.098	3.43

Annual (tpy)					
Stream Sent to Flare/Vapor Combustor Name	BD MSS	Tank MSS	Tank Working/Breathing	Loading Vapor Balance to Tanks	-
NOx	0.141	0.000	2.013	0.930	3.08
CO	0.281	0.001	4.019	1.856	6.16
PM2.5	0.008	0.000	0.109	0.050	0.17
PM10	0.008	0.000	0.109	0.050	0.17
H2S	2.31E-05	0.00E+00	5.87E-04	1.02E-06	6.11E-04
SO2	6.00E-04	5.23E-07	2.22E-03	1.02E-03	3.83E-03
Natural Gas VOC	0.006	0.000	4.217	0.036	4.26
Total VOC	0.006	0.000	4.217	0.036	4.26
Total HAPs	0.032	0.000	0.355	4.352	4.74

Flare/Vapor Combustor Total Emissions		
	Hourly Emissions (lb/hr)	Annual Emissions (tpy)
Natural Gas VOC	37.61	4.26
Total HAPs	3.43	4.74
NOx	7.83	3.08
CO	15.63	6.16
PM2.5	0.42	0.17
PM10	0.42	0.17
H2S	0.00	0.00
SO2	0.16	0.00

Haul Road Inputs

Site-Wide

Description	Value	Unit
Annual Operating Hours:	8,760	hr
Daily Operating Hours:	24	hr

Unpaved Haul Road

Parameter	Value	Unit
Empty Vehicle Weight ¹	16	ton
Load Size ²	21.2	ton
Loaded Vehicle Weight ³	37.2	ton
Mean Vehicle Weight ⁴	26.6	ton
Vehicles Per Day ⁵	12	VPD
Vehicles Per Year	4380	VPY
Segment Length	0.06	mile
Trips per Segment	2	-
Effective Segment Length ⁶	0.12	mile
Trips per Hour ⁷	1.00	-
Wet Days ⁸	70	day
Surface Silt Content ⁹	4.8	%
Control Efficiency	0	%

¹ Empty vehicle weight includes driver and occupants and full fuel load.

² Include cargo, transported materials, etc. (5.6 lb/gal RVP10 *7560 gal truck/ 2000lb/ton)

³ Loaded vehicle weight = Empty + Load Size

⁴ Mean Vehicle weight = (Loaded Weight + Empty Weight) / 2

⁵ Vehicles per day = (Turnovers/year) / (365 days/year)

⁶ Effective segment length = trips per segment * segment length

⁷ Trips per hour = Vehicles per day * Segments per trip ÷ Hours of Operation per Day

⁸ Wet days is the NM default allowed by NMED without additional justification

⁹ Surface silt content based on AP-42 Section 13.2.2.2, Table 13.2.2-1

Unpaved Road Emission Factors

Route	Calculation Parameters ¹												Hourly Emission Factors			Annual Emission Factors		
	s	W	P	k			a			b			E ²			E _{ext} ⁵		
	Silt Content ¹ %	Mean Vehicle Weight tons	Wet Days day	PM ₃₀ lb/VMT	PM ₁₀ lb/VMT	PM _{2.5} lb/VMT	PM ₃₀	PM ₁₀	PM _{2.5}	PM ₃₀	PM ₁₀	PM _{2.5}	PM ₃₀ ³ lb/VMT	PM ₁₀ lb/VMT	PM _{2.5} lb/VMT	PM ₃₀	PM ₁₀	PM _{2.5}
Condensate Trucks	4.8	26.6	70	4.9	1.5	0.15	0.70	0.90	0.90	0.45	0.45	0.45	6.9	1.8	0.18	5.6	1.4	0.14

¹ Constants are from AP-42 Table 13.2.2-2 in Section 13.2.2.2, and emission factors are calculated using equation 1a.

Unpaved Road Emissions

Route	Calculation Inputs						Uncontrolled Emissions						Controlled Emissions ⁶					
	Annual Operation	Segment Length	Trips per Segment	Number of Trucks per Year	Effective Segment Length	Average VMT/yr ⁴	PM ₃₀		PM ₁₀		PM _{2.5}		PM ₃₀		PM ₁₀		PM _{2.5}	
	hr	mi		trucks/yr	mi	mi/yr	lb/hr	tpy	lb/hr	tpy	lb/hr	tpy	lb/hr	tpy	lb/hr	tpy	lb/hr	tpy
Condensate Trucks	8,760	0.06	2	4380	0.12	526	0.41	1.5	0.11	0.37	0.011	0.037	0.41	1.5	0.11	0.37	0.011	0.037
Totals							0.41	1.5	0.11	0.37	0.011	0.037	0.41	1.5	0.11	0.37	0.011	0.037

¹ Surface silt = % of 75 micron diameter and smaller particles

² $E = k \times (s/12)^a \times (W/3)^b$ (AP-42 page 13.2.2-4 Equation 1a, November 2006)

E= Size Specific Emission Factor (lb/VMT)

s = surface material silt content (%)

k, a, b = constants from AP-42 Table 13.2.2-2

W = Weighted Mean Vehicle Weight from Haul Road Inputs (tons)

³ PM₃₀ emission factor in equation is assumed as a surrogate for TSP emissions

⁴ VMT/yr = Vehicle Miles Travelled per year= Trips per year * Segment Length

⁵ Wet Day Emission Factor = $E \times (365 - \text{Wet Days})/365$. Wet days value is the NM default allowed by NMED without additional justification.

⁶ Controlled Emissions = Uncontrolled Emissions * (1 - Control Factor/100%)

Control Efficiency = 0%

Emission Unit	MSSM
Identifier	MSS Pigging

Describe this MSS event in detail, include specifically what is being done and how it is being done.

Emissions from routine pigging activities.

Actual Volume of the Vented Unit (scf - standard cubic feet)	3,850.00
Actual Volume of the Vented Unit (acf - actual cubic feet)	62.43
Pressure of Gas Inside the Unit Before Venting (psig)	900
Atmospheric Pressure (psia)	14.7
Pressure of Gas Inside the Unit Before Venting (psia)	914.7
Temperature of Gas Inside the Unit Before Venting (°F)	65.00
Temperature of Gas Inside the Unit Before Venting (°R)	524.67
Duration of Each Event (hours/event)	0.17
Frequency of Events (events/year)	175
Venting Gas Molecular Weight (lb/lb-mol)	21.65
VOC wt %	21.42
benzene wt%	0.082
H ₂ S wt%	0.001
HAPs wt %	1.166
CO ₂ wt%	4.879
CH ₄ wt%	56.628
Are planned MSS vapors (A) uncontrolled; (B) controlled by a flare, vapor combustor, thermal oxidizer, or vapor recovery unit (VRU); or (C) controlled by another type of control device?	(A) uncontrolled
VOC Control Efficiency (%)	0
H ₂ S Control Efficiency (%)	0

Ideal Gas Constant, [(ft³*psia)/(R*lb-mol)]

10.73159

Gas Molecular Weight and Weight Percents From Inlet Gas Stream from Amine ProMax

Molecular Weight	21.65
VOC wt %	21.42
Benzene wt %	0.082
H ₂ S wt %	0.001
HAPs wt%	1.1656
CO ₂ wt%	4.8792
CH ₄ wt%	56.6276

Vapors Captured by Control Device

You need to input these values into the appropriate control device emission calculation tab.

	Hourly Emissions (lb/hr)	Annual Emissions (tpy)
VOC Results:	0.00	0.0000
Benzene Results:	0.00	0.0000
H ₂ S Results:	0.00	0.0000
HAPs Results:	0.00	0.0000
CO ₂ Results:	0.00	0.0000
CH ₄ Results:	0.00	0.0000

Planned MSS Emissions

	Hourly Emissions (lb/hr)	Annual Emissions (tpy)
VOC Results:	276.65	4.12
Benzene Results:	1.06	0.02
H ₂ S Results:	0.01	<0.01
HAPs Results:	15.05	0.2239
CO ₂ Results:	63.01	0.9373
CH ₄ Results:	731.29	10.8779

VOC Type: (pick from list)
Natural Gas VOC

Emission Type: (pick from list)
High Pressure Periodic

VENTING EMISSION CALCULATION (for blowdowns, starter vents, gas operated controllers, etc):

Constant:

379.48 scf/lb-mol

Gas Wt % From Inlet Stream from Amine Pro

Emission Unit	MSSB
Venting Volume per Event (SCF/event):	50000 (standard cubic feet)
Number of events per hour:	1
Number of events per year:	40
Venting Gas Molecular Weight	20.94
VOC wt %	21.42
HAPs wt%	1.17
H₂S wt%	0.0008
VOC & HAP Control Efficiency (%)	95.00
H₂S Control Efficiency (%)	98.00

VOC wt %	21.42
HAPs wt%	1.17
H ₂ S wt %	0.0008
CO ₂ wt%	4.8792
CH ₄ wt%	56.6276

	lb/hr	tpy
Uncontrolled VOC Emissions:	591.0	11.8197
Uncontrolled HAPs Emissions:	32.1564	0.6431
Uncontrolled H₂S Emissions:	0.0231	0.0005
VOC Results:	29.5	0.5910
HAPs Results:	1.6078	0.0322
H₂S Results:	0.0005	0.0000

Default VOC emissions for Miscellaneous MSS activities

Company Name	Targa Midstream
Site Name	Roadrunner Gas Processing Plant

Default VOC emissions (tpy) associated with miscellaneous MSS activities	0.250
Add default VOC emissions from miscellaneous MSS activities to the emissions summary	Yes

#	Activity	Description / comments	Default parameters	Equation used	Input parameters	Annual emissions (tpy)			
1	(b)(1) Engine Oil changes / Filter changes The emissions associated with an engine oil/filter change occur during the draining of the used engine oil into oil pan or container.	-Engine has been isolated and blow down occurs prior to oil change. The emissions associated with the blow down [106.359 (b) (8)] need to be accounted for in the oil and gas emission calculation spreadsheet. -Oil is drained into a 4 ft x 4 ft open pan and transferred to a closed container per Best Management Practice (BMP). -Input parameters based on manufacturer specifications of engine oil SAE 10W (a). -Used a 1380 hp Caterpillar G3516B LE engine (b) as basis for calculation. In order to account for emissions from larger horse power engines, the emissions are doubled. An average engine uses 112 gallons of motor oil and manufacturer recommends changing oil every 1000 hrs. We used 10 changes of oil per year as a conservative estimate. -Emission estimates for 1380 hp engine are being doubled to be conservative and to accommodate engines with higher hp.	Temperature (°F)	212	Loading loss L_L (lb/1000 gal)	0.009	Number of engines	0	0.000
			Vapor pressure (psia)	0.001					
			Saturation factor	1	Loading loss per activity (lb/activity)	0.001			
			Molecular weight (lb/lbmol)	500					
			Motor oil (gal/activity)	112	Evaporation Loss (lb/activity)	1.027			
			U wind speed (m/s)	3.52					
			Vapor pressure P_v (Pa)	10					
			Molecular weight (lb/lbmol)	500					
			Surface Area A_p (m ²) (4ft * 4ft)	1.48					
			Evaporation time t (hrs)	10	Total (lbs/yr/engine)	20.565			
Number of activities per year (Number of oil changes per engine per year)	10								
Factor used to account for larger horsepower engines	2								
2	(b)(1) & (b)(4) Changing Engine Rod Packings Emissions from changing of the rod would be from clingage of lubricant in the casing.	-Engine has been isolated and blow down occurs prior to changing rod packing. The emissions associated with the blow down [106.359 (b) (8)] need to be accounted for in the oil and gas emission calculation spreadsheet. -Emissions from clingage are the evaporation of the lubricant adhered to the rod packing casing. -Casing volume for calculations is based on field observation of casing for a 1380hp G3516B LE engine(b). -Input parameters based on material specifications for AP 101(c) grease.	Temperature (°F)	104	Clingage loss (lb/activity)	0.0001	Number of engines	0	0
			Vapor pressure (psia)	0.001					
			Molecular weight (lb/lb-mole)	500	Total (lbs/yr/engine)	0.0012			
			V_v Casing volume (ft ³) (1ft * 3ft)	2.355					
			Ideal gas constant (psia-ft ³ /lb-mol-°R)	10.73					
			Number of activities per year (Number of rod packing changes per year per engine)	10					
3	(b)(3) Changing wet and dry seals Emissions from changing seals would be from clingage of lubricant in the casing.	-Engine has been isolated and blow down occurs prior to changing seals. The emissions associated with the blow down [106.359 (b) (8)] need to be accounted for in the oil and gas emission calculation spreadsheet. -Emissions from clingage are the evaporation of the lubricant adhered to the rod packing casing. -Casing volume for calculations is based on field observation of casing for a 1380 hp Caterpillar G3516B LE engine (b). -Input parameters based on material specifications for AP 101(c) grease.	Temperature (°F)	104	Clingage loss (lb/activity)	0.0001	Number of engines	0	0.00000
			Vapor pressure of material stored (psia)	0.001					
			Molecular weight (lb/lb-mole)	500	Total (lbs/yr/engine)	0.0002			
			V_v Casing volume (ft ³) (1ft * 3ft)	2.355					
			Ideal gas constant (psia-ft ³ /lb-mol-°R)	10.73					
			Number of activities per year (Number of seal changes per year)	2					
4	(b)(2) Glycol dehydration unit Emissions associated with replacement of glycol solution used in dehydration unit. There are two vessels in a dehydration unit: contactor and regenerator.	-Calculations based on physical properties of mono ethylene glycol (MEG)(d) because of its low molecular weight and high vapor pressure which gives the most conservative emissions estimate. -Typically the glycol solution used in dehydration unit is not entirely replaced but it is conservatively assumed that the glycol solution is drained once per year for vessel maintenance. -Per field experience, 4000 gal of glycol solution is used in a large dehydration unit.	Temperature (°F)	68	Loading loss L_L (lb/1000 gal)	0.0015	Number of Dehy units	4	0.000043
			Vapor pressure (psia)	0.001					
			Saturation factor	1	Loading loss per activity (lb/activity)	0.0059			
			Molecular weight (lb/lbmol)	62.07					
			Glycol solution (gal/activity)	4000	Clingage loss (lb/activity)	0.0155			
			Temperature (°F)	68					
			Vapor pressure (psia)	0.001					
			Molecular weight (lb/lb-mole)	62.07					
			V_v Vessel volume (ft ³) (5 ft radii * 30 ft height)	2355					
			Ideal gas constant (psia-ft ³ /lb-mol-°R)	10.73	Total (lbs/yr/unit)	0.0213			
Number of activities per year	1								

5	(b)(2) Amine unit Emissions associated with replacement of solution used in the amine unit. There are two vessels in an amine unit: Contactor and regenerator.	-Calculations based on physical properties of mono ethanol amine (MEA)(e) because of its low molecular weight and high vapor pressure which gives the most conservative emissions estimate. -Typically the solution used in amine unit is not entirely replaced but it is conservatively assumed that the amine solution is drained once per year for vessel maintenance. -Per field experience, 4000 gal of solution is used in a large amine unit.	Temperature (°F)	68	Loading loss L _i (lb/1000 gal)	0.0058	Number of Amine units	2	0.000084
			Vapor pressure (psia)	0.004					
			Saturation factor	1	Loading loss per activity (lb/activity)	0.0231			
			Molecular weight (lb/lbmol)	61.08					
			Amine solution (gal/activity)	4000	Clingage loss (lb/activity)	0.0609			
			Temperature (°F)	68					
			Vapor pressure (psia)	0.004					
			Molecular weight (lb/lb-mole)	61.08					
			V _v Vessel volume (ft ³) (5 ft radii * 30 ft height)	2355					
			Ideal gas constant (psia-ft ³ /lb-mol-°R)	10.73					
Number of activities per year	1	Total (lbs/yr/unit)	0.0840						
6	(b)(2) Heater Treater	-Calculations based on condensate (RVP 10) because it has higher vapor pressure than crude oil (RVP 5) and results in a more conservative emission estimate. -Emission estimates are based on a large site that typically has 4 heater treaters.	Temperature (°F)	100	Clingage loss (lb/activity)	8.6913	Number of Heater Treaters	0	0.000
			Vapor pressure (psia)	10.5					
			Molecular weight (lb/lb-mole)	66					
			V _v Vessel volume (ft ³) (2ft radii * 10 ft height)	125.6					
			Ideal gas constant (psia-ft ³ /lb-mol-°R)	10.73					
			Number of activities per year	1	Total (lbs/yr/unit)	8.6913			
7	(b)(2) Aerosol Lubricants	-45-50% VOC by weight volatilizes. -Material specification per Lubricant MSDS (f). -VOC evaporation is based off standard engineering judgment consistent with product specification. - Standard Industrial Size Cans (oz.) 16	Pounds of emissions per can (lb/can)	0.5	Number of 16 oz cans used	200	0.050		
8	(b)(3) Piping Components	-Calculations based on condensate (RVP 10) because it has higher vapor pressure than crude oil (RVP 5) and results in a more conservative emission estimate. -100 foot long pipe sections conservatively assumed for emission calculations.	Temperature (°F)	100	Clingage loss (lb/activity)	5.4321	Number of 100 ft in length of pipes	200	0.543
			Vapor pressure (psia)	10.5					
			Molecular weight (lb/lb-mole)	66					
			V _v Vessel volume (ft ³) (0.5 ft radii * 100 ft height)	78.50					
			Ideal gas constant (psia-ft ³ /lb-mol-°R)	10.73					
			Number of activities per year	1	Total (lbs/yr)	5.4321			
9	(b)(3) Pneumatic controllers	Based on field experience and recent site visits to two plants in Central Texas area, changing pneumatic controllers of equipment under pressure requires isolation of pipe section or process equipment and a blow down. There are no emissions associated with changing the controller.							
10	(b)(2) Calibration	-Per Monitoring Division's Laboratory and Quality Assurance Section - One cylinder of pentane or other calibration gas used per year and a typical cylinder contains 100 lbs.	Pounds of pentane in one cylinder (lb)	100	Pounds of pentane in one cylinder (lb/cylinder)	100	Number of cylinders	2	0.100
11	(b)(6)	Safety factor to account for MSS activities with the same character and quantity of emissions as those listed in paragraphs (b) (1) - (5) of §106.359.							

		TPY	lbs/hr
	Total VOC emissions	0.721	0.165

VOC Type: (pick from list)

Crude Oil or Condensate VOC

Emission Type: (pick from list)

Steady State (continuous)

GHG Emissions from Natural Gas Combustion

Emission Source	Source Description	Heat Rate	CO ₂ EF	CO ₂ Emissions		CH ₄ EF	CH ₄ Emissions		N ₂ O EF	N ₂ O Emissions	
		mmbtu/hr	kg/mmbtu	metric TPY	short tpy	kg/mmbtu	metric TPY	short tpy	kg/mmbtu	metric TPY	short tpy
EP-2	Trim Reboiler	26.5	53.06	12317.35	13577.41	0.001	0.232	0.256	0.0001	0.023	0.026
2-EP-2, 3-EP-2	Trim Reboiler	26.5	53.06	12317.35	13577.41	0.001	0.232	0.256	0.0001	0.023	0.026
EP-3A	Amine Reboiler	70.28	53.06	32666.54	36008.32	0.001	0.616	0.679	0.0001	0.062	0.068
EP-3B	Amine Reboiler	70.28	53.06	32666.54	36008.32	0.001	0.616	0.679	0.0001	0.062	0.068
EP-4	Glycol Reboiler	3.9	53.06	1812.74	1998.19	0.001	0.034	0.038	0.0001	0.003	0.004
2-EP-4, 3-EP-4	Glycol Reboiler	3.9	53.06	1812.74	1998.19	0.001	0.034	0.038	0.0001	0.003	0.004
EP-5	Regen Reboiler	9.5	53.06	4415.65	4867.37	0.001	0.083	0.092	0.0001	0.008	0.009
2-EP-5, 3-EP-5	Regen Reboiler	9.5	53.06	4415.65	4867.37	0.001	0.083	0.092	0.0001	0.008	0.009
EP-6, 2-EP-6	Stabilizer Heater	23.4	53.06	10876.45	11989.11	0.001	0.205	0.226	0.0001	0.020	0.023
EP-9	Thermal Oxidizer	75.00	53.06	34860.42	38426.64	0.001	0.657	0.724	0.0001	0.066	0.072
EP-1	Flare Pilot	0.19	53.06	88.31	97.35	0.001	0.002	0.002	0.0001	0.000	0.000
2/3-EP1	Flare Pilot	0.38	53.06	176.63	194.69	0.001	0.003	0.004	0.0001	0.000	0.000
2-HT-1	Hot Oil Heater	84.77	53.06	39401.57	43432.35	0.001	0.743	0.819	0.0001	0.074	0.082

Emission Factors (EF) from Tables C-1 and C-2 to 40 CFR 98 Subpart C

Emergency Flare GHG Emissions

§98.233(n) Flare stack GHG emissions.

Step 1. Calculate contribution of un-combusted CH₄ emissions

$$E_{a,CH_4} \text{ (un-combusted)} = V_a * (1 - \eta) * X_{CH_4} \quad (\text{Equation W-39B})$$

where:

E_{a,CH_4} = contribution of annual un-combusted CH₄ emissions from regenerator in cubic feet under actual conditions.

V_a = volume of gas sent to combustion unit during the year (cf)

η = Fraction of gas combusted by a burning flare (or regenerator), default value from Subpart W =

0.98

For gas sent to an unlit flare, η is zero.

X_{CH_4} = Mole fraction of CH₄ in gas to the flare = 0.7641 (Client gas analysis)

Step 2. Calculate contribution of un-combusted CO₂ emissions

$$E_{a,CO_2} = V_a * X_{CO_2} \quad (\text{Equation W-20})$$

where:

E_{a,CO_2} = contribution of annual un-combusted CO₂ emissions from regenerator in cubic feet under actual conditions.

V_a = volume of gas sent to combustion unit during the year (cf)

X_{CO_2} = Mole fraction of CO₂ in gas to the flare = 0.024

Step 3. Calculate contribution of combusted CO₂ emissions

$$E_{a,CO_2} \text{ (combusted)} = \sum (\eta * V_a * Y_j * R_j) \quad (\text{Equation W-21})$$

where:

η = Fraction of gas combusted by a burning flare (or regenerator) = 0.98

For gas sent to an unlit flare, η is zero.

V_a = volume of gas sent to combustion unit during the year (cf)

Y_j = mole fraction of gas hydrocarbon constituents j:

Constituent j, Methane =	0.7641	(Client gas analysis)
Constituent j, Ethane =	0.1118	
Constituent j, Propane =	0.0530	
Constituent j, Butane =	0.0233	
Constituent j, Pentanes Plus =	0.9348	

R_j = number of carbon atoms in the gas hydrocarbon constituent j:

Constituent j, Methane =	1
Constituent j, Ethane =	2
Constituent j, Propane =	3
Constituent j, Butane =	4
Constituent j, Pentanes Plus =	5

Step 4. Calculate GHG volumetric emissions at standard conditions (scf).

$$E_{s,n} = \frac{E_{a,n} * (459.67 + T_a) * P_a}{(459.67 + T_s) * P_s} \quad (\text{Equation W-33})$$

where:

$E_{s,n}$ = GHG i volumetric emissions at standard temperature and pressure (STP) in cubic feet

$E_{a,n}$ = GHG i volumetric emissions at actual conditions (cf)

T_s = Temperature at standard conditions (F) = 60 F

T_a = Temperature at actual conditions (F) = 76 F

P_s = Absolute pressure at standard conditions (psia) = 14.7 psia

P_a = Absolute pressure at actual conditions (psia) = 12.73 psia

Constant = 459.67 (temperature conversion from F to R)

(Based on Annual Avg Max Temperature for Hobbs, NM from Western Regional Climate Center)

(Assumption)

Step 5. Calculate annual CH₄ and CO₂ mass emissions (ton).

$$\text{Mass}_{s,i} = E_{s,i} * \rho_i * 0.001 * 1.1023 \quad (\text{Equation W-36})$$

where:

Mass_{s,i} = GHG i (CO₂, CH₄, or N₂O) mass emissions at standard conditions in tons (tpy)

E_{s,i} = GHG i (CO₂, CH₄, or N₂O) volumetric emissions at standard conditions (cf)

ρ_i = Density of GHG i. Use:

CH₄: 0.0192 kg/ft³ (at 60F and 14.7 psia)
 CO₂: 0.0526 kg/ft³ (at 60F and 14.7 psia)

1 x 10⁻³ = conversion factor from kg to metric tons.

1.1203 = conversion factor from metric tons to short tons.

Step 6. Calculate annual N₂O emissions from portable or stationary fuel combustion sources under actual conditions (cf) using Equation W-40 .

$$\text{Mass}_{\text{N}_2\text{O}} = 0.001 * \text{Fuel} * \text{HHV} * \text{EF} * 1.1023 \quad (\text{Equation W-40})$$

where:

Mass_{N₂O} = annual N₂O emissions from combustion of a particular type of fuel (tons).

Fuel = mass or volume of the fuel combusted

HHV = high heat value of the fuel

SSM flaring gas HHV = 0.00107 MMBtu/scf

EF = 1.00E-04 kg N₂O/MMBtu

10⁻³ = conversion factor from kg to metric tons.

1.1203 = conversion factor from metric tons to short tons.

Step 7. Calculate total annual emission from flare by summing Equations W-40, W-19, W-20, and W-21.

Gas Sent to Emergency Flare	Gas Sent to Flare (cf/yr)	CH ₄ Un-Combusted, E _{a,CH4} (cf)	CO ₂ Un-Combusted, E _{a,CO2} (cf)	CO ₂ Combusted, E _{a,CO2} (cf)	CH ₄ Un-Combusted, E _{a,CH4} (scf)	CO ₂ Un-Combusted, E _{a,CO2} (scf)	CO ₂ Combusted, E _{a,CO2} (scf)	CH ₄ Un-Combusted, E _{a,CH4} (tpy)	CO ₂ Un-Combusted, E _{a,CO2} (tpy)	CO ₂ Combusted, E _{a,CO2} (tpy)	N ₂ O Mass Emissions (tpy)	CO ₂ e (tpy)
SSM Flaring (EP-1, 2-EP-1, and 3-EP-1)	240,000,000	3,667,739	5,759,941	1,390,856,608	3,079,617	4,836,334	1,167,832,593	65.18	280.42	67,712.08	0.02831	69,630
Total	240,000,000	3,667,739	5,759,940.8	1,390,856,608	3,079,617	4,836,333.6	1,167,832,593	65.2	280.4	67,712.1	0.02831	69,630
								GWP	1	25	298	

Combuster GHG Emissions

§98.233(n) Flare stack GHG emissions.

Step 1. Calculate contribution of un-combusted CH₄ emissions

$$E_{a,CH_4} \text{ (un-combusted)} = V_a * (1 - \eta) * X_{CH_4} \quad (\text{Equation W-39B})$$

where:

E_{a,CH_4} = contribution of annual un-combusted CH₄ emissions from regenerator in cubic feet under actual conditions.

V_a = volume of gas sent to combustion unit during the year (cf)

η = Fraction of gas combusted by a burning flare (or regenerator), default value from Subpart W = 0.98
For gas sent to an unlit flare, η is zero.

X_{CH_4} = Mole fraction of CH₄ in gas to the flare = 0.0041 (Client gas analysis)

Step 2. Calculate contribution of un-combusted CO₂ emissions

$$E_{a,CO_2} = V_a * X_{CO_2} \quad (\text{Equation W-20})$$

where:

E_{a,CO_2} = contribution of annual un-combusted CO₂ emissions from regenerator in cubic feet under actual conditions.

V_a = volume of gas sent to combustion unit during the year (cf)

X_{CO_2} = Mole fraction of CO₂ in gas to the flare = 0.000

Step 3. Calculate contribution of combusted CO₂ emissions

$$E_{a,CO_2} \text{ (combusted)} = \sum (\eta * V_a * Y_j * R_j) \quad (\text{Equation W-21})$$

where:

η = Fraction of gas combusted by a burning flare (or regenerator) = 0.98
For gas sent to an unlit flare, η is zero.

V_a = volume of gas sent to combustion unit during the year (cf)

Y_j = mole fraction of gas hydrocarbon constituents j:

Constituent j, Methane =	0.0041	(Client gas analysis)
Constituent j, Ethane =	0.0011	
Constituent j, Propane =	0.0027	
Constituent j, Butane =	0.0574	
Constituent j, Pentanes Plus =	0.9348	

R_j = number of carbon atoms in the gas hydrocarbon constituent j:

Constituent j, Methane =	1
Constituent j, Ethane =	2
Constituent j, Propane =	3
Constituent j, Butane =	4
Constituent j, Pentanes Plus =	5

Step 4. Calculate GHG volumetric emissions at standard conditions (scf).

$$E_{s,n} = \frac{E_{a,n} * (459.67 + T_a) * P_a}{(459.67 + T_s) * P_s} \quad (\text{Equation W-33})$$

where:

$E_{s,n}$ = GHG i volumetric emissions at standard temperature and pressure (STP) in cubic feet

$E_{a,n}$ = GHG i volumetric emissions at actual conditions (cf)

T_s = Temperature at standard conditions (F) = 60 F

T_a = Temperature at actual conditions (F) = 76 F

P_s = Absolute pressure at standard conditions (psia) = 14.7 psia

P_a = Absolute pressure at actual conditions (psia) = 12.73 psia

Constant = 459.67 (temperature conversion from F to R) (Assumption)

(Based on Annual Avg Max Temperature for Hobbs, NM from Western Regional Climate Center)

Step 5. Calculate annual CH₄ and CO₂ mass emissions (ton).

$$\text{Mass}_{s,j} = E_{s,j} * \rho_j * 0.001 * 1.1023 \quad (\text{Equation W-36})$$

where:

$Mass_{s,i}$ = GHG i (CO₂, CH₄, or N₂O) mass emissions at standard conditions in tons (tpy)
 $E_{s,i}$ = GHG i (CO₂, CH₄, or N₂O) volumetric emissions at standard conditions (cf)
 ρ_i = Density of GHG i. Use:

CH₄: 0.0192 kg/ft³ (at 60F and 14.7 psia)
 CO₂: 0.0526 kg/ft³ (at 60F and 14.7 psia)

1 x 10⁻³ = conversion factor from kg to metric tons.
 1.1203 = conversion factor from metric tons to short tons.

Step 6. Calculate annual N₂O emissions from portable or stationary fuel combustion sources under actual conditions (cf) using Equation W-40 .

$Mass_{N_2O} = 0.001 * Fuel * HHV * EF * 1.1023$ (Equation W-40)

where:

$Mass_{N_2O}$ = annual N₂O emissions from combustion of a particular type of fuel (tons).

Fuel = mass or volume of the fuel combusted

HHV = high heat value of the fuel

SSM flaring gas HHV = 0.00107 MMBtu/scf

EF = 1.00E-04 kg N₂O/MMBtu

1 x 10⁻³ = conversion factor from kg to metric tons.

1.1203 = conversion factor from metric tons to short tons.

Step 7. Calculate total annual emission from flare by summing Equations W-40, W-19, W-20, and W-21.

Gas Sent to Combuster	Gas Sent to Combuster (cf/yr)	CH ₄ Un-Combusted, E _{a,CH4} (cf)	CO ₂ Un-Combusted, E _{a,CO2} (cf)	CO ₂ Combusted, E _{a,CO2} (cf)	CH ₄ Un-Combusted, E _{a,CH4} (scf)	CO ₂ Un-Combusted, E _{a,CO2} (scf)	CO ₂ Combusted, E _{a,CO2} (scf)	CH ₄ Un-Combusted, E _{a,CH4} (tpy)	CO ₂ Un-Combusted, E _{a,CO2} (tpy)	CO ₂ Combusted, E _{a,CO2} (tpy)	N ₂ O Mass Emissions (tpy)	CO2e (tpy)
COMB-1	12,745,387	1,033	0	61,425,499	867	0	51,575,913	0.02	0.00	2,990.42	0.00150	2,991
Total	12,745,387	1,033	0.0	61,425,499	867	0.0	51,575,913	0.0	0.0	2,990.4	0.00150	2,991

	CO ₂	CH ₄	N ₂ O
GWP	1	25	298

Section 7

Information Used To Determine Emissions

Information Used to Determine Emissions shall include the following:

- If manufacturer data are used, include specifications for emissions units and control equipment, including control efficiencies specifications and sufficient engineering data for verification of control equipment operation, including design drawings, test reports, and design parameters that affect normal operation.
 - If test data are used, include a copy of the complete test report. If the test data are for an emissions unit other than the one being permitted, the emission units must be identical. Test data may not be used if any difference in operating conditions of the unit being permitted and the unit represented in the test report significantly effect emission rates.
 - If the most current copy of AP-42 is used, reference the section and date located at the bottom of the page. Include a copy of the page containing the emissions factors, and clearly mark the factors used in the calculations.
 - If an older version of AP-42 is used, include a complete copy of the section.
 - If an EPA document or other material is referenced, include a complete copy.
 - Fuel specifications sheet.
 - If computer models are used to estimate emissions, include an input summary (if available) and a detailed report, and a disk containing the input file(s) used to run the model. For tank-flashing emissions, include a discussion of the method used to estimate tank-flashing emissions, relative thresholds (i.e., permit or major source (NSPS, PSD or Title V)), accuracy of the model, the input and output from simulation models and software, all calculations, documentation of any assumptions used, descriptions of sampling methods and conditions, copies of any lab sample analysis.
-

Heaters and Reboilers (EP-2, 2-EP-2, 3-EP-2, EP-3B, EP-4, 2-EP-4, 3-EP-4, EP-5, 2-EP-5, 3-EP-5, EP-6, 2-EP-6)

- AP-42 Chapter 1.4 *Natural Gas Combustion*
- Manufacturer specifications
- 20.2.50.119.B(1) NMAC
- 40 CFR 98 Subpart C Table C-1 and Table C-2

TEG Glycol Dehydrators (EP-7, 2-EP-7, and 3-EP-7)

- BR&E ProMax

Amine Units

- BR&E ProMax
- Inlet gas analysis dated November 19, 2019

Thermal Oxidizer (EP-9)

- Manufacturer specifications
- 40 CFR 98 Subpart C Table C-1 and Table C-2

Thermal Oxidizer SSM

- BR&E ProMax

Flares (EP-1, 2-EP-1, 3-EP-1)

- TNRCC RG-109 Emission Factors
- Inlet gas analysis dates November 19, 2019
- Residue gas analysis dated September 14, 2021
- Fuel gas analysis dated July 27, 2021
- 40 CFR 98 Subpart C Table C-1 and Table C-2
- Manufacturer specifications

Condensate Tanks (T-1 through T-5)

- BR&E ProMax
- Condensate analysis dated February 3, 2022

Produced Water Storage Tank (T-6)

- BR&E ProMax

Condensate Loading (LOAD)

- AP-42 Chapter 5.2, *Transportation and Marketing of Petroleum Liquids*
- BR&E ProMax

Tank Combustor (COMB-1)

- TNRCC RG-109 Emission Factors
- BR&E ProMax
- 40 CFR 98 Subpart C Table C-1 and Table C-2

Fugitives (FUG)

- Inlet gas analysis dates November 19, 2019
- Residue gas analysis dated September 14, 2021
- Condensate analysis dated February 3, 2022
- Table 2-4 of the EPA Protocol for Equipment Leak Emission Estimates, November 1995

Haul Roads (HAUL)

- AP-42 Chapter 13.2.2, *Unpaved Roads*, Table 13.2.2-2



Certificate of Analysis
 Number: 6030-22020089-001A

Artesia Laboratory
 200 E Main St.
 Artesia, NM 88210
 Phone 575-746-3481

Tom Cleveland
 Lucid Energy Group
 3100 McKinnon St. #800
 Dallas, TX 75201

Feb. 07, 2022

Station Name: Road Runner Gas Plant Tank Condensate
 Station Number: N/A
 Station Location: Lucid
 Analyzed: 02/07/2022 10:58:32

Sampled By: Michael Mirabal
 Sample Of: Liquid Spot
 Sample Date: 02/03/2022 01:43
 Sample Conditions:
 Method: GPA 2186

Analytical Data

Components	Mol. %	Wt. %	L.V. %
Nitrogen	0.074	0.023	0.020
Methane	0.002	NIL	0.001
Carbon Dioxide	NIL	NIL	NIL
Ethane	0.003	0.001	0.002
Propane	0.024	0.012	0.016
Iso-Butane	0.086	0.056	0.069
n-Butane	1.731	1.124	1.333
Iso-Pentane	10.631	8.570	9.496
n-Pentane	17.244	13.901	15.267
i-Hexanes	15.924	15.104	15.680
n-Hexane	12.169	11.715	12.221
Benzene	1.126	0.983	0.771
Cyclohexane	5.756	5.413	4.786
i-Heptanes	13.147	13.810	13.237
n-Heptane	4.094	4.583	4.614
Toluene	1.328	1.368	1.088
i-Octanes	9.110	10.700	9.898
n-Octane	0.853	1.089	1.066
Ethylbenzene	0.150	0.179	0.141
Xylenes	0.623	0.741	0.590
i-Nonanes	1.549	2.099	1.926
n-Nonane	0.342	0.490	0.472
i-Decanes	0.248	0.354	0.301
Decanes Plus	3.786	7.685	7.005
	<u>100.000</u>	<u>100.000</u>	<u>100.000</u>

Calculated Physical Properties

	Total	C10+
API Gravity at 60°F	72.7803	54.3309
Pounds per Gallon (in Air)	5.769	6.341
Pounds per Gallon (in Vacuum)	5.775	6.348
Cu. Ft. Vapor per Gallon @ 14.696 psia	24.487	13.502
Specific Gravity at 60°F	0.6927	0.7614
Molecular Weight	89.496	178.418
BTU / GAL. (as a vapor)	119204	130237
BTU / LB. (as a vapor)	20640	20514

Data reviewed by: Krystle Fitzwater, Laboratory Manager

Quality Assurance: The above analyses are performed in accordance with ASTM, UOP, GPA guidelines for quality assurance, unless otherwise stated.



Certificate of Analysis
Number: 6030-22020089-001A

Artesia Laboratory
200 E Main St.
Artesia, NM 88210
Phone 575-746-3481

Tom Cleveland
Lucid Energy Group
3100 McKinnon St. #800
Dallas, TX 75201

Feb. 07, 2022

Station Name: Road Runner Gas Plant Tank Condensate
Station Number: N/A
Station Location: Lucid

Sampled By: Michael Mirabal
Sample Of: Liquid Spot
Sample Date: 02/03/2022 01:43
Sample Conditions:

Analytical Data

Test	Method	Result	Units	Detection Limit	Lab Tech.	Analysis Date
VP of Crude Oil: V/L = 4:1 @ 37.8 °F	ASTM D-6377	9.09	psi		KNF	02/07/2022
RVPE (D323 Equivalent) @ 3.2 °C	ASTM D-6377	8.32	psi		KNF	02/07/2022

Data reviewed by: Krystle Fitzwater, Laboratory Manager

Quality Assurance:

The above analyses are performed in accordance with ASTM, UOP, GPA guidelines for quality assurance, unless otherwise stated.



Certificate of Analysis
 Number: 5030-19110424-001A

Midland Laboratory
 2200 East I-20
 Midland, TX 79706
 Phone 432-689-7252

Lucid Energy Group
 416 E. Main St.
 Artesia, NM 88210

Nov. 21, 2019

Station Name: ROAD RUNNER INLET
 Method: GPA 2286
 Cylinder No: A102
 Analyzed: 11/20/2019 19:30:36 by WH

Sampled By: DEREK SAUDER
 Sample Of: Gas Spot
 Sample Date: 11/19/2019
 Sample Conditions: 797.5 psig, @ 75 °F

Analytical Data

Components	Mol. %	Wt. %	GPM at 14.696 psia	
Hydrogen Sulfide	0.000	0.000		GPM TOTAL C2+ 5.985
Nitrogen	1.397	1.840		GPM TOTAL C3+ 2.710
Carbon Dioxide	0.330	0.683		GPM TOTAL iC5+ 0.409
Methane	76.983	58.062		
Ethane	12.234	17.295	3.275	
Propane	5.668	11.750	1.563	
Iso-butane	0.717	1.959	0.235	
n-Butane	1.595	4.358	0.503	
Iso-pentane	0.287	0.973	0.105	
n-Pentane	0.288	0.977	0.105	
Hexanes Plus	0.501	2.103	0.199	
	100.000	100.000	5.985	

Calculated Physical Properties	Total	C6+
Relative Density Real Gas	0.7367	3.0526
Calculated Molecular Weight	21.27	88.41
Compressibility Factor	0.9964	
GPA 2172 Calculation:		
Calculated Gross BTU per ft³ @ 14.696 psia & 60°F		
Real Gas Dry BTU	1264	4785
Water Sat. Gas Base BTU	1242	4701

Hydrocarbon Laboratory Manager

Quality Assurance: The above analyses are performed in accordance with ASTM, UOP, GPA guidelines for quality assurance, unless otherwise stated.



Certificate of Analysis
 Number: 5030-19110424-001A

Midland Laboratory
 2200 East I-20
 Midland, TX 79706
 Phone 432-689-7252

Lucid Energy Group
 416 E. Main St.
 Artesia, NM 88210

Nov. 21, 2019

Station Name: ROAD RUNNER INLET
 Method: GPA 2286
 Cylinder No: A102
 Analyzed: 11/20/2019 19:30:36 by WH

Sampled By: DEREK SAUDER
 Sample Of: Gas Spot
 Sample Date: 11/19/2019
 Sample Conditions: 797.5 psig, @ 75 °F

Analytical Data

Components	Mol. %	Wt. %	GPM at 14.696 psia	
Hydrogen Sulfide	0.000	0.000		GPM TOTAL C2+ 5.9850
Nitrogen	1.397	1.840		GPM TOTAL C3+ 2.7100
Methane	76.983	58.062		GPM TOTAL iC5+ 0.4090
Carbon Dioxide	0.330	0.683		
Ethane	12.234	17.295	3.275	
Propane	5.668	11.750	1.563	
Iso-Butane	0.717	1.959	0.235	
n-Butane	1.595	4.358	0.503	
Iso-Pentane	0.287	0.973	0.105	
n-Pentane	0.288	0.977	0.105	
Hexanes	0.284	1.122	0.113	
Heptanes Plus	0.217	0.981	0.086	
	100.000	100.000	5.985	

Calculated Physical Properties	Total	C7+
Relative Density Real Gas	0.7367	3.1977
Calculated Molecular Weight	21.27	92.61
Compressibility Factor	0.9964	
GPA 2172 Calculation:		
Calculated Gross BTU per ft³ @ 14.696 psia & 60°F		
Real Gas Dry BTU	1263.6	4913.3
Water Sat. Gas Base BTU	1241.5	4827.6

Hydrocarbon Laboratory Manager

Quality Assurance: The above analyses are performed in accordance with ASTM, UOP, GPA guidelines for quality assurance, unless otherwise stated.



Certificate of Analysis
 Number: 5030-19110424-001A

Midland Laboratory
 2200 East I-20
 Midland, TX 79706
 Phone 432-689-7252

Lucid Energy Group
 416 E. Main St.
 Artesia, NM 88210

Nov. 21, 2019

Station Name: ROAD RUNNER INLET
 Method: GPA 2286
 Cylinder No: A102
 Analyzed: 11/20/2019 19:30:36 by WH

Sampled By: DEREK SAUDER
 Sample Of: Gas Spot
 Sample Date: 11/19/2019
 Sample Conditions: 797.5 psig, @ 75 °F

Analytical Data

Components	Mol. %	Wt. %	GPM at 14.696 psia	
Nitrogen	1.397	1.840	GPM TOTAL C2+ 5.985	
Methane	76.983	58.062		
Carbon Dioxide	0.330	0.683		
Hydrogen Sulfide	NIL	NIL		
Ethane	12.234	17.295	3.275	
Propane	5.668	11.750	1.563	
Iso-Butane	0.717	1.959	0.235	
n-Butane	1.595	4.358	0.503	
Iso-Pentane	0.287	0.973	0.105	
n-Pentane	0.288	0.977	0.105	
i-Hexanes	0.179	0.700	0.070	
n-Hexane	0.105	0.422	0.043	
Benzene	0.017	0.062	0.005	
Cyclohexane	0.048	0.190	0.016	
i-Heptanes	0.091	0.387	0.036	
n-Heptane	0.017	0.079	0.008	
Toluene	0.007	0.029	0.002	
i-Octanes	0.034	0.174	0.016	
n-Octane	0.002	0.012	0.001	
Ethylbenzene	NIL	0.001	NIL	
Xylenes	NIL	0.007	0.001	
i-Nonanes	0.001	0.016	0.001	
n-Nonane	NIL	0.004	NIL	
i-Decanes	NIL	0.008	NIL	
n-Decane	NIL	0.002	NIL	
Undecanes	NIL	0.002	NIL	
Dodecanes	NIL	0.002	NIL	
Tridecanes	NIL	0.005	NIL	
Tetradecanes Plus	NIL	0.001	NIL	
	100.000	100.000	5.985	

Calculated Physical Properties	Total	C14+
Relative Density Real Gas	0.7367	NIL
Calculated Molecular Weight	21.271	NIL
Compressibility Factor	0.9964	
GPA 2172 Calculation:		
Calculated Gross BTU per ft³ @ 14.696 psia & 60°F		
Real Gas Dry BTU	1263.6	NIL
Water Sat. Gas Base BTU	1241.5	NIL

Hydrocarbon Laboratory Manager

Quality Assurance: The above analyses are performed in accordance with ASTM, UOP, GPA guidelines for quality assurance, unless otherwise stated.



Analytical Report

Customer:	Lucid Energy Delaware	Order:	O29-2140
Location:	Road Runner Plant	Received:	7/27/2021
Description:	Fuel Gas	Primary Contact:	Jaylen Fuentes

REPORT DISTRIBUTION:

Jaylen Fuentes

All data reported in this Analytical Report is in compliance with the test method(s) performed as of the date noted above. The validity and integrity of this report will remain intact as long as it is accompanied by this page and reproduced in full. Any datafile (e.g. txt, csv, etc.) produced which is associated with the results in this report shall be considered for convenience only and does not supersede this report as the official test results. We reserve the right to return to you any unused samples received if we consider so necessary (e.g. samples identified as hazardous waste).

We appreciate you choosing Pantechs Laboratories. If you have any questions concerning this report, please feel free to contact us at any time.

Pantechs Laboratories, Inc.
Order: O29-2140 Order Date: 7/27/2021
Order Description: Road Runner Plant, Fuel Gas

Sample List						
Fluid	Operator	Location	Site	Sample Point	Date	Time
Gas	Lucid Energy Delaware	Road Runner Plant	Fuel Gas	Fuel Meter	7/27/2021	12:23 PM

No Sample List				
Operator	Location	Site	Sample Point	Comment

Pantechs Laboratories, Inc. - Order: 029-2140 - Order Date: 7/27/2021
Order Description: Road Runner Plant, Fuel Gas

SAMPLE ID		COLLECTION DATA	
Operator	Lucid Energy Delaware	Pressure	15 psig
Location	Road Runner Plant	Sample Temp	N/A
Site	Fuel Gas	Atm Temp	80 F
Site Type	Meter	Collection Date	07/27/2021
Sample Point	Fuel Meter	Collection Time	12:23 PM
Spot/Comp	Spot	Collection By	Cody Carson
Meter ID		Pressure Base	14.730 psi
Purchaser		Temperature Base	60 F
Fluid	Gas	Container(s)	PLS029 , PL2136

Onsite Testing by Stain Tube

METHOD	TYPE	MOL%	GRAINS/100	PPMV
GPA2377	H2S	0.0000	0.00	0.0

GPA 2286 Gas Extended Fractional Analysis

COMPOUND	FORMULA	MOL%	WT%	GPM
HELIUM	He	0.0064	0.0014	0.0006
NITROGEN	N2	1.1398	1.8037	0.1251
CARBON DIOXIDE	CO2	0.5582	1.3878	0.0950
*OXYGEN+ARGON	O2+Ar	0.0037	0.0067	0.0003
HYDROGEN SULFIDE	H2S	0.0000	0.0000	0.0000
METHANE	C1	88.8585	80.5282	15.0243
ETHANE	C2	9.1322	15.5122	2.4358
PROPANE	C3	0.2906	0.7239	0.0798
I-BUTANE	iC4	0.0071	0.0233	0.0023
N-BUTANE	nC4	0.0027	0.0089	0.0008
I-PENTANE	iC5	0.0001	0.0004	0.0000
N-PENTANE	nC5	0.0001	0.0004	0.0000
NEO-PENTANE	neC5	0.0002	0.0008	0.0001
HEXANES PLUS	C6+	0.0004	0.0023	0.0001
TOTALS:		100.0000	100.0000	17.7645

Value of "0.0000" interpreted as below detectable limit. Onsite H2S value is used in fractional if performed.
 *Oxygen+Argon: Compounds elute as single peak; additional testing required to distinguish each.

LIQUID YIELD	C2+	C3+	C4+	C5+	26# Liquid	10# Liquid
GAL/MSCF	2.5191	0.0833	0.0035	0.0002	0.0004	
CALC PROP	BTU/CF	Specific Gr.	Z Factor	Mol Weight	LB/SCF	Wobbe IDX
DRY	1,071.8	0.6124	0.9976	18.70	0.0495	1,369.5
WATER SAT.	1,054.4	0.6128	0.9973	18.38	0.0486	
C6+ ONLY	5,052.8	3.4484		99.88		

Hexanes Plus Detail - Road Runner Plant:Fuel Gas:Fuel Meter:7/27/2021

C6 GROUP	FORMULA	MOL%	WT%
2,2-dimethylbutane	C6H14	0.000000	0.000000
2,3-dimethylbutane+cyclopentane	C6H14	0.000000	0.000000
2-methylpentane	C6H14	0.000000	0.000000
3-methylpentane	C6H14	0.000000	0.000000
benzene	C6H6	0.000183	0.000808
cyclohexane	C6H12	0.000000	0.000000
methylcyclopentane	C6H12	0.000000	0.000000
n-hexane	C6H14	0.000054	0.000263
TOTALS:		0.000237	0.001071

C7 GROUP	FORMULA	MOL%	WT%
1,1-dimethylcyclopentane+3-methylhexane	C7H16	0.000000	0.000000
2,2-dimethylpentane	C7H16	0.000000	0.000000
2,3-dimethylpentane	C7H16	0.000000	0.000000
2,4-dimethylhexane+ethylcyclopentane	C7H14	0.000000	0.000000
2,4-dimethylpentane	C7H16	0.000000	0.000000
2-methylhexane	C7H16	0.000000	0.000000
3,3-dimethylpentane	C7H16	0.000000	0.000000
cis-1,3-dimethylcyclopentane+3-Ethylpentane	C7H14	0.000000	0.000000
cycloheptane	C7H14	0.000000	0.000000
Methylcyclohexane+1,1,3-Trimethylpentane	C7H14	0.000000	0.000000
n-heptane	C7H16	0.000030	0.000170
toluene	C7H8	0.000093	0.000484
trans-1,2-dimethylcyclopentane+cis-1,2-Dimethylcyclopentane	C7H14	0.000000	0.000000
trans-1,3-dimethylcyclopentane	C7H14	0.000000	0.000000
TOTALS:		0.000123	0.000654

C8 GROUP	FORMULA	MOL%	WT%
1-ethyl-1-methylcyclopentane	C8H16	0.000000	0.000000
2,2,3-trimethylpentane	C8H18	0.000000	0.000000
2,2,4-trimethylpentane	C8H18	0.000000	0.000000
2,3,4-trimethylpentane	C8H18	0.000000	0.000000
2,5-dimethylhexane	C8H18	0.000000	0.000000
2-methylheptane+4-methylheptane	C8H18	0.000000	0.000000
3,3-dimethylhexane	C8H18	0.000000	0.000000
3-methylheptane	C8H18	0.000000	0.000000
cis-1,2-dimethylcyclohexane	C8H16	0.000000	0.000000
cis-1,3-dimethylcyclohexane	C8H16	0.000000	0.000000

cyclooctane	C8H16	0.000000	0.000000
ethylbenzene	C8H10	0.000029	0.000174
ethylcyclohexane	C8H16	0.000000	0.000000
m-xylene+p-xylene	C8H10	0.000000	0.000000
n-octane	C8H18	0.000032	0.000206
o-xylene	C8H10	0.000000	0.000000
trans-1,3-dimethylcyclohexane	C8H16	0.000000	0.000000
TOTALS:		0.000061	0.000380

C9 GROUP	FORMULA	MOL%	WT%
1,1,2-trimethylcyclohexane	C9H18	0.000000	0.000000
1,2,3-trimethylbenzene	C9H12	0.000000	0.000000
1,2,4-trimethylbenzene+tert-butylbenzene	C9H12	0.000000	0.000000
1,3,5-trimethylbenzene	C9H12	0.000000	0.000000
2,2,3-trimethylhexane	C9H20	0.000000	0.000000
2,2,4-trimethylhexane	C9H20	0.000000	0.000000
2,2-dimethylheptane	C9H20	0.000000	0.000000
2,3,4-trimethylhexane	C9H20	0.000000	0.000000
2,4,4-trimethylhexane	C9H20	0.000000	0.000000
2,5-dimethylheptane	C9H20	0.000000	0.000000
2-methyloctane	C9H20	0.000000	0.000000
3,4-dimethylheptane	C9H20	0.000000	0.000000
cis-1,2,trans-1,4-1,2,4-trimethylcyclohexane	C9H18	0.000000	0.000000
cis,cis-1,2,3-trimethylcyclohexane	C9H18	0.000000	0.000000
isopropylbenzene	C9H12	0.000000	0.000000
methylcyclooctane	C9H18	0.000000	0.000000
m-ethyltoluene+p-ethyltoluene	C9H12	0.000000	0.000000
n-nonane	C9H20	0.000021	0.000152
propylbenzene	C9H12	0.000000	0.000000
propylcyclohexane	C9H18	0.000000	0.000000
r-1,t-2,c-3-trimethylcyclohexane	C9H18	0.000000	0.000000
r-1,t-2,t-4-trimethylcyclohexane	C9H18	0.000000	0.000000
Unidentified C9	C9	0.000000	0.000000
TOTALS:		0.000021	0.000152

C10 GROUP	FORMULA	MOL%	WT%
1,2,3,4-tetramethylbenzene	C10H14	0.000000	0.000000
1,2,3,5-tetramethylbenzene	C10H14	0.000000	0.000000
1,2,4,5-tetramethylbenzene	C10H14	0.000000	0.000000
1,2-diethylbenzene	C10H14	0.000000	0.000000

1,2-dimethyl-3-ethylbenzene	C10H14	0.000000	0.000000
1,2-dimethyl-4-ethylbenzene	C10H14	0.000000	0.000000
1,3-diethylbenzene	C10H14	0.000000	0.000000
1,3-dimethyl-2-ethylbenzene	C10H14	0.000000	0.000000
1,4-diethylbenzene	C10H14	0.000000	0.000000
1,4-dimethyl-2-ethylbenzene	C10H14	0.000000	0.000000
1-methyl-2-isopropylbenzene	C10H14	0.000000	0.000000
1-methyl-2-propylbenzene	C10H14	0.000000	0.000000
1-methyl-3-isopropylbenzene	C10H14	0.000000	0.000000
1-methyl-4-isopropylbenzene	C10H14	0.000000	0.000000
2-methylnonane	C10H22	0.000000	0.000000
3-ethyloctane	C10H22	0.000000	0.000000
3-methylnonane	C10H22	0.000000	0.000000
4-methylnonane	C10H22	0.000000	0.000000
butylbenzene	C10H14	0.000000	0.000000
butylcyclohexane	C10H20	0.000000	0.000000
isobutylbenzene	C10H14	0.000000	0.000000
naphthalene	C10H8	0.000000	0.000000
n-decane	C10H22	0.000000	0.000000
sec-butylbenzene	C10H14	0.000000	0.000000
tert-butylcyclohexane	C10H20	0.000000	0.000000
Unidentified C10	C10	0.000000	0.000000
TOTALS:		0.000000	0.000000

C11 GROUP	FORMULA	MOL%	WT%
n-undecane	C11H24	0.000000	0.000000
pentylbenzene	C11H16	0.000000	0.000000
Unidentified C11	C11	0.000000	0.000000
TOTALS:		0.000000	0.000000

C12 GROUP	FORMULA	MOL%	WT%
n-dodecane	C12H26	0.000000	0.000000
Unidentified C12	C12	0.000000	0.000000
TOTALS:		0.000000	0.000000

C13 GROUP	FORMULA	MOL%	WT%
n-tridecane	C13H28	0.000000	0.000000
Unidentified C13	C13	0.000000	0.000000
TOTALS:		0.000000	0.000000

C14 GROUP	FORMULA	MOL%	WT%
-----------	---------	------	-----

n-tetradecane	C14H30	0.000000	0.000000
Unidentified C14	C14	0.000000	0.000000
TOTALS:		0.000000	0.000000

C15+ GROUP	FORMULA	MOL%	WT%
n-pentadecane	C15H32	0.000000	0.000000
Unidentified C15	C15	0.000000	0.000000
TOTALS:		0.000000	0.000000

Road Runner Plant:Fuel Gas:Fuel Meter:7/27/2021

ASTM D5504 Gas Sulfur Speciation

SUMMARY	PPMV	GRAINS/100 SCF	PPMW
COMPOUND TOTALS:	0.0	0.00	0.0
TOTAL SULFUR, AS MASS OF SULFUR (PPMW):			0.0

Speciation Detail

SULFIDE GROUP	PPMV	GRAINS/100 SCF	PPMW
hydrogen sulfide	0.0	0.00	0.0
carbonyl sulfide	0.0	0.00	0.0
Dimethyl Sulfide	0.0	0.00	0.0
Methyl Ethyl Sulfide	0.0	0.00	0.0
Diethyl Sulfide	0.0	0.00	0.0
t-Butyl Methyl Sulfide	0.0	0.00	0.0
Methyl sec-Butyl Sulfide	0.0	0.00	0.0
Ethyl n-Propyl Sulfide	0.0	0.00	0.0
Diisopropyl Sulfide	0.0	0.00	0.0
Propyl Sulfide	0.0	0.00	0.0
tert-Butyl Sulfide	0.0	0.00	0.0
SULFIDE TOTALS:	0.0	0.00	0.0

DISULFIDE GROUP	PPMV	GRAINS/100 SCF	PPMW
Carbon Disulfide	0.0	0.00	0.0
Dimethyl Disulfide	0.0	0.00	0.0
Ethyl Methyl Disulfide	0.0	0.00	0.0
Methyl i-Propyl Disulfide	0.0	0.00	0.0
Diethyl Disulfide	0.0	0.00	0.0
Propyl Methyl Disulfide	0.0	0.00	0.0
Methyl tert-Butyl Disulfide	0.0	0.00	0.0
Ethyl i-Propyl Disulfide	0.0	0.00	0.0
Methyl sec-Butyl Disulfide	0.0	0.00	0.0
Ethyl Propyl Disulfide+1-Heptanethiol	0.0	0.00	0.0
i-Propyl Disulfide	0.0	0.00	0.0
n-Propyl Disulfide	0.0	0.00	0.0
t-Butyl Disulfide	0.0	0.00	0.0
Diphenyl Disulfide	0.0	0.00	0.0
DISULFIDE TOTALS:	0.0	0.00	0.0

MERCAPTAN GROUP	PPMV	GRAINS/100 SCF	PPMW
Methyl Mercaptan	0.0	0.00	0.0
Ethyl Mercaptan	0.0	0.00	0.0

i-Propyl Mercaptan	0.0	0.00	0.0
n-Propyl Mercaptan	0.0	0.00	0.0
tert-Butyl Mercaptan	0.0	0.00	0.0
sec-Butyl Mercaptan	0.0	0.00	0.0
i-Butyl Mercaptan	0.0	0.00	0.0
n-Butyl Mercaptan	0.0	0.00	0.0
1,5-Pentanedithiol	0.0	0.00	0.0
2 and 3-Methyl-1-Butanethiol+Tetrahydrothiophene	0.0	0.00	0.0
1-Pentanethiol	0.0	0.00	0.0
1,2-Ethanethiol	0.0	0.00	0.0
1-Hexanethiol	0.0	0.00	0.0
Thiophenol	0.0	0.00	0.0
1,4-Butanethiol	0.0	0.00	0.0
1-Octanethiol	0.0	0.00	0.0
1-Nonanethiol	0.0	0.00	0.0
1-Decanethiol	0.0	0.00	0.0
MERCAPTAN TOTALS:	0.0	0.00	0.0

THIOPHENE GROUP	PPMV	GRAINS/100 SCF	PPMW
Thiophene	0.0	0.00	0.0
2-Methylthiophene+3-Methylthiophene	0.0	0.00	0.0
2-Ethyl Thiophene	0.0	0.00	0.0
2-Bromothiophene	0.0	0.00	0.0
2-Propylthiophene	0.0	0.00	0.0
2-Butylthiophene	0.0	0.00	0.0
3-Butylthiophene	0.0	0.00	0.0
Benzothiophene	0.0	0.00	0.0
2-Methylbenzothiophene	0.0	0.00	0.0
THIOPHENE TOTALS:	0.0	0.00	0.0

OTHER SULFUR GROUP	PPMV	GRAINS/100 SCF	PPMW
sulfur dioxide	0.0	0.00	0.0
Unidentified Sulfur	0.0	0.00	0.0
OTHER SULFUR TOTALS:	0.0	0.00	0.0

Value of "0.0" interpreted as below detectable limit of 0.1 PPM Mol.



Analytical Report

9/21/2021

Customer:	Lucid Energy Delaware	Order:	0148-2309
Location:	Red Hills Processing Complex	Received:	9/14/2021
Description:	Flare Scrubbers and Amine/Glycol Waste Streams	Primary Contact:	Jaylen Fuentes

REPORT DISTRIBUTION:

Jaylen Fuentes

All data reported in this Analytical Report is in compliance with the test method(s) performed as of the date noted above. The validity and integrity of this report will remain intact as long as it is accompanied by this page and reproduced in full. Any datafile (e.g. txt, csv, etc.) produced which is associated with the results in this report shall be considered for convenience only and does not supersede this report as the official test results. We reserve the right to return to you any unused samples received if we consider so necessary (e.g. samples identified as hazardous waste).

We appreciate you choosing Pantechs Laboratories. If you have any questions concerning this report, please feel free to contact us at any time.

Pantechs Laboratories, Inc. - Order: 0148-2309 - Order Date: 9/14/2021
Order Description: Red Hills Processing Complex, Flare Scrubbers and Amine/Glycol Waste Streams

SAMPLE ID		COLLECTION DATA	
Operator	Lucid Energy Delaware	Pressure	48 psig
Location	Road Runner Plant	Sample Temp	N/A
Site	Flare Header	Atm Temp	88 F
Site Type	Plant	Collection Date	09/14/2021
Sample Point	Cold Side	Collection Time	12:20 PM
Spot/Comp	Spot	Collection By	Cody Carson
Meter ID		Pressure Base	14.730 psi
Purchaser		Temperature Base	60 F
Fluid	Gas	Container(s)	PLS022 , PL2473

GPA 2286 Gas Extended Fractional Analysis

COMPOUND	FORMULA	MOL%	WT%	GPM
HELIUM	He	0.0071	0.0016	0.0007
NITROGEN	N2	1.2421	1.9343	0.1363
CARBON DIOXIDE	CO2	0.0560	0.1370	0.0095
*OXYGEN+ARGON	O2+Ar	0.0047	0.0084	0.0004
HYDROGEN SULFIDE	H2S	0.0000	0.0000	0.0000
METHANE	C1	88.3783	78.8166	14.9414
ETHANE	C2	9.0801	15.1779	2.4216
PROPANE	C3	0.6880	1.6865	0.1890
I-BUTANE	iC4	0.0644	0.2081	0.0210
N-BUTANE	nC4	0.1371	0.4430	0.0431
I-PENTANE	iC5	0.0350	0.1404	0.0128
N-PENTANE	nC5	0.0481	0.1929	0.0174
NEO-PENTANE	neC5	0.0013	0.0052	0.0005
HEXANES PLUS	C6+	0.2578	1.2481	0.0904
TOTALS:		100.0000	100.0000	17.8841

Value of "0.0000" interpreted as below detectable limit. Onsite H2S value is used in fractional if performed.
 *Oxygen+Argon: Compounds elute as single peak; additional testing required to distinguish each.

LIQUID YIELD	C2+	C3+	C4+	C5+	26# Liquid	10# Liquid
GAL/MSCF	2.7958	0.3742	0.1852	0.1205	0.1868	
CALC PROP	BTU/CF	Specific Gr.	Z Factor	Mol Weight	LB/SCF	Wobbe IDX
DRY	1,097.4	0.6224	0.9975	18.64	0.0493	1,391.0
WATER SAT.	1,079.5	0.6227	0.9971	18.31	0.0485	
C6+ ONLY	4,475.3	3.0069		87.09		

Hexanes Plus Detail - Road Runner Plant:Flare Header:Cold Side:9/14/2021

C6 GROUP	FORMULA	MOL%	WT%
2,2-dimethylbutane	C6H14	0.000442	0.002117
2,3-dimethylbutane+cyclopentane	C6H14	0.004374	0.020954
2-methylpentane	C6H14	0.012563	0.060184
3-methylpentane	C6H14	0.007080	0.033917
benzene	C6H6	0.091849	0.398834
cyclohexane	C6H12	0.029683	0.138871
methylcyclopentane	C6H12	0.018108	0.084718
n-hexane	C6H14	0.019024	0.091135
TOTALS:		0.183123	0.830730

C7 GROUP	FORMULA	MOL%	WT%
1,1-dimethylcyclopentane+3-methylhexane	C7H16	0.002711	0.015101
2,2-dimethylpentane	C7H16	0.000000	0.000000
2,3-dimethylpentane	C7H16	0.000620	0.003454
2,4-dimethylhexane+ethylcyclopentane	C7H14	0.000059	0.000322
2,4-dimethylpentane	C7H16	0.000000	0.000000
2-methylhexane	C7H16	0.001847	0.010288
3,3-dimethylpentane	C7H16	0.000000	0.000000
cis-1,3-dimethylcyclopentane+3-Ethylpentane	C7H14	0.001783	0.009732
cycloheptane	C7H14	0.000019	0.000104
Methylcyclohexane+1,1,3-Trimethylpentane	C7H14	0.013266	0.072409
n-heptane	C7H16	0.004923	0.027422
toluene	C7H8	0.027159	0.139109
trans-1,2-dimethylcyclopentane+cis-1,2-Dimethylcyclopentane	C7H14	0.000951	0.005191
trans-1,3-dimethylcyclopentane	C7H14	0.002893	0.015791
TOTALS:		0.056231	0.298923

C8 GROUP	FORMULA	MOL%	WT%
1-ethyl-1-methylcyclopentane	C8H16	0.000194	0.001210
2,2,3-trimethylpentane	C8H18	0.003386	0.021501
2,2,4-trimethylpentane	C8H18	0.004538	0.028816
2,3,4-trimethylpentane	C8H18	0.000151	0.000959
2,5-dimethylhexane	C8H18	0.000320	0.002032
2-methylheptane+4-methylheptane	C8H18	0.000912	0.005791
3,3-dimethylhexane	C8H18	0.000292	0.001854
3-methylheptane	C8H18	0.000171	0.001086
cis-1,2-dimethylcyclohexane	C8H16	0.001204	0.007511
cis-1,3-dimethylcyclohexane	C8H16	0.000198	0.001235

cyclooctane	C8H16	0.000079	0.000493
ethylbenzene	C8H10	0.000424	0.002502
ethylcyclohexane	C8H16	0.000483	0.003013
m-xylene+p-xylene	C8H10	0.001805	0.010653
n-octane	C8H18	0.000960	0.006096
o-xylene	C8H10	0.000444	0.002620
trans-1,3-dimethylcyclohexane	C8H16	0.000068	0.000424
TOTALS:		0.015629	0.097796

C9 GROUP	FORMULA	MOL%	WT%
1,1,2-trimethylcyclohexane	C9H18	0.000087	0.000611
1,2,3-trimethylbenzene	C9H12	0.000063	0.000421
1,2,4-trimethylbenzene+tert-butylbenzene	C9H12	0.000151	0.001009
1,3,5-trimethylbenzene	C9H12	0.000068	0.000454
2,2,3-trimethylhexane	C9H20	0.000000	0.000000
2,2,4-trimethylhexane	C9H20	0.000225	0.001604
2,2-dimethylheptane	C9H20	0.000043	0.000307
2,3,4-trimethylhexane	C9H20	0.000086	0.000613
2,4,4-trimethylhexane	C9H20	0.000207	0.001476
2,5-dimethylheptane	C9H20	0.000259	0.001847
2-methyloctane	C9H20	0.000085	0.000606
3,4-dimethylheptane	C9H20	0.000080	0.000570
cis-1,2,trans-1,4-1,2,4-trimethylcyclohexane	C9H18	0.000031	0.000218
cis,cis-1,2,3-trimethylcyclohexane	C9H18	0.000068	0.000477
isopropylbenzene	C9H12	0.000053	0.000354
methylcyclooctane	C9H18	0.000000	0.000000
m-ethyltoluene+p-ethyltoluene	C9H12	0.000051	0.000341
n-nonane	C9H20	0.000218	0.001554
propylbenzene	C9H12	0.000052	0.000347
propylcyclohexane	C9H18	0.000105	0.000737
r-1,t-2,c-3-trimethylcyclohexane	C9H18	0.000020	0.000140
r-1,t-2,t-4-trimethylcyclohexane	C9H18	0.000072	0.000505
Unidentified C9	C9	0.000186	0.001326
TOTALS:		0.002210	0.015517

C10 GROUP	FORMULA	MOL%	WT%
1,2,3,4-tetramethylbenzene	C10H14	0.000000	0.000000
1,2,3,5-tetramethylbenzene	C10H14	0.000000	0.000000
1,2,4,5-tetramethylbenzene	C10H14	0.000000	0.000000
1,2-diethylbenzene	C10H14	0.000000	0.000000

1,2-dimethyl-3-ethylbenzene	C10H14	0.000000	0.000000
1,2-dimethyl-4-ethylbenzene	C10H14	0.000000	0.000000
1,3-diethylbenzene	C10H14	0.000000	0.000000
1,3-dimethyl-2-ethylbenzene	C10H14	0.000000	0.000000
1,4-diethylbenzene	C10H14	0.000000	0.000000
1,4-dimethyl-2-ethylbenzene	C10H14	0.000000	0.000000
1-methyl-2-isopropylbenzene	C10H14	0.000000	0.000000
1-methyl-2-propylbenzene	C10H14	0.000000	0.000000
1-methyl-3-isopropylbenzene	C10H14	0.000000	0.000000
1-methyl-4-isopropylbenzene	C10H14	0.000043	0.000321
2-methylnonane	C10H22	0.000089	0.000704
3-ethyloctane	C10H22	0.000054	0.000427
3-methylnonane	C10H22	0.000000	0.000000
4-methylnonane	C10H22	0.000029	0.000229
butylbenzene	C10H14	0.000022	0.000164
butylcyclohexane	C10H20	0.000000	0.000000
isobutylbenzene	C10H14	0.000000	0.000000
naphthalene	C10H8	0.000011	0.000078
n-decane	C10H22	0.000063	0.000498
sec-butylbenzene	C10H14	0.000000	0.000000
tert-butylcyclohexane	C10H20	0.000000	0.000000
Unidentified C10	C10	0.000186	0.001471
TOTALS:		0.000497	0.003892

C11 GROUP	FORMULA	MOL%	WT%
n-undecane	C11H24	0.000052	0.000452
pentylbenzene	C11H16	0.000000	0.000000
Unidentified C11	C11	0.000000	0.000000
TOTALS:		0.000052	0.000452

C12 GROUP	FORMULA	MOL%	WT%
n-dodecane	C12H26	0.000052	0.000492
Unidentified C12	C12	0.000000	0.000000
TOTALS:		0.000052	0.000492

C13 GROUP	FORMULA	MOL%	WT%
n-tridecane	C13H28	0.000026	0.000266
Unidentified C13	C13	0.000000	0.000000
TOTALS:		0.000026	0.000266

C14 GROUP	FORMULA	MOL%	WT%
-----------	---------	------	-----

n-tetradecane	C14H30	<i>0.000000</i>	<i>0.000000</i>
Unidentified C14	C14	<i>0.000000</i>	<i>0.000000</i>
TOTALS:		0.000000	0.000000

C15+ GROUP	FORMULA	MOL%	WT%
n-pentadecane	C15H32	<i>0.000000</i>	<i>0.000000</i>
Unidentified C15	C15	<i>0.000000</i>	<i>0.000000</i>
TOTALS:		0.000000	0.000000

Road Runner Plant:Flare Header:Cold Side:9/14/2021

ASTM D5504 Gas Sulfur Speciation

SUMMARY	PPMV	GRAINS/100 SCF	PPMW
COMPOUND TOTALS:	0.3	0.02	1.7
TOTAL SULFUR, AS MASS OF SULFUR (PPMW):			1.0

Speciation Detail

SULFIDE GROUP	PPMV	GRAINS/100 SCF	PPMW
hydrogen sulfide	0.0	0.00	0.0
carbonyl sulfide	0.0	0.00	0.0
Dimethyl Sulfide	0.0	0.00	0.0
Methyl Ethyl Sulfide	0.0	0.00	0.0
Diethyl Sulfide	0.0	0.00	0.0
t-Butyl Methyl Sulfide	0.0	0.00	0.0
Methyl sec-Butyl Sulfide	0.0	0.00	0.0
Ethyl n-Propyl Sulfide	0.0	0.00	0.0
Diisopropyl Sulfide	0.0	0.00	0.0
Propyl Sulfide	0.0	0.00	0.0
tert-Butyl Sulfide	0.0	0.00	0.0
SULFIDE TOTALS:	0.0	0.00	0.0

DISULFIDE GROUP	PPMV	GRAINS/100 SCF	PPMW
Carbon Disulfide	0.0	0.00	0.0
Dimethyl Disulfide	0.0	0.00	0.0
Ethyl Methyl Disulfide	0.0	0.00	0.0
Methyl i-Propyl Disulfide	0.0	0.00	0.0
Diethyl Disulfide	0.0	0.00	0.0
Propyl Methyl Disulfide	0.0	0.00	0.0
Methyl tert-Butyl Disulfide	0.0	0.00	0.0
Ethyl i-Propyl Disulfide	0.0	0.00	0.0
Methyl sec-Butyl Disulfide	0.0	0.00	0.0
Ethyl Propyl Disulfide+1-Heptanethiol	0.1	0.01	0.8
i-Propyl Disulfide	0.0	0.00	0.0
n-Propyl Disulfide	0.0	0.00	0.0
t-Butyl Disulfide	0.0	0.00	0.0
Diphenyl Disulfide	0.0	0.00	0.0
DISULFIDE TOTALS:	0.1	0.01	0.8

MERCAPTAN GROUP	PPMV	GRAINS/100 SCF	PPMW
Methyl Mercaptan	0.0	0.00	0.0
Ethyl Mercaptan	0.0	0.00	0.0

i-Propyl Mercaptan	0.0	0.00	0.0
n-Propyl Mercaptan	0.0	0.00	0.0
tert-Butyl Mercaptan	0.0	0.00	0.0
sec-Butyl Mercaptan	0.0	0.00	0.0
i-Butyl Mercaptan	0.0	0.00	0.0
n-Butyl Mercaptan	0.0	0.00	0.0
1,5-Pentanedithiol	0.0	0.00	0.0
2 and 3-Methyl-1-Butanethiol+Tetrahydrothiophene	0.0	0.00	0.0
1-Pentanethiol	0.0	0.00	0.0
1,2-Ethanethiol	0.0	0.00	0.0
1-Hexanethiol	0.0	0.00	0.0
Thiophenol	0.0	0.00	0.0
1,4-Butanethiol	0.1	0.01	0.9
1-Octanethiol	0.0	0.00	0.0
1-Nonanethiol	0.0	0.00	0.0
1-Decanethiol	0.0	0.00	0.0
MERCAPTAN TOTALS:	0.1	0.01	0.9

THIOPHENE GROUP	PPMV	GRAINS/100 SCF	PPMW
Thiophene	0.0	0.00	0.0
2-Methylthiophene+3-Methylthiophene	0.0	0.00	0.0
2-Ethyl Thiophene	0.0	0.00	0.0
2-Bromothiophene	0.0	0.00	0.0
2-Propylthiophene	0.0	0.00	0.0
2-Butylthiophene	0.0	0.00	0.0
3-Butylthiophene	0.0	0.00	0.0
Benzothiophene	0.0	0.00	0.0
2-Methylbenzothiophene	0.0	0.00	0.0
THIOPHENE TOTALS:	0.0	0.00	0.0

OTHER SULFUR GROUP	PPMV	GRAINS/100 SCF	PPMW
sulfur dioxide	0.0	0.00	0.0
Unidentified Sulfur	0.0	0.00	0.0
OTHER SULFUR TOTALS:	0.0	0.00	0.0

Value of "0.0" interpreted as below detectable limit of 0.1 PPM Mol.

1.0 INTRODUCTION

1.1 Summary of Scope of Supply

The vertical thermal oxidizer is intended to oxidize the combustibles present in the specified waste stream. This is understood to apply only when the system is operated in accordance with the operating conditions stipulated in the design summary and for the waste(s) in Section 1.2.1 below.

The firing rate of the system is controlled by maintaining a specified operating temperature inside of the thermal oxidizer while the waste gas flow rates fluctuate. Efficient destruction of the waste is achieved at a thermal oxidizer operating temperature set point controlled at approximately 1,600 °F. The temperature works in conjunction with the thermal oxidizer volume and its associated residence time to achieve the efficient destruction of the waste gas stream.

The thermal oxidizer design includes internal shop installed refractory insulation. The selected materials are designed for a long, trouble-free operating lifetime. The list below summarizes the services and equipment provided in Zeeco's supply.

One (1) Thermal Oxidizer Package Including:

- One (1) Vertical Thermal Oxidizer w/ Integral Stack (10'-0" O.D. x 76'-0" OAH)
- Shop Installed and dried to 500°F Refractory Lining
- One (1) GB Style Burner
- One (1) Fuel Control Rack w/ Local Control Panel
- One (1) Combustion Air Fan w/ Ducting

1.2 Process Description

The vertical forced draft thermal oxidizer is equipped with one (1) forced draft fuel gas GB-Series burner. When the purge cycle is complete, the burner pilot is ignited via electric ignition. Once the burner pilot flame is proven, the main burner flame is ignited. The thermal oxidizer is then allowed to achieve a waste permissive temperature of 1,600 °F, following the recommended field cure procedures and schedule in APPENDIX D. Waste gas is then injected around the burner via the inlet nozzle. This high temperature accompanied with thermal oxidizer volume, known as residence time, destroys the hydrocarbon constituents of the waste gas stream. The flue gases from the thermal oxidizer then exit to atmosphere.

A temperature controller (supplied by others in DCS) monitors the combustion product's temperature through a thermocouple input and modulates both the fuel gas and combustion air flows into the burner. This ensures that sufficient temperature is maintained to provide complete destruction of varying waste gas compositions.

The fuel gas alone is used for start-up, burner stability, and refractory cure. The normal heat release for burner stability on fuel gas is ~44.8 MM BTU/HR. When more heat is needed for refractory curing, or if the heat produced by the combustion of the waste gas during operation is not sufficient to maintain a thermal oxidizer temperature of 1,600 °F, a maximum fuel gas heat release of 75 MM BTU/HR is available from the burner.

Combustion air is supplied by the blower. All air enters the thermal oxidizer through the burner via the combustion air nozzle (N9) located on the thermal oxidizer. The flue gas exits the vent stack at an elevation of 76 feet.

1.2.1 Process Design Conditions for Waste Streams

<u>Acid Gas Stream: Normal Operating Conditions (note 4)</u>			<u>Glycol System OVHD Stream</u>		
Temperature	120 °F		Temperature	120 °F	
Pressure (at Still Column)	3 psig		Pressure (at Still Column)	1 psig	
Flow Rate	15.52 MMSCFD		Flow Rate	0.03 MMSCFD	
	646,716.7 SCFH			1,175.0 SCFH	
Mol. Wt.	41.2074		Mol. Wt.	49.7237	
Mass Flow Rate	74,750 lb/hr		Mass Flow Rate	154.10 lb/hr	
Gross Heating Value (HHV)	38.63 BTU/SCF		Gross Heating Value (HHV)	2,585 BTU/SCF	
Net Heating Value (LHV)	31.29 BTU/SCF		Net Heating Value (LHV)	2397 BTU/SCF	
<u>Gas Composition</u>			<u>Gas Composition</u>		
Carbon Dioxide	88.74 mol%		Carbon Dioxide	0.17605 mol%	
Hydrogen Sulfide	0.354 mol%		Hydrogen Sulfide	0.00483 mol%	
Nitrogen	0.00940 mol%		Nitrogen	0.00820 mol%	
Methane	2.0149 mol%		Methane	9.80494 mol%	
Ethane	0.3716 mol%		Ethane	14.09657 mol%	
Propane	0.1227 mol%		Propane	18.96782 mol%	
i-Butane	0.0098 mol%		i-Butane	2.56932 mol%	
n-Butane	0.02933 mol%		n-Butane	9.91378 mol%	
i-Pentane	0.00224 mol%		i-Pentane	3.61200 mol%	
n-Pentane	0.00300 mol%		n-Pentane	4.83441 mol%	
Hexane	0.0007231 mol%		Hexane	3.17734 mol%	
Heptane	0.000088 mol%		Heptane	1.60118 mol%	
Cyclopentane	0.000665 mol%		Cyclopentane	1.96478 mol%	
Cyclohexane	0.000743 mol%		Cyclohexane	1.87261 mol%	
Methylcyclohexane	0.000133 mol%		Methylcyclohexane	1.01041 mol%	
2,2,4-Trimethylpentane	0.000006 mol%		2,2,4-Trimethylpentane	0.09706 mol%	
n-Octane	0.0000054 mol%		n-Octane	0.13357 mol%	
Water	8.32375 mol%		Water	12.72109 mol%	
Benzene	0.01188 mol%		Benzene	8.93524 mol%	
Toluene	0.00250 mol%		Toluene	3.43888 mol%	
Ethylbenzene	0.00026 mol%		Ethylbenzene	0.61876 mol%	
p-Xylene	0.00000 mol%		m-Xylene	0.00000 mol%	
o-Xylene	0.00018 mol%		o-Xylene	0.43941 mol%	
Location:					
Site Elevation	3070	FASL			
Max Ambient	105	F			
Min Ambient	0	F			
Wind Speed	100	mph			
Notes:					
1. Above information is applicable to the request for quote for a Thermal Oxidizer.					
2. Unit to achieve best destruction efficiency possible, 99% minimum if possible					
3. Unit to be designed with two separate connections; one connection to be designated for the amine acid gas stream and one connection to be designated for the glycol system OVHD stream					
4. Amine Acid Gas Stream is the amine OVHD gas combined with the Amine Flash Gas, to increase the heating value					
5. Fuel gas is available					
6. Excess capacity of 10% requested					

Zeeco has considered that the Amine Flash Gas and Amine OVHD Gas will be introduced to the unit on separate connections. While the above composition does not cause a combustion instability problem, injecting the Flash Gas and OVHD Gas together can cause combustion instability during start-up or process upset conditions, when the heating value fluctuates. We will be happy to discuss this point in additional detail if necessary. Please contact us.

1.2.2 System Performance @ 1600°F

Stack Emission	Expected Performance
Destruction Efficiency	> 99.9% of all Hydrocarbons
NO _x , ppm _{vd} @ 3% O ₂	50
CO, ppm _{vd} @ 3% O ₂	50

Note: These values are understood to apply only when the system is operated in accordance with the above operating conditions and waste(s) stipulated in section 1.2.1 above, and design temperature.

1.2.3 Combustion Air Performance

Reference AirPro Fan vendor literature in APPENDIX G for combustion air blower performance curve information.

1.2.4 Burner Performance

Reference the burner capacity curve (32339-G009A-001) in APPENDIX D for burner performance information.

1.3 Equipment Description

The forced draft thermal oxidizer system is described below.

1.3.1 Burner (Reference Zeeco Drawing 32339-G006A-001)

The forced draft burner assembly consists of one (1) GB Series gas burner. The burner is complete with the following features:

- One (1) GB Series (75 MM BTU/HR) forced draft burner with 10:1 fuel gas turndown.
- AR/GS-1 HEI electric spark ignited pilot assembly (85,000 BTU/HR Intermittent Pilot)
NOTE: During normal operation, the purge air to cool the pilot must remain on even when pilot is not in operation.
- One (1) 42-3/4" fabricated plate flange burner mounting connection.
- One (1) 4" 150# RFWN fuel gas connection.
- One (1) 2" 150# RFWN glycol vent connection.
- One (1) 1-1/2" 150# RFWN pilot mounting connection.
- One (1) 2" NPS sight port assembly with purge connection.
- Two (2) 2" FNPT swivel scanner mount assemblies with purge connection.
- One (1) 1-1/2" 150# RFWN drain connection w/ blind.
- A-36 carbon steel construction.
- 60% Al₂O₃ burner tile, shipped in eight (8) loose segments.
- Paint per Zeeco document 32339-4030 (See APPENDIX E).

1.3.2 Thermal Oxidizer (Reference Zeeco Drawing 32339-G064A-001)

The thermal oxidizer design is a vertically fired unit supported by legs, and is designed to operate at 1600 °F. The thermal oxidizer is designed and furnished with the following companion features for the Zeeco burner design:

- Nominal 10'-0" O.D. integral stack x 76'-0" overall height.
- One (1) 42-3/4" fabricated plate flange burner mounting connection
- One (1) 30" 150# RFWN Amine waste gas connection.

- One (1) 40" fabricated plate flange combustion air connection.
- Two (2) 1-1/2" RFWN thermocouple connections.
- Two (2) 4" RFWN sample connections w/ blind.
- One (1) 4" RFWN O₂ analyzer connection.
- One (1) 4" sight port connection w/ purge and blast gate.
- Two (2) 2" RFWN spare scanner connections w/ blind.
- One (1) 1-1/2" RFWN drain connection w/ blind.
- One (1) 36" fabricated plate flange manway w/ davit.
- A-36 carbon steel shell with 1/8" corrosion allowance.
- Two (2) lifting trunnions for use with spreader beam and tailing lug.
- One (1) lot of ladders & platforms consisting of two (2) service platforms and one (1) step off platform. Ladders & platforms are trial fit in the shop, then shipped loose to prevent damage. All safety gates are the same size and interchangeable.
- Shop fit stack strakes (shipped loose to prevent damage)
- Shop installed castable refractory lining dried out to 500 °F.
- One (1) lot of rainshield material (shipped loose to prevent damage)
- One (1) 304SS leg mounted grounding lug.
- Paint per Zeeco document 32339-4030 (See APPENDIX E).

1.3.3 Refractory Lining (Reference Zeeco Drawing 32339-R064A-001)

The refractory supplied includes insulating castable and medium weight castable. The castable refractory is held in place using 310 stainless steel anchors located on 9" centers. Refractory anchors and castable are shop installed and dried to 500°F.

Thermal Oxidizer Floor

4" thick 3000 °F, medium weight castable, backed with 2" thick 2300 °F light weight insulating castable with 310 SS Hanlock HL-201-4 (or equal) anchors on 9" centers.

Combustion Zone (First ~ 10' of Thermal Oxidizer Vessel)

4" thick 3000 °F, medium weight castable, backed with 2" thick 2300 °F light weight insulating castable with 310 SS Hanlock HL-201-4 (or equal) 3" tall anchors on 9" centers.

Mixing Zone (Final ~ 51'-9" of Thermal Oxidizer Vessel)

4" thick 2300 °F, light weight insulating castable, with 310 SS Hanlock HL-208-7 (or equal) anchors on 8" centers.

Additional details may be seen in the general arrangement drawings included in APPENDIX D.

1.3.4 Instrumentation & Controls

The Zeeco supplied Control System includes all field-mounted instrumentation and valves, along with controls and rack mounted piping for the burner management system (BMS). Interconnecting conduit, wiring, tubing, and piping between the rack and the Thermal Oxidizer is supplied and field installed by others. For more information, please see Zeeco P&ID drawings 32339-04-11001-001 and 32339-04-11001-002 in APPENDIX D.

Zeeco has supplied a Burner Ignition System, one (1) temperature transmitter (TT-5500), five (5) Pressure Gauges (PI-5501A, -5501B, -5502A, -5503A, -5503B), two (2) Flame Scanners (BE/BSL-5501/5502), two (2) thermocouples (TE-5500 & TE-5504), and the burner controls rack. Refer

to the Zeeco Shipping List located in APPENDIX F for reference to shipped loose items. The Zeeco supplied instruments and controls (above) are certified to Class I Div. II Group C & D operation.

The P & ID drawing series is included in APPENDIX D (for the Zeeco supplied controls and instruments) to provide detailed information on the instrumentation and mounting. Detailed instrument specification sheets and selected vendors are included in APPENDIX E (documents) and APPENDIX G (vendors).

1.3.5 Combustion Air Blower (Reference AirPro fan drawing in Appendix G)

One (1) Combustion air blower complete with the following features:

- Designed for 23,238 CFM @ 3.5" w.c.
- AirPro Model BIHS290, Arrangement 4 Fan Assembly
- 30 hp., 1760 rpm, 460/60/3 Premium Eff. TEFC Motor
- Silencer w/ bird screen
- Flanged inlet/outlet connections
- Outlet Flex Connector
- Bolted Access Door
- Drain Connection with plug

Appendix A

Customer Process Data Sheets

PRIMARY FLARE

BY: GLM	JOB NO: 6353	PAGE 1 OF 2
DATE: 7/28/2011	ITEM NO.: FL-991	
CUSTOMER: Southcross Energy		
PLANT: Woodsboro Plant		
SERVICE: PRIMARY FLARE		
QUANTITY: 1	SIZE: By Mfgr	



**SAULSBURY
Engineering &
Construction**

Texas Registered Engineering Firm F-518
Work by Saulsbury Engineering: Rev RFQ

Request for Quotation
7/29/2011
GLM
WST
RFQ
SE&C

Design Cases	Cold Flare Riser	Warm Flare Riser	
Flow Rate (Lb/Hr)	392,000	180,000	
Controlling Point Sources	PSV-501	PSV-361,161,162,163	
Molecular Weight	18-19	44	
Temperature, °F at inlet to Riser	-50 to -100	+250	
Maximum Pressure at Inlet Nozzle, PSIG	50	50	
Smokeless Operation Required (Yes/No)		Yes, Note 3	
Lower Heating Value, BTU/SCF			
Composition (Mol % / Weight %)			
Nirtogen			
Carbon Dioxide			
Methane	80-85 Mol%		
Ethane			
Propane		Essentially 100%	
Butanes			
Pentanes			
Hexanes Plus			
Hydrogen			
Oxygen			
TOTAL			
Flare Riser Diameter & Inlet Nozzle Size, Note 2	16"	10"	
Max Wind During Flaring Operation, MPH	30	30	

- Notes
- 1) Elevated, Self-Supported Flare
 - 2) Flare will consist of 2 risers with sizes as shown. As an option, vendor may propose different size with rationale.
 - 3) Smokeless Rate - 20% of Warm Flare Rate
 - 4) Features not specifically identified should be similar to the Zeeco SO 17716 or Ref T80793F.
 - 5) Instrument Air available at 85-125 psig.
 - 6) Provide radiation shielding for any JB's, panels, boxes, or other electrical equipment if required to prevent operating temp out of spec during extended release.
 - 7) Supply heavy duty vaneaxial blower air assist, non-overloading two speed TEAO motor and manually adjustable prop.

PRIMARY FLARE

BY: GLM	JOB NO: 6353	PAGE 2 OF 2
DATE: 6/1/2011	ITEM NO.: FL-991	
CUSTOMER: Southcross Energy		
PLANT: Woodsboro Plant		
SERVICE: PRIMARY FLARE		
QUANTITY: 1	SIZE:	By Mfgr



**SAULSBURY
Engineering &
Construction**

Texas Registered Engineering Firm F-518
Work by Saulsbury Engineering: Rev RFQ

Request for Quotation
7/29/2011
GLM
WST
RFQ
SE&C

Power Available	460Vac 3 P 60 Hz	120 Vac 1 P 60 Hz
Control Power	120 Vac 1 P 60 Hz	
Electric Classification Area	Class 1, Div 2, Grp C,D, Temp T2B	
Pilot Gas	Pipeline gas, 100 psia	
Utility Gas	Pipeline Gas, 100 psia	
Purge Reduction	Pipeline Gas, 100 psia	
Flare Tip	304SS	
Maximum Allowable Thermal Radiation, BTU/Hr/SqFt	1750 - Note 6	
At Grade, Specify Distance from Flare Base, Ft	100	
Stack Support	Self Supported	
Structural Design Wind Velocity, MPH	100	
Seismic Zone	1	
Flare Knockout Drum	NO	
Design Pressure, PSIG / Temperature, F / Corr Allow	50 psig	
ASME Code Stamp / National Board Registration	NO	
Ignition Device (Note 8)	FFG	
Enclosure	Class 1 Div 2, Grp C,D, T2B	
Ladder Platforms	No	
Special Instrumentation	Air Assist Flow switch	

NOTES:

- 1) Applicable specifications: NEC NEMA AISC
- 2) ASME B31.3 Piping and Shell, AWS 1.1 Welding , and ASCE 7-05 Structural specs are required.
- 3) Use Rosemount 3051 pressure transmitters for all pressure instrumentation, Rosemount as applicable elsewhere.
- 5) Ignition system: Manual with Automatic relight Pilot status monitors
- 6) No point on the ground is to receive more than 2000 BTU/hr/sq ft under any condition.
- 7) Specify freight charges with proposal, and include drawings, schedules and deliveries.
- 8) FFG = Flame Front Generator type.
- 9) Direct high energy spark ignition HEI with optical pilot monitoring device.

Appendix B

Drawings

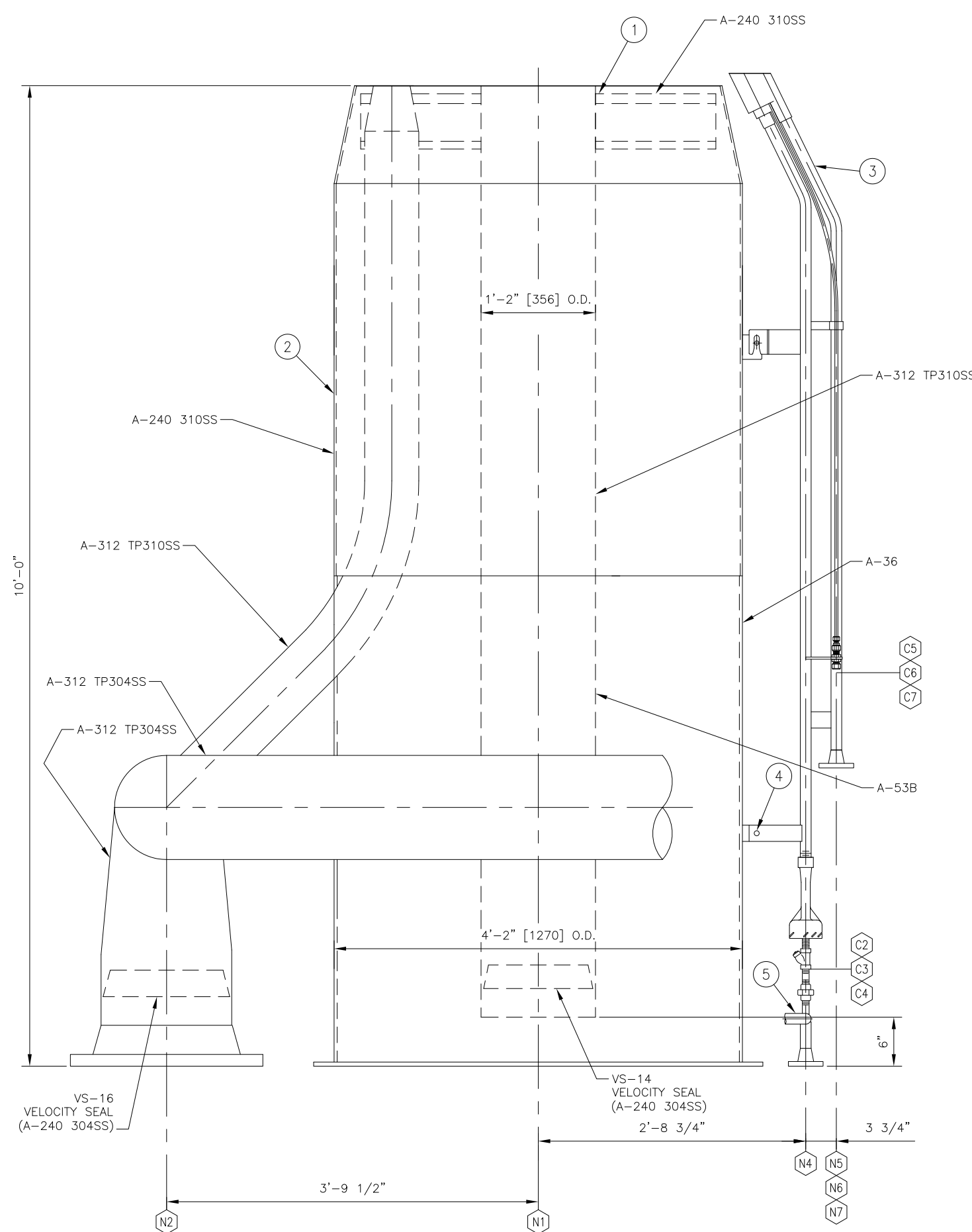

ELEVATION VIEW
 (PORTIONS ROTATED FOR CLARITY)

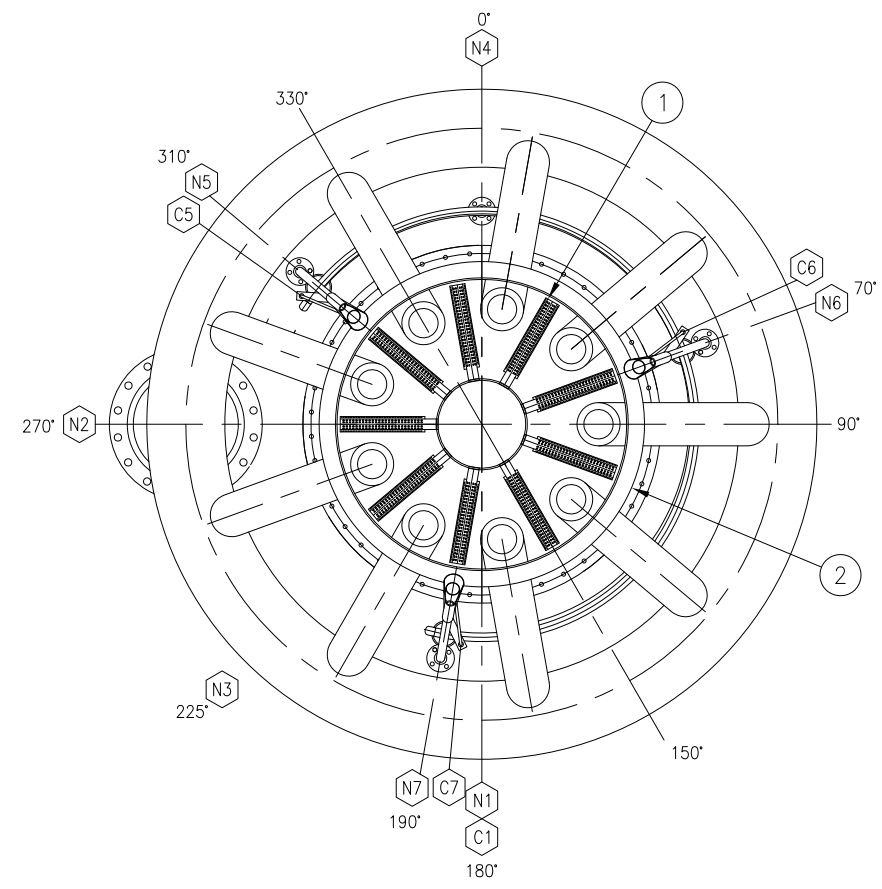

PLAN VIEW
 (TRUE ORIENTATION)

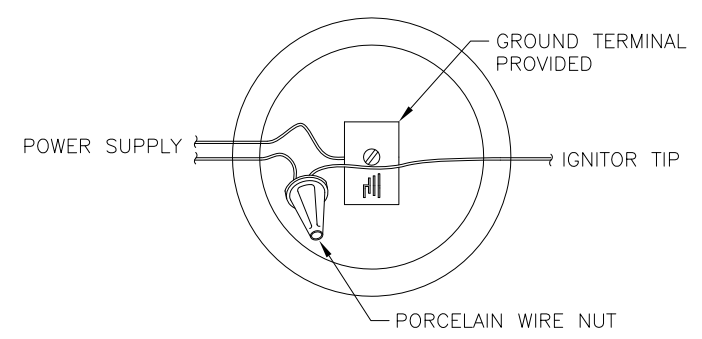

HEI CUSTOMER CONNECTION

- PARTS LIST -

ITEM	QTY	DESCRIPTION	PART NO	MATERIAL
1	1	AFDSGA-14/50 CENTER ASS'Y	KC-2207	310SS/CS
2	1	AFDSGA-14/50 PLENUM ASS'Y	KC-2208	310SS/CS
3	3	HSLF-Z RT/C PILOT NIPPLE ASSEMBLY	MB-1562	310SS
COMPLETE WITH:				
		HSLF-Z MIXER BODY		A-743 CF3M
		HSLF-Z MIXER SPUD		F837 18-8
		PIPE		A-312 TP316
		STRAINER W/ PLUG		A-743 CF8M
4	3	MACHINE BOLT	1/2" X 1 1/4" LG	A-193 B8
		W/ HEAVY HEX NUT		A-194 Gr 8
5	1	PILOT MANIFOLD ASS'Y	KC-2209	CS

- NOTES -

- PILOT MIXER ORIFICE DRILLED: #55φ [1.32 mm]
- PILOT GAS CONSUMPTION TWO CASES:
 PILOT GAS CONSUMPTION CASE: 78 SCFH @ 15 PSIG PER PILOT [2.09 Nm³/HR @ 1.05 kg/cm²g]
 PILOT GAS CONSUMPTION CASE: 75 SCFH @ 15 PSIG PER PILOT [2.01 Nm³/HR @ 1.05 kg/cm²g]
- PILOT ORIFICE DRILLING BASED ON TWO CASES:
 CASE 1: 908 BTU/SCF (LHV) [8542 kcal/Nm³] GAS WITH 0.57 SP. GR.
 CASE 2 RECOVERY CASE: 959 BTU/SCF (LHV) [9021 kcal/Nm³] GAS WITH 0.60 SP. GR.
- THE FLARE TIP REQUIRES A CONTINUOUS PURGE OF COLD=1040 SCFH [27.86 Nm³/HR] AND WARM=290 SCFH [7.77 Nm³/HR] [10.18 Nm³/HR] OF A GAS THAT WILL NOT GO TO DEW POINT AT OPERATING TEMPERATURES.
- ALL FLANGE BOLTING TO STRADDLE NORMAL CENTERLINES.
- ALL EXTERNAL CARBON STEEL SURFACES TO BE PREPARED PER SSPC-SP6. PRIME WITH ONE COAT INORGANIC ZINC (2 1/2 MILS DFT MIN.) PAINT ONE COAT HIGH TEMP ALUMINUM (1 MIL DFT MIN.)
- ALL TESTING PER INSPECTION TEST PLAN DOCUMENT NO. 20238-4010
- THE PILOT THERMOCOUPLE IS FOR ON/OFF INDICATION ONLY, NOT FOR ACCURATE MEASUREMENT OF THE PILOT FLAME TEMPERATURE.
- WHEN INSTALLING THE CENTER ASSEMBLY THE GAS EXIT ARMS MUST BE CENTERED ON THE PILOT AS PER THE PLAN VIEW.
- APPROXIMATE WEIGHT FOR FLARE TIP ASS'Y: 4613 LBS [2092 KG]
- APPROXIMATE WEIGHT FOR EACH PILOT: 100 LBS [45 KG]

- NOZZLE LEGEND -

ITEM	SERVICE	SIZE	RATING	TYPE	SCH/BORE	FLG. MAT'L
N1	FLARE GAS INLET	55" O.D. X 1/2" THK. X 50 1/4" I.D. W/ (44) 5/8" HOLES ON A 52 1/2" B.C. EQ. SPCD.		A-36		
C1	WARM GAS INLET	14"	N/A	BW	S/10	A-53B
N2	COLD GAS INLET	16"	150#	RFWN	S/10S	A-182 F304
N4	PILOT MANIFOLD GAS INLET	1"	150#	RFWN	S/40	A-105
N5-N7	IGNITION GAS INLET	1"	150#	RFWN	S/40	A-182 F310
C2-C4	PILOT GAS INLET	1/2"	N/A	FNPT	N/A	CF8M
C5-C7	T/C GUIDE TUBE	1/2"	N/A	TUBE	N/A	N/A

JOBSITE: SOUTHCROSS, TX
 END USER: ENOGEX
 S.O. NO.: 20238 P.O. NO.: 6353-004 APP SKS

ZECCO, INC.
 22151 EAST 91st STREET
 BROKEN ARROW, OK 74014
 PHONE: (918) 258-8551
 FAX: (918) 251-5519
 www.zecco.com
 sales@zecco.com

AFDSGA-14/50 FLARE TIP ASSEMBLY (TAG: FL-991)

SE & C

FOR: DRAWN DATE 23AUG11
 CHK APP KAL
 SCALE NONE REV 0
 DRAWING NUMBER B-SC-6349 SHT. 1 OF 1

NO.	DATE	REVISION DESCRIPTION	BY	CKD.	APP.
0	23AUG11	ISSUED FOR APPROVAL			KAL



10231: Lucid Energy – Road Runner Flare Study

Background

The purpose of the flare and relief valve study performed by Saulsbury Industries was to evaluate the hydraulics in both the main flare header system and the inlet/outlet piping on the individual relief devices. Several different scenarios were considered when evaluating the flare header system hydraulics and flare stack/tip specifications for maximum relieving loads. Some of these scenarios include, but are not limited to:

- Point-source failure of an instrument or controller (i.e. control valve failure into 100% open position)
- External pool fire around an area containing single or multiple pieces of equipment whose relief valves discharge into the flare header. Per API 521 guidelines, a fire circle area of 2500 ft² was used to determine which pieces of equipment could be subjected to a common pool fire.
- Blocked-in flow of single or multiple pieces of rotating equipment, causing the equipment to deadhead and reach the designated relieving pressure.
- Heat exchanger tube rupture
- Process control vents to flare, whose purpose is to provide “pre-relief” on equipment before a relief valve opens during operating pressure upsets.

The flare system consists of both a carbon steel “warm” flare header and a stainless steel “cold” flare header. Each of these individual flare headers are routed to dedicated flare risers on the main flare stack, where they are combined into a single flare-tip at the top of the stack. The stainless steel flare header is designed to collect and handle relief valve discharges from the cryo plant area (routed to/from the UOP-provided V-403 Cold Drain Tank). Some relief valves in the cryo plant area have relieving temperatures far below the 0°F minimum temperature limit for standard carbon steel piping and would otherwise potentially result in significant thermal stress or shock if they are routed to the carbon steel “warm” flare header piping. Only relief valves from the cryo plant equipment will be routed into the stainless steel “cold” flare header. All other relief valves in the plant that are routed to flare and have a relieving temperature comfortably above 0°F are discharged into the warm flare header.

The Aspen Flare System Analyzer v10 software was used to evaluate and confirm flare header hydraulics once the location and arrangement of the plant relief devices was known. The software utilizes isothermal compressible flow models to predict pressure drop throughout the flare system, as well as the Peng-Robinson equation of state to approximate outlet temperatures from relief valve discharges based on the composition of the relieving fluid.



Assumptions

- 1) Inlet and outlet piping configurations are an approximation based on information available at the time the flare study was performed. However, small changes in pipe routing/distance will not affect the overall operation of the flare system or adversely affect the reported results.
- 2) Residue and flash gas compressor blowdown (manual operation) do not discharge into the flare header, and therefore the flare system analysis excludes this scenario.
- 3) Bypass valves around control valve stations are assumed, via standard plant operating procedures, to be normally closed during plant operation. Inadvertent opening to full 100% trim capacity in these bypass globes valves are not considered.
- 4) Mach number in sub-headers and main header is limited to 90% of sonic velocity. The exception this is when a “sonic break” occurs during a sudden size change at a tie-point between a relief valve discharge lateral into the larger main flare header or sub-header.
- 5) Conventional PSV backpressure limit: 10% of PSV set pressure for non-fire scenario
- 6) Conventional PSV backpressure limit: 21% of PSV set pressure for fire scenario
- 7) Balanced Bellow PSV backpressure limit: 40% of PSV set pressure
- 8) Pilot-Operated PSV backpressure limit: 80% of PSV set pressure
- 9) Relief valve inlet piping pressure drop limit: 3% of PSV set pressure

Flare Headers

The carbon steel “warm” flare header/system at the Lucid Energy Road Runner gas plant consists of the following:

- 12” plant flare header up to the warm flare KO drum with the following sub-headers:
 - o 8” flare header branch in the mol sieve dehydration area rack
 - o 10” flare header branch in refrigeration area rack
 - o 12” flare header branch in amine and TEG regeneration area rack
 - o 12” flare header branch in stabilizer area rack
- 72” OD x 30’-0” S/S warm flare knockout drum, 100 psig @ 350°F design
- 12” flare header from the warm flare KO drum up to the flare stack inlet

The stainless steel “cold” flare header/system at the Lucid Energy RoadRunner gas plant consists of the following:

- 12” plant flare header up to the cold drain tank
- 54” ID x 30’-0” S/S cold drain tank, 150 psig @ 150/-200°F design
- 14” flare header from the cold drain tank to the flare stack inlet



Flare Stack/Tip Design

The flare tip is an air-assisted, sonic-tip flare that contains two, staged vane-axial blowers that allow the flare to achieve smokeless combustion for all relieving flow rates at 20% or less of the maximum design case outlined in the flare datasheet. The sonic-tip flare is designed to take as much pressure drop at the tip as possible because this not only improves performance, it also increases longevity of the tip itself. The reasoning behind this is that at a higher pressure, and thus higher exit velocity, the flame is more erect and does not lean on the tip and create a hot spot, which over time could cause failure. In addition to improved lifespan, the smokeless performance of the flare is aided by the higher exit velocity – so at full flow rates the flare will likely be 100% smokeless because the air mixes in better at the tip than it would if the flare gas was exiting at lower velocities. By sizing the flare to take the max pressure drop allowable, the flare riser piping is smaller, the tip is smaller and this leads to a more economical flare system.

Each flare riser also contains a velocity seal to reduce the amount of purge gas required to prevent oxygen intrusion into the flare header systems. Furthermore, each dead-leg in the overall plant flare header system contains a purge gas connection at the very end of these headers to ensure that all areas of the flare header maintain a constant sweep and positive pressure.

The flare contains a variable-speed vane axial blower (150 HP) operating on a VFD, where the blower speed ramps up and down depending on the flare gas header flow rate that is present. The blower on the flare is mostly required for lower flowrates where the velocity and operating pressure of the relieving fluids in the flare stack are much lower than the maximum relieving cases by which the tip and flare system were designed for. During these lower flow rate scenarios, much less air is induced by turbulent mixing at the flare tip due to the low pressure drop at the tip, and therefore the blower is needed to help keep the flare smokeless at reduced rates. The blower speed, and thus air flow capacity is controlled via flare header gas pressure vs. air flow control curves provided by Zeeco. These curves relate pressure in the flare gas header to the % Blower VFD that should be applied.

If the event that a simultaneous flaring event should occur in both gas headers (cold and warm flare headers), then the flow rate that is measured in each header is converted into its equivalent %VFD per the charts provided by Zeeco. These percentages are then summed together to give the final applied %VFD.



Summary of Maximum Flare Relief System Cases

The attached plant flare datasheet summarizes the maximum flow cases by which the flare stack and blower were sized for. The two controlling cases for the cold flare header were wide-open failure of the JT-valve (327,800 lb/hr flow) and an external pool fire around the NGL Surge Tank (200,756 lb/hr flow). Likewise, the controlling case for the warm flare header was an external fire around the Condensate Surge Tank (364,824 lb/hr flow) one of the Amine Contactor level control valves failure (210,253 lb/hr). The initial main flare header hydraulics was evaluated using these estimated relief loads to determine the required flare header diameters.

The process data identified on the flare stack datasheet was an up-front estimate of expected maximum relieving loads at the time of the flare stack purchase. However, the actual maximum relieving cases/loads that were analysed during detailed design were less than or very close to the capacity loads used to design the flare stack, thus confirming the flare stack and blowers contain adequate capacity to handle all relieving cases in the plant.

The following table is a summary of some of the largest relieving loads into the warm and cold flare headers that were determined during detailed design. The results of all cases that were evaluated will be included in the appendix of this report.

<u>System</u>	<u>Relieving Case</u>	<u>Relieving Rate</u>
Warm Flare	FIRE: Mole-Sieve Area	89,656 lb/hr
Warm Flare	FIRE: Amine HMO Heater	109,693 lb/hr
Warm Flare	Fire: Condensate Surge Tank Area	461,914 lb/hr
Warm Flare	Fire: Stabilizer Skid Area	221,816 lb/hr
Warm Flare	OPER: Refrig. Compressor Blocked Flow	221,526 lb/hr
Warm Flare	OPER: LV-1201 (or) LV-1202 Control Failure	210,253 lb/hr
Warm Flare	OPER: Demethanizer Overpressure CV Open	345,000 lb/hr
Cold Flare	OPER: PCV-402B (JT-Valve) Control Failure	327,800 lb/hr
Cold Flare	FIRE: NGL Product Surge Tank	268,265 lb/hr
Cold Flare	FIRE: UOP Process Skids Area	212,722 lb/hr

The flare header hydraulics of both main flare headers, all flare sub-headers, and individual relief valve discharge piping laterals were evaluated utilizing all expected relief loads to verify that the backpressure induced by a single or multiple relief valves of various types (conventional, balanced, pilot-operated) would not cause backpressure issues on the operation of the relief valves. Based on the reported flare study results, all sections of the warm and cold flare headers contain adequate hydraulic capacity to handle all of the relief loads from the various emergency scenarios that were evaluated. The flare header diameters and relief valve discharge piping laterals are of adequate diameter to prevent backpressure in the system from building up that would either exceed the backpressure limitations set forth by the relief valve type and/or the design/test pressures of the flare knockout drums, the main flare header piping, and the individual relief valve discharge piping laterals.

The maximum backpressure seen in the cold flare header at the Cold Drain Tank, V-403, occurs during a JT-Valve failure scenario (PCV-402B wide-open) that would overpressure the demethanizer tower. The backpressure at the Cold Drain Tank inlet nozzle is 8 psig, which is well below the 150 psig design pressure of this vessel. Likewise, the maximum backpressure seen in the warm flare header at the Warm Flare KO Drum, V-5000, occurs during a fire near the Condensate Surge Tank. The backpressure at the Warm Flare KO Drum inlet nozzle is 86 psig, which is below the 100 psig design pressure of this vessel.

Warm and Cold Flare Knockout Drum Performance

The primary and critical function of the flare knockout drums on the cold and warm flare headers is to separate and remove any incoming liquid streams in the flare header that are present during relieving events or if condensation occurs in the flare header during cold ambient temperatures. The main flare headers and all plant sub-headers contain a slope of 1" per 100 ft to ensure that the main headers remain devoid of liquid inventory that would cause liquid slugs and/or water hammer during high-load relieving events.

Per API 521, flare knockout drums are sized to remove a maximum droplet size of between 300-600 microns from the incoming fluid stream to prevent large quantities of liquid carryover to the flare tack/tip in the form of liquid droplets. Utilizing the terminal liquid velocity and horizontal gas flowing velocity equations outlined in API 521 and the GPSA Engineering databook, the attached results indicate that both the Warm Flare KO Drum, V-5000, and the Cold Drain Tank, V-403, are sufficiently sized to achieve separation of liquid droplets below the 600 micron limit established by API 521.

When the Warm Flare KO Drum contains a liquid level above its secondary high level switch alarm point (67% full), the vessel is still capable of removing 300 micron and larger diameter liquid droplets from the incoming fluid stream. The incoming fluid streams that were analysed for the liquid level vs. droplet removal for the Warm Flare KO Drum were the 364,824 lb/hr relieving flow created during an external fire near the Condensate Surge Tank. When the Cold Drain Tank contains a liquid level above its high level alarm point (67% full), the vessel is still capable of removing 500 micron and larger diameter liquid

droplets from the incoming fluid stream. The incoming fluid stream that was analysed for the liquid level vs. droplet removal for the Warm Flare KO Drum was the 327,800 lb/hr relieving flow created during a JT-valve failure.

Radiation Levels

During evaluation of the maximum design cases for flaring events, Zeeco was instructed to design the height of the flare to be such that a maximum radiation exposure level of 1,750 BTU/hr-ft² would be encountered at a ground-level point 100 feet away from the base of the flare. This specification takes into account a radiation intensity of 250 BTU/hr-ft² for solar radiation, and 1,500 BTU/hr-ft² radiation intensity for combustion at the flare tip during maximum relieving scenarios.

Based on the attached radiation isopleths supplied by Zeeco, there will be no relieving cases where radiation intensity in excess of 1,750 BTU/hr-ft² will be encountered at any point further than 100 feet away from the flare stack. Since the nearest piece of equipment to the flare stack is ~200 feet away (flare flow meters and platform), the radiation isopleths indicate that excessive radiation exposure will not be encountered during normal maintenance and routine operator rounds, with exception to inspecting the blower at the base of the flare.



Saulsbury Industries

SAULSBURY

Corporate Office: 2951 E Interstate 20, Odessa, TX 79766 · P: 432-366-3686 · F: 432-368-0061

Appendix A: Flare Design Basis

FLARE			
BY: EMG	JOB NO: 10231	PAGE 1 OF 2	
DATE: 5/3/2017	ITEM NO.: FL-5100 FLARE		
CUSTOMER: Lucid Energy			
PLANT: Roadrunner			

REV. 0
 Issue for Construction
 Request for Quotation
 DATE: 5/3/2017
 BY: EMG
 APPR: DLS
 NO. 0
 FRM: SI

SERVICE: Flare	Texas Registered Engineering Firm F-518
QUANTITY: 1 SIZE: 4' - 10" DIA X 100' - 0" OAH	Work by Saulsbury Engineering: REV. 0

Design Cases	Cold Flare Riser (Case #1)	Cold Flare Riser (Case #2)	Warm Flare Riser (Case #1)	Warm Flare Riser (Case #2)
Flow Rate (Lb/Hr)	392,000	267,780	221,526	355,000
Relief Scenario	JT-Valve Failure	Fire - NGL Surge Tank	Refrigeration Comp. Blocked Flow	Condensate Surge Tank & Stabilizer PSVs
Controlling Point Sources	PSV-501	PSV-404	PSV-161,162,163	PSV-1301 and Others
Molecular Weight	17.6446	38.602	44.17	50.46
Temperature at Inlet Nozzle, °F	-127	170	140 -190	255
Pressure at Inlet Nozzle, PSIG	25	15	10	25
Smokeless Operation Required (Yes/No)	Yes	Yes, Note 3	Yes, Note 3	
Lower Heating Value, BTU/SCF	979	2039	2318	2553
Composition (Mol %)				
Nitrogen	0.656%	0.000%		0.023%
Carbon Dioxide	0.021%	0.077%		2.9830%
Methane	89.660%	0.497%		10.210%
Ethane	8.589%	57.194%	0.25%	15.643%
Propane	0.995%	27.995%	99.00%	25.187%
i-Butane	0.031%	3.312%	0.75%	6.070%
n-Butane	0.043%	7.146%		17.287%
i-Pentane	0.002%	1.423%		6.200%
n-Pentane	0.001%	1.438%		7.288%
Hexane	0.000%	0.510%		5.938%
Heptane	0.000%	0.142%		2.254%
Benzene	0.000%	0.038%		0.425%
Toluene	0.000%	0.009%		0.193%
O-Xylene	0.000%	0.001%		0.037%
P-Xylene	0.000%	0.000%		0.000%
Octanes+	0.000%	0.008%		0.2522%
Water	0.000%	0.000%		0.000%
Hydrogren Sulfide	0.000045%	0.00032%		0.0098%
Flare Riser Diameter & Inlet Nozzle Size, Note 2	By Vendor		By Vendor	
Radiation Design Parameters: Temp, F / Wind, MPH	90 / 30		90 / 30	

Notes

- 1) Elevated, self-supported flare.
- 2) Vendor to propose optimum size of two risers
- 3) Smokeless rate is 20% of the warm flare design rate.
- 4) Flare shall be of one-piece lift/erection design for site installation.
- 5) Instrument air available at 85 to 125 psig.
- 6) Provide radiation shielding for any JB's, panels, boxes, or other electrical equipment if required to prevent operating temperature out of spec during extended release.
- 7) Supply heavy duty vaneaxial blower for air assist with VFD control.
- 8) Pressure at flare base for majority of other cases will be 5 psig or less.

FLARE



BY:	EMG	JOB NO:	10231	PAGE	2	OF	2
DATE:	3/7/2017	ITEM NO.:	FL-5100 FLARE				
CUSTOMER:	Lucid Energy						
PLANT:	Roadrunner						
SERVICE:	Flare						
QUANTITY:	1	SIZE:	*				

Texas Registered Engineering Firm F-518
Work by Saulsbury Engineering: **REV. 0**

Power Available	460Vac 3 P 60 Hz		
Control Power	120 Vac 1 P 60 Hz		
Electric Classification Area	Class 1, Div 2, Grp C,D, Temp T2B		
Pilot Gas	Pipeline gas, 100 psia		
Utility Gas	Pipeline Gas, 100 psia		
Purge Reduction	Pipeline Gas, 100 psia		
Flare Tip	By Vendor		
Maximum Allowable Thermal Radiation, BTU/Hr/SqFt	1750 - Note 6		
At Grade, Specify Distance from Flare Base, Ft	100		
Stack Support	Self Supported		
Structural Design Wind Velocity, MPH	120		
Seismic Zone	1		
Flare Knockout Drum	Supplied by Others		
Design Pressure, PSIG / Temperature, F / MDMT, F	50 / 350 / -150		
ASME Code Stamp / National Board Registration	No		
Ignition Device	HEI		
Enclosure	Class 1 Div 2, Grp C,D, T2B		
Ladder Platforms	No		
Special Instrumentation	Air Assist Flow switch		

Notes:

- 1) Applicable specifications: NEC NEMA AISC
- 2) Specifications: Piping - ASME B31.3; Welding - AWS 1.1; Structural - ASCE 7-05 / ASME STS-1-2011
- 3) Use pressure transmitters for all pressure instrumentation.
- 4) Ignition system: Manual with automatic re-light; provide temperature or optical pilot monitoring
- 5) Ignition device: HEI - high energy spark ignition; FFG - flame front generator
- 6) General documentation to include general arrangement drawings, detail flare stack drawings, ASME STS-1-2011 analysis and required foundation loads.
- 7) Preferred base design is a base plate, top plate and intermediate gussets.



Process Conditions -- English Units

Client: Saulsbury	Zeeco Ref.: 2017-01312FL-01	Date: 16-Mar-17
Location: Loving, NM	Client Ref.: 0	Rev. 0

	Mol %					
	Cold Case 1	Cold Case 2	Warm Case 1	Warm Case 2	Case K	Case L
METHANE	89.66	0.50		10.21		
ETHANE	8.59	57.19	0.25	15.64		
PROPANE	1.00	28.00	99.00	25.19		
BUTANE	0.07	10.46	0.75	25.36		
PENTANE	0.00	2.86		13.49		
HEXANE		0.51		5.94		
HEPTANE		0.14		2.25		
OCTANE		0.01		0.25		
NONANE						
DECANE						
DODECANE						
TRIDECANE						
CYCLOPENTANE						
ETHYLENE						
PROPYLENE						
BUTYLENE						
ACETYLENE						
BENZENE		0.04		0.43		
TOLUENE		0.01		0.19		
XYLENE		0.00		0.04		
CARBON MONOXIDE						
CARBON DIOXIDE	0.02	0.08		0.98		
HYDROGEN SULFIDE				0.01		
SULFUR DIOXIDE						
AMMONIA						
AIR						
HYDROGEN						
OXYGEN						
NITROGEN	0.66			0.02		
WATER						
BUTADIENE						
METHANOL						
Total	100	100	100	100		
Mol. Wt.	17.64	38.43	44.17	50.57		
L. H. V. (BTU/SCF):	979	2,030	2,319	2,606		
Temperature (Deg. F):	-127.0	170.0	190.0	255.0		
Avail. Static Pressure (psig):	25.00	15.00	10.00	25.00		
Flow Rate (lbs/hr):	392,000	267,780	221,526	355,000		
Smokeless Rate (lbs/hr):				71,000		



Saulsbury Industries

SAULSBURY

Corporate Office: 2951 E Interstate 20, Odessa, TX 79766 · P: 432-366-3686 · F: 432-368-0061

Appendix B: Warm and Cold Flare Relieving Scenario Summary Sheets



SAULSBURY INDUSTRIES
 2951 EAST INTERSTATE 20, ODESSA, TX 79766
 TEXAS REGISTERED ENGINEERING FIRM F-518

FLARE STUDY

JOB NO.: 10231 REVISION: 1
 CLIENT: LUCID ENERGY GROUP DATE: 8/30/2017
 PROJECT: ROADRUNNER GAS PLANT
 LOCATION: EDDY COUNTY, NM BY: EMG/APL

COLD FLARE RELIEVING SCENARIOS SUMMARY

FIRE: NGL Product Surge Tank														
PSV	PSV Type	Equipment	Set Pressure (psig)	Size	Required Rate (lb/hr)	PSV Capacity (lb/hr)	Required Orifice (in ²)	Installed Orifice (in ²)	Inlet Piping DP (psi)	Back Pressure Limit (psig)	Back Pressure at PSV (psig)	Back Pressure at Header (psig)	Back Pressure at KO Drum (psig)	Back Pressure at Flare Base (psig)
PSV-404	Pilot	V-404 NGL Product Surge Tank	400	4" P 6"	268,265	301,251	6.360	6.380	1	200**	89	46	32	8.5

FIRE: UOP Process Area														
PSV	PSV Type	Equipment	Set Pressure (psig)	Size	Required Rate (lb/hr)	PSV Capacity (lb/hr)	Required Orifice (in ²)	Installed Orifice (in ²)	Inlet Piping DP (psi)	Back Pressure Limit (psig)	Back Pressure at PSV (psig)	Back Pressure at Header (psig)	Back Pressure at KO Drum (psig)	Back Pressure at Flare Base (psig)
PSV-202A	Pilot	E-202 Gas/Product Exchanger	1100	2" J 3"	10,000	189,012	0.145	1.287	0.005	200**	36	34	20	5
PSV-202B	Balanced	E-202 Gas/Product Exchanger	1440	1" D 1"	4,888	32,780	0.034	0.110	0.751	200**	35	34	20	5
PSV-206	Pilot	E-206 Reflux Condenser	1100	1" F 2"	28,804	31,852	0.296	0.307	5.589	200**	100	30	20	5
PSV-203	Pilot	E-203 Chiller	270	4" N 6"	83,326	157,460	2.153	4.340	0.016	200**	40	34	20	5
PSV-402	Pilot	V-402 Cold Separator	1100	2" J 3"	85,704	156,018	0.947	1.287	1.208	200**	120	32	20	5

****Note: Backpressure limit set by design pressure of PSV discharge piping lateral**

OPER: PCV-402B (JT-Valve) Control Valve Failure														
PSV	PSV Type	Equipment	Set Pressure (psig)	Size	Required Rate (lb/hr)	PSV Capacity (lb/hr)	Required Orifice (in ²)	Installed Orifice (in ²)	Inlet Piping DP (psi)	Back Pressure Limit (psig)	Back Pressure at PSV (psig)	Back Pressure at Header (psig)	Back Pressure at KO Drum (psig)	Back Pressure at Flare Base (psig)
PSV-501	Pilot	T-501 Demethanizer	400	6" Q 8"	327,800	349,749	11.500	12.270	0.23	200**	29	20	8	2

****Note: Backpressure limit set by design pressure of PSV discharge piping lateral**

OPER: E-203 Tube Rupture														
PSV	PSV Type	Equipment	Set Pressure (psig)	Size	Required Rate (lb/hr)	PSV Capacity (lb/hr)	Required Orifice (in ²)	Installed Orifice (in ²)	Inlet Piping DP (psi)	Back Pressure Limit (psig)	Back Pressure at PSV (psig)	Back Pressure at Header (psig)	Back Pressure at KO Drum (psig)	Back Pressure at Flare Base (psig)
PSV-203	Pilot	E-203 Chiller	270	4" N 6"	88,033	89,267	4.280	4.340	0.047	200**	31	9	5	0.6

****Note: Backpressure limit set by design pressure of PSV discharge piping lateral**

OPER: E-202 Tube Rupture														
PSV	PSV Type	Equipment	Set Pressure (psig)	Size	Required Rate (lb/hr)	PSV Capacity (lb/hr)	Required Orifice (in ²)	Installed Orifice (in ²)	Inlet Piping DP (psi)	Back Pressure Limit (psig)	Back Pressure at PSV (psig)	Back Pressure at Header (psig)	Back Pressure at KO Drum (psig)	Back Pressure at Flare Base (psig)
PSV-202A	Pilot	E-202 Gas/Product Exchanger	1100	2" J 3"	87,224	91,044	1.233	1.287	0.574	200**	108	38	1	0.3

****Note: Backpressure limit set by design pressure of PSV discharge piping lateral**



SAULSBURY INDUSTRIES
 2951 EAST INTERSTATE 20, ODESSA, TX 79766
 TEXAS REGISTERED ENGINEERING FIRM F-518

FLARE STUDY

JOB NO.: 10231 REVISION: 1
 CLIENT: LUCID ENERGY GROUP DATE:
 PROJECT: ROAD RUNNER 200MMSCD CRYO
 LOCATION: EDDY COUNTY, NM BY: APL/EMG

WARM FLARE RELIEVING SCENARIOS SUMMARY - FIRE CASES

FIRE: Refrigeration Area														
PSV	PSV Type	Equipment	Set Pressure (psig)	Size	Required Rate (lb/hr)	PSV Capacity (lb/hr)	Required Orifice (in ²)	Installed Orifice (in ²)	Inlet Piping DP (psi)	Back Pressure Limit (psig)	Back Pressure at PSV (psig)	Back Pressure at Header (psig)	Back Pressure at KO Drum (psig)	Back Pressure at Flare Base (psig)
PSV-462	Pilot	V-462 Refrigerant Economizer	270	1.5" F 2"	6,313	10,486	0.185	0.307	4.175	200**	10	6	4	0.7
PSV-463	Pilot	V-463 Refrigerant Accumulator	325	3" K 4"	44,846	65,617	1.256	1.838	1.728	200**	43	7	4	0.7

****Note: Backpressure limit set by design pressure of PSV discharge piping lateral**

FIRE: Mole-Sieve Area														
PSV	PSV Type	Equipment	Set Pressure (psig)	Size	Required Rate (lb/hr)	PSV Capacity (lb/hr)	Required Orifice (in ²)	Installed Orifice (in ²)	Inlet Piping DP (psi)	Back Pressure Limit (psig)	Back Pressure at PSV (psig)	Back Pressure at Header (psig)	Back Pressure at KO Drum (psig)	Back Pressure at Flare Base (psig)
PSV-441	Conv.	F-441 Inlet Filter Coalescer	1100	1" D 1"	8,628	8,768	0.123	0.125	10.267	231	262	157	13	2.9
PSV-442	Balanced	V-442 Mole Sieve Dehydrator	1095	1.5" G 3"	23,891	29,672	0.405	0.503	4.975	200**	36	29	13	2.9
PSV-443	Balanced	V-443 Mole Sieve Dehydrator	1095	1.5" G 3"	23,891	29,672	0.405	0.503	4.975	200**	37	29	13	2.9
PSV-444	Balanced	V-444 Mole Sieve Dehydrator	1095	1.5" G 3"	23,891	29,672	0.405	0.503	4.975	200**	36	28	13	2.9
PSV-445	Conv.	F-445 Mole Sieve Dust Filter	1100	1" D 1"	3,638	7,656	0.059	0.125	0.255	231	182	168	13	2.9
PSV-446	Conv.	F-446 Mole Sieve Dust Filter	1100	1" D 1"	3,638	7,656	0.059	0.125	0.255	231	183	166	13	2.9
PSV-447	Pilot	V-447 Regen Gas Scrubber	1100	2" J 3"	2,079	84,749	0.032	1.287	10.273	260	43	40	13	2.9

****Note: Backpressure limit set by design pressure of PSV discharge piping lateral**

FIRE: Amine HMO Heater														
PSV	PSV Type	Equipment	Set Pressure (psig)	Size	Required Rate (lb/hr)	PSV Capacity (lb/hr)	Required Orifice (in ²)	Installed Orifice (in ²)	Inlet Piping DP (psi)	Back Pressure Limit (psig)	Back Pressure at PSV (psig)	Back Pressure at Header (psig)	Back Pressure at KO Drum (psig)	Back Pressure at Flare Base (psig)
PSV-0801	Balanced	V-0801 Hot Oil Expansion Tank	150	4" M 6"	109,693	133,496	2.958	3.6	0.039	68	11	7	3	0.6

FIRE: Cryo HMO Heater														
PSV	PSV Type	Equipment	Set Pressure (psig)	Size	Required Rate (lb/hr)	PSV Capacity (lb/hr)	Required Orifice (in ²)	Installed Orifice (in ²)	Inlet Piping DP (psi)	Back Pressure Limit (psig)	Back Pressure at PSV (psig)	Back Pressure at Header (psig)	Back Pressure at KO Drum (psig)	Back Pressure at Flare Base (psig)
PSV-781	Pilot	H-781 HMO Expansion Tank	150	1.5" H 3"	29,658	39,398	0.591	0.785	3.069	150	39	38	1	0.2

FIRE: Inlet High Pressure Area														
PSV	PSV Type	Equipment	Set Pressure (psig)	Size	Required Rate (lb/hr)	PSV Capacity (lb/hr)	Required Orifice (in ²)	Installed Orifice (in ²)	Inlet Piping DP (psi)	Back Pressure Limit (psig)	Back Pressure at PSV (psig)	Back Pressure at Header (psig)	Back Pressure at KO Drum (psig)	Back Pressure at Flare Base (psig)
PSV-1225	Pilot	F-1225 Inlet Filter Coalescer	1100	1" E 2"	21,620	21,645	0.140	0.196	0.318	200**	48	3	1	0.1

****Note: Backpressure limit set by design pressure of PSV discharge piping lateral**



SAULSBURY INDUSTRIES
 2951 EAST INTERSTATE 20, ODESSA, TX 79766
 TEXAS REGISTERED ENGINEERING FIRM F-518

FLARE STUDY

JOB NO.: 10231 REVISION: 1
 CLIENT: LUCID ENERGY GROUP DATE:
 PROJECT: ROAD RUNNER 200MMSCD CRYO
 LOCATION: EDDY COUNTY, NM BY: APL/EMG

WARM FLARE RELIEVING SCENARIOS SUMMARY - FIRE CASES

FIRE: TEG Treating High Pressure Area														
PSV	PSV Type	Equipment	Set Pressure (psig)	Size	Required Rate (lb/hr)	PSV Capacity (lb/hr)	Required Orifice (in ²)	Installed Orifice (in ²)	Inlet Piping DP (psi)	Back Pressure Limit (psig)	Back Pressure at PSV (psig)	Back Pressure at Header (psig)	Back Pressure at KO Drum (psig)	Back Pressure at Flare Base (psig)
PSV-1275	Pilot	F-1275 TEG Filter Coalescer	1100	1" E 2"	12,771	14,034	0.161	0.196	0.464	200**	6	3	1	0.08

****Note: Backpressure limit set by design pressure of PSV discharge piping lateral**

FIRE: Condensate Surge Tank														
PSV	PSV Type	Equipment	Set Pressure (psig)	Size	Required Rate (lb/hr)	PSV Capacity (lb/hr)	Required Orifice (in ²)	Installed Orifice (in ²)	Inlet Piping DP (psi)	Back Pressure Limit (psig)	Back Pressure at PSV (psig)	Back Pressure at Header (psig)	Back Pressure at KO Drum (psig)	Back Pressure at Flare Base (psig)
PSV-9060	Pilot	V-9060 Condensate Surge Tank	325	6" R 8"	364,824	291,076	12.0137	16.000	0.26365	200**	181	183	86	84
PSV-1403	Pilot	V-1403 Off-Spec Condensate Drum	325	2" J 3"	53,194	64,296	1.152	1.287	0.3582	200**	176	183	86	84
PSV-1001A	Pilot	F-1001A Condensate Filter	1100	1" D 2"	11,223	19,219	0.051	0.110	0.12693	200**	184	183	86	84
PSV-1001B	Pilot	F-1001B Condensate Filter	1100	1" D 2"	11,223	19,219	0.051	0.110	0.12693	200**	184	183	86	84
PSV-9501	Pilot	F-9500 Flash Gas Filter Coalescer	1200	1 1/2" F 2"	21,450	33,568	0.2002	0.307	0.792	200**	186	183	86	84

****Note: Backpressure limit set by design pressure of PSV discharge piping lateral**

461,914

FIRE: Stabilizer Area														
PSV	PSV Type	Equipment	Set Pressure (psig)	Size	Required Rate (lb/hr)	PSV Capacity (lb/hr)	Required Orifice (in ²)	Installed Orifice (in ²)	Inlet Piping DP (psi)	Back Pressure Limit (psig)	Back Pressure at PSV (psig)	Back Pressure at Header (psig)	Back Pressure at KO Drum (psig)	Back Pressure at Flare Base (psig)
PSV-3101	Balanced	F-3101 Filter	325	1" D 2"	5,430	7,905	0.045	0.110	3.587	100	84	78	38	30
PSV-3102	Balanced	F-3102 Filter	325	1" D 2"	5,430	7,905	0.045	0.110	3.528	100	84	78	38	30
PSV-3202	Balanced	T-3202 Deethanizer Tower	325	3" J 4"	27,268	31,730	0.942	1.287	2.180	100	81	78	38	30
PSV-3201A	Balanced	E-3201 Feed/Bottoms Exchanger	325	1 1/2" F 2"	28,345	22,061	0.285	0.307	2.557	100	97	78	38	30
PSV-3201B	Balanced	E-3201 Feed/Bottoms Exchanger	325	1 1/2" F 2"	28,345	14,471	0.218	0.307	3.257	100	85	78	38	30
PSV-3301	Pilot	T-3301 Stabilizer Tower	325	4" L 6"	90,664	58,064	2.612	2.853	0.883	100	78	81	38	30
PSV-3702	Balanced	Stabilizer Feed Separator	325	3" J 4"	36,333	38,586	1.231	1.287	0.699	100	85	78	38	30

****Note: Backpressure limit set by design pressure of PSV discharge piping lateral**

FIRE: Stabilizer HMO Expansion Tank														
PSV	PSV Type	Equipment	Set Pressure (psig)	Size	Required Rate (lb/hr)	PSV Capacity (lb/hr)	Required Orifice (in ²)	Installed Orifice (in ²)	Inlet Piping DP (psi)	Back Pressure Limit (psig)	Back Pressure at PSV (psig)	Back Pressure at Header (psig)	Back Pressure at KO Drum (psig)	Back Pressure at Flare Base (psig)
PSV-3501	Balanced	V-3501 Hot Oil Expansion Tank	150	2" H 3"	15,617	52,715	0.563	0.785	0.839	100	0.304	-1.316	0.5	0.1

****Note: Backpressure limit set by design pressure of PSV discharge piping lateral**

FIRE: LPG Surge Tank														
-----------------------------	--	--	--	--	--	--	--	--	--	--	--	--	--	--



SAULSBURY INDUSTRIES
 2951 EAST INTERSTATE 20, ODESSA, TX 79766
 TEXAS REGISTERED ENGINEERING FIRM F-518

FLARE STUDY

JOB NO.: 10231 REVISION: 1
 CLIENT: LUCID ENERGY GROUP DATE:
 PROJECT: ROAD RUNNER 200MMSCD CRYO
 LOCATION: EDDY COUNTY, NM BY: APL/EMG

WARM FLARE RELIEVING SCENARIOS SUMMARY - FIRE CASES

PSV	PSV Type	Equipment	Set Pressure (psig)	Size	Required Rate (lb/hr)	PSV Capacity (lb/hr)	Required Orifice (in ²)	Installed Orifice (in ²)	Inlet Piping DP (psi)	Back Pressure Limit (psig)	Back Pressure at PSV (psig)	Back Pressure at Header (psig)	Back Pressure at KO Drum (psig)	Back Pressure at Flare Base (psig)
PSV-3801	Pilot	V-3801 LPG Surge Tank	325	4" L 6"	88,783	105,217	2.39	2.853	1.461	100	17	18.2074	6.844	5.31

****Note: Backpressure limit set by design pressure of PSV discharge piping lateral**

FIRE: Flash Gas Compressors														
PSV	PSV Type	Equipment	Set Pressure (psig)	Size	Required Rate (lb/hr)	PSV Capacity (lb/hr)	Required Orifice (in ²)	Installed Orifice (in ²)	Inlet Piping DP (psi)	Back Pressure Limit (psig)	Back Pressure at PSV (psig)	Back Pressure at Header (psig)	Back Pressure at KO Drum (psig)	Back Pressure at Flare Base (psig)
PSV-9300	Pilot	C-9300 Flash Gas Compressor	400	1 1/2" H 3"	22,325	20,808	0.5744	0.785	0.323	100	36	8.9	2.47	2
PSV-9400	Pilot	C-9400 Flash Gas Compressor	400	1 1/2" H 3"	22,325	20,690	0.5744	0.785	0.326	100	42	8.9	2.47	2

****Note: Backpressure limit set by design pressure of PSV discharge piping lateral**



SAULSBURY INDUSTRIES
 2951 EAST INTERSTATE 20, ODESSA, TX 79766
 TEXAS REGISTERED ENGINEERING FIRM F-518

FLARE STUDY

JOB NO.: 10231 REVISION: 0
 CLIENT: LUCID ENERGY GROUP DATE:
 PROJECT: ROAD RUNNER 200MMSCD CRYO
 LOCATION: EDDY COUNTY, NM BY: APL/EMG

WARM FLARE RELIEVING SCENARIOS SUMMARY - OPERATING CASES

OPER: E-207 Tube Rupture

PSV	PSV Type	Equipment	Set Pressure (psig)	Size	Required Rate (lb/hr)	PSV Capacity (lb/hr)	Required Orifice (in ²)	Installed Orifice (in ²)	Inlet Piping DP (psi)	Back Pressure Limit (psig)	Back Pressure at PSV (psig)	Back Pressure at Header (psig)	Back Pressure at KO Drum (psig)	Back Pressure at Flare Base (psig)
PSV-207	Pilot	E-207 Trim Reboiler	150	4" P 6"	68,964	70,966	6.200	6.380	1.050	120	31	10	7	1.4

OPER: Refrigeration Compressor Blocked Flow

PSV	PSV Type	Equipment	Set Pressure (psig)	Size	Required Rate (lb/hr)	PSV Capacity (lb/hr)	Required Orifice (in ²)	Installed Orifice (in ²)	Inlet Piping DP (psi)	Back Pressure Limit (psig)	Back Pressure at PSV (psig)	Back Pressure at Header (psig)	Back Pressure at KO Drum (psig)	Back Pressure at Flare Base (psig)
PSV-161	Pilot	C-161 Refrigerant Compressor	325	3" L 4"	73,842	79,506	2.552	2.853	1.779	200**	79	58	39	13
PSV-162	Pilot	C-162 Refrigerant Compressor	325	3" L 4"	73,842	79,506	2.552	2.853	1.913	200**	80	60	39	13
PSV-163	Pilot	C-163 Refrigerant Compressor	325	3" L 4"	73,842	79,506	2.552	2.853	2.086	200**	75	61	39	13

**Note: Backpressure limit set by design pressure of PSV discharge piping lateral

OPER: LV-1201/1202 Control Valve Failure**

PSV	PSV Type	Equipment	Set Pressure (psig)	Size	Required Rate (lb/hr)	PSV Capacity (lb/hr)	Required Orifice (in ²)	Installed Orifice (in ²)	Inlet Piping DP (psi)	Back Pressure Limit (psig)	Back Pressure at PSV (psig)	Back Pressure at Header (psig)	Back Pressure at KO Drum (psig)	Back Pressure at Flare Base (psig)
PSV-0101	Pilot	V-0101 Amine Flash Tank	150	FB, 6" x 8"	210,253	268,644	16.099	20.570	0.432	120	91	70	48	18

**Note: The sizing scenario only considers one of the Amine Contactor Level Control Valves (LV-1201 OR LV-1202) to fail open, allowing gas blow-by. Accounting for failure of both valves would be considered a double jeopardy scenario and therefore invalid.

OPER: LV-2701 Control Valve Failure

PSV	PSV Type	Equipment	Set Pressure (psig)	Size	Required Rate (lb/hr)	PSV Capacity (lb/hr)	Required Orifice (in ²)	Installed Orifice (in ²)	Inlet Piping DP (psi)	Back Pressure Limit (psig)	Back Pressure at PSV (psig)	Back Pressure at Header (psig)	Back Pressure at KO Drum (psig)	Back Pressure at Flare Base (psig)
PSV-2101	Pilot	V-2101 Glycol Flash Separator	150	3" J 4"	9,675	14,781	0.936	1.287	0.108	120	2.5	0.8	0.3	0.1

OPER: Regen Gas Heater Thermal

PSV	PSV Type	Equipment	Set Pressure (psig)	Size	Required Rate (lb/hr)	PSV Capacity (lb/hr)	Required Orifice (in ²)	Installed Orifice (in ²)	Inlet Piping DP (psi)	Back Pressure Limit (psig)	Back Pressure at PSV (psig)	Back Pressure at Header (psig)	Back Pressure at KO Drum (psig)	Back Pressure at Flare Base (psig)
PSV-741	Conv.	H-741 Regen Gas Heater	1095	1" D 1"	6,000	6,637	0.113	0.125	5.321	110	112	6.8	0.1	0.1

OPER: PV-481 Control Valve Failure (Fuel Gas Scrubber Overpressure)

PSV	PSV Type	Equipment	Set Pressure (psig)	Size	Required Rate (lb/hr)	PSV Capacity (lb/hr)	Required Orifice (in ²)	Installed Orifice (in ²)	Inlet Piping DP (psi)	Back Pressure Limit (psig)	Back Pressure at PSV (psig)	Back Pressure at Header (psig)	Back Pressure at KO Drum (psig)	Back Pressure at Flare Base (psig)
PSV-481	Balanced	V-481 Fuel Gas Scrubber	265	1.5" D 3"	1,062	2,081	0.056	0.110	0.159	132	1	0.1	0.1	0.1



SAULSBURY INDUSTRIES
 2951 EAST INTERSTATE 20, ODESSA, TX 79766
 TEXAS REGISTERED ENGINEERING FIRM F-518

FLARE STUDY

JOB NO.: 10231 REVISION: 0
 CLIENT: LUCID ENERGY GROUP DATE:
 PROJECT: ROAD RUNNER 200MMSCD CRYO
 LOCATION: EDDY COUNTY, NM BY: APL/EMG

WARM FLARE RELIEVING SCENARIOS SUMMARY - OPERATING CASES

OPER: A-361 Bay Shutdown

PSV	PSV Type	Equipment	Set Pressure (psig)	Size	Required Rate (lb/hr)	PSV Capacity (lb/hr)	Required Orifice (in ²)	Installed Orifice (in ²)	Inlet Piping DP (psi)	Back Pressure Limit (psig)	Back Pressure at PSV (psig)	Back Pressure at Header (psig)	Back Pressure at KO Drum (psig)	Back Pressure at Flare Base (psig)
1" Gate Valves	N/A	A-361 Refrigerant Condenser	230	1" GV	355	N/A	N/A	N/A	1.459	210	114	0.1	0.1	0.1

OPER: V-9060 OH Blocked

PSV	PSV Type	Equipment	Set Pressure (psig)	Size	Required Rate (lb/hr)	PSV Capacity (lb/hr)	Required Orifice (in ²)	Installed Orifice (in ²)	Inlet Piping DP (psi)	Back Pressure Limit (psig)	Back Pressure at PSV (psig)	Back Pressure at Header (psig)	Back Pressure at KO Drum (psig)	Back Pressure at Flare Base (psig)
PV-9060B	N/A	V-9060 Condensate Surge Tank	275	3" bv	355	N/A	N/A	N/A	0.018	210	114	0.1	0.1	0.1

OPER: Flash Gas Compressors Blocked Flow (Control Failure)

PSV	PSV Type	Equipment	Set Pressure (psig)	Size	Required Rate (lb/hr)	PSV Capacity (lb/hr)	Required Orifice (in ²)	Installed Orifice (in ²)	Inlet Piping DP (psi)	Back Pressure Limit (psig)	Back Pressure at PSV (psig)	Back Pressure at Header (psig)	Back Pressure at KO Drum (psig)	Back Pressure at Flare Base (psig)
PSV-9301	Pilot	Flash Gas Compressors Header	400	3" K 4"	54,205	31,353	1.546	1.828	0.052	320	51	39.2	15.7	4.5



Saulsbury Industries

SAULSBURY

Corporate Office: 2951 E Interstate 20, Odessa, TX 79766 · P: 432-366-3686 · F: 432-368-0061

Appendix C: Warm and Cold Flare Knockout Drum Sizing Sheets

Separator Design	Flare KO Drum				
Unit	OPER: LV-1201 Control Failure				
Basis	Highest Individual Flow Plus			0%	Overdesign
Flow Rates	Gas	110	mmscfd	Vessel ID	72 Inch
	Oil	1000	bpd	Vessel S/S	30.000 Ft
	Water	1000	bpd		
	Total Liq	2000	bpd		
Operating Pressure		48	psig		
Gas Compressibility		0.808			
Gas MW		23.0017			
Gas Temperature		90	F		
Bulk Liquid Retention		20	Minutes		
Surge Capacity (NLL to HLL)		0%	of Design Liquid Capacity including Overdesign		
Oil SpGr		1.024			
Liquid Volume (Percentage)		67%		Liquid Flow	58.3 GPM
Vessel Crosssectional Area		28.274	SqFt	Bulk Liquid Volume	1166.7 Gallons
Available Crosssectional Area		9.331	SqFt	Bulk Liquid Volume	156.0 CuFt
Gas Density		0.302	Lb/CuFt	Minimum Liquid Area	5.198 SqFt
Gas Flow		277798	Lb/Hr	Surge Area Required	0.000 SqFt
Gas ACFS		255.269	Ft3/Sec at TP		
Droplet Size	300	Micron			
	0.0009843	ft			
Gas Viscosity	0.0134	cP			
<u>Drag Coefficient</u>					
"X" Axis on Fig 5-19 GPSA	9.700				
From Chart, Drag Coef, C	2.00		**Figure 5-19 to determine droplet drag coefficient		
Drop Terminal Velocity	2.0998	ft/s	**Eq. 7-1 GPSA		
Distance for Droplet to Fall	23.76	Inches			
Time for Droplet to Fall	0.94	Seconds			
Gas Horizontal Velocity	9.03	ft/s			
Horiz. Distance for Gas Travel	28.00	ft	**Seam to seam length of vessel minus 2 feet		
Time for Gas to Travel	3.10	Seconds	**This number must be GREATER THAN "time for droplet to fall from mist eliminator" value so gas can fall into liquid phase before reaching the end of the vessel where gas outlet nozzle is located		

If the Horizontal Time Exceeds Vertical Time, Design is met or exceeded.

Separator Design Cold Flare KO Drum
 Unit OPER: PCV-402B JT-Valve Failure

Basis Highest Individual Flow Plus 0% Overdesign

Flow Rates	Gas	101.643	mmscfd	Vessel ID	54	Inch
	Oil	1616	bpd	Vessel S/S	30.000	Ft
	Water	0	bpd			
	Total Liq	1616	bpd			

Operating Pressure	32	psig
Gas Compressibility	0.808	
Gas MW	18.16	
Gas Temperature	-88	F
Bulk Liquid Retention	24.2	Minutes
Surge Capacity (NLL to HLL)	0%	of Design Liquid Capacity including Overdesign
Oil SpGr	0.537	

Liquid Volume (Percentage)	63%		Liquid Flow	47.1	GPM
Vessel Crosssectional Area	15.904	SqFt	Bulk Liquid Volume	1140.6	Gallons
Available Crosssectional Area	5.885	SqFt	Bulk Liquid Volume	152.5	CuFt
Gas Density	0.263	Lb/CuFt	Minimum Liquid Area	5.082	SqFt
Gas Flow	202661	Lb/Hr	Surge Area Required	0.000	SqFt
Gas ACFS	214.197	Ft3/Sec at TP			

Droplet Size	300	Micron
Gas Viscosity	0.0009843	ft cP

<u>Drag Coefficient</u>		
"X" Axis on Fig 5-19 GPSA	5.497	
From Chart, Drag Coef, C	1.20	**Figure 5-19 to determine droplet drag coefficient
Drop Terminal Velocity	2.1020	ft/s **Eq. 7-1 GPSA

Distance for Droplet to Fall	18	Inches
Time for Droplet to Fall	0.71	Seconds

Gas Horizontal Velocity	36.40	ft/s	
Horiz. Distance for Gas Travel	28.00	ft	**Seam to seam length of vessel minus 2 feet
Time for Gas to Travel	0.77	Seconds	**This number must be GREATER THAN "time for droplet to fall from mist eliminator" value so gas can fall into liquid phase before reaching the end of the vessel where gas outlet nozzle is located

If the Horizontal Time Exceeds Vertical Time, Design is met or exceeded.



Saulsbury Industries

SAULSBURY

Corporate Office: 2951 E Interstate 20, Odessa, TX 79766 · P: 432-366-3686 · F: 432-368-0061

Appendix D: Flare Radiation Isopleths



Zeeco Ref: SO 31927 Rev. 1

Flare Radiation Isoleths

Solar Radiation Included = 0 BTU/hr-ft²; Wind Speed = 30 ft/s; Rel. Humidity = 85%

Flare Tag No. = FL-5100 ; Operating Case = Cold Case 1

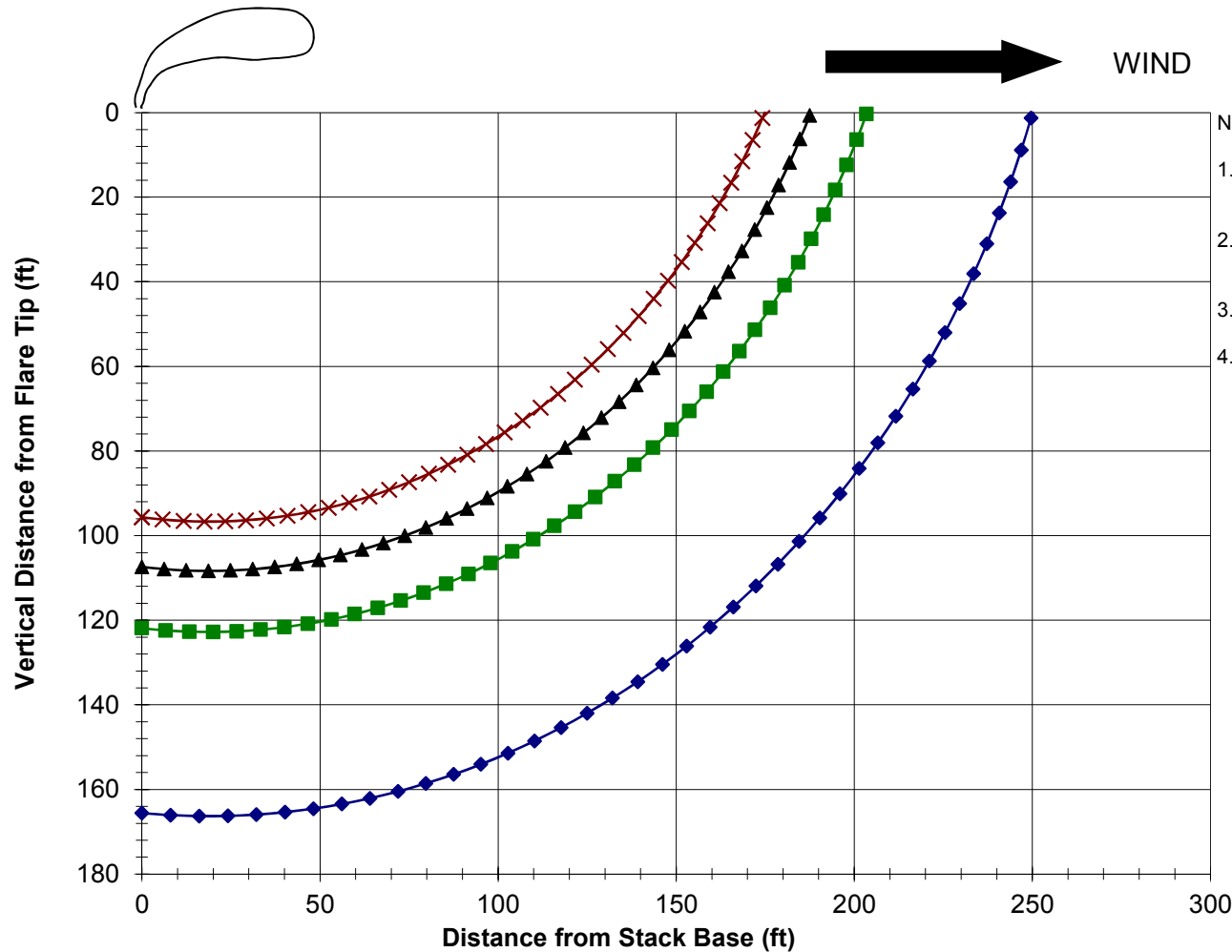

NOTES:

- 1. Basis: API RP-521, App.'C.3', "Brzustowski & Sommers Method.
- 2. Calculated radiation is +/-10%, or 100 BTU/hr-ft², whichever is larger.
- 3. Point 0,0 is the exit point of the flare tip.
- 4. Absorptivity due to relative humidity is included (Tau<1.0)



Zeeco Ref: SO 31927 Rev. 1
Radiation At Grade Versus Distance From Stack Base
Stack Height = 100 ft ; Relative Humidity = 85%
Solar Radiation Included = 0 BTU/hr-ft² ; Wind Speed = 30 ft/s
Flare Tag No. = FL-5100 ; Operating Case = Cold Case 1

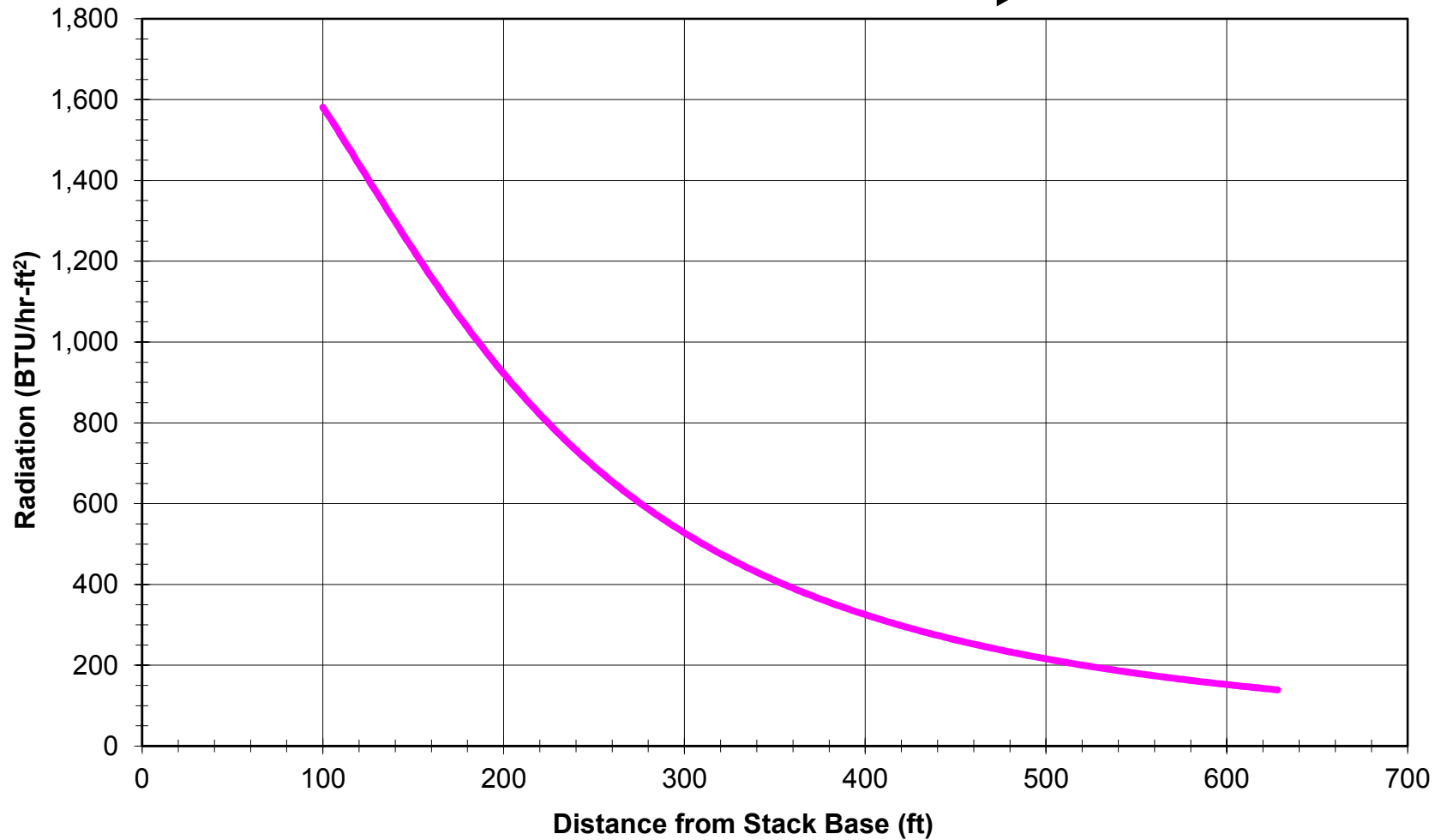
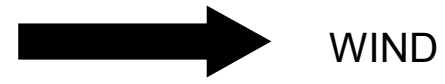



Saulsbury Industries

Corporate Office: 2951 E Interstate 20, Odessa, TX 79766 · P: 432-366-3686 · F: 432-368-0061

Appendix E: Misc. Flare Information



Air Assisted Flare Tip Specification Sheet

Client: Saulsbury	Zeeco Ref.: 2017-01312FL-01	Date: 16-Mar-17
Location: Loving, NM	Client Ref.: 0	Rev. 0

General Information:

Tag No.:	FL-5100	
Model:	AFDSMJ-16-14/58	Type: Air-Assisted
Length:	10'- 0 "	
Weight:	5000 lbs	
No. of Pilots:	3	

Design Case:

Governing Case:	Cold Case 1
Molecular weight:	17.6
L. H. V. :	979 BTU/SCF
Temperature:	-127 Deg. F
Available Static Pressure:	25.0 psig
Design Flow Rate:	392,000 lbs/hr
Governing Smokeless Case:	Warm Case 1
Design Smokeless Rate:	0 lbs/hr
Approximate Exit Velocity:	1133 ft/s
Mach No.:	1.00
Approx. Tip Press. Drop:	29.50 psig

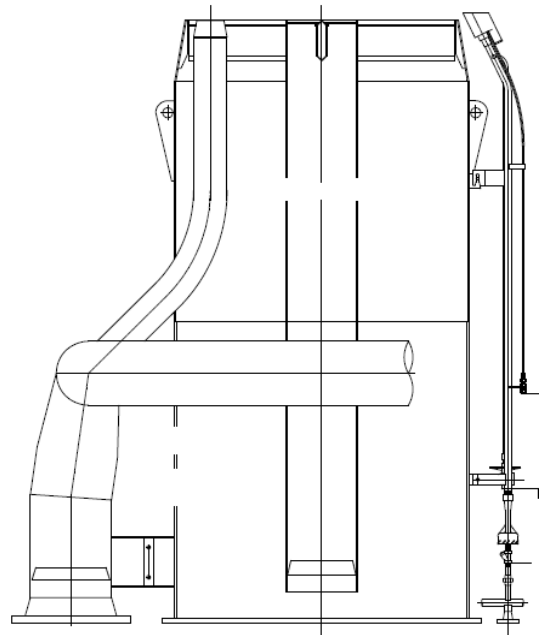

(Typical drawing only)

Construction:

Upper Section:	310 SS	Windshield:	YES
Lower Section:	Carbon Steel	Flame retention Ring:	310 SS
		Lifting Lugs:	YES - C.S. Type

Surface Finish (Carbon Steel Surfaces):

Surface Preparation:	SSPC-SP6	Primer:	Inorganic Zinc
Paint (c. s. surfaces):	High Heat Aluminum		

Connections:

	Qty.	Size	Type	Material
N1 - Cold Gas Inlet:	1	16 "	150# RFWN	304 SS
N2 - Combustion Air Inlet:	1	58 "	Fab. Plate Flange	Carbon Steel
N3 - Warm Gas Inlet:	1	14 "	Beveled ; Weld	Carbon Steel
N4 - Pilot Gas Manifold:	1	1 "	150# RFSW	Carbon Steel

Miscellaneous Notes:

1. Includes Integral Purge Reducing Velocity Seal.
2. Warm Flare Required Fuel Gas Purge Rate = 290 SCFH.
3. Cold Flare Required Fuel Gas Purge Rate = 980 SCFH.

Note: Please refer to process conditions for all flare design conditions.



Self-supported Flare Stack Specification Sheet

Client: Saulsbury	Zeeco Ref.: 2017-01312FL-01	Date: 16-Mar-17
Location: Loving, NM	Client Ref.: 0	Rev.: 0

General Information:

Tag No.: FL-5100
 Overall Height: 100'- 0 "

Design Criteria:

Wind Design Code: ASCE 7-05
 Seismic Design Code: UBC
 Importance Factor: 1.00
 Structural Design Code: AISC
 Wind Speed (Structural): 120 mph
 Seismic Zone: 1
 Warm Min/Max. Design Temp: -20 / 350 Deg. F
 Cold Min/Max. Design Temp: -150 / 350 Deg. F
 Design Pressure: 50 psig
 Riser Corrosion Allow.: 0.063 in.



(Typical drawing only)

Construction:

Air Riser Diameter: 58"	Ladders & Step-offs: None
Cold Riser Diameter: 16"	Platform at Tip: None
Warm Riser Diameter: 14"	Additional Platforms: None
Air / Warm Riser Material: CS	ACWL: None
Cold Riser Material: 304 SS	

Surface Finish (Carbon Steel Surfaces):

Surface Preparation: SSPC-SP-6	Primer: Inorganic Zinc
Int. Coat: None	Finish Paint: None

Utility Piping:

Per Attached Utility Piping Scope of Supply

Miscellaneous Notes:

1. Vane Axial blower mounted at base of stack
2. Blower Power Available: 460 V, 3 Ph, 60 Hz
3. Elevation considered for blower sizing: 3,051 feet. Ambient temp considered: 20 / 100 F
4. See GA attached for duplicate flare system.

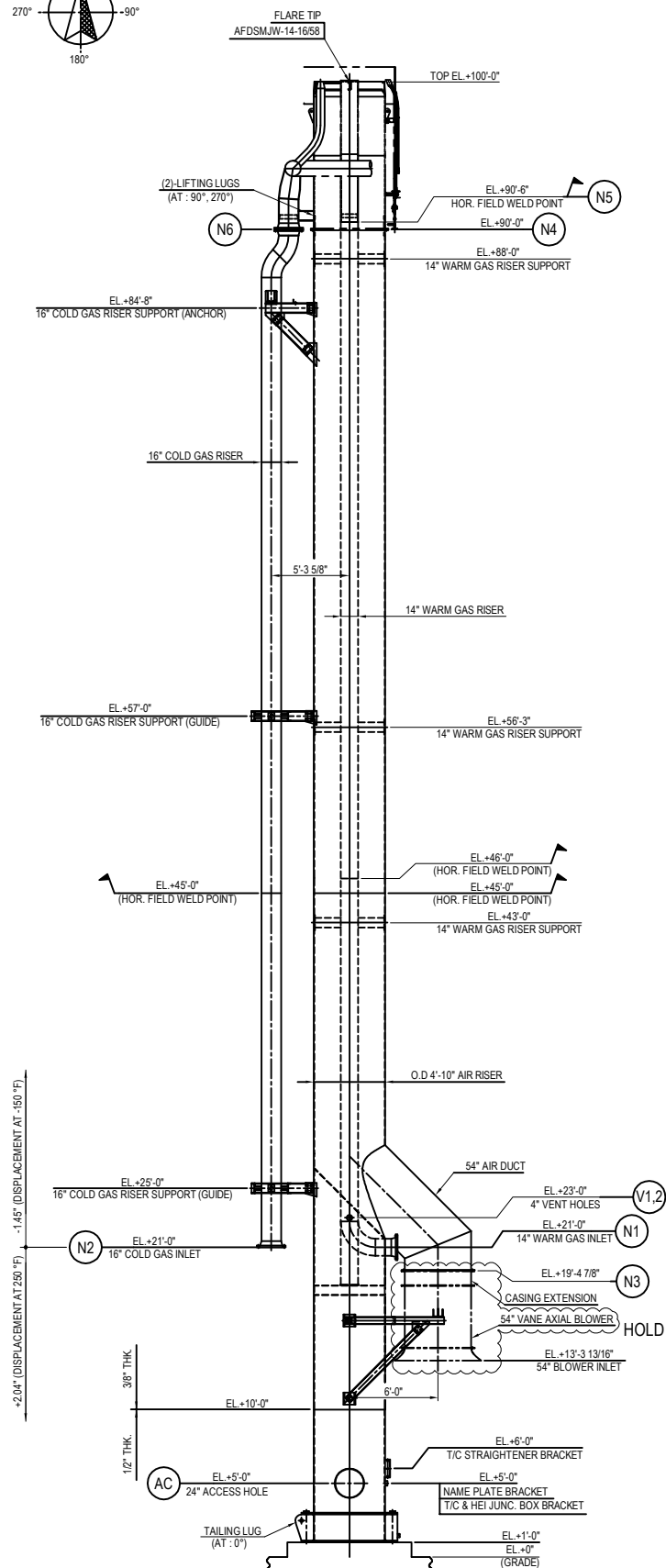
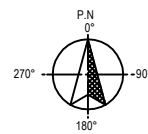

ELEVATION
(*NOT TRUE ORIENTATION)

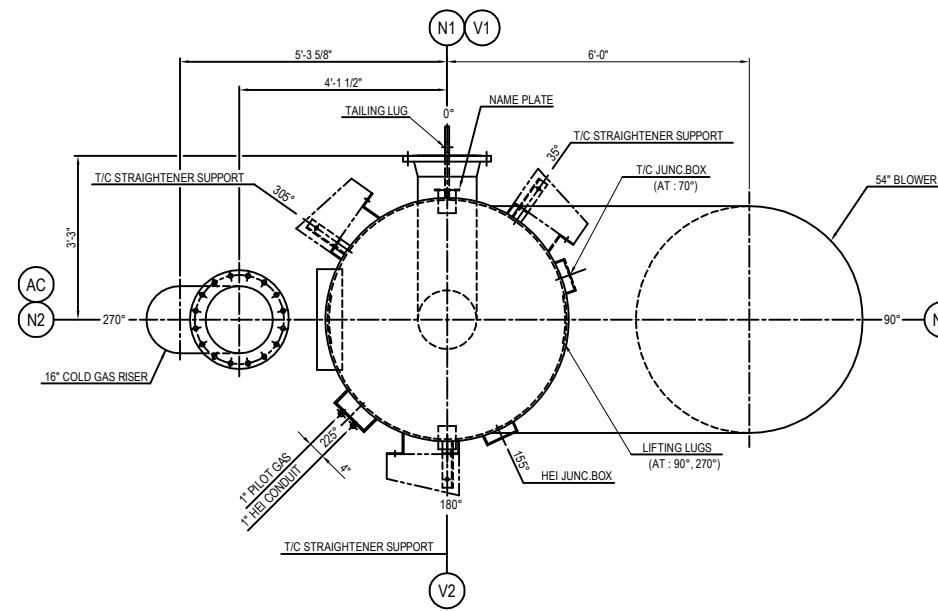

PLAN LAYOUT

TEMPERATURE	DISPLACEMENT
COLD (-150 °F)	1.45"
HOT (250 °F)	2.04"

NOZZLE THERMAL DISPLACEMENT
(FOR N2 NOZZLE)

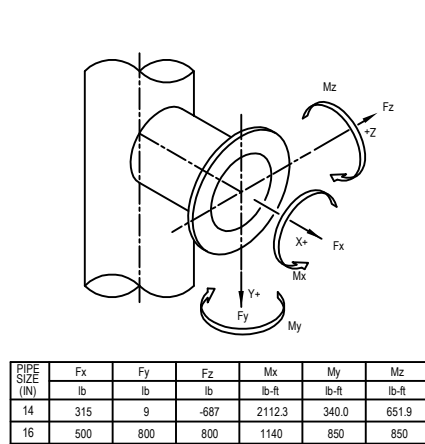

MAX. ALLOWABLE INLET NOZZLE LOAD
(PER API 537)

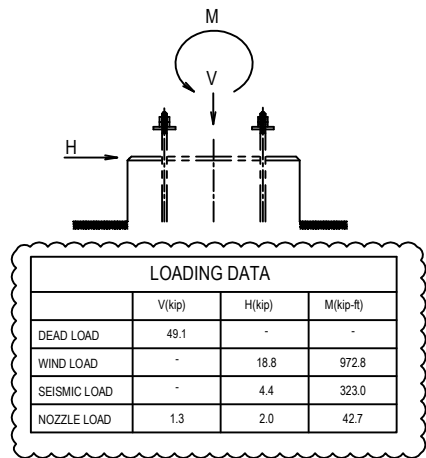

LOADING DATA
(FOR STACK RISER)

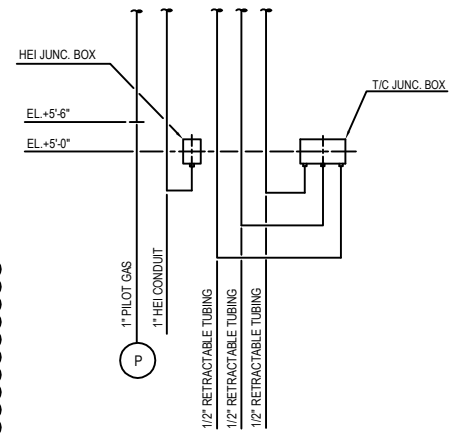

DETAIL OF UTILITY PIPING

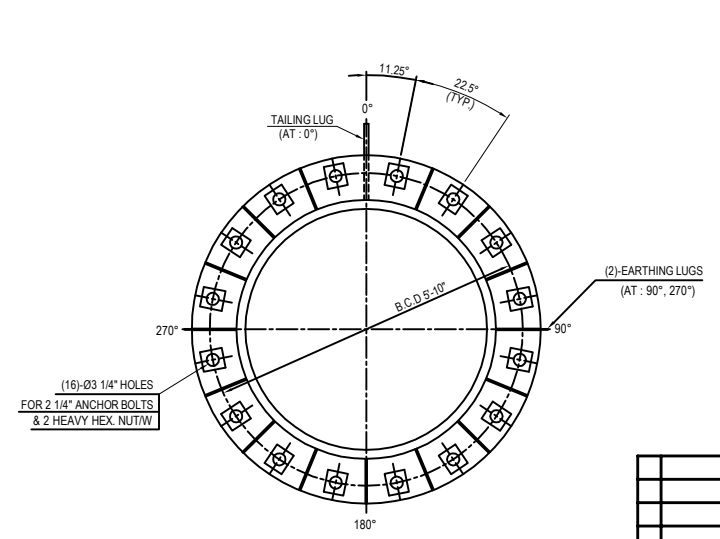

ANCHOR PLAN

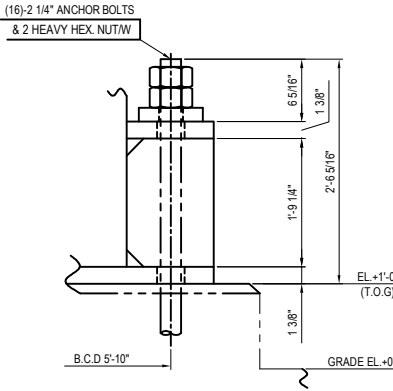

ANCHOR PROJECTION

MATERIAL SPECIFICATIONS		DESIGN DATA	
WARM GAS RISER	A53-B ERW	TYPE	SELF SUPPORTED
COLD GAS RISER	A312-TP304	STRUCTURAL DESIGN CODE	ASME STS-1 / ASCE
AIR RISER	A36	CODE	ASCE 7-05
FLARE TIP	SEE FLARE TIP DWG.	WIND LOAD	V 120 m EXP. C IF 1.0
WARM GAS RISER FLANGE	A105	SEISMIC LOAD	CODE UBC-97 ZONE 1 SOIL TYPE SD IF 1.25
COLD GAS RISER FLANGE	A182-F304	DESIGN PRESS.	WARM 50 P COLD 50 P AIR ATM
AIR RISER FLANGE	A36	DESIGN TEMP.	WARM -20 - 350 COLD -150 - 350 AIR AMB
RISER GASKET	C4401	OPERATING PRESS.	WARM 10 - 20 P COLD 15 - 25 P
BASE PLATE	A36	OPERATING TEMP.	WARM 140 - 300 COLD -127 - 91 AIR AMB
EARTHING LUG	304 S.S.	PAINTING	SEE NOTE 2
UTILITY LINE	A106-B		
CONDUIT	C.S. + GALV.		
RETRACTABLE T/C TUBING	316L S.S.		
NAME PLATE	304 S.S.		
NAME PLATE BRACKET	A36		
LIFTING LUG	A36		
TAILING LUG	A36		
STRAIGHTENER SUPPORT	A36		
ANCHOR BOLT	A307-C		
BOLTNUT (C.S.)	A193-B7 / A194-2H		
BOLTNUT (S.S.)	A320-B8 / A194-8		
		NDE	AS PER ITP
		CORROSION ALLOWANCE	C.S. 1/16 IN S.S. N/A

NOZZLE AND CONNECTIONS								
MARK	QTY	SIZE	SCH.	RATING	FACING	FLG. MATL.	MATERIAL NOZZLE	SERVICE
N1	1	14"	STD.	ASME 150#	RF. WN	A105	A53-B ERW	WARM GAS INLET
N2	1	16"	10S	ASME 150#	RF. WN	A182-F304	A312-TP304	COLD GAS INLET
N3	1	54"	3/8" THK.	3/4" THK. PLATE FLG	FF	A36	A36	AIR INLET
N4	1	58"	3/8" THK.	3/4" THK. PLATE FLG	FF	A36	A36	AIR OUTLET
N5	1	14"	STD.	PIPE END	B.W.	-	A53-B ERW.	WARM GAS OUTL
N6	1	16"	10S	ASME 150#	RF. WN	A182-F304	A312-TP304	COLD GAS OUTL
V1,2	2	4"	40	-	-	-	A53-B ERW.	VENT HOLE
AC	1	24"	3/8" THK.	-	-	-	A36	ACCESS HOLE
P	1	1"	STD.	ASME 150#	RF. SW	A105	A106-B	PILOT GAS

NOTE

- FLANGE BOLTING TO STRADDLE CENTERLINES INDICATED BY CENTERLINE UNLESS NOTED OTHERWISE.
- PAINTING
 - AIR RISER (EXTERNAL CARBON STEEL SURFACE)
 - SURFACE PREPARATION : SSPC-SP6
 - PRIMER : INORGANIC ZINC (DFT : 2.4 MILS)
 - FINISH : HIGH HEAT ALUMINUM (DFT : 1-1.5 MILS)
 - AIR RISER SKIRT (INTERNAL CARBON STEEL SURFACE) - PRIMER ONLY
 - SURFACE PREPARATION : SSPC-SP6
 - PRIMER : INORGANIC ZINC (DFT : 2.4 MILS)
 - WARM GAS RISER (EXTERNAL CARBON STEEL SURFACE) - PRIMER ONLY
 - SURFACE PREPARATION : SSPC-SP6
 - PRIMER : INORGANIC ZINC (DFT : 2.4 MILS)
 - COLD GAS RISER : NO PAINT
 - UTILITY (EXTERNAL CARBON STEEL SURFACE) - PRIMER ONLY
 - SURFACE PREPARATION : SSPC-SP6
 - PRIMER : INORGANIC ZINC (DFT : 2.4 MILS)
- ALL PIPING 2" & SMALLER WILL BE SUPPLIED IN RANDOM LENGTH FOR FIELD ASSEMBLY.

REFERENCE DRAWING NO.	DESCRIPTION
SD-5776	AFDSMJW-14-16/58 TIP ASSEMBLY
SD-5783	RETRACTABLE T/C TUBING DETAIL
SD-5782	CONDUIT DETAIL
SD-5781	PIPING DETAIL
SD-5780	PIPING ARRANGEMENT
SD-5779	RISER DETAIL
SD-5778	TEMPLATE

JOB SITE: LOVING, NM		END USER: SAULSBURY INDUSTRIES	
S.O. NO.: 31927	P.O. NO.: 10231-78352	APP: AMZ	
ZEECO, INC. 22151 EAST 91st STREET BROOKS AERODROME, OK 74614 PHONE: (918) 258-8551 FAX: (918) 251-9519 www.zeeco.com sales@zeeco.com		SELF SUPPORTED FLARE STACK GENERAL ARRANGEMENT & LOADING DATA (TAG: FL-5100) FOR: LUCID ROAD RUNNER	
DATE	REVISION DESCRIPTION	BY	APP.
		CKD	APP.

6/6/2017 7:39:50 AM

Mkn

Q:\Job-Information\Flares\31000\31927 Saulsbury (Matthew Adair)\Drafting\Customer\SD-5776-SLR0.dwg

6/6/2017 11:48:55 AM

Doug M. Wade

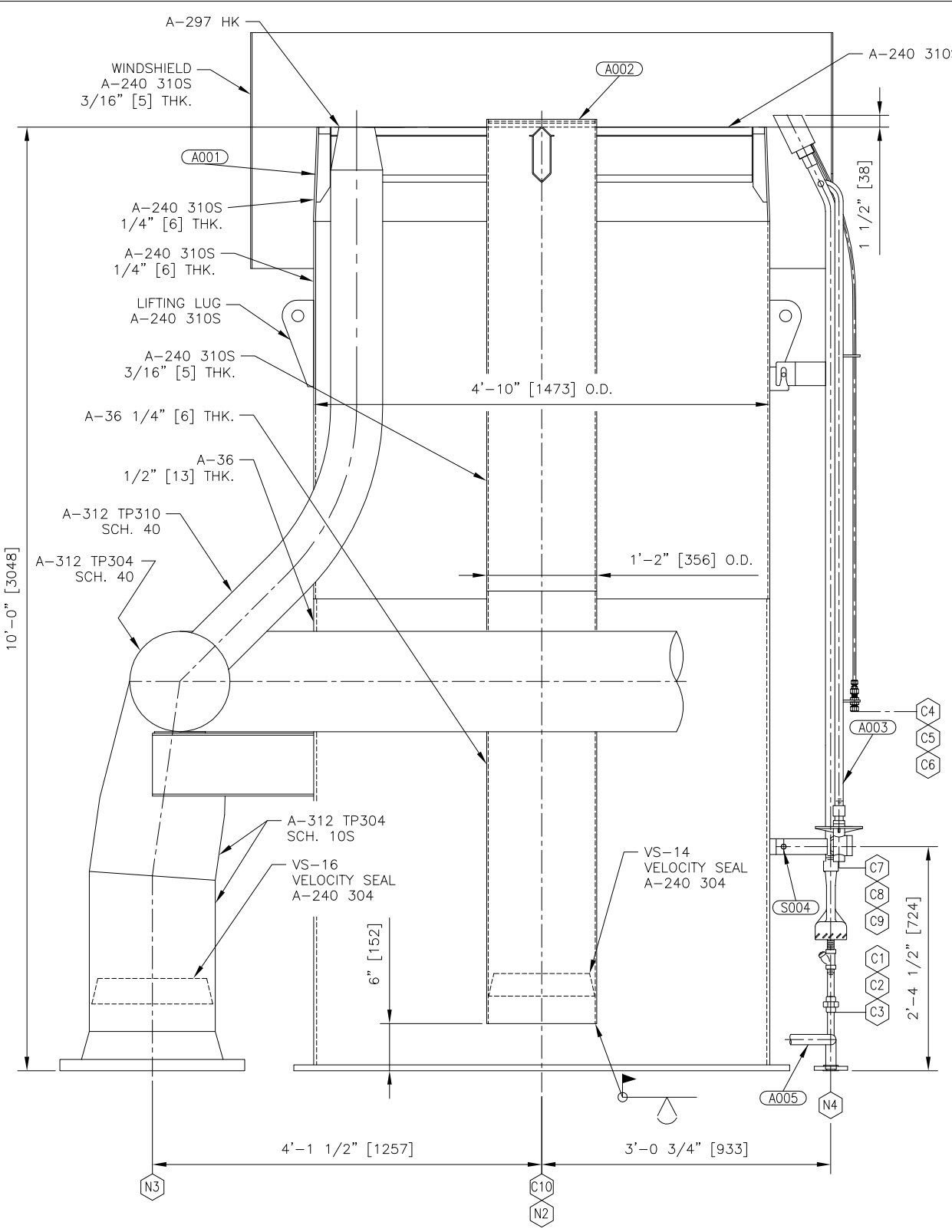

ELEVATION VIEW
(PORTIONS ROTATED FOR CLARITY)

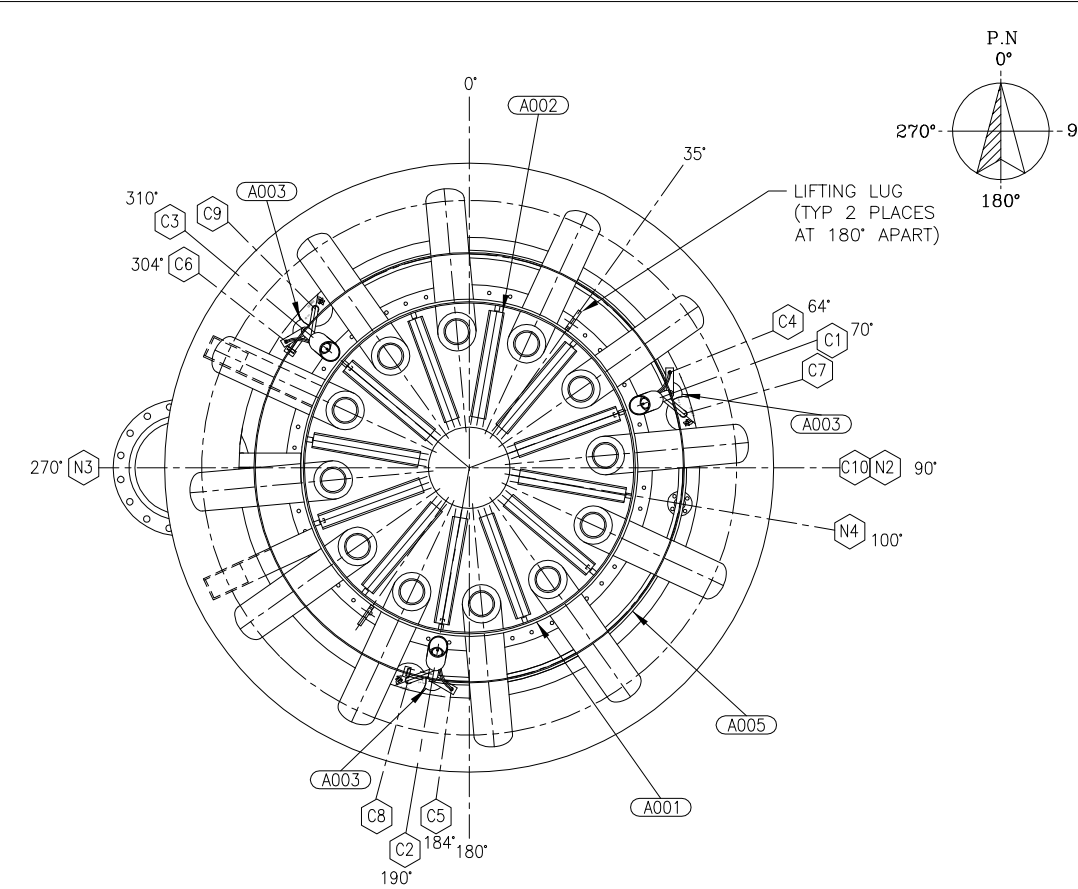

PLAN VIEW
(TRUE ORIENTATION)

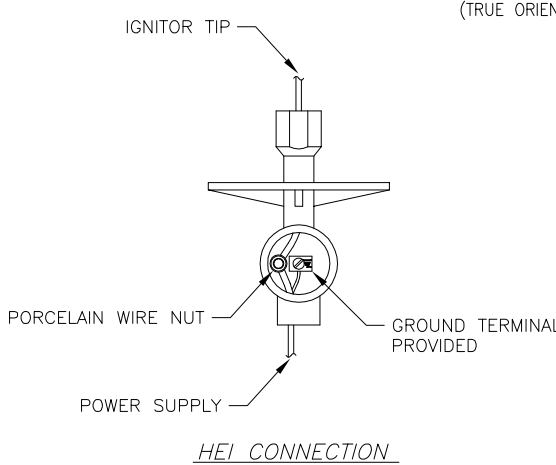

HEI CONNECTION

ZEECO, INC.
Tulsa, Oklahoma USA

Combustion and Environmental Solutions. Pure and Simple.®

AFDSMJW-14-16/58 FLARE TIP ASSEMBLY

TAG: FL-5100

P.O. 10231-78352

2017 31927
YEAR BUILT S.O. NUMBER

For parts & service: +1-918-258-8551 / sales@zeeco.com

ZEECO NAMEPLATE

- REFERENCE DRAWINGS -

SD-5777	GENERAL ARRANGEMENT
WC-9055	HEIC-3-T/S IGNITION SYSTEM
YA-2821	P & I DIAGRAM FOR FLARE SYSTEM

- NOZZLE LEGEND -

ITEM	SERVICE	SIZE	RATING	TYPE	SCH/BORE	FLG. MAT'L
C10	WARM GAS INLET	14"	N/A	BW	13 1/2"	A-36
N2	PLENUM AIR INLET	63" O.D. X 3/4" THK. X 58 1/4" I.D. W/ (52) 7/8"Ø HOLES ON A 60 1/2" B.C. EQU. SPCD.				A-36
N3	COLD GAS INLET	16"	150#	RFWN	S/10S	304 SS
N4	PILOT GAS MANIFOLD INLET	1"	150#	RFSW	S/40	A-105
C1/C2/C3	PILOT GAS INLET	1/2"	3000#	SW UNION	S/40	304 SS
C4/C5/C6	RT/C CONNECTION	1/2"	N/A	TUBING	N/A	316L SS
C7/C8/C9	HEI CONNECTION	3/4"	N/A	FNPT	N/A	CF3M

0	02JUN17	ISSUED FOR APPROVAL	MKN	GDH	BP
NO.	DATE	REVISION DESCRIPTION	BY	CKD.	APP.

Item	QTY	Description	P/N
A001	1	AFDSMJW-14-16/58 PLENUM ASS'Y	KC-6504-A001
A002	1	AFDSMJW-14-16/58 CENTER ASS'Y	KC-6505-A002
A003	3	HSLF-Z-HEI-RT/C PILOT ASS'Y	MB-4280-A003
COMPLETE WITH:			
HEI IGNITION PROBE			
THERMOCOUPLE (SEE DATASHEET)			
HSLF-Z MIXER BODY (A-743 CF3M)			
HSLF-Z MIXER SPUD (316 SS)			
STRAINER W/PLUG (A-743 CF8M)			
S004	3	HEAVY HEX BOLT: 1/2-13UNC X 1 1/2" LG. (A-193 B8M)	080-001-0069
		W/ HEAVY HEX NUT: 1/2-13 UNC (A-194 GR. 8M)	081-001-0135
A005	1	PILOT MANIFOLD ASS'Y	KC-6506-A005

- NOTES -
- PILOT MIXER ORIFICE DRILLED: 3/64"Ø [1.19 mm]
 - PILOT GAS CONSUMPTION: 65 SCFH @ 15 PSIG PER PILOT [1.74 Nm³/HR @ 1.05 kg/cm²g]
 - PILOT ORIFICE DRILLING BASED ON 1000 BTU/SCF (LHV) [9407 kcal/Nm³] GAS WITH 0.6 SP. GR.
 - WARM GAS FLARE REQUIRES A MINIMUM CONTINUOUS PURGE RATE OF 290 SCFH [7.77 Nm³/HR] AND THE COLD GAS FLARE REQUIRES A MINIMUM CONTINUOUS PURGE RATE OF 980 SCFH [26.25 Nm³/HR] OF A GAS THAT WILL NOT GO TO DEW POINT AT OPERATING TEMPERATURES TO ENSURE AIR DOES NOT MIGRATE DOWN THE FLARE STACK. IT SHOULD BE NOTED THAT DEPENDING UPON THE TURNDOWN OPERATION OF THE FAN AND THE TYPE OF PURGE GAS USED IT MAY BE NECESSARY TO INCREASE THIS MINIMUM PURGE RATE TO ENSURE PROPER COMBUSTION OF THE PURGE GAS DURING IDLE OPERATION.
 - ALL FLARE TIP LIFTING LUGS ARE DESIGNED FOR VERTICAL LIFTS ONLY, NO HORIZONTAL LIFTS OR SIDE LOADS ARE PERMITTED. LUGS ARE INTENDED FOR THE INITIAL INSTALLATION OF ALL FLARE TIPS AND PILOTS ONLY. LIFT LUGS ARE IN THE HEAT AFFECTED ZONE OF ALL FLARE TIPS AND ARE INTENDED TO BE REMOVED BEFORE OPERATION. IF LIFT LUGS ARE USED FOR SUBSEQUENT LIFTS, THEY SHOULD BE THOROUGHLY INSPECTED BY A QUALIFIED INSPECTOR AND DYE PENETRANT TESTS OF 100% OF THE WELDS ATTACHING THE LUGS TO THE FLARE TIP SHELL SHOULD BE PERFORMED
 - ALL FLANGE BOLTING TO STRADDLE NORMAL CENTERLINES.
 - ALL EXTERNAL CARBON STEEL SURFACES TO BE PREPARED PER SSPC-SP6. PRIME WITH ONE COAT INORGANIC ZINC AMERON DIMETCOTE 9 (2-4 MILS DFT MIN.). PAINT ONE COAT SILICONE ENAMEL ALUMINUM (LASTER CASTER LOCK-COAT 9814 ALUMINUM) (1-1.5 MILS DFT MIN.). FINISH COLOR: ALUMINUM
 - ALL TESTING PER INSPECTION TEST PLAN DOCUMENT NO. 31927-4010
 - THE PILOT THERMOCOUPLE IS FOR ON/OFF INDICATION ONLY, NOT FOR ACCURATE MEASUREMENT OF THE PILOT FLAME TEMPERATURE.
 - WHEN INSTALLING THE CENTER ASSEMBLY THE GAS EXIT ARMS MUST BE CENTERED ON THE PILOT AS PER THE PLAN VIEW.
 - APPROXIMATE WEIGHT FOR FLARE TIP ASS'Y: 7,039 LBS [3193 KG]
 - APPROXIMATE WEIGHT FOR EACH PILOT: 100 LBS. [45 KG]

JOBSITE: LOVING, NM
END USER: LUCID ENERGY

S.O. NO.: 31927 P.O. NO.: 10231-78352 APP AMZ

AFDSMJW-14-16/58 FLARE TIP ASSEMBLY
 TAG: FL-5100

DRAWN MKN DATE 02JUN17
 CHK GDH APP BP
 SCALE NONE REV 0

PROPRIETARY DATA IS INCLUDED IN THE INFORMATION DISCLOSED HEREIN AND IS THE PROPERTY OF ZEECO, INC. THIS INFORMATION IS SUBMITTED IN CONFIDENCE AND MUST BE USED IN CONNECTION WITH WORK DONE FOR ZEECO, INC. AND ALL RIGHTS OF DESIGN OR INVENTION ARE RESERVED. UNAUTHORIZED DISCLOSURE OR USE IS PROHIBITED BY LAW.

SAULSBURY INDUSTRIES DRAWING NUMBER SD-5776
 SHT. 1 OF 1

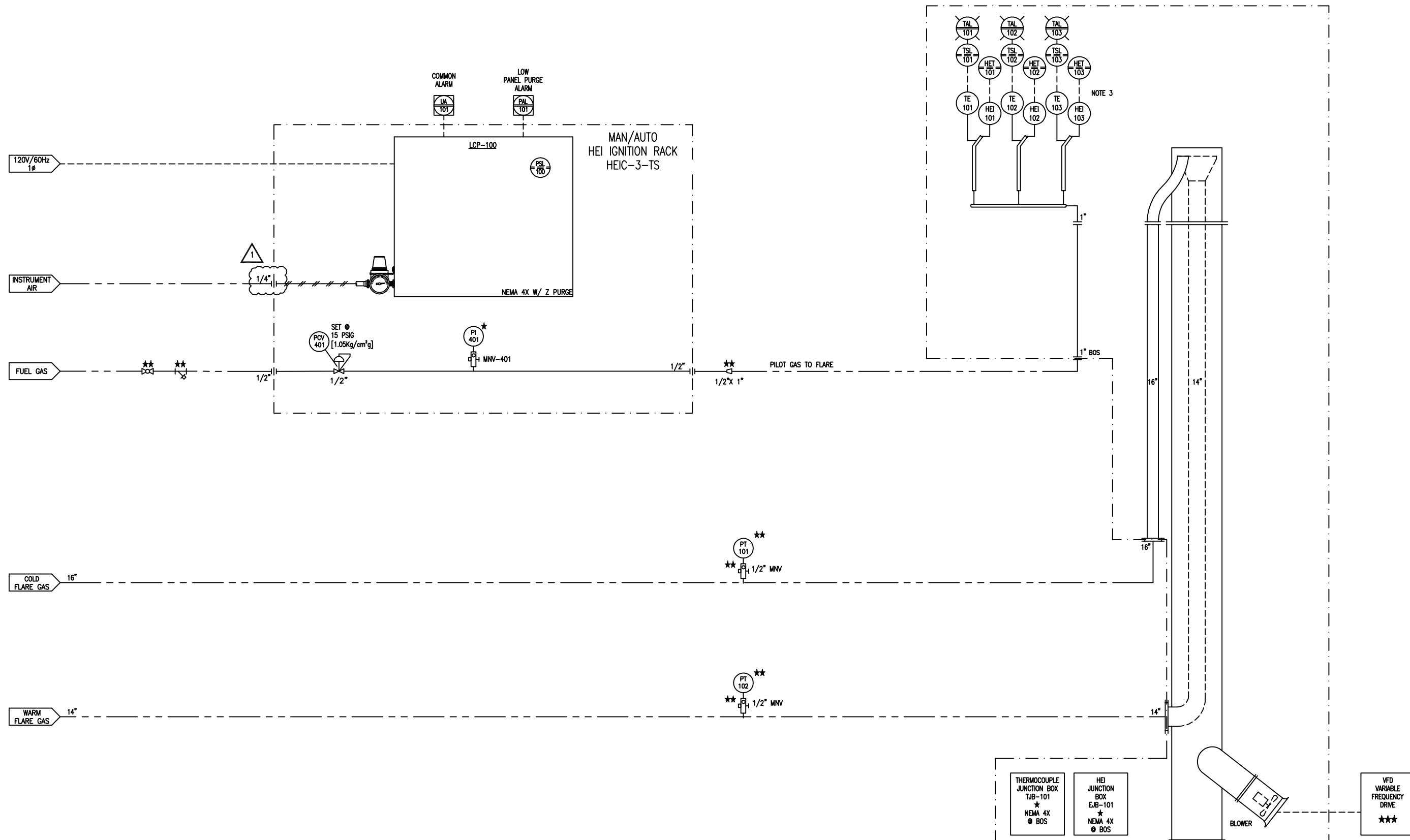

LEGEND

- ELECTRICAL SIGNAL
- PIPING / DUCTING (BY OTHERS)
- BY ZEECO
- 316SS TUBING & FITTINGS (HOKE OR EQUAL)
- 1/4" UNLESS NOTED OTHERWISE
- * ITEMS SHIPPED LOOSE
- ** ITEMS SUPPLIED BY OTHERS
- *** MOTOR CONTROL CENTER AND MOTOR STARTER BY OTHERS

- DCS-DISTRIBUTED CONTROL SYSTEM
- LOCAL MOUNTED
- MOUNTED ON LOCAL PANEL
- MOUNTED INSIDE LOCAL PANEL
- LOGIC DEVICE/PLC

NOTES:

1. CLASSIFICATION 1, DIVISION 2 GROUP C,D T2B.
2. THERMOCOUPLES ARE TYPE K, RETRACTABLE.
3. THERMOCOUPLE/HEI WIRING BETWEEN JUNCTION BOXES AT BASE OF STACK AND LOCAL CONTROL PANEL IS SUPPLIED AND INSTALLED BY OTHERS.
4. FUEL GAS SUPPLY FOR PILOT OPERATION IS CONTINUOUS.
5. THE PILOT THERMOCOUPLE IS FOR ON/OFF INDICATION ONLY. IT IS NOT FOR ACCURATE MEASUREMENT OF THE PILOT FLAME TEMPERATURE.

FOR INFORMATION ONLY

NO.	DATE	REVISION DESCRIPTION	BY	CKD.	APP.
1	08JUN17	PER ENGINEERING	MCM	BGB	MAA
0	30MAY17	ISSUED FOR APPROVAL	DWB	BGB	MAA

JOBSITE: LOVING, NEW MEXICO		END USER: LUCID ENERGY	
S.O. NO.: 31927	P.O. NO.: 10231-78352	APP AMZ	
ZEECO, INC. 22151 EAST 91st STREET BROKEN ARROW, OK 74014 PHONE: (918) 258-8551 FAX: (918) 251-0519 www.zeeco.com soles@zeeco.com		DRAWN DWB DATE 30MAY17 CHK BGB APP MAA SCALE NONE REV 1	
PROPRIETARY DATA IS INCLUDED IN THE INFORMATION DISCLOSED HEREIN AND IS THE PROPERTY OF ZEECO, INC. THIS INFORMATION IS SUBMITTED IN CONFIDENCE AND MUST BE USED IN CONNECTION WITH WORK DONE FOR ZEECO, INC. AND ALL RIGHTS OF DESIGN OR INVENTION ARE RESERVED. UNAUTHORIZED DISCLOSURE OR USE IS PROHIBITED BY LAW.		FOR: SAULSBURY INDUSTRIES DRAWING NUMBER YA-2821 SHT. 1 OF 1	

1					
2	Owner:	Targa	Owner Ref.:	H-1054	
3	Purchaser:	Targa	Purchaser Ref.:	TBD	
4	Manufacturer:	Tulsa Heaters Midstream	THM Ref.:	MJ16-199	
5	Service:	Hot Oil Heater	Project:	Roadrunner Plant	
6	Number:	1	Location:	Jal, NM	
7	SHO Duty:	55.00 MMBTU/ hr	SHO Model:	SHO5000	
8					

Guarantees:

11	NOx	0.0401	Lb/MMBTU	30	ppm
12	SOx	no quote	Lb/MMBTU	-	ppm
13	CO	0.0407	Lb/MMBTU	50	ppm
14	VOC	0.0192	Lb/MMBTU	15	ppm
15	UHC	0.007	Lb/MMBTU	15	ppm
16	SPM	0.0133	Lb/MMBTU	15	ppm

Design Case

Heat Release LHV Basis

63.89 MMBTU/hr

Products of Combustion

MW

24	O2	32.00	1,786	Lbm/ hr	
25	N2 + Ar	28.15	45,262	Lbm/ hr	
26	CO2	44.01	8,217	Lbm/ hr	
27	H2O	18.02	6,961	Lbm/ hr	
29	NOx	46.01	2.56	Lbm/ hr /	30 ppm
30	SOx	64.06	0.00	Lbm/ hr /	0 ppm
31	CO	28.01	2.60	Lbm/ hr /	50 ppm
32	VOC	44.10	1.23	Lbm/ hr /	15 ppm
33	UHC	16.04	0.45	Lbm/ hr /	15 ppm
34	SPM		0.85	Lbm/ hr /	15 ppm

Total 62,234 Lbm/ hr

38	Flue Gas Exit Temp.	517	°F
39	Flue Gas Exit Velocity	35.9	Ft/sec
40	Stack Height	34.3	ft
41	Stack ID	48	in

NOTE:

THM emissions guarantees applicable between 50-100% of Design Case combustion conditions w/ 15% excess air.

THM emissions guarantees applicable for firebox temperatures above 1100°F.

Emissions above are for Design Case operation with air and fuel in ratio control. Upset conditions, such as operation outside the design, high turndown or start-up are not considered as guaranteed emissions cases.

57					
58					
59					
60					
61					
62					
63					
64	revision	date	description	by	chk'd app'v'd



USA Applications

SHO = Superior Quality, Flexibility, Dependability & Modularity

EMISSIONS PERMIT DATA SHEET
AMERICAN ENGINEERING SYSTEM of UNITS

MJ16-199-Emissions-

Pg 1 of 1

1										
2	Owner:	Targa	Owner Ref.:	H-1054						Ftnt
3	Purchaser:	Targa	Purchaser Ref.:	TBD						&
4	Manufacturer:	Tulsa Heaters Midstream, LLC	THM Ref.:	MJ16-199	/					Rev
5	Service:	Hot Oil Heater	Project:	Roadrunner Plant						
6	Quantity:	1	Location:	Jal, NM						
7	SHO Duty:	55.00 MMBTU/ hr	SHO Model:	SHO5000						
8	BMS Release:	70.28 MMBTU/ hr	BMS Model:	BMS8500						
9	SHOS Flow:	2,160 USgpm @ 196 ft TDH	SHOS.Model:	SHOS2220						
10										

PROCESS DESIGN CONDITIONS

Heater Section		Radiant / Convection	Radiant / Convection	Radiant / Convection	Radiant / Convection
Operating Case	---	Design			
Service	---	Hot Oil Heater			
Heat Absorption (R/C)	MMBTU/ hr	36.39 / 18.61			
Process Fluid	---	Chemtherm 550			
Process Mass Flow Rate, Total	Lb/ hr	885,000			
Process Bulk Velocity (calc. R/C)	ft/ s	8 / 8			
Process Mass Velocity (calc. R/C)	Lb/ s ft2	408 / 408			
Coking Allowance (dP calcs)	in				
Pressure Drop, Clean (allow. / calc.)	psi	30 / 16			
Pressure Drop, Fouled (allow. / calc.)	psi				
Average Heat Flux (allowable)	BTU/ hr ft2	13,000			
Average Heat Flux (calculated)	BTU/ hr ft2	12,410			
Maximum Heat Flux (allowable)	BTU/ hr ft2				
Maximum Heat Flux (calc. R/C)	BTU/ hr ft2	22,700 / 26,310			
Fouling Factor, Internal	hr ft2 °F/ BTU	0.002			
Corrosion or Erosion Characteristics	---				
Max. Film Temperature (allow. / calc.)	°F	635 / 518			
Inlet Conditions:					
Temperature	°F	295			
Pressure	psig	80			
Mass Flow Rate, Liquid	Lb/ hr	885,000			
Mass Flow Rate, Vapor	Lb/ hr	0			
Weight Percent, Liquid / Vapor	wt%	100% / 0%			
Density, Liquid / Vapor	Lb/ ft3	51.10 / 0.00			
Molecular Weight, Liquid / Vapor	Lb/ Lbmole	--- / 0.0			
Viscosity, Liquid / Vapor	cp	2.046 / 0.000			
Specific Heat, Liquid / Vapor	BTU/ Lb °F	0.5675 / 0.000			
Thermal Conductivity, Liq./Vap.	BTU/hr ft °F	0.0702 / 0.000			
Outlet Conditions:					
Temperature	°F	400			
Pressure	psig	64			
Mass Flow Rate, Liquid	Lb/ hr	885,000			
Mass Flow Rate, Vapor	Lb/ hr	0			
Weight Percent, Liquid / Vapor	wt%	100% / 0%			
Density, Liquid / Vapor	Lb/ ft3	48.82 / 0.00			
Molecular Weight, Liquid / Vapor	Lb/ Lbmole	--- / 0.0			
Viscosity, Liquid / Vapor	cp	1.001 / 0.000			
Specific Heat, Liquid / Vapor	BTU/ Lb °F	0.618 / 0.000			
Thermal Conductivity, Liq./Vap.	BTU/hr ft °F	0.068 / 0.000			

57					
58					
59					
60					
61					
62					
63	A		Issued with Proposal		
64	revision	date	description	by	chk'd appv'd



USA Applications
 SHO = Superior Quality, Flexibility, Dependability & Modularity

FIRED HEATER DATA SHEET
 AMERICAN ENGINEERING SYSTEM of UNITS

MJ16-199-HTRds- Pg 1 of 6

This document contains confidential information proprietary to THM. This document shall not be used, reproduced or disclosed without the prior written consent of THM.

COMBUSTION DESIGN CONDITIONS

1									
2									
3	Overall Performance:								
4	Operating Case	---	Design						
5	Service	---	Hot Oil Heater						
6	Excess Air	mol%	15.0%						
7	Calculated Heat Release (LHV)	MMBTU/ hr	63.89						
8	Guaranteed Efficiency	HR%	84.1%						
9	Calculated Efficiency	HR%	86.1%						
10	Radiation Loss	HR%	2.00%						
11	Flow Rate, Combustion Gen./ Imp.	Lb/ hr	62,234						
12	Flue Gas Temp. Leaving (R/C)	°F	1,520 / 517						
13	Flue Gas Mass Velocity	Lb/ sec ft2	0.667						
14									

15	Fuel(s) Data:	Gas 1	Gas 2	Gas 3	Design	Burner Design:			
16		Mol.Wt.	Mol.Wt.	Mol.Wt.	Fuel Oil	OEM	---	Callidus Technologies, LLC	
17	LHV	BTU/ scf	937		---	Type	---	Enhanced IFGR	
18	LHV	BTU/ Lb	21,012			Quantities	---	1	ULTRA Low NOx
19	P @ Burner	psig	75			Model No.	---	CUBL-16W-HC-HZ	Cylindrical
20	T @ Burner	°F	100			Windbox	---	yes ...	
21	MW	Lb/ Lbmole	16.93		---	Location	---	EndWall Center ...	Horizontally Fired
22	Flow @ design	lb/hr	3,041			Pilot Design:			
23	Flow @ design	scfh	68,172			Type / Model		Self-Inspiring	/ by O.E.M.
24	Atomizing Media		---			Ignition	---	Electric	requires elec.ign.system
25	Atom. Media P & T		---			Heat Release	---	> 350000	BTU/ hr on ... Gas 1
26									

27	Components:					Burner Performance:			
28	N	wt%	---			Minimum Heat Release	MMBTU/ hr	14.06	
29	S	wt%	---			Design Heat Release	MMBTU/ hr	63.89	
30	Ash	wt%	---			Maximum Heat Release	MMBTU/ hr	70.28	
31	Ni	ppm	---			Burner Turndown	Max:Min	5.00	
32	Va	ppm	---			Volumetric Ht. Release	BTU/ hr ft3	7,743	
33	Na	ppm	---			Pressure @ Arch	inH2O	1.60	
34	Fe	ppm	---			Pressure @ Burner	inH2O	8.22	
35						Combustion Air T @ Burner	°F	60	
36	H2	mol%	0.0%		---	Flue Gas T @ Burner	°F	1,320	
37	O2	mol%	0.0%		---				

38	N2 + Ar	mol%	1.0%		---	Guaranteed Emissions:			
39	CO	mol%	0.0%		---	Basis of Guarantee	---	3.0% O2, dry (LHV)	
40	CO2	mol%	0.1%		---	NOx Emissions	Lb/MMBTU	0.040	30 ppm
41	CH4	mol%	97.0%		---	SOx Emissions	Lb/MMBTU	no quote	
42	C2H6	mol%	2.3%		---	CO Emissions	Lb/MMBTU	0.041	50 ppm
43	C2H4	mol%	0.0%		---	VOC Emissions	Lb/MMBTU	0.019	15 ppm
44	C3H8	mol%	0.1%		---	UHC Emissions	Lb/MMBTU	0.007	15 ppm
45	C3H6	mol%	0.0%		---	SPM10 Emissions	Lb/MMBTU	0.013	15 ppm
46	C4H10	mol%	0.6%		---	Noise Emissions	dBA @ 3ft	85	
47	C4H8	mol%	0.0%		---				
48	C5H12	mol%	0.0%		---				

49	C5H10	mol%	0.0%		---	Net Flame Clearances:			
50	C6+	mol%	0.0%		---	Est. Flame Size	approx. 34.5 ft L x 6 ft Diameter		
51	H2S	ppmv	0.0%		---	Hor Clearance	3.5 ft NET Tube Clearance		
52	SO2	mol%	0.0%		---	Vert. Clearance	3.5 ft NET Tube Clearance		
53	NH3	mol%	0.0%		---	Axial Clearance	6.67 ft NET Refractory Clearance (to Target hot face)		

54	H2O	mol%	0.0%		---	Nominal Flame Clearances:			
55	spare	mol%	0.0%		---	from burner CL ...	Vertical	Horizontal	
56						to Tube CL, API	ft	28.60	19.07
57						to Tube CL, calc.	ft	6.50	6.50
58						to Refrac., calc.	ft	n / a	41.17

59	Blower/Fan Performance:								
60	Volumetric Flow	acfm	13,000						
61	Rated Power	HP	40						
62	Fan Speed	RPM	1,800						
63	Sound Pressure	dBA	< 85						
64	Area Classification	NEC	Class I, Div. II, Groups C&D						

PRESSURE PARTS DESIGN

1					
2					
3	Coil Design:		RADIANT	SHIELD	CONVECTION
4	Service		Hot Oil Heater	Hot Oil Heater	Hot Oil Heater
5	Design Basis for Tube Temperature		API 530	API 530	API 530
6	Design Basis for Tube Wall Thickness		ASME Sec. VIII-1	ASME Sec. VIII-1	ASME Sec. VIII-1
7	Design Life	hr	100,000	100,000	100,000
8	Design Pressure (elastic / rupture)	psig	250 /	250 /	250 /
9	Design Fluid Temperature	°F	400	400	400
10	Design Temperature Allowance	°F	25	25	25
11	Design Corrosion Allowance (tubes/fittings)	in	0.063 / 0.063	0.063 / 0.063	0.063 / 0.063
12					
13	Maximum Tube Temperature (clean)	°F	540		
14	Maximum Tube Temperature (fouled)	°F	590	485	588
15	Design Tube Temperature	°F	615	613	613
16	Inside Film Coefficient	BTU/ hr ft ² °F	210	164	164
17	Weld Inspection	RT or Other	100 of 10%	100 of 10%	100 of 10%
18	Weld Heat Treatment	s.rel., t.stab. or none	None	None	None
19	Hydrostatic Test Pressure	psig	per API	per API	per API
20					
21	Coil Arrangement:		Horizontal	Horizontal	Horizontal
22	Coil Type	---	Helical	Serpentine	Serpentine
23	Tube Material (pipe or tube spec)	ASTM	SA106GrB	SA106GrB	SA106GrB
24	Supplementary Mfg Requirements	ASTM	None	None	None
25	Tube Outside Diameter	in	6.625	6.625	6.625
26	Tube Wall Thickness (aw / mw)	in	0.280 / 0.245	0.280 / 0.245	0.280 / 0.245
27	Number of Cells (radiant or convection)	---	1	1	1
28	Number of Flow Passes (total / cell)	---	3 / 3	3 / 3	3 / 3
29	Number of Tubes per Row (total / cell)	---		4 / 4	4 / 4
30	Overall Tube (1 turn in radiant) Length	ft	40.84	16.04	16.04
31	Effective Tube Length / Helix Diameter	ft	40.84 / 13.00	14.46	14.46
32	Number of Turns or Tubes (total / pass)		41.4 / 13.8	4.0 / 4.0	0.0 / 0.0
33	Total Exposed Surface	ft ²	2,932	100	0
34	Number of Ext.Surf. Tubes (total / cell)	---	0 / 0.0	0 / 0.0	36 / 36.0
35	Total Exposed Surface	ft ²	0	0	8,599
36	Tube Spacing (horiz. / tube centers)	in	--- / 11.50	12.00 / 12.00	12.00 / 12.00
37	Tube Spacing (horiz. to refractory)	in	9.00	6.00	6.00
38	Coil Fluid Volume	USgal	2632	104	935
39					
40	Coil Fittings:		Hot Oil Heater	Hot Oil Heater	Hot Oil Heater
41	Fitting Type	---	SR 90° Elbows	SR 180° U-Bends	SR 180° U-Bends
42	Fitting Material	ASTM	SA234 WPB	SA234 WPB	SA234 WPB
43	Supplementary Mfg Requirements	ASTM	None	None	None
44	Fitting Outside Diameter	in	6.625	6.625	6.625
45	Fitting Wall Thickness (aw / mw)	in	0.280 / 0.245	0.280 / 0.245	0.280 / 0.245
46	Fitting Location	internal or external	Internal	External	External
47	Tube Attachment	welded or rolled	Welded	Welded	Welded
48					
49	Coil Terminals:		Outlet		Inlet
50	Terminal Type	beveled or flanged	Flanged		Flanged
51	Flange Material	ASTM	SA105N		SA105N
52	Supplementary Mfg Requirements	ASTM	None		None
53	Flange Size and Rating	NPS/ ASME	6" NPS / 300#		6" NPS / 300#
54	Flange Type	RFWN or RTJ	RFWN		RFWN
55	Location	---	Burner Endwall		Terminal End
56					
57	Extended Surface:		CONVECTION	CONVECTION	CONVECTION
58	Service	---	Hot Oil Heater	Hot Oil Heater	Hot Oil Heater
59	Fin or Stud Row Number	starting @ bottom	No.1 / No.2-3	No.4-5 / No.6-9	/
60	Ext. Surface Type	seg.fins, solid fins, studs	HF Seg. Fins	HF Seg. Fins	
61	Fin/Stud Material	---	C.S. / C.S.	C.S. / C.S.	/
62	Fin/Stud Height	in	0.50 / 0.50	0.75 / 1.00	/
63	Fin/Stud Thickness	in	0.06 / 0.06	0.06 / 0.06	/
64	Fin/Stud Density	fin/ in	3.00 / 5.00	5.00 / 5.00	/
65					

PRESSURE PARTS DESIGN (continued)

1				
2				
3	Crossovers:		<u>RADIANT</u>	<u>SHIELD</u>
4	Type, location / connections	---	<u>External</u>	<u>Flanged</u>
5	Tube / Fittings Material	ASTM	<u>SA106GrB</u>	<u>SA234 WPB</u>
6	Tube & Fitting OD / Thickness (aw)	in	<u>6.625</u>	<u>0.280</u>
7				
8	Inlet Manifold(s):	type		<u>Simple LOG</u>
9	Location	---		<u>Top - Term. End</u>
10	Design Basis for Manifold Thickness:	---		<u>ASME B31.3</u>
11	Design Conditions (temp./press.)	°F/ psig	<u>613</u>	<u>250</u>
12	Pipe Material	ASTM	<u>SA106GrB</u>	
13	Fittings Material	ASTM	<u>SA234 WPB</u>	
14	Flange Material / Style	ASTM	<u>SA105N/ RFWN</u>	
15	Outside Diameters, each Branch	in	<u>16" NPS</u>	
16	Wall Thickness(es); aw or mw	in	<u>SCH40 (0.5)</u>	
17	End Types (terminal/ dead)	beveled or flanged	<u>Flanged / W.Cap</u>	
18	Manifold Terminal Type	NPS/ ASME	<u>16" NPS/ 300# Flg</u>	
19	Coil Connection Type	extrusion, olet, etc.	<u>Weld-O-Let</u>	
20	Coil Terminal Type	NPS/ ASME	<u>6" NPS / 300# Flg</u>	
21				
22	Outlet Manifold(s):	type	<u>Simple LOG</u>	
23	Location	---	<u>Burner Endwal</u>	
24	Design Basis for Manifold Thickness:	---	<u>ASME B31.3</u>	
25	Design Conditions (temp./press.)	°F/ psig	<u>615</u>	<u>250</u>
26	Pipe Material	ASTM	<u>SA106GrB</u>	
27	Fittings Material	ASTM	<u>SA234 WPB</u>	
28	Flange Material / Style	ASTM	<u>SA105N/ RFWN</u>	
29	Outside Diameters, each Branch	in	<u>16" NPS</u>	
30	Wall Thickness(es); aw or mw	in	<u>SCH40 (0.5)</u>	
31	End Types (terminal/ dead)	beveled or flanged	<u>Flanged / W.Cap</u>	
32	Manifold Terminal Type	NPS/ ASME	<u>16" NPS/ 300# Flg</u>	
33	Coil Connection Type	extrusion, olet, etc.	<u>Weld-O-Let</u>	
34	Coil Terminal Type	NPS/ ASME	<u>6" NPS / 300# Flg</u>	
35				

COIL & MANIFOLD SUPPORTS DESIGN

36				
37				
38				
39	Tube Supports:		<u>RADIANT</u>	<u>SHIELD</u>
40	Service		<u>Hot Oil Heater</u>	<u>Hot Oil Heater</u>
41	Location	Top, Bottom, Ends	<u>Bottom</u>	<u>Ends</u>
42	Support Type	casting, tubesht, spring, etc.	<u>SS Pipe Rail</u>	<u>Welded Tbsheets</u>
43	Support Thicknesses	in	<u>SCH40</u>	<u>0.375</u>
44	Support Materials	ASTM	<u>A240 T304</u>	<u>A36 CS</u>
45	Support Temperatures (calc./ design)	°F / °F	<u>951 / 1,140</u>	<u>628 / 780</u>
46	TbSht Ferrules Thickness/Materials	in/ ASTM	<u>---</u>	<u>14 ga. / 304 SS</u>
47	Refractory & Anchor Materials & Types		<u>none</u>	<u>per refrac. section</u>
48				
49	Intermediate Guides & Supports:		<u>None</u>	<u>None</u>
50	Location	---		
51	Guide/ Support Type	casting, spring, etc.		
52	Material	ASTM		
53	Spacing, average	ft		
54				
55	Tube Guides:	Top, Bottom, Ends	<u>None</u>	<u>None</u>
56	Material	ASTM		
57				
58	Manifold Supports:		<u>Outlet Manifold</u>	<u>Intlet Manifold</u>
59	Material	ASTM	<u>A36</u>	<u>N/A</u>
60	Materials Design & Supply	---	<u>by THM</u>	
61	Location	Top, Bottom, Ends	<u>Burner Endwal</u>	
62	Support Type	roller, shoe, spring, etc.	<u>Simple Shelf</u>	
63	Number of Supports	---	<u>One (1)</u>	
64				

CASING / REFRACTORY SYSTEMS DESIGN

1					
2					
3		BURNER	SHIELDED	TARGET	
4	Radiant Section Design:	ENDWALL	SIDEWALLS	ENDWALL	
5	Total Refractory Thickness	in 5.0	3.0	5.0	
6	Hot Face Temperature (design)	°F 2,000	2,000	2,000	
7	Hot Face Temperature (calculated)	°F 1,520	951	1,520	
8	Hot Face Layer	in/ --- 1/ 8# CF Blanket	1/ 8# CF Blanket	1/ 8# CF Blanket	
9	Back-Up Layer No.1	in/ --- 1/ 8# CF Blanket	2/ 6# CF Blanket	1/ 8# CF Blanket	
10	Back-Up Layer No.2	in/ --- 3/ 6# CF Blanket	None	3/ 6# CF Blanket	
11	Foil Vapor Barrier	in/ --- None	None	None	
12	Castable Reinforcement (SS Needles)	wt% None	None	None	
13	Anchors / Tie Backs:	--- Pins & Clips	Pins & Clips	Pins & Clips	
14	Material	--- 310 S.S.	304 S.S.	310 S.S.	
15	Attachment	--- Welded	Welded	Welded	
16	Casing:				
17	Material	in/ ASTM 0.1875 / A36	0.1875 / A36	0.1875 / A36	
18	Internal Coating	--- None	None	None	
19	External Temperature, Typical	°F 180	180	180	
20	Comments / Clarifications	--- w/ cfb wraps	w/o cfb wraps	w/ cfb wraps	
21		SHOP Installed	SHOP Installed	SHOP Installed	
22					
23		SIDEWALLS	ENDWALLS		
24	Convection Section Design	SHIELD	FINNED	TUBESHEETS	HEADER BOXES
25	Total Refractory Thickness	in 3.0	3.0	3.0	2.0
26	Hot Face Temperature (design)	°F 2,000	2,000	2,200	2,000
27	Hot Face Temperature (calculated)	°F 1,019	1,019	1,019	739
28	Hot Face Layer	in/ --- 1/ 8# CF Blanket	1/ 8# CF Blanket	3/ Sparlite HS	1/ 8# CF Blanket
29	Back-Up Layer No.1	in/ --- 2/ 6# CF Blanket	2/ 6# CF Blanket	None	1/ 8# CF Blanket
30	Back-Up Layer No.2	in/ --- None	None	None	None
31	Foil Vapor Barrier	in/ --- None	None	None	None
32	Castable Reinforcement (SS Needles)	wt% None	None	None	None
33	Anchors / Tie Backs:	--- Pins & Clips	Pins & Clips	Bullhorns	Pins & Clips
34	Material	--- 310 S.S.	304 S.S.	304 S.S.	304 S.S.
35	Attachment	--- Welded	Welded	Welded	Welded
36	Casing:				
37	Material	in/ ASTM 0.1875 / A36	0.1875 / A36		0.1345 / A36
38	Internal Coating	--- None	None	None	None
39	External Temperature, Typical	°F 180	180		180
40	Comments / Clarifications	--- Cleaning/Sootblowing lanes: none			Bolted Assembly
41		SHOP Installed	SHOP Installed	SHOP Installed	SHOP Installed
42					
43		FLUE GAS DUCTS			
44	Stack & Uptakes Design:	BREECHING	15° TRANSITION	DISCH. DUCT	
45	Quantity	One	One	One	
46	Type / Location	--- Full L / Conv	Full L / Conv	Self.Spt/ Grade	
47	Length / Metal Outside Diameter (top)	ft/ ft 1.00 / n/a	2.02 / n/a	7 / 4.000	
48	Discharge Elev., minimum/ calculated	ft/ ft n/a / n/a	n/a / n/a	20 / 34	
49	Total Refractory Thickness	in 3.0	0.0	0.0	
50	Hot Face Temperature (design)	°F 2,000			
51	Hot Face Temperature (calculated)	°F 517	517	517	
52	Hot Face Layer	in/ --- 1/ 8# CF Blanket	None	None	
53	Back-Up Layer No.1	in/ --- 2/ 6# CF Blanket			
54	Castable Reinforcement (SS Needles)	None			
55	Anchors / Tie Backs:	--- Pins & Clips			
56	Material	--- 304 S.S.			
57	Attachment	--- Welded			
58	Casing:				
59	Minimum Thickness/ Material	in/ ASTM 0.1875 / A36	0.1875 / A36	0.1875 / A36	
60	Corrosion Allowance	in None	None	None	
61	Internal Coating	--- None	None	None	
62	External Temperature, Typical	°F 180	517	517	
63	Comments / Clarifications	--- SHOP Installed			
64					

MECHANICAL / STRUCTURAL DESIGN BASIS

Refractory & Coatings Design:

3	Refractory Design	Per Std560: 180°F Avg. Casing Temperature @ Ambient Conditions of 0 MPH & 80°F
4	Refractory Dryout	SHOP dryout = None // FIELD dryout per THM standard.
5	Coating, Internal	None
6	Coating, External	Base Coat: 3-4 PPG Dimetcote 9 IOZ Silicate - Flat Green on SP-6
7		Int. Coat: None
8		Top Coat: 1.5-2 PPG Pitt-Therm 97-724 Series Air Dry Silicone - Federal Standard 595B #16132 Gray

Applicable Standards:

14	API	Std 560 (ISO 13705); Fired Heaters for ...	AISC	Specification for Design, ... Steel for Buildings
15	API	Std 530 (ISO 13704); Calc. of Heater Tube ...	AWS	D 1.1; Structural Welding Code
16	ASME	B31.3, Chemical Plant and ... Pipinc	ASTM	tube/ smls pipe/ fitting spec's noted herein
17	ASME	Sections I, II, VIII, IX; ASME B&PV Code	ASTM	refractories per C27, C155, C401 & C612
18	ASME	Section V; Non Destructive Examination	NFPA	NFPA 70; National Electrical Code

Wind Design:

21	Spec. or Standard	ASCE 7-10
22	Velocity/ Imp. Factor	120 mph / 1
23	Site Exposure	"C"
24	Physical Design:	
25	Plot Limitations	None
26	Tube Limitations	None
27	Firebox Pressure	Positive; approximately +1.0 inH2O
28	Ambient Temp's	-20 °F Min/ 60 °F Dsn/ 105 °F Max

Seismic Design:

21	Spec. or Standard	ASCE 7-10
22	Risck Cat./Imp. Factor	III / 1.25
23	Ss/S1/Soil Class	0.5 / 0.15 / D
24	Site Design Basis:	
25	Site Elevation	25 ft AMSL
26	Stack Design Temp.	90 °F
27	FG Discharge Elev.	34 ft AG
28	Area Classification	Class I, Div. II, Groups C&D

MAJOR SUBSYSTEMS & ACCESSORIES

Major Services & Subsystems

34	Process Design	INCLUDED in base pricing
35	Mechanical Design	INCLUDED in base pricing
36	Structural Design	INCLUDED in base pricing
37	Radiant Section	INCLUDED in base pricing
38	Convection Section	INCLUDED in base pricing
39	Burner Mgmt	INCLUDED in base pricing
40	Burner Piping	INCLUDED in base pricing
41	Forced Draft System	INCLUDED in base pricing

Major Accessories:

12	TubeSox; Radiant & Conv.	
2	4 in Dia. w/ H.T. glass	
1	4 in Dia. w/ HT glass on Arch	
1	Std 24" x 24"	
	Expansion Joints	None
	Ladders & Platforms	Not Included
	L&P Coating	N/A

Casing Penetrations

44	Fbox Purge/ Snuff	None
45	CA Temp/Pres	None
46	FG Temperature	2 1.5"NPS 3000# Coupling
47	FG Pressure	2 1.5"NPS 3000# Coupling
48	FG Comp. (Sample)	2 1.5"NPS 3000# Coupling
49	FG Sample	2 4"NPS 150# RFWN's
50	O2 Analyzer Port	None

Pressure Part Penetrations

	Coil TSTC's, Radiant	None
	Coil TSTC's, Convection	None
3	Process TI conn's	1.5" NPS 300# RFWN
1	Process PI conn's	1.5" NPS 300# RFWN
	spare	
	spare	
	spare	

Dampers

53	FD Fan (blower)	qty = 0	Uptake Ducts	Stack	qty = 0
54	Function	Note:		Note:	
55	Design	Fan inlet damper is inappropriate		Stack Damper (which provides draft control) is inappropriate for forced	
56	Materials	for forced draft SHO's where O2		draft SHO's where the combustion	
57	Bearings	Control is provided by the BMS O2		conditions are controlled real-time	
58	Operator	Trim Module which controls the fan		via the BMS.	
59	Positioner	(blower) motor's VFD/ VSD.			

Instruments

61	Sootblowers:	Qty.	Type	Location	FG T	Material	Steam T & P	O.E.M. / Ref.
62	Lane 1:	None						
63	Lane 2 :	None						

THOMAS RUSSELL CO.
Tulsa, Oklahoma

JOB NO: TRJ-250		DATE: 9/21/2010
CLIENT: Southcross Energy		BY: JRG
SUBJECT: 200 MMscfd Cryo Plant		

FIRED HEATER

Service: Regen Gas Heater	Tag No: H-741
Design Duty, MBTU/Hr 5248	Type: Helical Coil
No. of Coils per Unit One	No. Units: One
Model: Heatec HCI-5010-40-G	

	Regen Gas				Burners		
		Inlet	Outlet		Gas	Oil	
Liquids Lbs/Hr	0	0		LHV (BTU/cf)	973		
Density Lbs/CuFt				Mol. Wt.	18.26		
Molecular Weight				Gravity			
Specific Heat BTU/Lb °F				Pressure Avail. (psig)	100		
Thermal Cond. BTU/Hr-Ft °F				Pressure Req'd (psig)	10		
Viscosity cP				Steam for Atomizing			
Vapor Lbs/Hr	19013	19013		Fuel Gas Req'd (MSCFD)	156.86	N/A	
Density Lbs/CuFt	3.389	1.716		Mfr:	Eclipse W/INOX		
Molecular Weight	19.68	19.68		Type:	Forced Draft - 20 Hp Blower		
Specific Heat BTU/Lb °F	0.6261	0.7407		Number Req'd	One		
Thermal Cond. BTU/HrFt °F	0.0239	0.0438		Pilots Req'd	Yes, electrical ignition		
Viscosity cP	0.0140	0.0195		NOx	40 ppm		
Operating Temp. °F	135	550		Structural Design			
Operating Pressure PSIA	950			Wind Load, MPH, (3)	90, Exp.C, I=1.15, Cf=0.7		
Velocity Ft/Sec		Allow.	Calc.	Seismic Zone, (3)	I = 1.25		
Pressure Drop PSI	10	Allow.	Calc.	Ambient, °F	-20 / 110		
Fouling Resistance SqFt°F/BTU	0.001			Elevation, Ft	750		
Design Press. / Temp.	1095 PSIG	650 °F		Stack Design			
Min. Design Mtl. Temp.	-20 °F @	1095 PSIG		Self-supporting	Yes		
Corrosion Allowance	0.0625			Minimum Height	8 ft above top of heater		
Insulation Thickness	3" - 5" ceramic fiber on the interior			Minimum Wall Thickness:	0.125		
Efficiency-Based on LHV (%)	85.0%	(Assume 3% Loss)		Lining Type	No		
Excess Air	15			Lining Thickness:	No		
Firebox Unit Heat Release	27,800	BTU/Hr- Ft³		Damper:	No		
Number of Passes	One - process, Two - fireside						

Coil Design		Radiant	Convection-Bare	Convection-Finned
Gas Temperature In/Out		135 / 550		
Number Tubes		One		
Tube O.D. In		Single Circuit 4"	4" 900# RTJ Flg	Inlet and Outlet
Tube Length Eff. Ft		----		
Bare Surface Sq Ft		697		
Finned Surface Sq Ft		N/A		
Avg. Heat Flux BTU/Hr-Sq Ft		8,278		
Tube Materials		SA-106 Gr.B Sch 80	SA-	SA-

Convection Fins (inch):	Height:	Thickness:	No. / inch:	Material:
Overall Dimension:	25' - 8" L x 7' - 0" W x 8' - 6" H (less stack)			Dry Weight: 18,450 lbs
Code Requirements:	ASME VIII Div I	Stamp:	Yes	Nat'l Board: Yes

Notes:

- 1) Add 30% to duty and 10% flow rates for design.
- 2) See attached Scope of Supply.
- ▲ 3) Wind design per ASCE 7-10, V=150 mph, Exposure C. Seismic design per ASCE 7-10, I=1.25, Site D., S_s=40% , S₁=8%
- 4) Electric power to be 480 v / 3 ph / 60 hz. Control enclosures to be NEMA 4.
- 5) Add Spare ignitor.

REVISION	A	0	1	▲ 2
ENGINEER/DATE	JRG 9/21/10	JRG 9/21/10	JRG 9/14/11	MTR 9/20/11
ISSUED FOR	RFQ	Purchase	Revised	Revised

HEATER DESIGN DATA

INPUT: 7,387,616 X 1.3 BTU/HR
 OUTPUT: 5,770,000 X 1.3 BTU/HR
 FLOW RATE: 20,840 X 1.1 LBS/HR
 TRANSFER MEDIA: REGENERATION GAS
 HEATING SURFACE: 741 SQ FT
 DESIGN: 1095 PSI @ 650 F
 ASME CODE: SECTION VIII, DIV 1 2010 EDITION,
 NO ADDENDA
 OUTLET MEDIA TEMP: 550 F
 PRESSURE DROP: 6 PSI
 ESTIMATED DRY WEIGHT: 23,500 LBS

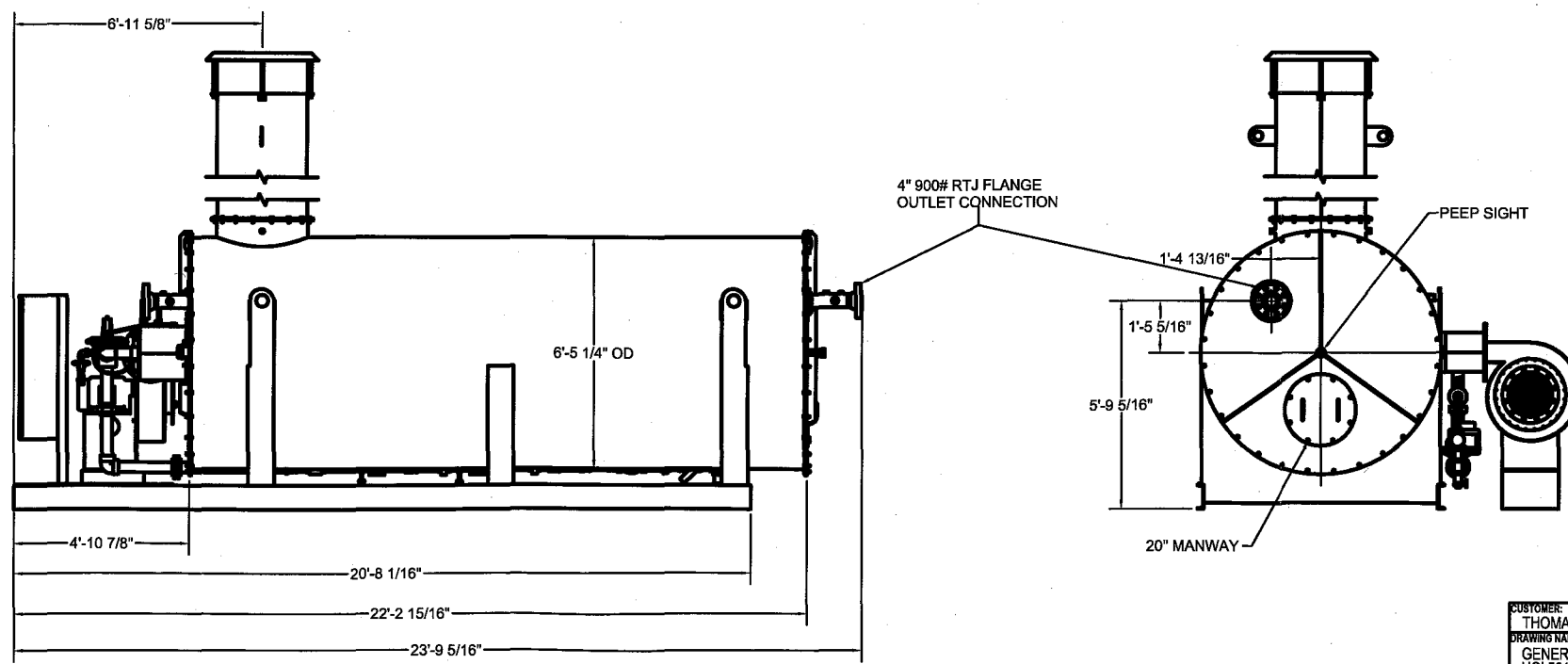
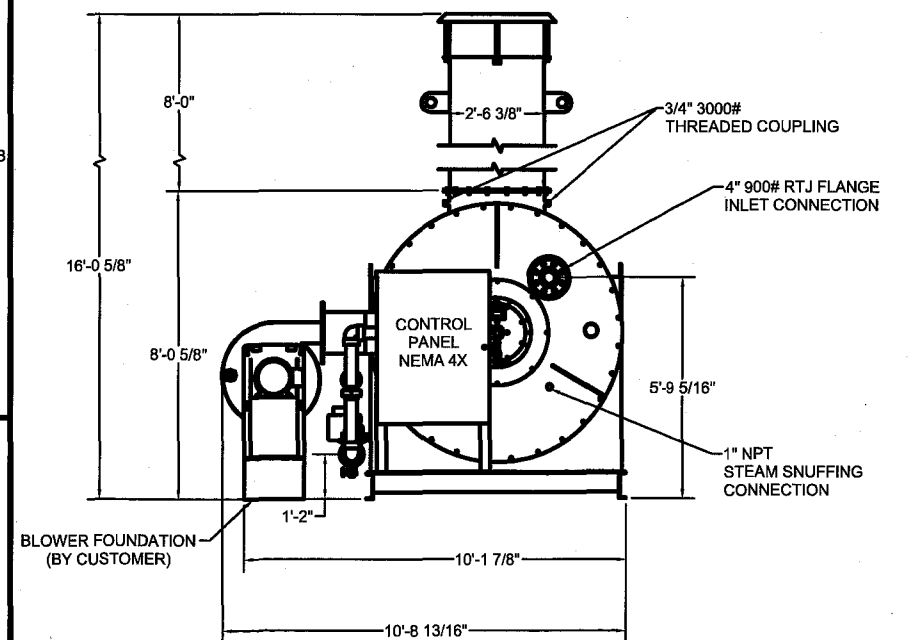
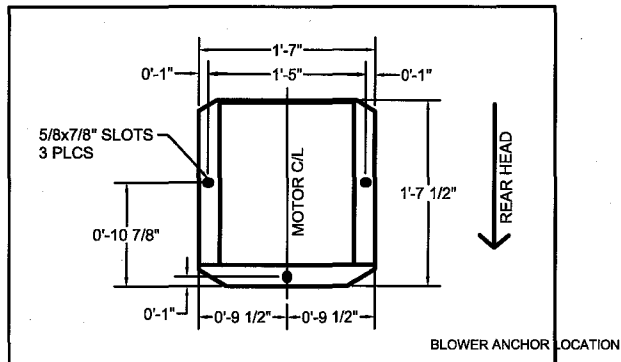
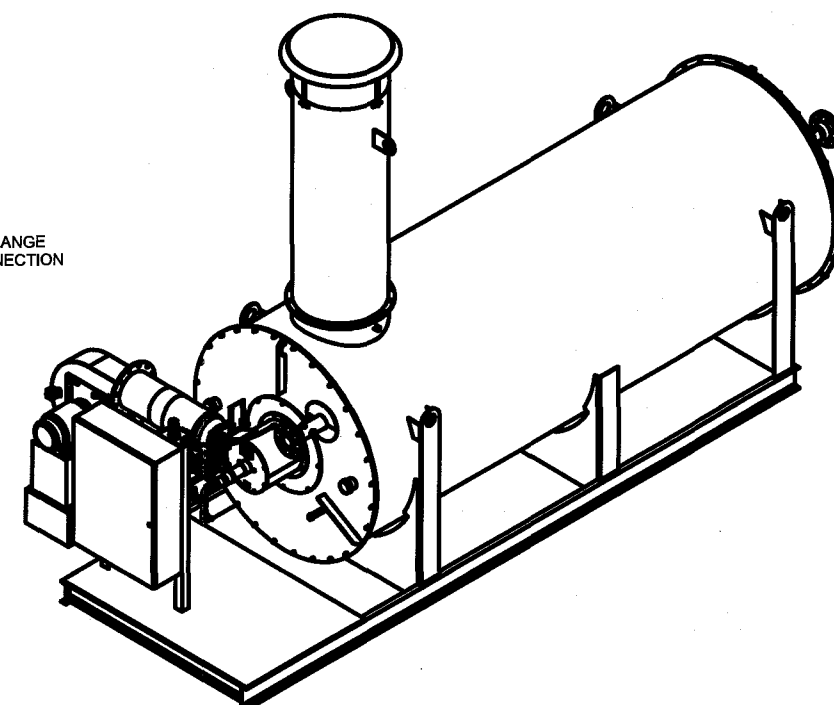
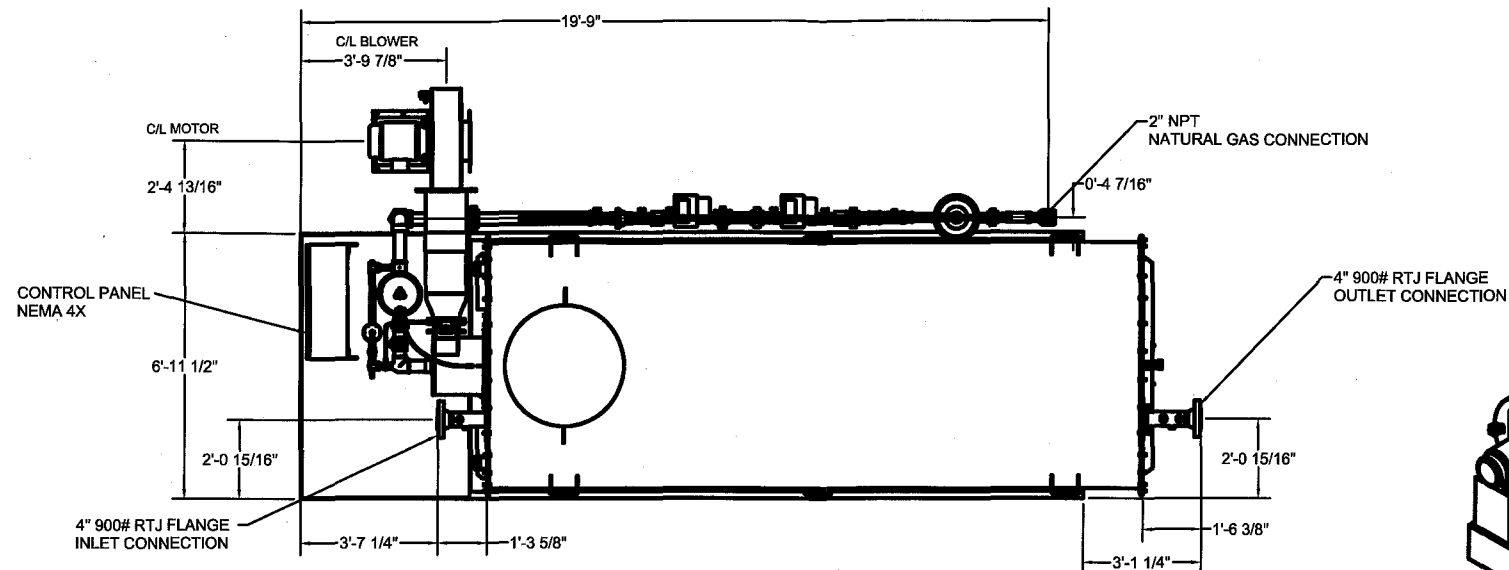

APPROVED FOR CONSTRUCTION

THOMAS RUSSELL CO. PO: 250-13
 TRCO. JOB NUMBER: TRJ-250
 TAG NUMBER: H-741
 REGEN GAS HEATER

CUSTOMER: THOMAS RUSSELL	JOB: HI 11-038
DRAWING NAME: GENERAL ARRANGEMENT HCI 5010-40-G	WOP: 11-038-000 ISSUE DATE:
HEATEC INC. <i>an Astec company</i>	
P.O. BOX 72760 CHATTANOOGA, TN 37407	PHONE: (423) 821-8200 FAX: (423) 821-7873
PRG. DATE: 02-04-2011 MRP	CHK. DATE:
PRG. PART: 11038 - GA	APPR. DATE:
REV.:	SCALE: WEIGHT:
0	NA NA
TOLERANCE IS +/- 1/16" UNLESS OTHERWISE NOTED.	
THIS DRAWING AND THE DESIGN SHOWN THEREIN IS THE PROPERTY OF HEATEC INC. AND THE USE OR COPIES THEREOF CANNOT BE MADE WITHOUT WRITTEN CONSENT.	

NOTES:

1. FUEL TYPE: NATURAL GAS
 2. MAXIMUM BURNER INPUT: 9.5 MMBTU/hr*
 3. MINIMUM BURNER INPUT: 500,000 BTU/hr
 4. AIR INLET PRESSURE: 28.7" W.C.*
 5. INLET GAS PRESSURE @ RATIO REGULATOR: 55.4-110" W.C.
 6. VOLTAGE: N/A
 7. ACTUATOR IS SUPPLIED AND INSTALLED BY OTHERS, ECLIPSE IS TO PROVIDE BRACKET KIT FOR HONEYWELL ACTUATOR (MODEL M7284C-1000 OR SIMILAR).
 8. UV SCANNER IS SUPPLIED AND INSTALLED BY OTHERS.
 9. FOLLOWING ITEMS WILL BE SHIPPED LOOSE WITH THIS ORDER.
 - a) SMJ10.202769_1-202AA32X BLOWER, SMJ, V1.0, CONFIGURED PRODUCT
 - b) 302050-4 ORIFICE, METERING, 3 in. STRIPPED, 1.781 DIAMETER
 - c) 302054 KIT, FLANGE, 3 in. 12fom
 - d) 302053 KIT, FLANGE, 3/4 in. THRU 3 in. METERING ORIFICE
 - e) 100205-22 IGNITER, SELF-GROUNDING, 590mm LONG, 1/2 in. NPT
- * VALUES ARE BASED ON OPERATING CONDITION @70°F & 2000 Feet ASL.

Per Heatec, Built for Nox= 40 ppm and CO= 50 ppm

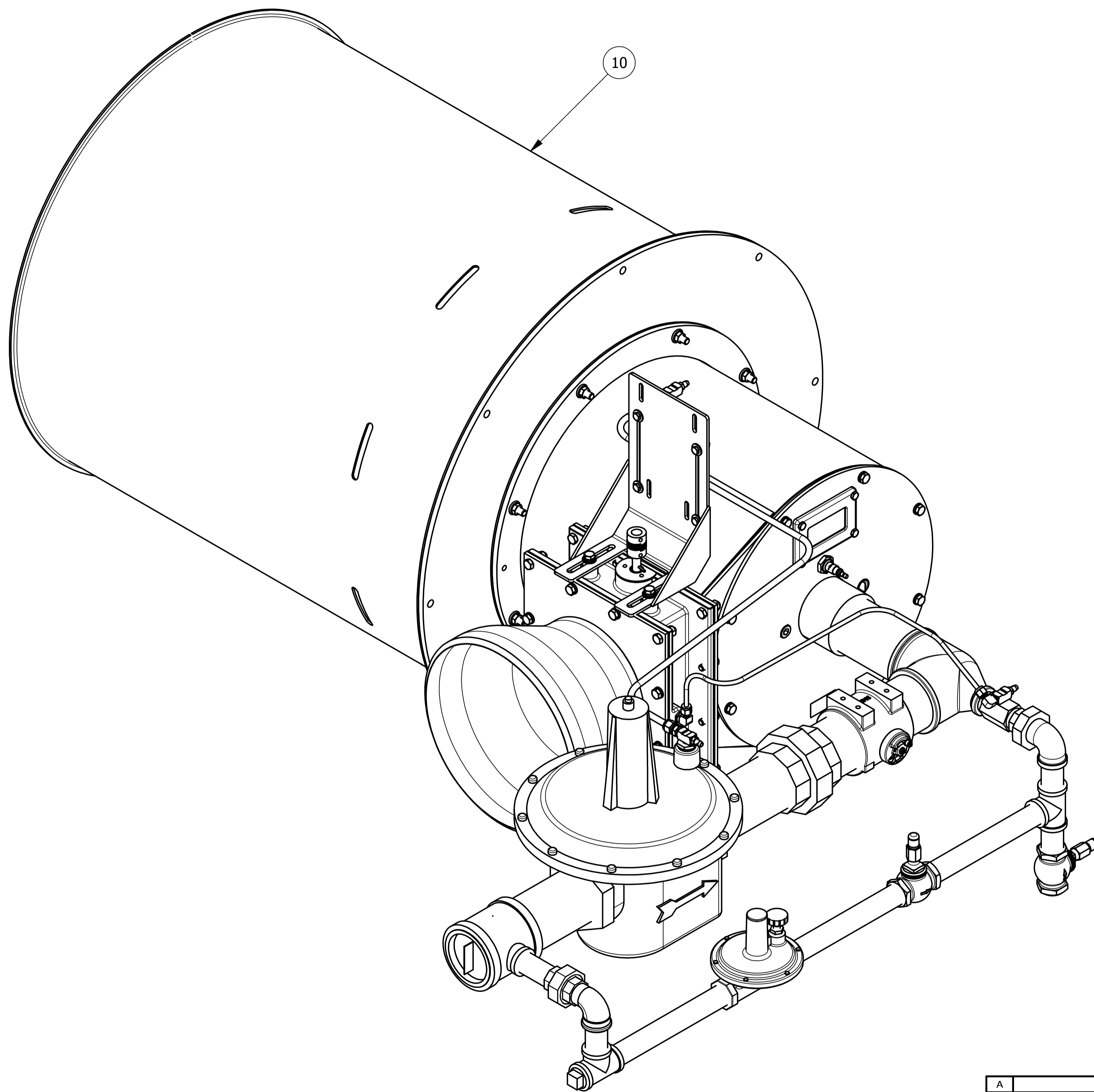

Parts List			
ITEM	QTY	PART NUMBER	DESCRIPTION
10	1	PRJ10057834	Burner, Winnox 0850, Natural Gas, Horizontal Firing, L.H. Piping, 9 O'Clock Weld

A	MOD106710	06/23/2011	DJV/HSK
REV	DESCRIPTION	DATE	APPROVED

REVISION HISTORY			
<small>THE INFORMATION HEREON IS THE PROPERTY OF ECLIPSE. WITHOUT WRITTEN PERMISSION ANY COPYING, TRANSMITTAL TO OTHERS, AND ANY USE EXCEPT THAT FOR WHICH IT IS LOANED, IS PROHIBITED.</small>			

Burner, Winnox 0850, Natural Gas, Customer Level, Horizontal Firing, L.H. Piping

SHIPPING INFORMATION	
WEIGHT:	814 Lbs [370 Kg]
LENGTH:	1892 [74.5]
WIDTH:	1438 [56.6]
HEIGHT:	871 [34.3]

THIRD ANGLE PROJECTION	SIZE A1	DWG NO	PRJ10057833
SCALE: NONE		REF: PRJ10057667	UNITS: mm[in] SHEET 1 OF 2

12 11 10 9 8 7 6 5 4 3 2 1

H
G
F
E
D
C
B
A

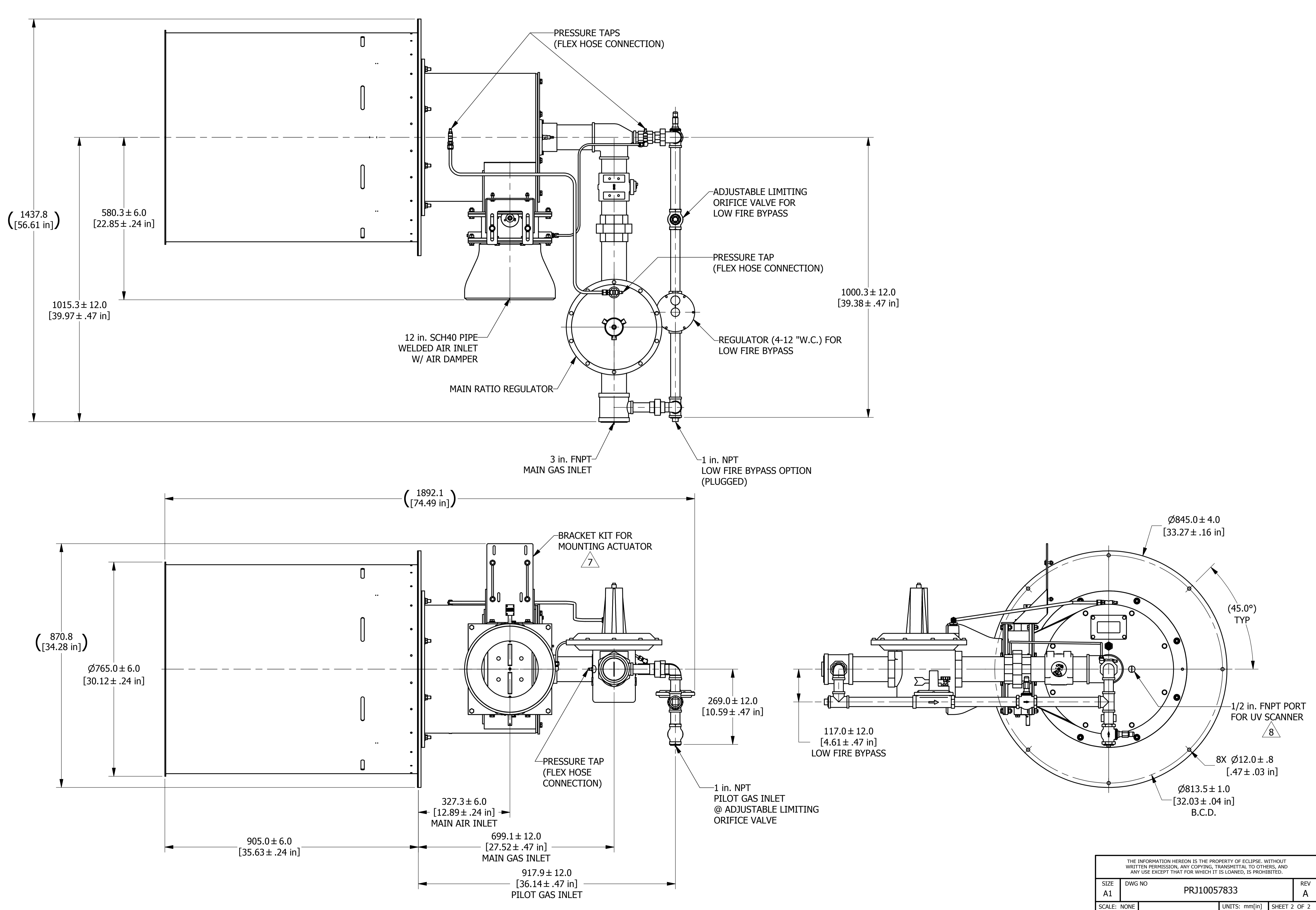

THE INFORMATION HEREON IS THE PROPERTY OF ECLIPSE. WITHOUT WRITTEN PERMISSION, ANY COPYING, TRANSMITTAL TO OTHERS, AND ANY USE EXCEPT THAT FOR WHICH IT IS LOANED, IS PROHIBITED.		
SIZE A1	DWG NO PRJ10057833	REV A
SCALE: NONE	UNITS: mm[in]	SHEET 2 OF 2

12 11 10 9 8 7 6 5 4 3 2 1

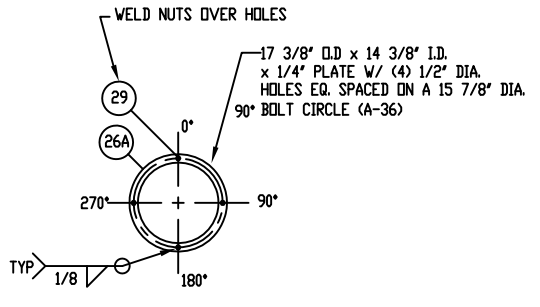
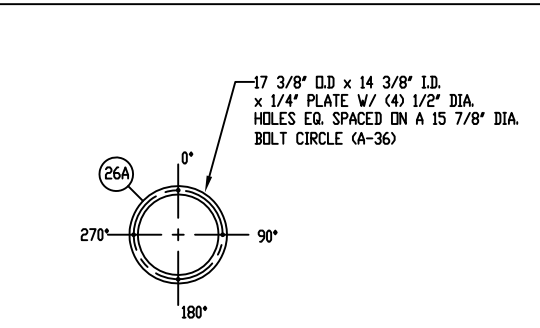
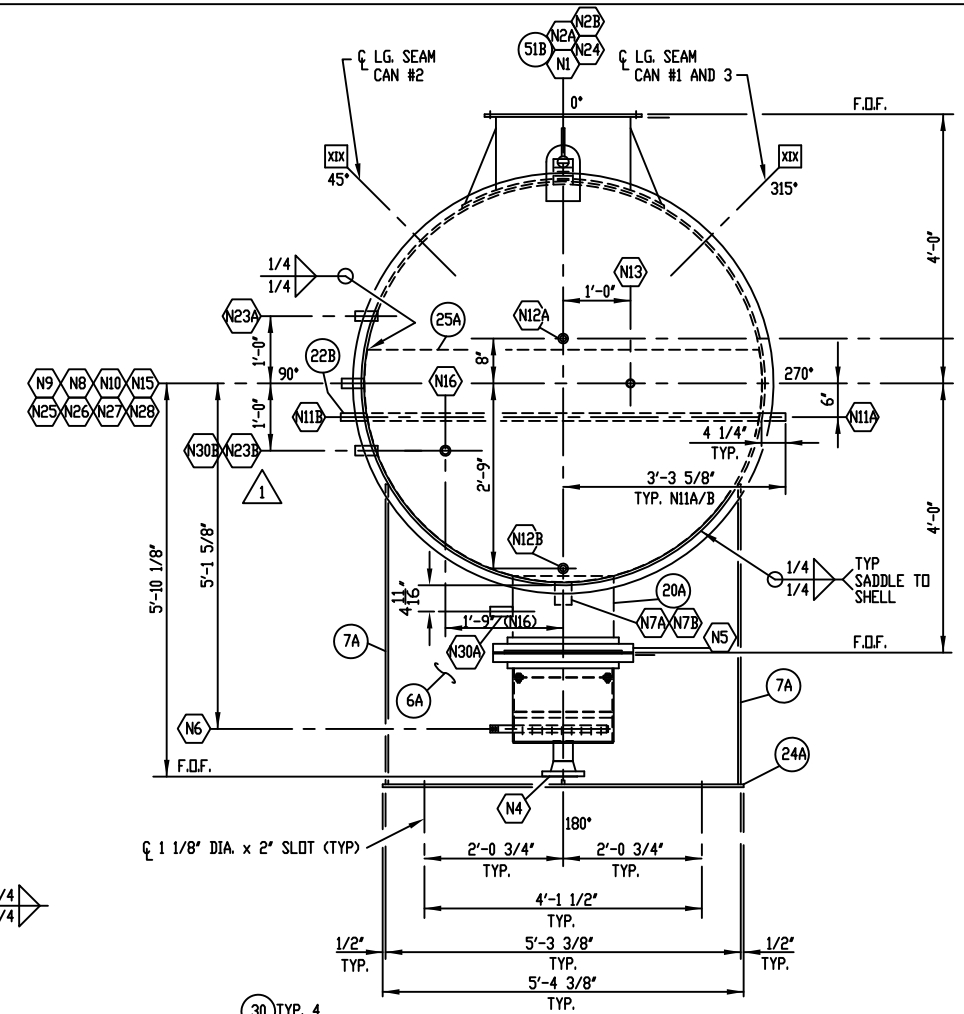
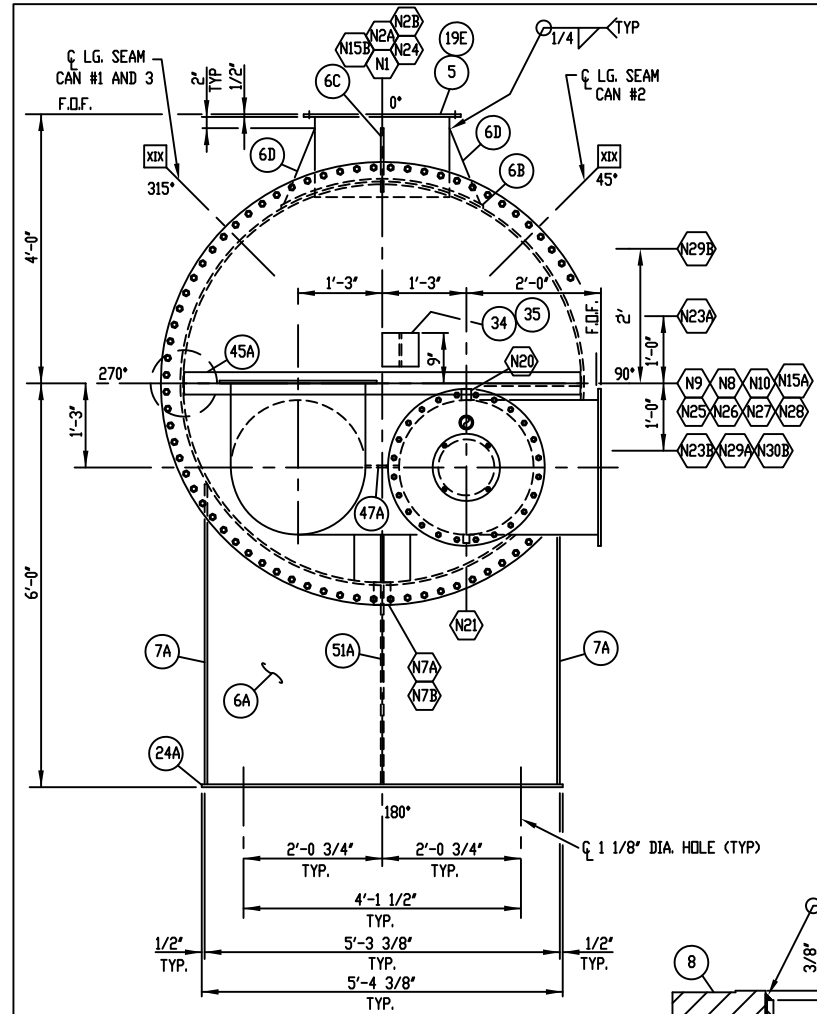

VIEW "A-A"
FROM SHT. 1

VIEW "B-B"
FROM SHT. 1

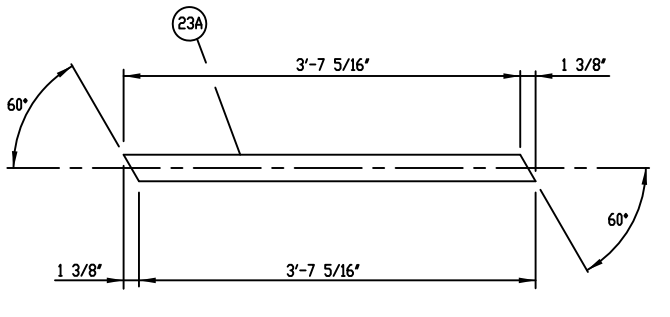
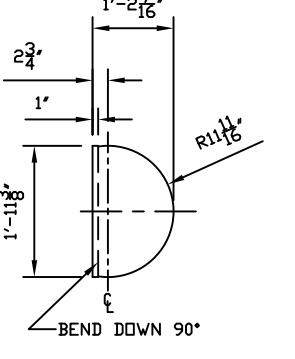
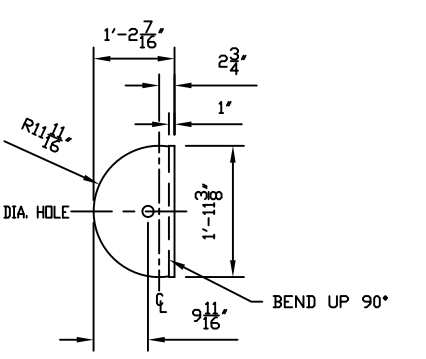
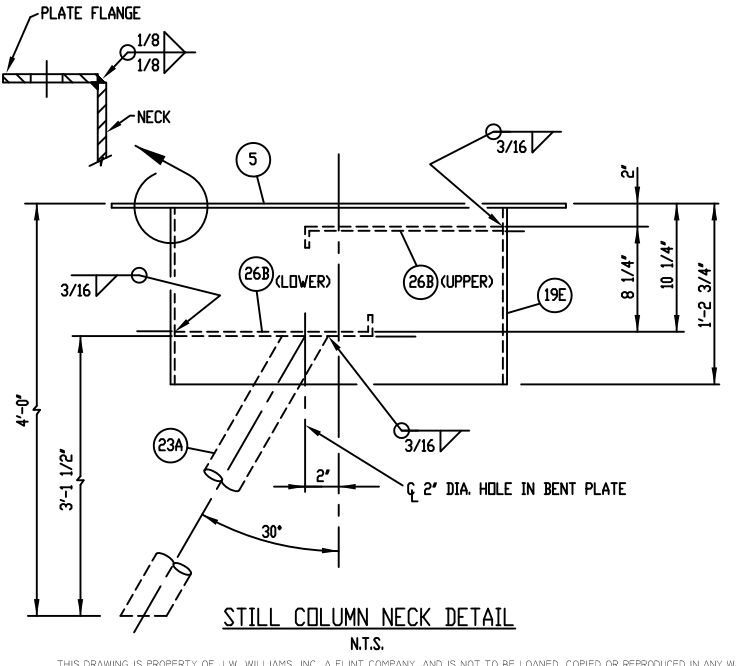
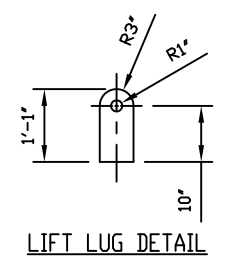
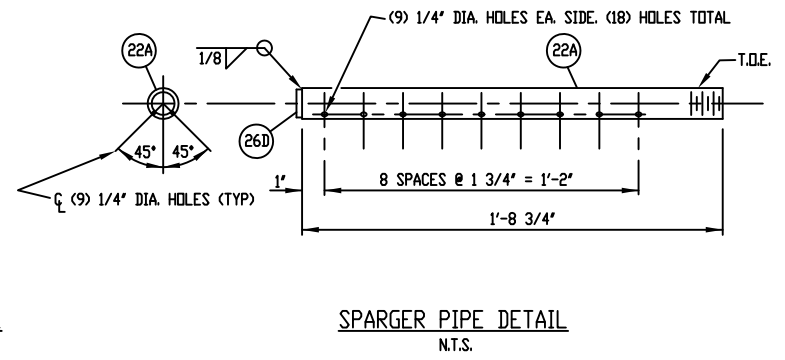
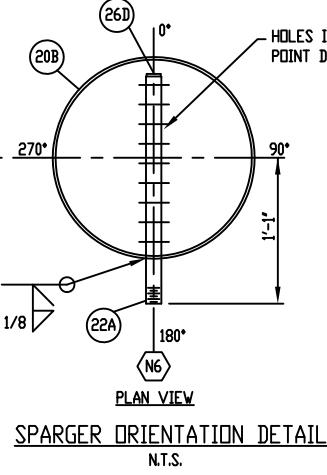
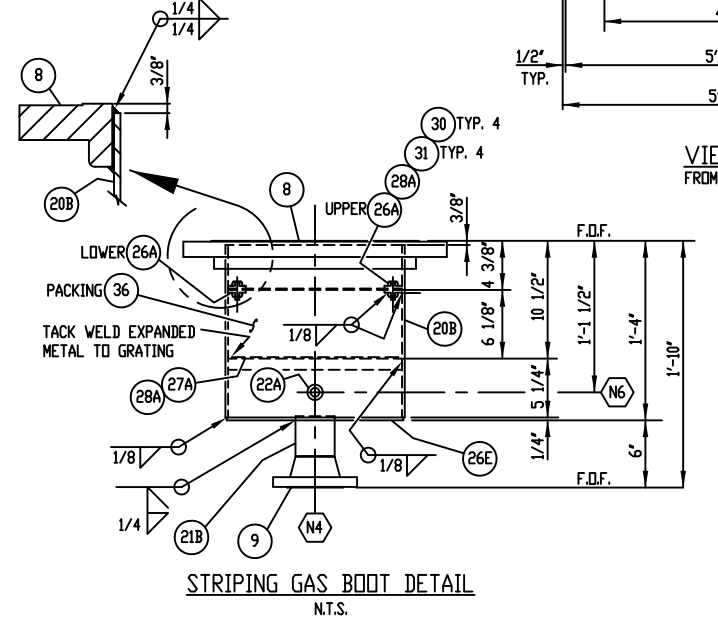
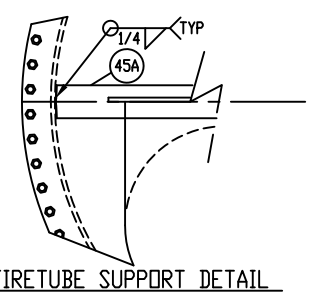

MATERIAL CUT LIST				
ITEM	QTY	SERVICE	DESCRIPTION	SPEC
6A	2	SADDLE	PLATE, 1/2" x 4'-5 1/2" x 5'-2 3/8" LG.	SA-36
6B	1	NI PAD	PLATE, 1/2" x 3'-0" O.D. x 2'-0 1/8" I.D.	SA-36
6C	2	NI GUSSET	PLATE, 1/2" x 5 1/2" x 9" LG.	SA-36
6D	2	NI GUSSET	PLATE, 1/2" x 5 1/2" x 1'-1 1/2" LG.	SA-36
7A	4	SADDLE	FLATBAR, 1/2" x 8" x 4'-5 1/2" LG.	SA-36
19A	1	FIRETUBE	PIPE, 24" S/10 (25" W.T.) x 29'-5 5/8" LG. P.B.E.	SA-53-E/B
19B	1	FIRETUBE	PIPE, 24" S/10 (25" W.T.) x 4'-6" LG. P.B.E.	SA-53-E/B
19C	1	FIRETUBE	PIPE, 24" S/10 (25" W.T.) x 27'-7 1/8" LG. P.B.E.	SA-53-E/B
19D	1	FIRETUBE	PIPE, 24" S/10 (25" W.T.) x 9'-11" LG. P.B.E.	SA-53-E/B
19E	1	NI	PIPE, 24" S/10 (25" W.T.) x 1'-2 1/4" LG. P.B.E.	SA-53-E/B
19F	1	STACK	PIPE, 24" S/10 (25" W.T.) x 13'-11 1/2" LG. P.B.E.	SA-53-E/B
19G	1	STILL CLMN	PIPE, 24" S/10 (25" W.T.) x 9'-11" LG. P.B.E.	SA-53-E/B
19H	1	FIRETUBE	PIPE, 24" S/10 (25" W.T.) x 1'-11 1/2" LG. P.B.E.	SA-53-E/B
20A	1	N5	PIPE, 18" S/10 (25" W.T.) x 1'-1 3/8" LG. P.B.E.	SA-53-E/B
20B	1	N5	PIPE, 18" S/10 (25" W.T.) x 1'-3 3/8" LG. P.B.E.	SA-53-E/B
21A	2	N2A/B	PIPE, 3" S/40 (216" W.T.) x 4 3/4" LG. T.D.E., P.D.E.	SA-106-B
21B	2	N3A/B	PIPE, 3" S/40 (216" W.T.) x 3 5/8" LG. B.D.E., P.D.E.	SA-106-B
22A	1	N6	PIPE, 1" S/80 (179" W.T.) x 1'-8 3/4" LG. T.D.E., P.D.E.	SA-106-B
22B	1	N1A/B	PIPE, 1" S/80 (179" W.T.) x 6'-7 5/16" LG. T.B.E.	SA-106-B
23A	1	STILL CLMN	PIPE, 2" S/80 (218" W.T.) x 3'-7 5/16" LG. P.B.E.	SA-106-B
23B	1	IGNITOR	PIPE, 2" S/80 (218" W.T.) x 6 3/8" LG. T.D.E., P.D.E.	SA-106-B
23C	2	REFLUX COIL	PIPE, 2" S/80 (218" W.T.) x 3'-10 15/16" LG. B.B.E.	SA-106-B
23D	18	REFLUX COIL	PIPE, 2" S/80 (218" W.T.) x 2'-0" LG. B.B.E.	SA-106-B
23E	1	PEEP SIGHT	PIPE, 2" S/80 (218" W.T.) x 4" LG. T.D.E. x P.D.E.	SA-106-B
24A	1	BASE	FLATBAR, 1/2" x 10" x 5'-4 3/8" LG.	SA-36
24B	1	FIRETUBE SUPPORT	FLATBAR, 1/2" x 10" x 9 1/2" LG.	SA-36
24C	1	BASE	FLATBAR, 1/2" x 10" x 5'-4 3/8" LG.	SA-36
25A	1	WEIR	PLATE, 3/8" x 3'-5 11/16" x 5'-11 3/8"	SA-36
26A	2	BOOT RING	PLATE, 1/4" x 1'-5 3/8" O.D. x 1'-2 3/8" I.D.	SA-36
26B	2	STILL CLMN RING	PLATE, 1/4" x 1'-11 3/8" O.D. x 1'-2 7/16" I.D.	SA-36
26C	2	STILL CLMN RING	PLATE, 1/4" x 1'-11 3/8" O.D. x 1'-8 3/8" I.D.	SA-36
26D	1	N6	PLATE, 1/4" x 1 1/4" DIA.	SA-36
26E	1	BOOT	PLATE, 1/4" x 1'-5 3/4" O.D. x 3 5/8" I.D.	SA-36
26F	1	FIRETUBE	PLATE, 1/4" x 12" O.D.	SA-36
27A	1	STEEP GAS BOOT	GRATING, 1" x 3/16" x 1'-5 3/8" O.D.	SA-36
27B	2	STILL CLMN BOOT	GRATING, 1" x 3/16" x 1'-11 3/8" O.D.	SA-36
28A	2	STEEP GAS BOOT	EXPANDED METAL, 3/4" 9GA, FLAT x 1'-5 1/4" O.D.	SA-36
28B	2	STILL CLMN BOOT	EXPANDED METAL, 3/4" 9GA, FLAT x 1'-11 1/4" O.D.	SA-36
33A	1	N14	PIPE, 6" S/40 (280" W.T.) x 3 3/8" LG. SMLS B.D.E. x P.D.E.	SA-36
45A	1	FIRETUBE SUPPORT	CHANNEL, 4" X 5.4#, X 70-0 3/4" LG.	SA-36
47A	1	FIRETUBE	FLATBAR, 6" x 1/4" x 10'-0" LG.	SA-36
51A	2	SADDLE	FLATBAR, 1/2" x 6" x 2'-11 1/2" LG.	SA-36
51B	1	LIFT LUG	FLATBAR, 1/2" x 6" x 1'-1" LG.	SA-36

REVISION				
REV	DATE	BY	DESCRIPTION	
A	8-10-11	RC	ISSUED FOR APPROVAL	
<p>J.W. WILLIAMS INC. <small>a FLINTY Company</small> FABRICATION & FIELD SERVICE</p>				
<p>30MM BTU/HR REBOILER WITH STRIPPING GAS 72" O.D. x 30'-0"</p>				
REV	DATE	BY	DESCRIPTION	
1	SEPT2011	27366	CHK: GF	DATE: 8/11/11
QTY	DATE	JOB	SCALE	N.T.S.
			SHEET: 2 OF 5	DATE: 8/11/11
				DWG NO: 72-30-RB-SOUTH TEX
				REV: A

THIS DRAWING IS PROPERTY OF J.W. WILLIAMS, INC. A FLINTY COMPANY, AND IS NOT TO BE LOANED, COPIED OR REPRODUCED IN ANY WAY WITHOUT THE WRITTEN CONSENT OF J.W. WILLIAMS, INC.

THOMAS RUSSELL CO.
Tulsa, Oklahoma

JOB NO: 250
CLIENT: TRCo.
SUBJECT: 200 MMscfd Cryo Plant

DATE: 9/21/2010
BY: JRG

FIRED HEATER

Service: HMO Heater for E-207		Tag No: H-781	
Design Duty, MBTU/Hr 17,400		Type: Helical Coil	
No. of Coils per Unit One	No. Units: One	Model: HCI-10010-40(D)-G	
Fluid	50:50 TEG - Water		Burners
	Inlet	Outlet	Gas Oil
Liquids Lbs/Hr	333,142	333,142	LHV (BTU/scf) 973
Density Lbs/CuFt	64.15	62.56	Mol. Wt. 18.26
Molecular Weight	32.17	32.17	Gravity
Specific Heat BTU/Lb °F	0.859	0.882	Pressure Avail. (psig) 100
Thermal Cond. BTU/Hr-Ft-°F	0.223	0.220	Pressure Req'd (psig)
Viscosity cP	1.186	0.831	Steam for Atomizing
Vapor Lbs/Hr	0	0	Fuel Gas Req'd (MSCFD) 539.10 N/A
Density Lbs/CuFt			Mfr: Eclipse Ratiomatic
Molecular Weight			Type: Forced Draft - 40 HP Blower
Specific Heat BTU/Lb °F			Number Req'd One
Thermal Cond. BTU/HrFt °F			Pilots Req'd (Note 4) Yes, electrical ignition
Viscosity cP			NOx < 75 ppmvd
Operating Temp. °F	195	255	Structural Design
Operating Pressure PSIA	90		Wind Load, MPH, (3)
Velocity Ft/Sec		8 Calc.	Seismic Zone, (3)
Pressure Drop PSI	20 Allow.	17 Calc.	Ambient, °F -20 / 110
Fouling Resistance SqFt°F/BTU	0.0020		Elevation, Ft 1300
Design Press. / Temp.	150 PSIG	400 °F	Stack Design
Min. Design Mtl. Temp.	-20 °F @	150 PSIG	Self-supporting Yes
Corrosion Allowance	0.125		Minimum Height 8 ft above top of heater
Insulation Thickness	3-5" high temp ceramic fiber		Minimum Wall Thickness: 0.125
Efficiency-Based on LHV (%)	82.0%	(Assume 3% Loss)	Lining Type No
Excess Air	15		Lining Thickness: No
Firebox Unit Heat Release	28,834	BTU/Hr- Ft³	Damper: No
Number of Passes	Two - Process, Two - Fireside		
Coil Design	Radiant	Convection-Bare	Convection-Finned
Gas Temperature In/Out	195 / 255		
Number Tubes	Two		
Tube O.D. In	4" Sch 40		
Tube Length Eff. Ft	-----		
Bare Surface Sq Ft	1,453		
Finned Surface Sq Ft	N/A		
Avg. Heat Flux BTU/Hr-Sq Ft	15,235		
Tube Materials	SA- 106 Gr. B		
Convection Fins (Inch):	Height:	Thickness:	No. / inch: Material:
Overall Dimension:	25.9' L x 9.2' W x 10' H (Less Stack)		30,000 lbs Dry Weight
Code Requirements:	ASME VIII Div I		Stamp: Yes Nat'l Board: Yes
Notes:	1) Add 10% to duty and flow rates for design. 2) See attached Scope of Supply. Δ 3) Wind design per ASCE 7-10, Exposure C, CATIII. Seismic design per ASCE 7-10, I=1.25, Site D. , S _S =40% , S ₁ =8% 4) Add Spare ignitor		
REVISION	3	Δ 4	1 2
ENGINEER/DATE	JRG 1/11/11	MTR 9/20/11	GER 11/22/10 JRG 1/10/11
ISSUED FOR	Revised - Purchase		Revised Revised

HEATER DESIGN DATA

INPUT: 26,318,977 BTU/HR
 OUTPUT: 19,161,995 BTU/HR
 FLOW RATE: 712 GPM
 TRANSFER MEDIA: 50/50 TEG/WATER
 HEATING SURFACE: 1,453 SQFT
 DESIGN: 150 PSIG @ 400 DEG F
 ASME CODE: SECT VIII, DIV. 1 2010 EDITION w/ NO ADDENDA
 OUTLET MEDIA TEMPERATURE: 255 DEG F
 LIQUID FILL: 812 GALLONS
 PRESSURE DROP: 20 PSIG

APPROX. SHIPPING WEIGHT:

HEATER DRY WT: 33,000 LBS
 HEATER OPER. WT: 41,000 LBS
 PUMP/TANK SKID DRY WT: 9,110 LBS
 PUMP/TANK SKID OPER. WT: 17,000 LBS
 TOTAL OPER. WEIGHT OF HEATER/PUMP SKID: 58,000 LBS

HEATEC ORDER INFO	HEATEC ORDER INFO	HEATEC ORDER INFO	HEATEC ORDER INFO
W.O.# 11-077-151	W.O.# 11-127-151	W.O.# 11-143-151	
JOB# HI 11-077	JOB# HI 11-127	JOB# HI 11-143	
ISSUE DATE:	ISSUE DATE:	ISSUE DATE:	
CODE: <input type="checkbox"/> YES <input type="checkbox"/> NO	CODE: <input type="checkbox"/> YES <input type="checkbox"/> NO	CODE: <input type="checkbox"/> YES <input type="checkbox"/> NO	
HEATEC ORDER INFO	HEATEC ORDER INFO	HEATEC ORDER INFO	HEATEC ORDER INFO
W.O.# 11-041-151	W.O.# 11-095-151	W.O.# 11-129-151	W.O.# 11-145-151
JOB# HI 11-041	JOB# HI 11-095	JOB# HI 11-129	JOB# HI 11-145
ISSUE DATE:	ISSUE DATE:	ISSUE DATE:	ISSUE DATE:
CODE: <input type="checkbox"/> YES <input type="checkbox"/> NO	CODE: <input type="checkbox"/> YES <input type="checkbox"/> NO	CODE: <input type="checkbox"/> YES <input type="checkbox"/> NO	CODE: <input type="checkbox"/> YES <input type="checkbox"/> NO

THOMAS RUSSELL CO. PO. 251-76 PROJECT NAME: TRCO JOB NUMBER: TRJ 251 TAG NUMBER: H-781 HMO HEATER HEATEC JOB NUMBER: HI 11-077	THOMAS RUSSELL CO. PO. 257-76 PROJECT NAME: TRCO JOB NUMBER: TRJ 257 TAG NUMBER: H-781 HMO HEATER HEATEC JOB NUMBER: HI 11-127	THOMAS RUSSELL CO. PO. 262-76 PROJECT NAME: TRCO JOB NUMBER: TRJ 262 TAG NUMBER: H-781 HMO HEATER HEATEC JOB NUMBER: HI 11-143	THOMAS RUSSELL CO. PO. 262-76 PROJECT NAME: TRCO JOB NUMBER: TRJ 262 TAG NUMBER: H-781 HMO HEATER HEATEC JOB NUMBER: HI 11-143
THOMAS RUSSELL CO. PO. 250-76 PROJECT NAME: TRCO JOB NUMBER: TRJ 250 TAG NUMBER: H-781 HMO HEATER HEATEC JOB NUMBER: HI 11-041	THOMAS RUSSELL CO. PO. 252-76 PROJECT NAME: TRCO JOB NUMBER: TRJ 252 TAG NUMBER: H-781 HMO HEATER HEATEC JOB NUMBER: HI 11-095	THOMAS RUSSELL CO. PO. 260-76 PROJECT NAME: TRCO JOB NUMBER: TRJ 260 TAG NUMBER: H-781 HMO HEATER HEATEC JOB NUMBER: HI 11-129	THOMAS RUSSELL CO. PO. 259-76 PROJECT NAME: TRCO JOB NUMBER: TRJ 259 TAG NUMBER: H-781 HMO HEATER HEATEC JOB NUMBER: HI 11-145

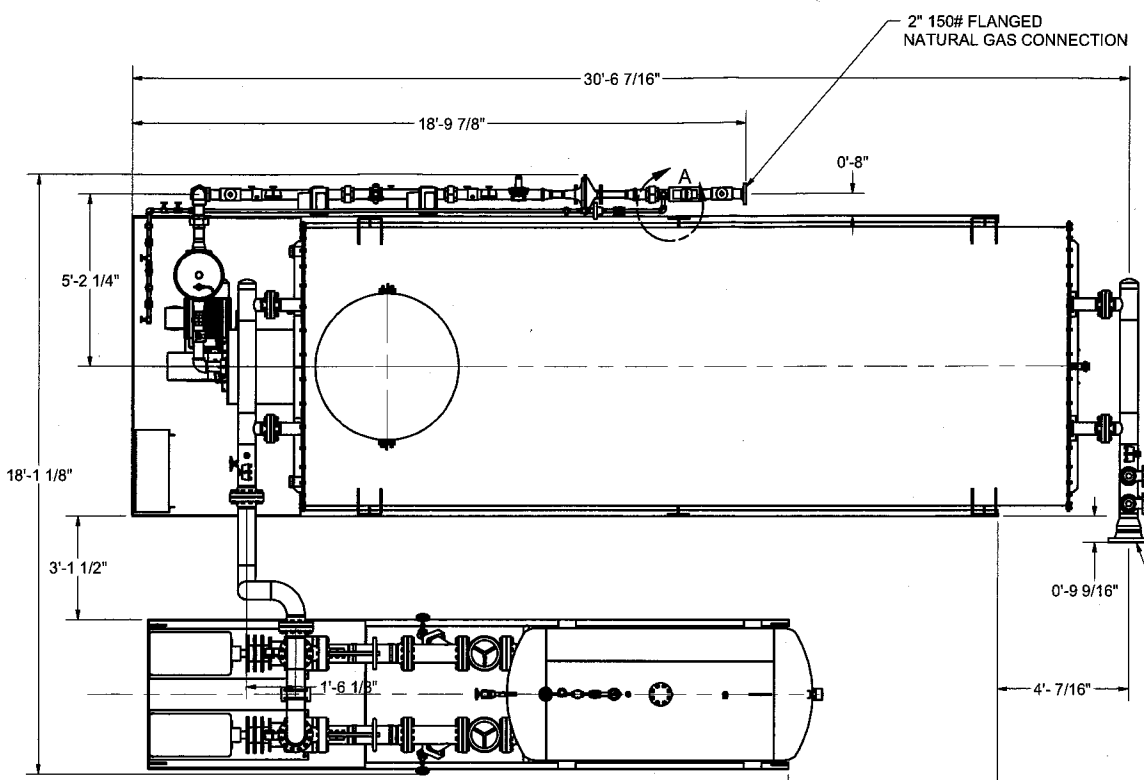

TOP VIEW
SCALE 1/35

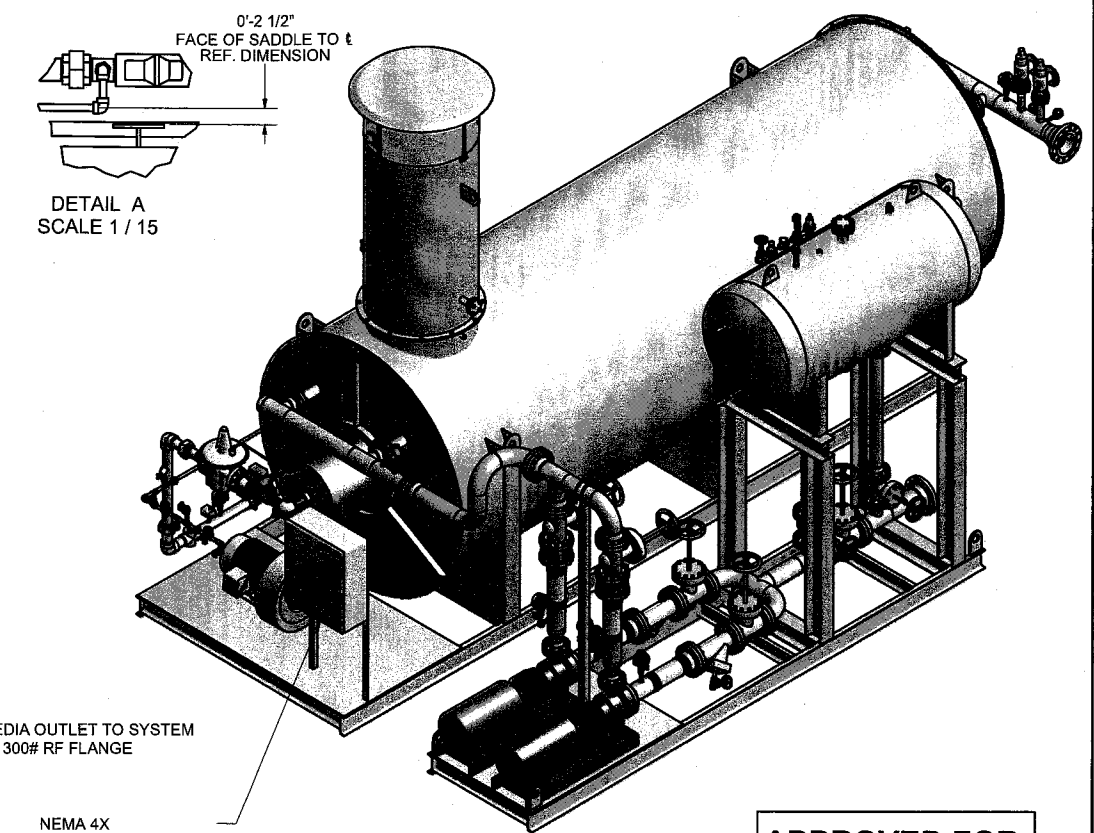

APPROVED FOR CONSTRUCTION

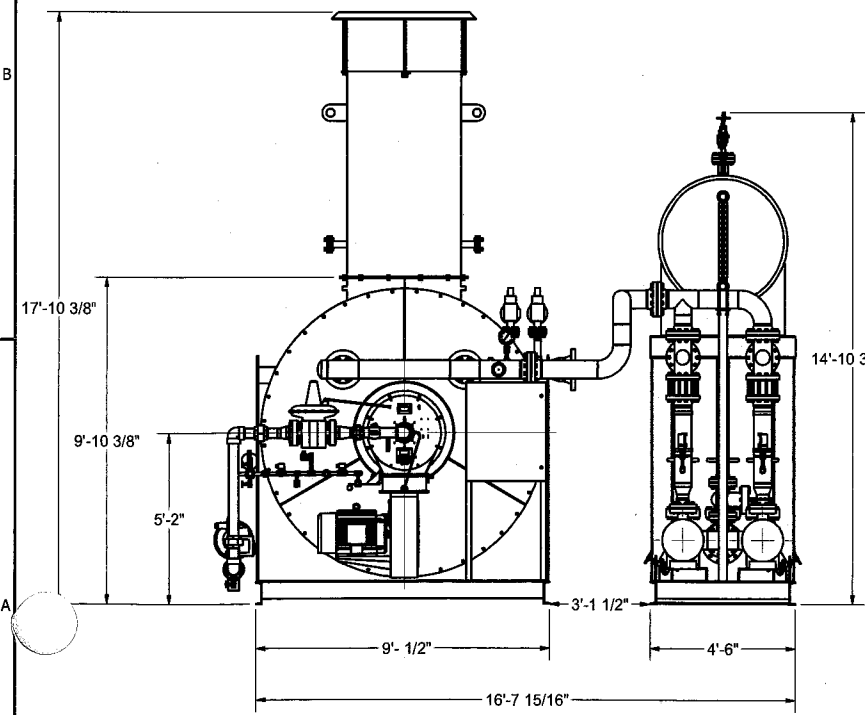

FRONT VIEW
SCALE 1/35

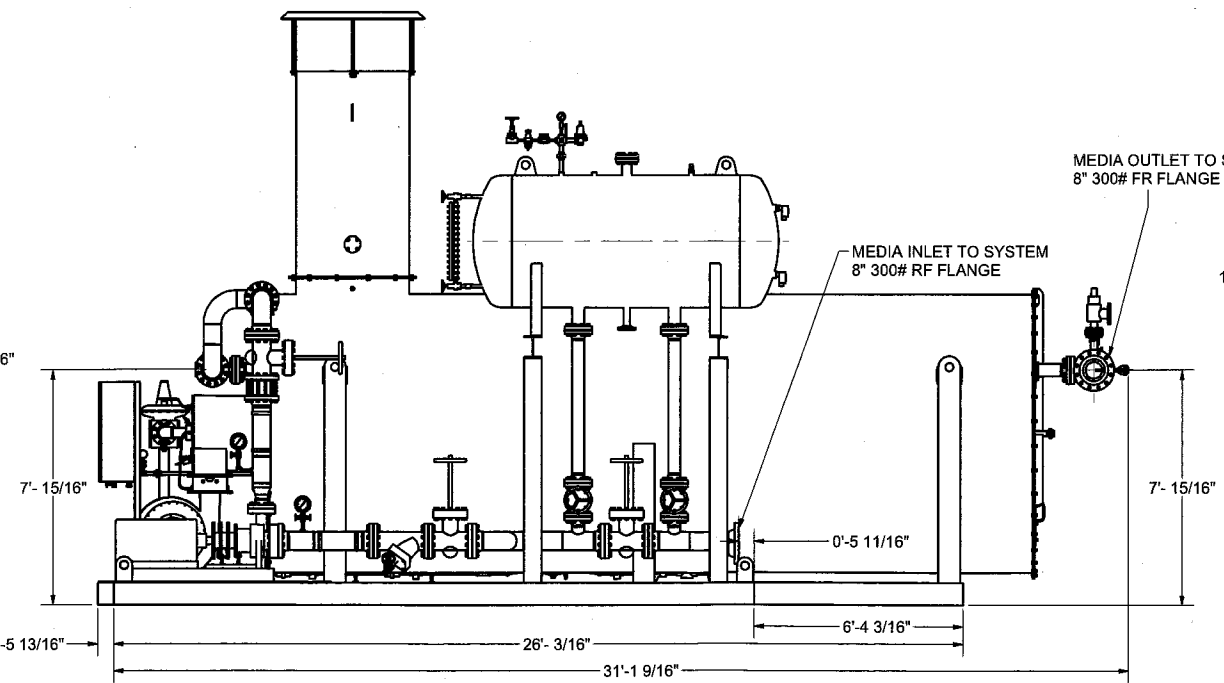

RIGHT SIDE VIEW
SCALE 1/35

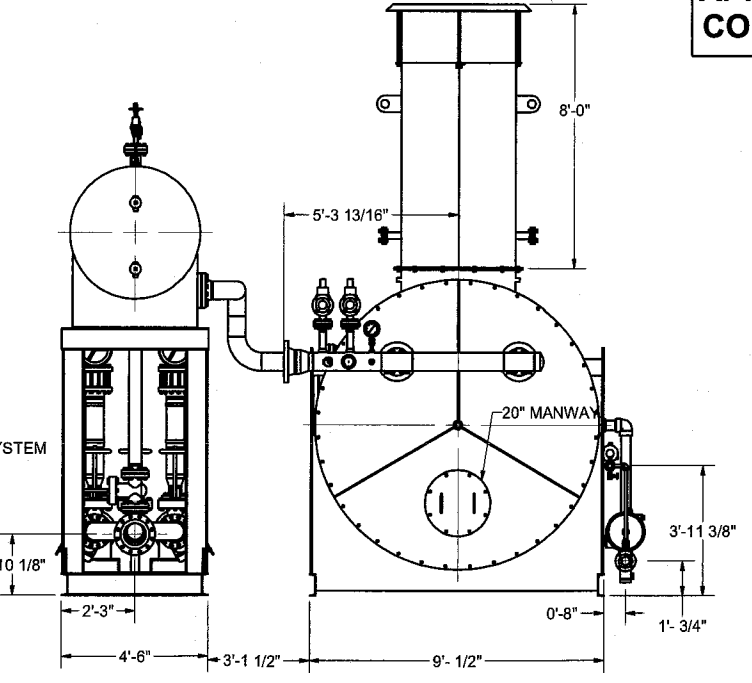

REAR VIEW
SCALE 1/35

CUSTOMER: THOMAS RUSSEL	JOB#: SEE TAGS
DRAWING NAME: GENERAL ARRANGEMENT HCI 10010-40-D-G	WOP: SEE TAGS
	ISSUE DATE:
HEATEC INC. an Asco company	
P.O. BOX 72760 CHATTANOOGA, TN 37407	PHONE: (423) 821-5200 FAX: (423) 821-7873
DWG. DATE: 06/11/11 TMM	CHK. DATE:
DWG. PART#: 11077-GA	APP. DATE:
REV. 0	SCALE: WEIGHT: NA NOTED
TOLERANCE IS +/- 1/4" UNLESS OTHERWISE NOTED.	
THIS DRAWING AND THE DESIGN SHOWN HEREIN IS THE PROPERTY OF HEATEC INC. AND THE USE OR COPIES THEREOF CANNOT BE MADE WITHOUT WRITTEN CONSENT.	

- NOTES:**
1. FUEL TYPE: NATURAL GAS
 2. MAXIMUM BURNER INPUT: 26.5 MMBTU/hr
 3. MINIMUM BURNER INPUT: 260,000 BTU/hr
 4. AIR INLET PRESSURE: 22.0 " W.C.
 5. MAIN GAS INLET MAX DESIGN PRESSURE: 5.0 PSI MAX.
 6. VOLTAGE: 230V/460V/3Ph/60Hz

Parts List			
ITEM	QTY	PART NUMBER	DESCRIPTION
10	1	PRJ10056395	Burner, Ratiomatic, RM3000, Natural Gas, Horizontal Firing, Inverted Left Hand B

Per Heatec, Built for Nox 75 ppm, CO 100 ppm

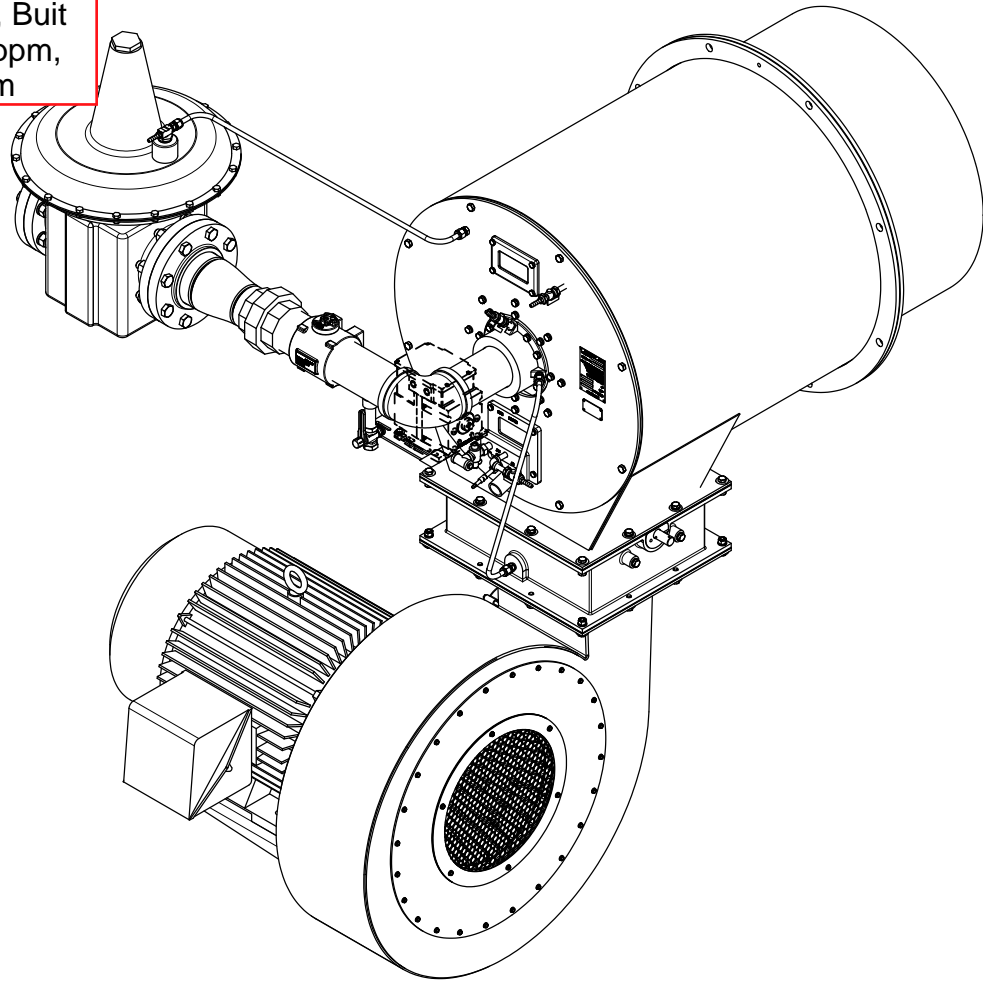

A	MOD106469	04/04/2011	CS/HSK
REV	DESCRIPTION	DATE	APPROVED

REVISION HISTORY

THE INFORMATION HEREON IS THE PROPERTY OF ECLIPSE. WITHOUT WRITTEN PERMISSION ANY COPYING, TRANSMITTAL TO OTHERS, AND ANY USE EXCEPT THAT FOR WHICH IT IS LOANED, IS PROHIBITED.

ECLIPSE

Burner, Ratiomatic, RM3000, Customer Level, Natural Gas, Horizontal Firing, Inve

SHIPPING INFORMATION	
WEIGHT:	440 Kg [968 Lbs]
LENGTH:	1570 mm [61.8 in]
WIDTH:	1456 mm [57.3 in]
HEIGHT:	1809 mm [71.2 in]

THIRD ANGLE PROJECTION	SIZE A1	DWG NO PRJ10056396
SCALE: NONE		REF: PRJ10055865 UNITS: mm(in) SHEET 1 OF 2

ELECTRONIC CODE OF FEDERAL REGULATIONS

e-CFR data is current as of August 23, 2017

Title 40 → Chapter I → Subchapter C → Part 98 → Subpart C → Appendix

Title 40: Protection of Environment
 PART 98—MANDATORY GREENHOUSE GAS REPORTING
 Subpart C—General Stationary Fuel Combustion Sources

TABLE C-1 TO SUBPART C OF PART 98—DEFAULT CO₂ EMISSION FACTORS AND HIGH HEAT VALUES FOR VARIOUS TYPES OF FUEL

[Link to an amendment published at 81 FR 89252, Dec. 9, 2016.](#)

DEFAULT CO₂ EMISSION FACTORS AND HIGH HEAT VALUES FOR VARIOUS TYPES OF FUEL

Fuel type	Default high heat value	Default CO ₂ emission factor
Coal and coke		kg CO ₂ /mmBtu
	mmBtu/short ton	
Anthracite	25.09	103.69
Bituminous	24.93	93.28
Subbituminous	17.25	97.17
Lignite	14.21	97.72
Coal Coke	24.80	113.67
Mixed (Commercial sector)	21.39	94.27
Mixed (Industrial coking)	26.28	93.90
Mixed (Industrial sector)	22.35	94.67
Mixed (Electric Power sector)	19.73	95.52
Natural gas		kg CO ₂ /mmBtu
	mmBtu/scf	
(Weighted U.S. Average)	1.026 × 10 ⁻³	53.06
Petroleum products		kg CO ₂ /mmBtu
	mmBtu/gallon	
Distillate Fuel Oil No. 1	0.139	73.25
Distillate Fuel Oil No. 2	0.138	73.96
Distillate Fuel Oil No. 4	0.146	75.04
Residual Fuel Oil No. 5	0.140	72.93
Residual Fuel Oil No. 6	0.150	75.10
Used Oil	0.138	74.00
Kerosene	0.135	75.20
Liquefied petroleum gases (LPG) ¹	0.092	61.71
Propane ¹	0.091	62.87
Propylene ²	0.091	67.77
Ethane ¹	0.068	59.60
Ethanol	0.084	68.44
Ethylene ²	0.058	65.96
Isobutane ¹	0.099	64.94
Isobutylene ¹	0.103	68.86
Butane ¹	0.103	64.77
Butylene ¹	0.105	68.72
Naphtha (<401 deg F)	0.125	68.02
Natural Gasoline	0.110	66.88
Other Oil (>401 deg F)	0.139	76.22
Pentanes Plus	0.110	70.02
Petrochemical Feedstocks	0.125	71.02
Petroleum Coke	0.143	102.41
Special Naphtha	0.125	72.34
Unfinished Oils	0.139	74.54
Heavy Gas Oils	0.148	74.92
Lubricants	0.144	74.27
Motor Gasoline	0.125	70.22
Aviation Gasoline	0.120	69.25
Kerosene-Type Jet Fuel	0.135	72.22
Asphalt and Road Oil	0.158	75.36
Crude Oil	0.138	74.54
Other fuels—solid		kg CO ₂ /mmBtu
	mmBtu/short ton	
Municipal Solid Waste	9.95 ³	90.7
Tires	28.00	85.97
Plastics	38.00	75.00

Petroleum Coke	30.00	102.41
Other fuels—gaseous	mmBtu/scf	kg CO ₂ /mmBtu
Blast Furnace Gas	0.092×10^{-3}	274.32
Coke Oven Gas	0.599×10^{-3}	46.85
Propane Gas	2.516×10^{-3}	61.46
Fuel Gas ⁴	1.388×10^{-3}	59.00
Biomass fuels—solid	mmBtu/short ton	kg CO ₂ /mmBtu
Wood and Wood Residuals (dry basis) ⁵	17.48	93.80
Agricultural Byproducts	8.25	118.17
Peat	8.00	111.84
Solid Byproducts	10.39	105.51
Biomass fuels—gaseous	mmBtu/scf	kg CO ₂ /mmBtu
Landfill Gas	0.485×10^{-3}	52.07
Other Biomass Gases	0.655×10^{-3}	52.07
Biomass Fuels—Liquid	mmBtu/gallon	kg CO ₂ /mmBtu
Ethanol	0.084	68.44
Biodiesel (100%)	0.128	73.84
Rendered Animal Fat	0.125	71.06
Vegetable Oil	0.120	81.55

¹The HHV for components of LPG determined at 60 °F and saturation pressure with the exception of ethylene.

²Ethylene HHV determined at 41 °F (5 °C) and saturation pressure.

³Use of this default HHV is allowed only for: (a) Units that combust MSW, do not generate steam, and are allowed to use Tier 1; (b) units that derive no more than 10 percent of their annual heat input from MSW and/or tires; and (c) small batch incinerators that combust no more than 1,000 tons of MSW per year.

⁴Reporters subject to subpart X of this part that are complying with §98.243(d) or subpart Y of this part may only use the default HHV and the default CO₂ emission factor for fuel gas combustion under the conditions prescribed in §98.243(d)(2)(i) and (d)(2)(ii) and §98.252(a)(1) and (a)(2), respectively. Otherwise, reporters subject to subpart X or subpart Y shall use either Tier 3 (Equation C-5) or Tier 4.

⁵Use the following formula to calculate a wet basis HHV for use in Equation C-1: $HHV_w = ((100 - M)/100) * HHV_d$ where HHV_w = wet basis HHV, M = moisture content (percent) and HHV_d = dry basis HHV from Table C-1.

[78 FR 71950, Nov. 29, 2013]

[Need assistance?](#)

ELECTRONIC CODE OF FEDERAL REGULATIONS

e-CFR data is current as of August 23, 2017

[Title 40](#) → [Chapter I](#) → [Subchapter C](#) → [Part 98](#) → [Subpart C](#) → Appendix

Title 40: Protection of Environment

[PART 98—MANDATORY GREENHOUSE GAS REPORTING](#)

[Subpart C—General Stationary Fuel Combustion Sources](#)

TABLE C-2 TO SUBPART C OF PART 98—DEFAULT CH₄ AND N₂O EMISSION FACTORS FOR VARIOUS TYPES OF FUEL

[Link to an amendment published at 81 FR 89252, Dec. 9, 2016.](#)

Fuel type	Default CH ₄ emission factor (kg CH ₄ /mmBtu)	Default N ₂ O emission factor (kg N ₂ O/mmBtu)
Coal and Coke (All fuel types in Table C-1)	1.1×10^{-02}	1.6×10^{-03}
Natural Gas	1.0×10^{-03}	1.0×10^{-04}
Petroleum (All fuel types in Table C-1)	3.0×10^{-03}	6.0×10^{-04}
Fuel Gas	3.0×10^{-03}	6.0×10^{-04}
Municipal Solid Waste	3.2×10^{-02}	4.2×10^{-03}
Tires	3.2×10^{-02}	4.2×10^{-03}
Blast Furnace Gas	2.2×10^{-05}	1.0×10^{-04}
Coke Oven Gas	4.8×10^{-04}	1.0×10^{-04}
Biomass Fuels—Solid (All fuel types in Table C-1, except wood and wood residuals)	3.2×10^{-02}	4.2×10^{-03}
Wood and wood residuals	7.2×10^{-03}	3.6×10^{-03}
Biomass Fuels—Gaseous (All fuel types in Table C-1)	3.2×10^{-03}	6.3×10^{-04}
Biomass Fuels—Liquid (All fuel types in Table C-1)	1.1×10^{-03}	1.1×10^{-04}

Note: Those employing this table are assumed to fall under the IPCC definitions of the “Energy Industry” or “Manufacturing Industries and Construction”. In all fuels except for coal the values for these two categories are identical. For coal combustion, those who fall within the IPCC “Energy Industry” category may employ a value of 1g of CH₄/mmBtu.

[78 FR 71952, Nov. 29, 2013]

[Need assistance?](#)



October 2000
RG-109 (Draft)

Air Permit Technical Guidance
for Chemical Sources:

Flares and Vapor Oxidizers

printed on
recycled paper

Air Permits Division

TEXAS NATURAL RESOURCE CONSERVATION COMMISSION



Barry R. McBee, Chairman
R. B. "Ralph" Marquez, Commissioner
John M. Baker, Commissioner

Jeffrey A. Saitas, P.E., Executive Director

Authorization for use or reproduction of any original material contained in this publication, i.e., not obtained from other sources, is freely granted. The Commission would appreciate acknowledgment.

Copies of this publication are available for public use through the Texas State Library, other state depository libraries, and the TNRCC Library, in compliance with the state depository law. For more information on TNRCC publications call (512)239-0028 or visit our Web site at:

<http://www.tnrcc.state.tx.us/publications>

Published and distributed by:
Texas Natural Resource Conservation Commission
P.O. Box 13087
Austin, Texas 78711-3087

The TNRCC is an equal opportunity/affirmative action employer. The agency does not allow discrimination on the basis of race, color, religion, national origin, sex, disability, age, sexual orientation or veteran status. In compliance with the Americans with Disabilities Act, this document may be requested in alternate formats by contacting the TNRCC at (512)239-0028, Fax 239-4488, or 1-800-RELAY-TX (TDD), or by writing P.O. Box 13087, Austin, TX 78711-3087.

Technical Disclaimer

This document is intended as guidance to explain the specific requirements for new source review permitting of flares and vapor oxidizers; it does not supersede or replace any state or federal law, regulation, or rule. References to abatement equipment technologies are not intended to represent minimum or maximum levels of Best Available Control Technology (BACT). Determinations of BACT are made on a case-by-case basis as part of the New Source Review of permit applications. BACT determinations are always subject to adjustment in consideration of specific process requirements, air quality concerns, and recent developments in abatement technology. Additionally, specific health effects concerns may indicate stricter abatement than required by the BACT determination.

The represented calculation methods are intended as an aid in the completion of acceptable submittals; alternate calculation methods may be equally acceptable if they are based upon, and adequately demonstrate, sound engineering assumptions or data.

These guidelines are applicable as of this document's publication date but are subject to revision during the permit application preparation and review period. It is the responsibility of the applicants to remain abreast of any guideline or regulation developments that may affect their industries.

The electronic version of this document may not contain attachments or forms (such as the PI-1, Standard Exemptions, or tables) that can be obtained electronically elsewhere on the TNRCC Web site.

The special conditions included with these guidelines are for purposes of example only. Special conditions included in an actual permit are written by the reviewing engineer to address specific permit requirements and operating conditions.

TABLE OF CONTENTS

Chapter 1—Overview	1
Chapter 2—Types of Flare and Oxidizer Systems	3
Flares	3
Vapor Oxidizers	4
Chapter 3—State and Federal Permitting Requirements	5
Preconstruction Authorization	5
General Regulation Applicability	6
Chapter 4—Best Available Control Technology	9
BACT for Flares	9
BACT for Vapor Oxidizers	13
Chapter 5—Emission Factors, Efficiencies, and Calculations	18
Flares: Introduction	18
Flare Emission Factors	18
Flare Destruction Efficiencies	18
Sample Calculations	22
Vapor Oxidizers	29
Chapter 6—Example Permit Conditions	29
General	30
Flares	30
Enclosed Flares or Vapor Oxidizers	31
Vapor Oxidizers	33
References	35
Glossary	37
Attachment A—General Control Device Requirements, 40 CFR § 60.18 ..	39
Attachment B—Typical Refinery Flare Data	42
Attachment C—Typical Acid Gas Flare Data	44
Attachment D—NSR Table 4, Combustion Units	46

Tables

Table 1. Applicable TNRCC Regulations	6
Table 2. Flare Pilot Requirements	12
Table 3. BACT, Sampling, and Monitoring Guidelines for Vapor Oxidizers	16
Table 4. Flare Factors	19
Table 5. 99.5 Percent DRE Flare Factors	21
Table 6. Waste Stream Constituents in Mole Percent	23
Table 7. Estimation of Average Mass Flow Rates	23
Table 8. Emission Rates	23
Table 9. Estimation of Net Heat Releases	24
Table 10. Estimation of Volume Average Molecular Weight	28

Chapter 2—Types of Flare and Oxidizer Systems

This document provides guidance for two classes of vapor combustion control devices: flares and vapor oxidizers. While there may be some overlap between the two, flares have generally been treated separately by the EPA and the TNRCC, in large part because flares have an open flame and often cannot be sampled, so emissions are estimated based on the results of flare testing performed in the early 1980s. Each of the two classes will be dealt with separately in each of the chapters of this document.

Combustion Control Devices NOT Discussed. This document will not cover permitting of RCRA or BIF units because the requirements for these units often go beyond the requirements for state air permitting. Incinerators used to treat solid wastes are covered in another technical guidance document, *Incinerators*. Guidance for combustion control devices associated with spray paint booths, coatings operations, and semiconductor facilities should be obtained by calling the TNRCC New Source Review Permits Division at (512) 239-1250.

Flares

Flare systems generally are open-flame control devices used for disposing of waste gas streams during both routine process and emergency or upset conditions. In addition to simple, unassisted flares, typical smokeless flare systems include, but are not limited to, the following:

- ***Enclosed Flares/Vapor Combustors.*** Enclosed flares are used in disposing of waste gas streams in instances where a visible flame is unacceptable. Applications include chemical processing, petroleum refining and production, and municipal waste gas treatment. These may be referred to as vapor combustors and can have more than one burner in the stack.
- ***Steam-Assisted Flares.*** Steam-assisted flares are used in disposing of low-pressure waste gas streams when steam is available and practical to minimize smoking from the flare. Applications are similar to those of enclosed flares. Flares might also be assisted with natural gas if readily available on site; these flares would undergo a case-by-case review.
- ***Air-Assisted Flares.*** Air-assisted flares are used in disposing of low-pressure waste gas streams when practical or when steam utilities are not available to minimize smoking from the flare. Applications include chemical processing, petroleum refining and production, and pipeline transportation.
- ***Sonic Flares.*** Sonic flares are used in disposing of high-pressure waste gas streams. Applications include gas production, pipeline transportation, and treatment plants.

- **Multipoint Flare Systems.** Multipoint flare systems are used in disposing of both high- and low-pressure waste gas streams. Multiple burner tips in conjunction with a staged control system provide for controlled combustion. Applications are similar to those of air-assisted flares.

Vapor Oxidizers

These devices generally do not have an open flame but have an exhaust stack which allows for sampling and monitoring of exhaust emissions. The most common type, thermal, relies on the combustion heat of the waste gas and assist fuel (if required) to oxidize the waste gas air contaminants. Other types include:

- **Recuperative.** In this case, the waste gas is directed to a heat exchanger to be preheated by the exhaust gas, to minimize the need for additional assist fuel. Recuperative oxidizers are considered a subset of thermal oxidizers in this document.
- **Regenerative.** Combustion takes place in a chamber with a heat sink, such as ceramic saddles, which retains the heat of combustion, allowing for combustion of more dilute vapor streams (which have a low heat of combustion) at a lower cost. These units generally have multiple chambers, which allow for the preheat of one chamber by exhaust gases while combustion takes place in another chamber.
- **Catalytic.** Combustion takes place over a catalyst that allows for combustion at a lower temperature (in the range of 600 to 800°F as opposed to greater than 1400°F for many thermal oxidizers). Catalytic oxidizers function best with a waste stream with constant flow and composition.

Chapter 5—Emission Factors, Efficiencies, and Calculations

This chapter provides detailed instructions for the calculations necessary to verify BACT and estimate emissions from flares and vapor oxidizers. Flares must be checked to determine whether they will satisfy the flow and thermal requirements of 40 CFR § 60.18, and their emissions are determined by the use of emission factors. Example calculations are provided for these flare calculations.

Oxidizer emissions are determined by using previous sampling results or emission factors from the manufacturer or AP-42. These calculations are very similar to the flare calculations and are only discussed in general terms.

Flares: Introduction

Although emissions from emergency flares are not included in a permit when it is issued, emissions should be estimated for both routine process flares and emergency flares. Sometimes, emissions of routine pilot gas combustion may be included in an issued permit for emergency flares (although not required).

In this section, the *flare* emission factors and destruction efficiencies are presented first. This information is followed by sample *calculations* that demonstrate how to ensure that the requirements of 40 CFR § 60.18 are satisfied and how to estimate emissions from a flare. Flare data in Attachment B (typical refinery flare) will be used as a basis in most of the following calculations. Flare data in Attachment C (acid gas flare) will be used as a basis in the example calculations for SO₂ emissions.

Flare Emission Factors

The usual flare destruction efficiencies and emission factors are provided in Table 4. The high-Btu waste streams referred to in the table have a heating value greater than 1,000 Btu/scf.

Flare Destruction Efficiencies

Claims for destruction efficiencies greater than those listed in Table 4 will be considered on a case-by-case basis. The applicant may make one of the three following demonstrations to justify the higher destruction efficiency: (1) general method, (2) 99.5 percent justification, or (3) flare stack sampling.

Table 4. Flare Factors

Waste Stream	Destruction/Removal Efficiency (DRE)
VOC	98 percent (generic) 99 percent for compounds containing no more than 3 carbons that contain no elements other than carbon and hydrogen in addition to the following compounds: methanol, ethanol, propanol, ethylene oxide and propylene oxide
H ₂ S	98 percent
NH ₃	case by case
CO	case by case
Air Contaminants	Emission Factors
thermal NO _x	steam-assist: high Btu 0.0485 lb/MMBtu low Btu 0.068 lb/MMBtu
	other: high Btu 0.138 lb/MMBtu low Btu 0.0641 lb/MMBtu
fuel NO _x	NO _x is 0.5 wt percent of inlet NH ₃ , other fuels case by case
CO	steam-assist: high Btu 0.3503 lb/MMBtu low Btu 0.3465 lb/MMBtu
	other: high Btu 0.2755 lb/MMBtu low Btu 0.5496 lb/MMBtu
PM	none, required to be smokeless
SO ₂	100 percent S in fuel to SO ₂

*The only exception of this is if inorganics might be emitted from the flare. In the case of landfills, the AP-42 PM factor may be used. In other cases, the emissions should be based on the composition of the waste stream routed to the flare.

1.4 Natural Gas Combustion

1.4.1 General¹⁻²

Natural gas is one of the major combustion fuels used throughout the country. It is mainly used to generate industrial and utility electric power, produce industrial process steam and heat, and heat residential and commercial space. Natural gas consists of a high percentage of methane (generally above 85 percent) and varying amounts of ethane, propane, butane, and inerts (typically nitrogen, carbon dioxide, and helium). The average gross heating value of natural gas is approximately 1,020 British thermal units per standard cubic foot (Btu/scf), usually varying from 950 to 1,050 Btu/scf.

1.4.2 Firing Practices³⁻⁵

There are three major types of boilers used for natural gas combustion in commercial, industrial, and utility applications: watertube, firetube, and cast iron. Watertube boilers are designed to pass water through the inside of heat transfer tubes while the outside of the tubes is heated by direct contact with the hot combustion gases and through radiant heat transfer. The watertube design is the most common in utility and large industrial boilers. Watertube boilers are used for a variety of applications, ranging from providing large amounts of process steam, to providing hot water or steam for space heating, to generating high-temperature, high-pressure steam for producing electricity. Furthermore, watertube boilers can be distinguished either as field erected units or packaged units.

Field erected boilers are boilers that are constructed on site and comprise the larger sized watertube boilers. Generally, boilers with heat input levels greater than 100 MMBtu/hr, are field erected. Field erected units usually have multiple burners and, given the customized nature of their construction, also have greater operational flexibility and NO_x control options. Field erected units can also be further categorized as wall-fired or tangential-fired. Wall-fired units are characterized by multiple individual burners located on a single wall or on opposing walls of the furnace while tangential units have several rows of air and fuel nozzles located in each of the four corners of the boiler.

Package units are constructed off-site and shipped to the location where they are needed. While the heat input levels of packaged units may range up to 250 MMBtu/hr, the physical size of these units are constrained by shipping considerations and generally have heat input levels less than 100 MMBtu/hr. Packaged units are always wall-fired units with one or more individual burners. Given the size limitations imposed on packaged boilers, they have limited operational flexibility and cannot feasibly incorporate some NO_x control options.

Firetube boilers are designed such that the hot combustion gases flow through tubes, which heat the water circulating outside of the tubes. These boilers are used primarily for space heating systems, industrial process steam, and portable power boilers. Firetube boilers are almost exclusively packaged units. The two major types of firetube units are Scotch Marine boilers and the older firebox boilers. In cast iron boilers, as in firetube boilers, the hot gases are contained inside the tubes and the water being heated circulates outside the tubes. However, the units are constructed of cast iron rather than steel. Virtually all cast iron boilers are constructed as package boilers. These boilers are used to produce either low-pressure steam or hot water, and are most commonly used in small commercial applications.

Natural gas is also combusted in residential boilers and furnaces. Residential boilers and furnaces generally resemble firetube boilers with flue gas traveling through several channels or tubes with water or air circulated outside the channels or tubes.

1.4.3 Emissions³⁻⁴

The emissions from natural gas-fired boilers and furnaces include nitrogen oxides (NO_x), carbon monoxide (CO), and carbon dioxide (CO₂), methane (CH₄), nitrous oxide (N₂O), volatile organic compounds (VOCs), trace amounts of sulfur dioxide (SO₂), and particulate matter (PM).

Nitrogen Oxides -

Nitrogen oxides formation occurs by three fundamentally different mechanisms. The principal mechanism of NO_x formation in natural gas combustion is thermal NO_x. The thermal NO_x mechanism occurs through the thermal dissociation and subsequent reaction of nitrogen (N₂) and oxygen (O₂) molecules in the combustion air. Most NO_x formed through the thermal NO_x mechanism occurs in the high temperature flame zone near the burners. The formation of thermal NO_x is affected by three furnace-zone factors: (1) oxygen concentration, (2) peak temperature, and (3) time of exposure at peak temperature. As these three factors increase, NO_x emission levels increase. The emission trends due to changes in these factors are fairly consistent for all types of natural gas-fired boilers and furnaces. Emission levels vary considerably with the type and size of combustor and with operating conditions (e.g., combustion air temperature, volumetric heat release rate, load, and excess oxygen level).

The second mechanism of NO_x formation, called prompt NO_x, occurs through early reactions of nitrogen molecules in the combustion air and hydrocarbon radicals from the fuel. Prompt NO_x reactions occur within the flame and are usually negligible when compared to the amount of NO_x formed through the thermal NO_x mechanism. However, prompt NO_x levels may become significant with ultra-low-NO_x burners.

The third mechanism of NO_x formation, called fuel NO_x, stems from the evolution and reaction of fuel-bound nitrogen compounds with oxygen. Due to the characteristically low fuel nitrogen content of natural gas, NO_x formation through the fuel NO_x mechanism is insignificant.

Carbon Monoxide -

The rate of CO emissions from boilers depends on the efficiency of natural gas combustion. Improperly tuned boilers and boilers operating at off-design levels decrease combustion efficiency resulting in increased CO emissions. In some cases, the addition of NO_x control systems such as low NO_x burners and flue gas recirculation (FGR) may also reduce combustion efficiency, resulting in higher CO emissions relative to uncontrolled boilers.

Volatile Organic Compounds -

The rate of VOC emissions from boilers and furnaces also depends on combustion efficiency. VOC emissions are minimized by combustion practices that promote high combustion temperatures, long residence times at those temperatures, and turbulent mixing of fuel and combustion air. Trace amounts of VOC species in the natural gas fuel (e.g., formaldehyde and benzene) may also contribute to VOC emissions if they are not completely combusted in the boiler.

Sulfur Oxides -

Emissions of SO₂ from natural gas-fired boilers are low because pipeline quality natural gas typically has sulfur levels of 2,000 grains per million cubic feet. However, sulfur-containing odorants are added to natural gas for detecting leaks, leading to small amounts of SO₂ emissions. Boilers combusting unprocessed natural gas may have higher SO₂ emissions due to higher levels of sulfur in the natural gas. For these units, a sulfur mass balance should be used to determine SO₂ emissions.

Particulate Matter -

Because natural gas is a gaseous fuel, filterable PM emissions are typically low. Particulate matter from natural gas combustion has been estimated to be less than 1 micrometer in size and has filterable and condensable fractions. Particulate matter in natural gas combustion are usually larger molecular weight hydrocarbons that are not fully combusted. Increased PM emissions may result from poor air/fuel mixing or maintenance problems.

Greenhouse Gases ⁻⁶⁻⁹

CO₂, CH₄, and N₂O emissions are all produced during natural gas combustion. In properly tuned boilers, nearly all of the fuel carbon (99.9 percent) in natural gas is converted to CO₂ during the combustion process. This conversion is relatively independent of boiler or combustor type. Fuel carbon not converted to CO₂ results in CH₄, CO, and/or VOC emissions and is due to incomplete combustion. Even in boilers operating with poor combustion efficiency, the amount of CH₄, CO, and VOC produced is insignificant compared to CO₂ levels.

Formation of N₂O during the combustion process is affected by two furnace-zone factors. N₂O emissions are minimized when combustion temperatures are kept high (above 1475°F) and excess oxygen is kept to a minimum (less than 1 percent).

Methane emissions are highest during low-temperature combustion or incomplete combustion, such as the start-up or shut-down cycle for boilers. Typically, conditions that favor formation of N₂O also favor emissions of methane.

1.4.4 Controls^{4,10}

NO_x Controls -

Currently, the two most prevalent combustion control techniques used to reduce NO_x emissions from natural gas-fired boilers are flue gas recirculation (FGR) and low NO_x burners. In an FGR system, a portion of the flue gas is recycled from the stack to the burner windbox. Upon entering the windbox, the recirculated gas is mixed with combustion air prior to being fed to the burner. The recycled flue gas consists of combustion products which act as inerts during combustion of the fuel/air mixture. The FGR system reduces NO_x emissions by two mechanisms. Primarily, the recirculated gas acts as a diluent to reduce combustion temperatures, thus suppressing the thermal NO_x mechanism. To a lesser extent, FGR also reduces NO_x formation by lowering the oxygen concentration in the primary flame zone. The amount of recirculated flue gas is a key operating parameter influencing NO_x emission rates for these systems. An FGR system is normally used in combination with specially designed low NO_x burners capable of sustaining a stable flame with the increased inert gas flow resulting from the use of FGR. When low NO_x burners and FGR are used in combination, these techniques are capable of reducing NO_x emissions by 60 to 90 percent.

Low NO_x burners reduce NO_x by accomplishing the combustion process in stages. Staging partially delays the combustion process, resulting in a cooler flame which suppresses thermal NO_x formation. The two most common types of low NO_x burners being applied to natural gas-fired boilers are staged air burners and staged fuel burners. NO_x emission reductions of 40 to 85 percent (relative to uncontrolled emission levels) have been observed with low NO_x burners.

Other combustion control techniques used to reduce NO_x emissions include staged combustion and gas reburning. In staged combustion (e.g., burners-out-of-service and overfire air), the degree of staging is a key operating parameter influencing NO_x emission rates. Gas reburning is similar to the use of overfire in the use of combustion staging. However, gas reburning injects additional amounts of natural gas in the upper furnace, just before the overfire air ports, to provide increased reduction of NO_x to NO₂.

Two postcombustion technologies that may be applied to natural gas-fired boilers to reduce NO_x emissions are selective noncatalytic reduction (SNCR) and selective catalytic reduction (SCR). The SNCR system injects ammonia (NH₃) or urea into combustion flue gases (in a specific temperature zone) to reduce NO_x emission. The Alternative Control Techniques (ACT) document for NO_x emissions from utility boilers, maximum SNCR performance was estimated to range from 25 to 40 percent for natural gas-fired boilers.¹² Performance data available from several natural gas fired utility boilers with SNCR show a 24 percent reduction in NO_x for applications on wall-fired boilers and a 13 percent reduction in NO_x for applications on tangential-fired boilers.¹¹ In many situations, a boiler may have an SNCR system installed to trim NO_x emissions to meet permitted levels. In these cases, the SNCR system may not be operated to achieve maximum NO_x reduction. The SCR system involves injecting NH₃ into the flue gas in the presence of a catalyst to reduce NO_x emissions. No data were available on SCR performance on natural gas fired boilers at the time of this publication. However, the ACT Document for utility boilers estimates NO_x reduction efficiencies for SCR control ranging from 80 to 90 percent.¹²

Emission factors for natural gas combustion in boilers and furnaces are presented in Tables 1.4-1, 1.4-2, 1.4-3, and 1.4-4.¹¹ Tables in this section present emission factors on a volume basis (lb/10⁶ scf). To convert to an energy basis (lb/MMBtu), divide by a heating value of 1,020 MMBtu/10⁶ scf. For the purposes of developing emission factors, natural gas combustors have been organized into three general categories: large wall-fired boilers with greater than 100 MMBtu/hr of heat input, boilers and residential furnaces with less than 100 MMBtu/hr of heat input, and tangential-fired boilers. Boilers within these categories share the same general design and operating characteristics and hence have similar emission characteristics when combusting natural gas.

Emission factors are rated from A to E to provide the user with an indication of how “good” the factor is, with “A” being excellent and “E” being poor. The criteria that are used to determine a rating for an emission factor can be found in the Emission Factor Documentation for AP-42 Section 1.4 and in the introduction to the AP-42 document.

1.4.5 Updates Since the Fifth Edition

The Fifth Edition was released in January 1995. Revisions to this section are summarized below. For further detail, consult the Emission Factor Documentation for this section. These and other documents can be found on the Emission Factor and Inventory Group (EFIG) home page (<http://www.epa.gov/ttn/chief>).

Supplement D, March 1998

- Text was revised concerning Firing Practices, Emissions, and Controls.
- All emission factors were updated based on 482 data points taken from 151 source tests. Many new emission factors have been added for speciated organic compounds, including hazardous air pollutants.

July 1998 - minor changes

- Footnote D was added to table 1.4-3 to explain why the sum of individual HAP may exceed VOC or TOC, the web address was updated, and the references were reordered.

Table 1.4-1. EMISSION FACTORS FOR NITROGEN OXIDES (NO_x) AND CARBON MONOXIDE (CO)
FROM NATURAL GAS COMBUSTION^a

Combustor Type (MMBtu/hr Heat Input) [SCC]	NO _x ^b		CO	
	Emission Factor (lb/10 ⁶ scf)	Emission Factor Rating	Emission Factor (lb/10 ⁶ scf)	Emission Factor Rating
Large Wall-Fired Boilers (>100) [1-01-006-01, 1-02-006-01, 1-03-006-01]				
Uncontrolled (Pre-NSPS) ^c	280	A	84	B
Uncontrolled (Post-NSPS) ^c	190	A	84	B
Controlled - Low NO _x burners	140	A	84	B
Controlled - Flue gas recirculation	100	D	84	B
Small Boilers (<100) [1-01-006-02, 1-02-006-02, 1-03-006-02, 1-03-006-03]				
Uncontrolled	100	B	84	B
Controlled - Low NO _x burners	50	D	84	B
Controlled - Low NO _x burners/Flue gas recirculation	32	C	84	B
Tangential-Fired Boilers (All Sizes) [1-01-006-04]				
Uncontrolled	170	A	24	C
Controlled - Flue gas recirculation	76	D	98	D
Residential Furnaces (<0.3) [No SCC]				
Uncontrolled	94	B	40	B

^a Reference 11. Units are in pounds of pollutant per million standard cubic feet of natural gas fired. To convert from lb/10⁶ scf to kg/10⁶ m³, multiply by 16. Emission factors are based on an average natural gas higher heating value of 1,020 Btu/scf. To convert from lb/10⁶ scf to lb/MMBtu, divide by 1,020. The emission factors in this table may be converted to other natural gas heating values by multiplying the given emission factor by the ratio of the specified heating value to this average heating value. SCC = Source Classification Code. ND = no data. NA = not applicable.

^b Expressed as NO₂. For large and small wall fired boilers with SNCR control, apply a 24 percent reduction to the appropriate NO_x emission factor. For tangential-fired boilers with SNCR control, apply a 13 percent reduction to the appropriate NO_x emission factor.

^c NSPS=New Source Performance Standard as defined in 40 CFR 60 Subparts D and Db. Post-NSPS units are boilers with greater than 250 MMBtu/hr of heat input that commenced construction modification, or reconstruction after August 17, 1971, and units with heat input capacities between 100 and 250 MMBtu/hr that commenced construction modification, or reconstruction after June 19, 1984.

TABLE 1.4-2. EMISSION FACTORS FOR CRITERIA POLLUTANTS AND GREENHOUSE GASES FROM NATURAL GAS COMBUSTION^a

Pollutant	Emission Factor (lb/10 ⁶ scf)	Emission Factor Rating
CO ₂ ^b	120,000	A
Lead	0.0005	D
N ₂ O (Uncontrolled)	2.2	E
N ₂ O (Controlled-low-NO _x burner)	0.64	E
PM (Total) ^c	7.6	D
PM (Condensable) ^c	5.7	D
PM (Filterable) ^c	1.9	B
SO ₂ ^d	0.6	A
TOC	11	B
Methane	2.3	B
VOC	5.5	C

^a Reference 11. Units are in pounds of pollutant per million standard cubic feet of natural gas fired. Data are for all natural gas combustion sources. To convert from lb/10⁶ scf to kg/10⁶ m³, multiply by 16. To convert from lb/10⁶ scf to lb/MMBtu, divide by 1,020. The emission factors in this table may be converted to other natural gas heating values by multiplying the given emission factor by the ratio of the specified heating value to this average heating value. TOC = Total Organic Compounds.

VOC = Volatile Organic Compounds.

^b Based on approximately 100% conversion of fuel carbon to CO₂. $CO_2[\text{lb}/10^6 \text{ scf}] = (3.67) (\text{CON}) (\text{C})(\text{D})$, where CON = fractional conversion of fuel carbon to CO₂, C = carbon content of fuel by weight (0.76), and D = density of fuel, $4.2 \times 10^{-4} \text{ lb}/10^6 \text{ scf}$.

^c All PM (total, condensable, and filterable) is assumed to be less than 1.0 micrometer in diameter. Therefore, the PM emission factors presented here may be used to estimate PM₁₀, PM_{2.5} or PM₁ emissions. Total PM is the sum of the filterable PM and condensable PM. Condensable PM is the particulate matter collected using EPA Method 202 (or equivalent). Filterable PM is the particulate matter collected on, or prior to, the filter of an EPA Method 5 (or equivalent) sampling train.

^d Based on 100% conversion of fuel sulfur to SO₂.

Assumes sulfur content is natural gas of 2,000 grains/10⁶ scf. The SO₂ emission factor in this table can be converted to other natural gas sulfur contents by multiplying the SO₂ emission factor by the ratio of the site-specific sulfur content (grains/10⁶ scf) to 2,000 grains/10⁶ scf.

TABLE 1.4-3. EMISSION FACTORS FOR SPECIATED ORGANIC COMPOUNDS FROM NATURAL GAS COMBUSTION^a

CAS No.	Pollutant	Emission Factor (lb/10 ⁶ scf)	Emission Factor Rating
91-57-6	2-Methylnaphthalene ^{b, c}	2.4E-05	D
56-49-5	3-Methylcholanthrene ^{b, c}	<1.8E-06	E
	7,12-Dimethylbenz(a)anthracene ^{b, c}	<1.6E-05	E
83-32-9	Acenaphthene ^{b, c}	<1.8E-06	E
203-96-8	Acenaphthylene ^{b, c}	<1.8E-06	E
120-12-7	Anthracene ^{b, c}	<2.4E-06	E
56-55-3	Benz(a)anthracene ^{b, c}	<1.8E-06	E
71-43-2	Benzene ^b	2.1E-03	B
50-32-8	Benzo(a)pyrene ^{b, c}	<1.2E-06	E
205-99-2	Benzo(b)fluoranthene ^{b, c}	<1.8E-06	E
191-24-2	Benzo(g,h,i)perylene ^{b, c}	<1.2E-06	E
207-08-9	Benzo(k)fluoranthene ^{b, c}	<1.8E-06	E
106-97-8	Butane	2.1E+00	E
218-01-9	Chrysene ^{b, c}	<1.8E-06	E
53-70-3	Dibenzo(a,h)anthracene ^{b, c}	<1.2E-06	E
25321-22-6	Dichlorobenzene ^b	1.2E-03	E
74-84-0	Ethane	3.1E+00	E
206-44-0	Fluoranthene ^{b, c}	3.0E-06	E
86-73-7	Fluorene ^{b, c}	2.8E-06	E
50-00-0	Formaldehyde ^b	7.5E-02	B
110-54-3	Hexane ^b	1.8E+00	E
193-39-5	Indeno(1,2,3-cd)pyrene ^{b, c}	<1.8E-06	E
91-20-3	Naphthalene ^b	6.1E-04	E
109-66-0	Pentane	2.6E+00	E
85-01-8	Phenanthrene ^{b, c}	1.7E-05	D
74-98-6	Propane	1.6E+00	E

TABLE 1.4-3. EMISSION FACTORS FOR SPECIATED ORGANIC COMPOUNDS FROM NATURAL GAS COMBUSTION (Continued)

CAS No.	Pollutant	Emission Factor (lb/10 ⁶ scf)	Emission Factor Rating
129-00-0	Pyrene ^{b, c}	5.0E-06	E
108-88-3	Toluene ^b	3.4E-03	C

- ^a Reference 11. Units are in pounds of pollutant per million standard cubic feet of natural gas fired. Data are for all natural gas combustion sources. To convert from lb/10⁶ scf to kg/10⁶ m³, multiply by 16. To convert from lb/10⁶ scf to lb/MMBtu, divide by 1,020. Emission Factors preceded with a less-than symbol are based on method detection limits.
- ^b Hazardous Air Pollutant (HAP) as defined by Section 112(b) of the Clean Air Act.
- ^c HAP because it is Polycyclic Organic Matter (POM). POM is a HAP as defined by Section 112(b) of the Clean Air Act.
- ^d The sum of individual organic compounds may exceed the VOC and TOC emission factors due to differences in test methods and the availability of test data for each pollutant.

TABLE 1.4-4. EMISSION FACTORS FOR METALS FROM NATURAL GAS COMBUSTION^a

CAS No.	Pollutant	Emission Factor (lb/10 ⁶ scf)	Emission Factor Rating
7440-38-2	Arsenic ^b	2.0E-04	E
7440-39-3	Barium	4.4E-03	D
7440-41-7	Beryllium ^b	<1.2E-05	E
7440-43-9	Cadmium ^b	1.1E-03	D
7440-47-3	Chromium ^b	1.4E-03	D
7440-48-4	Cobalt ^b	8.4E-05	D
7440-50-8	Copper	8.5E-04	C
7439-96-5	Manganese ^b	3.8E-04	D
7439-97-6	Mercury ^b	2.6E-04	D
7439-98-7	Molybdenum	1.1E-03	D
7440-02-0	Nickel ^b	2.1E-03	C
7782-49-2	Selenium ^b	<2.4E-05	E
7440-62-2	Vanadium	2.3E-03	D
7440-66-6	Zinc	2.9E-02	E

^a Reference 11. Units are in pounds of pollutant per million standard cubic feet of natural gas fired. Data are for all natural gas combustion sources. Emission factors preceded by a less-than symbol are based on method detection limits. To convert from lb/10⁶ scf to kg/10⁶ m³, multiply by 16. To convert from lb/10⁶ scf to lb/MMBtu, divide by 1,020.

^b Hazardous Air Pollutant as defined by Section 112(b) of the Clean Air Act.

References For Section 1.4

1. *Exhaust Gases From Combustion And Industrial Processes*, EPA Contract No. EHSD 71-36, Engineering Science, Inc., Washington, DC, October 1971.
2. *Chemical Engineers' Handbook, Fourth Edition*, J. H. Perry, Editor, McGraw-Hill Book Company, New York, NY, 1963.
3. *Background Information Document For Industrial Boilers*, EPA-450/3-82-006a, U. S. Environmental Protection Agency, Research Triangle Park, NC, March 1982.
4. *Background Information Document For Small Steam Generating Units*, EPA-450/3-87-000, U. S. Environmental Protection Agency, Research Triangle Park, NC, 1987.
5. J. L. Muhlbaier, "Particulate and Gaseous Emissions From Natural Gas Furnaces and Water Heaters", *Journal Of The Air Pollution Control Association*, December 1981.
6. L. P. Nelson, *et al.*, *Global Combustion Sources Of Nitrous Oxide Emissions*, Research Project 2333-4 Interim Report, Sacramento: Radian Corporation, 1991.
7. R. L. Peer, *et al.*, *Characterization Of Nitrous Oxide Emission Sources*, Prepared for the U. S. EPA Contract 68-D1-0031, Research Triangle Park, NC: Radian Corporation, 1995.
8. S. D. Piccot, *et al.*, *Emissions and Cost Estimates For Globally Significant Anthropogenic Combustion Sources Of NO_x, N₂O, CH₄, CO, and CO₂*, EPA Contract No. 68-02-4288, Research Triangle Park, NC: Radian Corporation, 1990.
9. *Sector-Specific Issues and Reporting Methodologies Supporting the General Guidelines for the Voluntary Reporting of Greenhouse Gases under Section 1605(b) of the Energy Policy Act of 1992* (1994) DOE/PO-0028, Volume 2 of 3, U.S. Department of Energy.
10. J. P. Kesselring and W. V. Krill, "A Low-NO_x Burner For Gas-Fired Firetube Boilers", *Proceedings: 1985 Symposium On Stationary Combustion NO_x Control, Volume 2*, EPRI CS-4360, Electric Power Research Institute, Palo Alto, CA, January 1986.
11. *Emission Factor Documentation for AP-42 Section 1.4—Natural Gas Combustion*, Technical Support Division, Office of Air Quality Planning and Standards, U. S. Environmental Protection Agency, Research Triangle Park, NC, 1997.
12. *Alternate Control Techniques Document - NO_x Emissions from Utility Boilers*, EPA-453/R-94-023, U. S. Environmental Protection Agency, Research Triangle Park, NC, March 1994.



Protocol for Equipment Leak Emission Estimates

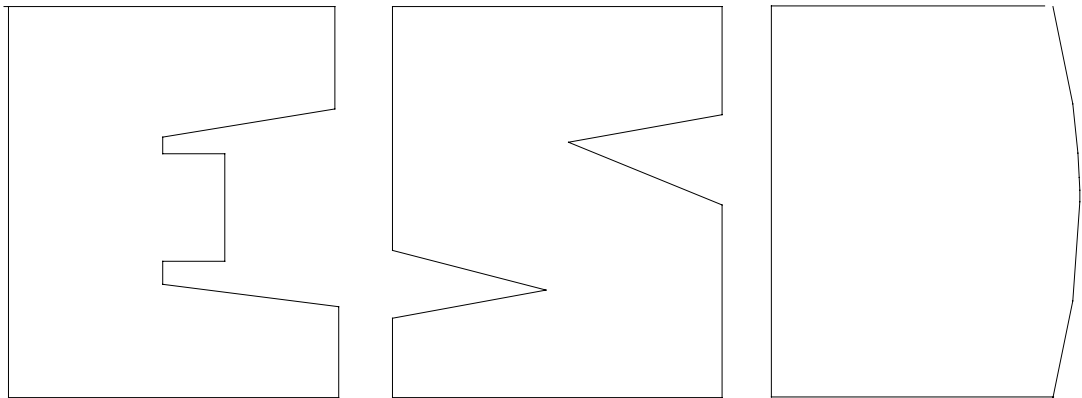
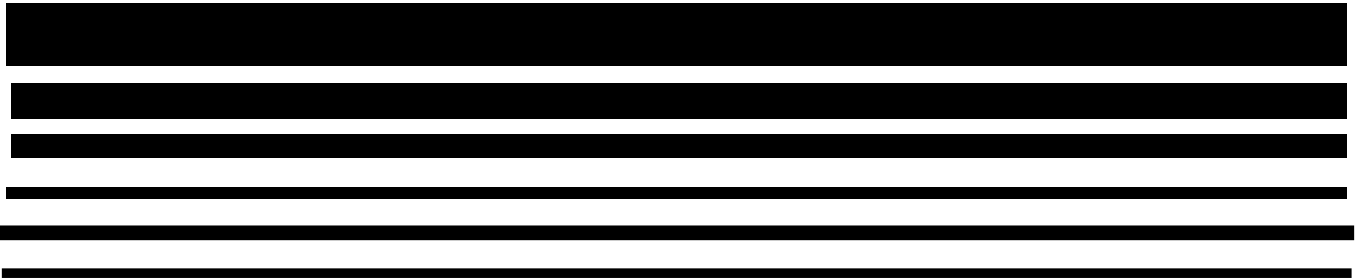

TABLE 2-4. OIL AND GAS PRODUCTION OPERATIONS AVERAGE EMISSION FACTORS (kg/hr/source)

Equipment Type	Service ^a	Emission Factor (kg/hr/source) ^b
Valves	Gas	4.5E-03
	Heavy Oil	8.4E-06
	Light Oil	2.5E-03
	Water/Oil	9.8E-05
Pump seals	Gas	2.4E-03
	Heavy Oil	NA
	Light Oil	1.3E-02
	Water/Oil	2.4E-05
Others ^c	Gas	8.8E-03
	Heavy Oil	3.2E-05
	Light Oil	7.5E-03
	Water/Oil	1.4E-02
Connectors	Gas	2.0E-04
	Heavy Oil	7.5E-06
	Light Oil	2.1E-04
	Water/Oil	1.1E-04
Flanges	Gas	3.9E-04
	Heavy Oil	3.9E-07
	Light Oil	1.1E-04
	Water/Oil	2.9E-06
Open-ended lines	Gas	2.0E-03
	Heavy Oil	1.4E-04
	Light Oil	1.4E-03
	Water/Oil	2.5E-04

^aWater/Oil emission factors apply to water streams in oil service with a water content greater than 50%, from the point of origin to the point where the water content reaches 99%. For water streams with a water content greater than 99%, the emission rate is considered negligible.

^bThese factors are for total organic compound emission rates (including non-VOC's such as methane and ethane) and apply to light crude, heavy crude, gas plant, gas production, and off shore facilities. "NA" indicates that not enough data were available to develop the indicated emission factor.

^cThe "other" equipment type was derived from compressors, diaphragms, drains, dump arms, hatches, instruments, meters, pressure relief valves, polished rods, relief valves, and vents. This "other" equipment type should be applied for any equipment type other than connectors, flanges, open-ended lines, pumps, or valves.

13.2.2 Unpaved Roads

13.2.2.1 General

When a vehicle travels an unpaved road, the force of the wheels on the road surface causes pulverization of surface material. Particles are lifted and dropped from the rolling wheels, and the road surface is exposed to strong air currents in turbulent shear with the surface. The turbulent wake behind the vehicle continues to act on the road surface after the vehicle has passed.

The particulate emission factors presented in the previous draft version of this section of AP-42, dated October 2001, implicitly included the emissions from vehicles in the form of exhaust, brake wear, and tire wear as well as resuspended road surface material²⁵. EPA included these sources in the emission factor equation for unpaved public roads (equation 1b in this section) since the field testing data used to develop the equation included both the direct emissions from vehicles and emissions from resuspension of road dust.

This version of the unpaved public road emission factor equation only estimates particulate emissions from resuspended road surface material^{23, 26}. The particulate emissions from vehicle exhaust, brake wear, and tire wear are now estimated separately using EPA's MOBILE6.2²⁴. This approach eliminates the possibility of double counting emissions. Double counting results when employing the previous version of the emission factor equation in this section and MOBILE6.2 to estimate particulate emissions from vehicle traffic on unpaved public roads. It also incorporates the decrease in exhaust emissions that has occurred since the unpaved public road emission factor equation was developed. The previous version of the unpaved public road emission factor equation includes estimates of emissions from exhaust, brake wear, and tire wear based on emission rates for vehicles in the 1980 calendar year fleet. The amount of PM released from vehicle exhaust has decreased since 1980 due to lower new vehicle emission standards and changes in fuel characteristics.

13.2.2.2 Emissions Calculation And Correction Parameters¹⁻⁶

The quantity of dust emissions from a given segment of unpaved road varies linearly with the volume of traffic. Field investigations also have shown that emissions depend on source parameters that characterize the condition of a particular road and the associated vehicle traffic. Characterization of these source parameters allow for "correction" of emission estimates to specific road and traffic conditions present on public and industrial roadways.

Dust emissions from unpaved roads have been found to vary directly with the fraction of silt (particles smaller than 75 micrometers [μm] in diameter) in the road surface materials.¹ The silt fraction is determined by measuring the proportion of loose dry surface dust that passes a 200-mesh screen, using the ASTM-C-136 method. A summary of this method is contained in Appendix C of AP-42. Table 13.2.2-1 summarizes measured silt values for industrial unpaved roads. Table 13.2.2-2 summarizes measured silt values for public unpaved roads. It should be noted that the ranges of silt content vary over two orders of magnitude. Therefore, the use of data from this table can potentially introduce considerable error. Use of this data is strongly discouraged when it is feasible to obtain locally gathered data.

Since the silt content of a rural dirt road will vary with geographic location, it should be measured for use in projecting emissions. As a conservative approximation, the silt content of the parent soil in the area can be used. Tests, however, show that road silt content is normally lower than in the surrounding parent soil, because the fines are continually removed by the vehicle traffic, leaving a higher percentage of coarse particles.

Other variables are important in addition to the silt content of the road surface material. For example, at industrial sites, where haul trucks and other heavy equipment are common, emissions are highly correlated with vehicle weight. On the other hand, there is far less variability in the weights of cars and pickup trucks that commonly travel publicly accessible unpaved roads throughout the United States. For those roads, the moisture content of the road surface material may be more dominant in determining differences in emission levels between, for example a hot, desert environment and a cool, moist location.

The PM-10 and TSP emission factors presented below are the outcomes from stepwise linear regressions of field emission test results of vehicles traveling over unpaved surfaces. Due to a limited amount of information available for PM-2.5, the expression for that particle size range has been scaled against the result for PM-10. Consequently, the quality rating for the PM-2.5 factor is lower than that for the PM-10 expression.

Table 13.2.2-1. TYPICAL SILT CONTENT VALUES OF SURFACE MATERIAL ON INDUSTRIAL UNPAVED ROADS^a

Industry	Road Use Or Surface Material	Plant Sites	No. Of Samples	Silt Content (%)	
				Range	Mean
Copper smelting	Plant road	1	3	16 - 19	17
Iron and steel production	Plant road	19	135	0.2 - 19	6.0
Sand and gravel processing	Plant road	1	3	4.1 - 6.0	4.8
	Material storage area	1	1	-	7.1
Stone quarrying and processing	Plant road	2	10	2.4 - 16	10
	Haul road to/from pit	4	20	5.0-15	8.3
Taconite mining and processing	Service road	1	8	2.4 - 7.1	4.3
	Haul road to/from pit	1	12	3.9 - 9.7	5.8
Western surface coal mining	Haul road to/from pit	3	21	2.8 - 18	8.4
	Plant road	2	2	4.9 - 5.3	5.1
	Scraper route	3	10	7.2 - 25	17
	Haul road (freshly graded)	2	5	18 - 29	24
Construction sites	Scraper routes	7	20	0.56-23	8.5
Lumber sawmills	Log yards	2	2	4.8-12	8.4
Municipal solid waste landfills	Disposal routes	4	20	2.2 - 21	6.4

^aReferences 1,5-15.

The following empirical expressions may be used to estimate the quantity in pounds (lb) of size-specific particulate emissions from an unpaved road, per vehicle mile traveled (VMT):

For vehicles traveling on unpaved surfaces at industrial sites, emissions are estimated from the following equation:

$$E = k (s/12)^a(W/3)^b \quad (1a)$$

and, for vehicles traveling on publicly accessible roads, dominated by light duty vehicles, emissions may be estimated from the following:

$$E = \frac{k (s/12)^a(S/30)^d}{(M/0.5)^c} - C \quad (1b)$$

where k , a , b , c and d are empirical constants (Reference 6) given below and

E = size-specific emission factor (lb/VMT)

s = surface material silt content (%)

W = mean vehicle weight (tons)

M = surface material moisture content (%)

S = mean vehicle speed (mph)

C = emission factor for 1980's vehicle fleet exhaust, brake wear and tire wear.

The source characteristics s , W and M are referred to as correction parameters for adjusting the emission estimates to local conditions. The metric conversion from lb/VMT to grams (g) per vehicle kilometer traveled (VKT) is as follows:

$$1 \text{ lb/VMT} = 281.9 \text{ g/VKT}$$

The constants for Equations 1a and 1b based on the stated aerodynamic particle sizes are shown in Tables 13.2.2-2 and 13.2.2-4. The PM-2.5 particle size multipliers (k -factors) are taken from Reference 27.

Table 13.2.2-2. CONSTANTS FOR EQUATIONS 1a AND 1b

Constant	Industrial Roads (Equation 1a)			Public Roads (Equation 1b)		
	PM-2.5	PM-10	PM-30*	PM-2.5	PM-10	PM-30*
k (lb/VMT)	0.15	1.5	4.9	0.18	1.8	6.0
a	0.9	0.9	0.7	1	1	1
b	0.45	0.45	0.45	-	-	-
c	-	-	-	0.2	0.2	0.3
d	-	-	-	0.5	0.5	0.3
Quality Rating	B	B	B	B	B	B

*Assumed equivalent to total suspended particulate matter (TSP)

“-“ = not used in the emission factor equation

Table 13.2.2-2 also contains the quality ratings for the various size-specific versions of Equation 1a and 1b. The equation retains the assigned quality rating, if applied within the ranges of source conditions, shown in Table 13.2.2-3, that were tested in developing the equation:

Table 13.2.2-3. RANGE OF SOURCE CONDITIONS USED IN DEVELOPING EQUATION 1a AND 1b

Emission Factor	Surface Silt Content, %	Mean Vehicle Weight		Mean Vehicle Speed		Mean No. of Wheels	Surface Moisture Content, %
		Mg	ton	km/hr	mph		
Industrial Roads (Equation 1a)	1.8-25.2	1.8-260	2-290	8-69	5-43	4-17 ^a	0.03-13
Public Roads (Equation 1b)	1.8-35	1.4-2.7	1.5-3	16-88	10-55	4-4.8	0.03-13

^a See discussion in text.

As noted earlier, the models presented as Equations 1a and 1b were developed from tests of traffic on unpaved surfaces. Unpaved roads have a hard, generally nonporous surface that usually dries quickly after a rainfall or watering, because of traffic-enhanced natural evaporation. (Factors influencing how fast a road dries are discussed in Section 13.2.2.3, below.) The quality ratings given above pertain to the mid-range of the measured source conditions for the equation. A higher mean vehicle weight and a higher than normal traffic rate may be justified when performing a worst-case analysis of emissions from unpaved roads.

The emission factors for the exhaust, brake wear and tire wear of a 1980's vehicle fleet (C) was obtained from EPA's MOBILE6.2 model ²³. The emission factor also varies with aerodynamic size range

as shown in Table 13.2.2-4

Table 13.2.2-4. EMISSION FACTOR FOR 1980'S VEHICLE FLEET
EXHAUST, BRAKE WEAR AND TIRE WEAR

Particle Size Range ^a	C, Emission Factor for Exhaust, Brake Wear and Tire Wear ^b lb/VMT
PM _{2.5}	0.00036
PM ₁₀	0.00047
PM ₃₀ ^c	0.00047

- ^a Refers to airborne particulate matter (PM-x) with an aerodynamic diameter equal to or less than x micrometers.
- ^b Units shown are pounds per vehicle mile traveled (lb/VMT).
- ^c PM-30 is sometimes termed "suspendable particulate" (SP) and is often used as a surrogate for TSP.

It is important to note that the vehicle-related source conditions refer to the average weight, speed, and number of wheels for all vehicles traveling the road. For example, if 98 percent of traffic on the road are 2-ton cars and trucks while the remaining 2 percent consists of 20-ton trucks, then the mean weight is 2.4 tons. More specifically, Equations 1a and 1b are *not* intended to be used to calculate a separate emission factor for each vehicle class within a mix of traffic on a given unpaved road. That is, in the example, one should *not* determine one factor for the 2-ton vehicles and a second factor for the 20-ton trucks. Instead, only one emission factor should be calculated that represents the "fleet" average of 2.4 tons for all vehicles traveling the road.

Moreover, to retain the quality ratings when addressing a group of unpaved roads, it is necessary that reliable correction parameter values be determined for the road in question. The field and laboratory procedures for determining road surface silt and moisture contents are given in AP-42 Appendices C.1 and C.2. Vehicle-related parameters should be developed by recording visual observations of traffic. In some cases, vehicle parameters for industrial unpaved roads can be determined by reviewing maintenance records or other information sources at the facility.

In the event that site-specific values for correction parameters cannot be obtained, then default values may be used. In the absence of site-specific silt content information, an appropriate mean value from Table 13.2.2-1 may be used as a default value, but the quality rating of the equation is reduced by two letters. Because of significant differences found between different types of road surfaces and between different areas of the country, use of the default moisture content value of 0.5 percent in Equation 1b is discouraged. The quality rating should be downgraded two letters when the default moisture content value is used. (It is assumed that readers addressing industrial roads have access to the information needed to develop average vehicle information in Equation 1a for their facility.)

The effect of routine watering to control emissions from unpaved roads is discussed below in Section 13.2.2.3, "Controls". However, all roads are subject to some natural mitigation because of rainfall and other precipitation. The Equation 1a and 1b emission factors can be extrapolated to annual

average uncontrolled conditions (but including natural mitigation) under the simplifying assumption that annual average emissions are inversely proportional to the number of days with measurable (more than 0.254 mm [0.01 inch]) precipitation:

$$E_{\text{ext}} = E [(365 - P)/365] \quad (2)$$

where:

E_{ext} = annual size-specific emission factor extrapolated for natural mitigation, lb/VMT

E = emission factor from Equation 1a or 1b

P = number of days in a year with at least 0.254 mm (0.01 in) of precipitation (see below)

Figure 13.2.2-1 gives the geographical distribution for the mean annual number of “wet” days for the United States.

Equation 2 provides an estimate that accounts for precipitation on an annual average basis for the purpose of inventorying emissions. It should be noted that Equation 2 does not account for differences in the temporal distributions of the rain events, the quantity of rain during any event, or the potential for the rain to evaporate from the road surface. In the event that a finer temporal and spatial resolution is desired for inventories of public unpaved roads, estimates can be based on a more complex set of assumptions. These assumptions include:

1. The moisture content of the road surface material is increased in proportion to the quantity of water added;
2. The moisture content of the road surface material is reduced in proportion to the Class A pan evaporation rate;
3. The moisture content of the road surface material is reduced in proportion to the traffic volume; and
4. The moisture content of the road surface material varies between the extremes observed in the area. The CHIEF Web site (<http://www.epa.gov/ttn/chief/ap42/ch13/related/c13s02-2.html>) has a file which contains a spreadsheet program for calculating emission factors which are temporally and spatially resolved. Information required for use of the spreadsheet program includes monthly Class A pan evaporation values, hourly meteorological data for precipitation, humidity and snow cover, vehicle traffic information, and road surface material information.

It is emphasized that the simple assumption underlying Equation 2 and the more complex set of assumptions underlying the use of the procedure which produces a finer temporal and spatial resolution have not been verified in any rigorous manner. For this reason, the quality ratings for either approach should be downgraded one letter from the rating that would be applied to Equation 1.

13.2.2.3 Controls¹⁸⁻²²

A wide variety of options exist to control emissions from unpaved roads. Options fall into the following three groupings:

1. Vehicle restrictions that limit the speed, weight or number of vehicles on the road;

2. Surface improvement, by measures such as (a) paving or (b) adding gravel or slag to a dirt road; and
3. Surface treatment, such as watering or treatment with chemical dust suppressants.

Available control options span broad ranges in terms of cost, efficiency, and applicability. For example, traffic controls provide moderate emission reductions (often at little cost) but are difficult to enforce. Although paving is highly effective, its high initial cost is often prohibitive. Furthermore, paving is not feasible for industrial roads subject to very heavy vehicles and/or spillage of material in transport. Watering and chemical suppressants, on the other hand, are potentially applicable to most industrial roads at moderate to low costs. However, these require frequent reapplication to maintain an acceptable level of control. Chemical suppressants are generally more cost-effective than water but not in cases of temporary roads (which are common at mines, landfills, and construction sites). In summary, then, one needs to consider not only the type and volume of traffic on the road but also how long the road will be in service when developing control plans.

Vehicle restrictions. These measures seek to limit the amount and type of traffic present on the road or to lower the mean vehicle speed. For example, many industrial plants have restricted employees from driving on plant property and have instead instituted bussing programs. This eliminates emissions due to employees traveling to/from their worksites. Although the heavier average vehicle weight of the busses increases the base emission factor, the decrease in vehicle-miles-traveled results in a lower overall emission rate.

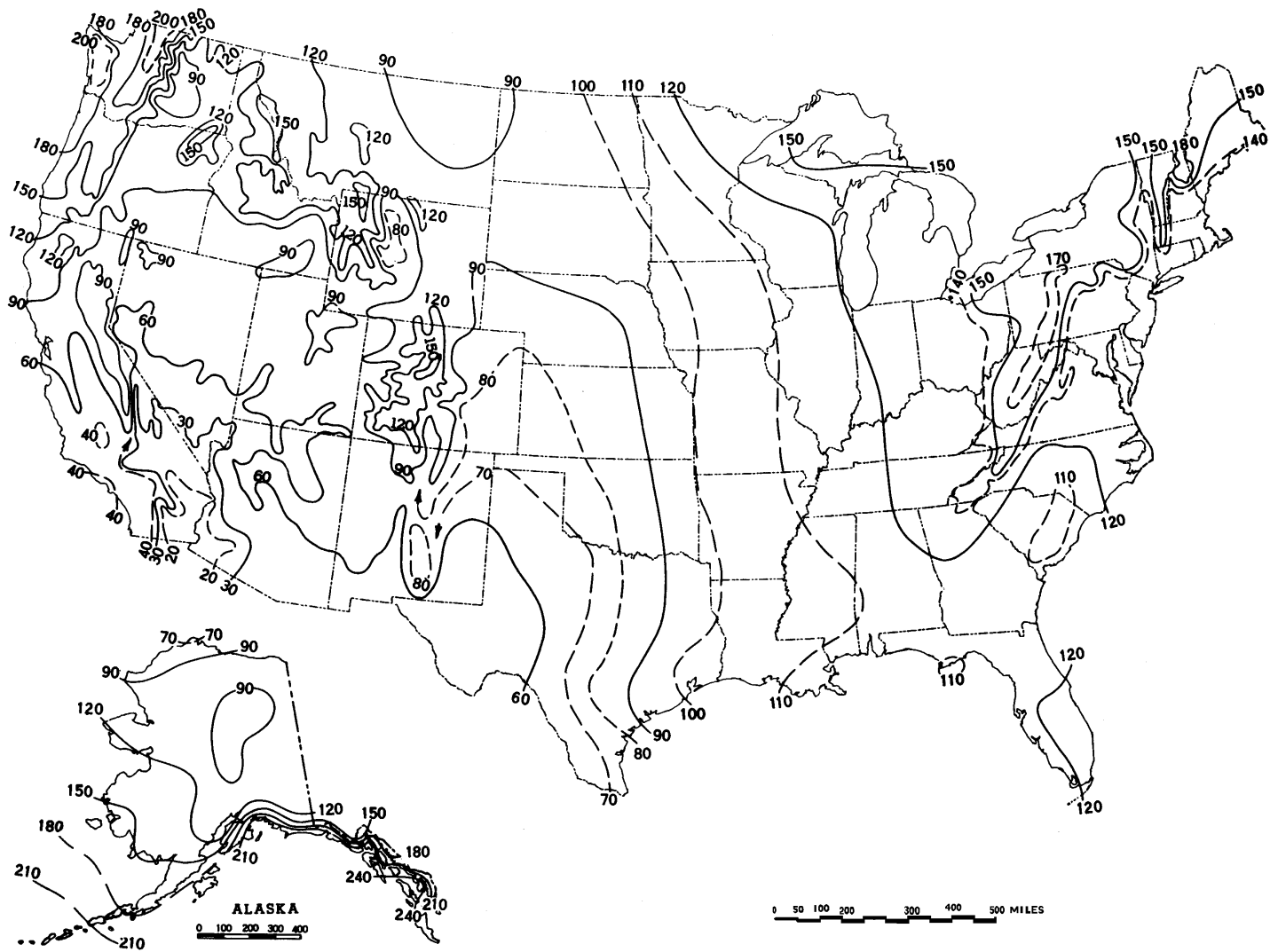

Figure 13.2.2-1. Mean number of days with 0.01 inch or more of precipitation in United States.

Surface improvements. Control options in this category alter the road surface. As opposed to the “surface treatments” discussed below, improvements are relatively “permanent” and do not require periodic retreatment.

The most obvious surface improvement is paving an unpaved road. This option is quite expensive and is probably most applicable to relatively short stretches of unpaved road with at least several hundred vehicle passes per day. Furthermore, if the newly paved road is located near unpaved areas or is used to transport material, it is essential that the control plan address routine cleaning of the newly paved road surface.

The control efficiencies achievable by paving can be estimated by comparing emission factors for unpaved and paved road conditions. The predictive emission factor equation for paved roads, given in Section 13.2.1, requires estimation of the silt loading on the traveled portion of the paved surface, which in turn depends on whether the pavement is periodically cleaned. Unless curbing is to be installed, the effects of vehicle excursion onto unpaved shoulders (berms) also must be taken into account in estimating the control efficiency of paving.

Other improvement methods cover the road surface with another material that has a lower silt content. Examples include placing gravel or slag on a dirt road. Control efficiency can be estimated by comparing the emission factors obtained using the silt contents before and after improvement. The silt content of the road surface should be determined after 3 to 6 months rather than immediately following placement. Control plans should address regular maintenance practices, such as grading, to retain larger aggregate on the traveled portion of the road.

Surface treatments refer to control options which require periodic reapplication. Treatments fall into the two main categories of (a) “wet suppression” (i. e., watering, possibly with surfactants or other additives), which keeps the road surface wet to control emissions and (b) “chemical stabilization/treatment”, which attempts to change the physical characteristics of the surface. The necessary reapplication frequency varies from several minutes for plain water under summertime conditions to several weeks or months for chemical dust suppressants.

Watering increases the moisture content, which conglomerates particles and reduces their likelihood to become suspended when vehicles pass over the surface. The control efficiency depends on how fast the road dries after water is added. This in turn depends on (a) the amount (per unit road surface area) of water added during each application; (b) the period of time between applications; (c) the weight, speed and number of vehicles traveling over the watered road during the period between applications; and (d) meteorological conditions (temperature, wind speed, cloud cover, etc.) that affect evaporation during the period.

Figure 13.2.2-2 presents a simple bilinear relationship between the instantaneous control efficiency due to watering and the resulting increase in surface moisture. The moisture ratio "M" (i.e., the x-axis in Figure 13.2.2-2) is found by dividing the surface moisture content of the watered road by the surface moisture content of the uncontrolled road. As the watered road surface dries, both the ratio M and the predicted instantaneous control efficiency (i.e., the y-axis in the figure) decrease. The figure shows that between the uncontrolled moisture content and a value twice as large, a small increase in moisture content results in a large increase in control efficiency. Beyond that, control efficiency grows slowly with increased moisture content.

Given the complicated nature of how the road dries, characterization of emissions from watered roadways is best done by collecting road surface material samples at various times between water truck passes. (Appendices C.1 and C.2 present the sampling and analysis procedures.) The moisture content measured can then be associated with a control efficiency by use of Figure 13.2.2-2. Samples that reflect average conditions during the watering cycle can take the form of either a series of samples between water applications or a single sample at the midpoint. It is essential that samples be collected during periods with active traffic on the road. Finally, because of different evaporation rates, it is recommended that samples be collected at various times during the year. If only one set of samples is to be collected, these must be collected during hot, summertime conditions.

When developing watering control plans for roads that do not yet exist, it is strongly recommended that the moisture cycle be established by sampling similar roads in the same geographic area. If the moisture cycle cannot be established by similar roads using established watering control plans, the more complex methodology used to estimate the mitigation of rainfall and other precipitation can be used to estimate the control provided by routine watering. An estimate of the maximum daytime Class A pan evaporation (based upon daily evaporation data published in the monthly Climatological Data for the state by the National Climatic Data Center) should be used to insure that adequate watering capability is available during periods of highest evaporation. The hourly precipitation values in the spreadsheet should be replaced with the equivalent inches of precipitation (where the equivalent of 1 inch of precipitation is provided by an application of 5.6 gallons of water per square yard of road). Information on the long term average annual evaporation and on the percentage that occurs between May and October was published in the Climatic Atlas (Reference 16). Figure 13.2.2-3 presents the geographical distribution for "Class A pan evaporation" throughout the United States. Figure 13.2.2-4 presents the geographical distribution of the percentage of this evaporation that occurs between May and October. The U. S. Weather Bureau Class A evaporation pan is a cylindrical metal container with a depth of 10 inches and a diameter of 48 inches. Periodic measurements are made of the changes of the water level.

The above methodology should be used only for prospective analyses and for designing watering programs for existing roadways. The quality rating of an emission factor for a watered road that is based on this methodology should be downgraded two letters. Periodic road surface samples should be collected and analyzed to verify the efficiency of the watering program.

As opposed to watering, chemical dust suppressants have much less frequent reapplication requirements. These materials suppress emissions by changing the physical characteristics of the existing road surface material. Many chemical unpaved road dust suppressants form a hardened surface that binds particles together. After several applications, a treated road often resembles a paved road except that the surface is not uniformly flat. Because the improved surface results in more grinding of small particles, the silt content of loose material on a highly controlled surface may be substantially higher than when the surface was uncontrolled. For this reason, the models presented as Equations 1a and 1b cannot be used to estimate emissions from chemically stabilized roads. Should the road be allowed to return to an

uncontrolled state with no visible signs of large-scale cementing of material, the Equation 1a and 1b emission factors could then be used to obtain conservatively high emission estimates.

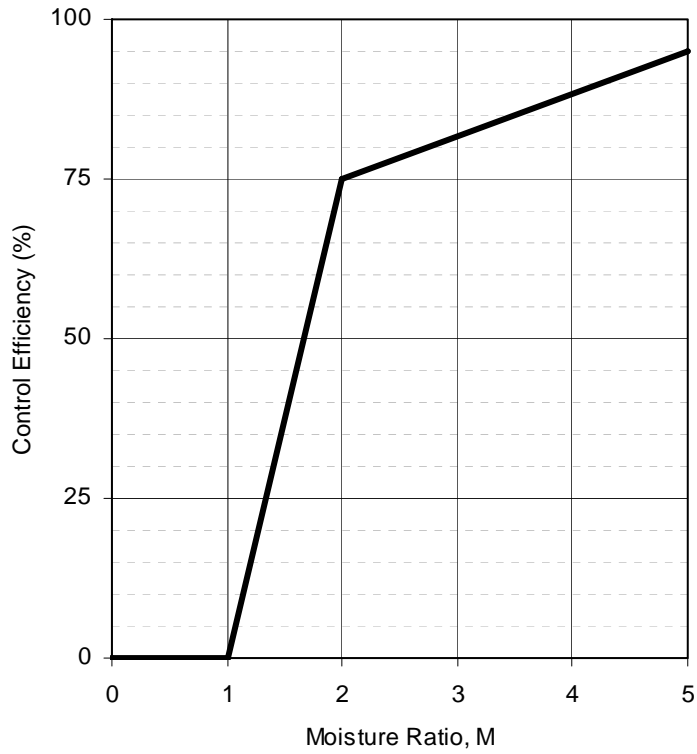

Figure 13.2.2-2. Watering control effectiveness for unpaved travel surfaces

The control effectiveness of chemical dust suppressants appears to depend on (a) the dilution rate used in the mixture; (b) the application rate (volume of solution per unit road surface area); (c) the time between applications; (d) the size, speed and amount of traffic during the period between applications; and (e) meteorological conditions (rainfall, freeze/thaw cycles, etc.) during the period. Other factors that affect the performance of dust suppressants include other traffic characteristics (e. g., cornering, track-on from unpaved areas) and road characteristics (e. g., bearing strength, grade). The variabilities in the above factors and differences between individual dust control products make the control efficiencies of chemical dust suppressants difficult to estimate. Past field testing of emissions from controlled unpaved roads has shown that chemical dust suppressants provide a PM-10 control efficiency of about 80 percent when applied at regular intervals of 2 weeks to 1 month.

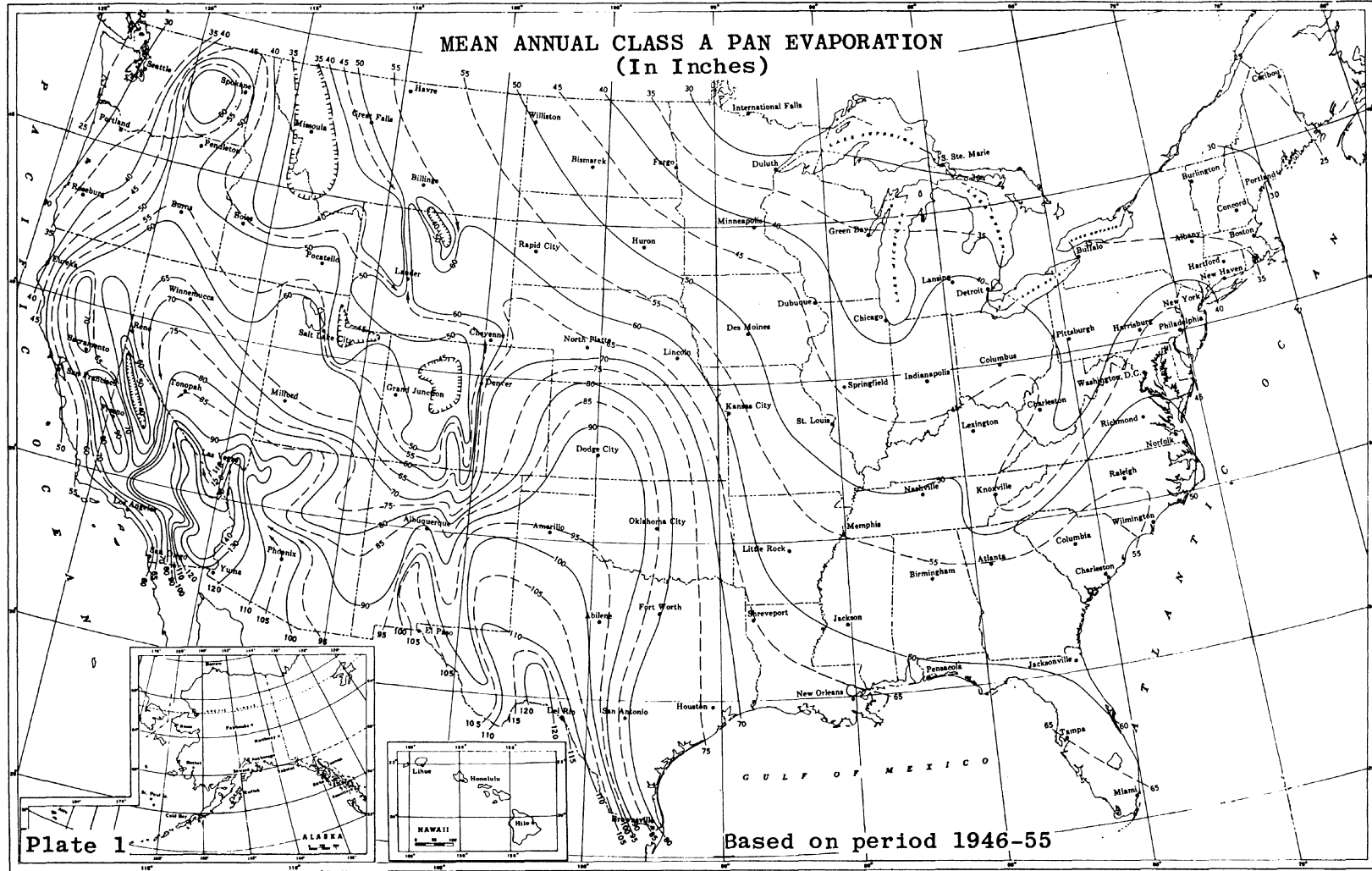

Figure 13.2.2-3. Annual evaporation data.

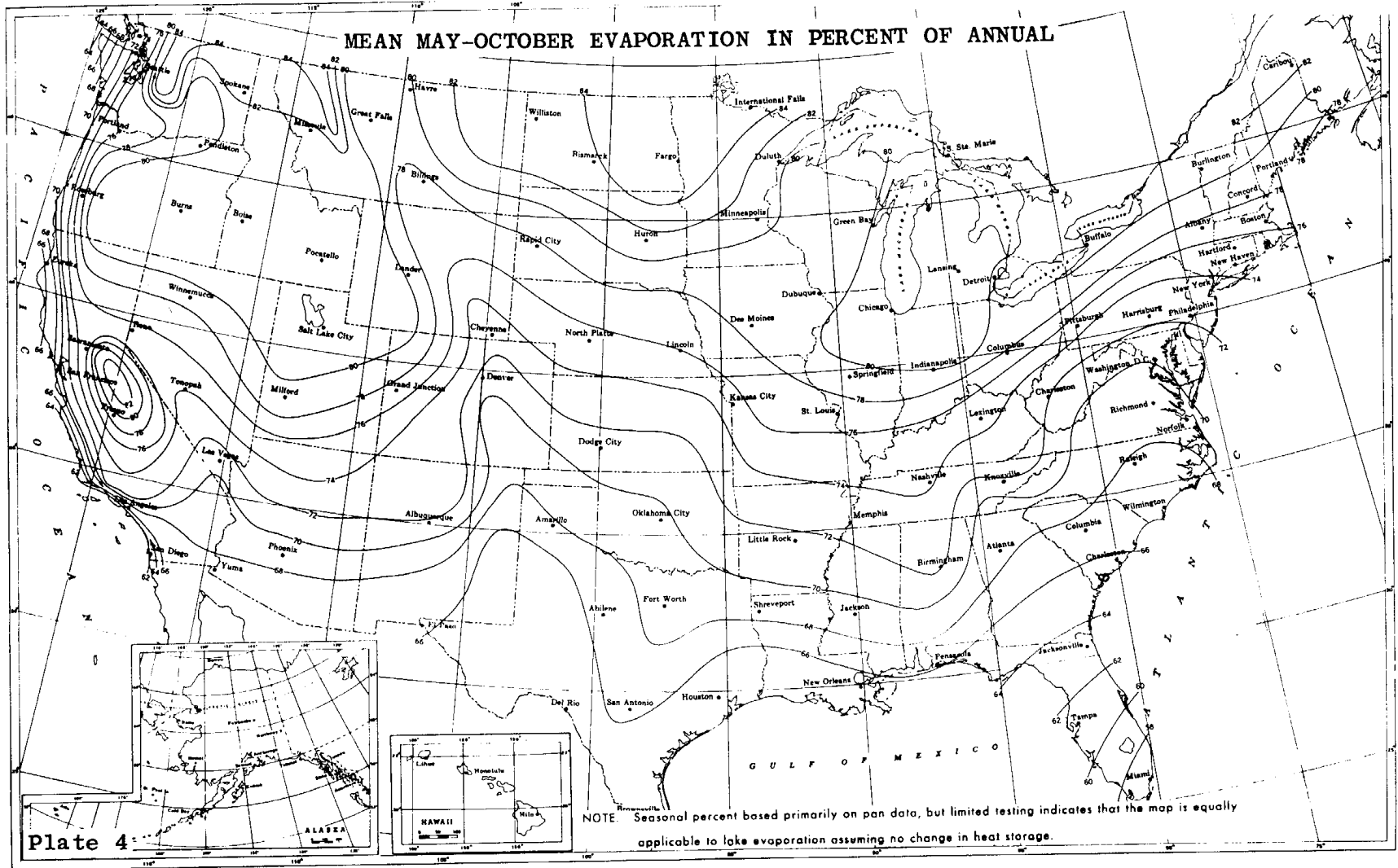

Figure 13.2.2-4. Geographical distribution of the percentage of evaporation occurring between May and October.

Petroleum resin products historically have been the dust suppressants (besides water) most widely used on industrial unpaved roads. Figure 13.2.2-5 presents a method to estimate average control efficiencies associated with petroleum resins applied to unpaved roads.²⁰ Several items should be noted:

1. The term "ground inventory" represents the total volume (per unit area) of petroleum resin concentrate (*not solution*) applied since the start of the dust control season.
2. Because petroleum resin products must be periodically reapplied to unpaved roads, the use of a time-averaged control efficiency value is appropriate. Figure 13.2.2-5 presents control efficiency values averaged over two common application intervals, 2 weeks and 1 month. Other application intervals will require interpolation.
3. Note that zero efficiency is assigned until the ground inventory reaches 0.05 gallon per square yard (gal/yd²). Requiring a minimum ground inventory ensures that one must apply a reasonable amount of chemical dust suppressant to a road before claiming credit for emission control. Recall that the ground inventory refers to the amount of petroleum resin concentrate rather than the total solution.

As an example of the application of Figure 13.2.2-5, suppose that Equation 1a was used to estimate an emission factor of 7.1 lb/VMT for PM-10 from a particular road. Also, suppose that, starting on May 1, the road is treated with 0.221 gal/yd² of a solution (1 part petroleum resin to 5 parts water) on the first of each month through September. Then, the average controlled emission factors, shown in Table 13.2.2-5, are found.

Table 13.2-2-5. EXAMPLE OF AVERAGE CONTROLLED EMISSION FACTORS FOR SPECIFIC CONDITIONS

Period	Ground Inventory, gal/yd ²	Average Control Efficiency, % ^a	Average Controlled Emission Factor, lb/VMT
May	0.037	0	7.1
June	0.073	62	2.7
July	0.11	68	2.3
August	0.15	74	1.8
September	0.18	80	1.4

^a From Figure 13.2.2-5, $\leq 10 \mu\text{m}$. Zero efficiency assigned if ground inventory is less than 0.05 gal/yd². 1 lb/VMT = 281.9 g/VKT. 1 gal/yd² = 4.531 L/m².

Besides petroleum resins, other newer dust suppressants have also been successful in controlling emissions from unpaved roads. Specific test results for those chemicals, as well as for petroleum resins and watering, are provided in References 18 through 21.

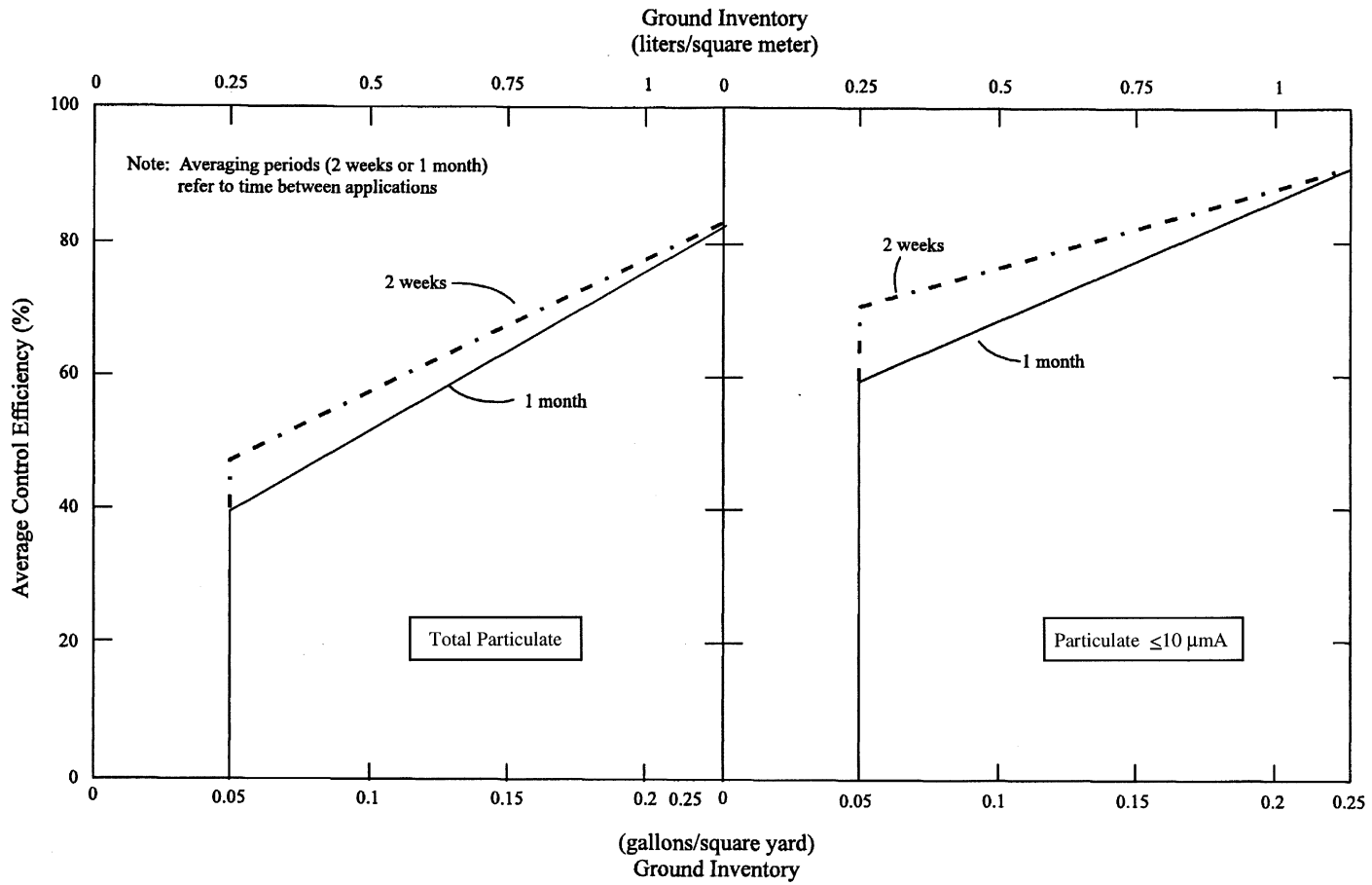

Figure 13.2.2-5. Average control efficiencies over common application intervals.

13.2.2.4 Updates Since The Fifth Edition

The Fifth Edition was released in January 1995. Revisions to this section since that date are summarized below. For further detail, consult the background report for this section (Reference 6).

October 1998 (Supplement E)– This was a major revision of this section. Significant changes to the text and the emission factor equations were made.

October 2001 – Separate emission factors for unpaved surfaces at industrial sites and publicly accessible roads were introduced. Figure 13.2.2-2 was included to provide control effectiveness estimates for watered roads.

December 2003 – The public road emission factor equation (equation 1b) was adjusted to remove the component of particulate emissions from exhaust, brake wear, and tire wear. The parameter *C* in the new equation varies with aerodynamic size range of the particulate matter. Table 13.2.2-4 was added to present the new coefficients.

January 2006 – The PM-2.5 particle size multipliers (i.e., factors) in Table 13.2.2-2 were modified and the quality ratings were upgraded from C to B based on the wind tunnel studies of a variety of dust emitting surface materials.

References For Section 13.2.2

1. C. Cowherd, Jr., *et al.*, *Development Of Emission Factors For Fugitive Dust Sources*, EPA-450/3-74-037, U. S. Environmental Protection Agency, Research Triangle Park, NC, June 1974.
2. R. J. Dyck and J. J. Stukel, "Fugitive Dust Emissions From Trucks On Unpaved Roads", *Environmental Science And Technology*, 10(10):1046-1048, October 1976.
3. R. O. McCaldin and K. J. Heidel, "Particulate Emissions From Vehicle Travel Over Unpaved Roads", Presented at the 71st Annual Meeting of the Air Pollution Control Association, Houston, TX, June 1978.
4. C. Cowherd, Jr., *et al.*, *Iron And Steel Plant Open Dust Source Fugitive Emission Evaluation*, EPA-600/2-79-013, U. S. Environmental Protection Agency, Cincinnati, OH, May 1979.
5. G. Muleski, *Unpaved Road Emission Impact*, Arizona Department of Environmental Quality, Phoenix, AZ, March 1991.
6. *Emission Factor Documentation For AP-42, Section 13.2.2, Unpaved Roads, Final Report*, Midwest Research Institute, Kansas City, MO, September 1998.
7. T. Cuscino, Jr., *et al.*, *Taconite Mining Fugitive Emissions Study*, Minnesota Pollution Control Agency, Roseville, MN, June 1979.
8. *Improved Emission Factors For Fugitive Dust From Western Surface Coal Mining Sources*, 2 Volumes, EPA Contract No. 68-03-2924, Office of Air Quality Planning and Standards, U. S. Environmental Protection Agency, Research Triangle Park, NC.

9. T. Cuscino, Jr., *et al.*, *Iron And Steel Plant Open Source Fugitive Emission Control Evaluation*, EPA-600/2-83-110, U. S. Environmental Protection Agency, Cincinnati, OH, October 1983.
10. *Size Specific Emission Factors For Uncontrolled Industrial And Rural Roads*, EPA Contract No. 68-02-3158, Midwest Research Institute, Kansas City, MO, September 1983.
11. C. Cowherd, Jr., and P. Englehart, *Size Specific Particulate Emission Factors For Industrial And Rural Roads*, EPA-600/7-85-038, U. S. Environmental Protection Agency, Cincinnati, OH, September 1985.
12. *PM-10 Emission Inventory Of Landfills In The Lake Calumet Area*, EPA Contract 68-02-3891, Work Assignment 30, Midwest Research Institute, Kansas City, MO, September 1987.
13. *Chicago Area Particulate Matter Emission Inventory — Sampling And Analysis*, EPA Contract No. 68-02-4395, Work Assignment 1, Midwest Research Institute, Kansas City, MO, May 1988.
14. *PM-10 Emissions Inventory Data For The Maricopa And Pima Planning Areas*, EPA Contract No. 68-02-3888, Engineering-Science, Pasadena, CA, January 1987.
15. *Oregon Fugitive Dust Emission Inventory*, EPA Contract 68-D0-0123, Midwest Research Institute, Kansas City, MO, January 1992.
16. *Climatic Atlas Of The United States*, U. S. Department Of Commerce, Washington, DC, June 1968.
17. National Climatic Data Center, *Solar And Meteorological Surface Observation Network 1961-1990*; 3 Volume CD-ROM. Asheville, NC, 1993.
18. C. Cowherd, Jr. *et al.*, *Control Of Open Fugitive Dust Sources*, EPA-450/3-88-008, U. S. Environmental Protection Agency, Research Triangle Park, NC, September 1988.
19. G. E. Muleski, *et al.*, *Extended Evaluation Of Unpaved Road Dust Suppressants In The Iron And Steel Industry*, EPA-600/2-84-027, U. S. Environmental Protection Agency, Cincinnati, OH, February 1984.
20. C. Cowherd, Jr., and J. S. Kinsey, *Identification, Assessment And Control Of Fugitive Particulate Emissions*, EPA-600/8-86-023, U. S. Environmental Protection Agency, Cincinnati, OH, August 1986.
21. G. E. Muleski and C. Cowherd, Jr., *Evaluation Of The Effectiveness Of Chemical Dust Suppressants On Unpaved Roads*, EPA-600/2-87-102, U. S. Environmental Protection Agency, Cincinnati, OH, November 1986.
22. *Fugitive Dust Background Document And Technical Information Document For Best Available Control Measures*, EPA-450/2-92-004, Office Of Air Quality Planning And Standards, U. S. Environmental Protection Agency, Research Triangle Park, NC, September 1992.
23. Written communication (Technical Memorandum) from P. Hemmer, E.H. Pechan & Associates, Inc., Durham, NC to B. Kuykendal, U. S. Environmental Protection Agency, Research Triangle Park, NC, August, 21, 2003.

24. MOBILE6 User Guide, United States Environmental Protection Agency, Office of Transportation and Air Quality. EPA420-R-02-028, October 2002.
25. Written communication (Technical Memorandum) from G. Muleski, Midwest Research Institute, Kansas City, MO, to B. Kuykendal, U. S. Environmental Protection Agency, Research Triangle Park, NC, Subject "Unpaved Roads", September 27, 2001.
26. Written communication (Technical Memorandum) from W. Kuykendal, U. S. Environmental Protection Agency, to File, Subject "Decisions on Final AP-42 Section 13.2.2 Unpaved Roads", November 24, 2003.
27. C. Cowherd, *Background Document for Revisions to Fine Fraction Ratios &sed for AP-42 Fugitive Dust Emission Factors*. Prepared by Midwest Research Institute for Western Governors Association, Western Regional Air Partnership, Denver, CO, February 1, 2006.

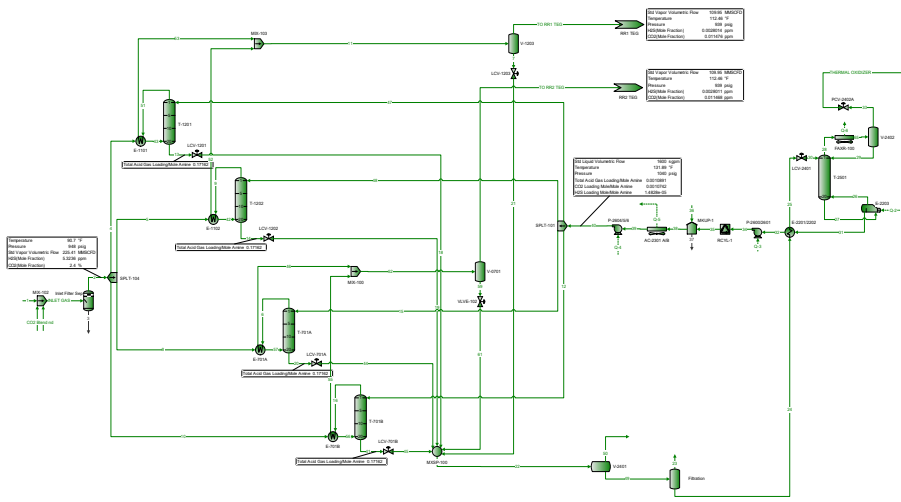

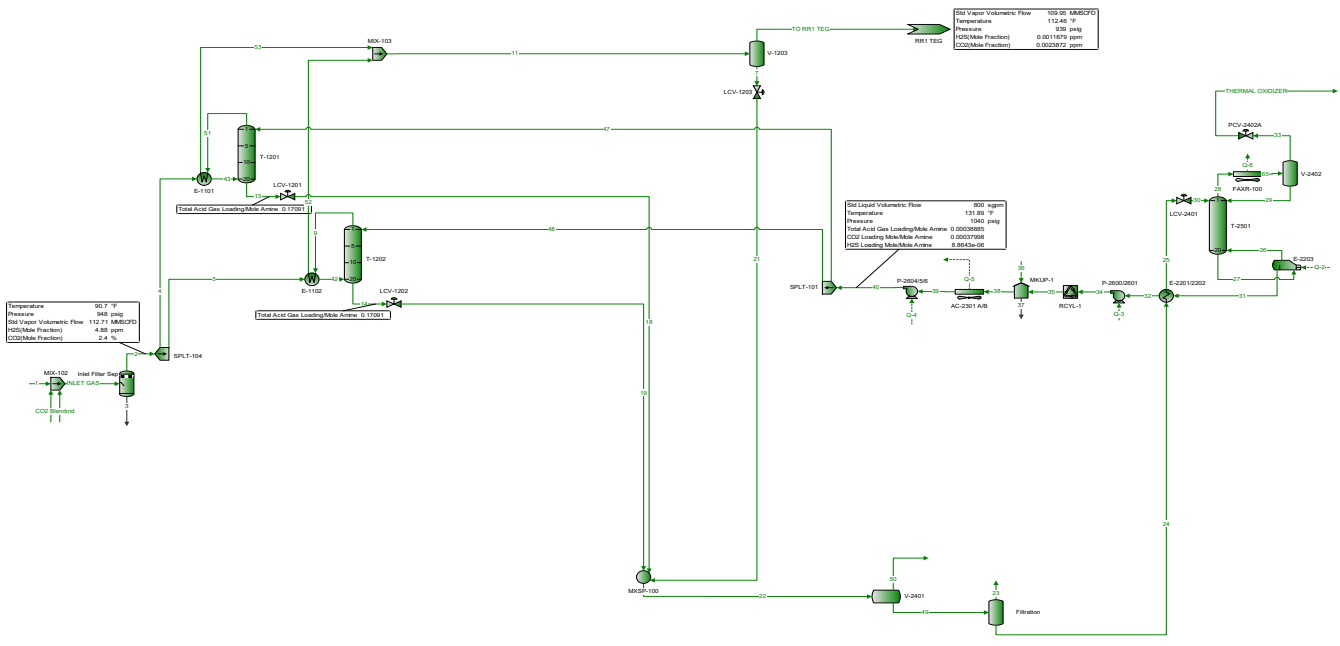

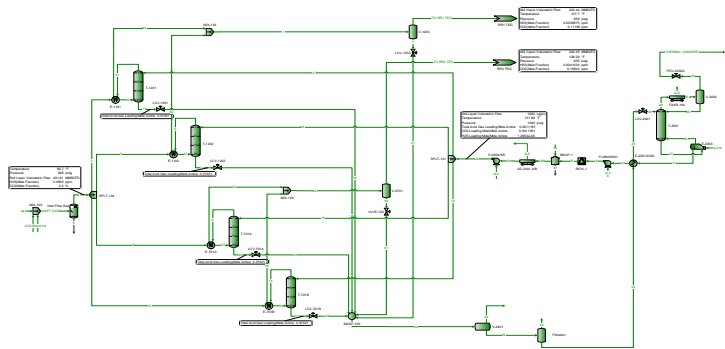

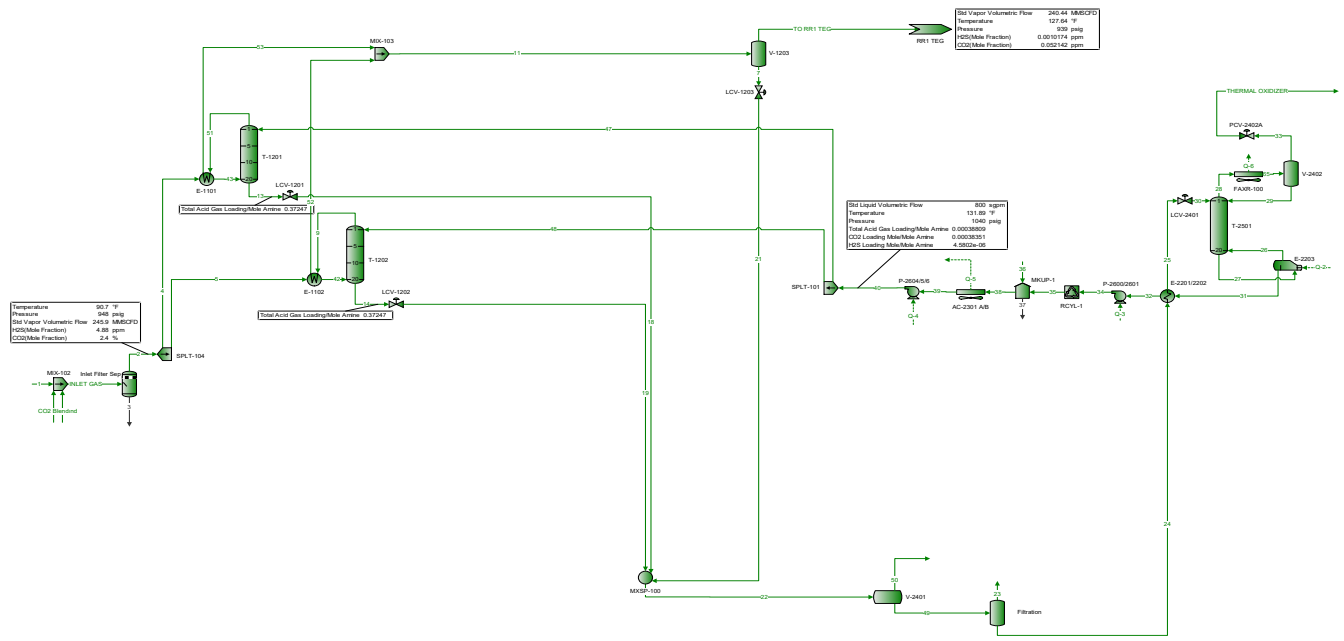

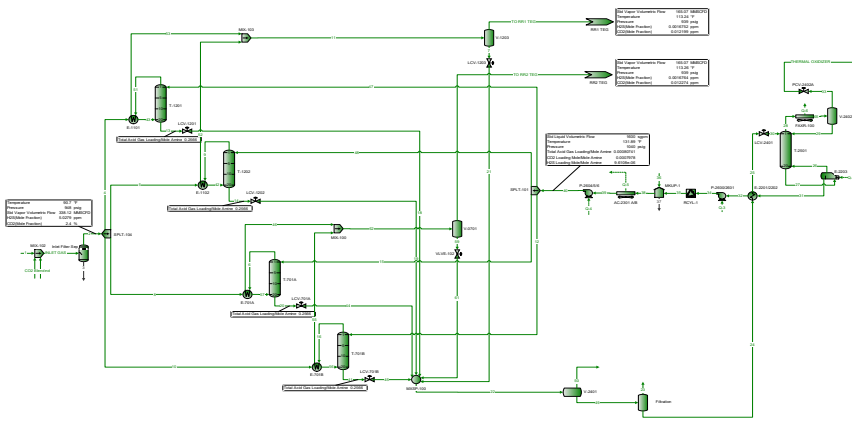

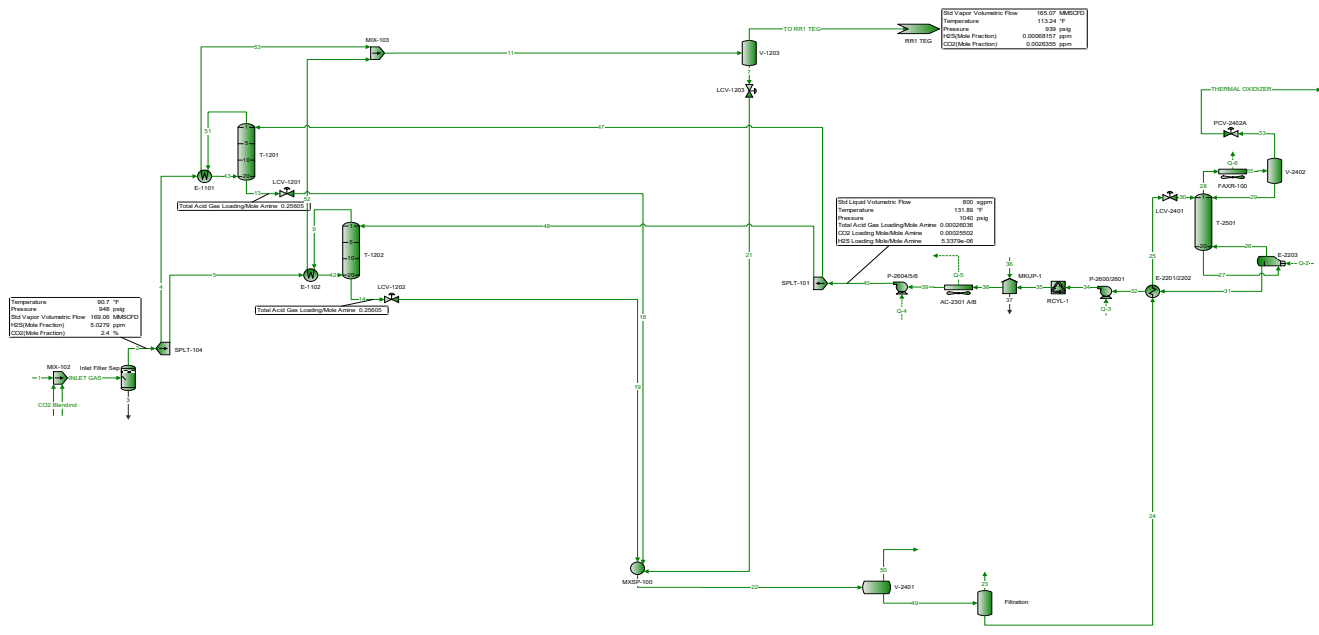

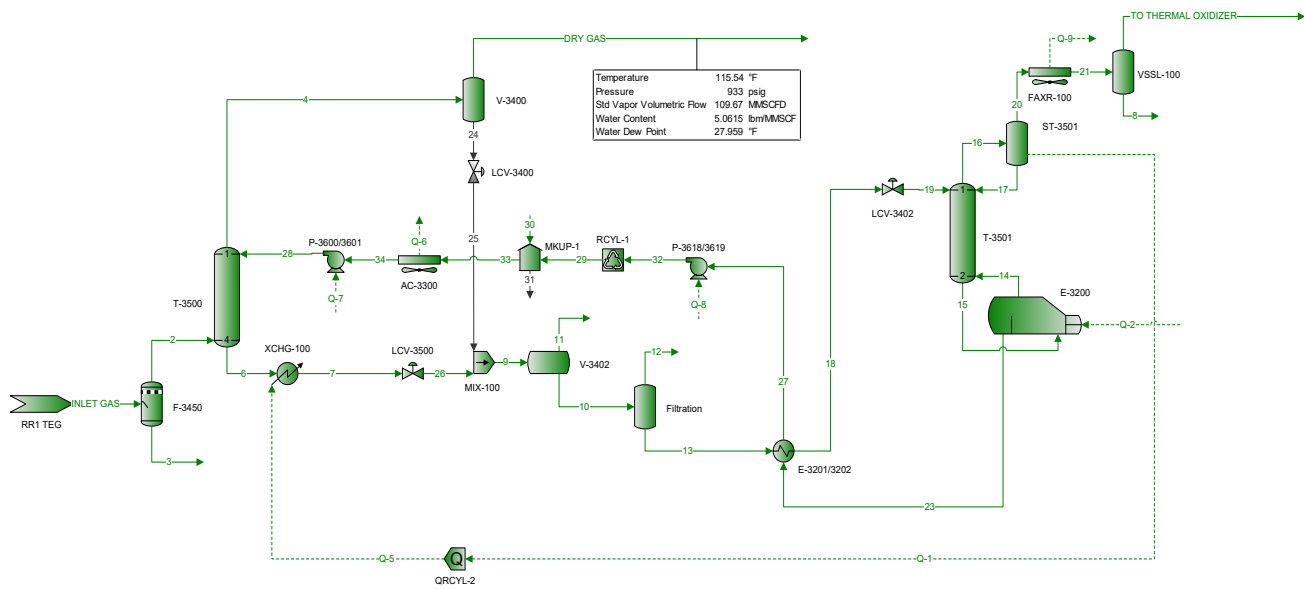

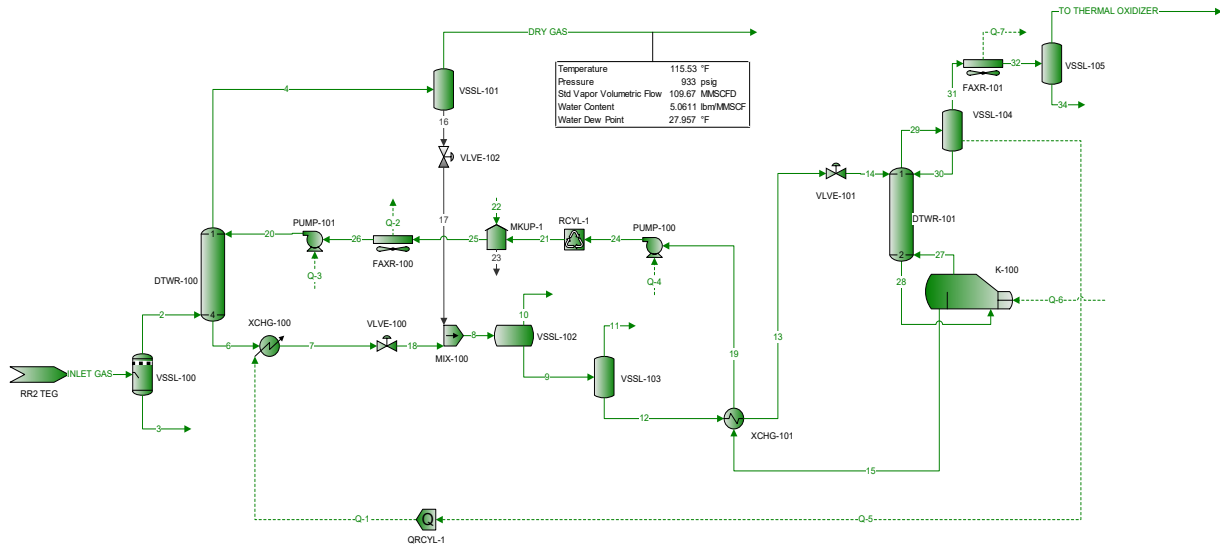

Temperature	115.53 °F
Pressure	933 psig
Std Vapor Volumetric Flow	109.67 MMSCFD
Water Content	5.0611 lbm/MMSCF
Water Dew Point	27.957 °F

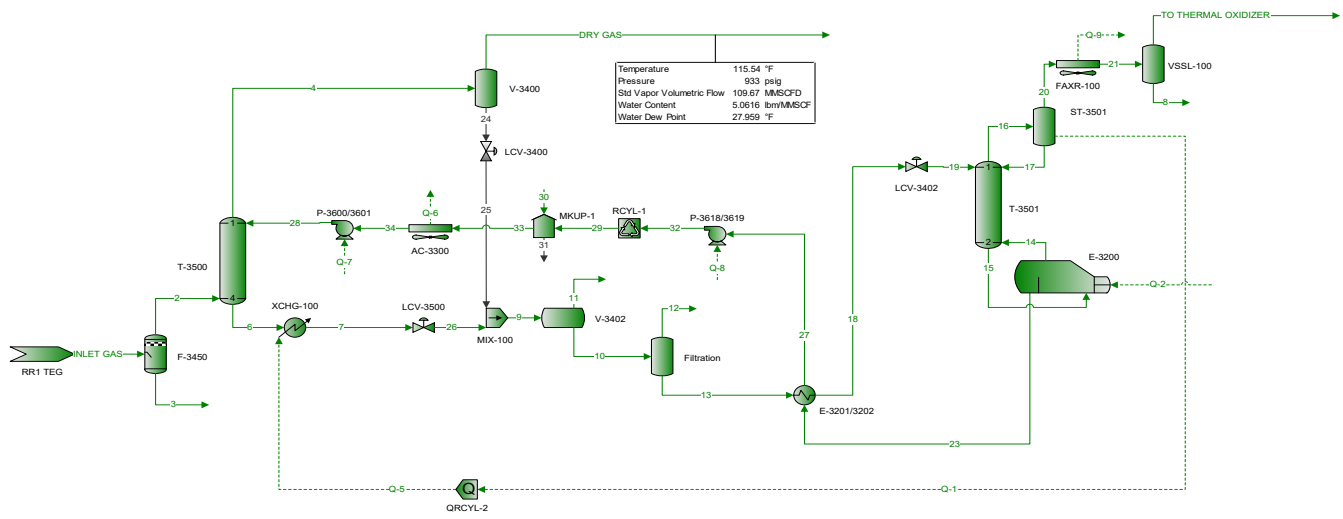

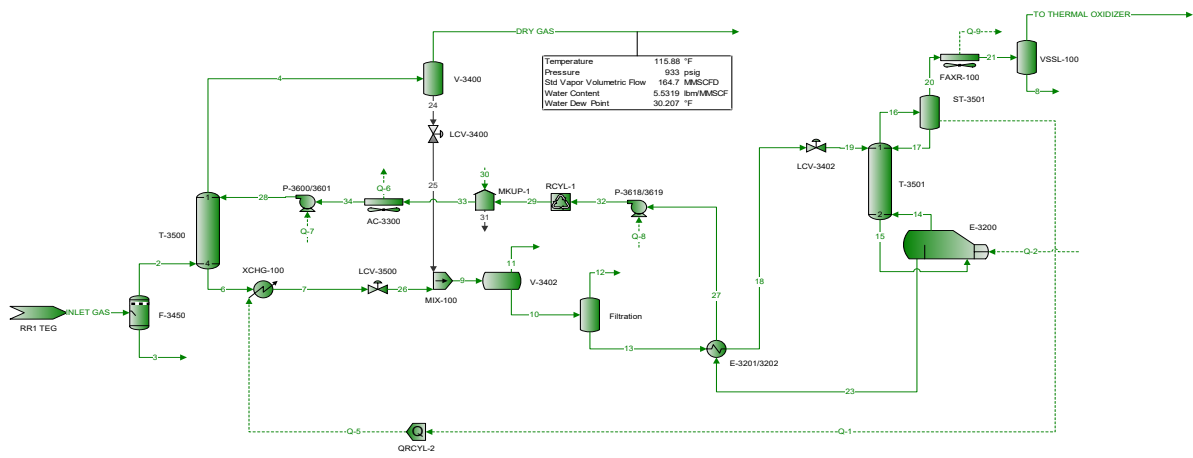

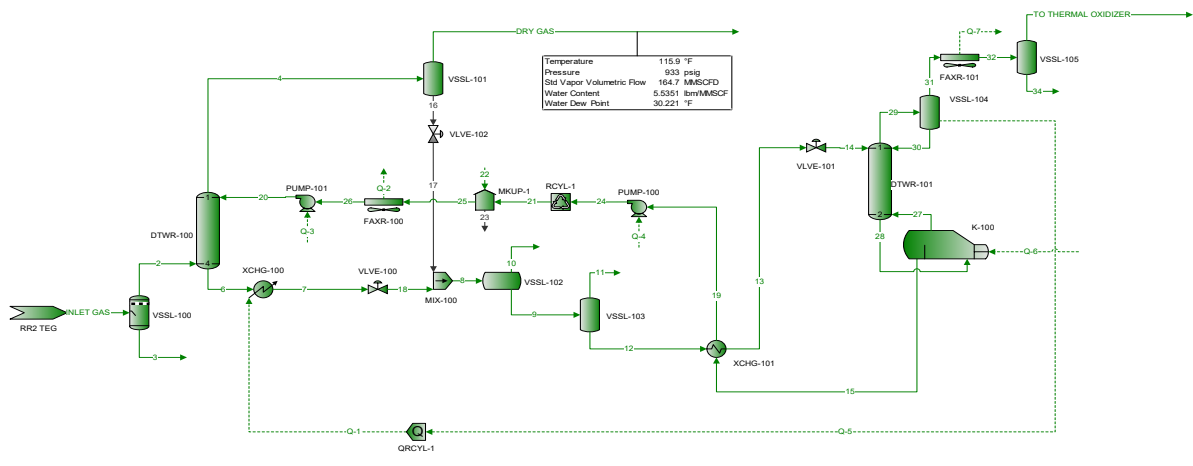

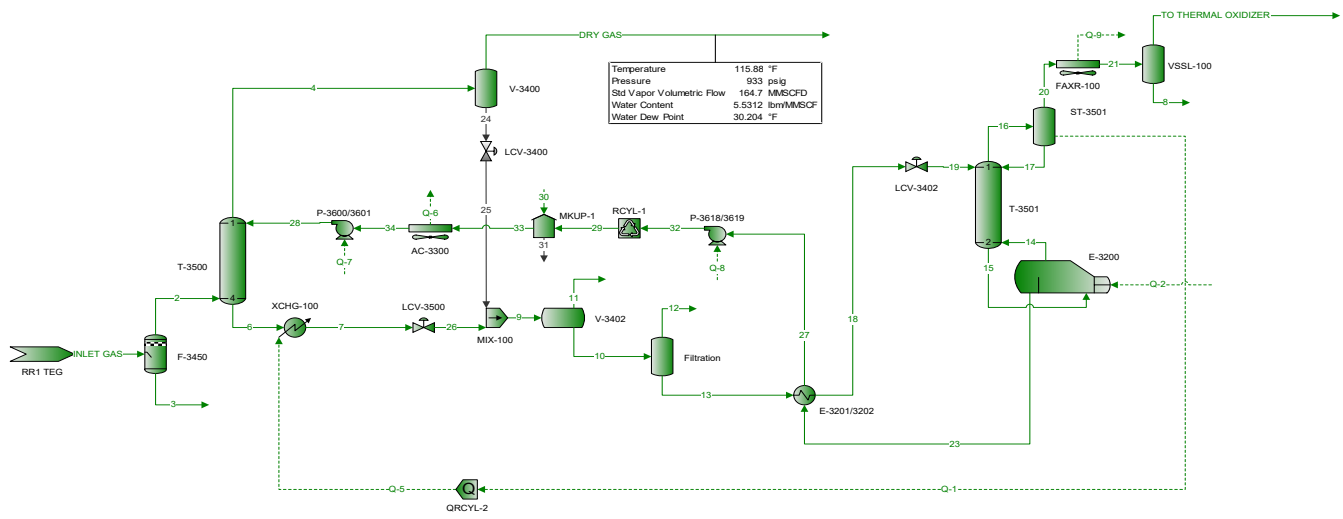

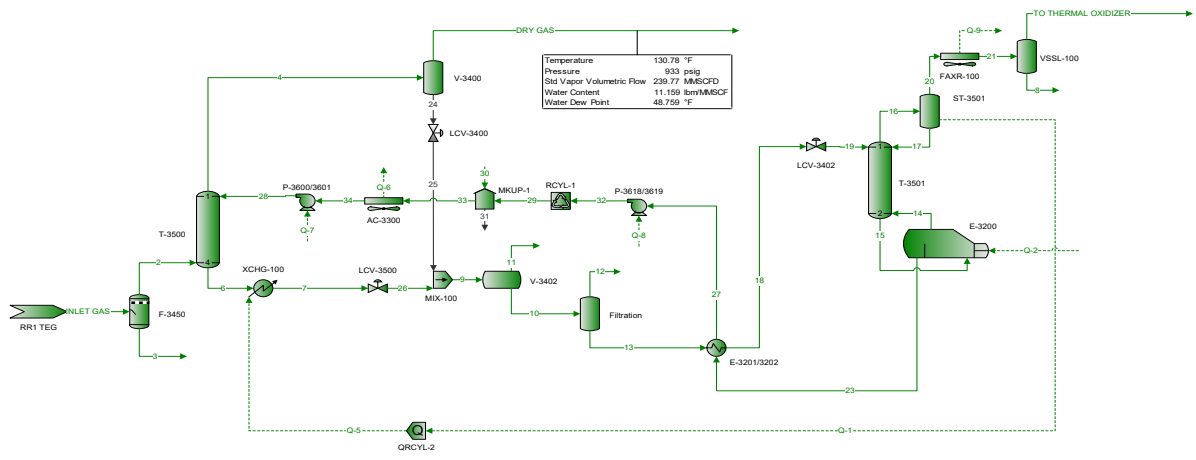

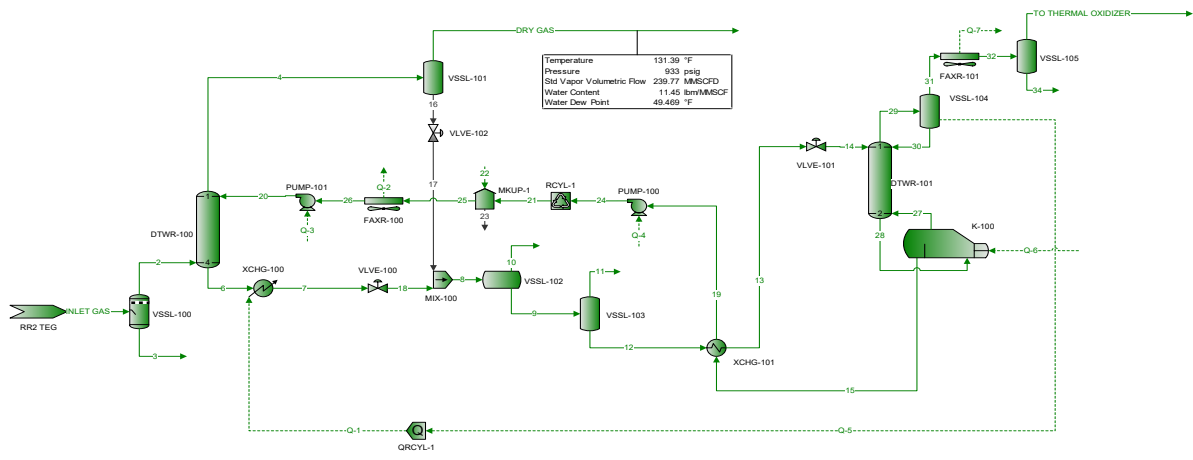

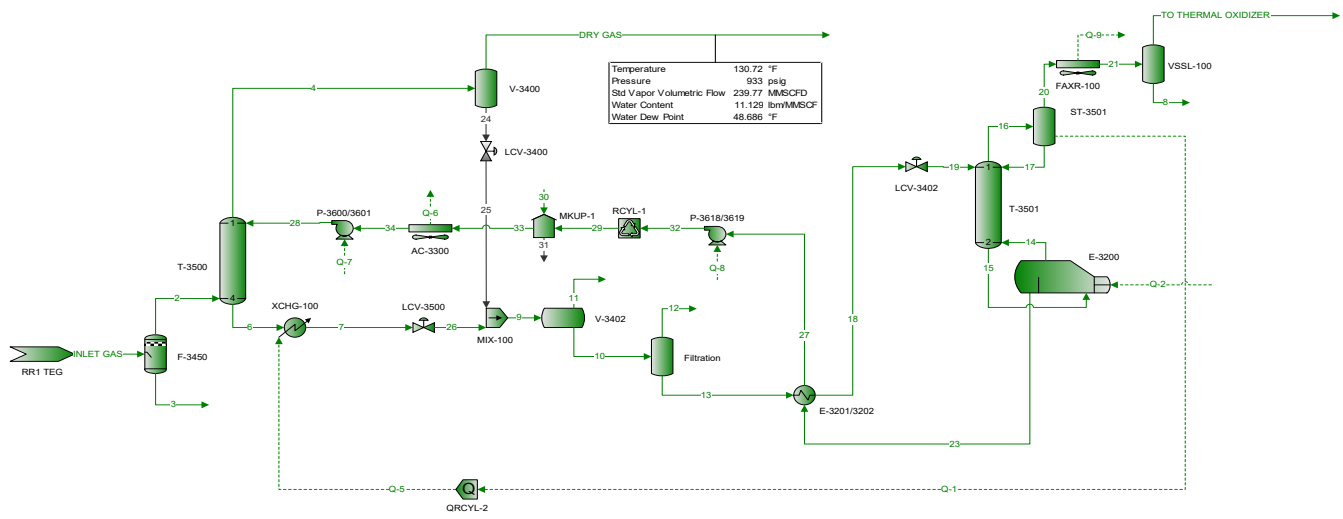

RR1 TEG

T-3500

F-3450

XCHG-100

P-3600/3601

Q-7

AC-3300

Q-6

LCV-3500

MIX-100

V-3402

Filtration

E-3201/3202

Q-1

LCV-3402

T-3501

E-3200

Q-2

ST-3501

FAXR-100

Q-9

VSSL-100

Q-5

QRCYL-2

LCV-3400

V-3400

Q-8

P-3618/3619

RCYL-1

MKUP-1

Q-3

Q-4

Q-10

Q-11

Q-12

Q-13

Q-14

Q-15

Q-16

Q-17

Q-18

Q-19

Q-20

Q-21

Q-22

Q-23

Q-24

Q-25

Q-26

Q-27

Q-28

Q-29

Q-30

Q-31

Q-32

Q-33

Q-34

Q-35

Q-36

Q-37

Q-38

Q-39

Q-40

Q-41

Q-42

Q-43

Q-44

Q-45

Q-46

Q-47

Q-48

Q-49

Q-50

Targa Midstream Services LLC Road Runner Gas Plant Hourly Crude Working/Breathing/Flash

July tank loss calculations for "1".
 Total working and breathing losses are 158.3 lb/h.
 Flashing losses are 24.96 lb/h.
 * Only Non-Exempt VOCs are reported.

WORKING →
 BREATHING →
 Loading →

Tank-1

Stream Vapor C3+ Mass Flow = 2.27 lb/h

Properties		Vapor
Mass Flow (Total)	3.05	lb/h
Mass Flow (Total)	13.4	ton/yr

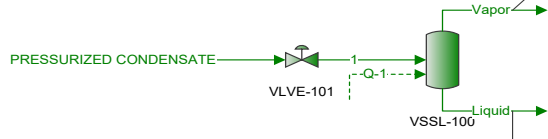

Properties		Liquid
Std Liquid Volumetric Flow (Total)	8e+03	bbbl/d

Names	Units	PRESSURIZED CONDENSATE	Liquid	Vapor
Temperature	°F	120*	95	95*
Pressure	psia	14.7*	14.7	14.7
Mass Fraction Vapor	%	0.19202	0	100
Molecular Weight	lb/lbmol	88.602	88.604	52.438
Vapor Volumetric Flow	ft ³ /h	2885.6	1913.6	23.24
Liquid Volumetric Flow	gpm	359.76	238.58	2.8975

Road Runner

Annual Crude Working/Breathing/Flash

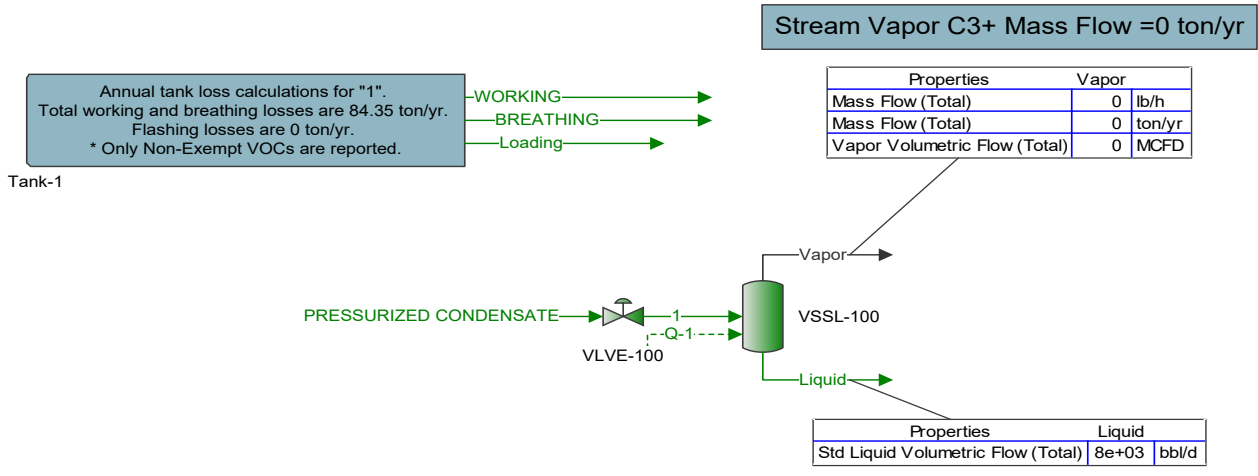

Names	Units	Liquid	Vapor
Temperature	°F	63.2	63.2*
Pressure	psig	0.0040512	0.0040512
Mass Fraction Vapor	%	0	
Molecular Weight	lb/lbmol	88.602	
Vapor Volumetric Flow	ft ³ /h	1867.5	0
Liquid Volumetric Flow	gpm	232.83	0

Road Runner

Hourly PW Working/Breathing/Flash

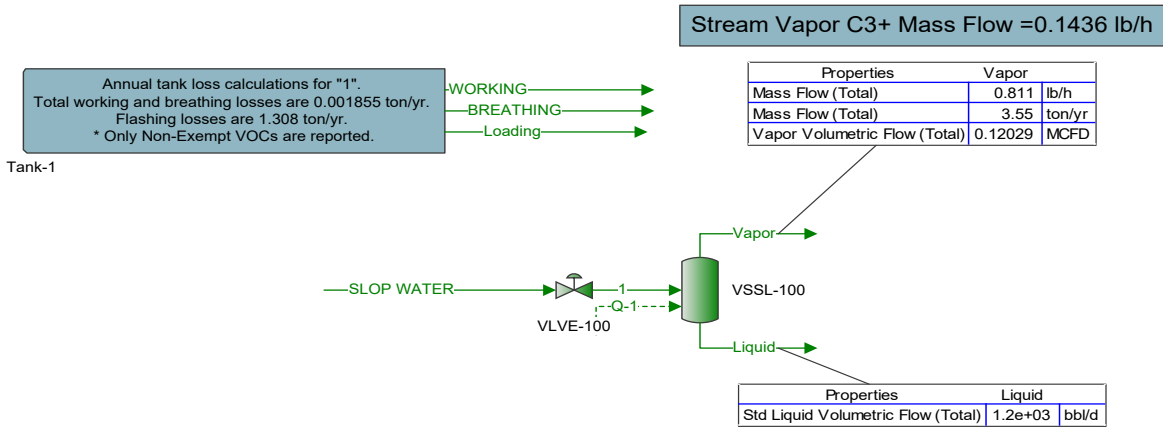

Names	Units	Liquid	Vapor
Temperature	°F	95	95*
Pressure	psig	20.223	20.223
Mass Fraction Vapor	%	0	100
Molecular Weight	lb/lbmol	18.02	27.302
Vapor Volumetric Flow	ft ³ /h	282.26	5.0121
Liquid Volumetric Flow	gpm	35.191	0.62488

Section 8

Map(s)

A map such as a 7.5 minute topographic quadrangle showing the exact location of the source. The map shall also include the following:

The UTM or Longitudinal coordinate system on both axes	An indicator showing which direction is north
A minimum radius around the plant of 0.8km (0.5 miles)	Access and haul roads
Topographic features of the area	Facility property boundaries
The name of the map	The area which will be restricted to public access
A graphical scale	

A topographical map is attached.

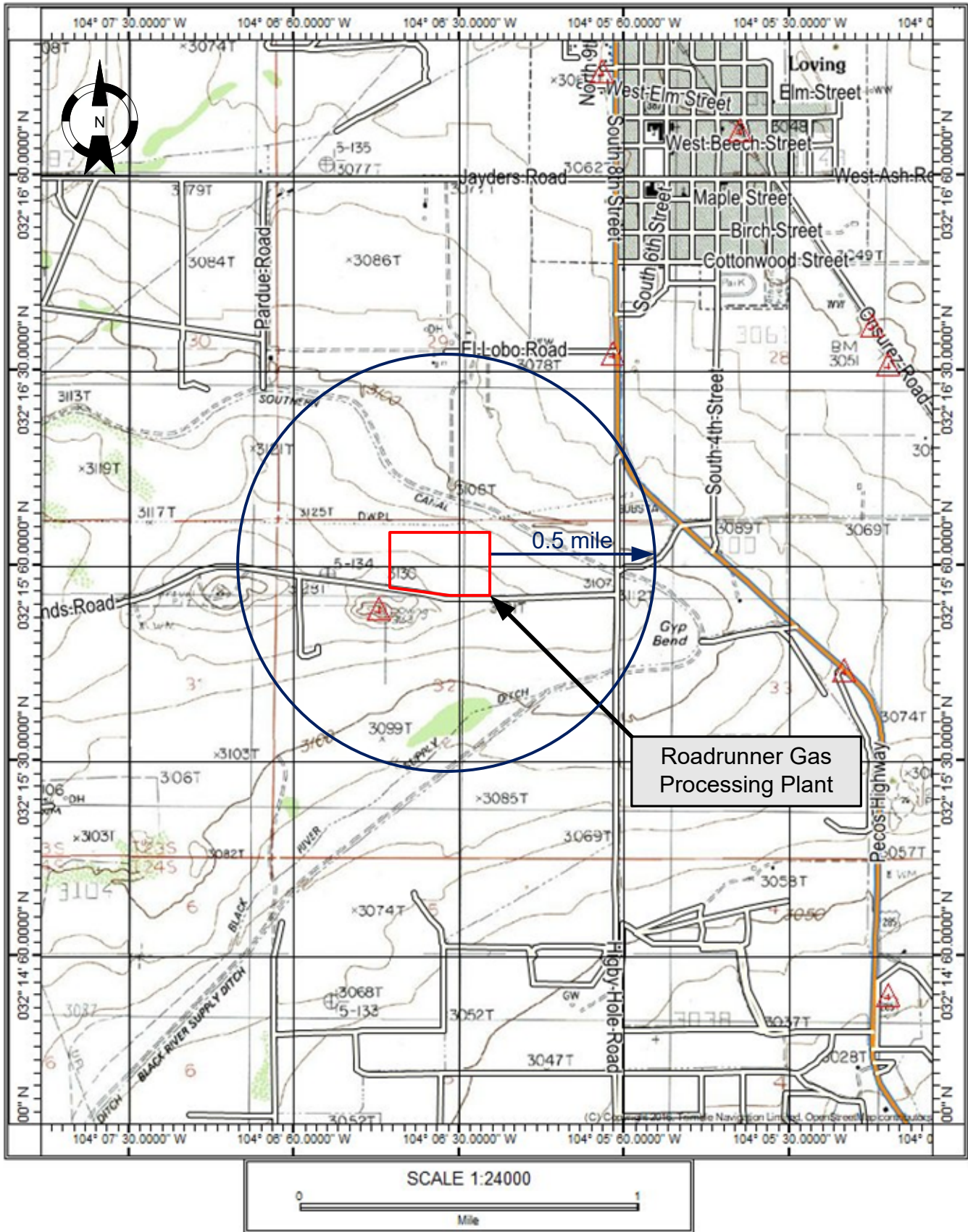

Scale:	Drawn by:	Date:
1:24,000	MDF	4/8/2020
	Chk'd by:	Date:

Area Map Roadrunner Gas Processing Plant N 32° 15' 56.71" Latitude W 104° 6' 29.97" Longitude
--

Lucid Energy Delaware, LLC		
Project No.:	File Name:	Figure:
097-002	Roadrunner Figures	Section 8

Section 9

Proof of Public Notice

(for NSR applications submitting under 20.2.72 or 20.2.74 NMAC)

(This proof is required by: 20.2.72.203.A.14 NMAC “Documentary Proof of applicant’s public notice”)

I have read the AQB “Guidelines for Public Notification for Air Quality Permit Applications”

This document provides detailed instructions about public notice requirements for various permitting actions. It also provides public notice examples and certification forms. Material mistakes in the public notice will require a re-notice before issuance of the permit.

Unless otherwise allowed elsewhere in this document, the following items document proof of the applicant’s Public Notification. Please include this page in your proof of public notice submittal with checkmarks indicating which documents are being submitted with the application.

New Permit and **Significant Permit Revision** public notices must include all items in this list.

Technical Revision public notices require only items 1, 5, 9, and 10.

Per the Guidelines for Public Notification document mentioned above, include:

1. A copy of the certified letter receipts with post marks (20.2.72.203.B NMAC)
2. A list of the places where the public notice has been posted in at least four publicly accessible and conspicuous places, including the proposed or existing facility entrance. (e.g: post office, library, grocery, etc.)
3. A copy of the property tax record (20.2.72.203.B NMAC).
4. A sample of the letters sent to the owners of record.
5. A sample of the letters sent to counties, municipalities, and Indian tribes.
6. A sample of the public notice posted and a verification of the local postings.
7. A table of the noticed citizens, counties, municipalities and tribes and to whom the notices were sent in each group.
8. A copy of the public service announcement (PSA) sent to a local radio station and documentary proof of submittal.
9. A copy of the classified or legal ad including the page header (date and newspaper title) or its affidavit of publication stating the ad date, and a copy of the ad. When appropriate, this ad shall be printed in both English and Spanish.
10. A copy of the display ad including the page header (date and newspaper title) or its affidavit of publication stating the ad date, and a copy of the ad. When appropriate, this ad shall be printed in both English and Spanish.
11. A map with a graphic scale showing the facility boundary and the surrounding area in which owners of record were notified by mail. This is necessary for verification that the correct facility boundary was used in determining distance for notifying land owners of record.

Public notice documents are attached.

General Posting of Notices – Certification

I, Jaylen Fuentes, the undersigned, certify that on **December 13, 2022**, posted a true and correct copy of the attached Public Notice in the following publicly accessible and conspicuous places in the **Village of Loving** of **Eddy** County, State of New Mexico on the following dates:

1. Facility entrance: 12/13/2022
2. Village of Loving City Hall: 12/13/2022
3. Loving Allsup’s Convenience Store: 12/13/2022
4. Loving USPS: 12/13/2022

Signed this 13th day of December, 2022,



Signature

12/13/2022

Date

Jaylen Fuentes

Printed Name

Environmental Specialist

Title

NOTICE

Targa Northern Delaware, LLC announces its application submittal to the New Mexico Environment Department for an air quality permit for the **modification** of its **Road Runner Gas Processing Plant** facility. The expected date of application submittal to the Air Quality Bureau is **December 13, 2022**.

The exact location for the proposed facility known as, **Road Runner Gas Processing Plant**, is at latitude **32 deg, 15 min, 56.71 sec** and longitude **-104 deg, 6 min, 29.97 sec**. The approximate location of this facility is **1.7 miles south-west** of Loving in Eddy County, New Mexico.

The proposed **modification** consists of updating NSR Permit 7200-M3 based on the most current plans, updating representations, and removing one proposed processing train from the permit. The estimated maximum quantities of any regulated air contaminant will be as follows in pound per hour (pph) and tons per year (tpy) and could change slightly during the course of the Department's review:

Pollutant:	Pounds per hour	Tons per year
Particulate Matter (PM)	5 pph	19 tpy
PM ₁₀	5 pph	18 tpy
PM _{2.5}	5 pph	17 tpy
Sulfur Dioxide (SO ₂)	2,764 pph	163 tpy
Nitrogen Oxides (NO _x)	5,241 pph	172 tpy
Carbon Monoxide (CO)	10,443 pph	249 tpy
Volatile Organic Compounds (VOC) (with fugitives)	8,952 pph	328 tpy
Volatile Organic Compounds (VOC) (without fugitives)	8,923 pph	201 tpy
Total sum of all Hazardous Air Pollutants (HAPs)	455 pph	24.9 tpy
Toxic Air Pollutant (TAP)	n/a pph	n/a tpy
Green House Gas Emissions as Total CO _{2e}	n/a	467,511 tpy

The standard and maximum operating schedules of the facility will be 24 hours a day, 7 days a week and a maximum of 52 weeks per year.

The owner and/or operator of the Facility is: **Targa Northern Delaware, LLC; 6 Desta Drive, Suite 3300, Midland, TX 79705**

If you have any comments about the construction or operation of this facility, and you want your comments to be made as part of the permit review process, you must submit your comments in writing to this address: Permit Programs Manager; New Mexico Environment Department; Air Quality Bureau; 525 Camino de los Marquez, Suite 1; Santa Fe, New Mexico; 87505-1816. Other comments and questions may be submitted verbally. (505) 476-4300; 1 800 224-7009.

With your comments, please refer to the company name and facility name, or send a copy of this notice along with your comments. This information is necessary since the Department may have not yet received the permit application. Please include a legible return mailing address. Once the Department has completed its preliminary review of the application and its air quality impacts, the Department's notice will be published in the legal section of a newspaper circulated near the facility location.

Atención

Este es un aviso de la oficina de Calidad del Aire del Departamento del Medio Ambiente de Nuevo México, acerca de las emisiones producidas por un establecimiento en esta área. Si usted desea información en español, por favor comuníquese con esa oficina al teléfono 505-372-8373.

Notice of Non-Discrimination

NMED does not discriminate on the basis of race, color, national origin, disability, age or sex in the administration of its programs or activities, as required by applicable laws and regulations. NMED is responsible for coordination of compliance efforts and receipt of inquiries concerning non-discrimination requirements implemented by 40 C.F.R. Part 7, including Title VI of the Civil Rights Act of 1964, as amended; Section 504 of the Rehabilitation Act of 1973; the Age Discrimination Act of 1975, Title IX of the Education Amendments of 1972, and Section 13 of the Federal Water Pollution Control Act Amendments of 1972. If you have any questions about this notice or any of NMED's non-discrimination programs, policies or procedures, or if you believe that you have been discriminated against with respect to a NMED program or activity, you may contact: Kathryn Becker, Non-Discrimination Coordinator, NMED, 1190 St. Francis Dr., Suite N4050, P.O. Box 5469, Santa Fe, NM 87502, (505) 827-2855, nd.coordinator@state.nm.us. You may also visit our website at <https://www.env.nm.gov/non-employee-discrimination-complaint-page/> to learn how and where to file a complaint of discrimination.

D

arding
arn how
mit
nts of

ts:
niles: Dawson's
object area which
eral, state, and
s
itance between
nning source
vibrois trucks

er sq. inch:
ced on the
ibrois truck



NOTICE

Targa Northern Delaware, LLC announces its application submittal to the New Mexico Environment Department for an air quality permit for the modification of its **Road Runner Gas Processing Plant** facility. The expected date of application submittal to the Air Quality Bureau is **December 13, 2022**.

The exact location for the proposed facility known as, **Road Runner Gas Processing Plant**, is at latitude **32 deg, 15 min, 56.71 sec** and longitude **-104 deg, 6 min, 29.97 sec**. The approximate location of this facility is 1.7 miles south-west of Loving in Eddy County, New Mexico.

The proposed modification consists of updating NSR Permit 7200-M3 based on the most current plans, updating representations, and removing one proposed processing train from the permit. The estimated maximum quantities of any regulated air contaminant will be as follows in pound per hour (pph) and tons per year (tpy) and could change slightly during the course of the Department's review:

Pollutant:	Pounds per hour	Tons per year
Particulate Matter (PM)	5 pph	19 tpy
PM ₁₀	5 pph	18 tpy
PM _{2.5}	5 pph	17 tpy
Sulfur Dioxide (SO ₂)	2,764 pph	163 tpy
Nitrogen Oxides (NO _x)	5,241 pph	172 tpy
Carbon Monoxide (CO)	10,443 pph	249 tpy
Volatile Organic Compounds (VOC) (with fugitives)	8,952 pph	328 tpy
Volatle Organic Compounds (VOC) (without fugitives)	8,923 pph	201 tpy
Total sum of all Hazardous Air Pollutants (HAPs)	455 pph	24.9 tpy
Toxic Air Pollutant (TAP)	n/a pph	n/a tpy
Green House Gas Emissions as Total CO ₂ e	n/a	467,511 tpy

The standard and maximum operating schedules of the facility will be 24 hours a day, 7 days a week and a maximum of 52 weeks per year.

The owner and/or operator of the Facility is: **Targa Northern Delaware, LLC; 6 Desta Drive, Suite 3300, Midland, TX 79705**

If you have any comments about the construction or operation of this facility, and you want your comments to be made as part of the permit review process, you must submit your comments in writing to this address: Permit Programs Manager, New Mexico Environment Department, Air Quality Bureau; 525 Camino de los Marquez, Suite 1; Santa Fe, New Mexico; 87505-1816. Other comments and questions may be submitted verbally. (505) 476-4300; 1 800 224-7009.

With your comments, please refer to the company name and facility name, or send a copy of this notice along with your comments. This information is necessary since the Department may have not yet received the permit application. Please include a legible return mailing address. Once the Department has completed its preliminary review of the application and its air quality impacts, the Department's notice will be published in the legal section of a newspaper circulated near the facility location.

Atención

Este es un aviso de la oficina de Calidad del Aire del Departamento del Medio Ambiente de Nuevo México, acerca de las emisiones producidas por un establecimiento en esta área. Si usted desea información en español, por favor comuníquese con esa oficina al teléfono 505-372-8373.

Notice of Non-Discrimination

NMED does not discriminate on the basis of race, color, national origin, disability, age or sex in the administration of its programs or activities, as required by applicable laws and regulations. NMED is responsible for coordination of compliance efforts and receipt of inquiries concerning non-discrimination requirements implemented by 40 C.F.R. Part 7, including Title VI of the Civil Rights Act of 1964, as amended; Section 504 of the Rehabilitation Act of 1973; the Age Discrimination Act of 1975, Title IX of the Education Amendments of 1972, and Section 13 of the Federal Water Pollution Control Act Amendments of 1972. If you have any questions about this notice or any of NMED's non-discrimination programs, policies or procedures, or if you believe that you have been discriminated against with respect to a NMED program or activity, you may contact: Kathryn Becker, Non-Discrimination Coordinator, NMED, 1190 St. Francis Dr., Suite N4050, P.O. Box 5469, Santa Fe, NM 87502, (505) 827-2855, nd.coordinator@state.nm.us. You may also visit our website at <https://www.env.nm.gov/non-employee-discrimination-complaint-page/> to learn how and where to file a complaint of discrimination.



NOTICE

Targa Northern Delaware, LLC announces its application submittal to the New Mexico Environment Department for an air quality permit for the modification of its Road Runner Gas Processing Plant facility. The expected date of application submittal to the Air Quality Bureau is December 13, 2022.

The exact location for the proposed facility known as, Road Runner Gas Processing Plant, is at latitude 32 deg, 15 min, 56.71 sec and longitude -104 deg, 6 min, 29.97 sec. The approximate location of this facility is 1.7 miles south-west of Loving in Eddy County, New Mexico.

The proposed modification consists of updating NSR Permit 7200-M3 based on the most current plans, updating representations, and removing one proposed processing train from the permit. The estimated maximum quantities of any regulated air contaminant will be as follows in pound per hour (pph) and tons per year (tpy) and could change slightly during the course of the Department's review:

Pollutant:	Pounds per hour	Tons per year
Particulate Matter (PM)	5 pph	19 tpy
PM ₁₀	5 pph	18 tpy
PM _{2.5}	5 pph	17 tpy
Sulfur Dioxide (SO ₂)	2,764 pph	163 tpy
Nitrogen Oxides (NO _x)	5,241 pph	172 tpy
Carbon Monoxide (CO)	10,443 pph	249 tpy
Volatile Organic Compounds (VOC) (with fugitives)	8,952 pph	328 tpy
Volatile Organic Compounds (VOC) (without fugitives)	8,923 pph	201 tpy
Total sum of all Hazardous Air Pollutants (HAPs)	455 pph	24.9 tpy
Toxic Air Pollutant (TAP)	n/a pph	n/a tpy
Green House Gas Emissions as Total CO ₂ e	n/a	467,511 tpy

The standard and maximum operating schedules of the facility will be 24 hours a day, 7 days a week and a maximum of 52 weeks per year.

The owner and/or operator of the Facility is: Targa Northern Delaware, LLC; 6 Desta Drive, Suite 3300, Midland, TX 79705

If you have any comments about the construction or operation of this facility, and you want your comments to be made as part of the permit review process, you must submit your comments in writing to this address: Permit Programs Manager, New Mexico Environment Department, Air Quality Bureau; 525 Camino de los Marquez, Suite 1; Santa Fe, New Mexico; 87505-1816. Other comments and questions may be submitted verbally. (505) 476-4300; 1 800 224-7009.

With your comments, please refer to the company name and facility name, or send a copy of this notice along with your comments. This information is necessary since the Department may have not yet received the permit application. Please include a legible return mailing address. Once the Department has completed its preliminary review of the application and its air quality impacts, the Department's notice will be published in the legal section of a newspaper circulated near the facility location.

Atención

Este es un aviso de la oficina de Calidad del Aire del Departamento del Medio Ambiente de Nuevo México, acerca de las emisiones producidas por un establecimiento en esta área. Si usted desea información en español, por favor comuníquese con esa oficina al teléfono 505-372-8373.

Notice of Non-Discrimination

NMED does not discriminate on the basis of race, color, national origin, disability, age or sex in the administration of its programs or activities, as required by applicable laws and regulations. NMED is responsible for coordination of compliance efforts and receipt of inquiries concerning non-discrimination requirements implemented by 40 C.F.R. Part 7, including Title VI of the Civil Rights Act of 1964, as amended; Section 504 of the Rehabilitation Act of 1973; the Age Discrimination Act of 1975, Title IX of the Education Amendments of 1972, and Section 13 of the Federal Water Pollution Control Act Amendments of 1972. If you have any questions about this notice or any of NMED's non-discrimination programs, policies or procedures, or if you believe that you have been discriminated against with respect to a NMED program or activity, you may contact: Kathryn Becker, Non-Discrimination Coordinator, NMED, 1190 St. Francis Dr., Suite N4050, P.O. Box 5469, Santa Fe, NM 87502, (505) 827-2855, nd.coordinator@state.nm.us. You may also visit our website at <https://www.env.nm.gov/non-employee-discrimination-complaint-page/> to learn how and where to file a complaint of discrimination.



P.O. Box 56 • 415 W. Cedar St
Loving, N.M. 88256
(575) 745-3511 • Fax (575) 745-3512

NOTICE OF INTENT TO

CONCERN:



NOTICE

Targa Northern Delaware, LLC announces its application submitted to the New Mexico Environment Department for an air quality permit for the modification of its Road Runner Gas Processing Plant facility. The expected date of application submitted to the Air Quality Bureau is December 13, 2022.

The exact location for the proposed facility known as, Road Runner Gas Processing Plant, is at latitude 32 deg, 15 min, 56.71 sec and longitude -104 deg, 4 min, 28.97 sec. The approximate location of this facility is 1.7 miles south-west of Loving in Eddy County, New Mexico.

The proposed modification consists of updating NSR Permit 7206-A3 based on the most current plans, updating representations, and removing one proposed processing train from the permit. The estimated maximum quantities of any regulated air contaminant will be as follows in pounds per hour (pph) and tons per year (tpy) and could change slightly during the course of the Department's review:

Pollutant	Pounds per hour	Tons per year
Particulate Matter (PM)		
PM ₁₀	3 pph	19 tpy
PM _{2.5}	3 pph	18 tpy
Sulfur Dioxide (SO ₂)	3 pph	17 tpy
Nitrogen Oxides (NO _x)	2,764 pph	163 tpy
Carbon Monoxide (CO)	5,241 pph	172 tpy
Volatile Organic Compounds (VOC) (with fugitives)	10,443 pph	249 tpy
Volatile Organic Compounds (VOC) (without fugitives)	8,923 pph	328 tpy
Total sum of all Hazardous Air Pollutants (HAPs)	453 pph	201 tpy
Toxic Air Pollutant (TAP)	n/a pph	24.9 tpy
Green House Gas Emissions as Total CO ₂ e	n/a	467,313 tpy

The standard and maximum operating schedules of the facility will be 24 hours a day, 7 days a week and a maximum of 52 weeks per year.

The owner and/or operator of the Facility is: Targa Northern Delaware, LLC; 6 Denta Drive, Suite 3306, Midland, TX 79705

If you have any comments about the construction or operation of this facility, and you want your comments to be made as part of the permit review process, you must submit your comments in writing to this address: Permit Programs Manager, New Mexico Environment Department, Air Quality Bureau, 525 Camino de los Marquez, Suite 1, Santa Fe, New Mexico, 87505-1816. Other comments and questions may be submitted verbally. (505) 476-4300, 1 800 224-7009.

With your comments, please refer to the company name and facility name, or send a copy of this notice along with your comment. This information is necessary since the Department may have not yet received the permit application. Please include a legible return mailing address. Once the Department has completed its preliminary review of the application and its air quality impacts, the Department's notice will be published in the legal section of a newspaper circulated near the facility location.

Atención

Este es un aviso de la oficina de Calidad del Aire del Departamento del Medio Ambiente de Nuevo México, acerca de las emisiones producidas por un establecimiento en esta área. Si usted desea información en español, por favor comuníquese con esa oficina al teléfono 505-372-8173.

Notice of Non-Discrimination

NMED does not discriminate on the basis of race, color, national origin, disability, age or sex in the administration of its programs or activities, as required by applicable laws and regulations. NMED is responsible for coordination of compliance efforts and receipt of inquiries concerning non-discrimination requirements implemented by 40 C.F.R. Part 7, including Title VI of the Civil Rights Act of 1964, as amended, Section 504 of the Rehabilitation Act of 1973, the Age Discrimination Act of 1975, Title IX of the Education Amendments of 1972, and Section 13 of the Federal Water Pollution Control Act Amendments of 1972. If you have any questions about this notice or any of NMED's non-discrimination programs, policies or procedures, or if you believe that you have been discriminated against with respect to a NMED program or activity, you may contact: Katelyn Becker, Non-Discrimination Coordinator, NMED, 1190 St. Francis Dr., Suite N4036, P.O. Box 2469, Santa Fe, NM 87502, (505) 827-2855, kd.becker@nmed.nm.gov. You may also visit our website at <https://www.nm.gov/non-employment-discrimination-complaints/> to learn how and where to file a complaint of discrimination.

ALL PI



LUCID
energy group

EMERGENCY PHONE 1-800-341-4881

SAFETY FIRST!

NOTICE CAUTION **NOTICE**
WARNING: High Voltage
MIS 24HR
LABORATORY

NOTICE NO OPEN FLAMES **NO** HIGH VOLTAGE

NOTICE

IF YOU PRESENT AT THE POINT YOU MUST FOLLOW ALL SAFETY POLICIES, CHANGING PROCEDURES AND OPERATIONAL PROTECTIVE EQUIPMENT POLICY.

SPEED
LIMIT
10

LUCID
energy group

ALL PERSONNEL
Entering This Facility
Must Sign-In At The
Office. NO EXCEPTONS!

LUCID
energy group

Roadrunner
Processing Plant
Control Room Number
575.748.7014

Carbon Monoxide (CO)	337 pph	152 tpy
Volatile Organic Compounds (VOC)	794 pph	188 tpy
Total sum of all Hazardous Air Pollutants (HAPs)	46 pph	24.9 tpy
Toxic Air Pollutant (TAP)	N/A	N/A
Green House Gas Emissions as Total CO ₂ e	N/A	130,000 tpy

The standard and maximum operating schedules of the facility will be continuous: 7 days a week and a maximum of 52 weeks per year.

The owner and/or operator of the Facility is:

Crestwood New Mexico Pipeline LLC
811 Main Street, Suite 3400
Houston, TX 77002

If you have any comments about the construction or operation of this facility, and you want your comments to be made as part of the permit review process, you must submit your comments in writing to this address: Permit Programs Manager, New Mexico Environment Department, Air Quality Bureau, 525 Camino de los Marquez, Suite 1, Santa Fe, New Mexico; 87505-1816; (505) 476-4300; 1 800 224-7009; https://www.env.nm.gov/aqb/permit/aqb_draft_permits.html. Other comments and questions may be submitted verbally.

Please refer to the company name and site name, or send a copy of this notice along with your comments, since the Department may have not yet received the permit application. Please include a legible return mailing address with your comments. Once the Department has performed a preliminary review of the application and its air quality impacts, the Department's notice will be published in the legal section of a newspaper circulated near the facility location.

General information about air quality and the permitting process can be found at the Air Quality Bureau's web site. The regulation dealing with public participation in the permit review process can be found in the "Permits" section of this web site.

Atención

Este es un aviso de la oficina de Calidad del Aire del Departamento del Medio Ambiente de Nuevo México, acerca de las emisiones producidas por un establecimiento en esta área. Si usted desea información en español, por favor comuníquese con esta oficina al teléfono 505-372-8373.

NOTICE

Targa Northern Delaware, LLC announces its application submitted to the New Mexico Environment Department for an air quality permit for the **modification of its Road Runner Gas Processing Plant** facility. The expected date of application submitted to the Air Quality Bureau is **December 13, 2022**.

The exact location for the proposed facility known as, **Road Runner Gas Processing Plant**, is at latitude 32 deg, 15 min, 56.71 sec and longitude -104 deg, 6 min, 29.97 sec. The approximate location of this facility is 1.7 miles south-west of Loving in Eddy County, New Mexico.

The proposed **modification** consists of updating NSR Permit 7200-MJ based on the most current plans, updating representations, and removing one proposed processing train from the permit. The estimated maximum quantities of any regulated air contaminant will be as follows in pound per hour (pph) and tons per year (tpy) and could change slightly during the course of the Department's review:

Pollutant:	Pounds per hour	Tons per year
Particulate Matter (PM)	5 pph	19 tpy
PM ₁₀	5 pph	18 tpy
PM _{2.5}	5 pph	17 tpy
Sulfur Dioxide (SO ₂)	2,764 pph	163 tpy
Nitrogen Oxides (NO _x)	5,241 pph	172 tpy
Carbon Monoxide (CO)	10,443 pph	249 tpy
Volatile Organic Compounds (VOC) (with fugitives)	8,952 pph	328 tpy
Volatile Organic Compounds (VOC) (without fugitives)	8,923 pph	201 tpy
Total sum of all Hazardous Air Pollutants (HAPs)	453 pph	24.9 tpy
Toxic Air Pollutant (TAP)	n/a pph	n/a tpy
Green House Gas Emissions as Total CO ₂ e	n/a	467,511 tpy

The standard and maximum operating schedules of the facility will be 24 hours a day, 7 days a week and a maximum of 52 weeks per year.

The owner and/or operator of the Facility is: **Targa Northern Delaware, LLC; 6 Desta Drive, Suite 3300, Midland, TX 79705**

If you have any comments about the construction or operation of this facility, and you want your comments to be made as part of the permit review process, you must submit your comments in writing to this address: Permit Programs Manager, New Mexico Environment Department, Air Quality Bureau, 525 Camino de los Marquez, Suite 1, Santa Fe, New Mexico; 87505-1816. Other comments and questions may be submitted verbally. (505) 476-4300; 1 800 224-7009.

With your comments, please refer to the company name and facility name, or send a copy of this notice along with your comments. This information is necessary since the Department may have not yet received the permit application. Please include a legible return mailing address. Once the Department has completed its preliminary review of the application and its air quality impacts, the Department's notice will be published in the legal section of a newspaper circulated near the facility location.

Atención

Este es un aviso de la oficina de Calidad del Aire del Departamento del Medio Ambiente de Nuevo México, acerca de las emisiones producidas por un establecimiento en esta área. Si usted desea información en español, por favor comuníquese con esta oficina al teléfono 505-372-8373.

Notice of Non-Discrimination

NMED does not discriminate on the basis of race, color, national origin, disability, age or sex in the administration of its programs or activities, as required by applicable laws and regulations. NMED is responsible for coordination of compliance efforts and receipt of inquiries concerning non-discrimination requirements implemented by 40 C.F.R. Part 7, including Title VI of the Civil Rights Act of 1964, as amended, Section 504 of the Rehabilitation Act of 1973, the Age Discrimination Act of 1975, Title IX of the Education Amendments of 1972, and Section 13 of the Federal Water Pollution Control Act Amendments of 1972. If you have any questions about this notice or any of NMED's non-discrimination programs, policies or procedures, or if you believe that you have been discriminated against with respect to a NMED program or activity, you may contact: Kathryn Becker, Non-Discrimination Coordinator, NMED, 1190 St. Francis Dr., Suite N4050, P.O. Box 2469, Santa Fe, NM 87502, (505) 427-2855, nd.coordinator@state.nm.us. You may also visit our website at <https://www.env.nm.gov/non-employee-discrimination-complaint-page/> to learn how and where to file a complaint of discrimination.

UP
8/22/21
DOWN
11/6/21



Obituary

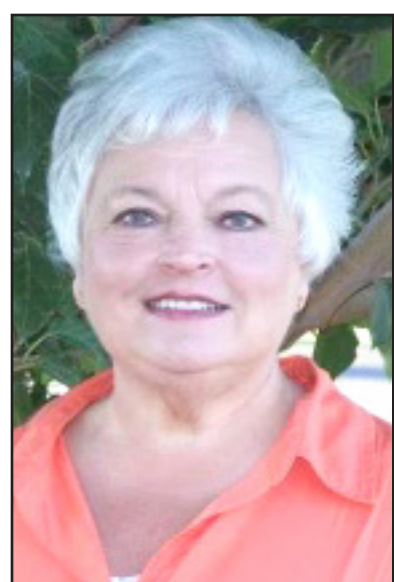

Diana Klontz

Memorial services are scheduled for 10 a.m. Wednesday, Dec. 14, at Hermosa Church of Christ for Diana Lynn Klontz of Artesia.

Klontz, 76, passed away Friday, Dec. 9, 2022, in Artesia.

Michael Joiner will officiate the services. Cremation has taken place under the direction of Terpening & Son Mortuary.

Diana was born Oct. 19, 1946, in Augusta, Kans., the daughter of William Jesse and Doris Ramons (Dennett) Cox.

In their early married years, she and Paul took in a host of foster children in North Carolina. After moving to New Mexico, she continued her love of and service to children by teaching Bible class and other related activities.

She was a bookkeeper for Mack Chase, First National Bank and Moncor Bank. Before her retirement, she was secretary at Hermosa Church of Christ.

Cooking, baking, crochet and cross stitch were Diana's love language. She passed these skills on to her kids and grandkids. She never lost her love of the coast and enjoyed fishing.

She bought her first personal computer in 1985, taught herself how to use it, and continued to enjoy learning technology.

Survivors include her husband, Paul Klontz; son Vaughn Klontz and wife Carla; daughter Vana Conner and husband Perry; sisters Anita Markman, and Billie Jo Kirschner and husband Buddy; grandchildren Bryan Klontz and wife Amber, Blake Klontz and wife Paige, Kaci Whitmire and husband Matt, Cayla Nelson, Caton Conner, and Kabryn Frost and husband Grady; and great-grandchildren Layton Whitmire, Kaydence Klontz, Tynlee Whitmire, Kenzie Klontz, Kailee Klontz and Ashlynn Klontz.

She was preceded in death by her parents and brother Bobby Cox.

Arrangements are under the direction of Terpening & Son Mortuary. Condolences may be expressed online at www.artesiafunerals.com.

Some Albuquerque-area hospitals dealing with surge

ALBUQUERQUE (AP) — Some hospitals in the Albuquerque area are taking measures to free up more space amid a surge of patients that are pushing some hospitals beyond their licensed capacity.

The University of New Mexico Hospital has opened a tent outside the emergency room to triage adult patients. Doctors at some local hospitals said they are busier than they were during the past two winters, when the COVID-19 pandemic was driving up hospital admissions.

They also say respiratory syncytial virus, influenza and COVID are all fueling the rise in hospitalizations.

Physicians at Albuquerque-area hospitals held a briefing Monday morning during which they asked the public to wear masks in some settings, stay up to date on COVID and influenza vaccines, and not to go into public when sick.

"The last couple of years, when we were masking, there was very, very little influenza, very little colds, very little RSV. So we know that masking works," Dr. Jason Mitchell, the chief medical officer at Presbyterian Healthcare Services, told the Journal.

Physicians at UNMH said that at any given time, about 100 adults and 20 children are waiting for a hospital bed and they have warned people to expect long wait times in the emergency room.

Biden signs gay marriage legislation into law, calling it 'a blow against hate'

WASHINGTON, D.C. (AP) — A celebratory crowd of thousands bundled up on a chilly Tuesday afternoon to watch President Joe Biden sign gay marriage legislation into law, a joyful ceremony that was tempered by the backdrop of an ongoing conservative backlash over gender issues.

"This law and the love it defends strike a blow against hate in all its forms," Biden said on the South Lawn of the White House. "And that's why this law matters to every single American."

Singers Sam Smith and Cyndi Lauper performed. Vice President Kamala Harris recalled officiating at a lesbian wedding in San Francisco. And the White House played a recording of Biden's television interview from a decade ago, when he caused a political furor by unexpectedly disclosing his support for gay marriage. Biden was vice president at the time, and President Barack Obama had not yet endorsed the idea.

"I got in trouble," Biden joked at that moment. Three days later, Obama himself publicly endorsed gay marriage.

Lawmakers from both parties attended Tuesday's ceremony, reflecting the growing acceptance of same-sex unions, once among the country's most contentious issues.

Senate Majority Leader Chuck Schumer, D-N.Y., wore the same purple tie to the ceremony that he wore to his daughter Alison's wedding. She and her wife are expecting their first child in the spring.

"Thanks to the millions out there who

spent years pushing for change, and thanks to the dogged work of my colleagues, my grandchild will get to live in a world that respects and honors their mothers' marriage," he said.

House Speaker Nancy Pelosi told the crowd that "inside maneuvering only takes us so far," and she thanked activists adding impetus with "your impatience, your persistence and your patriotism."

Despite Tuesday's excitement, there was concern about the nationwide proliferation of conservative policies on gender issues at the state level.

Biden criticized the "callous, cynical laws introduced in the states targeting transgender children, terrifying families and criminalizing doctors who give children the care they need."

"Racism, antisemitism, homophobia, transphobia, they're all connected," Biden said. "But the antidote to hate is love."

Among the attendees were the owner of Club Q, a gay nightclub in Colorado where five people were killed in a shooting last month, and two survivors of the attack. The suspect has been charged with hate crimes.

"It's not lost on me that our struggle for freedom hasn't been achieved," said Kelley Robinson, president of the Human Rights Campaign. "But this is a huge step forward, and we have to celebrate the victories we achieve and use that to fuel the future of the fight."

Robinson attended the ceremony with her wife and 1-year-old child.

"Our kids are watching this moment,"

she said. "It's very special to have them here and show them that we're on the right side of history."

The new law is intended to safeguard gay marriages if the U.S. Supreme Court ever reverses Obergefell v. Hodges, its 2015 decision legalizing same-sex unions nationwide. The new law also protects interracial marriages. In 1967, the Supreme Court in Loving v. Virginia struck down laws in 16 states barring interracial marriage.

The signing marks the culmination of a months-long bipartisan effort sparked by the Supreme Court's decision in June to overturn Roe v. Wade, the 1973 ruling that made abortion available across the country.

In a concurring opinion in the case that overturned Roe, Justice Clarence Thomas suggested revisiting other decisions, including the legalization of gay marriage, generating fear that more rights could be imperiled by the court's conservative majority. Thomas did not reference interracial marriage with the other cases he said should be reconsidered.

Lawmakers crafted a compromise that was intended to assuage conservative concerns about religious liberty, such as ensuring churches could still refuse to perform gay marriages.

In addition, states would not be required to issue marriage licenses to same-sex couples if the court overturns its 2015 ruling. But they will be required to recognize marriages conducted elsewhere in the country.

A majority of Republicans in Con-

gress still voted against the legislation. However, enough supported it to sidestep a filibuster in the Senate and ensure its passage.

Tuesday's ceremony marks another chapter in Biden's legacy on gay rights, which includes his surprise endorsement of marriage equality in 2012.

"What this is all about is a simple proposition: Who do you love?" Biden said then on NBC's "Meet the Press." "Who do you love and will you be loyal to the person you love? And that is what people are finding out is what all marriages at their root are about."

A Gallup poll showed only 27% of U.S. adults supported same-sex unions in 1996, when President Bill Clinton signed the Defense of Marriage Act, which said the federal government would only recognize heterosexual marriages. Biden voted for the legislation.

By the time of Biden's 2012 interview, gay marriage remained controversial, but support had expanded to roughly half of U.S. adults, according to Gallup. Earlier this year, 71% said same-sex unions should be recognized by law.

Biden has pushed to expand LGBT rights since taking office. He reversed President Donald Trump's efforts to strip transgender people of anti-discrimination protections. His administration includes the first openly gay Cabinet member, Transportation Secretary Pete Buttigieg, and the first transgender person to receive Senate confirmation, Assistant Secretary for Health Rachel Levine.

Inflation

(Continued from Page 1)

... to a record 19,000 families across Arizona last month.

"They're eating snacks and granola all day long," Rosa Davila, an unemployed single mother, said of her three teenagers while waiting in line for a package Tuesday. "The food bank really resolves things for us."

Alma Quintera, also waiting in her car, said that even with her husband working full time as a house painter, they have to visit the food bank two or three times a month to adequately feed their three school-age children.

"The high prices have really affected us — the rent, the bills and especially the food," she said.

Jerry Brown, a spokesman for St. Mary's, said the food bank's main Phoenix location last week distributed packages to 4,717 families, up 63% from the same week a year ago.

Economists say the latest inflation figures, though, suggest the likelihood of some relief in the coming months.

"Inflation was terrible in 2022, but the outlook for 2023 is much better," said Bill Adams, chief economist for Comerica Bank. "Supply chains are working better, business inventories are higher, ending most of the shortages that fueled inflation in 2020."

President Joe Biden called the inflation report "welcome news for families across the country" and noted that lower auto and toy prices should benefit holiday shoppers. Still, Biden acknowledged that inflation might not return to "normal levels" until the end of next year.

One sign of progress in November's figures was that prices for new cars didn't budge from October. On average, new cars are still 7.2% costlier than they were a year ago. But that's down from a 13.2% year-over-year jump in April, which was the highest on records dating to 1953.

The decline in new-car prices helps illustrate how supply chain snarls, which have unwound for most goods, are also easing for semiconductors and other key automotive parts. Economists say this should enable automakers to boost production and give buyers an expanded supply of vehicles.

It also suggests that the Fed's aggressive interest rate hikes, which have made it more expensive to borrow for homes, cars and on credit cards, have begun to slow demand and limit the ability of auto dealers to charge more.

Wall Street welcomed the better-than-expected inflation data as providing further support for the Fed to slow and potentially pause its rate hikes by

early next year.

On Wednesday, the Fed is widely expected to raise its benchmark rate by a half-point, its seventh hike this year. The move would follow four three-quarter-point hikes in a row. A half-point increase would put the Fed's key short-term rate in a range of 4.25% to 4.5%, the highest in 15 years.

The increase will further raise loan rates for consumers and businesses. Economists have warned that in continuing to tighten credit to fight inflation, the Fed is likely to cause a recession next year.

"There's growing evidence that the worst of the inflation scare may be in the rearview mirror," said Jim Baird, an economist at Plante Moran Financial Advisers. "On the horizon is the potential for a recession — the next hazard in the road that policymakers will need to navigate the economy around or potentially through."

Fed Chair Jerome Powell has said he is tracking price trends in three separate categories to best understand the likely path of inflation: Goods, excluding volatile food and energy costs; housing, which includes rents and the cost of homeownership; and services excluding housing, such as auto insurance, pet services and education.

In a speech two weeks ago in Washington, Powell noted that there had been some progress in easing inflation in goods and housing but not so in most services. Some of those trends extended into last month's data, with goods prices, excluding food and energy, falling 0.5% from October to November, the second straight monthly drop.

Housing costs, which make up nearly a third of the consumer price index, are still rising. But real-time measures of apartment rents and home prices are starting to drop after having posted sizzling price acceleration at the height of the pandemic. Powell said those declines will likely emerge in government data next year and should help reduce overall inflation.

As a result, Powell's biggest focus has been on services, which he said are likely to stay persistently high. In part, that's because sharp increases in wages are becoming a key contributor to inflation. Services companies, like hotels and restaurants, are particularly labor-intensive. And with average wages growing at a brisk 5%-6% a year, price pressures keep building in that sector of the economy.

Services businesses tend to pass on some of their higher labor costs to their customers by charging more, thereby perpetuating inflation. Higher pay also fuels more consumer spending, which allows companies to raise prices.

Prices for many services kept rising in November. Dental care jumped 1.1% just from October and is 6.4% costlier than it was a year ago. Restaurant prices rose 0.5%. They're 8.5% higher

than a year earlier.

Auto insurance prices jumped 0.9% in November and are 13.4% more expensive than a year earlier. The average cost of an auto repair rose 1.3% last month and 11.7% over the past

year.

Yet even in services, excluding housing, there were some signs of cooling prices. The cost of car rentals, airline fares and hotel prices, for example, all dropped in November.

Overall, a measure that approximates services excluding rent was unchanged in November, after having dipped 0.1% in October. That measure had soared 1.1% in both April and June this year.

NOTICE OF AIR QUALITY PERMIT APPLICATION

Targa Northern Delaware, LLC announces its application submittal to the New Mexico Environment Department for an air quality permit for the modification of its Road Runner Gas Processing Plant facility. The expected date of application submittal to the Air Quality Bureau is Tuesday, December 13, 2022.

The exact location for the proposed facility known as, Road Runner Gas Processing Plant, is at latitude 32 deg, 15 min, 56.71 sec and longitude -104 deg, 6 min, 29.97 sec. The approximate location of this facility is 1.7 miles south-west of Loving in Eddy County, New Mexico.

The proposed modification consists of updating NSR Permit 7200-M3 based on the most current plans, updating representations, and removing one proposed processing train from the permit. The estimated maximum quantities of any regulated air contaminant will be as follows in pound per hour (pph) and tons per year (tpy) and could change slightly during the course of the Department's review:

Pollutant:	Pounds per hour	Tons per year
Particulate Matter (PM)	5 pph	19 tpy
PM 10	5 pph	18 tpy
PM 2.5	5 pph	17 tpy
Sulfur Dioxide (SO2)	2,764 pph	163 tpy
Nitrogen Oxides (NOx)	5,241 pph	172 tpy
Carbon Monoxide (CO)	10,443 pph	249 tpy
Volatile Organic Compounds (VOC) (with fugitives)	8,952 pph	328 tpy
Volatile Organic Compounds (VOC) (without fugitives)	8,923 pph	201 tpy
Total sum of all Hazardous Air Pollutants (HAPs)	455 pph	24.9 tpy
Toxic Air Pollutant (TAP)	n/a pph	n/a tpy
Green House Gas Emissions as Total CO2e	n/a	467,511 tpy

The standard and maximum operating schedules of the facility will be 24 hours a day, 7 days a week and a maximum of 52 weeks per year.

The owner and/or operator of the Facility is: Targa Northern Delaware, LLC; 6 Desta Drive, Suite 3300, Midland, TX 79705

If you have any comments about the construction or operation of this facility, and you want your comments to be made as part of the permit review process, you must submit your comments in writing to this address: Permit Programs Manager; New Mexico Environment Department; Air Quality Bureau; 525 Camino de los Marquez, Suite 1; Santa Fe, New Mexico; 87505-1816. Other comments and questions may be submitted verbally. (505) 476-4300; 1 800 224-7009.

Please refer to the company name and site name, or send a copy of this notice along with your comments, since the Department may have not yet received the permit application. Please include a legible return mailing address with your comments. Once the Department has performed a preliminary review of the application and its air quality impacts, the Department's notice will be published in the legal section of a newspaper circulated near the facility location.

General information about air quality and the permitting process, and links to the regulations can be found at the Air Quality Bureau's website: www.env.nm.gov/air-quality/permitting-section-home-page/. The regulation dealing with public participation in the permit review process is 20.2.72.206 NMAC.

Atención

Este es un aviso de la oficina de Calidad del Aire del Departamento del Medio Ambiente de Nuevo México, acerca de las emisiones producidas por un establecimiento en esta área. Si usted desea información en español, por favor comuníquese con esa oficina al teléfono 505-372-8373.

Notice of Non-Discrimination

NMED does not discriminate on the basis of race, color, national origin, disability, age or sex in the administration of its programs or activities, as required by applicable laws and regulations. NMED is responsible for coordination of compliance efforts and receipt of inquiries concerning non-discrimination requirements implemented by 40 C.F.R. Part 7, including Title VI of the Civil Rights Act of 1964, as amended; Section 504 of the Rehabilitation Act of 1973; the Age Discrimination Act of 1975, Title IX of the Education Amendments of 1972, and Section 13 of the Federal Water Pollution Control Act Amendments of 1972. If you have any questions about this notice or any of NMED's non-discrimination programs, policies or procedures, or if you believe that you have been discriminated against with respect to a NMED program or activity, you may contact: Kathryn Becker, Non-Discrimination Coordinator, NMED, 1190 St. Francis Dr., Suite N4050, P.O. Box 5469, Santa Fe, NM 87502, (505) 827-2855, nd.coordinator@state.nm.us. You may also visit our website at <https://www.env.nm.gov/non-employee-discrimination-complaint-page/> to learn how and where to file a complaint of discrimination.

Assistance Funds

A GoFundMe account has been established for Mike Porras of Lake Arthur, who is recovering from open-heart surgery. To donate, visit www.gofundme.com/f/miracle-mike-porras.

From: [Jaimy Karacaoglu](mailto:jaimy.karacaoglu@trinityconsultants.com)
To: don@carlsbadradio.com
Cc: [Rob Liles](#)
Subject: Road Runner Gas Processing Plant Public Service Announcement
Date: Friday, December 2, 2022 9:54:46 AM
Attachments: [image001.png](#)

Dear Carlsbad Radio, KAMQ 1240 AM,

Per New Mexico Administrative Code 20.2.72.203.B NMAC and according to the Guidance for Public Notice for Air Quality Permit Applications – **(5) Notifications: Submittal of Public Service Announcement (PSA):** A public service announcement required for permits and significant permit revisions must be submitted to at least one radio or television station, which services the municipality, or county which the facility is or will be located. **Therefore, based on the above, we respectfully ask you to air the information shown below as a Public Service Announcement.**

The public service announcement request must contain the following information about the facility or proposed facility (20.2.72.203.D NMAC).

- a. The name: **Road Runner Gas Processing Plant**, location: **latitude 32 deg, 15 min, 56.71 sec and longitude -104 deg, 6 min, 29.97 sec. The approximate location of this facility is 1.7 miles south-west of Loving in Eddy County, New Mexico.** and type of business: **gas processing plant.**
- b. The name and principal owner or operator: **Targa Northern Delaware, LLC** – owner and operator.
- c. The type of process or change for which the permit is sought: **NSR Significant Revision – updates in accordance with most current plans, updating representations, and removing one proposed processing train from the permit.**
- d. Locations where the notices have been posted in Loving, NM: **(1) Road Runner Gas Processing Plant Facility Entrance – 1098 Bounds Rd, Loving, NM 88256 (2) Loving Allsup’s Convenience Store – 105 N 8th St, Loving, NM 88256 (3) Village of Loving City Hall – 415 W Cedar St., Loving, NM 88256 (4) Loving USPS – 402 W Beech St., Loving, NM 88256**
- e. The Department’s address or telephone number to which comments may be directed: **Permit Programs manager; New Mexico Environment Department; Air Quality Bureau; 525 Camino de los Marquez, Suite 1, Santa Fe, New Mexico; 87505-1816; (505) 476-4300; 1 (800) 224-7009.**

Regards,
Jaimy Karacaoglu
Consultant

P 505.266.6611 M 410.903.0750
9400 Holly Avenue NE, Building 3, Suite B, Albuquerque, NM 87122
Email: jaimy.karacaoglu@trinityconsultants.com



Connect with us: [LinkedIn](#) / [Facebook](#) / [Twitter](#) / [YouTube](#) / trinityconsultants.com

Stay current on environmental issues. [Subscribe](#) today to receive Trinity’s free *EHS Quarterly*.

Submittal of Public Service Announcement – Certification

I, Jaimy Karacaoglu, the undersigned, certify that on **December 2, 2022**, submitted a public service announcement to **Carlsbad Radio, KAMQ 1240 AM** that serves the Village of **Loving, Eddy County**, New Mexico, in which the source is or is proposed to be located and that **Carlsbad Radio, KAMQ 1240 AM DID NOT RESPOND.**

Signed this 6 day of December, 2022.



Signature

12/6/2022

Date

Jaimy Karacaoglu

Printed Name

Consultant with Trinity Consultants

Title {APPLICANT OR RELATIONSHIP TO APPLICANT}

7014 2870 0001 4722 9897

U.S. Postal Service™
CERTIFIED MAIL® RECEIPT
Domestic Mail Only

For delivery information, visit our website at www.usps.com

OFFICIAL

Postage	\$
Certified Fee	
Return Receipt Fee (Endorsement Required)	
Restricted Delivery Fee (Endorsement Required)	
Total Postage & Fees	\$

\$0.00¹
US POSTAGE
12/13/2022
062S12395454
87113
000024305



Sent To
Susan D. & John E. Blackmon
3501 Bonniebrook Drive
Plano, TX 75075

Street & Apt. No.
or PO Box No.
City, State, ZIP+

PS Form 3800, July 2014

7014 2870 0001 4722 9910

U.S. Postal Service™
CERTIFIED MAIL® RECEIPT
Domestic Mail Only

For delivery information, visit our website at www.usps.com

OFFICIAL

Postage	\$
Certified Fee	
Return Receipt Fee (Endorsement Required)	
Restricted Delivery Fee (Endorsement Required)	
Total Postage & Fees	\$

\$0.00¹
US POSTAGE
12/13/2022
062S12395454
87113
000024307



Sent To
Mrs. F.W. Sooby
921 Montcrest Drive
Redding, CA 96003

Street & Apt. No.
or PO Box No.
City, State, ZIP+

PS Form 3800, July 2014

7014 2870 0001 4722 9934

U.S. Postal Service™
CERTIFIED MAIL® RECEIPT
Domestic Mail Only

For delivery information, visit our website at www.usps.com

OFFICIAL

Postage	\$
Certified Fee	
Return Receipt Fee (Endorsement Required)	
Restricted Delivery Fee (Endorsement Required)	
Total Postage & Fees	\$

\$0.00¹
US POSTAGE
12/13/2022
062S12395454
87113
000024309



Sent To
State of New Mexico
310 Old Santa Fe Trail
Santa Fe, NM 87504

Street & Apt. No.
or PO Box No.
City, State, ZIP+

PS Form 3800, July 2014

7014 2870 0001 4722 9927

U.S. Postal Service™
CERTIFIED MAIL® RECEIPT
Domestic Mail Only

For delivery information, visit our website at www.usps.com

OFFICIAL

Postage	\$
Certified Fee	
Return Receipt Fee (Endorsement Required)	
Restricted Delivery Fee (Endorsement Required)	
Total Postage & Fees	\$

\$0.00¹
US POSTAGE
12/13/2022
062S12395454
87113
000024308



Sent To
Henry McDonald
P.O. Box 597
Loving, NM 88256

Street & Apt. No.
or PO Box No.
City, State, ZIP+

PS Form 3800, July 2014

7014 2870 0001 4722 9941

U.S. Postal Service™
CERTIFIED MAIL® RECEIPT
Domestic Mail Only

For delivery information, visit our website at www.usps.com

OFFICIAL

Postage	\$
Certified Fee	
Return Receipt Fee (Endorsement Required)	
Restricted Delivery Fee (Endorsement Required)	
Total Postage & Fees	\$

\$0.00¹
US POSTAGE
12/13/2022
062S12395454
87113
000024310



Sent To
Mitchell & Wendy Ballard
273 Higby Rd.
Loving, NM 88256

Street & Apt. No.
or PO Box No.
City, State, ZIP+

PS Form 3800, July 2014

7014 2870 0001 4722 9958

U.S. Postal Service™
CERTIFIED MAIL® RECEIPT
Domestic Mail Only

For delivery information, visit our website at www.usps.com

OFFICIAL

Postage	\$
Certified Fee	
Return Receipt Fee (Endorsement Required)	
Restricted Delivery Fee (Endorsement Required)	
Total Postage & Fees	\$

\$0.00¹
US POSTAGE
12/13/2022
062S12395454
87113
000024311



Sent To
Antonio & Gloria Onsurez
P.O. Box 598
Loving, NM 88256

Street & Apt. No.
or PO Box No.
City, State, ZIP+

PS Form 3800, July 2014

7014 2870 0001 4722 9965

**U.S. Postal Service™
CERTIFIED MAIL® RECEIPT**
Domestic Mail Only

For delivery information, visit our website at www.usps.com

OFFICIAL

Postage	\$
Certified Fee	
Return Receipt Fee (Endorsement Required)	
Restricted Delivery Fee (Endorsement Required)	
Total Postage & Fees	\$

\$0.00⁹
US POSTAGE
12/13/2022
062S12395454
87113
000024312

Sent To
Southwestern Public Service Co.
P.O. Box 1979
Denver, CO 80201

Street & Apt. No. or PO Box No.
City, State, ZIP+4

PS Form 3800, July 2017

7014 2870 0001 4722 9972

**U.S. Postal Service™
CERTIFIED MAIL® RECEIPT**
Domestic Mail Only

For delivery information, visit our website at www.usps.com

OFFICIAL

Postage	\$
Certified Fee	
Return Receipt Fee (Endorsement Required)	
Restricted Delivery Fee (Endorsement Required)	
Total Postage & Fees	\$

\$0.00⁹
US POSTAGE
12/13/2022
062S12395454
87113
000024313

Sent To
Joel Santos Onsurez
P.O. Box 1058
Loving, NM 88256

Street & Apt. No. or PO Box No.
City, State, ZIP+4

PS Form 3800, July 2017

7014 2870 0001 4722 9989

**U.S. Postal Service™
CERTIFIED MAIL® RECEIPT**
Domestic Mail Only

For delivery information, visit our website at www.usps.com

OFFICIAL

Postage	\$
Certified Fee	
Return Receipt Fee (Endorsement Required)	
Restricted Delivery Fee (Endorsement Required)	
Total Postage & Fees	\$

\$0.00⁹
US POSTAGE
12/13/2022
062S12395454
87113
000024314

Sent To
Nelda Wyrick Cox
3101 Sexton Drive
Norman, OK 73026

Street & Apt. No. or PO Box No.
City, State, ZIP+4

PS Form 3800, July 2017

7014 2870 0001 4722 9996

**U.S. Postal Service™
CERTIFIED MAIL® RECEIPT**
Domestic Mail Only

For delivery information, visit our website at www.usps.com

OFFICIAL

Postage	\$
Certified Fee	
Return Receipt Fee (Endorsement Required)	
Restricted Delivery Fee (Endorsement Required)	
Total Postage & Fees	\$

\$0.00⁹
US POSTAGE
12/13/2022
062S12395454
87113
000024315

Sent To
George A. Huffer
4713 Craig Ave.
Metairie, LA 70003

Street & Apt. No. or PO Box No.
City, State, ZIP+4

PS Form 3800, July 2017

7014 2870 0001 4723 0008

**U.S. Postal Service™
CERTIFIED MAIL® RECEIPT**
Domestic Mail Only

For delivery information, visit our website at www.usps.com

OFFICIAL

Postage	\$
Certified Fee	
Return Receipt Fee (Endorsement Required)	
Restricted Delivery Fee (Endorsement Required)	
Total Postage & Fees	\$

\$0.00⁹
US POSTAGE
12/13/2022
062S12395454
87113
000024316

Sent To
Ryan M. Zuniga
24 Mesquite Lane
Artesia, NM 88210

Street & Apt. No. or PO Box No.
City, State, ZIP+4

PS Form 3800, July 2017

7014 2870 0001 4718 5612

**U.S. Postal Service™
CERTIFIED MAIL® RECEIPT**
Domestic Mail Only

For delivery information, visit our website at www.usps.com

OFFICIAL

Postage	\$
Certified Fee	
Return Receipt Fee (Endorsement Required)	
Restricted Delivery Fee (Endorsement Required)	
Total Postage & Fees	\$

\$0.00⁹
US POSTAGE
12/13/2022
062S12395454
87113
000024317

Sent To
Pablo Hernandez, Maria Hernandez Trust
1971 Pecos Hwy
Loving, NM 88256

Street & Apt. No. or PO Box No.
City, State, ZIP+4

PS Form 3800, July 2017

7014 2870 0001 4722 9866

U.S. Postal Service™
CERTIFIED MAIL® RECEIPT
Domestic Mail Only

For delivery information, visit our website at www.usps.com®

OFFICIAL

Postage	\$
Certified Fee	
Return Receipt Fee (Endorsement Required)	
Restricted Delivery Fee (Endorsement Required)	
Total Postage & Fees	

\$0.00
US POSTAGE
12/13/2022
062S12395454
87113
000024302



Sent To
Street & Apt. No.,
or PO Box No.
City, State, ZIP+4

Reymundo & Victoria Pina
P.O. Box 356
Loving, NM 88256

PS Form 3800, July 2011 See Reverse for Instructions

7014 2870 0001 4718 5629

U.S. Postal Service™
CERTIFIED MAIL® RECEIPT
Domestic Mail Only

For delivery information, visit our website at www.usps.com®

OFFICIAL

Postage	\$
Certified Fee	
Return Receipt Fee (Endorsement Required)	
Restricted Delivery Fee (Endorsement Required)	
Total Postage & Fees	

\$0.00
US POSTAGE
12/13/2022
062S12395454
87113
000024318



Sent To
Street & Apt. No.,
or PO Box No.
City, State, ZIP+4

Parker & Whitney Ballard
P.O. Box 716
Loving, NM 88256

PS Form 3800, July 2011 See Reverse for Instructions

7014 2870 0001 4718 5636

U.S. Postal Service™
CERTIFIED MAIL® RECEIPT
Domestic Mail Only

For delivery information, visit our website at www.usps.com®

OFFICIAL

Postage	\$
Certified Fee	
Return Receipt Fee (Endorsement Required)	
Restricted Delivery Fee (Endorsement Required)	
Total Postage & Fees	

\$0.00
US POSTAGE
12/13/2022
062S12395454
87113
000024319



Sent To
Street & Apt. No.,
or PO Box No.
City, State, ZIP+4

Damian & Cynthia Kay Onsurez
P.O. Box 1088
Carlsbad, NM 88221

PS Form 3800, July 2011 See Reverse for Instructions

7014 2870 0001 4718 5643

U.S. Postal Service™
CERTIFIED MAIL® RECEIPT
Domestic Mail Only

For delivery information, visit our website at www.usps.com®

OFFICIAL

Postage	\$
Certified Fee	
Return Receipt Fee (Endorsement Required)	
Restricted Delivery Fee (Endorsement Required)	
Total Postage & Fees	

\$0.00
US POSTAGE
12/13/2022
062S12395454
87113
000024320



Sent To
Street & Apt. No.,
or PO Box No.
City, State, ZIP+4

Lucid Energy Delaware, LLC
3100 McKinnon St., Suite 800
Dallas, TX 75201

PS Form 3800, July 2011 See Reverse for Instructions

7014 2870 0001 4722 9880

U.S. Postal Service™
CERTIFIED MAIL® RECEIPT
Domestic Mail Only

For delivery information, visit our website at www.usps.com®

OFFICIAL

Postage	\$
Certified Fee	
Return Receipt Fee (Endorsement Required)	
Restricted Delivery Fee (Endorsement Required)	
Total Postage & Fees	

\$0.00
US POSTAGE
12/13/2022
062S12395454
87113
000024304



Sent To
Street & Apt. No.,
or PO Box No.
City, State, ZIP+4

Jose D. & Elisa Zuniga
211 W. Fiesta Drive
Carlsbad, NM 88220

PS Form 3800, July 2011 See Reverse for Instructions

7014 2870 0001 4718 5650

U.S. Postal Service™
CERTIFIED MAIL® RECEIPT
Domestic Mail Only

For delivery information, visit our website at www.usps.com®

OFFICIAL

Postage	\$
Certified Fee	
Return Receipt Fee (Endorsement Required)	
Restricted Delivery Fee (Endorsement Required)	
Total Postage & Fees	

\$0.00
US POSTAGE
12/13/2022
062S12395454
87113
000024321



Sent To
Street & Apt. No.,
or PO Box No.
City, State, ZIP+4

Longwood Midstream Delaware, LLC
5400 LBJ Freeway, Suite 1500
Dallas, TX 75240

PS Form 3800, July 2011 See Reverse for Instructions

7014 2870 0001 4722 9859

U.S. Postal Service™
CERTIFIED MAIL® RECEIPT
Domestic Mail Only

For delivery information, visit our website at www.usps.com®

OFFICIAL

Postage	\$
Certified Fee	
Return Receipt Fee (Endorsement Required)	
Restricted Delivery Fee (Endorsement Required)	
Total Postage & Fees	\$

\$0.00⁹
US POSTAGE
12/13/2022
062S12395454
87113
000024301



Sent To
Street & Apt. No.
or PO Box No.
City, State, ZIP+4

Pardue Limited Company
P.O. Box 2018
Carlsbad, NM 88221

PS Form 3800,

7014 2870 0001 4722 9835

U.S. Postal Service™
CERTIFIED MAIL® RECEIPT
Domestic Mail Only

For delivery information, visit our website at www.usps.com®

OFFICIAL

Postage	\$
Certified Fee	
Return Receipt Fee (Endorsement Required)	
Restricted Delivery Fee (Endorsement Required)	
Total Postage & Fees	\$

\$0.00⁹
US POSTAGE
12/13/2022
062S12395454
87113
000024299



Sent To
Street & Apt. No.,
or PO Box No.
City, State, ZIP+4

Felix & Deborah Calderon
P.O. Box 64
Loving, NM 88256

PS Form 3800, July 2014

7014 2870 0001 4722 9842

U.S. Postal Service™
CERTIFIED MAIL® RECEIPT
Domestic Mail Only

For delivery information, visit our website at www.usps.com®

OFFICIAL

Postage	\$
Certified Fee	
Return Receipt Fee (Endorsement Required)	
Restricted Delivery Fee (Endorsement Required)	
Total Postage & Fees	\$

\$0.00⁹
US POSTAGE
12/13/2022
062S12395454
87113
000024300



Sent To
Street & Apt. No.
or PO Box No.
City, State, ZIP+4

Vickie Connally
125 Brinkley Lane
Elgrin, TX 78621

PS Form 3800,

7014 2870 0001 4722 9828

U.S. Postal Service™
CERTIFIED MAIL® RECEIPT
Domestic Mail Only

For delivery information, visit our website at www.usps.com®

OFFICIAL

Postage	\$
Certified Fee	
Return Receipt Fee (Endorsement Required)	
Restricted Delivery Fee (Endorsement Required)	
Total Postage & Fees	\$

\$0.00⁹
US POSTAGE
12/13/2022
062S12395454
87113
000024298



Sent To
Street & Apt. No.,
or PO Box No.
City, State, ZIP+4

Christy Moreno & Jose Valentin Lugo
1991 Pecos Hwy
Loving, NM 88256

PS Form 3800, July 2014

7014 2870 0001 4722 9811

U.S. Postal Service™
CERTIFIED MAIL® RECEIPT
Domestic Mail Only

For delivery information, visit our website at www.usps.com®

OFFICIAL

Postage	\$
Certified Fee	
Return Receipt Fee (Endorsement Required)	
Restricted Delivery Fee (Endorsement Required)	
Total Postage & Fees	\$

\$0.00⁹
US POSTAGE
12/13/2022
062S12395454
87113
000024297



Sent To
Street & Apt. No.
or PO Box No.
City, State, ZIP+4

Ogden Estate Heirs
2302 Forehand Rd.
Carlsbad, NM 88220

PS Form 3800,

7014 2870 0001 4722 9873

U.S. Postal Service™
CERTIFIED MAIL® RECEIPT
Domestic Mail Only

For delivery information, visit our website at usps.com

OFFICIAL

Postage	\$
Certified Fee	
Return Receipt Fee (Endorsement Required)	
Restricted Delivery Fee (Endorsement Required)	
Total Postage & Fees	Ⓢ

\$0.00
US POSTAGE
12/13/2022
062512395454
87113
000024303



Sent To

Street & Apt. No.
or PO Box No.
City, State, ZIP+

Village of Loving, NM
P.O. Box 56
Loving, NM 88256

PS Form 3800, 12/13/2022

7014 2870 0001 4722 9903

U.S. Postal Service™
CERTIFIED MAIL® RECEIPT
Domestic Mail Only

For delivery information, visit our website at usps.com

OFFICIAL

Postage	\$
Certified Fee	
Return Receipt Fee (Endorsement Required)	
Restricted Delivery Fee (Endorsement Required)	
Total Postage & Fees	Ⓢ

\$0.00
US POSTAGE
12/13/2022
062512395454
87113
000024306



Sent To

Street & Apt. No.
or PO Box No.
City, State, ZIP+

Eddy County Manager
101 W. Greene St. Suite 110
Carlsbad, NM 88220

PS Form 3800, 12/13/2022

CERTIFIED MAIL XXXX XXXX XXXX XXXX

RETURN RECEIPT REQUESTED (certified mail is required, return receipt is optional)

Dear [Neighbor/Environmental Director/county or municipal official]

Targa Northern Delaware, LLC announces its application submittal to the New Mexico Environment Department for an air quality permit for the **modification** of its **Road Runner Gas Processing Plant** facility. The expected date of application submittal to the Air Quality Bureau is **Tuesday, December 13, 2022**.

The exact location for the proposed facility known as, **Road Runner Gas Processing Plant**, is at latitude **32 deg, 15 min, 56.71 sec** and longitude **-104 deg, 6 min, 29.97 sec**. The approximate location of this facility is **1.7 miles south-west** of Loving in Eddy County, New Mexico.

The proposed **modification** consists of updating NSR Permit 7200-M3 based on the most current plans, updating representations, and removing one proposed processing train from the permit. The estimated maximum quantities of any regulated air contaminant will be as follows in pound per hour (pph) and tons per year (tpy) and could change slightly during the course of the Department's review:

Pollutant:	Pounds per hour	Tons per year
Particulate Matter (PM)	5 pph	19 tpy
PM ₁₀	5 pph	18 tpy
PM _{2.5}	5 pph	17 tpy
Sulfur Dioxide (SO ₂)	2,764 pph	163 tpy
Nitrogen Oxides (NO _x)	5,241 pph	172 tpy
Carbon Monoxide (CO)	10,443 pph	249 tpy
Volatile Organic Compounds (VOC) (with fugitives)	8,952 pph	328 tpy
Volatile Organic Compounds (VOC) (without fugitives)	8,923 pph	201 tpy
Total sum of all Hazardous Air Pollutants (HAPs)	455 pph	24.9 tpy
Toxic Air Pollutant (TAP)	n/a pph	n/a tpy
Green House Gas Emissions as Total CO ₂ e	n/a	467,511 tpy

The standard and maximum operating schedules of the facility will be 24 hours a day, 7 days a week and a maximum of 52 weeks per year.

The owner and/or operator of the Facility is: **Targa Northern Delaware, LLC; 6 Desta Drive, Suite 3300, Midland, TX 79705**

If you have any comments about the construction or operation of this facility, and you want your comments to be made as part of the permit review process, you must submit your comments in writing to this address: Permit Programs Manager; New Mexico Environment Department; Air Quality Bureau; 525 Camino de los Marquez, Suite 1; Santa Fe, New Mexico; 87505-1816. Other comments and questions may be submitted verbally. (505) 476-4300; 1 800 224-7009.

Please refer to the company name and facility name, or send a copy of this notice along with your comments, since the Department may have not yet received the permit application. Please include a legible return mailing address with your comments. Once the Department has performed a preliminary review of the application and its air quality impacts, the Department's notice will be published in the legal section of a newspaper circulated near the facility location.

Atención

Este es un aviso de la oficina de Calidad del Aire del Departamento del Medio Ambiente de Nuevo México, acerca de las emisiones producidas por un establecimiento en esta área. Si usted desea información en español, por favor comuníquese con esa oficina al teléfono 505-372-8373.

Sincerely,

Targa Northern Delaware, LLC
6 Desta Drive, Suite 3300, Midland, TX 79705

Notice of Non-Discrimination

NMED does not discriminate on the basis of race, color, national origin, disability, age or sex in the administration of its programs or activities, as required by applicable laws and regulations. NMED is responsible for coordination of compliance efforts and receipt of inquiries concerning non-discrimination requirements implemented by 40 C.F.R. Part 7, including Title VI of the Civil Rights Act of 1964, as amended; Section 504 of the Rehabilitation Act of 1973; the Age Discrimination Act of 1975, Title IX of the Education Amendments of 1972, and Section 13 of the Federal Water Pollution Control Act Amendments of 1972. If you have any questions about this notice or any of NMED's non-discrimination programs, policies or procedures, or if you believe that you have been discriminated against with respect to a NMED program or activity, you may contact: Kathryn Becker, Non-Discrimination Coordinator, NMED, 1190 St. Francis Dr., Suite N4050, P.O. Box 5469, Santa Fe, NM 87502, (505) 827-2855, nd.coordinator@state.nm.us. You may also visit our website at <https://www.env.nm.gov/non-employee-discrimination-complaint-page/> to learn how and where to file a complaint of discrimination.

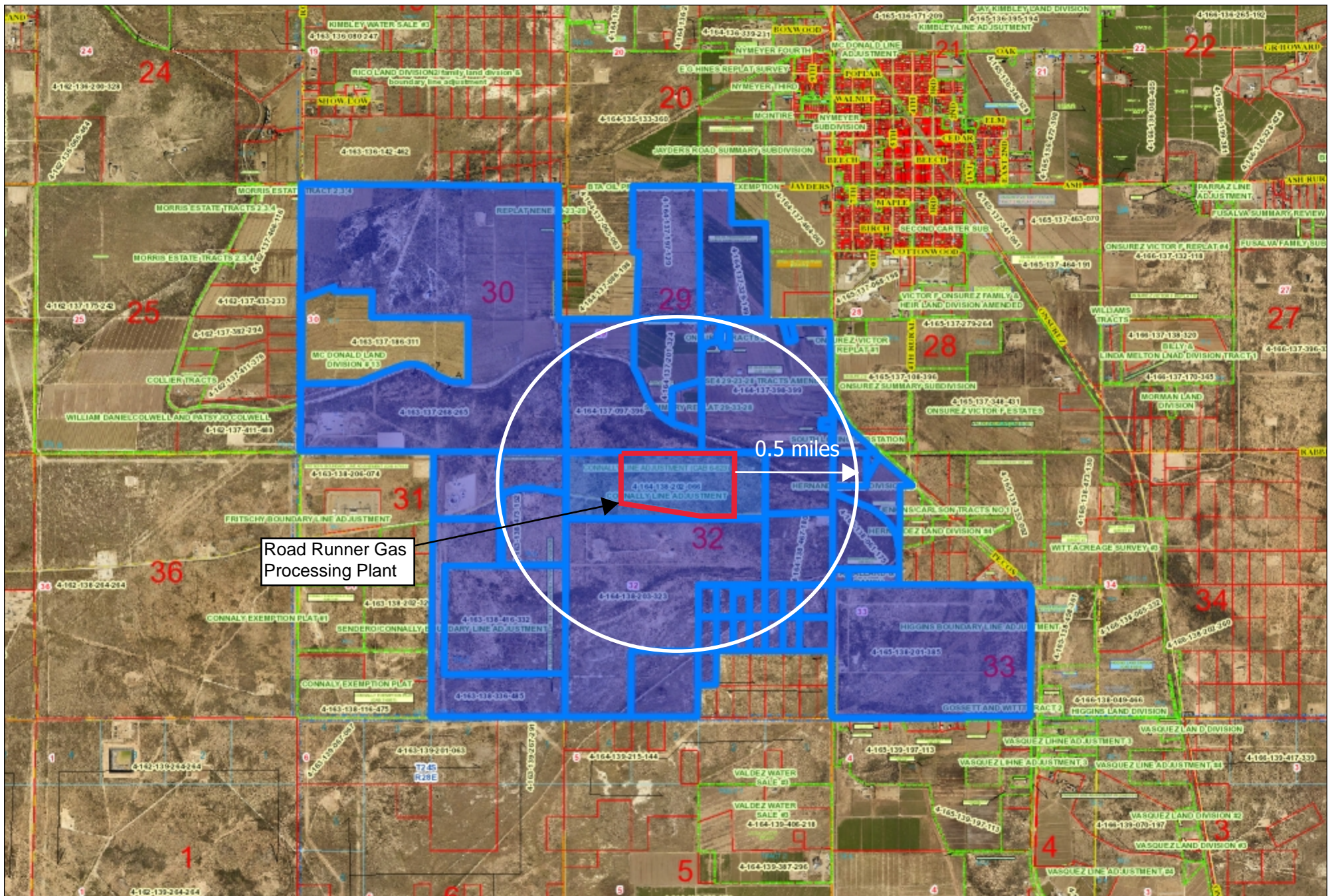

Road Runner Gas Processing Plant

0.5 miles

Road Runner GP Surrounding Properties
 Web Print: 11/11/2022

This map is a user generated static output from an Internet mapping site and is for reference only. Data layers that appear on this map may or may not be accurate, current, or otherwise reliable.

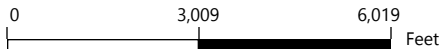

Targa Midstream Services LLC - Road Runner Gas Plant Public Notice List:

Name	Mailing Address	Category of Notice
LUCID ENERGY DELAWARE LLC	3100 MCKINNON ST STE 800, DALLAS, TX 75201-7014	Nearby Landowner
MCDONALD, HENRY	PO BOX 597, LOVING, NM 88256-0597	Nearby Landowner
CONNALLY, VICKIE	125 BRINKLEY LN, ELGIN, TX 78621-5046	Nearby Landowner
STATE OF NEW MEXICO	310 OLD SANTA FE TRAIL, SANTA FE, NM 87504	Nearby Landowner
OGDEN ESTATE HEIRS	2302 FOREHAND RD, CARLSBAD, NM 88220	Nearby Landowner
ZUNIGA, RYAN M	24 MESQUITE LANE, ARTESIA, NM 88210	Nearby Landowner
SOOBY, F W MRS	921 MONTCREST DR, REDDING, CA 96003	Nearby Landowner
HUFFER, GEORGE A	4713 CRAIG AVE, METAIRIE, LA 70003	Nearby Landowner
COX, NELDA WYRICK ETAL (JT)	3101 SEXTON DR, NORMAN, OK 73026	Nearby Landowner
BLACKMON, SUSAN D & BLACKMON, JOHN E	3501 BONNIEBROOK DR, PLANO, TX 75075	Nearby Landowner
SOUTHWESTERN PUBLIC SERVICE CO	ATTN: PROPERTY TAX DEPT, PO BOX 1979, DENVER, CO 80201-0840	Nearby Landowner
ESCARCEGA, JOSE VALENTIN LUGO & LUGO, CHRISTY MORENO (JT)	1991 PECOS HWY, LOVING, NM 88256	Nearby Landowner
HERNANDEZ, PABLO & MARIA REV TRUST HERNANDEZ, PABLO P & MARIA Q TRUSTEES	1971 PECOS HWY , LOVING, NM 88256	Nearby Landowner
BALLARD, PARKER & WHITNEY (N-JT)	PO BOX 716, LOVING, NM 882560716	Nearby Landowner
BALLARD, MITCHELL & WENDY	273 HIGBY HOLE RD, LOVING, NM 88256-9737	Nearby Landowner
PARDUÉ LIMITED COMPANY	PO BOX 2018, CARLSBAD, NM 88221-2018	Nearby Landowner
ONSUREZ, ANTONIO C & GLORIA S	PO BOX 598, LOVING, NM 88256-0598	Nearby Landowner
ONSUREZ, DAMIAN S & CYNTHIA KAY (JT)	PO BOX 1088, CARLSBAD, NM 88221-1088	Nearby Landowner
PINA, REYMUNDO & VICTORIA (JT)	PO BOX 356, LOVING, NM 88256-0356	Nearby Landowner
ONSUREZ, JOEL SANTOS	PO BOX 1058, LOVING, NM 88256-1058	Nearby Landowner
CALDERON, FELIX & DEBRA (JT)	PO BOX 64, LOVING, NM 88256-0064	Nearby Landowner
ZUNIGA, JOSE D & ELISA (N-JT)	211 W FIESTA DR , CARLSBAD, NM 88220	Nearby Landowner
MCDONALD, HENRY	PO BOX 597, LOVING, NM 88256-0597	Nearby Landowner
LONGWOOD MIDSTREAM DELAWARE LLC	5400 LBJ FREEWAY SUITE 1500, DALLAS, TX 75240	Nearby Landowner
CONNALLY, VICKIE	125 BRINKLEY LN , ELGIN, TX 78621-5046	Nearby Landowner
Eddy County Manager	101 W Greene Street, Suite 110, Carlsbad, NM 88220	County and Nearby Landowner
Village of Loving, NM	P.O. Box 56, Loving, NM 88256	Municipality and Nearby Landowner

UPC
4-164-138-202-066

Map Number
320-CLA-A , CAB# 6-623-1,

Owner
LUCID ENERGY DELAWARE LLC

Owner Address1
3100 MCKINNON ST STE 800

Owner Address2
N/A

Owner Address City
DALLAS

Actual Area
122

Tax Area
CO_NR

Land Code
122_1_8

Book
N/A

Page
N/A

Owner Address State
TX

Owner Address Zip Code
752017014

Site Address
E OF 1011 BOUNDS ROAD

Legal Description
Subd: CONNALLY LINE ADJUSTMENT Tract: A
THIS TRACT IS IN TWO DIFFERENT SEC'S AND
HAS TO BE SOLD TOGETHER SEE 4-163-138-
471-039 Quarter: NE S: 31 T: 23S R: 28E

Model Type
Land

Land Acreage
220

Section 10

Written Description of the Routine Operations of the Facility

A written description of the routine operations of the facility. Include a description of how each piece of equipment will be operated, how controls will be used, and the fate of both the products and waste generated. For modifications and/or revisions, explain how the changes will affect the existing process. In a separate paragraph describe the major process bottlenecks that limit production. The purpose of this description is to provide sufficient information about plant operations for the permit writer to determine appropriate emission sources.

The Roadrunner Gas Processing Plant is a natural gas processing plant located in Eddy County near Loving, NM. The primary function of the plant is to separate natural gas (methane) from heavier (liquid) hydrocarbons, raw sweet field gas so that the gas can meet pipeline specifications. The plant has been designated a primary Standard Industrial Classification (SIC) Code of 1311.

The operation of the Roadrunner Gas Processing Plant is intended to process 660 MMscfd of gas. The gas will be treated to remove CO₂ and H₂S, dehydrated to remove water, and processed to remove heavy (liquid) hydrocarbons from the gas stream. Several plant systems will be involved to perform these functions.

Slug Catcher / Separator

A large slug catcher has been placed at the front of the plant to catch and separate any free hydrocarbon liquids and water present in the inlet pipeline gas stream. It is capable of handling large slugs of liquid brought into the plant from pipeline pigging operations. The equipment also serves as a three-phase separator to separate the free hydrocarbons, gas to be processed, and any water that may have condensed out in the pipeline after field dehydration.

Stabilizers

The overhead stabilization system is in place to lower the Reid Vapor Pressure (RVP) of the pipeline liquids and condensate after they are dropped out of the gas stream. Through a process that heats the condensate to flash off lighter hydrocarbons so the RVP is lowered to 9. The liquids out of the slug catcher are stabilized and sent to the tank farm for truck sales. Any remaining vapors are recycled back to the front of the Slug Catcher. The liquid in the tank farm is then stable and thus does not give off significant flashing vapors. Significant working and standing losses will occur at the tank farm. These emissions will be controlled with a vapor combustor.

Amine Treating

The amine units are designed to remove CO₂ and H₂S (from the natural gas stream) to meet pipeline specifications. Streams containing up to 5 ppm H₂S will be processed at the plant. Amine treating is an exothermic chemical reaction process. The treating solution is a mixture of 50% RO water, 40% methyl-diethanolamine (MDEA) and 10% Piperazine. This aqueous mixture is regenerated and reused. Lean MDEA solution is pumped to the top of the contactor and allowed to flow downward. Wet gas is fed into the bottom of the contactor and flows upward.

As the lean MDEA solution flows down through the contactor, it comes into contact with the wet gas. The CO₂ and H₂S are absorbed by amine. The amine is now known as rich amine and the remaining gas is sweet and continues to the dehydration systems.

The regeneration of the amine utilizes one 70.28 MMBtu/hr heater (EP-3A) and one 84.77 MMBtu/hr heater (EP-3B). Significant amounts of VOC and HAP can be generated in this process. The acid gas is sent to a thermal oxidizer where additional combustion will further minimize VOC and H₂S emissions.

Glycol Dehydration

Triethylene glycol (TEG) is used to remove water from the natural gas stream. Water is saturated into the sweet gas stream during the Amine Treating process. This water is absorbed by the TEG solution. The wet gas is brought into contact with dry glycol in an absorber. Water vapor is absorbed in the glycol and consequently, the water content is reduced. The wet rich glycol then flows

from the absorber to a regeneration system in which the entrained gas is separated and fractionated in a column and re-boiler. The heating allows boiling off the absorbed water vapor and the water dry lean glycol is cooled (via heat exchange) and pumped back to the absorber.

The regeneration of the TEG utilizes small (less than 10 MMBtu/hr) heaters. This process produces VOC and HAP emission. This stream is condensed. The wastewater stream is sent to a wastewater tank. The non-condensable stream is sent to the thermal oxidizer for control where further combustion reduces the emissions. The dehydration flash gas stream is used as plant fuel.

Molecular Sieve Dehydration

Molecular sieve dehydration is used upstream of the cryogenic processes to achieve a -160°F water dew point. The process uses three molecular sieve vessels with two vessels in service adsorbing moisture from the gas stream and the other vessel in the regeneration mode.

During the regeneration mode, hot, dry gas (regen gas) is passed up through the vessel to drive off the adsorbed moisture from the molecular sieve. The gas comes from the discharge of the residue compressors and it is passed through a heat exchanger and a heater to achieve a temperature of approximately 500°F. After the gas passes through the bed it is cooled in an air cooled exchanger. The water in the gas condenses and is separated from the gas stream in a separator. The regen gas is routed to the inlet of the cryogenic unit.

Cryogenic Unit (3)

The cryogenic units are designed to liquefy natural gas components from the sweet, dehydrated inlet gas by removing work from the gas by means of the turbo expander/compressor. The cryogenic unit recovers natural gas liquids (NGL) by cooling the gas stream to extremely cold temperatures (-160°F and lower) and condensing components such as ethane, propane, butanes and heavier. The gas is cooled by a series of heat exchangers and by lowering the pressure of the gas from around 950 PSIG to approximately 190 PSIG. Once the gas has passed through the system of heat exchangers and expansion it is re-compressed using the energy obtained from expanding the gas.

The gas will flow through the following heat exchangers:

- **Gas to Gas Exchanger** – This unit exchanges heat from the warm inlet gas and the cold residue gas that has already been expanded. This cools the inlet gas.
- **Product Heater** – This unit will cool the inlet gas by exchanging heat with the cold liquid product that has been recovered.
- **Side-Reboiler** – This unit uses heat from the inlet gas to boil the methane out of the liquid. One stream comes off the side of the tower and one stream comes off of the bottom of the tower. This also cools the inlet gas.

The gas is expanded and recompressed in the expander/compressor.

Emergency Flares

Three flares are proposed. These flares' header system gathers hydrocarbons from Pressure Safety Devices in the plant, and routes them to the flares. These systems are also used to safely control blow-down hydrocarbons from equipment in the plant.

Compressors

The site will operate a total of 23 electric-driven compressors. No internal combustion engines or turbines will be used to drive compressors.

Section 11

Source Determination

Source submitting under 20.2.70, 20.2.72, 20.2.73, and 20.2.74 NMAC

Sources applying for a construction permit, PSD permit, or operating permit shall evaluate surrounding and/or associated sources (including those sources directly connected to this source for business reasons) and complete this section. Responses to the following questions shall be consistent with the Air Quality Bureau's permitting guidance, Single Source Determination Guidance, which may be found on the Applications Page in the Permitting Section of the Air Quality Bureau website.

Typically, buildings, structures, installations, or facilities that have the same SIC code, that are under common ownership or control, and that are contiguous or adjacent constitute a single stationary source for 20.2.70, 20.2.72, 20.2.73, and 20.2.74 NMAC applicability purposes. Submission of your analysis of these factors in support of the responses below is optional, unless requested by NMED.

A. Identify the emission sources evaluated in this section (list and describe):

Roadrunner Gas Plant by itself is the source represented in this application. There are no nearby or adjacent sources.

B. Apply the 3 criteria for determining a single source:

SIC Code: Surrounding or associated sources belong to the same 2-digit industrial grouping (2-digit SIC code) as this facility, OR surrounding or associated sources that belong to different 2-digit SIC codes are support facilities for this source.

Yes **No**

Common Ownership or Control: Surrounding or associated sources are under common ownership or control as this source.

Yes **No**

Contiguous or Adjacent: Surrounding or associated sources are contiguous or adjacent with this source.

Yes **No**

C. Make a determination:

The source, as described in this application, constitutes the entire source for 20.2.70, 20.2.72, 20.2.73, or 20.2.74 NMAC applicability purposes. If in "A" above you evaluated only the source that is the subject of this application, all "YES" boxes should be checked. If in "A" above you evaluated other sources as well, you must check **AT LEAST ONE** of the boxes "NO" to conclude that the source, as described in the application, is the entire source for 20.2.70, 20.2.72, 20.2.73, and 20.2.74 NMAC applicability purposes.

The source, as described in this application, **does not** constitute the entire source for 20.2.70, 20.2.72, 20.2.73, or 20.2.74 NMAC applicability purposes (A permit may be issued for a portion of a source). The entire source consists of the following facilities or emissions sources (list and describe):

Section 12

Section 12.A

PSD Applicability Determination for All Sources

(Submitting under 20.2.72, 20.2.74 NMAC)

A PSD applicability determination for all sources. For sources applying for a significant permit revision, apply the applicable requirements of 20.2.74.AG and 20.2.74.200 NMAC and to determine whether this facility is a major or minor PSD source, and whether this modification is a major or a minor PSD modification. It may be helpful to refer to the procedures for Determining the Net Emissions Change at a Source as specified by Table A-5 (Page A.45) of the EPA New Source Review Workshop Manual to determine if the revision is subject to PSD review.

A. This facility is:

- a minor PSD source before and after this modification (if so, delete C and D below).
- a major PSD source before this modification. This modification will make this a PSD minor source.
- an existing PSD Major Source that has never had a major modification requiring a BACT analysis.
- an existing PSD Major Source that has had a major modification requiring a BACT analysis
- a new PSD Major Source after this modification.

B. This facility **is not** one of the listed 20.2.74.501 Table I – PSD Source Categories. The “project” emissions for this modification are **not significant. Project emission increases are less than 250 tpy for all criteria pollutants.** The “project” emissions listed below **do only result from changes described in this permit application, thus no emissions from other revisions or modifications, past or future** to this facility. Also, specifically discuss whether this project results in “de-bottlenecking”, or other associated emissions resulting in higher emissions. **Debottlenecked emissions are not accounted for since the source is an existing minor NSR site.** The project emissions (before netting) for this project are as follows [see Table 2 in 20.2.74.502 NMAC for a complete list of significance levels]:

- a. NO_x: **155.90** TPY
- b. CO: **231.39** TPY
- c. VOC: **297.30** TPY
- d. VOC (without fugitives): **181.82** TPY
- e. SO_x: **147.88** TPY
- f. PM: **16.81** TPY
- g. PM₁₀: **15.72** TPY
- h. PM_{2.5}: **15.39** TPY
- i. Fluorides: **N/A** TPY
- j. Lead: **N/A** TPY
- k. Sulfur compounds (listed in Table 2): **0.54** TPY
- l. GHG: **416,731.67** TPY

C. Netting **NA**

D. BACT **NA**

E. If this is an existing PSD major source, or any facility with emissions greater than 250 TPY (or 100 TPY for 20.2.74.501 Table 1 – PSD Source Categories), determine whether any permit modifications are related, or could be considered a single project with this action, and provide an explanation for your determination whether a PSD modification is triggered. **NA**

Section 13

Determination of State & Federal Air Quality Regulations

This section lists each state and federal air quality regulation that may apply to your facility and/or equipment that are stationary sources of regulated air pollutants.

Not all state and federal air quality regulations are included in this list. Go to the Code of Federal Regulations (CFR) or to the Air Quality Bureau's regulation page to see the full set of air quality regulations.

Required Information for Specific Equipment:

For regulations that apply to specific source types, in the 'Justification' column **provide any information needed to determine if the regulation does or does not apply. For example**, to determine if emissions standards at 40 CFR 60, Subpart IIII apply to your three identical stationary engines, we need to know the construction date as defined in that regulation; the manufacturer date; the date of reconstruction or modification, if any; if they are or are not fire pump engines; if they are or are not emergency engines as defined in that regulation; their site ratings; and the cylinder displacement.

Required Information for Regulations that Apply to the Entire Facility:

See instructions in the 'Justification' column for the information that is needed to determine if an 'Entire Facility' type of regulation applies (e.g. 20.2.70 or 20.2.73 NMAC).

Regulatory Citations for Regulations That Do Not, but Could Apply:

If there is a state or federal air quality regulation that does not apply, but you have a piece of equipment in a source category for which a regulation has been promulgated, you must **provide the low level regulatory citation showing why your piece of equipment is not subject to or exempt from the regulation. For example** if you have a stationary internal combustion engine that is not subject to 40 CFR 63, Subpart ZZZZ because it is an existing 2 stroke lean burn stationary RICE with a site rating of more than 500 brake HP located at a major source of HAP emissions, your citation would be 40 CFR 63.6590(b)(3)(i). **We don't want a discussion of every non-applicable regulation, but if it is possible a regulation could apply, explain why it does not. For example**, if your facility is a power plant, you do not need to include a citation to show that 40 CFR 60, Subpart OOO does not apply to your non-existent rock crusher.

Regulatory Citations for Emission Standards:

For each unit that is subject to an emission standard in a source specific regulation, such as 40 CFR 60, Subpart OOO or 40 CFR 63, Subpart HH, include the low level regulatory citation of that emission standard. Emission standards can be numerical emission limits, work practice standards, or other requirements such as maintenance. **Here are examples:** a glycol dehydrator is subject to the general standards at 63.764C(1)(i) through (iii); an engine is subject to 63.6601, Tables 2a and 2b; a crusher is subject to 60.672(b), Table 3 and all transfer points are subject to 60.672(e)(1)

Federally Enforceable Conditions:

All federal regulations are federally enforceable. All Air Quality Bureau State regulations are federally enforceable except for the following: affirmative defense portions at 20.2.7.6.B, 20.2.7.110(B)(15), 20.2.7.11 through 20.2.7.113, 20.2.7.115, and 20.2.7.116; 20.2.37; 20.2.42; 20.2.43; 20.2.62; 20.2.63; 20.2.86; 20.2.89; and 20.2.90 NMAC. Federally enforceable means that EPA can enforce the regulation as well as the Air Quality Bureau and federally enforceable regulations can count toward determining a facility's potential to emit (PTE) for the Title V, PSD, and nonattainment permit regulations.

INCLUDE ANY OTHER INFORMATION NEEDED TO COMPLETE AN APPLICABILITY DETERMINATION OR THAT IS RELEVANT TO YOUR FACILITY'S NOTICE OF INTENT OR PERMIT.

EPA Applicability Determination Index for 40 CFR 60, 61, 63, etc: <http://cfpub.epa.gov/adi/>

Table for State Regulations:

<u>State Regulation Citation</u>	Title	Applies? Enter Yes or No	Unit(s) or Facility	Justification: (You may delete instructions or statements that do not apply in the justification column to shorten the document.)
20.2.1 NMAC	General Provisions	Yes	Facility	General Provisions apply to Notice of Intent, Construction, and Title V permit applications.
20.2.3 NMAC	Ambient Air Quality Standards NMAAQS	Yes	Facility	If subject, this would normally apply to the entire facility. 20.2.3 NMAC is a State Implementation Plan (SIP) approved regulation that limits the maximum allowable concentration of, Sulfur Compounds, Carbon Monoxide and Nitrogen Dioxide. Title V applications, see exemption at 20.2.3.9 NMAC The TSP NM ambient air quality standard was repealed by the EIB effective November 30, 2018.
20.2.7 NMAC	Excess Emissions	Yes	Facility	If subject, this would normally apply to the entire facility. If your entire facility or individual pieces of equipment are subject to emissions limits in a permit or numerical emissions standards in a federal or state regulation, this applies. This would not apply to Notices of Intent since these are not permits.
20.2.23 NMAC	Fugitive Dust Control	No	N/A	Sources exempt from 20.2.23 NMAC are activities and facilities subject to a permit issued pursuant to the NM Air Quality Control Act, the Mining Act, or the Surface Mining Act (20.2.23.108.B NMAC).
20.2.33 NMAC	Gas Burning Equipment - Nitrogen Dioxide	No	N/A	The site does not have gas burning equipment larger than 1,000,000 MM Btu/year.
20.2.34 NMAC	Oil Burning Equipment: NO ₂	No	N/A	The site does not have oil burning equipment larger than 1,000,000 MM Btu/year.
20.2.35 NMAC	Natural Gas Processing Plant – Sulfur	Yes	Facility	This regulation establishes sulfur emission standards for natural gas processing plants. The proposed facility meets the definition of a new natural gas processing plant under this regulation and is subject to the requirements of this regulation [20.2.35.7 (B) NMAC]. The facility will comply with all requirements under 20.2.35 NMAC as applicable.
20.2.37 and 20.2.36 NMAC	Petroleum Processing Facilities and Petroleum Refineries	N/A	N/A	These regulations were repealed by the Environmental Improvement Board. If you had equipment subject to 20.2.37 NMAC before the repeal, your combustion emission sources are now subject to 20.2.61 NMAC.
20.2.38 NMAC	Hydrocarbon Storage Facility	No	N/A	Site does not have tank sizes that meet the applicability criteria.
20.2.39 NMAC	Sulfur Recovery Plant - Sulfur	No	N/A	The site is a natural gas processing facility. As such, this regulation does not apply.
20.2.50 NMAC	Oil and Gas Sector – Ozone Precursor Pollutants	Yes	Facility	The site is a natural gas processing facility in Eddy County, NM. Parts of the site commenced operation prior to the effective date of this Part and will therefore comply with provisions for Existing units. The proposed equipment will be treated as New units for the rule. Targa will comply with all applicable elements of this Part.

20.2.61.109 NMAC	Smoke & Visible Emissions	Yes	EP-1; 2-EP-1; 3-EP-1; EP-2; 2-EP-2; 3-EP2; EP-3A; EP-3B; EP-4; 2-EP-4; 3-EP-4; EP-5; 2-EP-5; 3-EP-5; EP-6; 2-EP-6; EP-9; COMB-1	This regulation that limits opacity to 20% applies to Stationary Combustion Equipment, such as engines, boilers, heaters, and flares unless your equipment is subject to another state regulation that limits particulate matter such as 20.2.19 NMAC (see 20.2.61.109 NMAC).
20.2.70 NMAC	Operating Permits	Yes	Facility	Title V major for criteria pollutants. Targa will submit an initial Title V Operating Permit application.
20.2.71 NMAC	Operating Permit Fees	Yes	Facility	If subject to 20.2.70 NMAC and your permit includes numerical ton per year emission limits, you are subject to 20.2.71 NMAC and normally applies to the entire facility.
20.2.72 NMAC	Construction Permits	Yes	Facility	This regulation establishes the requirements for obtaining a construction permit. The facility is a stationary source that has a potential emission rate greater than 10 pounds per hour or 25 tons per year of any regulated air contaminant for which there is a National or New Mexico Air Quality Standard. The facility has a construction permit to meet the requirements of this regulation.
20.2.73 NMAC	NOI & Emissions Inventory Requirements	Yes	Facility	Emissions Inventory Reporting per 20.2.73.300 NMAC applies to the site. All facilities that are a Title V Major Source as defined at 20.2.70.7.R NMAC are subject to Emissions Inventory Reporting.
20.2.74 NMAC	Permits – Prevention of Significant Deterioration (PSD)	No	N/A	Minor NSR site.
20.2.75 NMAC	Construction Permit Fees	Yes	Facility	This regulation applies since this submittal is an application pursuant to 20.2.72.
20.2.77 NMAC	New Source Performance	Yes	Units subject to 40 CFR 60	This is a stationary source which is subject to the requirements of 40 CFR Part 60.
20.2.78 NMAC	Emission Standards for HAPS	No	N/A	No units at the site are subject to 40 CFR Part 61.
20.2.79 NMAC	Permits – Nonattainment Areas	No	Facility	Site is not located in a nonattainment county.
20.2.80 NMAC	Stack Heights	No	N/A	Not cited in NSR permit. No stacks exceed GEP height.

20.2.82 NMAC	MACT Standards for source categories of HAPS	Yes	Units Subject to 40 CFR 63	The site has equipment that is subject to a MACT Subparts HH.
-----------------	--	-----	----------------------------	---

Table for Applicable Federal Regulations:

<u>Federal Regulation Citation</u>	Title	Applies? Enter Yes or No	Unit(s) or Facility	Justification:
40 CFR 50	NAAQS	Yes	Facility	This applies since the site is subject to 20.2.72 NMAC.
NSPS 40 CFR 60, Subpart A	General Provisions	Yes	Units subject to 40 CFR 60	The site has units subject to an NSPS as shown below.
NSPS 40 CFR60.40a, Subpart Da	Subpart Da, Performance Standards for Electric Utility Steam Generating Units	No	N/A	No units are subject to NSPS Subpart Da.
NSPS 40 CFR60.40b Subpart Db	Electric Utility Steam Generating Units	No	N/A	No units are subject to NSPS Subpart Db.
40 CFR 60.40c, Subpart Dc	Standards of Performance for Small Industrial-Commercial-Institutional Steam Generating Units	Yes	EP-2; 2-EP-2; 3-EP-2; EP-3A; EP-3B; EP-6; 2-EP-6	This facility has steam generating units for which construction, modification or reconstruction is commenced after June 9, 1989 and that have a maximum design heat input capacity of 29 MW (100 MMBtu/hr) or less, but greater than or equal to 2.9 MW (10 MMBtu/hr). Only recordkeeping and notification requirements apply as the units burn only natural gas.
NSPS 40 CFR 60, Subpart Ka	Standards of Performance for Storage Vessels for Petroleum Liquids for which Construction, Reconstruction, or Modification Commenced After May 18, 1978, and Prior to July 23, 1984	No	N/A	All hydrocarbon tanks have a storage capacity less than 151,416 liters (40,000 gallons). that are used to store petroleum liquids for which construction is commenced after May 18, 1978.
NSPS 40 CFR 60, Subpart Kb	Standards of Performance for Volatile Organic Liquid Storage Vessels (Including Petroleum Liquid Storage Vessels) for Which Construction, Reconstruction, or Modification Commenced After July 23, 1984	Yes	T-1; T-2; T-3; T-4; T-5	This facility has storage vessels with a capacity greater than or equal to 75 cubic meters (m ³) that is used to store volatile organic liquids (VOL) for which construction, reconstruction, or modification is commenced after July 23, 1984.

<u>Federal Regulation Citation</u>	Title	Applies? Enter Yes or No	Unit(s) or Facility	Justification:
NSPS 40 CFR 60.330 Subpart GG	Stationary Gas Turbines	No	N/A	No stationary gas turbines are operated at the site.
NSPS 40 CFR 60, Subpart KKK	Leaks of VOC from Onshore Gas Plants	No	N/A	This facility commenced construction after August 23, 2011. Thus, the facility is not subject to this subpart.
NSPS 40 CFR Part 60 Subpart LLL	Standards of Performance for Onshore Natural Gas Processing: SO₂ Emissions	No	N/A	The facility is a natural gas processing plant; however, there is no sulfur recovery plant. Thus, this location does not meet the applicability criteria of 40 CFR 60.640.
NSPS 40 CFR Part 60 Subpart OOOO	Standards of Performance for Crude Oil and Natural Gas Production, Transmission, and Distribution	Yes	Train 2	Reciprocating electric compressors 2-D-1 through 2-D-8 and fugitive components associated with Train 2 are existing affected facilities that will be relocated from another site and were previously subject to NSPS OOOO. Targa will make a final determination of NSPS OOOO/a/b applicability for these relocated sources and will comply with the NSPS as required. Train 2 will rely on the existing amine sweetening unit installed with Train 1, which is subject to NSPS OOOOa. Pneumatic devices and pumps will utilize instrument air.
NSPS 40 CFR Part 60 Subpart OOOOa	Standards of Performance for Crude Oil and Natural Gas Facilities for which Construction, Modification or Reconstruction Commenced After September 18, 2015	Yes	See Justification column	D-1 through D-7 are electric-driven compressors associated with Train 1 and were manufactured after September 18, 2015 and are thus subject to 60.5385a, 60.5410a, 60.5415a, and 60.5420a. T-1, T-2, T-3, T-4, and T-5 are storage vessels constructed after September 18, 2015 with federally enforceable limitations that limit emissions to less than 6 tpy of VOCs. T-6 is a storage vessel that emits less than 6 tpy of VOCs. As such, T1 to T6 are not subject to 60.5395a, 60.5410a, 60.5417a, 60.5420a. The amine units (single still vent EP-8) are sweetening units as defined in this subpart that were constructed after September 18, 2015. Per 60.5365a(g) (3) the amine units are required to comply with 60.5423a(c) but not required to comply with 60.5405a through 60.5407 and 60.5410a(g) and 60.5415a(g). The facility is defined as an onshore natural gas processing plant. Therefore fugitives are covered by 60.5400a, 60.5401a, 60.5402a, 60.5421a, and 60.5422a. Pneumatic devices and pumps will utilize instrument air.
NSPS 40 CFR Part 60 Subpart OOOOb	Standards of Performance for Crude Oil and Natural Gas Facilities for which Construction, Modification or Reconstruction Commenced After November 15, 2021	Yes (upon rule becoming final)	Train 3	Reciprocating electric compressors 3-D-1 through 3-D-8 and fugitives associated with Train 3 will be new affected facilities for the purpose of NSPS OOOOb. Targa will make a final applicability determination once the rule is final and will comply as required. Train 3 will rely on the existing amine sweetening unit installed with Train 1, which is subject to NSPS OOOOa. Pneumatic devices and pumps will utilize instrument air.
NSPS 40 CFR 60 Subpart IIII	Standards of performance for Stationary Compression Ignition Internal Combustion Engines	No	N/A	No RICE operated at the site.

<u>Federal Regulation Citation</u>	Title	Applies? Enter Yes or No	Unit(s) or Facility	Justification:
NSPS 40 CFR Part 60 Subpart JJJJ	Standards of Performance for Stationary Spark Ignition Internal Combustion Engines	No	N/A	No RICE operated at the site.
NESHAP 40 CFR 61 Subpart A	General Provisions	No	Units Subject to 40 CFR 61	No 40 CFR Part 61 sources at the site.
NESHAP 40 CFR 61 Subpart V	National Emission Standards for Equipment Leaks (Fugitive Emission Sources)	No	N/A	No units at the site operate in more than 10 wt% VHAP service.
MACT 40 CFR 63, Subpart A	General Provisions	Yes	Units Subject to 40 CFR 63	This facility is an area source for HAPs. Area source provisions of 40 CFR Part 63 subpart HH apply to the glycol dehydrators at the site.
MACT 40 CFR 63.760 Subpart HH	Oil and Natural Gas Production Facilities	Yes	EP-7 2-EP-7 3-EP-7	This facility is a HAP Area Source and is subject to the requirements of 40 CFR 63 Subpart HH. Dehydrators EP-7, 2-EP-7, 3-EP-7 have actual and potential emissions less than 1 tpy (0.9 Megagrams per year) and are therefore exempt from control requirements per 40 CFR 63.764(e)(1)(ii). Records of the exempt status will be maintained as required in 40 CFR 63.774(d)(1).
MACT 40 CFR 63 Subpart HHH	National Emission Standards for Hazardous Air Pollutants From Natural Gas Transmission and Storage Facilities	No	N/A	This facility is not a natural gas transmission or storage facility. Thus, this subpart does not apply.
MACT 40 CFR 63 Subpart DDDDD	National Emission Standards for Hazardous Air Pollutants for Major Industrial, Commercial, and Institutional Boilers & Process Heaters	No	N/A	This regulation establishes national emission standards for hazardous air pollutants for major industrial, commercial, and institutional boilers and process heaters at Major sources of HAPs. The facility is an area source of HAPs; therefore, this regulation does not apply.
MACT 40 CFR 63 Subpart ZZZZ	National Emissions Standards for Hazardous Air Pollutants for Stationary Reciprocating Internal Combustion Engines (RICE MACT)	No	N/A	No RICE operated at the site

<u>Federal Regulation Citation</u>	Title	Applies? Enter Yes or No	Unit(s) or Facility	Justification:
MACT 40 CFR 63, Subpart JJJJJ	NESHAPS for Industrial, Commercial, and Institutional Boilers Area Sources	No	N/A	Heaters at the site only burn gaseous fuel and are therefore exempt per 40 CFR 63.1195(e) and 63.1127.
40 CFR 64	Compliance Assurance Monitoring			CAM will be addressed as part of the initial Title V permit application.
40 CFR 68	Chemical Accident Prevention	Yes	Facility	An owner or operator of a stationary source that has more than a threshold quantity of a regulated substance in a process, as determined under §68.115, See 40 CFR 68
Title VI – 40 CFR 82	Protection of Stratospheric Ozone	No	N/A	This regulation establishes a regulation for protection of the stratospheric ozone. The regulation is not applicable because the facility does not “service”, “maintain”, or “repair” class I or class II appliances nor “disposes” of the appliances [40 CFR Part 82.1(a)].

Section 14

Operational Plan to Mitigate Emissions

(Submitting under 20.2.70, 20.2.72, 20.2.74 NMAC)

- Title V Sources** (20.2.70 NMAC): By checking this box and certifying this application the permittee certifies that it has developed an **Operational Plan to Mitigate Emissions During Startups, Shutdowns, and Emergencies** defining the measures to be taken to mitigate source emissions during startups, shutdowns, and emergencies as required by 20.2.70.300.D.5(f) and (g) NMAC. This plan shall be kept on site to be made available to the Department upon request. This plan should not be submitted with this application.
- NSR** (20.2.72 NMAC), **PSD** (20.2.74 NMAC) **& Nonattainment** (20.2.79 NMAC) **Sources:** By checking this box and certifying this application the permittee certifies that it has developed an **Operational Plan to Mitigate Source Emissions During Malfunction, Startup, or Shutdown** defining the measures to be taken to mitigate source emissions during malfunction, startup, or shutdown as required by 20.2.72.203.A.5 NMAC. This plan shall be kept on site to be made available to the Department upon request. This plan should not be submitted with this application.
- Title V** (20.2.70 NMAC), **NSR** (20.2.72 NMAC), **PSD** (20.2.74 NMAC) **& Nonattainment** (20.2.79 NMAC) **Sources:** By checking this box and certifying this application the permittee certifies that it has established and implemented a Plan to Minimize Emissions During Routine or Predictable Startup, Shutdown, and Scheduled Maintenance through work practice standards and good air pollution control practices as required by 20.2.7.14.A and B NMAC. This plan shall be kept on site or at the nearest field office to be made available to the Department upon request. This plan should not be submitted with this application.
-

Section 15

Alternative Operating Scenarios

(Submitting under 20.2.70, 20.2.72, 20.2.74 NMAC)

Alternative Operating Scenarios: Provide all information required by the department to define alternative operating scenarios. This includes process, material and product changes; facility emissions information; air pollution control equipment requirements; any applicable requirements; monitoring, recordkeeping, and reporting requirements; and compliance certification requirements. Please ensure applicable Tables in this application are clearly marked to show alternative operating scenario.

Construction Scenarios: When a permit is modified authorizing new construction to an existing facility, NMED includes a condition to clearly address which permit condition(s) (from the previous permit and the new permit) govern during the interval between the date of issuance of the modification permit and the completion of construction of the modification(s). There are many possible variables that need to be addressed such as: Is simultaneous operation of the old and new units permitted and, if so for example, for how long and under what restraints? In general, these types of requirements will be addressed in Section A100 of the permit, but additional requirements may be added elsewhere. Look in A100 of our NSR and/or TV permit template for sample language dealing with these requirements. Find these permit templates at: www.env.nm.gov/air-quality/permitting-section-procedures-and-guidance/. Compliance with standards must be maintained during construction, which should not usually be a problem unless simultaneous operation of old and new equipment is requested.

In this section, under the bolded title “Construction Scenarios”, specify any information necessary to write these conditions, such as: conservative-realistic estimated time for completion of construction of the various units, whether simultaneous operation of old and new units is being requested (and, if so, modeled), whether the old units will be removed or decommissioned, any PSD ramifications, any temporary limits requested during phased construction, whether any increase in emissions is being requested as SSM emissions or will instead be handled as a separate Construction Scenario (with corresponding emission limits and conditions, etc).

There are no alternative operating scenarios at this facility.

Section 16

Air Dispersion Modeling

- 1) Minor Source Construction (20.2.72 NMAC) and Prevention of Significant Deterioration (PSD) (20.2.74 NMAC) ambient impact analysis (modeling): Provide an ambient impact analysis as required at 20.2.72.203.A(4) and/or 20.2.74.303 NMAC and as outlined in the Air Quality Bureau’s Dispersion Modeling Guidelines found on the Planning Section’s modeling website. If air dispersion modeling has been waived for one or more pollutants, attach the AQB Modeling Section modeling waiver approval documentation.
- 2) SSM Modeling: Applicants must conduct dispersion modeling for the total short term emissions during routine or predictable startup, shutdown, or maintenance (SSM) using realistic worst case scenarios following guidance from the Air Quality Bureau’s dispersion modeling section. Refer to "Guidance for Submittal of Startup, Shutdown, Maintenance Emissions in Permit Applications (http://www.env.nm.gov/aqb/permit/app_form.html) for more detailed instructions on SSM emissions modeling requirements.
- 3) Title V (20.2.70 NMAC) ambient impact analysis: Title V applications must specify the construction permit and/or Title V Permit number(s) for which air quality dispersion modeling was last approved. Facilities that have only a Title V permit, such as landfills and air curtain incinerators, are subject to the same modeling required for preconstruction permits required by 20.2.72 and 20.2.74 NMAC.

What is the purpose of this application?	Enter an X for each purpose that applies
New PSD major source or PSD major modification (20.2.74 NMAC). See #1 above.	
New Minor Source or significant permit revision under 20.2.72 NMAC (20.2.72.219.D NMAC). See #1 above. Note: Neither modeling nor a modeling waiver is required for VOC emissions.	<input checked="" type="checkbox"/>
Reporting existing pollutants that were not previously reported.	
Reporting existing pollutants where the ambient impact is being addressed for the first time.	
Title V application (new, renewal, significant, or minor modification. 20.2.70 NMAC). See #3 above.	
Relocation (20.2.72.202.B.4 or 72.202.D.3.c NMAC)	
Minor Source Technical Permit Revision 20.2.72.219.B.1.d.vi NMAC for like-kind unit replacements.	
Other: i.e. SSM modeling. See #2 above.	
This application does not require modeling since this is a No Permit Required (NPR) application.	
This application does not require modeling since this is a Notice of Intent (NOI) application (20.2.73 NMAC).	
This application does not require modeling according to 20.2.70.7.E(11), 20.2.72.203.A(4), 20.2.74.303, 20.2.79.109.D NMAC and in accordance with the Air Quality Bureau’s Modeling Guidelines.	

Check each box that applies:

- See attached, approved modeling **waiver for all** pollutants from the facility.
- See attached, approved modeling **waiver for some** pollutants from the facility.
- Attached in Universal Application Form 4 (UA4) is a **modeling report for all** pollutants from the facility.
- Attached in UA4 is a **modeling report for some** pollutants from the facility.
- No modeling is required.

Section 17

Compliance Test History

(Submitting under 20.2.70, 20.2.72, 20.2.74 NMAC)

To show compliance with existing NSR permits conditions, you must submit a compliance test history. The table below provides an example.

N/A – there is no compliance test history for this facility.

Section 20

Other Relevant Information

Other relevant information. Use this attachment to clarify any part in the application that you think needs explaining. Reference the section, table, column, and/or field. Include any additional text, tables, calculations or clarifying information.

Additionally, the applicant may propose specific permit language for AQB consideration. In the case of a revision to an existing permit, the applicant should provide the old language and the new language in track changes format to highlight the proposed changes. If proposing language for a new facility or language for a new unit, submit the proposed operating condition(s), along with the associated monitoring, recordkeeping, and reporting conditions. In either case, please limit the proposed language to the affected portion of the permit.

The required Compliance History Disclosure Form is attached.



Air Permit Application Compliance History Disclosure Form

Pursuant to Subsection 74-2-7(S) of the New Mexico Air Quality Control Act (“AQCA”), NMSA §§ 74-2-1 to -17, the New Mexico Environment Department (“Department”) may deny any permit application or revoke any permit issued pursuant to the AQCA if, within ten years immediately preceding the date of submission of the permit application, the applicant met any one of the criteria outlined below. In order for the Department to deem an air permit application administratively complete, or issue an air permit for those permits without an administrative completeness determination process, the applicant must complete this Compliance History Disclosure Form as specified in Subsection 74-2-7(P). An existing permit holder (permit issued prior to June 18, 2021) shall provide this Compliance History Disclosure Form to the Department upon request.

Permittee/Applicant Company Name		Expected Application Submittal Date
Targa Northern Delaware, LLC		December 6, 2022
Permittee/Company Contact	Phone	Email
Tammy Wallace	713-584-1292	twallace@targaresources.com
Within the 10 years preceding the expected date of submittal of the application, has the permittee or applicant:		
1	Knowingly misrepresented a material fact in an application for a permit?	<input type="checkbox"/> Yes <input checked="" type="checkbox"/> No
2	Refused to disclose information required by the provisions of the New Mexico Air Quality Control Act?	<input type="checkbox"/> Yes <input checked="" type="checkbox"/> No
3	Been convicted of a felony related to environmental crime in any court of any state or the United States?	<input type="checkbox"/> Yes <input checked="" type="checkbox"/> No
4	Been convicted of a crime defined by state or federal statute as involving or being in restraint of trade, price fixing, bribery, or fraud in any court of any state or the United States?	<input type="checkbox"/> Yes <input checked="" type="checkbox"/> No
5a	Constructed or operated any facility for which a permit was sought, including the current facility, without the required air quality permit(s) under 20.2.70 NMAC, 20.2.72 NMAC, 20.2.74 NMAC, 20.2.79 NMAC, or 20.2.84 NMAC?	<input type="checkbox"/> Yes <input checked="" type="checkbox"/> No
5b	<p>If “No” to question 5a, go to question 6.</p> <p>If “Yes” to question 5a, state whether each facility that was constructed or operated without the required air quality permit met at least one of the following exceptions:</p> <p>a. The unpermitted facility was discovered after acquisition during a timely environmental audit that was authorized by the Department; or</p> <p>b. The operator of the facility estimated that the facility’s emissions would not require an air permit, and the operator applied for an air permit within 30 calendar days of discovering that an air permit was required for the facility.</p>	<input type="checkbox"/> Yes <input type="checkbox"/> No
6	Had any permit revoked or permanently suspended for cause under the environmental laws of any state or the United States?	<input type="checkbox"/> Yes <input checked="" type="checkbox"/> No
7	For each “yes” answer, please provide an explanation and documentation.	

Section 22: Certification

Company Name: Targa Northern Delaware, LLC

I, Jimmy E Oxford, hereby certify that the information and data submitted in this application are true and as accurate as possible, to the best of my knowledge and professional expertise and experience.

Signed this 12th day of December, 2022, upon my oath or affirmation, before a notary of the State of

Texas

[Signature]
*Signature

12/12/2022
Date

Jimmy E Oxford
Printed Name

VP operations
Title

Scribed and sworn before me on this 12th day of December, 2022.

My authorization as a notary of the State of Texas expires on the

CR 2nd day of December, 2024.

Colton Rainey
Notary's Signature

12-12-2022
Date

Colton Rainey
Notary's Printed Name

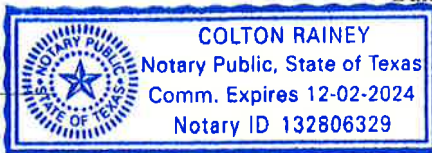

*For Title V applications, the signature must be of the Responsible Official as defined in 20.2.70.7.AE NMAC.