



---

# MX Series Interface Module Reference



---

Modified: 2019-02-11

Juniper Networks, Inc.  
1133 Innovation Way  
Sunnyvale, California 94089  
USA  
408-745-2000  
www.juniper.net

Juniper Networks, the Juniper Networks logo, Juniper, and Junos are registered trademarks of Juniper Networks, Inc. in the United States and other countries. All other trademarks, service marks, registered marks, or registered service marks are the property of their respective owners.

Juniper Networks assumes no responsibility for any inaccuracies in this document. Juniper Networks reserves the right to change, modify, transfer, or otherwise revise this publication without notice.

*MX Series Interface Module Reference*

Copyright © 2019 Juniper Networks, Inc. All rights reserved.

The information in this document is current as of the date on the title page.

#### YEAR 2000 NOTICE

Juniper Networks hardware and software products are Year 2000 compliant. Junos OS has no known time-related limitations through the year 2038. However, the NTP application is known to have some difficulty in the year 2036.

#### END USER LICENSE AGREEMENT

The Juniper Networks product that is the subject of this technical documentation consists of (or is intended for use with) Juniper Networks software. Use of such software is subject to the terms and conditions of the End User License Agreement ("EULA") posted at <https://support.juniper.net/support/eula/>. By downloading, installing or using such software, you agree to the terms and conditions of that EULA.

# Table of Contents

	About the Documentation . . . . .	xvii
	Documentation and Release Notes . . . . .	xvii
	Documentation Conventions . . . . .	xvii
	Documentation Feedback . . . . .	xix
	Requesting Technical Support . . . . .	xx
	Self-Help Online Tools and Resources . . . . .	xx
	Creating a Service Request with JTAC . . . . .	xxi
<b>Part 1</b>	<b>Overview</b>	
<b>Chapter 1</b>	<b>Interface Module Overview . . . . .</b>	<b>3</b>
	MX Series Interface Module Overview . . . . .	3
<b>Chapter 2</b>	<b>DPCs Supported on MX Series Routers . . . . .</b>	<b>7</b>
	MX Series DPC Overview . . . . .	7
	DPCs Supported on MX240, MX480, and MX960 Routers . . . . .	8
<b>Chapter 3</b>	<b>MPCs Supported on MX Series Routers . . . . .</b>	<b>11</b>
	MX Series MPC Overview . . . . .	11
	MPCs Supported by MX Series Routers . . . . .	12
<b>Chapter 4</b>	<b>MICs Supported on MX Series Routers . . . . .</b>	<b>17</b>
	MX Series MIC Overview . . . . .	17
	MICs Supported by MX Series Routers . . . . .	18
	MIC/MPC Compatibility . . . . .	26
<b>Chapter 5</b>	<b>FPCs and PICs Supported on MX Series Routers . . . . .</b>	<b>35</b>
	MX Series FPC and PIC Overview . . . . .	35
	High Availability Features . . . . .	36
	FPCs Supported by MX240, MX480, and MX960 Routers . . . . .	36
	PICs Supported by MX240, MX480, and MX960 Routers . . . . .	37
<b>Chapter 6</b>	<b>Network Interface Specifications . . . . .</b>	<b>39</b>
	Determining Transceiver Support and Specifications . . . . .	39
	Cable and Connector Specifications for MX Series and PTX Series Devices . . . . .	40
	12-Fiber MPO Connectors . . . . .	40
	12-Fiber Ribbon Patch Cables with MPO Connectors . . . . .	40
	12-Fiber Ribbon Breakout Cables with MPO-to-LC Duplex Connectors . . . . .	42
	12-Ribbon Patch and Breakout Cables Available from Juniper Networks . . . . .	43
	24-Fiber MPO Connectors . . . . .	44
	LC Duplex Connectors . . . . .	44

<b>Part 2</b>	<b>DPC, MPC, MIC, and PIC Descriptions</b>	
<b>Chapter 7</b>	<b>MX Series DPC Descriptions</b>	<b>49</b>
	Gigabit Ethernet DPC with SFP	50
	Gigabit Ethernet Enhanced DPC with SFP	52
	Gigabit Ethernet Enhanced Ethernet Services DPC with SFP	54
	Gigabit Ethernet Enhanced Queuing Ethernet Services DPC with SFP	56
	Gigabit Ethernet Enhanced Queuing IP Services DPCs with SFP	58
	10-Gigabit Ethernet DPC with XFP	61
	10-Gigabit Ethernet Enhanced DPCs with XFP	63
	10-Gigabit Ethernet Enhanced Ethernet Services DPC with XFP	65
	10-Gigabit Ethernet Enhanced Queuing Ethernet Services DPC with XFP	67
	10-Gigabit Ethernet Enhanced Queuing IP Services DPC with XFP	69
	Multi-Rate Ethernet Enhanced DPC with SFP and XFP	71
	Multi-Rate Ethernet Enhanced Ethernet Services DPC with SFP and XFP	73
	Multi-Rate Ethernet Enhanced Queuing IP Services DPC with SFP and XFP	75
	Multiservices DPC	77
	Tri-Rate Enhanced DPC	79
	Tri-Rate Enhanced Ethernet Services DPC	81
<b>Chapter 8</b>	<b>MX Series MPC Descriptions</b>	<b>83</b>
	16x10GE MPC	84
	Multiservices MPC	86
	MPC1	88
	MPC1E	89
	MPC1 Q	91
	MPC1E Q	93
	MPC2	95
	MPC2E	97
	MPC2 Q	99
	MPC2E Q	101
	MPC2 EQ	103
	MPC2E EQ	105
	MPC2E P	107
	MPC2E NG	109
	MPC2E NG Q	111
	MPC3E	113
	MPC3E NG	115
	MPC3E NG Q	117
	32x10GE MPC4E	119
	2x100GE + 8x10GE MPC4E	120
	6x40GE + 24x10GE MPC5E	122
	6x40GE + 24x10GE MPC5EQ	124
	2x100GE + 4x10GE MPC5E	126
	2x100GE + 4x10GE MPC5EQ	127
	MPC6E	129
	MPC7E (Multi-Rate)	130
	MPC7E 10G	132
	MPC8E	134
	MPC9E	135



	MX10003 MPC (Multi-Rate) . . . . .	136
	MX10K-LC2101 . . . . .	138
<b>Chapter 9</b>	<b>MX Series MIC Descriptions . . . . .</b>	<b>141</b>
	ATM MIC with SFP . . . . .	142
	DS3/E3 MIC . . . . .	145
	Gigabit Ethernet MIC with SFP . . . . .	149
	Port Numbering . . . . .	150
	Gigabit Ethernet MIC with SFP (E) . . . . .	152
	Gigabit Ethernet MIC with SFP (EH) . . . . .	156
	10-Gigabit Ethernet MICs with XFP . . . . .	157
	10-Gigabit Ethernet MIC with SFP+ (10 Ports) . . . . .	159
	10-Gigabit Ethernet MIC with SFP+ (24 Ports) . . . . .	161
	10-Gigabit Ethernet OTN MIC with SFP+ (24 Ports) . . . . .	162
	40-Gigabit Ethernet MIC with QSFP+ . . . . .	164
	100-Gigabit Ethernet MIC with CFP . . . . .	165
	100-Gigabit Ethernet MIC with CXP . . . . .	167
	100-Gigabit Ethernet MIC with CXP (4 Ports) . . . . .	168
	100-Gigabit Ethernet MIC with CFP2 . . . . .	169
	100-Gigabit DWDM OTN MIC with CFP2-ACO . . . . .	171
	Channelized SONET/SDH OC3/STM1 (Multi-Rate) MICs with SFP . . . . .	180
	Channelized OC3/STM1 (Multi-Rate) Circuit Emulation MIC with SFP . . . . .	185
	Channelized OC3/STM1 (Multi-Rate) Circuit Emulation MIC with SFP (H) . . . . .	187
	Channelized E1/T1 Circuit Emulation MIC . . . . .	190
	Channelized E1/T1 Circuit Emulation MIC (H) . . . . .	193
	Tri-Rate MIC . . . . .	196
	MIC MRATE . . . . .	200
	Multiservices MIC . . . . .	202
	SONET/SDH OC3/STM1 (Multi-Rate) MICs with SFP . . . . .	204
	Multi-Rate Ethernet MIC . . . . .	208
	Multi-Rate Ethernet MIC . . . . .	211
	SONET/SDH OC192/STM64 MIC with XFP . . . . .	213
<b>Chapter 10</b>	<b>MX Series PIC Descriptions . . . . .</b>	<b>217</b>
	Channelized OC12/STM4 Enhanced IQ (IQE) PIC with SFP . . . . .	217
	Channelized OC48/STM16 Enhanced IQ (IQE) PIC with SFP . . . . .	218
	SONET/SDH OC3/STM1 (Multi-Rate) PIC with SFP . . . . .	224
	SONET/SDH OC12/STM4 (Multi-Rate) PIC with SFP . . . . .	227
	SONET/SDH OC48/STM16 Enhanced IQ (IQE) PIC with SFP . . . . .	230
	SONET/SDH OC48/STM16 (Multi-Rate) PIC with SFP . . . . .	234
	SONET/SDH OC48/STM16 PIC with SFP . . . . .	237
	SONET/SDH OC192c/STM64 PIC . . . . .	240
	SONET/SDH OC192c/STM64 PIC with XFP . . . . .	243
<b>Part 3</b>	<b>SFB, SCB, ADC, and CB-RE Descriptions</b>	
<b>Chapter 11</b>	<b>MX Switch Fabric Board Descriptions . . . . .</b>	<b>249</b>
	MX2000 Switch Fabric Board (SFB) . . . . .	249
	MX2000 Enhanced Switch Fabric Board (SFB2) . . . . .	252

<b>Chapter 12</b>	<b>MX Switch Control Board Descriptions . . . . .</b>	<b>255</b>
	MX-Series Switch Control Board (SCB) Overview . . . . .	255
	CLI Identification . . . . .	256
	SCBE2-MX Description . . . . .	257
	SCBE2-MX Interoperability with Existing Hardware . . . . .	260
	SCBE2-MX LEDs . . . . .	260
	SCBE-MX Description . . . . .	261
	Routing Engines and MPCs for the SCBE-MX . . . . .	263
	SCBE-MX LEDs . . . . .	263
	SCB-MX Description . . . . .	264
	SCB-MX LEDs . . . . .	266
	SCB-MX Fabric Plane Scale and Redundancy . . . . .	267
	Supported Routing Engines . . . . .	267
<b>Chapter 13</b>	<b>MX Adapter Control Board Description . . . . .</b>	<b>269</b>
	MX2000 Adapter Card (ADC) Description . . . . .	269
<b>Chapter 14</b>	<b>RE, CB-RE, and RCB Descriptions . . . . .</b>	<b>271</b>
	MX2000 Host Subsystem CB-RE Description . . . . .	271
	Routing Engine Specifications . . . . .	272
	MX Routing Engine LEDs . . . . .	277
	MX960 Routing Engine Description . . . . .	277
	Supported Routing Engines . . . . .	277
	Routing Engine Function . . . . .	278
	Routing Engine Slots . . . . .	278
	Routing Engine Interface Ports . . . . .	278
	MX480 Routing Engine Description . . . . .	279
	Routing Engine Components . . . . .	280
	Routing Engine Interface Ports . . . . .	280
	Routing Engine Boot Sequence . . . . .	281
	MX240 Routing Engine Description . . . . .	281
	RE-S-X6-64G and RE-S-X6-64G-LT Routing Engine Components . . . . .	283
	Routing Engine Interface Ports . . . . .	284
	RE-S-X6-64G and RE-S-X6-64G-LT Routing Engine Interface Ports . . . . .	284
	Routing Engine Boot Sequence . . . . .	285
	MX5, MX10, MX40, and MX80 Routing Engine Description . . . . .	285
	MX2008 Routing and Control Board (MX2008 RCB) Description . . . . .	286
	Supported RCBs . . . . .	286
	RCB Function . . . . .	286
	RCB Slots . . . . .	286
	RCB Front Panel . . . . .	287
	RCB Interface Ports . . . . .	288
	MX10003 Routing and Control Board (RCB) Description . . . . .	289
	Routing and Control Board Functions . . . . .	290
	Routing and Control Board Components . . . . .	290
	RCB Front Panel . . . . .	290

RCB Interface Ports . . . . .	292
MX10008 Routing and Control Board Components and Descriptions . . . . .	293
MX10008 Routing and Control Board Description . . . . .	293
Routing and Control Board Functions . . . . .	294
Routing and Control Board (JNP10K-RE1) Components . . . . .	294
Routing and Control Board LEDs . . . . .	296
MX Routing Engine LEDs . . . . .	298
RE-S-1800 Routing Engine Description . . . . .	298
RE-S-1800 Routing Engine Components . . . . .	299
RE-S-1800 Routing Engine LEDs . . . . .	300
RE-S-1800 Routing Engine Boot Sequence . . . . .	300
RE-S-X6-64G Routing Engine Description . . . . .	301
RE-S-X6-64G Routing Engine Components . . . . .	301
RE-S-X6-64G Routing Engine Boot Sequence . . . . .	302
RE-S-X6-128G Routing Engine Description . . . . .	303
RE-S-X6-128G Routing Engine Components . . . . .	303
RE-S-X6-128G Routing Engine LEDs . . . . .	304
RE-S-X6-128G Routing Engine Boot Sequence . . . . .	305
Supported Routing Engines by Router . . . . .	305
M7i Routing Engines . . . . .	306
M10i Routing Engines . . . . .	306
M40e Routing Engines . . . . .	307
M120 Routing Engines . . . . .	307
M320 Routing Engines . . . . .	308
MX5, MX10, MX40, and MX80 Routing Engine . . . . .	308
MX104 Routing Engines . . . . .	309
MX240 Routing Engines . . . . .	309
MX480 Routing Engines . . . . .	310
MX960 Routing Engines . . . . .	311
MX2008 Routing Engines . . . . .	312
MX2010 Routing Engines . . . . .	313
MX2020 Supported Routing Engines . . . . .	313
MX10003 Routing Engines . . . . .	314
MX10008 Routing Engines . . . . .	314
PTX1000 Routing Engines . . . . .	315
PTX3000 Routing Engines . . . . .	315
PTX5000 Routing Engines . . . . .	316
PTX10008 and PTX10016 Routing Engines . . . . .	316
T320 Routing Engines . . . . .	317
T640 Routing Engines . . . . .	317
T1600 Routing Engines . . . . .	318
T4000 Routing Engines . . . . .	319
TX Matrix Routing Engines . . . . .	320
TX Matrix Plus Routing Engines . . . . .	320
TX Matrix Plus (with 3D SIBs) Routing Engines . . . . .	321

<b>Part 4</b>	<b>Protocol and Application Support</b>	
<b>Chapter 15</b>	<b>DPC Protocol and Application Support for MX240, MX480, and MX960</b>	<b>325</b>
	Protocols and Applications Supported by DPCs and Enhanced DPCs (DPC and DPCE-R)	325
	Protocols and Applications Supported by Enhanced Ethernet Services DPCs (DPCE-X)	331
	Protocols and Applications Supported by Enhanced Queuing IP Services DPCs (DPCE-R-Q)	335
	Protocols and Applications Supported by Enhanced Queuing Ethernet Services DPCs (DPCE-X-Q)	340
	Protocols and Applications Supported by the Multiservices DPC (MS-DPC)	345
<b>Chapter 16</b>	<b>MPC Protocol and Application Support for MX240, MX480, MX960, MX2010, MX2020, and MX10003</b>	<b>347</b>
	Protocols and Applications Supported on MPCs for MX Series Routers	347
	Protocols and Applications Supported on the MPC1E for MX Series Routers	356
	Protocols and Applications Supported by the MX240, MX480, MX960, MX2010, and MX2020 MPC2E	362
	Protocols and Applications Supported by the MPC3E on MX Series Routers	371
	Protocols and Applications Supported on the MPC4E for MX Series Routers	379
	Protocols and Applications Supported by the MPC5E for MX Series Routers	388
	Protocols and Applications Supported by the MPC6E for MX2000 Routers	394
	Protocols and Applications Supported by the MPC7E for MX Series Routers	401
	Protocols and Applications Supported by the MPC8E and MPC9E on the MX2010 and MX2020 Routers	410
	Protocols and Applications Supported by the MS-MIC and MS-MPC	417
	Protocols and Applications Supported by the MX10003 MPC (Multi-Rate) on the MX10003 Router	419
	Protocols and Applications Supported by the JNP10K-LC2101 on the MX10008 Routers	425

# List of Figures

<b>Part 1</b>	<b>Overview</b>	
<b>Chapter 6</b>	<b>Network Interface Specifications</b> . . . . .	<b>39</b>
	Figure 1: 24-Fiber MPO Optical Lane Assignments . . . . .	44
	Figure 2: LC Duplex Connector . . . . .	45
<b>Part 2</b>	<b>DPC, MPC, MIC, and PIC Descriptions</b>	
<b>Chapter 7</b>	<b>MX Series DPC Descriptions</b> . . . . .	<b>49</b>
	Figure 3: 20-Port Gigabit Ethernet Enhanced Queuing IP Services DPC with SFP . . . . .	58
	Figure 4: 40-Port Gigabit Ethernet Enhanced Queuing IP Services DPC with SFP . . . . .	58
	Figure 5: 2-Port 10-Gigabit Ethernet Enhanced DPC with XFP . . . . .	63
	Figure 6: 4-Port 10-Gigabit Ethernet Enhanced DPC with XFP . . . . .	63
<b>Chapter 8</b>	<b>MX Series MPC Descriptions</b> . . . . .	<b>83</b>
	Figure 7: Multiservices MPC . . . . .	86
<b>Chapter 9</b>	<b>MX Series MIC Descriptions</b> . . . . .	<b>141</b>
	Figure 8: 8-Port ATM MIC with SFP . . . . .	142
	Figure 9: DS3/E3 MIC . . . . .	145
	Figure 10: 20-Port Gigabit Ethernet MIC with SFP . . . . .	149
	Figure 11: Port Numbering for the Gigabit Ethernet MIC with SFP (MX960) . . . . .	150
	Figure 12: Port Numbering for the Gigabit Ethernet MIC with SFP (MX480) . . . . .	151
	Figure 13: Port Numbering for Gigabit Ethernet MIC with SFP (MX240) . . . . .	151
	Figure 14: 20-Port Gigabit Ethernet MIC with SFP (E) . . . . .	152
	Figure 15: Port Numbering for the MIC-3D-20GE-SFP-E (MX960) . . . . .	154
	Figure 16: Port Numbering for the MIC-3D-20GE-SFP-E (MX480) . . . . .	155
	Figure 17: Port Numbering for the MIC-3D-20GE-SFP-E (MX240) . . . . .	155
	Figure 18: 20-Port Gigabit Ethernet MIC with SFP (EH) . . . . .	156
	Figure 19: 2-Port 10-Gigabit Ethernet MIC with XFP . . . . .	157
	Figure 20: 4-Port 10-Gigabit Ethernet MIC with XFP . . . . .	158
	Figure 21: 10-Gigabit Ethernet MIC with SFP+ . . . . .	159
	Figure 22: 40-Gigabit Ethernet MIC with QSFP+ . . . . .	164
	Figure 23: 1-Port 100 Gigabit Ethernet MIC with CFP . . . . .	165
	Figure 24: 100-Gigabit Ethernet MIC with CXP . . . . .	167
	Figure 25: 4-Port Channelized SONET/SDH OC3/STM1 (Multi-Rate) MIC with SFP . . . . .	180
	Figure 26: 8-Port Channelized SONET/SDH OC3/STM1 (Multi-Rate) MIC with SFP . . . . .	181

	Figure 27: Channelized OC3/STM1 (Multi-Rate) Circuit Emulation MIC with SFP . . . . .	185
	Figure 28: Channelized OC3/STM1 (Multi-Rate) Circuit Emulation MIC with SFP (H) . . . . .	187
	Figure 29: Channelized E1/T1 Circuit Emulation MIC . . . . .	190
	Figure 30: Channelized E1/T1 Circuit Emulation MIC (H) . . . . .	193
	Figure 31: 40-Port Tri-Rate MIC . . . . .	196
	Figure 32: Port Numbering for the Tri-Rate MIC (MX960) . . . . .	198
	Figure 33: Port Numbering for the Tri-Rate MIC (MX480) . . . . .	199
	Figure 34: Port Numbering for the Tri-Rate MIC (MX240) . . . . .	199
	Figure 35: 12-Port Multi-Rate MIC with QSFP+ . . . . .	200
	Figure 36: MS-MIC-16G . . . . .	202
	Figure 37: 4-Port SONET/SDH OC3/STM1 (Multi-Rate) MIC with SFP . . . . .	204
	Figure 38: 8-Port SONET/SDH OC3/STM1 (Multi-Rate) MIC with SFP . . . . .	204
	Figure 39: JNP-MIC . . . . .	208
	Figure 40: JNP-MIC1-MACSEC . . . . .	208
	Figure 41: MIC-MACSEC-MRATE . . . . .	208
	Figure 42: MIC-MACSEC-MRATE . . . . .	211
	Figure 43: SONET/SDH OC192/STM64 MIC with XFP . . . . .	213
<b>Part 3</b>	<b>SFB, SCB, ADC, and CB-RE Descriptions</b>	
<b>Chapter 11</b>	<b>MX Switch Fabric Board Descriptions . . . . .</b>	<b>249</b>
	Figure 44: Switch Fabric Board . . . . .	249
	Figure 45: Enhanced Switch Fabric Board . . . . .	252
<b>Chapter 12</b>	<b>MX Switch Control Board Descriptions . . . . .</b>	<b>255</b>
	Figure 46: SCBE2-MX . . . . .	257
	Figure 47: SCBE-MX . . . . .	262
	Figure 48: SCB-MX . . . . .	264
<b>Chapter 13</b>	<b>MX Adapter Control Board Description . . . . .</b>	<b>269</b>
	Figure 49: ADC for the MX2000 Routers . . . . .	270
<b>Chapter 14</b>	<b>RE, CB-RE, and RCB Descriptions . . . . .</b>	<b>271</b>
	Figure 50: RE-S-1800 Routing Engine . . . . .	279
	Figure 51: RE-S-X6-64G Routing Engine Front View . . . . .	280
	Figure 52: RE-S-X6-64G-LT Routing Engine Front View . . . . .	280
	Figure 53: RE-S-2000 Routing Engine . . . . .	282
	Figure 54: RE-S-1800 . . . . .	282
	Figure 55: RE-S-X6-64G Routing Engine Front View . . . . .	283
	Figure 56: RE-S-X6-64G-LT Routing Engine Front View . . . . .	283
	Figure 57: RCB Front View . . . . .	287
	Figure 58: RCB (REMX2008-X8-64G-LT) Front View . . . . .	287
	Figure 59: RCB (REMX20008-X8-128G) Front View . . . . .	287
	Figure 60: JNP10003-RE1 RCB Ports . . . . .	291
	Figure 61: JNP10003-RE1-LT RCB Ports . . . . .	291
	Figure 62: Routing and Control Board (JNP10K-RE1) . . . . .	294
	Figure 63: Routing and Control Board Faceplate . . . . .	295
	Figure 64: Routing and Control Board (JNP10K-RE1) LEDs . . . . .	296

Figure 65: Management Port LEDs on a MX10008 . . . . .	297
Figure 66: RE-S-1800 Front View . . . . .	299
Figure 67: RE-S-X6-64G Routing Engine Front View . . . . .	301
Figure 68: RE-S-X6-128G Routing Engine Front View . . . . .	303
Figure 69: RE-S-X6-128G Routing Engine LEDs . . . . .	304





# List of Tables

	<b>About the Documentation</b> . . . . .	<b>xvii</b>
	Table 1: Notice Icons . . . . .	xviii
	Table 2: Text and Syntax Conventions . . . . .	xviii
<b>Part 1</b>	<b>Overview</b>	
<b>Chapter 2</b>	<b>DPCs Supported on MX Series Routers</b> . . . . .	<b>7</b>
	Table 3: DPCs Supported in MX240, MX480, and MX960 Routers . . . . .	8
<b>Chapter 3</b>	<b>MPCs Supported on MX Series Routers</b> . . . . .	<b>11</b>
	Table 4: MPCs Supported by MX240, MX480, MX960, MX2008, MX2010, MX2020, and MX10003 Routers . . . . .	12
<b>Chapter 4</b>	<b>MICs Supported on MX Series Routers</b> . . . . .	<b>17</b>
	Table 5: MICs Supported by MX240, MX480, MX960 and MX2008 Routers . . . . .	18
	Table 6: MICs Supported by MX2010 and MX2020 Routers . . . . .	20
	Table 7: MICs Supported by MX5, MX10, and MX40 Routers . . . . .	22
	Table 8: MICs Supported by MX80 and MX104 Routers . . . . .	24
	Table 9: MICs Supported by MX10003 Router . . . . .	26
	Table 10: MIC/MPC1 Compatibility . . . . .	26
	Table 11: MIC/MPC2 Compatibility . . . . .	28
	Table 12: MIC/MPC3 Compatibility . . . . .	30
	Table 13: MIC/MPC6 Compatibility . . . . .	32
	Table 14: MIC/MPC8 Compatibility . . . . .	32
	Table 15: MIC/MPC9 Compatibility . . . . .	33
	Table 16: MIC/MPC10003 Compatibility . . . . .	33
<b>Chapter 5</b>	<b>FPCs and PICs Supported on MX Series Routers</b> . . . . .	<b>35</b>
	Table 17: FPCs Supported by MX Series Routers . . . . .	36
	Table 18: PICs Supported by MX240, MX480, and MX960 Routers . . . . .	37
<b>Chapter 6</b>	<b>Network Interface Specifications</b> . . . . .	<b>39</b>
	Table 19: Cable Signals for 12-Fiber Ribbon Patch Cables . . . . .	41
	Table 20: Cable Pinouts for 12-Fiber Ribbon Patch Cables . . . . .	41
	Table 21: Cable Pinouts for 12-Fiber Ribbon Breakout Cables . . . . .	42
	Table 22: 12-Ribbon Patch and Breakout Cables Available from Juniper Networks . . . . .	43
<b>Part 2</b>	<b>DPC, MPC, MIC, and PIC Descriptions</b>	
<b>Chapter 8</b>	<b>MX Series MPC Descriptions</b> . . . . .	<b>83</b>
	Table 23: MX10003 MPC (Multi-Rate) Port Speed . . . . .	138

<b>Chapter 9</b>	<b>MX Series MIC Descriptions</b> . . . . .	<b>141</b>
	Table 24: OTN Alarms and Defects . . . . .	178
	Table 25: MIC MRATE Gigabit Ethernet Port Speed Capabilities . . . . .	201
	Table 26: Multi Rate Ethernet MIC Port Speed Capabilities for JNP-MIC1 and JNP-MIC1-MACSEC . . . . .	210
	Table 27: Multi Rate Ethernet MIC Port Speed Capabilities for MIC-MACSEC-MRATE . . . . .	210
	Table 28: Multi Rate Ethernet MIC Port Speed Capabilities for MIC-MACSEC-MRATE . . . . .	212
<b>Part 3</b>	<b>SFB, SCB, ADC, and CB-RE Descriptions</b>	
<b>Chapter 12</b>	<b>MX Switch Control Board Descriptions</b> . . . . .	<b>255</b>
	Table 29: Switch Control Board Capacities for MX Series Universal Routers . . . . .	256
	Table 30: Supported Routing Engines for MX Series Universal Router Switch Control Boards . . . . .	256
	Table 31: SCBE2-MX LEDs . . . . .	261
	Table 32: SCBE-MX Specifications . . . . .	262
	Table 33: Supported Routing Engines and MPCs for the SCBE-MX . . . . .	263
	Table 34: SCBE-MX LEDs . . . . .	263
	Table 35: SCB-MX LED Descriptions . . . . .	266
	Table 36: SCB-MX Fabric Plane Scale and Redundancy Assuming Four PFEs per FPC . . . . .	267
<b>Chapter 14</b>	<b>RE, CB-RE, and RCB Descriptions</b> . . . . .	<b>271</b>
	Table 37: Routing Engine Specifications . . . . .	273
	Table 38: End-of-Life Routing Engine Specifications . . . . .	275
	Table 39: Routing Engine LEDs . . . . .	277
	Table 40: Components on the RCB . . . . .	287
	Table 41: Routing and Control Board Status LEDs . . . . .	296
	Table 42: RJ-45 Management Port LEDs on a MX10008 Routing and Control Board . . . . .	297
	Table 43: JCS Port LEDs on a MX10008 Routing and Control Board . . . . .	297
	Table 44: Routing and Control Board SSD Status LEDs . . . . .	298
	Table 45: Routing Engine LEDs . . . . .	298
	Table 46: Routing Engine LEDs . . . . .	300
	Table 47: RE-S-X6-128G Routing Engine LEDs . . . . .	304
	Table 48: M7i Routing Engines . . . . .	306
	Table 49: M10i Routing Engines . . . . .	306
	Table 50: M40e Routing Engines . . . . .	307
	Table 51: M120 Routing Engines . . . . .	307
	Table 52: M320 Routing Engines . . . . .	308
	Table 53: MX5, MX10, MX40, and MX80 Routing Engine . . . . .	309
	Table 54: MX104 Routing Engines . . . . .	309
	Table 55: MX240 Supported Routing Engines . . . . .	309
	Table 56: MX480 Supported Routing Engines . . . . .	310
	Table 57: MX960 Supported Routing Engines . . . . .	311
	Table 58: MX2008 Supported Routing Engines . . . . .	312
	Table 59: MX2010 Supported Routing Engines . . . . .	313

	Table 60: MX2020 Supported Routing Engines . . . . .	313
	Table 61: MX10003 Supported Routing Engines . . . . .	314
	Table 62: MX10008 Routing Engines . . . . .	314
	Table 63: PTX1000 Routing Engines . . . . .	315
	Table 64: PTX3000 Routing Engines . . . . .	315
	Table 65: PTX5000 Routing Engines . . . . .	316
	Table 66: PTX10008 and PTX10016 Routing Engines . . . . .	317
	Table 67: T320 Routing Engines . . . . .	317
	Table 68: T640 Routing Engines . . . . .	318
	Table 69: T1600 Routing Engines . . . . .	318
	Table 70: T4000 Routing Engines . . . . .	319
	Table 71: TX Matrix Routing Engines . . . . .	320
	Table 72: TX Matrix Plus Routing Engines . . . . .	320
	Table 73: Routing Engines on TX Matrix Plus with 3D SIBs . . . . .	321
<b>Part 4</b>	<b>Protocol and Application Support</b>	
<b>Chapter 15</b>	<b>DPC Protocol and Application Support for MX240, MX480, and MX960 . . . . .</b>	<b>325</b>
	Table 74: Protocols and Applications Supported by the DPCs and Enhanced DPCs (DPC and DPCE-R) . . . . .	325
	Table 75: Protocols and Applications Supported by the Enhanced Ethernet Services DPCs (DPCE-X) . . . . .	331
	Table 76: Protocols and Applications Supported by the Enhanced Queuing IP Services DPCs (DPCE-R-Q) . . . . .	336
	Table 77: Protocols and Applications Supported by the Enhanced Queuing Ethernet Services DPCs (DPCE-X-Q) . . . . .	340
	Table 78: Protocols and Applications Supported by the Multiservices DPC (MS-DPC) . . . . .	345
<b>Chapter 16</b>	<b>MPC Protocol and Application Support for MX240, MX480, MX960, MX2010, MX2020, and MX10003 . . . . .</b>	<b>347</b>
	Table 79: Protocols and Applications Supported by the MX240, MX480, MX960, MX2010, and MX2020 MPCs . . . . .	348
	Table 80: Protocols and Applications Supported by the MX240, MX480, MX960, MX2010, and MX2020 Enhanced MPCs (MPC1Es) . . . . .	357
	Table 81: Protocols and Applications Supported by the MX240, MX480, MX960, MX2010, and MX2020 MPC2E . . . . .	363
	Table 82: Protocols and Applications Supported by MPC3E Cards for MX Series Routers . . . . .	372
	Table 83: Protocols and Applications Supported by the MX Series MPC4E . . . . .	379
	Table 84: Protocols and Applications Supported by the MX240, MX480, MX960, MX2010, and MX2020 MPC5E . . . . .	388
	Table 85: Protocols and Applications Supported by the MX2010 and MX2020 MPC6E . . . . .	395
	Table 86: Protocols and Applications Supported by MPC7Es in the MX240, MX480, MX960, MX2010, and MX2020 Routers . . . . .	401
	Table 87: Protocols and Applications Supported by MPC8E and MPC9E on the MX2010 and MX2020 Routers . . . . .	410

Table 88: Protocols and Applications Supported by the MS-MIC and MS-MPC .....	417
Table 89: Protocols and Applications Supported by MX10003MPC on the MX10003 Router .....	419
Table 90: Protocols and Applications Supported by JNP10K-LC2101 on the MX10008 Routers .....	425

# About the Documentation

- Documentation and Release Notes on page xvii
- Documentation Conventions on page xvii
- Documentation Feedback on page xix
- Requesting Technical Support on page xx

## Documentation and Release Notes

---

To obtain the most current version of all Juniper Networks<sup>®</sup> technical documentation, see the product documentation page on the Juniper Networks website at <https://www.juniper.net/documentation/>.

If the information in the latest release notes differs from the information in the documentation, follow the product Release Notes.

Juniper Networks Books publishes books by Juniper Networks engineers and subject matter experts. These books go beyond the technical documentation to explore the nuances of network architecture, deployment, and administration. The current list can be viewed at <https://www.juniper.net/books>.

## Documentation Conventions

---

Table 1 on page xviii defines notice icons used in this guide.

Table 1: Notice Icons







Icon	Meaning	Description
	Informational note	Indicates important features or instructions.
	Caution	Indicates a situation that might result in loss of data or hardware damage.
	Warning	Alerts you to the risk of personal injury or death.
	Laser warning	Alerts you to the risk of personal injury from a laser.
	Tip	Indicates helpful information.
	Best practice	Alerts you to a recommended use or implementation.

Table 2 on page xviii defines the text and syntax conventions used in this guide.

Table 2: Text and Syntax Conventions

Convention	Description	Examples
<b>Bold text like this</b>	Represents text that you type.	To enter configuration mode, type the <b>configure</b> command:  user@host> <b>configure</b>
Fixed-width text like this	Represents output that appears on the terminal screen.	user@host> <b>show chassis alarms</b>  No alarms currently active
<i>Italic text like this</i>	<ul style="list-style-type: none"> <li>Introduces or emphasizes important new terms.</li> <li>Identifies guide names.</li> <li>Identifies RFC and Internet draft titles.</li> </ul>	<ul style="list-style-type: none"> <li>A policy <i>term</i> is a named structure that defines match conditions and actions.</li> <li><i>Junos OS CLI User Guide</i></li> <li>RFC 1997, <i>BGP Communities Attribute</i></li> </ul>
<i>Italic text like this</i>	Represents variables (options for which you substitute a value) in commands or configuration statements.	Configure the machine's domain name:  [edit] root@# <b>set system domain-name</b> <i>domain-name</i>

Table 2: Text and Syntax Conventions (continued)

Convention	Description	Examples
<b>Text like this</b>	Represents names of configuration statements, commands, files, and directories; configuration hierarchy levels; or labels on routing platform components.	<ul style="list-style-type: none"> <li>To configure a stub area, include the <b>stub</b> statement at the <b>[edit protocols ospf area area-id]</b> hierarchy level.</li> <li>The console port is labeled <b>CONSOLE</b>.</li> </ul>
< > (angle brackets)	Encloses optional keywords or variables.	<b>stub &lt;default-metric metric&gt;;</b>
(pipe symbol)	Indicates a choice between the mutually exclusive keywords or variables on either side of the symbol. The set of choices is often enclosed in parentheses for clarity.	<b>broadcast   multicast</b> <b>(string1   string2   string3)</b>
# (pound sign)	Indicates a comment specified on the same line as the configuration statement to which it applies.	<b>rsvp { # Required for dynamic MPLS only</b>
[ ] (square brackets)	Encloses a variable for which you can substitute one or more values.	<b>community name members [ community-ids ]</b>
Indentation and braces ( { } )	Identifies a level in the configuration hierarchy.	<b>[edit]</b> routing-options { static { route default { nexthop address; retain; } } }
;(semicolon)	Identifies a leaf statement at a configuration hierarchy level.	
<b>GUI Conventions</b>		
<b>Bold text like this</b>	Represents graphical user interface (GUI) items you click or select.	<ul style="list-style-type: none"> <li>In the Logical Interfaces box, select <b>All Interfaces</b>.</li> <li>To cancel the configuration, click <b>Cancel</b>.</li> </ul>
> (bold right angle bracket)	Separates levels in a hierarchy of menu selections.	In the configuration editor hierarchy, select <b>Protocols&gt;Ospf</b> .

## Documentation Feedback

We encourage you to provide feedback so that we can improve our documentation. You can use either of the following methods:

- Online feedback system—Click TechLibrary Feedback, on the lower right of any page on the [Juniper Networks TechLibrary](#) site, and do one of the following:

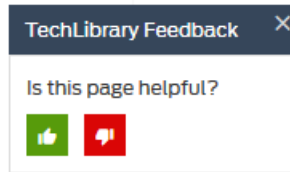

- Click the thumbs-up icon if the information on the page was helpful to you.
- Click the thumbs-down icon if the information on the page was not helpful to you or if you have suggestions for improvement, and use the pop-up form to provide feedback.
- E-mail—Send your comments to [techpubs-comments@juniper.net](mailto:techpubs-comments@juniper.net). Include the document or topic name, URL or page number, and software version (if applicable).

## Requesting Technical Support

Technical product support is available through the Juniper Networks Technical Assistance Center (JTAC). If you are a customer with an active J-Care or Partner Support Service support contract, or are covered under warranty, and need post-sales technical support, you can access our tools and resources online or open a case with JTAC.

- JTAC policies—For a complete understanding of our JTAC procedures and policies, review the *JTAC User Guide* located at <https://www.juniper.net/us/en/local/pdf/resource-guides/7100059-en.pdf>.
- Product warranties—For product warranty information, visit <https://www.juniper.net/support/warranty/>.
- JTAC hours of operation—The JTAC centers have resources available 24 hours a day, 7 days a week, 365 days a year.

## Self-Help Online Tools and Resources

For quick and easy problem resolution, Juniper Networks has designed an online self-service portal called the Customer Support Center (CSC) that provides you with the following features:

- Find CSC offerings: <https://www.juniper.net/customers/support/>
- Search for known bugs: <https://prsearch.juniper.net/>
- Find product documentation: <https://www.juniper.net/documentation/>
- Find solutions and answer questions using our Knowledge Base: <https://kb.juniper.net/>
- Download the latest versions of software and review release notes: <https://www.juniper.net/customers/csc/software/>
- Search technical bulletins for relevant hardware and software notifications: <https://kb.juniper.net/InfoCenter/>



- Join and participate in the Juniper Networks Community Forum:  
<https://www.juniper.net/company/communities/>
- Create a service request online: <https://myjuniper.juniper.net>

To verify service entitlement by product serial number, use our Serial Number Entitlement (SNE) Tool: <https://entitlementsearch.juniper.net/entitlementsearch/>

## Creating a Service Request with JTAC

You can create a service request with JTAC on the Web or by telephone.

- Visit <https://myjuniper.juniper.net>.
- Call 1-888-314-JTAC (1-888-314-5822 toll-free in the USA, Canada, and Mexico).

For international or direct-dial options in countries without toll-free numbers, see <https://support.juniper.net/support/requesting-support/>.



## PART 1

# Overview

- [Interface Module Overview on page 3](#)
- [DPCs Supported on MX Series Routers on page 7](#)
- [MPCs Supported on MX Series Routers on page 11](#)
- [MICs Supported on MX Series Routers on page 17](#)
- [FPCs and PICs Supported on MX Series Routers on page 35](#)
- [Network Interface Specifications on page 39](#)



# Interface Module Overview

- [MX Series Interface Module Overview on page 3](#)

## MX Series Interface Module Overview

---

Juniper Networks MX Series 5G Universal Routing Platforms process incoming and outgoing packets on several different types of interface modules (also known as line cards), including Dense Port Concentrators (DPCs), Flexible Port Concentrators (FPCs) with associated Physical Interface Cards (PICs), Trio Modular Port Concentrators (MPCs) with associated Modular Interface Cards (MICs). FPCs are populated with PICs for various interface types. DPCs and MPCs combine the functions of FPCs and the PICs, and with associated physical interfaces support a variety of interface types. The configuration syntax for each type of line card is the same: *type-fpc/pic/port*.

Switch Control Boards (MX-SCBs, MX-SCBEs, MX-SCBE2s) provide full line-rate performance and redundancy without a loss of bandwidth for all MX series routers. Switch Fabric Boards (SFBs) provide increased fabric bandwidth per slot for MX2000 routers. Routing Engines (REs) and Control Boards with Routing Engines (CB-REs) provide the software processes that run Junos OS.

- Dense Port Concentrators (DPCs)—A DPC provides multiple physical interfaces and Packet Forwarding Engines on a single board that installs into a slot within the MX240, MX480, and MX960 routers. See the following topics for more information about DPCs:
  - [MX Series DPC Overview on page 7](#)
  - [DPCs Supported on MX240, MX480, and MX960 Routers on page 8](#)
- Modular Port Concentrators (MPCs) provide packet forwarding services. The MPCs are inserted into a slot in an MX240, MX480, MX960, MX2008, MX2010, and MX2020 router. MPCs for MX5, MX10, MX40, MX80, and MX104 routers install directly into the router chassis. Modular Interface Cards (MICs) provide the physical interfaces and install into the MPCs. You can install up to two MICs of different media types in the same MPC as long as the MPC supports those MICs. See the following topics for information about MPCs:
  - [MX Series MPC Overview on page 11](#)
  - [MPCs Supported by MX Series Routers on page 12](#)
  - [MIC/MPC Compatibility on page 26](#)

- [Protocols and Applications Supported on MPCs for MX Series Routers on page 347](#)
- [Protocols and Applications Supported by the MPC3E on MX Series Routers on page 371](#)
- [Protocols and Applications Supported on the MPC4E for MX Series Routers on page 379](#)
- [Protocols and Applications Supported by the MPC5E for MX Series Routers on page 388](#)
- [Protocols and Applications Supported by the MPC6E for MX2000 Routers on page 394](#)
- [Protocols and Applications Supported by the MPC7E for MX Series Routers on page 401](#)
- [Protocols and Applications Supported by the MPC8E and MPC9E on the MX2010 and MX2020 Routers on page 410](#)
- [Protocols and Applications Supported by the MS-MIC and MS-MPC on page 417](#)
- [Protocols and Applications Supported by the MX10003 MPC \(Multi-Rate\) on the MX10003 Router on page 419](#)
- Modular Interface Cards (MICs) provide physical interfaces for the router. MICs install into Modular Port Concentrators (MPCs) which provide packet forwarding services. MICs and MPCs function similarly to PICs and FPCs. MPCs install vertically in the MX2020, MX2010, MX2008, and MX960 router chassis, and horizontally in the MX480 and MX240 router chassis. On MX5, MX10, MX40, MX80, and MX104 routers, MICs install directly into the router chassis. There are also fixed-configuration MPCs, with built-in network ports or services functionality, that do not accept MICs. The maximum number of supported MPCs varies per router and hardware configuration. See the following topics for information about MICs:
  - [MX Series MIC Overview on page 17](#)
  - [MICs Supported by MX Series Routers on page 18](#)
  - [MIC/MPC Compatibility on page 26](#)
- Flexible PIC Concentrators (FPCs) and Physical Interface Cards (PICs) function similarly to MICs and MPCs. PICs provide physical interfaces for the router, and install into FPCs, which provide packet forwarding services. FPCs are installed into a slot in an MX240, MX480, and MX960 router. See the following topics for information about PICs and FPCs:
  - [MX Series FPC and PIC Overview on page 35](#)
  - [High Availability Features on page 36](#)
  - [FPCs Supported by MX240, MX480, and MX960 Routers on page 36](#)
  - [PICs Supported by MX240, MX480, and MX960 Routers on page 37](#)
- Switch Fabric Boards (SFBs) provide increased fabric bandwidth per slot. The MX2000 line of routers can support eight Switch Fabric Boards (SFB) and eight Enhanced Switch Fabric Boards (SFB2) but not both at the same time. The SFB is supported on MX2010 and MX2020 routers. See the following topics for information about SFBs:
  - [MX2000 Switch Fabric Board \(SFB\) on page 249](#)

- [MX2000 Enhanced Switch Fabric Board \(SFB2\) on page 252](#)
- MX Switch Control Boards (SCB-MX, SCBE-MX, SCBE2-MX) provide full line-rate performance and redundancy without a loss of bandwidth. The SCB-MX is the first-generation switch control board and was designed to work with the first-generation DPC line cards. The SCBE-MX was designed specifically for use with the MPC3e line cards. The SCBE2-MX provides improved fabric performance for high-capacity line cards using the third generation fabric XF2 chip (MPC4e, MPC5e, MPC2/3 NG, and MPC7e). See the following topics for information about Juniper switch control boards:
  - [MX-Series Switch Control Board \(SCB\) Overview on page 255](#)
  - [SCBE2-MX Description on page 257](#)
  - [SCBE-MX Description on page 261](#)
  - [MX480 SCBE-MX Description](#)
  - [MX240 SCBE-MX Description](#)
  - [SCB-MX Description on page 264](#)
  - [MX480 SCB-MX Description](#)
  - [MX240 SCB-MX Description](#)
  - [MX240 SCBE-MX Description](#)
  - [SCB-MX Description on page 264](#)
  - [MX480 SCB-MX Description](#)
  - [MX240 SCB-MX Description](#)
- MX-ADC is a special line card adapter (ADC) for line cards that were designed to work with the MX-SCB and MX-SCBE line cards (MPC1E, MPC2E, and MPC3E). It is supported only for MX2010 and MX2020 routers. The ADC is a hardware casing that fits into a line card slot. The MPCs attach to the ADCs which in turn attach to the backplane. See the following topics for more information about the MX-ADC:
  - [MX2000 Adapter Card \(ADC\) Description on page 269](#)
- Routing Engines (REs) and Control Boards with Routing Engines (CB-REs) provide the software processes that run Junos OS. The routing engine maintains the routing tables, manages the routing protocols used on the router, controls the router interfaces, controls some chassis components, and provides the interface for system management and user access to the router. Each CB-RE is a combined Routing Engine and Switch Control Board in one unit. See the following topics for information about REs and CB-REs for MX routers:
  - [MX2000 Host Subsystem CB-RE Description on page 271](#)
  - [MX960 Routing Engine Description on page 277](#)
  - [MX480 Routing Engine Description on page 279](#)
  - [MX240 Routing Engine Description on page 281](#)
  - [MX5, MX10, MX40, and MX80 Routing Engine Description on page 285](#)

- [RE-S-X6-64G Routing Engine Description on page 301](#)
- [RE-MX2000-1800x4 CB-RE Description](#)
- [REMX2K-X8-64G and REMX2K-X8-64G-LT CB-RE Description](#)
- [Routing Engine Specifications on page 272](#)



## CHAPTER 2

# DPCs Supported on MX Series Routers

- [MX Series DPC Overview on page 7](#)
- [DPCs Supported on MX240, MX480, and MX960 Routers on page 8](#)

## MX Series DPC Overview

---

A Dense Port Concentrator (DPC) provides multiple physical interfaces and Packet Forwarding Engines (PFEs) on a single board that installs into a slot within the MX240, MX480, and MX9603D Universal Edge Routers. A DPC receives incoming packets from the network and sends outgoing packets to the network. The PFEs on a DPC are equipped with purpose-built ASICs that perform packet processing and forwarding.

In addition to Layer 3 routing capabilities, the DPCs also have many Layer 2 functions that allow MX Series routers to be used for many virtual LAN (VLAN) and other Layer 2 network applications.



**NOTE:** In the Junos OS CLI, you use the FPC syntax to configure or display information about DPCs, and you use the PIC syntax to configure or display information about Packet Forwarding Engines on the DPCs.

DPCs install vertically in the MX960 router chassis and horizontally in the MX480 and MX240 router chassis. The maximum number of supported DPCs varies per router:

- MX960 router—up to 12 DPCs
- MX480 router—up to 6 DPCs
- MX240 router—up to 3 DPCs

When a slot is not occupied by a DPC, you must insert a blank DPC to fill the empty slot and ensure proper cooling of the system. For complete information about installing and handling DPCs, see the hardware guide for your router.

### Related Documentation

- [DPCs Supported on MX240, MX480, and MX960 Routers on page 8](#)
- [Protocols and Applications Supported by DPCs and Enhanced DPCs \(DPC and DPCE-R\) on page 325](#)

- Protocols and Applications Supported by Enhanced Ethernet Services DPCs (DPCE-X) on page 331
- Protocols and Applications Supported by Enhanced Queuing IP Services DPCs (DPCE-R-Q) on page 335
- Protocols and Applications Supported by Enhanced Queuing Ethernet Services DPCs (DPCE-X-Q) on page 340
- Protocols and Applications Supported by the Multiservices DPC (MS-DPC) on page 345

## DPCs Supported on MX240, MX480, and MX960 Routers



**NOTE:** These DPCs have all been announced as End of Life (EOL). The End of Support (EOS) milestone dates for each model are published at [https://www.juniper.net/support/eol/mseries\\_hw.html](https://www.juniper.net/support/eol/mseries_hw.html).

Table 3 on page 8 lists the DPCs supported by the MX240, MX480, and MX960 routers.

**Table 3: DPCs Supported in MX240, MX480, and MX960 Routers**

DPC Name	DPC Model Number	Ports	Maximum Throughput per DPC	First Junos OS Release
<b>Gigabit Ethernet</b>				
"Gigabit Ethernet DPC with SFP" on page 50	DPCE-R-40GE-SFP  EOL (see PSN-2009-06-400)	40	40 Gbps	8.2
"Gigabit Ethernet Enhanced DPC with SFP" on page 52	DPCE-R-40GE-SFP  EOL (see PSN-TSB16810)	40	40 Gbps	8.4
"Gigabit Ethernet Enhanced Ethernet Services DPC with SFP" on page 54	DPCE-X-40GE-SFP  EOL (see PSN-TSB16810)	40	40 Gbps	8.4
"Gigabit Ethernet Enhanced Queuing Ethernet Services DPC with SFP" on page 56	DPCE-X-Q-40GE-SFP  EOL (see PSN-2013-02-851)	40	40 Gbps	8.5
"Gigabit Ethernet Enhanced Queuing IP Services DPCs with SFP" on page 58	DPCE-R-Q-20GE-SFP  EOL (see PSN-2013-02-851)	20	20 Gbps	9.1

Table 3: DPCs Supported in MX240, MX480, and MX960 Routers (continued)

DPC Name	DPC Model Number	Ports	Maximum Throughput per DPC	First Junos OS Release
"Gigabit Ethernet Enhanced Queuing IP Services DPCs with SFP" on page 58	DPCE-R-Q-40GE-SFP  EOL (see PSN-2011-07-314)	40	40 Gbps	8.5
"10-Gigabit Ethernet DPC with XFP" on page 61	DPC-R-4XGE-XFP  EOL (see PSN-2009-06-400)	4	40 Gbps	8.2
<b>10-Gigabit Ethernet</b>				
"10-Gigabit Ethernet Enhanced DPCs with XFP" on page 63	DPCE-R-2XGE-XFP  EOL (see PSN-2011-02-314)	2	20 Gbps	9.1
"10-Gigabit Ethernet Enhanced DPCs with XFP" on page 63	DPCE-R-4XGE-XFP  EOL (see PSN-TSB16810)	4	40 Gbps	8.4
"10-Gigabit Ethernet Enhanced Ethernet Services DPC with XFP" on page 65	DPCE-X-4XGE-XFP  EOL (see PSN-TSB16810)	4	40 Gbps	8.4
"10-Gigabit Ethernet Enhanced Queuing Ethernet Services DPC with XFP" on page 67	DPCE-X-Q-4XGE-XFP  EOL (see PSN-2013-02-851)	4	40 Gbps	8.5
"10-Gigabit Ethernet Enhanced Queuing IP Services DPC with XFP" on page 69	DPCE-R-Q-4XGE-XFP  EOL (see PSN-2011-02-314)	4	40 Gbps	8.5
<b>Mult-Rate Ethernet</b>				
"Multi-Rate Ethernet Enhanced DPC with SFP and XFP" on page 71	DPCE-R-20GE-2XGE  EOL (see PSN-TSB16810)	22	40 Gbps	9.2
"Multi-Rate Ethernet Enhanced Ethernet Services DPC with SFP and XFP" on page 73	DPCE-X-20GE-2XGE  EOL (see PSN-2011-02-314)	22	40 Gbps	9.2

Table 3: DPCs Supported in MX240, MX480, and MX960 Routers (continued)

DPC Name	DPC Model Number	Ports	Maximum Throughput per DPC	First Junos OS Release
"Multi-Rate Ethernet Enhanced Queuing IP Services DPC with SFP and XFP" on page 75	DPCE-R-Q-20GE-2XGE  EOL (see PSN-TSB16810)	22	40 Gbps	9.3
<b>Tri-Rate Ethernet</b>				
"Tri-Rate Enhanced DPC" on page 79	DPCE-R-40GE-TX  EOL (see PSN-2013-02-851)	40	40 Gbps	9.1
"Tri-Rate Enhanced Ethernet Services DPC" on page 81	DPCE-X-40GE-TX  EOL (see PSN-2011-07-315.)	40	40 Gbps	9.1
<b>Services</b>				
"Multiservices DPC" on page 77	MS-DPC  EOL (see PSN-TSB16812)	2 (Not supported)	–	9.3

**Related Documentation**

- [Protocols and Applications Supported by DPCs and Enhanced DPCs \(DPC and DPCE-R\) on page 325](#)
- [Protocols and Applications Supported by Enhanced Ethernet Services DPCs \(DPCE-X\) on page 331](#)
- [Protocols and Applications Supported by Enhanced Queuing IP Services DPCs \(DPCE-R-Q\) on page 335](#)
- [Protocols and Applications Supported by Enhanced Queuing Ethernet Services DPCs \(DPCE-X-Q\) on page 340](#)
- [Protocols and Applications Supported by the Multiservices DPC \(MS-DPC\) on page 345](#)

## CHAPTER 3

# MPCs Supported on MX Series Routers

- [MX Series MPC Overview on page 11](#)
- [MPCs Supported by MX Series Routers on page 12](#)

## MX Series MPC Overview

---

Modular Port Concentrators (MPCs) provide packet forwarding services. The MPCs are inserted into a slot in an MX240, MX480, MX960, MX2008, MX2010, MX2020, and MX10003 router. MPCs for MX5, MX10, MX40, MX80, and MX104 routers install directly into the router chassis. Modular Interface Cards (MICs) provide the physical interfaces and install into the MPCs. You can install up to two MICs of different media types in the same MPC as long as the MPC supports those MICs.

A specialized fixed configuration MPC provides higher port density over MICs and combines packet forwarding and Ethernet interfaces onto a single line card. The fixed configuration MPC is inserted into a slot in a router and contains no slots for MICs.

MICs receive incoming packets from the network and transmit outgoing packets to the network. During this process, each MIC performs framing and high-speed signaling for its media type. Before transmitting outgoing data packets through the MIC interfaces, the MPCs encapsulate the packets received. Each MPC is equipped with up to four Junos Trio chipsets, which perform control functions tailored to the MPC's media type.

You must install a high-capacity fan tray to use an MPC. When a slot is not occupied by an MPC, you must insert a blank DPC to fill the empty slot and ensure proper cooling of the system. For complete information about installing and handling MPCs, see the hardware guide for your router.

The maximum number of supported MPCs varies per router and hardware configuration:

- MX2020 router—Up to 20 MPCs (For power requirements, see *Calculating AC Power Requirements for MX2020 Routers* and *Calculating DC Power Requirements for MX2020 Routers*).
- MX2010 router—Up to 10 MPCs (For power requirements, see *Calculating AC Power Requirements for MX2010 Routers* and *Calculating DC Power Requirements for MX2010 Routers*.)
- MX960 router—Up to 12 MPCs (For power requirements, see *Calculating Power Requirements for MX960 Routers*.)

- MX480 router—Up to 6 MPCs (For power requirements, see *Calculating Power Requirements for MX480 Routers*.)
- MX240 router—Up to 3 MPCs (For power requirements, see *Calculating Power Requirements for MX240 Routers*.)

MX80 router—One fixed 10-Gigabit Ethernet MIC with four ports for uplink connections.



**NOTE:** The MX80 router is available as a modular (MX80) or fixed (MX80-48T) chassis. Both chassis have a fixed Modular Interface Card (MIC) that has 3 10-Gigabit Ethernet ports. The fixed MX80 router has an additional 48 10/100/1000Base-T RJ45 ports. The modular chassis has two dedicated slots for MICs.

#### Related Documentation

- [MPCs Supported by MX Series Routers on page 12](#)
- [Protocols and Applications Supported on MPCs for MX Series Routers on page 347](#)
- [Protocols and Applications Supported by the MPC3E on MX Series Routers on page 371](#)
- [Protocols and Applications Supported on the MPC4E for MX Series Routers on page 379](#)
- [Protocols and Applications Supported by the MPC5E for MX Series Routers on page 388](#)
- [Protocols and Applications Supported by the MPC6E for MX2000 Routers on page 394](#)
- [MX Series MIC Overview on page 17](#)
- [MICs Supported by MX Series Routers on page 18](#)

## MPCs Supported by MX Series Routers

Table 4 on page 12 lists the MPCs and their first supported Junos OS release on MX240, MX480, MX960, MX2008, MX2010, MX2020, and MX10003 routers.

Table 4: MPCs Supported by MX240, MX480, MX960, MX2008, MX2010, MX2020, and MX10003 Routers

MPC Name	MPC Model Number	First Junos OS Release on MX240, MX480, and MX960 Routers	First Junos OS Release on MX2008 Routers	First Junos OS Release on MX2010 Routers	First Junos OS Release on MX2020 Routers	First Junos OS Release on MX10003 Routers	First Junos OS Release on MX10008 Routers
<b>Fixed Configuration MPCs</b>							
"16x10GE MPC" on page 84	MPC-3D-16XGE-SFP	10.0R2	15.1F7	12.3	12.3	–	–

**Table 4: MPCs Supported by MX240, MX480, MX960, MX2008, MX2010, MX2020, and MX10003 Routers (continued)**

MPC Name	MPC Model Number	First Junos OS Release on MX240, MX480, and MX960 Routers	First Junos OS Release on MX2008 Routers	First Junos OS Release on MX2010 Routers	First Junos OS Release on MX2020 Routers	First Junos OS Release on MX10003 Routers	First Junos OS Release on MX10008 Routers
"Multiservices MPC" on page 86	MS-MPC	13.2R4	15.1F7	15.1	15.1	–	–
"32x10GE MPC4E" on page 119	MPC4E-3D-32XGE-SFPP	12.3R2	15.1F7	12.3R2	12.3R2	–	–
"2x100GE + 8x10GE MPC4E" on page 120	MPC4E-3D-2CGE-8XGE	12.3R2	15.1F7	12.3R2	12.3R2	–	–
"6x40GE + 24x10GE MPC5E" on page 122	MPC5E-40G10G	13.3R2	15.1F7	13.3R2	13.3R2	–	–
"6x40GE + 24x10GE MPC5EQ" on page 124	MPC5EQ-40G10G	13.3R2	15.1F7	13.3R2	13.3R2	–	–
"2x100GE + 4x10GE MPC5E" on page 126	MPC5E-100G10G	13.3R3	15.1F7	13.3R3	13.3R3	–	–
"2x100GE + 4x10GE MPC5EQ" on page 127	MPC5EQ-100G10G	13.3R3	15.1F7	13.3R3	13.3R3	–	–
"MPC7E (Multi-Rate)" on page 130	MPC7E-MRATE	<ul style="list-style-type: none"> <li>• 15.1F4 with Junos Continuity</li> <li>• 16.1R1 and later</li> </ul>	15.1F7	<ul style="list-style-type: none"> <li>• 15.1F4 with Junos Continuity</li> <li>• 16.1R1 and later</li> </ul>	<ul style="list-style-type: none"> <li>• 15.1F4 with Junos Continuity</li> <li>• 16.1R1 and later</li> </ul>	–	–

**Table 4: MPCs Supported by MX240, MX480, MX960, MX2008, MX2010, MX2020, and MX10003 Routers (continued)**

MPC Name	MPC Model Number	First Junos OS Release on MX240, MX480, and MX960 Routers	First Junos OS Release on MX2008 Routers	First Junos OS Release on MX2010 Routers	First Junos OS Release on MX2020 Routers	First Junos OS Release on MX10003 Routers	First Junos OS Release on MX10008 Routers
"MPC7E 10G" on page 132	MPC7E-10G	<ul style="list-style-type: none"> <li>15.1F5 with Junos Continuity</li> <li>16.1R1 and later</li> </ul>	15.1F7	<ul style="list-style-type: none"> <li>15.1F5 with Junos Continuity</li> <li>16.1R1 and later</li> </ul>	<ul style="list-style-type: none"> <li>15.1F5 with Junos Continuity</li> <li>16.1R1 and later</li> </ul>	–	–
<b>MPCs</b>							
"MPC1" on page 88	MX-MPC1-3D	10.2	15.1F7	12.3	12.3	–	–
"MPC1E" on page 89	MX-MPC1E-3D	11.2R4	15.1F7	12.3	12.3	–	–
"MPC1 Q" on page 91	MX-MPC1-3D-Q	10.2	15.1F7	12.3	12.3	–	–
"MPC1E Q" on page 93	MX-MPC1E-3D-Q	11.2R4	15.1F7	12.3	12.3	–	–
"MPC2" on page 95	MX-MPC2-3D	10.1	15.1F7	12.3	12.3	–	–
"MPC2E" on page 97	MX-MPC2E-3D	11.2R4	15.1F7	12.3	12.3	–	–
"MPC2 Q" on page 99	MX-MPC2-3D-Q	10.1	15.1F7	12.3	12.3	–	–
"MPC2E Q" on page 101	MX-MPC2E-3D-Q	11.2R4	15.1F7	12.3	12.3	–	–
"MPC2 EQ" on page 103	MX-MPC2-3D-EQ	10.1	15.1F7	12.3	12.3	–	–
"MPC2E EQ" on page 105	MX-MPC2E-3D-EQ	11.2R4	15.1F7	12.3	12.3	–	–
"MPC2E P" on page 107	MX-MPC2E-3D-P	12.2	15.1F7	12.3	12.3	–	–



**Table 4: MPCs Supported by MX240, MX480, MX960, MX2008, MX2010, MX2020, and MX10003 Routers (continued)**

MPC Name	MPC Model Number	First Junos OS Release on MX240, MX480, and MX960 Routers	First Junos OS Release on MX2008 Routers	First Junos OS Release on MX2010 Routers	First Junos OS Release on MX2020 Routers	First Junos OS Release on MX10003 Routers	First Junos OS Release on MX10008 Routers
"MPC2E NG" on page 109	MX-MPC2E-3D-NG	14.1R4, 14.2R3 and Junos Continuity 15.1	15.1F7	14.1R4, 14.2R3 and Junos Continuity 15.1	14.1R4, 14.2R3 and Junos Continuity 15.1	–	–
"MPC2E NG Q" on page 111	MX-MPC2E-3D-NG-Q	14.1R4, 14.2R3 and Junos Continuity 15.1	15.1F7	14.1R4, 14.2R3 and Junos Continuity 15.1	14.1R4, 14.2R3 and Junos Continuity 15.1	–	–
"MPC3E" on page 113	MX-MPC3E-3D	12.1	15.1F7	12.3	12.3	–	–
"MPC3E NG" on page 115	MX-MPC3E-3D-NG	14.1R4, 14.2R3 and Junos Continuity 15.1	15.1F7	14.1R4, 14.2R3 and Junos Continuity 15.1	14.1R4, 14.2R3 and Junos Continuity 15.1	–	–
"MPC3E NG Q" on page 117	MX-MPC3E-3D-NG-Q	14.1R4, 14.2R3 and Junos Continuity 15.1	15.1F7	14.1R4, 14.2R3 and Junos Continuity 15.1	14.1R4, 14.2R3 and Junos Continuity 15.1	–	–
"MPC6E" on page 129	MX2K-MPC6E	–	15.1F7	13.3R2	13.3R2	–	–
"MPC8E" on page 134	MX2K-MPC8E	–	15.1F7	<ul style="list-style-type: none"> <li>• 15.1F5 with Junos Continuity</li> <li>• 16.1R1 and later</li> </ul>	<ul style="list-style-type: none"> <li>• 15.1F5 with Junos Continuity</li> <li>• 16.1R1 and later</li> </ul>	–	–

**Table 4: MPCs Supported by MX240, MX480, MX960, MX2008, MX2010, MX2020, and MX10003 Routers (continued)**

MPC Name	MPC Model Number	First Junos OS Release on MX240, MX480, and MX960 Routers	First Junos OS Release on MX2008 Routers	First Junos OS Release on MX2010 Routers	First Junos OS Release on MX2020 Routers	First Junos OS Release on MX10003 Routers	First Junos OS Release on MX10008 Routers
"MPC9E" on page 135	MX2K-MPC9E	–	15.1F7	<ul style="list-style-type: none"> <li>15.1F5 with Junos Continuity</li> <li>16.1R1 and later</li> </ul>	<ul style="list-style-type: none"> <li>15.1F5 with Junos Continuity</li> <li>16.1R1 and later</li> </ul>	–	–
"MX10003 MPC (Multi-Rate)" on page 136	MX10003-LC2103	–	–	–	–	17.3	–
"MX10K-LC2101" on page 138	JNP10K-LC2101	–	–	–	–	–	18.2R1

- Related Documentation**
- [MX Series MPC Overview on page 11](#)
  - [MIC/MPC Compatibility on page 26](#)
  - [MX Series MIC Overview on page 17](#)
  - [MICs Supported by MX Series Routers on page 18](#)
  - [Junos Continuity Software Overview](#)
  - [Pathfinder: Hardware Supported by Junos Continuity Software](#)

# MICs Supported on MX Series Routers

- [MX Series MIC Overview on page 17](#)
- [MICs Supported by MX Series Routers on page 18](#)
- [MIC/MPC Compatibility on page 26](#)

## MX Series MIC Overview

---

MICs provide the physical connections to various network media types. MICs allow different physical interfaces to be supported on a single line card. You can install MICs of different media types on the same router as long as the router supports those MICs.

MICs receive incoming packets from the network and transmit outgoing packets to the network. During this process, each MIC performs framing and high-speed signaling for its media type. MICs install into Modular Port Concentrators (MPCs) which provide packet forwarding services. Before transmitting outgoing data packets through the MIC interfaces, the Modular Port Concentrator (MPCs) encapsulate the packets received. Each MPC is equipped with up to four Junos Trio chipsets, which perform control functions tailored to the MPC's media type.

MICs and MPCs function similarly to PICs and FPCs. MICs are hot-removable and hot-insertable. You can install up to two MICs of different media types in the same MPC as long as the MPC supports those MICs. Depending on the MX router chassis, the MICs install vertically or horizontally into MPCs, or directly into the MX router chassis as follows:

- Vertically into MPCs— MX960, MX2008, MX2010, and MX2020 routers
- Horizontally into MPCs—MX10003, MX480, and MX240 routers
- Directly into the router chassis—MX5, MX10, MX40, MX80, and MX104 routers



**NOTE:** The MX80 router is available as a modular (MX80) or fixed (MX80-48T) chassis. Both chassis have a fixed Modular Interface Card (MIC) that has 3 10-Gigabit Ethernet ports. The fixed MX80 router has an additional 48 10/100/1000Base-T RJ45 ports. The modular chassis has two dedicated slots for MICs.

- Related Documentation**
- [MX Series MPC Overview on page 11](#)
  - [MICs Supported by MX Series Routers on page 18](#)
  - [MIC/MPC Compatibility on page 26](#)
  - [MPCs Supported by MX Series Routers on page 12](#)

## MICs Supported by MX Series Routers

The following tables list the first supported Junos OS release for the MX Series.

- [Table 5 on page 18](#) lists the first supported Junos OS release for MICs on MX240, MX480, MX960, and MX2008 routers.
- [Table 6 on page 20](#) lists the first supported Junos OS release for MICs on MX2010 and MX2020 routers.
- [Table 7 on page 22](#) list the first supported Junos OS release for MICs on MX5, MX10, and MX40 routers.
- [Table 8 on page 24](#) lists the first supported Junos OS release for MICs on MX80 and MX104 routers.
- [Table 9 on page 26](#) lists the first supported Junos OS release for MICs on MX10003 router.

**Table 5: MICs Supported by MX240, MX480, MX960 and MX2008 Routers**

MIC Name	MIC Model Number	Ports	MX240, MX480, and MX960 Routers	MX2008 Routers
<b>ATM</b>				
<a href="#">"ATM MIC with SFP" on page 142</a>	MIC-3D-8OC3-2OC12-ATM	8	12.1	15.1F7
<b>DS3/E3</b>				
<a href="#">"DS3/E3 MIC" on page 145</a>	MIC-3D-8DS3-E3, MIC-3D-8CHDS3-E3-B	8	11.4	15.1F7
<b>Circuit Emulation</b>				
<a href="#">"Channelized E1/T1 Circuit Emulation MIC" on page 190</a>	MIC-3D-16CHE1-T1-CE	16	12.3	15.1F7
<b>Gigabit Ethernet</b>				
<a href="#">"Gigabit Ethernet MIC with SFP" on page 149</a>	MIC-3D-20GE-SFP	20	10.1	15.1F7
<a href="#">"Gigabit Ethernet MIC with SFP (E)" on page 152</a>	MIC-3D-20GE-SFP-E	20	13.3	15.1F7

Table 5: MICs Supported by MX240, MX480, MX960 and MX2008 Routers (continued)

MIC Name	MIC Model Number	Ports	MX240, MX480, and MX960 Routers	MX2008 Routers
<i>Gigabit Ethernet MIC with 256b-AES MACSEC</i>	MIC-MACSEC-20GE	20	18.3	-
<b>10-Gigabit Ethernet</b>				
"10-Gigabit Ethernet MICs with XFP" on page 157	MIC-3D-2XGE-XFP	2	10.2	15.1F7
"10-Gigabit Ethernet MICs with XFP" on page 157	MIC-3D-4XGE-XFP	4	10.1	15.1F7
"10-Gigabit Ethernet MIC with SFP+ (10 Ports)" on page 159	MIC3-3D-10XGE-SFPP	10	12.3	15.1F7
"10-Gigabit Ethernet MIC with SFP+ (24 Ports)" on page 161	MIC6-10G	24	-	15.1F7
"10-Gigabit Ethernet OTN MIC with SFP+ (24 Ports)" on page 162	MIC6-10G-OTN	24	-	15.1F7
<b>40-Gigabit Ethernet</b>				
"40-Gigabit Ethernet MIC with QSFP+" on page 164	MIC3-3D-2X40GE-QSFPP	2	12.2	15.1F7
<b>100-Gigabit Ethernet</b>				
"100-Gigabit Ethernet MIC with CFP" on page 165	MIC3-3D-1X100GE-CFP	1	12.1	15.1F7
"100-Gigabit Ethernet MIC with CXP" on page 167	MIC3-3D-1X100GE-CXP	1	12.2	15.1F7
"100-Gigabit Ethernet MIC with CXP (4 Ports)" on page 168	MIC6-100G-CXP	4	-	15.1F7
"100-Gigabit Ethernet MIC with CFP2" on page 169	MIC6-100G-CFP2	2	-	15.1F7
<b>100-Gigabit DWDM OTN</b>				
"100-Gigabit DWDM OTN MIC with CFP2-ACO" on page 171	MIC3-100G-DWDM	1	15.1F5 15.1F6 17.1R1	15.1F7
<b>Multi-Rate</b>				
"SONET/SDH OC3/STM1 (Multi-Rate) MICs with SFP" on page 204	MIC-3D-4OC3OC12-1OC48	4	11.2	15.1F7

**Table 5: MICs Supported by MX240, MX480, MX960 and MX2008 Routers (continued)**

MIC Name	MIC Model Number	Ports	MX240, MX480, and MX960 Routers	MX2008 Routers
"SONET/SDH OC3/STM1 (Multi-Rate) MICs with SFP" on page 204	MIC-3D-8OC3OC12-4OC48	8	11.2	15.1F7
"Channelized SONET/SDH OC3/STM1 (Multi-Rate) MICs with SFP" on page 180	MIC-3D-4CHOC3-2CHOC12	4	11.4	15.1F7
"Channelized SONET/SDH OC3/STM1 (Multi-Rate) MICs with SFP" on page 180	MIC-3D-8CHOC3-4CHOC12	8	11.4	15.1F7
"Channelized OC3/STM1 (Multi-Rate) Circuit Emulation MIC with SFP" on page 185	MIC-3D-4COC3-1COC12-CE	4	12.2	15.1F7
"MIC MRATE" on page 200 (12-Port Multi-Rate MIC with QSFP+)	MIC-MRATE	12	-	15.1F7
"Multi-Rate Ethernet MIC" on page 208 (12-Port Multi-Rate MACsec MIC with QSFP+)	MIC-MACSEC-MRATE	12		17.4
<b>Tri-Rate</b>				
"Tri-Rate MIC" on page 196	MIC-3D-40GE-TX	40	10.2	15.1F7
<b>Services</b>				
"Multiservices MIC" on page 202	MS-MIC-16G	0	13.2	15.1F7
<b>SONET/SDH</b>				
"SONET/SDH OC192/STM64 MIC with XFP" on page 213	MIC-3D-1OC192-XFP	1	12.2	15.1F7

**Table 6: MICs Supported by MX2010 and MX2020 Routers**

MIC Name	MIC Model Number	Ports	MX2010 Routers	MX2020 Routers
<b>ATM</b>				
"ATM MIC with SFP" on page 142	MIC-3D-8OC3-2OC12-ATM	8	12.3	12.3
<b>DS3/E3</b>				
"DS3/E3 MIC" on page 145	MIC-3D-8DS3-E3, MIC-3D-8CHDS3-E3-B	8	12.3	12.3

Table 6: MICs Supported by MX2010 and MX2020 Routers (continued)

MIC Name	MIC Model Number	Ports	MX2010 Routers	MX2020 Routers
<b>Circuit Emulation</b>				
"Channelized E1/T1 Circuit Emulation MIC" on page 190	MIC-3D-16CHE1-T1-CE	16	–	–
<b>Gigabit Ethernet</b>				
"Gigabit Ethernet MIC with SFP" on page 149	MIC-3D-20GE-SFP	20	12.3	12.3
"Gigabit Ethernet MIC with SFP (E)" on page 152	MIC-3D-20GE-SFP-E	20	13.3	13.3
<b>10-Gigabit Ethernet</b>				
"10-Gigabit Ethernet MICs with XFP" on page 157	MIC-3D-2XGE-XFP	2	12.3	12.3
"10-Gigabit Ethernet MICs with XFP" on page 157	MIC-3D-4XGE-XFP	4	12.3	12.3
"10-Gigabit Ethernet MIC with SFP+ (10 Ports)" on page 159	MIC3-3D-10XGE-SFPP	10	12.3	12.3
"10-Gigabit Ethernet MIC with SFP+ (24 Ports)" on page 161	MIC6-10G	24	13.3R2	13.3R2
"10-Gigabit Ethernet OTN MIC with SFP+ (24 Ports)" on page 162	MIC6-10G-OTN	24	13.3R3	13.3R3
<b>40-Gigabit Ethernet</b>				
"40-Gigabit Ethernet MIC with QSFP+" on page 164	MIC3-3D-2X40GE-QSFPP	2	12.3	12.3
<b>100-Gigabit Ethernet</b>				
"100-Gigabit Ethernet MIC with CFP" on page 165	MIC3-3D-1X100GE-CFP	1	12.3	12.3
"100-Gigabit Ethernet MIC with CXP" on page 167	MIC3-3D-1X100GE-CXP	1	12.3	12.3
"100-Gigabit Ethernet MIC with CXP (4 Ports)" on page 168	MIC6-100G-CXP	4	13.3R2	13.3R2
"100-Gigabit Ethernet MIC with CFP2" on page 169	MIC6-100G-CFP2	2	13.3R3	13.3R3
<b>100-Gigabit DWDM OTN</b>				

Table 6: MICs Supported by MX2010 and MX2020 Routers (continued)

MIC Name	MIC Model Number	Ports	MX2010 Routers	MX2020 Routers
"100-Gigabit DWDM OTN MIC with CFP2-ACO" on page 171	MIC3-100G-DWDM	1	15.1F5 15.1F6 17.1R1	15.1F5 15.1F6 17.1R1
<b>Multi-Rate</b>				
"SONET/SDH OC3/STM1 (Multi-Rate) MICs with SFP" on page 204	MIC-3D-4OC3OC12-1OC48	4	12.3	12.3
"SONET/SDH OC3/STM1 (Multi-Rate) MICs with SFP" on page 204	MIC-3D-8OC3OC12-4OC48	8	12.3	12.3
"Channelized SONET/SDH OC3/STM1 (Multi-Rate) MICs with SFP" on page 180	MIC-3D-4CHOC3-2CHOC12	4	12.3	12.3
"Channelized SONET/SDH OC3/STM1 (Multi-Rate) MICs with SFP" on page 180	MIC-3D-8CHOC3-4CHOC12	8	12.3	12.3
"Channelized OC3/STM1 (Multi-Rate) Circuit Emulation MIC with SFP" on page 185	MIC-3D-4COC3-1COC12-CE	4	12.3	12.3
"MIC MRATE" on page 200 (12-Port Multi-Rate MIC with QSFP+)	MIC-MRATE	12	<ul style="list-style-type: none"> <li>• 15.1F5 with Junos Continuity</li> <li>• 16.1R1 and later</li> </ul>	<ul style="list-style-type: none"> <li>• 15.1F5 with Junos Continuity</li> <li>• 16.1R1 and later</li> </ul>
"Multi-Rate Ethernet MIC" on page 208 (12-Port Multi-Rate MACsec MIC with QSFP+)	MIC-MACSEC-MRATE	12	17.4	17.4
<b>Tri-Rate</b>				
"Tri-Rate MIC" on page 196	MIC-3D-40GE-TX	40	12.3	12.3
<b>Services</b>				
"Multiservices MIC" on page 202	MS-MIC-16G	0	13.2	13.2
<b>SONET/SDH</b>				
"SONET/SDH OC192/STM64 MIC with XFP" on page 213	MIC-3D-1OC192-XFP	1	12.3	12.3

Table 7: MICs Supported by MX5, MX10, and MX40 Routers

MIC Name	MIC Model Number	Ports	MX5	MX10	MX40
<b>ATM</b>					



Table 7: MICs Supported by MX5, MX10, and MX40 Routers (continued)

MIC Name	MIC Model Number	Ports	MX5	MX10	MX40
"ATM MIC with SFP" on page 142	MIC-3D-8OC3-2OC12-ATM	8	12.1	12.1	12.1
<b>DS3/E3</b>					
"DS3/E3 MIC" on page 145	MIC-3D-8DS3-E3, MIC-3D-8CHDS3-E3-B	8	11.4	11.4	11.4
<b>Circuit Emulation</b>					
"Channelized E1/T1 Circuit Emulation MIC" on page 190	MIC-3D-16CHE1-T1-CE	16	13.2R2	13.2R2	13.2R2
"Channelized E1/T1 Circuit Emulation MIC (H)" on page 193	MIC-3D-16CHE1-T1-CE-H	16	–	–	–
<b>Gigabit Ethernet</b>					
"Gigabit Ethernet MIC with SFP" on page 149	MIC-3D-20GE-SFP	20	11.2R4	11.2R4	11.2R4
"Gigabit Ethernet MIC with SFP (E)" on page 152	MIC-3D-20GE-SFP-E	20	13.2R2	13.2R2	13.2R2
"Gigabit Ethernet MIC with SFP (EH)" on page 156	MIC-3D-20GE-SFP-EH	20	–	–	–
<b>10-Gigabit Ethernet</b>					
"10-Gigabit Ethernet MICs with XFP" on page 157	MIC-3D-2XGE-XFP	2	11.2R4	11.2R4	11.2R4
<b>Multi-Rate</b>					
"SONET/SDH OC3/STM1 (Multi-Rate) MICs with SFP" on page 204	MIC-3D-4OC3OC12-1OC48	4	11.2R4	11.2R4	11.2R4
"SONET/SDH OC3/STM1 (Multi-Rate) MICs with SFP" on page 204	MIC-3D-8OC3OC12-4OC48	8	11.2R4	11.2R4	11.2R4
"Channelized SONET/SDH OC3/STM1 (Multi-Rate) MICs with SFP" on page 180	MIC-3D-4CHOC3-2CHOC12	4	11.4	11.4	11.4
"Channelized SONET/SDH OC3/STM1 (Multi-Rate) MICs with SFP" on page 180	MIC-3D-8CHOC3-4CHOC12	8	11.4	11.4	11.4
"Channelized OC3/STM1 (Multi-Rate) Circuit Emulation MIC with SFP" on page 185	MIC-3D-4COC3-1COC12-CE	4	12.2	12.2	12.2

Table 7: MICs Supported by MX5, MX10, and MX40 Routers (continued)

MIC Name	MIC Model Number	Ports	MX5	MX10	MX40
"Channelized OC3/STM1 (Multi-Rate) Circuit Emulation MIC with SFP (H)" on page 187	MIC-4COC3-1COC12-CE-H	-	-	-	-
<b>Tri-Rate</b>					
"Tri-Rate MIC" on page 196	MIC-3D-40GE-TX	40	-	11.2R4	11.2R4
<b>Services</b>					
"Multiservices MIC" on page 202	MS-MIC-16G	0	13.2 Rear slot only.	13.2 Rear slot only.	13.2 Rear slot only.
"SONET/SDH OC192/STM64 MIC with XFP" on page 213	MIC-3D-1OC192-XFP	1	12.2	12.2	12.2

Table 8: MICs Supported by MX80 and MX104 Routers

MIC Name	MIC Model Number	Ports	MX80	MX104
<b>ATM</b>				
"ATM MIC with SFP" on page 142	MIC-3D-8OC3-2OC12-ATM	8	12.1	13.3
<b>DS3/E3</b>				
"DS3/E3 MIC" on page 145	MIC-3D-8DS3-E3, MIC-3D-8CHDS3-E3-B	8	11.4	13.3
<b>Circuit Emulation</b>				
"Channelized E1/T1 Circuit Emulation MIC" on page 190	MIC-3D-16CHE1-T1-CE	16	13.2R2	13.2R2
"Channelized E1/T1 Circuit Emulation MIC (H)" on page 193	MIC-3D-16CHE1-T1-CE-H	16	-	13.2R2
<b>Gigabit Ethernet</b>				
"Gigabit Ethernet MIC with SFP" on page 149	MIC-3D-20GE-SFP	20	10.2	13.2R2
"Gigabit Ethernet MIC with SFP (E)" on page 152	MIC-3D-20GE-SFP-E	20	13.2R2	13.2R2
"Gigabit Ethernet MIC with SFP (EH)" on page 156	MIC-3D-20GE-SFP-EH	20	-	13.2R2
Gigabit Ethernet MIC with 256b-AES MACSEC	MIC-MACSEC-20GE	20	18.3	18.3

Table 8: MICs Supported by MX80 and MX104 Routers (continued)

MIC Name	MIC Model Number	Ports	MX80	MX104
"10-Gigabit Ethernet MICs with XFP" on page 157	MIC-3D-2XGE-XFP	2	10.2	13.2R2
<b>Multi-Rate</b>				
"SONET/SDH OC3/STM1 (Multi-Rate) MICs with SFP" on page 204	MIC-3D-4OC3OC12-1OC48	4	11.2	13.3
"SONET/SDH OC3/STM1 (Multi-Rate) MICs with SFP" on page 204	MIC-3D-8OC3OC12-4OC48	8	11.2	13.3
"Channelized SONET/SDH OC3/STM1 (Multi-Rate) MICs with SFP" on page 180	MIC-3D-4CHOC3-2CHOC12	4	11.4	13.3
"Channelized SONET/SDH OC3/STM1 (Multi-Rate) MICs with SFP" on page 180	MIC-3D-8CHOC3-4CHOC12	8	11.4	13.3
"Channelized OC3/STM1 (Multi-Rate) Circuit Emulation MIC with SFP" on page 185	MIC-3D-4COC3-1COC12-CE	4	12.2	13.2R2
"Channelized OC3/STM1 (Multi-Rate) Circuit Emulation MIC with SFP (H)" on page 187	MIC-4COC3-1COC12-CE-H	-	-	13.2R2
<b>Tri-Rate</b>				
"Tri-Rate MIC" on page 196	MIC-3D-40GE-TX	40	10.2	13.2R2
<b>Services</b>				
"Multiservices MIC" on page 202	MS-MIC-16G	0	13.2	13.3R2
			Rear slot only. Supported on the modular MX80 and fixed MX80-48T	<b>NOTE</b> See From Junos OS 13.3R3, 14.1R2, and 14.2R1, MX104 supports only two Multiservices MICs.

**SONET/SDH**

**Table 8: MICs Supported by MX80 and MX104 Routers (continued)**

MIC Name	MIC Model Number	Ports	MX80	MX104
"SONET/SDH OC192/STM64 MIC with XFP" on page 213	MIC-3D-1OC192-XFP	1	12.2	13.3

**Table 9: MICs Supported by MX10003 Router**

MIC Name	MIC Model Number	Ports	MX10003
<b>Multi-Rate</b>			
"Multi-Rate Ethernet MIC" on page 208 (12-Port Multi-Rate MIC with QSFP+)	JNP-MIC1	12	17.3
"Multi-Rate Ethernet MIC" on page 208 (12-Port Multi-Rate MACsec MIC with QSFP+)	JNP-MIC1-MACSEC	12	17.3R2

- Related Documentation**
- [MX Series MIC Overview on page 17](#)
  - [MIC/MPC Compatibility on page 26](#)

## MIC/MPC Compatibility

The following tables provide a compatibility matrix for the MICs currently supported by MPC1, MPC2, MPC3, MPC6, MPC8, and MPC9 on MX240, MX480, MX960, MX2008, MX2010, MX2020, and MX10003 routers. Each table lists the first Junos OS release in which the MPC supports the MIC. For example, Junos OS Release 10.2 is the first release in which the MX-MPC1-3D supports the Gigabit Ethernet MIC with SFP. An en dash indicates that the MIC is not supported.

**Table 10: MIC/MPC1 Compatibility**

MIC Name	MPC1	MPC1E	MPC1 Q	MPC1E Q
MIC-3D-8OC3-2OC12-ATM ( <a href="#">"ATM MIC with SFP" on page 142</a> )	—	—	12.1	12.1R4
MIC-3D-20GE-SFP ( <a href="#">"Gigabit Ethernet MIC with SFP" on page 149</a> )	10.2	11.2R4	10.2	11.2R4
MIC-3D-20GE-SFP-E ( <a href="#">"Gigabit Ethernet MIC with SFP (E)" on page 152</a> )	13.2R2	13.2R2	13.2R2	13.2R2
MIC-3D-2XGE-XFP ( <a href="#">"10-Gigabit Ethernet MICs with XFP" on page 157</a> )	10.2	11.2R4	10.2	11.2R4

Table 10: MIC/MPC1 Compatibility (continued)

MIC Name	MPC1	MPC1E	MPC1 Q	MPC1E Q
MIC-3D-4XGE-XFP (“10-Gigabit Ethernet MICs with XFP” on page 157)	—	—	—	—
MIC-3D-40GE-TX (“Tri-Rate MIC” on page 196)	10.2	11.2R4	10.2	11.2R4
MIC-3D-4OC3OC12-1OC48, MIC-3D-8OC3OC12-4OC48 (“SONET/SDH OC3/STM1 (Multi-Rate) MICs with SFP” on page 204)	11.2	11.2R4	11.2	11.2R4
MIC-3D-4COC3-1COC12-CE (“Channelized OC3/STM1 (Multi-Rate) Circuit Emulation MIC with SFP” on page 185)	—	—	12.2	12.2
MIC-3D-1OC192-XFP (“SONET/SDH OC192/STM64 MIC with XFP” on page 213)	12.2	12.2	12.2	12.2
MIC-3D-4CHOC3-2CHOC12, MIC-3D-8CHOC3-4CHOC12 MIC-4COC3-2COC12-G, MIC-8COC3-4COC12-G (“Channelized SONET/SDH OC3/STM1 (Multi-Rate) MICs with SFP” on page 180)	—	—	11.4	11.4
MIC-3D-16CHE1-T1-CE (“Channelized E1/T1 Circuit Emulation MIC” on page 190)	For MPC1 and MPC1E: 13.2		12.3	12.3
	NOTE: Support for Non-Channelized MIC only.			
MIC-3D-8DS3-E3, MIC-3D-8CHDS3-E3-B (“DS3/E3 MIC” on page 145)  NOTE: You cannot run Channelized DS3 (MIC-3D-8CHDS3-E3) on non-Q MPCs. Channelized DS3 is supported only on Q and EQ-based MPCs.	11.4	11.4	11.4	11.4
MIC-MACSEC-20GE Gigabit Ethernet MIC with 256b-AES MACSEC	18.3R1	18.3R1	18.3R1	18.3R1
MS-MIC-16G (“Multiservices MIC” on page 202)	13.2	13.2	13.2	13.2

Table 11: MIC/MPC2 Compatibility

MIC Name	MPC2	MPC2E	MPC2E NG	MPC2 Q	MPC2E Q	MPC2 EQ	MPC2E EQ	MPC2E P	MPC2E NG Q
MIC-3D-8OC3-2OC12-ATM (“ATM MIC with SFP” on page 142)	—	—	14.1R4, 14.2R3 with Junos Continuity  15.1	12.1	12.1R4	12.1	12.1R4	—	14.1R4, 14.2R3 with Junos Continuity  15.1
MIC-3D-20GE-SFP (“Gigabit Ethernet MIC with SFP” on page 149)	10.1	11.2R4	14.1R4, 14.2R3 with Junos Continuity  15.1	10.1	11.2R4	10.1	11.2R4	12.2	14.1R4, 14.2R3 with Junos Continuity  15.1
MIC-3D-20GE-SFP-E (“Gigabit Ethernet MIC with SFP (E)” on page 152)	13.2R2	13.2R2	14.1R4, 14.2R3 with Junos Continuity  15.1	13.2R2	13.2R2	13.2R2	13.2R2	13.2R2	14.1R4, 14.2R3 with Junos Continuity  15.1
MIC-3D-2XGE-XFP (“10-Gigabit Ethernet MIC with XFP” on page 157)	10.2	11.2R4	14.1R4, 14.2R3 with Junos Continuity  15.1	10.2	11.2R4	10.2	11.2R4	12.2	14.1R4, 14.2R3 with Junos Continuity  15.1
MIC-3D-4XGE-XFP (“10-Gigabit Ethernet MICs with XFP” on page 157)	10.1	11.2R4	14.1R4, 14.2R3 with Junos Continuity  15.1	10.1	11.2R4	10.1	11.2R4	12.2	14.1R4, 14.2R3 with Junos Continuity  15.1
MIC-3D-40GE-TX (“Tri-Rate MIC” on page 196)	10.2	11.2R4	14.1R4, 14.2R3 with Junos Continuity  15.1	10.2	11.2R4	10.2	11.2R4	12.2	14.1R4, 14.2R3 with Junos Continuity  15.1
MIC-3D-4OC3OC12-1OC48, MIC-3D-8OC3OC12-4OC48 (“SONET/SDH OC3/STM1 (Multi-Rate) MICs with SFP” on page 204)	11.4	11.4	14.1R4, 14.2R3 with Junos Continuity  15.1	11.4	11.4	11.4	11.4	-	14.1R4, 14.2R3 with Junos Continuity  15.1

Table 11: MIC/MPC2 Compatibility (continued)

MIC Name	MPC2	MPC2E	MPC2E NG	MPC2 Q	MPC2E Q	MPC2 EQ	MPC2E EQ	MPC2E P	MPC2E NG Q
MIC-3D-4COC3-1COC12-CE  ("Channelized OC3/STM1 (Multi-Rate) Circuit Emulation MIC with SFP" on page 185)	—	—	—	12.2	12.2	12.2	12.2	12.2	14.1R4, 14.2R3 with Junos Continuity  15.1
MIC-3D-1OC192-XFP  ("SONET/SDH OC192/STM64 MIC with XFP" on page 213)	12.2	12.2	14.1R4, 14.2R3 with Junos Continuity  15.1	12.2	12.2	12.2	12.2	12.2	14.1R4, 14.2R3 with Junos Continuity  15.1
MIC-3D-4CHOC3-2CHOC12, MIC-3D-8CHOC3-4CHOC12  MIC-4COC3-2COC12-G, MIC-8COC3-4COC12-G  ("Channelized SONET/SDH OC3/STM1 (Multi-Rate) MICs with SFP" on page 180)	—	—	15.1 with flexible queuing option	11.4	11.4	11.4	11.4	—	15.1  14.1R4, 14.2R3 with Junos Continuity
MIC-3D-16CHE1-T1-CE  ("Channelized E1/T1 Circuit Emulation MIC" on page 190)	For MPC2 and MPC2E : 13.2		15.1 with flexible queuing option	12.3	12.3	12.3	12.3	—	14.1R4, 14.2R3 with Junos Continuity  15.1
MIC-3D-8DS3-E3, MIC-3D-8CHDS3-E3-B  ("DS3/E3 MIC" on page 145)  NOTE: You cannot run Channelized DS3 (MIC-3D-8CHDS3-E3) on non-Q MPCs. Channelized DS3 is supported only on Q and EQ-based MPCs.	11.4	11.4	14.1R4, 14.2R3 with Junos Continuity  15.1	11.4	11.4	11.4	11.4	12.2	14.1R4, 14.2R3 with Junos Continuity  15.1
MS-MIC-16G  ("Multiservices MIC" on page 202)  NOTE: Only one MS-MIC-16G can be installed into any MPC.	13.2	13.2	14.1R4, 14.2R3 with Junos Continuity  15.1	13.2	13.2	13.2	13.2	13.2	14.1R4, 14.2R3 with Junos Continuity  15.1

Table 11: MIC/MPC2 Compatibility (continued)

MIC Name	MPC2	MPC2E	MPC2E NG	MPC2 Q	MPC2E Q	MPC2 EQ	MPC2E EQ	MPC2E P	MPC2E NG Q
MIC-MACSEC-20GE <i>Gigabit Ethernet MIC with 256b-AES MACSEC</i>	18.3R1	18.3R1	18.3R1	18.3R1	18.3R1	18.3R1	18.3R1	18.3R1	18.3R1

Table 12: MIC/MPC3 Compatibility

MIC Name	MPC3E	MPC3E NG	MPC3E NG Q
MIC-3D-8OC3-2OC12-ATM ( <a href="#">“ATM MIC with SFP” on page 142</a> )	—	14.1R4, 14.2R3 with Junos Continuity 15.1	14.1R4, 14.2R3 with Junos Continuity 15.1
MIC-3D-20GE-SFP ( <a href="#">“Gigabit Ethernet MIC with SFP” on page 149</a> )	12.1	14.1R4, 14.2R3 with Junos Continuity 15.1	14.1R4, 14.2R3 with Junos Continuity 15.1
MIC-3D-20GE-SFP-E ( <a href="#">“Gigabit Ethernet MIC with SFP (E)” on page 152</a> )	13.2R2	14.1R4, 14.2R3 with Junos Continuity 15.1	14.1R4, 14.2R3 with Junos Continuity 15.1
MIC3-3D-1X100GE-CFP ( <a href="#">“100-Gigabit Ethernet MIC with CFP” on page 165</a> )	12.1	14.1R4, 14.2R3 with Junos Continuity 15.1	14.1R4, 14.2R3 with Junos Continuity 15.1
MIC-3D-2XGE-XFP ( <a href="#">“10-Gigabit Ethernet MICs with XFP” on page 157</a> )	12.2	14.1R4, 14.2R3 with Junos Continuity 15.1	14.1R4, 14.2R3 with Junos Continuity 15.1
MIC-3D-4XGE-XFP ( <a href="#">“10-Gigabit Ethernet MICs with XFP” on page 157</a> )	—	14.1R4, 14.2R3 with Junos Continuity 15.1	14.1R4, 14.2R3 with Junos Continuity 15.1
MIC3-3D-10XGE-SFPP ( <a href="#">“10-Gigabit Ethernet MIC with SFP+ (10 Ports)” on page 159</a> )	12.3	14.1R4, 14.2 R3 and Junos Continuity 15.1	14.1R4, 14.2R3 with Junos Continuity 15.1
MIC3-3D-2X40GE-QSFPP ( <a href="#">“40-Gigabit Ethernet MIC with QSFP+” on page 164</a> )	12.2	14.1R4, 14.2R3 with Junos Continuity 15.1	14.1R4, 14.2R3 with Junos Continuity 15.1
MIC3-3D-1X100GE-CXP ( <a href="#">“100-Gigabit Ethernet MIC with CXP” on page 167</a> )	12.2	14.1R4, 14.2R3 with Junos Continuity 15.1	14.1R4, 14.2R3 with Junos Continuity 15.1



Table 12: MIC/MPC3 Compatibility (continued)

MIC Name	MPC3E	MPC3E NG	MPC3E NG Q
MIC3-100G-DWDM ( <a href="#">"100-Gigabit DWDM OTN MIC with CFP2-ACO" on page 171</a> )	15.1F5 15.1F6 17.1R1	15.1F5 15.1F6 17.1R1	15.1F5 15.1F6 17.1R1
MIC-3D-4OC3OC12-1OC48  MIC-3D-8OC3OC12-4OC48  ( <a href="#">"SONET/SDH OC3/STM1 (Multi-Rate) MICs with SFP" on page 204</a> )	13.3	14.1R4, 14.2R3 with Junos Continuity  15.1	14.1R4, 14.2R3 with Junos Continuity  15.1
MIC-3D-1OC192-XFP ( <a href="#">"SONET/SDH OC192/STM64 MIC with XFP" on page 213</a> )	13.3	14.1R4, 14.2R3 with Junos Continuity  15.1	14.1R4, 14.2R3 with Junos Continuity  15.1
MIC-3D-4COC3-1COC12-CE  ( <a href="#">"Channelized OC3/STM1 (Multi-Rate) Circuit Emulation MIC with SFP" on page 185</a> )	—	—	14.1R4, 14.2R3 with Junos Continuity  15.1
MIC-3D-16CHE1-T1-CE ( <a href="#">"Channelized E1/T1 Circuit Emulation MIC" on page 190</a> )	—	15.1 with flexible queuing option	15.1
MS-MIC-16G  ( <a href="#">"Multiservices MIC" on page 202</a> )  NOTE: On MPC3E, the installation of the Multiservices MIC (MS-MIC-16G) with MIC3-3D-2X40GE-QSFPP, MIC3-3D-10XGE-SFPP, or MIC3-3D-1X100GE-CFP does not meet the NEBS criteria.  NOTE: Only one MS-MIC-16G can be installed into any MPC.	13.2R2	14.1R4, 14.2R3 with Junos Continuity  15.1	14.1R4, 14.2R3 with Junos Continuity  15.1
MIC-3D-40GE-TX <a href="#">"Tri-Rate MIC" on page 196</a>	—	14.1R4, 14.2R3 with Junos Continuity  15.1	14.1R4, 14.2R3 with Junos Continuity  15.1
MIC-3D-4OC3OC12-1OC48, MIC-3D-8OC3OC12-4OC48 <a href="#">"SONET/SDH OC3/STM1 (Multi-Rate) MICs with SFP" on page 204</a>	12.1	14.1R4, 14.2R3 with Junos Continuity  15.1	14.1R4, 14.2R3 with Junos Continuity  15.1

**Table 12: MIC/MPC3 Compatibility (continued)**

MIC Name	MPC3E	MPC3E NG	MPC3E NG Q
MIC-3D-4CHOC3-2CHOC12, MIC-3D-8CHOC3-4CHOC12 MIC-4COC3-2COC12-G, MIC-8COC3-4COC12-G "Channelized SONET/SDH OC3/STM1 (Multi-Rate) MICs with SFP" on page 180	—	15.1 with flexible queuing option	14.1R4, 14.2R3 with Junos Continuity  15.1
MIC-3D-8DS3-E3, MIC-3D-8CHDS3-E3-B "DS3/E3 MIC" on page 145	12.1	14.1R4, 14.2R3 with Junos Continuity  15.1	14.1R4, 14.2R3 with Junos Continuity  15.1
<b>NOTE:</b> You cannot run Channelized DS3 (MIC-3D-8CHDS3-E3) on non-Q MPCs. Channelized DS3 is supported only on Q and EQ-based MPCs.			
MIC-MACSEC-20GE Gigabit Ethernet MIC with 256b-AES MACSEC	18.3R1	18.3R1	18.3R1

**Table 13: MIC/MPC6 Compatibility**

MIC Name	MPC6E
MIC6-10G  "10-Gigabit Ethernet MIC with SFP+ (24 Ports)" on page 161	13.3R2
MIC6-10G-OTN  "10-Gigabit Ethernet OTN MIC with SFP+ (24 Ports)" on page 162	13.3R3
MIC6-100G-CXP  "100-Gigabit Ethernet MIC with CXP (4 Ports)" on page 168	13.3R2
MIC6-100G-CFP2  "100-Gigabit Ethernet MIC with CFP2" on page 169	13.3R3

**Table 14: MIC/MPC8 Compatibility**

MIC Name	MPC8E
MIC-MRATE  "MIC MRATE" on page 200	<ul style="list-style-type: none"> <li>15.1F5 with Junos Continuity</li> <li>16.1R1</li> </ul>
MIC-MACSEC-MRATE  "Multi-Rate Ethernet MIC" on page 208	17.4

Table 15: MIC/MPC9 Compatibility

MIC Name	MPC9E
MIC-MRATE "MIC MRATE" on page 200	<ul style="list-style-type: none"> <li>15.1F5 with Junos Continuity</li> <li>16.1R1</li> </ul>
MIC-MACSEC-MRATE "Multi-Rate Ethernet MIC" on page 208	17.4

Table 16: MIC/MPC10003 Compatibility

MIC Name	MPC10003
JNP-MIC1 "Multi-Rate Ethernet MIC" on page 208	17.3
JNP-MIC1-MACSEC "Multi-Rate Ethernet MIC" on page 208	17.3R2

- Related Documentation**
- [MICs Supported by MX Series Routers on page 18](#)
  - *Junos Continuity Software User Guide (Junos OS Release 14.1R4 and Later Releases)*



## CHAPTER 5

# FPCs and PICs Supported on MX Series Routers

- [MX Series FPC and PIC Overview on page 35](#)
- [High Availability Features on page 36](#)
- [FPCs Supported by MX240, MX480, and MX960 Routers on page 36](#)
- [PICs Supported by MX240, MX480, and MX960 Routers on page 37](#)

## MX Series FPC and PIC Overview

---

Flexible PIC Concentrators (FPCs) and Physical Interface Cards (PICs) function similarly to MICs and MPCs. PICs provide physical interfaces for the router and install into FPCs which provide packet forwarding services. Each FPC supports up to two Physical Interface Cards (PICs). You can install PICs of different media types on the same router as long as the router supports those PICs.

PICs receive incoming packets from the network and transmit outgoing packets to the network. During this process, each PIC performs framing and high-speed signaling for its media type. Before transmitting outgoing data packets, the PICs encapsulate the packets received. Each PIC is equipped with a media-specific ASIC that performs control functions tailored to the PIC's media type.

An FPC occupies two Dense Port Concentrator (DPC) slots on an MX Series router. FPCs install vertically in the MX960 router chassis, and horizontally in the MX480 and MX240 router chassis. The maximum number of supported FPCs varies per router:

- MX960 router—6 FPCs
- MX480 router—3 FPCs
- MX240 router—1 FPC

MX240, MX480, and MX960 Universal Routing Platforms support 2 PICs per FPC. The maximum number of supported PICs varies per router:

- MX960 router—12 PICs
- MX480 router—6 PICs
- MX240 router—2 PICs

Blank PICs resemble other PICs but do not provide any physical connection or activity. When a slot is not occupied by a PIC, you must insert a blank PIC to fill the empty slot and ensure proper cooling of the system.

- Related Documentation**
- [High Availability Features on page 36](#)
  - [FPCs Supported by MX240, MX480, and MX960 Routers on page 36](#)
  - [PICs Supported by MX240, MX480, and MX960 Routers on page 37](#)

## High Availability Features

High availability features include Routing Engine redundancy, graceful Routing Engine switchover (GRES), nonstop bridging, nonstop active routing, graceful restart for routing protocols, Virtual Router Redundancy Protocol (VRRP), and unified in-service software upgrade (ISSU). Some high availability features are not supported by all platforms and all PICs. For more information, see the *Unified ISSU System Requirements* in the *High Availability Feature Guide*.

- Related Documentation**
- [MX Series FPC and PIC Overview on page 35](#)
  - [FPCs Supported by MX240, MX480, and MX960 Routers on page 36](#)
  - [PICs Supported by MX240, MX480, and MX960 Routers on page 37](#)

## FPCs Supported by MX240, MX480, and MX960 Routers

An FPC occupies two slots when installed in an MX240, MX480, or MX960 router. The maximum number of supported FPCs varies per router:

- MX960 router—6 FPCs
- MX480 router—3 FPCs
- MX240 router—1 FPC

[Table 17 on page 36](#) lists FPCs supported by MX240 routers.

*Table 17: FPCs Supported by MX Series Routers*

FPC Type	FPC Name	FPC Model Number	Maximum Number of PICs Supported	Maximum Throughput per FPC (Full-duplex)	First Junos OS Release
3	FPC3	MX-FPC3	2	20 Gbps	9.4
2	FPC2	MX-FPC2	2	10 Gbps	9.5

- Related Documentation**
- [MX Series FPC and PIC Overview on page 35](#)
  - [PICs Supported by MX240, MX480, and MX960 Routers on page 37](#)

- [High Availability Features on page 36](#)

## PICs Supported by MX240, MX480, and MX960 Routers

Table 18 on page 37 lists the PICs supported by MX240, MX480, and MX960 routers.

*Table 18: PICs Supported by MX240, MX480, and MX960 Routers*

PIC Name	PIC Model Number	Ports	Type	First Junos OS Release
<b>Channelized IQ PICs</b>				
"Channelized OC12/STM4 Enhanced IQ (IQE) PIC with SFP" on page 217	PB-4CHOC12-STM4-IQE-SFP	4	2	9.5
"Channelized OC48/STM16 Enhanced IQ (IQE) PIC with SFP" on page 218	PB-1CHOC48-STM16-IQE	1	2	9.5
<b>SONET/SDH PICs</b>				
"SONET/SDH OC3/STM1 (Multi-Rate) PIC with SFP" on page 224	PB-4OC3-1OC12-SON2-SFP	4	2	9.5
"SONET/SDH OC12/STM4 (Multi-Rate) PIC with SFP" on page 227	PB-4OC3-4OC12-SON-SFP	4	2	9.5
"SONET/SDH OC48/STM16 Enhanced IQ (IQE) PIC with SFP" on page 230	PC-4OC48-STM16-IQE-SFP	4	3	10.4R2
"SONET/SDH OC48/STM16 (Multi-Rate) PIC with SFP" on page 234	PB-1OC48-SON-B-SFP	1	2	9.5
"SONET/SDH OC48/STM16 PIC with SFP" on page 237	PC-4OC48-SON-SFP	4	3	9.4
"SONET/SDH OC192c/STM64 PIC" on page 240	PC-1OC192-SON-VSR	1	3	9.4
"SONET/SDH OC192c/STM64 PIC with XFP" on page 243	PC-1OC192-SON-XFP	1	3	9.4

### Related Documentation

- [MX Series FPC and PIC Overview on page 35](#)
- [FPCs Supported by MX240, MX480, and MX960 Routers on page 36](#)
- [High Availability Features on page 36](#)





# Network Interface Specifications

- Determining Transceiver Support and Specifications on page 39
- Cable and Connector Specifications for MX Series and PTX Series Devices on page 40

## Determining Transceiver Support and Specifications

---

You can find information about the pluggable transceivers supported on your Juniper Networks device by using the Hardware Compatibility Tool. In addition to transceiver and connector type, the optical and cable characteristics—where applicable—are documented for each transceiver. The Hardware Compatibility Tool allows you to search by product, displaying all the transceivers supported on that device, or category, displaying all the transceivers by interface speed or type. The Hardware Compatibility Tool is located at <https://apps.juniper.net/hct/>.

Some transceivers support additional monitoring using the operational mode CLI command **show interfaces diagnostics optics**. Use the Hardware Compatibility Tool to determine if your transceiver supports monitoring. See the Junos OS documentation for your device for a description of the monitoring fields.



**CAUTION:** If you face a problem running a Juniper Networks device that uses a third-party optic or cable, the Juniper Networks Technical Assistance Center (JTAC) can help you diagnose the source of the problem. Your JTAC engineer might recommend that you check the third-party optic or cable and potentially replace it with an equivalent Juniper Networks optic or cable that is qualified for the device.

### Related Documentation

- *show interfaces diagnostics optics (Gigabit Ethernet, 10-Gigabit Ethernet, 40-Gigabit Ethernet, 100-Gigabit Ethernet, and Virtual Chassis Port)*
- *show interfaces diagnostics optics (SONET)*
- *show interfaces diagnostics optics*
- *show interfaces diagnostics optics*
- *show interfaces diagnostics optics*

## Cable and Connector Specifications for MX Series and PTX Series Devices

The transceivers that are supported on MX Series and PTX Series devices use fiber-optic cables and connectors. The type of connector and the type of fiber depends on the transceiver type.

You can determine the type of cable and connector required for your specific transceiver by using the [Hardware Compatibility Tool](#).



**CAUTION:** To maintain agency approvals, use only a properly constructed, shielded cable.



**NOTE:** The terms multifiber push-on (MPO) and multifiber termination push-on (MTP) describe the same connector type. The rest of this topic uses MPO to mean MPO or MTP.

- [12-Fiber MPO Connectors on page 40](#)
- [24-Fiber MPO Connectors on page 44](#)
- [LC Duplex Connectors on page 44](#)

### 12-Fiber MPO Connectors

There are two types of cables used with 12-fiber MPO connectors on Juniper Networks devices—patch cables with MPO connectors on both ends, and breakout cables with an MPO connector on one end and four LC duplex connectors on the opposite end. Depending on the application, the cables might use single-mode fiber (SMF) or multimode fiber (MMF). Juniper Networks sells cables that meet the supported transceiver requirements, but it is not required to purchase cables from Juniper Networks.

Ensure that you order cables with the correct polarity. Vendors refer to these crossover cables as *key up to key up*, *latch up to latch up*, *Type B*, or *Method B*. If you are using patch panels between two transceivers, ensure that the proper polarity is maintained through the cable plant.

Also, ensure that the fiber end in the connector is finished correctly. Physical contact (PC) refers to fiber that has been polished flat. Angled physical contact (APC) refers to fiber that has been polished at an angle. Ultra physical contact (UPC) refers to fiber that has been polished flat, to a finer finish. The required fiber end is listed with the connector type in the [Hardware Compatibility Tool](#).

#### 12-Fiber Ribbon Patch Cables with MPO Connectors

You can use 12-fiber ribbon patch cables with female MPO connectors to connect two transceivers of the same type—for example, 40GBASE-SR4-to-40GBASESR4 or 100GBASE-SR4-to-100GBASE-SR4. You can also connect 4x10GBASE-LR or 4x10GBASE-SR transceivers by using patch cables—for example,

4x10GBASE-LR-to-4x10GBASE-LR or 4x10GBASE-SR-to-4x10GBASE-SR—instead of breaking the signal out into four separate signals.

Table 19 on page 41 describes the signals on each fiber. Table 20 on page 41 shows the pin-to-pin connections for proper polarity.

**Table 19: Cable Signals for 12-Fiber Ribbon Patch Cables**

Fiber	Signal
1	Tx0 (Transmit)
2	Tx1 (Transmit)
3	Tx2 (Transmit)
4	Tx3 (Transmit)
5	Unused
6	Unused
7	Unused
8	Unused
9	Rx3 (Receive)
10	Rx2 (Receive)
11	Rx1 (Receive)
12	Rx0 (Receive)

**Table 20: Cable Pinouts for 12-Fiber Ribbon Patch Cables**

MPO Pin	MPO Pin
1	12
2	11
3	10
4	9
5	8
6	7

**Table 20: Cable Pinouts for 12-Fiber Ribbon Patch Cables (continued)**

MPO Pin	MPO Pin
7	6
8	5
9	4
10	3
11	2
12	1

### 12-Fiber Ribbon Breakout Cables with MPO-to-LC Duplex Connectors

You can use 12-ribbon breakout cables with MPO-to-LC duplex connectors to connect a QSFP+ transceiver to four separate SFP+ transceivers—for example, 4x10GBASE-LR-to-10GBASE-LR or 4x10GBASE-SR-to-10GBASE-SR SFP+ transceivers. The breakout cable is constructed out of a 12-fiber ribbon fiber-optic cable. The ribbon cable splits from a single cable with a female MPO connector on one end, into four cable pairs with four LC duplex connectors on the opposite end.

[Table 21 on page 42](#) describes the way the fibers are connected between the MPO and LC duplex connectors. The cable signals are the same as those described in [Table 19 on page 41](#).

**Table 21: Cable Pinouts for 12-Fiber Ribbon Breakout Cables**

MPO Connector Pin	LC Duplex Connector Pin
1	Tx on LC Duplex 1
2	Tx on LC Duplex 2
3	Tx on LC Duplex 3
4	Tx on LC Duplex 4
5	Unused
6	Unused
7	Unused
8	Unused
9	Rx on LC Duplex 4

**Table 21: Cable Pinouts for 12-Fiber Ribbon Breakout Cables (continued)**

MPO Connector Pin	LC Duplex Connector Pin
10	Rx on LC Duplex 3
11	Rx on LC Duplex 2
12	Rx on LC Duplex 1

### 12-Ribbon Patch and Breakout Cables Available from Juniper Networks

Juniper Networks sells 12-ribbon patch and breakout cables with MPO connectors that meet the requirements described above. It is not required to purchase cables from Juniper Networks. [Table 22 on page 43](#) describes the available cables.

**Table 22: 12-Ribbon Patch and Breakout Cables Available from Juniper Networks**

Cable Type	Connector Type	Fiber Type	Cable Length	Juniper Model Number
12-ribbon patch	Female MPO/PC to female MPO/PC, key up to key up	MMF (OM3)	1 m	MTP12-FF-M1M
			3 m	MTP12-FF-M3M
			5 m	MTP12-FF-M5M
			10 m	MTP12-FF-M10M
	Female MPO/APC to female MPO/APC, key up to key up	SMF	1 m	MTP12-FF-S1M
			3 m	MTP12-FF-S3M
			5 m	MTP12-FF-S5M
			10 m	MTP12-FF-S10M
12-ribbon breakout	Female MPO/PC, key up, to four LC/UPC duplex	MMF (OM3)	1 m	MTP-4LC-M1M
			3 m	MTP-4LC-M3M
			5 m	MTP-4LC-M5M
			10 m	MTP-4LC-M10M
	Female MPO/APC, key up, to four LC/UPC duplex	SMF	1 m	MTP-4LC-S1M
			3 m	MTP-4LC-S3M
			5 m	MTP-4LC-S5M
			10 m	MTP-4LC-S10M

## 24-Fiber MPO Connectors

You can use patch cables with 24-fiber MPO connectors to connect two supported transceivers of the same type—for example, 100GBASE-SR10-to-100GBASE-SR10.

Figure 1 on page 44 shows the 24-fiber MPO optical lane assignments.

Figure 1: 24-Fiber MPO Optical Lane Assignments

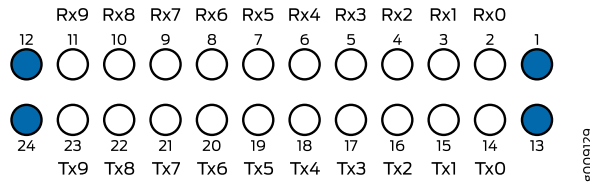

**NOTE:** Ensure that you order cables with the correct polarity. Vendors refer to these crossover cables as *key up to key up*, *latch up to latch up*, *Type B*, or *Method B*. If you are using patch panels between two transceivers, ensure that the proper polarity is maintained through the cable plant.

The MPO optical connector for the CFP2-100G-SR10-D3 is defined in Section 5.6 of the CFP2 Hardware Specification and Section 88.10.3 of IEEE STD 802.3-2012. These specifications include the following requirements:

- Recommended Option A in IEEE STD 802.3-2012 is required.
- The transceiver receptacle is male. A patch cable with female connector is required to mate with the module.
- Ferrule finish shall be flat polished interface that is compliant with IEC 61754-7.
- Alignment key is key up.

The optical interface must meet the requirement FT-1435-CORE in *Generic Requirements for Multi-Fiber Optical Connectors*. The module must pass wiggle test defined by IEC 62150-3.

## LC Duplex Connectors

You can use patch cables with LC duplex connectors to connect two supported transceivers of the same type—for example, 40GBASE-LR4-to-40GBASE-LR4 or 100GBASE-LR4-to-100GBASE-LR4. The patch cable is one fiber pair with two LC duplex connectors at opposite ends. LC duplex connectors are also used with 12-fiber ribbon breakout cables, as described in “12-Fiber Ribbon Breakout Cables with MPO-to-LC Duplex Connectors” on page 42.

Figure 2 on page 45 shows an LC duplex connector being installed in a transceiver.

Figure 2: LC Duplex Connector

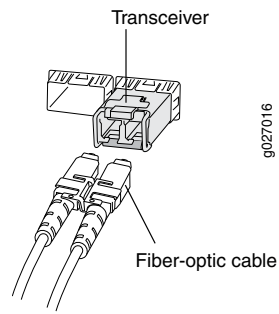





## PART 2

# DPC, MPC, MIC, and PIC Descriptions

- [MX Series DPC Descriptions on page 49](#)
- [MX Series MPC Descriptions on page 83](#)
- [MX Series MIC Descriptions on page 141](#)
- [MX Series PIC Descriptions on page 217](#)



## CHAPTER 7

# MX Series DPC Descriptions

- [Gigabit Ethernet DPC with SFP on page 50](#)
- [Gigabit Ethernet Enhanced DPC with SFP on page 52](#)
- [Gigabit Ethernet Enhanced Ethernet Services DPC with SFP on page 54](#)
- [Gigabit Ethernet Enhanced Queuing Ethernet Services DPC with SFP on page 56](#)
- [Gigabit Ethernet Enhanced Queuing IP Services DPCs with SFP on page 58](#)
- [10-Gigabit Ethernet DPC with XFP on page 61](#)
- [10-Gigabit Ethernet Enhanced DPCs with XFP on page 63](#)
- [10-Gigabit Ethernet Enhanced Ethernet Services DPC with XFP on page 65](#)
- [10-Gigabit Ethernet Enhanced Queuing Ethernet Services DPC with XFP on page 67](#)
- [10-Gigabit Ethernet Enhanced Queuing IP Services DPC with XFP on page 69](#)
- [Multi-Rate Ethernet Enhanced DPC with SFP and XFP on page 71](#)
- [Multi-Rate Ethernet Enhanced Ethernet Services DPC with SFP and XFP on page 73](#)
- [Multi-Rate Ethernet Enhanced Queuing IP Services DPC with SFP and XFP on page 75](#)
- [Multiservices DPC on page 77](#)
- [Tri-Rate Enhanced DPC on page 79](#)
- [Tri-Rate Enhanced Ethernet Services DPC on page 81](#)

## Gigabit Ethernet DPC with SFP

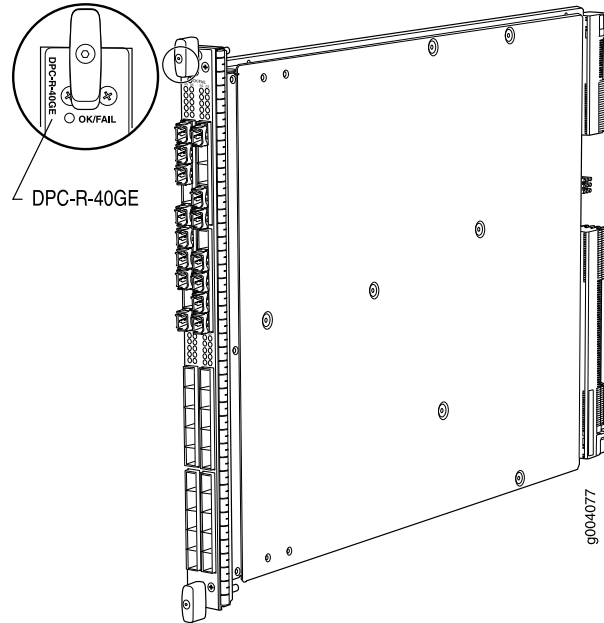

Software release	<ul style="list-style-type: none"> <li>Junos OS Release 8.2 and later</li> <li>End-of-life (see notification <a href="#">PSN-2009-06-400</a>)</li> </ul>
Description	<ul style="list-style-type: none"> <li>40 Gigabit Ethernet ports</li> <li>Power requirement: 6.98 A @ 48 V (335 W)</li> <li>Weight: 13.1 lb (5.9 kg)</li> <li>Supports large Ethernet frame sizes for more efficient throughput across the intra-POP network</li> <li>Model number: DPC-R-40GE-SFP</li> <li>Name in the CLI: <b>DPC 40x 1GE R</b></li> </ul>
Hardware features	<ul style="list-style-type: none"> <li>High-performance throughput on each port at speeds up to 1 Gbps</li> <li>Autonegotiation between Gigabit Ethernet circuit partners</li> <li>Full-duplex mode</li> <li>Maximum transmission units (MTUs) of up to 9192 bytes</li> </ul>
Software features	<ul style="list-style-type: none"> <li>Optical diagnostics and related alarms</li> <li>See “<a href="#">Protocols and Applications Supported by DPCs and Enhanced DPCs (DPC and DPCE-R)</a>” on <a href="#">page 325</a> for information about the protocols and applications that this DPC supports.</li> </ul>
Interfaces	<p>Syntax: <i>ge-fpc/pic/port</i> where:</p> <ul style="list-style-type: none"> <li>fpc: Slot in the router where the DPC is installed</li> <li>pic: 0 (bottom left row of 10 ports), 1 (bottom right row of 10 ports), 2 (top left row of 10 ports), or 3 (top right row of 10 ports)</li> <li>port: 0 through 9</li> </ul> <p>For example, <i>ge-1/3/0</i> is the interface for port 0 in the top right row of 10 ports on a DPC installed in slot 1.</p>

**Cables and connectors** **TIP:** You can use the [Hardware Compatibility Tool](#) to find information about the pluggable transceivers supported on your Juniper Networks device.

The list of supported transceivers for the MX Series is located at <https://pathfinder.juniper.net/hct/category/#catKey=100001&modelType;=All&pf;=MX+Series>.

You can install any transceiver supported by the DPC. For information about installing and removing transceivers, see the hardware guide for your router.

**NOTE:** Do not install Gigabit Ethernet SFPs in the SONET/SDH port. The port will not recognize the SFP.

**LEDs**

**OK/FAIL LED, one bicolor:**

- Steady green—DPC is functioning normally.
- Blinking green—DPC is transitioning online or offline.
- Red—DPC has failed.

**Link LED, one green per port:**

- Off—No link.
- On steadily—Link is active.

The Link LEDs are labeled in groups of five:

- 0/0 for 0/0 through 0/4
- 0/5 for 0/5 through 0/9
- 1/0 for 1/0 through 1/4
- 1/5 for 1/5 through 1/9
- 2/0 for 2/0 through 2/4
- 2/5 for 2/5 through 2/9
- 3/0 for 3/0 through 3/4
- 3/5 for 3/5 through 3/9

---

**Related Documentation**

- [MX Series DPC Overview on page 7](#)
- [DPCs Supported on MX240, MX480, and MX960 Routers on page 8](#)

## Gigabit Ethernet Enhanced DPC with SFP

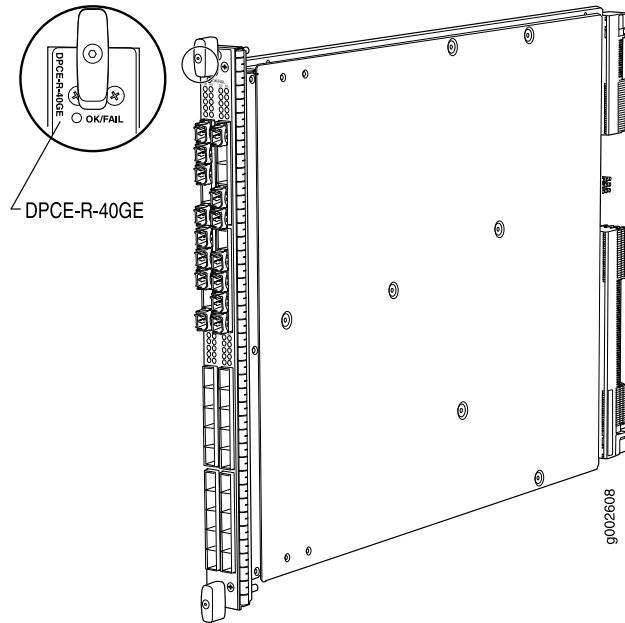

Software release	<ul style="list-style-type: none"> <li>Junos OS Release 8.4 and later</li> </ul>
Description	<ul style="list-style-type: none"> <li>40 Gigabit Ethernet ports</li> <li>Power requirement: 6.98 A @ 48 V (335 W)</li> <li>Weight: 13.1 lb (5.9 kg)</li> <li>Supports large Ethernet frame sizes for more efficient throughput across the intra-POP network</li> <li>Model number: DPCE-R-40GE-SFP</li> <li>Name in the CLI: DPCE 40x 1GE R</li> </ul>
Hardware features	<ul style="list-style-type: none"> <li>High-performance throughput on each port at speeds up to 1 Gbps</li> <li>Autonegotiation between Gigabit Ethernet circuit partners</li> <li>Full-duplex mode</li> <li>Maximum transmission units (MTUs) of up to 9192 bytes</li> <li>Enhanced ASICs for increased performance and scalability of Layer 2 features</li> </ul>
Software features	<ul style="list-style-type: none"> <li>Optical diagnostics and related alarms</li> <li>See <a href="#">“Protocols and Applications Supported by DPCs and Enhanced DPCs (DPC and DPCE-R)”</a> on <a href="#">page 325</a> for information about the protocols and applications that this DPC supports.</li> </ul>

Interfaces	<p>Syntax: <i>ge-fpc/pic/port</i> where:</p> <ul style="list-style-type: none"> <li>• fpc: Slot in the router where the DPC is installed</li> <li>• pic: 0 (bottom left row of 10 ports), 1 (bottom right row of 10 ports), 2 (top left row of 10 ports), or 3 (top right row of 10 ports) when installed horizontally</li> <li>• port: 0 through 9</li> </ul> <p>For example, <i>ge-1/3/0</i> is the interface for port 0 in the top right row of 10 ports on a DPC installed in slot 1.</p> <p>For information on the interface numbering, see the <i>DPC Port and Interface Numbering</i> topic for the respective MX router.</p>
------------	--

Cables and connectors	<p><b>TIP:</b> You can use the <a href="#">Hardware Compatibility Tool</a> to find information about the pluggable transceivers supported on your Juniper Networks device.</p> <p>The list of supported transceivers for the MX Series is located at <a href="https://pathfinder.juniper.net/hct/category/#catKey=100001&amp;modelType=All&amp;pf=MX+Series">https://pathfinder.juniper.net/hct/category/#catKey=100001&amp;modelType=All&amp;pf=MX+Series</a>.</p> <p>You can install any transceiver supported by the DPC. For information about installing and removing transceivers, see the hardware guide for your router.</p> <p><b>NOTE:</b> Do not install Gigabit Ethernet SFPs in the SONET/SDH port. The port will not recognize the SFP.</p>
-----------------------	---

LEDs	<p><b>OK/FAIL LED</b>, one bicolor:</p> <ul style="list-style-type: none"> <li>• Steady green—DPC is functioning normally.</li> <li>• Blinking green—DPC is transitioning online or offline.</li> <li>• Red—DPC has failed.</li> </ul> <p>Link LED, one green per port:</p> <ul style="list-style-type: none"> <li>• Off—No link.</li> <li>• On steadily—Link is active.</li> </ul> <p>The Link LEDs are labeled in groups of five:</p> <ul style="list-style-type: none"> <li>• 0/0 for 0/0 through 0/4</li> <li>• 0/5 for 0/5 through 0/9</li> <li>• 1/0 for 1/0 through 1/4</li> <li>• 1/5 for 1/5 through 1/9</li> <li>• 2/0 for 2/0 through 2/4</li> <li>• 2/5 for 2/5 through 2/9</li> <li>• 3/0 for 3/0 through 3/4</li> <li>• 3/5 for 3/5 through 3/9</li> </ul>
------	--

<b>Related Documentation</b>	<ul style="list-style-type: none"> <li>• <a href="#">MX Series DPC Overview on page 7</a></li> <li>• <a href="#">DPCs Supported on MX240, MX480, and MX960 Routers on page 8</a></li> </ul>
------------------------------	---

## Gigabit Ethernet Enhanced Ethernet Services DPC with SFP

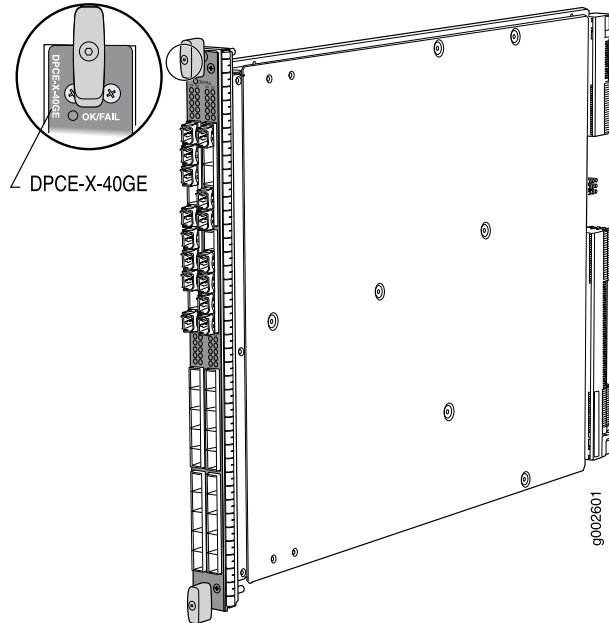

Software release	<ul style="list-style-type: none"> <li>Junos OS Release 8.4 and later</li> </ul>
Description	<ul style="list-style-type: none"> <li>40 Gigabit Ethernet ports</li> <li>Power requirement: 6.98 A @ 48 V (335 W)</li> <li>Weight: 13.1 lb (5.9 kg)</li> <li>Supports large Ethernet frame sizes for more efficient throughput across the intra-POP network</li> <li>Model number: DPCE-X-40GE-SFP</li> <li>Name in the CLI: DPCE 40x 1GE X</li> </ul>
Hardware features	<ul style="list-style-type: none"> <li>High-performance throughput on each port at speeds up to 1 Gbps</li> <li>Autonegotiation between Gigabit Ethernet circuit partners</li> <li>Full-duplex mode</li> <li>Maximum transmission units (MTUs) of up to 9192 bytes</li> <li>Enhanced ASICs for increased performance and scalability of Layer 2 features</li> </ul>
Software features	<ul style="list-style-type: none"> <li>Optical diagnostics and related alarms</li> <li>See <a href="#">“Protocols and Applications Supported by Enhanced Ethernet Services DPCs (DPCE-X)” on page 331</a> for information about the protocols and applications that this DPC supports.</li> </ul> <p><b>NOTE:</b> The routing table is limited to 32,000 IP routes. This limitation applies to any manner in which the routes are learned, such as OSPF, RIP, and so on. The DPC supports BGP for L2 VPNs only.</p>



**Interfaces**                      Syntax: *ge-fpc/pic/port* where:

- fpc: Slot in the router where the DPC is installed
- pic: 0 (bottom left row of 10 ports), 1 (bottom right row of 10 ports), 2 (top left row of 10 ports), or 3 (top right row of 10 ports)
- port: 0 through 9

For example, *ge-1/3/0* is the interface for port 0 in the top right row of 10 ports on a DPC installed in slot 1.

**Cables and connectors**      **TIP:** You can use the [Hardware Compatibility Tool](#) to find information about the pluggable transceivers supported on your Juniper Networks device.

The list of supported transceivers for the MX Series is located at <https://pathfinder.juniper.net/hct/category/#catKey=100001&modelType=All&pf=MX+Series>.

You can install any transceiver supported by the DPC. For information about installing and removing transceivers, see the hardware guide for your router.

**NOTE:** Do not install Gigabit Ethernet SFPs in the SONET/SDH port. The port will not recognize the SFP.

**LEDs**                                **OK/FAIL LED**, one bicolor:

- Steady green—DPC is functioning normally.
- Blinking green—DPC is transitioning online or offline.
- Red—DPC has failed.

Link LED, one green per port:

- Off—No link.
- On steadily—Link is active.

The Link LEDs are labeled in groups of five:

- 0/0 for 0/0 through 0/4
- 0/5 for 0/5 through 0/9
- 1/0 for 1/0 through 1/4
- 1/5 for 1/5 through 1/9
- 2/0 for 2/0 through 2/4
- 2/5 for 2/5 through 2/9
- 3/0 for 3/0 through 3/4
- 3/5 for 3/5 through 3/9

**Related Documentation**

- [MX Series DPC Overview on page 7](#)
- [DPCs Supported on MX240, MX480, and MX960 Routers on page 8](#)

## Gigabit Ethernet Enhanced Queuing Ethernet Services DPC with SFP

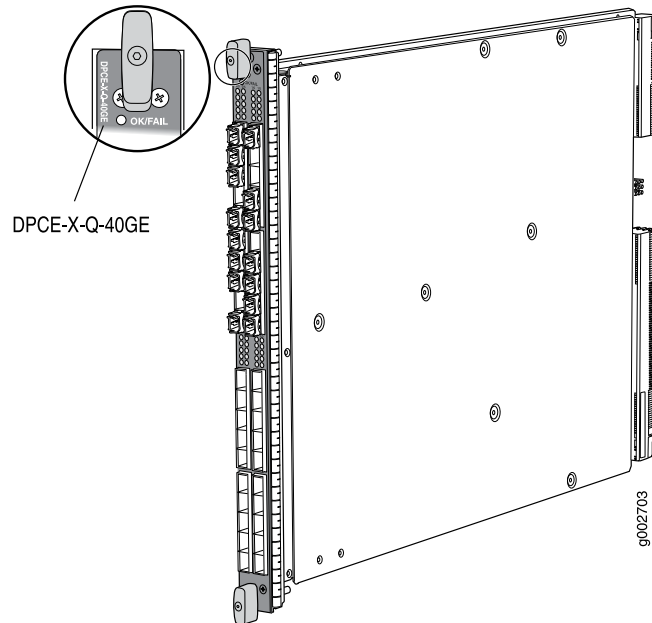

Software release	<ul style="list-style-type: none"> <li>Junos OS Release 8.5 and later</li> </ul>
Description	<ul style="list-style-type: none"> <li>40 Gigabit Ethernet ports</li> <li>Power requirement: 7.6 A @ 48 V (365 W)</li> <li>Weight: 13.1 lb (5.9 kg)</li> <li>Supports large Ethernet frame sizes for more efficient throughput across the intra-POP network</li> <li>Model number: DPCE-X-Q-40GE-SFP</li> <li>Name in the CLI: DPCE 40x 1GE X EQ</li> </ul>
Hardware features	<ul style="list-style-type: none"> <li>High-performance throughput on each port at speeds up to 1 Gbps</li> <li>Autonegotiation between Gigabit Ethernet circuit partners</li> <li>Full-duplex mode</li> <li>Maximum transmission units (MTUs) of up to 9192 bytes</li> <li>Enhanced ASICs for increased performance and scalability of Layer 2 features</li> </ul>
Software features	<ul style="list-style-type: none"> <li>Optical diagnostics and related alarms</li> <li>See <a href="#">“Protocols and Applications Supported by Enhanced Queuing Ethernet Services DPCs (DPCE-X-Q)”</a> on page 340 for information about the protocols and applications that this DPC supports.</li> </ul> <p><b>NOTE:</b> The routing table is limited to 32,000 IP routes. This limitation applies to any manner in which the routes are learned, such as OSPF, RIP, and so on. The DPC supports BGP for L2 VPNs only.</p>

**Interfaces**                      Syntax: *ge-fpc/pic/port* where:

- fpc: Slot in the router where the DPC is installed
- pic: 0 (bottom left row of 10 ports), 1 (bottom right row of 10 ports), 2 (top left row of 10 ports), or 3 (top right row of 10 ports)
- port: 0 through 9

For example, ge-1/3/0 is the interface for port 0 in the top right row of 10 ports on a DPC installed in slot 1.

**Cables and connectors**      **TIP:** You can use the [Hardware Compatibility Tool](#) to find information about the pluggable transceivers supported on your Juniper Networks device.

The list of supported transceivers for the MX Series is located at <https://pathfinder.juniper.net/hct/category/#catKey=100001&modelType=All&pf=MX+Series>.

You can install any transceiver supported by the DPC. For information about installing and removing transceivers, see the hardware guide for your router.

**NOTE:** Do not install Gigabit Ethernet SFPs in the SONET/SDH port. The port will not recognize the SFP.

**LEDs**                                **OK/FAIL LED**, one bicolor:

- Steady green—DPC is functioning normally.
- Blinking green—DPC is transitioning online or offline.
- Red—DPC has failed.

Link LED, one green per port:

- Off—No link.
- On steadily—Link is active.

The Link LEDs are labeled in groups of five:

- 0/0 for 0/0 through 0/4
- 0/5 for 0/5 through 0/9
- 1/0 for 1/0 through 1/4
- 1/5 for 1/5 through 1/9
- 2/0 for 2/0 through 2/4
- 2/5 for 2/5 through 2/9
- 3/0 for 3/0 through 3/4
- 3/5 for 3/5 through 3/9

**Related Documentation**

- [MX Series DPC Overview on page 7](#)
- [DPCs Supported on MX240, MX480, and MX960 Routers on page 8](#)

## Gigabit Ethernet Enhanced Queuing IP Services DPCs with SFP

Figure 3: 20-Port Gigabit Ethernet Enhanced Queuing IP Services DPC with SFP

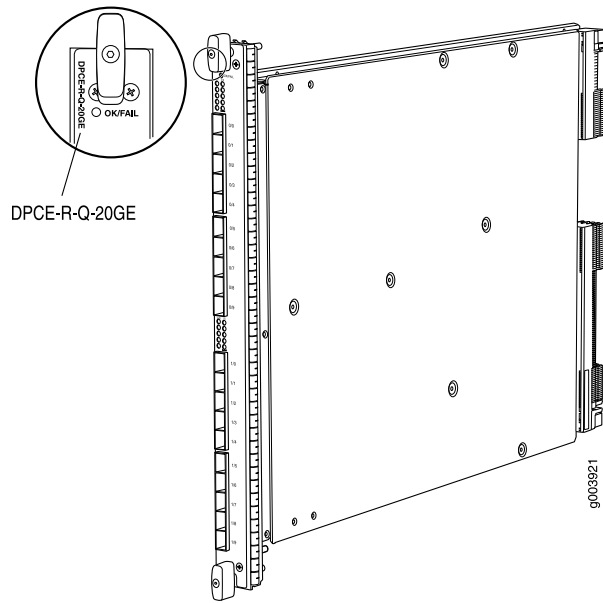
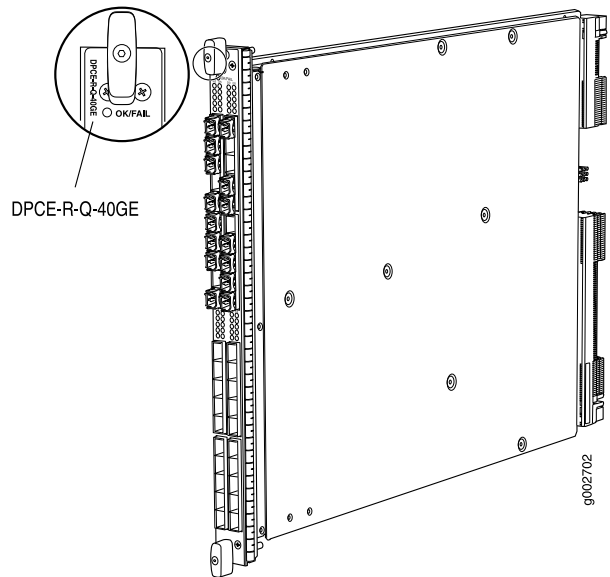

Figure 4: 40-Port Gigabit Ethernet Enhanced Queuing IP Services DPC with SFP



Software release	<ul style="list-style-type: none"> <li>20-port: Junos OS Release 9.1 and later</li> <li>40-port: Junos OS Release 8.5 and later</li> </ul> End-of-life (see notification <a href="#">PSN-2011-07-314</a> )
------------------	--

Description	20-port: <ul style="list-style-type: none"> <li>20 Gigabit Ethernet ports</li> <li>Power requirement: 4.2 A @ 48 V (200 W)</li> <li>Weight: 13 lb (5.9 kg)</li> <li>Model number: DPCE-R-Q-20GE-SFP</li> <li>Name in the CLI: DPCE 20x 1GE R EQ</li> </ul> 40-port: <ul style="list-style-type: none"> <li>40 Gigabit Ethernet ports</li> <li>Power requirement: 7.6 A @ 48 V (365 W)</li> <li>Weight: 13.1 lb (5.9 kg)</li> <li>Model number: DPCE-R-Q-40GE-SFP</li> <li>Name in the CLI: DPCE 40x 1GE R EQ</li> </ul>
-------------	---

Hardware features	<ul style="list-style-type: none"> <li>High-performance throughput on each port at speeds up to 1 Gbps</li> <li>Autonegotiation between Gigabit Ethernet circuit partners</li> <li>Full-duplex mode</li> <li>Maximum transmission units (MTUs) of up to 9192 bytes</li> <li>Enhanced ASICs for increased performance and scalability of Layer 2 features</li> </ul>
-------------------	---

Software features	<ul style="list-style-type: none"><li>• Optical diagnostics and related alarms</li><li>• See “<a href="#">Protocols and Applications Supported by Enhanced Queuing IP Services DPCs (DPCE-R-Q)</a>” on <a href="#">page 335</a> for information about the protocols and applications that this DPC supports.</li></ul>
Interfaces	<p>Syntax: <code>ge-fpc/pic/port</code> where:</p> <ul style="list-style-type: none"><li>• fpc: Slot in the router where the DPC is installed</li><li>• pic:<ul style="list-style-type: none"><li>• 20-port: 0 (left row of 10 ports), or 1 (right row of 10 ports)</li><li>• 40-port: 0 (bottom left row of 10 ports), 1 (bottom right row of 10 ports), 2 (top left row of 10 ports), or 3 (top right row of 10 ports)</li></ul></li><li>• port: 0 through 9</li></ul> <p>For example, <code>ge-1/1/0</code> is the interface for port 0 in the (top for 40-port) right row of 10 ports on a DPC installed in slot 1.</p>
Cables and connectors	<p><b>TIP:</b> You can use the <a href="#">Hardware Compatibility Tool</a> to find information about the pluggable transceivers supported on your Juniper Networks device.</p> <p>The list of supported transceivers for the MX Series is located at <a href="https://pathfinder.juniper.net/hct/category/#catKey=100001&amp;modelType;=All&amp;pf;=MX+Series">https://pathfinder.juniper.net/hct/category/#catKey=100001&amp;modelType;=All&amp;pf;=MX+Series</a>.</p> <p>You can install any transceiver supported by the DPC. For information about installing and removing transceivers, see the hardware guide for your router.</p> <p><b>NOTE:</b> Do not install Gigabit Ethernet SFPs in the SONET/SDH port. The port will not recognize the SFP.</p>

LEDs

**OK/FAIL LED**, one bicolor:

- Steady green—DPC is functioning normally.
- Blinking green—DPC is transitioning online or offline.
- Red—DPC has failed.

**Link LED**, one green per port:

- Off—No link.
- On steadily—Link is active.

The Link LEDs are labeled in groups of five:

- 20-port:
    - 0/0 for 0/0 through 0/4
    - 0/5 for 0/5 through 0/9
    - 1/0 for 1/0 through 1/4
    - 1/5 for 1/5 through 1/9
  - 40-port:
    - 0/0 for 0/0 through 0/4
    - 0/5 for 0/5 through 0/9
    - 1/0 for 1/0 through 1/4
    - 1/5 for 1/5 through 1/9
    - 2/0 for 2/0 through 2/4
    - 2/5 for 2/5 through 2/9
    - 3/0 for 3/0 through 3/4
    - 3/5 for 3/5 through 3/9
-

- Related Documentation**
- [MX Series DPC Overview on page 7](#)
  - [DPCs Supported on MX240, MX480, and MX960 Routers on page 8](#)

## 10-Gigabit Ethernet DPC with XFP

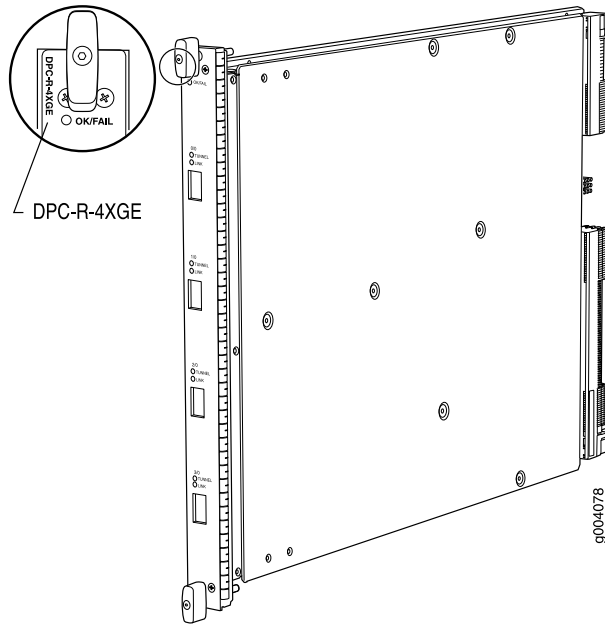

Software release	<ul style="list-style-type: none"> <li>• Junos OS Release 8.2 and later</li> <li>• End-of-life (see notification <a href="#">PSN-2009-06-400</a>)</li> </ul>
Description	<ul style="list-style-type: none"> <li>• Four 10-Gigabit Ethernet ports</li> <li>• Power requirement: 6.46 A @ 48 V (310 W)</li> <li>• Weight: 13.1 lb (5.9 kg)</li> <li>• Model number: DPC-R-4XGE-XFP</li> <li>• Name in the CLI: DPC 4x 10GE R</li> </ul>
Hardware features	<ul style="list-style-type: none"> <li>• High-performance throughput on each port at speeds up to 10 Gbps</li> <li>• WAN-PHY mode at 9.953 Gbps</li> <li>• LAN-PHY mode at 10.3125 Gbps</li> <li>• Full-duplex mode</li> <li>• Maximum transmission units (MTUs) of up to 9192 bytes</li> </ul>
Software features	<ul style="list-style-type: none"> <li>• Configurable WAN-PHY mode options</li> <li>• See "<a href="#">Protocols and Applications Supported by DPCs and Enhanced DPCs (DPC and DPCE-R)</a>" on <a href="#">page 325</a> for information about the protocols and applications that this DPC supports.</li> </ul>

**Interfaces**                      Syntax: *xe-fpc/pic/port* where:

- fpc: Slot in the router where the DPC is installed
- pic: 0 through 3
- port: 0

For example, xe-1/3/0 is the interface for the last port on a DPC installed in slot 1.

---

**Cables and connectors**      **TIP:** You can use the [Hardware Compatibility Tool](#) to find information about the pluggable transceivers supported on your Juniper Networks device.

The list of supported transceivers for the MX Series is located at <https://pathfinder.juniper.net/hct/category/#catKey=100001&modelType;=All&pf;=MX+Series>.

You can install any transceiver supported by the DPC. For information about installing and removing transceivers, see the hardware guide for your router.

---

**LEDs**                              **OK/FAIL LED**, one bicolor:

- Steady green—DPC is functioning normally.
- Blinking green—DPC is transitioning online or offline.
- Red—DPC has failed.

**TUNNEL LED**, one green per port:

- Off—Normal operating mode.
- On steadily—Port configured in tunnel mode.

**LINK LED**, one green per port:

- Off—No link.
- On steadily—Link is active.

The **TUNNEL** and **LINK** LEDs are labeled top to bottom **0/0** through **3/0**.

---

**Related Documentation**

- [MX Series DPC Overview on page 7](#)
- [DPCs Supported on MX240, MX480, and MX960 Routers on page 8](#)



## 10-Gigabit Ethernet Enhanced DPCs with XFP

Figure 5: 2-Port 10-Gigabit Ethernet Enhanced DPC with XFP

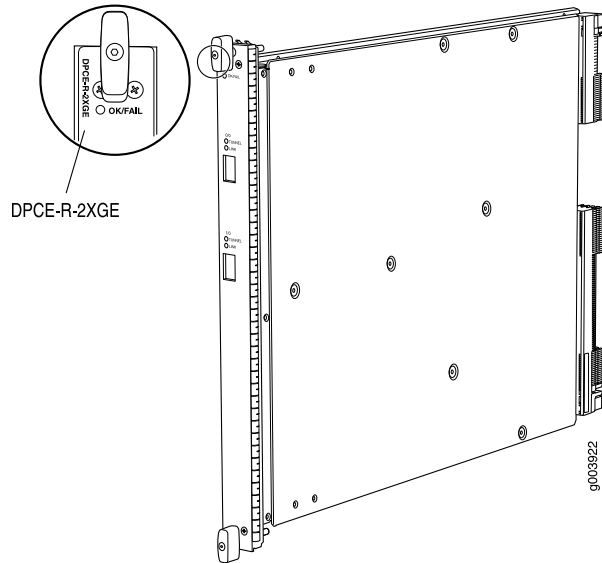
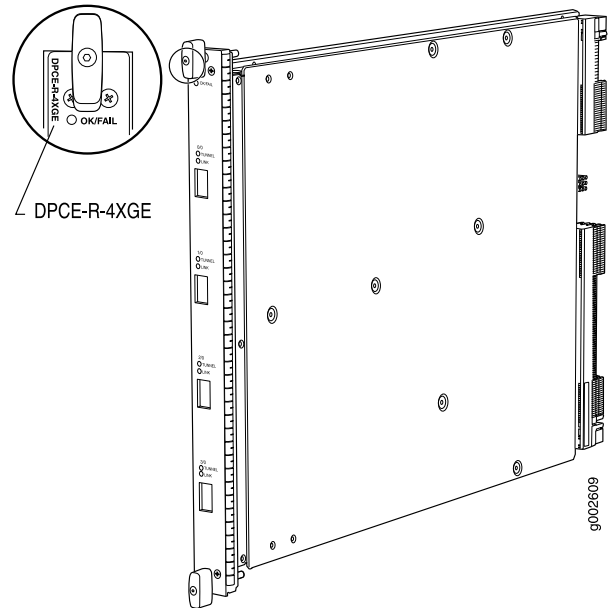

Figure 6: 4-Port 10-Gigabit Ethernet Enhanced DPC with XFP



- |                  |   |
|------------------|---|
| Software release | <ul style="list-style-type: none"> <li>• 2-port: Junos OS Release 9.1 and later<br/>End-of-life (see notification <a href="#">PSN-2011-02-314</a>)</li> <li>• 4-port: Junos OS Release 8.4 and later</li> </ul> |
|------------------|---|

- |             |  |
|-------------|--|
| Description | <p>2-port:</p> <ul style="list-style-type: none"> <li>• Two 10-Gigabit Ethernet ports</li> <li>• Power requirement: 3.65 A @ 48 V (175 W)</li> <li>• Weight: 12 lb (5.4 kg)</li> <li>• Model number: DPCE-R-2XGE-XFP</li> <li>• Name in the CLI: DPCE 2x 10GE R</li> </ul> <p>4-port:</p> <ul style="list-style-type: none"> <li>• Four 10-Gigabit Ethernet ports</li> <li>• Power requirement: 6.46 A @ 48 V (310 W)</li> <li>• Weight: 13.1 lb (5.9 kg)</li> <li>• Model number: DPCE-R-4XGE-XFP</li> <li>• Name in the CLI: DPCE 4x 10GE R</li> </ul> |
|-------------|--|

Hardware features	<ul style="list-style-type: none"> <li>• High-performance throughput on each port at speeds up to 10 Gbps</li> <li>• WAN-PHY mode at 9.953 Gbps</li> <li>• LAN-PHY mode at 10.3125 Gbps</li> <li>• Full-duplex mode</li> <li>• Maximum transmission units (MTUs) of up to 9192 bytes</li> <li>• Enhanced ASICs for increased performance and scalability of Layer 2 features</li> </ul>
Software features	<ul style="list-style-type: none"> <li>• Configurable WAN-PHY mode options</li> <li>• See “<a href="#">Protocols and Applications Supported by DPCs and Enhanced DPCs (DPC and DPCE-R)</a>” on <a href="#">page 325</a> for information about the protocols and applications that these DPCs support.</li> </ul>
Interfaces	<p>Syntax: <code>xe-fpc/pic/port</code> where:</p> <ul style="list-style-type: none"> <li>• fpc: Slot in the router where the DPC is installed</li> <li>• pic: <ul style="list-style-type: none"> <li>• 2-port: 0 or 1</li> <li>• 4-port: 0 through 3</li> </ul> </li> <li>• port: 0</li> </ul> <p>For example, <code>xe-1/0/0</code> is the interface for the first port on a DPC installed in slot 1.</p>
Cables and connectors	<p><b>TIP:</b> You can use the <a href="#">Hardware Compatibility Tool</a> to find information about the pluggable transceivers supported on your Juniper Networks device.</p> <p>The list of supported transceivers for the MX Series is located at <a href="https://pathfinder.juniper.net/hct/category/#catKey=100001&amp;modelType;=All&amp;pf;=MX+Series">https://pathfinder.juniper.net/hct/category/#catKey=100001&amp;modelType;=All&amp;pf;=MX+Series</a>.</p> <p>You can install any transceiver supported by the DPC. For information about installing and removing transceivers, see the hardware guide for your router.</p>
LEDs	<p><b>OK/FAIL LED</b>, one bicolor:</p> <ul style="list-style-type: none"> <li>• Steady green—DPC is functioning normally.</li> <li>• Blinking green—DPC is transitioning online or offline.</li> <li>• Red—DPC has failed.</li> </ul> <p><b>TUNNEL LED</b>, one green per port:</p> <ul style="list-style-type: none"> <li>• Off—Normal operating mode.</li> <li>• On steadily—Port configured in tunnel mode.</li> </ul> <p><b>LINK LED</b>, one green per port:</p> <ul style="list-style-type: none"> <li>• Off—No link.</li> <li>• On steadily—Link is active.</li> </ul> <p>The <b>TUNNEL</b> and <b>LINK</b> LEDs are labeled top to bottom:</p> <ul style="list-style-type: none"> <li>• 2-port: <b>0/0</b> through <b>1/0</b></li> <li>• 4-port: <b>0/0</b> through <b>3/0</b></li> </ul>
<b>Related Documentation</b>	<ul style="list-style-type: none"> <li>• <a href="#">MX Series DPC Overview on page 7</a></li> <li>• <a href="#">DPCs Supported on MX240, MX480, and MX960 Routers on page 8</a></li> </ul>

## 10-Gigabit Ethernet Enhanced Ethernet Services DPC with XFP

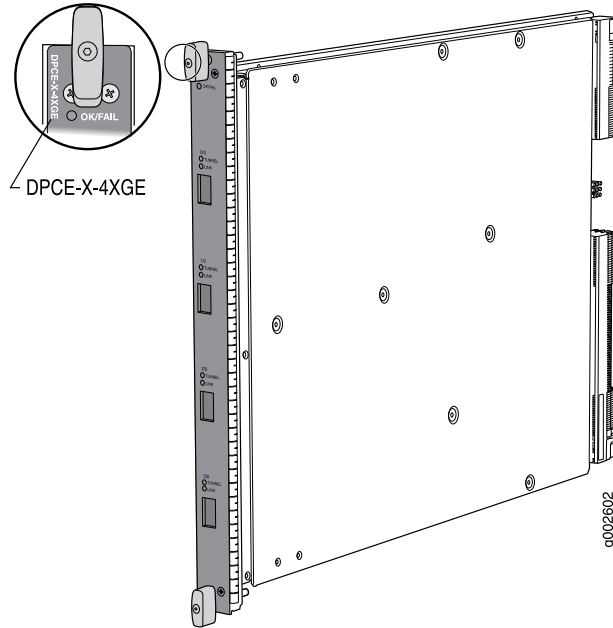

Software release	<ul style="list-style-type: none"> <li>Junos OS Release 8.4 and later</li> </ul>
Description	<ul style="list-style-type: none"> <li>Four 10-Gigabit Ethernet ports</li> <li>Power requirement: 6.46 A @ 48 V (310 W)</li> <li>Weight: 13.1 lb (5.9 kg)</li> <li>Model number: DPCE-X-4XGE-XFP</li> <li>Name in the CLI: DPCE 4x 10GE X</li> </ul>
Hardware features	<ul style="list-style-type: none"> <li>High-performance throughput on each port at speeds up to 10 Gbps</li> <li>WAN-PHY mode at 9.953 Gbps</li> <li>LAN-PHY mode at 10.3125 Gbps</li> <li>Full-duplex mode</li> <li>Maximum transmission units (MTUs) of up to 9192 bytes</li> <li>Enhanced ASICs for increased performance and scalability of Layer 2 features</li> </ul>
Software features	<ul style="list-style-type: none"> <li>Configurable WAN-PHY mode options</li> <li>See <a href="#">“Protocols and Applications Supported by Enhanced Ethernet Services DPCs (DPCE-X)” on page 331</a> for information about the protocols and applications that this DPC supports.</li> </ul> <p><b>NOTE:</b> The routing table is limited to 32,000 IP routes. This limitation applies to any manner in which the routes are learned, such as OSPF, RIP, and so on. The DPC supports BGP for L2 VPNs only.</p>

**Interfaces**                      Syntax: *xe-fpc/pic/port* where:

- fpc: Slot in the router where the DPC is installed
- pic: 0 through 3
- port: 0

For example, *xe-1/0/0* is the interface for the first port on a DPC installed in slot 1.

**Cables and connectors**      **TIP:** You can use the [Hardware Compatibility Tool](#) to find information about the pluggable transceivers supported on your Juniper Networks device.

The list of supported transceivers for the MX Series is located at <https://pathfinder.juniper.net/hct/category/#catKey=100001&modelType;=All&pf;=MX+Series>.

You can install any transceiver supported by the DPC. For information about installing and removing transceivers, see the hardware guide for your router.

**LEDs**                              **OK/FAIL LED**, one bicolor:

- Steady green—DPC is functioning normally.
- Blinking green—DPC is transitioning online or offline.
- Red—DPC has failed.

**TUNNEL LED**, one green per port:

- Off—Normal operating mode.
- On steadily—Port configured in tunnel mode.

**LINK LED**, one green per port:

- Off—No link.
- On steadily—Link is active.

The **TUNNEL** and **LINK** LEDs are labeled top to bottom **0/0** through **3/0**.

**Related Documentation**

- [MX Series DPC Overview on page 7](#)
- [DPCs Supported on MX240, MX480, and MX960 Routers on page 8](#)

## 10-Gigabit Ethernet Enhanced Queuing Ethernet Services DPC with XFP

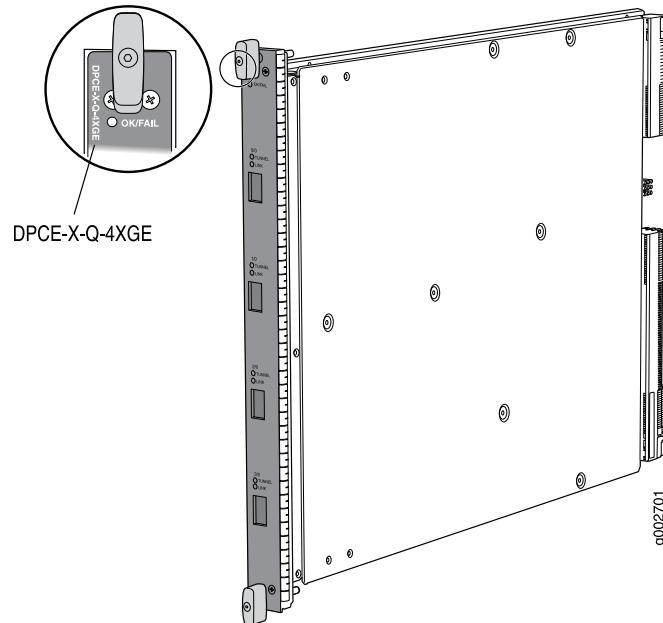

Software release	<ul style="list-style-type: none"> <li>Junos OS Release 8.5 and later</li> </ul>
Description	<ul style="list-style-type: none"> <li>Four 10-Gigabit Ethernet ports</li> <li>Power requirement: 6.87 A @ 48 V (330 W)</li> <li>Weight: 13.1 lb (5.9 kg)</li> <li>Model number: DPCE-X-Q-4XGE-XFP</li> <li>Name in the CLI: DPCE 4x 10GE X EQ</li> </ul>
Hardware features	<ul style="list-style-type: none"> <li>High-performance throughput on each port at speeds up to 10 Gbps</li> <li>WAN-PHY mode at 9.953 Gbps</li> <li>LAN-PHY mode at 10.3125 Gbps</li> <li>Full-duplex mode</li> <li>Maximum transmission units (MTUs) of up to 9192 bytes</li> <li>Enhanced ASICs for increased performance and scalability of Layer 2 features</li> </ul>
Software features	<ul style="list-style-type: none"> <li>Configurable WAN-PHY mode options</li> <li>See <a href="#">“Protocols and Applications Supported by Enhanced Queuing Ethernet Services DPCs (DPCE-X-Q)”</a> on page 340 for information about the protocols and applications that this DPC supports.</li> </ul> <p><b>NOTE:</b> The routing table is limited to 32,000 IP routes. This limitation applies to any manner in which the routes are learned, such as OSPF, RIP, and so on. The DPC supports BGP for L2 VPNs only.</p>

**Interfaces**                      Syntax: *xe-fpc/pic/port* where:

- fpc: Slot in the router where the DPC is installed
- pic: 0 through 3
- port: 0

For example, xe-1/0/0 is the interface for the first port on a DPC installed in slot 1.

**Cables and connectors**      **TIP:** You can use the [Hardware Compatibility Tool](#) to find information about the pluggable transceivers supported on your Juniper Networks device.

The list of supported transceivers for the MX Series is located at <https://pathfinder.juniper.net/hct/category/#catKey=100001&modelType;=All&pf;=MX+Series>.

You can install any transceiver supported by the DPC. For information about installing and removing transceivers, see the hardware guide for your router.

**LEDs**                              **OK/FAIL LED**, one bicolor:

- Steady green—DPC is functioning normally.
- Blinking green—DPC is transitioning online or offline.
- Red—DPC has failed.

**TUNNEL LED**, one green per port:

- Off—Normal operating mode.
- On steadily—Port configured in tunnel mode.

**LINK LED**, one green per port:

- Off—No link.
- On steadily—Link is active.

The **TUNNEL** and **LINK** LEDs are labeled top to bottom **0/0** through **3/0**.

---

**Related Documentation**

- [MX Series DPC Overview on page 7](#)
- [DPCs Supported on MX240, MX480, and MX960 Routers on page 8](#)

## 10-Gigabit Ethernet Enhanced Queuing IP Services DPC with XFP

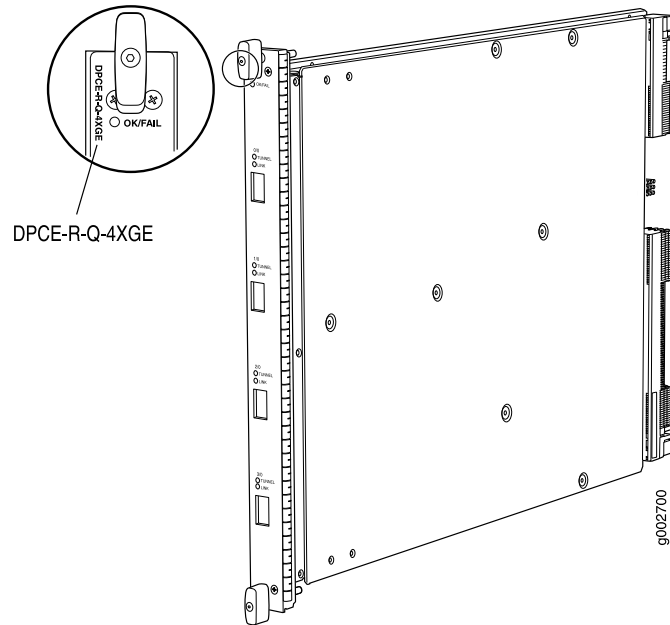

Software release	<ul style="list-style-type: none"> <li>Junos OS Release 8.5 and later</li> <li>End-of-life (see notification <a href="#">PSN-2011-07-314</a>)</li> </ul>
Description	<ul style="list-style-type: none"> <li>Four 10-Gigabit Ethernet ports</li> <li>Power requirement: 6.87 A @ 48 V (330 W)</li> <li>Weight: 13.1 lb (5.9 kg)</li> <li>Model number: DPCE-R-Q-4XGE-XFP</li> <li>Name in the CLI: DPCE 4x 10GE R EQ</li> </ul>
Hardware features	<ul style="list-style-type: none"> <li>High-performance throughput on each port at speeds up to 10 Gbps</li> <li>WAN-PHY mode at 9.953 Gbps</li> <li>LAN-PHY mode at 10.3125 Gbps</li> <li>Full-duplex mode</li> <li>Maximum transmission units (MTUs) of up to 9192 bytes</li> <li>Enhanced ASICs for increased performance and scalability of Layer 2 features</li> </ul>
Software features	<ul style="list-style-type: none"> <li>Configurable WAN-PHY mode options</li> <li>See “<a href="#">Protocols and Applications Supported by Enhanced Queuing IP Services DPCs (DPCE-R-Q)</a>” on <a href="#">page 335</a> for information about the protocols and applications that this DPC supports.</li> </ul>
Interfaces	<p>Syntax: <code>xe-fpc/pic/port</code> where:</p> <ul style="list-style-type: none"> <li>fpc: Slot in the router where the DPC is installed</li> <li>pic: 0 through 3</li> <li>port: 0</li> </ul> <p>For example, <code>xe-1/0/0</code> is the interface for the first port on a DPC installed in slot 1.</p>

**Cables and connectors** **TIP:** You can use the [Hardware Compatibility Tool](#) to find information about the pluggable transceivers supported on your Juniper Networks device.

The list of supported transceivers for the MX Series is located at <https://pathfinder.juniper.net/hct/category/#catKey=100001&modelType;=All&pf;=MX+Series>.

You can install any transceiver supported by the DPC. For information about installing and removing transceivers, see the hardware guide for your router.

**LEDs**

**OK/FAIL LED**, one bicolor:

- Steady green—DPC is functioning normally.
- Blinking green—DPC is transitioning online or offline.
- Red—DPC has failed.

**TUNNEL LED**, one green per port:

- Off—Normal operating mode.
- On steadily—Port configured in tunnel mode.

**LINK LED**, one green per port:

- Off—No link.
- On steadily—Link is active.

The **TUNNEL** and **LINK** LEDs are labeled top to bottom **0/0** through **3/0**.

---

**Related Documentation**

- [MX Series DPC Overview on page 7](#)
- [DPCs Supported on MX240, MX480, and MX960 Routers on page 8](#)



## Multi-Rate Ethernet Enhanced DPC with SFP and XFP

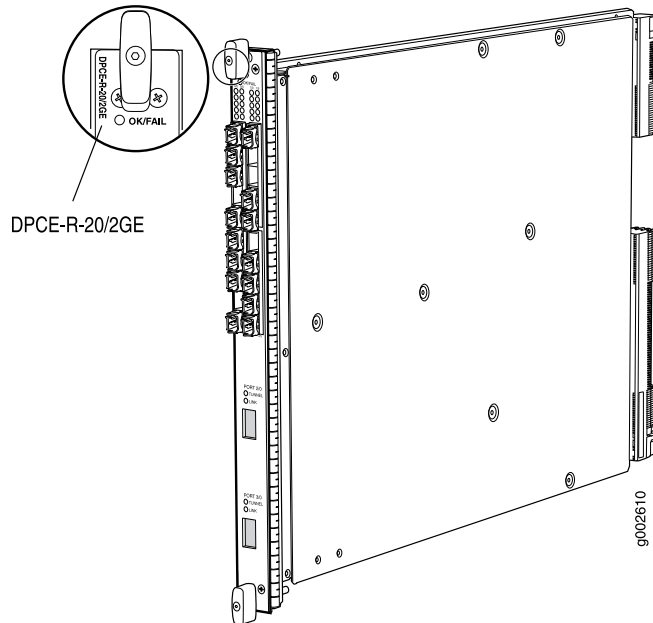

Software release	<ul style="list-style-type: none"> <li>Junos OS Release 9.2 and later</li> </ul>
Description	<ul style="list-style-type: none"> <li>20 Gigabit Ethernet ports</li> <li>2 10-Gigabit Ethernet ports</li> <li>Power requirement: 6.94 A @ 48 V (333 W)</li> <li>Weight: 13.1 lb (5.9 kg)</li> <li>Supports large Ethernet frame sizes for more efficient throughput across the intra-POP network</li> <li>Model number: DPCE-R-20GE-2XGE</li> <li>Name in the CLI: DPCE 20x 1GE + 2x 10GE R</li> </ul>
Hardware features	<ul style="list-style-type: none"> <li>SFP ports: <ul style="list-style-type: none"> <li>High-performance throughput on each port at speeds up to 1 Gbps</li> </ul> </li> <li>XFP ports: <ul style="list-style-type: none"> <li>High-performance throughput on each port at speeds up to 10 Gbps</li> <li>WAN-PHY mode at 9.953 Gbps</li> <li>LAN-PHY mode at 10.3125 Gbps</li> </ul> </li> <li>Autonegotiation between Gigabit Ethernet circuit partners</li> <li>Full-duplex mode</li> <li>Maximum transmission units (MTUs) of up to 9192 bytes</li> <li>Enhanced ASICs for increased performance and scalability of Layer 2 features</li> </ul>
Software features	<ul style="list-style-type: none"> <li>Configurable WAN-PHY mode options</li> <li>Optical diagnostics and related alarms</li> <li>See <a href="#">“Protocols and Applications Supported by DPCs and Enhanced DPCs (DPC and DPCE-R)”</a> on page 325 for information about the protocols and applications that this DPC supports.</li> </ul>

Interfaces	<p>Syntax: <i>mediatype-fpc/pic/port</i> where:</p> <ul style="list-style-type: none"> <li>• mediatype: ge or xe</li> <li>• fpc: Slot in the router where the DPC is installed</li> <li>• pic: <ul style="list-style-type: none"> <li>• ge: 0 or 1</li> <li>• xe: 2 or 3</li> </ul> </li> <li>• port: <ul style="list-style-type: none"> <li>• ge: 0 through 9</li> <li>• xe: 0</li> </ul> </li> </ul> <p>For example, xe-1/3/0 is the interface for the port labeled <b>PORT 3/0</b> on a DPC installed in slot 1.</p>
Cables and connectors	<p><b>TIP:</b> You can use the <a href="#">Hardware Compatibility Tool</a> to find information about the pluggable transceivers supported on your Juniper Networks device.</p> <p>The list of supported transceivers for the MX Series is located at <a href="https://pathfinder.juniper.net/hct/category/#catKey=100001&amp;modelType;=All&amp;pf;=MX+Series">https://pathfinder.juniper.net/hct/category/#catKey=100001&amp;modelType;=All&amp;pf;=MX+Series</a>.</p> <p>You can install any transceiver supported by the DPC. For information about installing and removing transceivers, see the hardware guide for your router.</p>
LEDs	<p><b>OK/FAIL LED</b>, one bicolor:</p> <ul style="list-style-type: none"> <li>• Steady green—DPC is functioning normally.</li> <li>• Blinking green—DPC is transitioning online or offline.</li> <li>• Red—DPC has failed.</li> </ul> <p><b>LINK LED</b>, one green per port:</p> <ul style="list-style-type: none"> <li>• Off—No link.</li> <li>• On steadily—Link is active.</li> </ul> <p><b>TUNNEL LED</b>, one green per XFP port:</p> <ul style="list-style-type: none"> <li>• Off—Normal operating mode.</li> <li>• On steadily—Port configured in tunnel mode.</li> </ul> <p>The SFP Link LEDs are labeled in groups of five:</p> <ul style="list-style-type: none"> <li>• 0/0 for 0/0 through 0/4</li> <li>• 0/5 for 0/5 through 0/9</li> <li>• 1/0 for 1/0 through 1/4</li> <li>• 1/5 for 1/5 through 1/9</li> </ul> <p>The XFP ports are labeled top to bottom 2/0 and 3/0.</p>

**Related Documentation**

- [MX Series DPC Overview on page 7](#)
- [DPCs Supported on MX240, MX480, and MX960 Routers on page 8](#)

## Multi-Rate Ethernet Enhanced Ethernet Services DPC with SFP and XFP

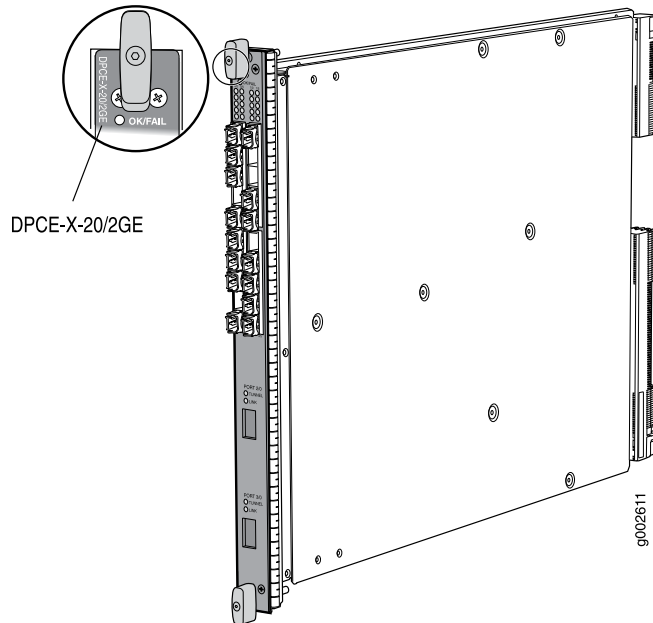

Software release	<ul style="list-style-type: none"> <li>Junos OS Release 9.2 and later</li> <li>End-of-life (see notification <a href="#">PSN-2011-07-314</a>)</li> </ul>
Description	<ul style="list-style-type: none"> <li>20 Gigabit Ethernet ports</li> <li>2 10-Gigabit Ethernet ports</li> <li>Power requirement: 6.94 A @ 48 V (333 W)</li> <li>Weight: 13.1 lb (5.9 kg)</li> <li>Supports large Ethernet frame sizes for more efficient throughput across the intra-POP network</li> <li>Model number: DPCE-X-20GE-2XGE</li> <li>Name in the CLI: DPCE 20x 1GE + 2x 10GE X</li> </ul>
Hardware features	<ul style="list-style-type: none"> <li>SFP ports: <ul style="list-style-type: none"> <li>High-performance throughput on each port at speeds up to 1 Gbps</li> </ul> </li> <li>XFP ports: <ul style="list-style-type: none"> <li>High-performance throughput on each port at speeds up to 10 Gbps</li> <li>WAN-PHY mode at 9.953 Gbps</li> <li>LAN-PHY mode at 10.3125 Gbps</li> </ul> </li> <li>Full-duplex mode</li> <li>Maximum transmission units (MTUs) of up to 9192 bytes</li> <li>Enhanced ASICs for increased performance and scalability of Layer 2 features</li> </ul>
Software features	<ul style="list-style-type: none"> <li>Configurable WAN-PHY mode options</li> <li>Optical diagnostics and related alarms</li> <li>See “<a href="#">Protocols and Applications Supported by Enhanced Ethernet Services DPCs (DPCE-X)</a>” on page 331 for information about the protocols and applications that this DPC supports.</li> </ul>

Interfaces	<p>Syntax: <i>mediatype-fpc/pic/port</i> where:</p> <ul style="list-style-type: none"><li>• mediatype: ge or xe</li><li>• fpc: Slot in the router where the DPC is installed</li><li>• pic:<ul style="list-style-type: none"><li>• ge: 0 or 1</li><li>• xe: 2 or 3</li></ul></li><li>• port:<ul style="list-style-type: none"><li>• ge: 0 through 9</li><li>• xe: 0</li></ul></li></ul> <p>For example, xe-1/3/0 is the interface for the port labeled <b>PORT 3/0</b> on a DPC installed in slot 1.</p>
Cables and connectors	<p><b>TIP:</b> You can use the <a href="#">Hardware Compatibility Tool</a> to find information about the pluggable transceivers supported on your Juniper Networks device.</p> <p>The list of supported transceivers for the MX Series is located at <a href="https://pathfinder.juniper.net/hct/category/#catKey=100001&amp;modelType;=All&amp;pf;=MX+Series">https://pathfinder.juniper.net/hct/category/#catKey=100001&amp;modelType;=All&amp;pf;=MX+Series</a>.</p> <p>You can install any transceiver supported by the DPC. For information about installing and removing transceivers, see the hardware guide for your router.</p>
LEDs	<p><b>OK/FAIL LED</b>, one bicolor:</p> <ul style="list-style-type: none"><li>• Steady green—DPC is functioning normally.</li><li>• Blinking green—DPC is transitioning online or offline.</li><li>• Red—DPC has failed.</li></ul> <p><b>LINK LED</b>, one green per port:</p> <ul style="list-style-type: none"><li>• Off—No link.</li><li>• On steadily—Link is active.</li></ul> <p><b>TUNNEL LED</b>, one green per XFP port:</p> <ul style="list-style-type: none"><li>• Off—Normal operating mode.</li><li>• On steadily—Port configured in tunnel mode.</li></ul> <p>The SFP Link LEDs are labeled in groups of five:</p> <ul style="list-style-type: none"><li>• 0/0 for 0/0 through 0/4</li><li>• 0/5 for 0/5 through 0/9</li><li>• 1/0 for 1/0 through 1/4</li><li>• 1/5 for 1/5 through 1/9</li></ul> <p>The XFP ports are labeled top to bottom 2/0 and 3/0.</p>

---

**Related Documentation**

- [MX Series DPC Overview on page 7](#)
- [DPCs Supported on MX240, MX480, and MX960 Routers on page 8](#)

## Multi-Rate Ethernet Enhanced Queuing IP Services DPC with SFP and XFP

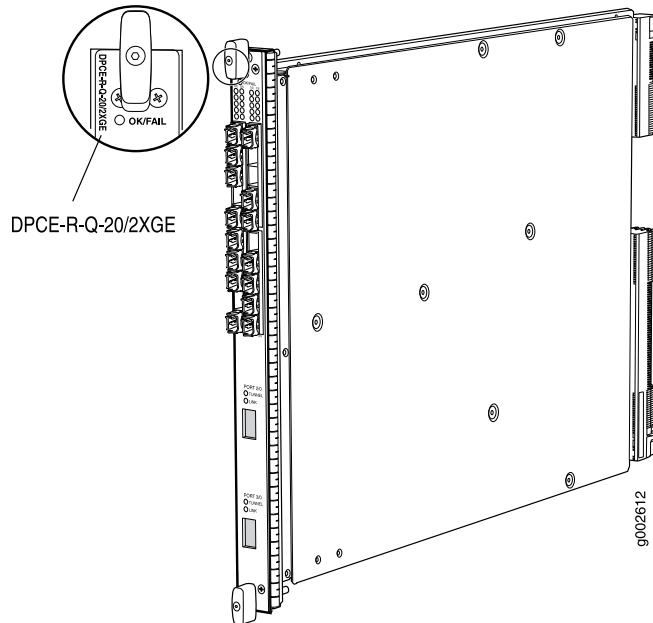

Software release	<ul style="list-style-type: none"> <li>Junos OS Release 9.3 and later</li> </ul>
Description	<ul style="list-style-type: none"> <li>20 Gigabit Ethernet ports</li> <li>2 10-Gigabit Ethernet ports</li> <li>Power requirement: 6.98 A @ 48 V (335 W)</li> <li>Weight: 13.1 lb (5.9 kg)</li> <li>Supports large Ethernet frame sizes for more efficient throughput across the intra-POP network</li> <li>Model number: DPCE-R-Q-20GE-2XGE</li> <li>Name in the CLI: DPCE 20x 1GE + 2x 10GE R EQ</li> </ul>
Hardware features	<ul style="list-style-type: none"> <li>SFP ports: <ul style="list-style-type: none"> <li>High-performance throughput on each port at speeds up to 1 Gbps</li> </ul> </li> <li>XFP ports: <ul style="list-style-type: none"> <li>High-performance throughput on each port at speeds up to 10 Gbps</li> <li>WAN-PHY mode at 9.953 Gbps</li> <li>LAN-PHY mode at 10.3125 Gbps</li> </ul> </li> <li>Full-duplex mode</li> <li>Maximum transmission units (MTUs) of up to 9192 bytes</li> <li>Enhanced ASICs for increased performance and scalability of Layer 2 features</li> </ul>
Software features	<ul style="list-style-type: none"> <li>Configurable WAN-PHY mode options</li> <li>Optical diagnostics and related alarms</li> <li>See <a href="#">“Protocols and Applications Supported by Enhanced Queuing IP Services DPCs (DPCE-R-Q)”</a> on page 335 for information about the protocols and applications that this DPC supports.</li> </ul>

Interfaces	<p>Syntax: <i>mediatype-fpc/pic/port</i> where:</p> <ul style="list-style-type: none"><li>mediatype: ge or xe</li><li>fpc: Slot in the router where the DPC is installed</li><li>pic:<ul style="list-style-type: none"><li>ge: 0 or 1</li><li>xe: 2 or 3</li></ul></li><li>port:<ul style="list-style-type: none"><li>ge: 0 through 9</li><li>xe: 0</li></ul></li></ul> <p>For example, xe-1/3/0 is the interface for the port labeled <b>PORT 3/0</b> on a DPC installed in slot 1.</p>
Cables and connectors	<p><b>TIP:</b> You can use the <a href="#">Hardware Compatibility Tool</a> to find information about the pluggable transceivers supported on your Juniper Networks device.</p> <p>The list of supported transceivers for the MX Series is located at <a href="https://pathfinder.juniper.net/hct/category/#catKey=100001&amp;modelType;=All&amp;pf;=MX+Series">https://pathfinder.juniper.net/hct/category/#catKey=100001&amp;modelType;=All&amp;pf;=MX+Series</a>.</p> <p>You can install any transceiver supported by the DPC. For information about installing and removing transceivers, see the hardware guide for your router.</p>
LEDs	<p><b>OK/FAIL LED</b>, one bicolor:</p> <ul style="list-style-type: none"><li>Steady green—DPC is functioning normally.</li><li>Blinking green—DPC is transitioning online or offline.</li><li>Red—DPC has failed.</li></ul> <p><b>LINK LED</b>, one green per port:</p> <ul style="list-style-type: none"><li>Off—No link.</li><li>On steadily—Link is active.</li></ul> <p><b>TUNNEL LED</b>, one green per XFP port:</p> <ul style="list-style-type: none"><li>Off—Normal operating mode.</li><li>On steadily—Port configured in tunnel mode.</li></ul> <p>The SFP Link LEDs are labeled in groups of five:</p> <ul style="list-style-type: none"><li>0/0 for 0/0 through 0/4</li><li>0/5 for 0/5 through 0/9</li><li>1/0 for 1/0 through 1/4</li><li>1/5 for 1/5 through 1/9</li></ul> <p>The XFP ports are labeled top to bottom 2/0 and 3/0.</p>

---

**Related Documentation**

- [MX Series DPC Overview on page 7](#)
- [DPCs Supported on MX240, MX480, and MX960 Routers on page 8](#)

## Multiservices DPC

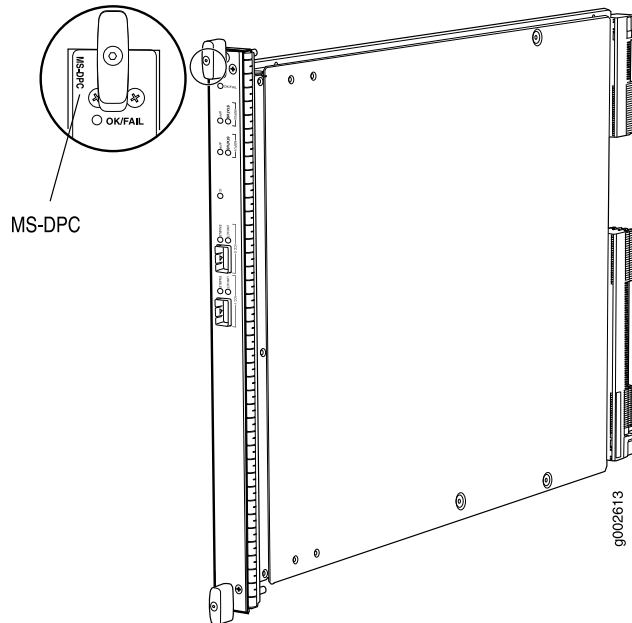

Software release	<ul style="list-style-type: none"> <li>Junos OS Release 9.3 and later</li> </ul>
Description	<ul style="list-style-type: none"> <li>Power requirement: 5.52 A @ 48 V (265 W)</li> <li>Weight: 14.7 lb (6.7 kg)</li> <li>Supports tunnel services. This feature is included with the DPC and does not require an individual license.</li> <li>Individual licenses must be purchased for additional services.</li> <li>Supports large Ethernet frame sizes for more efficient throughput across the intra-POP network</li> <li>The maximum number of supported MS-DPCs is as follows except where noted in <a href="#">"Protocols and Applications Supported by the Multiservices DPC (MS-DPC)"</a> on page 345:             <ul style="list-style-type: none"> <li>MX240 router: 2</li> <li>MX480 router: 4</li> <li>MX960 router: 6</li> </ul> </li> <li>Model number: MS-DPC</li> </ul>
Hardware features	<ul style="list-style-type: none"> <li>Active monitoring on up to 10 million flows</li> <li>Maximum transmission units (MTUs) of up to 9192 bytes</li> <li>Two Multiservices Processing Units (MSPUs) per DPC, which include two 1.1Ghz multicore CPUs, each with 4GB of memory for processing integrated services</li> </ul>
Software features	<ul style="list-style-type: none"> <li>Support for up to 12,000 service sets</li> <li>See <a href="#">"Protocols and Applications Supported by the Multiservices DPC (MS-DPC)"</a> on page 345 for information about the protocols and applications that this DPC supports.</li> </ul>

## Interfaces

Syntax: *mediatype-fpc/pic/port* where:

- mediatype: gr, pc, pd, etc
- fpc: Slot in the router where the MPC is installed
- pic: 0 or 1
- port: 0

**NOTE:** Port number reflects the internal interface and is not a physical port.

## Cables and connectors

**TIP:** You can use the [Hardware Compatibility Tool](#) to find information about the pluggable transceivers supported on your Juniper Networks device.

The list of supported transceivers for the MX Series is located at <https://pathfinder.juniper.net/hct/category/#catKey=100001&modelType;=All&pf;=MX+Series>.

- SFPs are not supported.

## LEDs

**OK/FAIL** LED, one bicolor:

- Steady green—DPC is functioning normally.
- Blinking green—DPC is transitioning online or offline.
- Red—DPC has failed.

**STATUS** LED, one tricolor per MSPU:

- Off—MSPU is offline. If both MSPUs are offline it is safe to remove the DPC from the chassis.
- Green—MSPU is operating normally.
- Yellow—MSPU is initializing.
- Red—MSPU has an error or failure.

Application (**APP**) LED, one tricolor per MSPU:

- Off—Service is not running on the MSPU.
- Green—Service is running on the MSPU under acceptable load.
- Yellow—Service on the MSPU is overloaded.

**Related Documentation**

- [MX Series DPC Overview on page 7](#)
- [DPCs Supported on MX240, MX480, and MX960 Routers on page 8](#)



## Tri-Rate Enhanced DPC

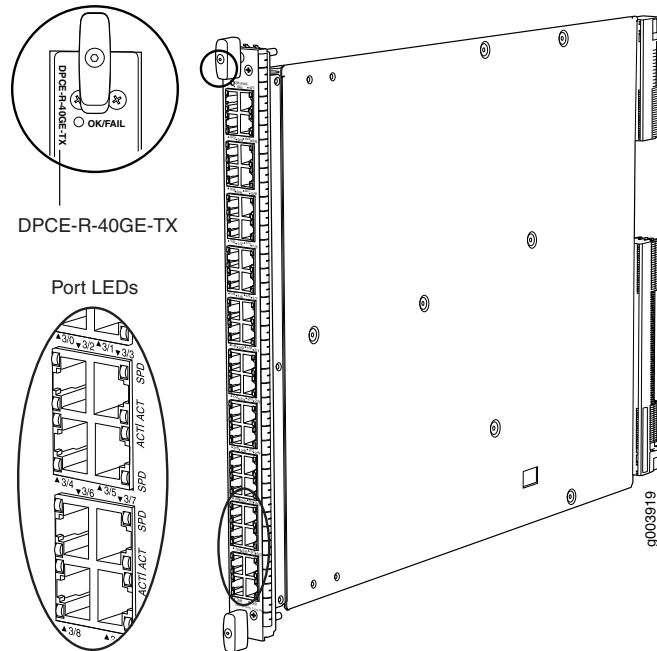

Software release	<ul style="list-style-type: none"> <li>Junos OS Release 9.1 and later</li> </ul>
Description	<ul style="list-style-type: none"> <li>40 autonegotiating 10BASE-T, 100BASE-TX, or 1000BASE-T Megabit Ethernet ports</li> <li>Power requirement: 6.67 A @ 48 V (320 W)</li> <li>Weight: 14.5 lb (6.6 kg)</li> <li>Supports large Ethernet frame sizes for more efficient throughput across the intra-POP network</li> <li>Model number: DPCE-R-40GE-TX</li> <li>Name in the CLI: DPCE 40x 1GE R TX</li> </ul>
Hardware features	<ul style="list-style-type: none"> <li>High-performance throughput on each port at speeds of 10 Mbps, 100 Mbps, or 1000 Mbps</li> <li>Autonegotiation between Gigabit Ethernet circuit partners</li> <li>Full-duplex mode</li> <li>Maximum transmission units (MTUs) of up to 9192 bytes</li> <li>Enhanced ASICs for increased performance and scalability of Layer 2 features</li> <li>There are four sets of 10 ports labeled: <ul style="list-style-type: none"> <li>0/0 through 0/9</li> <li>1/0 through 1/9</li> <li>2/0 through 2/9</li> <li>3/0 through 3/9</li> </ul> </li> </ul>
Software features	<ul style="list-style-type: none"> <li>See <a href="#">“Protocols and Applications Supported by DPCs and Enhanced DPCs (DPC and DPCE-R)”</a> on page 325 for information about the protocols and applications that this DPC supports.</li> </ul>

**Interfaces**                      Syntax: *ge-fpc/pic/port* where:

- fpc: Slot in the router where the DPC is installed
- pic: Grouping of 10-ports, numbered 0 through 3
- port: 0 through 9

For example, ge-1/3/0 is the interface for port 0 (labeled **3/0**) in the right-most grouping of ports on a DPC installed in slot 1.

**Cables and connectors**      **TIP:** You can use the [Hardware Compatibility Tool](#) to find information about the pluggable transceivers supported on your Juniper Networks device.

The list of supported transceivers for the MX Series is located at <https://pathfinder.juniper.net/hct/category/#catKey=100001&modelType;=All&pf;=MX+Series>.

- Connector: Four-pair, Category 5 shielded twisted-pair connectivity through an RJ-45 connector
- Pinout:
  - Junos OS Release 9.1: MDI
  - Junos OS Release 9.2 and later: MDI, MDI crossover
- Maximum distance: 328 ft/100 m

**CAUTION:** Do not use RJ-45 cables with strain-relief boots exceeding 1.5 mm from the bottom of the connector. Cable boots that exceed this measurement can damage the port.

**LEDs**                              **OK/FAIL LED**, one bicolor:

- Steady green—DPC is functioning normally.
- Blinking green—DPC is transitioning online or offline.
- Red—DPC has failed.

**ACT LED**, one green per port:

- Off—No active traffic.
- Blinking—Link is active.

**SPD LED**, one bicolor:

- Green—DPC is functioning in 1000BASE-T mode.
- Yellow—DPC is functioning in 10BASE-T or 100BASE-TX mode.
- Off—No link.

The **ACT** and **SPD** LEDs are located on either side of the ports labeled horizontally and top to bottom 0/0 through 3/9.

**Related Documentation**

- [MX Series DPC Overview on page 7](#)
- [DPCs Supported on MX240, MX480, and MX960 Routers on page 8](#)

## Tri-Rate Enhanced Ethernet Services DPC

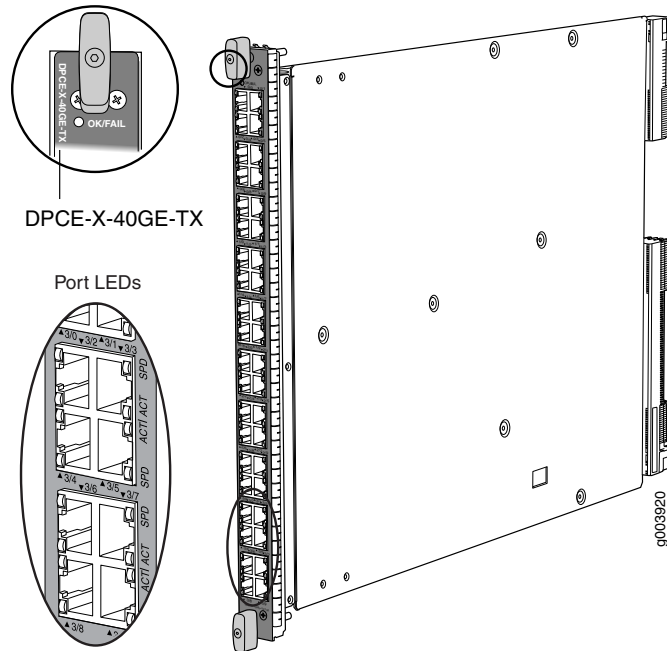

Software release	<ul style="list-style-type: none"> <li>Junos OS Release 9.1 and later</li> <li>EOL (see <a href="#">PSN-2009-06-400</a>)</li> </ul>
Description	<ul style="list-style-type: none"> <li>40 autonegotiating 10BASE-T, 100.BASE-TX, or 1000BASE-T Megabit Ethernet ports</li> <li>Power requirement: 6.67 A @ 48 V (320 W)</li> <li>Weight: 14.5 lb (6.6 kg)</li> <li>Supports large Ethernet frame sizes for more efficient throughput across the intra-POP network</li> <li>Model number: DPCE-X-40GE-TX</li> <li>Name in the CLI:</li> </ul>
Hardware features	<ul style="list-style-type: none"> <li>High-performance throughput on each port at speeds of 10 Mbps, 100 Mbps, or 1000 Mbps</li> <li>Autonegotiation between Gigabit Ethernet circuit partners</li> <li>Full-duplex mode</li> <li>Maximum transmission units (MTUs) of up to 9192 bytes</li> <li>Enhanced ASICs for increased performance and scalability of Layer 2 features</li> </ul>
Software features	<ul style="list-style-type: none"> <li>See "<a href="#">Protocols and Applications Supported by Enhanced Ethernet Services DPCs (DPCE-X)</a>" on <a href="#">page 331</a> for information about the protocols and applications that this DPC supports.</li> </ul>
Interfaces	<p>Syntax: <code>ge-fpc/pic/port</code> where:</p> <ul style="list-style-type: none"> <li>fpc: Slot in the router where the DPC is installed</li> <li>pic: Grouping of 10-ports, numbered 0 through 3</li> <li>port: 0 through 9</li> </ul> <p>For example, <code>ge-1/3/0</code> is the interface for port 0 (labeled <b>3/0</b>) in the right-most grouping of ports on a DPC installed in slot 1.</p>

**Cables and connectors** **TIP:** You can use the [Hardware Compatibility Tool](#) to find information about the pluggable transceivers supported on your Juniper Networks device.

The list of supported transceivers for the MX Series is located at <https://pathfinder.juniper.net/hct/category/#catKey=100001&modelType;=All&pf;=MX+Series>.

- Connector: Four-pair, Category 5 shielded twisted-pair connectivity through an RJ-45 connector
- Pinout:
  - Junos OS Release 9.1: MDI
  - Junos OS Release 9.2 and later: MDI, MDI crossover
- Maximum distance: 328 ft/100 m

**CAUTION:** Do not use RJ-45 cables with strain-relief boots exceeding 1.5 mm from the bottom of the connector. Cable boots that exceed this measurement can damage the port.

**LEDs**

**OK/FAIL LED, one bicolor:**

- Steady green—DPC is functioning normally.
- Blinking green—DPC is transitioning online or offline.
- Red—DPC has failed.

**ACT LED, one green per port:**

- Off—No active traffic.
- Blinking—Link is active.

**SPD LED, one bicolor:**

- Green—DPC is functioning in 1000BASE-T mode.
- Yellow—DPC is functioning in 10BASE-T or 100BASE-TX mode.
- Off—No link.

The **ACT** and **SPD** LEDs are located on either side of the ports labeled horizontally and top to bottom **0/0** through **3/9**.

---

**Related Documentation**

- [MX Series DPC Overview on page 7](#)
- [DPCs Supported on MX240, MX480, and MX960 Routers on page 8](#)

## CHAPTER 8

# MX Series MPC Descriptions

- 16x10GE MPC on page 84
- Multiservices MPC on page 86
- MPC1 on page 88
- MPC1E on page 89
- MPC1 Q on page 91
- MPC1E Q on page 93
- MPC2 on page 95
- MPC2E on page 97
- MPC2 Q on page 99
- MPC2E Q on page 101
- MPC2 EQ on page 103
- MPC2E EQ on page 105
- MPC2E P on page 107
- MPC2E NG on page 109
- MPC2E NG Q on page 111
- MPC3E on page 113
- MPC3E NG on page 115
- MPC3E NG Q on page 117
- 32x10GE MPC4E on page 119
- 2x100GE + 8x10GE MPC4E on page 120
- 6x40GE + 24x10GE MPC5E on page 122
- 6x40GE + 24x10GE MPC5EQ on page 124
- 2x100GE + 4x10GE MPC5E on page 126
- 2x100GE + 4x10GE MPC5EQ on page 127
- MPC6E on page 129
- MPC7E (Multi-Rate) on page 130
- MPC7E 10G on page 132
- MPC8E on page 134

- MPC9E on page 135
- MX10003 MPC (Multi-Rate) on page 136
- MX10K-LC2101 on page 138

## 16x10GE MPC

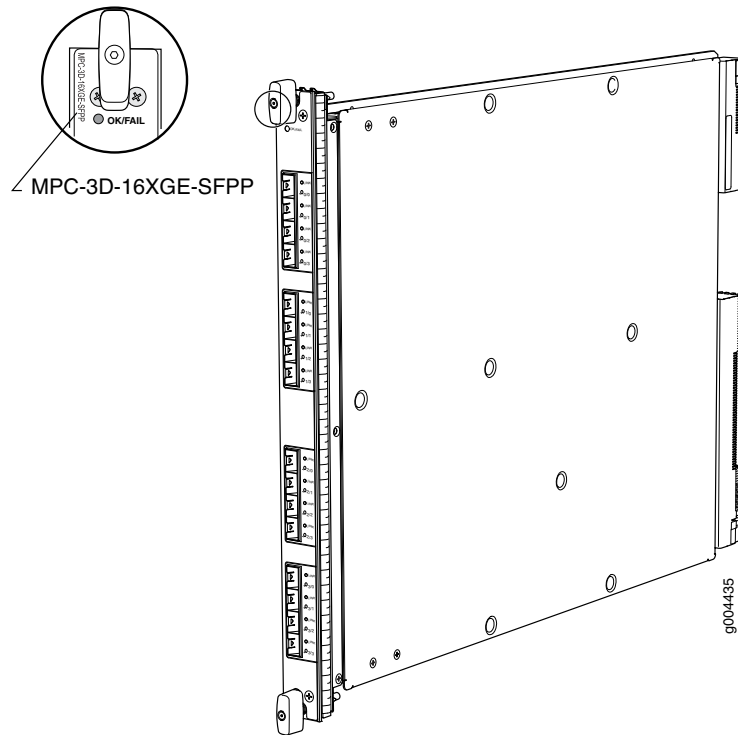

Software release

- MX240, MX480, and MX960 routers : Junos OS Release 10.0R2 and later
- MX2010 and MX2020 router: Junos OS Release 12.3 and later

Description

- Fixed configuration MPC with sixteen 10-Gigabit Ethernet ports
- Power requirement: 9.17 A @ 48 V (440 W)
- Weight: 18.35 lb (8.3 kg)
- Model numbers:
  - MPC-3D-16XGE-SFPP
  - MPC-3D-16XGE-SFPP-R-B
- Name in the CLI:
  - **MPC 3D 16x10GE**
  - **MPC 3D 16x10GE EM**

Hardware features

- High-performance throughput on each port at speeds up to 10 Gbps
- Four fully programmable Junos Trio chipsets for increased scaling for bandwidth, subscribers, and services
- One Junos Trio chipset per set of four ports
- LAN-PHY mode at 10.3125 Gbps

**NOTE:** The 16x10GE 3D MPC does not support WAN-PHY mode.

**Software features**

- Optical diagnostics and related alarms
- See “[Protocols and Applications Supported on MPCs for MX Series Routers](#)” on page 347 for information about the protocols and applications that this MPC supports.

**Interfaces**

Syntax: `xe-fpc/pic/port` where:

- `fpc`: Slot in the router where the MPC is installed
- `pic`: Grouping of 4 ports, numbered 0 through 3
- `port`: 0 through 3

For example, `xe-1/3/3` is the interface for the last port (labeled **3/3**) on an MPC installed in slot 1.

**Cables and connectors**

**TIP:** You can use the [Hardware Compatibility Tool](#) to find information about the pluggable transceivers supported on your Juniper Networks device.

The list of supported transceivers for the MX Series is located at <https://pathfinder.juniper.net/hct/category/#catKey=100001&modelType;=All&pf;=MX+Series>.

**NOTE:** The 16x10GE 3D MPC does not support WAN-PHY mode.

**NOTE:** SFPP-10G-CT50-ZR is not NEBS compliant when plugged into the MPC-3D-16XGE-SFPP. If the ambient air temperature exceeds 40 degrees C, Junos OS disables the transmitter, which takes the optical transceiver offline.

**LEDs**

**OK/FAIL LED**, one bicolor:

- Steady green—MPC is functioning normally.
- Blinking green—MPC is transitioning online or offline.
- Red—MPC has failed.

**Enable/disable LED**, one bicolor per port:

- Green—Port is enabled.
- Yellow—Port is not functioning normally.
- Off—Port is disabled.

The enable/disable LEDs are labeled in groups of four:

- 0/0 through 0/3
- 1/0 through 1/3
- 2/0 through 2/3
- 3/0 through 3/3

**Related Documentation**

- [MX Series MPC Overview on page 11](#)
- [MPCs Supported by MX Series Routers on page 12](#)
- [Media MTU Sizes by Interface Type](#)

## Multiservices MPC

Figure 7: Multiservices MPC

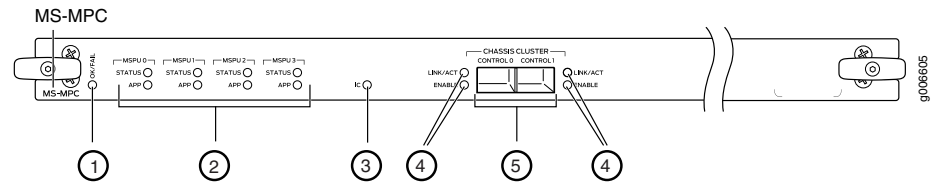

1—OK/Fail LED	4—Link/Act and Enable LEDs
2—MSPU Status and APP LEDs	5—Control 0 and Control 1 ports
3—IC LED	

Software release • Junos OS Release 13.2R4 and later

For information on which MPCs are supported on MX Series routers, see [“MPCs Supported by MX Series Routers”](#) on page 12.

Description • Power requirement: 12.2 Amps @ 48 V (585 W)  
 • Weight: 14 lbs.  
 • Model number: MS-MPC  
 • Name in the CLI: **MS-MPC**

Hardware features • One Junos Trio chipset for increased scaling for bandwidth, subscribers, and services.  
 • Enhanced memory with 128 GB of memory (32 GB per NPU) and processing capabilities.  
 • NPU CPU Clock Cycle of 1.2GHz.  
 • Four NPUs per MPC.  
 • Works with SCBs and SCBEs.  
 • Interoperable with MS-DPCs. Both MS-MPCs and MS-DPCs can co-exist in the same chassis.

Software features • Active flow monitoring and export of flow monitoring version 9 records based on RFC 3954  
 • IP Security (IPsec) encryption  
 • Network Address Translation (NAT) for IP addresses  
 • Port Address Translation (PAT) for port numbers  
 • Traffic sampling  
 • Stateful firewall with packet inspection—detects SYN attacks, ICMP and UDP floods, and ping-of-death attacks  
 • Network Attack Protection (NAP)  
 • Support for up to 6000 service sets  
 • Support for MTUs up to 9192 bytes.  
 • Multiple services can be supported. See *Junos OS Services Interfaces Library for Routing Devices* for more information.  
 • See [“Protocols and Applications Supported by the MS-MIC and MS-MPC”](#) on page 417 for information about the protocols and applications that this MIC supports.



## LEDs

**OK/FAIL LED**, one bicolor:

- Steady green—MPC is functioning normally.
- Blinking green—MPC is transitioning online or offline.
- Red—MPC has failed.

IC LED—Reserved for future use.

**STATUS LED**, one tricolor per MSPU:

- Off—MSPU is offline. If both MSPUs are offline it is safe to remove the DPC from the chassis.
- Green—MSPU is operating normally.
- Yellow—MSPU is initializing.
- Red—MSPU has an error or failure.

Application (**APP**) LED, one tricolor per MSPU:

- Off—Service is not running on the MSPU.
- Green—Service is running on the MSPU under acceptable load.
- Yellow—Service on the MSPU is reconfiguring.
- Red—Service on the MSPU has failed.

Activity (**LINK/ACT**) LED, one per control port:

- Off—No link.
- Green—Chassis cluster control port link is active.

**ENABLE LED**, one per control port:

- Off—Chassis cluster control port is disabled.
- Green—Chassis cluster control port is enabled.

**Related  
Documentation**

- [MX Series MPC Overview on page 11](#)
- [Multiservices MIC and Multiservices MPC \(MS-MIC and MS-MPC\) Overview](#)
- [Multiservices MIC on page 202](#)

## MPC1

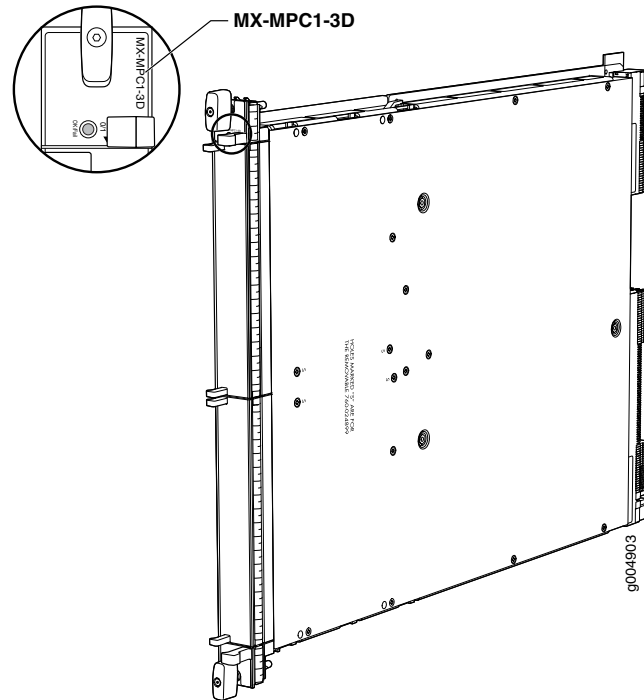

Software release	<ul style="list-style-type: none"> <li>MX240, MX480, and MX960 routers: Junos OS Release 10.2 and later</li> <li>MX2010 and MX2020 router: Junos OS Release 12.3 and later</li> </ul> <p>For information on which MICs are supported on this MPC, "<a href="#">MIC/MPC Compatibility</a>" on page 26.</p>
Description	<ul style="list-style-type: none"> <li>Power requirement: 3.4 A @ 48 V (165 W)</li> <li>Weight: 13.8 lb (6.3 kg)</li> <li>Model number: MX-MPC1-3D</li> <li>Name in the CLI: <b>MPC Type 1 3D</b></li> </ul>
Hardware features	<ul style="list-style-type: none"> <li>Two slots for MICs labeled <b>PIC 0/1</b> and <b>PIC 2/3</b></li> <li>One Junos Trio chipset for increased scaling for bandwidth, subscribers, and services</li> <li>LAN-PHY mode at 10.3125 Gbps</li> <li>WAN-PHY mode at 9.953 Gbps</li> </ul>
Software features	<ul style="list-style-type: none"> <li>See "<a href="#">Protocols and Applications Supported on MPCs for MX Series Routers</a>" on page 347 for information about the protocols and applications that this MPC supports.</li> </ul>
LEDs	<p><b>OK/FAIL LED</b>, one bicolor:</p> <ul style="list-style-type: none"> <li>Steady green—MPC is functioning normally.</li> <li>Blinking green—MPC is transitioning online or offline.</li> <li>Red—MPC has failed.</li> </ul>

- Related Documentation**
- [MX Series MPC Overview on page 11](#)
  - [MPCs Supported by MX Series Routers on page 12](#)

## MPC1E

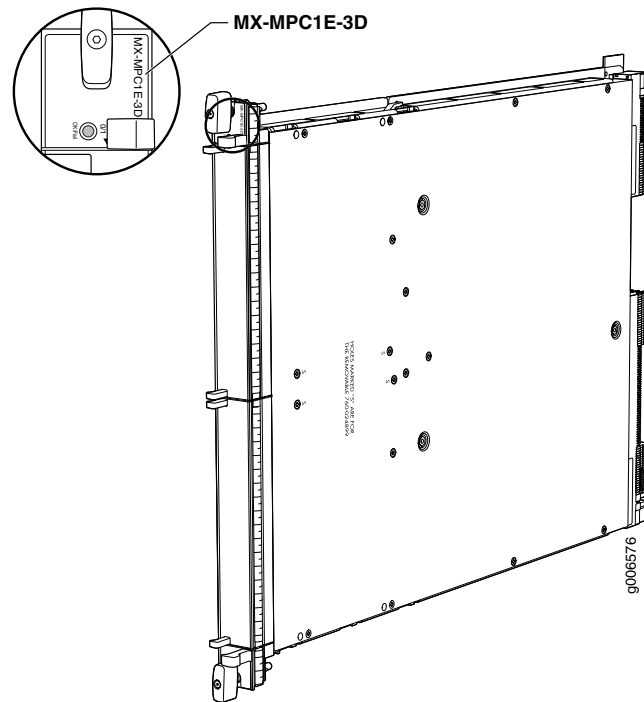

Software release	<ul style="list-style-type: none"> <li>• MX240, MX480, and MX960 routers: Junos OS Release 11.2R4 and later</li> <li>• MX2010 and MX2020 router: Junos OS Release 12.3 and later</li> </ul> <p>For information on which MICs are supported on this MPC, "<a href="#">MIC/MPC Compatibility</a>" on page 26.</p>
Description	<ul style="list-style-type: none"> <li>• Power requirement: 3.4 A @ 48 V (165 W)</li> <li>• Weight: 13.8 lb (6.3 kg)</li> <li>• Model number: MX-MPC1E-3D</li> <li>• Name in the CLI: <b>MPCE Type 1 3D</b></li> </ul>
Hardware features	<ul style="list-style-type: none"> <li>• Two slots for MICs labeled <b>PIC 0/1</b> and <b>PIC 2/3</b></li> <li>• One Junos Trio chipset for increased scaling for bandwidth, subscribers, and services</li> <li>• LAN-PHY mode at 10.3125 Gbps</li> <li>• WAN-PHY mode at 9.953 Gbps</li> </ul>
Software features	<ul style="list-style-type: none"> <li>• See "<a href="#">Protocols and Applications Supported on the MPC1E for MX Series Routers</a>" on page 356 for information about the protocols and applications that this MPC supports.</li> </ul>

LEDs

**OK/FAIL LED**, one bicolor:

- Steady green—MPC is functioning normally.
  - Blinking green—MPC is transitioning online or offline.
  - Red—MPC has failed.
-

- Related Documentation**
- [MX Series MPC Overview on page 11](#)
  - [MPCs Supported by MX Series Routers on page 12](#)

## MPC1 Q

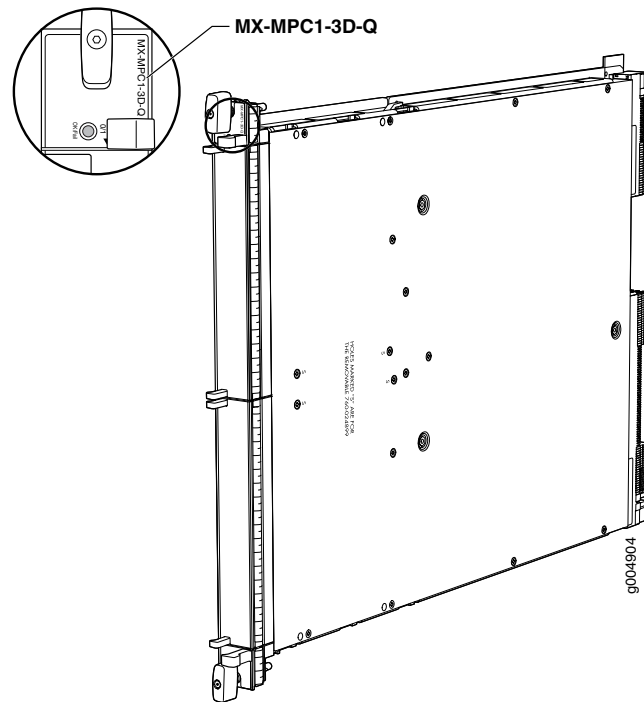

Software release	<ul style="list-style-type: none"> <li>• MX240, MX480, and MX960 routers: Junos OS Release 10.2 and later</li> <li>• MX2010 and MX2020 router: Junos OS Release 12.3 and later</li> </ul> <p>For information on which MICs are supported on this MPC, “<a href="#">MIC/MPC Compatibility</a>” on page 26.</p>
Description	<ul style="list-style-type: none"> <li>• Power requirement: 3.65 A @ 48 V (175 W)</li> <li>• Weight: 13.8 lb (6.3 kg)</li> <li>• Model number: MX-MPC1-3D-Q</li> <li>• Name in the CLI: <b>MPC Type 1 3D Q</b></li> </ul>
Hardware features	<ul style="list-style-type: none"> <li>• Two slots for MICs labeled <b>PIC 0/1</b> and <b>PIC 2/3</b></li> <li>• One Junos Trio chipset for increased scaling for bandwidth, subscribers, and services</li> <li>• LAN-PHY mode at 10.3125 Gbps</li> <li>• WAN-PHY mode at 9.953 Gbps</li> </ul>
Software features	<ul style="list-style-type: none"> <li>• See “<a href="#">Protocols and Applications Supported on MPCs for MX Series Routers</a>” on page 347 for information about the protocols and applications that this MPC supports.</li> </ul>

LEDs

**OK/FAIL LED**, one bicolor:

- Steady green—MPC is functioning normally.
  - Blinking green—MPC is transitioning online or offline.
  - Red—MPC has failed.
-

- Related Documentation**
- [MX Series MPC Overview on page 11](#)
  - [MPCs Supported by MX Series Routers on page 12](#)

## MPC1E Q

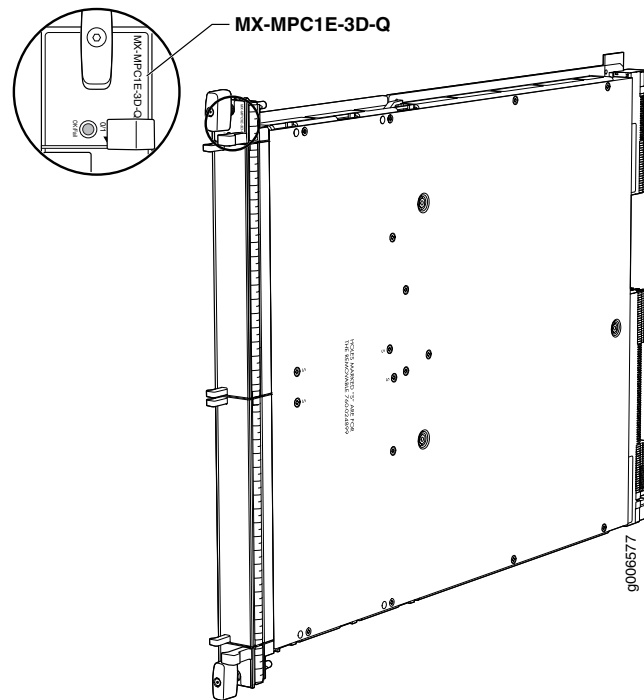

Software release	<ul style="list-style-type: none"> <li>• MX240, MX480, and MX960 routers: Junos OS Release 11.2R4 and later</li> <li>• MX2010 and MX2020 router: Junos OS Release 12.3 and later</li> </ul> <p>For information on which MICs are supported on this MPC, “<a href="#">MIC/MPC Compatibility</a>” on page 26.</p>
Description	<ul style="list-style-type: none"> <li>• Power requirement: 3.65 A @ 48 V (175 W)</li> <li>• Weight: 13.8 lb (6.3 kg)</li> <li>• Model number: MX-MPC1E-3D-Q</li> <li>• Name in the CLI: <b>MPCE Type 1 3D Q</b></li> </ul>
Hardware features	<ul style="list-style-type: none"> <li>• Two slots for MICs labeled <b>PIC 0/1</b> and <b>PIC 2/3</b></li> <li>• One Junos Trio chipset for increased scaling for bandwidth, subscribers, and services</li> <li>• LAN-PHY mode at 10.3125 Gbps</li> <li>• WAN-PHY mode at 9.953 Gbps</li> </ul>
Software features	<ul style="list-style-type: none"> <li>• See “<a href="#">Protocols and Applications Supported on the MPC1E for MX Series Routers</a>” on page 356 for information about the protocols and applications that this MPC supports.</li> </ul>

LEDs

**OK/FAIL LED**, one bicolor:

- Steady green—MPC is functioning normally.
  - Blinking green—MPC is transitioning online or offline.
  - Red—MPC has failed.
-



- Related Documentation**
- [MX Series MPC Overview on page 11](#)
  - [MPCs Supported by MX Series Routers on page 12](#)

## MPC2

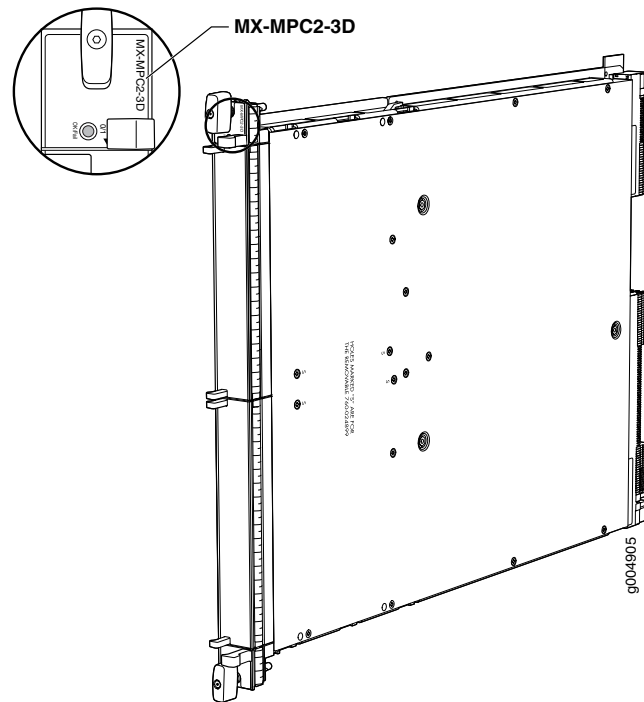

Software release	<ul style="list-style-type: none"> <li>• MX240, MX480, and MX960 routers : Junos OS Release 10.1 and later</li> <li>• MX2010 and MX2020 router: Junos OS Release 12.3 and later</li> </ul> <p>For information on which MICs are supported on this MPC, "<a href="#">MIC/MPC Compatibility</a>" on page 26.</p>
Description	<ul style="list-style-type: none"> <li>• Power requirement: 5.7 A @ 48 V (274 W)</li> <li>• Weight: 14 lb (6.4 kg)</li> <li>• Model number: MX-MPC2-3D</li> <li>• Name in the CLI: <b>MPC Type 2 3D</b></li> </ul>
Hardware features	<ul style="list-style-type: none"> <li>• Two slots for MICs labeled <b>PIC 0/1</b> and <b>PIC 2/3</b></li> <li>• Two Junos Trio chipsets for increased scaling for bandwidth, subscribers, and services</li> <li>• LAN-PHY mode at 10.3125 Gbps</li> <li>• WAN-PHY mode at 9.953 Gbps</li> </ul>
Software features	<ul style="list-style-type: none"> <li>• See "<a href="#">Protocols and Applications Supported on MPCs for MX Series Routers</a>" on page 347 for information about the protocols and applications that this MPC supports.</li> </ul>

LEDs

**OK/FAIL LED**, one bicolor:

- Steady green—MPC is functioning normally.
  - Blinking green—MPC is transitioning online or offline.
  - Red—MPC has failed.
-

- Related Documentation**
- [MX Series MPC Overview on page 11](#)
  - [MPCs Supported by MX Series Routers on page 12](#)

## MPC2E

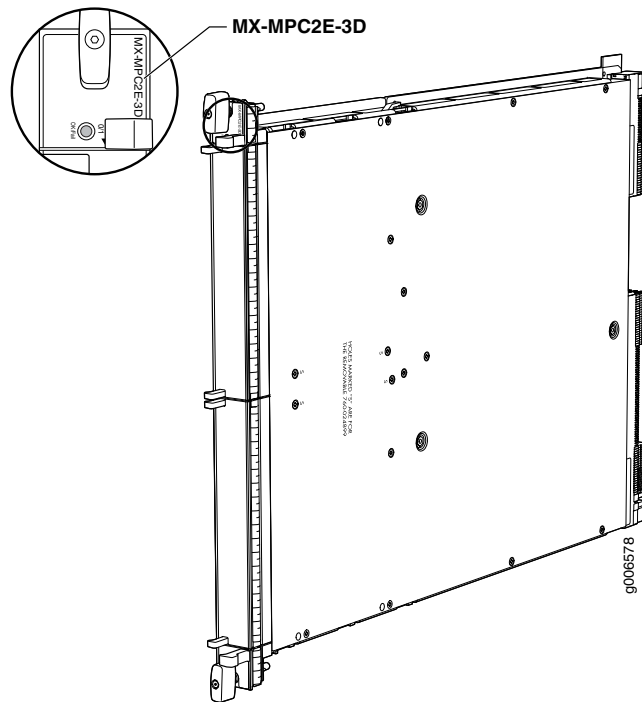

Software release	<ul style="list-style-type: none"> <li>• MX240, MX480, and MX960 routers : Junos OS Release 11.2R4 and later</li> <li>• MX2010 and MX2020 router: Junos OS Release 12.3 and later</li> </ul> <p>For information on which MICs are supported on this MPC, "<a href="#">MIC/MPC Compatibility</a>" on page 26.</p>
Description	<ul style="list-style-type: none"> <li>• Power requirement: 5.7 A @ 48 V (274 W)</li> <li>• Weight: 14 lb (6.4 kg)</li> <li>• Model number: MX-MPC2E-3D</li> <li>• Name in the CLI: <b>MPCE Type 2 3D</b></li> </ul>
Hardware features	<ul style="list-style-type: none"> <li>• Two slots for MICs labeled <b>PIC 0/1</b> and <b>PIC 2/3</b></li> <li>• Two Junos Trio chipsets for increased scaling for bandwidth, subscribers, and services</li> <li>• LAN-PHY mode at 10.3125 Gbps</li> <li>• WAN-PHY mode at 9.953 Gbps</li> </ul>
Software features	<ul style="list-style-type: none"> <li>• See "<a href="#">Protocols and Applications Supported by the MX240, MX480, MX960, MX2010, and MX2020 MPC2E</a>" on page 362 for information about the protocols and applications that this MPC supports.</li> </ul>

LEDs

**OK/FAIL LED**, one bicolor:

- Steady green—MPC is functioning normally.
  - Blinking green—MPC is transitioning online or offline.
  - Red—MPC has failed.
-

- Related Documentation**
- [MX Series MPC Overview on page 11](#)
  - [MPCs Supported by MX Series Routers on page 12](#)

## MPC2 Q

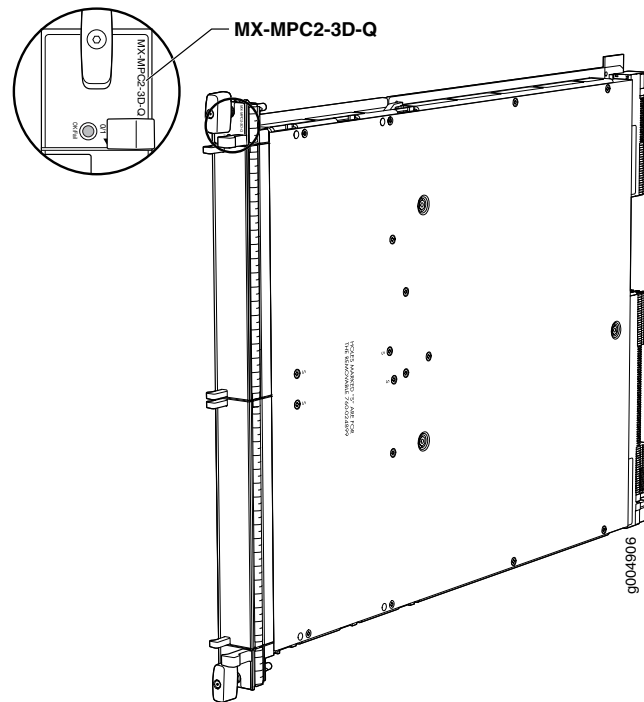

Software release	<ul style="list-style-type: none"> <li>• MX240, MX480, and MX960 routers : Junos OS Release 10.1 and later</li> <li>• MX2010 and MX2020 router: Junos OS Release 12.3 and later</li> </ul> <p>For information on which MICs are supported on this MPC, "<a href="#">MIC/MPC Compatibility</a>" on page 26.</p>
Description	<ul style="list-style-type: none"> <li>• Power requirement: 6.13 A @ 48 V (294 W)</li> <li>• Weight: 14 lb (6.4 kg)</li> <li>• Model number: MX-MPC2-3D-Q</li> <li>• Name in the CLI: <b>MPC Type 2 3D Q</b></li> </ul>
Hardware features	<ul style="list-style-type: none"> <li>• Two slots for MICs labeled <b>PIC 0/1</b> and <b>PIC 2/3</b></li> <li>• Two Junos Trio chipsets for increased scaling for bandwidth, subscribers, and services</li> <li>• LAN-PHY mode at 10.3125 Gbps</li> <li>• WAN-PHY mode at 9.953 Gbps</li> </ul>
Software features	<ul style="list-style-type: none"> <li>• See "<a href="#">Protocols and Applications Supported on MPCs for MX Series Routers</a>" on page 347 for information about the protocols and applications that this MPC supports.</li> </ul>

LEDs

**OK/FAIL LED**, one bicolor:

- Steady green—MPC is functioning normally.
  - Blinking green—MPC is transitioning online or offline.
  - Red—MPC has failed.
-

- Related Documentation**
- [MX Series MPC Overview on page 11](#)
  - [MPCs Supported by MX Series Routers on page 12](#)

## MPC2E Q

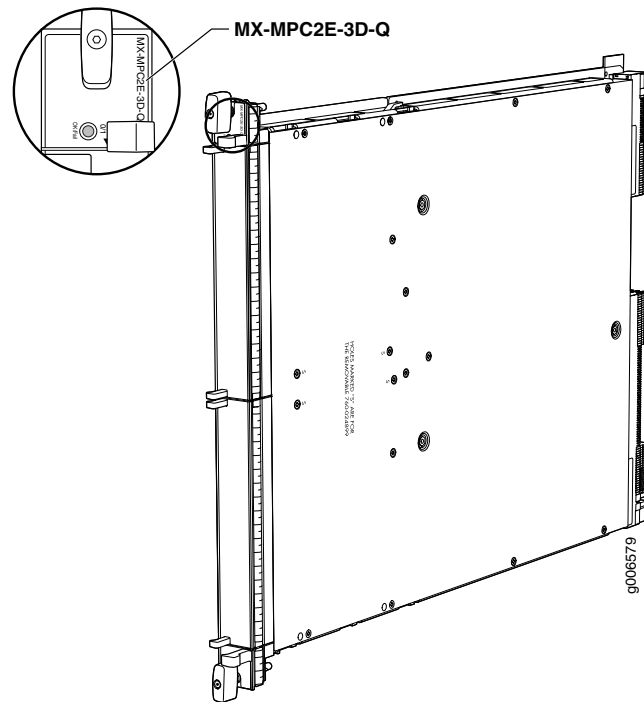

Software release	<ul style="list-style-type: none"> <li>• MX240, MX480, and MX960 routers : Junos OS Release 11.2R4 and later</li> <li>• MX2010 and MX2020 router: Junos OS Release 12.3 and later</li> </ul> <p>For information on which MICs are supported on this MPC, "<a href="#">MIC/MPC Compatibility</a>" on page 26.</p>
Description	<ul style="list-style-type: none"> <li>• Power requirement: 6.13 A @ 48 V (294 W)</li> <li>• Weight: 14 lb (6.4 kg)</li> <li>• Model number: MX-MPC2E-3D-Q</li> <li>• Name in the CLI: <b>MPCE Type 2 3D Q</b></li> </ul>
Hardware features	<ul style="list-style-type: none"> <li>• Two slots for MICs labeled <b>PIC 0/1</b> and <b>PIC 2/3</b></li> <li>• Two Junos Trio chipsets for increased scaling for bandwidth, subscribers, and services</li> <li>• LAN-PHY mode at 10.3125 Gbps</li> <li>• WAN-PHY mode at 9.953 Gbps</li> </ul>
Software features	<ul style="list-style-type: none"> <li>• See "<a href="#">Protocols and Applications Supported by the MX240, MX480, MX960, MX2010, and MX2020 MPC2E</a>" on page 362 for information about the protocols and applications that this MPC supports.</li> </ul>

LEDs

**OK/FAIL LED**, one bicolor:

- Steady green—MPC is functioning normally.
  - Blinking green—MPC is transitioning online or offline.
  - Red—MPC has failed.
-



- Related Documentation**
- [MX Series MPC Overview on page 11](#)
  - [MPCs Supported by MX Series Routers on page 12](#)

## MPC2 EQ

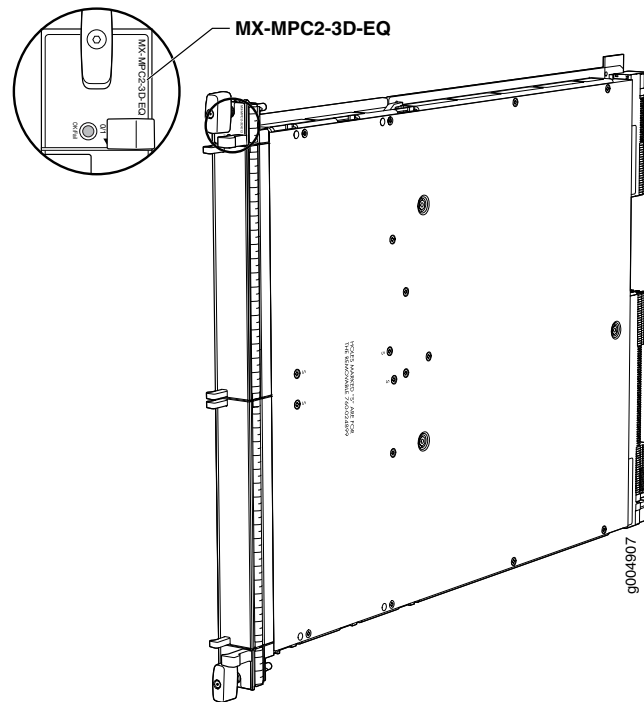

Software release	<ul style="list-style-type: none"> <li>• MX240, MX480, and MX960 routers : Junos OS Release 10.1 and later</li> <li>• MX2010 and MX2020 router: Junos OS Release 12.3 and later</li> </ul> <p>For information on which MICs are supported on this MPC, "<a href="#">MIC/MPC Compatibility</a>" on page 26.</p>
Description	<ul style="list-style-type: none"> <li>• Power requirement: 6.13 A @ 48 V (294 W)</li> <li>• Weight: 14 lb (6.4 kg)</li> <li>• Model number: MX-MPC2-3D-EQ</li> <li>• Name in the CLI: <b>MPC Type 2 3D EQ</b></li> </ul>
Hardware features	<ul style="list-style-type: none"> <li>• Two slots for MICs labeled <b>PIC 0/1</b> and <b>PIC 2/3</b></li> <li>• Two Junos Trio chipsets for increased scaling for bandwidth, subscribers, and services</li> <li>• LAN-PHY mode at 10.3125 Gbps</li> <li>• WAN-PHY mode at 9.953 Gbps</li> </ul>
Software features	<ul style="list-style-type: none"> <li>• See "<a href="#">Protocols and Applications Supported on MPCs for MX Series Routers</a>" on page 347 for information about the protocols and applications that this MPC supports.</li> </ul>

LEDs

**OK/FAIL LED**, one bicolor:

- Steady green—MPC is functioning normally.
  - Blinking green—MPC is transitioning online or offline.
  - Red—MPC has failed.
-

- Related Documentation**
- [MX Series MPC Overview on page 11](#)
  - [MPCs Supported by MX Series Routers on page 12](#)

## MPC2E EQ

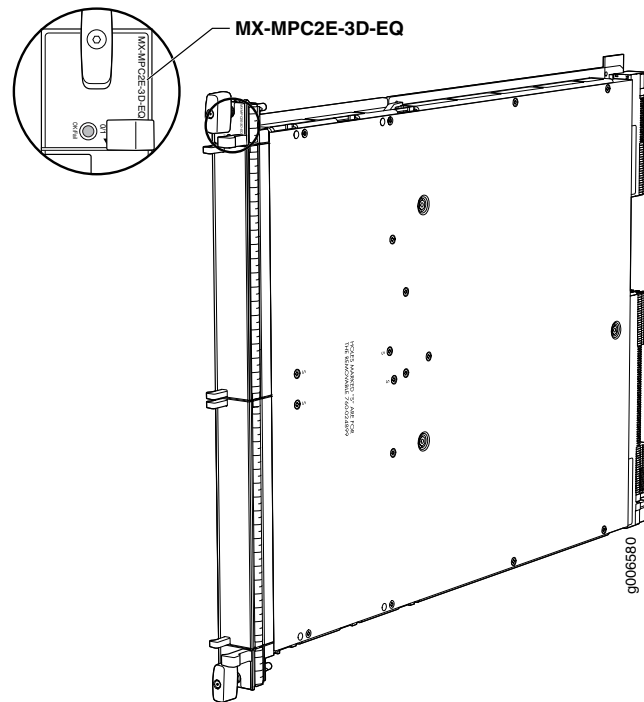

Software release	<ul style="list-style-type: none"> <li>• MX240, MX480, and MX960 routers : Junos OS Release 11.2R4 and later</li> <li>• MX2010 and MX2020 router: Junos OS Release 12.3 and later</li> </ul> <p>For information on which MICs are supported on this MPC, "<a href="#">MIC/MPC Compatibility</a>" on page 26.</p>
Description	<ul style="list-style-type: none"> <li>• Power requirement: 6.13 A @ 48 V (294 W)</li> <li>• Weight: 14 lb (6.4 kg)</li> <li>• Model number: MX-MPC2E-3D-EQ</li> <li>• Name in the CLI: <b>MPCE Type 2 3D EQ</b></li> </ul>
Hardware features	<ul style="list-style-type: none"> <li>• Two slots for MICs labeled <b>PIC 0/1</b> and <b>PIC 2/3</b></li> <li>• Two Junos Trio chipsets for increased scaling for bandwidth, subscribers, and services</li> <li>• LAN-PHY mode at 10.3125 Gbps</li> <li>• WAN-PHY mode at 9.953 Gbps</li> </ul>
Software features	<ul style="list-style-type: none"> <li>• See "<a href="#">Protocols and Applications Supported by the MX240, MX480, MX960, MX2010, and MX2020 MPC2E</a>" on page 362 for information about the protocols and applications that this MPC supports.</li> </ul>

LEDs

**OK/FAIL LED**, one bicolor:

- Steady green—MPC is functioning normally.
  - Blinking green—MPC is transitioning online or offline.
  - Red—MPC has failed.
-

- Related Documentation**
- [MX Series MPC Overview on page 11](#)
  - [MPCs Supported by MX Series Routers on page 12](#)

## MPC2E P

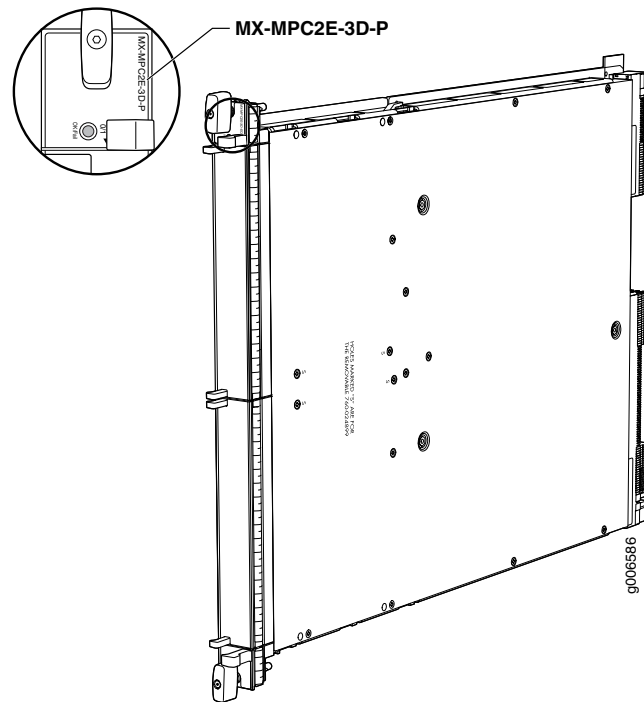

Software release	<ul style="list-style-type: none"> <li>• MX240, MX480, and MX960 routers : Junos OS Release 12.2 and later</li> <li>• MX2010 and MX2020 router: Junos OS Release 12.3 and later</li> </ul> <p>For information on which MICs are supported on this MPC, “<a href="#">MIC/MPC Compatibility</a>” on page 26.</p>
Description	<ul style="list-style-type: none"> <li>• Power requirement: 6.13 A @ 48 V (294 W)</li> <li>• Weight: 14 lb (6.4 kg)</li> <li>• Model number: MX-MPC2E-3D-P</li> <li>• Name in the CLI: <b>MPCE Type 2 3D P</b></li> </ul>
Hardware features	<ul style="list-style-type: none"> <li>• Two slots for MICs labeled <b>PIC 0/1</b> and <b>PIC 2/3</b></li> <li>• Two Junos Trio chipsets for increased scaling for bandwidth, subscribers, and services</li> <li>• LAN-PHY mode at 10.3125 Gbps</li> <li>• WAN-PHY mode at 9.953 Gbps</li> </ul>
Software features	<ul style="list-style-type: none"> <li>• See “<a href="#">Protocols and Applications Supported by the MX240, MX480, MX960, MX2010, and MX2020 MPC2E</a>” on page 362 for information about the protocols and applications that this MPC supports.</li> </ul>

LEDs

**OK/FAIL LED**, one bicolor:

- Steady green—MPC is functioning normally.
  - Blinking green—MPC is transitioning online or offline.
  - Red—MPC has failed.
-

- Related Documentation**
- [MX Series MPC Overview on page 11](#)
  - [MPCs Supported by MX Series Routers on page 12](#)

## MPC2E NG

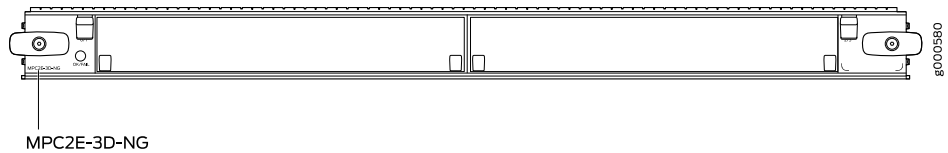

Software release	<ul style="list-style-type: none"> <li>• Junos OS releases 14.1R4, 14.2R3 and Junos Continuity, Junos OS release 15.1 and later.</li> <li>• Refer to “<a href="#">MIC/MPC Compatibility</a>” on page 26 for information about which MICs are supported on this MPC.</li> <li>• Refer to the JTAC Knowledgebase article <a href="https://kb.juniper.net/KB21476">https://kb.juniper.net/KB21476</a> for recommended software releases.</li> </ul>
Description	<ul style="list-style-type: none"> <li>• 80 Gbps capacity without hierarchical quality of service (HQoS)</li> <li>• Requires high-capacity fan trays and high-capacity filter trays</li> <li>• Weight: 15.96 lb (7.26 kg)</li> <li>• Model numbers: MPC2E-3D-NG</li> <li>• Name in the CLI: <b>MPC2E NG PQ &amp; Flex Q</b></li> <li>• Add-on license provides limited additional flexible queuing.</li> </ul> <p><b>NOTE:</b> MPC2E-3D-NG is not compatible with SCB, you must use either SCBE-MX or SCBE2-MX for the switch fabric interface.</p>
Hardware features	<ul style="list-style-type: none"> <li>• Line-rate throughput of up to 80 Gbps</li> <li>• Supports WAN-PHY mode at 9.95 Gbps and LAN-PHY mode at 10.31 Gbps</li> <li>• Two slots for MICs</li> <li>• Junos Trio chipsets for increased scaling for bandwidth, subscribers, and services.</li> </ul> <p><b>NOTE:</b> MPC2E-3D-NG is not compatible with SCB, you must use either SCBE-MX or SCBE2-MX for the switch fabric interface.</p> <p><b>NOTE:</b> MPC2E-3D-NG does not support MIC3-3D-10XGE-SFPP, MIC3-3D-1X100GE-CFP, MIC3-3D-1X100GE-CXP, and MIC3-3D-2X40GE-QSFPP.</p> <p><b>NOTE:</b> The non-HQOS MPC3E NG and MPC2E NG MPCs support MIC-3D-8CHOC3-4CHOC12 and MIC-3D-4CHOC3-2CHOC12 only with a limited queuing license.</p>

Software features	<ul style="list-style-type: none"><li>• Chained composite next hops</li><li>• Layer 3 VPN localization</li><li>• Detection of Layer 2 loops</li><li>• Entropy label support in mixed mode</li><li>• SNMP and CLI support for Routing Engine memory monitoring</li><li>• Mixed-mode LAG support on core interfaces</li><li>• Dynamic power management for MICs</li><li>• Support for flexible-queuing</li><li>• See <a href="#">“Protocols and Applications Supported by the MX240, MX480, MX960, MX2010, and MX2020 MPC2E”</a> on page 362 for information about the protocols and applications that this MPC supports.</li></ul>
Power requirement	<p>Maximum with highest-power MICs at 55° C: 9.88 A @ 48 V (474 W)</p> <p>At different temperatures:</p> <ul style="list-style-type: none"><li>• 55° C: 474 W</li><li>• 40° C: 417 W</li><li>• 25° C: 400 W</li></ul>
LEDs	<p><b>OK/FAIL LED</b>, one bicolor:</p> <ul style="list-style-type: none"><li>• Steady green—MPC is functioning normally.</li><li>• Blinking green—MPC is transitioning online or offline.</li><li>• Red—MPC has failed.</li></ul>



- Related Documentation**
- [MX Series MPC Overview on page 11](#)
  - [MPCs Supported by MX Series Routers on page 12](#)
  - [Junos Continuity Software](#)

## MPC2E NG Q

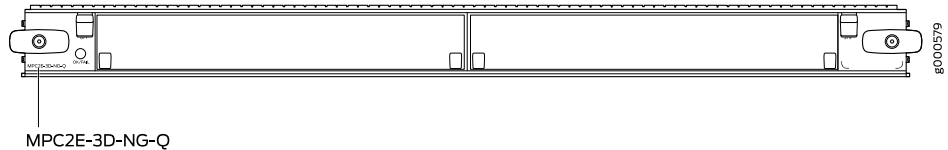

Software release	<ul style="list-style-type: none"> <li>• Junos OS releases 14.1R4, 14.2R3 and Junos Continuity, Junos OS release 15.1 and later.</li> <li>• Refer to <a href="#">“MIC/MPC Compatibility” on page 26</a> for information about which MICs are supported on this MPC.</li> <li>• Refer to the JTAC Knowledgebase article <a href="https://kb.juniper.net/KB21476">https://kb.juniper.net/KB21476</a> for recommended software releases.</li> </ul>
Description	<ul style="list-style-type: none"> <li>• 80 Gbps capacity with hierarchical quality of service (HQoS)</li> <li>• Requires high-capacity fan trays and high capacity filter trays</li> <li>• Weight: 15.96 lb (7.26 kg)</li> <li>• Model number: MPC2E-3D-NG-Q</li> <li>• Name in the CLI: <b>MPC2E NG HQoS</b></li> </ul> <p><b>NOTE:</b> MPC2E-3D-NG-Q is not compatible with SCB, you must use either SCBE-MX or SCBE2-MX for the switch fabric interface.</p>
Hardware features	<ul style="list-style-type: none"> <li>• Line-rate throughput of up to 80 Gbps</li> <li>• Supports up to 512,000 queues per slot</li> <li>• Supports WAN-PHY mode at 9.95 Gbps and LAN-PHY mode at 10.31 Gbps</li> <li>• Two slots for MICs</li> <li>• Junos Trio chipsets for increased scaling for bandwidth, subscribers, and services.</li> </ul> <p><b>NOTE:</b> The MPC2E-3D-NG-Q has only one lookup chip (LU).</p> <p><b>NOTE:</b> MPC2E-3D-NG-Q does not support MIC3-3D-10XGE-SFPP, MIC3-3D-1X100GE-CFP, MIC3-3D-1X100GE-CXP, and MIC3-3D-2X40GE-QSFPP.</p>
Software features	<ul style="list-style-type: none"> <li>• Chained composite next hops</li> <li>• Layer 3 VPN localization</li> <li>• Detection of Layer 2 loops</li> <li>• Entropy label support in mixed mode</li> <li>• SNMP and CLI support for Routing Engine memory monitoring</li> <li>• BFD support for inline MLPPP/MLFR</li> <li>• Mixed Mode LAG support on core interfaces</li> <li>• Dynamic power management for MICs</li> <li>• See <a href="#">“Protocols and Applications Supported by the MX240, MX480, MX960, MX2010, and MX2020 MPC2E” on page 362</a> for information about the protocols and applications that this MPC supports.</li> </ul>

Power requirement      Maximum with highest-power MICs at 55° C: 11.02 A @ 48 V (529 W)

At different temperatures:

- 55° C: 529 W
- 40° C: 460 W
- 25° C: 438 W

LEDs

**OK/FAIL LED**, one bicolor:

- Steady green—MPC is functioning normally.
- Blinking green—MPC is transitioning online or offline.
- Red—MPC has failed.

- Related Documentation**
- [MX Series MPC Overview on page 11](#)
  - [MPCs Supported by MX Series Routers on page 12](#)
  - [Junos Continuity Software](#)

## MPC3E

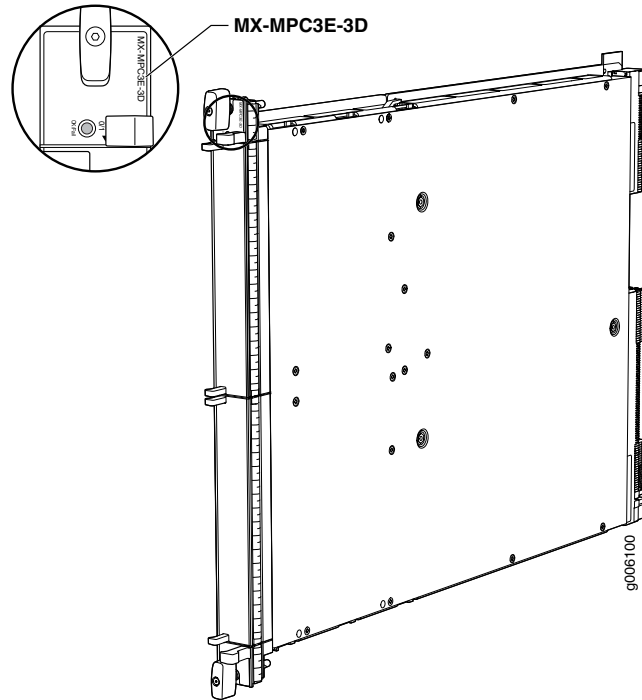

Software release	<ul style="list-style-type: none"> <li>• MX240, MX480, and MX960 routers : Junos OS Release 12.1 and later</li> <li>• MX2010 and MX2020 router: Junos OS Release 12.3 and later</li> </ul> <p>For information on which MICs are supported on this MPC, "<a href="#">MIC/MPC Compatibility</a>" on page 26.</p>
Description	<ul style="list-style-type: none"> <li>• Power requirement: 10.83 A @ 48 V (440 W; plus 40 W for each of the two MICs)</li> <li>• Requires high-capacity fan trays</li> <li>• Weight: 14.94 lb (6.78 kg)</li> <li>• Model number: MX-MPC3E-3D</li> <li>• Name in the CLI: <b>MPCE Type 3 3D</b></li> </ul>
Hardware features	<ul style="list-style-type: none"> <li>• Two slots for MICs</li> <li>• Chipset for increased scaling for bandwidth, subscribers, and services</li> <li>• Supports maximum transmission unit (MTU) size of 9,192 bytes for host bound packets. For Junos OS 16.1R1 and later releases, the MTU size supported is 9,500 bytes.</li> </ul>
Software features	<ul style="list-style-type: none"> <li>• See "<a href="#">Protocols and Applications Supported by the MPC3E on MX Series Routers</a>" on page 371 for information about the protocols and applications that this MPC supports.</li> </ul>

LEDs

**OK/FAIL LED**, one bicolor:

- Steady green—MPC is functioning normally.
  - Blinking green—MPC is transitioning online or offline.
  - Red—MPC has failed.
-

- Related Documentation**
- [MX Series MPC Overview on page 11](#)
  - [MPCs Supported by MX Series Routers on page 12](#)

## MPC3E NG

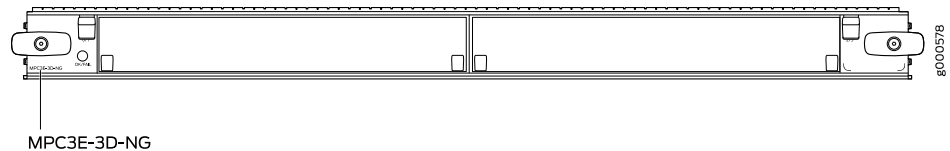

Software release	<ul style="list-style-type: none"> <li>• Junos OS releases 14.1R4, 14.2R3 and Junos Continuity, Junos OS release 15.1 and later.</li> <li>• Refer to <a href="#">“MIC/MPC Compatibility” on page 26</a> for information about which MICs are supported on this MPC.</li> <li>• Refer to the JTAC Knowledgebase article <a href="https://kb.juniper.net/KB21476">https://kb.juniper.net/KB21476</a> for recommended software releases.</li> </ul>
Description	<ul style="list-style-type: none"> <li>• 130 Gbps capacity without hierarchical quality of service (HQoS)</li> <li>• Requires high-capacity fan trays and high-capacity filter trays</li> <li>• Weight: 15.96 lb (7.26 kg)</li> <li>• Model number: MPC3E-3D-NG</li> <li>• Name in the CLI: <b>MPC3E NG PQ &amp; Flex Q</b></li> <li>• Add-on license provides limited additional flexible queuing.</li> </ul> <p><b>NOTE:</b> MPC3E-3D-NG is not compatible with SCB, you must use either SCBE-MX or SCBE2-MX for the switch fabric interface.</p>
Hardware features	<ul style="list-style-type: none"> <li>• Line-rate throughput of up to 130 Gbps</li> <li>• Supports WAN-PHY mode at 9.95 Gbps and LAN-PHY mode at 10.31 Gbps</li> <li>• Supports maximum transmission unit (MTU) size of 9,192 bytes for host bound packets. For Junos OS 16.1R1 and later releases, the MTU size supported is 9,500 bytes.</li> <li>• Two slots for MICs</li> <li>• Junos Trio chipsets for increased scaling for bandwidth, subscribers, and services</li> </ul> <p><b>NOTE:</b> The non-HQoS MPC3E NG and MPC2E NG MPCs support MIC-3D-8CHOC3-4CHOC12 and MIC-3D-4CHOC3-2CHOC12 only with a limited queuing license.</p>
Software features	<ul style="list-style-type: none"> <li>• Chained composite next hops</li> <li>• Layer 3 VPN localization</li> <li>• Detection of Layer 2 loops</li> <li>• Entropy label support in mixed mode</li> <li>• SNMP and CLI support for Routing Engine memory monitoring</li> <li>• Mixed Mode LAG support on core interfaces</li> <li>• Dynamic power management for MICs</li> <li>• Support for flexible-queuing</li> <li>• See <a href="#">“Protocols and Applications Supported by the MPC3E on MX Series Routers” on page 371</a> for information about the protocols and applications that this MPC supports.</li> </ul>

Power requirement      Maximum with highest-power MICs at 55° C: 11.13 A @ 48 V (534 W)

At different temperatures:

- 55° C: 534 W
- 40° C: 485 W
- 25° C: 461 W

LEDs

OK/FAIL LED, one bicolor:

- Steady green—MPC is functioning normally.
- Blinking green—MPC is transitioning online or offline.
- Red—MPC has failed.



**NOTE:** On the MX960 router, FPC slot 0 and slot 11 are not NEBS compliant beyond 104°F (40°C) with MPC3E-3D-NG and MPC3E-3D-NG-Q. This is a cooling restriction.

---

- Related Documentation**
- [MX Series MPC Overview on page 11](#)
  - [MPCs Supported by MX Series Routers on page 12](#)
  - [Junos Continuity Software](#)

## MPC3E NG Q

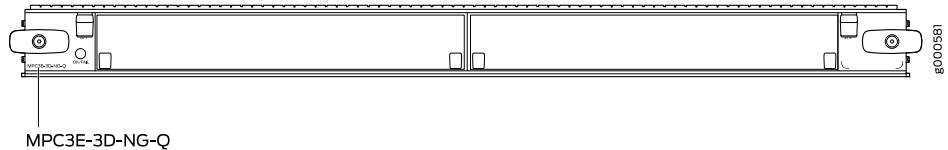

- Software release**
- Junos OS releases 14.1R4, 14.2R3 and Junos Continuity, Junos OS release 15.1 and later.
  - Refer to [“MIC/MPC Compatibility” on page 26](#) for information about which MICs are supported on this MPC.
  - Refer to the JTAC Knowledgebase article <https://kb.juniper.net/KB21476> for recommended software releases.

- Description**
- 130 Gbps capacity with hierarchical quality of service (HQoS)
  - Requires high-capacity fan trays and high-capacity filter trays
  - Weight: 15.96 lb (7.26 kg)
  - Model number: MPC3E-3D-NG-Q
  - Name in the CLI: **MPC3E NG HQoS**
- NOTE:** MPC3E-3D-NG-Q is not compatible with SCB, you must use either SCBE-MX or SCBE2-MX for the switch fabric interface.

- Hardware features**
- Line-rate throughput of up to 130 Gbps
  - Supports up to 512,000 queues per slot
  - Supports WAN-PHY mode at 9.95 Gbps and LAN-PHY mode at 10.31 Gbps
  - Supports maximum transmission unit (MTU) size of 9,192 bytes for host bound packets. For Junos OS 16.1R1 and later releases, the MTU size supported is 9,500 bytes.
  - Two slots for MICs
  - Junos Trio chipsets for increased scaling for bandwidth, subscribers, and services

- Software features**
- Chained composite next hops
  - Layer 3 VPN localization
  - Detection of Layer 2 loops
  - Entropy label support in mixed mode
  - SNMP and CLI support for Routing Engine memory monitoring
  - BFD support for inline MLPPP/MLFR
  - Mixed Mode LAG support on core interfaces
  - Dynamic power management for MICs
  - See [“Protocols and Applications Supported by the MPC3E on MX Series Routers” on page 371](#) for information about the protocols and applications that this MPC supports.
- See *MPC3E on MX Series Routers Overview* for additional information.

Power requirement      Maximum with highest-power MICs at 55° C: 12.15 A @ 48 V (583 W)

At different temperatures:

- 55° C: 583 W
- 40° C: 532 W
- 25° C: 503 W

LEDs

OK/FAIL LED, one bicolor:

- Steady green—MPC is functioning normally.
- Blinking green—MPC is transitioning online or offline.
- Red—MPC has failed.



**NOTE:** On the MX960 router, FPC slot 0 and slot 11 are not NEBS compliant beyond 104°F (40°C) with MPC3E-3D-NG and MPC3E-3D-NG-Q. This is a cooling restriction.

---



- Related Documentation**
- [MX Series MPC Overview on page 11](#)
  - [MPCs Supported by MX Series Routers on page 12](#)
  - [Junos Continuity Software](#)

## 32x10GE MPC4E

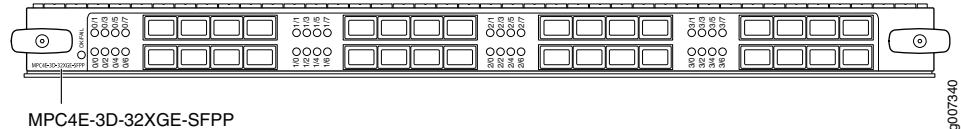

Software release	<ul style="list-style-type: none"> <li>• Junos OS Release 12.3R2 and later</li> </ul>
Description	<ul style="list-style-type: none"> <li>• Fixed configuration MPC with thirty-two 10-Gigabit Ethernet ports</li> <li>• Power requirement: 12.7 A @ 48 V (610 W)</li> <li>• Weight: 19.4 lb (8.8 kg)</li> <li>• Model number: MPC4E-3D-32XGE-SFPP</li> </ul>
Hardware features	<ul style="list-style-type: none"> <li>• Line-rate throughput of up to 260 Gbps</li> <li>• WAN-PHY mode at 10 Gbps on a per-port basis</li> <li>• Supports maximum transmission unit (MTU) size of 9,192 bytes for host bound packets. For Junos OS 16.1R1 and later releases, the MTU size supported is 9,500 bytes.</li> <li>• Supported on MX2020, MX2010, MX960, MX480, and MX240 routers with both normal-capacity and high-capacity power supplies and fan trays.</li> </ul>
Software features	<ul style="list-style-type: none"> <li>• Optical diagnostics and related alarms</li> <li>• Up to 260 Gbps of full-duplex traffic</li> <li>• Intelligent oversubscription services</li> <li>• Configurable LAN-PHY and WAN-PHY mode options per port</li> <li>• Local loopback</li> <li>• Configurable to interoperate with routers that use the 100-Gigabit Ethernet PIC (Type 4 PIC on Type 4 FPC)</li> <li>• See <a href="#">“Protocols and Applications Supported on the MPC4E for MX Series Routers” on page 379</a> for information about the protocols and applications that this MPC supports.</li> </ul>
Cables and connectors	<p><b>TIP:</b> You can use the <a href="#">Hardware Compatibility Tool</a> to find information about the pluggable transceivers supported on your Juniper Networks device.</p> <p>The list of supported transceivers for the MX Series is located at <a href="https://pathfinder.juniper.net/hct/category/#catKey=100001&amp;modelType;=All&amp;pf;=MX+Series">https://pathfinder.juniper.net/hct/category/#catKey=100001&amp;modelType;=All&amp;pf;=MX+Series</a>.</p> <p><b>NOTE:</b> SFPP-10GE-ZR has a commercial temperature rating and is not NEBS compliant when plugged into the 32x10GE MPC4E with SFP+. If the ambient air temperature exceeds 40°C, Junos OS disables the transmitter, which takes the optical transceiver offline.</p> <p><b>NOTE:</b> SFPP-10G-DT-ZRC2 is not NEBS compliant when plugged into the MPC4E-3D-32XGE-SFPP MPC. If the ambient air temperature exceeds 40°C, Junos OS disables the transmitter, which takes the optical transceiver offline.</p> <p><b>NOTE:</b> On the MX960 router, FPC slot 0 and FPC slot 11 are not NEBS compliant beyond 104°F (40°C). This is a cooling restriction.</p>

## LEDs

OK/FAIL LED, one bicolor:

- Steady green—MPC is functioning normally.
- Blinking green—MPC is transitioning online or offline.
- Red—MPC has failed.

Enable/disable LED, one bicolor per port:

- Green—Port is enabled.
- Red—Port has failed.
- Off—Port is disabled.

The enable/disable LEDs are arranged in four groups:

- 0/0 through 0/7
- 1/0 through 1/7
- 2/0 through 2/7
- 3/0 through 3/7

**Related  
Documentation**

- [MX Series MPC Overview on page 11](#)
- [MPC4E on MX Series Routers Overview](#)
- [MPCs Supported by MX Series Routers on page 12](#)
- [Configuring MPC4E \(MPC4E-3D-2CGE-8XGE\) to Interoperate with 100-Gigabit Ethernet PICs on Type 4 FPC Using SA Multicast Mode](#)

## 2x100GE + 8x10GE MPC4E

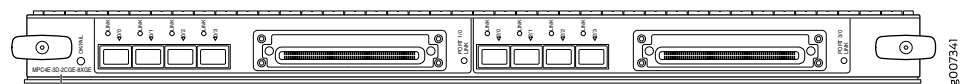

MPC4E-3D-2CGE-8XGE

**Software release**

- Junos OS Release 12.3R2 and later

**Description**

- Fixed configuration MPC with two 100-Gigabit Ethernet ports and eight 10-Gigabit Ethernet ports
- Power requirement: 12.7 A @ 48 V (610 W)
- Weight: 19.4 lb (8.8 kg)
- Model number: MPC4E-3D-2CGE-8XGE

<b>Hardware features</b>	<ul style="list-style-type: none"> <li>• Line-rate throughput of up to 260 Gbps</li> <li>• WAN-PHY mode at 10 Gbps on a per-port basis</li> <li>• Supported only on the MX960, MX480, and MX240 routers with high-capacity power supplies and high-capacity fan trays.</li> <li>• Supports maximum transmission unit (MTU) size of 9,192 bytes for host bound packets. For Junos OS 16.1R1 and later releases, the MTU size supported is 9,500 bytes.</li> <li>• The ports are labeled as: <ul style="list-style-type: none"> <li>• 10-Gigabit Ethernet ports: <b>0/0</b> through <b>0/3</b></li> <li>• 100-Gigabit Ethernet ports: <b>PORT 1/0</b></li> <li>• 10-Gigabit Ethernet ports: <b>2/0</b> through <b>2/3</b></li> <li>• 100-Gigabit Ethernet ports: <b>PORT 3/0</b></li> </ul> </li> </ul>
--------------------------	---

<b>Software features</b>	<ul style="list-style-type: none"> <li>• Optical diagnostics and related alarms</li> <li>• Configurable LAN-PHY and WAN-PHY mode options per 10-Gigabit Ethernet port</li> <li>• Up to 260 Gbps of full-duplex traffic</li> <li>• Intelligent oversubscription services</li> <li>• Local loopback</li> <li>• Configurable to interoperate with routers that use the 100-Gigabit Ethernet PIC (Type 4 PIC on Type 4 FPC)</li> <li>• See “<a href="#">Protocols and Applications Supported on the MPC4E for MX Series Routers</a>” on page 379 for information about the protocols and applications that this MPC supports.</li> </ul>
--------------------------	--

**Cables and connectors** **TIP:** You can use the [Hardware Compatibility Tool](#) to find information about the pluggable transceivers supported on your Juniper Networks device.

The list of supported transceivers for the MX Series is located at <https://pathfinder.juniper.net/hct/category/#catKey=100001&modelType=All&pf=MX+Series>.

**NOTE:** SFPP-10GE-ZR has a commercial temperature rating and is not NEBS compliant when plugged into the 2x100GE + 8x10GE MPC4E. If the ambient air temperature exceeds 40°C, Junos OS disables the transmitter, which takes the optical transceiver offline.

**NOTE:** SFPP-10G-DT-ZRC2 is not NEBS compliant when plugged into the MPC4E-3D-2CGE-8XGE MPC. If the ambient air temperature exceeds 40°C, Junos OS disables the transmitter, which takes the optical transceiver offline.

**NOTE:** CFP-100GBASE-LR4 and CFP-100GBASE-ZR are not NEBS compliant when plugged into the 2x100GE + 8x10GE MPC4E. If the ambient air temperature exceeds 40°C, the software disables the transmitter, which takes the optical transceiver offline.

**NOTE:** On the MX960 router, FPC slot 0 and FPC slot 11 are not NEBS compliant beyond 104°F (40°C). This is a cooling restriction.

<b>LEDs</b>	<p><b>OK/FAIL LED, one bicolor:</b></p> <ul style="list-style-type: none"> <li>• Steady green—MPC is functioning normally.</li> <li>• Blinking green—MPC is transitioning online or offline.</li> <li>• Red—MPC has failed.</li> </ul> <p><b>LINK LED, one tricolor per port:</b></p> <ul style="list-style-type: none"> <li>• Green—Port is enabled.</li> <li>• Red—Port has failed.</li> <li>• Yellow—Port is disabled by configuration.</li> <li>• Off—Port is disabled.</li> </ul>
-------------	--

- Related Documentation**
- [MX Series MPC Overview on page 11](#)
  - [MPC4E on MX Series Routers Overview](#)
  - [MPCs Supported by MX Series Routers on page 12](#)
  - [Configuring MPC4E \(MPC4E-3D-2CGE-8XGE\) to Interoperate with 100-Gigabit Ethernet PICs on Type 4 FPC Using SA Multicast Mode](#)

## 6x40GE + 24x10GE MPC5E

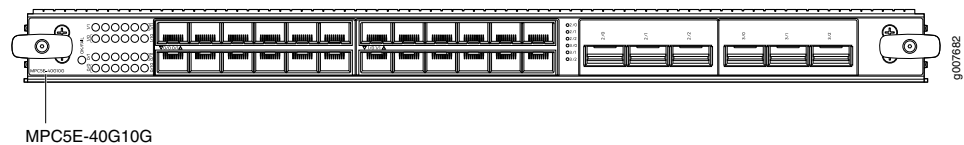

Software release	<ul style="list-style-type: none"> <li>• Junos OS Release 13.3R2 and later</li> </ul>
Description	<ul style="list-style-type: none"> <li>• Fixed-port MPC with six 40-Gigabit Ethernet ports and twenty-four 10-Gigabit Ethernet ports</li> <li>• Weight: 21 lb (9.52 kg)</li> <li>• Model number: MPC5E-40G10G</li> <li>• Name in the CLI: <b>MPC5E 3D 24XGE+6XLGE</b></li> </ul>
Hardware features	<ul style="list-style-type: none"> <li>• Line-rate throughput of up to 240 Gbps</li> <li>• Supports one of the following port combinations: <ul style="list-style-type: none"> <li>• Six 40-Gigabit Ethernet ports</li> <li>• Twenty-four 10-Gigabit Ethernet ports</li> <li>• Three 40-Gigabit Ethernet ports and twelve 10-Gigabit Ethernet ports</li> </ul> </li> <li>• Supports up to 32,000 queues per-slot</li> <li>• LAN-PHY mode at 10.3125 Gbps on a per-port basis</li> <li>• WAN-PHY mode at 9.95328 Gbps on a per-port basis</li> <li>• Supports maximum transmission unit (MTU) size of 9,192 bytes for host bound packets. For Junos OS 16.1R1 and later releases, the MTU size supported is 9,500 bytes.</li> <li>• The ports are labeled as: <ul style="list-style-type: none"> <li>• 10-Gigabit Ethernet ports: <ul style="list-style-type: none"> <li>0/0 through 0/11</li> <li>1/0 through 1/11</li> </ul> </li> <li>• 40-Gigabit Ethernet ports: <ul style="list-style-type: none"> <li>2/0 through 2/2</li> <li>3/0 through 3/2</li> </ul> </li> </ul> </li> </ul> <p><b>NOTE:</b> On MX960 routers, all the MPC slots work with the ambient temperature of up to 40° C. However, when the chassis temperature exceeds 40° C, slots <b>0</b> and <b>11</b> can work with MPC1s, MPC2s, and the 16x10GE MPC.</p>

**Software features**

- Optical diagnostics and related alarms
- Support for optical transport network (OTN) on 10-Gigabit Ethernet ports
- Two packet-forwarding engines, PFE0 and PFE1. PFE0 hosts PIC0 and PIC2. PFE1 hosts PIC1 and PIC3.
- Configurable LAN-PHY and WAN-PHY mode options per 10-Gigabit Ethernet port
- See “[Protocols and Applications Supported by the MPC5E for MX Series Routers](#)” on page 388 for information about the protocols and applications that this MPC supports.

**NOTE:** On MX240, MX480, and MX960 routers, MPC5E powers on only if the **network-services** mode on the router is configured to either **enhanced-ip** or **enhanced-ethernet**. On MX2010 and MX2020 routers, only **enhanced-ip** is supported.

**NOTE:** A maximum of two PICs can be powered on at any one time (PIC0 or PIC2, and PIC1 or PIC3). The other PICs must be powered off.

**Cables and connectors**

**TIP:** You can use the [Hardware Compatibility Tool](#) to find information about the pluggable transceivers supported on your Juniper Networks device.

The list of supported transceivers for the MX Series is located at <https://pathfinder.juniper.net/hct/category/#catKey=100001&modelType;=All&pf;=MX+Series>.

**NOTE:** QSFP-40GE-LX4 is not NEBS compliant on the MX960 router in FPC slot 0 or FPC slot 11.

**Power requirements**

- Typical: 9.68 A @ 48 V (460 W)
- At different temperatures with default configuration:
  - 55° C: 558 W
  - 40° C: 496 W
  - 25° C: 469 W
- At different temperatures when **flexible-queueing-mode** CLI knob is configured under **set chassis fpc 1 flexible-queueing-mode**:
  - 55° C: 607 W
  - 40° C: 541 W
  - 25° C: 511 W

**LEDs**

**OK/FAIL LED**, one bicolor:

- Steady green—MPC is functioning normally.
- Blinking green—MPC is transitioning online or offline.
- Red—MPC has failed.

10-Gigabit Ethernet **LINK LED**, one green per port:

- Green—Link is up.
- Off—Link is down or disabled.

40-Gigabit Ethernet **LINK LED**, one bicolor per port:

- Green—Link is up.
- Yellow—Link is disabled.
- Off—Link is down.

**Related Documentation**

- [MX Series MPC Overview on page 11](#)

- [MPCs Supported by MX Series Routers on page 12](#)
- [MPC5E on MX Series Routers Overview](#)
- [10-Gigabit Ethernet OTN Options Configuration Overview](#)

## 6x40GE + 24x10GE MPC5EQ

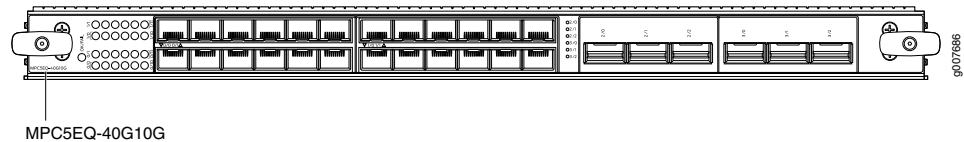

Software release	<ul style="list-style-type: none"> <li>• Junos OS Release 13.3R2 and later</li> </ul>
Description	<ul style="list-style-type: none"> <li>• Fixed-configuration MPC with six 40-Gigabit Ethernet ports and twenty-four 10-Gigabit Ethernet ports</li> <li>• Weight: 21 lb (9.52 kg)</li> <li>• Model number: MPC5EQ-40G10G</li> <li>• Name in the CLI: <b>MPC5E 3D Q 24XGE+6XLGE</b></li> </ul>
Hardware features	<ul style="list-style-type: none"> <li>• Line-rate throughput of up to 240 Gbps</li> <li>• Supports one of the following port combinations: <ul style="list-style-type: none"> <li>• Six 40-Gigabit Ethernet ports</li> <li>• Twenty-four 10-Gigabit Ethernet ports</li> <li>• Three 40-Gigabit Ethernet ports and twelve 10-Gigabit Ethernet ports</li> </ul> </li> <li>• Supports up to 1 million queues per-slot</li> <li>• LAN-PHY mode at 10.3125 Gbps on a per-port basis</li> <li>• WAN-PHY mode at 9.95328 Gbps on a per-port basis</li> <li>• Supports maximum transmission unit (MTU) size of 9,192 bytes for host bound packets. For Junos OS 16.1R1 and later releases, the MTU size supported is 9,500 bytes.</li> <li>• The ports are labeled as: <ul style="list-style-type: none"> <li>• 10-Gigabit Ethernet ports: <ul style="list-style-type: none"> <li>0/0 through 0/11</li> <li>1/0 through 1/11</li> </ul> </li> <li>• 40-Gigabit Ethernet ports: <ul style="list-style-type: none"> <li>2/0 through 2/2</li> <li>3/0 through 3/2</li> </ul> </li> </ul> </li> </ul> <p><b>NOTE:</b> On MX960 routers, all the MPC slots work with the ambient temperature of up to 40° C. However, when the chassis temperature exceeds 40° C, slots <b>0</b> and <b>11</b> can work with MPC1s, MPC2s, and the 16x10GE MPC.</p>

- Software features**
- Supports hierarchical QoS (HQoS)
  - Optical diagnostics and related alarms
  - Support for optical transport network (OTN) on 10-Gigabit Ethernet ports
  - Configurable LAN-PHY and WAN-PHY mode options per 10-Gigabit Ethernet port
  - Intelligent oversubscription services
  - See “[Protocols and Applications Supported by the MPC5E for MX Series Routers](#)” on page 388 for information about the protocols and applications that this MPC supports.

**NOTE:** On MX240, MX480, and MX960 routers, MPC5E powers on only if the **network-services** mode on the router is configured to either **enhanced-ip** or **enhanced-ethernet**. On MX2010 and MX2020 routers, only **enhanced-ip** is supported.

- Cables and connectors** **TIP:** You can use the [Hardware Compatibility Tool](#) to find information about the pluggable transceivers supported on your Juniper Networks device.

The list of supported transceivers for the MX Series is located at <https://pathfinder.juniper.net/hct/category/#catKey=100001&modelType;=All&pf;=MX+Series>.

**NOTE:** QSFPP-40GE-LX4 is not NEBS compliant on the MX960 router in FPC slot 0 or FPC slot 11.

- Power requirements**
- Typical: 9.68 A @ 48 V (460 W)
  - At different temperatures:
    - 55° C: 607 W
    - 40° C: 541 W
    - 25° C: 511 W

**LEDs**

**OK/FAIL LED, one bicolor:**

- Steady green—MPC is functioning normally.
- Blinking green—MPC is transitioning online or offline.
- Red—MPC has failed.

10-Gigabit Ethernet **LINK LED**, one green per port:

- Green—Link is up.
- Off—Link is down or disabled.

40-Gigabit Ethernet **LINK LED**, one bicolor per port:

- Green—Link is up.
- Yellow—Link is disabled.
- Off—Link is down.

**Related Documentation**

- [MX Series MPC Overview on page 11](#)
- [MPCs Supported by MX Series Routers on page 12](#)
- [MPC5E on MX Series Routers Overview](#)
- [10-Gigabit Ethernet OTN Options Configuration Overview](#)

## 2x100GE + 4x10GE MPC5E

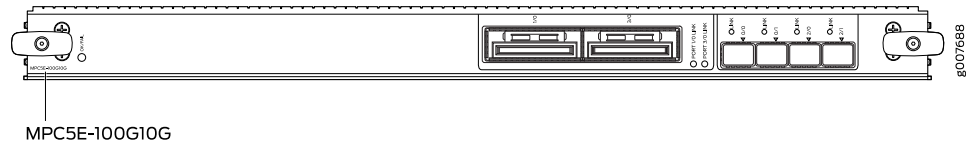

Software release

- Junos OS Release 13.3R3 and later

Description

- Fixed-configuration MPC with two 100-Gigabit Ethernet ports and four 10-Gigabit Ethernet ports
- Weight: 21 lb (9.52 kg)
- Model number: MPC5E-100G10G
- Name in the CLI: **MPC5E 3D 2CGE+4XGE**

Hardware features

- Line-rate throughput of up to 240 Gbps
- Supports up to 32,000 queues per-slot
- LAN-PHY mode at 10.3125 Gbps on a per-port basis
- WAN-PHY mode at 9.95328 Gbps on a per-port basis
- Supports maximum transmission unit (MTU) size of 9,192 bytes for host bound packets. For Junos OS 16.1R1 and later releases, the MTU size supported is 9,500 bytes.
- The ports are labeled as:
  - 10-Gigabit Ethernet ports: **0/0**, **0/1**, **2/0**, and **2/1**
  - 100-Gigabit Ethernet ports: **1/0** and **3/0**

**NOTE:** On MX960 routers, all the MPC slots work with the ambient temperature of up to 40° C. However, when the chassis temperature exceeds 40° C, slots **0** and **11** can work with MPC1s, MPC2s, and the 16x10GE MPC.

Software features

- Configurable LAN-PHY and WAN-PHY mode options per 10-Gigabit Ethernet port
- Optical diagnostics and related alarms
- Intelligent oversubscription services
- See “[Protocols and Applications Supported by the MPC5E for MX Series Routers](#)” on page 388 for information about the protocols and applications that this MPC supports.

**NOTE:** On MX240, MX480, and MX960 routers, MPC5E powers on only if the **network-services** mode on the router is configured to either **enhanced-ip** or **enhanced-ethernet**. On MX2010 and MX2020 routers, only **enhanced-ip** is supported.

Cables and connectors **TIP:** You can use the [Hardware Compatibility Tool](#) to find information about the pluggable transceivers supported on your Juniper Networks device.

The list of supported transceivers for the MX Series is located at <https://pathfinder.juniper.net/hct/category/#catKey=100001&modelType;=All&pf;=MX+Series>.

**NOTE:**

- CFP2-100G-ER4-D is not NEBS compliant on the MX960 router in FPC slot **0** or FPC slot **11**.
- CFP2-DCO-T-WDM-1 is not NEBS compliant on the MX960 router or the MX2020 router in FPC slot **0** or FPC slot **11**. Slots **0** and **11** can only work with an ambient temperature of up to 40° C.



Power requirements	<ul style="list-style-type: none"> <li>• Typical: 10.52 A @ 48 V (505 W)</li> <li>• At different temperatures: <ul style="list-style-type: none"> <li>55° C: 607 W</li> <li>40° C: 541 W</li> <li>25° C: 511 W</li> </ul> </li> </ul>
--------------------	---

LEDs	<p><b>OK/FAIL LED</b>, one bicolor:</p> <ul style="list-style-type: none"> <li>• Steady green—MPC is functioning normally.</li> <li>• Blinking green—MPC is transitioning online or offline.</li> <li>• Red—MPC has failed.</li> </ul> <p><b>10-Gigabit Ethernet LINK LED</b>, one bicolor per port:</p> <ul style="list-style-type: none"> <li>• Green—Link is up.</li> <li>• Yellow—Link is disabled.</li> <li>• Off—Link is down or disabled.</li> </ul> <p><b>100-Gigabit Ethernet LINK LED</b>, one bicolor per port:</p> <ul style="list-style-type: none"> <li>• Green—Link is up.</li> <li>• Yellow—Link is disabled.</li> <li>• Off—Link is down.</li> </ul>
------	---

<b>Related Documentation</b>	• <a href="#">MX Series MPC Overview on page 11</a>
	• <a href="#">MPCs Supported by MX Series Routers on page 12</a>
	• <a href="#">MPC5E on MX Series Routers Overview</a>
	• <a href="#">10-Gigabit Ethernet OTN Options Configuration Overview</a>
	• <a href="#">100-Gigabit Ethernet OTN Options Configuration Overview</a>

## 2x100GE + 4x10GE MPC5EQ

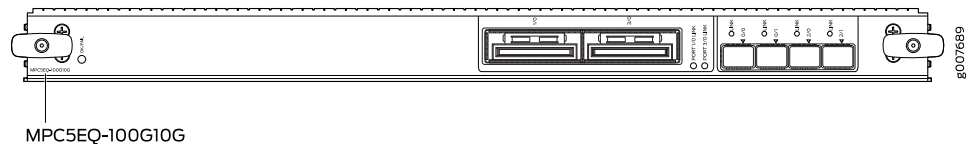

Software release	<ul style="list-style-type: none"> <li>• Junos OS Release 13.3R3 and later</li> </ul>
------------------	---

Description	<ul style="list-style-type: none"> <li>• Fixed-configuration MPC with two 100-Gigabit Ethernet ports and four 10-Gigabit Ethernet ports</li> <li>• Weight: 21 lb (9.52 kg)</li> <li>• Model number: MPC5EQ-100G10G</li> <li>• Name in the CLI: <b>MPC5E 3D Q 2CGE+4XGE</b></li> </ul>
-------------	---

- Hardware features**
- Line rate throughput of up to 240 Gbps
  - Supports up to 1 million queues per-slot
  - LAN-PHY mode at 10.3125 Gbps on a per-port basis
  - WAN-PHY mode at 9.95328 Gbps on a per-port basis
  - Supports maximum transmission unit (MTU) size of 9,192 bytes for host bound packets. For Junos OS 16.1R1 and later releases, the MTU size supported is 9,500 bytes.
  - The ports are labeled as:
    - 10-Gigabit Ethernet ports: **0/0**, **0/1**, **2/0**, and **2/1**
    - 100-Gigabit Ethernet ports: **1/0** and **3/0**

**NOTE:** On MX960 routers, all the MPC slots work with the ambient temperature of up to 40° C. However, when the chassis temperature exceeds 40° C, slots **0** and **11** can work with MPC1s, MPC2s, and the 16x10GE MPC.

- Software features**
- Supports hierarchical QoS (HQoS)
  - Configurable LAN-PHY and WAN-PHY mode options per 10-Gigabit Ethernet port
  - Optical diagnostics and related alarms
  - Intelligent oversubscription services
  - See “[Protocols and Applications Supported by the MPC5E for MX Series Routers](#)” on page 388 for information about the protocols and applications that this MPC supports.

**NOTE:** On MX240, MX480, and MX960 routers, MPC5E powers on only if the **network-services** mode on the router is configured to either **enhanced-ip** or **enhanced-ethernet**. On MX2010 and MX2020 routers, only **enhanced-ip** is supported.

- Cables and connectors** **TIP:** You can use the [Hardware Compatibility Tool](#) to find information about the pluggable transceivers supported on your Juniper Networks device.

The list of supported transceivers for the MX Series is located at <https://pathfinder.juniper.net/hct/category/#catKey=100001&modelType;=All&pf;=MX+Series>.

**NOTE:**

- CFP2-100G-ER4-D is not NEBS compliant on the MX960 router in FPC slot **0** or FPC slot **11**.
- CFP2-DCO-T-WDM-1 is not NEBS compliant on the MX960 router or the MX2020 router in FPC slot **0** or FPC slot **11**. Slots **0** and **11** can only work with an ambient temperature of up to 40° C.

- Power requirements**
- Typical: 10.52 A @ 48 V (505 W)
  - At different temperatures:
    - 55° C: 607 W
    - 40° C: 541 W
    - 25° C: 511 W

- LEDs
- OK/FAIL LED**, one bicolor:
- Steady green—MPC is functioning normally.
  - Blinking green—MPC is transitioning online or offline.
  - Red—MPC has failed.
- 10-Gigabit Ethernet LINK LED**, one bicolor per port:
- Green—Link is up.
  - Yellow—Link is disabled.
  - Off—Link is down or disabled.
- 100-Gigabit Ethernet LINK LED**, one bicolor per port:
- Green—Link is up.
  - Yellow—Link is disabled.
  - Off—Link is down.

- Related Documentation**
- [MX Series MPC Overview on page 11](#)
  - [MPCs Supported by MX Series Routers on page 12](#)
  - [MPC5E on MX Series Routers Overview](#)
  - [10-Gigabit Ethernet OTN Options Configuration Overview](#)
  - [100-Gigabit Ethernet OTN Options Configuration Overview](#)

## MPC6E

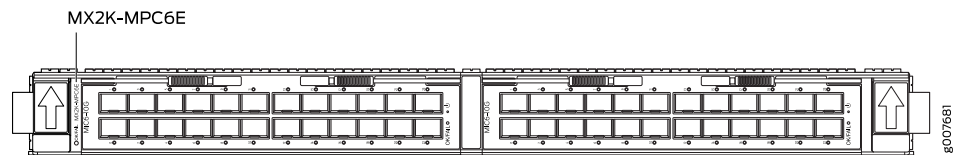

- Software release**
- Junos OS Release 13.3R2 and later
- For information about which MICs are supported on this MPC, "[MIC/MPC Compatibility](#)" on page 26.
- Description**
- Two slots for MICs
  - Weight: 27.4 lb (12.43 kg) (net weight without blank panels)
  - Model number: MX2K-MPC6E
  - Name in the CLI: **MPC6E 3D**
- Hardware features**
- Two slots for MICs
  - Line-rate throughput of up to 480 Gbps
  - Field-removable septum, to accommodate future full-height MICs
  - Supports maximum transmission unit (MTU) size of 9,192 bytes for host bound packets. For Junos OS 16.1R1 and later releases, the MTU size supported is 9,500 bytes.

Maximum Power Requirements	<p>Power requirement: 20.9 A @ 52 V (880 W; plus 104 W for each MIC)</p> <p>MX2K-MPC6E:</p> <ul style="list-style-type: none"> <li>• Typical: 648 W</li> <li>• 880 W at 55° C</li> <li>• 834 W at 40° C</li> <li>• 824 W at 25° C</li> </ul>
Software features	<ul style="list-style-type: none"> <li>• Optical diagnostics and related alarms</li> <li>• Configurable LAN-PHY and WAN-PHY mode options per 10-Gigabit Ethernet port</li> <li>• Two Packet Forwarding Engines for each MIC slot</li> <li>• Intelligent oversubscription services</li> <li>• See <a href="#">"Protocols and Applications Supported by the MPC6E for MX2000 Routers"</a> on page 394 for information about the protocols and applications that this MPC supports.</li> </ul>
LEDs	<p><b>OK/FAIL LED</b>, one bicolor:</p> <ul style="list-style-type: none"> <li>• Steady green—MPC is functioning normally.</li> <li>• Blinking green—MPC is transitioning online or offline.</li> <li>• Red—MPC has failed.</li> </ul> <p><b>LINK LED</b>, one bicolor per port:</p> <ul style="list-style-type: none"> <li>• Green—Link is up.</li> <li>• Yellow—Link is disabled.</li> <li>• Off—Link is down.</li> </ul>

- Related Documentation**
- [MX Series MPC Overview on page 11](#)
  - [MPCs Supported by MX Series Routers on page 12](#)
  - [MPC6E on MX Series Routers Overview](#)

## MPC7E (Multi-Rate)

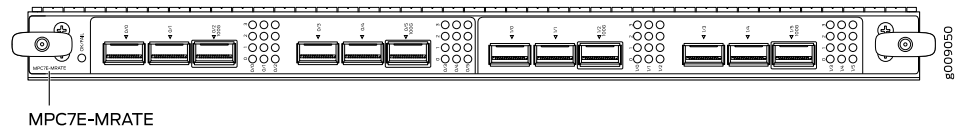

- Software release**
- Junos OS Release 15.1F4 with Junos Continuity.
  - Junos OS Release 15.1F6 and later.
  - Junos OS release 16.1R1 and later.

- Description**
- Fixed-configuration MPC with 10-Gbps, 40-Gbps, and 100-Gbps port speeds
  - Weight: 15.7 lb (7.12 kg)
  - Model number: MPC7E-MRATE
  - Name in the CLI: **MPC7E-MRATE**

## Hardware features

- Line-rate throughput of up to 480 Gbps on MX240, MX480, and MX960 routers.
- Line-rate throughput of up to 400 Gbps on MX2000 routers with SFB, and up to 430 Gbps on MX2000 routers with SFB2.
- Junos Trio chipsets for increased scaling for bandwidth, subscribers, and services
- Twelve Gigabit Ethernet ports that can be configured as 40-Gigabit Ethernet port or as 4 10-Gigabit Ethernet port using a breakout cable. The ports support quad small-form factor pluggable plus (QSFP+) transceivers.
- Four out of the twelve ports can be configured as 100-Gigabit Ethernet ports. Port numbers **0/2**, **0/5**, **1/2** and **1/5** are the four 100-Gigabit Ethernet ports.
- You can configure different combination of port speeds as long as the aggregate capacity per group of six ports labeled **0/0** through **0/5** does not exceed 240 Gbps. Similarly, aggregate capacity per group of the other six ports labeled **1/0** through **1/5** should not exceed 240 Gbps.
- Requires high-capacity power supplies, high-capacity fan trays, and SCBE2 on MX240, MX480, and MX960 routers.
- Requires an adapter card to be housed in MX2000 routers.
- The ports are labeled as (with the MPC orientation as shown in the above figure):
  - 10-Gigabit Ethernet or 40-Gigabit Ethernet ports:  
**0/0**, **0/1**, **0/2 100G**, **0/3**, **0/4**, **0/5 100G**, **1/0**, **1/1**, **1/2 100G**, **1/3**, **1/4**, and **1/5 100G**
  - 100-Gigabit Ethernet ports:  
**0/2 100G**, **0/5 100G**, **1/2 100G** and **1/5 100G**

**NOTE:** Only ports marked **100G** support 100-Gigabit Ethernet speed using QSFP28 transceivers.

- Supports maximum transmission units (MTUs) from 256 bytes through 16,000 bytes for transit traffic, and from 256 bytes through 9,500 bytes for host bound packets.

**NOTE:** On MX960 routers, all the MPC slots can be occupied by MPC7E (Multi-Rate) at an ambient temperature of up to 40° C and at any altitude. All the MPC slots can be occupied by MPC7E (Multi-Rate) at temperatures of up to 55° C and at sea level. At an ambient temperature of 55° C and above, and at an altitude above sea level, slot 11 cannot host MPC7E (Multi-Rate).

## Software features

- Supports rate selectability at the port level.
- By default, the ports are configured as 10-Gigabit Ethernet ports.
- Optical diagnostics and related alarms
- See “[Protocols and Applications Supported by the MPC7E for MX Series Routers](#)” on page 401 for information about the protocols and applications that the MPC7E supports.

**NOTE:** On MX240, MX480, and MX960 routers, MPC7E powers on only if the **network-services** mode on the router is configured as either **enhanced-ip** or **enhanced-ethernet**. On MX2000 router no additional configuration is required as by default the router operates in **enhanced-ip** mode.

## Cables and connectors

**TIP:** You can use the [Hardware Compatibility Tool](#) to find information about the pluggable transceivers supported on your Juniper Networks device.

The list of supported transceivers for the MX Series is located at <https://pathfinder.juniper.net/hct/category/#catKey=100001&modelType;=All&pf;=MX+Series>.

## Power requirements

- At different temperatures:
  - 55° C: 545 W
  - 40° C: 465 W
  - 25° C: 440 W

## LEDs

**OK/FAIL LED**, one bicolor:

- Steady green—MPC is functioning normally.
- Yellow—MPC has failed.

**LINK LED**, one green per port (4 per QSFP+ cage):

- Steady green—Link is up.
- Off—Link is down or disabled.

**Related Documentation**

- [MPC7E \(Multi-Rate\) on MX Series Routers Overview](#)
- [MX Series MPC Overview on page 11](#)
- [MPCs Supported by MX Series Routers on page 12](#)
- [Junos Continuity Software User Guide \(Junos OS Release 14.1R4 and Later Releases\)](#)

## MPC7E 10G

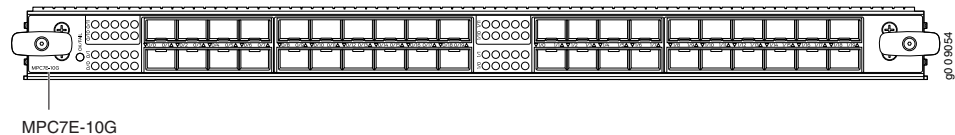

**Software release**

- Junos OS Release 15.1F5 with Junos Continuity
- Junos OS release 16.1R1 and later

**Description**

- Fixed-configuration MPC with forty 10-Gbps ports
- Weight: 17 lb (7.7 kg)
- Model number: MPC7E-10G
- Name in the CLI: **MPC7E 3D 40XGE**

**Hardware features**

- Line-rate throughput of up to 400 Gbps on MX240, MX480, and MX960 routers.
- Line-rate throughput of up to 400 Gbps on MX2000 routers.
- Junos Trio chipsets for increased scaling for bandwidth, subscribers, and services.
- Forty 10-Gigabit Ethernet ports. The ports support SFP+ transceivers.
- Requires high-capacity power supplies, high-capacity fan trays, and SCBE2 on MX240, MX480, and MX960 routers.
- Requires an adapter card to be housed in MX2000 routers.
- Supports maximum transmission units (MTUs) from 256 bytes through 16,000 bytes for transit traffic, and from 256 bytes through 9,500 bytes for host bound packets.
- The ports are labeled as (with the MPC orientation as shown in the figure):
  - 0/0 through 0/9
  - 0/10 through 0/19
  - 1/0 through 1/9
  - 1/10 through 1/19

**Software features**

- Supports MACsec using the following encryption algorithms: gcm-aes-128 and gcm-aes-256.
- Supports **Hyper mode** to speed up packet processing.
- Supports **Flexible queuing** using an add-on license to support 32,000 queues per line card, including queues on both ingress and egress interfaces. You can use an additional license to support up to 512,000 queues.
- Optical diagnostics and related alarms
- See “[Protocols and Applications Supported by the MPC7E for MX Series Routers](#)” on page 401 for information about the protocols and applications that MPC7Es support.

**NOTE:** On MX240, MX480, and MX960 routers, MPC7E powers on only if the **network-services** mode on the router is configured as either **enhanced-ip** or **enhanced-ethernet**. On MX2000 routers, no additional configuration is required because by default the router operates in **enhanced-ip** mode.

**Cables and connectors**

**TIP:** You can use the [Hardware Compatibility Tool](#) to find information about the pluggable transceivers supported on your Juniper Networks device.

The list of supported transceivers for the MX Series is located at <https://pathfinder.juniper.net/hct/category/#catKey=100001&modelType;=All&pf;=MX+Series>.

- 10GBASE-ZR (model number: SFPP-10G-ZR-OTN-XT)

**NOTE:** MPC7E 10G does not support OTN rates.

- 10GBASE-ZR (model number: SFPP-10G-DT-ZRC2)

**NOTE:**

- Supported from Junos OS release 16.1R1 and later.
- Supports 40° C ambient temperature operation at any altitude, and 55° C ambient temperature operation at sea level.

**Power requirements**

- Typical: 405 W
- At different temperatures:
  - 55° C: 500 W
  - 40° C: 465 W
  - 25° C: 430 W

**NOTE:** On MX960 routers, all the MPC slots can be occupied by MPC7E 10G at an ambient temperature of up to 40° C and at any altitude. All the MPC slots can be occupied by MPC7E 10G at temperatures of up to 55° C and at sea level. At an ambient temperature of 55° C and above, and at an altitude above sea level, slot 11 cannot host MPC7E 10G.

**LEDs**

**OK/FAIL LED**, one bicolor:

- Steady green—MPC is functioning normally.
- Yellow—MPC has failed.

**Link LED**, one green per port:

- Steady green—Link is up.
- Off—Link is down or disabled.

**Related Documentation**

- [MPC7E 10G on MX Series Routers Overview](#)
- [MX Series MPC Overview on page 11](#)
- [MPCs Supported by MX Series Routers on page 12](#)
- [Junos Continuity Software User Guide \(Junos OS Release 14.1R4 and Later Releases\)](#)

## MPC8E

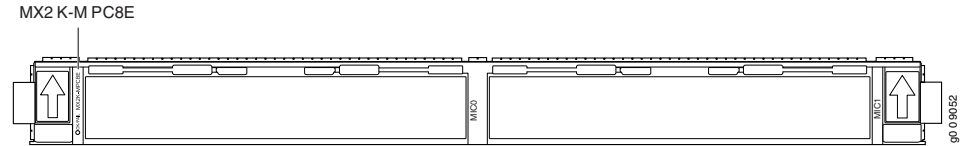

Software release	<ul style="list-style-type: none"> <li>Junos OS Release 15.1F5 with Junos Continuity</li> <li>Junos OS release 16.1R1 and later</li> </ul>
Description	<ul style="list-style-type: none"> <li>Weight: 31.4 lb (14.24 kg) (net weight without blank panels)</li> <li>Model number: MX2K-MPC8E</li> <li>Name in the CLI: <b>MPC8E 3D</b></li> </ul>
Hardware features	<ul style="list-style-type: none"> <li>Line-rate throughput of up to 960 Gbps on the MX2000 routers.</li> <li>Line-rate throughput of up to 1600 Gbps (1.6 Tbps) on the MX2000 routers with software upgrade.</li> </ul> <p><b>NOTE:</b> Starting from Junos OS Release 16.1R1, you can upgrade MPC8E to provide an increased bandwidth of 1600 Gbps (1.6 Tbps) by using an add-on license. After you perform the upgrade, MPC8E provides a bandwidth of 1.6 Tbps, which is equivalent to the bandwidth of "MPC9E" on page 135. However, the MPC continues to be identified as MPC8E.</p> <ul style="list-style-type: none"> <li>Four Packet Forwarding Engines, each providing a maximum bandwidth of 240 Gbps in normal mode and 400 Gbps in 1.6Tbps upgraded mode. A license is required to operate in 1.6 Tbps upgraded mode.</li> <li>Supports two MICs. For information about which MICs are supported on this MPC, see "MIC/MPC Compatibility" on page 26.</li> <li>Junos Trio chipsets for increased scaling for bandwidth, subscribers, and services.</li> <li>Supports the Switch Fabric Boards SFB and SFB2. When MPC8E is used with SFB, the line-rate throughput is limited to 800 Gbps.</li> <li>Supports maximum transmission units (MTUs) from 256 bytes through 16,000 bytes for transit traffic, and from 256 bytes through 9,500 bytes for host bound packets.</li> </ul>
Software features	<ul style="list-style-type: none"> <li><b>Dynamic power management</b> for effective utilization of available power.</li> <li><b>Inline flow monitoring</b> for higher scalability and performance.</li> <li><b>Flexible queuing</b> using an add-on license to support 32,000 queues per line card, including queues on both ingress and egress interfaces. You can use an additional license to support up to 512,000 queues per slot or 1,000,000 queues per slot.</li> <li><b>Hyper mode</b> to speed up packet processing.</li> <li>Optical diagnostics and related alarms.</li> </ul> <p>For more information about features supported on MPC8E, see "Protocols and Applications Supported by the MPC8E and MPC9E on the MX2010 and MX2020 Routers" on page 410.</p>



Power requirements Normal mode with line-rate throughput of 960 Gbps:

(without MICs)

- Typical: 688 W
- At different temperatures:
  - 55° C: 805 W
  - 40° C: 720 W
  - 25° C: 690 W

Upgrade mode with line-rate throughput of 1.6 Tbps:

- Typical: 838 W
- At different temperatures:
  - 55° C: 1018 W
  - 40° C: 870 W
  - 25° C: 840 W

LEDs

OK/FAIL LED, one bicolor:

- Steady green—MPC is functioning normally.
- Yellow—MPC has failed.

#### Related Documentation

- [MPC8E on MX Series Routers Overview](#)
- [MX Series MPC Overview on page 11](#)
- [MPCs Supported by MX Series Routers on page 12](#)
- [Junos Continuity Software User Guide \(Junos OS Release 14.1R4 and Later Releases\)](#)
- [Understanding Rate Selectability](#)

## MPC9E

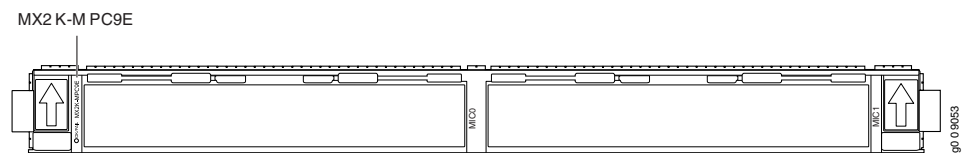

Software release

- Junos OS Release 15.1F5 with Junos Continuity
- Junos OS release 16.1R1 and later

Description

- Weight: 31.4 lb (14.24 kg) (net weight without blank panels)
- Model number: MX2K-MPC9E
- Name in the CLI: **MPC9E 3D**

- Hardware features**
- Line-rate throughput of up to 1600 Gbps (1.6 Tbps) on MX2000 routers.
  - Four Packet Forwarding Engines, each providing a maximum bandwidth of 400 Gbps.
  - Supports two MICs. For information about which MICs are supported on this MPC, see [“MIC/MPC Compatibility” on page 26](#).
  - Junos Trio chipsets for increased scaling for bandwidth, subscribers, and services
  - Supports the Switch Fabric Boards SFB and SFB2. When MPC9E is used with SFB, the line-rate throughput is limited to 800 Gbps.
  - Supports maximum transmission units (MTUs) from 256 bytes through 16,000 bytes for transit traffic, and from 256 bytes through 9,500 bytes for host bound packets.

- Software features**
- *Dynamic Power Management* for effective utilization of available power.
  - *Inline Active Flow Monitoring* for higher scalability and performance.
  - *Flexible Queuing Mode* using an add-on license to support 32,000 queues per line card, including queues on both ingress and egress interfaces. You can use an additional license to support up to 512,000 queues per slot or 1,000,000 queues per slot.
  - *Hyper Mode* to speed up packet processing.
  - Optical diagnostics and related alarms.

For more information about features supported on MPC9E, see [“Protocols and Applications Supported by the MPC8E and MPC9E on the MX2010 and MX2020 Routers” on page 410](#).

- Power requirements**  
(without MICs)
- Typical: 838 W
  - At different temperatures:  
55° C: 1018 W  
40° C: 870 W  
25° C: 840 W

- LEDs**
- OK/FAIL LED, one bicolor:
- Steady green—MPC is functioning normally.
  - Yellow—MPC has failed.

- Related Documentation**
- [MPC9E on MX Series Routers Overview](#)
  - [MX Series MPC Overview on page 11](#)
  - [MPCs Supported by MX Series Routers on page 12](#)
  - [Junos Continuity Software User Guide \(Junos OS Release 14.1R4 and Later Releases\)](#)
  - [Understanding Rate Selectability](#)

## MX10003 MPC (Multi-Rate)

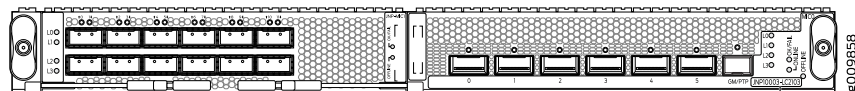

JNP10003-LC2103

- Software release**
- Junos OS release 17.3R1 and later

Description	<ul style="list-style-type: none"> <li>Weight: 30 lb (13.61 kg) (net weight without blank panel and without any MIC in slot 1)</li> <li>Model number: MX10003-LC2103</li> <li>Power requirement: <ul style="list-style-type: none"> <li>715 W at 55° C</li> <li>660 W at 25° C</li> </ul> </li> <li>Name in the CLI: <b>LC2103</b></li> </ul>
Hardware features	<ul style="list-style-type: none"> <li>The MX10003 MPC is a 1.2-Terabit capable MPC with three Packet Forwarding Engine complexes (that is, three EA ASICs). The EA ASIC operates in 400G mode.</li> <li>The Packet Forwarding Engine is based on the third generation of the Trio chipset architecture---namely, the EA (Eagle) ASIC. The Packet Forwarding Engine offers 400 Gbps of WAN and fabric bandwidth each.</li> <li>MX10003 MPC has six built-in QSFP+ optics ports, and one MIC slot.</li> <li>Supports Multi-Rate Ethernet Modular Interface Card (MIC) (model numbers: JNP-MIC1 and JNP-MIC1-MACSEC), and the fixed-port PIC (6xQSFP). For information about which MICs are supported on this MPC, see “MIC/MPC Compatibility” on page 26.</li> <li>Supports maximum transmission units (MTUs) from 256 bytes through 16,000 bytes for transit traffic, and from 256 bytes through 9,500 bytes for host bound packets.</li> </ul>
Software features	<ul style="list-style-type: none"> <li><i>Dynamic Power Management</i> for effective utilization of available power.</li> <li><i>Inline Active Flow Monitoring</i> for higher scalability and performance.</li> <li><i>Flexible Queuing Mode</i> to support 32,000 queues per line card, including queues on both ingress and egress interfaces. Supports up to 512,000 queues per slot or 768,000 queues per slot.</li> <li><i>Hyper Mode</i> to speed up packet processing.</li> <li>Optical diagnostics and related alarms.</li> </ul> <p>For more information about features supported on MX10003 MPC, see “Protocols and Applications Supported by the MX10003 MPC (Multi-Rate) on the MX10003 Router” on page 419.</p>
Cables and connectors	<p><b>TIP:</b> You can use the <a href="#">Hardware Compatibility Tool</a> to find information about the pluggable transceivers supported on your Juniper Networks device.</p> <p>The list of supported transceivers for the MX Series is located at <a href="https://pathfinder.juniper.net/hct/category/#catKey=100001&amp;modelType;=All&amp;pf;=MX+Series">https://pathfinder.juniper.net/hct/category/#catKey=100001&amp;modelType;=All&amp;pf;=MX+Series</a>.</p>
Power requirements (without MICs)	<ul style="list-style-type: none"> <li>At different temperatures: <ul style="list-style-type: none"> <li>55° C: 715 W</li> <li>25° C: 660 W</li> </ul> </li> </ul>
LEDs	<p><b>OK/FAIL LED</b>, one bicolor:</p> <ul style="list-style-type: none"> <li>Steady green—MPC is functioning normally and the link is up.</li> <li>Off—MPC is plugged-in but not powered on.</li> <li>Red—MPC has failed.</li> </ul> <p>For information on the lane LEDs (<b>L0</b>, <b>L1</b>, <b>L2</b>, and <b>L3</b>), see <i>MPC and MIC Lane LED Scheme Overview</i>.</p>

Table 23 on page 138 summarize the port speed capability of MX10003 MPCs.

Table 23: MX10003 MPC (Multi-Rate) Port Speed

MIC	Port Number	Port Speed Supported
PIC 0	0-5	40 Gigabit Ethernet 4X10-Gigabit Ethernet
PIC 1	0-11	100 Gigabit Ethernet 40 Gigabit Ethernet 4X10-Gigabit Ethernet

- Related Documentation**
- [MPC and MIC Lane LED Scheme Overview](#)
  - [Configuring Rate Selectability on MX10003 MPC to Enable Different Port Speeds](#)
  - [MX10003 MPC Rate-Selectability Overview](#)
  - [Understanding Interface Naming Conventions for MX10003 MPC](#)
  - [Understanding Rate Selectability](#)
  - [MX Series MPC Overview on page 11](#)
  - [MPCs Supported by MX Series Routers on page 12](#)
  - [Replacing an MX10003 MIC](#)

## MX10K-LC2101

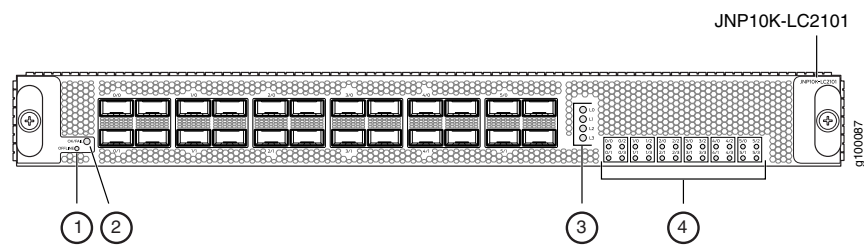

1— OFFLINE button	3— Lane LEDs
2— OK/FAIL LED	4— Port LEDs

Software release Junos OS Release 18.2R1 and later

Description

- Weight: 31.57 lbs (14.32 Kgs)
- Model number: JNP10K-LC2101
- Name in the CLI: **JNP10K-LC2101**
- Dimensions: Height = 1.89 in (48.01 mm), Width = 17.2 in (436.88 mm), Depth = 19.05 in (484 mm) (Excluding FRU Ejector)

Hardware features	<ul style="list-style-type: none"> <li>• Fixed-configuration MPC with 10-Gbps, 40-Gbps, and 100-Gbps port speeds.</li> <li>• All the ports are multi-rate ports. Each port is capable of supporting either 100-Gbps or 40-Gbps or 10-Gbps (4x10-Gbps with breakout cable).</li> <li>• Line-rate throughput of up to 2.4 Tbps.</li> <li>• Six Packet Forwarding Engines, each providing a maximum bandwidth of 400 Gbps.</li> <li>• EA chipsets for increased scaling for bandwidth, subscribers, and services.</li> <li>• Supports the Switch Fabric Boards, JNP10008-SF and JNP10016-SF.</li> <li>• Supports maximum transmission units (MTUs) from 256 bytes through 16,000 bytes for transit traffic, and from 256 bytes through 9,500 bytes for host bound packets.</li> </ul>
Software features	<ul style="list-style-type: none"> <li>• Supports rate selectability at the port level.</li> <li>• By default, the ports are configured as 10-Gigabit Ethernet ports.</li> <li>• Optical diagnostics and related alarms.</li> </ul>
Power requirements	<p>Line-rate throughput of 4.0 Tbps:</p> <ul style="list-style-type: none"> <li>• Power consumption At different temperatures: 40° C: 1335 W 25° C: 1425 W</li> </ul>
LEDs	<p><b>OK/FAIL LED</b>, one bicolor:</p> <ul style="list-style-type: none"> <li>• Steady green—MPC is functioning normally.</li> <li>• Yellow—MPC has failed.</li> </ul> <p><b>Port LED—Link</b></p> <ul style="list-style-type: none"> <li>• Off—Port not enabled.</li> <li>• Green—Port link is up with no alarms or failures.</li> <li>• Red—Port link is down with alarms.</li> </ul> <p><b>NOTE:</b> When a QSFP+ port is configured for the 10-Gigabit mode with a breakout cable, the link status for 10-Gigabit port is indicated with the addition of 4 LEDs provided on the line card. The lane LEDs for the corresponding port indicates the port status.</p> <p>Like the port status LED, each individual lane LED support four states as: OFF, AMBER, GREEN, RED. See <i>MPC and MIC Lane LED Scheme Overview</i> for more details.</p> <p>For the 40-Gigabit mode the lane number LED is not applicable. The port LED indicates the port status irrespective of whichever lane number LED is ON.</p>
Cables and connectors	<p><b>TIP:</b> You can use the <a href="#">Hardware Compatibility Tool</a> to find information about the pluggable transceivers supported on your Juniper Networks device.</p> <p>The list of supported transceivers for the MX Series is located at: <a href="#">MX Series Supported Transceivers</a>.</p>



## CHAPTER 9

# MX Series MIC Descriptions

- ATM MIC with SFP on page 142
- DS3/E3 MIC on page 145
- Gigabit Ethernet MIC with SFP on page 149
- Gigabit Ethernet MIC with SFP (E) on page 152
- Gigabit Ethernet MIC with SFP (EH) on page 156
- 10-Gigabit Ethernet MICs with XFP on page 157
- 10-Gigabit Ethernet MIC with SFP+ (10 Ports) on page 159
- 10-Gigabit Ethernet MIC with SFP+ (24 Ports) on page 161
- 10-Gigabit Ethernet OTN MIC with SFP+ (24 Ports) on page 162
- 40-Gigabit Ethernet MIC with QSFP+ on page 164
- 100-Gigabit Ethernet MIC with CFP on page 165
- 100-Gigabit Ethernet MIC with CXP on page 167
- 100-Gigabit Ethernet MIC with CXP (4 Ports) on page 168
- 100-Gigabit Ethernet MIC with CFP2 on page 169
- 100-Gigabit DWDM OTN MIC with CFP2-ACO on page 171
- Channelized SONET/SDH OC3/STM1 (Multi-Rate) MICs with SFP on page 180
- Channelized OC3/STM1 (Multi-Rate) Circuit Emulation MIC with SFP on page 185
- Channelized OC3/STM1 (Multi-Rate) Circuit Emulation MIC with SFP (H) on page 187
- Channelized E1/T1 Circuit Emulation MIC on page 190
- Channelized E1/T1 Circuit Emulation MIC (H) on page 193
- Tri-Rate MIC on page 196
- MIC MRATE on page 200
- Multiservices MIC on page 202
- SONET/SDH OC3/STM1 (Multi-Rate) MICs with SFP on page 204
- Multi-Rate Ethernet MIC on page 208
- Multi-Rate Ethernet MIC on page 211
- SONET/SDH OC192/STM64 MIC with XFP on page 213

## ATM MIC with SFP

Figure 8: 8-Port ATM MIC with SFP

MIC-3D-OCx-ATM

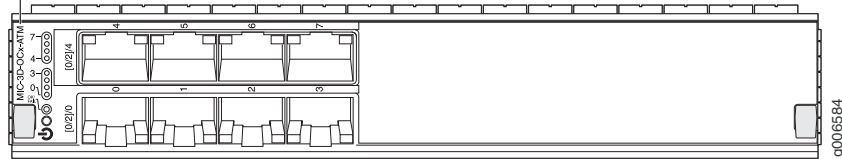

Software release	<ul style="list-style-type: none"> <li>Junos 12.1 and later</li> </ul> <p>For information on which MPCs support this MIC, see <a href="#">“MIC/MPC Compatibility” on page 26</a>. For information on which MICs are supported on MX Series routers, see <a href="#">“MICs Supported by MX Series Routers” on page 18</a>.</p>
Description	<ul style="list-style-type: none"> <li>Rate-selectable using one of the following rates:             <ul style="list-style-type: none"> <li>8-port OC3</li> <li>2-port OC12</li> </ul> </li> <li>Power requirement: 0.73 A @ 48 V (35 W)</li> <li>Weight: 1.2 lb (0.54 kg)</li> <li>Model number: MIC-3D-8OC3-2OC12-ATM</li> <li>Name in the CLI: <b>3D 8OC3 2OC12 ATM</b></li> </ul>
Hardware features	<ul style="list-style-type: none"> <li>High-performance parsing of SONET/SDH frames</li> <li>Packet segmentation and reassembly (SAR) management and output port queuing</li> <li>Packet buffering, Layer 2 parsing</li> <li>Line rate throughput for each port</li> </ul>



## Software features

- Circuit cross-connect (CCC) for leveraging ATM access networks
- User-configurable virtual circuit (VC) and virtual path (VP) support
- Support for idle cell or unassigned cell transmission
- OAM fault management processes alarm indication signal (AIS), remote defect indication (RDI) cells, and loop cells
- Point-to-point and point-to-multipoint mode Layer 2 counters per VC and per VP
- Local and remote loopback
- Simple Network Management Protocol (SNMP):
  - Management Information Base (MIB) 2 (RFC 1213)
  - ATM MIB (RFC 1695)
  - SONET MIB
  - PWE3 MIB (RFC 5603)
  - PW-ATM-MIB (RFC 5605)
  - PW-FRAME-MIB (RFC 5601)
  - MIB for CoS
- Unspecified bit rate (UBR), non-real-time variable bit rate (VBR), and constant bit rate (CBR) traffic shaping
- Per-VC or per-VP traffic shaping
- Support for F4 OAM cells (AIS, RDI, Loopback, and Continuity Check)
- Support for F5 OAM cells (AIS, RDI, Loopback, and Continuity Check)
- Support for 16 bit VCI range
- Encapsulations:
  - atm-ccc-cell-relay (Junos 12.1 and later)
  - atm-ccc-vc-mux (Junos 12.1 and later)
  - atm-snap (Junos 12.2 and later)
  - atm-vc-mux (Junos 12.2 and later)
  - atm-tcc-snap (Junos 13.3 and later)
  - atm-tcc-vc-mux (Junos 13.3 and later)
  - vlan-vci-ccc (Junos 16.1 and later)
  - ether-over-atm-llc
  - ppp-over-ether-over-atm-llc
  - atm-ppp-vc-mux

**NOTE:** Inline MLPPP is not supported on this MIC.

## Cables and connectors

**TIP:** You can use the [Hardware Compatibility Tool](#) to find information about the pluggable transceivers supported on your Juniper Networks device.

The list of supported transceivers for the MX Series is located at <https://pathfinder.juniper.net/hct/category/#catKey=100001&modelType;=All&pf;=MX+Series>.

---

LEDs	<p><b>OK/FAIL LED</b>, one bicolor:</p> <ul style="list-style-type: none"><li>• Green—MIC is functioning normally.</li><li>• Red—MIC has failed.</li></ul> <p>Link LED, one green per port:</p> <ul style="list-style-type: none"><li>• Off—No link.</li><li>• On steadily—Link is up.</li><li>• Blinking—Online with alarms for remote failures</li><li>• Blinking rapidly—Active with a local alarm; router has detected a failure</li></ul>
Alarms, errors, and events	<ul style="list-style-type: none"><li>• Alarm indication signal—line (AIS-L)</li><li>• Alarm indication signal—path (AIS-P)</li><li>• Bit error rate—signal degrade (BERR-SD)</li><li>• Bit error rate—signal fail (BERR-SF)</li><li>• Loss of cell delineation (LOC)</li><li>• Loss of frame (LOF)</li><li>• Loss of pointer (LOP-P)</li><li>• Loss of signal (LOS)</li><li>• Payload mismatch (PLM-P)</li><li>• Payload unequipped (unequipped STS at path level) (UNEQ-P)</li><li>• Remote defect indication—line (RDI-L)</li><li>• Remote defect indication—path (RDI-P)</li><li>• Error detection:<ul style="list-style-type: none"><li>• Bit interleaved parity errors B1, B2, B3</li><li>• Errored seconds (ES-S, ES-L, ES-P)</li><li>• Far-end bit errors, remote error indication—line (REI-L), far-end line coding violations (CV-LFE)</li><li>• Far-end bit errors, remote error indication—path (REI-P), far-end path coding violations (CV-PFE)</li><li>• Far-end errored seconds (ES-LFE, ES-PFE)</li><li>• Far-end severely errored seconds (SES-LFE, SES-PFE)</li><li>• Far-end unavailable seconds (UAS-LFE, UAS-PFE)</li><li>• Severely errored framing (SEF)</li><li>• Severely errored framing seconds (SEFS-S)</li><li>• Severely errored seconds (SES-S, SES-L, SES-P)</li><li>• Unavailable seconds (UAS-L, UAS-P)</li></ul></li></ul>

---



**NOTE:** MIC-3D-8OC3-2OC12-ATM Revision 8 and Revision 22 are supported only by the following Junos OS releases:

- Junos OS Release 12.3—12.3R9 and later
- Junos OS Release 13.3—13.3R6 and later
- Junos OS Release 14.1—14.1R4 and later
- Junos OS Release 14.2—14.2R3 and later
- Junos OS Release 15.1 and later

You must upgrade to a supported Junos OS release to use MIC-3D-8OC3-2OC12-ATM Revision 8 and Revision 22 and later.

**Related Documentation**

- [MX Series MIC Overview on page 17](#)

## DS3/E3 MIC

*Figure 9: DS3/E3 MIC*

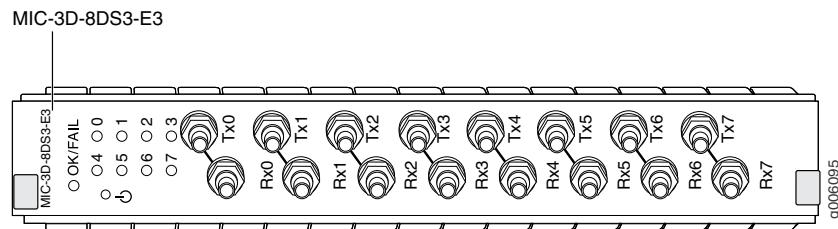

**Software release**

- Junos OS Release 11.4 and later

For information on which MPCs support this MIC, see [“MIC/MPC Compatibility” on page 26](#). For information on which MICs are supported on MX Series routers, see [“MICs Supported by MX Series Routers” on page 18](#).

## Description

- Eight E3 or DS3 ports
- DS3/E3 MIC ports can be configured as one of the following:
  - 8 clear-channel DS3 ports
  - 8 channelized DS3 ports
  - 8 clear-channel E3 ports

**NOTE:** You can upgrade the DS3/E3 MIC with the S-MIC-3D-8CHDS3 software license (purchased separately) to support DS3 channelization. Channelized DS3/E3 MIC is supported only on queuing MPCs. On the MX80 router, you also need an S-MX80-Q software license.

- DS3 or E3 is configurable on a per-port granularity
- DS3 channelization for the 8-port Channelized DS3/E3 MIC:
  - 8 DS3 channels
  - 224 DS1 channels
  - 2038 DS0 channels
- Power requirement: 4.0 A @ 9 V (36W)
- Weight: 4.4 lb (2 kg)
- Model numbers:
  - DS3/E3 MIC: MIC-3D-8DS3-E3
  - Channelized DS3/E3 MIC: MIC-3D-8CHDS3-E3-B

## Hardware features

- Ports are numbered 0 through 7, Tx0 through Tx7 and Rx0 through Rx7
-

## Software features

- Maximum transmission units (MTUs) of up to 9192 bytes
- Framing: M13, C-bit parity, framed clear channel
- Subrate and scrambling:

**NOTE:** Only DS3 interfaces support subrate and scrambling.

- Digital Link/Quick Eagle
- Kentrox
- Larscom
- ADTRAN
- Verilink
- Internal and look clocking
- DS3 far-end alarm and control (FEAC) channel
- Full bit error rate test (BERT) for DS0, DS1, and DS3
- Encapsulations:
  - MPLS fast reroute
  - MPLS CCC (circuit cross-connection)
  - MPLS TCC (translational cross-connection)
  - Cisco High-Level Data Link Control (cHDLC)
  - Cisco HDLC CCC
  - Cisco HDLC TCC
  - Point-to-Point Protocol (PPP)
  - PPP for CCC
  - PPP for TCC
  - Flexible Frame Relay
  - Frame Relay
  - Frame Relay for CCC
  - Frame Relay for TCC
  - PPP over Frame Relay

**NOTE:** Ethernet over Frame Relay is not supported.

- Encapsulations available only for Channelized DS3/E3 MIC (Junos OS Release 12.1 and later):
  - Multilink Point-to-Point Protocol (MLPPP)
  - Multiclass MLPPP
  - Multilink Frame Relay (MLFR) end-to-end (FRF.15)
  - Multilink Frame Relay (MLFR) UNI NNI (FRF.16, also referred to as MFR)
  - Compressed Real-Time Transport Protocol (CRTP)

**NOTE:** When you configure multilink services on a MIC in an MX Series router, ensure that a Multiservices DPC is present in the same router.

## Cables and connectors

**TIP:** You can use the [Hardware Compatibility Tool](#) to find information about the pluggable transceivers supported on your Juniper Networks device.

The list of supported transceivers for the MX Series is located at <https://pathfinder.juniper.net/hct/category/#catKey=100001&modelType;=All&pf;=MX+Series>.

- Coaxial:
  - Custom 10-ft (3-m) mini-SMB to BNC cable (model number: CBL-DS3-E3-M-S), set of 8 cables (bundled RX and TX)

**LEDs****OK/FAIL LED, one bicolor:**

- Green—MIC is functioning normally
- Red—MIC has failed

**Link LED, one green per port:**

- Off—Not enabled
- Green—Online with no alarms or failures
- Yellow—Online with alarms for remote failures
- Red—Active with a local alarm; router has detected a failure

**Alarms, errors, and events****DS3 alarms:**

- Alarm indication signal (AIS)
- Loss of frame (LOF)
- Loss of signal seconds (LOS)
- Phase lock loop (PLL)

**DS3 error detection:**

- C-bit code violations (CCV)
- C-bit errored seconds (CES)
- C-bit severely errored seconds (CSES)
- CRC errors
- Excessive zeros (EXZ)
- Far-end block error (FEBE)
- Far-end receive failure (FERF)
- Line errored seconds (LES)
- Parity bit (P-bit) code violations (PCV)
- Parity bit (P-bit) errored seconds (PES)
- Parity bit (P-bit) severely errored framing seconds (PSES)
- Severely errored framing seconds (SEFS)
- Unavailable seconds (UAS)

---

**Related Documentation**

- [MX Series MIC Overview on page 17](#)

## Gigabit Ethernet MIC with SFP

Figure 10: 20-Port Gigabit Ethernet MIC with SFP

MIC-3D-20GE-SFP

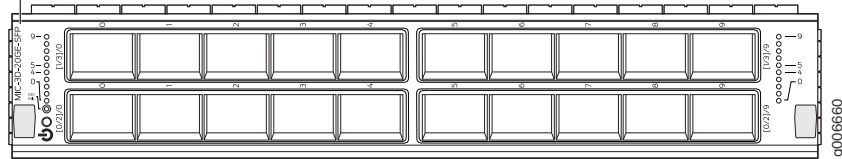

Software release	<ul style="list-style-type: none"> <li>Junos 10.1 and later</li> </ul> <p>For information on which MPCs support this MIC, see <a href="#">“MIC/MPC Compatibility” on page 26</a>. For information on which MICs are supported on MX Series routers, see <a href="#">“MICs Supported by MX Series Routers” on page 18</a>.</p>
Description	<ul style="list-style-type: none"> <li>20 Gigabit Ethernet ports</li> <li>Power requirement: 0.77 A @ 48 V (37 W)</li> <li>Weight: 1.2 lb (0.54 kg)</li> <li>Model number: MIC-3D-20GE-SFP</li> <li>Name in the CLI: <b>3D 20GE SFP</b></li> </ul>
Hardware features	<ul style="list-style-type: none"> <li>High-performance throughput on each port at speeds up to 1 Gbps</li> <li>Autonegotiation between Gigabit Ethernet circuit partners</li> <li>Up to 20-Gbps of full-duplex traffic</li> <li>Maximum transmission units (MTUs) of up to 9192 bytes</li> </ul>
Software features	<ul style="list-style-type: none"> <li>Optical diagnostics and related alarms</li> <li>Virtual Router Redundancy Protocol (VRRP) support</li> <li>IEEE 802.1Q virtual LANs (VLANs) support</li> <li>Remote monitoring (RMON) EtherStats</li> <li>Source MAC learning</li> <li>MAC accounting and policing—Dynamic local address learning of source MAC addresses</li> <li>Flexible Ethernet encapsulation</li> <li>Multiple tag protocol identifiers (TPID)</li> </ul>
Interfaces	<p>Syntax: <i>ge-fpc/pic/port</i> where:</p> <ul style="list-style-type: none"> <li>fpc: Slot in the router where the MPC is installed</li> <li>pic: The logical PIC number on the MIC, numbered 0, 1, 2, and 3.</li> <li>port: 0 through 9</li> </ul> <p>For example, <i>ge-3/3/0</i> is the interface for port 0 in PIC 3 on the MPC installed in slot 3.</p> <p><a href="#">Figure 11 on page 150</a>, <a href="#">Figure 12 on page 151</a>, and <a href="#">Figure 13 on page 151</a> show examples of the port numbering for the Gigabit Ethernet MIC with SFP installed in an MX960, MX480, and MX240, respectively.</p>

Cables and connectors

**TIP:** You can use the [Hardware Compatibility Tool](#) to find information about the pluggable transceivers supported on your Juniper Networks device.

The list of supported transceivers for the MX Series is located at <https://pathfinder.juniper.net/hct/category/#catKey=100001&modelType;=All&pf;=MX+Series>.

LEDs

OK/FAIL LED, one bicolor:

- Green—MIC is functioning normally.
- Red—MIC has failed.

Link LED, one green per port:

- Off—No link.
- On steadily—Link is up.

## Port Numbering

Figure 11 on page 150, Figure 12 on page 151, and Figure 13 on page 151 show examples of the port numbering for the Gigabit Ethernet MIC with SFP on the MX960, MX480, and MX240, respectively.

**Figure 11: Port Numbering for the Gigabit Ethernet MIC with SFP (MX960)**

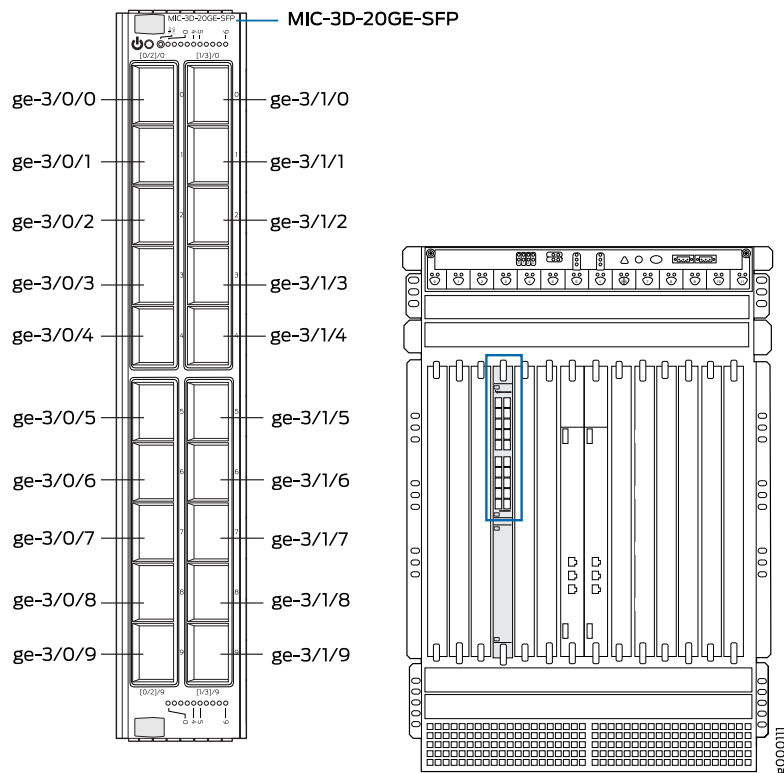
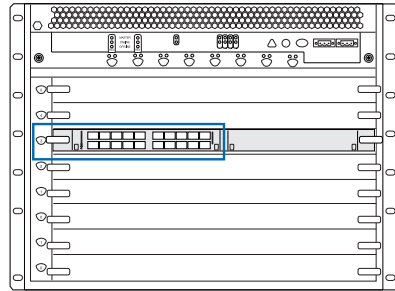



Figure 12: Port Numbering for the Gigabit Ethernet MIC with SFP (MX480)



MIC-3D-20GE-SFP

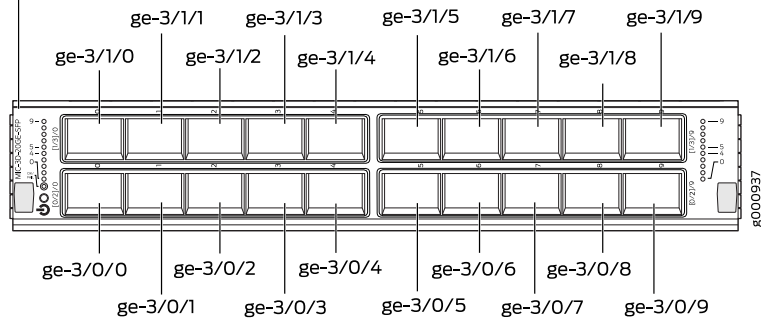
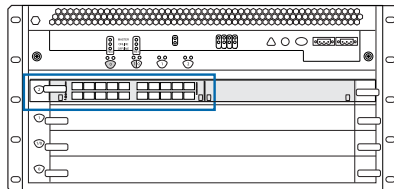
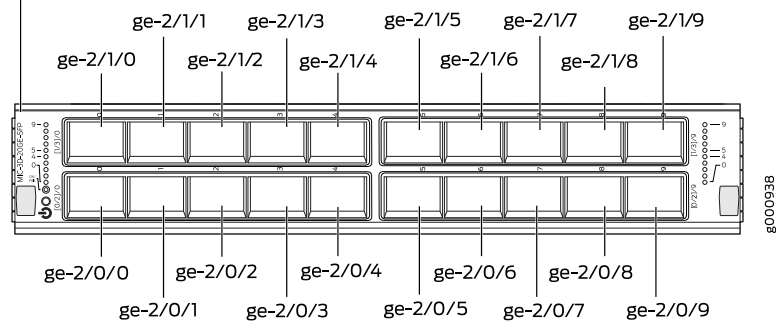

Figure 13: Port Numbering for Gigabit Ethernet MIC with SFP (MX240)



MIC-3D-20GE-SFP



- Related Documentation**
- [MX Series MIC Overview on page 17](#)

## Gigabit Ethernet MIC with SFP (E)

*Figure 14: 20-Port Gigabit Ethernet MIC with SFP (E)*

MIC-3D-20GE-SFP-E

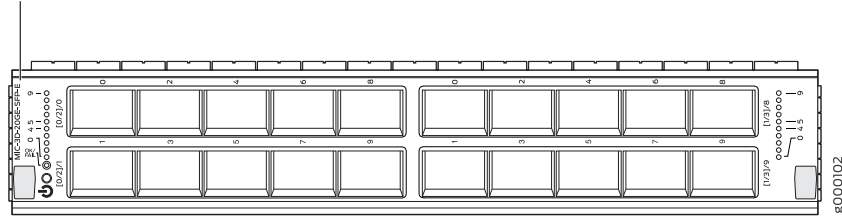

- Software release**
- Junos 13.2R2 and later

For information on which MPCs support this MIC, see [“MIC/MPC Compatibility” on page 26](#). For information on which MICs are supported on MX Series routers, see [“MICs Supported by MX Series Routers” on page 18](#).

- Description**
- 20 Gigabit Ethernet ports
  - Power requirement: 0.77 A @ 48 V (37 W)
  - Weight: 1.2 lb (0.54 kg)
  - Model number: MIC-3D-20GE-SFP-E
  - Name in the CLI: **3D 20x 1GE(LAN)-E,SFP**

- Hardware features**
- High-performance throughput on each port at speeds up to 1 Gbps
  - Auto-negotiation between Gigabit Ethernet circuit partners
  - Up to 20-Gbps of full-duplex traffic
  - Maximum transmission units (MTUs) of up to 9192 bytes
  - Environmentally hardened for 32° F (0° C) to 131° F (55° C) operating temperatures
  - SEC PHY
  - Timing PHY

- Software features**
- Optical diagnostics and related alarms
  - Virtual Router Redundancy Protocol (VRRP) support
  - IEEE 802.1Q virtual LANs (VLANs) support
  - Remote monitoring (RMON) EtherStats
  - Source MAC learning
  - MAC accounting and policing—Dynamic local address learning of source MAC addresses
  - Flexible Ethernet encapsulation
  - Multiple tag protocol identifiers (TPID)
  - Precision Time Protocol (PTP) or IEEE 1588v2
  - Media Access Control Security (MACsec)

- Interfaces
- Syntax: `ge-fpc/pic/port` where:
- fpc: Slot in the router where the MPC is installed. The MPCs are represented in the CLI as **FPC0** through **FPC19**.
  - pic: The logical PIC number on the MIC, numbered 0 or 1. [Figure 15 on page 154](#), [Figure 16 on page 155](#), and [Figure 17 on page 155](#) illustrate the port numbering for the Gigabit Ethernet MIC with SFP (E) installed in the MX960, MX480, and MX240, respectively.
  - port: 0 through 9.

For example, `ge-3/1/0` is the interface for port 0 in PIC 1 on the MPC installed in slot 3.

[Figure 15 on page 154](#), [Figure 16 on page 155](#), and [Figure 17 on page 155](#) illustrate the port numbering for the MIC-3D-20GE-SFP-E installed in an MX960, MX480, and MX280, respectively.

Cables and connectors **TIP:** You can use the [Hardware Compatibility Tool](#) to find information about the pluggable transceivers supported on your Juniper Networks device.

The list of supported transceivers for the MX Series is located at <https://pathfinder.juniper.net/hct/category/#catKey=100001&modelType;=All&pf;=MX+Series>.

- LEDs
- OK/FAIL LED**, one bicolor:
- Green—MIC is functioning normally.
  - Red—MIC has failed.

**Link LED**, one green per port:

- Off—No link.
- On steadily—Link is up.

Figure 15: Port Numbering for the MIC-3D-20GE-SFP-E (MX960)

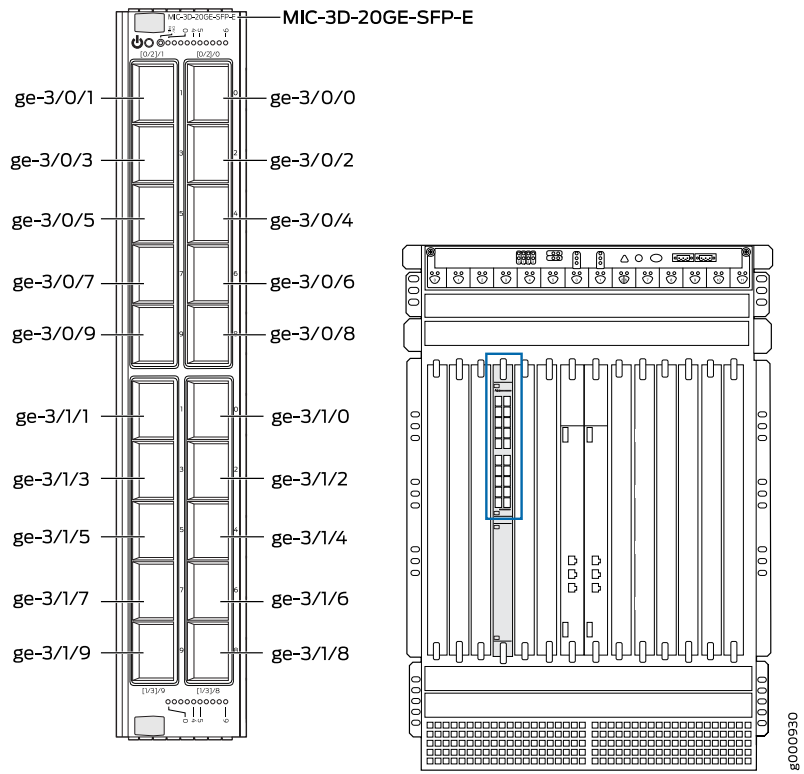
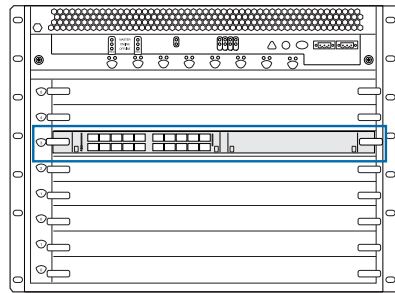

Figure 16: Port Numbering for the MIC-3D-20GE-SFP-E (MX480)



MIC-3D-20GE-SFP-E

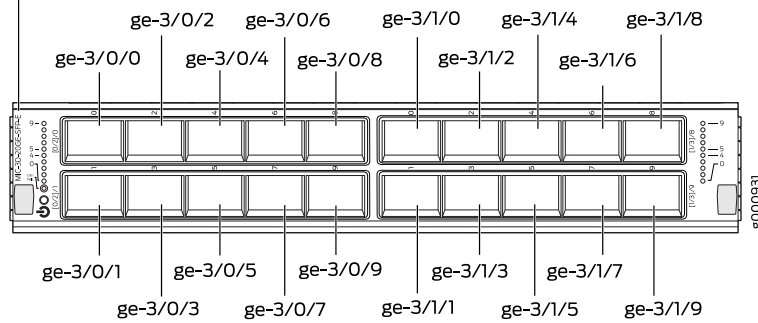
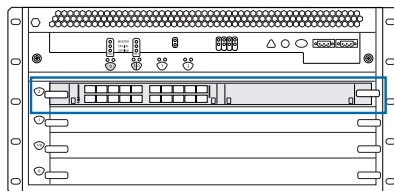
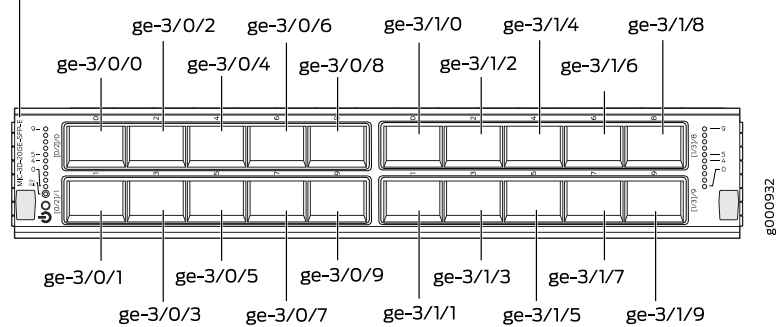

Figure 17: Port Numbering for the MIC-3D-20GE-SFP-E (MX240)



MIC-3D-20GE-SFP-E



- Related Documentation**
- [MX Series MIC Overview on page 17](#)

## Gigabit Ethernet MIC with SFP (EH)

**Figure 18: 20-Port Gigabit Ethernet MIC with SFP (EH)**

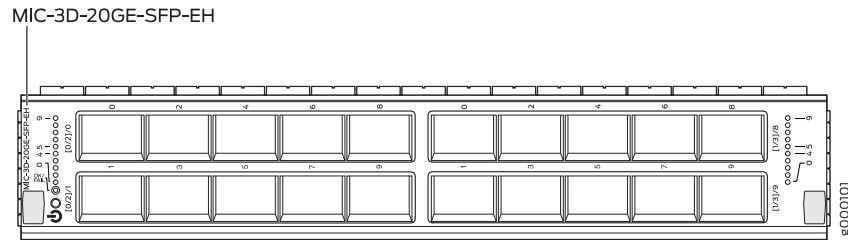

Software release	<ul style="list-style-type: none"> <li>• Junos 13.2R2 and later</li> </ul> <p>For information on which MPCs support this MIC, see <a href="#">“MIC/MPC Compatibility” on page 26</a>. For information on which MICs are supported on MX Series Routers, see <a href="#">“MICs Supported by MX Series Routers” on page 18</a>.</p>
Description	<ul style="list-style-type: none"> <li>• 20 Gigabit Ethernet ports</li> <li>• Power requirement: 0.77 A @ 48 V (37 W)</li> <li>• Weight: 1.2 lb (0.54 kg)</li> <li>• Model number: MIC-3D-20GE-SFP-EH</li> <li>• Name in the CLI: <b>3D 20x 1GE(LAN)-EH,SFP</b></li> </ul>
Hardware features	<ul style="list-style-type: none"> <li>• High-performance throughput on each port at speeds up to 1 Gbps</li> <li>• Autonegotiation between Gigabit Ethernet circuit partners</li> <li>• Up to 20-Gbps of full-duplex traffic</li> <li>• Maximum transmission units (MTUs) of up to 9192 bytes</li> <li>• Environmentally hardened for <math>-40^{\circ}\text{F}</math> (<math>-40^{\circ}\text{C}</math>) to <math>149^{\circ}\text{F}</math> (<math>65^{\circ}\text{C}</math>) operating temperatures</li> <li>• SEC PHY</li> <li>• Timing PHY</li> </ul>
Software features	<ul style="list-style-type: none"> <li>• Optical diagnostics and related alarms</li> <li>• Virtual Router Redundancy Protocol (VRRP) support</li> <li>• IEEE 802.1Q virtual LANs (VLANs) support</li> <li>• Remote monitoring (RMON) EtherStats</li> <li>• Source MAC learning</li> <li>• MAC accounting and policing—Dynamic local address learning of source MAC addresses</li> <li>• Flexible Ethernet encapsulation</li> <li>• Multiple tag protocol identifiers (TPID)</li> <li>• Precision Time Protocol (PTP) or IEEE 1588v2</li> <li>• Media Access Control Security (MACsec)</li> </ul>

Interfaces	<p>Syntax: <i>ge-fpc/pic/port</i> where:</p> <ul style="list-style-type: none"> <li>fpc: Slot in the router where the MPC is installed</li> <li>pic: 0 (left grouping of 10 ports) or 1 (right grouping of 10 ports) when installed in MIC slot 0; 2 (left grouping of 10 ports) or 3 (right grouping of 10 ports) when installed in MIC slot 1</li> <li>port: 0 through 9</li> </ul> <p>For example, <i>ge-1/3/0</i> is the interface for port 0 in the right grouping of ports on the MIC installed in MIC slot 1 on an MPC installed in slot 1.</p>
------------	--

Cables and connectors	<p><b>TIP:</b> You can use the <a href="#">Hardware Compatibility Tool</a> to find information about the pluggable transceivers supported on your Juniper Networks device.</p> <p>The list of supported transceivers for the MX Series is located at <a href="https://pathfinder.juniper.net/hct/category/#catKey=100001&amp;modelType;=All&amp;pf;=MX+Series">https://pathfinder.juniper.net/hct/category/#catKey=100001&amp;modelType;=All&amp;pf;=MX+Series</a>.</p>
-----------------------	---

LEDs	<p><b>OK/FAIL LED</b>, one bicolor:</p> <ul style="list-style-type: none"> <li>Green—MIC is functioning normally.</li> <li>Red—MIC has failed.</li> </ul> <p><b>Link LED</b>, one green per port:</p> <ul style="list-style-type: none"> <li>Off—No link.</li> <li>On steadily—Link is up.</li> </ul>
------	---

**Related Documentation**

- [MX Series MIC Overview on page 17](#)

## 10-Gigabit Ethernet MICs with XFP

**Figure 19: 2-Port 10-Gigabit Ethernet MIC with XFP**

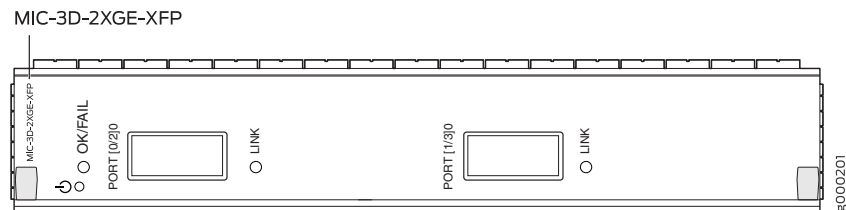
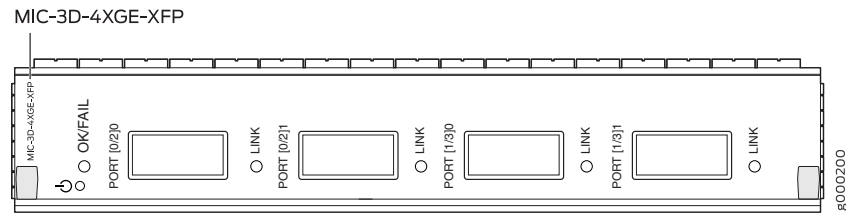

Figure 20: 4-Port 10-Gigabit Ethernet MIC with XFP



Software release	<ul style="list-style-type: none"> <li>• 2-port: Junos 10.2 and later</li> <li>• 4-port: Junos 10.1 and later</li> </ul>
<p>For information on which MPCs support these MICs, see <a href="#">“MIC/MPC Compatibility” on page 26</a>. For information on which MICs are supported on MX Series routers, see <a href="#">“MICs Supported by MX Series Routers” on page 18</a>.</p>	
Description	<ul style="list-style-type: none"> <li>• Two or four 10-Gigabit Ethernet ports</li> <li>• Power requirement: <ul style="list-style-type: none"> <li>• 2-port: 0.6 A @ 48 V (29 W)</li> <li>• 4-port: 0.56 A @ 48 V (27 W)</li> </ul> </li> <li>• Weight: <ul style="list-style-type: none"> <li>• 2-port: 1 lb (0.45 kg)</li> <li>• 4-port: 1.1 lb (0.5 kg)</li> </ul> </li> <li>• Model number: <ul style="list-style-type: none"> <li>• 2-port: MIC-3D-2XGE-XFP</li> <li>• 4-port: MIC-3D-4XGE-XFP</li> </ul> </li> <li>• Name in the CLI: <ul style="list-style-type: none"> <li>• 2-port: <b>3D 2X10GE XFP</b></li> <li>• 4:-port <b>3D 4X10GE XFP</b></li> </ul> </li> </ul>
Hardware features	<ul style="list-style-type: none"> <li>• High-performance throughput on each port at speeds up to 10 Gbps</li> <li>• LAN-PHY mode at 10.3125 Gbps</li> <li>• WAN-PHY mode at 9.953 Gbps</li> <li>• Maximum transmission units (MTUs) of up to 9192 bytes</li> </ul>
Software features	<ul style="list-style-type: none"> <li>• Configurable LAN-PHY and WAN-PHY mode options</li> <li>• Synchronous Ethernet support</li> <li>• Optical diagnostics and related alarms</li> <li>• Virtual Router Redundancy Protocol (VRRP) support</li> <li>• IEEE 802.1Q virtual LANs (VLANs) support</li> <li>• Remote monitoring (RMON) EtherStats</li> <li>• Source MAC learning</li> <li>• MAC accounting and policing—Dynamic local address learning of source MAC addresses</li> <li>• Flexible Ethernet encapsulation</li> <li>• Multiple tag protocol identifiers (TPID)</li> </ul>



## Interfaces

Syntax: `xe-fpc/pic/port` where:

- fpc: Slot in the router where the MPC is installed
- pic:
  - 2-port: 0 when installed in MIC slot 0; 3 when installed in MIC slot 1
  - 4-port: 0 or 1 when installed in MIC slot 0; 2 or 3 when installed in MIC slot 1
- port:
  - 2-port: 0 or 1
  - 4-port: 0 or 1

For example, `xe-1/3/0` is the interface for port 0 on the MIC installed in MIC slot 1 on an MPC installed in slot 1.

## Cables and connectors

**TIP:** You can use the [Hardware Compatibility Tool](#) to find information about the pluggable transceivers supported on your Juniper Networks device.

The list of supported transceivers for the MX Series is located at <https://pathfinder.juniper.net/hct/category/#catKey=100001&modelType;=All&pf;=MX+Series>.

## LEDs

**OK/FAIL LED**, one bicolor:

- Green—MIC is functioning normally.
- Red—MIC has failed.

**LINK LED**, one green per port:

- Off—No link.
- On steadily—Link is up with or without activity.

The ports are labeled:

- 2-port: [0/2]0, [1/3]0
- 4-port: [0/2]0, [0/2]1, [1/3]0, and [1/3]1

**Related Documentation**

- [MX Series MIC Overview on page 17](#)

## 10-Gigabit Ethernet MIC with SFP+ (10 Ports)

**Figure 21: 10-Gigabit Ethernet MIC with SFP+**

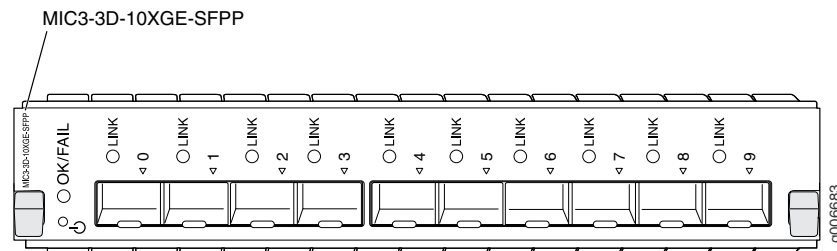

## Software release

- Junos 12.3 and later

Description	<ul style="list-style-type: none"> <li>• Ten 10-Gigabit Ethernet ports</li> <li>• Power requirement: 0.62 A @ 48 V (29.8 W)</li> <li>• Weight: 1.54 lb (0.70 kg)</li> <li>• Model number: MIC3-3D-10XGE-SFPP</li> <li>• Name in the CLI: <b>3D 10xGE SFPP</b></li> </ul>
Hardware features	<ul style="list-style-type: none"> <li>• High-performance throughput on each port at speeds up to 10 Gbps</li> <li>• Supports 10 SFP+ pluggable optic ports</li> <li>• Voltage Sequencer for local voltage sequence control and monitoring</li> <li>• LAN-PHY mode at 10.3125 Gbps</li> <li>• WAN-PHY mode at 9.95328 Gbps</li> <li>• Maximum transmission units (MTUs) of up to 9192 bytes</li> </ul>
Software features	<ul style="list-style-type: none"> <li>• Configurable LAN-PHY and WAN-PHY mode options per port</li> <li>• Synchronous Ethernet support</li> <li>• Optical diagnostics and related alarms</li> <li>• Virtual Router Redundancy Protocol (VRRP) support</li> <li>• IEEE 802.1Q virtual LANs (VLANs) support</li> <li>• Remote monitoring (RMON) EtherStats</li> <li>• Source MAC learning</li> <li>• MAC accounting and policing—Dynamic local address learning of source MAC addresses</li> <li>• Flexible Ethernet encapsulation</li> <li>• Multiple tag protocol identifiers (TPID)</li> </ul>
Cables and connectors	<p><b>TIP:</b> You can use the <a href="#">Hardware Compatibility Tool</a> to find information about the pluggable transceivers supported on your Juniper Networks device.</p> <p>The list of supported transceivers for the MX Series is located at <a href="https://pathfinder.juniper.net/hct/category/#catKey=100001&amp;modelType;=All&amp;pf;=MX+Series">https://pathfinder.juniper.net/hct/category/#catKey=100001&amp;modelType;=All&amp;pf;=MX+Series</a>.</p> <p><b>NOTE:</b> SFPP-10GE-ZR has a commercial temperature rating and is not NEBS compliant when plugged into the 10-Gigabit Ethernet MIC with SFP+. If the ambient air temperature exceeds 40 degrees C, the software disables the transmitter, which takes the optical transceiver offline.</p> <p><b>NOTE:</b> SFPP-10G-DT-ZRC2 is not NEBS compliant when plugged into the MIC3-3D-10XGE-SFPP MIC. If the ambient air temperature exceeds 40 degrees C, Junos OS disables the transmitter, which takes the optical transceiver offline.</p>
LEDs	<p><b>OK/FAIL LED</b>, one bicolor:</p> <ul style="list-style-type: none"> <li>• Green—MIC is functioning normally.</li> <li>• Red—MIC has failed.</li> </ul> <p><b>LINK LED</b>, one per SFP+ port:</p> <ul style="list-style-type: none"> <li>• Off—No link.</li> <li>• Green—Link is up.</li> <li>• Yellow—Link is disabled.</li> </ul> <p>The ports are labeled:</p> <ul style="list-style-type: none"> <li>• <b>Port [0] to Port [9]</b></li> </ul>



**NOTE:** The MIC3-3D-10XGE-SFPP MIC has one logical PIC. When the MIC is installed in slot 0 of an MPC the PIC number is 0, and when the MIC is installed in slot 1 of an MPC the PIC number is 2. For example, when the MIC is installed in slot 3 of the MX960 router, in slot 1 of the MPC, the interfaces are numbered ge-3/2/0 through ge-3/2/9.

#### Related Documentation

- [MX Series MIC Overview on page 17](#)
- [MICs Supported by MX Series Routers on page 18](#)
- [MIC/MPC Compatibility on page 26](#)

## 10-Gigabit Ethernet MIC with SFP+ (24 Ports)

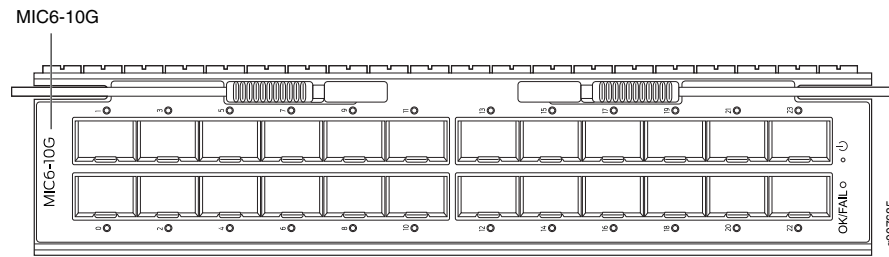

Software release	<ul style="list-style-type: none"> <li>• Junos 13.3R2 and later</li> </ul> <p>For information about which MPCs support this MIC, see <a href="#">“MIC/MPC Compatibility” on page 26</a>. For information about which MICs are supported on MX Series routers, see <a href="#">“MICs Supported by MX Series Routers” on page 18</a>.</p>
Description	<ul style="list-style-type: none"> <li>• Twenty-four 10-Gigabit Ethernet ports</li> <li>• Power requirement: 7.1 A @ 10.4 V (74 W)</li> <li>• Weight: 3.2 lb (1.45 kg)</li> <li>• Model number: MIC6-10G</li> <li>• Name in the CLI: <code>24x10GE SFPP</code></li> </ul>
Hardware features	<ul style="list-style-type: none"> <li>• Supports 24 SFP+ pluggable optic ports</li> <li>• High-performance throughput on each port at speeds up to 10 Gbps</li> <li>• LAN-PHY mode at 10.3125 Gbps</li> <li>• WAN-PHY mode at 9.95328 Gbps</li> <li>• Supports LOS-squelch, enabling Synchronous Ethernet fast-clock-failover on a port down event</li> <li>• Maximum transmission units (MTUs) of up to 9192 bytes</li> </ul>

- Software features
- Configurable LAN-PHY and WAN-PHY mode options per port
  - Compliant to ITU-T specifications
  - Optical diagnostics and related alarms
  - Virtual Router Redundancy Protocol (VRRP) support
  - IEEE 802.1Q virtual LANs (VLANs) support
  - IEEE 802.1ad support
  - Remote monitoring (RMON) EtherStats
  - Source MAC learning
  - MAC accounting and policing—Dynamic local address learning of source MAC addresses
  - In-service software upgrade (Unified ISSU)

Cables and connectors **TIP:** You can use the [Hardware Compatibility Tool](#) to find information about the pluggable transceivers supported on your Juniper Networks device.

The list of supported transceivers for the MX Series is located at <https://pathfinder.juniper.net/hct/category/#catKey=100001&modelType=All&pf=MX+Series>.

- LEDs
- OK/FAIL LED**, one bicolor:
- Green—MIC is functioning normally.
  - Yellow—MIC is coming online.
  - Red—MIC has failed.
- LINK LED**, one bicolor per SFP+ port:
- Off—No link.
  - Green—Link is up.
  - Yellow—Link is disabled.
- The ports are labeled:
- Port [0] to Port [23]

**Related Documentation**

- [MX Series MIC Overview on page 17](#)

## 10-Gigabit Ethernet OTN MIC with SFP+ (24 Ports)

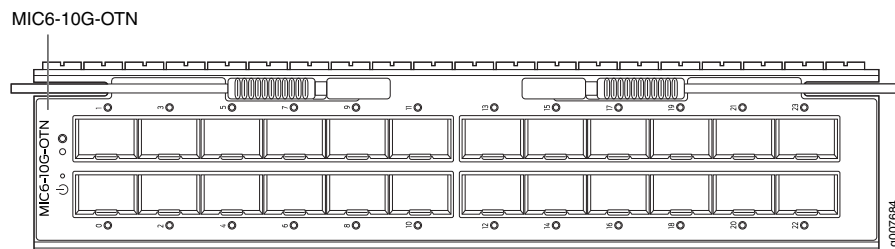

- Software release
- Junos 13.3R3 and later
- For information about which MPCs support this MIC, see [“MIC/MPC Compatibility” on page 26](#). For information about which MICs are supported on MX Series routers, see [“MICs Supported by MX Series Routers” on page 18](#).

Description	<ul style="list-style-type: none"> <li>• Twenty-four 10-Gigabit optical transport network (OTN) ports for transport of 10-Gigabit Ethernet (10GBASE-R) traffic</li> <li>• Power requirement: 1.5 A @ 52 V (84 W)</li> <li>• Weight: 3.4 lb (1.54 kg)</li> <li>• Model number: MIC6-10G-OTN</li> <li>• Name in the CLI: <b>24x10GE OTN</b></li> </ul>
Hardware features	<ul style="list-style-type: none"> <li>• High-performance throughput on each port at speeds up to 10 Gbps</li> <li>• LAN-OTU2e mode (G.Sup43, 7.1) at 11.09 Gbps</li> <li>• WAN-OTU2 mode (G.Sup43, 6.1) at 10.70 Gbps</li> <li>• Supports LOS-squelch, enabling Synchronous Ethernet fast-clock-failover on a port-down event</li> <li>• Provides IEEE 1588 time-stamping at physical interface for improved accuracy</li> <li>• Maximum transmission units (MTUs) of up to 9192 bytes</li> </ul>
Software features	<ul style="list-style-type: none"> <li>• OTN support for 10-Gigabit Ethernet interface</li> <li>• Compliant with ITU-T specifications</li> <li>• Transparent transport of 10-Gigabit Ethernet signals with optical channel transport unit 2 (OTU2/OTU2e) framing</li> <li>• Optical diagnostics and related alarms</li> <li>• Configurable LAN-PHY, WAN-PHY, or OTN mode options per port</li> <li>• Virtual Router Redundancy Protocol (VRRP) support</li> <li>• IEEE 802.1Q VLAN support</li> <li>• IEEE 802.1ad support</li> <li>• Remote monitoring (RMON) EtherStats</li> <li>• Source MAC learning</li> <li>• MAC accounting and policing—Dynamic local address learning of source MAC addresses</li> <li>• In-service software upgrade (Unified ISSU)</li> </ul>
Cables and connectors	<p><b>TIP:</b> You can use the <a href="#">Hardware Compatibility Tool</a> to find information about the pluggable transceivers supported on your Juniper Networks device.</p> <p>The list of supported transceivers for the MX Series is located at <a href="https://pathfinder.juniper.net/hct/category/#catKey=100001&amp;modelType;=All&amp;pf;=MX+Series">https://pathfinder.juniper.net/hct/category/#catKey=100001&amp;modelType;=All&amp;pf;=MX+Series</a>.</p>
LEDs	<p><b>OK/FAIL LED</b>, one bicolor:</p> <ul style="list-style-type: none"> <li>• Green—MIC is functioning normally.</li> <li>• Yellow—MIC is coming online.</li> <li>• Red—MIC has failed.</li> </ul> <p><b>LINK LED</b>, one bicolor per port:</p> <ul style="list-style-type: none"> <li>• Off—No link.</li> <li>• Green—Link is up.</li> <li>• Yellow—Link is disabled.</li> </ul> <p>The ports are labeled:</p> <ul style="list-style-type: none"> <li>• Port <b>[0]</b> through Port <b>[23]</b></li> </ul>

- Related Documentation**
- [MX Series MIC Overview on page 17](#)

## 40-Gigabit Ethernet MIC with QSFP+

Figure 22: 40-Gigabit Ethernet MIC with QSFP+

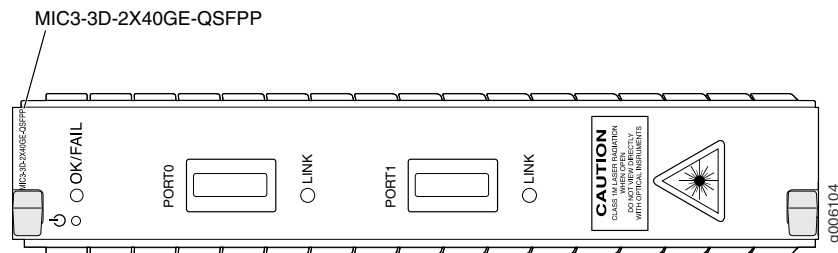

Software release	<ul style="list-style-type: none"> <li>• 12.2 and later</li> </ul> <p>For information on which MPCs support this MIC, see “<a href="#">MIC/MPC Compatibility</a>” on page 26. For information on which MICs are supported on MX Series routers, see “<a href="#">MICs Supported by MX Series Routers</a>” on page 18.</p>
Description	<ul style="list-style-type: none"> <li>• Two 40-Gigabit Ethernet ports</li> <li>• Power requirement: 0.38 A @ 48 V (18 W)</li> <li>• Weight: 1.19 lb (0.54 kg)</li> <li>• Model number: MIC3-3D-2X40GE-QSFPP</li> </ul>
Hardware features	<ul style="list-style-type: none"> <li>• High-performance throughput on each port at speeds up to 40 Gbps</li> <li>• Up to 40-Gbps of full-duplex traffic</li> <li>• Maximum transmission units (MTUs) of up to 9192 bytes</li> </ul>
Software features	<ul style="list-style-type: none"> <li>• Synchronous Ethernet support</li> <li>• Optical diagnostics and related alarms</li> <li>• Virtual Router Redundancy Protocol (VRRP) support</li> <li>• IEEE 802.1Q virtual LANs (VLANs) support</li> <li>• Remote monitoring (RMON) EtherStats</li> <li>• Source MAC learning</li> <li>• MAC accounting and policing—Dynamic local address learning of source MAC addresses</li> <li>• Flexible Ethernet encapsulation</li> <li>• Multiple tag protocol identifiers (TPID)</li> </ul>
Cables and connectors	<p><b>TIP:</b> You can use the <a href="#">Hardware Compatibility Tool</a> to find information about the pluggable transceivers supported on your Juniper Networks device.</p> <p>The list of supported transceivers for the MX Series is located at <a href="https://pathfinder.juniper.net/hct/category/#catKey=100001&amp;modelType;=All&amp;pf;=MX+Series">https://pathfinder.juniper.net/hct/category/#catKey=100001&amp;modelType;=All&amp;pf;=MX+Series</a>.</p>

LEDs	<p><b>OK/FAIL LED</b>, one bicolor:</p> <ul style="list-style-type: none"> <li>Green—MIC is functioning normally.</li> <li>Red—MIC has failed.</li> </ul> <p><b>LINK LED</b>, one green per port:</p> <ul style="list-style-type: none"> <li>Off—No link.</li> <li>On steadily—Link is up with or without activity.</li> <li>Yellow—Link is disabled.</li> </ul> <p>The ports are labeled:</p> <ul style="list-style-type: none"> <li><b>PORT [0] - PORT [1]</b></li> </ul>
------	---

**Related Documentation**

- [MX Series MIC Overview on page 17](#)

## 100-Gigabit Ethernet MIC with CFP

*Figure 23: 1-Port 100 Gigabit Ethernet MIC with CFP*

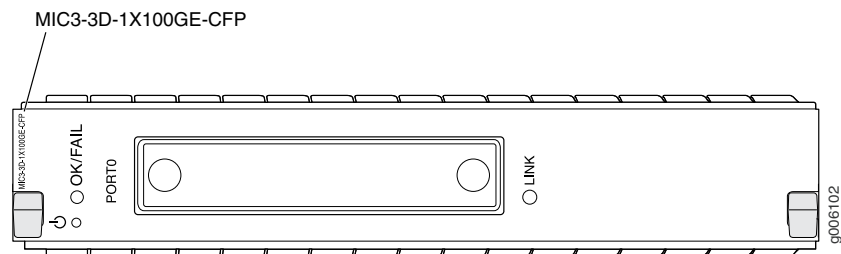

Software release	<ul style="list-style-type: none"> <li>12.1 and later</li> </ul> <p>For information about which MPCs support this MIC, see <a href="#">“MIC/MPC Compatibility” on page 26</a>. For information about which MICs are supported on MX Series routers, see <a href="#">“MICs Supported by MX Series Routers” on page 18</a>.</p>
Description	<ul style="list-style-type: none"> <li>One 100-Gigabit Ethernet port</li> <li>Power requirement: 0.83 A @ 48 V (40 W)</li> <li>Weight: 1.94 lb (0.88 kg)</li> <li>Model number: MIC3-3D-1X100GE-CFP</li> <li>Name in the CLI: 1X100GE CFP</li> </ul>
Hardware features	<ul style="list-style-type: none"> <li>High-performance throughput on each port at speeds up to 100 Gbps</li> <li>Up to 100-Gbps of full-duplex traffic</li> <li>Maximum transmission units (MTUs) of up to 9192 bytes</li> <li>The port is labeled <b>PORT0</b></li> </ul>

- Software features**
- Synchronous Ethernet support
  - Optical diagnostics and related alarms
  - Virtual Router Redundancy Protocol (VRRP) support
  - IEEE 802.1Q virtual LANs (VLANs) support
  - Remote monitoring (RMON) EtherStats
  - Source MAC learning
  - MAC accounting and policing—Dynamic local address learning of source MAC addresses
  - Flexible Ethernet encapsulation
  - Multiple tag protocol identifiers (TPID)

**Cables and connectors** **TIP:** You can use the [Hardware Compatibility Tool](#) to find information about the pluggable transceivers supported on your Juniper Networks device.

The list of supported transceivers for the MX Series is located at <https://pathfinder.juniper.net/hct/category/#catKey=100001&modelType;=All&pf;=MX+Series>.

**NOTE:** The CFP-100GBASE-ER4 transceiver is NEBS-compliant in the 100-Gigabit Ethernet MIC with CFP, but only when the other MIC slot in the MPC3E is empty. If another MIC is present and the ambient temperature exceeds 40 degrees C, the software converts CFP-100GBASE-ER4 to low power mode, which takes the transceiver offline.

- Fiber-optic 100-Gigabit C form-factor Pluggable

**NOTE:** The CFP-100GBASE-ZR transceiver is NEBS compliant in the 100-Gigabit Ethernet MIC with CFP, but only when the other MIC slot in the MPC3E is empty. If another MIC is present and the ambient air temperature exceeds 40 degrees C, the software disables the transmitter, which takes the optical transceiver offline. The other MIC slot must be filled with a blank panel.

- LEDs**
- OK/FAIL LED, one bicolor:**
- Green—MIC is functioning normally.
  - Red—MIC has failed.
- LINK LED, one green per port:**
- Off—No link.
  - On steadily—Link is up.
  - Yellow—Link is disabled.

**Related Documentation**

- [MX Series MIC Overview on page 17](#)



## 100-Gigabit Ethernet MIC with CXP

Figure 24: 100-Gigabit Ethernet MIC with CXP

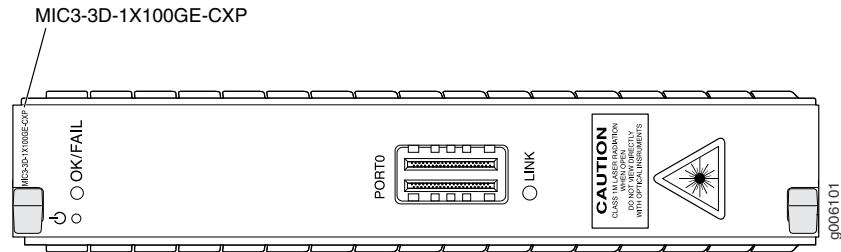

Software release	<ul style="list-style-type: none"> <li>12.2 and later</li> </ul> <p>For information about which MPCs support this MIC, see “<a href="#">MIC/MPC Compatibility</a>” on page 26. For information about which MICs are supported on MX Series routers, see “<a href="#">MICs Supported by MX Series Routers</a>” on page 18.</p>
Description	<ul style="list-style-type: none"> <li>One 100-gigabit Ethernet port</li> <li>Power requirement: 0.42 A @ 48 V (20 W)</li> <li>Weight: 1.03 lb (0.47 kg)</li> <li>Model number: MIC3-3D-1X100GE-CXP</li> <li>Name in the CLI: <b>3D 1x100GE CXP</b></li> </ul>
Hardware features	<ul style="list-style-type: none"> <li>High-performance throughput on each port at speeds up to 100 Gbps</li> <li>Up to 100-Gbps of full-duplex traffic</li> <li>Maximum transmission units (MTUs) of up to 9192 bytes</li> <li>The port is labeled <b>PORTO</b></li> </ul>
Software features	<ul style="list-style-type: none"> <li>Synchronous Ethernet support</li> <li>Optical diagnostics and related alarms</li> <li>Virtual Router Redundancy Protocol (VRRP) support</li> <li>IEEE 802.1Q virtual LANs (VLANs) support</li> <li>Remote monitoring (RMON) EtherStats</li> <li>Source MAC learning</li> <li>MAC accounting and policing—Dynamic local address learning of source MAC addresses</li> <li>Flexible Ethernet encapsulation</li> <li>Multiple tag protocol identifiers (TPID)</li> </ul>
Cables and connectors	<p><b>TIP:</b> You can use the <a href="#">Hardware Compatibility Tool</a> to find information about the pluggable transceivers supported on your Juniper Networks device.</p> <p>The list of supported transceivers for the MX Series is located at <a href="https://pathfinder.juniper.net/hct/category/#catKey=100001&amp;modelType;=All&amp;pf;=MX+Series">https://pathfinder.juniper.net/hct/category/#catKey=100001&amp;modelType;=All&amp;pf;=MX+Series</a>.</p>

LEDs	<p><b>OK/FAIL LED</b>, one bicolor:</p> <ul style="list-style-type: none"> <li>Green—MIC is functioning normally.</li> <li>Red—MIC has failed.</li> </ul> <p><b>LINK LED</b>, one green per port:</p> <ul style="list-style-type: none"> <li>Off—No link.</li> <li>On steadily—Link is up with or without activity.</li> <li>Yellow—Link is disabled.</li> </ul>
------	--

**Related Documentation**

- [MX Series MIC Overview on page 17](#)

## 100-Gigabit Ethernet MIC with CXP (4 Ports)

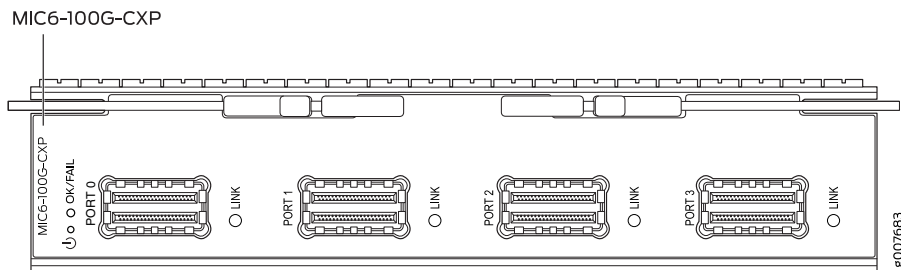

Software release	<ul style="list-style-type: none"> <li>• Junos 13.3R2 and later</li> </ul> <p>For information about which MPCs support this MIC, see <a href="#">“MIC/MPC Compatibility” on page 26</a>. For information about which MICs are supported on MX Series routers, see <a href="#">“MICs Supported by MX Series Routers” on page 18</a>.</p>
Description	<ul style="list-style-type: none"> <li>• Four 100-Gigabit Ethernet ports</li> <li>• Power requirement: 5.5 A @ 10.4 V (57 W)</li> <li>• Weight: 2.7 lb (1.22 kg)</li> <li>• Model number: MIC6-100G-CXP</li> <li>• Name in the CLI: <b>4X100GE CXP</b></li> </ul>
Hardware features	<ul style="list-style-type: none"> <li>• Line-rate throughput of up to 100Gbps per port.</li> <li>• Supports 100GBASE-SR10 over CXP pluggable optics</li> <li>• Supports LOS-squelch, enabling Synchronous Ethernet fast-clock-failover on a port down event</li> <li>• Maximum transmission units (MTUs) of up to 9192 bytes</li> </ul>

- Software features**
- Compliant to ITU-T specifications
  - Optical diagnostics and related alarms
  - Virtual Router Redundancy Protocol (VRRP) support
  - IEEE 802.1Q virtual LANs (VLANs) support
  - IEEE 802.1ad support
  - Remote monitoring (RMON) EtherStats
  - Source MAC learning
  - MAC accounting and policing—Dynamic local address learning of source MAC addresses
  - In-service software upgrade (Unified ISSU)

**Cables and connectors** **TIP:** You can use the [Hardware Compatibility Tool](#) to find information about the pluggable transceivers supported on your Juniper Networks device.

The list of supported transceivers for the MX Series is located at <https://pathfinder.juniper.net/hct/category/#catKey=100001&modelType=All&pf=MX+Series>.

- LEDs**
- OK/FAIL LED, one tricolor:**
- Green—MIC is functioning normally.
  - Yellow—MIC is coming online.
  - Red—MIC has failed.
- LINK LED, one bicolor per port:**
- Off—No link.
  - Green—Link is up.
  - Yellow—Link is disabled.
- The ports are labeled:
- **Port 0 to Port 3**

**Related Documentation**

- [MX Series MIC Overview on page 17](#)

## 100-Gigabit Ethernet MIC with CFP2

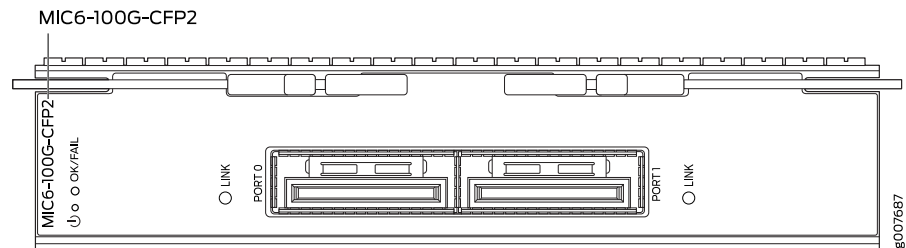

- Software release**
- Junos 13.3R3 and later
- For information about which MPCs support this MIC, see [“MIC/MPC Compatibility” on page 26](#). For information about which MICs are supported on MX Series routers, see [“MICs Supported by MX Series Routers” on page 18](#).

Description	<ul style="list-style-type: none"><li>• Two 100-Gigabit Ethernet CFP2 ports</li><li>• Power requirement: 2 A @ 52 V (104 W)</li><li>• Weight: 2.4 lb (1.09 kg)</li><li>• Model number: MIC6-100G-CFP2</li><li>• Name in the CLI: <b>2X100GE CFP2 OTN</b></li></ul>
Hardware features	<ul style="list-style-type: none"><li>• Line-rate throughput of up to 100 Gbps per port</li><li>• Supports CFP2 pluggable optics</li><li>• Supports LAN (103.125 Gbps) and OTN/OTU4 (111.81 Gbps) on a per-port basis</li><li>• Provides IEEE 1588 time-stamping at physical interface for improved accuracy</li><li>• Maximum transmission units (MTUs) of up to 9192 bytes</li></ul>
Software features	<ul style="list-style-type: none"><li>• Optical transport network (OTN) support for 100-Gigabit Ethernet interfaces</li><li>• Compliant with ITU-T specifications</li><li>• Transparent transport of 100-Gigabit Ethernet signals with OTU4 framing</li><li>• Optical diagnostics and related alarms</li><li>• Configurable 100-Gigabit Ethernet or OTN options per port</li><li>• Virtual Router Redundancy Protocol (VRRP) support</li><li>• IEEE 802.1Q VLAN support</li><li>• IEEE 802.1ad support</li><li>• Remote monitoring (RMON) EtherStats</li><li>• Source MAC learning</li><li>• MAC accounting and policing—Dynamic local address learning of source MAC addresses</li><li>• In-service software upgrade (Unified ISSU)</li></ul>
Cables and connectors	<p><b>TIP:</b> You can use the <a href="#">Hardware Compatibility Tool</a> to find information about the pluggable transceivers supported on your Juniper Networks device.</p> <p>The list of supported transceivers for the MX Series is located at <a href="https://pathfinder.juniper.net/hct/category/#catKey=100001&amp;modelType;=All&amp;pf;=MX+Series">https://pathfinder.juniper.net/hct/category/#catKey=100001&amp;modelType;=All&amp;pf;=MX+Series</a>.</p> <p><b>NOTE:</b></p> <ul style="list-style-type: none"><li>• CFP2-100G-ER4-D is not NEBS compliant on the MX960 router in FPC slot 0 or FPC slot 11.</li><li>• CFP2-DCO-T-WDM-1 is not NEBS compliant on the MX960 router or the MX2020 router in FPC slot 0 or FPC slot 11. Slots 0 and 11 can only work with an ambient temperature of up to 40° C.</li></ul> <p><b>NOTE:</b> When inserting the CFP2 transceiver, ensure that the transceiver sits tightly in the port. You will hear a distinct click sound when the latch locks into the corresponding port. The latch must be fully engaged in the corresponding port for the CFP2 transceiver to function properly. Failing to do so will result in loss of connection.</p> <p>To verify that the CFP2 transceiver module is inserted properly, give a gentle pull by grasping the sides of the module. The module should sit tightly.</p>

LEDs	<p><b>OK/FAIL LED</b>, one tricolor:</p> <ul style="list-style-type: none"> <li>Green—MIC is functioning normally.</li> <li>Yellow—MIC is coming online.</li> <li>Red—MIC has failed.</li> </ul> <p><b>LINK LED</b>, one bicolor per port:</p> <ul style="list-style-type: none"> <li>Off—No link.</li> <li>Green—Link is up.</li> <li>Yellow—Link is disabled.</li> </ul> <p>Port labels:</p> <ul style="list-style-type: none"> <li><b>Port 0</b> and <b>Port 1</b></li> </ul>
------	--

**Related Documentation**

- [MX Series MIC Overview on page 17](#)

## 100-Gigabit DWDM OTN MIC with CFP2-ACO

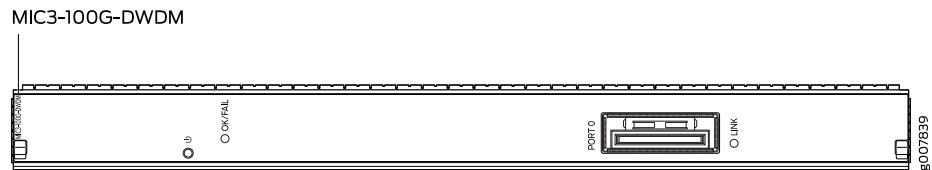

Software release	<ul style="list-style-type: none"> <li>Junos OS Release 15.1F5 and 15.1F6, Junos OS Release 17.1R1 and later</li> </ul> <p>For information about which MPCs support this MIC, see <a href="#">“MIC/MPC Compatibility” on page 26</a>. For information about which MICs are supported on MX Series routers, see <a href="#">“MICs Supported by MX Series Routers” on page 18</a>.</p>
Description	<ul style="list-style-type: none"> <li>One 100-Gigabit DWDM OTN port</li> <li>Power requirements (including transceiver) at different temperatures: <ul style="list-style-type: none"> <li>55° C: 1.90 A @ 48 V (91 W)</li> <li>25° C: 1.73 A @ 48 V (83 W)</li> </ul> </li> <li>Weight: 2.3 lb (1.04 kg)</li> <li>Model number: MIC3-100G-DWDM</li> <li>Name in the CLI: 1X100GE DWDM CFP2-ACO</li> </ul>

## Hardware features

- Dual-wide MIC that installs into two MIC slots
- Supports CFP2 analog coherent optics (CFP2-ACO)
- Transparent transport of a 100-Gigabit Ethernet signal with OTU4V framing
- ITU-standard OTN performance monitoring and alarm management
- Dual-polarization quadrature phase shift keying (DP-QPSK) modulation
- Supports three types of forward error correction (FEC):
  - Soft-decision FEC (SD-FEC)
  - High-gain FEC (HG-FEC)
  - G.709 FEC (GFEC)
- 100 channels on C-band ITU grid with 50-GHz spacing
- Latency:
  - SD-FEC: 14  $\mu$ s (TX + RX)
  - HG-FEC: 22  $\mu$ s (TX + RX)
  - GFEC: 6  $\mu$ s (TX + RX)
- Interoperable with the CFP-100GBASE-ZR transceiver supported on the 100-Gigabit Ethernet MIC with CFP (MIC3-3D-1X100GE-CFP) on MX Series routers and the 100-Gigabit Ethernet PIC with CFP (P1-PTX-2-100GE-CFP) on PTX Series routers.
- Interoperable with the 100-Gigabit DWDM OTN PIC with CFP2 (PTX-5-100G-WDM) on PTX Series routers when the 100-Gigabit DWDM OTN MIC is configured to use SD-FEC or GFEC.

**NOTE:** The 1-port 100-Gigabit DWDM OTN MIC is not directly interoperable with the 2-port 100-Gigabit DWDM OTN PIC (P1-PTX-2-100G-WDM), but they can both operate over the same DWDM line system.

---

## Software features

**NOTE:** For information about configuring the MIC, see [Configuring OTN Interfaces on MIC3-100G-DWDM MIC](#). For information about upgrading the firmware on the PIC, see [Upgrading Firmware on the 100-Gigabit DWDM OTN MIC \(MIC3-100G-DWDM\)](#).

- Compliant with ITU G.709 and G.798
  - Provides a transport interface and state model (GR-1093)
  - Performance monitoring features such as alarms, threshold-crossing alarms, OTU/ODU error seconds and FEC and bit error rate (BER) statistics
  - SNMP management of the MIC based on *RFC 3591, Managed Objects for the Optical Interface Type*, including the following:
    - Set functionality
    - Black Link MIB
    - IFOTN MIB
    - Optics MIB
    - FRU MIB
  - Pre-FEC BER monitoring provides interrupt-driven, BER-based detection of link signal degradation for MPLS fast reroute.
  - User-configurable optics options:
    - Transmit (TX) laser enable and disable
    - TX output power
    - Wavelength
    - Receive (RX) LOS warning or alarm thresholds
    - Threshold crossing alarms (TCAs)
- User-configurable card options:
- FEC mode (SD-FEC, HG-FEC, or GFEC)
  - TCAs

## Cables and connectors

**TIP:** You can use the [Hardware Compatibility Tool](#) to find information about the pluggable transceivers supported on your Juniper Networks device.

The list of supported transceivers for the MX Series is located at <https://pathfinder.juniper.net/hct/category/#catKey=100001&modelType;=All&pf;=MX+Series>.

**NOTE:** When inserting the C form-factor pluggable 2 (CFP2) transceiver, ensure that the transceiver sits tightly in the port. You hear a distinct click sound when the latch locks into the corresponding port. The latch must be fully engaged in the corresponding port for the CFP2 transceiver to function properly. Failing to do so can result in loss of connection.

To verify that the CFP2 transceiver module is inserted properly, give a gentle pull by grasping the sides of the module. The module should sit tightly.

## LEDs

**OK/FAIL LED**, one bicolor:

- Off—MIC is powered off.
- Green—MIC is initialized and online, functioning normally.
- Amber—MIC is coming online, or is in fault state.

**LINK LED**, one bicolor per port:

- Off—Port is offline.
- Solid green—Link is up.
- Red—Port failure is detected.

**NOTE:** The port is labeled **Port 0**.

## Alarms, Errors, and Events

**NOTE:** For OTN alarms, see [Table 24 on page 178](#).

Chassis and MIC:

- MIC (FRU) inserted or removed
- MIC (FRU) Administrative State: In Service, Out Of Service
- MIC (FRU) Operational State: Unequipped, Init, Normal, Mismatch, Fault, Upgrade
- Mismatch equipment
- Temperature alarm

Port (interface):

- Interface Administrative State: In Service, Out Of Service, Service MA, Out of Service MA
- Interface Operational State: Init, Normal, Fault, Degraded

Optical channel transport unit (OTU) TCAs:

- OTU-TCA-BBE—15-minute background block error TCA
- OTU-TCA-ES—15-minute far-end errored seconds TCA
- OTU-TCA-SES—15-minute severely errored seconds TCA
- OTU-TCA-UAS—15-minute unavailable seconds TCA

Optical channel data unit (ODU) TCAs:

- ODU-TCA-BBE—15-minute background block error TCA
- ODU-TCA-ES—15-minute far-end errored seconds TCA
- ODU-TCA-SES—15-minute severely errored seconds TCA
- ODU-TCA-UAS—15-minute unavailable seconds TCA

**TIP:** You can view OTU and ODU TCAs by using the **show interfaces transport pm otn** operational-mode CLI command.



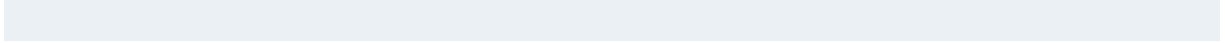

**NOTE:** If you insert an invalid CFP module, the CLI displays **unsupported module** and a syslog message is generated.

Optics-related status:

- Module temperature
- Module voltage
- Module temperature alarm:
  - High alarm
  - Low alarm
  - High warning
  - Low warning
- Module voltage alarm:
  - High alarm
  - Low alarm
  - High warning
  - Low warning
- Module not ready alarm
- Module low power alarm
- Module initialization incomplete alarm
- Module fault alarm
- TX laser disabled alarm
- RX loss of signal alarm
- Modem lock state
- TX output power:
  - Current TX output power
  - Minimum over PM interval
  - Maximum over PM interval
  - Average over PM interval
- TX power alarm:
  - High alarm
  - Low alarm
  - High warning
  - Low warning
- RX input power (signal)
- RX input power (total):
  - Current RX input power (total)
  - Minimum over PM interval
  - Maximum over PM interval
  - Average over PM interval
- RX power alarm:
  - High alarm
  - Low alarm
  - High warning
  - Low warning
- RX loss of signal alarm
- Wavelength unlocked alarm

**TIP:** You can view optics-related status by using the **show interfaces transport pm optics** and **show interfaces diagnostics optics** operational-mode CLI commands.

Network lane receive-related status:

- Chromatic dispersion:
  - Current chromatic dispersion
  - Minimum over PM interval
  - Maximum over PM interval
  - Average over PM interval
- Differential group delay:
  - Current differential group delay
  - Minimum over PM interval
  - Maximum over PM interval
  - Average over PM interval
- Q<sup>2</sup>-factor:
  - Current Q<sup>2</sup>-factor
  - Minimum over PM interval
  - Maximum over PM interval
  - Average over PM interval
- Carrier frequency offset
  - Current carrier frequency offset
  - Minimum over PM interval
  - Maximum over PM interval
  - Average over PM interval
- Signal-to-noise ratio (SNR)
  - Current SNR
  - Minimum over PM interval
  - Maximum over PM interval
  - Average over PM interval

**TIP:** You can view network lane receive-related status by using the **show interfaces transport pm optics** operational-mode CLI command.

FEC statistics:

- Corrected Errors—the number of bits received that were in error, but corrected.
- Uncorrected Words—the number of FEC codewords received that were uncorrectable.
- Corrected Error Ratio—the number of corrected bits divided by the number of bits received

**TIP:** You can view FEC statistics by using the **show interfaces *interface-name* extensive** operational-mode CLI command.

**Table 24 on page 178** describes the OTN alarms and defects that can occur on the MIC and the link status when the alarm or defect occurs.



**TIP:** You can view OTN alarms and defects by using the **show interfaces *interface-name* extensive** operational-mode CLI command.

Table 24: OTN Alarms and Defects

Category	Alarm	Description	Link Status
OTN	LOS	Loss of signal	Link down
	LOF	Loss of frame	Link down
	LOM	Loss of multiframe	Link down
OTN FEC	FEC Degrade (OTU-FEC-DEG)	Forward error correction degraded	Link down if signal degrade or backward FRR thresholds are met
	FEC Excessive (OTU-FEC-EXE)	There are uncorrected words and there are errors in the frame header	Possible link down
OTN OTU	OTU-AIS	Alarm indication signal or all ones signal	Link down
	OTU-BDI	Backward defect identification	Link down
	OTU-IAE	Incoming alignment error	Warning
	OTU-TTIM	Destination access point identifier (DAPI), source access point identifier (SAPI), or both mismatch from expected to received	Can cause the link to be down if <b>otu-ttim-act-enable</b> is configured at the <b>[edit interfaces <i>interface-name</i> otn-options]</b> hierarchy level
	OTU-BIAE	Backward incoming alignment error	Warning
	OTU-TSF	OTU trail signal fail	Warning
	OTU-SSF	OTU server signal fail	Warning

Table 24: OTN Alarms and Defects (continued)

Category	Alarm	Description	Link Status
OTN ODU	ODU-AIS	Alarm indication signal or all ones signal	Link down
	ODU-OCI	Open connection error	Link down
	ODU-LCK	ODU lock triggers for path monitoring and TCM levels 1 through 6	Link down
	ODU-BDI	Backward defect indication	Link down
	ODU-TTIM	DAPI or SAPI mismatch from expected to received	Can cause the link to be down if <code>odu-ttim-act-enable</code> is configured at the <code>[edit interfaces interface-name otn-options]</code> hierarchy level
	ODU-IAE	Incoming alignment error	Warning
	ODU-LTC	Loss of tandem connection	Warning
	ODU-CSF	Client signal failure	Warning
	ODU-TSF	Trail signal fail	Warning
	ODU-SSF	Server signal fail	Warning
	ODU-PTIM	Payload type mismatch	Link down

#### Related Documentation

- [100-Gigabit DWDM OTN CFP2-ACO Transceiver Wavelengths](#)
- [MX Series MIC Overview on page 17](#)
- [Configuring OTN Interfaces on MIC3-100G-DWDM MIC](#)
- [Upgrading Firmware on the 100-Gigabit DWDM OTN MIC \(MIC3-100G-DWDM\)](#)
- *show interfaces extensive*
- *show interfaces transport pm*
- *show interfaces diagnostics optics (Gigabit Ethernet, 10-Gigabit Ethernet, 40-Gigabit Ethernet, 100-Gigabit Ethernet, and Virtual Chassis Port)*

## Channelized SONET/SDH OC3/STM1 (Multi-Rate) MICs with SFP

Figure 25: 4-Port Channelized SONET/SDH OC3/STM1 (Multi-Rate) MIC with SFP

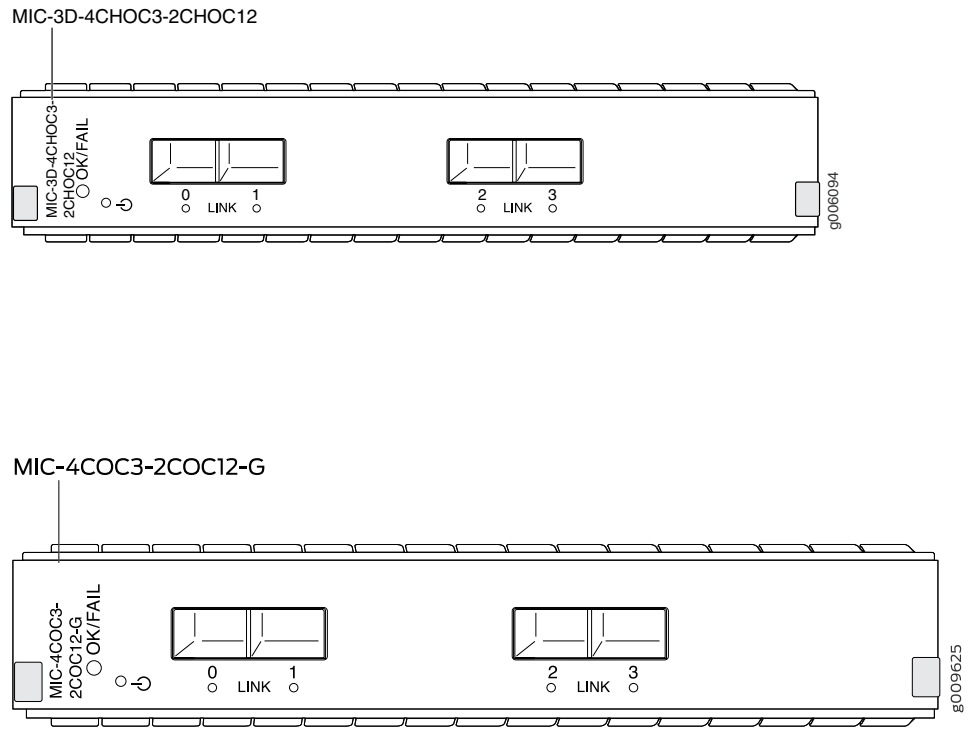
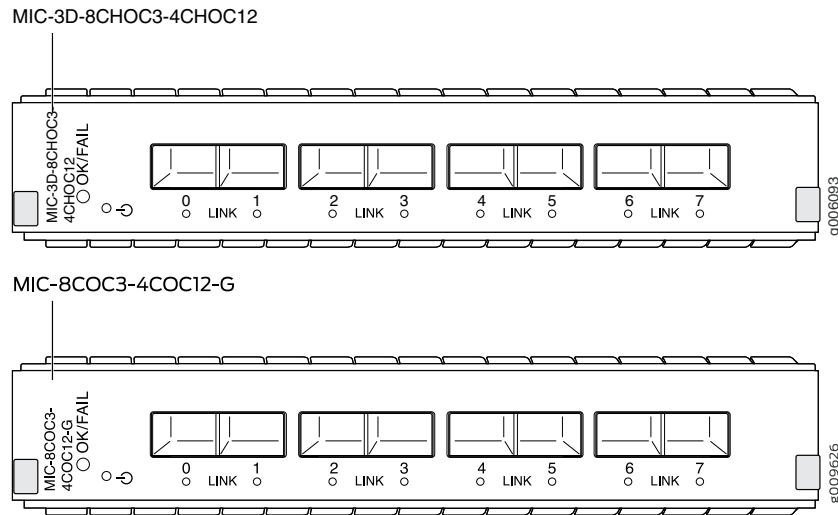

Figure 26: 8-Port Channelized SONET/SDH OC3/STM1 (Multi-Rate) MIC with SFP



## Software release

- Junos OS Release 11.4 and later

For information on which MPCs support these MICs, see [“MIC/MPC Compatibility” on page 26](#). For information on which MICs are supported on MX Series routers, see [“MICs Supported by MX Series Routers” on page 18](#).

## Description

- 4-port: Rate-selectable using one of the following rates:
  - 4-port OC3/STM1
  - 2-port OC12/STM4
- 8-port: Rate-selectable using one of the following rates:
  - 8-port OC3/STM1
  - 4-port OC12/STM4
- Channelization: OC3, DS3, DS1, DS0, E3, E1. For information on channelization numbers, see *Channelized Interfaces Feature Guide for Routing Devices*.
- Power requirement:
  - 4-port: 4.56 A @ 9 V (41 W)
  - 8-port: 5.78 A @ 9 V (52 W)
- Weight:
  - 4-port: 4.4 lb (2 kg)
  - 8-port: 4.4 lb (2 kg)
- Model number:
  - 4-port: MIC-3D-4CHOC3-2CHOC12
  - 4-port: MIC-4COC3-2COC12-G
  - 8-port: MIC-3D-8CHOC3-4CHOC12
  - 4-port: MIC-4COC3-2COC12-G
  - 8-port: MIC-3D-8CHOC3-4CHOC12
  - 8-port: MIC-8COC3-4COC12-G

**NOTE:** MIC-4COC3-2COC12-G and MIC-8COC3-4COC12-G are RoHS 6/6 compliant.

- Hardware features
- The ports are labeled:
    - 4-port: 0-3
    - 8-port: 0-7

- Software features
- Maximum transmission units (MTUs) of up to 9192 bytes
  - Per-port SONET/SDH framing
  - Local and remote loopback on each port
  - Optical diagnostics and monitoring
  - Clocking options: internal or external/loop mode
  - Encapsulations:
    - MPLS fast reroute
    - MPLS CCC (circuit cross-connection)
    - MPLS TCC (translational cross-connection)
    - Cisco High-Level Data Link Control (cHDLC)
    - Cisco HDLC CCC
    - Cisco HDLC TCC
    - Point-to-Point Protocol (PPP)
    - PPP for CCC
    - PPP for TCC
    - Flexible Frame Relay
    - Frame Relay
    - Frame Relay for CCC
    - Frame Relay for TCC
    - PPP over Frame Relay
  - Multilink-based protocols (Junos OS Release 12.1 and later):
    - Multilink Point-to-Point Protocol (MLPPP)
    - Multiclass MLPPP
    - Multilink Frame Relay (MLFR) end-to-end (FRF.15)
    - Multilink Frame Relay (MLFR) UNI NNI (FRF.16, also referred to as MFR)
    - Compressed Real-Time Transport Protocol (CRTP)

**NOTE:** When you configure multilink services on a MIC in an MX Series router, ensure that a Multiservices DPC is present in the same router.

**NOTE:** Ethernet over Frame Relay is not supported.

- Cables and connectors **TIP:** You can use the [Hardware Compatibility Tool](#) to find information about the pluggable transceivers supported on your Juniper Networks device.

The list of supported transceivers for the MX Series is located at <https://pathfinder.juniper.net/hct/category/#catKey=100001&modelType;=All&pf;=MX+Series>.



## LEDs

**OK/FAIL LED**, one bicolor:

- Green—MIC is functioning normally
- Red—MIC has failed

**LINK LED**, one green per port:

- Off—Not enabled
- Green—Online with no alarms or failures
- Yellow—Online with alarms for remote failures
- Red—Active with a local alarm; router has detected a failure

## Alarms, errors, and events

## SONET alarms:

- Loss of light (LOL)
- Loss of signal (LOS)
- Loss of frame (LOF)
- Phase lock loop (PLL)
- Severely errored frame (SEF)
- Alarm indicator signal—line (AIS-L)
- Alarm indicator signal—path (AIS-P)
- Remote defect indicator—line (RDI-L)
- Remote defect indicator—path (RDI-P)
- Loss of pointer—path (LOP-P)
- Bit error rate—signal degrade (BERR-SD)
- Bit error rate—signal fail (BERR-SF)
- Payload label mismatch—Path (PLM-P)
- Unequipped—path (UNEQ-P)
- Remote error indicator—path (REI-P)
- Alarm indicator signal—virtual container (V-AIS)
- Loss of pointer—virtual container (V-LOP)
- Remote defect indicator—virtual container (V-RDI)
- Unequipped—virtual container (V-UNEQ)
- Mismatch—virtual container (V-MIS)

## SDH alarms:

- Loss of light (LOL)
- Phase lock loop (PLL)
- Loss of frame (LOF)
- Loss of signal (LOS)
- Severely errored frame (SEF)
- Multiplex-section alarm indicator signal (MS-AIS)
- Higher order path—alarm indication signal (HP-AIS)
- Loss of pointer (LOP)
- Bit error rate—signal degrade (BER-SD)
- Bit error rate—signal fail (BER-SF)
- Multiplex section—far end receive failure (MS-FERF)
- Higher order path—far-end receive failure (HP-FERF)
- Higher order path—payload label mismatch (HP-PLM)
- Remote error indicator (REI)

- Unequipped (UNEQ)
- Tributary unit–alarm indicator signal (TU-AIS)
- Tributary unit–loss of pointer (TU-LOP)
- Tributary unit–remote defect indicator (TU-RDI)
- Tributary unit–unequipped (TU-UNEQ)
- Tributary unit–mismatch (TU-MIS)

DS3 alarms:

- Alarm indication signal (AIS)
- Loss of frame (LOF)
- Loss of signal seconds (LOS)
- Phase lock loop (PLL)

DS3 error detection:

- C-bit code violations (CCV)
- C-bit errored seconds (CES)
- C-bit severely errored seconds (CSES)
- CRC errors
- Excessive zeros (EXZ)
- Far-end block error (FEBE)
- Far-end receive failure (FERF)
- Line errored seconds (LES)
- Parity bit (P-bit) code violations (PCV)
- Parity bit (P-bit) errored seconds (PES)
- Parity bit (P-bit) severely errored framing seconds (PSES)
- Severely errored framing seconds (SEFS)
- Unavailable seconds (UAS)

---

**Related Documentation** • [MX Series MIC Overview on page 17](#)

## Channelized OC3/STM1 (Multi-Rate) Circuit Emulation MIC with SFP

Figure 27: Channelized OC3/STM1 (Multi-Rate) Circuit Emulation MIC with SFP

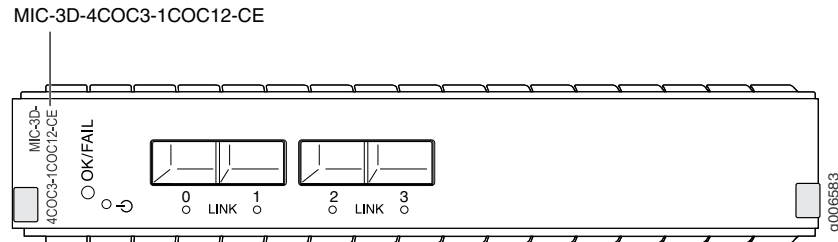

Software release	<ul style="list-style-type: none"> <li>Junos OS Release 12.2 and later</li> </ul> <p>For information on which MPCs support this MIC, see <a href="#">“MIC/MPC Compatibility”</a> on page 26. For information on which MICs are supported on MX Series routers, see <a href="#">“MICs Supported by MX Series Routers”</a> on page 18.</p>
Description	<ul style="list-style-type: none"> <li>Four OC3/STM1 ports</li> <li>Rate-selectable using one of the following rates: <ul style="list-style-type: none"> <li>4-port OC3/STM1</li> <li>1-port OC12/STM4</li> </ul> </li> <li>One channelized OC12/STM4 port (down to DS0)</li> <li>SONET or SDH is configurable on a MIC level</li> <li>OC3 channelization: <ul style="list-style-type: none"> <li>4 OC3 channel</li> <li>336 DS1 channels</li> <li>2016 DS0 channels (combination of nxDS0)</li> </ul> </li> <li>SDH channelization: <ul style="list-style-type: none"> <li>4 STM1 channel</li> <li>252 E1 channels</li> <li>2016 DS0 channels (combination of nxDS0)</li> </ul> </li> <li>Power requirement: 2.83 A @ 12 V (33.96 W)</li> <li>Weight: 1.63 lb (0.74 kg)</li> <li>Model number: MIC-3D-4COC3-1COC12-CE</li> </ul>
Hardware features	<ul style="list-style-type: none"> <li>Ports are numbered 0 through 3</li> </ul>

- Software features
- Per-MIC SONET/SDH framing
  - Internal and loop clocking
  - Encapsulations:
    - Pseudo Wire Emulation Edge-to-Edge (PWE3) Architecture (RFC 3985)
    - Requirements for Pseudo-Wire Emulation Edge-to-Edge (PWE3) (RFC 3916)
    - Structure-Agnostic Time Division Multiplexing (TDM) over Packet (SAToP) (RFC 4553)
    - Structure-Aware Time Division Multiplexed (TDM) Circuit Emulation Service over Packet Switched Network (CESoPSN) (RFC 5086)
    - Pseudowire Emulation Edge-to-Edge (PWE3) Control Word for Use over an MPLS PSN (RFC 4385)
    - L2 Network Interconnections (protocol stitching):
      - TDM LDP PWs to BGP L2VPN—see *Using the Layer 2 Interworking Interface to Interconnect a Layer 2 Circuit to a Layer 2 VPN* for more information. Note that stitching CESoPSN PW to BGP L2VPN is not supported.
    - Unified in-service software upgrade (unified ISSU)

Interfaces

Syntax: *mediatype-fpc/pic/port* where:

- mediatype: coc3, coc12, cstm1, cstm4, or ds
- fpc: Slot in the router where the MPC is installed
- pic: 0 when installed in MIC slot 0 or 2 when installed in MIC slot 1
- port: 0 through 3

For example, cstm4-1/2/0 is the channelized STM4 interface for port 0 on the MIC installed in MIC slot 1 on an MPC installed in slot 1.

Cables and connectors **TIP:** You can use the [Hardware Compatibility Tool](#) to find information about the pluggable transceivers supported on your Juniper Networks device.

The list of supported transceivers for the MX Series is located at <https://pathfinder.juniper.net/hct/category/#catKey=100001&modelType;=All&pf;=MX+Series>.

**NOTE:** To extend the life of the laser, when a MIC is not being actively used with any valid links, take the MIC offline until you are ready to establish a link to another device. For information about taking a MIC offline, see the **request chassis pic offline** command in the *Junos OS System Basics and Services Command Reference*.

LEDs

**OK/FAIL LED**, one bicolor:

- Green—MIC is functioning normally
- Red—MIC has failed

**LINK LED**, one tricolor per port:

- Off—Not enabled
- Green—Online with no alarms or failures
- Yellow—Online with alarms for remote failures
- Red—Active with a local alarm; router has detected a failure

## Alarms, errors, and events

Structure-agnostic alarms for T1 and E1 interface:

- Alarm indication signal (AIS)
- Loss of signal (LOS)
- Line code violation (LCV)
- Errored seconds (ES)
- Line-errored seconds (LES)
- Severely errored seconds (SES)
- Unavailable errored seconds (UAS)

Structure aware alarms for T1 and E1 interface:

- Severely errored frame (SEF)
- Block error event (BEE)
- Loss of frame (LOF)
- Yellow alarm (remote alarm indication RAI)
- Path code violation (PCV)
- Severely errored frame seconds (SEFS)
- Bursty errored seconds (BES)

## Related Documentation

- [MX Series MIC Overview on page 17](#)
- [Using the Layer 2 Interworking Interface to Interconnect a Layer 2 Circuit to a Layer 2 VPN](#)

## Channelized OC3/STM1 (Multi-Rate) Circuit Emulation MIC with SFP (H)

Figure 28: Channelized OC3/STM1 (Multi-Rate) Circuit Emulation MIC with SFP (H)

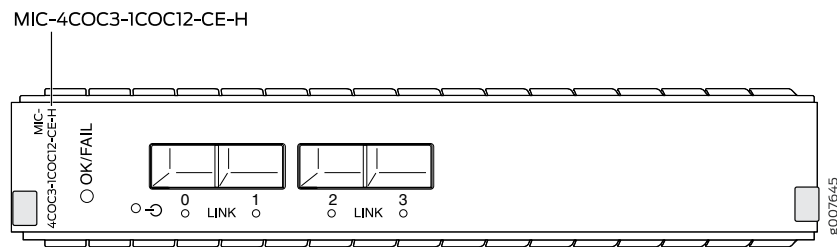

## Software release

- Junos OS Release 13.2R2 and later

For information on which MPCs support this MIC, see [“MIC/MPC Compatibility” on page 26](#). For information on which MICs are supported on MX Series routers, see [“MICs Supported by MX Series Routers” on page 18](#).

Description	<ul style="list-style-type: none"><li>• Four OC3/STM1 ports</li><li>• Rate-selectable using one of the following rates:<ul style="list-style-type: none"><li>• 4-port OC3/STM1</li><li>• 1-port OC12/STM4</li></ul></li><li>• One channelized OC12/STM4 port (down to DS0)</li><li>• SONET or SDH is configurable on a MIC level</li><li>• SONET channelization:<ul style="list-style-type: none"><li>• 4 OC3 channel</li><li>• 336 DS1 channels</li><li>• 2016 DS0 channels (combination of nxDS0)</li></ul></li><li>• SDH channelization:<ul style="list-style-type: none"><li>• 4 STM1 channel</li><li>• 252 E1 channels</li><li>• 2016 DS0 channels (combination of nxDS0)</li></ul></li><li>• Power requirement: 2.83 A @ 12 V (33.96 W)</li><li>• Weight: 1.63 lb (0.74 kg)</li><li>• Model number: MIC-4COC3-1COC12-CE-H</li></ul>
Hardware features	<ul style="list-style-type: none"><li>• Ports are numbered 0 through 3</li><li>• Environmentally hardened for -40° F (-40° C) to 149° F (65° C) operating temperatures</li></ul>
Software features	<ul style="list-style-type: none"><li>• Per-MIC SONET/SDH framing</li><li>• Internal and loop clocking</li><li>• Encapsulations:<ul style="list-style-type: none"><li>• Pseudo Wire Emulation Edge-to-Edge (PWE3) Architecture (RFC 3985)</li><li>• Requirements for Pseudo-Wire Emulation Edge-to-Edge (PWE3) (RFC 3916)</li><li>• Structure-Agnostic Time Division Multiplexing (TDM) over Packet (SAToP) (RFC 4553)</li><li>• Structure-Aware Time Division Multiplexed (TDM) Circuit Emulation Service over Packet Switched Network (CESoPSN) (RFC 5086)</li><li>• Pseudowire Emulation Edge-to-Edge (PWE3) Control Word for Use over an MPLS PSN (RFC 4385)</li></ul></li></ul>
Interfaces	<p>Syntax: <i>mediatype-fpc/pic/port</i> where:</p> <ul style="list-style-type: none"><li>• mediatype: coc3, coc12, cstm1, cstm4, or ds</li><li>• fpc: Slot in the router where the MPC is installed</li><li>• pic: 0 when installed in MIC slot 0 or 2 when installed in MIC slot 1</li><li>• port: 0 through 3</li></ul> <p>For example, cstm4-1/2/0 is the channelized STM4 interface for port 0 on the MIC installed in MIC slot 1 on an MPC installed in slot 1.</p>

Cables and connectors **TIP:** You can use the [Hardware Compatibility Tool](#) to find information about the pluggable transceivers supported on your Juniper Networks device.

The list of supported transceivers for the MX Series is located at <https://pathfinder.juniper.net/hct/category/#catKey=100001&modelType;=All&pf;=MX+Series>.

**NOTE:** To extend the life of the laser, when a MIC is not being actively used with any valid links, take the MIC offline until you are ready to establish a link to another device. For information about taking a MIC offline, see the **request chassis pic offline** command in the *Junos OS System Basics and Services Command Reference*.

**LEDs****OK/FAIL LED**, one bicolor:

- Green—MIC is functioning normally
- Red—MIC has failed

**LINK LED**, one tricolor per port:

- Off—Not enabled
- Green—Online with no alarms or failures
- Yellow—Online with alarms for remote failures
- Red—Active with a local alarm; router has detected a failure

**Alarms, errors, and events**

Structure-agnostic alarms for T1 and E1 interface:

- Alarm indication signal (AIS)
- Loss of signal (LOS)
- Line code violation (LCV)
- Errored seconds (ES)
- Line-errored seconds (LES)
- Severely errored seconds (SES)
- Unavailable errored seconds (UAS)

Structure aware alarms for T1 and E1 interface:

- Severely errored frame (SEF)
- Block error event (BEE)
- Loss of frame (LOF)
- Yellow alarm (remote alarm indication RAI)
- Path code violation (PCV)
- Severely errored frame seconds (SEFS)
- Bursty errored seconds (BES)

**Related Documentation**

- [MX Series MIC Overview on page 17](#)

## Channelized E1/T1 Circuit Emulation MIC

Figure 29: Channelized E1/T1 Circuit Emulation MIC

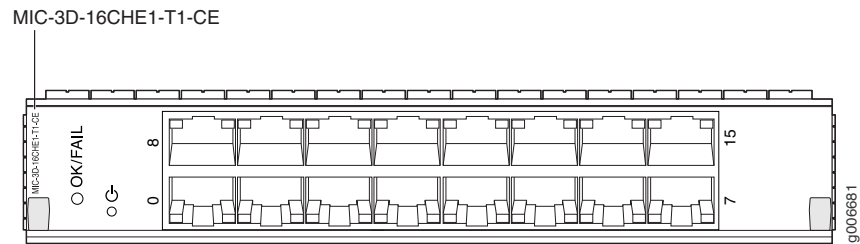

### Software release

- Junos OS Release 12.3 and later

For information on which MPCs support this MIC, see “MIC/MPC Compatibility” on page 26. For information on which MICs are supported on MX Series routers, see “MICs Supported by MX Series Routers” on page 18.

### Description

- Sixteen E1 or T1 ports
- Per-MIC E1/T1 framing
- DS1 channelization per port:
  - 1 DS1 channel
  - 24 DS0 channels
- E1 channelization per port:
  - 1 E1 channel
  - 32 DS0 channels
- Internal and loop clocking
- Power requirement: 2.21 A @ 12 V (26.55 W)
- Weight: 1.57 lb (0.71 kg)
- Model number: MIC-3D-16CHE1-T1-CE

### Hardware features

- Ports are numbered:
  - Top row: 8 and 15 from left to right
  - Bottom row: 0 and 7 from left to right



Software features	<ul style="list-style-type: none"> <li>• Full bit error rate test (BERT)</li> <li>• DS1 and E1 interfaces are selectable on a per-port granularity</li> <li>• Per-port framing is not supported</li> <li>• You can configure the following framing modes using the CLI: <ul style="list-style-type: none"> <li>• T1—SF, ESF, D4/superframe, ESF (extended superframe)</li> <li>• E1—G704, G704—no-crc4, unframed</li> </ul> </li> <li>• Local, remote, and per-port loopback diagnostics</li> <li>• Encapsulations: <ul style="list-style-type: none"> <li>• Pseudowire Emulation Edge to Edge (PWE3) Architecture (RFC 3985)</li> <li>• Requirements for Pseudowire Emulation Edge to Edge (PWE3) (RFC 3916)</li> <li>• Structure-Agnostic Time Division Multiplexing (TDM) over Packet (SAToP) (RFC 4553)</li> <li>• Structure-Aware Time Division Multiplexed (TDM) Circuit Emulation Service over Packet-Switched Network (CESoPSN) (RFC 5086)</li> <li>• Pseudowire Emulation Edge to Edge (PWE3) Control Word for Use over an MPLS PSN (RFC 4385)</li> </ul> </li> <li>• In-service software upgrade (Unified ISSU)</li> </ul>
-------------------	--

**Cables and connectors** **TIP:** You can use the [Hardware Compatibility Tool](#) to find information about the pluggable transceivers supported on your Juniper Networks device.

The list of supported transceivers for the MX Series is located at <https://pathfinder.juniper.net/hct/category/#catKey=100001&modelType;=All&pf;=MX+Series>.

- RJ-48 connector

LEDs	<p><b>OK/FAIL LED, one bicolor:</b></p> <ul style="list-style-type: none"> <li>• Green—MIC is functioning normally.</li> <li>• Red—MIC has failed.</li> </ul> <p>One tricolor per port:</p> <ul style="list-style-type: none"> <li>• Off—Not enabled.</li> <li>• Green—Online with no alarms or failures.</li> <li>• Yellow—Online with alarms for remote failures.</li> <li>• Red—Active with a local alarm; router has detected a failure.</li> </ul>
------	---

**Alarms, errors, and events**

- Structure-agnostic alarms for T1 and E1 interface:
  - Alarm indication signal (AIS)
  - Loss of signal (LOS)
- Structure-aware alarms for T1 and E1 interface:
  - Loss of signal (LOS)
  - Alarm indication signal (AIS)
  - Loss of frame (LOF)
  - Remote alarm indication signal (RAIS)
- Structure-agnostic error detection for T1 and E1 interface:
  - Errored seconds (ES)
  - Line code violation (LCV)
  - Line errored seconds (LES)
  - Severely errored seconds (SES)
  - Unavailable seconds (UAS)
  - Loss of signal seconds (LOSS)
- Structure-aware error detection for T1 and E1 interface:
  - Severely errored frame (SEF)
  - Block error event (BEE)
  - Line code violation (LCV)
  - Path code violation (PCV)
  - Line errored seconds (LES)
  - Errored seconds (ES)
  - Severely errored seconds (SES)
  - Severely errored frame seconds (SEFS)
  - Bursty errored seconds (BES)
  - Unavailable seconds (UAS)
  - Loss of signal seconds (LOSS)
  - Loss of framing seconds (LOFS)
  - Far-end block error (FEBE) (E1 only)
  - CRC errors (E1 only)

---

**Related Documentation**

- [MX Series MIC Overview on page 17](#)

## Channelized E1/T1 Circuit Emulation MIC (H)

Figure 30: Channelized E1/T1 Circuit Emulation MIC (H)

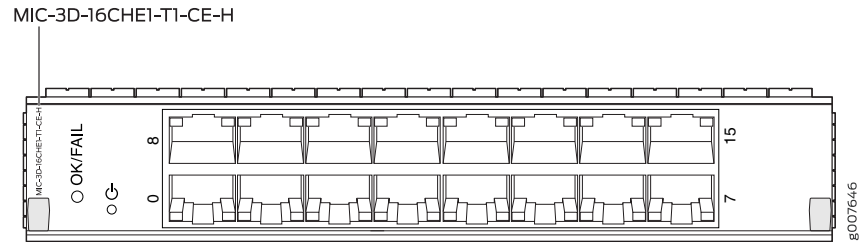

### Software release

- Junos OS Release 13.2R2 and later

For information on which MPCs support this MIC, see “MIC/MPC Compatibility” on page 26. For information on which MICs are supported on MX Series routers, see “MICs Supported by MX Series Routers” on page 18.

### Description

- Sixteen E1 or T1 ports
- Per-MIC E1/T1 framing
- DS1 channelization per port:
  - 1 DS1 channel
  - 24 DS0 channels
- E1 channelization per port:
  - 1 E1 channel
  - 32 DS0 channels
- Internal and loop clocking
- Power requirement: 2.21 A @ 12 V (26.55 W)
- Weight: 1.57 lb (0.71 kg)
- Model number: MIC-3D-16CHE1-T1-CE-H

### Hardware features

- Ports are numbered:
  - Top row: 8 and 15 from left to right
  - Bottom row: 0 and 7 from left to right
- Environmentally hardened for  $-40^{\circ}\text{F}$  ( $-40^{\circ}\text{C}$ ) to  $149^{\circ}\text{F}$  ( $65^{\circ}\text{C}$ ) operating temperatures

- Software features
- Full bit error rate test (BERT)
  - DS1 and E1 interfaces are selectable on a per-port granularity
  - Per-port framing is not supported
  - You can configure the following framing modes using the CLI:
    - T1—SF, ESF, D4/superframe, ESF (extended superframe)
    - E1—G704, G704—no-crc4, unframed
  - Local, remote, and per-port loopback diagnostics
  - Encapsulations:
    - Pseudowire Emulation Edge to Edge (PWE3) Architecture (RFC 3985)
    - Requirements for Pseudowire Emulation Edge to Edge (PWE3) (RFC 3916)
    - Structure-Agnostic Time Division Multiplexing (TDM) over Packet (SAToP) (RFC 4553)
    - Structure-Aware Time Division Multiplexed (TDM) Circuit Emulation Service over Packet-Switched Network (CESoPSN) (RFC 5086)
    - Pseudowire Emulation Edge to Edge (PWE3) Control Word for Use over an MPLS PSN (RFC 4385)

- Interfaces
- Syntax: *media-type-fpc/pic/port* where:
- media-type: ct1, ds, t1, or e1
  - fpc: Slot in the router where the MPC is installed
  - pic: 0 when installed in MIC slot 0 or 2 when installed in MIC slot 1
  - port: 0 through 15
- For example, t1-2/2/0 is the T1 interface for port 0 on the MIC installed in MIC slot 1 on an MPC installed in slot 2.

- Cables and connectors
- TIP:** You can use the [Hardware Compatibility Tool](#) to find information about the pluggable transceivers supported on your Juniper Networks device.
- The list of supported transceivers for the MX Series is located at <https://pathfinder.juniper.net/hct/category/#catKey=100001&modelType;=All&pf;=MX+Series>.
- RJ-48 connector

- LEDs
- OK/FAIL LED**, one bicolor:
- Green—MIC is functioning normally.
  - Red—MIC has failed.
- One tricolor per port:
- Off—Not enabled.
  - Green—Online with no alarms or failures.
  - Yellow—Online with alarms for remote failures.
  - Red—Active with a local alarm; router has detected a failure.

#### Alarms, errors, and events

- Structure-agnostic alarms for T1 and E1 interface:
  - Alarm indication signal (AIS)
  - Loss of signal (LOS)
- Structure-aware alarms for T1 and E1 interface:
  - Loss of signal (LOS)
  - Alarm indication signal (AIS)
  - Loss of frame (LOF)
  - Remote alarm indication signal (RAIS)
- Structure-agnostic error detection for T1 and E1 interface:
  - Errored seconds (ES)
  - Line code violation (LCV)
  - Line errored seconds (LES)
  - Severely errored seconds (SES)
  - Unavailable seconds (UAS)
  - Loss of signal seconds (LOSS)
- Structure-aware error detection for T1 and E1 interface:
  - Severely errored frame (SEF)
  - Block error event (BEE)
  - Line code violation (LCV)
  - Path code violation (PCV)
  - Line errored seconds (LES)
  - Errored seconds (ES)
  - Severely errored seconds (SES)
  - Severely errored frame seconds (SEFS)
  - Bursty errored seconds (BES)
  - Unavailable seconds (UAS)
  - Loss of signal seconds (LOSS)
  - Loss of framing seconds (LOFS)
  - Far-end block error (FEBE) (E1 only)
  - CRC errors (E1 only)

**Related Documentation** • [MX Series MIC Overview on page 17](#)

## Tri-Rate MIC

Figure 31: 40-Port Tri-Rate MIC

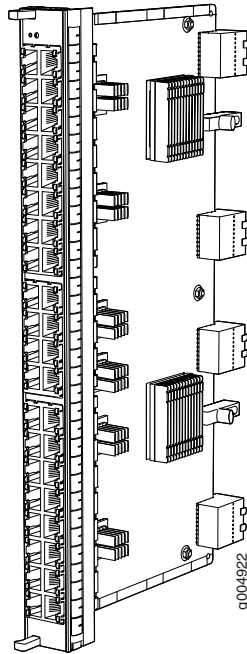

Software release	<ul style="list-style-type: none"> <li>Junos 10.2 and later</li> </ul> <p>For information on which MPCs support this MIC, see <a href="#">“MIC/MPC Compatibility” on page 26</a>. For information on which MICs are supported on MX Series routers, see <a href="#">“MICs Supported by MX Series Routers” on page 18</a>.</p>
Description	<ul style="list-style-type: none"> <li>40 autonegotiating 10BASE-T, 100BASE-TX, or 1000BASE-T Megabit Ethernet ports</li> <li>Power requirement: 0.85 A @ 48 V (41 W)</li> <li>Weight: 1.9 lb (0.9 kg)</li> <li>Model number: MIC-3D-40GE-TX</li> <li>Name in the CLI: <b>3D 40GE TX</b></li> </ul>
Hardware features	<ul style="list-style-type: none"> <li>Dual-wide MIC that installs into 2 slots.           <p>For information on how to install dual-wide MICs, see the <i>Installing Dual-Wide MIC</i> topic in the respective <i>MX Series Router Hardware Guide</i>.</p> </li> <li>High-performance throughput on each port at speeds of 10 Mbps, 100 Mbps, or 1000 Mbps</li> <li>Up to 40-Gbps of full-duplex traffic</li> <li>Autonegotiation between Gigabit Ethernet circuit partners</li> <li>Maximum transmission units (MTUs) of up to 9192 bytes</li> </ul>

---

Software features	<ul style="list-style-type: none"><li>• Virtual Router Redundancy Protocol (VRRP) support</li><li>• IEEE 802.1Q virtual LANs (VLANs) support</li><li>• Remote monitoring (RMON) EtherStats</li><li>• Source MAC learning</li><li>• MAC accounting and policing—Dynamic local address learning of source MAC addresses</li><li>• Flexible Ethernet encapsulation</li><li>• Multiple tag protocol identifiers (TPID)</li></ul>
Interfaces	<p>Syntax: <i>ge-fpc/pic/port</i> where:</p> <ul style="list-style-type: none"><li>• fpc: Slot in the router where the MPC is installed.</li><li>• pic: The ports on the MPC are divided into four logical PICs numbered 0, 1, 2, and 3.</li><li>• port: 0 through 9</li></ul> <p>For example, <i>ge-2/3/0</i> is the interface for port 0 in logical PIC 3 on the MPC installed in slot 2.</p> <p><a href="#">Figure 15 on page 154</a>, <a href="#">Figure 33 on page 199</a>, and <a href="#">Figure 34 on page 199</a> illustrate the port numbering for the Tri-Rate MIC installed in the MX960, MX480, and MX240, respectively.</p>
Cables and connectors	<ul style="list-style-type: none"><li>• Connector: Four-pair, Category 5 shielded twisted-pair connectivity through an RJ-45 connector</li><li>• Pinout: MDI, MDI crossover</li><li>• Maximum distance: 328 ft (100 m)</li></ul> <p><b>CAUTION:</b> Do not use RJ-45 cables with strain-relief boots exceeding 1.5 mm from the bottom of the connector. Cable boots that exceed this measurement can damage the port.</p>
LEDs	<p>OK/fail LED, one bicolor:</p> <ul style="list-style-type: none"><li>• Green—MIC is functioning normally.</li><li>• Red—MIC has failed.</li></ul> <p>Link LED, one green per port:</p> <ul style="list-style-type: none"><li>• Off—No link.</li><li>• On steadily—Link is up.</li></ul>

---

[Figure 15 on page 154](#), [Figure 33 on page 199](#), and [Figure 34 on page 199](#) illustrate the port numbering for the Tri-Rate MIC installed in the MX960, MX480, and MX240, respectively.

Figure 32: Port Numbering for the Tri-Rate MIC (MX960)

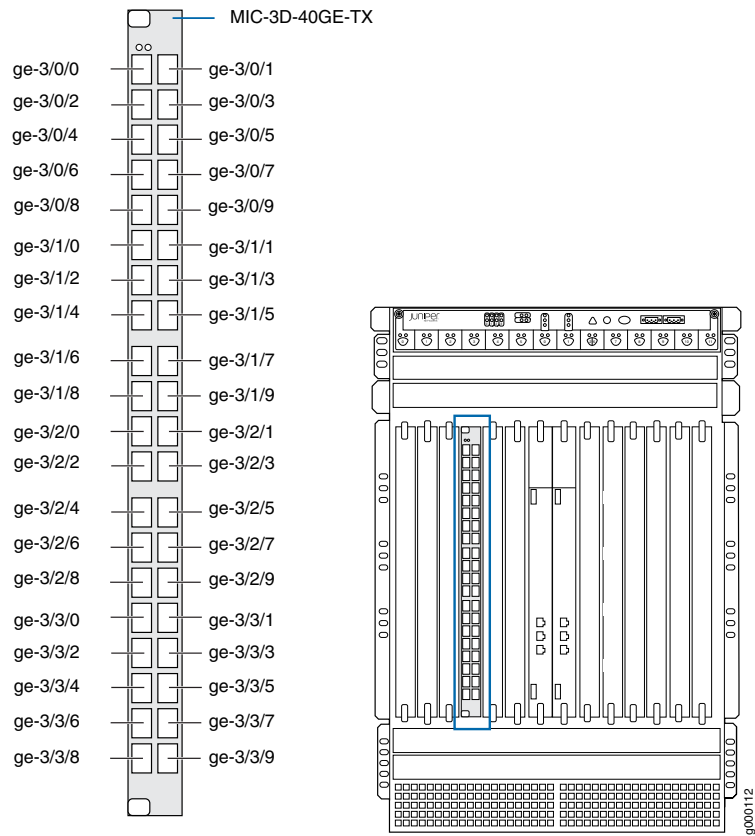



Figure 33: Port Numbering for the Tri-Rate MIC (MX480)

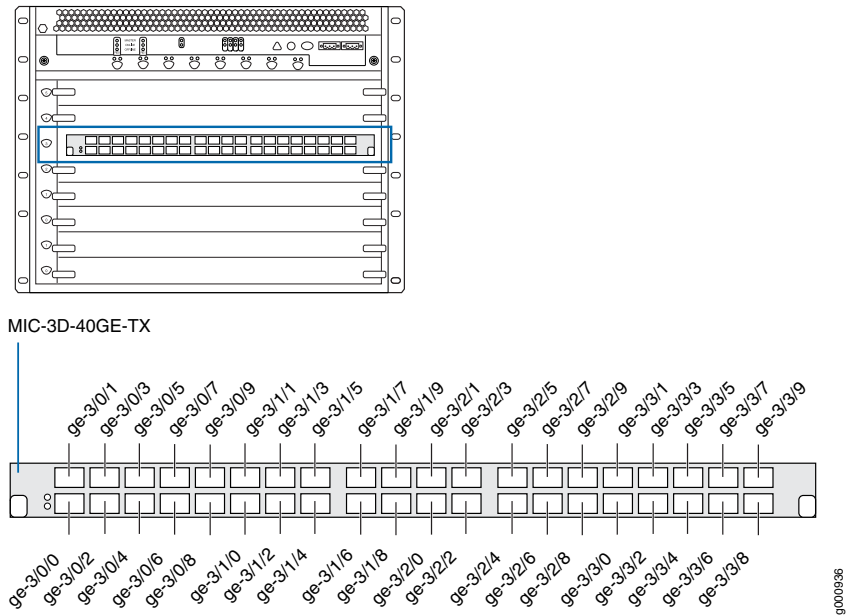
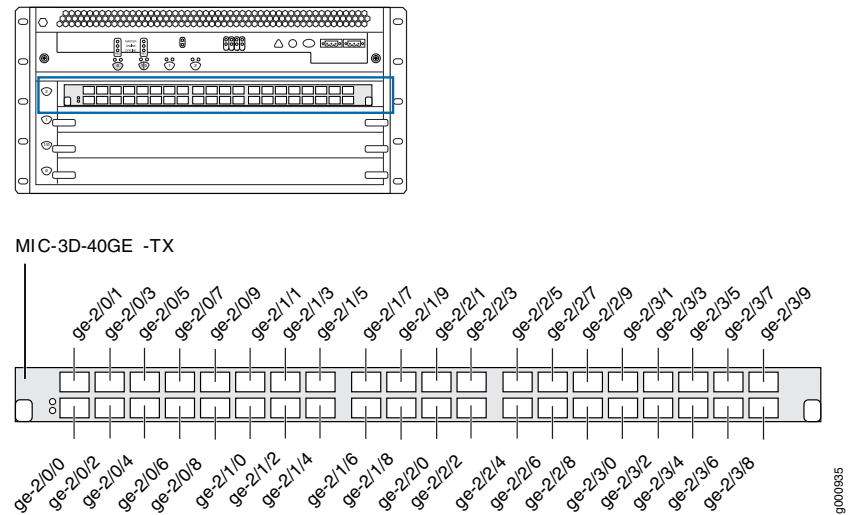

Figure 34: Port Numbering for the Tri-Rate MIC (MX240)



Related Documentation • [MX Series MIC Overview on page 17](#)

## MIC MRATE

Figure 35: 12-Port Multi-Rate MIC with QSFP+

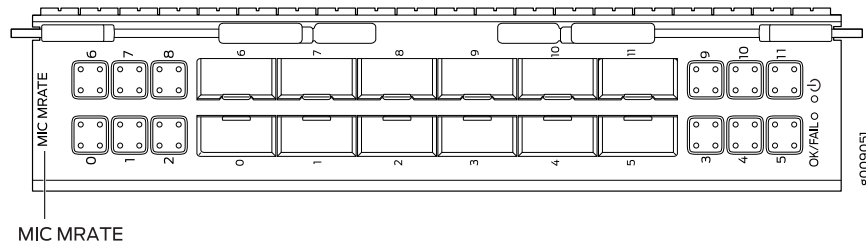

Software release	<ul style="list-style-type: none"> <li>Junos OS Release 15.1F5 with Junos Continuity</li> <li>Junos OS release 16.1R1 and later</li> </ul> <p>For information about which MPCs support this MIC, see <a href="#">“MIC/MPC Compatibility”</a> on page 26. For information about which MICs are supported on MX Series routers, see <a href="#">“MICs Supported by MX Series Routers”</a> on page 18.</p>
Description	<ul style="list-style-type: none"> <li>Twelve Gigabit Ethernet ports that support quad small form-factor pluggable plus (QSFP+) transceivers</li> <li>Power requirement; <ul style="list-style-type: none"> <li>When installed into MPC8E: 1.250 A @ 48 V (60 W)</li> <li>When installed into MPC9E, or into MPC8E operating in 1.6 Tbps upgrade mode (licensed feature): 1.771 A @ 48 V (85 W)</li> </ul> </li> <li>Weight: 3.9 lb (1.77 kg)</li> <li>Model number: MIC-MRATE</li> <li>Name in the CLI: <b>MRATE-12xQSFP+XGE-XLGE-CGE</b></li> </ul>
Hardware features	<ul style="list-style-type: none"> <li>The ports are numbered 0 through 11.</li> <li>Twelve Gigabit Ethernet QSFP+ ports, each of which can be configured as a 40-Gigabit Ethernet port or as four 10-Gigabit Ethernet ports by using a breakout cable.</li> <li>Eight out of the twelve ports can be configured as 100-Gigabit Ethernet ports. Port numbers 0 through 3, and 6 through 9 are the eight 100-Gigabit Ethernet ports.</li> <li>When used in MX2K-MP8CE: <ul style="list-style-type: none"> <li>4 ports out of the total 12 support 100-Gigabit Ethernet speed</li> <li>Maximum aggregate port capacity across ports 0 through 5 should not exceed 240 Gbps</li> <li>Maximum aggregate port capacity across ports 6 through 11 should not exceed 240 Gbps</li> </ul> </li> <li>When used in MX2K-MPC9E: <ul style="list-style-type: none"> <li>8 ports out of the total 12 support 100-Gigabit Ethernet speed</li> <li>Maximum aggregate port capacity across ports 0 through 5 should not exceed 400 Gbps</li> <li>Maximum aggregate port capacity across ports 6 through 11 should not exceed 400 Gbps</li> </ul> </li> </ul> <p><a href="#">Table 25</a> on page 201 lists the configurable Gbps Ethernet port speeds for each port.</p>
Software features	<ul style="list-style-type: none"> <li>Supports rate selectability at the port level.</li> <li>By default, the ports are configured as 10-Gigabit Ethernet ports.</li> <li>Supports remote port identification.</li> </ul>

Cables and connectors **TIP:** You can use the [Hardware Compatibility Tool](#) to find information about the pluggable transceivers supported on your Juniper Networks device.

The list of supported transceivers for the MX Series is located at <https://pathfinder.juniper.net/hct/category/#catKey=100001&modelType;=All&pf;=MX+Series>.

## LEDs

- **OK/FAIL LED**, one bicolor:
  - Steady green—MIC is functioning normally.
  - Yellow—MIC has failed.
- **Link LED**, one green per port (4 per QSFP+ cage):
  - Steady green—Link is up.
  - Off—Link is down or disabled.

Each QSFP+ cage contains four LEDs, logically numbered from 0 through 3. These numbers help you identify the corresponding cable when a breakout cable (4x10 Gigabit) is connected to a port. On an installed MRATE MIC, the orientation of these LEDs is as follows: upper left **0**, upper right **1**, lower left **2**, and lower right **3**.

**Table 25: MIC MRATE Gigabit Ethernet Port Speed Capabilities**

Port #	4x10 Gbps Ethernet	40 Gbps Ethernet	100 Gbps Ethernet
0	yes	yes	yes
1	yes	yes	yes
2	yes	yes	yes
3	yes	yes	yes
4	yes	yes	no
5	yes	yes	no
6	yes	yes	yes
7	yes	yes	yes
8	yes	yes	yes
9	yes	yes	yes
10	yes	yes	no
11	yes	yes	no

**Related Documentation**

- *Junos Continuity Software User Guide (Junos OS Release 14.1R4 and Later Releases)*
- *Understanding Interface Naming Conventions for MIC-MRATE*
- *Understanding Rate Selectability*

- [Configuring Rate Selectability on MIC-MRATE to Enable Different Port Speeds](#)

## Multiservices MIC

Figure 36: MS-MIC-16G

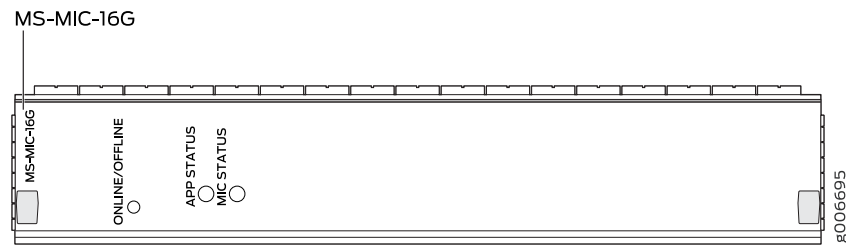

Supported Junos OS Release	<ul style="list-style-type: none"> <li>• Junos OS Release 13.2 and later</li> <li>• Model number: MS-MIC-16G</li> <li>• Name in the CLI: <b>MS-MIC-16G</b></li> </ul>
Description	The Multiservices Modular Interfaces Card (MS-MIC) provides improved scaling and high performance for MX series routers. The MS-MIC has enhanced memory (16 GB) and enhanced processing capabilities.
Software Features	<ul style="list-style-type: none"> <li>• Active flow monitoring and export of flow monitoring version 9 records based on RFC 3954</li> <li>• IP Security (IPsec) encryption</li> <li>• Network Address Translation (NAT) for IP addresses</li> </ul> <p><b>NOTE:</b> The Multiservices MIC does not support Network Address Translation-Traversal (NAT-T).</p> <ul style="list-style-type: none"> <li>• Port Address Translation (PAT) for port numbers</li> <li>• Traffic sampling</li> <li>• Stateful firewall with packet inspection—detects SYN attacks, ICMP and UDP floods, and ping-of-death attacks</li> <li>• Network Attack Protection (NAP)</li> <li>• Support for up to 6000 service sets</li> <li>• Support for MTUs up to 9192 bytes.</li> <li>• Multiple services can be supported. See <i>Junos OS Services Interfaces Library for Routing Devices</i> for more information.</li> <li>• See <a href="#">“Protocols and Applications Supported by the MS-MIC and MS-MPC” on page 417</a> for information about the protocols and applications that this MIC supports.</li> </ul>
Hardware Features and Requirements	<ul style="list-style-type: none"> <li>• MICs are hot-removable and hot-insertable</li> <li>• MS-MIC CPU Clock Cycle – 800MHz</li> <li>• Works with SBCs and SBCEs</li> <li>• Interoperable with MS-DPCs. Both MS-MPCs and MS-DPCs can co-exist in the same chassis</li> <li>• Chassis requires enhanced fan trays and high-capacity DC or AC power supplies</li> </ul> <p><b>NOTE:</b> Only one Multiservices MIC is supported in each MPC.</p> <p><b>NOTE:</b> Starting in Junos OS Release 13.3R3, 14.1R2, and 14.2R1, MX104 routers support only two Multiservices MICs.</p>

Input/Output Power Requirements	MS-MIC—6.67 amps @ 9V (60W)
Weight and Dimensions	Weight: 2 lbs (.91 kg); Height: 0.9 in. (2.26 cm); Width: 6 in. (15.24 cm); Depth: 7 in. (17.78 cm)
MPC Support	<ul style="list-style-type: none"> <li>• <a href="#">Multiservices MPC on page 86</a></li> <li>• See “MIC/MPC Compatibility” on page 26 for a list of the MPCs that support the MS-MIC.</li> </ul>
LEDs	<p>Application activity tricolor LED, labeled <b>APP STATUS</b>:</p> <ul style="list-style-type: none"> <li>• Off—Application is not running.</li> <li>• Red—Application has failed.</li> <li>• Yellow—Application is reconfiguring.</li> <li>• Green—Application is running.</li> </ul> <p>MIC activity tricolor LED, labeled <b>MIC STATUS</b>:</p> <ul style="list-style-type: none"> <li>• Off—MIC has failed.</li> <li>• Red—MIC has an error or failure.</li> <li>• Yellow—MIC is transitioning online or offline.</li> <li>• Green—MIC is functioning normally.</li> </ul>

- Related Documentation**
- [Multiservices MPC on page 86](#)
  - [MX Series MIC Overview on page 17](#)
  - *Junos OS Services Interfaces Library for Routing Devices*
  - [Protocols and Applications Supported by the MS-MIC and MS-MPC on page 417](#)
  - [MIC/MPC Compatibility on page 26](#)
  - *Example: Inter-Chassis Stateful High Availability for NAT and Stateful Firewall (MS-MIC, MS-MPC)*
  - *Example: Configuring Flow Monitoring on an MX Series Router with MS-MIC and MS-MPC*
  - *Inter-Chassis High Availability for MS-MIC and MS-MPC (Release 15.1 and earlier)*
  - *Example: Configuring Junos VPN Site Secure on MS-MIC and MS-MPC*
  - *ICMP, Ping, and Traceroute ALGs for MS-MICs and MS-MPCs*
  - [MICs Supported by MX Series Routers on page 18](#)

## SONET/SDH OC3/STM1 (Multi-Rate) MICs with SFP

Figure 37: 4-Port SONET/SDH OC3/STM1 (Multi-Rate) MIC with SFP

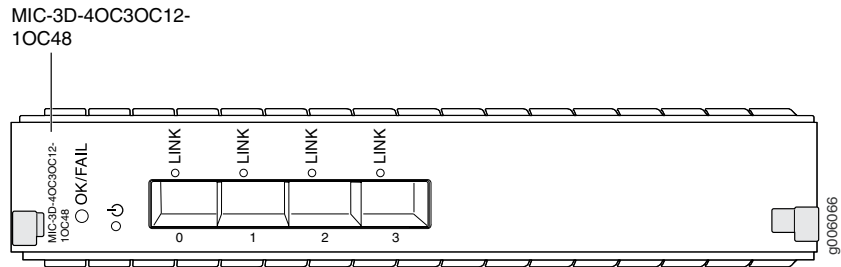
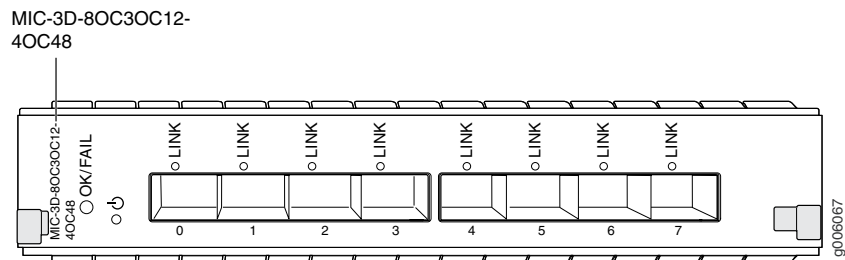

Figure 38: 8-Port SONET/SDH OC3/STM1 (Multi-Rate) MIC with SFP



Software release

- 4-port: Junos OS Release 11.2 and later
- 8-port: Junos OS Release 11.2 and later

For information on which MPCs support these MICs, see [“MIC/MPC Compatibility”](#) on page 26. For information on which MICs are supported on MX Series routers, see [“MICs Supported by MX Series Routers”](#) on page 18.

- Description
- 4-port: 4 OC3/STM1 or OC12/STM4 ports
    - Each port is rate-selectable and supports OC3, OC12, or OC48.
    - The ports can be configured to support a combination of OC3, OC12, and OC48 rates. In the combination, you can configure only one port to support OC48, whereas OC3 or OC12 can be configured on all four ports.
  - 8-port: 8 OC3/STM1 or OC12/STM4 ports
    - Each port is rate-selectable and supports OC3, OC12, or OC48.
    - The ports can be configured to support a combination of OC3, OC12, and OC48 rates. In the combination, you can configure only four ports to support OC48, whereas OC3 or OC12 can be configured on all eight ports.
  - Power requirement:
    - 4-port: 2.6 A @ 9 V (23.4 W)
    - 8-port: 3.1 A @ 9 V (27.9 W)
  - Weight:
    - 4-port: 1.27 lb (0.58 kg)
    - 8-port: 1.47 lb (0.67 kg)
  - Model number:
    - 4-port: MIC-3D-4OC3OC12-1OC48
    - 8-port: MIC-3D-8OC3OC12-4OC48

- Hardware features
- The ports are labeled:
    - 4-port: 0-3
    - 8-port: 0-7
  - Maximum transmission units (MTUs) of up to 9192 bytes

- Software features
- Per-port SONET/SDH framing
  - Local and remote loopback on each port
  - Optical diagnostics and monitoring
  - Clocking options: internal or external/loop mode.
  - Unified in-service software upgrade (unified ISSU)
  - Encapsulations:
    - Multiprotocol Label Switching (MPLS) fast reroute
    - MPLS CCC (circuit cross-connect)
    - MPLS TCC (translational cross-connect)
    - Cisco High-Level Data Link Control
    - Cisco HDLC CCC
    - Cisco HDLC TCC
    - Point-to-Point Protocol (PPP)
    - PPP for CCC
    - PPP for TCC
    - Flexible Frame Relay
    - Frame Relay
    - Frame Relay for CCC
    - Frame Relay for TCC
    - PPP over Frame Relay

**NOTE:** Ethernet over Frame Relay is not supported.

Cables and connectors **TIP:** You can use the [Hardware Compatibility Tool](#) to find information about the pluggable transceivers supported on your Juniper Networks device.

The list of supported transceivers for the MX Series is located at <https://pathfinder.juniper.net/hct/category/#catKey=100001&modelType;=All&pf;=MX+Series>.

**LEDs**

**OK/FAIL LED**, one bicolor:

- Green—MIC is functioning normally
- Red—MIC has failed

**LINK LED**, one green per port:

- Off—Not enabled
- Green—Online with no alarms or failures
- Yellow—Online with alarms for remote failures
- Red—Active with a local alarm; router has detected a failure



**Alarms, errors, and events****SONET alarms:**

- Loss of light (LOL)
- Loss of signal (LOS)
- Loss of frame (LOF)
- Phase lock loop (PLL)
- Severely errored frame (SEF)
- Alarm indicator signal–line (AIS-L)
- Alarm indicator signal–path (AIS-P)
- Remote defect indicator–line (RDI-L)
- Remote defect indicator–path (RDI-P)
- Loss of pointer–path (LOP-P)
- Bit error rate–signal degrade (BERR-SD)
- Bit error rate–signal fail (BERR-SF)
- Payload label mismatch–Path (PLM-P)
- Unequipped–path (UNEQ-P)
- Remote error indicator–path (REI-P)

**SDH alarms:**

- Loss of light (LOL)
- Phase lock loop (PLL)
- Loss of frame (LOF)
- Loss of signal (LOS)
- Severely errored frame (SEF)
- Multiplex-section alarm indicator signal (MS-AIS)
- H Path alarm indicator signal (HP-AIS)
- Loss of pointer (LOP)
- Bit error rate–signal degrade (BER-SD)
- Bit error rate–signal fail (BER-SF)
- Multiplex section–far end receive failure (MS-FERF)
- High order path–far end receive failure (HP-FERF)
- High order path–payload label mismatch (HP-PLM)
- Remote error indicator (REI)
- Unequipped (UNEQ)

**Related Documentation**

- [MX Series MIC Overview on page 17](#)

## Multi-Rate Ethernet MIC

Figure 39: JNP-MIC

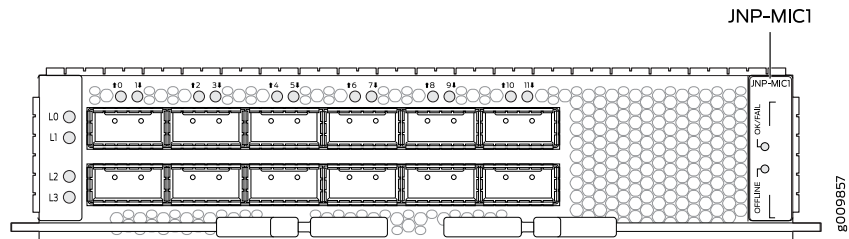

Figure 40: JNP-MIC1-MACSEC

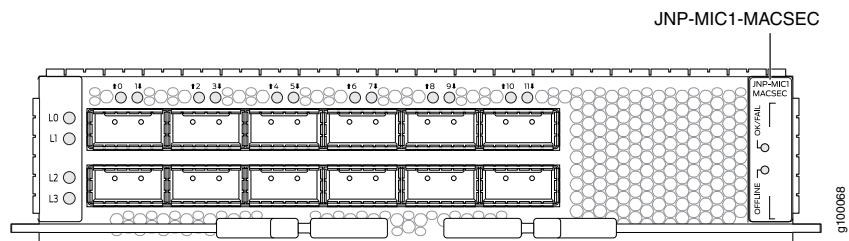
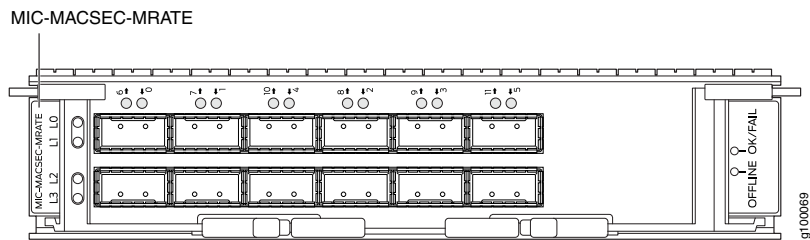

Figure 41: MIC-MACSEC-MRATE



Software release

- JNP-MIC1:  
Junos OS release 17.3R1 and later
- JNP-MIC1-MACSEC:  
Junos OS release 17.3R2 and later
- MIC-MACSEC-MRATE:  
Junos OS release 17.4R1 and later

For information about which MPCs support this MIC, see [“MIC/MPC Compatibility”](#) on page 26. For information about which MICs are supported on MX Series routers, see [“MICs Supported by MX Series Routers”](#) on page 18.

Description	<ul style="list-style-type: none"> <li>• Weight: 3 lb (1.36 kg)</li> <li>• Model numbers: Without MACsec support: JNP-MIC1 With MACsec support: JNP-MIC1-MACSEC With MACsec support: MIC-MACSEC-MRATE</li> <li>• Power requirement: <ul style="list-style-type: none"> <li>• JNP-MIC1: 85 W at 55° C 80 W at 25° C</li> <li>• JNP-MIC1-MACSEC: 130 W at 55° C 125 W at 25° C</li> <li>• MIC-MACSEC-MRATE: 110 W at 45° C 105 W at 25° C</li> </ul> </li> <li>• Name in the CLI: JNP-MIC1: <b>MIC1</b> JNP-MIC1-MACSEC: <b>MIC1-MACSEC</b> MIC-MACSEC-MRATE: <b>MACSEC-12xQSFP-XGE-XLGE-CGE</b></li> </ul>
Hardware features	<ul style="list-style-type: none"> <li>• JNP-MIC1 and JNP-MIC1-MACSEC: <ul style="list-style-type: none"> <li>• Twelve 100-Gigabit Ethernet ports that support quad small form-factor pluggable (QSFP28) transceivers</li> <li>• The ports are numbered <b>0</b> through <b>11</b>.</li> <li>• Each port can be configured as a 100-Gigabit Ethernet port, 40-Gigabit Ethernet port, or as four 10-Gigabit Ethernet ports (by using a breakout cable).</li> </ul> <p><a href="#">Table 26 on page 210</a> lists the configurable Gigabit Ethernet port speeds for each port.</p> </li> <li>• MIC-MACSEC-MRATE: <ul style="list-style-type: none"> <li>• Twelve Gigabit Ethernet QSFP+ ports, each of which can be configured as a 40-Gigabit Ethernet port or as four 10-Gigabit Ethernet ports (by using a breakout cable).</li> <li>• The ports are numbered <b>0</b> through <b>11</b>.</li> <li>• Eight out of the twelve ports can be configured as 100-Gigabit Ethernet ports. Port numbers <b>0</b> through <b>3</b>, and <b>6</b> through <b>9</b> are the eight 100-Gigabit Ethernet ports.</li> <li>• When used in MP8CE: <ul style="list-style-type: none"> <li>• Four ports out of the total twelve ports support 100-Gigabit Ethernet speed</li> <li>• Maximum aggregate port capacity across ports <b>0</b> through <b>5</b> should not exceed 240 Gbps</li> <li>• Maximum aggregate port capacity across ports <b>6</b> through <b>11</b> should not exceed 240 Gbps</li> </ul> </li> <li>• When used in MPC9E: <ul style="list-style-type: none"> <li>• Eight ports out of the total twelve ports support 100-Gigabit Ethernet speed</li> <li>• Maximum aggregate port capacity across ports <b>0</b> through <b>5</b> should not exceed 400 Gbps</li> <li>• Maximum aggregate port capacity across ports <b>6</b> through <b>11</b> should not exceed 400 Gbps</li> </ul> </li> </ul> <p><a href="#">Table 27 on page 210</a> lists the configurable Gigabit Ethernet port speeds for each port.</p> </li> </ul>
Software features	<ul style="list-style-type: none"> <li>• Supports rate selectability at the port level.</li> <li>• By default, the ports are configured as 10-Gigabit Ethernet ports.</li> <li>• Supports remote port identification.</li> <li>• MICs with model numbers JNP-MIC1-MACSEC and MIC-MACSEC-MRATE support Media Access Control Security (MACsec)</li> </ul>

Cables and connectors **TIP:** You can use the [Hardware Compatibility Tool](#) to find information about the pluggable transceivers supported on your Juniper Networks device.

The list of supported transceivers for the MX Series is located at <https://pathfinder.juniper.net/hct/category/#catKey=100001&modelType;=All&pf;=MX+Series>.

LEDs	<ul style="list-style-type: none"> <li>• <b>OK/FAIL LED</b>, one bicolor:             <ul style="list-style-type: none"> <li>• OFF—MIC is offline or MIC has fault.</li> <li>• Red—MIC is in power failure state.</li> <li>• Green—MIC is online.</li> </ul> </li> <li>• <b>Link LED</b>, one green per port:             <ul style="list-style-type: none"> <li>• Steady green—Link is up.</li> <li>• Off—Link is down or disabled.</li> </ul> </li> <li>• Like port status LED, each individual lane LED support four states as: OFF, AMBER, GREEN, RED. See <i>MPC and MIC Lane LED Scheme Overview</i> for more details.</li> </ul>
------	---

**Table 26: Multi Rate Ethernet MIC Port Speed Capabilities for JNP-MIC1 and JNP-MIC1-MACSEC**

Port #	4x10-Gigabit Ethernet	40-Gigabit Ethernet	100-Gigabit Ethernet
0	yes	yes	yes
1	yes	yes	yes
2	yes	yes	yes
3	yes	yes	yes
4	yes	yes	yes
5	yes	yes	yes
6	yes	yes	yes
7	yes	yes	yes
8	yes	yes	yes
9	yes	yes	yes
10	yes	yes	yes
11	yes	yes	yes

**Table 27: Multi Rate Ethernet MIC Port Speed Capabilities for MIC-MACSEC-MRATE**

Port #	4x10-Gigabit Ethernet	40-Gigabit Ethernet	100-Gigabit Ethernet
0	yes	yes	yes

Table 27: Multi Rate Ethernet MIC Port Speed Capabilities for MIC-MACSEC-MRATE (continued)

Port #	4x10-Gigabit Ethernet	40-Gigabit Ethernet	100-Gigabit Ethernet
1	yes	yes	yes
2	yes	yes	yes
3	yes	yes	yes
4	yes	yes	no
5	yes	yes	no
6	yes	yes	yes
7	yes	yes	yes
8	yes	yes	yes
9	yes	yes	yes
10	yes	yes	no
11	yes	yes	no

- Related Documentation**
- [MPC and MIC Lane LED Scheme Overview](#)
  - [Configuring Rate Selectability on MX10003 MPC to Enable Different Port Speeds](#)
  - [MX10003 MPC Rate-Selectability Overview](#)
  - [Understanding Rate Selectability](#)

## Multi-Rate Ethernet MIC

Figure 42: MIC-MACSEC-MRATE

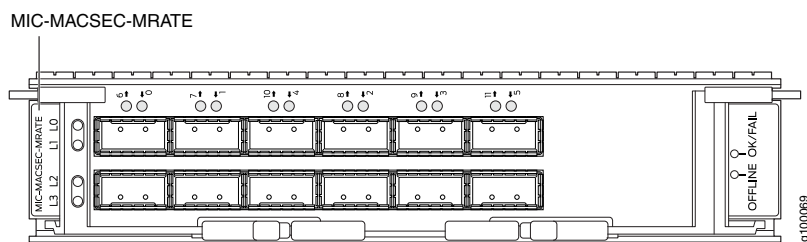

Software release Junos OS release 17.4R1 and later

For information about which MPCs support this MIC, see [“MIC/MPC Compatibility” on page 26](#). For information about which MICs are supported on MX Series routers, see [“MICs Supported by MX Series Routers” on page 18](#).

Description	<ul style="list-style-type: none"> <li>Weight: 3 lb (1.36 kg)</li> <li>Model number: MIC-MACSEC-MRATE</li> <li>Power requirement: <ul style="list-style-type: none"> <li>110 W at 45° C</li> <li>105 W at 25° C</li> </ul> </li> <li>Name in the CLI: <b>MACSEC-12xQSFP+XGE-XLGE-CGE</b></li> </ul>
Hardware features	<ul style="list-style-type: none"> <li>Twelve Gigabit Ethernet QSFP+ ports, each of which can be configured as a 40-Gigabit Ethernet port or as four 10-Gigabit Ethernet ports (by using a breakout cable).</li> <li>The ports are numbered 0 through 11.</li> <li>Eight out of the twelve ports can be configured as 100-Gigabit Ethernet ports. Port numbers 0 through 3, and 6 through 9 are the eight 100-Gigabit Ethernet ports.</li> <li>When used in MP8CE: <ul style="list-style-type: none"> <li>Four ports out of the total twelve ports support 100-Gigabit Ethernet speed</li> <li>Maximum aggregate port capacity across ports 0 through 5 should not exceed 240 Gbps</li> <li>Maximum aggregate port capacity across ports 6 through 11 should not exceed 240 Gbps</li> </ul> </li> <li>When used in MPC9E: <ul style="list-style-type: none"> <li>Eight ports out of the total twelve ports support 100-Gigabit Ethernet speed</li> <li>Maximum aggregate port capacity across ports 0 through 5 should not exceed 400 Gbps</li> <li>Maximum aggregate port capacity across ports 6 through 11 should not exceed 400 Gbps</li> </ul> </li> <li><a href="#">Table 27 on page 210</a> lists the configurable Gigabit Ethernet port speeds for each port.</li> </ul>
Software features	<ul style="list-style-type: none"> <li>Supports rate selectability at the port level.</li> <li>By default, the ports are configured as 10-Gigabit Ethernet ports.</li> <li>Supports remote port identification.</li> <li>Supports Media Access Control Security (MACsec)</li> </ul>
Cables and connectors	<p><b>TIP:</b> You can use the <a href="#">Hardware Compatibility Tool</a> to find information about the pluggable transceivers supported on your Juniper Networks device.</p> <p>The list of supported transceivers for the MX Series is located at <a href="https://pathfinder.juniper.net/hct/category/#catKey=100001&amp;modelType=All&amp;pf=MX+Series">https://pathfinder.juniper.net/hct/category/#catKey=100001&amp;modelType=All&amp;pf=MX+Series</a>.</p>
LEDs	<ul style="list-style-type: none"> <li>OK/FAIL LED, one bicolor: <ul style="list-style-type: none"> <li>OFF—MIC is offline or MIC has fault.</li> <li>Red—MIC is in power failure state.</li> <li>Green—MIC is online.</li> </ul> </li> <li>Link LED, one green per port: <ul style="list-style-type: none"> <li>Steady green—Link is up.</li> <li>Off—Link is down or disabled.</li> </ul> </li> <li>Like port status LED, each individual lane LED support four states as: OFF, AMBER, GREEN, RED. See <i>MPC and MIC Lane LED Scheme Overview</i> for more details.</li> </ul>

**Table 28: Multi Rate Ethernet MIC Port Speed Capabilities for MIC-MACSEC-MRATE**

Port #	4x10-Gigabit Ethernet	40-Gigabit Ethernet	100-Gigabit Ethernet
0	yes	yes	yes

Table 28: Multi Rate Ethernet MIC Port Speed Capabilities for MIC-MACSEC-MRATE (continued)

Port #	4x10-Gigabit Ethernet	40-Gigabit Ethernet	100-Gigabit Ethernet
1	yes	yes	yes
2	yes	yes	yes
3	yes	yes	yes
4	yes	yes	no
5	yes	yes	no
6	yes	yes	yes
7	yes	yes	yes
8	yes	yes	yes
9	yes	yes	yes
10	yes	yes	no
11	yes	yes	no

**Related Documentation**

- [MPC and MIC Lane LED Scheme Overview](#)

## SONET/SDH OC192/STM64 MIC with XFP

Figure 43: SONET/SDH OC192/STM64 MIC with XFP

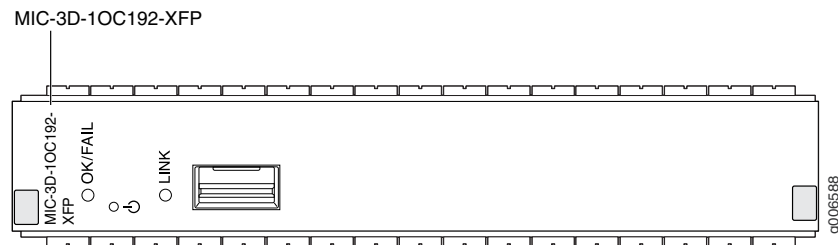

**Software release**

- Junos OS Release 12.2 and later

For information on which MPCs support this MIC, see [“MIC/MPC Compatibility” on page 26](#). For information on which MICs are supported on MX Series routers, see [“MICs Supported by MX Series Routers” on page 18](#).

Description	<ul style="list-style-type: none"> <li>• One OC192 port</li> <li>• Clear channel functionality</li> <li>• Power requirement: 4.25 A @ 9 V (38.25 W)</li> <li>• Weight: 1.34 lb (0.61 kg)</li> <li>• Model number: MIC-3D-1OC192-XFP</li> </ul>
Hardware features	<ul style="list-style-type: none"> <li>• Maximum transmission units (MTUs) of up to 9192 bytes</li> <li>• MIC bandwidth of up to 10 Gbps</li> </ul>
Software features	<ul style="list-style-type: none"> <li>• SONET/SDH framing</li> <li>• Multiprotocol Label Switching (MPLS) fast reroute</li> <li>• Ingress behavior aggregate (BA) classification</li> <li>• Internal and loop clocking</li> <li>• Encapsulations: <ul style="list-style-type: none"> <li>• MPLS fast reroute</li> <li>• MPLS CCC (circuit cross-connection)</li> <li>• MPLS TCC (translational cross-connection)</li> <li>• Cisco High-Level Data Link Control (cHDLC)</li> <li>• Cisco HDLC CCC</li> <li>• Cisco HDLC TCC</li> <li>• Point-to-Point Protocol (PPP)</li> <li>• PPP for CCC</li> <li>• PPP for TCC</li> <li>• Flexible Frame Relay</li> <li>• Frame Relay</li> <li>• Frame Relay for CCC</li> <li>• Frame Relay for TCC</li> <li>• PPP over Frame Relay</li> </ul> </li> </ul> <p><b>NOTE:</b> Ethernet over Frame Relay is not supported.</p>
Cables and connectors	<p><b>TIP:</b> You can use the <a href="#">Hardware Compatibility Tool</a> to find information about the pluggable transceivers supported on your Juniper Networks device.</p> <p>The list of supported transceivers for the MX Series is located at <a href="https://pathfinder.juniper.net/hct/category/#catKey=100001&amp;modelType;=All&amp;pf;=MX+Series">https://pathfinder.juniper.net/hct/category/#catKey=100001&amp;modelType;=All&amp;pf;=MX+Series</a>.</p> <p><b>NOTE:</b> To extend the life of the laser, when a MIC is not being actively used with any valid links, take the MIC offline until you are ready to establish a link to another device. For information about taking a MIC offline, see the <b>request chassis pic offline</b> command in the <a href="#">CLI Explorer</a>.</p>
LEDs	<p><b>OK/FAIL LED</b>, one bicolor:</p> <ul style="list-style-type: none"> <li>• Green—MIC is functioning normally</li> <li>• Red—MIC has failed</li> </ul> <p><b>LINK LED</b>, one tricolor per port:</p> <ul style="list-style-type: none"> <li>• Off—Not enabled</li> <li>• Green—Online with no alarms or failures</li> <li>• Yellow—Online with alarms for remote failures</li> <li>• Red—Active with a local alarm; router has detected a failure</li> </ul>



## Alarms, errors, and events

## SONET alarms:

- Loss of light (LOL)
- Phase lock loop (PLL)
- Loss of signal (LOS)
- Loss of frame (LOF)
- Severely errored frame (SEF)
- Alarm indicator signal–line (AIS-L)
- Alarm indicator signal–path (AIS-P)
- Remote defect indicator–line (RDI-L)
- Remote defect indicator–path (RDI-P)
- Loss of pointer–path (LOP-P)
- Bit error rate–signal degrade (BERR-SD)
- Bit error rate–signal fail (BERR-SF)
- Payload label mismatch–Path (PLM-P)
- Unequipped–path (UNEQ-P)
- Remote error indicator–path (REI-P)

## SDH alarms:

- Loss of light (LOL)
- Phase lock loop (PLL)
- Loss of frame (LOF)
- Loss of signal (LOS)
- Severely errored frame (SEF)
- Multiplex-section alarm indicator signal (MS-AIS)
- Higher order path–alarm indication signal (HP-AIS)
- Loss of pointer (LOP)
- Bit error rate–signal degrade (BER-SD)
- Bit error rate–signal fail (BER-SF)
- Multiplex section–far end receive failure (MS-FERF)
- Higher order path–far-end receive failure (HP-FERF)
- Higher order path–payload label mismatch (HP-PLM)
- Remote error indicator (REI)
- Unequipped (UNEQ)

---

**Related Documentation**

- [MX Series MIC Overview on page 17](#)



## CHAPTER 10

# MX Series PIC Descriptions

- Channelized OC12/STM4 Enhanced IQ (IQE) PIC with SFP on page 217
- Channelized OC48/STM16 Enhanced IQ (IQE) PIC with SFP on page 218
- SONET/SDH OC3/STM1 (Multi-Rate) PIC with SFP on page 224
- SONET/SDH OC12/STM4 (Multi-Rate) PIC with SFP on page 227
- SONET/SDH OC48/STM16 Enhanced IQ (IQE) PIC with SFP on page 230
- SONET/SDH OC48/STM16 (Multi-Rate) PIC with SFP on page 234
- SONET/SDH OC48/STM16 PIC with SFP on page 237
- SONET/SDH OC192c/STM64 PIC on page 240
- SONET/SDH OC192c/STM64 PIC with XFP on page 243

## Channelized OC12/STM4 Enhanced IQ (IQE) PIC with SFP

---

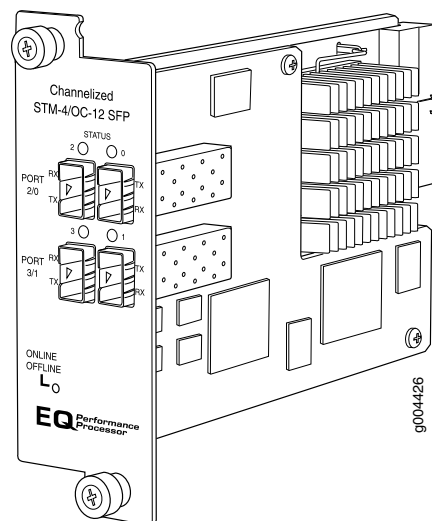

Software release

- Junos 9.5 and later

### Related Documentation

- [MX Series FPC and PIC Overview on page 35](#)
- [FPCs Supported by MX240, MX480, and MX960 Routers on page 36](#)

- [PICs Supported by MX240, MX480, and MX960 Routers on page 37](#)
- [High Availability Features on page 36](#)

## Channelized OC48/STM16 Enhanced IQ (IQE) PIC with SFP

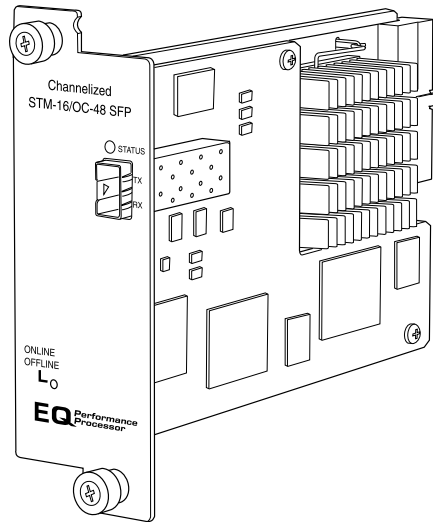

Software release	<ul style="list-style-type: none"> <li>• Junos 9.5 and later</li> </ul>
Description	<ul style="list-style-type: none"> <li>• One OC48/STM16 port</li> <li>• SONET or SDH is configurable on a per-port granularity</li> <li>• SONET channelization:             <ul style="list-style-type: none"> <li>• 4 OC12 channel</li> <li>• 16 OC3 channels</li> <li>• 48 DS3 channels</li> <li>• 672 DS1 channels</li> <li>• 975 DS0 channels</li> </ul> </li> <li>• SDH channelization:             <ul style="list-style-type: none"> <li>• 4 STM4 channel</li> <li>• 16 STM1 channels</li> <li>• 48 E3 channels</li> <li>• 504 E1 channels</li> <li>• 975 DS0 channels</li> </ul> </li> <li>• Power requirement: 1.10 A @ 48V (53 W)</li> <li>• Model Number: PB-1CHOC48-STM16-IQE-SFP</li> </ul>
Hardware features	<ul style="list-style-type: none"> <li>• Port is numbered 0.</li> </ul>

Software features	<ul style="list-style-type: none"> <li>• Quality of service (QoS) per channel: weighted round-robin (WRR), random early detection (RED), weighted random early detection (WRED)</li> <li>• Enhanced fine-grained queuing per logical interface. See the <i>Class of Service Feature Guide for Routing Devices and EX9200 Switches</i> for more information about class of service features.</li> <li>• Subrate and scrambling: <ul style="list-style-type: none"> <li>• Digital Link/Quick Eagle</li> <li>• Kentrox</li> <li>• Larscom</li> <li>• ADTRAN</li> <li>• Verilink</li> </ul> </li> <li>• Packet buffering, Layer 2 parsing</li> <li>• M13/C-bit parity encoding</li> <li>• DS3 far-end alarm and control (FEAC) channel support</li> <li>• Local line, remote line, and remote payload loopback testing</li> <li>• Simple Network Management Protocol (SNMP): OC12, OC3 MIB, DS3 MIB, T1 MIB</li> <li>• Dynamic, arbitrary channel configuration</li> <li>• Full bit error rate test (BERT)</li> <li>• Encapsulations: <ul style="list-style-type: none"> <li>• Circuit cross-connect (CCC)</li> <li>• Translational cross-connect (TCC)</li> <li>• Extended Frame Relay for CCC and TCC</li> <li>• Flexible Frame Relay</li> <li>• Frame Relay</li> <li>• Frame Relay for CCC</li> <li>• Frame Relay for TCC</li> <li>• Frame Relay port CCC</li> <li>• High-Level Data Link Control (HDLC)</li> <li>• HDLC framing for CCC</li> <li>• HDLC framing for TCC</li> <li>• MPLS CCC</li> <li>• MPLS TCC</li> <li>• Multilink Frame Relay (MLFR) UNI NNI (MFR FRF.16)</li> <li>• Point-to-Point Protocol (PPP)</li> <li>• PPP for CCC</li> <li>• PPP for TCC</li> </ul> </li> <li>• Encapsulations available only for DSI: <ul style="list-style-type: none"> <li>• Multilink Frame Relay end-to-end (MLFR FRF.15)</li> <li>• Multilink PPP (MLPPP)</li> <li>• PPP over Frame Relay</li> </ul> </li> </ul>
-------------------	---

Cables and connectors **TIP:** You can use the [Hardware Compatibility Tool](#) to find information about the pluggable transceivers supported on your Juniper Networks device.

The list of supported transceivers for the MX Series is located at <https://pathfinder.juniper.net/hct/category/#catKey=100001&modelType=All&pf=MX+Series>.

LEDs

One tricolor per port:

- Off—Not enabled
- Green—Online with no alarms or failures
- Yellow—Online with alarms for remote failures
- Red—Active with a local alarm; router has detected a failure

Alarms, errors, and events

## SONET alarms:

- Alarm indication signal—line (AIS-L)
- Alarm indication signal—path (AIS-P)
- Bit error rate—signal degrade (BERR-SD)
- Bit error rate—signal fail (BERR-SF)
- Loss of frame (LOF)
- Loss of light (LOL)
- Loss of pointer (LOP)
- Loss of signal (LOS)
- Payload label mismatch (PLM-P)
- Remote defect indication—line (RDI-L)
- Remote defect indication—path (RDI-P)
- Remote error indication (REI)
- Payload unequipped (unequipped STS at path level) (UNEQ-P)
- Virtual container—alarm indication signal (VAIS)
- Virtual container—loss of pointer (VLOP)
- Virtual container—mismatch (VMIS)
- Virtual container—remote defect indication (VRDI)
- Virtual container—unequipped (VUNEQ)

## SDH alarms:

- Administrative unit alarm indication signal (AU-AIS)
- Bit error rate—signal degrade (BERR-SD)
- Bit error rate—signal fail (BERR-SF)
- Bit interleaved parity (BIP) error B1, B2, B3
- Higher order path—alarm indication signal (HP-AIS)
- Higher order path—far-end receive failure (HP-FERF)
- Higher order path—payload label mismatch (HP-PLM)
- Higher order path—loss of pointer (HP-LOP)
- Higher order path—remote defect indication (HP-RDI)
- Higher order path—unequipped (HP-UNEQ)
- Loss of frame (LOF)
- Loss of light (LOL)
- Loss of signal (LOS)
- Multiplex section—alarm indication signal (MS-AIS)
- Multiplex section—far-end receive failure (MS-FERF)
- Multiplex section—remote defect indication (MS-RDI)
- Multiplex section—remote error indication (MS-REI)
- Phase lock loop (PLL)
- Remote error indication (REI)
- Severely errored frame (SEF)
- Tributary unit—alarm indication signal (TU-AIS)
- Tributary unit—loss of pointer (TU-LOP)
- Tributary unit—mismatch (TU-MIS)
- Tributary unit—remote defect indication (TU-RDI)
- Tributary unit—unequipped (TU-UNEQ)

## DS1 alarms:



- Alarm indication signal (AIS)
- Loss of frame (LOF)
- Remote alarm indication signal (RAIS)
- DS1 error detection:
  - Bursty errored seconds (BES)
  - CRC errors
  - Errored seconds (ES)
  - Line errored seconds (LES)
  - Loss of framing seconds (LOFS)
  - Severely errored seconds (SES)
  - Severely errored framing seconds (SEFS)
  - Unavailable seconds (UAS)
  - DS3 alarms:
    - Alarm indication signal (AIS)
    - Loss of frame (LOF)
    - Yellow alarm
  - DS3 error detection:
    - C-bit code violations (CCV)
    - C-bit errored seconds (CES)
    - C-bit severely errored framing seconds (CEFS)
    - CRC errors
    - Excessive zeros (EXZ)
    - Far-end block error (FEBE)
    - Far-end receive failure (FERF)
    - Line errored seconds (LES)
    - Parity bit (P-bit) code violations (PCV)
    - Parity bit (P-bit) errored seconds (PES)
    - Parity bit (P-bit) severely errored framing seconds (PSES)
    - Severely errored framing seconds (SEFS)
    - Unavailable seconds (UAS)

Instrumentation  
(counters)

- Layer 2 per-queue and per-channel packet and byte counters

**Related  
Documentation**

- [MX Series FPC and PIC Overview on page 35](#)
- [FPCs Supported by MX240, MX480, and MX960 Routers on page 36](#)
- [PICs Supported by MX240, MX480, and MX960 Routers on page 37](#)
- [High Availability Features on page 36](#)

## SONET/SDH OC3/STM1 (Multi-Rate) PIC with SFP

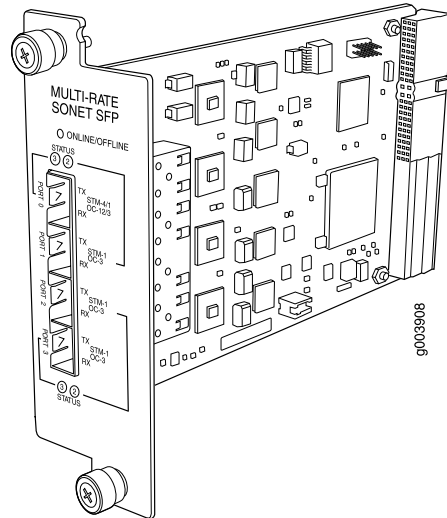

Software release	<ul style="list-style-type: none"> <li>Junos 9.5 and later</li> </ul>
Description	<ul style="list-style-type: none"> <li>Rate-selectable using one of the following rates:             <ul style="list-style-type: none"> <li>1-port OC12/STM4</li> <li>1-port OC12c/STM4c</li> <li>4-port OC3c/STM1c</li> </ul> </li> <li>Power requirement: 0.40 A @ 48 V (19 W)</li> <li>Model Number: PB-4OC3-IOC12-SON-SFP</li> </ul>
Hardware features	<ul style="list-style-type: none"> <li>Multiplexing and demultiplexing</li> <li>Rate policing on input</li> <li>Rate shaping on output</li> <li>Packet buffering, Layer 2 parsing</li> </ul>
Software features	<ul style="list-style-type: none"> <li>Optical diagnostics and related alarms</li> <li>Per-port SONET/SDH framing</li> <li>Link aggregation</li> <li>Alarm and event counting and detection</li> <li>Dual-router automatic protection switching (APS)</li> <li>Multiprotocol Label Switching (MPLS) fast reroute</li> <li>Encapsulations:             <ul style="list-style-type: none"> <li>Circuit cross-connect (CCC)</li> <li>Translational cross-connect (TCC)</li> <li>Frame Relay</li> <li>High-Level Data Link Control (HDLC)</li> <li>Point-to-Point Protocol (PPP)</li> </ul> </li> </ul>

Cables and connectors **TIP:** You can use the [Hardware Compatibility Tool](#) to find information about the pluggable transceivers supported on your Juniper Networks device.

The list of supported transceivers for the MX Series is located at <https://pathfinder.juniper.net/hct/category/#catKey=100001&modelType;=All&pf;=MX+Series>.

**NOTE:** To extend the life of the laser, when a PIC is not being actively used with any valid links, take the PIC offline until you are ready to establish a link to another device. For information about taking a PIC offline, see the `request chassis pic offline` command in the [CLI Explorer](#).

#### LEDs

One tricolor per port:

- Off—Not enabled
- Green—Online with no alarms or failures
- Yellow—Online with alarms for remote failures
- Red—Active with a local alarm; router has detected a failure

## Alarms, errors, and events

- SONET alarms:
  - Alarm indication signal—line (AIS-L)
  - Alarm indication signal—path (AIS-P)
  - Bit error rate—signal degrade (BERR-SD)
  - Bit error rate—signal fail (BERR-SF)
  - Bit interleaved parity (BIP) error B1, B2, B3
  - Far-end bit error: remote error indication—line (REI-L), far-end line coding violations (CV-LFE)
  - Far-end bit error: remote error indication—path (REI-P), far-end path coding violations (CV-PFE)
  - Loss of frame (LOF)
  - Loss of pointer (LOP-P)
  - Loss of signal (LOS)
  - Payload label mismatch (PLM-P)
  - Payload unequipped (unequipped STS at path level) (UNEQ-P)
  - Remote defect indication—line (RDI-L)
  - Remote defect indication—path (RDI-P)
- SDH alarms:
  - Administrative unit alarm indication signal (AU-AIS)
  - Bit error rate signal degrade (BERR-SD)
  - Bit error rate signal fail (BERR-SF)
  - Bit interleaved parity (BIP) error B1, B2, B3
  - Higher order path—payload label mismatch (HP-PLM)
  - Higher order path—loss of pointer (HP-LOP)
  - Higher order path—remote defect indication (HP-RDI)
  - Higher order path—unequipped (HP-UNEQ)
  - Loss of frame (LOF)
  - Loss of signal (LOS)
  - Multiplex section—alarm indication signal (MS-AIS)
  - Multiplex section—remote defect indication (MS-RDI)
  - Multiplex section—remote error indication (MS-REI)
- Error detection:
  - Errored seconds (ES-S, ES-L, ES-P)
  - Far-end errored seconds (ES-LFE, ES-PFE)
  - Far-end severely errored seconds (SES-LFE, SES-PFE)
  - Far-end unavailable seconds (UAS-LFE, UAS-PFE)
  - Severely errored frames (SEF)
  - Severely errored framing seconds (SEFS-S)
  - Severely errored seconds (SES-S, SES-L, SES-P)
  - Unavailable seconds (UAS-L, UAS-P)

---

**Related Documentation**

- [MX Series FPC and PIC Overview on page 35](#)
- [FPCs Supported by MX240, MX480, and MX960 Routers on page 36](#)
- [PICs Supported by MX240, MX480, and MX960 Routers on page 37](#)
- [High Availability Features on page 36](#)

## SONET/SDH OC12/STM4 (Multi-Rate) PIC with SFP

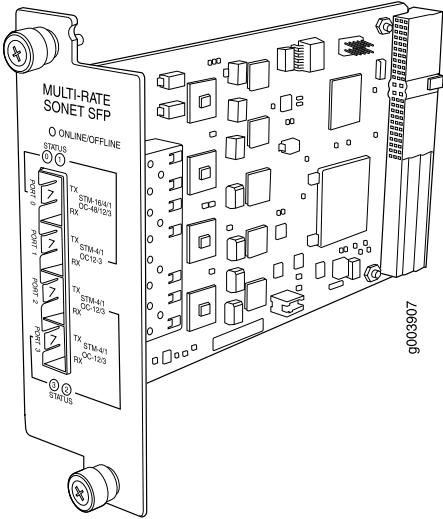

Software release	<ul style="list-style-type: none"><li>• Junos 9.5 and later</li></ul>
Description	<ul style="list-style-type: none"><li>• Rate-selectable using one of the following rates:<ul style="list-style-type: none"><li>• 1-port OC12</li><li>• 1-port OC48</li><li>• 1-port OC48c</li><li>• 4-port OC3c</li><li>• 4-port OC12c</li></ul></li><li>• Power requirement: 0.40 A @ 48 V (19 W)</li><li>• Model Number: PB-4OC3-4OC12-SON-SFP</li></ul>
Hardware features	<ul style="list-style-type: none"><li>• Multiplexing and demultiplexing</li><li>• Rate policing on input</li><li>• Rate shaping on output</li><li>• Packet buffering, Layer 2 parsing</li></ul>
Software features	<ul style="list-style-type: none"><li>• Optical diagnostics and related alarms</li><li>• Per-port SONET/SDH framing</li><li>• Link aggregation</li><li>• Alarm and event counting and detection</li><li>• Dual-router automatic protection switching (APS)</li><li>• Multiprotocol Label Switching (MPLS) fast reroute</li><li>• Encapsulations:<ul style="list-style-type: none"><li>• Circuit cross-connect (CCC)</li><li>• Translational cross-connect (TCC)</li><li>• Frame Relay</li><li>• High-Level Data Link Control (HDLC)</li><li>• Point-to-Point Protocol (PPP)</li></ul></li></ul>

Cables and connectors **TIP:** You can use the [Hardware Compatibility Tool](#) to find information about the pluggable transceivers supported on your Juniper Networks device.

The list of supported transceivers for the MX Series is located at <https://pathfinder.juniper.net/hct/category/#catKey=100001&modelType;=All&pf;=MX+Series>.

**NOTE:** To extend the life of the laser, when a PIC is not being actively used with any valid links, take the PIC offline until you are ready to establish a link to another device. For information about taking a PIC offline, see the `request chassis pic offline` command in the [CLI Explorer](#).

---

**LEDs**

One tricolor per port:

- Off—Not enabled
- Green—Online with no alarms or failures
- Yellow—Online with alarms for remote failures
- Red—Active with a local alarm; router has detected a failure

## Alarms, errors, and events

- SONET alarms:
  - Alarm indication signal—line (AIS-L)
  - Alarm indication signal—path (AIS-P)
  - Bit error rate—signal degrade (BERR-SD)
  - Bit error rate—signal fail (BERR-SF)
  - Bit interleaved parity (BIP) error B1, B2, B3
  - Far-end bit error: remote error indication—line (REI-L), far-end line coding violations (CV-LFE)
  - Far-end bit error: remote error indication—path (REI-P), far-end path coding violations (CV-PFE)
  - Loss of frame (LOF)
  - Loss of pointer (LOP-P)
  - Loss of signal (LOS)
  - Payload label mismatch (PLM-P)
  - Payload unequipped (unequipped STS at path level) (UNEQ-P)
  - Remote defect indication—line (RDI-L)
  - Remote defect indication—path (RDI-P)
- SDH alarms:
  - Administrative unit alarm indication signal (AU-AIS)
  - Bit error rate signal degrade (BERR-SD)
  - Bit error rate signal fail (BERR-SF)
  - Bit interleaved parity (BIP) error B1, B2, B3
  - Higher order path—payload label mismatch (HP-PLM)
  - Higher order path—loss of pointer (HP-LOP)
  - Higher order path—remote defect indication (HP-RDI)
  - Higher order path—unequipped (HP-UNEQ)
  - Loss of frame (LOF)
  - Loss of signal (LOS)
  - Multiplex section—alarm indication signal (MS-AIS)
  - Multiplex section—remote defect indication (MS-RDI)
  - Multiplex section—remote error indication (MS-REI)
- Error detection:
  - Errored seconds (ES-S, ES-L, ES-P)
  - Far-end errored seconds (ES-LFE, ES-PFE)
  - Far-end severely errored seconds (SES-LFE, SES-PFE)
  - Far-end unavailable seconds (UAS-LFE, UAS-PFE)
  - Severely errored frames (SEF)
  - Severely errored framing seconds (SEFS-S)
  - Severely errored seconds (SES-S, SES-L, SES-P)
  - Unavailable seconds (UAS-L, UAS-P)

---

**Related Documentation**

- [MX Series FPC and PIC Overview on page 35](#)
- [FPCs Supported by MX240, MX480, and MX960 Routers on page 36](#)
- [PICs Supported by MX240, MX480, and MX960 Routers on page 37](#)
- [High Availability Features on page 36](#)

## SONET/SDH OC48/STM16 Enhanced IQ (IQE) PIC with SFP

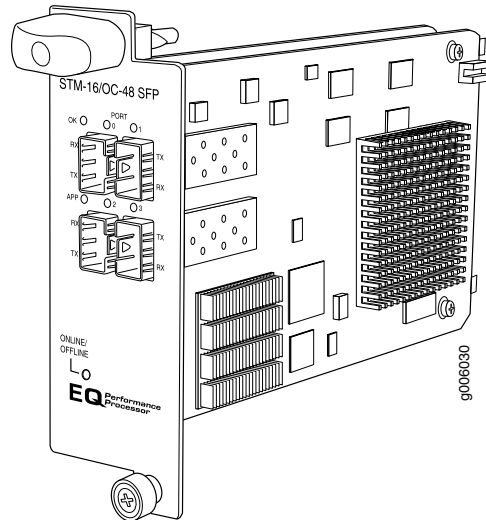

Software release	<ul style="list-style-type: none"> <li>Junos OS Release 10.4R2 and later (Type 3)</li> </ul>
Description	<ul style="list-style-type: none"> <li>Four OC48/STM16 ports</li> <li>Clear channel functionality</li> <li>SONET and SDH is configured on a per-port granularity</li> <li>Power requirement: 1.06 A @ 48 V (51 W)</li> <li>Weight: 1.6 lb (0.725 kg)</li> <li>Model number: PC-4OC48-STM16-IQE-SFP</li> </ul>
Hardware features	<ul style="list-style-type: none"> <li>Ports are numbered: <ul style="list-style-type: none"> <li>Top row: 0 and 1 from left to right</li> <li>Bottom row: 2 and 3 from left to right</li> </ul> </li> <li>Maximum transmission units (MTUs) of up to 9192 bytes</li> </ul>



- Software features
- Quality of service (QoS) per channel: weighted round-robin (WRR), random early detection (RED), weighted random early detection (WRED)
  - Fine-grained egress queuing per logical interface. See the *Class of Service Feature Guide for Routing Devices and EX9200 Switches* for more information about class-of-service features
  - Packet buffering
  - Local line and remote payload loopback testing
  - Optical diagnostics and monitoring
  - Clocking options: internal or external/loop mode. Each OC48 transmitter port is configured either in internal or external mode. The default clocking option is internal mode.
  - Encapsulations:
    - Extended Frame Relay for circuit cross-connect (CCC) and translational cross-connect (TCC)
    - Flexible Frame Relay
    - Frame Relay
    - Frame Relay for CCC
    - Frame Relay for TCC
    - Frame Relay port CCC
    - High-Level Data Link Control (HDLC)
    - HDLC framing for CCC
    - HDLC framing for TCC
    - MPLS CCC
    - MPLS TCC
    - Point-to-Point Protocol (PPP)
    - PPP for CCC
    - PPP for TCC

Cables and connectors **TIP:** You can use the [Hardware Compatibility Tool](#) to find information about the pluggable transceivers supported on your Juniper Networks device.

The list of supported transceivers for the MX Series is located at <https://pathfinder.juniper.net/hct/category/#catKey=100001&modelType;=All&pf;=MX+Series>.

**NOTE:** To extend the life of the laser, when a PIC is not being actively used with any valid links, take the PIC offline until you are ready to establish a link to another device. For information about taking a PIC offline, see the **request chassis pic offline** command in the [CLI Explorer](#).

LEDs

OK LED, one tricolor:

- Off—PIC is offline and safe to remove from the router
- Green—PIC is operating normally
- Yellow—PIC is initializing
- Red—PIC has an error or failure

APP LED, one green per port:

- Off—Service is not running
- Green—Service is running under acceptable load

Port LEDs, one tricolor per port:

- Off—Not enabled
- Green—Online with no alarms or failures
- Yellow—Online with alarms for remote failures
- Red—Active with a local alarm; router has detected a failure

## Alarms, errors, and events

## SONET alarms:

- Loss of light (LOL)
- Phase lock loop (PLL)
- Loss of frame (LOF)
- Loss of signal (LOS)
- Severely errored frame (SEF)
- Alarm indicator signal—line (AIS-L)
- Alarm indicator signal—path (AIS-P)
- Loss of pointer (LOP)
- Bit error rate—signal degrade (BERR-SD)
- Bit error rate—signal fail (BERR-SF)
- Remote defect indicator—line (RDI-L)
- Remote defect indicator—path (RDI-P)
- Remote error indicator (REI)
- Unequipped (UNEQ)
- Payload label mismatch—path (PLM-P)

## SDH alarms:

- Loss of light (LOL)
- Phase lock loop (PLL)
- Loss of frame (LOF)
- Loss of signal (LOS)
- Severely errored frame (SEF)
- Multiplex-section alarm indicator signal (MS-AIS)
- H Path alarm indicator signal (HP-AIS)
- Loss of pointer (LOP)
- Bit error rate—signal degrade (BERR-SD)
- Bit error rate—signal fail (BERR-SF)
- Multiplex section—far end receive failure (MS-FERF)
- High order path—far end receive failure (HP-FERF)
- Remote error indicator (REI)
- Unequipped (UNEQ)
- High order path—payload label mismatch - Path (HP-PLM)

## Optical diagnostics related alarms:

**NOTE:** Transceivers from some vendors do not support these fields.

- Temperature high/low alarms and warnings
- Supply voltage high/low alarms and warnings
- Tx bias current high/low alarms and warnings
- Tx output power high/low alarms and warnings
- Rx received power high/low alarms and warnings

**Related Documentation**

- [MX Series FPC and PIC Overview on page 35](#)
- [FPCs Supported by MX240, MX480, and MX960 Routers on page 36](#)
- [PICs Supported by MX240, MX480, and MX960 Routers on page 37](#)

- High Availability Features on page 36

## SONET/SDH OC48/STM16 (Multi-Rate) PIC with SFP

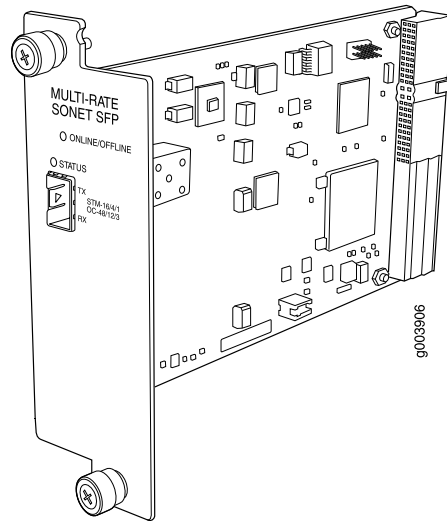

Software release

- Junos 9.5 and later

Description

- Rate-selectable using one of the following rates:
  - 1-port OC3c/STM1c
  - 1-port OC12/STM4
  - 1-port OC12c/STM4c
  - 1-port OC48/STM16
  - 1-port OC48c/STM16c
- Power requirement: 0.20 A @ 48 V (9.5 W)
- Model Number: PB-1OC48-SON-B-SFP

Hardware features

- Multiplexing and demultiplexing
- Rate policing on input
- Rate shaping on output
- Packet buffering, Layer 2 parsing

- |                   |   |
|-------------------|---|
| Software features | <ul style="list-style-type: none"><li>• Optical diagnostics and related alarms</li><li>• Per-port SONET/SDH framing</li><li>• Link aggregation</li><li>• Alarm and event counting and detection</li><li>• Dual-router automatic protection switching (APS)</li><li>• Multiprotocol Label Switching (MPLS) fast reroute</li><li>• Encapsulations:<ul style="list-style-type: none"><li>• Circuit cross-connect (CCC)</li><li>• Translational cross-connect (TCC)</li><li>• Frame Relay</li><li>• High-Level Data Link Control (HDLC)</li><li>• Point-to-Point Protocol (PPP)</li></ul></li></ul> |
|-------------------|---|

Cables and connectors	<p><b>TIP:</b> You can use the <a href="#">Hardware Compatibility Tool</a> to find information about the pluggable transceivers supported on your Juniper Networks device.</p>
-----------------------	--

The list of supported transceivers for the MX Series is located at <https://pathfinder.juniper.net/hct/category/#catKey=100001&modelType;=All&pf;=MX+Series>.

**NOTE:** To extend the life of the laser, when a PIC is not being actively used with any valid links, take the PIC offline until you are ready to establish a link to another device. For information about taking a PIC offline, see the `request chassis pic offline` command in the [CLI Explorer](#).

- |      |  |
|------|--|
| LEDs | <p>One tricolor per port:</p> <ul style="list-style-type: none"><li>• Off—Not enabled</li><li>• Green—Online with no alarms or failures</li><li>• Yellow—Online with alarms for remote failures</li><li>• Red—Active with a local alarm; router has detected a failure</li></ul> |
|------|--|

## Alarms, errors, and events

- SONET alarms:
  - Alarm indication signal—line (AIS-L)
  - Alarm indication signal—path (AIS-P)
  - Bit error rate—signal degrade (BERR-SD)
  - Bit error rate—signal fail (BERR-SF)
  - Bit interleaved parity (BIP) error B1, B2, B3
  - Far-end bit error: remote error indication—line (REI-L), far-end line coding violations (CV-LFE)
  - Far-end bit error: remote error indication—path (REI-P), far-end path coding violations (CV-PFE)
  - Loss of frame (LOF)
  - Loss of pointer (LOP-P)
  - Loss of signal (LOS)
  - Payload label mismatch (PLM-P)
  - Payload unequipped (unequipped STS at path level) (UNEQ-P)
  - Remote defect indication—line (RDI-L)
  - Remote defect indication—path (RDI-P)
- SDH alarms:
  - Administrative unit alarm indication signal (AU-AIS)
  - Bit error rate signal degrade (BERR-SD)
  - Bit error rate signal fail (BERR-SF)
  - Bit interleaved parity (BIP) error B1, B2, B3
  - Higher order path—payload label mismatch (HP-PLM)
  - Higher order path—loss of pointer (HP-LOP)
  - Higher order path—remote defect indication (HP-RDI)
  - Higher order path—unequipped (HP-UNEQ)
  - Loss of frame (LOF)
  - Loss of signal (LOS)
  - Multiplex section—alarm indication signal (MS-AIS)
  - Multiplex section—remote defect indication (MS-RDI)
  - Multiplex section—remote error indication (MS-REI)
- Error detection:
  - Errored seconds (ES-S, ES-L, ES-P)
  - Far-end errored seconds (ES-LFE, ES-PFE)
  - Far-end severely errored seconds (SES-LFE, SES-PFE)
  - Far-end unavailable seconds (UAS-LFE, UAS-PFE)
  - Severely errored frames (SEF)
  - Severely errored framing seconds (SEFS-S)
  - Severely errored seconds (SES-S, SES-L, SES-P)
  - Unavailable seconds (UAS-L, UAS-P)

---

**Related Documentation**

- [MX Series FPC and PIC Overview on page 35](#)
- [FPCs Supported by MX240, MX480, and MX960 Routers on page 36](#)
- [PICs Supported by MX240, MX480, and MX960 Routers on page 37](#)
- [High Availability Features on page 36](#)

## SONET/SDH OC48/STM16 PIC with SFP

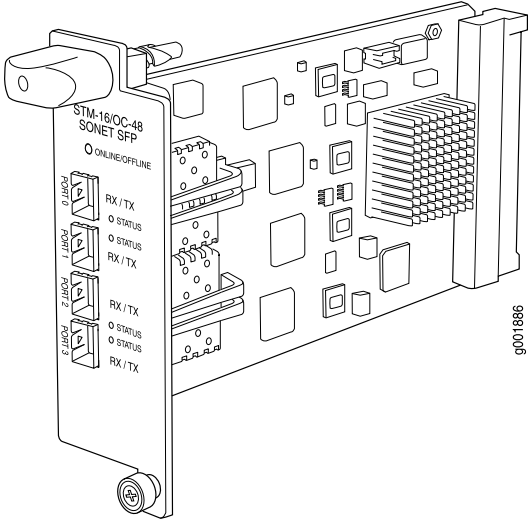

Software release	<ul style="list-style-type: none"><li>• Junos 9.4 and later</li></ul>
Description	<ul style="list-style-type: none"><li>• Four OC48 ports</li><li>• Power requirement: 0.86 A @ 48 V (41.4 W)</li><li>• Model Number: PC-4OC48-SON-SFP</li></ul>
Hardware features	<ul style="list-style-type: none"><li>• Rate policing on input</li><li>• Rate shaping on output</li><li>• Packet buffering, Layer 2 parsing</li></ul>
Software features	<ul style="list-style-type: none"><li>• Optical diagnostics and related alarms</li><li>• Configuration of SONET or SDH framing on a per-port basis</li><li>• SONET/SDH framing</li><li>• Link aggregation</li><li>• Alarm and event counting and detection</li><li>• Dual-router automatic protection switching (APS)</li><li>• Multiprotocol Label Switching (MPLS) fast reroute</li><li>• Encapsulations:<ul style="list-style-type: none"><li>• High-Level Data Link Control (HDLC)</li><li>• Frame Relay</li><li>• Circuit cross-connect (CCC)</li><li>• Translational cross-connect (TCC)</li><li>• Point-to-Point Protocol (PPP)</li></ul></li></ul>

Cables and connectors **TIP:** You can use the [Hardware Compatibility Tool](#) to find information about the pluggable transceivers supported on your Juniper Networks device.

The list of supported transceivers for the MX Series is located at <https://pathfinder.juniper.net/hct/category/#catKey=100001&modelType;=All&pf;=MX+Series>.

**NOTE:** To extend the life of the laser, when a PIC is not being actively used with any valid links, take the PIC offline until you are ready to establish a link to another device. For information about taking a PIC offline, see the `request chassis pic offline` command in the [CLI Explorer](#).

---

**LEDs**

One tricolor per port:

- Off—Not enabled
  - Green—Online with no alarms or failures
  - Yellow—Online with alarms for remote failures
  - Red—Active with a local alarm; router has detected a failure
-



## Alarms, errors, and events

- SONET alarms:
  - Alarm indication signal—line (AIS-L)
  - Alarm indication signal—path (AIS-P)
  - Bit error rate—signal degrade (BERR-SD)
  - Bit error rate—signal fail (BERR-SF)
  - Bit interleaved parity (BIP) error B1, B2, B3
  - Far-end bit error: remote error indication—line (REI-L), far-end line coding violations (CV-LFE)
  - Far-end bit error: remote error indication—path (REI-P), far-end path coding violations (CV-PFE)
  - Loss of frame (LOF)
  - Loss of pointer (LOP-P)
  - Loss of signal (LOS)
  - Payload label mismatch (PLM-P)
  - Payload unequipped (unequipped STS at path level) (UNEQ-P)
  - Remote defect indication—line (RDI-L)
  - Remote defect indication—path (RDI-P)
- SDH alarms:
  - Administrative unit alarm indication signal (AU-AIS)
  - Bit error rate signal degrade (BERR-SD)
  - Bit error rate signal fail (BERR-SF)
  - Bit interleaved parity (BIP) error B1, B2, B3
  - Higher order path—payload label mismatch (HP-PLM)
  - Higher order path—loss of pointer (HP-LOP)
  - Higher order path—remote defect indication (HP-RDI)
  - Higher order path—unequipped (HP-UNEQ)
  - Loss of frame (LOF)
  - Loss of signal (LOS)
  - Multiplex section—alarm indication signal (MS-AIS)
  - Multiplex section—remote defect indication (MS-RDI)
  - Multiplex section—remote error indication (MS-REI)
- Error detection:
  - Errored seconds (ES-S, ES-L, ES-P)
  - Far-end errored seconds (ES-LFE, ES-PFE)
  - Far-end severely errored seconds (SES-LFE, SES-PFE)
  - Far-end unavailable seconds (UAS-LFE, UAS-PFE)
  - Severely errored framing (SEF)
  - Severely errored framing seconds (SEFS-S)
  - Severely errored seconds (SES-S, SES-L, SES-P)
  - Unavailable seconds (UAS-L, UAS-P)

**Related Documentation**

- [MX Series FPC and PIC Overview on page 35](#)
- [FPCs Supported by MX240, MX480, and MX960 Routers on page 36](#)
- [PICs Supported by MX240, MX480, and MX960 Routers on page 37](#)

- [High Availability Features on page 36](#)

## SONET/SDH OC192c/STM64 PIC

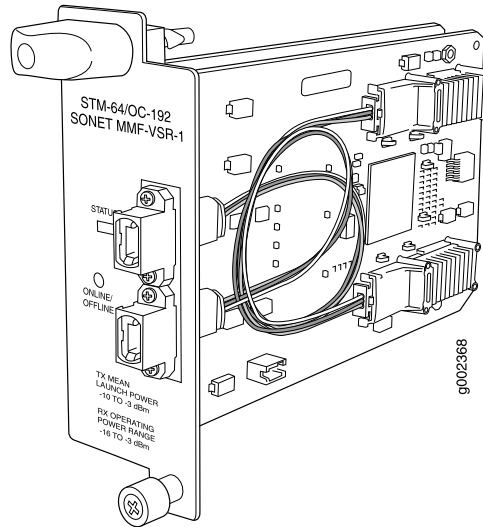

Software release	<ul style="list-style-type: none"> <li>• Junos 9.4 and later</li> </ul>
Description	<ul style="list-style-type: none"> <li>• One OC192 port</li> <li>• Power requirement: 0.45 A @ 48 V (21.6 W)</li> <li>• Model Number: PC-1OC192-SON-VSR</li> </ul>
Hardware features	<ul style="list-style-type: none"> <li>• Multiplexing and demultiplexing</li> <li>• Rate policing on input</li> <li>• Rate shaping on output</li> <li>• Packet buffering, Layer 2 parsing</li> </ul>
Software features	<ul style="list-style-type: none"> <li>• SONET/SDH framing</li> <li>• Link aggregation</li> <li>• Alarm and event counting and detection</li> <li>• Dual-router automatic protection switching (APS)</li> <li>• Multiprotocol Label Switching (MPLS) fast reroute</li> <li>• Encapsulations: <ul style="list-style-type: none"> <li>• High-Level Data Link Control (HDLC)</li> <li>• Frame Relay</li> <li>• Circuit cross-connect (CCC)</li> <li>• Translational cross-connect (TCC)</li> <li>• Point-to-Point Protocol (PPP)</li> </ul> </li> </ul>

Cables and connectors **TIP:** You can use the [Hardware Compatibility Tool](#) to find information about the pluggable transceivers supported on your Juniper Networks device.

The list of supported transceivers for the MX Series is located at <https://pathfinder.juniper.net/hct/category/#catKey=100001&modelType;=All&pf;=MX+Series>.

- Very short reach (VSR 1): 12-ribbon multimode fiber with MTP connector (Rx and Tx)
- Fiber-optic 10-gigabit small form-factor pluggable (XFP) transceivers: 10GBASE-S very short reach (VSR-1) (model number: XFP-10G-S)

**NOTE:** To extend the life of the laser, when a PIC is not being actively used with any valid links, take the PIC offline until you are ready to establish a link to another device. For information about taking a PIC offline, see the **request chassis pic offline** command in the [CLI Explorer](#).

#### LEDs

One tricolor LED per port:

- Off—Not enabled
- Green—Online with no alarms or failures
- Yellow—Online with alarms for remote failures
- Red—Active with a local alarm; router has detected a failure

## Alarms, errors, and events

- SONET alarms:
  - Alarm indication signal—line (AIS-L)
  - Alarm indication signal—path (AIS-P)
  - Bit error rate—signal degrade (BERR-SD)
  - Bit error rate—signal fail (BERR-SF)
  - Bit interleaved parity (BIP) error B1, B2, B3
  - Far-end bit error: remote error indication—line (REI-L), far-end line coding violations (CV-LFE)
  - Far-end bit error: remote error indication—path (REI-P), far-end path coding violations (CV-PFE)
  - Loss of frame (LOF)
  - Loss of pointer (LOP-P)
  - Loss of signal (LOS)
  - Payload label mismatch (PLM-P)
  - Payload unequipped (unequipped STS at path level) (UNEQ-P)
  - Remote defect indication—line (RDI-L)
  - Remote defect indication—path (RDI-P)
- SDH alarms:
  - Administrative unit alarm indication signal (AU-AIS)
  - Bit error rate signal degrade (BERR-SD)
  - Bit error rate signal fail (BERR-SF)
  - Bit interleaved parity (BIP) error B1, B2, B3
  - Higher order path—payload label mismatch (HP-PLM)
  - Higher order path—loss of pointer (HP-LOP)
  - Higher order path—remote defect indication (HP-RDI)
  - Higher order path—unequipped (HP-UNEQ)
  - Loss of frame (LOF)
  - Loss of signal (LOS)
  - Multiplex section—alarm indication signal (MS-AIS)
  - Multiplex section—remote defect indication (MS-RDI)
  - Multiplex section—remote error indication (MS-REI)
- Error detection:
  - Errored seconds (ES-S, ES-L, ES-P)
  - Far-end errored seconds (ES-LFE, ES-PFE)
  - Far-end severely errored seconds (SES-LFE, SES-PFE)
  - Far-end unavailable seconds (UAS-LFE, UAS-PFE)
  - Severely errored framing (SEF)
  - Severely errored framing seconds (SEFS-S)
  - Severely errored seconds (SES-S, SES-L, SES-P)
  - Unavailable seconds (UAS-L, UAS-P)

---

**Related Documentation**

- [MX Series FPC and PIC Overview on page 35](#)
- [FPCs Supported by MX240, MX480, and MX960 Routers on page 36](#)
- [PICs Supported by MX240, MX480, and MX960 Routers on page 37](#)

- High Availability Features on page 36

## SONET/SDH OC192c/STM64 PIC with XFP

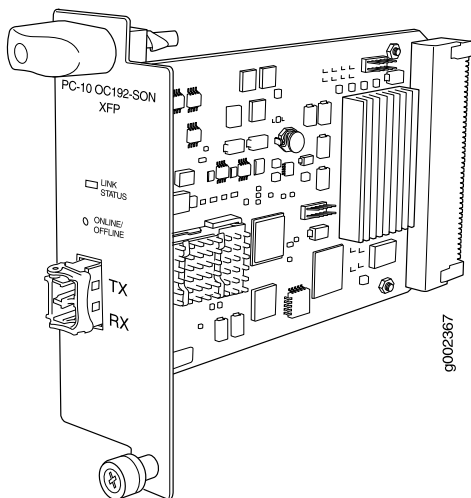

Software release	<ul style="list-style-type: none"> <li>• Junos 9.4 and later</li> </ul>
Description	<ul style="list-style-type: none"> <li>• One OC192 port</li> <li>• Power requirement: 0.52A @ 48 V (25 W)</li> <li>• Model number: PB-1OC192-SON-XFP</li> </ul>
Hardware features	<ul style="list-style-type: none"> <li>• Multiplexing and demultiplexing</li> <li>• Rate policing on input</li> <li>• Rate shaping on output</li> <li>• Packet buffering, Layer 2 parsing</li> </ul>
Software features	<ul style="list-style-type: none"> <li>• SONET/SDH framing</li> <li>• Link aggregation</li> <li>• Alarm and event counting and detection</li> <li>• Dual-router automatic protection switching (APS)</li> <li>• Multiprotocol Label Switching (MPLS) fast reroute</li> <li>• Encapsulations: <ul style="list-style-type: none"> <li>• Circuit cross-connect (CCC)</li> <li>• Translational cross-connect (TCC)</li> <li>• Frame Relay</li> <li>• High-Level Data Link Control (HDLC)</li> <li>• Point-to-Point Protocol (PPP)</li> </ul> </li> </ul>

Cables and connectors **TIP:** You can use the [Hardware Compatibility Tool](#) to find information about the pluggable transceivers supported on your Juniper Networks device.

**NOTE:** To extend the life of the laser, when a PIC is not being actively used with any valid links, take the PIC offline until you are ready to establish a link to another device. For information about taking a PIC offline, see the **request chassis pic offline** command in the [CLI Explorer](#).

---

LEDs

One tricolor LED per port:

- Off—Not enabled
- Green—Online with no alarms or failures
- Yellow—Online with alarms for remote failures
- Red—Active with a local alarm; router has detected a failure

---

## Alarms, errors, and events

- SONET alarms:
  - Alarm indication signal—line (AIS-L)
  - Alarm indication signal—path (AIS-P)
  - Bit error rate—signal degrade (BERR-SD)
  - Bit error rate—signal fail (BERR-SF)
  - Bit interleaved parity (BIP) error B1, B2, B3
  - Far-end bit error: remote error indication—line (REI-L), far-end line coding violations (CV-LFE)
  - Far-end bit error: remote error indication—path (REI-P), far-end path coding violations (CV-PFE)
  - Loss of frame (LOF)
  - Loss of pointer (LOP-P)
  - Loss of signal (LOS)
  - Payload label mismatch (PLM-P)
  - Payload unequipped (unequipped STS at path level) (UNEQ-P)
  - Remote defect indication—line (RDI-L)
  - Remote defect indication—path (RDI-P)
- SDH alarms:
  - Administrative unit alarm indication signal (AU-AIS)
  - Bit error rate signal degrade (BERR-SD)
  - Bit error rate signal fail (BERR-SF)
  - Bit interleaved parity (BIP) error B1, B2, B3
  - Higher order path—payload label mismatch (HP-PLM)
  - Higher order path—loss of pointer (HP-LOP)
  - Higher order path—remote defect indication (HP-RDI)
  - Higher order path—unequipped (HP-UNEQ)
  - Loss of frame (LOF)
  - Loss of signal (LOS)
  - Multiplex section—alarm indication signal (MS-AIS)
  - Multiplex section—remote defect indication (MS-RDI)
  - Multiplex section—remote error indication (MS-REI)
- Error detection:
  - Errored seconds (ES-S, ES-L, ES-P)
  - Far-end errored seconds (ES-LFE, ES-PFE)
  - Far-end severely errored seconds (SES-LFE, SES-PFE)
  - Far-end unavailable seconds (UAS-LFE, UAS-PFE)
  - Severely errored framing (SEF)
  - Severely errored framing seconds (SEFS-S)
  - Severely errored seconds (SES-S, SES-L, SES-P)
  - Unavailable seconds (UAS-L, UAS-P)

**Related Documentation**

- [MX Series FPC and PIC Overview on page 35](#)
- [FPCs Supported by MX240, MX480, and MX960 Routers on page 36](#)
- [PICs Supported by MX240, MX480, and MX960 Routers on page 37](#)

- [High Availability Features on page 36](#)



## PART 3

# SFB, SCB, ADC, and CB-RE Descriptions

- [MX Switch Fabric Board Descriptions on page 249](#)
- [MX Switch Control Board Descriptions on page 255](#)
- [MX Adapter Control Board Description on page 269](#)
- [RE, CB-RE, and RCB Descriptions on page 271](#)



# MX Switch Fabric Board Descriptions

- MX2000 Switch Fabric Board (SFB) on page 249
- MX2000 Enhanced Switch Fabric Board (SFB2) on page 252

## MX2000 Switch Fabric Board (SFB)

---

Switch Fabric Boards (SFBs) are the data plane for the subsystems in the MX router chassis. Switch Fabric Boards (SFBs) create a highly scalable and resilient “all-active” centralized switch fabric that delivers up to 2 Tbps of full-duplex switching capacity to each MPC slot in an MX2000 router.

The SFB and Enhanced Switch Fabric Board (SFB2) are the same except that the SFB has three XF fabric chips per card whereas the SFB2 has two PF fabric chips per card.

*Figure 44: Switch Fabric Board*

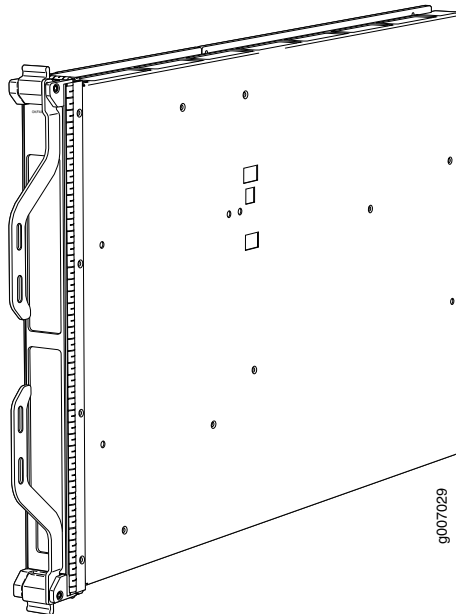

---

Name in CLI	Switch Fabric Board
-------------	---------------------

---

Description	<p>The MX2000 Switch Fabric Board (SFB; model number: MX2000-SFB-S) provides increased fabric bandwidth per slot. The MX2000 line of routers can support eight Switch Fabric Boards (SFB) and eight Enhanced Switch Fabric Boards (SFB2) but not both at the same time. The MX2000-SFB-S is supported on MX2010 and MX2020 routers. Refer to <a href="#">Figure 44 on page 249</a>.</p> <p><b>NOTE:</b> If you decide to upgrade from an SFB to an SFB2, the MX2000 line of routers support both the SFB and SFB2 at the same time for the duration of the upgrade.</p>
Features and Components	<ul style="list-style-type: none"> <li>• Powers the device on and off</li> <li>• PCIe control of three XF ASICs</li> <li>• I2C bus logic interface, used for component management and monitoring of temperature, and voltage</li> <li>• Switch fabric—Provides switching functions for the MPCs</li> <li>• Fabric capacity—Supports 750-Gbps per slot with eight SFBs, and 860-Gbps per slot with seven SFBs.</li> <li>• Front panel components—Service ports, system LEDs, and operational buttons</li> </ul>
SFB Slots	<p>You can install up to eight SFBs in the MX2000 router. The SFBs install vertically into the front of the chassis in the slots labeled 0 through 7. If any slots are empty, you must install a blank panel.</p> <p><b>CAUTION:</b> If one of the SFBs fails, do not remove the failed SFB until you have a replacement or blank panel to install.</p> <p><b>CAUTION:</b> A blank panel cannot be installed in slot 0. Slot 0 should always have a functioning SFB. If the slot 0 SFB fails, you must replace it with a functioning SFB from another slot, and then put a blank panel in place of the SFB that is used to replace the slot 0 SFB.</p>
SFB Redundancy	<p>Seven of eight SFBs are required for line rate operation. The system can continue operating with fewer than seven SFBs, but forwarding performance will be impacted.</p>
Weight and Dimensions	<ul style="list-style-type: none"> <li>• Weight: 12 lb (5.44 kg)</li> <li>• Width: 1.7 in. (4.31 cm)</li> <li>• Depth: 23.6 in. (59.94 cm). With ejector handle: 26.14 in. (66.39 cm)</li> <li>• Height: 16.225 in. (41.21 cm)</li> </ul>
Maximum Power Requirements (without MICs)	<p>MX2020:</p> <ul style="list-style-type: none"> <li>• Typical: 250 W</li> <li>• At different temperatures: <ul style="list-style-type: none"> <li>295 W at 55° C</li> <li>280 W at 40° C</li> <li>270 W at 25° C</li> </ul> </li> </ul> <p>MX2010:</p> <ul style="list-style-type: none"> <li>• Typical: 220 W</li> <li>• At different temperatures: <ul style="list-style-type: none"> <li>265 W at 55° C</li> <li>250 W at 40° C</li> <li>240 W at 25° C</li> </ul> </li> </ul>

## LEDs

**OK/FAIL LED**, one bicolor:

- Steady green—SFB is online and functioning normally.
- Slow blinking green—SFB is initializing.
- Fast blinking green—SFB is being identified by software.

**NOTE:** This is used to guide the operator to correct any action needed on the SFB.

- Red—SFB has failed.
- Off—SFB is offline.

Each SFB also has a set of bicolor LEDs on the craft interface that indicate its status. The SFB LEDs, labeled 0 through 7, are located along the bottom center of the craft interface. For more information about the SFB LED on the craft interface, see *MX2000 Switch Fabric Board LED*.

**Related  
Documentation**

- [MX2000 Host Subsystem CB-RE Description on page 271](#)
- *MX2000 Switch Fabric Board LED*
- *Replacing an MX2000 SFB*
- *Installing an MX2000 SFB*
- *Removing an MX2000 SFB*
- *Replacing an MX2000 SFB*
- *Performing a Smooth Upgrade to Enhanced Switch Fabric Board (SFB2) with Minimal Impact on Traffic*
- [MX2000 Enhanced Switch Fabric Board \(SFB2\) on page 252](#)

## MX2000 Enhanced Switch Fabric Board (SFB2)

The MX2000 Switch Fabric Board (SFB) straddles the two backplanes. It has connectors connecting to both backplanes, (see [Figure 44 on page 249](#)). The SFB and SFB2 are exactly the same except that the SFB2 has two PF fabric chips per card whereas SFB has three XF fabric chips per card.

*Figure 45: Enhanced Switch Fabric Board*

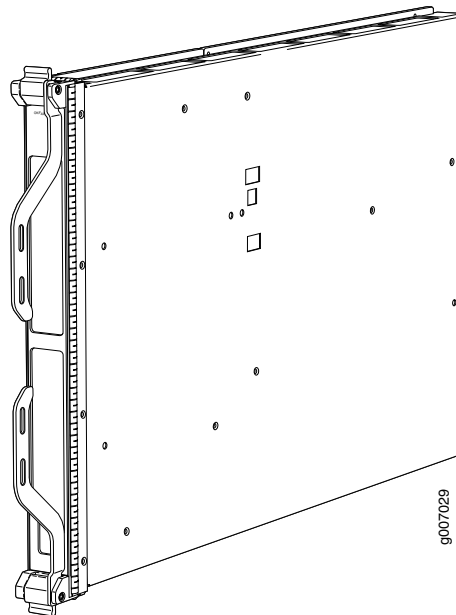

Software release	<ul style="list-style-type: none"> <li>Junos OS Release 11.4 and later</li> <li>Name in CLI: <b>Switch Fabric Board</b></li> </ul>
Description	<p>The MX2000 Enhanced Switch Fabric Board (SFB2; model number: MX2000-SFB2-S) provides increased fabric bandwidth per slot. MX2000 line of routers can support eight Switch Fabric Boards (SFB) and eight Enhanced Switch Fabric Boards (SFB2) but not both at the same time. The SFB2 is supported on MX2010 and MX2020 routers. Refer to <a href="#">Figure 44 on page 249</a>.</p> <p><b>NOTE:</b> During an upgrade from SFB to SFB2, the MX2000 line of routers support both SFB and SFB2 at the same time for the duration of the upgrade.</p>
SFB2 Features and Components	<ul style="list-style-type: none"> <li>PCIe control of two PF ASICs</li> <li>I2C bus logic interface, used for component management and monitoring of temperature, and voltage</li> <li>Switch fabric—Provides switching functions for the MPCs</li> <li>Fabric capacity—Supports 2 Tbps per slot with eight SFB2 and 1.7 Tbps per slot with seven SFB</li> <li>Circuits for chassis management and control</li> <li>Power circuits for the SFB2</li> <li>LED—Provides status of the SFB2</li> </ul>

SFB2 Slots	<p>You can install up to eight SFB2s in the MX2000 router. The SFB2s install vertically into the front of the chassis in the slots labeled 0 through 7. If any slots are empty, you must install a blank panel.</p> <p><b>CAUTION:</b> If one of the SFB2s fails, do not remove the failed SFB2 until you have a replacement or blank panel to install.</p>
SFB2 Redundancy	Seven of eight SFB2s are required for line rate operation. The system can continue operating with fewer than seven SFB2s, but forwarding performance will be impacted.
Weight and Dimensions	<ul style="list-style-type: none"> <li>Weight: 16 lb (7.2 kg)</li> <li>Width: 1.7 in. (4.31 cm)</li> <li>Depth: 23.6 in. (59.94 cm). With ejector handle: 26.14 in. (66.39 cm)</li> <li>Height: 16.225 in. (41.21 cm)</li> </ul>
Maximum Power Requirements (without MICs)	<p>MX2020:</p> <ul style="list-style-type: none"> <li>Typical: 250 W</li> <li>At different temperatures: <ul style="list-style-type: none"> <li>295 W at 55° C</li> <li>280 W at 40° C</li> <li>270 W at 25° C</li> </ul> </li> </ul> <p>MX2010:</p> <ul style="list-style-type: none"> <li>Typical: 220 W</li> <li>At different temperatures: <ul style="list-style-type: none"> <li>265 W at 55° C</li> <li>250 W at 40° C</li> <li>240 W at 25° C</li> </ul> </li> </ul>
LEDs	<p><b>OK/FAIL LED</b>, one bicolor:</p> <ul style="list-style-type: none"> <li>Steady green—SFB2 is online and functioning normally.</li> <li>Slow blinking green—SFB2 is initializing.</li> <li>Fast blinking green—SFB2 is being identified by software.</li> </ul> <p><b>NOTE:</b> This is used to guide the operator to correct any action needed on the SFB2.</p> <ul style="list-style-type: none"> <li>Red—SFB2 has failed.</li> <li>Off—SFB2 is offline.</li> </ul> <p>Each SFB2 also has a set of bicolor LEDs on the craft interface that indicate its status. The SFB2 LEDs, labeled 0 through 7, are located along the bottom center of the craft interface. For more information about the SFB2 LED on the craft interface, see <i>MX2000 Switch Fabric Board LED</i></p>

**Related Documentation**

- *MX2000 Switch Fabric Board LED*
- [MX2000 Host Subsystem CB-RE Description on page 271](#)
- *Replacing an MX2000 SFB*
- *Understanding Fabric Fault Handling on Enhanced Switch Fabric Board (SFB2)*

- *Performing a Smooth Upgrade to Enhanced Switch Fabric Board (SFB2) with Minimal Impact on Traffic*



# MX Switch Control Board Descriptions

- [MX-Series Switch Control Board \(SCB\) Overview on page 255](#)
- [SCBE2-MX Description on page 257](#)
- [SCBE-MX Description on page 261](#)
- [SCB-MX Description on page 264](#)

## MX-Series Switch Control Board (SCB) Overview

---

At the heart of the MX Series Universal Routers is the Switch and Control Board (SCB). The SCB has three primary functions: switch data between the line cards, control the chassis, and house the Routing Engine. The SCB is a single-slot card and has a carrier for the Routing Engine on the front.

Switch Control Boards control power to MPCs, monitor and control system functions such as fan speed and the system front panel, and manage clocking, resets, and boots.

Depending on the MX chassis and the level of redundancy, the number of SCBs can vary. The MX240 and MX480 require two SCBs for 1+1 redundancy, whereas the MX960 requires three SCBs for 2+1 redundancy.

There are three generations of SCBs for MX Series Universal Routers: SCB-MX, SCBE-MX, and SCBE2-MX.

- SCB-MX is the first-generation switch control board. The SCB-MX is designed to work with first-generation DPC line cards.
- The SCBE-MX is the second generation switch control board and was designed specifically for use with MPC3E line cards to provide full line-rate performance and redundancy without a loss of bandwidth.
- The SCBE2-MX provides improved fabric performance for high-capacity line cards using the third generation fabric XF2 chip (MPC4E, MPC5E, MPC2/3 NG, and MPC7E).

[Table 29 on page 256](#) compares the SCB capacities of MX series universal routers.

[Table 30 on page 256](#) lists the supported routing engines per SCB.

**Table 29: Switch Control Board Capacities for MX Series Universal Routers**

Switch Control Board	Fabric Bandwidth Per Slot (full duplex)	MX240 Chassis Fabric Bandwidth (full duplex)	MX480 Chassis Fabric Bandwidth (full duplex)	MX960 Chassis Fabric Bandwidth (full duplex)
SCBE2-MX	Up to 480 Gbps	Up to 1.92 Tbps	Up to 5.76 Tbps	Up to 10.56 Tbps
SCBE-MX	Up to 240 Gbps	Up to 930 Gbps	Up to 2.79 Tbps	Up to 5.25 Tbps
SCB-MX	Up to 240 Gbps	Up to 465 Gbps	Up to 1.39 Tbps	Up to 2.6 Tbps

**Table 30: Supported Routing Engines for MX Series Universal Router Switch Control Boards**

Switch Control Board	Supported Routing Engines
SCBE2-MX	RE-S-1300 (EOled) RE-S-2000 (EOled) RE-S-1800* RE-S-X6*
SCBE-MX	RE-S-1300 (EOled) RE-S-2000 (EOled) RE-S-1800*
SCB-MX	RE-S-1300 (EOled) RE-S-2000 (EOled) RE-S-1800

\* All variants

## CLI Identification

The SCBs are identified in the CLI as SCB, SCBE, and SCBE2.

```
user@host> show chassis hardware | match SCB
```

```
Item  Version  Part Number  Serial Number  Description
CB0   REV 07  710-021523  ABBC8281     MX SCB
CB1   REV 07  710-021523  ABBC8323     MX SCB
CB2   REV 07  710-021523  ABBD1410     MX SCB
```

```
user@host> show chassis hardware models | match SCBE
```

```
Item  Version  Part Number  Serial Number  Description
CB0   REV 02  750-031391  YE8505     Enhanced MX SCB
CB1   REV 07  710-031391  YL6769     Enhanced MX SCB
```

```
CB2 REV 07 710-031391 YE8492 Enhanced MX SCB
```

```
user@host> show chassis hardware models | match SCBE2
```

Item	Version	Part Number	Serial Number	Description
CB0	REV 01	750-062572	CAGN2123	SCBE2-MX-S
CB1	REV 07	750-062572	CAGN2456	SCBE2-MX-S
CB2	REV 07	750-062572	CAGN2789	SCBE2-MX-S

## SCBE2-MX Description

The MX Enhanced Switch Control Board (SCBE2-MX) serves the carrier Ethernet services router and carrier Ethernet transport markets that require higher-capacity traffic support, demanding greater interface density (slot and capacity scale) as well as improved services. The SCBE2-MX is supported on MX960, MX480, and MX240 routers.

The SCBE2-MX is installed vertically in the MX960 chassis and horizontally in the MX480 and MX240 chassis. The routing engine is installed directly into a slot on the SCBE2-MX (see Figure 46 on page 257).

Figure 46: SCBE2-MX

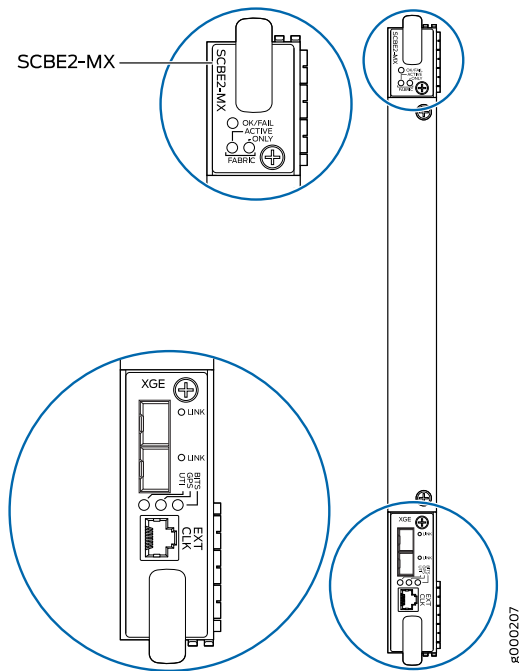

- Software release
- Junos OS Release 13.3 R1 and later
  - Name in CLI: **SCBE2**

Requirements For proper cooling, you must install MX-series high-capacity fan trays in the MX chassis. Additionally, for the MX960, you must install a high-capacity filter tray.

- SCBE2-MX Features
- Provides improved fabric performance for high-capacity line cards using the third generation fabric XF2 chip.
  - Provides bandwidth of up to 340 Gbps per slot with redundant fabric support and 480 Gbps per slot without redundant fabric support.
  - Provides a central clocking module and a centralized clocking architecture that supports clock cleanup and distribution. The Stratum 3 clock module performs clock monitoring, filtering, and holdover at a centralized chassis location.
  - Supports dynamic multicast replication.
  - Supports GRES.
  - Supports MPC line cards. Does not support DPCs.
  - Allows you to configure the system such that one SCBE2-MX supports a GPS interface, and the other SCBE2-MX supports a BITS interface.
  - Provides support for cross-coupling of clock input. This requires an enhanced midplane:
    - MX960—CHAS-BP3-MX960-S
    - MX480—CHAS-BP3-MX480-S
    - MX240—CHAS-BP3-MX240-S

- SCBE2-MX Components
- Control Board and Routing Engine (CB-RE) mastership mechanism.
  - External clock interface—Allows BITS or GPS clock source input to the centralized timing circuit, or allows centralized timing to be output to BITS or GPS.
  - Switch fabric—Provides switching functions for MPCs.
  - 1000Base-T Ethernet controller—Provides a 1 Gbps Ethernet link between the Routing Engines.
  - Power circuits for the Routing Engine and the SCBE2-MX.
  - LEDs—Provide status of the SCBE2-MX and the clocking interface.

- SCBE2-MX Slots
- For the MX960:
- You can install up to three SCBE2-MX's in the MX960 router chassis.
  - SCBE2-MX's are installed vertically into the front of the MX960 chassis in the slots labeled 0, 1, and 2. If any slots are empty, you must install a blank panel.
  - The two SCBE2-MX's residing in slot 6 and slot 7 of the MX960 chassis provide both control and switch fabric features, while the third SCBE2-MX residing in slot 8 of the chassis (hybrid slot) will only do fabric functions.
- For the MX480 and MX240 routers:
- You can install either one or two SCBE2-MX's in the MX480 and MX240 router chassis. SCBE2-MX's are installed horizontally into the front of the MX480 and MX240 chassis in the slots labeled 0 and 1. If any slots are empty, you must install a blank panel.

SCBE2-MX Fabric  
Planes and Redundancy

For the MX960:

- Each SCBE2-MX provides two switch fabric planes for packet forwarding among the MPCs in the MX960.
- The MX960 chassis may contain up to three SCBE2-MX's. Therefore, six fabric planes are available.
- Three SCBE2-MX's are required for 2 + 1 redundancy.
- In redundant fabric mode, four fabric planes from the first two SCBE2-MX's will be in Active mode, and two fabric planes from the third SCBE2-MX will be in Spare mode.
- In a non-redundant fabric mode, all six fabric planes will be in Active mode to increase fabric bandwidth.

For the MX240 and MX480 routers:

- Each SCBE2-MX provides four switch fabric planes for packet forwarding among the MPCs in the MX480 and MX240 chassis.
- The MX480 and MX240 routers contain a maximum of two SCBE2-MX's. Therefore, eight logical planes are available.
- Two SCBE2-MX's are required for 1 + 1 redundancy.
- In redundant fabric mode, four fabric planes from the first SCBE2-MX will be in Active mode, and four fabric planes from the second SCBE2-MX will be in Spare mode.
- In a non-redundant fabric mode, all eight fabric planes will be in Active mode to provide increased fabric bandwidth.
- Each fabric ASIC is configured in virtual plane mode, where two virtual planes exist on one fabric ASIC.

## Weight and Dimensions

- Weight: 9.6 lb (4.4 kg) (with Routing Engine installed)
- Width: 17 in (43.2 cm)
- Depth: 22 in (55.9 cm)
- Height: 1.25 in (3.2 cm) height.

Maximum Power  
Requirements

SCBE2-MX (applies to MX240, MX480, and MX960)

185 W at 55° C

160 W at 40° C

155 W at 25° C

## LEDs

- **FABRIC ACTIVE**, **FABRIC ONLY**, and **OK/FAIL** LEDs indicate the status of the SCBE2-MX.
- The **BITS**, **GPS**, and **UTI** LEDs, located next to the **EXT CLK** port, indicate the status of the respective clocking interface.
- The **LINK** LED located next to the two Ethernet ports, indicate the status of the respective SFP+ interface.

For more information about the SCBE2-MX LEDs, see *SCBE2-MX LEDs*.

## SCBE2-MX Interoperability with Existing Hardware

SCBE2 Operating Mode	MX240/480/960	Supported
Enhanced IP/Enhanced Ethernet Mode Only	DPC/MS-DPC	No
	MS-MPC	Yes
	MPC1	Yes
	MPC2	Yes
	MPC3	Yes
	MPC4	Yes
	MPC2-NG	Yes
	MPC3-NG	Yes
	16x10GE MPC	Yes
	MPC5	Yes
	MPC6	No
	MPC7 (480 Gbps)	Yes
	MPC8 (960 Gbps)	No
	MPC9 (1.6 Tbps)	No
Routing Engines	RE-S-1300(EOLed)	yes
	RE-S-2000 (EOLed)	yes
	RE-S-1800 (all variants)	yes
	RE-S-X6 (all variants)	yes

## SCBE2-MX LEDs

**FABRIC ACTIVE**, **FABRIC ONLY**, and **OK/FAIL** LEDs indicate the status of the SCBE2-MX. The **BITS**, **GPS**, and **UTI** LEDs, located next to the **EXT CLK** port, indicate the status of the respective clocking interface. The **LINK** LED located next to the two Ethernet ports, indicate the status of the respective SFP+ interface. [Table 31 on page 261](#) describes the functions of the SCBE2-MX LEDs.

Table 31: SCBE2-MX LEDs

Label	Color	State	Description
<b>FABRIC ACTIVE</b>	Green	On steadily	Fabric is in active mode.
<b>FABRIC ONLY</b>	Green	On steadily	SCBE2-MX operates in fabric-only mode.
	–	Off	SCBE2-MX operates in fabric or control-board mode.
<b>OK/FAIL</b>	Green	On steadily	SCBE2-MX is online.
	Red	On steadily	SCBE2-MX has failed.
	–	Off	SCBE2-MX is offline.
<b>BITS</b>	Green	On steadily	Building-integrated timing supply (BITS) clocking interface is active.
	Red	On steadily	BITS clocking interface has failed.
	–	Off	BITS clocking interface is offline.
<b>GPS</b>	Green	On steadily	Global positioning system (GPS) clocking interface is active.
	Red	On steadily	GPS clocking interface has failed.
	–	Off	GPS clocking interface is offline.
<b>UTI</b>	Green	On steadily	Universal Timing Interface (UTI) clocking interface is active.
	Red	On steadily	UTI clocking interface has failed.
	–	Off	UTI clocking interface is offline.
<b>LINK</b>	Green	On steadily	Port is enabled and link is established.
	–	Off	Port is disabled or no link is established.

## SCBE-MX Description

The MX Enhanced Switch Control Board (SCBE-MX) for MX960, MX480, and MX240 routers serves the carrier Ethernet services router and carrier Ethernet transport markets that require higher-capacity traffic support, demanding greater interface density (slot and capacity scale), as well as improved services. The SCBE-MX provides:

- 160 Gbps/slot bandwidth with redundant fabric support, and improved fabric performance by using the next-generation fabric (XF) chip

- A central clocking module and a centralized clocking architecture that supports clock cleanup and distribution. The Stratum 3 clock module performs clock monitoring, filtering, and holdover in a centralized chassis location
- Full performance with fabric redundancy for higher capacity line cards such as 16x10GE and MPC3

The Routing Engine installs directly into a slot on the SCBE-MX (see [Figure 47 on page 262](#)).

**Figure 47: SCBE-MX**

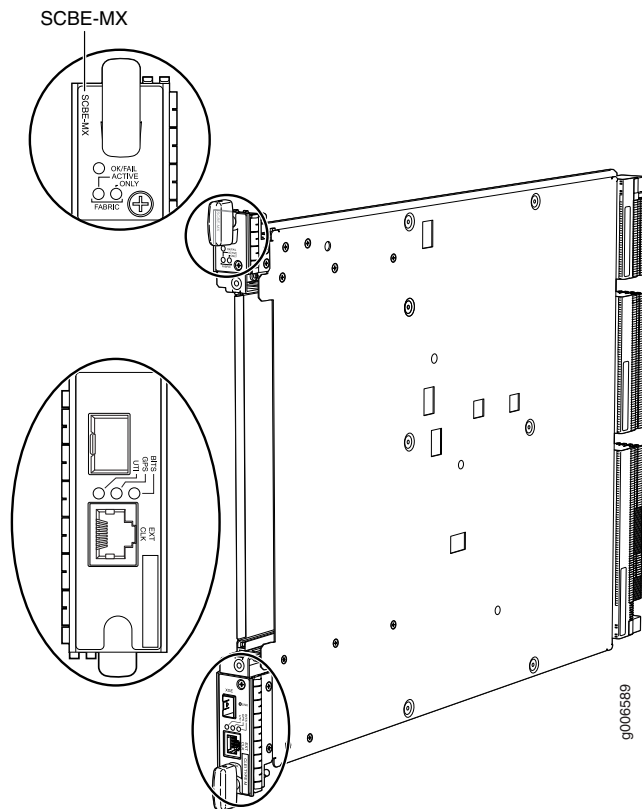

[Table 32 on page 262](#) lists the maximum number of SCBE-MXs you can install in the MX chassis, the corresponding slot labels, and the backup slot used for redundancy. If any slots are empty, you must install a blank panel.

**Table 32: SCBE-MX Specifications**

Chassis	Maximum SCBE-MXs	Slot Labels	Backup Slot
MX960	3	0, 1, and 2	2
MX480	2	0 and 1	1
MX240	2	0 and 1	1



## Routing Engines and MPCs for the SCBE-MX

The SCBE-MX supports the routing engines and MPCs in [Table 33 on page 263](#).

*Table 33: Supported Routing Engines and MPCs for the SCBE-MX*

Supported Routing Engines	Supported MPCs
RE-S-1300	MPC3e
RE-S-1800 (all variants)	MPC3e
RE-S-2000	MPC3e

## SCBE-MX LEDs

The **FABRIC ACTIVE**, **FABRIC ONLY**, and **OK/FAIL** LEDs indicate the status of the SCBE-MX. The **BITS**, **GPS**, and **UTI** LEDs (next to the **EXT CLK** port) indicate the status of the respective clocking interface. [Table 34 on page 263](#) describes the behavior of the SCBE-MX LEDs.

*Table 34: SCBE-MX LEDs*

Label	Color	State	Description
<b>FABRIC ACTIVE</b>	Green	On steadily	Fabric is in active mode.
<b>FABRIC ONLY</b>	Green	On steadily	SCBE-MX operates in fabric-only mode.
	–	Off	SCBE-MX operates in fabric/control board mode.
<b>OK/FAIL</b>	Green	On steadily	SCBE-MX is online.
	Red	On steadily	SCBE-MX has failed.
	–	Off	SCBE-MX is offline.
	Red	On steadily	GPS clocking interface has failed.
	–	Off	GPS clocking interface is offline.
<b>NOTE:</b> The LEDs <b>BITS</b> , <b>GPS</b> , and <b>UTI</b> are not currently supported.			
<b>BITS</b>	Green	On steadily	Building-integrated timing supply (BITS) clocking interface is active.
	Red	On steadily	BITS clocking interface has failed.
	–	Off	BITS clocking interface is offline.

Table 34: SCBE-MX LEDs (continued)

Label	Color	State	Description
GPS	Green	On steadily	Global positioning system (GPS) clocking interface is active.
	Red	On steadily	GPS clocking interface has failed.
	–	Off	GPS clocking interface is offline.
UTI	Green	On steadily	Universal Timing Interface (UTI) clocking interface is active.
	Red	On steadily	UTI clocking interface has failed.
	–	Off	UTI clocking interface is offline.

## SCB-MX Description

The MX Switch Control Board (SCB-MX) provides control plane functions, chassis management functions, and switch plane functions for MX960, MX480, and MX240 routers. It is also a carrier for the Routing Engine which installs directly into a slot on the SCB-MX. See [Figure 48 on page 264](#).

Figure 48: SCB-MX

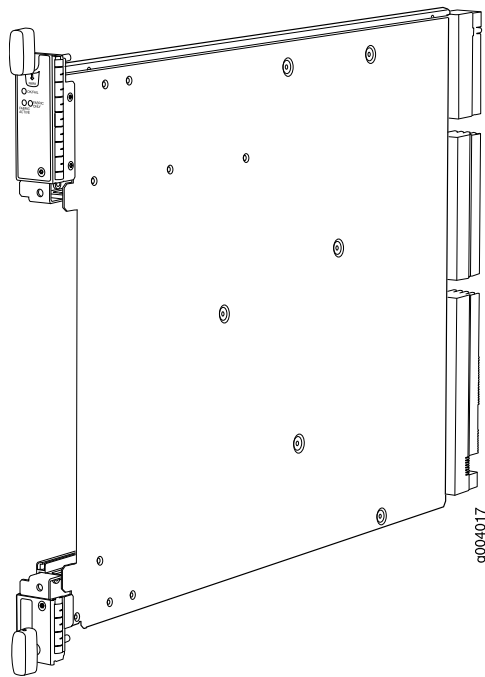

### Software release

- Junos OS Release 12.3 R1 and later
- Name in CLI: **SCB**

SCB-MX Functions	<ul style="list-style-type: none"> <li>• Powers on and powers off DPCs, FPCs, and MPCs.</li> <li>• Controls clocking, system resets, and booting.</li> <li>• Monitors and controls system functions, including fan speed, board power status, power distribution module status and control, and the craft interface</li> <li>• Provides Ethernet connectivity to all processors in the chassis for control plane communications.</li> <li>• Provides bandwidth of up to 160 Gbps per slot with redundant fabric support.</li> <li>• Provides interconnections to all the DPCs, FPCs, and MPCs within the chassis through the switch fabrics integrated into the SCB-MX.</li> </ul>
SCB-MX Components	<ul style="list-style-type: none"> <li>• Control Board and Routing Engine (CB-RE) mastership mechanism.</li> <li>• External clock interface—Allows BITS or GPS clock source input to the centralized timing circuit, or allows centralized timing to be output to BITS or GPS.</li> <li>• Switch fabric—Provides switching functions for MPCs.</li> <li>• 1000Base-T Ethernet controller—Provides a 1 Gbps Ethernet link between the Routing Engines.</li> <li>• Power circuits for the Routing Engine and the SCBE2-MX.</li> <li>• LEDs—Provide status of the SCBE2-MX and the clocking interface.</li> </ul>
SCB-MX Slot Numbers	<p>For the MX960:</p> <ul style="list-style-type: none"> <li>• You can install up to three SCB-MXs in the MX960 chassis for a total of six switch fabrics and six fabric planes. The SCB-MXs install vertically into the front of the MX960 chassis in the slots labeled <b>0</b>, <b>1</b>, and <b>2/6</b>.</li> </ul> <p><b>NOTE:</b> On the MX960, either a SCB-MX or a DPC can be plugged into slot 8. A third SCB-MX is used only for switch fabric redundancy. Therefore, if an application does not require switch fabric redundancy, a DPC can be used in slot 8.</p> <p>For the MX480 and MX240 routers:</p> <ul style="list-style-type: none"> <li>• You can install one or two SCB-MXs in the MX240 and MX480 for a total of four switch fabrics and eight fabric planes. The SCB-MX installs horizontally into the front of the chassis in the slots labeled <b>0</b> and <b>1</b>. If any slots are empty, you must install a blank panel.</li> </ul>
Weight and Dimensions	<ul style="list-style-type: none"> <li>• Weight: 9.6 lb (4.4 kg) (with Routing Engine installed)</li> <li>• Width: 17 in (43.2 cm)</li> <li>• Depth: 22 in (55.9 cm)</li> <li>• Height: 1.25 in (3.2 cm) height.</li> </ul>

## SCB-MX Fabric Planes and Redundancy

For MX960 routers:

- Each SCB-MX provides two switch fabric planes for packet forwarding among the DPCs and MPCs in the MX960.
- The MX960 chassis may contain up to three SCB-MX's. Therefore, six fabric planes are available.
- The MX960 provides 2 + 1 SCB-MX redundancy when used with DPC line cards.
- In redundant fabric mode, four fabric planes from the first two SCB-MX's will be in Active mode, and two fabric planes from the third SCB-MX will be in Spare mode.
- In a non-redundant fabric mode, all six fabric planes will be in Active mode to increase fabric bandwidth.
- SCB-MXs installed in slots 0 and 1 provide non-redundant fabric connections. An SCB-MX installed in slot 2/6, in conjunction with SCB-MXs in slots 0 and 1, provides redundant fabrics, but the Routing Engine installed on it receives no power and provides no additional routing functions. If no SCB-MX is installed in slot 2/6, you must install a blank panel in the slot.

For MX240 and MX480 routers:

- Each fabric ASIC is configured in virtual plane mode, where two virtual planes exist on one fabric ASIC. This means that the MX240 and MX480 require only a single SCB-MX to provide line rate throughput, and an additional SCB-MX to provide 1 + 1 SCB redundancy.
- In redundant fabric mode, four virtual planes from the first SCB-MX will be in Active mode, and four virtual planes from the second SCB-MX will be in Spare mode.
- In a non-redundant fabric mode, all eight virtual planes will be in Active mode to provide the maximum fabric bandwidth.

## Maximum Power Requirements

SCB-MX (applies to MX240, MX480, and MX960)

185 W at 55° C

160 W at 40° C

155 W at 25° C

## SCB-MX LEDs

Three LEDs on the SCB indicate the status of the SCB. The LEDs, labeled **FABRIC ACTIVE**, **FABRIC ONLY**, and **OK/FAIL**, are located directly on the SCB. [Table 35 on page 266](#) describes the functions of the SCB LEDs.

*Table 35: SCB-MX LED Descriptions*

Label	Color	State	Description
<b>FABRIC ACTIVE</b>	Green	On steadily	Fabric is in active mode.
<b>FABRIC ONLY</b>	Green	On steadily	SCB-MX operates in fabric-only mode.
	–	Off	SCB-MX operates in fabric/control board mode.
<b>OK/FAIL</b>	Green	On steadily	SCB-MX is online.
	Red	On steadily	SCB-MX has failed.
	–	Off	SCB-MX is offline.

## SCB-MX Fabric Plane Scale and Redundancy

Each of the fabric planes on the SCB-MX is able to process 20 Gbps of bandwidth. The MX240 and MX480 use eight fabric planes across two SCB-MXs, whereas the MX960 uses six fabric planes across three SCB-MX's. Because of the fabric plane virtualization, the aggregate fabric bandwidth between the MX240, MX480, and MX960 is different. Refer to [Table 36 on page 267](#).

**Table 36: SCB-MX Fabric Plane Scale and Redundancy Assuming Four PFEs per FPC**

SCB-MX	MX240	MX480	MX960
PFEs	12	24	48
SCBs	2	2	3
Switch Fabrics	4	4	6
Fabric Planes	8	8	6
Spare Planes	4 (1+1 SCB-MX redundancy)	4 (1+1 SCB-MX redundancy)	2 (2+1 SCB-MX redundancy)
Fabric Bandwidth Per Slot	160 Gbps	160 Gbps	120 Gbps

## Supported Routing Engines

The SCB-MX supports the following routing engines (REs):

- [RE-S-1300 Routing Engine Description](#)
- [RE-S-2000 Routing Engine Description](#)
- [RE-S-1800 Routing Engine Description on page 298](#)

### Related Documentation

- [MX-Series Switch Control Board \(SCB\) Overview on page 255](#)



# MX Adapter Control Board Description

- [MX2000 Adapter Card \(ADC\) Description on page 269](#)

## MX2000 Adapter Card (ADC) Description

---

The MX2000 routers are compatible with all Trio-based MPC line cards; However, because the MX2000 routers use a newer-generation Switch Fabric Board (SFB) with faster bandwidth, line cards that were designed to work with the SCB and SCBE (MPC1E, MPC2E, and MPC3E) must use a special Line Card Adapter (ADC). The ADC is merely a shell that accepts MPC1E, MPC2E, and MPC3E line cards in the front and converts power and switch fabric in the rear. ADCs install vertically in the front of the router.



**NOTE:** When a slot is not occupied by a combined ADC and MPC, you must insert a blank panel to fill the empty slot and ensure proper cooling of the system.

ADCs are hot-removable and hot-insertable. [Figure 49 on page 270](#) shows the ADC supported on MX2000 routers.

Figure 49: ADC for the MX2000 Routers

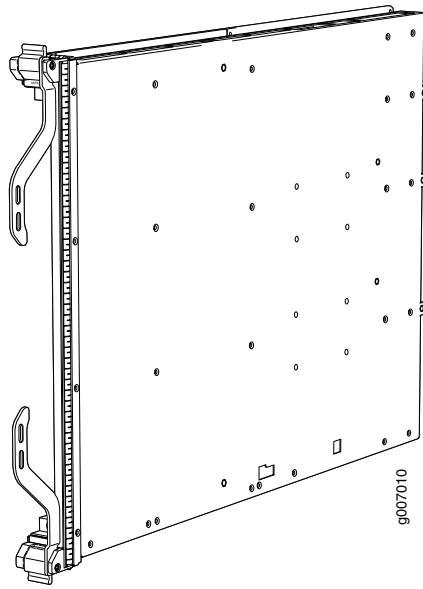

**Related Documentation**

- *Maintaining the MX2010 Adapter Cards*
- *Maintaining MX2020 Adapter Cards*
- [MPCs Supported by MX Series Routers on page 12](#)
- *Replacing an MX2008 MPC*
- *Replacing an MX2010 MPC*
- *Replacing an MX2020 MPC*



# RE, CB-RE, and RCB Descriptions

- [MX2000 Host Subsystem CB-RE Description on page 271](#)
- [Routing Engine Specifications on page 272](#)
- [MX Routing Engine LEDs on page 277](#)
- [MX960 Routing Engine Description on page 277](#)
- [MX480 Routing Engine Description on page 279](#)
- [MX240 Routing Engine Description on page 281](#)
- [MX5, MX10, MX40, and MX80 Routing Engine Description on page 285](#)
- [MX2008 Routing and Control Board \(MX2008 RCB\) Description on page 286](#)
- [MX10003 Routing and Control Board \(RCB\) Description on page 289](#)
- [MX10008 Routing and Control Board Components and Descriptions on page 293](#)
- [MX Routing Engine LEDs on page 298](#)
- [RE-S-1800 Routing Engine Description on page 298](#)
- [RE-S-X6-64G Routing Engine Description on page 301](#)
- [RE-S-X6-128G Routing Engine Description on page 303](#)
- [Supported Routing Engines by Router on page 305](#)

## MX2000 Host Subsystem CB-RE Description

---

The host subsystem provides routing protocol processes, as well as software processes that control the router's interface, the chassis components, system management, and user access to the router. These routing processes run on top of a kernel that interacts with the Packet Forwarding Engine (PFE). You can install one or two host subsystems on the router. Each host subsystem functions as a unit—the Control Board and Routing Engine (CB-RE). The MX2000 line of routers supports the following CB-RE's:

- RE-MX2000-1800x4 CB-RE
- REMX2K-X8-64G-LT CB-RE

The CB-RE is hot-pluggable. You can install one or two CB-REs in the router. Each CB-RE is a combined Routing Engine and Control Board in one unit. A USB port on the CB-RE accepts a USB memory device that allows you to load Junos OS. The CB-RE installs into the front of the chassis in vertical slots labeled **0** and **1**. If two CB-REs are installed, one

functions as the master and the other acts as the backup. If the master CB-RE fails or is removed and the backup is configured appropriately, the backup takes over as the master. If no CB-RE is installed in a slot, install a blank panel in the slot.

A minimum of one CB-RE must be installed in either slot 0 or slot 1 at all times.



**CAUTION:** If one of the CB-REs fails, do not remove the failed CB-RE until you have a replacement or blank panel to install.



**NOTE:** REMX2K-X8-64G-LT CB-RE is equipped with limited encryption support only.

#### Related Documentation

- *RE-MX2000-1800x4 CB-RE Description*
- *REMX2K-X8-64G and REMX2K-X8-64G-LT CB-RE Description*
- *Maintaining the MX2010 Host Subsystem*
- *Maintaining the MX2020 Host Subsystem*
- *Taking an MX2000 Host Subsystem Offline*
- *RJ-45 Connector Pinouts for MX Series CB-RE or RCB Auxillary and Console Ports*
- *RJ-45 Connector Pinouts for an MX Series CB-RE or RCB Management Port*

## Routing Engine Specifications

Table 37 on page 273 lists the current specifications for Routing Engines supported on M Series, MX Series, and T Series routers. Table 38 on page 275 lists the specifications for end-of-life Routing Engines.



**NOTE:** For a list of the routing engines that are supported on the M Series, MX Series, T Series, and PTX routers, see [“Supported Routing Engines by Router”](#) on page 305.



**NOTE:** For information about PTX Series Routing Engine specifications, see *Routing Engines Supported on PTX Series Routers*. For information about

Table 37: Routing Engine Specifications

Routing Engine	Processor	Memory	Connection to PFES	Disk	Media	First Junos OS Support	Switch Control Board
RE-400-768	400-MHz Celeron	768 MB	Fast Ethernet	40 GB hard disk	1 GB CompactFlash card	9.0	–
RE-A1000-2048	1.0-GHz Pentium	2048 MB	Gigabit Ethernet	40 GB hard disk	1 GB CompactFlash card	8.1	–
RE-A2000-4096	2.0-GHz Pentium	4096 MB	Gigabit Ethernet	40 GB hard disk	1 GB CompactFlash card	8.1	–
RE-S300-2048	1.3-GHz Pentium	2048 MB	Gigabit Ethernet	40 GB hard disk	1 GB CompactFlash card	8.2	SCB, SCBE
RE-S2000-4096	2.0-GHz Pentium	4096 MB	Gigabit Ethernet	40 GB hard disk	1 GB CompactFlash card	8.2	SCB, SCBE
RE-C1800	1.8-GHz	8 GB	Gigabit Ethernet	SSD	4 GB CompactFlash card	T1600 router in a routing matrix: 9.6R2	CB-T for a standalone router.
						Standalone T640 or T1600 router:11.2	CB-LCC for a router in a routing matrix.
						32-bit Junos OS on a standalone T1600 router: 11.4R2 32-bit Junos OS on a T1600 router in a routing matrix: 11.4R2	CB-T for a standalone router.  CB-LCC for a router in a routing matrix.
RE-C1800	1.8 Ghz	16 GB	Gigabit Ethernet	SSD	4 GB CompactFlash card	64-bit Junos OS on a standalone T1600 router: 11.4R2 64-bit Junos OS on a T1600 router in a routing matrix: 11.4R2	CB-T for a standalone router.  CB-LCC for a router in a routing matrix.
RE-C2600	2.6-GHz	16 GB	Gigabit Ethernet	SSD	4 GB CompactFlash card	TX Matrix Plus router: 9.6R2	–

Table 37: Routing Engine Specifications (continued)

Routing Engine	Processor	Memory	Connection to PFEs	Disk	Media	First Junos OS Support	Switch Control Board
RE-A-1800x2	1800-MHz	8 GB or 16 GB	Gigabit Ethernet	32 GB SSD	4 GB CompactFlash card	10.4	–
RE-S-1800x2	1800-MHz	8 GB or 16 GB	Gigabit Ethernet	32 GB SSD	4 GB CompactFlash card	10.4	SCB, SCBE
RE-S-1800x4	1800-MHz	8GB or 16 GB	Gigabit Ethernet	32 GB SSD	4 GB CompactFlash card	10.4	SCB, SCBE, SCBE2
RE-S-MX104	1.8-GHz	4 GB	Gigabit Ethernet	–	8 GB NAND Flash	13.2	–
<del>RE-B-1800x4G</del>	1.73-GHz	4 GB	Gigabit Ethernet	64 GB SSD	4 GB CompactFlash card	12.1R2, 11.4R4, and 12.2R1	–
<del>RE-MX1800x4</del>	1.8- GHz	16 GB	Gigabit Ethernet	32 GB SSD	4 GB Fixed Internal CompactFlash card	12.3R2	SCB, SCBE
<del>RE-S1800x4GS</del>	1.8- Ghz	32 GB	Gigabit Ethernet	32 GB SSD	4 GB Fixed Internal CompactFlash card	<ul style="list-style-type: none"> <li>• 12.3R4</li> <li>• 13.2R1</li> </ul>	SCB, SCBE SCBE2
<del>RE-MX1800GS</del>	1.8- Ghz	32 GB	Gigabit Ethernet	32 GB SSD	4GB Fixed Internal CompactFlash card	<ul style="list-style-type: none"> <li>• 12.3R4</li> <li>• 13.2R1</li> </ul>	–
RE-S-X6-64G, RE-S-X6-64GLT	2 Ghz	64 GB	Gigabit Ethernet	Two 50-GB SSDs	–	15.1F4, 16.1	SCBE2
<del>RE-MX1864G</del>	2.3 Ghz	64 GB	Gigabit Ethernet	Two 100-GB SSDs	–	15.1F5-S1, 16.1R2, and 16.2R1	–
<del>RE-MX186GLT</del>	2.3 Ghz	64 GB	Gigabit Ethernet	Two 100-GB SSDs	–	17.2R1	–
<del>RE-MX186G</del>	2.3 Ghz	64 GB	Gigabit Ethernet	Two 50-GB SSDs	–	15.1F7	–
RE-S-1600x8	1.6 Ghz	64 GB	Gigabit Ethernet	Two 50-GB SSDs	–	17.3R1	–

Table 37: Routing Engine Specifications (continued)

Routing Engine	Processor	Memory	Connection to PFEs	Disk	Media	First Junos OS Support	Switch Control Board
RE-X6-64G	2.1 Ghz	64 GB	Gigabit Ethernet	Two 100-GB SSDs	-	17.2R1	-
RE-X8-64G	2.3 Ghz	128 GB	Gigabit Ethernet	Two 200-GB SSDs	-	18.2R1	-
RE-S-X6-128G	2.1 Ghz	128 GB	Gigabit Ethernet	Two 200-GB SSDs	-	18.1R1	-
RE-X8-128G	2.1 Ghz	128 GB	Gigabit Ethernet	Two 200-GB SSDs	-	18.1R1	-
JNP10003-REI	1.6-GHz	64 GB	Gigabit Ethernet	Two 100 GB SSDs	-	17.3R1	-
JNP10003-RELT	1.6-GHz	64 GB	Gigabit Ethernet	Two 100 GB SSDs	-	18.1R1	-
JNP10K-RE0	2.5 GhZ	32 GB	Gigabit Ethernet	Two 50 GB SSDs	-	17.2R1	-
JNP10K-RE1	2.3 GhZ	64 GB	Gigabit Ethernet	Two 200 GB SSDs	-	18.2R1	-
JNP10K-RE1LT	2.3 GhZ	64 GB	Gigabit Ethernet	Two 200 GB SSDs	-	18.3R1	-
JNP10K-RE128	2.3 GhZ	128 GB	Gigabit Ethernet	Two 200 GB SSDs	-	18.3R1	-



**NOTE:** Use shielded CAT5e cable for connecting the AUX, CONSOLE, and MGMT ports in RE-S-X6-64G, REMX2K-X8-64G, and REMX2008-X8-64G Routing Engines.

Table 38: End-of-Life Routing Engine Specifications

Routing Engine	Processor	Memory	Connection to PFEs	Disk	Media	First Junos OS Support	EOL Details
RE-333-256	333-MHz Pentium II	256 MB	Fast Ethernet	6.4 GB hard disk	80 MB CompactFlash card	3.4	PSN-2003-01-063

Table 38: End-of-Life Routing Engine Specifications (continued)

Routing Engine	Processor	Memory	Connection to PFEs	Disk	Media	First Junos OS Support	EOL Details
RE-333-768	333-MHz Pentium II	768 MB	Fast Ethernet	6.4 GB hard disk	80 MB CompactFlash card	3.4	<a href="#">PSN-2003-01-063</a>
RE-600-512	600-MHz Pentium III	512 MB	Fast Ethernet	30 GB hard disk	256 MB CompactFlash card	5.4	<a href="#">PSN-2004-07-019</a>
RE-600-2048	600-MHz Pentium III	2048 MB	Fast Ethernet	40 GB hard disk	1 GB CompactFlash card	5.3	<a href="#">PSN-2008-02-018</a>
RE-850-1536	850-MHz Pentium III	1536 MB	Fast Ethernet	40 GB hard disk	1 GB CompactFlash card	7.2	<a href="#">PSN-2011-04-226</a>
RE-M40	200-MHz Pentium	256 MB	Fast Ethernet	6.4 GB hard disk	80 MB CompactFlash card	3.2	<a href="#">FA-HW-0101-001</a>
<del>RE-M40-333-768</del>	333-MHz Pentium II	768 MB	Fast Ethernet	10 GB hard disk	80 MB CompactFlash card	4.2	<a href="#">PSN-2003-01-063</a>
<del>RE-M40-600-2048</del>	600-MHz Pentium III	2048 MB	Fast Ethernet	30 GB hard disk	128 MB CompactFlash card	5.4	<a href="#">PSN-2004-11-020</a>
RE-1600-2048	1.6-GHz Pentium M	2048 MB	Gigabit Ethernet	40 GB hard disk	1 GB CompactFlash card	6.2	<a href="#">PSN-2008-02-019</a>



**NOTE:** The memory in [Table 37 on page 273](#) indicates the amount of total memory. To determine the amount of available memory, issue the `show chassis routing-engine` CLI command.

On routers that accept two Routing Engines, you cannot mix Routing Engine types except for a brief period (one minute or so) during an upgrade or downgrade to two Routing Engines of the same type.

#### Related Documentation

- [Supported Routing Engines by Router on page 305](#)

## MX Routing Engine LEDs

Each Routing Engine has four LEDs that indicate its status. The LEDs, labeled **MASTER**, **HDD**, **ONLINE**, and **FAIL**, are located directly on the faceplate of the Routing Engine. [Table 39 on page 277](#) describes the functions of the Routing Engine LEDs.

*Table 39: Routing Engine LEDs*

Label	Color	State	Description
<b>MASTER</b>	Blue	On steadily	Routing Engine is the Master.
<b>HDD</b>	Green	Blinking	Indicates activity on the hard disk drive.
<b>ONLINE</b>	Green	Blinking	Routing Engine is transitioning online.
		On steadily	Routing Engine is functioning normally.
<b>FAIL</b>	Red	On steadily	Routing Engine has failed.

### Related Documentation

- [MX960 Routing Engine Description on page 277](#)
- [Replacing an MX960 Routing Engine](#)

## MX960 Routing Engine Description

If the host system is redundant, the backup Routing Engine is hot-removable and hot-insertable, but the master Routing Engine is hot-pluggable. A Routing Engine that is not redundant is hot-pluggable.

- [Supported Routing Engines on page 277](#)
- [Routing Engine Function on page 278](#)
- [Routing Engine Slots on page 278](#)
- [Routing Engine Interface Ports on page 278](#)

## Supported Routing Engines

The MX960 router supports the following Routing Engines:

- RE-S-1300-2048 supported for Junos OS Release 8.2 and later.
- RE-S-2000-4096 supported for Junos OS Release 8.2 and later.
- RE-S-1800x2 supported for Junos OS Release 10.4 and later.
- RE-S-1800x4 supported for Junos OS Release 10.4 and later.
- RE-S-X6-64G supported for Junos OS Release 15.1F4, 16.1 and later.
- RE-S-X6-64G-LT supported for Junos OS Release 17.2R1 and later.



**NOTE:** The Routing Engine is equipped with limited encryption support only.



**NOTE:** If two Routing Engines are installed, they must both be the same hardware model.

## Routing Engine Function

The Routing Engine runs the Junos OS. Software processes that run on the Routing Engine maintain the routing tables, manage the routing protocols used on the router, control the router interfaces, control some chassis components, and provide the interface for system management and user access to the router.

## Routing Engine Slots

You can install one or two Routing Engines in the router. Each Routing Engine must be installed directly into an SCB. A USB port on the Routing Engine accepts a USB memory device that allows you to load Junos OS. The Routing Engines install into the front of the chassis in vertical slots directly into the SCBs labeled 0 and 1. If two Routing Engines are installed, one functions as the master and the other acts as the backup. If the master Routing Engine fails or is removed and the backup is configured appropriately, the backup takes over as the master.

On the MX960 router, a Routing Engine installed in SCB slot 2/6 receives no power and supplies no additional routing functions. If no SCB is installed in slot 2/6, install a blank panel in the slot.

## Routing Engine Interface Ports

Three ports, located on the right side of the routing engine, connect the Routing Engine to one or more external devices on which system administrators can issue Junos OS command-line interface (CLI) commands to manage the router.

The ports with the indicated labels function as follows:

- **AUX**—Connects the Routing Engine to a laptop, modem, or other auxiliary device through a serial cable with an RJ-45 connector.
- **CONSOLE**—Connects the Routing Engine to a system console through a serial cable with an RJ-45 connector.
- **ETHERNET or MGMT**—Connects the Routing Engine through an Ethernet connection to a management LAN (or any other device that plugs into an Ethernet connection) for out-of-band management. The port uses an autosensing RJ-45 connector to support 10-Mbps or 100-Mbps connections. Two small LEDs on the right of the port indicate the connection in use: the LED flashes yellow or green for a 10-Mbps or 100-Mbps connection, and the LED is light green when traffic is passing through the port.



- Related Documentation**
- *RJ-45 Connector Pinouts for MX Series Routing Engine AUX and CONSOLE Ports*
  - *RJ-45 Connector Pinouts for an MX Series Routing Engine ETHERNET Port*
  - *Replacing an MX960 Routing Engine*

## MX480 Routing Engine Description

The Routing Engine is an Intel-based PC platform that runs Junos OS. Software processes that run on the Routing Engine maintain the routing tables, manage the routing protocols used on the router, control the router interfaces, control some chassis components, and provide the interface for system management and user access to the router.

You can install one or two Routing Engines in the router. The Routing Engines install into the front of the chassis in horizontal slots in the SCBs labeled 0 and 1. If two Routing Engines are installed, one functions as the master and the other acts as the backup. If the master Routing Engine fails or is removed, and the backup is configured appropriately, the backup takes over as the master.

The Routing Engines are hot-pluggable. Each Routing Engine must be installed directly into an SCB. A USB port on the Routing Engine accepts a USB memory card that allows you to load Junos OS. [Figure 50 on page 279](#) shows RE-S-1800 Routing Engine and [Figure 51 on page 280](#) shows the RE-S-X6-64G Routing Engine.

*Figure 50: RE-S-1800 Routing Engine*

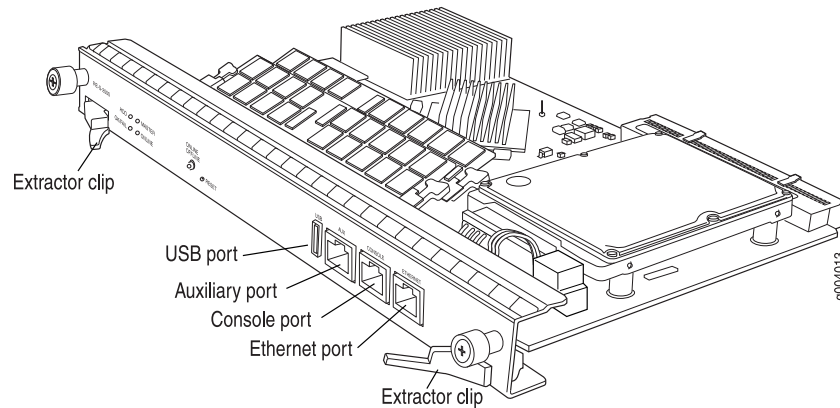
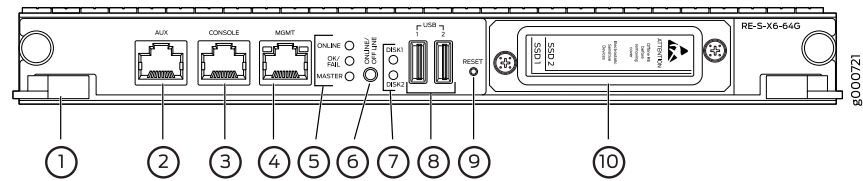
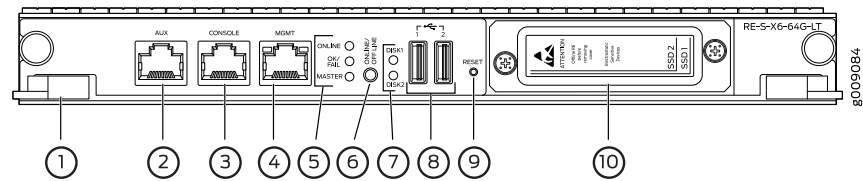

Figure 51: RE-S-X6-64G Routing Engine Front View



1—Extractor clips	6— <b>ONLINE/OFFLINE</b> Button
2—Auxiliary port ( <b>AUX</b> )	7—SSD LEDs— <b>DISK1</b> and <b>DISK2</b>
3—Console port ( <b>Con</b> )	8—Ports— <b>USB1</b> and <b>USB2</b>
4—Management port ( <b>MGMT</b> )	9— <b>RESET</b> Button
5—LEDs— <b>ONLINE</b> , <b>OK/FAIL</b> , and <b>MASTER</b>	10—SSD card slot cover

Figure 52: RE-S-X6-64G-LT Routing Engine Front View



1—Extractor clips	6— <b>ONLINE/OFFLINE</b> Button
2—Auxiliary port ( <b>AUX</b> )	7—SSD LEDs— <b>DISK1</b> and <b>DISK2</b>
3—Console port ( <b>Con</b> )	8—Ports— <b>USB1</b> and <b>USB2</b>
4—Management port ( <b>MGMT</b> )	9— <b>RESET</b> Button
5—LEDs— <b>ONLINE</b> , <b>OK/FAIL</b> , and <b>MASTER</b>	10—SSD card slot cover

## Routing Engine Components



**NOTE:** For specific information about Routing Engine components (for example, the amount of DRAM), issue the `show vmhost hardware` command.

## Routing Engine Interface Ports

Three ports, located on the right side of the Routing Engine, connect the Routing Engine to one or more external devices on which system administrators can issue Junos OS command-line interface (CLI) commands to manage the router.

The ports with the indicated labels function as follows:

- **AUX**—Connects the Routing Engine to a laptop, modem, or other auxiliary device through a serial cable with an RJ-45 connector.
- **CONSOLE**—Connects the Routing Engine to a system console through a serial cable with an RJ-45 connector.

- **ETHERNET or MGMT**—Connects the Routing Engine through an Ethernet connection to a management LAN (or any other device that plugs into an Ethernet connection) for out-of-band management. The port uses an autosensing RJ-45 connector to support 10-Mbps or 100-Mbps connections. Two small LEDs on the right of the port indicate the connection in use: The LED on the left indicates speed—green for 1000-Mbps, yellow for 100-Mbps and when the LED is dark, it indicates 10-Mbps speed. The LED on the right indicates activity—flashing green when packets are passing through the port.

## Routing Engine Boot Sequence

The Routing Engine boots from the storage media in this order: the USB device (if present), then the CompactFlash card, then the hard disk, then the LAN. The disk from which the router boots is called the *primary boot device*, and the other disk is the *alternate boot device*.



**NOTE:** If the router boots from an alternate boot device, a yellow alarm lights the LED on the router's craft interface.

Booting in a RE-S-X6-64G Routing Engine follows this sequence—the USB device, SSD1, SSD2, and LAN. SSD1 is the primary boot device. Boot sequence is tried twice for SSD1 and SSD2.

If the Routing Engines are configured for *graceful switchover*, the backup Routing Engine automatically synchronizes its configuration and state with the master Routing Engine. Any update to the master Routing Engine state is replicated on the backup Routing Engine. If the backup Routing Engine assumes mastership, packet forwarding continues through the router without interruption. For more information about graceful switchover, see the *Junos OS Administration Library*.



**NOTE:** If two Routing Engines are installed, they must both be the same hardware model.

### Related Documentation

- [MX480 Router Description](#)
- [MX480 Routing Engine LEDs](#)
- [MX480 Host Subsystem Description](#)
- [MX480 SCB-MX Description](#)

## MX240 Routing Engine Description

The Routing Engine is an Intel-based PC platform that runs Junos OS. Software processes that run on the Routing Engine maintain the routing tables, manage the routing protocols used on the router, control the router interfaces, control some chassis components, and provide the interface for system management and user access to the router.

You can install one or two Routing Engines in the router. The Routing Engines install into the front of the chassis in horizontal slots in the SCBs labeled **0** and **1/0**. Each Routing Engine must be installed directly into an SCB. A USB port on the Routing Engine accepts a USB memory card that allows you to load Junos OS.

If two Routing Engines are installed, one functions as the master and the other acts as the backup. If the master Routing Engine fails or is removed and the backup is configured appropriately, the backup takes over as the master. The Backup Routing Engine is hot-insertable and hot-removable.

The MX240 router supports the RE-S-1300-2048, EE-S-2000-4096, RE-S-1800, RE-S-X6-64G, and RE-S-X6-64G-LT Routing Engines. See [Figure 50 on page 279](#), [Figure 54 on page 282](#), and [Figure 51 on page 280](#).



**NOTE:** If two Routing Engines are installed, they must both be the same hardware model.

The RE-S-X6-64G-LT Routing Engine is equipped with limited encryption support only.

*Figure 53: RE-S-2000 Routing Engine*

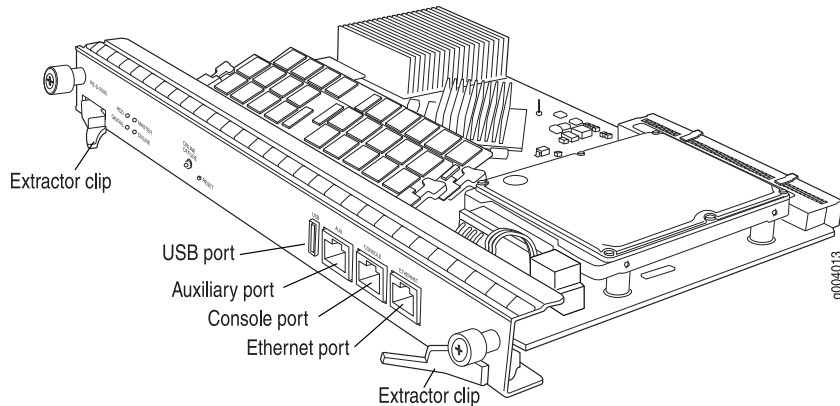

*Figure 54: RE-S-1800*

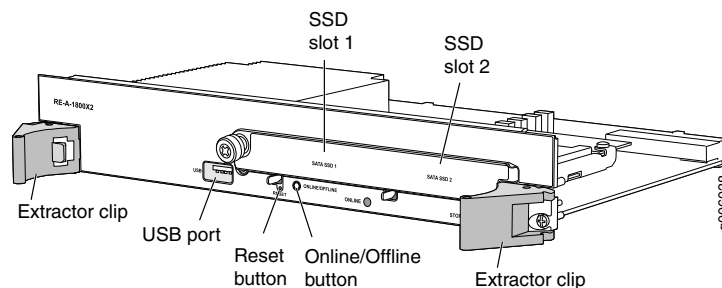
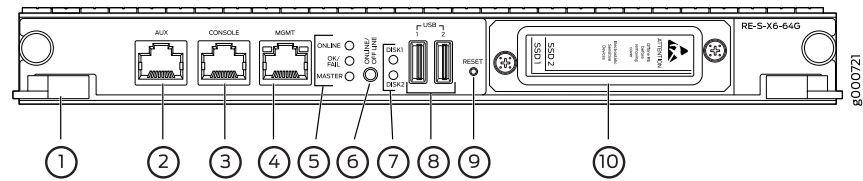
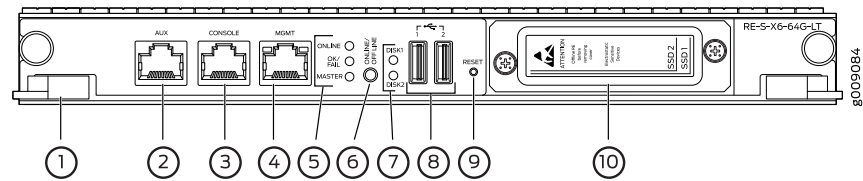

Figure 55: RE-S-X6-64G Routing Engine Front View



1—Auxiliary port (AUX)	6—LEDs—ONLINE, OK/FAIL, and MASTER
2—Console port (Con)	7—RESET Button
3—Management port (MGMT)	8—SSD LEDs—DISK1 and DISK2
4—ONLINE/OFFLINE Button	9—SSD card slot cover
5—Ports—USB1 and USB2	

Figure 56: RE-S-X6-64G-LT Routing Engine Front View



1—Extractor clips	6—ONLINE/OFFLINE Button
2—Auxiliary port (AUX)	7—SSD LEDs—DISK1 and DISK2
3—Console port (Con)	8—Ports—USB1 and USB2
4—Management port (MGMT)	9—RESET Button
5—LEDs—ONLINE, OK/FAIL, and MASTER	10—SSD card slot cover

## RE-S-X6-64G and RE-S-X6-64G-LT Routing Engine Components

In MX240 routers with dual Routing Engines, both the Routing Engines must be RE-S-X6-64G Routing Engines.

Each RE-S-X6-64G Routing Engine (shown in [Figure 51 on page 280](#)) consists of the following components:

- CPU—Runs Junos OS to maintain the routing tables and routing protocols.
- EEPROM—Stores the serial number of the Routing Engine.
- DRAM—Provides storage for the routing and forwarding tables and for other Routing Engine processes.
- One 10-Gigabit Ethernet interface between Routing Engine and Switch Control Board.
- Two 50 GB slim Solid State Drives—SSD1 (primary) and SSD2 (secondary)—Provide storage for software images, configuration files, microcode, log files, and memory dumps. The Routing Engine reboots from SSD2 when boot from primary SSD fails.

- Two USB ports (**USB1** and **USB2**)—Provide a removable media interface through which you can install Junos OS manually. The Junos OS supports USB versions 3.0, 2.0, and 1.1.
- Interface ports—The **AUX**, **CONSOLE**, and **MGMT** provide access to management devices. Each Routing Engine has one 10/100/1000-Mbps Ethernet port for connecting to a management network, and two asynchronous serial ports—one for connecting to a console and one for connecting to a modem or other auxiliary device.
- **RESET** Button—Reboots the Routing Engine when pressed.
- **ONLINE/OFFLINE** Button—Makes the Routing Engine online or offline when pressed.
- Extractor clips—Control the locking system that secures the Routing Engine.
- LEDs—*MX240 Routing Engine LEDs* describes the functions of these LEDs.



**NOTE:** For specific information about Routing Engine components (for example, the amount of DRAM), issue the `show vmhost hardware` command.

## Routing Engine Interface Ports

Three ports, located on the right side of the Routing Engine, connect the Routing Engine to one or more external devices on which system administrators can issue Junos OS command-line interface (CLI) commands to manage the router.

The ports with the indicated labels function as follows:

- **AUX**—Connects the Routing Engine to a laptop, modem, or other auxiliary device through a serial cable with an RJ-45 connector.
- **CONSOLE**—Connects the Routing Engine to a system console through a serial cable with an RJ-45 connector.
- **ETHERNET or MGMT**—Connects the Routing Engine through an Ethernet connection to a management LAN (or any other device that plugs into an Ethernet connection) for out-of-band management. The port uses an autosensing RJ-45 connector to support 10/100/1000-Mbps connections. Two small LEDs on the right of the port indicate the connection in use: The LED on the left indicates speed—green for 1000-Mbps, yellow for 100-Mbps and when the LED is dark, it indicates 10-Mbps speed. The LED on the right indicates activity—flashing green when packets are passing through the port.

## RE-S-X6-64G and RE-S-X6-64G-LT Routing Engine Interface Ports

Three ports, located on the left side of the Routing Engine, connect the Routing Engine to one or more external devices on which system administrators can issue Junos OS command-line interface (CLI) commands to manage the router.

The ports with the indicated labels function as follows:

- **AUX**—Connects the Routing Engine to a laptop, modem, or other auxiliary device through a serial cable with an RJ-45 connector.

- **CONSOLE**—Connects the Routing Engine to a system console through a serial cable with an RJ-45 connector.
- **MGMT**—Connects the Routing Engine through an Ethernet connection to a management LAN (or any other device that plugs into an Ethernet connection) for out-of-band management. The port uses an autosensing RJ-45 connector to support 10/100/1000-Mbps connections. Two small LEDs on the right of the port indicate the connection in use: The LED on the left indicates speed—green for 1000-Mbps, yellow for 100-Mbps and when the LED is dark, it indicates 10-Mbps speed. The LED on the right indicates activity—flashing green when packets are passing through the port.

## Routing Engine Boot Sequence

The Routing Engine boots from the storage media in this order: the USB device (if present), then the CompactFlash card, then the hard disk, then the LAN. The disk from which the router boots is called the *primary boot device*, and the other disk is the *alternate boot device*.



**NOTE:** If the router boots from an alternate boot device, a yellow alarm lights the LED on the router's craft interface.

Booting in a RE-S-X6-64G and in a RE-S-X6-64G-LT Routing Engine follows this sequence—the USB device, SSD1, SSD2, and LAN. SSD1 is the primary boot device. Boot sequence is tried twice for SSD1 and SSD2.

### Related Documentation

- *Removing an MX240 Routing Engine*
- *Installing an MX240 Routing Engine*
- *MX240 Routing Engine Serial Number Label*

## MX5, MX10, MX40, and MX80 Routing Engine Description

The Routing Engine is built-in on the MX5, MX10, MX40, and MX80 baseboard and cannot be replaced.

The Routing Engine consists of the following components:

- **Processor**—Runs Junos OS to maintain the router's routing tables and routing protocols.
- **DRAM**—Buffers incoming packets and provides storage for the routing and forwarding tables and for other Routing Engine processes. To view the amount of DRAM installed on your router, issue the **show chassis routing-engine** command.
- **NAND flash**—Provides primary storage for software images, configuration files, and microcode.

### Related Documentation

- *Maintaining the MX5, MX10, MX40, and MX80 Routing Engine*
- *show chassis routing-engine*

## MX2008 Routing and Control Board (MX2008 RCB) Description

---

The MX2008 Routing and Control Board (MX2008 RCB) is an integrated board and a single FRU that provides Routing Engine and Control Board functionality.

The REMX2008-X8-128G RCB is equipped with a 8-Core 2.3 GHz processor, 128 GB memory, and two 200 GB SSDs and also supports Secure Boot for enhanced boot security.

The REMX2008-X8-64G-LT RCB is equipped with a 8-Core 2.3 GHz processor, 64 GB memory, and two 100 GB SSDs. The RCB is equipped with limited encryption support only.

- [Supported RCBs on page 286](#)
- [RCB Function on page 286](#)
- [RCB Slots on page 286](#)
- [RCB Front Panel on page 287](#)
- [RCB Interface Ports on page 288](#)

### Supported RCBs

The following are some key attributes of the MX2008 RCB:

- The RCB combined the Control Board and the Routing Engine in a single FRU.
- The RCB is hot-pluggable.
- The RCB is less than half the size of native MX2000 CB-RE.

The MX2008 router supports the following RCBs:

- REMX2008-X8-64G
- REMX2008-X8-64G-LT
- REMX2008-X8-128G

### RCB Function

The RCB runs Junos OS. Software processes that run on the RCB maintain the routing tables, manage the routing protocols used on the router, control the router interfaces, control some chassis components, and provide the interface for system management and user access to the router.

### RCB Slots

The user can install one or two RCBs in the router. Each RCB is a combined Routing Engine and Control Board in one unit. A USB port on the RCB accepts a USB storage device that enables you to load Junos OS. You can install the RCBs into the front of the chassis in vertical slots labeled 0 and 1. If two RCBs are installed, one functions as the master and the other acts as the backup. If the master RCB fails or is removed and the backup is



configured appropriately, the backup takes over as the master. If no RCB is installed in a slot, install a blank panel in the slot.

A minimum of one RCB must be installed in either slot 0 or slot 1 at all times.



**CAUTION:** If one of the RCBs fails, do not remove the failed RCB until you have a replacement or blank panel to install.

## RCB Front Panel

Table 40 on page 287 describes the Routing and Control Board (RCB).

Figure 57: RCB Front View

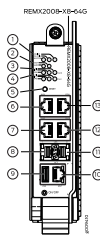

Figure 58: RCB (REM2008-X8-64G-LT) Front View

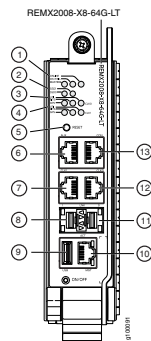

Figure 59: RCB (REM2008-X8-128G) Front View

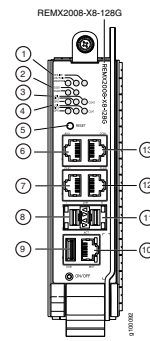

Table 40: Components on the RCB

Function No.	Label	Description
1	ONLINE, MASTER, and OK/FAIL	There is one bicolor LED for each RCB control. The <b>ONLINE</b> LED indicates that the RCB is transitioning online and functioning properly. The <b>MASTER</b> LED indicates that this board is a master RCB, and the <b>OK/FAIL</b> LED indicates the RCB has failed.
2	SSD0 and SSD1	LEDs shows the state of the two solid-state drives (SSDs) in the RCB.
3	GPS, UTI, and BITS	These ports shows the external clocking interface status. There is one bicolor LED for each external clock interface—GPS, UTI and BITS.
4		
5	RESET	This button used to reboot the RCB.
6	AUX	This port is used to connect a laptop, modem, or other auxiliary unit.

Table 40: Components on the RCB (continued)

Function No.	Label	Description
7 12	CLK0 and CLK1	Connects the RCB to two external clock interfaces for BITS and GPS function through a serial cable with an RJ-45 connector.
8 11	LNK-0 and LNK-1	Two SFP+ ports connects the RCB through an Ethernet connection to support hardware diagnostics and JCS port testing. The port supports two 1-Gbps or 10-Gbps connections.  The LED on these ports are associated with each of the SFP+ port (XGE-0 and XGE-1) and indicates the connection in use.
9	USB	This port is used to install a USB flash drive that contains Junos OS.
10	MGT	This port is a dedicated management channel for device maintenance. It is also used for system administrators to monitor and manage the MX2008 router remotely.
13	CONSOLE	This port is used to configure the MX2008 router.

## RCB Interface Ports

Three ports, located on the RCB, connect the RCB to one or more external devices on which system administrators can issue Junos OS CLI commands to manage the router. In addition, four ports located on the RCB include, two 10-Gigabit Ethernet SFP+ interface connectors supporting hardware diagnostics (JCS port testing), and two external clock interfaces for BITS and GPS function.

The RCB interface ports with the indicated labels function as follows:

- **AUX**—Connects the RCB to a laptop, modem, or other auxiliary device through a serial cable with an RJ-45 connector.
- **CONSOLE**—Connects the RCB to a system console through a serial cable with an RJ-45 connector.
- **MGT**—Connects the RCB through an Ethernet connection to a management LAN (or any other device that plugs into an Ethernet connection) for out-of-band management. The port uses an autosensing RJ-45 connector to support 10-Mbps, 100-Mbps, or 1000-Mbps connections. Two small LEDs on the bottom of the port indicate the connection in use: the LED flashes yellow or green for a 10-Mbps, 100-Mbps, or 1000-Mbps connection, and the LED is lit green when traffic is passing through the port.

The Control Board interface ports function as follows:

- **USB**—Provides a removable media interface through which you can install the Junos OS manually. Junos OS supports USB version 1.0 and later.
- **LNK-0** and **LNK-1**—Two SFP+ port connect the RCB through Ethernet to support two 1-Gbps or 10-Gbps connections to any external control box. Two small LEDs on the side of each SFP+ port indicate the connection in use: the LED flashes yellow when there is no link, flashes green when there is activity, or is lit green for a 1-Gbps or 10-Gbps connection.
- **CLK-0** and **CLK-1**—Connect the RCB to an external clock device through a serial cable with an RJ-45 connector.

**Related Documentation**

- *RJ-45 Connector Pinouts for MX Series CB-RE or RCB Auxillary and Console Ports*
- *RJ-45 Connector Pinouts for an MX Series CB-RE or RCB Management Port*
- *Replacing an MX2008 RCB*
- *MX2008 Host Subsystem Description*
- [Supported Routing Engines by Router on page 305](#)
- [Routing Engine Specifications on page 272](#)

## MX10003 Routing and Control Board (RCB) Description

The host subsystem provides routing protocol processes, as well as software processes that control the router's interface, the chassis components, system management, and user access to the router. These routing processes run on top of a kernel that interacts with the Packet Forwarding Engine. The MX10003 host subsystem consists of two Routing and Control Boards, or RCBs. The RCB is an integrated board and a single FRU that provides Routing Engine (RE) and Control Board (CB) functionality. The RE performs all route-processing functions, whereas the CB performs chassis control and management plane functionality. The RCB provides control plane functions. You can install one or two RCBs on the router. Each RCB functions as a unit.



**NOTE:** Install two RCBs for redundant protection. If you install only one RCB, you can install it in slot 0 or slot 1. By default, slot 0 functions as the master.



**CAUTION:** If one of the RCBs fails, do not remove the failed RCB until you have a replacement or blank panel to install.

The MX10003 router supports the following RCBs:

- JNP10003-RE1
- JNP10003-RE1-LT

This topic covers:

- [Routing and Control Board Functions on page 290](#)
- [Routing and Control Board Components on page 290](#)
- [RCB Front Panel on page 290](#)
- [RCB Interface Ports on page 292](#)

## Routing and Control Board Functions

The Routing and Control Board integrates the Routing Engine and Control Board functions into a single management unit. Each RCB provides all the functions needed to manage the operation of the modular chassis:

- System control functions such as environmental monitoring
- Routing Layer 2 and Layer 3 protocols
- Communication to all components such as line cards, power, and cooling
- Transparent clocking
- Alarm and logging functions

## Routing and Control Board Components

Each RCB consists of the following internal components:

- High-performance 1.6-GHz Intel 8 Core X86 CPU
- 64-GB DDR4 RAM
- 100-GB SATA SSD

## RCB Front Panel

[Figure 60 on page 291](#) shows the front panel of the MX10003 RCB (model number: JNP10003-RE1).

Figure 60: JNP10003-RE1 RCB Ports

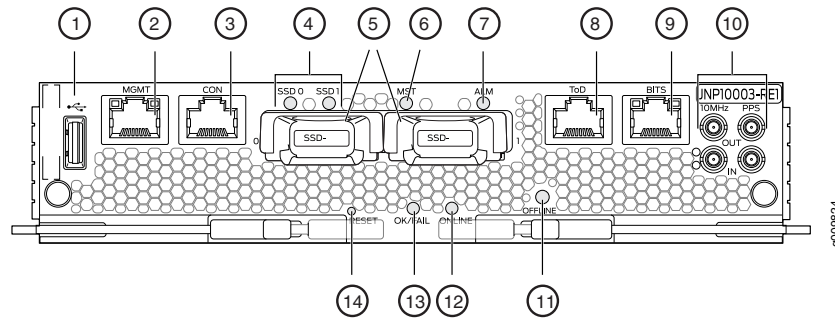

1—USB port	8—Time of day ( <b>ToD</b> ) port with LEDs (This port is reserved for future use)
2—Management ( <b>MGMT</b> ) port	9— <b>BITS</b> port with LEDs
3—Console ( <b>CON</b> ) port	10—Clocking ports
4—SSD LEDs	11— <b>OFFLINE</b> button
5—SSD slots ( <b>0</b> and <b>1</b> )	12— <b>ONLINE</b> LED
6—Master ( <b>MST</b> ) LED	13— <b>OK/FAIL</b> LED
7—Alarm ( <b>ALM</b> ) LED	14— <b>RESET</b> button

Figure 61 on page 291 shows the front panel of the MX10003 RCB with limited encryption support (model number: JNP10003-RE1-LT).

Figure 61: JNP10003-RE1-LT RCB Ports

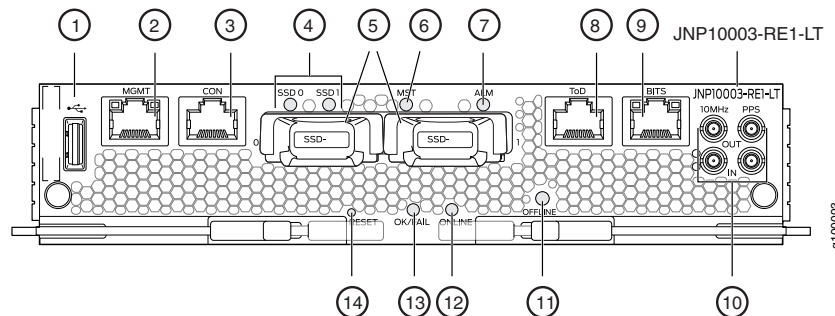

1—USB port	8—Time of day ( <b>ToD</b> ) port with LEDs (This port is reserved for future use)
2—Management ( <b>MGMT</b> ) port	9— <b>BITS</b> port with LEDs
3—Console ( <b>CON</b> ) port	10—Clocking ports
4—SSD LEDs	11— <b>OFFLINE</b> button
5—SSD slots ( <b>0</b> and <b>1</b> )	12— <b>ONLINE</b> LED
6—Master ( <b>MST</b> ) LED	13— <b>OK/FAIL</b> LED
7—Alarm ( <b>ALM</b> ) LED	14— <b>RESET</b> button

The MX10003 router with JNP10003-RE1-LT RCB supports only Junos Limited image. The Junos Limited image does not have data-plane encryption and is intended only for countries in the Eurasian Customs Union because these countries have import restrictions on software containing data-plane encryption. Unlike the Junos Worldwide image, the Junos Limited image supports control plane encryption through Secure Shell (SSH) and Secure Sockets Layer (SSL), thus allowing secure management of the system. The Limited Restriction RCB boots only the encryption free Junos software and fails to boot if the fully encrypted Junos software is used for booting. The Junos upgrade and VMHost upgrade using non-limited version of Junos software fails on the JNP10003-RE1-LT RCB.

The command **show chassis hardware [models | clei-models | extensive]** displays the model number and helps identifying the different SKUs. An alarm, **Mixed Master and Backup RE types** is displayed when dissimilar Routing Engines are present on the chassis (see *Chassis Alarms*).

## RCB Interface Ports

The ports located on the RCB, connect the RCB to one or more external devices on which system administrators can issue Junos OS CLI commands to manage the router. In addition, ports to connect external clock interfaces for BITS and GPS function are also available on the RCB.

The RCB interface ports with the indicated labels function are as follows (see [Figure 60 on page 291](#)):

- **CON**—Connects the RCB to a system console through a serial cable with an RJ-45 connector.
- **MGMT**—Connects the RCB through an Ethernet connection to a management LAN (or any other device that plugs into an Ethernet connection) for out-of-band management. The port uses an autosensing RJ-45 connector to support 10-Mbps, 100-Mbps, or 1000-Mbps connections. Two small LEDs on the port indicate the connection in use: the LED flashes yellow or green for a 10-Mbps, 100-Mbps, or 1000-Mbps connection, and the LED is lit green when traffic is passing through the port.
- **BITS**—Building-integrated timing supply (BITS) external clocking interface for connection to external clocking devices.
- **ToD**—Time-of-day (TOD) port on the front panel of the router allows you to connect external timing signal sources.



**NOTE:** This port is reserved for future use.

- **10MHZ** (one input and one output)—The 10-MHz timing connectors on the front panel of the router connect to external clock signal sources. The clocking ports provide the synchronized output clocks from any one of the reference clock inputs based on the clock's priority.
- **PPS** (one input and one output)—1-pulse-per-second (PPS) connectors on the front panel of the router connect to external clock signal sources. The clocking ports provide

the synchronized output clocks from any one of the reference clock inputs based on the clock's priority.

- USB—Provides a removable media interface through which you can install Junos OS manually. Junos OS supports USB version 1.0 and later.

**Related Documentation**

- *Replacing an MX10003 RCB*
- *RJ-45 Connector Pinouts for MX Series CB-RE or RCB Auxillary and Console Ports*
- *RJ-45 Connector Pinouts for an MX Series CB-RE or RCB Management Port*
- [Supported Routing Engines by Router on page 305](#)
- [Routing Engine Specifications on page 272](#)

## MX10008 Routing and Control Board Components and Descriptions

- [MX10008 Routing and Control Board Description on page 293](#)
- [Routing and Control Board LEDs on page 296](#)

### MX10008 Routing and Control Board Description

The MX10008 Routing and Control Board (RCB) is responsible for system management in an MX10008 router. (see [Figure 62 on page 294](#)). The chassis can run with one or two RCBs. Base configurations ship with one RCB that can be expanded with a second RCB for a fully-redundant system. When two RCBs are installed, one functions as the master and the second as a backup. If the master RCB is removed, the backup becomes the master if GRES is configured.

MX10008 supports the following Routing Engines:

- JNP10K-RE1
- JNP10K-RE1-LT
- JNP10K-RE1-128G

Figure 62: Routing and Control Board (JNP10K-RE1)

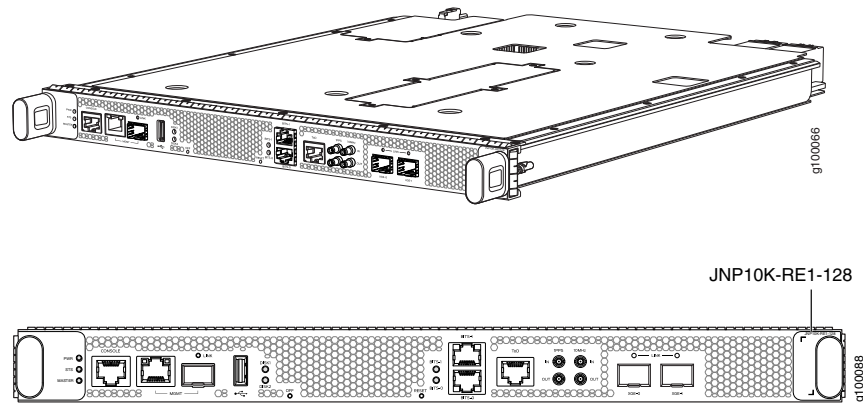

This topic covers:

- [Routing and Control Board Functions on page 294](#)
- [Routing and Control Board \(JNP10K-RE1\) Components on page 294](#)

### [Routing and Control Board Functions](#)

The Routing and Control Board integrates the control plane and Routing Engine functions into a single management unit. Each RCB provides all the functions needed to manage the operation of the modular chassis:

- System control functions such as environmental monitoring
- Routing Layer 2 and Layer 3 protocols
- Communication to all components such as line cards, Switch Fabric Boards (SFBs), and power and cooling
- Transparent clocking
- Alarm and logging functions

### [Routing and Control Board \(JNP10K-RE1\) Components](#)

Each RCB consists of the following internal components:



Figure 63: Routing and Control Board Faceplate

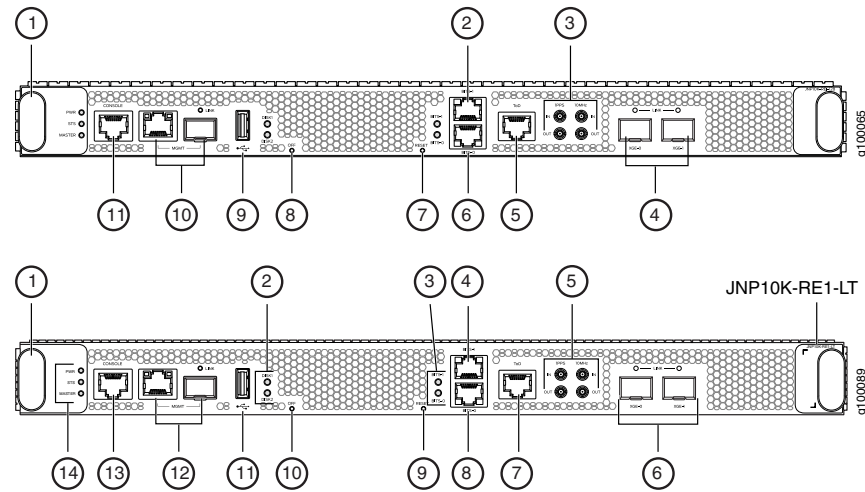

1—Handles	7—Reset button
2—BITS0 clock port	8—Online/Offline button
3—GPS clock ports	9—USB port
4—XGE-0 and XGE-1 JCS ports	10—Management ( <b>MGMT</b> ) ports
5— <b>ToD</b> —Time-of-day (TOD) port	11—Console ( <b>CONSOLE</b> ) port
6—BITS1 clock port	

Each RCB (JNP10K-RE1) consists of the following internal components:

- CPU—Runs Junos OS to maintain the routing tables and routing protocols.
- EEPROM—Stores the serial number of the Routing Engine.
- DRAM—Provides storage for the routing and forwarding tables and for other Routing Engine processes.
- One 10-Gigabit Ethernet interface between the Routing Engine and Switch Control Board.
- One USB port—Provides a removable media interface through which you can install Junos OS manually. The Junos OS supports USB versions 3.0, 2.0, and 1.1.
- Management ports—Two ports, one copper (RJ-45 port) and one SFP port provide access to management devices. Use only one of the two management ports at a time. Use an RJ-45 connector for the copper port or use a fiber optic connector for the SFP port. Do not use copper SFP or SFP-T modules in the SFP port as they are not supported.
- **RESET** button—Reboots the Routing Engine when pressed.
- LEDs—Provide status of the Routing Engine.



**NOTE:** For specific information about Routing Engine components (for example, the amount of DRAM), issue the `show vmhost hardware` command.

- See Also**
- *Handling and Storing MX10008 Line Cards, RCBs, and SFBs*
  - *Installing a Routing and Control Board*

## Routing and Control Board LEDs

The Routing and Control Boards have four types of LED indicators (see [Figure 64 on page 296](#)).

**Figure 64: Routing and Control Board (JNP10K-RE1) LEDs**

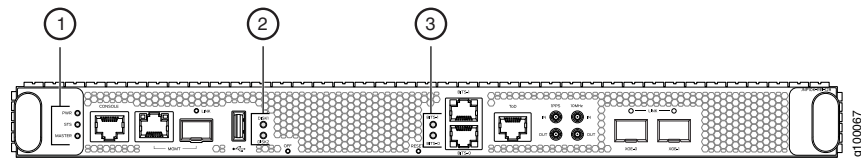

1— Routing and Control Board status panel	3— Clock LEDs- BITS0, and BITS1
2— SSD LEDs, DISK1 and DISK2	

[Table 41 on page 296](#) describes the LEDs on the RCB status panel.

**Table 41: Routing and Control Board Status LEDs**

LED	Color	State	Description
<b>PWR</b>	Green	On steadily	RCB is receiving adequate power.
	Yellow	Blinking	RCB has detected an error.
	Dark	Unlit	RCB is not powered up.
<b>STS</b>	Green	On steadily	RCB is online and functioning correctly.
	Green	Blinking	The beacon feature is enabled.
	Yellow	On steadily	RCB is booting.
	Yellow	Blinking	The Control Board has detected an error.
	Dark	Unlit	The power supply is switched off.
<b>MST</b>	Green	On steadily	RCB is the master.
	Dark	Unlit	RCB is the backup.

Figure 65: Management Port LEDs on a MX10008

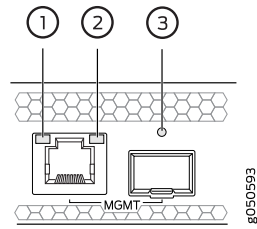

1— Status LED (RJ-45)	3—LINKLED—Green indicates the link is up; blinking indicates activity (SFP)
2— Activity LED (RJ-45)	

Table 42 on page 297 describes the RJ-45 management port and SFP LEDs, and Table 43 on page 297 describes the SFP status LEDs.

Table 42: RJ-45 Management Port LEDs on a MX10008 Routing and Control Board

LED	Color	State	Description
Activity/Status LED	Unlit	Off	The port speed is 10 M.
	Green	Blinking	The port speed is 100 M.
	Green	On steadily	The port speed is 1000 M.
LINK	Unlit	Off	No link is established, there is a fault, or the link is down.
	Green	On steadily	A link is established.
		Blinking	There is link activity.
	Yellow	Blinking or flickering	The beacon feature is enabled.

Table 43: JCS Port LEDs on a MX10008 Routing and Control Board

LED	Color	State	Description
LINK LEDs for JCS Ports (XGE0 and XGE1)	Unlit	Off	No transceiver is present.
	Green	On steadily	A link is established. The interface is up.
	Green	Blinking or flickering	The beacon feature is enabled.
	Yellow	Blinking	An error has occurred.

Table 44 on page 298 describes the LEDs for the secondary SATA drives.

Table 44: Routing and Control Board SSD Status LEDs

LED	Color	State	Description
DISK1 and DISK2	Green	On steadily	A SATA drive is present.
	Green	Blinking	The drive is active.
	Yellow	On steadily	The drive is active.
	Dark	Unlit	A drive is not installed.

**See Also** • [Connecting an MX10008 to a Network for Out-of-Band Management](#)

## MX Routing Engine LEDs

Each Routing Engine has four LEDs that indicate its status. The LEDs, labeled **MASTER**, **HDD**, **ONLINE**, and **FAIL**, are located directly on the faceplate of the Routing Engine. [Table 39 on page 277](#) describes the functions of the Routing Engine LEDs.

Table 45: Routing Engine LEDs

Label	Color	State	Description
<b>MASTER</b>	Blue	On steadily	Routing Engine is the Master.
<b>HDD</b>	Green	Blinking	Indicates activity on the hard disk drive.
<b>ONLINE</b>	Green	Blinking	Routing Engine is transitioning online.
		On steadily	Routing Engine is functioning normally.
<b>FAIL</b>	Red	On steadily	Routing Engine has failed.

**Related Documentation**

- [MX960 Routing Engine Description on page 277](#)
- [Replacing an MX960 Routing Engine](#)

## RE-S-1800 Routing Engine Description

[Figure 66 on page 299](#) shows RE-S-1800 routing engine.

Figure 66: RE-S-1800 Front View

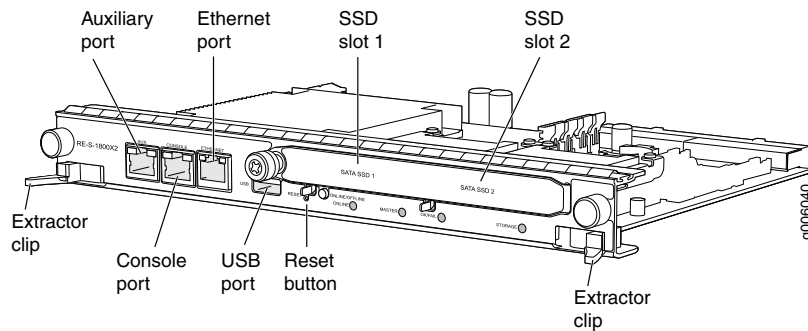

- [RE-S-1800 Routing Engine Components on page 299](#)
- [RE-S-1800 Routing Engine LEDs on page 300](#)
- [RE-S-1800 Routing Engine Boot Sequence on page 300](#)

## RE-S-1800 Routing Engine Components

Each Routing Engine consists of the following components:

- CPU—Runs Junos OS to maintain the router's routing tables and routing protocols.
- DRAM—Provides storage for the routing and forwarding tables and for other Routing Engine processes.
- USB port—Provides a removable media interface through which you can install Junos OS manually. Junos OS supports USB version 1.0.
- CompactFlash card—Provides primary storage for software images, configuration files, and microcode. The CompactFlash card is fixed and is inaccessible from outside the router.
- Solid-state Drive (SSD)—Provides secondary storage for log files, memory dumps, and rebooting the system if the CompactFlash card fails.
- Interface ports—The **AUX**, **CONSOLE**, and **ETHERNET** provide access to management devices. Each Routing Engine has one 10/100/1000-Mbps Ethernet port for connecting to a management network, and two asynchronous serial ports—one for connecting to a console and one for connecting to a modem or other auxiliary device.
- EEPROM—Stores the serial number of the Routing Engine.
- **RESET** button—Reboots the Routing Engine when pressed.
- **ONLINE/OFFLINE** button—Takes the Routing Engine online or offline when pressed.
- Extractor clips—Used for inserting and extracting the Routing Engine.
- Captive screws—Secure the Routing Engine in place.



**NOTE:** For specific information about Routing Engine components (for example, the amount of DRAM), issue the `show chassis routing-engine` command.

## RE-S-1800 Routing Engine LEDs

Each Routing Engine has four LEDs that indicate its status. The LEDs, labeled **MASTER**, **STORAGE**, **ONLINE**, and **OK/FAIL**, are located directly on the faceplate of the Routing Engine. [Table 46 on page 300](#) describes the functions of the Routing Engine LEDs.

*Table 46: Routing Engine LEDs*

Label	Color	State	Description
<b>MASTER</b>	Blue	On steadily	Routing Engine is the Master.
<b>STORAGE</b>	Green	Blinking	Indicates activity on the SSD or Compact Flash.
<b>ONLINE</b>	Green	Blinking	Routing Engine is transitioning online.
		On steadily	Routing Engine is functioning normally.
<b>OK/FAIL</b>	Red	On steadily	Routing Engine has failed.

## RE-S-1800 Routing Engine Boot Sequence

The router is shipped with Junos OS preinstalled on the Routing Engine. There are three copies of software:

- One copy on the CompactFlash card in the Routing Engine.
- One copy on the hard disk in the Routing Engine.
- One copy on a USB flash drive that can be inserted into the slot on the Routing Engine faceplate.

The Routing Engine boots from the storage media in this order: the USB device (if present), then the CompactFlash card, then the Solid State Disk (SSD), then the LAN. Normally, the router boots from the copy of the software on the CompactFlash card.

### Related Documentation

- [RJ-45 Connector Pinouts for MX Series Routing Engine AUX and CONSOLE Ports](#)
- [RJ-45 Connector Pinouts for an MX Series Routing Engine ETHERNET Port](#)
- [Replacing an MX960 Routing Engine](#)
- [Supported Routing Engines by Router on page 305](#)

## RE-S-X6-64G Routing Engine Description

Figure 67 on page 301 shows the Routing Engine.

Figure 67: RE-S-X6-64G Routing Engine Front View

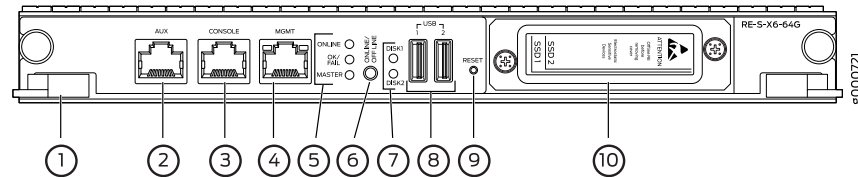

1—Extractor clips	6— <b>ONLINE/OFFLINE</b> button
2—Auxiliary port ( <b>AUX</b> )	7—SSD LEDs— <b>DISK1</b> and <b>DISK2</b>
3—Console port ( <b>CONSOLE</b> )	8—Ports— <b>USB1</b> and <b>USB2</b>
4—Management port ( <b>MGMT</b> )	9— <b>RESET</b> button
5—LEDs— <b>ONLINE</b> , <b>OK/FAIL</b> , and <b>MASTER</b>	10—SSD card slot cover

- [RE-S-X6-64G Routing Engine Components on page 301](#)
- [RE-S-X6-64G Routing Engine Boot Sequence on page 302](#)

## RE-S-X6-64G Routing Engine Components

In routers with dual Routing Engines, both Routing Engines must be RE-S-X6-64G Routing Engines.

Each RE-S-X6-64G Routing Engine (shown in [Figure 67 on page 301](#)) consists of the following components:

- CPU—Runs Junos OS to maintain the routing tables and routing protocols.
- EEPROM—Stores the serial number of the Routing Engine.
- DRAM—Provides storage for the routing and forwarding tables and for other Routing Engine processes.
- One 10-Gigabit Ethernet interface between the Routing Engine and Switch Control Board.
- Two 50-GB slim solid-state drives—**SSD1** (primary) and **SSD2** (secondary)—Provide storage for software images, configuration files, microcode, log files, and memory dumps. The Routing Engine reboots from **SSD2** when boot from primary **SSD** fails.
- Two USB ports (**USB1** and **USB2**)—Provide a removable media interface through which you can install Junos OS manually. The Junos OS supports USB versions 3.0, 2.0, and 1.1.
- Interface ports—The **AUX**, **CONSOLE**, and **MGMT** provide access to management devices. Each Routing Engine has one 10/100/1000-Mbps Ethernet port for connecting to a management network, and two asynchronous serial ports—one for connecting to a console and one for connecting to a modem or other auxiliary device.

- **RESET** button—Reboots the Routing Engine when pressed.
- **ONLINE/OFFLINE** button—Brings the Routing Engine online or takes it offline when pressed.



**NOTE:** The **ONLINE/OFFLINE** button must be pressed for a minimum of 4 seconds for the power off or power on to occur.

- Extractor clips—Control the locking system that secures the Routing Engine.
- LEDs—*RE-S-X6-64G Routing Engine LEDs* describes the functions of these LEDs.



**NOTE:** For specific information about Routing Engine components (for example, the amount of DRAM), issue the `show vmhost hardware` command.

## RE-S-X6-64G Routing Engine Boot Sequence

Booting in a RE-S-X6-64G Routing Engine follows this sequence—the USB device, SSD1, SSD2, LAN. SSD1 is the primary boot device. The boot sequence is tried twice for SSD1 and SSD2.

### Related Documentation

- *Upgrading to the RE-S-X6-64G Routing Engine in a Redundant Host Subsystem*
- *Upgrading to the RE-S-X6-64G Routing Engine in a Nonredundant Host Subsystem*



## RE-S-X6-128G Routing Engine Description

Figure 67 on page 301 shows the Routing Engine.

Figure 68: RE-S-X6-128G Routing Engine Front View

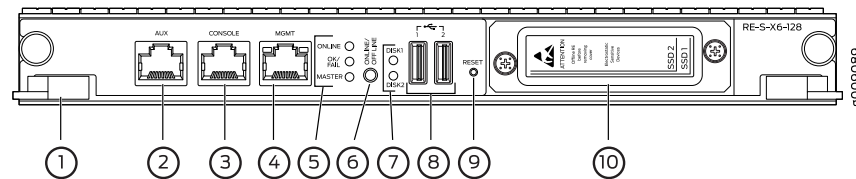

1—Extractor clips	6— <b>ONLINE/OFFLINE</b> button
2—Auxiliary port ( <b>AUX</b> )	7—SSD LEDs— <b>DISK1</b> and <b>DISK2</b>
3—Console port ( <b>CONSOLE</b> )	8—Ports— <b>USB1</b> and <b>USB2</b>
4—Management port ( <b>MGMT</b> )	9— <b>RESET</b> button
5—LEDs— <b>ONLINE</b> , <b>OK/FAIL</b> , and <b>MASTER</b>	10—SSD card slot cover

- [RE-S-X6-128G Routing Engine Components on page 303](#)
- [RE-S-X6-128G Routing Engine LEDs on page 304](#)
- [RE-S-X6-128G Routing Engine Boot Sequence on page 305](#)

### RE-S-X6-128G Routing Engine Components

In routers with dual Routing Engines, both Routing Engines must be RE-S-X6-128G Routing Engines.

Each RE-S-X6-128G Routing Engine (shown in [Figure 67 on page 301](#)) consists of the following components:

- CPU—Runs Junos OS to maintain the routing tables and routing protocols.
- EEPROM—Stores the serial number of the Routing Engine.
- DRAM—Provides storage for the routing and forwarding tables and for other Routing Engine processes.
- One 10-Gigabit Ethernet interface between the Routing Engine and Switch Control Board.
- Two 50-GB slim solid-state drives—**SSD1** (primary) and **SSD2** (secondary)—Provide storage for software images, configuration files, microcode, log files, and memory dumps. The Routing Engine reboots from SSD2 when boot from primary SSD fails.
- Two USB ports (**USB1** and **USB2**)—Provide a removable media interface through which you can install Junos OS manually. The Junos OS supports USB versions 3.0, 2.0, and 1.1.
- Interface ports—The **AUX**, **CONSOLE**, and **MGMT** provide access to management devices. Each Routing Engine has one 10/100/1000-Mbps Ethernet port for connecting

to a management network, and two asynchronous serial ports—one for connecting to a console and one for connecting to a modem or other auxiliary device.

- **RESET** button—Reboots the Routing Engine when pressed.
- **ONLINE/OFFLINE** button—Brings the Routing Engine online or takes it offline when pressed.



**NOTE:** The **ONLINE/OFFLINE** button must be pressed for a minimum of 4 seconds for the power off or power on to occur.

- Extractor clips—Control the locking system that secures the Routing Engine.
- LEDs—Table 47 on page 304 describes the functions of these LEDs.



**NOTE:** For specific information about Routing Engine components (for example, the amount of DRAM), issue the `show vmhost hardware` command.

### RE-S-X6-128G Routing Engine LEDs

Each Routing Engine has five LEDs that indicate its status. The LEDs—labeled **MASTER**, **DISK1**, **DISK2**, **ONLINE**, and **OK/FAIL**—are located on the faceplate of the Routing Engine. Table 47 on page 304 describes the functions of the Routing Engine LEDs.

Figure 69: RE-S-X6-128G Routing Engine LEDs

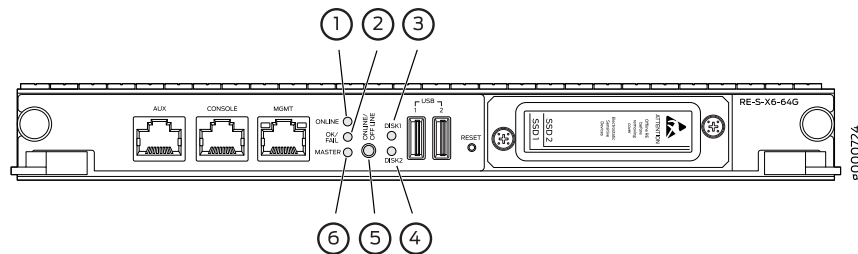

1—ONLINE LED	4—DISK2 LED
2—OK/FAIL LED	5—ONLINE/OFFLINE button
3—DISK1 LED	6—MASTER LED

Table 47: RE-S-X6-128G Routing Engine LEDs

Label	Color	State	Description
ONLINE	Green	Blinking slowly	Routing Engine is in the process of booting BIOS, and the host OS.
		Blinking rapidly	Routing Engine is in the process of booting Junos OS.
-	-	Off	Routing Engine is not online or not functioning normally.

Table 47: RE-S-X6-128G Routing Engine LEDs (continued)

Label	Color	State	Description
DISK1	Green	Blinking	Indicates presence of disk activity.
	-	Off	There is no disk activity.
DISK2	Green	Blinking	Indicates presence of disk activity.
	-	Off	There is no disk activity.
OK/FAIL	Green	On steadily	Routing Engine is powering up.
	Yellow	On steadily	Routing Engine is not powering up, which indicates failure.
MASTER	Blue	On steadily	This Routing Engine is the Master Routing Engine.

## RE-S-X6-128G Routing Engine Boot Sequence

Booting in a RE-S-X6-128G Routing Engine follows this sequence—the USB device, SSD1, SSD2, LAN. SSD1 is the primary boot device. The boot sequence is tried twice for SSD1 and SSD2.

- Related Documentation**
- [Supported Routing Engines by Router on page 305](#)
  - [Routing Engine Specifications on page 272](#)

## Supported Routing Engines by Router

The following tables list the Routing Engines that each router supports, the first supported release for the Routing Engine in the specified router, the management Ethernet interface, and the internal Ethernet interfaces for each Routing Engine.

- [M7i Routing Engines on page 306](#)
- [M10i Routing Engines on page 306](#)
- [M40e Routing Engines on page 307](#)
- [M120 Routing Engines on page 307](#)
- [M320 Routing Engines on page 308](#)
- [MX5, MX10, MX40, and MX80 Routing Engine on page 308](#)
- [MX104 Routing Engines on page 309](#)
- [MX240 Routing Engines on page 309](#)
- [MX480 Routing Engines on page 310](#)
- [MX960 Routing Engines on page 311](#)
- [MX2008 Routing Engines on page 312](#)
- [MX2010 Routing Engines on page 313](#)

- [MX2020 Supported Routing Engines on page 313](#)
- [MX10003 Routing Engines on page 314](#)
- [MX10008 Routing Engines on page 314](#)
- [PTX1000 Routing Engines on page 315](#)
- [PTX3000 Routing Engines on page 315](#)
- [PTX5000 Routing Engines on page 316](#)
- [PTX10008 and PTX10016 Routing Engines on page 316](#)
- [T320 Routing Engines on page 317](#)
- [T640 Routing Engines on page 317](#)
- [T1600 Routing Engines on page 318](#)
- [T4000 Routing Engines on page 319](#)
- [TX Matrix Routing Engines on page 320](#)
- [TX Matrix Plus Routing Engines on page 320](#)
- [TX Matrix Plus \(with 3D SIBs\) Routing Engines on page 321](#)

## M7i Routing Engines

[Table 48 on page 306](#) lists the Routing Engines supported by the M7i router. The M7i router supports 32-bit Junos OS only.

*Table 48: M7i Routing Engines*

Model Number	Name in CLI Output	First Supported 32-bit Junos OS Release	Management Ethernet Interface	Internal Ethernet Interface
RE-400-768 (EOL details: <a href="#">TSB16445</a> )	<b>RE-5.0</b>	9.0	fxp0	fxp1
RE-850-1536 (EOL details: <a href="#">TSB15553</a> )	<b>RE-850</b>	7.2	fxp0	fxp1
RE-B-1800X1-4G	<b>RE-B-1800x1</b>	11.4R4 12.1R2	fxp0	em0

## M10i Routing Engines

[Table 49 on page 306](#) lists the Routing Engines supported by the M10i router. The M10i router supports 32-bit Junos OS only.

*Table 49: M10i Routing Engines*

Model Number	Name in CLI Output	First Supported 32-bit Junos OS Release	Management Ethernet Interface	Internal Ethernet Interface
RE-400-768 (EOL details: <a href="#">TSB16445</a> )	<b>RE-5.0</b>	9.0	fxp0	fxp1 fxp2

Table 49: M10i Routing Engines (continued)

Model Number	Name in CLI Output	First Supported 32-bit Junos OS Release	Management Ethernet Interface	Internal Ethernet Interface
RE-850-1536 (EOL details: <a href="#">TSB15553</a> )	<b>RE-850</b>	7.2	fxp0	fxp1 fxp2
RE-B-1800X1-4G	<b>RE-B-1800x1</b>	11.4R4 12.1R2	fxp0	em0

## M40e Routing Engines

Table 50 on page 307 lists the Routing Engines supported by the M40e router.

Table 50: M40e Routing Engines

Model Number	Name in CLI Output	First Supported Junos OS Release	Management Ethernet Interface	Internal Ethernet Interface
RE-600-2048 (EOL details: <a href="#">TSB14373</a> )	<b>RE-3.0 or RE-3.0 (RE-600)</b>	5.3	fxp0	fxp1 fxp2
RE-A-1000-2048	<b>RE-A-1000</b>	8.1	fxp0	fxp1 fxp2

## M120 Routing Engines

Table 51 on page 307 lists the Routing Engines supported by the M120 router.

Table 51: M120 Routing Engines

Model Number	Name in CLI Output	First Supported 32-bit Junos OS Release	First Supported 64-bit Junos OS Release	Management Ethernet Interface	Internal Ethernet Interface
RE-A-1000-2048	<b>RE-A-1000</b>	8.0R2	–	fxp0	fxp1 fxp2
RE-A-2000-4096	<b>RE-A-2000</b>	8.0R2	–	fxp0	em0 bcm0
RE-A-1800X2-8G	<b>RE-A-1800x2</b>	<ul style="list-style-type: none"> <li>• 11.4R5</li> <li>• 12.1R3</li> </ul>	10.4	fxp0	fxp1 fxp2

Table 51: M120 Routing Engines (continued)

Model Number	Name in CLI Output	First Supported 32-bit Junos OS Release	First Supported 64-bit Junos OS Release	Management Ethernet Interface	Internal Ethernet Interface
RE-A-1800X2-16G	RE-A-1800x2	<ul style="list-style-type: none"> <li>11.4R5</li> <li>12.1R3</li> </ul>	10.4	fxp0	fxp1 fxp2
RE-A-1800X4-16G	RE-A-1800x4	<ul style="list-style-type: none"> <li>11.4R5</li> <li>12.1R3</li> </ul>	10.4	fxp0	em0 em1

## M320 Routing Engines

Table 52 on page 308 lists the Routing Engines supported by the M320 router.

Table 52: M320 Routing Engines

Model Number	Name in CLI Output	First Supported 32-bit Junos OS Release	First Supported 64-bit Junos OS Release	Management Ethernet Interface	Internal Ethernet Interface
RE-1600-2048 (EOL details: <a href="#">TSB14374</a> )	RE-4.0	6.2	–	fxp0	fxp1 fxp2
RE-A-2000-4096	RE-A-2000	8.1	–	fxp0	em0 bcm0
RE-A-1800X2-8G	RE-A-1800x2	<ul style="list-style-type: none"> <li>11.4R5</li> <li>12.1R3</li> </ul>	10.4	fxp0	em0 bcm0
RE-A-1800X2-16G	RE-A-1800x2	<ul style="list-style-type: none"> <li>11.4R5</li> <li>12.1R3</li> </ul>	10.4	fxp0	em0 bcm0
RE-A-1800X4-8G	RE-A-1800x4	<ul style="list-style-type: none"> <li>11.4R5</li> <li>12.1R3</li> <li>12.2</li> </ul>	10.4	fxp0	em0 em1

## MX5, MX10, MX40, and MX80 Routing Engine

Table 53 on page 309 lists the Routing Engines supported by the MX5, MX10, MX40, and MX80 routers.

**Table 53: MX5, MX10, MX40, and MX80 Routing Engine**

Model Number	Name in CLI Output	First Supported 32-bit Junos OS Release	First Supported 64-bit Junos OS Release	Management Ethernet Interface	Internal Ethernet Interface
Built-in Routing Engine	<b>Routing Engine RE-MX80</b>	12.3	-	fxp0	em0 em1  <i>NOTE:</i> em1 is used to communicate with the MS-MIC when it is inserted.

## MX104 Routing Engines

Table 54 on page 309 lists the Routing Engines supported by MX104 routers.

**Table 54: MX104 Routing Engines**

Model Number	Name in CLI Output	First Supported 32-bit Junos OS Release	First Supported 64-bit Junos OS Release	Management Ethernet Interface	Internal Ethernet Interface
RE-S-MX104	<b>Routing Engine</b>	13.2	-	fxp0	fxp1 fxp2

## MX240 Routing Engines

Table 55 on page 309 lists the Routing Engines supported by MX240 routers.

**Table 55: MX240 Supported Routing Engines**

Model Number	Name in CLI Output	First Supported 32-bit Junos OS Release	First Supported 64-bit Junos OS Release	Management Ethernet Interface	Internal Ethernet Interface
RE-S-1300-2048 (EOL details: <a href="#">TSB16556</a> )	<b>RE-S-1300</b>	9.0	-	fxp0	fxp1 fxp2
RE-S-2000-4096 (EOL details: <a href="#">TSB16735</a> )	<b>RE-S-2000</b>	9.0	-	fxp0	fxp1 fxp2
RE-S-1800X2-8G (EOL details: <a href="#">TSB16556</a> )	<b>RE-S-1800x2</b>	<ul style="list-style-type: none"> <li>11.4R5</li> <li>12.1R3</li> </ul>	10.4	fxp0	em0 em1
RE-S-1800x2-16G (EOL details: <a href="#">TSB16556</a> )	<b>RE-S-1800x2</b>	<ul style="list-style-type: none"> <li>11.4R5</li> <li>12.1R3</li> </ul>	10.4	fxp0	em0 em1

Table 55: MX240 Supported Routing Engines (continued)

Model Number	Name in CLI Output	First Supported 32-bit Junos OS Release	First Supported 64-bit Junos OS Release	Management Ethernet Interface	Internal Ethernet Interface
RE-S-1800X4-8G	RE-S-1800X4	<ul style="list-style-type: none"> <li>11.4R5</li> <li>12.1R3</li> </ul>	10.4	fxp0	em0 em1
RE-S-1800X4-16G	RE-S-1800x4	<ul style="list-style-type: none"> <li>11.4R5</li> <li>12.1R3</li> </ul>	10.4	fxp0	em0 em1
RE-S-1800X4-32G-S	RE-S-1800X4	<ul style="list-style-type: none"> <li>12.3R4</li> <li>13.2R1</li> </ul>	<ul style="list-style-type: none"> <li>12.3R4</li> <li>13.2R1</li> </ul>	fxp0	em0, em1
RE-S-X6-64G	RE-S-2X00x6	–	15.1F4 16.1R1	fxp0	ixlv0, igb0
RE-S-X6-64G-LT	RE-S-2X00x6-LT	–	17.2R1	fxp0	ixlv0, igb0 em0
RE-S-X6-128G	RE-S-2X00x6-128	–	18.1R1	fxp0	ixlv0, igb0 em0

## MX480 Routing Engines

Table 56 on page 310 lists the Routing Engines supported by MX480 routers.

Table 56: MX480 Supported Routing Engines

Model Number	Name in CLI Output	First Supported 32-bit Junos OS Release	First Supported 64-bit Junos OS Release	Management Ethernet Interface	Internal Ethernet Interface
RE-S-1300-2048 (EOL details: <a href="#">TSB16556</a> )	RE-S-1300	8.4	–	fxp0	fxp1 fxp2
RE-S-2000-4096 (EOL details: <a href="#">TSB16735</a> )	RE-S-2000	8.4	–	fxp0	fxp1 fxp2
RE-S-1800X2-8G (EOL details: <a href="#">TSB16556</a> )	RE-S-1800x2	<ul style="list-style-type: none"> <li>11.4R5</li> <li>12.1R3</li> </ul>	10.4	fxp0	em0 em1
RE-S-1800X2-16G (EOL details: <a href="#">TSB16556</a> )	RE-S-1800x2	<ul style="list-style-type: none"> <li>11.4R5</li> <li>12.1R3</li> </ul>	10.4	fxp0	em0 em1



Table 56: MX480 Supported Routing Engines (continued)

Model Number	Name in CLI Output	First Supported 32-bit Junos OS Release	First Supported 64-bit Junos OS Release	Management Ethernet Interface	Internal Ethernet Interface
RE-S-1800X4-8G	RE-S-1800X4	<ul style="list-style-type: none"> <li>11.4R5</li> <li>12.1R3</li> </ul>	10.4	fxp0	em0 em1
RE-S-1800X4-16G	RE-S-1800x4	<ul style="list-style-type: none"> <li>11.4R5</li> <li>12.1R3</li> </ul>	10.4	fxp0	em0 em1
RE-S-1800X4-32G-S	RE-S-1800X4	<ul style="list-style-type: none"> <li>12.3R4</li> <li>13.2R1</li> </ul>	<ul style="list-style-type: none"> <li>12.3R4</li> <li>13.2R1</li> </ul>	fxp0	em0 em1
RE-S-X6-64G	RE-S-2X00x6	–	15.1F4 16.1R1	fxp0	ixlv0, igb0
RE-S-X6-64G-LT	RE-S-2X00x6-LT	–	17.2R1	fxp0	ixlv0, igb0 em0
RE-S-X6-128G	RE-S-2X00x6-128	–	18.1R1	fxp0	ixlv0, igb0 em0

## MX960 Routing Engines

Table 57 on page 311 lists the Routing Engines supported by MX960 routers.

Table 57: MX960 Supported Routing Engines

Model Number	Name in CLI Output	First Supported 32-bit Junos OS Release	First Supported 64-bit Junos OS Release	Management Ethernet Interface	Internal Ethernet Interface
RE-S-1300-2048 (EOL details: <a href="#">TSB16556</a> )	RE-S-1300	8.2	–	fxp0	fxp1 fxp2
RE-S-2000-4096 (EOL details: <a href="#">TSB16735</a> )	RE-S-2000	8.2	–	fxp0	fxp1 fxp2
RE-S-1800X2-8G (EOL details: <a href="#">TSB16556</a> )	RE-S-1800x2	<ul style="list-style-type: none"> <li>11.4R5</li> <li>12.1R3</li> </ul>	10.4	fxp0	em0 em1
RE-S-1800X2-16G (EOL details: <a href="#">TSB16556</a> )	RE-S-1800x2	<ul style="list-style-type: none"> <li>11.4R5</li> <li>12.1R3</li> </ul>	10.4	fxp0	em0 em1

Table 57: MX960 Supported Routing Engines (continued)

Model Number	Name in CLI Output	First Supported 32-bit Junos OS Release	First Supported 64-bit Junos OS Release	Management Ethernet Interface	Internal Ethernet Interface
RE-S-1800X4-8G	RE-S-1800x4	<ul style="list-style-type: none"> <li>11.4R5</li> <li>12.1R3</li> </ul>	10.4	fxp0	em0 em1
RE-S-1800X4-16G	RE-S-1800x4	<ul style="list-style-type: none"> <li>11.4R5</li> <li>12.1R3</li> </ul>	10.4	fxp0	em0 em1
RE-S-1800X4-32G-S	RE-S-1800x4	<ul style="list-style-type: none"> <li>12.3R4</li> <li>13.2R1</li> </ul>	<ul style="list-style-type: none"> <li>12.3R4</li> <li>13.2R1</li> </ul>	fxp0	em0 em1
RE-S-X6-64G	RE-S-2X00x6	–	15.1F4 16.1R1	fxp0	ixlv0, igb0
RE-S-X6-64G (For MX960-VC)	RE-S-2X00x6	–	17.1R2	fxp0	ixlv0, igb0
RE-S-X6-64G-LT	RE-S-2X00x6-LT	–	17.2R1	fxp0	ixlv0, igb0 em0
RE-S-X6-128G	RE-S-2X00x6-128	–	18.1R1	fxp0	ixlv0, igb0 em0

## MX2008 Routing Engines

Table 58 on page 312 lists the Routing Engines supported by MX2008 routers.

Table 58: MX2008 Supported Routing Engines

Model Number	Name in CLI Output	First Supported 64-bit Junos OS Release	Management Ethernet Interface	Internal Ethernet Interface
REMX2008-X8-64G	RE-MX2008-X8-64G	15.1F7	fxp0	ixlv0 ixlv1
REMX2008-X8-64G-LT	RE-MX2008-X8-64G-LT	17.2R1	fxp0	ixlv0 ixlv1
REMX2008-X8-128G	RE-MX2008-X8-128G	18.2R1	fxp0	ixlv0 ixlv1

## MX2010 Routing Engines

Table 59 on page 313 lists the Routing Engines supported by MX2010 routers.

*Table 59: MX2010 Supported Routing Engines*

Model Number	Name in CLI Output	First Supported 64-bit Junos OS Release	Management Ethernet Interface	Internal Ethernet Interface
RE-MX2000-1800X4	RE-S-1800x4	12.3R2	fxp0	em0 em1
REMX2K-1800-32G-S	RE-S-1800x4	<ul style="list-style-type: none"> <li>12.3R4</li> <li>13.2R1</li> </ul>	fxp0	em0 em1
REMX2K-X8-64G	RE-S-2X00x8	<ul style="list-style-type: none"> <li>15.1F5-S1</li> <li>16.1R2</li> <li>16.2R1</li> </ul>	fxp0	ixlv0 ixlv1 em0
REMX2K-X8-64G-LT	RE-S-2X00x8	17.2R1	fxp0	ixlv0 ixlv1 em0
REMX2K-X8-128G	RE-MX200X8-128G	18.1R1	fxp0	ixlv0 ixlv1

## MX2020 Supported Routing Engines

Table 60 on page 313 lists the Routing Engines supported by MX2020 routers.

*Table 60: MX2020 Supported Routing Engines*

Model Number	Name in CLI Output	First Supported 64-bit Junos OS Release	Management Ethernet Interface	Internal Ethernet Interface
RE-MX2000-1800X4	RE-S-1800x4	12.3R2	fxp0	em0 em1
REMX2K-1800-32G-S	RE-S-1800x4	<ul style="list-style-type: none"> <li>12.3R4</li> <li>13.2R1</li> </ul>	fxp0	em0 em1

**Table 60: MX2020 Supported Routing Engines (continued)**

Model Number	Name in CLI Output	First Supported 64-bit Junos OS Release	Management Ethernet Interface	Internal Ethernet Interface
REMX2K-X8-64G	RE-S-2X00x8	<ul style="list-style-type: none"> <li>15.1F5-S1</li> <li>16.1R2</li> <li>16.2R1</li> </ul>	fxp0	ixlv0 ixlv1 em0
REMX2K-X8-64G-LT	RE-S-2X00x8	17.2R1	fxp0	ixlv0 ixlv1 em0
REMX2K-X8-128G	RE-MX200X8-128G	18.1R1	fxp0	ixlv0 ixlv1 em0

## MX10003 Routing Engines

Table 61 on page 314 lists the Routing Engines supported by MX10003 routers.

**Table 61: MX10003 Supported Routing Engines**

Model Number	Name in CLI Output	First Supported 64-bit Junos OS Release	Management Ethernet Interface	Internal Ethernet Interface
JNP10003-RE1	RE-S-2X00x6	17.3R1	fxp0	em3 em4
JNP10003-RE1-LT	RE-S-1600x8	18.1R1	fxp0	em3 em4

## MX10008 Routing Engines

Table 62 on page 314 lists the Routing Engines supported on the MX10008 router.

**Table 62: MX10008 Routing Engines**

Model Number	Name in CLI Output	First Supported Junos OS Release	Management Ethernet Interface	Internal Ethernet Interface
JNP10K-RE1	RE X10	18.2R1	em0	bme0 bme1

Table 62: MX10008 Routing Engines (continued)

Model Number	Name in CLI Output	First Supported Junos OS Release	Management Ethernet Interface	Internal Ethernet Interface
JNP10K-RE1-LT	RE X10 LT	18.3R1	em0	bme0 bme1
JNP10K-RE1-128	RE X10 128G	18.3R1	em0	bme0 bme1

## PTX1000 Routing Engines

Table 63 on page 315 lists the Routing Engine supported on the PTX1000.



**NOTE:** The PTX1000 supports 64-bit Junos OS only.

Table 63: PTX1000 Routing Engines

Model Number	Name in CLI Output	First Supported Junos OS Release	Management Ethernet Interface	Internal Ethernet Interface
Built-in Routing Engine	RE-PTX1000	<ul style="list-style-type: none"> <li>16.1X65-D30</li> <li>17.2R1</li> </ul>	em0	bme0 em1

## PTX3000 Routing Engines

Table 64 on page 315 lists the Routing Engines supported on the PTX3000.



**NOTE:** The PTX3000 supports 64-bit Junos OS only.

Table 64: PTX3000 Routing Engines

Model Number	Name in CLI Output	First Supported Junos OS Release	Management Ethernet Interface	Internal Ethernet Interface
RE-DUO-C2600-16G	RE-DUO-2600	13.2R2	em0	ixgbe0 ixgbe1
RCB-PTX-X6-32G	RE-PTX-2X00x6	16.1R4 17.1R1 This Routing Engine does not support Junos OS Release 16.2.	em0	ixlv0 ixlv1

## PTX5000 Routing Engines

Table 65 on page 316 lists the Routing Engines supported on the PTX5000.



### NOTE:

- PTX5000 supports 64-bit Junos OS only.
- The PTX5000 router supports two midplanes. The midplane identified as **Midplane-8S** in the CLI output is supported in Junos OS releases, 12.1X48, 12.3, and 13.2. The enhanced midplane, identified as **Midplane-8SeP** is supported from Junos OS release 14.1 onwards.

The RE-DUO-2600 routing engine with Junos OS 13.2 or earlier is not supported on the PTX5000BASE2 midplane.

Table 65: PTX5000 Routing Engines

Model Number	Name in CLI Output	First Supported Junos OS Release	Management Ethernet Interface	Internal Ethernet Interface
RE-DUO-C2600-16G	RE-DUO-2600	12.1X48	em0	ixgbe0
		12.3		ixgbe1
		13.2		
		NOTE: The PTX5000 does not support Junos OS Releases 12.1, 12.2, or 13.1.		
RE-PTX-X8-64G	RE-PTX-2X00x8	15.1F4	em0	ixlv0
		16.1R1		ixlv1
				em1
RE-PTX-X8-128G	RE-PTX-2X00x8-128G	18.1R1	em0	ixlv0
				ixlv1
				em1

## PTX10008 and PTX10016 Routing Engines

Table 66 on page 317 lists the Routing Engines supported on the PTX10008 and PTX10016 routers.

**Table 66: PTX10008 and PTX10016 Routing Engines**

Model Number	Name in CLI Output	First Supported Junos OS Release	Management Ethernet Interface	Internal Ethernet Interface
JNP10K-RE0	RE-PTX-2X00x4	17.2R1	em0, em1	bme0 bme1
JNP10K-RE1	RE X10	18.2R1	em0	bme0 bme1
JNP10K-RE1-LT	RE X10 LT	18.3R1	em0	bme0 bme1
JNP10K-RE1-128	RE X10 128G	18.3R1	em0	bme0 bme1

## T320 Routing Engines

Table 67 on page 317 lists the Routing Engines supported by the T320 router.

**Table 67: T320 Routing Engines**

Model Number	Name in CLI Output	First Supported 32-bit Junos OS Release	Management Ethernet Interface	Internal Ethernet Interface
RE-600-2048 (EOL details: <a href="#">TSB14373</a> )	RE-3.0 or RE-3.0 (RE-600)	5.3	fxp0	fxp1 fxp2
RE-1600-2048 (EOL details: <a href="#">TSB14374</a> )	RE-4.0	6.2	fxp0	fxp1 fxp2
RE-A-2000-4096	RE-A-2000	8.1	fxp0	fxp1 fxp2

The T320 router supports the CB-T control board.

## T640 Routing Engines

Table 68 on page 318 lists the Routing Engines supported by the T640 router.

Table 68: T640 Routing Engines

Model Number	Name in CLI Output	First Supported 32-bit Junos OS Release	First Supported 64-bit Junos OS Release	Management Ethernet Interface	Internal Ethernet Interface
RE-600-2048 (EOL details: <a href="#">TSB14373</a> )	RE-3.0 or RE-3.0 (RE-600)	5.3	–	fxp0	fxp1 fxp2
RE-1600-2048 (EOL details: <a href="#">TSB14374</a> )	RE-4.0	6.2	–	fxp0	fxp1 fxp2
RE-A-2000-4096	RE-A-2000	8.1	–	fxp0	em0 bcm0
RE-DUO-C1800-8G	RE-DUO-1800	32-bit Junos OS on a standalone T640 router: 11.2 32-bit Junos OS on a T640 router in a routing matrix: 11.4R9	64-bit Junos OS on a standalone T640 router: 11.3 64-bit Junos OS on a T640 router in a routing matrix: 11.4R9	em0	bcm0 em1
RE-DUO-C1800-16G	RE-DUO-1800	32-bit Junos OS on a standalone T640 router: 11.4R2 32-bit Junos OS on a T640 router in a routing matrix: 11.4R9	64-bit Junos OS on a standalone T640 router: 11.4R2 64-bit Junos OS on a T640 router in a routing matrix: 11.4R9	em0	bcm0 em1

The T640 standalone router supports CB-T control board and CB-LCC in a T640 routing matrix.

## T1600 Routing Engines

Table 69 on page 318 lists the Routing Engines supported by the T1600 router.



**NOTE:** (Two RE-DUO-C1800-8G or two RE-DUO-C1800-16G are required to connect to a Routing Matrix)

Table 69: T1600 Routing Engines

Model Number	Name in CLI Output	First Supported 32-bit Junos OS Release	First Supported 64-bit Junos OS Release	Management Ethernet Interface	Internal Ethernet Interface
RE-600-2048 (EOL details: <a href="#">TSB14373</a> )	RE-3.0 or RE-3.0 (RE-600)	8.5	–	fxp0	fxp1 fxp2



Table 69: T1600 Routing Engines (continued)

Model Number	Name in CLI Output	First Supported 32-bit Junos OS Release	First Supported 64-bit Junos OS Release	Management Ethernet Interface	Internal Ethernet Interface
RE-1600-2048 (EOL details: <a href="#">TSB14374</a> )	RE-4.0 (RE-1600)	8.5	–	fxp0	fxp1 fxp2
RE-A-2000-4096	RE-A-2000	8.5	–	fxp0	em0 bcm0
RE-DUO-C1800-8G	RE-TXP-LCC or RE-DUO-1800	32-bit Junos OS on a T1600 router in a routing matrix: 9.6  <i>NOTE:</i> Junos OS Releases 9.6 through 10.4 support RE-DUO-C1800-8G only during upgrade to a line-card chassis (LCC) in a routing matrix.  32-bit Junos OS on a standalone T1600 router: 11.1	64-bit Junos OS on a T1600 router in a routing matrix: 9.6  64-bit Junos OS on a standalone T1600 router: 11.1	em0	bcm0 em1
RE-DUO-C1800-16G	RE-DUO-1800	32-bit Junos OS on a standalone T1600 router: 11.4R2  32-bit Junos OS on a T1600 router in a routing matrix: 11.4R2	64-bit Junos OS on a standalone T1600 router: 11.4R2  64-bit Junos OS on a T1600 router in a routing matrix: 11.4R2	em0	bcm0 em1

## T4000 Routing Engines

Table 70 on page 319 lists the Routing Engines supported by the T4000 router.



**NOTE:** The T4000 router supports 64-bit Junos OS only.

Table 70: T4000 Routing Engines

Model Number	Name in CLI Output	First Supported 64-bit Junos OS Release	Management Ethernet Interface	Internal Ethernet Interface
RE-DUO-C1800-8G	RE-DUO-1800	Standalone T4000 router: 12.1 T4000 router in a routing matrix: 13.1	em0	bcm0 em1
RE-DUO-C1800-16G	RE-DUO-1800	Standalone T4000 router: 12.1R2 T4000 router in a routing matrix: 13.1	em0	bcm0 em1

The T4000 router supports the CB-LCC control board.

## TX Matrix Routing Engines

Table 71 on page 320 lists the Routing Engines supported by the TX Matrix router.

Table 71: TX Matrix Routing Engines

Model Number	Name in CLI Output	First Supported 32-bit Junos OS Release	First Supported 64-bit Junos OS Release	Management Ethernet Interface	Internal Ethernet Interface
RE-600-2048 (EOL details: <a href="#">TSB14373</a> )	RE-3.0 or RE-3.0 (RE-600)	7.0	–	fxp0	fxp1 fxp2
RE-1600-2048 (EOL details: <a href="#">TSB14374</a> )	RE-4.0 (RE-1600)	7.0	–	fxp0	fxp1 fxp2
RE-A-2000-4096	RE-A-2000	8.5	–	fxp0	em0 bcm0
RE-DUO-C1800-8G	RE-DUO-1800	11.4R9	11.4R9	em0	bcm0 em1
RE-DUO-C1800-16G	RE-DUO-1800	11.4R9	11.4R9	em0	bcm0 em1

The TXP router supports two control boards, CB-TX and CB-LCC. The CB-LCC is required for both RE-DUO-C1800-8G and RE-DUO-C1800-16G Routing Engines.

## TX Matrix Plus Routing Engines

Table 72 on page 320 lists the Routing Engines supported by the TX Matrix Plus router.

Table 72: TX Matrix Plus Routing Engines

Model Number	Name in CLI Output	First Supported 32-bit Junos OS Release	First Supported 64-bit Junos OS Release	Management Ethernet Interface	Internal Ethernet Interface
RE-DUO-C2600-16G	RE-TXP-SFC or RE-DUO-2600	32-bit Junos OS: 9.6	64-bit Junos OS: 11.4	em0	ixgbe0 ixgbe1

The TX Matrix Plus router supports the CB-TXP control board.

## TX Matrix Plus (with 3D SIBs) Routing Engines

Table 73 on page 321 lists the Routing Engines supported by the TX Matrix Plus router with 3D SIBs.

*Table 73: Routing Engines on TX Matrix Plus with 3D SIBs*

Model Number	Name in CLI Output	First Supported 32-bit Junos OS Release	First Supported 64-bit Junos OS Release	Management Ethernet Interface	Internal Ethernet Interface
RE-DUO-C2600-16G	RE-TXP-SFC or RE-DUO-2600	-	64-bit Junos OS: 11.4	em0	ixgbe0 ixgbe1

- Related Documentation**
- [Routing Engine Specifications on page 272](#)
  - [Understanding Internal Ethernet Interfaces](#)
  - [Understanding Management Ethernet Interfaces](#)



## PART 4

# Protocol and Application Support

- DPC Protocol and Application Support for MX240, MX480, and MX960 on page 325
- MPC Protocol and Application Support for MX240, MX480, MX960, MX2010, MX2020, and MX10003 on page 347



## CHAPTER 15

# DPC Protocol and Application Support for MX240, MX480, and MX960

- Protocols and Applications Supported by DPCs and Enhanced DPCs (DPC and DPCE-R) on page 325
- Protocols and Applications Supported by Enhanced Ethernet Services DPCs (DPCE-X) on page 331
- Protocols and Applications Supported by Enhanced Queuing IP Services DPCs (DPCE-R-Q) on page 335
- Protocols and Applications Supported by Enhanced Queuing Ethernet Services DPCs (DPCE-X-Q) on page 340
- Protocols and Applications Supported by the Multiservices DPC (MS-DPC) on page 345

### Protocols and Applications Supported by DPCs and Enhanced DPCs (DPC and DPCE-R)

Table 74 on page 325 contains the first Junos OS Release support for protocols and applications on the MX240, MX480, and MX960 DPCs and Enhanced DPCs. A dash indicates that the protocol or application is not supported.

*Table 74: Protocols and Applications Supported by the DPCs and Enhanced DPCs (DPC and DPCE-R)*

Protocol or Application	First Junos OS Release Supported by DPC Model Number (DPC Name)				
	DPC-R-4XGE-XFP DPC-R-40GE-SFP (DPC)	DPCE-R-2XGE-XFP (Enhanced DPC)	DPCE-R-4XGE-XFP DPCE-R-40GE-SFP (Enhanced DPC)	DPCE-R-40GE-TX (Tri-Rate Enhanced DPC)	DPCE-R-20GE-2XGE (Multi-Rate Enhanced DPC)
<i>Access Node Control Protocol (ANCP)</i>	9.4	9.4	9.4	9.4	9.4
Accepts traffic destined for GRE tunnels or DVMRP (IP-in-IP) tunnels	8.2	9.1	8.4	9.1	9.2

Table 74: Protocols and Applications Supported by the DPCs and Enhanced DPCs (DPC and DPCE-R) (continued)

Protocol or Application	First Junos OS Release Supported by DPC Model Number (DPC Name)				
	DPC-R-4XGE-XFP DPC-R-40GE-SFP (DPC)	DPCE-R-2XGE-XFP (Enhanced DPC)	DPCE-R-4XGE-XFP DPCE-R-40GE-SFP (Enhanced DPC)	DPCE-R-40GE-TX (Tri-Rate Enhanced DPC)	DPCE-R-20GE-2XGE (Multi-Rate Enhanced DPC)
<i>Bidirectional Forwarding Detection protocol (BFD)</i>	8.2	9.1	8.4	9.1	9.2
<i>Border Gateway Protocol (BGP)</i>	8.2	9.1	8.4	9.1	9.2
<i>BGP/Multiprotocol Label Switching (MPLS) virtual private networks (VPNs)</i>	8.2	9.1	8.4	9.1	9.2
<i>Distance Vector Multicast Routing Protocol (DVMRP) and generic routing encapsulation (GRE) support—access side and server side</i>	8.2	9.1	8.4	9.1	9.2
<i>IEEE 802.1ag Ethernet OAM Continuity Check protocol</i>	8.4	9.1	8.4	9.1	9.2
<i>IEEE 802.1ag Ethernet OAM Linktrace protocol</i>	9.0	9.1	9.0	9.1	9.2
<i>IEEE 802.1ag Ethernet OAM Loopback protocol</i>	9.1	9.1	9.1	9.1	9.2
<i>Firewall filters</i>	8.2	9.1	8.4	9.1	9.2
<i>Flexible Ethernet encapsulation</i>	8.2	9.1	8.4	9.1	9.2
<i>Graceful Routing Engine Switchover (GRES)</i>	8.3	9.1	8.4	9.1	9.2
Ingress hierarchical quality of service (HQoS) shaping and <i>hierarchical-scheduler</i> : <ul style="list-style-type: none"> <li>• Group of virtual LANs (VLANs) level</li> <li>• Virtual LAN (VLAN) level</li> <li>• Port level</li> </ul>	–	–	–	–	–



Table 74: Protocols and Applications Supported by the DPCs and Enhanced DPCs (DPC and DPCE-R) (continued)

Protocol or Application	First Junos OS Release Supported by DPC Model Number (DPC Name)				
	DPC-R-4XGE-XFP DPC-R-40GE-SFP (DPC)	DPCE-R-2XGE-XFP (Enhanced DPC)	DPCE-R-4XGE-XFP DPCE-R-40GE-SFP (Enhanced DPC)	DPCE-R-40GE-TX (Tri-Rate Enhanced DPC)	DPCE-R-20GE-2XGE (Multi-Rate Enhanced DPC)
IPv4	8.2	9.1	8.4	9.1	9.2
IP multicast	8.2	9.1	8.4	9.1	9.2
IPv6	8.2	9.1	8.4	9.1	9.2
IPv6 multicast	8.2	9.1	8.4	9.1	9.2
IPv6 Neighbor Discovery	8.2	9.1	8.4	9.1	9.2
Intermediate System-to-Intermediate System (IS-IS)	8.2	9.1	8.4	9.1	9.2
Layer 2 frame filtering	8.2	9.1	8.4	9.1	9.2
IEEE 802.3ad link aggregation	8.2	9.1	8.4	9.1	9.2
Link Aggregation Control Protocol (LACP)	8.2	9.1	8.4	9.1	9.2
Local loopback	8.2	9.1	8.4	9.1	9.2
MAC learning, policing, accounting, and filtering	8.2	9.1	8.4	9.1	9.2
IEEE 802.1s Multiple Spanning Tree Protocol (MSTP) (part of IEEE 802.1Q VLANs)	8.4	9.1	8.4	9.1	9.2
Multi-chassis link aggregation (MC-AE)	10.0	10.0	10.0	10.0	10.0
Multiple tag protocol identifiers (TPIDs)	8.2	9.1	8.4	9.1	9.2
Multiprotocol Label Switching (MPLS)	8.2	9.1	8.4	9.1	9.2

Table 74: Protocols and Applications Supported by the DPCs and Enhanced DPCs (DPC and DPCE-R) (continued)

Protocol or Application	First Junos OS Release Supported by DPC Model Number (DPC Name)				
	DPC-R-4XGE-XFP DPC-R-40GE-SFP (DPC)	DPCE-R-2XGE-XFP (Enhanced DPC)	DPCE-R-4XGE-XFP DPCE-R-40GE-SFP (Enhanced DPC)	DPCE-R-40GE-TX (Tri-Rate Enhanced DPC)	DPCE-R-20GE-2XGE (Multi-Rate Enhanced DPC)
<i>mvrp</i>	10.1	10.1	10.1	10.1	10.1
IEEE 802.3ah OAM <ul style="list-style-type: none"> <li>Discovery and link monitoring</li> <li>Fault signaling and detection</li> <li>Remote loopback</li> </ul>	8.2	9.1	8.4	9.1	9.2
<i>Multitopology Routing (MTR)</i>	9.0	9.1	9.0	9.1	9.2
<i>Open Shortest Path First (OSPF)</i>	8.2	9.1	8.4	9.1	9.2
Packet mirroring	8.2	9.1	8.4	9.1	9.2
IEEE 802.1ah provider backbone bridges (PBB)	10.0	10.0	10.0	10.0	10.0
Quality of service (QoS) per port: <ul style="list-style-type: none"> <li>8 queues per port</li> <li>Shaping at queue level</li> <li>Scheduling of queues based on weighted round-robin (WRR) per priority class</li> <li>Random early detection (RED)</li> <li>Weighted random early detection (WRED)</li> </ul>	8.2	9.1	8.4	9.1	9.2
<ul style="list-style-type: none"> <li>Shaping at port level</li> </ul>	–	–	–	–	–

Table 74: Protocols and Applications Supported by the DPCs and Enhanced DPCs (DPC and DPCE-R) (continued)

Protocol or Application	First Junos OS Release Supported by DPC Model Number (DPC Name)				
	DPC-R-4XGE-XFP DPC-R-40GE-SFP (DPC)	DPCE-R-2XGE-XFP (Enhanced DPC)	DPCE-R-4XGE-XFP DPCE-R-40GE-SFP (Enhanced DPC)	DPCE-R-40GE-TX (Tri-Rate Enhanced DPC)	DPCE-R-20GE-2XGE (Multi-Rate Enhanced DPC)
Quality of service (QoS) per virtual LAN (VLAN):	8.2	9.1	8.4	9.1	9.2
<ul style="list-style-type: none"> <li>Accounting, filtering, and policing</li> <li>IEEE 802.1p rewrite</li> <li>Classification</li> <li>Tricolor marking</li> </ul>					
Quality of service (QoS) queuing per virtual LAN (VLAN)	–	–	–	–	–
<i>IEEE 802.1w Rapid Spanning Tree Protocol (RSTP)</i>	8.4	9.1	8.4	9.1	9.2
Per-VLAN Spanning Tree (PVST)+	9.0	9.1	9.0	9.1	9.2
<i>RSVP</i>	8.2	9.1	8.4	9.1	9.2
<i>Routing Information Protocol (RIP)</i>	8.2	9.1	8.4	9.1	9.2
<i>SNMP</i>	8.2	9.1	8.4	9.1	9.2
<i>IEEE 802.1D Spanning Tree Protocol (STP)</i>	8.4	9.1	8.4	9.1	9.2
Subscriber Management:	9.2	9.2	9.2	9.2	9.2
NOTE: Starting in Junos OS Release 15.1R4, MS-DPCs are not supported for subscriber management on MX Series routers.					
<ul style="list-style-type: none"> <li>Access Node Control Protocol (ANCP)</li> </ul>	9.4	9.4	9.4	9.4	9.4
<ul style="list-style-type: none"> <li>Dynamic profiles</li> </ul>	9.2	9.2	9.2	9.2	9.2

Table 74: Protocols and Applications Supported by the DPCs and Enhanced DPCs (DPC and DPCE-R) (continued)

Protocol or Application	First Junos OS Release Supported by DPC Model Number (DPC Name)				
	DPC-R-4XGE-XFP DPC-R-40GE-SFP (DPC)	DPCE-R-2XGE-XFP (Enhanced DPC)	DPCE-R-4XGE-XFP DPCE-R-40GE-SFP (Enhanced DPC)	DPCE-R-40GE-TX (Tri-Rate Enhanced DPC)	DPCE-R-20GE-2XGE (Multi-Rate Enhanced DPC)
• Dynamic VLANs	–	9.5	9.5	9.5	9.5
• Enhanced Dynamic Host Configuration Protocol (DHCP) local server	9.3	9.3	9.3	9.3	9.3
• Enhanced DHCP relay	9.3	9.3	9.3	9.3	9.3
• Firewall filters	9.2	9.2	9.2	9.2	9.2
• Internet Group Management Protocol (IGMP)	9.2	9.2	9.2	9.2	9.2
• QoS	9.2	9.2	9.2	9.2	9.2
• Subscriber Secure Policy	9.4	9.4	9.4	9.4	9.4
<i>Two-Way Active Measurement Protocol (TWAMP)</i>	9.5	9.5	9.5	9.5	9.5
<i>IEEE 802.1Q VLANs:</i>	8.2	9.1	8.4	9.1	9.2
• VLAN stacking and rewriting					
• Channels defined by two stacked VLAN tags					
• Flexible VLAN tagging					
• IP service for nonstandard TPID and stacked VLAN tags					
<i>Virtual private LAN service (VPLS)</i>	8.2	9.1	8.4	9.1	9.2
Virtual private network (VPN)	8.2	9.1	8.4	9.1	9.2
<i>Virtual Router Redundancy Protocol (VRRP) for IPv4</i>	8.2	9.1	8.4	9.1	9.2

- Related Documentation**
- [DPCs Supported on MX240, MX480, and MX960 Routers on page 8](#)
  - [Protocols and Applications Supported by Enhanced Ethernet Services DPCs \(DPCE-X\) on page 331](#)
  - [Protocols and Applications Supported by Enhanced Queuing IP Services DPCs \(DPCE-R-Q\) on page 335](#)
  - [Protocols and Applications Supported by Enhanced Queuing Ethernet Services DPCs \(DPCE-X-Q\) on page 340](#)
  - [Protocols and Applications Supported by the Multiservices DPC \(MS-DPC\) on page 345](#)

## Protocols and Applications Supported by Enhanced Ethernet Services DPCs (DPCE-X)

Table 75 on page 331 contains the first Junos OS Release support for protocols and applications on the MX240, MX480, and MX960 Enhanced Ethernet Services DPCs. A dash indicates that the protocol or application is not supported.

*Table 75: Protocols and Applications Supported by the Enhanced Ethernet Services DPCs (DPCE-X)*

Protocol or Application	First Junos OS Release Supported by DPC Model Number (DPC Name)		
	DPCE-X-4XGE-XFP DPCE-X-40GE-SFP (Enhanced Ethernet Services DPC)	DPCE-X-40GE-TX (Tri-Rate Enhanced Ethernet Services DPC)	DPCE-X-20GE-2XGE (Multi-Rate Enhanced Ethernet Services DPC)
Access Node Control Protocol (ANCP)	9.4	9.4	9.4
Accepts traffic destined for GRE tunnels or DVMRP (IP-in-IP) tunnels	8.4	9.1	9.2
Bidirectional Forwarding Detection protocol (BFD)	8.4	9.1	9.2
Border Gateway Protocol (BGP)	8.4	9.1	9.2
BGP/Multiprotocol Label Switching (MPLS) virtual private networks (VPNs)	8.4	9.1	9.2
Distance Vector Multicast Routing Protocol (DVMRP) and generic routing encapsulation (GRE) support—access side and server side	8.4	9.1	9.2
IEEE 802.1ag Ethernet OAM Continuity Check protocol	8.4	9.1	9.2
IEEE 802.1ag Ethernet OAM Linktrace protocol	9.0	9.1	9.2

Table 75: Protocols and Applications Supported by the Enhanced Ethernet Services DPCs (DPCE-X) (continued)

Protocol or Application	First Junos OS Release Supported by DPC Model Number (DPC Name)		
	DPCE-X-4XGE-XFP	DPCE-X-40GE-TX	DPCE-X-20GE-2XGE
	DPCE-X-40GE-SFP (Enhanced Ethernet Services DPC)	(Tri-Rate Enhanced Ethernet Services DPC)	(Multi-Rate Enhanced Ethernet Services DPC)
IEEE 802.1ag Ethernet OAM Loopback protocol	9.1	9.1	9.2
Firewall filters	8.4 (Limited filter terms)	9.1 (Limited filter terms)	9.2 (Limited filter terms)
Flexible Ethernet encapsulation	8.4	9.1	9.2
Graceful Routing Engine Switchover (GRES)	8.4	9.1	9.2
Ingress hierarchical quality of service (HQoS) shaping and scheduling: <ul style="list-style-type: none"> <li>• Group of virtual LANs (VLANs) level</li> <li>• Virtual LAN (VLAN) level</li> <li>• Port level</li> </ul>	–	–	–
Intermediate System-to-Intermediate System (IS-IS)	8.4	9.1	9.2
IPv4 (No BGP)	8.4	9.1	9.2)
IP multicast (No BGP)	8.4	9.1	9.2
IPv6 (No BGP)	8.4	9.1	9.2)
IPv6 multicast (No BGP)	8.4	9.1	9.2)
IPv6 Neighbor Discovery (No BGP)	8.4	9.1)	9.2)
Layer 2 frame filtering	8.4	9.1	9.2
IEEE 802.3ad link aggregation	8.4	9.1	9.2
Link Aggregation Control Protocol (LACP)	8.4	9.1	9.2
Local loopback	8.4	9.1	9.2
MAC learning, policing, accounting, and filtering	8.4	9.1	9.2

Table 75: Protocols and Applications Supported by the Enhanced Ethernet Services DPCs (DPCE-X) (continued)

Protocol or Application	First Junos OS Release Supported by DPC Model Number (DPC Name)		
	DPCE-X-4XGE-XFP	DPCE-X-40GE-TX	DPCE-X-20GE-2XGE
	(Enhanced Ethernet Services DPC)	(Tri-Rate Enhanced Ethernet Services DPC)	(Multi-Rate Enhanced Ethernet Services DPC)
IEEE 802.1s Multiple Spanning Tree Protocol (MSTP) (part of IEEE 802.1Q VLANs)	8.4	9.1	9.2
Multiple tag protocol identifiers (TPIDs)	8.4	9.1	9.2
Multiprotocol Label Switching (MPLS)	8.4	9.1	9.2
IEEE 802.3ah OAM <ul style="list-style-type: none"> <li>Discovery and link monitoring</li> <li>Fault signaling and detection</li> <li>Remote loopback</li> </ul>	8.4	9.1	9.2
Multitopology Routing (MTR)	9.0	9.1	9.2
Open Shortest Path First (OSPF)	8.4	9.1	9.2
Packet mirroring	8.4	9.1	9.2
Quality of service (QoS) per port: <ul style="list-style-type: none"> <li>8 queues per port</li> <li>Shaping at queue level</li> <li>Scheduling of queues based on weighted round-robin (WRR) per priority class</li> <li>Random early detection (RED)</li> <li>Weighted random early detection (WRED)</li> </ul>	8.4	9.1	9.2
Quality of service (QoS) per virtual LAN (VLAN): <ul style="list-style-type: none"> <li>Accounting, filtering, and policing</li> <li>IEEE 802.1p rewrite</li> <li>Classification</li> <li>Tricolor marking</li> </ul>	8.4	9.1	9.2
Quality of service (QoS) queuing per virtual LAN (VLAN)	–	–	–

Table 75: Protocols and Applications Supported by the Enhanced Ethernet Services DPCs (DPCE-X) (continued)

Protocol or Application	First Junos OS Release Supported by DPC Model Number (DPC Name)		
	DPCE-X-4XGE-XFP	DPCE-X-40GE-TX	DPCE-X-20GE-2XGE
	DPCE-X-40GE-SFP (Enhanced Ethernet Services DPC)	(Tri-Rate Enhanced Ethernet Services DPC)	(Multi-Rate Enhanced Ethernet Services DPC)
IEEE 802.1w Rapid Spanning Tree Protocol (RSTP)	8.4	9.1	9.2
Per-VLAN Spanning Tree (PVST)+	9.0	9.1	9.2
RSVP	8.4	9.1	9.2
Routing Information Protocol (RIP)	8.4	9.1	9.2
SNMP	8.4	9.1	9.2
IEEE 802.1D Spanning Tree Protocol (STP)	8.4	9.1	9.2
Subscriber Management:	9.4	9.4	9.4
Starting in Junos OS Release 15.1R4, MS-DPCs are not supported for subscriber management on MX Series routers.			
• Access Node Control Protocol (ANCP)	9.4	9.4	9.4
• Dynamic profiles	9.2	9.2	9.2
• Dynamic VLANs	9.5	9.5	9.5
• Enhanced Dynamic Host Configuration Protocol (DHCP) local server	9.3	9.3	9.3
• Enhanced DHCP relay	9.3	9.3	9.3
• Firewall filters	9.2	9.2	9.2
• Internet Group Management Protocol (IGMP)	9.2	9.2	9.2
• QoS	9.2	9.2	9.2
• Subscriber Secure Policy	9.4	9.4	9.4
Two-Way Active Measurement Protocol (TWAMP)	9.5	9.5	9.5



**Table 75: Protocols and Applications Supported by the Enhanced Ethernet Services DPCs (DPCE-X) (continued)**

Protocol or Application	First Junos OS Release Supported by DPC Model Number (DPC Name)		
	DPCE-X-4XGE-XFP		
	DPCE-X-40GE-SFP (Enhanced Ethernet Services DPC)	DPCE-X-40GE-TX (Tri-Rate Enhanced Ethernet Services DPC)	DPCE-X-20GE-2XGE (Multi-Rate Enhanced Ethernet Services DPC)
IEEE 802.1Q VLANs: <ul style="list-style-type: none"> <li>VLAN stacking and rewriting</li> <li>Channels defined by two stacked VLAN tags</li> <li>Flexible VLAN tagging</li> <li>IP service for nonstandard TPID and stacked VLAN tags</li> </ul>	8.4	9.1	9.2
Virtual private LAN service (VPLS)	8.4	9.1	9.2
Virtual private network (VPN) (L2 VPN only)	8.4	9.1	9.2
Virtual Router Redundancy Protocol (VRRP) for IPv4	8.4	9.1	9.2

**Related Documentation**

- [DPCs Supported on MX240, MX480, and MX960 Routers on page 8](#)
- [Protocols and Applications Supported by DPCs and Enhanced DPCs \(DPC and DPCE-R\) on page 325](#)
- [Protocols and Applications Supported by Enhanced Queuing IP Services DPCs \(DPCE-R-Q\) on page 335](#)
- [Protocols and Applications Supported by Enhanced Queuing Ethernet Services DPCs \(DPCE-X-Q\) on page 340](#)
- [Protocols and Applications Supported by the Multiservices DPC \(MS-DPC\) on page 345](#)

**Protocols and Applications Supported by Enhanced Queuing IP Services DPCs (DPCE-R-Q)**

Table 76 on page 336 contains the first Junos OS Release support for protocols and applications on the MX240, MX480, and MX960 Enhanced Queuing IP Services DPCs. A dash indicates that the protocol or application is not supported.

Table 76: Protocols and Applications Supported by the Enhanced Queuing IP Services DPCs (DPCE-R-Q)

Protocol or Application	First Junos OS Release Supported by DPC Model Number (DPC Name)		
	DPCE-R-Q-4XGE-XFP DPCE-R-Q-40GE-SFP Enhanced Queuing IP Services DPC	DPCE-R-Q-20GE-SFP Enhanced Queuing IP Services DPC	DPCE-R-Q-20GE-2XGE Enhanced Queuing IP Services Multi-Rate DPC
Access Node Control Protocol (ANCP)	9.4	9.4	9.4
Accepts traffic destined for GRE tunnels or DVMRP (IP-in-IP) tunnels	8.5	9.1	9.3
Bidirectional Forwarding Detection protocol (BFD)	8.5	9.1	9.3
Border Gateway Protocol (BGP)	8.5	9.1	9.3
BGP/Multiprotocol Label Switching (MPLS) virtual private networks (VPNs)	8.5	9.1	9.3
Distance Vector Multicast Routing Protocol (DVMRP) and generic routing encapsulation (GRE) support—access side and server side	8.5	9.1	9.3
IEEE 802.1ag Ethernet OAM Continuity Check protocol	8.5	9.1	9.3
IEEE 802.1ag Ethernet OAM Linktrace protocol	9.0	9.1	9.3
IEEE 802.1ag Ethernet OAM Loopback protocol	9.1	9.1	9.3
Firewall filters	8.5	9.1	9.3
Flexible Ethernet encapsulation	8.5	9.1	9.3
Graceful Routing Engine Switchover (GRES)	8.5	9.1	9.3
Ingress hierarchical quality of service (HQoS) shaping and scheduling: <ul style="list-style-type: none"> <li>• Group of virtual LANs (VLANs) level</li> <li>• Virtual LAN (VLAN) level</li> <li>• Port level</li> </ul>	9.0	9.1	9.3
Intermediate System-to-Intermediate System (IS-IS)	8.5	9.1	9.3
IPv4	8.5	9.1	9.3

**Table 76: Protocols and Applications Supported by the Enhanced Queuing IP Services DPCs (DPCE-R-Q) (continued)**

Protocol or Application	First Junos OS Release Supported by DPC Model Number (DPC Name)		
	DPCE-R-Q-4XGE-XFP	DPCE-R-Q-20GE-SFP	DPCE-R-Q-20GE-2XGE
	Enhanced Queuing IP Services DPC	Enhanced Queuing IP Services DPC	Enhanced Queuing IP Services Multi-Rate DPC
IP multicast	8.5	9.1	9.3
IPv6	8.5	9.1	9.3
IPv6 multicast	8.5	9.1	9.3
IPv6 Neighbor Discovery	8.5	9.1	9.3
Layer 2 frame filtering	8.5	9.1	9.3
IEEE 802.3ad link aggregation	8.5	9.1	9.3
Link Aggregation Control Protocol (LACP)	8.5	9.1	9.3
Local loopback	8.5	9.1	9.3
MAC learning, policing, accounting, and filtering	8.5	9.1	9.3
IEEE 802.1s Multiple Spanning Tree Protocol (MSTP) (part of IEEE 802.1Q VLANs)	8.5	9.1	9.3
Multiple tag protocol identifiers (TPIDs)	8.5	9.1	9.3
Multiprotocol Label Switching (MPLS)	8.5	9.1	9.3
IEEE 802.3ah OAM <ul style="list-style-type: none"> <li>• Discovery and link monitoring</li> <li>• Fault signaling and detection</li> <li>• Remote loopback</li> </ul>	8.5	9.1	9.3
Multitopology Routing (MTR)	9.0	9.1	9.3
Open Shortest Path First (OSPF)	8.5	9.1	9.3
Packet mirroring	8.5	9.1	9.3

**Table 76: Protocols and Applications Supported by the Enhanced Queuing IP Services DPCs (DPCE-R-Q) (continued)**

Protocol or Application	First Junos OS Release Supported by DPC Model Number (DPC Name)		
	DPCE-R-Q-4XGE-XFP	DPCE-R-Q-20GE-SFP	DPCE-R-Q-20GE-2XGE
	DPCE-R-Q-40GE-SFP		Enhanced Queuing IP Services Multi-Rate DPC
	Enhanced Queuing IP Services DPC	Enhanced Queuing IP Services DPC	
Quality of service (QoS) per port:	8.5	9.1	9.3
<ul style="list-style-type: none"> <li>• 8 queues per port</li> <li>• Shaping at port level</li> <li>• Scheduling of queues based on weighted round-robin (WRR) per priority class</li> <li>• Random early detection (RED)</li> <li>• Weighted random early detection (WRED)</li> </ul>			
Quality of service (QoS) per virtual LAN (VLAN):	8.5	9.1	9.3
<ul style="list-style-type: none"> <li>• Accounting, filtering, and policing</li> <li>• IEEE 802.1p rewrite</li> <li>• Classification</li> <li>• Tricolor marking</li> <li>• Shaping at queue and port level</li> <li>• Scheduling of queues based on weighted round-robin (WRR) per priority class</li> <li>• Random early detection (RED)</li> <li>• Weighted random early detection (WRED)</li> </ul>			
Quality of service (QoS) queuing per virtual LAN (VLAN)	8.5	9.1	9.3
IEEE 802.1w Rapid Spanning Tree Protocol (RSTP)	8.5	9.1	9.3
Per-VLAN Spanning Tree (PVST)+	9.0	9.1	9.3
RSVP	8.5	9.1	9.3
Routing Information Protocol (RIP)	8.5	9.1	9.3
SNMP	8.5	9.1	9.3
IEEE 802.1D Spanning Tree Protocol (STP)	8.5	9.1	9.3

**Table 76: Protocols and Applications Supported by the Enhanced Queuing IP Services DPCs (DPCE-R-Q) (continued)**

Protocol or Application	First Junos OS Release Supported by DPC Model Number (DPC Name)		
	DPCE-R-Q-4XGE-XFP	DPCE-R-Q-20GE-SFP	DPCE-R-Q-20GE-2XGE
	DPCE-R-Q-40GE-SFP		Enhanced Queuing IP Services Multi-Rate DPC
	Enhanced Queuing IP Services DPC	Enhanced Queuing IP Services DPC	
Subscriber Management:	9.4	9.4	9.4
NOTE: Starting in Junos OS Release 15.1R4, MS-DPCs are not supported for subscriber management on MX Series routers.			
• Access Node Control Protocol (ANCP)	9.4	9.4	9.4
• Dynamic profiles	9.2	9.2	9.2
• Dynamic VLANs	9.5	9.5	9.5
• Enhanced Dynamic Host Configuration Protocol (DHCP) local server	9.3	9.3	9.3
• Enhanced DHCP relay	9.3	9.3	9.3
• Firewall filters	9.2	9.2	9.2
• Internet Group Management Protocol (IGMP)	9.2	9.2	9.2
• QoS	9.2	9.2	9.2
• Subscriber Secure Policy	9.4	9.4	9.4
• VLAN demux	–	–	–
Two-Way Active Measurement Protocol (TWAMP)	9.5	9.5	9.5
IEEE 802.1Q VLANs:	8.5	9.1	9.3
• VLAN stacking and rewriting			
• Channels defined by two stacked VLAN tags			
• Flexible VLAN tagging			
• IP service for nonstandard TPID and stacked VLAN tags			
Virtual private LAN service (VPLS)	8.5	9.1	9.3
Virtual private network (VPN)	8.5	9.1	9.3

**Table 76: Protocols and Applications Supported by the Enhanced Queuing IP Services DPCs (DPCE-R-Q) (continued)**

Protocol or Application	First Junos OS Release Supported by DPC Model Number (DPC Name)		
	DPCE-R-Q-4XGE-XFP	DPCE-R-Q-20GE-SFP	DPCE-R-Q-20GE-2XGE
	DPCE-R-Q-40GE-SFP		Enhanced Queuing IP Services Multi-Rate DPC
Virtual Router Redundancy Protocol (VRRP) for IPv4	8.5	9.1	9.3

- Related Documentation**
- [DPCs Supported on MX240, MX480, and MX960 Routers on page 8](#)
  - [Protocols and Applications Supported by DPCs and Enhanced DPCs \(DPC and DPCE-R\) on page 325](#)
  - [Protocols and Applications Supported by Enhanced Ethernet Services DPCs \(DPCE-X\) on page 331](#)
  - [Protocols and Applications Supported by Enhanced Queuing Ethernet Services DPCs \(DPCE-X-Q\) on page 340](#)
  - [Protocols and Applications Supported by the Multiservices DPC \(MS-DPC\) on page 345](#)

## Protocols and Applications Supported by Enhanced Queuing Ethernet Services DPCs (DPCE-X-Q)

Table 77 on page 340 contains the first Junos OS Release support for protocols and applications on the MX240, MX480, and MX960 Enhanced Queuing Ethernet Services DPCs. A dash indicates that the protocol or application is not supported.

**Table 77: Protocols and Applications Supported by the Enhanced Queuing Ethernet Services DPCs (DPCE-X-Q)**

Protocol or Application	DPCE-X-Q-4XGE-XFP
	DPCE-X-Q-40GE-SFP (Enhanced Queuing Ethernet Services DPC)
Access Node Control Protocol (ANCP)	9.4
Accepts traffic destined for GRE tunnels or DVMRP (IP-in-IP) tunnels	8.5
Bidirectional Forwarding Detection protocol (BFD)	8.5
Border Gateway Protocol (BGP)	8.5

**Table 77: Protocols and Applications Supported by the Enhanced Queuing Ethernet Services DPCs (DPCE-X-Q) (continued)**

Protocol or Application	DPCE-X-Q-4XGE-XFP DPCE-X-Q-40GE-SFP (Enhanced Queuing Ethernet Services DPC)
BGP/Multiprotocol Label Switching (MPLS) virtual private networks (VPNs)	8.5
Distance Vector Multicast Routing Protocol (DVMRP) and generic routing encapsulation (GRE) support—access side and server side	8.5
IEEE 802.1ag Ethernet OAM Continuity Check protocol	8.5
IEEE 802.1ag Ethernet OAM Linktrace protocol	9.0
IEEE 802.1ag Ethernet OAM Loopback protocol	9.1
Firewall filters	8.5 (Limited filter terms)
Flexible Ethernet encapsulation	8.5
Graceful Routing Engine Switchover (GRES)	8.5
Ingress hierarchical quality of service (HQoS) shaping and scheduling: <ul style="list-style-type: none"> <li>• Group of virtual LANs (VLANs) level</li> <li>• Virtual LAN (VLAN) level</li> <li>• Port level</li> </ul>	9.0
Intermediate System-to-Intermediate System (IS-IS)	8.5
IPv4 (No BGP)	8.5
IP multicast (No BGP)	8.5
IPv6 (No BGP)	8.5
IPv6 multicast (No BGP)	8.5
IPv6 Neighbor Discovery (No BGP)	8.5
Layer 2 frame filtering	8.5
IEEE 802.3ad link aggregation	8.5

*Table 77: Protocols and Applications Supported by the Enhanced Queuing Ethernet Services DPCs (DPCE-X-Q) (continued)*

Protocol or Application	DPCE-X-Q-4XGE-XFP DPCE-X-Q-40GE-SFP (Enhanced Queuing Ethernet Services DPC)
Link Aggregation Control Protocol (LACP)	8.5
Local loopback	8.5
MAC learning, policing, accounting, and filtering	8.5
IEEE 802.1s Multiple Spanning Tree Protocol (MSTP) (part of IEEE 802.1Q VLANs)	8.5
Multiple tag protocol identifiers (TPIDs)	8.5
Multiprotocol Label Switching (MPLS)	8.5
IEEE 802.3ah OAM <ul style="list-style-type: none"> <li>Discovery and link monitoring</li> <li>Fault signaling and detection</li> <li>Remote loopback</li> </ul>	8.5
Multitopology Routing (MTR)	9.0
Open Shortest Path First (OSPF)	8.5
Packet mirroring	8.5
Quality of service (QoS) per port: <ul style="list-style-type: none"> <li>8 queues per port</li> <li>Shaping at port level</li> <li>Scheduling of queues based on weighted round-robin (WRR) per priority class</li> <li>Random early detection (RED)</li> <li>Weighted random early detection (WRED)</li> </ul>	8.5
Shaping at queue level	—



**Table 77: Protocols and Applications Supported by the Enhanced Queuing Ethernet Services DPCs (DPCE-X-Q) (continued)**

Protocol or Application	DPCE-X-Q-4XGE-XFP DPCE-X-Q-40GE-SFP (Enhanced Queuing Ethernet Services DPC)
Quality of service (QoS) per virtual LAN (VLAN):	8.5
<ul style="list-style-type: none"> <li>• Accounting, filtering, and policing</li> <li>• IEEE 802.1p rewrite</li> <li>• Classification</li> <li>• Tricolor marking</li> <li>• Shaping at port level</li> <li>• Scheduling of queues based on weighted round-robin (WRR) per priority class</li> <li>• Random early detection (RED)</li> <li>• Weighted random early detection (WRED)</li> </ul>	
Shaping at queue level	–
Quality of service (QoS) queuing per virtual LAN (VLAN)	8.5
IEEE 802.1w Rapid Spanning Tree Protocol (RSTP)	8.5
Per-VLAN Spanning Tree (PVST)+	9.0
Remote loopback	8.5
RSVP	8.5
Routing Information Protocol (RIP)	8.5
SNMP	8.5
IEEE 802.1D Spanning Tree Protocol (STP)	8.5
Subscriber Management:	9.4
Starting in Junos OS Release 15.1R4, MS-DPCs are not supported for subscriber management on MX Series routers.	
<ul style="list-style-type: none"> <li>• Access Node Control Protocol (ANCP)</li> </ul>	9.4
<ul style="list-style-type: none"> <li>• Dynamic profiles</li> </ul>	9.2
<ul style="list-style-type: none"> <li>• Dynamic VLANs</li> </ul>	9.5

**Table 77: Protocols and Applications Supported by the Enhanced Queuing Ethernet Services DPCs (DPCE-X-Q) (continued)**

Protocol or Application	DPCE-X-Q-4XGE-XFP DPCE-X-Q-40GE-SFP (Enhanced Queuing Ethernet Services DPC)
<ul style="list-style-type: none"> <li>Enhanced Dynamic Host Configuration Protocol (DHCP) local server</li> </ul>	9.3
<ul style="list-style-type: none"> <li>Enhanced DHCP relay</li> </ul>	9.3
<ul style="list-style-type: none"> <li>Firewall filters</li> </ul>	9.2
<ul style="list-style-type: none"> <li>Internet Group Management Protocol (IGMP)</li> </ul>	9.2
<ul style="list-style-type: none"> <li>QoS</li> </ul>	9.2
<ul style="list-style-type: none"> <li>Subscriber Secure Policy</li> </ul>	9.4
<ul style="list-style-type: none"> <li>VLAN demux</li> </ul>	–
Two-Way Active Measurement Protocol (TWAMP)	9.5
IEEE 802.1Q VLANs: <ul style="list-style-type: none"> <li>VLAN stacking and rewriting</li> <li>Channels defined by two stacked VLAN tags</li> <li>Flexible VLAN tagging</li> <li>IP service for nonstandard TPID and stacked VLAN tags</li> </ul>	8.5
Virtual private LAN service (VPLS)	8.5
Virtual private network (VPN)	8.5 (L2 VPN only)
Virtual Router Redundancy Protocol (VRRP) for IPv4	8.5

**Related Documentation**

- [DPCs Supported on MX240, MX480, and MX960 Routers on page 8](#)
- [Protocols and Applications Supported by DPCs and Enhanced DPCs \(DPC and DPCE-R\) on page 325](#)
- [Protocols and Applications Supported by Enhanced Ethernet Services DPCs \(DPCE-X\) on page 331](#)
- [Protocols and Applications Supported by Enhanced Queuing IP Services DPCs \(DPCE-R-Q\) on page 335](#)
- [Protocols and Applications Supported by the Multiservices DPC \(MS-DPC\) on page 345](#)

## Protocols and Applications Supported by the Multiservices DPC (MS-DPC)

Table 78 on page 345 contains the first Junos OS Release support for protocols and applications on the MX240, MX480, and MX960 Multiservices DPCs. A dash indicates that the protocol or application is not supported.



**NOTE:** The maximum number of supported MS-DPCs is as follows except where noted in Table 78 on page 345:

- MX240 router: 2
- MX480 router: 4
- MX960 router: 8

*Table 78: Protocols and Applications Supported by the Multiservices DPC (MS-DPC)*

Protocol or Application	MS-DPC
Accepts traffic destined for GRE tunnels	9.3
Active flow monitoring exports cflowd version 5 and version 8 records	9.3
Active flow monitoring exports flow monitoring version 9 records, based on RFC 3954	9.3
Graceful Routing Engine Switchover (GRES)	9.4
GRE dont fragment	9.3
GRE Key	9.3
GRE reassembly	9.3
IP Security (IPSec) encryption	9.3
Network Address Translation (NAT) for IP addresses	9.3
<b>NOTE:</b> The MX960 supports 8 MS-DPCs using this feature.	
NAPT - Preserve parity	15.1
NAPT - Preserve range	15.1
No translation	15.1
Twice NAT	15.1

**Table 78: Protocols and Applications Supported by the Multiservices DPC (MS-DPC) (continued)**

Protocol or Application	MS-DPC
Packet-triggered dynamic subscribers and policy control (PTSP)	10.2
<p><b>NOTE:</b> Starting in Junos OS Release 13.1R1, the packet-triggered subscribers and policy control (PTSP) feature is no longer supported.</p>	
Port Address Translation (PAT) for port numbers	9.3
Real-time Performance Monitoring (RPM)	9.3
Stateful firewall with packet inspection: detects SYN attacks, ICMP and UDP floods, and ping-of-death attacks	9.3
<p><b>NOTE:</b> The MX960 supports 8 MS-DPCs using this feature.</p>	
Tunnel services:	
• GRE unicast tunneling-Supports GRE fragmentation	9.3
• IP-IP unicast tunneling	9.4
• Multicast tunneling	9.4
• Protocol Independent Multicast (PIM) sparse mode unicast tunneling	9.4
• Virtual loopback tunneling (VT)	9.4
Voice over IP (VoIP) services:	
• Border Gateway Function (BGF) using external H.248/Ia control	10.2
• Integrated Multi-Service Gateway (IMSG)-Session Border Controller	

**Related Documentation**

- [DPCs Supported on MX240, MX480, and MX960 Routers on page 8](#)
- [Protocols and Applications Supported by DPCs and Enhanced DPCs \(DPC and DPCE-R\) on page 325](#)
- [Protocols and Applications Supported by Enhanced Ethernet Services DPCs \(DPCE-X\) on page 331](#)
- [Protocols and Applications Supported by Enhanced Queuing IP Services DPCs \(DPCE-R-Q\) on page 335](#)
- [Protocols and Applications Supported by Enhanced Queuing Ethernet Services DPCs \(DPCE-X-Q\) on page 340](#)

## CHAPTER 16

# MPC Protocol and Application Support for MX240, MX480, MX960, MX2010, MX2020, and MX10003

- Protocols and Applications Supported on MPCs for MX Series Routers on page 347
- Protocols and Applications Supported on the MPC1E for MX Series Routers on page 356
- Protocols and Applications Supported by the MX240, MX480, MX960, MX2010, and MX2020 MPC2E on page 362
- Protocols and Applications Supported by the MPC3E on MX Series Routers on page 371
- Protocols and Applications Supported on the MPC4E for MX Series Routers on page 379
- Protocols and Applications Supported by the MPC5E for MX Series Routers on page 388
- Protocols and Applications Supported by the MPC6E for MX2000 Routers on page 394
- Protocols and Applications Supported by the MPC7E for MX Series Routers on page 401
- Protocols and Applications Supported by the MPC8E and MPC9E on the MX2010 and MX2020 Routers on page 410
- Protocols and Applications Supported by the MS-MIC and MS-MPC on page 417
- Protocols and Applications Supported by the MX10003 MPC (Multi-Rate) on the MX10003 Router on page 419
- Protocols and Applications Supported by the JNP10K-LC2101 on the MX10008 Routers on page 425

## Protocols and Applications Supported on MPCs for MX Series Routers

---

Table 79 on page 348 contains the first Junos OS Release support for protocols and applications on the MX240, MX480, MX960, MX2010, and MX2020 MPCs.



**NOTE:** The MX2010 router supports protocols and applications in Junos OS 12.3R3 and later. Features added after the Junos OS 12.3R3 release are supported on the MX2010 router in the release indicated.



**NOTE:** The MX2020 router supports protocols and applications in Junos OS 12.3R2 and later. Features added after the Junos OS 12.3R2 release are supported on the MX2020 router in the release indicated.

A dash indicates that the protocol or application is not supported.

**Table 79: Protocols and Applications Supported by the MX240, MX480, MX960, MX2010, and MX2020 MPCs**

Protocol or Application	First Junos OS Release Supported by MPC Model Number (MPC Name)					
	MPC-3D-16XGE-SFPP (16x10GE MPC)	MX-MPC1-3D (MPC1)	MX-MPC2-3D (MPC2)	MX-MPC1-3D-Q (MPC1 Q)	MX-MPC2-3D-Q (MPC2 Q)	MX-MPC2-3D-EQ (MPC2EQ)
Access Node Control Protocol (ANCP)	–	10.2	10.2	10.2	10.2	10.2
Accepts traffic destined for GRE tunnels or DVMRP (IP-in-IP) tunnels	10.0R2	10.2	10.1	10.2	10.1	10.1
Active-active bridging in multichassis link aggregation	13.1	13.1	13.1	13.1	13.1	13.1
Bidirectional Forwarding Detection protocol (BFD)	10.0R2	10.2	10.1	10.2	10.1	10.1
Border Gateway Protocol (BGP)	10.0R2	10.2	10.1	10.2	10.1	10.1
BGP/Multiprotocol Label Switching (MPLS) virtual private networks (VPNs)	10.0R2	10.2	10.1	10.2	10.1	10.1
Distance Vector Multicast Routing Protocol (DVMRP) and generic routing encapsulation (GRE) support—access side and server side	10.0R2	10.2	10.1	10.2	10.1	10.1
Distributed denial-of-service (DDoS) protection	11.2	11.2	11.2	11.2		11.2
IEEE 802.1ag Ethernet OAM Continuity Check protocol	10.2 (bridge family supported in 10.4)	10.2 (bridge family supported in 10.4)	10.2 (bridge family supported in 10.4)	10.2 (bridge family supported in 10.4)	10.2 (bridge family supported in 10.4)	10.2 (bridge family supported in 10.4)

**Table 79: Protocols and Applications Supported by the MX240, MX480, MX960, MX2010, and MX2020 MPCs (continued)**

Protocol or Application	First Junos OS Release Supported by MPC Model Number (MPC Name)					
	MPC-3D-16XGE-SFPP (16x10GE MPC)	MX-MPC1-3D (MPC1)	MX-MPC2-3D (MPC2)	MX-MPC1-3D-Q (MPC1 Q)	MX-MPC2-3D-Q (MPC2 Q)	MX-MPC2-3D-EQ (MPC2 EQ)
IEEE 802.1ag Ethernet OAM Linktrace protocol	10.2  (bridge family supported in 10.4)	10.2  (bridge family supported in 10.4)	10.2  (bridge family supported in 10.4)	10.2  (bridge family supported in 10.4)	10.2  (bridge family supported in 10.4)	10.2  (bridge family supported in 10.4)
IEEE 802.1ag Ethernet OAM Loopback protocol	10.2  (bridge family supported in 10.4)	10.2  (bridge family supported in 10.4)	10.2  (bridge family supported in 10.4)	10.2  (bridge family supported in 10.4)	10.2  (bridge family supported in 10.4)	10.2  (bridge family supported in 10.4)
Firewall filters	10.0R2	10.2	10.1	10.2	10.1	10.1
Flexible Ethernet encapsulation	10.0R2	10.2	10.1	10.2	10.1	10.1
Graceful Routing Engine Switchover (GRES)	10.0R2	10.2	10.1	10.2	10.1	10.1
Ingress Differentiated Services code point (DSCP) rewrite	10.0R2	10.2	10.1	10.2	10.1	10.1
Ingress hierarchical quality-of-service (HQoS) shaping and scheduling: <ul style="list-style-type: none"> <li>• Group of virtual LANs (VLANs) level</li> <li>• Virtual LAN (VLAN) level</li> <li>• Port level</li> </ul>	12.1R3	12.1R3	12.1R3	12.1R3	12.1R3	12.1R3
Intelligent oversubscription	10.0R2	10.2	10.1	10.2	10.1	10.1
Integrated routing and bridging (IRB)	10.1	10.2	10.1	10.2	10.1	10.1
Intermediate System-to-Intermediate System (IS-IS)	10.0R2	10.2	10.1	10.2	10.1	10.1
Internet Group Management Protocol (IGMP) (excluding snooping)	10.0R2	10.2	10.1	10.2	10.1	10.1

**Table 79: Protocols and Applications Supported by the MX240, MX480, MX960, MX2010, and MX2020 MPCs (continued)**

Protocol or Application	First Junos OS Release Supported by MPC Model Number (MPC Name)					
	MPC-3D-16XGE-SFPP (16x10GE MPC)	MX-MPC1-3D (MPC1)	MX-MPC2-3D (MPC2)	MX-MPC1-3D-Q (MPC1 Q)	MX-MPC2-3D-Q (MPC2 Q)	MX-MPC2-3D-EQ (MPC2EQ)
Internet Group Management Protocol (IGMP) snooping	11.4	11.4	11.4	11.4	11.4	11.4
IPv4	10.0R2	10.2	10.1	10.2	10.1	10.1
IP multicast	10.0R2	10.2	10.1	10.2	10.1	10.1
IPv6	10.2	10.2	10.2	10.2	10.2	10.2
IPv6 MLD	10.2	10.2	10.2	10.2	10.2	10.2
IPv6 multicast	10.2	10.2	10.2	10.2	10.2	10.2
IPv6 Neighbor Discovery	10.2	10.2	10.2	10.2	10.2	10.2
Label Distribution Protocol (LDP)	10.0R2	10.2	10.1	10.2	10.1	10.1
Labeled switched paths (LSPs) including accounting, policers, and filtering	10.0R2	10.2	10.1	10.2	10.1	10.1
LAN-PHY mode	10.0R2	10.2	10.1	10.2	10.1	10.1
Layer 2 frame filtering	10.0R2	10.2	10.1	10.2	10.1	10.1
Layer 2 Tunneling Protocol (L2TP):  (MX2010, MX2020: 12.3R4, 13.2R2, 13.3)						
• L2TP access concentrator (LAC)	10.4	10.4	10.4	10.4	10.4	10.4
• L2TP network server (LNS)	11.4	11.4	11.4	11.4	11.4	11.4
• LNS inline service support with CoS per-session shaping	11.4	11.4	11.4	11.4	11.4	11.4
• LNS inline service support without CoS per-session shaping	11.4	11.4	11.4	11.4	11.4	11.4



**Table 79: Protocols and Applications Supported by the MX240, MX480, MX960, MX2010, and MX2020 MPCs (continued)**

Protocol or Application	First Junos OS Release Supported by MPC Model Number (MPC Name)					
	MPC-3D-16XGE-SFPP (16x10GE MPC)	MX-MPC1-3D (MPC1)	MX-MPC2-3D (MPC2)	MX-MPC1-3D-Q (MPC1 Q)	MX-MPC2-3D-Q (MPC2 Q)	MX-MPC2-3D-EQ (MPC2EQ)
• Peer interface	–	11.4	11.4	11.4	11.4	11.4
• Inline IP reassembly	13.1	13.1	13.1	13.1	13.1	13.1
IEEE 802.3ad link aggregation	10.0R2	10.2	10.1	10.2	10.1	10.1
Link Aggregation Control Protocol (LACP)	10.0R2	10.2	10.1	10.2	10.1	10.1
Local loopback	10.0R2	10.2	10.1	10.2	10.1	10.1
MAC learning, policing, accounting, and filtering	10.0R2	10.2	10.1	10.2	10.1	10.1
Mobile IP	–	–	–	–	–	–
<i>Multi-chassis link aggregation</i>	11.1	11.1	11.1	11.1	11.1	11.1
Multiple Tag Protocol Identifiers (TPIDs)	10.0R2	10.2	10.1	10.2	10.1	10.1
Multiprotocol Label Switching (MPLS)	10.0R2	10.2	10.1	10.2	10.1	10.1
Nonstop active routing (NSR)	10.0R2	10.2	10.1	10.2	10.1	10.1
IEEE 802.3ah OAM	11.1	11.1	11.1	11.1	11.1	11.1
• Discovery and link monitoring						
• Fault signaling and detection						
• Remote loopback						
Multi-topology routing (MTR)	10.0R2	10.2	10.1	10.2	10.1	10.1
Open Shortest Path First (OSPF)	10.0R2	10.2	10.1	10.2	10.1	10.1
Packet mirroring	10.0R2	10.2	10.1	10.2	10.1	10.1
IEEE 802.1ah provider backbone bridges (PBB)	–	–	–	–	–	–

**Table 79: Protocols and Applications Supported by the MX240, MX480, MX960, MX2010, and MX2020 MPCs (continued)**

Protocol or Application	First Junos OS Release Supported by MPC Model Number (MPC Name)					
	MPC-3D-16XGE-SFPP (16x10GE MPC)	MX-MPC1-3D (MPC1)	MX-MPC2-3D (MPC2)	MX-MPC1-3D-Q (MPC1 Q)	MX-MPC2-3D-Q (MPC2 Q)	MX-MPC2-3D-EQ (MPC2EQ)
Quality of service (QoS) per port:	10.0R2	10.2	10.1	10.2	10.1	10.1
<ul style="list-style-type: none"> <li>• Eight queues per port</li> <li>• Excess-rate configuration at the traffic-control-profile level</li> <li>• Excess-rate and excess-priority configuration at the queue level</li> <li>• Shaping at port level</li> <li>• Shaping at queue level</li> <li>• Scheduling of queues based on weighted round-robin (WRR) per priority class</li> <li>• Tricolor marking</li> <li>• Weighted random early detection (WRED)</li> </ul>						
Quality of service (QoS) per virtual LAN (VLAN):						
<ul style="list-style-type: none"> <li>• Accounting, filtering, and policing</li> </ul>	10.0R2	10.2	10.1	10.2	10.1	10.1
<ul style="list-style-type: none"> <li>• IEEE 802.1p rewrite</li> </ul>	10.0R2	10.2	10.1	10.2	10.1	10.1
<ul style="list-style-type: none"> <li>• Classification</li> </ul>	10.0R2	10.2	10.1	10.2	10.1	10.1
<ul style="list-style-type: none"> <li>• Excess-rate configuration at the traffic-control-profile level</li> </ul>	–	–	–	10.2	10.1	10.1
<ul style="list-style-type: none"> <li>• Excess-rate and excess-priority configuration at the queue level</li> </ul>	–	–	–	10.2	10.1	10.1
<ul style="list-style-type: none"> <li>• Tricolor marking</li> </ul>	10.0R2	10.2	10.1	10.2	10.1	10.1
<ul style="list-style-type: none"> <li>• Shaping at the queue level</li> </ul>	–	–	–	10.2	10.1	10.1
<ul style="list-style-type: none"> <li>• Scheduling of queues based on weighted round-robin (WRR) per priority class</li> </ul>	–	–	–	10.2	10.1	10.1
<ul style="list-style-type: none"> <li>• Weighted random early detection (WRED)</li> </ul>	–	–	–	10.2	10.1	10.1

**Table 79: Protocols and Applications Supported by the MX240, MX480, MX960, MX2010, and MX2020 MPCs (continued)**

Protocol or Application	First Junos OS Release Supported by MPC Model Number (MPC Name)					
	MPC-3D-16XGE-SFPP (16x10GE MPC)	MX-MPC1-3D (MPC1)	MX-MPC2-3D (MPC2)	MX-MPC1-3D-Q (MPC1 Q)	MX-MPC2-3D-Q (MPC2 Q)	MX-MPC2-3D-EQ (MPC2EQ)
Quality of service (QoS) per Point-to-Point Protocol over Ethernet (PPPoE) or Dynamic Host Configuration Protocol (DHCP) subscriber interfaces:						
• Accounting, filtering, and policing	–	10.2	10.1	10.2	10.1	10.1
• IEEE 802.1p rewrite	–	10.2	10.1	10.2	10.1	10.1
• Classification	–	10.2	10.1	10.2	10.1	10.1
• Excess-rate configuration at the traffic-control-profile level	–	–	–	10.2	10.1	10.1
• Excess-rate and excess-priority configuration at the queue level	–	–	–	10.2	10.1	10.1
• Tricolor marking	–	10.2	10.1	10.2	10.1	10.1
• Shaping at the queue level	–	–	–	10.2	10.1	10.1
• Scheduling of queues based on weighted round-robin (WRR) per priority class	–	–	–	10.2	10.1	10.1
• Weighted random early detection (WRED)	–	–	–	10.2	10.1	10.1
RSVP	10.0R2	10.2	10.1	10.2	10.1	10.1
RIP	10.0R2	10.2	10.1	10.2	10.1	10.1
SNMP	10.0R2	10.2	10.1	10.2	10.1	10.1

**Table 79: Protocols and Applications Supported by the MX240, MX480, MX960, MX2010, and MX2020 MPCs (continued)**

Protocol or Application	First Junos OS Release Supported by MPC Model Number (MPC Name)					
	MPC-3D-16XGE-SFPP (16x10GE MPC)	MX-MPC1-3D (MPC1)	MX-MPC2-3D (MPC2)	MX-MPC1-3D-Q (MPC1 Q)	MX-MPC2-3D-Q (MPC2 Q)	MX-MPC2-3D-EQ (MPC2EQ)
Spanning Tree Protocols:	10.2	10.2	10.2	10.2	10.2	10.2
<ul style="list-style-type: none"> <li>• IEEE 802.1D Spanning Tree Protocol (STP)</li> <li>• IEEE 802.1s Multiple Spanning Tree Protocol</li> <li>• Per-VLAN Spanning Tree (PVST)+</li> <li>• IEEE 802.1w Rapid Spanning Tree Protocol (RSTP)</li> </ul>						
Subscriber management and services:						
(MX2010, MX2020: 12.3R4, 13.2R2, 13.3)						
<ul style="list-style-type: none"> <li>• Aggregated Ethernet over static VLANs</li> </ul>	–	10.2	10.1	10.2	10.1	10.1
<ul style="list-style-type: none"> <li>• Aggregated Ethernet over dynamic VLANs</li> </ul>	–	10.2	10.2	10.2	10.2	10.2
<ul style="list-style-type: none"> <li>• Access Node Control Protocol (ANCP) and ANCP agent</li> </ul>	–	10.2	10.2	10.2	10.2	10.2
<ul style="list-style-type: none"> <li>• DHCP access model</li> </ul>	–	10.2	10.1	10.2	10.1	10.1
<ul style="list-style-type: none"> <li>• Dynamic adjustment of shapers</li> </ul>	–	10.2	10.1	10.2	10.1	10.1
<ul style="list-style-type: none"> <li>• Dynamic PPPoE subscriber interface creation based on PPPoE service name table configuration</li> </ul>	–	10.2	10.1	10.2	10.1	10.1
<ul style="list-style-type: none"> <li>• Dynamic profiles</li> </ul>	–	10.2	10.1	10.2	10.1	10.1
<ul style="list-style-type: none"> <li>• Dynamic shaping, scheduling, and queuing</li> </ul>	–	10.2	10.1	10.2	10.1	10.1
<ul style="list-style-type: none"> <li>• Dynamic VLANs</li> </ul>	–	10.2	10.2	10.2	10.2	10.2
<ul style="list-style-type: none"> <li>• Enhanced subscriber management</li> </ul>	15.1R4	15.1R4	15.1R4	15.1R4	15.1R4	15.1R4

**Table 79: Protocols and Applications Supported by the MX240, MX480, MX960, MX2010, and MX2020 MPCs (continued)**

Protocol or Application	First Junos OS Release Supported by MPC Model Number (MPC Name)					
	MPC-3D-16XGE-SFPP (16x10GE MPC)	MX-MPC1-3D (MPC1)	MX-MPC2-3D (MPC2)	MX-MPC1-3D-Q (MPC1 Q)	MX-MPC2-3D-Q (MPC2 Q)	MX-MPC2-3D-EQ (MPC2EQ)
<ul style="list-style-type: none"> <li>Static and dynamic PPPoE subscriber interfaces</li> </ul>	–	10.2	10.1	10.2	10.1	10.1
Synchronous Ethernet (SyncE)	11.2R4	12.3 with SCBE and later	12.3 with SCBE and later	12.3 with SCBE and later	12.3 with SCBE and later	12.3 with SCBE and later
Tunnel services: <ul style="list-style-type: none"> <li>GRE unicast tunneling-Supports GRE fragmentation</li> <li>IP-IP unicast tunneling</li> <li>Multicast tunneling</li> <li>Protocol Independent Multicast (PIM) sparse mode unicast tunneling</li> <li>Virtual loopback tunneling (VT)</li> </ul>	10.0R2	10.2	10.1	10.2	10.1	10.1
Two-Way Active Measurement Protocol (TWAMP)	10.0R2	10.2	10.1	10.2	10.1	10.1
IEEE 802.1Q VLANs: <ul style="list-style-type: none"> <li>VLAN stacking and rewriting</li> <li>Channels defined by two stacked VLAN tags</li> <li>Flexible VLAN tagging</li> <li>IP service for nonstandard TPID and stacked VLAN tags</li> </ul>	10.0R2	10.2	10.1	10.2	10.1	10.1
Virtual Chassis redundancy	11.2	11.2	11.2	11.2	11.2	11.2
Virtual private LAN service (VPLS)	10.0R2	10.2	10.1	10.2	10.1	10.1
Virtual private network (VPN)	10.0R2	10.2	10.1	10.2	10.1	10.1
Virtual Router Redundancy Protocol (VRRP) for IPv4	10.0R2	10.2	10.1	10.2	10.1	10.1
VRRP over integrated routing and bridging (IRB) on multichassis link aggregation	13.1	13.1	13.1	13.1	13.1	13.1

**Table 79: Protocols and Applications Supported by the MX240, MX480, MX960, MX2010, and MX2020 MPCs (continued)**

Protocol or Application	First Junos OS Release Supported by MPC Model Number (MPC Name)					
	MPC-3D-16XGE-SFPP (16x10GE MPC)	MX-MPC1-3D (MPC1)	MX-MPC2-3D (MPC2)	MX-MPC1-3D-Q (MPC1 Q)	MX-MPC2-3D-Q (MPC2 Q)	MX-MPC2-3D-EQ (MPC2EQ)
WAN-PHY mode	–	10.2	10.2	10.2	10.2	10.2

**Related Documentation**

- [MX Series MPC Overview on page 11](#)
- [MPCs Supported by MX Series Routers on page 12](#)
- [ANCP and the ANCP Agent Overview](#)
- [Understanding BGP](#)
- [Understanding MPLS Inter-AS Link Protection](#)
- [IEEE 802.1ag OAM Connectivity Fault Management Overview](#)
- [Understanding IGMP](#)
- [Understanding IPv6](#)
- [Understanding LDP-IGP Synchronization](#)
- [mc-ae](#)

## Protocols and Applications Supported on the MPC1E for MX Series Routers

Table 80 on page 357 contains the first Junos OS Release support for protocols and applications on the MX240, MX480, MX960, MX2010, and MX2020 Enhanced MPCs (MPCEs).



**NOTE:** The MX2010 and M2020 routers support protocols and applications in Junos OS 12.3 and later. Features added after the Junos OS 12.3 release are supported on the MX2010 and MX2020 routers in the release indicated.

A dash indicates that the protocol or application is not supported.

**Table 80: Protocols and Applications Supported by the MX240, MX480, MX960, MX2010, and MX2020 Enhanced MPCs (MPCIEs)**

First Junos OS Release Supported by MPCIE Model Number (MPCE Name)		
Protocol or Application	MX-MPCIE-3D (MPCIE)	MX-MPCIE-3D-Q (MPCIE Q)
Access Node Control Protocol (ANCP)	11.2R4	11.2R4
Accepts traffic destined for GRE tunnels or DVMRP (IP-in-IP) tunnels	11.2R4	11.2R4
Bidirectional Forwarding Detection protocol (BFD)	11.2R4	11.2R4
Border Gateway Protocol (BGP)	11.2R4	11.2R4
BGP/Multiprotocol Label Switching (MPLS) virtual private networks (VPNs)	11.2R4	11.2R4
Distance Vector Multicast Routing Protocol (DVMRP) and generic routing encapsulation (GRE) support—access side and server side	11.2R4	11.2R4
IEEE 802.1ag Ethernet OAM Continuity Check protocol	11.2R4	11.2R4
IEEE 802.1ag Ethernet OAM Linktrace protocol	11.2R4	11.2R4
IEEE 802.1ag Ethernet OAM Loopback protocol	11.2R4	11.2R4
Firewall filters	11.2R4	11.2R4
Flexible Ethernet encapsulation	11.2R4	11.2R4
Graceful Routing Engine Switchover (GRES)	11.2R4	11.2R4
Ingress Differentiated Services code point (DSCP) rewrite	11.2R4	11.2R4
Hierarchical quality-of-service (HQoS)	-	12.1R3
Intelligent oversubscription	11.2R4	11.2R4
Integrated routing and bridging (IRB)	11.2R4	11.2R4
Intermediate System-to-Intermediate System (IS-IS)	11.2R4	11.2R4
Internet Group Management Protocol (IGMP) (excluding snooping)	11.2R4	11.2R4
Internet Group Management Protocol (IGMP) snooping	11.2R4	11.2R4
IPv4	11.2R4	11.2R4
IP multicast	11.2R4	11.2R4

**Table 80: Protocols and Applications Supported by the MX240, MX480, MX960, MX2010, and MX2020 Enhanced MPCs (MPCIEs) (continued)**

First Junos OS Release Supported by MPCIE Model Number (MPCIE Name)		
Protocol or Application	MX-MPCIE-3D (MPCIE)	MX-MPCIE-3D-Q (MPCIE Q)
IPv6	11.2R4	11.2R4
IPv6 MLD	11.2R4	11.2R4
IPv6 multicast	11.2R4	11.2R4
IPv6 Neighbor Discovery	11.2R4	11.2R4
Label Distribution Protocol (LDP)	11.2R4	11.2R4
Labeled switched paths (LSPs) including accounting, policers, and filtering	11.2R4	11.2R4
LAN-PHY mode	11.2R4	11.2R4
Layer 2 frame filtering	11.2R4	11.2R4
Layer 2 Tunneling Protocol (L2TP):		
• L2TP access concentrator (LAC)	11.3	11.3
• L2TP network server (LNS)	11.4	11.4
• LNS inline service support with CoS per-session shaping	11.4	11.4
• LNS inline service support without CoS per-session shaping	11.4	11.4
• Peer interface	11.4	11.4
• Inline IP Reassembly	13.1	13.1
IEEE 802.3ad link aggregation	11.2R4	11.2R4
Link Aggregation Control Protocol (LACP)	11.2R4	11.2R4
Local loopback	11.2R4	11.2R4
MAC learning, policing, accounting, and filtering	11.2R4	11.2R4
Mobile IP	–	–
<i>Multi-chassis link aggregation</i>	11.2R4	11.2R4



**Table 80: Protocols and Applications Supported by the MX240, MX480, MX960, MX2010, and MX2020 Enhanced MPCs (MPCIEs) (continued)**

First Junos OS Release Supported by MPCIE Model Number (MPCE Name)		
Protocol or Application	MX-MPCIE-3D (MPCIE)	MX-MPCIE-3D-Q (MPCIE Q)
Multiple Tag Protocol Identifiers (TPIDs)	11.2R4	11.2R4
Multiprotocol Label Switching (MPLS)	11.2R4	11.2R4
Nonstop active routing (NSR)	11.2R4	11.2R4
IEEE 802.3ah OAM <ul style="list-style-type: none"> <li>Discovery and link monitoring</li> <li>Fault signaling and detection</li> <li>Remote loopback</li> </ul>	11.2R4	11.2R4
Multitopology routing	11.2R4	11.2R4
OSPF	11.2R4	11.2R4
Packet mirroring	11.2R4	11.2R4
Per-unit scheduling	12.1R3	12.1R3
Precision Time Protocol (PTP) or IEEE 1588v2	12.3	12.3
IEEE 802.1ah provider backbone bridges (PBB)	11.2R4	11.2R4
Quality of service (QoS) per port: <ul style="list-style-type: none"> <li>Eight queues per port</li> <li>Excess-rate configuration at the traffic-control-profile level</li> <li>Excess-rate and excess-priority configuration at the queue level</li> <li>Shaping at port level</li> <li>Shaping at queue level</li> <li>Scheduling of queues based on weighted round-robin (WRR) per priority class</li> <li>Tricolor marking</li> <li>Weighted random early detection (WRED)</li> </ul>	11.2R4	11.2R4
Quality of service (QoS) per virtual LAN (VLAN):		
<ul style="list-style-type: none"> <li>Accounting, filtering, and policing</li> </ul>	11.2R4	11.2R4
<ul style="list-style-type: none"> <li>IEEE 802.1p rewrite</li> </ul>	11.2R4	11.2R4
<ul style="list-style-type: none"> <li>Classification</li> </ul>	11.2R4	11.2R4

**Table 80: Protocols and Applications Supported by the MX240, MX480, MX960, MX2010, and MX2020 Enhanced MPCs (MPCIEs) (continued)**

First Junos OS Release Supported by MPCIE Model Number (MPCIE Name)		
Protocol or Application	MX-MPCIE-3D (MPCIE)	MX-MPCIE-3D-Q (MPCIE Q)
• Excess-rate configuration at the traffic-control-profile level	–	11.2R4
• Excess-rate and excess-priority configuration at the queue level	–	11.2R4
• Tricolor marking	11.2R4	11.2R4
• Shaping at the queue level	–	11.2R4
• Scheduling of queues based on weighted round-robin (WRR) per priority class	–	11.2R4
• Weighted random early detection (WRED)	–	11.2R4
Quality of service (QoS) per Point-to-Point Protocol over Ethernet (PPPoE) or Dynamic Host Configuration Protocol (DHCP) subscriber interfaces:		
• Accounting, filtering, and policing	11.2R4	11.2R4
• IEEE 802.1p rewrite	11.2R4	11.2R4
• Classification	11.2R4	11.2R4
• Excess-rate configuration at the traffic-control-profile level	–	11.2R4
• Excess-rate and excess-priority configuration at the queue level	–	11.2R4
• Tricolor marking	11.2R4	11.2R4
• Shaping at the queue level	–	11.2R4
• Scheduling of queues based on weighted round-robin (WRR) per priority class	–	11.2R4
• Weighted random early detection (WRED)	–	11.2R4
RSVP	11.2R4	11.2R4
RIP	11.2R4	11.2R4
SNMP	11.2R4	11.2R4

**Table 80: Protocols and Applications Supported by the MX240, MX480, MX960, MX2010, and MX2020 Enhanced MPCs (MPCIEs) (continued)**

First Junos OS Release Supported by MPCIE Model Number (MPCE Name)		
Protocol or Application	MX-MPCIE-3D (MPCIE)	MX-MPCIE-3D-Q (MPCIE Q)
Spanning Tree Protocols:	11.2R4	11.2R4
<ul style="list-style-type: none"> <li>• IEEE 802.1D Spanning Tree Protocol (STP)</li> <li>• IEEE 802.1s Multiple Spanning Tree Protocol</li> <li>• Per-VLAN Spanning Tree (PVST)+</li> <li>• IEEE 802.1w Rapid Spanning Tree Protocol (RSTP)</li> </ul>		
Subscriber Management:		
<ul style="list-style-type: none"> <li>• Aggregated Ethernet over static VLANs</li> </ul>	11.2R4	11.2R4
<ul style="list-style-type: none"> <li>• Aggregated Ethernet over dynamic VLANs</li> </ul>	11.2R4	11.2R4
<ul style="list-style-type: none"> <li>• DHCP access model</li> </ul>	11.2R4	11.2R4
<ul style="list-style-type: none"> <li>• Dynamic adjustment of shapers</li> </ul>	11.2R4	11.2R4
<ul style="list-style-type: none"> <li>• Dynamic PPPoE subscriber interface creation based on PPPoE service name table configuration</li> </ul>	11.2R4	11.2R4
<ul style="list-style-type: none"> <li>• Dynamic profiles</li> </ul>	11.2R4	11.2R4
<ul style="list-style-type: none"> <li>• Dynamic shaping, scheduling, and queuing</li> </ul>	11.2R4	11.2R4
<ul style="list-style-type: none"> <li>• Dynamic VLANs</li> </ul>	11.2R4	11.2R4
<ul style="list-style-type: none"> <li>• Enhanced subscriber management</li> </ul>	15.1R4	15.1R4
<ul style="list-style-type: none"> <li>• Static and dynamic PPPoE subscriber interfaces</li> </ul>	11.2R4	11.2R4
Synchronous Ethernet (SyncE)	11.2R4	11.2R4
Tunnel services:	11.2R4	11.2R4
<ul style="list-style-type: none"> <li>• Clear DF-Bit (Don't Fragment Bit)</li> <li>• GRE unicast tunneling-Supports GRE fragmentation</li> <li>• IP-IP unicast tunneling</li> <li>• Multicast tunneling</li> <li>• Protocol Independent Multicast (PIM) sparse mode unicast tunneling</li> <li>• Virtual loopback tunneling (VT)</li> </ul>		
Two-Way Active Measurement Protocol (TWAMP)	11.2R4	11.2R4

**Table 80: Protocols and Applications Supported by the MX240, MX480, MX960, MX2010, and MX2020 Enhanced MPCs (MPCIEs) (continued)**

First Junos OS Release Supported by MPCIE Model Number (MPCIE Name)		
Protocol or Application	MX-MPCIE-3D (MPCIE)	MX-MPCIE-3D-Q (MPCIE Q)
IEEE 802.1Q VLANs: <ul style="list-style-type: none"> <li>VLAN stacking and rewriting</li> <li>Channels defined by two stacked VLAN tags</li> <li>Flexible VLAN tagging</li> <li>IP service for nonstandard TPID and stacked VLAN tags</li> </ul>	11.2R4	11.2R4
Virtual Chassis redundancy	11.2R4	11.2R4
Virtual private LAN service (VPLS)	11.2R4	11.2R4
Virtual private network (VPN)	11.2R4	11.2R4
Virtual Router Redundancy Protocol (VRRP) for IPv4	11.2R4	11.2R4
WAN-PHY mode	11.2R4	11.2R4

- Related Documentation**
- [MX Series MPC Overview on page 11](#)
  - [MPCs Supported by MX Series Routers on page 12](#)

## Protocols and Applications Supported by the MX240, MX480, MX960, MX2010, and MX2020 MPC2E

Table 81 on page 363 contains the first Junos OS Release support for protocols and applications on the MX240, MX480, MX960, MX2010, and MX2020 MPC2E.

A dash indicates that the protocol or application is not supported.



**NOTE:** The MX2010 and M2020 routers support protocols and applications in Junos OS 12.3 and later. Features added after the Junos OS 12.3 release are supported on the MX2010 and MX2020 routers in the release indicated.

A dash indicates that the protocol or application is not supported.

Table 81: Protocols and Applications Supported by the MX240, MX480, MX960, MX2010, and MX2020 MPC2E

Protocol or Application	First Supported Junos OS Release					
	MX-MPC2E-3D (MPC2E)	MX-MPC2E-3D-Q (MPC2E Q)	MX-MPC2E-3D-EQ (MPC2EEQ)	MX-MPC2E-3D-P (MPC2E P)	MX-MPC2E-3D-NG (MPC2ENG)	MX-MPC2E-3D-NG-Q (MPC2E NG-Q)
<i>Access Node Control Protocol (ANCP)</i>	11.2R4	11.2R4	11.2R4	12.2	14.1R4	14.1R4
Accepts traffic destined for generic routing encapsulation (GRE) tunnels or Distance Vector Multicast Routing Protocol (DVMRP) (IP-in-IP) tunnels <ul style="list-style-type: none"> <li>• <i>Dynamic</i></li> <li>• <i>Manual</i></li> </ul>	11.2R4	11.2R4	11.2R4	12.2	14.1R4	14.1R4
<i>Bidirectional Forwarding Detection protocol (BFD)</i>	11.2R4	11.2R4	11.2R4	12.2	14.1R4	14.1R4
<i>Border Gateway Protocol (BGP)</i>	11.2R4	11.2R4	11.2R4	12.2	14.1R4	14.1R4
BGP/MPLS virtual private networks (VPNs)	11.2R4	11.2R4	11.2R4	12.2	14.1R4	14.1R4
DVMRP and GRE support—access side and server side	11.2R4	11.2R4	11.2R4	12.2	14.1R4	14.1R4
<i>Dynamic Power Management</i>	—	—	—	—	15.1	15.1
<i>Flexible Queuing Mode</i>  NOTE: Flexible queuing mode is supported only on non-HQoS variants.	—	—	—	—	15.1	—
<i>IEEE 802.1ag Ethernet OAM Continuity Check protocol</i>	11.2R4	11.2R4	11.2R4	12.2	14.1R4	14.1R4
<i>IEEE 802.1ag Ethernet OAM Linktrace protocol</i>	11.2R4	11.2R4	11.2R4	12.2	14.1R4	14.1R4
<i>IEEE 802.1ag Ethernet OAM Loopback protocol</i>	11.2R4	11.2R4	11.2R4	12.2	14.1R4	14.1R4

**Table 81: Protocols and Applications Supported by the MX240, MX480, MX960, MX2010, and MX2020 MPC2E (continued)**

Protocol or Application	First Supported Junos OS Release					
	MX-MPC2E-3D (MPC2E)	MX-MPC2E-3D-Q (MPC2E Q)	MX-MPC2E-3D-EQ (MPC2EEQ)	MX-MPC2E-3D-P (MPC2E P)	MX-MPC2E-3D-NG (MPC2ENG)	MX-MPC2E-3D-NG-Q (MPC2E NG-Q)
Firewall filters	11.2R4	11.2R4	11.2R4	12.2	14.1R4	14.1R4
<i>Flexible Ethernet encapsulation</i>	11.2R4	11.2R4	11.2R4	12.2	14.1R4	14.1R4
<i>Graceful Routing Engine Switchover (GRES)</i>	11.2R4	11.2R4	11.2R4	12.2	14.1R4	14.1R4
Ingress Differentiated Services code point (DSCP) rewrite	11.2R4	11.2R4	11.2R4	12.2	14.1R4	14.1R4
Ingress hierarchical quality-of-service (HQoS) shaping and <i>hierarchical-scheduler</i> : <ul style="list-style-type: none"> <li>Group of virtual LANs (VLANs) level</li> <li>Virtual LAN (VLAN) level</li> <li>Port level</li> </ul>	–	–	–	–	15.1R1	15.1R1
Hierarchical quality-of-service (HQoS)	–	12.1R3	12.1R3	–	–	15.1R1
<i>Intelligent Oversubscription on MIC and MPC Interfaces Overview</i>	11.2R4	11.2R4	11.2R4	12.2	14.1R4	14.1R4
<i>Integrated routing and bridging (IRB)</i>	11.2R4	11.2R4	11.2R4	12.2	14.1R4	14.1R4
<i>Unified In-service software upgrade (Unified ISSU)</i>	11.2R1	11.2R1	11.2R1	11.2R1	17.1R1	17.1R1
<i>IS-IS</i>	11.2R4	11.2R4	11.2R4	12.2	14.1R4	14.1R4
Internet Group Management Protocol (IGMP) (excluding snooping)	11.2R4	11.2R4	11.2R4	12.2	14.1R4	14.1R4

**Table 81: Protocols and Applications Supported by the MX240, MX480, MX960, MX2010, and MX2020 MPC2E (continued)**

Protocol or Application	First Supported Junos OS Release					
	MX-MPC2E-3D (MPC2E)	MX-MPC2E-3D-Q (MPC2E Q)	MX-MPC2E-3D-EQ (MPC2EEQ)	MX-MPC2E-3D-P (MPC2E P)	MX-MPC2E-3D-NG (MPC2ENG)	MX-MPC2E-3D-NG-Q (MPC2E NG-Q)
Internet Group Management Protocol (IGMP) snooping	11.2R4	11.2R4	11.2R4	12.2	14.1R4	14.1R4
IPv4	11.2R4	11.2R4	11.2R4	12.2	14.1R4	14.1R4
IP multicast	11.2R4	11.2R4	11.2R4	12.2	14.1R4	14.1R4
IPv6	11.2R4	11.2R4	11.2R4	12.2	14.1R4	14.1R4
IPv6 MLD	11.2R4	11.2R4	11.2R4	12.2	14.1R4	14.1R4
IPv6 multicast	11.2R4	11.2R4	11.2R4	12.2	14.1R4	14.1R4
IPv6 Neighbor Discovery	11.2R4	11.2R4	11.2R4	12.2	14.1R4	14.1R4
Label Distribution Protocol (LDP)	11.2R4	11.2R4	11.2R4	12.2	14.1R4	14.1R4
<i>Labeled-switched-paths (LSPs)</i> including accounting, policers, and filtering	11.2R4	11.2R4	11.2R4	12.2	14.1R4	14.1R4
LAN-PHY mode	11.2R4	11.2R4	11.2R4	12.2	14.1R4	14.1R4
Layer 2 frame filtering	11.2R4	11.2R4	11.2R4	12.2	14.1R4	14.1R4
Layer 2 Tunneling Protocol (L2TP):					14.1R4	14.1R4
• L2TP access concentrator (LAC)	11.3	11.3	11.3	12.2	14.1R4	14.1R4
• L2TP network server (LNS)	11.4	11.4	11.4	12.2	14.1R4	14.1R4
• LNS inline service support with CoS per-session shaping	11.4	11.4	11.4	12.2	14.1R4	14.1R4

**Table 81: Protocols and Applications Supported by the MX240, MX480, MX960, MX2010, and MX2020 MPC2E (continued)**

Protocol or Application	First Supported Junos OS Release					
	MX-MPC2E-3D (MPC2E)	MX-MPC2E-3D-Q (MPC2E Q)	MX-MPC2E-3D-EQ (MPC2EEQ)	MX-MPC2E-3D-P (MPC2E P)	MX-MPC2E-3D-NG (MPC2ENG)	MX-MPC2E-3D-NG-Q (MPC2E NG-Q)
<ul style="list-style-type: none"> <li>LNS inline service support without CoS per-session shaping</li> </ul>	11.4	11.4	11.4	12.2	14.1R4	14.1R4
<ul style="list-style-type: none"> <li>Peer interface</li> </ul>	11.4	11.4	11.4	12.2	14.1R4	14.1R4
<ul style="list-style-type: none"> <li>Inline IP Reassembly</li> </ul>	13.1	13.1	13.1	13.1	14.1R4	14.1R4
<i>Link aggregation (IEEE 802.3ad)</i>	11.2R4	11.2R4	11.2R4	12.2	14.1R4	14.1R4
<i>Link Aggregation Control Protocol (LACP)</i>	11.2R4	11.2R4	11.2R4	12.2	14.1R4	14.1R4
Local loopback	11.2R4	11.2R4	11.2R4	12.2	14.1R4	14.1R4
<i>MAC learning, policing, accounting, and filtering</i>	11.2R4	11.2R4	11.2R4	12.2	14.1R4	14.1R4
Mobile IP	–	–	–	–		
<i>Multi-chassis link aggregation</i>	11.2R4	11.2R4	11.2R4	12.2	14.1R4	14.1R4
Multiple Tag Protocol Identifiers (TPIDs)	11.2R4	11.2R4	11.2R4	12.2	14.1R4	14.1R4
Multiprotocol Label Switching (MPLS)	11.2R4	11.2R4	11.2R4	12.2	14.1R4	14.1R4
Nonstop active routing (NSR)	11.2R4	11.2R4	11.2R4	12.2	14.1R4	14.1R4
IEEE 802.3ah OAM <ul style="list-style-type: none"> <li>Discovery and link monitoring</li> <li>Fault signaling and detection</li> <li>Remote loopback</li> </ul>	11.2R4	11.2R4	11.2R4	12.2	14.1R4	14.1R4
Multitopology routing	11.2R4	11.2R4	11.2R4	12.2	14.1R4	14.1R4



**Table 81: Protocols and Applications Supported by the MX240, MX480, MX960, MX2010, and MX2020 MPC2E (continued)**

Protocol or Application	First Supported Junos OS Release					
	MX-MPC2E-3D (MPC2E)	MX-MPC2E-3D-Q (MPC2E Q)	MX-MPC2E-3D-EQ (MPC2EEQ)	MX-MPC2E-3D-P (MPC2E P)	MX-MPC2E-3D-NG (MPC2ENG)	MX-MPC2E-3D-NG-Q (MPC2E NG-Q)
OSPF	11.2R4	11.2R4	11.2R4	12.2	14.1R4	14.1R4
Packet mirroring	11.2R4	11.2R4	11.2R4	12.2	14.1R4	14.1R4
Precision Time Protocol (PTP) or IEEE 1588v2	12.3	12.3	12.3	12.2	15.1R2	15.1R2
IEEE 802.1ah provider backbone bridges (PBB)	–	–	–	–	–	–
Quality of service (QoS) per port: <ul style="list-style-type: none"> <li>• Eight queues per port</li> <li>• Excess-rate configuration at the traffic-control-profile level</li> <li>• Excess-rate and excess-priority configuration at the queue level</li> <li>• Shaping at port level</li> <li>• Shaping at queue level</li> <li>• Scheduling of queues based on weighted round-robin (WRR) per priority class</li> <li>• Tricolor marking</li> <li>• Weighted random early detection (WRED)</li> </ul>	11.2R4	11.2R4	11.2R4	12.2	14.1R4	14.1R4
Quality of service (QoS) per virtual LAN (VLAN):				–	14.1R4	14.1R4
• Accounting, filtering, and policing	11.2R4	11.2R4	11.2R4	12.2	14.1R4	14.1R4
• IEEE 802.1p rewrite	11.2R4	11.2R4	11.2R4	12.2	14.1R4	14.1R4
• Classification	11.2R4	11.2R4	11.2R4	12.2	14.1R4	14.1R4

**Table 81: Protocols and Applications Supported by the MX240, MX480, MX960, MX2010, and MX2020 MPC2E (continued)**

Protocol or Application	First Supported Junos OS Release					
	MX-MPC2E-3D (MPC2E)	MX-MPC2E-3D-Q (MPC2E Q)	MX-MPC2E-3D-EQ (MPC2EEQ)	MX-MPC2E-3D-P (MPC2E P)	MX-MPC2E-3D-NG (MPC2ENG)	MX-MPC2E-3D-NG-Q (MPC2E NG-Q)
• Excess-rate configuration at the traffic-control-profile level	–	11.2R4	11.2R4	12.2	14.1R4	14.1R4
• Excess-rate and excess-priority configuration at the queue level	–	11.2R4	11.2R4	12.2	14.1R4	14.1R4
• Tricolor marking	11.2R4	11.2R4	11.2R4	12.2	14.1R4	14.1R4
• Shaping at the queue level	–	11.2R4	11.2R4	12.2	14.1R4	14.1R4
• Scheduling of queues based on weighted round-robin (WRR) per priority class	–	11.2R4	11.2R4	12.2	14.1R4	14.1R4
• Weighted random early detection (WRED)	–	11.2R4	11.2R4	12.2	14.1R4	14.1R4
Quality of service (QoS) per Point-to-Point Protocol over Ethernet (PPPoE) or Dynamic Host Configuration Protocol (DHCP) subscriber interfaces:					14.1R4	14.1R4
• Accounting, filtering, and policing	11.2R4	11.2R4	11.2R4	12.2	14.1R4	14.1R4
• IEEE 802.1p rewrite	11.2R4	11.2R4	11.2R4	12.2	14.1R4	14.1R4
• Classification	11.2R4	11.2R4	11.2R4	12.2	14.1R4	14.1R4
• Excess-rate configuration at the traffic-control-profile level	–	11.2R4	11.2R4	12.2	14.1R4	14.1R4

**Table 81: Protocols and Applications Supported by the MX240, MX480, MX960, MX2010, and MX2020 MPC2E (continued)**

Protocol or Application	First Supported Junos OS Release					
	MX-MPC2E-3D (MPC2E)	MX-MPC2E-3D-Q (MPC2E Q)	MX-MPC2E-3D-EQ (MPC2EEQ)	MX-MPC2E-3D-P (MPC2E P)	MX-MPC2E-3D-NG (MPC2ENG)	MX-MPC2E-3D-NG-Q (MPC2E NG-Q)
<ul style="list-style-type: none"> <li>Excess-rate and excess-priority configuration at the queue level</li> </ul>	–	11.2R4	11.2R4	12.2	14.1R4	14.1R4
<ul style="list-style-type: none"> <li>Tricolor marking</li> </ul>	11.2R4	11.2R4	11.2R4	12.2	14.1R4	14.1R4
<ul style="list-style-type: none"> <li>Shaping at the queue level</li> </ul>	–	11.2R4	11.2R4	12.2	14.1R4	14.1R4
<ul style="list-style-type: none"> <li>Scheduling of queues based on weighted round-robin (WRR) per priority class</li> </ul>	–	11.2R4	11.2R4	12.2	14.1R4	14.1R4
<ul style="list-style-type: none"> <li>Weighted random early detection (WRED)</li> </ul>	–	11.2R4	11.2R4	12.2	14.1R4	14.1R4
RSVP	11.2R4	11.2R4	11.2R4	12.2	14.1R4	14.1R4
RIP	11.2R4	11.2R4	11.2R4	12.2	14.1R4	14.1R4
SNMP	11.2R4	11.2R4	11.2R4	12.2	14.1R4	14.1R4
Spanning Tree Protocols: <ul style="list-style-type: none"> <li>IEEE 802.1D Spanning Tree Protocol (STP)</li> <li>IEEE 802.1s Multiple Spanning Tree Protocol</li> <li>Per-VLAN Spanning Tree (PVST)+</li> <li>IEEE 802.1w Rapid Spanning Tree Protocol (RSTP)</li> </ul>	11.2R4	11.2R4	11.2R4	12.2	14.1R4	14.1R4
Subscriber Management:					14.1R4	14.1R4
<ul style="list-style-type: none"> <li>Aggregated Ethernet over static VLANs</li> </ul>	11.2R4	11.2R4	11.2R4	12.2	14.1R4	14.1R4
<ul style="list-style-type: none"> <li>Aggregated Ethernet over dynamic VLANs</li> </ul>	11.2R4	11.2R4	11.2R4	12.2	14.1R4	14.1R4
<ul style="list-style-type: none"> <li>DHCP access model</li> </ul>	11.2R4	11.2R4	11.2R4	12.2	14.1R4	14.1R4

**Table 81: Protocols and Applications Supported by the MX240, MX480, MX960, MX2010, and MX2020 MPC2E (continued)**

Protocol or Application	First Supported Junos OS Release					
	MX-MPC2E-3D (MPC2E)	MX-MPC2E-3D-Q (MPC2E Q)	MX-MPC2E-3D-EQ (MPC2EEQ)	MX-MPC2E-3D-P (MPC2E P)	MX-MPC2E-3D-NG (MPC2ENG)	MX-MPC2E-3D-NG-Q (MPC2E NG-Q)
<ul style="list-style-type: none"> <li>Dynamic adjustment of shapers</li> </ul>	11.2R4	11.2R4	11.2R4	12.2	14.1R4	14.1R4
<ul style="list-style-type: none"> <li>Dynamic PPPoE subscriber interface creation based on PPPoE service name table configuration</li> </ul>	11.2R4	11.2R4	11.2R4	12.2	14.1R4	14.1R4
<ul style="list-style-type: none"> <li>Dynamic profiles</li> </ul>	11.2R4	11.2R4	11.2R4	12.2	14.1R4	14.1R4
<ul style="list-style-type: none"> <li>Dynamic shaping, scheduling, and queuing</li> </ul>	11.2R4	11.2R4	11.2R4	12.2	14.1R4	14.1R4
<ul style="list-style-type: none"> <li>Dynamic VLANs</li> </ul>	11.2R4	11.2R4	11.2R4	12.2	14.1R4	14.1R4
<ul style="list-style-type: none"> <li>Enhanced subscriber management</li> </ul>	15.1R4	15.1R4	15.1R4	15.1R4	15.1R4	15.1R4
<ul style="list-style-type: none"> <li>Static and dynamic PPPoE subscriber interfaces</li> </ul>	11.2R4	11.2R4	11.2R4	12.2	14.1R4	14.1R4
Synchronous Ethernet (SyncE)	11.2R4	11.2R4	11.2R4	12.2	14.1R4	14.1R4
Tunnel services:	11.2R4	11.2R4	11.2R4	12.2	14.1R4	14.1R4
<ul style="list-style-type: none"> <li>Clear DF-Bit (Don't Fragment Bit)</li> <li>GRE unicast tunneling-Supports GRE fragmentation</li> <li>IP-IP unicast tunneling</li> <li>Multicast tunneling</li> <li>Protocol Independent Multicast (PIM) sparse mode unicast tunneling</li> <li>Virtual loopback tunneling (VT)</li> </ul>						
<i>Two-Way Active Measurement Protocol (TWAMP)</i>	11.2R4	11.2R4	11.2R4	12.2	14.1R4	14.1R4

**Table 81: Protocols and Applications Supported by the MX240, MX480, MX960, MX2010, and MX2020 MPC2E (continued)**

Protocol or Application	First Supported Junos OS Release					
	MX-MPC2E-3D (MPC2E)	MX-MPC2E-3D-Q (MPC2E Q)	MX-MPC2E-3D-EQ (MPC2E EQ)	MX-MPC2E-3D-P (MPC2E P)	MX-MPC2E-3D-NG (MPC2E NG)	MX-MPC2E-3D-NG-Q (MPC2E NG-Q)
VLANs <i>IEEE 802.1Q</i>	11.2R4	11.2R4	11.2R4	12.2	14.1R4	14.1R4
<ul style="list-style-type: none"> <li>VLAN stacking and rewriting</li> <li>Channels defined by two stacked VLAN tags</li> <li>Flexible VLAN tagging</li> <li>IP service for nonstandard TPID and stacked VLAN tags</li> </ul>						
Virtual Chassis redundancy	11.2R4	11.2R4	11.2R4	12.2	14.1R4	14.1R4
Virtual private LAN service (VPLS)	11.2R4	11.2R4	11.2R4	12.2	14.1R4	14.1R4
Virtual private network (VPN)	11.2R4	11.2R4	11.2R4	12.2	14.1R4	14.1R4
Virtual Router Redundancy Protocol (VRRP) for IPv4	11.2R4	11.2R4	11.2R4	12.2	14.1R4	14.1R4
WAN-PHY mode	11.2R4	11.2R4	11.2R4	12.2	14.1R4	14.1R4

- Related Documentation**
- [MX Series MPC Overview on page 11](#)
  - [MPCs Supported by MX Series Routers on page 12](#)

## Protocols and Applications Supported by the MPC3E on MX Series Routers

Table 82 on page 372 lists the first supported Junos OS Release for MPC3E protocols and applications for the MX240, MX480, MX960, MX2010, and MX2020 routers. The protocols and applications support feature parity with Junos OS Release 10.4.



**NOTE:** The MX2010 and M2020 routers support protocols and applications in Junos OS 12.3 and later. Features added after the Junos OS 12.3 release are supported on the MX2010 and MX2020 routers in the release indicated.

A dash indicates that the protocol or application is not supported.

**Table 82: Protocols and Applications Supported by MPC3E Cards for MX Series Routers**

Protocol or Application	First Supported Junos OS Release		
	MPC3E-3D	MPC3E-3D-NG	MPC3E-3DNGQ
Access Node Control Protocol (ANCP)	—	14.1R4	14.1R4
Bidirectional Forwarding Detection protocol (BFD)	12.1	14.1R4	14.1R4
Border Gateway Protocol (BGP)	12.1	14.1R4	14.1R4
Bridge protocol data units (BPDUs)	12.2	14.1R4	14.1R4
BGP/MPLS virtual private networks (VPNs)	12.1	14.1R4	14.1R4
Class of service (CoS): <ul style="list-style-type: none"> <li>Maintain CoS across internal tunnel interfaces</li> <li>Packet rewrites</li> <li>Rate limit option for per-port queues</li> <li>Configurable 802.1p inheritance: push and swap from the hidden tag</li> <li>Configurable shaping overhead for scheduling</li> <li>Behavior aggregate (BA) classification</li> <li>BA classification based on 802.1p of "payload" for core-facing VPLS interfaces</li> <li>BA DSCP classification of MPLS packets for L3VPN/VPLS LSI and MPLS interfaces</li> <li>BA DSCP classification for VPLS/CCC family</li> </ul>	12.1	14.1R4	14.1R4
Class of service (CoS) per port: <ul style="list-style-type: none"> <li>Eight queues per port</li> <li>Excess-rate and excess-priority configurations at the queue level</li> <li>Shaping at the port level</li> <li>Shaping at the queue level</li> <li>Scheduling of queues based on the weighted round-robin (WRR) per excess-priority class</li> <li>Round-robin scheduling of the queues per priority class</li> <li>Weighted random early detection (WRED)</li> </ul> <p><b>NOTE:</b> Fine-grained queuing and input queuing are not supported for the MPC3E-3D.</p>	12.1	14.1R4	14.1R4
Class of service (CoS) per virtual LAN (VLAN): <ul style="list-style-type: none"> <li>Accounting, filtering, and policing</li> <li>IEEE 802.1p rewrite</li> <li>Classification</li> <li>Tricolor marking</li> </ul>	12.1	14.1R4	14.1R4

Table 82: Protocols and Applications Supported by MPC3E Cards for MX Series Routers (continued)

Protocol or Application	First Supported Junos OS Release		
	MPC3E-3D	MPC3E-3D-NG	MPC3E-3DNGQ
Class of service (CoS) per Point-to-Point Protocol over Ethernet (PPPoE) or Dynamic Host Configuration Protocol (DHCP) subscriber interfaces: <ul style="list-style-type: none"> <li>Accounting, filtering, and policing</li> <li>IEEE 802.1p rewrite</li> <li>Classification</li> <li>Excess-rate and excess-priority configuration at the queue level</li> <li>Tricolor marking</li> <li>Shaping at the queue level</li> <li>Scheduling of queues based on weighted round-robin (WRR) per priority class</li> <li>Weighted random early detection (WRED)</li> </ul>	—	14.1R4	14.1R4
<i>Distributed Denial-of-Service (DDoS) Protection</i>	12.1	14.1R4	14.1R4
<i>DVMRP and GRE support—access side and server side</i>	—	14.1R4	14.1R4
<i>Dynamic Power Management</i>	15.1	15.1	15.1
Push a tag on Ethernet VPLS and Ethernet CCC tag encapsulations	—	14.1R4	14.1R4
Enhanced subscriber management	15.1R4	15.1R4	15.1R4
<i>Ethernet Ring Protection Switching with multiple G.8032 instances</i>	—	14.1R4	14.1R4
<i>Flexible Queuing Mode</i>	15.1	15.1	15.1
NOTE: Flexible queuing mode is supported only on non-HQoS variants.			
<i>IEEE 802.1ag Ethernet OAM Continuity Check protocol</i>	12.2	14.1R4	14.1R4
<i>IEEE 802.1ag Ethernet OAM Linktrace protocol</i>	12.2	14.1R4	14.1R4
<i>IEEE 802.1ag Ethernet OAM Loopback protocol</i>	12.2	14.1R4	14.1R4
IEEE 802.1ag Maintenance Association Intermediate Point (MIP) support, continuity check message (CCM), stacked VLAN tagging, trunk ports, support for VPLS/VPWS, VLAN circuit cross-connect (CCC) encapsulation and translational cross-connect (TCC) encapsulation	12.2	14.1R4	14.1R4
IEEE 802.1ag Optional type, length, and value (TLVs) support <i>Port Status TLV and Interface Status TLV</i>	—	14.1R4	14.1R4
IEEE 802.3ah distributed periodic packet management (PPM) process, alarm indication signal (AIS), and remote defect indication (RDI)	12.2	14.1R4	14.1R4

Table 82: Protocols and Applications Supported by MPC3E Cards for MX Series Routers (continued)

Protocol or Application	First Supported Junos OS Release		
	MPC3E-3D	MPC3E-3D-NG	MPC3E-3DNGQ
<p><i>Firewall filters and policers:</i></p> <ul style="list-style-type: none"> <li>• Policer support for aggregated Ethernet</li> <li>• Aggregate firewall-based policer for all families of a logical interface</li> <li>• Intelligent hierarchial policers</li> </ul> <p><b>NOTE:</b> Intelligent hierarchial policers are supported from Junos OS Release 13.3.</p> <ul style="list-style-type: none"> <li>• Set forwarding class and loss priority for Routing Engine-generated packets by using a firewall</li> <li>• Physical interface policers, applying policers to the entire port</li> <li>• Lower policer limit from 32K to 8K</li> <li>• Egress IEEE 802.1p multi-field (MF) and BA classification for VPLS</li> <li>• Differentiated Services Code Point (DSCP) rewrite for IPv4 and IPv6</li> </ul> <p><b>NOTE:</b> The packet length used for the policer included in the Layer 2 header is not supported for the MPC3E-3D in release 12.2.</p>	12.1	14.1R4	14.1R4
<i>Flexible Ethernet encapsulation</i>	12.1	14.1R4	14.1R4
<p>Generic Routing Encapsulation (GRE) tunnels or Distance Vector Multicast Routing Protocol (DVMRP) (IP-in-IP) tunnels</p> <ul style="list-style-type: none"> <li>• <i>Dynamic</i></li> <li>• <i>Manual</i></li> </ul>	12.1	14.1R4	14.1R4
<i>Graceful Routing Engine Switchover (GRES)</i>	12.1	14.1R4	14.1R4
Hierarchical Quality of Service (HQoS)	—	14.1R4	14.1R4
IGMP snooping with bridging, IRB, and VPLS	—	14.1R4	14.1R4
IGMPv3 support with snooping disabled	12.1	14.1R4	14.1R4
<p>Ingress and egress hierarchical class-of-service (CoS) shaping and <i>hierarchical-scheduler:</i></p> <ul style="list-style-type: none"> <li>• Group of virtual LANs (VLANs) level</li> <li>• VLAN level</li> <li>• Port level</li> </ul>	—	14.1R4	14.1R4
<i>Inline flow monitoring</i>	12.2	14.1R4	14.1R4
<i>Intelligent Oversubscription on MIC and MPC Interfaces Overview</i>	12.1	14.1R4	14.1R4
<i>Integrated routing and bridging (IRB)</i>	12.2	14.1R4	14.1R4



Table 82: Protocols and Applications Supported by MPC3E Cards for MX Series Routers (continued)

Protocol or Application	First Supported Junos OS Release		
	MPC3E-3D	MPC3E-3D-NG	MPC3E-3DNGQ
Unified <i>In-service software upgrade (Unified ISSU)</i> .	13.3	17.1R1	17.1R1
<i>NOTE: ISSU is not supported on MPC3E-NG with 14.1R4.</i>			
Interoperability with MPCs and existing DPCs	12.1	14.1R4	14.1R4
Interoperability with multiservices DPCs	12.2	14.1R4	14.1R4
Interoperability with MX Series Flexible PIC Concentrators (MX-FPC)	—	14.1R4	14.1R4
IPv4	12.1	14.1R4	14.1R4
<i>IPv4 multicast</i>	12.1	14.1R4	14.1R4
<i>IPv6</i>	12.1	14.1R4	14.1R4
IPv6 MLD	12.1	14.1R4	14.1R4
<i>IPv6 multicast</i>	12.1	14.1R4	14.1R4
<i>IPv6 Neighbor Discovery</i>	12.1	14.1R4	14.1R4
<i>IS-IS</i>	12.1	14.1R4	14.1R4
ITU-T Y.1731 timestamping support on MX Series routers	—	14.1R4	14.1R4
Flow monitoring and services:	12.2	14.1R4	14.1R4
<ul style="list-style-type: none"> <li>• Active monitoring (multiple v8 version j-flow templates)</li> <li>• Active monitoring (cfloved version 9 templates)</li> <li>• Port mirroring family VPLS, bridge CCC encapsulation (VPWS)</li> <li>• Packet slice for port mirroring</li> <li>• Inline flow monitoring on MPC3E</li> <li>• Flow monitoring on multiservices DPCs</li> </ul>			
<i>NOTE: Flow monitoring on Multiservices DPCs is not supported for the MPC3E-3D in release 12.2..</i>			
<i>Labeled-switched-paths (LSPs)</i> including accounting, policers, and filtering	12.1	14.1R4	14.1R4

Table 82: Protocols and Applications Supported by MPC3E Cards for MX Series Routers (continued)

Protocol or Application	First Supported Junos OS Release		
	MPC3E-3D	MPC3E-3D-NG	MPC3E-3DNGQ
Layer 2 features: <ul style="list-style-type: none"> <li>• Trunk ports</li> <li>• Layer 2 support for MX Series Virtual Chassis</li> <li>• Layer 2 and Layer 2.5, IRB and Spanning Tree Protocols (xSTP)</li> <li>• IEEE 802.1ad provider bridges</li> <li>• Layer 2 protocol tunneling (L2PT) support</li> <li>• Layer 2 Tunneling Protocol (L2TP)</li> <li>• Multi-chassis LAG—active/active and active/standby</li> <li>• Multi-chassis LAG—active/active with IGMP snooping</li> <li>• Link aggregation group (LAG)—VLAN-CCC encapsulation</li> </ul> <p><b>NOTE:</b> LAG features and IGMP snooping with bridging, IRB, and VPLS are not supported for the MPC3E-3D in release 12.2.</p>	12.2	14.1R4	14.1R4
Layer 2 VPN interfaces support VLAN ID list	12.1	14.1R4	14.1R4
Label Distribution Protocol (LDP)	12.1	14.1R4	14.1R4
Link aggregation (IEEE 802.3ad)	12.1	14.1R4	14.1R4
Link Aggregation Control Protocol (LACP)	12.1	14.1R4	14.1R4
Link Layer Discovery Protocol (LLDP)	—	14.1R4	14.1R4
Local loopback	12.1	14.1R4	14.1R4
MAC learning, policing, accounting, and filtering	12.1	14.1R4	14.1R4
Mobile IP	—	14.1R4	14.1R4
Multichassis link aggregation	—	14.1R4	14.1R4
Multiple Tag Protocol Identifiers (TPIDs)	12.1	14.1R4	14.1R4

Table 82: Protocols and Applications Supported by MPC3E Cards for MX Series Routers (continued)

Protocol or Application	First Supported Junos OS Release		
	MPC3E-3D	MPC3E-3D-NG	MPC3E-3DNGQ
<i>MPLS:</i>	12.1	14.1R4	14.1R4
<ul style="list-style-type: none"> <li>Switching of pseudowire segments (multisegment pseudowires with BGP-L2VPN)</li> <li>LDP signaling for VPLS (LDP-VPLS) and MAC flush message processing (MAC-FLUSH-TLV)</li> <li>RSVP graceful restart interoperability with Cisco using Nodal Hello</li> <li>Failure action on BFD session down of RSVP LSPs</li> <li>OSPF and IS-IS loop-free alternates (LFA)</li> <li>4/5 label MPLS operation</li> <li>Virtual circuit connectivity verification (VCCV) BFD</li> <li>Point to multipoint using the enhanced-ip command (support for NG-MVPN and P2MP load balancing over aggregated Ethernet)</li> <li>MPLS-FRR bypass link protection</li> <li>Load sharing across 64 ECMP next hops</li> <li>MPLS-FRR VPLS instance prioritization</li> <li>Five label stack on ingress</li> </ul>			
MPLS node protection, link protection, and statistics for static LSPs	12.1	14.1R4	14.1R4
<i>mvrp</i>	—	14.1R4	14.1R4
<i>Multitopology routing</i>	12.1	14.1R4	14.1R4
Nonstop active routing (NSR)	12.1	14.1R4	14.1R4
<i>OSPF</i>	12.1	14.1R4	14.1R4
Packet mirroring	12.2	14.1R4	14.1R4
IEEE 802.1ah Provider Bridging (PBB)	—	14.1R4	14.1R4
<i>RSVP</i>	12.1	14.1R4	14.1R4
<i>RIP</i>	12.1	14.1R4	14.1R4
<i>SNMP</i>	12.1	14.1R4	14.1R4

Table 82: Protocols and Applications Supported by MPC3E Cards for MX Series Routers (continued)

Protocol or Application	First Supported Junos OS Release		
	MPC3E-3D	MPC3E-3D-NG	MPC3E-3DNGQ
Spanning Tree Protocols: <ul style="list-style-type: none"> <li>• IEEE 802.1s Multiple Spanning Tree Protocol (MSTP) (part of IEEE 802.1Q VLANs)</li> <li>• IEEE 802.1w Rapid Spanning Tree Protocol (RSTP)</li> <li>• Spanning-Tree Protocols (STP)</li> <li>• Per-VLAN Spanning Tree (PVST)</li> <li>• Bridge protocol data units (BPDUs) guard and loop guard</li> <li>• STP inter-protocol action profiles and MAC flush (in VPLS multi-homing, flush all MACs when there is a change in the STP interface state due to root protect)</li> </ul>	12.2	14.1R4	14.1R4
Subscriber management and services (MX2010, MX2020: 12.3R4, 13.2R2, 13.3): <ul style="list-style-type: none"> <li>• Aggregated Ethernet over static VLANs</li> <li>• Aggregated Ethernet over dynamic VLANs</li> <li>• ANCP and the ANCP Agent Overview</li> <li>• DHCP access model</li> <li>• Dynamic adjustment of shapers</li> <li>• Dynamic PPPoE subscriber interface creation based on PPPoE service name tables</li> <li>• Dynamic profiles</li> <li>• Dynamic shaping, scheduling, and queuing</li> <li>• Dynamic VLANs</li> <li>• Per unit scheduling</li> <li>• Static and dynamic PPPoE subscriber interfaces</li> </ul>	—	14.1R4	14.1R4
Synchronous Ethernet	13.2	14.1R4	14.1R4
Two-Way Active Measurement Protocol (TWAMP)	—	14.1R4	14.1R4
Tunnel services <ul style="list-style-type: none"> <li>• Clear DF-Bit (Don't Fragment Bit)</li> </ul>	12.1	14.1R4	14.1R4
Unified in-service software upgrade (ISSU)	13.3	17.1R1	17.1R1
<b>NOTE:</b> ISSU is not supported on MPC3E-NG with 14.1R4.			
Unnumbered Ethernet Interface	12.1	14.1R4	14.1R4

Table 82: Protocols and Applications Supported by MPC3E Cards for MX Series Routers (continued)

Protocol or Application	First Supported Junos OS Release		
	MPC3E-3D	MPC3E-3D-NG	MPC3E-3DNGQ
VLANs <i>IEEE 802.1Q</i> : <ul style="list-style-type: none"> <li>VLAN stacking and rewriting</li> <li>Channels defined by two stacked VLAN tags</li> <li>Flexible VLAN tagging</li> <li>IP service for nonstandard TPID and stacked VLAN tags</li> </ul>	12.1	14.1R4	14.1R4
Virtual Chassis: MPLS IPv4 and IPv6, unicast, multicast forwarding, VPLS, NSR for Layer 3/MPLS services	13.2R1	14.1R4	14.1R4
Virtual private LAN service ( <i>VPLS</i> ): <ul style="list-style-type: none"> <li>BGP multihoming for inter-AS VPLS</li> <li>Gigabit Ethernet as core-facing interface</li> <li>Configurable label block sizes</li> <li>Hashing L3/L4 fields under Ethernet pseudowire for VPLS encapsulation, CCC encapsulation, and MPLS encapsulation</li> <li>VPLS flood forwarding table filter (FTF), input FTF</li> <li>Broadcast, unicast unknown, and multicast (BUM) traffic hashing over LAG</li> </ul>	12.1	14.1R4	14.1R4
Virtual private network (VPN)	12.1	14.1R4	14.1R4
Virtual Router Redundancy Protocol ( <i>VRRP</i> ) for IPv4	12.1	14.1R4	14.1R4
VPLS packet flooding to the right set of interfaces across mesh groups	—	14.1R4	14.1R4
WAN-PHY mode	12.2	14.1R4	14.1R4

- Related Documentation**
- [MPC3E on page 113](#)
  - [MICs Supported by MX Series Routers on page 18](#)

## Protocols and Applications Supported on the MPC4E for MX Series Routers

Table 83 on page 379 contains the first Junos OS Release support for protocols and applications on the MPC4E. The protocols and applications support feature parity with Junos OS Release 12.2. A dash indicates that the protocol or application is not supported.

Table 83: Protocols and Applications Supported by the MX Series MPC4E

Protocol or Application	First Supported Junos OS Release
<i>Bidirectional Forwarding Detection protocol (BFD)</i>	12.3R2

Table 83: Protocols and Applications Supported by the MX Series MPC4E (continued)

Protocol or Application	First Supported Junos OS Release
Border Gateway Protocol (BGP)	12.3R2
Bridge protocol data units (BPDUs)	12.3R2
Class of service (CoS): <ul style="list-style-type: none"> <li>Behavior Aggregate (BA) classification</li> <li>Forwarding class loss priority through logical tunnels (LT)</li> <li>Static VLAN mapping to a specific forwarding class using a multi-field (MF) classifier</li> <li>Targeted traffic distribution for a logical subscriber interface across a Link Aggregate Group (LAG) bundle</li> <li>Packet rewrites</li> <li>Configurable IEEE 802.1p inheritance</li> <li>Rate-limit option for per-port queues</li> <li>Configurable shaping overhead for scheduling</li> <li>Weighted Random Early Detection (WRED)</li> <li>Intelligent oversubscription on MIC and MPC interfaces</li> <li>Class of Service on Ethernet pseudowires on Logical Tunnel (LT) interfaces</li> <li>Fine-grained authentication for RE-generated packets</li> <li>IEEE 802.1ad S-TAG, exiting/incoming core with label-switched interfaces (LSIs)</li> <li>Egress IEEE 802.1p multifield (MF) and BA classification for VPLS (MX series only)</li> </ul>	12.3R2
Class of service (CoS) per port: <ul style="list-style-type: none"> <li>Eight queues per port</li> <li>Excess-rate and excess-priority configuration at the queue level</li> <li>Shaping at the port level and queue level</li> <li>Scheduling of queues based on weighted round-robin (WRR) per excess-priority class</li> <li>Round-robin scheduling of the queues per priority class</li> <li>Weighted random early detection (WRED)</li> <li>Rate limit option for per-port queues</li> </ul>	12.3R2  <b>NOTE:</b> Fine-grained queuing and input queuing are not supported.
Class of service (CoS) per virtual LAN (VLAN): <ul style="list-style-type: none"> <li>Accounting, filtering, and policing</li> <li>IEEE 802.1p rewrite</li> <li>Classification</li> <li>Tricolor marking</li> </ul>	12.3R2

Table 83: Protocols and Applications Supported by the MX Series MPC4E (continued)

Protocol or Application	First Supported Junos OS Release
Class of service (CoS) per Point-to-Point Protocol over Ethernet (PPPoE) or Dynamic Host Configuration Protocol (DHCP) subscriber interfaces: <ul style="list-style-type: none"> <li>Accounting, filtering, and policing</li> <li>IEEE 802.1p rewrite</li> <li>Excess-rate and excess-priority configuration at the queue level</li> <li>Tricolor marking</li> <li>Shaping at the queue level</li> <li>Scheduling of queues based on weighted round-robin (WRR) per priority class</li> <li>Weighted random early detection (WRED)</li> </ul>	–
Connectivity Fault Management (CFM) protocols and features (IEEE 802.1ag): <ul style="list-style-type: none"> <li>Ethernet OAM Continuity Check Message (CCM) protocol</li> <li>Ethernet OAM Linktrace protocol</li> <li>Ethernet OAM Loopback protocol</li> <li>Maintenance Intermediate Points (MIPs)</li> <li>Stacked VLAN tagging</li> <li>Trunk ports</li> <li>VPLS/VPWS</li> <li>VLAN circuit cross-connect (CCC) encapsulation</li> <li>Transitional cross-connect (TCC) encapsulation</li> </ul>	12.3R2
<i>Distributed Denial-of-Service (DDoS) Protection</i>	12.3R2
<i>Distributed Periodic Packet Management Process (PPMP)</i>	12.3R2
<i>Distance Vector Multicast Routing Protocol (DVMRP) Tunnels—access side and server side</i>	12.3R2
<i>Ethernet Alarm Indication Signal (ETH-AIS)</i>	12.3R2
<i>Ethernet Ring Protection Switching with multiple G.8032 instances</i>	12.3R2
<i>Firewall filters and policers:</i> <ul style="list-style-type: none"> <li>Intelligent Hierarchical Policers</li> <li>Policer support for aggregated Ethernet</li> <li>Aggregate firewall-based policer for all families of a logical interface</li> <li>Layer 2 policers</li> <li>Set forwarding class loss priority for Routing Engine (RE)-generated packets by using a firewall</li> <li>Physical interface policers, applying policer to the entire port</li> <li>Filter-specific counters and filters</li> </ul>	12.3R2
<i>Flexible Ethernet encapsulation</i>	12.3R2
<i>Graceful routing engine switchover (GRES)</i>	12.3R2

Table 83: Protocols and Applications Supported by the MX Series MPC4E (continued)

Protocol or Application	First Supported Junos OS Release
<i>Configuring Generic Routing Encapsulation Tunneling—access side and server side</i>	12.3R2
IGMPv3 support with snooping disabled	12.3R2
Ingress and egress hierarchical class-of-service (CoS) shaping and <i>hierarchical-scheduler</i> : <ul style="list-style-type: none"> <li>• Group of virtual LANs (VLANs) level</li> <li>• VLAN level</li> <li>• Port level</li> </ul>	–
<i>Inline flow monitoring</i>	12.3R2
<i>Intelligent oversubscription on the Trio MPC/MIC interfaces</i>	12.3R2
<i>Integrated Routing and Bridging (IRB)</i>	12.3R2
<i>Unified In-service software upgrade (Unified ISSU)</i>	13.3
Interoperability with MX Series Flexible PIC Concentrators (MX-FPC)	12.3R2
Interoperability with MPCs and existing DPCs	12.3R2
Interoperability with Juniper Networks 100-Gigabit Ethernet PIC	12.3R2
Interoperability with MX Series Application Services Modular Line Card (AS-MLC)	12.3R2
IPv4	12.3R2
<i>IPv4 multicast</i>	12.3R2
IPv6	12.3R2
<i>IPv6 Multicast Listener Discovery (MLD)</i>	12.3R2
<i>IPv6 multicast</i>	12.3R2
<i>IPv6 Neighbor Discovery Protocol (NDP)</i>	12.3R2
<i>Immediate System-to-Intermediate System (IS-IS)</i>	12.3R2
ITU-T Y.1731 timestamping support (MX Series routers)	12.3R2



Table 83: Protocols and Applications Supported by the MX Series MPC4E (continued)

Protocol or Application	First Supported Junos OS Release
Flow monitoring and services: <ul style="list-style-type: none"> <li>Active monitoring (multiple v9 j-flow templates)</li> <li>Active monitoring: cflowed v9 IPv6 templates</li> <li>Active Monitoring: cflowd V9 per-PFE sampling support</li> <li>Port mirroring for Layer 2 bridging traffic (family ethernet-switching) <ul style="list-style-type: none"> <li>Port mirroring for Layer 2 VPLS traffic (family vpls)</li> <li>Port mirroring for Layer 2 VPN traffic over a circuit cross-connect (CCC)</li> <li>Virtual private wire service (VPWS)</li> <li>Flow monitoring on Multiservices DPCs</li> <li>Packet slice for port mirroring</li> <li>Inline Jflow monitoring (IPFIX)</li> </ul> </li> </ul>	12.3R2
<i>Labeled-switched-paths (LSPs)</i> including accounting, policers, and filtering	12.3R2
<i>Label Distribution Protocol (LDP)</i>	12.3R2
Layer 2 features:	Release
<ul style="list-style-type: none"> <li>Integrated Routing and Bridging (IRB)</li> <li>Spanning Tree Protocols</li> <li>Link Layer Discovery Protocol (LLDP)</li> <li>Bridge Protocol Data Unit (BPDU) guard</li> <li>Bridge Protocol Data Unit (BPDU) loop guard</li> <li>Layer 2 Tunneling Protocol (L2TP)</li> <li>Trunk ports</li> <li>IEEE 802.1ad provider bridges</li> <li>Multi-chassis Link Aggregation Group (MC-LAG)—active/active and active/standby</li> <li>MC-LAG—active/active with IGMP snooping</li> <li>MC-LAG VLAN –ccc interface encapsulation</li> <li>Layer 2 Protocol Tunneling (L2PT) support</li> <li>IGMP snooping with bridging, IRB, and VPLS</li> <li><i>Layer 2 forwarding support under logical systems</i></li> <li>Static Route Support</li> <li>64 members in a link aggregation group</li> <li>Periodic packet management daemon (ppmd) and distributed PPMD for Link Aggregation Control Protocol process (LACPd)</li> </ul>	<ul style="list-style-type: none"> <li>12.3R2</li> <li>12.3R2</li> <li>13.3R1 , 12.3R4</li> <li>12.3R2</li> <li>12.3R2</li> <li>12.3R2</li> <li>13.3R1</li> <li>13.3R1</li> <li>13.3R1</li> <li>–</li> <li>13.3R1</li> <li>13.3R1</li> <li>12.3R2</li> <li>12.3R2</li> <li>13.2R1</li> <li>13.2R1</li> </ul>

Table 83: Protocols and Applications Supported by the MX Series MPC4E (continued)

Protocol or Application	First Supported Junos OS Release
Layer 3 Features:	Release
<ul style="list-style-type: none"> <li>IPv6</li> <li>Protocol Independent Multicast Source-Specific Multicast (PIM SSM)</li> <li>Bidirectional Forwarding Detection (BFD)</li> <li>Any-source multicast (ASM) group override of source-specific multicast (SSM) range</li> <li>Connectionless Network Service (CLNS)</li> <li>Data Multicast Domain Tunnels (MDT) Subsequent Address Family Identifiers (SAFI)</li> <li>Draft-Rosen 7 Multicast VPNs</li> <li>Multicast over Integrated Routing and Bridging (IRB) interfaces</li> <li>Composite next hop with External and Internal BGP (EIBGP) paths</li> <li>VPN load balancing and IP header filtering of traffic across External and Internal BGP (EIBGP) paths</li> <li>Multiprotocol Label Switching (MPLS) over Generic Routing Encapsulation (GRE)</li> <li>Multicast routing on Integrated Routing and Bridging (IRB) interfaces using logical tunnel interfaces systems with a Trio MPC/MIC module</li> </ul>	<ul style="list-style-type: none"> <li>12.3R2</li> <li>12.3R2</li> <li>12.3R2</li> <li>12.3R2</li> <li>12.3R2</li> <li>12.3R2</li> <li>12.3R2</li> <li>12.3R2</li> <li>12.3R2</li> <li>13.2R1</li> <li>13.2R1</li> <li>13.2R1</li> </ul>
Link aggregation (IEEE 802.3ad)	12.3R2
Link Aggregation Control Protocol (LACP)	12.3R2
Link Layer Discovery Protocol (LLDP)	–
Local loopback	12.3R2
MAC learning, policing, accounting, and filtering	12.3R2
Mobile IP	–
Multiservices DPC (MS-DPC):	13.2R1
<ul style="list-style-type: none"> <li>Junos Address Aware Network Addressing Overview</li> <li>Intrusion Detection Service (IDS)</li> <li>Graceful Routing Engine Switchover (GRES) for NAT</li> <li>Intrusion Detection and Prevention (IDP) interoperability</li> <li>IP Security (IPSec) detection</li> <li>Two-Way Active Measurement Protocol (TWAMP) interoperability</li> <li>Real-Time Performance Monitor (RPM) interoperability</li> <li>GRE interoperability</li> </ul>	
Multi-chassis Link Aggregation (MC-LAG)	13.3R1
Multiple Tag Protocol Identifiers (TPIDs)	12.3R2

Table 83: Protocols and Applications Supported by the MX Series MPC4E (continued)

Protocol or Application	First Supported Junos OS Release
<i>Multiprotocol Label Switching (MPLS):</i> <ul style="list-style-type: none"> <li>• Switching of pseudowire segments (multi-segment pseudowires with BGP-L2VPN)</li> <li>• LDP signaling for VPLS (LDP-VPLS) and MAC flush message processing (MAC-FLUSH-TLV)</li> <li>• RSVP graceful restart interoperability with Cisco using Nodal Hello</li> <li>• Failure action on BFD session down of RSVP LSPs</li> <li>• OSPF and IS-IS loop-free alternates (LFA)</li> <li>• 4/5 label MPLS operation</li> <li>• Virtual circuit connection verification (VCCV) BFD</li> <li>• Point-to-multipoint using the <b>enhanced-ip</b> command (support for NG-MVPN and P2MP load balancing over aggregated Ethernet)</li> <li>• MPLS-FRR bypass link protection</li> <li>• Load sharing across 64 ECMP next hops</li> <li>• MPLS-FRR VPLS instance prioritization</li> <li>• Five label stack on ingress</li> <li>• Generic Routing Encapsulation (GRE) keepalive messages</li> <li>• MPLS node protection, link protection, and statistics for static LSPs</li> </ul>	12.3R2
<i>mvrp</i>	–
<i>Multitopology routing (MTR)</i>	–
Nonstop Active Routing (NSR)	12.3R2
<i>Open Shortest Path First (OSPF)</i>	12.3R2
Packet mirroring	12.3R2
Precision Time Protocol (IEEE 1588)	15.1R1
IEEE 802.1ah provider backbone bridges (PBB)	–
<i>Periodic Packet Management Process (PPMP) and Distributed PPMP</i>	12.3R2
Push a tag on Ethernet VPLS and Ethernet CCC tag encapsulations	–
Remote Defect Indication (RDI)	12.3R2
<i>Resource Reservation Protocol (RSVP)</i>	12.3R2
<i>Routing Information Protocol (RIP)</i>	12.3R2
<i>SNMP</i>	12.3R2

Table 83: Protocols and Applications Supported by the MX Series MPC4E (continued)

Protocol or Application	First Supported Junos OS Release
Spanning Tree Protocols:	12.3R2
<ul style="list-style-type: none"> <li>• IEEE 802.1s Multiple Spanning Tree Protocol (MSTP) (part of IEEE 802.1Q VLANs)</li> <li>• IEEE 802.1w Rapid Spanning Tree Protocol (RSTP)</li> <li>• IEEE 802.1D Spanning Tree Protocol (STP)</li> <li>• Per-VLAN Spanning Tree (PVST)</li> <li>• Bridge Protocol Data Units (BPDUs) guard and loop guard</li> <li>• STP interprotocol action profiles and MAC flush (in VPLS multihoming, flush all MACs when there is a change in the STP interface state due to root protect)</li> </ul>	
Subscriber management and services:	Release
(MX2010, MX2020: 12.3R4, 13.2R2, 13.3)	
<ul style="list-style-type: none"> <li>• Aggregated Ethernet over static VLANs</li> <li>• Aggregated Ethernet over dynamic VLANs</li> <li>• ANCP and the ANCP Agent Overview</li> <li>• DHCP access model</li> <li>• Dynamic adjustment of shapers</li> <li>• Dynamic PPPoE subscriber interfaces creation based on PPPoE service name tables</li> <li>• Dynamic profiles</li> <li>• Dynamic shaping, scheduling, and queuing</li> <li>• Dynamic VLANs</li> <li>• Enhanced subscriber management</li> <li>• Static and dynamic PPPoE subscriber interfaces</li> </ul>	<ul style="list-style-type: none"> <li>• 12.3R2</li> <li>• 12.3R2</li> <li>• 12.3R2</li> <li>• 12.3R2</li> <li>• 12.3R2</li> <li>• 12.3R2</li> <li>• 12.3R2</li> <li>• 12.3R2</li> <li>• 12.3R2</li> <li>• 12.3R2</li> <li>• 15.1R4</li> <li>• 12.3R2</li> </ul>
Synchronous Ethernet (SyncE)	12.3 with SCBE and later
Two-Way Active Measurement Protocol (TWAMP)	13.2
Tunnel services	12.3R2
<ul style="list-style-type: none"> <li>• Clear DF-Bit (Don't Fragment Bit)</li> </ul>	
Type, Length, and Value (TLVs) support (IEEE 802.1ag)	–
Unnumbered Ethernet Interface	12.3R2
VLANs IEEE 802.1Q:	12.3R2
<ul style="list-style-type: none"> <li>• VLAN stacking and rewriting</li> <li>• Channels defined by two stacked VLAN tags</li> <li>• Flexible VLAN tagging</li> <li>• IP service for nonstandard TPID and stacked VLAN tags</li> </ul>	

Table 83: Protocols and Applications Supported by the MX Series MPC4E (continued)

Protocol or Application	First Supported Junos OS Release
<i>Virtual Chassis (MX Series):</i> <ul style="list-style-type: none"> <li>• <i>Class of Service (CoS) Support for Virtual Ports</i></li> <li>• Layer 2 support</li> <li>• DHCP Access Model and authentication, authorization, and accounting (AAA) services</li> <li>• Layer 3 Provider Edge (PE) router support</li> <li>• Dynamic Lawful Intercept (DLI)</li> <li>• <i>Layer 2 Access Node Control Protocol (ANCP)</i></li> <li>• <i>Wireline Subscriber Management scaling to 64K subscribers</i></li> <li>• Non-stop active routing (NSR) support for Layer 3 services</li> <li>• Local, Global, and VCCP Graceful Routing Engine Switchover (GRES)</li> <li>• SNMP trap generation when <code>vc-port</code> command fails</li> <li>• Virtual Chassis Port (VCP) masking</li> <li>• <i>Access to the Virtual Chassis Through the Management Interface</i></li> </ul>	13.2R1 (12.3R4 TRD)
<i>Virtual Private LAN service (VPLS):</i> <ul style="list-style-type: none"> <li>• BGP multihoming for inter-AS VPLS</li> <li>• Gigabit Ethernet as core-facing interface</li> <li>• Configurable label block sizes</li> <li>• Hashing L3/L4 fields under Ethernet pseudowire for VPLS encapsulation, CCC encapsulation, and MPLS encapsulation</li> <li>• VPLS flood forwarding table filter (FTF), input FTF</li> <li>• Broadcast, unicast unknown, and multicast (BUM) traffic hashing over LAG</li> <li>• Configurable multichassis link aggregation (MC-LAG) interfaces to improve the Layer 2 and Layer 3 convergence time to subsecond values when a multichassis aggregated Ethernet link goes down or comes up in a bridge domain</li> <li>• <i>MAC Pinning to control MAC moves in a bridging environment and in VPLS networks</i></li> </ul>	12.3R2
Virtual private network (VPN): <ul style="list-style-type: none"> <li>• <i>Multiprotocol Label Switching (MPLS)</i></li> </ul>	12.3R2
<i>Virtual Router Redundancy Protocol (VRRP) for IPv4</i> <ul style="list-style-type: none"> <li>• Scale VRRP using instance grouping</li> <li>• <i>Periodic Packet Management Process (PPMP) and Distributed Periodic Packet Management Process (PPMP)</i></li> </ul>	12.3R2
VPLS packet flooding to the right set of interfaces across mesh groups	12.3R2
WAN-PHY mode	12.3R2

**Related Documentation**

- [32x10GE MPC4E on page 119](#)
- [2x100GE + 8x10GE MPC4E on page 120](#)
- [MICs Supported by MX Series Routers on page 18](#)

- [MPCs Supported by MX240, MX480, MX960, MX2010, and MX2020 Routers on page 12](#)

## Protocols and Applications Supported by the MPC5E for MX Series Routers

Table 84 on page 388 contains the first Junos OS Release support for protocols and applications in the MPC5E installed on the MX240, MX480, MX960, MX2010, and MX2020 routers. The protocols and applications support feature parity with Junos OS Release 12.3.

A dash indicates that the protocol or application is not supported.

**Table 84: Protocols and Applications Supported by the MX240, MX480, MX960, MX2010, and MX2020 MPC5E**

Protocol or Application	First Supported Junos OS Release
<i>Access Node Control Protocol (ANCP)</i>	-
Accepts traffic destined for generic routing encapsulation (GRE) tunnels or Distance Vector Multicast Routing Protocol (DVMRP) (IP-in-IP) tunnels <ul style="list-style-type: none"> <li>• <i>Dynamic</i></li> <li>• <i>Manual</i></li> </ul>	13.3R3
<i>Bidirectional Forwarding Detection protocol (BFD)</i>	13.3R3
<i>Border Gateway Protocol (BGP)</i>	13.3R3
Bridge protocol data units (BPDUs)	13.3R3
BGP/MPLS virtual private networks (VPNs)	13.3R3
Class of service (CoS): <ul style="list-style-type: none"> <li>• Maintain CoS across internal tunnel interfaces</li> <li>• Packet rewrites</li> <li>• Behavior aggregate (BA) classification</li> <li>• BA classification based on 802.1p of <i>payload</i> for core-facing VPLS interfaces</li> <li>• BA DSCP classification of MPLS packets for Layer 3 VPN/VPLS LSI and MPLS interfaces</li> <li>• Rate limit option for per-port queues</li> <li>• BA DSCP classification for VPLS/CCC family</li> <li>• Configurable .1p inheritance: push and swap from the hidden tag</li> <li>• Configurable shaping overhead for scheduling</li> </ul>	13.3R3

**Table 84: Protocols and Applications Supported by the MX240, MX480, MX960, MX2010, and MX2020 MPC5E (continued)**

Protocol or Application	First Supported Junos OS Release
Class of service (CoS) per port: <ul style="list-style-type: none"> <li>• Eight queues per port</li> <li>• Excess-rate and excess-priority configurations at the queue level</li> <li>• Shaping at the port level</li> <li>• Shaping at the queue level</li> <li>• Scheduling of queues based on the weighted round-robin (WRR) per excess-priority class</li> <li>• Round-robin scheduling of the queues per priority class</li> <li>• Weighted random early detection (WRED)</li> </ul>	13.3R3
Class of service (CoS) per virtual LAN (VLAN): <ul style="list-style-type: none"> <li>• Accounting, filtering, and policing</li> <li>• IEEE 802.1p rewrite</li> <li>• Classification</li> <li>• Tricolor marking</li> </ul>	13.3R3
Class of service (CoS) per Point-to-Point Protocol over Ethernet (PPPoE) or Dynamic Host Configuration Protocol (DHCP) subscriber interfaces: <ul style="list-style-type: none"> <li>• Accounting, filtering, and policing</li> <li>• IEEE 802.1p rewrite</li> <li>• Classification</li> <li>• Excess-rate and excess-priority configuration at the queue level</li> <li>• Tricolor marking</li> <li>• Shaping at the queue level</li> <li>• Scheduling of queues based on weighted round-robin (WRR) per priority class</li> <li>• Weighted random early detection (WRED)</li> </ul>	13.3R3
<i>Damping</i>	15.1R2
<i>Distributed Denial-of-Service (DDoS) Protection</i>	13.3R3
<i>DVMRP and GRE support—access side and server side</i>	13.3R3
<i>Ethernet Ring Protection Switching with multiple G.8032 instances</i>	13.3R3
<i>IEEE 802.1ag Ethernet OAM Continuity Check protocol</i>	13.3R3
<i>IEEE 802.1ag Ethernet OAM Linktrace protocol</i>	13.3R3
<i>IEEE 802.1ag Ethernet OAM Loopback protocol</i>	13.3R3
IEEE 802.1ag Maintenance Association Intermediate Point (MIP) support, continuity check message (CCM), stacked VLAN tagging, trunk ports, support for VPLS/VPWS, VLAN circuit cross-connect (CCC) encapsulation and translational cross-connect (TCC) encapsulation	13.3R3

**Table 84: Protocols and Applications Supported by the MX240, MX480, MX960, MX2010, and MX2020 MPC5E (continued)**

Protocol or Application	First Supported Junos OS Release
<i>Port Status TLV and Interface Status TLV</i>	-
IEEE 802.3ah distributed periodic packet management (PPM) process, alarm indication signal (AIS), and remote defect indication (RDI)	13.3R3
<i>Firewall filters and policers:</i>	13.3R3
<ul style="list-style-type: none"> <li>• Policer support for aggregated Ethernet</li> <li>• Aggregate firewall-based policer for all families of a logical interface</li> <li>• Set forwarding class and loss priority for Routing Engine-generated packets by using a firewall</li> <li>• Physical interface policers, applying policers to the entire port</li> <li>• Lower policer limit from 32,000 to 8000</li> <li>• Egress .1p MF and BA classification for VPLS</li> <li>• Differentiated Services Code Point (DSCP) rewrite for IPv4 and IPv6</li> </ul>	
<i>Flexible Ethernet encapsulation</i>	13.3R3
<i>Flexible Queuing Mode</i>	14.1R1
<b>NOTE:</b> Flexible queuing mode is supported only on non-HQoS variants.	
<i>Graceful Routing Engine Switchover (GRES)</i>	13.3R3
IGMPv3 support with snooping disabled	13.3R3
Ingress and egress hierarchical class-of-service (CoS) shaping and <i>hierarchical-scheduler:</i>	13.3R3
<ul style="list-style-type: none"> <li>• Group of virtual LANs (VLANs) level</li> <li>• VLAN level</li> <li>• Port level</li> </ul>	
Hierarchical CoS on generic routing encapsulation (GRE) tunnels	15.1R2
<i>Inline active flow monitoring</i>	13.3R3
<i>Intelligent Oversubscription</i>	13.3R3
<i>Integrated routing and bridging (IRB)</i>	13.3R3
Unified <i>In-service software upgrade (Unified ISSU)</i>	16.1R1
Interoperability with MPCs and existing DPCs	-
Interoperability with Multiservices DPCs	13.3R3
Interoperability with MX Series Flexible PIC Concentrators (MX-FPC)	13.3R3



**Table 84: Protocols and Applications Supported by the MX240, MX480, MX960, MX2010, and MX2020 MPC5E (continued)**

Protocol or Application	First Supported Junos OS Release
Interoperability with Juniper Networks 100-Gigabit Ethernet PIC	13.3R3
Interoperability with MX Series Application Services Modular Line Card (AS-MLC)	13.3R3
IPv4	13.3R3
<i>IPv4 multicast</i>	13.3R3
<i>IPv6</i>	13.3R3
IPv6 MLD	13.3R3
<i>IPv6 multicast</i>	13.3R3
<i>IPv6 Neighbor Discovery</i>	13.3R3
<i>IS-IS</i>	13.3R3
ITU-T Y.1731 timestamping support on MX Series routers	13.3R3
Flow monitoring and services:	Release
• Active monitoring (multiple version 8 j-flow templates)	• 13.3R3
• Active monitoring (cflowed version 9 templates)	• 13.3R3
• Port mirroring family VPLS, bridge CCC encapsulation (VPWS)	• 13.3R3
• Packet slice for port mirroring	• 13.3R3
• Flow monitoring on Multiservices DPCs	• -
• Inline active flow monitoring on MPC5E	• 13.3R3
<i>Labeled-switched-paths (LSPs)</i> including accounting, policers, and filtering	13.3R3
<i>LDP</i>	13.3R3
<i>Layer 2 features:</i>	Release
• Trunk ports	• 13.3R3
• Layer 2 support for MX Series Virtual Chassis	• 13.3R3
• Layer 2 and Layer 2.5, IRB, and Spanning Tree Protocols (xSTP)	• -
• IEEE 802.1ad provider bridges	• 13.3R3
• Layer 2 protocol tunneling (L2PT) support	• 13.3R3
• Layer 2 Tunneling Protocol (L2TP)	• 13.3R3
• Multichassis LAG—active/active and active/standby	• 13.3R3
• Multichassis LAG—active/active with IGMP snooping	• 13.3R3
• Link aggregation group (LAG)—VLAN-CCC encapsulation	• 13.3R3
• IGMP snooping with bridging, IRB, and VPLS	• 13.3R3

**Table 84: Protocols and Applications Supported by the MX240, MX480, MX960, MX2010, and MX2020 MPC5E (continued)**

Protocol or Application	First Supported Junos OS Release
Layer 2 VPN interfaces support VLAN ID list	13.3R3
<i>Link aggregation (IEEE 802.3ad)</i>	13.3R3
<i>Link Aggregation Control Protocol (LACP)</i>	13.3R3
<i>Link Layer Discovery Protocol (LLDP)</i>	13.3R3
Local loopback	13.3R3
<i>MAC learning, policing, accounting, and filtering</i>	13.3R3
Mobile IP	-
Multichassis link aggregation	-
Multiple Tag Protocol Identifiers (TPIDs)	13.3R3
<i>MPLS:</i>	13.3R3
<ul style="list-style-type: none"> <li>• Switching of pseudowire segments (multisegment pseudowires with BGP-L2VPN)</li> <li>• LDP signaling for VPLS (LDP-VPLS) and MAC flush message processing (MAC-FLUSH-TLV)</li> <li>• RSVP graceful restart interoperability with Cisco using Nodal Hello</li> <li>• Failure action on BFD session down of RSVP LSPs</li> <li>• OSPF and IS-IS loop-free alternates (LFA)</li> <li>• 4/5 label MPLS operation</li> <li>• Virtual circuit connectivity verification (VCCV) BFD</li> <li>• <i>Point to multipoint</i> using the <b>enhanced-ip</b> command (support for NG-MVPN and <i>point-to-multipoint</i> load balancing over aggregated Ethernet)</li> <li>• MPLS-FRR bypass link protection</li> <li>• Load sharing across 64 ECMP next hops</li> <li>• MPLS-FRR VPLS instance prioritization</li> <li>• Five label stack on ingress</li> </ul>	
MPLS node protection, link protection, and statistics for static LSPs	13.3R3
<i>mvrp</i>	-
<i>Multitopology routing</i>	-
Nonstop active routing (NSR)	13.3R3
<i>OSPF</i>	13.3R3
Packet mirroring	13.3R3

**Table 84: Protocols and Applications Supported by the MX240, MX480, MX960, MX2010, and MX2020 MPC5E (continued)**

Protocol or Application	First Supported Junos OS Release
Precision Time Protocol (IEEE 1588)	14.2R2
IEEE 802.1ah provider backbone bridging (PBB)	-
Push a tag on Ethernet VPLS and Ethernet CCC tag encapsulations	13.3R3
<i>RSVP</i>	13.3R3
<i>RIP</i>	13.3R3
<i>SNMP</i>	13.3R3
Spanning Tree Protocols:	13.3R3
<ul style="list-style-type: none"> <li>• <i>IEEE 802.1s Multiple Spanning Tree Protocol (MSTP)</i> (part of IEEE 802.1Q VLANs)</li> <li>• <i>IEEE 802.1w Rapid Spanning Tree Protocol (RSTP)</i></li> <li>• <i>IEEE 802.1D Spanning Tree Protocol (STP)</i></li> <li>• Per-VLAN Spanning Tree (PVST)</li> <li>• Bridge protocol data units (BPDUs) guard and loop guard</li> <li>• STP inter-protocol action profiles and MAC flush</li> </ul>	
<i>Subscriber management and services:</i> (MX2010, MX2020: 12.3R4, 13.3R2, 13.3)	Release
<ul style="list-style-type: none"> <li>• Aggregated Ethernet over static VLANs</li> <li>• Aggregated Ethernet over dynamic VLANs</li> <li>• <i>ANCP and the ANCP Agent Overview</i></li> <li>• DHCP access model</li> <li>• Dynamic adjustment of shapers</li> <li>• Dynamic PPPoE subscriber interface creation based on PPPoE service name tables</li> <li>• Dynamic profiles</li> <li>• Dynamic shaping, scheduling, and queuing</li> <li>• Dynamic VLANs</li> <li>• Enhanced subscriber management</li> <li>• Static and dynamic PPPoE subscriber interfaces</li> </ul>	<ul style="list-style-type: none"> <li>• 13.3R3</li> <li>• 13.3R3</li> <li>• 13.3R3</li> <li>• 13.3R3</li> <li>• 13.3R3</li> <li>• 13.3R3</li> <li>• 13.3R3</li> <li>• 13.3R3</li> <li>• 13.3R3</li> <li>• 15.1R4</li> <li>• 13.3R3</li> </ul>
Synchronous Ethernet	13.3R3
<i>Two-Way Active Measurement Protocol (TWAMP)</i>	13.3R3
Tunnel services	13.3R3
<ul style="list-style-type: none"> <li>• Clear DF-Bit (Don't Fragment Bit)</li> </ul>	
Unnumbered Ethernet Interface	13.3R3

**Table 84: Protocols and Applications Supported by the MX240, MX480, MX960, MX2010, and MX2020 MPC5E (continued)**

Protocol or Application	First Supported Junos OS Release
VLANs IEEE 802.1Q: <ul style="list-style-type: none"> <li>VLAN stacking and rewriting</li> <li>Channels defined by two stacked VLAN tags</li> <li>Flexible VLAN tagging</li> <li>IP service for nonstandard TPID and stacked VLAN tags</li> </ul>	13.3R3
Virtual Chassis: MPLS IPv4 and IPv6, unicast, multicast forwarding, VPLS, NSR for Layer 3/MPLS services	13.3R3
Virtual private LAN service (VPLS): <ul style="list-style-type: none"> <li>BGP multihoming for inter-AS VPLS</li> <li>Gigabit Ethernet as core-facing interface</li> <li>Configurable label block sizes</li> <li>Hashing L3/L4 fields under Ethernet pseudowire for VPLS encapsulation, CCC encapsulation, and MPLS encapsulation</li> <li>VPLS flood forwarding table filter (FTF), input FTF</li> <li>Broadcast, unicast unknown, and multicast traffic hashing over LAG</li> </ul>	13.3R3
Virtual private network (VPN)	13.3R3
Virtual Router Redundancy Protocol (VRRP) for IPv4	13.3R3
VPLS packet flooding to the right set of interfaces across mesh groups	13.3R3
WAN-PHY mode	13.3R3

- Related Documentation**
- [6x40GE + 24x10GE MPC5E on page 122](#)
  - [6x40GE + 24x10GE MPC5EQ on page 124](#)
  - [MICs Supported by MX Series Routers on page 18](#)

## Protocols and Applications Supported by the MPC6E for MX2000 Routers

Table 85 on page 395 contains the first Junos OS Release support for protocols and applications on the MX2010 and MX2020 MPC6E. The protocols and applications support feature parity with Junos OS Release 13.3.

A dash indicates that the protocol or application is not supported.

**Table 85: Protocols and Applications Supported by the MX2010 and MX2020 MPC6E**

Protocol or Application	First Supported Junos OS Release
<i>Access Node Control Protocol (ANCP)</i>	-
Accepts traffic destined for generic routing encapsulation (GRE) tunnels or Distance Vector Multicast Routing Protocol (DVMRP) (IP-in-IP) tunnels <ul style="list-style-type: none"> <li>• <i>Dynamic</i></li> <li>• <i>Manual</i></li> </ul>	13.3R3
<i>Bidirectional Forwarding Detection protocol (BFD)</i>	13.3R3
<i>Border Gateway Protocol (BGP)</i>	13.3R3
Bridge protocol data units (BPDUs)	13.3R3
BGP/MPLS virtual private networks (VPNs)	13.3R3
Class of service (CoS): <ul style="list-style-type: none"> <li>• Maintain CoS across internal tunnel interfaces</li> <li>• Packet rewrites</li> <li>• Behavior aggregate (BA) classification</li> <li>• BA classification based on 802.1p of <i>payload</i> for core-facing VPLS interfaces</li> <li>• BA DSCP classification of MPLS packets for L3VPN/VPLS LSI and MPLS interfaces</li> <li>• Rate limit option for per-port queues</li> <li>• BA DSCP classification for VPLS/CCC family</li> <li>• Configurable .1p inheritance: push and swap from the hidden tag</li> <li>• Configurable shaping overhead for scheduling</li> </ul>	13.3R3
Class of service (CoS) per port: <ul style="list-style-type: none"> <li>• Eight queues per port</li> <li>• Excess-rate and excess-priority configurations at the queue level</li> <li>• Shaping at the port level</li> <li>• Shaping at the queue level</li> <li>• Scheduling of queues based on the weighted round-robin (WRR) per excess-priority class</li> <li>• Round-robin scheduling of the queues per priority class</li> <li>• Weighted random early detection (WRED)</li> </ul>	13.3R2
Class of service (CoS) per virtual LAN (VLAN): <ul style="list-style-type: none"> <li>• Accounting, filtering, and policing</li> <li>• IEEE 802.1p rewrite</li> <li>• Classification</li> <li>• Tricolor marking</li> </ul>	13.3R3

Table 85: Protocols and Applications Supported by the MX2010 and MX2020 MPC6E (continued)

Protocol or Application	First Supported Junos OS Release
Class of service (CoS) per Point-to-Point Protocol over Ethernet (PPPoE) or Dynamic Host Configuration Protocol (DHCP) subscriber interfaces: <ul style="list-style-type: none"> <li>Accounting, filtering, and policing</li> <li>IEEE 802.1p rewrite</li> <li>Classification</li> <li>Excess-rate and excess-priority configuration at the queue level</li> <li>Tricolor marking</li> <li>Shaping at the queue level</li> <li>Scheduling of queues based on weighted round-robin (WRR) per priority class</li> <li>Weighted random early detection (WRED)</li> </ul>	13.3R3
<i>Damping</i>	15.1R2
<i>Distributed Denial-of-Service (DDoS) Protection</i>	13.3R3
<i>DVMRP and GRE support—access side and server side</i>	13.3R3
<i>Ethernet Ring Protection Switching with multiple G.8032 instances</i>	13.3R3
<i>IEEE 802.1ag Ethernet OAM Continuity Check protocol</i>	13.3R3
<i>IEEE 802.1ag Ethernet OAM Linktrace protocol</i>	13.3R3
<i>IEEE 802.1ag Ethernet OAM Loopback protocol</i>	13.3R3
IEEE 802.1ag Maintenance Association Intermediate Point (MIP) support, continuity check message (CCM), stacked VLAN tagging, trunk ports, support for VPLS/VPWS, VLAN circuit cross-connect (CCC) encapsulation and translational cross-connect (TCC) encapsulation	13.3R3
IEEE 802.1ag optional type, length, and value (TLV) ( <i>Port Status TLV and Interface Status TLV</i> )	-
IEEE 802.3ah distributed periodic packet management (PPM) process, alarm indication signal (AIS), and remote defect indication (RDI)	13.3R3
<i>Firewall filters and policers:</i> <ul style="list-style-type: none"> <li>Policer support for aggregated Ethernet</li> <li>Aggregate firewall-based policer for all families of a logical interface</li> <li>Set forwarding class and loss priority for Routing Engine-generated packets by using a firewall</li> <li>Physical interface policers, applying policers to the entire port</li> <li>Lower policer limit from 32,000 to 8000</li> <li>Egress .1p MF and BA classification for VPLS</li> <li>Differentiated Services Code Point (DSCP) rewrite for IPv4 and IPv6</li> </ul>	13.3R3

Table 85: Protocols and Applications Supported by the MX2010 and MX2020 MPC6E (continued)

Protocol or Application	First Supported Junos OS Release
<i>Flexible Ethernet encapsulation</i>	13.3R3
<i>Graceful Routing Engine Switchover (GRES)</i>	13.3R3
IGMPv3 support with snooping disabled	13.3R3
Ingress and egress hierarchical class-of-service (CoS) shaping and <i>hierarchical-scheduler</i> : <ul style="list-style-type: none"> <li>• Group of virtual LANs (VLANs) level</li> <li>• VLAN level</li> <li>• Port level</li> </ul>	13.3R3
<i>Inline active flow monitoring</i>	13.3R3
<i>Intelligent oversubscription on MIC and MPC interfaces</i>	13.3R3
<i>Integrated routing and bridging (IRB)</i>	13.3R3
Unified <i>In-service software upgrade (Unified ISSU)</i>	16.1R1
Interoperability with MPCs and existing DPCs	13.3R3
Interoperability with Multiservices DPCs	13.3R3
Interoperability with MX Series Flexible PIC Concentrators (MX-FPC)	13.3R3
IPv4	13.3R3
<i>IPv4 multicast</i>	13.3R3
<i>IPv6</i>	13.3R3
IPv6 MLD	13.3R3
<i>IPv6 multicast</i>	13.3R3
<i>IPv6 neighbor discovery</i>	13.3R3
<i>IS-IS</i>	13.3R3
ITU-T Y.1731 timestamping support on MX Series routers	13.3R3

Table 85: Protocols and Applications Supported by the MX2010 and MX2020 MPC6E (continued)

Protocol or Application	First Supported Junos OS Release
Flow monitoring and services:	Release
<ul style="list-style-type: none"> <li>Active monitoring (multiple v8 version j-flow templates)</li> <li>Active monitoring (cflowed version 9 templates)</li> <li>Port mirroring family VPLS, bridge CCC encapsulation (VPWS)</li> <li>Packet slice for port mirroring</li> <li>Flow monitoring on Multiservices DPCs</li> <li>Inline active flow monitoring on MPC5E</li> </ul>	<ul style="list-style-type: none"> <li>13.3R3</li> <li>13.3R3</li> <li>13.3R3</li> <li>13.3R3</li> <li>-</li> <li>13.3R3</li> </ul>
<i>Labeled-switched-paths (LSPs)</i> including accounting, policers, and filtering	13.3R3
<i>LDP</i>	13.3R3
<i>Layer 2 features:</i>	Release
<ul style="list-style-type: none"> <li>Trunk ports</li> <li>Layer 2 support for MX Series Virtual Chassis</li> <li>Layer 2 and Layer 2.5, IRB and Spanning Tree Protocols (xSTP)</li> <li>IEEE 802.1ad provider bridges</li> <li>Layer 2 protocol tunneling (L2PT) support</li> <li>Layer 2 Tunneling Protocol (L2TP)</li> <li>Multichassis LAG—active/active and active/standby</li> <li>Multichassis LAG—active/active with IGMP snooping</li> <li>Link aggregation group (LAG)—VLAN-CCC encapsulation</li> <li>IGMP snooping with bridging, IRB, and VPLS</li> </ul>	<ul style="list-style-type: none"> <li>13.3R3</li> <li>13.3R3</li> <li>15.1R2</li> <li>13.3R3</li> <li>13.3R3</li> <li>13.3R3</li> <li>13.3R3</li> <li>13.3R3</li> <li>15.1R2</li> <li>13.3R2</li> </ul>
Layer 2 VPN interfaces	
<i>Link aggregation (IEEE 802.3ad)</i>	13.3R3
<i>Link Aggregation Control Protocol (LACP)</i>	13.3R3
<i>Link Layer Discovery Protocol (LLDP)</i>	-
Local loopback	13.3R3
<i>MAC learning, policing, accounting, and filtering</i>	13.3R3
Mobile IP	-
Multichassis link aggregation	-
Multiple Tag Protocol Identifiers (TPIDs)	13.3R3



Table 85: Protocols and Applications Supported by the MX2010 and MX2020 MPC6E (continued)

Protocol or Application	First Supported Junos OS Release
<p><i>MPLS:</i></p> <ul style="list-style-type: none"> <li>Switching of pseudowire segments (multisegment pseudowires with BGP-L2VPN)</li> <li>LDP signaling for VPLS (LDP-VPLS) and MAC flush message processing (MAC-FLUSH-TLV)</li> <li>RSVP graceful restart interoperability with Cisco using Nodal Hello</li> <li>Failure action on BFD session down of RSVP LSPs</li> <li>OSPF and IS-IS loop-free alternates (LFA)</li> <li>4/5 label MPLS operation</li> <li>Virtual circuit connectivity verification (VCCV) BFD</li> <li>Point to multipoint using the <b>enhanced-ip</b> command (support for NG-MVPN and P2MP load balancing over aggregated Ethernet)</li> <li>MPLS-FRR bypass link protection</li> <li>Load sharing across 64 ECMP next hops</li> <li>MPLS-FRR VPLS instance prioritization</li> <li>Five label stack on ingress</li> </ul>	13.3R3
MPLS node protection, link protection, and statistics for static LSPs	13.3R3
<i>mvrp</i>	-
<i>Multitopology routing</i>	-
Nonstop active routing (NSR)	-
<i>OSPF</i>	13.3R3
Packet mirroring	13.3R3
Precision Time Protocol (IEEE 1588)	-
IEEE 802.1ah provider backbone bridging (PBB)	-
Push a tag on Ethernet VPLS and Ethernet CCC tag encapsulations	13.3R3
<i>RSVP</i>	13.3R3
<i>RIP</i>	13.3R3
<i>SNMP</i>	13.3R3

Table 85: Protocols and Applications Supported by the MX2010 and MX2020 MPC6E (continued)

Protocol or Application	First Supported Junos OS Release
Spanning Tree Protocols:	13.3R3
<ul style="list-style-type: none"> <li>• IEEE 802.1s Multiple Spanning Tree Protocol (MSTP) (part of IEEE 802.1Q VLANs)</li> <li>• IEEE 802.1w Rapid Spanning Tree Protocol (RSTP)</li> <li>• IEEE 802.1D Spanning Tree Protocol (STP)</li> <li>• Per-VLAN Spanning Tree (PVST)</li> <li>• Bridge protocol data units (BPDUs) guard and loop guard</li> <li>• STP inter-protocol action profiles and MAC flush</li> </ul>	
Subscriber management and services (MX2010, MX2020: 12.3R4, 13.3R2, 13.3):	Release
<ul style="list-style-type: none"> <li>• Aggregated Ethernet over static VLANs</li> <li>• Aggregated Ethernet over dynamic VLANs</li> <li>• ANCP and the ANCP Agent Overview</li> <li>• DHCP access model</li> <li>• Dynamic adjustment of shapers</li> <li>• Dynamic PPPoE subscriber interface creation based on PPPoE service name tables</li> <li>• Dynamic profiles</li> <li>• Dynamic shaping, scheduling, and queuing</li> <li>• Dynamic VLANs</li> <li>• Enhanced subscriber management (uplink services)</li> <li>• Static and dynamic PPPoE subscriber interfaces</li> </ul>	<ul style="list-style-type: none"> <li>• 13.3R3</li> <li>• 13.3R3</li> <li>• 13.3R3</li> <li>• 13.3R3</li> <li>• 13.3R3</li> <li>• 13.3R3</li> <li>• 13.3R3</li> <li>• 13.3R3</li> <li>• 13.3R3</li> <li>• 15.1R4</li> <li>• 13.3R3</li> </ul>
Synchronous Ethernet	13.3R3
Two-Way Active Measurement Protocol (TWAMP)	13.3R3
Tunnel services	13.3R3
Unnumbered Ethernet Interface	13.3R3
VLANs IEEE 802.1Q:	13.3R3
<ul style="list-style-type: none"> <li>• VLAN stacking and rewriting</li> <li>• Channels defined by two stacked VLAN tags</li> <li>• Flexible VLAN tagging</li> <li>• IP service for nonstandard TPID and stacked VLAN tags</li> </ul>	
Virtual private LAN service (VPLS):	13.3R3
<ul style="list-style-type: none"> <li>• BGP multihoming for inter-AS VPLS</li> <li>• Gigabit Ethernet as core-facing interface</li> <li>• Configurable label block sizes</li> <li>• Hashing L3/L4 fields under Ethernet pseudowire for VPLS encapsulation, CCC encapsulation, and MPLS encapsulation</li> <li>• VPLS flood forwarding table filter (FTF), input FTF</li> <li>• Broadcast, unknown unicast, and multicast traffic hashing over LAG</li> </ul>	

**Table 85: Protocols and Applications Supported by the MX2010 and MX2020 MPC6E (continued)**

Protocol or Application	First Supported Junos OS Release
Virtual private network (VPN)	13.3R3
<i>Virtual Router Redundancy Protocol (VRRP) for IPv4</i>	13.3R3
VPLS packet flooding to the right set of interfaces across mesh groups	13.3R3
WAN-PHY mode	13.3R3

- Related Documentation**
- [MPC6E on page 129](#)
  - [MICs Supported by MX Series Routers on page 18](#)

## Protocols and Applications Supported by the MPC7E for MX Series Routers

Table 82 on page 372 contains the first Junos OS Release support for protocols and applications on the MX240, MX480, MX960, MX2010, and MX2020 MPC7Es (“MPC7E 10G” on page 132 and “MPC7E (Multi-Rate)” on page 130). The protocols and applications support feature parity with Junos OS Release 15.1R1.

A dash indicates that the protocol or application is not supported.

**Table 86: Protocols and Applications Supported by MPC7Es in the MX240, MX480, MX960, MX2010, and MX2020 Routers**

Protocol or Application	First Supported Junos OS Release for MPC7E-MRATE	First Supported Junos OS Release for MPC7E-10G
<i>Access Node Control Protocol (ANCP)</i>	-	-
Accepts traffic destined for generic routing encapsulation (GRE) tunnels or Distance Vector Multicast Routing Protocol (DVMRP) (IP-in-IP) tunnels <ul style="list-style-type: none"> <li>• <i>Dynamic</i></li> <li>• <i>Manual</i></li> </ul>	15.1F4	15.1F5
<i>Bidirectional Forwarding Detection protocol (BFD)</i>	15.1F4	15.1F5
<i>Border Gateway Protocol (BGP)</i>	15.1F4	15.1F5
Bridge protocol data units (BPDUs)	15.1F4	15.1F5
BGP/MPLS virtual private networks (VPNs)	15.1F4	15.1F5

**Table 86: Protocols and Applications Supported by MPC7Es in the MX240, MX480, MX960, MX2010, and MX2020 Routers (continued)**

Protocol or Application	First Supported Junos OS Release for MPC7E-MRATE	First Supported Junos OS Release for MPC7E-10G
Class of service (CoS): <ul style="list-style-type: none"> <li>Maintain CoS across internal tunnel interfaces</li> <li>Packet rewrites</li> <li>Behavior aggregate (BA) classification</li> <li>BA classification based on 802.1p of payload for core-facing VPLS interfaces</li> <li>BA DSCP classification of MPLS packets for L3VPN/VPLS LSI and MPLS interfaces</li> <li>Rate limit option for per-port queues</li> <li>BA DSCP classification for VPLS/CCC family</li> <li>Configurable .1p inheritance: push and swap from the hidden tag</li> <li>Configurable shaping overhead for scheduling</li> </ul>	15.1F4	15.1F5
Class of service (CoS) per port: <ul style="list-style-type: none"> <li>Eight queues per port</li> <li>Excess-rate and excess-priority configurations at the queue level</li> <li>Shaping at the port level</li> <li>Shaping at the queue level</li> <li>Scheduling of queues based on the weighted round-robin (WRR) per excess-priority class</li> <li>Round-robin scheduling of the queues per priority class</li> <li>Weighted random early detection (WRED)</li> </ul>	15.1F4  <i>NOTE:</i> MPC7E-MRATE MPC supports 5 guaranteed and 4 excess priorities.	15.1F5  <i>NOTE:</i> MPC7E-10G MPC supports 5 guaranteed and 4 excess priorities.
Class of service (CoS) per virtual LAN (VLAN): <ul style="list-style-type: none"> <li>Accounting, filtering, and policing</li> <li>IEEE 802.1p rewrite</li> <li>Classification</li> <li>Tricolor marking</li> </ul>	15.1F4	15.1F5

**Table 86: Protocols and Applications Supported by MPC7Es in the MX240, MX480, MX960, MX2010, and MX2020 Routers (continued)**

Protocol or Application	First Supported Junos OS Release for MPC7E-MRATE	First Supported Junos OS Release for MPC7E-10G
Class of service (CoS) per Point-to-Point Protocol over Ethernet (PPPoE) or Dynamic Host Configuration Protocol (DHCP) subscriber interfaces: <ul style="list-style-type: none"> <li>Accounting, filtering, and policing</li> <li>IEEE 802.1p rewrite</li> <li>Classification</li> <li>Excess-rate and excess-priority configuration at the queue level</li> <li>Tricolor marking</li> <li>Shaping at the queue level</li> <li>Scheduling of queues based on weighted round-robin (WRR) per priority class</li> <li>Weighted random early detection (WRED)</li> </ul>	-	-
<i>Distributed Denial-of-Service (DDoS) Protection</i>	15.1F4	15.1F5
<i>DVMRP and GRE support—access side and server side</i>	15.1F4	15.1F5
<i>Dynamic Power Management</i>	15.1F4	15.1F5
<i>Ethernet Ring Protection Switching with multiple G.8032 instances</i>	15.1F4	15.1F5
<i>Flexible Queuing Mode</i>	15.1F4	15.1F5
<i>IEEE 802.1ag Ethernet OAM Continuity Check protocol</i>	15.1F4	15.1F5
<i>IEEE 802.1ag Ethernet OAM Linktrace protocol</i>	15.1F4	15.1F5
<i>IEEE 802.1ag Ethernet OAM Loopback protocol</i>	15.1F4	15.1F5
IEEE 802.1ag maintenance association intermediate point (MIP) support, continuity check message (CCM), stacked VLAN tagging, trunk ports, support for VPLS/VPWS, VLAN circuit cross-connect (CCC) encapsulation and translational cross-connect (TCC) encapsulation	15.1F4	15.1F5

**Table 86: Protocols and Applications Supported by MPC7Es in the MX240, MX480, MX960, MX2010, and MX2020 Routers (continued)**

Protocol or Application	First Supported Junos OS Release for MPC7E-MRATE	First Supported Junos OS Release for MPC7E-10G
IEEE 802.1ag optional type, length, and value (TLVs) support <i>Port Status TLV</i> and <i>Interface Status TLV</i>	15.1F4	15.1F5
IEEE 802.3ah distributed periodic packet management (PPM) process, alarm indication signal (AIS), and remote defect indication (RDI)	15.1F4	15.1F5
<p><i>Firewall filters and policers:</i></p> <ul style="list-style-type: none"> <li>• Policer support for aggregated Ethernet</li> <li>• Aggregate firewall-based policer for all families of a logical interface</li> <li>• Intelligent hierarchical policers</li> <li>• Set forwarding class and loss priority for Routing Engine-generated packets by using a firewall</li> <li>• Physical interface policers, applying policers to the entire port</li> <li>• Lower policer limit from 32K to 8K</li> <li>• Egress .1p MF and BA classification for VPLS</li> <li>• Differentiated Services Code Point (DSCP) rewrite for IPv4 and IPv6</li> </ul>	<p>15.1F4</p> <p><b>NOTE:</b> Layer 2 overhead adjustment (packet length used for the policer included in the Layer 2 header) is not supported in 15.1F4.</p>	<p>15.1F5</p> <p><b>NOTE:</b> Layer 2 overhead adjustment (packet length used for the policer included in the Layer 2 header) is not supported in 15.1F5.</p>
<i>Flexible Ethernet encapsulation</i>	15.1F4	15.1F5
<i>Graceful Routing Engine Switchover (GRES)</i>	15.1F4	15.1F5
IGMPv3 support with snooping disabled	15.1F4	15.1F5
<p>Ingress and egress hierarchical class-of-service (CoS) shaping and <i>hierarchical-scheduler:</i></p> <ul style="list-style-type: none"> <li>• Group of virtual LANs (VLANs) level</li> <li>• VLAN level</li> <li>• Port level</li> </ul>	15.1F4	15.1F5
<i>Inline flow monitoring</i>	15.1F4	15.1F5
<i>Intelligent Oversubscription on MIC and MPC Interfaces Overview</i>	15.1F4	15.1F5
<i>Integrated routing and bridging (IRB)</i>	15.1F4	15.1F5

**Table 86: Protocols and Applications Supported by MPC7Es in the MX240, MX480, MX960, MX2010, and MX2020 Routers (continued)**

Protocol or Application	First Supported Junos OS Release for MPC7E-MRATE	First Supported Junos OS Release for MPC7E-10G
Unified <i>In-service software upgrade (Unified ISSU)</i>	17.4R1	17.4R1
Interoperability with MPCs	15.1F4	15.1F5
Interoperability with MS-DPCs	-	-
Interoperability with MX Series Flexible PIC Concentrators (MX-FPC)	-	-
IPv4	15.1F4	15.1F5
<i>IPv4 multicast</i>	15.1F4	15.1F5
<i>IPv6</i>	15.1F4	15.1F5
IPv6 MLD	15.1F4	15.1F5
<i>IPv6 multicast</i>	15.1F4	15.1F5
<i>IPv6 Neighbor Discovery</i>	15.1F4	15.1F5
<i>IS-IS</i>	15.1F4	15.1F5
ITU-T Y.1731 timestamping support on MX Series routers	15.1F4	15.1F5
Flow monitoring and services	First Supported Junos OS Release for MPC7E-MRATE	First Supported Junos OS Release for MPC7E-10G
Inline IP Flow Information Export (IPFIX)	15.1F4	15.1F5
Active monitoring	15.1F4	15.1F5
Port mirroring family VPLS, bridge CCC encapsulation (VPWS)	15.1F4	15.1F5
Packet slice for port mirroring	15.1F4	15.1F5
Flow monitoring on MS-MPCs	17.3R1	17.3R1
Inline flow monitoring	15.1F4	15.1F5
<i>Labeled-switched-paths (LSPs) including accounting, policers, and filtering</i>	15.1F4	15.1F5

**Table 86: Protocols and Applications Supported by MPC7Es in the MX240, MX480, MX960, MX2010, and MX2020 Routers (continued)**

Protocol or Application	First Supported Junos OS Release for MPC7E-MRATE	First Supported Junos OS Release for MPC7E-10G
<i>LDP</i>	15.1F4	15.1F5
Layer 2 Features	First Supported Junos OS Release for MPC7E-MRATE	First Supported Junos OS Release for MPC7E-10G
Trunk ports	15.1F4	15.1F5
Layer 2 support for MX Series Virtual Chassis	17.3R1	17.3R1
Layer 2 and Layer 2.5, IRB and Spanning Tree Protocols (xSTP)	15.1F4	15.1F5
IEEE 802.1ad provider bridges	15.1F4	15.1F5
Layer 2 protocol tunneling (L2PT) support	15.1F4	15.1F5
Layer 2 Tunneling Protocol (L2TP)	15.1F4	15.1F5
Multichassis LAG—active/active and active/standby	15.1F4	15.1F5
Multichassis LAG—active/active with IGMP snooping	15.1F4	15.1F5
Link aggregation group (LAG)—VLAN-CCC encapsulation	15.1F4	15.1F5
IGMP snooping with bridging, IRB, and VPLS	15.1F4	15.1F5
Layer 2 VPN interfaces support VLAN ID list	15.1F4	15.1F5
<i>Link aggregation (IEEE 802.3ad)</i>	15.1F4	15.1F5
<i>Link Aggregation Control Protocol (LACP)</i>	15.1F4	15.1F5
<i>Link Layer Discovery Protocol (LLDP)</i>	15.1F4	15.1F5
Local loopback	15.1F4	15.1F5



**Table 86: Protocols and Applications Supported by MPC7Es in the MX240, MX480, MX960, MX2010, and MX2020 Routers (continued)**

Protocol or Application	First Supported Junos OS Release for MPC7E-MRATE	First Supported Junos OS Release for MPC7E-10G
MAC learning, policing, accounting, and filtering	15.1F4	15.1F5
<b>MACSec</b>	<b>First Supported Junos OS Release for MPC7E-MRATE</b>	<b>First Supported Junos OS Release for MPC7E-10G</b>
GCM-AES-128 MACSec Encryption, 802.1AE-2006	-	16.1R1
GCM-AES-256 MACSec Encryption, 802.1AEbn-2011	-	16.2R1
Mobile IP	-	-
Multichassis link aggregation	15.1F4	15.1F5
Multiple Tag Protocol Identifiers (TPIDs)	15.1F4	15.1F5
<b>MPLS:</b>	15.1F4	15.1F5
<ul style="list-style-type: none"> <li>• Switching of pseudowire segments (multisegment pseudowires with BGP-L2VPN)</li> <li>• LDP signaling for VPLS (LDP-VPLS) and MAC flush message processing (MAC-FLUSH-TLV)</li> <li>• RSVP graceful restart interoperability with Cisco using Nodal Hello</li> <li>• Failure action on BFD session down of RSVP LSPs</li> <li>• OSPF and IS-IS loop-free alternates (LFA)</li> <li>• 4/5 label MPLS operation</li> <li>• Virtual circuit connectivity verification (VCCV) BFD</li> <li>• Point to multipoint using the enhanced-ip command (support for NG-MVPN and P2MP load balancing over aggregated Ethernet)</li> <li>• MPLS-FRR bypass link protection</li> <li>• Load sharing across 64 ECMP next hops</li> <li>• MPLS-FRR VPLS instance prioritization</li> <li>• Five label stack on ingress</li> </ul>		
MPLS node protection, link protection, and statistics for static LSPs	15.1F4	15.1F5

**Table 86: Protocols and Applications Supported by MPC7Es in the MX240, MX480, MX960, MX2010, and MX2020 Routers (continued)**

Protocol or Application	First Supported Junos OS Release for MPC7E-MRATE	First Supported Junos OS Release for MPC7E-10G
<i>mvrp</i>	15.1F4	15.1F5
<i>Multitopology routing</i>	15.1F4	15.1F5
Nonstop active routing (NSR)	15.1F4	15.1F5
<i>OSPF</i>	15.1F4	15.1F5
Packet mirroring	15.1F4	15.1F5
Precision Time Protocol (IEEE 1588)	17.4R1	17.4R1
IEEE 802.1ah provider backbone bridging (PBB)	-	-
Push a tag on Ethernet VPLS and Ethernet CCC tag encapsulations	15.1F4	15.1F5
<i>RSVP</i>	15.1F4	15.1F5
<i>RIP</i>	15.1F4	15.1F5
<i>SNMP</i>	15.1F4	15.1F5
Spanning Tree Protocols:	15.1F4	15.1F5
<ul style="list-style-type: none"> <li>• <i>IEEE 802.1s Multiple Spanning Tree Protocol (MSTP)</i> (part of IEEE 802.1Q VLANs)</li> <li>• <i>IEEE 802.1w Rapid Spanning Tree Protocol (RSTP)</i></li> <li>• <i>IEEE 802.1D Spanning Tree Protocol (STP)</i></li> <li>• Per-VLAN Spanning Tree (PVST)</li> <li>• Bridge protocol data units (BPDUs) guard and loop guard</li> <li>• STP inter-protocol action profiles and MAC flush (in VPLS multi-homing, flush all MACs when there is a change in the STP interface state due to root protect)</li> </ul>		
<i>Subscriber management and services:</i>	16.1R4; 17.1R1	16.1R4; 17.1R1
<ul style="list-style-type: none"> <li>• Enhanced subscriber management</li> </ul>		
Synchronous Ethernet	16.1R1	16.1R1

**Table 86: Protocols and Applications Supported by MPC7Es in the MX240, MX480, MX960, MX2010, and MX2020 Routers (continued)**

Protocol or Application	First Supported Junos OS Release for MPC7E-MRATE	First Supported Junos OS Release for MPC7E-10G
<i>Two-Way Active Measurement Protocol (TWAMP)</i>	16.1R4  <i>NOTE:</i> TWAMP is not supported on the MX2020 and MX2010 chassis.	16.1R4  <i>NOTE:</i> TWAMP is not supported on the MX2020 and MX2010 chassis.
Tunnel services <ul style="list-style-type: none"> <li>• Clear DF-Bit (Don't Fragment Bit)</li> </ul>	15.1F4	15.1F5
Unified in-service software upgrade (ISSU)	-	-
Unnumbered Ethernet Interface	15.1F4	15.1F5
<i>VLANs IEEE 802.1Q:</i> <ul style="list-style-type: none"> <li>• VLAN stacking and rewriting</li> <li>• Flexible VLAN tagging</li> <li>• IP service for nonstandard TPID and stacked VLAN tags</li> </ul>	15.1F4	15.1F5
Virtual Chassis: MPLS IPv4 and IPv6, unicast, multicast forwarding, VPLS, NSR for Layer 3/MPLS services	17.3R1	17.3R1
<i>Virtual private LAN service (VPLS):</i> <ul style="list-style-type: none"> <li>• BGP multihoming for inter-AS VPLS</li> <li>• Gigabit Ethernet as core-facing interface</li> <li>• Configurable label block sizes</li> <li>• Hashing L3/L4 fields under Ethernet pseudowire for VPLS encapsulation, CCC encapsulation, and MPLS encapsulation</li> <li>• VPLS flood forwarding table filter (FTF), input FTF</li> <li>• Broadcast, unicast unknown, and multicast (BUM) traffic hashing over LAG</li> </ul>	15.1F4	15.1F5
Virtual private network (VPN)	15.1F4	15.1F5
<i>Virtual Router Redundancy Protocol (VRRP) for IPv4</i>	15.1F4	15.1F5
VPLS packet flooding to the right set of interfaces across mesh groups	15.1F4	15.1F5

**Table 86: Protocols and Applications Supported by MPC7Es in the MX240, MX480, MX960, MX2010, and MX2020 Routers (continued)**

Protocol or Application	First Supported Junos OS Release for MPC7E-MRATE	First Supported Junos OS Release for MPC7E-10G
WAN-PHY mode	-	-

- Related Documentation**
- [MPC7E \(Multi-Rate\) on page 130](#)
  - [MPC7E 10G on page 132](#)

## Protocols and Applications Supported by the MPC8E and MPC9E on the MX2010 and MX2020 Routers

[Table 82 on page 372](#) lists the protocols and applications supported by MPC8E and MPC9E on the MX2010 and MX2020 routers.

An en dash indicates that the protocol or application is not supported.

**Table 87: Protocols and Applications Supported by MPC8E and MPC9E on the MX2010 and MX2020 Routers**

Protocol or Application	First Supported Junos OS Release	
	MPC8E	MPC9E
<i>Access Node Control Protocol (ANCP)</i>	-	-
Accepts traffic destined for generic routing encapsulation (GRE) tunnels or Distance Vector Multicast Routing Protocol (DVMRP) (IP-in-IP) tunnels <ul style="list-style-type: none"> <li>• <i>Dynamic</i></li> <li>• <i>Manual</i></li> </ul>	15.1F5	15.1F5
<i>Bidirectional Forwarding Detection protocol (BFD)</i>	15.1F5	15.1F5
<i>Border Gateway Protocol (BGP)</i>	15.1F5	15.1F5
Bridge protocol data units (BPDUs)	15.1F5	15.1F5
BGP/MPLS virtual private networks (VPNs)	15.1F5	15.1F5

**Table 87: Protocols and Applications Supported by MPC8E and MPC9E on the MX2010 and MX2020 Routers (continued)**

Protocol or Application	First Supported Junos OS Release	
	MPC8E	MPC9E
Class of service (CoS): <ul style="list-style-type: none"> <li>Maintain CoS across internal tunnel interfaces</li> <li>Packet rewrites</li> <li>Behavior aggregate (BA) classification</li> <li>BA classification based on 802.1p of payload for core-facing VPLS interfaces</li> <li>BA DSCP classification of MPLS packets for L3VPN/VPLS LSI and MPLS interfaces</li> <li>Rate-limit option for per-port queues</li> <li>BA DSCP classification for VPLS/CCC family</li> <li>Configurable .1p inheritance: push and swap from the hidden tag</li> <li>Configurable shaping overhead for scheduling</li> </ul>	15.1F5	15.1F5
Class of service (CoS) per port: <ul style="list-style-type: none"> <li>Eight queues per port</li> <li>Excess-rate and excess-priority configurations at the queue level</li> <li>Shaping at the port level</li> <li>Shaping at the queue level</li> <li>Scheduling of queues based on the weighted round-robin (WRR) per excess-priority class</li> <li>Round-robin scheduling of the queues per priority class</li> <li>Weighted random early detection (WRED)</li> </ul>	15.1F5	15.1F5
Class of service (CoS) per virtual LAN (VLAN): <ul style="list-style-type: none"> <li>Accounting, filtering, and policing</li> <li>IEEE 802.1p rewrite</li> <li>Classification</li> <li>Tricolor marking</li> </ul>	15.1F5	15.1F5
Class of service (CoS) per Point-to-Point Protocol over Ethernet (PPPoE) or Dynamic Host Configuration Protocol (DHCP) subscriber interfaces: <ul style="list-style-type: none"> <li>Accounting, filtering, and policing</li> <li>IEEE 802.1p rewrite</li> <li>Classification</li> <li>Excess-rate and excess-priority configuration at the queue level</li> <li>Tricolor marking</li> <li>Shaping at the queue level</li> <li>Scheduling of queues based on weighted round-robin (WRR) per priority class</li> <li>Weighted random early detection (WRED)</li> </ul>	-	-
<i>Damping</i>	16.1R1	16.1R1

**Table 87: Protocols and Applications Supported by MPC8E and MPC9E on the MX2010 and MX2020 Routers (continued)**

Protocol or Application	First Supported Junos OS Release	
	MPC8E	MPC9E
<i>Distributed Denial-of-Service (DDoS) Protection</i>	15.1F5	15.1F5
<i>DVMRP and GRE support—access side and server side</i>	15.1F5	15.1F5
<i>Dynamic Power Management</i>	15.1F5	15.1F5
<i>Ethernet Ring Protection Switching with multiple G.8032 instances</i>	15.1F5	15.1F5
<i>Flexible Queuing Mode</i>	15.1F5	15.1F5
<i>IEEE 802.1ag Ethernet OAM Continuity Check protocol</i>	15.1F5	15.1F5
<i>IEEE 802.1ag Ethernet OAM Linktrace protocol</i>	15.1F5	15.1F5
<i>IEEE 802.1ag Ethernet OAM Loopback protocol</i>	15.1F5	15.1F5
IEEE 802.1ag maintenance association intermediate point (MIP) support, continuity check message (CCM), stacked VLAN tagging, trunk ports, support for VPLS/VPWS, VLAN circuit cross-connect (CCC) encapsulation and translational cross-connect (TCC) encapsulation	15.1F5	15.1F5
IEEE 802.1ag optional type, length, and value (TLVs) support <i>Port Status TLV and Interface Status TLV</i>	15.1F5	15.1F5
IEEE 802.3ah distributed periodic packet management (PPM) process, alarm indication signal (AIS), and remote defect indication (RDI)	15.1F5	15.1F5
<i>Firewall filters and policers:</i>	15.1F5	15.1F5
<ul style="list-style-type: none"> <li>• Policer support for aggregated Ethernet</li> <li>• Aggregate firewall-based policer for all families of a logical interface</li> <li>• Intelligent hierarchical policers</li> <li>• Set forwarding class and loss priority for Routing Engine-generated packets by using a firewall</li> <li>• Physical interface policers, applying policers to the entire port</li> <li>• Lower policer limit from 32,000 to 8000</li> <li>• Egress .ip MF and BA classification for VPLS</li> <li>• Differentiated Services Code Point (DSCP) rewrite for IPv4 and IPv6</li> </ul>		
<i>Flexible Ethernet encapsulation</i>	15.1F5	15.1F5
<i>Graceful Routing Engine Switchover (GRES)</i>	15.1F5	15.1F5
IGMPv3 support with snooping disabled	15.1F5	15.1F5

**Table 87: Protocols and Applications Supported by MPC8E and MPC9E on the MX2010 and MX2020 Routers (continued)**

Protocol or Application	First Supported Junos OS Release	
	MPC8E	MPC9E
Ingress and egress hierarchical class-of-service (CoS) shaping and <i>hierarchical-scheduler</i> : <ul style="list-style-type: none"> <li>• Set of Interfaces</li> <li>• VLAN level</li> <li>• Port level</li> </ul>	15.1F5	15.1F5
<i>Inline flow monitoring</i>	15.1F5	15.1F5
<i>Intelligent Oversubscription</i>	15.1F5	15.1F5
<i>Integrated routing and bridging (IRB)</i>	15.1F5	15.1F5
Unified <i>In-service software upgrade (Unified ISSU)</i>	17.4R1	17.4R1
Interoperability with existing MPCs	15.1F5	15.1F5
IPv4	15.1F5	15.1F5
<i>IPv4 multicast</i>	15.1F5	15.1F5
<i>IPv6</i>	15.1F5	15.1F5
IPv6 MLD	15.1F5	15.1F5
<i>IPv6 multicast</i>	15.1F5	15.1F5
<i>IPv6 Neighbor Discovery</i>	15.1F5	15.1F5
<i>IS-IS</i>	15.1F5	15.1F5
ITU-T Y.1731 timestamping support on MX Series routers	15.1F5	15.1F5
Flow monitoring and services:	<b>Release</b>	<b>Release</b>
• Active monitoring (cflowed version 9 templates)	• 15.1F5	• 15.1F5
• Port mirroring family VPLS, bridge CCC encapsulation (VPWS)	• 15.1F5	• 15.1F5
• Packet slice for port mirroring	• 15.1F5	• 15.1F5
• Flow monitoring on MS-DPCs	• -	• -
• Inline flow monitoring on MPC8E and MPC9E	• 15.1F5	• 15.1F5
<i>Labeled-switched-paths (LSPs)</i> including accounting, policers, and filtering	15.1F5	15.1F5
<i>LDP</i>	15.1F5	15.1F5

**Table 87: Protocols and Applications Supported by MPC8E and MPC9E on the MX2010 and MX2020 Routers (continued)**

Protocol or Application	First Supported Junos OS Release	
	MPC8E	MPC9E
Layer 2 features:	Release	Release
<ul style="list-style-type: none"> <li>• Trunk ports</li> <li>• Layer 2 support for MX Series Virtual Chassis</li> <li>• Layer 2 and Layer 2.5, IRB and spanning tree protocols (xSTP)</li> <li>• IEEE 802.1ad provider bridges</li> <li>• Layer 2 protocol tunneling (L2PT) support</li> <li>• Layer 2 Tunneling Protocol (L2TP)</li> <li>• Multichassis LAG—active/active and active/standby</li> <li>• Multichassis LAG—active/active with IGMP snooping</li> <li>• IGMP snooping with bridging, IRB, and VPLS</li> </ul>	<ul style="list-style-type: none"> <li>• 15.1F5</li> <li>• 17.3R1</li> <li>• 15.1F5</li> <li>• 15.1F5</li> <li>• 15.1F5</li> <li>• 15.1F5</li> <li>• 15.1F5</li> <li>• 15.1F5</li> <li>• 15.1F5</li> </ul>	<ul style="list-style-type: none"> <li>• 15.1F5</li> <li>• 17.3R1</li> <li>• 15.1F5</li> <li>• 15.1F5</li> <li>• 15.1F5</li> <li>• 15.1F5</li> <li>• 15.1F5</li> <li>• 15.1F5</li> <li>• 15.1F5</li> </ul>
Layer 2 VPN interfaces support VLAN ID list	15.1F5	15.1F5
<i>Link aggregation (IEEE 802.3ad)</i>	15.1F5	15.1F5
<i>Link Aggregation Control Protocol (LACP)</i>	15.1F5	15.1F5
<i>Link Layer Discovery Protocol (LLDP)</i>	15.1F5	15.1F5
Local loopback	15.1F5	15.1F5
<i>MAC learning, policing, accounting, and filtering</i>	15.1F5	15.1F5
Mobile IP	-	-
Multichassis Link Aggregation	15.1F5	15.1F5
Multiple Tag Protocol Identifiers (TPIDs)	15.1F5	15.1F5



**Table 87: Protocols and Applications Supported by MPC8E and MPC9E on the MX2010 and MX2020 Routers (continued)**

Protocol or Application	First Supported Junos OS Release	
	MPC8E	MPC9E
<p><i>MPLS:</i></p> <ul style="list-style-type: none"> <li>Switching of pseudowire segments (multisegment pseudowires with BGP-L2VPN)</li> <li>LDP signaling for VPLS (LDP-VPLS) and MAC flush message processing (MAC-FLUSH-TLV)</li> <li>RSVP graceful restart interoperability with Cisco using Nodal Hello</li> <li>Failure action on BFD session down of RSVP LSPs</li> <li>OSPF and IS-IS loop-free alternates (LFA)</li> <li>4/5 label MPLS operation</li> <li>Virtual circuit connectivity verification (VCCV) BFD</li> <li>MPLS-FRR bypass link protection</li> <li>Load sharing across 64 ECMP next hops</li> <li>MPLS-FRR VPLS instance prioritization</li> <li>Five label stack on ingress</li> </ul>	15.1F5	15.1F5
MPLS node protection, link protection, and statistics for static LSPs	15.1F5	15.1F5
<i>mvrp</i>	-	-
<i>Multitopology routing</i>	15.1F5	15.1F5
Nonstop active routing (NSR)	15.1F5	15.1F5
<i>OSPF</i>	15.1F5	15.1F5
Packet mirroring	15.1F5	15.1F5
Precision Time Protocol (IEEE 1588)	17.4R1	17.4R1
IEEE 802.1ah provider backbone bridging (PBB)	-	-
<i>RSVP</i>	15.1F5	15.1F5
<i>RIP</i>	15.1F5	15.1F5
<i>SNMP</i>	15.1F5	15.1F5

**Table 87: Protocols and Applications Supported by MPC8E and MPC9E on the MX2010 and MX2020 Routers (continued)**

Protocol or Application	First Supported Junos OS Release	
	MPC8E	MPC9E
Spanning tree protocols: <ul style="list-style-type: none"> <li>• <i>IEEE 802.1s Multiple Spanning Tree Protocol (MSTP)</i> (part of IEEE 802.1Q VLANs)</li> <li>• <i>IEEE 802.1w Rapid Spanning Tree Protocol (RSTP)</i></li> <li>• <i>IEEE 802.1D Spanning Tree Protocol (STP)</i></li> <li>• Per-VLAN Spanning Tree (PVST)</li> <li>• Bridge protocol data units (BPDUs) guard and loop guard</li> <li>• STP inter-protocol action profiles and MAC flush (in VPLS multi-homing, flush all MACs when there is a change in the STP interface state due to root protect)</li> </ul>	15.1F5	15.1F5
Subscriber management and services: <ul style="list-style-type: none"> <li>• Enhanced subscriber management</li> </ul>	16.1R4; 17.1R1	16.1R4; 17.1R1
Synchronous Ethernet	16.1R1	16.1R1
Two-Way Active Measurement Protocol ( <i>TWAMP</i> )	17.3R1	17.3R1
Tunnel services <ul style="list-style-type: none"> <li>• Clear DF-Bit (Don't Fragment Bit)</li> </ul>	15.1F5	15.1F5
Unnumbered Ethernet Interface	15.1F5	15.1F5
VLANs <i>IEEE 802.1Q</i> : <ul style="list-style-type: none"> <li>• VLAN stacking and rewriting</li> <li>• Channels defined by two stacked VLAN tags</li> <li>• Flexible VLAN tagging</li> <li>• IP service for nonstandard TPID and stacked VLAN tags</li> </ul>	15.1F5	15.1F5
Virtual Chassis: MPLS IPv4 and IPv6, unicast, multicast forwarding, VPLS, NSR for Layer 3/MPLS services	17.3R1	17.3R1
Virtual private LAN service ( <i>VPLS</i> ): <ul style="list-style-type: none"> <li>• BGP multihoming for inter-AS VPLS</li> <li>• Gigabit Ethernet as core-facing interface</li> <li>• Configurable label block sizes</li> <li>• Hashing L3/L4 fields under Ethernet pseudowire for VPLS encapsulation, CCC encapsulation, and MPLS encapsulation</li> <li>• VPLS flood forwarding table filter (FTF), input FTF</li> <li>• Broadcast, unicast unknown, and multicast (BUM) traffic hashing over LAG</li> </ul>	15.1F5	15.1F5
Virtual private network (VPN)	15.1F5	15.1F5

**Table 87: Protocols and Applications Supported by MPC8E and MPC9E on the MX2010 and MX2020 Routers (continued)**

Protocol or Application	First Supported Junos OS Release	
	MPC8E	MPC9E
Virtual Router Redundancy Protocol (VRRP) for IPv4	15.1F5	15.1F5
VPLS packet flooding to the right set of interfaces across mesh groups	15.1F5	-
MACSec Capabilities: Starting in Junos OS Release 17.4R1, the JNP-MIC-100G MIC extends Media Access Control Security (MACsec) capabilities on MPC8E and MPC9E MPCs installed in MX2010, MX2020, and MX2008 routers.  Only MPC8E/9E with JNP-MIC-100G MIC supports MACsec feature.	17.4R1	17.4R1
<ul style="list-style-type: none"> <li>GCM-AES-128 MACSec Encryption, 802.1AE-2006</li> <li>GCM-AES-256 MACSec Encryption, 802.1AEbn-2011</li> <li>GCM-AES-XPB-128 Cipher Suite, 802.1AEbw-2013</li> <li>GCM-AES-XPB-256 Cipher Suite, 802.1AEbw-2013</li> </ul>		

Release History Table	Release	Description
	17.4R1	Starting in Junos OS Release 17.4R1, the JNP-MIC-100G MIC extends Media Access Control Security (MACsec) capabilities on MPC8E and MPC9E MPCs installed in MX2010, MX2020, and MX2008 routers.

- Related Documentation**
- [MPC8E on MX Series Routers Overview](#)
  - [MPC9E on MX Series Routers Overview](#)

## Protocols and Applications Supported by the MS-MIC and MS-MPC

Table 88 on page 417 contains the first Junos OS Release support for protocols and applications on the MX104, MX240, MX480, MX960, MX2010, and MX2020 Multiservices MIC (MS-MIC) and Multiservices MPC (MS-MPC). A dash indicates that the protocol or application is not supported.

**Table 88: Protocols and Applications Supported by the MS-MIC and MS-MPC**

Software Feature	First Supported Junos OS Release
GRE Key	-
GRE dont-fragment	-
HTTP redirect services	15.1R4
Stateful firewall	13.2R4

Table 88: Protocols and Applications Supported by the MS-MIC and MS-MPC (continued)

Software Feature	First Supported Junos OS Release
Network Address Translation (NAT) for IP addresses	13.2R4
Port Address Translation (PAT) for port numbers	13.2R4
IP Security (IPSec) encryption	13.2R4
Flow aggregation	–
Active flow monitoring exports cflowd version 5 and version 8 records	–
Active flow monitoring exports flow monitoring version 9 records, based on RFC 3954	13.2R4
<i>Graceful Routing Engine Switchover (GRES)</i>	13.3  <i>NOTE: GRES is not supported for MS-MIC on MX104 router.</i>
Passive flow monitoring	–
Passive flow collection	–
Flow-tap	–
Dynamic flow capture	–
Real-time performance monitoring	13.3
Link Services	–
MX Series Virtual Chassis with stateful firewall	14.2
MX Series Virtual Chassis with IPv4-to-IPv4 basic NAT, dynamic NAT, static destination NAT, dynamic NAT with port mapping, and stateful NAT64	16.1R4 and 18.3R1. Starting in Junos OS Release 18.4R1, these features are supported on the MX Series Virtual Chassis for the Juniper broadband network gateway (BNG).
MX Series Virtual Chassis with DS-Lite	18.4R1
Traffic sampling	13.2R4
Tunnel services: <ul style="list-style-type: none"> <li>• IP-IP unicast tunneling</li> <li>• GRE unicast tunneling—Supports GRE fragmentation</li> <li>• Protocol Independent Multicast (PIM) sparse mode unicast tunneling</li> </ul>	–
Virtual tunnel interface for Layer 3 VPNs	–

**Table 88: Protocols and Applications Supported by the MS-MIC and MS-MPC (continued)**

Software Feature	First Supported Junos OS Release
Layer 2 Tunneling Protocol (L2TP)	–
Voice services:	–
<ul style="list-style-type: none"> <li>Compressed Real-Time Transport Protocol (CRTP)</li> </ul>	
Encapsulations:	–
<ul style="list-style-type: none"> <li>Multilink Frame Relay (MLFR)</li> <li>Multilink Point-to-Point Protocol (MLPP)</li> </ul>	

- Related Documentation**
- [MX Series MPC Overview on page 11](#)
  - [MPCs Supported by MX Series Routers on page 12](#)
  - [Multiservices MIC on page 202](#)
  - [Multiservices MPC on page 86](#)

## Protocols and Applications Supported by the MX10003 MPC (Multi-Rate) on the MX10003 Router

[Table 82 on page 372](#) lists the protocols and applications supported by MX10003 MPC (Multi-Rate) on the MX10003 router.

An en dash indicates that the protocol or application is not supported.

**Table 89: Protocols and Applications Supported by MX10003MPC on the MX10003 Router**

Protocol or Application	First Supported Junos OS Release
<i>Access Node Control Protocol (ANCP)</i>	–
Accepts traffic destined for generic routing encapsulation (GRE) tunnels or Distance Vector Multicast Routing Protocol (DVMRP) (IP-in-IP) tunnels	17.3R1
<ul style="list-style-type: none"> <li><i>Dynamic</i></li> <li><i>Manual</i></li> </ul>	
<i>Bidirectional Forwarding Detection protocol (BFD)</i>	17.3R1
<i>Border Gateway Protocol (BGP)</i>	17.3R1
Bridge protocol data units (BPDUs)	17.3R1
BGP/MPLS virtual private networks (VPNs)	17.3R1

Table 89: Protocols and Applications Supported by MX10003MPC on the MX10003 Router (continued)

Protocol or Application	First Supported Junos OS Release
Class of service (CoS): <ul style="list-style-type: none"> <li>• Maintain CoS across internal tunnel interfaces</li> <li>• Packet rewrites</li> <li>• Behavior aggregate (BA) classification</li> <li>• BA classification based on 802.1p of payload for core-facing VPLS interfaces</li> <li>• BA DSCP classification of MPLS packets for L3VPN/VPLS LSI and MPLS interfaces</li> <li>• Rate-limit option for per-port queues</li> <li>• BA DSCP classification for VPLS/CCC family</li> <li>• Configurable .1p inheritance: push and swap from the hidden tag</li> <li>• Configurable shaping overhead for scheduling</li> </ul>	17.3R1
Class of service (CoS) per port: <ul style="list-style-type: none"> <li>• Eight queues per port</li> <li>• Excess-rate and excess-priority configurations at the queue level</li> <li>• Shaping at the port level</li> <li>• Shaping at the queue level</li> <li>• Scheduling of queues based on the weighted round-robin (WRR) per excess-priority class</li> <li>• Round-robin scheduling of the queues per priority class</li> <li>• Weighted random early detection (WRED)</li> </ul>	17.3R1
Class of service (CoS) per virtual LAN (VLAN): <ul style="list-style-type: none"> <li>• Accounting, filtering, and policing</li> <li>• IEEE 802.1p rewrite</li> <li>• Classification</li> <li>• Tricolor marking</li> </ul>	17.3R1
Class of service (CoS) per Point-to-Point Protocol over Ethernet (PPPoE) or Dynamic Host Configuration Protocol (DHCP) subscriber interfaces: <ul style="list-style-type: none"> <li>• Accounting, filtering, and policing</li> <li>• IEEE 802.1p rewrite</li> <li>• Classification</li> <li>• Excess-rate and excess-priority configuration at the queue level</li> <li>• Tricolor marking</li> <li>• Shaping at the queue level</li> <li>• Scheduling of queues based on weighted round-robin (WRR) per priority class</li> <li>• Weighted random early detection (WRED)</li> </ul>	17.3R1
<i>Damping</i>	17.3R1
<i>Distributed Denial-of-Service (DDoS) Protection</i>	17.3R1
<i>DVMRP and GRE support—access side and server side</i>	17.3R1

Table 89: Protocols and Applications Supported by MX10003MPC on the MX10003 Router (continued)

Protocol or Application	First Supported Junos OS Release
<i>Dynamic Power Management</i>	17.3R1
<i>Ethernet Ring Protection Switching</i> with multiple G.8032 instances	17.3R1
<i>Flexible Queuing Mode</i>	17.3R1
<i>IEEE 802.1ag Ethernet OAM Continuity Check protocol</i>	17.3R1
<i>IEEE 802.1ag Ethernet OAM Linktrace protocol</i>	17.3R1
<i>IEEE 802.1ag Ethernet OAM Loopback protocol</i>	17.3R1
IEEE 802.1ag maintenance association intermediate point (MIP) support, continuity check message (CCM), stacked VLAN tagging, trunk ports, support for VPLS/VPWS, VLAN circuit cross-connect (CCC) encapsulation and translational cross-connect (TCC) encapsulation	17.3R1
IEEE 802.1ag optional type, length, and value (TLVs) support <i>Port Status TLV and Interface Status TLV</i>	17.3R1
IEEE 802.3ah distributed periodic packet management (PPM) process, alarm indication signal (AIS), and remote defect indication (RDI)	17.3R1
<i>Firewall filters and policers:</i>	17.3R1
<ul style="list-style-type: none"> <li>• Policer support for aggregated Ethernet</li> <li>• Aggregate firewall-based policer for all families of a logical interface</li> <li>• Intelligent hierarchical policers</li> <li>• Set forwarding class and loss priority for Routing Engine-generated packets by using a firewall</li> <li>• Physical interface policers, applying policers to the entire port</li> <li>• Lower policer limit from 32,000 to 8000</li> <li>• Egress .1p MF and BA classification for VPLS</li> <li>• Differentiated Services Code Point (DSCP) rewrite for IPv4 and IPv6</li> </ul>	
<i>Flexible Ethernet encapsulation</i>	17.3R1
<i>Graceful Routing Engine Switchover (GRES)</i>	17.3R1
IGMPv3 support with snooping disabled	17.3R1
Ingress and egress hierarchical class-of-service (CoS) shaping and <i>hierarchical-scheduler:</i>	17.3R1
<ul style="list-style-type: none"> <li>• Set of Interfaces</li> <li>• VLAN level</li> <li>• Port level</li> </ul>	
<i>Inline flow monitoring</i>	17.3R1

Table 89: Protocols and Applications Supported by MX10003MPC on the MX10003 Router (continued)

Protocol or Application	First Supported Junos OS Release
<i>Intelligent Oversubscription</i>	17.3R1
<i>Integrated routing and bridging (IRB)</i>	17.3R1
Interoperability with existing MPCs	17.3R1
IPv4	17.3R1
<i>IPv4 multicast</i>	17.3R1
<i>IPv6</i>	17.3R1
IPv6 MLD	17.3R1
<i>IPv6 multicast</i>	17.3R1
<i>IPv6 Neighbor Discovery</i>	17.3R1
<i>IS-IS</i>	17.3R1
ITU-T Y.1731 timestamping support on MX Series routers	-
Flow monitoring and services:	Release
<ul style="list-style-type: none"> <li>Active monitoring (cflowed version 9 templates)</li> <li>Port mirroring family VPLS, bridge CCC encapsulation (VPWS)</li> <li>Packet slice for port mirroring</li> <li>Flow monitoring on MS-DPCs</li> <li>Inline flow monitoring</li> </ul>	<ul style="list-style-type: none"> <li>17.3R1</li> <li>17.3R1</li> <li>17.3R1</li> <li>-</li> <li>17.3R1</li> </ul>
<i>Labeled-switched-paths (LSPs)</i> including accounting, policers, and filtering	17.3R1
<i>LDP</i>	17.3R1
Layer 2 features:	Release
<ul style="list-style-type: none"> <li>Trunk ports</li> <li>Layer 2 support for MX Series Virtual Chassis</li> <li>Layer 2 and Layer 2.5, IRB and spanning tree protocols (xSTP)</li> <li>IEEE 802.1ad provider bridges</li> <li>Layer 2 protocol tunneling (L2PT) support</li> <li>Layer 2 Tunneling Protocol (L2TP)</li> <li>Multichassis LAG—active/active and active/standby</li> <li>Multichassis LAG—active/active with IGMP snooping</li> <li>IGMP snooping with bridging, IRB, and VPLS</li> </ul>	<ul style="list-style-type: none"> <li>17.3R1</li> <li>-</li> <li>17.3R1</li> <li>17.3R1</li> <li>17.3R1</li> <li>17.3R1</li> <li>17.3R1</li> <li>17.3R1</li> <li>17.3R1</li> </ul>



Table 89: Protocols and Applications Supported by MX10003MPC on the MX10003 Router (continued)

Protocol or Application	First Supported Junos OS Release
Layer 2 VPN interfaces support VLAN ID list	17.3R1
<i>Link aggregation (IEEE 802.3ad)</i>	17.3R1
<i>Link Aggregation Control Protocol (LACP)</i>	17.3R1
<i>Link Layer Discovery Protocol (LLDP)</i>	17.3R1
Local loopback	17.3R1
<i>MAC learning, policing, accounting, and filtering</i>	17.3R1
MACSec with GCM-AES-256 Encryption and GCM-AES-XPB-256 Encryption	17.3R2
<b>NOTE:</b> MACSec is supported on JNP-MIC1-MACSEC only.	
Mobile IP	-
Multichassis Link Aggregation	17.3R1
Multiple Tag Protocol Identifiers (TPIDs)	17.3R1
<i>MPLS:</i>	17.3R1
<ul style="list-style-type: none"> <li>• Switching of pseudowire segments (multisegment pseudowires with BGP-L2VPN)</li> <li>• LDP signaling for VPLS (LDP-VPLS) and MAC flush message processing (MAC-FLUSH-TLV)</li> <li>• RSVP graceful restart interoperability with Cisco using Nodal Hello</li> <li>• Failure action on BFD session down of RSVP LSPs</li> <li>• OSPF and IS-IS loop-free alternates (LFA)</li> <li>• 4/5 label MPLS operation</li> <li>• Virtual circuit connectivity verification (VCCV) BFD</li> <li>• MPLS-FRR bypass link protection</li> <li>• Load sharing across 64 ECMP next hops</li> <li>• MPLS-FRR VPLS instance prioritization</li> <li>• Five label stack on ingress</li> </ul>	
MPLS node protection, link protection, and statistics for static LSPs	17.3R1
<i>mvrp</i>	-
<i>Multitopology routing</i>	17.3R1
Nonstop active routing (NSR)	17.3R1
<i>OSPF</i>	17.3R1

Table 89: Protocols and Applications Supported by MX10003MPC on the MX10003 Router (continued)

Protocol or Application	First Supported Junos OS Release
Packet mirroring	17.3R1
Precision Time Protocol (IEEE 1588)	17.3R1
IEEE 802.1ah provider backbone bridging (PBB)	-
<i>RSVP</i>	17.3R1
<i>RIP</i>	17.3R1
<i>SNMP</i>	17.3R1
Spanning tree protocols: <ul style="list-style-type: none"> <li>• <i>IEEE 802.1s Multiple Spanning Tree Protocol (MSTP)</i> (part of IEEE 802.1Q VLANs)</li> <li>• <i>IEEE 802.1w Rapid Spanning Tree Protocol (RSTP)</i></li> <li>• <i>IEEE 802.1D Spanning Tree Protocol (STP)</i></li> <li>• Per-VLAN Spanning Tree (PVST)</li> <li>• Bridge protocol data units (BPDUs) guard and loop guard</li> <li>• STP inter-protocol action profiles and MAC flush (in VPLS multi-homing, flush all MACs when there is a change in the STP interface state due to root protect)</li> </ul>	17.3R1
<i>Subscriber management and services:</i> <ul style="list-style-type: none"> <li>• Enhanced subscriber management</li> </ul>	17.3R1
Synchronous Ethernet	17.3R1
<i>Two-Way Active Measurement Protocol (TWAMP)</i>	-
Tunnel services <ul style="list-style-type: none"> <li>• Clear DF-Bit (Don't Fragment Bit)</li> </ul>	17.3R1
Unnumbered Ethernet Interface	17.3R1
<i>VLANs IEEE 802.1Q:</i> <ul style="list-style-type: none"> <li>• VLAN stacking and rewriting</li> <li>• Channels defined by two stacked VLAN tags</li> <li>• Flexible VLAN tagging</li> <li>• IP service for nonstandard TPID and stacked VLAN tags</li> </ul>	17.3R1
Virtual Chassis: MPLS IPv4 and IPv6, unicast, multicast forwarding, VPLS, NSR for Layer 3/MPLS services	--

**Table 89: Protocols and Applications Supported by MX10003MPC on the MX10003 Router (continued)**

Protocol or Application	First Supported Junos OS Release
<i>Virtual private LAN service (VPLS):</i> <ul style="list-style-type: none"> <li>• BGP multihoming for inter-AS VPLS</li> <li>• Gigabit Ethernet as core-facing interface</li> <li>• Configurable label block sizes</li> <li>• Hashing L3/L4 fields under Ethernet pseudowire for VPLS encapsulation, CCC encapsulation, and MPLS encapsulation</li> <li>• VPLS flood forwarding table filter (FTF), input FTF</li> <li>• Broadcast, unicast unknown, and multicast (BUM) traffic hashing over LAG</li> </ul>	17.3R1
Virtual private network (VPN)	17.3R1
<i>Virtual Router Redundancy Protocol (VRRP) for IPv4</i>	17.3R1
VPLS packet flooding to the right set of interfaces across mesh groups	-

## Protocols and Applications Supported by the JNP10K-LC2101 on the MX10008 Routers

[Table 90 on page 425](#) lists the protocols and applications supported by JNP10K-LC2101 on the MX10008 routers.

An en dash indicates that the protocol or application is not supported.

**Table 90: Protocols and Applications Supported by JNP10K-LC2101 on the MX10008 Routers**

Protocol or Application	JNP10K-LC2101
<i>Access Node Control Protocol (ANCP)</i>	-
Accepts traffic destined for generic routing encapsulation (GRE) tunnels or Distance Vector Multicast Routing Protocol (DVMRP) (IP-in-IP) tunnels <ul style="list-style-type: none"> <li>• <i>Dynamic</i></li> <li>• <i>Manual</i></li> </ul>	18.2R1
<i>Bidirectional Forwarding Detection protocol (BFD)</i>	18.2R1
<i>Border Gateway Protocol (BGP)</i>	18.2R1
Bridge protocol data units (BPDUs)	18.2R1
BGP/MPLS virtual private networks (VPNs)	18.2R1

Table 90: Protocols and Applications Supported by JNP10K-LC2101 on the MX10008 Routers (continued)

Protocol or Application	JNP10K-LC2101
Chassis: <ul style="list-style-type: none"> <li>• Fabric Management</li> <li>• Redundancy Mode</li> <li>• Fabric Grant Bypass Mode</li> <li>• Hypermode</li> <li>• License Mode (IR, R, Base)</li> <li>• Port Identification</li> <li>• Rate Selectability</li> <li>• Lane LED</li> <li>• Smooth Upgrade</li> </ul>	<b>Release</b> <ul style="list-style-type: none"> <li>• 18.2R1</li> <li>• 18.2R1</li> <li>• -</li> <li>• 18.2R1</li> <li>• -</li> <li>• 18.2R1</li> <li>• 18.2R1</li> <li>• 18.2R1</li> <li>• NA</li> </ul>
Class of service (CoS): <ul style="list-style-type: none"> <li>• Maintain CoS across internal tunnel interfaces</li> <li>• Packet rewrites</li> <li>• Behavior aggregate (BA) classification</li> <li>• BA classification based on 802.1p of payload for core-facing VPLS interfaces</li> <li>• BA DSCP classification of MPLS packets for L3VPN/VPLS LSI and MPLS interfaces</li> <li>• Rate-limit option for per-port queues</li> <li>• BA DSCP classification for VPLS/CCC family</li> <li>• Configurable .1p inheritance: push and swap from the hidden tag</li> <li>• Configurable shaping overhead for scheduling</li> <li>• Dedicated CoS Queues</li> <li>• Per Unit Queuing</li> <li>• Hierarchical Queuing</li> <li>• Per Priority Shaping and support for <b>enhanced-priority-mode</b></li> <li>• Logical Interface Scheduling (DLCIs and VLANs)</li> </ul>	18.2R1
Class of service (CoS) per port: <ul style="list-style-type: none"> <li>• Eight queues per port</li> <li>• Excess-rate and excess-priority configurations at the queue level</li> <li>• Shaping at the port level</li> <li>• Shaping at the queue level</li> <li>• Scheduling of queues based on the weighted round-robin (WRR) per excess-priority class</li> <li>• Round-robin scheduling of the queues per priority class</li> <li>• Weighted random early detection (WRED)</li> </ul>	18.2R1

Table 90: Protocols and Applications Supported by JNP10K-LC2101 on the MX10008 Routers (continued)

Protocol or Application	JNP10K-LC2101
Class of service (CoS) per virtual LAN (VLAN): <ul style="list-style-type: none"> <li>• Accounting, filtering, and policing</li> <li>• IEEE 802.1p rewrite</li> <li>• Classification</li> <li>• Tricolor marking</li> <li>• Cos Scaling on Non Queuing MPCs (per VLAN queuing)</li> </ul>	18.2R1
Class of service (CoS) per Point-to-Point Protocol over Ethernet (PPPoE) or Dynamic Host Configuration Protocol (DHCP) subscriber interfaces: <ul style="list-style-type: none"> <li>• Accounting, filtering, and policing</li> <li>• IEEE 802.1p rewrite</li> <li>• Classification</li> <li>• Excess-rate and excess-priority configuration at the queue level</li> <li>• Tricolor marking</li> <li>• Shaping at the queue level</li> <li>• Scheduling of queues based on weighted round-robin (WRR) per priority class</li> <li>• Weighted random early detection (WRED)</li> </ul>	-
<i>Damping</i>	18.2R1
<i>Distributed Denial-of-Service (DDoS) Protection</i>	18.2R1
<i>DVMRP and GRE support—access side and server side</i>	18.2R1
<i>Dynamic Power Management</i>	18.2R1
<i>Ethernet Ring Protection Switching with multiple G.8032 instances</i>	18.2R1
<i>Flexible Queuing Mode</i>	18.2R1
<i>IEEE 802.1ag Ethernet OAM Continuity Check protocol</i>	18.2R1
<i>IEEE 802.1ag Ethernet OAM Linktrace protocol</i>	18.2R1
<i>IEEE 802.1ag Ethernet OAM Loopback protocol</i>	18.2R1
IEEE 802.1ag maintenance association intermediate point (MIP) support, continuity check message (CCM), stacked VLAN tagging, trunk ports, support for VPLS/VPWS, VLAN circuit cross-connect (CCC) encapsulation and translational cross-connect (TCC) encapsulation	18.2R1

Table 90: Protocols and Applications Supported by JNP10K-LC2101 on the MX10008 Routers (continued)

Protocol or Application	JNP10K-LC2101
IEEE 802.1ag optional type, length, and value (TLVs) support <i>Port Status TLV and Interface Status TLV</i>	18.2R1
IEEE 802.3ah distributed periodic packet management (PPM) process, alarm indication signal (AIS), and remote defect indication (RDI)	18.2R1
<p data-bbox="203 636 462 657"><i>Firewall filters and policers:</i></p> <ul data-bbox="203 688 787 1129" style="list-style-type: none"> <li>• Policer support for aggregated Ethernet</li> <li>• Aggregate firewall-based policer for all families of a logical interface</li> <li>• Intelligent hierarchical policers</li> <li>• Set forwarding class and loss priority for Routing Engine-generated packets by using a firewall</li> <li>• Physical interface policers, applying policers to the entire port</li> <li>• Lower policer limit from 32,000 to 8000</li> <li>• Egress .1p MF and BA classification for VPLS</li> <li>• Differentiated Services Code Point (DSCP) rewrite for IPv4 and IPv6</li> <li>• Filter-based GRE Tunneling across IPv4 Networks</li> <li>• Filter-based L2TP Tunneling across IPv4 Networks</li> </ul>	18.2R1
<i>Flexible Ethernet encapsulation</i>	18.2R1
<i>Graceful Routing Engine Switchover (GRES)</i>	18.2R1
IGMPv3 support with snooping disabled	18.2R1
<p data-bbox="203 1350 787 1402">Ingress and egress hierarchical class-of-service (CoS) shaping and <i>hierarchical-scheduler:</i></p> <ul data-bbox="203 1434 389 1528" style="list-style-type: none"> <li>• Set of Interfaces</li> <li>• VLAN level</li> <li>• Port level</li> </ul>	18.2R1
<p data-bbox="203 1560 414 1581"><i>Inline flow monitoring</i></p> <ul data-bbox="203 1612 657 1665" style="list-style-type: none"> <li>• 256K Flow entries for VPLS (IPv4 and IPv6)</li> <li>• 256K Flow entries for MPLS (IPv4 and IPv6)</li> </ul>	18.2R1
<i>Inline Video Monitoring</i>	-
<i>Inline 6rd and 6to4</i>	-
<i>Intelligent Oversubscription</i>	18.2R1

Table 90: Protocols and Applications Supported by JNP10K-LC2101 on the MX10008 Routers (continued)

Protocol or Application	JNP10K-LC2101
<i>Integrated routing and bridging (IRB)</i>	18.2R1
Unified In-service software upgrade ( <i>Unified ISSU</i> )	-
Interoperability <ul style="list-style-type: none"> <li>• Interoperability with existing MPCs</li> <li>• Interoperability with 100-Gigabit Ethernet Interfaces</li> </ul>	-
IPv4	18.2R1
<i>IPv4 multicast</i>	18.2R1
<i>IPv6</i>	18.2R1
IPv6 MLD	18.2R1
<i>IPv6 multicast</i>	18.2R1
<i>IPv6 Neighbor Discovery</i>	18.2R1
<i>IS-IS</i>	18.2R1
ITU-T Y.1731 timestamping support on MX Series routers	18.2R1
Flow monitoring and services: <ul style="list-style-type: none"> <li>• Active monitoring (cflowed version 9 templates)</li> <li>• Port mirroring family VPLS, bridge CCC encapsulation (VPWS)</li> <li>• Packet slice for port mirroring</li> </ul>	<b>Release</b> <ul style="list-style-type: none"> <li>• 18.2R1</li> <li>• 18.2R1</li> <li>• 18.2R1</li> </ul>
<i>Junos Continuity Supported HW</i>	NA
<i>Labeled-switched-paths (LSPs)</i> including accounting, policers, and filtering	18.2R1
<i>LDP</i>	18.2R1

**Table 90: Protocols and Applications Supported by JNP10K-LC2101 on the MX10008 Routers (continued)**

Protocol or Application	JNP10K-LC2101
Layer 2 features: <ul style="list-style-type: none"> <li>• Trunk ports</li> <li>• Layer 2 support for MX Series Virtual Chassis</li> <li>• Layer 2 and Layer 2.5, IRB and spanning tree protocols (xSTP)</li> <li>• IEEE 802.1ad provider bridges</li> <li>• Layer 2 protocol tunneling (L2PT) support</li> <li>• Layer 2 Tunneling Protocol (L2TP)</li> <li>• Multichassis LAG—active/active and active/standby</li> <li>• Multichassis LAG—active/active with IGMP snooping</li> <li>• IGMP snooping with bridging, IRB, and VPLS</li> </ul>	Release <ul style="list-style-type: none"> <li>• 18.2R1</li> <li>• -</li> <li>• 18.2R1</li> <li>• 18.2R1</li> <li>• 18.2R1</li> <li>• 18.2R1</li> <li>• 18.2R1</li> <li>• 18.2R1</li> <li>• 18.2R1</li> </ul>
Layer 2 VPN interfaces support VLAN ID list	18.2R1
<i>Link aggregation (IEEE 802.3ad)</i>	18.2R1
<i>Link Aggregation Control Protocol (LACP)</i>	18.2R1
<i>Link Layer Discovery Protocol (LLDP)</i>	18.2R1
Local loopback	18.2R1
<i>MAC learning, policing, accounting, and filtering</i>	18.2R1
Mobile IP	-
Multichassis Link Aggregation	18.2R1
Multiple Tag Protocol Identifiers (TPIDs)	18.2R1



Table 90: Protocols and Applications Supported by JNP10K-LC2101 on the MX10008 Routers (continued)

Protocol or Application	JNP10K-LC2101
<i>MPLS</i> :	18.2R1
<ul style="list-style-type: none"> <li>Switching of pseudowire segments (multisegment pseudowires with BGP-L2VPN)</li> <li>LDP signaling for VPLS (LDP-VPLS) and MAC flush message processing (MAC-FLUSH-TLV)</li> <li>RSVP graceful restart interoperability with Cisco using Nodal Hello</li> <li>Failure action on BFD session down of RSVP LSPs</li> <li>OSPF and IS-IS loop-free alternates (LFA)</li> <li>4/5 label MPLS operation</li> <li>Virtual circuit connectivity verification (VCCV) BFD</li> <li>MPLS-FRR bypass link protection</li> <li>Load sharing across 64 ECMP next hops</li> <li>MPLS-FRR VPLS instance prioritization</li> <li>Five label stack on ingress</li> </ul>	
MPLS node protection, link protection, and statistics for static LSPs	18.2R1
<i>mvrp</i>	-
<i>Multitopology routing</i>	18.2R1
Nonstop active routing (NSR)	18.2R1
Network Edge Security (802.1x)	-
<i>OSPF</i>	18.2R1
Optical Transport Network	-
<ul style="list-style-type: none"> <li>Link Degrade Monitoring</li> <li>FEC Modes</li> <li>Bit Error Rate (BER)</li> </ul>	
Packet mirroring	18.2R1
Precision Time Protocol (IEEE 1588)	-
IEEE 802.1ah provider backbone bridging (PBB)	-
<i>RSVP</i>	18.2R1
<i>RIP</i>	18.2R1
RFC2544 Benchmarking Tests	-

Table 90: Protocols and Applications Supported by JNP10K-LC2101 on the MX10008 Routers (continued)

Protocol or Application	JNP10K-LC2101
<i>SNMP</i>	18.2R1
Spanning tree protocols: <ul style="list-style-type: none"> <li>• <i>IEEE 802.1s Multiple Spanning Tree Protocol (MSTP)</i> (part of IEEE 802.1Q VLANs)</li> <li>• <i>IEEE 802.1w Rapid Spanning Tree Protocol (RSTP)</i></li> <li>• <i>IEEE 802.1D Spanning Tree Protocol (STP)</i></li> <li>• Per-VLAN Spanning Tree (PVST)</li> <li>• Bridge protocol data units (BPDUs) guard and loop guard</li> <li>• STP inter-protocol action profiles and MAC flush (in VPLS multi-homing, flush all MACs when there is a change in the STP interface state due to root protect)</li> </ul>	18.2R1
Stateful Load Balancing for Aggregated Ethernet Interfaces	-
<i>Subscriber management and services:</i> <ul style="list-style-type: none"> <li>• Enhanced subscriber management</li> </ul>	-
Synchronous Ethernet <ul style="list-style-type: none"> <li>• Hybrid Mode</li> <li>• Line Card Redundancy</li> </ul>	-
<i>Two-Way Active Measurement Protocol (TWAMP)</i>	-
Tunnel services <ul style="list-style-type: none"> <li>• Clear DF-Bit (Don't Fragment Bit)</li> </ul>	18.2R1
Unnumbered Ethernet Interface	18.2R1
<i>VLANs IEEE 802.1Q:</i> <ul style="list-style-type: none"> <li>• VLAN stacking and rewriting</li> <li>• Channels defined by two stacked VLAN tags</li> <li>• Flexible VLAN tagging</li> <li>• IP service for nonstandard TPID and stacked VLAN tags</li> </ul>	18.2R1
Virtual Chassis: MPLS IPv4 and IPv6, unicast, multicast forwarding, VPLS, NSR for Layer 3/MPLS services	-

**Table 90: Protocols and Applications Supported by JNP10K-LC2101 on the MX10008 Routers (continued)**

Protocol or Application	JNP10K-LC2101
Virtual private LAN service (VPLS): <ul style="list-style-type: none"> <li>• BGP multihoming for inter-AS VPLS</li> <li>• Gigabit Ethernet as core-facing interface</li> <li>• Configurable label block sizes</li> <li>• Hashing L3/L4 fields under Ethernet pseudowire for VPLS encapsulation, CCC encapsulation, and MPLS encapsulation</li> <li>• VPLS flood forwarding table filter (FTF), input FTF</li> <li>• Broadcast, unicast unknown, and multicast (BUM) traffic hashing over LAG</li> </ul>	18.2R1
Virtual private network (VPN)	18.2R1
<i>Virtual Router Redundancy Protocol (VRRP) for IPv4</i>	18.2R1
VPLS packet flooding to the right set of interfaces across mesh groups	-
MACSec Capabilities: <ul style="list-style-type: none"> <li>• GCM-AES-128 MACSec Encryption, 802.1AE-2006</li> <li>• GCM-AES-256 MACSec Encryption, 802.1AEbn-2011</li> <li>• GCM-AES-XPN-128 Cipher Suite, 802.1AEbw-2013</li> <li>• GCM-AES-XPN-256 Cipher Suite, 802.1AEbw-2013</li> </ul>	-

- Related Documentation**
- [JNP10K-LC2101 MPC on MX10008 Routers Overview](#)
  - [MX10K-LC2101 on page 138](#)

