

Hi-Cyclic[®]

2, 3 and 4-Way Directional Control Valves
for Pneumatic and Hydraulic Service

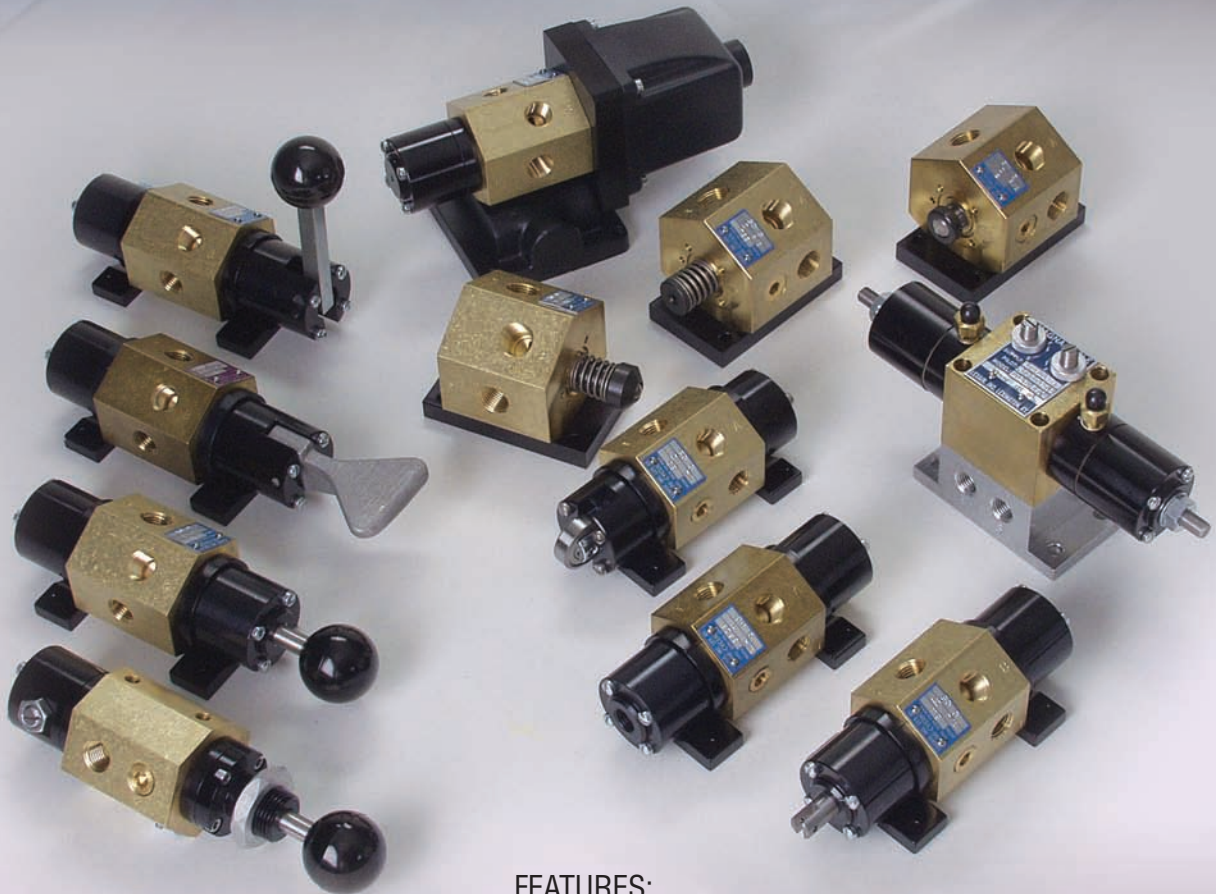

FEATURES:

- Manual, Pilot, Solenoid or Mechanical Operators
- Two and three position models
- Many types of spools to choose from, one for any application

Hi-Cyclic® Valve Line

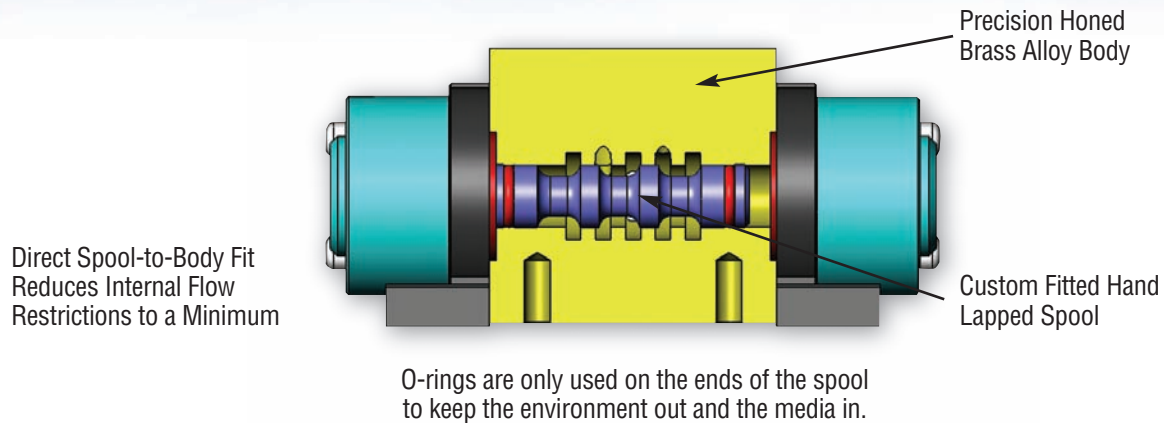

Hi-Cyclic® is a directional control valve line that has become synonymous with operating dependability over many years of service. One reason for such an association to quality is our solid brass body that serves as a strong foundation for durability, allowing our valves to stand up to even the most severe applications. A second reason for them being so rugged is our sleeveless spool-to-body design. Internal restrictions are kept to a minimum, resulting in a very efficient high flow valve. Each spool is individually matched to a body, so Hi-Cyclic® valves function with a precision fit that reduces internal leakage to a minimum. We also use a simple, basic design principle — we keep moving parts and wear points to a minimum.

The key to the product's versatility is in its modular component design. We use a few basic body styles that can be joined with a number of spool, operator and mounting options to create a magnitude of combinations. Because of our non-ferrous construction, we can handle air or hydraulic oils with pressures from 30" Hg vacuum to 250 PSI in air service, and up to 3000 PSI when used in hydraulic service. Models are available in 1/8" NPT to 1/2" NPT as well as 7/16-20 and 9/16-18 SAE straight thread port sizes with foot or subplate mounts (Magna-Cycle® only). Hi-Cyclic® valves may be specified with almost any type of direct solenoid, direct pilot (air or hydraulic), manual or mechanical operators to meet your specific application requirements.

Hi-Cyclic® valve response characteristics are exceptional, making them ideal where rapid cycling is required. This fast action is due in part to its extremely short spool travel – only 0.217" maximum. Rapid response is also aided by its precision honed body that is individually matched to custom lapped, pressure balanced spools, giving each valve almost frictionless operation and effortless shifting.

The valve line features a compact, space saving design. With a maximum body length of only 2 1/4" and a maximum height of only 2 5/8" for foot mounted models, the product line yields an extremely compact envelope size and a low silhouette for installations with limited space.

NOTE: A minimum filtration rating of 10 microns is recommended for pneumatic or hydraulic service.

Hi-Cyclic[®] Manually Operated

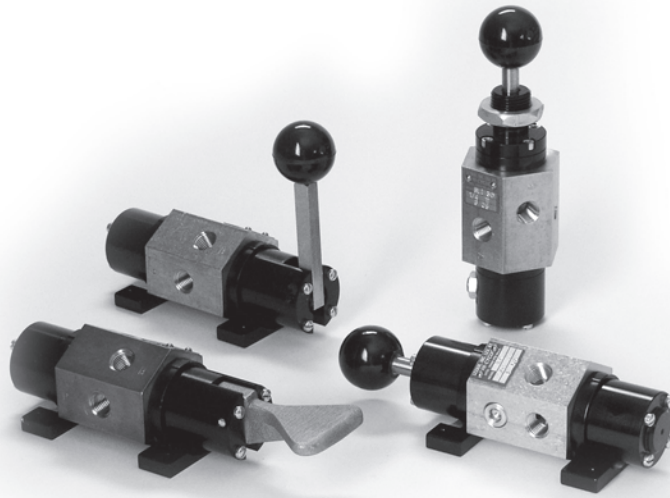

Manual operators provide a “human interface” capability for the directional control of air or oil in circuit design. Operators include hand levers, foot pedals, knobs, panel mount knobs, and palm buttons. All models are available for air or hydraulic service in two and three position configurations with a wide range of spool functions.

Applications include:

- Manually controlled machine tool applications
- Operation of pneumatic and hydraulic double acting or single acting cylinders, rotary actuators, etc.
- Oilfield equipment
- Control valves for agricultural, construction or other types of on/off highway equipment
- Any pneumatic or hydraulic control circuit that needs the ability for “human interface” capability

SPECIFICATIONS

Body	Brass Alloy 360
Seals	Buna-N (See options page for other seal options.)
Spool	303 Stainless Steel (See options page for spool functions.)
Port Size	See options page for available port sizes.
Temperature Range	-20°F to +160°F (With Buna-N seals)
Pressure Rating	Pneumatic service - vacuum through 250 PSI Hydraulic service - 2000 PSI for 1/8”, 1/4”, 3/8” and 1/2” models (1/4” BH and BHL models are rated at 1000 PSI); 3000 PSI for 7/16-20 or 9/16-18 SAE models
Flow	Pneumatic 1/8” and 1/4” up to 1.00 Cv, 3/8” and 1/2” up to 1.13 Cv Hydraulic up to 16 GPM

Hi-Cyclic[®] Manually Operated

Model Numbers – Spring Return or Dual Operators

Primary Actuator	Secondary Actuator	* Function	Model Number
Hand Lever	None	2 or 3 Position	BRL
		2 Position Detented	BRL-2D
		3 Position Detented	BRL-3D
	Spring	2 Position, Spring Return	BRL-2S
		3 Position, Spring Center	BRL-3S
Pedal	Spring	2 Position, Spring Return	BRF
	Pedal	2 Position	BRF-RF
		3 Position, Spring Center	BRF-RF-3S
Knob	None	2 or 3 Position	BK
		2 Position Detented	BK-2D
		3 Position Detented	BK-3D
	Spring	2 Position, Spring Return	BK-2S
		3 Position, Spring Center	BK-3S
Pilot	2 Position	BK-P	
Panel Mounted Knob	None	2 or 3 Position	BLI
		2 Position Detented	BLI-2D
		3 Position Detented	BLI-3D
	Spring	2 Position, Spring Return	BLI-2S
		3 Position, Spring Center	BLI-3S
Pilot	2 Position	BLI-P	
Palm Button	None	2 Position	BH
	Spring	2 Position, Spring Return	BHL

* Two position models without return springs must be mounted with the spool in the horizontal position.

Hi-Cyclic[®] Manually Operated

How to Order Example

BRL-2S – 1/4 – AIR – TYPE I

↑ ↑ ↑ ↑
Model Port Size Media Spool Type

This would be a hand lever operated, 4-way, 5-ported, 2-position, spring return valve with 1/4" NPT ports for air service with a Type I spool.

Note: When ordering, always state:

1. Model
2. Port Size
3. Media to be used (air or hydraulic). If special hydraulic fluids are to be used, advise type of fluid or specify your O-ring material.
4. Spool type desired.

For Dimensional Drawings, please refer to the CD attached to the back cover.

Hi-Cyclic® Mechanically Operated

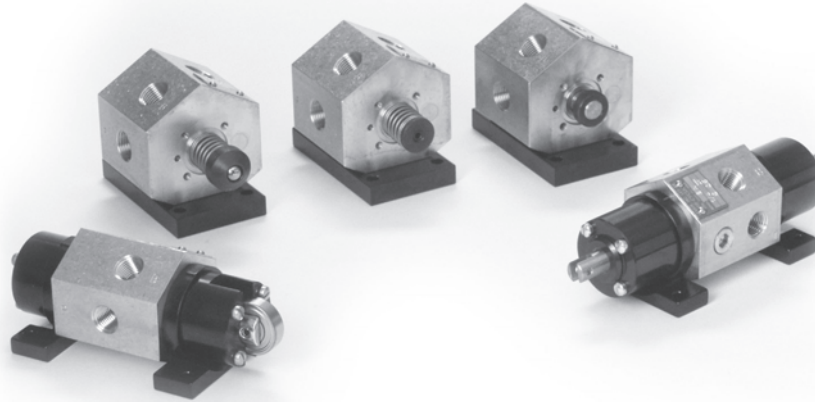

Mechanically actuated valves are ideal for integration into machine tools, production machines, or any type of machine or equipment requiring a compact, high flow valve. Operators include the basic valve with a threaded spool for custom applications in spring return and non-spring versions, a unique “ball point” operator for actuation via a sliding or rolling cam in almost any plane, a cam roller and a clevis for actuation via mechanical linkage.

Applications include:

- Mechanically controlled machine tool applications
- Operation of pneumatic and hydraulic double acting or single acting cylinders, rotary actuators, etc.
- Oilfield equipment
- Control valves for agricultural, construction or other types of on/off highway equipment
- Control and sequencing in pneumatic or hydraulic circuits that require mechanical “signals” or “triggers” from the process

SPECIFICATIONS

Body	Brass Alloy 360
Seals	Buna-N (See options page for other seal options.)
Spool	303 Stainless Steel (See options page for spool functions.)
Port Size	See options page for available port sizes.
Temperature Range	-20°F to +160°F (With Buna-N seals)
Pressure Rating	Pneumatic service - vacuum through 250 PSI Hydraulic service - 2000 PSI for 1/8”, 1/4”, 3/8” and 1/2” models (1/4” B, BSL and BB models are rated at 1000 PSI); 3000 PSI for 7/16-20 or 9/16-18 SAE models
Flow	Pneumatic 1/8” and 1/4” up to 1.00 Cv, 3/8” and 1/2” up to 1.13 Cv Hydraulic up to 16 GPM

Hi-Cyclic[®] Mechanically Operated

Model Numbers

Model	Model Number	Description
Basic Valve	B	Can be actuated by any type of moving linkage. The spool ends are threaded for ease of adapting to your connection. Spool ends are provided with stroke adjustment nuts with “micrometer barrel” type thread which can be used to restrict spool travel so flow through the valve can be adjusted in both directions.
Spring Loaded	BSL	This is a spring-loaded version of the basic valve designed for straight line actuation. It comes standard with a 10 lb. spring. Two lighter weight springs and one heavier are available upon request. Spool end adaptors may be used to restrict spool travel as noted above with the basic valve.
Spring Loaded Ball Point	BB	The ball point, spring-loaded valve is used for actuation via a cam. The rolling ball tip provides for operation via sliding or rolling of a cam in almost any plane in addition to straight line actuation. It comes standard with a 10 lb. spring. Two lighter weight springs and one heavier are available upon request.

* Two position models without return springs must be mounted with the spool in the horizontal position.

Model Numbers

Primary Actuator	Secondary Actuator	* Function	Model Number
Cam	Spring	2 Position, Spring Return	BC
	Cam	2 Position	BC-C
	Pilot	2 Position	BC-P
	Hand Lever	2 Position	BC-RL
Clevis	None	2 or 3 Position	BN
		2 Position Detented	BN-2D
		3 Position Detented	BN-3D
	Spring	2 Position, Spring Return	BN-2S
		3 Position, Spring Center	BN-3S

* Two position models without return springs must be mounted with the spool in the horizontal position.

Hi-Cyclic[®] Mechanically Operated

How to Order Example

BC – 3/8 – AIR – TYPE I

↑
Model

↑
Port Size

↑
Media

↑
Spool Type

This would be a Cam Roller Operated, 4-way, 5-ported, 2-position, spring return valve with 3/8" NPT ports for air service with a Type I spool.

Note: When ordering, always state:

1. Model
2. Port Size
3. Media to be used (air or hydraulic). If special hydraulic fluids are to be used, advise type of fluid or specify your O-ring material.
4. Spool type desired.

For Dimensional Drawings, please refer to the CD attached to the back cover.

Hi-Cyclic® Direct Solenoid Operated

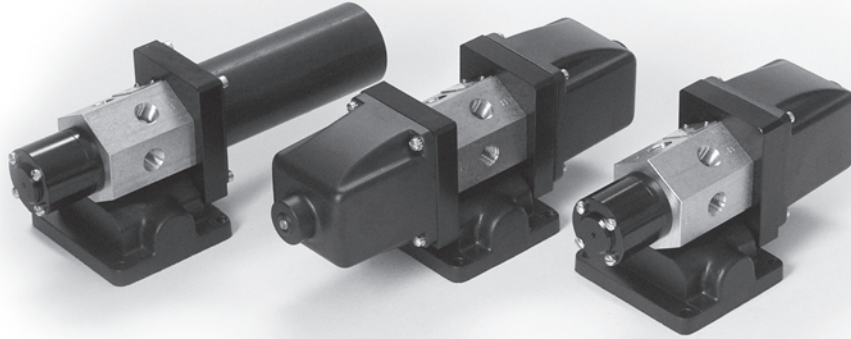

Lexair direct solenoid operated valves feature fast reaction times due to the short stroke and spool-to-body frictionless fit discussed above. Operators are available in AC or DC voltages and come standard with non-locking manual overrides. All coils are rated for continuous duty.

Applications include:

- Electrically controlled machine tool applications
- Operation of pneumatic and hydraulic double acting or single acting cylinders, rotary actuators, etc.
- Oilfield equipment
- Control valves for agricultural, construction or other types of on/off highway equipment
- Any pneumatic or hydraulic circuit where positive, fast acting electrical control is needed

SPECIFICATIONS

Body	Brass Alloy 360
Seals	Buna-N (See options page for other seal options.)
Spool	303 Stainless Steel (See options page for spool functions.)
Port Size	See options page for available port sizes.
Temperature Range	-20°F to +160°F (With Buna-N seals)
Pressure Rating	Pneumatic service - vacuum through 250 PSI Hydraulic service - 2000 PSI for 1/4", 3/8" and 1/2" models; 3000 PSI for 7/16-20 or 9/16-18 SAE models
Flow	Pneumatic 1/4" up to 1.00 Cv, 3/8" and 1/2" up to 1.13 Cv Hydraulic up to 16 GPM
Voltages and Electrical Characteristics	See solenoid options charts on next page.

Hi-Cyclic® Direct Solenoid Operated

Model Numbers

Primary Actuator	Secondary Actuator	* Function	Model Number
Solenoid	Spring	2 Position, Spring Return	B1A
	Solenoid	2 Position	B2A
		3 Position, Spring Center	B2A-3S

* Two position models without return springs must be mounted with the spool in the horizontal position.

Solenoid

Voltage	Coil Part Number	Solenoid Part Number	Inrush Amps	Holding Amps
120V/60Hz	03-0300	03-0378	2.3	0.470
230V/60Hz	03-0303	03-0379	1.15	0.235
460V/60Hz	03-0306	03-0380	0.57	0.117
110V/50Hz	03-0286	03-0377	2.2	0.450
220V/50Hz	03-0290	03-0376	1.1	0.255
460V/50Hz	03-0294	03-0734	0.55	0.113
6V DC	03-0355	03-0366	0	7.3
12V DC	03-0356	03-0367	0	3.32
24V DC	03-0357	03-0368	0	1.66

Hi-Cyclic[®] Direct Solenoid Operated

How to Order Example

B2A-3S - 3/8 - HYD - TYPE V - 120V/60Hz

↑
Model

↑
Port Size

↑
Media

↑
Spool Type

↑
Solenoid Coil Voltage

This would be a double solenoid, 3-position, spring centered, 4-way, 4-ported valve with 3/8" NPT ports and 120V/60Hz operators for hydraulic service with a Type V spool (supply blocked with cylinder ports to tank).

Note: When ordering, always state:

1. Model
2. Port Size
3. Media to be used (air or hydraulic). If special hydraulic fluids are to be used, advise type of fluid or specify your O-ring material
4. Spool type desired
5. Desired coil type and voltage

NOTE: Solenoid/Pilot operated models are still available for sale as replacements but are no longer cataloged items for new applications, consult the factory.

For Dimensional Drawings, please refer to the CD attached to the back cover.

Hi-Cyclic® Pilot Operated

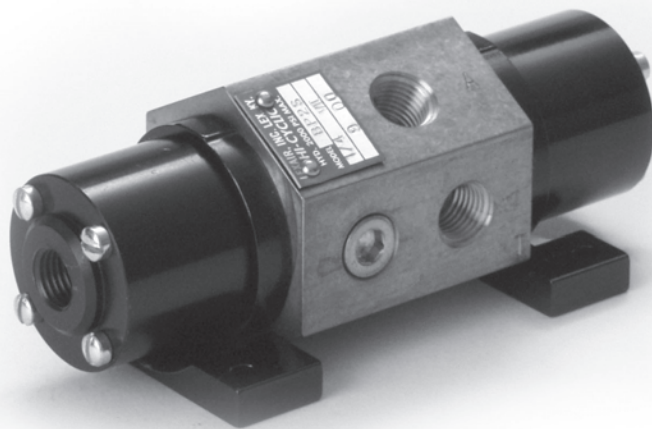

Versions are available for actuation via pneumatic or hydraulic pilot signals. The main valve media may be either pneumatic or hydraulic with either type of actuation, allowing different media types for control versus pilot sources.

Applications include:

- Pneumatically or hydraulically controlled machine tool applications
- Operation of pneumatic and hydraulic double acting or single acting cylinders, rotary actuators, etc.
- Oilfield equipment
- Control valves for agricultural, construction or other types of on/off highway equipment
- Control or sequencing in pneumatic or hydraulic circuits that require pilot signals to achieve action
- Used in hazardous locations where solenoids or other types of operators cannot be used

SPECIFICATIONS

Body	Brass Alloy 360
Seals	Buna-N (See options page for other seal options.)
Spool	303 Stainless Steel (See options page for spool functions.)
Port Size	See options page for available port sizes. Pilot ports are 1/4" NPT for all air pilot versions and 7/16-20 for all hydraulic pilot versions.
Temperature Range	-20°F to +160°F (With Buna-N seals)
Pressure Rating	Pneumatic service - vacuum through 250 PSI Hydraulic service - 2000 PSI for 1/8", 1/4", 3/8" and 1/2" models; 3000 PSI for 7/16-20 or 9/16-18 SAE models
Flow	Pneumatic 1/8" and 1/4" up to 1.00 Cv, 3/8" and 1/2" up to 1.13 Cv Hydraulic up to 16 GPM
Pilot Pressures	Air 35-250 PSI Hydraulic 35-2000 PSI

Hi-Cyclic® Pilot Operated

Model Numbers

Primary Actuator	Secondary Actuator	* Function	Model Number
Pilot (Air)	Pilot (Air)	2 Position	BP
	Spring	2 Position, Spring Return	BP-2S
	Pilot (Air)	3 Position, Spring Center	BP-3S
Pilot (Hydraulic)	Pilot (Hydraulic)	2 Position	BDP
	Spring	2 Position, Spring Return	BDP-2S
	Pilot (Hydraulic)	3 Position, Spring Center	BDP-3S

* Two position models without return springs must be mounted with the spool in the horizontal position.

How to Order Example

BDP-3S - 9/16-18 SAE - HYD - TYPE II

↑
Model

↑
Port Size

↑
Media

↑
Spool Type

This would be a double hydraulic pilot, 4-way, 4-ported, 3-position, spring centered valve with 9/16-18 SAE ports for hydraulic service with a Type II spool (closed center).

Note: When ordering, always state:

1. Model
2. Port Size
3. Media to be used (air or hydraulic). If special hydraulic fluids are to be used, advise type of fluid or specify your O-ring material.
4. Spool type desired.

For Dimensional Drawings, please refer to the CD attached to the back cover.

Hi-Cyclic® Magna-Cycle® Valves

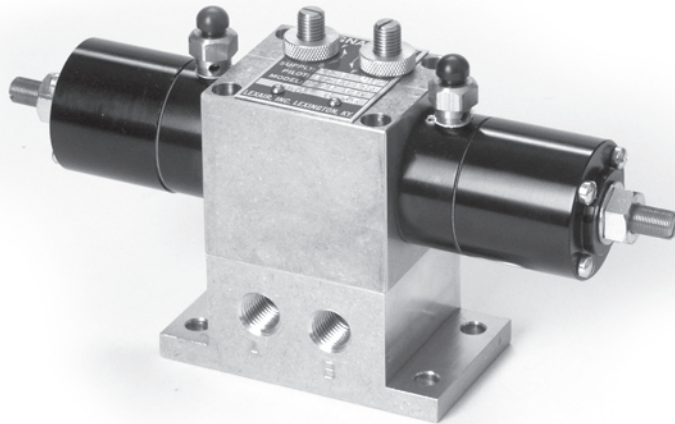

Magna-Cycle® valves are pneumatic 4-way, 2-position directional control models that are air pilot actuated. They contain adjustable permanent magnets in both pilot chambers which detent and hold the spool in one of two positions until building pilot pressure exceeds the holding force of the magnet. The adjustment screws allow any pilot pressure between 20 and 80 PSI to actuate the valve to the opposite position. The magnetic detent action in the pilot chambers allows automatic control actions to be consistently and reliably repeated. Due to the fact that they are pneumatically controlled, they are explosion-proof and may be installed in hazardous locations. Operations that may be performed include: continuous reciprocation of a double acting cylinder, sequential operation of two or more cylinders, adjustable or fixed time delays for cylinder movement, force sensing of cylinder loads, pressure sensing, etc. all with no mechanical or electrical connections. Models available include internal pilot connections, external pilot connections and mixed pilots (one internal, one external). For detailed operating information and circuit examples, see pages 17-18.

Magna-Cycle® valves are based on the time proven Hi-Cyclic® valve line. They utilize a brass body with a sleeveless spool-to-body design featuring an individually precision matched fit, which provides for nearly frictionless operation.

Applications include:

- Operations of any sort requiring continuous reciprocation of a cylinder without the use of electrical or mechanical connections, such as to operate a diaphragm pump, shaking of a hopper for compacting or discharging of material, shaking large containers for mixing, etc.
- Sequential operation or sequencing of cylinders
- Cylinder force or pressure sensing operations
- Circuits operating in hostile or hazardous locations where electrical control is impractical or dangerous to use.

Hi-Cyclic[®] Magna-Cycle[®] Valves

SPECIFICATIONS

Body	Brass Alloy 360
Spool	303 Stainless (See options page for other spool options).
Seals	Buna-N
Port Size	1/4" or 3/8" NPT Subbase
Temperature Range	-0°F to +160°F (with Buna-N)
Pressure Rating	20 - 80 PSI for MCR and MCE series Vacuum to 250 PSI for MCS series (pilot pressure 20 - 80 PSI)
Flow	1/4" 1.00 Cv, 3/8" 1.13 Cv

Model Numbers

NPT Port Size (inches)	* Model Number	Description
◆ 1/4	MCR-521-1001	Pilot signals received from cylinder ports internally.
3/8	MCR-531-1001	
◆ 1/4	MCE-521-1001	One pilot signal received from cylinder port internally, one received from an external source.
3/8	MCE-531-1001	
◆ 1/4	MCS-521-1001	Both pilot signals received from an external source.
3/8	MCS-531-1001	

* Note: Adjusting screw caps which cover magnet detent adjustment screws to discourage tampering by unauthorized personnel are available, simply add a "-P" suffix to the part number. Ex: MCR-531-1001-P would be 3/8" NPT, MCR series with adjusting screw caps factory installed.

◆ Note: 1/4" models are supplied with exhaust flow controls in the body (see dimensional drawings) - 3/8" models require the use of flow controls in the subplate exhaust ports - use two Lexair 10-0076 flow controls.

* All models must be mounted with the spool in the horizontal position.

For Dimensional Drawings, please refer to the CD attached to the back cover.

Hi-Cyclic[®] Magna-Cycle[®] Valves

Mounting Base Options

There are two base sizes available to match the valve body size chosen by valve model number. There are side ported and bottom ported versions available in both body/port sizes.

Base Model Numbers

NPT Port Size	Part Number	Description	Used with
1/4"	10-0332	Bottom Ports	MCR-521-1001
1/4"	10-0333	Side Ports	MCE-521-1001
3/8"	10-0289	Bottom Ports	MCS-521-1001
3/8"	10-1115	Side Ports	MCR-531-1001
			MCE-531-1001
			MCS-531-1001

How to Order

1. Choose valve model desired from page 15.
2. Choose base model desired from chart above.
3. Indicate on your order if you would like to have the valve and base assembled. Otherwise, we will ship the two items separately.

For Dimensional Drawings, please refer to the CD attached to the back cover.

Hi-Cyclic® Magna-Cycle® Valves

Typical Applications

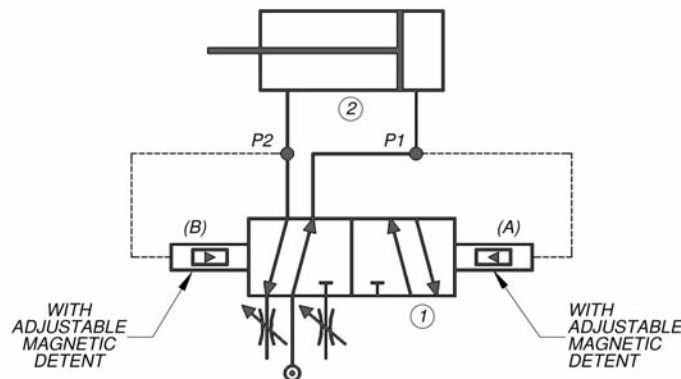

Continuous Cylinder Reciprocation (one MCR valve)

The cylinder continually reciprocates due to the pilot lines being internally connected to the cylinder lines. The reciprocating motion is started by turning on the air supply to the valve. The motion is then stopped by turning off this air supply.

The reciprocating motion is started by supplying air to the valve (1), allowing pressure at P1 to extend the cylinder (2). Exhaust back pressure on P2 plus magnetic detent action prevents the spool from shifting. When the cylinder (2) reaches the end-of-stroke position, pressure at P2 drops to zero and the pressure at P1 builds and overrides the force of the magnetic detent in (A). The spool shifts to the opposite position, reversing flow to the cylinder (2) and causing P2 to start to pressurize as P1 starts to exhaust. The cylinder (2) continues to reciprocate in this manner until supply pressure is removed from the valve (1).

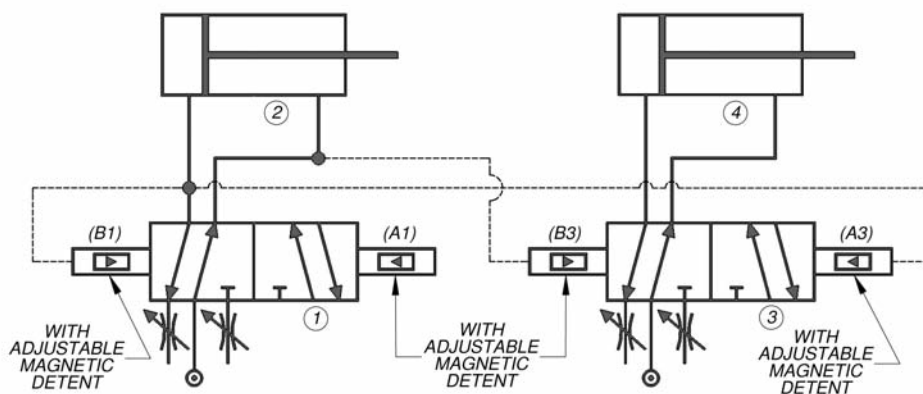

Sequential Operation of Two Cylinders (Two MCS Valves)

To start the sequential operation of the cylinders, a momentary pilot signal is applied to pilot chamber (A1) of Valve (1). This signal shifts Valve (1) and extends Cylinder (2). When (2) is fully extended, pressure builds in the pilot line (B1) of Valve (1) and pilot line (A3) of Valve (3) shifting both of them. This action retracts Cylinder (2) and extends Cylinder (4). When Cylinder (2) is fully retracted, pressure in the pilot line of (B3) going to Valve (3) builds causing Cylinder (4) to retract.

Hi-Cyclic® Magna-Cycle® Valves

Typical Applications

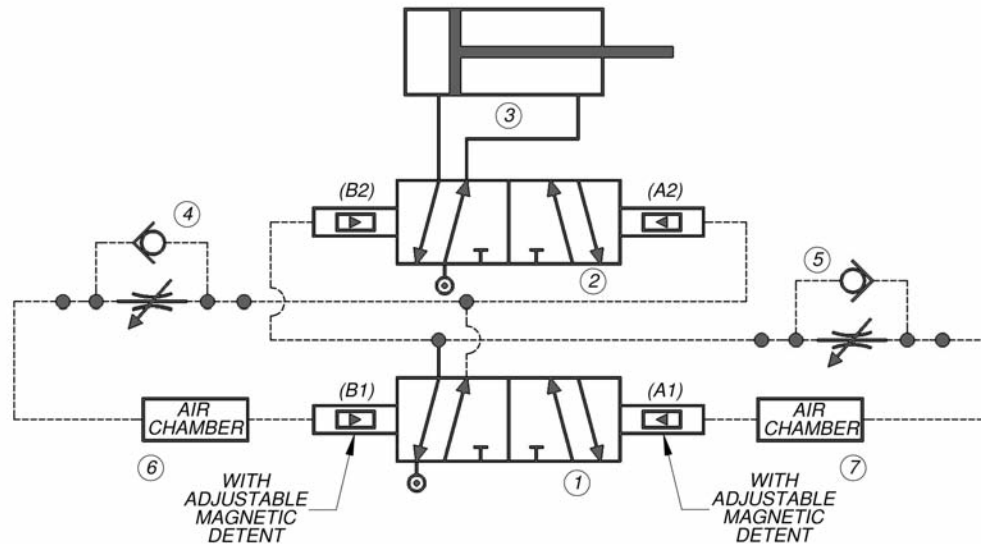

Time Delayed Cylinder Operation (One MCS and one double air piloted valve sized for cylinder operation)

As pressure flows through valve (1), it shifts valve (2) and at the same time is metered into air chamber (6) and actuating chamber (B1) through flow control (4). Once chambers (6) and (B1) are fully pressurized and overcome the magnetic detent setting, valve (1) shifts to the opposite position. This action also shifts valve (2), causing the cylinder (3) to retract and air pressure to build in chambers (7) and (A1) through flow control (5). Once chambers (7) and (A1) are fully pressurized and overcome the magnetic detent setting, valve (1) shifts back, as does valve (2), starting the cycle again.

Flow control valves (4) and (5) adjust the time delay. Maximum time delay depends upon the size of air chambers (6) and (7) plus the adjustability/sensitivity of flow controls (4) and (5). For the most accurate time control, it is best to have the Magna-Cycle® valve operate a piloted valve as shown. This keeps system pressure fluctuations caused by variations in the work load on the cylinder from affecting the timing cycle.

Hi-Cyclic® Options

Porting Options

Port Sizes Available in Valve Body

1/8" NPT	Pneumatic or hydraulic media (not available in solenoid operated models)
1/4" NPT	Pneumatic or hydraulic media
7/16"-20 SAE-4	Hydraulic media only (pneumatic by special request and pricing)
3/8" NPT	Pneumatic or hydraulic media
1/2" NPT	Pneumatic or hydraulic media
9/16"-18 SAE-6	Hydraulic media only (pneumatic by special request and pricing)



Note: Pilot ports are 1/4" NPT for all air pilot versions and 7/16-20 for all hydraulic pilot versions.

Seal Types

Buna-N or Viton®

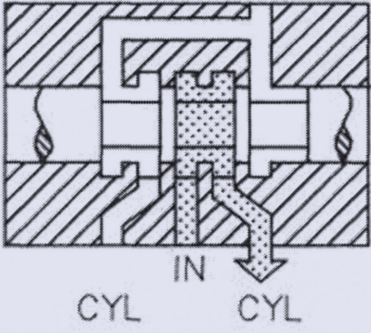
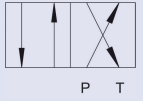

Viton® is a registered trademark of the DuPont Corporation.

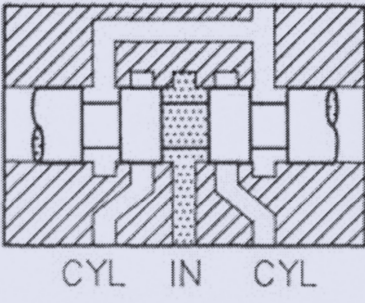
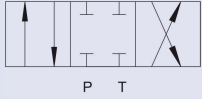
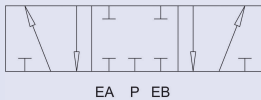
Spool Function Options

Spool Diagrams <i>(See "Note 1" on pg. 22)</i>	Type	Spool Options	ANSI Symbol <i>(See "Note 2" on pg. 22)</i>
	Type I	<p>Two position, positive lap spool used for conventional 4-way, 2-position applications. Can be used as a normally open or normally closed 3-way valve by simply plugging one cylinder port. Use for air and hydraulic service.</p> <p>This spool type will be furnished unless otherwise specified.</p>	<p>Hydraulic</p>  <p>Pneumatic</p> 
	Type II	<p>Three position, closed center spool with wide lands. All ports are blocked and isolated in the center position. Typically used for "position-and-hold" or "inching" circuits (will not hold position for long periods of time). Use for air and hydraulic service.</p>	<p>Hydraulic</p>  <p>Pneumatic</p> 

Hi-Cyclic® Options

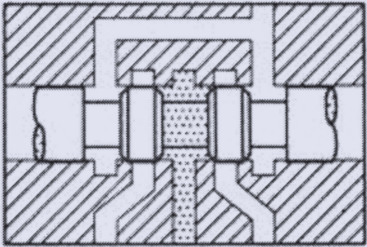
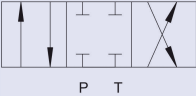
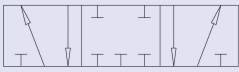
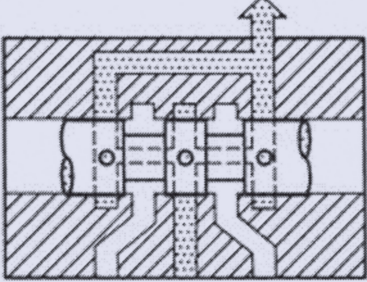
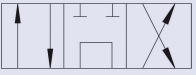
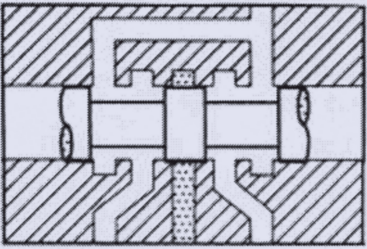
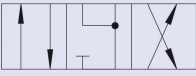
Spool Function Options

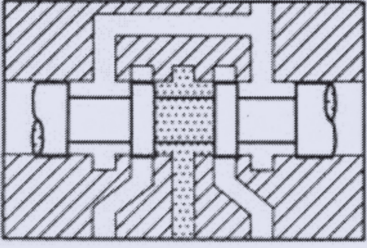
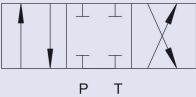
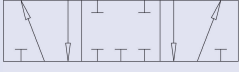
Spool Diagrams <i>(See "Note 1" on pg. 22)</i>	Type	Spool Options	ANSI Symbol <i>(See "Note 2" on pg. 22)</i>
 <p style="text-align: center;">CYL IN CYL</p>	Type II-A	<p>Three position, closed center spool with wide lands that are tapered. All ports are blocked and isolated in the center position. The tapering of the lands provides a more linear flow versus spool travel and therefore better speed control. Typically used for "position-and-hold" or "inching" circuits (will not hold position for long periods of time). Use for air and hydraulic service.</p>	<p>Hydraulic A B</p>  <p>P T</p> <p>Pneumatic A B</p>  <p>EA P EB</p>
 <p style="text-align: center;">CYL IN CYL</p>	Type IV	<p>Three position, cylinder ports blocked with cross drilled spool to allow pressure to bleed to tank port. Do not use in a "series" circuit and limit tank back pressure to 250 PSI maximum. Use for hydraulic service only.</p>	<p>Hydraulic A B</p>  <p>P T</p>
 <p style="text-align: center;">CYL IN CYL</p>	Type V	<p>Three position supply blocked with cylinder ports to tank (commonly referred to as exhaust open center in pneumatic terminology). Use for air and hydraulic service.</p>	<p>Hydraulic A B</p>  <p>P T</p> <p>Pneumatic A B</p>  <p>EA P EB</p>
 <p style="text-align: center;">CYL IN CYL</p>	Type VI	<p>Three position, closed center spool with narrow lands (minimal lap). Spool movement yields almost immediate action. Must be used with sensing devices that will mechanically or electrically position the spool. Use for air and hydraulic service.</p>	<p>Hydraulic A B</p>  <p>P T</p> <p>Pneumatic A B</p>  <p>EA P EB</p>

Hi-Cyclic® Options

Spool Function Options

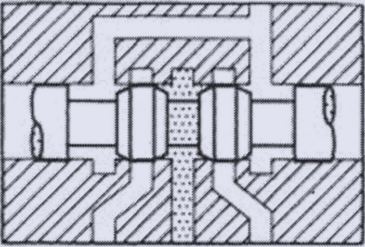
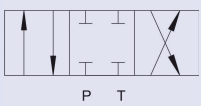
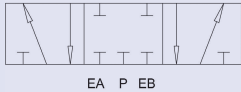
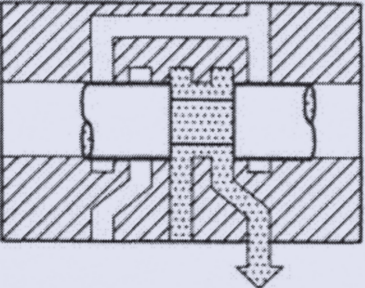
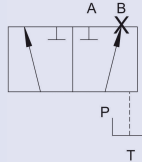
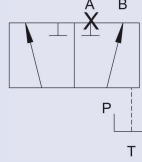
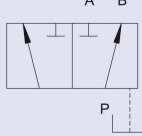
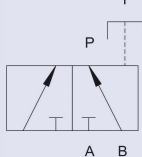
Spool Diagrams <i>(See "Note 1" on pg. 22)</i>	Type	Spool Options	ANSI Symbol <i>(See "Note 2" on pg. 22)</i>
 <p style="text-align: center;">CYL IN CYL</p>	Type VI-A	<p>Three position, closed center spool with narrow, tapered lands (spools with positive or negative lap can be supplied for special applications). The tapered lands help decelerate the cylinder as the spool approaches the center position, which assists in reducing shock and system instability. May be used with sensing devices that will mechanically or electrically position the spool. Use for hydraulic service only.</p>	<p>Hydraulic</p>  <p>Pneumatic</p> 
 <p style="text-align: center;">CYL IN CYL</p>	Type VII	<p>Two position specially machined spool that allows the valve to be used as either a 2-way normally open or normally closed unit. Valves with this spool function are supplied with a "loose plug" that can be customer installed in outlet port "A" or "B" to yield the normally open or normally closed function that is desired. These models may also be used as a pressure selector with two different pressures being piped into the cylinder ports while using the inlet port as a common outlet. The third type of function is to be used as a pressure diverter with the inlet pressure being diverted to one of the two outlet ports. Use for hydraulic service only. Note: Tank port must be left open.</p>	<p>Hydraulic 2-way N/C</p>  <p>Hydraulic 2-way N/O</p>  <p>Hydraulic Diverter</p>  <p>Hydraulic Selector</p> 

Hi-Cyclic® Options

Spool Function Options

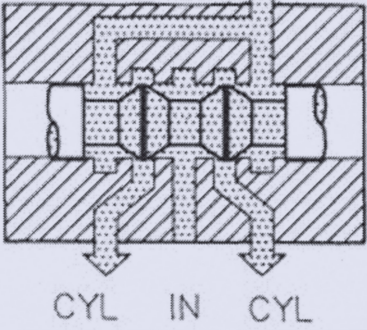
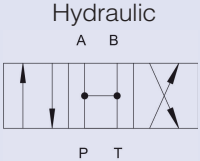
Spool Diagrams <i>(See "Note 1" below)</i>	Type	Spool Options	ANSI Symbol <i>(See "Note 2" below)</i>
	Type VIII	Three position, all ports open to tank. Unique function that can also be suitable for negative lap servo applications. Use for hydraulic service only.	<p>Hydraulic</p> 

Note 1: All spool diagrams shown are for hydraulic valve bodies. Four ports are shown, all pneumatic valves will have 5 ports.

Note 2: Single operator, spring return valves will have supply "P" connected to outlet "B" in the non-actuated (spring return) condition. Outlet "A" will be connected to exhaust port "EA" in the non-actuated condition.

Miscellaneous Information

NOTE:

Manifold and subplate (except for Magna-Cycle®) mounted valves are no longer available for new applications but are supplied as replacements only. Please consult the factory for assistance.

NOTE:

Due to the vast numbers of combinations of operators, spools and port sizes available, please consult the factory for repair kits for various valves and operators.

Dimensional Drawings

Lexair® Valves for Every Application

Four different lines—each the best of its kind.
It could be the smartest valve decision you have ever made.

TUBE-O-MATIC® Series: This line features 2-Way operation in a unique pinch valve design that was developed for long service life while being used in abrasive/aggressive media applications. Direct air pilot or solenoid pilot versions are available. Port sizes range from 1/4" – 2-1/2" NPT with working pressures to 150 PSI. Sleeve material options allow a wide range of media and temperatures to be used.

Hi-Cyclic® Series: Features a complete line of 2, 3 and 4-way valves for pneumatic or hydraulic service. A wide range of manual, mechanical, pilot (air or oil) and solenoid operators are available. Multiple spool configurations cover any application need. Working pressures to 250 PSI (pneumatic) or 3000 PSI (hydraulic) are standard. Port sizes range from 1/8" – 1/2" NPT with 7/16-20 and 9/16-18 SAE available as well. Our Magna-Cycle® models feature built-in, adjustable control functions available in three different models depending upon your application requirements.

Mini 1 Series: These 1/4" NPT pneumatic valves boast a Cv capacity of 1.0 to pack a lot of punch in a small package (basic envelope is 1 inch thick and 2 inches wide). The lineup includes manual, mechanical, solenoid and air pilot versions. Most models are offered in either a three port 3-Way or five port 4-Way version. Working pressures are from vacuum through 150 PSI and the balanced spool design assures that this series can be used as a selector, diverter, in dual pressure service as well as in many other non-standard plumbing applications.

Lexair 2 and 3-Way Poppet valves provide high flow, positive shut-off operation for a variety of industrial and process control needs. Constructed of non-corrosive materials, they can be used with a wide range of liquids and gases or vacuum where quick-acting control is required. Working pressures to 500 PSI are standard, higher pressures are available upon request. Available operators include, direct pilot, solenoid pilot (with integrated DIN style operators), direct solenoid and mechanical cam operation. Port sizes range from 1/4" – 2" NPT and the 2-Way series features both normally closed and normally open models. Many choices of seal materials are available providing for a wide range of media and temperatures to be used. High ratio pilots are available as standard catalog items for use in high media pressure/low pilot pressure applications. This catalog also includes: Our bubble-tight, poppet style Check Valves in 1/2" - 2" NPT port sizes with features that are the same as our 2 and 3-Way Poppet Valve line. Our Shuttle Valve lineup featuring port sizes from 1/4" - 1-1/2" NPT and working pressures to 250 PSI for use with gases or liquids. Our Multifunction Solenoid Valves for use with gases or liquids up to 150 PSI. These solenoid valves can be used in stand-alone applications and also work great as operators for our other valve lines.

Lexair, Inc.

2025 Mercer Road | Lexington, KY 40511-1018
859-255-5001 | 859-255-6656 Fax | www.lexairinc.com



National
FLUID POWER
Association

MEMBER

Catalog LX-325
Supersedes LX-135 & LX-300
Revised 12/08