

D-HV-9 STATIONARY LOUVER

P.O. Box 86
159 Genco Drive
Hartford, AL 36344
Phone: (334) 588-0070
Fax: (334) 588-0071



HIGH PERFORMANCE 9" FIXED LOUVER

MIAMI-DADE COUNTY, FLORIDA NOTICE OF ACCEPTANCE #: 21-0216.02

D-HV-9 Meets the following requirements:
 • AMCA 540 & AMCA 550 Listed
 • Florida Product Approval
 • AMCA 500-L Pressure Drop Tested
 • ASTM E330 & ASTM E1886

STANDARD CONSTRUCTION:

- Front Frame:** .081 Extruded Aluminum, 4.16" Deep
- Front Blade:** .081 Extruded Aluminum positioned on a 40° angle on approximately 4.625" centers
- Rear Frame:** .081 Extruded Aluminum, 5.1" Deep
- Rear Blade:** .063 Extruded Aluminum positioned on approximately 1.50" centers
- Birdscreen:** 0.50" x .050" Flattened Aluminum in removable frame. Screen is mounted as standard on inside (rear) as looking from exterior of building.
- Finish:** Mill Aluminum (Std.)
- Minimum Size:** 12"w x 12"h
- Maximum Single Section:** 72"w x 120"h
Unlimited Multisection w x 120"h

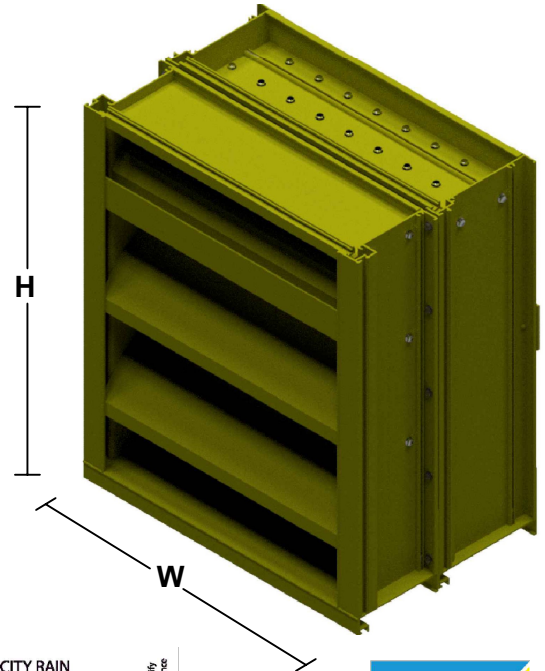

OPTIONS:

- Flanged Frame (1.50" [38mm] std.)
- Custom Flange (1", 2" , or 3")
[25mm, 51mm, or 76mm]
- Extended Sill
- Insect Screen (Other Screens Available, See Screen Page)
- Filter Racks (no screen)
- Security Bars
- Blank-off, Alum., non-insulated, no screen, non-removeable
- Blank-off, Alum., non-insulated, with bird screen or insect screen
- Blank-off, Alum., insulated double wall, with bird screen, removable
- Blank-off, Alum., insulated double wall, no screen, non-removeable

AVAILABLE FINISHES:

- Baked Enamel
- Kynar
- Prime Coat
- Clear and Color Anodized. (Some variation in Anodized color consistency is possible)



HIGH VELOCITY RAIN
RESISTANT WITH BLADES
FULLY OPEN AND
IMPACT RESISTANT LOUVER
Enhanced Protection Level E
See www.AMCA.org for all certified or listed products

This label does not signify
AMCA airflow performance
certification.

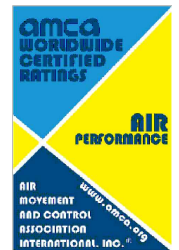

Air Performance certifies that the D-HV-9 shown herein is approved to bear the AMCA Listing Label. The ratings shown are based on tests and procedures performed in accordance with AMCA Publications and comply with the requirements of the AMCA Listing Label applies to Wind Borne Debris Impact Resistant Louvers and High Velocity Rain Resistant Louvers

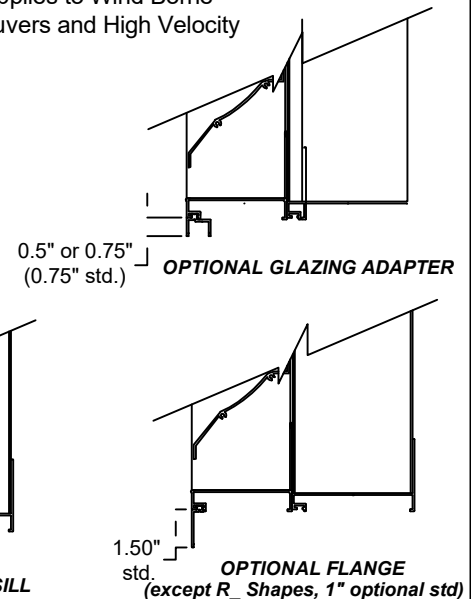
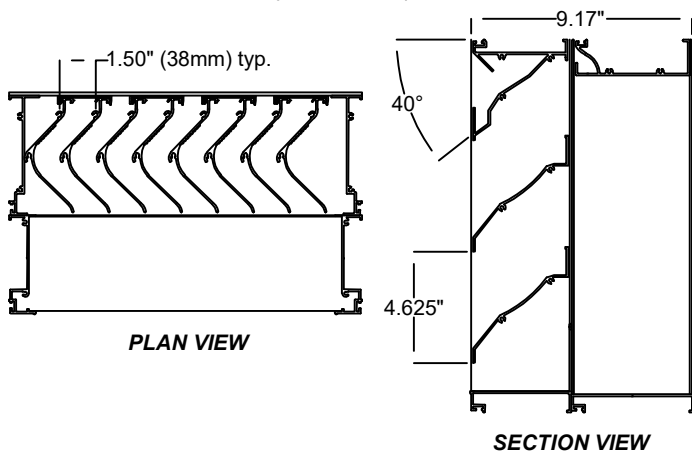

*Width and Height dimensions are approximately 1/4" under listed size.