



## NOTICE OF PUBLIC MEETING

**The Adel City Council will meet in regular session at Adel City Hall, 301 S. 10<sup>th</sup> St., Adel, Iowa, Tuesday, April 11, 2017, at 6:00 PM**

### AGENDA

#### PUBLIC HEARING

1. Rate Increases for the Proposed Improvements to the City's Water, Sanitary Sewer and Storm Water Utility Systems
2. Minor Zoning Changes to the Current City of Adel Zoning Code

#### PROCLAMATION

Arbor Day – April 28, 2017

#### COMMENTS FROM THE PUBLIC

#### CONSENT AGENDA

- a) Consider Approval of City Council Minutes Dated March 14, 2017
- b) Consider Approval of City Council Minutes Dated March 27, 2017
- c) Consider Approval of March Bills and March 31, 2017, Treasurer's Report
- d) Consider Approval of Full Member Firefighters – Justin Kitzinger and Nick Orstad
- e) Consider Approval of Probationary Firefighter – Joel Steenhoek

#### DEPARTMENT HEAD REPORT

Tuesday, April 25, 2017 – Special Council Meeting

#### NEW BUSINESS

- a) Discussion/Possible Action Regarding Negotiations with Xenia Rural Water Association
- b) Consider Approval of Setting Public Hearing Date for the Proposed Annexation to the South of Adel along Highway 169 (approximately 1,000 acres) – June 13, 2017 at 6:00 p.m.
- c) Consider Approval of Ordinance No. 313, Amending the Zoning Classification of Certain Real Property Located at 29456 Old Portland Road – Bloomfield Acres from A-1 to P.U.D. – Third Reading
- d) Consider Approval of Bloomfield Acres P.U.D. Developer's Agreement and Master Plan
- e) Consider Approval of Retracting Approval for 3 Chickens at 1506 Main Street – Originally Approved on July 10, 2012
- f) Consider Approval of Ordinance No. 316, Amending Water Use Charges and Implementing Debt Service Charge (1<sup>st</sup> Reading)
- g) Consider Approval of Ordinance No. 317, Amending Sewer Use Charges and Implementing Debt Service Charge (1<sup>st</sup> Reading)
- h) Consider Approval of Ordinance No. 318, Amending Storm Sewer Rate and Implementing Debt Service Charge (1<sup>st</sup> Reading)
- i) Consider Approval of Water Committee's Recommendation on the East Annex Sewer Extension Agreement with McClure Engineering
- j) Consider Approval of Ordinance No. 319, Water Conservation Plan (1<sup>st</sup> Reading)
- k) Consider Approval of Issuing a Check in the Amount of \$1,664.10 to the Dallas County Treasurer to Correct the County Fund Distribution for the Library
- l) Consider Approval of Ordinance No. 320, Revisions to Chapter 165 – Zoning Code (1<sup>st</sup> Reading)
- m) Discussion/Possible Action of Moving Forward with Sale of City-Owned Property – 425 River Street

- n) Consider Approval of Resolution No. 17-21, Budget Transfers
- o) Consider Approval of Resolution No. 17-22, Authorizing Agreement with Ahlers & Cooney for the Purpose of Obtaining Bond Counsel for USDA Loans and/or Grants
- p) Consider Approval of Resolution No. 17-23, Fixing Date for a Meeting on the Authorization of a Loan Agreement and the Issuance of Not to Exceed \$1,600,000 Sewer Revenue Capital Loan Notes, and Providing for Publication of Notice Thereof
- q) Consider Approval of Resolution No. 17-24, Fixing Date for a Meeting on the Authorization of a Loan Agreement and the Issuance of Not to Exceed \$5,500,000 General Obligation Capital Loan Notes (For Essential Corporate Purposes), and Providing for Publication of Notice Thereof
- r) Consider Approval of Resolution No. 17-25, Amending Building Address from 618 N. 7<sup>th</sup> Street to 618 Main Street
- s) Discussion/Possible Action on Tom Fuller's Offer to Purchase City-Owned Land Near Archery Range
- t) Consider Approval of Setting Public Hearing Date for Fiscal Year 2016-2017 Budget Amendments – May 9, 2017 at 6:00 p.m.

OTHER BUSINESS

4/7/2017 4:53:48 PM



## NOTICE OF PUBLIC MEETING

**The Adel City Council will meet in regular session at Adel City Hall, 301 S. 10<sup>th</sup> St., Adel, Iowa, Tuesday, April 11, 2017, at 6:00 PM**

### AGENDA

#### PUBLIC HEARING

1. Rate Increases for the Proposed Improvements to the City's Water, Sanitary Sewer and Storm Water Utility Systems

This public hearing is for the proposed rate increases and debt service charges for the City's proposed improvements to the City's Water, Sanitary Sewer, and Storm Water utility systems. As of Friday, April 7, 2017, no written or oral comments have been received.

2. Minor Zoning Changes to the Current City of Adel Zoning Code

This public hearing is for the proposed changes to the City's Zoning Code. As of Friday, April 7, 2017, no written or oral comments have been received.

#### PROCLAMATION

Arbor Day – April 28, 2017

#### COMMENTS FROM THE PUBLIC

#### CONSENT AGENDA

- a) Consider Approval of City Council Minutes Dated March 14, 2017
- b) Consider Approval of City Council Minutes Dated March 27, 2017
- c) Consider Approval of March Bills and March 31, 2017, Treasurer's Report
- d) Consider Approval of Full Member Firefighters – Justin Kitzinger and Nick Orstad
- e) Consider Approval of Probationary Firefighter – Joel Steenhoek

#### DEPARTMENT HEAD REPORT

Tuesday, April 25, 2017 – Special Council Meeting

A special council meeting will be held on Tuesday, April 25, 2017 at 6:00 p.m. in the council chambers. Anticipated topics include presentations by McClure Engineering on their Utility Capacity report and on their study for the proposed annexation.

#### NEW BUSINESS

- a) Discussion/Possible Action Regarding Negotiations with Xenia Rural Water Association

Attorney Dan Manning, Sr. and representatives from McClure Engineering will be on hand to provide an update on the City's negotiations with Xenia Rural Water. The purpose of this agenda item will be to determine the City's next steps in the negotiations. The council packet contains correspondence between the City and Xenia as well as information provided by Xenia earlier this year.

- b) Consider Approval of Setting Public Hearing Date for the Proposed Annexation to the South of Adel along Highway 169 (approximately 1,000 acres) – June 13, 2017 at 6:00 p.m.

Mayor James F. Peters has placed this item back on the agenda following last month's action. This action item would set a public hearing on Tuesday, June 13, 2017 at 6:00 p.m. for the proposed annexation south of town. Attorney Dan Manning, Sr. and representatives from McClure Engineering will be on hand. City staff is recommending approval.

- c) Consider Approval of Ordinance No. 313, Amending the Zoning Classification of Certain Real Property Located at 29456 Old Portland Road – Bloomfield Acres from A-1 to P.U.D. – Third Reading

The public hearing for this rezoning was held at the December 13, 2016 council meeting. The first reading was approved at the February 14, 2017 council meeting, and the second reading was approved at the March 27, 2017 council meeting. This is the third reading.

This ordinance would rezone a section of land along Old Portland Road (across from the River Vista trailer court) from A-1 (Agriculture) to a planned unit development (P.U.D.). City staff has reviewed the documents and has had a number of discussions with Kading Properties about this project.

Related agenda items include items "a" and "d." City staff is recommending approval of the rezoning.

- d) Consider Approval of Bloomfield Acres P.U.D. Developer's Agreement and Master Plan

This action item would approve the development agreement and the Master Plan for the Twin Eagles Riverview P.U.D. project. Related agenda items include "a" and "c."

It should be noted that both the development agreement and the Master Plan show the P.U.D. connecting its water lines to Xenia Rural Water. If the development agreement and the Master Plan are approved, the project could begin construction. The project would not come back to council unless it sought changes to the agreement or the Master Plan.

- e) Consider Approval of Retracting Approval for 3 Chickens at 1506 Main Street – Originally Approved on July 10, 2012

City staff is recommending that approval for three chickens at 1506 Main Street be retracted based on several recent police reports and numerous letters addressing the issue since 2012 (see council packet for details). As of Friday, April 7, 2017, no response has been received to the letter that was mailed last month.

- f) Consider Approval of Ordinance No. 316, Amending Water Use Charges and Implementing Debt Service Charge (1<sup>st</sup> Reading)

For the past few years, the Adel City Council has been considering a number of improvements and capital projects to the City's Water system. These improvements include a replacement of the City's 40 year-old water treatment plant, new wells, a new raw water transmission main, and other projects.

The public hearing for this ordinance was held earlier in the meeting. This ordinance would set three fiscal years' worth of rate increases for the City's water rates based on calculations by PFM, the City's financial advisor. In addition, this ordinance would implement a new debt service charge for proposed improvements to the City's water utility system. The ordinance spells out the debt service adjustments for each fiscal year through FY19-20. Future debt service increases will be evaluated in 2020. More information is included in the council packet. Representatives from McClure Engineering will be on hand.

This is the first reading. City staff is recommending approval of the first reading.

- g) Consider Approval of Ordinance No. 317, Amending Sewer Use Charges and Implementing Debt Service Charge (1<sup>st</sup> Reading)

For the past few years, the Adel City Council has been considering a number of improvements and capital projects to the City's Sanitary Sewer system. These improvements include a replacement of the City's sewer treatment plant due to DNR regulations, an extension of sewer east of the Raccoon River, and other projects.

The public hearing for this ordinance was held earlier in the meeting. This ordinance would set three fiscal years' worth of rate increases for the City's sanitary sewer rates based on calculations by PFM, the City's financial advisor. In addition, this ordinance would implement a new debt service charge for proposed improvements to the City's sewer utility system. The ordinance spells out the debt service adjustments for each fiscal year through FY19-20. Future debt service increases will be evaluated in 2020. More information is included in the council packet. Representatives from McClure Engineering will be on hand.

This is the first reading. City staff is recommending approval of the first reading.

- h) Consider Approval of Ordinance No. 318, Amending Storm Sewer Rate and Implementing Debt Service Charge (1<sup>st</sup> Reading)

For the past few years, the Adel City Council has been considering a number of improvements and capital projects to the City's Storm Water system. These improvements include new lines and projects proposed after the heavy rainfall event in the summer of 2015.

The public hearing for this ordinance was held earlier in the meeting. This ordinance would set three fiscal years' worth of rate increases for the City's storm sewer rates based on calculations by PFM, the City's financial advisor. In addition, this ordinance would implement a new debt service charge for proposed improvements to the City's storm sewer utility system. The ordinance spells out the debt service adjustments for each fiscal year through FY19-20. Future debt service increases will be evaluated in 2020. More information is included in the council packet. Representatives from McClure Engineering will be on hand.

This is the first reading. City staff is recommending approval of the first reading.

- i) Consider Approval of Water Committee's Recommendation on the East Annex Sewer Extension Agreement with McClure Engineering

The City's Water Committee recommended approval of this agreement with McClure Engineering to prepare for the proposed East Annex Sewer Extension project. City staff is recommending approval.

- j) Consider Approval of Ordinance No. 319, Water Conservation Plan (1<sup>st</sup> Reading)

The City's Water Committee recommended approval of this ordinance to implement a Water Conservation Plan for the City. The DNR has been recommending that all cities have this kind of a plan since the Iowa droughts in 2012. The ordinance in the packet includes sections in the color red that City staff have edited upon further review. This is the first reading. City staff is recommending approval of the first reading.

- k) Consider Approval of Issuing a Check in the Amount of \$1,664.10 to the Dallas County Treasurer to Correct the County Fund Distribution for the Library

Library Director Paula James was informed that the Library received an incorrect revenue check from Dallas County recently. To correct this error, the City will need to refund a portion of that check in the amount of \$1,664.10 back to the Dallas County Treasurer. City staff is recommending approval of issuing this check.

l) Consider Approval of Ordinance No. 320, Revisions to Chapter 165 – Zoning Code (1<sup>st</sup> Reading)

This is the first reading. The public hearing for this ordinance was held earlier in the meeting. These minor changes to the City's Zoning Code were prepared by City staff and recommended by the City's Planning & Zoning Commission. A related agenda item is item "m." City staff is recommending approval of the first reading and that the second and third readings be waived.

m) Discussion/Possible Action of Moving Forward with Sale of City-Owned Property – 425 River Street

A public hearing for the possible sale of a City-owned property at 425 River Street was held last year. After discussion with City Attorney John Reich, this item had been delayed until the minor zoning changes were implemented in agenda item "l." City staff is recommending that the council take further action to solicit bids for this property. City staff has at least four interested parties that can be contacted.

n) Consider Approval of Resolution No. 17-21, Budget Transfers

The Adel City Council approved the Budget Committee's recommended transfers at the September 13, 2016 council meeting. Upon further review, City staff is recommending that this resolution be approved to initiate the transfers.

o) Consider Approval of Resolution No. 17-22, Authorizing Agreement with Ahlers & Cooney for the Purpose of Obtaining Bond Counsel for USDA Loans and/or Grants

This resolution authorizes an agreement with Ahlers & Cooney for their work on the City's pursuit of USDA-RD financing. City staff is recommending approval.

p) Consider Approval of Resolution No. 17-23, Fixing Date for a Meeting on the Authorization of a Loan Agreement and the Issuance of Not to Exceed \$1,600,000 Sewer Revenue Capital Loan Notes, and Providing for Publication of Notice Thereof

This resolution has been recommended by Ahlers & Cooney regarding the Adel Brick Streets 2017 project. A portion of the project will be financed with USDA-RD funding. City staff is recommending approval.

q) Consider Approval of Resolution No. 17-24, Fixing Date for a Meeting on the Authorization of a Loan Agreement and the Issuance of Not to Exceed \$5,500,000 General Obligation Capital Loan Notes (For Essential Corporate Purposes), and Providing for Publication of Notice Thereof

This resolution has been recommended by Ahlers & Cooney regarding the Adel Brick Streets 2017 project and two potential refundings. City staff is recommending approval.

r) Consider Approval of Resolution No. 17-25, Amending Building Address from 618 N. 7<sup>th</sup> Street to 618 Main Street

City staff is recommending approval of this resolution. There was a discrepancy between the City's address and the County's address, and this resolution will fix that issue.

s) Discussion/Possible Action on Tom Fuller's Offer to Purchase City-Owned Land Near Archery Range

The City has received an offer to purchase roughly one acre of City-owned land split between two parcels near the City's Archery Range along Old Portland Road. The offer, made by Tom Fuller of Fuller's Standard gas station, would expand Fuller's property. After discussion with City Attorney John Reich, this item has been included to determine the council's views and possible next steps. The City's Parks & Recreation Board has asked that the City determine how the Archery Range will be protected from storm water runoff before proceeding.

t) Consider Approval of Setting Public Hearing Date for Fiscal Year 2016-2017 Budget Amendments – May 9, 2017 at 6:00 p.m.

## NOTICE OF PUBLIC HEARING

PUBLIC NOTICE is hereby given that the Council of the City of Adel, Iowa, will hold a public hearing on the 11<sup>th</sup> day of April, 2017, at 6:00 p.m., in the Council Chambers, Adel City Hall, 301 S. 10<sup>th</sup> Street, Adel, Iowa. The purpose of the hearing will be to discuss proposed rate increases for the proposed improvements to the City's Water, Sanitary Sewer, and Storm Water utility systems. As part of the proposed increases, the Adel City Council will consider the implementation of a Debt Service Charge for each utility to meet debt service requirements related to the following improvements:

Water Utility: source, treatment, and distribution system improvements

Sanitary Sewer Utility: collection and treatment system improvements

Storm Water Utility: collection system improvements

Proposed debt service fees to be implemented over the next three years are as follows:

Water Utility: \$24.00 per month

Sanitary Sewer Utility: \$15.00 per month

Storm Water Utility: \$6.00 per month

At the above meeting the Council shall receive oral or written objections from any resident or property owner of the City to the above action. After all objections have been received and considered, the Council will, at this meeting or at any adjournment thereof, take additional action for the authorization and implementation of the proposed rate increases.

This Notice is given by order of the Council of the City of Adel, Iowa, pursuant to Section 362.3 of the Code of Iowa.

Dated this 6<sup>th</sup> day of April, 2017.

Jackie Steele  
City Clerk, Adel, Iowa

## NOTICE OF PUBLIC HEARING

PUBLIC NOTICE is hereby given that the Council of the City of Adel, Iowa, will hold a public hearing on the 11<sup>th</sup> day of April, 2017, at 6:00 p.m., in the Council Chambers, Adel City Hall, 301 S. 10<sup>th</sup> Street, Adel, Iowa. During the public hearing, the Council will consider the minor zoning changes for the current City of Adel Zoning Code. A list of all changes may be viewed at City Hall, 301 S. 10<sup>th</sup> Street, Adel, IA during business hours of 8:30 a.m. to 4:30 p.m.

At the above meeting the Council shall receive oral or written objections from any resident or property owner of the City to the above action. After all objections have been received and considered, the Council will, at this meeting or at any adjournment thereof, take additional action for the authorization of said rezoning described above or will abandon the proposal.

This Notice is given by order of the Council of the City of Adel, Iowa, pursuant to Section 362.3 of the Code of Iowa.

Dated this 30<sup>th</sup> day of March, 2017.

Jackie Steele  
City Clerk, Adel, Iowa





**City of Adel**

P.O. Box 248  
301 S. 10th Street  
Adel, Iowa 50003

P: (515) 993-4525  
F: (515) 993-4527  
www.adeliowa.org

## PROCLAMATION

- Whereas, Trees are one of Iowa's most valuable natural resources that clean our air and water, create employment for over 7,000 Iowans, help to conserve our soil and energy resources, provide critical wildlife habitat for over 300 different species, yield bountiful outdoor recreation opportunities, and make our communities a more pleasant place to live and work; and
- Whereas, Insects, diseases, stormy weather, and pollutants have damaged and continue to threaten our trees, creating the need for reforestation and management programs toward ensuring the future of Iowa's trees and forests; and
- Whereas, Each year, during Arbor Day, the people of Iowa pay special attention to the benefits of our trees and dedicate themselves to the planting and management of all of Iowa's trees and forests; and
- Whereas, The City of Adel, specifically has planted more than 50 trees in the past year and finds them to be beautiful, energy efficient, and a benefit to the community.

Now, therefore, I, James F. Peters, Mayor of the City of Adel, Iowa, do hereby proclaim Friday, April 28, 2017 as

### Arbor Day

in Adel, and urge our citizens to participate in tree planting and maintenance programs that will ensure a more beautiful City and State, and to nurture, protect, and wisely use Iowa's natural wonder of trees.

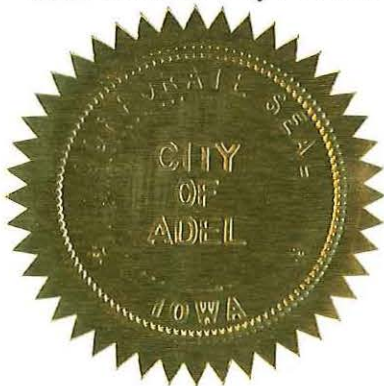

In testimony whereof, I have hereunto subscribed my name and caused the Great Seal of the City of Adel to be affixed. Done on the 11<sup>th</sup> day of April in the year of our Lord two thousand and Seventeen.

\_\_\_\_\_  
James F. Peters, Mayor

Attest:

\_\_\_\_\_  
Jackie Steele, City Clerk

**Adel City Council**  
**March 14, 2017 – Meeting Minutes**

The Adel City Council met in regular session at Adel City Hall, 301 S. 10<sup>th</sup> St., Adel, Iowa, on Tuesday, March 14, 2017 at 6:00 p.m. Mayor Peters called the meeting to order and the following answered roll: Ockerman, Hillmer, McAvoy, and Haynes. Council Member McAdon was absent.

Staff Present: City Attorney Reich, City Administrator Brown, City Clerk Steele, Finance Director Sandquist, Public Works Director Overton, Parks and Recreation Director Schenck, Code Compliance Officer Nichols, Library Director James, and Fire Chief Morlan.

**\*\*\*\* NOTE: Council Member McAdon was absent from all votes \*\*\*\***

**PUBLIC HEARING**

1. Loan Agreement and Issuance of Not to Exceed \$5,500,000 General Obligation Capital Loan Notes  
**Motion by McAvoy, seconded by Hillmer, to open the public hearing**  
**Roll: Ayes-Unanimous. Motion carried.**  
*No written comments were received. No oral comments were received.*  
**Motion by McAvoy, seconded by Haynes, to close the public hearing**  
**Roll: Ayes-Unanimous. Motion carried.**
  
2. FY 17-18 Budget  
**Mayor Peters made a note that the City's tax levy rate went down about \$0.04**  
**Motion by Hillmer, seconded by McAvoy, to open the public hearing**  
**Roll: Ayes-Unanimous. Motion carried.**  
*No written comments were received. No oral comments were received.*  
**Motion by McAvoy, seconded by Haynes, to close the public hearing**  
**Roll: Ayes-Unanimous. Motion carried.**
  
3. Filing Application with the USDA Rural Development for Financial Assistance to Develop Public Infrastructure  
**Motion by Hillmer, seconded by Haynes, to open the public hearing**  
**Roll: Ayes-Unanimous. Motion carried.**  
*No written comments were received. No oral comments were received.*  
**Motion by McAvoy, seconded by Hillmer, to close the public hearing**  
**Roll: Ayes-Unanimous. Motion carried.**
  
4. Plans, Specifications, Form of Contract and Estimate of Costs on the Adel Brick Streets 2017  
**Motion by Hillmer, seconded by McAvoy, to open the public hearing**  
**Roll: Ayes-Unanimous. Motion carried.**  
*No written comments were received. No oral comments were received.*  
**Motion by McAvoy, seconded by Haynes, to close the public hearing**  
**Roll: Ayes-Unanimous. Motion carried.**

**COMMENTS FROM THE PUBLIC**

Adel Resident, Kelly Broyles – Tag Fee and Shut-Off Notice - **would like to see 30 days after delinquent notice before shut off occurs. Council Member Ockerman, Chair of the Water Committee, stated the committee can review the shut off process when they review water rates later this year.**

## CONSENT AGENDA

- a) Consider Approval of City Council Minutes Dated February 14, 2017
- b) Consider Approval of February Bills and February 28, 2017, Treasurer's Report
- c) Consider Approval of Updated Class C Liquor License with Sunday Sales for Adel Family Fun Center – Change in Ownership
- d) Consider Approval of Class E Liquor License, Class B Wine Permit, and Class C Beer Permit (Carryout Beer) for Fareway Stores, Inc. #124
- e) Consider Approval of Class C Liquor License with Outdoor Services and Sunday Sales for Rendezvous Lounge

**Motion by Haynes, seconded by Ockerman, to approve the consent agenda**

**Roll: Ayes-Ockerman, McAvoy, Haynes. Nays-Hillmer. Motion carried.**

## DEPARTMENT HEAD REPORT

Monday, March 27, 2017 at 6:00 p.m. – Second Regular Council Meeting

## NEW BUSINESS

- a) Consider Approval of Resolution No. 17-15, Instituting Proceedings to Take Additional Action for the Issuance of Not to Exceed \$5,500,000 General Obligation Capital Loan Notes  
**Council Member Hillmer mentioned the City will use some of the proceeds to buy down current rates on other debts as well.**  
**Motion by Hillmer, seconded by McAvoy, to approve Resolution No. 17-15**  
**Roll: Ayes-Unanimous. Motion carried.**
- b) Consider Approval of Resolution No. 17-16, Authorizing the Issuance of Not to Exceed \$5,500,000 General Obligation Capital Loan Notes, and Levying a Tax for the Payment Thereof  
**Motion by Hillmer, seconded by McAvoy, to approve Resolution No. 17-16**  
**Roll: Ayes-Unanimous. Motion carried.**
- c) Consider Approval of Resolution No. 17-17, Approving the Fiscal Year 2017-2018 Budget  
**Council Member Haynes acknowledged the great job City staff did with preparing the budget and is very proud of the end result.**  
**Motion by McAvoy, seconded by Haynes, to approve Resolution No. 17-17**  
**Roll: Ayes-Unanimous. Motion carried.**
- d) Consider Approval of Resolution No. 17-18, Approving Filing Applications with the USDA Rural Development for Financial Assistance to Develop Public Infrastructure  
**Motion by McAvoy, seconded by Haynes, to approve Resolution No. 17-18**  
**Roll: Ayes-Unanimous. Motion carried.**
- e) Consider Approval of Patio Lease with Brick Street Bakery Located at 109 N. 9<sup>th</sup> Street, Adel  
**City Administrator Brown presented the background for this item, noting Brick Street Bakery approached the City in the Fall of 2016 to negotiate a lease with the City. They came to an agreement of \$100/month and a few contingencies consisting of a deadline for construction completion and the patio must be open to the public.**  
**Motion by Haynes, seconded by McAvoy, to approve patio lease with Brick Street Bakery with the following contingencies: 1. Construction of patio must be completed by the end of the year 2017 or contract will be null and void; 2. The patio must be made available to the public at all times even when the bakery is closed; and 3. If there are any legal complications, the City has the right to terminate the lease immediately at any time without any repercussions.**  
**Roll: Ayes-McAvoy, Haynes, Ockerman. Nays-Hillmer. Motion carried.**

- f) Consider Approval of Resolution No. 17-19, Amending Resolution No. 17-07 and Resolution No. 17-13, Approving Tax Abatement Applications for the New Construction Completed in 2016  
**Code Compliance Officer Nichols noted these three properties were brought forward by the Dallas County Assessor's Office.**  
**Motion by McAvoy, seconded by Hillmer, to approve Resolution No. 17-19**  
**Roll: Ayes-Unanimous. Motion carried.**
- g) Consider Approval of Setting Public Hearing Date for the Proposed Annexation to the South of Adel along Highway 169 (approximately 1,000 acres) – April 11, 2017 at 6:00 p.m.  
**Motion by Ockerman, seconded by Haynes, to postpone setting a public hearing date until McClure Engineering has finished their review and Dallas County and ADM Schools have time to respond.**  
**Mayor Peters noted the motion was out of order because the motion was a subsidiary motion that has to be applied to a main motion and there was no main motion.**
- Gary Brons with McClure Engineering advised council they should easily be able to have their review to council by the April 11, 2017 council meeting. Fire Chief Morlan confirmed De Soto's voluntary fire department currently covers the area west of Highway 169 and South of Grace Lutheran Church.**  
**Motion by Hillmer, seconded by McAvoy, to approve setting the public hearing date for the proposed annexation south of Adel for April 11, 2017 at 6:00 p.m.**
- Motion by Haynes, seconded by Ockerman, to postpone indefinitely until McClure Engineering and all council committees have had time to review and Dallas County and ADM Schools have had a chance to respond.**  
**Roll: Ayes-Haynes, Ockerman, McAvoy. Nays-Hillmer. Motion carried.**
- h) Consider Approval of Setting Public Hearing Date for Minor Zoning Changes in the City of Adel's Zoning Code – April 11, 2017 at 6:00 p.m.  
**Council Member Ockerman noted per our code any land annexed is automatically zoned as Agriculture (A-1); however, if the County has recently rezoned a section of land then would we honor their zoning change or change it to the A-1? Code Compliance Officer Nichols stated he would look into it.**  
**Motion by Ockerman, seconded by McAvoy, to approve setting public hearing date for minor zoning changes to the Zoning Code on April 11, 2017 at 6:00 p.m.**  
**Roll: Ayes-Unanimous. Motion carried.**
- i) Consider Approval of Amendment No. 1 to the McClure Engineering Agreement for Adel Water Utility Improvements – Phase 1  
**Motion by Haynes, seconded by Ockerman, to approve Amendment No. 1 to the agreement for Adel water utility improvements – Phase 1**  
**Roll: Ayes-Unanimous. Motion carried.**
- j) Consider Approval of McClure Engineering's Recommendation for the Soil Boring Contract with Team Services for the Adel Water Utility Improvements in the amount of \$15,265.00  
**Motion by Haynes, seconded by McAvoy, to approve soil boring contract with Team Services**  
**Roll: Ayes-Unanimous. Motion carried.**
- k) Consider Approval of Special Event Permit for Rock'N Friday – Adel Partners Chamber for May 19, June 23, July 21, and August 18, 2017  
**Motion by McAvoy, seconded by Haynes, to approve special event permit for Rock'N Friday on May 19, June 23, July 21, and August 18, 2017**  
**Roll: Ayes-Unanimous. Motion carried.**

- l) Consider Approval of Support Letter for Brittany Sandquist Scholarship Application to GCMOA for the Iowa Municipal Professionals Institute and Academy in July 2017  
**Motion by McAvoy, seconded by Hillmer, to approve support letter for Brittany Sandquist for scholarship application**  
**Roll: Ayes-Unanimous. Motion carried.**
- m) Consider Approval of Contract with Region XII  
**Motion by Haynes, seconded by Ockerman, to approve contract with Region XII**  
**Roll: Ayes-Unanimous. Motion carried.**
- n) Consider Approval of Contract with McClure Engineering  
**Mayor Peters announced the committee negotiating with Xenia Rural Water is City Administrator Brown, Dan Manning, Sr., and McClure Engineering.**  
**Motion by McAvoy, seconded by Haynes, to approve contract with McClure Engineering regarding negotiations with Xenia Rural Water Association**  
**Roll: Ayes-Unanimous. Motion carried.**

#### OTHER BUSINESS

1. Council Member McAvoy gave an update from the MAC meeting.
2. City Attorney Reich advised council on page 23 of the Cityscape magazine that there is an article on collective bargaining and suggested all members read it.
3. Council Member McAvoy noted an editorial in the Des Moines Register from the Mayor of Carlisle regarding the possibility that the State would stop backfilling commercial property taxes.
4. Meeting adjourned 6:49 p.m.

\_\_\_\_\_  
James F. Peters, Mayor

Attest: \_\_\_\_\_  
Jackie Steele, City Clerk

**Adel City Council**  
**March 27, 2017 – Meeting Minutes**

The Adel City Council met in regular session at Adel City Hall, 301 S. 10<sup>th</sup> St., Adel, Iowa, on Tuesday, March 27, 2017 at 6:00 p.m. Mayor Peters called the meeting to order and the following answered roll: Ockerman, Hillmer, McAvoy, and McAdon. Council Member Haynes was absent.

Staff Present: City Attorney Reich, City Administrator Brown, City Clerk Steele, Finance Director Sandquist, Public Works Director Overton, Police Chief Shepherd, and Fire Chief Morlan.

**\*\*\*\* NOTE: Council Member Haynes was absent from all votes \*\*\*\***

**NEW BUSINESS**

- a) Consider Approval of Ordinance No. 313, Amending the Zoning Classification of Certain Real Property Located at 29456 Old Portland Road – Bloomfield Acres from A-1 to P.U.D. – Second Reading  
**Council Member Ockerman requested that Mayor Peters remove this item from the agenda since there would not be a full council present to vote. Mayor Peters stated he would not remove the item. Motion by McAvoy, seconded by Hillmer, to approve second reading of Ordinance No. 313 Roll: Ayes-Hillmer, McAvoy, McAdon. Nays-Ockerman. Motion carried.**
  
- b) Consider Approval of Resolution No. 17-20, Ratifying, Confirming, and Approving the Change in Deadline for Submission of Bids and the Public Hearing Date and Ordering Clerk to Post Notice and Fixing a New Date for Receiving Bids and for a Public Hearing on Plans, Specifications, Form of Contract, and Estimate of Costs for the Adel Brick Streets 2017  
**Council Member Hillmer asked Gary Brons with McClure Engineering if approving the resolution would be giving the City enough time to get USDA's approval. Mr. Brons stated "yes" it should be. Hillmer also questioned how our applications would be affected if the proposed Federal budget to remove the USDA loan grant program was approved. Mr. Brons stated, once we receive a letter of condition of reservation of funds for the projects, those funds are considered obligated and will not be removed from the program. Motion by Hillmer, seconded by McAdon, to approve Resolution No. 17-20 Roll: Ayes-Unanimous. Motion carried.**
  
- c) Consider Approval of Fire Department / Public Safety Building Improvements and Purchases, including Quotes from Turnkey Construction (\$3,795.00 and \$4,720.00) and Purchase of Washing Machine (not to exceed \$8,000)  
**Fire Chief Morlan gave a brief overview of the quotes. After more research, the washing machine will not be \$8,000 as originally thought but the bathroom will still need to be remodeled to make room for the new, larger washing machine and to keep the shower stalls to be able to stay OSHA compliant. The other quote is to have the roof drain redirected to go into the storm water drain to alleviate the pool or ice patch that occurs in front of the building. \*\*\* NOTE: The City of Adel did attempt to obtain additional quotes; however, they did not receive any additional responses. \*\*\* Motion by McAvoy, seconded by McAdon, to approve Fire Department / Public Safety Building Improvements in the amount of \$8515.00 and Purchases (not to exceed \$8,000.00) Roll: Ayes-Unanimous. Motion carried.**
  
- d) Discussion / Possible Action on RISE Broadband Monthly Lease Agreement Price  
**City Administrator Brown reported that City Attorney Reich, Ahlers & Cooney, and he have been negotiating with Rise Broadband regarding monthly rental fee for keeping their equipment on our water tower. The City originally proposed \$1700.00/month and RISE Broadband countered with \$400/month. No action was taken.**

- e) Discussion / Possible Action of Water, Sewer, and Storm Water Rate Increases, including possibly Setting a Public Hearing for Tuesday, April 11 at 6:00 p.m. – McClure Engineering  
**Gary Brons with McClure Engineering informed council this is for the proposed rate increases for the upcoming infrastructure upgrades. The City would be using a debt service fee over a certain number of years (determined by council) to cover the upgrades. This would be a flat rate for all customers, both residential and commercial. Council Member Ockerman requested consideration to have the service fee higher for commercial users, compared to residential users. Motion by McAvoy, seconded by McAdon, to approve setting a date for public hearing for April 11, 2017 at 6:00 p.m. Roll: Ayes-Unanimous. Motion carried.**

OTHER BUSINESS

1. Meeting adjourned 6:37 p.m.

---

James F. Peters, Mayor

Attest: \_\_\_\_\_  
Jackie Steele, City Clerk

VENDOR NAME	DATE	DESCRIPTION	FUND	DEPARTMENT	AMOUNT
Ahlers & Cooney, P.C.	3/29/17	srvc for Rise Broadband	GENERAL FUND	Finance	280.00
	3/29/17	srvc for Hotel/Motel tax	GENERAL FUND	Finance	247.00
	4/07/17	Amend. No. 6 - Revital Pla	GENERAL FUND	Finance	177.00
	4/07/17	RISE Broadband	GENERAL FUND	Finance	576.00
				TOTAL:	1,280.00
American Family Life Assur Co	3/20/17	PY-AFLAC POST TAX DEDUCTIO	GENERAL FUND	NON-DEPARTMENTAL	18.43
	3/20/17	PY-AFLAC PRETAX	GENERAL FUND	NON-DEPARTMENTAL	187.86
	3/20/17	PY-AFLAC POST TAX DEDUCTIO	ROAD USE TAX	NON-DEPARTMENTAL	5.17
	3/20/17	PY-AFLAC PRETAX	ROAD USE TAX	NON-DEPARTMENTAL	16.37
	3/20/17	PY-AFLAC POST TAX DEDUCTIO	WATER UTILITY	NON-DEPARTMENTAL	12.84
	3/20/17	PY-AFLAC PRETAX	WATER UTILITY	NON-DEPARTMENTAL	18.64
	3/20/17	PY-AFLAC POST TAX DEDUCTIO	SEWER UTILITY FUND	NON-DEPARTMENTAL	12.87
	3/20/17	PY-AFLAC PRETAX	SEWER UTILITY FUND	NON-DEPARTMENTAL	22.50
	4/05/17	PY-AFLAC POST TAX DEDUCTIO	GENERAL FUND	NON-DEPARTMENTAL	18.43
	4/05/17	PY-AFLAC PRETAX	GENERAL FUND	NON-DEPARTMENTAL	187.86
	4/05/17	PY-AFLAC POST TAX DEDUCTIO	ROAD USE TAX	NON-DEPARTMENTAL	5.11
	4/05/17	PY-AFLAC PRETAX	ROAD USE TAX	NON-DEPARTMENTAL	16.14
	4/05/17	PY-AFLAC POST TAX DEDUCTIO	WATER UTILITY	NON-DEPARTMENTAL	12.88
	4/05/17	PY-AFLAC PRETAX	WATER UTILITY	NON-DEPARTMENTAL	18.80
	4/05/17	PY-AFLAC POST TAX DEDUCTIO	SEWER UTILITY FUND	NON-DEPARTMENTAL	12.89
	4/05/17	PY-AFLAC PRETAX	SEWER UTILITY FUND	NON-DEPARTMENTAL	22.57
			TOTAL:	589.36	
Ankeny Sanitation	4/07/17	Mar. 2017 GB & RC Svcs	GARBAGE/RECYCLING	Garbage	16,320.85
	4/07/17	Mar. 2017 GB & RC Svcs	GARBAGE/RECYCLING	Garbage	5,244.33
				TOTAL:	21,565.18
Assurant Employee Benefits	3/29/17	April 2017 premiums	TRUST AND AGENCY	General Government	866.54
	3/29/17	April 2017 premiums	WATER UTILITY	Water	133.32
	3/29/17	April 2017 premiums	SEWER UTILITY FUND	Sewer	111.10
				TOTAL:	1,110.96
BSN Sports	3/29/17	2017 baseball/softball equ	GENERAL FUND	Recreation	1,692.88
	3/29/17	2017 baseball/softball equ	GENERAL FUND	Recreation	2,505.26
	4/07/17	home plates & bases for yo	GENERAL FUND	Recreation	803.94
	4/07/17	home plates & bases for yo	GENERAL FUND	Recreation	1,079.77
				TOTAL:	6,081.85
Baker & Taylor Inc.	4/07/17	Books	TRUST AND AGENCY	Library	1,855.31
				TOTAL:	1,855.31
Baker Electric Inc.	4/07/17	work on stoplights	ROAD USE TAX	Road Use Tax	5,671.50
				TOTAL:	5,671.50
Barco Municipal Products Inc	3/29/17	blue survey flags	WATER UTILITY	Water	99.95
				TOTAL:	99.95
Base	4/07/17	HRA / Flex	ROAD USE TAX	Road Use Tax	10.68
	4/07/17	HRA / Flex	ROAD USE TAX	Road Use Tax	3.75
	4/07/17	HRA / Flex	TRUST AND AGENCY	General Government	66.22
	4/07/17	HRA / Flex	TRUST AND AGENCY	General Government	18.75
	4/07/17	HRA / Flex	WATER UTILITY	Water	16.02
	4/07/17	HRA / Flex	WATER UTILITY	Water	7.12
	4/07/17	HRA / Flex	SEWER UTILITY FUND	Sewer	13.88
	4/07/17	HRA / Flex	SEWER UTILITY FUND	Sewer	7.88



VENDOR NAME	DATE	DESCRIPTION	FUND	DEPARTMENT	AMOUNT
				TOTAL:	144.30
Bound Tree Medical	3/29/17	exam gloves	GENERAL FUND	Fire Department	167.85
				TOTAL:	167.85
Brittany Sandquist	3/29/17	reimbursement GCMOA lunche	GENERAL FUND	Finance	3.00
	3/29/17	reimbursement GCMOA lunche	ROAD USE TAX	Road Use Tax	3.00
	3/29/17	reimbursement GCMOA lunche	WATER UTILITY	Water	3.00
	3/29/17	reimbursement GCMOA lunche	SEWER UTILITY FUND	Sewer	3.00
				TOTAL:	12.00
Bruske Products	4/07/17	brooms,squeegees,wash brus	ROAD USE TAX	Road Use Tax	196.46
				TOTAL:	196.46
CITY OF ADEL (FLEX SPENDING ACCOUNTS)	3/20/17	PY-FLEX SPENDING W/H	GENERAL FUND	NON-DEPARTMENTAL	214.49
	3/20/17	PY-FLEX SPENDING W/H	ROAD USE TAX	NON-DEPARTMENTAL	21.57
	3/20/17	PY-FLEX SPENDING W/H	WATER UTILITY	NON-DEPARTMENTAL	38.46
	3/20/17	PY-FLEX SPENDING W/H	SEWER UTILITY FUND	NON-DEPARTMENTAL	41.97
	4/05/17	PY-FLEX SPENDING W/H	GENERAL FUND	NON-DEPARTMENTAL	214.49
	4/05/17	PY-FLEX SPENDING W/H	ROAD USE TAX	NON-DEPARTMENTAL	21.00
	4/05/17	PY-FLEX SPENDING W/H	WATER UTILITY	NON-DEPARTMENTAL	39.00
	4/05/17	PY-FLEX SPENDING W/H	SEWER UTILITY FUND	NON-DEPARTMENTAL	42.00
				TOTAL:	632.98
Cargill Inc.	3/29/17	bulk salt	WATER UTILITY	Water	4,189.18
				TOTAL:	4,189.18
Carpenter Uniform Co.	4/07/17	shirts-J.Kitzinger/D.Schne	GENERAL FUND	Fire Department	126.48
				TOTAL:	126.48
Central States Lab	4/07/17	6 gal of 2-4-D,GR 441 weed	ROAD USE TAX	Road Use Tax	283.69
				TOTAL:	283.69
CenturyLink	4/07/17	phone svcs 3/28 thru 4/27	GENERAL FUND	Police Department	220.85
	4/07/17	phone svcs 3/28 thru 4/27	GENERAL FUND	Library	220.86
	4/07/17	phone svcs 3/28 thru 4/27	GENERAL FUND	Pool	54.81
	4/07/17	phone svcs 3/28 thru 4/27	GENERAL FUND	Finance	165.97
	4/07/17	phone svcs 3/28 thru 4/27	ROAD USE TAX	Road Use Tax	55.22
	4/07/17	phone svcs 3/28 thru 4/27	WATER UTILITY	Water	55.22
				TOTAL:	772.93
Christian Printers	3/29/17	2017 Spring/Summer Act. Gu	GENERAL FUND	Recreation	3,685.28
				TOTAL:	3,685.28
Cintas Corporation	4/07/17	first aid kit refill	ROAD USE TAX	Road Use Tax	34.93
	4/07/17	first aid kit refill	WATER UTILITY	Water	34.93
	4/07/17	first aid kit refill	SEWER UTILITY FUND	Sewer	34.93
	4/07/17	first aid kit refill	STORM WATER UTILIT	STORM WATER UTILITY	34.93
				TOTAL:	139.72
City of Adel	3/29/17	reimb. Nick DQ use on city	GENERAL FUND	Parks	6.36
	3/29/17	Bic Stik pens for front de	GENERAL FUND	Pool	1.91
	3/29/17	Bic Stik pens for front de	GENERAL FUND	Finance	1.93
	3/29/17	parking-GDMP dinner/IA Lea	GENERAL FUND	Finance	24.00
	3/29/17	mailings-Brick St pjct/Can	GENERAL FUND	Finance	9.77
	3/29/17	app. sticker - old microwa	GENERAL FUND	Finance	10.00

VENDOR NAME	DATE	DESCRIPTION	FUND	DEPARTMENT	AMOUNT
	3/29/17	reimb. Kathy ovrpd lunch o	GENERAL FUND	Finance	1.00-
	3/29/17	cert. ltr for Koopman Anne	GENERAL FUND	Zoning/Compliance/Perm	7.67
	3/29/17	wash trucks	ROAD USE TAX	Road Use Tax	50.00
	3/29/17	parking @ IRWA Conf	WATER UTILITY	Water	24.00
				TOTAL:	121.92
Continental Research Corp.	3/29/17	graffiti remover	GENERAL FUND	Parks	188.24
	3/29/17	grave stone cleaner	GENERAL FUND	Cemetery	238.24
	3/29/17	graffiti remover	GENERAL FUND	Cemetery	188.25
				TOTAL:	614.73
Cummins Central Power LLC	4/07/17	work on gen. main lift	SEWER UTILITY FUND	Sewer	2,569.34
				TOTAL:	2,569.34
Dallas County Treasurer	4/07/17	Mar.2017 parking tickets	GENERAL FUND	Police Department	40.00
	4/07/17	Hydro-seeding @ Island Par	GENERAL FUND	Island Park	892.65
				TOTAL:	932.65
Demco	4/07/17	book processing supplies	GENERAL FUND	Library	115.14
	4/07/17	book processing supplies	GENERAL FUND	Library	178.89
				TOTAL:	294.03
Electric Pump & Tool Inc	4/07/17	Effluent pump	SEWER UTILITY FUND	Sewer	782.47
				TOTAL:	782.47
Excel Mechanical Co Inc	4/07/17	chngd fltrs & work on hea	FRIENDS/FOUNDATION	Library	405.50
				TOTAL:	405.50
Gale Cengage Learning	4/07/17	large print books	TRUST AND AGENCY	Library	469.29
				TOTAL:	469.29
Gatehouse Media Iowa Holdings	4/07/17	budget, PH-USDA, Floodplain	GENERAL FUND	Finance	482.22
				TOTAL:	482.22
Hach Co.	3/29/17	buffer PWD PLWS/KTO bottle	WATER UTILITY	Water	56.80
				TOTAL:	56.80
Heiman Inc	3/29/17	hoses & replcd shut off ha	GENERAL FUND	Fire Department	432.02
				TOTAL:	432.02
IPERS	3/20/17	PY-IPERS REG	GENERAL FUND	NON-DEPARTMENTAL	841.83
	3/20/17	PY-POLICE IPERS	GENERAL FUND	NON-DEPARTMENTAL	1,215.46
	3/20/17	PY-IPERS REG	ROAD USE TAX	NON-DEPARTMENTAL	322.78
	3/20/17	PY-IPERS REG	ROAD USE TAX	Road Use Tax	484.44
	3/20/17	PY-IPERS REG	TRUST AND AGENCY	General Government	1,263.41
	3/20/17	PY-POLICE IPERS	TRUST AND AGENCY	General Government	1,823.22
	3/20/17	PY-IPERS REG	WATER UTILITY	NON-DEPARTMENTAL	427.88
	3/20/17	PY-IPERS REG	WATER UTILITY	Water	642.19
	3/20/17	PY-IPERS REG	SEWER UTILITY FUND	NON-DEPARTMENTAL	445.12
	3/20/17	PY-IPERS REG	SEWER UTILITY FUND	Sewer	668.07
	3/20/17	PY-IPERS REG	STORM WATER UTILIT	NON-DEPARTMENTAL	36.73
	3/20/17	PY-IPERS REG	STORM WATER UTILIT	STORM WATER UTILITY	55.12
	4/05/17	PY-IPERS REG	GENERAL FUND	NON-DEPARTMENTAL	782.75
	4/05/17	PY-POLICE IPERS	GENERAL FUND	NON-DEPARTMENTAL	1,208.91
	4/05/17	PY-IPERS REG	ROAD USE TAX	NON-DEPARTMENTAL	291.25
	4/05/17	PY-IPERS REG	ROAD USE TAX	Road Use Tax	437.10

VENDOR NAME	DATE	DESCRIPTION	FUND	DEPARTMENT	AMOUNT
	4/05/17	PY-IPERS REG	TRUST AND AGENCY	General Government	1,174.75
	4/05/17	PY-POLICE IPERS	TRUST AND AGENCY	General Government	1,813.41
	4/05/17	PY-IPERS REG	WATER UTILITY	NON-DEPARTMENTAL	407.81
	4/05/17	PY-IPERS REG	WATER UTILITY	Water	612.07
	4/05/17	PY-IPERS REG	SEWER UTILITY FUND	NON-DEPARTMENTAL	423.53
	4/05/17	PY-IPERS REG	SEWER UTILITY FUND	Sewer	635.65
	4/05/17	PY-IPERS REG	STORM WATER UTILIT	NON-DEPARTMENTAL	37.38
	4/05/17	PY-IPERS REG	STORM WATER UTILIT	STORM WATER UTILITY	56.11
				TOTAL:	16,106.97
International Union of Operating Engin	3/20/17	PY-PW UNION DUES	ROAD USE TAX	NON-DEPARTMENTAL	15.89
	3/20/17	PY-PW UNION DUES	WATER UTILITY	NON-DEPARTMENTAL	14.45
	3/20/17	PY-PW UNION DUES	SEWER UTILITY FUND	NON-DEPARTMENTAL	1.66
	4/05/17	PY-PW UNION DUES	ROAD USE TAX	NON-DEPARTMENTAL	15.20
	4/05/17	PY-PW UNION DUES	WATER UTILITY	NON-DEPARTMENTAL	15.04
	4/05/17	PY-PW UNION DUES	SEWER UTILITY FUND	NON-DEPARTMENTAL	1.76
				TOTAL:	64.00
Iowa State University	3/29/17	Fire School Reg - T.Morlan	GENERAL FUND	Fire Department	100.00
				TOTAL:	100.00
Jackie Steele	3/29/17	reimb. GCMOA luncheon	GENERAL FUND	Finance	3.00
	3/29/17	reimb. GCMOA luncheon	ROAD USE TAX	Road Use Tax	3.00
	3/29/17	reimb. GCMOA luncheon	WATER UTILITY	Water	3.00
	3/29/17	reimb. GCMOA luncheon	SEWER UTILITY FUND	Sewer	3.00
				TOTAL:	12.00
John L Wright	4/07/17	removd 2 trees/stumps-8th/	ROAD USE TAX	Road Use Tax	800.00
				TOTAL:	800.00
Keystone Laboratories, Inc.	4/07/17	Mar. 2017 testing	WATER UTILITY	Water	60.50
	4/07/17	Mar. 2017 testing	SEWER UTILITY FUND	Sewer	1,027.20
				TOTAL:	1,087.70
Law Enforcement Systems	3/29/17	door hangers	GENERAL FUND	Police Department	78.00
				TOTAL:	78.00
Linda Johnson	4/07/17	Safety Facility	GENERAL FUND	Police Department	174.00
	4/07/17	City Hall	GENERAL FUND	Finance	228.00
				TOTAL:	402.00
MSA Professional Services Inc.	3/29/17	2017 Subdiv. regulation re	GENERAL FUND	Zoning/Compliance/Perm	1,045.00
				TOTAL:	1,045.00
Manatts Inc.	4/07/17	concrete for culvert - 288	STORM WATER UTILIT	STORM WATER UTILITY	231.00
				TOTAL:	231.00
Martin Marietta Materials	3/29/17	2 loads of 1" road stone	TRUST AND AGENCY	Park	602.39
	3/29/17	2 loads of 1" road stone	SEWER UTILITY FUND	Sewer	608.96
				TOTAL:	1,211.35
Menards	3/29/17	materials for Island Park	GENERAL FUND	Island Park	20.13
	3/29/17	materials for Island Park	TRUST AND AGENCY	Park	213.83
				TOTAL:	233.96
MicroMarketing LLC	4/07/17	books on CD	GENERAL FUND	Library	155.00

VENDOR NAME	DATE	DESCRIPTION	FUND	DEPARTMENT	AMOUNT
				TOTAL:	155.00
Mike's Adel Power Equipment	3/29/17	chainsaw chisel & 2 sharpn	GENERAL FUND	Parks	31.98
	3/29/17	chain loop & misc for chai	ROAD USE TAX	Road Use Tax	41.33
				TOTAL:	73.31
Murray's Auto Pit Stop	3/29/17	work Unit #101/battrry repl	GENERAL FUND	Fire Department	334.92
				TOTAL:	334.92
Nationwide Office Cleaners	4/07/17	janitorial	GENERAL FUND	Library	627.85
				TOTAL:	627.85
Nationwide Retirement Solutions	3/20/17	EE deferred comp w/h	GENERAL FUND	NON-DEPARTMENTAL	115.00
	3/20/17	EE deferred comp w/h	ROAD USE TAX	NON-DEPARTMENTAL	101.04
	3/20/17	EE deferred comp w/h	WATER UTILITY	NON-DEPARTMENTAL	69.77
	3/20/17	EE deferred comp w/h	SEWER UTILITY FUND	NON-DEPARTMENTAL	64.19
	4/05/17	EE deferred comp w/h	GENERAL FUND	NON-DEPARTMENTAL	115.00
	4/05/17	EE deferred comp w/h	ROAD USE TAX	NON-DEPARTMENTAL	100.00
	4/05/17	EE deferred comp w/h	WATER UTILITY	NON-DEPARTMENTAL	70.50
	4/05/17	EE deferred comp w/h	SEWER UTILITY FUND	NON-DEPARTMENTAL	64.50
				TOTAL:	700.00
Northern Tool & Equipment	3/29/17	coupler for power washer	ROAD USE TAX	Road Use Tax	22.24
				TOTAL:	22.24
Temporary Vendo Alyssa Subbert,	3/29/17	Alyssa Subbert, :,pitching	GENERAL FUND	Recreation	160.00
BURG, AMY	4/07/17	03-10420-01	WATER UTILITY	Water	62.11
CROW, KAYLA	4/07/17	02-05600-10	WATER UTILITY	Water	26.39
Casa Lepe, Inc,	3/29/17	Casa Lepe, Inc, :,refund	GENERAL FUND	Non Departmental	463.13
Charles Bandy,	3/29/17	Charles Bandy, :,boot reimb	WATER UTILITY	Water	128.35
City of Waukee,	3/24/17	City of Waukee, :,Street Sw	ROAD USE TAX	Road Use Tax	75,000.00
City of Waukee,	3/24/17	City of Waukee, :,Street Sw	STORM WATER UTILIT	STORM WATER UTILITY	25,000.00
DESTINY HOMES	4/07/17	03-17180-00	WATER UTILITY	Water	391.89
FOSTER, JAIME & MATT	4/07/17	06-02350-02	WATER UTILITY	Water	76.71
GARRETT, BRIAN	4/07/17	01-02000-02	WATER UTILITY	Water	54.85
HACHMEISTER, JAMIE	4/07/17	01-06440-04	WATER UTILITY	Water	4.95
HOWARD, ALEX & ALLIS	4/07/17	02-03020-02	WATER UTILITY	Water	23.34
MILLER, JUSTIN	4/07/17	01-10220-04	WATER UTILITY	Water	10.31
SLOSS, CONNIE	4/07/17	03-07930-01	WATER UTILITY	Water	90.88
Taser International,	3/29/17	Taser International, :, tas	GENERAL FUND	Police Department	14,381.45
				TOTAL:	115,874.36
On Ramp	3/29/17	qrtly website hosting 4/1-	GENERAL FUND	Finance	79.00
	3/29/17	qrtly website hosting 4/1-	WATER UTILITY	Water	79.00
	3/29/17	qrtly website hosting 4/1-	SEWER UTILITY FUND	Sewer	79.00
				TOTAL:	237.00
People's Bank	3/20/17	PY-STATE W/H	GENERAL FUND	NON-DEPARTMENTAL	1,258.20
	3/20/17	PY-STATE W/H	ROAD USE TAX	NON-DEPARTMENTAL	215.81
	3/20/17	PY-STATE W/H	WATER UTILITY	NON-DEPARTMENTAL	307.97
	3/20/17	PY-STATE W/H	SEWER UTILITY FUND	NON-DEPARTMENTAL	316.96
	3/20/17	PY-STATE W/H	STORM WATER UTILIT	NON-DEPARTMENTAL	22.06
	4/05/17	PY-STATE W/H	GENERAL FUND	NON-DEPARTMENTAL	1,199.77
	4/05/17	PY-STATE W/H	ROAD USE TAX	NON-DEPARTMENTAL	190.87
	4/05/17	PY-STATE W/H	WATER UTILITY	NON-DEPARTMENTAL	280.61
	4/05/17	PY-STATE W/H	SEWER UTILITY FUND	NON-DEPARTMENTAL	288.28

VENDOR NAME	DATE	DESCRIPTION	FUND	DEPARTMENT	AMOUNT
	4/05/17	PY-STATE W/H	STORM WATER UTILIT	NON-DEPARTMENTAL	22.47
				TOTAL:	4,103.00
Peoples Trust & Savings	3/20/17	PY-W/H FED TAXES	GENERAL FUND	NON-DEPARTMENTAL	3,030.34
	4/05/17	PY-W/H FED TAXES	GENERAL FUND	NON-DEPARTMENTAL	2,919.78
	3/20/17	PY-FICA W/H & MATCH	GENERAL FUND	NON-DEPARTMENTAL	1,931.76
	4/05/17	PY-FICA W/H & MATCH	GENERAL FUND	NON-DEPARTMENTAL	1,858.30
	3/20/17	PY-MC W/H & MATCH	GENERAL FUND	NON-DEPARTMENTAL	451.79
	4/05/17	PY-MC W/H & MATCH	GENERAL FUND	NON-DEPARTMENTAL	434.59
	3/20/17	PY-W/H FED TAXES	ROAD USE TAX	NON-DEPARTMENTAL	474.80
	4/05/17	PY-W/H FED TAXES	ROAD USE TAX	NON-DEPARTMENTAL	425.81
	3/20/17	PY-FICA W/H & MATCH	ROAD USE TAX	NON-DEPARTMENTAL	318.12
	4/05/17	PY-FICA W/H & MATCH	ROAD USE TAX	NON-DEPARTMENTAL	285.05
	3/20/17	PY-MC W/H & MATCH	ROAD USE TAX	NON-DEPARTMENTAL	74.40
	4/05/17	PY-MC W/H & MATCH	ROAD USE TAX	NON-DEPARTMENTAL	66.67
	3/20/17	PY-FICA W/H & MATCH	ROAD USE TAX	Road Use Tax	318.12
	4/05/17	PY-FICA W/H & MATCH	ROAD USE TAX	Road Use Tax	285.04
	3/20/17	PY-MC W/H & MATCH	ROAD USE TAX	Road Use Tax	74.41
	4/05/17	PY-MC W/H & MATCH	ROAD USE TAX	Road Use Tax	66.66
	3/20/17	PY-FICA W/H & MATCH	TRUST AND AGENCY	General Government	1,931.78
	4/05/17	PY-FICA W/H & MATCH	TRUST AND AGENCY	General Government	1,858.30
	3/20/17	PY-MC W/H & MATCH	TRUST AND AGENCY	General Government	451.79
	4/05/17	PY-MC W/H & MATCH	TRUST AND AGENCY	General Government	434.61
	3/20/17	PY-W/H FED TAXES	WATER UTILITY	NON-DEPARTMENTAL	746.69
	4/05/17	PY-W/H FED TAXES	WATER UTILITY	NON-DEPARTMENTAL	703.32
	3/20/17	PY-FICA W/H & MATCH	WATER UTILITY	NON-DEPARTMENTAL	432.01
	4/05/17	PY-FICA W/H & MATCH	WATER UTILITY	NON-DEPARTMENTAL	402.70
	3/20/17	PY-MC W/H & MATCH	WATER UTILITY	NON-DEPARTMENTAL	101.05
	4/05/17	PY-MC W/H & MATCH	WATER UTILITY	NON-DEPARTMENTAL	94.19
	3/20/17	PY-FICA W/H & MATCH	WATER UTILITY	Water	432.02
	4/05/17	PY-FICA W/H & MATCH	WATER UTILITY	Water	402.70
	3/20/17	PY-MC W/H & MATCH	WATER UTILITY	Water	101.05
	4/05/17	PY-MC W/H & MATCH	WATER UTILITY	Water	94.19
	3/20/17	PY-W/H FED TAXES	SEWER UTILITY FUND	NON-DEPARTMENTAL	754.04
	4/05/17	PY-W/H FED TAXES	SEWER UTILITY FUND	NON-DEPARTMENTAL	708.01
	3/20/17	PY-FICA W/H & MATCH	SEWER UTILITY FUND	NON-DEPARTMENTAL	448.17
	4/05/17	PY-FICA W/H & MATCH	SEWER UTILITY FUND	NON-DEPARTMENTAL	417.10
	3/20/17	PY-MC W/H & MATCH	SEWER UTILITY FUND	NON-DEPARTMENTAL	104.80
	4/05/17	PY-MC W/H & MATCH	SEWER UTILITY FUND	NON-DEPARTMENTAL	97.54
	3/20/17	PY-FICA W/H & MATCH	SEWER UTILITY FUND	Sewer	448.16
	4/05/17	PY-FICA W/H & MATCH	SEWER UTILITY FUND	Sewer	417.10
	3/20/17	PY-MC W/H & MATCH	SEWER UTILITY FUND	Sewer	104.79
	4/05/17	PY-MC W/H & MATCH	SEWER UTILITY FUND	Sewer	97.52
	3/20/17	PY-W/H FED TAXES	STORM WATER UTILIT	NON-DEPARTMENTAL	29.54
	4/05/17	PY-W/H FED TAXES	STORM WATER UTILIT	NON-DEPARTMENTAL	29.96
	3/20/17	PY-FICA W/H & MATCH	STORM WATER UTILIT	NON-DEPARTMENTAL	36.40
	4/05/17	PY-FICA W/H & MATCH	STORM WATER UTILIT	NON-DEPARTMENTAL	37.00
	3/20/17	PY-MC W/H & MATCH	STORM WATER UTILIT	NON-DEPARTMENTAL	8.51
	4/05/17	PY-MC W/H & MATCH	STORM WATER UTILIT	NON-DEPARTMENTAL	8.65
	3/20/17	PY-FICA W/H & MATCH	STORM WATER UTILIT	STORM WATER UTILITY	36.38
	4/05/17	PY-FICA W/H & MATCH	STORM WATER UTILIT	STORM WATER UTILITY	37.01
	3/20/17	PY-MC W/H & MATCH	STORM WATER UTILIT	STORM WATER UTILITY	8.51
	4/05/17	PY-MC W/H & MATCH	STORM WATER UTILIT	STORM WATER UTILITY	8.66
				TOTAL:	25,039.89
Peoples Trust & Savings Bank	3/29/17	1st Responders training	GENERAL FUND	Fire Department	29.55

VENDOR NAME	DATE	DESCRIPTION	FUND	DEPARTMENT	AMOUNT
	3/29/17	wash brushes & squeegees	GENERAL FUND	Fire Department	80.96
	3/29/17	postage	GENERAL FUND	Library	144.47
	3/29/17	book processing supplies	GENERAL FUND	Library	399.62
	3/29/17	books & DVDs	GENERAL FUND	Library	316.89
	3/29/17	floor liners for 2017 Ford	GENERAL FUND	Parks	103.95
	3/29/17	floor liners for 2017 Ford	GENERAL FUND	Recreation	103.95
	3/29/17	donuts for v-ball workers	GENERAL FUND	Recreation	7.49
	3/29/17	suckers for front desk	GENERAL FUND	Finance	15.18
	3/29/17	South of Adel Annex mailin	GENERAL FUND	Zoning/Compliance/Perm	92.52
	3/29/17	suckers for front desk	GENERAL FUND	Zoning/Compliance/Perm	15.18
	3/29/17	file storage & clamps	ROAD USE TAX	Road Use Tax	78.86
	3/29/17	APWA Spring conf - K. Over	ROAD USE TAX	Road Use Tax	185.00
	3/29/17	file storage & clamps	WATER UTILITY	Water	78.87
	3/29/17	suckers for front desk	WATER UTILITY	Water	15.18
	3/29/17	file storage & clamps	SEWER UTILITY FUND	Sewer	78.86
	3/29/17	Sewer Conf-K.Overton/R.Fos	SEWER UTILITY FUND	Sewer	275.54
	3/29/17	file storage & clamps	STORM WATER UTILIT	STORM WATER UTILITY	78.86
				TOTAL:	2,100.93
Postmaster -Adel Post Office	3/31/17	MARCH 2017 BILL POSTAG	WATER UTILITY	Water	249.04
	3/31/17	MARCH 2017 BILL POSTAG	SEWER UTILITY FUND	Sewer	203.76
				TOTAL:	452.80
Register Media	4/07/17	budget	GENERAL FUND	Finance	127.14
	4/07/17	P&Z public meeting	GENERAL FUND	Zoning/Compliance/Perm	16.72
				TOTAL:	143.86
Road Husky Trailer Co. LLC	3/29/17	(5) steel for shop 1 1/2	ROAD USE TAX	Road Use Tax	30.00
				TOTAL:	30.00
Sam's Club	4/07/17	library supplies	GENERAL FUND	Library	72.42
				TOTAL:	72.42
Staples Advantage	3/29/17	DVD/CDs, copy paper, folder	GENERAL FUND	Police Department	176.33
	3/29/17	copy paper	GENERAL FUND	Parks	11.42
	3/29/17	copy paper	GENERAL FUND	Cemetery	6.20
	3/29/17	copy paper	GENERAL FUND	Recreation	11.40
	3/29/17	copy paper, binder clips, ai	GENERAL FUND	Finance	182.88
	3/29/17	copy paper	GENERAL FUND	Zoning/Compliance/Perm	16.20
	3/29/17	copy paper	WATER UTILITY	Water	16.19
	3/29/17	copy paper	SEWER UTILITY FUND	Sewer	16.18
				TOTAL:	436.80
Stivers Ford Inc	3/29/17	replcd blind door actuator-	GENERAL FUND	Police Department	542.77
				TOTAL:	542.77
Teamsters Local 238	3/20/17	PD-UNION DUES	GENERAL FUND	NON-DEPARTMENTAL	154.74
	4/05/17	PD-UNION DUES	GENERAL FUND	NON-DEPARTMENTAL	154.74
				TOTAL:	309.48
Terry Wright	4/07/17	HRA reimbursement	TRUST AND AGENCY	General Government	64.59
				TOTAL:	64.59
The Graphic Edge	4/07/17	2017 Adult VB Winner T-shi	GENERAL FUND	Recreation	339.12
				TOTAL:	339.12

VENDOR NAME	DATE	DESCRIPTION	FUND	DEPARTMENT	AMOUNT
Treasurer State of Iowa - Sales Tax	4/07/17	3rd Quarter Sales Tax 2017	GENERAL FUND	Pool	9.60
	4/07/17	3rd Quarter Sales Tax 2017	GENERAL FUND	Pool	1.40
	3/22/17	JAN & FEB 2017 SALES TAX D	WATER UTILITY	Water	4,636.80
	4/07/17	3rd Quarter Sales Tax 2017	WATER UTILITY	Water	4,627.00
	4/07/17	3rd Quarter Sales Tax 2017	WATER UTILITY	Water	1,471.00
	3/22/17	JAN & FEB 2017 SALES TAX D	SEWER UTILITY FUND	Sewer	618.24
	4/07/17	3rd Quarter Sales Tax 2017	SEWER UTILITY FUND	Sewer	108.00
	4/07/17	3rd Quarter Sales Tax 2017	SEWER UTILITY FUND	Sewer	111.00
				TOTAL:	11,583.04
	Utility Equipment Co.	4/07/17	4",6", & 8" max adaptors	SEWER UTILITY FUND	Sewer
				TOTAL:	442.00
VanWall Powersports	3/29/17	seasonal maint. ballfld gr	GENERAL FUND	Recreation	606.96
				TOTAL:	606.96
Verizon Wireless	3/29/17	PD cells & MDTs thru 3/15/	GENERAL FUND	Police Department	426.27
	4/07/17	cell phone svcs thru 3/15/	GENERAL FUND	Parks	30.11
	4/07/17	cell phone svcs thru 3/15/	GENERAL FUND	Recreation	77.32
	4/07/17	cell phone svcs thru 3/15/	GENERAL FUND	Finance	19.33
	4/07/17	cell phone svcs thru 3/15/	GENERAL FUND	Zoning/Compliance/Perm	77.32
	4/07/17	cell phone svcs thru 3/15/	ROAD USE TAX	Road Use Tax	64.09
	4/07/17	cell phone svcs thru 3/15/	WATER UTILITY	Water	89.57
	4/07/17	cell phone svcs thru 3/15/	SEWER UTILITY FUND	Sewer	121.73
	4/07/17	cell phone svcs thru 3/15/	STORM WATER UTILIT	STORM WATER UTILITY	10.02
				TOTAL:	915.76
Voya	3/20/17	PY-ING DEFERRED COMP	GENERAL FUND	NON-DEPARTMENTAL	81.50
	3/20/17	PY-ING DEFERRED COMP	ROAD USE TAX	NON-DEPARTMENTAL	4.55
	3/20/17	PY-ING DEFERRED COMP	WATER UTILITY	NON-DEPARTMENTAL	23.40
	3/20/17	PY-ING DEFERRED COMP	SEWER UTILITY FUND	NON-DEPARTMENTAL	30.55
	4/05/17	PY-ING DEFERRED COMP	GENERAL FUND	NON-DEPARTMENTAL	81.50
	4/05/17	PY-ING DEFERRED COMP	ROAD USE TAX	NON-DEPARTMENTAL	4.55
	4/05/17	PY-ING DEFERRED COMP	WATER UTILITY	NON-DEPARTMENTAL	23.40
	4/05/17	PY-ING DEFERRED COMP	SEWER UTILITY FUND	NON-DEPARTMENTAL	30.55
			TOTAL:	280.00	
Wellmark/BCBS of Iowa	3/20/17	PY-INSURANCE PREMIUM BCBS	GENERAL FUND	NON-DEPARTMENTAL	1,184.53
	3/20/17	PY-INSURANCE PREMIUM BCBS	ROAD USE TAX	NON-DEPARTMENTAL	253.85
	3/29/17	April 2017 premiums	ROAD USE TAX	Road Use Tax	1,411.13
	3/29/17	April 2017 premiums	TRUST AND AGENCY	General Government	10,257.06
	3/20/17	PY-INSURANCE PREMIUM BCBS	WATER UTILITY	NON-DEPARTMENTAL	264.67
	3/29/17	April 2017 premiums	WATER UTILITY	Water	2,038.30
	3/20/17	PY-INSURANCE PREMIUM BCBS	SEWER UTILITY FUND	NON-DEPARTMENTAL	290.55
	3/29/17	April 2017 premiums	SEWER UTILITY FUND	Sewer	1,972.72
	3/20/17	PY-INSURANCE PREMIUM BCBS	STORM WATER UTILIT	NON-DEPARTMENTAL	30.41
	4/05/17	PY-INSURANCE PREMIUM BCBS	GENERAL FUND	NON-DEPARTMENTAL	1,188.10
	4/05/17	PY-INSURANCE PREMIUM BCBS	ROAD USE TAX	NON-DEPARTMENTAL	239.52
	4/05/17	PY-INSURANCE PREMIUM BCBS	WATER UTILITY	NON-DEPARTMENTAL	269.98
	4/05/17	PY-INSURANCE PREMIUM BCBS	SEWER UTILITY FUND	NON-DEPARTMENTAL	294.91
4/05/17	PY-INSURANCE PREMIUM BCBS	STORM WATER UTILIT	NON-DEPARTMENTAL	31.50	
			TOTAL:	19,727.23	
Wells Fargo Vendor Financial Svcs	3/29/17	rent 3/4-4/3 & copies to 2	GENERAL FUND	Police Department	193.17
	4/07/17	copier rent 4/22 - 5/21	GENERAL FUND	Recreation	23.08
	4/07/17	copier rent 4/22 - 5/21	GENERAL FUND	Finance	23.08

VENDOR NAME	DATE	DESCRIPTION	FUND	DEPARTMENT	AMOUNT
	4/07/17	copier rent 4/22 - 5/21	GENERAL FUND	Zoning/Compliance/Perm	23.07
	4/07/17	copier rent 4/22 - 5/21	ROAD USE TAX	Road Use Tax	23.08
	4/07/17	copier rent 4/22 - 5/21	WATER UTILITY	Water	23.08
	4/07/17	copier rent 4/22 - 5/21	SEWER UTILITY FUND	Sewer	23.08
				TOTAL:	331.64
Wilcox Printing and Publishing, Inc.	4/07/17	10 x PO Books	GENERAL FUND	Police Department	17.11
	4/07/17	10 x PO Books	GENERAL FUND	Fire Department	17.11
	4/07/17	10 x PO Books	GENERAL FUND	Parks	17.11
	4/07/17	10 x PO Books	GENERAL FUND	Pool	17.11
	4/07/17	10 x PO Books	GENERAL FUND	Recreation	17.11
	4/07/17	10 x PO Books	ROAD USE TAX	Road Use Tax	17.12
	4/07/17	10 x PO Books	WATER UTILITY	Water	17.12
	4/07/17	10 x PO Books	SEWER UTILITY FUND	Sewer	17.12
	4/07/17	10 x PO Books	STORM WATER UTILIT	STORM WATER UTILITY	17.11
				TOTAL:	154.02
Xerox Business Services LLC	3/29/17	renewal-firehouse support	GENERAL FUND	Fire Department	360.00
				TOTAL:	360.00
Temporary Vendo	4/07/17	reimb lifeguard mngmnt cou	GENERAL FUND	Pool	58.00
	4/07/17	2017 youth softball fees	GENERAL FUND	Recreation	2,034.00
	4/07/17	2017 youth baseball fees	GENERAL FUND	Recreation	3,555.00
	4/07/17	baseballs for all age leve	GENERAL FUND	Recreation	1,221.12
	4/07/17	two playaways	TRUST AND AGENCY	Library	209.98
	4/07/17	purchase memorial bricks	OAKDALE PRIDE	CEMETERY	486.85
				TOTAL:	7,564.95



\* REFUND CHECKS \*

VENDOR NAME	DATE	DESCRIPTION	FUND	DEPARTMENT	AMOUNT
CULP, KAITII& J	3/29/17	US REFUNDS	WATER UTILITY	Water	29.85
				TOTAL:	29.85
HUARD, STEPHANI	3/29/17	US REFUNDS	WATER UTILITY	Water	25.79
				TOTAL:	25.79
MARSHALL, MORGA	3/29/17	US REFUNDS	WATER UTILITY	Water	21.08
				TOTAL:	21.08

\*\*PAYROLL EXPENSES

3/16/2017 - 4/07/2017

GENERAL FUND	Police Department	40,389.00
GENERAL FUND	Library	11,373.46
GENERAL FUND	Parks	1,402.72
GENERAL FUND	Island Park	1,136.53
GENERAL FUND	Cemetery	514.25
GENERAL FUND	Pool	1,551.39
GENERAL FUND	Recreation	2,381.09
GENERAL FUND	Finance	2,961.95
GENERAL FUND	Zoning/Compliance/Perm	2,639.18
ROAD USE TAX	Road Use Tax	10,338.39
WATER UTILITY	Water	14,175.06
SEWER UTILITY FUND	Sewer	14,732.51
STORM WATER UTILIT	STORM WATER UTILITY	1,245.60
	TOTAL:	104,841.13

===== FUND TOTALS =====

001	GENERAL FUND	129,728.44
110	ROAD USE TAX	99,474.76
112	TRUST AND AGENCY	25,375.23
600	WATER UTILITY	40,226.03
610	SEWER UTILITY FUND	31,269.81
615	STORM WATER UTILITY	27,149.92
670	GARBAGE/RECYCLING UTILITY	21,565.18
950	OAKDALE PRIDE	486.85
951	FRIENDS/FOUNDATION	405.50
-----		
	GRAND TOTAL:	375,681.72
-----		

SELECTION CRITERIA

-----  
SELECTION OPTIONS

VENDOR SET: 01-ADEL  
VENDOR: All  
CLASSIFICATION: All  
BANK CODE: All  
ITEM DATE: 3/16/2017 THRU 4/07/2017  
ITEM AMOUNT: 99,999,999.00CR THRU 99,999,999.00  
GL POST DATE: 0/00/0000 THRU 99/99/9999  
CHECK DATE: 0/00/0000 THRU 99/99/9999

-----  
PAYROLL SELECTION

PAYROLL EXPENSES: YES  
EXPENSE TYPE: GROSS  
CHECK DATE: 3/16/2017 THRU 4/07/2017

-----  
PRINT OPTIONS

PRINT DATE: Item Date  
SEQUENCE: By Vendor Name  
DESCRIPTION: Distribution  
GL ACCTS: NO  
REPORT TITLE: C O U N C I L R E P O R T  
SIGNATURE LINES: 0

-----  
PACKET OPTIONS

INCLUDE REFUNDS: YES  
INCLUDE OPEN ITEM: YES  
-----

CITY OF ADEL  
MONTH TO DATE TREASURERS REPORT  
AS OF: MARCH 31ST, 2017

FUND	BEGINNING CASH BALANCE	MTD REVENUES	MTD EXPENSES	ACCOUNTS PAYABLE	ENDING CASH BALANCE	TOTAL INVESTMENTS	TOTAL CASH & INVESTMENTS
GENERAL FUND	585,324.48	130,960.67	134,184.26	40.80	582,141.69	0.00	582,141.69
SPECIAL RESERVE TRANSFER	413,247.42	81.64	0.00	0.00	413,329.06	0.00	413,329.06
ROAD USE TAX	287,001.26	36,289.08	108,755.33	20.80	214,555.81	0.00	214,555.81
TRUST AND AGENCY	126,570.73	13,920.96	43,928.29	0.00	96,563.40	0.00	96,563.40
TIF	( 241,585.62)	12,114.04	0.00	0.00	( 229,471.58)	0.00	( 229,471.58)
1998 ASPHALT PAVING SPEC	0.00	0.00	0.00	0.00	0.00	0.00	0.00
2010 BRICK ST SPEC ASSES	18,199.73	0.00	0.00	0.00	18,199.73	0.00	18,199.73
2002 ST/UTIL-SPEC ASSESS	28,274.00	0.00	0.00	0.00	28,274.00	0.00	28,274.00
DEBT SERVICE	741,681.32	6,477.02	0.00	0.00	748,158.34	0.00	748,158.34
CAPITAL IMPROVE - VEHICLE	0.00	0.00	0.00	0.00	0.00	0.00	0.00
CAPITAL IMPRV BLDG MAINT	41,840.51	0.00	0.00	0.00	41,840.51	0.00	41,840.51
WATER UPGRADE FUND	70,359.50	0.00	0.00	0.00	70,359.50	0.00	70,359.50
SEWER UPGRADE FUND	167,079.43	0.00	0.00	0.00	167,079.43	0.00	167,079.43
CAPITAL IMP OFFICE EQUIP	0.00	0.00	0.00	0.00	0.00	0.00	0.00
2006 STREET IMP PROJECT	( 11,825.83)	0.00	0.00	0.00	( 11,825.83)	0.00	( 11,825.83)
I-JOBS ROAD PROJECT	0.00	0.00	0.00	0.00	0.00	0.00	0.00
BROWNFIELD PROJECT	2,359.33	0.00	0.00	0.00	2,359.33	0.00	2,359.33
DEMOLITION PROJECT	0.00	0.00	0.00	0.00	0.00	0.00	0.00
STORM SEWER PROJECT	50,902.03	0.00	0.00	0.00	50,902.03	0.00	50,902.03
SEWER PROJECT	0.00	0.00	0.00	0.00	0.00	0.00	0.00
2008 FLOOD REPAIR PROJEC	2,949.18	0.00	0.00	0.00	2,949.18	0.00	2,949.18
LIBRARY BLDG PROJECT	0.00	0.00	0.00	0.00	0.00	0.00	0.00
2010 STREET PROJECT	2,691.86	0.00	0.00	0.00	2,691.86	0.00	2,691.86
SIDEWALK PROJECT	( 16,043.00)	0.00	0.00	0.00	( 16,043.00)	0.00	( 16,043.00)
EVANS VIEW PAVING	( 23,175.28)	0.00	0.00	0.00	( 23,175.28)	0.00	( 23,175.28)
SUBDRAIN PROJECT	0.00	0.00	0.00	0.00	0.00	0.00	0.00
INDUSTRIAL PARK PROJECT	( 56,358.69)	0.00	4,190.00	0.00	( 60,548.69)	0.00	( 60,548.69)
ANNEXATION	( 177,289.06)	0.00	0.00	0.00	( 177,289.06)	0.00	( 177,289.06)
PUBLIC SAFETY BLDG	0.00	0.00	0.00	0.00	0.00	0.00	0.00
12TH STREET PAV PROJECT	0.00	0.00	0.00	0.00	0.00	0.00	0.00
FIRE EQUIP UPGRADE	6,159.37	0.00	0.00	0.00	6,159.37	0.00	6,159.37
CAPITAL IMPROV-PARKS	826.00	0.00	0.00	0.00	826.00	0.00	826.00
BALL DIAMOND PROJECT	0.00	0.00	0.00	0.00	0.00	0.00	0.00
LOST FUNDS - AQUATIC CEN	127,608.33	36,642.25	0.00	0.00	164,250.58	0.00	164,250.58
DISC GOLF MAINT PROJECT	0.00	0.00	0.00	0.00	0.00	0.00	0.00
2013 WATER PROJECT	235,727.57	0.00	0.00	0.00	235,727.57	0.00	235,727.57
2013 SEWER PROJECT	197,544.03	0.00	0.00	0.00	197,544.03	0.00	197,544.03
2014 FIRE TRUCK	3,820.69	0.00	0.00	0.00	3,820.69	0.00	3,820.69
WATER UTILITY	633,715.84	68,409.24	86,139.84	31.20	616,016.44	0.00	616,016.44
SEWER UTILITY FUND	576,323.87	62,446.55	44,970.44	31.20	593,831.18	0.00	593,831.18
STORM WATER UTILITY	161,606.17	9,440.86	38,305.03	0.00	132,742.00	0.00	132,742.00
GARBAGE/RECYCLING UTILITY	90,382.32	25,050.58	22,981.18	0.00	92,451.72	0.00	92,451.72
OAKDALE PRIDE	9,663.10	1,385.00	234.26	0.00	10,813.84	0.00	10,813.84
FRIENDS/FOUNDATION	0.00	10,000.00	4,091.09	0.00	5,908.91	0.00	5,908.91
GRAND TOTAL	4,055,580.59	413,217.89	487,779.72	124.00	3,981,142.76	0.00	3,981,142.76

\*\*\* END OF REPORT \*\*\*

	Balance 3-1-17	RECEIPTS	TRANSFERS IN	DISBURSEMENTS	TRANSFERS OUT	Accounts Payable	BALANCE 3-31-17
<b>General Funds</b>							
General	594,575.15	130,960.67		134,184.26		40.80	591,392.36
Nile Kinnick Fund	(9,079.49)						(9,079.49)
SPEC RESERVE	413,247.42	81.64					413,329.06
Emergency Levv	(1,544.01)	597.74					(946.27)
Police Academy	8,625.17						8,625.17
Police cops fast	10.00						10.00
Island Park Improvements	1,396.45			2,342.33			(945.88)
Fire	2,636.03						2,636.03
Refunds	28,307.08						28,307.08
CP - Fire Equipment Upgrade	6,159.37						6,159.37
CP - Capital Improvement Park	826.00						826.00
CP - Industrial Park	(56,358.69)			4,190.00			(60,548.69)
Donations - Rec	2,708.00						2,708.00
Oakdale Pride	9,663.10	1,385.00		234.26			10,813.84
Friends/Foundation	-	10,000.00		4,091.09			5,908.91
<b>Total</b>	<b>1,001,171.58</b>	<b>143,025.05</b>	<b>-</b>	<b>145,041.94</b>	<b>-</b>	<b>40.80</b>	<b>999,195.49</b>
<b>Special Revenue Funds</b>							
Road Use Tax	287,001.26	36,289.08		108,755.33		20.80	214,555.81
Urban Renewal Tax Increment	(241,585.62)	12,114.04					(229,471.58)
Employee Benefits/HRA	(14,374.89)	7,376.83	150.00	39,163.61			(46,011.67)
LOST FUNDS	127,608.33	36,642.25					164,250.58
Library Memorial	12,187.90	3,248.56		1,478.60			13,957.86
Police DARE	717.88						717.88
Historical Museum	16.00						16.00
POLICE FORFEITURE FUND	236.20						236.20
<b>Total</b>	<b>171,807.06</b>	<b>95,670.76</b>	<b>150.00</b>	<b>149,397.54</b>	<b>-</b>	<b>20.80</b>	<b>118,251.08</b>
<b>Capital Project Funds</b>							
CP - Brownfield Project	2,359.33						2,359.33
CP - 2008 Flood Repair	2,949.18						2,949.18
CP - 2010 St Project	2,691.86						2,691.86
CP - Sidewalk Project	(16,043.00)						(16,043.00)
CP - 2006 Street Improvement	(11,825.83)						(11,825.83)
CP - Evans View Paving	(23,175.28)						(23,175.28)
CP - Annexation	(177,289.06)						(177,289.06)
DS - 2002 Street	28,274.00						28,274.00
DS - Fire Truck	3,820.69						3,820.69
2010 Brick St Spec Assess	18,199.73						18,199.73
<b>Total</b>	<b>(170,038.38)</b>	<b>-</b>	<b>-</b>	<b>-</b>	<b>-</b>	<b>-</b>	<b>(170,038.38)</b>
<b>Debt Service Fund</b>							
Debt Service-Property Tax	741,681.32	6,477.02					748,158.34
	741,681.32	6,477.02	-	-	-	-	748,158.34
<b>Internal Service Funds</b>							
Flex Plan	(7,281.15)	658.98		18.75	150.00		(6,770.92)
CP - Building Maintenance	41,840.51						41,840.51
	34,579.36	658.98	-	18.75	150.00	-	35,069.59
<b>Enterprise Funds</b>							
Water	40,765.74	50,521.58		86,139.84		31.20	5,178.68
Sinking Bond & Interest	45,288.81	7,819.33					53,108.14
Improvement	451,705.03	10,068.33					461,773.36
Bond Reserve	96,231.26						96,231.26
Water Deposits	92,463.89	2,038.85		925.00			93,577.74
CP - Water Upgrades	70,359.50						70,359.50
CP - 2013 Water Project	235,727.57						235,727.57
Sewer	92,060.33	45,277.87		44,970.44		31.20	92,398.76
Sinking Bond & Interest	31,911.46	4,704.42					36,615.88
Improvement	353,457.58	12,464.46					365,922.04
Bond Reserve	98,894.50						98,894.50
CP - Sewer Upgrades	167,079.43						167,079.43
CP - 2013 Sewer Project	197,544.03						197,544.03
Storm Water	161,606.17	9,440.86		38,305.03			132,742.00
CP - Storm Water Upgrade	50,902.03						50,902.03
Garbage / Recycling	90,382.32	25,050.58		22,981.18			92,451.72
	2,276,379.65	167,386.08	-	193,321.49	-	62.40	2,250,506.64
<b>Total</b>	<b>4,055,580.59</b>	<b>413,217.89</b>	<b>150.00</b>	<b>487,779.72</b>	<b>150.00</b>	<b>124.00</b>	<b>3,981,142.76</b>
<b>CASH</b>							
Certificate of Deposit - RVB	100,000.00						
Peoples Bank Balance	3,339,783.11						
Wells Fargo Balance	337,750.68						
IPAIT	363,999.98						
<b>Total CIB</b>	<b>4,141,533.77</b>	<b>Outstanding (160,391.01)</b>		<b>Total 3,981,142.76</b>			

STATEMENT OF REVENUES - BUDGET VS. ACTUAL

AS OF: MARCH 31ST, 2017

REVENUES	ORIGINAL BUDGET	CURRENT BUDGET	MONTHLY REVENUE	YEAR-TO-DATE REVENUE	PRIOR YEAR YEAR-TO-DATE	BUDGET REMAINING	% BUDGET REMAINING
001-GENERAL FUND	1,931,073	1,931,073	130,960.67	1,492,795.09	1,157,781.62	438,277.91	22.70
002-SPECIAL RESERVE TRANS	296,294	296,294	81.64	297,761.36	39.50 (	1,467.36)	0.50-
110-ROAD USE TAX	448,430	448,430	36,289.08	402,708.78	358,002.37	45,721.22	10.20
112-TRUST AND AGENCY	457,340	457,340	13,920.96	288,493.81	252,219.11	168,846.19	36.92
125-TIF	640,200	640,200	12,114.04	360,749.98	356,878.95	279,450.02	43.65
133-2010 BRICK SPEC ASSES	1,472	1,472	0.00	1,725.00	4,752.00 (	253.00)	17.19-
134-2002 ST/UTIL-SPEC ASS	2,745	2,745	0.00	3,352.00	3,351.00 (	607.00)	22.11-
200-DEBT SERVICE	1,010,012	1,010,012	6,477.02	868,152.38	212,971.32	141,859.62	14.05
300-CAPITAL IMPROVE - VEH	0	0	0.00	0.00	0.00	0.00	0.00
301-CAPITAL IMPRV BLDG MA	0	0	0.00	0.00	0.00	0.00	0.00
302-WATER UPGRADE FUND	0	0	0.00	0.00	0.00	0.00	0.00
303-SEWER UPGRADE FUND	0	0	0.00	0.00	0.00	0.00	0.00
305-2006 STREET IMP PROJE	10,585	10,585	0.00	11,017.00	12,276.00 (	432.00)	4.08-
306-I-JOBS ROAD PROJECT	0	0	0.00	0.00	0.00	0.00	0.00
307-BROWNFIELD PROJECT	0	0	0.00	0.00	0.00	0.00	0.00
315-EVANS VIEW PAVING	0	0	0.00	0.00	0.00	0.00	0.00
317-INDUSTRIAL PARK PROJE	104,385	104,385	0.00	129,710.78	397,336.54 (	25,325.78)	24.26-
320-12TH STREET PAVING PR	0	0	0.00	0.00	0.00	0.00	0.00
321-FIRE EQUIP UPGRADE	0	0	0.00	0.00	0.00	0.00	0.00
322-CAPITAL IMPROV-PARKS	5,000	5,000	0.00	2,450.00	8,994.00	2,550.00	51.00
324-LOST FUNDS - AQUATIC	452,129	452,129	36,642.25	393,813.89	362,349.48	58,315.11	12.90
326-2013 WATER PROJECT	0	0	0.00	0.00	0.00	0.00	0.00
327-2013 SEWER PROJECT	0	0	0.00	0.00	0.00	0.00	0.00
328-FIRE TRUCK 2014	0	0	0.00	0.00	0.00	0.00	0.00
600-WATER UTILITY	700,500	700,500	68,409.24	636,801.35	542,708.20	63,698.65	9.09
610-SEWER UTILITY FUND	600,000	600,000	62,446.55	523,022.46	474,289.06	76,977.54	12.83
615-STORM WATER UTILITY	105,000	105,000	9,440.86	84,199.79	79,023.82	20,800.21	19.81
670-GARBAGE/RECYCLING UTI	270,000	270,000	25,050.58	213,141.47	197,008.48	56,858.53	21.06
950-OAKDALE PRIDE	0	0	1,385.00	11,840.61	0.00 (	11,840.61)	0.00
951-FRIENDS/FOUNDATION	0	0	10,000.00	10,000.00	0.00 (	10,000.00)	0.00
999-POOLED CASH FUND	0	0	0.00	0.00	0.00	0.00	0.00
<b>TOTAL REVENUES</b>	<b>7,035,165</b>	<b>7,035,165</b>	<b>413,217.89</b>	<b>5,731,735.75</b>	<b>4,419,981.45</b>	<b>1,303,429.25</b>	<b>18.53</b>

STATEMENT OF EXPENDITURES - BUDGET vs ACTUAL

AS OF: MARCH 31ST, 2017

EXPENDITURES	ORIGINAL BUDGET	CURRENT BUDGET	MONTHLY EXPENDITURES	YEAR-TO-DATE EXP. + ENCUMB.	PRIOR YEAR YEAR-TO-DATE	BUDGET REMAINING	% BUDGET REMAINING
001-GENERAL FUND	1,873,767	1,873,767	134,184.26	1,543,413.78	1,203,599.04	330,353.22	17.63
002-SPECIAL RESERVE TRANS	0	0	0.00	845.40	1,954.00	(845.40)	0.00
110-ROAD USE TAX	448,173	448,173	108,755.33	371,767.83	408,867.29	76,405.17	17.05
112-TRUST AND AGENCY	435,134	435,134	43,928.29	345,117.02	321,821.77	90,016.98	20.69
125-TIF	640,200	640,200	0.00	640,200.00	0.00	0.00	0.00
132-1998 ASPHALT PAVING S	0	0	0.00	0.00	0.00	0.00	0.00
133-2010 BRICK SPEC ASSES	1,472	1,472	0.00	1,472.00	0.00	0.00	0.00
134-2002 ST/UTIL-SPEC ASS	2,745	2,745	0.00	2,745.00	0.00	0.00	0.00
200-DEBT SERVICE	986,530	986,530	0.00	115,765.00	130,278.75	870,765.00	88.27
300-CAPITAL IMPROVE - VEH	0	0	0.00	0.00	0.00	0.00	0.00
301-CAPITAL IMPRV BLDG MA	0	0	0.00	0.00	0.00	0.00	0.00
302-WATER UPGRADE FUND	0	0	0.00	0.00	14,000.00	0.00	0.00
303-SEWER UPGRADE FUND	0	0	0.00	0.00	21,000.00	0.00	0.00
304-CAPITAL IMP OFFICE EQ	0	0	0.00	0.00	0.00	0.00	0.00
305-2006 STREET IMP PROJE	10,238	10,238	0.00	10,238.00	0.00	0.00	0.00
307-BROWNFIELD PROJECT	0	0	0.00	0.00	0.00	0.00	0.00
308-DEMOLITION PROJECT	0	0	0.00	0.00	0.00	0.00	0.00
316-SUBDRAIN PROJECT	0	0	0.00	0.00	0.00	0.00	0.00
317-INDUSTRIAL PARK PROJE	104,385	104,385	4,190.00	58,379.50	370,717.44	46,005.50	44.07
319-PUBLIC SAFETY BLDG	0	0	0.00	0.00	0.00	0.00	0.00
321-FIRE EQUIP UPGRADE	0	0	0.00	0.00	0.00	0.00	0.00
322-CAPITAL IMPROV-PARKS	5,000	5,000	0.00	6,675.87	12,576.31	(1,675.87)	33.52-
323-BALL DIAMOND PROJECT	0	0	0.00	0.00	0.00	0.00	0.00
324-LOST FUNDS - AQUATIC	449,780	449,780	0.00	449,972.92	300,866.57	(192.92)	0.04-
326-2013 WATER PROJECT	0	0	0.00	0.00	34,782.50	0.00	0.00
327-2013 SEWER PROJECT	0	0	0.00	0.00	0.00	0.00	0.00
328-FIRE TRUCK 2014	0	0	0.00	0.00	2,774.28	0.00	0.00
600-WATER UTILITY	700,091	700,091	86,139.84	612,990.29	428,731.12	87,100.71	12.44
610-SEWER UTILITY FUND	599,833	599,833	44,970.44	519,797.69	326,302.50	80,035.31	13.34
615-STORM WATER UTILITY	140,505	140,505	38,305.03	90,193.95	49,574.90	50,311.05	35.81
670-GARBAGE/RECYCLING UTI	291,000	291,000	22,981.18	223,054.74	193,759.81	67,945.26	23.35
950-OAKDALE PRIDE	0	0	234.26	1,026.77	0.00	(1,026.77)	0.00
951-FRIENDS/FOUNDATION	0	0	4,091.09	4,091.09	0.00	(4,091.09)	0.00
999-POOLED CASH FUND	0	0	0.00	0.00	0.00	0.00	0.00
<b>TOTAL EXPENDITURES</b>	<b>6,688,853</b>	<b>6,688,853</b>	<b>487,779.72</b>	<b>4,997,746.85</b>	<b>3,821,606.28</b>	<b>1,691,106.15</b>	<b>25.28</b>
<b>REVENUE OVER/(UNDER) EXPENDITURES</b>	<b>346,312</b>	<b>346,312</b>	<b>(74,561.83)</b>	<b>733,988.90</b>	<b>598,375.17</b>	<b>(387,676.90)</b>	<b>9,905.06-</b>

## Jackie Steele

---

**From:** Tim Morlan <timmorlan@mchsi.com>  
**Sent:** Tuesday, April 4, 2017 8:38 PM  
**To:** Jackie Steele  
**Subject:** Members

Adel volunteer fire department Membership vote 04/04/2017.

Justin Kitzinger and Nick Orstad were both voted to full membership status by a majority vote.

Joel Steenhoek was voted to probationary status by a majority vote.

It is my recommendation the Adel City Council accepts this vote.

Sent from my iPhone

# LILLIS O'MALLEY OLSON MANNING POSE TEMPLEMAN LLP

ATTORNEYS AT LAW

(ESTABLISHED 1917)

317 SIXTH AVENUE, SUITE 300  
DES MOINES, IOWA 50309-4127

TELEPHONE (515) 243-8157

FAX (515) 243-3919

WWW.LILLISOMALLEY.COM

JOHN CONNOLLY, JR. (1891-1975)  
GEORGE E. O'MALLEY (1905-1982)  
JOHN CONNOLLY III (1918-1998)  
BERNARD J. CONNOLLY (1920-1970)  
C. I. MCNUTT (1901-1958)  
STREETAR CAMERON (1957-2008)

WILLIAM J. LILLIS  
MICHAEL W. O'MALLEY  
EUGENE E. OLSON  
DANIEL L. MANNING, SR.  
CHRISTOPHER R. POSE  
JOEL B. TEMPLEMAN\*  
BRIDGET O'MALLEY KAUTZKY  
DANIEL M. MANNING, JR.

\*LICENSED IN IOWA & ILLINOIS

Writer's Direct Email Address: [dmanning@lolaw.com](mailto:dmanning@lolaw.com)

April 7, 2017

Frank Smith  
Frank Smith Law Office  
4215 Hubbell Ave.  
Des Moines, IA 50317

Re: Adel and Xenia Rural Water District

Dear Frank:

This is a follow-up to the letter I sent to you on March 31, 2017. The City's goal is to reach an understanding with Xenia concerning the water service to be provided as growth and development occurs in areas that are presently beyond the City's corporate boundaries. This information will assist the City in making a proposal to Xenia concerning the possible transfer of service territory that was originally carved out for Xenia in the 1992 and 1993 agreements between our respective clients. At this point, there are four items that we ask Xenia to either provide or confirm:

1. **Information requested in the March 31, 2017 letter.** Please provide the information previously requested. Specifically, we would appreciate receiving any information that you have in your files concerning the installation of the 16 inch transmission main that runs through a portion of the City and parallels Highway 169 south. My understanding is that the 16 inch transmission line was originally constructed for the purpose of delivering water to the communities of Menlo and Dexter in order to serve the ethanol plants located there. My understanding is one of the ethanol plants was never constructed. Any information you have in that regard would help the City to better understand the nature of Xenia's claim to the territory south of Meadow Road. The information will also assist us in determining whether an appropriate offer to acquire territory can be made to your client concerning the 1992 and 1993 agreements between the parties. I am unaware of any subsequent agreements or addendums between our clients after the 1993 agreement. If you could confirm that fact for me, I would appreciate it.



2. **Xenia providing water service to the City of Adel (Permanent)**. Please confirm our understanding that the following rates and charges would be applied in the event that Xenia provided water service to the City of Adel on a permanent basis:

- (a) \$2,544,000 to purchase 600,000 gallons/day with a charge of \$3.25/1000 gallons of water used;
- (b) \$5,088,000.00 to purchase 1,200,000 gallons/day with a charge of \$3.25/1000 gallons of water used;

3. **Xenia providing Water Service to the City of Adel (Temporary)**. The City would purchase water at \$4.25/1,000 gallons of water used.

4. **Xenia providing service to individual customers**. The rate for individual customers acquiring water from Xenia would be:

- (a) 0-2,000 gallons. Minimum bill \$65.20;
- (b) 2,001-10,000 gallons at \$13.00/1,000 gallons;
- (c) 10,001 + gallons \$5.50/1,000 gallons.

For example if a household used 5,000 gallons of water per month, the monthly water bill would be \$104.20.

If you could provide the information requested and confirm the information contained in this letter that would be appreciated.

Very truly yours,

  
Daniel L. Manning, Sr.  
For the Firm

DLM/dj  
Enclosures

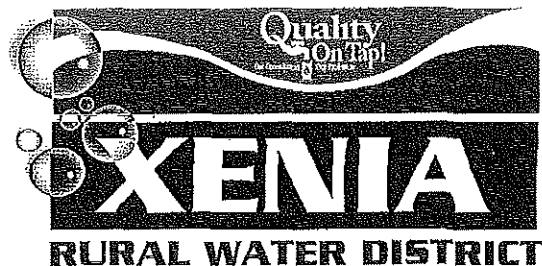

April 3, 2017

Anthony Brown  
City Administrator  
City of Adel  
P.O. Box 248  
Adel, IA 50003

Anthony,

Thank you for meeting with us last Thursday morning to discuss the issue of water service in the Adel area. One item that was discussed near the end of the meeting was the Southbridge Plat 1 development. I relayed during the discussion that the portion of the development south of Meadow Road is in Xenia's service area so those lots need to receive their water service from Xenia.

I sensed that not everyone at the meeting agreed with my statement so I am following up the discussion with this letter to make our position clear

[a] that the area south of Meadow Road is in Xenia's service area,

[b] that Adel should not provide water service to any lots or other properties south of Meadow Road or in any other part of Xenia's water service territory, and

[c] that Xenia stands ready, willing and able to provide water service to these lots and other customers in its water service territory.

We are also advising the developer, engineer and contractor for this development of the foregoing.

Xenia requests that Adel respect the foregoing – insofar as if Adel elects not to do so, Xenia will be compelled under the terms of its loan agreements and fiduciary obligations to its membership to take action to secure its water service territory rights. Xenia seeks to avoid the latter outcome and looks forward to a harmonious

and mutually beneficial relationship with Adel as both work to facilitate development in and around Adel.

Thank you for your attention to this issue.

Sincerely,

A handwritten signature in cursive script that reads "Gary Benjamin". The signature is written in black ink and is positioned above the printed name.

Gary Benjamin, P.E.  
CEO/General Manager  
Xenia Rural Water District

## FRANK SMITH LAW OFFICE

---

---

4215 Hubbell Avenue  
Des Moines, Iowa 50317  
Phone: (515) 265-6210  
Fax: (515) 265-4584  
Email: [franksmith@franksmithlawoffice.com](mailto:franksmith@franksmithlawoffice.com)

Frank Murray Smith  
*Attorney and Counselor at Law*

April 3, 2017

Mr. Daniel Manning  
317 Sixth Avenue, Suite 300  
Des Moines, Iowa 50309-4127

Re: Your Client: Adel  
My Client: Xenia

Dear Dan:

Thank you and other Adel representatives for meeting last Thursday morning to discuss water service territory matters.

Although we did not reach an accord, I believe both sides have a much clearer understanding of their respective positions. Further both will benefit from continuing collaboration to facilitate development in and around Adel.

Also thank you for your letter of March 31, 2017. I have forwarded same to Mr. Benjamin of Xenia and anticipate having a response to you shortly.

In the interim, I am writing to assure there are no misunderstandings and to make it clear that unless there are agreements reached to the contrary, Xenia retains the exclusive right to provide public water supply services to the areas depicted on the enclosed map.

Among other things, as it relates to currently active developments, absent an agreement to the contrary with Xenia, this means

[a] the Bloomfield Acres / Twin Eagles Riverview development and the Southridge development south of Meadow Road remain in Xenia's service area,

[b] Adel should not provide water service to any lots or other properties south of Meadow Road or in any other part of Xenia's water service territory, and

[c] Xenia stands ready, willing and able to provide water service to these lots and other customers in its water service territory and to coordinate billing with Adel so that the customers receive a unified bill for Xenia water services and Adel sewer services.

Xenia is also advising the developer, engineer and contractor for the Southridge development and for the Bloomfield Acres / Twin Eagles Riverview development of the foregoing.

Further Xenia requests that Adel take no actions which interfere with its prospective customer contracts in the proposed Bloomfield Acres / Twin Eagles Riverview development or which delay approval of that development (because of Xenia being the public water supply provider to the Bloomfield Acres / Twin Eagles Riverview development).

If Adel asserts a position contrary to any of the foregoing, please let me know.

Thank you for your cooperation regarding these matters.

Sincerely,

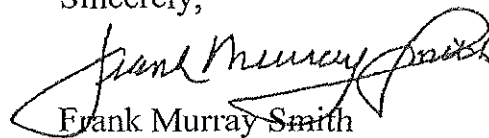

Frank Murray Smith

FMS\abz

Enclosure

cc: Client

David Wetsch attorney for Bloomfield Acres / Twin Eagles Riverview

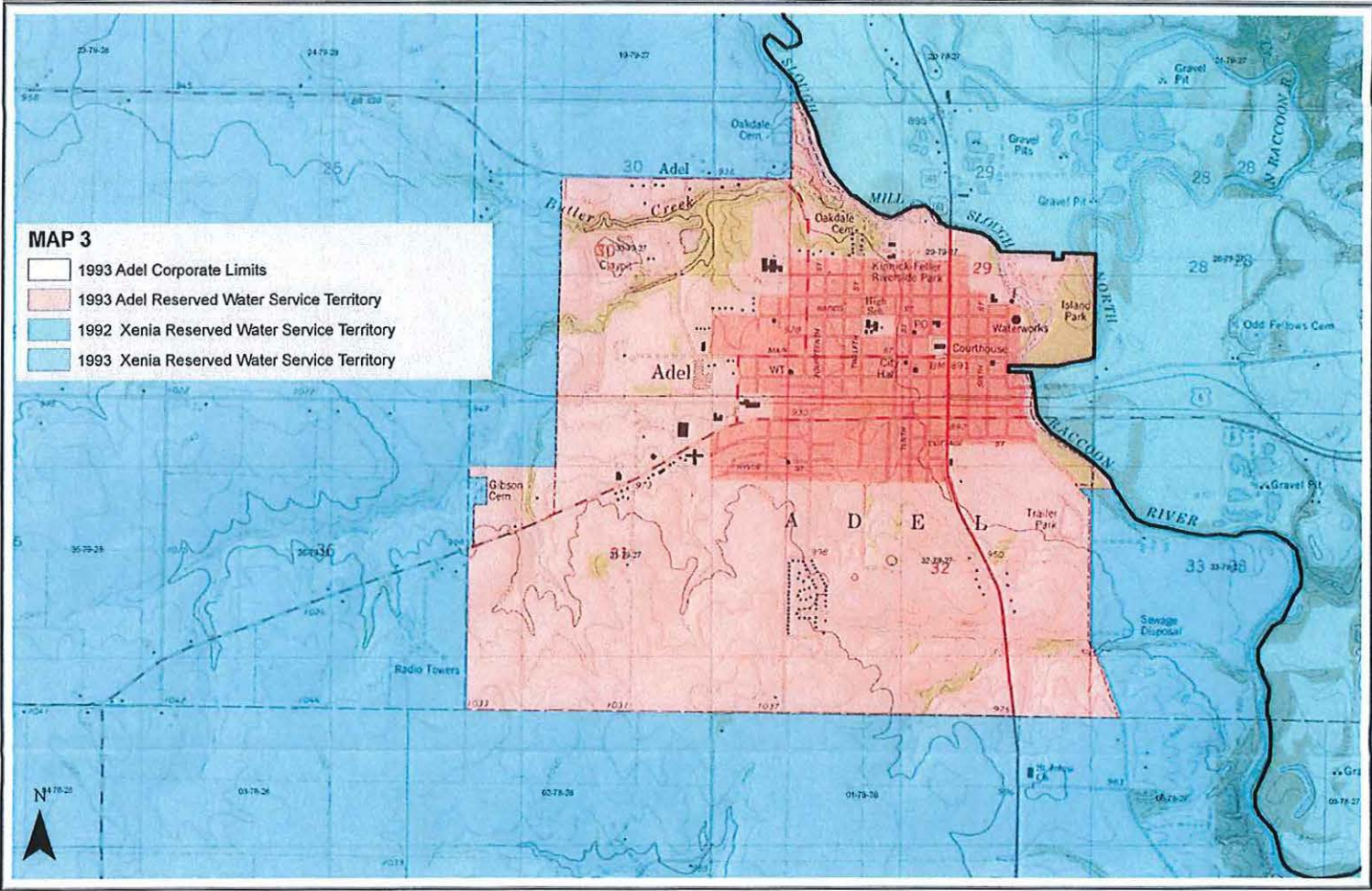

**MAP 3**

- 1993 Adel Corporate Limits
- 1993 Adel Reserved Water Service Territory
- 1992 Xenia Reserved Water Service Territory
- 1993 Xenia Reserved Water Service Territory



# LILLIS O'MALLEY OLSON MANNING POSE TEMPLEMAN LLP

WILLIAM J. LILLIS  
MICHAEL W. O'MALLEY  
EUGENE E. OLSON  
DANIEL L. MANNING, SR.  
CHRISTOPHER R. POSE  
JOEL B. TEMPLEMAN\*  
BRIDGET O'MALLEY KAUTZKY  
DANIEL M. MANNING, JR.

\*LICENSED IN IOWA & ILLINOIS

ATTORNEYS AT LAW  
(ESTABLISHED 1917)  
317 SIXTH AVENUE, SUITE 300  
DES MOINES, IOWA 50309-4127

TELEPHONE (515) 243-8157  
FAX (515) 243-3919  
WWW.LILLISOMALLEY.COM

JOHN CONNOLLY, JR. (1891-1975)  
GEORGE E. O'MALLEY (1905-1982)  
JOHN CONNOLLY III (1918-1998)  
BERNARD J. CONNOLLY (1920-1970)  
C. I. MCNUTT (1901-1958)  
STREETAR CAMERON (1957-2008)

Writer's Direct Email Address: [dmanning@lolaw.com](mailto:dmanning@lolaw.com)

March 31, 2017

*Via Email*

Frank Smith  
Frank Smith Law Office  
4215 Hubbell Ave.  
Des Moines, IA 50317

Re: Xenia Rural Water District

Dear Frank:

On behalf of the City of Adel, we appreciated the opportunity to meet with your client, Xenia Rural Water District, concerning water service to customers both within the City of Adel and outside of its corporate boundaries. In our conversation, Derick Anderson, with McClure Engineering had asked for the following:

1. The calculations made in determining the capital cost and commodity charge for Xenia selling water to the City of Adel; and
2. The bid tabs for the construction of a 16 inch water main that runs parallel with Hwy. 6 and Hwy. 169.

The purpose of this information is to make a proposal to your client related to the Southbridge Development. We ask that you forward this request onto Gary Benjamin and I have no problem with Mr. Benjamin providing that information directly to Derick Anderson. Derick's contact information is as follows:

Derick A. Anderson, P.E.  
1360 N.W. 121<sup>th</sup> St., Ste. A  
Clive, IA 50325  
(515) 964-1229  
Cell: (515) 570-3995  
Email address: [danderson@mecresults.com](mailto:danderson@mecresults.com)

LILLIS O'MALLEY OLSON MANNING POSE TEMPLEMAN LLP

March 31, 2017

Page 2

---

Please contact me if you have any questions or concerns. Thank you.

Very truly yours,

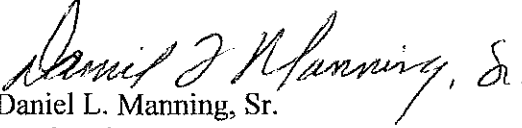
  
Daniel L. Manning, Sr.  
For the Firm

DLM/dj

cc: Anthony Brown, City Administrator  
City of Adel

Derick Anderson





January 16, 2017

Anthony Brown  
City Administrator  
City of Adel  
P.O. Box 248  
Adel, IA 50003

Anthony,

I am responding to your November 30, 2016 email. I want to start by stating that Xenia is excited about the potential growth of Adel, stands ready to serve as a catalyst to that growth and looks forward to working with Adel in this regard.

I have included information that will address your questions:

1. **Adel Inquiry:** *Please provide copies of information, including descriptions, tables, figures and other related documents, which detail the scope and territory limits of the Dallas Project Phase II as identified in the attached Two Mile Agreement dated November 18, 1993.*

**Xenia Response:** Copies of the 1992 and 1993 2-mile agreements are enclosed. The 1992 Agreement identified and established Xenia's reserved service territory in relation to Adel under Phase I of Xenia's Dallas Project. The 1993 Agreement identified and established Xenia's reserved service territory in relation to Adel under Phase II of the Dallas Project.

In researching our files we found the correct Exhibit A for the 1993 Agreement. With the information found in our files and construction drawings, we have generated five (5) maps for clarification of the service territory boundary. The following maps are included with this correspondence:

- a. Map 1 shows the Xenia reserved service territory in relation to Adel under the terms of the 1992 Agreement /Exhibit A.

- b. Map 2 shows the principal Xenia water mains installed in the service territory reserved to Xenia under the terms of the 1992 Agreement as part of the 1992 Phase I project.
  - c. Map 3 shows the service territory reserved to Xenia under the terms of the 1993 Agreement in relation to the territory within two miles of its corporate limits Adel reserved the right to serve under the terms of the 1993 Agreement. Map 3 is a larger scale map of Exhibit A to the 1993 Agreement.
  - d. Map 4 shows the Xenia water mains installed in the service territory reserved to Xenia under the terms of the 1993 Agreement as part of the Phase II project plus service to the Fuller Subdivision in Adel's reserved service territory which was installed with Adel's approval as part of the Phase II Project.
  - e. Map 5 shows Xenia water mains installed in the service territory reserved to Xenia after the Phase II project. The longest length of main on this map is the 16-inch feeder main which was installed in 2008. Prior to installation of this feeder main, Xenia offered Adel the opportunity to make a connection to this feeder main and become a wholesale customer, a standby only customer, or a franchise community. Adel did not choose to pursue any of these three options.
2. **Adel Inquiry:** *In paragraph 2 of Section 1, the Agreement states that written approval of the City of Adel is required for all improvements, modifications or service line extension in the area defined in Exhibit "A". Please provide copies of requests and subsequent written approvals for all improvements, modifications, or service line extensions within the Dallas Project Phase II project area.*

**Xenia Response:** Other than service to the Fuller Subdivision (which Adel approved), Xenia has made no "improvements, modifications or service line extensions" in the "area defined in Exhibit "A"" (i.e. the water service territory reserved to Adel under the terms of the 1993 Agreement); and accordingly, other than for the Fuller Subdivision, no such requests have been made.

3. **Adel Inquiry:** *In paragraph 3 of Section 1, the Agreement states, "As new areas develop or as the request for additional service becomes necessary, within the Dallas Project Phase II, the City and Xenia shall negotiate which entity shall provide service to those customers." Please provide all correspondence related to additional service requests received by Xenia Rural Water for water service within the Dallas Project Phase II project area and all correspondence related to negotiation which occurred with the City of Adel as required in the Agreement.*

**Xenia Response:** Xenia has not received requests to provide public water supply services to any customer in the water service territory reserved to Adel under the terms of the 1993 Agreement other than for the Fuller Subdivision.

4. **Adel Inquiry:** *As was discussed at our meeting at Adel City Hall and shown on the attached handout labeled Exhibit E, there are multiple developments within the City limits that Adel intends to service with water, stormwater, and sanitary sewer service. As required in Paragraph 3 of Part 1, Xenia is required to enter into an agreement with the City identifying the terms and conditions in which service is provided to any areas or residents within the City Limits of Adel. If Xenia intends to serve water to any of the identified developments on the attached Exhibit E, the City of Adel would request that Xenia Rural Water submit their proposal for such service for consideration by the Adel City Council.*

**Xenia Response:** Xenia plans to serve those developments within its reserved water service territory as shown on Map 4. This would include the Twin Eagles Riverview Property, the Eagle Vista Property and the southern portion of the South Bridge Property as shown on Adel's Exhibit E sent previously. Xenia can easily serve these properties at fire suppression pressures with existing infrastructure (16-inch water main).

Please understand that Xenia has no obligation under either federal or state law to obtain Adel's permission to serve developments within Xenia's reserved water service territory any more than Adel has an obligation to obtain Xenia's permission to serve developments within Adel's reserved water service territory. That is not to say there should not be thoughtful collaboration and coordination in the provision of such public water supply services. Indeed, Xenia stands ready to assure that Adel is provided with water meter readings it will need to bill customers in Xenia's reserved water service territory for wastewater services. Xenia also stands ready to

coordinate emergency connections and consider other actions that assure the uninterrupted provision of public water supply services to both Xenia's and Adel's customers in their respective water service territories.

It should also be noted that (as shown on Exhibit 4), Xenia is serving the Fuller Subdivision within Adel's reserved territory. This service was provided with Adel's approval. Please see the enclosed correspondence from former Adel City Administrator James P. Sanders regarding this service.

5. **Adel Inquiry:** *In relation to the requested information by Adel City Council member Bob Ockerman, the Water/Sewer Committee Chair, the City would request the following information regarding Xenia Rural Water service in the Dallas Project Phase II service area:*
  - a. *Please provide a response to the assumed water pressure at the fire hydrant at the St. John's Catholic Church.*
    - i. *Static*
    - ii. *Dynamic (@ 1500 gpm)*
  - b. *Please provide a copy of your water service rates for customers served in the Dallas Project Phase II service area.*

**Xenia Response:** The static pressure at the node near St. John's Catholic Church varies from 76 to 82 psi for a 5-hour modeling run. The residual pressure for a 5-hour, 500 gpm fire flow varies from 70 to 78.5 psi. The residual pressure for a five-hour, 1,000 gpm fire flow varies from 59.5 to 72.5 psi. The residual pressure for a five-hour, 1,500 gpm fire flow varies from 47 to 64 psi. Xenia water rates for similar customers are \$65.20 for a minimum bill that covers the first 2,000 gallons, \$13.00 per 1,000 gallons for 2,000 to 10,000 gallons and \$5.50/1,000 gallons over 10,000 gallons. Our Board just approved a 0% rate increase for 2017 and the projection for the following 5 years is that a 1% annual increase in revenue will be adequate to fund all expected costs, capital improvements, etc. We fully expect to generate the 1% increase in revenue through added customers and added services, not through increased water rates.

6. **Adel Inquiry:** *As identified in Paragraph 3 of Section 4, an Addendum to the Agreement was to be signed acknowledging the initial construction costs*

*of the Xenia property located within Exhibit "A". Subsequently, addenda submitted to the City are required at the close of each calendar year upon the completion of improvements or other modifications to the property defined on Exhibit "A", including the addition of new water users on existing lines within the property defined in Exhibit "A". The City would appreciate copies of the initial Agreement Addendum and any subsequent Addenda that have been completed and submitted to the City as per the terms of the Agreement.*

**Xenia Response:** Regarding your item #6, we can find no addendum to the agreement. Enclosed are the bid tabs for the Phase I and Phase II projects which would be the basis for the addendum. Regarding the subsequent addenda upon completion of improvements or modifications to the property defined on Exhibit A, Xenia has not made any improvements or modifications to the referenced property, as shown on Map 4; therefore no subsequent addenda would be required.

Xenia has [a] spent countless hours planning and [b] spent millions of dollars developing the public water supply system infrastructure essential to serving customers within its reserved water service territory. Accordingly, Xenia stands ready, willing and able to provide public water supply services (at fire suppression pressures) to the proposed developments near Adel within its - Xenia's - reserved water service territory. Legal issues aside, I respectfully submit it would be a questionable and inefficient use of limited public resources for Adel to expand its water treatment facilities to serve customers Xenia already has the capability of serving.

Furthermore, Xenia is also a federally indebted rural water district and has pledged the stream of income from its present and future customers to collateralize and secure repayment of its federal indebtedness. Xenia would breach its fiduciary duties to its customers and be in default of its loan agreements if it allowed Adel - or any other city - to receive the stream of income from customers within its (Xenia's) reserved water service territory thereby jeopardizing its ability to meet its federal contractual loan obligations.

Indeed, to assure such federal government loans are repaid, Congress many years ago enacted 7 U.S.C §1926(b) which expressly states that a City may not (by annexation or otherwise) take any action to curtail or limit a federally indebted rural water district, like Xenia, from providing public water services to customers within its (Xenia's) reserved service territory.

Cities that have attempted to wrongly appropriate a federally indebted rural water district's territory have been enjoined from doing so and held liable for the damages and attorney fees the rural water district has incurred in defending its service territory rights.

Please understand that Xenia does not want a territorial dispute. Xenia also respectfully disagrees with Adel's apparent assumption that Xenia needs Adel's approval to serve customers near Adel (but in its - Xenia's - reserved water service territory that was established by the 1993 Agreement and developed initially as part of the Phase II Project) any more than Xenia needs Adel's permission to serve customers near DeSoto or Waukee who were also part of the Phase II Project.

Please remember also that federal law and Iowa law make no distinction whatsoever between regional rural public water supply systems and municipal public water supply systems. Both are subject to the same rules, regulations, inspections and regulatory oversight.

In summary, Xenia stands ready to work with Adel every step of the way to assure that these proposed developments become reality and that the developers and potential future Adel residents in Xenia's reserved water service territory receive the public water supply services they need.

Thank you for your consideration of the foregoing.

Respectfully submitted,

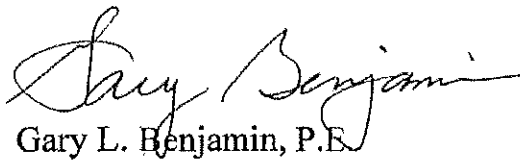

Gary L. Benjamin, P.E.  
CEO/General Manager  
Xenia Rural Water District

Enclosures

## TWO-MILE AGREEMENT

4087  
FILED  
BOOK 728 PAGE 902-  
1992 NOV -6 PM 1:07  
905  
20

This Agreement is made and entered into this 14th July, 1992 by and between the City of Adel, Iowa, a corporation organized and existing under the laws of the State of Iowa ("City"), and Xenia Rural Water District ("Xenia"), organized and incorporated as a body politic pursuant to Chapter 357A of the Code of Iowa.

### RECITALS

WHEREAS, Xenia desires to construct and expand its water system to include territory that is located within two miles of the limits of the City (the "Dallas Project").

WHEREAS, Section 357A.2 of the Code provides that a rural water district incorporated under 357A may not provide services within two miles of the limits of a city unless the city has approved a new water system plan.

WHEREAS, the City is willing to consent to the boundaries of the Dallas Project as set forth and shown on Exhibit A attached hereto, which boundaries include territory within two miles of the City's limits and to waive its right to provide water service within such boundaries during the terms of this Agreement, except as set forth herein.

NOW THEREFORE, the parties hereto agree as follows:

1. TWO-MILE AREA. Xenia has and shall have the full unrestricted and exclusive right to construct, operate, maintain, repair, replace and reconstruct the Xenia water system to include that territory located in Exhibit "A". The City hereby waives its right to provide water service within such area and therefore the City shall not sell or provide water to any property within the boundaries of such area.

After completion of the initial construction, Xenia may make additional improvements or modifications to the area defined on Exhibit "A" only upon the written consent of the City (except such consent shall not be required for the installation of additional meter pits and other service connections for new users on existing lines). The City shall not sell or provide water to any property served by Xenia or participating member of Xenia within the boundaries of the Dallas Project except as specifically provided in this Agreement.

2. CONSTRUCTION STANDARDS. The City recognizes that the water system is not constructed to provide fire protection and will not attempt to impose construction standards upon Xenia greater than ASTM standards that apply to water line construction unless the City agrees to pay the difference between the cost of waterline to be installed by Xenia and the cost of line that meets City construction standards. Xenia agrees to notify the City prior to construction of any new water service, including initial

construction, to provide information relative to the new construction, and to allow the City to pay the cost of any upgrade in construction standards requested by the City.

3. EMERGENCY WATER AGREEMENT. The City and Xenia agree that they intend to negotiate an agreement under terms and conditions mutually agreeable to the parties to provide for water purchases each from the other in the event of certain emergency needs for water by either of them; subject, however, to all applicable laws and regulations, and any and all approvals and proceedings necessary including consent, if required, from Farmers Home Administration, Xenia's lenders, the Des Moines Water Works, and the Adel City Council.

4. PURCHASE OPTION. With regard to any property in the Dallas Project that is within two miles of the City and in the event of the annexation of any additional territory within the boundaries of the Dallas Project, the City and Xenia may negotiate the purchase of the water system within such two-mile area (the "Purchase Area"). Issues to be considered during negotiation of the purchase price include but are not limited to: the cost of initial construction of the Purchase Area as well as any improvements or modifications to the Purchase Area subsequent to the initial construction; the outstanding principal balance owed by Xenia to the Farmer's Home Administration or the successor lender; the depreciation of the improvements or the appraised value of the Purchase Area as determined by an MAI - certified appraiser acceptable to Xenia and the City and Xenia's reasonable out-of-pocket expenses necessarily incurred in the connection with the sale of the Purchase Area to the City. In the event the parties agree to negotiate the purchase price, both parties shall negotiate in good faith giving due consideration to the items set forth above.

Xenia shall continue to own all right, title and interest to that portion of the water system within the Purchase Area that Xenia uses or in the future shall use to serve members outside the Purchase Area, including in particular, the transmission mains.

Upon the completion of the initial construction, Xenia and the City shall sign an addendum to this Agreement acknowledging the initial construction costs of the property located within Exhibit "A". Such addendum shall be updated at the close of each calendar year upon the completion of improvements or other modifications to the property defined on Exhibit "A", including the addition of any new water users on the existing lines to the water system within the property defined on Exhibit "A".

5. TERMINATION. This Agreement shall be in full force and effect until the earlier of (i) such time as fully performed by the parties hereto or (ii) termination by the mutual agreement of the parties hereto in writing.

6. NOTICES. Any notices or mailings required by this



Agreement shall be sent to the respective parties by personal delivery or certified mail to the following persons at the following addresses:

Xenia Rural Water District  
119 Main Street, P.O. Box 485  
Woodward, Iowa 50276

City of Adel  
P.O. Box 230  
Adel, Iowa 50003

7. FMHA APPROVAL. This Agreement shall not become effective until the terms and conditions herein contained have been approved by Farmers Home Administration.

8. RESOLUTIONS AND EXECUTION. The City and the Xenia shall become a party hereto upon its execution by their respective chief executive officers after the passage of a resolution or ordinance, as applicable, approving this Agreement and authorizing the execution of the same.

Executed the day and year first written above.

CITY OF ADEL, IOWA

  
\_\_\_\_\_  
Mayor

ATTEST:

  
\_\_\_\_\_  
City Administrator

XENIA RURAL WATER DISTRICT

By:   
\_\_\_\_\_

Its president \_\_\_\_\_

Approved this 24 day of Sept, 1992.

FARMERS HOME ADMINISTRATION

By:   
\_\_\_\_\_

**DENNIS A. O'FLYNN**  
Its Chief, Community and Business Programs

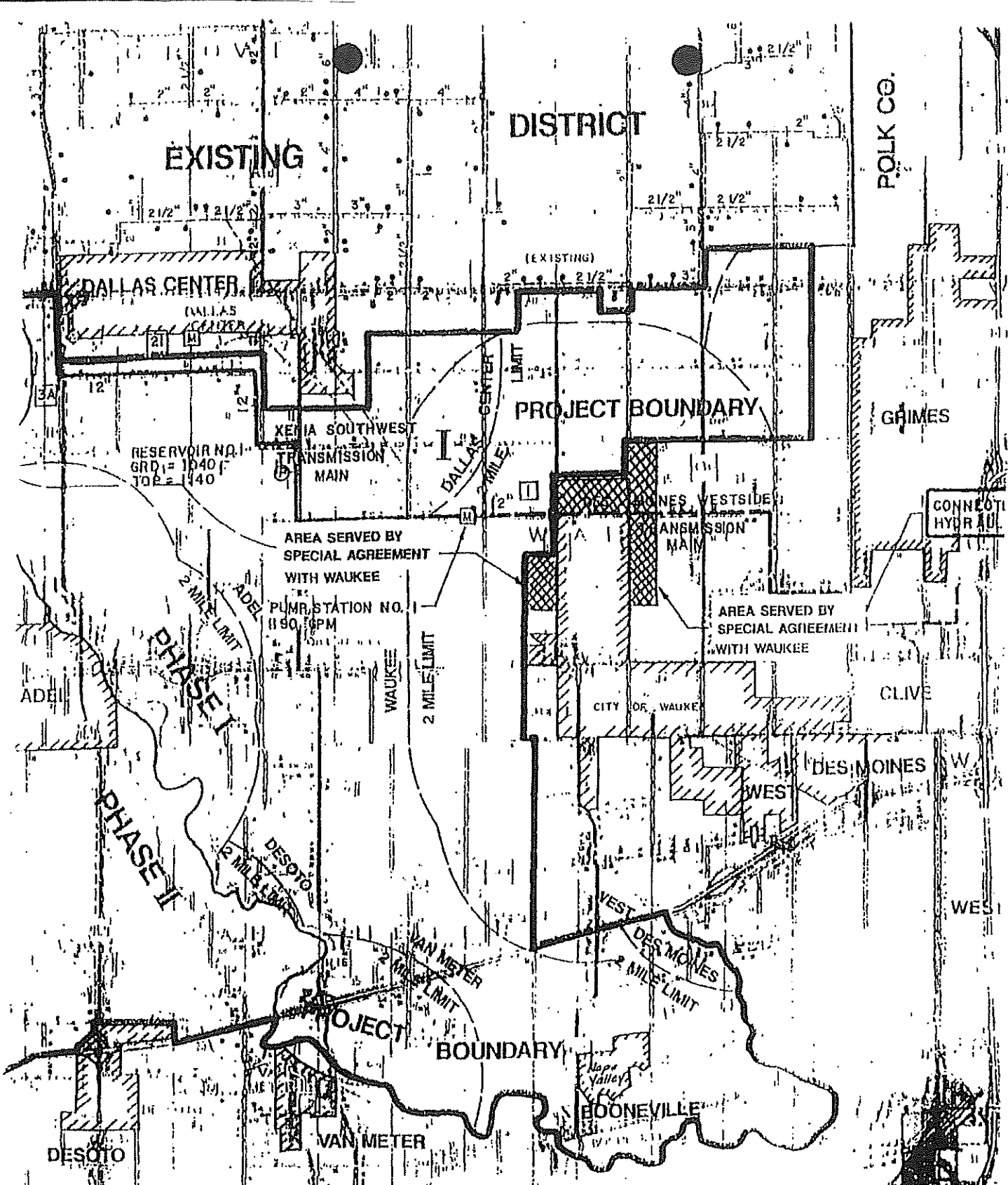

WARREN WATER DISTRICT  
R27W

BOOK -728 PAGE 0905 1126W.

REV. 9792  
REV. 1992

**Bartlett & West**  
Engineers, Inc.

COMPREHENSIVE WATER PLAN  
DALLAS COUNTY

DAD 1990  
GULLI & S  
MASHII

XENIA RURAL WATER ASSOCIATION

## TWO-MILE AGREEMENT

This Agreement is made and entered into this 18th day of November, 1993 by and between the City of Adel, Iowa, a municipal corporation organized and existing under the laws of the State of Iowa ("City"), and Xenia Rural Water District ("Xenia"), organized and incorporated as a body politic pursuant to Chapter 357A of the Code of Iowa.

### RECITALS

WHEREAS, Xenia desires to construct and expand its water system to include territory that is located within two miles of the limits of the City (the "Dallas Project Phase II").

WHEREAS, Section 357A.2 of the Code provides that a rural water district incorporated under 357A may not provide services within two miles of the limits of a city unless the city has approved a new water system plan.

WHEREAS, the City is willing to consent to the boundaries of the Dallas Project Phase II as set forth and shown on Exhibit A attached hereto, which boundaries include territory within two miles of the City's limits and to waive its right to provide water service within such boundaries during the terms of this Agreement, except as set forth herein.

NOW THEREFORE, the parties hereto agree as follows:

1. TWO-MILE AREA. Xenia has and shall have the full unrestricted and exclusive right to construct, operate, maintain, repair, replace and reconstruct the Xenia water system as detailed in Exhibit "A". The City shall not sell or provide water service to any property served by Xenia or participating member of Xenia within the boundaries of the Dallas Project Phase II except as specifically provided in this agreement.

After completion of the initial construction as detailed at Exhibit "A", Xenia may make additional improvements, modifications, or service line extensions to the area defined in Exhibit "A" only upon written approval by City of a new water service plan (except such approval shall not be required for the installation of additional meter pits and other service connections for new users on existing lines).

As new areas develop or as the request for additional service becomes necessary, within the Dallas Project Phase II, the City and Xenia shall negotiate which entity shall provide service to those customers. If Xenia desires to serve any areas or residents within the City limits, Xenia shall enter into an agreement with the City identifying the terms and conditions in which such service may be provided.

2. CONSTRUCTION STANDARDS. The City recognizes that the water system is not constructed to provide fire protection and will not attempt to impose construction standards upon Xenia greater than ASTM standards that apply to water line construction unless the City agrees to pay the difference between the cost of the water line to be installed by Xenia and the cost of line that meets City construction standards. Xenia agrees to notify the City prior to construction of any new water service, including initial construction, to provide information relative to the new construction, and to allow the City to pay the cost of any upgrade in construction standards requested by the City.

3. EMERGENCY WATER AGREEMENT. The City and Xenia agree that they intend to negotiate an agreement under terms and conditions mutually agreeable to the parties to provide for water purchases each from the other in the event of certain emergency needs for water by either of them; subject, however to all applicable laws and regulations, and any and all approvals and proceedings necessary including consent, if required, from Farmers Home Administration, Xenia's lenders, the Des Moines Water Works, and the Adel City Council.

4. PURCHASE OPTION. With regard to any property in the Dallas Project that is within two miles of the City and in the event of the annexation of any additional territory within the boundaries of the Dallas Project Phase II, the City and Xenia may negotiate the purchase of the water system within such two-mile area (the "Purchase Area"). Issues to be considered during negotiation of the purchase price include but are not limited to: the cost of the initial construction of the Purchase Area as well as any improvements or modifications to the Purchase Area subsequent to the initial construction; the outstanding principal balance owed by Xenia to the Farmer's Home Administration or the successor lender; the depreciation of the improvements or the appraised value of the Purchase Area as determined by an MAI - certified appraiser acceptable to Xenia and the City and Xenia's reasonable out-of-pocket expenses necessarily incurred in the connection with the sale of the Purchase Area to the City. In the event the parties agree to negotiate the purchase price, both parties shall negotiate in good faith giving due consideration to the items set forth above.

Xenia shall continue to own all right, title and interest to that portion of the water system within the Purchase Area that Xenia uses or in the future shall use to serve members outside the Purchase Area, including in particular, the transmission mains.

Upon completion of the initial construction, Xenia and the City shall sign an addendum to this Agreement acknowledging the initial construction costs of the property located within Exhibit "A". Such addendum shall be updated at the close of each calendar year upon the completion of improvements or other modifications to the property defined on Exhibit "A", including the addition of any new water users on the existing lines to the water system within the property defined on Exhibit "A".

5. TERMINATION. This Agreement shall be in full force and effect until the earlier of (i) such time as fully performed by the parties hereto or (ii) termination by the mutual agreement of the parties hereto in writing.

6. NOTICES. Any notices or mailings required by this Agreement shall be sent to the respective parties by personal delivery or certified mail to the following persons at the following addresses:

Xenia Rural Water District  
119 Main Street, P.O. Box 485  
Woodward, Iowa 50276

City of Adel  
P.O. Box 230  
Adel, Iowa 50003

7. FHMA APPROVAL. This Agreement shall not become effective until the terms and conditions herein contained have been approved by Farmers Home Administration.

8. RESOLUTIONS AND EXECUTION. The City and the Xenia shall become a party hereto upon its execution by their respective chief executive officers after the passage of a resolution or ordinance, as applicable, approving this Agreement and authorizing the execution of the same.

Executed the day and year first written above.

CITY OF ADEL, IOWA

  
\_\_\_\_\_  
Mayor

ATTEST:

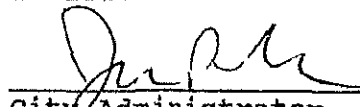
  
\_\_\_\_\_  
City Administrator

TWO-MILE AGREEMENT  
CITY OF ADEL/XENIA  
PAGE FOUR

XENIA RURAL WATER DISTRICT

By: Tom E. Nowan  
Its President

Approved this 18 day of NOVEMBER, 1993.

FARMERS HOME ADMINISTRATION

By: Dorman A. Otte  
Its DORMAN A. OTTE  
Chief, Community and Business Programs

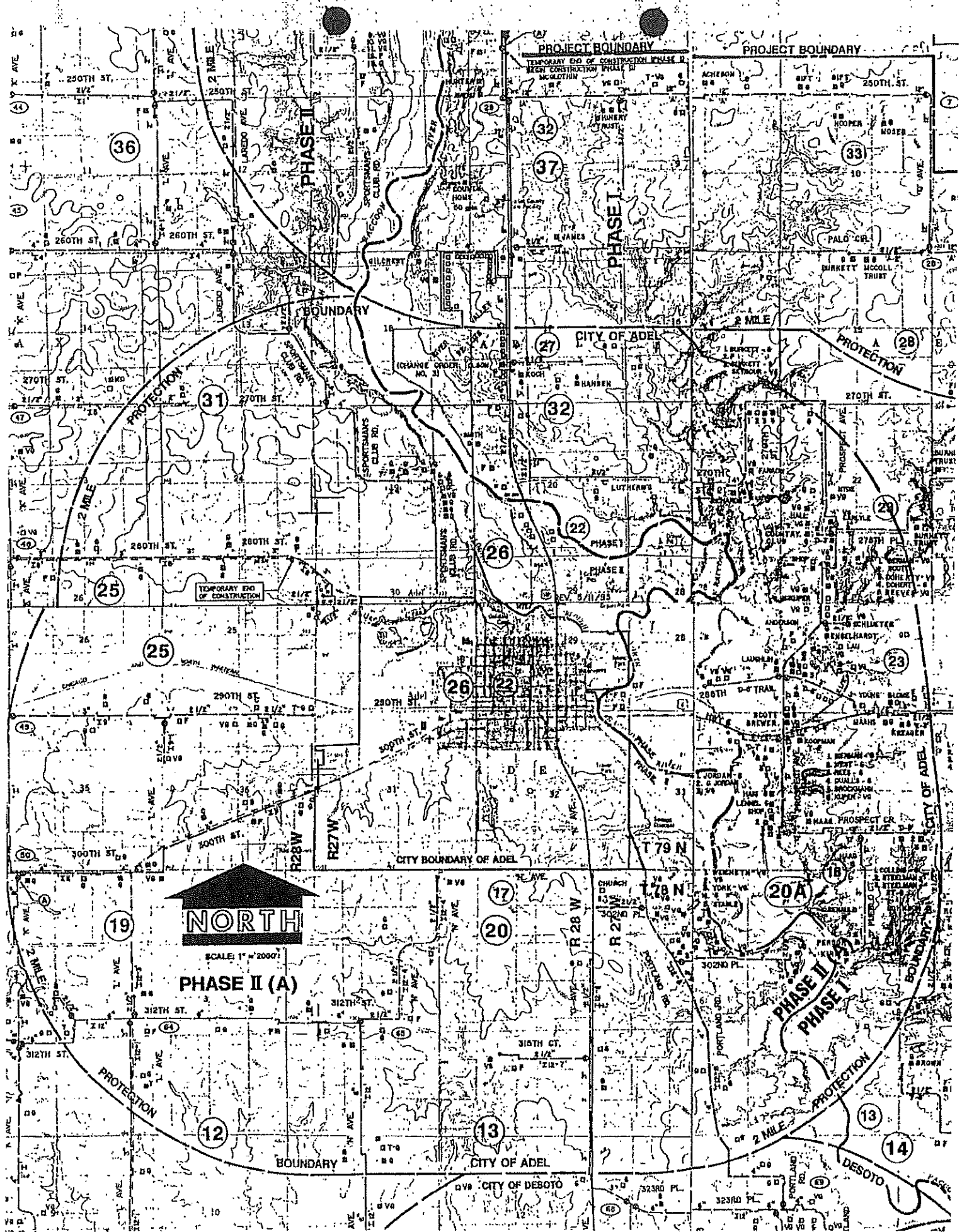

PROJECT BOUNDARY

PROJECT BOUNDARY

TEMPORARY END OF CONSTRUCTION PHASE II  
HIGH CONSTRUCTION PHASE II

PHASE I

PHASE I

BOUNDARY

CITY OF ADEL

PROTECTION

PROTECTION

25

25

26

26

CITY BOUNDARY OF ADEL

17

20

19

NORTH

SCALE 1" = 2000'

PHASE II (A)

13

CITY OF ADEL

CITY OF DEBOTO

20A

PHASE II (A)

PHASE I

14

DESOTO

PROTECTION

BOUNDARY

PROTECTION

14

DESOTO

DESOTO

DESOTO

DESOTO

# MAP 1

- Phase I / Adel Boundary
- Adel Corporate Limits 1993

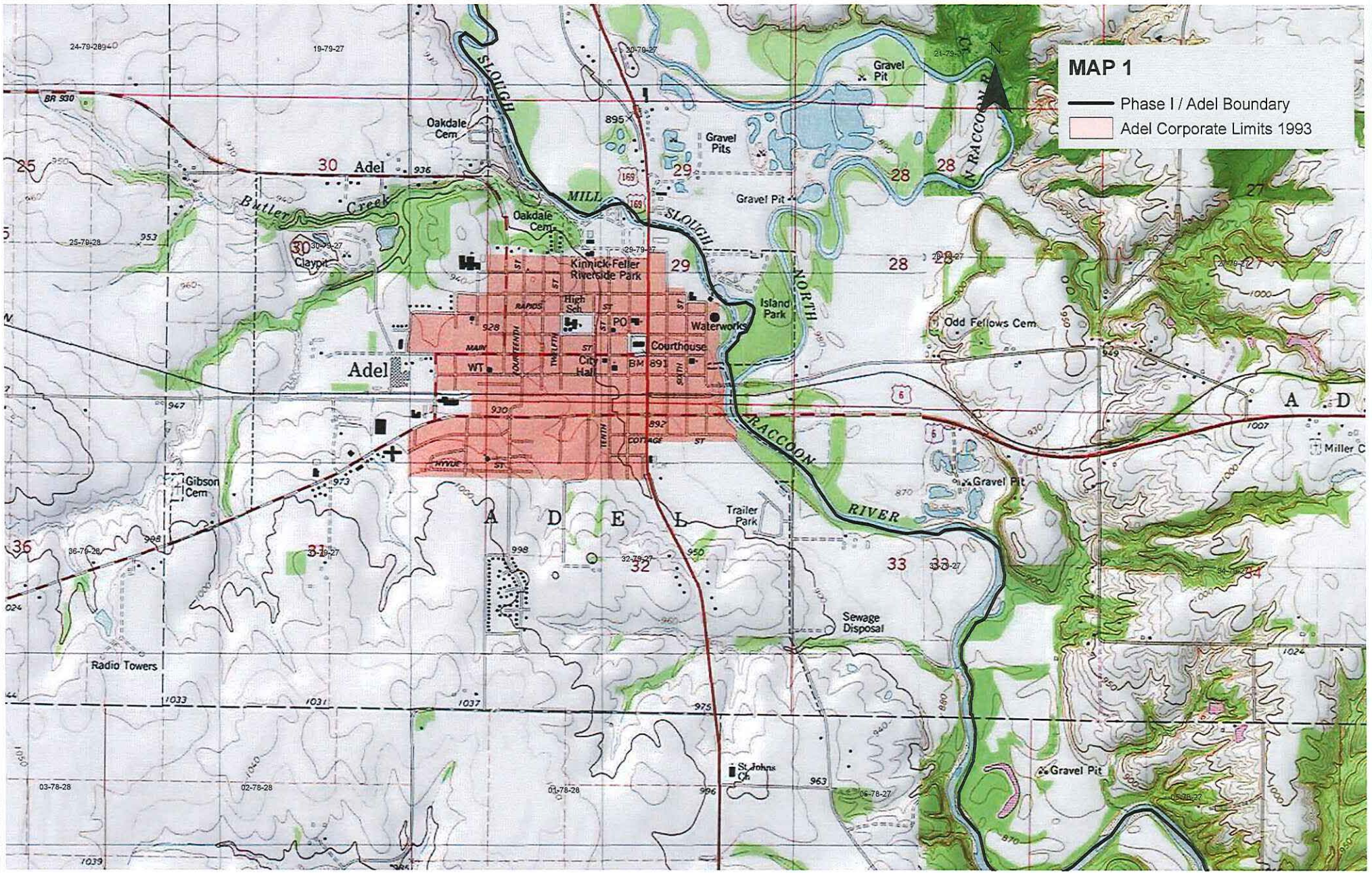



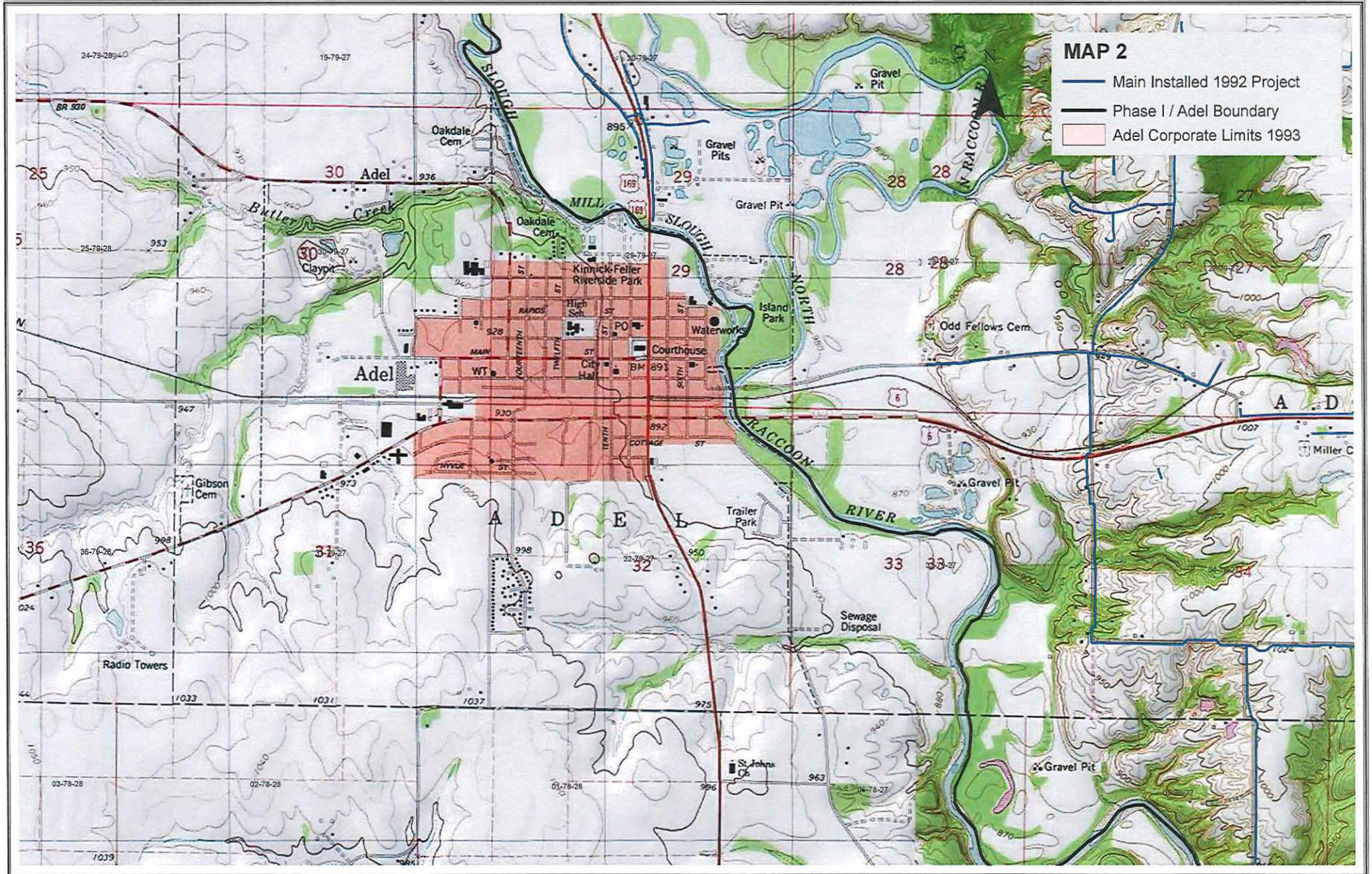

## MAP 2

- Main Installed 1992 Project
- Phase I / Adel Boundary
- Adel Corporate Limits 1993



**MAP 3**

-  Adel City Boundary 1993
-  Adel Corporate Limits 1993

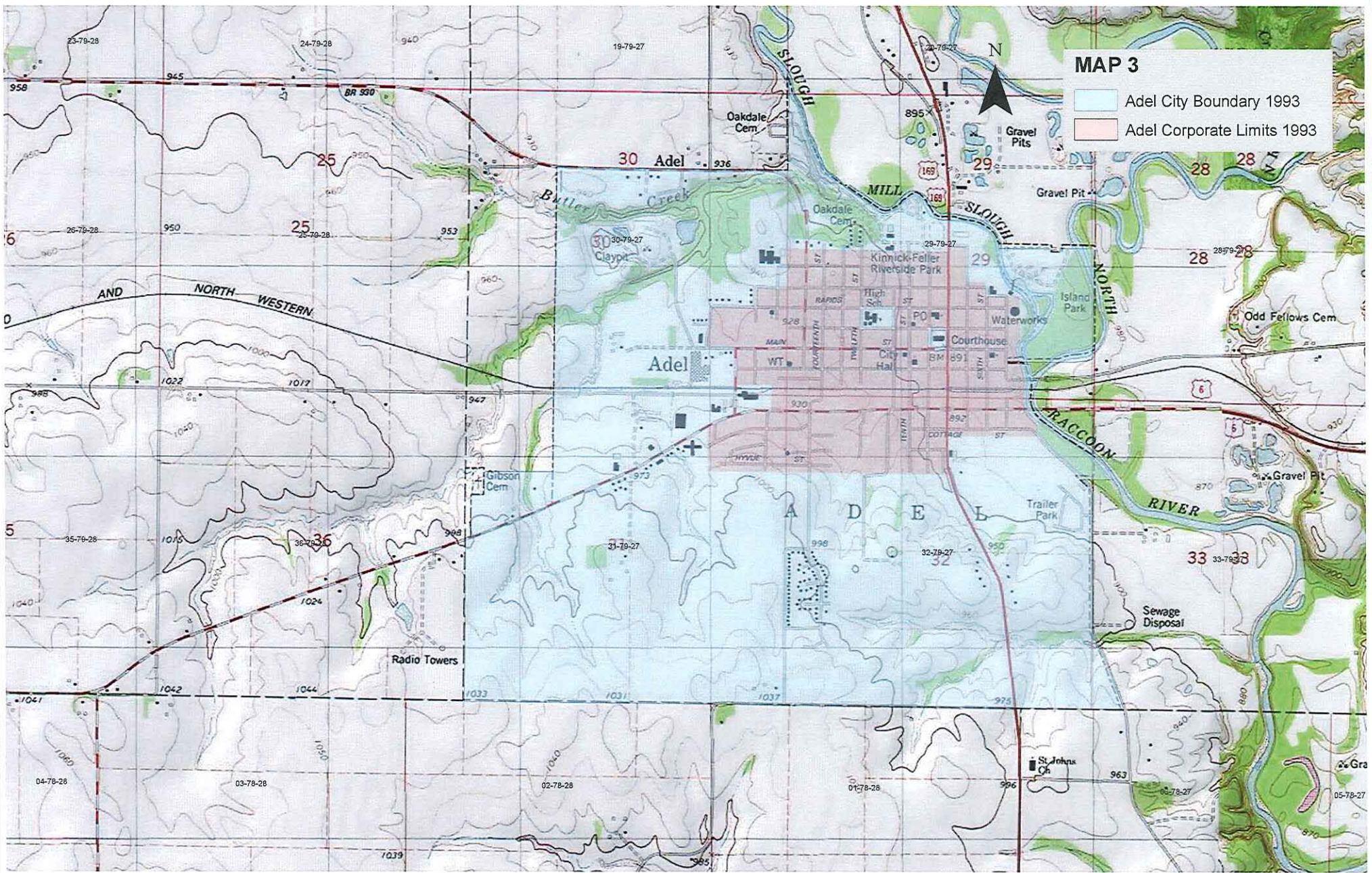

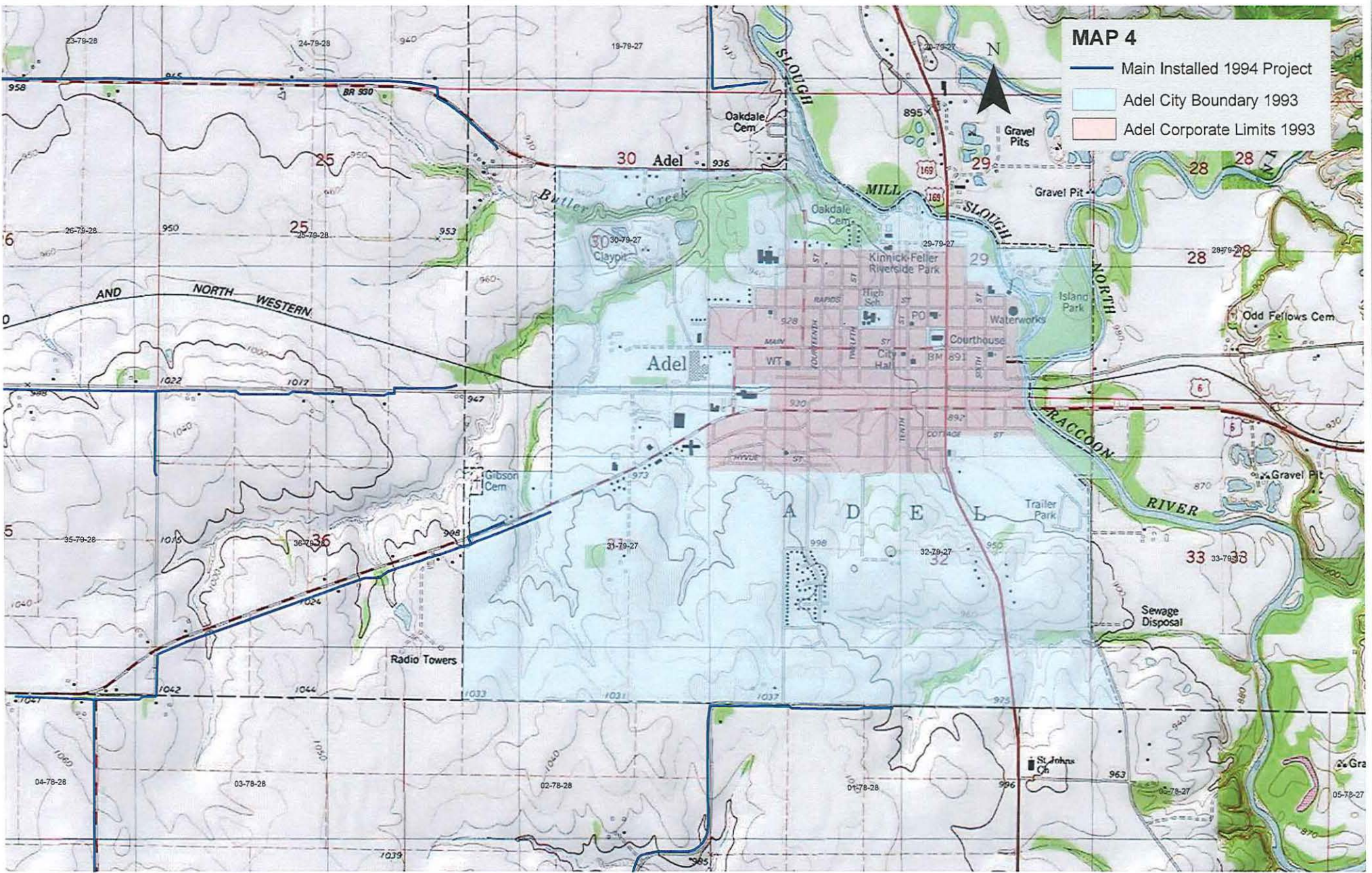

**MAP 4**

-  Main Installed 1994 Project
-  Adel City Boundary 1993
-  Adel Corporate Limits 1993



### MAP 5

-  Main Installed After 1994 Project
-  City Boundary of Adel 1993
-  Adel Corporate Limits 1993

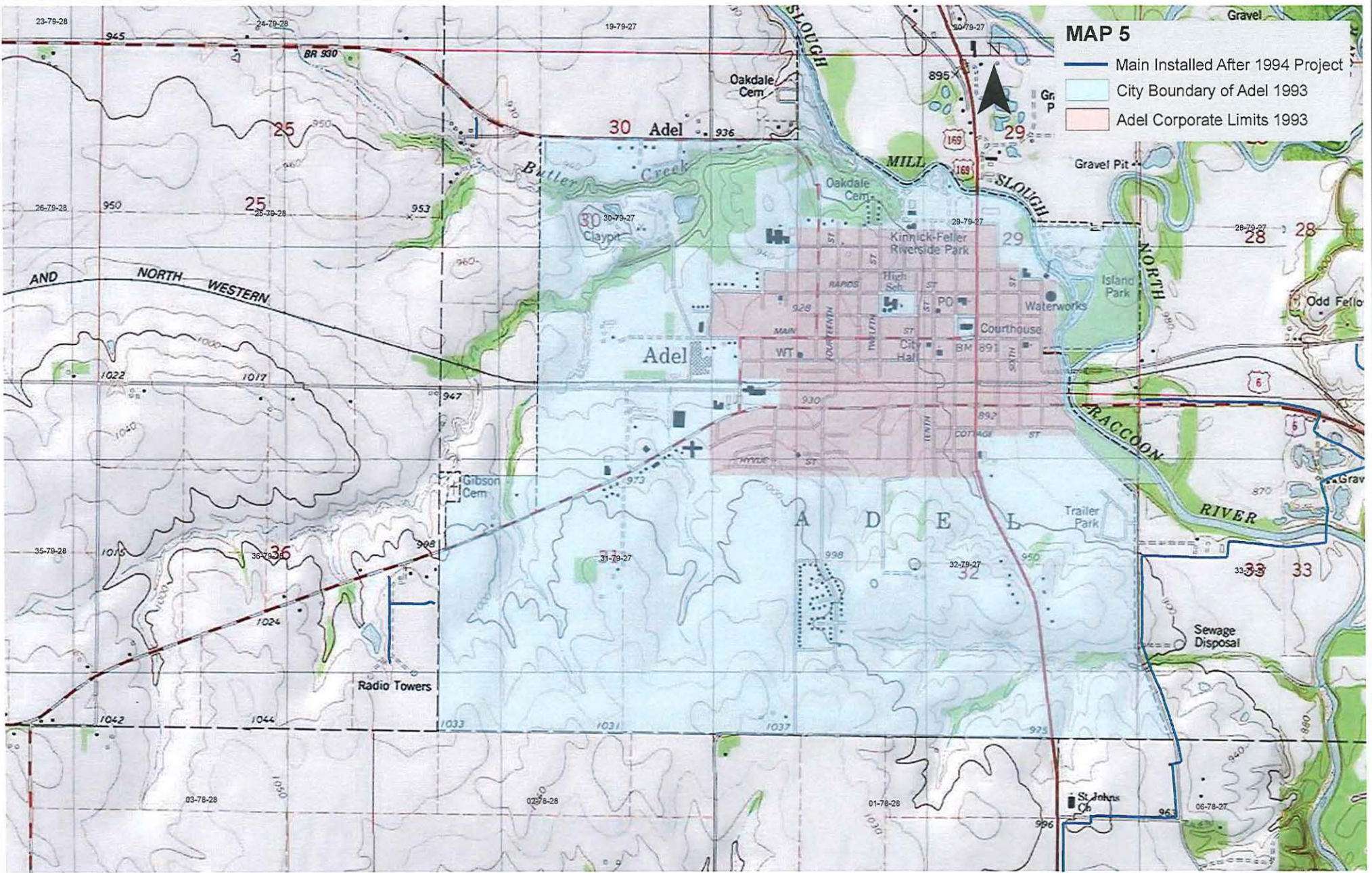

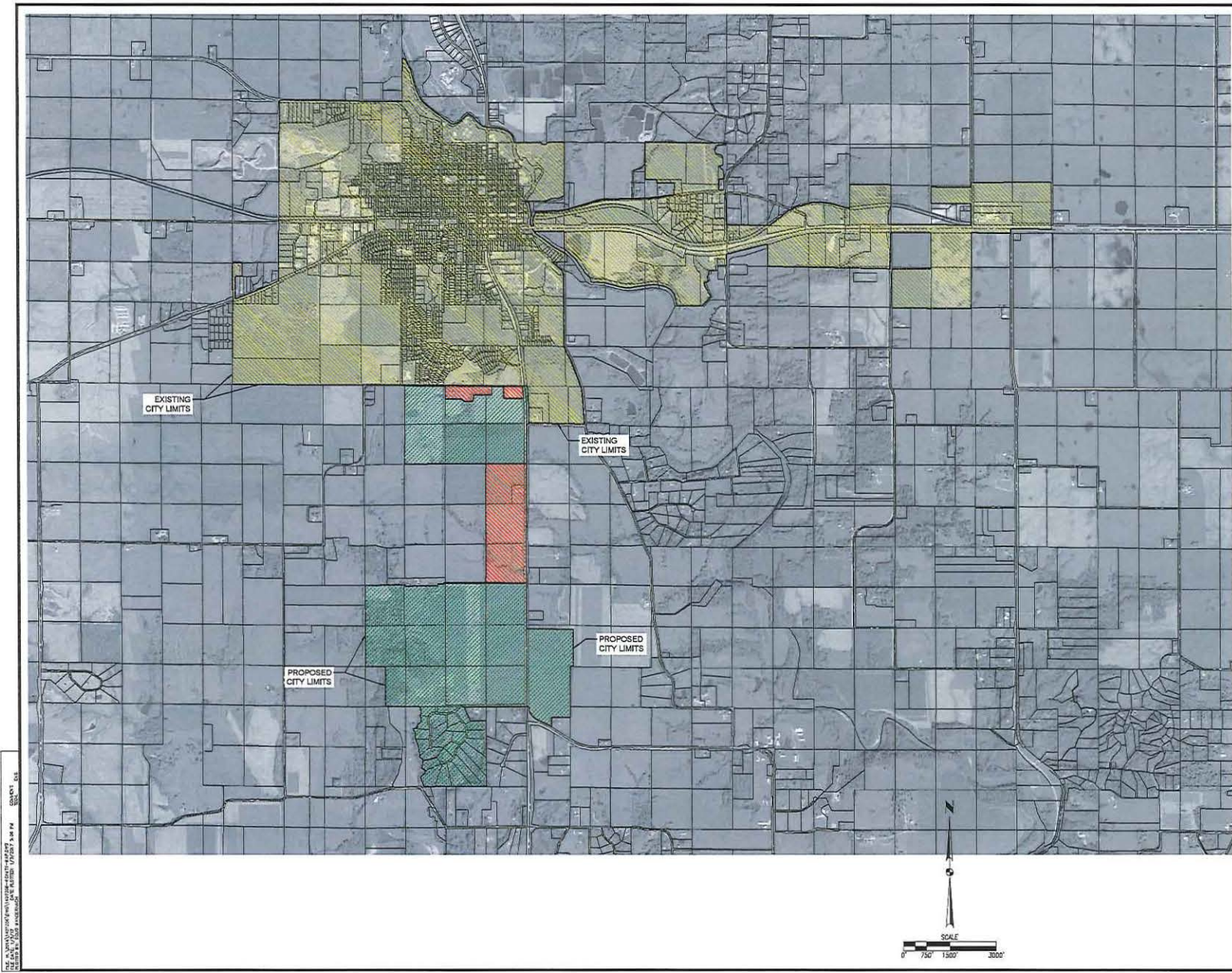

# EXHIBIT A



THE ABOVE MAP WAS PREPARED BY THE ENGINEER FROM DATA PROVIDED BY THE CITY OF ADEL. THE ENGINEER HAS NOT CONDUCTED A FIELD SURVEY TO VERIFY THE ACCURACY OF THE DATA. THE ENGINEER IS NOT RESPONSIBLE FOR THE ACCURACY OF THE DATA.

DATE: \_\_\_\_\_

REVISIONS: \_\_\_\_\_

UPDATED: \_\_\_\_\_

PREPARED: \_\_\_\_\_

3405 S.E. CROSSROADS DRIVE, SUITE G  
 GRIMES, IOWA 50111  
 PHONE: (515) 369-4400 FAX: (515) 369-4410

CIVIL DESIGN ADVANTAGE ENGINEER

DALLAS COUNTY, IOWA

**ADEL**  
**ANNEXATION EXHIBIT**

1  
1  
1407.356

## Ordinance No. 313

### AN ORDINANCE AMENDING THE CODE OF ORDINANCES OF THE CITY OF ADEL, IOWA, 2013, BY AMENDING THE ZONING CLASSIFICATION OF CERTAIN REAL PROPERTY LOCATED WITHIN THE CITY LIMITS OF ADEL, IOWA, FROM ITS CURRENT CLASSIFICATION OF A-1 (Agricultural District) TO P.U.D. (Planned Urban Development District), AS RECOMMENDED BY THE ADEL PLANNING AND ZONING COMMISSION, AND PROVIDING FOR THE AMENDMENT OF THE OFFICIAL ZONING MAP OF THE CITY OF ADEL, IOWA, TO REFLECT SAID CHANGE BE IT ENACTED BY THE CITY COUNCIL OF THE CITY OF ADEL, IOWA:

Section 1. **PURPOSE.** The Code of Ordinances of the City of Adel, Iowa (2013) is amended by changing the zoning classification of the following described real property, from Bloomfield Acres for Parcel #1133100013, 29456 Old Portland Road (approximately 14.35 acres) from the current zoning A-1 (Agricultural District) to P.U.D. (Planned Urban Development District) to be named Twin Eagles Riverview.

#### *Legal Description:*

*Parcel DD, a part of parcel "A" of the plat of survey recorded in book 1999, page 3508 in the office of the Dallas County Recorder's, being a part of the Southwest ¼ of the Northwest ¼ of Section 33, Township 79 North, Range 27 West of the 5<sup>th</sup> P.M., now included in and forming a part of Dallas County, Iowa and described as follows:*

*Commencing at the Northwest corner of the Southwest ¼ of the Northwest ¼ of said Section 33 also being the Northwest corner of said parcel "BB"; thence South 0° 08' 30" West along the West line of said Southwest ¼ of the Northwest ¼ and also the West line of said parcel "BB", 175.46 feet to the Southwest corner of said parcel "BB" and the point of beginning; thence South 67° 14' 07" East along the South line of said parcel "BB", 241.78 feet; thence South 47° 16' 49" East continuing along said South line, 203.88 feet; thence South 43° 18' 07" East continuing along said South line, 201.09 feet to the Southerly corner of said parcel "BB"; thence South 55° 41' 41" East, 320.00 feet; thence South 01° 10' 27" West, 140.00 feet; thence South 79° 22' 57" East, 30.00 feet; thence North 33° 44' 32" East, 90.00 feet; thence North 72° 04' 22" East, 97.91 feet; thence South 34° 36' 17" East, 64.99 feet; thence South 76° 11' 29" East, 363.05 feet to the East line of said parcel "A"; thence South 00° 08' 35" West along said East line, 210.00 feet to the Southeast corner of said parcel "A"; thence North 88° 12' 45" West along the South line of said parcel "A", 1336.58 feet to the Southwest corner of said parcel "A"; thence North 00° 08' 30" East along the East line of said parcel "A", 907.54 feet; to the point of beginning and containing 15.18 acres (661,144 s.f.) and subject to 0.83 acres (36,156 s.f.) of roadway easement.*

The Zoning Administrator is directed to amend the Official Zoning Map to indicate said changes.

Section 2. **REPEALER.** All ordinances or parts of ordinances that are in conflict with this ordinance are hereby repealed.

Section 3. **SEVERABILITY.** If any section, provision or part of this ordinance shall be adjudged invalid or unconstitutional, such adjudication shall not affect the validity of the ordinance as a whole or any section, provision or part thereof not adjudged invalid or unconstitutional.

Section 4. **WHEN EFFECTIVE.** This Ordinance shall be in effect from and after its final passage, approval and publication as provided by law, whichever shall later occur.

Passed and approved by the Adel City Council this \_\_\_\_ day of \_\_\_\_\_, 2017.

\_\_\_\_\_  
James F. Peters, Mayor

Attest: \_\_\_\_\_  
Jackie Steele, City Clerk

1<sup>st</sup> Reading \_\_\_\_\_

2<sup>nd</sup> Reading \_\_\_\_\_

3<sup>rd</sup> Reading \_\_\_\_\_

I certify that the foregoing was published as Ordinance No. 313 in the Dallas County News on the  
\_\_\_\_\_ day of \_\_\_\_\_, 2017.

\_\_\_\_\_  
Jackie Steele, City Clerk

**TWIN EAGLES RIVERVIEW - BLOOMFIELD ACRES, L.L.C.**

**DEVELOPMENT AGREEMENT**

This Development Agreement ("Agreement") is made as of this day of 2017, by and between the CITY OF ADEL, IOWA ("City") a municipal corporation with its general offices at 301 South Tenth Street, Adel, Iowa 50003, and BLOOMFIELD ACRES, L.L.C. , an Iowa limited liability company, ("Developer") with its office at 7008 Madison Avenue, Urbandale, Iowa 50322.

**RECITALS:**

The City desires to have the ability to provide services and public safety to areas annexed in the City located in southeastern Dallas County.

- A. The City desires to have the ability to provide services and public safety to areas annexed in the City located in Dallas County, Iowa.
- B. The City desires Developer to construct certain infrastructure in accordance with a comprehensive plan and Developer agrees that all infrastructure will be constructed to SUDAS and City standards. In the event that Xenia serves this project with water, certification of available fire flows and pressures must be provided. Xenia must also provide the City with water usage so the City may bill for sewer.
- C. Developer is the owner of certain real property locally known as 29456 Old Portland Road, Adel, Iowa, and legally described as:

Parcel "DD" and Parcel "CC" being a part of Parcel "A" of the Southwest Quarter (SW 1/4) of the Northwest Quarter (NW 1/4) of Section Thirty-three (33), Township Seventy-nine (79) North, Range Twenty-seven (27) West of the 5th P.M., Dallas County, Iowa, as shown on Plat of Survey recorded in Book 2015 Page 19888.

("Developer's Property") to be known as "TWIN EAGLES RIVERVIEW".



- D. The City and Developer desire to enter into this Agreement for the purpose of detailing the responsibilities of each party to construct certain improvements associated with Developer's Property.

NOW, THEREFORE, in consideration of the above stated recitals, undertakings and conditions it is agreed as follows:

1. THE PROJECT: The Project shall consist of the Developer constructing a housing project currently designed as consisting of 118 market-rate 3 bedroom leased condominiums constructed in bi-attached structures to a density of 8.22 units per acre. Occupancy loads per unit are governed by the adopted leasing standards of the developer/owner: 5 persons (3 adult maximum, 3 un-related adult maximum, each resident over 18 must sign the associated lease. This PUD is limited to a density of 10 units per acre. All recitals are derived from the governing document, Twin Eagles Riverview PUD Masterplan, and associated site plans, landscape plans, grading plans, etc...any and all inquiries are to be directed to the aforementioned plans.
  
2. CONTRIBUTIONS, OBLIGATIONS AND UNDERTAKINGS OF DEVELOPER:
  - a) Developer agrees to utilize standard construction practices, including architectural shingles, engineered wood siding (or comparable) with 50-year warranty stone veneer, and neutral earth tone colors.
  
  - b) The Development will be served by a private drive with private storm sewer lines and private sanitary sewer lines connected to City's infrastructure. The installation cost of all infrastructure to be paid by developer. All maintenance on private infrastructure will be performed by developer/owner.
  
  - c) Developer agrees to provide 24/ 7 on-site management of the Project and provide contact information for such property management to City Hall.
  
  - d) Developer agrees to pave the unimproved section of Old Portland Road immediately adjacent to Development, with rural cross-section PCC pavement as required by SUDAS and City standards.

- e) Developer agrees to provide a 15-foot wide Trail Easement containing a hard surface 10-foot wide public bike trail along the river connected to the interior of the development via a 5 foot wide sidewalk in NE corner of development and a hard surface 10-foot wide public sidewalk along Old Portland Road.
- f) Developer agrees to dedicate to City park land having an agreed upon fair market value of \$87,504.00 derived from required parkland dedication formula based on sq. ft. purchase price.
- g) Developer agrees to install trees and other landscaping pursuant to PUD Master Plan, as filed with the City, and to replace any trees or other landscaping features that die within one-year of final occupancy.
- h) Developer agrees to prohibit parking on the private streets and to enforce such rule by management company.
- i) Onsite lighting will be provided by photocell controlled building mounted lighting as well as private street lights placed throughout the development as indicated on associated PUD Master Plan.
- j) Developer agrees to install onsite water mains and appurtenances to connect to Xenia water system. Developer agrees to provide two 8” diameter water main extensions across Old Portland road for future connection to a City of Adel public water main installed at a future date. As well as provide an easement for future City of Adel water main along Old Portland Road if needed.

3. CITY OBLIGATIONS AND UNDERTAKINGS:

The City agrees to provide Developer and to Developer’s Property the following:

- a) The current 7-year 100% property tax abatement.

- b) Allow 15-foot wide Trail Easement and hard surface 10-foot wide bike trail along river and 10-foot wide public sidewalk along Old Portland Road to satisfy park land dedication requirement, having an agreed fair market value of \$87,504.00 derived from required parkland dedication formula based on sq. ft. purchase price.
- d) Provide garbage services to Developer's Project to be billed on monthly sewer bill to be administered by City contract with individual pick-ups and billed individually to each unit.

4. REPRESENTATIONS AND WARRANTIES OF THE CITY:

- a) The City is a municipal corporation and municipality organized under the provisions of the constitution and the laws of the State of Iowa and has power to enter into this Agreement and carry out its obligations and undertakings hereunder.
- b) The execution and delivery of this Agreement, the consummation of the transactions contemplated hereby and the fulfillment of or compliance with the terms and conditions of the Agreement are not prevented by, limited by, in conflict with, or result in a breach of, the terms, conditions or provisions of any contractual restriction, evidence of indebtedness, agreement or instrument of whatever nature to which the City of now a party by which it is bound, nor do they constitute a default under any of the foregoing.
- c) All covenants, stipulations, promises and agreements and obligations of the City contained herein shall be deemed to be the covenants, stipulations, promises, agreements and obligations of the City and not of any governing body member, officer, agent, servant or employee of the City in the individual capacity hereof.

5) REPRESENTATIONS AND WARRANTIES OF DEVELOPER:

- a) Bloomfield Acres, L.L.C., is an Iowa limited liability company, duly organized and validly existing under the laws of the State of Iowa and it has all requisite power and authority to own and operate its properties, to carry on its businesses now conducted and as presently proposed to

be conducted, and to enter into to perform its obligations under this Agreement.

- b) This Agreement has been duly and validly authorized, executed, and delivered by Developer and, assuming due authorization execution and delivery by the City, is in full force and effect and is a validly legally binding instrument of Developer enforceable in accordance with its terms, except as may be limited by bankruptcy, insolvency, reorganization or other laws relating to or effecting creditors' rights generally.
- c) The execution and delivery of this Agreement, the consummation of the transactions contemplated hereby, and the fulfillment of or compliance with the terms and conditions of this Agreement are not prevented by, limited by, in conflict with or result in a violation or breach of the terms conditions or provisions of the governing documents of Developer or of any contractual restriction, evidence of indebtedness, agreement of instrument of whatever nature to which Developer is now a party or by which it or its property is bound, nor do they constitute a default under any of the foregoing.
- d) There are no actions, lawsuits or proceedings pending or threatened against or affecting Developer in any court or before any arbitrator or before or by any governmental body for which there is a reasonable possibility of an adverse decision which could materially adversely affect the business (present or prospective), financial position or results of operations of Developer or which in manner raises any questions affecting the validity of the Agreement or Developers ability to perform its obligations under this Agreement.
- e) Developer has not received any notice from any local, state or federal official that the activities of Developer with respect to the right-of-way property may or will be in violation of any environmental law or regulation (other than those notices, if any, of which the City has been previously notified in writing). Developer is not aware of any state or federal claim filed or planned to be filed by any party relating to any violation of any local, state or federal environmental law, regulation or review procedure applicable to the Project and Developer is not

currently aware of any violation of any local, state or environmental law, regulation or review procedure which would give any person a valid claim under any state or environmental statute with respect thereto.

- f) Developer has good and marketable title to the Developer Right-of-Way for the Project and shall work with the City and other adjacent land owners to deliver good and marketable title to the right-of-way for the Project which is not a part of the Developer Right-of-Way.

6. EVENTS OF DEFAULT DEFINED: The following shall be Events of Default under this Agreement and the term Event of Default shall mean, whenever it is used in this Agreement, any one or more of the following events:

- a) Failure by the Developer to observe or perform any covenant, condition, obligation or agreement on its part to be observed or performed under this Agreement;
- b) The Developer shall:
  - (i) file any petition in bankruptcy or for any reorganization, arrangement, composition, readjustment, liquidation, dissolution, or similar relief under the United States Bankruptcy Act of 1978, as amended, or under any similar federal or state law; or
  - (ii) make an assignment for the benefit of its creditors; or
  - (iii) admit in writing its inability to pay its debts generally as they become due; or
  - (iv) be adjudicated a bankrupt or insolvent; or if a petition or answer proposing the adjudication of the Developer as a bankrupt or its reorganization under any present or future federal bankruptcy act or any similar federal or state law shall be filed in any court and such petition or answer shall not be discharged or denied within ninety (90) days after the filing thereof; or a receiver, trustee or liquidator of the Developer or part thereof, shall be appointed in any proceedings brought against the Developer and shall not be

discharged within ninety (90) days after such appointment, or if the Developer shall consent to or acquiesce in such appointment;

- c) Any representation or warranty made by the Developer in this Agreement, or made by the Developer in any written statement or certificate furnished by the Developer pursuant to this Agreement, shall prove to have been incorrect, incomplete or misleading in any material respect on, or as of the date of the issuance or making thereof; or
- d) Any representation or warranty made by the City in this Agreement shall prove to have been incorrect, incomplete or misleading in any material respect on or as of the date of the issuance.

City's Remedies on Default. Whenever any Event of Default referred to in Section 6 of this Agreement occurs and is continuing, the City, as specified below, may take any one or more of the following actions after (except in the case of an Event of Default under subsections (b) of said Section VI) the giving of thirty (30) days written notice by the City to the Developer of the Event of Default, but only if the Event of Default has not been cured within said thirty (30) days, or if the Event of Default cannot reasonably be cured within thirty (30) days and the Developer does not provide assurances reasonably satisfactory to the City that the Event of Default will be cured as soon as reasonably possible:

- a) The City may suspend its performance under this Agreement until it receives assurances from the Developer, deemed adequate by the City, that the Developer will cure its default and continue its performance under this Agreement;
  - b) The City may terminate this Agreement;
  - c) The City may take any other action, including legal, equitable or administrative action, which may appear necessary or desirable to recover damages or enforce performance and observance of any obligation, agreement, or covenant of the Developer under this Agreement.
7. NO REMEDY EXCLUSIVE. No remedy herein conferred upon or reserved to the City is intended to be exclusive of any other available remedy or remedies, but each and every remedy shall be cumulative and shall be in addition to

every other remedy given under this Agreement or now or hereafter existing at law or in equity or by statute. No delay or omission to exercise any right or power accruing upon any default shall impair any such right or power or shall be construed to be a waiver thereof, but any such right and power may be exercised from time to time and as often as may be deemed expedient.

8. DEVELOPER'S REMEDIES ON DEFAULT. Whenever any Event of Default occurs by the City, the Developer may terminate this Agreement, and the Developer may take any legal action it considers necessary to recover damages from the City or to enforce this Agreement, subject to a 120 day written notice to the City with an opportunity for the City to cure the Event of Default during the 120 day notice period.
9. NO IMPLIED WAIVER. In the event any agreement contained in this Agreement should be breached by the Developer and thereafter waived by the City, such waiver shall be limited to the particular breach so waived and shall not be deemed to waive any other concurrent, previous or subsequent breach hereunder.
10. AGREEMENT TO PAY ATTORNEYS' FEES AND EXPENSES. Whenever any Event of Default occurs and either party employs attorneys or incurs other expenses for the collection of payments due or to become due or for the enforcement or performance or observance of any obligation or agreement on the part of the other party, the non-prevailing party shall pay to the prevailing party its reasonable attorneys fees and costs.
11. THIRD PARTY COMPLIANCE. Fulfillment of this Agreement is contingent upon compliance with the obligations of third parties referenced herein, and upon the failure of a third party or parties to fulfill its obligations, this Agreement may be terminated by either the Developer, the City, or both.
12. NO THIRD PARTY BENEFICIARIES. No rights or privileges of either party hereto shall inure to the benefit of any landowner, contractor, subcontractor, material supplier, or any other person or entity and no such contactor, landowner, subcontractor, material supplier, or any other person or entity shall be deemed to be a third-party beneficiary of any of the provisions contained in this Agreement.

13. MISCELLANEOUS.

- a) Notices and Demands. A notice, demand or other communication wider this Agreement by any party to the other shall be sufficiently given or delivered if it is dispatched by a registered or certified mail, postage prepaid, return receipt requested or delivered personally and
  - i) in the case the Developer is addressed or delivered personally to Bloomfield Acres, L.L.C. at 7008 Madison Avenue, Urbandale, IA 50322; and
  - ii) in the case of the City it is addressed to or delivered personally to the City at 301 South Tenth Street, Adel, IA 50003, Attn: City Manager.
- b) Counterparts. This agreement may be executed in any number of counterparts each of which will constitute one in the same instrument.
- c) Governing Office. This agreement shall be governed and construed in accordance with the laws of the state of Iowa.
- d) Entire Agreement. This Agreement and the exhibits hereto reflect the entire agreement among the parties regarding the subject matter hereof and supersedes all prior agreements, negotiations or discussions weather oral or written. This agreement may not be amended except by subsequent writing signed by all parties hereto.
- e) Successors and Assigns. This Agreement is intended to and shall inure to the benefit of and be binding upon the parties hereto and their respective permitted accessors and assigns.

14. TERMINATION. Unless otherwise terminated as provided in Section 6 above, this Agreement shall terminate upon fulfillment by each party of the obligations set forth herein.



IN WITNESS WHEREOF, the City has caused this Agreement to be duly executed in name and its behalf by its Mayor and its sealed to be duly affixed and attested by its City Clerk, and Developer has caused this Agreement to be duly executed in its name and behalf by its authorized representatives all on as of the day first above written.

CITY OF ADEL, IOWA

By: \_\_\_\_\_

Mayor

ATTEST:

By: \_\_\_\_\_

Jackie Steele / City Clerk

STATE OF IOWA

COUNTY OF DALLAS

On this day of , 2017, before me a Notary Public in and for said State, personally appeared and to me personally known, who being duly sworn, did say that they are the Mayor and City Clerk, respectively, or the City of Adel, Iowa, a municipality created and existing under the laws of the State of Iowa, and that the seal affixed to the foregoing instrument is the seal of said municipality, and that said instrument was signed and sealed on behalf of said municipality by authority and resolution of its City Council, and said Mayor and City Clerk acknowledged said instrument to be the free act and deed of said Municipality by it voluntarily executed.

\_\_\_\_\_  
Notary Public - State of Iowa

BLOOMFIELD ACRES, L.L.C.

By: \_\_\_\_\_  
Karie Ramsey, Manager

STATE OF IOWA )

COUNTY OF POLK )

This record was acknowledged before me on the \_\_\_\_\_ day of \_\_\_\_\_, 2017, by Karie Kading Ramsey, to me personally known, who being by me duly sworn, did say that she is the Manager of the Limited Liability Company executing the within and foregoing instrument, that no seal has been procured by said Limited Liability Company; that said instrument was signed on behalf of the Limited Liability Company by authority of the Limited Liability Company; and that Karie Kading Ramsey, as Manager, acknowledged the execution of the foregoing instrument to be the voluntary act and deed of the Limited Liability Company, by it and by her voluntarily executed.

\_\_\_\_\_  
NOTARY PUBLIC - STATE OF IOWA

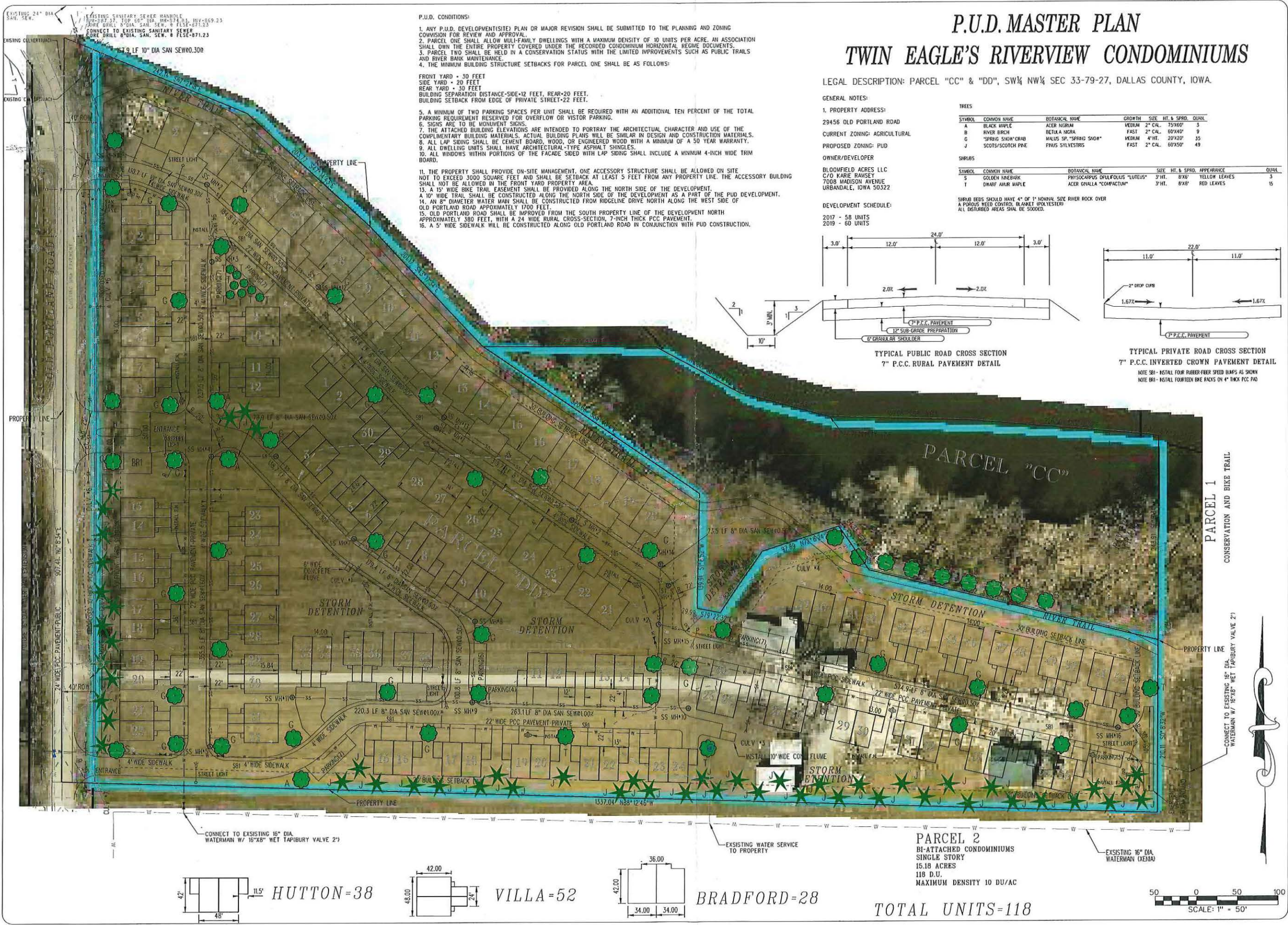

- P.U.D. CONDITIONS:**
1. ANY P.U.D. DEVELOPMENT(SITE) PLAN OR MAJOR REVISION SHALL BE SUBMITTED TO THE PLANNING AND ZONING COMMISSION FOR REVIEW AND APPROVAL.
  2. PARCEL ONE SHALL ALLOW MULTI-FAMILY DWELLINGS WITH A MAXIMUM DENSITY OF 10 UNITS PER ACRE, AN ASSOCIATION SHALL OWN THE ENTIRE PROPERTY COVERED UNDER THE RECORDED CONDOMINIUM HORIZONTAL REGIME DOCUMENTS.
  3. PARCEL TWO SHALL BE HELD IN A CONSERVATION STATUS WITH THE LIMITED IMPROVEMENTS SUCH AS PUBLIC TRAILS AND RIVER BANK MAINTENANCE.
  4. THE MINIMUM BUILDING STRUCTURE SETBACKS FOR PARCEL ONE SHALL BE AS FOLLOWS:  
 FRONT YARD - 30 FEET  
 SIDE YARD - 20 FEET  
 REAR YARD - 30 FEET  
 BUILDING SEPARATION DISTANCE-SIDE-12 FEET, REAR-20 FEET.  
 BUILDING SETBACK FROM EDGE OF PRIVATE STREET-22 FEET.
  5. A MINIMUM OF TWO PARKING SPACES PER UNIT SHALL BE REQUIRED WITH AN ADDITIONAL TEN PERCENT OF THE TOTAL PARKING REQUIREMENT RESERVED FOR OVERFLOW OR VISITOR PARKING.
  6. SIGNS ARE TO BE MONUMENT SIGNS.
  7. THE ATTACHED BUILDING ELEVATIONS ARE INTENDED TO PORTRAY THE ARCHITECTURAL CHARACTER AND USE OF THE COMPLIMENTARY BUILDING MATERIALS. ACTUAL BUILDING PLANS WILL BE SIMILAR IN DESIGN AND CONSTRUCTION MATERIALS.
  8. ALL LAP SIDING SHALL BE CEMENT BOARD, WOOD, OR ENGINEERED WOOD WITH A MINIMUM OF A 50 YEAR WARRANTY.
  9. ALL DWELLING UNITS SHALL HAVE ARCHITECTURAL-TYPE ASPHALT SHINGLES.
  10. ALL WINDOWS WITHIN PORTIONS OF THE FACADE SIDED WITH LAP SIDING SHALL INCLUDE A MINIMUM 4-INCH WIDE TRIM BOARD.
  11. THE PROPERTY SHALL PROVIDE ON-SITE MANAGEMENT. ONE ACCESSORY STRUCTURE SHALL BE ALLOWED ON SITE NOT TO EXCEED 5000 SQUARE FEET AND SHALL BE SETBACK AT LEAST 5 FEET FROM ANY PROPERTY LINE. THE ACCESSORY BUILDING SHALL NOT BE ALLOWED IN THE FRONT YARD PROPERTY AREA.
  12. A 10' WIDE BIKE TRAIL EASEMENT SHALL BE PROVIDED ALONG THE NORTH SIDE OF THE DEVELOPMENT.
  13. A 10' WIDE TRAIL SHALL BE CONSTRUCTED ALONG THE NORTH SIDE OF THE DEVELOPMENT AS A PART OF THE PUD DEVELOPMENT.
  14. AN 8" DIAMETER WATER MAIN SHALL BE CONSTRUCTED FROM RIDGELINE DRIVE NORTH ALONG THE WEST SIDE OF OLD PORTLAND ROAD APPROXIMATELY 1700 FEET.
  15. OLD PORTLAND ROAD SHALL BE IMPROVED FROM THE SOUTH PROPERTY LINE OF THE DEVELOPMENT NORTH APPROXIMATELY 380 FEET, WITH A 24' WIDE RURAL CROSS-SECTION, 7-INCH THICK PCC PAVEMENT.
  16. A 5' WIDE SIDEWALK WILL BE CONSTRUCTED ALONG OLD PORTLAND ROAD IN CONJUNCTION WITH PUD CONSTRUCTION.

# P.U.D. MASTER PLAN

## TWIN EAGLE'S RIVERVIEW CONDOMINIUMS

LEGAL DESCRIPTION: PARCEL "CC" & "DD", SW¼ NW¼ SEC 33-79-27, DALLAS COUNTY, IOWA.

**GENERAL NOTES:**

1. PROPERTY ADDRESS:  
29456 OLD PORTLAND ROAD

CURRENT ZONING: AGRICULTURAL

PROPOSED ZONING: PUD

OWNER/DEVELOPER:  
BLOOMFIELD ACRES LLC  
C/O KARIE RAWSEY  
7008 MADISON AVENUE  
URBANDALE, IOWA 50322

TREES						
SYMBOL	COMMON NAME	BOTANICAL NAME	GROWTH	SIZE	HT. & SPRD.	QUAN.
A	BLACK MAPLE	ACER NIGRA	MEDIUM	2" CAL.	75'X60'	3
B	RIVER BIRCH	BETULA NEGRA	FAST	2" CAL.	60'X40'	9
G	"SPRING SHOW" CRAB	MALUS SP. "SPRING SHOW"	MEDIUM	4" HT.	20'X20'	35
J	SCOTS/SCOTCH PINE	PINUS SYLVESTRIS	FAST	2" CAL.	60'X50'	49

SHRUBS						
SYMBOL	COMMON NAME	BOTANICAL NAME	SIZE	HT. & SPRD.	APPEARANCE	QUAN.
S	GOLDEN YEWBARK	PHYSCOCARPUS OXYFOLIUS "LUTEUS"	3" HT.	8'X8'	YELLOW LEAVES	3
T	DWARF AMUR MAPLE	ACER GRANULA "COMPACTUM"	3" HT.	8'X8'	RED LEAVES	15

SHRUB BEDS SHOULD HAVE 4" OF 1" NOMINAL SIZE RIVER ROCK OVER A POROUS NEED CONTROL BLANKET (POLYESTER)  
ALL DISTURBED AREAS SHALL BE SOODED.

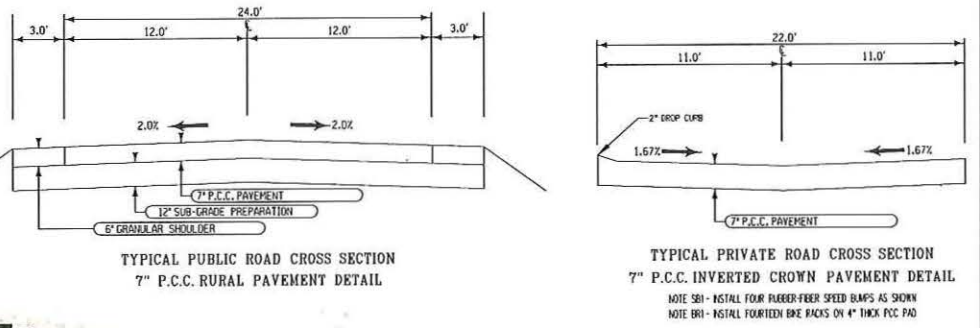

DESIGN START DATE: 08-01-16  
 DATE PLOTTED: 07-08-16  
 PRELIMINARY FIELD WORK COMPLETED: 06-17-16  
 FIELD BOOK NO. 2016-02

TWIN EAGLE'S RIVERVIEW CONDOMINIUMS  
ADEL, DALLAS COUNTY, IOWA

CHAMBRLIN CONSULTANT ENGINEERS

3117 115TH STREET  
VAN METER, IOWA 50261  
TELE: (515) 669-4188  
EMAIL ADDRESS: mark.lectee-engineers.net

DRAWING TITLE:  
**MASTER PLAN**

DRAWN BY: N.L.L.  
 CHECKED BY: N.L.L.  
 DATE: 02-10-17  
 JOB NO. 16012  
 SHEET C-2

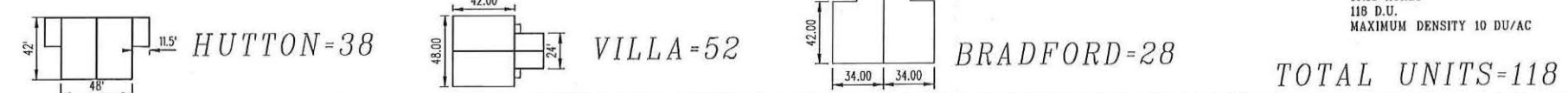



**City of Adel**

P.O. Box 248  
301 S. 10th Street  
Adel, Iowa 50003

P: (515) 993-4525  
F: (515) 993-4527  
[www.adeliowa.org](http://www.adeliowa.org)

March 23, 2017

Stephanie Calligan  
1506 Main Street  
Adel, Iowa 50003

Dear Stephanie Calligan,

Over the course of the few years, we have tried to work with you on the chickens that you possess. Part of the approval of you being allowed to have chickens was to have them contained on your property and not roaming free. The City Council also noted that they could revisit their decision if these conditions were not met. They also noted that city personnel would work with you if any problems would occur. I have sent you a letter dated August 9<sup>th</sup>, 2012, a letter dated November 6<sup>th</sup>, 2012 and again on September 4, 2013 about the chickens running loose. On all these occasions, you were warned that the City Council stated that the birds need to be contained on your property. On April 14, 2015 the Council gave you another chance at the Council meeting when it was brought to them for action. We have recently received a police report and pictures dated February 27, 2017 showing and stating the chickens were running loose and off of your property. This matter will be brought to the City Council April 11, 2017 to have them rescind their decision on allowing you to have any chickens in the city limits.

Section 50.08 states: Any person ordered to abate a nuisance may have a hearing with the Council as to whether a nuisance exists. A request for a hearing must be made in writing and delivered to the Clerk within the time stated in the notice, or it will be conclusively presumed that a nuisance exists and it must be abated as ordered. The hearing will be before the Council at a time and place fixed by the Council. The findings of the Council shall be conclusive and, if a nuisance is found to exist, it shall be ordered abated within a reasonable time under the circumstances.

Respectfully

Steve Nichols  
Code Compliance Officer  
City of Adel  
515-993-4525  
[snichols@adeliowa.org](mailto:snichols@adeliowa.org)

Cc: Adel Police Department  
City Administrator



# IOWA INCIDENT REPORT SUPPLEMENTAL

## ADEL POLICE DEPARTMENT

102 S 10TH ST  
ADEL, IA 50003  
(515) 993-6723

rlc030102

<b>C A S E  I N F O</b>	Case Number <b>17-0834-02</b>	Date of This Report <b>03/02/2017</b>	County in which Incident Occurred <b>DALLAS - 25</b>	
	ORI Number <b>ADEL POLICE DEPARTMENT - IA0250200</b>			
	Date of Original Occurrence <b>03/21/2017</b>		Type of Offense <b>LOOSE CHICKENS</b>	
	Name - Last <b>KELLER</b>	First <b>MONTE</b>	Middle	Suffix
	Clearance Classification <input type="checkbox"/> Unfounded <input type="checkbox"/> Exceptionally Cleared <input type="checkbox"/> Cleared by Arrest		Investigative Status <input checked="" type="checkbox"/> Open <input type="checkbox"/> Closed <input type="checkbox"/> Suspended	

### Narrative

At approximately 1625 hours, on 03-02-17, I saw 1 brown chicken in the front yard of 1506 Main Street. This address belongs Stephanie Calligan who is the owner of the chickens. I have included a photo of the chicken as well.

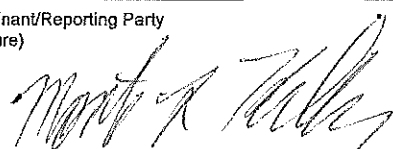
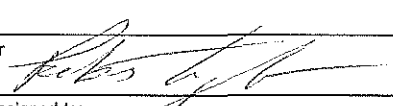
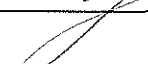
<b>O F F I C E R</b>	Complainant/Reporting Party (Signature) 	
	Reporting Officer <b>KELLER, MONTE</b>	Badge Number <b>04-173</b>
	Assisting Officer / Administrative Reviewer	Badge Number
	Supervisor 	Badge Number <b>171</b>
	Incident Assigned to: 	

1506 Main

1625 hrs

Photo taken 03-02-17





INCIDENT PUBLIC SUMMARY RELEASE
ADEL POLICE DEPARTMENT

102 S 10TH ST
ADEL, IA 50003
(515) 993-6723

Case Number: 17-0834-02
Date/Time of Report: 2/27/2017 14:42 Hrs
Status: 01 - ACTIVE

SUMMARY

County: DALLAS - 25
ORI Number: IA0250200
Inc.Date/Time Known: YES
Inc.Date/Lower Rng: 02/21/2017
Upper Time Rng:
Weekday of Inc.: TUESDAY
Exceptionally Cleared: N - NOT APPLICABLE

INCIDENT REPORTED BY

Inc. Reported by Victim: NO
Reporting Victim Seq.#:
Name - Last: KELLER
First: MONTE
Middle: STEVEN
Suffix:
Reporting Business: 102 SOUTH 10TH STREET
Address:
City: ADEL
State: IA
Zip Code: 50003

OFFENSE 001

Seq.#: 001
Code Section: AD/55.06
Charges/Offense: DOG AT LARGE
UCR Off. Code: All Other Offenses - 90Z
Attempt/Complete: C - COMPLETED
# Premises Entered:
Method of Entry:
Criminal Activity Type:
Weapon/Force Type:
Gang Information:
Offender Suspected of Using: N - NOT APPLICABLE

LOCATION OF OFFENSE

Location Type: 20 - RESIDENCE/HOME
Literal Description: 1510 MAIN STREET
X Coordinate: 00414402
Y Coordinate: 04607791

VICTIM 001

Type of Victim: S - SOCIETY/PUBLIC
Sequence#: 001
Name - Last:
First:
Middle:
Suffix:
Association:
Address:
City:
State:
Zip Code:
Alias(es):
Age/Lower Age Rng:
Upper Age Rng:
Resident Status:
License State:
Gender:
Height:
Weight:
Eye Color:
Hair Color:
Skin Tone:
Race:
Ethnicity:
Scars/ Marks/Tattoos:
Type of Injuries:

EMPLOYMENT OR SCHOOL INFO

Employer or School:
Occupation:
Address:
City:
State:
Zip Code:

VICTIM CONNECTED TO UCR OFFENSE CODES

UCR Offense Code 1: ALL OTHER OFFENSES - 90Z
UCR Offense Code 2:
UCR Offense Code 3:
UCR Offense Code 4:
UCR Offense Code 5:
UCR Offense Code 6:
UCR Offense Code 7:
UCR Offense Code 8:
UCR Offense Code 9:
UCR Offense Code 10:

ADDITIONAL OFFENSE CIRCUMSTANCE INFO

Aggravated Assault / Homicide Circum.:
Additional Justifiable Homicide Circumstances.:

VICTIM'S RELATIONSHIP TO OFFENDER(S)

1st Off. Seq.#:
Victim Rlt 1st Off.:
2nd Off. Seq.#:
Victim Rlt 2nd Off.:
3rd Off. Seq.#:
Victim Rlt 3rd Off.:
4th Off. Seq.#:
Victim Rlt 4th Off.:
5th Off. Seq.#:
Victim Rlt 5th Off.:
6th Off. Seq.#:
Victim Rlt 6th Off.:
7th Off. Seq.#:
Victim Rlt 7th Off.:
8th Off. Seq.#:
Victim Rlt 8th Off.:
9th Off. Seq.#:
Victim Rlt 9th Off.:
10th Off. Seq.#:
Victim Rlt 10th Off.:

SPECIAL CIRCUMSTANCES:

BIAS CRIME

Bias Motivation:
Target Code:
Bias Group Aff.:

DOMESTIC ABUSE

Children Present:
Seq.# D.A. Offender:
Domestic Abuse Referrals:

LAW ENFORCEMENT OFFICER KILLED OR ASSAULTED

Officer Killed/Assaulted:
Body Armor:
Type of Assignment:
Call Type:

---

**END OFFENSE 001**

---

**VEHICLE 001**

Veh. Year:	State:	Assoc. Off. Seq. #:
Make:	Year:	Veh. Impounded:
Model:	Color(s):	Impound Location:
Style:		Impound Tag #:
License Plate #:		

**OFFICER**

Reporting Officer:	<b>KELLER MONTE</b>	Evidence Seized:	<b>NO</b>	Badge #:
Badge #:	<b>04-173</b>	Photos Taken:	<b>YES</b>	Assigned To:
Video Taken:	<b>00</b>	Supervisor:		

**REPORT SUMMARY**

---





# IOWA INCIDENT REPORT SUPPLEMENTAL

## ADEL POLICE DEPARTMENT

102 S 10TH ST  
 ADEL, IA 50003  
 (515) 993-6723

ric030102

CASE INFORMATION	Case Number	Date of This Report	County in which Incident Occurred	
	17-0834-02	2/27/2017	DALLAS - 25	
	ORI Number ADEL POLICE DEPARTMENT - IA0250200			
	Date of Original Occurrence		Type of Offense	
	2/21/2017		CHICKENS AT LARGE	
	Name - Last	First	Middle	Suffix
KELLER	MONTE	STEVEN		
Clearance Classification		Investigative Status		
<input type="checkbox"/> Unfounded <input type="checkbox"/> Exceptionally Cleared <input type="checkbox"/> Cleared by Arrest		<input checked="" type="checkbox"/> Open <input type="checkbox"/> Closed <input type="checkbox"/> Suspended		

**Narrative**

At approximately 17:50 hours, on 02-21-17, I Officer Monte S. Keller was off-duty at 1510 Main Street in Adel. While at that location I noticed three chickens, (two brown and one black) that were in the front yard of 1507 Main Street. This address is across the street from the owner of the chickens, Stephanie Calligan. Calligan lives at 1506 Main Street which is the first house to the east of 1510 Main Street. After taking a photo of the chickens at 1507 Main Street, I then saw the chickens walk into the front yard of 1510 Main Street. I am aware that Calligan has been warned about keeping the chickens in a pen by the city on more than one occasion.

I additionally saw one of the brown chickens in the front yard of Calligan's residence on 02-26-17, at approximately 1820 hours.

I will forward this information on to Adel code compliance officer Steve Nichols.

Nothing further at this time.

OFFICER	Complainant/Reporting Party (Signature)	
	Reporting Officer	Badge Number
	KELLER MONTE	04-173
	Assisting Officer / Administrative Reviewer	Badge Number
Supervisor	Badge Number	
		171
Incident Assigned to:		



April 14, 2015 Adel City Council Minutes

- g) Consider Approval of Purchase Order No. 015223 for New Snow Plow  
**Public Works Overton** advised after his discussion with Dallas County mechanics, he would suggest purchasing an extended warranty. There were options from 36 months up to 84 months. Overton suggested the 84 month warranty for \$3500.00.  
**Motion by Haynes, seconded by Hillmer, to approve Purchase Order No. 015223, with the longest extended warranty – 84 months at \$3500.00**  
**Roll: Ayes-unanimous. Motion carried.**  
**City Administrator Brown** asked Overton when the new snow plow would be delivered and Overton advised it wouldn't be until January 2016.
- h) Consider Approval of Job Description for Street Laborer/Wastewater Operator  
**Motion by Hillmer, seconded by McAvoy, to approve job description for Street Laborer/Wastewater Operator**  
**Roll: Ayes-unanimous. Motion carried.**
- i) Consider Approval of Final Plat for Bear Estates Plat 2  
**Motion by McAvoy, seconded by Welch, to approve final plat for Bear Estates Plat 2**  
**Roll: Ayes-unanimous. Motion carried.**
- j) Consider Approval of Preliminary Plats for Northwater 2, Timberview West, and Midtown Greene  
**Motion by Hillmer, seconded by McAvoy, to approve preliminary plats for Northwater 2, Timberview West, and Midtown Greene**  
**Roll: Ayes-unanimous. Motion carried.**
- k) Consider Approval of Retracting Approval for 3 Chickens at 1506 Main Street - Approved on July 10, 2012  
**Resident Stephanie Calligan, 1506 Main Street, noted on November 24, 2014, her chicken coop caught on fire due to a faulty heater. She stated she contacted an attorney and is currently in a lawsuit and her attorney has advised her not to do anything with the burned chicken coop until the lawsuit has settled. She did admit there have been a few times her chickens were loose since they have lost weight and were able to squeeze through her fence in her backyard. She stated the lawsuit should be settled in the next few days and she has already contacted someone to build a new chicken coop once the lawsuit is settled. She is asking the Council to allow her to keep her chickens as they are used for eggs and her son's 4H project and to give her a little extra time to get her new coop built. Council Member McAdon asked what would be the time frame the new chicken coop would be done and Stephanie advised within the next two weeks.**  
**Motion by Welch, seconded by Hillmer, to approve retracting approval for 3 chickens at 1506 Main St**  
**Roll: Ayes-McAvoy, Haynes. Nays-Welch, Hillmer, McAdon. Motion fails.**
- l) Consider Approval of Mayoral Board Appointment  
a. Library Board – Wayne Rebischke and Bill Kimber – two applications for one opening  
**Mayor selected Wayne Rebischke**  
**Motion by Hillmer, seconded by Welch, to approve the Mayor's selection for Library Board**  
**Roll: Ayes-unanimous. Motion carried**
- m) Discussion/Possible Action on New City Hall Copier  
**Motion by Haynes, seconded by Welch, to approve City Administrator Brown to enter into a copier lease agreement with Ricoh.**  
**Roll: Ayes-unanimous. Motion carried.**
- n) Consider Approval of Payment No. 4 for Adel Main Street Façade Rehabilitation Project  
**Motion by Hillmer, seconded by McAvoy, to approve Payment No. 4**  
**Roll: Ayes-unanimous. Motion carried.**

April 8, 2015

Information for topics on the agenda:

Dear Council Members,

- 1) The following tax abatement sheets were brought to my attention from the County Assessor Office. Tim Newberry the owner of 1624 Main Street and 418 Cottage Street worked directly with Larry Stone from the county and did not realize it needed to be turned into the City of Adel for approval. Steve Helm stated that you could act on this and still get in for this year.
- 2) On July 11, 2012 the Council gave Stephanie Calligan at 1506 Main Street permission to have 3 hens with the condition that they would be contained on her property at all times. We reserved the right to revisit this decision if these conditions weren't met or if there were complaints. It was also asked that the City personnel would work with her on any complaints. I have sent letters dated:  
August 10, 2012  
November 6, 2012  
September 4, 2013  
These are all dealing with the chickens running loose. I have viewed them on one occasion and just recently, two of our city employees have noticed them running free. I ask the Council to reconsider the decision from July 11, 2012 and ask that Nuisance Abatement proceedings start so the chickens could be removed from the city limits of Adel.
- 3) The school is asking for some type of break on their permit for the High School/Middle School Addition. I also would assume they are asking for the same break on the Old Middle School Renovation. The breakdown for the quotes I gave the Contractors are as follow:
  - A) High School Addition- 6511 square feet is figured at \$5381.00
  - B) Middle School Addition- 13,269 square feet is figured at \$8606.00
  - C) Plan Review Fee- 65% of Permit fee is \$9092.00
  - D) Renovation to Old Middle School figured on \$500,000.00 is \$2900.00 and no review fee.Total cost - \$25979.00

I am assuming that all the bidders asked for this information and it was figured in with their bids. So I'm not sure why the school is asking for the break unless they want it for change orders or for some other items that might be added. We already have money invested into McClure's for sight plan and storm water calculations and me reviewing plans. I brought this forward when they pulled the permit for the Elementary and the DeSoto Schools. They paid the permit fee without asking for any consideration. I'm not sure what changed.

Respectfully  
Steve Nichols  
Code Compliance Officer  
City of Adel



**City of Adel**

P.O. Box 248  
301 S. 10th Street  
Adel, Iowa 50003

P: (515) 993-4525  
F: (515) 993-4527  
[www.adeliowa.org](http://www.adeliowa.org)

March 19, 2015

Stephanie Calligan  
1506 Main Street  
Adel, Iowa 50003

Dear Stephanie Calligan,

Over the course of the few years, I have tried to work with you on the chickens that you possess. It took two months to get you to get Council approval which they were approved on July 11<sup>th</sup>, 2012. Part of the approval of you being allowed to have 3 chickens was to have them contain on your property and not roaming free. The City Council also noted that they could revisit their decision if these conditions were not met. They also noted that city personnel would work with you if any problems would occur. I have sent you a letter dated August 9<sup>th</sup>, 2012, a letter dated November 6<sup>th</sup>, 2012 and again on September 4, 2013 about the chickens running loose. On all these occasions, you were warned that the City Council stated that the birds need to be contained on your property. Recently two of our city employees also noticed them running loose this week. I feel the city have been very patient with you and your birds and the numerous complaints from the neighbors now force me to take actions. This matter will be brought to the City Council April 14th 2015 to have them rescind their decision on allowing you to have any chickens in the city limits.

Section 50.08 states: Any person ordered to abate a nuisance may have a hearing with the Council as to whether a nuisance exists. A request for a hearing must be made in writing and delivered to the Clerk within the time stated in the notice, or it will be conclusively presumed that a nuisance exists and it must be abated as ordered. The hearing will be before the Council at a time and place fixed by the Council. The findings of the Council shall be conclusive and, if a nuisance is found to exist, it shall be ordered abated within a reasonable time under the circumstances.

Respectfully

Steve Nichols  
Code Compliance Officer  
City of Adel  
515-993-4525  
[snichols@adeliowa.org](mailto:snichols@adeliowa.org)

Cc: Adel Police Department

September 4, 2013

Stephanie Calligan  
1506 Main Street  
Adel, Iowa 50003

Dear Stephanie,

Over the course of the last year and a half, I have tried to work with you on the chickens that you possess. It took two months to get you to get Council approval which they were approved on July 11<sup>th</sup>, 2012. Part of the approval of you being allowed to have 3 chickens was to have them contain on your property and not roaming free. The City Council also noted that they could revisit their decision if these conditions were not met. They also noted that city personnel would work with you if any problems would occur. I have sent you a letter dated August 9<sup>th</sup>, 2012 for the chickens running loose. A letter dated November 6<sup>th</sup>, 2012 was sent for the chickens running loose. On all these occasions, you were warned that the City Council stated that the birds need to be contained on your property. On August 30<sup>th</sup> of 2013 I noticed two of the chickens loose across the street at 1515 Main Street. I feel the city have been very patient with you and your birds. This matter will be brought to the City Council October 8<sup>th</sup> 2013 to have them rescind their decision on allowing you to have any chickens in the city limits.

November 6, 2012

Stephanie & Jamison Calligan  
1506 Main Street  
Adel, Iowa 50003

Dear Stephanie & Jamison:

On Tuesday, July 10, 2012, the Adel City Council approved your request to allow you to raise chickens as pets on your property at its regular Council meeting. You filed the request under section 55.05 of the Adel City Code.

The Council approved your request to keep and raise up to three chickens on your property. It was noted per City Code, the chickens must be contained at all times on your property and should there ever be a sustained complaint from a neighbor or other resident, the council would reserve the right to revisit the issue and act accordingly. A complaint was registered on November 5, 2012 that the chickens were running loose again. Your first letter about the chickens running loose was issued on August 9, 2012. The city has tried to work with you on this problem and it doesn't seem to work, so this letter is to inform you that the next complaints will cause it to go back to Council for reconsideration on the action taken July 11, 2012. I also noticed a fence that has been constructed that did not have a permit. I need the permit filled out and handed in along with the fee of \$25.00 for the building permit.

Thank you for your involvement and cooperation in this matter.  
Sincerely,

Steve Nichols  
Code Compliance Officer  
City Of Adel  
515-993-4525  
[snichols@adeliowa.org](mailto:snichols@adeliowa.org)

Cc: Police Department  
Public Works Department

August 9, 2012

Stephanie & Jamison Calligan  
1506 Main Street  
Adel, Iowa 50003

Dear Stephanie & Jamison:

On Tuesday, July 10, 2012, the Adel City Council approved your request to allow you to raise chickens as pets on your property at its regular Council meeting. You filed the request under section 55.05 of the Adel City Code.

The Council approved your request to keep and raise up to three chickens on your property. It was noted per City Code, the chickens must be contained at all times on your property and should there ever be a sustained complaint from a neighbor or other resident, the council would reserve the right to revisit the issue and act accordingly. A complaint was taken this last weekend that the chickens were loose and destroyed some plants in a neighbors new landscaping. This letter is to inform you that the next complaints will cause it to go back to Council for reconsideration on the action taken July 11, 2012. I was also informed that Stephanie stopped by for a building permit to construct a fence and I'm looking forward to review and give the approval when submitted.

Thank you for your involvement and cooperation in this matter.

Sincerely,

Steve Nichols  
Code Compliance Officer  
City Of Adel  
515-993-4525  
[snichols@adeliowa.org](mailto:snichols@adeliowa.org)

Cc: Police Department  
Public Works Department



July 11, 2012

Stephanie & Jamison Calligan  
1506 Main Street  
Adel, Iowa 50003

Dear Stephanie & Jamison:

On Tuesday, July 10, 2012, the Adel City Council considered your request to allow you to raise chickens as pets on your property at its regular Council meeting. You filed the request under section 55.05 of the Adel City Code.

The Council approved your request to keep and raise up to three chickens on your property. Please note per City Code, the chickens must be contained at all times on your property and should there ever be a sustained complaint from a neighbor or other resident, the council would reserve the right to revisit the issue and act accordingly. Should that ever happen, City staff will work with you prior to council discussion and action.

Thank you for your involvement and cooperation in this matter.

Sincerely,

Steve Nichols  
Code Compliance Officer  
City Of Adel  
515-993-4525  
[snichols@adeliowa.org](mailto:snichols@adeliowa.org)

Brett Klein  
City Administrator  
City Of Adel  
515-993-4525  
[bklein@adeliowa.org](mailto:bklein@adeliowa.org)

Cc: Police Department  
Public Works Department

b) Consider approval of Ordinance No. 285, Amending the Code of Ordinances of the City of Adel, Iowa, 2007, as Amended by Amending Section 92.02 Pertaining to Amending Water Rates for Fiscal Year 2013  
**Motion by McAvoy, seconded by Haynes, to approve the First Reading of Ordinance No. 285, Amending the Code of Ordinances of the City of Adel, Iowa, 2007, as Amended by Amending Section 92.02 Pertaining to Amending Water Rates for Fiscal Year 2013**

**Roll: Ayes – unanimous. Motion carries.**

**Motion by McAvoy, seconded by Haynes, to waive the Second and Third Readings and adopt Ordinance No. 285, Amending the Code of Ordinances of the City of Adel, Iowa, 2007, as Amended by Amending Section 92.02 Pertaining to Amending Water Rates for Fiscal Year 2013**

**Roll: Ayes – unanimous. Motion carries.**

c) Consider request from resident to maintain chickens for private use at 1506 Main Street  
Mayor Peters explained this was a last minute addition to the agenda because he received an email over the weekend regarding this issue that requires timely action.

**Motion by Haynes, seconded by McAvoy, to allow the chickens with the understanding that if there are any further complaints or any issues or problems, Council can rescind the decision**

Haynes stated there have already been issues, hence, the wording he used in the motion. Discussion followed. Swanson added a friendly clarification that an at-large chicken does not need to be complaint driven for this council action to be rescinded. Haynes accepted the clarification

**Roll: Ayes – unanimous. Motion carries.**

d) Consider approval of updated job descriptions (Director of Public Works; Director of Parks & Recreation)  
**Motion by Swanson, seconded by Haynes, to approve updated descriptions for the Director of Public Works and Director of Parks & Recreation**

**Roll: Ayes – unanimous. Motion carries.**

e) Discussion and possible action on 12<sup>th</sup> street paving project engineering contract  
Klein explained the City has received the private contribution agreements as of today. The next step is engineering, bidding, and approval of contract. Timeline for construction to begin will probably be late September.

**Motion by McAvoy, seconded by Haynes, to accept the 12<sup>th</sup> Street Paving Project engineering contract with McClure Engineering**

Swanson asked if there was any advantage to the City if this paving project were combined with the Aquatic Center since they will be constructed during the same time period. Jeff Schug from McClure stated these two projects would be handled by different type of contractors, so no.

**Roll: Ayes – unanimous. Motion carries.**

f) Discussion and possible action on non-budgeted item PO #013259 (Sewer controls)  
Klein explained the new purchasing policy requires non-budgeted items to come before council for approval. Overton received three bids and is recommending the low bid.

**Motion by Haynes, seconded by Welch, to approve the low bidder, Jetco Electric Inc. as the provider for the sewer controls**

**Roll: Ayes – unanimous. Motion carries.**

g) Consider approval of Resolution No. 12-37 Authorizing the Renewal of a Code Enforcement Officer 28E Agreement With the City of Dallas Center

**Motion by Swanson, seconded by McAvoy, to approve Resolution No. 12-37 Authorizing the Renewal of a Code Enforcement Officer 28E Agreement With the City of Dallas Center**

**Roll: Ayes – unanimous. Motion carries.**

June 25, 2012

Stephanie A Calligan  
1506 Main Street  
Adel, Iowa 50003

Dear Stephanie:

I sent you a letter dated May 31, 2012 which I have enclosed. I still have not received any letter from you regarding the chickens which you own. I am now getting complaints from people in the neighborhood that they are tearing up landscaping in their yards. If this does not get Ok'ed by council and stipulations put forth, like containing the birds to a fenced in area, I will be forced to take action under our city code to issue a ticket for a nuisance that could carry a fine of \$250.00 plus court cost.

Respectfully

Steve Nichols  
Code Compliance Officer  
City Of Adel  
PO Box 248  
515-993-4525  
[snichols@adeliowa.org](mailto:snichols@adeliowa.org)

May 31, 2012

Stephanie A Calligan  
1506 Main Street  
Adel, Iowa 50003

Dear Stephanie:

I have researched all of the minutes of the city council for 2011 and I do not find any actions on the chickens that you have. I do not know who you sent the letter to, but we need to get this resolved. Please forward a letter to me at the address below and I will get this on the docket for the next council meeting. You need to state the number of birds and how they will be contained on your property. If you can get it to me by next week, I can probably get you on for the June 12<sup>th</sup> meeting and if not then it will be the July 10<sup>th</sup> council meeting.

We are still noticing that the trash containers are being put in the street for pickup. Section 135.02 Obstructing or Defacing a street states: it is unlawful for any person to obstruct, deface or injure any street or alley in any manner. The containers need to remain on the parking for pickup.

Respectfully

Steve Nichols  
Code Compliance Officer  
City Of Adel  
PO Box 248  
515-993-4525  
[snichols@adeliowa.org](mailto:snichols@adeliowa.org)

May 15, 2012

Stephanie A Calligan  
1506 Main Street  
Adel, Iowa 50003

Dear Stephanie:

Last year I mention that is against city code to have poultry with in city limits. There is a proper way to have poultry by going thru the City Council to obtain permission and to get the guide line for housing and rearing the number of birds set by the council.

Section 55.05 of the Adel City Code states: It is unlawful for a person to keep livestock within the City except by written consent of the Council or except in compliance with the City's zoning regulations. The definition of livestock means an animal belonging to the bovine, caprine, equine, ovine or porcine species, ostriches, rheas and emus; farm deer as defined in Section 170.1 of the Code of Iowa; or poultry.

This could be declared as a municipal infraction with a fine of 25.00 dollars first offense, 50.00 dollars second offense and 100.00 dollars third offense. Please contact me within 10 days of this letter so we can get this situation corrected.

I also noticed that trash can and other materials are put in the street for pickup. Section 135.02 Obstructing or Defacing a street states: it is unlawful for any person to obstruct, deface or injure any street or alley in any manner. The containers or debris needs to remain on the parking for pickup.

Respectfully

Steve Nichols  
Code Compliance Officer  
City Of Adel  
515-993-4525  
[snichols@adeliowa.org](mailto:snichols@adeliowa.org)

**Ordinance No. 316**

**AN ORDINANCE AMENDING THE CODE OF ORDINANCES OF THE CITY OF ADEL, IOWA, BY AMENDING CHAPTER 92**

**BE IT ENACTED BY THE CITY COUNCIL, THE CITY OF ADEL, IOWA;**

**SECTION 1.** Section 92.02 of the Code of Ordinances of the City of Adel, Iowa, 2007, as amended, is repealed and the following adopted in lieu thereof:

92.02 RATES FOR SERVICE. Water service shall be furnished at the following monthly rates within the City:

*(Code of Iowa, Sec. 384.84)*

<b>Gallons Used Per Month</b>	<b>July 1, 2017 – June 30, 2018 Rate (3% increase)</b>
<b>First 5,000 gallons</b>	\$7.67 per 1,000 gallons (minimum bill \$15.34)
<b>6,000 – 20,000 gallons</b>	\$5.17 per 1,000 gallons
<b>21,000 – 100,000 gallons</b>	\$4.18 per 1,000 gallons
<b>101,000 gallons and over</b>	\$3.27 per 1,000 gallons

<b>Gallons Used Per Month</b>	<b>July 1, 2018 – June 30, 2019 Rate (3% increase)</b>
<b>First 5,000 gallons</b>	\$7.90 per 1,000 gallons (minimum bill \$15.80)
<b>6,000 – 20,000 gallons</b>	\$5.33 per 1,000 gallons
<b>21,000 – 100,000 gallons</b>	\$4.31 per 1,000 gallons
<b>101,000 gallons and over</b>	\$3.36 per 1,000 gallons

<b>Gallons Used Per Month</b>	<b>July 1, 2019 – June 30, 2020 Rate (3% increase)</b>
<b>First 5,000 gallons</b>	\$8.14 per 1,000 gallons (minimum bill \$16.28)
<b>6,000 – 20,000 gallons</b>	\$5.49 per 1,000 gallons
<b>21,000 – 100,000 gallons</b>	\$4.44 per 1,000 gallons
<b>101,000 gallons and over</b>	\$3.46 per 1,000 gallons

**SECTION 2.** Section 92.11 of the Code of Ordinances of the City of Adel, Iowa, 2007, as amended, is repealed and the following adopted in lieu thereof:

92.11 RATE ADJUSTMENTS. Rate adjustments will be considered and computed before the first of July each year by City staff, including consultation with the City’s Engineer and the City’s Financial Advisor. The proposed adjustments shall be submitted to the Council for review and approval. Any adjustments shall go into effect on the July bill, payable July 20<sup>th</sup>.

**SECTION 3.** Section 92.12 will be created with the following language:

92.12 COMMUNITY WATER INITIATIVE (CWI) SURCHARGE. Every person, firm, or corporation whose premises now or hereafter are directly or indirectly served by a connection to the City Water System shall pay a CWI surcharge in the amount of five dollars (\$5.00) per month beginning July 1, 2017, twelve dollars (\$12.00) per month beginning July 1, 2018, and twenty-four dollars (\$24.00) per month beginning July 1, 2019.

**SECTION 4. WHEN EFFECTIVE:** This ordinance shall be effective from and after the 1st day of July, 2017.

Passed and approved by the Adel City Council this \_\_\_\_\_ day of \_\_\_\_\_, 2017.

\_\_\_\_\_  
James F. Peters, Mayor

Attest: \_\_\_\_\_  
Jackie Steele, City Clerk

1<sup>st</sup> Reading \_\_\_\_\_

2<sup>nd</sup> Reading \_\_\_\_\_

3<sup>rd</sup> Reading \_\_\_\_\_

I certify that the foregoing was published as Ordinance No. 316 in the Dallas County News on the \_\_\_\_\_ day of \_\_\_\_\_, 2017.

\_\_\_\_\_  
Jackie Steele, City Clerk

City of Adel, Iowa  
Water Enterprise Fund  
Cash-Basis Cashflow Analysis

EXHIBIT 1

<i>Growth Assumptions</i>				<i>Water Revenue Adjustments</i>						
Operating Expenses	Various			1-Jul-16	2.25%	1-Jul-21	0.00%			
Water Usage	1.00%			1-Jul-17	3.00%	1-Jul-22	0.00%			
Interest Rate	n/a			1-Jul-18	3.00%	1-Jul-23	n.a			
				1-Jul-19	3.00%	1-Jul-24	n.a			
				1-Jul-20	3.00%	1-Jul-25	n.a			
	Audited Financial Statements			Budget	Budget	Projected	Projected	Projected	Projected	Projected
	FY 2013-14	FY 2014-15	FY 2015-16	FY 2016-17	FY 2017-18	FY 2018-19	FY 2019-20	FY 2020-21	FY 2021-22	FY 2022-23
<b>Water Rates</b>	7/1/2013	7/1/2014	9/1/2015	7/1/2016	7/1/2017	7/1/2018	7/1/2019	7/1/2020	7/1/2021	7/1/2022
Water Flat Rate 1	\$13.88	\$14.25	\$14.56	\$14.90	\$15.35	\$15.81	\$16.28	\$16.77	\$16.77	\$16.77
First 5,000 gallons 2	\$6.94	\$7.13	\$7.28	\$7.45	\$7.67	\$7.90	\$8.14	\$8.39	\$8.39	\$8.39
Next 6,000-20,000 gallons 3	\$4.68	\$4.81	\$4.91	\$5.02	\$5.17	\$5.33	\$5.49	\$5.65	\$5.65	\$5.65
Next 21,000-100,000 gallons 4	\$3.79	\$3.89	\$3.97	\$4.06	\$4.18	\$4.31	\$4.44	\$4.57	\$4.57	\$4.57
> 100,000 gallons 5	\$2.96	\$3.04	\$3.10	\$3.17	\$3.27	\$3.36	\$3.46	\$3.57	\$3.57	\$3.57
Debt Service Charge 6	\$0.00	\$0.00	\$0.00	\$0.00	\$5.00	\$12.00	\$24.00	\$31.00	\$33.00	\$33.00
Beginning of FY No. of Accounts 7	-	-	-	1,730	1,745	1,760	1,775	1,790	1,805	1,820
<b>Average Rate/1,000 gallons 8</b>	\$6.97	\$7.08	\$6.82	\$6.98	\$7.19	\$7.40	\$7.62	\$7.85	\$7.85	\$7.85
<b>WATER (1,000 gallons) 9</b>	85,591	87,921	97,240	98,213	99,195	100,187	101,189	102,200	103,222	104,255
<b>OPERATING REVENUES</b>										
Water Usage Charge Revenues 10	\$596,381	\$622,675	\$663,495	\$685,208	\$712,822	\$741,548	\$771,433	\$802,522	\$810,547	\$818,652
Bulk Sales 11	1,130	508	611	500	500	500	500	500	500	500
Connecting Fees 12	21,500	26,950	57,500	45,500	7,500	7,500	7,500	7,500	7,500	7,500
Debt Service Charge 13	0	0	0	0	104,700	253,440	511,200	665,880	714,780	720,720
Miscellaneous Revenues 14	0	4,523	22,776	3,300	0	0	0	0	0	0
<b>Total Operating Revenues 15</b>	\$619,011	\$654,656	\$744,382	\$734,508	\$825,522	\$1,002,988	\$1,290,633	\$1,476,402	\$1,533,327	\$1,547,372
<b>OPERATING EXPENSES</b>										
Business Type Expenditures 16	\$457,543	\$526,273	\$538,239	\$610,502	\$591,658	\$621,241	\$652,303	\$684,918	\$719,164	\$755,122
Reserved 17	0	0	0	0	0	0	0	0	0	0
<b>Total Operating Expense 18</b>	\$457,543	\$526,273	\$538,239	\$610,502	\$591,658	\$621,241	\$652,303	\$684,918	\$719,164	\$755,122
<b>Net Operating Revenues 19</b>	161,468	128,383	206,143	124,006	233,864	381,747	638,330	791,483	814,163	792,250
<b>Non Operating Revenues (Expenses)</b>										
Investment Interest 20	\$0	\$0	\$0	\$0	\$0	\$0	\$0	\$0	\$0	\$0
Miscellaneous 21	0	0	0	0	0	0	0	0	0	0
<b>Total Other Income 22</b>	\$0	\$0	\$0	\$0	\$0	\$0	\$0	\$0	\$0	\$0
<b>Net Revenue for Debt Service 23</b>	\$161,468	\$128,383	\$206,143	\$124,006	\$233,864	\$381,747	\$638,330	\$791,483	\$814,163	\$792,250



City of Adel, Iowa  
Water Enterprise Fund  
Cash-Basis Cashflow Analysis

EXHIBIT 1

<i>Growth Assumptions</i>							<i>Water Revenue Adjustments</i>					
Operating Expenses	Various						1-Jul-16	2.25%	1-Jul-21	0.00%		
Water Usage	1.00%						1-Jul-17	3.00%	1-Jul-22	0.00%		
Interest Rate	n/a						1-Jul-18	3.00%	1-Jul-23	n.a		
							1-Jul-19	3.00%	1-Jul-24	n.a		
							1-Jul-20	3.00%	1-Jul-25	n.a		
Audited Financial Statements				Budget	Budget	Projected	Projected	Projected	Projected	Projected		
FY 2013-14				FY 2014-15	FY 2015-16	FY 2016-17	FY 2017-18	FY 2018-19	FY 2019-20	FY 2020-21	FY 2021-22	FY 2022-23
<b>Net Revenue for Debt Service</b>	24	\$161,468	\$128,383	\$206,143	\$124,006	\$233,864	\$381,747	\$638,330	\$791,483	\$814,163	\$792,250	
<b>Water Debt Service</b>												
Series 2006B Water Revenue Notes	25	\$0	\$0	\$0	\$0	\$0	\$0	\$0	\$0	\$0	\$0	
Series 2013 Water Revenue Notes	26	87,474	94,381	93,931	93,331	92,731	15,916	0	0	0	0	
Interim Construction Loan #3 (1AB,2A,3AB, 6EF)	27	0	0	0	0	0	0	0	0	0	0	
Interim Construction Loan #4 (6A)	28	0	0	0	0	0	0	0	0	0	0	
Proposed USDA Loan #3 (1AB,2A,3AB, 6EF)	29	0	0	0	0	0	136,236	233,547	222,152	187,969	187,969	
Proposed USDA Loan #4 (6A)	30	0	0	0	0	0	0	0	115,846	463,383	463,383	
Service Fee	31	600	500	500	500	500	500	0	0	0	0	
Miscellaneous	32	250	0	0	0	0	0	0	0	0	0	
<b>Total Water Revenue Debt</b>	33	\$88,324	\$94,881	\$94,431	\$93,831	\$93,231	\$152,651	\$233,547	\$337,998	\$651,351	\$651,351	
<b>Subordinated Debt</b>												
Series 2017 General Obligation Bonds	34	\$0	\$0	\$0	\$0	\$0	\$0	\$0	\$0	\$0	\$0	
<b>Total Water Debt</b>	35	\$88,324	\$94,881	\$94,431	\$93,831	\$93,231	\$152,651	\$233,547	\$337,998	\$651,351	\$651,351	
<b>Debt Service Coverage</b>					<i>Target = 1.25x for Parity Test / 1.35x for S&amp;P 'A' rating / 1.10x for USDA Loans</i>							
Net Revenues/ Revenue Debt	36	1.83	1.35	2.18	1.32	2.51	2.50	2.73	2.34	1.25	1.22	
Net Revenues/Total Debt	37	1.83	1.35	2.18	1.32	2.51	2.50	2.73	2.34	1.25	1.22	
<b>NET CASHFLOW AFTER DEBT</b>	38	\$73,144	\$33,502	\$111,712	\$30,175	\$140,632	\$229,096	\$404,783	\$453,485	\$162,811	\$140,899	
Capital Improvement Projects	39	(621,129)	(408,795)	(34,783)	(112,044)	(4,365,000)	(2,895,000)	(7,010,000)	(3,755,000)	(60,000)	(60,000)	
Other cash (uses)/sources	40	0	0	1	0	0	0	0	(1,069,783)	0	0	
Bond Proceeds	41	0	0	0	0	4,069,272	2,835,000	6,950,000	3,695,000	0	0	
Transfers (to)/from General Fund	42	0	0	0	0	0	0	0	0	0	0	
Transfers (to)/from LOST	43	0	0	0	0	0	0	0	0	0	0	
Transfers (to)/from USDA Reserve Fund	44	0	0	0	0	0	(13,624)	(23,355)	(33,800)	(65,135)	(65,135)	
Transfers (to)/from Other Funds	45	700,819	344,534	106,567	0	131,028	(7,350)	(254,298)	255,918	1,706	(4,234)	
<b>Annual Surplus/ (Deficit)</b>	46	\$152,834	(\$30,759)	\$183,497	(\$81,869)	(\$24,068)	\$148,123	\$67,130	(\$454,179)	\$39,383	\$11,530	
Beginning Unrestricted Cash Balance	47	\$345,889	\$498,723	\$383,604	\$567,101	\$485,232	\$461,164	\$609,287	\$676,417	\$222,237	\$261,620	
<b>Ending Unrestricted Cash Balance</b>	48	\$498,723	\$383,604	\$567,101	\$485,232	\$461,164	\$609,287	\$676,417	\$222,237	\$261,620	\$273,150	
Unrestricted Cash % of Expenses	49	109%	73%	105%	79%	78%	98%	104%	32%	36%	36%	

City of Adel, Iowa  
Water Enterprise Fund  
Cash-Basis Cashflow Analysis

EXHIBIT 1

Growth Assumptions	
Operating Expenses	Various
Water Usage	1.00%
Interest Rate	n/a

Water Revenue Adjustments			
1-Jul-16	2.25%	1-Jul-21	0.00%
1-Jul-17	3.00%	1-Jul-22	0.00%
1-Jul-18	3.00%	1-Jul-23	n.a
1-Jul-19	3.00%	1-Jul-24	n.a
1-Jul-20	3.00%	1-Jul-25	n.a

	Audited Financial Statements			Budget	Budget	Projected	Projected	Projected	Projected	Projected
	FY 2013-14	FY 2014-15	FY 2015-16	FY 2016-17	FY 2017-18	FY 2018-19	FY 2019-20	FY 2020-21	FY 2021-22	FY 2022-23
<b>RESTRICTED FUNDS</b>										
Sinking Fund 50	\$0	\$0	\$0	\$0	\$0	\$0	\$0	\$0	\$0	\$0
Bond Reserve Fund 51	96,231	96,231	96,231	96,231	96,231	0	0	0	0	0
Debt Service Charge Fund 52	0	0	0	0	104,700	208,281	462,579	206,661	204,955	209,188
USDA Reserve Fund 53	0	0	0	0	0	13,624	36,978	70,778	135,913	201,048
Water Deposits 54	64,993	71,078	83,653	83,653	83,653	83,653	83,653	83,653	83,653	83,653
2013 Note Fund 55	679,306	270,510	235,728	235,728	0	0	0	0	0	0
Water Improvement Fund 56	(58,177)	84,360	0	0	0	0	0	0	0	0
Total Restricted Cash 57	\$782,353	\$522,179	\$415,612	\$415,612	\$284,584	\$305,557	\$583,210	\$361,092	\$424,521	\$493,890
Total Cash 58	\$1,281,076	\$905,783	\$982,712	\$900,843	\$745,748	\$914,844	\$1,259,627	\$583,330	\$686,141	\$767,039
<b>Capital Improvement Plan</b>										
Operating Capital Outlays				60,000	60,000	60,000	60,000	60,000	60,000	60,000
Well Improvements - Well 5 & 6 and Raw Water Transmission Main				0	1,675,000	425,000	0	0	0	0
South 14th Street & HWY 169 Booster Pump Station				0	625,000	525,000	0	0	0	0
Rapids Street & HWY 169 Water Main Replacement				0	945,000	0	0	0	0	0
New WTP Phase One				0	0	1,525,000	6,950,000	3,695,000	0	0
New WTP Phase Two				0	0	0	0	0	0	0
Connection to Xenia Water				0	0	0	0	0	0	0
Engineering & Legal Fees USDA Loan #3				52,044	400,000	0	0	0	0	0
Engineering & Legal Fees USDA Loan #4				0	660,000	360,000	0	0	0	0
2017 Bonds - Water Portion				0	0	0	0	0	0	0
Total				112,044	4,365,000	2,895,000	7,010,000	3,755,000	60,000	60,000

City of Adel, Iowa  
Water Enterprise Fund  
Operational Expenses

EXHIBIT 2

	Audited Financial Statements			YTD/Budget	Budget	Projected Operating Expenses					Expense
	FY 2013-14	FY 2014-15	FY 2015-16	FY 2016-17	FY 2017-18	FY 2018-19	FY 2019-20	FY 2020-21	FY 2021-22	FY 2022-23	Growth
<b>Personal</b>											
Full Time Wages	\$141,305	\$170,726	\$155,726	\$163,701	\$171,886	\$180,480	\$189,504	\$198,980	\$208,929	\$219,375	5%
Part Time Wages	3,750	245	296	643	675	709	744	782	821	862	5%
Overtime Wages	1,152	1,189	1,059	1,315	1,381	1,450	1,522	1,598	1,678	1,762	5%
FICA	10,210	12,634	11,498	12,146	12,753	13,391	14,061	14,764	15,502	16,277	5%
IPERS	11,937	12,980	13,595	14,178	14,887	15,631	16,413	17,233	18,095	19,000	5%
Flex Plan TPA	0	36	78	90	95	99	104	109	115	121	5%
Flex Plan	794	980	126	0	0	0	0	0	0	0	5%
HRA Reimbursement	6,635	8,968	9,834	13,100	13,755	14,443	15,165	15,923	16,719	17,555	5%
HRA Plan TPA	0	109	192	206	216	227	238	250	263	276	5%
Medical Insurance	21,334	22,589	25,343	27,193	28,553	29,980	31,479	33,053	34,706	36,441	5%
Life & Disability Ins.	733	1,014	1,185	1,678	1,762	1,850	1,942	2,040	2,142	2,249	5%
Workmen's Comp	0	1,324	0	2,827	2,968	3,117	3,273	3,436	3,608	3,788	5%
Dues, Memberships, Subscriptions	3,164	3,554	2,532	3,500	3,675	3,859	4,052	4,254	4,467	4,690	5%
Education & Training	1,576	967	2,700	2,626	2,757	2,895	3,040	3,192	3,352	3,519	5%
Meeting & Travel	305	369	880	1,000	1,050	1,103	1,158	1,216	1,276	1,340	5%
<b>Total Personal Services</b>	\$202,895	\$237,684	\$225,044	\$244,203	\$256,413	\$269,234	\$282,695	\$296,830	\$311,672	\$327,255	

City of Adel, Iowa  
Water Enterprise Fund  
Operational Expenses

EXHIBIT 2

	Audited Financial Statements			YTD/Budget	Budget	Projected Operating Expenses					Expense
	FY 2013-14	FY 2014-15	FY 2015-16	FY 2016-17	FY 2017-18	FY 2018-19	FY 2019-20	FY 2020-21	FY 2021-22	FY 2022-23	Growth
<b>Services and Commodities</b>											
Vehicle Fuel-Oil-Lubricants	\$4,832	\$5,254	\$4,078	\$6,090	\$6,395	\$6,714	\$7,050	\$7,402	\$7,773	\$8,161	5%
Vehicle, Equip & Radio Maint.	3,470	5,025	1,638	3,061	3,214	3,375	3,543	3,721	3,907	4,102	5%
Utilities	40,029	36,487	33,818	38,570	40,499	42,523	44,650	46,882	49,226	51,687	5%
Telephone/Radio	1,162	1,528	2,733	1,531	1,608	1,688	1,772	1,861	1,954	2,052	5%
Advertising & Legal	16	0	204	184	193	203	213	224	235	247	5%
Professional Fees	2,737	4,477	7,567	9,883	5,075	5,329	5,595	5,875	6,169	6,477	5%
Insurance - Fire & Auto	13,996	13,868	10,140	14,113	14,819	15,560	16,338	17,154	18,012	18,913	5%
Uniform Rental	1,118	892	1,310	1,000	1,050	1,103	1,158	1,216	1,276	1,340	5%
Sales Tax	34,414	33,629	38,187	50,000	52,500	55,125	57,881	60,775	63,814	67,005	5%
Building & Grounds Maint	8,329	11,630	3,952	7,612	7,993	8,392	8,812	9,252	9,715	10,201	5%
Wells Maint	13,815	36,549	8,227	60,232	25,375	26,644	27,976	29,375	30,843	32,386	5%
Plant Maint	12,739	17,621	21,398	23,303	18,270	19,184	20,143	21,150	22,207	23,318	5%
Distribution/Line Maint	12,429	27,883	33,513	35,535	37,312	39,177	41,136	43,193	45,353	47,620	5%
Service/Maint Agreements	5,263	5,918	6,810	7,724	8,110	8,516	8,941	9,389	9,858	10,351	5%
Testing	1,386	1,817	2,457	2,538	2,665	2,798	2,938	3,085	3,239	3,401	5%
Refunds	0	0	0	63	66	69	73	77	80	84	5%
Chemicals	7,770	8,707	7,479	7,612	7,993	8,392	8,812	9,252	9,715	10,201	5%
Minor Equip	2,267	3,530	359	3,450	3,623	3,804	3,994	4,193	4,403	4,623	5%
Office Supplies	6,379	7,015	6,622	7,613	7,994	8,393	8,813	9,254	9,716	10,202	5%
Plant Supplies - Meters	14,247	13,460	30,036	32,390	34,010	35,710	37,495	39,370	41,339	43,406	5%
Salt for Plant	56,267	45,878	51,281	50,750	53,288	55,952	58,749	61,687	64,771	68,010	5%
Misc. Supplies	1,440	549	558	3,045	3,197	3,357	3,525	3,701	3,886	4,081	5%
<b>Total Services and Commodities</b>	<b>\$244,105</b>	<b>\$281,717</b>	<b>\$272,367</b>	<b>\$366,299</b>	<b>\$335,245</b>	<b>\$352,007</b>	<b>\$369,608</b>	<b>\$388,088</b>	<b>\$407,492</b>	<b>\$427,867</b>	
<b>Capital Outlay</b>											
Vehicle	\$1,832	\$0	\$20,000	\$0	\$0	\$0	\$0	\$0	\$0	\$0	
Building	0	0	0	0	0	0	0	0	0	0	
Water Upgrade	20,000	0	2,328	60,000	60,000	60,000	60,000	60,000	60,000	60,000	
<b>Total Capital Outlay</b>	<b>\$21,832</b>	<b>\$0</b>	<b>\$22,328</b>	<b>\$60,000</b>	<b>\$60,000</b>	<b>\$60,000</b>	<b>\$60,000</b>	<b>\$60,000</b>	<b>\$60,000</b>	<b>\$60,000</b>	
<b>Subtotal</b>	<b>\$468,832</b>	<b>\$519,401</b>	<b>\$519,739</b>	<b>\$670,502</b>	<b>\$651,658</b>	<b>\$681,241</b>	<b>\$712,303</b>	<b>\$744,918</b>	<b>\$779,164</b>	<b>\$815,122</b>	
<b>Total Operating Expenses</b>	<b>\$447,000</b>	<b>\$519,401</b>	<b>\$537,411</b>	<b>\$610,502</b>	<b>\$591,658</b>	<b>\$621,241</b>	<b>\$652,303</b>	<b>\$684,918</b>	<b>\$719,164</b>	<b>\$755,122</b>	
<b>Internal-Audit Adjustments</b>	<b>10,543</b>	<b>6,872</b>	<b>828</b>	<b>0</b>	<b>0</b>	<b>0</b>	<b>0</b>	<b>0</b>	<b>0</b>	<b>0</b>	
<b>Audit Report Totals</b>	<b>\$457,543</b>	<b>\$526,273</b>	<b>\$538,239</b>	<b>\$610,502</b>	<b>\$591,658</b>	<b>\$621,241</b>	<b>\$652,303</b>	<b>\$684,918</b>	<b>\$719,164</b>	<b>\$755,122</b>	

City of Adel, Iowa  
 Water Enterprise Fund  
 USDA Loan #3 Parity Test Calculation Summary

EXHIBIT 3

*Aggregate Annual Debt Service*

<u>Period Ending</u>	<u>Series 2013 Debt Service</u>	<u>Interim #3 Interest</u>	<u>Interim #4 Interest</u>	<u>USDA #3 Debt Service</u>	<u>USDA #4 Debt Service</u>	<u>Total Debt Service</u>
6/1/2019				136,235.72		136,235.72
6/1/2020				233,546.95		233,546.95
6/1/2021				233,546.95		233,546.95
6/1/2022				233,546.95		233,546.95
6/1/2023				233,546.95		233,546.95
6/1/2024				233,546.95		233,546.95
6/1/2025				233,546.95		233,546.95
6/1/2026				233,546.95		233,546.95
6/1/2027				233,546.95		233,546.95
6/1/2028				233,546.95		233,546.95
6/1/2029				233,546.95		233,546.95
6/1/2030				233,546.95		233,546.95
6/1/2031				233,546.95		233,546.95
6/1/2032				233,546.95		233,546.95
6/1/2033				233,546.95		233,546.95
6/1/2034				233,546.95		233,546.95
6/1/2035				233,546.95		233,546.95
6/1/2036				233,546.95		233,546.95
6/1/2037				233,546.95		233,546.95
6/1/2038				233,546.95		233,546.95
6/1/2039				233,546.95		233,546.95
6/1/2040				233,546.95		233,546.95
6/1/2041				233,546.95		233,546.95
6/1/2042				233,546.95		233,546.95
6/1/2043				233,546.95		233,546.95
6/1/2044				233,546.95		233,546.95
6/1/2045				233,546.95		233,546.95
6/1/2046				233,546.95		233,546.95
6/1/2047				233,546.95		233,546.95
6/1/2048				233,546.95		233,546.95
6/1/2049				233,546.95		233,546.95
6/1/2050				233,546.95		233,546.95
6/1/2051				233,546.95		233,546.95
6/1/2052				233,546.95		233,546.95
6/1/2053				233,546.95		233,546.95
6/1/2054				233,546.95		233,546.95
6/1/2055				233,546.95		233,546.95
6/1/2056				233,546.95		233,546.95
6/1/2057				233,546.95		233,546.95
6/1/2058				233,546.95		233,546.95
						9,244,566.63

FY 2017-18 Historical Bond Parity Test		
2017-18 RAD	<u>\$233,864</u>	
Max D/S	233,547	1.00

FY 2018-19 Projected Bond Parity Test		
2018-19 RAD	<u>\$381,747</u>	
Max D/S	233,547	1.63

City of Adel, Iowa  
Water Enterprise Fund  
USDA Loan #4 Parity Test Calculation Summary

EXHIBIT 4

*Aggregate Annual Debt Service*

<u>Period Ending</u>	<u>Series 2013 Debt Service</u>	<u>Interim #3 Interest</u>	<u>Interim #4 Interest</u>	<u>USDA #3 Debt Service</u>	<u>USDA #4 Debt Service</u>	<u>Total Debt Service</u>
6/1/2021				222,152.37	115,845.65	337,998.02
6/1/2022				187,968.64	463,382.61	651,351.25
6/1/2023				187,968.64	463,382.61	651,351.25
6/1/2024				187,968.64	463,382.61	651,351.25
6/1/2025				187,968.64	463,382.61	651,351.25
6/1/2026				187,968.64	463,382.61	651,351.25
6/1/2027				187,968.64	463,382.61	651,351.25
6/1/2028				187,968.64	463,382.61	651,351.25
6/1/2029				187,968.64	463,382.61	651,351.25
6/1/2030				187,968.64	463,382.61	651,351.25
6/1/2031				187,968.64	463,382.61	651,351.25
6/1/2032				187,968.64	463,382.61	651,351.25
6/1/2033				187,968.64	463,382.61	651,351.25
6/1/2034				187,968.64	463,382.61	651,351.25
6/1/2035				187,968.64	463,382.61	651,351.25
6/1/2036				187,968.64	463,382.61	651,351.25
6/1/2037				187,968.64	463,382.61	651,351.25
6/1/2038				187,968.64	463,382.61	651,351.25
6/1/2039				187,968.64	463,382.61	651,351.25
6/1/2040				187,968.64	463,382.61	651,351.25
6/1/2041				187,968.64	463,382.61	651,351.25
6/1/2042				187,968.64	463,382.61	651,351.25
6/1/2043				187,968.64	463,382.61	651,351.25
6/1/2044				187,968.64	463,382.61	651,351.25
6/1/2045				187,968.64	463,382.61	651,351.25
6/1/2046				187,968.64	463,382.61	651,351.25
6/1/2047				187,968.64	463,382.61	651,351.25
6/1/2048				187,968.64	463,382.61	651,351.25
6/1/2049				187,968.64	463,382.61	651,351.25
6/1/2050				187,968.64	463,382.61	651,351.25
6/1/2051				187,968.64	463,382.61	651,351.25
6/1/2052				187,968.64	463,382.61	651,351.25
6/1/2053				187,968.64	463,382.61	651,351.25
6/1/2054				187,968.64	463,382.61	651,351.25
6/1/2055				187,968.64	463,382.61	651,351.25
6/1/2056				187,968.64	463,382.61	651,351.25
6/1/2057				187,968.64	463,382.61	651,351.25
6/1/2058				187,968.64	463,382.61	651,351.25
6/1/2059					463,382.61	463,382.61
6/1/2060					463,382.61	463,382.61
						18,575,833.14

FY 2019-20 Historical Bond Parity Test		
2019-20 RAD	<u>\$638,330</u>	
Average Annual D/S	634,119	1.01
FY 2020-21 Projected Bond Parity Test		
2020-21 RAD	<u>\$791,483</u>	
Average Annual D/S	634,119	1.25
FY 2021-22 Projected Bond Parity Test		
2021-22 RAD	<u>\$814,163</u>	
Average Annual D/S	634,119	1.28

EXHIBIT 5

<u>Project(s)</u>	<u>Interest Rate</u>	<u>Grant %</u>	<u>Project Cost Amount</u>	<u>Costs of Issuance</u>	<u>Capitalized Interest</u>	<u>Borrowing Amount</u>	<u>Loan Date</u>	<u>Construction Time</u>	<u>USDA Loan Date</u>
Interim Loan #3	3.00%	0.00%	4,359,272	40,000	117,838	4,517,110	6/1/2017	18	12/1/2018
Interim Loan #4	3.00%	0.00%	13,190,000	60,000	545,363	13,795,363	7/1/2017	45	4/1/2021
USDA Loan #3	2.75%	0.00%	4,517,110	40,000	0	4,557,110	12/1/2018	\$15,664.05	MTH PMT
USDA Loan #4	2.75%	19.00%	11,174,244	60,000	0	11,234,244	4/1/2021	\$38,615.22	MTH PMT

2,621,119

Refinancing 2013 Water Notes through USDA Loan #3

Ref 2013 Notes USDA	2.75%	0.00%	1,105,000	0	0	1,105,000	12/1/2018	\$3,798.19	MTH PMT
Start		12/1/2018	-35,217						
Redemption		3/1/2021	1,069,783						

## Ordinance No. 317

### AN ORDINANCE AMENDING THE CODE OF ORDINANCES OF THE CITY OF ADEL, BY AMENDING CHAPTER 99

**BE IT ENACTED BY THE CITY COUNCIL, THE CITY OF ADEL, IOWA;**

**SECTION 1.** Section 99.07 of the Code of Ordinances of the City of Adel, Iowa, 2007, as amended, is repealed and the following adopted in lieu thereof:

99.07 USER CHARGES. Each customer shall pay a user charge in accordance with the following:

July 1, 2017 – June 30, 2018 Rates (3% Increase)

1. Based on water usage:
  - a. First 5,000 gallons - \$7.30 per 1,000 gallons
  - b. Everything thereafter - \$5.24 per 1,000 gallons
2. Septic Haulers – minimum 1,500 gallons = \$111.75
3. Minimum Sewer Charge - \$14.60

In no case shall the minimum user charge be less than \$14.60 per month, which is necessary to retire the indebtedness, operating and maintenance, and reserve necessary for maintaining the sanitary sewer facility.

July 1, 2018 – June 30, 2019 Rates (3% Increase)

1. Based on water usage:
  - a. First 5,000 gallons - \$7.52 per 1,000 gallons
  - b. Everything thereafter - \$5.40 per 1,000 gallons
2. Septic Haulers – minimum 1,500 gallons = \$115.10
3. Minimum Sewer Charge - \$15.04

In no case shall the minimum user charge be less than \$15.04 per month, which is necessary to retire the indebtedness, operating and maintenance, and reserve necessary for maintaining the sanitary sewer facility.

July 1, 2019 – June 30, 2020 Rates (3% Increase)

1. Based on water usage:
  - a. First 5,000 gallons - \$7.75 per 1,000 gallons
  - c. Everything thereafter - \$5.56 per 1,000 gallons
2. Septic Haulers – minimum 1,500 gallons = \$118.55
3. Minimum Sewer Charge - \$15.50

In no case shall the minimum user charge be less than \$15.50 per month, which is necessary to retire the indebtedness, operating and maintenance, and reserve necessary for maintaining the sanitary sewer facility.



**SECTION 2.** Section 99.16 of the Code of Ordinances of the City of Adel, Iowa, 2007, as amended, is repealed and the following adopted in lieu thereof:

99.16 Rate adjustments will be considered and computed before the first of July each year by City staff, including consultation with the City’s Engineer and the City’s Financial Advisor. The proposed adjustments shall be submitted to the Council for review and approval. Any adjustments shall go into effect on the July bill, payable July 20th.

**SECTION 3.** Section 99.17 will be created with the following language:

99.17 COMMUNITY SEWER INITIATIVE (CSI) SURCHARGE: Every person, firm, or corporation whose premises now or hereafter are directly or indirectly served by a connection to the City Sewer System shall pay a CSI surcharge in the amount of seven dollars (\$7.00) per month beginning July 1, 2017, twelve dollars (\$12.00) per month beginning July 1, 2018, and fifteen dollars (\$15.00) per month beginning July 1, 2019.

**SECTION 4. WHEN EFFECTIVE:** This ordinance shall be effective from and after the 1<sup>st</sup> day of July, 2017.

Passed and approved by the Adel City Council this \_\_\_\_ day of \_\_\_\_\_, 2017

\_\_\_\_\_  
James F. Peters, Mayor

Attest: \_\_\_\_\_  
Jackie Steele, City Clerk

1<sup>st</sup> Reading \_\_\_\_\_

2<sup>nd</sup> Reading \_\_\_\_\_

3<sup>rd</sup> Reading \_\_\_\_\_

I certify that the foregoing was published as Ordinance No. 317 in the Dallas County News on the \_\_\_\_ day of \_\_\_\_\_, 2017.

\_\_\_\_\_  
Jackie Steele, City Clerk

City of Adel, Iowa  
Sewer Enterprise Fund  
Cash-Basis Cashflow Analysis

EXHIBIT 1

Growth Assumptions	
Operating Expenses	Various
Water Usage	1.00%
Interest Rate	n/a

Sewer Revenue Adjustments			
1-Jul-16	2.30%	1-Jul-21	2.50%
1-Jul-17	3.00%	1-Jul-22	0.00%
1-Jul-18	3.00%	1-Jul-23	n.a.
1-Jul-19	3.00%	1-Jul-24	n.a.
1-Jul-20	2.50%	1-Jul-25	n.a.

	Audited Financial Statements			Budget	Budget	Projected	Projected	Projected	Projected	Projected
	FY 2013-14	FY 2014-15	FY 2015-16	FY 2016-17	FY 2017-18	FY 2018-19	FY 2019-20	FY 2020-21	FY 2021-22	FY 2022-23
<b>Sewer Rates</b>	7/1/2013	7/1/2014	9/1/2015	7/1/2016	7/1/2017	7/1/2018	7/1/2019	7/1/2020	7/1/2021	7/1/2022
Sewer Flat Rate 1	\$13.20	\$13.56	\$13.86	\$14.18	\$14.61	\$15.04	\$15.49	\$15.88	\$16.28	\$16.28
First 5,000 gallons per 1,000 gallons 2	\$6.60	\$6.78	\$6.93	\$7.09	\$7.30	\$7.52	\$7.75	\$7.94	\$8.14	\$8.14
> 5,000 gallons per 1,000 gallons 3	\$4.75	\$4.88	\$4.98	\$5.09	\$5.24	\$5.40	\$5.56	\$5.70	\$5.84	\$5.84
Debt Service Charge 4	\$0.00	\$0.00	\$0.00	\$0.00	\$7.00	\$12.00	\$15.00	\$23.00	\$33.00	\$33.00
Beginning of FY # of Accounts 5	-	-	-	1,730	1,745	1,760	1,775	1,790	1,805	1,820
<b>Average Rate/1,000 gallons 6</b>	\$5.70	\$5.93	\$5.94	\$6.08	\$6.26	\$6.45	\$6.64	\$6.81	\$6.98	\$6.98
<b>WATER SOLD (1,000 gallons) 7</b>	85,591	87,921	97,240	98,213	99,195	100,187	101,189	102,200	103,222	104,255
<b>OPERATING REVENUES</b>										
Sewer Usage Charge Revenues 8	\$487,498	\$521,634	\$577,788	\$597,133	\$620,959	\$646,204	\$671,892	\$695,985	\$720,493	\$727,698
Connection Fee 9	18,850	24,350	51,750	43,250	7,500	7,500	7,500	7,500	7,500	7,500
Debt Service Charge 10	0	0	0	0	146,580	253,440	319,500	494,040	714,780	720,720
Miscellaneous Revenues 11	104	0	2,308	3,150	0	0	0	0	0	0
Total Operating Revenues 12	\$506,452	\$545,984	\$631,846	\$643,533	\$775,039	\$907,144	\$998,892	\$1,197,525	\$1,442,773	\$1,455,918
<b>OPERATING EXPENSES</b>										
Business Type Expenditures 13	\$361,396	\$331,241	\$438,841	\$435,600	\$457,379	\$480,248	\$504,261	\$529,474	\$555,948	\$583,745
Reserved 14	0	0	0	0	0	0	0	0	0	0
Total Operating Expense 15	\$361,396	\$331,241	\$438,841	\$435,600	\$457,379	\$480,248	\$504,261	\$529,474	\$555,948	\$583,745
<b>Net Operating Revenues 16</b>	145,056	214,743	193,005	207,933	317,660	426,896	494,631	668,051	886,825	872,173
<b>Non Operating Revenues (expenses)</b>										
Interest 17	\$0	\$0	\$0	\$0	\$0	\$0	\$0	\$0	\$0	\$0
<b>Total Other Income 18</b>	\$0	\$0	\$0	\$0	\$0	\$0	\$0	\$0	\$0	\$0
<b>Net Revenue for Debt Service 19</b>	\$145,056	\$214,743	\$193,005	\$207,933	\$317,660	\$426,896	\$494,631	\$668,051	\$886,825	\$872,173

City of Adel, Iowa  
Sewer Enterprise Fund  
Cash-Basis Cashflow Analysis

EXHIBIT 1

Growth Assumptions	
Operating Expenses	Various
Water Usage	1.00%
Interest Rate	n/a

Sewer Revenue Adjustments			
1-Jul-16	2.30%	1-Jul-21	2.50%
1-Jul-17	3.00%	1-Jul-22	0.00%
1-Jul-18	3.00%	1-Jul-23	n.a.
1-Jul-19	3.00%	1-Jul-24	n.a.
1-Jul-20	2.50%	1-Jul-25	n.a.

	Audited Financial Statements			Budget	Budget	Projected	Projected	Projected	Projected	Projected
	FY 2013-14	FY 2014-15	FY 2015-16	FY 2016-17	FY 2017-18	FY 2018-19	FY 2019-20	FY 2020-21	FY 2021-22	FY 2022-23
<b>Net Revenue for Debt Service</b> 20	\$145,056	\$214,743	\$193,005	\$207,933	\$317,660	\$426,896	\$494,631	\$668,051	\$886,825	\$872,173
<b>Sewer Debt Service</b>										
Series 1997 SRF 21	\$15,800	\$16,380	\$15,930	\$16,480	\$0	\$0	\$0	\$0	\$0	\$0
Series 2013 Sewer Revenue Notes 22	34,494	40,013	39,763	39,513	39,263	0	0	0	0	0
Interim Construction Loan #1 (2A) 23	0	0	0	0	0	0	0	0	0	0
Interim Construction Loan #6 (6) 24	0	0	0	0	0	0	0	0	0	0
Interim Construction Loan #5 (1A) 25	0	0	0	0	0	0	0	0	0	0
Proposed USDA Loan #1 (2A) 26	0	0	0	0	0	60,885	60,885	60,885	60,885	60,885
Proposed USDA Loan #6 (6) 27	0	0	0	0	0	0	92,585	123,446	123,446	123,446
Proposed USDA Loan #5 (1A) 28	0	0	0	0	0	0	0	0	0	516,719
Service Fee 29	630	622	515	508	508	0	0	0	0	0
Miscellaneous 30	0	0	0	0	0	0	0	0	0	0
<b>Total Sewer Debt</b> 31	\$50,924	\$57,015	\$56,208	\$56,501	\$39,771	\$60,885	\$153,469	\$184,331	\$184,331	\$701,050
<b>Debt Service Coverage</b>				<i>Target = 1.25x for Parity Test until FY18 Defeasance/ 1.10x for USDA Loan</i>						
<b>Net Revenues/ Revenue Debt</b> 32	<b>2.85</b>	<b>3.77</b>	<b>3.43</b>	<b>3.68</b>	<b>7.99</b>	<b>7.01</b>	<b>3.22</b>	<b>3.62</b>	<b>4.81</b>	<b>1.24</b>
<b>Net Revenues/ Total Debt</b> 33	<b>2.85</b>	<b>3.77</b>	<b>3.43</b>	<b>3.68</b>	<b>7.99</b>	<b>7.01</b>	<b>3.22</b>	<b>3.62</b>	<b>4.81</b>	<b>1.24</b>
<b>NET CASHFLOW AFTER DEBT</b> 34	\$94,132	\$157,729	\$136,798	\$151,433	\$277,889	\$366,011	\$341,162	\$483,720	\$702,494	\$171,123
Capital Improvement Projects 35	(310,776)	(19,291)	(2,328)	(218,423)	(2,137,000)	(3,615,000)	(2,600,000)	(6,100,000)	(4,115,000)	(50,000)
Other cash (uses)/sources 36	0	0	(1)	0	(450,000)	0	0	0	0	0
Bond Proceeds 37	0	0	0	0	2,025,000	3,565,000	2,550,000	5,850,000	4,065,000	0
Transfers (to)/from General Fund 38	0	(292,512)	0	0	0	0	0	0	0	0
Transfers (to)/from LOST 39	0	0	0	0	0	0	0	0	0	0
Transfers (to)/from USDA Reserve Fund 40	0	0	0	0	0	(6,088)	(15,347)	(18,433)	(18,433)	(642,749)
Transfers (to)/from Other Funds 41	323,876	(74,846)	20,999	0	92,002	(186,467)	(150,684)	(291,276)	(512,016)	623,079
<b>Annual Surplus/ (Deficit)</b> 42	<b>\$107,232</b>	<b>(\$228,921)</b>	<b>\$155,468</b>	<b>(\$66,990)</b>	<b>(\$192,109)</b>	<b>\$123,456</b>	<b>\$125,131</b>	<b>(\$75,989)</b>	<b>\$122,045</b>	<b>\$101,453</b>
Beginning Unrestricted Cash Balance 43	\$457,755	\$564,987	\$336,066	\$491,534	\$424,544	\$232,435	\$355,891	\$481,023	\$405,034	\$527,080
Ending Unrestricted Cash Balance 44	\$564,987	\$336,066	\$491,534	\$424,544	\$232,435	\$355,891	\$481,023	\$405,034	\$527,080	\$628,532
Unrestricted Cash % of Expenses 45	156%	101%	112%	97%	51%	74%	95%	76%	95%	108%

City of Adel, Iowa  
Sewer Enterprise Fund  
Cash-Basis Cashflow Analysis

EXHIBIT 1

<i>Growth Assumptions</i>	
Operating Expenses	Various
Water Usage	1.00%
Interest Rate	n/a

<i>Sewer Revenue Adjustments</i>			
1-Jul-16	2.30%	1-Jul-21	2.50%
1-Jul-17	3.00%	1-Jul-22	0.00%
1-Jul-18	3.00%	1-Jul-23	n.a.
1-Jul-19	3.00%	1-Jul-24	n.a.
1-Jul-20	2.50%	1-Jul-25	n.a.

	Audited Financial Statements			Budget	Budget	Projected	Projected	Projected	Projected	Projected
	FY 2013-14	FY 2014-15	FY 2015-16	FY 2016-17	FY 2017-18	FY 2018-19	FY 2019-20	FY 2020-21	FY 2021-22	FY 2022-23
<b>RESTRICTED FUNDS</b>										
Sinking Fund 46	\$57,857	\$57,857	\$57,857	\$57,857	\$57,857	\$57,857	\$57,857	\$57,857	\$57,857	\$57,857
Bond Reserve Fund 47	41,038	41,038	41,038	41,038	0	0	0	0	0	0
Debt Service Charge Fund 48	0	0	0	0	146,580	333,047	483,731	775,007	1,287,023	663,944
USDA Reserve Fund 49	0	0	0	0	0	6,088	21,435	39,868	58,302	701,050
2013 Bond Fund 50	216,835	197,544	197,544	197,544	0	0	0	0	0	0
Sewer Improvement Fund 51	93,941	188,078	167,079	167,079	167,079	167,079	167,079	167,079	167,079	167,079
Total Restricted Cash 52	\$409,671	\$484,517	\$463,518	\$463,518	\$371,516	\$564,071	\$730,102	\$1,039,811	\$1,570,260	\$1,589,930
Total Cash 53	\$974,658	\$820,583	\$955,052	\$888,062	\$603,951	\$919,963	\$1,211,125	\$1,444,845	\$2,097,340	\$2,218,462
<b>Capital Improvement Plan</b>										
Operating Capital Outlays				159,503	112,000	50,000	50,000	50,000	50,000	50,000
Main Street Sewer Phase One				0	0	0	0	0	0	0
Main Street Sewer Phase Two				0	0	0	0	0	0	0
Wastewater Treatment Plant Phase One (2.3 MGD)				0	0	0	2,225,000	6,050,000	4,065,000	0
East Annex Sewer Extension (Phased Lift Station)				0	200,000	2,850,000	140,000	0	0	0
Engineering & Legal Fees USDA Loan # 5				48,920	200,000	715,000	185,000	0	0	0
Engineering & Legal Fees USDA Loan # 6				10,000	275,000	0	0	0	0	0
2017 Bonds - Sewer Portion - Brick Streets				0	1,350,000	0	0	0	0	0
Total				218,423	2,137,000	3,615,000	2,600,000	6,100,000	4,115,000	50,000

City of Adel, Iowa  
 Sewer Enterprise Fund  
 Operational Expenses

EXHIBIT 2

	Audited Financial Statements			YTD/Budget	Budget	Projected Operating Expenses					Expense
	FY 2013-14	FY 2014-15	FY 2015-16	FY 2016-17	FY 2017-18	FY 2018-19	FY 2019-20	FY 2020-21	FY 2021-22	FY 2022-23	Growth
<b>Personal</b>											
Full Time Wages	\$125,203	\$152,549	\$150,056	\$162,046	\$170,148	\$178,656	\$187,589	\$196,968	\$206,816	\$217,157	5%
Part Time Wages	12,203	8,785	7,019	14,115	14,821	15,562	16,340	17,157	18,015	18,915	5%
Overtime Wages	0	0	0	99	104	109	115	120	126	133	5%
FICA	9,585	11,855	11,462	13,050	13,703	14,388	15,107	15,862	16,655	17,488	5%
IPERS	11,867	12,095	13,675	15,233	15,995	16,794	17,634	18,516	19,442	20,414	5%
Flex Plan TPA	0	26	87	71	75	78	82	86	91	95	5%
Flex Plan TPA	934	1,365	248	292	307	322	338	355	373	391	5%
HRA Reimbursement	6,010	7,903	13,280	12,775	13,414	14,084	14,789	15,528	16,304	17,120	5%
HRA Plan TPA	0	97	167	201	211	222	233	244	257	269	5%
Medical Insurance	17,315	17,599	19,746	29,318	30,784	32,323	33,939	35,636	37,418	39,289	5%
Life & Disability Ins.	608	845	987	1,681	1,765	1,853	1,946	2,043	2,145	2,253	5%
Workmen's Comp	0	1,419	0	309	324	341	358	376	394	414	5%
Unemployment	0	0	0	0	0	0	0	0	0	0	5%
Dues, Subscriptions	1,612	1,758	1,058	2,500	2,625	2,756	2,894	3,039	3,191	3,350	5%
Education & Training	535	1,167	2,380	2,000	2,100	2,205	2,315	2,431	2,553	2,680	5%
Meeting & Travel	305	577	1,414	1,000	1,050	1,103	1,158	1,216	1,276	1,340	5%
<b>Total Personal Services</b>	<b>\$186,177</b>	<b>\$218,040</b>	<b>\$221,579</b>	<b>\$254,690</b>	<b>\$267,425</b>	<b>\$280,796</b>	<b>\$294,836</b>	<b>\$309,577</b>	<b>\$325,056</b>	<b>\$341,309</b>	

City of Adel, Iowa  
Sewer Enterprise Fund  
Operational Expenses

EXHIBIT 2

	Audited Financial Statements			YTD/Budget	Budget	Projected Operating Expenses					Expense
	FY 2013-14	FY 2014-15	FY 2015-16	FY 2016-17	FY 2017-18	FY 2018-19	FY 2019-20	FY 2020-21	FY 2021-22	FY 2022-23	Growth
<b>Services and Commodities</b>											
Vehicle Fuel-Oil-Lubricants	\$1,477	\$2,601	\$2,550	\$2,500	\$2,625	\$2,756	\$2,894	\$3,039	\$3,191	\$3,350	5%
Vehicle, Equip & Radio Maint.	2,514	3,073	3,173	7,464	7,837	8,229	8,641	9,073	9,526	10,002	5%
Utilities	27,009	24,035	29,459	30,000	31,500	33,075	34,729	36,465	38,288	40,203	5%
Telephone/Radio	902	1,066	2,478	1,200	1,260	1,323	1,389	1,459	1,532	1,608	5%
LP Gas	1,286	602	335	800	840	882	926	972	1,021	1,072	5%
Professional Fees	8,394	3,860	49,168	10,033	10,534	11,061	11,614	12,195	12,804	13,445	5%
Insurance - Fire & Auto	6,004	5,948	3,489	6,047	6,349	6,667	7,000	7,350	7,718	8,104	5%
Uniform Rental	1,069	897	1,254	1,000	1,050	1,103	1,158	1,216	1,276	1,340	5%
Sales Tax	3,657	5,922	3,702	8,000	8,400	8,820	9,261	9,724	10,210	10,721	5%
Building & Grounds Maint.	2,050	1,827	7,030	2,500	2,625	2,756	2,894	3,039	3,191	3,350	5%
Plant Maint.	4,896	5,577	3,301	5,000	5,250	5,513	5,788	6,078	6,381	6,700	5%
Distribution/Line Maint.	43,461	20,053	33,953	35,000	36,750	38,588	40,517	42,543	44,670	46,903	5%
Service/Maint. Agreements	5,564	9,218	12,527	18,000	18,900	19,845	20,837	21,879	22,973	24,122	5%
Testing	7,955	10,553	15,070	20,000	21,000	22,050	23,153	24,310	25,526	26,802	5%
Refunds	0	0	0	0	0	0	0	0	0	0	5%
Chemicals	6,989	2,279	2,572	6,000	6,300	6,615	6,946	7,293	7,658	8,041	5%
Minor Equipment	1,714	2,048	302	2,106	2,211	2,322	2,438	2,560	2,688	2,822	5%
Office Supplies	5,590	4,416	5,245	6,000	6,300	6,615	6,946	7,293	7,658	8,041	5%
Plant Supplies	3,419	8,998	19,423	18,260	19,173	20,132	21,138	22,195	23,305	24,470	5%
Misc. Supplies	861	516	1,253	1,000	1,050	1,103	1,158	1,216	1,276	1,340	5%
<b>Services and Commodities</b>	<b>\$134,811</b>	<b>\$113,489</b>	<b>\$196,284</b>	<b>\$180,910</b>	<b>\$189,955</b>	<b>\$199,453</b>	<b>\$209,425</b>	<b>\$219,897</b>	<b>\$230,891</b>	<b>\$242,436</b>	
<b>Capital Outlay</b>											
Vehicle	\$4,581	\$0	\$0	\$110,503	\$62,000	\$0	\$0	\$0	\$0	\$0	
Building	0	0	0	0	0	0	0	0	0	0	
Sewer Upgrades	75,602	0	2,328	49,000	50,000	50,000	50,000	50,000	50,000	50,000	
<b>Total Capital Outlay</b>	<b>\$80,183</b>	<b>\$0</b>	<b>\$2,328</b>	<b>\$159,503</b>	<b>\$112,000</b>	<b>\$50,000</b>	<b>\$50,000</b>	<b>\$50,000</b>	<b>\$50,000</b>	<b>\$50,000</b>	
<b>Subtotal</b>	<b>\$401,171</b>	<b>\$331,529</b>	<b>\$420,191</b>	<b>\$595,103</b>	<b>\$569,379</b>	<b>\$530,248</b>	<b>\$554,261</b>	<b>\$579,474</b>	<b>\$605,948</b>	<b>\$633,745</b>	
<b>Total Operating Expenses</b>	<b>\$320,988</b>	<b>\$331,529</b>	<b>\$441,169</b>	<b>\$435,600</b>	<b>\$457,379</b>	<b>\$480,248</b>	<b>\$504,261</b>	<b>\$529,474</b>	<b>\$555,948</b>	<b>\$583,745</b>	
<b>Internal-Audit Adjustments</b>	<b>40,408</b>	<b>(288)</b>	<b>(2,328)</b>	<b>0</b>	<b>0</b>	<b>0</b>	<b>0</b>	<b>0</b>	<b>0</b>	<b>0</b>	
<b>Audit Report Totals</b>	<b>\$361,396</b>	<b>\$331,241</b>	<b>\$438,841</b>	<b>\$435,600</b>	<b>\$457,379</b>	<b>\$480,248</b>	<b>\$504,261</b>	<b>\$529,474</b>	<b>\$555,948</b>	<b>\$583,745</b>	

City of Adel, Iowa  
Sewer Enterprise Fund  
USDA Loan #1 Parity Test Calculation Summary

EXHIBIT 3

*Aggregate Annual Debt Service*

<u>Period Ending</u>	<u>Series 2013 Debt Service</u>	<u>Interim #1 Interest</u>	<u>Interim #6 Interest</u>	<u>Interim #5 Interest</u>	<u>USDA #1 Debt Service</u>	<u>USDA #6 Debt Service</u>	<u>USDA #5 Debt Service</u>	<u>Total Debt Service</u>
6/1/2019					60,884.62			60,884.62
6/1/2020					60,884.62			60,884.62
6/1/2021					60,884.62			60,884.62
6/1/2022					60,884.62			60,884.62
6/1/2023					60,884.62			60,884.62
6/1/2024					60,884.62			60,884.62
6/1/2025					60,884.62			60,884.62
6/1/2026					60,884.62			60,884.62
6/1/2027					60,884.62			60,884.62
6/1/2028					60,884.62			60,884.62
6/1/2029					60,884.62			60,884.62
6/1/2030					60,884.62			60,884.62
6/1/2031					60,884.62			60,884.62
6/1/2032					60,884.62			60,884.62
6/1/2033					60,884.62			60,884.62
6/1/2034					60,884.62			60,884.62
6/1/2035					60,884.62			60,884.62
6/1/2036					60,884.62			60,884.62
6/1/2037					60,884.62			60,884.62
6/1/2038					60,884.62			60,884.62
6/1/2039					60,884.62			60,884.62
6/1/2040					60,884.62			60,884.62
6/1/2041					60,884.62			60,884.62
6/1/2042					60,884.62			60,884.62
6/1/2043					60,884.62			60,884.62
6/1/2044					60,884.62			60,884.62
6/1/2045					60,884.62			60,884.62
6/1/2046					60,884.62			60,884.62
6/1/2047					60,884.62			60,884.62
6/1/2048					60,884.62			60,884.62
6/1/2049					60,884.62			60,884.62
6/1/2050					60,884.62			60,884.62
6/1/2051					60,884.62			60,884.62
6/1/2052					60,884.62			60,884.62
6/1/2053					60,884.62			60,884.62
6/1/2054					60,884.62			60,884.62
6/1/2055					60,884.62			60,884.62
6/1/2056					60,884.62			60,884.62
6/1/2057					60,884.62			60,884.62
6/1/2058					60,884.62			60,884.62

2,435,384.89

FY 2016-17 Historical Bond Parity Test		
2016-17 RAD	\$207,933	
Average Annual D/S	60,885	3.42

FY 2017-18 Historical Bond Parity Test		
2017-18 RAD	\$317,660	
Average Annual D/S	60,885	5.22

City of Adel, Iowa  
Sewer Enterprise Fund  
USDA Loan #6 Parity Test Calculation Summary

EXHIBIT 4

Aggregate Annual Debt Service

Period Ending	Series 2013 Debt Service	Interim #1 Interest	Interim #6 Interest	Interim #5 Interest	USDA #1 Debt Service	USDA #6 Debt Service	USDA #5 Debt Service	Total Debt Service
6/1/2020					60,884.62	92,584.74		153,469.36
6/1/2021					60,884.62	123,446.31		184,330.94
6/1/2022					60,884.62	123,446.31		184,330.94
6/1/2023					60,884.62	123,446.31		184,330.94
6/1/2024					60,884.62	123,446.31		184,330.94
6/1/2025					60,884.62	123,446.31		184,330.94
6/1/2026					60,884.62	123,446.31		184,330.94
6/1/2027					60,884.62	123,446.31		184,330.94
6/1/2028					60,884.62	123,446.31		184,330.94
6/1/2029					60,884.62	123,446.31		184,330.94
6/1/2030					60,884.62	123,446.31		184,330.94
6/1/2031					60,884.62	123,446.31		184,330.94
6/1/2032					60,884.62	123,446.31		184,330.94
6/1/2033					60,884.62	123,446.31		184,330.94
6/1/2034					60,884.62	123,446.31		184,330.94
6/1/2035					60,884.62	123,446.31		184,330.94
6/1/2036					60,884.62	123,446.31		184,330.94
6/1/2037					60,884.62	123,446.31		184,330.94
6/1/2038					60,884.62	123,446.31		184,330.94
6/1/2039					60,884.62	123,446.31		184,330.94
6/1/2040					60,884.62	123,446.31		184,330.94
6/1/2041					60,884.62	123,446.31		184,330.94
6/1/2042					60,884.62	123,446.31		184,330.94
6/1/2043					60,884.62	123,446.31		184,330.94
6/1/2044					60,884.62	123,446.31		184,330.94
6/1/2045					60,884.62	123,446.31		184,330.94
6/1/2046					60,884.62	123,446.31		184,330.94
6/1/2047					60,884.62	123,446.31		184,330.94
6/1/2048					60,884.62	123,446.31		184,330.94
6/1/2049					60,884.62	123,446.31		184,330.94
6/1/2050					60,884.62	123,446.31		184,330.94
6/1/2051					60,884.62	123,446.31		184,330.94
6/1/2052					60,884.62	123,446.31		184,330.94
6/1/2053					60,884.62	123,446.31		184,330.94
6/1/2054					60,884.62	123,446.31		184,330.94
6/1/2055					60,884.62	123,446.31		184,330.94
6/1/2056					60,884.62	123,446.31		184,330.94
6/1/2057					60,884.62	123,446.31		184,330.94
6/1/2058					60,884.62	123,446.31		184,330.94
6/1/2059						123,446.31		123,446.31

7,281,491.25

FY 2017-18 Historical Bond Parity Test		
2017-18 RAD	\$317,660	
Average Annual D/S	182,037	1.75

FY 2018-19 Historical Bond Parity Test		
2018-19 RAD	\$426,896	
Average Annual D/S	182,037	2.35

FY 2019-20 Projected Bond Parity Test		
2019-20 RAD	\$494,631	
Average Annual D/S	182,037	2.72



City of Adel, Iowa  
Sewer Enterprise Fund  
USDA Loan #5 Parity Test Calculation Summary

EXHIBIT 5

*Aggregate Annual Debt Service*

<u>Period Ending</u>	<u>Series 2013 Debt Service</u>	<u>Interim #1 Interest</u>	<u>Interim #6 Interest</u>	<u>Interim #5 Interest</u>	<u>USDA #1 Debt Service</u>	<u>USDA #6 Debt Service</u>	<u>USDA #5 Debt Service</u>	<u>Total Debt Service</u>
6/1/2023					60,884.62	123,446.31	516,719.18	701,050.12
6/1/2024					60,884.62	123,446.31	516,719.18	701,050.12
6/1/2025					60,884.62	123,446.31	516,719.18	701,050.12
6/1/2026					60,884.62	123,446.31	516,719.18	701,050.12
6/1/2027					60,884.62	123,446.31	516,719.18	701,050.12
6/1/2028					60,884.62	123,446.31	516,719.18	701,050.12
6/1/2029					60,884.62	123,446.31	516,719.18	701,050.12
6/1/2030					60,884.62	123,446.31	516,719.18	701,050.12
6/1/2031					60,884.62	123,446.31	516,719.18	701,050.12
6/1/2032					60,884.62	123,446.31	516,719.18	701,050.12
6/1/2033					60,884.62	123,446.31	516,719.18	701,050.12
6/1/2034					60,884.62	123,446.31	516,719.18	701,050.12
6/1/2035					60,884.62	123,446.31	516,719.18	701,050.12
6/1/2036					60,884.62	123,446.31	516,719.18	701,050.12
6/1/2037					60,884.62	123,446.31	516,719.18	701,050.12
6/1/2038					60,884.62	123,446.31	516,719.18	701,050.12
6/1/2039					60,884.62	123,446.31	516,719.18	701,050.12
6/1/2040					60,884.62	123,446.31	516,719.18	701,050.12
6/1/2041					60,884.62	123,446.31	516,719.18	701,050.12
6/1/2042					60,884.62	123,446.31	516,719.18	701,050.12
6/1/2043					60,884.62	123,446.31	516,719.18	701,050.12
6/1/2044					60,884.62	123,446.31	516,719.18	701,050.12
6/1/2045					60,884.62	123,446.31	516,719.18	701,050.12
6/1/2046					60,884.62	123,446.31	516,719.18	701,050.12
6/1/2047					60,884.62	123,446.31	516,719.18	701,050.12
6/1/2048					60,884.62	123,446.31	516,719.18	701,050.12
6/1/2049					60,884.62	123,446.31	516,719.18	701,050.12
6/1/2050					60,884.62	123,446.31	516,719.18	701,050.12
6/1/2051					60,884.62	123,446.31	516,719.18	701,050.12
6/1/2052					60,884.62	123,446.31	516,719.18	701,050.12
6/1/2053					60,884.62	123,446.31	516,719.18	701,050.12
6/1/2054					60,884.62	123,446.31	516,719.18	701,050.12
6/1/2055					60,884.62	123,446.31	516,719.18	701,050.12
6/1/2056					60,884.62	123,446.31	516,719.18	701,050.12
6/1/2057					60,884.62	123,446.31	516,719.18	701,050.12
6/1/2058					60,884.62	123,446.31	516,719.18	701,050.12
6/1/2059						123,446.31	516,719.18	640,165.50
6/1/2060							516,719.18	516,719.18
6/1/2061							516,719.18	516,719.18
6/1/2062							516,719.18	516,719.18

27,428,127.27

FY 2020-21 Historical Bond Parity Test			
2020-21 RAD	\$668,051		
Average Annual D/S	685,703	0.97	

FY 2021-22 Historical Bond Parity Test			
2021-22 RAD	\$886,825		
Average Annual D/S	685,703	1.29	

FY 2022-23 Projected Bond Parity Test			
2022-23 RAD	\$872,173		
Average Annual D/S	685,703	1.27	

**EXHIBIT 6**

<u>Project</u>	<u>Interest Rate</u>	<u>Grant %</u>	<u>Project Cost Amount</u>	<u>Costs of Issuance</u>	<u>Capitalized Interest</u>	<u>Borrowing Amount</u>	<u>Loan Date</u>	<u>Construction Time</u>	<u>USDA Loan Date</u>
Interim Loan #1	3.00%	0.00%	1,350,000	50,000	26,086	1,426,086	5/1/2017	14	7/1/2018
Interim Loan #6	3.00%	0.00%	3,475,000	50,000	108,125	3,633,125	7/1/2017	27	10/1/2019
Interim Loan #5	3.00%	0.00%	13,240,000	75,000	676,388	13,991,388	3/1/2018	52	7/1/2022
USDA Loan #1	2.75%	0.00%	1,426,086	50,000	0	1,476,086	7/1/2018	\$5,073.72	MTH PMT
USDA Loan #6	2.75%	19.00%	2,942,831	50,000	0	2,992,831	10/1/2019	\$10,287.19	MTH PMT
USDA Loan #5	2.75%	11.00%	12,452,335	75,000	0	12,527,335	7/1/2022	\$43,059.93	MTH PMT

## Ordinance No. 318

### AN ORDINANCE AMENDING THE CODE OF ORDINANCES OF THE CITY OF ADEL, BY AMENDING CHAPTER 161

**BE IT ENACTED BY THE CITY COUNCIL, THE CITY OF ADEL, IOWA;**

**SECTION 1.** Section 161.09(2) of the Code of Ordinances of the City of Adel, Iowa, 2007, as amended, is repealed and the following adopted in lieu thereof:

2. Developed. From July 1, 2017 through June 30, 2018, three dollars and twenty cents (\$3.20) per month for those properties which impervious coverage is less than two (2) times the average impervious coverage, or 6,000 square feet. From July 1, 2018 through June 30, 2019, three dollars and forty cents (\$3.40) per month for those properties which impervious coverage is less than two (2) times the average impervious coverage, or 6,000 square feet. From July 1, 2019 through June 30, 2020, three dollars and sixty cents (\$3.60) per month for those properties which impervious coverage is less than two (2) times the average impervious coverage, or 6,000 square feet; OR

**SECTION 2.** Section 161.09(3) of the Code of Ordinances of the City of Adel, Iowa, 2007, as amended, is repealed and the following adopted in lieu thereof:

3. Developed. From July 1, 2017 through June 30, 2018, three dollars and twenty cents (\$3.20) per month per equivalent service unit (ESU) of impervious surface for those properties which impervious coverage is equal to or greater than two (2) times the average impervious coverage, or 6,000 square feet. From July 1, 2018 through June 30, 2019, three dollars and forty cents (\$3.40) per month per equivalent service unit (ESU) of impervious surface for those properties which impervious coverage is equal to or greater than two (2) times the average impervious coverage, or 6,000 square feet. From July 1, 2019 through June 30, 2020, three dollars and sixty cents (\$3.60) per month per equivalent service unit (ESU) of impervious surface for those properties which impervious coverage is equal to or greater than two (2) times the average impervious coverage, or 6,000 square feet.

**SECTION 3.** Section 161.19 will be created with the following language:

99.17 COMMUNITY STORM WATER INITIATIVE (CSWI) SURCHARGE: Every person, firm, or corporation whose premises now or hereafter are directly or indirectly served by a connection to the City Sewer System shall pay a CSWI surcharge in the amount of three dollars (\$3.00) per month beginning July 1, 2017, and six dollars (\$6.00) per month beginning July 1, 2018.

**SECTION 4. WHEN EFFECTIVE:** This ordinance shall be effective from and after the 1<sup>st</sup> day of July, 2017.

Passed and approved by the Adel City Council this \_\_\_\_ day of \_\_\_\_\_, 2017

\_\_\_\_\_  
James F. Peters, Mayor

Attest: \_\_\_\_\_  
Jackie Steele, City Clerk

1<sup>st</sup> Reading \_\_\_\_\_  
2<sup>nd</sup> Reading \_\_\_\_\_  
3<sup>rd</sup> Reading \_\_\_\_\_

I certify that the foregoing was published as Ordinance No. 318 in the Dallas County News on the \_\_\_\_ day of \_\_\_\_\_, 2017.

\_\_\_\_\_  
Jackie Steele, City Clerk

City of Adel, Iowa  
Storm Water Enterprise Fund  
Cash-Basis Cashflow Analysis

EXHIBIT 1

Growth Assumptions	
Operating Expenses	Various
ESU Growth	0.00%
Interest Rate	n/a

Storm Water Revenue Adjustments			
1-Jul-16	\$0.00	1-Jul-21	\$0.20
1-Jul-17	\$0.20	1-Jul-22	\$0.20
1-Jul-18	\$0.20	1-Jul-23	n.a
1-Jul-19	\$0.20	1-Jul-24	n.a
1-Jul-20	\$0.20	1-Jul-25	n.a

	Audited Financial Statements			YTD/Budget	Budget	Projected	Projected	Projected	Projected	Projected
	FY 2013-14	FY 2014-15	FY 2015-16	FY 2016-17	FY 2017-18	FY 2018-19	FY 2019-20	FY 2020-21	FY 2021-22	FY 2022-23
<b>Rates: (Per Month/per ESU)</b>										
Undeveloped	1	\$0.00	\$0.00	\$0.00	\$0.00	\$0.00	\$0.00	\$0.00	\$0.00	\$0.00
Developed < 6,000 sq. ft. (Per month)	2	\$3.00	\$3.00	\$3.00	\$3.00	\$3.20	\$3.40	\$3.60	\$3.80	\$4.00
Developed >= 6,000 sq. ft. (Per ESU)	3	\$3.00	\$3.00	\$3.00	\$3.00	\$3.20	\$3.40	\$3.60	\$3.80	\$4.00
Debt Service Charge	4	\$0.00	\$0.00	\$0.00	\$0.00	\$3.00	\$6.00	\$6.00	\$6.00	\$6.00
No. of Accounts	5	-	-	-	1,730	1,745	1,760	1,775	1,790	1,805
Average \$\$ Per ESU	6	\$2.88	\$3.04	\$3.29	\$3.29	\$3.49	\$3.69	\$3.89	\$4.09	\$4.29
<b>Total ESU's</b>	7	35,385	34,754	32,085	32,085	32,085	32,085	32,085	32,085	32,085
<b>OPERATING REVENUES</b>										
Storm Water Usage Charge Revenues	8	\$101,755	\$105,679	\$105,437	\$105,437	\$111,854	\$118,271	\$124,688	\$131,105	\$137,522
Debt Service Charge	9	0	0	0	0	62,820	126,720	127,800	128,880	129,960
Miscellaneous Revenues	10	0	0	84	0	0	0	0	0	0
<b>Total Operating Revenues</b>	11	\$101,755	\$105,679	\$105,521	\$105,437	\$174,674	\$244,991	\$252,488	\$259,985	\$267,482
<b>OPERATING EXPENSES</b>										
Business Type Expenditures	12	\$182,311	\$44,506	\$55,068	\$84,722	\$89,424	\$93,895	\$98,590	\$103,519	\$108,695
Reserved	13	0	0	0	0	0	0	0	0	0
<b>Total Operating Expense</b>	14	\$182,311	\$44,506	\$55,068	\$84,722	\$89,424	\$93,895	\$98,590	\$103,519	\$108,695
<b>Net Operating Revenues</b>	15	<b>(\$80,556)</b>	61,173	50,453	20,716	85,250	151,096	153,898	156,466	158,787
<b>Non Operating Revenues (Expenses)</b>										
Investment Interest	16	\$0	\$0	\$0	\$0	\$0	\$0	\$0	\$0	\$0
<b>Total Other Income</b>	17	\$0	\$0	\$0	\$0	\$0	\$0	\$0	\$0	\$0
<b>Net Revenue for Debt Service</b>	18	<b>(\$80,556)</b>	\$61,173	\$50,453	\$20,716	\$85,250	\$151,096	\$153,898	\$156,466	\$158,787

City of Adel, Iowa  
Storm Water Enterprise Fund  
Cash-Basis Cashflow Analysis

EXHIBIT 1

Growth Assumptions				Storm Water Revenue Adjustments							
Operating Expenses	Various			1-Jul-16	\$0.00	1-Jul-21	\$0.20				
ESU Growth	0.00%			1-Jul-17	\$0.20	1-Jul-22	\$0.20				
Interest Rate	n/a			1-Jul-18	\$0.20	1-Jul-23	n.a				
				1-Jul-19	\$0.20	1-Jul-24	n.a				
				1-Jul-20	\$0.20	1-Jul-25	n.a				
	Audited Financial Statements			YTD/Budget	Budget	Projected	Projected	Projected	Projected	Projected	
	FY 2013-14	FY 2014-15	FY 2015-16	FY 2016-17	FY 2017-18	FY 2018-19	FY 2019-20	FY 2020-21	FY 2021-22	FY 2022-23	
Net Revenue for Debt Service	19	(\$80,556)	\$61,173	\$50,453	\$20,716	\$85,250	\$151,096	\$153,898	\$156,466	\$158,787	\$160,849
<b>Storm Water Debt Service</b>											
Interim Construction Loan #2 (2, 4, 6, 7)	20	\$0	\$0	\$0	\$8,100	\$44,550	\$0	\$0	\$0	\$0	\$0
Proposed USDA Loan #2 (2, 4, 6, 7) 20YRs	21	0	0	0	0	9,673	116,070	116,070	116,070	116,070	116,070
Reserved	22	0	0	0	0	0	0	0	0	0	0
<b>Total Water Debt</b>	23	\$0	\$0	\$0	\$8,100	\$54,223	\$116,070	\$116,070	\$116,070	\$116,070	\$116,070
<b>Debt Service Coverage</b>											
Net Revenues/ Revenue Debt	24	N/A	N/A	N/A	<i>Target = 1.10x needed by the USDA and 1.35x needed to fund cash requirements</i>						
Net Revenues/Total Debt	25	N/A	N/A	N/A	2.56	1.57	1.30	1.33	1.35	1.37	1.39
					2.56	1.57	1.30	1.33	1.35	1.37	1.39
<b>NET CASHFLOW AFTER DEBT</b>	26	(\$80,556)	\$61,173	\$50,453	\$12,616	\$31,028	\$35,026	\$37,828	\$40,396	\$42,717	\$44,779
Capital Improvement Projects	27	0	0	(4,000)	(222,873)	(1,479,625)	(25,000)	(25,000)	(25,000)	(25,000)	(25,000)
Other cash (uses)/sources	28	0	0	1	0	0	0	0	0	0	0
Bond Proceeds	29	0	0	0	160,000	1,430,000	0	0	0	0	0
Transfers (to)/from General Fund	30	0	0	0	0	0	0	0	0	0	0
Transfers (to)/from LOST	31	0	0	0	0	0	0	0	0	0	0
Transfers (to)/from USDA Reserve Fund	32	0	0	0	0	(484)	(5,804)	(5,804)	(5,804)	(5,804)	(5,804)
Transfers (to)/from Other Funds	33	0	0	0	0	(8,114)	(4,846)	(5,926)	(7,006)	(8,086)	(9,166)
<b>Annual Surplus/ (Deficit)</b>	34	(\$80,556)	\$61,173	\$46,454	(\$50,257)	(\$27,195)	(\$624)	\$1,098	\$2,586	\$3,827	\$4,809
Beginning Unrestricted Cash Balance	35	\$111,665	\$31,109	\$92,282	\$138,736	\$88,479	\$61,284	\$60,660	\$61,758	\$64,344	\$68,171
<b>Ending Unrestricted Cash Balance</b>	36	\$31,109	\$92,282	\$138,736	\$88,479	\$61,284	\$60,660	\$61,758	\$64,344	\$68,171	\$72,980
Unrestricted Cash % of Expenses	37	17%	207%	252%	104%	69%	65%	63%	62%	63%	64%

City of Adel, Iowa  
Storm Water Enterprise Fund  
Cash-Basis Cashflow Analysis

EXHIBIT 1

Growth Assumptions	
Operating Expenses	Various
ESU Growth	0.00%
Interest Rate	n/a

Storm Water Revenue Adjustments			
1-Jul-16	\$0.00	1-Jul-21	\$0.20
1-Jul-17	\$0.20	1-Jul-22	\$0.20
1-Jul-18	\$0.20	1-Jul-23	n.a
1-Jul-19	\$0.20	1-Jul-24	n.a
1-Jul-20	\$0.20	1-Jul-25	n.a

	Audited Financial Statements			YTD/Budget	Budget	Projected	Projected	Projected	Projected	Projected
	FY 2013-14	FY 2014-15	FY 2015-16	FY 2016-17	FY 2017-18	FY 2018-19	FY 2019-20	FY 2020-21	FY 2021-22	FY 2022-23
<b>RESTRICTED FUNDS</b>										
Sinking Fund 38	\$0	\$0	\$0	\$0	\$0	\$0	\$0	\$0	\$0	\$0
USDA Reserve Fund 39	0	0	0	0	484	6,287	12,091	17,894	23,698	29,501
Debt Service Charge Fund 40	0	0	0	0	8,114	12,960	18,887	25,893	33,980	43,146
Water Deposits 41	0	0	0	0	0	0	0	0	0	0
Storm Water Improvement Fund 42	<u>50,902</u>	<u>50,902</u>	<u>50,902</u>	<u>50,902</u>	<u>50,902</u>	<u>50,902</u>	<u>50,902</u>	<u>50,902</u>	<u>50,902</u>	<u>50,902</u>
Total Restricted Cash 43	\$50,902	\$50,902	\$50,902	\$50,902	\$59,499	\$70,149	\$81,879	\$94,689	\$108,579	\$123,549
Total Cash 44	\$82,011	\$143,184	\$189,638	\$139,381	\$120,784	\$130,809	\$143,638	\$159,033	\$176,750	\$196,529
<b>Capital Improvement Plan</b>										
Operating Capital Outlays				\$49,625	\$49,625	\$25,000	\$25,000	\$25,000	\$25,000	\$25,000
Lynne Drive & South 14th & South 11th Streets				0	950,000	0	0	0	0	0
Rapids Street Water Main Replacement				0	0	0	0	0	0	0
Horse n' Buggy Secondary & Pleasant Street				0	480,000	0	0	0	0	0
Engineering & Legal Fees				13,248	0	0	0	0	0	0
Engineering & Legal Fees USDA Loan #2				160,000	0	0	0	0	0	0
Reserved				0	0	0	0	0	0	0
Total				\$222,873	\$1,479,625	\$25,000	\$25,000	\$25,000	\$25,000	\$25,000

City of Adel, Iowa  
Storm Water Enterprise Fund  
Operational Expenses

EXHIBIT 2

	Audited Financial Statements			YTD/Budget	Budget	Projected Operating Expenses					Expense
	FY 2013-14	FY 2014-15	FY 2015-16	FY 2016-17	FY 2017-18	FY 2018-19	FY 2019-20	FY 2020-21	FY 2021-22	FY 2022-23	Growth
<b>Personal</b>											
Full Time Wages	\$0	\$0	\$5,601	\$7,376	\$7,745	\$8,132	\$8,539	\$8,966	\$9,414	\$9,885	5%
Part Time Wages	0	828	9,538	13,473	14,147	14,854	15,597	16,377	17,195	18,055	5%
FICA	0	63	1,125	1,595	1,675	1,758	1,846	1,939	2,036	2,137	5%
IPERS	0	74	1,362	1,862	1,955	2,053	2,155	2,263	2,376	2,495	5%
Flex Plan TPA	0	0	0	0	0	0	0	0	0	0	5%
HRA Reimbursement	0	0	0	1,000	1,050	1,103	1,158	1,216	1,276	1,340	5%
HRA Plan TPA	0	0	0	16	17	18	19	19	20	21	5%
Medical & Dental Ins	0	0	0	2,989	3,138	3,295	3,460	3,633	3,815	4,006	5%
Life & Disability Ins	0	0	0	94	99	104	109	114	120	126	5%
Work Comp Ins	0	0	0	0	0	0	0	0	0	0	5%
Dues, Memberships & Subscriptions	1,375	1,375	1,563	1,375	1,444	1,516	1,592	1,671	1,755	1,843	5%
Education & Training	0	0	344	0	0	0	0	0	0	0	5%
<b>Total Personal Services</b>	\$1,375	\$2,340	\$19,533	\$29,780	\$31,269	\$32,832	\$34,474	\$36,198	\$38,008	\$39,908	



City of Adel, Iowa  
Storm Water Enterprise Fund  
Operational Expenses

EXHIBIT 2

	Audited Financial Statements			YTD/Budget	Budget	Projected Operating Expenses					Expense
	FY 2013-14	FY 2014-15	FY 2015-16	FY 2016-17	FY 2017-18	FY 2018-19	FY 2019-20	FY 2020-21	FY 2021-22	FY 2022-23	Growth
<b>Services and Commodities</b>											
Vehicle Fuel, Oil & Lubricant	\$939	\$1,078	\$821	\$2,000	\$2,100	\$2,205	\$2,315	\$2,431	\$2,553	\$2,680	5%
Vehicle Equip & Radio Maint.	5,517	2,336	236	4,000	4,200	4,410	4,631	4,862	5,105	5,360	5%
Utilities	0	0	0	0	0	0	0	0	0	0	5%
Telephone/Radio	0	0	1,161	0	0	0	0	0	0	0	5%
Professional Fees	17,758	5,781	7,491	3,842	5,500	5,775	6,064	6,367	6,685	7,020	5%
Insurance	0	0	0	0	0	0	0	0	0	0	5%
Street Sweeping	3,211	5,951	1,045	5,000	5,250	5,513	5,788	6,078	6,381	6,700	5%
Sales Tax	0	0	0	0	0	0	0	0	0	0	5%
Line Maint.	1,434	3,955	13,639	7,500	7,875	8,269	8,682	9,116	9,572	10,051	5%
Service & Maint. Agreements	1,852	8,704	9,107	10,000	10,500	11,025	11,576	12,155	12,763	13,401	5%
Testing	0	0	0	0	0	0	0	0	0	0	5%
Refunds	0	0	0	500	525	551	579	608	638	670	5%
Chemicals	0	178	0	0	0	0	0	0	0	0	5%
Minor Equipment	504	0	121	500	525	551	579	608	638	670	5%
Office Supplies	130	276	459	100	105	110	116	122	128	134	5%
SWU Intake Repairs	19,427	10,434	165	20,000	20,000	21,000	22,050	23,153	24,310	25,526	5%
Misc.	1,476	494	1,290	1,500	1,575	1,654	1,736	1,823	1,914	2,010	5%
<b>Total Services and Commodities</b>	<b>\$52,248</b>	<b>\$39,187</b>	<b>\$35,535</b>	<b>\$54,942</b>	<b>\$58,155</b>	<b>\$61,063</b>	<b>\$64,116</b>	<b>\$67,322</b>	<b>\$70,688</b>	<b>\$74,222</b>	
<b>Capital Outlay</b>											
Vehicle Equip	\$1,374	\$3,000	\$4,000	\$0	\$0	\$0	\$0	\$0	\$0	\$0	
SWU Upgrade	127,598	0	0	49,625	49,625	0	0	0	0	0	
Building	0	0	0	0	0	0	0	0	0	0	
Miscellaneous	0	0	0	0	0	25,000	25,000	25,000	25,000	25,000	
<b>Total Capital Outlay</b>	<b>\$128,972</b>	<b>\$3,000</b>	<b>\$4,000</b>	<b>\$49,625</b>	<b>\$49,625</b>	<b>\$25,000</b>	<b>\$25,000</b>	<b>\$25,000</b>	<b>\$25,000</b>	<b>\$25,000</b>	
<b>Subtotal</b>	<b>\$182,595</b>	<b>\$44,527</b>	<b>\$59,068</b>	<b>\$134,347</b>	<b>\$139,049</b>	<b>\$118,895</b>	<b>\$123,590</b>	<b>\$128,519</b>	<b>\$133,695</b>	<b>\$139,130</b>	
<b>Total Operating Expenses</b>	<b>\$53,623</b>	<b>\$41,527</b>	<b>\$55,068</b>	<b>\$84,722</b>	<b>\$89,424</b>	<b>\$93,895</b>	<b>\$98,590</b>	<b>\$103,519</b>	<b>\$108,695</b>	<b>\$114,130</b>	
<b>Internal-Audit Adjustments</b>	<b>128,688</b>	<b>2,979</b>	<b>0</b>	<b>0</b>	<b>0</b>	<b>0</b>	<b>0</b>	<b>0</b>	<b>0</b>	<b>0</b>	
<b>Audit Report Totals</b>	<b>\$182,311</b>	<b>\$44,506</b>	<b>\$55,068</b>	<b>\$84,722</b>	<b>\$89,424</b>	<b>\$93,895</b>	<b>\$98,590</b>	<b>\$103,519</b>	<b>\$108,695</b>	<b>\$114,130.20</b>	

**EXHIBIT 3**

<u>Projects</u>	<u>Interest Rate</u>	<u>Grant%</u>	<u>Project Cost Amount</u>	<u>Costs of Issuance</u>	<u>Capitalized Interest</u>	<u>Borrowing Amount</u>	<u>Loan Date</u>	<u>Construction Time</u>	<u>USDA Loan Date</u>
Interim Loan #2	3.00%	0.00%	1,590,000	30,000	0	1,620,000	5/1/2017	13	6/1/2018
USDA Loan #2	2.75%	15.00%	1,377,000	30,000	0	1,407,000	6/1/2018	\$4,836.25	MTH PMT



Item	Included	Not Included
<p><b>D.</b>      <u><b>Advertising, Bidding, Contract Award</b></u></p> <ol style="list-style-type: none"> <li>1. Assist <b>OWNER</b> in advertising for and obtaining bids. <input checked="" type="checkbox"/> <input type="checkbox"/></li> <li>2. Conduct Prebid Conference at <b>OWNER'S</b> location (1-meeting). <input checked="" type="checkbox"/> <input type="checkbox"/></li> <li>3. Provide drawings, specifications, contract documents and bid documents to prospective bidders. <input checked="" type="checkbox"/> <input type="checkbox"/></li> <li>4. Issue addenda to interpret or clarify bid documents. <input checked="" type="checkbox"/> <input type="checkbox"/></li> <li>5. Review prebid submittals from bidders. <input checked="" type="checkbox"/> <input type="checkbox"/></li> <li>6. Attend Bid opening (at <b>OWNER</b> location), prepare bid tabulation (1-meeting). <input checked="" type="checkbox"/> <input type="checkbox"/></li> <li>7. Review bidder's qualifications, bids, and other documents and make recommendation for award of contract. <input checked="" type="checkbox"/> <input type="checkbox"/></li> <li>8. Attend one (1) meeting to present Bids to Owner. <input checked="" type="checkbox"/> <input type="checkbox"/></li> </ol>		
<p><b>E.</b>      <u><b>Paper Copies of Final Project Documents</b></u></p> <ol style="list-style-type: none"> <li>1. Print sufficient number of paper copies of final project documents, per Iowa Code 26.3, and distribute to prospective bidders: <ul style="list-style-type: none"> <li>• 24 x 36 Drawings (up to 5 included)</li> <li>• 11 x 17 Drawings (up to 10 included)</li> <li>• Contract Documents and Specifications</li> <li>• Engineer's Opinion of Probable Cost</li> </ul> </li> </ol>	<input checked="" type="checkbox"/>	<input type="checkbox"/>
<p><b>F.</b>      <u><b>Construction Administration</b></u></p> <ol style="list-style-type: none"> <li>1. Provide general administration of construction contract as <b>OWNER'S</b> representative. <input checked="" type="checkbox"/> <input type="checkbox"/></li> <li>2. Visit site of construction at appropriate stages of construction to observe the Contractors work. <input checked="" type="checkbox"/> <input type="checkbox"/></li> <li>3. Issue interpretations and clarifications of contract documents. <input checked="" type="checkbox"/> <input type="checkbox"/></li> <li>4. Review shop drawings and contractor submittals. <input checked="" type="checkbox"/> <input type="checkbox"/></li> <li>5. Act as initial interpreter of the requirements of the contract documents. <input checked="" type="checkbox"/> <input type="checkbox"/></li> <li>6. Review and process Contractor's application for payment. <input checked="" type="checkbox"/> <input type="checkbox"/></li> <li>7. Attend Construction Progress Meetings. <input checked="" type="checkbox"/> <input type="checkbox"/></li> </ol>		
<p><b>G.</b>      <u><b>Construction Staking</b></u></p> <ol style="list-style-type: none"> <li>1. Establish Field Controls <input checked="" type="checkbox"/> <input type="checkbox"/></li> <li>2. Stake Construction Control Points <input checked="" type="checkbox"/> <input type="checkbox"/></li> </ol>		
<p><b>H</b>      <u><b>Resident Project Representative</b></u></p> <ol style="list-style-type: none"> <li>1. Provide a Resident Project Representative to be on site during construction (see Exhibit "D", A Listing of Duties, Responsibilities and Limitations of Authority of the Resident Project Representative). <input checked="" type="checkbox"/> <input type="checkbox"/></li> </ol>		
<p><b>I.</b>      <u><b>Land and Easement Acquisition</b></u></p> <p><u><b>Phase I Services:</b></u></p> <ol style="list-style-type: none"> <li>1. Develop property map that clearly delineates the land to be required <ul style="list-style-type: none"> <li>• Initiate contact with affected land owners <input checked="" type="checkbox"/> <input type="checkbox"/></li> <li>• Meet individually with each affected land owner <input checked="" type="checkbox"/> <input type="checkbox"/></li> <li>• Determine willingness to sell <input checked="" type="checkbox"/> <input type="checkbox"/></li> <li>• Report to Council/Staff summary of findings. <input checked="" type="checkbox"/> <input type="checkbox"/></li> </ul> </li> <li>2. Verify requirements of the National Environmental Policy Act (NEPA) are met <input checked="" type="checkbox"/> <input type="checkbox"/></li> </ol> <p><u><b>Phase II Services:</b></u></p> <ol style="list-style-type: none"> <li>3. Surveys and Plats <ul style="list-style-type: none"> <li>• Identify surveys and plats needed for proposed property acquisition <input checked="" type="checkbox"/> <input type="checkbox"/></li> <li>• Prepare Survey Plats and Legal Descriptions for parcels <input checked="" type="checkbox"/> <input type="checkbox"/></li> </ul> </li> <li>4. Preliminary Title Search <ul style="list-style-type: none"> <li>• Identify title search companies <input checked="" type="checkbox"/> <input type="checkbox"/></li> <li>• Order Preliminary title searches to confirm ownership and encumbrances <input checked="" type="checkbox"/> <input type="checkbox"/></li> </ul> </li> <li>5. Appraisals <ul style="list-style-type: none"> <li>• Select and Negotiate contract for Appraisals and Review Appraisals <input checked="" type="checkbox"/> <input type="checkbox"/></li> </ul> </li> <li>6. Select and negotiate contract for Environmental Site Assessment (ESA) consultant, if required <input checked="" type="checkbox"/> <input type="checkbox"/></li> <li>7. Select and negotiate contract for land acquisition and relocation consultant, if required <input type="checkbox"/> <input checked="" type="checkbox"/></li> <li>8. Conduct a due diligence environmental audit to determine if hazardous material or contamination are present on the subject properties. <input type="checkbox"/> <input checked="" type="checkbox"/></li> <li>9. Prepare relocation plan if there are any persons to be displaced <input type="checkbox"/> <input checked="" type="checkbox"/></li> <li>10. Coordinate appraisals and appraisal review; approve fair market value. <input checked="" type="checkbox"/> <input type="checkbox"/></li> </ol> <p><u><b>Phase III Services:</b></u></p> <ol style="list-style-type: none"> <li>11. Assist Attorney in making written offer of just compensation. <ul style="list-style-type: none"> <li>• At initiation of negotiations, provide general notice of the property owner's rights and entitlements on the acquisition of their property and an explanation of the relocation assistance and payment entitlements. <input type="checkbox"/> <input checked="" type="checkbox"/></li> </ul> </li> <li>12. Assist Attorney in negotiating purchase agreements <input type="checkbox"/> <input checked="" type="checkbox"/></li> <li>13. Assist Attorney in coordinating Closing/Court Award, Title Conveyance and Scheduled Possession <input type="checkbox"/> <input checked="" type="checkbox"/></li> </ol>		

Item	Included	Not Included
<b>J. <u>Geotechnical Coordination</u></b> 1. Request for Proposal to Geotechnical Firms 2. Review Proposals/Recommendation for Award 3. Review Geotechnical Results with the Owner (1-meeting)	<input checked="" type="checkbox"/> <input checked="" type="checkbox"/> <input checked="" type="checkbox"/>	<input type="checkbox"/> <input type="checkbox"/> <input type="checkbox"/>
<b>K. <u>Record Drawings</u></b> 1. As-Built Record Drawings (2 Hard Copies & 1 Electronic Copy Included) 2. Additional Hard Copies - 1 EA @ \$100.00 3. Additional Electronic Copies - 1 EA @ \$25.00	<input checked="" type="checkbox"/> <input checked="" type="checkbox"/> <input checked="" type="checkbox"/>	<input type="checkbox"/> <input type="checkbox"/> <input type="checkbox"/>
<b>L. <u>Operator Training / Startup Services</u></b> 1. Operator Training/Workshops 2. Equipment Startup Services	<input type="checkbox"/> <input type="checkbox"/>	<input checked="" type="checkbox"/> <input checked="" type="checkbox"/>
<b>M. <u>Operation / Maintenance Manuals</u></b> 1. O&M Manual Preparation 2. Hard Copies _____ EA @ \$ _____ 3. Electronic Copies _____ EA @ \$ _____	<input type="checkbox"/> <input type="checkbox"/> <input type="checkbox"/>	<input checked="" type="checkbox"/> <input checked="" type="checkbox"/> <input checked="" type="checkbox"/>
<b>N. <u>Loan Application and Administrative Services:</u></b> 1. Prepare Loan Applications 2. Environmental Review Checklist and Coordination. 3. Attend Public Hearing on Finding of No Significant Impact (FONSI). 4. Environmental Assessment. 5. Prepare Outlay Requests. 6. Review of Payroll records. 7. Wage Interviews. 8. Prepare and Submit Loan Closeout documents. 9. Administration of other funding sources.	<input checked="" type="checkbox"/> <input type="checkbox"/> <input checked="" type="checkbox"/> <input type="checkbox"/> <input type="checkbox"/> <input type="checkbox"/> <input type="checkbox"/> <input checked="" type="checkbox"/> <input type="checkbox"/>	<input type="checkbox"/> <input checked="" type="checkbox"/> <input type="checkbox"/> <input checked="" type="checkbox"/> <input checked="" type="checkbox"/> <input checked="" type="checkbox"/> <input checked="" type="checkbox"/> <input checked="" type="checkbox"/> <input type="checkbox"/> <input checked="" type="checkbox"/>
<b>O. <u>Other Meetings</u></b> 1. Special meetings with Council/Staff 2. Public Informational Meetings 3. Regulatory Agencies	<input checked="" type="checkbox"/> <input checked="" type="checkbox"/> <input checked="" type="checkbox"/>	<input type="checkbox"/> <input type="checkbox"/> <input type="checkbox"/>

3. Fee Schedule:

	PART A East Annex Lift Station & Forcemain	PART B East Annex Central Sanitary Trunk Sewer	PART C Puckerbrush Road Sanitary Trunk Sewer
<input checked="" type="checkbox"/> A. Schematic Design and Financial Feasibility (LS)	\$ 10,000.00	\$ 20,000.00	\$ 20,000.00
<input checked="" type="checkbox"/> B. Preliminary Design (LS)	\$ TBD	\$ TBD	\$ TBD
<input checked="" type="checkbox"/> C. Final Design (LS)	\$ TBD	\$ TBD	\$ TBD
<input checked="" type="checkbox"/> D. Advertising, Bidding, Contract Award (LS)	\$ TBD	\$ TBD	\$ TBD
<input checked="" type="checkbox"/> E. Paper Copies of Final Contract Documents (LS)	\$ TBD	\$ TBD	\$ TBD
<input checked="" type="checkbox"/> F. Construction Administration (LS)	\$ TBD	\$ TBD	\$ TBD
<input checked="" type="checkbox"/> G. Construction Staking (LS)	\$ TBD	\$ TBD	\$ TBD
<input checked="" type="checkbox"/> H. Resident Project Representative (T&M)	\$ TBD	\$ TBD	\$ TBD
<input checked="" type="checkbox"/> I. Land & Easement Acquisition			
<input checked="" type="checkbox"/> I. Phase 1 Services - Land & Easement Acquisition (LS)	\$ 750.00	\$ 2,000.00	\$ 2,000.00
<input checked="" type="checkbox"/> I. Phase 2 Services - Land & Easement Acquisition (LS)	\$ TBD	\$ TBD	\$ TBD
<input type="checkbox"/> I. Phase 3 Services - Land & Easement Acquisition (T&M)	\$ NIC	\$ NIC	\$ NIC
<input checked="" type="checkbox"/> J. Geotechnical Coordination (LS)	\$ TBD	\$ TBD	\$ TBD
<input checked="" type="checkbox"/> K. Record Drawings (LS)	\$ TBD	\$ TBD	\$ TBD
<input type="checkbox"/> L. Operator Training / Startup Services (NIC)	\$ NIC	\$ NIC	\$ NIC
<input type="checkbox"/> M. Operation / Maintenance Manuals (NIC)	\$ NIC	\$ NIC	\$ NIC
<input checked="" type="checkbox"/> N. Loan Application and Admin. Services (LS)	\$ TBD	\$ TBD	\$ TBD
<input checked="" type="checkbox"/> O. Other Meetings (T&M)	\$ TBD	\$ TBD	\$ TBD

LS Lump Sum  
 NTE Not To Exceed  
 N/A Not Applicable  
 NIC Not Included  
 TBD To Be Determined  
 T&M Time & Materials

The Hourly Rate Schedule is included in Exhibit 'A' and attached to this Agreement to be used for work performed on a *Time and Material* basis.

- Past due amounts owed shall accrue interest at 1.5% per month from the 30<sup>th</sup> day. If the **Owner** fails to make monthly payments due the **Engineer**, the **Engineer** may, after giving (7) days written notice to the **Owner**, suspend services under this Agreement.
- This Agreement represents the entire and integrated agreement between the Owner and the Engineer and supersedes all prior negotiations, representations or agreements, either written or oral. This Agreement may be amended only by written instrument signed by both the Owner and the Engineer.
- This Agreement is subject to all the Terms and Conditions listed on the following page.

Exhibits		Included	Not Included
Exhibit 'A'	Hourly Rate Schedule	<input checked="" type="checkbox"/>	<input type="checkbox"/>
Exhibit 'B'	Preliminary Project Scope	<input checked="" type="checkbox"/>	<input type="checkbox"/>
Exhibit 'C'	Owner's Responsibilities	<input checked="" type="checkbox"/>	<input type="checkbox"/>
Exhibit 'D'	Duties, Responsibilities and Limitations of Authority of the Resident Project Representative	<input type="checkbox"/>	<input checked="" type="checkbox"/>

**SPECIAL INSTRUCTIONS:**

---

---

---

---

**OWNER:** CITY OF ADEL, IA

**ENGINEER:** MCCLURE ENGINEERING COMPANY  
CLIVE, IA

Signed: \_\_\_\_\_

Signed: \_\_\_\_\_  
Derick Anderson, P.E.

Title: \_\_\_\_\_

Title: \_\_\_\_\_  
Vice President - Water

Phone: \_\_\_\_\_

Phone: \_\_\_\_\_  
515-964-1229

Email: \_\_\_\_\_

Email: \_\_\_\_\_  
danderson@mecresults.com

EXHIBIT 'A'  
 McCLURE ENGINEERING COMPANY  
 HOURLY RATE SCHEDULE  
 (Effective through December 31, 2017)

<u>PERSONNEL</u>	<u>HOURLY RATE</u>
Administrative.....	\$70.00
Staff Engineer.....	\$110.00
Project Engineer.....	\$140.00
Senior Project Engineer .....	\$190.00
Project Manager .....	\$170.00
Principal.....	\$200.00
Senior Principal .....	\$225.00
Senior Engineering Technician.....	\$130.00
Engineering Technician (ET).....	\$100.00
Registered Land Surveyor .....	\$170.00
Landscape Architect.....	\$130.00
On-Site Representative (OSR) .....	\$95.00
Senior On-Site Representative (OSR).....	\$130.00
Crew Chief (CC).....	\$100.00
Crew Member (CM).....	\$85.00
Survey Crew.....	\$220.00
Survey Crew with Scanner.....	\$285.00
Intern Crew Member.....	\$65.00

MISCELLANEOUS EXPENSES

Survey Vehicle Mileage.....	\$0.70/Mile
Automobile Mileage .....	\$0.540/Mile
Plans .....	\$0.15/Sq. Ft.
Vellums.....	\$0.55/Sq. Ft.
Out-of-Pocket Expenses (Meals, Hotels, etc.).....	At Cost + 10%
Large Format Color Prints.....	\$5.25/Sq. Ft





## McCLURE ENGINEERING COMPANY STANDARD TERMS AND CONDITIONS

**ACCESS TO SITE:** The Engineer shall at all times have access to the site to complete his Work.

**INFORMATION PROVIDED BY OTHERS:** The Engineer shall be entitled to rely upon the accuracy and completeness of data provided by the Owner and shall not assume liability for such data. The Engineer does not practice law, insurance or financing, therefore, the Owner shall furnish all legal, accounting and insurance counseling services as may be necessary to protect themselves at any time during the Project. Owner shall hold Engineer harmless from damages that may arise as a result of inaccuracies of information or data supplied by Owner or others to Engineer.

**ADDITIONAL SERVICES:** As an Additional Service in connection with changes in the scope of the Engineer's work by the Owner, the Engineer shall prepare Drawings, Specifications and other documentation and data, evaluate Contractor's proposal and provide any other services made necessary by such Change Orders and Construction Change Directives. The Engineer will be entitled to additional compensation to coordinate such changes and schedules shall be adjusted accordingly.

**OWNERSHIP AND REUSE OF DOCUMENTS:** All reports, plans, specifications, field data and other documents written and/or electronic, prepared by Engineer in doing work on the project, shall remain the property of the Engineer. The documents prepared by the Engineer for this Project are for use solely with respect to this Project. The Engineer's Drawings, Specifications or other documents shall not be used by the Owner on other projects or for additions to this Project, except by agreement in writing and with appropriate compensation to the Engineer.

**OPINIONS OF PROBABLE COSTS:** It is recognized that neither the Engineer nor the Owner has control over the cost of labor, materials or equipment, over the Contractor's methods of determining bid prices, or over competitive bidding, market or negotiating conditions. Accordingly, the Engineer cannot and does not warrant or represent that bids or negotiated prices will not vary from any estimate of costs or evaluation prepared or agreed to by the Engineer.

**DISPUTE RESOLUTION:** Claims, disputes or other matters, involving a value less than \$200,000.00, in question between the parties to this Agreement arising out of or relating to this Agreement or breach thereof shall be subject to mediation unless each of the parties mutually agrees otherwise. No mediation arising out of or relating to this Agreement shall include, by consolidation, joinder or in any other manner, an additional person or entity not a party to this Agreement, except by written consent containing a specific reference to this Agreement signed by the Owner, Engineer, and any other person or entity sought to be joined. In no event shall the demand for mediation be made after the date when the institution of legal or equitable proceedings based upon such claim would be barred by the applicable statute of limitations. The award rendered in the mediation shall be non-binding.

**TERMINATION:** This Agreement may be terminated by either party upon not less than seven days written notice should the other party fail substantially to perform in accordance with the terms of the Agreement through no fault of the party initiating the termination. This Agreement may be terminated by the Owner upon not less than seven days' written notice to the Engineer in the event the Project is permanently abandoned.

Failure of the Owner to make payments to the Engineer in accordance with the Agreement shall be considered substantial non-performance and cause for termination. If the Owner fails to make payment when due the Engineer for services, the Engineer may, upon seven days' written notice to the Owner, suspend performance of services under this Agreement. Unless payment in full is received by the Engineer within seven days of the date of the notice, the suspension shall take effect without further notice. In the event of a suspension of services, the Engineer shall have no liability to the Owner for delay or damage caused the Owner because of such suspension of services.

In the event of termination not the fault of the Engineer, the Engineer shall be compensated for services performed prior to termination and all termination expenses. Termination expenses are in addition to compensation for *Basic and Additional Services*, and include expenses which are directly attributable to termination.

**CONTRACTOR MATTERS:** The Engineer has no control over the Contractor's means, methods, schedule, costs, quality control, workmanship, on-site storm water runoff/erosion control, or project safety measures. For this reason, the Engineer shall not be responsible for or assume liability for the same.

**UNDERGROUND UTILITIES:** Information for location of underground utilities may come from the Owner, third parties, and/or research performed by the Engineer or its subcontractors. Unfortunately, the information the Engineer must rely on from various utilities and other records may be inaccurate or incomplete. Therefore, the Owner agrees to indemnify and hold harmless the Engineer for all claims, losses, costs and damages arising out of the location of underground utilities provided by the Engineer under this Agreement.

**SHOP DRAWING REVIEW:** If, as part of this Agreement Engineer reviews Contractor submittals, such as shop drawings, product data, samples and other data, as required by Engineer, these reviews and approvals shall be only for the limited purpose of checking for conformance with the design concept and the information expressed in the contract documents. This review shall not include review of the accuracy or completeness of details, such as quantities, dimensions, weights or gauges, fabrication processes, construction means or methods, coordination of the work with other trades or construction safety precautions, all of which are the sole responsibility of the Contractor. Engineer shall not be responsible for any deviations from the contract documents not brought to the attention of Engineer in writing by the contractor. Engineer shall not be required to review partial submissions or those for which submissions of correlated items have not been received.

**CONSTRUCTION OBSERVATION:** If, as part of this Agreement, Engineer is providing construction observation services, Engineer shall visit the project at appropriate intervals during construction to become generally familiar with the progress and quality of the Contractor's work and to determine if the work is proceeding in general accordance with the Contract Documents. Unless otherwise specified in this Agreement, the Owner has not retained the Engineer to make detailed inspections or to provide exhaustive or continuous project review and observation services. Engineer does not guarantee the performance of, and shall have no responsibility for, the acts or omissions of any contractor, subcontractor, supplier or any other entity furnishing materials or performing any work on the project.

**HAZARDOUS MATERIALS – INDEMNIFICATION:** The Engineer is not in the business of making environmental site assessments for purposes of determining the presence of any toxic, hazardous or other environmental damaging substances. The purpose of this provision is to be certain that the Owner is aware of the potential liability if toxic, hazardous or environmental damaging substances are found on or under the property. Engineer makes no representations regarding an environmental site assessment, relies upon Owner to have fully investigated the need and/or scope of such assessment and assumes no responsibility for the determination to make an environmental site assessment on the subject property.

**PAYMENT:** Amounts unpaid 30 days after invoice date shall bear interest from the date payment is due at a rate of 1.5% per month compounded and shall include costs for attorney fees and other collection fees related to collecting fees for service.

**LIMITATION OF LIABILITY:** The Engineer's liability shall be limited to \$50,000.00 or the fee for the work performed, whichever is greater, or as specifically agreed to by separate agreement.

**WAIVERS:** The Owner and the Engineer waive all rights against each other and against the contractors, consultants, agents and employees of the other for damages, but only to the extent covered by property insurance during construction. The Owner and Engineer each shall require similar waivers from their contractors, consultants and agents.

**ASSIGNMENT:** The Owner and Engineer, respectively, bind themselves, their partners, successors, assigns and legal representatives to the other party to this Agreement and to the partners, successors, assigns and legal representatives of such other party with respect to all covenants of this Agreement. Neither Owner nor Engineer shall assign this Agreement without the written consent of the other.

**GOVERNING LAW:** Unless otherwise provided, the Agreement shall be governed by the law of the principal place of business of the Engineer.

**COMPLETE AGREEMENT:** This Agreement represents the entire and integrated agreement between the Owner and Engineer and supersedes all prior negotiations, representations or agreements, either written or oral. This Agreement may be amended only by written instrument signed by both Owner and Engineer. Nothing contained in this Agreement shall create a contractual relationship with or a cause of action in favor of a third party against either the Owner or Engineer.

(Effective 10/01/11)  
(Supersedes 11/01/08)

## EXHIBIT 'B'

### PRELIMINARY PROJECT SCOPE

---

#### Exhibit B – Scope of Work

The City of Adel has been actively involved in planning the necessary improvements to replace aging infrastructure while also planning for future growth, including growth of City annexed area east of the North Raccoon River. The *Scope of Work* included in the Adel East Annex Sanitary Utility Extension will include, but not necessarily be limited to:

#### Schematic Design and Financial Feasibility

To accurately describe and reflect project scope, extent and character, it is proposed to first complete schematic design and associated land and easement acquisition. Schematic design services include identification of design criteria, establishment of preliminary piping alignments and hydraulic profiles, and development of a conceptual site plan for the proposed lift station location. Through completion of schematic design, identification of the extent of the probable service area will be developed.

Additionally, the financial feasibility of the proposed East Annex Sanitary Utility Extension will be evaluated and presented to the City. Steps to determine financial feasibility may include updated preliminary cost estimates, engagement with existing and potential customers, review of project financing alternatives, and identification of potential sanitary sewer connection fee district.

#### Land and Easement Acquisition – Phase I

To complete Land and Easement Acquisition services necessary for the construction of the Adel East Annex Sanitary Utility Extension, work will be completed in a phased approach. Completion of Phase I services will include the development of a property acquisition and owner map which details the location, owner, and area of land and easements to be acquired. Initial contact with owners will also be completed to inform owners of the proposed project and determine their willingness to provide easement and/or sell land as necessary for project completion. Following completion of Phase I services, the Engineer will report to City Council on findings.

Phase II of Land and Easement Acquisition services will include the development of Legal Surveys and Plats, Preliminary Title Search, and coordination of Land Appraisals for associated parcels necessary to acquire for the proposed project(s).

Following completion of Schematic Design and Land and Easement Acquisition services, the Engineer will report to City Council on findings and provide recommendations for proceeding with design and construction of the proposed project. Services to be completed by the Engineer in the Design and Construction Phases will include, but not necessarily be limited to:

- Preliminary Design
- Geotechnical Coordination
- Final Design
- Advertising, Bidding & Contract Award
- Construction Administration
- Construction Staking
- Resident Project Representative Services
- Loan Application & Administration Services
- Record Drawings

MEC shall prepare the plans and specifications necessary to acquire construction permits and receive bids on the projects. After award of a construction contract, MEC shall provide Construction Administration, Construction Staking and Resident Project Representative Services.

MEC anticipates working closely with City staff as project plans and specifications are developed. MEC shall report to the City Public Works Department at periodic intervals during design and construction. At critical milestones, MEC shall meet with the City Council and/or City Water, Sewer, and Sanitation Utility Subcommittee to keep them informed of the overall progress.

Once the design and cost estimating work is nearing 90% complete on each individual project, MEC shall review the findings with the City Council.

The Adel East Annex Sanitary Utility Extension includes the following projects:

**Part A – East Annex Lift Station and Force Main**

East Annex Lift Station and Force Main

Part A of the East Annex Sanitary Utility Extension includes the construction of a new lift station and force main to convey flows of the proposed East Annex Sanitary Sewer area to the City’s WWTP. The initial size of the East Annex Lift Station is recommended to be 2.30 MGD, and will include approximately 3,700 feet of 12” sanitary forcemain to convey flows of the East Annex area to the City’s WWTP. The engineer’s opinion of probable cost for a 2.30 MGD lift station and 3,700 feet of 12” forcemain in 2017 is \$3,475,000.

**Part B – East Annex Central Sanitary Trunk Sewer**

East Annex Central Sanitary Trunk Sewer

Part B of the East Annex Sanitary Utility Extension includes the construction of a new sanitary trunk sewer to transport flows of the entire East Annex Sanitary Sewer collection system to the newly constructed East Annex Pump Station. Beginning at Puckerbrush Road, the new trunk sewer would receive flows from the Puckerbrush Road Sanitary Trunk Sewer Main and convey them, along with additional branch sewer mains to the new East Annex Pump Station for conveyance to the City’s WWTP. The engineer’s opinion of probable cost for approximately 7,700 feet of 24” gravity sewer main in 2017 is \$3,025,000.

**Part C – Puckerbrush Road Sanitary Trunk Sewer**

Puckerbrush Road Sanitary Trunk Sewer Main

Part C of the East Annex Sanitary Utility Extension includes the construction of a new sanitary trunk sewer to serve areas along and East of Puckerbrush Road, including the area currently developed along HWY 6 and R Avenue (Ortonville) which is served by an existing sanitary collection and treatment system owned by Dallas County. The proposed Puckerbrush Road trunk main would provide gravity sanitary sewer service to existing and future development. The engineer’s opinion of probable project cost for approximately 11,000 feet of 15-18” gravity sewer main in 2017 is \$3,115,000.

Attached for reference are an Exhibit identifying the proposed project area and preliminary Engineer’s Opinion of Probable Cost for the above identified projects.

CITY OF ADEL

East Annex Sanitary Sewer System Improvements

December 2016

Project 1 - East Annex Lift Station & Forcemain

Project 1

ITEM	DESCRIPTION	QUANTITY	UNIT COST	AMOUNT
1	Mobilization & Bonding	1 LS	\$ 111,200	\$ 111,200
2	Clearing and Grubbing	0.6 AC	\$ 15,000	\$ 9,000
3	Topsoil Strip, Stockpile, Respread	510 CY	\$ 10	\$ 5,100
4	Overexcavation	0 CY	\$ 15	\$ -
5	Stockpile & Repread of Overexcavation	0 CY	\$ 3	\$ -
6	Backfill & Grading of Overexcavation	0 CY	\$ 15	\$ -
7	Replace Unsuitable Soils	515 CY	\$ 20	\$ 10,300
8	Trench Compaction Testing	1 LS	\$ 4,700	\$ 4,700
9	6-IN PVC Sanitary Forcemain, Trenched	0 LF	\$ 35	\$ -
10	8-IN PVC Sanitary Forcemain, Trenched	0 LF	\$ 40	\$ -
11	10-IN PVC Sanitary Forcemain, Trenched	0 LF	\$ 46	\$ -
12	12-IN PVC Sanitary Forcemain, Trenched	3,185 LF	\$ 53	\$ 168,805
13	16-IN PVC Sanitary Forcemain, Trenched	0 LF	\$ 62	\$ -
14	18-IN PVC Sanitary Forcemain, Trenched	0 LF	\$ 75	\$ -
15	6-IN PVC Sanitary Forcemain, Trenchless (No Casing)	0 LF	\$ 105	\$ -
16	8-IN PVC Sanitary Forcemain, Trenchless (No Casing)	0 LF	\$ 120	\$ -
17	10-IN PVC Sanitary Forcemain, Trenchless (No Casing)	0 LF	\$ 135	\$ -
18	12-IN PVC Sanitary Forcemain, Trenchless (No Casing)	520 LF	\$ 155	\$ 80,600
19	16-IN PVC Sanitary Forcemain, Trenchless (No Casing)	0 LF	\$ 175	\$ -
20	18-IN PVC Sanitary Forcemain, Trenchless (No Casing)	0 LF	\$ 210	\$ -
21	6-IN DIP Sanitary Forcemain, Trenchless (Casing)	0 LF	\$ 510	\$ -
22	8-IN DIP Sanitary Forcemain, Trenchless (Casing)	0 LF	\$ 535	\$ -
23	10-IN DIP Sanitary Forcemain, Trenchless (Casing)	0 LF	\$ 560	\$ -
24	12-IN DIP Sanitary Forcemain, Trenchless (Casing)	0 LF	\$ 590	\$ -
25	16-IN DIP Sanitary Forcemain, Trenchless (Casing)	0 LF	\$ 615	\$ -
26	18-IN DIP Sanitary Forcemain, Trenchless (Casing)	0 LF	\$ 670	\$ -
27	Connection to Existing Sanitary Manhole	1 EA	\$ 3,500	\$ 3,500
28	Post Construction CCTV Inspection of Sanitary Forcemain	0 LF	\$ 2	\$ -
29	Railroad Crossing Surcharge	0 EA	\$ 25,000	\$ -
30	River Crossing Surcharge	1 EA	\$ 50,000	\$ 50,000
31	PCC Removal & Replacement w/Subbase & Subgrade Prep (Paving)	0 SY	\$ 95	\$ -
32	PCC Removal & Replacement w/Subbase & Subgrade Prep (Patching)	0 SY	\$ 125	\$ -
33	HMA Removal & Replacement w/Subbase & Subgrade Prep (Paving)	0 SY	\$ 90	\$ -
34	HMA Removal & Replacement w/Subbase & Subgrade Prep (Patching)	0 SY	\$ 120	\$ -
35	Gravel Removal & Replacement w/Subgrade Prep (Paving)	1,695 SY	\$ 27	\$ 45,765
36	Gravel Removal & Replacement w/Subgrade Prep (Patching)	0 SY	\$ 37	\$ -
37	Driveway Culvert Removal & Replacement	0 EA	\$ 750	\$ -
38	Urban Hydro Seeding	0 AC	\$ 4,500	\$ -
39	Rural Seeding	3 AC	\$ 3,000	\$ 9,000
40	Uncharted Utilities Parallel	530 LF	\$ 50	\$ 26,500
41	Uncharted Utilities Crossing	30 EA	\$ 650	\$ 19,500
42	Drain Tile Repair	15 EA	\$ 750	\$ 11,250
43	Dewatering Excavation	1 LS	\$ 28,500	\$ 28,500
44	Temporary Traffic Control (Urban)	0 LS	\$ 11,400	\$ -
45	Temporary Traffic Control (Rural)	1 LS	\$ 4,600	\$ 4,600
46	Construction Staking	1 LS	\$ 4,600	\$ 4,600
47	Storm Water Pollution Prevention Plan Preparation & Management	1 LS	\$ 2,900	\$ 2,900
48	Erosion Control Maintenance	1 LS	\$ 5,200	\$ 5,200
49	Silt Fence	1,060 LF	\$ 3	\$ 3,180
50				
51	2.3-MGD (1600 GPM) Lift Station, Complete	1 LS	\$ 1,725,000	\$ 1,725,000
52	Standby Power & Accessories, Complete	1 LS	\$ 180,000	\$ 180,000
53	Extension of 3-Phase Power Supply from Electric Utility	1 LS	\$ 80,000	\$ 80,000
54				
55	Miscellaneous Items Allowance (5%)	1 LS	\$ 123,900	\$ 123,900
<b>ENGINEER'S OPINION OF PROBABLE CONSTRUCTION COST</b>				<b>\$ 2,713,100</b>
Temporary Construction Easements				\$ 2,500
Permanent Easements				\$ 6,500
Land Acquisition				\$ 19,500
Contingency (10%)				\$ 271,400
Engineering, Legal, Administration				\$ 461,300
<b>ENGINEER'S OPINION OF PROBABLE PROJECT COST</b>				<b>\$ 3,474,300</b>
<b>TOTAL ENGINEER'S OPINION OF PROBABLE PROJECT COST</b>				<b>\$ 3,475,000</b>

NOTES

1 - The preliminary average depth of forcemain in this phase is 6 feet.

2 - Sewer crossing at Prospect Avenue is assumed to be trenchless construction without casing. All other road crossings assumed to include trenching with surface replacement.

**CITY OF ADEL**  
*East Annex Sanitary Sewer System Improvements*  
 December 2016  
 Project 1A - East Central Ravine Sanitary Trunk Sewer

Project 1A

ITEM	DESCRIPTION	QUANTITY	UNIT COST	AMOUNT
1	Mobilization & Bonding	1 LS	\$ 99,100	\$ 99,100
2	Clearing and Grubbing	4.5 AC	\$ 10,000	\$ 45,000
3	Topsoil Strip, Stockpile, Respread	1,240 CY	\$ 10	\$ 12,400
4	Overexcavation	21,800 CY	\$ 15	\$ 327,000
5	Stockpile & Respread of Overexcavation	21,800 CY	\$ 3	\$ 65,400
6	Backfill & Grading of Overexcavation	0 CY	\$ 15	-
7	Replace Unsuitable Soils	1,080 CY	\$ 20	\$ 21,600
8	Trench Compaction Testing	1 LS	\$ 9,800	\$ 9,800
9	48-IN Sanitary Manhole (SW-301 with External Chimney Seal)	24 EA	\$ 4,800	\$ 115,200
10	60-IN Sanitary Manhole (SW-301 with External Chimney Seal)	0 EA	\$ 6,300	-
11	Sanitary Sewer Wye for Future Connections	0 EA	\$ 750	-
12	4 or 6-IN Sanitary Service Stub	0 EA	\$ 3,200	-
13	8-IN PVC Sanitary Sewer Gravity Main, Trenched	0 LF	\$ 87	-
14	10-IN PVC Sanitary Sewer Gravity Main, Trenched	0 LF	\$ 92	-
15	12-IN PVC Sanitary Sewer Gravity Main, Trenched	0 LF	\$ 105	-
16	15-IN PVC Sanitary Sewer Gravity Main, Trenched	0 LF	\$ 117	-
17	18-IN PVC Sanitary Sewer Gravity Main, Trenched	0 LF	\$ 129	-
18	21-IN PVC Sanitary Sewer Gravity Main, Trenched	0 LF	\$ 137	-
19	24-IN PVC Sanitary Sewer Gravity Main, Trenched	7,685 LF	\$ 152	\$ 1,168,120
20	27-IN DIP Sanitary Sewer Gravity Main, Trenched	0 LF	\$ 237	-
21	30-IN DIP Sanitary Sewer Gravity Main, Trenched	0 LF	\$ 287	-
22	36-IN DIP Sanitary Sewer Gravity Main, Trenched	0 LF	\$ 337	-
23	8-IN PVC Sanitary Sewer Gravity Main, Trenchless (No Casing)	0 LF	\$ 225	-
24	10-IN PVC Sanitary Sewer Gravity Main, Trenchless (No Casing)	0 LF	\$ 255	-
25	12-IN PVC Sanitary Sewer Gravity Main, Trenchless (No Casing)	0 LF	\$ 265	-
26	15-IN PVC Sanitary Sewer Gravity Main, Trenchless (No Casing)	0 LF	\$ 300	-
27	18-IN PVC Sanitary Sewer Gravity Main, Trenchless (No Casing)	0 LF	\$ 340	-
28	21-IN PVC Sanitary Sewer Gravity Main, Trenchless (No Casing)	0 LF	\$ 375	-
29	24-IN PVC Sanitary Sewer Gravity Main, Trenchless (No Casing)	80 LF	\$ 405	\$ 32,400
30	27-IN DIP Sanitary Sewer Gravity Main, Trenchless (No Casing)	0 LF	\$ 640	-
31	30-IN DIP Sanitary Sewer Gravity Main, Trenchless (No Casing)	0 LF	\$ 730	-
32	36-IN DIP Sanitary Sewer Gravity Main, Trenchless (No Casing)	0 LF	\$ 830	-
33	8-IN PVC Sanitary Sewer Gravity Main, Trenchless (Casing)	0 LF	\$ 450	-
34	10-IN PVC Sanitary Sewer Gravity Main, Trenchless (Casing)	0 LF	\$ 500	-
35	12-IN PVC Sanitary Sewer Gravity Main, Trenchless (Casing)	0 LF	\$ 505	-
36	15-IN PVC Sanitary Sewer Gravity Main, Trenchless (Casing)	0 LF	\$ 555	-
37	18-IN PVC Sanitary Sewer Gravity Main, Trenchless (Casing)	0 LF	\$ 615	-
38	21-IN PVC Sanitary Sewer Gravity Main, Trenchless (Casing)	0 LF	\$ 660	-
39	24-IN PVC Sanitary Sewer Gravity Main, Trenchless (Casing)	0 LF	\$ 690	-
40	27-IN DIP Sanitary Sewer Gravity Main, Trenchless (Casing)	0 LF	\$ 900	-
41	30-IN DIP Sanitary Sewer Gravity Main, Trenchless (Casing)	0 LF	\$ 990	-
42	36-IN DIP Sanitary Sewer Gravity Main, Trenchless (Casing)	0 LF	\$ 1,080	-
43	Connection to Existing Sanitary Manhole	0 EA	\$ 3,500	-
44	Post Construction CCTV Inspection of Sanitary Sewer	7,765 LF	\$ 2	\$ 15,530
45	Railroad Crossing Surcharge	0 EA	\$ 25,000	-
46	Creek Crossing Surcharge	9 EA	\$ 15,000	\$ 135,000
47	PCC Removal & Replacement w/Subbase & Subgrade Prep (Paving)	0 SY	\$ 95	-
48	PCC Removal & Replacement w/Subbase & Subgrade Prep (Patching)	0 SY	\$ 125	-
49	HMA Removal & Replacement w/Subbase & Subgrade Prep (Paving)	0 SY	\$ 90	-
50	HMA Removal & Replacement w/Subbase & Subgrade Prep (Patching)	0 SY	\$ 120	-
51	Gravel Removal & Replacement w/Subgrade Prep (Paving)	0 SY	\$ 27	-
52	Gravel Removal & Replacement w/Subgrade Prep (Patching)	180 SY	\$ 37	\$ 6,660
53	Driveway Culvert Removal & Replacement	1 EA	\$ 750	\$ 750
54	Urban Hydro Seeding	0 AC	\$ 4,500	-
55	Rural Seeding	6 AC	\$ 3,000	\$ 18,000
56	Uncharted Utilities Parallel	1,110 LF	\$ 50	\$ 55,500
57	Uncharted Utilities Crossing	60 EA	\$ 650	\$ 39,000
58	Drain Tile Repair	35 EA	\$ 750	\$ 26,250
59	Dewatering Excavation	1 LS	\$ 12,000	\$ 12,000
60	Temporary Traffic Control (Urban)	0 LS	\$ 23,900	-
61	Temporary Traffic Control (Rural)	1 LS	\$ 6,000	\$ 6,000
62	Construction Staking	1 LS	\$ 9,600	\$ 9,600
63	Storm Water Pollution Prevention Plan Preparation & Management	1 LS	\$ 6,000	\$ 6,000
64	Erosion Control Maintenance	1 LS	\$ 10,800	\$ 10,800
65	Silt Fence	2,220 LF	\$ 3	\$ 6,660
66				
67				
68				
69				
70	Miscellaneous Items Allowance (5%)	1 LS	\$107,300	\$ 107,300
<b>ENGINEER'S OPINION OF PROBABLE CONSTRUCTION COST</b>				<b>\$ 2,351,070</b>
Temporary Construction Easements				\$ 7,000
Permanent Easements				\$ 28,500
Land Acquisition				-
Contingency (10%)				\$ 235,200
Engineering, Legal, Administration				\$ 399,700
<b>ENGINEER'S OPINION OF PROBABLE PROJECT COST</b>				<b>\$ 3,021,470</b>
<b>TOTAL ENGINEER'S OPINION OF PROBABLE PROJECT COST</b>				<b>\$ 3,025,000</b>

**NOTES**

- 1 - The preliminary average depth of sewer in this phase is 14.2 feet, and the construction environment is anticipated to be difficult.
- 2 - Sewer crossing at Prospect Avenue is assumed to be trenchless construction without casing. All other road crossings assumed to include trenching with surface replacement.

**CITY OF ADEL**  
*East Annex Sanitary Sewer System Improvements*  
 December 2016  
 Project 2 - Puckerbrush Road Sanitary Trunk Sewer

Project 2

ITEM	DESCRIPTION	QUANTITY	UNIT COST	AMOUNT
1	Mobilization & Bonding	1 LS	\$ 101,400	\$ 101,400
2	Clearing and Grubbing	1.2 AC	\$ 10,000	\$ 12,000
3	Topsoil Strip, Stockpile, Respread	8,680 CY	\$ 10	\$ 86,800
4	Overexcavation	0 CY	\$ 15	-
5	Stockpile & Reprpad of Overexcavation	0 CY	\$ 3	-
6	Backfill & Grading of Overexcavation	0 CY	\$ 15	-
7	Replace Unsuitable Soils	1,565 CY	\$ 20	\$ 31,300
8	Trench Compaction Testing	1 LS	\$ 8,500	\$ 8,500
9	48-IN Sanitary Manhole (SW-301 with External Chimney Seal)	35 EA	\$ 6,000	\$ 210,000
10	60-IN Sanitary Manhole (SW-301 with External Chimney Seal)	0 EA	\$ 7,800	-
11	Sanitary Sewer Wye for Future Connections	0 EA	\$ 750	-
12	4 or 6-IN Sanitary Service Stub	0 EA	\$ 3,200	-
13	8-IN PVC Sanitary Sewer Gravity Main, Trenched	0 LF	\$ 83	-
14	10-IN PVC Sanitary Sewer Gravity Main, Trenched	0 LF	\$ 88	-
15	12-IN PVC Sanitary Sewer Gravity Main, Trenched	0 LF	\$ 98	-
16	15-IN PVC Sanitary Sewer Gravity Main, Trenched	3,895 LF	\$ 108	\$ 420,660
17	18-IN PVC Sanitary Sewer Gravity Main, Trenched	7,155 LF	\$ 118	\$ 844,290
18	21-IN PVC Sanitary Sewer Gravity Main, Trenched	0 LF	\$ 126	-
19	24-IN PVC Sanitary Sewer Gravity Main, Trenched	0 LF	\$ 138	-
20	27-IN DIP Sanitary Sewer Gravity Main, Trenched	0 LF	\$ 223	-
21	30-IN DIP Sanitary Sewer Gravity Main, Trenched	0 LF	\$ 273	-
22	36-IN DIP Sanitary Sewer Gravity Main, Trenched	0 LF	\$ 323	-
23	8-IN PVC Sanitary Sewer Gravity Main, Trenchless (No Casing)	0 LF	\$ 225	-
24	10-IN PVC Sanitary Sewer Gravity Main, Trenchless (No Casing)	0 LF	\$ 255	-
25	12-IN PVC Sanitary Sewer Gravity Main, Trenchless (No Casing)	0 LF	\$ 265	-
26	15-IN PVC Sanitary Sewer Gravity Main, Trenchless (No Casing)	0 LF	\$ 300	-
27	18-IN PVC Sanitary Sewer Gravity Main, Trenchless (No Casing)	0 LF	\$ 340	-
28	21-IN PVC Sanitary Sewer Gravity Main, Trenchless (No Casing)	0 LF	\$ 375	-
29	24-IN PVC Sanitary Sewer Gravity Main, Trenchless (No Casing)	0 LF	\$ 405	-
30	27-IN DIP Sanitary Sewer Gravity Main, Trenchless (No Casing)	0 LF	\$ 640	-
31	30-IN DIP Sanitary Sewer Gravity Main, Trenchless (No Casing)	0 LF	\$ 730	-
32	36-IN DIP Sanitary Sewer Gravity Main, Trenchless (No Casing)	0 LF	\$ 830	-
33	8-IN PVC Sanitary Sewer Gravity Main, Trenchless (Casing)	0 LF	\$ 450	-
34	10-IN PVC Sanitary Sewer Gravity Main, Trenchless (Casing)	0 LF	\$ 500	-
35	12-IN PVC Sanitary Sewer Gravity Main, Trenchless (Casing)	0 LF	\$ 505	-
36	15-IN PVC Sanitary Sewer Gravity Main, Trenchless (Casing)	0 LF	\$ 555	-
37	18-IN PVC Sanitary Sewer Gravity Main, Trenchless (Casing)	250 LF	\$ 615	\$ 153,750
38	21-IN PVC Sanitary Sewer Gravity Main, Trenchless (Casing)	0 LF	\$ 660	-
39	24-IN PVC Sanitary Sewer Gravity Main, Trenchless (Casing)	0 LF	\$ 690	-
40	27-IN DIP Sanitary Sewer Gravity Main, Trenchless (Casing)	0 LF	\$ 900	-
41	30-IN DIP Sanitary Sewer Gravity Main, Trenchless (Casing)	0 LF	\$ 990	-
42	36-IN DIP Sanitary Sewer Gravity Main, Trenchless (Casing)	0 LF	\$ 1,080	-
43	Connection to Existing Sanitary Manhole	2 EA	\$ 3,500	\$ 7,000
44	Post Construction CCTV Inspection of Sanitary Sewer	11,300 LF	\$ 2	\$ 22,600
45	Railroad Crossing Surcharge	0 EA	\$ 25,000	-
46	Creek Crossing Surcharge	1 EA	\$ 5,000	\$ 5,000
47	PCC Removal & Replacement w/Subbase & Subgrade Prep (Paving)	0 SY	\$ 95	-
48	PCC Removal & Replacement w/Subbase & Subgrade Prep (Patching)	125 SY	\$ 125	\$ 15,625
49	HMA Removal & Replacement w/Subbase & Subgrade Prep (Paving)	0 SY	\$ 90	-
50	HMA Removal & Replacement w/Subbase & Subgrade Prep (Patching)	0 SY	\$ 120	-
51	Gravel Removal & Replacement w/Subgrade Prep (Paving)	4,070 SY	\$ 27	\$ 109,890
52	Gravel Removal & Replacement w/Subgrade Prep (Patching)	70 SY	\$ 37	\$ 2,590
53	Driveway Culvert Removal & Replacement	0 EA	\$ 750	-
54	Urban Hydro Seeding	0 AC	\$ 4,500	-
55	Rural Seeding	8 AC	\$ 3,000	\$ 24,000
56	Uncharted Utilities Parallel	1,615 LF	\$ 50	\$ 80,750
57	Uncharted Utilities Crossing	85 EA	\$ 650	\$ 55,250
58	Drain Tile Repair	50 EA	\$ 750	\$ 37,500
59	Dewatering Excavation	1 LS	\$ 26,100	\$ 26,100
60	Temporary Traffic Control (Urban)	0 LS	\$ 34,800	-
61	Temporary Traffic Control (Rural)	1 LS	\$ 8,700	\$ 8,700
62	Construction Staking	1 LS	\$ 12,200	\$ 12,200
63	Storm Water Pollution Prevention Plan Preparation & Management	1 LS	\$ 8,700	\$ 8,700
64	Erosion Control Maintenance	1 LS	\$ 15,700	\$ 15,700
65	Silt Fence	3,230 LF	\$ 3	\$ 9,690
66				
67				
68				
69				
70	Miscellaneous Items Allowance (5%)	1 LS	\$ 110,500	\$ 110,500
<b>ENGINEER'S OPINION OF PROBABLE CONSTRUCTION COST</b>				<b>\$ 2,420,495</b>
Temporary Construction Easements				\$ 8,000
Permanent Easements				\$ 32,500
Land Acquisition				-
Contingency (10%)				\$ 242,100
Engineering, Legal, Administration				\$ 411,500
<b>ENGINEER'S OPINION OF PROBABLE PROJECT COST</b>				<b>\$ 3,114,595</b>
<b>TOTAL ENGINEER'S OPINION OF PROBABLE PROJECT COST</b>				<b>\$ 3,115,000</b>

**NOTES**

- 1 - The preliminary average depth of sewer in this phase is 20.7 feet, and the construction environment is anticipated to be undeveloped rural.
- 2 - Sewer crossing at Highway 6 is assumed to be trenchless construction with casing. All other road crossings assumed to include trenching with surface replacement.
- 3 - Sewer parallel to Puckerbrush Road is assumed to be alongside roadway requiring only 1/2 street width surface replacement.

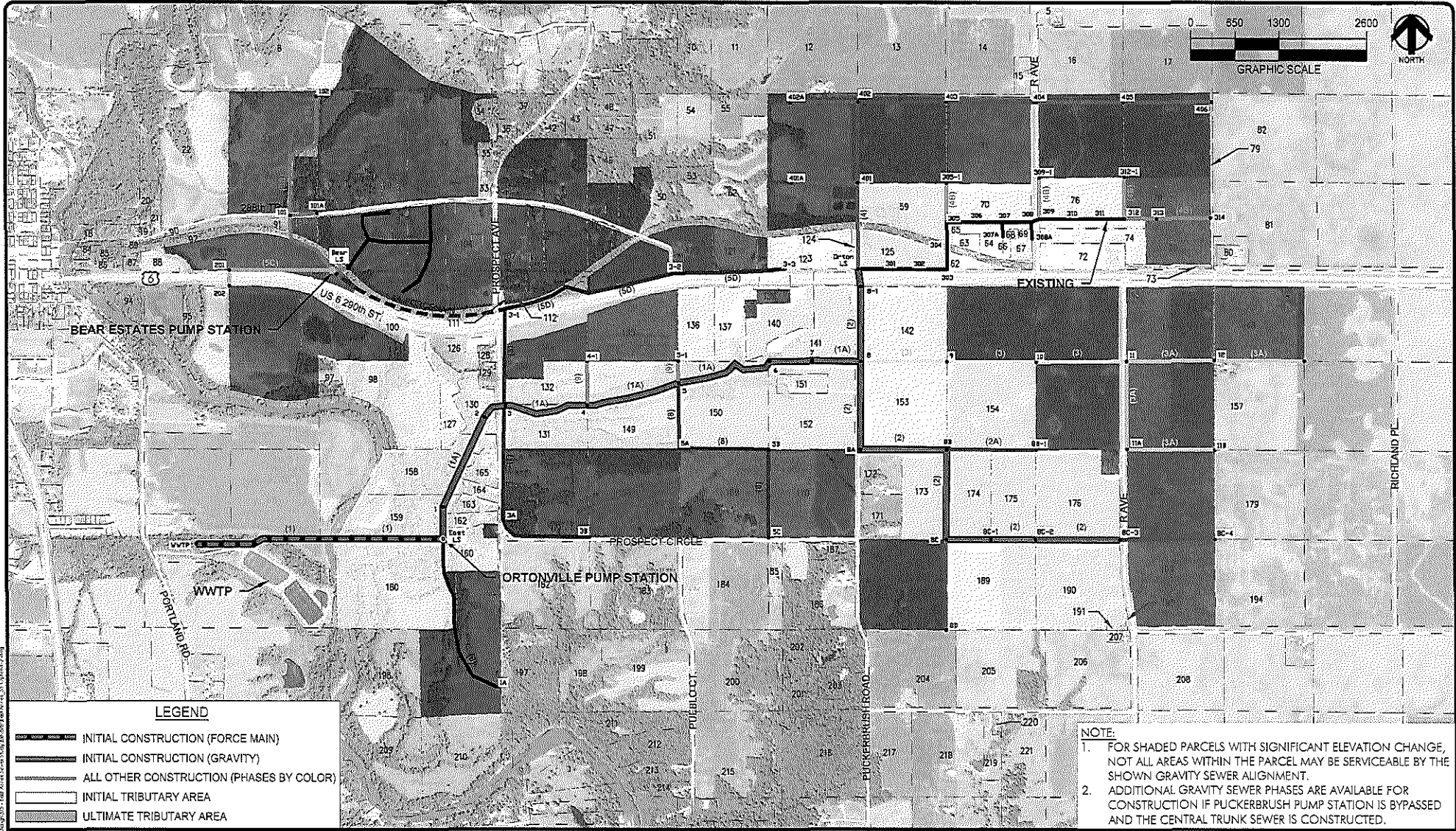

**LEGEND**

- INITIAL CONSTRUCTION (FORCE MAIN)
- INITIAL CONSTRUCTION (GRAVITY)
- ALL OTHER CONSTRUCTION (PHASES BY COLOR)
- INITIAL TRIBUTARY AREA
- ULTIMATE TRIBUTARY AREA

**NOTE:**

1. FOR SHADED PARCELS WITH SIGNIFICANT ELEVATION CHANGE, NOT ALL AREAS WITHIN THE PARCEL MAY BE SERVICEABLE BY THE SHOWN GRAVITY SEWER ALIGNMENT.
2. ADDITIONAL GRAVITY SEWER PHASES ARE AVAILABLE FOR CONSTRUCTION IF PUCKERBRUSH PUMP STATION IS BYPASSED AND THE CENTRAL TRUNK SEWER IS CONSTRUCTED.

**Option 3B**  
 East Annex Sanitary Service Evaluation - New East Annex Gravity Sewer to City WWTW  
 City of Adel, IA



I:\Projects\11672\11672\_001\DWG\11672-001-01-01.dwg - Bear Estes from 11/21/2017 10:58:37 AM - 11/21/2017 10:58:37 AM

## EXHIBIT 'C'

### ENGINEER'S RESPONSIBILITIES

---

OWNER shall do the following in a timely manner so as not to delay the services of the ENGINEER.

1. Designate in writing a person to act as OWNER'S representative with respect to the services to be rendered under this Agreement. Such person shall have complete authority to transmit instructions, receive information, interpret and define OWNER'S policies and decisions with respect to ENGINEER'S services for the project.
2. Provide all criteria and full information as to OWNER'S requirements for the Project, including design objectives and constraints, space, capacity and performance requirements, flexibility and expendability, and any budgetary limitations; and furnish copies of all design and construction standards, which OWNER will require to be included in the drawings and specifications.
3. Assist ENGINEER by placing at ENGINEER'S disposal all available information pertinent to the Project, including previous reports and any other data relative to design or construction of the Project.
4. Arrange for access to make all provisions for the ENGINEER to enter upon public and private property as required for the ENGINEER to perform services under this Agreement.
5. Examine all studies, reports, sketches, drawings, specifications, proposals and other documents presented by the ENGINEER, obtain advice of an attorney, insurance counselor and other consultants as OWNER deems appropriate for such examination and render in writing decisions pertaining thereto within a reasonable time so as not to delay the services of the ENGINEER.
6. Furnish approvals and permits from all governmental authorities having jurisdiction over the Project and such approvals and consents from others as may be necessary completion of the Project.
7. Attend the Prebid Conference, Bid opening, Preconstruction Conferences, Construction Progress Meetings and other job related meetings and Substantial Completion Inspection and Final Payment Inspection.
8. Give prompt written notice to the ENGINEER whenever the OWNER observes or otherwise becomes aware of any development that affects the scope or timing of the ENGINEER'S services, or any defect or non-conformance in the work of any Contractor.
9. Arrange for financing and pay for services as agreed to in this Agreement.



## Ordinance No. 319

### AN ORDINANCE ESTABLISHING A WATER CONSERVATION PLAN

**WHEREAS**, the City Council of the City of Adel, Iowa, recognizes that supplies of potable water are essential for the health, safety and welfare of its citizens; and

**WHEREAS**, the City of Adel's Water Utility has limited capacity and from time to time during and following drought conditions or due to equipment failure, the City's water supply may become significantly and seriously depleted such that there is an insufficient supply of water to meet all customary and usual demands; and

**WHEREAS**, the City deems it essential to protect the safety of its citizens in the event that the limited capacity of the Water Utility may be threatened.

**NOW, THEREFORE, BE IT ORDAINED BY THE CITY COUNCIL OF THE CITY OF ADEL, STATE OF IOWA:**

Section 1. That the Municipal Code of Adel, Iowa be and is hereby amended by adding thereto a new chapter to be known as Chapter 93, relating to the City's Water Conservation Plan, as follows:

#### "CHAPTER 93

#### WATER CONSERVATION PLAN

93.01	Purpose	93.06	Surcharges
93.02	Definitions	93.07	Water Appeal
93.03	Water Shortages	93.08	Repealer Clause
93.04	Conditions	93.09	Severability Clause
93.05	General Procedure	93.10	Effective Date

93.01 **PURPOSE.** The purpose of this chapter is to impose a Water Conservation Plan within the City of Adel, Iowa.

93.02 **DEFINITIONS.** The following terms are defined for use in this chapter:

1. "Customer" means any person, company, or organization using processed potable water supplied by the City of Adel.
2. "Consumed" means water has passed through a customer's meter or is otherwise furnished by the City's Water Utility.
3. "Domestic Water Use" means water use for personal needs or for household purposes such as drinking, bathing, heating, cooking, or sanitation.
4. "Commercial and Industrial Use" means water used to produce goods or to furnish services by any establishment having financial profit as a primary aim.

93.03 **WATER SHORTAGES.** Under the conditions set forth in this Ordinance, the City Administrator and Public Works Director, in consultation with the Water Department personnel, may find, and by Proclamation declare, a public Water Watch, Water Warning, or Water Emergency, during which time the following measures and provisions shall be in effect to prevent depleting the water supply for human consumption and sanitation and to produce an orderly and equitable reduction of water consumption.

Immediately upon the issuance of such a Proclamation, regulations and restrictions set forth under this Ordinance shall become effective and remain in effect until the water shortage is terminated and the Proclamation rescinded.

Water uses, regulated or prohibited under the Ordinance, are considered to be non-essential and continuation of such uses during time of water shortage is deemed to constitute a waste of water, subjecting the users to surcharges, disconnection costs and excess consumption fees.

#### 93.04 **CONDITIONS.**

1. Water Watch: A Water Watch may be declared when a water shortage or equipment failure poses a potential threat to the ability of the water system to meet the needs of its customers currently or in the foreseeable future. Indicators of the need to impose a Water Watch include but are not limited to:

- A. System operating at 70% of pumping capacity.
- B. Moderate decrease in the pumping water levels of wells.
- C. Moderate decrease in the recovery rate of water levels in wells.

2. Water Warning: A Tier I or Tier II Water Warning may be declared when a water shortage or equipment failure poses a serious threat to the ability of the water system to meet the needs of its customers currently and in the foreseeable future.

Indicators of the need to impose a Tier I Water Warning include but are not limited to:

- A. System operating at 80% of pumping capacity.
- B. Significant decrease in the pumping water level of wells.
- C. Significant decrease in the recovery rate of water levels in wells.

Indicators of the need to impose a Tier II Water Warning include but are not limited to:

- A. Severe system emergencies (e.g., chemical spill).
- B. Major system failure in feeder mains or treatment plant.
- C. Other factors which pose a significant threat to the ability of the Water Utility to furnish adequate supplies of potable processed water.

3. Water Emergency: A Water Emergency may be declared when a water shortage or equipment failure poses a severe and immediate threat to the ability of the water system to meet the needs of its customers. Indicators of the need to impose a Water Emergency include but are not limited to:

- A. System operation at 90% of pumping capacity.
- B. Serious decrease in the recovery rate of water level in wells.

C. Major system failure in feeder mains or treatment plant.

D. Other factors which pose a significant threat to the ability of the Water Utility to furnish adequate supplies of potable processed water.

93.05 **GENERAL PROCEDURE.** In the time during or following drought conditions or equipment failure, the following procedures shall be followed:

1. Water Watch: Under a Water Watch, all customers of the municipal water service are encouraged to limit or curtail all nonessential uses of water in order to conserve precious water resources during the time of shortage.

A. No watering of lawns, shrubs, or gardens between the hours of 8:00 a.m. and 8:00 p.m.

B. Car washing is prohibited except in commercial establishments that provide that service.

C. No water should be used to fill private swimming pools, children's wading pools, or any other outdoor pool or pond.

D. No water should be used to wash streets, parking lots, driveways, sidewalks, or building exteriors.

E. No water should be used for nonessential cleaning of commercial and industrial equipment, machinery, and interior spaces.

F. Water should be served at restaurants only upon the request of the customer.

2. Water Warning – Tier I: Under a Tier I Water Warning, no person shall use potable processed water of the municipal water service in any manner contrary to the following:

A. Outdoor watering or irrigation of lawn is prohibited.

B. Car washing is prohibited except in commercial establishments that provide that service.

C. No water shall be used to fill private swimming pools, children's wading pools, reflecting pools, or any other pool or pond.

D. No water shall be used to wash streets, parking lots, driveways, sidewalks, or building exteriors.

E. No water shall be used for nonessential cleaning of commercial and industrial equipment, machinery, and interior spaces.

F. Water shall be served at restaurants only upon the request of the customer.

G. Tank load water sales may be curtailed or eliminated.

Water reclaimed or recycled after some other primary use, such as water that has been used for washing or cooling, may be used without restriction. Additionally, water derived from sources other than the City water utility, such as water

condensed from the atmosphere by air conditioners or collected from rain or snow, may be used without restriction.

3. Water Warning – Tier II: Under a Tier II Water Warning, no person shall use potable processed water of the municipal water service in any manner contrary to the following:

- A. All outside water use, except for domestic, sanitation, and fire is prohibited.
- B. All commercial and industrial uses of water not essential in providing products or services are prohibited.
- C. Irrigation, of absolutely all forms, is prohibited.
- D. Recreational and leisure water use, including lawn and golf course watering and other incidental or recreational use is prohibited.
- E. Water use not necessary for the preservation of life or the general welfare of the community is prohibited.

4. Water Emergency: Under a Water Emergency, Tier I and Tier II Water Warning use restrictions shall in effect and, in addition, all violations that occur under a water emergency shall fall under, for a first offense, the second violation rule and shall have double the surcharge rates listed. All violations and misuse of public drinking water shall be considered a direct threat to public health and service will be discontinued immediately. Service shall resume only when all fines and fees have been paid for. Any further subsequent violations which are considered a threat to public health shall result in service disconnect and shall only be lifted after requirements for safety assurances have been set in place by the **City Administrator and the Public Works Director** and met by the owner once all fees and fines have been paid.

5. The City of Adel Water Department has the right, at any given time with just cause, to disconnect service to various non-vital/recreational services for the purpose of water preservation in times of need. These non-vital/recreational services may be, but not limited to:

- A. Irrigation for recreational fields and any agreements of irrigation.
- B. Public restrooms serviced by the City of Adel.
- C. Water fountains and spigots provided by the City of Adel for recreational use.
- D. Water supply to camp ground facilities.
- E. Water supply to the public pool.

93.06 **SURCHARGES**. The following surcharges shall be applied for violations of Water Warning use restrictions imposed under this chapter. Violations during a Water Emergency are considered a minimum “second violation” and are double the rates listed below.

1. First Violation: For a first violation, the Water Utility shall issue a written notice of violation to the water user violating the water use restrictions imposed during a Water Watch, Water Warning, or Water Emergency.

2. Second Violation: For a second violation within a twelve month period, an administrative surcharge shall be imposed on the customer's account in an amount of one hundred dollars (\$100.00) plus two hundred percent (200%) of the fiscal year's highest month's water bill.

3. Subsequent Violation: For any subsequent violation within a twelve month period, an administrative surcharge shall be imposed in an amount equal to five hundred dollars (\$500.00) plus two hundred percent (200%) of the fiscal year's highest month's water bill, and, in addition, the utility shall interrupt water service to the customer at the premises at which the violation occurred. Service shall not be restored until the customer has paid the surcharge and the reconnection fee and has provided reasonable assurance that future violations of Water Watch, Water Warning, or Water Emergency use restrictions will not occur.

Any customer charged with a violation of the Water Watch, Water Warning, or Water Emergency use restriction may request a hearing before the Adel City Council. The council may conclude that a violation did not occur or that the circumstances under which the violation occurred warrant a complete or partial mitigation of the administrative surcharge.

93.07 **WATER APPEAL.** The Adel City Council shall oversee appeals of any action taken pursuant to a Water Watch, Water Warning or Water Emergency; however, if a customer is charged with a municipal infraction relating to this ordinance, that proceeding shall be conducted pursuant to Section 364.22 of the Code of Iowa. Appeals shall be requested in writing and delivered to the City Clerk within the time stated in the notice, or it will be conclusively presumed that the directive or surcharge must be followed as ordered. The hearing shall be before the Council at a time and place fixed by the Council. The findings of the Council shall be conclusive and, if the directive or surcharge are found valid, it shall be ordered and fulfilled within a reasonable time under the circumstances.

93.08 **REDUCTION IN FLOW OF WATER TO ANY PERSON.** The Water Department, under authorization of the City Administrator and the Public Works Director, may reduce or disconnect the flow of water to any customer determined to be using water in any manner not in accordance with this ordinance during a Water Watch, Water Warning, or Water Emergency or for any matter that may be deemed a risk to public health. All unmetered usage, without absolute consent from the City, is considered a threat to public health and may receive a reduction of flow or disconnect of flow if a Water Watch, Water Warning, or Water Emergency is or is not in affect.

This reduction or potential disconnection may occur with or without notice, as judgement of severity has been decided by the City Administrator and the Public Works Director with the assistance of the Water Department.

93.08 **REPEALER CLAUSE.** All ordinances or parts of ordinances in conflict herewith are hereby repealed.

93.09 **SEVERABILITY CLAUSE.** If any section, provision, or part of this ordinance shall be adjudged invalid or unconstitutional, such adjudication shall not affect the validity if the ordinance as a whole or any section, provision or part thereof not adjudged invalid or unconstitutional.

93.10 **EFFECTIVE DATE.** This ordinance shall be effective from and after the final passage, approval and publication as provided by law.”

Section 2. All ordinances or parts of ordinances in conflict with the provisions of this Ordinance are hereby repealed. In the event that any provision of this Ordinance shall be determined to be contrary to law it shall not affect other provisions or application of this Ordinance.

Section 3. This Ordinance shall be in effect after its final passage, approval and publication as provided by law.

Passed and approved by the Adel City Council this \_\_\_\_\_ day of \_\_\_\_\_, 2017

\_\_\_\_\_  
James F. Peters, Mayor

Attest: \_\_\_\_\_  
Jackie Steele, City Clerk

1<sup>st</sup> Reading \_\_\_\_\_

2<sup>nd</sup> Reading \_\_\_\_\_

3<sup>rd</sup> Reading \_\_\_\_\_

I certify that the foregoing was published as Ordinance No. 319 in the Dallas County News on the \_\_\_\_\_ day of \_\_\_\_\_, 2017.

\_\_\_\_\_  
Jackie Steele, City Clerk

**From:** De Soto Public Library [<mailto:desotolibrary@mchsi.com>]

**Sent:** Wednesday, March 29, 2017 3:14 PM

**To:** 'De Soto Public Library'; 'Mary K. Murphy'; [dexterpl@mchsi.com](mailto:dexterpl@mchsi.com); 'Dorothy Knight'; [harriet.peterson@granger.lib.ia.us](mailto:harriet.peterson@granger.lib.ia.us); 'Kristine Larson'; [library@minburnlibrary.com](mailto:library@minburnlibrary.com); [llibrary@netins.net](mailto:llibrary@netins.net); 'Lori Stonehocker'; 'Myrna Griffith'; [scory@dallascenter.lib.ia.us](mailto:scory@dallascenter.lib.ia.us); [wpublic@netins.net](mailto:wpublic@netins.net); 'Paula James'; 'Maryann Mori'; [amber\\_rowley@yahoo.com](mailto:amber_rowley@yahoo.com); 'Amber Ridley'; [ltompson@vanmeteria.gov](mailto:ltompson@vanmeteria.gov)

**Subject:** County Funds mixup

Hello all,

There was a mixup with the county fund distribution—entirely my fault! As you know, we work out one year ahead the amount of funds each library will receive, so as to properly work on our budgets and know what we can expect to receive. I sent Eric Webber at the county the list of funds that should be given to each library, but I accidentally sent him the spreadsheet I created in 2016 for the 2017/2018 fiscal year, rather than the one I made in 2015 for the 2015/2016 fiscal year. Therefore, everyone got checks that were in the wrong amount. I'm attaching the spreadsheets here so you can double check the numbers for yourself, but here's the quick details.

Four of us got too much money and eight libraries got too little.

Adel got \$1664.10 too much

De Soto got \$1491.98 too much

Granger got \$569.33 too much

Van Meter got \$4291.79 too much

Dallas Center received \$2452.28 too little

Dexter received \$340.26 too little.

Linden received \$75.05 too little

Minburn received \$995.98 too little

Perry received \$587.55 too little

Redfield received \$1522.88 too little

Waukee received \$741.93 too little

Woodward received \$1301.28 too little.

So what do you need to do with this information? Adel, Van Meter and myself (De Soto) need to send checks for the overages made out to the Dallas County Treasury, sent attn: Eric Webber, 902 Court St. Adel, IA. Granger hasn't deposited their check yet, so they'll just destroy it and get a new check written for the proper amount. It'll be a few weeks, as the libraries that received too much will have to turn into their boards the reason why they are writing a large check back to the county, but hopefully as soon as the county receives the money back, they can redistribute it to the libraries that were supposed to have it. Therefore, it is imperative that those of us that need to give money back get it approved at the next possible chance so that the libraries that need it get it as soon as possible.

I'm sorry for the mixup, everybody! I know it's kind of a huge pain—thanks to Mary from Dexter for catching the error! If anybody has any questions at all, let me know!

Brianna

*Brianna Glenn*

*Library Director*

*De Soto Public Library*

*515-834-2690*

*[desotolibrary@mchsi.com](mailto:desotolibrary@mchsi.com)*

*"The more that you read, the more things you will know. The more that you learn, the more places you'll go."*

*~Dr. Seuss*

## Ordinance No. 320

### AN ORDINANCE AMENDING CHAPTER 165 OF THE ZONING CODE OF THE CITY OF ADEL, IOWA

**BE IT ENACTED BY THE CITY COUNCIL, THE CITY OF ADEL, IOWA;**

**SECTION 1.** Section 165 of the Zoning Code of the City of Adel, Iowa, is hereby amended and adopted;

#### CHAPTER 165

#### ZONING CODE

165.01	Title	165.27	Nonconforming Uses of Structures or of Structures and Premises in Combination
165.02	Purpose	165.28	Repairs and Maintenance
165.03	Interpretation of Standards	165.29	Uses Under Special Exception Provisions Non Nonconforming Use
165.04	Application of District Regulations	165.30	Zoning Districts
165.05	Establishment of District Provision for Official Zoning Map	165.31	Boundaries
165.06	Rules for Interpretation of District Boundaries	165.32	Annexation
165.07	Definitions	165.33	“A-1” Existing Agricultural District
165.08	Zoning Administrator	165.34	“A-2” Rural / Estates District
165.09	Enforcement Responsibilities	165.35	“CN” Conservation District
165.10	Principal Permitted Uses	165.36	“R-1” High Density Single-Family Residential District
165.11	Zoning / Building Permits Required	165.37	“R-2” Medium Density Single-Family Residential District
165.12	Application for Zoning / Building Permits	165.38	“R-3” Low Density Single-Family Residential District
165.13	Issuance of Conditional and Permanent Zoning / Building Permit	165.39	“R-4” Multi-Family Residential District
165.14	Expiration of Conditional and Permanent Zoning / Building Permits	165.40	“R-5” Townhouse Residential District
165.15	Residential Dwelling Standards	165.41	“R-6” Mobile Home Park District
165.16	Board of Adjustment: Establishment and Procedure	165.42	“C-1” General Commercial District
165.17	Board of Adjustment: Power and Duties	165.43	Repealed Reserved for Later Use
165.18	Appeals from the Board of Adjustment	165.44	“C-2” Business and Neighborhood District ) Older Square District)
165.19	Amendments to Zoning Code	165.45	“C-3” Highway Commercial District
165.20	Complaints Regarding Violations	165.46	“M-1” Light Industrial District
165.21	Violations and Penalties	165.47	“M-2” Medium Industrial District
165.22	Other Remedies	165.48	“M-3” Heavy Industrial District
165.23	Intent of Nonconforming Lots, Nonconforming Uses of Land, Nonconforming Structures; Nonconforming uses of Structures and Premises and Nonconforming Characteristics of Use	165.49	Supplementary District Regulations
165.24	Nonconforming Lots of Record	165.50	Zero Lot Line Criteria



165.25	Nonconforming Uses of Land	165.51	Parking Regulations for C-1, C-2, C-3, M-1, M-2, and M-3
165.26	Nonconforming Structures	165.52	Deferral of Parking Spaces
		165.53	Reserved for P.U.D.
		165.54	Administration: Duties of Administrative Official, Board of Adjustment, City Commission and Courts on Matter of Appeal
		165.55	Sign Regulations

AMENDMENTS, MODIFICATIONS, ADDITIONS, REPEAL AND DELETIONS.

**Section 165.34 A-2 Rural/Estates District**

Amended subsection 3. Accessory uses incidental to and on the same zoning lot as the principal use as follows.

Modified Item 3(c). Garages.

**Section 165.39 R-4 Multi-Family Residential District**

Amended subsection 2. Permitted Uses.

Modified Item 2(b). Multiple-family apartment and condominium buildings designed for more than two (2) dwelling units providing such use shall not exceed 4 buildings per one-half acre of lot area, and 24 dwelling units for each building.

**Section 165.42 C-1 General Commercial District**

Amended subsection 4. Conditional Uses.

Added Item 4(j). Storage facilities.

Amended subsection 6. Bulk Requirements. The following requirements shall be observed.

Modified Item 6(a). Minimum Lot Area: None.

Modified Item 6(b). Minimum Lot Width: None.

**Section 165.44 C-2 Business and Neighborhood District (Older Square District)**

Amended subsection 4. Conditional Uses.

Modified Item 4(f). One and two family dwellings subjected to R-1 lot area, frontage and yard setback requirements.

**Section 165.45 C-3 Highway Commercial District**

Modified subsection 2. Permitted Uses. Only those uses listed below shall be permitted, in accordance with all of the provisions of this district and permitted uses in C-2.

Amended subsection 4. Conditional Uses.

Added Item 4(k). Storage facilities.

Amended subsection 6. Bulk Requirements. The following requirements shall provide for light and air around permitted uses and building in the C-4 District.

Modified Item 6(a). Minimum Lot Area: None.

Modified Item 6(b). Minimum Lot Width: None.

**Section 165.46 M-1 Light Industrial District**

Amended subsection 2. Permitted Uses.

Added Item 2(y). Storage facilities.

**Section 165.48 M-3 Heavy Industrial District**

Modified subsection 2. Permitted Uses. Uses in M-2 District and manufacture, storage, assembly, fabrication or processing of the following uses:

Amended subsection 4. Conditional Uses.

- Modified Item 4(m). Logging and lumber products.
- Added Item 4(n). Chemical, industrial (inorganic and organic)
- Added Item 4(o). Petroleum refining and related industries
- Added Item 4(p). Asbestos and non-metallic mineral products
- Added Item 4(q). Blast furnace, steel works, drop hammer forge, rolling and finishing mills
- Added Item 4(r). Smelting and refining (non-ferrous metals)
- Added Item 4(s). Secondary smelting and refining (non-ferrous metals)
- Added Item 4(t). Coal and scrap iron (wholesalers)
- Added Item 4(u). Scrap and waste materials (wholesale)
- Added Item 4(v). All other uses of a similar character as determined by the Board of Adjustment

**Section 165.49 Supplementary District Regulations**

Modified subsection 4. Accessory Buildings. No accessory building shall be erected in any required front yard, and no separate accessory building shall be erected within 10 feet of a main building. No accessory building shall be closer than 5 feet to the rear or side lot line except that where a garage is entered perpendicular or near perpendicular directly from an alley, the setback shall be 15 feet. Accessory buildings located in the rear yard may not occupy more than 35 percent of the rear yard and the aggregate of all accessory buildings shall not exceed 750 square feet. No accessory building shall be used without occupancy of the principal building, and no accessory building shall exceed 18 feet in average height. Garages are limited to 1,200 square feet for lot size of less than 1.0 acres and 2,400 square feet for lot size of 1.0 acres or more and may not occupy more than 35 percent of the rear yard and the aggregate of all other accessory buildings. (See definition of private garage).

**SECTION 2. WHEN EFFECTIVE:** This Ordinance shall be in effect from and after its final passage, approval and publication as provided by law, whichever shall later occur.

Passed and approved by the Adel City Council this 11<sup>th</sup> day of April, 2017.

\_\_\_\_\_  
James F. Peters, Mayor

Attest: \_\_\_\_\_  
Jackie Steele, City Clerk

1<sup>st</sup> Reading \_\_\_\_\_

2<sup>nd</sup> Reading \_\_\_\_\_

3<sup>rd</sup> Reading \_\_\_\_\_

I certify that the foregoing was published as Ordinance No. 320 in the Dallas County News on the \_\_\_\_ day of \_\_\_\_\_, 2017.

\_\_\_\_\_  
Jackie Steele, City Clerk



The Adel Planning and Zoning meet at City Hall on Wednesday, March 8, 2017  
At 6:30 PM.

Commissioners present were: Tom Waltz, Kent McAdon, Rebecca Reed, Melody Marshall and Code Compliance Officer Steve Nichols. Absent: Todd Cook, Ed Origer and Susan Way. Guest present Christopher Janson MSA

### **Minutes for March 8, 2017 Public Hearing Meeting**

- I. **Discussion / Possible Action.** Marshall made a motion to go into public hearing at 6:30 PM and Waltz second the motion and the vote was unanimous. Nichols presented the changes for the current Zoning Code. There was no public comments. Nichols stated the City Attorney John Reich has reviewed and had no comments. Reed made the motion to go out of the public hearing and Waltz second and the vote was unanimous. There was no further discussion.  
**Waltz made a motion to recommend Council to set a public hearing at the next council meeting for April for the recommended changes to the current zoning code. Second by Reed and Passed unanimously.**
- II. **Other Business.** Christopher Janson from MSA was introduced and he gave a small presentation of their services that they are providing to the City of Adel for the updating our Sub-division code. He gave a time line and how the Planning and Zoning will be involved.

Meeting was adjourned at 7:15 p.m.

**Respectfully,  
Steve Nichols**

# Dallas County GIS

Home Parcel Search Survey Points Contact Us Print



### Parcel Info

Parcel ID:	1129462004
Primary Name:	City of Adel, Iowa
Address:	425 RIVER ST ADEL
Legal Desc:	LOT 3 /EX N16/ BLK 37
Net Acres:	0
Links:	Assessor Info Tax Info (Solutions)

### Parcel Search Options

Deedholder:

Parcel #:

Property Address: 425 River

Legal Desc:

Map Id	Primary Name	Property Address	Legal Desc
	City of Adel, Iowa	425 RIVER ST ADEL	LOT 3 /EX N16/ BLK 37

XMin: 1499463.95 YMin: 588730.02 XMax: 1500496.26 YMax: 589357.29  
 1500373.4895550099, 588731.6122008531 0 66ft

**NOTICE OF PUBLIC HEARING OF THE CITY COUNCIL OF THE  
CITY OF ADEL IN THE STATE OF IOWA, ON THE MATTER OF  
SELLING, TRADING, OR OTHERWISE DISPOSING OF  
PROPERTY LOCATED AT 425 RIVER STREET  
OWNED BY THE CITY OF ADEL, IOWA**

**PUBLIC NOTICE** is hereby given that the Council of the City of Adel in the State of Iowa, will hold a public hearing on the 11<sup>th</sup> day of October, 2016, at 6:00 p.m. in the Council Chambers, City Hall, 301 S. 10<sup>th</sup> Street, Adel, Iowa, at which meeting the Council proposes to sell, trade, or otherwise dispose of the property located at 425 River Street owned by the City of Adel pursuant to section 364.7 of the 2015 Code of Iowa.

At the above meeting the Council shall receive oral or written objections from any resident or property owner of said City and consider any other offers to sell, trade, or dispose of said property. After all objections have been received and considered, the Council will, at this meeting or at any adjournment thereof, take additional action on the proposal or will abandon the proposal to authorize the disposing of property.

It is proposed that the council adopt a resolution selling said property "as is". The City will advertise said property publically and anyone may make a written offer to purchase said property on the form provided by the City. That offer will include a \$1,000.00 earnest money check to be held in escrow until the bid-off is completed. The five top bidders will be invited to City Hall on a date yet undecided to bid off against each other. The top bidder will sign an Offer to Purchase and deposit 10% of his bid to be held in escrow. The City may reject any and all bids. The property is subject to current zoning. Closing and possession contemplated to occur within sixty days.

This notice is given by order of the City Council of the City of Adel in the State of Iowa, as provided by Section 364.7 of the Code of Iowa.

Dated this 6<sup>th</sup> day of October, 2016.

Jackie Steele

City Clerk, City of Adel in the State of Iowa

**Adel City Council**  
**October 11, 2016 – Meeting Minutes**

The Adel City Council met in regular session at Adel City Hall, 301 S. 10<sup>th</sup> St., Adel, Iowa, on Tuesday, October 11, 2016 at 6:02 p.m. Mayor Peters called the meeting to order and the following answered roll: Ockerman, Hillmer, McAvoy, Haynes, and McAdon.

Staff Present: City Attorney Reich, City Administrator Brown, City Clerk Steele, Public Works Director Overton, Parks and Recreation Director Schenck, Code Compliance Officer Nichols, Library Director James, and Police Chief Shepherd.

**PUBLIC HEARING**

1. Voluntary Annexation Request – Karie Ramsey – Bloomfield Acres LLC  
**Motion by McAvoy, seconded by Hillmer, to open the public hearing**  
**Roll: Ayes-Unanimous. Motion carried.**  
No written or oral comments were received.  
**Motion by McAvoy, seconded by Hillmer, to close the public hearing**  
**Roll: Ayes-Unanimous. Motion carried.**
  
2. Sale of City Owned Property – 425 River Street Lot  
**Motion by McAvoy, seconded by Haynes, to open the public hearing**  
**Roll: Ayes-Unanimous. Motion carried.**  
No written or oral comments were received.  
**Motion by McAvoy, seconded by Haynes, to close the public hearing**  
**Roll: Ayes-Unanimous. Motion carried.**

**COMMENTS FROM THE PUBLIC**

Mayor Peters introduced Girl Scout Troop # 837 and their leader Leann Putman Thomas.

**CONSENT AGENDA**

- a) Consider Approval of City Council Minutes Dated September 13, 2016
- b) Consider Approval of September Bills and September 30, 2016, Treasurer's Report
- c) Consider Approval of Firefighters – Justin Kitzinger, Patrick Halsey, and Trevor Fowler (*pending drug screens*)  
**Motion by Hillmer, seconded by McAdon, to approve the consent agenda**  
**Roll: Ayes-Unanimous. Motion carried.**

**DEPARTMENT HEAD REPORT**

City Administrator Brown – Council Meeting on Monday, October 24, 2016 for the Main Street Reconstruction Project

**NEW BUSINESS**

- a) Consider Approval of Ordinance No. 311, Amending Zoning Classification of Certain Real Property in the City Limits of Adel – Cramer & Associates, from C-3 and R-3 to R-1 – Second Reading  
**Motion by McAvoy, seconded by McAdon, to approve Ordinance No. 311 – Second Reading**  
**Roll: Ayes-Unanimous. Motion carried.**  
  
**Motion by Hillmer, seconded by McAvoy, to waive the third reading and adopt Ordinance No. 311**  
**Roll: Ayes-Unanimous. Motion carried.**

**Resolution No. 17-21**

**A RESOLUTION APPROVING BUDGET TRANSFERS RECOMMENDED BY  
THE CITY'S BUDGET COMMITTEE AND THE ADEL CITY COUNCIL**

**WHEREAS**, on September 7, 2016, the City of Adel Budget Committee recommended certain budget transfers for Fiscal Year 2016-2017, detailed in Exhibit A; and

**WHEREAS**, on September 13, 2016, the Adel City Council agreed with and approved the Budget Committee's recommendation; and

**WHEREAS**, the City of Adel staff have prepared the aforementioned transfers to be considered for approval via a resolution and are recommending the same.

**NOW, THEREFORE, BE IT HEREBY RESOLVED** by the City Council of the City of Adel, Iowa on this 11<sup>th</sup> day of April, 2017 that the proposed transfers in Exhibit A for the City of Adel's Fiscal Year 2016-2017 Budget be approved and authorize staff to complete said transfers.

Passed and approved this 11<sup>th</sup> day of April, 2017.

---

James F. Peters, Mayor

Attest: \_\_\_\_\_  
Jackie Steele, City Clerk

TRANSFERS IN		04-11-2017 Transfers - 2016/2017 Budget		TRANSFERS OUT		04-11-2017 Transfers - 2016/2017 Budget	
<b>PROJECTS</b>				<b>GENERAL</b>			
317-4-750-4-4845	Industrial Park	\$22,000.00	from GF	001-5-000-5-6910	GF - Non-departmental	\$22,000.00	to Industrial Park
315-4-750-4-4821	Evans View Paving	\$23,175.28	from GF	001-5-000-5-6910	GF - Non-departmental	\$23,175.28	to Evans View Paving
318-4-750-4-4846	Annexation	\$88,644.53	from GF	001-5-000-5-6910	GF - Non-departmental	\$88,644.53	to Annexation
<b>TOTAL</b>		\$133,819.81		<b>TOTAL</b>		\$133,819.81	
<b>EXHIBIT</b> <u>A</u>							



**Budget Committee Recommendation for General Fund's FY15-16 Balance**

**Total FY15-16 General Fund Balance\*:** **\$403,416.11**

\*Total Balance represents the FY15-16 general fund balance minus the FY15-16 Industrial Park fund

Item	Transfer	Cost
Pay off HESCO Barrier system for flood mitigation	To Industrial Park	\$22,000.00
Pay off Evans View Paving debt	To CP - Evans View Paving	\$23,175.28
Pay off half of annexation debt	To CP - Annexation	\$88,644.53

Recommendation**	
<b>Total Proposed:</b>	<b>\$133,819.81</b>
<b>Percentage of Proposed to FY15-16 General Fund Balance:</b>	<b>33.172%</b>
<b>Total FY15-16 General Fund Balance Remaining after Proposed:</b>	<b>\$269,596.30</b>

\*\*This recommendation represents items as identified by department heads.

September 13, 2016 Adel City Council Minutes

- e) Consider Approval of Budget Committee Recommendation on FY15-16 General Fund Balance  
Council Member McAdon noted the Budget Committee recommends that part of the balance be used to lower the City's debt on the following projects: Pay off HESCO Barrier system for flood mitigation (\$22,000.00); Pay off Evans View Paving (\$23,175.28); and Pay off half of annexation debt (\$88,644.53).  
Motion by McAdon, seconded by Haynes, to approve the Budget Committee Recommendation  
Roll: Ayes-Unanimous. Motion carried.
- f) Discussion/Possible Action on Rise Broadband (Prairie iNet) Breach of Contract  
Council Member Haynes started discussion stating staff and council should pursue this breach of contract. It is important to have quality internet service for both city and public safety needs. City Administrator Brown informed council he has obtained quotes for service from both Mediacom and Centurylink. City Attorney Reich does feel there was a breach of contract on the part of Rise Broadband that can be pursued.  
Motion by Haynes, seconded by Hillmer, to approve pursuing a breach of contract by Rise Broadband and terminating the contract for services.  
Roll: Ayes-Unanimous. Motion carried.
- g) Consider Approval of Staff Recommendation for a No Parking Sign (7-5/M-F) on the North Side of Prairie Street between HWY 169/Nile Kinnick and 9<sup>th</sup> Street  
Council Member Hillmer asked staff why there is a need for the sign. Public Works Director Overton responded stating there is significant congestion and the traffic flow is very slow during those hours so he feels the sign will help increase traffic flow and safety.  
Motion by McAvoy, seconded by McAdon to approve the No Parking Sign (7-5/M-F)  
Motion to amend by Hillmer, seconded by McAdon, to change the time frame to (7-6/M-F)  
Roll: Ayes-Unanimous. Motion to amend carried.  
Roll: Ayes-Unanimous. Main motion carried.
- h) Consider Approval of Staff Recommendation for a 2 Hour Parking Sign (7-5/M-F) on Prairie Street between 9<sup>th</sup> Street and 10<sup>th</sup> Street  
Motion by McAvoy, seconded by Haynes, to approve the 2 Hour Parking Sign (7-6/M-F)  
Roll: Ayes-Unanimous. Motion carried.
- i) Discussion/Possible Action on Possible Sale of City-Owned 425 River Street Lot  
Motion by Hillmer, seconded by Haynes, to direct City Administrator Brown to start the process for selling the City-owned lot and to set a public hearing for October 11, 2016 at 6 p.m.  
Roll: Ayes-Unanimous. Motion carried.
- j) Consider Approval of Purchase of Parks and Recreation CIP Item – Truck  
Motion by Haynes, seconded by McAdon, to approve purchasing a Chevy Silverado 2500HD Standard Cab 8' Body 4x4 from Karl Chevrolet for \$26,910.75 and purchasing the service body for the truck from Truck Equipment, Inc. for \$13,397.00. (Lowest Bid Received)  
Roll: Ayes-Unanimous. Motion carried.
- k) Consider Approval of Change Order No. 3 for Adel Historic Museum Addition  
Motion by McAdon, seconded by McAvoy, to approve Change Order No. 3  
Roll: Ayes-Unanimous. Motion carried.
- l) Consider Approval of Payment Application No. 4 for Adel Historic Museum Addition  
Motion by Hillmer, seconded by McAdon, to approve Payment Application No. 4  
Roll: Ayes-Unanimous. Motion carried.

**Resolution No. 17-22**

**A RESOLUTION AUTHORIZING AN AGREEMENT BETWEEN THE CITY OF ADEL, IOWA, AND AHLERS & COONEY FOR THE PURPOSE OF OBTAINING BOND COUNSEL FOR USDA LOANS AND/OR GRANTS FOR FINANCING ON CITY UTILITY INFRASTRUCTURE IMPROVEMENTS**

**WHEREAS**, the City of Adel has several preliminary steps currently in process by USDA for financing on City utility infrastructure improvements; and

**WHEREAS**, USDA requires the borrower in a USDA loan transaction to engage bond council; and

**WHEREAS**, the City of Adel received a proposed agreement with Ahlers & Cooney, that defines the scope of the work that would be provided on the City of Adel's behalf as Bond Counsel and sets out the usual practices and procedures of the firm which have been established through working on financing projects involving, in whole or in part, the U.S. Government, acting through the U.S. Department of Agriculture, Rural Development loans and/or grants.

**NOW THEREFORE, IT IS HEREBY RESOLVED BY THE CITY COUNCIL OF THE CITY OF ADEL, IOWA** that the City of Adel enter into an agreement with Ahlers & Cooney for the purpose obtaining Bond Counsel for USDA loans and/or grants for financing on City utility infrastructure improvements.

Passed and approved this 11th day of April, 2017.

\_\_\_\_\_  
James F. Peters Mayor

Attest: \_\_\_\_\_  
Jackie Steele, City Clerk



**AHLERS COONEY**  
ATTORNEYS

COMPLETE AND RETURN TO  
MR. NADEL

Ahlers & Cooney, P.C.  
Attorneys at Law

100 Court Avenue, Suite 600  
Des Moines, Iowa 50309-2231  
Phone: 515-243-7611  
Fax: 515-243-2149  
www.ahlerslaw.com

Steven M. Nadel  
515.246.0306  
snadel@ahlerslaw.com

April 3, 2017

Mr. Anthony Brown  
City Administrator  
City of Adel  
P.O. Box 248 - 301 S. 10th Street  
Adel, IA 50003

Re: The City of Adel, State of Iowa  
Not to exceed \$1,600,000 Sewer Revenue Capital Loan Notes (USDA #1)

Dear Mayor & Council:

I look forward to receiving a copy of the forthcoming USDA Letter of Conditions relating to the financing of the above named project. I understand several preliminary steps are currently in process by USDA, your local counsel and/or engineers involved, however, USDA requires the borrower in a USDA loan transaction to engage bond counsel. Therefore this letter defines the scope of the work we would undertake on your behalf as Bond Counsel to the above project, and sets out the usual practices and procedures of the firm which have been established through working on financing projects involving, in whole or in part, the U.S. Government, acting through the U.S. Department of Agriculture, Rural Development (the "Government") loans and/or grants. The undersigned shareholder will have primary responsibility for this matter.

The scope of our services for Government projects under this program can usually be divided into three categories. In the first phase covering construction, when retained for this phase of the project, we prepare, submit, review and transcript legal proceedings, public notices and certifications covering the bid letting, contract award, and acceptance of the project by the borrower. Upon conclusion, we provide an opinion to USDA's Engineering Department as to the validity of the contract proceedings. Our involvement in this phase is generally initiated with a review of the notice to bidders and notice of hearing prepared by the Engineer for the project. We need those documents to prepare the necessary proceedings. Please keep us advised as to the status and progress of the project as it approaches the contracting phase. **Jim Wainwright of our firm is assisting with the bid letting/contract award proceedings due to his role in connection with the proposed special assessment.**

Second, pursuant to the Government's standard letter of conditions, projects involving a permanent loan of more than \$500,000 will typically require interim financing as the permanent loan is generally not funded until construction is complete. If this phase is necessary, we provide

April 3, 2017

Page 2

the required documentation, instruction and legal opinion for a loan or loans with lenders other than the Government pending the permanent loan closing. An interim financing may include necessary research and certification should grant proceeds also need to be anticipated in payment thereof. Please keep us advised as to the status of interim financing for this project. **USDA has indicated that interim financing will be required for the project.**

In the third phase governing the permanent financing of the project, we prepare all required notices, proceedings for public hearings, authorizing resolutions, tax and closing certifications and prepare and deliver the required number of loan transcripts pursuant to your loan commitment with the Government. As Bond Counsel, our examination will extend to the actions and approvals necessary to authorize the issuance and delivery of the notes to the Government. We will review applicable state and federal tax regulations, prepare the legal proceedings with respect to any public hearings, the approval of the loan agreement, and the issuance of notes, supervise the note printing, prepare all note proceedings and final papers, including the tax exemption certificate, if applicable. When that review is completed to our satisfaction, we will deliver our legal opinion with respect to the validity of the loan and notes, and the tax status thereof. Our examination, review, and legal opinion will not extend to the contents of offering materials, re-offering materials, or to compliance with Government regulations related to the project, but will be limited to the legality of issuance in accordance with Iowa law and the tax status of interest on the loan pursuant to Federal tax regulations. At loan closing we deliver, along with the transcripts, closing instructions and our executed opinion as to the legality and tax status of the loan obligations issued by you.

It is not anticipated that it will ordinarily be necessary for us to personally attend meetings of the Council in order to accomplish the above phases. We will be coordinating our services with local officials and your local attorney. However, we will be available in the event that circumstances require. In the event that public hearings, or litigation should occur in the course of this matter, we would expect same to be handled by the local attorney, unless special arrangements are made for our participation under separate representation.

At the completion of each phase of the project as described more fully herein, our statement for services will be submitted to you at which time our statement will be payable in full. Our fee for the contract proceedings phase is addressed in our November 8, 2016 Engagement Agreement. Our fee for services in connection with interim financing, if required, will be approximately \$13,000, plus out of pocket cash advance and expenses. Payment for these services is due at the closing of the interim financing loan unless other arrangements have been agreed to. Finally, our fee for the USDA Loan (the permanent financing currently estimated at not to exceed \$1,600,000) will be approximately \$15,000, plus out of pocket cash advance and expenses. This shall be payable upon closing of the USDA loan. Be advised, these amounts are subject to change based upon changes in the character, scope or cost of the project, and the nature and amount of the loan with the Government. We will submit a summary invoice for the professional services described herein in connection with the interim financing and the permanent financing, respectively, after the closing of each loan.

April 3, 2017

Page 3

In the event you require additional services not outlined herein, such services will be provided at the hourly rate of the attorney completing the work. Rates currently vary from \$210 to \$360 per hour. These rates are periodically revised. All such work will be itemized in a separate billing, payable upon receipt.

The above is submitted with the understanding that you have retained local counsel who has or will separately contract with you in satisfaction of the other Government loan conditions and requirements.

As you know, our firm represents and in the future will represent other clients who are involved in similar Government loan programs. We understand that you consent to our continued and future representation of these other clients without the need for any further consents from you when there is no direct conflict. This will confirm our understanding that you are our client, not the Government or other lenders.

In the future it will be our usual practice to issue a similar letter of engagement for all financing involving the Government. If the above correctly reflects our mutual understanding please sign, date and return to us the enclosed copy of this letter. To accommodate any time requirements you may have we will provide proceedings and services prior to your returning this letter to us. We will, however, consider your use of such documents as an acceptance of this proposal. If you have questions regarding any aspect of the above or our representations of you, please call.

We are pleased you have included us as part of your legal team.

Very truly yours,

AHLERS & COONEY, P.C.

By



Steven M. Nadel

SMN:ke

Accepted:

Adel, Iowa\*

By \_\_\_\_\_ Date: \_\_\_\_\_

\*Approved by Resolution No. \_\_\_\_\_ of the governing body on \_\_\_\_\_, 2017.

**Resolution No. 17-23**

**RESOLUTION FIXING DATE FOR A MEETING ON THE AUTHORIZATION OF A LOAN AGREEMENT AND THE ISSUANCE OF NOT TO EXCEED \$1,600,000 SEWER REVENUE CAPITAL LOAN NOTES, OF THE CITY OF ADEL, STATE OF IOWA, AND PROVIDING FOR PUBLICATION OF NOTICE THEREOF**

**WHEREAS**, it is deemed necessary and advisable that the City of Adel, State of Iowa, should provide for the authorization of a Loan Agreement and the issuance of Sewer Revenue Capital Loan Notes, in the amount of not to exceed \$1,600,000, as authorized by Sections 384.24A and 384.83, Code of Iowa, as amended, for the purpose of providing funds to pay costs as hereinafter described; and

**WHEREAS**, the Loan Agreement and Notes shall be payable solely and only out of the net earnings of the Municipal Sewer System and shall be a first lien on the future net earnings of the Utility; and shall not be general obligations of the City or payable in any manner by taxation and the City shall be in no manner liable by reason of the failure of the net revenues to be sufficient for the payment of the Loan Agreement and Notes; and

**WHEREAS**, the Issuer has applied for a loan with the United States of America (the "Government"), acting under the provisions of the Consolidated Farm and Rural Development Act (7 U.S.C. 1921 et seq.) pursuant to which the Government has agreed to purchase the Issuer's notes and has requested that such note be issued as a single note in a denomination equal to the total amount of the issue as authorized by Sections 384.24A and 384.83; and

**WHEREAS**, before a Loan Agreement may be authorized and Sewer Revenue Capital Loan Notes issued to evidence the obligation of the City thereunder, it is necessary to comply with the provisions of the City Code of Iowa, as amended, and to publish a notice of the proposal and of the time and place of the meeting at which the Council proposes to take action for the authorization of the Loan Agreement and Notes and to receive oral and/or written objections from any resident or property owner of the City to such action.

**NOW, THEREFORE, BE IT RESOLVED BY THE CITY COUNCIL OF THE CITY OF ADEL, STATE OF IOWA:**

Section 1. That this Council meet in the Council Chambers, City Hall, 301 S. 10th Street, Adel, Iowa, at 6:00 p.m., on the 9th day of May, 2017, for the purpose of taking action on the matter of the authorization of a Loan Agreement and the issuance of not to exceed \$1,600,000 Sewer Revenue Capital Loan Notes, to evidence the obligations of the City thereunder, the proceeds of which will be used to provide funds to pay the costs of improvements and extensions of the Municipal Sewer Utility, including construction of sewer main along Main Street and 11<sup>th</sup> Street, and refunding any outstanding Project Notes with accrued interest thereon issued in payment for such project.

Section 2. The Clerk is authorized and directed to proceed on behalf of the City with the negotiation of terms of a Loan Agreement and the issuance of Sewer Revenue Capital Loan Notes, to a principal amount of not to exceed \$1,600,000, to select a date for the final approval thereof, to cause to be prepared such notice and sale information as may appear appropriate, to publish and distribute the same on behalf of the City and this Council and otherwise to take all action necessary to permit the completion of a loan on a basis favorable to the City and acceptable to the Council.

Section 3. That the Clerk is hereby directed to cause at least one publication to be made of a notice of the meeting, in a legal newspaper, printed wholly in the English language, published at least once weekly, and having general circulation in the City. The publication to be not less than four clear days nor more than twenty days before the date of the public meeting on the issuance of the Notes.

Section 4. The notice of the proposed action shall be in substantially the following form:

NOTICE OF MEETING OF THE CITY COUNCIL OF THE CITY OF  
ADEL, STATE OF IOWA, ON THE MATTER OF THE PROPOSED  
AUTHORIZATION OF A LOAN AGREEMENT AND THE ISSUANCE OF  
NOT TO EXCEED \$1,600,000 SEWER REVENUE CAPITAL LOAN  
NOTES, AND THE PUBLIC HEARING ON THE AUTHORIZATION AND  
ISSUANCE THEREOF

PUBLIC NOTICE is hereby given that the City Council of the City of Adel, State of Iowa, will hold a public hearing on the 9th day of May, 2017, at 6:00 p.m., in the Council Chambers, City Hall, 301 S. 10th Street, Adel, Iowa, at which meeting the Council proposes to take additional action for the authorization of a Loan Agreement and the issuance of not to exceed \$1,600,000 Sewer Revenue Capital Loan Notes, in order to provide funds to pay the costs of improvements and extensions of the Municipal Sewer Utility, including construction of sewer main along Main Street and 11<sup>th</sup> Street, and refunding any outstanding Project Notes with accrued interest thereon issued in payment for such project. The Notes will not constitute general obligations or be payable in any manner by taxation, but will be payable from and secured by the net revenues of the Municipal Sewer System.

The proceeds of the Sewer Revenue Capital Loan Notes may be applied to pay project costs directly or to pay interim Project Notes which the City will issue in the amount of not to exceed \$1,600,000 in anticipation of the future receipt of funds or note proceeds applicable to the foregoing project and purpose.

At the above meeting the Council shall receive oral or written objections from any resident or property owner of the City, to the above action. After all objections have been received and considered, the Council will at this meeting or at any adjournment thereof, take additional action for the authorization of a Loan Agreement and the issuance of Notes or will abandon the proposal to issue the Notes.



This Notice is given by order of the City Council of the City of Adel, State of Iowa, as provided by Sections 384.24A and 384.83 of the City Code of Iowa, as amended.

Dated this \_\_\_\_\_ day of \_\_\_\_\_, 2017.

\_\_\_\_\_  
City Clerk, City of Adel, State of Iowa

(End of Notice)

Passed and approved this 11th day of April, 2017.

\_\_\_\_\_  
James F. Peters, Mayor

Attest: \_\_\_\_\_  
Jackie Steele, City Clerk

## **Resolution No. 17-24**

### **RESOLUTION FIXING DATE FOR A MEETING ON THE AUTHORIZATION OF A LOAN AGREEMENT AND THE ISSUANCE OF NOT TO EXCEED \$5,500,000 GENERAL OBLIGATION CAPITAL LOAN NOTES OF THE CITY OF ADEL, STATE OF IOWA (FOR ESSENTIAL CORPORATE PURPOSES), AND PROVIDING FOR PUBLICATION OF NOTICE THEREOF**

**WHEREAS**, on March 14, 2017 the City of Adel, Iowa previously held a hearing and approved the issuance of not to exceed \$5,500,000 General Obligation Capital Loan Notes, for essential corporate purposes, the proceeds to be used to provide funds to pay the costs of (i) the construction, reconstruction, and repairing of any street or sidewalk improvement, including costs associated with the Adel Brick Streets 2017 project, and (ii) refunding or refinancing certain outstanding indebtedness of the City, including the General Obligation Refunding Capital Loan Notes, Series 2011A dated September 27, 2011, and the General Obligation Refunding Capital Loan Notes, Series 2011C, dated September 27, 2011; and

**WHEREAS**, it has now been determined that the street projects described above will also include sewer and water improvements; and

**WHEREAS**, it is deemed necessary and advisable that the City of Adel, State of Iowa, should provide for the authorization of a Loan Agreement and issuance of General Obligation Capital Loan Notes, to the amount of not to exceed \$5,500,000, as authorized by Sections 384.24A and 384.25, of the Code of Iowa, for the purpose of providing funds to pay costs of carrying out essential corporate purpose project(s) as described in the March 14, 2017 resolution, and also including additional sewer and water improvements as hereinafter described; and

**WHEREAS**, the Loan Agreement and Notes shall be payable from the Debt Service Fund; and

**WHEREAS**, before a Loan Agreement may be authorized and General Obligation Capital Loan Notes, issued to evidence the obligation of the City thereunder, it is necessary to comply with the provisions of the Code of Iowa, as amended, and to publish a notice of the proposal and of the time and place of the meeting at which the Council proposes to take action for the authorization of the Loan Agreement and Notes and to receive oral and/or written objections from any resident or property owner of the City to such action.

**NOW, THEREFORE, BE IT RESOLVED BY THE CITY COUNCIL OF CITY OF ADEL, STATE OF IOWA:**

Section 1. That this Council meet in the Council Chambers, City Hall, 301 S. 10th Street, Adel, Iowa 50003, at 6:00 p.m., on the 9th day of May, 2017, for the purpose of taking action on the matter of the authorization of a Loan Agreement and issuance of not to exceed \$5,500,000 General Obligation Capital Loan Notes, for essential corporate purposes, the proceeds of which notes will be used to provide funds to pay the costs of (i) the construction, reconstruction, and repairing of any street or sidewalk improvements, including costs associated with the Adel Brick Streets 2017 project, and (ii) the acquisition, construction, improvement, extension, repair or equipping of the municipal water utility and the municipal sewer utility, including the acquisition, installation, and repair of storm sewers, sanitary sewers, and water service lines; and (iii) refunding or refinancing certain outstanding indebtedness of the City, including the General Obligation Refunding Capital Loan Notes, Series 2011A dated September 27, 2011, and the General Obligation Refunding Capital Loan Notes, Series 2011C, dated September 27, 2011.

Section 2. To the extent any of the projects or activities described in this resolution may be reasonably construed to be included in more than one classification under Division III of Chapter 384 of the Code of Iowa, the Council hereby elects the "essential corporate purpose" classification and procedure with respect to each such project or activity, pursuant to Section 384.28 of the Code of Iowa.

Section 3. The Clerk is authorized and directed to proceed on behalf of the City with the negotiation of terms of a Loan Agreement and the issuance of General Obligation Capital Loan Notes, evidencing the City's obligations to a principal amount of not to exceed \$5,500,000, to select a date for the final approval thereof, to cause to be prepared such notice and sale information as may appear appropriate, to publish and distribute the same on behalf of the City and this Council and otherwise to take all action necessary to permit the completion of a loan on a basis favorable to the City and acceptable to the Council.

Section 4. That the Clerk is hereby directed to cause at least one publication to be made of a notice of the meeting, in a legal newspaper, printed wholly in the English language, published at least once weekly, and having general circulation in the City. The publication to be not less than four clear days nor more than twenty days before the date of the public meeting on the issuance of the Notes.

Section 5. The notice of the proposed action to issue notes shall be in substantially the following form:

NOTICE OF MEETING OF THE CITY COUNCIL OF THE  
CITY OF ADEL, STATE OF IOWA, ON THE MATTER OF  
THE PROPOSED AUTHORIZATION OF A LOAN  
AGREEMENT AND THE ISSUANCE OF NOT TO EXCEED  
\$5,500,000 GENERAL OBLIGATION CAPITAL LOAN NOTES  
OF THE CITY (FOR ESSENTIAL CORPORATE PURPOSES),  
AND THE HEARING ON THE ISSUANCE THEREOF

PUBLIC NOTICE is hereby given that the City Council of the City of Adel, State of Iowa, will hold a public hearing on the 9th day of May, 2017, at 6:00 p.m., in the Council Chambers, City Hall, 301 S. 10th Street, Adel, Iowa 50003, at which meeting the Council proposes to take additional action for the authorization of a Loan Agreement and the issuance of not to exceed \$5,500,000 General Obligation Capital Loan Notes, for essential corporate purposes, to provide funds to pay the costs of (i) the construction, reconstruction, and repairing of any street or sidewalk improvements, including costs associated with the Adel Brick Streets 2017 project; (ii) the acquisition, construction, improvement, extension, repair or equipping of the municipal water utility and the municipal sewer utility, including the acquisition, installation, and repair of storm sewers, sanitary sewers, and water service lines; and (iii) refunding or refinancing certain outstanding indebtedness of the City, including the General Obligation Refunding Capital Loan Notes, Series 2011A dated September 27, 2011, and the General Obligation Refunding Capital Loan Notes, Series 2011C, dated September 27, 2011. Principal and interest on the proposed Loan Agreement will be payable from the Debt Service Fund.

At the above meeting the Council shall receive oral or written objections from any resident or property owner of the City to the above action. After all objections have been received and considered, the Council will at the meeting or at any adjournment thereof, take additional action for the authorization of a Loan Agreement and the issuance of the Notes to evidence the obligation of the City thereunder or will abandon the proposal to issue said Notes.

This notice is given by order of the City Council of the City of Adel, State of Iowa, as provided by Sections 384.24A and 384.25 of the Code of Iowa.

Dated this \_\_\_\_\_ day of \_\_\_\_\_, 2017.

\_\_\_\_\_  
City Clerk, City of Adel, State of Iowa

(End of Notice)

Passed and approved this 11th day of April, 2017.

\_\_\_\_\_  
James F. Peters, Mayor

Attest: \_\_\_\_\_  
Jackie Steele, City Clerk

**Resolution No. 17-25**

**AMENDING BUILDING ADDRESS CURRENTLY RECORDED AS 618 N. 7<sup>TH</sup> STREET, ADEL, IOWA TO 618 MAIN STREET, ADEL, IOWA**

**WHEREAS**, due to a recording error, the building located at Lot 5 Block 11 of Adel Corp Res 2, Parcel # 11-29-452-005, was incorrectly assigned the address of 618 N. 7<sup>th</sup> Street; and

**WHEREAS**, the correct address for the building located on Lot 5 Block 11 of Adel Corp Res 2, Parcel # 11-29-452-005 is 618 Main Street.

**NOW, THEREFORE, BE IT RESOLVED** by the City Council of the City of Adel, Iowa, on this 11th day of April, 2017, that the address for the building located at Lot 5 Block 11 of Adel Corp Res 2, Parcel # 11-29-452-005 be 618 Main Street.

Passed and approved this 11th day of April, 2017.

\_\_\_\_\_  
James F. Peters Mayor

Attest: \_\_\_\_\_  
Jackie Steele, City Clerk

## Office of the Assessor - Dallas County, Iowa - Parcel: 11-29-452-005

### Summary

<b>Parcel # (Map ID)</b>	11-29-452-005
<b>Tax District</b>	540-000 ADEL-ADM
<b>Map Area</b>	ADEL CORP RES 2
<b>Deed Holder</b>	SISTERS TWO LLC
<b>Contract</b>	
<b>Address</b>	618 N 7TH ST, ADEL
<b>Brief Legal</b>	LOT 5 BLK 11
<b>Sec-Twp-Rng</b>	029-079-027
<b>Subdivision</b>	
<b>School District</b>	ADM
<b>DBA</b>	APARTMENT - GARDEN LEVEL ADEL
NOTE: Legal descriptions on the web may have been shortened for computer purposes, therefore, they cannot be used for legal matters. Please contact the proper office for full legal descriptions.	

### Valuation

Date	Class	Land	Dwelling/Improvements	Ag Bldgs.	Total
2017	Multi-Res (L)	\$34,850	\$123,180	\$0	\$158,030
2016	Multi-Res (L)	\$34,850	\$90,570	\$0	\$125,420

### Images



[GeoDallas](#)  
[Google Map](#)  
[Bing Map](#)

### Sketches

APPEARS TO BE REMODELING INTO APARTMENTS. CAC 2008 - MOVED TO NEW MANUAL - REVALUE FOR 2009 ASSESSMENT YEAR

**Sales**

Date	Amount	NUTC	Recording	Remarks
06/19/2007	\$57,500	24 Auction sales	2007-10520	

**Permits**

Date	Number	Amount	Reason
10/06/2009	080074	\$0	Int-Remodel

**Tax Information**

Year Payable	Receipt Number	100% Value	Rollback Value	Net Taxes	Credits Homestead	Credits Military	Credits Family	Credits Farm	Credits AgLand	Credits Elderly
2016/2017	23909	\$125,420	\$108,175	\$4,102	\$0.00	\$0.00	\$0.00	\$0.00	\$0.00	\$0.00
2015/2016	23414	\$102,030	\$91,827	\$3,486	\$0.00	\$0.00	\$0.00	\$0.00	\$0.00	\$0.00
2014/2015	23102	\$102,030	\$96,929	\$3,592	\$0.00	\$0.00	\$0.00	\$0.00	\$0.00	\$0.00
2013/2014	21977	\$102,030	\$102,030	\$3,866	\$0.00	\$0.00	\$0.00	\$0.00	\$0.00	\$0.00
2012/2013	21950	\$99,850	\$99,850	\$3,844	\$0.00	\$0.00	\$0.00	\$0.00	\$0.00	\$0.00

**Real Estate Liabilities**

Year Payable	Receipt Number	1st Half Due	1st Half Paid	2nd Half Due	2nd Half Paid	Assessment Year
2016/2017	23909	\$2,051	\$2,051	\$2,051	\$2,051	2015
2015/2016	23414	\$1,743	\$1,743	\$1,743	\$1,743	2014
2014/2015	23102	\$1,796	\$1,796	\$1,796	\$1,796	2013
2013/2014	21977	\$1,933	\$1,933	\$1,933	\$1,933	2012
2012/2013	21950	\$1,922	\$1,922	\$1,922	\$1,922	2011

**Deed Information**

Grantor/Grantee Type Name	Book Page	Recorded Date	Instrument Date	Doc#
Grantor RATHERT KEITH A Grantee SISTERS TWO LLC	2007 10520	07/09/2007	06/19/2007	10520
See Cott Website	732 35			

Disclaimer: Every effort is made to insure accurate information is posted to the site. However, the Dallas County Assessor Office does not warrant or guarantee the accuracy, reliability or timeliness of the content on this site or content which is referenced by or linked to this site.

Dallas County Courthouse || 801 Court Street || Adel, IA 50003  
Phone: 515.993.5802 Fax: 515.993.5822

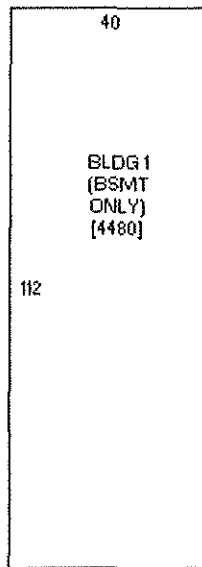

F

**Owner(s)**

Entity #	Name	Mailing Addr.
009954371	SISTERS TWO LLC~07/09/2007~ Current Deed Holder	24839 River Bye Rd Adel, IA 50003
004537090	RATHERT, KEITH A~07/09/2007 Prior Deed Holder	618 Main St Adel, IA 50003-

**Land**

Lot Basis	Square Feet	Acres
Sq. Ft x Rate	8,712	0.20

NOTE: See GeoDallas For Actual Size & Dimensions

**Commercial Buildings**

Addition	Occupancy	Year Built	Area
Building	702 Apartment	1950	4,480

**Parcel Notes**

Notes
GARDEN LEVEL ONLY OF AN APARTMENT BUILDING THAT NEVER HAD THE UPPER FLOORS BUILT. 2017 - Reduced obsol for layout from 10% to 5%. BA REVALUE AFTER COST UPDATE CAC. 2015 - CHANGE CLASSIFICATION FROM COMMERCIAL TO MULTI RESIDENTIAL. REVALUE TO NEW MANUAL. CAC 2012 - ESTIMATE REMODEL COMPLETE. NOT ABLE TO GAIN ENTRY. ESTIMATE 6 UNITS. CAC 2010 - BUILDING PERMIT ISSUED. ESTIMATE WORK PROGRESSING ON APARTMENTS. ESTIMATE 6 APTS. PARTIAL VALUE. CHECK FOR 2012. 04/13/2011 CAC CHECK FOR 2010. FRAMING HAS STARTED.



**BERGKAMP, HEMPHILL & McCLURE, P.C.**  
**ATTORNEYS**

218 SOUTH NINTH STREET • POST OFFICE BOX 8  
ADEL, IOWA 50003

**JAMES L. BERGKAMP, JR.**  
**MATTHEW J. HEMPHILL**  
**KARA L. McCLURE\***

\*CERTIFIED MEDIATOR

TELEPHONE: 515-993-1000  
FACSIMILE: 515-993-3746  
EMAIL: matthewhemphill@adellaw.com

March 17, 2017

John O. Reich  
Reich Law Firm  
801 Main Street  
Adel, IA 50003

Re: Offer to Purchase City Property

Dear John:

I represent Tom and Linda Fuller and their LLC, T & L Enterprises, L.L.C. As I mentioned on the phone, my clients are interested in purchasing property owned by the city on both the east and west side of my clients' current property on Old Portland Road. Specifically, my clients own:

Parcel CC in the South 349.64 feet of the West 794 feet of the Northwest Quarter (NW $\frac{1}{4}$ ) of the Southwest Quarter (SW $\frac{1}{4}$ ) in Section 33, Township 79 North, Range 27 West of the 5th P.M.

I had a difficult time finding the legal descriptions of the city parcels which my clients wish to purchase. I attach an aerial photograph with an outline of the properties which the city owns. Specifically, both parcels are approximately 110 x 200 feet, and one lies immediately west of Parcel CC, and the second parcel lies immediately east of Parcel CC. The eastern parcel would be the piece of ground between my client's property and the city's archery property. My clients do not wish to purchase any part of the road providing access to the parcels referenced or the archery property.

In exchange for a deed from the city for both parcels, my clients will pay \$7,500. If approved by the city, I presume you and I would then draft a purchase agreement providing for the standard terms in any real estate transaction. Please let me know if you have any questions regarding this offer. Please do let me know when this matter will appear on the agenda for a council meeting, and I will let my clients know as I believe they would like to attend the meeting to answer any questions from the council. Thank you.

John O. Reich  
March 17, 2017  
Page 2

Yours truly,

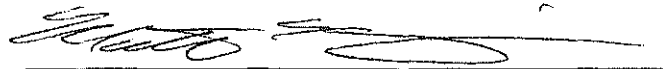
A handwritten signature in black ink, appearing to read "Matthew J. Hemphill", written over a horizontal line.

Matthew J. Hemphill

MJH:ikt  
Encl.  
cc: Tom and Linda Fuller



Google Earth



# Dallas County GIS

- Home
- Parcel Search
- Survey Points
- Contact Us
- Print



### Parcel Info

Parcel ID:	1133300008
Primary Name:	T & L Enterprises LLC
Address:	1505 OLD PORTLAND RD ADEL
Legal Desc:	PARCEL CC S349.64' W794' NW SW
Net Acres:	1
Links:	<a href="#">Assessor Info</a> <a href="#">Tax Info (Solutions)</a>

### Parcel Search Options

Deedholder:

Parcel #:

Property Address:

Legal Desc:

XMin: 1500417.87 YMin: 584378.84 XMax: 1502714.95 YMax: 585774.64  
 1501719.9476366073, 585232.2700886158 0 191ft

**Dallas County GIS** Home Parcel Search Survey Points Contact Us Print



**Parcel Info**

Parcel ID:	1133300009
Primary Name:	Adel, City Of
Address:	
Legal Desc:	S349.64' W794' NW SW /EX PARCEL CC/
Net Acres:	5
Links:	Assessor Info Tax Info (Solutions)

**Parcel Search Options**

Deedholder:

Parcel #:

Property Address:

Legal Desc:

Chris Whitaker  
 2017 Western Iowa Advantage Annual Banquet  
 View this email in your browser  
<http://us2.campaign-archive2.com/?l>  
 Outlook 2013

XMin: 1500417.87 YMin: 584378.84 XMax: 1502714.95 YMax: 585774.64  
 1502712.95793578127, 584562.2876261157 0 191ft

Recreation Update Continued

**D. Final Program Report**

Schenck and the board discussed the Final Program report for the 2017 Adult Coed Indoor Volleyball League.

Parks Department Update

**A. Seasonal Tasks Preparations**

The Parks Department is in high gear preparing for the start to the 2017 outside season in our local parks. Water sources such as restrooms and water fountains should be re-energized the week of April 10<sup>th</sup>. Schenck anticipates the mowing season to begin around April 12-13. Volleyball and Tennis Court nets are up and trash receptacles have been put out all outdoor venues.

**B. Archery Range land purchase**

The board viewed a map of some City-owned land around the City of Adel Archery Range and also around Fuller's bulk fuel storage area. The City of Adel has noticed the Fuller Property to be moving closer and closer to the Archery Range. Mr. Fuller has offered to purchase land on both sides of his business for \$7,500.00 A **motion to recommend that the City of Adel consult with an engineer to ensure that no flooding issues or wash-outs occur to the Archery Range or City Land before any sale of land was made by Board Member Nordman. Board Member Fisher Seconded. Ayes 6, Nays-0 Motion Carries**