

Contents

Brief Introduction.....	2
1. USE:.....	2
2. MANUAL OPERATION:	2
3. AUTOMATED OPERATION:	2
4. GENERAL INFORMATION FOR ON-SITE INSTALLATION:	2
5. GENERAL SAFETY PRECAUTIONS BEFORE DISASSEMBLING & CLEANING THE VALVE:.....	2
6. DISASSEMBLING, CLEANING AND REBUILDING THE VALVE:.....	2
REASSEMBLY OF VALVE	3
Assembling handle for 1-1/2” and 2” valves:	8
Assembling handle for 2-1/2” thru 4”	9
Assembling handle for 6” Valve.....	10
Table A: Torque Values to Tighten the Body/Cover Studs and Nuts.....	12
Table B: Torque Values to Tighten the Gland Bolt /Nut For Stem Packing	12
TABLE C: COVER STUD AND COVER NUT, BODY STUD AND BODY NUT TIGHTENING SEQUENCE.....	13
COVER STUD AND NUT TIGHTEN SEQUENCE:	13
BODY STUD AND NUT TIGHTEN SEQUENCE:.....	13
EXPLODED VIEW AND BILL OF MATERIALS	14
EXPLODED VIEW	14
BILL OF MATERIALS.....	15
REPAIR KITS	16

Brief Introduction

The Series 31 Three-way multi-port ball valve allows for easy replacement of gasket, seal, and seats without special tools. Series 31 ball valves use a trunnion ball design. The ball stem, ball and lower trunnion shaft are one piece.

1. USE:

- 1.1 Life of valve can be maximized if the valve is used within the rated range, in accordance with pressure, temperature, and corrosion data.
- 1.2 As shipped from the factory, valves contain silicone-free lubricant. If silicone free lubricate is unacceptable for your application, you may disassemble the valve and wash the parts in solvent. The valves may also be ordered from the factory either degreased and bagged or oxygen cleaned.

2. MANUAL OPERATION:

- 2.1 To change flow pattern of the valve, turn the handle ¼ turn (90 degrees).
- 2.2 Both T port and L port are available.
- 2.3 Flow path is clearly marked on the stem and handle washer.

3. AUTOMATED OPERATION:

- 3.1 Valves with actuators should be checked for valve stem alignment. Angular or linear misalignment will result in high operational torque and unnecessary wear on the stem seal.

4. GENERAL INFORMATION FOR ON-SITE INSTALLATION:

- 4.1 The valve may be fitted in any position on the pipeline.
- 4.2 To prevent damage to the seats and ball surface, the pipeline must be flushed, free of dirt, burrs, and welding residues before installing the valve.

5. GENERAL SAFETY PRECAUTIONS BEFORE DISASSEMBLING & CLEANING THE VALVE:

CAUTION, FLUIDS CAN BE TRAPPED IN THE BODY OF THE VALVE POSSIBLY UNDER HIGH PRESSURE.

!!!WARNING!!!

FOR YOUR SAFETY, IT IS IMPORTANT THAT THE FOLLOWING PRECAUTIONS BE TAKEN BEFORE REMOVAL OF THE VALVE FROM THE LINE OR ANY DISASSEMBLY.

- 5.1 If the valve has been used to control hazardous media, it must be decontaminated before disassembly. It is recommended that the following steps are taken for safe removal and reassembly.
- 5.2. Wear protective clothing and equipment when working with potentially harmful fluids.
- 5.3. Depressurize the line and cycle the valve as follows:
- 5.4. Place the valve in a mid-port position and drain the line.
- 5.5. Cycle the valve to relieve residual pressure in the body cavity before removal from the line.
- 5.6. Allow valve to cool if valve is used in high temperature applications.
- 5.7. After removal and before any disassembly, cycle the valve again several times to relieve extra trapped fluids or gases in the body section.

6. DISASSEMBLING, CLEANING AND REBUILDING THE VALVE:

Caution When replacing Teflon parts, please replace all seats, joint gaskets, Gland packing and stem O-ring.

- 6.1 Carefully mark the orientation of the top cover to the body and each end cap to the body. This will make reassembly of the valve more accurate.
- 6.2 Loosen and remove handle stop bolt (21) & bolt nut (22). Loose set screw in the side of the handle. Then remove handle screw (19), lift off handle. For valves 2-1/2" thru 6" remove handle screw (19), remove indicator plate (18), and lift off handle (16) and handle hub (17) together.

- 6.3 Remove gland nuts (28) then remove gland bolts (27) Note on the 6" valve only the Belleville washers (14) are on the packing gland bolts. Lift packing gland (20) straight up. Remove Belleville washers (14) note orientation of washers then remove gland bushing (13). **DO NOT ATTEMPT TO REMOVE PACKING FROM THE GLAND NOW.**
- 6.4 Loosen nuts (24), take out end cap (2), the seats (5) should come out with the end caps. Also remove the joint gasket (9).
- 6.5 Remove cover nuts (25), lift off top cover (3) and cover joint gasket (10).
- 6.6 Carefully remove packing (part no. 10) from top cover by using a suitable tool that will not damage/scratch the packing gland.
- 6.7 Carefully remove ball / stem (4) from body. Remove stem O-ring (11) from stem.
- 6.8 Remove thrust washer (6), trunnion bushing (7) and anti-static spring (8).
- 6.9 Clean all the metal parts the valve. Then inspect for damage or wear. Any parts that are worn or damaged must be replaced before valve can be reassembled.

REASSEMBLY OF VALVE

- 6.10 Install the Trunnion bushing (7) into the trunnion cavity in the bottom of the body.



- 6.11 Put the anti-static spring (8) into the trunnion bushing.

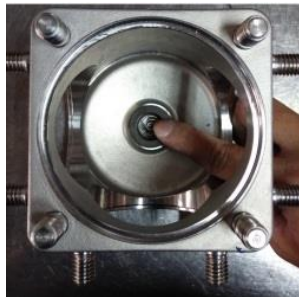

- 6.12 Place the thrust washer (6) on top of the trunnion bushing.



6.13 Carefully lower ball/stem into the body. Use care that the lower trunnion slides thru the thrust washer (6) and into the trunnion bushing (7). Rotate to make sure ball rotates freely in trunnion bushing.



6.14 Lightly lubricate O-ring (11) with a compatible lubricate for the service. Carefully install O-ring (11) onto the ball/stem groove (4). Make sure the top cover studs and all end cap studs are fully seated in the body.



6.15 Place cover gasket (10) in place on the top cover. Realign the top cover to the body per the alignment marks when the valve was disassembled. Lower top cover (3) carefully over O-ring until top cover contacts the body (1). Check to make sure, the cover gasket is properly seated.



6.16 Install top cover nuts (25) hand tight. Rotate stem to check for freedom of rotation. Then torque nuts to 25% of torque value in Table A and tighten in diagonal pattern per Table C. Rotate stem again to check smooth rotation. Tighten top cover nuts to 100% of torque value again in a diagonal pattern per Table A. Stem should rotate freely.



6.17 Place the seats (5) into the end caps (2), make certain that the seats are installed correctly. Then slide the joint gaskets (9) onto the end caps (2). For the 6" valve only see the drawing below for the correct installation of the seat.



6" SERIES 31 SEAT ORIENTATION

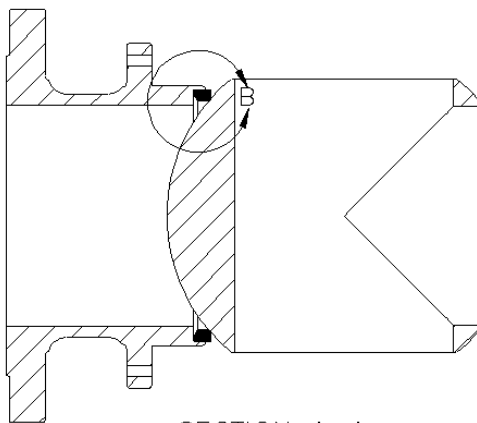

SECTION A-A
SCALE 1 : 4

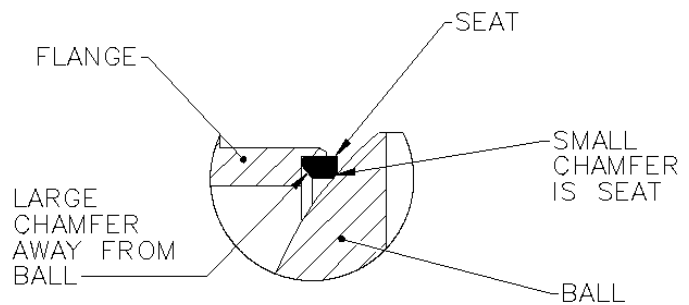

DETAIL B
SCALE 1 : 2

6.18 Mount end cap (2) to the body (1), material code must be facing up. Hand tighten end cap nuts (24). Then move on to the next end cap and repeat process for remaining 2 end caps. Rotate valve and make sure all seats and end caps are in alignment. Rotate stem/ball till a closed port is facing you. Then tighten end cap nuts to 25% of torque value in Table A in a diagonal pattern per Table A. Rotate valve stem 90 degrees or until the port is closed on the next end cap. Then tighten end cap nuts to 25% of torque value in Table A in a diagonal pattern per Table A. Repeat for the last end cap. Rotate the stem and check for smooth operation. Repeat entire process tightening the end cap nuts to the torque value in Table A. This process allows the seats to confirm to the ball gradually and greatly increases the life of the seats.



6.19 Rotate the valve to the correct port orientation.



6.20 Slide the PTFE gland packing (12) over the stem and into the body. The darker colored (RTFE) piece goes in last or on top.



6.21 Place the gland bush (13) over the stem and slide down to contact the gland packing.



6.22 Install the Belleville washers (14) onto the stem. Except for the 6" size see below installation pictures.



6.23 Place the packing gland (20) over the stem and slide down to the Belleville washers.



6.24 Slide the gland bolt (27), into the packing gland (20), tighten the gland nut (28) by hand, keeping the packing gland level.



6.25 Please refer to the torque figure (See Table B) to tighten the gland (#13).



For 6" Valve Only

6.26 Put the 4 each Belleville washers (14) and packing gland nut (29), tighten up per the torque value in Table B. Use care to tighten each side equally.



Assembling handle for 1-1/2" and 2" valves:

Place handle (20), over the valve stem in the correct orientation. Insert handle bolt (19) and tighten. Also retighten setscrew on lower portion of handle against stem flats. Place handle stop bolt (22) in the mounting pad hole, and then put nut & washer (23) on the handle stop bolt and tighten.

If the valve was equipped with an actuator or manual gear replace in the reverse order that it was removed.

Check the valve assembly for smooth operation. Test for leakage both externally and the seats based on the application requirements.



Assembling handle for 2-1/2” thru 4”

1. Place handle hub (17) over stem in correct orientation.



2. Place the handle (16) thru the hub.



3. Place handle bushing into hub.



4. Insert indicator plate (18), and lock washer onto handle bolt (19). Feed assembly thru handle bushing and into valve stem and tighten. Make sure indicator plate indicates correct flow pattern. Install handle stop bolt and tighten.
5. If the valve was equipped with an actuator or manual gear replace in the reverse order that it was removed.
6. Check the valve assembly for smooth operation. Test for leakage both externally and the seats based on the application requirements.



Assembling handle for 6" Valve

1. Place handle hub (17) over stem in correct orientation.



2. Place the handle (16) thru the hub.



3. Place the washer and indicator plate (18), over the handle bolt (19) and tighten. Also tighten set screw in lower portion of hub next to stem flats.
4. Make sure indicator plate indicates correct flow pattern.

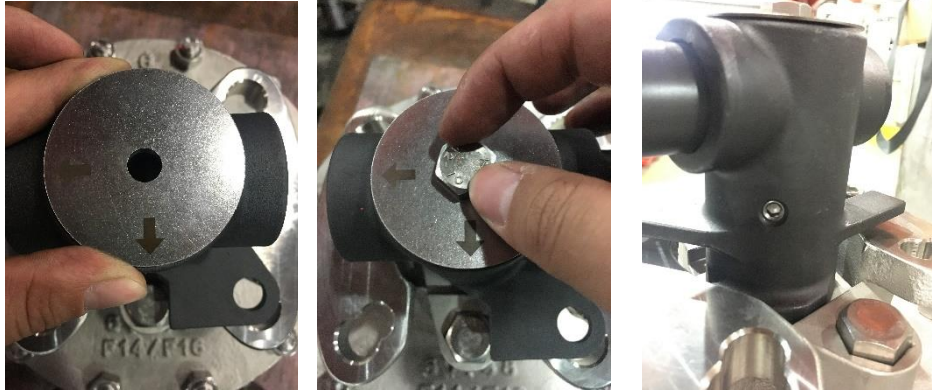

5. Install handle stop bolt (22) and tighten.



7. If the valve was equipped with an actuator or manual gear replace in the reverse order that it was removed.
8. Check the valve assembly for smooth operation. Test for leakage both externally and the seats based on the application requirements.

Table A: Torque Values to Tighten the Body/Cover Studs and Nuts.

Valve Size	Bolt specification	Torque FT*LBS
1-1/2"	3/8"-16UNC	35
2"	7/16"-14UNC	45
2-1/2"	9/16"-12UNC	850
3"	5/8"-11UNC	70
4" (End Cap)	1/2"-13UNC	70
4" (Top Cover)	5/8"-11UNC	48
6"	5/8"-11UNC	70

Table B: Torque Values to Tighten the Gland Bolt /Nut For Stem Packing

Valve Size	Bolt Specification	Torque FT*LBS
1-1/2"	M10	7
2"	M10	7
2-1/2"	M12	13
3"	M12	13
4"	M14	20
6"	M16	26

TABLE C: COVER STUD AND COVER NUT, BODY STUD AND BODY NUT TIGHTENING SEQUENCE

The illustrations below illustrate how to tighten the Studs and nuts on the top cover and end caps in a diagonal pattern.

COVER STUD AND NUT TIGHTEN SEQUENCE:

1-1/2" ~ 3"

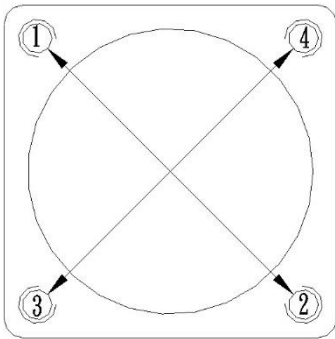

4"

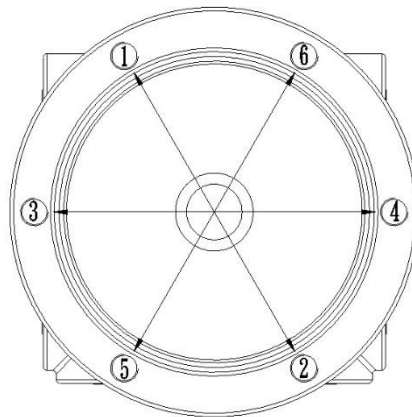

6"

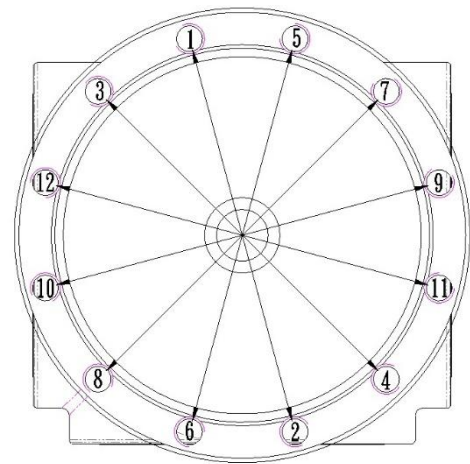

BODY STUD AND NUT TIGHTEN SEQUENCE:

1-1/2"~3"

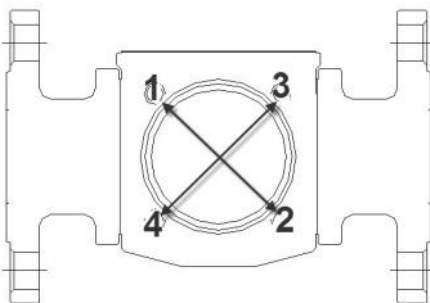

4"

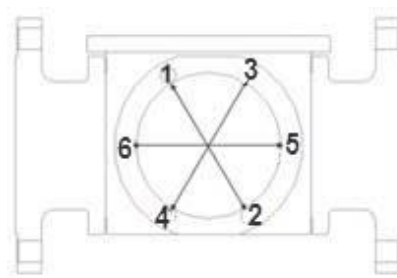

6"

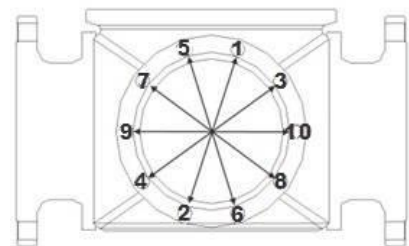

EXPLODED VIEW AND BILL OF MATERIALS

EXPLODED VIEW

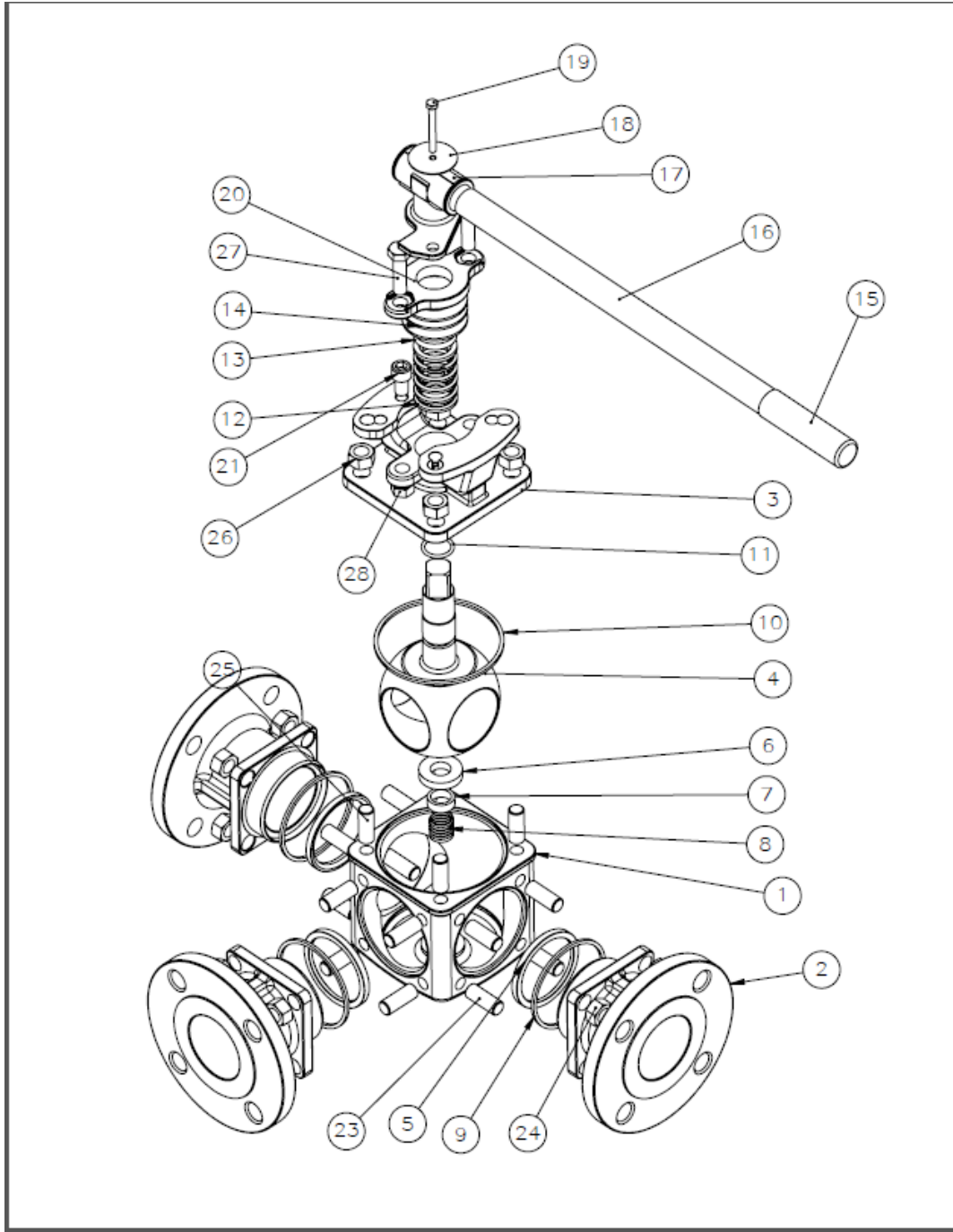

BILL OF MATERIALS

NO.	PART NAME	QTY	STAINLESS	CARBON	SPARE
			STEEL	STEEL	PART
1	BODY	1	ASTM A351 GRADE CF8M	ASTM A216 GRADE WCB	
2	END CAP	3	ASTM A351 GRADE CF8M	ASTM A216 GRADE WCB	
3	TOP COVER	1	ASTM A351 GRADE CF8M	ASTM A216 GRADE WCB	
4	BALL & STEM	1	ASTM A351 GRADE CF8M	ASTM A351 GRADE CF8M	
5	SEAT	3	RTFE	RTFE	*
6	THRUST WASHER	1	50/50 STFE	50/50 STFE	*
7	TRUNNION BUSHING	1	PEEK	PEEK	*
8	ANTI-STATIC SPRING	1	AISI 316	AISI 316	*
9	JOINT GASKET	3	PTFE	PTFE	*
10	COVER GASKET	1	PTFE	PTFE	*
11	STEM O-RING	1	FKM	FKM	*
12	GLAND PACKING	1 SET	PTFE	PTFE	*
13	GLAND BUSHING	1	AISI 304	AISI 304	
14	BELLEVILLE WASHER	3 *	AISI 301	AISI 301	
15	HANDLE SLEEVE	1	VINYL	VINYL	
16	HANDLE BAR -2-1/2" -3"	1	AISI 304	AISI 304	
16	HANDLE BAR -4"-6"	1	CARBON STEEL	CARBON STEEL	
17	HANDLE HUB-2-1/2" -4"	1	ASTM A351 GRADE CF8	ASTM A351 GRADE CF8	
17	HANDLE HUB-6"	1	WCB	WCB	
18	INDICATOR PLATE	1	AISI 304	AISI 304	
19	HANDLE BOLT	1	AISI 304	AISI 304	
20	HANDLE -1-1/2" -2"	1	AISI 304	AISI 304	
21	PACKING GLAND	1	ASTM A351 GRADE CF8	ASTM A351 GRADE CF8	
22	HANDLE STOP BOLT	1	AISI 304	AISI 304	
23	NUT & WASHER	1	AISI 304	AISI 304	
24	BODY STUD	#	ASTM A193 GRADE B8	ASTM A193 GRADE B8	
25	BODY NUT	#	ASTM A194 GRADE 8	ASTM A194 GRADE 8	
26	COVER NUT	^	ASTM A193 GRADE B8	ASTM A193 GRADE B8	
27	COVER STUD	^	ASTM A194 GRADE 8	ASTM A194 GRADE 8	
28	PACKING GLAND BOLT	2	AISI 304	AISI 304	
29	PACKING GLAND NUT	2	AISI 304	AISI 304	
A set of Gland Packing is 6 pcs for 1.1/2" thru 4", 7 pcs for 6"					
* 6" 8 PCS. (4 EA ON THE PACKING GLAND BOLT)					
# 1-1/2" THRU 3" 12 PCS, 4" 18 PCS., 6" 30 PCS					
^ 1-1/2" THRU 3" 4 PCS, 4" 6 PCS., 6" 12 PCS					

REPAIR KITS

SIZE	RTFE	STFE	PTFE	TFM-1600
1-1/2"	31-RK-0150-RTFE	31-RK-0150-STFE	31-RK-0150-PTFE	31-RK-0150-TFM
2"	31-RK-0200-RTFE	31-RK-0200-STFE	31-RK-0200-PTFE	31-RK-0200-TFM
2-1/2"	31-RK-0250-RTFE	31-RK-0250-STFE	31-RK-0250-PTFE	31-RK-0250-TFM
3"	31-RK-0300-RTFE	31-RK-0300-STFE	31-RK-0300-PTFE	31-RK-0300-TFM
4"	31-RK-0400-RTFE	31-RK-0400-STFE	31-RK-0400-PTFE	31-RK-0400-TFM
6"	31-RK-0600-RTFE	31-RK-0600-STFE	31-RK-0600-PTFE	31-RK-0600-TFM

REPAIR KITS INCLUDE: 3 SEATS, PTFE GLAND PACKING SET, FKM O-RING, PTFE COVER GASKET & 3 EA. JOINT GASKETS, PEEK TRUNNION BEARING AND 50/50 STFE TRUNNION WASHER, 316 SST ANTI STATIC SPRING

SIZE	TFM-1600 SEATS/ PACKING/GASKETS,FFKM O-RING	STFE SEAT /GRAFOIL PACKING/GASKETS, FFKM O-RING
1-1/2"	31-RK-0150-TFM-TFM	31-RK-0150-STFE-GFF
2"	31-RK-0200-TFM-TFM	31-RK-0200-STFE-GFF
2-1/2"	31-RK-0250-TFM-TFM	31-RK-0250-STFE-GFF
3"	31-RK-0300-TFM-TFM	31-RK-0300-STFE-GFF
4"	31-RK-0400-TFM-TFM	31-RK-0400-STFE-GFF
6"	31-RK-0600-TFM-TFM	31-RK-0600-STFE-GFF

REPAIR KITS INCLUDE: 3 SEATS, GLAND PACKING SET, FFKM O-RING, COVER GASKET & 3 EA. JOINT GASKETS,PEEK TRUNNION BEARING AND 50/50 STFE TRUNNION WASHER, 316 SST ANTI-STATIC SPRING

A-T Controls product, when properly selected, is designed to perform its intended function safely during its useful life. However, the purchaser or user of A-T Controls products should be aware that A-T Controls products might be used in numerous applications under a wide variety of industrial service conditions. Although A-T Controls can provide general guidelines, it cannot provide specific data and warnings for all possible applications. The purchaser / user must therefore assume the ultimate responsibility for the proper sizing and selection, installation, operation, and maintenance of A-T Controls products. The user should read and understand the installation operation maintenance (IOM) instructions included with the product, and train its employees and contractors in the safe use of A-T Controls products in connection with the specific application.

While the information and specifications contained in this literature are believed to be accurate, they are supplied for informative purposes only. Because A-T Controls is continually improving and upgrading its product design, the specifications, dimensions and information contained in this literature are subject to change without notice. Should any question arise concerning these specifications, the purchaser/user should contact A-T Controls.

For product specifications go to <http://download.a-tcontrols.com/>

A-T Controls, Inc. • 9955 International Boulevard, Cincinnati, OH 45246 • Phone: (513) 530-5175 • Fax: (513) 247-5462 • www.a-tcontrols.com